



Project _____
 AIA # _____ SIS # _____
 Item # _____ Quantity _____ C.S.I. Section 114000



PW2E Double Wide Proof Box



SPECIFIER STATEMENT

The proofer shall be of stainless steel construction, manufactured in the United States by Baxter Mfg. The unit footprint shall be no wider than 62.0" and have two height options to meet the needs of the site and the project. Built using modular panel construction with cam lock attachment, the proofer shall incorporate foam insulation and gaskets to form a strong, energy efficient enclosure. Nonmetallic Interior bumpers shall protect the interior on all sides.

The proofer shall include eye level, digital controls in the door and a patented air flow system. No ramp is required for this unit. The controls will independently set temperature and humidity for precise proofing control. Four individual count-down timers for products with different time requirements shall be provided. The air flow system will include an internally mounted humidifier. No flush cleaning is required. The door shall be hinged so as not to require a center jamb, giving maximum access to the proofer interior.

The proofer will bear the following agency approvals: UL for safety and sanitation for the U.S. and Canada.

STANDARD FEATURES

- + Patented air flow system
- + Easy access heat and humidity system
 - Internally mounted
 - No flushing required
- + Eye-level digital control panel
 - Set heat/humidity system
 - Four independent timers
- + Stainless steel interior and exterior
- + Modular panel construction with cam lock attachment
- + Field assembled – shipped knocked down
- + Open floor – no ramp required
- + 99.5" overall height to match rack oven

OPTIONS & ACCESSORIES

- Low profile, 94" overall height
- Stainless steel floor – no ramp required
- Interior light
- Prison package
- Upper side trim – 1 or 2 sides

MODEL CONFIGURATIONS

- 40.5"D** – May be shipped assembled
 - Two Single End or Three Side Load Racks, or One Double Rack
- 60.5"D**
 - Four Single End or Side Load Racks, or Two Double Racks
- 80.5"D**
 - Five Single End or Six Side Load Racks, or Two Double Racks
- 100.5"D**
 - Six Single End or Eight Side Load Racks, or Three Double Racks
- 120.5"D**
 - Eight Single End or Ten Side Load Racks, or Three Double Racks

PW2E DOUBLE WIDE PROOF BOX

Approved by _____ Date _____ Approved by _____ Date _____



PW2E Double Wide Proof Box

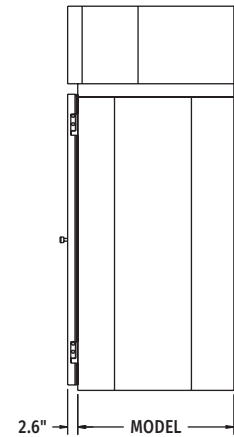
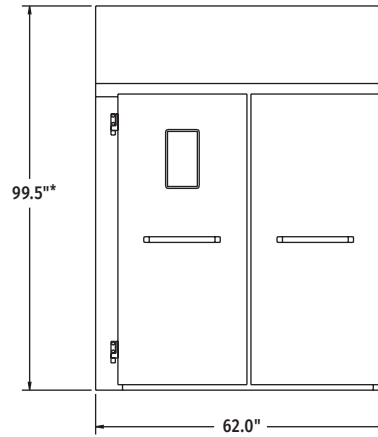
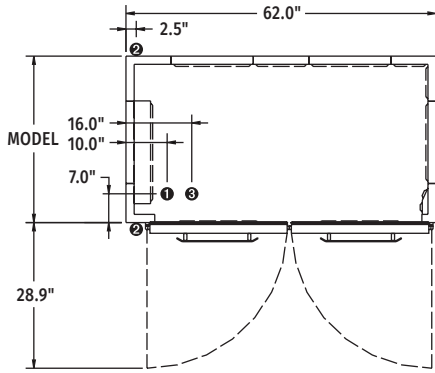

*94.0" height if low profile front trim is ordered.

Maximum Rack Height: 74" (188cm) Freight Class: 85

PHYSICAL DATA	MODEL 40.5"D	MODEL 60.5"D	MODEL 80.5"D	MODEL 100.5" D	MODEL 120.5"D
Interior Dimensions	37.8"D x 52.6"W x 74.5"H	57.8"D x 52.6"W x 74.5"H	77.8"D x 52.6"W x 74.5"H	97.8"D x 52.6"W x 74.5"H	117.8"D x 52.6"W x 74.5"H
Exterior Dimensions	43.3"D x 62.0"W	63.3"D x 62.0"W	83.3"D x 62.0"W	103.3"D x 62.0"W	123.3"D x 62.0"W
Net Door Opening Height	74.5"	74.5"	74.5"	74.5"	74.5"
Net Door Opening Width	51.0"	51.0"	51.0"	51.0"	51.0"
Power Input with Neutral ^A	208-240V/60/1/18-21A or 208-240V/60/3/18-21A	208-240V/60/1/37-41A or 208-240V/60/3/32-36A	208-240V/60/1/37-41A or 208-240V/60/3/32-36A	208-240V/60/1/37-41A or 208-240V/60/3/32-36A	208-240V/60/1/37-41A or 208-240V/60/3/32-36A
Heat Wattage (KW)	3.3-4.4	6.6-8.8	6.6-8.8	6.6-8.8	6.6-8.8
Water Flow Rate (GPM)	0.5	1.0	1.0	1.0	1.0
Maximum Water Usage (GPH)	1.0	2.0	2.0	2.0	2.0

UTILITIES & NOTES

- ❶ **Water:** ½" FNPT cold water 30-80 psi at 85" (215.9 cm) AFF. Maximum water usage varies by depth. See chart above for specific information.
Note: Water supply must have the proper hardness, pH & chloride concentration. Consult your local water company and/or water conditioner dealer before installation.
 - **Required water hardness range:** 2-4 grains per gallon.
 - **Required pH range:** 7.0-8.0.
 - **Acceptable range for chloride concentration:** 0-30 ppm.
- ❷ **Drain:** ½" FNPT, front or rear drain at 5" (12.7 cm) AFF. Route to air-gap drain.
- ❸ **Power:** Provide connection(s) at 85" (215.9 cm) AFF. See chart above for specific information.
- ^A **Neutral wire circuitry** needed to provide 110-120V for control components. A separate line may be run or a transformer will be required if 110-120V is not available.

INSTALLATION

- Floor should be level within ¼" per foot for proper installation. Slope should not exceed ¼" in all directions under the unit. Proofers without the floor option must be installed on a corrosion resistant and cleanable surface.
- ❷ **Shipping:** Contact factory for shipping information.
 - Important:**
 - Do not route utilities (wiring, plumbing, etc.) in or under the non-combustible floor beneath the proofer.
 - A minimum of 1" airgap between proofer and oven recommended to ensure proper proofer operation.
 - 10' ceiling height is recommended for proper airflow and service access.

As continued product improvement is a policy of Baxter, specifications are subject to change without notice.

CAD and/or Revit Files Available