

AQ-F213

Feeder protection IED

Instruction manual



Table of contents

1 Document information	6
1.1 Version 2 revision notes	6
1.2 Version 1 revision notes	8
2 Abbreviations	9
3 General	11
4 IED user interface	12
4.1 Panel structure	12
4.1.1 Local panel structure	12
4.2 Mimic and main menu	13
4.2.1 Basic configuration	13
4.2.2 Navigation in the main configuration menus	13
4.3 General menu	14
4.4 Protection menu	17
4.5 Control menu	23
4.6 Communication menu	38
4.7 Measurement menu	41
4.8 Monitoring menu	46
4.9 Configuring user levels and their passwords	49
5 Functions	52
5.1 Functions included in AQ-F213	52
5.2 Measurements	54
5.2.1 Current measurement and scaling	54
5.2.2 Voltage measurements and scaling	67
5.2.3 Power and energy calculation	76
5.2.4 Frequency tracking and scaling	84
5.3 Protection functions	87
5.3.1 General properties of a protection function	87
5.3.2 Non-directional overcurrent protection ($I>$; 50/51)	95
5.3.3 Non-directional earth fault protection ($I0>$; 50N/51N)	102
5.3.4 Directional overcurrent protection ($I_{dir}>$; 67)	106
5.3.5 Directional earth fault protection ($I0_{dir}>$; 67N/32N)	114
5.3.6 Negative sequence overcurrent/ phase current reversal/ current unbalance protection ($I2>$; 46/46R/46L)	127
5.3.7 Harmonic overcurrent protection ($I_h>$; 50H/51H/68H)	132
5.3.8 Circuit breaker failure protection (CBFP; 50BF/52BF)	139
5.3.9 Low-impedance or high-impedance restricted earth fault/ cable end differential protection ($I0d>$; 87N)	154
5.3.10 Overvoltage protection ($U>$; 59)	163
5.3.11 Undervoltage protection ($U<$; 27)	168
5.3.12 Neutral overvoltage protection ($U0>$; 59N)	175
5.3.13 Sequence voltage protection ($U1/U2>/<$; 47/27P/59PN)	181
5.3.14 Overfrequency and underfrequency protection ($f>/<$; 81O/81U)	189
5.3.15 Rate-of-change of frequency ($df/dt>/<$; 81R)	194
5.3.16 Overpower protection ($P>$; 32O)	200
5.3.17 Underpower protection ($P<$; 32U)	203
5.3.18 Reverse power protection (P_r ; 32R)	207
5.3.19 Line thermal overload protection ($TF>$; 49F)	210
5.3.20 Resistance temperature detectors	231
5.3.21 Arc fault protection ($I_{Arc}>/I0_{Arc}>$; 50Arc/50NArc)	236
5.3.22 Programmable stage ($PGx>/<$; 99)	245
5.3.23 Voltage memory	259
5.4 Control functions	262
5.4.1 Setting group selection	262
5.4.2 Object control and monitoring	271
5.4.3 Indicator object monitoring	281

5.4.4 Auto-recloser (79)	282
5.4.5 Cold load pick-up (CLPU).....	309
5.4.6 Switch-on-to-fault (SOTF)	318
5.4.7 Milliampere output control	320
5.4.8 Vector jump ($\Delta\phi$; 78)	322
5.4.9 Programmable control switch	328
5.4.10 Analog input scaling curves	329
5.4.11 Logical outputs	331
5.4.12 Logical inputs	332
5.5 Monitoring functions	333
5.5.1 Current transformer supervision	333
5.5.2 Voltage transformer supervision (60)	343
5.5.3 Circuit breaker wear	347
5.5.4 Fault locator (21FL)	351
5.5.5 Total harmonic distortion (THD)	353
5.5.6 Disturbance recorder (DR)	358
5.5.7 Measurement recorder	369
5.5.8 Measurement value recorder	373
6 System integration.....	378
6.1 Communication protocols	378
6.1.1 NTP	378
6.1.2 Modbus/TCP and Modbus/RTU	379
6.1.3 Modbus I/O	380
6.1.4 IEC 61850	380
6.1.5 GOOSE	382
6.1.6 IEC 103	382
6.1.7 DNP3	383
6.1.8 IEC 101/104	385
6.1.9 SPA	387
6.2 Analog fault registers	387
6.3 Real-time measurements to communication	387
7 Connections and application examples.....	390
7.1 Connections of AQ-F213	390
7.2 Application example and its connections.....	392
7.3 Two-phase, three-wire ARON input connection	393
7.4 Trip circuit supervision (95)	394
8 Construction and installation	399
8.1 Construction.....	399
8.2 CPU module	402
8.3 Current measurement module	404
8.4 Voltage measurement module.....	405
8.5 Digital input module (optional).....	406
8.6 Digital output module (optional)	408
8.7 Arc protection module (optional)	409
8.8 RTD input module (optional).....	410
8.9 Serial RS-232 communication module (optional)	411
8.10 LC 100 Mbps Ethernet communication module (optional).....	413
8.11 Double ST 100 Mbps Ethernet communication module (optional)	414
8.12 Double RJ-45 10/100 Mbps Ethernet communication module (optional)	416
8.13 Milliampere (mA) I/O module (optional)	418
8.14 Dimensions and installation.....	418
9 Technical data	421
9.1 Hardware.....	421
9.1.1 Measurements	421
9.1.1.1 Current measurement.....	421
9.1.1.2 Voltage measurement.....	422
9.1.1.3 Power and energy measurement.....	423
9.1.1.4 Frequency measurement	423
9.1.2 CPU & Power supply	423

9.1.2.1	Auxiliary voltage.....	423
9.1.2.2	CPU communication ports.....	424
9.1.2.3	CPU digital inputs.....	425
9.1.2.4	CPU digital outputs.....	425
9.1.3	Option cards.....	426
9.1.3.1	Digital input module.....	426
9.1.3.2	Digital output module.....	427
9.1.3.3	Arc protection module.....	427
9.1.3.4	Milliampere module (mA out & mA in).....	428
9.1.3.5	RTD input module.....	429
9.1.3.6	RS-232 & serial fiber communication module.....	429
9.1.3.7	Double LC 100 Mbps Ethernet communication module.....	429
9.1.4	Display.....	429
9.2	Functions.....	430
9.2.1	Protection functions.....	430
9.2.1.1	Non-directional overcurrent protection ($I>$; 50/51).....	430
9.2.1.2	Non-directional earth fault protection ($I0>$; 50N/51N).....	431
9.2.1.3	Directional overcurrent protection ($I_{dir}>$; 67).....	432
9.2.1.4	Directional earth fault protection ($I0_{dir}>$; 67N/32N).....	433
9.2.1.5	Negative sequence overcurrent/ phase current reversal/ current unbalance protection ($I2>$; 46/46R/46L).....	434
9.2.1.6	Harmonic overcurrent protection ($I_h>$; 50H/51H/68H).....	434
9.2.1.7	Circuit breaker failure protection (CBFP; 50BF/52BF).....	435
9.2.1.8	Low-impedance or high-impedance restricted earth fault/ cable end differential protection ($I0d>$; 87N).....	436
9.2.1.9	Overvoltage protection ($U>$; 59).....	437
9.2.1.10	Undervoltage protection ($U<$; 27).....	437
9.2.1.11	Neutral overvoltage protection ($U0>$; 59N).....	438
9.2.1.12	Sequence voltage protection ($U1/U2>/<$; 47/27P/59NP).....	439
9.2.1.13	Overfrequency and underfrequency protection ($f>/<$; 81O/81U).....	440
9.2.1.14	Rate-of-change of frequency protection ($df/dt>/<$; 81R).....	440
9.2.1.15	Line thermal overload protection ($TF>$; 49F).....	441
9.2.1.16	Overpower ($P>$; 32O), underpower ($P<$; 32U) and reverse power (P_r ; 32R) protection.....	442
9.2.1.17	Resistance temperature detectors.....	443
9.2.1.18	Arc fault protection ($I_{Arc}>/I0_{Arc}>$; 50Arc/50NArc) (optional).....	443
9.2.1.19	Voltage memory.....	444
9.2.2	Control functions.....	444
9.2.2.1	Setting group selection.....	444
9.2.2.2	Object control and monitoring.....	445
9.2.2.3	Auto-reclosing ($0 \rightarrow 1$; 79).....	445
9.2.2.4	Cold load pick-up (CLPU).....	446
9.2.2.5	Switch-on-to-fault (SOTF).....	446
9.2.2.6	Vector jump ($\Delta\phi$; 78).....	446
9.2.3	Monitoring functions.....	447
9.2.3.1	Current transformer supervision.....	447
9.2.3.2	Voltage transformer supervision (60).....	448
9.2.3.3	Circuit breaker wear monitoring.....	448
9.2.3.4	Total harmonic distortion.....	449
9.2.3.5	Fault locator (21FL).....	449
9.2.3.6	Disturbance recorder.....	450
9.3	Tests and environmental.....	450
10	Ordering information.....	453
11	Contact and reference information.....	454

Disclaimer

Please read these instructions carefully before using the equipment or taking any other actions with respect to the equipment. Only trained and qualified persons are allowed to perform installation, operation, service or maintenance of the equipment. Such qualified persons have the responsibility to take all appropriate measures, including e.g. use of authentication, encryption, anti-virus programs, safe switching programs etc. necessary to ensure a safe and secure environment and usability of the equipment. The warranty granted to the equipment remains in force only provided that the instructions contained in this document have been strictly complied with.

Nothing contained in this document shall increase the liability or extend the warranty obligations of the manufacturer Arcteq Relays Ltd. The manufacturer expressly disclaims any and all liability for any damages and/or losses caused due to a failure to comply with the instructions contained herein or caused by persons who do not fulfil the aforementioned requirements. Furthermore, the manufacturer shall not be liable for possible errors in this document.

Please note that you must always comply with applicable local legislation and regulations. The manufacturer gives no warranties that the content of this document is in all respects in line with local laws and regulations and assumes no liability for such possible deviations.

You are advised to notify the manufacturer in case you become aware of any errors in this document or of defects in the equipment.

The manufacturer reserves the right to update or amend this document at any time.

Copyright

Copyright © Arcteq Relays Ltd. 2021. All rights reserved.

1 Document information

1.1 Version 2 revision notes

Table. 1.1 - 1. Version 2 revision notes

Revision	2.00
Date	6.6.2019
Changes	<ul style="list-style-type: none"> - New more consistent look. - Improved descriptions generally in many chapters. - Improved readability of a lot of drawings and images. - Updated protection functions included in every IED manual. - Every protection IED type now has connection drawing, application example drawing with function block diagram and application example with wiring. - Added General-menu description.
Revision	2.01
Date	6.11.2019
Changes	<ul style="list-style-type: none"> - Added description for LED test and button test. - Complete rewrite of every chapter. - Improvements to many drawings and formula images. - Order codes revised. - Added double ST 100 Mbps Ethernet communication module and Double RJ45 10/100 Mbps Ethernet communication module descriptions
Revision	2.02
Date	7.7.2020
Changes	- A number of image descriptions improved.
Revision	2.03
Date	27.8.2020

Changes	<ul style="list-style-type: none"> - Terminology consistency improved (e.g. binary inputs are now always called digital inputs). - Tech data modified to be more informative about what type of measurement inputs are used (phase currents/voltages, residual currents/voltages), what component of that measurement is available (RMS, TRMS, peak-to-peak) and possible calculated measurement values (powers, impedances, angles etc.). - Tech data updated: non-directional overcurrent - Tech data updated: non-directional earthfault - Tech data updated: current unbalance - Tech data updated: overfrequency, underfrequency and rate-of-change-of-frequency. - Improvements to many drawings and formula images. - Improved and updated IED user interface display images. - AQ-F213 Functions included list Added: Undervoltage to function package C. - AQ-F213 Functions included list Added: Voltage memory, programmable control switch, mA output control, indicator objects, vector jump protection and measurement recorder. - AQ-F213 Functions included list Removed: Programmable stage. - Added 1LL+U0 mode description. - Added "32N" ANSI code to directional earth fault protection modes "unearthed" and "petersen coil grounded". - Added 6th harmonic to harmonic overcurrent protection function. - Fixed reset ratio of under- and overfrequency protection function from 103 % / 97 % to +/- 20 mHz.. - Fixed reset ratio of rate-of-change-of-frequency protection function from 20 mHz/s to 100 mHz/s. - Changed disturbance recorder maximum digital channel amount from 32 to 95. - Added residual current coarse and fine measurement data to disturbance recorder description. - HSO1 and HSO2 connection swapped in arc protection card (was way wrong before). - Updated I01 and I02 rated current range. - Added inches to Dimensions and installation chapter. - Added raising frames, wall mounting bracket, combiflex frame to order code. - Added logical input and logical output function descriptions. - Additions to Abbreviations chapter. - Added button test description to Local panel structure chapter. - Added Fault register view to Basic configuration chapter. - Added parameter descriptions to General menu IED user interface chapter. - Protection IED user interface chapter almost completely rewritten and restructured. - Added new parameter descriptions to Monitoring menu IED user interface chapter. - Added note to Configuring user levels and passwords chapter that user level with a password automatically locks itself after 30 minutes of inactivity. - Added more "Tripped stage" indications and fault types to Measurement value recorder function. - Updated: Digital input activation and release threshold setting ranges and added drop-off delay setting. - Added sample rate to voltage and current measurement tech data. - Fixed overvoltage, undervoltage, neutral overvoltage and sequence voltage stage misspelled IDMT curve formula.
Revision	2.04

Date	8.6.2021
Changes	<ul style="list-style-type: none"> - increased the consistency in terminology - various image upgrades - visual update to the order codes

1.2 Version 1 revision notes

Table. 1.2 - 2. Version 1 revision notes

Revision	1.00
Date	7.12.2015
Changes	- The first revision for AQ-F213 IED.
Revision	1.01
Date	30.8.2016
Changes	- Added password set up guide (previously only in AQtivate user guide)
Revision	1.02
Date	10.2.2017
Changes	- Order code updated
Revision	1.03
Date	27.2.2017
Changes	<ul style="list-style-type: none"> - Order code updated - Technical data revised according to ordering code
Revision	1.04
Date	11.12.2017
Changes	<ul style="list-style-type: none"> - Measurement value recorder description - ZCT connection added to current measurement description - Internal harmonics blocking to >,I0>,Idir>,I0dir> function descriptions - Non-standard delay curves added - AQ-F213 function package contents revised - Event lists revised on several functions - RTD&mA card description improvements - Auto-recloser function readability improvements - Ring-lug CT card option description added - AQ-F213 voltage measurement modes revised - Fault view description added
Revision	1.05
Date	14.8.2018
Changes	- Added mA output option card description and ordercode
Revision	1.06
Date	18.1.2018
Changes	- HMI display technical data added

2 Abbreviations

AI – Analog input

AR – Auto-recloser

ASDU – Application service data unit

AVR – Automatic voltage regulator

BCD – Binary-coded decimal

CB – Circuit breaker

CBFP – Circuit breaker failure protection

CLPU – Cold load pick-up

CPU – Central processing unit

CT – Current transformer

CTM – Current transformer module

CTS – Current transformer supervision

DG – Distributed generation

DHCP – Dynamic Host Configuration Protocol

DI – Digital input

DO – Digital output

DOL – Direct-on-line

DR – Disturbance recorder

DT – Definite time

FF – Fundamental frequency

FFT – Fast Fourier transform

FTP – File Transfer Protocol

GI – General interrogation

HMI – Human-machine interface

HR – Holding register

HV – High voltage

HW – Hardware

IDMT– Inverse definite minimum time

IED – Intelligent electronic device

IGBT – Insulated-gate bipolar transistor

I/O – Input and output

IRIG-B – Inter-range instruction group, timecode B

LCD – Liquid-crystal display

LED – Light emitting diode

LV – Low voltage

NC – Normally closed

NO – Normally open

NTP – Network Time Protocol

RMS – Root mean square

RSTP – Rapid Spanning Tree Protocol

RTD – Resistance temperature detector

RTU – Remote terminal unit

SCADA – Supervisory control and data acquisition

SG – Setting group

SOTF – Switch-on-to-fault

SW – Software

THD – Total harmonic distortion

TRMS – True root mean square

VT – Voltage transformer

VTM – Voltage transformer module

VTS – Voltage transformer supervision

3 General

The AQ-F213 feeder protection IED is a member of the AQ-200 product line. The hardware and software are modular: the hardware modules are assembled and configured according to the application's I/O requirements and the software determines the available functions. This manual describes the specific application of the AQ-F213 feeder protection IED. For other AQ-200 series products please consult their respective device manuals.

AQ-F213 offers a modular feeder protection and control solution for applications that require both current-based and voltage-based protections as well as complete measurements. There are up to three (3) option card slots available for additional I/O or communication cards for more comprehensive monitoring and control applications. AQ-F213 communicates using various protocols including the IEC 61850 substation communication standard.

4 IED user interface

4.1 Panel structure

The user interface section of an AQ-200 series device is divided into two user interface sections: one for the hardware and the other for the software. You can access the software interface either through the front panel or through the AQtivate freeware software suite.

4.1.1 Local panel structure

The front panel of AQ-200 series devices have multiple LEDs, control buttons and a local RJ-45 Ethernet port for configuration. Each unit is also equipped with an RS-485 serial interface and an RJ-45 Ethernet interface on the back of the device. See the image and list below.

Figure. 4.1.1 - 1. Local panel structure.

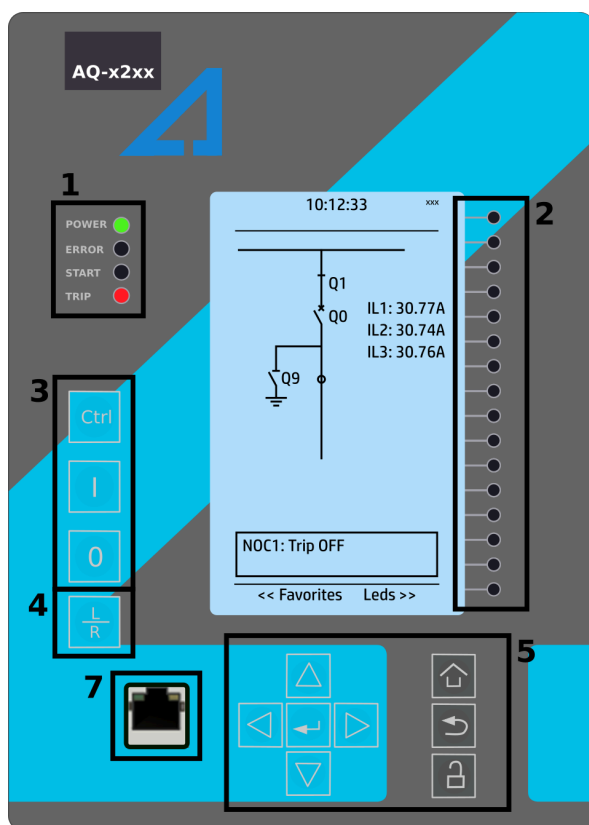

1. Four (4) default LEDs: "Power", "Error", "Start" (configurable) and "Trip" (configurable).
2. Sixteen (16) freely configurable LEDs with programmable legend texts.
3. Three (3) object control buttons: Choose the controllable object with the **Ctrl** button and control the breaker or other object with the **I** and **O** buttons.
4. The **L/R** button switches between the local and the remote control modes.
5. Eight (8) buttons for IED local programming: the four navigation arrows and the **Enter** button in the middle, as well as the **Home**, the **Back** and the password activation buttons.
6. One (1) RJ-45 Ethernet port for IED configuration.

When the unit is powered on, the green "Power" LED is lit. When the red "Error" LED is lit, the relay has an internal (hardware or software) error that affects the operation of the unit. The activation of the yellow "Start" LED and the red "Trip" LED are based on the setting the user has put in place in the software.

The sixteen freely configurable LEDs are located on the right side of the display. Their activation and color (green or yellow) are based on the settings the user has put in place in the software.

Holding the I (object control) button down for five seconds brings up the button test menu. It displays all the physical buttons on the front panel. Pressing any of the listed buttons marks them as tested. When all buttons are marked as having been tested, device will return back to default view.

4.2 Mimic and main menu

4.2.1 Basic configuration

The user interface is divided into seven (7) quick displays: "Mimic", "LEDs", "Events", "Clock", "Measurement", "Favorites" and "Fault register". The default quick display (as presented in the image below) is the mimic view; you can move through these menus by pressing the left and right arrow buttons. Please note that the available quick display carousel view might be different if you have changed the view with AQtivate's Carousel Designer tool.

Figure. 4.2.1 - 2. Basic navigation (general).

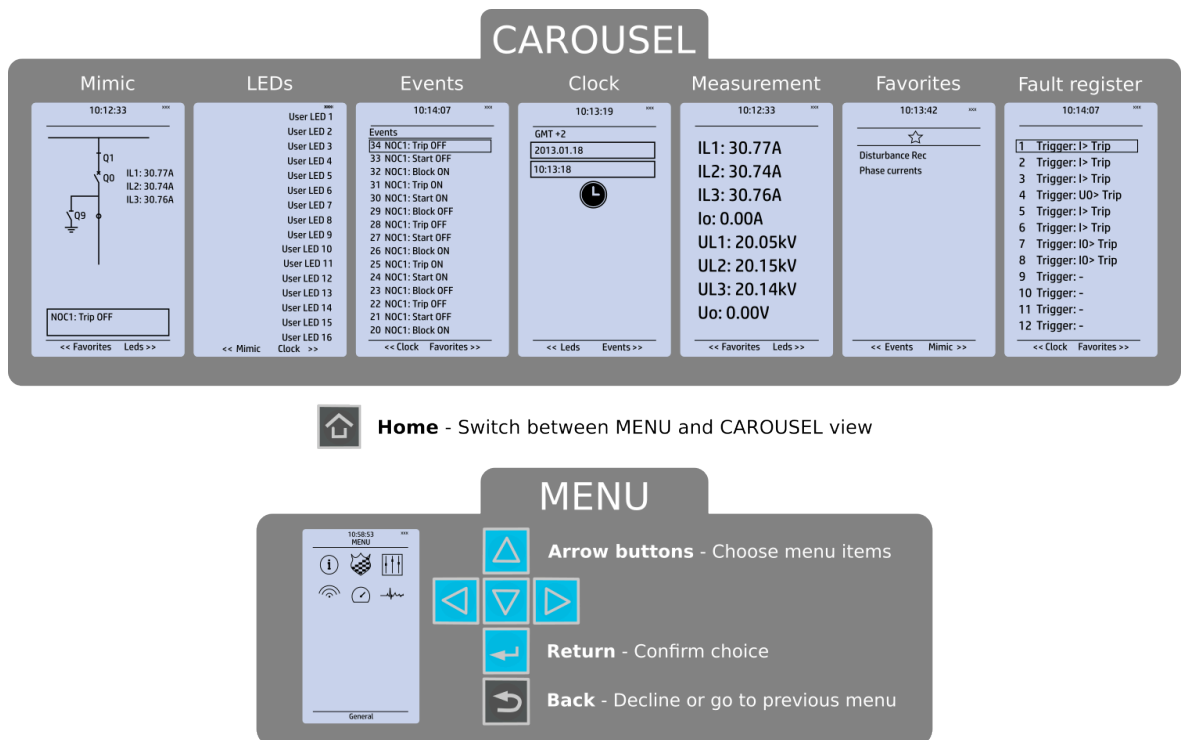

The **Home** button switches between the quick display carousel and the main display with the six (6) main configuration menus (*General, Protection, Control, Communication, Measurements and Monitoring*). Note that the available menus vary depending on the device type. You can select one of the menus by using the four navigation arrows and pressing **Enter** in the middle. The **Back** button takes you back one step. If you hold it down for three seconds, it takes you back to the main menu. You can also use it to reset the alarm LEDs you have set. The password activation button (with the padlock icon) takes you to the password menu where you can enter the passwords for the various user levels (User, Operator, Configurator, and Super-user).

4.2.2 Navigation in the main configuration menus

All the settings in this device have been divided into the following six (6) main configuration menus:

- General
- Protection

- Control
- Communication
- Measurement
- Monitoring.

They are presented in the image below. The available menus vary according to the device type.

Figure. 4.2.2 - 3. Main configuration menus.

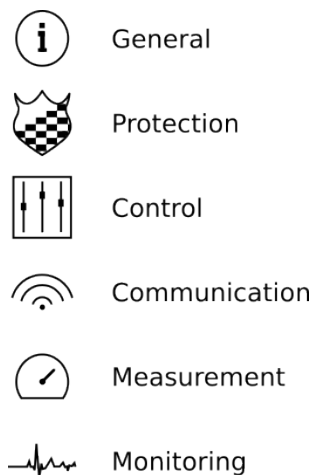

4.3 General menu

The *General* main menu is divided into two submenus: the *Device info* tab presents the information of the device, while the *Function comments* tab allows you to view all comments you have added to the functions.

Figure. 4.3 - 4. General menu structure

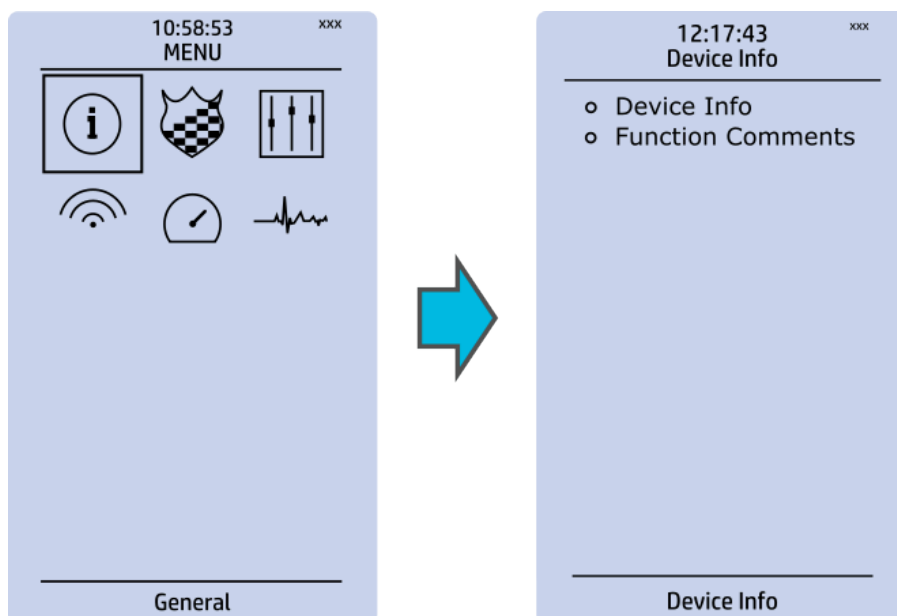

Device info

Figure. 4.3 - 5. Device info.

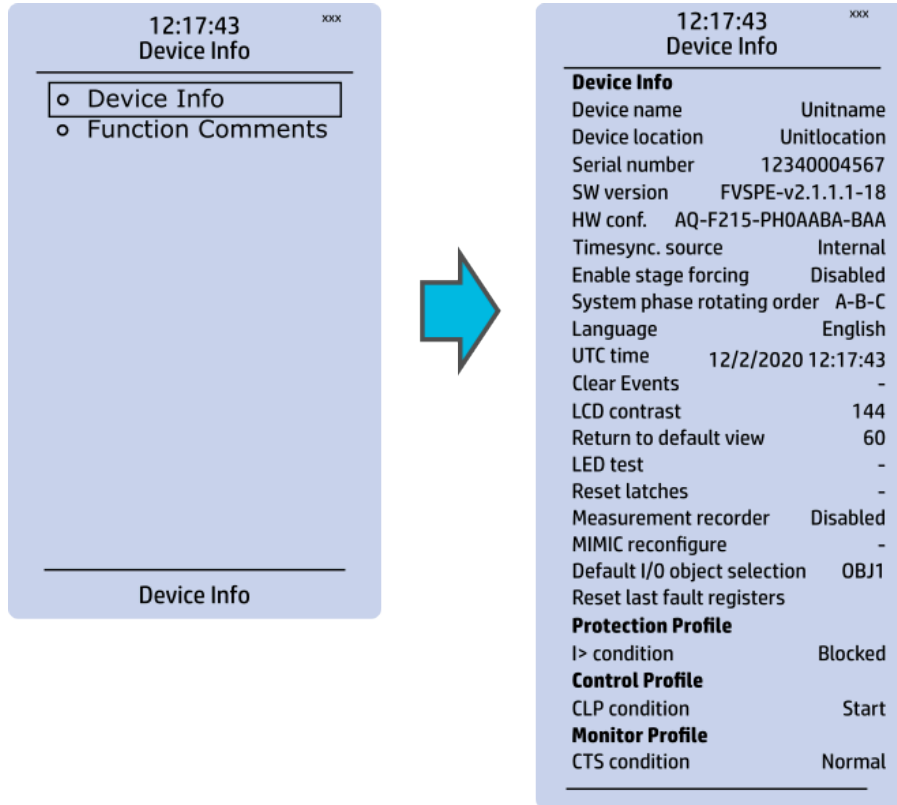

Table. 4.3 - 3. Parameters and indications in the *General* menu.

Name	Range	Step	Default	Description
Device name	-	-	Unitname	The file name uses these fields when loading the .aqc configuration file from the AQ-200 unit.
Device location	-	-	Unitlocation	
Serial number	-	-	-	Displays the unit's unique serial number. The serial number is also printed on the sticker located on the side of the unit.
Firmware version	-	-	-	Displays the software version (firmware) used by the unit. Upgradable by the user if a newer version is available.
Hardware configuration	-	-	-	Displays the hardware configuration of the unit. The hardware configuration is also printed on the sticker located on the side of the unit.
Time synchronization source	0: Internal 1: External NTP 2: External Serial 3: IRIG-B	-	0: Internal	If an external clock time synchronization source is available, the type is defined with this parameter. In the internal mode there is no external Timesync source. IRIG-B requires a serial fiber communication option card.
Enable stage forcing	0: Disabled 1: Enabled	-	0: Disabled	When this parameter is enabled it is possible for the user to force the protection, control and monitoring functions to different statuses like START and TRIP. This is done in the function's <i>Info</i> page with the <i>Force status to</i> parameter.
System phase rotating order	0: A-B-C 1: A-C-B	-	0: A-B-C	Allows the user to switch the expected order in which the phase measurements are wired to the unit.

Name	Range	Step	Default	Description
Language	0: User defined 1: English 2: Finnish 3: Swedish 4: Spanish 5: French 6: German 7: Russian 8: Ukraine	-	1: English	Changes the language of the parameter descriptions in the HMI. If the language has been set to "Other" in the settings of the AQtivate setting tool, AQtivate follows the value set into this parameter.
UTC time	-	-	-	Displays the UTC time used by the unit without time zone corrections.
Clear events	0: - 1: Clear	-	0: -	Clears the event history recorded in the AQ-200 device.
LCD Contrast	0...255	1	120	Changes the contrast of the LCD display.
Return to default view	0...3600 s	10 s	0 s	If the user navigates to a menu and gives no input after a period of time defined with this parameter, the unit automatically returns to the default view. If set to 0 s, this feature is not in use.
LED test	0: - 1: Activated	-	0: -	When activated, all LEDs are lit up. LEDs with multiple possible colors blink each color.
Reset latches	0: - 1: Reset	-	0: -	Resets the latched signals in the logic and the matrix. When a reset command is given, the parameter automatically returns back to "-".
Measurement recorder	0: Disabled 1: Enabled	-	0: Disabled	Enables the measurement recorder tool, further configured in <i>Tools</i> → <i>Misc</i> → <i>Measurement recorder</i> .
Reconfigure mimic	0: - 1: Reconfigure	-	0: -	Reloads the mimic to the unit.
Reset last fault registers	-	-	-	Activation of input selected here resets the values in "Fault registers" view in carousel.
Protection/Control/Monitor profile	-	-	-	Displays the status of all enabled functions.

Function comments

Function comments displays notes of each function that has been activated in the Protection, Control and Monitoring menu. Function notes can be edited by the user.

Figure. 4.3 - 6. Function comments.

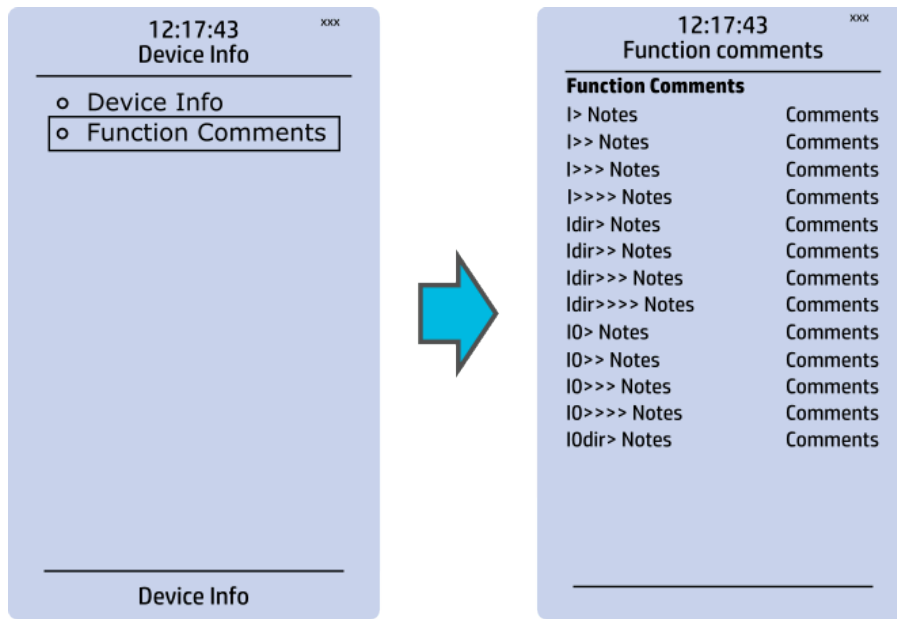

4.4 Protection menu

General

Figure. 4.4 - 7. Protection menu structure

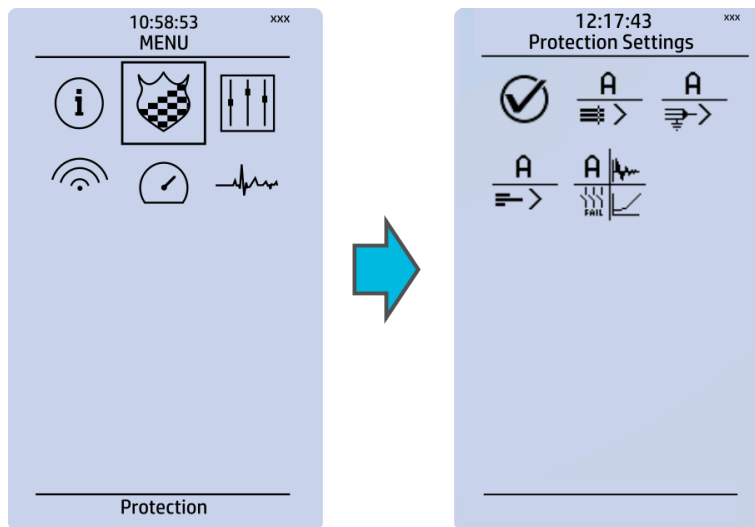

The *Protection* main menu includes the *Stage activation* submenu as well as the submenus for all the various protection functions, categorized under the following modules: "Arc protection", "Current", "Voltage", "Frequency", "Sequence" and "Supporting" (see the image below). The available functions depend on the device type in use.

Figure. 4.4 - 8. Protection menu view.

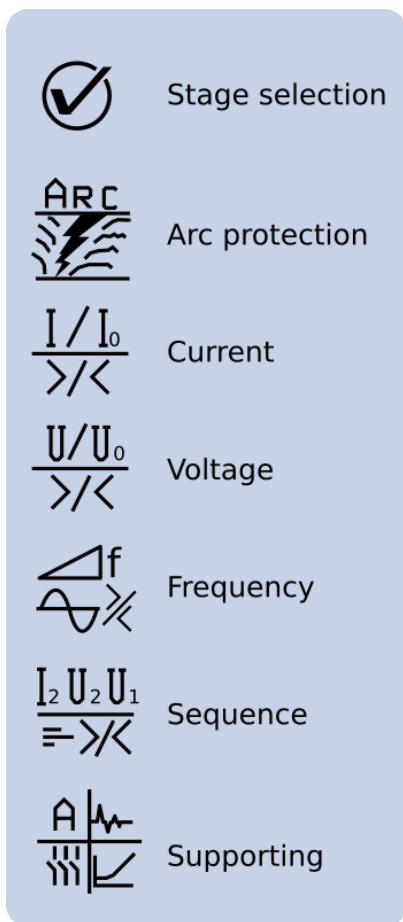

Stage activation

You can activate the various protection stages in the *Stage activation* submenu (see the images below). Each protection stage and supporting function is disabled by default. When you activate one of the stages, its activated menu appears in the stage-specific submenu. For example, the I> (overcurrent) protection stage can be found in the "Current" module, whereas the U< (undervoltage) protection stage can be found in the "Voltage" module.

Figure. 4.4 - 9. Submenus for Stage activation.

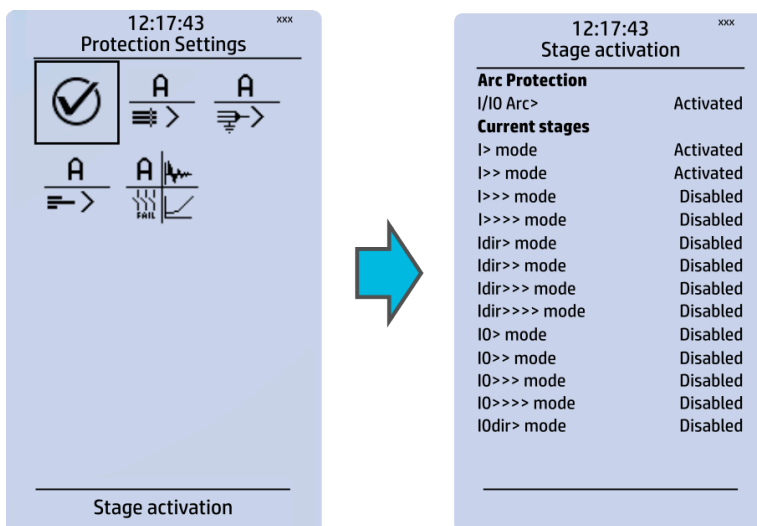

Example of a protection stage and its use

Once a protection stage has been activated in the *Stage activation* submenu, you can open its own submenu. In the image series below, the user has activated three current stages. The user accesses the list of activated current stages through the "Current" module, and selects the I> stage for further inspection.

Figure. 4.4 - 10. Accessing the submenu of an individual activated stage.

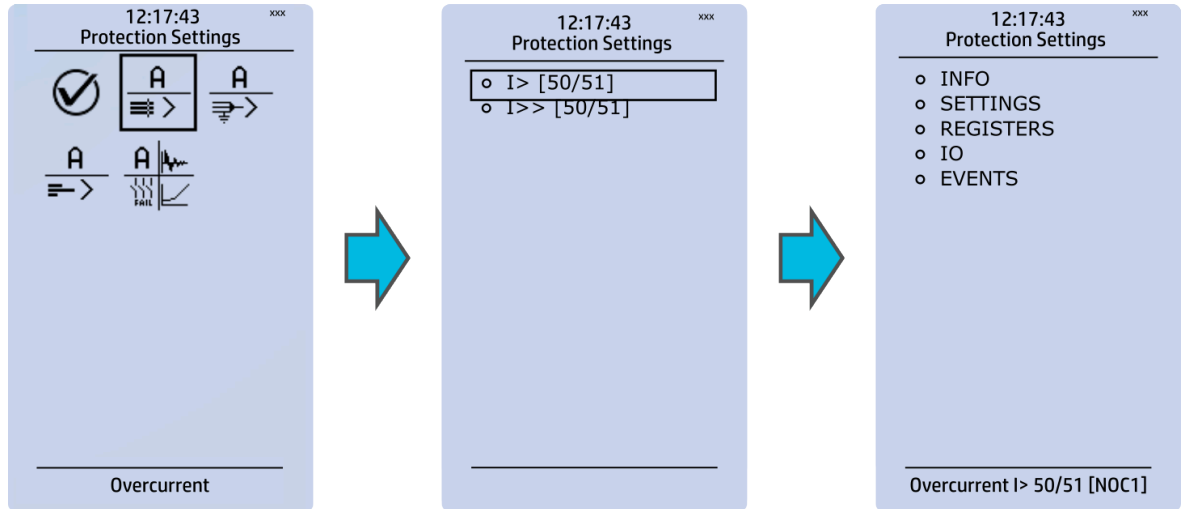

Each protection stage and supporting function has five sections in their stage submenus: "Info", "Settings", "Registers", "I/O" and "Events".

Figure. 4.4 - 11. Info.

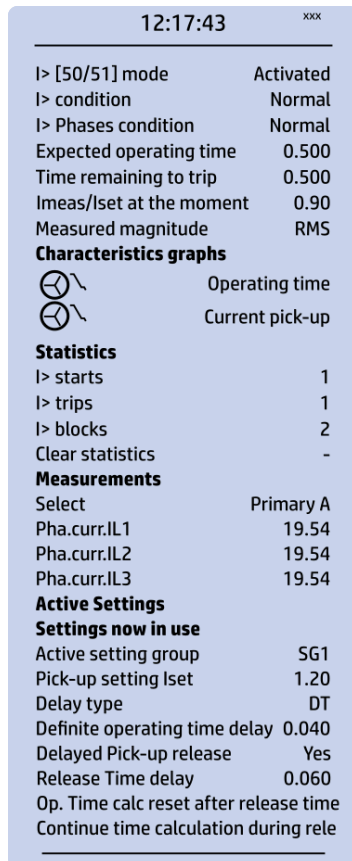

The "Info" section offers many details concerning the function and its status:

- Function condition: indicates the stage's condition which can be Normal, Start, Trip, or Blocked.
- Expected operating time: Expected time delay from detecting a fault to tripping the breaker. This value can vary during a fault if an inverse curve time delay (IDMT) is used.
- Time remaining to trip: When a fault is detected this value counts down towards zero. When zero is reached, the function will trip.
- Imeas/lset at the moment: Displays the ratio between the measured value and the pick-up level.
- Measured magnitude: In some functions it is possible to choose the monitored magnitude between Peak-to-peak, TRMS, or RMS (the default is RMS; the available magnitudes depend on the function).
- Characteristics graphs: opens graphs related to the protection function.
- Statistics: indicates the number of function starts, trips and blocks (can be cleared through "Clear statistics" → "Clear").
- Measurements: displays the measurements carried out by the function.
- Active settings: displays the setting group that is currently in use and its settings (other setting groups can be set in the "Settings" section).

While the function is activated and disabled in the *Stage activation* submenu, you can disable the function through the "Info" section ("Function mode" at the top of the section).

Figure. 4.4 - 12. Settings.

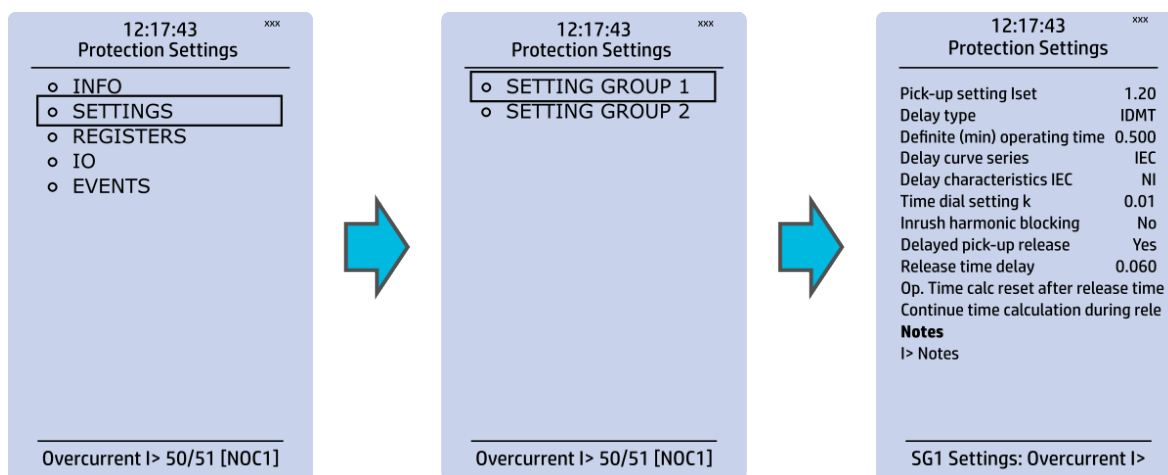

The stage settings vary depending on which protection function they are a part of. By default only one setting group of the eight available setting groups is activated. You can enable more groups in the *Control* → *Setting groups* menu, although they are set here in the "Settings" section.

Most protection functions follow the same structure:

- Pick-up setting: Defines the fault magnitude. Most functions pick-up value is in relation to the current transformer or voltage transformer nominal, but some functions use kW, ohm, Hz and other units. Voltage and current transformers nominal values can be set at *Measurement* → *Transformers*.
- Delay type and operating time delay settings are described in detail in chapter *General properties of a protection function*.

Figure. 4.4 - 13. Registers.

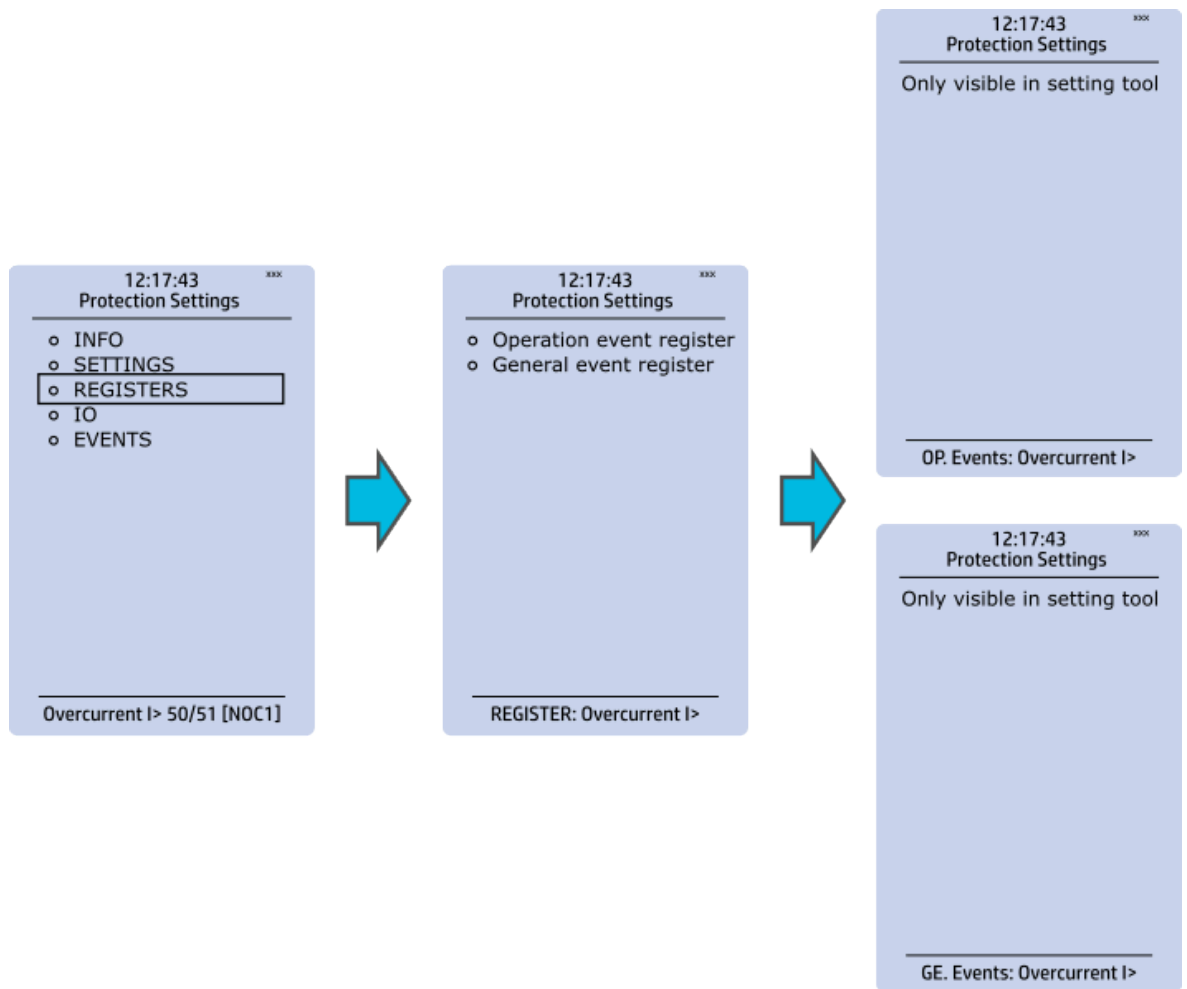

Register menu content is not available in the HMI. It can only be accessed with AQtivate setting tool. Stored in the "Registers" section you can find both "Operation event register" and "General event register".

"Operation event register" stores the function's specific fault data. There are twelve (12) registers, and each of them includes data like the pre-fault value, the fault value, the time stamp and the active group during the trigger. Data included in the register depend on the protection function. You can clear the the operation register by choosing "Clear registers" → "Clear".

"General event register" stores the event generated by the stage. These general event registers cannot be cleared.

Figure. 4.4 - 14. I/O.

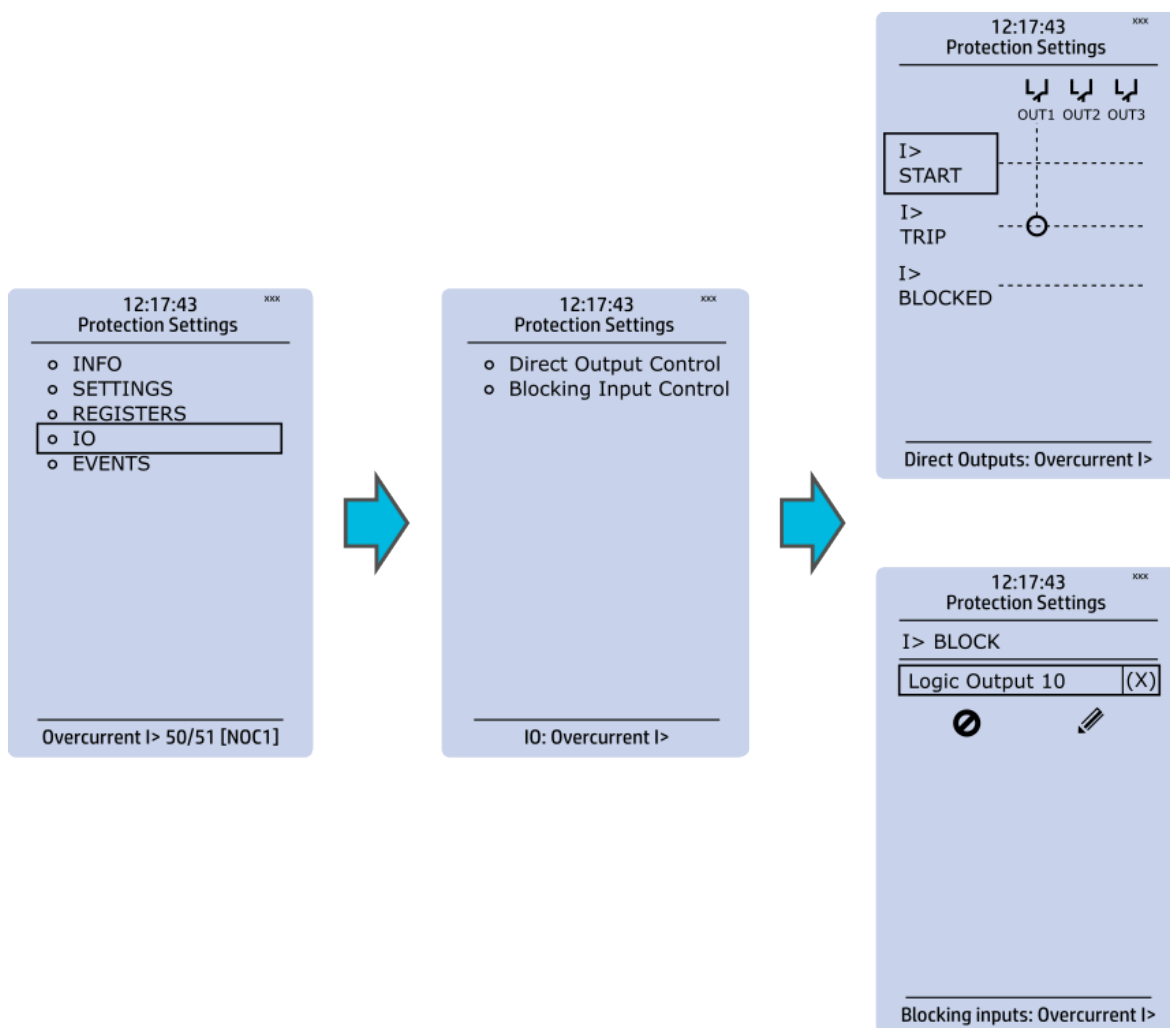

The "I/O" section is divided into two subsections: "Direct output control" and "Blocking input control".

In "Direct output control" you can connect the stage's signals to physical outputs, either to an output relay or an LED (START or TRIP LEDs or one of the 16 user configurable LEDs). If the stage is blocked internally (DI or another signal), you can configure an output to indicate the stage that is blocked. A connection to an output can be either latched ("|x|") or non-latched ("x").

"Blocking input control" allows you to block stages. The blocking can be done by using any of the following:

- digital inputs
- logical inputs or outputs
- the START, TRIP or BLOCKED information of another protection stage
- object status information.

Figure. 4.4 - 15. Events.



You can mask on and mask off the protection stage related events in "Event mask". By default events are masked off. You can activate the desired events by masking them ("x"). Remember to save your maskings by confirming the changes with the check mark icon. If you want to cancel the changes, select the strike-through circle to do so. Only masked events are recorded to event history (which can be accessed in the "Events" view in the user view section).

4.5 Control menu

Main menu

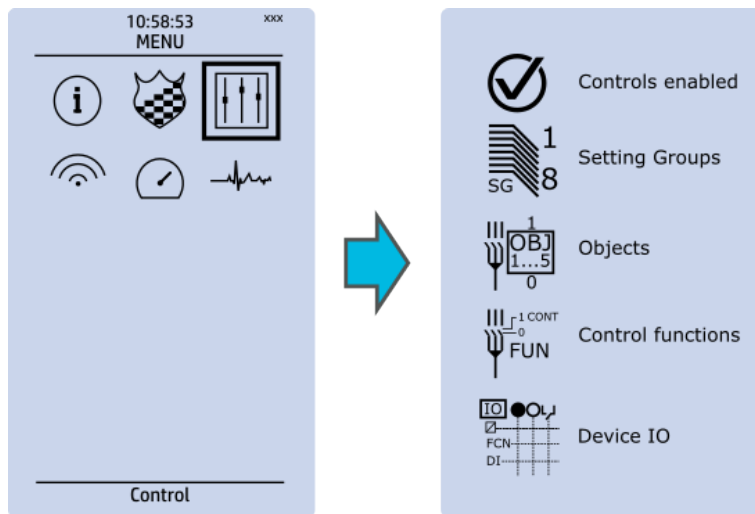

The *Control* main menu includes submenus (see the image above) for enabling the various control functions and objects (*Controls enabled*), for enabling and controlling the setting groups (*Setting groups*), for configuring the objects (*Objects*), for setting the various control functions (*Control functions*), and for configuring the inputs and outputs (*Device I/O*). The available control functions depend on the model of the device in use.

Controls enabled

Figure. 4.5 - 16. Controls enabled submenu.

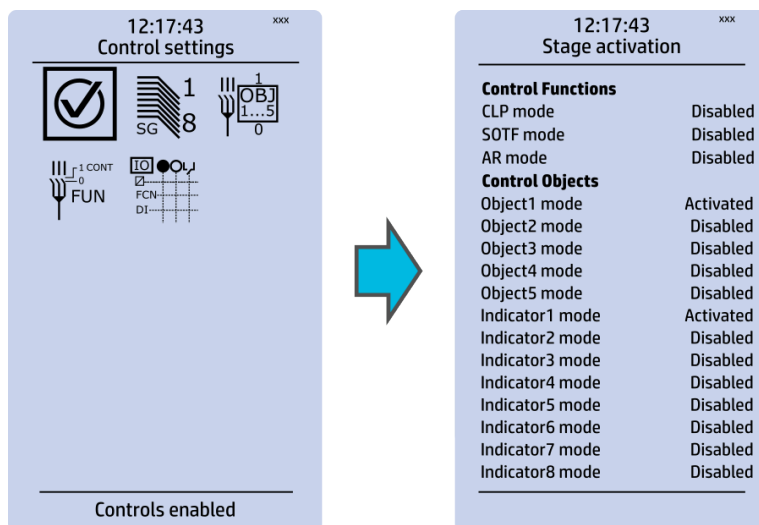

You can activate the selected control functions in the *Controls enabled* submenu. By default all the control functions are disabled. All activated functions can be viewed in the *Control functions* submenu (see the section "Control functions" below for more information).

In this submenu you can also activate and disable controllable objects. As with control functions, all objects are disabled by default. All activated objects can be viewed in the *Objects* submenu (see the section "Objects" below for more information).

Setting groups

Figure. 4.5 - 17. Setting groups submenu.

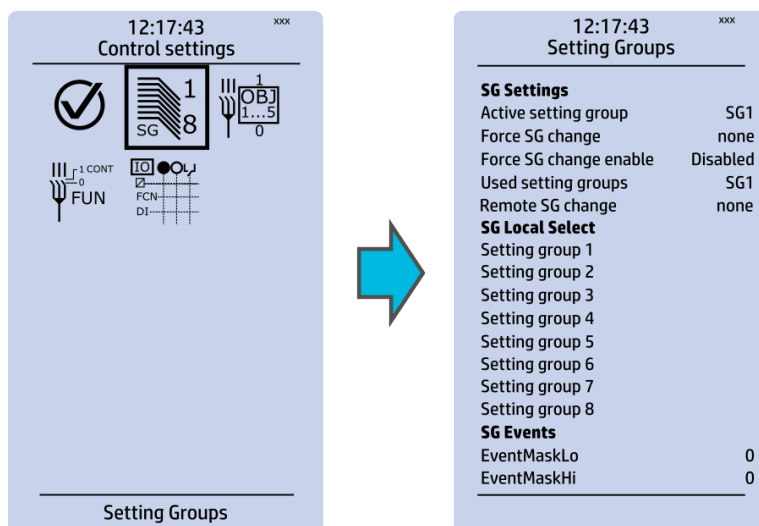

The *Setting groups* submenu displays all the information related to setting group changing, such as the following:

- **Active setting group:** displays the current active setting group (SG1...SG8).
- **Force setting group change:** this setting allows the activation of a setting group at will (please note that Force SG change enable must be "Enabled").
- **Used setting groups:** this setting allows the activation of setting groups SG1...SG8 (only one group is active by default).

- **SG local select:** selects the local control for the different setting groups (can use digital inputs, logical inputs or outputs, RTDs, object status information as well as stage starts, trips or blocks).
- **Remote setting group change:** When enabled it is possible to change the setting group manually through SCADA.
- **SG events:** event masking for setting groups (masks are OFF by default; please note that only masked events are recorded into the event history).

Setting group 1 (SG1) has the highest priority, while Setting group 8 (SG8) has the lowest priority. Setting groups can be controlled with pulses or with both pulses and static signals (see the image below).

Figure. 4.5 - 18. Example of setting group (SG) changing.

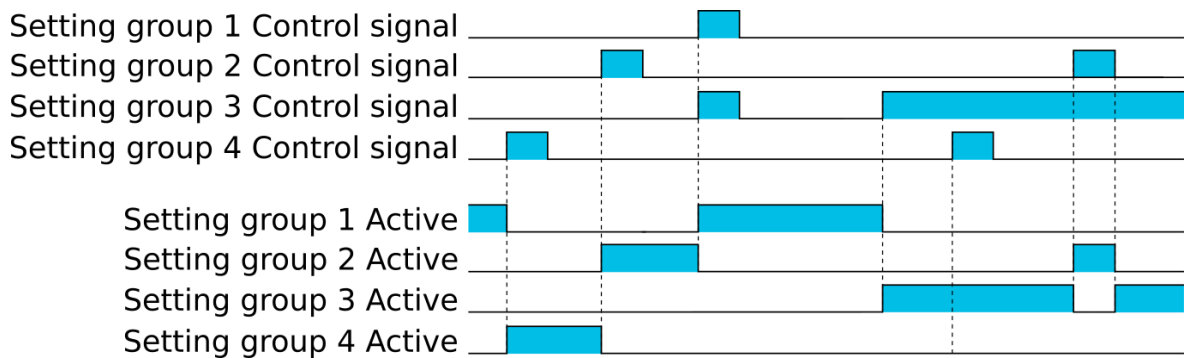

Objects

Figure. 4.5 - 19. Objects submenu.

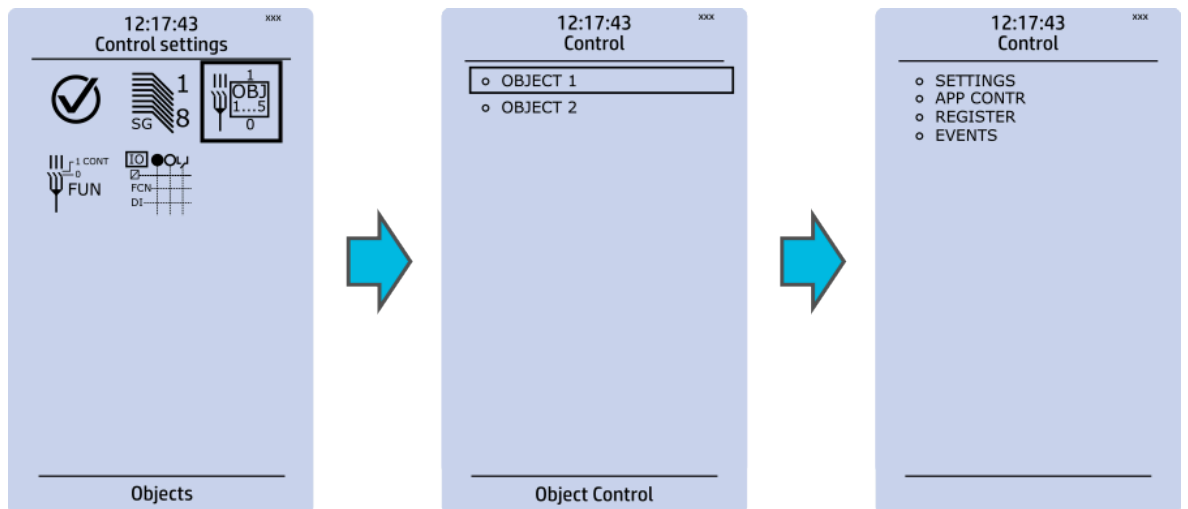

Each activated object is visible in the *Objects* submenu. By default all objects are disabled unless specifically activated in the *Controls* → *Controls enabled* submenu. Each active object has four sections in their submenus: "Settings", "Application control" ("App contr"), "Registers" and "Events". These are described in further detail below.

Figure. 4.5 - 20. Settings section.

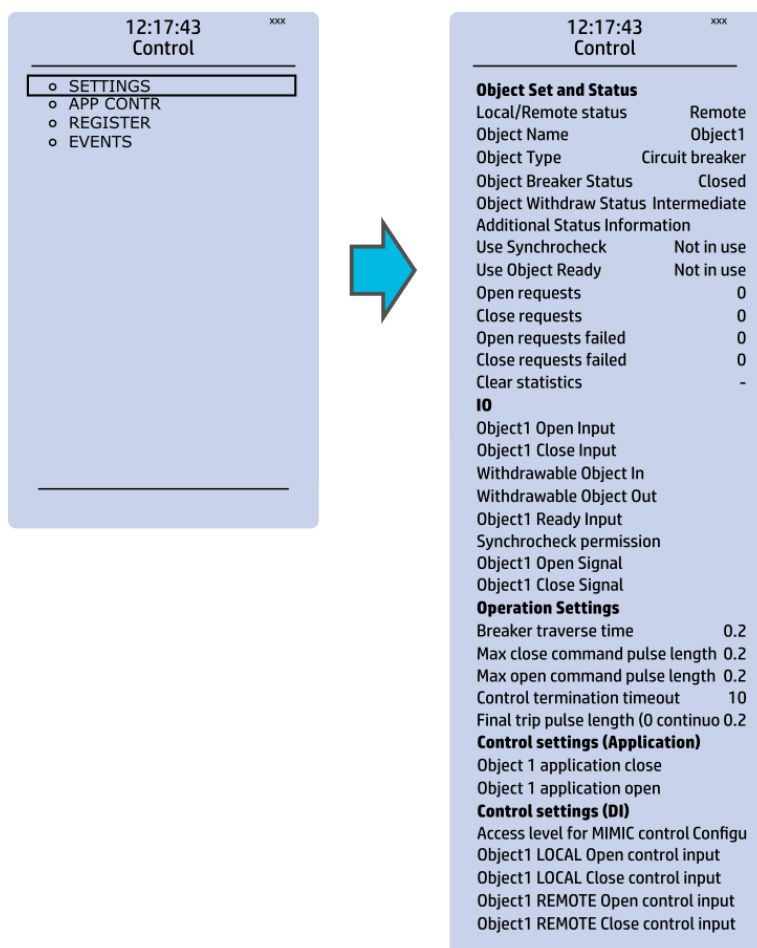

OBJECT SET AND STATUS

- **Local/Remote status:** control access may be set to Local or Remote (Local by default; please note that when local control is enabled, the object cannot be controlled through the bus and vice versa).
- **Object name:** the name of the object (objects are named "ObjectX" by default).
- **Object type:** selects the type of the object from Grounding disconnector, Motor-controlled disconnector, Circuit breaker and Withdrawable circuit breaker (Circuit breaker by default).
- **Object x status:** the status can be Bad, Closed, Open and Intermittent. The status "Intermittent" is the phase between "Open" and "Closed" where both status inputs are 0. The status "Bad" occurs when both status inputs of the object/cart are 1.
- **Additional status information:** gives feedback from the object on whether the opening and closing are allowed or blocked, whether the object is ready, and whether the synchronization status is ok.
- **Use synchrocheck and Use Object ready:** closing the object is forbidden when the sides are not synchronized or when the object is not ready to be closed.
- **Open requests and Close requests:** displays the statistics, i.e. the number of Open and Close requests.
- **Open requests failed and Close requests failed:** displays the statistics of Open and Close request failures. A request is considered to have failed when the object does not change its status as a result of that request.
- **Clear statistics:** statistics can be cleared by choosing "Clear statistics" and then "Clear".

I/O

- An object has both **Open input** and **Close input** signals which are used for indicating the status of the breaker on the HMI and in SCADA. Status can be indicated by any of the following: digital inputs, logical inputs or outputs.
- A withdrawable object has both **In** and **Out** inputs. The status can be indicated by any of the following: digital inputs, logical inputs or outputs.
- Both **Object ready** and **Synchrocheck permission** have status inputs. If either one is used, the input(s) must be active for the relay to be able to give the "Object Close" command.
- **Object open** and **Object close** signals define which digital output is controlled.

OPERATION SETTINGS

- **Breaker traverse time:** determines how long a gap there can be between a status change from "Open" to "Closed" before an intermittent status is reported by the function.
- **Max close/open command pulse length:** defines the maximum length of "Open" and "Close" commands. If the status has changed before the maximum pulse length has elapsed, the pulse is cut short.
- **Control termination timeout:** If the status of the object does not change during the set time, an "Open/Close request failed" event is recorded.
- After the set delay, if the controlled object does not respond accordingly, the procedure is terminated and a fail message is issued.

CONTROL SETTINGS (APPLICATION)

- **Object application close** and **Object application open:** a signal set to these points can be used to open and close the object. Controlling the object through this point does not follow the local/remote status of the relay.

CONTROL SETTINGS (DI)

- **Access level for MIMIC control:** determines the access level required to control the MIMIC (each level has its own password). By default, the access level is set to "Configurator".
- You can use digital inputs to control the object locally or remotely. Remote controlling via the bus is configured on the protocol level.

Figure. 4.5 - 21. Application control section.

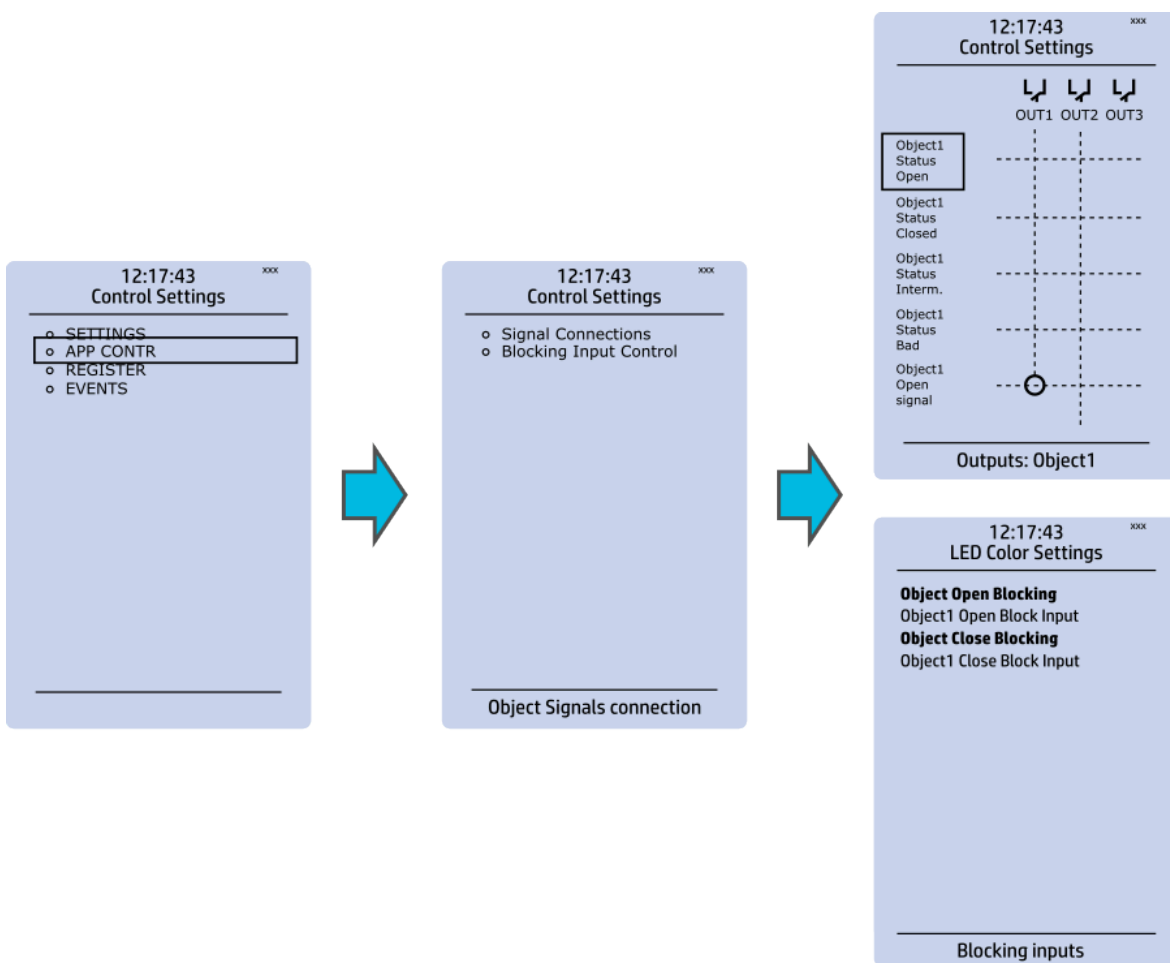

You can connect object statuses directly to specific physical outputs in the "Signal connections" subsection (*Control* → *Application control*). A status can be connected to output relays, as well as to user-configurable LEDs. A connection to an output can be either latched ("|x|") or non-latched ("x").

Object blocking is done in the "Blocking input control" subsection. It can be done by any of the following: digital inputs, logical inputs or outputs, object status information as well as stage starts, trips or blocks.

Figure. 4.5 - 22. Registers section.

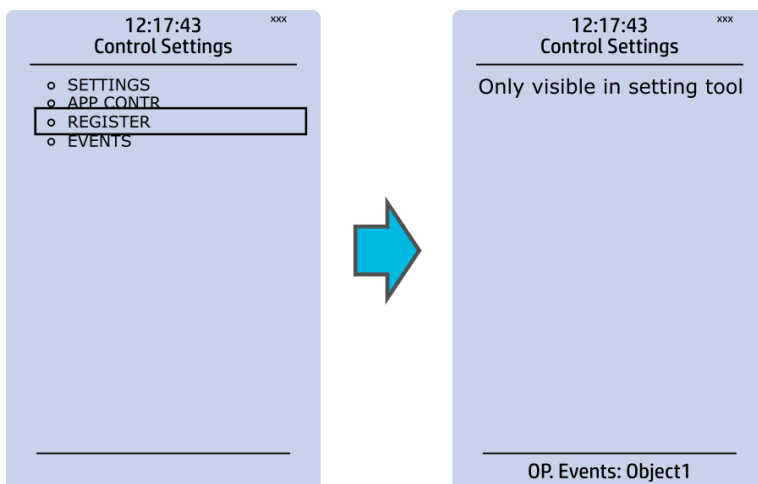

The "Registers" section stores the function's specific fault data. There are twelve (12) registers, and each of them includes data such as opening and closing times, command types and request failures. The data included in the register depend on the protection function. You can clear the the operation register by choosing "Clear registers" → "Clear".

Please note that the content of the *Registers* section is not available in the HMI. It can only be accessed via the AQtivate setting tool.

Figure. 4.5 - 23. Events section.



You can mask on and mask off events related to an object's stage in "Event mask". By default all events are masked off. You can activate the desired events by masking them ("x"). Please remember to save your maskings by confirming the changes with the check mark icon. If you want to cancel the changes, select the strike-through circle to do so. Only masked events are recorded to the event history (which can be accessed in the "Events" view in the user view section).

Control functions

Once a control function has been activated in the *Controls* → *Controls enabled* submenu, its own submenu can be opened. In the image series below, the user has activated three control functions. The user accesses the list of activated control stages through the "Control functions" module, and selects the control function for further inspection.

Figure. 4.5 - 24. Control functions submenu.

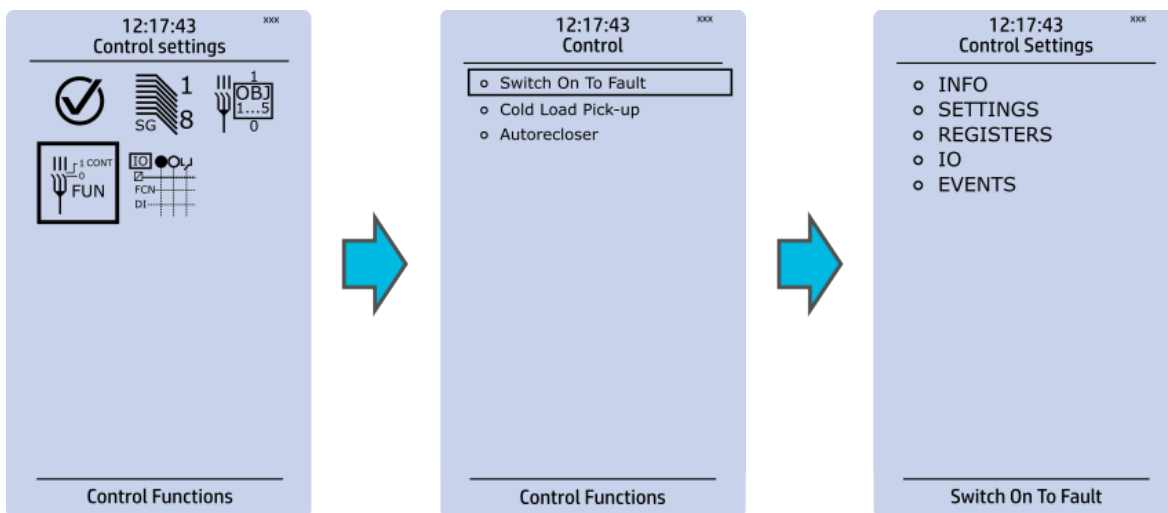

Each control function that has been activated is listed in the *Control functions* submenu (see the middle image above). This submenu includes the following sections: "Info", "Settings", "Registers", "I/O" and "Events". The text below describes these in further detail.

Figure. 4.5 - 25. Info section.

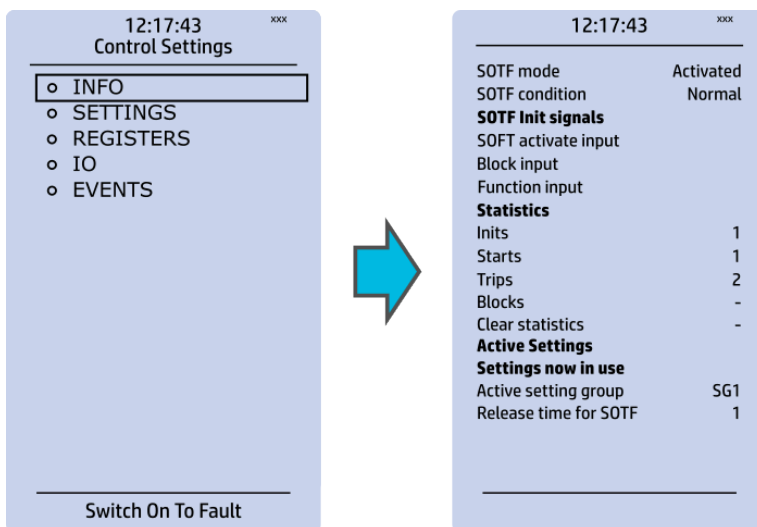

The "Info" section offers many details concerning the function and its status:

- **Function condition:** indicates the stage's condition which can be Normal, Start, Trip, or Blocked.
- **Measured magnitude:** In some functions it is possible to choose the monitored magnitude between Peak-to-peak, TRMS, or RMS (the default is RMS; the available magnitudes depend on the function).
- **Statistics:** indicates the number of function starts, trips and blocks (can be cleared through "Clear statistics" → "Clear").
- **Measurements:** displays the measurements carried out by the function.
- **Active settings:** displays the setting group that is currently in use and its settings (other setting groups can be set in the "Settings" section).

While the function is activated and disabled in the *Control* → *Controls enabled* submenu, you can disable the function through the "Info" section (the [function name] mode at the top of the section).

Figure. 4.5 - 26. Settings section.

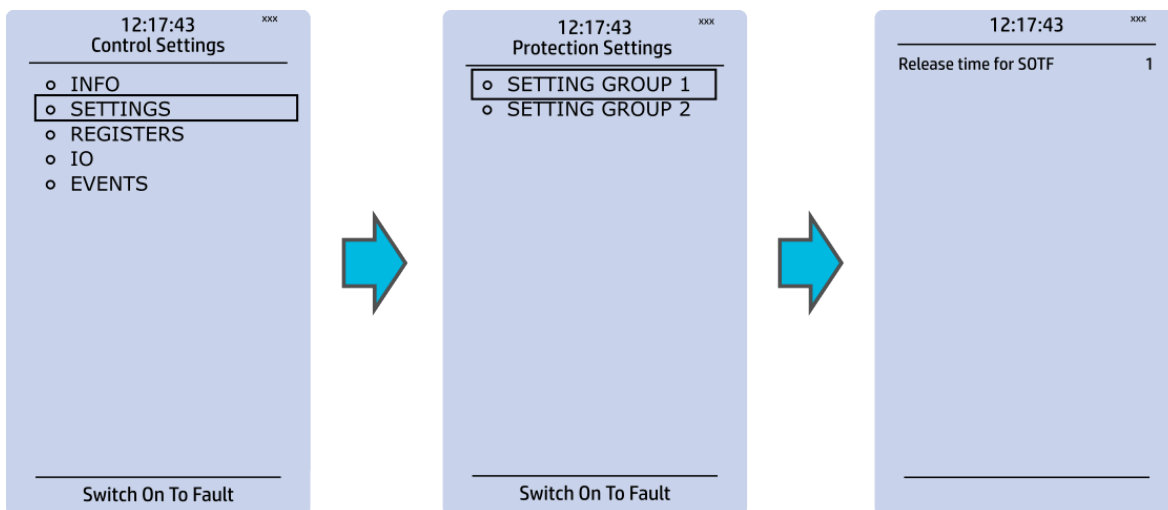

The stage settings vary depending on which control function they are a part of. By default only one setting group of the eight available setting groups is activated. You can enable more groups in the *Control* → *Setting groups* menu, although they are set here in the "Settings" section.

Figure. 4.5 - 27. Registers section.

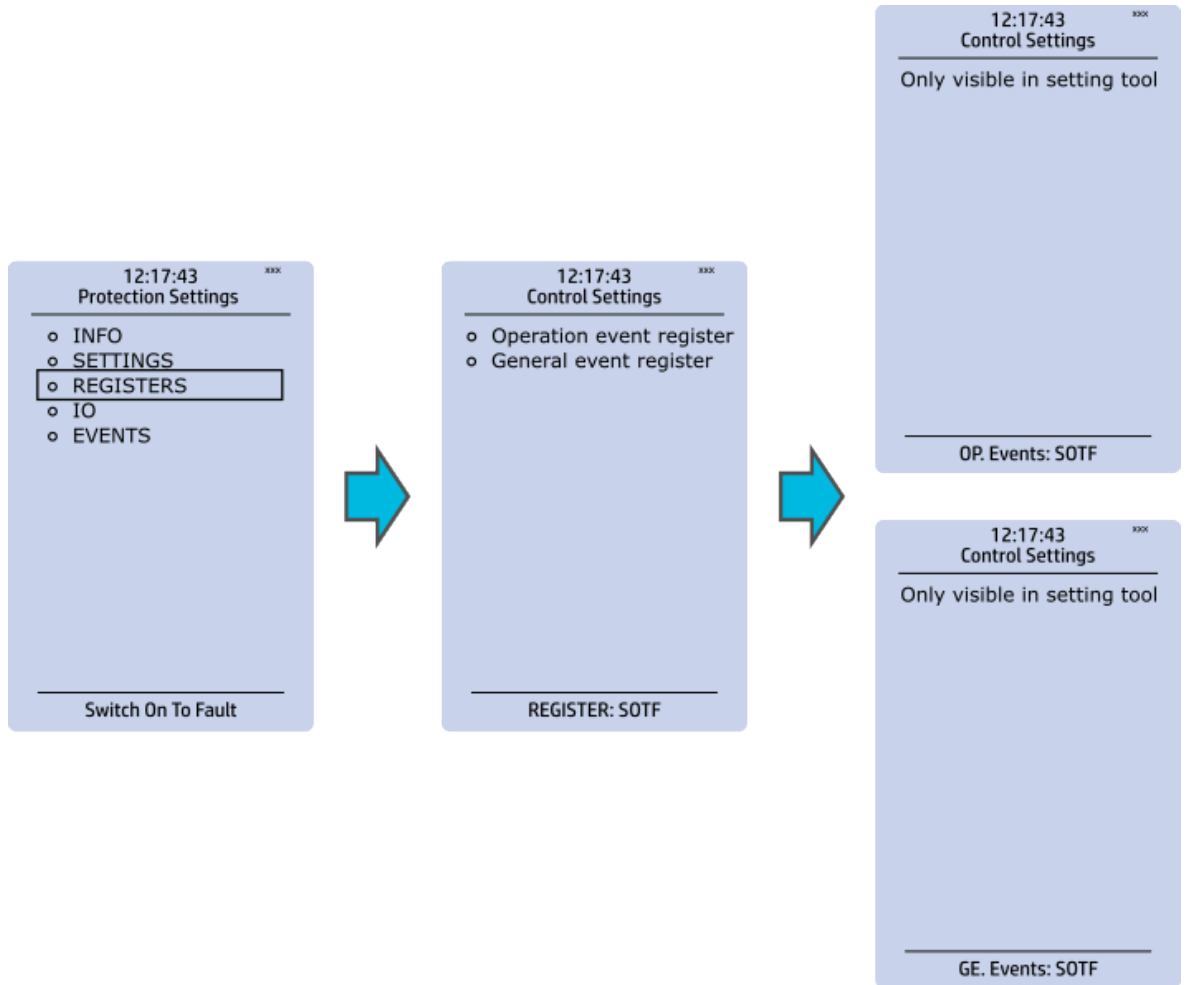

Please note that the content of the "Registers" section is not available in the HMI. It can only be accessed via the AQtivate setting tool. Stored in the "Registers" section you can find both "Operation event register" and "General event register".

"Operation event register" stores the function's specific operation data. There are twelve (12) registers, and each of them includes data like the pre-fault value, the fault value, the time stamp and the active group during the trigger. Data included in the register depend on the control function. You can clear the the operation register by choosing "Clear registers" → "Clear".

"General event register" stores the event generated by the stage. These general event registers cannot be cleared.

Figure. 4.5 - 28. I/O section.

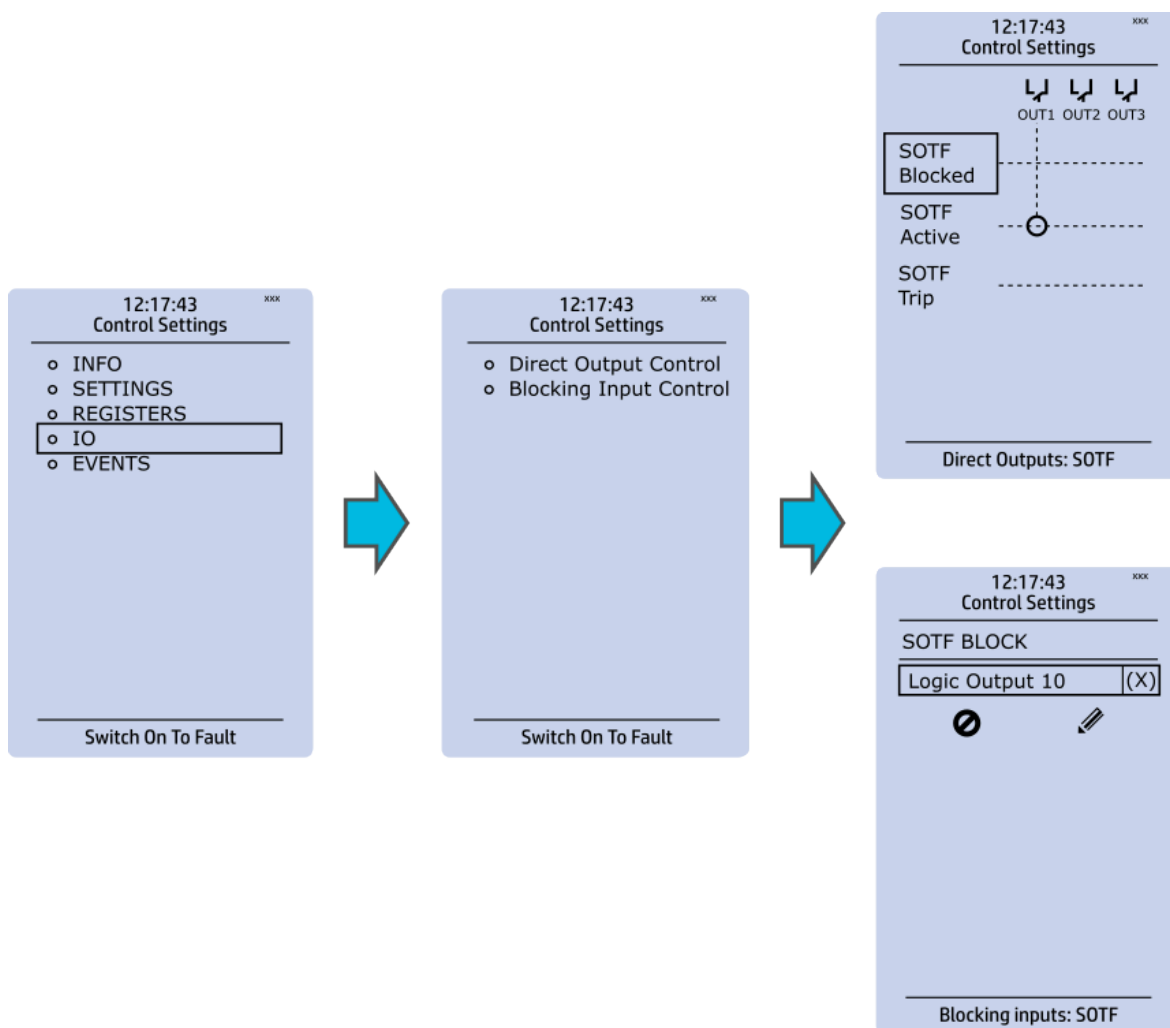

The "I/O" section is divided into two subsections: "Direct output control" and "Blocking input control".

In "Direct output control" you can connect the stage's signals to physical outputs, either to an output relay or an LED (START or TRIP LEDs or one of the 16 user configurable LEDs). If the stage is blocked internally (by a digital input or another signal), you can configure an output to indicate the stage that is blocked. A connection to an output can be either latched ("|x|") or non-latched ("x").

"Blocking input control" allows you to block stages. The blocking can be done by using any of the following:

- digital inputs.
- logical inputs or outputs.
- the START, TRIP or BLOCKED information of another protection stage.
- object status information.

Figure. 4.5 - 29. Events section.

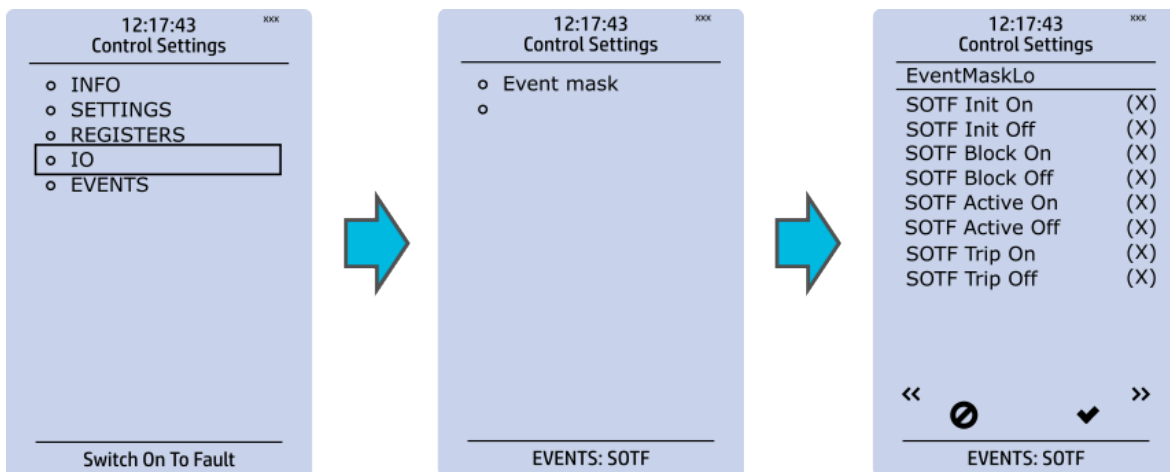

You can mask on and mask off events related to an object's stage in "Event mask". By default all events are masked off. You can activate the desired events by masking them ("x"). Please remember to save your maskings by confirming the changes with the check mark icon. If you want to cancel the changes, select the strike-through circle to do so. Only masked events are recorded to the event history (which can be accessed in the "Events" view in the user view section).

Device I/O

Figure. 4.5 - 30. Device I/O submenu.

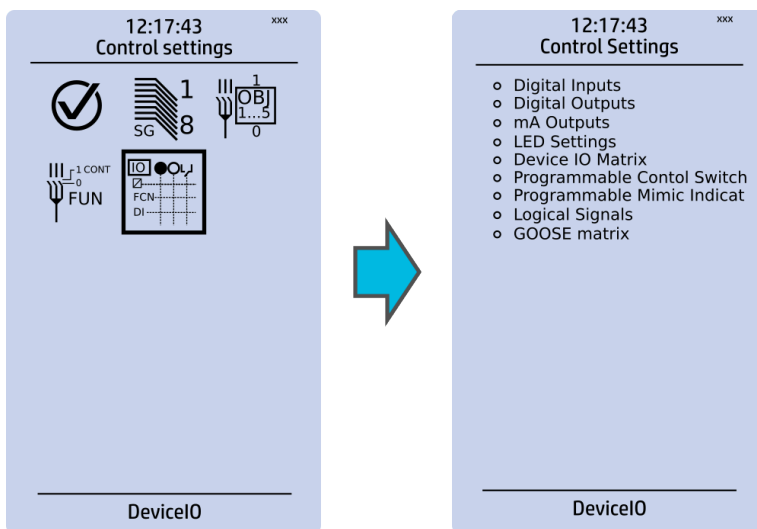

The *Device I/O* submenu is divided into the following nine sections: "Digital inputs", "Digital outputs", "mA Outputs", "LED settings", "Device I/O matrix", "Programmable control switch", "Programmable Mimic Indicator", "Logic signals" and "GOOSE matrix". Please note that digital inputs, logic outputs, protection stage status signals (START, TRIP, BLOCKED, etc.) as well as object status signals can be connected to an output relay or to LEDs in the "Device I/O matrix" section.

Figure. 4.5 - 31. Digital input section.

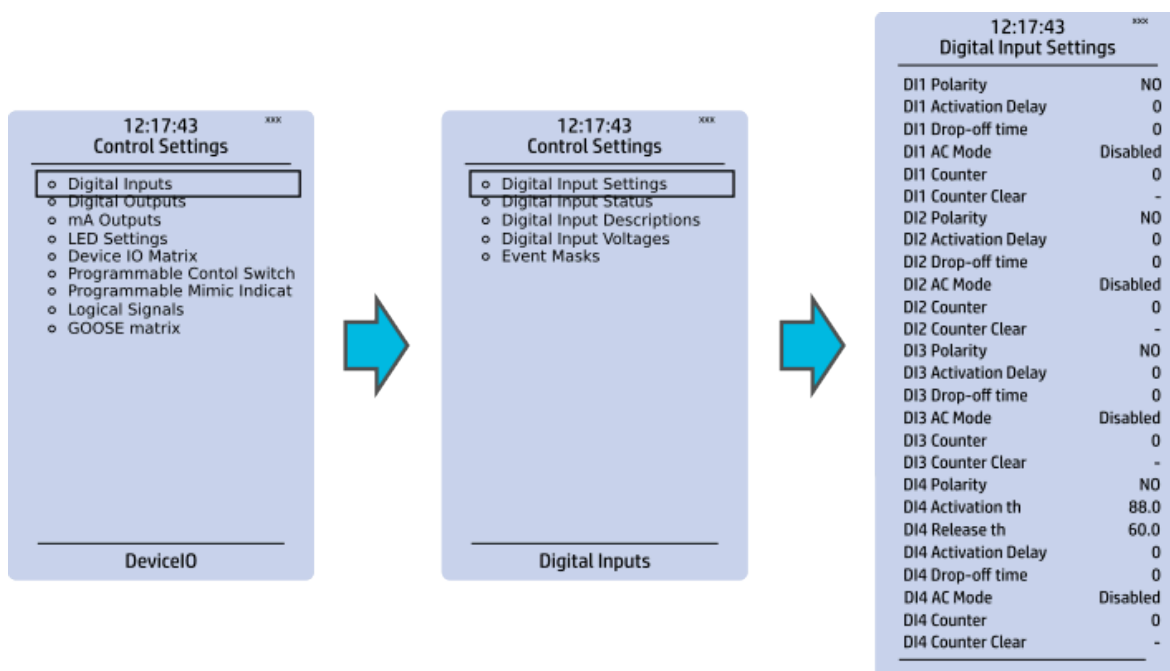

All settings related to digital inputs can be found in the "Digital inputs" section.

The "Digital inputs settings" subsection includes various settings for the inputs: the polarity selection determines whether the input is Normal Open (NO) or Normal Closed (NC) as well as the activation threshold voltage (16...200 V AC/DC, step 0.1 V) and release threshold voltage (10...200 V AC/DC, step 0.1 V) for each available input. There is also a setting to determine the wanted activation and release delay (0...1800 s, step 1 ms). Digital input activation and release threshold follow the measured peak value. The activation time of an input is 5...10 ms. The release time with DC is 5...10 ms, while with AC it is less than 25 ms. The first three digital inputs don't have activation and release threshold voltage settings as these have already been defined when the unit was ordered.

Digital input statuses can be checked from the corresponding subsection ("Digital input status"). The "Digital input descriptions" subsection displays the texts the user has written for each digital input. In the "Event masks" subsection you can determine which events are masked –and therefore recorded into the event history– and which are not.

Figure. 4.5 - 32. Digital outputs section.

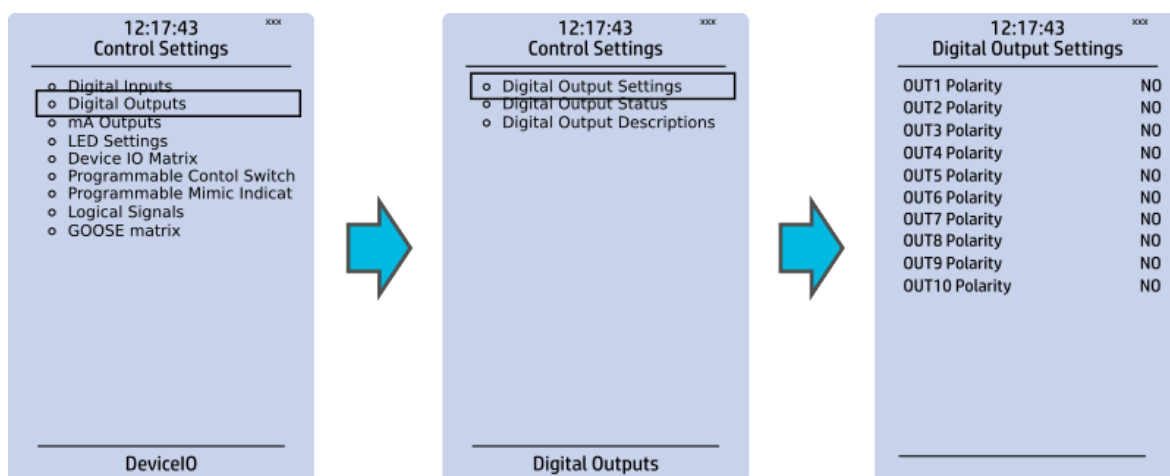

All settings related to digital outputs can be found in the "Digital outputs" section.

The "Digital outputs settings" subsection lets you select the polarity for each output; they can be either Normal Open (NO) or Normal Closed (NC). The default polarity is Normal Open. The operational delay of an output contact is approximately 5 ms. You can view the digital output statuses in the corresponding subsection ("Digital output status"). The "Digital output descriptions" subsection allows you to configure the description text for each output. All name changes affect the matrices as well as input–output selection lists.

NOTE!



An NC signal goes to the default position (NO) if the relay loses the auxiliary voltage or if the system is fully reset. However, an NC signal does not open during voltage or during System full reset. An NC output signal does not open during a Communication or Protection reset.

Figure. 4.5 - 33. LED settings section.

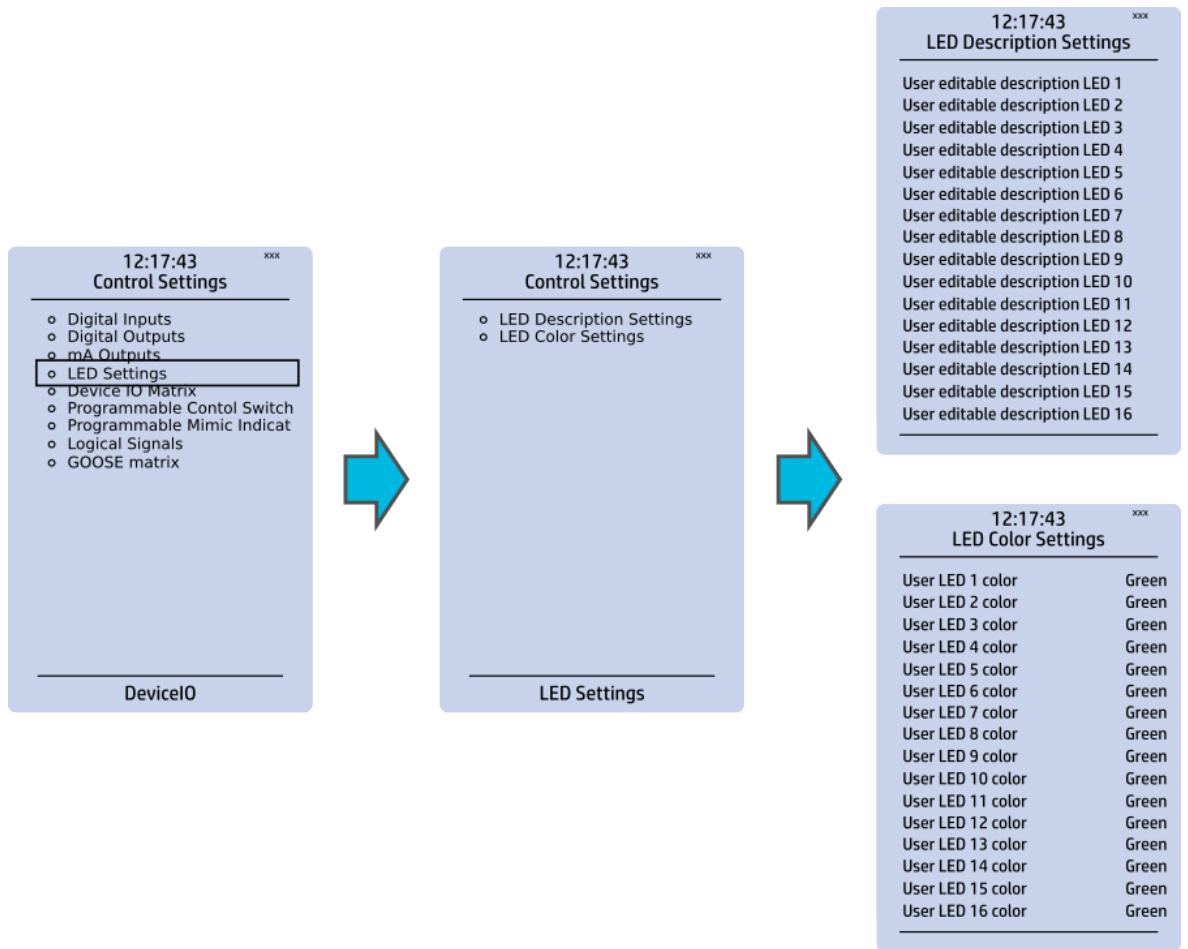

The "LED settings" section allows you to modify the individual label text attached to an LED ("LED description settings"); that label is visible in the LED quick displays and the matrices. You can also modify the color of the LED ("LED color settings") between green and yellow; by default all LEDs are green.

Figure. 4.5 - 34. Device I/O matrix section.

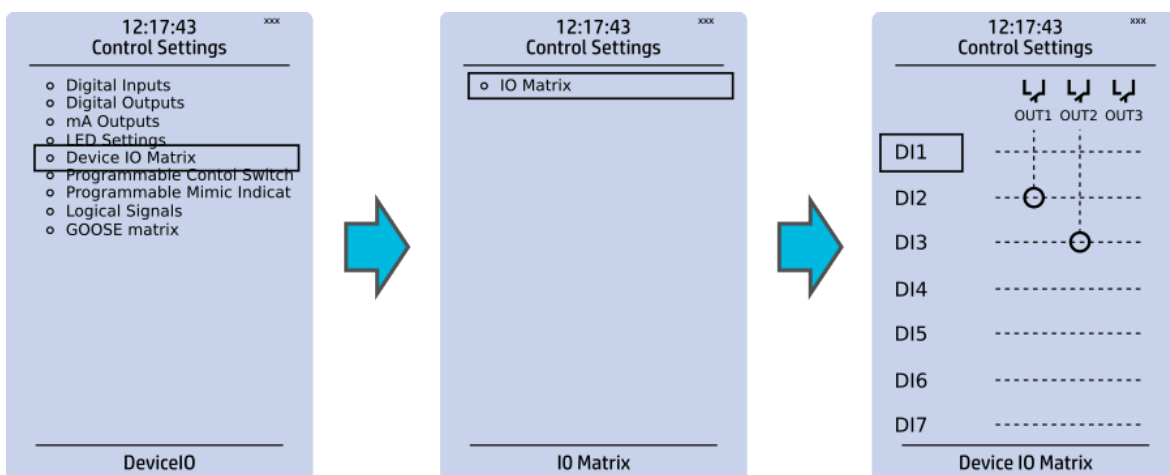

Through the "Device I/O matrix" section you can connect digital inputs, logical outputs, protection stage status signals (START, TRIP, BLOCKED, etc.), object status signals and many other binary signals to output relays, or to LEDs configured by the used. A connection can be latched ("|x|") or non-latched ("x"). Please note that a non-latched output is deactivated immediately when the triggering signal is disabled, while a latched signal stays active until the triggering signal deactivates and the latched function is manually cleared.

You can clear latched signals by entering the mimic display and the pressing the Back button on the panel.

Figure. 4.5 - 35. Programmable control switch section.

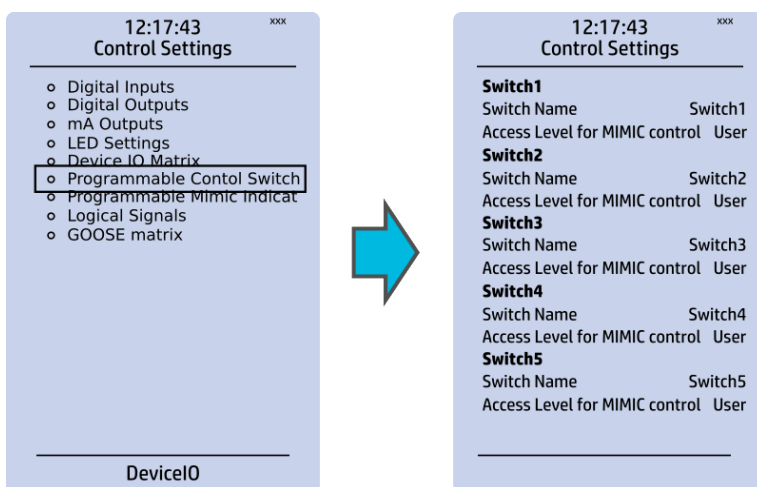

Programmable control switches (PCSs) are switches that can be used to control signals while in the mimic view. These signals can be used in a variety of situations, such as for controlling the logic program, for function blocking, etc. You can name each switch and set the access level to determine who can control the switch.

Figure. 4.5 - 36. Programmable mimic indicators section

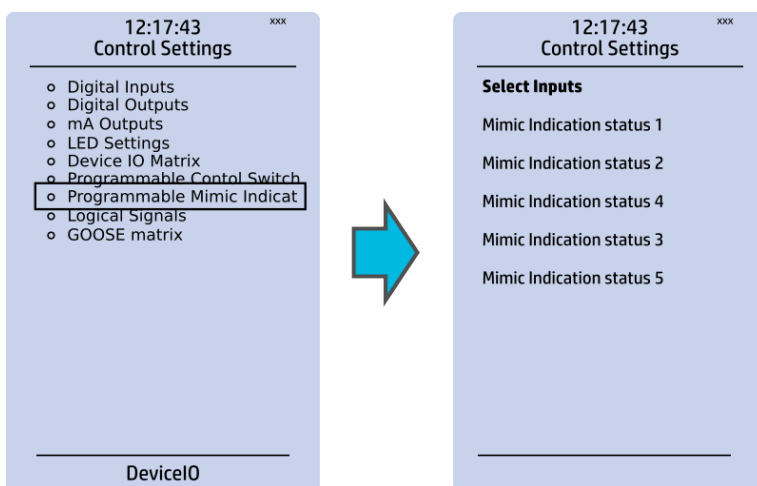

Programmable mimic indicators can be placed into the mimic to display a text based on the status of a given binary signal (digital input, logical signal, status of function start/tripped/blocked signals etc.). When configuring the mimic with the AQtivate setting tool, it is possible to set a text to be shown when an input signal is ON and a separate text for when the signal is OFF.

Figure. 4.5 - 37. Logical signals section.

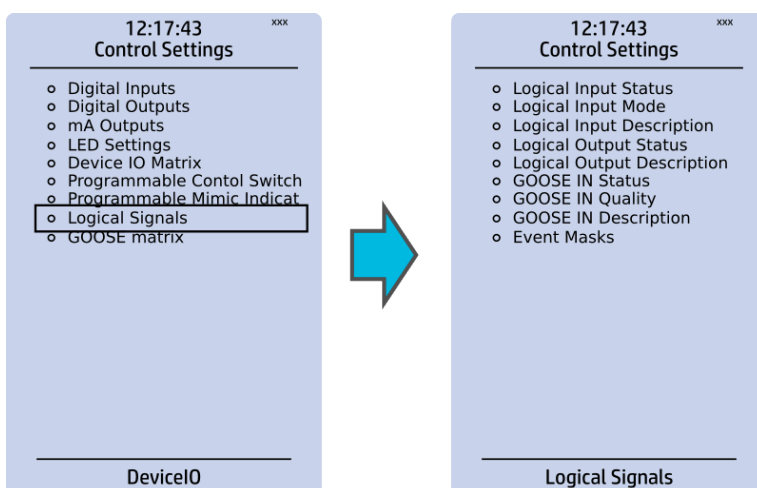

All AQ-200 series units have three different types of logical signals:

- 32 logical input signal status bits; the status of a bit is either 0 or 1.
- 32 logical output signal status bits; the status of a bit is either 0 or 1.
- 64 GOOSE input signal status bits; the status of a bit is either 0 or 1.
- 64 quality bits for GOOSE input signals; the status of a bit is either 0 or 1.

Logical input signals can be used when building a logic with the AQtivate setting tool. The status of a logical input signal can be changed either from the mimic or through SCADA. By default logical inputs use "Hold" mode in which the status changes from 0 to 1 and from 1 to 0 only through user input. The mode of each input can be changed to "Pulse" in which a logical input's status changes from 0 to 1 through user input and then immediately back to 0.

Logical output signals can be used as the end result of a logic that has been built in the AQtivate setting tool. The end result can then be connected to a digital output or a LED in the matrix, block functions and much more.

GOOSE inputs are mainly used for controlling purposes and in conjunction with the IEC 61850 communication protocol. There are 64 GOOSE inputs signal status bits, and their status can be either 0 or 1. "GOOSE IN quality" checks the quality of a GOOSE input message. There are 64 GOOSE input quality signals, and their status can be either 0 ("Good" or "Valid") or 1 ("Bad" or "Invalid"). Logical outputs can be used when building a programmable logic. Activating a logic gate does not create an event but when a logical output is connected to a logic gate it is possible to create an event from the gate's activation. All logical inputs and outputs have both ON and OFF events, and they can be masked on when necessary (they are masked off by default).

NOTE!



Please refer to the "System integration" chapter for a more detailed description of the use of logical signals.

4.6 Communication menu

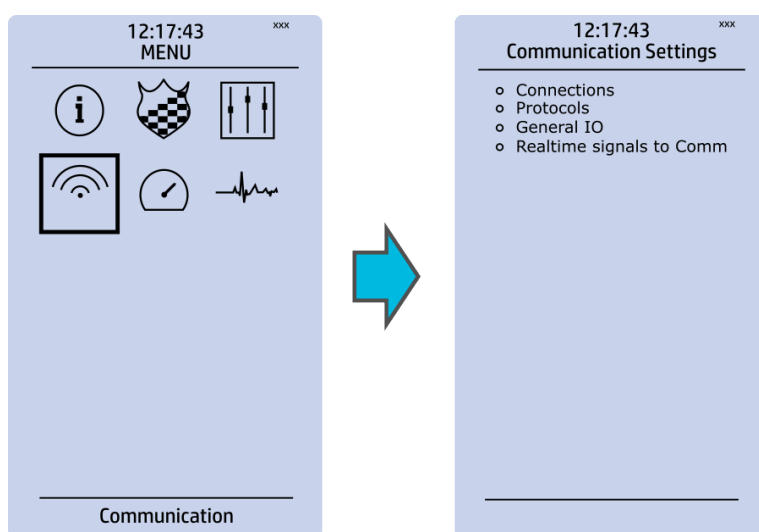

The *Communication* main menu includes four submenus: *Connections*, *Protocols*, *General IO* and *Realtime signals to Comm*. All devices can be configured through the Ethernet connection in the back panel with the AQtivate setting tool software. Connecting to the AQtivate software requires knowing the IP address of your device (can be found in the *Communication* → *Connections* submenu). As a standard, the devices support the following communication protocols: NTP, IEC 61850, Modbus/TCP, Modbus/RTU, IEC 103, IEC 101/104, SPA, DNP3 and Modbus/IO.

Connections

Figure. 4.6 - 38. View of the Connections submenu.

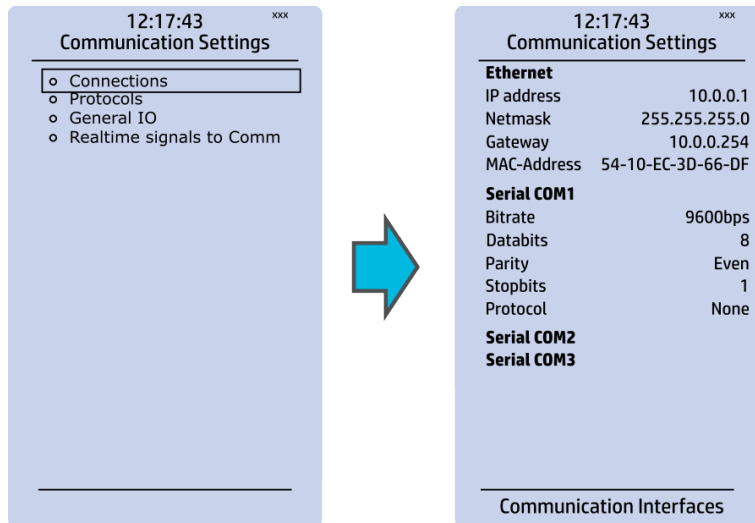

The *Connections* submenu offers the following bits of information and settings:

ETHERNET

This section defines the IP settings for the ethernet port in the back panel of the unit.

- IP address: the IP address of the device which can be set by the user (the default IP address depends on the device).
- Network: the network subnet mask is entered here.
- Gateway: the gateway is configured only when communicating with the devices in a separate subnet.
- MAC-Address: Unique MAC address of the device. Not configurable by user.

SERIAL COM

This section defines the basic settings of RS-485 port in the back panel of the unit.

- Bitrate: displays the bitrate of the RS-485 serial communication interface (9600 bps as standard, although can be changed to 19 200 bps or 38 400 bps if an external device supports the faster speed).
- Databits, Parity and Stopbits: these can be set according the connected external devices.
- Protocol: by default the device does not have any serial protocol activated, although IEC 103, Modbus I/O and Modbus/RTU can be used for communication.

NOTE!



When communicating with a device through a front Ethernet port connection, the IP address is always 192.168.66.9.

SERIAL COM1 & COM2

SERIAL COM1 and SERIAL COM2 are reserved for serial communication option cards. They have the same settings as RS-485 port.

Protocols

Figure. 4.6 - 39. View of the Protocols submenu.

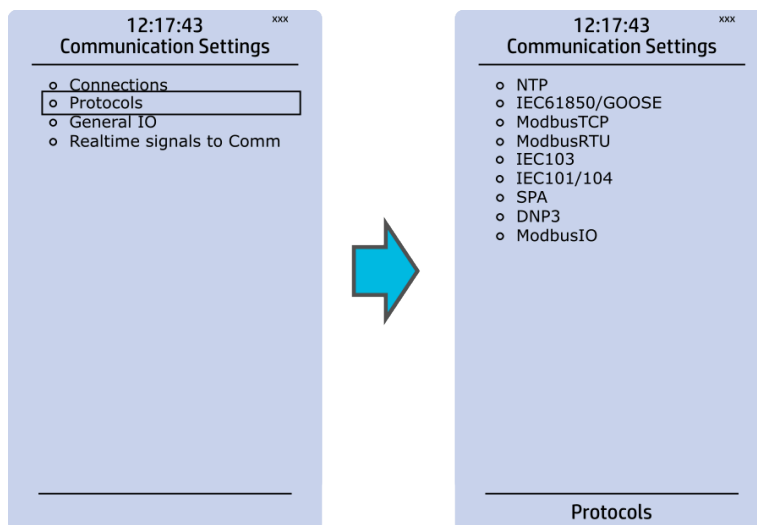

The *Protocols* submenu offers access to the various communication protocol configuration menus. Some of the communication protocols use serial communication and some use Ethernet communication. Serial communication protocols can be used either with the RS-485 port that is always equipped in AQ-200 series units or with serial communication option card. Ethernet communication protocols can be used either with the RJ-45 port in the back of the unit or with an ethernet communication option card.

The communication protocols are:

- NTP: this protocol is used for time synchronization over Ethernet, and can be used simultaneously with the ethernet based communication protocols.
- IEC 61850: Ethernet based communication protocol.
- Modbus/TCP: Ethernet communication protocol.
- Modbus/RTU: Serial communication protocol.
- IEC103: Serial communication protocol.
- IEC101/104: The standards IEC 60870-5-101 and IEC 60870-5-104 are closely related. On the physical layer the IEC 101 protocol uses serial communication whereas the IEC 104 protocol uses Ethernet communication.
- SPA: Serial communication protocol.
- DNP3: Supports serial and Ethernet communication.
- ModbusIO: Used for connecting external devices like ADAM RTD measurement units.

NOTE!



Please refer to the "System integration" chapter for a more detailed text on the various communication options.

4.7 Measurement menu

Figure. 4.7 - 40. Measurement section.

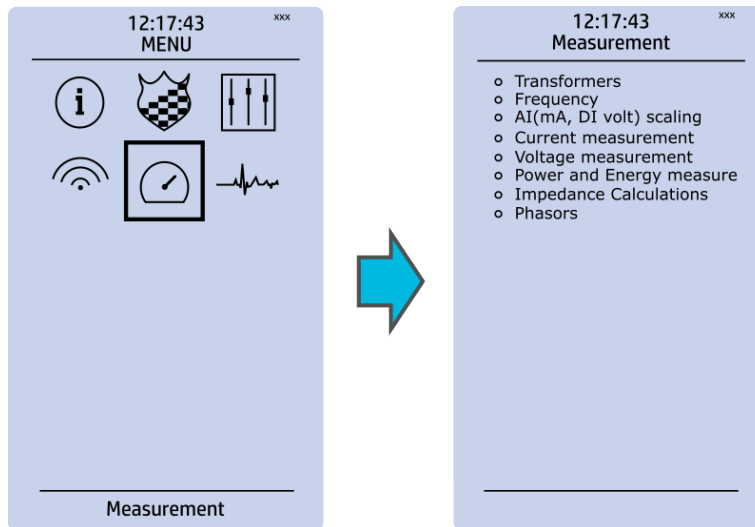

The *Measurement* menu includes the following submenus: *Transformers*, *Frequency*, *Current measurement*, *Voltage measurement*, *Power and energy measurement*, *Impedance calculations*, and *Phasors*. The available measurement submenus depends on the type of IED in use. The ratio used by the current and voltage transformers is defined in the *Transformers* submenu, while the system nominal frequency is specified in the *Frequency* submenu. Other submenus are mainly for monitoring purposes.

Transformers

Figure. 4.7 - 41. Transformers section.

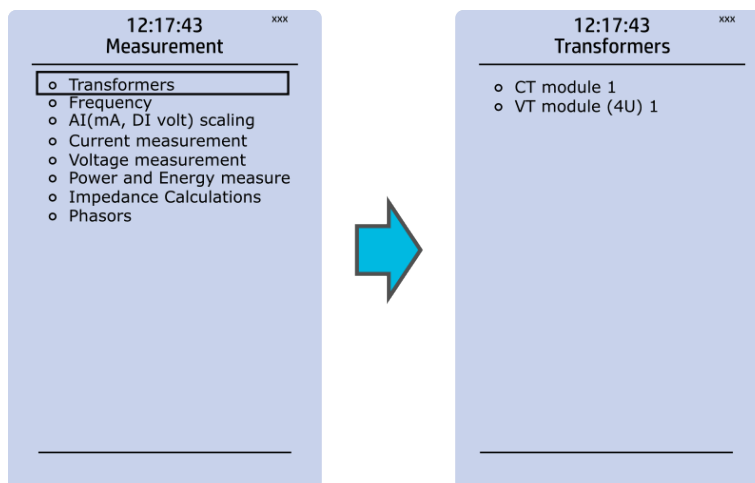

Transformers menu is used for setting up the measurement settings of available current transformer modules or voltage transformer modules. Some unit types have more than one CT or VT module. Some unit types like AQ-S214 do not have current or voltage transformers at all.

CT module

Figure. 4.7 - 42. CT module section.

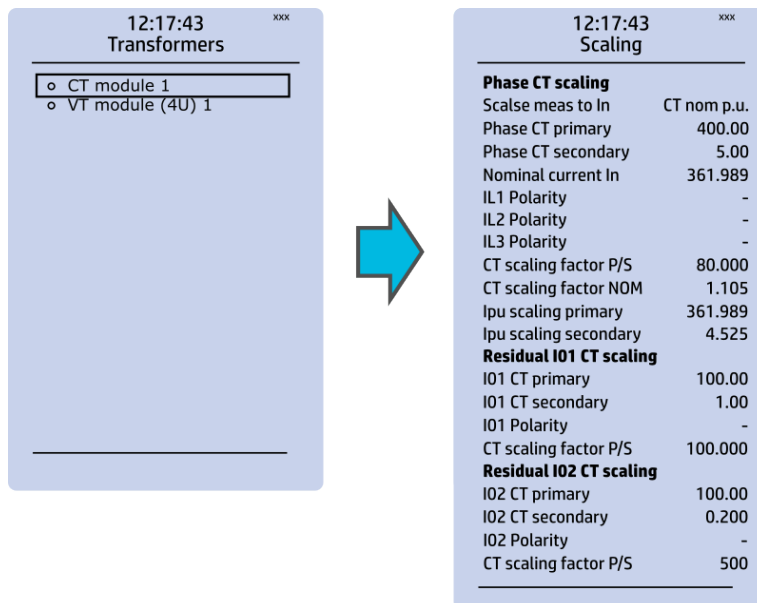

The three main sections ("Phase CT scaling", "Residual I01 CT scaling" and "Residual I02 CT scaling") determine the ratio of the used transformers. Additionally, the nominal values are also determined in the *CT module* submenu. Sometimes a mistake in the wiring can cause the polarity to be changed; in such cases, you can invert the polarity of each phase current individually. The *CT module* submenu also displays additional information such as CT scaling factors and per-unit scaling factors.

Frequency

Figure. 4.7 - 43. Frequency submenu.

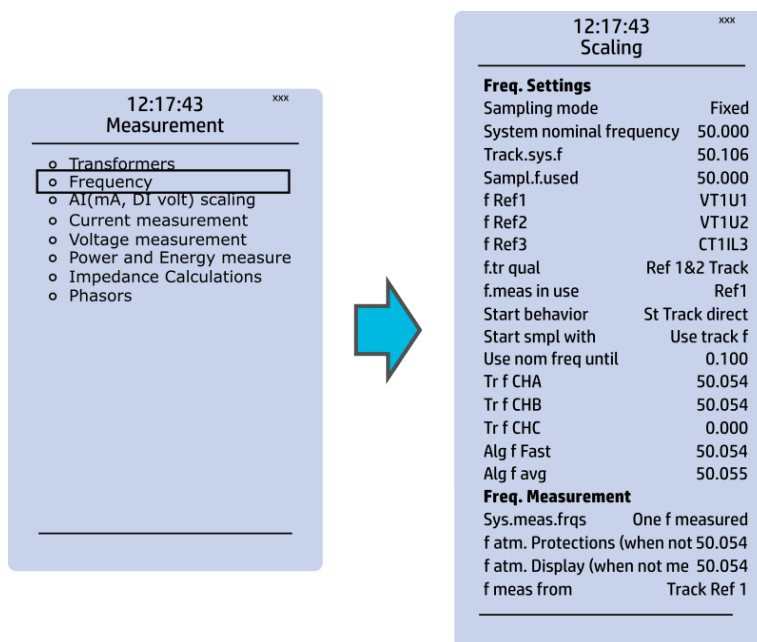

Frequency measurements use the fixed sampling mode as the default, and "System nominal frequency" should be set to the desired level. When "Sampling mode" is set to "Tracking", the device uses the measured frequency value as the system nominal frequency. There are three frequency reference channels: f Ref1, fRef2 and fRef3. With these parameters it is possible to set up three voltage or current channels to be used for frequency sampling. Parameter "f.meas in use" indicates which of the three channels are used for sampling if any.

Current measurement

Figure. 4.7 - 44. Current measurement submenu.

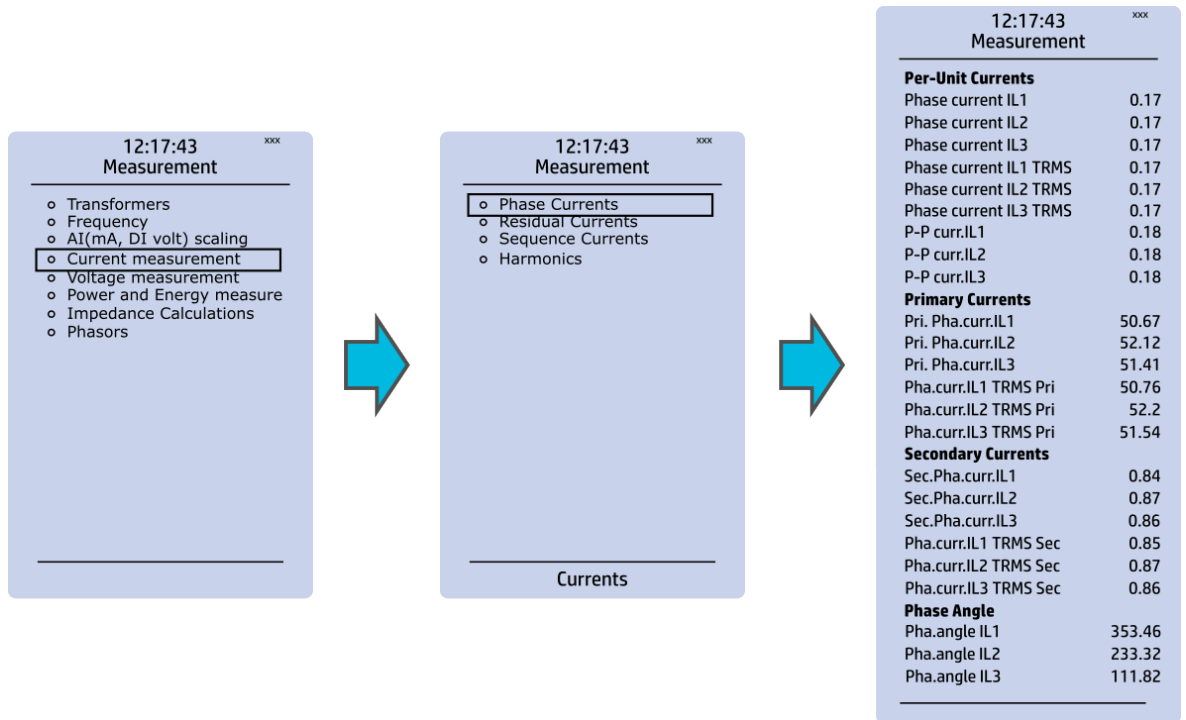

Current measurement submenu includes various individual measurements for each phase or phase-to-phase measurement.

The *Current measurement* submenu has been divided into four sections: "Phase currents", "Residual currents", "Sequence currents", and "Harmonics".

- "Phase currents" and "Residual currents" have been further divided into four subsections ("Per-unit currents", "Primary currents", "Secondary currents" and "Phase angle"), and they display the RMS, TRMS and peak-to-peak values, amplitude and power THD values as well as the angle of each measured component.
- "Sequence currents" has also been further divided into the four above-mentioned sections, and it calculates the positive, negative and neutral sequence currents.
- "Harmonics" displays current harmonics up to the 31st harmonic for the three phase current (IL1, IL2, IL3) as well as the two residual currents (I01, I02); each component can be displayed as absolute or percentage values, and as primary or secondary amperages or in per-unit values.

Voltage measurement

Figure. 4.7 - 45. Voltage measurement submenu and System Voltages menu.

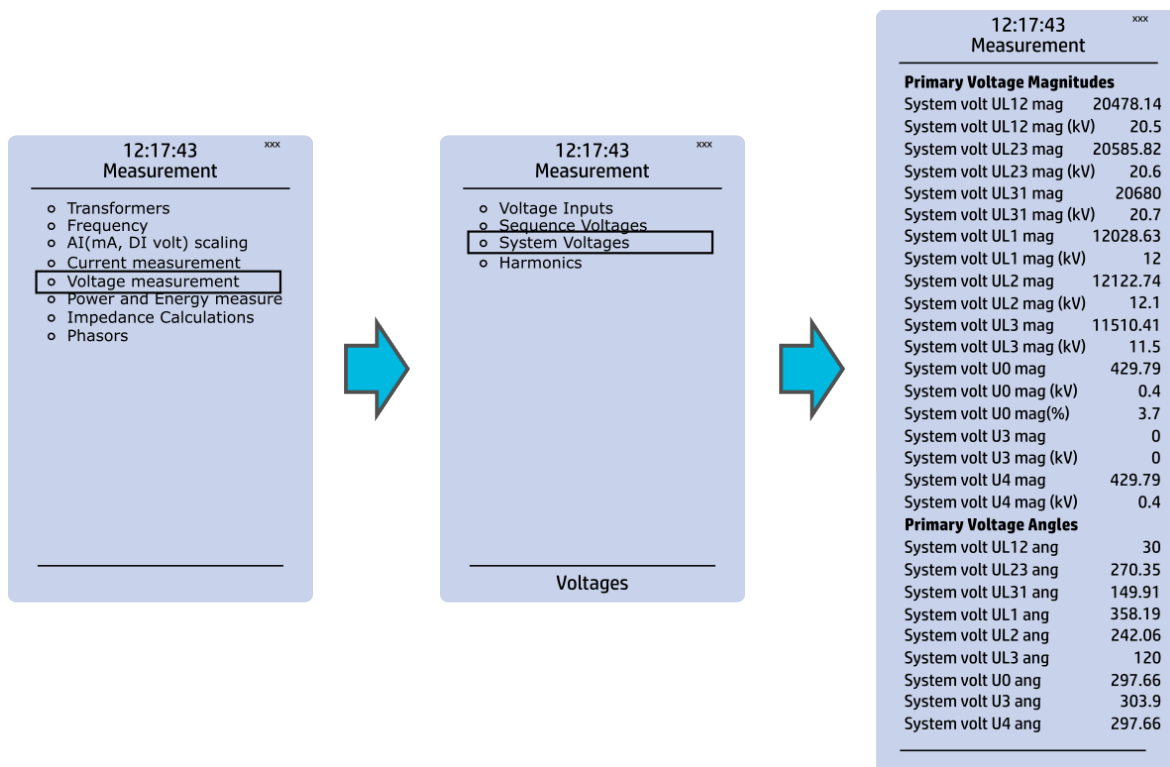

Voltage measurement submenu includes various individual measurements for each phase or phase-to-phase measurement.

The *Voltage measurement* submenu has been also divided into four sections: "Voltage inputs", "Sequence voltages", "System voltages", and "Harmonics".

- "Voltage inputs" displays the values of per-unit and secondary voltages as well as phase angles.
- "Sequence voltages" displays the per-unit, primary and secondary voltages as well as phase angles, and it calculates the positive, negative and neutral sequence voltages.
- "System voltages" displays primary voltage magnitudes and primary voltage angles.
- "Harmonics" displays harmonics up to the 31st harmonic for all four voltages (U1, U2, U3, U4); each component can be displayed as absolute or percentage values, and as primary or secondary voltages or in per-unit values.

Power and energy measurement

Figure. 4.7 - 46. Power and Energy measurement submenu.

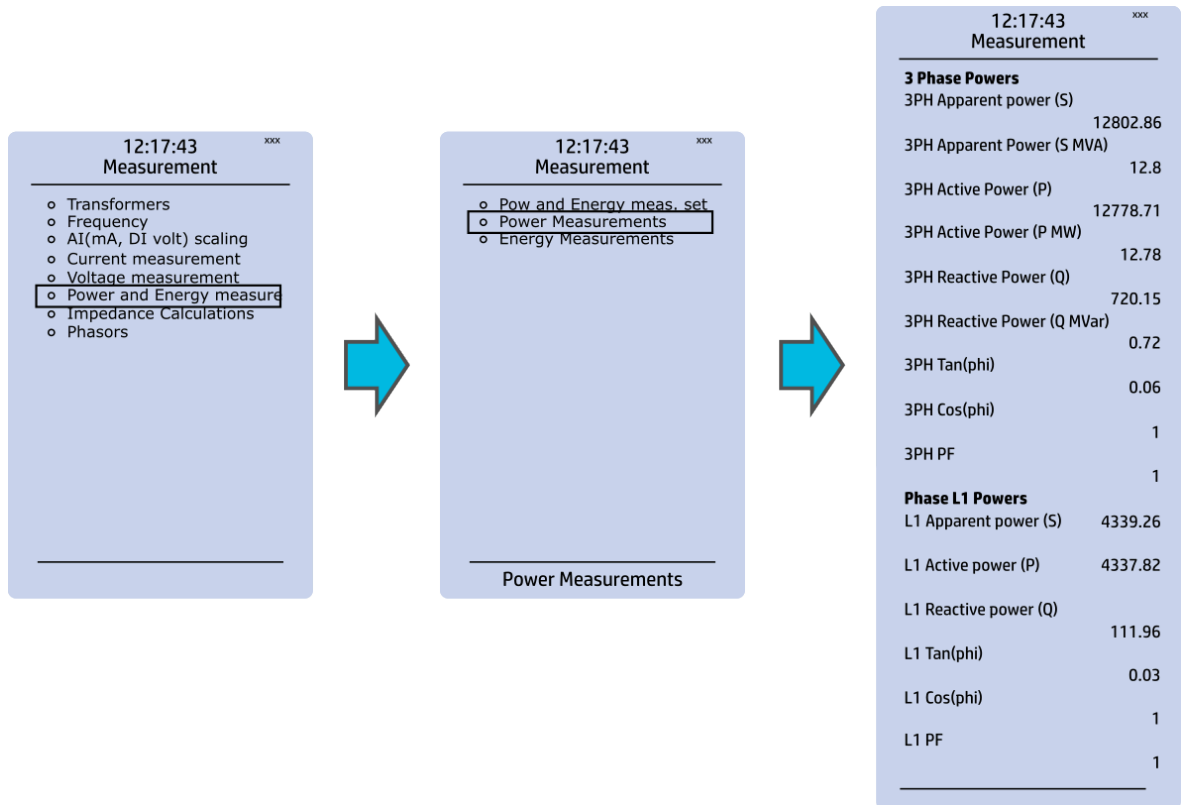

The Power and energy measurement submenu includes three sections: "Power and energy measurement settings", "Power measurements" and "Energy measurements". As the name suggests, the first section determines the settings by which the power and energy calculations are made. In the settings you can also activate (and then set the parameters) for the Energy dose counter mode. "Power measurements" displays all three-phase powers as well as the powers of individual phases. "Energy measurements" displays the three-phase energy as well as the energies of the individual phases.

Impedance calculations

Figure. 4.7 - 47. Impedance calculations submenu.

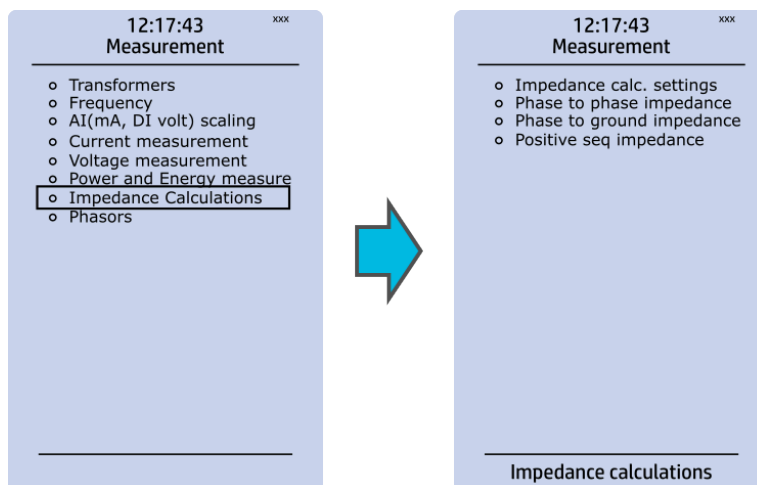

The *Impedance calculations* submenu is divided into four sections: "Impedance calculation settings", "Phase-to-phase impedances", "Phase-to-earth impedances" and "Positive sequence impedance". You can activate impedance calculations in the first section. "Phase-to-phase impedances" display the resistances and reactances of the three phase-to-phase connections, both primary and secondary, as well as the primary and secondary impedances and impedance angles. "Phase-to-earth impedances" displays the resistances and reactances of the three phases as well the primary and secondary impedances and impedance angles. "Positive sequence impedance" displays the resistances and reactances (both primary and secondary) of the positive sequence as well as its primary and secondary impedances and the impedance angle.

Phasors

Figure. 4.7 - 48. Phasors submenu.

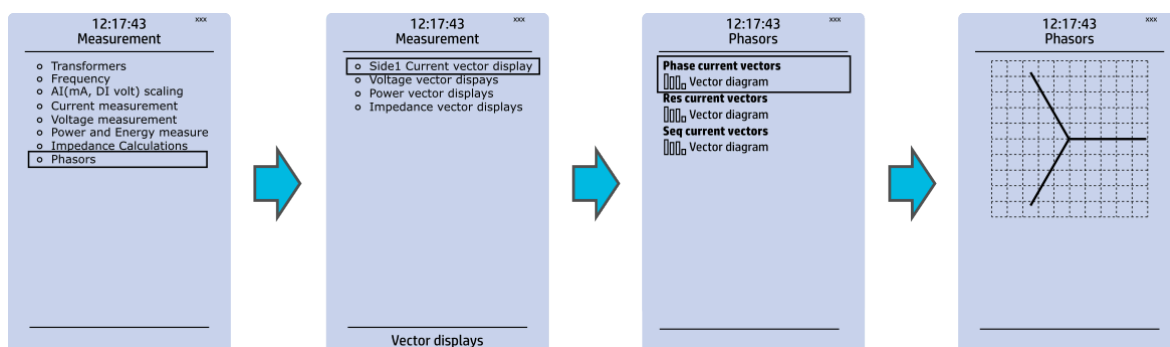

The *Phasors* submenu holds the vector displays for voltages and currents, as well as the various calculated components the IED may have (e.g. power, impedance). Phasors are helpful when solving incorrect wiring issues.

4.8 Monitoring menu

The *Monitoring* main menu includes submenus (see the image below) for enabling the various monitoring functions (*Monitors enabled*), setting the various monitoring functions (*Monitor functions*), controlling the disturbance recorder (*Disturbance REC*) and accessing the device diagnostics (*Device diagnostics*). The available monitoring functions depend on the type of the device in use.

Figure. 4.8 - 49. Monitoring menu view.

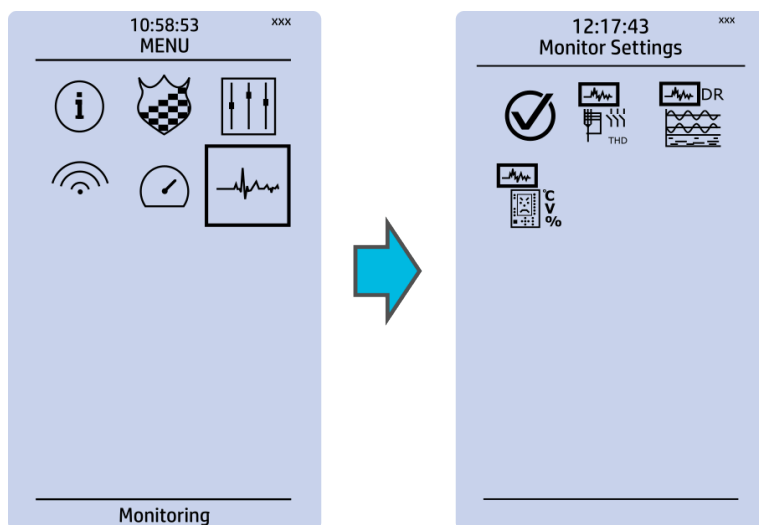

Monitors enabled

Figure. 4.8 - 50. Monitors enabled submenu.

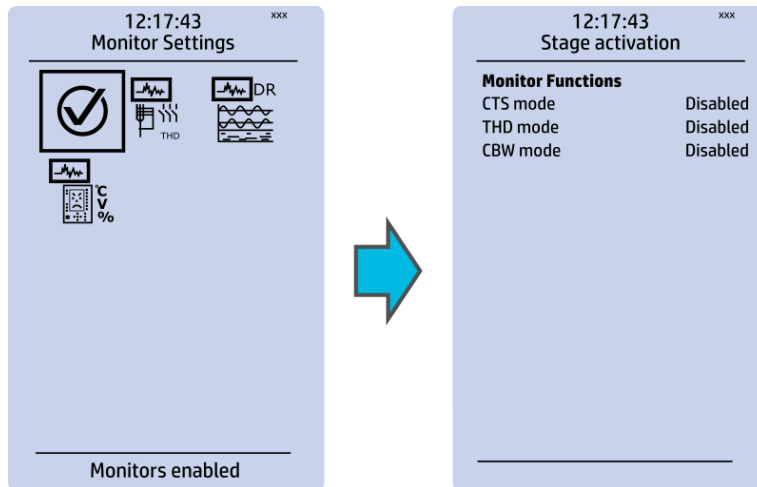

You can activate the selected monitor functions in the *Monitors enabled* submenu. By default all the control functions are disabled. All activated functions can be viewed in the *Monitor functions* submenu (see the section "Monitor functions" below for more information).

Monitor functions

Figure. 4.8 - 51. Monitor function view.

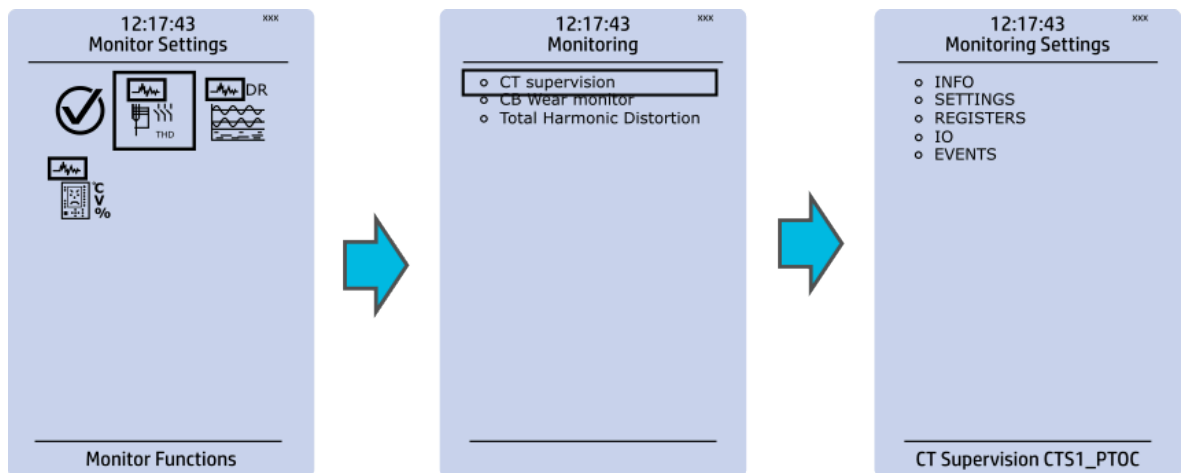

Configuring monitor functions is very similar to configuring protection and control stages. They, too, have the five sections that display information ("Info"), set the parameters ("Settings"), show the inputs and outputs ("I/O") and present the events and registers ("Events" and "Registers").

Disturbance recorder

Figure. 4.8 - 52. Disturbance recorder settings.

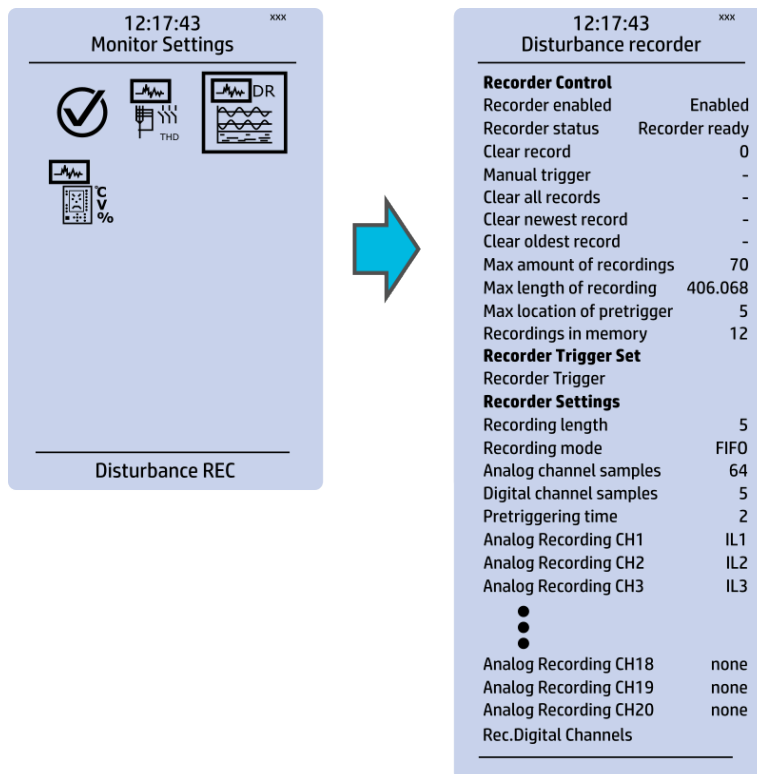

The *Disturbance recorder* submenu has the following settings:

- "Recorder enabled" enables or disables the recorder.
- "Recorder status" indicates the status of the recorder.
- "Clear record" records the chosen record in the memory.
- "Manual trigger" triggers the recorder when set to "Clear". Goes back to "-" when afterwards.
- "Clear all records", "Clear newest record" and "Clear oldest record" allows the clearing of all, the latest, or the oldest recording.
- "Max. amount of recordings" displays the maximum number of recordings; depends on the number of channels, the sample rate and the length of the file.
- "Max. length of recording" displays the maximum length of a single recording; depends on the number of chosen channels and the sample rate.
- "Recordings in memory" displays the number of recordings currently in the disturbance recorder's memory.
- "Recorder trigger" shows which signals or other states has been selected to trigger the recording (digital input, logical input or output, signals of a stage, object position, etc.); by default nothing triggers the recorder.
- "Recording length" displays the length of a single recording and can be set between 0.1...1800 seconds.
- "Recording mode" can be selected to replace the oldest recording ("FIFO") or to keep the old recordings ("FILO").
- "Analog channel samples" determines the sample rate of analog channels, and it can be selected to be 8/16/32/62 samples per cycle.
- "Digital channel samples" displays the sample rate in a digital channel; this is a fixed 5 ms.
- "Pretriggering time" can be selected between 0.1...15.0 s.
- The IED can record up to 20 (20) analog channels that can be selected from the twenty (20) available channels. Every measured current or voltage signal can be selected to be recorded.

- Enabling "Auto. get recordings" allows the device to automatically upload recordings to the designated FTP folder (which, in turn, allows any FTP client to read the recordings from the IED's memory).
- "Rec. digital channels" is a long list of the possible digital channels that can be recorded (including primary and secondary amplitudes and currents, calculated signals, TRMS values, sequence components, inputs and outputs, etc.).

Device diagnostics

Figure. 4.8 - 53. Device diagnostics submenu.

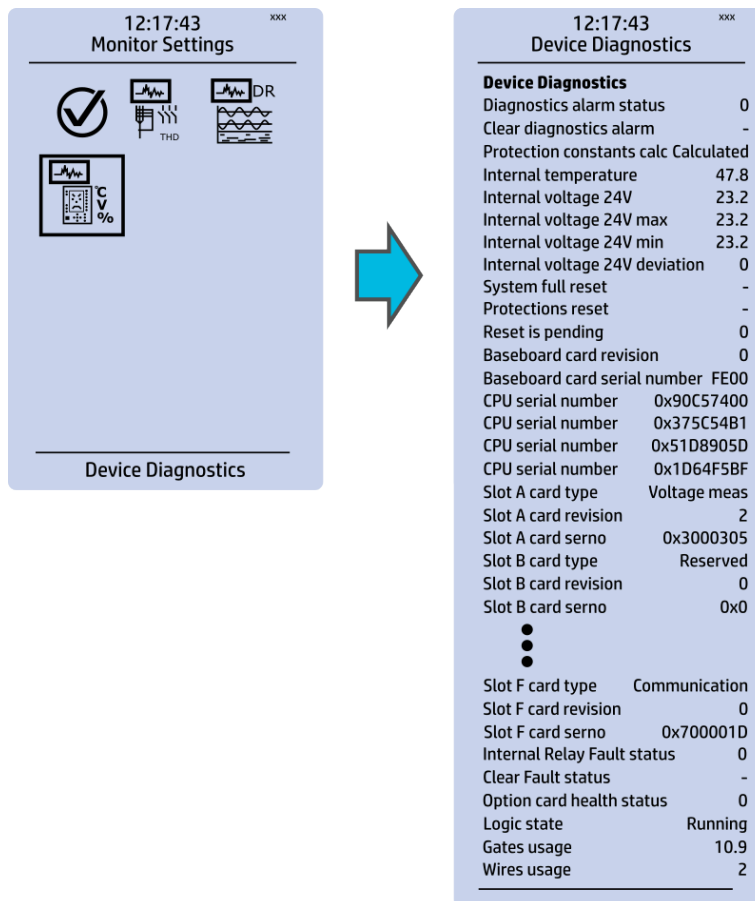

The *Device Diagnostics* submenu gives a detailed feedback of the device's current condition. It also shows whether option cards have been installed correctly without problems. If you see something out of the ordinary in the *Device diagnostics* submenu and cannot reset it, please contact the closest representative of the manufacturer or the manufacturer of the device itself.

4.9 Configuring user levels and their passwords

As a factory default, no user level is locked with a password in an IED. In order to activate the different user levels, click the **Lock** button in the device's HMI and set the desired passwords for the different user levels.



NOTE!

Passwords can only be set locally in an HMI.

A number of stars are displayed in the upper right corner of the HMI; these indicate the current user level. The different user levels and their star indicators are as follows (also, see the image below for the HMI view):

- Super user (***)
- Configurator (**)
- Operator (*)
- User (-)

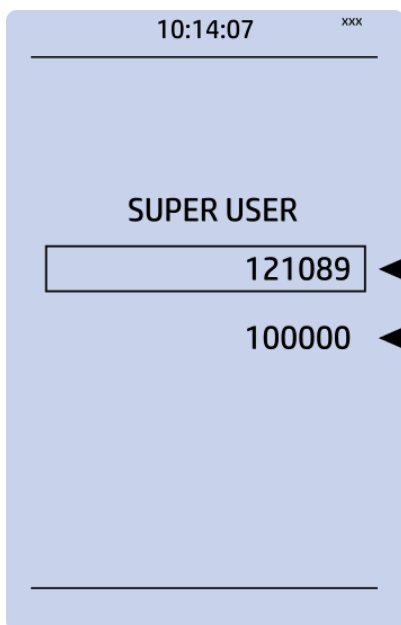
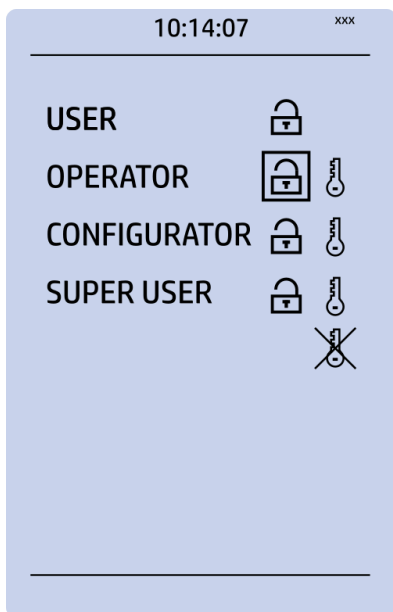

← Password field - Entered password

← Password step - This is the step which determines how much will be added or subtracted from the password in the field

You can set a new password for a user level by selecting the key icon next to the user level's name. After this you can lock the user level by pressing the **Return** key while the lock is selected. If you need to change the password, you can select the key icon again and give a new password. Please note that in order to do this the user level whose password is being changed must be unlocked.

As mentioned above, the access level of the different user levels is indicated by the number of stars. The required access level to change a parameter is indicated with a star (*) symbol if such is required. As a general rule the access levels are divided as follows:

- *User*: Can view any menus and settings but cannot change any settings, nor operate breakers or other equipment.
- *Operator*: Can view any menus and settings but cannot change any settings BUT can operate breakers and other equipment.

- *Configurator*: Can change most settings such as basic protection pick-up levels or time delays, breaker control functions, signal descriptions etc. and can operate breakers and other equipment.
- *Super user*: Can change any setting and can operate breakers and other equipment.

NOTE!



Any user level with a password automatically locks itself after half an hour (30 minutes) of inactivity.

5 Functions

5.1 Functions included in AQ-F213

The AQ-F213 feeder protection relay has five (5) function packages, A...E. The packages include the following functions as well as the number of stages for those functions.

Table. 5.1 - 4. Protection functions of AQ-F213.

				Function package				
Name (number of stages)	IEC	ANSI	Description	A	B	C	D	E
NOC (4)	I> I>> I>>> I>>>>	50/51	Non-directional overcurrent protection	X	X	X	X	X
DOC (4)	I _{dir} > I _{dir} >> I _{dir} >>> I _{dir} >>>>	67	Directional overcurrent protection				X	X
NEF (4)	I0> I0>> I0>>> I0>>>>	50N/51N	Non-directional earth fault protection	X	X	X	X	X
DEF (4)	I0 _{dir} > I0 _{dir} >> I0 _{dir} >>> I0 _{dir} >>>>	67N/32N	Directional earth fault protection			X	X	X
OV (4)	U> U>> U>>> U>>>>	59	Overvoltage protection			X	X	X
UV (4)	U< U<< U<<< U<<<<	27	Undervoltage protection			X	X	X
NOV (4)	U0> U0>> U0>>> U0>>>>	59N	Neutral overvoltage protection			X	X	X
FRQV (8)	f> f>> f>>> f>>>> f< f<< f<<< f<<<<	81O/81U	Overfrequency and underfrequency protection				X	X
ROCOF (1)	df/dt>< (1...8)	81R	Rate-of-change of frequency					X
CUB (4)	I2> I2>> I2>>> I2>>>>	46/46R/46L	Negative sequence overcurrent/ phase current reversal/ current unbalance protection	X	X	X	X	X

VUB (4)	U1/U2>/< U1/U2>>/<< U1/U2>>>/<<<< U1/U2>>>>/<<<<<	47/27P/59PN	Sequence voltage protection							X
HOC (4)	Ih> Ih>> Ih>>> Ih>>>>	50H/51H/68H	Harmonic overcurrent protection	X	X	X	X	X	X	X
CBFP (1)	CBFP	50BF/52BF	Circuit breaker failure protection	X	X	X	X	X	X	X
REF (1)	I0d>	87N	Low-impedance or high-impedance restricted earth fault/ cable end differential protection	X	X	X	X	X	X	X
TOLF (1)	TF>	49F	Line thermal overload protection	X	X	X	X	X	X	X
OPW (1)	P>	32O	Overpower protection							X
UPW (1)	P<	32U	Underpower protection							X
RPW (1)	Pr	32R	Reverse power protection							X
VMEM (1)	-	-	Voltage memory		X	X	X	X	X	X
ARC (1)	IArc>/I0Arc>	50Arc/50NArc	Arc fault protection (optional)	X	X	X	X	X	X	X

Table. 5.1 - 5. Control functions of AQ-F213.

				Function package				
Name	IEC	ANSI	Description	A	B	C	D	E
SGS	-	-	Setting group selection	X	X	X	X	X
OBJ	-	-	Object control and monitoring (5 objects available)	X	X	X	X	X
CIN	-	-	Indicator object monitoring (5 indicators available)	X	X	X	X	X
AR	0 → 1	79	Auto-recloser	X	X	X	X	X
CLPU	CLPU	-	Cold load pick-up	X	X	X	X	X
SOTF	SOTF	-	Switch-on-to-fault	X	X	X	X	X
VJP	$\Delta\phi$	78	Vector jump protection	X	X	X	X	X
PCS	-	-	Programmable control switch	X	X	X	X	X
mA output	-	-	Milliampere output control	X	X	X	X	X

Table. 5.1 - 6. Monitoring functions of AQ-F213.

				Function package				
Name	IEC	ANSI	Description	A	B	C	D	E
CTS	-	-	Current transformer supervision	X	X	X	X	X
VTS	-	60	Voltage transformer supervision			X	X	X
DR	-	-	Disturbance recorder	X	X	X	X	X
CBW	-	-	Circuit breaker wear monitor	X	X	X	X	X
THD	-	-	Total harmonic distortion			X	X	X
FLX	-	21FL	Fault locator				X	X
MR	-	-	Measurement recorder	X	X	X	X	X

VREC	-	-	Measurement value recorder	X	X	X	X	X
------	---	---	----------------------------	---	---	---	---	---

Table. 5.1 - 7. Communication protocols of AQ-F213.

Name	Function package				
	A	B	C	D	E
NTP	X	X	X	X	X
Modbus/TCP	X	X	X	X	X
Modbus/RTU	X	X	X	X	X
Modbus I/O	X	X	X	X	X
IEC 61850		X	X	X	X
GOOSE		X	X	X	X
IEC 103	X	X	X	X	X
DNP3	X	X	X	X	X
IEC 101/104	X	X	X	X	X
SPA	X	X	X	X	X

5.2 Measurements

5.2.1 Current measurement and scaling

The current measurement module (CT module, or CTM) is used for measuring the currents from current transformers. The measured values are processed into the measurement database and they are used by measurement and protection functions. It is essential to understand the concept of current measurements to be able to get correct measurements.

Figure. 5.2.1 - 54. Current measurement terminology

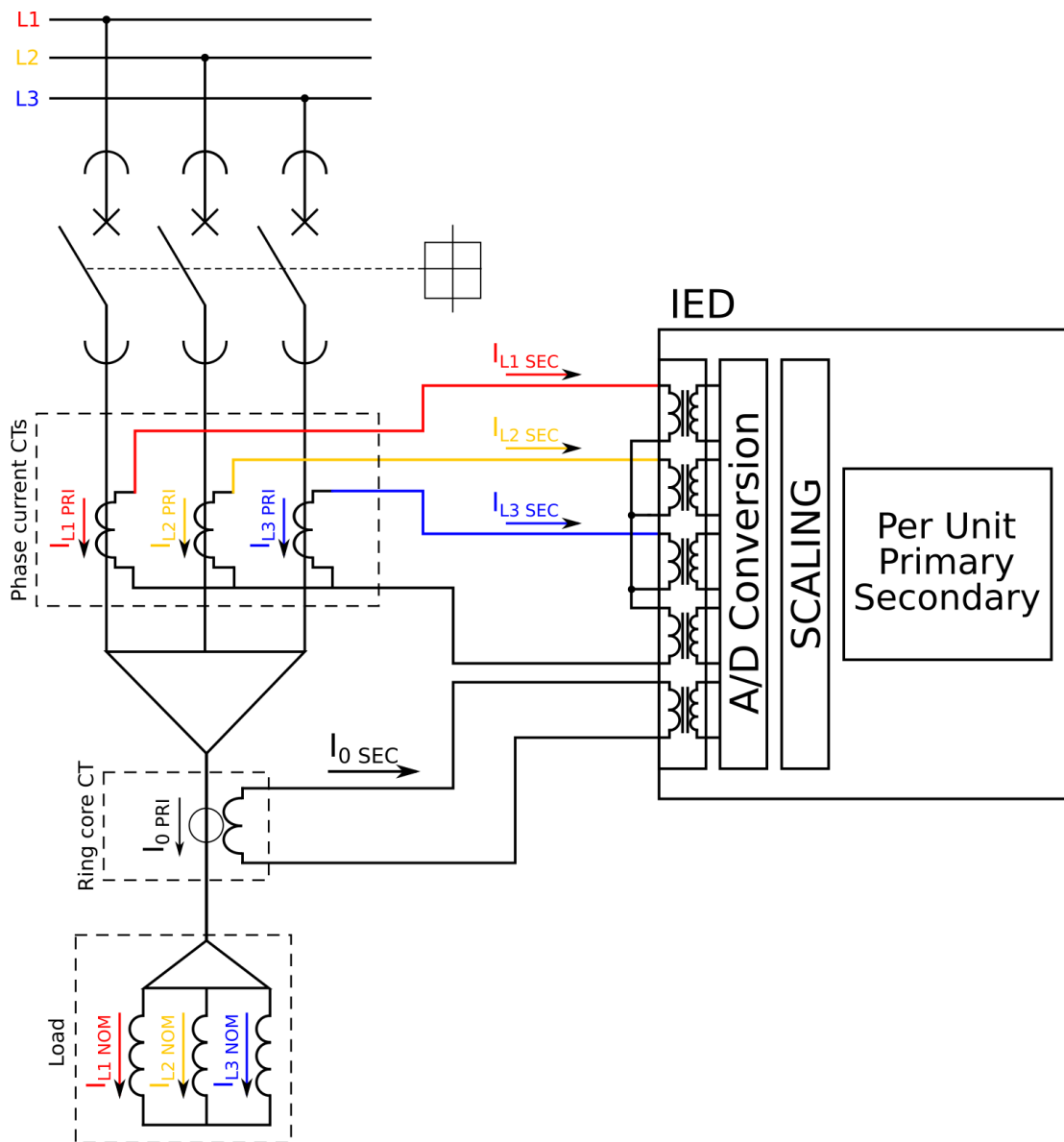

PRI: The primary current, i.e. the current which flows in the primary circuit and through the primary side of the current transformer.

SEC: The secondary current, i.e. the current which the current transformer transforms according to its ratios. This current is measured by the protection relay.

NOM: The nominal primary current of the protected object.

For the measurements to be correct the user needs to ensure that the measurement signals are connected to the correct inputs, that the current direction is connected to the correct polarity, and that the scaling is set according to the nominal values of the current transformer.

The relay calculates the scaling factors based on the set values of the CT primary, the CT secondary and the nominal current settings. The relay measures the secondary current, the current output from the current transformer installed into application's primary circuit. The rated primary and secondary currents of the CT need to be set for the relay to "know" the primary and per-unit values. With motors and other specific electrical apparatus protections, the motor's nominal current should be set for the values to be in per unit with regards to the apparatus nominal instead of the CT nominal. This is not always mandatory as some relays still require manual calculations for the correct settings; however, setting the motors nominal current makes motor protection much easier and more straightforward. In modern protection devices this scaling calculation is done internally after the current transformer's primary current, secondary current and motor nominal current are set.

Normally, the primary current ratings for phase current transformers are 10 A, 12.5 A, 15 A, 20 A, 25 A, 30 A, 40 A, 50 A, 60 A and 75 A as well as their decimal multiples, while the secondary current ratings are 1 A and 5 A. Other, non-standard ratings can be directly connected as the scaling settings are flexible and have large ranges. For example, the ring core current transformer ratings may vary. Ring core current transformers are commonly used for sensitive earth fault protection and their rated secondary current may be as low as 0.2 A in some cases.

The following chapter is an example on how to set the scaling of the current measurements for the selected current transformer and system load.

Example of CT scaling

The following figure presents how CTs are connected to the relay's measurement inputs. It also shows example CT ratings and nominal current of the load.

Figure. 5.2.1 - 55. Connections.

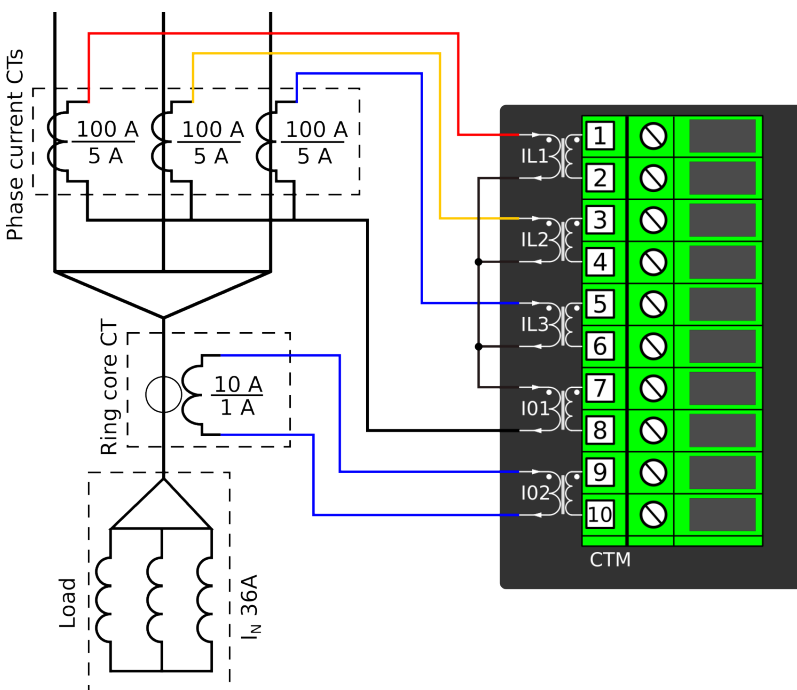

The following table presents the initial data of the connection.

Table. 5.2.1 - 8. Initial data.

Phase current CT	Ring core CT in Input I02	Load (nominal)
- CT primary: 100 A	- IOCT primary: 10 A	36 A
- CT secondary: 5 A	- IOCT secondary: 1 A	

- the phase currents are connected to the I01 residual via a Holmgren connection
- the starpoint of the phase current CT's secondary current is towards the line

Phase CT scaling

Next, to scale the current to per-unit values, we have to select whether the basis of the phase CT scaling is the protected object's nominal current or the CT primary value.

If the CT values are chosen to be the basis for the per-unit scaling, the option "CT nom. p.u." is selected for the "Scale meas to In" setting (see the image below).

Figure. 5.2.1 - 56. Setting the phase current transformer scalings to CT nominal.

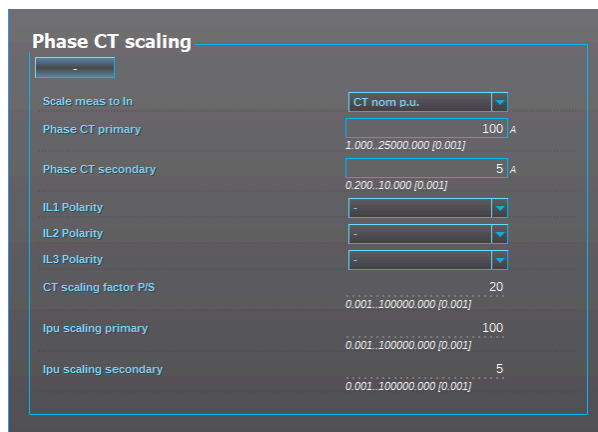

Once the setting have been sent to the device, relay calculates the scaling factors and displays them for the user. The "CT scaling factor P/S" describes the ratio between the primary current and the secondary current. The per-unit scaling factors ("Ipu scaling") for both primary and secondary values are also displayed (in this case they are the set primary and secondary currents of the CT).

If the protected object's nominal current is chosen to be the basis for the per-unit scaling, the option "Object in p.u." is selected for the "Scale meas to In" setting (see the image below).

Figure. 5.2.1 - 57. Setting the phase current transformer scalings to the protected object's nominal current.



Once the measurement scaling is tied to the protected object's nominal current, the user must set the appropriate input for the "Nominal current In" setting. One can now see the differences between the two scaling options (CT nominal vs. object nominal). The "CT scaling factor P/S" is the direct ratio between the set CT current values, and the "CT scaling factor NOM" is now the ratio between the set CT primary and the nominal current. The "Ipu scaling primary" is now equal to the set nominal current, and the "Ipu scaling secondary" is the ratio between the nominal current and the "CT scaling factor P/S".

Residual I0 CT scaling

Next, we set the residual IO CT scalings according to how the phase current CTs and the ring core CT are connected to the module (see the Connections image at the beginning of this chapter).

The phase current CTs are connected to the module via a Holmgren (summing) connection, which requires the use of coarse residual current measurement settings: the "I01 CT" settings are set according to the phase current CTs' ratings (100/5 A).

Figure. 5.2.1 - 58. Residual I01 CT scaling (coarse).

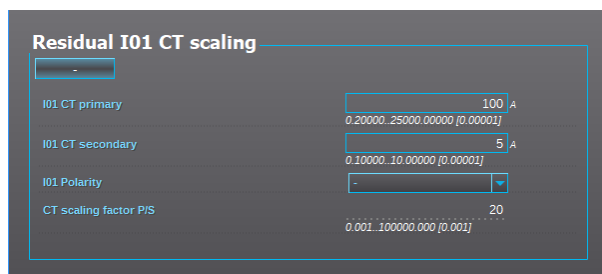

The ring core CT is connected to the CTM directly, which requires the use of sensitive residual current measurement settings: the "I02 CT" settings are set according to the ring core CT's ratings (10/1 A).

Figure. 5.2.1 - 59. Residual I02 CT scaling (sensitive).

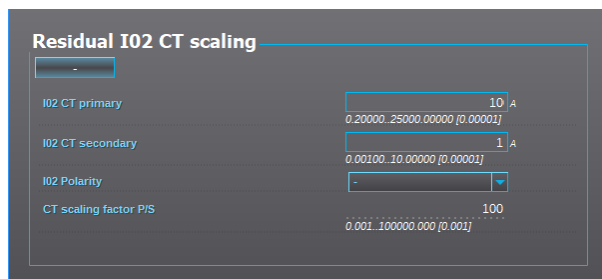

Displaying the scaling

Depending on whether the scaling was done based on the CT primary values or the protected object's nominal current, the measurements are displayed slightly differently. The first of the two images shows how the measurements are displayed when the CT primary values are the basis for the scaling; the second shows them when the protected object's nominal current is the basis for the scaling.

Figure. 5.2.1 - 60. Scalings display (based on the CT nominal).



Figure. 5.2.1 - 61. Scalings display (based on the protected object's nominal current).

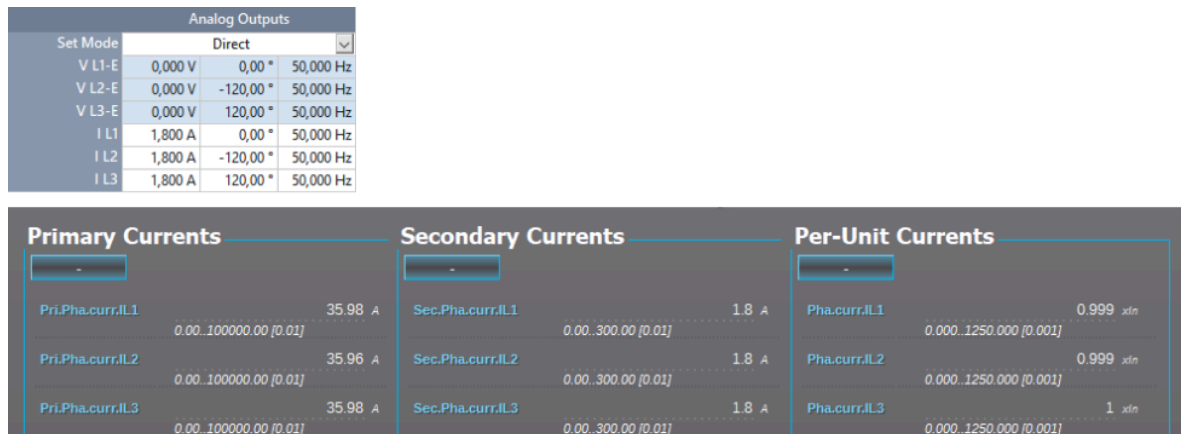

As the images above show, the scaling selection does not affect how primary and secondary currents are displayed (as actual values). The only effect is that the per-unit system in the relay is scaled either to the CT nominal or to the object nominal, making the settings input straightforward.

Example of zero sequence CT scaling

Zero sequence CT scaling (ZCT scaling) is done when a zero sequence CT instead of a ring core CT is part of the measurement connection. In such a case the zero sequence CT should be connected to the I02 channel which has lower CT scaling ranges (see the image below).

Figure. 5.2.1 - 62. Connections of ZCT scaling.

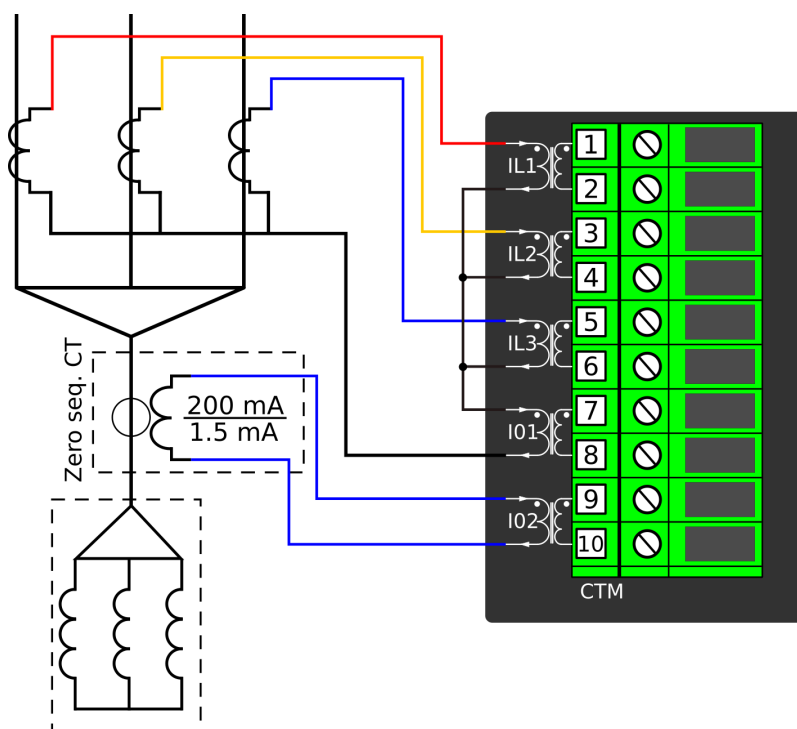

Troubleshooting

When the measured current values differ from the expected current values, the following table offers possible solutions for the problems.

NOTE!



If you work with energized CTs, extreme caution needs to be taken when checking the connections! An opened CT secondary circuit may generate dangerously high voltages. A "buzzing" sound from the connector can indicate an open circuit.

Problem	Solution
The measured current amplitude in all phases does not match the injected current.	The scaling settings may be wrong, check that the settings match with the connected current transformer (<i>Measurement</i> → <i>Transformers</i> → <i>Phase CT scaling</i>). Also check that the "Scale meas. to In" is set accordingly. If possible, check the actual CTs and their ratings as there may have been a need to change the original plan.
The measured current amplitude does not match one of the measured phases./ The calculated I0 is measured even though it should not.	Check the wiring connections between the injection device or the CTs and the relay.

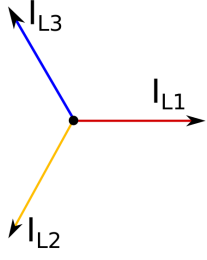
Problem	Solution
<p>The measured current amplitudes are OK but the angles are strange./</p> <p>The phase unbalance protection trips immediately after activation./</p> <p>The earth fault protection trips immediately after activation.</p>	<p>The phase currents are connected to the measurement module but the order or polarity of one or all phases is incorrect. In relay settings, go to <i>Measurement</i> → <i>Phasors</i> and check the "Phase current vectors" diagram. When all connections are correct, the diagram (symmetric feeding) should look like this:</p>  <p>See the following tables for the most common problems with phase polarity and network rotation (mixed phases).</p>

The following image presents the most common problems with phase polarity. Problems with phase polarity are easy to find because the vector diagram points towards the opposite polarity when a phase has been incorrectly connected.

Figure. 5.2.1 - 63. Common phase polarity problems.

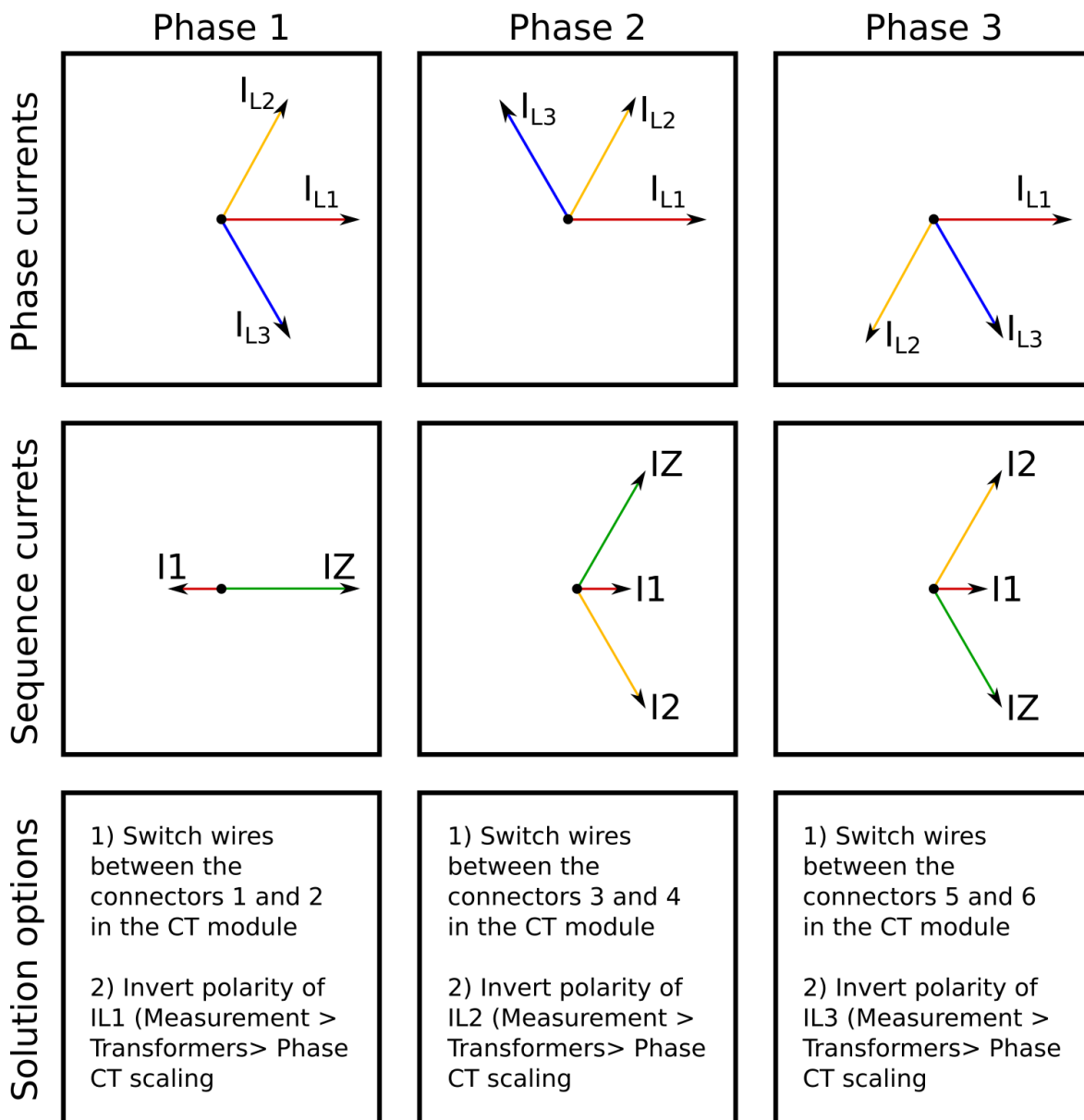

The following image presents the most common problems with network rotation (mix phases). These problems can be difficult to find because the measurement result is always the same in the relay. If two phases are mixed together, the network rotation always follows the pattern IL1-IL3-IL2 and the measured negative sequence current is therefore always 1.00 (in. p.u.).

Figure. 5.2.1 - 64. Common network rotation (mixed phases) problems.

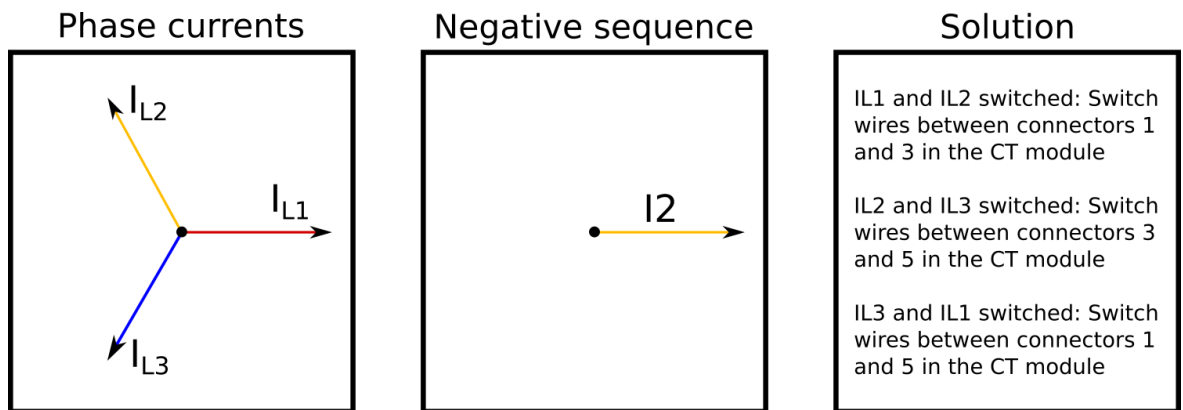

Settings

Table. 5.2.1 - 9. Settings of the Phase CT scaling.

Name	Unit	Range	Step	Default	Description
Scale measurement to In	-	0: CT nom p.u. 1: Object In p.u.	-	0: CT nom p.u.	The selection of the reference used in the relay's per-unit system scaling. Either the set phase current CT primary or the protected object's nominal current.
Phase CT primary	A	1...25000	0.001	100	The rated primary current of the current transformer.
Phase CT secondary	A	0.2...10	0.001	5	The rated secondary current of the current transformer.
Nominal current In	A	1...25000	0.001	100	The nominal current of the protected object. This setting is only visible if the option "Object In p.u." has been selected in the "Scale measurement to In" setting.
IL1 Polarity	-	0: - 1: Invert	-	0: -	The selection of the first current measurement channel's (IL1) polarity (direction). The default setting is for the positive current to flow from connector 1 to connector 2, with the secondary currents' starpoint pointing towards the line.
IL2 Polarity	-	0: - 1: Invert	-	0: -	The selection of the second current measurement channel's (IL2) polarity (direction). The default setting is for the positive current to flow from connector 3 to connector 4, with the secondary currents' starpoint pointing towards the line.
IL3 Polarity	-	0: - 1: Invert	-	0: -	The selection of the third current measurement channel's (IL3) polarity (direction). The default setting is for the positive current to flow from connector 5 to connector 6, with the secondary currents' starpoint pointing towards the line.
CT scaling factor P/S	-	-	-	-	A relay feedback value; the calculated scaling factor that is the ratio between the primary current and the secondary current.
CT scaling factor NOM	-	-	-	-	A relay feedback value; the calculated scaling factor that is the ratio between the set primary current and the set nominal current. This parameter is only visible if the option "Object In p.u." has been selected in the "Scale measurement to In" setting.
Ipu scaling primary	-	-	-	-	A relay feedback value; the scaling factor for the primary current's per-unit value.
Ipu scaling secondary	-	-	-	-	A relay feedback value; the scaling factor for the secondary current's per-unit value.

Table. 5.2.1 - 10. Settings of the Residual I01 CT scaling.

Name	Unit	Range	Step	Default	Description
I01 CT primary	A	0.2...25 000	0.00001	100	The rated primary current of the current transformer.
I01 CT secondary	A	0.1...10.000	0.00001	1	The rated secondary current of the current transformer.
I01 Polarity	-	0: - 1: Invert	-	0: -	The selection of the coarse residual measurement channel's (I01) polarity (direction). The default setting is for the positive current to flow from connector 7 to connector 8.
CT scaling factor P/S	-	-	-	-	A relay feedback value; the calculated scaling factor that is the ratio between the primary current and the secondary current.

Table. 5.2.1 - 11. Settings of the Residual I02 CT scaling.

Name	Unit	Range	Step	Default	Description
I02 CT primary	A	0.2...25 000	0.00001	100	The rated primary current of the current transformer.
I02 CT secondary	A	0.001...10	0.00001	0.2	The rated secondary current of the current transformer.
I02 Polarity	-	0: - 1: Invert	-	0: -	The selection of the sensitive residual measurement channel's (I02) polarity (direction). The default setting is for the positive current to flow from connector 9 to connector 10.
CT scaling factor P/S	-	-	-	-	A relay feedback value; the calculated scaling factor that is the ratio between the primary current and the secondary current.

Measurements

The following measurements are available in the measured current channels.

Table. 5.2.1 - 12. Per-unit phase current measurements.

Name	Unit	Range	Step	Description
Phase current ILx ("Pha.curr.ILx")	× In	0.000...1250.000	0.001	The RMS current measurement (in p.u.) from each of the phase current channels.
Phase current ILx TRMS ("Pha.curr.ILx TRMS")	× In	0.00...1250.00	0.01	The TRMS current (inc. harmonics up to 31 st) measurement (in p.u.) from each of the phase current channels.
Peak-to-peak current ILx ("P-P curr.ILx")	× In	0.00...500.00	0.01	The peak-to-peak current measurement (in p.u.) from each of the phase current channels.

Table. 5.2.1 - 13. Primary phase current measurements.

Name	Unit	Range	Step	Description
Primary phase current ILx ("Pri.Pha.curr.ILx")	A	0.00...1 000 000.00	0.01	The primary RMS current measurement from each of the phase current channels.
Primary phase current ILx TRMS ("Pha.curr.ILx TRMS Pri")	A	0.00...1 000 000.00	0.01	The primary TRMS current (inc. harmonics up to 31 st) measurement from each of the phase current channels.

Table. 5.2.1 - 14. Secondary phase current measurements.

Name	Unit	Range	Step	Description
Secondary phase current ILx ("Sec.Pha.curr.ILx")	A	0.00...300.00	0.01	The primary RMS current measurement from each of the phase current channels.
Secondary phase current ILx TRMS ("Pha.curr.ILx TRMS Sec")	A	0.00...300.00	0.01	The primary TRMS current (inc. harmonics up to 31 st) measurement from each of the phase current channels.

Table. 5.2.1 - 15. Phase angle measurements.

Name	Unit	Range	Step	Description
Phase angle ILx ("Pha.angle ILx")	deg	0.00...360.00	0.01	The phase angle measurement from each of the three phase current inputs.

Table. 5.2.1 - 16. Per-unit residual current measurements.

Name	Unit	Range	Step	Description
Residual current I0x ("Res.curr.I0x")	× In	0.00...1250.00	0.01	The RMS current measurement (in p.u.) from the residual current channel I01 or I02.
Calculated I0	× In	0.00...1250.00	0.01	The RMS current measurement (in p.u.) from the calculated I0 current channel.
Phase current I0x TRMS ("Res.curr.I0x TRMS")	× In	0.00...1250.00	0.01	The TRMS current (inc. harmonics up to 31 st) measurement (in p.u.) from the residual current channel I01 or I02.
Peak-to-peak current I0x ("P-P curr.I0x")	× In	0.00...500.00	0.01	The peak-to-peak current measurement (in p.u.) from the residual current channel I01 or I02.

Table. 5.2.1 - 17. Primary residual current measurements.

Name	Unit	Range	Step	Description
Primary residual current I0x ("Pri.Res.curr.I0x")	A	0.00...1 000 000.00	0.01	The primary RMS current measurement from the residual current channel I01 or I02.
Primary calculated I0 ("Pri.calc.I0")	A	0.00...1 000 000.00	0.01	The primary RMS current measurement from the calculated current channel I0.
Primary residual current I0x TRMS ("Res.curr.I0x TRMS Pri")	A	0.00...1 000 000.00	0.01	The TRMS current (inc. harmonics up to 31 st) measurement from the primary residual current channel I01 or I02.

Table. 5.2.1 - 18. Secondary residual current measurements.

Name	Unit	Range	Step	Description
Secondary residual current I0x ("Sec.Res.curr.I0x")	A	0.00...300.00	0.01	The secondary RMS current measurement from the residual current channel I01 or I02.
Secondary calculated I0 ("Sec.calc.I0")	A	0.00...300.00	0.01	The secondary RMS current measurement from the calculated current channel I0.
Secondary residual current I0x TRMS (Res.curr.I0x TRMS Sec")	A	0.00...300.00	0.01	The secondary TRMS current (inc. harmonics up to 31 st) measurement from the secondary residual current channel I01 or I02.

Table. 5.2.1 - 19. Residual phase angle measurements.

Name	Unit	Range	Step	Description
Residual current angle I0x ("Res.curr.angle I0x")	deg	0.00...360.00	0.01	The residual current angle measurement from the I01 or I02 current input.
calc.I0 Pha.angle	deg	0.00...360.00	0.01	The calculated residual current angle measurement.

Table. 5.2.1 - 20. Per-unit sequence current measurements.

Name	Unit	Range	Step	Description
Positive sequence current	× In	0.00...1250.00	0.01	The measurement (in p.u.) from the calculated positive sequence current.
Negative sequence current	× In	0.00...1250.00	0.01	The measurement (in p.u.) from the calculated negative sequence current.
Zero sequence current	× In	0.00...1250.00	0.01	The measurement (in p.u.) from the calculated zero sequence current.

Table. 5.2.1 - 21. Primary sequence current measurements.

Name	Unit	Range	Step	Description
Primary positive sequence current ("Pri.Positive sequence curr.")	A	0.00...1 000 000.00	0.01	The primary measurement from the calculated positive sequence current.
Primary negative sequence current ("Pri.Negative sequence curr.")	A	0.00...1 000 000.00	0.01	The primary measurement from the calculated negative sequence current.
Primary zero sequence current ("Pri.Zero sequence curr.")	A	0.00...1 000 000.00	0.01	The primary measurement from the calculated zero sequence current.

Table. 5.2.1 - 22. Secondary sequence current measurements.

Name	Unit	Range	Step	Description
Secondary positive sequence current ("Sec.Positive sequence curr.")	A	0.00...300.00	0.01	The secondary measurement from the calculated positive sequence current.
Secondary negative sequence current ("Sec.Negative sequence curr")	A	0.00...300.00	0.01	The secondary measurement from the calculated negative sequence current.
Secondary zero sequence current ("Sec.Zero sequence curr.")	A	0.00...300.00	0.01	The secondary measurement from the calculated zero sequence current.

Table. 5.2.1 - 23. Sequence phase angle measurements.

Name	Unit	Range	Step	Description
Positive sequence current angle ("Positive sequence curr.angle")	deg	0.00...360.00	0.01	The calculated positive sequence current angle.
Negative sequence current angle ("Negative sequence curr.angle")	deg	0.00...360.00	0.01	The calculated negative sequence current angle.
Zero sequence current angle ("Zero sequence curr.angle")	deg	0.00...360.00	0.01	The calculated zero sequence current angle.

Table. 5.2.1 - 24. Harmonic current measurements.

Name	Range	Step	Default	Description
Harmonics calculation values ("Harm Abs.or Perc.")	- 0: Percent 1: Absolute	-	0: Percent	Defines whether the harmonics are calculated as percentage or absolute values.
Harmonics display	- 0: Per unit 1: Primary A 2: Secondary A	-	0: Per unit	Defines how the harmonics are displayed: in p.u values, as primary current values, or as secondary current values.
Maximum harmonics value ("Ixx maximum harmonic")	A 0.00...100 000.00	0.01	-	Displays the maximum harmonics value of the selected current input ILx or IOx.
Fundamental frequency ("Ixx fundamental")	A 0.00...100 000.00	0.01	-	Displays the current value of the fundamental frequency (RMS) from the selected current input ILx or IOx.
Ixx harmonics (2 nd ...31 st harmonic)	A 0.00...100 000.00	0.01	-	Displays the selected harmonic from the current input ILx or IOx.

5.2.2 Voltage measurements and scaling

The voltage measurement module (VT module, or VTM) is used for measuring the voltages from voltage transformers. The measured values are processed into the measurement database and they are used by measurement and protection functions. It is essential to understand the concept of voltage measurements to be able to get correct measurements.

Figure. 5.2.2 - 65. Voltage measurement terminology

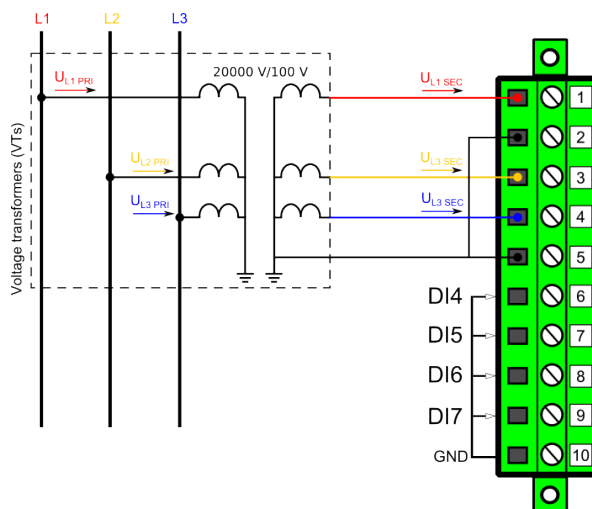

PRI: The primary voltage, i.e. the voltage in the primary circuit which is connected to the primary side of the voltage transformer.

SEC: The secondary voltage, i.e. the voltage which the voltage transformer transforms according to the ratio. This voltage is measured by the protection relay.

For the measurements to be correct the user needs to ensure that the measurement signals are connected to the correct inputs, that the voltage direction correct, and that the scaling is set correctly.

The relay calculates the scaling factors based on the set VT primary, and secondary voltage values. The relay measures secondary voltages, which are the voltage outputs from the VT installed into the application's primary circuit. The rated primary and secondary voltages of the VT need to be set for the relay to "know" the primary and per-unit values. In modern protection devices this scaling calculation is done internally after the voltage transformer's primary and secondary voltages are set.

Normally, the primary line-to-line voltage rating for VTs is 400 V...60 kV, while the secondary voltage ratings are 100 V...210 V. Non-standard ratings can also be directly connected as the scaling settings are flexible and have large ranges.

Example of VT scaling

The following figure presents how VTs are connected to the relay's measurement inputs. It also shows the VT ratings. In the figure below, two line-to-line voltages are connected along with the zero sequence voltage; therefore, the 2LN+U0 mode must be selected. Other possible connections are presented later in this chapter.

Figure. 5.2.2 - 66. Connections.

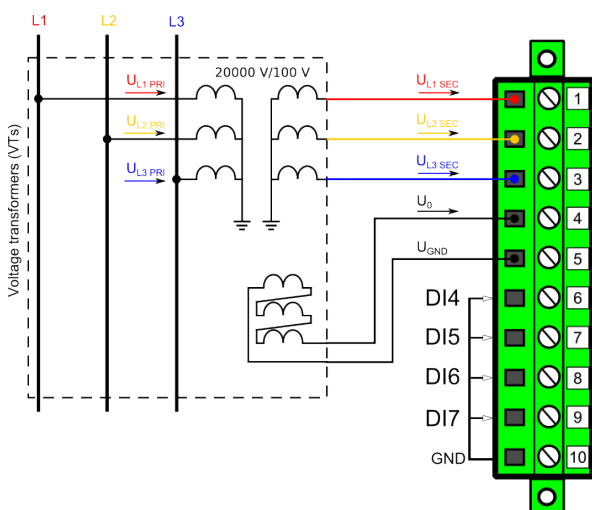

The following table presents the initial data of the connection.

Table. 5.2.2 - 25. Initial data.

Phase voltage VT - VT primary: 20 000 V - VT secondary: 100 V	Zero sequence voltage VT - U4 VT primary: 20 000 V - U4 VT secondary: 100 V
- the zero sequence voltage is connected similarly to line-to-line voltages (+U0). - in case wiring is incorrect, all polarities can be individually switched by 180 degrees in the relay.	

The protection can be based on line-to-line voltages or on line-to-earth voltages. This selection is defined in the "Measured magnitude" of each protection stage menu separately (*Protection* → *Voltage* → [protection stage menu] → *INFO*; see the image below).

Figure. 5.2.2 - 67. Selecting the measured magnitude.



Voltage protection itself is based on the nominal voltage. A 20 000 V nominal voltage equals a 100 % setting in voltage-based protection functions. A 120 % trip setting in the overvoltage stage equals to 24 000 V on the primary level (in this case a 20 % increase equals 4000 V).

Once the setting have been sent to the device, relay calculates the scaling factors and displays them for the user. The "VT scaling factor P/S" describes the ratio between the primary voltage and the secondary voltage. The per-unit scaling factors ("VT scaling factor p.u.") for both primary and secondary values are also displayed.

The triggering of a voltage protection stage can be based on one, two, or three voltages (the "Pick-up terms" setting at *Protection* → *Voltage* → [protection stage menu] → *Settings*). Fault loops are either line-to-line or line-to-neutral according to the "Measured magnitude" setting. As a default, the activation of any one voltage trips the voltage protection stage.

Figure. 5.2.2 - 68. Selecting the operating mode.

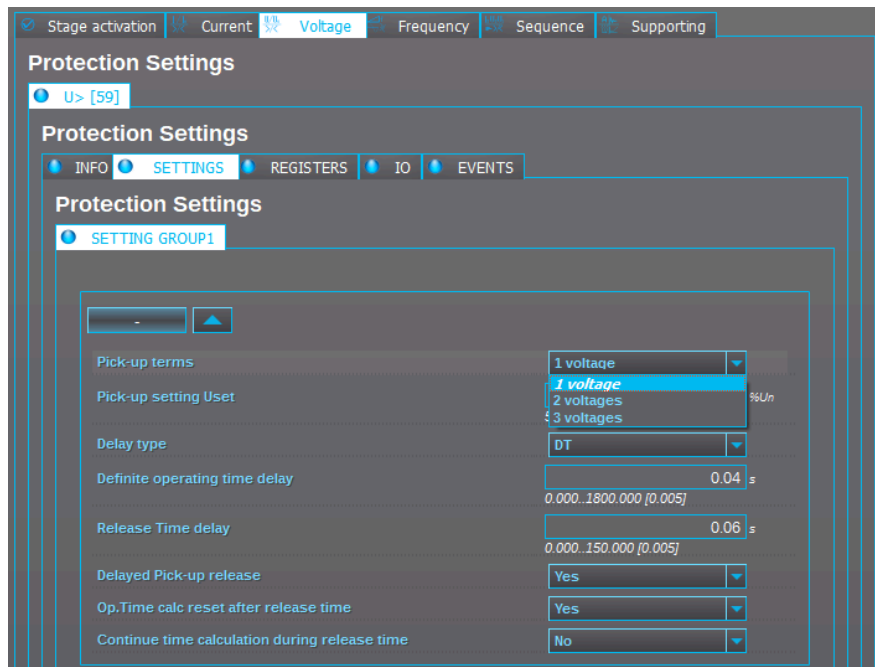

There are several different ways to use all three voltage channels. The voltage measurement modes are the following:

- 3LN
- 2LL+U0 (3LN)

- 2LL+U0 (Open delta 2LL)
- U0

See below for three example connections: the first one is for three line-to-neutral voltage measurements, the second for two line-to-line and the zero sequence voltage measurements, and the third one is for the two line-to-line (open delta) and the zero sequence voltage measurement.

Figure. 5.2.2 - 69. Example connections for 3LN voltage measurement.

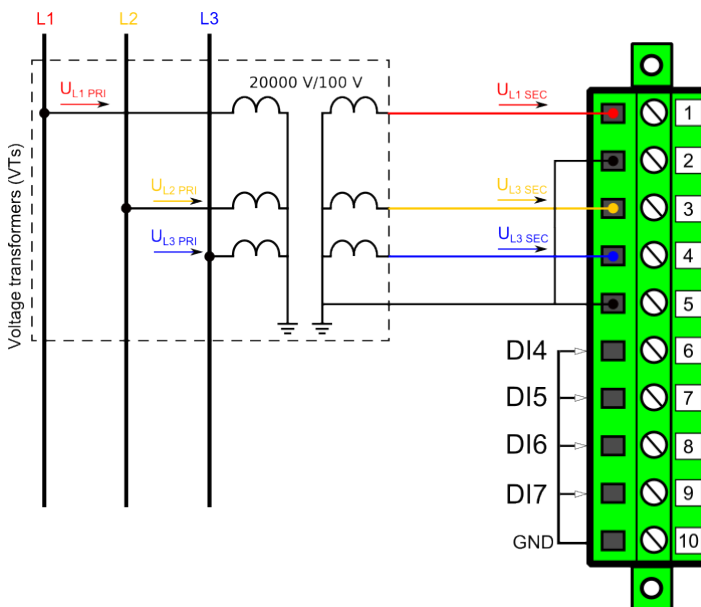

Figure. 5.2.2 - 70. Example connections for 2LL+U0 voltage measurement.

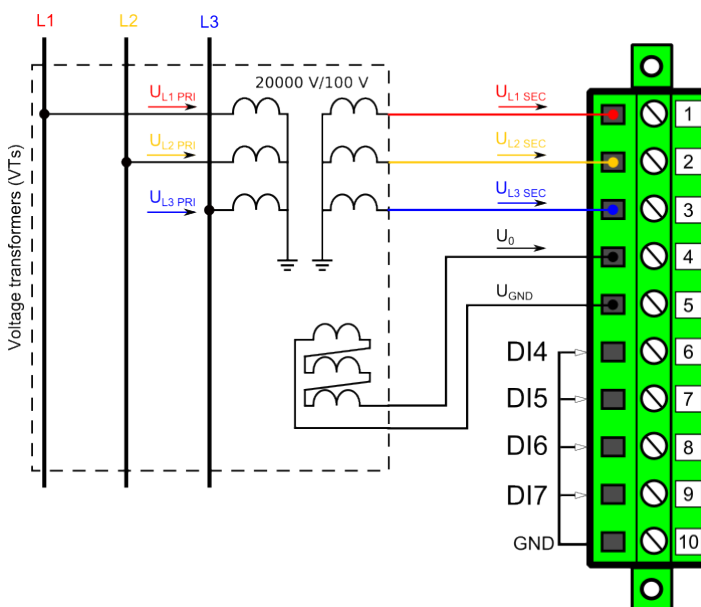

Figure. 5.2.2 - 71. Example connections for 2LL+U0 (open delta 2LL) voltage measurement.

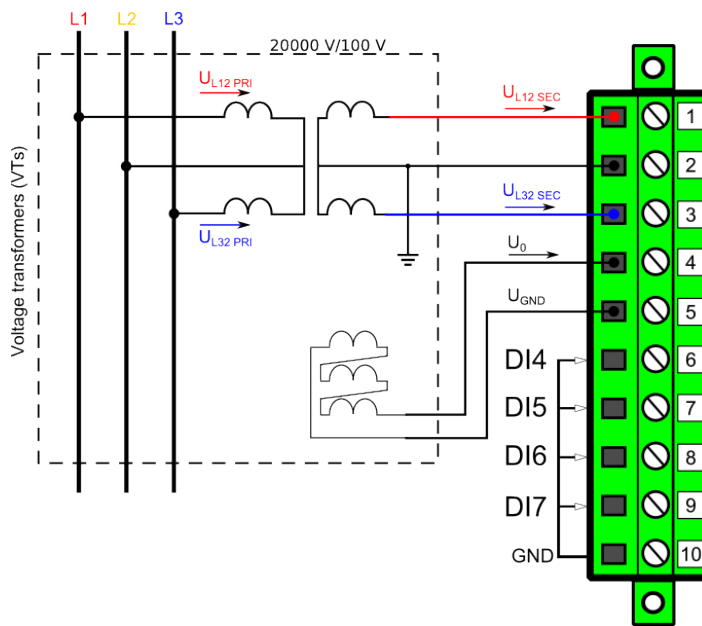
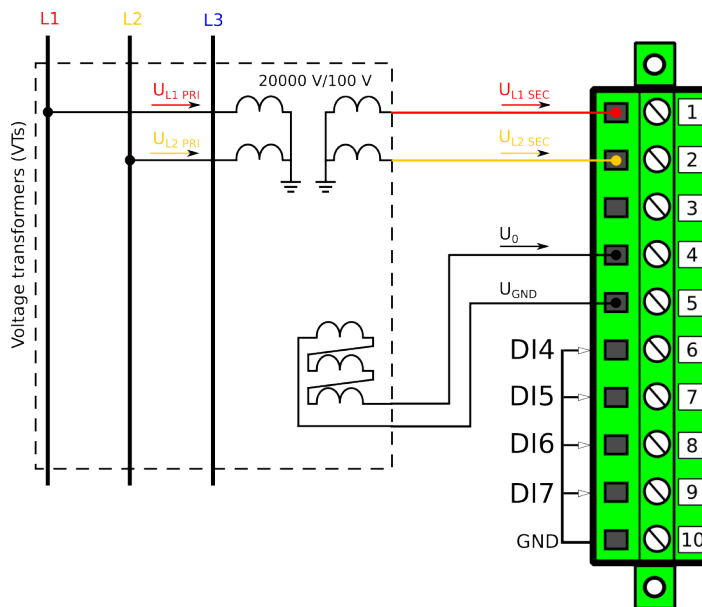

Figure. 5.2.2 - 72. Example connections for 1LL+U0 voltage measurement.



If only two line-to-line voltages are measured, the third one is calculated based on the U_{12} and U_{23} vectors. When measuring line-to-line voltages, the line-to-neutral voltages can also be calculated as long as the value of U_0 is measured and known.

The voltage measurement channel U_3 can also be used to measure the zero sequence voltage (U_0) when the "2LL+U0" or "1LL+U0" mode is selected.

The image collection below presents the relay's behavior when nominal voltage is injected into the relay via secondary test equipment while the relay is measuring line-to-neutral voltages (the mode is 3LN). The VT scaling has been set to 20 000 : 100 V. The images also present a fraction of the available information from the relay.

Figure. 5.2.2 - 73. Relay behavior when nominal voltage injected during LN voltage measurements.

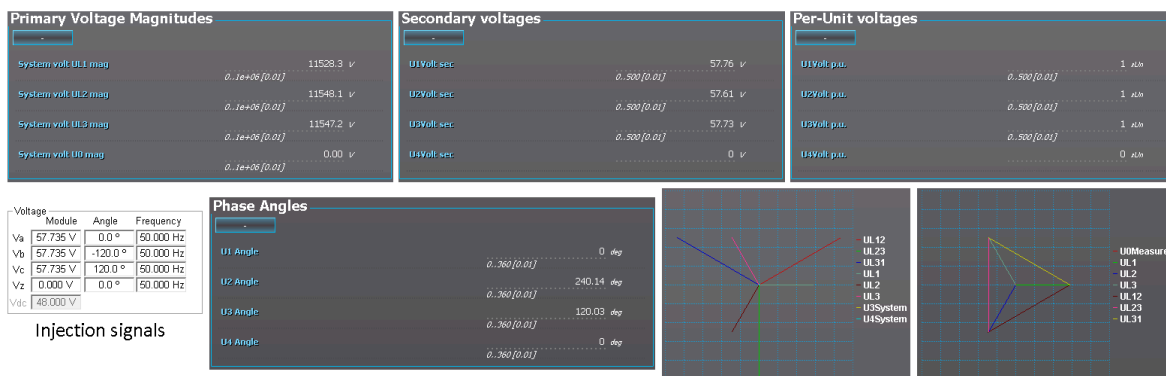

Troubleshooting

When the measured voltage values differ from the expected voltage values, the following table offers possible solutions for the problems.

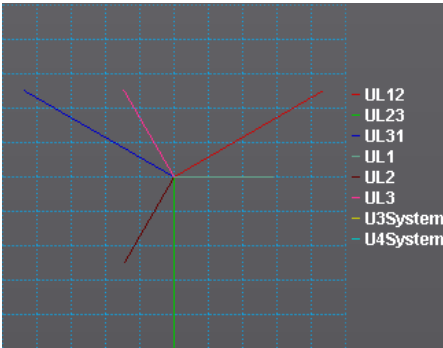
Problem	Check / Resolution
The measured voltage amplitude in all phases does not match the injected voltage.	The scaling settings or the voltage measurement mode may be wrong, check that the settings match with the connected voltage transformer (<i>Measurement</i> → <i>Transformers</i> → <i>VT Module</i>).
The measured voltage amplitude does not match one of the measured phases./ The calculated U0 is measured even though it should not.	Check the wiring connections between the injection device or the VTs and the relay.
The measured voltage amplitudes are OK but the angles are strange./ The voltage unbalance protection trips immediately after activation./ The earth fault protection trips immediately after it is activated and voltage calculated.	The voltages are connected to the measurement module but the order or polarity of one or all phases is incorrect. In relay settings, go to <i>Measurement</i> → <i>Phasors</i> and check the "System voltage vectors" diagram. When all connections are correct, the diagram (symmetric feeding) should look like this: 

Settings

Table. 5.2.2 - 26. Settings of the VT scaling.

Name	Range	Step	Default	Description
Voltage measurement mode	0: 3LN 1: 2LL+U0 (3LN) 2: 2LL+U0 (Open delta 2LL) 3: 2LL+U0 4: 1LL+U0	-	0: 3LN	The relay's voltage wiring method. The voltages are scaled according the set voltage measurement mode.
Voltage measurements	0: No PE voltages avail. 1: PE Voltages calculated 2: PE Voltages measured 3: PP voltages calculated 4: No full voltages available 5: Only U0 available 6: 1Phase-Phase measurement + U0"	-	-	Indicates whether or not phase-to-earth voltages are available. Also indicates whether P-E voltages are measured from the voltage channels directly or if they are calculated from line-to-line and line-to-neutral voltages.
VT primary	1...1 000 000.0 V	0.1V	20 000.0V	The rated primary voltage of the voltage transformer.
VT secondary	0.2...120.0 V	0.1V	100.0V	The rated secondary voltage of the voltage transformer.
U3 Res/SS VT primary	1...1 000 000.0 V	0.1V	20 000.0V	The primary nominal voltage of the connected U0 VT. This setting is visible for all modes except "3LN".
U3 Res/SS VT secondary	0.2...120 V	0.1V	100.0V	The secondary nominal voltage of the connected U0 VT. This setting is visible for all modes except "3LN".
U1 Polarity	0: - 1: Invert	-	0: -	The selection of the first voltage measurement channel's (U1) polarity (direction). The default setting is for the positive voltage to flow from connector 1 to connector 2, with the secondary voltage's starpoint pointing towards the line.
U2 Polarity	0: - 1: Invert	-	0: -	The selection of the second voltage measurement channel's (U2) polarity (direction). The default setting is for the positive voltage to flow from connector 1 to connector 2, with the secondary voltage's starpoint pointing towards the line.
U3 Polarity	0:- 1:Invert	-	0:-	The selection of the third voltage measurement channel's (U3) polarity (direction). The default setting is for the positive voltage to flow from connector 1 to connector 2, with the secondary voltage's starpoint pointing towards the line.
VT scaling factor P/S	-	-	-	A relay feedback value; the calculated scaling factor that is the ratio between the primary voltage and the secondary voltage.
VT scaling factor p.u. Pri	-	-	-	A relay feedback value; the scaling factor for the primary voltage's per-unit value.
VT scaling factor p.u. Sec	-	-	-	A relay feedback value; the scaling factor for the secondary voltage's per-unit value.

Name	Range	Step	Default	Description
U3 VT scaling factor P/S U0/SS	-	-	-	A relay feedback value; the calculated scaling factor that is the ratio between the U3 channel's primary and secondary voltages. This setting is only valid if the "2LL+U3" or the "2LN+U3" mode is selected.
U3 scaling factor p.u. Pri	-	-	-	IED voltage channel U3 feedback value, scaling factor from p.u. value to primary voltage. (Valid only in 2LL+U3 and 2LN+U3 mode)
U3 scaling factor p.u. Sec	-	-	-	IED voltage channel U3 feedback value, scaling factor from p.u. value to secondary voltage. (Valid only in 2LL+U3 and 2LN+U3 mode)

Measurements

The following measurements are available in the measured voltage channels.

Table. 5.2.2 - 27. Per-unit voltage measurements.

Name	Unit	Range	Step	Description
Voltage Ux ("Ux Volt p.u.")	$\times U_N$	0.00...500.0	0.01	The RMS voltage measurement (in p.u.) from each of the phase current channels.
Voltage Ux TRMS ("UxVolt TRMS p.u.")	$\times U_N$	0.00...500.0	0.01	The TRMS current (inc. harmonics up to 31 st) measurement (in p.u.) from each of the phase current channels.

Table. 5.2.2 - 28. Secondary voltage measurements.

Name	Unit	Range	Step	Description
Secondary voltage Ux ("Ux Volt sec")	V	0.00...500.0	0.01	The secondary RMS voltage measurement from each of the phase current channels.
Secondary voltage Ux TRMS ("UxVolt TRMS sec")	V	0.00...500.0	0.01	The secondary TRMS current (inc. harmonics up to 31 st) measurement from each of the voltage channels.

Table. 5.2.2 - 29. Voltage phase angle measurements.

Name	Unit	Range	Step	Description
Ux Angle	deg	0.00...360.00	0.01	The phase angle measurement from each of the four voltage inputs.

Table. 5.2.2 - 30. Per-unit sequence voltage measurements.

Name	Unit	Range	Step	Description
Positive sequence voltage ("Pos.seq.Volt.p.u.")	$\times U_N$	0.00...500.0	0.01	The measurement (in p.u.) from the calculated positive sequence voltage.
Negative sequence voltage ("Neg.seq.Volt.p.u.")	$\times U_N$	0.00...500.0	0.01	The measurement (in p.u.) from the calculated negative sequence voltage.
Zero sequence voltage ("Zero.seq.Volt.p.u.")	$\times U_N$	0.00...500.0	0.01	The measurement (in p.u.) from the calculated zero sequence voltage.

Table. 5.2.2 - 31. Primary sequence voltage measurements.

Name	Unit	Range	Step	Description
Primary positive sequence voltage ("Pos.seq.Volt.pri")	V	0.00...1 000000.00	0.01	The primary measurement from the calculated positive sequence voltage.
Primary negative sequence voltage ("Neg.seq.Volt.pri")	V	0.00...1 000000.00	0.01	The primary measurement from the calculated negative sequence voltage.
Primary zero sequence voltage ("Zero.seq.Volt.pri")	V	0.00...1 000000.00	0.01	The primary measurement from the calculated zero sequence voltage.

Table. 5.2.2 - 32. Secondary sequence voltage measurements.

Name	Unit	Range	Step	Description
Secondary positive sequence voltage ("Pos.seq.Volt.sec")	V	0.00...4800.0	0.01	The secondary measurement from the calculated positive sequence voltage.
Secondary negative sequence voltage ("Neg.seq.Volt.sec")	V	0.00...4800.0	0.01	The secondary measurement from the calculated negative sequence voltage.
Secondary zero sequence voltage ("Zero.seq.Volt.sec")	V	0.00...4800.0	0.01	The secondary measurement from the calculated zero sequence voltage.

Table. 5.2.2 - 33. Sequence voltage angle measurements.

Name	Unit	Range	Step	Description
Positive sequence voltage angle ("Pos.seq.Volt.Angle")	deg	0.00...360.0	0.01	The calculated positive sequence voltage angle.
Negative sequence voltage angle ("Neg.seq.Volt.Angle")	deg	0.00...360.0	0.01	The calculated negative sequence voltage angle.
Zero sequence voltage angle ("Zero.seq.Volt.Angle")	deg	0.00...360.0	0.01	The calculated zero sequence voltage angle.

Table. 5.2.2 - 34. Primary voltage measurements.

Name	Unit	Range	Step	Description
System voltage magnitude UL12 ("System volt UL12 mag")	V	0.00...1 000000.00	0.01	The primary RMS line-to-line UL12 voltage (measured or calculated).
System voltage magnitude UL23 ("System volt UL23 mag")	V	0.00...1 000000.00	0.01	The primary RMS line-to-line UL23 voltage (measured or calculated).
System voltage magnitude UL31 ("System volt UL31 mag")	V	0.00...1 000000.00	0.01	The primary RMS line-to-line UL31 voltage (measured or calculated).
System voltage magnitude UL1 ("System volt UL1 mag")	V	0.00...1 000000.00	0.01	The primary RMS line-to-neutral UL1 voltage (measured or calculated).
System voltage magnitude UL2 ("System volt UL2 mag")	V	0.00...1 000000.00	0.01	The primary RMS line-to-neutral UL2 voltage (measured or calculated).
System voltage magnitude UL3 ("System volt UL3 mag")	V	0.00...1 000000.00	0.01	The primary RMS line-to-neutral UL3 voltage (measured or calculated).

Name	Unit	Range	Step	Description
System voltage magnitude U0 ("System volt U0 mag")	V	0.00...1 000000.00	0.01	The primary RMS zero sequence U0 voltage (measured or calculated).

Table. 5.2.2 - 35. Primary system voltage angles.

Name	Unit	Range	Step	Description
System voltage angle UL12 ("System volt UL12 ang")	deg	0.00...360.0	0.01	The primary line-to-line angle UL12 (measured or calculated).
System voltage angle UL23 ("System volt UL23 ang")	deg	0.00...360.0	0.01	The primary line-to-line angle UL23 (measured or calculated).
System voltage angle UL31 ("System volt UL31 ang")	deg	0.00...360.0	0.01	The primary line-to-line angle UL31 (measured or calculated).
System voltage angle UL1 ("System volt UL1 ang")	deg	0.00...360.0	0.01	The primary line-to-neutral angle UL1 (measured or calculated).
System voltage angle UL2 ("System volt UL2 ang")	deg	0.00...360.0	0.01	The primary line-to-neutral angle UL2 (measured or calculated).
System voltage angle UL3 ("System volt UL3 ang")	deg	0.00...360.0	0.01	The primary line-to-neutral angle UL3 (measured or calculated).
System voltage angle U0 ("System volt U0 ang")	deg	0.00...360.0	0.01	The primary zero sequence angle U0 (measured or calculated).

Table. 5.2.2 - 36. Harmonic voltage measurements.

Name	Unit	Range	Step	Default	Description
Harmonics calculation values ("Harm Abs.or Perc.")	-	0: Percent 1: Absolute	-	0: Percent	Defines whether the harmonics are calculated as percentages or absolute values.
Harmonics display	-	0: Per unit 1: Primary V 2: Secondary V	-	0: Per unit	Defines how the harmonics are displayed: in p.u. values, as primary voltage values, or as secondary voltage values.
Maximum harmonics value ("UxMaxH")	V	0.00...100000.00	0.01	-	Displays the maximum harmonics value of the selected voltage input Ux.
Fundamental frequency ("Ux Fund")	V	0.00...100000.00	0.01	-	Displays the voltage value of the fundamental frequency from the selected voltage input Ux.
Ux harmonics (2nd ...31 st harmonic)	V	0.00...100000.0	0.01	-	Displays the selected harmonic from the voltage input Ux.

5.2.3 Power and energy calculation

The relays that are equipped with both a voltage and a current measurement card can calculate power, and can therefore have power-based protection and monitoring functions (the number of available functions depends of the relay type). In addition to power calculations, energy magnitudes are also calculated.

Power is divided into three magnitudes: apparent power (S), active power (P) and reactive power (Q). Energy measurement calculates magnitudes for active and reactive energy. Energy can flow to the forward direction (exported) or to the reverse direction (imported).

If a unit has more than one CT measurement module, the user can choose which module's current measurement is used by the power calculation.

Line-to-neutral voltages available

Power is calculated from line-to-neutral voltages and phase currents. If line-to-line voltages are connected, the relay can calculate line-to-neutral voltages based on the measured zero sequence voltage. The following equations apply for power calculations with the line-to-neutral mode and the line-to-line voltage mode (with U0 connected and measured):

Figure. 5.2.3 - 74. Three-phase power (S) calculation.

$$S_{L1} = U_{L1} \times I_{L1}$$

$$S_{L2} = U_{L2} \times I_{L2}$$

$$S_{L3} = U_{L3} \times I_{L3}$$

$$S = S_{L1} + S_{L2} + S_{L3}$$

Figure. 5.2.3 - 75. Three-phase active power (P) calculation.

$$P_{L1} = U_{L1} \times I_{L1} \cos \varphi$$

$$P_{L2} = U_{L2} \times I_{L2} \cos \varphi$$

$$P_{L3} = U_{L3} \times I_{L3} \cos \varphi$$

$$P = P_{L1} + P_{L2} + P_{L3}$$

In these equations, phi (φ) is the angle difference between voltage and current.

Figure. 5.2.3 - 76. Three-phase reactive power (Q) calculation.

$$Q_{L1} = U_{L1} \times I_{L1} \sin \varphi$$

$$Q_{L2} = U_{L2} \times I_{L2} \sin \varphi$$

$$Q_{L3} = U_{L3} \times I_{L3} \sin \varphi$$

$$Q = Q_{L1} + Q_{L2} + Q_{L3}$$

Active power can be to the forward or the reverse direction. The direction of active power can be indicated with the power factor (Cos (φ), or Cosine phi), which is calculated according the following formula:

$$3PH \text{ Cos}(\text{phi}) = P/S$$

$$L1 \text{ Cos}(\text{phi}) = P_{L1}/S_{L1}$$

$$L2 \text{ Cos}(\text{phi}) = P_{L2}/S_{L2}$$

$$L3 \text{ Cos}(\text{phi}) = P_{L3}/S_{L3}$$

The direction of reactive power is divided into four quadrants. Reactive power may be inductive or capacitive on both forward and reverse directions. Reactive power quadrant can be indicated with Tan (ϕ) (tangent phi), which is calculated according the following formula:

$$3PH \tan(\phi) = Q/P$$

$$L1 \tan(\phi) = Q_{L1}/P_{L1}$$

$$L2 \tan(\phi) = Q_{L2}/P_{L2}$$

$$L3 \tan(\phi) = Q_{L3}/P_{L3}$$

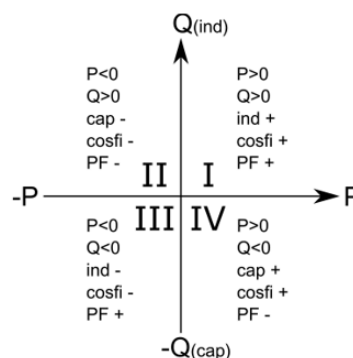

Power factor calculation is done similarly to the Cosine phi calculation but the polarity is defined by the reactive power direction. Therefore, the power factor is calculated with the following formula:

$$3PH PF = P/S * Q/|Q|$$

$$L1 PF = P_{L1}/S_{L1} * Q_{L1}/|Q_{L1}|$$

$$L2 PF = P_{L2}/S_{L2} * Q_{L2}/|Q_{L2}|$$

$$L3 PF = P_{L3}/S_{L3} * Q_{L3}/|Q_{L3}|$$

Only line-to-line voltages available

If the line-to-line voltages are measured but the zero sequence voltage is not measured or is not otherwise known, the three-phase power calculation is based on Aron's theorem:

$$S = U_{23} \times I_{L1} \cos(30) + U_{31} \times I_{L2} \cos(30)$$

$$P = U_{23} \times I_{L1} \cos(30 - \phi) + U_{31} \times I_{L2} \cos(30 + \phi)$$

$$Q = U_{23} \times I_{L1} \sin(30 - \phi) + U_{31} \times I_{L2} \sin(30 + \phi)$$

Both $\cos(\phi)$ and $\tan(\phi)$ are calculated in the same way as in the line-to-neutral mode.

Troubleshooting

Check the "Troubleshooting" section in chapters "Current measurement and scaling" and "Voltage measurement and scaling" for more information. Most power and energy measurement problems are usually related to the same issues (i.e. wiring errors, wrong measurement modes, faulty frequency settings, etc.).

Settings

Table. 5.2.3 - 37. Power and energy measurement settings

Name	Range	Step	Default	Description
3ph active energy measurement	0: Disabled 1: Enabled	-	0: Disabled	Enables/disables the active energy measurement.
3ph reactive energy measurement	0: Disabled 1: Enabled	-	0: Disabled	Enables/disables the reactive and apparent energy measurement.
3ph energy megas or kilos	0: Mega 1: Kilo	-	0: Mega	Defines whether energy is measured with the prefix 'kilo' (10^3) or 'mega' (10^6).
Edit energy values	0: Disabled 1: Enabled	-	0: Disabled	When this parameter is enabled it is possible to manually edit exported and imported active energy values. NOTE: "E 3ph M or k" parameter has to be set to "kilo" for this feature to function.
Invert imp/exp energy directions	0: Not inverted 1: Inverted	-	0: Not inverted	Inverts the direction of imported and exported energy without affecting the direction of power calculation.
Nominal power kVA	0.10...500000.00kVA	0.01kVA	100kVA	Defines the nominal power of the protected object.
PQ Quadrant	0: Undefined 1: Q1 Fwd Ind 2: Q2 Rev Cap 3: Q3 Rev Ind 4: Q4 Fwd Cap	-	0: Undefined	Indicates what the power PQ quadrant is at that moment.
VA Quadrant	0: Undefined 1: Q1 Fwd Cap AV 2: Q2 Rev Ind AV 3: Q3 Rev Cap VA 4: Q4 Fwd Ind VA	-	0: Undefined	Indicates what the power VA quadrant is at that moment.
Reset energy calculators ("Reset 3ph Energies")	0: - 1: Reset	-	0: -	Resets the memory of the three-phase energy calculators. Goes automatically back to the "-" state after the reset is finished.
Phase active energy measurement	0: Disabled 1: Enabled	-	0: Disabled	Enables/disables the active energy per phase measurement.
Phase reactive energy measurement	0: Disabled 1: Enabled	-	0: Disabled	Enables/disables the reactive energy per phase measurement.
Phase energies megas or kilos	0: Mega 1: Kilo	-	0: Mega	Defines whether energy (per phase) is measured with the prefix 'kilo' (10^3) or 'mega' (10^6).
Reset energy calculators (per phase) ("Reset E per phase")	0: - 1: Reset	-	0: -	Resets the memory of the individual phase energy calculator. Goes automatically back to the "-" state after the reset is finished.

Table. 5.2.3 - 38. Energy Dose Counter 1 settings

Name	Range	Step	Default	Description
Energy dose counter mode	0: Disabled 1: Activated	-	0: Disabled	Enables/disables energy dose counters generally.

Name	Range	Step	Default	Description
Clear pulse counter	0: - 1: Clear	-	0: -	Resets the "DC 1...4 Pulses sent" counters back to zero.
DC 1...4 enable	0: Disabled 1: Enabled	-	0: Disabled	Enables/disables the energy dose counter 1...4 individually.
DC 1...4 Input signal select	0: 3PH.Fwd.Act.EP 1: 3PH.Rev.Avt.EP 2: 3PH.Fwd.React.EQ.CAP 3: 3PH.Fwd.React.EQ.IND 4: 3PH.Rev.React.EQ.CAP 5: 3PH.Rev.React.EQ.IND	-	0: 3PH.Fwd.Act.EP	Selects whether the energy is active or reactive, whether the direction of the energy is forward of reverse, and whether reactive energy is inductive or capacitive.
DC 1...4 Input signal	$-1 \times 10^6 \dots 1 \times 10^6$	0.01	-	The total amount of energy consumed.
DC 1...4 Pulse magnitude	0...1800kW/var	0.005kW/ var	1kW/Var	The set pulse size. An energy pulse is given every time the set magnitude is exceeded.
DC 1...4 Pulse length	0...1800s	0.005s	1s	The total length of a control pulse.
DC1...4 Pulses sent	0...4 294 967 295	1	-	Indicates the total number of pulses sent.

Table. 5.2.3 - 39. DC 1...4 Pulse out settings

Name	Range	Step	Default	Description
DC 1...4 Pulse out	OUT1...OUTx	-	None selected	The selection of the controlled physical outputs.

Power measurements

The following power calculations are available when the voltage and the current cards are available.

Table. 5.2.3 - 40. Three-phase power calculations.

Name	Unit	Range	Step	Description
3PH Apparent power (S)	kVA	$-1 \times 10^6 \dots 1 \times 10^6$	0.01	The total three-phase apparent power in kilo-volt-ampere
3PH Active power (P)	kW	$-1 \times 10^6 \dots 1 \times 10^6$	0.01	The total three-phase active power in kilowatts
3PH Reactive power (Q)	kVar	$-1 \times 10^6 \dots 1 \times 10^6$	0.01	The total three-phase reactive power in kilovars
3PH Apparent power (S MVA)	MVA	$-1 \times 10^5 \dots 1 \times 10^5$	0.01	The total three-phase apparent power in megawatts
3PH Active power (P MW)	MW	$-1 \times 10^5 \dots 1 \times 10^5$	0.01	The total three-phase active power in mewatts
3PH Reactive power (QMVar)	MVar	$-1 \times 10^5 \dots 1 \times 10^5$	0.01	The total three-phase active power in megavars
3PH Tan(phi)	-	$-1 \times 10^6 \dots 1 \times 10^6$	0.01	The direction of three-phase active power
3PH Cos(phi)	-	$-1 \times 10^6 \dots 1 \times 10^6$	0.01	The direction of three-phase reactive power
3PH Power factor	-	$-1 \times 10^6 \dots 1 \times 10^6$	0.0001	The three-phase power factor

Table. 5.2.3 - 41. Single-phase power calculations (L1...L3).

Name	Unit	Range	Step	Description
Lx Apparent power (S)	kVA	-1x10 ⁶ ...1x10 ⁶	0.01	The apparent power of Phase Lx in kilo-volt-amperes
Lx Active power (P)	kW	-1x10 ⁶ ...1x10 ⁶	0.01	The active power of Phase Lx in kilowatts
Lx Reactive power (Q)	kVar	-1x10 ⁶ ...1x10 ⁶	0.01	The reactive power of Phase Lx kilovars
Lx Tan(phi)	-	-1x10 ⁶ ...1x10 ⁶	0.01	The direction of Phase Lx's active power
Lx Cos(phi)	-	-1x10 ⁶ ...1x10 ⁶	0.01	The direction of Phase Lx's reactive power
Lx Power factor	-	-1x10 ⁶ ...1x10 ⁶	0.0001	The power factor of Phase Lx

Energy measurements

The following energy calculations are available when the voltage and the current cards are available. Please note that the unit prefix is determined by the user's selection between 'kilo' and 'mega' in "Three-phase energy prefix ("E 3ph M or k")" under the general "Power and energy measurement settings".

Table. 5.2.3 - 42. Three-phase energy calculations.

Name	Range	Step	Description
Exported Active Energy (P) (kWh or MWh)	-999 999 995 904.00...999 999 995 904.00	0.01	The total amount of exported active energy.
Imported Active Energy (P) (kWh or MWh)	-999 999 995 904.00...999 999 995 904.00	0.01	The total amount of imported active energy.
Active Energy (P) Export/Import balance (kWh or MWh)	-999 999 995 904.00...999 999 995 904.00	0.01	The sum of imported and exported active energy.
Exported (Q) while Export (P) (kVarh or MVarh)	-999 999 995 904.00...999 999 995 904.00	0.01	The total amount of exported reactive energy while active power is exported.
Imported (Q) while Export (P). (kVarh or MVarh)	-999 999 995 904.00...999 999 995 904.00	0.01	Total amount of imported reactive energy while active energy is exported.
Reactive energy (Q) balance while export (P) (kVarh or MVarh)	-999 999 995 904.00...999 999 995 904.00	0.01	The sum of imported and exported reactive capacitive energy while active power is exported.
Exported (Q) while Import (P) (kVarh or MVarh)	-999 999 995 904.00...999 999 995 904.00	0.01	The total amount of exported reactive energy while active energy is imported.
Imported (Q) while Import (P) (kVarh or MVarh)	-999 999 995 904.00...999 999 995 904.00	0.01	The total amount of imported reactive energy while active energy is imported.
Reactive energy (Q) balance while Import (P) (kVarh or MVarh)	-999 999 995 904.00...999 999 995 904.00	0.01	The sum of imported and exported reactive energy while active energy is imported.
Apparent Energy (S) while Export (P) (kVAh or MVAh)	-999 999 995 904.00...999 999 995 904.00	0.01	The total amount of exported apparent energy while active energy is exported.
Apparent Energy (S) while Import (P) (kVAh or MVAh)	-999 999 995 904.00...999 999 995 904.00	0.01	The total amount of exported apparent energy while active energy is imported.

Table. 5.2.3 - 43. Single-phase energy calculations (L1...L3).

Name	Range	Step	Description
Export Active Energy Lx (kWh or MWh)	$-1 \times 10^9 \dots 1 \times 10^9$	0.01	The exported active energy of the phase.
Import Active Energy (kWh or MWh)	$-1 \times 10^9 \dots 1 \times 10^9$	0.01	The imported active energy of the phase.
Active Energy (P) Export/Import balance (kWh or MWh)	$-1 \times 10^9 \dots 1 \times 10^9$	0.01	The sum of the phase's imported and exported active energy.
Exported (Q) while Export (P) Lx (kVarh or MVarh)	$-1 \times 10^9 \dots 1 \times 10^9$	0.01	The exported reactive energy of the phase while active energy is exported.
Imported (Q) while Export (P) Lx (kVarh or MVarh)	$-1 \times 10^9 \dots 1 \times 10^9$	0.01	The imported reactive energy of the phase while active energy is exported.
Reactive Energy (Q) balance while Export (P) Lx (kVarh or MVarh)	$-1 \times 10^9 \dots 1 \times 10^9$	0.01	The sum of the phase's imported and exported reactive energy while active energy is exported.
Exported (Q) while Import (P) Lx (kVarh or MVarh)	$-1 \times 10^9 \dots 1 \times 10^9$	0.01	The exported reactive energy of the phase while active energy is imported.
Imported (Q) while Import (P) Lx (kVarh or MVarh)	$-1 \times 10^9 \dots 1 \times 10^9$	0.01	The imported reactive energy of the phase while active energy is imported.
Reactive energy (Q) balance while Import (P) Lx (kVarh or MVarh)	$-1 \times 10^9 \dots 1 \times 10^9$	0.01	The sum of the phase's imported and exported reactive energy while active energy is imported.
Apparent Energy (S) while Export (P) Lx	$-1 \times 10^9 \dots 1 \times 10^9$	0.01	The apparent energy of the phase while active energy is exported.
Apparent Energy (S) while Import (P) Lx	$-1 \times 10^9 \dots 1 \times 10^9$	0.01	The apparent energy of the phase while active energy is imported.

Calculation examples

Here is an example of power calculation. Both wiring methods (line-to-line and line-to-neutral) are checked with the same signal injection. The voltage scaling is set to 20 000 : 100 V and the current scaling is set to 1000 : 5 A.

Voltages (line-to-neutral):	Currents:
$U_{L1} = 40.825 \text{ V}, 45.00^\circ$	$I_{L1} = 2.5 \text{ A}, 0.00^\circ$
$U_{L2} = 61.481 \text{ V}, -159.90^\circ$	$I_{L2} = 2.5 \text{ A}, -120.00^\circ$
$U_{L3} = 97.742 \text{ V}, 126.21^\circ$	$I_{L3} = 2.5 \text{ A}, 120.00^\circ$

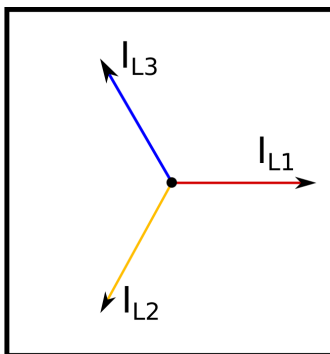
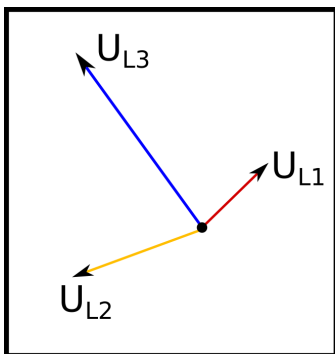

$$S_{L1} = U_{L1} \times I_{L1} = 40.825 \text{ V} \times 2.5 \text{ A} = 102 \text{ VA (secondary)} \quad \mathbf{4.08 \text{ MVA (primary)}}$$

$$P_{L1} = U_{L1} \times I_{L1} \cos \varphi = 40.825 \text{ V} \times 2.5 \text{ A} \cos(45^\circ - 0^\circ) = 72.2 \text{ W (secondary)} \quad \mathbf{2.89 \text{ MW (primary)}}$$

$$Q_{L1} = U_{L1} \times I_{L1} \sin \varphi = 40.825 \text{ V} \times 2.5 \text{ A} \sin(45^\circ - 0^\circ) = 72.2 \text{ var (secondary)} \quad \mathbf{2.89 \text{ MVar (primary)}}$$

$$L1 \tan(\phi) = Q_{L1}/P_{L1} = 2.89/2.89 = \mathbf{1.00}$$

$$L1 \cos(\phi) = P_{L1}/S_{L1} = 2.89/4.08 = \mathbf{0.71}$$

Name	Value	Name	Value	Name	Value	Name	Value
L1 (S)	4.08 MVA	L2 (S)	6.15 MVA	L3 (S)	9.77 MVA	3PH (S)	20.00 MVA
L1 (P)	2.89 MW	L2 (P)	4.72 MW	L3 (P)	9.71 MW	3PH (P)	17.32 MW
L1 (Q)	2.89 Mvar	L2 (Q)	-3.94 Mvar	L3 (Q)	1.06 Mvar	3PH (Q)	0.01 Mvar
L1 Tan	1.00	L2 Tan	-0.83	L3 Tan	0.11	3PH Tan	0.00
L1 Cos	0.71	L2 Cos	0.77	L3 Cos	0.99	3PH Cos	0.87

Voltages (line-to-line):	Currents:
$U_{L12} = 100.00 \text{ V}, 30.00^\circ$	$I_{L1} = 2.5 \text{ A}, 0.00^\circ$
$U_{L23} = 100.00 \text{ V}, -90.00^\circ$	$I_{L2} = 2.5 \text{ A}, -120.00^\circ$
	$I_{L3} = 2.5 \text{ A}, 120.00^\circ$

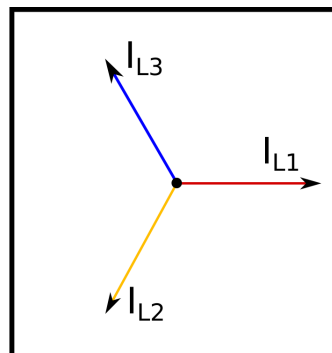
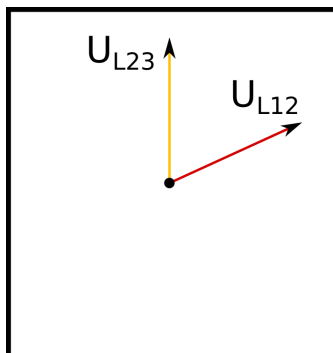

$$S = U_{12} \times I_{L1} + U_{23} \times I_{L2}$$

$$S = 100 \text{ V} \times 2.5 \text{ A} + 100 \text{ V} \times 2.5 \text{ A} = 500 \text{ VA (sec)} \quad \mathbf{20.00 \text{ MVA (pri)}}$$

$$P = U_{12} \times I_{L1} \cos(-\varphi) + U_{23} \times I_{L2} \cos(\varphi)$$

$$P = 100 \text{ V} \times 2.5 \text{ A} \cos-(30^\circ - 0^\circ) + 100 \text{ V} \times 2.5 \text{ A} \cos(270^\circ - 240^\circ) = 433 \text{ W (sec)} \quad \mathbf{17.32 \text{ MW (pri)}}$$

$$Q = U_{12} \times I_{L1} \sin(-\varphi) + U_{23} \times I_{L2} \sin(\varphi)$$

$$Q = 100 \text{ V} \times 2.5 \text{ A} \sin-(30^\circ - 0^\circ) + 100 \text{ V} \times 2.5 \text{ A} \sin(270^\circ - 240^\circ) = 0 \text{ var (sec)} \quad \mathbf{0 \text{ Mvar (pri)}}$$

$$3PH \tan(\phi) = Q/P = 0.01/17.32 = \mathbf{0.00}$$

$$3PH \cos(\phi) = P/S = 17.32/20.00 = \mathbf{0.87}$$

Name	Values
3PH (S)	20.00 MVA

Name	Values
3PH (P)	17.32 MW
3PH (Q)	0.00 Mvar
3PH Tan	0.00
3PH Cos	0.87

5.2.4 Frequency tracking and scaling

Measurement sampling can be set to the frequency tracking mode or to the fixed user-defined frequency sampling mode. The benefit of frequency tracking is that the measurements are within a pre-defined accuracy range even when the fundamental frequency of the power system changes.

Table. 5.2.4 - 44. Frequency tracking effect (FF changes from 6 Hz to 75 Hz).

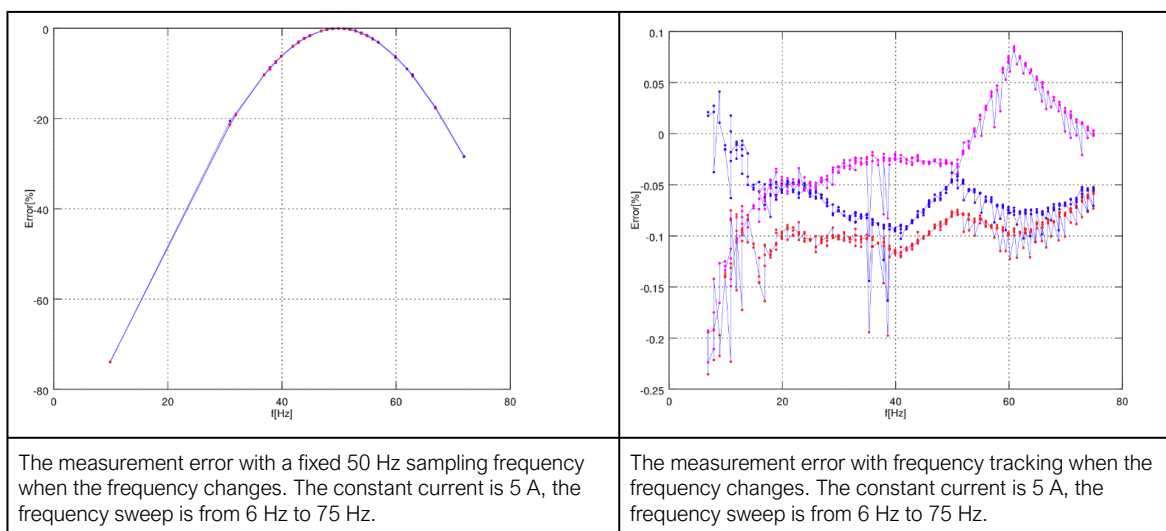

As the figures above show, the sampling frequency has a major effect on the relay's measurement accuracy. If the sampling is not tracked to the system frequency, for example a 10 Hz difference between the measured and the set system frequency can give a measurement error of over 5 %. The figures also show that when the frequency is tracked and the sampling is adjusted according to the detected system frequency, the measurement accuracy has an approximate error of 0.1...- 0.2 % error in the whole frequency range.

AQ -200 series devices have a measurement accuracy that is independent of the system frequency. This has been achieved by adjusting the sample rate of the measurement channels according to the measured system frequency; this way the FFT calculation always has a whole power cycle in the buffer. The measurement accuracy is further improved by Arcteq's patented calibration algorithms that calibrate the analog channels against eight (8) system frequency points for both magnitude and angle. This frequency-dependent correction compensates the frequency dependencies in the used, non-linear measurement hardware and improves the measurement accuracy significantly. Combined, these two methods give an accurate measurement result that is independent of the system frequency.

Troubleshooting

When the measured current, voltage or frequency values differ from the expected values, the following table offers possible solutions for the problems.

Problem	Check / Resolution
The measured current or voltage amplitude is lower than it should be./ The values are "jumping" and are not stable.	The set system frequency may be wrong. Please check that the frequency settings match the local system frequency, or change the measurement mode to "Tracking" (<i>Measurement</i> → <i>Frequency</i> → "Smpl mode") so the relay adjusts the frequency itself.
The frequency readings are wrong.	In Tracking mode the relay may interpret the frequency incorrectly if no current is injected into the CT (or voltage into the VT). Please check the frequency measurement settings (<i>Measurement</i> → <i>Frequency</i>).

Settings

Table. 5.2.4 - 45. Settings of the frequency tracking.

Name	Range	Step	Default	Description
Sampling mode	0: Fixed 1: Tracking	-	0: Fixed	Defines which measurement sampling mode is in use: the fixed user-defined frequency, or the tracked system frequency.
System nominal frequency	7.000...75.000Hz	0.001Hz	50Hz	The user-defined system nominal frequency that is used when the "Sampling mode" setting has been set to "Fixed".
Tracked system frequency	0.000...75.000Hz	0.001Hz	-	Displays the rough measured system frequency.
Sampling frequency in use	0.000...75.000Hz	0.001Hz	-	Displays the tracking frequency that is in use at that moment.
Frequency reference 1	0: None 1: CT1IL1 2: CT2IL1 3: VT1U1 4: VT2U1	-	1: CT1IL1	The first reference source for frequency tracking.
Frequency reference 2	0: None 1: CT1IL2 2: CT2IL2 3: VT1U2 4: VT2U2	-	1: CT1IL2	The second reference source for frequency tracking.
Frequency reference 3	0: None 1: CT1IL3 2: CT2IL3 3: VT1U3 4: VT2U3	-	1: CT1IL3	The third reference source for frequency tracking.
Frequency tracking quality	0: No trackable channels 1: Reference 1 trackable 2: Reference 2 trackable 3: References 1 & 2 trackable 4: Reference 3 trackable 5: Reference 1 & 3 trackable 6: References 2 & 3 trackable 7: All references trackable	-	-	Defines the frequency tracker quality. If the measured current (or voltage) amplitude is below the threshold, the channel tracking quality is 0 and cannot be used for frequency tracking. If all channels' magnitudes are below the threshold, there are no trackable channels.

Name	Range	Step	Default	Description
Frequency measurement in use	0: No track ch 1: Ref1 2: Ref2 3: Ref3	-	-	Indicates which reference is used at the moment for frequency tracking.
Start behavior	0: Start tracking immediately 1: First nominal or tracked	-	0: Start tracking immediately	Defines the how the tracking starts. Tracking can start immediately, or there can be a set delay time between the receiving of the first trackable channel and the start of the tracking.
Start sampling with	0: Use track frequency 1: Use nom frequency	-	0: Use track frequency	Defines the start of the sampling. Sampling can begin with a previously tracked frequency, or with a user-set nominal frequency.
Use nominal frequency until	0...1800.000s	0.005s	0.100s	Defines how long the nominal frequency is used after the tracking has started. This setting is only valid when the "Sampling mode" setting is set to "Tracking" and when the "Start behavior" is set to "First nominal or tracked".
Tracked f channel A	0.000...75.000Hz	0.001Hz	-	Displays the rough value of the tracked frequency in Channel A.
Tracked f channel B	0.000...75.000Hz	0.001Hz	-	Displays the rough value of the tracked frequency in Channel B.
Tracked f channel C	0.000...75.000Hz	0.001Hz	-	Displays the rough value of the tracked frequency in Channel C.
Alg f fast	0.000...75.000Hz	0.001Hz	-	Frequency measurement built from tracked frequencies and U4 voltage channel samples.
Alg f avg	0.000...75.000Hz	0.001Hz	-	Averaged frequency measurement built from tracked frequencies and U4 voltage channel samples.
System measured frequency	0: One f measured 1: Two f measured 2: Three f measured	-	-	Displays the amount of frequencies that are measured.
f.atm. Protections	0.000...75.000Hz	0.001Hz	-	Frequency measurement value used by protection functions. When frequency is not measurable this value returns to value set to "System nominal frequency" parameter.
f.atm. Display	0.000...75.000Hz	0.001Hz	-	Frequency measurement value used in display. When frequency is not measurable this value is "0 Hz".
f measurement from	0: Not measurable 1: Avg Ref 1 2: Avg Ref 2 3: Avg Ref 3 4: Track Ref 1 5: Track Ref 2 6: Track Ref 3 7: Fast Ref 1 8: Fast Ref 2 9: Fast Ref 3	-	-	Displays which reference is used for frequency measurement.
SS1.meas.frqs	0.000...75.000Hz	0.001Hz	-	Displays frequency used by "system set" channel 1 and 2.
SS2.meas.frqs				
SS1f meas.from	0: Not measurable 1: Fast Ref U3 2: Fast Ref U4	-	-	Displays which voltage channel frequency reference is used by "system set" voltage channel.
SS2f meas.from	0: Not measurable 1: Fast Ref U4	-	-	Displays if U4 channel frequency reference is measurable or not when the channel has been set to "system set" mode.

5.3 Protection functions

5.3.1 General properties of a protection function

The following flowchart describes the basic structure of any protection function. The basic structure is composed of analog measurement values being compared to the pick-up values and operating time characteristics.

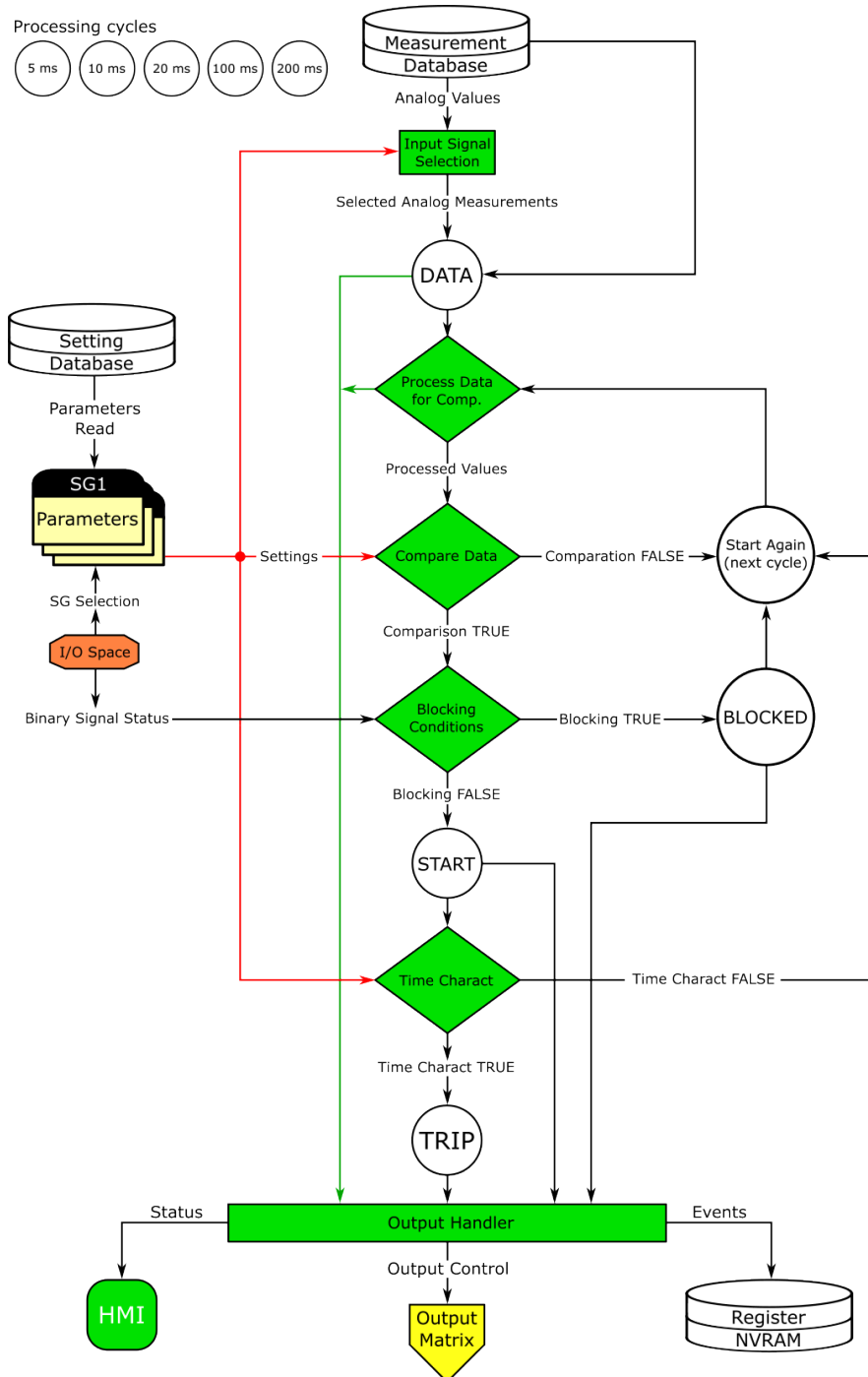

The protection function is run in a completely digital environment with a protection CPU microprocessor which also processes the analog signals transformed into the digital form.

Figure. 5.3.1 - 77. Principle diagram of the protection relay platform.

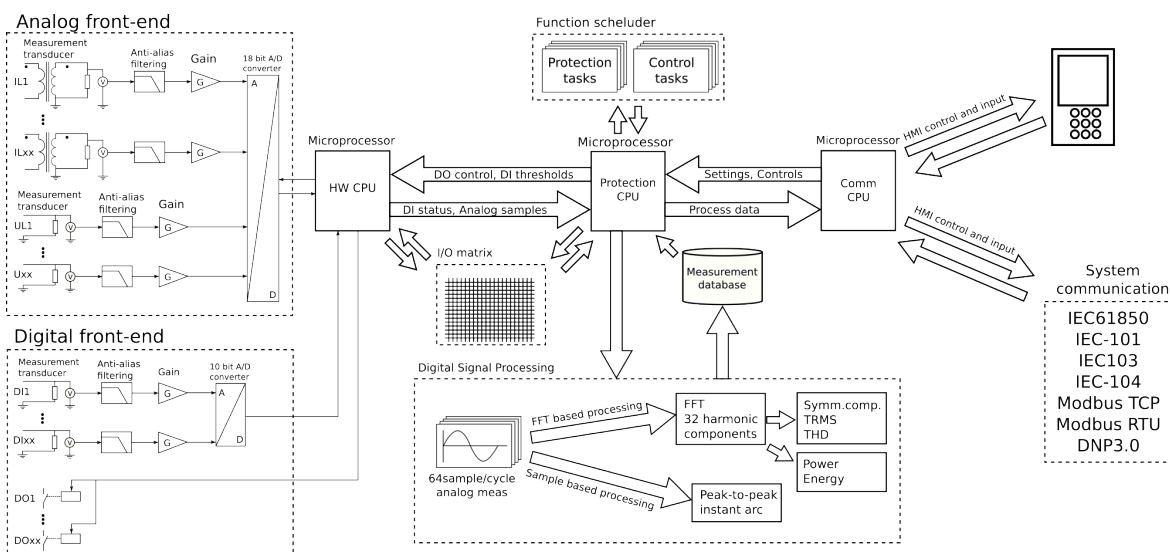

In the following chapters the common functionalities of protection functions are described. If a protection function deviates from this basic structure, the difference is described in the corresponding chapter of the manual.

Pick-up

The X_{set} parameter defines the pick-up level of the function, and this in turn defines the maximum or minimum allowed measured magnitude (in per unit, absolute or percentage value) before the function takes action. The function constantly calculates the ratio between the pick-up parameter set by the user and the measured magnitude (X_m). The reset ratio of 97 % is built into the function and is always relative to the X_{set} value. If a function's pick-up characteristics vary from this description, they are defined in the function section in the manual.

Figure. 5.3.1 - 78. Pick up and reset.

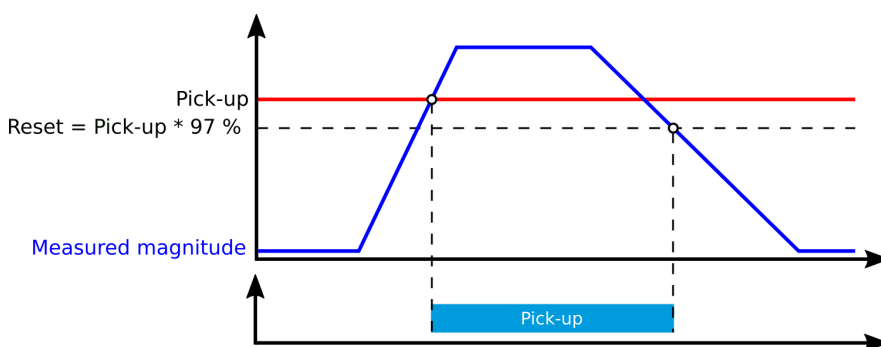

The pick-up activation of the function is not directly equal to the START signal generation of the function. The START signal is allowed if a blocking condition is not active.

Figure. 5.3.1 - 79. Measurement range in relation to the nominal current.

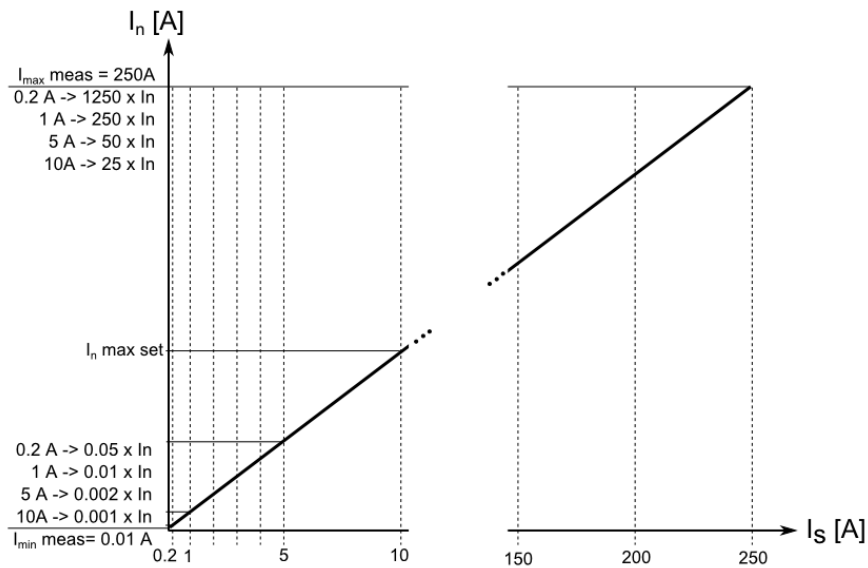

The I_n magnitude refers to the user set nominal current which can range from 0.2...10 A, typically 0.2 A, 1A or 5 A. With its own current measurement card, the IED will measure secondary currents from 0.001 A up to 250 A. To this relation the pick-up setting in secondary amperes will vary.

Function blocking

The blocking signals are checked in the beginning of each program cycle. A blocking signal is received from the blocking matrix for the function dedicated input. If the blocking signal is not activated when the pick-up element activates, a START signal is generated and the function proceeds to the time characteristics calculation.

If the blocking signal is active when pick-up element activates, a BLOCKED signal is generated and the function will not process the situation further. If the START function has been activated before the blocking signal, it resets and the release time characteristics are processed similarly to when the pick-up signal is reset.

The blocking of the function causes an HMI display event and a time stamped blocking event with information of the startup current values and its fault type to be issued.

The blocking signal can also be tested in the commissioning phase by a software switch signal when the relay's common and global testing mode is activated.

The variables users can set are binary signals from the system. The blocking signal needs to reach the IED minimum of 5 ms before the set operating delay has passed in order for the blocking to activate in time.

Operating time characteristics for trip and reset

The operating timers' behavior during a function can be set for trip signal and for the release of the function in case the pick-up element is reset before the trip time has been reached. There are three basic operating modes available for the function:

- Instant operation: activates the trip signal with no additional time delay simultaneously with the start signal.
- Definite time operation (DT): activates the trip signal after a user-defined time delay regardless of the measured current as long as the current is above or below the X_{Set} value and thus the pick-up element is active (independent time characteristics).

- Inverse definite minimum time (IDMT): activates the trip signal after a time which is in relation to the set pick-up value X_{set} and the measured value X_m (dependent time characteristics).

Both IEC and IEEE/ANSI standard characteristics as well as user settable parameters are available for the IDMT operation. Please note that in the IDMT mode *Definite (Min)* operating time delay is also determines the minimum time for protection tripping (see the figure below). If this function is not desired the parameter should be set to 0 seconds.

Figure. 5.3.1 - 80. Operating time delay: *Definite (Min)* and the minimum for tripping.

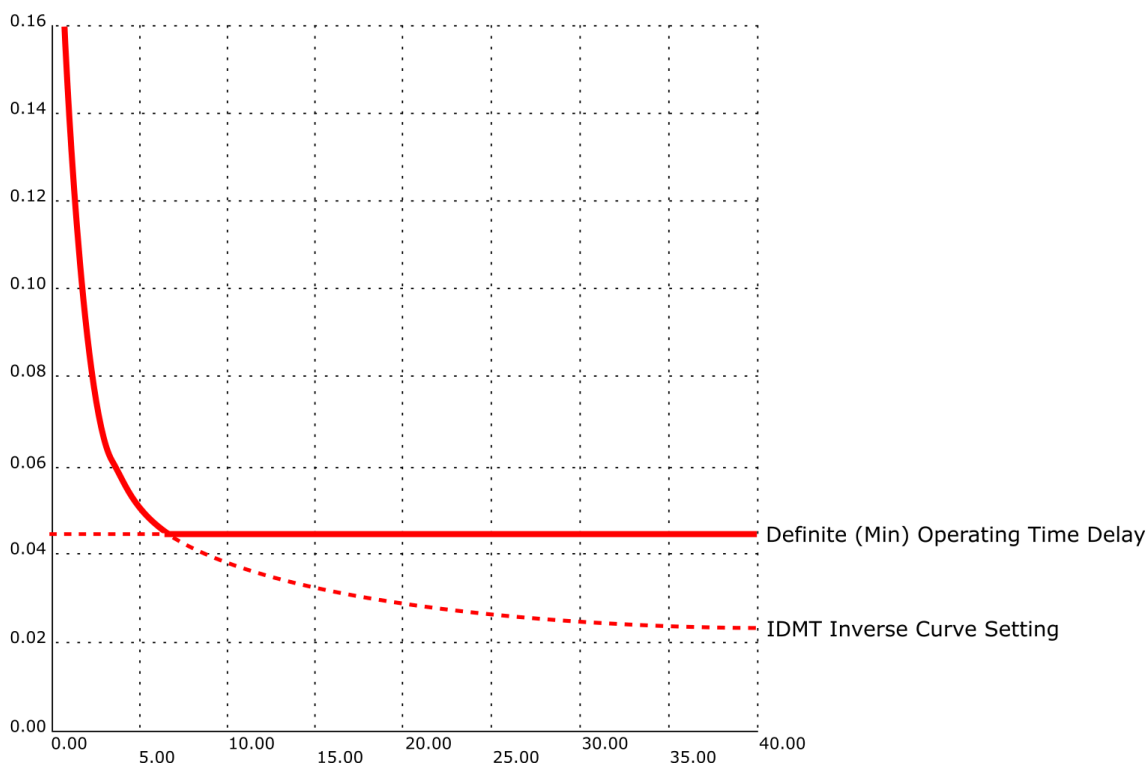

Table. 5.3.1 - 46. Operating time characteristics setting parameters (general).

Name	Range	Step	Default	Description
Delay type	0: DT 1: IDMT	-	0: DT	Selects the delay type for the time counter. The selection is made between dependent (IDMT) and independent (DT) characteristics.
Definite (min) operating time delay	0.000...1800.000s	0.005s	0.040s	When the "Delay type" parameter is set to "DT", this parameter acts as the expected operating time for the protection function. When set to 0 s, the stage operates instantaneously without any additional delay. When the parameter is set to 0.005...1800 s, the stage operates as independent delayed. When the "Delay type" parameter has been set to "IDMT", this parameter can be used to determine the minimum operating time for the protection function. Example of this is presented in the figure above.
Delay curve series	0: IEC 1: IEEE	-	0: IEC	Selects whether the delay curve series for an IDMT operation follows either IEC or IEEE/ANSI standard defined characteristics. This setting is active and visible when the "Delay type" parameter is set to "IDMT".

Name	Range	Step	Default	Description
Delay characteristics IEC	0: NI 1: EI 2: VI 3: LTI 4: Param	-	0: NI	<p>Selects the IEC standard delay characteristics.</p> <p>The options include the following: Normally Inverse ("NI"), Extremely Inverse ("EI"), Very Inverse ("VI") and Long Time Inverse ("LTI") characteristics. Additionally, the "Param" option allows the tuning of the constants A and B which then allows the setting of characteristics following the same formula as the IEC curves mentioned here.</p> <p>This setting is active and visible when the "Delay type" parameter is set to "IDMT" and the "Delay curve series" parameter is set to "IEC".</p>
Delay characteristics IEEE	0: ANSI NI 1: ANSI VI 2: ANSI EI 3: ANSI LTI 4: IEEE MI 5: IEEE VI 6: IEEE EI 7: Param	-	0: ANSI NI	<p>Selects the IEEE and ANSI standard delay characteristics.</p> <p>The options for ANSI include the following: Normal Inverse ("ANSI NI"), Very Inverse ("ANSI VI"), Extremely inverse ("ANSI EI"), Long time inverse ("ANSI LTI") characteristics. IEEE: Moderately Inverse ("IEEE MI"), Very Inverse ("IEEE VI"), Extremely Inverse ("IEEE EI") characteristics. Additionally, the "Param" option allows the tuning of the constants A, B and C which then allows the setting of characteristics following the same formula as the IEEE curves mentioned here.</p> <p>This setting is active and visible when the "Delay type" parameter is set to "IDMT" and the "Delay curve series" parameter is set to "IEEE".</p>
Time dial setting k	0.01...25.00s	0.01s	0.05s	<p>Defines the time dial/multiplier setting for IDMT characteristics.</p> <p>This setting is active and visible when the "Delay type" parameter is set to "IDMT".</p>
A	0.0000...250.0000	0.0001	0.0860	<p>Defines the Constant A for IEC/IEEE characteristics.</p> <p>This setting is active and visible when the "Delay type" parameter is set to "IDMT" and the "Delay characteristic" parameter is set to "Param".</p>
B	0.0000...5.0000	0.0001	0.1850	<p>Defines the Constant B for IEC/IEEE characteristics.</p> <p>This setting is active and visible when the "Delay type" parameter is set to "IDMT" and the "Delay characteristic" parameter is set to "Param".</p>
C	0.0000...250.0000	0.0001	0.0200	<p>Defines the Constant C for IEEE characteristics.</p> <p>This setting is active and visible when the "Delay type" parameter is set to "IDMT" and the "Delay characteristic" parameter is set to "Param".</p>

Figure. 5.3.1 - 81. Inverse operating time formulas for IEC and IEEE standards.

IEC	IEEE/ANSI																																																			
$t = \frac{kA}{\left(\frac{I_m}{I_{set}}\right)^B - 1}$	$t = k \left(\frac{A}{\left(\frac{I_m}{I_{set}}\right)^C - 1} + B \right)$																																																			
<p><i>t</i> = Operating delay (s) <i>k</i> = Time dial setting <i>I_m</i> = Measured maximum current <i>I_{set}</i> = Pick-up setting <i>A</i> = Operating characteristics constant <i>B</i> = Operating characteristics constant</p>	<p><i>t</i> = Operating delay (s) <i>k</i> = Time dial setting <i>I_m</i> = Measured maximum current <i>I_{set}</i> = Pick-up setting <i>A</i> = Operating characteristics constant <i>B</i> = Operating characteristics constant <i>C</i> = Operating characteristics constant</p>																																																			
<p>Standard delays IEC constants</p> <table border="1"> <thead> <tr> <th>Type</th> <th>A</th> <th>B</th> </tr> </thead> <tbody> <tr> <td>Normally Inverse (NI)</td> <td>0,14</td> <td>0,02</td> </tr> <tr> <td>Extremely Inverse (EI)</td> <td>80</td> <td>2</td> </tr> <tr> <td>Very Inverse (VI)</td> <td>13,5</td> <td>1</td> </tr> <tr> <td>Long Time Inverse (LTI)</td> <td>120</td> <td>1</td> </tr> </tbody> </table>	Type	A	B	Normally Inverse (NI)	0,14	0,02	Extremely Inverse (EI)	80	2	Very Inverse (VI)	13,5	1	Long Time Inverse (LTI)	120	1	<p>Standard delays ANSI constants</p> <table border="1"> <thead> <tr> <th>Type</th> <th>A</th> <th>B</th> <th>C</th> </tr> </thead> <tbody> <tr> <td>Normally Inverse (NI)</td> <td>8,934</td> <td>0,1797</td> <td>2,094</td> </tr> <tr> <td>Very Inverse (VI)</td> <td>3,922</td> <td>0,0982</td> <td>2</td> </tr> <tr> <td>Extremely Inverse (EI)</td> <td>5,64</td> <td>0,02434</td> <td>2</td> </tr> <tr> <td>Long Time Inverse (LTI)</td> <td>5,614</td> <td>2,186</td> <td>1</td> </tr> </tbody> </table> <p>Standard delays IEEE constants</p> <table border="1"> <thead> <tr> <th>Type</th> <th>A</th> <th>B</th> <th>C</th> </tr> </thead> <tbody> <tr> <td>Moderately Inverse (MI)</td> <td>0,0515</td> <td>0,114</td> <td>0,02</td> </tr> <tr> <td>Very Inverse (VI)</td> <td>19,61</td> <td>0,491</td> <td>2</td> </tr> <tr> <td>Extremely Inverse (EI)</td> <td>28,2</td> <td>0,1217</td> <td>2</td> </tr> </tbody> </table>	Type	A	B	C	Normally Inverse (NI)	8,934	0,1797	2,094	Very Inverse (VI)	3,922	0,0982	2	Extremely Inverse (EI)	5,64	0,02434	2	Long Time Inverse (LTI)	5,614	2,186	1	Type	A	B	C	Moderately Inverse (MI)	0,0515	0,114	0,02	Very Inverse (VI)	19,61	0,491	2	Extremely Inverse (EI)	28,2	0,1217	2
Type	A	B																																																		
Normally Inverse (NI)	0,14	0,02																																																		
Extremely Inverse (EI)	80	2																																																		
Very Inverse (VI)	13,5	1																																																		
Long Time Inverse (LTI)	120	1																																																		
Type	A	B	C																																																	
Normally Inverse (NI)	8,934	0,1797	2,094																																																	
Very Inverse (VI)	3,922	0,0982	2																																																	
Extremely Inverse (EI)	5,64	0,02434	2																																																	
Long Time Inverse (LTI)	5,614	2,186	1																																																	
Type	A	B	C																																																	
Moderately Inverse (MI)	0,0515	0,114	0,02																																																	
Very Inverse (VI)	19,61	0,491	2																																																	
Extremely Inverse (EI)	28,2	0,1217	2																																																	

Non-standard delay characteristics

In addition to the previously mentioned delay characteristics, some functions also have delay characteristics that deviate from the IEC or IEEE standards. These functions are the following:

- overcurrent stages
- residual overcurrent stages
- directional overcurrent stages
- directional residual overcurrent stages.

The setting parameters and their ranges are documented in the chapters of the respective function blocks.

Table. 5.3.1 - 47. Inverse operating time formulas for nonstandard characteristics.

RI-type	RD-type
Used to get time grading with mechanical relays	Mostly used in earth fault protection which grants selective tripping even in non-directional protection
$t = \frac{k}{0,339 - 0,236 * \frac{I_{set}}{I_m}}$	$t = 5,8 - 1,35 * \ln \left(\frac{I_m}{k * I_{set}} \right)$
<p><i>t</i> = Operating delay (s) <i>k</i> = Time dial setting <i>I_m</i> = Measured maximum current <i>I_{set}</i> = Pick-up setting</p>	<p><i>t</i> = Operating delay (s) <i>k</i> = Time dial setting <i>I_m</i> = Measured maximum current <i>I_{set}</i> = Pick-up setting</p>

Table. 5.3.1 - 48. Setting parameters for reset time characteristics.

Name	Range	Step	Default	Description
Delayed pick-up release	0: No 1: Yes	-	1: Yes	Resetting characteristics selection (either time-delayed or instant) after the pick-up element is released. If activated, the START signal is reset after a set release time delay.
Release time delay	0.000...150.000s	0.005s	0.06s	Resetting time. The time allowed between pick-ups if the pick-up has not led into a trip operation. If the "Delayed pick-up release" setting is active, the START signal is held on for the duration of the timer.
Op.Time calculation reset after release time	0: No 1: Yes	-	1: Yes	Operating timer resetting characteristics selection. When active, the operating time counter is reset after a set release time if the pick-up element is not activated during this time. When disabled, the operating time counter is reset directly after the pick-up element is reset.
Continue time calculation during release time	0: No 1: Yes	-	0: No	Time calculation characteristics selection. If activated, the operating time counter continues until a set release time even if the pick-up element is reset.

The behavior of the stages with different release time configurations are presented in the figures below.

Figure. 5.3.1 - 82. No delayed pick-up release.

Delayed pick-up release: Disabled

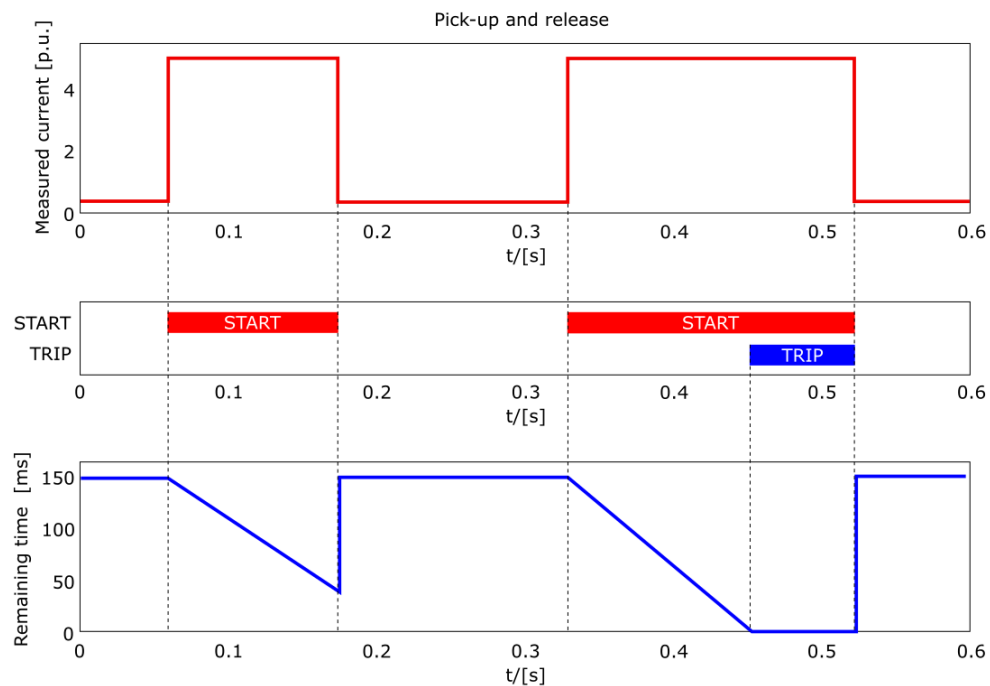

Figure. 5.3.1 - 83. Delayed pick-up release, delay counter is reset at signal drop-off.

Delayed pick-up release: Enabled
Op.time calc reset after release time: Disabled
Continue time calculation during release time: Disabled

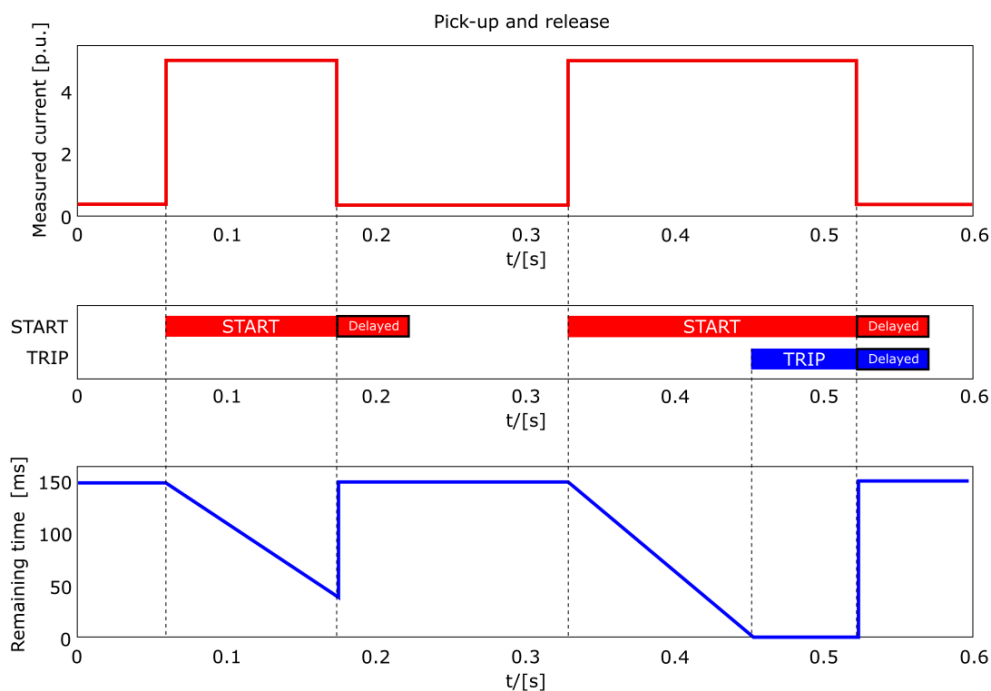

Figure. 5.3.1 - 84. Delayed pick-up release, delay counter value is held during the release time.

Delayed pick-up release: Enabled
Op.time calc reset after release time: Enabled
Continue time calculation during release time: Disabled

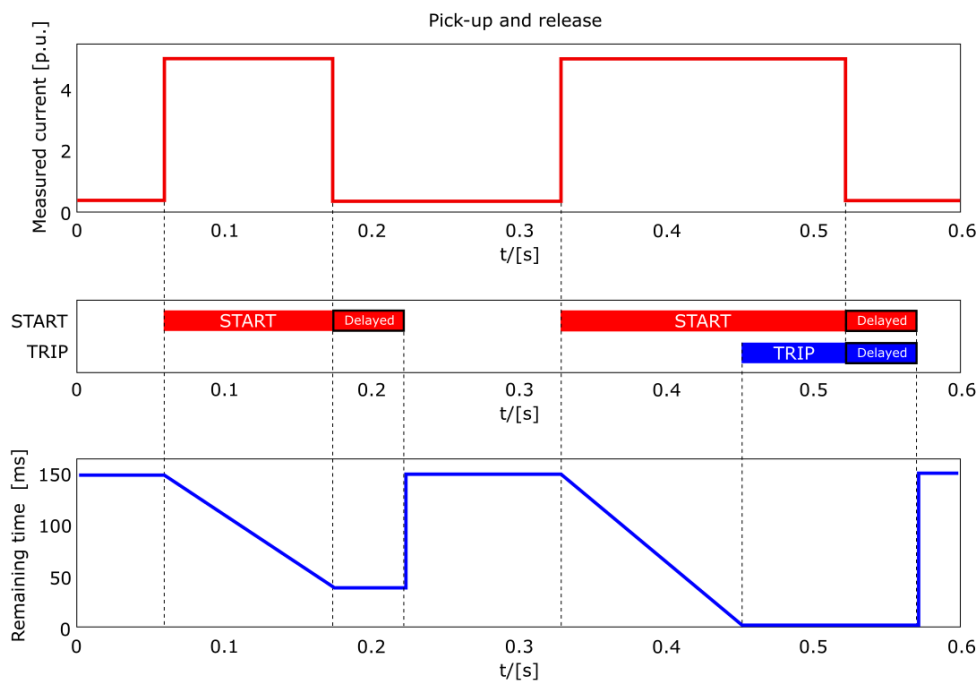
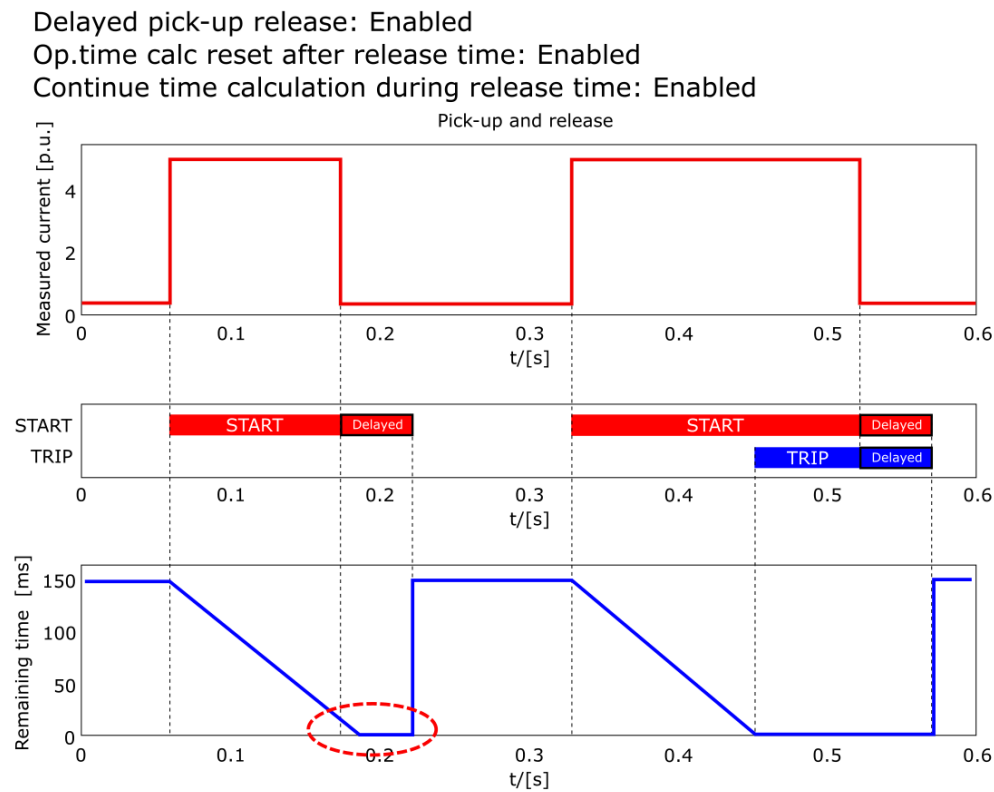

Figure. 5.3.1 - 85. Delayed pick-up release, delay counter value is decreasing during the release time.



The resetting characteristics can be set according to the application. The default setting is delayed 60 ms and the time calculation is held during the release time.

When using the release delay option where the operating time counter is calculating the operating time during the release time, the function will not trip if the input signal is not activated again during the release time counting.

Stage forcing

It is possible to test the logic, event processing and the operation of the relay's protection system by controlling the state of the protection functions manually without injecting any current into the relay with stage forcing. To enable *Stage forcing* set the *Enable stage forcing* to ENABLED in the *General* menu. After this it is possible to control the status of a protection function (Normal, Start, Trip, Blocked etc.) in the *Info* page of the function.

NOTE!



When *Stage forcing* is enabled protection functions will also change state through user input. Injected currents/voltages also affect the behavior of the relay. Regardless, it is recommended to disable *Stage Forcing* after testing has ended.

5.3.2 Non-directional overcurrent protection ($I >$; 50/51)

The non-directional overcurrent function is used for instant and time-delayed overcurrent and short-circuit protection. The number of stages in the function depends on the relay model. The operating decisions are based on phase current magnitude, constantly measured by the function. The available phase current magnitudes are equal to RMS values, to TRMS values (including harmonics up to 32nd), or to peak-to-peak values. The blocking signal and the setting group selection control the operating characteristics of the function during normal operation, i.e. the user or user-defined logic can change function parameters while the function is running.

The outputs of the function are the START, TRIP and BLOCKED signals. The non-directional overcurrent function uses a total of eight (8) separate setting groups which can be selected from one common source.

The function can operate on instant or time-delayed mode. In time-delayed mode the operation can be selected between definite time (DT) mode and inverse definite minimum time (IDMT) mode. The IDMT operation supports both IEC and ANSI standard time delays as well as custom parameters. The function includes CT saturation checking which allows the function to start and operate accurately during CT saturation.

The operational logic consists of the following:

- input magnitude selection
- input magnitude processing
- saturation check
- threshold comparator
- block signal check
- time delay characteristics
- output processing.

The basic design of the protection function is the three-pole operation.

The inputs for the function are the following:

- operating mode selections
- setting parameters
- digital inputs and logic signals
- measured and pre-processed current magnitudes.

The function outputs the START, TRIP and BLOCKED signals which can be used for direct I/O controlling and user logic programming. The function generates general time-stamped ON/OFF events to the common event buffer from each of the three (3) output signals. In the instant operating mode the function outputs START and TRIP events simultaneously with an equivalent time stamp. The time stamp resolution is 1 ms. The function also provides a resettable cumulative counter for the START, TRIP and BLOCKED events.

The following figure presents a simplified function block diagram of the non-directional overcurrent function.

Figure. 5.3.2 - 86. Simplified function block diagram of the I> function.

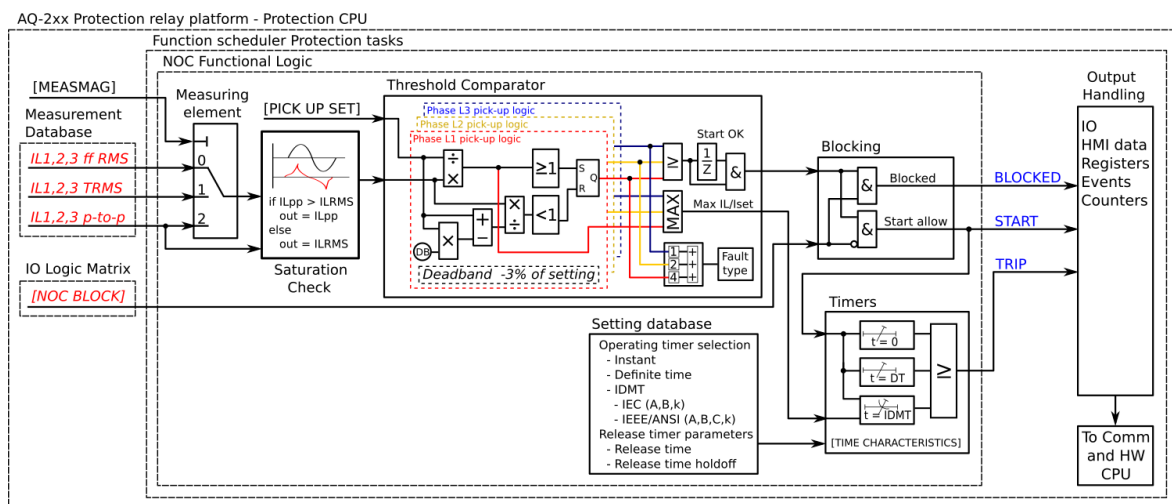

Measured input

The function block uses analog current measurement values. However, when the peak-to-peak mode is selected for the function's "Measured magnitude" setting, the values are taken directly from the samples. The user can select the monitored magnitude to be equal either to RMS values, to TRMS values from the whole harmonic specter of 32 components, or to peak-to-peak values. A -20ms averaged value of the selected magnitude is used for pre-fault data registering.

Table. 5.3.2 - 49. Measurement inputs of the I> function.

Signal	Description	Time base
IL1RMS	RMS measurement of phase L1 (A) current	5ms
IL2RMS	RMS measurement of phase L2 (B) current	5ms
IL3RMS	RMS measurement of phase L3 (C) current	5ms
IL1TRMS	TRMS measurement of phase L1 (A) current	5ms
IL2TRMS	TRMS measurement of phase L2 (B) current	5ms
IL3TRMS	TRMS measurement of phase L3 (C) current	5ms
IL1PP	Peak-to-peak measurement of phase L1 (A) current	5ms
IL2PP	Peak-to-peak measurement of phase L2 (B) current	5ms
IL3PP	Peak-to-peak measurement of phase L3 (C) current	5ms

The selection of the used AI channel is made with a setting parameter. In all possible input channel variations the pre-fault condition is presented with a 20 ms averaged history value from -20 ms from START or TRIP event.

General settings

The following general settings define the general behavior of the function. These settings are static i.e. it is not possible to change them by editing the setting group.

Table. 5.3.2 - 50. General settings of the function.

Name	Range	Step	Default	Description
Setting control from comm bus	1: Disabled 2: Allowed	-	1: Disabled	Activating this parameter allows changing the pick-up level of the protection stage via SCADA.
Measured magnitude	1: RMS 2: TRMS 3: Peak-to-peak	-	1: RMS	Defines which available measured magnitude is used by the function.

Pick-up

The I_{set} setting parameter controls the pick-up of the I> function. This defines the maximum allowed measured current before action from the function. The function constantly calculates the ratio between the I_{set} and the measured magnitude (I_m) for each of the three phases. The reset ratio of 97 % is built into the function and is always relative to the I_{set} value. The setting value is common for all measured phases, and when the I_m exceeds the I_{set} value (in single, dual or all phases) it triggers the pick-up operation of the function.

Table. 5.3.2 - 51. Pick-up settings.

Name	Description	Range	Step	Default
I _{set}	Pick-up setting	0.10...50.00×I _n	0.01×I _n	1.20×I _n

The pick-up activation of the function is not directly equal to the START signal generation of the function. The START signal is allowed if the blocking condition is not active.

Read-only parameters

The relay's *Info* page displays useful, real-time information on the state of the protection function. It is accessed either through the relay's HMI display, or through the setting tool software when it is connected to the relay and its Live Edit mode is active.

Table. 5.3.2 - 52. Information displayed by the function.

Name	Range	Step	Description
I> condition	0: Normal 1: Start 2: Trip 3: Blocked	-	Displays status of the protection function.
I> phases condition	0: Normal 1: Start A 2: Start B 3: Start C 4: Trip A 5: Trip B 6: Trip C 7: Start AB 8: Start BC 9: Start CA 10: Start ABC 11: Trip AB 12: Trip BC 13: Trip CA 14: Trip ABC	-	Displays the status of phases individually.
Expected operating time	-1800.000...1800.000s	0.005s	Displays the expected operating time when a fault occurs. When IDMT mode is used, the expected operating time depends on the measured highest phase current value. If the measured current changes during a fault, the expected operating time changes accordingly.
Time remaining to trip	0.000...1800.000s	0.005s	When the function has detected a fault and counts down time towards a trip, this displays how much time is left before tripping occurs.
I _{meas} /I _{set} at the moment	0.00...1250.00	0.01	The ratio between the highest measured phase current and the pick-up value.

Function blocking

The block signal is checked in the beginning of each program cycle. The blocking signal is received from the blocking matrix in the function's dedicated input. Additionally, the non-directional overcurrent function includes an internal inrush harmonic blocking option which is applied according to the parameters set by the user. If the blocking signal is not activated when the pick-up element activates, a START signal is generated and the function proceeds to the time characteristics calculation.

Table. 5.3.2 - 53. Internal inrush harmonic blocking settings.

Name	Range	Step	Default	Description
Inrush harmonic blocking (internal-only trip)	0: No 1: Yes	-	0: No	Enables and disables the 2 nd harmonic blocking.
2 nd harmonic blocking limit (I _{harm} /I _{fund})	0.10...50.00%I _{fund}	0.01%I _{fund}	0.01%I _{fund}	Defines the limit of the 2 nd harmonic blocking.

If the blocking signal is active when the pick-up element activates, a BLOCKED signal is generated and the function does not process the situation further. If the START function has been activated before the blocking signal, it resets and the release time characteristics are processed similarly to when the pick-up signal is reset.

The blocking of the function causes an HMI display event and a time stamped blocking event with information of the startup current values and its fault type to be issued.

The blocking signal can also be tested in the commissioning phase by a software switch signal when the relay's testing mode "Enable stage forcing" is activated (*General* → *Device*).

The variables the user can set are binary signals from the system. The blocking signal needs to reach the device minimum of 5 ms before the set operating delay has passed in order for the blocking to activate in time.

Operating time characteristics for trip and reset

This function supports definite time delay (DT) and inverse definite minimum time delay (IDMT). For detailed information on these delay types please refer to the chapter "General properties of a protection function" and its section "Operating time characteristics for trip and reset".

Events and registers

The non-directional overcurrent function (abbreviated "NOC" in event block names) generates events and registers from the status changes in START, TRIP and BLOCKED. The user can select which event messages are stored in the main event buffer: ON, OFF, or both. The function offers four (4) independent stages; the events are segregated for each stage operation.

The events triggered by the function are recorded with a time stamp and with process data values.

Table. 5.3.2 - 54. Event codes.

Event number	Event channel	Event block name	Event code	Description
1280	20	NOC1	0	Start ON
1281	20	NOC1	1	Start OFF
1282	20	NOC1	2	Trip ON
1283	20	NOC1	3	Trip OFF
1284	20	NOC1	4	Block ON
1285	20	NOC1	5	Block OFF
1286	20	NOC1	6	Phase A Start ON
1287	20	NOC1	7	Phase A Start OFF
1288	20	NOC1	8	Phase B Start ON
1289	20	NOC1	9	Phase B Start OFF
1290	20	NOC1	10	Phase C Start ON

Event number	Event channel	Event block name	Event code	Description
1291	20	NOC1	11	Phase C Start OFF
1292	20	NOC1	12	Phase A Trip ON
1293	20	NOC1	13	Phase A Trip OFF
1294	20	NOC1	14	Phase B Trip ON
1295	20	NOC1	15	Phase B Trip OFF
1296	20	NOC1	16	Phase C Trip ON
1297	20	NOC1	17	Phase C Trip OFF
1344	21	NOC2	0	Start ON
1345	21	NOC2	1	Start OFF
1346	21	NOC2	2	Trip ON
1347	21	NOC2	3	Trip OFF
1348	21	NOC2	4	Block ON
1349	21	NOC2	5	Block OFF
1350	21	NOC2	6	Phase A Start ON
1351	21	NOC2	7	Phase A Start OFF
1352	21	NOC2	8	Phase B Start ON
1353	21	NOC2	9	Phase B Start OFF
1354	21	NOC2	10	Phase C Start ON
1355	21	NOC2	11	Phase C Start OFF
1356	21	NOC2	12	Phase A Trip ON
1357	21	NOC2	13	Phase A Trip OFF
1358	21	NOC2	14	Phase B Trip ON
1359	21	NOC2	15	Phase B Trip OFF
1360	21	NOC2	16	Phase C Trip ON
1361	21	NOC2	17	Phase C Trip OFF
1408	22	NOC3	0	Start ON
1409	22	NOC3	1	Start OFF
1410	22	NOC3	2	Trip ON
1411	22	NOC3	3	Trip OFF
1412	22	NOC3	4	Block ON
1413	22	NOC3	5	Block OFF
1414	22	NOC3	6	Phase A Start ON
1415	22	NOC3	7	Phase A Start OFF
1416	22	NOC3	8	Phase B Start ON
1417	22	NOC3	9	Phase B Start OFF
1418	22	NOC3	10	Phase C Start ON
1419	22	NOC3	11	Phase C Start OFF
1420	22	NOC3	12	Phase A Trip ON

Event number	Event channel	Event block name	Event code	Description
1421	22	NOC3	13	Phase A Trip OFF
1422	22	NOC3	14	Phase B Trip ON
1423	22	NOC3	15	Phase B Trip OFF
1424	22	NOC3	16	Phase C Trip ON
1425	22	NOC3	17	Phase C Trip OFF
1472	23	NOC4	0	Start ON
1473	23	NOC4	1	Start OFF
1474	23	NOC4	2	Trip ON
1475	23	NOC4	3	Trip OFF
1476	23	NOC4	4	Block ON
1477	23	NOC4	5	Block OFF
1478	23	NOC4	6	Phase A Start ON
1479	23	NOC4	7	Phase A Start OFF
1480	23	NOC4	8	Phase B Start ON
1481	23	NOC4	9	Phase B Start OFF
1482	23	NOC4	10	Phase C Start ON
1483	23	NOC4	11	Phase C Start OFF
1484	23	NOC4	12	Phase A Trip ON
1485	23	NOC4	13	Phase A Trip OFF
1486	23	NOC4	14	Phase B Trip ON
1487	23	NOC4	15	Phase B Trip OFF
1488	23	NOC4	16	Phase C Trip ON
1489	23	NOC4	17	Phase C Trip OFF

The function registers its operation into the last twelve (12) time-stamped registers; this information is available for all provided instances separately. The register of the function records the ON event process data for START, TRIP or BLOCKED. The table below presents the structure of the function's register content.

Table. 5.3.2 - 55. Register content.

Date and time	Event code	Fault type	Trigger current	Fault current	Pre-fault current	Trip time remaining	Used SG
dd.mm.yyyy hh:mm:ss.mss	1280-1489 Descr.	L1-E...L1-L2-L3	Start average current	Trip -20ms averages	Start -200ms averages	0 ms...1800s	Setting group 1...8 active

5.3.3 Non-directional earth fault protection ($I_{0>}$; 50N/51N)

The non-directional earth fault function is used for instant and time-delayed earth fault protection. The number of stages in the function depend on the device model. The operating characteristics are based on the selected neutral current magnitudes which the function measures constantly. The available analog measurement channels are I01 and I02 (residual current measurement) and I0Calc (residual current calculated from phase current). The user can select these channels to use RMS values, TRMS values (including harmonics up to 32nd), or peak-to-peak values. The blocking signal and the setting group selection control the operating characteristics of the function during normal operation, i.e. the user or user-defined logic can change function parameters while the function is running.

The outputs of the function are the START, TRIP and BLOCKED signals. The non-directional earth fault function uses a total of eight (8) separate setting groups which can be selected from one common source.

The function can operate on instant or time-delayed mode. In the time-delayed mode the operation can be selected for definite time (DT) or for inverse definite minimum time (IDMT); the IDMT operation supports both IEC and ANSI standard time delays as well as custom parameters. The function includes the checking of CT saturation which allows the function to start and operate accurately even during CT saturation.

The operational logic consists of the following:

- input magnitude selection
- input magnitude processing
- saturation check
- threshold comparator
- block signal check
- time delay characteristics
- output processing.

The inputs for the function are the following:

- operating mode selections
- setting parameters
- digital inputs and logic signals
- measured and pre-processed current magnitudes.

The function outputs the START, TRIP and BLOCKED signals which can be used for direct I/O controlling and user logic programming. The function generates general time-stamped ON/OFF events to the common event buffer from each of the three (3) output signals. In the instant operating mode the function outputs START and TRIP events simultaneously with an equivalent time stamp. The time stamp resolution is 1 ms. The function also provides a resettable cumulative counter for the START, TRIP and BLOCKED events.

The following figure presents a simplified function block diagram of the non-directional earth fault function.

Figure. 5.3.3 - 87. Simplified function block diagram of the I0> function.

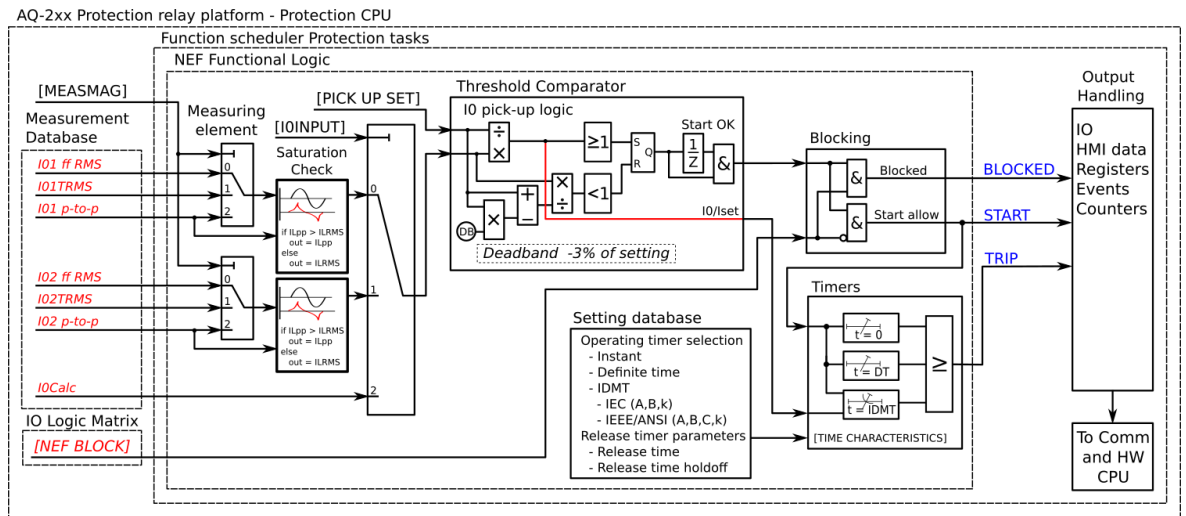

Measured input

The function block uses analog current measurement values. The user can select the monitored magnitude to be equal either to RMS values, to TRMS values, or to peak-to-peak values. TRMS mode uses values from the whole harmonic spectrum of 32 components. Peak-to-peak mode picks measurement values directly from the samples. A -20 ms averaged value of the selected magnitude is used for pre-fault data registering.

Table. 5.3.3 - 56. Measurement inputs of the I0> function.

Signal	Description	Time base
I01RMS	RMS measurement of coarse residual current measurement input I01	5 ms
I01TRMS	TRMS measurement of coarse residual current measurement input I01	5 ms
I01PP	Peak-to-peak measurement of coarse residual current measurement input I01	5 ms
I02RMS	RMS measurement of sensitive residual current measurement input I02	5 ms
I02TRMS	TRMS measurement of coarse sensitive current measurement input I02	5 ms
I02PP	Peak-to-peak measurement of sensitive residual current measurement input I02	5 ms
I0Calc	RMS value of the calculated zero sequence current from the three phase currents	5 ms

The selection of the used AI channel is made with a setting parameter. In all possible input channel variations the pre-fault condition is presented with a 20 ms averaged history value from -20 ms from a START or TRIP event.

General settings

The following general settings define the general behavior of the function. These settings are static i.e. it is not possible to change them by editing the setting group.

Table. 5.3.3 - 57. General settings of the function.

Name	Description	Range	Default
Setting control from comm bus	Activating this parameter permits changing the pick-up level of the protection stage via SCADA.	1: Disabled 2: Allowed	1: Disabled

Name	Description	Range	Default
Measured magnitude	Defines which available measured magnitude is used by the function. This parameter is available when "Input selection" has been set to "I01" or "I02".	1: RMS 2: TRMS 3: Peak-to-peak	1: RMS
Input selection	Defines which measured residual current is used by the function.	1: I01 2: I02 3: I0Calc	1: I01

Pick-up

The I_{0set} setting parameter controls the the pick-up of the I0> function. This defines the maximum allowed measured current before action from the function. The function constantly calculates the ratio between the I_{0set} and the measured magnitude (I_m) for each of the three phases. The reset ratio of 97 % is built into the function and is always relative to the I_{0set} value. The setting value is common for all measured phases. When the I_m exceeds the I_{0set} value (in single, dual or all phases) it triggers the pick-up operation of the function.

Table. 5.3.3 - 58. Pick-up settings.

Name	Description	Range	Step	Default
I_{0set}	Pick-up setting	0.0001...40.00 × I_n	0.0001 × I_n	1.20 × I_n

The pick-up activation of the function is not directly equal to the START signal generation of the function. The START signal is allowed if the blocking condition is not active.

Read-only parameters

The relay's *Info* page displays useful, real-time information on the state of the protection function. It is accessed either through the relay's HMI display, or through the setting tool software when it is connected to the relay and its Live Edit mode is active.

Table. 5.3.3 - 59. Information displayed by the function.

Name	Range	Step	Description
I0> condition	0: Normal 1: Start 2: Trip 3: Blocked	-	Displays status of the protection function.
Detected I0 angle	-360.00...360.00 deg	0.01 deg	Angle of I0 against reference. If phase voltages are available, positive sequence voltage angle is used as reference. If voltages are not available, positive sequence current angle is used as reference.
Detected fault type	0: - 1: A-G-R 2: B-G-F 3: C-G-R 4: A-G-F 5: B-G-R 6: C-G-F	-	Displays the detected fault type and direction of previous fault. "A/B/C" stand for one of the three phases. "G" stands for "ground". "F" stands for "forward" direction and "R" stands for "reverse" direction.
Expected operating time	-1800.000...1800.000 s	0.005 s	Displays the expected operating time when a fault occurs. When IDMT mode is used, the expected operating time depends on the measured current value. If the measured current changes during a fault, the expected operating time changes accordingly.
Time remaining to trip	0.000...1800.000 s	0.005 s	When the function has detected a fault and counts down time towards a trip, this displays how much time is left before tripping occurs.

Name	Range	Step	Description
I _{meas} /I _{set} at the moment	0.00...1250.00	0.01	The ratio between the measured current and the pick-up value.

Function blocking

The block signal is checked in the beginning of each program cycle. The blocking signal is received from the blocking matrix in the function's dedicated input. Additionally, non-directional earth fault protection includes an internal inrush harmonic blocking option which is applied according to the parameters set by the user. If the blocking signal is not activated when the pick-up element activates, a START signal is generated and the function proceeds to the time characteristics calculation.

Table. 5.3.3 - 60. Internal inrush harmonic blocking settings.

Name	Description	Range	Step	Default
Inrush harmonic blocking (internal-only trip)	2 nd harmonic blocking enable/disable	0: No 1: Yes	-	0: No
2 nd harmonic block limit (I _{harm} /I _{fund})	2 nd harmonic blocking limit	0.10...50.00%I _{fund}	0.01%I _{fund}	0.01%I _{fund}

If the blocking signal is active when the pick-up element activates, a BLOCKED signal is generated and the function does not process the situation further. If the START function has been activated before the blocking signal, it resets and processes the release time characteristics similarly to when the pick-up signal is reset.

The blocking of the function causes an HMI display event and a time-stamped blocking event with information of the startup current values and its fault type to be issued.

The blocking signal can also be tested in the commissioning phase by a software switch signal when the relay's testing mode "Enable stage forcing" is activated (*General* → *Device*).

The variables the user can set are binary signals from the system. The blocking signal needs to reach the device minimum of 5 ms before the set operating delay has passed in order for the blocking to activate in time.

Operating time characteristics for trip and reset

This function supports definite time delay (DT) and inverse definite minimum time delay (IDMT). For detailed information on these delay types please refer to the chapter "General properties of a protection function" and its section "Operating time characteristics for trip and reset".

Events and registers

The non-directional earth fault function (abbreviated "NEF" in event block names) generates events and registers from the status changes in START, TRIP and BLOCKED. The user can select which event messages are stored in the main event buffer: ON, OFF, or both. The function offers four (4) independent stages; the events are segregated for each stage operation.

The events triggered by the function are recorded with a time stamp and with process data values.

Table. 5.3.3 - 61. Event codes.

Event number	Event channel	Event block name	Event code	Description
1664	26	NEF1	0	Start ON
1665	26	NEF1	1	Start OFF

Event number	Event channel	Event block name	Event code	Description
1666	26	NEF1	2	Trip ON
1667	26	NEF1	3	Trip OFF
1668	26	NEF1	4	Block ON
1669	26	NEF1	5	Block OFF
1728	27	NEF2	0	Start ON
1729	27	NEF2	1	Start OFF
1730	27	NEF2	2	Trip ON
1731	27	NEF2	3	Trip OFF
1732	27	NEF2	4	Block ON
1733	27	NEF2	5	Block OFF
1792	28	NEF3	0	Start ON
1793	28	NEF3	1	Start OFF
1794	28	NEF3	2	Trip ON
1795	28	NEF3	3	Trip OFF
1796	28	NEF3	4	Block ON
1797	28	NEF3	5	Block OFF
1856	29	NEF4	0	Start ON
1857	29	NEF4	1	Start OFF
1858	29	NEF4	2	Trip ON
1859	29	NEF4	3	Trip OFF
1860	29	NEF4	4	Block ON
1861	29	NEF4	5	Block OFF

The function registers its operation into the last twelve (12) time-stamped registers. The register of the function records the ON event process data for START, TRIP or BLOCKED. The table below presents the structure of the function's register content.

Table. 5.3.3 - 62. Register content.

Date and time	Event code	Fault type	Trigger current	Fault current	Pre-fault current	Trip time remaining	Used SG
dd.mm.yyyy hh:mm:ss.mss	1664-1861 Descr.	A-G- R...C-G- F	Start average current	Trip -20ms averages	Start -200ms averages	0 ms...1800s	Setting group 1...8 active

5.3.4 Directional overcurrent protection (Idir>; 67)

The directional overcurrent function is used for instant and time-delayed overcurrent and short-circuits. A device with both voltage and current protection modules can have four (4) available stages of the function (Idir>, Idir>>, Idir>>>, Idir>>>>). The operating decisions are based on phase current magnitudes which the function constantly measures. The selectable monitored phase current magnitudes are equal to RMS values, to TRMS values (including harmonics up to 31st), or to peak-to-peak values. The blocking signal and the setting group selection control the operating characteristics of the function during normal operation, i.e. the user or user-defined logic can change function parameters while the function is running.

The outputs of the function are the START, TRIP and BLOCKED signals. The directional overcurrent function uses a total of eight (8) separate setting groups which can be selected from one common source.

The function can operate on instant or time-delayed mode. In time-delayed mode the operation can be selected between definite time (DT) mode and inverse definite minimum time (IDMT). The IDMT operation supports both IEC and ANSI standard time delays as well as custom parameters. The function includes CT saturation checking which allows the function to start and operate accurately during CT saturation.

The operational logic consists of the following:

- input magnitude selection
- input magnitude and angle processing
- saturation check
- threshold comparator
- block signal check
- time delay characteristics
- output processing.

The basic design of the protection function is the three-pole operation.

The inputs for the function are the following:

- operating mode selections
- setting parameters
- digital inputs and logic signals
- measured and pre-processed current magnitudes.

The function outputs the START, TRIP and BLOCKED signals which can be used for direct I/O controlling and user logic programming. The function generates general time-stamped ON/OFF events to the common event buffer from each of the three (3) output signals. In the instant operating mode the function outputs START and TRIP events simultaneously with an equivalent time stamp. The time stamp resolution is 1 ms. The function also provides a resettable cumulative counter for the START, TRIP and BLOCKED events.

The following figure presents a simplified function block diagram of the directional overcurrent function.

Figure. 5.3.4 - 88. Simplified function block diagram of the Idir> function.

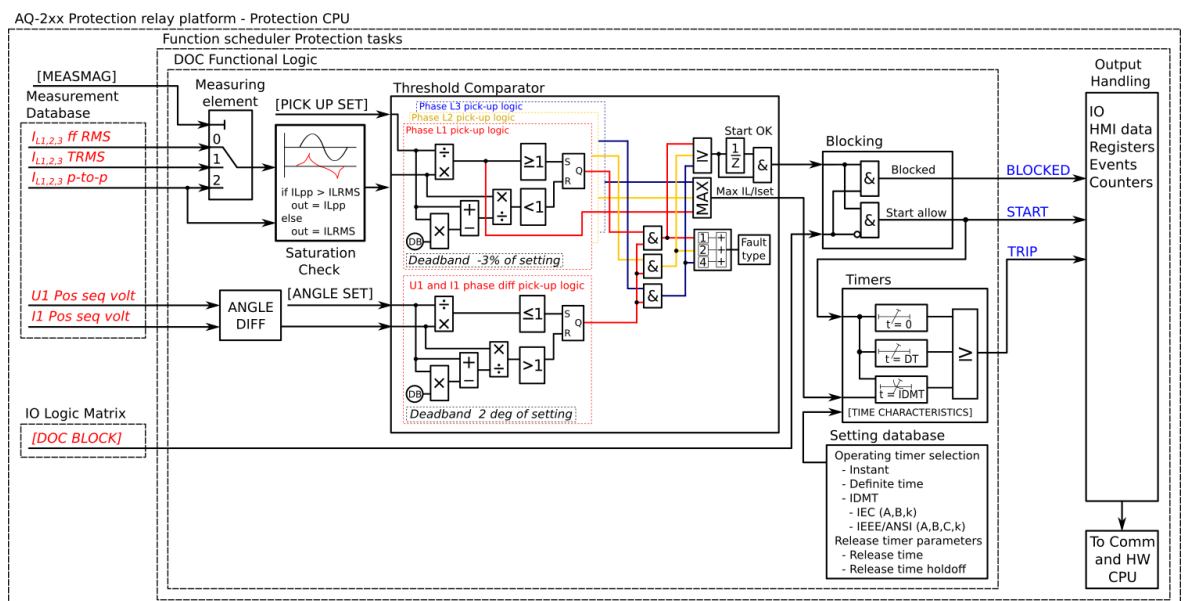

Measured input

The function block uses analog current measurement values. The user can select the monitored magnitude to be equal either to RMS values, to TRMS values, or to peak-to-peak values. TRMS mode uses values from the whole harmonic spectrum of 32 components. Peak-to-peak mode picks measurement values directly from the samples. A -20 ms averaged value of the selected magnitude is used for pre-fault data registering.

The fault current angle is based on the comparison between the positive sequence voltage U_1 and the positive sequence current I_1 . If the positive sequence voltage is not available (three line-to-line voltages but no U_0), the voltage angle is based on a faulty phase line-to-line voltage. If the voltage drops below 1 V in the secondary side during a fault, the voltage memory is used for 0.5 seconds. After that the reference angle of voltage is forced to 0°.

Table. 5.3.4 - 63. Measurement inputs of the Idir> function.

Signal	Description	Time base
IL1RMS	RMS measurement of phase L1 (A) current	5ms
IL2RMS	RMS measurement of phase L2 (B) current	5ms
IL3RMS	RMS measurement of phase L3 (C) current	5ms
IL1TRMS	TRMS measurement of phase L1 (A) current	5ms
IL2TRMS	TRMS measurement of phase L2 (B) current	5ms
IL3TRMS	TRMS measurement of phase L3 (C) current	5ms
IL1PP	Peak-to-peak measurement of phase L1 (A) current	5ms
IL2PP	Peak-to-peak measurement of phase L2 (B) current	5ms
IL3PP	Peak-to-peak measurement of phase L3 (C) current	5ms
U ₁ RMS	RMS measurement of voltage U ₁ /V	5ms
U ₂ RMS	RMS measurement of voltage U ₂ /V	5ms
U ₃ RMS	RMS measurement of voltage U ₃ /V	5ms
U ₄ RMS	RMS measurement of voltage U ₄ /V	5ms

The selection of the used AI channel is made with a setting parameter. In all possible input channel variations the pre-fault condition is presented with a 20 ms averaged history value from -20 ms from START or TRIP event.

General settings

The following general settings define the general behavior of the function. These settings are static i.e. it is not possible to change them by editing the setting group.

Table. 5.3.4 - 64. General settings of the function.

Name	Description	Range	Step	Default
Measured magnitude	Defines which available measured magnitude is used by the function.	1: RMS 2: TRMS 3: Peak-to-peak	-	1: RMS

Pick-up

The I_{set} setting parameter controls the pick-up of the $I >$ function. This defines the maximum allowed measured current before action from the function. The function constantly calculates the ratio between the I_{set} and the measured magnitude (I_m) for each of the three phases. The reset ratio of 97 % is built into the function and is always relative to the I_{set} value. The setting value is common for all measured phases, and when the I_m exceeds the I_{set} value (in single, dual or all phases) it triggers the pick-up operation of the function.

The trip characteristic can be set to directional or non-directional. In the non-directional mode only the pick-up value of the positive sequence current magnitude must be fulfilled in order for the function to trip. In the directional mode the fault must also be in the monitored direction to fulfill the terms to trip. By default, the tripping area is $\pm 88^\circ$ (176°). The reference angle is based on the calculated positive sequence voltage U_1 angle. If the U_1 voltage is not available and only line-to-line voltages are measured, the reference angle is based on a healthy line-to-line voltage. During a short-circuit the reference angle is based on impedance calculation.

If the voltage drops below 1 V in the secondary side, the angle memory is used for 0.5 seconds. The angle memory forces the reference angle to be equal to the value measured or calculated before the fault. The angle memory captures the measured voltage angle 100 ms before the fault starts. After 0.5 seconds the angle memory is no longer used, and the reference angle is forced to 0° . The inbuilt reset ratio for the tripping area angle is 2° .

Table. 5.3.4 - 65. Pick-up settings.

Name	Description	Range	Step	Default
Characteristic direction	Switches between directional and non-directional overcurrent mode.	Directional Non-directional	-	Directional
Operating sector size (+ / -)	Pick-up area size in degrees.	$\pm 1.0 \dots 170.0^\circ$	0.1°	$\pm 88^\circ$
Operating sector center	Turns the operating sector	$-180.0 \dots 180.0^\circ$	0.1°	0°
Pick-up setting I_{set}	Pick-up setting	$0.10 \dots 40.00 \times I_n$	$0.01 \times I_n$	$1.20 \times I_n$

The pick-up activation of the function is not directly equal to the START signal generation of the function. The START signal is allowed if the blocking condition is not active.

Figure. 5.3.4 - 89. Angle tracking of the $I_{dir} >$ function (3LN/3LL + U_0 mode).

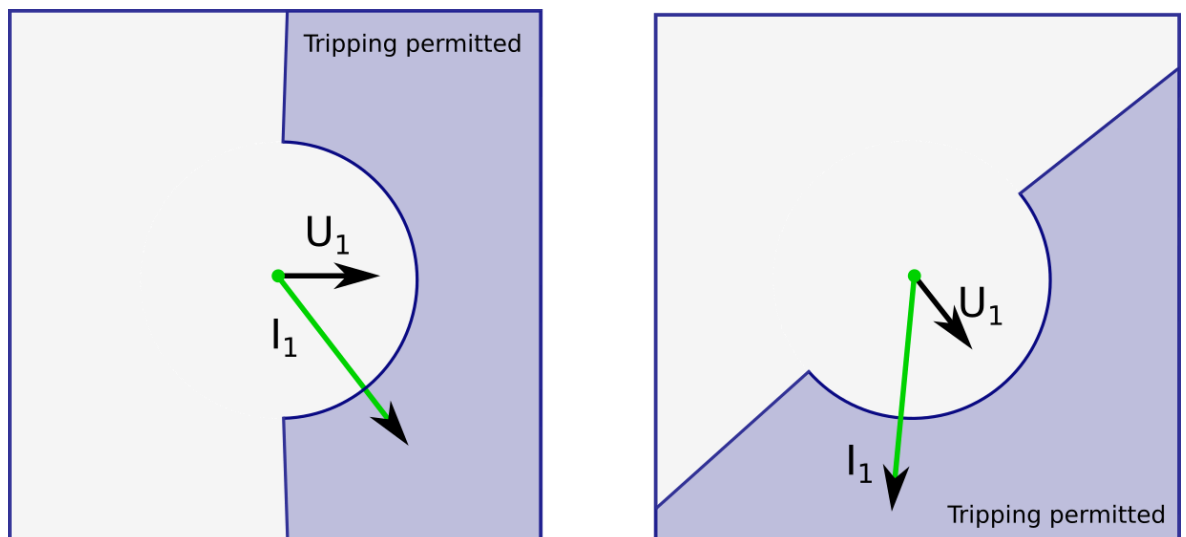

Please note in the picture above that the tripping area is linked to the angle of the positive sequence voltage U_1 . The angle of the positive sequence current I_1 is compared to U_1 angle, and if the fault is in the correct direction, it is possible to perform a trip when the amplitude of I_{L1} , I_{L2} or I_{L3} increases above the pick-up limit.

If the 3LL mode is used without the U_0 measurement in a single-phase fault situation, the voltage reference comes from the healthy phase and the current reference from the faulty phase. In a short-circuit the angle comes from impedance calculation.

Figure. 5.3.4 - 90. Operation sector area when the sector center has been set to -45 degrees.

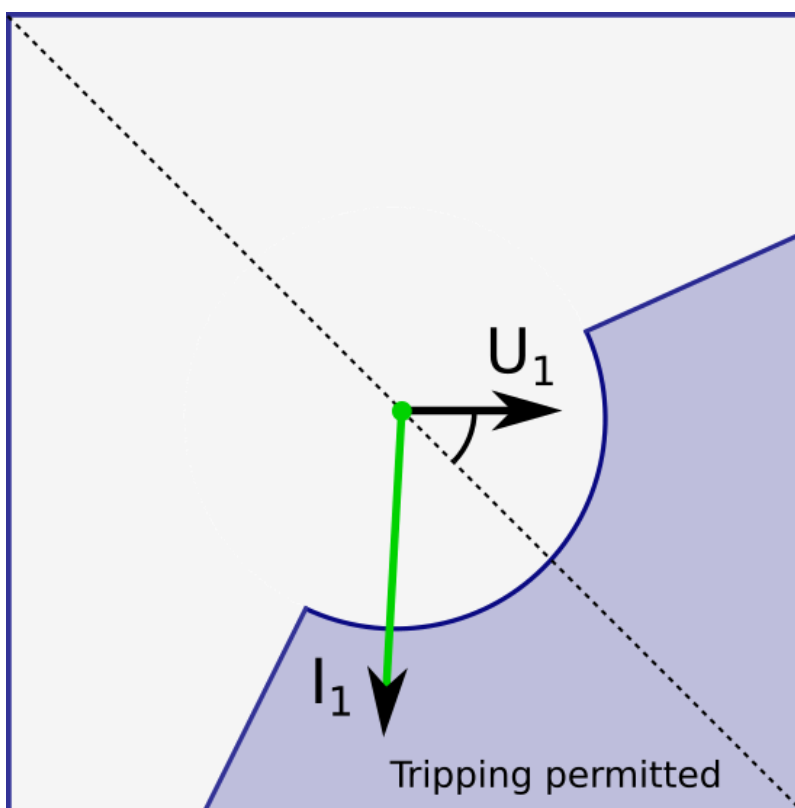
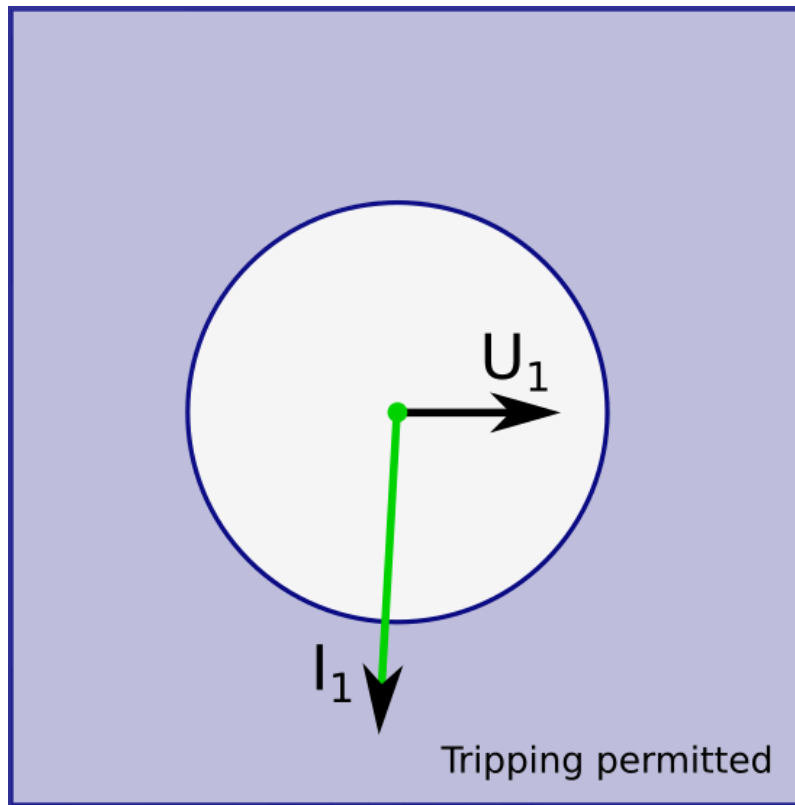

Figure. 5.3.4 - 91. When I_{dir} function has been set to "Non-directional" the function works basically just like a traditional non-directional overcurrent protection function.



Read-only parameters

The relay's *Info* page displays useful, real-time information on the state of the protection function. It is accessed either through the relay's HMI display, or through the setting tool software when it is connected to the relay and its Live Edit mode is active.

Table. 5.3.4 - 66. Information displayed by the function.

Name	Range	Step	Description
Operating angle now	-360.00...360.00deg	0.01deg	The positive sequence current angle in relation to the positive sequence voltage.
Expected operating time	0.000...1800.00s	0.005s	Displays the expected operating time when a fault occurs. When IDMT mode is used, the expected operating time depends on the highest measured phase current value. If the measured current changes during a fault, the expected operating time changes accordingly.
Time remaining to trip	-1800.000...1800.00s	0.005s	When the function has detected a fault and counts down time towards a trip, this displays how much time is left before tripping occurs.
I_{meas}/I_{set} at the moment	0.00...1250.00 I_m/I_{set}	0.01 I_m/I_{set}	The ratio between the highest measured phase current and the pick-up value.

Function blocking

The block signal is checked in the beginning of each program cycle. The blocking signal is received from the blocking matrix in the function's dedicated input. Additionally, the non-directional overcurrent function includes an internal inrush harmonic blocking option which is applied according to the parameters set by the user. If the blocking signal is not activated when the pick-up element activates, a START signal is generated and the function proceeds to the time characteristics calculation.

Table. 5.3.4 - 67. Internal inrush harmonic blocking settings.

Name	Description	Range	Step	Default
Inrush harmonic blocking (internal-only trip)	Enables and disables the 2 nd harmonic blocking.	0: No 1: Yes	-	0: No
2 nd harmonic blocking limit (I _{harm} /I _{fund})	The 2 nd harmonic blocking limit.	0.10...50.00%I _{fund}	0.01%I _{fund}	0.01%I _{fund}

If the blocking signal is active when the pick-up element activates, a BLOCKED signal is generated and the function does not process the situation further. If the START function has been activated before the blocking signal, it resets and the release time characteristics are processed similarly to when the pick-up signal is reset.

The blocking of the function causes an HMI display event and a time-stamped blocking event with information of the startup current values and its fault type to be issued.

The blocking signal can also be tested in the commissioning phase by a software switch signal when the relay's testing mode "Enable stage forcing" is activated (*General* → *Device*).

The variables the user can set are binary signals from the system. The blocking signal needs to reach the device minimum of 5 ms before the set operating delay has passed in order for the blocking to activate in time.

Operating time characteristics for trip and reset

This function supports definite time delay (DT) and inverse definite minimum time delay (IDMT). For detailed information on these delay types please refer to the chapter "General properties of a protection function" and its section "Operating time characteristics for trip and reset".

Events and registers

The directional overcurrent function (abbreviated "DOC" in event block names) generates events and registers from the status changes in START, TRIP and BLOCKED. The user can select which event messages are stored in the main event buffer: ON, OFF, or both. The function offers four (4) independent stages; the events are segregated for each stage operation.

The events triggered by the function are recorded with a time stamp and with process data values.

Table. 5.3.4 - 68. Event codes.

Event Number	Event channel	Event block name	Event Code	Description
4800	75	DOC1	0	Start ON
4801	75	DOC1	1	Start OFF
4802	75	DOC1	2	Trip ON
4803	75	DOC1	3	Trip OFF
4804	75	DOC1	4	Block ON

Event Number	Event channel	Event block name	Event Code	Description
4805	75	DOC1	5	Block OFF
4806	75	DOC1	6	No voltage, Blocking ON
4807	75	DOC1	7	Voltage measurable, Blocking OFF
4808	75	DOC1	8	Measuring live angle ON
4809	75	DOC1	9	Measuring live angle OFF
4810	75	DOC1	10	Using voltmem ON
4811	75	DOC1	11	Using voltmem OFF
4864	76	DOC2	0	Start ON
4865	76	DOC2	1	Start OFF
4866	76	DOC2	2	Trip ON
4867	76	DOC2	3	Trip OFF
4868	76	DOC2	4	Block ON
4869	76	DOC2	5	Block OFF
4870	76	DOC2	6	No voltage, Blocking ON
4871	76	DOC2	7	Voltage measurable, Blocking OFF
4872	76	DOC2	8	Measuring live angle ON
4873	76	DOC2	9	Measuring live angle OFF
4874	76	DOC2	10	Using voltmem ON
4875	76	DOC2	11	Using voltmem OFF
4928	77	DOC3	0	Start ON
4929	77	DOC3	1	Start OFF
4930	77	DOC3	2	Trip ON
4931	77	DOC3	3	Trip OFF
4932	77	DOC3	4	Block ON
4933	77	DOC3	5	Block OFF
4934	77	DOC3	6	No voltage, Blocking ON
4935	77	DOC3	7	Voltage measurable, Blocking OFF
4936	77	DOC3	8	Measuring live angle ON
4937	77	DOC3	9	Measuring live angle OFF
4938	77	DOC3	10	Using voltmem ON
4939	77	DOC3	11	Using voltmem OFF
4992	78	DOC4	0	Start ON
4993	78	DOC4	1	Start OFF
4994	78	DOC4	2	Trip ON
4995	78	DOC4	3	Trip OFF
4996	78	DOC4	4	Block ON
4997	78	DOC4	5	Block OFF
4998	78	DOC4	6	No voltage, Blocking ON

Event Number	Event channel	Event block name	Event Code	Description
4999	78	DOC4	7	Voltage measurable, Blocking OFF
5000	78	DOC4	8	Measuring live angle ON
5001	78	DOC4	9	Measuring live angle OFF
5002	78	DOC4	10	Using voltmem ON
5003	78	DOC4	11	Using voltmem OFF

The function registers its operation into the last twelve (12) time-stamped registers; this information is available for all provided instances separately. The register of the function records the ON event process data for START, TRIP or BLOCKED. The table below presents the structure of the function's register content.

Table. 5.3.4 - 69. Register content.

Register name	Description
Date and time	dd.mm.yyyy hh:mm:ss.mss
Event code	4800-5003 Descr.
Fault type	L1-E...L1-L2-L3
Trigger current	Start average current
Fault current	Trip -20ms averages
Pre-fault current	Start -200ms averages
Trip time remaining	0 s...1800s
Used SG	Setting group 1...8 active
Operating angle	0...250°

5.3.5 Directional earth fault protection (I0dir>; 67N/32N)

The directional earth fault function is used for instant and time-delayed earth fault protection. A device with both voltage and current protection modules can have four (4) stages in the function (I0dir>, I0dir>>, I0dir>>>, I0dir>>>>). The operating decisions are based on selected neutral current and voltage magnitudes which the function constantly measures. The available residual current magnitudes are RMS values, TRMS values (including harmonics up to 31st), or peak-to-peak values that come from inputs I01 or I02 (residual current measurement) or from I0Calc (residual current calculated from phase current measurements). The current angle is compared to the angle of measured or calculated zero sequence voltage. A certain amount of zero sequence voltage has to be present to activate the trip. The blocking signal and the setting group selection control the operating characteristics of the function during normal operation, i.e. the user or user-defined logic can change function parameters while the function is running.

The outputs of the function are the START, TRIP and BLOCKED signals. The directional earth fault function uses a total of eight (8) separate setting groups which can be selected from one common source.

The function can operate on instant or time-delayed mode. In the time-delayed mode the operation can be selected for definite time (DT) or for inverse definite minimum time (IDMT); the IDMT operation supports both IEC and ANSI standard time delays as well as custom parameters.

The operational logic consists of the following:

- input magnitude selection
- input magnitude processing

- threshold comparator
- angle check
- block signal check
- time delay characteristics
- output processing.

The inputs for the function are the following:

- operating mode selections
- setting parameters
- digital inputs and logic signals
- measured and pre-processed current magnitudes.

The function outputs the START, TRIP and BLOCKED signals which can be used for direct I/O controlling and user logic programming. The function generates general time-stamped ON/OFF events to the common event buffer from each of the three (3) output signals. In the instant operating mode the function outputs START and TRIP events simultaneously with an equivalent time stamp. The time stamp resolution is 1 ms. The function also provides a cumulative counter for the START, TRIP and BLOCKED events.

The following figure presents a simplified function block diagram of the directional earth fault function.

Figure. 5.3.5 - 92. Simplified function block diagram of the I0dir> function.

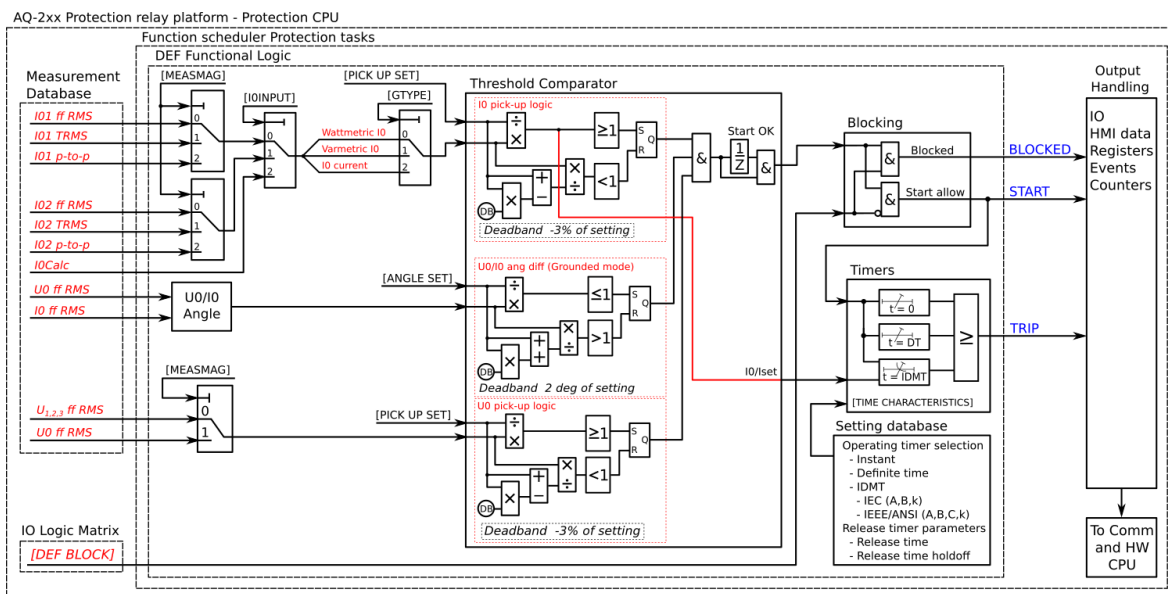

Measured input

The function block uses analog current measurement values. The user can select the monitored magnitude to be equal either to RMS values, to TRMS values, or to peak-to-peak values. TRMS mode uses values from the whole harmonic spectrum of 32 components. Peak-to-peak mode picks measurement values directly from the samples. A -20 ms averaged value of the selected magnitude is used for pre-fault data registering.

The fault current angle is based on comparing the neutral voltage U_0 angle to the residual current I_0 angle. Both I_0 and U_0 must be above the squelch limit to be able to detect the angle. The squelch limit for the I_0 current is $0.01 \times I_n$ and for the U_0 voltage $0.01 \times U_n$.

Table. 5.3.5 - 70. Measurement inputs of the I0dir> function.

Signal	Description	Time base
I01RMS	RMS measurement of coarse residual current measurement input I01	5ms
I01TRMS	TRMS measurement of coarse residual current measurement input I01	5ms
I01PP	Peak-to-peak measurement of coarse residual current measurement input I01	5ms
I02RMS	RMS measurement of sensitive residual current measurement input I02	5ms
I02TRMS	TRMS measurement of coarse sensitive current measurement input I02	5ms
I02PP	Peak-to-peak measurement of sensitive residual current measurement input I02	5ms
I0Calc	RMS value of the calculated residual current from the three phase currents	5ms
U0RMS	RMS measurement of zero sequence voltage measurement input U0	5ms
U0Calc	RMS value of the calculated zero sequence voltage from the three phase voltages	5ms

The selection of the used AI channel is made with a setting parameter. In all possible input channel variations the pre-fault condition is presented with a 20 ms averaged history value from -20 ms from a START or TRIP event.

General settings

The following general settings define the general behavior of the function. These settings are static i.e. it is not possible to change them by editing the setting group.

Table. 5.3.5 - 71. General settings of the function.

Name	Description	Range	Step	Default
U0 directional phase	If the connected neutral voltage polarity is opposite to the connected residual current, this parameter can swap the angle reference.	1: U0 2: -U0	-	1: U0
U0> Meas input select	Defines which available neutral voltage measurement is used. Available neutral voltages depend on measurement settings (<i>Measurements</i> → <i>Transformers</i> → <i>VT module</i>).	1: Select 2: U0 3: U3 4: U4 Input	-	1: Select
Measured magnitude	Defines which available measured magnitude is used by the function. This parameter is available when "Input selection" has been set to "I01" or "I02".	1: RMS 2: TRMS 3: Peak-to-peak	-	1: RMS
Input selection	Defines which measured residual current is used by the function.	1: I01 2: I02 3: I0Calc	-	1: I01

Pick-up

The the pick-up of the I0dir> function is controlled by the I_{0set} setting parameter and the U_{0set} setting parameter. The former defines the maximum allowed measured current, while the latter defines the maximum allowed measured voltage and checks the angle difference before action from the function. The function constantly calculates the ratio between the I_{0set} and the U_{0set} and the measured magnitudes (I_m and U_m). The reset ratio of 97 % is built into the function and is always relative to the I_{0set} (or U_{0set}) value. When the I_m exceeds the I_{0set} value it triggers the pick-up operation of the function.

Table. 5.3.5 - 72. Pick-up settings.

Name	Description	Range	Step	Default
I_{0set}	Pick-up setting	$0.005...40.00 \times I_n$	$0.001 \times I_n$	$1.20 \times I_n$
U_{0set}	Pick-up setting	$1...75\%U_n$	$0.01\%U_n$	$20\%U_n$
Grounding type	Network grounding method	1: Unearthed [32N Var] 2: Petersen coil GND [32N Watt] 3: Grounded [67N] 4: I_{0Cos} & I_{0Sin} broad range with MCD [32N Var/Watt]	-	1: Unearthed
Multi-criteria detection	Activation of detecting healthy or unhealthy feeder by analyzing symmetrical components of currents and voltages. Visible when earthing type is set to I_{0Cos} & I_{0Sin} broad range mode.	1: Not used 2: Used	-	1: Not used
Unearthed/Compensated border angle	Dividing the angle between unearthed and compensated tripping (see description later in this document). Visible when earthing type is set to I_{0Cos} & I_{0Sin} broad range mode.	$-45.0...90^\circ$	0.1°	45°
Angle	Tripping area size (earthed network)	$\pm 45.0...135.0^\circ$	0.1°	$\pm 88^\circ$
Angle offset	Protection area direction (earthed network)	$0.0...360.0^\circ$	0.1°	0.0°
Angle blinder	I_0 angle blinder (Petersen coil earthed)	$-90.0...0.0^\circ$	0.1°	-90°

The pick-up activation of the function is not directly equal to the START signal generation of the function. The START signal is allowed if the blocking condition is not active.

Unearthed network

Figure. 5.3.5 - 93. Angle tracking of I_{0dir} function (unearthed network model) (32N)

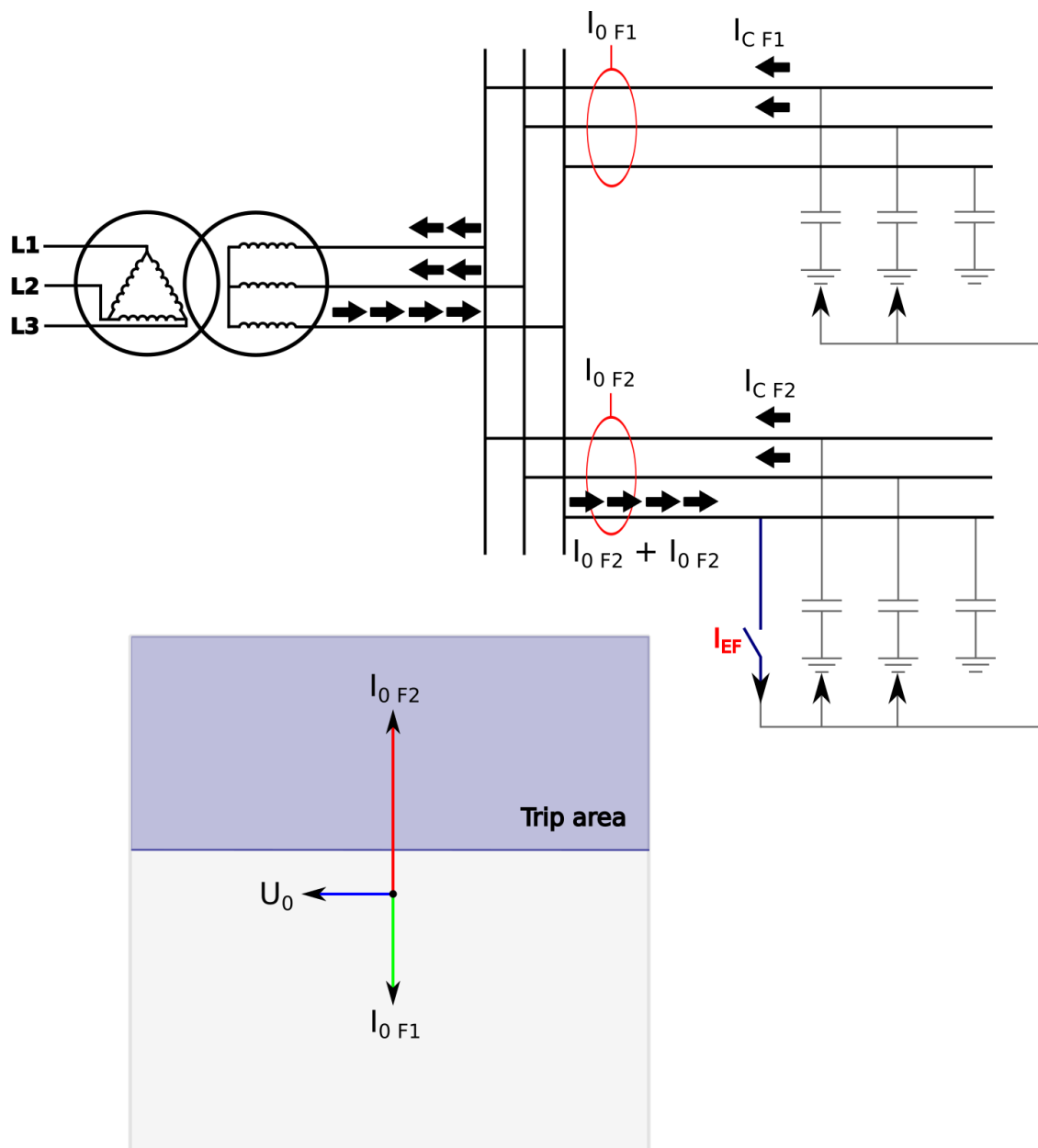

When the unearthed (capacitive) network mode is chosen, the device expects the fault current to be lagging zero sequence voltage by 90 degrees. Healthy phases of healthy feeders produce capacitive current during earth fault just like a faulty feeder but the current is floating towards the busbar and through an incoming transformer or a earthing transformer and into a faulty feeder. Healthy feeders do not trip since capacitive current is floating to the opposite direction and selective tripping can be ensured.

The amplitude of the fault current depends on the capacitance of the network. The outgoing feeders are the sources for capacitive currents. The bigger the network the greater the capacitive current during a fault. Each outgoing feeder produces capacitance according to the zero sequence capacitive reactance of the line (ohms per kilometer). It is normal that in cable networks fault currents are higher than in overhead lines.

The resistance of the fault affects the size of the voltage drop during a fault. In direct earth fault the zero sequence voltage amplitude is equal to the system's line-to-earth voltage. In direct earth fault the voltage of a faulty phase drops close to zero and healthy phase voltages increase to the amplitude of line-to-line voltages.

Petersen coil earthed (Compensated) network (32N)

There are many benefits to a Petersen coil earthed network. The amount of automatic reclosing is highly decreased and the maintenance of the breakers is therefore diminished. Arc faults die on their own, and cables and equipment suffer less damage. In emergency situations a line with an earth fault can be used for a specific time.

Figure. 5.3.5 - 94. Angle tracking of I_{0dir} function (Petersen coil earthed network model).

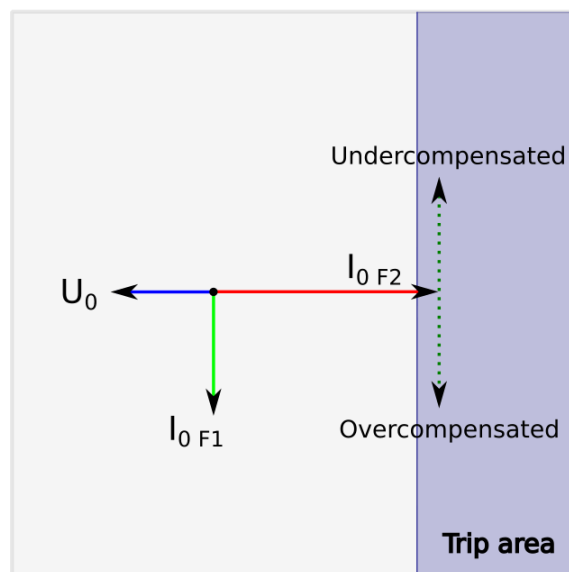
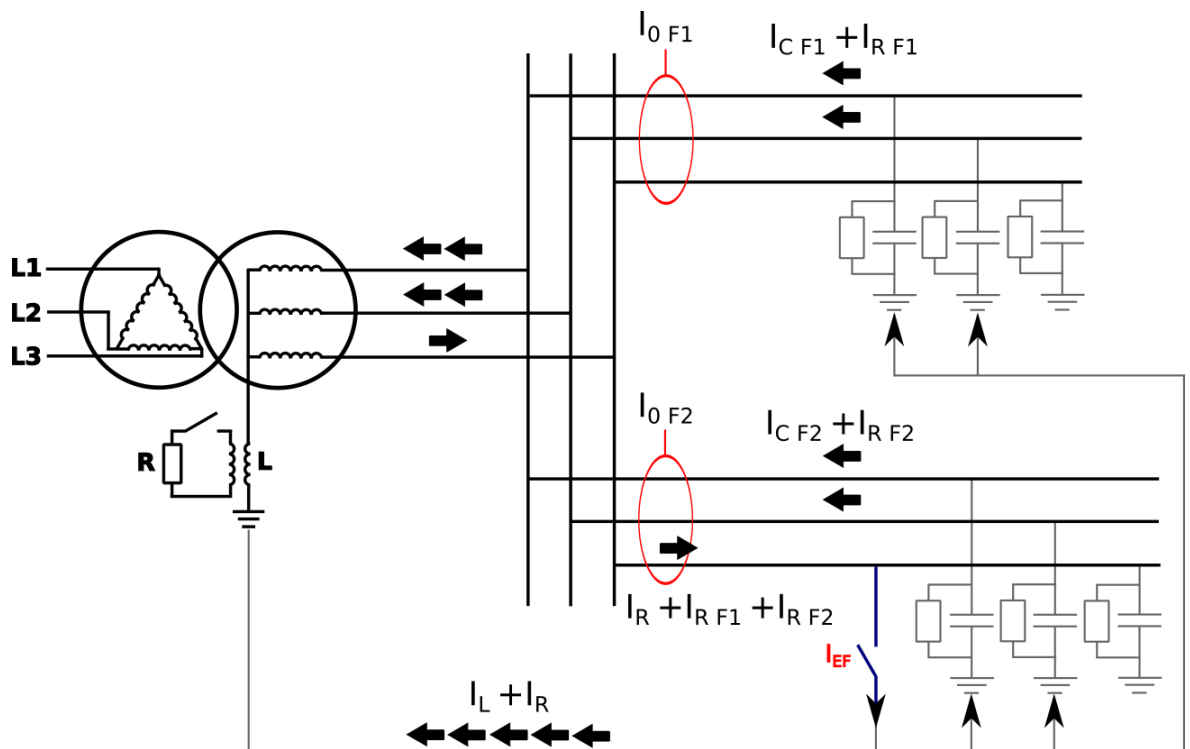

When the Petersen coil earthed (compensated) network mode is chosen, the device expects the fault current to be in the opposite direction to the zero sequence voltage. Healthy phases of both healthy and faulty feeders produce a capacitive current similar to the unearthed network. The inductance of the Petersen coil compensates the capacitive current and therefore the residual current in a fault location is close to zero. The size of the inductance is chosen according to the prospective earth fault current of the network. The desired compensation grade is achieved when the K factor is close to 1.0 and the network is fully compensated. The network is overcompensated when the K factor is greater than 1.0, and undercompensated when the K factor is smaller than 1.0.

The inductance connected to the star point of an incoming transformer or -as in most cases- to a earthing transformer compensates the capacitance of the network; however, this prevents the capacitive fault current to be measured. The fault detection is handled by connecting the resistance in parallel with the inductance. This resistance includes the amplitude of the fault current. In undercompensated or overcompensated situations the resistive component does not change during the fault; therefore, selective tripping is ensured even when the network is slightly undercompensated or overcompensated.

Directly earthed or small impedance network (67N)

Figure. 5.3.5 - 95. Angle tracking of I_{0dir} function (directly earthed or small impedance network).

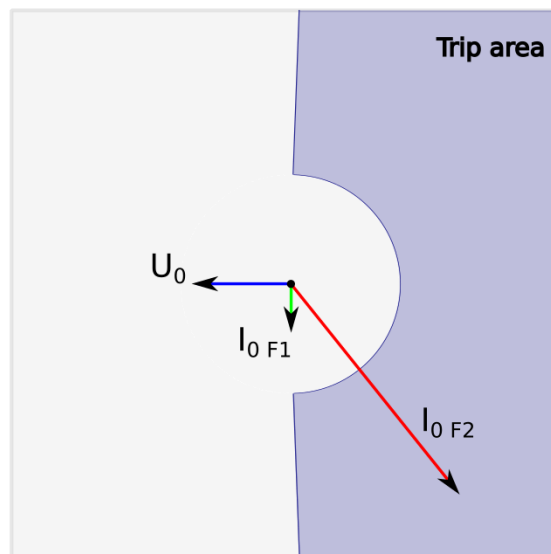
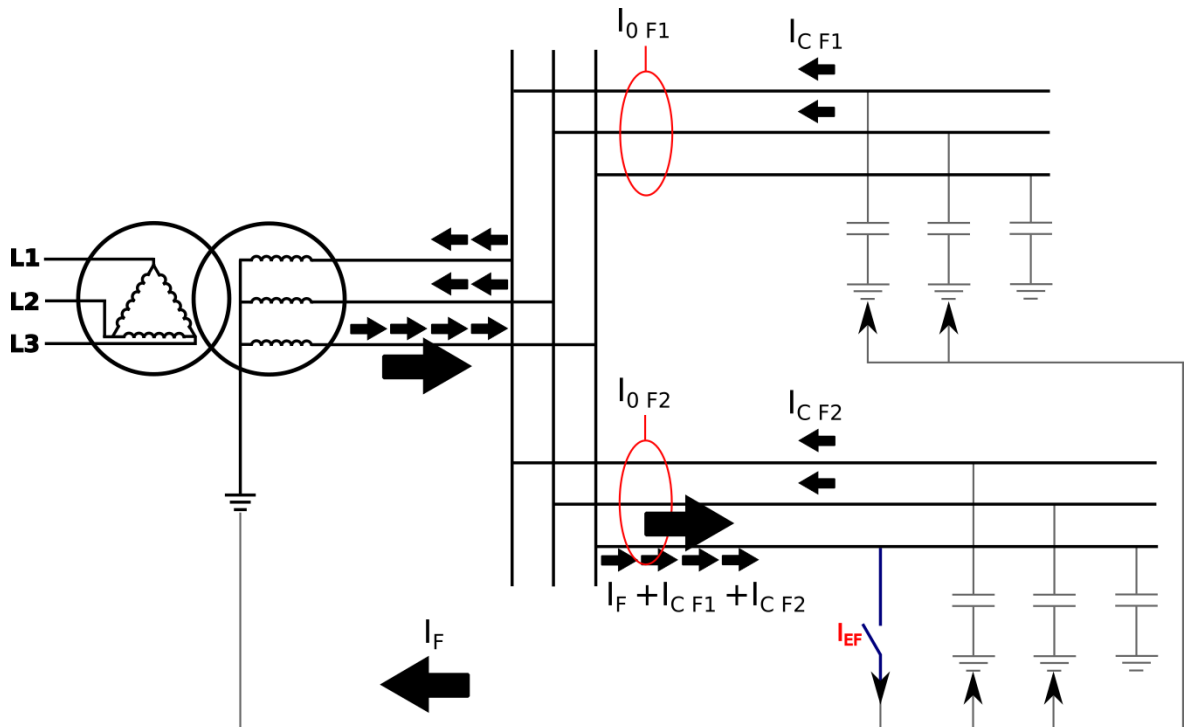

In a directly earthed network the amplitude of a single-phase fault current is similar to the amplitude of a short-circuit current. Directly earthed or small impedance network schemes are normal in transmission, distribution and industry.

The phase angle setting of the tripping area is adjustable as is the base direction of the area (angle offset).

Broad range mode with multi-criteria detection for unearthed and compensated networks

When detecting earth faults in compensated long-distance cables and overhead lines, it is in some cases difficult to distinguish between a healthy and a faulty feeder. Merely measuring the angle and the magnitude of residual voltage and currents is not always enough, as changes in symmetrical components of phase currents and voltages are also needed. Additionally, when protecting feeders from earth faults, two modes are used depending on the network status (unearthed or compensated). When changing between these two statuses the setting group must be changed, and especially with distributed compensation the change may be difficult or impossible to arrange. Finally, in a compensated network protection the relay with traditional algorithms may sporadically detect an earth fault in a long healthy feeder due to CT errors. For all these reasons, Arcteq has developed an improved alternative to these traditional directional earth fault protections.

Figure. 5.3.5 - 96. Angle tracking of the I_{0dir} function (broad range mode).

New broadrange mode

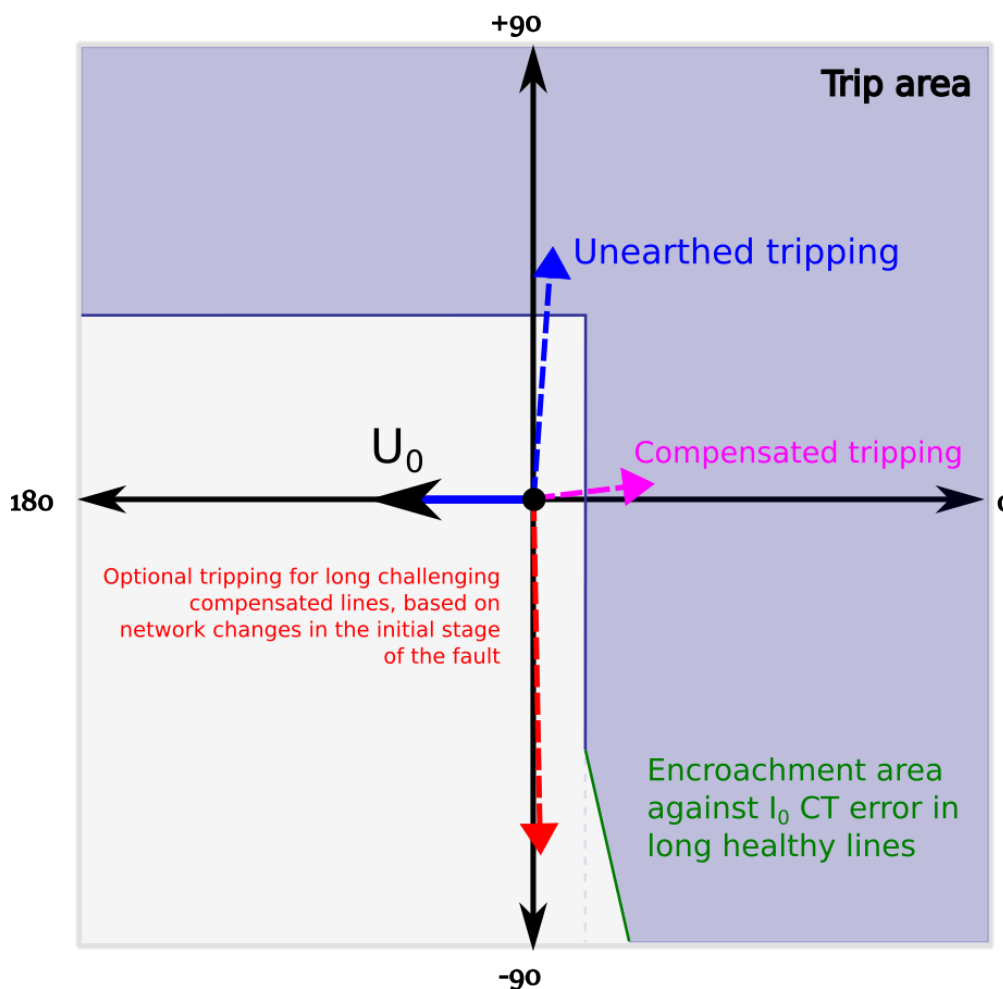

The new broad range mode is capable of detecting an earth fault directionally in both unearthed and compensated networks not only by combining the two stages together but by using a new multi-criteria detection. This optional additional tripping condition for compensated networks uses Arcteq's patented, high-resolution intermittent earth fault algorithm with added symmetrical component calculation of phase currents and voltages. If this mode is activated, the alarming criteria is comprised of a measured residual current in the fourth quadrant and the symmetrical components of voltages and currents detecting a fault. No extra parameterization is required compared to the traditional method. The multi-criteria algorithm can be tested with COMTRADE files supplied by Arcteq. The function requires a connection of three-phase currents, residual current and residual voltage to operate correctly.

To avoid unnecessary alarms the user can add an encroachment area against IO CT errors in compensated long healthy lines.

Figure. 5.3.5 - 97. Effect of angle divider when in use and when disabled.

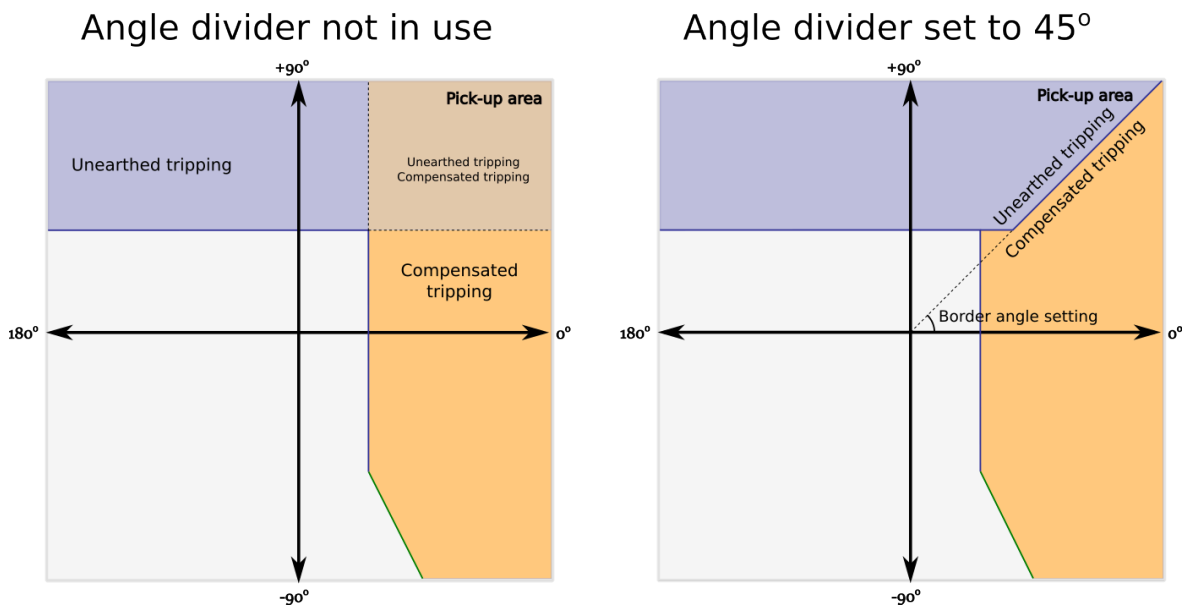

To receive a more accurate indication as to whether the fault was in a compensated or an unearthed network the angle divider can divide the area which would otherwise be overlapped between the two network models. By default the setting is 45 degrees. When the divider is disabled the angle is set to zero degrees.

Read-only parameters

The relay's *Info* page displays useful, real-time information on the state of the protection function. It is accessed either through the relay's HMI display, or through the setting tool software when it is connected to the relay and its Live Edit mode is active.

Table. 5.3.5 - 73. Information displayed by the function.

Name	Range	Step	Description
I0dir> condition	0: Normal 1: Start 2: Trip 3: Blocked	-	Displays the status of the protection function.
U0> Measuring now	0: No U0 avail! 1: U0Calc 2: U3 Input 3: U4 Input	-	Displays which voltage channel is used by the function. If no voltage channel has been selected the function defaults to calculated residual voltage if line-to-neutral voltages have been connected to device. If no channel is set to "U0" mode and line-to-line voltages are connected, no residual voltage is available and "No U0 avail!" will be displayed.

Name	Range	Step	Description
U0> Pick-up setting	0.0...1 000 000V	0.1V	The required residual voltage on the primary side for the relay to trip.
Detected U0/ I0 angle (fi)	-360.00...360.00deg	0.01deg	The angle in degrees between the monitored residual voltage and the current.
I0 Magnitude	0.000...250.000×I0n	0.001×I0n	The per-unit-value of the monitored residual current.
I0 Wattmetric I0xCos(fi)	-250.000...250.000×I0n	0.001×I0n	The wattmetric per-unit-value of the monitored residual current.
I0 Varmetric I0xSin(fi)	-250.000...250.000×I0n	0.001×I0n	The varmetric per-unit-value of the monitored residual current.
I0 direction now	0: Undefined 1: Forward 2: Reverse	-	The detected direction of the residual current.
I0 meas/ I0 set now	-250.000...250.000×I0n	0.001×I0n	The ratio between the monitored residual current and the pick-up value.
U0 measurement now	0.000...500.000%U0n	0.001%U0n	The measured voltage in the chosen voltage channel.
Expected operating time	0.000...1800.000s	0.005s	Displays the expected operating time when a fault occurs. When IDMT mode is used, the expected operating time depends on the measured current value. If the measured current changes during a fault, the expected operating time changes accordingly.
Time remaining to trip	-1800.000...1800.000s	0.005s	When the function has detected a fault and counts down time towards a trip, this displays how much time is left before tripping occurs.

Function blocking

The block signal is checked in the beginning of each program cycle. The blocking signal is received from the blocking matrix in the function's dedicated input. Additionally, the directional earth fault protection function includes an internal inrush harmonic blocking option which is applied according to the parameters set by the user. If the blocking signal is not activated when the pick-up element activates, a START signal is generated and the function proceeds to the time characteristics calculation.

Table. 5.3.5 - 74. Internal inrush harmonic blocking settings.

Name	Description	Range	Step	Default
Inrush harmonic blocking (internal-only trip)	Enables and disables the 2 nd harmonic blocking.	0: No 1: Yes	-	0: No
2 nd harmonic blocking limit (Iharm/ Ifund)	The 2 nd harmonic blocking limit.	0.10...50.00%Ifund	0.01%Ifund	0.01%Ifund

If the blocking signal is active when the pick-up element activates, a BLOCKED signal is generated and the function does not process the situation further. If the START function has been activated before the blocking signal, it resets and the release time characteristics are processed similarly to when the pick-up signal is reset.

The blocking of the function causes an HMI display event and a time-stamped blocking event with information of the startup current values and its fault type to be issued.

The blocking signal can also be tested in the commissioning phase by a software switch signal when the relay's testing mode "Enable stage forcing" is activated (*General* → *Device*).

The variables the user can set are binary signals from the system. The blocking signal needs to reach the device minimum of 5 ms before the set operating delay has passed in order for the blocking to activate in time.

Operating time characteristics for trip and reset

This function supports definite time delay (DT) and inverse definite minimum time delay (IDMT). For detailed information on these delay types please refer to the chapter "General properties of a protection function" and its section "Operating time characteristics for trip and reset".

Events and registers

The directional overcurrent function (abbreviated "DEF" in event block names) generates events and registers from the status changes in START, TRIP and BLOCKED. The user can select which event messages are stored in the main event buffer: ON, OFF, or both. The function offers four (4) independent stages; the events are segregated for each stage operation.

The events triggered by the function are recorded with a time stamp and with process data values.

Table. 5.3.5 - 75. Event codes.

Event number	Event channel	Event block name	Event code	Description
5184	81	DEF1	0	Start ON
5185	81	DEF1	1	Start OFF
5186	81	DEF1	2	Trip ON
5187	81	DEF1	3	Trip OFF
5188	81	DEF1	4	Block ON
5189	81	DEF1	5	Block OFF
5190	81	DEF1	6	I0Cosfi Start ON
5191	81	DEF1	7	I0Cosfi Start OFF
5192	81	DEF1	8	I0Sinfi Start ON
5193	81	DEF1	9	I0Sinfi Start OFF
5194	81	DEF1	10	I0Cosfi Trip ON
5195	81	DEF1	11	I0Cosfi Trip OFF
5196	81	DEF1	12	I0Sinfi Trip ON
5197	81	DEF1	13	I0Sinfi Trip OFF
5248	82	DEF2	0	Start ON
5249	82	DEF2	1	Start OFF
5250	82	DEF2	2	Trip ON
5251	82	DEF2	3	Trip OFF
5252	82	DEF2	4	Block ON
5253	82	DEF2	5	Block OFF
5254	82	DEF2	6	I0Cosfi Start ON
5255	82	DEF2	7	I0Cosfi Start OF
5256	82	DEF2	8	I0Sinfi Start ON
5257	82	DEF2	9	I0Sinfi Start OFF

Event number	Event channel	Event block name	Event code	Description
5258	82	DEF2	10	I0Cosfi Trip ON
5259	82	DEF2	11	I0Cosfi Trip OFF
5260	82	DEF2	12	I0Sinfi Trip ON
5261	82	DEF2	13	I0Sinfi Trip OFF
5312	83	DEF3	0	Start ON
5313	83	DEF3	1	Start OFF
5314	83	DEF3	2	Trip ON
5315	83	DEF3	3	Trip OFF
5316	83	DEF3	4	Block ON
5317	83	DEF3	5	Block OFF
5318	83	DEF3	6	I0Cosfi Start ON
5319	83	DEF3	7	I0Cosfi Start OFF
5320	83	DEF3	8	I0Sinfi Start ON
5321	83	DEF3	9	I0Sinfi Start OFF
5322	83	DEF3	10	I0Cosfi Trip ON
5323	83	DEF3	11	I0Cosfi Trip OFF
5324	83	DEF3	12	I0Sinfi Trip ON
5325	83	DEF3	13	I0Sinfi Trip OFF
5376	84	DEF4	0	Start ON
5377	84	DEF4	1	Start OFF
5378	84	DEF4	2	Trip ON
5379	84	DEF4	3	Trip OFF
5380	84	DEF4	4	Block ON
5381	84	DEF4	5	Block OFF
5382	84	DEF4	6	I0Cosfi Start ON
5383	84	DEF4	7	I0Cosfi Start OFF
5384	84	DEF4	8	I0Sinfi Start ON
5385	84	DEF4	9	I0Sinfi Start OFF
5386	84	DEF4	10	I0Cosfi Trip ON
5387	84	DEF4	11	I0Cosfi Trip OFF
5388	84	DEF4	12	I0Sinfi Trip ON
5389	84	DEF4	13	I0Sinfi Trip OFF

The function registers its operation into the last twelve (12) time-stamped registers; this information is available for all provided instances separately. The register of the function records the ON event process data for START, TRIP or BLOCKED. The table below presents the structure of the function's register content.

Table. 5.3.5 - 76. Register content.

Register	Description
Event code	dd.mm.yyyy hh:mm:ss.mss
Date and time	5184-5389 Descr.
I_0 pre-triggering current	Start average current
I_0 fault current	Trip -20ms averages
Fault capacity I_0	Trip -20ms averages
Fault resist I_0	Trip -20ms averages
Fault U_0 (%)	Trip -20ms averages
Fault U_0 (V)	Trip -20ms averages
I_0 fault angle	0...360°
Trip time remaining	0 ms...1800s
Used SG	Setting group 1...8 active
Network GND	Unearthed, Petersen coil earthed, Earthed network
I_0 pre-fault current	Start -200ms averages

5.3.6 Negative sequence overcurrent/ phase current reversal/ current unbalance protection (I_2 >; 46/46R/46L)

The current unbalance function is used for instant and time-delayed unbalanced network protection and for detecting broken conductors. The number of stages in the function depends on the relay model. The operating decisions are based on negative and positive sequence current magnitudes which the function constantly measures. In the broken conductor mode (I_2/I_1) the minimum allowed loading current is also monitored in the phase current magnitudes.

There are two possible operating modes available: the I_2 mode monitors the negative sequence current, while the I_2/I_1 mode monitors the ratio between the negative sequence current and the positive sequence current. The relay calculates the symmetrical component magnitudes in use from the phase current inputs I_{L1} , I_{L2} and I_{L3} . The zero sequence current is also recorded into the registers as well as the angles of the positive, negative and zero sequence currents in order to better verify any fault cases. The blocking signal and the setting group selection control the operating characteristics of the function during normal operation, i.e. the user or user-defined logic can change function parameters while the function is running.

The outputs of the function are the START, TRIP and BLOCKED signals. The current unbalance function uses a total of eight (8) separate setting groups which can be selected from one common source.

The function can operate on instant or time-delayed mode. In time-delayed mode the operation can be selected between definite time (DT) or inverse definite minimum time (IDMT). The IDMT operation supports both IEC and ANSI standard time delays as well as custom parameters.

The operational logic consists of the following:

- input magnitude selection
- input magnitude processing
- threshold comparator
- block signal check
- time delay characteristics
- output processing.

The inputs for the function are the following:

- operating mode selections
- setting parameters
- digital inputs and logic signals
- measured and pre-processed current magnitudes.

The function outputs START, TRIP and BLOCKED signals which can be used for direct I/O controlling and user logic programming. The function generates general time-stamped ON/OFF events to the common event buffer from each of the three (3) output signals. In instant operating mode the function outputs START and TRIP events simultaneously with an equivalent time stamp. The time stamp resolution is 1 ms. The function also provides a resettable cumulative counter for the START, TRIP and BLOCKED events.

The following figure presents a simplified function block diagram of the current unbalance function.

Figure. 5.3.6 - 98. Simplified function block diagram of the I2> function.

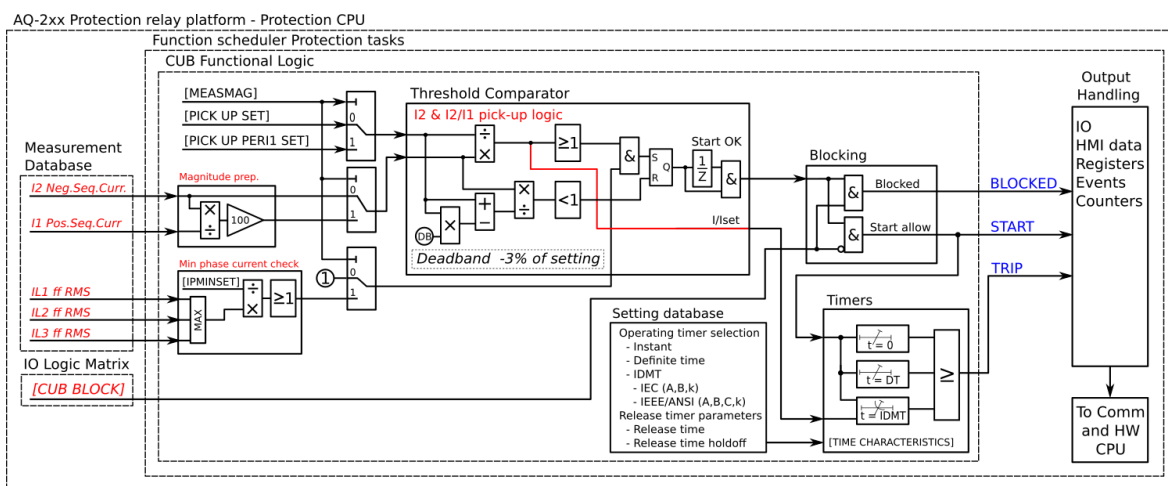

Measured input

The function block uses analog current measurement values and always uses calculated positive and negative sequence currents. In the broken conductor mode (I2/I1) the function also uses the RMS values of all phase currents to check the minimum current. Zero sequence and component sequence angles are used for fault registering and for fault analysis processing. A -20 ms averaged value of the selected magnitude is used for pre-fault data registering.

Table. 5.3.6 - 77. Measurement inputs of the I2> function.

Signal	Description	Time base
I1	Positive sequence current magnitude	5 ms
I2	Negative sequence current magnitude	5 ms
Iz	Zero sequence current magnitude	5 ms
I1 ANG	Positive sequence current angle	5 ms
I2 ANG	Negative sequence current angle	5 ms
Iz ANG	Zero sequence current angle	5 ms
IL1RMS	Phase L1 (A) measured RMS current	5 ms
IL2RMS	Phase L2 (B) measured RMS current	5 ms
IL3RMS	Phase L3 (C) measured RMS current	5 ms

General settings

The following general settings define the general behavior of the function. These settings are static i.e. it is not possible to change them by editing the setting group.

Name	Description	Range	Step	Default
Measured magnitude	Defines whether the ratio between the positive and the negative sequence currents are supervised or whether only the negative sequence is used in detecting unbalance.	1: I2pu 2: I2/I1	-	1: I2pu

Pick-up

The setting parameters I_{2set} and $I_{2/I1set}$ control the the pick-up of the I2> function. They define the maximum allowed measured negative sequence current or the negative/positive sequence current ratio before action from the function. The function constantly calculates the ratio between the I_{set} and the measured magnitude (I_m). The reset ratio of 97 % is built into the function and is always relative to the I_{xset} value. The reset ratio is the same for both modes.

Table. 5.3.6 - 78. Pick-up settings.

Name	Description	Range	Step	Default
I2set	Pick-up setting for I2 mode.	0.01...40.00×I _n	0.01×I _n	0.2×I _n
I2/I1set	Pick-up setting for I2/I1 mode	1...200%	0.01%	20%

The pick-up activation of the function is not directly equal to the START signal generation of the function. The START signal is allowed if the blocking condition is not active.

Read-only parameters

The relay's *Info* page displays useful, real-time information on the state of the protection function. It is accessed either through the relay's HMI display, or through the setting tool software when it is connected to the relay and its Live Edit mode is active.

Table. 5.3.6 - 79. Information displayed by the function.

Name	Range	Step	Description
I2> condition	0: Normal 1: Start 2: Trip 3: Blocked	-	Displays the status of the protection function.

Function blocking

The block signal is checked in the beginning of each program cycle. The blocking signal is received from the blocking matrix in the function's dedicated input. If the blocking signal is not activated when the pick-up element activates, a START signal is generated and the function proceeds to the time characteristics calculation.

If the blocking signal is active when the pick-up element activates, a BLOCKED signal is generated and the function does not process the situation further. If the START function has been activated before the blocking signal, it resets and processes the release time characteristics similarly to when the pick-up signal is reset.

The blocking of the function causes an HMI display event and a time-stamped blocking event with information of the startup current values and its fault type to be issued.

The blocking signal can also be tested in the commissioning phase by a software switch signal when the relay's testing mode "Enable stage forcing" is activated (*General* → *Device*).

The variables the user can set are binary signals from the system. The blocking signal needs to reach the device minimum of 5 ms before the set operating delay has passed in order for the blocking to activate in time.

Operating time characteristics for trip and reset

The operating timers' behavior during a function can be set for TRIP signal and also for the release of the function in case the pick-up element is reset before the trip time has been reached. There are three basic operating modes available for the function:

- Instant operation: gives the TRIP signal with no additional time delay simultaneously with the start signal.
- Definite time operation (DT): gives the TRIP signal after a user-defined time delay regardless of the measured current as long as the current is above or below the I_{set} value and thus the pick-up element is active (independent time characteristics).
- Inverse definite minimum time (IDMT): gives the TRIP signal after a time which is in relation to the set pick-up value I_{set} and the measured current I_m (dependent time characteristics).

Both IEC and IEEE/ANSI standard characteristics as well as user settable parameters are available for the IDMT operation.

Unique to the current unbalance protection is the availability of the "Curve2" delay which follows the formula below:

$$t = \frac{k}{I_{2meas}^2 - I_{set}^2}$$

- t = Operating time
- I_{2meas} = Calculated negative sequence
- k = Constant k value (user settable delay multiplier)
- I_{set} = Pick-up setting of the function

Figure. 5.3.6 - 99. Operation characteristics curve for I2> Curve2.

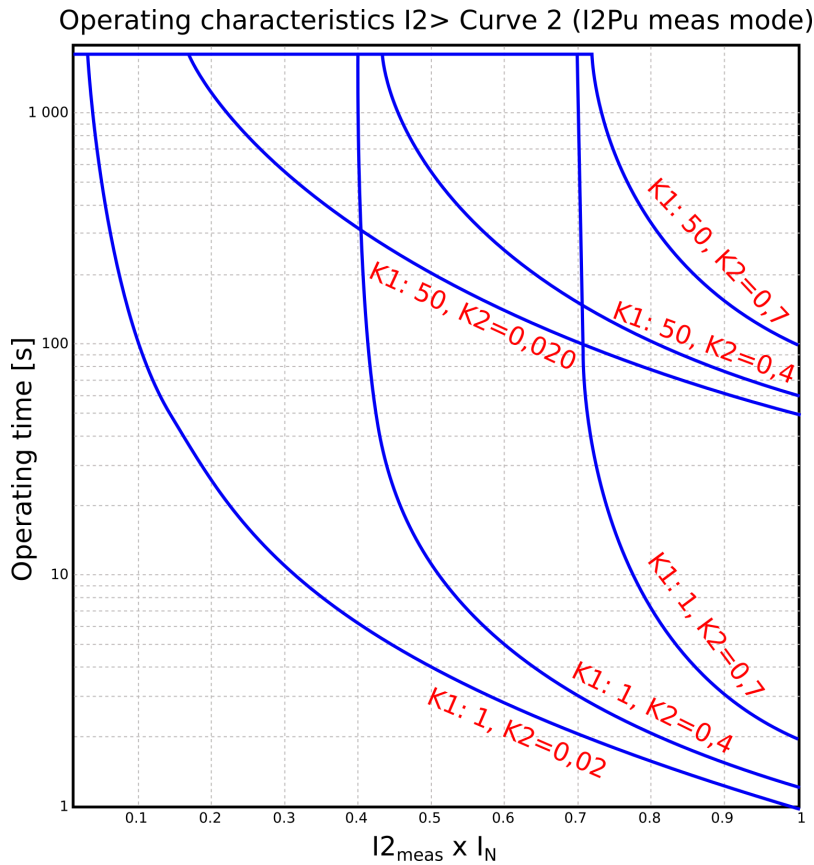

For a more detailed description on the time characteristics and their setting parameters, please refer to the "General properties of a protection function" chapter and its "Operating time characteristics for trip and reset" section.

The user can reset characteristics through the application. The default setting is a 60 ms delay; the time calculation is held during the release time.

In the release delay option the operating time counter calculates the operating time during the release. When using this option the function does not trip if the input signal is not re-activated while the release time count is on-going.

Events and registers

The current unbalance function (abbreviated "CUB" in event block names) generates events and registers from the status changes in START, TRIP, and BLOCKED. The user can select the status ON or OFF for messages in the main event buffer. The function offers four (4) independent stages; the events are segregated for each stage operation.

The triggering event of the function (START, TRIP or BLOCKED) is recorded with a time stamp and with process data values.

Table. 5.3.6 - 80. Event codes.

Event Number	Event channel	Event block name	Event Code	Description
2048	32	CUB1	0	Start ON
2049	32	CUB1	1	Start OFF
2050	32	CUB1	2	Trip ON

Event Number	Event channel	Event block name	Event Code	Description
2051	32	CUB1	3	Trip OFF
2052	32	CUB1	4	Block ON
2053	32	CUB1	5	Block OFF
2112	33	CUB2	0	Start ON
2113	33	CUB2	1	Start OFF
2114	33	CUB2	2	Trip ON
2115	33	CUB2	3	Trip OFF
2116	33	CUB2	4	Block ON
2117	33	CUB2	5	Block OFF
2176	34	CUB3	0	Start ON
2177	34	CUB3	1	Start OFF
2178	34	CUB3	2	Trip ON
2179	34	CUB3	3	Trip OFF
2180	34	CUB3	4	Block ON
2181	34	CUB3	5	Block OFF
2240	35	CUB4	0	Start ON
2241	35	CUB4	1	Start OFF
2242	35	CUB4	2	Trip ON
2243	35	CUB4	3	Trip OFF
2244	35	CUB4	4	Block ON
2245	35	CUB4	5	Block OFF

The function registers its operation into the last twelve (12) time-stamped registers. The register of the function records the ON event process data for START, TRIP or BLOCKED. The table below presents the structure of the function's register content.

Table. 5.3.6 - 81. Register content.

Date and time	Event code	Fault type	Trigger current	Fault current	Pre-fault current	Fault currents	Trip time remaining	Used SG
dd.mm.yyyy hh:mm:ss.mss	2048-2245 Descr.	Unbalance	Start average current	Trip -20ms averages	Start -200ms averages	I1, I2, IZ mag. and ang.	0 ms...1800s	Setting group 1...8 active

5.3.7 Harmonic overcurrent protection (Ih>; 50H/51H/68H)

The harmonic overcurrent function is used for non-directional instant and time-delayed overcurrent detection and clearing. The number of stages in the function depends on the relay model. The function constantly measures the selected harmonic component of the selected measurement channels, the value being either absolute value or relative to the RMS value. The blocking signal and the setting group selection control the operating characteristics of the function during normal operation, i.e. the user or user-defined logic can change function parameters while the function is running.

The outputs of the function are the START, TRIP and BLOCKED signals. The non-directional harmonic overcurrent function uses a total of eight (8) separate setting groups which can be selected from one common source.

The function can operate on instant or time-delayed mode. Either START or TRIP signal can be used when the instant mode is selected to block other protection stages. In time-delayed mode the operation can be selected between definite time (DT) mode and inverse definite minimum time (IDMT) mode. The START signal can be used to block other stages; if the situation lasts longer, the TRIP signal can be used on other actions as time-delayed. The IDMT operation supports both IEC and ANSI standard time delays as well as custom parameters.

The operational logic consists of the following:

- input magnitude selection
- input magnitude processing
- saturation check
- threshold comparator
- block signal check
- time delay characteristics
- output processing.

The basic design of the protection function is the three-pole operation.

The inputs of the function are the following:

- operating mode selections
- setting parameters
- digital inputs and logic signals
- measured and pre-processed current magnitudes.

The function outputs the START, TRIP and BLOCKED signals which can be used for direct I/O controlling and user logic programming. The function generates general time-stamped ON/OFF events to the common event buffer from each of the three (3) output signals. In the instant operating mode the function outputs START and TRIP events simultaneously with an equivalent time stamp. The time stamp resolution is 1 ms. The function also provides a resettable cumulative counter for the START, TRIP and BLOCKED events.

The following figure presents a simplified function block diagram of the non-directional harmonic overcurrent function.

Figure. 5.3.7 - 100. Simplified function block diagram of the I_h> function.

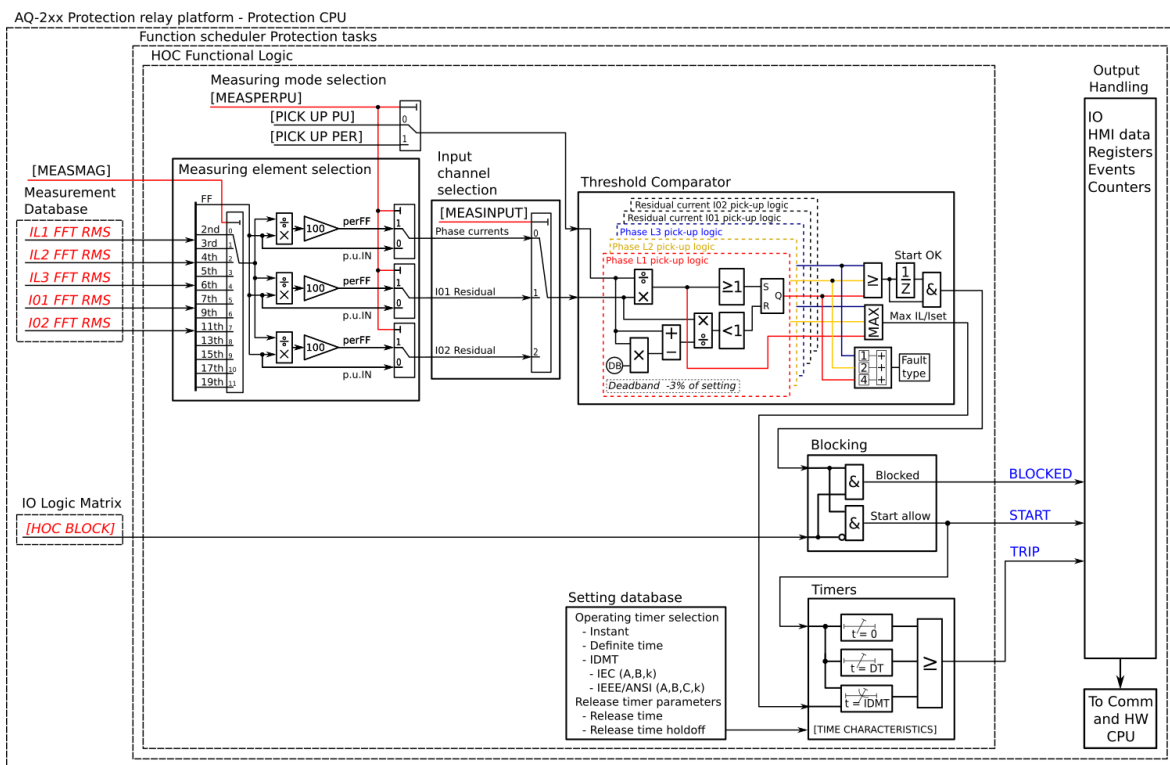

Measured input

The function block uses analog current measurement values from phase or residual currents. Each measurement input of the function block uses RMS values and harmonic components of the selected current input. The user can select the monitored magnitude to be equal to the per-unit RMS values of the harmonic component, or to the harmonic component percentage content compared to the RMS values. A -20 ms averaged value of the selected magnitude is used for pre-fault data registering.

Table. 5.3.7 - 82. Measurement inputs of the I_h> function.

Signal	Description	Time base
IL1FFT	<p>The magnitudes (RMS) of phase L1 (A) current components:</p> <ul style="list-style-type: none"> - Fundamental - 2nd harmonic - 3rd harmonic - 4th harmonic - 5th harmonic - 6th harmonic - 7th harmonic - 9th harmonic - 11th harmonic - 13th harmonic - 15th harmonic - 17th harmonic - 19th harmonic. 	5 ms

Signal	Description	Time base
IL2FFT	<p>The magnitudes (RMS) of phase L2 (B) current components:</p> <ul style="list-style-type: none"> - Fundamental - 2nd harmonic - 3rd harmonic - 4th harmonic - 5th harmonic - 6th harmonic - 7th harmonic - 9th harmonic - 11th harmonic - 13th harmonic - 15th harmonic - 17th harmonic - 19th harmonic. 	5 ms
IL3FFT	<p>The magnitudes (RMS) of phase L3 (C) current components:</p> <ul style="list-style-type: none"> - Fundamental - 2nd harmonic - 3rd harmonic - 4th harmonic - 5th harmonic - 6th harmonic - 7th harmonic - 9th harmonic - 11th harmonic - 13th harmonic - 15th harmonic - 17th harmonic - 19th harmonic. 	5 ms
I01FFT	<p>The magnitudes (RMS) of residual I01 current components:</p> <ul style="list-style-type: none"> - Fundamental - 2nd harmonic - 3rd harmonic - 4th harmonic - 5th harmonic - 6th harmonic - 7th harmonic - 9th harmonic - 11th harmonic - 13th harmonic - 15th harmonic - 17th harmonic - 19th harmonic. 	5 ms

Signal	Description	Time base
I02FFT	<p>The magnitudes (RMS) of residual I02 current components:</p> <ul style="list-style-type: none"> - Fundamental - 2nd harmonic - 3rd harmonic - 4th harmonic - 5th harmonic - 6th harmonic - 7th harmonic - 9th harmonic - 11th harmonic - 13th harmonic - 15th harmonic - 17th harmonic - 19th harmonic. 	5 ms

The selection of the used AI channel, the monitored harmonic, and the monitoring type (per unit or percentage of fundamental frequency) are made with setting parameters. In all possible input channel variations the pre-fault condition is presented with a 20 ms averaged history value from -20 ms from START or TRIP event.

General settings

The function can be set to monitor the ratio between the measured harmonic and either the measured fundamental component or the per unit value of the harmonic current. The user must select the correct measurement input.

Table. 5.3.7 - 83. Operating mode selection settings.

Name	Range	Step	Default	Description
Harmonic selection	2 nd harmonic 3 rd harmonic 4 th harmonic 5 th harmonic 6 th harmonic 7 th harmonic 9 th harmonic 11 th harmonic 13 th harmonic 15 th harmonic 17 th harmonic 19 th harmonic	-	2 nd harmonic	Selection of the monitored harmonic component.
Per unit or relative	$\times I_n$ I_h/I_L	-	$\times I_n$	Selection of the monitored harmonic mode. Either directly per unit $\times I_n$ or in relation to the fundamental frequency magnitude.

Name	Range	Step	Default	Description
Measurement input	IL1/IL2/ IL3 I01 I02	-	IL1/IL2/ IL3	Selection of the measurement input (either phase current or residual current).

Each function stage provides these same settings. Multiple stages of the function can be set to operate independently of each other.

Pick-up

The setting parameter I_{hset} per unit or I_h/IL (depending on the selected operating mode) controls the pick-up of the $I_h >$ function. This defines the maximum allowed measured current before action from the function. The function constantly calculates the ratio between the I_{hset} per unit or I_h/IL and the measured magnitude (I_m) for each of the three phases. The reset ratio of 97 % is built into the function and is always relative to the I_{hset} per unit or I_h/IL value. The setting value is common for all measured phases, and when the I_m exceeds the I_{set} value (in single, dual or all phases) it triggers the pick-up operation of the function.

Table. 5.3.7 - 84. Pick-up settings.

Name	Range	Step	Default	Description
I_{hset} pu	0.05...2.00× I_n	0.01× I_n	0.20× I_n	Pick-up setting (per unit monitoring)
I_h/IL	5.00...200.00%	0.01%	20.00%	Pick-up setting (percentage monitoring)

The pick-up activation of the function is not directly equal to the START signal generation of the function. The START signal is allowed if the blocking condition is not active.

Read-only parameters

The relay's *Info* page displays useful, real-time information on the state of the protection function. It is accessed either through the relay's HMI display, or through the setting tool software when it is connected to the relay and its Live Edit mode is active.

Table. 5.3.7 - 85. Information displayed by the function.

Name	Range	Step	Description
$I_h >$ condition	0: Normal 1: Start 2: Trip 3: Blocked	-	Displays the status of the protection function.
I_h meas/ I_h set now	0.00...100000.00 I_m/I_{set}	0.01 I_m/I_{set}	The ratio between the monitored residual current and the pick-up value.
Expected operating time	0.000...1800.000s	0.005s	Displays the expected operating time when a fault occurs. When IDMT mode is used, the expected operating time depends on the measured voltage value. If the measured voltage changes during a fault, the expected operating time changes accordingly.
Time remaining to trip	-1800.000...1800.000s	0.005s	When the function has detected a fault and counts down time towards a trip, this displays how much time is left before tripping occurs.

Function blocking

The block signal is checked in the beginning of each program cycle. The blocking signal is received from the blocking matrix in the function's dedicated input. If the blocking signal is not activated when the pick-up element activates, a START signal is generated and the function proceeds to the time characteristics calculation.

If the blocking signal is active when the pick-up element activates, a BLOCKED signal is generated and the function does not process the situation further. If the START function has been activated before the blocking signal, it resets and the release time characteristics are processed similarly to when the pick-up signal is reset.

The blocking of the function causes an HMI display event and a time-stamped blocking event with information of the startup current values and its fault type to be issued.

The blocking signal can also be tested in the commissioning phase by a software switch signal when the relay's testing mode "Enable stage forcing" is activated (*General* → *Device*).

The variables the user can set are binary signals from the system. The blocking signal needs to reach the device minimum of 5 ms before the set operating delay has passed in order for the blocking to activate in time.

Operating time characteristics for trip and reset

This function supports definite time delay (DT) and inverse definite minimum time delay (IDMT). For detailed information on these delay types please refer to the chapter "General properties of a protection function" and its section "Operating time characteristics for trip and reset".

Events and registers

The harmonic overcurrent function (abbreviated "HOC" in event block names) generates events and registers from the status changes in START, TRIP and BLOCKED. The user can select which event messages are stored in the main event buffer: ON, OFF, or both. The function offers four (4) independent stages; the events are segregated for each stage operation.

The events triggered by the function are recorded with a time stamp and with process data values.

Table. 5.3.7 - 86. Event codes.

Event number	Event channel	Event block name	Event code	Description
2368	37	HOC1	0	Start ON
2369	37	HOC1	1	Start OFF
2370	37	HOC1	2	Trip ON
2371	37	HOC1	3	Trip OFF
2372	37	HOC1	4	Block ON
2373	37	HOC1	5	Block OFF
2432	38	HOC2	0	Start ON
2433	38	HOC2	1	Start OFF
2434	38	HOC2	2	Trip ON
2435	38	HOC2	3	Trip OFF
2436	38	HOC2	4	Block ON
2437	38	HOC2	5	Block OFF

Event number	Event channel	Event block name	Event code	Description
2496	39	HOC3	0	Start ON
2497	39	HOC3	1	Start OFF
2498	39	HOC3	2	Trip ON
2499	39	HOC3	3	Trip OFF
2500	39	HOC3	4	Block ON
2501	39	HOC3	5	Block OFF
2560	40	HOC4	0	Start ON
2561	40	HOC4	1	Start OFF
2562	40	HOC4	2	Trip ON
2563	40	HOC4	3	Trip OFF
2564	40	HOC4	4	Block ON
2565	40	HOC4	5	Block OFF

The function registers its operation into the last twelve (12) time-stamped registers. The register of the function records the ON event process data for START, TRIP or BLOCKED. The table below presents the structure of the function's register content.

Table. 5.3.7 - 87. Register content.

Date and time	Event code	Fault type	Trigger current	Fault current	Pre-fault current	Trip time remaining	Used SG
dd.mm.yyyy hh:mm:ss.mss	2368-2565 Descr.	L1-G...L1-L2-L3	Start average current	Trip -20ms averages	Start -200ms averages	0 ms...1800s	Setting group 1...8 active

5.3.8 Circuit breaker failure protection (CBFP; 50BF/52BF)

The circuit breaker failure protection function is used for monitoring the circuit breaker operation after it has received a TRIP signal. The function can also be used to retrip a failing breaker; if the retrip fails, an incomer breaker can be tripped by using the function's CBFP output. The retrip functionality can be disabled if the breaker does not have two trip coils.

The function can be triggered by the following:

- overcurrent (phase and residual)
- digital output monitor
- digital signal
- any combination of the above-mentioned triggers.

In the current-dependent mode the function constantly measures phase current magnitudes and the selected residual current. In the signal-dependent mode any of the device's binary signals (trips, starts, logical signals etc.) can be used to trigger the function. In the digital output-dependent mode the function monitors the status of the selected output relay control signal. The blocking signal and the setting group selection control the operating characteristics of the function during normal operation, i.e. the user or user-defined logic can change function parameters while the function is running.

The outputs of the function are CBFP START, RETRIP, CBFP ACT and BLOCKED signals. The circuit breaker failure protection function uses a total of eight (8) separate setting groups which can be selected from one common source. Additionally, the function's operating mode can be changed via setting group selection.

The operational logic consists of the following:

- input magnitude processing
- input magnitude selection
- threshold comparator
- block signal check
- time delay characteristics
- output processing.

The inputs of the function are the following:

- operating mode selections
- setting parameters
- digital input signals
- measured and pre-processed current magnitudes.

The function' output signals can be used for direct I/O controlling and user logic programming. The function generates general time-stamped ON/OFF events to the common event buffer from each of the two (2) output signals. The time stamp resolution is 1 ms. The function also provides a resettable cumulative counters for RETRIP, CBFP, CBFP START and BLOCKED events.

The following figure presents a simplified function block diagram of the circuit breaker failure protection function.

Figure. 5.3.8 - 101. Simplified function block diagram of the CBFP function.

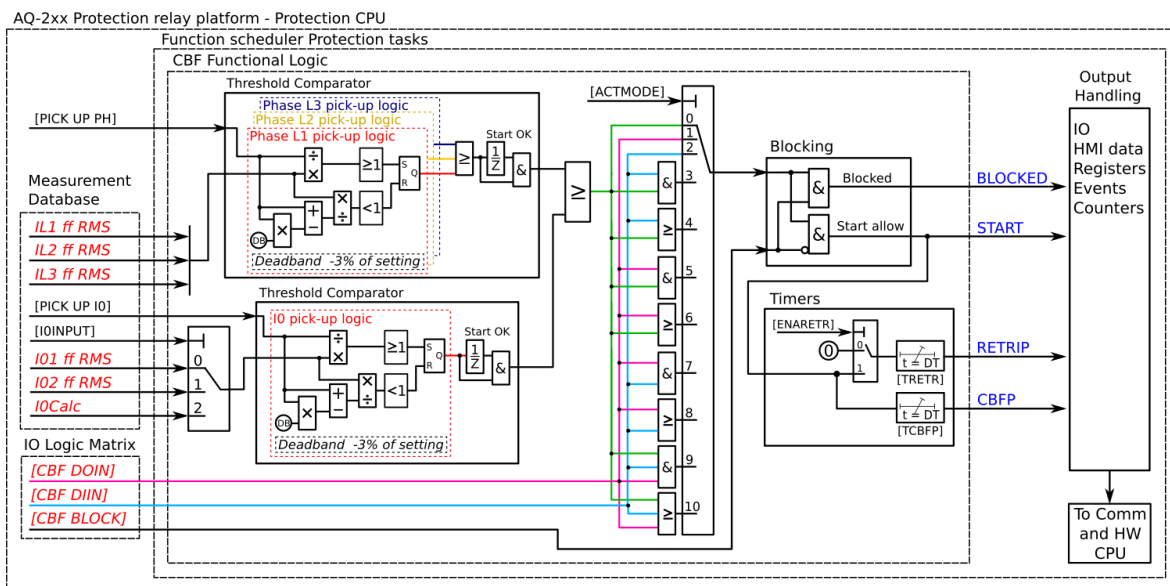

Measured input

The function block uses analog current measurement values. It always uses the RMS magnitude of the current measurement input. The user can select IO1, IO2 or the calculated IO for the residual current measurement. A -20 ms averaged value of the selected magnitude is used for pre-fault data registering.

Table. 5.3.8 - 88. Measurement inputs of the CBFP function.

Signal	Description	Time base
IL1RMS	RMS measurement of phase L1 (A) current	5ms
IL2RMS	RMS measurement of phase L2 (B) current	5ms

Signal	Description	Time base
IL3RMS	RMS measurement of phase L3 (C) current	5ms
I01RMS	RMS measurement of residual input I01	5ms
I02RMS	RMS measurement of residual input I02	5ms
I0Calc	Calculated residual current from the phase current inputs	5ms
DOIN	Monitors digital output relay status	5ms
DIIN	Monitors digital input status	5ms

The selection of the used AI channel is made with a setting parameter. In all possible input channel variations the pre-fault condition is presented with a 20 ms averaged history value from -20 ms from START or TRIP event.

General settings

The following general settings define the general behavior of the function. These settings are static i.e. it is not possible to change them by editing the setting group.

Table. 5.3.8 - 89. CBFP monitoring signal definitions.

Name	Description
Signal in monitor	Defines which TRIP events of the used protection functions trigger the CBFP countdown. For the CBFP function to monitor the signals selected here, the "Operation mode selection" parameter must be set to a mode that includes signals (e.g. "Signals only", "Signals or DO", "Current and signals and DO").
Trip monitor	Defines which output relay of the used protection functions trigger the CBFP countdown. For the CBFP function to monitor the output relays selected here, the "Operation mode selection" parameter must be set to a mode that includes digital outputs (e.g. "DO only", "Current and DO", "Current or signals or DO").

Pick-up

The setting parameters I_{set} and I_{0set} control the pick-up and the activation of the current-dependent CBFP function. They define the minimum allowed measured current before action from the function. The function constantly calculates the ratio between the I_{set} or the I_{0set} and the measured magnitude (I_m) for each of the three phases and the selected residual current input. The reset ratio of 97 % is built into the function and is always relative to the I_{set} value. The setting value is common for all measured phases. When the I_m exceeds the I_{set} value (in single, dual or all phases) it triggers the pick-up operation of the function.

Table. 5.3.8 - 90. Operating mode and input signals selection.

Name	Range	Step	Default	Description
I0Input	0: Not in use 1: I01 2: I02 3: I0Calc	-	0: Not in use	Selects the residual current monitoring source, which can be either from the two separate residual measurements (I01 and I02) or from the phase current's calculated residual current.

Name	Range	Step	Default	Description
Actmode	0: Current only 1: DO only 2: Signals only 3: Current and DO 4: Current or DO 5: Current and signals 6: Current or signals 7: Signals and DO 8: Signals or DO 9: Current or DO or signals 10: Current and DO and Signals	-	0: Current only	Selects the operating mode. The mode can be dependent on current measurement, binary signal status, output relay status ("DO"), or a combination of the three.

Table. 5.3.8 - 91. Pick-up settings.

Name	Range	Step	Default	Description
I_{set}	$0.01 \dots 40.00 \times I_n$	$0.01 \times I_n$	$0.20 \times I_n$	The pick-up threshold for the phase current measurement. This setting limit defines the upper limit for the phase current pick-up element.
I_{0set}	$0.005 \dots 40.000 \times I_n$	$0.001 \times I_n$	$1.200 \times I_n$	The pick-up threshold for the residual current measurement. This setting limit defines the upper limit for the phase current pick-up element.

The pick-up activation of the function is not directly equal to the START signal generation of the function. The START signal is allowed if the blocking condition is not active. There is no delay between the activation of the monitored signal and the activation of the pick-up when using binary signals.

Function blocking

The block signal is checked in the beginning of each program cycle. The blocking signal is received from the blocking matrix in the function's dedicated input. If the blocking signal is not activated when the pick-up element activates, a START signal is generated and the function proceeds to the time characteristics calculation.

If the blocking signal is active when the pick-up element activates, a BLOCKED signal is generated and the function does not process the situation further. If the START function has been activated before the blocking signal, it resets and processes the release time characteristics similarly to when the pick-up signal is reset.

The blocking of the function causes an HMI display event and a time-stamped blocking event with information of the startup current values and its fault type to be issued.

The blocking signal can also be tested in the commissioning phase by a software switch signal when the relay's testing mode "Enable stage forcing" is activated (*General* → *Device*).

The variables the user can set are binary signals from the system. The blocking signal needs to reach the device minimum of 5 ms before the set operating delay has passed in order for the blocking to activate in time.

Operating time characteristics

The operating timers' behavior during a function can be set depending on the application. The same pick-up signal starts both timers. When retrip is used the time grading should be set as follows: the sum of specific times (i.e. the retrip time, the expected operating time, and the pick-up conditions' release time) is shorter the set CBFP time. This way, when retripping another breaker coil clears the fault, any unnecessary function triggers are avoided.

The following table presents the setting parameters for the function's operating time characteristics.

Table. 5.3.8 - 92. Setting parameters for operating time characteristics.

Name	Range	Step	Default	Description
Retrip	0: No 1: Yes	-	1: Yes	Retrip enabled or disabled. When the retrip is disabled, the output will not be visible and the TRetr setting parameter will not be available.
Retrip time delay	0.000...1800.000s	0.005s	0.100s	Retrip start the timer. This setting defines how long the starting condition has to last before a RETRIP signal is activated.
CBFP	0.000...1800.000s	0.005s	0.200s	CBFP starts the timer. This setting defines how long the starting condition has to last before the CBFP signal is activated.

The following figures present some typical cases of the CBFP function.

Trip, Retrip and CBFP in the device configuration

Figure. 5.3.8 - 102. Wiring diagram when Trip, Retrip and CBFP are configured to the device.

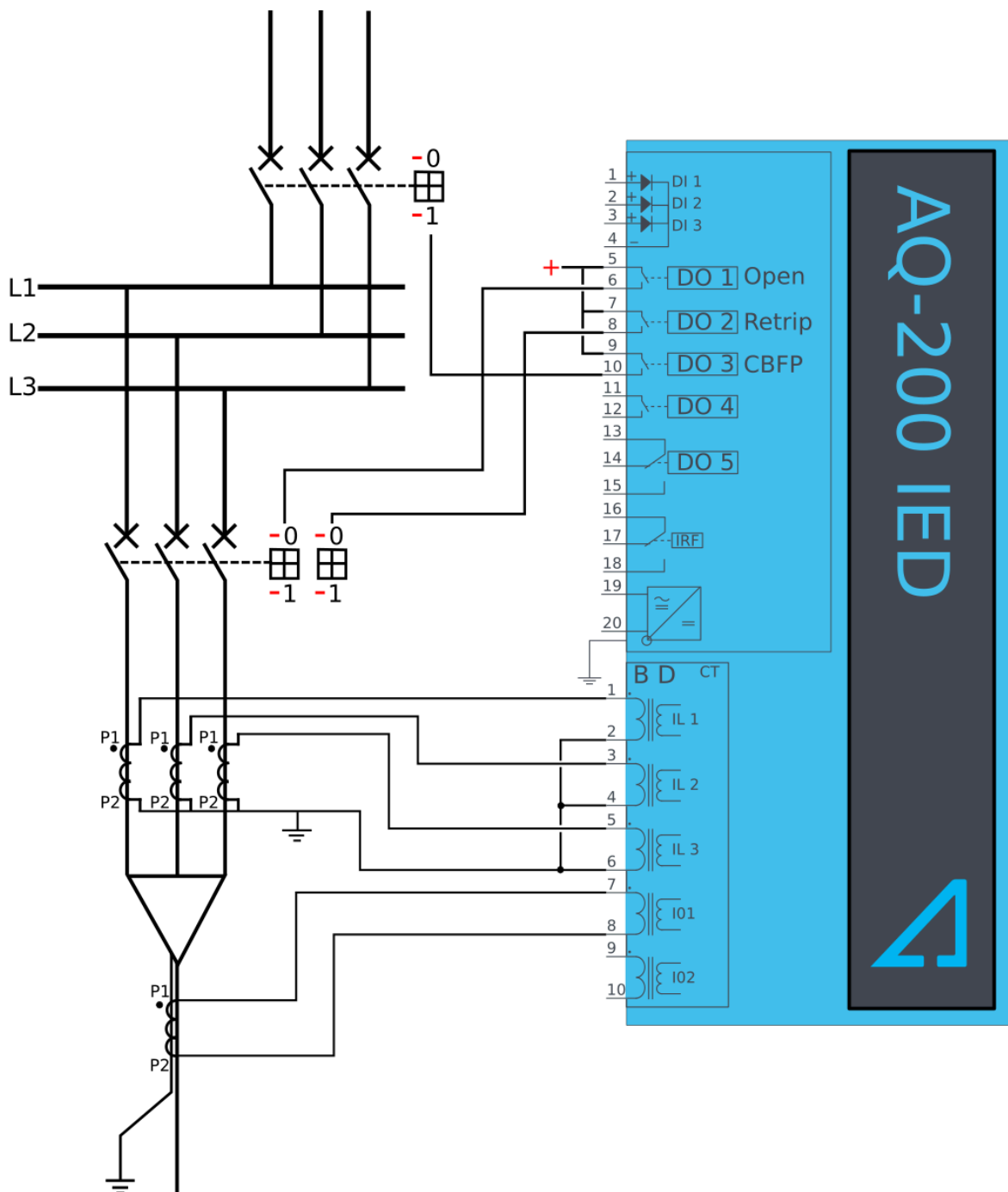

The retrip functionality can be used in applications whose circuit breaker has a retrip or a redundant trip coil available. The TRIP signal is normally wired to the breaker's trip coil from the device's trip output. The retrip is wired from its own device output contact in parallel with the circuit breaker's redundant trip coil. The CBFP signal is normally wired from its device output contact to the incomer breaker. Below are a few operational cases regarding the various applications.

Figure. 5.3.8 - 103. Retrip and CBFP when "Current" is the selected criterion.

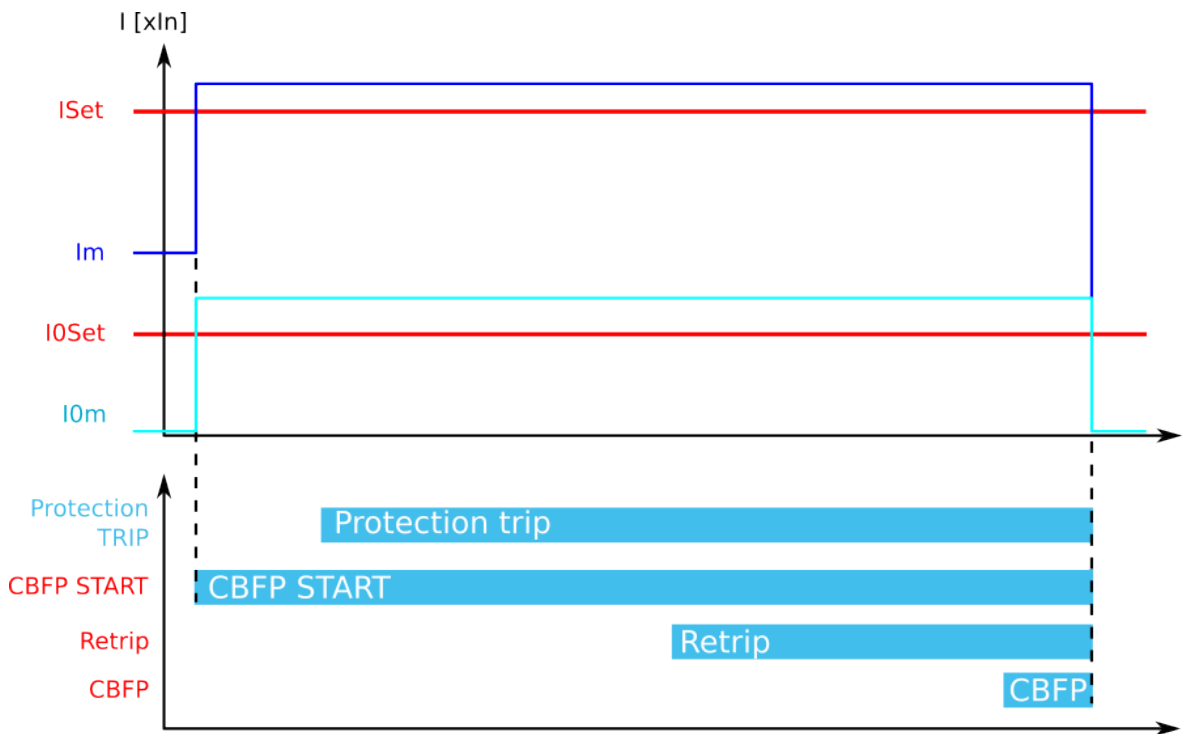

When the current threshold setting of I_{Set} and/or I_{OSet} is exceeded, the current-based protection is activated and the counters for RETRIP and CBFP start calculating the set operating time. The tripping of the primary protection stage is not monitored in this configuration. Therefore, if the current is not reduced below the setting limit, a RETRIP signal is sent to the redundant trip coil. If the current is not reduced within the set time limit, the function also sends a CBFP signal to the incomer breaker. If the primary protection function clears the fault, both counters (RETRIP and CBFP) are reset as soon as the measured current is below the threshold settings.

Figure. 5.3.8 - 104. Retrip and CBFP when "Current and DO" is the selected criterion.

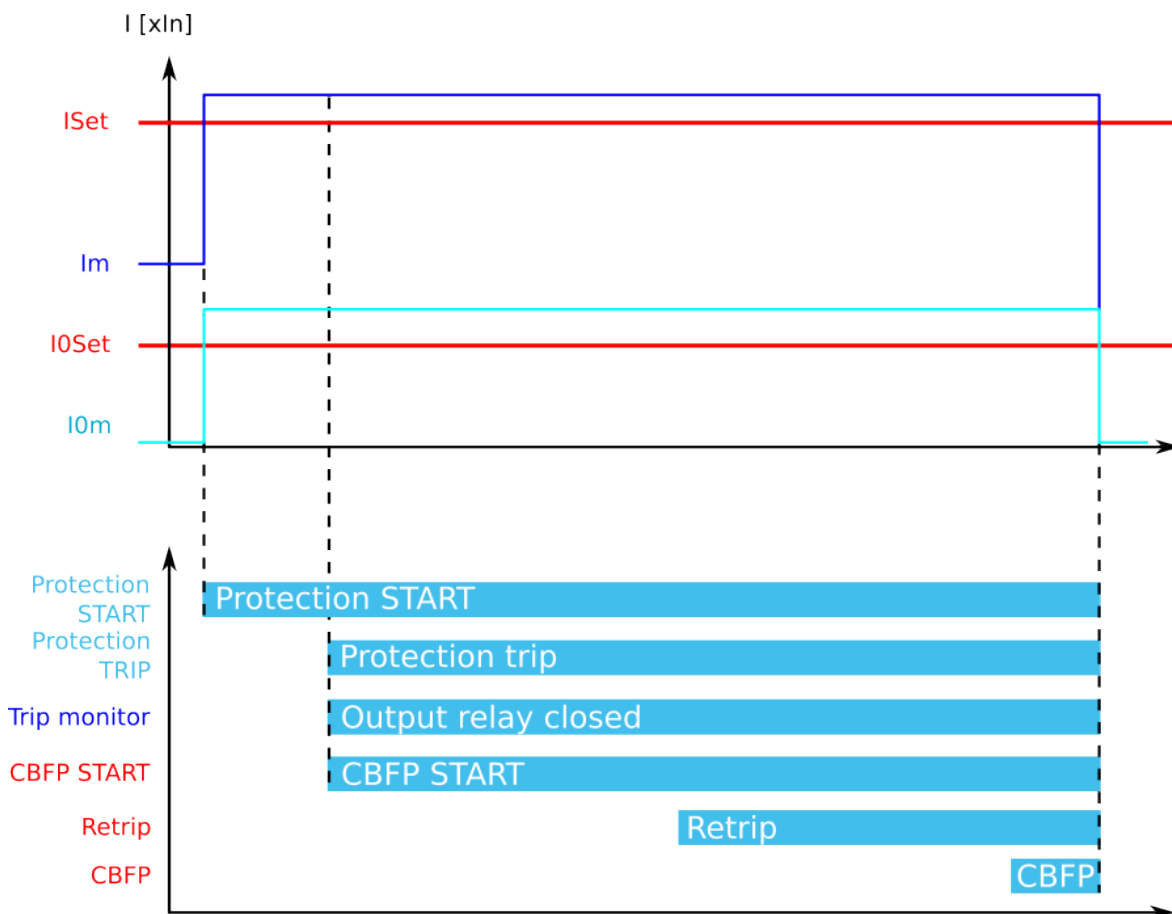

When the current threshold setting of I_{set} and/or I_{Oset} is exceeded, the current-based protection is activated. At the same time, the counters for RETRIP and CBFP are halted until the monitored output contact is controlled (that is, until the primary protection operates). When the tripping signal reaches the primary protection stage, the RETRIP and CBFP counters start calculating the set operating time. The tripping of the primary protection stage is constantly monitored in this configuration. If the current is not reduced below the setting limit or the primary stage tripping signal is not reset, a RETRIP signal is sent to the redundant trip coil. If the retripping fails and the current is not reduced below the setting limit or the primary stage tripping signal is not reset, the function also sends a CBFP signal to the incomer breaker. If the primary protection function clears the fault, both counters (RETRIP and CBFP) are reset as soon as the measured current is below the threshold settings or the tripping signal is reset. This configuration allows the CBFP to be controlled with current-based functions alone, and other function trips can be excluded from the CBFP functionality.

Figure. 5.3.8 - 105. Retrip and CBFP when "Current or DO" is the selected criterion.

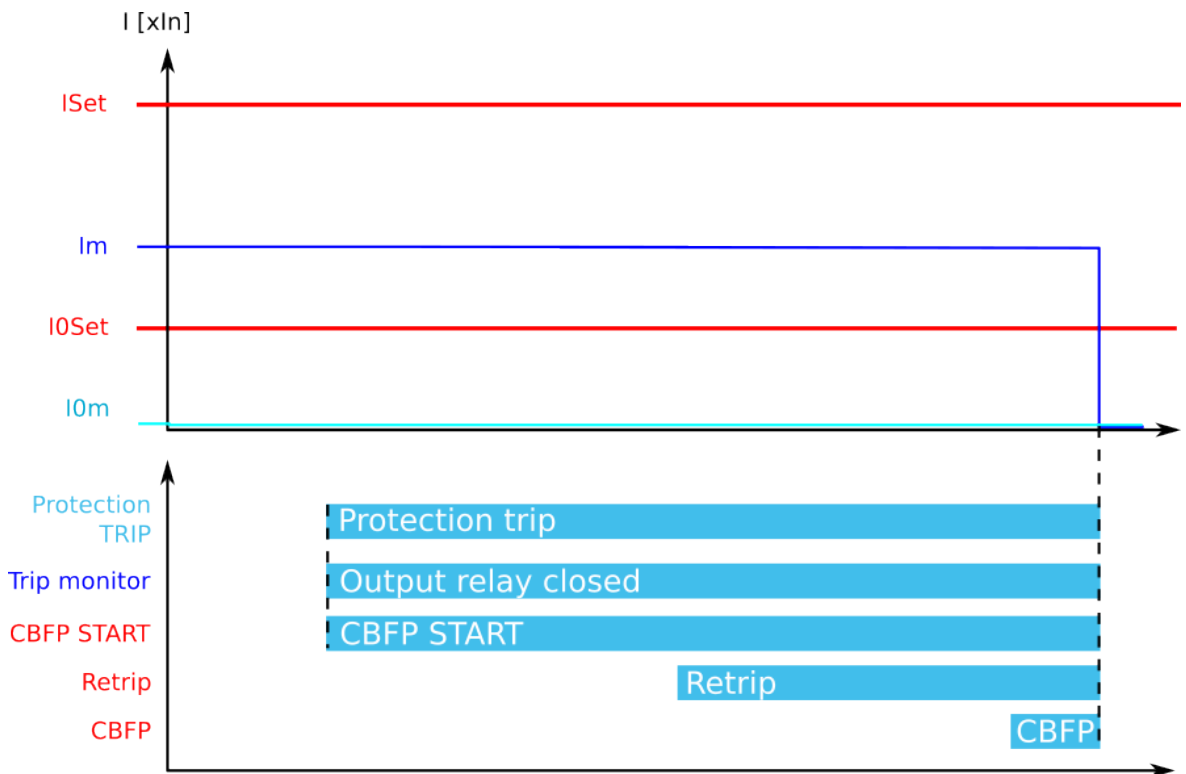

When the current threshold setting of I_{set} and/or I_{Oset} is exceeded, or the TRIP signal reaches the primary protection stage, the function starts counting down towards the RETRIP and CBFP signals. The tripping of the primary protection stage is constantly monitored in this configuration regardless of the current's status. The pick-up of the CBFP is active unless the current is reduced below the setting limit and the primary stage tripping signal is reset. If either of these conditions is met (i.e. the current is above the limit or the signal is active) for the duration of the set RETRIP time delay, a RETRIP signal is sent to the redundant trip coil. If either of the conditions is active for the duration of the set CBFP time delay, a CBFP signal is sent to the incomer breaker. If the primary protection function clears the fault, both counters (RETRIP and CBFP) are reset as soon as the measured current is below the threshold settings and the tripping signal is reset. This configuration allows the CBFP to be controlled with current-based functions alone, with added security from current monitoring. Other function trips can also be included in the CBFP functionality.

Trip and CBFP in the device configuration

Figure. 5.3.8 - 106. Wiring diagram when Trip and CBFP are configured to the device.

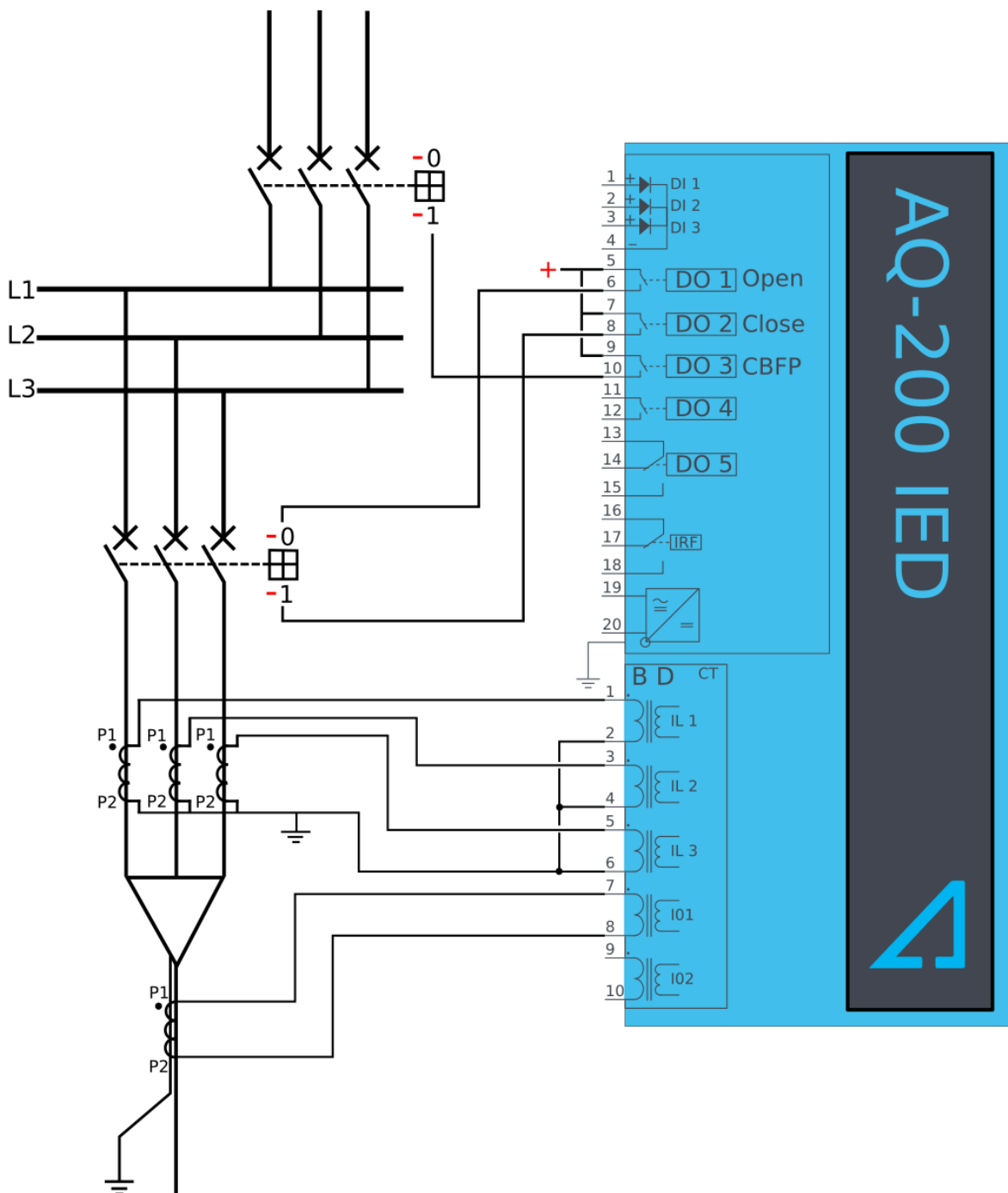

Probably the most common application is when the device's trip output controls the circuit breaker trip coil, while one dedicated CBFP contact controls the CBFP function. Below are a few operational cases regarding the various applications and settings of the CBFP function.

Figure. 5.3.8 - 107. CBFP when "Current" is the selected criterion.

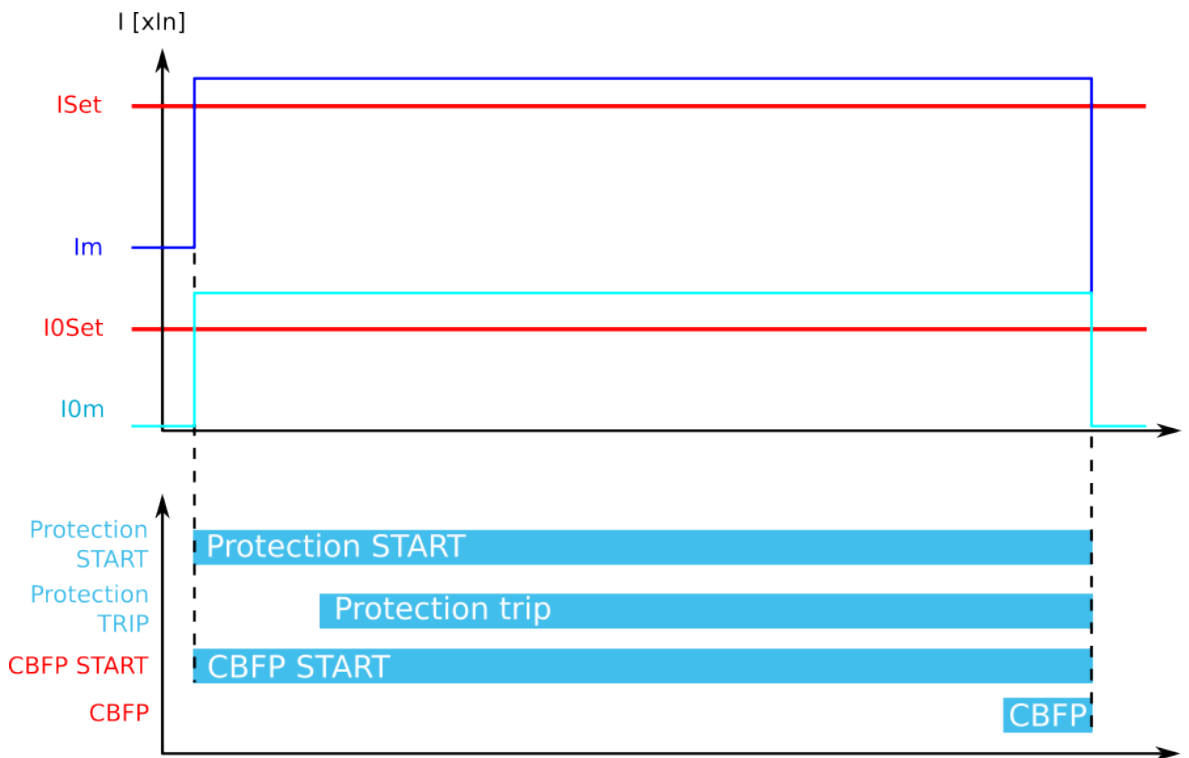

When the current threshold setting of I_{set} and/or I_{Oset} is exceeded, the current-based protection is activated and the counter for CBFP starts calculating the set operating time. The tripping of the primary protection stage is not monitored in this configuration. Therefore, if the current is not reduced below the setting limit, a CBFP signal is sent to the incomer breaker. If the primary protection function clears the fault, the counter for CBFP resets as soon as the measured current is below the threshold settings.

Figure. 5.3.8 - 108. CBFP when "Current and DO" is the selected criterion.

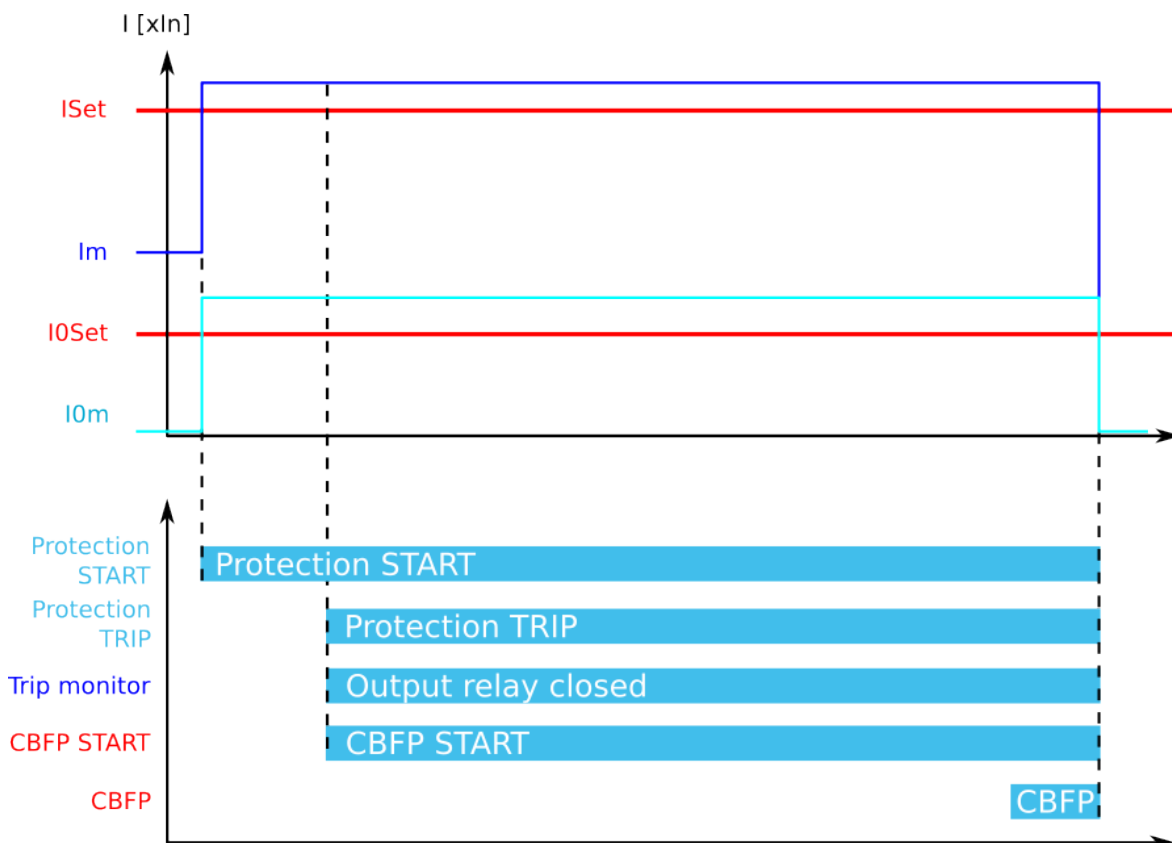

When the current threshold setting of I_{Set} and/or I_{OSet} is exceeded, the current-based protection is activated. At the same time, the counter for CBFP is halted until the monitored output contact is controlled (that is, until the primary protection operates). When the tripping signal reaches the primary protection stage, the CBFP counter starts calculating the set operating time. The tripping of the primary protection stage is constantly monitored in this configuration. If the current is not reduced below the setting limit or the primary stage tripping signal is not reset, a CBFP signal is sent to the incomer breaker. The time delay counter for CBFP is reset as soon as the measured current is below the threshold settings or the tripping signal is reset. This configuration allows the CBFP to be controlled by current-based functions alone, and other function trips can be excluded from the CBFP functionality.

Figure. 5.3.8 - 109. CBFP when "Current or DO" is the selected criterion.

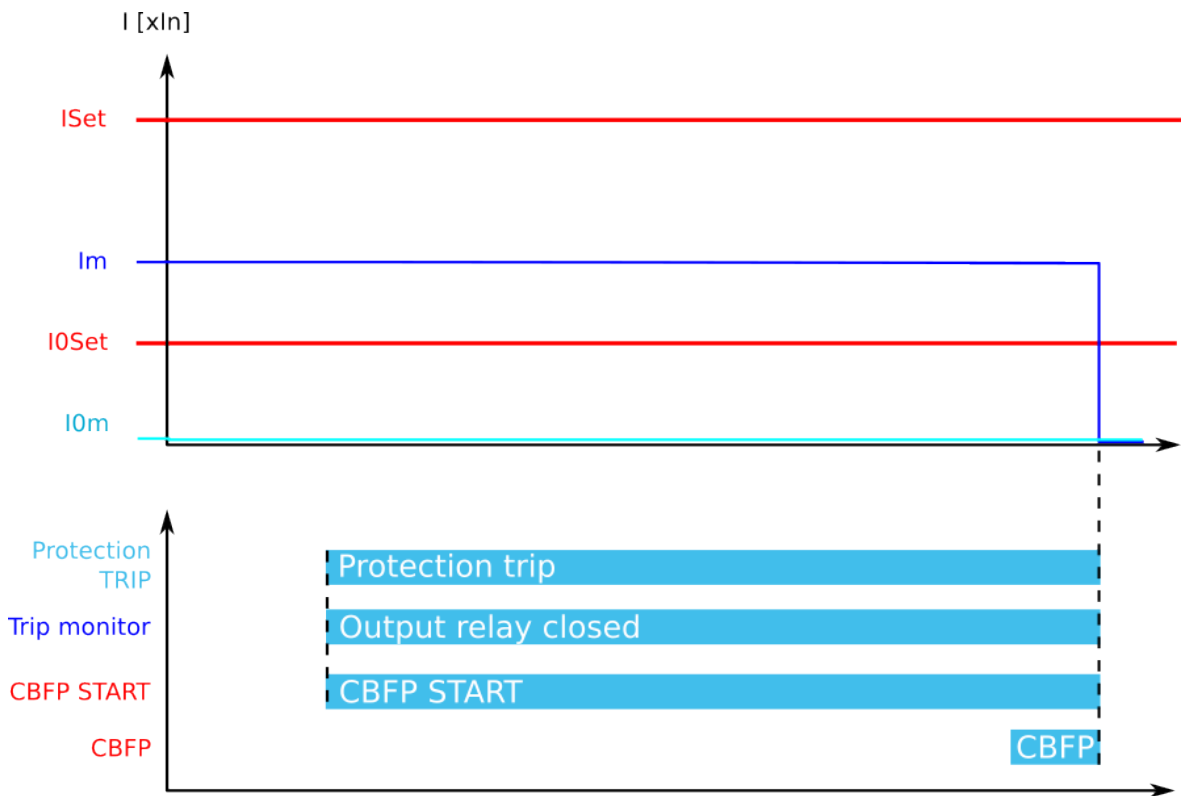

When the current threshold setting of I_{set} and/or I_{0set} is exceeded, or the TRIP signal reaches the primary protection stage, the function starts counting down towards the CBFP signal. The tripping of the primary protection stage is constantly monitored in this configuration regardless of the current's status. The pick-up of the CBFP is active unless the current is reduced below the setting limit and the primary stage tripping signal is reset. If either of these conditions is met (i.e. the current is above the limit or the signal is active) for the duration of the set CBFP time delay, a CBFP signal is sent to the incomer breaker. The time delay counter for CBFP is reset as soon as the measured current is below the threshold settings and the tripping signal is reset. This configuration allows the CBFP to be controlled by current-based functions alone, with added security from current monitoring. Other function trips can also be included to the CBFP functionality.

Device configuration as a dedicated CBFP unit

Figure. 5.3.8 - 110. Wiring diagram when the device is configured as a dedicated CBFP unit.

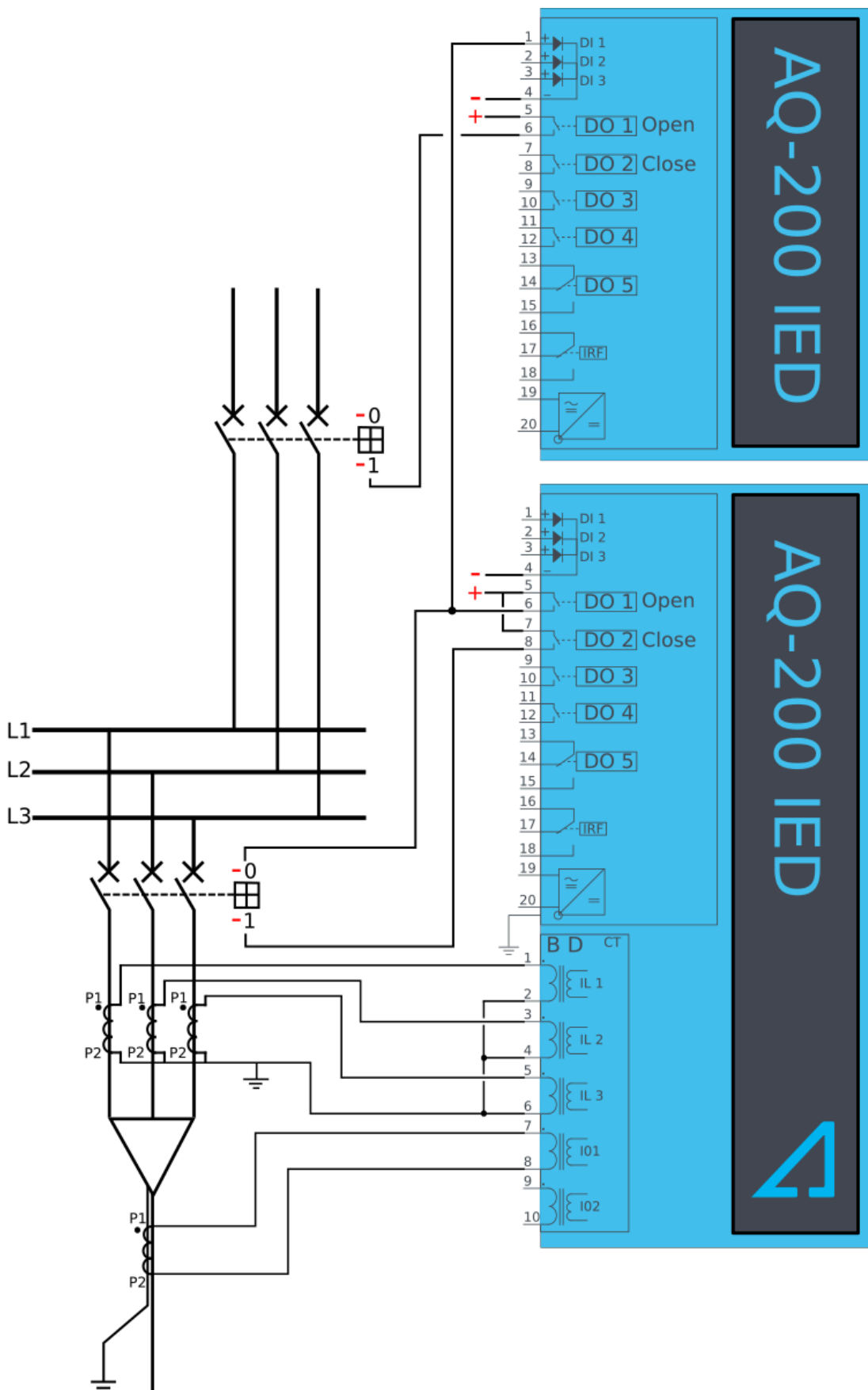

Some applications require a dedicated circuit breaker protection unit. When the CBFP function is configured to operate with a digital input signal, it can be used in these applications. When a device is used for this purpose, the tripping signal is wired to the device's digital input and the device's own TRIP signal is used only for the CBFP purpose. In this application's incomer the RETRIP and CBFP signals are also available with different sets of requirements. The RETRIP signal can be used for tripping the section's feeder breaker and the CBFP signal for tripping the incomer. The following example does not use retripping and the CBFP signal is used as the incomer trip from the outgoing breaker trip signal. The TRIP signal can also be transported between different devices by using GOOSE messages.

Figure. 5.3.8 - 111. Dedicated CBFP operation from digital input signal.

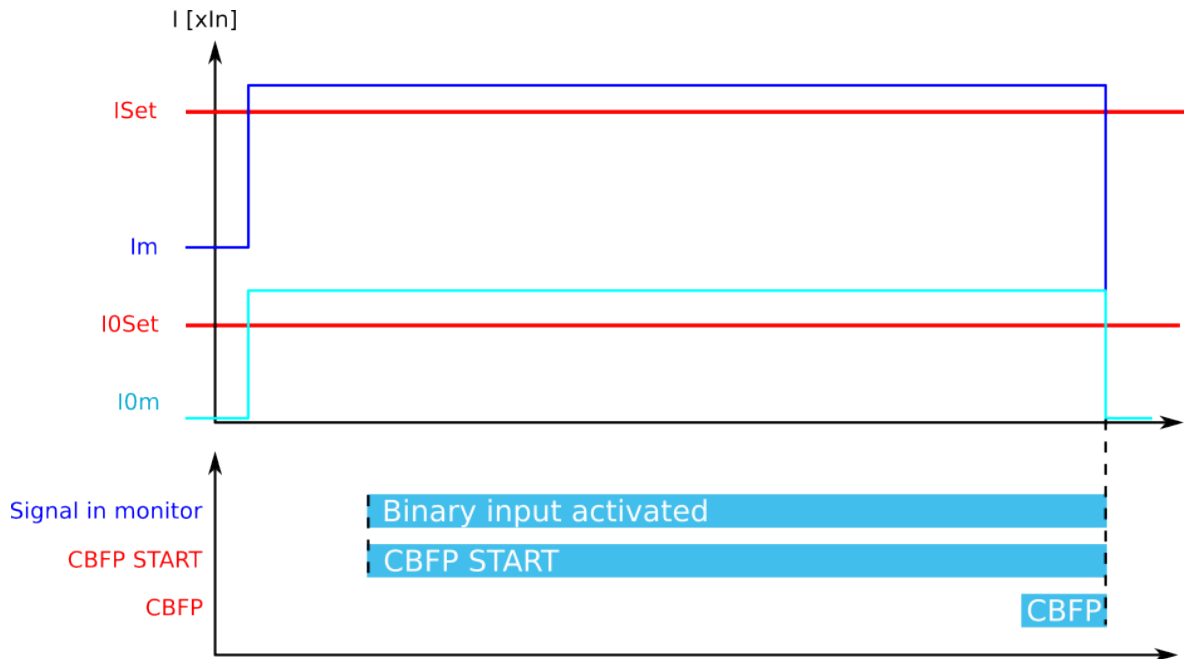

In this mode the CBFP operates only from a digital input signal. Both current and output relay monitoring can be used. The counter for the CBFP signal begins when the digital input is activated. If the counter is active until the CBFP counter is used, the device issues a CBFP command to the incomer breaker. In this application the device tripping signals from all outgoing feeders can be connected to one, dedicated CBFP device which operates either on current-based protection or on all possible faults' CBFP protection.

Events and registers

The circuit breaker failure protection function (abbreviated "CBF" in event block names) generates events and registers from the status changes in RETRIP, in CBFP-activated and CBFP-blocked signals, as well as in internal pick-up comparators. The user can select which event messages are stored in the main event buffer: ON, OFF, or both.

The events triggered by the function are recorded with a time stamp and with process data values.

Table. 5.3.8 - 93. Event codes.

Event number	Event channel	Event block name	Event code	Description
2816	44	CBF1	0	Start ON
2817	44	CBF1	1	Start OFF
2818	44	CBF1	2	Retrip ON
2819	44	CBF1	3	Retrip OFF

Event number	Event channel	Event block name	Event code	Description
2820	44	CBF1	4	CBFP ON
2821	44	CBF1	5	CBFP OFF
2822	44	CBF1	6	Block ON
2823	44	CBF1	7	Block OFF
2824	44	CBF1	8	DO monitor ON
2825	44	CBF1	9	DO monitor OFF
2826	44	CBF1	10	Signal ON
2827	44	CBF1	11	Signal OFF
2828	44	CBF1	12	Phase current ON
2829	44	CBF1	13	Phase current OFF
2830	44	CBF1	14	Res current ON
2831	44	CBF1	15	Res current OFF

The function registers its operation into the last twelve (12) time-stamped registers. The register of the function records the ON event process data for ACTIVATED, BLOCKED, etc. The table below presents the structure of the function's register content.

Table. 5.3.8 - 94. Register content.

Date and time	Event code	Trigger current	Time to RETRact	Time to CBFpact	F type	S type	Used SG
dd.mm.yyyy hh:mm:ss.mss	2816-2831 Descr.	Phase and residual currents on trigger time	Time remaining before RETR is active	Time remaining before CBFp is active	Monitored current status code	Activate start triggers	Setting group 1...8 active

5.3.9 Low-impedance or high-impedance restricted earth fault/ cable end differential protection (I0d>; 87N)

The low-impedance or high-impedance restricted earth fault function is used for residual differential current measurement for transformers. This function can also be used as the cable end differential function. The operating principle is low-impedance differential protection with bias characteristics the user can set. A differential current is calculated with the sum of the phase currents and the selected residual current input. In cable end differential mode the function provides natural measurement unbalance compensation for higher operating sensitivity in monitoring cable end faults.

The restricted earth fault function constantly monitors phase currents and selected residual current instant values as well as calculated bias current and differential current magnitudes.

The blocking signal and the setting group selection control the operating characteristics of the function during normal operation, i.e. the user or user-defined logic can change function parameters while the function is running.

The outputs of the function are TRIP and BLOCKED signals. The function uses a total of eight (8) separate setting groups which can be selected from one common source. The operating mode of the function can be changed via setting group selection.

The operational logic consists of the following:

- input magnitude selection
- input magnitude processing

- differential characteristic comparator
- block signal check
- output processing.

The inputs for the function are the following:

- setting parameters
- measured and pre-processed current magnitudes.

The function's output signals can be used for direct I/O controlling and user logic programming. The function generates general time-stamped ON/OFF events to the common event buffer from each of the two (2) output signals. The time stamp resolution is 1 ms. The function also provides a resettable cumulative counter for the REF, TRIP and BLOCKED events.

The following figure presents a simplified function block diagram of the restricted earth fault function.

Figure. 5.3.9 - 112. Simplified function block diagram of the I0d> function.

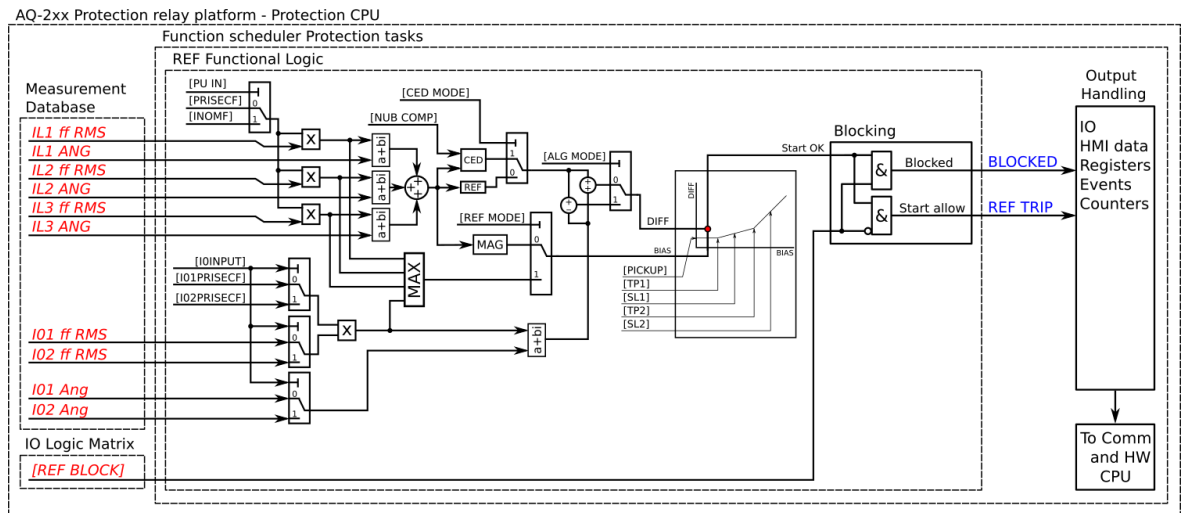

Measured input

The function block uses analog current measurement values. It uses the RMS magnitude of the current measurement inputs. Both calculated residual currents and measured residual currents are always used. The user can select inputs I01 or I02 for residual current measurement.

Please note that when the function is in cable end differential mode, the difference is only calculated when the measured I0 current is available.

Table. 5.3.9 - 95. Measurement inputs of the I0d> function.

Signal	Description	Time base
IL1RMS	RMS measurement of phase L1 (A) current	5ms
IL2RMS	RMS measurement of phase L2 (B) current	5ms
IL3RMS	RMS measurement of phase L3 (C) current	5ms
I01RMS	RMS measurement of residual input I01	5ms
I02RMS	RMS measurement of residual input I02	5ms
IL1Ang	Angle of phase L1 (A) current	5ms
IL2 Ang	Angle of phase L2 (B) current	5ms

Signal	Description	Time base
IL3 Ang	Angle of phase L3 (C) current	5ms
I01 Ang	Angle of residual input I01	5ms
I02 Ang	Angle of residual input I02	5ms

The selection of the used AI channel is made with a setting parameter.

General settings

The following general settings define the general behavior of the function. These settings are static i.e. it is not possible to change them by editing the setting group.

Table. 5.3.9 - 96. General settings.

Name	Range	Step	Default	Description
Restricted earth fault (REF) or Cable End Differential	0: REF 1: CED	-	0: REF	Selection of the operating characteristics. If REF is selected, the function operates with normal accuracies. If CED is selected, the natural unbalance created by the phase current CT:s can be compensated for more sensitive operation. The default setting is REF.
Compenstate natural unbalance	0:- 1: Comp	-	-	When activated while the line is energized, the currently present calculated residual current is compensated to 0. This compensation only has an effect in the CED mode.

Operating characteristics

The current-dependent pick-up and activation of the function are controlled by setting parameters, which define the current calculating method used as well as the operating characteristics.

Table. 5.3.9 - 97. Pick-up settings.

Name	Range	Step	Default	Description
I0 Input	0: I01 1: I02	-	0: I01	Selection of the used residual current measurement input.
I0 Direction	0: Add 1: Subtract	-	0: Add	Differential current calculation mode. This matches the directions of the calculated and measured residual currents to the application. The default setting (0: Add) means that $I0Calc + I01$ or $I0Calc + I02$ in a through fault yields no differential current.
Bias current calculation	0: Residual current $(3I0 + I0Calc)/2$ 1: Maximum (Phase and I0 max)	-	0: Residual current	Selection of the bias current calculation. Differential characteristics biasing can use either the calculated residual current averages or the maximum of all measured currents. The residual current mode is more sensitive while the maximum current is coarser.
I0d> pick-up	0.01...50.00% (of I_n)	0.01%	10%	Setting for basic sensitivity of the differential characteristics.
Turnpoint 1	0.01...50.00 $\times I_n$	0.01 $\times I_n$	1.00 $\times I_n$	Setting for first turn point in the bias axe of the differential characteristics.
Slope 1	0.01...150.00%	0.01%	10.00%	Setting for the first slope of the differential characteristics.
Turnpoint 2	0.01...50.00 $\times I_n$	0.01 $\times I_n$	3.00 $\times I_n$	Setting for second turn point in the bias axe of the differential characteristics.
Slope 2	0.01...250.00%	0.01%	40.00%	Setting for the second slope of the differential characteristics.

The pick-up settings can be selected via setting groups. The pick-up activation of the function is not directly equal to the TRIP signal generation of the function. The TRIP signal is allowed if the blocking condition is not active.

The following figure presents the differential characteristics with default settings.

Figure. 5.3.9 - 113. Differential characteristics for the I0d> function with default settings.

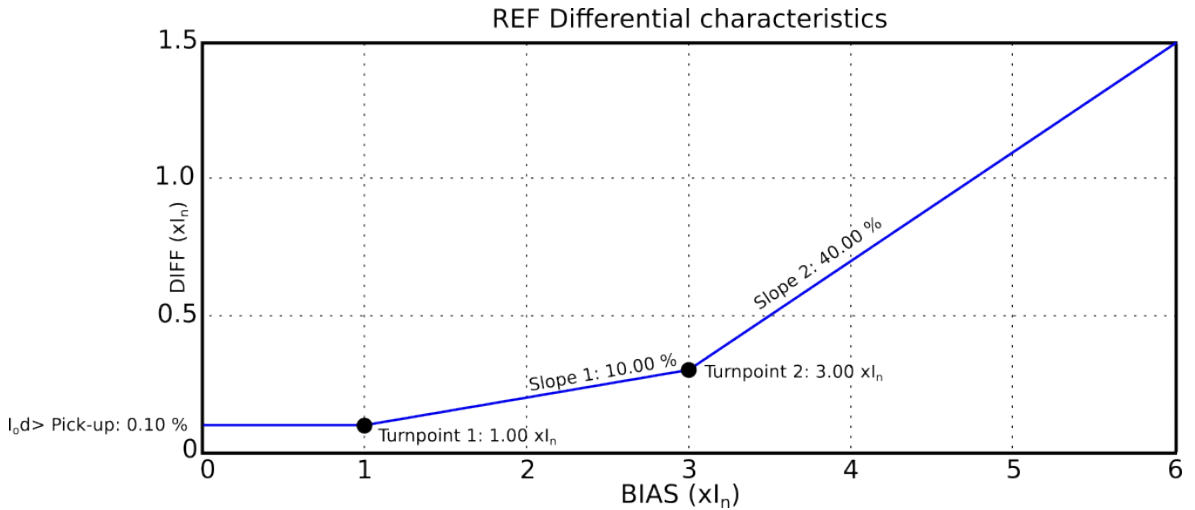

The equations for the differential characteristics are the following:

Figure. 5.3.9 - 114. Differential current (the calculation is based on user-selected inputs and direction).

$$I_{Diff+I01} = (\overline{IL1} + \overline{IL2} + \overline{IL3}) + \overline{I01}$$

$$I_{Diff-I01} = (\overline{IL1} + \overline{IL2} + \overline{IL3}) - \overline{I01}$$

$$I_{Diff+I02} = (\overline{IL1} + \overline{IL2} + \overline{IL3}) + \overline{I02}$$

$$I_{Diff-I02} = (\overline{IL1} + \overline{IL2} + \overline{IL3}) - \overline{I02}$$

Figure. 5.3.9 - 115. Bias current (the calculation is based on the user-selected mode).

$$I_{Bias1} = (\overline{IL1} + \overline{IL2} + \overline{IL3})$$

$$I_{Bias2I01} = \text{MAX}(|IL1|, |IL2|, |IL3|, |I01|)$$

$$I_{Bias2I02} = \text{MAX}(|IL1|, |IL2|, |IL3|, |I02|)$$

Figure. 5.3.9 - 116. Characteristics settings.

$$Diff_{bias < TP1} = I0_{d > pick-up}$$

$$Diff_{bias TP1...TP2} = SL1 \times (Ix - TP1) + I0_{d > pick-up}$$

$$Diff_{bias > TP2} = SL2 \times (Ix - TP2) + SL1 \times (TP2 - TP1) + I0_{d > pick-up}$$

Read-only parameters

The relay's *Info* page displays useful, real-time information on the state of the protection function. It is accessed either through the relay's HMI display, or through the setting tool software when it is connected to the relay and its Live Edit mode is active.

Table. 5.3.9 - 98. Information displayed by the function.

Name	Range	Step	Description
I0d> condition	0: Normal 1: Trip 2: Blocked	-	Displays the status of the protection function.

Function blocking

The block signal is checked in the beginning of each program cycle. The blocking signal is received from the blocking matrix in the function's dedicated input. If the blocking signal is not activated when the pick-up element activates, a TRIP signal is generated and the function proceeds to the time characteristics calculation.

If the blocking signal is active when the pick-up element activates, a BLOCKED signal is generated and the function does not process the situation further. If the TRIP function has been activated before the blocking signal, it resets and processes the release time characteristics similarly to when the pick-up signal is reset.

The blocking of the function causes an HMI display event and a time-stamped blocking event with information of the startup current values and its fault type to be issued.

The blocking signal can also be tested in the commissioning phase by a software switch signal when the relay's testing mode "Enable stage forcing" is activated (*General* → *Device*).

The variables the user can set are binary signals from the system. The blocking signal needs to reach the device minimum of 5 ms before the set operating delay has passed in order for the blocking to activate in time.

The following figures present some typical applications for this function.

Figure. 5.3.9 - 117. Cable end differential with natural unbalance in the phase current measurement.

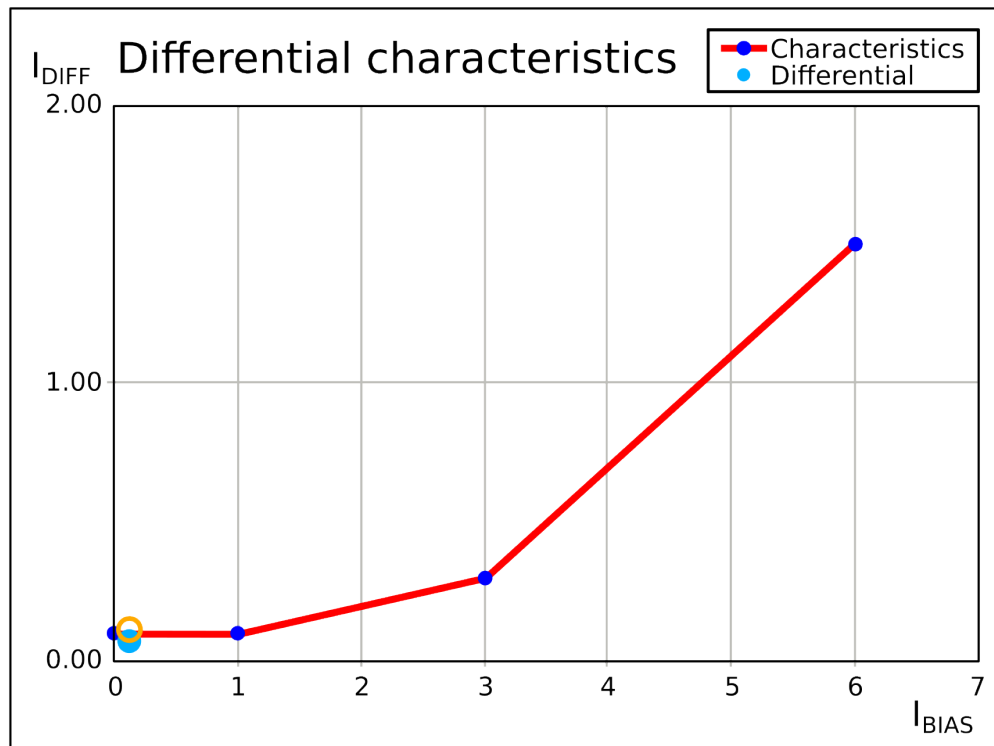
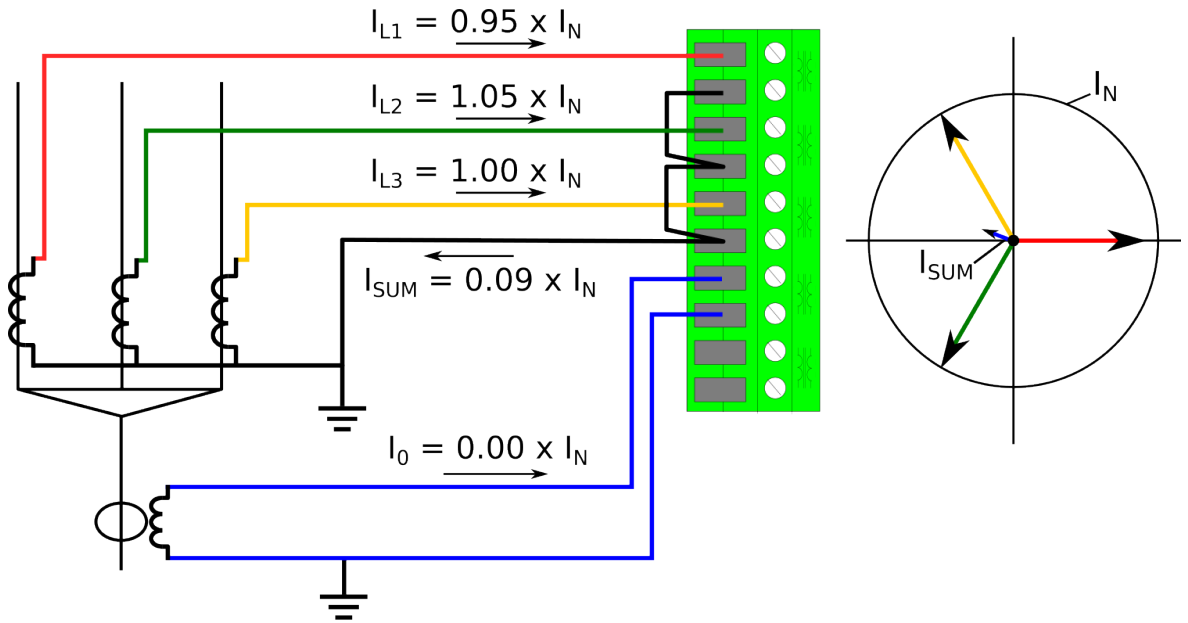

When calculating residual current from the phase currents, the natural unbalance can be around 10 % while the used CTs are still within the promised 5P class (which is probably the most common CT accuracy class). When the current natural unbalance is compensated in this situation, the differential settings may be set to be more sensitive and the natural unbalance does not, therefore, affect the calculation.

Figure. 5.3.9 - 118. Cable end differential when a fault occurs.

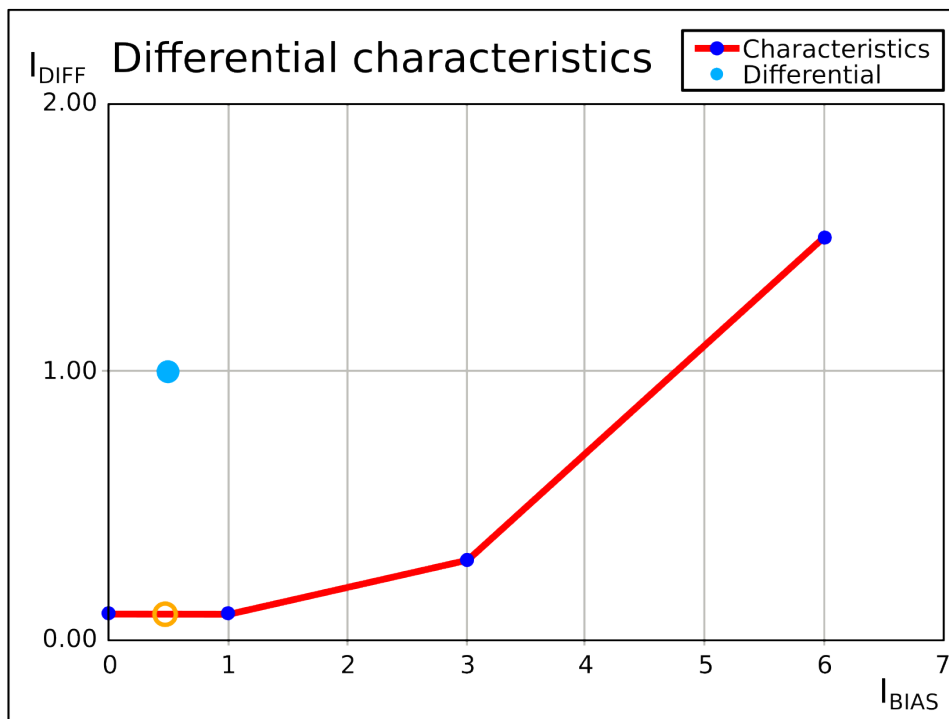
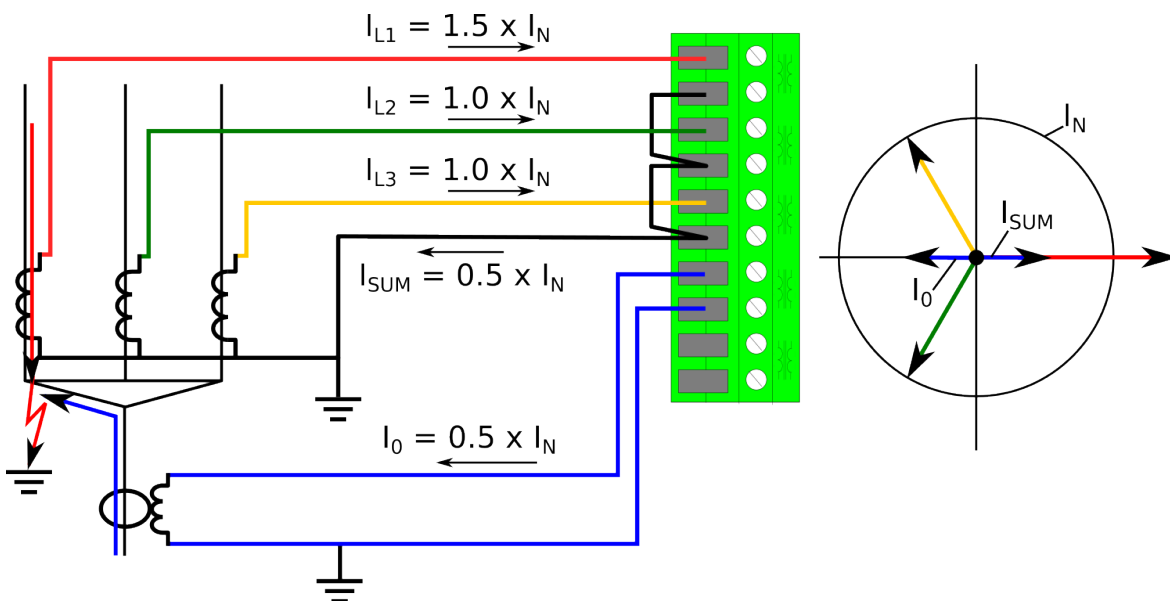

If a starting fault occurs in the cable end, the CED mode catches the difference between the ingoing and the outgoing residual currents. The resulting signal can be used for alarming or tripping purposes for the feeder with the failing cable end. The user can freely change both the settings and the sensitivity of the algorithm.

Restricted earth fault protection is usually used in the Y winding of a power transformer. This function is needed to prevent the main differential protection from being tripped by faults occurring outside the protection area; in some cases, the function has to be disabled or its sensitivity limited to catch earth faults inside the protection area. For this purpose, the restricted earth fault function is stable since it only monitors the side it is wired to, and compares the calculated and measured residual currents. During an outside earth fault the circulating residual current in the faulty phase winding does not cause a trip because the comparison of the measured starpoint current and the calculated residual current differential is close to zero.

Figure. 5.3.9 - 119. Restricted earth fault outside a Y winding transformer.

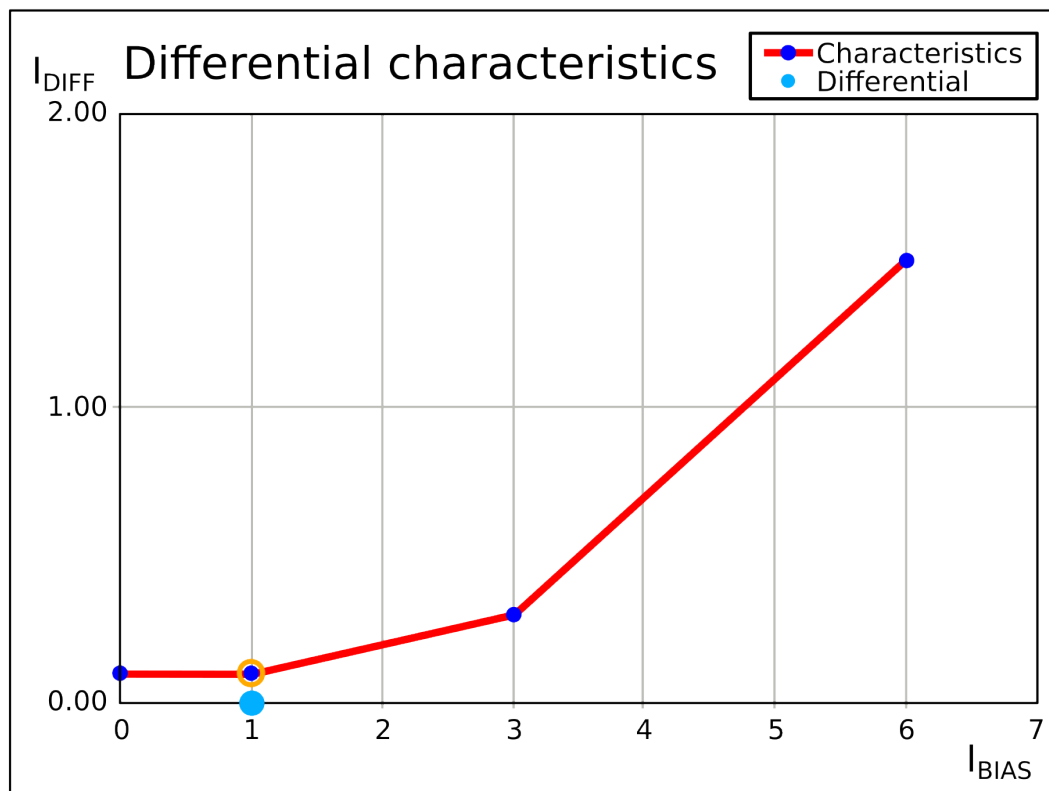
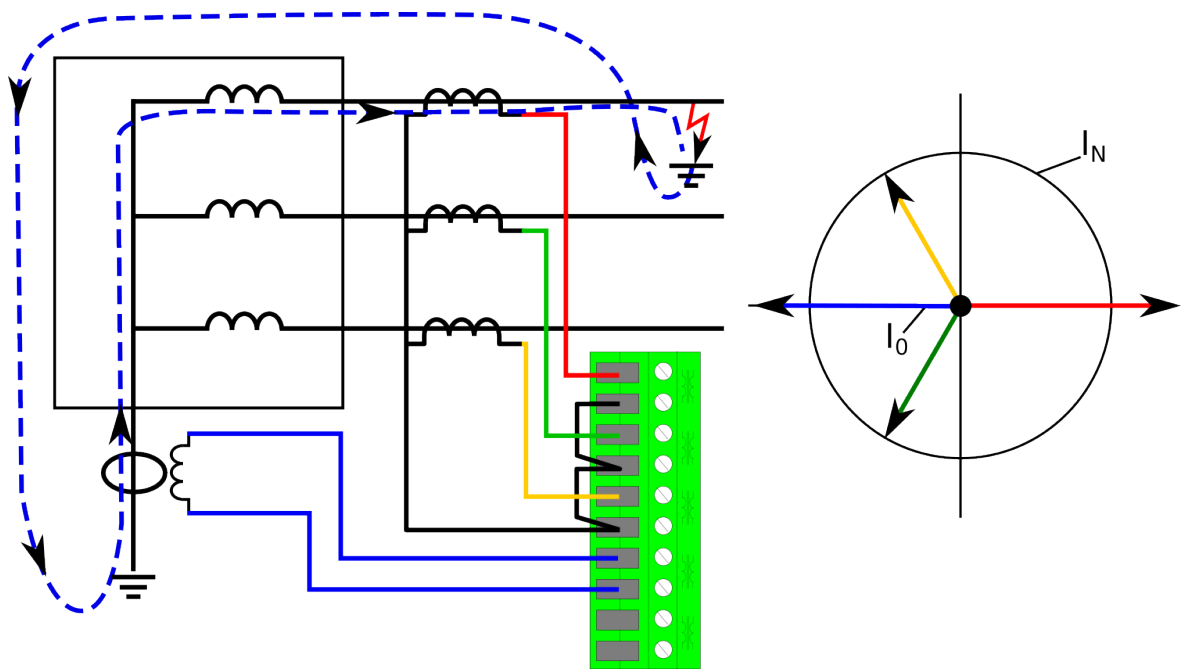

If the fault is located inside of the transformer and thus inside of the protection area, the function catches the fault with high sensitivity. Since the measured residual current now flows in the opposite direction than in the outside fault situation, the measured differential current is high.

Figure. 5.3.9 - 120. Restricted earth fault inside a Y winding transformer.

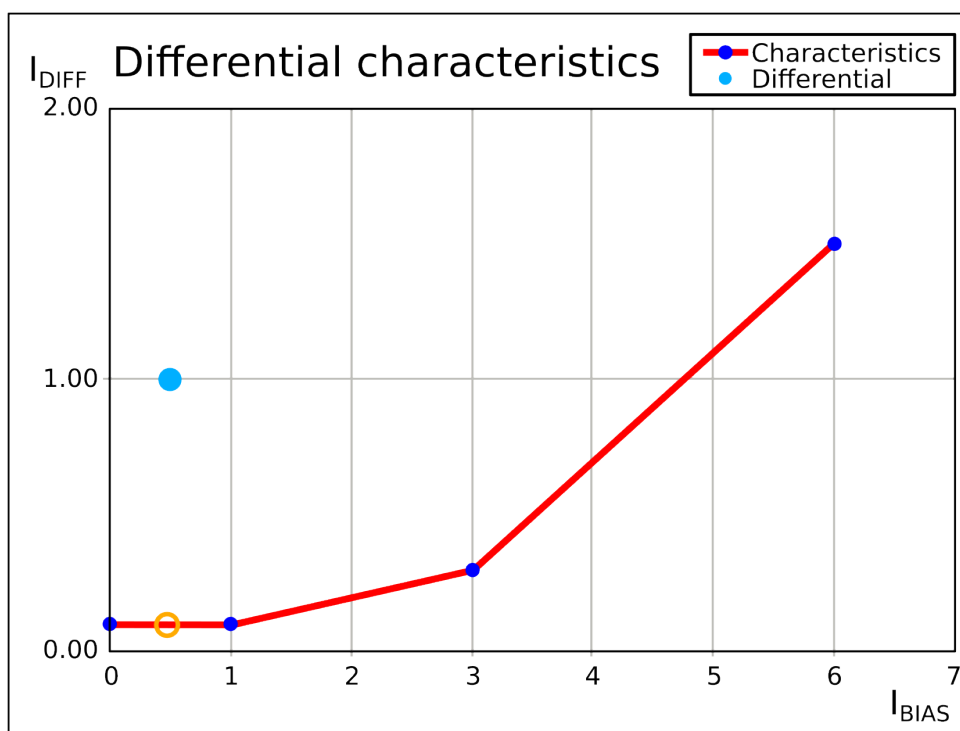
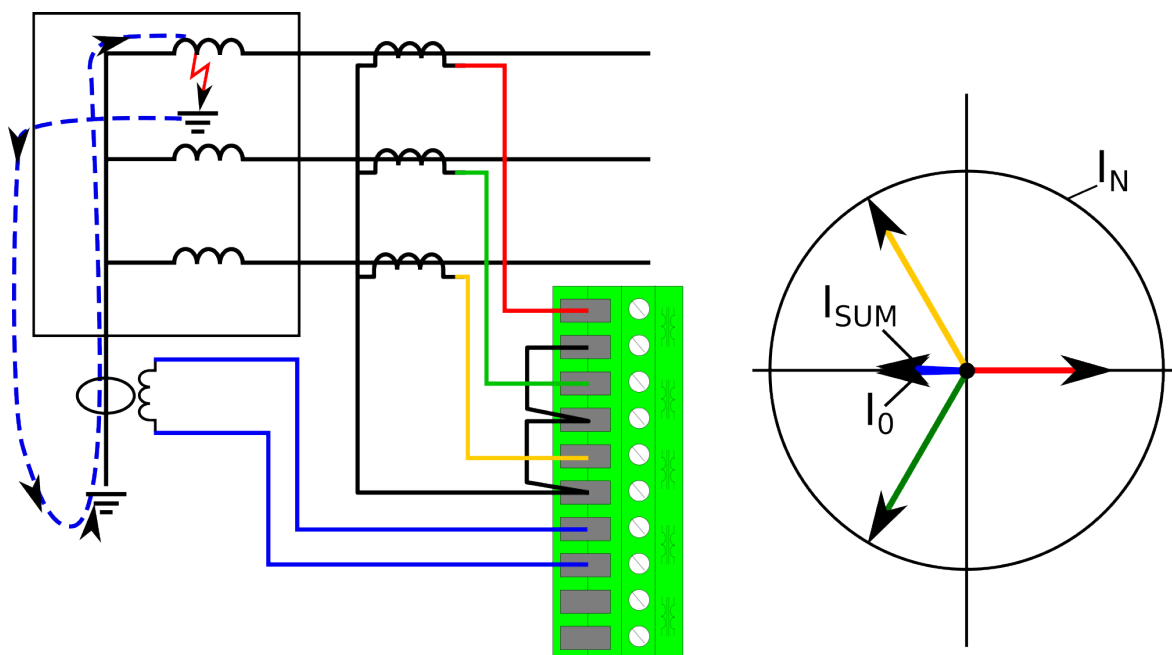

Events and registers

The restricted earth fault function (abbreviated "REF" in event block names) generates events and registers from the status changes in TRIP-activated and BLOCKED signals. The user can select which event messages are stored in the main event buffer: ON, OFF, or both.

The events triggered by the function are recorded with a time stamp and with process data values.

Table. 5.3.9 - 99. Event codes.

Event number	Event channel	Event block name	Event code	Description
4224	66	REF1	0	I0d> (87N) Trip ON
4225	66	REF1	1	I0d> (87N) Trip OFF
4226	66	REF1	2	I0d> (87N) Block ON
4227	66	REF1	3	I0d> (87N) Block OFF

The function registers its operation into the last twelve (12) time-stamped registers. The register of the function records the ON event process data for ACTIVATED, BLOCKED, etc. The table below presents the structure of the function's register content.

Table. 5.3.9 - 100. Register content.

Date and time	Event code	Average trigger currents	Maximum trigger currents	Residual currents	Used SG
dd.mm.yyyy hh:mm:ss.mss	4224-4227 Descr.	Biascurrent trig Diffcurrent trig Characteristics diff trig	Biascurrent max Diffcurrent max Characteristics diff max	I0Calc I0 meas	Setting group 1...8 active

5.3.10 Overvoltage protection (U>; 59)

The overvoltage function is used for instant and time-delayed overvoltage protection. Each relay with a voltage protection module has four (4) available stages of the function (U>, U>>, U>>>, U>>>>). The function constantly measures phase voltage magnitudes or line-to-line magnitudes. Overvoltage protection is based on line-to-line RMS voltage or to line-to-neutral RMS voltage (as the user selects). If the protection is based on line-to-line voltage, overvoltage protection is not affected by earth faults in isolated or compensated networks. The blocking signal and the setting group selection control the operating characteristics of the function during normal operation, i.e. the user or user-defined logic can change function parameters while the function is running.

The outputs of the function are the START, TRIP and BLOCKED signals. The overvoltage function uses a total of eight (8) separate setting groups which can be selected from one common source.

The function can operate on instant or time-delayed mode. In time-delayed mode the operation can be selected between definite time (DT) mode and inverse definite minimum time (IDMT).

The operational logic consists of the following:

- input magnitude selection
- input magnitude processing
- threshold comparator
- block signal check
- time delay characteristics
- output processing.

The inputs for the function are the following:

- operating mode selections
- setting parameters
- digital inputs and logic signals
- measured and pre-processed current magnitudes.

The function outputs the START, TRIP and BLOCKED signals which can be used for direct I/O controlling and user logic programming. The function generates general time-stamped ON/OFF events to the common event buffer from each of the three (3) output signals. In the instant operating mode the function outputs START and TRIP events simultaneously with an equivalent time stamp. The time stamp resolution is 1 ms. The function also provides a resettable cumulative counter for the START, TRIP and BLOCKED events.

The following figure presents a simplified function block diagram of the overvoltage function.

Figure. 5.3.10 - 121. Simplified function block diagram of the U> function.

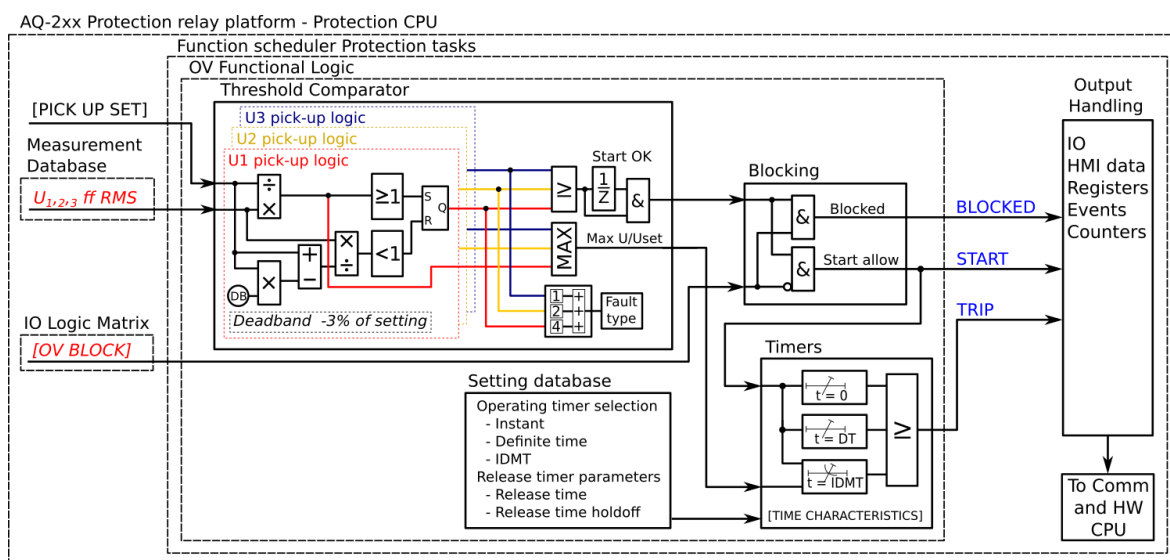

Measured input

The function block uses analog voltage measurement values. The monitored magnitudes are equal to RMS values. A -20 ms averaged value of the selected magnitude is used for pre-fault data registering.

Table. 5.3.10 - 101. Measurement inputs of the the U> function.

Signal	Description	Time base
U _{L12} RMS	RMS measurement of voltage U _{L12} /V	5 ms
U _{L23} RMS	RMS measurement of voltage U _{L23} /V	5 ms
U _{L31} RMS	RMS measurement of voltage U _{L31} /V	5 ms
U _{L1} RMS	RMS measurement of voltage U _{L1} /V	5 ms
U _{L2} RMS	RMS measurement of voltage U _{L2} /V	5 ms
U _{L3} RMS	RMS measurement of voltage U _{L3} /V	5 ms

Pick-up

The U_{set} setting parameter controls the pick-up of the U> function. This defines the maximum allowed measured voltage before action from the function. The function constantly calculates the ratio between the U_{set} and the measured magnitude (U_m) for each of the three voltages. The reset ratio of 97 % is built into the function and is always relative to the U_{set} value. The setting value is common for all measured amplitudes, and when the U_m exceeds the U_{set} value (in single, dual or all voltages) it triggers the pick-up operation of the function.

Table. 5.3.10 - 102. Pick-up settings.

Name	Range	Step	Default	Description
Pick-up terms	0: 1 voltage 1: 2 voltages 2: 3 voltages	-	0: 1 voltage	Selects the pick-up criterion.
U_{set}	50.00...150.00 % U_n	0.01 % U_n	105 % U_n	The pick-up setting.
Delay type	0: DT 1: IDMT	-	0: DT	Selects the delay type time counter. The selection possibilities are dependent (IDMT, Inverse Definite Minimum Time) and independent (DT, Definite Time) characteristics.
Time dial setting k	0.01...60.00	0.01	0.01	The time dial/multiplier setting for IDMT characteristics. This setting is only visible when "IDMT" is the selected delay type.
Definite operating time delay	0.000...1800.000 s	0.005 s	0.04 s	The definite time operating delay. This setting is active and visible when "DT" is the selected delay type. When set to 0.000 s, the stage operates as instant without added delay. When the parameter is set to 0.005...1800 s, the stage operates as independent delayed.
IDMT multiplier	0.01...25.00	0.01	1.00	The IDMT time multiplier in the U_m/U_{set} power. This setting is only visible when "IDMT" is the selected delay type.
Release time delay	0.000...150.000 s	0.005 s	0.06 s	Determines the time allowed between pick-ups if the pick-up has not led into a trip operation. During this time the START signal is held on for the timers if the delayed pick-up release is active.
Delayed pick-up release	0: Yes 1: No	-	0: Yes	Selects the resetting characteristics. Either time-delayed or instant after the pick-up element is released. If activated the START signal is reset after a set release time delay.
Op.Time calc reset after release time	0: Yes 1: No	-	0: Yes	Selects the operating timer resetting characteristics. When activated, the operating time counter is reset after a set release time if the pick-up element is not activated during this time. When disabled, the operating time counter is reset directly after the pick-up element reset.
Continue time calculation during release time	0: Yes 1: No	-	1: No	Selects the time calculation characteristics. If activated, the operating time counter continues until a set release time even if the pick-up element is reset.

The pick-up activation of the function is not directly equal to the START signal generation of the function. The START signal is allowed if the blocking condition is not active.

Read-only parameters

The relay's *Info* page displays useful, real-time information on the state of the protection function. It is accessed either through the relay's HMI display, or through the setting tool software when it is connected to the relay and its Live Edit mode is active.

Table. 5.3.10 - 103. Information displayed by the function.

Name	Range	Step	Description
$U <$ pick-up setting	0.0...1 000 000.0 V	0.1 V	The primary voltage required for tripping. The displayed pick-up voltage level depends on the pick-up setting and the voltage transformer settings.
Expected operating time	0.000...1800.000 s	0.005 s	Displays the expected operating time when a fault occurs. When IDMT mode is used, the expected operating time depends on the measured voltage value. If the measured voltage changes during a fault, the expected operating time changes accordingly.

Name	Range	Step	Description
Time remaining to trip	-1800.000...1800.000 s	0.005 s	When the function has detected a fault and counts down time towards a trip, this displays how much time is left before tripping occurs.
$U_{A(B)}^{\text{meas}}/U_{\text{set}}$ at the moment	0.00...1250.00 U_m/U_{set}	0.01 U_m/U_{set}	The ratio between U_A or U_{AB} voltage and the pick-up value.
$U_{B(C)}^{\text{meas}}/U_{\text{set}}$ at the moment	0.00...1250.00 U_m/U_{set}	0.01 U_m/U_{set}	The ratio between U_B or U_{BC} voltage and the pick-up value.
$U_{C(A)}^{\text{meas}}/U_{\text{set}}$ at the moment	0.00...1250.00 U_m/U_{set}	0.01 U_m/U_{set}	The ratio between U_C or U_{CA} voltage and the pick-up value.
$U^{\text{meas}}/U_{\text{set}}$ at the moment	0.00...1250.00 U_m/U_{set}	0.01 U_m/U_{set}	The ratio between the measured voltage and the pick-up value.

Function blocking

The block signal is checked in the beginning of each program cycle. The blocking signal is received from the blocking matrix in the function's dedicated input. If the blocking signal is not activated when the pick-up element activates, a START signal is generated and the function proceeds to the time characteristics calculation.

If the blocking signal is active when the pick-up element activates, a BLOCKED signal is generated and the function does not process the situation further. If the START function has been activated before the blocking signal, it resets and the release time characteristics are processed similarly to when the pick-up signal is reset.

The blocking of the function causes an HMI display event and a time-stamped blocking event with information of the startup voltage values and its fault type to be issued.

The blocking signal can also be tested in the commissioning phase by a software switch signal when the relay's testing mode "Enable stage forcing" is activated (*General* → *Device*).

The variables the user can set are binary signals from the system. The blocking signal needs to reach the device minimum of 5 ms before the set operating delay has passed in order for the blocking to activate in time.

Operating time characteristics for trip and reset

The operating timers' behavior during a function can be set for TRIP signal and also for the release of the function in case the pick-up element is reset before the trip time has been reached. There are three basic operating modes available for the function:

- Instant operation: gives the TRIP signal with no additional time delay simultaneously with the START signal.
- Definite time operation (DT): gives the TRIP signal after a user-defined time delay regardless of the measured voltage as long as the voltage is above the U_{set} value and thus the pick-up element is active (independent time characteristics).
- Inverse definite minimum time (IDMT): gives the TRIP signal after a time which is in relation to the set pick-up voltage U_{set} and the measured voltage U_m (dependent time characteristics).

The IDMT function follows this formula:

$$t = \frac{k}{\left(\frac{U_m}{U_s}\right)^a - 1}$$

Where:

- t = operating time
- k = time dial setting
- U_m = measured voltage
- U_s = pick-up setting
- a = IDMT multiplier setting

The following parameters are for setting the operating time characteristics (can be found in the Pick-up settings):

- Delay type
- Definite operating time delay
- Time dial setting k
- IDMT multiplier

The following parameters are for resetting the time characteristics (can be found in the Pick-up settings):

- Release time delay
- Delayed pick-up release
- Operating time calc reset after release time
- Continue time calculation during release time

The user can reset characteristics through the application. The default setting is a 60 ms delay; the time calculation is held during the release time.

In the release delay option the operating time counter calculates the operating time during the release. When using this option the function does not trip if the input signal is not re-activated while the release time count is on-going.

Events and registers

The overvoltage function (abbreviated "OV" in event block names) generates events and registers from the status changes in START, TRIP, and BLOCKED. The user can select which event messages are stored in the main event buffer: ON, OFF, or both. The function offers four (4) independent stages; the events are segregated for each stage operation.

The events triggered by the function are recorded with a time stamp and with process data values.

Table. 5.3.10 - 104. Event codes.

Event number	Event channel	Event block name	Event code	Description
5440	85	OV1	0	Start ON
5441	85	OV1	1	Start OFF
5442	85	OV1	2	Trip ON
5443	85	OV1	3	Trip OFF

Event number	Event channel	Event block name	Event code	Description
5444	85	OV1	4	Block ON
5445	85	OV1	5	Block OFF
5504	86	OV2	0	Start ON
5505	86	OV2	1	Start OFF
5506	86	OV2	2	Trip ON
5507	86	OV2	3	Trip OFF
5508	86	OV2	4	Block ON
5509	86	OV2	5	Block OFF
5568	87	OV3	0	Start ON
5569	87	OV3	1	Start OFF
5570	87	OV3	2	Trip ON
5571	87	OV3	3	Trip OFF
5572	87	OV3	4	Block ON
5573	87	OV3	5	Block OFF
5632	88	OV4	0	Start ON
5633	88	OV4	1	Start OFF
5634	88	OV4	2	Trip ON
5635	88	OV4	3	Trip OFF
5636	88	OV4	4	Block ON
5637	88	OV4	5	Block OFF

The function registers its operation into the last twelve (12) time-stamped registers; this information is available for all provided instances separately. The register of the function records the ON event process data for START, TRIP or BLOCKED. The table below presents the structure of the function's register content.

Table. 5.3.10 - 105. Register content.

Date and time	Event code	Fault type	Trigger voltage	Fault voltage	Pre-fault voltage	Trip time remaining	Used SG
dd.mm.yyyy hh:mm:ss.mss	5440-5637 Descr.	L1-G...L1-L2-L3	Start average voltage	Trip -20ms averages	Start -200ms averages	0 ms...1800s	Setting group 1...8 active

5.3.11 Undervoltage protection (U<; 27)

The undervoltage function is used for instant and time-delayed undervoltage protection. Each device with a voltage protection module has four (4) available stages of the function (U>, U>>, U>>>, U>>>>). The function constantly measures phase voltage magnitudes or line-to-line voltage magnitudes. Undervoltage protection is based on line-to-line RMS voltage or to line-to-line RMS voltage (as the user selects). If the protection is based on line-to-line voltage, undervoltage protection is not affected by earth faults in isolated or compensated networks. Undervoltage protection has two blocking stages: internal blocking (based on voltage measurement and low voltage), or external blocking (e.g. during voltage transformer fuse failure). The blocking signal and the setting group selection control the operating characteristics of the function during normal operation, i.e. the user or user-defined logic can change function parameters while the function is running.

The outputs of the function are the START, TRIP and BLOCKED signals. The undervoltage function uses a total of eight (8) separate setting groups which can be selected from one common source.

The function can operate on instant or time-delayed mode. In time-delayed mode the operation can be selected between definite time (DT) mode and inverse definite minimum time (IDMT).

The operational logic consists of the following:

- input magnitude selection
- input magnitude processing
- threshold comparator
- two block signal check
- time delay characteristics
- output processing.

The inputs for the function are the following:

- operating mode selections
- setting parameters
- digital inputs and logic signals
- measured and pre-processed voltage magnitudes.

The function outputs the START, TRIP and BLOCKED signals which can be used for direct I/O controlling and user logic programming. The function generates general time-stamped ON/OFF events to the common event buffer from each of the three (3) output signals. In the instant operating mode the function outputs START and TRIP events simultaneously with an equivalent time stamp. The time stamp resolution is 1 ms. The function also a resettable cumulative counter for the START, TRIP and BLOCKED events.

The following figure presents a simplified function block diagram of the undervoltage function.

Figure. 5.3.11 - 122. Simplified function block diagram of the U < function.

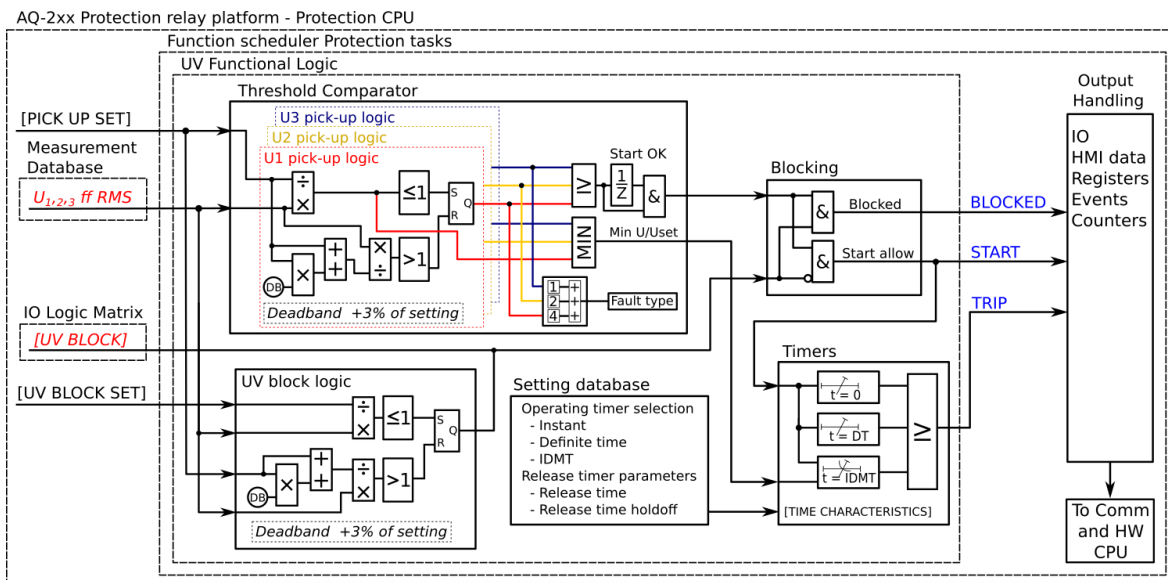

Measured input

The function block uses analog voltage measurement values. The monitored magnitudes are equal to RMS values. A -20 ms averaged value of the selected magnitude is used for pre-fault data registering.

Table. 5.3.11 - 106. Measurement inputs of the U< function.

Signal	Description	Time base
U _{L12} RMS	RMS measurement of voltage U _{L12} /V	5ms
U _{L23} RMS	RMS measurement of voltage U _{L23} /V	5ms
U _{L31} RMS	RMS measurement of voltage U _{L31} /V	5ms
U _{L1} RMS	RMS measurement of voltage U _{L1} /V	5ms
U _{L2} RMS	RMS measurement of voltage U _{L2} /V	5ms
U _{L3} RMS	RMS measurement of voltage U _{L3} /V	5ms

Pick-up

The U_{set} setting parameter controls the pick-up of the U< function. This defines the minimum allowed measured voltage before action from the function. The function constantly calculates the ratio between the U_{set} and the measured magnitude (U_m) for each of the three voltages. The reset ratio of 103 % is built into the function and is always relative to the U_{set} value. The setting value is common for all measured amplitudes, and when the U_m exceeds the U_{set} value (in single, dual or all voltages) it triggers the pick-up operation of the function.

Table. 5.3.11 - 107. Pick-up settings.

Name	Description	Range	Step	Default
U _{set}	Pick-up setting	20.00...120.00%U _n	0.01%U _n	60%U _n
U Block setting	Block setting. If set to zero, blocking is not in use. The operation is explained in the next chapter.	0.00...100.00%U _n	0.01%U _n	10%U _n

The pick-up activation of the function is not directly equal to the START signal generation of the function. The START signal is allowed if the blocking condition is not active.

Using *Block setting* to prevent nuisance trips

It is recommended to use the *Block setting* parameter to prevent the relay from tripping in a situation where the network is de-energized. When the measured voltage drops below the set value, the relay does not give a tripping signal. If the measured voltage has dropped below the *Block setting* parameter, the blocking continues until all of the line voltages have increased above the U< pick-up setting. Please see the image below for a visualization of this function. If the block level is set to zero (0), blocking is not in use.

Figure. 5.3.11 - 123. Example of the block setting operation.

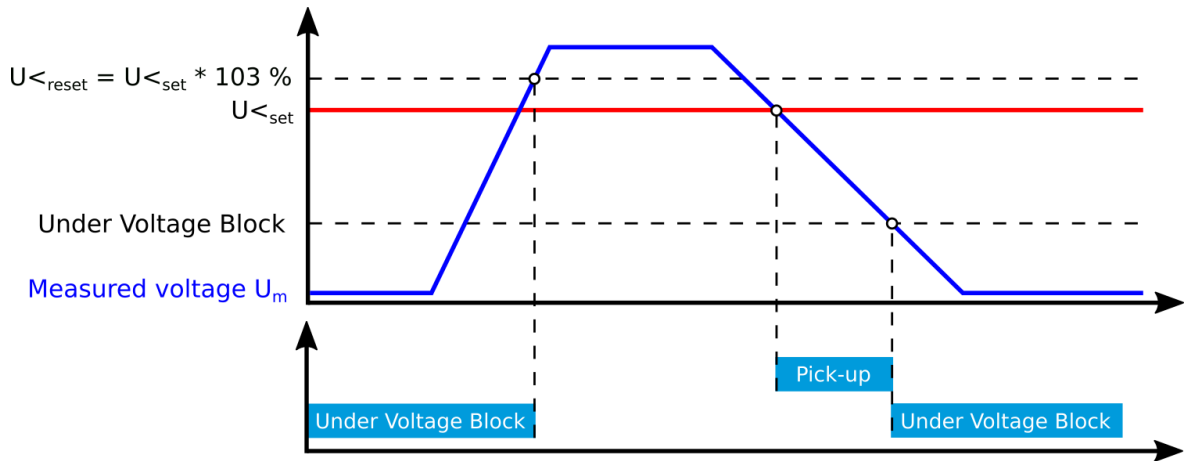

Read-only parameters

The relay's *Info* page displays useful, real-time information on the state of the protection function. It is accessed either through the relay's HMI display, or through the setting tool software when it is connected to the relay and its Live Edit mode is active.

Table. 5.3.11 - 108. Information displayed by the function.

Name	Range	Step	Description
U< pick-up setting	0.0...1 000 000.0V	0.1V	The primary voltage required for tripping. The displayed pick-up voltage level depends on the pick-up setting and the voltage transformer settings.
U< block setting	0.0...1 000 000.0V	0.1V	The primary voltage level required for trip blocking. If the measured voltage is below this value, the network is considered de-energized and the function will not trip. To deactivate the blocking the measured voltage must exceed the pick-up setting value.
Expected operating time	0.000...1800.000s	0.005s	Displays the expected operating time when a fault occurs. When IDMT mode is used, the expected operating time depends on the measured voltage value. If the measured voltage changes during a fault, the expected operating time changes accordingly.
Time remaining to trip	-1800.000...1800.000s	0.005s	When the function has detected a fault and counts down time towards a trip, this displays how much time is left before tripping occurs.
U _{A(B)} meas/U _{set} at the moment	0.00...1250.00U _m /U _{set}	0.01U _m /U _{set}	The ratio between U _A or U _{AB} voltage and the pick-up value.
U _{B(c)} meas/U _{set} at the moment	0.00...1250.00U _m /U _{set}	0.01U _m /U _{set}	The ratio between U _B or U _{BC} voltage and the pick-up value.
U _{C(A)} meas/U _{set} at the moment	0.00...1250.00U _m /U _{set}	0.01U _m /U _{set}	The ratio between U _C or U _{CA} voltage and the pick-up value.
U _{meas} /U _{set} at the moment	0.00...1250.00U _m /U _{set}	0.01U _m /U _{set}	The ratio between the lowest measured phase or line voltage and the pick-up value.

Function blocking

The block signal is checked in the beginning of each program cycle. The blocking signal is received from the blocking matrix in the function's dedicated input. If the blocking signal is not activated when the pick-up element activates, a START signal is generated and the function proceeds to the time characteristics calculation.

If the blocking signal is active when the pick-up element activates, a BLOCKED signal is generated and the function does not process the situation further. If the START function has been activated before the blocking signal, it resets and the release time characteristics are processed similarly to when the pick-up signal is reset.

The blocking of the function causes an HMI display event and a time-stamped blocking event with information of the startup voltage values and its fault type to be issued.

The blocking signal can also be tested in the commissioning phase by a software switch signal when the relay's testing mode "Enable stage forcing" is activated (*General* → *Device*).

The variables the user can set are binary signals from the system. The blocking signal needs to reach the device minimum of 5 ms before the set operating delay has passed in order for the blocking to activate in time.

Operating time characteristics for trip and reset

The operating timers' behavior during a function can be set for TRIP signal and also for the release of the function in case the pick-up element is reset before the trip time has been reached. There are three basic operating modes available for the function:

- Instant operation: gives the TRIP signal with no additional time delay simultaneously with the START signal.
- Definite time operation (DT): gives the TRIP signal after a user-defined time delay regardless of the measured voltage as long as the voltage is above the U_{set} value and thus the pick-up element is active (independent time characteristics).
- Inverse definite minimum time (IDMT): gives the TRIP signal after a time which is in relation to the set pick-up voltage U_{set} and the measured voltage U_m (dependent time characteristics).

The IDMT function follows this formula:

$$t = \frac{k}{1 - \left(\frac{U_m}{U_s}\right)^a}$$

Where:

- t = operating time
- k = time dial setting
- U_m = measured voltage
- U_s = pick-up setting
- a = IDMT multiplier setting

The following table presents the setting parameters for the function's time characteristics.

Table. 5.3.11 - 109. Setting parameters for operating time characteristics.

Name	Range	Step	Default	Description
Delay type	1: DT 2: IDMT	-	1: DT	Selection of the delay type time counter. The selection possibilities are dependent (IDMT, Inverse Definite Minimum Time) and independent (DT, Definite Time) characteristics.
Definite operating time delay	0.000...1800.000s	0.005s	0.040s	Definite time operating delay. The setting is active and visible when DT is the selected delay type. When set to 0.000 s, the stage operates as instant (PIOC, 50) stage without added delay. When the parameter is set to 0.005...1800 s, the stage operates as independent delayed.
Time dial setting k	0.01...60.00s	0.01s	0.05s	The setting is active and visible when IDMT is the selected delay type. Time dial/multiplier setting for IDMT characteristics.
IDMT Multiplier	0.01...25.00s	0.01s	1.00s	The setting is active and visible when IDMT is the selected delay type. IDMT time multiplier in the U_m/U_{set} power.

Table. 5.3.11 - 110. Setting parameters for reset time characteristics.

Name	Range	Step	Default	Description
Release time delay	0.000...150.000s	0.005s	0.06s	Resetting time. The time allowed between pick-ups if the pick-up has not led to a trip operation. During this time the START signal is held on for the timers if the delayed pick-up release is active.
Delayed pick-up release	1: No 2: Yes	-	2: Yes	Resetting characteristics selection, either time-delayed or instant after the pick-up element is released. If activated, the START signal is reset after a set release time delay.
Time calc reset after release time	1: No 2: Yes	-	2: Yes	Operating timer resetting characteristics selection. When activated, the operating time counter is reset after a set release time if the pick-up element is not activated during this time. When disabled, the operating time counter is reset directly after the pick-up element reset.
Continue time calculation during release time	1: No 2: Yes	-	1: No	Time calculation characteristics selection. If activated, the operating time counter continues until a set release time has passed even if the pick-up element is reset.

The user can reset characteristics through the application. The default setting is a 60 ms delay; the time calculation is held during the release time.

In the release delay option the operating time counter calculates the operating time during the release. When using this option the function does not trip if the input signal is not re-activated while the release time count is on-going.

Events and registers

The undervoltage function (abbreviated "UV" in event block names) generates events and registers from the status changes in START, TRIP, and BLOCKED. The user can select which event messages are stored in the main event buffer: ON, OFF, or both. The function offers four (4) independent stages; the events are segregated for each stage operation.

The events triggered by the function are recorded with a time stamp and with process data values.

Table. 5.3.11 - 111. Event codes.

Event number	Event channel	Event block name	Event code	Description
5696	89	UV1	0	Start ON

Event number	Event channel	Event block name	Event code	Description
5697	89	UV1	1	Start OFF
5698	89	UV1	2	Trip ON
5699	89	UV1	3	Trip OFF
5700	89	UV1	4	Block ON
5701	89	UV1	5	Block OFF
5702	89	UV1	6	Undervoltage Block ON
5703	89	UV1	7	Undervoltage Block OFF
5760	90	UV2	0	Start ON
5761	90	UV2	1	Start OFF
5762	90	UV2	2	Trip ON
5763	90	UV2	3	Trip OFF
5764	90	UV2	4	Block ON
5765	90	UV2	5	Block OFF
5766	90	UV2	6	Undervoltage Block ON
5767	90	UV2	7	Undervoltage Block OFF
5824	91	UV3	0	Start ON
5825	91	UV3	1	Start OFF
5826	91	UV3	2	Trip ON
5827	91	UV3	3	Trip OFF
5828	91	UV3	4	Block ON
5829	91	UV3	5	Block OFF
5830	91	UV3	6	Undervoltage Block ON
5831	91	UV3	7	Undervoltage Block OFF
5888	92	UV4	0	Start ON
5889	92	UV4	1	Start OFF
5890	92	UV4	2	Trip ON
5891	92	UV4	3	Trip OFF
5892	92	UV4	4	Block ON
5893	92	UV4	5	Block OFF
5894	92	UV4	6	Undervoltage Block ON
5895	92	UV4	7	Undervoltage Block OFF

The function registers its operation into the last twelve (12) time-stamped registers; this information is available for all provided instances separately. The register of the function records the ON event process data for START, TRIP or BLOCKED. The table below presents the structure of the function's register content.

Table. 5.3.11 - 112. Register content.

Date and time	Event code	Fault type	Pre-trig voltage	Fault voltage	Pre-fault voltage	Trip time remaining	Used SG
dd.mm.yyyy hh:mm:ss.mss	5696-5895 Descr.	A...A- B-C	Start average voltage	Trip -20ms averages	Start -200ms averages	0 ms...1800s	Setting group 1...8 active

5.3.12 Neutral overvoltage protection (U0>; 59N)

The neutral overvoltage function is used for non-directional instant and time-delayed earth fault protection. Each device with a voltage protection module has four (4) available stages of the function (U0>, U0>>, U0>>>, U0>>>>). The function constantly measures phase-to-earth voltage magnitudes and calculates the zero sequence component. Neutral overvoltage protection is scaled to line-to-line RMS level. When the line-to-line voltage of a system is 100 V in the secondary side, the earth fault is 100 % of the U_n and the calculated zero sequence voltage reaches $100/\sqrt{3}$ V = 57.74 V.

Below is the formula for symmetric component calculation (and therefore to zero sequence voltage calculation).

$$U_0 = 1/3(U_{L1} + U_{L2} + U_{L3})$$

$U_{L1...3}$ = Line to neutral voltages

Below are some examples of zero sequence calculation.

Figure. 5.3.12 - 124. Normal situation.

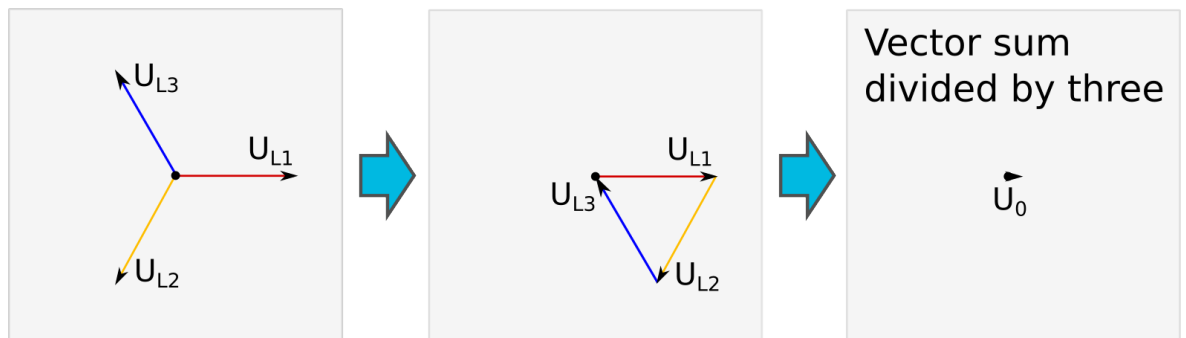

Figure. 5.3.12 - 125. Earth fault in isolated network.

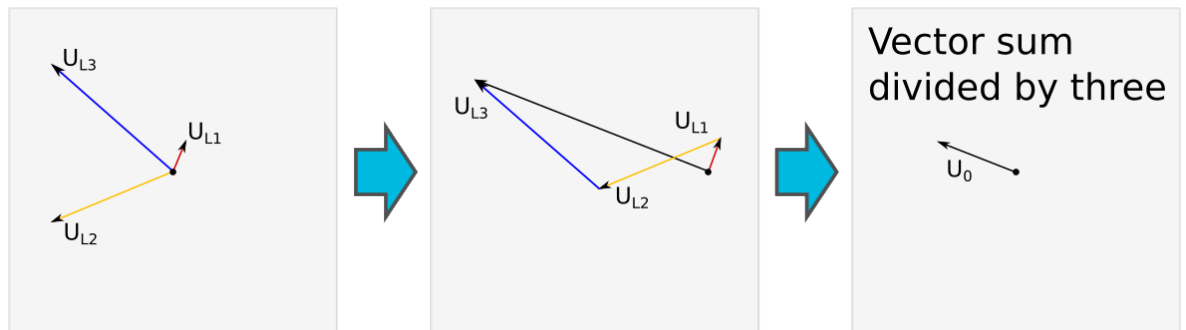
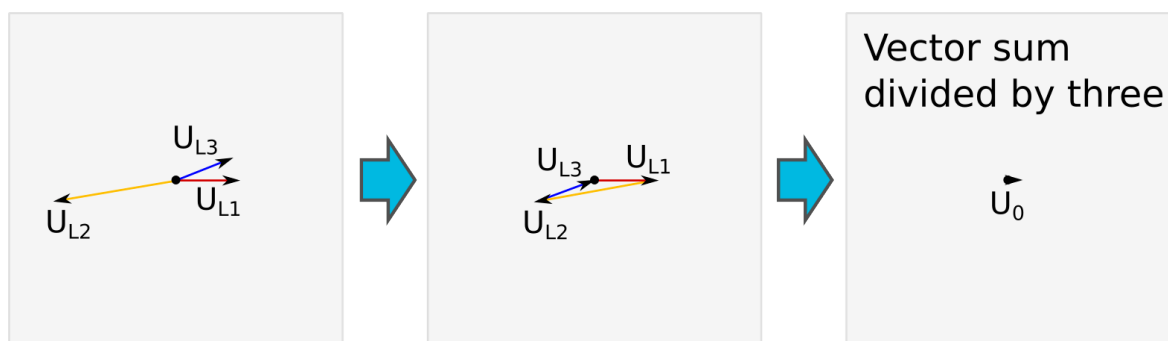

Figure. 5.3.12 - 126. Close-distance short-circuit between phases 1 and 3.



The monitored voltage magnitudes are equal to RMS values. The blocking signal and the setting group selection control the operating characteristics of the function during normal operation, i.e. the user or user-defined logic can change function parameters while the function is running.

The outputs of the function are the START, TRIP and BLOCKED signals. The neutral overvoltage function uses a total of eight (8) separate setting groups which can be selected from one common source.

The function can operate on instant or time-delayed mode. In the time-delayed mode the operation can be selected for definite time (DT) or for inverse definite minimum time (IDMT); the IDMT operation supports both IEC and ANSI standard time delays as well as custom parameters.

The operational logic consists of the following:

- input magnitude selection
- input magnitude processing
- threshold comparator
- block signal check
- time delay characteristics
- output processing.

The inputs for the function are the following:

- operating mode selections
- setting parameters
- digital inputs and logic signals
- measured and pre-processed voltage magnitudes.

The function outputs the START, TRIP and BLOCKED signals which can be used for direct I/O controlling and user logic programming. The function generates general time-stamped ON/OFF events to the common event buffer from each of the three (3) output signals. In the instant operating mode the function outputs START and TRIP events simultaneously with an equivalent time stamp. The time stamp resolution is 1 ms. The function also provides a cumulative counter for the START, TRIP and BLOCKED events.

The following figure presents a simplified function block diagram of the neutral overvoltage function.

Figure. 5.3.12 - 127. Simplified function block diagram of the U0> function.

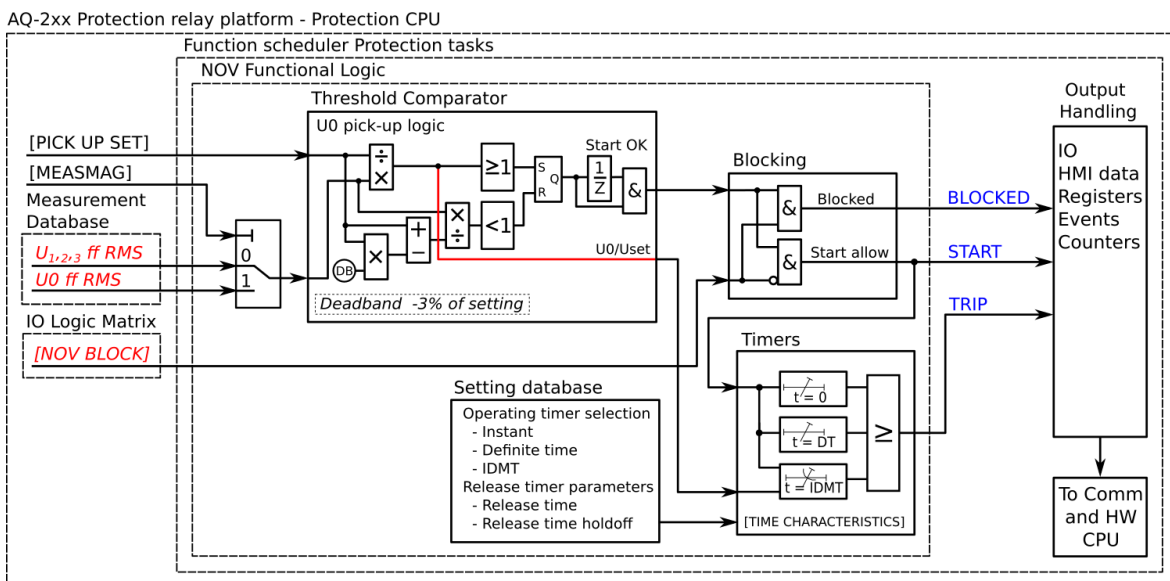

Measured input

The function block uses analog voltage measurement values. The function block uses RMS values. A -20 ms averaged value of the selected magnitude is used for pre-fault data registering.

Table. 5.3.12 - 113. Measurement inputs of the U0> function.

Signal	Description	Time base
U0RMS	RMS measurement of voltage U0/V	5ms
UL1RMS	RMS measurement of voltage UL1/V	5ms
UL2RMS	RMS measurement of voltage UL2/V	5ms
UL3RMS	RMS measurement of voltage UL3/V	5ms

The selection of the AI channel currently in use is made with a setting parameter. In all possible input channel variations the pre-fault condition is presented with a 20 ms averaged history value from -20 ms from a START or TRIP event.

Pick-up

The U_{set} setting parameter controls the pick-up of the U0> function. This defines the maximum allowed measured voltage before action from the function. The function constantly calculates the ratio between the U_{set} and the measured magnitude (U_m) for neutral voltage. The reset ratio of 97 % is built into the function and is always relative to the U_{set} value. The setting value is common for all measured amplitudes, and when the U_m exceeds the U_{set} value it triggers the pick-up operation of the function.

Table. 5.3.12 - 114. Pick-up settings.

Name	Description	Range	Step	Default
Pick-up setting U0set>	Pick-up setting	1.00...99.00%U _n	0.01%U _n	20.00%U _n

The pick-up activation of the function is not directly equal to the START signal generation of the function. The START signal is allowed if the blocking condition is not active.

Read-only parameters

The relay's *Info* page displays useful, real-time information on the state of the protection function. It is accessed either through the relay's HMI display, or through the setting tool software when it is connected to the relay and its Live Edit mode is active.

Name	Range	Step	Default	Description
U0> Measuring now	0: No U0 avail! 1: U0Calc 2: U3 Input 3: U4 Input	-	0: Select	Displays which voltage channel is used by the function. If no voltage channel has been selected the function defaults to calculated residual voltage if line-to-neutral voltages have been connected to device. If no channel is set to "U0" mode and line-to-line voltages are connected, no residual voltage is available and "No U0 avail!" will be displayed.
U0> Pick-up setting	0.0...1 000 000.0V	0.1V	-	Primary voltage required for tripping. The displayed pick-up voltage level depends on the chosen U0 measurement input selection, on the pick-up settings and on the voltage transformer settings.
Expected operating time	0.000...1800.000s	0.005s	-	Displays the expected operating time when a fault occurs. When IDMT mode is used, the expected operating time depends on the measured voltage value. If the measured voltage changes during a fault, the expected operating time changes accordingly.
Time remaining to trip	-1800.000...1800.000s	0.005s	-	When the function has detected a fault and counts down time towards a trip, this displays how much time is left before tripping occurs.
U _{meas} /U _{set} at the moment	0.00...1250.00	0.01	-	The ratio between the measured or calculated neutral voltage and the pick-up value.

Function blocking

The block signal is checked in the beginning of each program cycle. The blocking signal is received from the blocking matrix in the function's dedicated input. If the blocking signal is not activated when the pick-up element activates, a START signal is generated and the function proceeds to the time characteristics calculation.

If the blocking signal is active when the pick-up element activates, a BLOCKED signal is generated and the function does not process the situation further. If the START function has been activated before the blocking signal, it resets and the release time characteristics are processed similarly to when the pick-up signal is reset.

The blocking of the function causes an HMI display event and a time-stamped blocking event with information of the startup voltage values and its fault type to be issued.

The blocking signal can also be tested in the commissioning phase by a software switch signal when the relay's testing mode "Enable stage forcing" is activated (*General* → *Device*).

The variables the user can set are binary signals from the system. The blocking signal needs to reach the device minimum of 5 ms before the set operating delay has passed in order for the blocking to activate in time.

Operating time characteristics for trip and reset

The operating timers' behavior during a function can be set for TRIP signal and also for the release of the function in case the pick-up element is reset before the trip time has been reached. There are three basic operating modes available for the function:

- Instant operation: gives the TRIP signal with no additional time delay simultaneously with the START signal.

- Definite time operation (DT): gives the TRIP signal after a user-defined time delay regardless of the measured or calculated voltage as long as the voltage is above the U_{set} value and thus the pick-up element is active (independent time characteristics).
- Inverse definite minimum time (IDMT): gives the TRIP signal after a time which is in relation to the set pick-up voltage U_{set} and the measured voltage U_m (dependent time characteristics).

The IDMT function follows this formula:

$$t = \frac{k}{\left(\frac{U_m}{U_s}\right)^a - 1}$$

Where:

- t = operating time
- k = time dial setting
- U_m = measured voltage
- U_s = pick-up setting
- a = IDMT multiplier setting

The following table presents the setting parameters for the function's time characteristics.

Table. 5.3.12 - 115. Setting parameters for operating time characteristics.

Name	Range	Step	Default	Description
Delay type	1: DT 2: IDMT	-	1: DT	Selection of the delay type time counter. The selection possibilities are dependent (IDMT, Inverse Definite Minimum Time) and independent (DT, Definite Time) characteristics.
Definite operating time delay	0.000...1800.000s	0.005s	0.040s	Definite time operating delay. The setting is active and visible when DT is the selected delay type. When set to 0.000 s, the stage operates as instant without added delay. When the parameter is set to 0.005...1800 s, the stage operates as independent delayed.
Time dial setting k	0.01...60.00s	0.01s	0.05s	The setting is active and visible when IDMT is the selected delay type. Time dial/multiplier setting for IDMT characteristics.
IDMT Multiplier	0.01...25.00s	0.01s	1.00s	The setting is active and visible when IDMT is the selected delay type. IDMT time multiplier in the U_m/U_{set} power.

Table. 5.3.12 - 116. Setting parameters for reset time characteristics.

Name	Range	Step	Default	Description
Release time delay	0.000...150.000s	0.005s	0.06s	Resetting time. Time allowed between pick-ups if the pick-up has not led to a trip operation. During this time the START signal is held on for the timers if the delayed pick-up release is active.
Delayed pick-up release	1: No 2: Yes	-	2: Yes	Resetting characteristics selection either as time-delayed or as instant after the pick-up element is released. If activated, the START signal is reset after a set release time delay.
Time calc reset after release time	1: No 2: Yes	-	2: Yes	Operating timer resetting characteristics selection. When active, the operating time counter is reset after a set release time if the pick-up element is not activated during this time. When disabled, the operating time counter is reset directly after the pick-up element reset.

Name	Range	Step	Default	Description
Continue time calculation during release time	1: No 2: Yes	-	1: No	Time calculation characteristics selection. If activated, the operating time counter continues until a set release time has passed even if the pick-up element is reset.

The user can reset characteristics through the application. The default setting is a 60 ms delay; the time calculation is held during the release time.

In the release delay option the operating time counter calculates the operating time during the release. When using this option the function does not trip if the input signal is not re-activated while the release time count is on-going.

Events and registers

The neutral overvoltage function (abbreviated "NOV" in event block names) generates events and registers from the status changes in START, TRIP, and BLOCKED. The user can select which event messages are stored in the main event buffer: ON, OFF, or both. The function offers four (4) independent stages; the events are segregated for each stage operation.

The events triggered by the function are recorded with a time stamp and with process data values.

Table. 5.3.12 - 117. Event codes.

Event number	Event channel	Event block name	Event code	Description
5952	93	NOV1	0	Start ON
5953	93	NOV1	1	Start OFF
5954	93	NOV1	2	Trip ON
5955	93	NOV1	3	Trip OFF
5956	93	NOV1	4	Block ON
5957	93	NOV1	5	Block OFF
6016	94	NOV2	0	Start ON
6017	94	NOV2	1	Start OFF
6018	94	NOV2	2	Trip ON
6019	94	NOV2	3	Trip OFF
6020	94	NOV2	4	Block ON
6021	94	NOV2	5	Block OFF
6080	95	NOV3	0	Start ON
6081	95	NOV3	1	Start OFF
6082	95	NOV3	2	Trip ON
6083	95	NOV3	3	Trip OFF
6084	95	NOV3	4	Block ON
6085	95	NOV3	5	Block OFF
6144	96	NOV4	0	Start ON
6145	96	NOV4	1	Start OFF
6146	96	NOV4	2	Trip ON

Event number	Event channel	Event block name	Event code	Description
6147	96	NOV4	3	Trip OFF
6148	96	NOV4	4	Block ON
6149	96	NOV4	5	Block OFF

The function registers its operation into the last twelve (12) time-stamped registers; this information is available for all provided instances separately. The register of the function records the ON event process data for START, TRIP or BLOCKED. The table below presents the structure of the function's register content.

Table. 5.3.12 - 118. Register content.

Date and time	Event code	Fault type	Trigger voltage	Fault voltage	Pre-fault voltage	Trip time remaining	Used SG
dd.mm.yyyy hh:mm:ss.mss	5952-6149 Descr.	L1-G...L1-L2-L3	Start average voltage	Trip -20ms averages	Start -200ms averages	0 ms...1800s	Setting group 1...8 active

5.3.13 Sequence voltage protection (U1/U2>/<; 47/27P/59PN)

The sequence voltage function is used for instant and time-delayed voltage protection. It has positive and negative sequence protection for both overvoltage and undervoltage (the user selects the needed function). Each device with a voltage protection module has four (4) available stages of the function. The function constantly measures the RMS value of phase-to-earth voltage magnitudes, or line-to-line and neutral voltage magnitudes to calculate the positive or negative sequence voltage. The user can select the voltage used. Sequence voltage is based on the system's line-to-line voltage level. Protection stages can be set to protect against both undervoltage and overvoltage. The blocking signal and the setting group selection control the operating characteristics of the function during normal operation, i.e. the user or user-defined logic can change function parameters while the function is running.

Positive sequence voltage calculation

Below is the formula for symmetric component calculation (and therefore to positive sequence voltage calculation).

$$U_1 = \frac{1}{3}(U_{L1} + aU_{L2} + a^2U_{L3})$$

$$a = 1 \angle 120^\circ$$

$$a^2 = 1 \angle 240^\circ$$

$$U_{L1...3} = \textit{Line to neutral voltages}$$

In what follows are three examples of positive sequence calculation (positive sequence component vector).

Figure. 5.3.13 - 128. Normal situation.

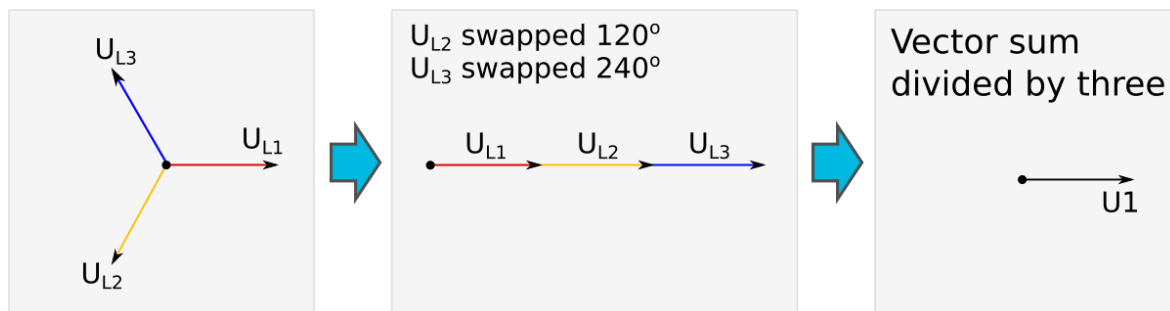

Figure. 5.3.13 - 129. Earth fault in an isolated network.

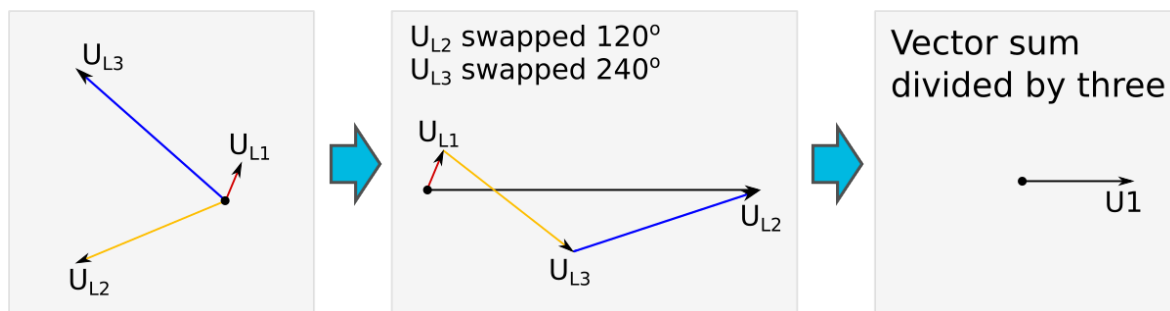
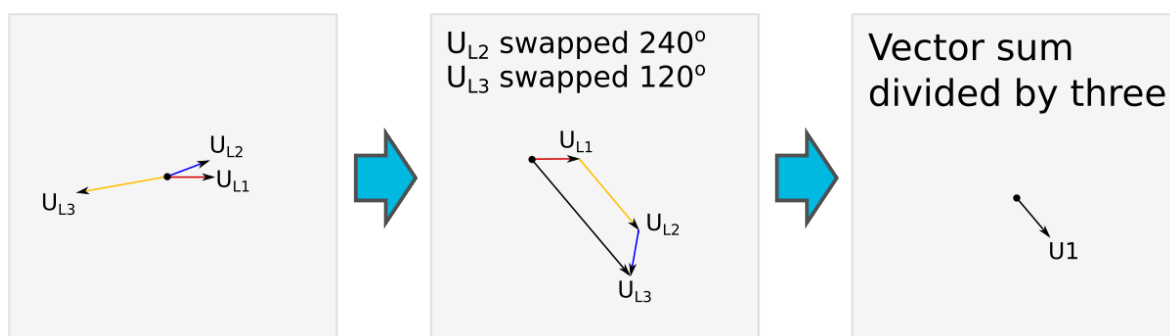

Figure. 5.3.13 - 130. Close-distance short-circuit between phases 1 and 3.



Negative sequence voltage calculation

Below is the formula for symmetric component calculation (and therefore to negative sequence voltage calculation).

$$U_2 = \frac{1}{3} (U_{L1} + a^2 U_{L2} + a U_{L3})$$

$$a = 1 \angle 120^\circ$$

$$a^2 = 1 \angle 240^\circ$$

$$U_{L1...3} = \text{Line to neutral voltages}$$

In what follows are three examples of negative sequence calculation (negative sequence component vector).

Figure. 5.3.13 - 131. Normal situation.

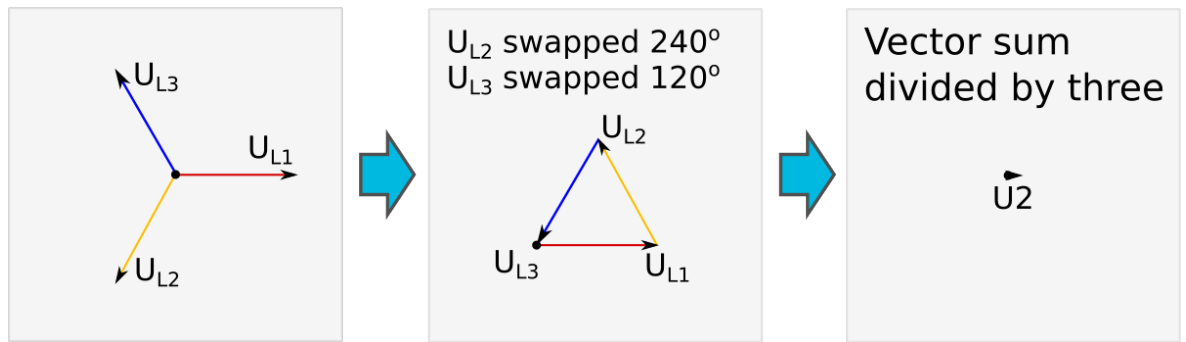

Figure. 5.3.13 - 132. Earth fault in isolated network.

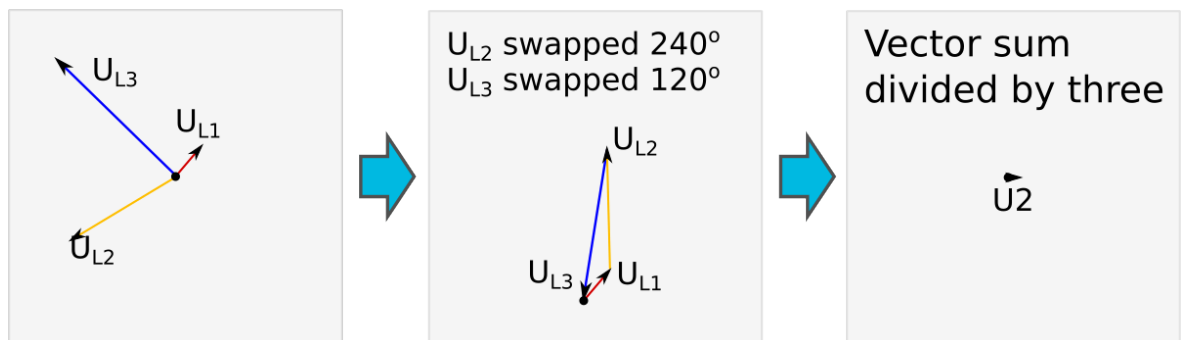
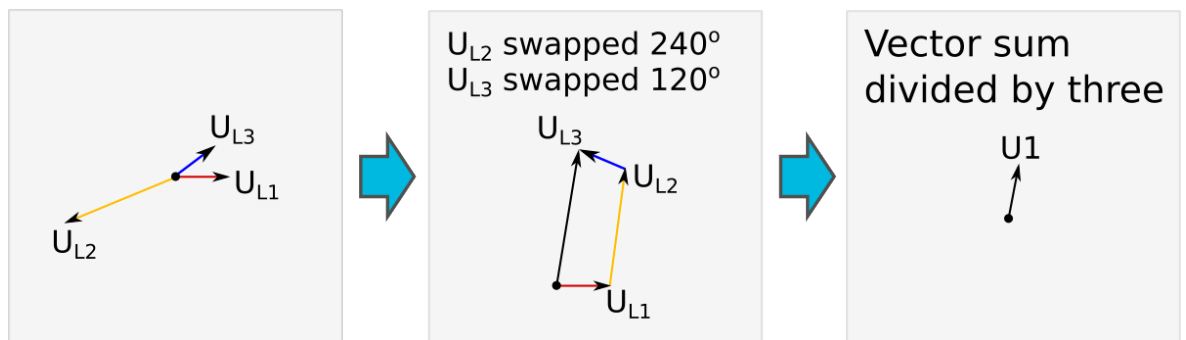

Figure. 5.3.13 - 133. Close-distance short-circuit between phases 1 and 3.



The sequence voltage function uses a total of eight (8) separate setting groups which can be selected from one common source.

The function can operate on instant or time-delayed mode. In time-delayed mode the operation can be selected between definite time (DT) mode and inverse definite minimum time (IDMT).

The operational logic consists of the following:

- input magnitude selection
- input magnitude processing
- threshold comparator
- block signal check
- time delay characteristics
- output processing.

The inputs for the function are the following:

- operating mode selections
- setting parameters

- digital inputs and logic signals
- measured and pre-processed voltage magnitudes.

The function outputs the START, TRIP and BLOCKED signals which can be used for direct I/O controlling and user logic programming. The function generates general time-stamped ON/OFF events to the common event buffer from each of the three (3) output signal. In the instant operating mode the function outputs START and TRIP events simultaneously with an equivalent time stamp. The time stamp resolution is 1 ms. The function also a resettable cumulative counter for the START, TRIP and BLOCKED events.

The following figure presents a simplified function block diagram of the sequence voltage function.

Figure. 5.3.13 - 134. Simplified function block diagram of the U1/U2>/< function.

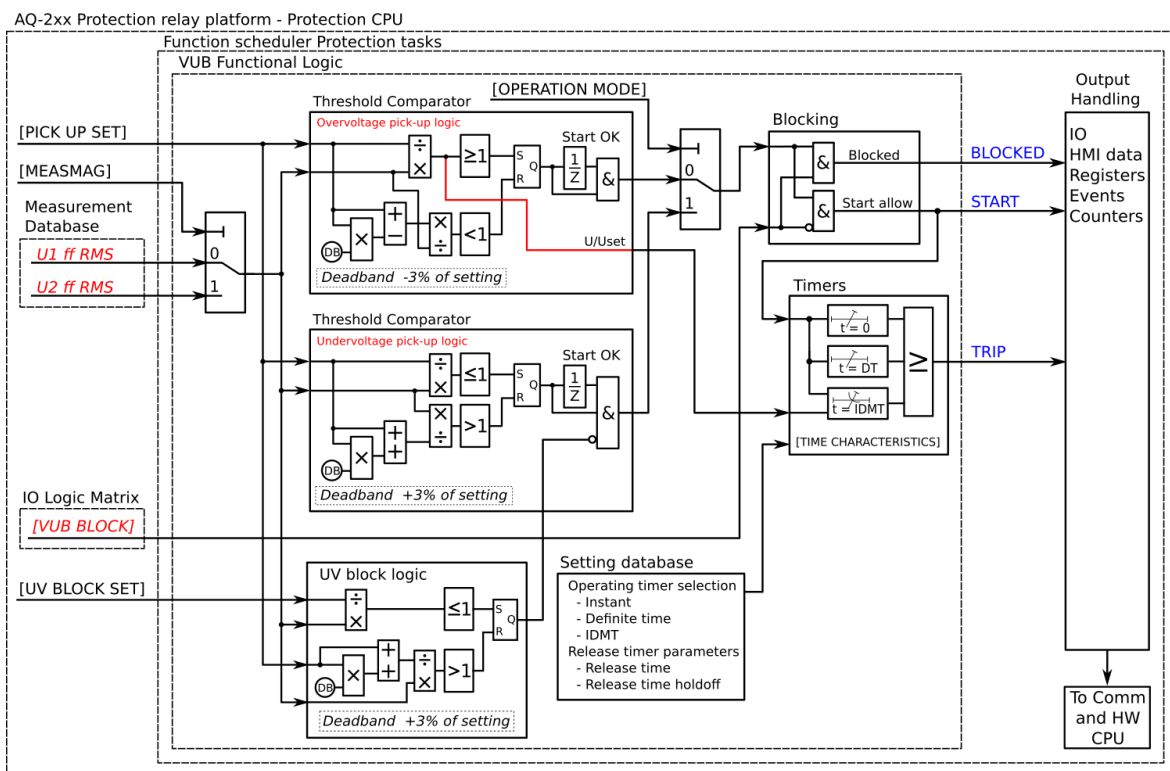

Measured input

The function block uses analog voltage measurement values and always uses RMS values. A -20 ms averaged value of the selected magnitude is used for pre-fault data registering.

Table. 5.3.13 - 119. Measurement inputs of the U1/U2>/< function.

Signal	Description	Time base
U ₁ RMS	RMS measurement of voltage U ₁ /V	5ms
U ₂ RMS	RMS measurement of voltage U ₂ /V	5ms
U ₃ RMS	RMS measurement of voltage U ₃ /V	5ms

Table. 5.3.13 - 120. Measured magnitude selection.

Name	Description	Range	Default
Measured magnitude	Selects which calculated voltage is supervised.	1: U1 Positive sequence voltage 2: U2 Negative sequence voltage	1: U1 Positive sequence voltage

In RMS values the pre-fault condition is presented with 20 ms averaged history value from -20 ms of START or TRIP event.

Pick-up

The U_{set} setting parameter controls the pick-up of the U1/U2>/< function. This defines the maximum or minimum allowed calculated U1 or U2 voltage before action from the function. The function constantly calculates the ratio between the U_{set} and the calculated U1 or U2 magnitude (U_C). The monitored voltage is chosen in the *Info* page with the parameter *Measured magnitude*. The reset ratio of 97 % in overvoltage applications is built into the function and is always relative to the U_{set} value. The reset ratio of 103 % in undervoltage applications is built into the function and is always relative to the U_{set} value. When the U_C goes above or below the U_{set} value it triggers the pick-up operation of the function.

Table. 5.3.13 - 121. Pick-up settings.

Name	Description	Range	Step	Default
Pick-up terms	Selects whether the function picks-up when the monitored voltage is under or over the set pick-up value.	Over > Under <	-	Over >
U_{set}	Pick-up setting	5.00...150.00% U_n	0.01% U_n	105% U_n
U_{blk}	Undervoltage blocking (visible when the pick-up term is Under <)	0.00...80.00% U_n	0.01% U_n	5% U_n

The pick-up activation of the function is not directly equal to the START signal generation of the function. The START signal is allowed if the blocking condition is not active.

Using *Block setting* to prevent nuisance trips

It is recommended to use the *Under block setting* U_{blk} parameter when Under < is the chosen tripping condition to prevent the relay from tripping in a situation where the network is de-energized. When the measured voltage drops below the set value, the relay does not give a tripping signal. If the measured voltage has dropped below the *Under block setting* U_{blk} parameter, the blocking continues until all of the line voltages have increased above the U < pick-up setting. Please see the image below for a visualization of this function. If the block level is set to zero (0), blocking is not in use.

Figure. 5.3.13 - 135. Example of the block setting operation.

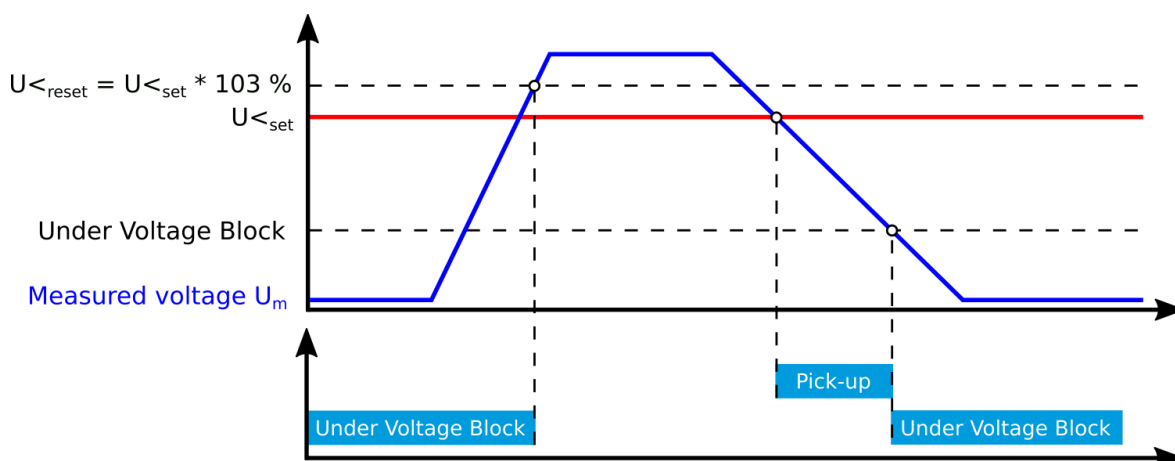

Read-only parameters

The relay's *Info* page displays useful, real-time information on the state of the protection function. It is accessed either through the relay's HMI display, or through the setting tool software when it is connected to the relay and its Live Edit mode is active.

Table. 5.3.13 - 122. Information displayed by the function.

Name	Range	Step	Description
U1/2 >/< Pick-up setting	0.0...1 000 000.0V	0.1V	The primary voltage required for tripping. The displayed pick-up voltage level depends on the pick-up setting and the voltage transformer settings.
Expected operating time	0.000...1800.000s	0.005s	Displays the expected operating time when a fault occurs. When IDMT mode is used, the expected operating time depends on the measured voltage value. If the measured voltage changes during a fault, the expected operating time changes accordingly.
Time remaining to trip	-1800.000...1800.000s	0.005s	When the function has detected a fault and counts down time towards a trip, this displays how much time is left before tripping occurs.
U_{meas}/U_{set} at the moment	0.00...1250.00 U_m/U_{set}	0.01 U_m/U_{set}	The ratio between the measured voltage and the pick-up value.

Function blocking

The block signal is checked in the beginning of each program cycle. The blocking signal is received from the blocking matrix in the function's dedicated input. If the blocking signal is not activated when the pick-up element activates, a START signal is generated and the function proceeds to the time characteristics calculation.

If the blocking signal is active when the pick-up element activates, a BLOCKED signal is generated and the function does not process the situation further. If the START function has been activated before the blocking signal, it resets and the release time characteristics are processed similarly to when the pick-up signal is reset.

The blocking of the function causes an HMI display event and a time-stamped blocking event with information of the startup voltage values and its fault type to be issued.

The blocking signal can also be tested in the commissioning phase by a software switch signal when the relay's testing mode "Enable stage forcing" is activated (*General* → *Device*).

The variables the user can set are binary signals from the system. The blocking signal needs to reach the device minimum of 5 ms before the set operating delay has passed in order for the blocking to activate in time.

Operating time characteristics for trip and reset

The operating timers' behavior during a function can be set for TRIP signal and also for the release of the function in case the pick-up element is reset before the trip time has been reached. There are three basic operating modes available for the function:

- Instant operation: gives the TRIP signal with no additional time delay simultaneously with the START signal.
- Definite time operation (DT): gives the TRIP signal after a user-defined time delay regardless of the measured or calculated voltage as long as the voltage is above the U_{set} value and thus the pick-up element is active (independent time characteristics).
- Inverse definite minimum time (IDMT): gives the TRIP signal after a time which is in relation to the set pick-up voltage U_{set} and the measured voltage U_m (dependent time characteristics).

The IDMT function follows one of the following formulas:

$$\begin{array}{cc}
 \text{Overvoltage} & \text{Undervoltage} \\
 t = \frac{k}{\left(\frac{U_m}{U_s}\right)^a - 1} & t = \frac{k}{1 - \left(\frac{U_m}{U_s}\right)^a}
 \end{array}$$

Where:

- t = operating time
- k = time dial setting
- U_m = measured voltage
- U_s = pick-up setting
- a = IDMT multiplier setting

The following table presents the setting parameters for the function's time characteristics.

Table. 5.3.13 - 123. Setting parameters for operating time characteristics.

Name	Range	Step	Default	Description
Delay type	1: DT 2: IDMT	-	1: DT	Selection of the delay type time counter. The selection possibilities are dependent (IDMT, Inverse Definite Minimum Time) and independent (DT, Definite Time) characteristics.
Definite operating time delay	0.000...1800.000s	0.005s	0.040s	Definite time operating delay. The setting is active and visible when DT is the selected delay type. When set to 0.000 s, the stage operates as instant without added delay. When the parameter is set to 0.005...1800 s, the stage operates as independent delayed.
Time dial setting k	0.01...60.00s	0.01s	0.05s	The setting is active and visible when IDMT is the selected delay type. Time dial/multiplier setting for IDMT characteristics.
IDMT Multiplier	0.01...25.00s	0.01s	1.00s	The setting is active and visible when IDMT is the selected delay type. IDMT time multiplier in the U_m/U_{set} power.

Table. 5.3.13 - 124. Setting parameters for reset time characteristics.

Name	Range	Step	Default	Description
Release time delay	0.000...150.000s	0.005s	0.06s	Resetting time. Time allowed between pick-ups if the pick-up has not led to a trip operation. During this time the START signal is held on for the timers if the delayed pick-up release is active.
Delayed pick-up release	1: No 2: Yes	-	2: Yes	Resetting characteristics selection either as time-delayed or as instant after the pick-up element is released. If activated, the START signal is reset after a set release time delay.
Time calc reset after release time	1: No 2: Yes	-	2: Yes	Operating timer resetting characteristics selection. When active, the operating time counter is reset after a set release time if the pick-up element is not activated during this time. When disabled, the operating time counter is reset directly after the pick-up element reset.
Continue time calculation during release time	1: No 2: Yes	-	1: No	Time calculation characteristics selection. If activated, the operating time counter continues until a set release time has passed even if the pick-up element is reset.

The user can reset characteristics through the application. The default setting is a 60 ms delay; the time calculation is held during the release time.

In the release delay option the operating time counter calculates the operating time during the release. When using this option the function does not trip if the input signal is not re-activated while the release time count is on-going.

Events and registers

The sequence voltage function (abbreviated "VUB" in event block names) generates events and registers from the status changes in START, TRIP and BLOCKED. The user can select which event messages are stored in the main event buffer: ON, OFF, or both. The function offers four (4) independent stages; the events are segregated for each stage operation.

The events triggered by the function are recorded with a time stamp and with process data values.

Table. 5.3.13 - 125. Event codes.

Event number	Event channel	Event block name	Event code	Description
8320	130	VUB1	0	Start ON
8321	130	VUB1	1	Start OFF
8322	130	VUB1	2	Trip ON
8323	130	VUB1	3	Trip OFF
8324	130	VUB1	4	Block ON
8325	130	VUB1	5	Block OFF
8384	131	VUB2	0	Start ON
8385	131	VUB2	1	Start OFF
8386	131	VUB2	2	Trip ON
8387	131	VUB2	3	Trip OFF
8388	131	VUB2	4	Block ON
8389	131	VUB2	5	Block OFF
8448	132	VUB3	0	Start ON

Event number	Event channel	Event block name	Event code	Description
8449	132	VUB3	1	Start OFF
8450	132	VUB3	2	Trip ON
8451	132	VUB3	3	Trip OFF
8452	132	VUB3	4	Block ON
8453	132	VUB3	5	Block OFF
8512	133	VUB4	0	Start ON
8513	133	VUB4	1	Start OFF
8514	133	VUB4	2	Trip ON
8515	133	VUB4	3	Trip OFF
8516	133	VUB4	4	Block ON
8517	133	VUB4	5	Block OFF

The function registers its operation into the last twelve (12) time-stamped registers; this information is available for all provided instances separately. The register of the function records the ON event process data for START, TRIP or BLOCKED. The table below presents the structure of the function's register content.

Table. 5.3.13 - 126. Register content.

Date and time	Event code	Trigger voltage	Fault voltage	Pre-fault voltage	Trip time remaining	Used SG
dd.mm.yyyy hh:mm:ss.mss	8320 - 8517 Descr.	Start average voltage	Trip -20ms averages	Start -200ms averages	0 ms...1800s	Setting group 1...8 active

5.3.14 Overfrequency and underfrequency protection ($f > / <$; 81O/81U)

The frequency protection function can be used both in overfrequency and in underfrequency situations, and it has four (4) stages for both. Frequency protection can be applied to protect feeder, bus, transformer, motor and generator applications. The difference between the generated power and the load demand can cause the frequency to drop below or rise above the allowed level. When the consumption is larger than the generated power, the frequency may drop. When more power is generated than is consumed, overfrequency can occur.

In generator applications too big a load or a malfunction in the power controller can cause the frequency to decrease. Underfrequency causes damage to turbine wings through vibration as well as heating due to increased iron losses, dropped cooling efficiency and over-magnetization in step-up transformers. Overfrequency protection prevents the generator from running too fast which can cause damage to the generator turbine.

Underfrequency and overfrequency protection can be used as an indicator of an accidental island operation in distributed generation and in some consumers (as it is unlikely that the consumed and generated power are the same). Overfrequency is also often used to control power generation to keep the system's frequency consistent.

Each stage can be activated and deactivated individually. After the $f > / <$ mode has been activated (*Protection* → *Stage activation* → *Frequency stages*), the user can activate and deactivate the individual stages at will (*Protection* → *Frequency* → *Frequency protection $f > / <$* → *INFO* → *Stage operational setup*).

The outputs of the function are the START, TRIP and BLOCKED signals. The frequency protection function uses a total of eight (8) separate setting groups which can be selected from one common source.

The function can operate on instant or time-delayed mode.

The operational logic consists of the following:

- input magnitude processing
- threshold comparator
- two block signal check
- time delay characteristics
- output processing.

The inputs for the function are the following:

- operating mode selections
- setting parameters
- digital inputs and logic signals
- measured and pre-processed frequency magnitudes.

The function outputs the START, TRIP and BLOCKED signals which can be used for direct I/O controlling and user logic programming. The function generates general time-stamped ON/OFF events to the common event buffer from each of the three (3) output signal. In the instant operating mode the function outputs START and TRIP events simultaneously with an equivalent time stamp. The time stamp resolution is 1 ms. The function also provides a resettable cumulative counter for the START, TRIP and BLOCKED events.

The following figures present simplified function block diagrams of the frequency function.

Figure. 5.3.14 - 136. Simplified function block diagram of the f> function.

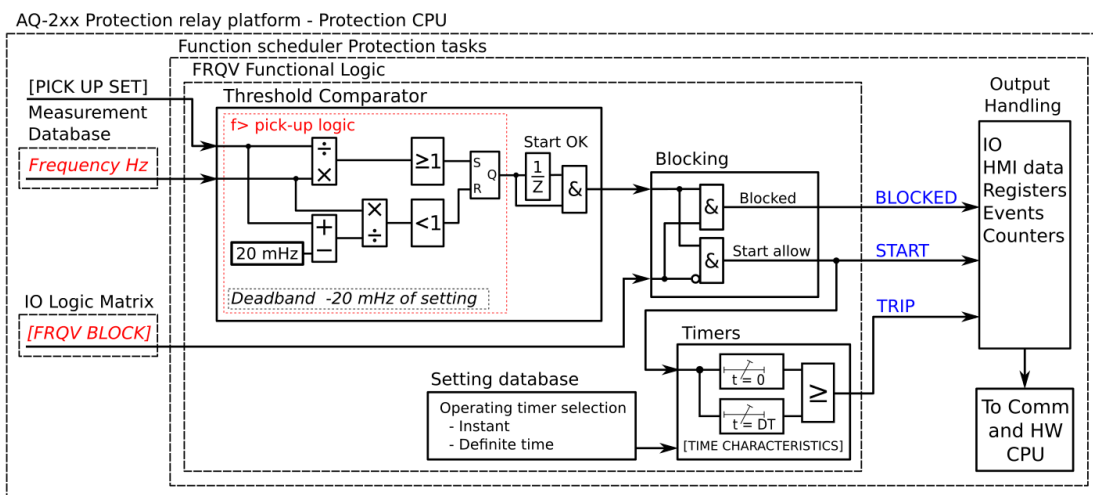
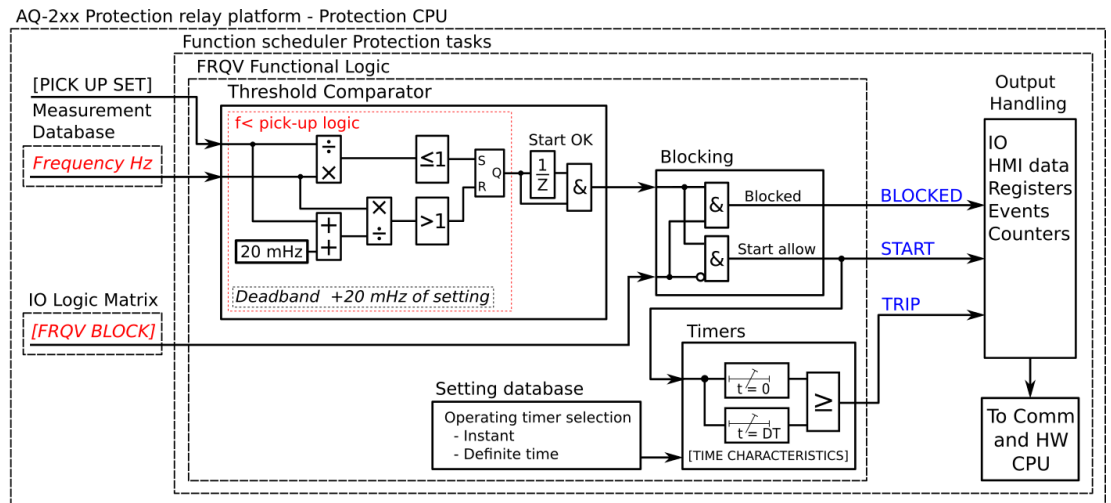

Figure. 5.3.14 - 137. Simplified function block diagram of the $f<$ function.



Measured input

The frequency protection function compares the measured frequency to the pick-up setting (given in Hz). The source of the measured frequency depends on the user-defined tracking reference which can be chosen from the *Frequency* tab of the *Measurement* menu.

Table. 5.3.14 - 127. Measurement inputs of the $f>/<$ function.

Signals	Description	Time base
VT1 U1, U2, U3	L-N voltages of the first voltage transformer	5ms
VT2 U1, U2, U3	L-N voltages of the second voltage transformer	5ms

Pick-up and time delay

The $f_{set>}$, $f_{set>>}$, etc. setting parameters control the pick-up of each stage of the $f>/<$ function. They define the maximum or minimum allowed measured frequency before action from the function. The function constantly calculates the ratio between the pick-up setting and the measured frequency. The reset ratio of 20mHz is built into the function and is always relative to the pick-up value.

Table. 5.3.14 - 128. Pick-up settings.

Name	Description	Range	Step	Default
$f>$ used in setting group $f>>$ used in setting group $f>>>$ used in setting group $f>>>>$ used in setting group $f<$ used in setting group $f<<$ used in setting group $f<<<$ used in setting group $f<<<<$ used in setting group	Enables or disables the protection stage in the setting group.	0: No 1: Yes	-	0: No
$f_{set>}$ $f_{set>>}$ $f_{set>>>}$ $f_{set>>>>}$	Pick-up setting	10.00...80.00Hz	0.01Hz	51Hz

Name	Description	Range	Step	Default
fset< fset<< fset<<< fset<<<<	Pick-up setting	5.00...75.00Hz	0.01Hz	49Hz
f> operating time f>> operating time f>>> operating time f>>>> operating time f< operating time f<< operating time f<<< operating time f<<<< operating time	Operation time	0.000...1800.00s	0.005s	0.1s

The pick-up activation of the function is not directly equal to the START signal generation of the function. The START signal is allowed if the blocking condition is not active.

Operating time characteristics for trip and reset

This function supports definite time delay (DT). For detailed information on this delay types please refer to the chapter "General properties of a protection function" and its section "Operating time characteristics for trip and reset".

Read-only parameters

The relay's *Info* page displays useful, real-time information on the state of the protection function. It is accessed either through the relay's HMI display, or through the setting tool software when it is connected to the relay and its Live Edit mode is active.

Table. 5.3.14 - 129. Information displayed by the function.

Name	Range	Step	Description
f>/< condition	0: Normal 1: Start 2: Trip 3: Blocked	-	Displays the status of the protection function.
f meas/f set	0.000..20.000 f_m/f_{set}	0.001 f_m/f_{set}	The ratio between the measured frequency and the pick-up value.
Expected operating time	0.000...1800.000s	0.005s	Displays the expected operating time when a fault occurs.
Time remaining to trip	-1800.000...1800.000s	0.005s	When the function has detected a fault and counts down time towards a trip, this displays how much time is left before tripping occurs.

Function blocking

The block signal is checked in the beginning of each program cycle. The blocking signal is received from the blocking matrix in the function's dedicated input. If the blocking signal is not activated when the pick-up element activates, a START signal is generated and the function proceeds to the time characteristics calculation.

If the blocking signal is active when the pick-up element activates, a BLOCKED signal is generated and the function does not process the situation further. If the START function has been activated before the blocking signal, it resets and the release time characteristics are processed similarly to when the pick-up signal is reset.

The blocking of the function causes an HMI display event and a time-stamped blocking event with information of the startup frequency values.

The blocking signal can also be tested in the commissioning phase by a software switch signal when the relay's testing mode "Enable stage forcing" is activated (*General* → *Device*).

The variables the user can set are binary signals from the system. The blocking signal needs to reach the device minimum of 5 ms before the set operating delay has passed in order for the blocking to activate in time.

Events and registers

The frequency function (abbreviated "FRQV" in event block names) generates events and registers from the status changes in START, TRIP and BLOCKED. The user can select which event messages are stored in the main event buffer: ON, OFF, or both.

The events triggered by the function are recorded with a time stamp and with process data values.

Table. 5.3.14 - 130. Event codes.

Event number	Event channel	Event block name	Event code	Description
6336	99	FRQV1	0	f> Start ON
6337	99	FRQV1	1	f> Start OFF
6338	99	FRQV1	2	f> Trip ON
6339	99	FRQV1	3	f> Trip OFF
6340	99	FRQV1	4	f>> Start ON
6341	99	FRQV1	5	f>> Start OFF
6342	99	FRQV1	6	f>> Trip ON
6343	99	FRQV1	7	f>> Trip OFF
6344	99	FRQV1	8	f>>> Start ON
6345	99	FRQV1	9	f>>> Start OFF
6346	99	FRQV1	10	f>>> Trip ON
6347	99	FRQV1	11	f>>> Trip OFF
6348	99	FRQV1	12	f>>>> Start ON
6349	99	FRQV1	13	f>>>> Start OFF
6350	99	FRQV1	14	f>>>> Trip ON
6351	99	FRQV1	15	f>>>> Trip OFF
6352	99	FRQV1	16	f< Start ON
6353	99	FRQV1	17	f< Start OFF
6354	99	FRQV1	18	f< Trip ON
6355	99	FRQV1	19	f< Trip OFF
6356	99	FRQV1	20	f<< Start ON
6357	99	FRQV1	21	f<< Start OFF
6358	99	FRQV1	22	f<< Trip ON
6359	99	FRQV1	23	f<< Trip OFF
6360	99	FRQV1	24	f<<< Start ON
6361	99	FRQV1	25	f<<< Start OFF
6362	99	FRQV1	26	f<<< Trip ON

Event number	Event channel	Event block name	Event code	Description
6363	99	FRQV1	27	f<<< Trip OFF
6364	99	FRQV1	28	f<<<< Start ON
6365	99	FRQV1	29	f<<<< Start OFF
6366	99	FRQV1	30	f<<<< Trip ON
6367	99	FRQV1	31	f<<<< Trip OFF
6368	99	FRQV1	32	f> Block ON
6369	99	FRQV1	33	f> Block OFF
6370	99	FRQV1	34	f>> Block ON
6371	99	FRQV1	35	f>> Block OFF
6372	99	FRQV1	36	f>>> Block ON
6373	99	FRQV1	37	f>>> Block OFF
6374	99	FRQV1	38	f>>>> Block ON
6375	99	FRQV1	39	f>>>> Block OFF
6376	99	FRQV1	40	f< Block ON
6377	99	FRQV1	41	f< Block OFF
6378	99	FRQV1	42	f<< Block ON
6379	99	FRQV1	43	f<< Block OFF
6380	99	FRQV1	44	f<<< Block ON
6381	99	FRQV1	45	f<<< Block OFF
6382	99	FRQV1	46	f<<<< Block ON
6383	99	FRQV1	47	f<<<< Block OFF

The function registers its operation into the last twelve (12) time-stamped registers. The table below presents the structure of the function's register content.

Table. 5.3.14 - 131. Register content.

Date and time	Event code	f Pre-trig (Hz)	f Fault (Hz)	Used SG
dd.mm.yyyy hh:mm:ss.mss	6336-6383 Descr.	Start –20ms averages	Fault frequency	Setting group 1...8 active

5.3.15 Rate-of-change of frequency (df/dt); 81R)

The rate-of-change of frequency function is used to detect fast drops or increases in frequency. If the load changes fast this function detects and clears the frequency-based faults faster than conventional underfrequency and overfrequency protections. One of the most common causes for the frequency to deviate from its nominal value is an unbalance between the generated power and the load demand. If the unbalance is big the frequency changes rapidly.

The rate-of-change of frequency protection can also be applied to detect a loss of mains situation. Loss of mains is a situation where a part of the network (incorporating generation) loses its connection with the rest of the system (i.e. becomes an islanded network). A generator that is not disconnected from the network can cause safety hazards. A generator can also be automatically reconnected to the network, which can cause damage to the generator and the network.

Figure. 5.3.15 - 138. Operation of the df/dt function when the frequency starts but doesn't trip.

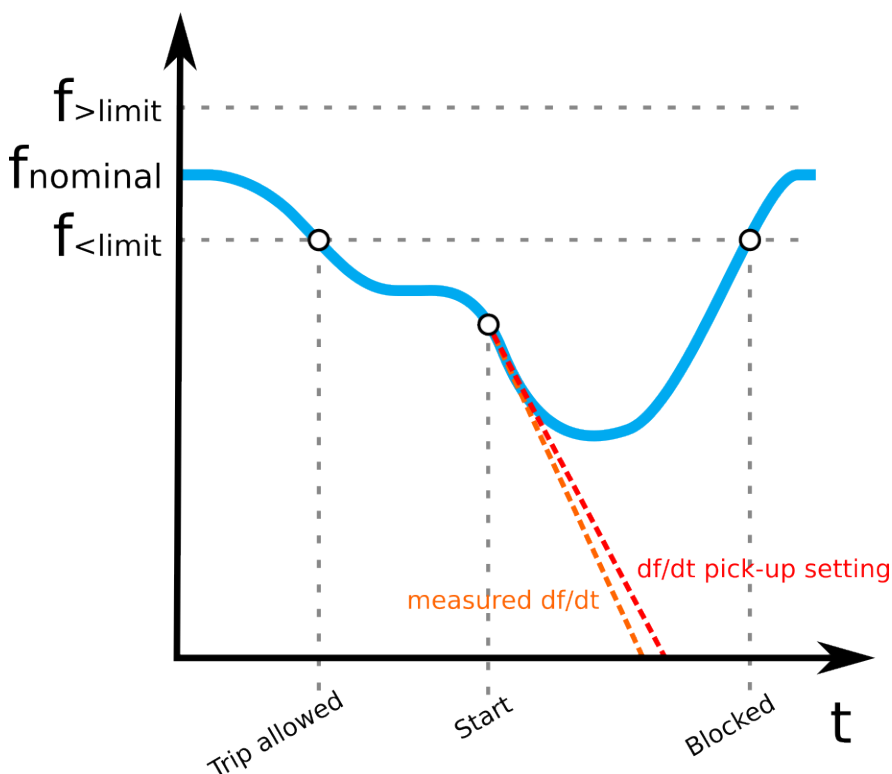

The figure above presents an example of the df/dt function's operation when the frequency is decreasing. If the $f_{<limit}$ and/or $f_{>limit}$ is activated, the function does not trip no matter how fast the measured frequency changes if it's over the $f_{<limit}$ or under $f_{>limit}$. As can be seen in the figure above, when the frequency decreases under the $f_{<limit}$, tripping is allowed although the change of frequency is not yet fast enough for the function to trip. Later the frequency makes a fast dip and as a result the change of frequency is faster than the set pick-up value which then causes the relay to operate.

Each stage can be activated and deactivated individually. After the $f_{>limit}$ mode has been activated (*Protection* → *Stage activation* → *Frequency stages*), the user can activate and deactivate the individual stages at will (*Protection* → *Frequency* → *Frequency protection $f_{>limit}$* → *INFO* → *Stage operational setup*).

The outputs of the function are the START, TRIP and BLOCKED signals. The frequency protection function uses a total of eight (8) separate setting groups which can be selected from one common source.

The function can operate on instant or time-delayed mode.

The operational logic consists of the following:

- input magnitude processing
- threshold comparator
- two block signal check
- time delay characteristics
- output processing.

The inputs for the function are the following:

- operating mode selections
- setting parameters
- digital inputs and logic signals

- measured and pre-processed frequency magnitudes.

The function outputs the START, TRIP and BLOCKED signals which can be used for direct I/O controlling and user logic programming. The function generates general time-stamped ON/OFF events to the common event buffer from each of the three (3) output signals. In the instant operating mode the function outputs START and TRIP events simultaneously with an equivalent time stamp. The time stamp resolution is 1 ms. The function also provides a resettable cumulative counter for the START, TRIP and BLOCKED events.

The following figure presents a simplified function block diagram of the df/dt function.

Figure. 5.3.15 - 139. Simplified function block diagram of the df/dt function.

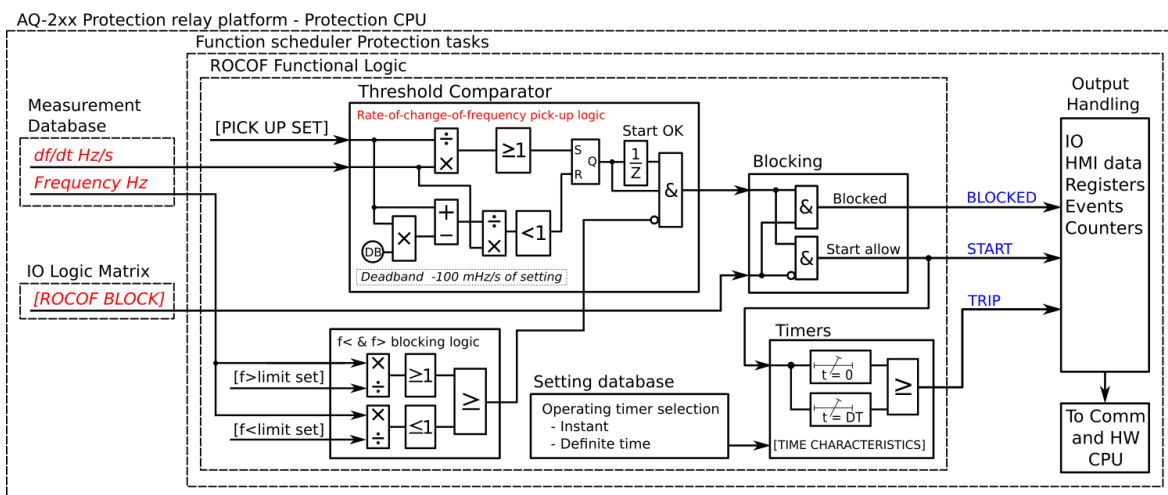

Measured input

The rate-of-change of frequency protection function compares the measured df/dt ratio to the pick-up setting (given in Hz/s). The source of the measured frequency depends on the factory-defined tracking reference which can be checked from the *Frequency* tab of the *Measurement* menu.

Table. 5.3.15 - 132. Measurement inputs of the df/dt function.

Signals	Description	Time base
VT1 U1, U2, U3	L-N voltages of the first voltage transformer	5ms
VT2 U1, U2, U3	L-N voltages of the second voltage transformer	5ms

Pick-up and time delay

The df/dt (1) pick-up, df/dt (2) pick-up, etc. setting parameters control the pick-up of each stage of the df/dt function. They define the maximum or minimum allowed change of frequency before action from the function. The function constantly calculates the ratio between the pick-up setting and the measured df/dt . The reset ratio of ± 100 mHz/s is built into the function and is always relative to the pick-up value. The f limit value is used to block the function from operating near the nominal frequency.

Table. 5.3.15 - 133. Pick-up settings.

Name	Description	Range	Step	Default
Max allowed df/dt rate	If df/dt rate exceeds this setting, the function is blocked.	0.10...50.00Hz/s	0.10Hz/s	20Hz/s

Name	Description	Range	Step	Default
df/dt>/< (1...8) used in setting group	Enables the protection stage in setting group.	0: No 1: Yes	-	0: No
df/dt>/< (1...8) operating mode	Defines the operation mode of the protection stage. In "Rising" mode df/dt function can trip only from increasing frequency. In "Falling" mode df/dt function can trip only from decreasing frequency. "Both" allows df/dt to trip from both.	0: Rising 1: Falling 2: Both	-	0: Rising
df/dt>/< (1...8) frequency limit	Displays if frequency limits are used or not.	0: Not used 1: Use f limit	-	0: Not used
df/dt>/< (1...8) pick-up	Pick-up setting.	0.01...10.00Hz/s	0.01Hz/s	0.2Hz/s
df/dt>/< (1...8) f< limit	Underfrequency limit. Tripping is permitted when measured frequency is under this value. This parameter is visible only when operation mode is set to "Falling" or "Both".	7.00...65.00Hz/s	0.01Hz/s	49.95Hz/s
df/dt>/< (1...8) f> limit	Overfrequency limit. Tripping is permitted if measured frequency is above this value. This parameter is visible only when operation mode is set to "Rising" or "Both".	10.00...70.00Hz/s	0.01Hz/s	51Hz/s
df/dt>/< (1...8) operating time	Operation time delay.	0.000...1800.000s	0.005s	0.1s

The pick-up activation of the function is not directly equal to the START signal generation of the function. The START signal is allowed if the blocking condition is not active.

Operating time characteristics for trip and reset

This function supports definite time delay (DT). For detailed information on this delay types please refer to the chapter "General properties of a protection function" and its section "Operating time characteristics for trip and reset".

Read-only parameters

The relay's *Info* page displays useful, real-time information on the state of the protection function. It is accessed either through the relay's HMI display, or through the setting tool software when it is connected to the relay and its Live Edit mode is active.

Table. 5.3.15 - 134. Information displayed by the function.

Name	Range	Step	Description
Measured df/dt	0.000...20.000Hz/s	0.001Hz/s	Rate-of-change-of-frequency at the moment.
df/dt >/< (1...8) condition	0: Normal 1: Start 2: Trip 3: Blocked	-	Displays the status of the protection function.
df/dt >/< (1...8) df/dt meas / df/dt set	0.000...20.000p.u.	0.005p.u.	The ratio between the rate-of-change-of-frequency and the pick-up value.
Expected operating time	0.000...1800.000s	0.005s	Displays the expected operating time when a fault occurs.
Time remaining to trip	-1800.000...1800.000s	0.005s	When the function has detected a fault and counts down time towards a trip, this displays how much time is left before tripping occurs.

Function blocking

The block signal is checked in the beginning of each program cycle. The blocking signal is received from the blocking matrix in the function's dedicated input. If the blocking signal is not activated when the pick-up element activates, a START signal is generated and the function proceeds to the time characteristics calculation.

If the blocking signal is active when the pick-up element activates, a BLOCKED signal is generated and the function does not process the situation further. If the START function has been activated before the blocking signal, it resets and the release time characteristics are processed similarly to when the pick-up signal is reset.

The blocking of the function causes an HMI display event and a time-stamped blocking event with information of the startup frequency values.

The blocking signal can also be tested in the commissioning phase by a software switch signal when the relay's testing mode "Enable stage forcing" is activated (*General* → *Device*).

The variables the user can set are binary signals from the system. The blocking signal needs to reach the device minimum of 5 ms before the set operating delay has passed in order for the blocking to activate in time.

Events and registers

The rate-of-change of frequency function (abbreviated "DFT" in event block names) generates events and registers from the status changes in START, TRIP and BLOCKED. The user can select which event messages are stored in the main event buffer: ON, OFF, or both.

The events triggered by the function are recorded with a time stamp and with process data values.

Table. 5.3.15 - 135. Event codes.

Event number	Event channel	Event block name	Event code	Description
6592	103	DFT1	0	df/dt>/< (1) Start ON
6593	103	DFT1	1	df/dt>/< (1) Start OFF
6594	103	DFT1	2	df/dt>/< (1) Trip ON
6595	103	DFT1	3	df/dt>/< (1) Trip OFF
6596	103	DFT1	4	df/dt>/< (2) Start ON
6597	103	DFT1	5	df/dt>/< (2) Start OFF
6598	103	DFT1	6	df/dt>/< (2) Trip ON
6599	103	DFT1	7	df/dt>/< (2) Trip OFF
6600	103	DFT1	8	df/dt>/< (3) Start ON
6601	103	DFT1	9	df/dt>/< (3) Start OFF
6602	103	DFT1	10	df/dt>/< (3) Trip ON
6603	103	DFT1	11	df/dt>/< (3) Trip OFF
6604	103	DFT1	12	df/dt>/< (4) Start ON
6605	103	DFT1	13	df/dt>/< (4) Start OFF
6606	103	DFT1	14	df/dt>/< (4) Trip ON
6607	103	DFT1	15	df/dt>/< (4) Trip OFF
6608	103	DFT1	16	df/dt>/< (5) Start ON

Event number	Event channel	Event block name	Event code	Description
6609	103	DFT1	17	df/dt>/< (5) Start OFF
6610	103	DFT1	18	df/dt>/< (5) Trip ON
6611	103	DFT1	19	df/dt>/< (5) Trip OFF
6612	103	DFT1	20	df/dt>/< (6) Start ON
6613	103	DFT1	21	df/dt>/< (6) Start OFF
6614	103	DFT1	22	df/dt>/< (6) Trip ON
6615	103	DFT1	23	df/dt>/< (6) Trip OFF
6616	103	DFT1	24	df/dt>/< (7) Start ON
6617	103	DFT1	25	df/dt>/< (7) Start OFF
6618	103	DFT1	26	df/dt>/< (7) Trip ON
6619	103	DFT1	27	df/dt>/< (7) Trip OFF
6620	103	DFT1	28	df/dt>/< (8) Start ON
6621	103	DFT1	29	df/dt>/< (8) Start OFF
6622	103	DFT1	30	df/dt>/< (8) Trip ON
6623	103	DFT1	31	df/dt>/< (8) Trip OFF
6624	103	DFT1	32	df/dt>/< (1) Block ON
6625	103	DFT1	33	df/dt>/< (1) Block OFF
6626	103	DFT1	34	df/dt>/< (2) Block ON
6627	103	DFT1	35	df/dt>/< (2) Block OFF
6628	103	DFT1	36	df/dt>/< (3) Block ON
6629	103	DFT1	37	df/dt>/< (3) Block OFF
6630	103	DFT1	38	df/dt>/< (4) Block ON
6631	103	DFT1	39	df/dt>/< (4) Block OFF
6632	103	DFT1	40	df/dt>/< (5) Block ON
6633	103	DFT1	41	df/dt>/< (5) Block OFF
6634	103	DFT1	42	df/dt>/< (6) Block ON
6635	103	DFT1	43	df/dt>/< (6) Block OFF
6636	103	DFT1	44	df/dt>/< (7) Block ON
6637	103	DFT1	45	df/dt>/< (7) Block OFF
6638	103	DFT1	46	df/dt>/< (8) Block ON
6639	103	DFT1	47	df/dt>/< (8) Block OFF

The function registers its operation into the last twelve (12) time-stamped registers. The table below presents the structure of the function's register content.

Table. 5.3.15 - 136. Register content.

Date and time	Event code	df/dt>/< Pre-trig (Hz/s)	f Pre-trig (Hz)	df/dt>/< Fault (Hz/s)	f Fault (Hz)	Used SG
dd.mm.yyyy hh:mm:ss.mss	6592-6639 Descr.	Start -20ms averages	Start -20ms averages	Fault df/dt>/<	Fault frequency	Setting groups 1...8 active

5.3.16 Overpower protection (P>; 32O)

The overpower function is used for instant and time-delayed active over-power protection. In applications like feeder, generator and motor protection this function is used to detect overload situations by measuring three-phase active power.

Figure. 5.3.16 - 140. Operating characteristics of overpower protection.

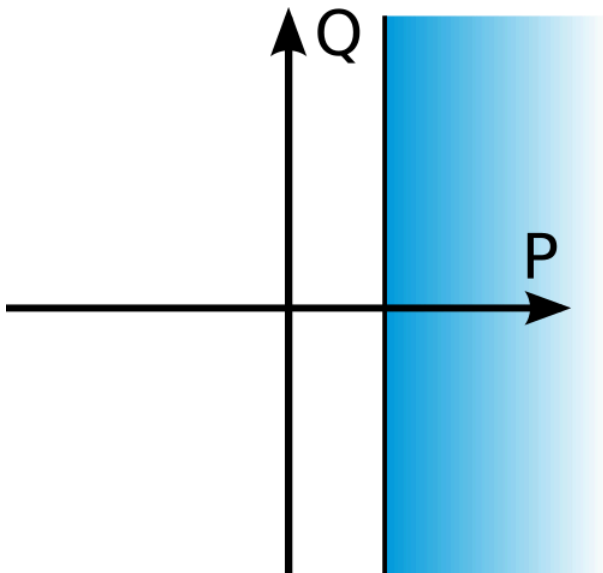

The outputs of the function are the START, TRIP and BLOCKED signals. The overpower function uses a total of eight (8) separate setting groups which can be selected from one common source.

The function can operate on instant or time-delayed mode.

The operational logic consists of the following:

- input magnitude selection
- input magnitude processing
- threshold comparator
- two block signal check
- time delay characteristics
- output processing.

The inputs for the function are the following:

- operating mode selections
- setting parameters
- digital inputs and logic signals
- measured and pre-processed power magnitudes.

The function outputs the START, TRIP and BLOCKED signals which can be used for direct I/O controlling and user logic programming. The function generates general time-stamped ON/OFF events to the common event buffer from each of the three (3) output signals. In the instant operating mode the function outputs START and TRIP events simultaneously with an equivalent time stamp. The time stamp resolution is 1 ms. The function also provides a resettable cumulative counter for the START, TRIP and BLOCKED events.

The following figure presents a simplified function block diagram of the overpower function.

Figure. 5.3.16 - 141. Simplified function block diagram of the P> function.

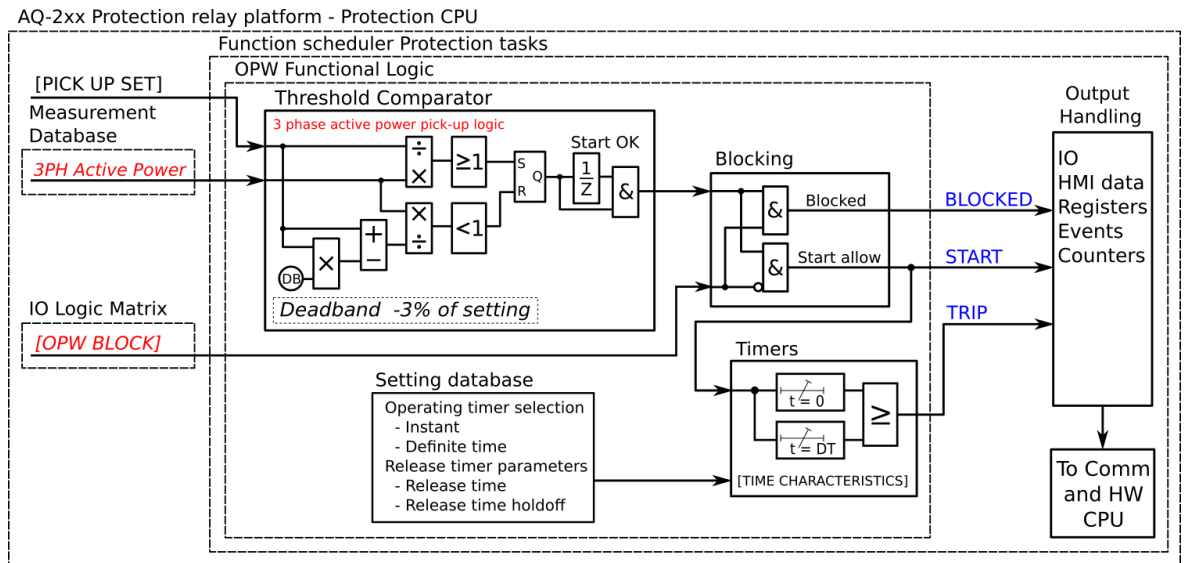

Measured input

The function block uses three-phase active power values. A -20 ms averaged value of the selected magnitude is used for pre-fault data registering. If the protection relay has more than one CT module, the *Measured side* parameter determines which current measurement is used for the power measurement.

Table. 5.3.16 - 137. Measurement inputs of the P> function.

Signal	Description	Time base
3PH Active power (P)	Total three-phase active power	5ms

Pick-up

The $P_{set>}$ setting parameter controls the pick-up of the P> function. This defines the maximum allowed measured three-phase active power before action from the function. The function constantly calculates the ratio between the $P_{set>}$ and the measured magnitude (P_m). The reset ratio of 97 % is built into the function and is always relative to the $P_{set>}$ value.

Table. 5.3.16 - 138. Pick-up settings.

Name	Description	Range	Step	Default
$P_{set>}$	Pick-up setting	0.0...100 000kW	0.01kW	100kW

The pick-up activation of the function is not directly equal to the START signal generation of the function. The START signal is allowed if the blocking condition is not active.

Read-only parameters

The relay's *Info* page displays useful, real-time information on the state of the protection function. It is accessed either through the relay's HMI display, or through the setting tool software when it is connected to the relay and its Live Edit mode is active.

Table. 5.3.16 - 139. Information displayed by the function.

Name	Range	Step	Description
P> condition	0: Normal 1: Start 2: Trip 3: Blocked	-	Displays the status of the protection function.
Expected operating time	0.000...1800.000s	0.005s	Displays the expected operating time when a fault occurs.
Time remaining to trip	-1800.000...1800.000s	0.005s	When the function has detected a fault and counts down time towards a trip, this displays how much time is left before tripping occurs.
P meas/P set at the moment	1250.00P _m /P _{set}	0.01P _m /P _{set}	The ratio between the measured power and the pick-up value.

Function blocking

The block signal is checked in the beginning of each program cycle. The blocking signal is received from the blocking matrix in the function's dedicated input. If the blocking signal is not activated when the pick-up element activates, a START signal is generated and the function proceeds to the time characteristics calculation.

If the blocking signal is active when the pick-up element activates, a BLOCKED signal is generated and the function does not process the situation further. If the START function has been activated before the blocking signal, it resets and the release time characteristics are processed similarly to when the pick-up signal is reset.

The blocking of the function causes an HMI display event and a time-stamped blocking event with information of the startup power value to be issued.

The blocking signal can also be tested in the commissioning phase by a software switch signal when the relay's testing mode "Enable stage forcing" is activated (*General* → *Device*).

The variables the user can set are binary signals from the system. The blocking signal needs to reach the device minimum of 5 ms before the set operating delay has passed in order for the blocking to activate in time.

Operating time characteristics for trip and reset

This function supports definite time delay (DT). For detailed information on this delay types please refer to the chapter "General properties of a protection function" and its section "Operating time characteristics for trip and reset".

Events and registers

The overpower function (abbreviated "OPW" in event block names) generates events and registers from the status changes in START, TRIP and BLOCKED. The user can select which event messages are stored in the main event buffer: ON, OFF, or both. The function offers one (1) independent stage.

The events triggered by the function are recorded with a time stamp and with process data values.

Table. 5.3.16 - 140. Event codes.

Event number	Event channel	Event block name	Event code	Description
6400	100	OPW1	0	Start ON
6401	100	OPW1	1	Start OFF
6402	100	OPW1	2	Trip ON
6403	100	OPW1	3	Trip OFF
6404	100	OPW1	4	Block ON
6405	100	OPW1	5	Block OFF

The function registers its operation into the last twelve (12) time-stamped registers. The register of the function records the ON event process data for START, TRIP or BLOCKED. The table below presents the structure of the function's register content.

Table. 5.3.16 - 141. Register content.

Date and time	Event code	Trigger power	Fault power	Pre-fault power	Trip time remaining	Used SG
dd.mm.yyyy hh:mm:ss.mss	6400-6405 Descr.	Start average power	Trip -20ms averages	Start -200ms averages	0 ms...1800s	Setting groups 1...8 active

5.3.17 Underpower protection (P<; 32U)

The underpower function is used for instant and time-delayed active underpower protection. This function is used to detect loss of load conditions when there is no significant loss of current.

Figure. 5.3.17 - 142. Operating characteristics of underpower protection.

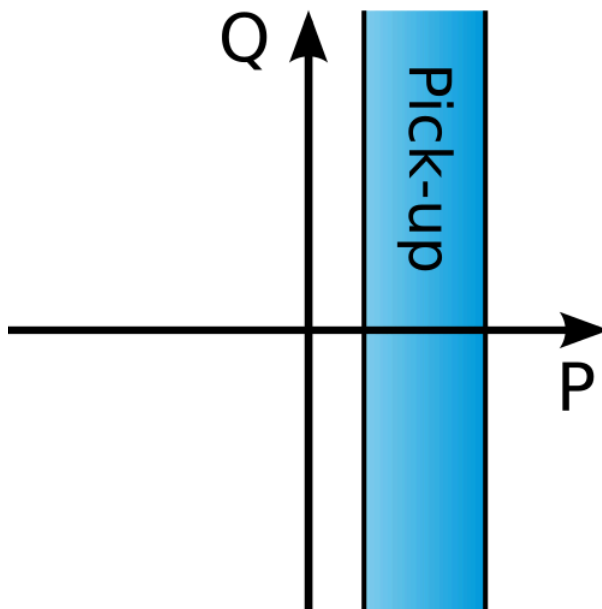

The outputs of the function are the START, TRIP and BLOCKED signals. The underpower function uses a total of eight (8) separate setting groups which can be selected from one common source.

The function can operate on instant or time-delayed mode.

The operational logic consists of the following:

- input magnitude selection
- input magnitude processing
- threshold comparator
- two block signal check
- time delay characteristics
- output processing.

The inputs for the function are the following:

- operating mode selections
- setting parameters
- digital inputs and logic signals
- measured and pre-processed power magnitudes.

The function outputs the START, TRIP and BLOCKED signals which can be used for direct I/O controlling and user logic programming. The function generates general time-stamped ON/OFF events to the common event buffer from each of the three (3) output signals. In the instant operating mode the function outputs START and TRIP events simultaneously with an equivalent time stamp. The time stamp resolution is 1 ms. The function also provides a resettable cumulative counter for the START, TRIP and BLOCKED events.

The following figure presents a simplified function block diagram of the underpower function.

Figure. 5.3.17 - 143. Simplified function block diagram of the P< function.

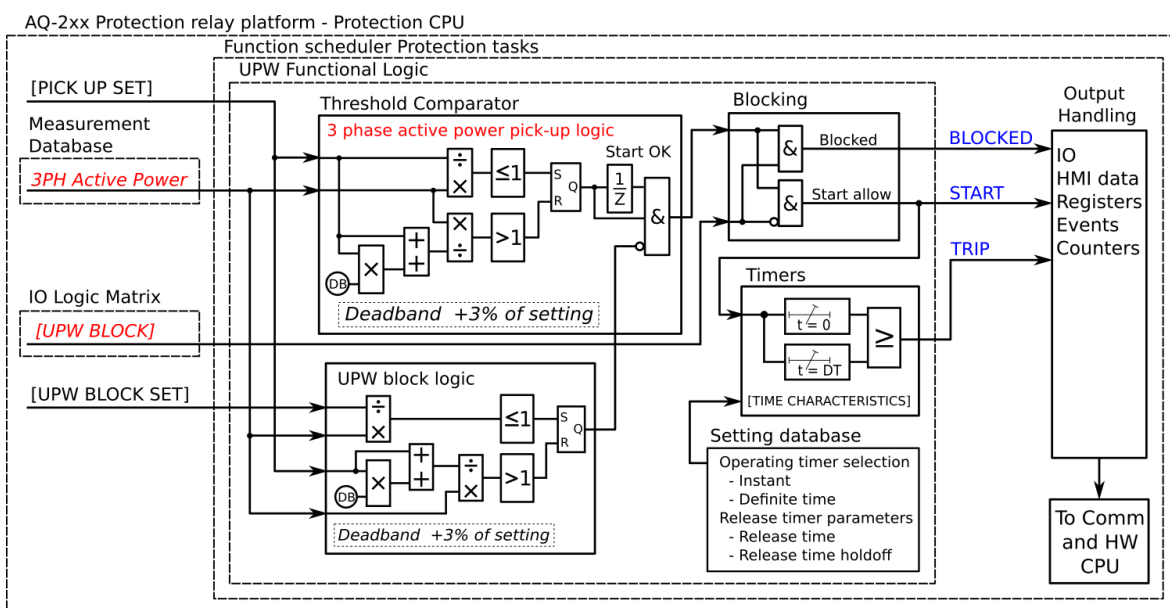

Measured input

The function block uses three-phase active power values. A -20 ms averaged value of the selected magnitude is used for pre-fault data registering. If the protection relay has more than one CT module, the parameter *Measured side* determines which current measurement is used for the power measurement.

Table. 5.3.17 - 142. Measurement inputs of the P< function.

Signal	Description	Time base
3PH Active power (P)	Total three-phase active power	5ms

Pick-up

The $P_{set<}$ setting parameter controls the pick-up of the $P<$ function. This defines the maximum allowed measured three-phase active power before action from the function. The function constantly calculates the ratio between the $P_{set<}$ and the measured magnitude (P_m). The reset ratio of 103 % is built into the function and is always relative to the $P_{set<}$ value.

Figure. 5.3.17 - 144. Activation and deactivation characteristics of low power blocking.

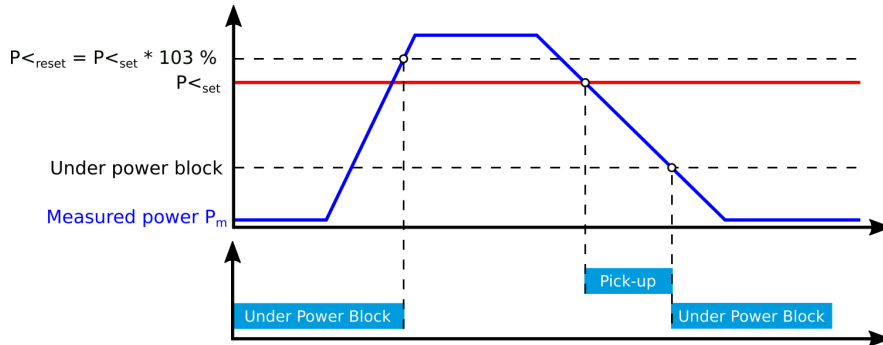

The *Low power block* setting parameter can be used to prevent an accidental trip before active power exceeds the pick-up setting. The LPB signal is deactivated when the measured active power exceeds the pick-up settings reset value ($= 1.03 \times P_{set<}$).

Table. 5.3.17 - 143. Pick-up settings.

Name	Description	Range	Step	Default
$P_{set<}$	Pick-up setting	0.0...100 000kW	0.01kW	100kW
$P_{set<}$	Low power block	0.0...100 000kW	0.01kW	50kW

The pick-up activation of the function is not directly equal to the START signal generation of the function. The START signal is allowed if the blocking condition is not active.

Read-only parameters

The relay's *Info* page displays useful, real-time information on the state of the protection function. It is accessed either through the relay's HMI display, or through the setting tool software when it is connected to the relay and its Live Edit mode is active.

Table. 5.3.17 - 144. Information displayed by the function.

Name	Range	Step	Description
$P<$ condition	0: Normal 1: Start 2: Trip 3: Blocked	-	Displays the status of the protection function.
Expected operating time	0.000...1800.000s	0.005s	Displays the expected operating time when a fault occurs.
Time remaining to trip	-1800.000...1800.000s	0.005s	When the function has detected a fault and counts down time towards a trip, this displays how much time is left before tripping occurs.
P meas/ P set at the moment	$1250.00P_m/P_{set}$	$0.01P_m/P_{set}$	The ratio between the measured power and the pick-up value.

Function blocking

The block signal is checked in the beginning of each program cycle. The blocking signal is received from the blocking matrix in the function's dedicated input. If the blocking signal is not activated when the pick-up element activates, a START signal is generated and the function proceeds to the time characteristics calculation.

If the blocking signal is active when the pick-up element activates, a BLOCKED signal is generated and the function does not process the situation further. If the START function has been activated before the blocking signal, it resets and the release time characteristics are processed similarly to when the pick-up signal is reset.

The blocking of the function causes an HMI display event and a time-stamped blocking event with information of the startup power value to be issued.

The blocking signal can also be tested in the commissioning phase by a software switch signal when the relay's testing mode "Enable stage forcing" is activated (*General* → *Device*).

The variables the user can set are binary signals from the system. The blocking signal needs to reach the device minimum of 5 ms before the set operating delay has passed in order for the blocking to activate in time.

Operating time characteristics for trip and reset

This function supports definite time delay (DT). For detailed information on this delay types please refer to the chapter "General properties of a protection function" and its section "Operating time characteristics for trip and reset".

Events and registers

The underpower function (abbreviated "UPW" in event block names) generates events and registers from the status changes in START, TRIP and BLOCKED. The user can select which event messages are stored in the main event buffer: ON, OFF, or both. The function offers one (1) independent stage.

The events triggered by the function are recorded with a time stamp and with process data values.

Table. 5.3.17 - 145. Event codes.

Event number	Event channel	Event block name	Event code	Description
6464	101	UPW1	0	Start ON
6465	101	UPW1	1	Start OFF
6466	101	UPW1	2	Trip ON
6467	101	UPW1	3	Trip OFF
6468	101	UPW1	4	Block ON
6469	101	UPW1	5	Block OFF

The function registers its operation into the last twelve (12) time-stamped registers. The register of the function records the ON event process data for START, TRIP or BLOCKED. The table below presents the structure of the function's register content.

Table. 5.3.17 - 146. Register content.

Date and time	Event code	Trigger power	Fault power	Pre-fault power	Trip time remaining	Used SG
dd.mm.yyyy hh:mm:ss.mss	6464-6469 Descr.	Start average power	Trip -20ms averages	Start -200ms averages	0 ms...1800s	Setting groups 1...8 active

5.3.18 Reverse power protection (Pr; 32R)

The reverse power function is used for instant and time-delayed active reverse power protection. In generator protection applications the reverse power protection function is used to prevent damage in situations where a synchronous generator is running like a motor when the generator draws active power. Reverse power protection is not used to protect the generator itself but to protect the generator's turbine.

Figure. 5.3.18 - 145. Operating characteristics of reverse power protection.

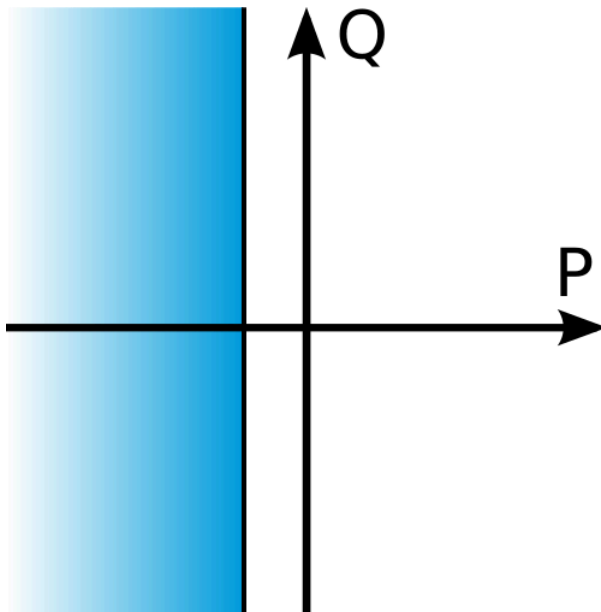

The outputs of the function are the START, TRIP and BLOCKED signals. The reverse power function uses a total of eight (8) separate setting groups which can be selected from one common source.

The function can operate on instant or time-delayed mode.

The operational logic consists of the following:

- input magnitude selection
- input magnitude processing
- threshold comparator
- two block signal check
- time delay characteristics
- output processing.

The inputs for the function are the following:

- operating mode selections
- setting parameters
- digital inputs and logic signals
- measured and pre-processed power magnitudes.

The function outputs the START, TRIP and BLOCKED signals which can be used for direct I/O controlling and user logic programming. The function generates general time-stamped ON/OFF events to the common event buffer from each of the three (3) output signals. In the instant operating mode the function outputs START and TRIP events simultaneously with an equivalent time stamp. The time stamp resolution is 1 ms. The function also provides a resettable cumulative counter for the START, TRIP and BLOCKED events.

The following figure presents a simplified function block diagram of the reverse power function.

Figure. 5.3.18 - 146. Simplified function block diagram of the Pr function.

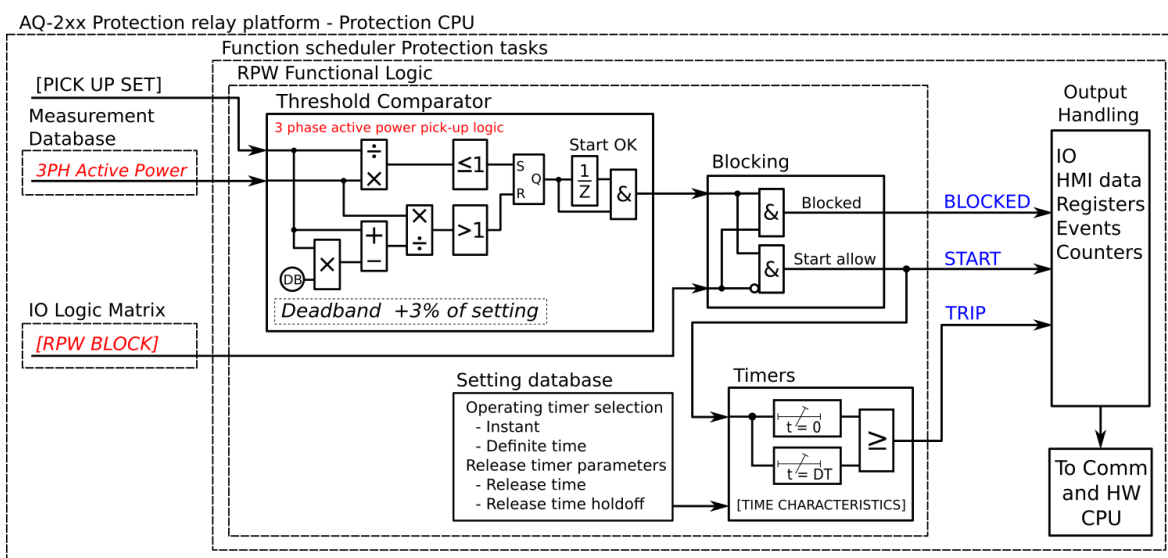

Measured input

The function block uses three-phase active power values. A -20 ms averaged value of the selected magnitude is used for pre-fault data registering. If the protection relay has more than one CT module, the parameter *Measured side* determines which current measurement is used for the power measurement.

Table. 5.3.18 - 147. Measurement inputs of the Pr function.

Signal	Description	Time base
3PH Active power (P)	Total three-phase active power	5ms

Pick-up

The $P_{set rev}$ setting parameter controls the pick-up of the Pr function. This defines the maximum allowed measured three-phase active power before action from the function. The function constantly calculates the ratio between the $P_{set rev}$ and the measured magnitude (P_m). The reset ratio of 97 % is built into the function and is always relative to the $P_{set rev}$ value.

Table. 5.3.18 - 148. Pick-up settings.

Name	Description	Range	Step	Default
$P_{set rev}$	Pick-up setting	0.0...100 000kW	0.01kW	100kW

The pick-up activation of the function is not directly equal to the START signal generation of the function. The START signal is allowed if the blocking condition is not active.

Read-only parameters

The relay's *Info* page displays useful, real-time information on the state of the protection function. It is accessed either through the relay's HMI display, or through the setting tool software when it is connected to the relay and its Live Edit mode is active.

Table. 5.3.18 - 149. Information displayed by the function.

Name	Range	Step	Description
Prev> condition	0: Normal 1: Start 2: Trip 3: Blocked	-	Displays the status of the protection function.
Expected operating time	0.000...1800.000s	0.005s	Displays the expected operating time when a fault occurs.
Time remaining to trip	-1800.000...1800.000s	0.005s	When the function has detected a fault and counts down time towards a trip, this displays how much time is left before tripping occurs.
P meas/P set at the moment	1250.00P _m /P _{set}	0.01P _m /P _{set}	The ratio between the measured power and the pick-up value.

Function blocking

The block signal is checked in the beginning of each program cycle. The blocking signal is received from the blocking matrix in the function's dedicated input. If the blocking signal is not activated when the pick-up element activates, a START signal is generated and the function proceeds to the time characteristics calculation.

If the blocking signal is active when the pick-up element activates, a BLOCKED signal is generated and the function does not process the situation further. If the START function has been activated before the blocking signal, it resets and the release time characteristics are processed similarly to when the pick-up signal is reset.

The blocking of the function causes an HMI display event and a time-stamped blocking event with information of the startup power value to be issued.

The blocking signal can also be tested in the commissioning phase by a software switch signal when the relay's testing mode "Enable stage forcing" is activated (*General* → *Device*).

The variables the user can set are binary signals from the system. The blocking signal needs to reach the device minimum of 5 ms before the set operating delay has passed in order for the blocking to activate in time.

Operating time characteristics for trip and reset

This function supports definite time delay (DT). For detailed information on this delay types please refer to the chapter "General properties of a protection function" and its section "Operating time characteristics for trip and reset".

Events and registers

The reverse power function (abbreviated "RPW" in event block names) generates events and registers from the status changes in START, TRIP and BLOCKED. The user can select which event messages are stored in the main event buffer: ON, OFF, or both. The function offers one (1) independent stage.

The events triggered by the function are recorded with a time stamp and with process data values.

Table. 5.3.18 - 150. Event codes.

Event number	Event channel	Event block name	Event code	Description
6528	102	RPW1	0	Start ON
6529	102	RPW1	1	Start OFF
6530	102	RPW1	2	Trip ON
6531	102	RPW1	3	Trip OFF
6532	102	RPW1	4	Block ON
6533	102	RPW1	5	Block OFF

The function registers its operation into the last twelve (12) time-stamped registers. The register of the function records the ON event process data for START, TRIP or BLOCKED. The table below presents the structure of the function's register content.

Table. 5.3.18 - 151. Register content.

Date and time	Event code	Trigger power	Fault power	Pre-fault power	Trip time remaining	Used SG
dd.mm.yyyy hh:mm:ss.mss	6528-6533 Descr.	Start average power	Trip -20ms averages	Start -200ms averages	0 ms...1800s	Setting group 1...8 active

5.3.19 Line thermal overload protection (TF>; 49F)

The line thermal overload function is used for the thermal capacity monitoring and protection of cables and overhead lines. This function can also be used for any single time constant application like inductor chokes, certain types of transformers and any other static units which do not have active cooling apart from the cables and overhead lines.

The function constantly monitors the instant values of phase TRMS currents (including harmonics up to 31st) and calculates the set thermal replica status in 5 ms cycles. The function includes a total memory function of the load current conditions according to IEC 60255-8.

The function is based on a thermal replica which represents the protected object's or cable's thermal loading in relation to the current going through the object. The thermal replica includes the calculated thermal capacity that the "memory" uses; it is an integral function which tells this function apart from a normal overcurrent function and its operating principle for overload protection applications.

The thermal image for the function is calculated according to the equation described below:

$$\theta_{t\%} = \left(\left(\theta_{t-1} - \left(\frac{I_{max}}{I_n \times k_{SF} \times k_{amb}} \right)^2 \times e^{-\frac{t}{\tau}} \right) + \left(\frac{I_{max}}{I_n \times k_{SF} \times k_{amb}} \right)^2 \right) \times 100\%$$

Where:

- $\theta_{t\%}$ = Thermal image status in percentages of the maximum thermal capacity available
- θ_{t-1} = Thermal image status in a previous calculation cycle (the memory of the function)
- I_{max} = Measured maximum of the three TRMS phase currents
- I_n = Current for the 100 % thermal capacity to be used (the pick-up current in p.u., t_{max} achieved in $\tau \times 5$)
- k_{SF} = Loading factor (service factor), the maximum allowed load current in p.u., dependent on the protected object or the cable/line installation

- k_{amb} = Temperature correction factor, either from a linear approximation or from a settable ten-point thermal capacity curve
- e = Euler's number
- t = Calculation time step in seconds (0.005 s)
- τ = Thermal time constant of the protected object (in minutes)

The basic operating principle of the thermal replica is based on the nominal temperature rise, which is achieved when the protected object is loaded with a nominal load in a nominal ambient temperature. When the object is loaded with a nominal load for a time equal to its heating constant τ , 63% of the nominal thermal capacity is used. When the loading continues until five times this given constant, the used thermal capacity approaches 100 % indefinitely but never exceeds it. With a single time constant model the cooling of the object follows this same behavior, the reverse of the heating when the current feeding is zero.

Figure. 5.3.19 - 147. Example of thermal image calculation with nominal conditions.

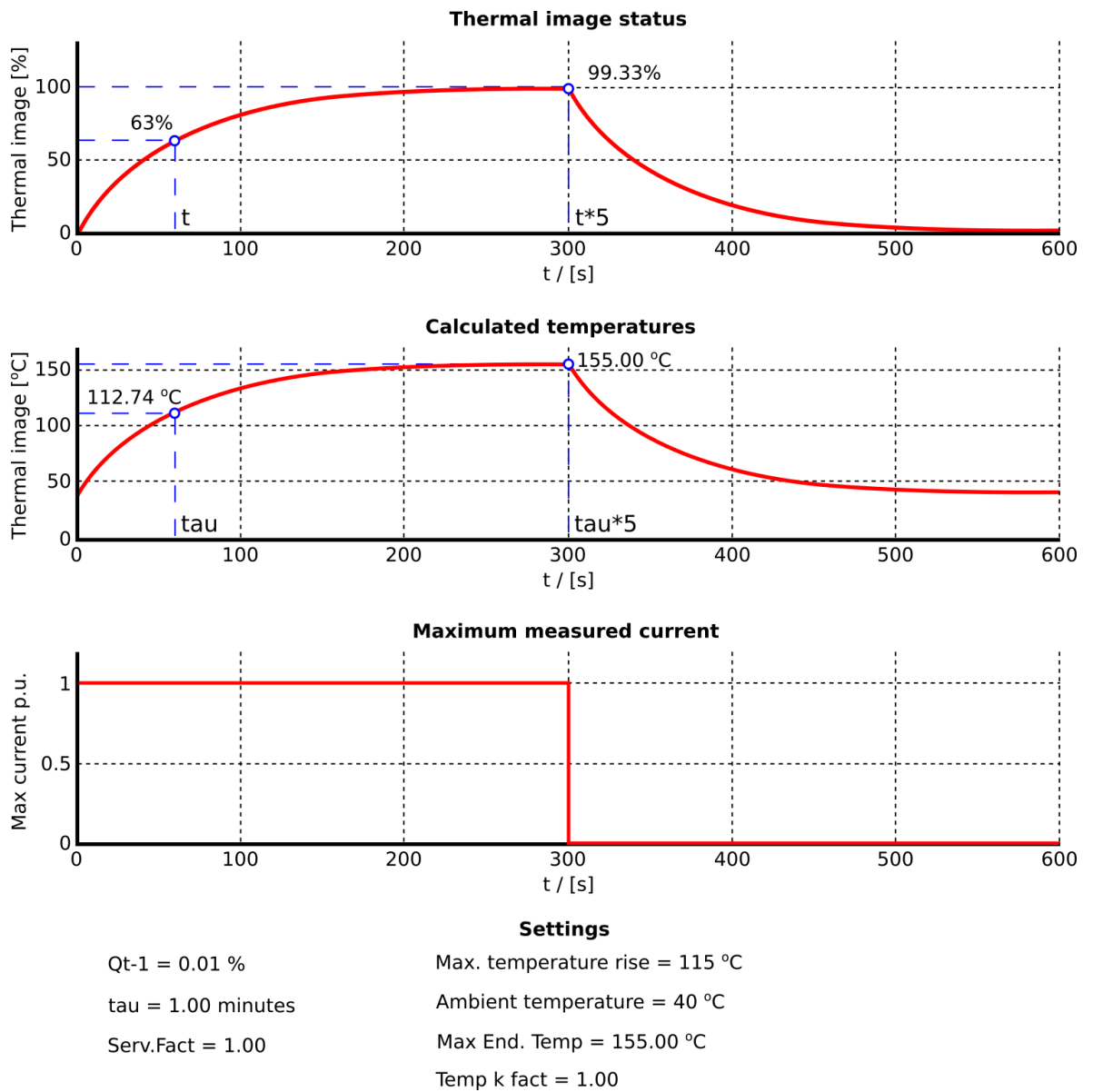

The described behavior is based on the assumption that the monitored object (whether a cable, a line or an electrical device) has a homogenous body which generates and dissipates heat with a rate proportional to the temperature rise caused by the current squared. This is usually the case with cables and other objects while the heat dissipation of overhead lines is dependent on the weather conditions. Weather conditions considering the prevailing conditions in the thermal replica are compensated with the ambient temperature coefficient which is constantly calculated and changing when using RTD sensor for the measurement. When the ambient temperature of the protected object is stable it can be set manually (e.g. underground cables).

The ambient temperature compensation takes into account the set minimum and maximum temperatures and the load capacity of the protected object as well as the measured or set ambient temperature. The calculated coefficient is a linear correction factor, as the following formula shows:

$$t_{amb} < t_{min} = k_{min}$$
$$t_{amb} < t_{ref} = \left(\frac{1 - k_{min}}{t_{ref} - t_{min}} \times (t_{amb} - t_{min}) \right) + k_{min}$$
$$t_{amb} > t_{ref} = \left(\frac{k_{max} - 1}{t_{max} - t_{ref}} \times (t_{amb} - t_{ref}) \right) + 1.0$$
$$t_{amb} > t_{max} = k_{max}$$

Where:

- t_{amb} = Measured (or set) ambient temperature (can be set in °C or in °F)
- t_{max} = Maximum temperature (can be set in °C or in °F) for the protected object
- k_{max} = Ambient temperature correction factor for the maximum temperature
- t_{min} = Minimum temperature (can be set in °C or in °F) for the protected object
- k_{min} = Ambient temperature correction factor for the minimum temperature
- t_{ref} = Ambient temperature reference (can be set in °C or in °F, the temperature in which the manufacturer's temperature presumptions apply, the temperature correction factor is 1.0)

Figure. 5.3.19 - 148. Ambient temperature coefficient calculation (a three-point linear approximation and a settable correction curve).

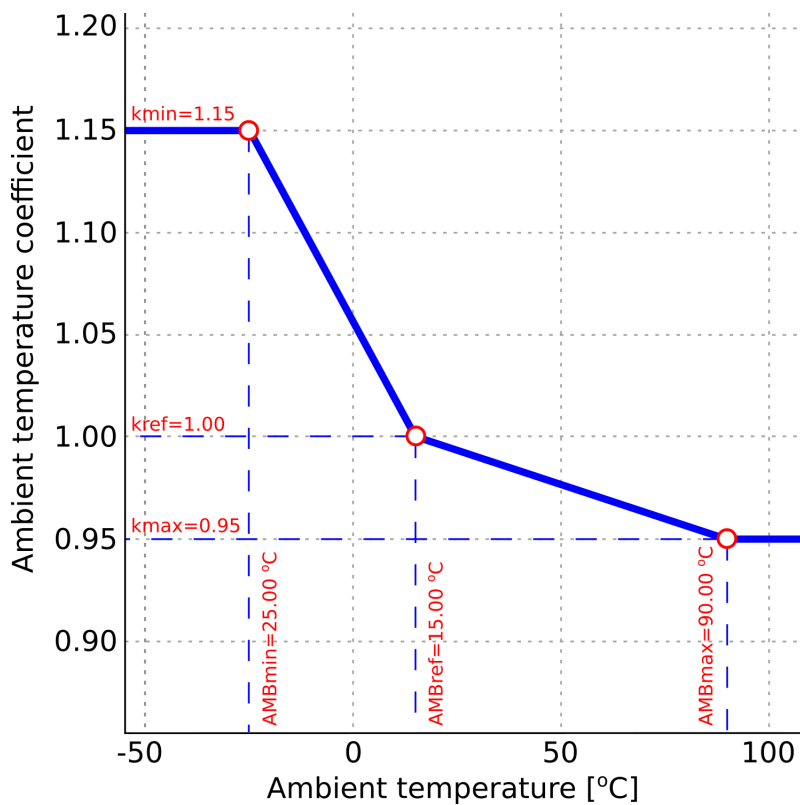

As can be seen in the diagram above, the ambient temperature coefficient is relative to the nominal temperature reference. By default the temperature reference is +15 °C (underground cables) which gives the correction factor value of 1.00 for the thermal replica.

A settable thermal capacity curve uses the linear interpolation for ambient temperature correction with a maximum of ten (10) pairs of temperature–correction factor pairs.

Figure. 5.3.19 - 149. Example of the relationship between ground temperature and correction factor.

Conductor temperature C°	Ground temperature, C°										
	-5	0	5	10	15	20	25	30	35	40	45
90	1.13	1.10	1.06	1.03	1.00	0.96	0.93	0.89	0.86	0.82	0.77

The temperature coefficient may be informed in a similar manner to the figure above in a datasheet provided by the manufacturer.

Figure. 5.3.19 - 150. Settings of the function's ambient temperature coefficient curve.

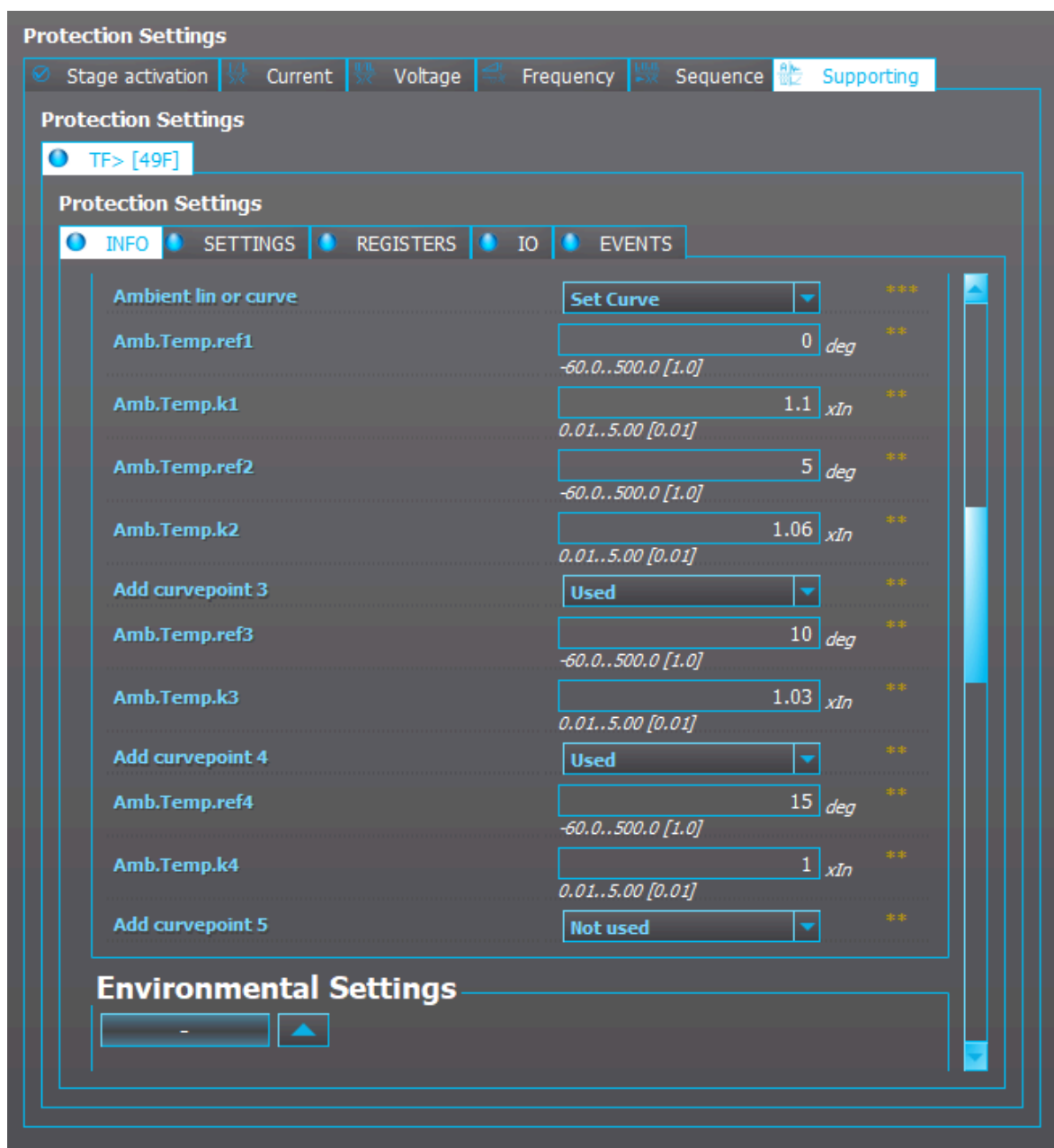

The temperature and correction factor pairs are set to the function's settable curve.

Figure. 5.3.19 - 151. Set correction curve for ambient temperature.

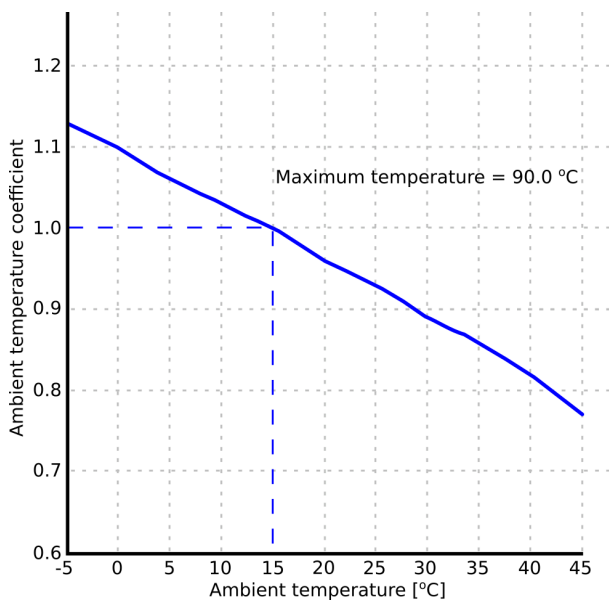

The correction curve for ambient temperature is shown in the figure above. The reference temperature for underground cables is usually +15 °C which gives a correction factor of 1.00 (in this case also the nominal temperature). The curve does not need to use as all the available points. The minimum setting is two pairs, resulting in a straight line.

For cables the ambient temperature correction is just one correction factor. The k_{SF} correction factor is used for non-changing corrections; its calculation is explained later in this manual. Calculating correction factors for a cable or overhead installation requires the consulting of the datasheet for the technical specifications of the used cable. This information is usually provided by the cable manufacturer. For example, cable data may be presented as in the figures below (an example from a Prysmian Group cable datasheet) which show the cable's temperature characteristics and voltage ratings (1st image) with different installations and copper or aluminum conductors (2nd and 3rd image).

Figure. 5.3.19 - 152. Example of a high-voltage cable datasheet.

Sample Constructions		72 kV Cables 36/66 kV Single core, XLPE-insulated high voltage power cables									
Rated voltages $U_o/U = 38/66$ kV $U_m = 72.5$ kV $U_p = 325$ kV Rated temperatures • Maximum permissible temp. of conductor in continuous use 90°C • Maximum permissible temp. of conductor in short-circuit 250°C (for durations up to 5 sec.) Standard IEC 60840											
Nominal cross-sectional area of conductor		mm ²	300	500	800	1200	1600				
Continuous current-carrying capacities											
Conductor	Cables laid	Conductor temperature	Laying formation	Screen circuit							
Aluminium	In ground of 15°C	65°C	Flat	Open	A	435	575	750	910	1040	
				Closed	A	415	525	640	710	750	
			Trefoil	Open	A	415	545	700	830	930	
		Closed		A	410	535	680	790	870		
		90°C	Flat	Open	A	515	680	890	1080	1235	
				Closed	A	490	625	770	860	920	
	Trefoil		Open	A	490	645	830	990	1110		
	Closed	A	485	635	805	945	1045				
	In air of 25°C	90°C	Flat	Open	A	685	930	1265	1555	1815	
				Closed	A	660	865	1105	1270	1390	
			Trefoil	Open	A	605	820	1095	1335	1535	
		Closed	A	600	810	1085	1320	1515			
Copper		In ground of 15°C	65°C	Flat	Open	A	560	730	940	1200	1390
					Closed	A	520	635	740	820	855
	Trefoil			Open	A	535	685	860	1095	1240	
			Closed	A	525	670	820	1005	1105		
	90°C		Flat	Open	A	660	865	1115	1415	1645	
				Closed	A	620	765	900	1005	1055	
Trefoil		Open	A	630	815	1025	1305	1485			
Closed	A	620	795	980	1205	1335					
In air of 25°C	90°C	Flat	Open	A	880	1185	1585	2040	2420		
			Closed	A	830	1065	1305	1505	1620		
		Trefoil	Open	A	775	1035	1355	1765	2065		
Closed	A	770	1025	1340	1685	1940					
Maximum permissible short-circuit currents for short-circuit duration of one second											
Aluminium conductor					kA	28.3	47.2	75.6	113.4	151.2	
Copper conductor					kA	42.8	71.4	114.2	171.4	228.5	

The datasheet shows the currents which in a combination with a specific installation and a specific construction method achieve a specific conductor temperature in give standard conditions (e.g. a copper conductor reaches a temperature of 90 °C when, for example, it has a continuous current-carrying capacity of 815 A, an open screen circuit, and is laid in a trefoil formation in soil whose temperature is 15 °C).

The most important parameters for setting a working thermal image are the cable's current and the installation place. In addition to the above-mentioned current-carrying capacity table, the manufacturer should also provide data to allow for fine-tuning the thermal image. Equally important to the ampere-temperature values are the presumptive conditions under which the given continuous current-carrying capacity values can be expected to apply. The following figure is an example of these general presumption as presented in a Prysmian Group cable datasheet.

Figure. 5.3.19 - 153. General presumptions of high-voltage cables.

Continuous current-carrying capacity A separate group of three single core cables can be continuously loaded according to the tables on pages 8 to 14 if the presumptions below are fulfilled. Correction factors for other installations are given in tables 1-7.

The current-carrying capacities are calculated in accordance with the IEC Publication 60287 and under the presumptions given below.

Presumptions

- One three-phase group of single core cables
- Maximum permissible temperature of inner conductor in continuous use:
 - XLPE insulated cables 90°C
 - Ambient air temperature 25°C
 - Ground temperature 15°C
 - Depth of laying of cables 1.0 m
- Distance between single core cables:
 - in case of flat formation = one cable diam.
 - in case of trefoil formation = cables touching each other
- Thermal resistivity of soil 1.0 K m/W
- Cable in air = heat dissipation conditions same as if cables in free air.
- Open screen circuit in single core cable group = circuit of metal sheaths, concentric conductors or metallic screens connected to each other and earthed at one point only = screens bonded at a single point. In addition, screen circuit is considered open when cross-bonded at equal interval.
- Closed screen circuit in single core cable group = circuit of metal sheaths, concentric conductors or metallic screens connected to each other at both ends of the group and earthed at least at one end = screens bonded at both ends.

XLPE-insulated cables buried directly in ground
XLPE-insulated cables can continuously be loaded to a conductor temperature of 90°C. In underground installations, if a cable in the ground is continuously operated at this highest rated conductor temperature, the thermal resistivity of the soil surrounding the cable may in the course of time increase from its original value as a result of the drying-out processes. As a consequence, the conductor temperature may greatly exceed the highest rated value.

Using single-point bonding or cross-bonding instead of both-end bonding results in considerable increase in current carrying capacity.

If the installation conditions vary from the presumed conditions manufacturers may give additional information on how to correct the the current-carrying capacity to match the changed conditions. Below is an example of the correction factors provided a manufacturer (Prysmian) for correcting the current-carrying capacity.

Figure. 5.3.19 - 154. Example of correction factors for the current-carrying capacity as given by a manufacturer.

Correction factors for the current-carrying capacity

The following tables of correction factors are to be applied to the current-carrying capacity when installation conditions vary from the presumptions above.

The rating for most conditions can be quickly estimated by multiplying the continuous current-carrying capacity value by the correction factors given in the appropriate tables 1-7.

Table 1. Correction factors for groups of cables buried directly in ground

Spacing between groups of cables, mm	Numbers of groups of single core cables beside each other						
	2	3	4	5	6	8	10
0 (touching)	0.79	0.69	0.63	0.58	0.55	0.50	0.46
70	0.85	0.75	0.68	0.64	0.60	0.56	0.53
250	0.87	0.79	0.75	0.72	0.69	0.66	0.64

The values apply to groups of three single core cables (in trefoil or flat formation) without or with spacing between the cable groups horizontally placed.

Table 2. Correction factors for different thermal resistivities of soil

Thermal resistivity of soil Km/W	0.7	1.0	1.2	1.5	2.0	2.5	3.0
Correction factor	1.10	1.00	0.92	0.85	0.75	0.69	0.63

Examples of thermal resistivities of soil:

- dry sand (moisture content 0%) 3.0 K m/W
- dry gravel and clay 1.5 K m/W
- semi-dry gravel and sand (moisture content 10%) 1.2 K m/W
- semi-dry and moist gravel 1.0 K m/W
- moist clay and sand (moisture content 25%) 0.7 K m/W

Table 3. Correction factors for different installation depths in ground

Depth of laying, m	0.50-0.70	0.71-0.90	0.91-1.10	1.11-1.30	1.31-1.50
Rating factor	1.05	1.02	1.00	0.97	0.95

Table 4. Correction factors for different ground temperatures

Conductor temperature C°	Ground temperature, C°										
	-5	0	5	10	15	20	25	30	35	40	45
90	1.13	1.10	1.06	1.03	1.00	0.96	0.93	0.89	0.86	0.82	0.77
80	1.14	1.11	1.07	1.04	1.00	0.96	0.92	0.88	0.83	0.78	0.73
70	1.17	1.13	1.09	1.04	1.00	0.95	0.90	0.85	0.80	0.73	0.67
65	1.18	1.14	1.10	1.05	1.00	0.95	0.89	0.84	0.77	0.71	0.63

Table 5. Correction factors for different cables in unfilled plastic pipes

Spacing between the tubes, mm	Numbers of tubes beside each other							
	1	2	3	4	5	6	8	10
0 (touching)	0.80	0.75	0.65	0.60	0.60	0.55	0.55	0.50
70		0.75	0.70	0.65	0.60	0.60	0.55	0.55
250		0.75	0.70	0.70	0.70	0.65	0.65	0.65

For parallel ducts with a group of three single core cables in each and with the cables equally loaded the current-carrying capacity indicated on pages 8 to 14 for cables buried directly in ground shall be reduced by correction factors given above.

The reduction in current carrying capacity can be avoided if the pipes after cable pulling are filled with material thermally equal to the ambient ground.

If factors in table 5 are used, factors in table 1 are not applicable.

Table 6. Correction factors for different ambient air temperatures

Conductor temperature C°	Ambient air temperature, C°									
	10	15	20	25	30	35	40	45	50	55
90	1.12	1.08	1.04	1.00	0.95	0.90	0.85	0.80	0.74	0.68
80	1.14	1.09	1.05	1.00	0.95	0.89	0.84	0.77	0.69	0.61
70	1.18	1.12	1.06	1.00	0.93	0.86	0.79	0.71	0.62	0.52
65	1.20	1.14	1.07	1.00	0.93	0.85	0.77	0.68	0.57	0.45

Table 7. Correction factors for different groups of three single core cables laid in the air

Type of laying	Number of groups	Cables laid in flat formation Spacing = One cable diameter (d). Distance from the wall not less than 20 mm.			Cables laid in trefoil formation Spacing = Two cable diameters (2d). Distance from the wall not less than 20 mm.		
		1	2	3	1	2	3
On floor		0.92	0.89	0.88	0.95	0.90	0.88
	Number of trays						
On metal trays (restricted air circulation)	1	0.92	0.89	0.88	0.95	0.90	0.88
	2	0.87	0.84	0.83	0.90	0.85	0.83
	3	0.84	0.82	0.81	0.88	0.83	0.81
	6	0.82	0.80	0.79	0.86	0.81	0.79
On metal ladders	1	1.00	0.97	0.96	1.00	0.98	0.96
	2	0.97	0.94	0.93	1.00	0.95	0.93
	3	0.96	0.93	0.92	1.00	0.94	0.92
	6	0.94	0.91	0.90	1.00	0.93	0.90

This applies only when the cable temperature does not affect the ambient air temperature.

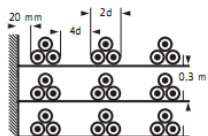
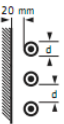
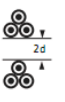
Arrangements where reduction of current is not necessary	The cooling of cables in flat formation by increased spacing will get better while the losses in metallic screens and sheaths will increase reducing the current-carrying capacity. Each case must be calculated separately.																					
Systems placed on top of each other	<table border="1"> <tr> <td>1</td> <td>2</td> <td>3</td> </tr> <tr> <td colspan="3">Correction factor</td> </tr> <tr> <td>0.94</td> <td>0.91</td> <td>0.89</td> </tr> </table>	1	2	3	Correction factor			0.94	0.91	0.89		<table border="1"> <tr> <td>1</td> <td>2</td> <td>3</td> </tr> <tr> <td colspan="3">Correction factor</td> </tr> <tr> <td>0.89</td> <td>0.86</td> <td>0.84</td> </tr> </table>	1	2	3	Correction factor			0.89	0.86	0.84	
1	2	3																				
Correction factor																						
0.94	0.91	0.89																				
1	2	3																				
Correction factor																						
0.89	0.86	0.84																				
On structures or on wall																						

To demonstrate the importance of the k_{SF} (service factor, current-carrying capacity), let us calculate a cable installation with the correct k factor but without setting it to correct value.

First we read the initial data for the setup of the thermal image:

A 66 kV copper cable with a cross-section of 500 mm² is installed into ground. Its 1 s permissible short-circuit current is 71.4 kA and its insulation is XLPE. The cable's screen circuit is open and the laying formation is flat. Its current-carrying capacity is 575 A in 65 °C and 680 A in 90 °C. The reference temperature for ground installation is 15 °C.

Let us calculate an estimation of the time constant τ based on the known one-second short-circuit current related to I_n . If the manufacturer has not provided the time constant, it can be estimated from the maximum permissible short-circuit current (usually a one second value). The function uses this same method to estimate the heating time constant.

$$\tau_{cable} = \frac{1 \text{ s}}{60 \text{ s}} \times \left(\frac{I_{1s}}{I_n} \right)^2 = \frac{1 \text{ s}}{60 \text{ s}} \times \left(\frac{71\,400 \text{ A}}{680 \text{ A}} \right)^2 = 183.75 \text{ min}$$

The rest of the settings are in the initial data text above:

- $I_n = 680 \text{ A}$
- $T_{max} = 90 \text{ °C}$
- $T_{amb} = 15 \text{ °C}$
- $T_{ref} = 15 \text{ °C}$
- $k_{SF} = 1.0$.

Figure. 5.3.19 - 155. Thermal image response with nominal load (installation according to presumptions).

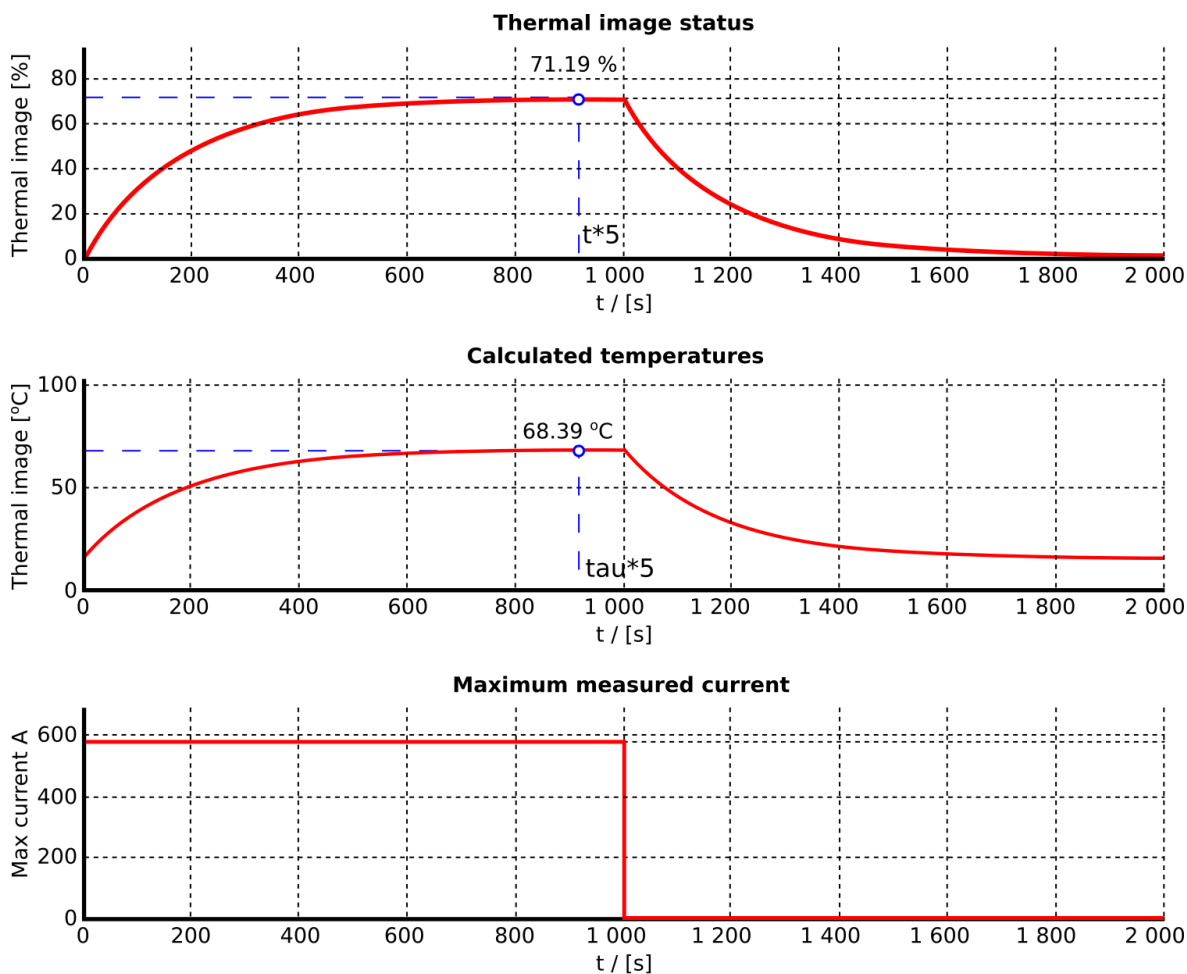

Settings

$I_N = 680$ A	Max. temperature rise = 75 °C	Reference temperature = 15 °C
Starting temp = 0 %	Ambient temperature = 15 °C	$I_{MAX} = 575$ A
$\tau = 183.75$ min	Max End. Temp = 90 °C	
Service factor = 1.00	Temperature k factor = 1.00	

As the results show, the end temperature of 68.39 °C is reached when the cable is loaded with a stable current for time equalling five times the time constant τ . This uses approximately 71 % of the thermal capacity. According to the datasheet, this current should set the temperature around 65 °C; therefore, the model overprotects by three degrees.

Figure. 5.3.19 - 156. Thermal image response with maximum load (installation according presumptions).

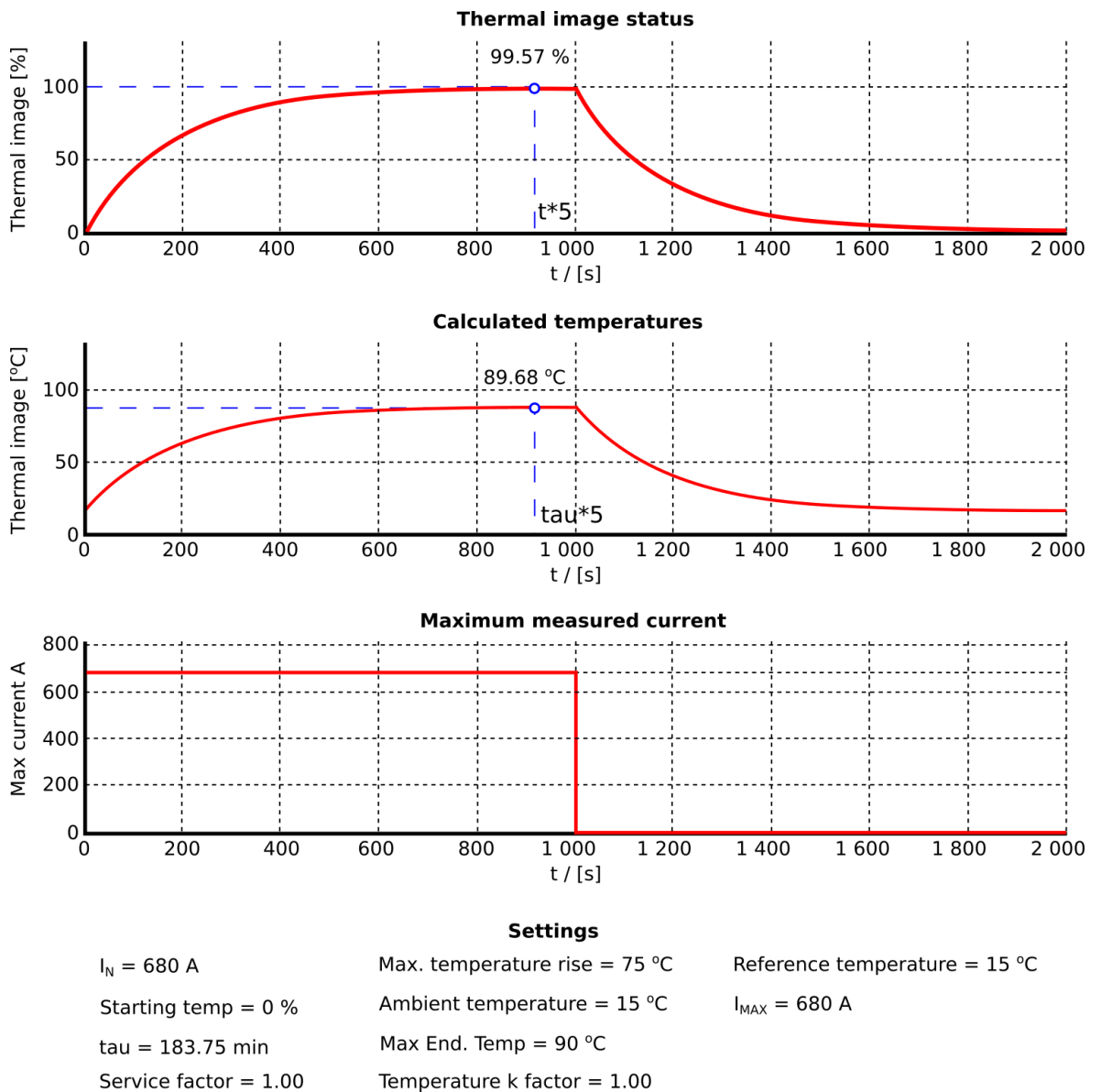

The maximum allowed load results in the end temperature of 89.68 °C which means that 99.57 % of the thermal capacity is used. This result matches the expectations of the thermal image perfectly. The user can now securely set the cable's overheating alarm.

When comparing the result to the fully-tuned model in the application, let us include all of the installation correction factors to the image.

A 66 kV copper cable with a cross-section of 500 mm² is installed *with no adjacent cables (k=1)* into a ground consisting of dry gravel and clay (*k=0.85*) and into the depth of 1.5 meters (*k=0.95*). The cable's 1 s permissible short-circuit current is 71.4 kA and its insulation is XLPE. The cable's screen circuit is open and the laying formation is flat. Its current-carrying capacity is 575 A in 65 °C and 680 A in 90 °C. The reference temperature for ground installation is 15 °C. The cable's thermal time constant is 183.8 min.

From this initial data one can calculate the k_{SF} correction factor according to the following formula (k factor related information in italics):

$$k_{SF} = 1 \times 0.85 \times 0.95 = 0.81$$

Therefore, the settings are as follows:

- $I_n = 680 \text{ A}$
- $T_{\text{max}} = 90 \text{ }^\circ\text{C}$
- $T_{\text{amb}} = 15 \text{ }^\circ\text{C}$
- $T_{\text{ref}} = 15 \text{ }^\circ\text{C}$
- $\tau = 183.8 \text{ min}$
- $k_{\text{SF}} = 0.81$.

Figure. 5.3.19 - 157. Thermal image response with nominal currents and fine-tuned k_{SF} correction factor.

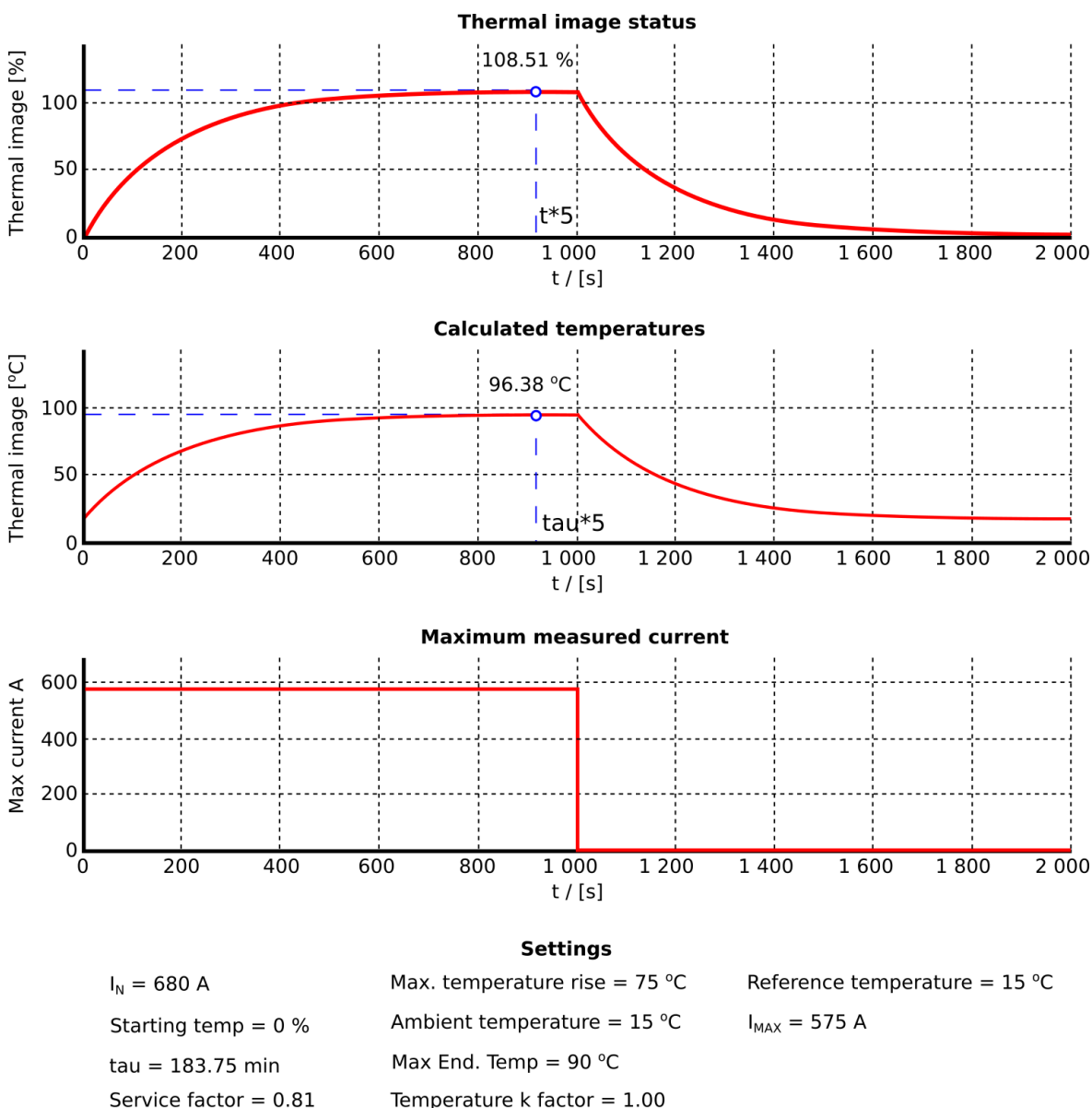

When trying to load the cable with the nominal current one can see the actual current-carrying capacity of the cable is much lower than in the presumptive conditions. A normal loading current can now warm up the cable too much and threaten its withstandability. If the k_{SF} had not been set, the thermal image would show a temperature of appr. 68 °C instead of the real temperature of 96 °C.

Figure. 5.3.19 - 158. Thermal response with k_{SF} factor correctly set.

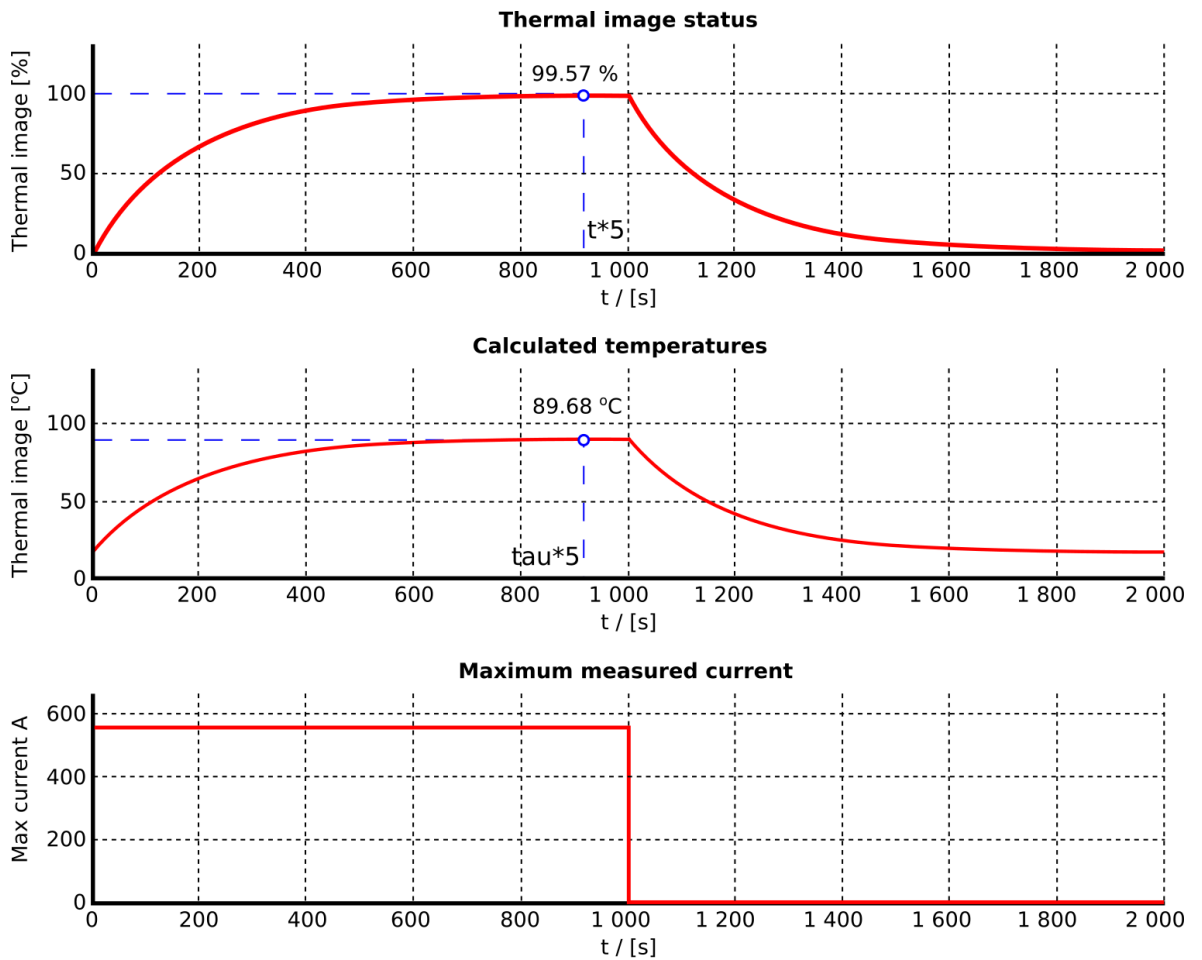

Settings

$I_N = 680 \text{ A}$	Max. temperature rise = 75 °C	Reference temperature = 15 °C
Starting temp = 0 %	Ambient temperature = 15 °C	$I_{MAX} = 550.8 \text{ A}$
$\tau = 183.75 \text{ min}$	Max End. Temp = 90 °C	
Service factor = 0.81	Temperature k factor = 1.00	

When the installation conditions vary from the presumptive conditions, the cable's current-carrying capacity can be reduced so that the temperature of 90 °C is achieved with a 550 A current instead of the 680 A current given in the initial data.

Estimating trip time

Calculated effective nominal current:

$$I_N = k_{SF} \times t_{amb\text{fact}} \times I_{Nom}$$

Where:

- I_N = calculated effective nominal current
- k_{SF} = the service factor
- k_{amb} = the ambient temperature factor
- I_{Nom} = the nominal current of the protected device

Calculated end heating:

$$\theta_{End} = (I_{meas}/I_N)^2$$

Where:

- I_{meas} = the measured current
- I_N = the calculated effective nominal current

Calculated time constant:

$$\tau = e^{(-0.005[s] \times (\tau_c[\text{min}] \times 60)[s])}$$

Where:

- e = Euler's number
- τ_c = the time constant set by the user
- 0.005s is the program cycle time

Calculated active thermal status:

$$\theta_{Calc} = ((\theta_{-1} - \theta_{End}) \times \tau) + \theta_{End}$$

Where:

- θ_{-1} = previous cycle calculation result (integrating function needs the memory to operate)
- θ_{End} = the calculated end heating (dependent on the measured current)
- τ = the calculated time constant

The tripping time can be calculated based on these previous calculations according to the following formula (the result in seconds). With this base information the tripping time can be calculated with the formula above (in seconds) when replacing the θ_{Calc} with the value of the thermal level which from the tripping time is wanted to be calculated (in per-unit value).

$$t_{est. trip} = I_n \left(\frac{I_{meas}^2 - (k_{fact} \times t_{amb_{fact}} \times \sqrt{\theta_{Calc}} \times I_n)^2}{(I_{meas}^2 - I_n^2)} \right) \times \tau \times 60$$

Function inputs and outputs

The blocking signal and the setting group selection control the operating characteristics of the function during normal operation, i.e. the user or user-defined logic can change function parameters while the function is running.

The outputs of the function are the TRIP and BLOCKED signals. The overvoltage function uses a total of eight (8) separate setting groups which can be selected from one common source. Additionally, the function's operating mode can be changed via the setting group selection.

The operational logic consists of the following:

- input magnitude processing
- thermal replica
- block signal check
- output processing.

The inputs for the function are the following:

- setting parameters
- measured and pre-processed current magnitudes.

The function's output signals can be used for direct I/O controlling and user logic programming. The function generates general time-stamped ON/OFF events to the common event buffer from each of the two (2) output signal. The time stamp resolution is 1 ms. The function also provides a resettable cumulative counter for the TRIP, ALARM 1, ALARM 2, INHIBIT and BLOCKED events.

The following figure presents a simplified function block diagram of the line thermal overload protection function.

Figure. 5.3.19 - 159. Simplified function block diagram of the TF> function.

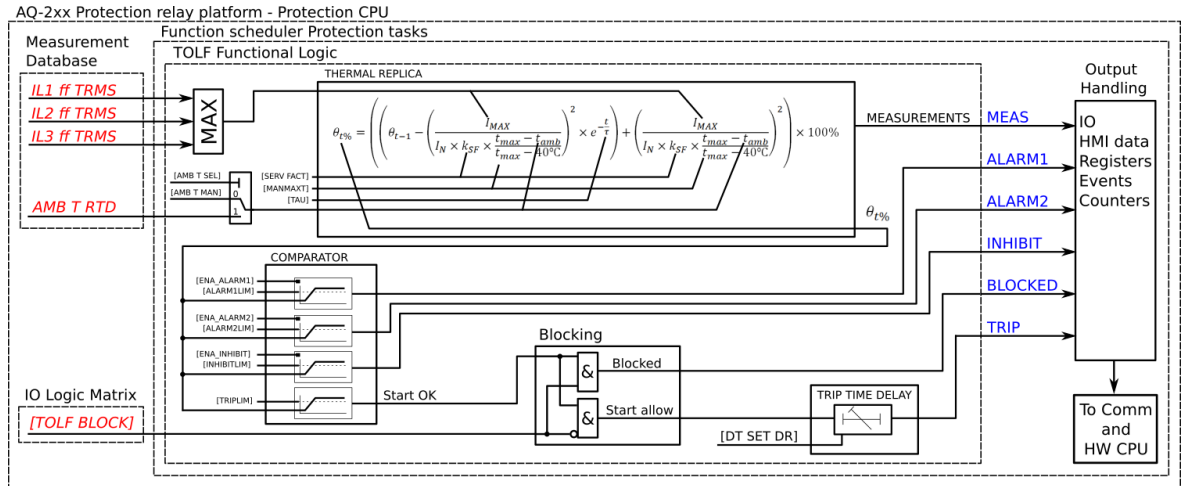

Measured input

The function block uses analog phase current measurement values. The function block uses TRMS values from the whole harmonic specter of 32 components.

Table. 5.3.19 - 152. Measurement inputs of the TF> function.

Signal	Description	Time base
IL1 TRMS	TRMS measurement of phase L1 (A) current	5ms
IL2 TRMS	TRMS measurement of phase L2 (B) current	5ms
IL3 TRMS	TRMS measurement of phase L3 (C) current	5ms
RTD	Temperature measurement for the ambient correction	5ms

Table. 5.3.19 - 153. General settings (not selectable under setting groups)

Name	Range	Step	Default	Description
TF> mode	0: Disabled 1: Activated	-	0: Disabled	The selection of the function is activated or disabled in the configuration. By default it is not in use.
Temp C or F deg	0: C 1: F	-	0: C	The selection of whether the temperature values of the thermal image and RTD compensation are shown in Celsius or in Fahrenheit.

Table. 5.3.19 - 154. Settings for thermal replica.

Name	Range	Step	Default	Description
IN thermal cap current	0.10...40.00xI _n	0.01xI _n	1.00xI _n	The current for the 100 % thermal capacity to be used (the pick-up current in p.u., with t _{max} achieved in time τ x 5).
Set or Estimate tau (t const)	0: Set 1: Estimate	-	0: Set	The selection of the time constant setting. If "Set" is selected, the Tau (t const) setting is available and the time constant to be used can be set there. If "Estimate" is selected, the cable's initial data parameters are visible.
Tau (t const)	0.1...500.0min	0.1min	10.0min	The time constant setting. This time constant is used for heating and cooling of the protected object. This setting is visible if the "Set" is selected for the "Set or Estimate tau" setting.
Max. perm. OC. current (norm **Ik**1s)	1...1 000 000A	1A	75 000A	The maximum-rated short-circuit current of the protected object (cable). Usually this value is presented as a one second value. This setting is visible if "Estimate" is selected for the "Set or Estimate tau" setting.
Max. OC. time (norm 1 s)	0.1...5s	0.1s	1.0s	The time of the maximum-rated short-circuit current of the protected object (usually 1 s). This setting is visible if "Estimate" is selected for the "Set or Estimate tau" setting.
Nominal current	1...1 000 000A	1A	700A	The rated nominal current in the primary value of the protected object under nominal-rated conditions. This setting is visible if "Estimate" is selected for the "Set or Estimate tau" setting.
Estimated tau	0...1800min	0.005min	191.3min (from defaults)	The estimated result which is used for the thermal replica's time constant. After the previous three required parameters are set the IED will calculate this value. This setting is visible if "Estimate" is selected for the "Set or Estimate tau" setting.
kSF (service factor)	0.01...5.00	0.01	1.00	The service factor which corrects the value of the maximum allowed current according to installation and other conditions varying from the presumptive conditions.
Cold reset default theta	0.0...150.0%	0.1%	60.0%	The thermal image status in the restart of the function/ IED. The value is given in percentages of the used thermal capacity of the protected object. It is also possible to reset the thermal element. This parameter can be used when testing the function to manually set the current thermal cap to any value.

Table. 5.3.19 - 155. Environmental settings

Name	Range	Step	Default	Description
Object max. temp. (t _{max} = 100%)	0...500deg	1deg	90deg	The maximum allowed temperature for the protected object. The default suits for Celsius range and for PEX-insulated cables.
Ambient temp. sel.	0: Manual set 1: RTD	-	0: Manual set	The selection of whether fixed or measured ambient temperature is used for the thermal image biasing.
Man. amb. temp. set.	0...500deg	1deg	15deg	The manual fixed ambient temperature setting for the thermal image biasing. Underground cables usually use 15 °C. This setting is visible if "Manual set" is selected for the "Ambient temp. sel." setting.
RTD amb. temp. read.	0...500deg	1deg	15deg	The RTD ambient temperature reading for the thermal image biasing. This setting is visible if "RTD" is selected for the "Ambient temp. sel." setting.
Ambient lin. or curve	0: Linear est. 1: Set curve	-	0: Linear est.	The selection of how to correct the ambient temperature, either by internally calculated compensation based on end temperatures or by a user-settable curve. The default setting is "0: Linear est." which means the internally calculated correction for ambient temperature.

Name	Range	Step	Default	Description
Temp. reference (t _{ref}) k _{amb} =1.0	-60...500deg	1deg	15deg	The temperature reference setting. The manufacturer's temperature presumptions apply and the thermal correction factor is 1.00 (rated temperature). For underground cables the set value for this is usually 15 °C and for cables in the air it is usually 25 °C. This setting is visible if "Ambient lin. or curve" is set to "Linear est."
Max. ambient temp.	0...500deg	1deg	45deg	The maximum ambient temperature setting. If the measured temperature is more than the maximum set temperature, the set correction factor for the maximum temperature is used. This setting is visible if "Ambient lin. or curve" is set to "Linear est."
k at max. amb. temp.	0.01...5.00xI _n	0.01xI _n	1.00xI _n	The temperature correction factor for the maximum ambient temperature setting. This setting is visible if "Ambient lin. or curve" is set to "Linear est."
Min. ambient temp.	-60...500deg	1deg	0deg	The minimum ambient temperature setting. If the measured temperature is below the minimum set temperature, the set correction factor for minimum temperature is used. This setting is visible if "Ambient lin. or curve" is set to "Linear est."
k at min. amb. temp.	0.01...5.00xI _n	0.01xI _n	1.00xI _n	The temperature correction factor for the minimum ambient temperature setting. This setting is visible if "Ambient lin. or curve" is set to "Linear est."
Amb. temp. ref. 1...10	-50.0...500.0deg	0.1deg	15deg	The temperature reference points for the user-settable ambient temperature coefficient curve. This setting is visible if "Ambient lin. or curve" is set to "Set curve".
Amb. temp. k1...k10	0.01...5.00	1.00	0.01	The coefficient value for the temperature reference point. The coefficient and temperature reference points must be set as pairs. This setting is visible if "Ambient lin. or curve" is set to "Set curve".
Add curvepoint 3...10	0: Not used 1: Used	-	0: Not used	The selection of whether or not the curve temperature/coefficient pair is in use. The minimum number to be set for the temperature/coefficient curve is two pairs and the maximum is ten pairs. If the measured temperature is below the set minimum temperature reference or above the maximum set temperature reference, the used temperature coefficient is the first or last value in the set curve. This setting is visible if "Ambient lin. or curve" is set to "Set curve".

Operation characteristics

The operating characteristics of the machine thermal overload protection function are completely controlled by the thermal image. The thermal capacity value calculated from the thermal image can set the I/O controls with ALARM 1, ALARM 2, INHIBIT and TRIP signals.

Table. 5.3.19 - 156. Pick-up settings.

Name	Range	Step	Default	Description
Enable TF> Alarm 1	0: Disabled 1: Enabled	-	0: Disabled	Enabling/disabling the ALARM 1 signal and the I/O.
TF> Alarm 1 level	0.0...150.0%	0.1%	40%	ALARM 1 activation threshold.
Enable TF> Alarm 2	0: Disabled 1: Enabled	-	0: Disabled	Enabling/disabling the ALARM 2 signal and the I/O.
TF> Alarm 2 level	0.0...150.0%	0.1%	40%	ALARM 2 activation threshold.

Name	Range	Step	Default	Description
Enable TF> Rest Inhibit	0: Disabled 1: Enabled	-	0: Disabled	Enabling/disabling the ALARM 1 signal and the I/O.
TF> Inhibit level	0.0...150.0%	0.1%	80%	INHIBIT activation threshold.
Enable TF> Trip	0: Disabled 1: Enabled	-	0: Disabled	Enabling/disabling the ALARM 1 signal and the I/O.
TF> Trip level	0.0...150.0%	0.1%	100%	TRIP activation threshold.
TF> Trip delay	0.000...3600.000s	0.005s	0.000s	The trip signal's additional delay. This delay delays the trip signal generation by a set time. The default setting is 0.000 s which does not give an added time delay for the trip signal.

The pick-up activation of the function is direct for all other signals except the TRIP signal which also has a blocking check before the signal is generated.

Function blocking

The block signal is checked in the beginning of each program cycle. The blocking signal is received from the blocking matrix in the function's dedicated input. If the blocking signal is not activated when the pick-up element activates, a START signal is generated and the function proceeds to the time characteristics calculation.

If the blocking signal is active when the pick-up element activates, a BLOCKED signal is generated and the function does not process the situation further. If the START function has been activated before the blocking signal, it resets and processes the release time characteristics similarly to when the pick-up signal is reset.

The blocking of the function causes an HMI display event and a time-stamped blocking event with information of the startup current values and its fault type to be issued.

The blocking signal can also be tested in the commissioning phase by a software switch signal when the relay's testing mode "Enable stage forcing" is activated (*General* → *Device*).

The variables the user can set are binary signals from the system. The blocking signal needs to reach the device minimum of 5 ms before the set operating delay has passed in order for the blocking to activate in time.

Measurements and indications

The function outputs measured process data from the following magnitudes:

Table. 5.3.19 - 157. General status codes.

Name	Range	Description
TF> Condition	0: Normal 1: Alarm 1 ON 2: Alarm 2 ON 3: Inhibit ON 4: Trip ON 5: Blocked	The function's operating condition at the moment considering binary IO signal status. No outputs are controlled when the status is "Normal".

Name	Range	Description
Thermal status	0: Light / No load 1: High overload 2: Overloading 3: Load normal	The function's thermal image status. When the measured current is below 1 % of the nominal current, the status "Light/No load" is shown. When the measured current is below the trip limit, the status "Load normal" is shown. When the measured current is above the pick-up limit but below $2 \times I_n$, the status "Overloading" is shown. When the measured current is above $2 \times I_n$, the status "High overload" is shown.
TF> Setting alarm	0: SF setting ok 1: Service factor set fault. Override to 1.0	Indicates if SF setting has been set wrong and the actually used setting is 1.0. Visible only when there is a setting fault.
TF> Setting alarm	0: Ambient setting ok 1: Ambient t set fault. Override to 1.0	Indicates if ambient temperature settings have been set wrong and actually used setting is 1.0. Visible only when there is a setting fault.
TF> Setting alarm	0: Nominal current calc ok 1: Nominal current set fault. Override to 1.0	Indicates if nominal current calculation is set wrong and actually used setting is 1.0. Visible only when there is a setting fault.
TF> Setting alarm	0: Ambient setting ok 1: Inconsistent setting of ambient k	Indicates if ambient k setting has been set wrong. Visible only when there is a setting fault.

Table. 5.3.19 - 158. Measurements.

Name	Range	Description/values
Currents	0: Primary A 1: Secondary A 2: Per unit	The active phase current measurement from IL1 (A), IL2 (B) and IL3 (C) phases in given scalings.
Thermal image	0: Thermal image calc.	<ul style="list-style-type: none"> - TF> Trip expect mode: No trip expected/Trip expected - TF> Time to 100 % theta: Time to reach the 100 % thermal cap - TF> Rreference T curr.: reference/pick-up value (IEQ) - TF> Active meas. curr.: the measured maximum TRMS current at a given moment - TF> T est. with act. curr.: estimation of the used thermal capacity including the current at a given moment - TF> T at a given moment: the thermal capacity used at that moment
	1: Temp. estimates	<ul style="list-style-type: none"> - TF> Used k for amb. temp: the ambient correction factor at a givenmoment - TF> Max. temp. rise all.: the maximum allowed temperature rise - TF> Temp. rise atm: the calculated temperature rise at a given moment - TF> Hot spot estimate: the estimated hot spot temperature including the ambient temperature - TF> Hot spot max. all.: the maximum allowed temperature for the object

Name	Range	Description/values
	2: Timing status	<ul style="list-style-type: none"> - TF> Trip delay remaining: the time to reach 100% theta - TF> Trip time to rel.: the time to reach theta while staying below the trip limit during cooling - TF> Alarm 1 time to rel.: the time to reach theta while staying below the Alarm 1 limit during cooling - TF> Alarm 2 time to rel.: the time to reach theta while staying below the Alarm 2 limit during cooling - TF> Inhibit time to rel.: the time to reach theta while staying below the Inhibit limit during cooling

Table. 5.3.19 - 159. Counters.

Name	Description / values
Alarm1 inits	The number of times the function has activated the Alarm 1 output
Alarm2 inits	The number of times the function has activated the Alarm 2 output
Restart inhibits	The number of times the function has activated the Restart inhibit output
Trips	The number of times the function has tripped
Trips Blocked	The number of times the function trips has been blocked

Events and registers

The line thermal overload protection function (abbreviated "TOLF" in event block names) generates events and registers from the status changes in TRIP and BLOCKED signals. The user can select which event messages are stored in the main event buffer: ON, OFF, or both.

The events triggered by the function are recorded with a time stamp and with process data values.

Table. 5.3.19 - 160. Event codes.

Event number	Event channel	Event block name	Event code	Description
4288	67	TOLF1	0	Alarm1 ON
4289	67	TOLF1	1	Alarm1 OFF
4290	67	TOLF1	2	Alarm2 ON
4291	67	TOLF1	3	Alarm2 OFF
4292	67	TOLF1	4	Inhibit ON
4293	67	TOLF1	5	Inhibit OFF
4294	67	TOLF1	6	Trip ON
4295	67	TOLF1	7	Trip OFF
4296	67	TOLF1	8	Block ON
4297	67	TOLF1	9	Block OFF

The function registers its operation into the last twelve (12) time-stamped registers. The register of the function records the ON event process data for TRIP or BLOCKED. The table below presents the structure of the function's register content.

Table. 5.3.19 - 161. Register content.

Name	Description
Date and time	dd.mm.yyyy hh:mm:ss.mss

Name	Description
Event code	4288-4297 Descr.
Time to reach 100 % theta	seconds
Ref. T current	x I _n
Active meas. current	x I _n
T at a given moment	%
Max. temp. rise allowed	degrees
Temp. rise at a given moment	degrees
Hot spot estimate	degrees
Hot spot maximum allowed	degrees
Trip delay rem.	seconds
Used SG	Setting group 1...8 active

5.3.20 Resistance temperature detectors

Resistance temperature detectors (or RTDs) can be used to measure both temperatures of motors/generators and ambient temperatures. Typically an RTD is a thermocouple or of type PT100. Up to three (3) separate RTD modules based on an external Modbus are supported; each can hold up to eight (8) measurement elements. Up to two (2) separate RTD option cards are supported by this function. Sixteen (16) individual element monitors can be set for this alarm function, and each of those can be set to alarm two (2) separate alarms from one selected input. The user can set alarms and measurements to be either in degrees Celsius or Fahrenheit.

The following figure shows the principal structure of the resistance temperature detection function.

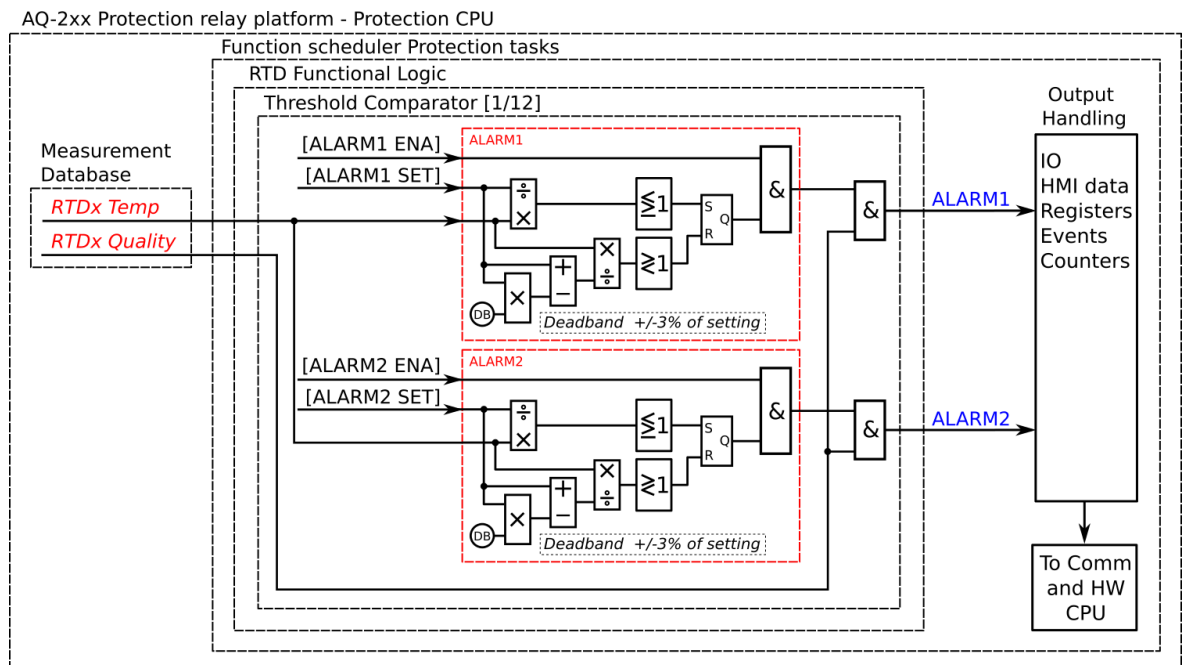

Setting up an RTD measurement, the user first needs to set the measurement module to scan the wanted RTD elements. A multitude of Modbus-based modules are supported. Communication requires bitrate, databits, parity, stopbits and Modbus I/O protocol to be set; this is done at *Communication* → *Connections*. Once communication is set, the wanted channels are selected at *Communication* → *Protocols* → *ModbusI/O*. Then the user selects the measurement module from the three (3) available modules (A, B and C), as well as the poll address. Additionally, both the module type and the polled channels need to be set. When using a thermocouple module, the thermo element type also needs to be set for each of the measurement channels. Once these settings are done the RTDs are ready for other functions.

Figure. 5.3.20 - 160. RTD alarm setup.

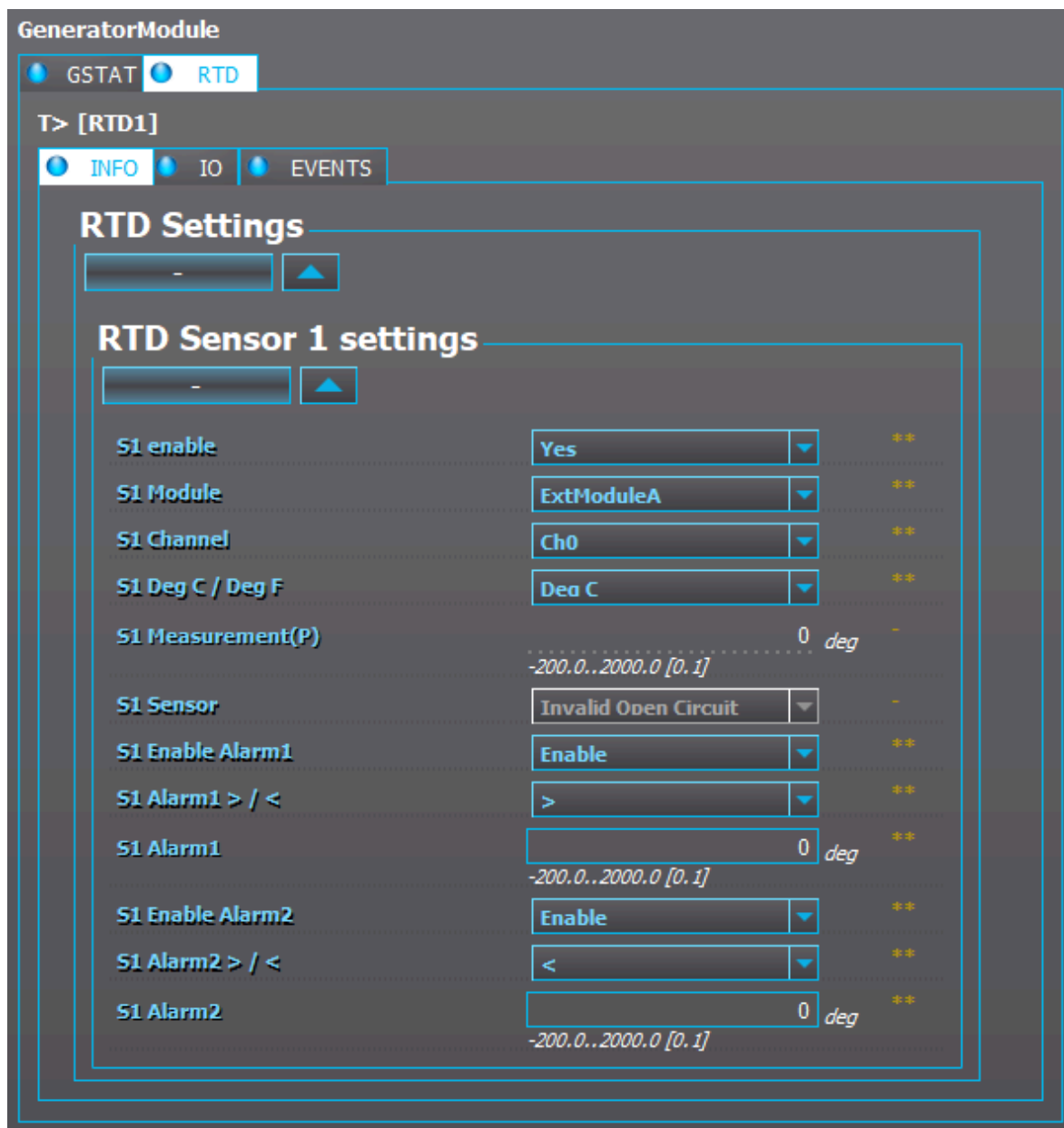

Function can be set to monitor the measurement data from previously set RTD channels. A single channel can be set to have several alarms if the user sets the channel to multiple sensor inputs. In each sensor setting the user can select the monitored module and channel, as well as the monitoring and alarm setting units (°C or °F). The alarms can be enabled, given a setting value (in degrees), and be set to trigger either above or below the setting value. There are sixteen (16) available sensor inputs in the function. An active alarm requires a valid channel measurement. It can be invalid if communication is not working or if a sensor is broken.

Settings

Table. 5.3.20 - 162. Function settings for Channel x (Sx).

Name	Range	Step	Default	Description
S1...S16 enable	0: No 1: Yes	-	0: No	Enables/disables the selection of sensor measurements and alarms.
S1...S16 module	0: InternalRTD1 1: InternalRTD2 2: ExtModuleA 3: ExtModuleB 4: ExtModuleC	-	0: InternalRTD1	Selects the measurement module. Internal RTD modules are option cards installed to the relay. External modules are Modbus based external devices.
S1...S16 channel	0: Channel 0 1: Channel 1 3: Channel 2 4: Channel 3 5: Channel 4 6: Channel 5 7: Channel 6 8: Channel 7	-	0: Channel 0	Selects the measurement channel in the selected module.
S1...S16 Deg C/Dec F	0: Deg C 1: Deg F	-	0: Deg C	Selects the measurement temperature scale (Celsius or Fahrenheit).
S1...S16 Measurement	-	-	-	Displays the measurement value in the selected temperature scale.
S1...S16 Sensor	0: Ok 1: Invalid	-	-	Displays the measured sensor's data validity. If the sensor reading has any problems, the sensor data is set to "Invalid" and the alarms are not activated.
S1...S16 Enable alarm 1	0: Disable 1: Enable	-	0: Disable	Enables/disables the selection of Alarm 1 for the measurement channel x.
S1...S16 Alarm1 >/<	0: > 1: <	-	0: >	Selects whether the alarm activates when measurement is above or below the pick-up setting value.
S1...S16 Alarm1	-101.0...2000.0deg	0.1deg	0.0deg	Sets the pick-up value for Alarm 1. The alarm is activated if the measurement goes above or below this setting mode (depends on the selected mode in "Sx Alarm1 >/<").
S1...S16 sensor	0: Ok 1: Invalid	-	-	Displays the measured sensor's data validity. If the sensor reading has any problems, the sensor data is set to "Invalid" and the alarms are not activated.
S1...S16 Enable alarm 2	0: Disable 1: Enable	-	0: Disable	Enables/disables the selection of Alarm 2 for the measurement channel x.
S1...S16 Alarm2 >/<	0: > 1: <	-	0: >	Selects whether the measurement is above or below the setting value.
S1...S16 Alarm2	-101.0...2000.0deg	0.1deg	0.0deg	Sets the value for Alarm 2. The alarm is activated if the measurement goes above or below this setting mode (depends on the selected mode in "Sx Alarm2 >/<").

When the RTDs have been set, the values can be read to SCADA (or some other control system). The alarms can also be used for direct output control as well as in logics.

Events

The resistance temperature detector function (abbreviated "RTD" in event block names) generates events and registers from the status changes in ALARM and MEAS INVALID. The user can select which event messages are stored in the main event buffer: ON, OFF, or both. The function offers sixteen (16) independent stages; the events are segregated for each stage operation.

The events triggered by the function are recorded with a time stamp and with process data values. The function registers its operation into the last twelve (12) time-stamped registers.

Table. 5.3.20 - 163. Event codes.

Event number	Event channel	Event block name	Event code	Description
4416	69	RTD1	0	S1 Alarm1 ON
4417	69	RTD1	1	S1 Alarm1 OFF
4418	69	RTD1	2	S1 Alarm2 ON
4419	69	RTD1	3	S1 Alarm2 OFF
4420	69	RTD1	4	S2 Alarm1 ON
4421	69	RTD1	5	S2 Alarm1 OFF
4422	69	RTD1	6	S2 Alarm2 ON
4423	69	RTD1	7	S2 Alarm2 OFF
4424	69	RTD1	8	S3 Alarm1 ON
4425	69	RTD1	9	S3 Alarm1 OFF
4426	69	RTD1	10	S3 Alarm2 ON
4427	69	RTD1	11	S3 Alarm2 OFF
4428	69	RTD1	12	S4 Alarm1 ON
4429	69	RTD1	13	S4 Alarm1 OFF
4430	69	RTD1	14	S4 Alarm2 ON
4431	69	RTD1	15	S4 Alarm2 OFF
4432	69	RTD1	16	S5 Alarm1 ON
4433	69	RTD1	17	S5 Alarm1 OFF
4434	69	RTD1	18	S5 Alarm2 ON
4435	69	RTD1	19	S5 Alarm2 OFF
4436	69	RTD1	20	S6 Alarm1 ON
4437	69	RTD1	21	S6 Alarm1 OFF
4438	69	RTD1	22	S6 Alarm2 ON
4439	69	RTD1	23	S6 Alarm2 OFF
4440	69	RTD1	24	S7 Alarm1 ON
4441	69	RTD1	25	S7 Alarm1 OFF
4442	69	RTD1	26	S7 Alarm2 ON
4443	69	RTD1	27	S7 Alarm2 OFF
4444	69	RTD1	28	S8 Alarm1 ON
4445	69	RTD1	29	S8 Alarm1 OFF
4446	69	RTD1	30	S8 Alarm2 ON
4447	69	RTD1	31	S8 Alarm2 OFF
4448	69	RTD1	32	S9 Alarm1 ON
4449	69	RTD1	33	S9 Alarm1 OFF
4450	69	RTD1	34	S9 Alarm2 ON

Event number	Event channel	Event block name	Event code	Description
4451	69	RTD1	35	S9 Alarm2 OFF
4452	69	RTD1	36	S10 Alarm1 ON
4453	69	RTD1	37	S10 Alarm1 OFF
4454	69	RTD1	38	S10 Alarm2 ON
4455	69	RTD1	39	S10 Alarm2 OFF
4456	69	RTD1	40	S11 Alarm1 ON
4457	69	RTD1	41	S11 Alarm1 OFF
4458	69	RTD1	42	S11 Alarm2 ON
4459	69	RTD1	43	S11 Alarm2 OFF
4460	69	RTD1	44	S12 Alarm1 ON
4461	69	RTD1	45	S12 Alarm1 OFF
4462	69	RTD1	46	S12 Alarm2 ON
4463	69	RTD1	47	S12 Alarm2 OFF
4464	69	RTD1	48	S13 Alarm1 ON
4465	69	RTD1	49	S13 Alarm1 OFF
4466	69	RTD1	50	S13 Alarm2 ON
4467	69	RTD1	51	S13 Alarm2 OFF
4468	69	RTD1	52	S14 Alarm1 ON
4469	69	RTD1	53	S14 Alarm1 OFF
4470	69	RTD1	54	S14 Alarm2 ON
4471	69	RTD1	55	S14 Alarm2 OFF
4472	69	RTD1	56	S15 Alarm1 ON
4473	69	RTD1	57	S15 Alarm1 OFF
4474	69	RTD1	58	S15 Alarm2 ON
4475	69	RTD1	59	S15 Alarm2 OFF
4476	69	RTD1	60	S16 Alarm1 ON
4477	69	RTD1	61	S16 Alarm1 OFF
4478	69	RTD1	62	S16 Alarm2 ON
4479	69	RTD1	63	S16 Alarm2 OFF
4480	70	RTD2	0	S1 Meas Ok
4481	70	RTD2	1	S1 Meas Invalid
4482	70	RTD2	2	S2 Meas Ok
4483	70	RTD2	3	S2 Meas Invalid
4484	70	RTD2	4	S3 Meas Ok
4485	70	RTD2	5	S3 Meas Invalid
4486	70	RTD2	6	S4 Meas Ok
4487	70	RTD2	7	S4 Meas Invalid
4488	70	RTD2	8	S5 Meas Ok

Event number	Event channel	Event block name	Event code	Description
4489	70	RTD2	9	S5 Meas Invalid
4490	70	RTD2	10	S6 Meas Ok
4491	70	RTD2	11	S6 Meas Invalid
4492	70	RTD2	12	S7 Meas Ok
4493	70	RTD2	13	S7 Meas Invalid
4494	70	RTD2	14	S8 Meas Ok
4495	70	RTD2	15	S8 Meas Invalid
4496	70	RTD2	16	S9 Meas Ok
4497	70	RTD2	17	S9 Meas Invalid
4498	70	RTD2	18	S10 Meas Ok
4499	70	RTD2	19	S10 Meas Invalid
4500	70	RTD2	20	S11 Meas Ok
4501	70	RTD2	21	S11 Meas Invalid
4502	70	RTD2	22	S12 Meas Ok
4503	70	RTD2	23	S12 Meas Invalid
4504	70	RTD2	24	S13 Meas Ok
4505	70	RTD2	25	S13 Meas Invalid
4506	70	RTD2	26	S14 Meas Ok
4507	70	RTD2	27	S14 Meas Invalid
4508	70	RTD2	28	S15 Meas Ok
4509	70	RTD2	29	S15 Meas Invalid
4510	70	RTD2	30	S16 Meas Ok
4511	70	RTD2	31	S16 Meas Invalid

5.3.21 Arc fault protection (IArc>/IOArc>; 50Arc/50NArc)

Arc faults occur for a multitude of reasons: e.g. insulation failure, incorrect operation of the protected device, corrosion, overvoltage, dirt, moisture, incorrect wiring, or even because of aging caused by electric load. It is important to detect the arc as fast as possible in order to minimize its effects. Using arc sensors to detect arc faults is much faster than merely measuring currents and voltages. In busbar protection IEDs with normal protection can be too slow to disconnect arcs within a safe time frame. For example, it may be necessary to delay operation time for hundreds of milliseconds when setting up an overcurrent protection relay to control the feeder breakers to achieve selectivity. This delay can be avoided by using arc protection. The arc protection card has a high-speed output to trip signals faster as well as to extend the speed of arc protection.

Figure. 5.3.21 - 161. IED equipped with arc protection.

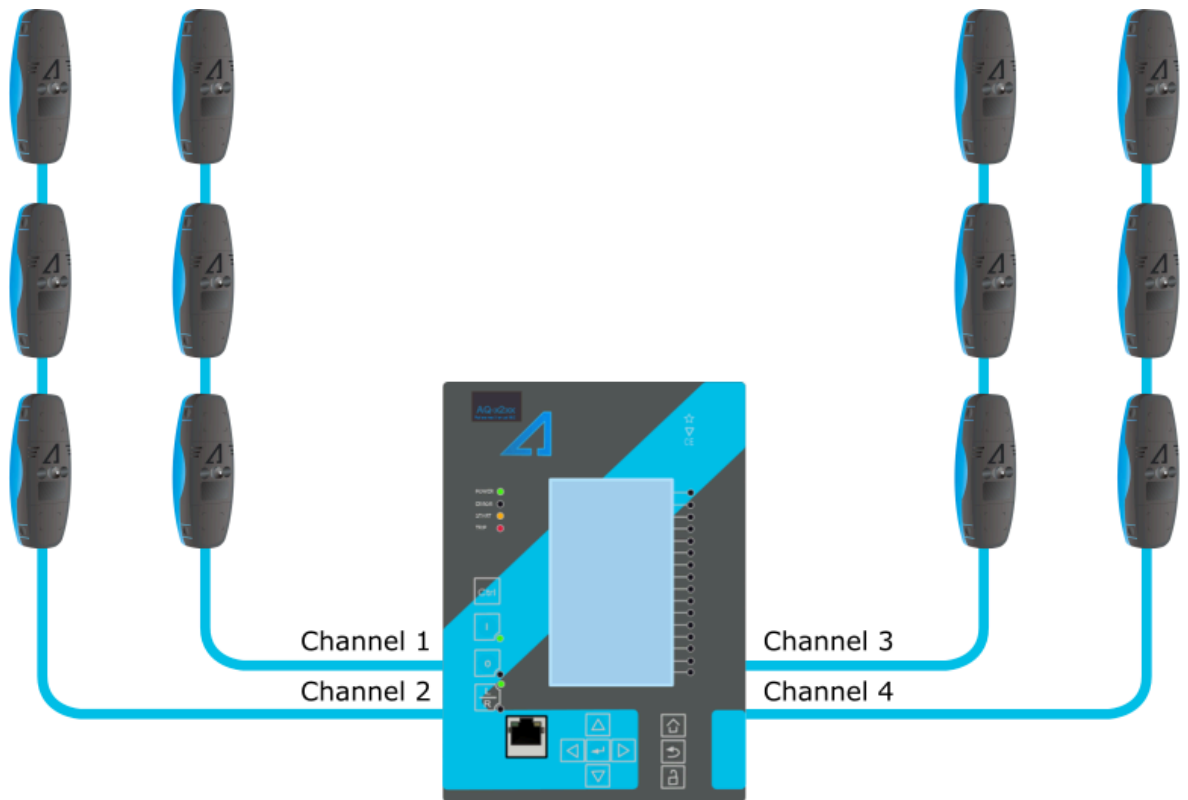

The arc protection card has four (4) sensor channels, and up to three (3) arc point sensors can be connected to each channel. The sensor channels support ArcTeq AQ-01 (light sensing) and AQ-02 (pressure and light sensing) units. Optionally, the protection function can also be applied with a phase current or a residual current condition: the function trips only if the light and overcurrent conditions are met.

The outputs of the function are the following:

- Light In
- Pressure In
- Arc binary input signal status
- Zone trip
- Zone blocked
- Sensor fault signals.

The arc protection function uses a total of eight (8) separate setting groups which can be selected from one common source.

Table. 5.3.21 - 164. Output signals of the IArc>/IOArc> function.

Outputs	Activation condition
Channel 1 Light In Channel 2 Light In Channel 3 Light In Channel 4 Light In	The arc protection card's sensor channel detects light.
Channel 1 Pressure In Channel 2 Pressure In Channel 3 Pressure In Channel 4 Pressure In	The arc protection card's sensor channel detects pressure.
ARC Binary input signal	The arc protection card's binary input is energized.

Outputs	Activation condition
I/O Arc> Ph. curr. START I/O Arc> Res. curr. START	The measured phase current or the residual current is over the set limit.
I/O Arc> Ph. curr. BLOCKED I/O Arc> Res. curr. BLOCKED	The phase current or the residual current measurement is blocked by an input.
I/O Arc> Zone 1 TRIP I/O Arc> Zone 2 TRIP I/O Arc> Zone 3 TRIP I/O Arc> Zone 4 TRIP	All required conditions for tripping the zone are met (light OR light and current).
I/O Arc> Zone 1 BLOCKED I/O Arc> Zone 2 BLOCKED I/O Arc> Zone 3 BLOCKED I/O Arc> Zone 4 BLOCKED	All required conditions for tripping the zone are met (light OR light and current) but the tripping is blocked by an input.
I/O Arc> S1 Sensor fault I/O Arc> S2 Sensor fault I/O Arc> S3 Sensor fault I/O Arc> S4 Sensor fault	The detected number of sensors in the channel does not match the settings.
I/O Arc> IO unit fault	The number of connected AQ-100 series units does not match the number of units set in the settings.

The operational logic consists of the following:

- input magnitude selection
- input magnitude processing
- threshold comparator
- two block signal checks
- output processing.

The inputs for the function are the following:

- operating mode selections
- setting parameters
- digital inputs and logic signals
- measured and pre-processed current magnitudes.

The function outputs the TRIP, BLOCKED, light sensing etc. signals which can be used for direct I/O controlling and user logic programming. The function generates general time-stamped ON/OFF events to the common event buffer from each of the 26 output signals. The time stamp resolution is 1 ms. The function also a resettable cumulative counter for the TRIP and BLOCKED events for each zone.

Example of scheme setting

The following examples helps the user better understand how the arc protection function is set. In the examples AQ-101 models are used to extend the protection of Zone 2 and to protect each outgoing feeder (Zone 3).

Scheme IA1 is a single-line diagram with AQ-2xx series relays and with AQ-101 arc protection relays. The settings are for an incomer AQ-200 relay.

Figure. 5.3.21 - 162. Scheme IA1 (with AQ-101 arc protection relays).

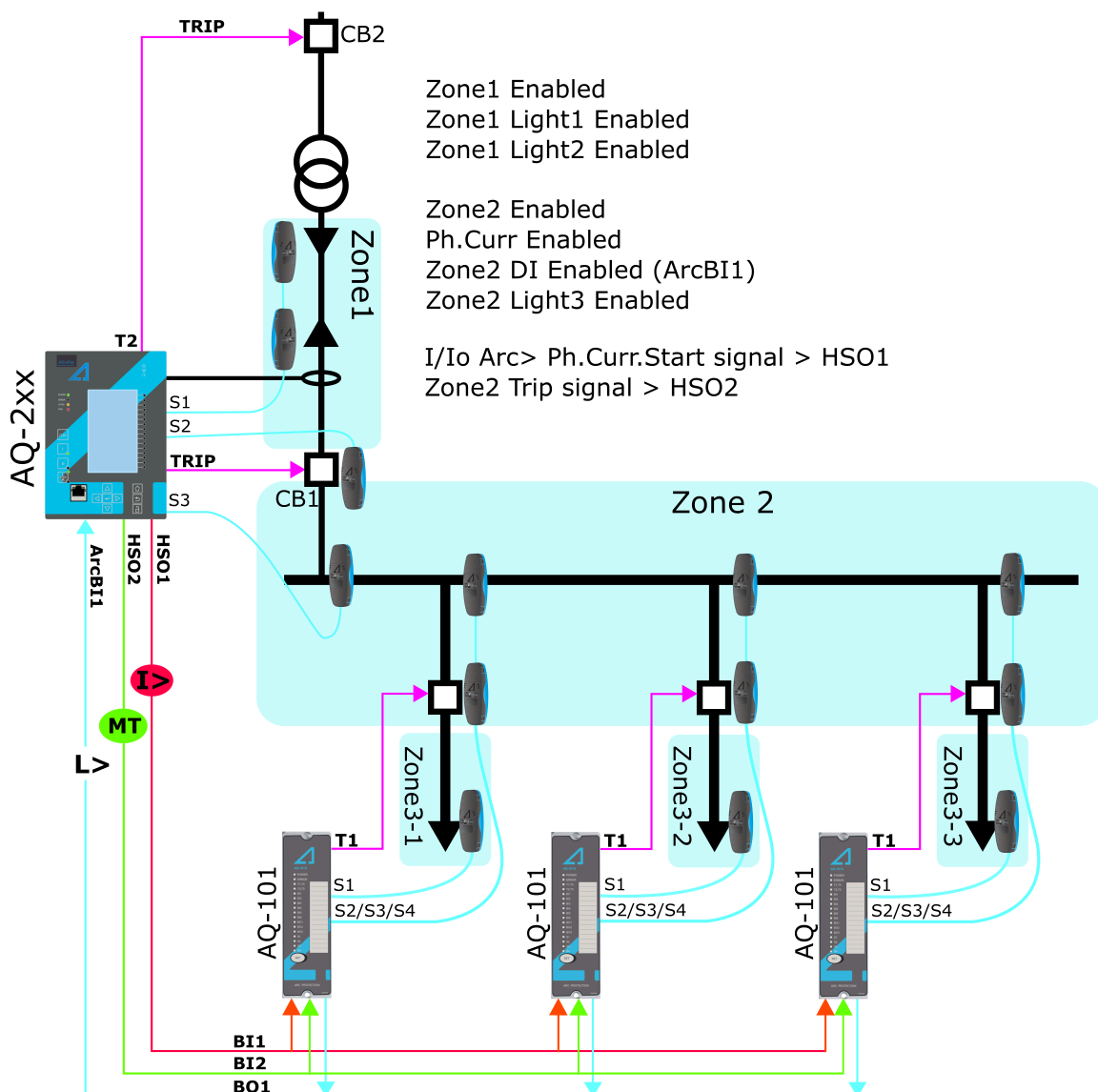

To set the zones for the AQ-2xx models sensor channels start by enabling the protected zones (in this case, Zones 1 and 2). Then define which sensor channels are sensing which zones (in this case, sensor channels S1 and S2 are protecting Zone 1). Enable Light 1 of Zone 1 as well as Light 2 of Zone 2. The sensor channel S3 deals with Zone 2. Enable Light 3 of Zone 2. The high-speed output contacts HSO1 and HSO2 have been set to send overcurrent and master trip signals to the AQ-101 arc protection relays. The AQ-100 series units send out test pulses in specific intervals to check the health of the wiring between the AQ-100 series units. The parameter *I/Io Arc> Self supervision test pulse* should be activated when connecting the AQ-100 series units to the AQ-200 series arc protection card to prevent the pulses from activating ArcBI1.

The next example is almost like the previous one: it is also a single-line diagram with AQ-2xx series relays. However, this time each outgoing feeder has an AQ-2xx protection relay instead of an AQ-101 arc protection relay.

Figure. 5.3.21 - 163. Scheme IA1 (with AQ-200 protection relays).

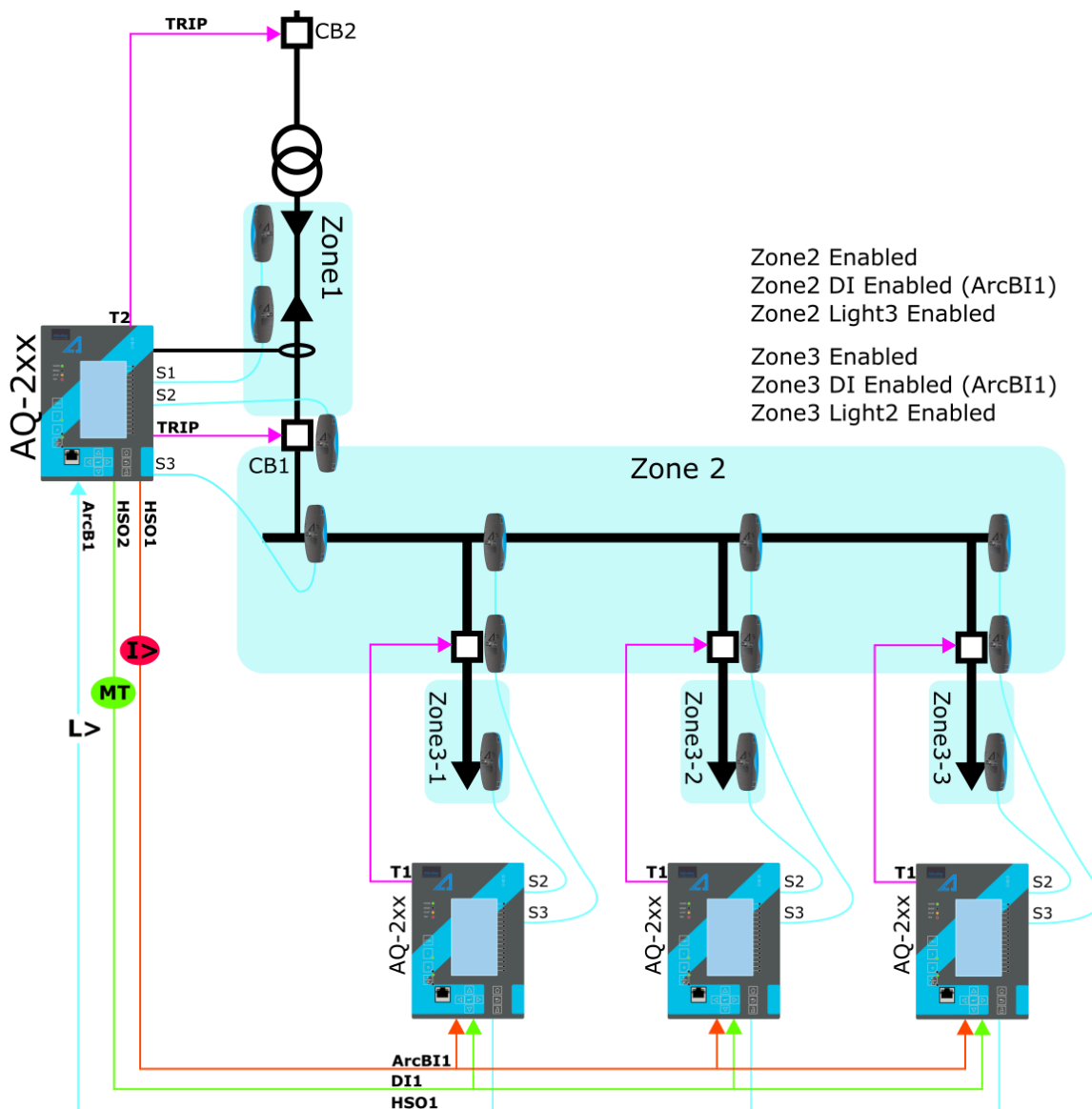

The settings for the relay supervising the incoming feeder are the same as in the first example. The relays supervising the busbar and the outgoing feeder, however, have a different setting. Both Zones 2 and 3 need to be enabled as there are sensors connected to both Zone 2 and 3 starts. Sensors connected to the channel S3 are in Zone 2. Then enable Light 3 of Zone 2. The sensor connected to the channel S2 is in Zone 3. Then enable Light 2 of Zone 3.

If any of the channels have a pressure sensing sensor, enable it the same way as the regular light sensors. If either phase overcurrent or residual overcurrent is needed for the tripping decision, they can be enabled in the same way as light sensors in the zone. When a current channel is enabled, the measured current needs to be above the set current limit in addition to light sensing.

Measured input

Arc protection uses samples based on current measurements. If the required number of samples is found to be above the setting limit, the current condition activates. The arc protection can alternatively use either phase currents or residual currents in the tripping decision.

General settings

The following general settings define the general behavior of the function. These settings are static i.e. it is not possible to change them by editing the setting group.

Table. 5.3.21 - 165. General settings of the function.

Name	Description	Range	Step	Default
Channel 1 sensors	Defines the amount of sensors connected to channel 1/2/3/4.	0: No sensors 1: 1 sensor 2: 2 sensors 3: 3 sensors	-	1: No sensors
Channel 2 sensors				
Channel 3 sensors				
Channel 4 sensors				
Channel 1 sensor status	Displays the status of the sensor channel. If amount of sensors connected to the channel don't match with "Channel 1/2/3/4 sensors" setting, this parameter will go to "Configuration fault" state.	0: Sensors OK 1: Configuration fault state	-	-
Channel 2 sensor status				
Channel 3 sensor status				
Channel 4 sensor status				

Pick-up

The pick-up of each zone of the $I_{arc} > I_0$ function is controlled by one of the following: the phase current pick-up setting, the residual current pick-up setting, or the sensor channels. The pick-up setting depends on which of these are activated in the zone.

Table. 5.3.21 - 166. Enabled Zone pick-up settings.

Name	Description	Range	Step	Default
Phase current pick-up	The phase current measurement's pick-up value (in p.u.).	0.05...40.00 x I_n	0.01 x I_n	1.2 x I_n
I0 input selection	Selects the residual current channel (I01 or I02).	0: None 1: I01 2: I02	-	0: None
Res.current pick-up	The residual current measurement's pick-up value (in p.u.).	0.05...40.00 x I_{0n}	0.01 x I_{0n}	1.2 x I_{0n}
Zone1/2/3/4 Enabled	Enables the chosen zone. Up to 4 zones can be enabled.	0: Disabled 1: Enabled	-	0: Disabled
Zone1/2/3/4 Ph. curr. Enabled	The phase overcurrent allows the zone to trip when light is detected.	0: Disabled 1: Enabled	-	0: Disabled
Zone1/2/3/4 Res. curr. Enabled	The residual overcurrent allows the zone to trip when light is detected.	0: Disabled 1: Enabled	-	0: Disabled

Name	Description	Range	Step	Default
Zone1/2/3/4 Light 1 Enabled	Light detected in sensor channel 1 trips the zone.	0: Disabled 1: Enabled	-	0: Disabled
Zone1/2/3/4 Light 2 Enabled	Light detected in sensor channel 2 trips the zone.	0: Disabled 1: Enabled	-	0: Disabled
Zone1/2/3/4 Light 3 Enabled	Light detected in sensor channel 3 trips the zone.	0: Disabled 1: Enabled	-	0: Disabled
Zone1/2/3/4 Light 4 Enabled	Light detected in sensor channel 4 trips the zone.	0: Disabled 1: Enabled	-	0: Disabled
Zone1/2/3/4 Pres. 1 Enabled	Pressure detected in sensor channel 1 trips the zone.	0: Disabled 1: Enabled	-	0: Disabled
Zone1/2/3/4 Pres. 2 Enabled	Pressure detected in sensor channel 2 trips the zone.	0: Disabled 1: Enabled	-	0: Disabled
Zone1/2/3/4 Pres. 3 Enabled	Pressure detected in sensor channel 3 trips the zone.	0: Disabled 1: Enabled	-	0: Disabled
Zone1/2/3/4 Pres. 4 Enabled	Pressure detected in sensor channel 4 trips the zone.	0: Disabled 1: Enabled	-	0: Disabled
Zone1/2/3/4 DI Enabled	Arc protection option card digital input has to be active for the zone to trip.	0: Disabled 1: Enabled	-	0: Disabled

The pick-up activation of the function is not directly equal to the TRIP signal generation of the function. The TRIP signal is allowed if the blocking condition is not active.

Read-only parameters

The relay's *Info* page displays useful, real-time information on the state of the protection function. It is accessed either through the relay's HMI display, or through the setting tool software when it is connected to the relay and its Live Edit mode is active.

Table. 5.3.21 - 167. Information displayed by the function.

Name	Range	Step	Description
I/O Arc> condition	0: Z1 Trip 1: Z1 Blocked 2: Z2 Trip 3: Z2 Blocked 4: Z3 Trip 5: Z3 Blocked 6: Z4 Trip 7:Z4 Blocked	-	Displays status of the protection function.
Sensor status	0: Ph Curr Blocked 1: Ph Curr Start 2: Res Curr Blocked 3: Res Curr Start 4: Channel1 Light 5: Channel1 Pressure 6: Channel2 Light 7: Channel2 Pressure 8: Channel3 Light 9: Channel3 Pressure 10: Channel4 Ligh t11: Channel4 Pressure 12: Digital input 13: I/O Arc> Sensor 1 Fault 14: I/O Arc> Sensor 2 Fault 15: I/O Arc> Sensor 3 Fault 16: I/O Arc> Sensor 4 Fault 17: I/O Arc> I/O-unit Fault	-	Displays the general status of sensors.

Function blocking

The block signal is checked in the beginning of each program cycle. The blocking signal is received from the blocking matrix in the function's dedicated input. If the blocking signal is not activated when the pick-up element activates, a TRIP signal is generated.

If the blocking signal is active when the pick-up element activates, a BLOCKED signal is generated and the function does not process the situation further.

The blocking of the function causes an HMI display event and a time-stamped blocking event with information of the startup current values and its fault type to be issued.

The blocking signal can also be tested in the commissioning phase by a software switch signal when the relay's testing mode "Enable stage forcing" is activated (*General* → *Device*).

The variables the user can set are binary signals from the system. The blocking signal needs to reach the device minimum of 5 ms before the set operating delay has passed in order for the blocking to activate in time.

Events and registers

The arc fault protection function (abbreviated "ARC" in event block names) generates events and registers from the status changes in START, TRIP, and BLOCKED. The user can select which event messages are stored in the main event buffer: ON, OFF, or both.

The events triggered by the function are recorded with a time stamp and with process data values.

Table. 5.3.21 - 168. Event codes.

Event number	Event channel	Event block name	Event code	Description
4736	74	ARC1	0	Zone 1 Trip ON
4737	74	ARC1	1	Zone 1 Trip OFF
4738	74	ARC1	2	Zone 1 Block ON
4739	74	ARC1	3	Zone 1 Block OFF
4740	74	ARC1	4	Zone 2 Trip ON
4741	74	ARC1	5	Zone 2 Trip OFF
4742	74	ARC1	6	Zone 2 Block ON
4743	74	ARC1	7	Zone 2 Block OFF
4744	74	ARC1	8	Zone 3 Trip ON
4745	74	ARC1	9	Zone 3 Trip OFF
4746	74	ARC1	10	Zone 3 Block ON
4747	74	ARC1	11	Zone 3 Block OFF
4748	74	ARC1	12	Zone 4 Trip ON
4749	74	ARC1	13	Zone 4 Trip OFF
4750	74	ARC1	14	Zone 4 Block ON
4751	74	ARC1	15	Zone 4 Block OFF
4752	74	ARC1	16	Phase current Blocked ON
4753	74	ARC1	17	Phase current Blocked OFF
4754	74	ARC1	18	Phase current Start ON

Event number	Event channel	Event block name	Event code	Description
4755	74	ARC1	19	Phase current Start OFF
4756	74	ARC1	20	Residual current Blocked ON
4757	74	ARC1	21	Residual current Blocked OFF
4758	74	ARC1	22	Residual current Start ON
4759	74	ARC1	23	Residual current Start OFF
4760	74	ARC1	24	Channel 1 Light ON
4761	74	ARC1	25	Channel 1 Light OFF
4762	74	ARC1	26	Channel 1 Pressure ON
4763	74	ARC1	27	Channel 1 Pressure OFF
4764	74	ARC1	28	Channel 2 Light ON
4765	74	ARC1	29	Channel 2 Light OFF
4766	74	ARC1	30	Channel 2 Pressure ON
4767	74	ARC1	31	Channel 2 Pressure OFF
4768	74	ARC1	32	Channel 3 Light ON
4769	74	ARC1	33	Channel 3 Light OFF
4770	74	ARC1	34	Channel 3 Pressure ON
4771	74	ARC1	35	Channel 3 Pressure OFF
4772	74	ARC1	36	Channel 4 Light ON
4773	74	ARC1	37	Channel 4 Light OFF
4774	74	ARC1	38	Channel 4 Pressure ON
4775	74	ARC1	39	Channel 4 Pressure OFF
4776	74	ARC1	40	DI Signal ON
4777	74	ARC1	41	DI Signal OFF
4778	74	ARC1	42	I/O Arc> Sensor 1 Fault ON
4779	74	ARC1	43	I/O Arc> Sensor 1 Fault OFF
4780	74	ARC1	44	I/O Arc> Sensor 2 Fault ON
4781	74	ARC1	45	I/O Arc> Sensor 2 Fault OFF
4782	74	ARC1	46	I/O Arc> Sensor 3 Fault ON
4783	74	ARC1	47	I/O Arc> Sensor 3 Fault OFF
4784	74	ARC1	48	I/O Arc> Sensor 4 Fault ON
4785	74	ARC1	49	I/O Arc> Sensor 4 Fault OFF
4786	74	ARC1	50	I/O Arc> I/O-unit Fault ON
4787	74	ARC1	51	I/O Arc> I/O-unit Fault OFF

The function registers its operation into the last twelve (12) time-stamped registers. The table below presents the structure of the function's register content.

Table. 5.3.21 - 169. Register content.

Date and time	Event code	Phase A current	Phase B current	Phase C current	Residual current	Active sensors	Used SG
dd.mm.yyyy hh:mm:ss.mss	4736-4787 Descr.	Trip -20ms averages	Trip -20ms averages	Trip -20ms averages	Trip -20ms averages	1...4	Setting group 1...8 active

5.3.22 Programmable stage (PGx>/<; 99)

The programmable stage is a stage that the user can program to create more advanced applications, either as an individual stage or together with programmable logic. The relay has ten programmable stages, and each can be set to follow one to three analog measurements. The programmable stages have three available pick up terms options: overX, underX and rate-of-change of the selected signal. Each stage includes a definite time delay to trip after a pick-up has been triggered.

The programmable stage cycle time is 5 ms. The pick-up delay depends on which analog signal is used as well as its refresh rate (typically under a cycle in a 50 Hz system).

The number of programmable stages to be used is set in the *INFO* tab. When this function has been set as "Activated", the number of programmable stages can be set anywhere between one (1) and ten (10) depending on how many the application needs. In the image below, the number of programmable stages have been set to two which makes PS1 and PS2 to appear. Inactive stages are hidden until they are activated.

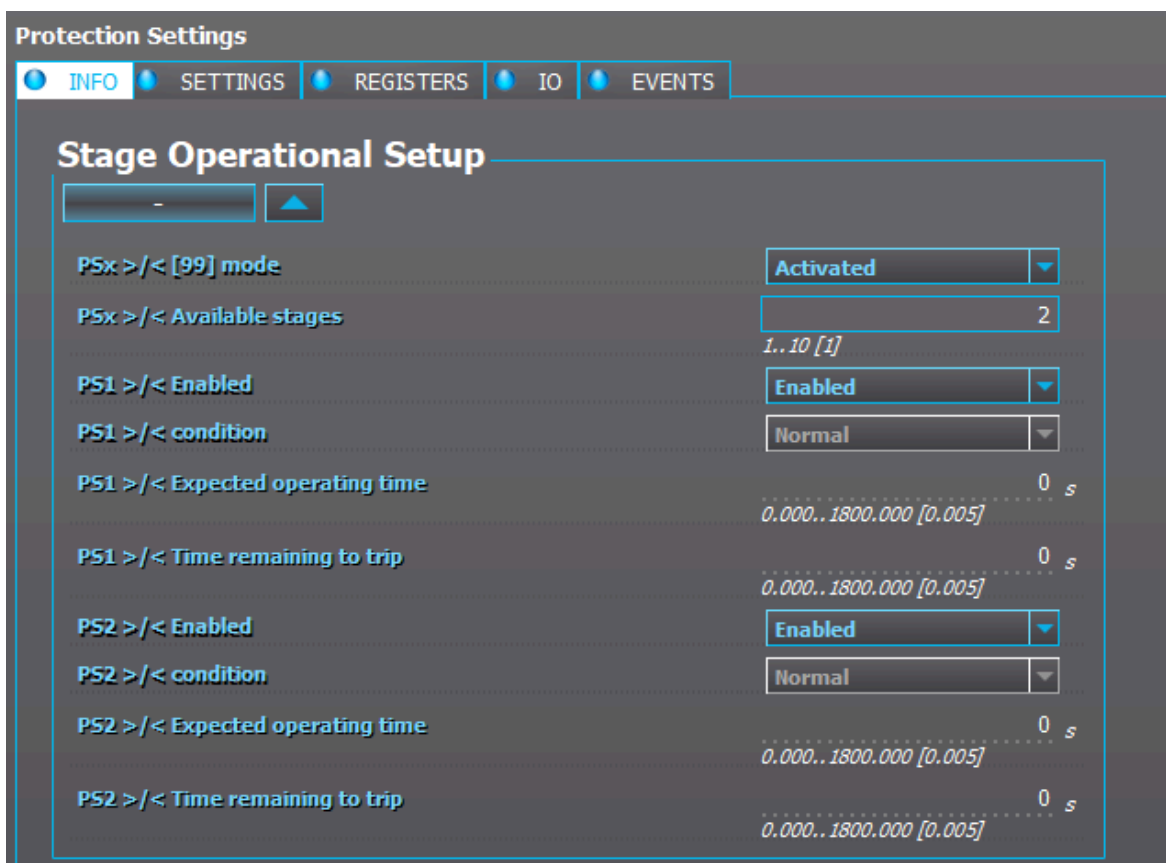

Please note that setting the number of available stages does not activate those stages, as they also need to be enabled individually with the *PSx >/< Enabled* parameter. When enabled an active stage shows its current state (condition), the expected operating time and the time remaining to trip under the activation parameters. If a stage is not active the *PSx >/< condition* parameter will merely display "Disabled".

Setting up programmable stages

Programmable stages can be set to follow one, two or three analog measurements with the *PSx >/< Measurement setting* parameter. The user must choose a measurement signal value to be compared to the set value, and possibly also set a scaling for the signal. The image below is an example of scaling: a primary neutral voltage has been scaled to a percentage value for easier handling when setting up the comparator.

The scaling factor was calculated by taking the inverse value of a 20 kV system:

$$k = \frac{1}{20\,000\text{ V}/\sqrt{3}} = 0.008\,66$$

When this multiplier is in use, the full earth fault neutral voltage is 11 547 V primary which is then multiplied with the above-calculated scaling factor, inverting the final result to 100%. This way a pre-processed signal is easier to set, although it is also possible to just use the scaling factor of 1.0 and set the desired pick-up limit as the primary voltage. Similarly, any chosen measurement value can be scaled to the desired form.

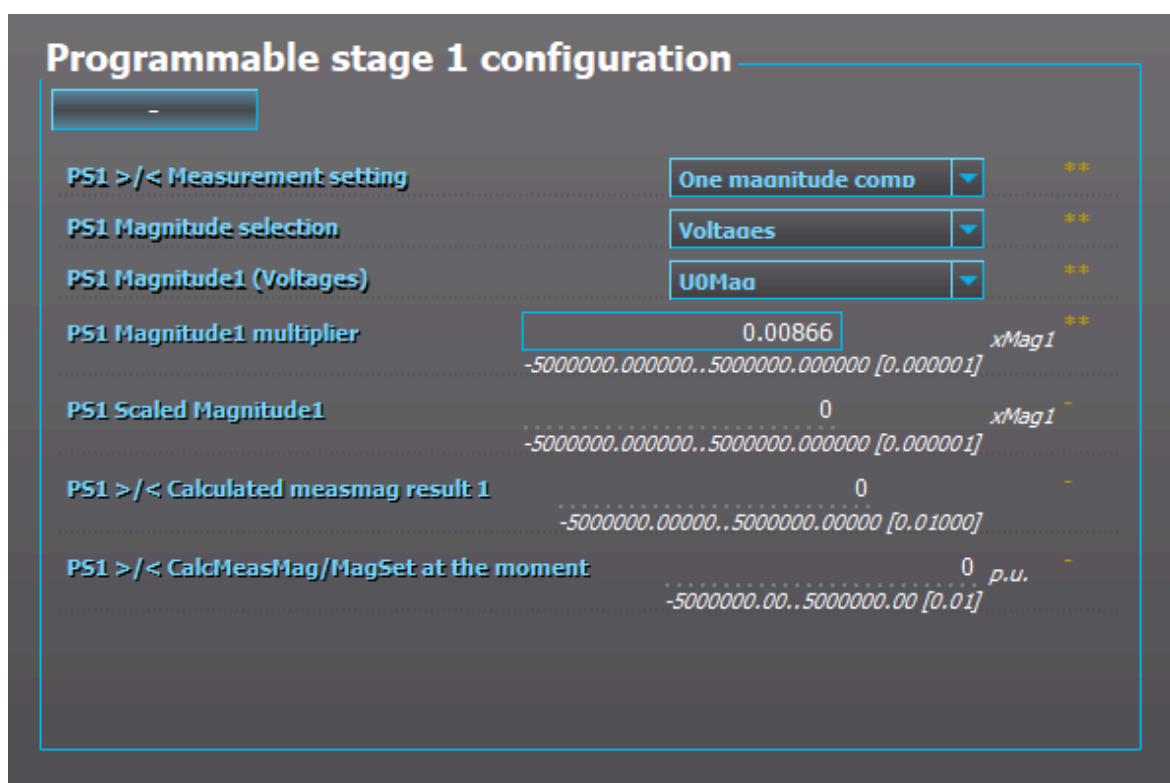

When two or three signals are chosen for comparison, an additional signal (*PSx Magnitude handling*) setting appears. From its drop-down menu the user chooses how the signals are pre-processed for comparison. The table below presents the available modes for a two-signal comparison.

Mode	Description
0: Mag1 x Mag2	Multiplies Signal 1 by Signal 2. The comparison uses the product of this calculation.
1: Mag1 / Mag2	Divides Signal 1 by Signal 2. The comparison uses the product of this calculation.
2: Max (Mag1, Mag2)	The bigger value of the chosen signals is used in the comparison.
3: Min (Mag1, Mag2)	The smaller value of the chosen signals is used in the comparison.

Mode	Description
4: Mag1 OR Mag2	Either of the chosen signals has to fulfill the pick-up condition. Both signals have their own pick-up setting.
5: Mag1 AND Mag2	Both of the chosen signals have to fulfill the pick-up condition. Both signals have their own pick-up setting.
6: Mag1 – Mag2	Subtracts Signal 2 from Signal 1. The comparison uses the product of this calculation.

The image below is an example of setting an analog comparison with two signals. The stage will trip if either of the measured signals fulfills the comparison condition.

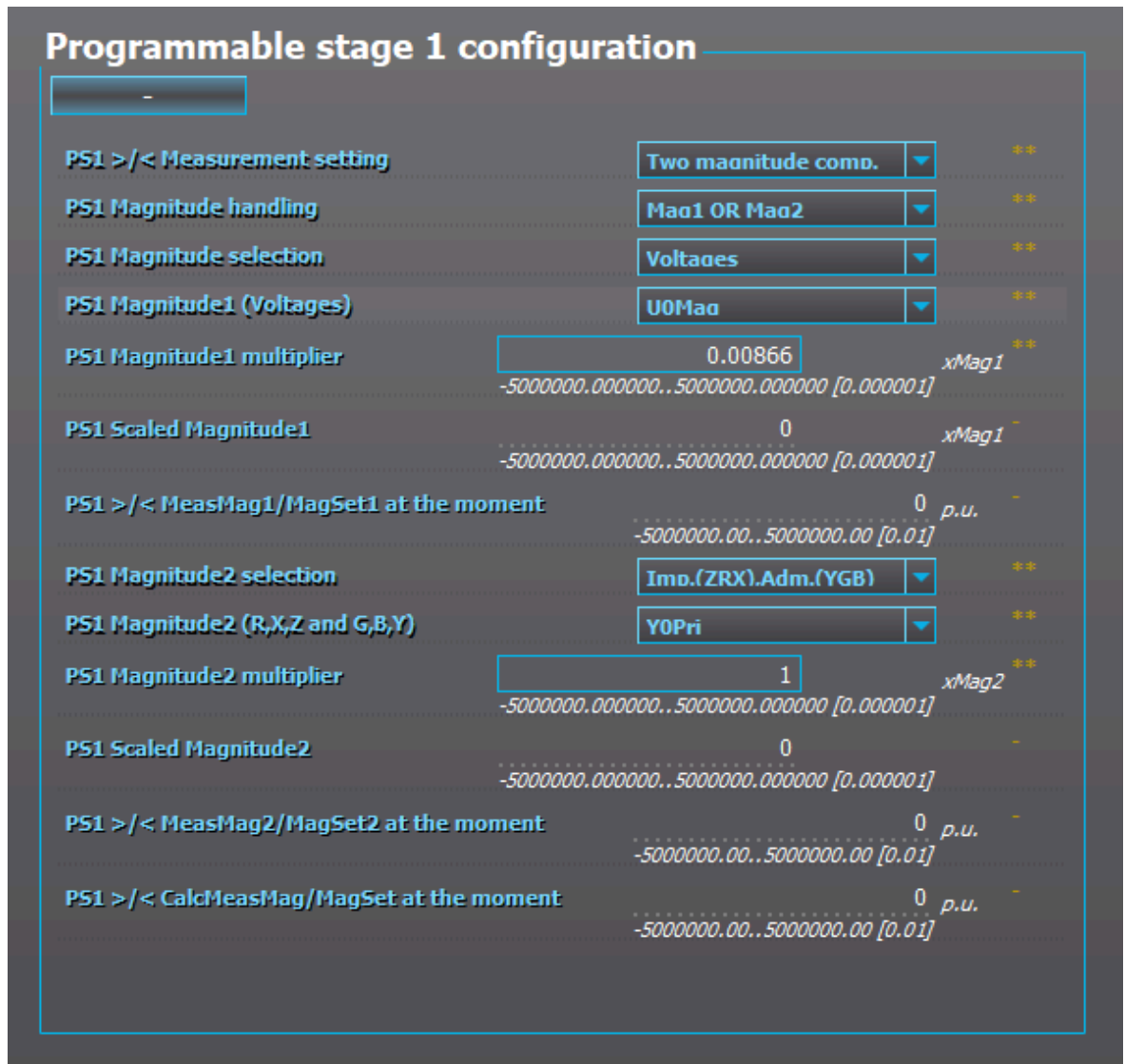

Similarly, the user can set up a comparison of three values. The table below presents the available modes for a three-signal comparison.

Mode	Description
0: Mag1 x Mag2 x Mag3	Multiplies Signals 1, 2 and 3. The comparison uses the product of this calculation.
1: Max (Mag1, Mag2, Mag3);	The biggest value of the chosen signals is used in the comparison.
2: Min (Mag1, Mag2, Mag3)	The smallest value of the chosen signals is used in the comparison.
3: Mag1 OR Mag2 OR Mag3	Any of the signals fulfills the pick-up condition. Each signal has their own pick-up setting.

Mode	Description
4: Mag1 AND Mag2 AND Mag3	All of the signals need to fulfill the pick-up condition. Each signal has their own pick-up setting.
5: (Mag1 OR Mag2) AND Mag3	Signals 1 OR 2 AND 3 need to fulfill the pick-up condition. Each signal has their own pick-up setting.

The image below is an example of setting an analog comparison with three signals. The stage will trip if Signal 1 or Signal 2 as well as Signal 3 fulfill the pick-up condition.

Programmable stage 1 configuration

-

PS1 >/< Measurement setting: Three magnitude comp. **

PS1 Magnitude handling: (Mag1 OR Mag2) AND M. **

PS1 Magnitude selection: Currents **

PS1 Magnitude1 (Currents): I01ResP **

PS1 Magnitude1 multiplier: -1 $xMag1$ **
 Range: -500000.000000..500000.000000 [0.000001]

PS1 Scaled Magnitude1: 0 $xMag1$ -
 Range: -500000.000000..500000.000000 [0.000001]

PS1 >/< MeasMag1/MagSet1 at the moment: 0 p.u. -
 Range: -500000.00..500000.00 [0.01]

PS1 Magnitude2 selection: Currents **

PS1 Magnitude2 (Currents): I01CapP **

PS1 Magnitude2 multiplier: -1 $xMag2$ **
 Range: -500000.000000..500000.000000 [0.000001]

PS1 Scaled Magnitude2: 0 -
 Range: -500000.000000..500000.000000 [0.000001]

PS1 >/< MeasMag2/MagSet2 at the moment: 0 p.u. -
 Range: -500000.00..500000.00 [0.01]

PS1 Magnitude3 selection: Voltages **

PS1 Magnitude3 (Voltages): U0Ma0 **

PS1 Magnitude3 multiplier: 0.00866 $xMag3$ **
 Range: -500000.000000..500000.000000 [0.000001]

PS1 Scaled Magnitude3: 0 -
 Range: -500000.000000..500000.000000 [0.000001]

PS1 >/< MeasMag3/MagSet3 at the moment: 0 p.u. -
 Range: -500000.00..500000.00 [0.01]

The settings for different comparisons are in the setting groups. This means that each signal parameter can be changed by changing the setting group.

When setting the comparators, the user must first choose a comparator mode. The following modes are available:

Mode	Description
0: Over >	Greater than. If the measured signal is greater than the set pick-up level, the comparison condition is fulfilled.
1: Over (abs) >	Greater than (absolute). If the absolute value of the measured signal is greater than the set pick-up level, the comparison condition is fulfilled.
2: Under <	Less than. If the measured signal is less than the set pick-up level, the comparison condition is fulfilled. The user can also set a blocking limit: the comparison is not active when the measured value is less than the set blocking limit.
3: Under (abs) <	Less than (absolute). If the absolute value of the measured signal is less than the set pick-up level, the comparison condition is fulfilled. The user can also set a blocking limit: the comparison is not active when the measured value is less than the set blocking limit.
4: Delta set (%) +/- >	Relative change over time. If the measured signal changes more than the set relative pick-up value in 20 ms, the comparison condition is fulfilled. The condition is dependent on direction.
5: Delta abs (%) >	Relative change over time (absolute). If the measured signal changes more than the set relative pick-up value in 20 ms in either direction, the comparison condition is fulfilled. The condition is not dependent on direction.
6: Delta +/- measval	Change over time. If the measured signal changes more than the set pick-up value in 20 ms, the comparison condition is fulfilled. The condition is dependent on direction.
7: Delta abs measval	Change over time (absolute). If the measured signal changes more than the set pick-up value in 20 ms in either direction, the comparison condition is fulfilled. The condition is not dependent on direction.

The pick-up level is set individually for each comparison. When setting up the pick-up level, the user needs to take into account the modes in use as well as the desired action. The pick-up limit can be set either as positive or as negative. Each pick-up level has a separate hysteresis setting which is 3 % by default.

The user can set the operating and releasing time delays for each stage.

Analog signals

The numerous analog signals have been divided into categories to help the user find the desired value.

Currents

IL1	Description
IL1 ff (p.u.)	IL1 Fundamental frequency RMS value (in p.u.)
IL1 2 nd h.	IL1 2 nd harmonic value (in p.u.)
IL1 3 rd h.	IL1 3 rd harmonic value (in p.u.)
IL1 4 th h.	IL1 4 th harmonic value (in p.u.)
IL1 5 th h.	IL1 5 th harmonic value (in p.u.)
IL1 7 th h.	IL1 7 th harmonic value (in p.u.)
IL1 9 th h.	IL1 9 th harmonic value (in p.u.)
IL1 11 th h.	IL1 11 th harmonic value (in p.u.)
IL1 13 th h.	IL1 13 th harmonic value (in p.u.)

IL1	Description
IL1 15 th h.	IL1 15 th harmonic value (in p.u.)
IL1 17 th h.	IL1 17 th harmonic value (in p.u.)
IL1 19 th h.	IL1 19 th harmonic value (in p.u.)
IL2	Description
IL2 ff (p.u.)	IL2 Fundamental frequency RMS value (in p.u.)
IL2 2 nd h.	IL2 2 nd harmonic value (in p.u.)
IL2 3 rd h.	IL2 3 rd harmonic value (in p.u.)
IL2 4 th h.	IL2 4 th harmonic value (in p.u.)
IL2 5 th h.	IL2 5 th harmonic value (in p.u.)
IL2 7 th h.	IL2 7 th harmonic value (in p.u.)
IL2 9 th h.	IL2 9 th harmonic value (in p.u.)
IL2 11 th h.	IL2 11 th harmonic value (in p.u.)
IL2 13 th h.	IL2 13 th harmonic value (in p.u.)
IL2 15 th h.	IL2 15 th harmonic value (in p.u.)
IL2 17 th h.	IL2 17 th harmonic value (in p.u.)
IL2 19 th h.	IL2 19 th harmonic value (in p.u.)
IL3	Description
IL3 ff (p.u.)	IL3 Fundamental frequency RMS value (in p.u.)
IL3 2 nd h.	IL3 2 nd harmonic value (in p.u.)
IL3 3 rd h.	IL3 3 rd harmonic value (in p.u.)
IL3 4 th h.	IL3 4 th harmonic value (in p.u.)
IL3 5 th h.	IL3 5 th harmonic value (in p.u.)
IL3 7 th h.	IL3 7 th harmonic value (in p.u.)
IL3 9 th h.	IL3 9 th harmonic value (in p.u.)
IL3 11 th h.	IL3 11 th harmonic value (in p.u.)
IL3 13 th h.	IL3 13 th harmonic value (in p.u.)
IL3 15 th h.	IL3 15 th harmonic value (in p.u.)
IL3 17 th h.	IL3 17 th harmonic value (in p.u.)
IL3 19 th h.	IL3 19 th harmonic value (in p.u.)
I01	Description
I01 ff (p.u.)	I01 Fundamental frequency RMS value (in p.u.)
I01 2 nd h.	I01 2 nd harmonic value (in p.u.)
I01 3 rd h.	I01 3 rd harmonic value (in p.u.)
I01 4 th h.	I01 4 th harmonic value (in p.u.)

IL1	Description
I01 5 th h.	I01 5 th harmonic value (in p.u.)
I01 7 th h.	I01 7 th harmonic value (in p.u.)
I01 9 th h.	I01 9 th harmonic value (in p.u.)
I01 11 th h.	I01 11 th harmonic value (in p.u.)
I01 13 th h.	I01 13 th harmonic value (in p.u.)
I01 15 th h.	I01 15 th harmonic value (in p.u.)
I01 17 th h.	I01 17 th harmonic value (in p.u.)
I01 19 th h.	I01 19 th harmonic value (in p.u.)
IL02	Description
I02 ff (p.u.)	I02 Fundamental frequency RMS value (in p.u.)
I02 2 nd h.	I02 2 nd harmonic value (in p.u.)
I02 3 rd h.	I02 3 rd harmonic value (in p.u.)
I02 4 th h.	I02 4 th harmonic value (in p.u.)
I02 5 th h.	I02 5 th harmonic value (in p.u.)
I02 7 th h.	I02 7 th harmonic value (in p.u.)
I02 9 th h.	I02 9 th harmonic value (in p.u.)
I02 11 th h.	I02 11 th harmonic value (in p.u.)
I02 13 th h.	I02 13 th harmonic value (in p.u.)
I02 15 th h.	I02 15 th harmonic value (in p.u.)
I02 17 th h.	I02 17 th harmonic value (in p.u.)
I02 19 th h.	I02 19 th harmonic value (in p.u.)
TRMS	Description
IL1 TRMS	IL1 TRMS value (in p.u.)
IL2 TRMS	IL2 TRMS value (in p.u.)
IL3 TRMS	IL3 TRMS value (in p.u.)
I01 TRMS	I01 TRMS value (in p.u.)
I02 TRMS	I02 TRMS value (in p.u.)
Calculated	Description
I0Z Mag	Zero sequence current value (in p.u.)
I0CALC Mag	Calculated I0 value (in p.u.)
I1 Mag	Positive sequence current value (in p.u.)
I2 Mag	Negative sequence current value (in p.u.)
IL1 Ang	IL1 angle of current
IL2 Ang	IL2 angle of current
IL3 Ang	IL3 angle of current
I01 Ang	I01 angle of current

IL1	Description
I02 Ang	I02 angle of current
I0CALC Ang	Angle of calculated residual current
I1 Ang	Angle of positive sequence current
I2 Ang	Angle of negative sequence current
I01ResP	I01 primary current of a current-resistive component
I01CapP	I01 primary current of a current-capacitive component
I01ResS	I01 secondary current of a current-resistive component
I01CapS	I01 secondary current of a current-capacitive component
I02ResP	I02 primary current of a current-resistive component
I02CapP	I02 primary current of a current-capacitive component

Voltages

Phase-to-phase voltages	Description
UL12Mag	UL12 Primary voltage V
UL23Mag	UL23 Primary voltage V
UL31Mag	UL31 Primary voltage V
Phase-to-neutral voltages	Description
UL1Mag	UL1 Primary voltage V
UL2Mag	UL2 Primary voltage V
UL3Mag	UL3 Primary voltage V
U0Mag	U0 Primary voltage V
Angles	Description
UL12Ang	UL12 angle
UL23Ang	UL23 angle
UL31Ang	UL31 angle
UL1Ang	UL1 angle
UL2Ang	UL2 angle
UL3Ang	UL3 angle
U0Ang	U0 angle
Calculated	Description
U0CalcMag	Calculated residual voltage
U1 pos.seq.V Mag	Positive sequence voltage
U2 neg.seq.V Mag	Negative sequence voltage
U0CalcAng	Calculated residual voltage angle
U1 pos.seq.V Ang	Positive sequence voltage angle
U2 neg.seq.V Ang	Negative sequence voltage angle

Powers

Name	Description
S3PH	Three-phase apparent power S (kVA)
P3PH	Three-phase active power P (kW)
Q3PH	Three-phase reactive power Q (kvar)
tanfi3PH	Three-phase active power direction
cosfi3PH	Three-phase reactive power direction
SL1	Apparent power L1 S (kVA)
PL1	Active power L1 P (kW)
QL1	Reactive power L1 Q (kVar)
tanfil1	Phase active power direction L1
cosfil1	Phase reactive power direction L1
SL2	Apparent power L2 S (kVA)
PL2	Active power L2 P (kW)
QL2	Reactive power L2 Q (kVar)
tanfil2	Phase active power direction L2
cosfil2	Phase reactive power direction L2
SL3	Apparent power L3 S (kVA)
PL3	Active power L3 P (kW)
QL3	Reactive power L3 Q (kVar)
tanfil3	Phase active power direction L3
cosfil3	Phase reactive power direction L3

Impedance and admittance (ZRX & YGB)

Name	Description
RL12Pri	Resistance R L12 primary (Ω)
XL12Pri	Reactance X L12 primary (Ω)
RL23Pri	Resistance R L23 primary (Ω)
XL23Pri	Reactance X L23 primary (Ω)
RL31Pri	Resistance R L31 primary (Ω)
XL31Pri	Reactance X L31 primary (Ω)
RL12Sec	Resistance R L12 secondary (Ω)
XL12Sec	Reactance X L12 secondary (Ω)
RL23Sec	Resistance R L23 secondary (Ω)
XL23Sec	Reactance X L23 secondary (Ω)
RL31Sec	Resistance R L31 secondary (Ω)
XL31Sec	Reactance X L31 secondary (Ω)
Z12Pri	Impedance Z L12 primary (Ω)
Z23Pri	Impedance Z L23 primary (Ω)
Z31Pri	Impedance Z L31 primary (Ω)

Name	Description
Z12Sec	Impedance Z L12 secondary (Ω)
Z23Sec	Impedance Z L23 secondary (Ω)
Z31Sec	Impedance Z L31 secondary (Ω)
Z12Angle	Impedance Z L12 angle
Z23Angle	Impedance Z L23 angle
Z31Angle	Impedance Z L31 angle
RL1Pri	Resistance R L1 primary (Ω)
XL1Pri	Reactance X L1 primary (Ω)
RL2Pri	Resistance R L2 primary (Ω)
XL2Pri	Reactance X L2 primary (Ω)
RL3Pri	Resistance R L3 primary (Ω)
XL3Pri	Reactance X L3 primary (Ω)
RL1Sec	Resistance R L1 secondary (Ω)
XL1Sec	Reactance X L1 secondary (Ω)
RL2Sec	Resistance R L2 secondary (Ω)
XL2Sec	Reactance X L2 secondary (Ω)
RL3Sec	Resistance R L3 secondary (Ω)
XL3Sec	Reactance X L3 secondary (Ω)
Z1Pri	Impedance Z L1 primary (Ω)
Z2Pri	Impedance Z L2 primary (Ω)
Z3Pri	Impedance Z L3 primary (Ω)
Z1Sec	Impedance Z L1 secondary (Ω)
Z2Sec	Impedance Z L2 secondary (Ω)
Z3Sec	Impedance Z L3 secondary (Ω)
Z1Angle	Impedance Z L1 angle
Z2Angle	Impedance Z L2 angle
Z3Angle	Impedance Z L3 angle
RSeqPri	Positive Resistance R primary (Ω)
XSeqPri	Positive Reactance X primary (Ω)
RSeqSec	Positive Resistance R secondary (Ω)
XSeqSec	Positive Reactance X secondary (Ω)
ZSeqPri	Positive Impedance Z primary (Ω)
ZSeqSec	Positive Impedance Z secondary (Ω)
ZSeqAngle	Positive Impedance Z angle
GL1Pri	Conductance G L1 primary (mS)
BL1Pri	Susceptance B L1 primary (mS)
GL2Pri	Conductance G L2 primary (mS)
BL2Pri	Susceptance B L2 primary (mS)

Name	Description
GL3Pri	Conductance G L3 primary (mS)
BL3Pri	Susceptance B L3 primary (mS)
GL1Sec	Conductance G L1 secondary (mS)
BL1Sec	Susceptance B L1 secondary (mS)
GL2Sec	Conductance G L2 secondary (mS)
BL2Sec	Susceptance B L2 secondary (mS)
GL3Sec	Conductance G L3 secondary (mS)
BL3Sec	Susceptance B L3 secondary (mS)
YL1PriMag	Admittance Y L1 primary (mS)
YL2PriMag	Admittance Y L2 primary (mS)
YL3PriMag	Admittance Y L3 primary (mS)
YL1SecMag	Admittance Y L1 secondary (mS)
YL2SecMag	Admittance Y L2 secondary (mS)
YL3SecMag	Admittance Y L3 secondary (mS)
YL1Angle	Admittance Y L1 angle
YL2Angle	Admittance Y L2 angle
YL3Angle	Admittance Y L3 angle
G0Pri	Conductance G0 primary (mS)
B0Pri	Susceptance B0 primary (mS)
G0Sec	Conductance G0 secondary (mS)
B0Sec	Susceptance B0 secondary (mS)
Y0Pri	Admittance Y0 primary (mS)
Y0Sec	Admittance Y0 secondary (mS)
Y0Angle	Admittance Y0 angle

Others

Name	Description
System f.	System frequency
Ref f1	Reference frequency 1
Ref f2	Reference frequency 2
M Thermal T	Motor thermal temperature
F Thermal T	Feeder thermal temperature
T Thermal T	Transformer thermal temperature
RTD meas 1...16	RTD measurement channels 1...16
Ext RTD meas 1...8	External RTD measurement channels 1...8 (ADAM)
mA input 7,8,15,16	mA input channels 7, 8, 15, 16
ASC 1...4	Analog scaled curves 1...4

The outputs of the function are the START, TRIP and BLOCKED signals. The overvoltage function uses a total of eight (8) separate setting groups which can be selected from one common source.

The function can operate on instant or time-delayed mode. Definite time (DT) delay can be selected in the In time-delayed mode.

The inputs for the function are the following:

- operating mode selections
- setting parameters
- digital inputs and logic signals
- measured and pre-processed magnitudes.

The function outputs the START, TRIP and BLOCKED signals which can be used for direct I/O controlling and user logic programming. The function generates general time-stamped ON/OFF events to the common event buffer from each of the three (3) output signals. In the instant operating mode the function outputs START and TRIP events simultaneously with an equivalent time stamp. The time stamp resolution is 1 ms. The function also provides a resettable cumulative counter for the START, TRIP and BLOCKED events.

Pick-up

The *Pick-up setting Mag* setting parameter controls the pick-up of the PGx>/< function. This defines the maximum or minimum allowed measured magnitude before action from the function. The function constantly calculates the ratio between the set and the measured magnitudes. The user can set the reset hysteresis in the function (by default 3 %). It is always relative to the *Pick-up setting Mag* value.

Table. 5.3.22 - 170. Pick-up settings.

Name	Description	Range	Step	Default
PS# Pick-up setting Mag#/calc >/<	Pick-up magnitude	-5 000 000.0000...5 000 000.0000	0.0001	0.01
PS# Setting hysteresis Mag#	Setting hysteresis	0.0000...50.0000%	0.0001%	3%
Definite operating time delay	Delay setting	0.000...1800.000s	0.005s	0.04s
Release time delays	Pick-up release delay	0.000...1800.000s	0.005s	0.06s

The pick-up activation of the function is not directly equal to the START signal generation of the function. The START signal is allowed if the blocking condition is not active.

The user can reset characteristics through the application. The default setting is a 60 ms delay; the time calculation is held during the release time.

In the release delay option the operating time counter calculates the operating time during the release. When using this option the function does not trip if the input signal is not re-activated while the release time count is on-going.

Function blocking

The block signal is checked in the beginning of each program cycle. The blocking signal is received from the blocking matrix in the function's dedicated input. If the blocking signal is not activated when the pick-up element activates, a START signal is generated and the function proceeds to the time characteristics calculation.

If the blocking signal is active when the pick-up element activates, a BLOCKED signal is generated and the function does not process the situation further. If the START function has been activated before the blocking signal, it resets and the release time characteristics are processed similarly to when the pick-up signal is reset.

The blocking of the function causes an HMI display event and a time-stamped blocking event with information of the startup values of the selected signal and its fault type to be issued.

The blocking signal can also be tested in the commissioning phase by a software switch signal when the relay's testing mode "Enable stage forcing" is activated (*General* → *Device*).

The variables the user can set are binary signals from the system. The blocking signal needs to reach the device minimum of 5 ms before the set operating delay has passed in order for the blocking to activate in time.

Events and registers

The programmable stage function (abbreviated "PGS" in event block names) generates events and registers from the status changes in START, TRIP, and BLOCKED. The user can select which event messages are stored in the main event buffer: ON, OFF, or both.

The events triggered by the function are recorded with a time stamp and with process data values.

Table. 5.3.22 - 171. Event codes.

Event number	Event channel	Event block name	Event code	Description
8576	134	PGS1	0	PS1 >/< Start ON
8577	134	PGS1	1	PS1 >/< Start OFF
8578	134	PGS1	2	PS1 >/< Trip ON
8579	134	PGS1	3	PS1 >/< Trip OFF
8580	134	PGS1	4	PS1 >/< Block ON
8581	134	PGS1	5	PS1 >/< Block OFF
8582	134	PGS1	6	PS2 >/< Start ON
8583	134	PGS1	7	PS2 >/< Start OFF
8584	134	PGS1	8	PS2 >/< Trip ON
8585	134	PGS1	9	PS2 >/< Trip OFF
8586	134	PGS1	10	PS2 >/< Block ON
8587	134	PGS1	11	PS2 >/< Block OFF
8588	134	PGS1	12	PS3 >/< Start ON
8589	134	PGS1	13	PS3 >/< Start OFF
8590	134	PGS1	14	PS3 >/< Trip ON
8591	134	PGS1	15	PS3 >/< Trip OFF
8592	134	PGS1	16	PS3 >/< Block ON
8593	134	PGS1	17	PS3 >/< Block OFF
8594	134	PGS1	18	PS4 >/< Start ON
8595	134	PGS1	19	PS4 >/< Start OFF
8596	134	PGS1	20	PS4 >/< Trip ON
8597	134	PGS1	21	PS4 >/< Trip OFF
8598	134	PGS1	22	PS4 >/< Block ON
8599	134	PGS1	23	PS4 >/< Block OFF
8600	134	PGS1	24	PS5 >/< Start ON

Event number	Event channel	Event block name	Event code	Description
8601	134	PGS1	25	PS5 >/< Start OFF
8602	134	PGS1	26	PS5 >/< Trip ON
8603	134	PGS1	27	PS5 >/< Trip OFF
8604	134	PGS1	28	PS5 >/< Block ON
8605	134	PGS1	29	PS5 >/< Block OFF
8606	134	PGS1	30	reserved
8607	134	PGS1	31	reserved
8608	134	PGS1	32	PS6 >/< Start ON
8609	134	PGS1	33	PS6 >/< Start OFF
8610	134	PGS1	34	PS6 >/< Trip ON
8611	134	PGS1	35	PS6 >/< Trip OFF
8612	134	PGS1	36	PS6 >/< Block ON
8613	134	PGS1	37	PS6 >/< Block OFF
8614	134	PGS1	38	PS7 >/< Start ON
8615	134	PGS1	39	PS7 >/< Start OFF
8616	134	PGS1	40	PS7 >/< Trip ON
8617	134	PGS1	41	PS7 >/< Trip OFF
8618	134	PGS1	42	PS7 >/< Block ON
8619	134	PGS1	43	PS7 >/< Block OFF
8620	134	PGS1	44	PS8 >/< Start ON
8621	134	PGS1	45	PS8 >/< Start OFF
8622	134	PGS1	46	PS8 >/< Trip ON
8623	134	PGS1	47	PS8 >/< Trip OFF
8624	134	PGS1	48	PS8 >/< Block ON
8625	134	PGS1	49	PS8 >/< Block OFF
8626	134	PGS1	50	PS9 >/< Start ON
8627	134	PGS1	51	PS9 >/< Start OFF
8628	134	PGS1	52	PS9 >/< Trip ON
8629	134	PGS1	53	PS9 >/< Trip OFF
8630	134	PGS1	54	PS9 >/< Block ON
8631	134	PGS1	55	PS9 >/< Block OFF
8632	134	PGS1	56	PS10 >/< Start ON
8633	134	PGS1	57	PS10 >/< Start OFF
8634	134	PGS1	58	PS10 >/< Trip ON
8635	134	PGS1	59	PS10 >/< Trip OFF
8636	134	PGS1	60	PS10 >/< Block ON
8637	134	PGS1	61	PS10 >/< Block OFF

The function registers its operation into the last twelve (12) time-stamped registers. The register of the function records the ON event process data for START, TRIP or BLOCKED. The table below presents the structure of the function's register content.

Table. 5.3.22 - 172. Register content.

Date and time	Event code	>/< Mag#	Mag#/Set#	Trip time remaining	Used SG
dd.mm.yyyy hh:mm:ss.mss	8576-8637 Descr.	The numerical value of the magnitude	Ratio between the measured magnitude and the pick-up setting	0 ms...1800s	Setting group 1...8 active

5.3.23 Voltage memory

Certain protection functions (such as impedance or directional overcurrent) use the relay's measured current and voltage to determine whether the electrical network fault appears to be inside the protected area. The determination is made by comparing the angle between the operating quantity (zone/tripping area) and the actual measured quantity. The function then produces an output when the required terms are met.

In close-in faults the system voltage on the secondary side may fall down to a few volts or close to nothing. In such cases, when the measured voltage is absent, the fault direction cannot be solved. As backup, non-directional protection can be used for tripping, but in such cases the selectivity of the network will reduce. However, an angle memory for voltage can be used to prevent this from happening. An adjustable voltage level with pre-fault voltage angles can be used as a reference for fault direction and/or distance. The reference can be set manually for duration. Thanks to the configurable voltage memory even time-delayed backup tripping can be initiated.

The user can activate voltage memory (and find all related settings) by following this path in relay settings: *Measurement* → *Transformers* → *VT Module (3U/4U) 1* → *Voltage memory* ("Activated"/"Disabled").

The activation of voltage memory depends of following criteria:

1. All used line-to-line or line-to-neutral voltages need to be below the set value for the "VMEM activation voltage" parameter.
2. At least one phase current must be above the set value for the "Measured current condition 3I>" parameter. This setting limit is optional.

Figure. 5.3.23 - 164. Distance protection characteristics and directional overcurrent.

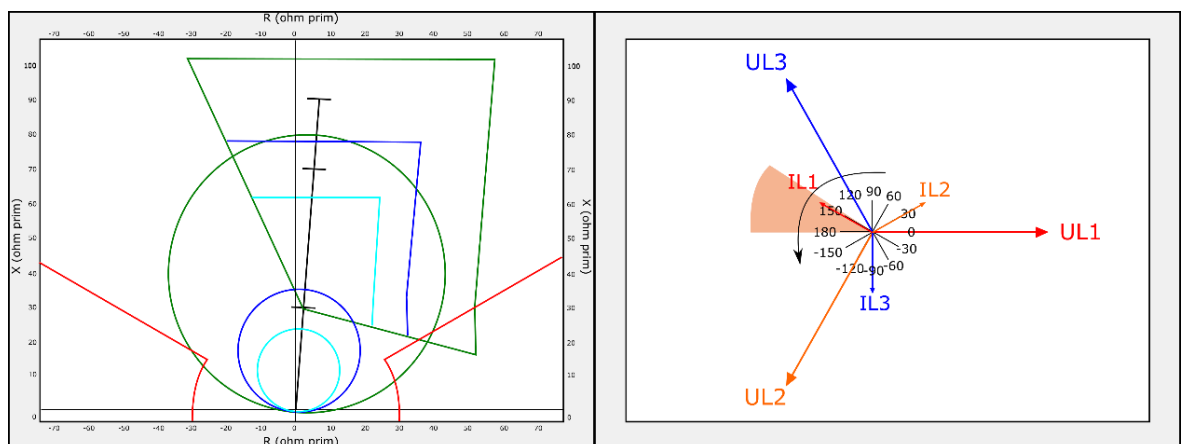

Voltage memory activates when the above-mentioned criteria are met. Voltage memory uses the "VMEM activation voltage" parameter as voltage amplitude even when the actual measured voltage has decreased below it or close to zero. The angle used by this function is the one captured the moment before the fault occurred and voltage memory was activated. When voltage memory is activated, the output "Voltage memory on" signal is activated. This signal can be found in the device's I/O matrix.

While voltage memory is active, voltages are absent and therefore angle measurement is not possible. Healthy state angles (before a fault) are used during a fault. This is why a drift between the assumed voltage angle and the actual measured phase current angle takes place. While voltage memory is used, the angle of phase currents drifts approximately one degree for each passing second (see the graph below).

Figure. 5.3.23 - 165. Voltage angle drift.

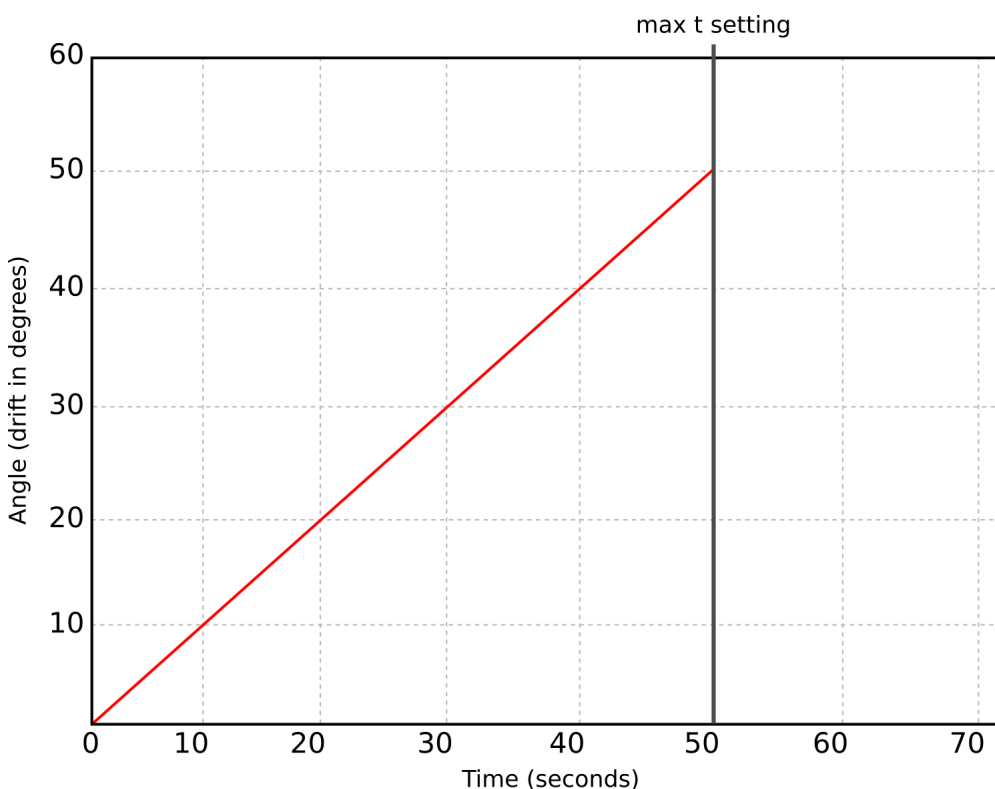

The blocking signal for voltage memory can be found among other stage-related settings in the tab *VT Module (3U/4U) 1*. The blocking signal is checked in the beginning of each program cycle.

Measured input

The function block uses analog voltage and current measurements' RMS values.

Table. 5.3.23 - 173. Measurement inputs of the voltage memory function.

Signal	Description	Time base
IL1RMS	RMS measurement of phase L1 (A) current	5ms
IL2RMS	RMS measurement of phase L2 (B) current	5ms
IL3RMS	RMS measurement of phase L3 (C) current	5ms
U ₁ RMS	RMS measurement of voltage U ₁ /V	5ms
U ₂ RMS	RMS measurement of voltage U ₂ /V	5ms

Signal	Description	Time base
U ₃ RMS	RMS measurement of voltage U ₃ /V	5ms
U ₄ RMS	RMS measurement of voltage U ₄ /V	5ms

Voltage measurement modes 3LN and 3LL use three voltage inputs: channels U_A, U_B and U_C. When the voltage mode is set to 2LL, only two channels (U_A and U_B) are in use, and the memory is based on the line-to-line voltages U₁₂ and U₃₂. When the mode 2LL+U₀ is used, the memory is based on calculated phase-to-neutral voltages.

Pick-up

VMEM activation voltage and Measured current condition 3I>

When the voltage memory function is enabled, it activates when all line voltages drop below the "VMEM activation voltage" threshold limit. This limit can be set to be anything between 2...50 V AC. When "Measured current condition 3I>" is used, activation cannot be based on just the voltage. Therefore, at least one of the three-phase currents must also rise above the set current pick-up setting.

VMEM max active time

Voltage memory can be active for a specific period of time, set in "VMAX active time". It can be anything between 0.02...50.00 seconds. The function supports the definite time (DT) delay type. It depends on the application for how long the memory should be used. During massive bolted faults, the fault should be cleared and the breaker opened as soon as possible; therefore, a short operating time for voltage memory is usually applied. A typical delay for voltage memory is between 0.5...1.0 s. When the operating time passes and voltage memory is no longer used, directional overcurrent and/or distance protection goes to the unidirectional mode to secure a safe tripping. The memory uses longer operating times when a backup protection is applied (e.g. in distance-protection zones are farther away).

Forced CT f tracking on VMEM

While fixed frequency tracking is used, all protection stage-based sampling (apart from frequency protection) is based on a set fixed frequency such as 50 Hz or 60 Hz. When the frequency drops massively during a fault while angle memory is in use, it is also possible that the frequency of the system starts to fluctuate. In such cases, if current sampling of used protection stages is based on 50/60 Hz, there could be an error in current magnitude and in angle measurement. To minimize these errors, it is recommended that the frequency is measured and protection-based sampling from the current is performed while voltages are gone.

When the "Forced CT f tracking" parameter is activated and voltages are gone, the frequency from the selected current-based reference channel 3 (the current from IL3) is used for current sampling. This eliminates any possible measurement errors in the fixed frequency mode.

Figure. 5.3.23 - 166. Frequency reference channels.



For example, let us say a 500 A current is measured on the primary side while the fixed frequency is set to 50 Hz. This results in the frequency dropping to 46 Hz, while the actual current measurement would be 460 A. Therefore, the system would have an error of 40 A.

Events

The voltage memory function (abbreviated "M1VT" in event block names) generates events from the status changes in various activities. The user can select which event messages are stored in the main event buffer: ON, OFF, or both.

Table. 5.3.23 - 174. Event codes.

Event number	Event channel	Event block name	Event code	Description
12160	190	M1VT1	0	Voltage memory enabled
12161	190	M1VT1	1	Voltage memory disabled
12162	190	M1VT1	2	Voltage low detected ON
12163	190	M1VT1	3	Voltage low detected OFF
12164	190	M1VT1	4	Current high detected ON
12165	190	M1VT1	5	Current high detected OFF
12166	190	M1VT1	6	Frequency tracked from CT ON
12167	190	M1VT1	7	Frequency tracked from CT OFF
12168	190	M1VT1	8	Using Voltage memory ON
12169	190	M1VT1	9	Using Voltage memory OFF
12170	190	M1VT1	10	Voltage memory blocked ON
12171	190	M1VT1	11	Voltage memory blocked OFF

5.4 Control functions

5.4.1 Setting group selection

All relay types support up to eight (8) separate setting groups. The Setting group selection function block controls the availability and selection of the setting groups. By default, only Setting group 1 (SG1) is active and therefore the selection logic is idle. When more than one setting group is enabled, the setting group selector logic takes control of the setting group activations based on the logic and conditions the user has programmed.

The following figure presents a simplified function block diagram of the setting group selection function.

Figure. 5.4.1 - 167. Simplified function block diagram of the setting group selection function.

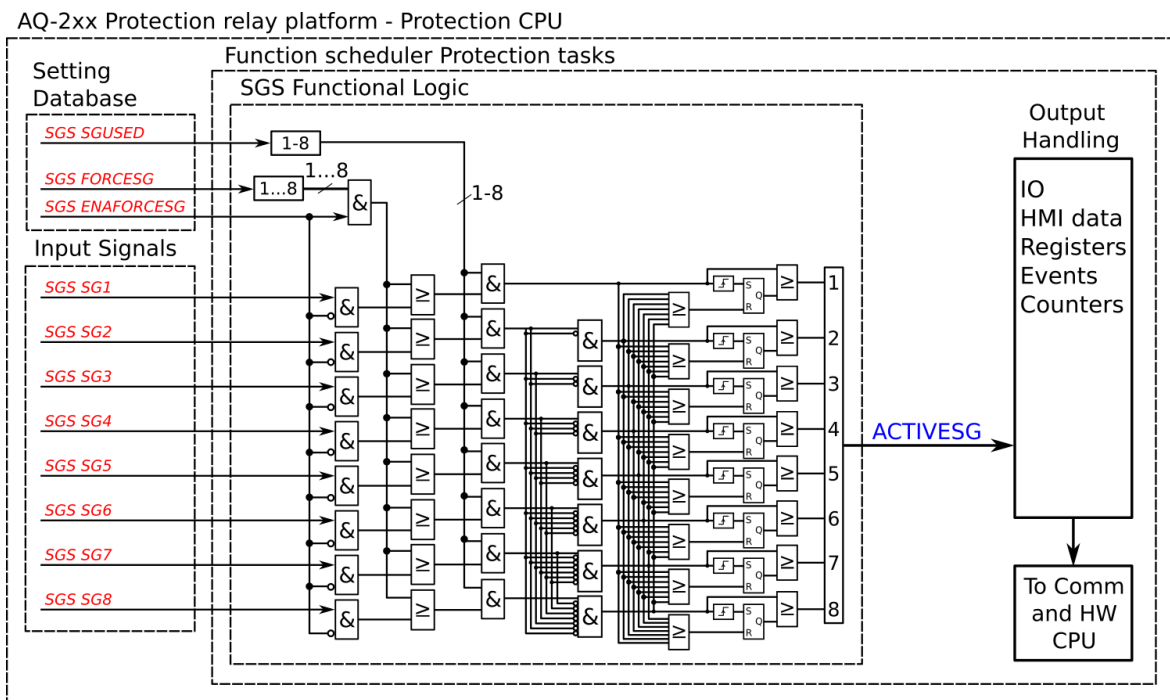

Setting group selection can be applied to each of the setting groups individually by activating one of the various internal logic inputs and connected digital inputs. The user can also force any of the setting groups on when the "Force SG change" setting is enabled by giving the wanted quantity of setting groups as a number in the communication bus or in the local HMI, or by selecting the wanted setting group from *Control* → *Setting groups*. When the forcing parameter is enabled, the automatic control of the local device is overridden and the full control of the setting groups is given to the user until the "Force SG change" is disabled again.

Setting groups can be controlled either by pulses or by signal levels. The setting group controller block gives setting groups priority values for situations when more than one setting group is controlled at the same time: the request from a higher-priority setting group is taken into use.

Setting groups follow a hierarchy in which setting group 1 has the highest priority, setting group 2 has second highest priority etc. If a static activation signal is given for two setting groups, the setting group with higher priority will be active. If setting groups are controlled by pulses, the setting group activated by pulse will stay active until another setting groups receives and activation signal.

Figure. 5.4.1 - 168. Example sequences of group changing (control with pulse only, or with both pulses and static signals).

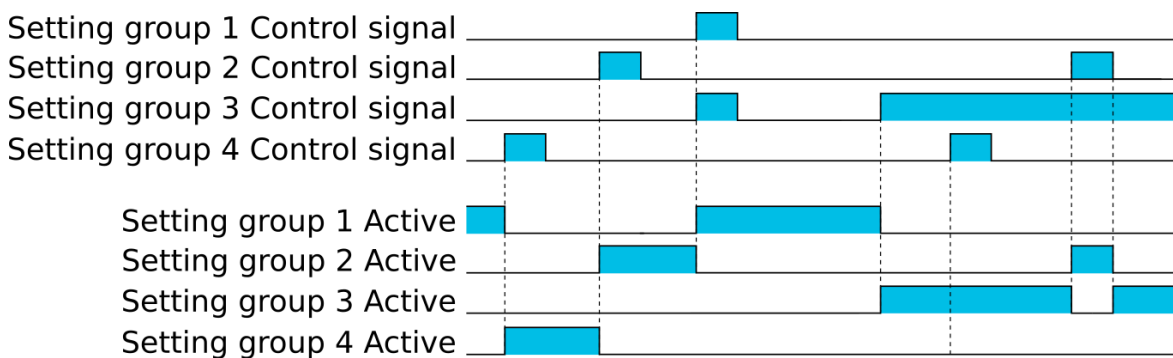

Settings and signals

The settings of the setting group control function include the active setting group selection, the forced setting group selection, the enabling (or disabling) of the forced change, the selection of the number of active setting groups in the application, as well as the selection of the setting group changed remotely. If the setting group is forced to change, the corresponding setting group must be enabled and the force change must be enabled. Then, the setting group can be set from communications or from HMI to any available group. If the setting group control is applied with static signals right after the "Force SG" parameter is released, the application takes control of the setting group selection.

Table. 5.4.1 - 175. Settings of the setting group selection function.

Name	Range	Step	Default	Description
Active setting group			SG1	Displays which setting group is active.
Force setting group	0: None 1: SG1 2: SG2 3: SG3 4: SG4 5: SG5 6: SG6 7: SG7 8: SG8	-	0: None	The selection of the overriding setting group. After "Force SG change" is enabled, any of the configured setting groups in the relay can be overridden. This control is always based on the pulse operating mode. It also requires that the selected setting group is specifically controlled to ON after "Force SG" is disabled. If there are no other controls, the last set setting group remains active.
Force setting group change	0: Disabled 1: Enabled	-	0: Disabled	The selection of whether the setting group forcing is enabled or disabled. This setting has to be active before the setting group can be changed remotely or from a local HMI. This parameter overrides the local control of the setting groups and it remains on until the user disables it.
Used setting groups	0: SG1 1: SG1...2 2: SG1...3 3: SG1...4 4: SG1...5 5: SG1...6 6: SG1...7 7: SG1...8	-	0: SG1	The selection of the activated setting groups in the application. Newly-enabled setting groups use default parameter values.
Remote setting group change	0: None 1: SG1 2: SG2 3: SG3 4: SG4 5: SG5 6: SG6 7: SG7 8: SG8	-	0: None	This parameter can be controlled through SCADA to change the setting group remotely. Please note that if a higher priority setting group is being controlled by a signal, a lower priority setting group cannot be activated with this parameter.

Table. 5.4.1 - 176. Signals of the setting group selection function.

Name	Range	Step	Default	Description
Setting group 1	0: Not active 1: Active	-	0: Not active	The selection of Setting group 1 ("SG1"). Has the highest priority input in setting group control. Can be controlled with pulses or static signals. If static signal control is applied, no other SG requests will be processed.

Name	Range	Step	Default	Description
Setting group 2	0: Not active 1: Active	-	0: Not active	The selection of Setting group 2 ("SG2"). Has the second highest priority input in setting group control. Can be controlled with pulses or static signals. If static signal control is applied, no requests with a lower priority than SG1 will be processed.
Setting group 3	0: Not active 1: Active	-	0: Not active	The selection of Setting group 3 ("SG3"). Has the third highest priority input in setting group control. Can be controlled with pulses or static signals. If static signal control is applied, no requests with a lower priority than SG1 and SG2 will be processed.
Setting group 4	0: Not active 1: Active	-	0: Not active	The selection of Setting group 4 ("SG4"). Has the fourth highest priority input in setting group control. Can be controlled with pulses or static signals. If static signal control is applied, no requests with a lower priority than SG1, SG2 and SG3 will be processed.
Setting group 5	0: Not active 1: Active	-	0: Not active	The selection of Setting group 5 ("SG5"). Has the fourth lowest priority input in setting group control. Can be controlled with pulses or static signals. If static signal control is applied, SG6, SG7 and SG8 requests will not be processed.
Setting group 6	0: Not active 1: Active	-	0: Not active	The selection of Setting group 6 ("SG6"). Has the third lowest priority input in setting group control. Can be controlled with pulses or static signals. If static signal control is applied, SG7 and SG8 requests will not be processed.
Setting group 7	0: Not active 1: Active	-	0: Not active	The selection of Setting group 7 ("SG7"). Has the second lowest priority input in setting group control. Can be controlled with pulses or static signals. If static signal control is applied, only SG8 requests will not be processed.
Setting group 8	0: Not active 1: Active	-	0: Not active	The selection of Setting group 8 ("SG8"). Has the lowest priority input in setting group control. Can be controlled with pulses or static signals. If static signal control is applied, all other SG requests will be processed regardless of the signal status of this setting group.

Example applications for setting group control

This chapter presents some of the most common applications for setting group changing requirements.

A Petersen coil compensated network usually uses directional sensitive earth fault protection. The user needs to control its characteristics between varmetric and wattmetric; the selection is based on whether the Petersen coil is connected when the network is compensated, or whether it is open when the network is unearthed.

Figure. 5.4.1 - 169. Setting group control – one-wire connection from Petersen coil status.

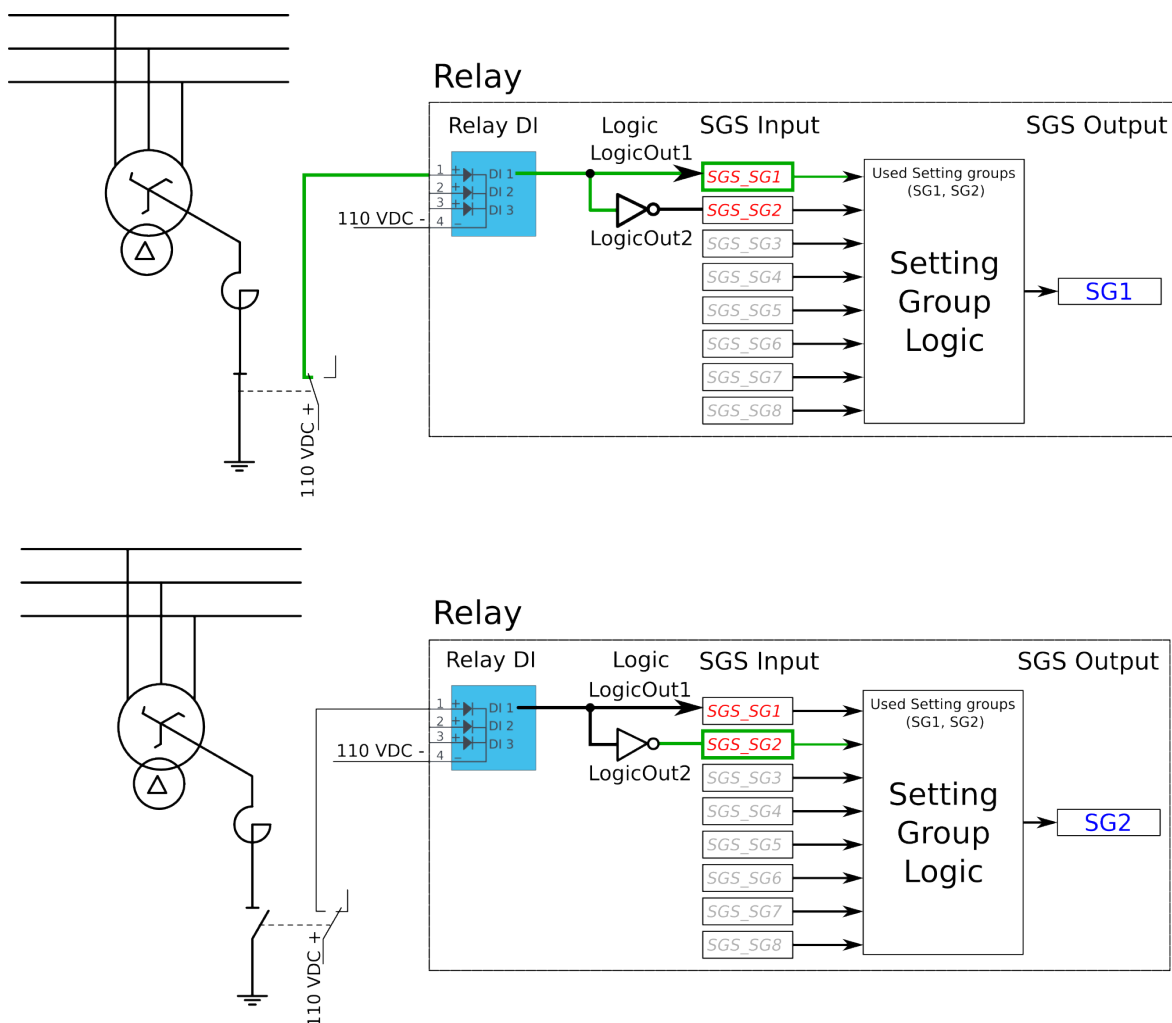

Depending on the application's requirements, the setting group control can be applied either with a one-wire connection or with a two-wire connection by monitoring the state of the Petersen coil connection.

When the connection is done with one wire, the setting group change logic can be applied as shown in the figure above. The status of the Petersen coil controls whether Setting group 1 is active. If the coil is disconnected, Setting group 2 is active. This way, if the wire is broken for some reason, the setting group is always controlled to SG2.

Figure. 5.4.1 - 170. Setting group control – two-wire connection from Petersen coil status.

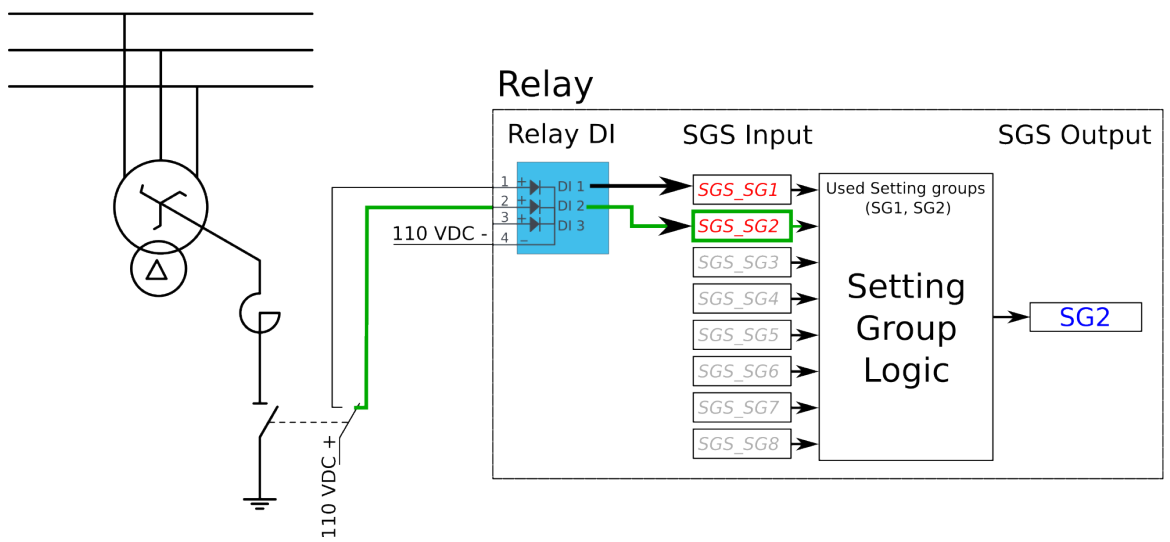
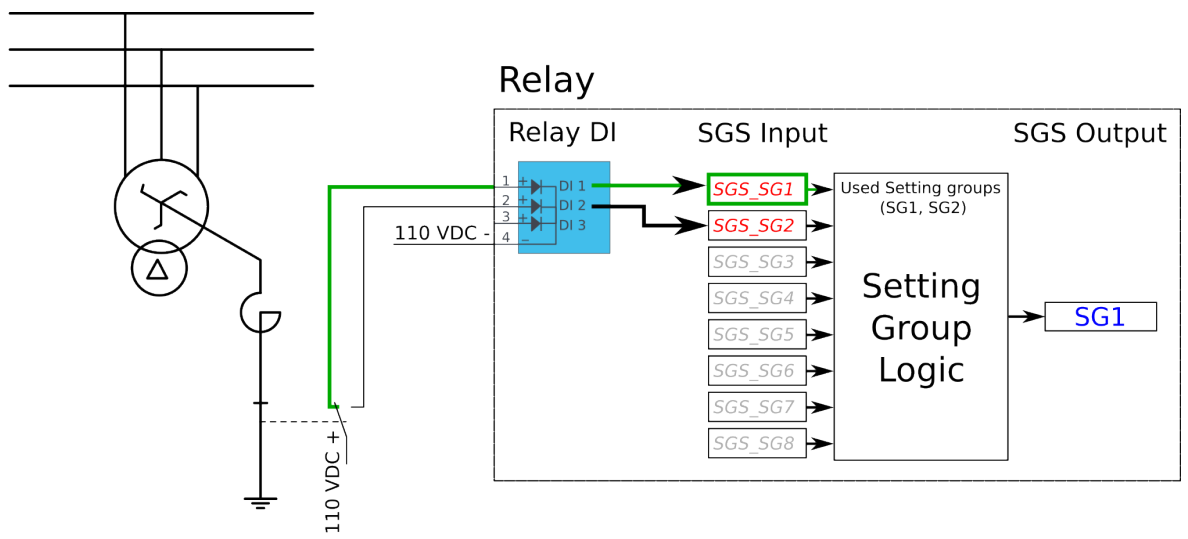
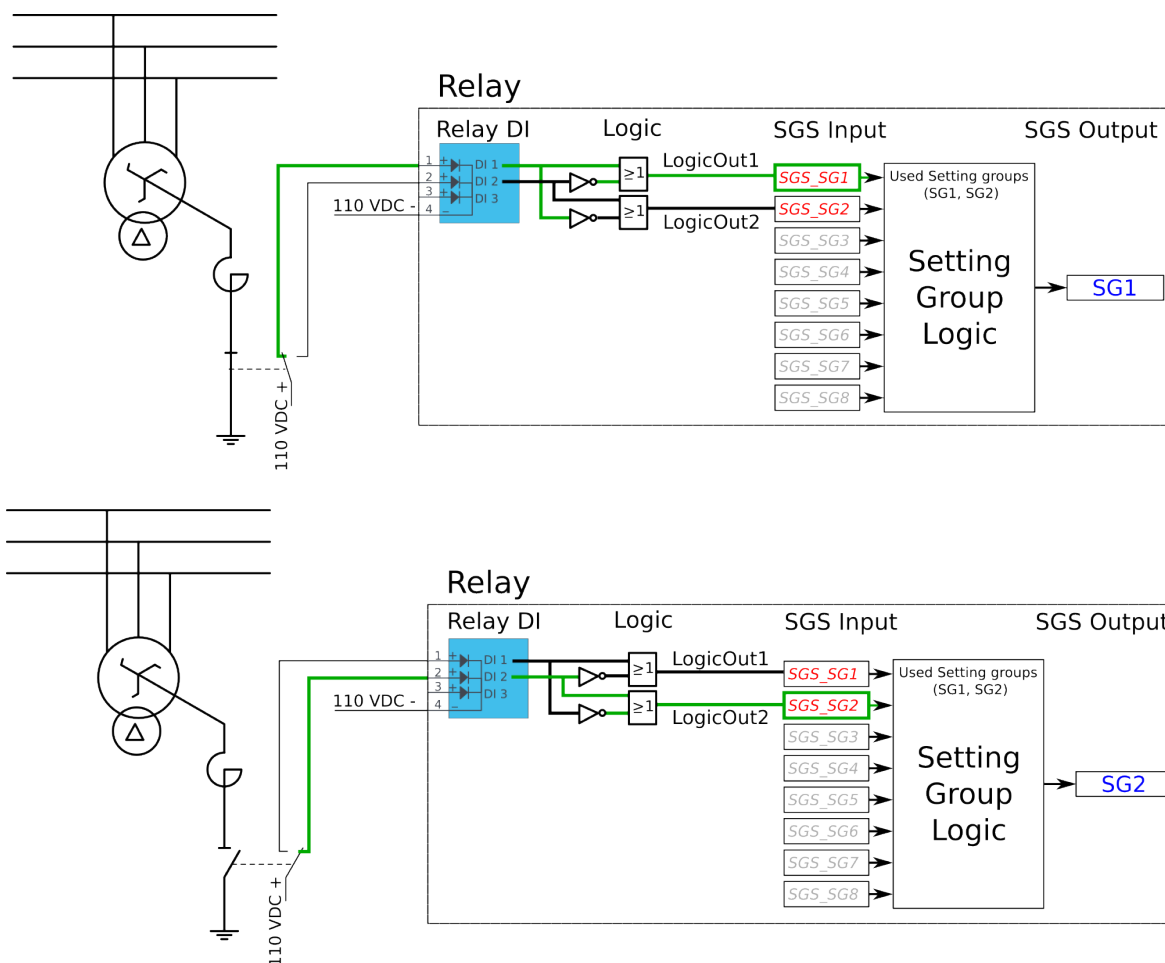

Figure. 5.4.1 - 171. Setting group control – two-wire connection from Petersen coil status with additional logic.



The images above depict a two-wire connection from the Petersen coil: the two images at the top show a direct connection, while the two images on the bottom include additional logic. With a two-wire connection the state of the Petersen coil can be monitored more securely. The additional logic ensures that a single wire loss will not affect the correct setting group selection.

The application-controlled setting group change can also be applied entirely from the relay's internal logics. For example, the setting group change can be based on the cold load pick-up function (see the image below).

Figure. 5.4.1 - 172. Entirely application-controlled setting group change with the cold load pick-up function.

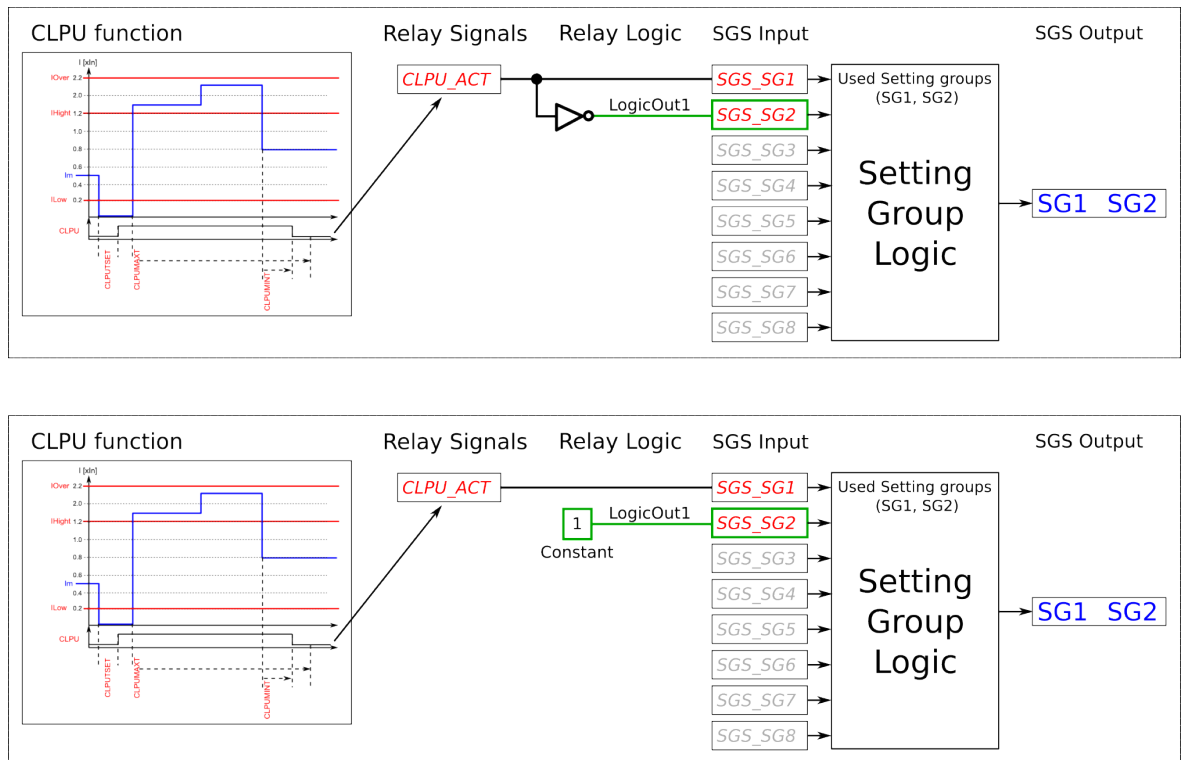

In these examples the cold load pick-up function's output is used for the automatic setting group change. Similarly to this application, any combination of the signals available in the relay's database can be programmed to be used in the setting group selection logic.

As all these examples show, setting group selection with application control has to be built fully before they can be used for setting group control. The setting group does not change back to SG1 unless it is controlled back to SG1 by this application; this explains the inverted signal NOT as well as the use of logics in setting group control. One could also have SG2 be the primary SG, while the ON signal would be controlled by the higher priority SG1; this way the setting group would automatically return to SG2 after the automatic control is over.

Events

The setting group selection function block (abbreviated "SGS" in event block names) generates events from its controlling status, its applied input signals, enabling and disabling of setting groups, as well as unsuccessful control changes. The function does not have a register.

Table. 5.4.1 - 177. Event codes.

Event number	Event channel	Event block name	Event code	Description
4160	65	SGS	0	SG2 Enabled
4161	65	SGS	1	SG2 Disabled
4162	65	SGS	2	SG3 Enabled
4163	65	SGS	3	SG3 Disabled
4164	65	SGS	4	SG4 Enabled
4165	65	SGS	5	SG4 Disabled
4166	65	SGS	6	SG5 Enabled
4167	65	SGS	7	SG5 Disabled

Event number	Event channel	Event block name	Event code	Description
4168	65	SGS	8	SG6 Enabled
4169	65	SGS	9	SG6 Disabled
4170	65	SGS	10	SG7 Enabled
4171	65	SGS	11	SG7 Disabled
4172	65	SGS	12	SG8 Enabled
4173	65	SGS	13	SG8 Disabled
4174	65	SGS	14	SG1 Request ON
4175	65	SGS	15	SG1 Request OFF
4176	65	SGS	16	SG2 Request ON
4177	65	SGS	17	SG2 Request OFF
4178	65	SGS	18	SG3 Request ON
4179	65	SGS	19	SG3 Request OFF
4180	65	SGS	20	SG4 Request ON
4181	65	SGS	21	SG4 Request OFF
4182	65	SGS	22	SG5 Request ON
4183	65	SGS	23	SG5 Request OFF
4184	65	SGS	24	SG6 Request ON
4185	65	SGS	25	SG6 Request OFF
4186	65	SGS	26	SG7 Request ON
4187	65	SGS	27	SG7 Request OFF
4188	65	SGS	28	SG8 Request ON
4189	65	SGS	29	SG8 Request OFF
4190	65	SGS	30	Remote Change SG Requeest ON
4191	65	SGS	31	Remote Change SG Request OFF
4192	65	SGS	32	Local Change SG Request ON
4193	65	SGS	33	Local Change SG Request OFF
4194	65	SGS	34	Force Change SG ON
4195	65	SGS	35	Force Change SG OFF
4196	65	SGS	36	SG Request Fail Not configured SG ON
4197	65	SGS	37	SG Request Fail Not configured SG OFF
4198	65	SGS	38	Force Request Fail Force ON
4199	65	SGS	39	Force Request Fail Force OFF
4200	65	SGS	40	SG Req. Fail Lower priority Request ON
4201	65	SGS	41	SG Req. Fail Lower priority Request OFF
4202	65	SGS	42	SG1 Active ON
4203	65	SGS	43	SG1 Active OFF
4204	65	SGS	44	SG2 Active ON
4205	65	SGS	45	SG2 Active OFF

Event number	Event channel	Event block name	Event code	Description
4206	65	SGS	46	SG3 Active ON
4207	65	SGS	47	SG3 Active OFF
4208	65	SGS	48	SG4 Active ON
4209	65	SGS	49	SG4 Active OFF
4210	65	SGS	50	SG5 Active ON
4211	65	SGS	51	SG5 Active OFF
4212	65	SGS	52	SG6 Active ON
4213	65	SGS	53	SG6 Active OFF
4214	65	SGS	54	SG7 Active ON
4215	65	SGS	55	SG7 Active OFF
4216	65	SGS	56	SG8 Active ON
4217	65	SGS	57	SG8 Active OFF

5.4.2 Object control and monitoring

The object control and monitoring function takes care of both for circuit breakers and disconnectors. The monitoring and controlling are based on the statuses of the relay's configured digital inputs and outputs. The number of controllable and monitored objects in each relay depends on the device type and amount of digital inputs. One controllable object requires a minimum of two (2) output contacts. The status monitoring of one monitored object usually requires two (2) digital inputs. Alternatively, object status monitoring can be performed with a single digital input: the input's active state and its zero state (switched to 1 with a NOT gate in the Logic editor).

An object can be controlled manually or automatically. Manual control can be done by local control, or by remote control. Local manual control can be done by relays front panel (HMI) or by external push buttons connected to relays digital inputs. Manual remote control can be done through one of the various communication protocols available (Modbus, IEC101/103/104 etc.). The function supports the modes "Direct control" and "Select before execute" while controlled remotely. Automatic controlling can be done with functions like auto-reclosing function (ANSI 79).

Object control consists of the following:

- control logic
- control monitor
- output handler.

In addition to these main parts, the user can add object-related circuit breaker failure protection (CBFP; 50BF) and object wear monitoring in the object control block. These additional functions are not included in the basic version of the object control block.

The main outputs of the function are the OBJECT OPEN and OBJECT CLOSE control signals. Additionally, the function reports the monitored object's status and applied operations. The setting parameters are static inputs for the function, which can only be changed by the user in the function's setup phase.

The inputs for the function are the following:

- digital input status indications (the OPEN and CLOSE status signals)
- blockings (if applicable)
- the OBJECT READY and SYNCHROCHECK monitor signals (if applicable).
- Withdrawable cart IN and OUT status signals (if applicable).

The function generates general time stamped ON/OFF events to the common event buffer from each of the two (2) output signals as well as several operational event signals. The time stamp resolution is 1 ms. The function also provides a resettable cumulative counter for OPEN, CLOSE, OPEN FAILED, and CLOSE FAILED events.

The following figure presents a simplified function block diagram of the object control and monitoring function.

Figure. 5.4.2 - 173. Simplified function block diagram of the object control and monitoring function.

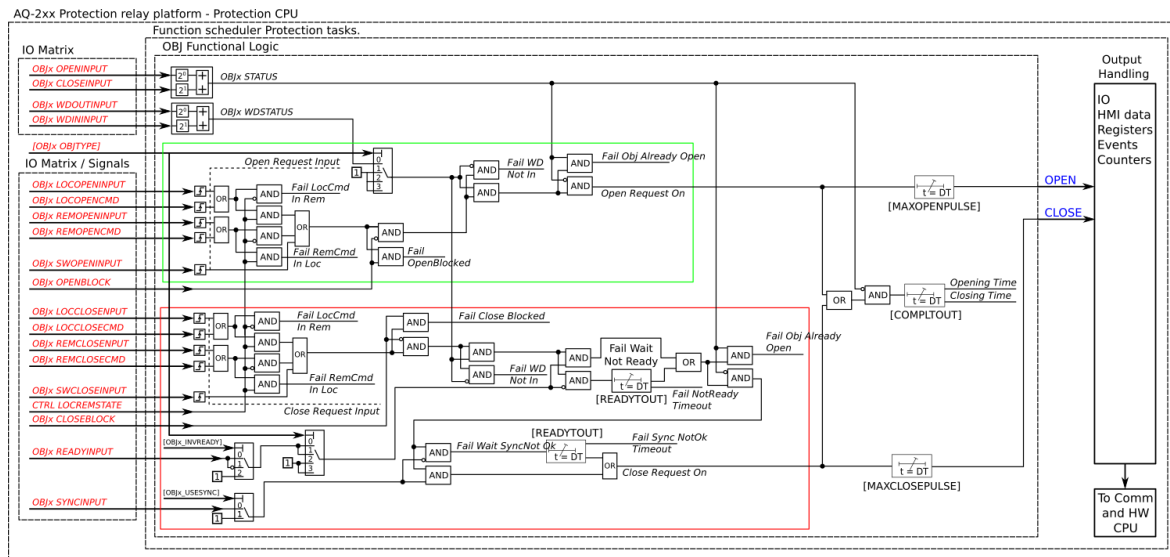

Settings

The following parameters help the user to define the object. The operation of the function varies based on these settings and the selected object type. The selected object type determines how much control is needed and which setting parameters are required to meet those needs.

Table. 5.4.2 - 178. Object set and status.

Name	Range	Step	Default	Description
Local/Remote status	0: Local 1: Remote	-	1: Remote	Displays the status of the relay's "local/remote" switch. Local controls cannot override the open and close commands while device is in "Remote" status. The remote controls cannot override the open and close commands while device is in "Local" status.
Object name	-	-	Objectx	The user-set name of the object, at maximum 32 characters long.
Object type	0: Withdrawable circuit breaker 1: Circuit breaker 2: Disconnecter (MC) 3: Disconnecter (GND)	-	1: Circuit breaker	The selection of the object type. This selection defines the number of required digital inputs for the monitored object. This affects the symbol displayed in the HMI and the monitoring of the circuit breaker. It also affects whether the withdrawable cart is in/out status is monitored. See the next table ("Object types") for a more detailed look at which functionalities each of the object types have.
Objectx Breaker status	0: Intermediate 1: Open 2: Closed 3: Bad	-	-	Displays the status of breaker. Intermediate is displayed when neither of the status signals (open or close) are active. Bad status is displayed when both status signals (open and close) are active.
Objectx Withdraw status	0: WDIntermediate 1: WDCartOut 2: WDCart In 3: WDBad 4: Not in use	-	-	Displays the status of circuit breaker cart. WDIntermediate is displayed when neither of the status signals (in or out) are active. WDBad status is displayed when both status signals (in and out) are active. If the selected object type is not set to "Withdrawable circuit breaker", this setting displays the "No in use" option.

Name	Range	Step	Default	Description
Additional status information	0: Open Blocked 1: Open Allowed 2: Close Blocked 3: Close Allowed 4: Object Ready 5: Object Not Ready 6: Sync Ok 7: Sync Not Ok	-	-	Displays additional information about the status of the object.
Use Synchrocheck	0: Not in use 1: Synchrocheck in use	-	0: Not in use	Selects whether the "Synchrocheck" condition is in use for the circuit breaker close command. If "In use" is selected the input chosen to "Sync.check status in" has to be active to be able to close circuit breaker.
Use Object ready	0: Ready High 1: Ready Low 2: Not in use	-	2: Not in use	Selects whether the "Object ready" condition is in use for the circuit breaker close command. If in use the signal connected to "Object ready status In" has to be high or low to be able to close the breaker (depending on "Ready High or Low" selection).
Open requests	0...2 ³² -1	1	-	Displays the number of successful "Open" requests.
Close requests	0...2 ³² -1	1	-	Displays the number of successful "Close" requests.
Open requests failed	0...2 ³² -1	1	-	Displays the number of failed "Open" requests.
Close requests failed	0...2 ³² -1	1	-	Displays the number of failed "Close" requests.
Clear statistics	0: - 1: Clear	-	0: -	Clears the request statistics, setting them back to zero (0). Automatically returns to "-" after the clearing is finished.

Table. 5.4.2 - 179. Object types.

Name	Functionalities	Description
Withdrawable circuit breaker	Breaker cart position Circuit breaker position Circuit breaker control Object ready check before closing breaker Synchrochecking before closing breaker Interlocks	The monitor and control configuration of the withdrawable circuit breaker.
Circuit breaker	Position indication Control Object ready check before closing breaker Synchrochecking before closing breaker Interlocks	The monitor and control configuration of the circuit breaker.
Disconnecter (MC)	Position indication Control	The position monitoring and control of the disconnecter.
Disconnecter (GND)	Position indication	The position indication of the earth switch.

Table. 5.4.2 - 180. I/O.

Signal	Range	Description
Objectx Open input ("Objectx Open Status In")	Digital input or other logical signal selected by the user (SWx)	A link to a physical digital input. The monitored object's OPEN status. "1" refers to the active open state of the monitored object. If IEC 61850 is enabled, GOOSE signals can be used for status indication.
Objectx Close input ("Objectx Close Status In")	Digital input or other logical signal selected by the user (SWx)	A link to a physical digital input. The monitored object's CLOSE status. "1" refers to the active close state of the monitored object. If IEC 61850 is enabled, GOOSE signals can be used for status indication.
WD Object In ("Withdrw.CartIn.Status In")	Digital input or other logical signal selected by the user (SWx)	A link to a physical digital input. The monitored withdrawable object's position is IN. "1" means that the withdrawable object cart is in. If IEC 61850 is enabled, GOOSE signals can be used for status indication.
WD Object Out ("Withdrw.CartOut.Status In")	Digital input or other logical signal selected by the user (SWx)	A link to a physical digital input. The monitored withdrawable object's position is OUT. "1" means that the withdrawable object cart is pulled out. If IEC 61850 is enabled, GOOSE signals can be used for status indication.
Object Ready (Objectx Ready status In")	Digital input or other logical signal selected by the user (SWx)	A link to a physical digital input. Indicates that status of the monitored object. "1" means that the object is ready and the spring is charged for a close command. If IEC 61850 is enabled, GOOSE signals can be used for status indication.
Syncrocheck permission ("Sync.Check status In")	Digital input or other logical signal selected by the user (SWx)	A link to a physical digital input or a synchrocheck function. "1" means that the synchrocheck conditions are met and the object can be closed. If IEC 61850 is enabled, GOOSE signals can be used for status indication.
Objectx Open command ("Objectx Open Command")	OUT1...OUTx	The physical "Open" command pulse to the device's output relay.
Objectx Close command ("Objectx Close Command")	OUT1...OUTx	The physical "Close" command pulse to the device's output relay.

Table. 5.4.2 - 181. Operation settings.

Name	Range	Step	Default	Description
Breaker traverse time	0.02...500.00 s	0.02 s	0.2 s	Determines the maximum time between open and close statuses when the breaker switches. If this set time is exceeded and both open and closed status inputs are active, the status "Bad" is activated in the "Objectx Breaker status" setting. If neither of the status inputs are active after this delay, the status "Intermediate" is activated.
Maximum Close command pulse length	0.02...500.00 s	0.02 s	0.2 s	Determines the maximum length for a Close pulse from the output relay to the controlled object. If the object operates faster than this set time, the control pulse is reset and a status change is detected.

Name	Range	Step	Default	Description
Maximum Open command pulse length	0.02...500.00 s	0.02 s	0.2 s	Determines the maximum length for a Open pulse from the output relay to the controlled object. If the object operates faster than this set time, the control pulse is reset and a status change is detected.
Control termination timeout	0.02...500.00 s	0.02 s	10 s	Determines the control pulse termination timeout. If the object has not changed its status in this given time the function will issue error event and the control is ended. This parameter is common for both open and close commands.
Final trip pulse length	0.00...500.00 s	0.02 s	0.2 s	Determines the length of the final trip pulse length. When the object has executed the final trip, this signal activates. If set to 0 s, the signal is continuous. If auto-recloser function controls the object, "final trip" signal is activated only when there are no automatic reclosings expected after opening the breaker.

Table. 5.4.2 - 182. Control settings (DI and Application).

Signal	Range	Description
Access level for MIMIC control	0: User 1: Operator 2: Configurator 3: Super user	Defines what level of access is required for MIMIC control. The default is the "Configurator" level.
Objectx LOCAL Close control input	Digital input or other logical signal selected by the user	The local Close command from a physical digital input (e.g. a push button).
Objectx LOCAL Open control input	Digital input or other logical signal selected by the user	The local Open command from a physical digital input (e.g. a push button).
Objectx REMOTE Close control input	Digital input or other logical signal selected by the user	The remote Close command from a physical digital input (e.g. RTU).
Objectx REMOTE Open control input	Digital input or other logical signal selected by the user	The remote Open command from a physical digital input (e.g. RTU).
Objectx Application Close	Digital input or other logical signal selected by the user	The Close command from the application. Can be any logical signal.
Objectx Application Open	Digital input or other logical signal selected by the user	The Open command from the application. Can be any logical signal.

Blocking and interlocking

The interlocking and blocking conditions can be set for each controllable object, with Open and Close set separately. Blocking and interlocking can be based on any of the following: other object statuses, a software function or a digital input.

The image below presents an example of an interlock application, where the closed earthing switch interlocks the circuit breaker close command.

Figure. 5.4.2 - 174. Example of an interlock application.

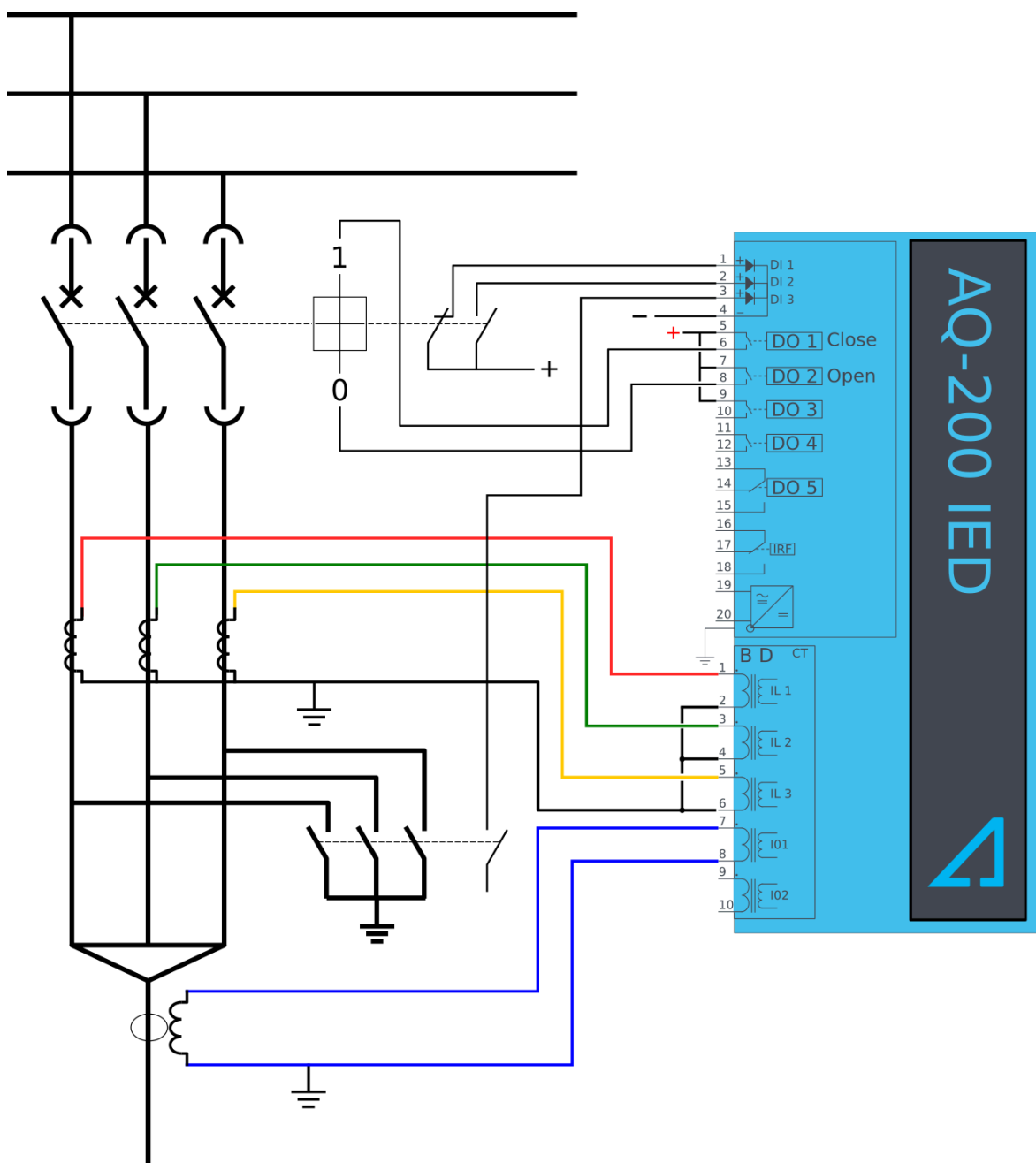

In order for the blocking signal to be received on time, it has to reach the function 5 ms before the control command.

Events and registers

The object control and monitoring function (abbreviated "OBJ" in event block names) generates events and registers from the status changes in monitored signals as well as control command fails and operations. The user can select which event messages are stored in the main event buffer: ON, OFF, or both.

The function registers its operation into the last twelve (12) time-stamped registers. The events triggered by the function are recorded with a time stamp and with process data values.

Table. 5.4.2 - 183. Event codes of the OBJ function instances 1 – 5.

Event Number	Event channel	Event block name	Event Code	Description
2944	46	OBJ1	0	Object Intermediate
2945	46	OBJ1	1	Object Open
2946	46	OBJ1	2	Object Close
2947	46	OBJ1	3	Object Bad
2948	46	OBJ1	4	WD Intermediate
2949	46	OBJ1	5	WD Out
2950	46	OBJ1	6	WD In
2951	46	OBJ1	7	WD Bad
2952	46	OBJ1	8	Open Request ON
2953	46	OBJ1	9	Open Request OFF
2954	46	OBJ1	10	Open Command ON
2955	46	OBJ1	11	Open Command OFF
2956	46	OBJ1	12	Close Request ON
2957	46	OBJ1	13	Close Request OFF
2958	46	OBJ1	14	Close Command ON
2959	46	OBJ1	15	Close Command OFF
2960	46	OBJ1	16	Open Blocked ON
2961	46	OBJ1	17	Open Blocked OFF
2962	46	OBJ1	18	Close Blocked ON
2963	46	OBJ1	19	Close Blocked OFF
2964	46	OBJ1	20	Object Ready
2965	46	OBJ1	21	Object Not Ready
2966	46	OBJ1	22	Sync Ok
2967	46	OBJ1	23	Sync Not Ok
2968	46	OBJ1	24	Open Command Fail
2969	46	OBJ1	25	Close Command Fail
2970	46	OBJ1	26	Final trip ON
2971	46	OBJ1	27	Final trip OFF
3008	47	OBJ2	0	Object Intermediate
3009	47	OBJ2	1	Object Open
3010	47	OBJ2	2	Object Close
3011	47	OBJ2	3	Object Bad
3012	47	OBJ2	4	WD Intermediate
3013	47	OBJ2	5	WD Out
3014	47	OBJ2	6	WD In
3015	47	OBJ2	7	WD Bad
3016	47	OBJ2	8	Open Request ON

Event Number	Event channel	Event block name	Event Code	Description
3017	47	OBJ2	9	Open Request OFF
3018	47	OBJ2	10	Open Command ON
3019	47	OBJ2	11	Open Command OFF
3020	47	OBJ2	12	Close Request ON
3021	47	OBJ2	13	Close Request OFF
3022	47	OBJ2	14	Close Command ON
3023	47	OBJ2	15	Close Command OFF
3024	47	OBJ2	16	Open Blocked ON
3025	47	OBJ2	17	Open Blocked OFF
3026	47	OBJ2	18	Close Blocked ON
3027	47	OBJ2	19	Close Blocked OFF
3028	47	OBJ2	20	Object Ready
3029	47	OBJ2	21	Object Not Ready
3030	47	OBJ2	22	Sync Ok
3031	47	OBJ2	23	Sync Not Ok
3032	47	OBJ2	24	Open Command Fail
3033	47	OBJ2	25	Close Command Fail
3034	47	OBJ2	26	Final trip ON
3035	47	OBJ2	27	Final trip OFF
3072	48	OBJ3	0	Object Intermediate
3073	48	OBJ3	1	Object Open
3074	48	OBJ3	2	Object Close
3075	48	OBJ3	3	Object Bad
3076	48	OBJ3	4	WD Intermediate
3077	48	OBJ3	5	WD Out
3078	48	OBJ3	6	WD In
3079	48	OBJ3	7	WD Bad
3080	48	OBJ3	8	Open Request ON
3081	48	OBJ3	9	Open Request OFF
3082	48	OBJ3	10	Open Command ON
3083	48	OBJ3	11	Open Command OFF
3084	48	OBJ3	12	Close Request ON
3085	48	OBJ3	13	Close Request OFF
3086	48	OBJ3	14	Close Command ON
3087	48	OBJ3	15	Close Command OFF
3088	48	OBJ3	16	Open Blocked ON
3089	48	OBJ3	17	Open Blocked OFF
3090	48	OBJ3	18	Close Blocked ON

Event Number	Event channel	Event block name	Event Code	Description
3091	48	OBJ3	19	Close Blocked OFF
3092	48	OBJ3	20	Object Ready
3093	48	OBJ3	21	Object Not Ready
3094	48	OBJ3	22	Sync Ok
3095	48	OBJ3	23	Sync Not Ok
3096	48	OBJ3	24	Open Command Fail
3097	48	OBJ3	25	Close Command Fail
3098	48	OBJ3	26	Final trip ON
3099	48	OBJ3	27	Final trip OFF
3136	49	OBJ4	0	Object Intermediate
3137	49	OBJ4	1	Object Open
3138	49	OBJ4	2	Object Close
3139	49	OBJ4	3	Object Bad
3140	49	OBJ4	4	WD Intermediate
3141	49	OBJ4	5	WD Out
3142	49	OBJ4	6	WD In
3143	49	OBJ4	7	WD Bad
3144	49	OBJ4	8	Open Request ON
3145	49	OBJ4	9	Open Request OFF
3146	49	OBJ4	10	Open Command ON
3147	49	OBJ4	11	Open Command OFF
3148	49	OBJ4	12	Close Request ON
3149	49	OBJ4	13	Close Request OFF
3150	49	OBJ4	14	Close Command ON
3151	49	OBJ4	15	Close Command OFF
3152	49	OBJ4	16	Open Blocked ON
3153	49	OBJ4	17	Open Blocked OFF
3154	49	OBJ4	18	Close Blocked ON
3155	49	OBJ4	19	Close Blocked OFF
3156	49	OBJ4	20	Object Ready
3157	49	OBJ4	21	Object Not Ready
3158	49	OBJ4	22	Sync Ok
3159	49	OBJ4	23	Sync Not Ok
3160	49	OBJ4	24	Open Command Fail
3161	49	OBJ4	25	Close Command Fail
3162	49	OBJ4	26	Final trip ON
3163	49	OBJ4	27	Final trip OFF
3200	50	OBJ5	0	Object Intermediate

Event Number	Event channel	Event block name	Event Code	Description
3201	50	OBJ5	1	Object Open
3202	50	OBJ5	2	Object Close
3203	50	OBJ5	3	Object Bad
3204	50	OBJ5	4	WD Intermediate
3205	50	OBJ5	5	WD Out
3206	50	OBJ5	6	WD In
3207	50	OBJ5	7	WD Bad
3208	50	OBJ5	8	Open Request ON
3209	50	OBJ5	9	Open Request OFF
3210	50	OBJ5	10	Open Command ON
3211	50	OBJ5	11	Open Command OFF
3212	50	OBJ5	12	Close Request ON
3213	50	OBJ5	13	Close Request OFF
3214	50	OBJ5	14	Close Command ON
3215	50	OBJ5	15	Close Command OFF
3216	50	OBJ5	16	Open Blocked ON
3217	50	OBJ5	17	Open Blocked OFF
3218	50	OBJ5	18	Close Blocked ON
3219	50	OBJ5	19	Close Blocked OFF
3220	50	OBJ5	20	Object Ready
3221	50	OBJ5	21	Object Not Ready
3222	50	OBJ5	22	Sync Ok
3223	50	OBJ5	23	Sync Not Ok
3224	50	OBJ5	24	Open Command Fail
3225	50	OBJ5	25	Close Command Fail
3226	50	OBJ5	26	Final trip ON
3227	50	OBJ5	27	Final trip OFF

Table. 5.4.2 - 184. Register content.

Name	Description
Date and time	dd.mm.yyyy hh:mm:ss.mss
Event code	2944-9883 Descr.
Recorded Object opening time	Time difference between the object receiving an "Open" command and the object receiving the "Open" status.
Recorded Object closing time	Time difference between the object receiving a "Close" command and object receiving the "Closed" status.
Object status	The status of the object.
WD status	The status of the withdrawable circuit breaker.
Open fail	The cause of an "Open" command's failure.

Name	Description
Close fail	The cause of a "Close" command's failure.
Open command	The source of an "Open" command.
Close command	The source of an "Open" command.
General status	The general status of the function.

5.4.3 Indicator object monitoring

The indicator object monitoring function takes care of the status monitoring of disconnectors. The function's sole purpose is indication and does not therefore have any control functionality. To control circuit breakers and/or disconnectors, please use the Object control and monitoring function. The monitoring is based on the statuses of the configured relay's digital inputs. The number of monitored indicators in a relay depends on the device type and available inputs. The status monitoring of one monitored object usually requires two (2) digital inputs. Alternatively, object status monitoring can be performed with a single digital input: the input's active state and its zero state (switched to 1 with a NOT gate in the Logic editor).

The outputs of the function are the monitored indicator statuses (Open, Close, Intermediate and Bad). The setting parameters are static inputs for the function, which can only be changed by the use in the function's setup phase.

The inputs of the function are the binary status indications. The function generates general time stamped ON/OFF events to the common event buffer from each of the following signals: OPEN, CLOSE, BAD and INTERMEDIATE event signals. The time stamp resolution is 1 ms.

Settings

Function uses available hardware and software digital signal statuses. These input signals are also setting parameters for the function.

Table. 5.4.3 - 185. Indicator status.

Name	Range	Default	Description
Indicator name ("Ind. Name")	-	IndX	The user-set name of the object, at maximum 32 characters long.
IndicatorX Object status ("Ind.X Object Status")	0: Intermediate 1: Open 2: Closed 3: Bad	-	Displays the status of the indicator object. Intermediate status is displayed when neither of the status conditions (open or close) are active. Bad status is displayed when both of the status conditions (open and close) are active.

Table. 5.4.3 - 186. Indicator I/O.

Signal	Range	Description
IndicatorX Open input ("Ind.X Open Status In")	Digital input or other logical signal selected by the user (SWx)	A link to a physical digital input. The monitored indicator's OPEN status. "1" refers to the active "Open" state of the monitored indicator. If IEC 61850 is enabled, GOOSE signals can be used for status indication.

Signal	Range	Description
IndicatorX Close input ("Ind.X Close Status In")	Digital input or other logical signal selected by the user (SWx)	A link to a physical digital input. The monitored indicator's CLOSE status. "1" refers to the active "Close" state of the monitored indicator. If IEC 61850 is enabled, GOOSE signals can be used for status indication.

Events

The indicator object monitoring function (abbreviated "CIN" in event block names) generates events from the status changes in the monitored signals, including the continuous status indications. The user can select which event messages are stored in the main event buffer: ON, OFF, or both.

Table. 5.4.3 - 187. Event codes (instances 1 – 5).

Event Number	Event channel	Event block name	Event Code	Description
6656	104	CIN1	0	Intermediate
6657	104	CIN1	1	Open
6658	104	CIN1	2	Close
6659	104	CIN1	3	Bad
6720	105	CIN2	0	Intermediate
6721	105	CIN2	1	Open
6722	105	CIN2	2	Close
6723	105	CIN2	3	Bad
6784	106	CIN3	0	Intermediate
6785	106	CIN3	1	Open
6786	106	CIN3	2	Close
6787	106	CIN3	3	Bad
6848	107	CIN4	0	Intermediate
6849	107	CIN4	1	Open
6850	107	CIN4	2	Close
6851	107	CIN4	3	Bad
6912	108	CIN5	0	Intermediate
6913	108	CIN5	1	Open
6914	108	CIN5	2	Close
6915	108	CIN5	3	Bad

5.4.4 Auto-recloser (79)

Auto-reclosing means a coordinated de-energization and re-energization of overhead lines (both transmission and distribution). Its purpose is to clear transient and semi-permanent fault causes from the line and automatically restore the supply to the line. These types of faults account for approximately 80...95 % of all faults found in transmission and distribution networks. The majority of these fault types can be cleared with high-speed auto-reclosing, while the rest can be cleared with delayed auto-reclosing by de-energizing the faulty line for a longer period of time.

Only a minority of overhead line faults are of the permanent type which require maintenance or repair in the actual fault location. This type of fault include lightning striking the line, a tree branch touching the line, an arc caused by animals, and a short-circuit caused by some other object touching the line. If the fault is permanent (e.g. a broken insulator or a fallen tree leaning on the overhead line), the auto-recloser cannot clear the fault and the faulty feeder is locked and prevented from closing until the cause of the fault is repaired in the actual fault location. Also, when a fault cannot be cleared by auto-reclosing the line, any close-distance short-circuits should avoid initiating the auto-recloser because that would only cause unnecessary stress for the lines and the circuit breakers. Similar situations also rise in mixed networks since cable network faults cannot be cleared with the auto-recloser. The function must therefore be aware of the fault location before applying the auto-recloser to the faulty line.

Auto-recloser as application

The main principle of the auto-recloser is to de-energize the faulty line and the fault location so the cause of the fault can drop out from the line. When the line is energized and an object either touches the line or drops onto the line, the current starts to flow through the object either to the ground or between the phases. This causes the surrounding air to heat and ionize, and it starts to operate as a conductor between the energized phase(s) and the ground causing an arc to ignite.

When the breaker is opened (either by an auto-recloser command or by a protection function), the voltage in the line goes to zero. This extinguishes the arc and lets the fault-causing object to drop from the line, thus clearing the cause of the fault. Auto-reclosing closes the breaker after a set time (called 'dead time' during which the line is not energized) and the supply is restored to the line. If the fault is not cleared by the first auto-recloser cycle (called 'shot'), more shots can be applied to the line. Alternatively, the function can be set to initiate the final trip, locking the feeder closing. The decision between a single-shot and a multi-shot auto-recloser depends on the following: protection type, switchgear, circuit breaker, stability requirements, network type, consumer loads as well as local utility knowledge and network practices.

The user can select whether there is a set time delay (called 'arcing time') between shots to burn the fault-causing object from the line, or whether normal protection operating times are applied. When a fault is not present when the breaker is closed but reappears soon after (called 'discrimination time' and 'reclaim time'), the auto-recloser function can either arm another shot or give the final trip command and the feeder becomes locked. The user can select the preferred method in the function's settings.

It is difficult to define a typical auto-recloser scheme because the above-mentioned parameters (and thus the main parameters of a scheme) vary greatly in distribution and transmission networks. This is why there are no universally applicable answers from the number of shots and the duration of the dead times to which protection functions should trigger the auto-recloser.

The minimum times for the "Dead time" setting is mostly dependent on the voltage level of the protected network: the air needs enough time to de-ionize before the circuit breaker is opened. For medium-voltage networks (20...75 kV) a 200 ms dead time should be sufficient. High-voltage networks require a longer dead time: a 110 kV network needs 300 ms and a 400 kV network needs 400...500 ms. This minimum time is not, however, less straightforward than this as it is affected by other parameters as well (such as conductor spacing, wind speed, fault type, fault duration, etc.). The main purpose of the "Dead time" setting is to give enough time for the air surrounding the fault location to return to its isolating state before the line is re-energized and therefore prevent the arc from reignite due to the heated and ionized air. The circuit breaker's open-close-open cycle capacity is another restricting factor for the minimum "Dead time" setting in low-voltage networks. In high-voltage networks, the time de-ionizing requires puts additional limitations on the minimum "Dead time" setting.

The user can build different schemes for evolving faults (such as transient earth faults that become multi-phase short-circuits or overcurrent faults) by changing the priorities and behaviors requests have. The auto-recloser function has five (5) independent priority requests for reclosing: REQ1 has the highest priority and REQ5 the lowest. The function also has one (1) critical request which halts the reclosing in any position when the request is received.

Auto-recloser scheme in radial networks

A typical medium-voltage overhead network is usually radial in structure. This does not cause any additional requirements for the auto-recloser scheme apart from the above-mentioned limitations from the required air de-ionization time and the capacity of the circuit breaker. Also, a typical medium-voltage overhead line consists only of consumers and has no power generation; thus, the main objective of the structure is to provide a stable and continuous supply of electricity.

Figure. 5.4.4 - 175. Diagram of a typical radial medium-voltage network in rural areas.

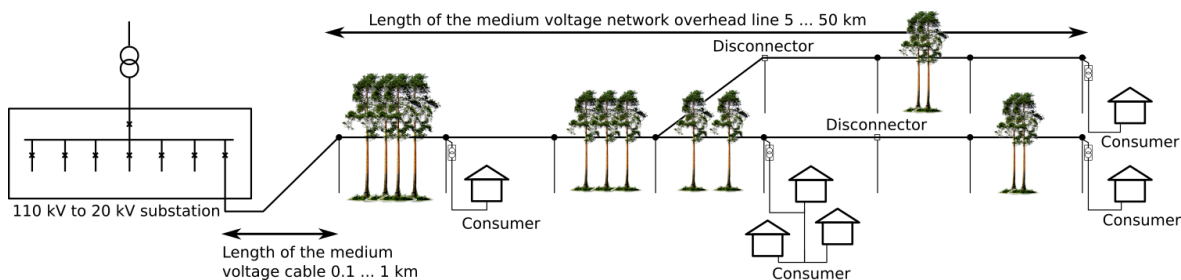

Usually, a radially built medium-voltage network in rural areas consists of a short cable connection from the substation to the overhead line, followed by a relatively long overhead line that normally ends with the consumer. The consumer (residence, farm, etc.) can connect to basically any point in the overhead line with a 20 kV/0.4 kV distribution transformer. The overhead line can have many branches, and it is not uncommon (especially in rural areas) that there are multiple forest areas the line runs through between the consumer connections. In longer lines in sparsely populated areas it is possible to isolate areas of the overhead line by dividing it up with disconnectors (at least in branches).

This type of application normally uses an auto-recloser with two shots (one high-speed and one delayed) which are triggered by earth fault protection or overcurrent protection. Short-circuit protection is used for interlocking the auto-recloser in case a clear short-circuit fault occurs in the line.

Figure. 5.4.4 - 176. Example of assigning request signals.

AR Request 1	I> START
AR Request 2	I0Dir> TRIP
AR Request 3	None
AR Request 4	None
AR Request 5	None
Critical request	I>> TRIP

Figure. 5.4.4 - 177. Example of shot settings (two requests and two initialized shots).

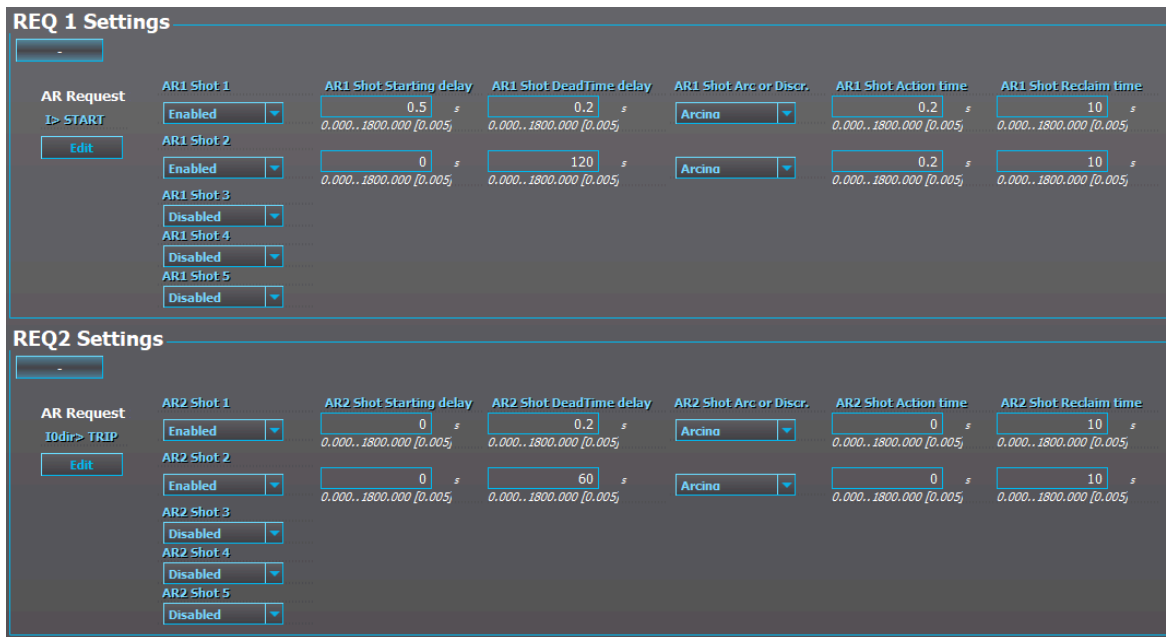

In this example, earth fault (REQ2) uses its own operating time settings, whereas the time delay for overcurrent (REQ1) comes from the auto-recloser's own settings. Both fault types can initialize both of the shots with different settings. If the fault evolves from earth fault into a multi-phase fault, the auto-recloser uses the AR1 settings for the reclosing. In this example, the dead time between the first and the second shot in REQ1 differs from the dead time in REQ2 because the air needs more time to cool and de-ionize after an overcurrent or a multi-phase fault than it does after an earth fault. If the high-set overcurrent stage activates in any situation, the auto-reclosing sequence is stopped, the final trip is issued and the feeder closing is locked by the auto-recloser. A manual reset of the auto-recloser's lock is required before one can attempt to close the breaker. A manual reset can be applied from SCADA or locally from the relay's HMI.

Based on the example above, the following six (6) sections present the principle signaling of the auto-recloser function. These are the auto-recloser sequence variations that can occur with this setup:

- from Trip with two shots (both fail)
- from Trip with two shots (high-speed fails, time-delayed succeeds)
- from Trip with two shots (high-speed succeeds)
- from Start with two shots (both fail)
- from Start with two shots (high-speed fails, time-delayed succeeds)
- from Start with two shots (high-speed succeeds).

The signal status graphs describe the statuses of available requests, the statuses of the auto-recloser's internal signals, the statuses of the timers, the breaker controls from the auto-recloser function as well as the breaker status signals.

The auto-recloser function operates closely with the object control and monitoring function, and all breaker status and monitor signals are forwarded from the selected object to the auto-recloser function. The circuit breaker's "Open" and "Close" signals are also controlled through the dedicated object. When the breaker cannot be closed (because it is not ready or the closing is waiting for a Synchrocheck allowance), the wait state is forwarded to the auto-recloser function to wait for the object's acknowledgement either of a successful closing or of a failure time-out. A similar situation can arise in the circuit breaker's "Open" command, for example, if the command is blocked because of an SF₆ gas leakage. In failure acknowledgement situations the auto-recloser function is always put to a lock-out state with a requirement for resetting once the cause of the lock-out is cleared. Resetting is done by an external input to the function or by closing the breaker.

Auto-recloser sequence from Trip with two shots (both fail).

In this auto-recloser scheme, the TRIP signal from the directional earth fault protection function (I0dir> TRIP) was set up as the operation starter for Request 2 (REQ2). REQ2 has two shots (Shots 1 and 2) enabled with the setting detailed in the image below; the first one is a high-speed shot (0.2 s) that is then followed by a time-delayed shot (60 s).

Figure. 5.4.4 - 178. Settings for I0dir> with two shots.

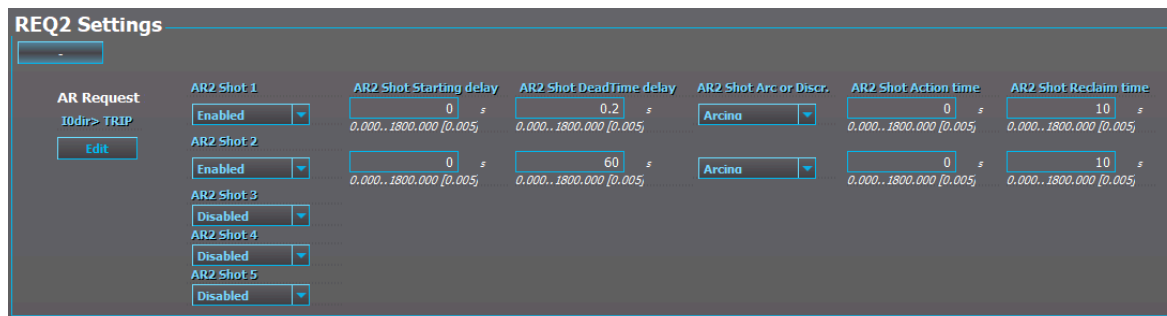

When the TRIP signal is used to initiate the auto-recloser sequence, no additional starting or discrimination times are needed as the protection stage's own operation takes care of the breaker opening timings directly. Therefore, the auto-recloser function only monitors the status of the directional earth fault stage's tripping before initiating requests and shots.

Figure. 5.4.4 - 179. Signal status graph of the permanent earth fault auto-recloser cycle.

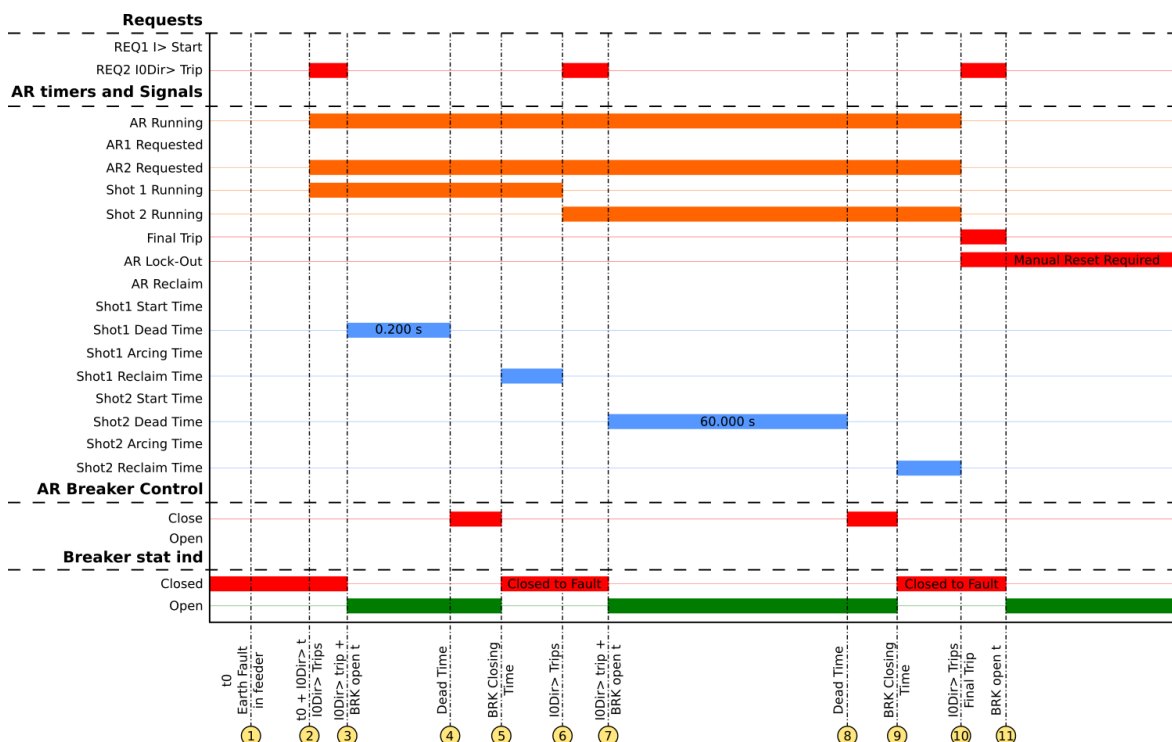

1. An earth fault is found in the protected line causing the I0Dir> protection to start calculating the operating time for a trip.
2. The I0Dir> trips and gives the "Open" command to the breaker's open coil. The auto-recloser function is initiated and the AR Running, AR2 Requested and Shot 1 Running signals are activated.
3. The circuit breaker is opened and the I0Dir> TRIP signal is released and simultaneously the REQ2 trip signal for the auto-recloser is released. The recloser starts calculating the Shot1 Dead Time to close the breaker.

4. The **Shot1 Dead Time** (200 ms) is exceeded and the function sends a "Close" request to the object breaker (**AR Breaker**): the conditions are met and the breaker's "Close" command is sent to the breaker's close coil.
5. The circuit breaker is closed towards the fault as it was not cleared by Shot 1 given the non-energized time. The I0dir> stage picks up and starts calculating the operating time for a trip. A "Close" command is dropped after the breaker's "Closed" indication is received and the auto-recloser function starts calculating **Shot1 Reclaim Time**.
6. The I0Dir> stage trips a second time and gives the REQ2 request to the function. However, as the function is in the process of calculating the Shot1 Reclaim Time when it receives this request, the function moves on to the next available shot (Shot 2) for the request. The **Shot2 Running** signal is set to active and the **Shot1 Running** is terminated.
7. The circuit breaker is opened and the I0Dir> TRIP signal is released and simultaneously REQ2 trip signal for auto-recloser is released. The recloser starts calculating the **Shot2 Dead Time** to close the breaker.
8. The **Shot2 Dead Time** (60 s) is exceeded and the function sends a "Close" request to the object breaker: the conditions are met and the breaker's "Close" command is sent to the breaker's close coil.
9. The circuit breaker is closed towards the fault since it was not cleared by Shot 2. The I0dir> stage picks up and starts calculating the operating time for a trip. A "Close" command is dropped after the breaker's "Closed" indication is received and the auto-recloser function starts calculating **Shot2 Reclaim Time**.
10. The I0Dir> stage trips a third time and gives the REQ2 request to the function. However, as the function is in the process of calculating the **Shot2 Reclaim Time** when it receives this request, the function tries to move on to the next available shot. Alas, this scheme does not have any more available shots and so the function begins the **Final Trip** state and drops the **AR Running**, **Shot2 Running** and **AR2 Requested** signals. The function enters the **AR Lock-out** state to prevent any further requests for reclosing.
11. The circuit breaker is opened and the I0Dir> TRIP signal is released, and simultaneously the REQ2 trip signal for the auto-recloser is released. The function is now in a steady lock-out state and waits for the user to manually reset and re-initialize the function by closing the breaker.

Auto-recloser sequence from Trip with two shots (high-speed fails, time-delayed succeeds).

This auto-recloser scheme has the same starters and shots as the previous example. The setting and signals are also the same. However, in this example the fault persists the high-speed shot but is cleared by the time-delayed shot.

Figure. 5.4.4 - 180. Settings for I0dir> with two shots.

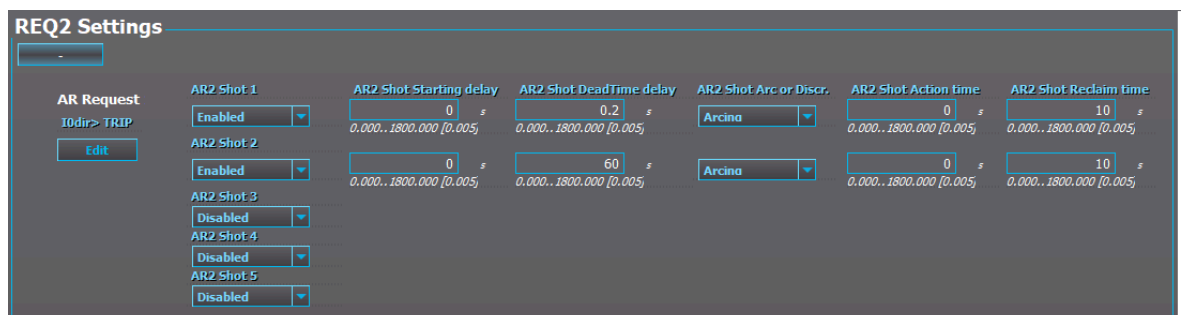

This type of sequence (i.e. two shots required to clear the fault) represents 10...15 % of all faults that occur in MV overhead line networks.

Figure. 5.4.4 - 181. Signal status graph of the semi-permanent earth fault auto-recloser cycle.

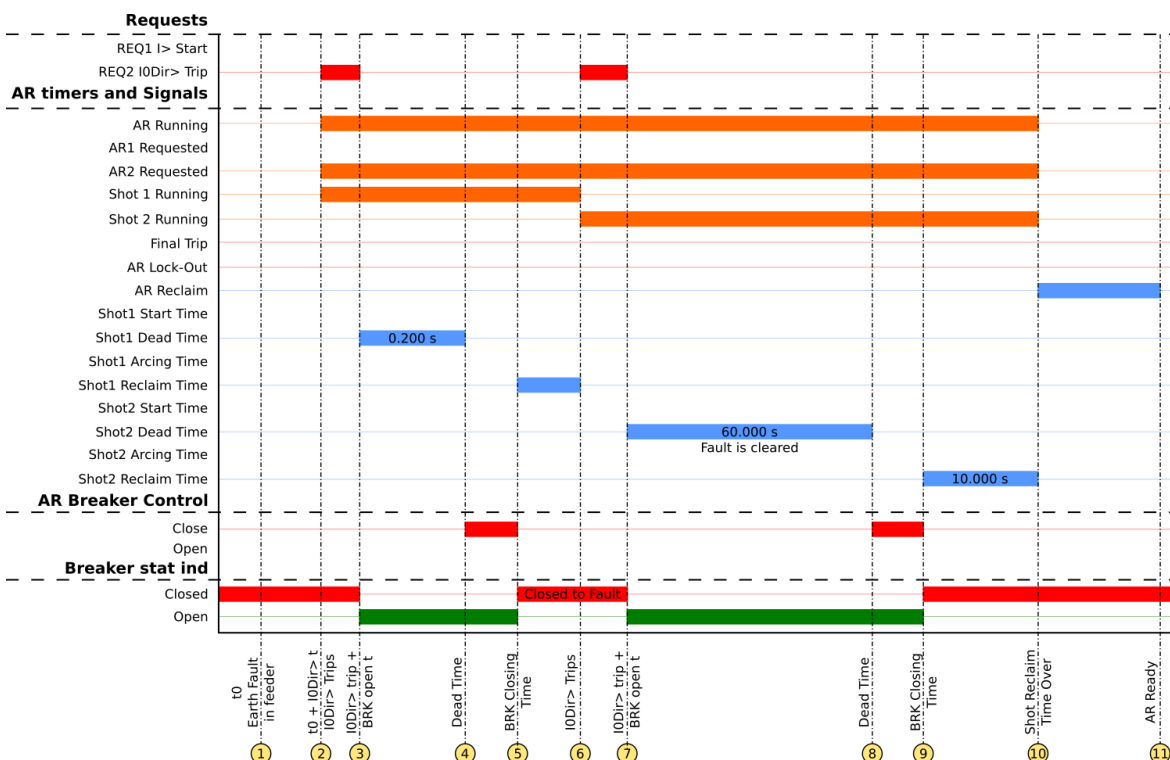

1. An earth fault is found in the protected line causing the IODir> protection to start calculating the operating time for a trip.
2. The IODir> trips and gives the "Open" command to the breaker's open coil. The auto-recloser function is initiated and the AR Running, AR2 Requested and Shot 1 Running signals are activated.
3. The circuit breaker is opened and the IODir> TRIP signal is released and simultaneously the REQ2 trip signal for the auto-recloser is released. The recloser starts calculating the Shot1 Dead Time to close the breaker.
4. The Shot1 Dead Time (200 ms) is exceeded and the function sends a "Close" request to the object breaker: the conditions are met and the breaker's "Close" command is sent to the breaker's close coil.
5. The circuit breaker is closed towards the fault as it was not cleared by Shot 1. The I0dir> stage picks up and starts calculating the operating time for a trip. A "Close" command is dropped after the breaker's "Closed" indication is received and the auto-recloser function starts calculating Shot1 Reclaim Time.
6. The IODir> stage trips a second time and gives the REQ2 request to the function. However, as the function is in the process of calculating the Shot1 Reclaim Time when it receives this request, the function moves on to the next available shot (Shot 2) for the request. The Shot2 Running signal is set to active and the Shot1 Running is terminated.
7. The circuit breaker is opened and the IODir> TRIP signal is released and simultaneously REQ2 trip signal for the auto-recloser is released. The recloser starts calculating the Shot2 Dead Time to close the breaker.
8. The fault is cleared during Shot2 Dead Time. After that time (60 s) is exceeded, the function sends a "Close" request to the object breaker: the conditions are met and the breaker's "Close" command is sent to the breaker's close coil.
9. The circuit breaker is closed and since the fault has been cleared, no pick-ups are detected. The "Close" command is dropped after the breaker's "Closed" indication is received and the auto-recloser function starts calculating Shot2 Reclaim Time.

- The Shot2 Reclaim Time (10 s) is exceeded, and so the AR Running, Shot 2 Running and AR2 Requested signals are terminated, and the AR Reclaim calculation begins. The difference between auto-reclosing and shot-specific reclaim times is that the function jumps to the next available shot should the fault return. If a fault returns after a successful cycle and the function's AR Reclaim signal is active, the function jumps directly to the Final Trip state and then enters the lock-out state. The user can control this behavior through the function settings. Both reclaim times can be set to 0 s when they are not needed, and the function skips all timers that are set to zero.
- The AR Reclaim time is exceeded and the function is set to "Ready" to wait for the next request.

Auto-recloser sequence from Trip with two shots (high-speed succeeds).

This auto-recloser scheme has the same starters and shots as the two previous examples. The setting and signals are also the same. However, in this example the fault is cleared by the high-speed shot.

Figure. 5.4.4 - 182. Settings for I0dir> with two shots.

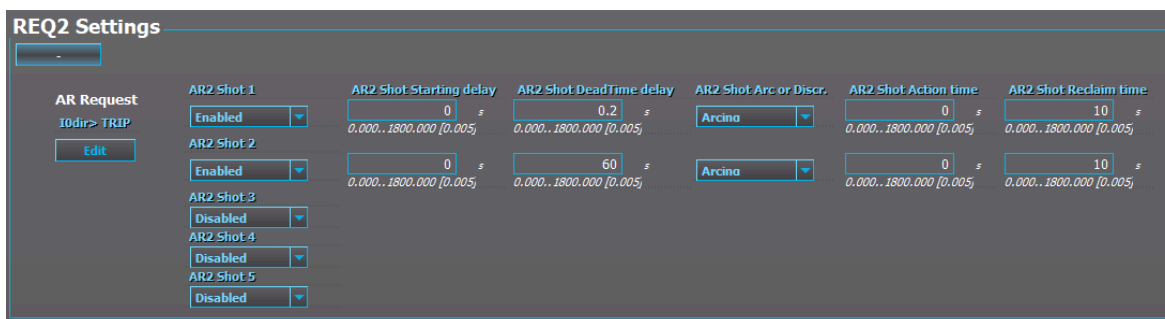

This type of sequence (i.e. the first shot clears the fault) represents 75...85 % of all faults that occur in MV overhead line networks.

Figure. 5.4.4 - 183. Signal status graph of the transient earth fault auto-recloser cycle.

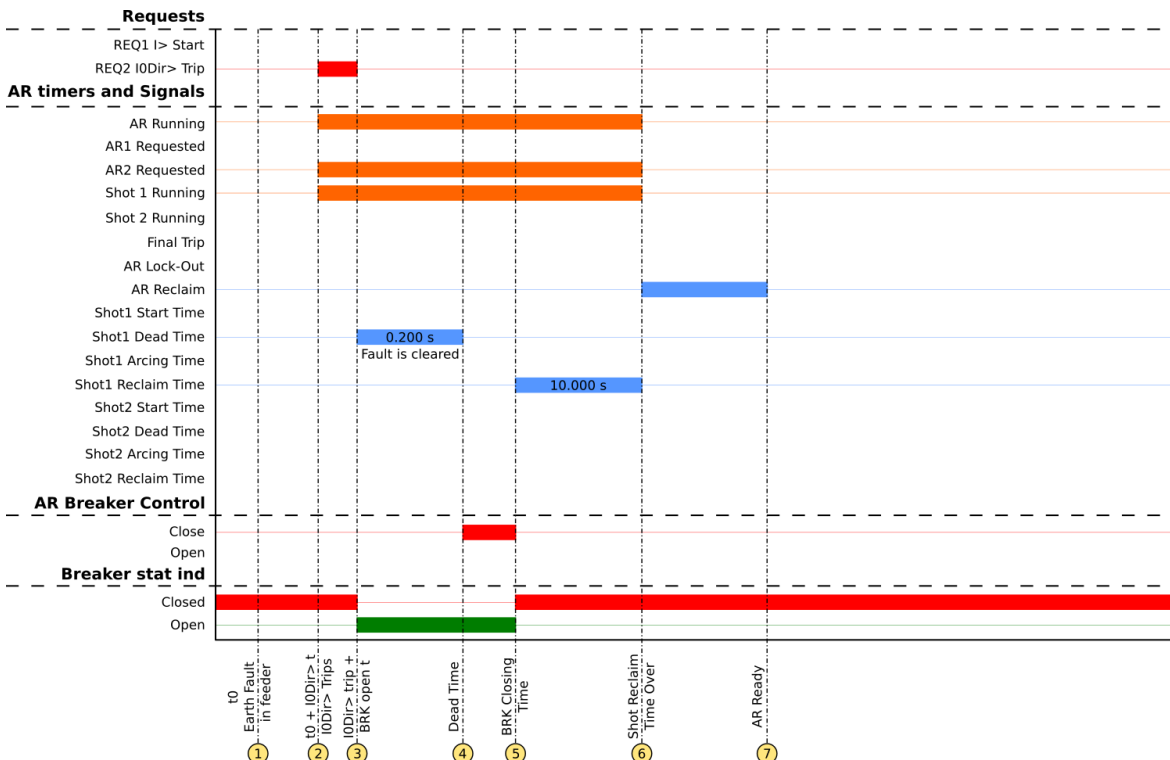

1. An earth fault is found in the protected line causing the I0Dir> protection to start calculating the operating time for a trip.
2. The I0Dir> trips and gives the "Open" command to the breaker's open coil. The auto-recloser function is initiated and the **AR Running**, **AR2 Requested** and **Shot 1 Running** signals are activated.
3. The circuit breaker is opened and the I0Dir> TRIP signal is released and simultaneously the REQ2 trip signal for the auto-recloser is released. The recloser starts calculating the **Shot1 Dead Time** to close the breaker.
4. The fault is cleared during **Shot1 Dead Time** calculation. When that time (200 ms) is exceeded and the function sends a "Close" request to the object breaker: the conditions are met and the breaker's "Close" command is sent to the breaker's close coil.
5. The circuit breaker is closed and since the fault was cleared, no pick-ups are detected. The "Close" command is dropped after the breaker's "Closed" indication is received and the auto-recloser function starts calculating **Shot1 Reclaim Time**.
6. The **Shot1 Reclaim Time** (10 s) is exceeded, and so the **AR Running**, **Shot 2 Running** and **AR2 Requested** signals are terminated, and the **AR Reclaim** calculation begins. The difference between auto-reclosing and shot-specific reclaim times is that the function jumps to the next available shot should the fault returns. If a fault returns after a successful cycle and the function's AR Reclaim signal is active, the function jumps directly to the Final Trip state and then enters the lock-out state. The user can control this behavior through the function settings. Both reclaim times can be set to 0 s when they are not needed, and the function skips all timers that are set to zero. The user can also set it so that AR Reclaim is not used at all after a successful reclosing cycle.
7. The **AR Reclaim** time is exceeded and the function is set to "Ready" to wait for the next request.

Auto-recloser sequence from Start with two shots (both fail).

In this auto-recloser scheme, the START signal from the non-directional overcurrent protection function (I> START) was set up as the operation starter for Request 1 (REQ1). REQ1 has two shots (Shots 1 and 2) enabled with the setting detailed in the image below; the first one is a high-speed shot (0.2 s) that is then followed by a time-delayed shot (120 s). In this scheme the starting delay time is longer than in REQ2's high-speed shot. The shot action time is also longer in REQ1. If the fault persists after both shots, the time determining how long the breaker stays closed is reduced.

Figure. 5.4.4 - 184. Settings for I> with two shots.

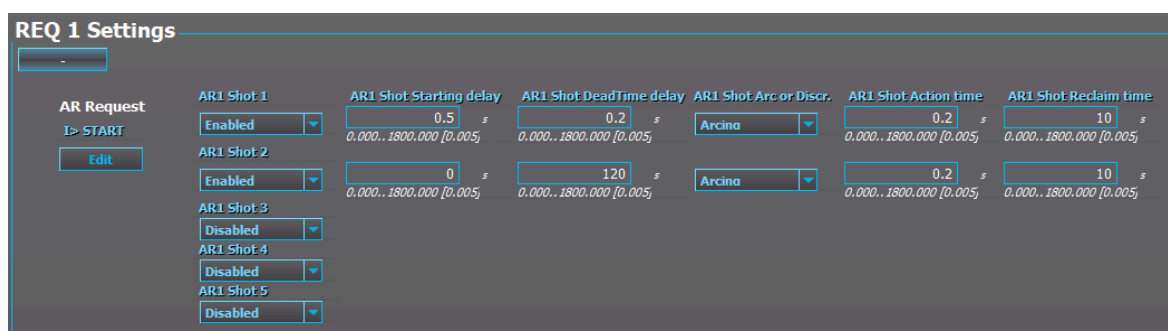

When the START signal is used to initiate the auto-recloser sequence, the fault duration timings are overseen by the auto-recloser function and thus both the starting time and the arcing time need to be set accordingly. The protection's main operating time settings should be longer than the values set to the auto-recloser function; this way the state changes work properly with this function.

Figure. 5.4.4 - 185. Signal status graph of the permanent overcurrent auto-recloser cycle.

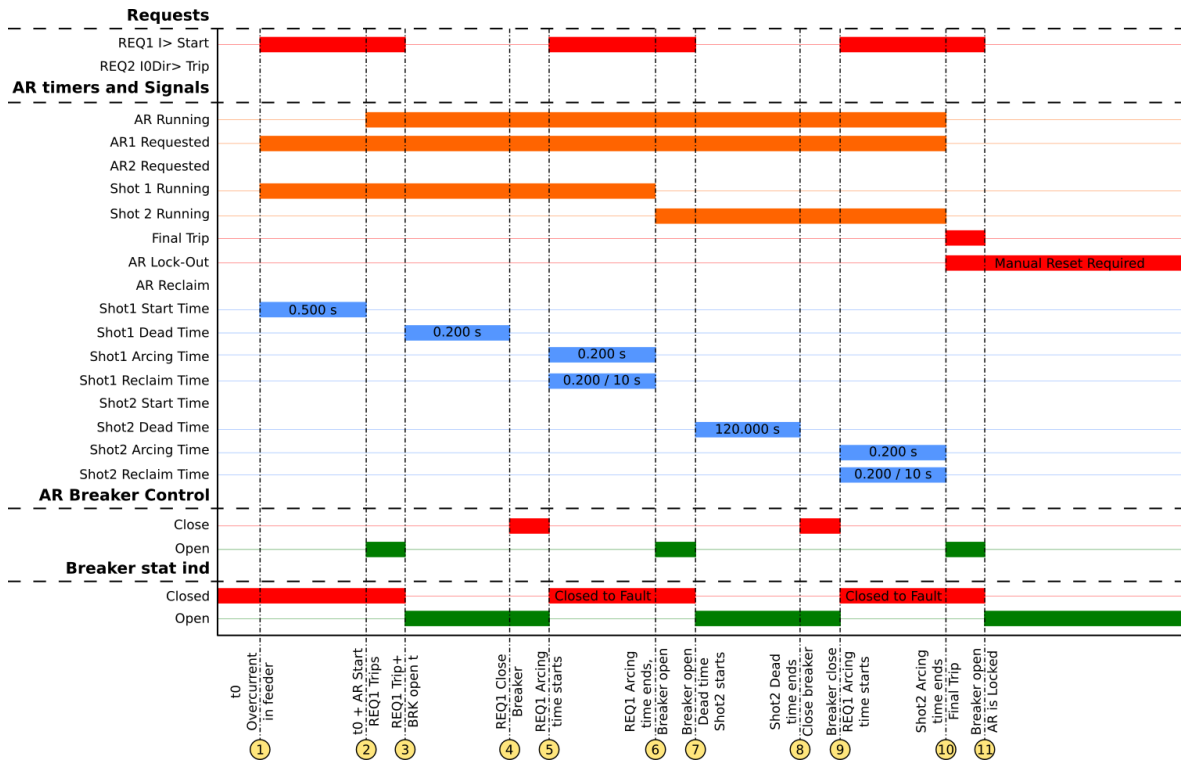

1. An overcurrent is found in the protected line causing the I> protection to pick up. This activates the AR1 Requested signal to begin to calculate the Shot1 Start Time. This activates the Shot 1 Running signal even though the auto-recloser function is not yet running.
2. The Shot1 Start Time (500 ms) has elapsed and the auto-recloser function starts running (AR Running). This sends an "Open" command to the breaker.
3. The circuit breaker is opened and the I> stage's START signal is released and simultaneously REQ1 trip signal for auto-reclosing is released. The auto-recloser function starts calculating the Shot1 Dead Time to close the breaker.
4. The Shot1 Dead Time (200 ms) is exceeded and the auto-recloser function sends a "Close" request to the object breaker: the conditions are met and the breaker's "Close" command is sent to the breaker's close coil.
5. The circuit breaker is closed and since fault was not cleared, a new pick-up of I> is detected. A "Close" command is dropped after the breaker's "Closed" indication is received and the auto-recloser function starts calculating the Shot1 Reclaim Time simultaneously with the Shot1 Arcing Time.
6. The Shot1 Arcing Time (200 ms) is exceeded which means that the fault is not cleared and the function sends an "Open" command to the breaker. The function deactivates the Shot1 Running signal and instead activates the Shot2 Running signal.
7. The circuit breaker opens and the Shot2 Dead Time calculation begins.
8. The Shot2 Dead Time (120 s) is exceeded and the auto-recloser function sends a "Close" command to the breaker.
9. The circuit breaker is closed towards the fault since it was not cleared by Shot 2. The I> stage picks up and starts calculating the Shot2 Arcing Time for the Final Trip. The "Close" command is dropped after the the breaker's "Closed" indication is received. The auto-recloser function also starts calculating the Shot2 Reclaim Time.
10. The Shot2 Arcing Time (200 ms) is exceeded and and the REQ1 request is given to the function. However, as the function is in the process of calculating the Shot2 Reclaim Time when it receives this request, the function tries to move on to the next available shot. Alas, this scheme does not have any more available shots and so the function begins the Final Trip state and drops the AR Running, Shot2 Running and AR1 Requested signals. The function enters the AR Lock-out state to prevent any further requests for reclosing.

- The circuit breaker is opened and the I> function's START signal is released, and simultaneously the REQ1 trip signal for auto-reclosing is released. The function is now in a steady lock-out state and waits for the user to manually reset and re-initialize the function by closing the breaker.

Auto-recloser sequence from Start with two shots (high-speed fails, time-delayed succeeds).

This auto-recloser scheme has the same starters and shots as the previous example. The setting and signals are also the same. However, in this example the fault persists the high-speed shot but is cleared by the time-delayed shot.

Figure. 5.4.4 - 186. Settings for I> with two shots.

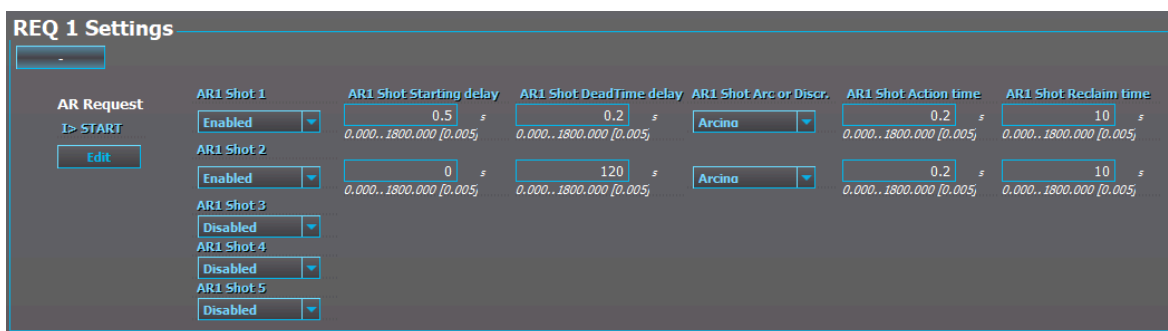

This type of sequence (i.e. two shots required to clear the fault) represents 10...15 % of all faults that occur in MV overhead line networks.

Figure. 5.4.4 - 187. Signal status graph of the semi-permanent overcurrent auto-recloser cycle.

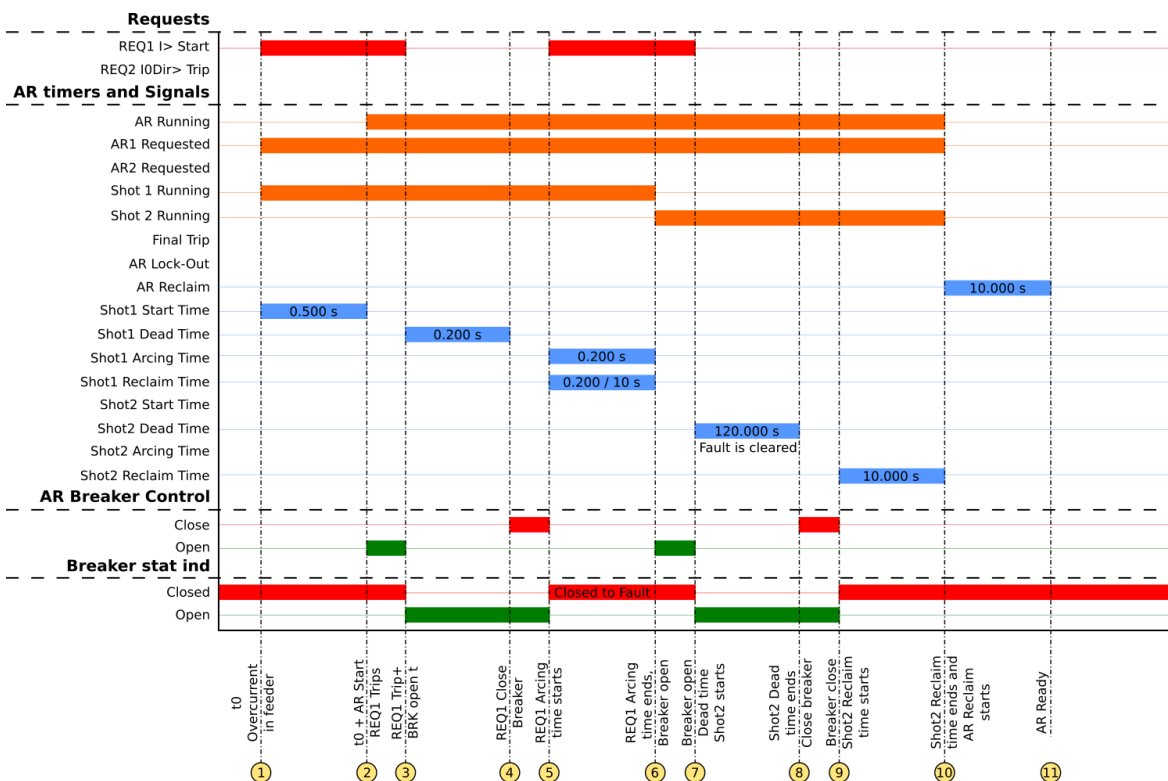

- An overcurrent is found in the protected line causing the I> protection to pick up. This activates the AR1 Requested signal to begin to calculate the Shot1 Start Time. This activates the Shot 1 Running signal even though the auto-recloser function is not yet running.

2. The **Shot1 Start Time** (500 ms) for has elapsed and the auto-recloser function starts running (**AR Running**). This sends an "Open" command to the breaker.
3. The circuit breaker is opened and the I> stage's START signal is released and simultaneously REQ1 trip signal for auto-reclosing is released. The auto-recloser function starts calculating the **Shot1 Dead Time** to close the breaker.
4. The **Shot1 Dead Time** (200 ms) is exceeded and the auto-recloser function sends a "Close" request to the object breaker: the conditions are met and the breaker's "Close" command is sent to the breaker's close coil.
5. The circuit breaker is closed and since fault was not cleared, a new pick-up of I> is detected. A "Close" command is dropped after the breaker's "Closed" indication is received and the auto-recloser function starts calculating the **Shot1 Reclaim Time** simultaneously with the **Shot1 Arcing Time**.
6. The **Shot1 Arcing Time** (200 ms) is exceeded which means that the fault is not cleared and the function sends an "Open" command to the breaker. The function deactivates the **Shot1 Running** signal and instead activates the **Shot2 Running** signal.
7. The circuit breaker opens and the **Shot2 Dead Time** calculation begins.
8. The fault is cleared during the **Shot2 Dead Time** (120 s). When that time is exceeded, the auto-recloser function sends a "Close" command to the breaker.
9. The circuit breaker is closed and since the fault was cleared by Shot 2, no more pick-ups are detected. The "Close" command is dropped after the the breaker's "Closed" indication is received. The auto-recloser function also starts calculating the **Shot2 Reclaim Time**.
10. The **Shot2 Reclaim Time** (10 s) is exceeded, and so the **AR Running**, **Shot2 Running** and **AR1 Requested** signals are terminated and the **AR Reclaim** calculation begins. The difference between auto-reclosing and shot-specific reclaim times is that the function jumps to the next available shot should the fault returns. If a fault returns after a successful cycle and the function's AR Reclaim signal is active, the function jumps directly to the Final Trip state and then enters the lock-out state. The user can control this behavior through the function settings. Both reclaim times can be set to 0 s when they are not needed, and the function skips all timers that are set to zero. The user can also set is so that AR Reclaim is not used at all after a successful recloser cycle.
11. The **AR Reclaim** time is exceeded and the function is set to "Ready" to wait for the next request.

Auto-recloser sequence from Start with two shots (high-speed succeeds).

This auto-recloser scheme has the same starters and shots as the two previous examples. The setting and signals are also the same. However, in this example the fault is cleared by the high-speed shot.

Figure. 5.4.4 - 188. Settings for I> with two shots.

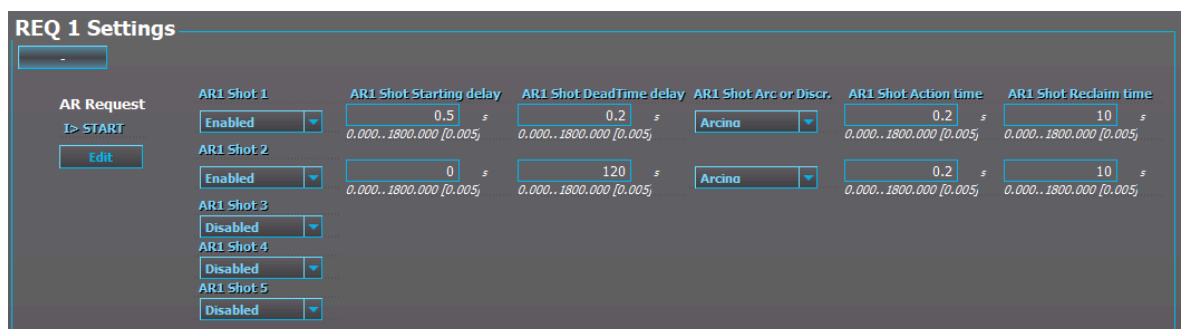

This type of sequence (i.e. the first shot clears the fault) represents 75...85 % of all faults that occur in MV overhead line networks.

Figure. 5.4.4 - 189. Signal status graph of the transient overcurrent auto-recloser cycle.

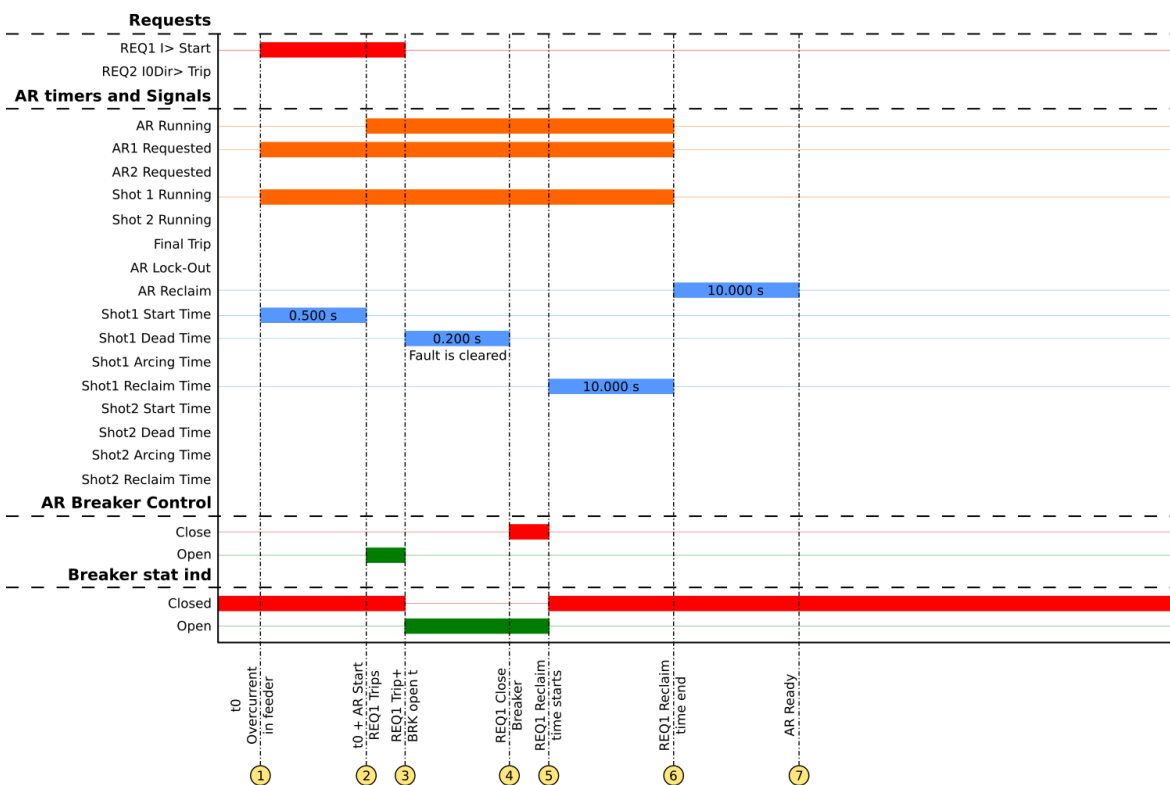

1. An overcurrent is found in the protected line causing the I> protection to pick up. This activates the **AR1 Requested** signal to begin to calculate the **Shot1 Start Time**. This activates the **Shot 1 Running** signal even though the auto-recloser function is not yet running.
2. The **Shot1 Start Time** (500 ms) has elapsed and the auto-recloser function starts running (**AR Running**). This sends an "Open" command to the breaker.
3. The circuit breaker is opened and the I> stage's START signal is released and simultaneously REQ1 trip signal for auto-reclosing is released. The auto-recloser function starts calculating the **Shot1 Dead Time** to close the breaker.
4. The fault is cleared during the **Shot1 Dead Time** (200 ms). When this time is exceeded, the auto-recloser function sends a "Close" request to the object breaker: the conditions are met and the breaker's "Close" command is sent to the breaker's close coil.
5. The circuit breaker is closed and since the fault was cleared, no pick-ups are detected. A "Close" command is dropped after the breaker's "Closed" indication is received and the auto-recloser function starts calculating the **Shot1 Reclaim Time**.
6. The **Shot1 Reclaim Time** (10 s) is exceeded, and so the **AR Running**, **AR1 Requested** and **Shot 1 Running** signals are terminated and the **AR Reclaim** calculation begins. The difference between auto-reclosing and shot-specific reclaim times is that the function jumps to the next available shot should the fault return. If a fault returns after a successful cycle and the function's AR Reclaim signal is active, the function jumps directly to the Final Trip state and then enters the lock-out state. The user can control this behavior through the function settings. Both reclaim times can be set to 0 s when they are not needed, and the function skips all timers that are set to zero. The user can also set it so that AR Reclaim is not used at all after a successful recloser cycle.
7. The AR Reclaim time is exceeded and the function is set to "Ready" to wait for the next request.

Auto-recloser in meshed or ring networks

A typical auto-recloser scheme cannot be applied directly to an overhead line network that has a distributed generation (DG) component; this situation will become more common as renewable power sources become more widespread. Instead, this requires a two-end auto-recloser scheme where the two relays at both ends of the line function in a master–follower operation. The DG power plant must be disconnected from the rest of the network before the breaker's "Close" command is applied; otherwise the plant keeps the fault on during the auto-recloser's dead time and thus fails the reclosing. Additionally, when the main grid is disconnected from the DG power plant, the closing of the breaker is likely to cause phase shifting issues during the dead time.

Figure. 5.4.4 - 190. Auto-reclosing with distributed generation in the line.

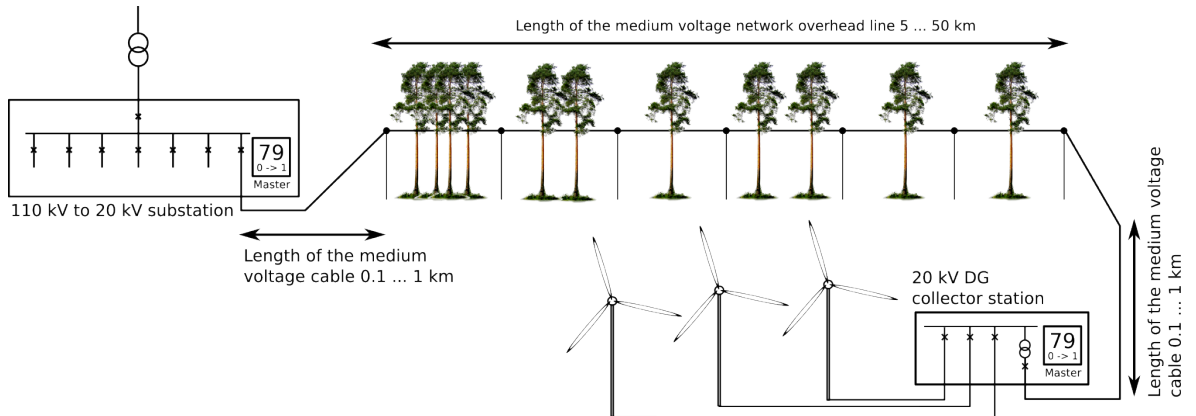

This operation requires a link between the 110/20 kV substation's master relay and the 20 kV collector substation's follower relay. When the auto-recloser function is initiated, the collector station's breaker is opened and remains open until the auto-recloser sequence is over as there is no reason to close the breaker until the auto-recloser cycle has successfully cleared the fault. When the sequence is successful, the collector substation's breaker is given permission to close after the reclaim time; the breaker should be closed with the Synchrocheck function.

Once the collector substation is disconnected, the previously described basic principles of auto-reclosing apply. This method applies to all meshed or ring networks where the same line is fed power from multiple directions. This problem does not exist for typical consumer (radial) networks.

Arcing time and discrimination time

Generally, after the dead time has elapsed and the breaker is closed by the auto-recloser, this happens: the reclaim time starts calculating and if the process is interrupted by a new reclosing request, the function continues to the next state (the next available shot, or the Final Trip if no more shots are available). However, the user can use the "Shot action time" setting to control this behavior. The two settings are mutually exclusive: when "Arcing" is selected for a shot, "Discrimination" cannot be selected for the same shot.

The "Arcing" setting is used to control the auto-recloser when the START signal of a stage makes the requests. If the request (e.g. $I > \text{START}$) activates during the reclaim time, an arcing time calculation begins. If the fault persists, the function continues to the next state. If an arcing time calculation begins but stops before the set time has passed, the reclaim calculation continues normally. When that time has elapsed, the auto-recloser function returns either to the general reclaim time or to the Ready mode; the shot is considered successful. The arcing time counter does not reset when the reclaim calculation continues: every time it activates, it continues from where it left off. This means that the time set to the "ARx Shot action time" parameter is a cumulative counter of time allowed before deciding whether a shot is failed or successful.

The auto-recloser is sometimes used in time-coordinated, IDMT-protected networks that have old mechanical relays with current-dependent release times. In these cases the operation of the protection selectivity must be guaranteed by allowing all relay timing devices to completely reset during dead time to maintain the correct time discrimination after reclosing to the fault. Some mechanical IDMT relays can require up to ten seconds (10 s) to reset. When short dead times are required, the relays should reset almost immediately for the current-dependent time grading to operate as expected, and set the discrimination time (instead of the arcing time) to start simultaneously with the reclaim time. If new reclosing requests are made during this discrimination time, the function halts and lets the protection devices operate based on their own settings, and does not interfere with the protection functions' or the breaker's operation. However, this means that the auto-recloser has to be manually reset and the breaker manually closed before further reclosing requests can be made.

Auto-recloser I/O

The main outputs of the auto-recloser function are the control signals OBJECT OPEN and OBJECT CLOSE. The function also reports the recloser status information which is used in the logics, LED indications, and applied operations.

The inputs of the function are the following:

- binary recloser request signals
- blockings
- controlling signals
- the controlled object's monitoring and status signals.

The function generates general time-stamped ON/OFF events to the common event buffer from each of the two (2) output signal as well as from several operational event signals. The time stamp resolution is 1 ms. The function also has a resettable cumulative counter for each of the applied reclosing events and requests.

The auto-recloser function can be divided into the starter, shot selector state machine, sorter and shot blocks which operate dynamically during the recloser sequences according to the given settings and input signal monitoring. The behavior of the function can be changed even during sequences that are based on programmed reclosing schemes and on active requests.

The following figure presents a simplified function block diagram of the auto-recloser function.

Figure. 5.4.4 - 191. Simplified function block diagram of the auto-recloser function.

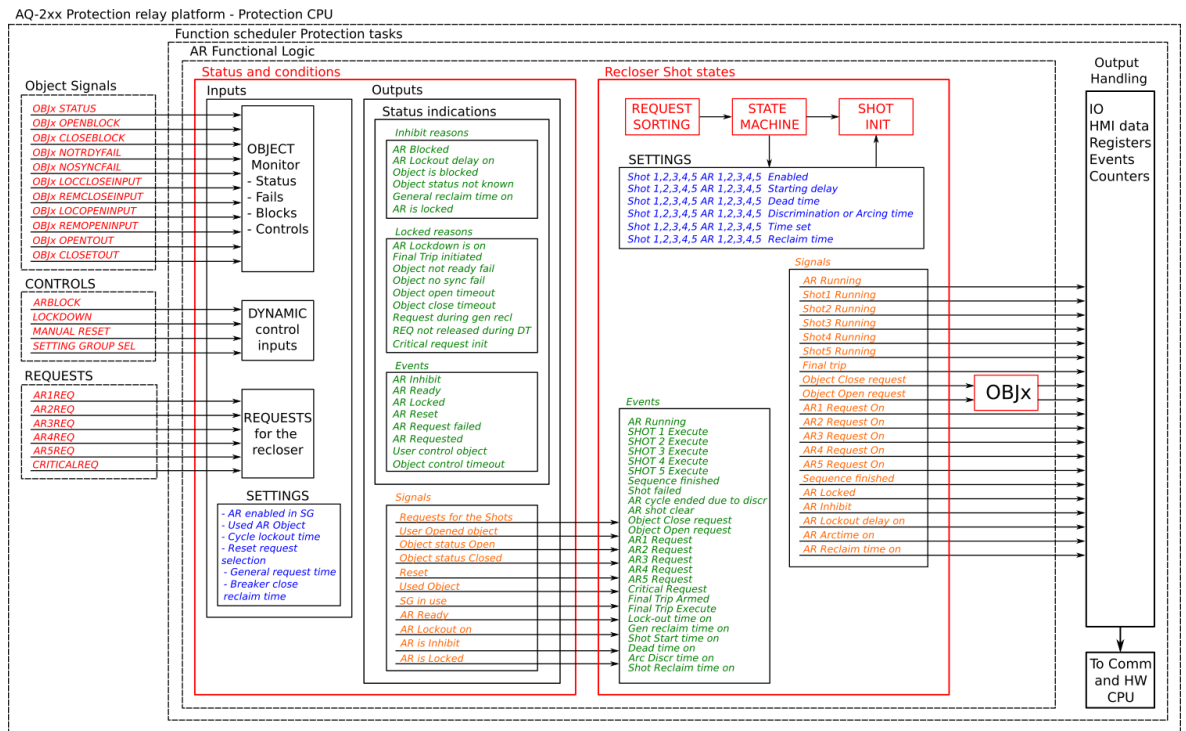

As the diagram above shows, the auto-recloser function is tied to and dependent on the block status information and configuration of the object control and monitoring function. This is why the controlled object must be configured before the auto-recloser function can be used. In AQ-2xx protection systems the object control block supervises all breaker operations: this means that breaker-related functionalities (e.g. synchrocheck, breaker status monitoring) are not noted separately by the auto-recloser function. If any of these fail during the circuit breaker opening or closing, the object control function reports the event to the auto-recloser function which then takes the corresponding action.

In addition to the previously mentioned cases, the manual control of the breaker (whether open or close during the auto-recloser sequence) also always causes a reset of the auto-recloser. For example, if a breaker is closed manually during dead time towards a fault, the auto-recloser function enters the general reclaim mode and causes a lock-out of the function.

The auto-recloser function gives exhaustive information about its operations and statuses through online indications, events, registered data as well as output signals which can be configured to any output or logical input in the device. If the network configuration is altered during an auto-reclosing sequence, the operation of the auto-recloser function can also be modified accordingly by switching to a setting group that matches the changed network situation.

Input signals of the auto-recloser function

The required auto-recloser scheme determines how many and which setting parameters are needed. All status changes in the input signals (inc. the requests) always cause recorded events, also in the object's registers and the object's continuous status indications. Events can be enabled or disabled according to the application requirements.

Table. 5.4.4 - 188. AR input signals.

Signal	Range	Description
AR On/Off	Any binary signal in the device	Enables or disables the auto-recloser function with any binary signal selected by the user. The parameter "Use AR On/Off signals" defines whether this input signal is in use or not.

Signal	Range	Description
AR Manual reset	Any binary signal in the device	Allows for the manual resetting of the recloser if locked (e.g. due to Final Trip).
AR Locking	Any binary signal in the device	Locks the auto-recloser so that it requires a manual reset before its operation can be set to "Ready".
AR Critical request	Any binary signal in the device	Defines the critical request for the function. If this signal is activated, the auto-recloser goes directly to the locked state the moment the request is received.

Table. 5.4.4 - 189. Request signals.

Signal	Range	Description
AR Request 1 (REQ1)	Any binary signal in the device	The request with the highest priority, it overrides all auto-reclosing requests with lower priorities. When this request signal is activated and other conditions for reclosing are met, a shot is applied.
AR Request 2 (REQ2)	Any binary signal in the device	The request with the second highest priority, it overrides all auto-reclosing requests with lower priorities. When this request signal is activated and other conditions for reclosing are met, a shot is applied.
AR Request 3 (REQ3)	Any binary signal in the device	The request with the third highest priority, it overrides all auto-reclosing requests with lower priorities. When this request signal is activated and other conditions for reclosing are met, a shot is applied.
AR Request 4 (REQ4)	Any binary signal in the device	The request with the fourth highest (and second lowest) priority, it overrides all auto-reclosing requests with lower priorities. When this request signal is activated and other conditions for reclosing are met, a shot is applied.
AR Request 5 (REQ5)	Any binary signal in the device	The request with the lowest priority, it is overridden by all other auto-reclosing requests. When this request signal is activated and other conditions for reclosing are met, a shot is applied.

Output signals of the auto-recloser function

The outputs of the function are only indication signals (*Control* → *Control functions* → *Auto-recloser* → *I/O*). The breaker's "Open" and "Close" commands are controlled by the object control and monitoring function.

Table. 5.4.4 - 190. AR output signals.

Signal	Description
AR ON AR OFF	The signal "AR ON" is displayed when the auto-recloser function is enabled. The signal "AR OFF" is displayed if the "Use AR On/Off signals" is set to "Yes" and the input of the AR On/Off is inactive.
AR In progress	The signal "AR In progress" is activated and displayed when the function has opened the breaker and is calculating the time towards closing it.
AR1 Request ON	The signal "AR1 Request ON" is activated and displayed when the function is executing a shot requested by REQ1. This signal can be connected to any relay I/O as well as to communication protocols.
AR2 Request ON	The signal "AR2 Request ON" is activated and displayed when the function is executing a shot requested by REQ2. This signal can be connected to any relay I/O as well as into communication protocols.
AR3 Request ON	The signal "AR3 Request ON" is activated and displayed when the function is executing a shot requested by REQ3. This signal can be connected to any relay I/O as well as to communication protocols.
AR4 Request ON	The signal "AR4 Request ON" is activated and displayed when the function is executing a shot requested by REQ4. This signal can be connected to any relay I/O as well as to communication protocols.

Signal	Description
AR5 Request ON	The signal "AR5 Request ON" is activated and displayed when the function is executing a shot requested by REQ5. This signal can be connected to any relay I/O as well as to communication protocols.
AR Running	The signal "AR Running" is activated and displayed when the function is in Running mode. This signal can be connected to any relay I/O as well as to communication protocols.
AR Shot 1 Running	The signal "AR Shot 1 Running" is activated and displayed when the function is executing Shot 1. This signal can be connected to any relay I/O as well as to communication protocols.
AR Shot 2 Running	The signal "AR Shot 2 Running" is activated and displayed when the function is executing Shot 2. This signal can be connected to any relay I/O as well as to communication protocols.
AR Shot 3 Running	The signal "AR Shot 3 Running" is activated and displayed when the function is executing Shot 3. This signal can be connected to any relay I/O as well as to communication protocols.
AR Shot 4 Running	The signal "AR Shot 4 Running" is activated and displayed when the function is executing Shot 4. This signal can be connected to any relay I/O as well as to communication protocols.
AR Shot 5 Running	The signal "AR Shot 5 Running" is activated and displayed when the function is executing Shot 5. This signal can be connected to any relay I/O as well as to communication protocols.
AR Sequence finished	The signal "AR Sequence finished" is activated and displayed when the function has closed the breaker after the last shot and is waiting for the Final Trip to occur or for the reclaim time to run out.
AR Final Trip	The signal "AR Final Trip" is activated and displayed when the function has executed the Final Trip command. This signal can be connected to any relay I/O as well as to communication protocols.
AR Dead time ON	The signal "AR Dead time ON" is activated and displayed when the function has opened the breaker and is calculating the time towards closing it.
AR Arcing time ON	The signal "AR Arcing time ON" is activated and displayed when the function is calculating the arcing time. This signal can be connected to any relay I/O as well as to communication protocols.
AR Reclaim time ON	The signal "AR Reclaim time ON" is activated and displayed when the function is calculating the reclaim time. This signal can be connected to any relay I/O as well as to communication protocols.
AR Ready	The signal "AR Ready" is activated and displayed when the function is ready to execute the auto-reclosing sequence if a fault is detected.
AR Lockout after successful sequence	The signal "AR Reclaim time ON" is activated and displayed when the auto-recloser sequence has been successful but a new fault was detected before the lock-out time was depleted. No new sequence will be started while this signal is active, instead the function goes into the locked mode.
AR Operation inhibit	The signal "AR Operation inhibit" is activated and displayed when the function is in Inhibit mode. This signal can be connected to any relay I/O as well as into communication protocols.
AR Locked	The signal "AR Locked" is activated and displayed when the function is in Locked mode. This signal can be connected to any relay I/O as well as into communication protocols.

Setting parameters

The auto-recloser function has settings that the user can freely configure. The setting cover all areas of the function so that the user can control the operational details of the function as needed. The function's operation can be static or dynamic depending on the setting group that is in use. The function has both general settings and active settings concerning requests and shots. The general settings control the desired object selection as well as the general behavior of the function in different operating schemes.

Table. 5.4.4 - 191. AR Status and basic settings.

Setting	Range	Step	Default	Description
AR Mode	0: Disabled 1: Enabled	-	0: Disabled	Enables and disables the auto-recloser function in the configuration.

Setting	Range	Step	Default	Description
Use AR On/Off signals	0: Yes 1: No	-	1: No	Selects whether or not the AR ON and AR OFF signals are used. If set to "No" the auto-recloser is always in use. If set to "Yes" binary signal set to "AR ON/OFF" has to be active for the auto-recloser to be enabled.
AR Status	0: AR is inhibit 1: AR is ready 2: AR is locked 3: AR is running 4: AR is not running 5: Lock out delay is running 6: Reclaim time counting 7: Start time counting 8: Dead time counting 9: Arcing or discr. time counting 10: Reclaim time counting 11: AR1 Requested 12: AR2 Requested 13: AR3 Requested 14: AR4 Requested 15: AR5 Requested 16: Executing Shot1 17: Executing Shot2 18: Executing Shot3 19: Executing Shot4 20: Executing Shot5 21: Shot Clear	-	-	When clicked open, displays the status of the function.
Timer active	0: - 1: AR Lockout 2: AR Reset Reclaim 3: AR Start Delay 4: AR Dead Time 5: AR Discrimination 6: AR Shot Reclaim	-	0: -	When the function is counting down towards any action, this parameter displays what is the next expected action when the "AR Timer value" reaches zero.
AR Timer value	0...1800.00s	0.005s	0s	When the function is counting down towards any action, this parameter displays how much time is left until the action is executed. The "Timer active" setting displays what is the action when this timer reaches zero.

Table. 5.4.4 - 192. AR General settings.

Setting	Range	Step	Default	SG	Description
Object for AR	0: Object 1 1: Object 2 2: Object 3 3: Object 4 4: Object 5	-	0: Object 1	8	Defines the monitored and/or controlled object, and the monitoring and/or controlling signals issued. This selection can be changed via the device's setting group selection in real time.
AR Enabled in SG	0: Disabled 1: Enabled	-	0: Disabled	8	Enables and disables the auto-recloser in the current setting group. Can be enabled and disabled in each setting group independently. This selection can be changed via the device's setting group selection in real time.
Require manual resetting	0: Required 1: Obj Close CMD resets	-	0: Required	8	Defines the auto-recloser resetting after locking (Final trip, error condition). Resetting can be set to be only done manually with a user defined signal, or it can be reset by a general breaker "Close" command (from any source). This selection can be changed via the device's setting group selection in real time.
Successful reclose start general reclaim	0: Only shot reclaim 1: Shot reclaim and general reclaim	-	0: Only shot reclaim	8	Defines whether the auto-recloser runs after a successful reclose (inc. shot reclaim time), or whether it enters the locked state after a request for auto-reclosing is applied. If "Shot reclaim and general reclaim" is selected, this selection defines the minimum time allowed between auto-reclosing cycles without changing the shot-specific reclaim times. This selection can be changed via the device's setting group selection in real time.
Lock-out time ("Lockout after successful AR")	0.000...1800.000s	0.005s	0.000s	8	Defines the lock-out time after a successful reclosing. When set to 0.00 s, the recloser goes directly into the "Ready" state after a successful reclosing. If this time is running while a new reclosing request is applied, the auto-recloser opens the breaker and enters the locked state to prevent further reclosing attempts. This selection can be changed via the device's setting group selection in real time.
Object close reclaim time	0.000...1800.000s	0.005s	10.000s	8	Defines the "Close" reclaim time of the object. This time starts when the object is manually closed or when the general reclaim time is selected after a successful auto-reclosing. If an auto-reclosing request is applied during this time, the auto-recloser enters the locked state to prevent further reclosing attempts. This selection can be changed via the device's setting group selection in real time.

Table. 5.4.4 - 193. Auto-recloser shot settings.

Setting	Range	Step	Default	SG	Description
ARx Shot x	0: Disabled 1: Enabled	-	0: Disabled	8	Enables/disables Shot x for request ARx. If "Disabled", the ARx request skips Shot 1 and moves on to the next enabled shot. If "Enabled", the ARx request executes a shot according to Shot 1 settings. This selection can be changed via the device's setting group selection in real time.
ARx Shot starting delay	0.000...1800.000s	0.005s	0.000s	8	Defines the starting delay of the shot, i.e. the minimum time an ARx request has to be active before opening the breaker and entering the dead time delay counting. This setting is used only when the ARx request comes from the function's START signal. If the function's TRIP request starting delay is not 0.000 s, the auto-recloser is prevented from starting. Whenever the shot is not the first one, this setting should be set to 0.000 s. This selection can be changed via the setting group selection in real time.

Setting	Range	Step	Default	SG	Description
ARx Shot dead time delay	0.000...1800.000s	0.005s	0.000s	8	Defines the dead time delay of the shot, i.e. the breaker's "Open" time before the auto-recloser closes the breaker. The time calculation starts from the breaker's "Open" signal. This selection can be changed via the device's setting group selection in real time.
ARx Shot Arc or Discr.	0: Arcing 1: Discrimination	-	0: Arcing	8	Determines what happens when a fault persists after a dead time when the breaker is closed. Can be chosen between arcing and discrimination behavior; the selection depends on the application. When "Arcing" time is selected, the auto-recloser keeps the breaker closed until Action time is spent (also with Discrimination time). If a new request received during the Action time calculation, the auto-recloser locks out during the reclaim time. This selection can be changed via the device's setting group selection in real time.
ARx Shot action time	0.000...1800.000s	0.005s	0.000s	8	Defines the action time for the shot after dead time and after the breaker is closed, i.e. the maximum arcing time or discrimination time when the reclaim time is running. When set to 0.000 s, the "Arcing" or "Discrimination" time is disabled in the auto-recloser scheme. This setting can be changed via the device's setting group selection in real time.
ARx Shot reclaim time	0.000...1800.000s	0.0005s	0.000s	0.000s	After the dead time has elapsed and the breaker is closed by the auto-recloser, the reclaim time starts calculating. If the process is interrupted by a new reclosing request, the function continues to the next shot.

Figure. 5.4.4 - 192. Auto-recloser shot setting parameters.

The image displays a configuration interface for auto-recloser shot settings, organized into five distinct sections: REQ 1 Settings, REQ 2 Settings, REQ 3 Settings, REQ 4 Settings, and REQ 5 Settings. Each section provides a detailed view of parameters for a specific request (REQ).

REQ 1 Settings: AR Request is 'I> START'. AR1 Shot 1 is 'Enabled' with a Starting delay of 0.5s, Dead Time delay of 0.2s, Arc or Discr. set to 'Arcina', Action time of 0.2s, and Reclaim time of 10s. AR1 Shot 2 is 'Enabled' with a Starting delay of 0s, Dead Time delay of 120s, Arc or Discr. set to 'Arcina', Action time of 0.2s, and Reclaim time of 10s. AR1 Shots 3, 4, and 5 are 'Disabled'.

REQ 2 Settings: AR Request is 'I> TRIP'. AR2 Shot 1 is 'Enabled' with a Starting delay of 0s, Dead Time delay of 0.2s, Arc or Discr. set to 'Arcina', Action time of 0s, and Reclaim time of 10s. AR2 Shot 2 is 'Enabled' with a Starting delay of 0s, Dead Time delay of 60s, Arc or Discr. set to 'Arcina', Action time of 0s, and Reclaim time of 10s. AR2 Shots 3, 4, and 5 are 'Disabled'.

REQ 3 Settings: AR Request is 'I0Int> TRIP'. AR3 Shot 1 is 'Disabled'. AR3 Shot 2 is 'Enabled' with a Starting delay of 0s, Dead Time delay of 60s, Arc or Discr. set to 'Arcina', Action time of 0s, and Reclaim time of 30s. AR3 Shots 3, 4, and 5 are 'Disabled'.

REQ 4 Settings: All AR Shots 1 through 5 are 'Disabled'.

REQ 5 Settings: All AR Shots 1 through 5 are 'Disabled'.

The auto-recloser function's shot settings are grouped into corresponding rows to make the setting of each shot straightforward. From the settings the user can see how the reclosing cycle is executed by each request, which functions initiate requests, and which shots and requests are in use.

The setting example in the image above presents a two-shot auto-recloser. One can see that the REQ1 is started by I> START signal. The starting delay is 500 ms, followed by a 200 ms dead time; after a 200 ms "Arcing" time and a 10 s reclaim time Shot 1 is executed. If Shot 1 fails, there is a 120 s dead time, a 200 ms "Arcing" time and a 10 s reclaim time before Shot 2 is executed. If Shot 2 fails, the auto-recloser initiates the Final Trip. In REQ2, the settings are otherwise the same, except I> TRIP and I0dir> TRIP are used to activate the request, Shot 1 does not have a starting delay, the dead time delay for Shot 2 is different and the action time for both shots is zero. REQ3 has just one shot with a 60 second dead time and a 30 ms shot reclaim. If REQ4 or REQ5 are activated, no shots are executed as none are set.

Inhibit and Locked states of the auto-recloser function

The auto-recloser function can have several reasons to go into "Lock-out" and "Inhibit" states where reclosing cannot be allowed for some reason. When the function enters the "Not ready" state, it gives an indication of the reason why it cannot be in the "Ready" state in order to quickly rectify whatever is causing the problem of the functions operation. The reason is indicated in the auto-recloser function's *Registers* menu.

The Inhibit reasons for the auto-recloser are the following:

- AR is blocked (from Blocking input)
- AR is not enabled (signal connected to "AR ON/OFF" is not active)
- AR is calculating the lock-out delay
- The object "Open" or "Close" command is blocked
- The object status is not known ("intermediate" or "bad" status)
- General reclaim time is running
- AR is locked

When the auto-recloser function is in the "Inhibit" state, it returns to the "Ready" state when the reason for the inhibition is removed.

The Lock-out reasons for the auto-recloser are the following:

- The "AR Locked" signal is initiated (from "AR Locking" input)
- The Final Trip signal is given
- The "object not ready" failed within a given time (from Object)
- The "object no sync" failed within a given time (from Object)
- The object's "Open" timeout (from Object)
- The object's "Close" timeout (from Object)
- AR request initiated during General reclaim time
- AR request was not released during Dead Time
- Critical request initiated in any state of the auto-reclosing cycle

When the auto-recloser function is in the "Locked" state, it can be recovered only through by reset input, or by manually resetting the breaker. This depends on what the "Require manual resetting" parameter's setting is.

Displaying auto-reclosing timers in MIMIC view

The user can enable timers to be displayed in the MIMIC view. Enable the AR timer value at *Tools* → *Events and logs* → *Set alarm events* (see the image below). The timer displays the reclaim time and the dead time delay.

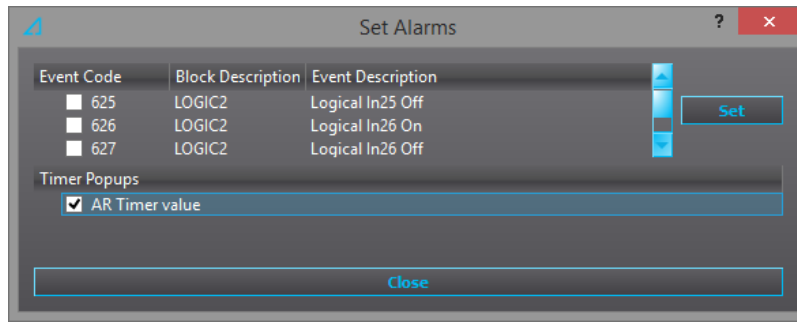

Events and registers

The auto-recloser function (abbreviated "AR" in event block names) generates events and registers from the status changes in the monitored signals as well as the control command fails and operations. The user can select which event messages are stored in the main event buffer: ON, OFF, or both.

The events triggered by the function are recorded with a time stamp and with process data values.

Table. 5.4.4 - 194. Event codes.

Event number	Event channel	Event block name	Event code	Description
4032	63	AR1	0	AR Ready ON
4033	63	AR1	1	AR Ready OFF
4034	63	AR1	2	AR Locked reset
4035	63	AR1	3	AR Reclosing request rejected ON
4036	63	AR1	4	AR Reclosing request rejected OFF
4037	63	AR1	5	AR Reclosing request ON
4038	63	AR1	6	AR Reclosing request OFF
4039	63	AR1	7	User-operated Object AR halted and reset
4040	63	AR1	8	Object failure, AR locked
4041	63	AR1	9	Shot failed
4042	63	AR1	10	AR cycle ends due to a discrimination request
4043	63	AR1	11	AR Shot clear
4044	63	AR1	12	Object "Close" request
4045	63	AR1	13	Object "Open" request
4046	63	AR1	14	Inhibit condition ON
4047	63	AR1	15	Inhibit condition OFF
4048	63	AR1	16	Locking condition ON
4049	63	AR1	17	Locking condition OFF
4050	63	AR1	18	Reserved
4051	63	AR1	19	AR1 Request ON
4052	63	AR1	20	AR1 Request OFF
4053	63	AR1	21	AR2 Request ON
4054	63	AR1	22	AR2 Request OFF
4055	63	AR1	23	AR3 Request ON

Event number	Event channel	Event block name	Event code	Description
4056	63	AR1	24	AR3 Request OFF
4057	63	AR1	25	AR4 Request ON
4058	63	AR1	26	AR4 Request OFF
4059	63	AR1	27	AR5 Request ON
4060	63	AR1	28	AR5 Request OFF
4061	63	AR1	29	Critical request ON
4062	63	AR1	30	Critical request OFF
4063	63	AR1	31	AR Running ON
4064	63	AR1	32	AR Running OFF
4065	63	AR1	33	Shot 1 Execute ON
4066	63	AR1	34	Shot 1 Execute OFF
4067	63	AR1	35	Shot 2 Execute ON
4068	63	AR1	36	Shot 2 Execute OFF
4069	63	AR1	37	Shot 3 Execute ON
4070	63	AR1	38	Shot 3 Execute OFF
4071	63	AR1	39	Shot 4 Execute ON
4072	63	AR1	40	Shot 4 Execute OFF
4073	63	AR1	41	Shot 5 Execute ON
4074	63	AR1	42	Shot 5 Execute OFF
4075	63	AR1	43	Sequeunce finished, the Final trip armed
4076	63	AR1	44	Final trip executed
4077	63	AR1	45	Lock-out time ON
4078	63	AR1	46	Lock-out time OFF
4079	63	AR1	47	General reclaim time ON
4080	63	AR1	48	General reclaim time OFF
4081	63	AR1	49	Shot start time ON
4082	63	AR1	50	Shot start time OFF
4083	63	AR1	51	Dead time ON
4084	63	AR1	52	Dead time OFF
4085	63	AR1	53	Arc Discr time ON
4086	63	AR1	54	Arc Discr time OFF
4087	63	AR1	55	Shot reclaim time ON
4088	63	AR1	56	Shot reclaim time OFF
4089	63	AR1	57	Sequence finished OFF
4090	63	AR1	58	Final trip executed OFF
4091	63	AR1	59	Object "Close" request OFF
4092	63	AR1	60	AR ON
4093	63	AR1	61	AR OFF

Event number	Event channel	Event block name	Event code	Description
4094	63	AR1	62	AR Running (DT) ON
4095	63	AR1	63	AR Running (DT) OFF

The function registers its operation into the last twelve (12) time-stamped registers. The register of the function records the ON event process data from statuses, commands, etc.

The table below presents the structure of the auto-recloser function's register content.

Table. 5.4.4 - 195. Register content.

Date and time	Event code	Setting group in use	Inhibit condition active	Inhibit condition release	Locked condition active	Locked condition release	AR status	Active timer	Active time
dd.mm.yyyy hh:mm:ss.mss	4032...4095 Descr.	1...8	Inhibit reason ON	Inhibit reason OFF	Locked reason ON	Locked reason OFF	The status code of the auto-recloser function	Timer ON	The value of the timer

The auto-recloser function's registers are treated differently than the registers of other functions.

Below is an exhaustive example of how the registers work based on a partial auto-recloser sequence. First is how the register list is displayed:

Date and time	Registers
dd.mm.yyyy hh:mm:ss.mss	AR Status: AR is ready, AR is not running, AR2 Requested, Executing Shot 1 AR Timers: No timers running 0.000 s
dd.mm.yyyy hh:mm:ss.mss	AR Status: AR is ready, AR is not running, Start time counting, AR2 Requested, Executing Shot 1 AR Timers: Start Delay 0.000 s
dd.mm.yyyy hh:mm:ss.mss	AR Status: AR is ready, AR is running, Start time counting, AR2 Requested, Executing Shot 1 AR Timers: Start Delay 0.000 s
dd.mm.yyyy hh:mm:ss.mss	AR Status: AR is ready, AR is running, Dead time counting, AR2 Requested, Executing Shot 1 AR Timers: Dead Time 0.195 s
dd.mm.yyyy hh:mm:ss.mss	AR Status: AR is ready, AR is running, Dead time counting, Reclaim time counting, AR2 Requested, Executing Shot1 AR Timers: Dead Time -0.270 s

The corresponding event list is as presented below (inc. object and protection events):

dd.mm.yyyy hh:mm:ss.mss	1664	NEF1 Start ON
dd.mm.yyyy hh:mm:ss.mss	1666	NEF1 Trip ON
dd.mm.yyyy hh:mm:ss.mss	4065	AR1 Shot 1 Execute ON
dd.mm.yyyy hh:mm:ss.mss	4037	AR1 AR Reclosing request ON
dd.mm.yyyy hh:mm:ss.mss	4053	AR1 AR2 Request ON
dd.mm.yyyy hh:mm:ss.mss	4081	AR1 Shot start time ON
dd.mm.yyyy hh:mm:ss.mss	4045	AR1 Object "Open" request
dd.mm.yyyy hh:mm:ss.mss	2944	OBJ1 Object Intermediate
dd.mm.yyyy hh:mm:ss.mss	2952	OBJ1 Open request ON
dd.mm.yyyy hh:mm:ss.mss	2955	OBJ1 Open command ON
dd.mm.yyyy hh:mm:ss.mss	4063	AR1 AR Running ON

dd.mm.yyyy hh:mm:ss.mss	2954	OBJ1 Open request OFF
dd.mm.yyyy hh:mm:ss.mss	1665	NEF1 Start OFF
dd.mm.yyyy hh:mm:ss.mss	1667	NEF1 Trip OFF
dd.mm.yyyy hh:mm:ss.mss	4038	AR1 AR Reclosing request OFF
dd.mm.yyyy hh:mm:ss.mss	2945	OBJ1 Open request
dd.mm.yyyy hh:mm:ss.mss	2956	OBJ1 Open command OFF
dd.mm.yyyy hh:mm:ss.mss	4082	AR1 Shot start time OFF
dd.mm.yyyy hh:mm:ss.mss	4083	AR1 Dead time ON
dd.mm.yyyy hh:mm:ss.mss	2963	OBJ1 Status change OFF
dd.mm.yyyy hh:mm:ss.mss	4044	AR1 Object "Close" request
dd.mm.yyyy hh:mm:ss.mss	2957	OBJ1 Close request ON
dd.mm.yyyy hh:mm:ss.mss	2958	OBJ1 Close Fail
dd.mm.yyyy hh:mm:ss.mss	2959	OBJ1 Close request OFF
dd.mm.yyyy hh:mm:ss.mss	2960	OBJ1 Close command ON
dd.mm.yyyy hh:mm:ss.mss	2962	OBJ1 Status change ON
dd.mm.yyyy hh:mm:ss.mss	2944	OBJ1 Object Intermediate
dd.mm.yyyy hh:mm:ss.mss	2946	OBJ1 Object Close
dd.mm.yyyy hh:mm:ss.mss	2961	OBJ1 Close command OFF
dd.mm.yyyy hh:mm:ss.mss	4087	AR1 Shot reclaim time ON

As these tables show, the register list complement the information from event lists when the control has encountered some unexpected behavior. The example above shows that the object had issues executing the "Close" command, which caused the dead time to be 270 ms longer than its set value. The reason for this behavior can be verified from the object control and monitoring function's registers.

The example below shows that the object was not ready when it received the closing request from the auto-recloser function and kept the request pending until it was ready to execute the "Close" command.

dd.mm.yyyy hh:mm:ss.mss	Object Open, WD In, Open Allowed, Close Allowed, Object Ready, Sync Ok, Obj open time: 0.025 s
dd.mm.yyyy hh:mm:ss.mss	Object Open, WD In, Object not ready for Close request, Open Allowed, Close Allowed, Object Not Ready, Sync Ok
dd.mm.yyyy hh:mm:ss.mss	Object Open, WD In, Close request from Auto-recloser, Close pending due to: Close wait for Ready, Open Allowed, Close Allowed, Object Not Ready, Sync Ok
dd.mm.yyyy hh:mm:ss.mss	Object Open, WD In, Open Allowed, Close Allowed, Object Ready, Sync Ok
dd.mm.yyyy hh:mm:ss.mss	Object Closed, WD In, Open Allowed, Close Allowed, Object Ready, Sync Ok, Obj close time: 0.030 s

Auto-recloser operation counters

The auto-recloser function keeps statistical track of the operated auto-reclosing cycles as well as of successful and failed shots.

The function records the following counters:

- Shot 1...5 started
- Shot 1...5 requested by AR1...5

- Shots failed
- Final trips
- Shots cleared
- AR started

The counters are cumulative and they update automatically according to the operations of the auto-recloser function. They can be found in the *Statistics* tab at *Control* → *Auto-recloser* → *Registers*.

5.4.5 Cold load pick-up (CLPU)

The cold load pick-up function is used for detecting so-called cold load situations, where a loss of load diversity has occurred after distribution has been re-energized. The characteristics of cold load situations vary according to the types of loads individual feeders have. This means that this function needs to be set specifically according to the load type of the feeder it is monitoring. For example, in residential areas there are relatively many thermostat-controlled devices (such as heating and cooling machinery) which normally run in asynchronous cycles. When restoring power after a longer power outage, these devices demand the full start-up power which can cause the inrush current to be significantly higher than what the load current was before the outage. This is uncommon in industrial environments since the restoring of the production process takes several hours, or even days, and the power level goes back to the level it was before the outage. However, some areas of the industrial network may find the cold load pick-up function useful.

The operating decisions are based on phase current magnitudes and magnitude changes which the function constantly measures. The blocking signal and the setting group selection control the operating characteristics of the function during normal operation, i.e. the user or user-defined logic can change function parameters while the function is running.

The outputs of the function are the CLPU ACT and BLOCKED signals. The cold load pick-up function uses a total of eight (8) separate setting groups which can be selected from one common source.

The operational logic consists of the following:

- input magnitude processing
- threshold comparator
- block signal check
- time delay characteristics
- output processing.

The inputs for the function are the following:

- setting parameters
- digital input signals
- measured and pre-processed current magnitudes.

The function outputs the CLPU ACT and BLOCKED signals which can be used for direct I/O controlling and user logic programming. The function generates general time-stamped ON/OFF events to the common event buffer from each of the two (2) output signals. The time stamp resolution is 1 ms. The function also provides a resettable cumulative counter for the CLPU ACT and BLOCKED events.

The following figure presents a simplified function block diagram of the cold load pick-up function.

Figure. 5.4.5 - 193. Simplified function block diagram of the cold load pick-up function.

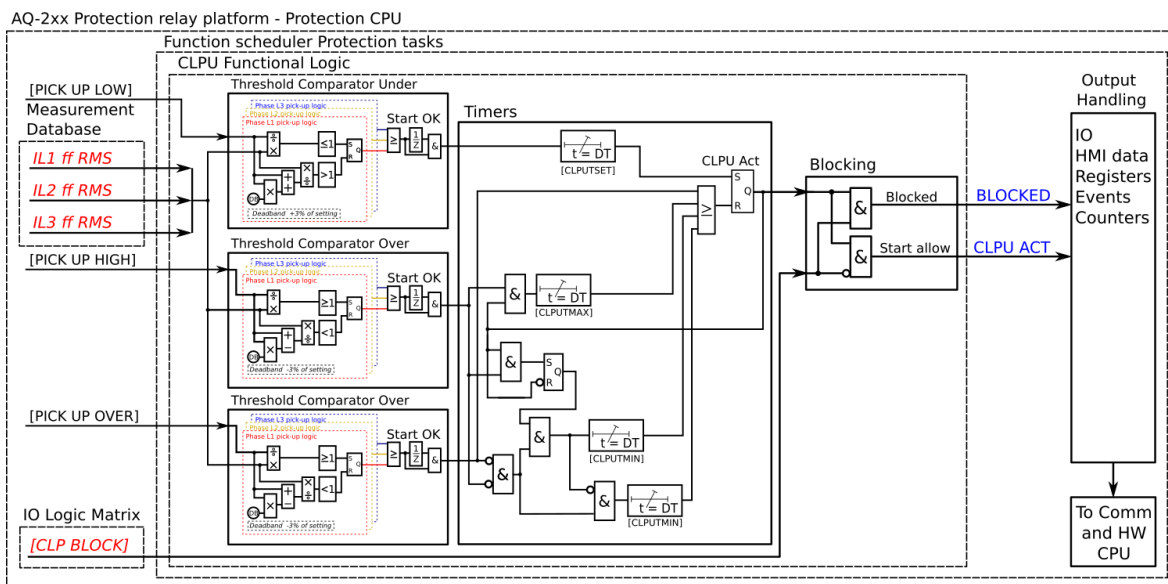

Measured input

The function block uses analog current measurement values. A -20 ms averaged value of the selected magnitude is used for pre-fault data registering.

Table. 5.4.5 - 196. Measurement inputs of the cold load pick-up function.

Signal	Description	Time base
IL1RMS	RMS measurement of phase L1 (A) current	5ms
IL2RMS	RMS measurement of phase L2 (B) current	5ms
IL3RMS	RMS measurement of phase L3 (C) current	5ms

The pre-fault condition is presented with a 20 ms averaged history value from -20 ms from CLPU ACT event.

Pick-up

The I_{low} , I_{high} and I_{over} setting parameters control the the pick-up and activation of the cold load pick-up function. They define the maximum and minimum allowed measured current before action from the function. The function constantly calculates the ratio between the setting values and the measured magnitude (I_m) for each of the three phases. The reset ratio of 97 % is built into the function and is always relative to the setting value. The setting value is common for all measured phases. When the I_m exceeds the setting value (in single, dual or all phases) it triggers the pick-up operation of the function.

Table. 5.4.5 - 197. Pick-up settings.

Name	Range	Step	Default	Description
I_{low}	0.01...40.00× I_n	0.01× I_n	0.20× I_n	The pick-up setting for low current detection. All measured currents must be below this setting in order for the cold load pick-up signal to be activated.
I_{high}	0.01...40.00× I_n	0.01× I_n	1.20× I_n	The pick-up setting for high current detection. All measured currents must exceed this setting in order for the cold load pick-up signal to be activated.
I_{over}	0.01...40.00× I_n	0.01× I_n	2.00× I_n	The pick-up setting for overcurrent detection. If this setting is exceeded by any of the measured currents, the cold load pick-up signal is released immediately.

The pick-up activation of the function is not directly equal to the CLPU ACT signal generation of the function. The CLPU ACT signal is allowed if the blocking condition is not active.

Read-only parameters

The relay's *Info* page displays useful, real-time information on the state of the protection function. It is accessed either through the relay's HMI display, or through the setting tool software when it is connected to the relay and its Live Edit mode is active.

Table. 5.4.5 - 198. Information displayed by the function.

Name	Range	Step	Description
CLP condition	0: Normal 1: Curr low 2: Overcurrent On 3: CLPU On 4: CLPU blocked	-	Displays status of the control function.

Function blocking

The block signal is checked in the beginning of each program cycle. The blocking signal is received from the blocking matrix in the function's dedicated input. If the blocking signal is not activated when the pick-up element activates, a CLPU ACT signal is generated and the function proceeds to the time characteristics calculation.

If the blocking signal is active when the pick-up element activates, a BLOCKED signal is generated and the function does not process the situation further. If the CLPU ACT function has been activated before the blocking signal, it resets and processes the release time characteristics similarly to when the pick-up signal is reset.

The blocking of the function causes an HMI display event and a time-stamped blocking event with information of the startup current values and its fault type to be issued.

The blocking signal can also be tested in the commissioning phase by a software switch signal when the relay's testing mode "Enable stage forcing" is activated (*General* → *Device*).

The variables the user can set are binary signals from the system. The blocking signal needs to reach the device minimum of 5 ms before the set operating delay has passed in order for the blocking to activate in time.

Operating time characteristics

The behavior of the function's operating timers can be set for activation as well as for the situation monitoring and release of the cold load pick-up.

The table below presents the setting parameters for the function's time characteristics.

Table. 5.4.5 - 199. Setting parameters for operating time characteristics.

Name	Range	Step	Default	Description
T_{set}	0.000...1800.000s	0.005s	10.000s	The function's start timer which defines how long the I_{low} condition has to last before the cold load pick-up is activated.
T_{max}	0.000...1800.000s	0.005s	30.000s	The function's maximum timer which defines how long the starting condition can last and for how long the current is allowed to be over I_{high} .
T_{min}	0.000...1800.000s	0.005s	0.040s	The function's minimum timer which defines how long the starting condition has to last at the minimum. If the start-up sequence includes more than one inrush situation, this parameter may be used to prolong the cold load pick-up time over the first inrush. Additionally, this parameter operates as the "reclaim" time for the function in case the inrush current is not immediately initiated in the start-up sequence.

The six examples below showcase some typical cases with the cold load pick-up function.

Figure. 5.4.5 - 194. Example of timers and pick-up parameters (normal CLPU situation).

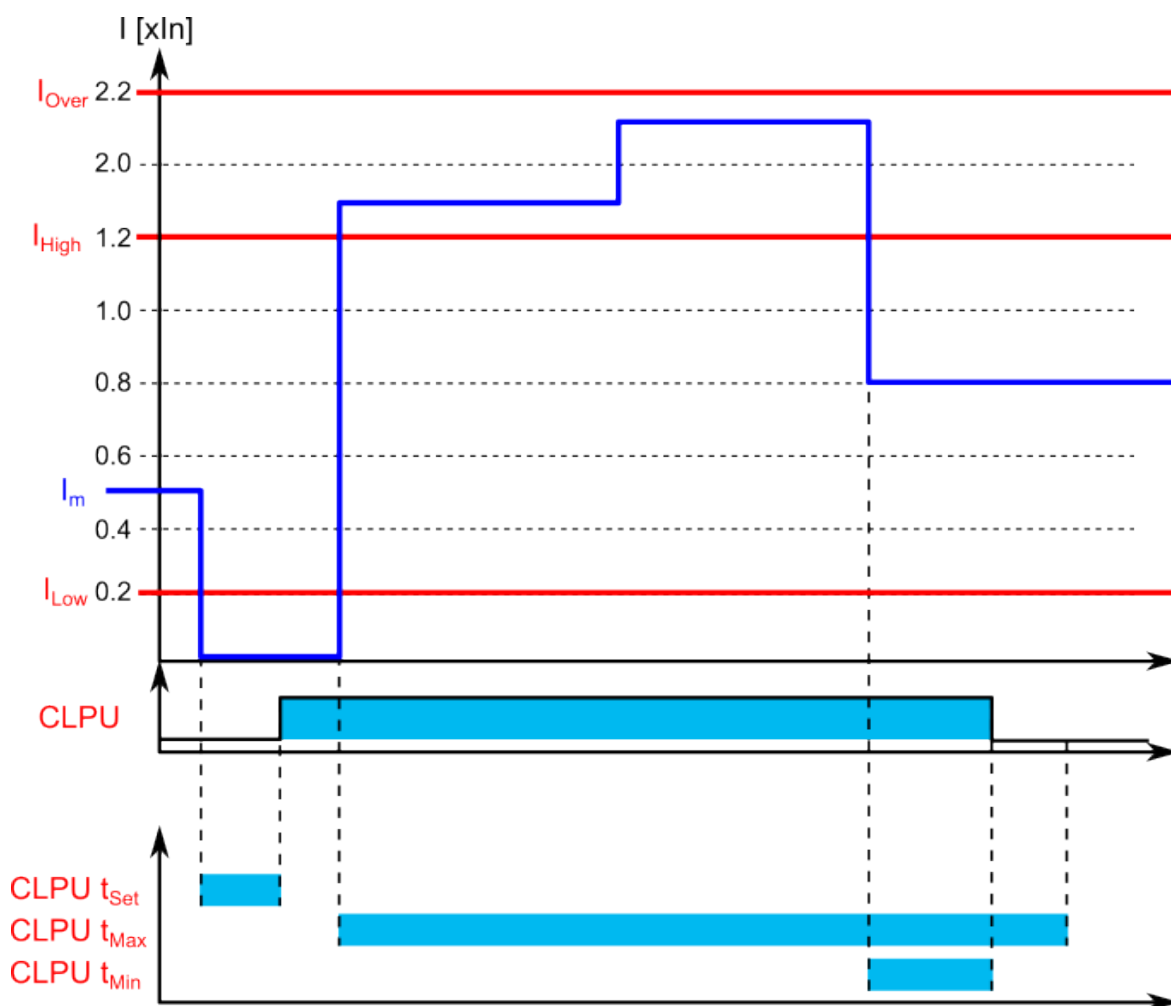

In the example above, the cold load pick-up function activates after the measured current dips below the I_{low} setting and has been there for T_{set} amount of time. When the current exceeds the I_{high} setting value, a timer starts counting towards the T_{max} time. The pick-up current is cleared before the the counter reaches the T_{max} time, when the measured current goes between of I_{low} and the I_{high} . This is when the start-up condition is considered to be over. The cold load pick-up signal can be prolonged beyond this time by setting the T_{min} to a value higher than 0.000 s.

Figure. 5.4.5 - 195. Example of timers and pick-up parameters (no cold load pick-up, I_{low} too short).

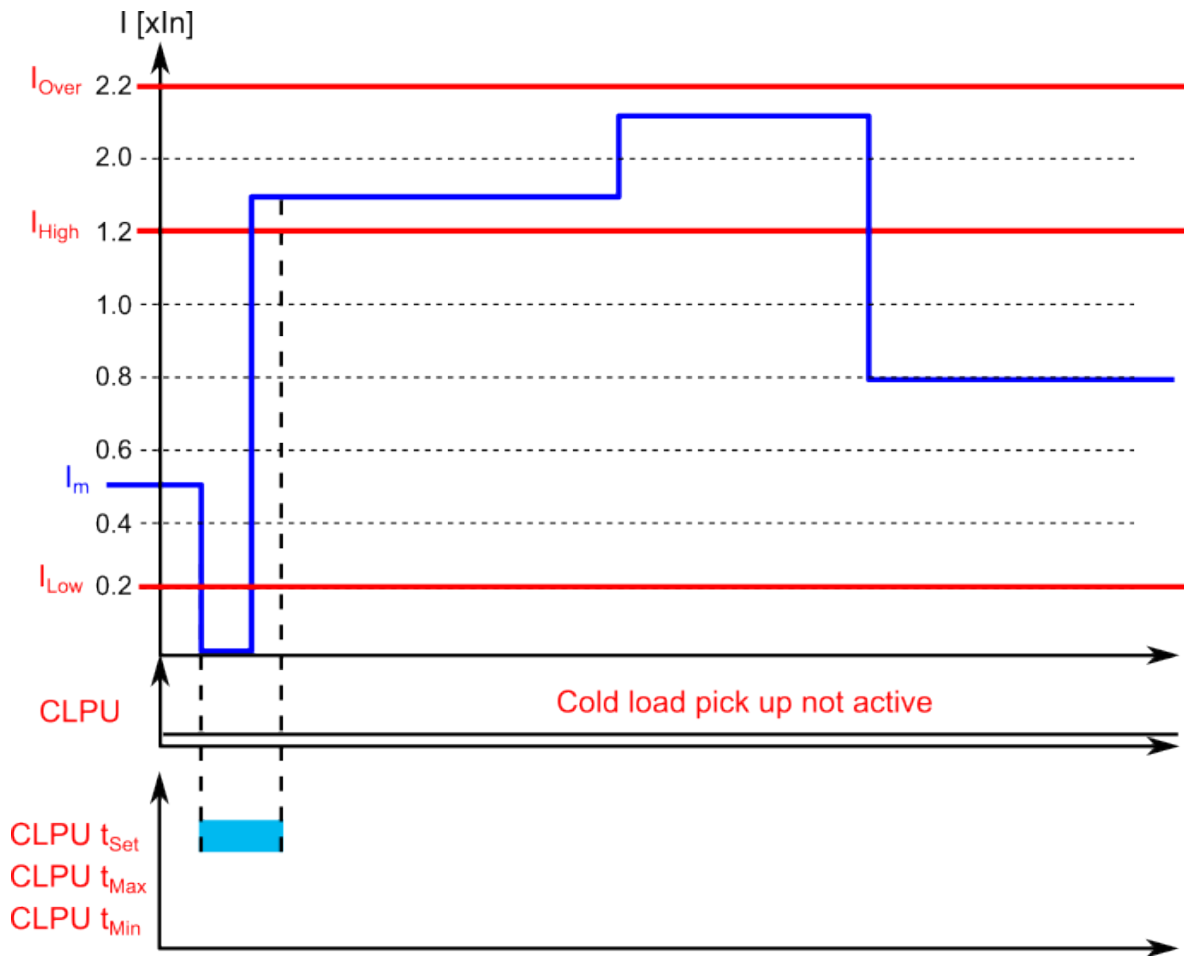

In the example above, the cold load pick-up function does not activate even when the measured current dips below the I_{low} setting, because the T_{set} is not exceeded and therefore no cold load pick-up signal is issued. If the user wants the function to activate within a shorter period of time, the T_{set} parameter can be set to a lower value. If the user wants no delay, the T_{set} can be zero seconds and the operation will be immediate.

Figure. 5.4.5 - 196. Example of timers and pick-up parameters (activated pick-up and instant release due to overcurrent).

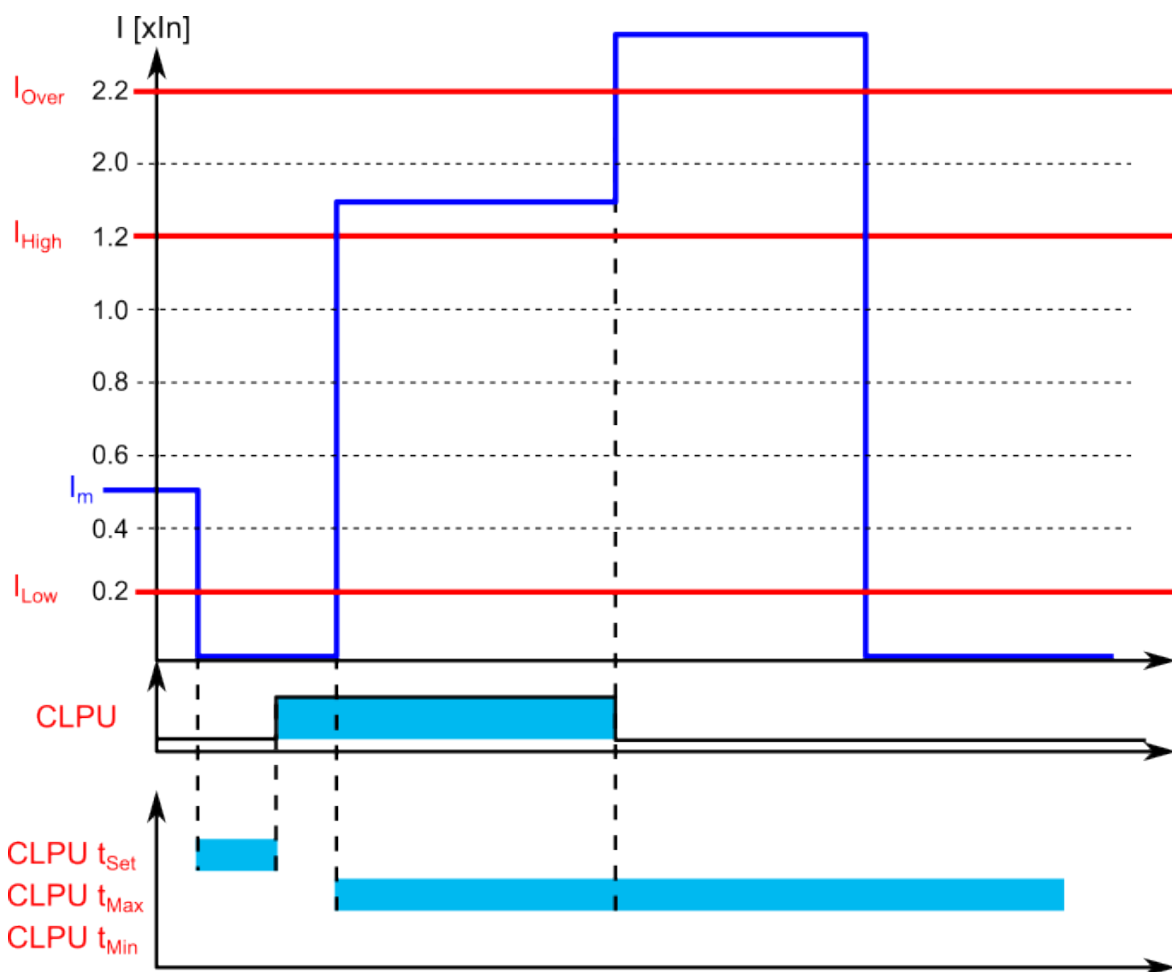

In the example above, the cold load pick-up function activates after the measured current dips below the I_{low} setting and has been there for T_{set} amount of time. When the I_m exceeds the I_{high} setting, a counter starts counting towards the T_{max} time. The measured current exceeds the I_{over} setting during the start-up situation and causes the cold load pick-up signal to be released immediately.

Figure. 5.4.5 - 197. Example of timers and pick-up parameters (activated pick-up and instant release due to too long starting).

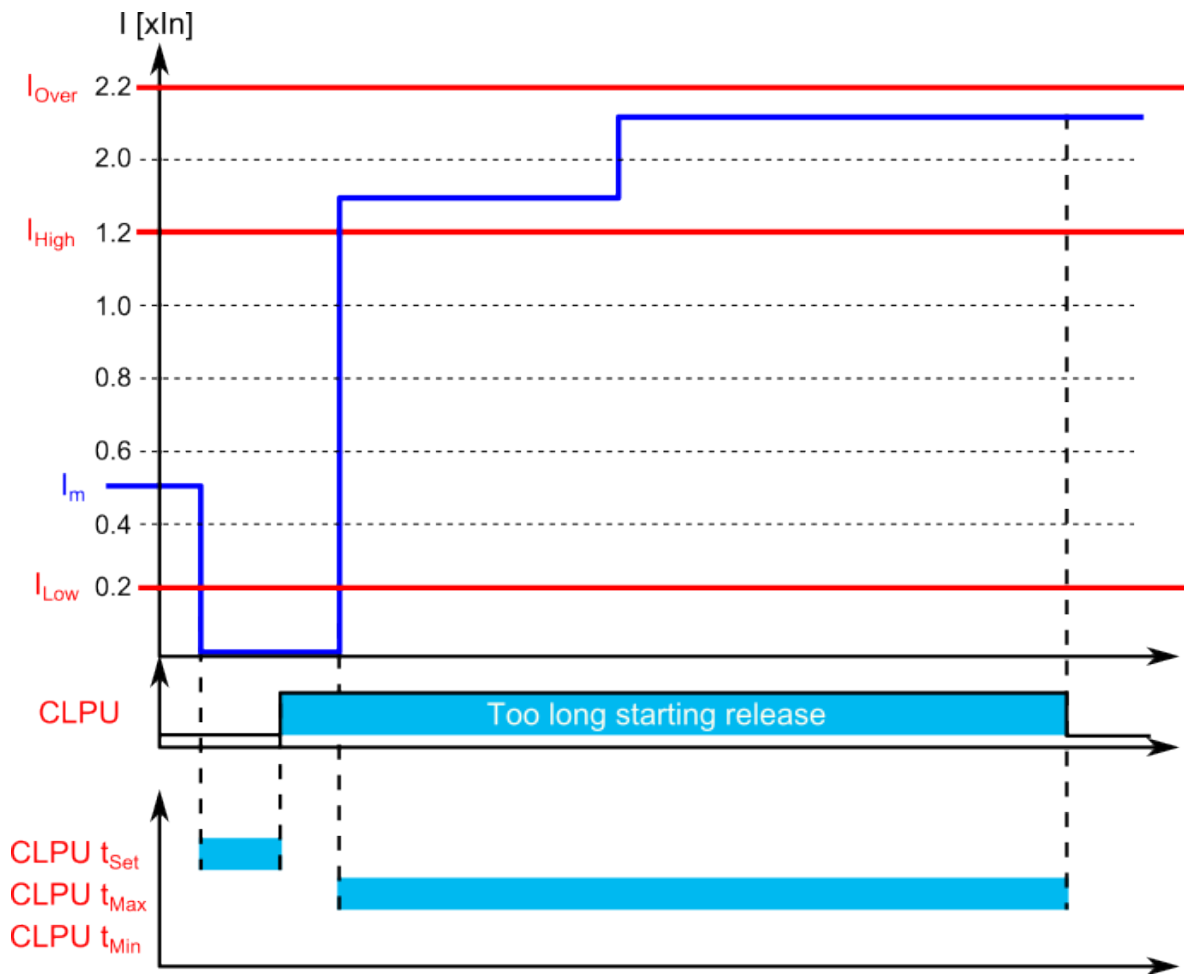

In the example above, the cold load pick-up function activates after the measured current has stayed below the I_{low} setting for a T_{set} amount of time. When the current exceeds the I_{high} setting, a timer starts counting towards the T_{max} time. The measured current stays above the I_{high} setting until the T_{max} is reached, which causes the release of the cold load pick-up signal.

Figure. 5.4.5 - 198. Example of timers and pick-up parameters (no inrush current detected in the starting).

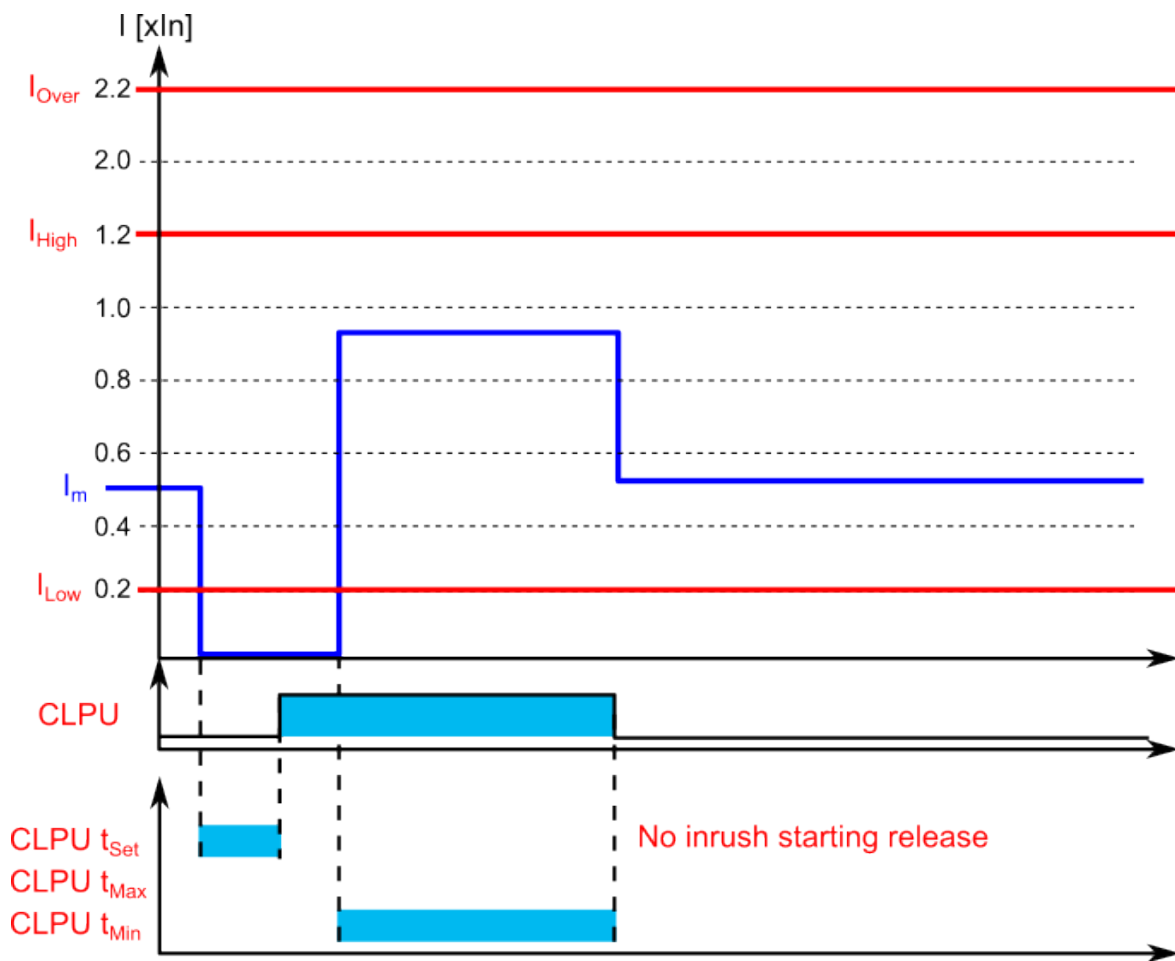

In the example above, the cold load pick-up function activates after the measured current has stayed below the I_{Low} setting for a T_{Set} amount of time. The current stays between the I_{Low} setting and the I_{High} setting, so the cold load pick-up signal is active for T_{Min} time. As no inrush current is detected during that time, the signal is released.

Figure. 5.4.5 - 199. Example of timers and pick-up parameters (an inrush current detected during T_{min} time).

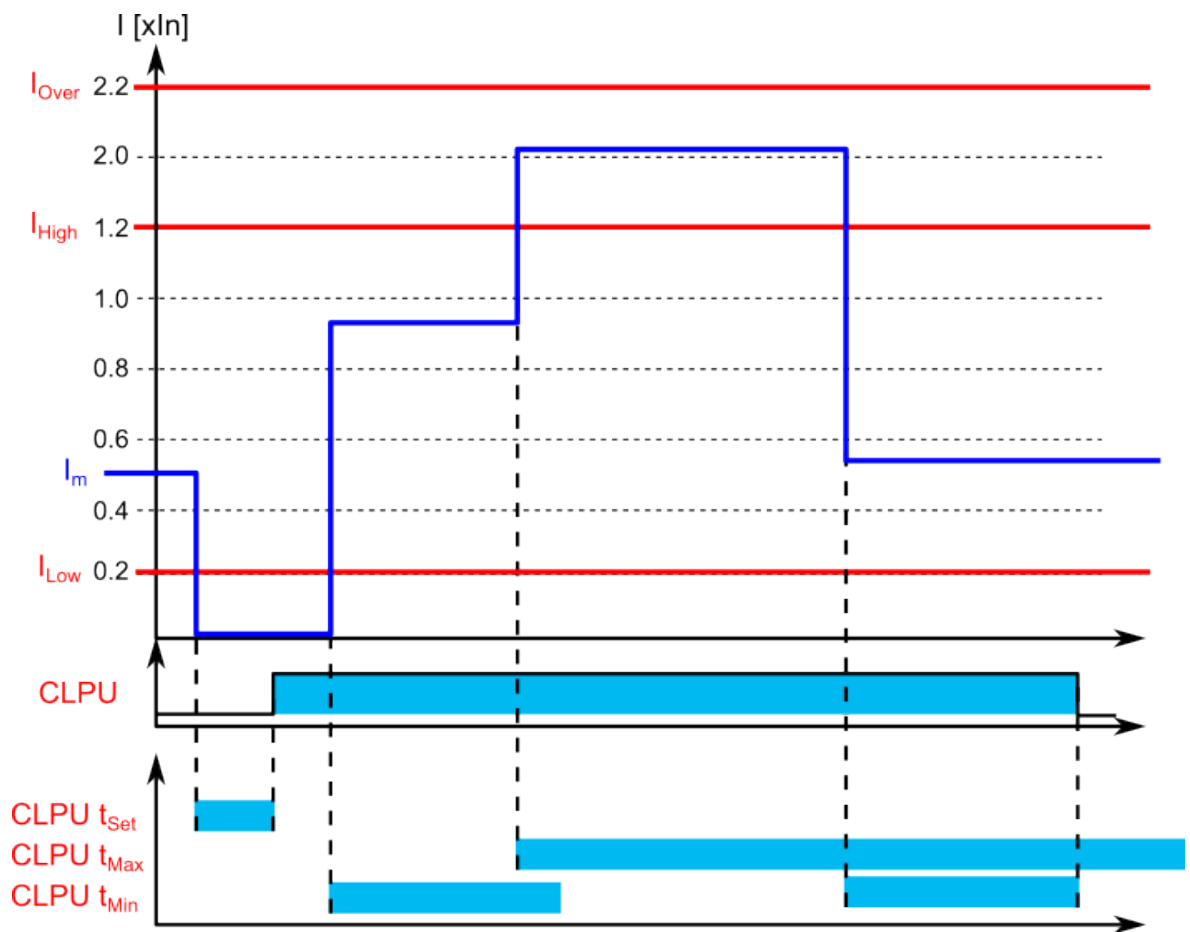

In the example above, the cold load pick-up function activates after the measured current has stayed below the I_{low} setting for a T_{set} amount of time. The current increases to between the I_{low} setting and the I_{high} setting, which causes a counter to start counting towards the T_{min} time. Before the counter reaches T_{min} , the current exceeds the I_{high} setting, which causes a counter to start counting towards the T_{max} time. The cold load pick-up signal remains active until the T_{max} has been reached, or until the start-up is over and the T_{min} time is over.

Events and registers

The cold load pick-up function (abbreviated "CLP" in event block names) generates events and registers from the status changes of the LowStart, HighStart, LoadNormal, Overcurrent, CLPUActivated and BLOCKED signals of the cold load pick-up function as well as from the internal pick-up comparators. The user can select which event messages are stored in the main event buffer: ON, OFF, or both.

The events triggered by the function are recorded with a time stamp and with process data values.

Table. 5.4.5 - 200. Event codes.

Event number	Event channel	Event block name	Event code	Description
2688	42	CLP1	0	LowStart ON
2689	42	CLP1	1	LowStart OFF
2690	42	CLP1	2	HighStart ON
2691	42	CLP1	3	HighStart OFF

Event number	Event channel	Event block name	Event code	Description
2692	42	CLP1	4	LoadNormal ON
2693	42	CLP1	5	LoadNormal OFF
2694	42	CLP1	6	Overcurrent ON
2695	42	CLP1	7	Overcurrent OFF
2696	42	CLP1	8	CLPUActivated ON
2697	42	CLP1	9	CLPUActivated OFF
2698	42	CLP1	10	Block ON
2699	42	CLP1	11	Block OFF

The function registers its operation into the last twelve (12) time-stamped registers. The register of the function records the ON event process data for ACTIVATED, BLOCKED, etc. The table below presents the structure of the function's register content.

Table. 5.4.5 - 201. Register content.

Date and time	Event code	Trigger current	Time to CLPUact	Act CLPU	Starting time	Recl time	Used SG
dd.mm.yyyy hh:mm:ss.mss	2688-2699 Descr.	Phase currents on trigger time	Time remaining before the function is active	The time the function has been active before starting	Recorded starting time	Reclaim time counter	Setting group 1...8 active

5.4.6 Switch-on-to-fault (SOTF)

The switch-on-to-fault (SOTF) function is used for speeding up the tripping when the breaker is closed towards a fault or forgotten earthing to reduce the damage in the fault location. The function can be used to control protection functions, or it can be used to directly trip a breaker if any of the connected protection functions starts during the set SOTF time. The operation of the function is instant after the conditions are met and any one signal connected to the "*Function input*" input activates.

The inputs of the function are the following:

- initiating
- blocking
- setting group selection
- function trigger inputs.

The function can be initiated by a digital input, or by a circuit breaker "Close" command connected to the "*SOTF activate input*" input. The duration of the SOTF-armed condition can be set by the "Release time for SOTF" setting parameter; it can be changed if the application so requires through setting group selection.

The outputs of the function are BLOCKED, ACTIVE and TRIP signals. Additionally, the function outputs the corresponding events and registers when any of these mentioned signals activate.

The following figure presents a simplified function block diagram of the switch-on-to-fault function.

Figure. 5.4.6 - 200. Simplified function block diagram of the switch-on-to-fault function.

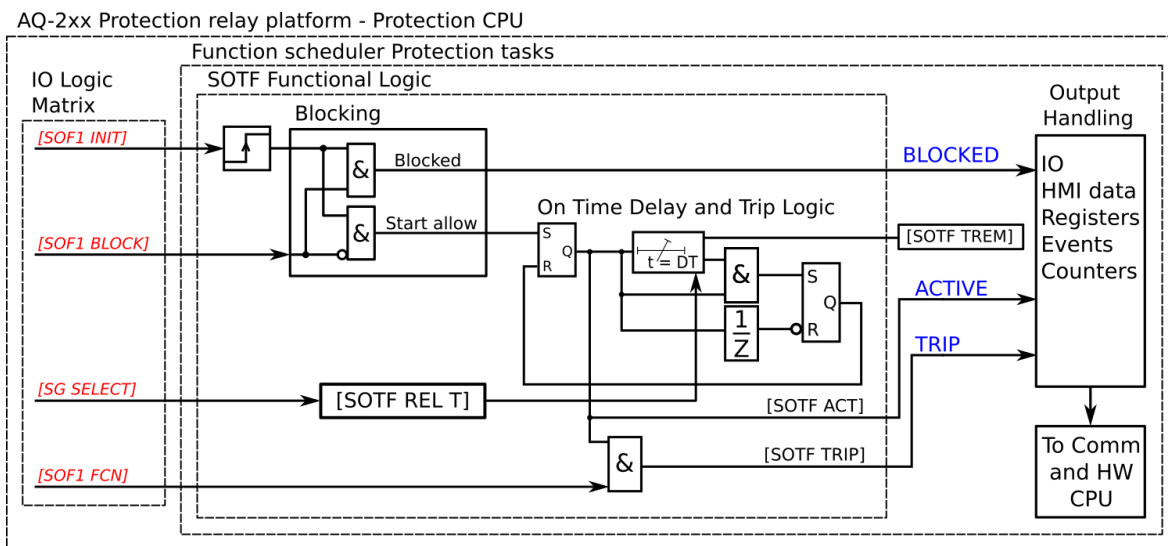

Input signals

The function block does not use analog measurement inputs. Instead, its operation is based entirely on binary signal statuses.

Table. 5.4.6 - 202. Input signals.

Input	Description
Activate input	The digital input or logic signal for the function to arm and start calculating the SOTF time. Any binary signal can be used to activate the function and start the calculation. The rising edge of the signal is considered as the start of the function.
Block input	The input for blocking the function. Any binary signal can be used to block the function from starting.
Function input	The function input activates the function's instant trip if applied when the function is calculating the SOTF time.

Settings

The switch-on-to-fault function has one setting and it determines how long the function remains active after it has been triggered. If the inputs receive any of the set signals during this time, the function's trip is activated.

Table. 5.4.6 - 203. Active settings.

Name	Range	Step	Default	Description
Release time for SOTF	0.000...1800.000s	0.005s	1.000s	The time the function is active after triggering.

Read-only parameters

The relay's *Info* page displays useful, real-time information on the state of the protection function. It is accessed either through the relay's HMI display, or through the setting tool software when it is connected to the relay and its Live Edit mode is active.

Table. 5.4.6 - 204. Information displayed by the function.

Name	Range	Step	Description
SOTF condition	0: Normal 1: Init 2: Active 3: Trip 4: Blocked	-	Displays status of the control function.

Function blocking

The function can be blocked by activating the BLOCK input. This prevents the function's active time from starting.

Events and registers

The switch-on-to-fault function (abbreviated "SOF" in event block names) generates events and registers from the status changes in ACTIVATED, TRIP and BLOCKED. The user can select which event messages are stored in the main event buffer: ON, OFF, or both.

The events triggered by the function are recorded with a time stamp and with process data values.

Table. 5.4.6 - 205. Event codes.

Event number	Event channel	Event block name	Event code	Description
3904	61	SOF1	0	SOTF Init ON
3905	61	SOF1	1	SOTF Init OFF
3906	61	SOF1	2	SOTF Block ON
3907	61	SOF1	3	SOTF Block OFF
3908	61	SOF1	4	SOTF Active ON
3909	61	SOF1	5	SOTF Active OFF
3910	61	SOF1	6	SOTF Trip ON
3911	61	SOF1	7	SOTF Trip OFF

The function registers its operation into the last twelve (12) time-stamped registers. The register of the function records the ON process data of ACTIVATED events. The table below presents the structure of the function's register content.

Table. 5.4.6 - 206. Register content.

Date and time	Event code	SOTF remaining time	SOTF been active time
dd.mm.yyyy hh:mm:ss.mss	3904...3911 Descr.	The time remaining of the set release time.	The time the function has been active.

5.4.7 Milliampere output control

The milliamp current loop is the prevailing process control signal in many industries. It is an ideal method of transferring process information because a current does not change as it travels from a transmitter to a receiver. It is also much more simple and cost-effective.

The benefits of 4...20 mA loops:

- the dominant standard in many industries

- the simplest option to connect and configure
- uses less wiring and connections than other signals, thus greatly reducing initial setup costs
- good for travelling long distances, as current does not degrade over long connections like voltage does
- less sensitive to background electrical noise
- detects a fault in the system incredibly easily since 4 mA is equal to 0 % output.

Milliampere (mA) outputs

AQ-200 series supports up to two (2) independent mA option cards. Each card has four (4) mA output channels and one (1) mA input channel. If the device has an mA option card, enable mA outputs at *Control* → *Device IO* → *mA outputs*. The outputs are activated in groups of two: channels 1 and 2 are activated together, as are channels 3 and 4 (see the image below).

Figure. 5.4.7 - 201. Activating mA output channels.

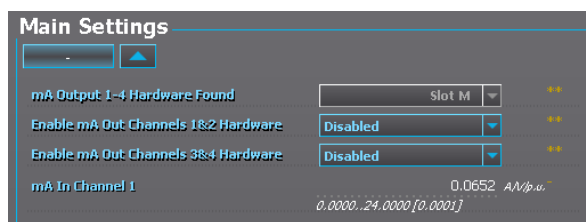

Table. 5.4.7 - 207. Main settings (output channels).

Name		Range	Default	Description
mA option card 1	Enable mA output channels 1 and 2	0: Disabled 1: Enabled	0: Disabled	Enables and disables the outputs of the mA output card 1.
	Enable mA output channels 3 and 4			
mA option card 2	Enable mA output channels 5 and 6	0: Disabled 1: Enabled	0: Disabled	Enables and disables the outputs of the mA output card 2.
	Enable mA output channels 7 and 8			

Table. 5.4.7 - 208. Settings for mA output channels.

Name	Range	Step	Default	Description
Enable mA output channel	0: Disabled 1: Enabled	-	0: Disabled	Enables and disables the selected mA output channel. If the channel is disabled, the channel settings are hidden.
Magnitude selection for mA output channel	0: Currents 1: Voltages 2: Powers 3: Impedance and admittance 4: Other	-	0: Currents	Defines the measurement category that is used for mA output control.
Magnitude of mA output channel	(dependent on the measurement category selection)	-	(dependent on the measurement category selection)	Defines the measurement magnitude used for mA output control. The available measurements depend on the selection of the "Magnitude selection for mA output channel" parameter.
Input value 1	$-10^7 \dots 10^7$	0.001	0	The first input point in the mA output control curve.
Scaled mA output value 1	0.0000...24.0000mA	0.0001mA	0mA	The mA output value when the measured value is equal to or less than Input value 1.

Name	Range	Step	Default	Description
Input value 2	$-10^7 \dots 10^7$	0.001	1	The second input point in the mA output control curve.
Scaled mA output value 2	0.0000...24.0000mA	0.0001mA	0mA	The mA output value when the measured value is equal to or greater than Input value 2.

Figure. 5.4.7 - 202. Example of the effects of mA output channel settings.

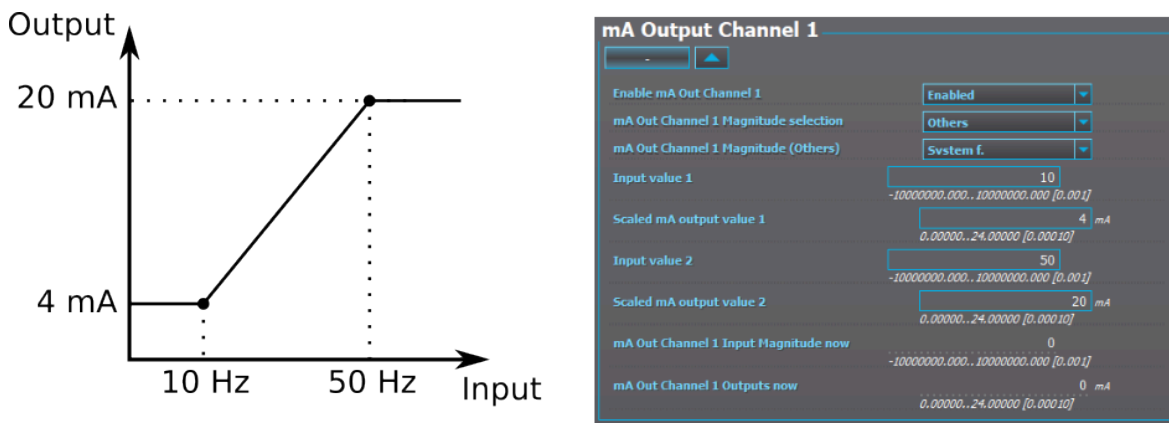

Table. 5.4.7 - 209. Hardware indications.

Name	Range	Step	Description
Hardware in mA output channels 1...4	0: None 1: Slot A 2: Slot B 3: Slot C 4: Slot D 5: Slot E 6: Slot F	-	Indicates the option card slot where the mA output card is located.
Hardware in mA output channels 5...8			

Table. 5.4.7 - 210. Measurement values reported by mA output cards.

Name	Range	Step	Description
mA in Channel 1	0.0000...24.0000mA	0.0001mA	Displays the measured mA value of the selected input channel.
mA in Channel 2			
mA Out Channel Input Magnitude now	$-10^7 \dots 10^7$	0.001	Displays the input value of the selected mA output channel at that moment.
mA Out Channel Outputs now	0.0000...24.0000mA	0.0001mA	Displays the output value of the selected mA output channel at that moment.

5.4.8 Vector jump ($\Delta\phi$; 78)

Distribution systems may include different kinds of distributed power generation sources, such as wind farms and diesel or fuel generators. When a fault occurs in the distribution system, it is usually detected and isolated by the protection system closest to the faulty point, resulting in the electrical power system shutting down either partially or completely. The remaining distributed generators try to deliver the power to the part of the distribution system that has been disconnected from the grid, and usually an overload condition can be expected. Under such overload conditions, it is normal to have a drop in voltage and frequency. This overload results in the final system disconnection from the islanding generator(s). The disconnection depends greatly on the ratio between the power generation and the demand of the islanded system. When any power is supplied to a load only from distributed generators, (due to the opening of the main switch), the situation is called an isolated island operation or an islanded operation of the electrical distribution network.

The vector jump control function is suitable to detect most islanding situations and to switch off the mains breaker in order to let the generator only supply loads according to their rated power value. Therefore, an overload does not cause any mechanical stress to the generator unit(s). The vector jump relay should be located either on the mains side of the operated breaker or on the islanding generator side.

The vector jump function is used for instant tripping and has only one operating stage. The function has an algorithm which follows the samples of chosen measured voltages (64 samples/cycle). The reference voltage used can be all or any of the phase-to-phase or phase-to-neutral voltages.

The outputs of the function are the ALARM, TRIP and BLOCKED signals. Both ALARM and TRIP signals have an individual pick-up setting. The blocking signal and the setting group selection control the operating characteristics of the function during normal operation, i.e. the user or user-defined logic can change function parameters while the function is running. The vector jump function uses a total of eight (8) separate setting groups which can be selected from one common source.

The operational logic consists of the following:

- input magnitude selection
- input magnitude processing
- threshold comparator
- two block signal checks (undervoltage block or stage external signal)
- time delay characteristics
- output processing.

The inputs for the function are the following:

- available stages
- setting parameters
- digital inputs and logic signals
- measured and pre-processed voltage magnitudes.

The function outputs the ALARM, TRIP and BLOCKED signals which can be used for direct I/O controlling and user logic programming. The function generates general time-stamped ON/OFF events to the common event buffer from each of the three (3) output signals. When tripping, the function outputs ALARM and TRIP events simultaneously with an equivalent time stamp. The time stamp resolution is 1 ms. The function also provides a resettable cumulative counter for the ALARM, TRIP and BLOCKED events.

The following figure presents a simplified function block diagram of the vector jump function.

Figure. 5.4.8 - 203. Simplified function block diagram of the $\Delta\phi$ function.

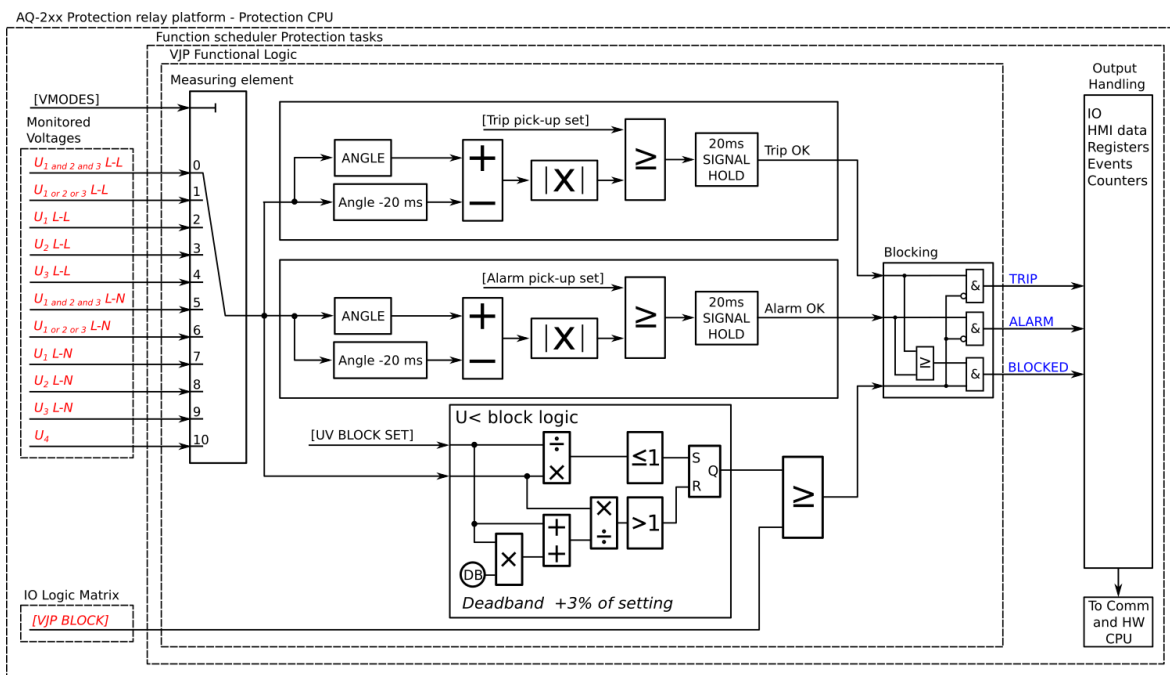

Measured input

The function block uses analog voltage measurement values and always uses complex measurement from samples. A -20 ms averaged value of the selected magnitude is used for pre-fault data registering.

Table. 5.4.8 - 211. Measurement inputs of the vector jump function.

Signal	Description	Time base
U ₁ L-L	Measured line-to-line voltage U ₁ /V	5ms
U ₂ L-L	Measured line-to-line voltage U ₂ /V	5ms
U ₃ L-L	Measured line-to-line voltage U ₃ /V	5ms
U ₁ L-N	Measured line-to-neutral voltage U ₁ /V	5ms
U ₂ L-N	Measured line-to-neutral voltage U ₂ /V	5ms
U ₃ L-N	Measured line-to-neutral voltage U ₃ /V	5ms
U ₄	Measured voltage U ₄ /V	5ms

The selection of the used AI channel is made with a setting parameter. In all possible input channel variations the pre-fault condition is presented with a 20 ms averaged history value from -20 ms from ALARM or TRIP event.

Pick-up

When a fault appears in the power system and some areas are disconnected, normally the remaining generators connected to the network must supply the area disconnected from the utility side supply. This results in an instantaneous demand of power that the generators must tackle. The excitation and the mechanical systems cannot answer such a huge demand of power quickly even if there were enough reserve power. The worst of the situation is received by the rotors of the generator units: they suffer a torsion torque that can even break the rotor and cause subsequent damage not only for the generator but for the entire power plant too.

Figure. 5.4.8 - 204. Generator islanding.

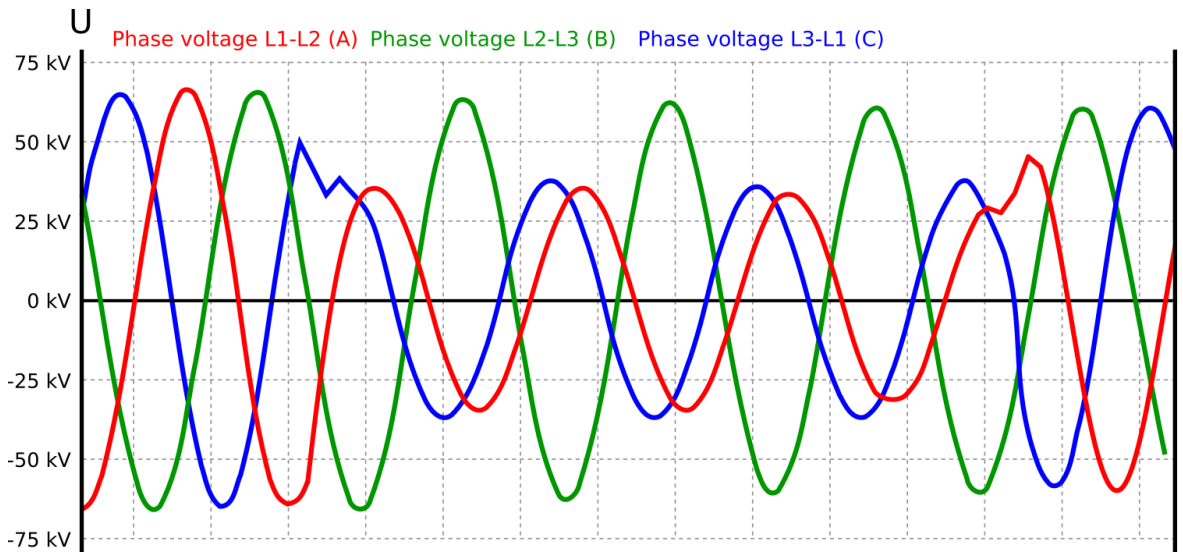

As can be seen in the example above, only phase-to-phase voltages L1-L2 and L3-L1 have been reduced, while voltage L2-L3 remains the same. This means that the problem occurred in phase L1 of the network. The voltage level is not reduced to zero, nor is the voltage in any phase is totally lost. The phases without the fault condition remain normal with the same value. On the other hand, the frequency can sag as can be seen in the figure above.

The $\Delta\alpha$ setting parameter controls the pick-up of the vector jump function. This defines the minimum allowed rapid measured voltage angle change before action from the function. The function constantly calculates the ratio between the $\Delta\alpha_{set}$ and the measured magnitude ($\Delta\alpha_m$) for each of the selected voltages. The function's stage trip signal lasts for 20 ms and automatically resets after that time has passed. The setting value is common for all measured amplitudes.

Figure. 5.4.8 - 205. Vector jump from the relay's point of view.

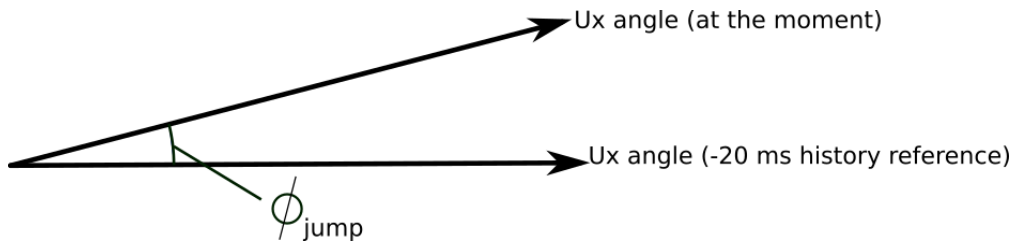

Table. 5.4.8 - 212. Pick-up settings.

Name	Description	Range	Step	Default
Available stages	Defines if alarm is included with trip or not.	0: Trip 1: Trip and alarm	-	0: Trip

Name	Description	Range	Step	Default
Monitored voltages	Defines the monitored voltage channel(s)	0: System all P-P Voltages 1: System any P-P Voltage 2: System L12 Voltage 3: System L23 Voltage 4: System L31 Voltage 5: System all P-E voltages 6: System any P-E voltage 7: System L1 Voltage 8: System L2 Voltage 9: System L3 Voltage 10: U4 Voltage	-	0: System all P-P Voltages
Pick-up setting $\Delta\alpha$ (lead or lag) Trip	Pick-up setting for trip signal	0.05...30.00°	0.01°	5°
Pick-up setting $\Delta\alpha$ (lead or lag) Alarm	Pick-up setting for alarm signal	0.05...30.00°	0.01°	5°
Undervoltage block limit % < U_n	Block setting. If set to zero, blocking is not in use. The operation is explained in the next chapter.	0.00...100.00% U_n	0.01% U_n	95% U_n

The pick-up activation of the function is not directly equal to the START or TRIP signal generation of the function. The START signal is allowed if the blocking condition is not active.

Read-only parameters

The relay's *Info* page displays useful, real-time information on the state of the protection function. It is accessed either through the relay's HMI display, or through the setting tool software when it is connected to the relay and its Live Edit mode is active.

Table. 5.4.8 - 213. Information displayed by the function.

Name	Range	Step	Description
$\Delta\alpha >$ condition	0: Normal 1: Blocked 2: Trip 3: Alarm	-	Displays status of the protection function.
Voltage meas selected	0: Selection Ok 1: Selection not available	-	Displays validity of the voltage channel(s) selected in "Monitored voltages" parameter.
$\Delta\alpha >$ U1 Angle difference	-360...360deg	0.01 deg	Displays the angle difference between present time and 20 ms ago.
$\Delta\alpha >$ U2 Angle difference			
$\Delta\alpha >$ U3 Angle difference			
$\Delta\alpha >$ U1meas/set	-360...360p.u.	0.01p.u.	Displays the ratio between the measured voltage and undervoltage block limit setting.
$\Delta\alpha >$ U2meas/set			
$\Delta\alpha >$ U3meas/set			

Function blocking

The block signal is checked in the beginning of each program cycle. The blocking signal is received from the blocking matrix in the function's dedicated input. If the blocking signal is not activated when the pick-up element activates, a ALARM or TRIP signal is generated and the function proceeds to the time characteristics calculation.

If the blocking signal is active when the pick-up element activates, a BLOCKED signal is generated and the function does not process the situation further.

The blocking of the function causes an HMI display event and a time-stamped blocking event with information of the startup voltage values and its fault type to be issued.

The blocking signal can also be tested in the commissioning phase by a software switch signal when the relay's testing mode "Enable stage forcing" is activated (*General* → *Device*).

The variables the user can set are binary signals from the system. The blocking signal needs to reach the device minimum of 5 ms before the set operating delay has passed in order for the blocking to activate in time.

Events and registers

The vector jump function (abbreviated "VJP" in event block names) generates events and registers from the status changes in START, TRIP, and BLOCKED. The user can select which event messages are stored in the main event buffer: ON, OFF, or both.

The events triggered by the function are recorded with a time stamp and with process data values.

Table. 5.4.8 - 214. Event codes.

Event number	Event channel	Event block name	Event code	Description
9920	155	VJP1	0	Block ON
9921	155	VJP1	1	Block OFF
9922	155	VJP1	2	Trip ON
9923	155	VJP1	3	Trip OFF
9924	155	VJP1	4	Alarm ON
9925	155	VJP1	5	Alarm OFF

The function registers its operation into the last twelve (12) time-stamped registers. The register of the function records the ON event process data for START, TRIP or BLOCKED. The table below presents the structure of the function's register content.

Table. 5.4.8 - 215. Register content.

Date and time	Event code	Fault type	Trip $\Delta\alpha$ meas / dataset	Alarm $\Delta\alpha$ meas / dataset	Used SG
dd.mm.yyyy hh:mm:ss.mss	9920-9925 Descr.	L1(2), L2(3), L3(1) and U4	Trip angle difference	Alarm angle difference	Setting group 1...8 active

5.4.9 Programmable control switch

The programmable control switch is a control function that controls its binary output signal. This output signal can be controlled locally from the relay's mimic (displayed as a box in the mimic) or remotely from the RTU. The main purpose of programmable control switches is to block or enable function and to change function properties by changing the setting group. However, this binary signal can also be used for any number of other purposes, just like all other binary signals. Once a programmable control switch has been activated or disabled, it remains in that state until given a new command to switch to the opposite state (see the image below). The switch cannot be controlled by an auxiliary input, such as digital inputs or logic signals; it can only be controlled locally (mimic) or remotely (RTU).

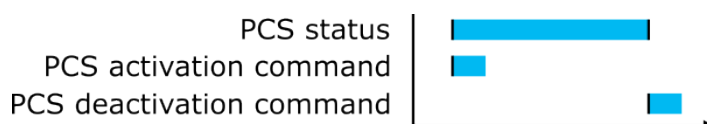

Settings.

These settings can be accessed at *Control* → *Device I/O* → *Programmable control switch*.

Table. 5.4.9 - 216. Settings.

Name	Range	Default	Description
Switch name	-	Switchx	The user-settable name of the selected switch. The name can be up to 32 characters long.
Access level for Mimic control	0: User 1: Operator 2: Configurator 3: Super user	2: Configurator	Determines which access level is required to be able to control the programmable control switch via the Mimic.

Events

The programmable control switch function (abbreviated "PCS" in event block names) generates events from status changes. The user can select which event messages are stored in the main event buffer: ON, OFF, or both. The function offers five (5) independent switches.

Table. 5.4.9 - 217. Event codes.

Event number	Event channel	Event block name	Event code	Description
384	6	PCS	0	Switch 1 ON
385	6	PCS	1	Switch 1 OFF
386	6	PCS	2	Switch 2 ON
387	6	PCS	3	Switch 2 OFF
388	6	PCS	4	Switch 3 ON
389	6	PCS	5	Switch 3 OFF
390	6	PCS	6	Switch 4 ON
391	6	PCS	7	Switch 4 OFF
392	6	PCS	8	Switch 5 ON
393	6	PCS	9	Switch 5 OFF

5.4.10 Analog input scaling curves

Sometimes when measuring with RTD inputs, milliampere inputs and digital inputs the measurement might be inaccurate because the signal coming from the source is inaccurate. One common example of this is tap changer location indication signal not changing linearly from step to step. If the output difference between the steps are not equal to each other, measuring the incoming signal accurately is not enough. "Analog input scaling curves" menu can be used to take these inaccuracies into account.

Analog input scaling curve settings can be found at *Measurement* → *AI(mA, DI volt) scaling* menu.

Currently following measurements can be scaled with analog input scaling curves:

- RTD inputs and mA inputs in "RTD & mA input" option cards
- mA inputs in "mA output & mA input" option cards
- Digital input voltages

Table. 5.4.10 - 218. Main settings (input channel).

Name	Range	Step	Default	Description
Analog input scaling	0: Disabled 1: Activated	-	0: Disabled	Enables and disables the input.
Scaling curve 1...4	0: Disabled 1: Activated	-	0: Disabled	Enables and disables the scaling curve and the input measurement.
Curve 1...4 input signal select	0: S7 mA Input 1: S8 mA Input 2: S15 mA Input 3: S16 mA Input 4: DI1 Voltage ... 23: DI20 Voltage 24: RTD S1 Resistance ... 39: RTD S16 Resistance 40: mA In 1 (I card 1) 41: mA In 2 (I card 2)	-	0: S7 mA Input	Defines the measurement used by scaling curve.
Curve 1...4 input signal filtering	0: No 1: Yes	-	0: No	Enables calculation of the average of received signal.
Curve 1...4 input signal filter time constant	0.005...3800.000 s	0.005 s	1 s	Time constant for input signal filtering. This parameter is visible when "Curve 1...4 input signal filtering" has been set to "Yes".
Curve 1...4 input signal out of range set	0: No 1: Yes	-	0: No	Enables out of range signals. If input signal is out of minimum and maximum limits, "ASC1...4 input out of range" signal is activated.
Curve1...4 input minimum	-1 000 000.00...1 000 000.00	0.00001	0	Defines the minimum input of the curve. If input is below the set limit, "ASC1...4 input out of range" is activated.
Curve 1...4 input	-1 000 000.00...1 000 000.00	0.00001	-	Displays the input measurement received by the curve.
Curve1...4 input maximum	-1 000 000.00...1 000 000.00	0.00001	0	Defines the maximum input of the curve. If input is above the set limit, "ASC1...4 input out of range" is activated.

Name	Range	Step	Default	Description
Curve1...4 output	-1 000 000.00...1 000 000.00	0.00001	-	Displays the output of the curve.

The input signal filter (see the image below) calculates the average of received signals according to the set time constant. This is why rapid changes and disturbances (such as fast spikes) are smothered.



The Nyquist rate states that the filter time constant must be at least double the period time of the disturbance process signal. For example, the value for the filter time constant is 2 seconds for a 1 second period time of a disturbance oscillation.

$$H(s) = \frac{Wc}{s+Wc} = \frac{1}{1+s/Wc}$$

When the curve signal is out of range, it activates the "ASC1...4 input out of range" signal, which can be used inside logic or with other relay functions. The signal can be assigned directly to an output relay or to an LED in the I/O matrix. The "Out of range" signal is activated, when the measured signal falls below the set input minimum limit, or when it exceeds the input maximum limit. The "Out of range" signal is very useful when e.g. a 4...20 mA input signal is used (see the image below).

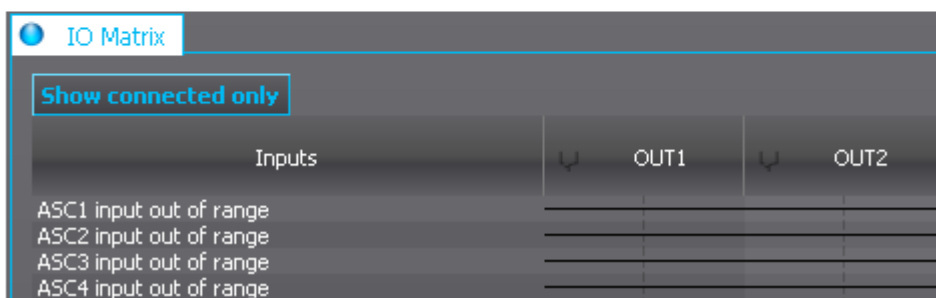
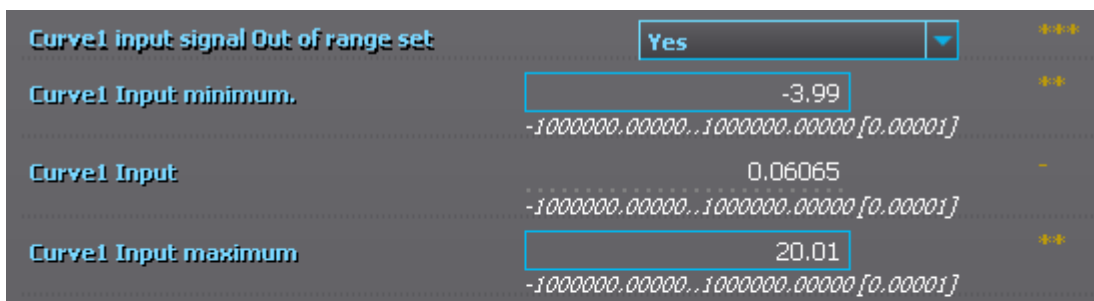

If for some reason the input signal is lost, the value is fixed to the last actual measured cycle value. The value does not go down to the minimum if it has been something else at the time of the signal breaking.

Table. 5.4.10 - 219. Output settings and indications.

Name	Range	Step	Default	Description
Curve 1...4 update cycle	5...10 000ms	5ms	150ms	Defines the length of the input measurement update cycle. If the user wants a fast operation, this setting should be fairly low.

Name	Range	Step	Default	Description
Scaled value handling	0: Floating point 1: Integer out (Floor) 2: Integer (Ceiling) 3: Integer (Nearest)	-	0: Floating point	Rounds the milliampere signal output as selected.
Input value 1	0...4000	0.000 01	0	The measured input value at Curve Point 1.
Scaled output value 1	-10 ⁷ ...10 ⁷	0.000 01	0	Scales the measured milliampere signal at Point 1.
Input value 2	0...4000	0.000 01	1	The measured input value at Curve Point 2.
Scaled output value 1	-10 ⁷ ...10 ⁷	0.000 01	0	Scales the measured milliampere signal at Point 2.
Add curvepoint 3...20	0: Not used 1: Used	-	0: Not used	Allows the user to create their own curve with up to twenty (20) curve points, instead of using a linear curve between two points.

5.4.11 Logical outputs

Logical outputs are used for sending binary signals out from a logic that has been built in the logic editor. Logical signals can be used for blocking functions, changing setting groups, controlling digital outputs, activating LEDs, etc. The status of logical outputs can also be reported to a SCADA system. The figure below presents a logic output example where a signal from the circuit breaker failure protection function controls the digital output relay number 5 ("OUT5") when the circuit breaker's cart status is "In". The image above is from the logic editor and the image below from AQivate 200.

Figure. 5.4.11 - 206. Logic output example.

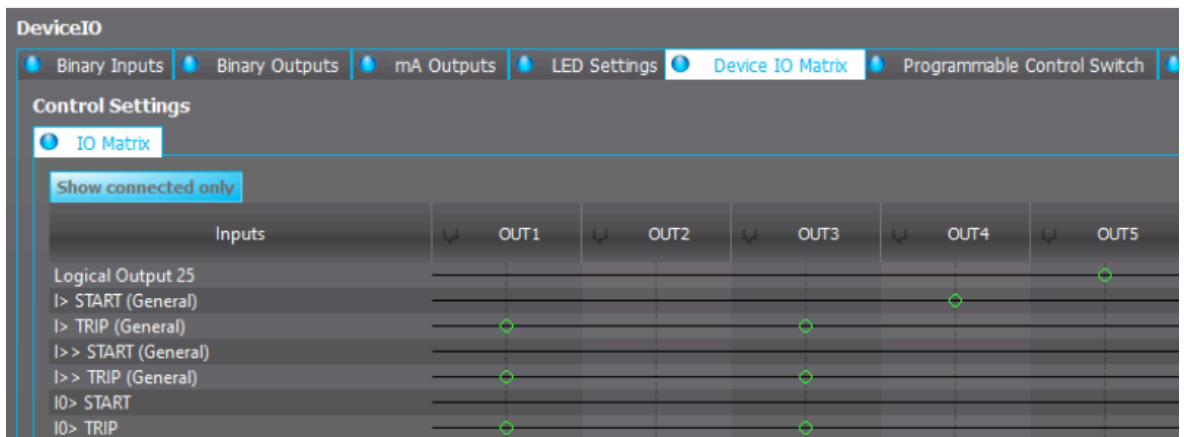
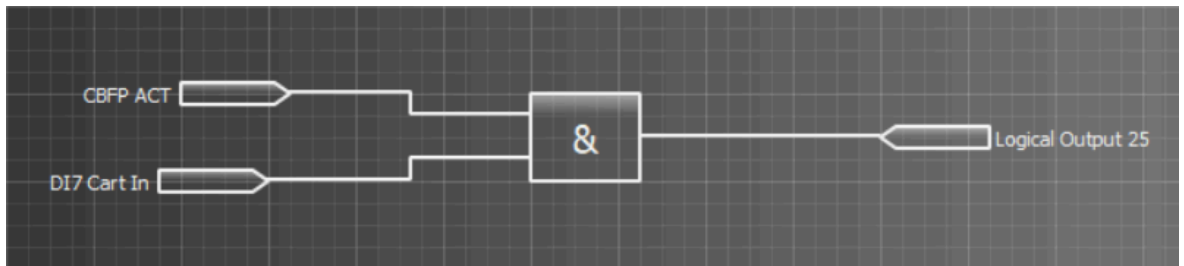

5.4.12 Logical inputs

Logical inputs are binary signals that a user can control manually to change the behavior of the AQ-200 unit or to give direct control commands. Logical inputs can be controlled with a virtual switch built in the mimic and from a SCADA system (IEC 61850, Modbus, IEC 101, etc.). Logical inputs are volatile signals: their status will always return to "0" when the AQ-200 device is rebooted.

Logical inputs have two modes available: Hold and Pulse. When a logical input which has been set to "Hold" mode is controlled to "1", the input will switch to status "1" and it stays in that status until it is given a control command to go to status "0" or until the device is rebooted. When a logical input which has been set to "Pulse" mode is controlled to "1", the input will switch to status "1" and return back to "0" after 5 ms.

The figure below presents the operation of a logical input in Hold mode and in Pulse mode.

Figure. 5.4.12 - 207. Operation of logical input in "Hold" and "Pulse" modes.

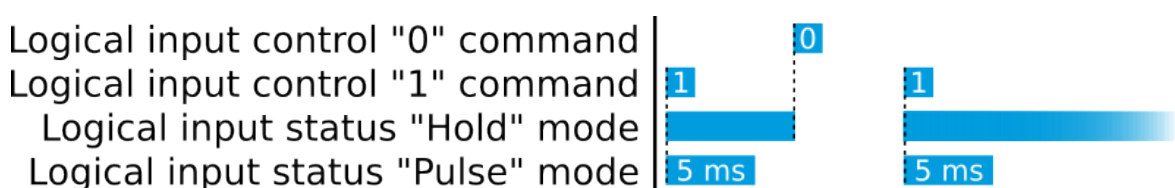

A logical input pulse can also be extended by connecting a DELAY-low gate to a logical output, as has been done in the example figure below.

Figure. 5.4.12 - 208. Extending a logical input pulse.

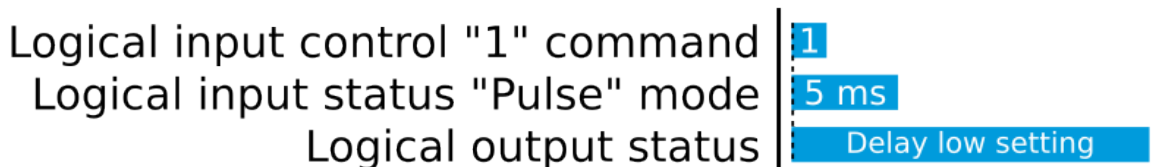
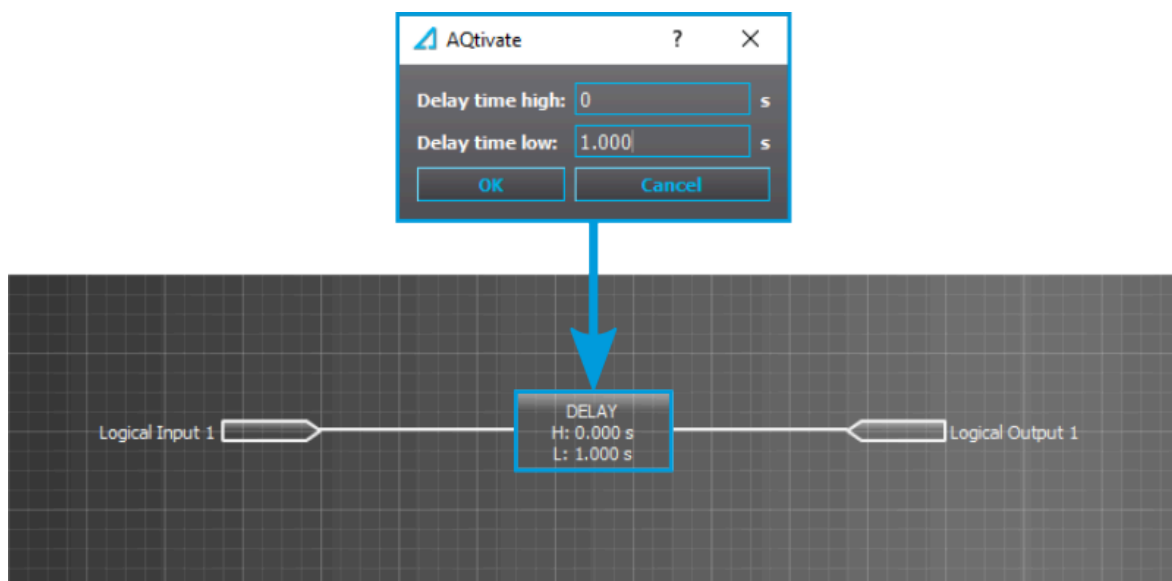

5.5 Monitoring functions

5.5.1 Current transformer supervision

The current transformer supervision function (abbreviated CTS in this document) is used for monitoring the CTs as well as the wirings between the device and the CT inputs for malfunctions and wire breaks. An open CT circuit can generate dangerously high voltages into the CT secondary side, and cause unintended activations of current balance monitoring functions.

Figure. 5.5.1 - 209. Secondary circuit fault in phase L1 wiring.

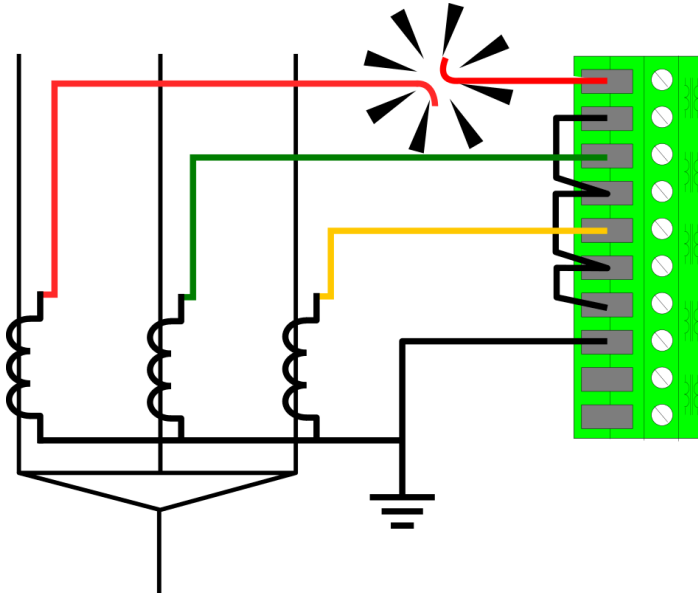

The function constantly monitors the instant values and the key calculated magnitudes of the phase currents. Additionally, the residual current circuit can be monitored if the residual current is measured from a dedicated residual current CT. The user can enable and disable the residual circuit monitoring at will.

The blocking signal and the setting group selection control the operating characteristics of the function during normal operation, i.e. the user or user-defined logic can change function parameters while the function is running.

The outputs of the function are the CTS ALARM and BLOCKED signals. The function uses a total of eight (8) separate setting groups which can be selected from one common source. Also, the operating mode of the function can be changed via setting group selection.

The operational logic consists of the following:

- input magnitude processing
- threshold comparator
- block signal check
- time delay characteristics
- output processing.

The following conditions have to met simultaneously for the function alarm to activate:

- None of the three-phase currents exceeds the I_{set} high limit setting.
- At least one of the three-phase currents exceeds the I_{set} low limit setting.
- At least one of the three-phase currents are below the I_{set} low limit setting.

- The ratio between the calculated minimum and maximum of the three-phase currents is below the $I_{set\ ratio}$ setting.
- The ratio between the negative sequence and the positive sequence exceeds the $I2/I1\ ratio$ setting.
- The calculated difference ($I_{L1}+I_{L2}+I_{L3}+I_0$) exceeds the $I_{sum\ difference}$ setting (optional).
- The above-mentioned condition is met until the set time delay for alarm.

The inputs of the function are the following:

- setting parameters
- measured and pre-processed current magnitudes.

The output signals can be used for direct I/O controlling and user logic programming. The function generates general time-stamped ON/OFF events to the common event buffer from each of the two (2) output signals. The time stamp resolution is 1 ms. The function also provides a resettable cumulative counter for the CTS ALARM and BLOCKED events.

The following figure presents a simplified function block diagram of the current transformer supervision function.

Figure. 5.5.1 - 210. Simplified function block diagram of the CTS function.

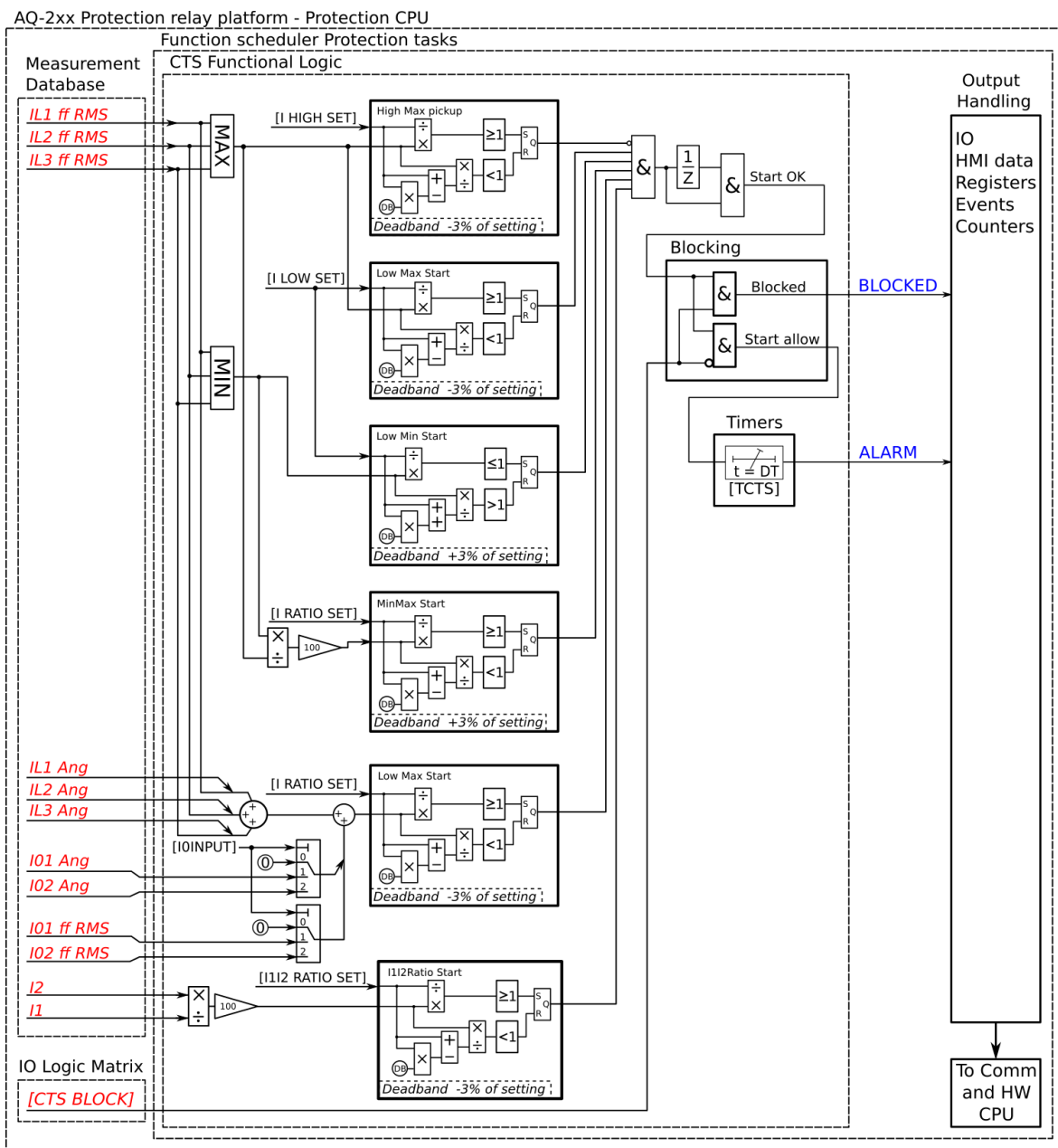

Measured input

The function block uses analog current measurement values, the RMS magnitude of the current measurement inputs, and the calculated positive and negative sequence currents. The user can select what is used for the residual current measurement: nothing, the I01 RMS measurement, or the I02 RMS measurement.

Table. 5.5.1 - 220. Measured inputs of the CTS function.

Signal	Description	Time base
IL1RMS	RMS measurement of phase L1 (A) current	5ms
IL2RMS	RMS measurement of phase L2 (B) current	5ms
IL3RMS	RMS measurement of phase L3 (C) current	5ms
I01RMS	RMS measurement of residual input I01	5ms

Signal	Description	Time base
I02RMS	RMS measurement of residual input I02	5ms
I1	Phase current's positive sequence component	5ms
I2	Phase current's negative sequence component	5ms
IL1Ang	Angle of phase L1 (A) current	5ms
IL2 Ang	Angle of phase L2 (B) current	5ms
IL3 Ang	Angle of phase L3 (C) current	5ms
I01 Ang	Angle of residual input I01	5ms
I02 Ang	Angle of residual input I02	5ms

The selection of the AI channel in use is made with a setting parameter. In all possible input channel variations the pre-fault condition is presented with a 20 ms averaged history value from -20 ms from START or TRIP event.

Table. 5.5.1 - 221. Residual current input signal settings

Name	Range	Step	Default	Description
I0 input selection	0: Not in use 1: I01 2: I02	-	0: Not in use	Selects the measurement input for the residual current. If the residual current is measured with a separate CT, the residual current circuit can be monitored with the CTS function as well. However, this does not apply to summing connections (Holmgren, etc.). If the phase current CT is summed with I01 or I02, this selection should be set to "Not in use".
I0 direction	0: Add 1: Subtract	-	0: Add	Defines the polarity of residual current channel connection.
Comp. natural unbalance	0: - 1: Comp	-	0: -	When activated while the line is energized, the currently present calculated residual current is compensated to 0.

Pick-up

The I_{set} and $I0_{set}$ setting parameters control the current-dependent pick-up and activation of the current transformer supervision function. They define the minimum and maximum allowed measured current before action from the function. The function constantly calculates the ratio between the setting values and the measured magnitude (I_m) for each of the three phases and for the selected residual current input. The reset ratio of 97 % and 103% are built into the function and is always relative to the I_{set} value. The setting value is common for all measured amplitudes, and when the I_m exceeds the I_{set} value (in single, dual or all currents) it triggers the pick-up operation of the function.

Table. 5.5.1 - 222. Pick-up settings.

Name	Range	Step	Default	Description
I_{set} high limit	$0.01 \dots 40.00 \times I_n$	$0.01 \times I_n$	$1.20 \times I_n$	Determines the pick-up threshold for phase current measurement. This setting limit defines the upper limit for the phase current's pick-up element. If this condition is met, it is considered as fault and the function is not activated.
I_{set} low limit	$0.01 \dots 40.00 \times I_n$	$0.01 \times I_n$	$0.10 \times I_n$	Determines the pick-up threshold for phase current measurement. This setting limit defines the lower limit for the phase current's pick-up element. This condition has to be met for the function to activate.

Name	Range	Step	Default	Description
I _{set} ratio	0.01...100.00%	0.01%	10.00%	Determines the pick-up ratio threshold between the minimum and maximum values of the phase current. This condition has to be met for the function to activate.
I _{2/I1} ratio	0.01...100.00%	0.01%	49.00%	Determines the pick-up ratio threshold for the negative and positive sequence currents calculated from the phase currents. This condition has to be met for the function to activate. The ratio is 50 % for a full single-phasing fault (i.e. when one of the phases is lost entirely). Setting this at 49 % allows a current of $0.01 \times I_n$ to flow in one phase, while the other two are at nominal current.
I _{sum} difference	0.01...40.00×I _n	0.01×I _n	0.10×I _n	Determines the pick-up ratio threshold for the calculated residual phase current and the measured residual current. If the measurement circuit is healthy, the sum of these two currents should be 0.
Time delay for alarm	0.000...1800.000s	0.005s	0.5s	Determines the delay between the activation of the function and the alarm.

The pick-up activation of the function is not directly equal to the START signal generation of the function. The START signal is allowed if the blocking condition is not active. When the activation of the pick-up is based on binary signals, the activation happens immediately after the monitored signal is activated.

Function blocking

The block signal is checked in the beginning of each program cycle. The blocking signal is received from the blocking matrix in the function's dedicated input. If the blocking signal is not activated when the pick-up element activates, a START signal is generated and the function proceeds to the time characteristics calculation.

If the blocking signal is active when the pick-up element activates, a BLOCKED signal is generated and the function does not process the situation further. If the START function has been activated before the blocking signal, it resets and the release time characteristics are processed similarly to when the pick-up signal is reset.

The blocking of the function causes an HMI display event and a time-stamped blocking event with information of the startup current values and its fault type to be issued.

The blocking signal can also be tested in the commissioning phase by a software switch signal when the relay's testing mode "Enable stage forcing" is activated (*General* → *Device*).

The variables the user can set are binary signals from the system. The blocking signal needs to reach the device minimum of 5 ms before the set operating delay has passed in order for the blocking to activate in time.

Operating time characteristics

This function supports definite time delay (DT). For detailed information on this delay type please refer to the chapter "General properties of a protection function" and its section "Operating time characteristics for trip and reset".

Typical cases of current transformer supervision

The following nine examples present some typical cases of the current transformer supervision and their setting effects.

Figure. 5.5.1 - 211. All works properly, no faults.

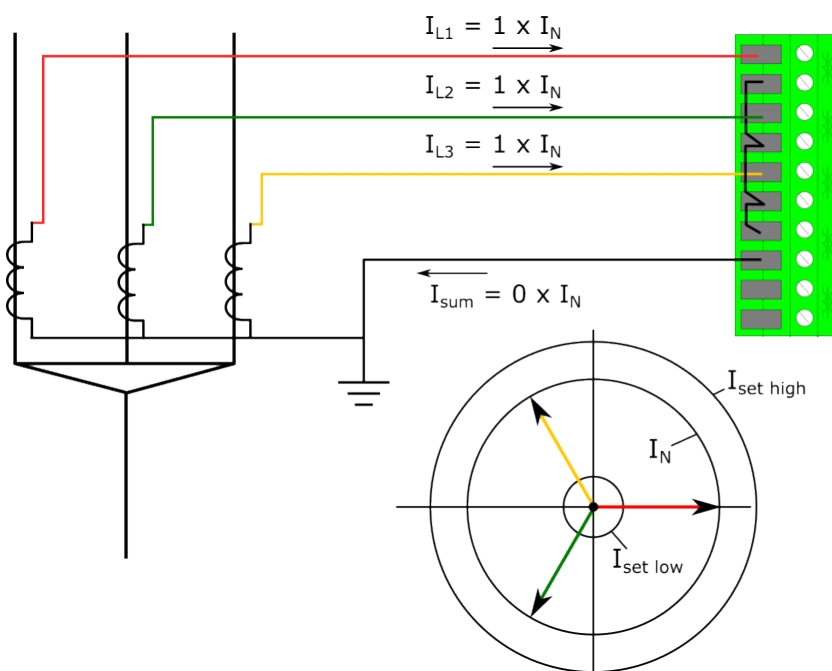

Settings:

$I_{set\ High\ limit} = 1.20 \times I_N$
 $I_{set\ Low\ limit} = 0.10 \times I_N$
 $I_{set\ ratio} = 10.00\ \%$
 $I1/I2\ ratio = 49.00\ \%$
 $I_0\ input = \text{Not in use}$

Measurements:

$I_{min} = 1 \times I_N$
 $I_{max} = 1 \times I_N$
 $I1 = 1 \times I_N$
 $I2 = 0 \times I_N$
 $I_{min}/I_{max} = 1$
 $I2/I1 = 0\%$

CTS conditions:

$I_{set\ High\ limit} < = 1$
 $I_{set\ Low\ limit\ low} < = 0$
 $I_{set\ Low\ limit\ high} > = 1$
 $I\ ratio < = 0$
 $I_{unbalance\ ratio} > = 0$

Figure. 5.5.1 - 212. Secondary circuit fault in phase L1 wiring.

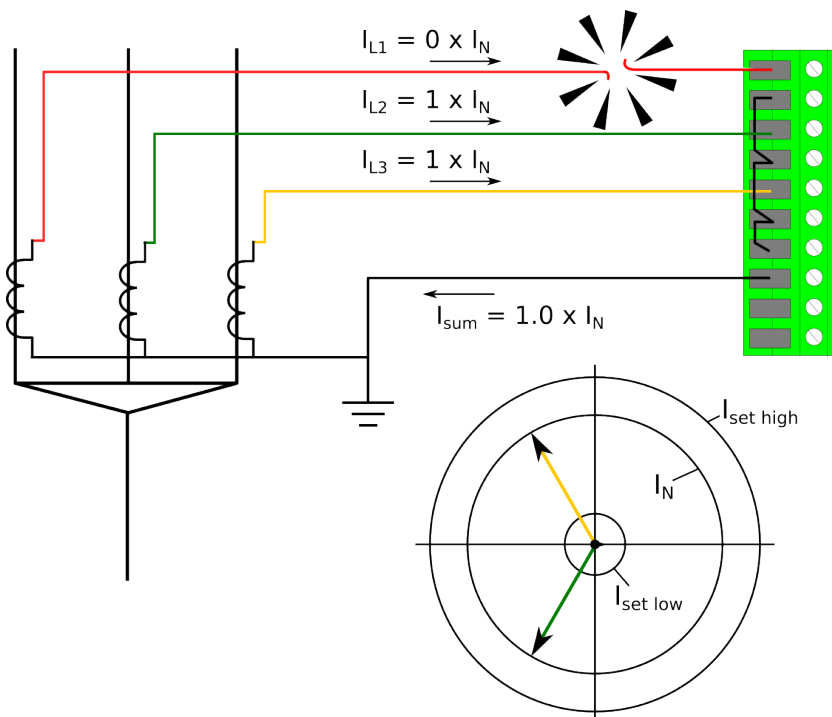

Settings:

$I_{set\ High\ limit} = 1.20 \times I_N$
 $I_{set\ Low\ limit} = 0.10 \times I_N$
 $I_{set\ ratio} = 10.00\ \%$
 $I1/I2\ ratio = 49.00\ \%$
 $I_0\ input = \text{Not in use}$

Measurements:

$I_{min} = 0 \times I_N$
 $I_{max} = 1 \times I_N$
 $I1 = 0.67 \times I_N$
 $I2 = 0.33 \times I_N$
 $I_{min}/I_{max} = 0$
 $I2/I1 = 50\%$

CTS conditions:

$I_{set\ High\ limit} < = 1$
 $I_{set\ Low\ limit\ low} < = 1$
 $I_{set\ Low\ limit\ high} > = 1$
 $I\ ratio < = 1$
 $I_{unbalance\ ratio} > = 1$

When a fault is detected and all conditions are met, the CTS timer starts counting. If the situation continues until the set time has passed, the function issues an alarm.

Figure. 5.5.1 - 213. Primary circuit fault in phase L1 wiring.

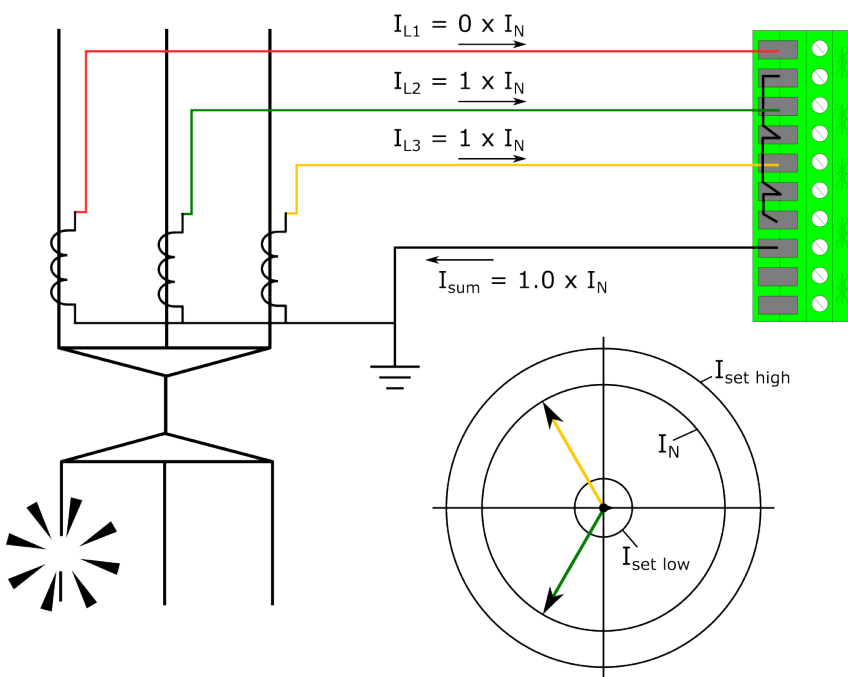

Settings:

I_{set} High limit = $1.20 \times I_N$
 I_{set} Low limit = $0.10 \times I_N$
 I_{set} ratio = 10.00 %
 I1/I2 ratio = 49.00 %
 I_0 input = Not in use

Measurements:

I_{min} = $0 \times I_N$
 I_{max} = $1 \times I_N$
 $I1$ = $0.67 \times I_N$
 $I2$ = $0.33 \times I_N$
 I_{min}/I_{max} = 0
 $I2/I1$ = 50%

CTS conditions:

I_{set} High limit < = 1
 I_{set} Low limit low < = 1
 I_{set} Low limit high > = 1
 I ratio < = 1
 $I_{unbalance}$ ratio > = 1

In this example, distinguishing between a primary fault and a secondary fault is impossible. However, the situation meets the function's activation conditions, and if this state (secondary circuit fault) continues until the set time has passed, the function issues an alarm. This means that the function supervises both the primary and the secondary circuit.

Figure. 5.5.1 - 214. No wiring fault but heavy unbalance.

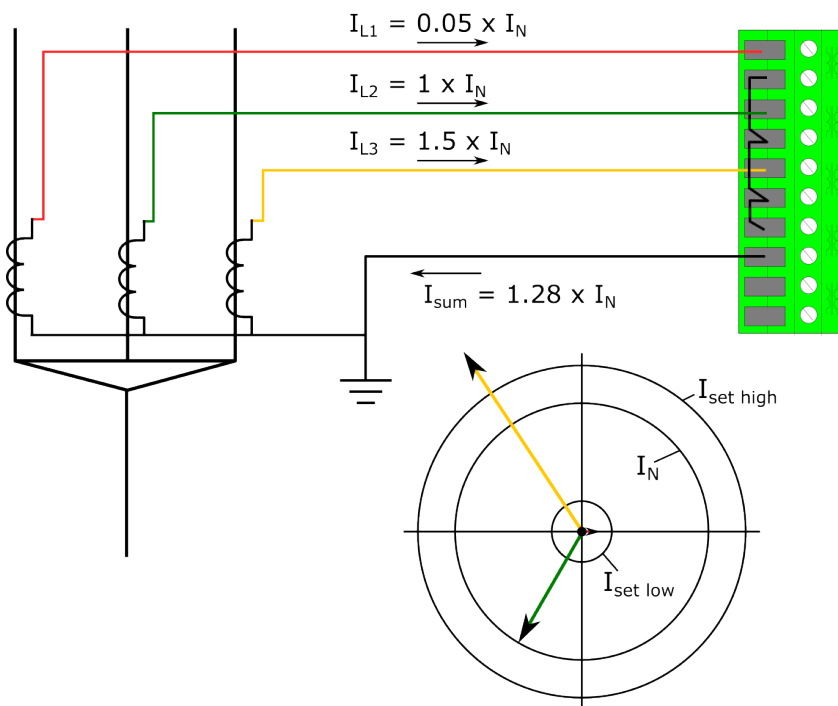

Settings:

I_{set} High limit = $1.20 \times I_N$
 I_{set} Low limit = $0.10 \times I_N$
 I_{set} ratio = 10.00 %
 I1/I2 ratio = 49.00 %
 I_0 input = Not in use

Measurements:

I_{min} = $0.05 \times I_N$
 I_{max} = $1.50 \times I_N$
 $I1$ = $0.85 \times I_N$
 $I2$ = $0.43 \times I_N$
 I_{min}/I_{max} = 0.7 %
 $I2/I1$ = 50.03 %

CTS conditions:

I_{set} High limit < = 0
 I_{set} Low limit low < = 1
 I_{set} Low limit high > = 1
 I ratio < = 1
 $I_{unbalance}$ ratio > = 1

If any of the phases exceed the I_{set} high limit setting, the operation of the function is not activated. This behavior is applied to short-circuits and earth faults even when the fault current exceeds the I_{set} high limit setting.

Figure. 5.5.1 - 215. Low current and heavy unbalance.

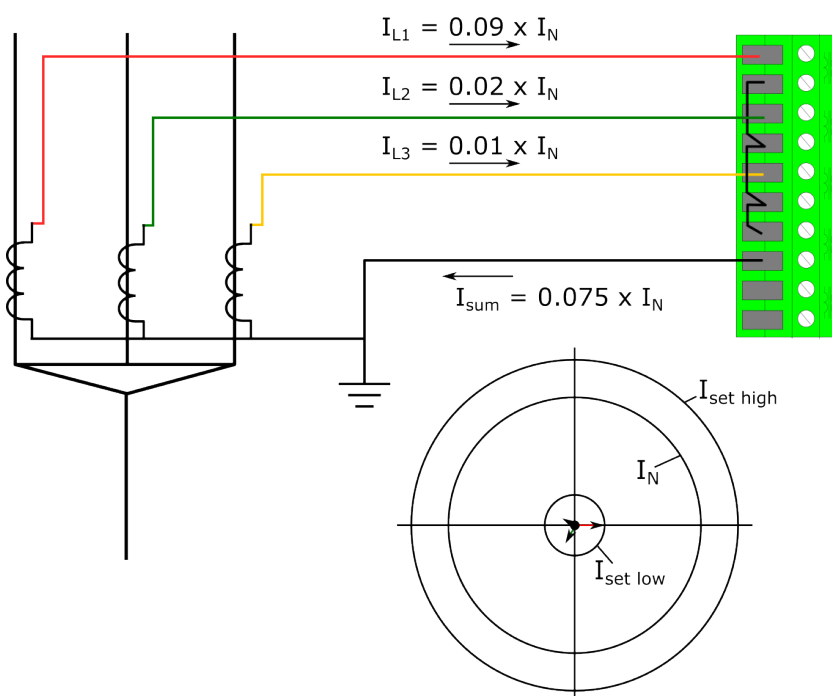

Settings:

I_{set} High limit = $1.20 \times I_N$
 I_{set} Low limit = $0.10 \times I_N$
 I_{set} ratio = 10.00 %
 $I1/I2$ ratio = 49.00 %
 I_0 input = Not in use

Measurements:

$I_{min} = 0.01 \times I_N$
 $I_{max} = 0.09 \times I_N$
 $I1 = 0.04 \times I_N$
 $I2 = 0.03 \times I_N$
 $I_{min}/I_{max} = 11.0 \%$
 $I2/I1 = 62.92 \%$

CTS conditions:

I_{set} High limit ≤ 1
 I_{set} Low limit low ≤ 1
 I_{set} Low limit high > 0
 I ratio ≤ 1
 $I_{unbalance}$ ratio > 1

If all of the measured phase magnitudes are below the I_{set} low limit setting, the function is not activated even when the other conditions (inc. the unbalance condition) are met.

If the I_{set} high limit and I_{set} low limit setting parameters are adjusted according to the application's normal behavior, the operation of the function can be set to be very sensitive for broken circuit and conductor faults.

Figure. 5.5.1 - 216. Normal situation, residual current also measured.

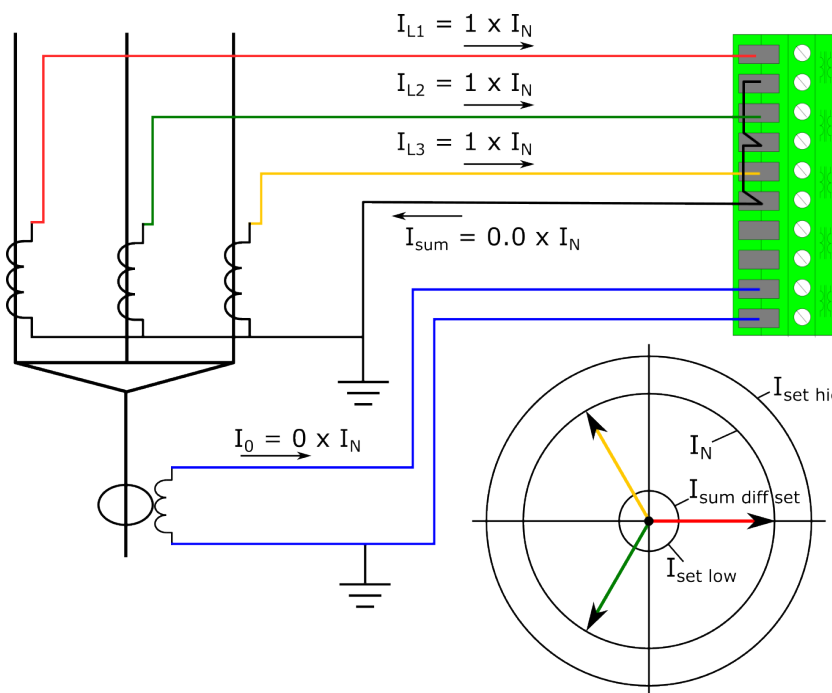

Settings:

I_{set} High limit = $1.20 \times I_N$
 I_{set} Low limit = $0.10 \times I_N$
 I_{set} ratio = 10.00 %
 $I1/I2$ ratio = 49.00 %
 I_0 input = I_{01}
 I_{sum} Difference = $0.10 \times I_N$

Measurements:

$I_{min} = 1 \times I_N$
 $I_{max} = 1 \times I_N$
 $I1 = 1 \times I_N$
 $I2 = 0 \times I_N$
 $I_{min}/I_{max} = 1$
 $I2/I1 = 0$
 I_{sum} Difference = $0.0 \times I_N$

CTS conditions:

I_{set} High limit ≤ 1
 I_{set} Low limit low ≤ 0
 I_{set} Low limit high ≥ 1
 I ratio ≤ 0
 $I_{unbalance}$ ratio > 0

When the residual condition is added with the "I0 input selection", the sum of the current and the residual current are compared against each other to verify the wiring condition.

Figure. 5.5.1 - 217. Broken secondary phase current wiring.

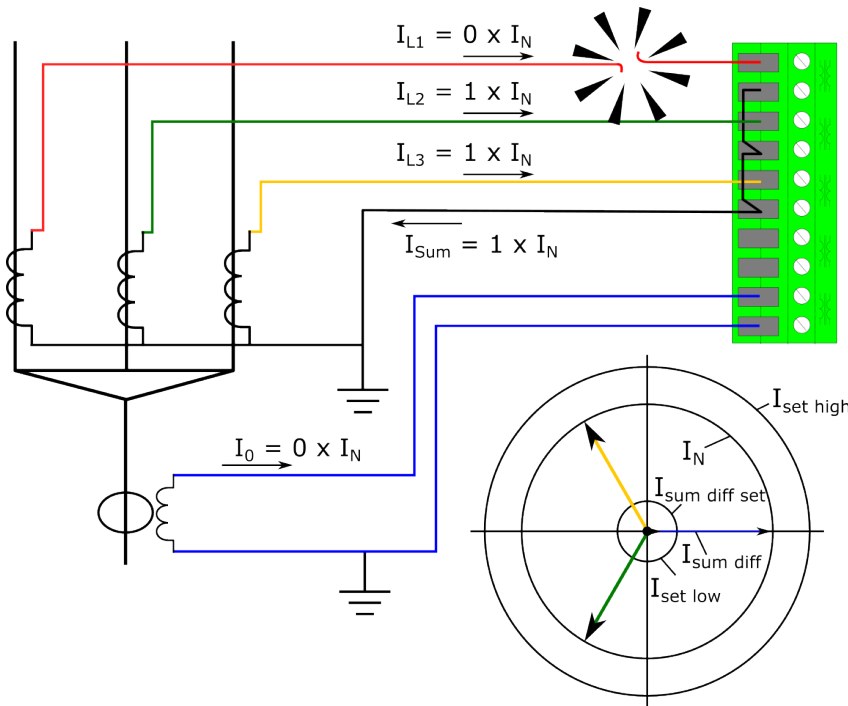

- Settings:**
 I_{set} High limit = $1.20 \times I_N$
 I_{set} Low limit = $0.10 \times I_N$
 I_{set} ratio = 10.00 %
 I1/I2 ratio = 49.00 %
 I_0 input = I_{01}
 I_{sum} Difference = $0.10 \times I_N$
- Measurements:**
 I_{min} = $1 \times I_N$
 I_{max} = $0 \times I_N$
 $I1$ = $0.67 \times I_N$
 $I2$ = $0.33 \times I_N$
 I_{min}/I_{max} = 0
 $I2/I1$ = 50 %
 I_{sum} Difference = $1.0 \times I_N$
- CTS conditions:**
 I_{set} High limit ≤ 1
 I_{set} Low limit low ≤ 1
 I_{set} Low limit high ≥ 1
 I ratio ≤ 1
 $I_{unbalance}$ ratio ≥ 1
 I_{sum} Difference ≥ 1

When phase current wire is broken all of the conditions are met in the CTS and alarm shall be issued in case if the situation continues until the set alarming time is met.

Figure. 5.5.1 - 218. Broken primary phase current wiring.

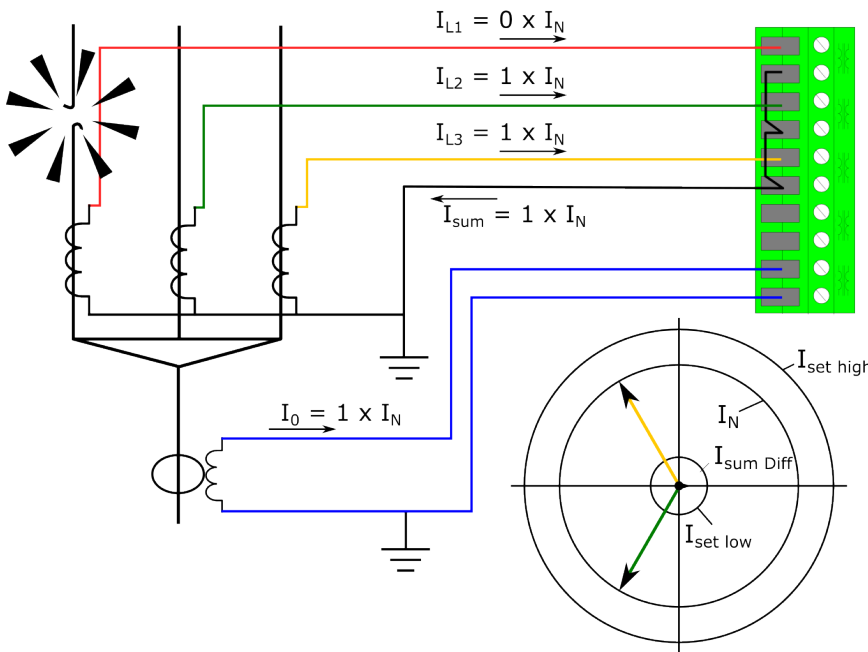

- Settings:**
 I_{set} High limit = $1.20 \times I_N$
 I_{set} Low limit = $0.10 \times I_N$
 I_{set} ratio = 10.00 %
 I1/I2 ratio = 49.00 %
 I_0 input = I_{01}
 I_{sum} Difference = $0.10 \times I_N$
- Measurements:**
 I_{min} = $0 \times I_N$
 I_{max} = $1 \times I_N$
 $I1$ = $0.67 \times I_N$
 $I2$ = $0.33 \times I_N$
 I_{min}/I_{max} = 0
 $I2/I1$ = 50 %
 I_{sum} Difference = $0.0 \times I_N$
- CTS conditions:**
 I_{set} High limit ≤ 1
 I_{set} Low limit low ≤ 1
 I_{set} Low limit high ≥ 1
 I ratio ≤ 1
 $I_{unbalance}$ ratio ≥ 1
 I_{sum} Difference ≥ 0

In this example, all other condition are met except the residual difference. That is now $0 \times I_n$, which indicates a primary side fault.

Figure. 5.5.1 - 219. Primary side high-impedance earth fault.

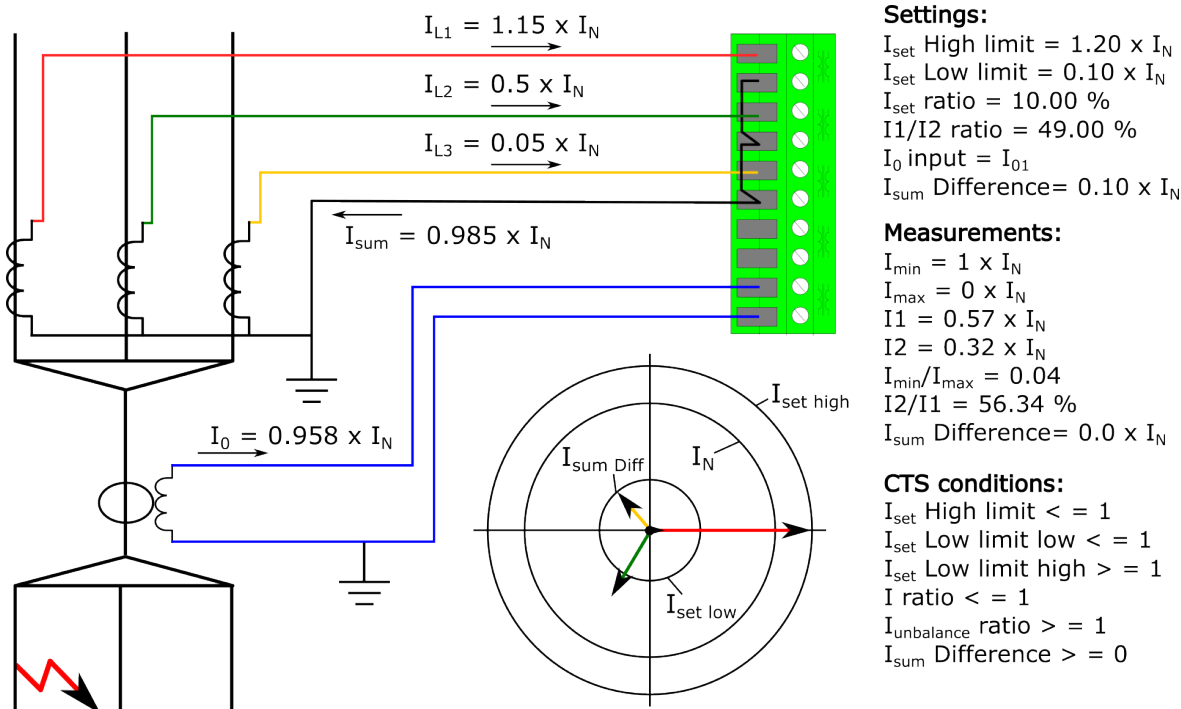

In this example there is a high-impedance earth fault. It does not activate the function, if the measurement conditions are met, while the calculated and measured residual current difference does not reach the limit. The $I_{sum\ difference}$ setting should be set according to the application in order to reach maximum security and maximum sensitivity for the network earthing.

Events and registers

The current transformer supervision function (abbreviated "CTS" in event block names) generates events and registers from the status changes in ALARM ACTIVATED and BLOCKED signals. The user can select which event messages are stored in the main event buffer: ON, OFF, or both.

The events triggered by the function are recorded with a time stamp and with process data values.

Table. 5.5.1 - 223. Event codes.

Event number	Event channel	Event block name	Event code	Description
3328	52	CTS1	0	Alarm ON
3329	52	CTS1	1	Alarm OFF
3330	52	CTS1	2	Block ON
3331	52	CTS1	3	Block OFF

The function registers its operation into the last twelve (12) time-stamped registers; this information is available for all provided instances separately. The register of the function records the ON event process data for ACTIVATED, BLOCKED, etc. The table below presents the structure of the function's register content.

Table. 5.5.1 - 224. Register content.

Date and time	Event code	Trigger currents	Time to CTSact	Ftype	Used SG
dd.mm.yyyy hh:mm:ss.mss	3328-3459 Descr.	The phase currents (L1, L2 & L3), the residual currents (I01 & I02), and the sequence currents (I1 & I2) on trigger time.	Time remaining before the function is active.	The status code of the monitored current.	Setting group 1...8 active.

5.5.2 Voltage transformer supervision (60)

Voltage transformer supervision is used to detect errors in the secondary circuit of the voltage transformer during fuse failure. This signal is mostly used as an alarming function or to disable functions that require adequate voltage measurement.

Figure. 5.5.2 - 220. Secondary circuit fault in phase L1 wiring.

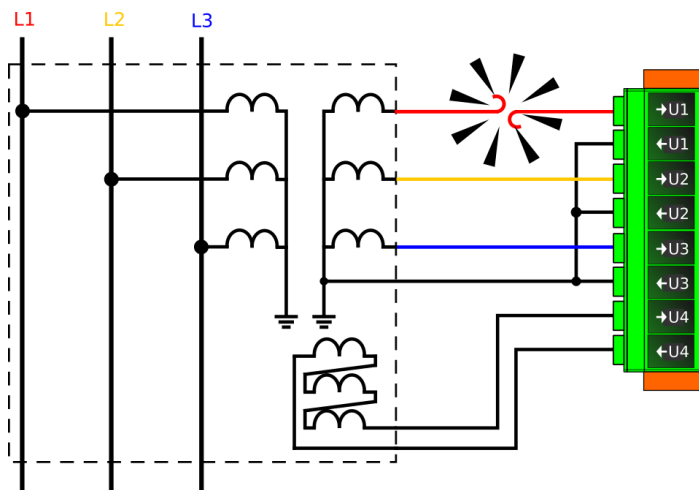

The following figure presents a simplified function block diagram of the voltage transformer supervision function.

Figure. 5.5.2 - 221. Simplified function block diagram of the VTS function.

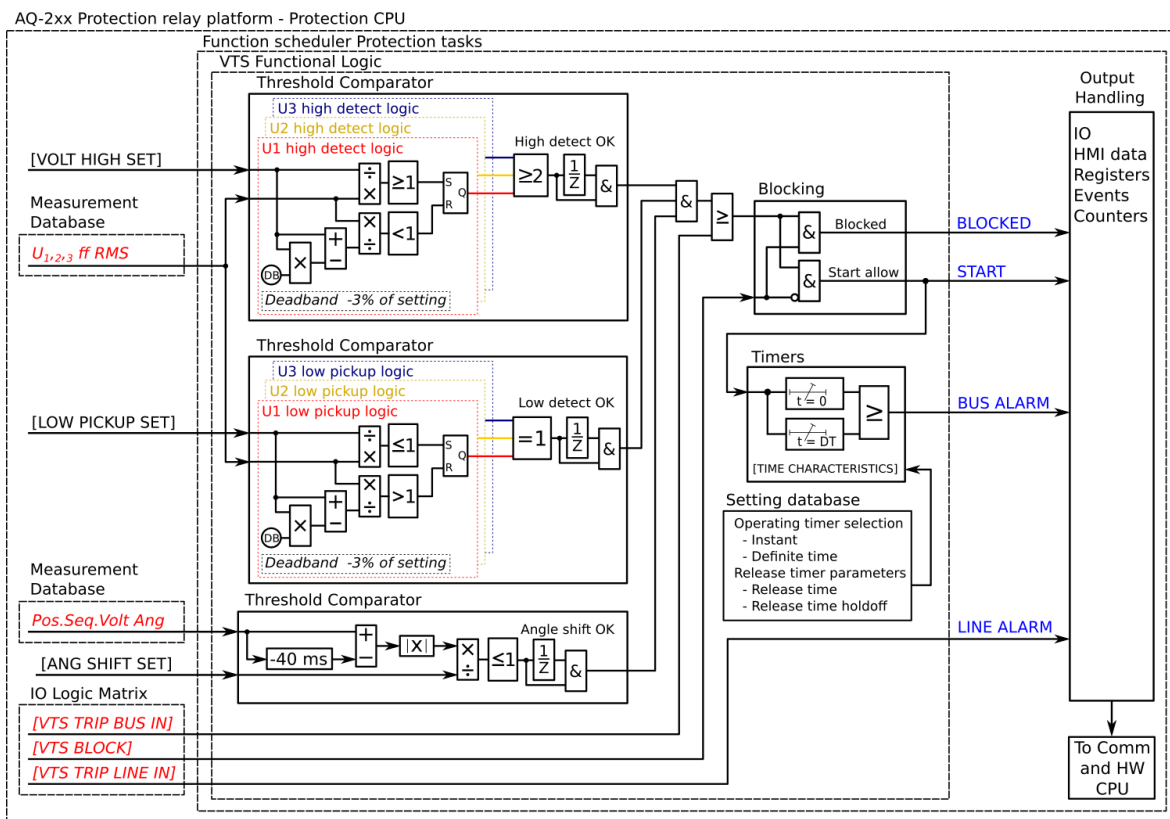

Measured input

The function block uses analog voltage measurement values. Function uses the RMS value of the voltage measurement inputs and the calculated (positive, negative and zero) sequence currents.

Table. 5.5.2 - 225. Measurement inputs of the voltage transformer supervision function.

Signal	Description	Time base
U _{L12} RMS	RMS measurement of voltage U _{L12} /V	5ms
U _{L23} RMS	RMS measurement of voltage U _{L23} /V	5ms
U _{L31} RMS	RMS measurement of voltage U _{L31} /V	5ms
U _{L1} RMS	RMS measurement of voltage U _{L1} /V	5ms
U _{L2} RMS	RMS measurement of voltage U _{L2} /V	5ms
U _{L3} RMS	RMS measurement of voltage U _{L3} /V	5ms
U1P	Positive sequence voltage	5ms
U2N	Negative sequence voltage	5ms
UZ0	Zero sequence voltage	5ms
U _{L12} Ang	Angle of U _{L12} voltage	5ms
U _{L23} Ang	Angle of U _{L23} voltage	5ms
U _{L31} Ang	Angle of U _{L31} voltage	5ms
U _{L1} Ang	Angle of U _{L1} voltage	5ms
U _{L2} Ang	Angle of U _{L2} voltage	5ms

Signal	Description	Time base
UL3Ang	Angle of UL3 voltage	5ms

The selection of the AI channel in use is made with a setting parameter. In all possible input channel variations the pre-fault condition is presented with a 20 ms averaged history value from -20 ms from START or TRIP event.

Pick-up

The *Voltage low pick-up* and *Voltage high detect* setting parameters control the voltage-dependent pick-up and activation of the voltage transformer supervision function. The function's pick-up activates, if at least one of the three voltages is under the set *Voltage low pick-up* value, or if at least two of the three voltages exceed the set *Voltage high detect* value. The function constantly calculates the ratio between the setting values and the measured magnitude for each of the three phases.

Table. 5.5.2 - 226. Pick-up settings.

Name	Range	Step	Default	Description
Voltage low pickup	0.05...0.50×U _n	0.01×U _n	0.05×U _n	If one the measured voltages is below low pickup value and two of the measured voltages exceed high detect value the function's pick-up activates.
Voltage high detect	0.01...1.10×U _n	0.01×U _n	0.80×U _n	
Angle shift limit	2.00...90.00deg	0.10deg	5.00deg	If the difference between the present angle and the angle 40 ms before is below the set value, the function's pick-up is blocked.
Bus fuse fail check	0: No 1: Yes	-	1: Yes	Selects whether or not the state of the bus fuse is supervised. The supervised signal is determined the "VTS MCB Trip bus" setting (// 0 → Fuse failure inputs).
Line fuse fail check	0: No 1: Yes	-	1: Yes	Selects whether or not the state of the line fuse is supervised. The supervised signal is determined by the "VTS MCB Trip line" setting (// 0 → Fuse failure inputs).

The pick-up activation of the function is not directly equal to the START signal generation of the function. The START signal is allowed if the blocking condition is not active. When the activation of the pick-up is based on binary signals, the activation happens immediately after the monitored signal is activated.

The voltage transformer supervision can also report several different states of the measured voltage. These can be seen in the function's *INFO* tab in the relay's HMI or in AQtivate.

Name	Description
Bus dead	No voltages.
Bus Live VTS Ok	All of the voltages are within the set limits.
Bus Live VTS Ok SEQ Rev	All of the voltages are within the set limits BUT the voltages are in a reversed sequence.
Bus Live VTS Ok SEQ Undef	Voltages are within the set limits BUT the sequence cannot be defined.
Bus Live VTS problem	Any of the VTS pick-up conditions are met.

Read-only parameters

The relay's *Info* page displays useful, real-time information on the state of the protection function. It is accessed either through the relay's HMI display, or through the setting tool software when it is connected to the relay and its Live Edit mode is active.

Table. 5.5.2 - 227. Information displayed by the function.

Name	Range	Step	Description
VTS condition	0: Normal 1: Start 2: VTLinefail 3: VTBusfail 4: Blocked	-	Displays status of the monitoring function.
Bus voltages	0: Bus dead 1: Bus Live VTS Ok SEQ Ok 2: Bus Live VTS Ok SEQ Rev 3: Bus Live VTS Ok SEQ Undef 4: Bus Live VTS problem	-	Displays the status of bus voltages.
Expected operating time	0.000...1800.000s	0.005s	Displays the expected operating time when a fault occurs.
Time remaining to trip	-1800.000...1800.000s	0.005s	When the function has detected a fault and counts down time towards a operation, this displays how much time is left before operation occurs.

Function blocking

The block signal is checked in the beginning of each program cycle. The blocking signal is received from the blocking matrix in the function's dedicated input. If the blocking signal is not activated when the pick-up element activates, a START signal is generated and the function proceeds to the time characteristics calculation.

If the blocking signal is active when the pick-up element activates, a BLOCKED signal is generated and the function does not process the situation further. If the START function has been activated before the blocking signal, it resets and the release time characteristics are processed similarly to when the pick-up signal is reset.

The blocking of the function causes an HMI display event and a time-stamped blocking event with information of the startup voltage values and its fault type to be issued.

The blocking signal can also be tested in the commissioning phase by a software switch signal when the relay's testing mode "Enable stage forcing" is activated (*General* → *Device*).

The variables the user can set are binary signals from the system. The blocking signal needs to reach the device minimum of 5 ms before the set operating delay has passed in order for the blocking to activate in time.

Operating time characteristics for activation

This function supports definite time delay (DT). For detailed information on this delay type please refer to the chapter "General properties of a protection function" and its section "Operating time characteristics for trip and reset".

Events and registers

The voltage transformer supervision function (abbreviated "VTS" in event block names) generates events and registers from the status changes in ALARM ACTIVATED and BLOCKED signals. The user can select which event messages are stored in the main event buffer: ON, OFF, or both.

The events triggered by the function are recorded with a time stamp and with process data values.

Table. 5.5.2 - 228. Event codes.

Event number	Event channel	Event block name	Event code	Description
3392	53	VTS1	0	Bus VT fail Start ON
3393	53	VTS1	1	Bus VT fail Start OFF
3394	53	VTS1	2	Bus VT fail Trip ON
3395	53	VTS1	3	Bus VT fail Trip OFF
3396	53	VTS1	4	Bus VT fail Block ON
3397	53	VTS1	5	Bus VT fail Block OFF
3398	53	VTS1	6	Line VT fail ON
3399	53	VTS1	7	Line VT fail OFF
3400	53	VTS1	8	Bus Fuse fail ON
3401	53	VTS1	9	Bus Fuse fail OFF
3402	53	VTS1	10	Line Fuse fail ON
3403	53	VTS1	11	Line Fuse fail OFF

The function registers its operation into the last twelve (12) time-stamped registers. The register of the function records the ON event process data for ACTIVATED, BLOCKED, etc. The table below presents the structure of the function's register content.

Table. 5.5.2 - 229. Register content.

Date and time	Event code	Volt 1, 2, 3, 4 status	System status	Input A, B, C, D angle diff	Trip time remaining	Used SG
dd.mm.yyyy hh:mm:ss.mss	3392-3403 Descr.	0: No voltage 1: Voltage OK 2: Low voltage	0: Bus dead 1: Bus live, VTS OK, Seq. OK 2: Bus live, VTS OK, Seq. reversed 3: Bus live, VTS OK, Seq. undefined 4: Bus live, VTS fault	0.00...360.00deg	0...1800s	Setting group 1...8 active

5.5.3 Circuit breaker wear

The circuit breaker wear function is used for monitoring the circuit breaker's lifetime and its maintenance needs caused by interrupting currents and mechanical wear. The function uses the circuit breaker's manufacturer-supplied data for the breaker operating cycles in relation to the interrupted current magnitudes. The function is integrated into the object control function and can be enabled and set under that function's settings. However, the circuit breaker wear function is an independent function and it initializes as an independent instance which has its own events and settings not related to the object it is linked to.

Figure. 5.5.3 - 222. Example of the circuit breaker interrupting life operations.

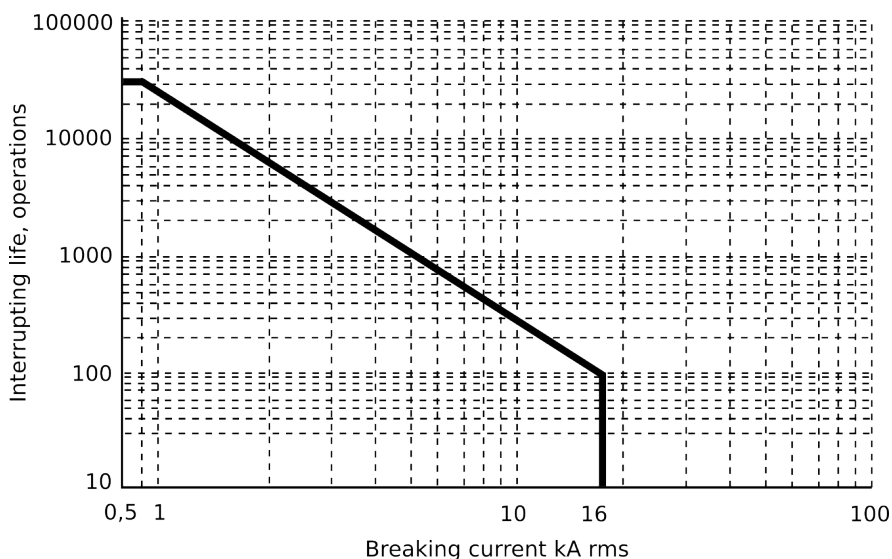

The function is triggered from the circuit breaker's "Open" command output and it monitors the three-phase current values in both the tripping moment and the normal breaker opening moment. The maximum value of interrupting life operations for each phase is calculated from these currents. The value is cumulatively deducted from the starting operations starting value. The user can set up two separate alarm levels, which are activated when the value of interrupting life operations is below the setting limit. The "Trip contact" setting defines the output that triggers the current monitoring at the breaker's "Open" command.

The outputs of the function are the ALARM 1 and ALARM 2 signals.

The inputs for the function are the following:

- setting parameters
- binary output signals
- measured and pre-processed current magnitudes.

The function's output signals can be used for direct I/O controlling and user logic programming. The function generates general time-stamped ON/OFF events to the common event buffer from each of the two (2) output signal. The time stamp resolution is 1 ms. The function also provides a resettable cumulative counter for the "Open" operations as well as the ALARM 1 and ALARM 2 events. The function can also monitor the operations left for each phase.

The following figure presents a simplified function block diagram of the circuit breaker wear function.

Figure. 5.5.3 - 223. Simplified function block diagram of the circuit breaker wear function.

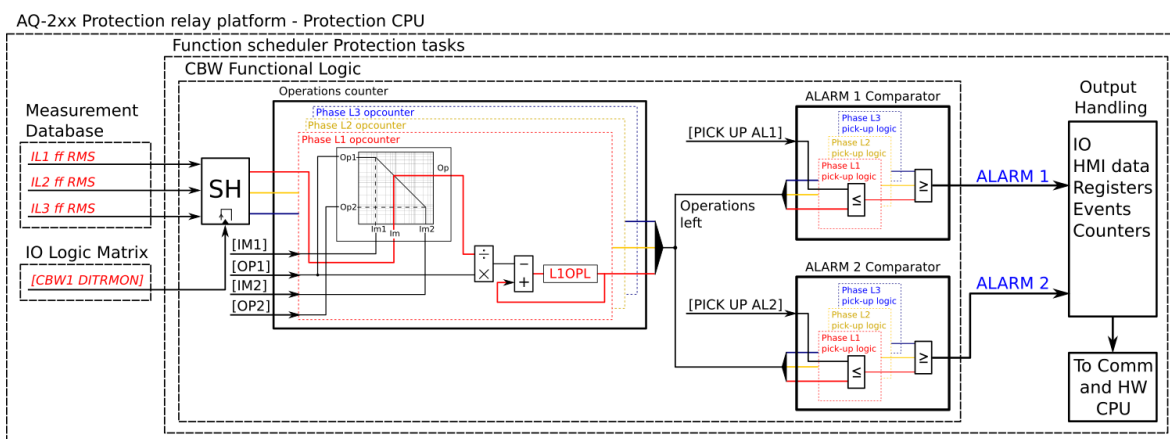

Measured input

The function block uses analog current measurement values and always uses the RMS magnitude of the current measurement input.

Table. 5.5.3 - 230. Measurement inputs of the circuit breaker wear function.

Signal	Description	Time base
IL1RMS	RMS measurement of phase L1 (A) current	5ms
IL2RMS	RMS measurement of phase L2 (B) current	5ms
IL3RMS	RMS measurement of phase L3 (C) current	5ms

Circuit breaker characteristics settings

The circuit breaker characteristics are set by two operating points, defined by the nominal breaking current, the maximum allowed breaking current and their respective operation settings. This data is provided by the circuit breaker's manufacturer.

Table. 5.5.3 - 231. Settings for circuit breaker characteristics.

Name	Range	Step	Default	Description
Operations 1	0...200 000	1	50 000	The number of interrupting life operations at the nominal current (Close - Open).
Operations 2	0...200 000	1	100	The number of interrupting life operations at the rated breaking current (Open).
Current 1 (I _{nom})	0...100.00kA	0.01kA	1kA	The rated normal current (RMS).
Current 2 (I _{max})	0...100.00kA	0.01kA	20kA	The rated short-circuit breaking current (RMS).

Pick-up for alarming

For the alarm stages Alarm 1 and Alarm 2, the user can set the pick-up level for the number of operations left. The pick-up setting is common for all phases and the alarm stage picks up if any of the phases goes below this setting.

Table. 5.5.3 - 232. Pick-up settings.

Name	Range	Step	Default	Description
Alarm 1	0: Disabled 1: Enabled	-	0: Disabled	Enable and disable the Alarm 1 stage.
Alarm 1 Set	0...200 000	1	1 000	Defines the pick-up threshold for remaining operations. When the number of remaining operations is below this setting, the ALARM 1 signal is activated.
Alarm 2	0: Disabled 1: Enabled	-	0: Disabled	Enable and disable the Alarm 2 stage.
Alarm 2 Set	0...200 000	1	100	Defines the pick-up threshold for remaining operations. When the number of remaining operations is below this setting, the ALARM 2 signal is activated.

Setting example

Let us examine the settings, using a low-duty vacuum circuit breaker (ISM25_LD_1/3) manufactured by Tavrida as an example. The image below presents the technical specifications provided by the manufacturer, with the data relevant to our settings highlighted in red:

Rated voltage, kV	24
Rated current, A	800
Rated power frequency test voltage, kV	50
Rated frequency, Hz	50/60
Rated impulse test voltage, kV peak	125
Partial discharge level at 1,1 rated voltage kV, pC	<10
Rated short-circuit breaking current, kA	16
Rated short-circuit making current, kA peak	41.5
Short time withstand current, 4s, kA	16
Mechanical life, CO cycles, not less than	30,000
Interrupting life operations, not less than	
at rated current	30,000
at breaking current	100
at other currents	see Fig.41
Closing time, ms, not more than	35
Opening time, ms, not more than	15
Breaking time, ms, not more than	25
Main contact resistance, μ Ohm, not more than	40
Maximum ambient temperature, C°	+55
Minimum ambient temperature, C°	-40
Design class (according to IEC 60932)	1
Electrical endurance class at rated IEEE/IEC duty	E2
Mechanical endurance class at rated IEEE/IEC duty	M2
Capacitive current switching class	C2
"Mechanical vibration and shock withstand capability, IEC 60721, IEC 60068"	Class 4M4
Maximum altitude above sea level, m	3000*
Maximum humidity, non condensing	98 %
Weight, kg - LD_1	35
Weight, kg - LD_6	55

Now, we set the stage as follows:

Parameter	Setting
Current 1	0.80 kA
Operation 1	30 000 operations
Current 2	16.00 kA
Operations 2	100 operations
Enable Alarm 1	1: Enabled
Alarm 1 Set	1000 operations
Enable Alarm 2	1: Enabled

Parameter	Setting
Alarm 2 Set	100 operations

With these settings, Alarm 1 is issued when the cumulative interruption counter for any of the three phases dips below the set 1000 remaining operations ("Alarm 1 Set"). Similarly, when any of the counters dips below 100 remaining operations, Alarm 2 is issued.

Events and registers

The circuit breaker wear function (abbreviated "CBW" in event block names) generates events and registers from the status changes in Triggered, Alarm 1 and Alarm 2 signals as well as in internal pick-up comparators. The user can select which event messages are stored in the main event buffer: ON, OFF, or both.

The events triggered by the function are recorded with a time stamp and with process data values.

Table. 5.5.3 - 233. Event codes.

Event number	Event channel	Event block name	Event code	Description
3712	58	CBW1	0	CBWEAR1 Triggered
3713	58	CBW1	1	CBWEAR1 Alarm 1 ON
3714	58	CBW1	2	CBWEAR1 Alarm 1 OFF
3715	58	CBW1	3	CBWEAR1 Alarm 2 ON
3716	58	CBW1	4	CBWEAR1 Alarm 2 OFF

The function registers its operation into the last twelve (12) time-stamped registers. The register of the function records the ON event process data. The table below presents the structure of the function's register content.

Table. 5.5.3 - 234. Register content.

Date and time	Event code	Trigger current	All.Op.ITrg	Deduct. Op	Op.Left
dd.mm.yyyy hh:mm:ss.mss	3712-3716 Descr.	Phase currents on trigger time	Allowed operations with trigger current	Deducted operations from the cumulative sum	Operations left

5.5.4 Fault locator (21FL)

The fault locator function is used for recording an estimated distance to the point where a fault has occurred. It is mostly used in directional overcurrent protection or distance protection applications but can be also triggered by other protections. The function can be used if all three phase currents and three phase voltages have been connected to the relay. The triggering signals, the triggering current and "Reactance per km" must be set in the configuration.

The inputs for the function are the following:

- operating mode selections
- setting parameters
- digital inputs and logic signals
- measured and pre-processed current magnitudes.

The function generates general time-stamped ON/OFF events to the common event buffer from each of the two (2) output signals. The time stamp resolution is 1 ms. The function also provides a resettable cumulative counter for the fault locator triggering events.

Measured input

Function block uses analog current and voltage measurements and calculated phase-to-phase or phase-to-ground loop impedances.

Table. 5.5.4 - 235. Measurement inputs of the 21FL function.

Signals	Description	Time base
VT1 U1, U2, U3	The line-to-neutral or line-to-line voltages of the first voltage transformer module.	5ms
CT1 IL1, IL2, IL3	The measurements of the phase currents L1 (A), L2 (B) and L3 (C).	5ms

Fault locator triggering

The "Trig fault locator" input defines which signal triggers the fault locator. This can be any binary signal generated by the unit. Typically, a TRIP signal of a protection function or the "Open" status of the breaker is used as the triggering input.

Several conditions have to be met before the fault locator can trigger and record the distance to a fault. First, when receiving a triggering signal, the function checks if the calculation is blocked. The calculation blocking signals are determined by the "Block calculation" matrix set by the user. Next, the function checks if any phase-to-earth voltages are available. If there are no available voltages, the function can only record phase-to-phase impedance loops. If there are available voltages, the function can also record phase-to-neutral impedance loops. Depending on the measured phase currents at the moment the triggering signal was received, the recorded impedance loop is selected from the available options. See the table "Required current conditions" for more information on which conditions have to be met to trigger impedance recording.

Table. 5.5.4 - 236. Pick-up settings.

Name	Range	Step	Default	Description
Trigger current>	0.0...40.0×I _n	0.1×I _n	1×I _n	Sets the trigger current. Affects which impedance loop is recorded, if anything is recorded at all (see the table below).
Reactance per km	0.000...5.000Ω/km	0.001Ω/km	0.125Ω/km	This setting helps calculate the distance to a fault.

Table. 5.5.4 - 237. Required current conditions.

Currents over limit	P-E voltages available	P-E voltages not available
	Recorded impedance	
IL1, IL2, IL3	XL12	XL12
IL1, IL2	XL12	XL12
IL2, IL3	XL23	XL23
IL1, IL3	XL31	XL31
IL1	XL1	No trigger
IL2	XL2	No trigger
IL3	XL3	No trigger

If no current measurement requirements are fulfilled when the function receives a triggering signal, the function will not record impedance at all.

Function blocking

The block signal is checked in the beginning of each program cycle. The blocking signal is received from the blocking matrix in the function's dedicated input. If the blocking signal is active when the pick-up element activates, a BLOCKED signal is generated and the function does not process the situation further.

The blocking of the function causes an HMI display event and a time-stamped blocking event with information of the startup voltage values and its fault type to be issued.

The blocking signal can also be tested in the commissioning phase by a software switch signal when the relay's testing mode "Enable stage forcing" is activated (*General* → *Device*).

The variables the user can set are binary signals from the system. The blocking signal needs to reach the device minimum of 5 ms before the set operating delay has passed in order for the blocking to activate in time.

Events

The fault locator function (abbreviated "FLX" in event block names) generates events and registers from the status changes in triggering and calculation. The user can select which event messages are stored in the main event buffer: ON, OFF, or both.

The events triggered by the function are recorded with a time stamp and with process data values.

Table. 5.5.4 - 238. Event codes.

Event Number	Event channel	Event block name	Event Code	Description
2752	43	FLX1	0	Flocator triggered ON
2753	43	FLX1	1	Flocator triggered OFF
2754	43	FLX1	2	Flocator Calculation ON
2755	43	FLX1	3	Flocator Calculation OFF

The function registers its operation into the last twelve (12) time-stamped registers. The table below presents the structure of the function's register content.

Table. 5.5.4 - 239. Register content.

Date and time	Event code	Fault type	Fault direction	Fault reactance	Fault current	Fault current	Fault distance	Setting group in use
dd.mm.yyyy hh:mm:ss.mss	2752-2755 Descr.	L1-L2; L2-L3; L3-L1; L1-N; L2-N; L3-N; L1-L2-L3	Not detected; Forward; Reverse	In ohms (Ω)	In per-unit value	In primary value	In kilometers (km)	Setting group 1...8 active

5.5.5 Total harmonic distortion (THD)

The total harmonic distortion (THD) function is used for monitoring the content of the current harmonic. The THD is a measurement of the harmonic distortion present, and it is defined as the ratio between the sum of all harmonic components' powers and the power of the fundamental frequency (RMS).

Harmonics can be caused by different sources in electric networks such as electric machine drives, thyristor controls, etc. The function's monitoring of the currents can be used to alarm of the harmonic content rising too high; this can occur when there is an electric quality requirement in the protected unit, or when the harmonics generated by the process need to be monitored.

The function constantly measures the phase and residual current magnitudes as well as the harmonic content of the monitored signals up to the 31st harmonic component. When the function is activated, the measurements are also available for the mimic and the measurement views in the HMI carousel. The user can also set the alarming limits for each measured channel if the application so requires.

The monitoring of the measured signals can be selected to be based either on an amplitude ratio or on the above-mentioned power ratio. The difference is in the calculation formula (as shown below):

Figure. 5.5.5 - 224. THD calculation formulas.

$$THD_P = \frac{I_{x2}^2 + I_{x3}^2 + I_{x4}^2 \dots I_{x31}^2}{I_{x1}^2}$$

, where
I = measured current,
x = measurement input,
n = harmonic number

$$THD_A = \sqrt{\frac{I_{x2}^2 + I_{x3}^2 + I_{x4}^2 \dots I_{x31}^2}{I_{x1}^2}}$$

, where
I = measured current,
x = measurement input,
n = harmonic number

While both of these formulas exist, the power ratio (THD_P) is recognized by the IEEE, and the amplitude ratio (THD_A) is recognized by the IEC.

The blocking signal and the setting group selection control the operating characteristics of the function during normal operation, i.e. the user or user-defined logic can change function parameters while the function is running. This only applies if the alarming is activated.

The outputs of the function are the START and ALARM ACT signals for the phase current ("THDPH") and the residual currents ("THDI01" and "THDI02") as well as BLOCKED signals. The function uses a total of eight (8) separate setting groups which can be selected from one common source.

The operational logic consists of the following:

- input magnitude processing
- threshold comparator
- block signal chec
- time delay characteristics
- output processing.

The inputs of the function are the following:

- setting parameters
- digital inputs and logic signals
- measured and pre-processed current magnitudes

The function outputs can be used for direct I/O controlling and user logic programming. The function generates general time-stamped ON/OFF events to the common event buffer from each of the seven (7) output signals. The time stamp resolution is 1 ms. The function also provides a resettable cumulative counter for the START, ALARM ACT and BLOCKED events.

The following figure presents a simplified function block diagram of the total harmonic distortion monitor function.

Figure. 5.5.5 - 225. Simplified function block diagram of the total harmonic distortion monitor function.

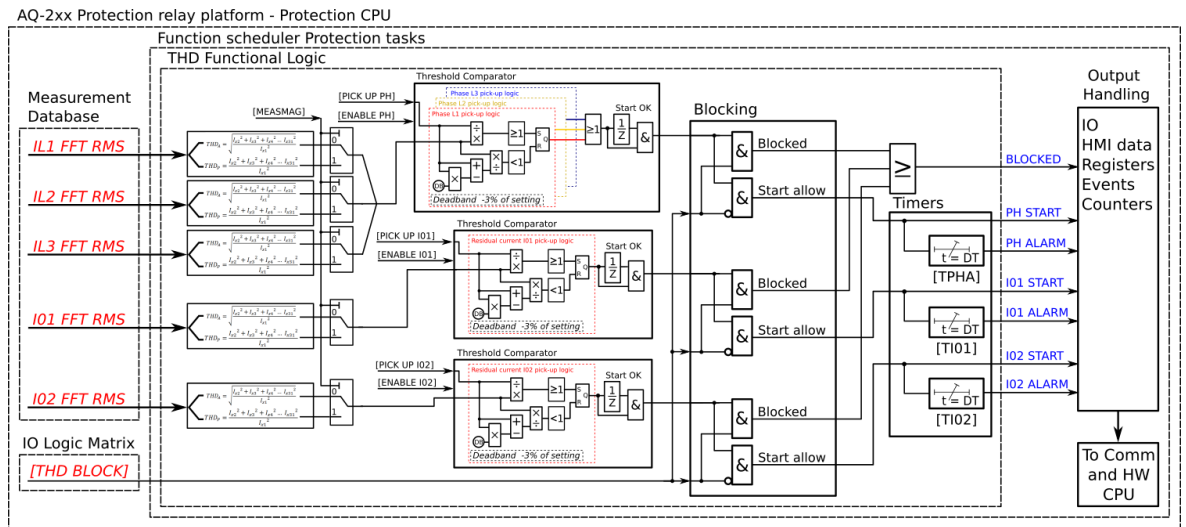

Measured input

The function block uses analog current measurement values. The function always uses FFT measurement of the whole harmonic specter of 32 components from each measured current channel. From these measurements the function calculates either the amplitude ratio or the power ratio. A -20 ms averaged value of the selected magnitude is used for pre-fault data registering.

Table. 5.5.5 - 240. Measurement inputs of the total harmonic distortion monitor function.

Signal	Description	Time base
IL1FFT	FFT measurement of phase L1 (A) current	5ms
IL2FFT	FFT measurement of phase L2 (B) current	5ms
IL3FFT	FFT measurement of phase L3 (C) current	5ms
I01FFT	FFT measurement of residual I01 current	5ms
I02FFT	FFT measurement of residual I02 current	5ms

The selection of the calculation method is made with a setting parameter (common for all measurement channels).

General settings

The following general settings define the general behavior of the function. These settings are static i.e. it is not possible to change them by editing the setting group.

Table. 5.5.5 - 241. General settings.

Name	Range	Step	Default	Description
Measurement magnitude	1: Amplitude 2: Power	-	1: Amplitude	Defines which available measured magnitude the function uses.

Pick-up

The $Phase_{THD}$, $I01_{THD}$ and $I02_{THD}$ setting parameters control the the pick-up and activation of the function. They define the maximum allowed measured current before action from the function. Before the function activates alarm signals, their corresponding pick-up elements need to be activated with the setting parameters *Enable phase THD alarm*, *Enable I01 THD alarm* and *Enable I02 THD alarm*. The function constantly calculates the ratio between the setting values and the measured magnitude for each of the three phases. The reset ratio of 97 % is built into the function and is always relative to the setting value. The setting value is common for all measured phases. When the I_m exceeds the I_{set} value (in single, dual or all phases), it triggers the pick-up operation of the function.

Table. 5.5.5 - 242. Pick-up settings.

Name	Range	Step	Default	Description
Enable phase THD alarm	0: Enabled 1: Disabled	-	0: Enabled	Enables and disables the THD alarm function from phase currents.
Enable I01 THD alarm	0: Enabled 1: Disabled	-	0: Enabled	Enables and disables the THD alarm function from residual current input I01.
Enable I02 THD alarm	0: Enabled 1: Disabled	-	0: Enabled	Enables and disables the THD alarm function from residual current input I02.
Phase THD pick-up	0.10...100.00%	0.01%	10.00%	The pick-up setting for the THD alarm element from the phase currents. At least one of the phases' measured THD value has to exceed this setting in order for the alarm signal to activate.
I01 THD pick-up	0.10...100.00%	0.01%	10.00%	The pick-up setting for the THD alarm element from the residual current I01. The measured THD value has to exceed this setting in order for the alarm signal to activate.
I02 THD pick-up	0.10...100.00%	0.01%	10.00%	The pick-up setting for the THD alarm element from the residual current I02. The measured THD value has to exceed this setting in order for the alarm signal to activate.

The pick-up activation of the function is not directly equal to the START signal generation of the function. The START signal is allowed if the blocking condition is not active.

Read-only parameters

The relay's *Info* page displays useful, real-time information on the state of the protection function. It is accessed either through the relay's HMI display, or through the setting tool software when it is connected to the relay and its Live Edit mode is active.

Table. 5.5.5 - 243. Information displayed by the function.

Name	Range	Step	Description
THD condition	0: Normal 1: Start 2: Alarm 3: Blocked	-	Displays status of the monitoring function.

Function blocking

The block signal is checked in the beginning of each program cycle. The blocking signal is received from the blocking matrix in the function's dedicated input. If the blocking signal is not activated when the pick-up element activates, a START signal is generated and the function proceeds to the time characteristics calculation.

If the blocking signal is active when the pick-up element activates, a BLOCKED signal is generated and the function does not process the situation further. If the START function has been activated before the blocking signal, it resets and the release time characteristics are processed similarly to when the pick-up signal is reset.

The blocking of the function causes an HMI display event and a time-stamped blocking event with information of the startup current values and its fault type to be issued.

The blocking signal can also be tested in the commissioning phase by a software switch signal when the relay's testing mode "Enable stage forcing" is activated (*General* → *Device*).

The variables the user can set are binary signals from the system. The blocking signal needs to reach the device minimum of 5 ms before the set operating delay has passed in order for the blocking to activate in time.

Operating time characteristics for activation and reset

This function supports definite time delay (DT). The following table presents the setting parameters for the function's time characteristics.

Table. 5.5.5 - 244. Settings for operating time characteristics.

Name	Range	Step	Default	Description
Phase THD alarm delay	0.000...1800.000s	0.005s	10.000s	Defines the delay for the alarm timer from the phase currents' measured THD.
I01 THD alarm delay	0.000...1800.000s	0.005s	10.000s	Defines the delay for the alarm timer from the residual current I01's measured THD.
I02 THD alarm delay	0.000...1800.000s	0.005s	10.000s	Defines the delay for the alarm timer from the residual current I02's measured THD.

Events and registers

The total harmonic distortion monitor function (abbreviated "THD" in event block names) generates events and registers from the status changes in the alarm function when it is activated. The recorded signals are START and ALARM signals for the monitoring elements as well as common BLOCKED signals. The user can select which event messages are stored in the main event buffer: ON, OFF, or both.

The events triggered by the function are recorded with a time stamp and with process data values.

Table. 5.5.5 - 245. Event codes.

Event number	Event channel	Event block name	Event code	Description
3520	55	THD1	0	THD Start Phase ON
3521	55	THD1	1	THD Start Phase OFF
3522	55	THD1	2	THD Start I01 ON
3523	55	THD1	3	THD Start I01 OFF
3524	55	THD1	4	THD Start I02 ON
3525	55	THD1	5	THD Start I02 OFF
3526	55	THD1	6	THD Alarm Phase ON
3527	55	THD1	7	THD Alarm Phase OFF
3528	55	THD1	8	THD Alarm I01 ON

Event number	Event channel	Event block name	Event code	Description
3529	55	THD1	9	THD Alarm I01 OFF
3530	55	THD1	10	THD Alarm I02 ON
3531	55	THD1	11	THD Alarm I02 OFF
3532	55	THD1	12	Blocked ON
3533	55	THD1	13	Blocked OFF

The function registers its operation into the last twelve (12) time-stamped registers. The register of the function records the ON event process data for ACTIVATED, BLOCKED, etc. The table below presents the structure of the function's register content.

Table. 5.5.5 - 246. Register content.

Date and time	Event code	L1h, L2h, L3h pretriggering current	L1h, L2h, L3h Fault current	L1h, L2h, L3h Prefault current	Used SG
dd.mm.yyyy hh:mm:ss.mss	3520-3533 Descr.	Start -200ms THD averages of each phase.	Trip -20 ms THD averages of each phase.	Trip -200 ms averages of each phase.	Setting group 1...8 active.

5.5.6 Disturbance recorder (DR)

The disturbance recorder is a high-capacity (64 MB) and fully digital recorder integrated to the protection relay. The maximum sample rate of the recorder's analog channels is 64 samples per cycle. The recorder also supports 95 digital channels simultaneously with the twenty (20) measured analog channels.

The recorder provides a great tool to analyze the performance of the power system during network disturbance situations. The recorder's output is in general COMTRADE format and it is compatible with most viewers and injection devices. The files are based on the IEEE standard C37.111-1999. Captured recordings can be injected as playback with secondary testing tools that support the COMTRADE file format. Playback of files might help to analyze the fault, or can be simply used for educational purposes.

Analog and digital recording channels

Up to 20 analog recording channels and 95 digital channels are supported. The available analog channels vary according to the device type.

Table. 5.5.6 - 247. Analog recording channels.

Signal	Description
IL1	Phase current I_{L1}
IL2	Phase current I_{L2}
IL3	Phase current I_{L3}
I01c	Residual current I_{01} coarse*
I01f	Residual current I_{01} fine*
I02c	Residual current I_{02} coarse*
I02f	Residual current I_{02} fine*
IL1"	Phase current I_{L1} (CT card 2)

Signal	Description
IL2"	Phase current I_{L2} (CT card 2)
IL3"	Phase current I_{L3} (CT card 2)
I01"c	Residual current I_{01} coarse* (CT card 2)
I01"f	Residual current I_{01} fine* (CT card 2)
I02"c	Residual current I_{02} coarse* (CT card 2)
I02"f	Residual current I_{02} fine* (CT card 2)
U1(2)VT1	Line-to-neutral U_{L1} or line-to-line voltage U_{12} (VT card 1)
U2(3)VT1	Line-to-neutral U_{L2} or line-to-line voltage U_{23} (VT card 1)
U3(1)VT1	Line-to-neutral U_{L3} or line-to-line voltage U_{31} (VT card 1)
U0(ss)VT1	Zero sequence voltage U_0 or synchrocheck voltage U_{SS} (VT card 1)
F tracked 1	Tracked frequency of reference 1
F tracked 2	Tracked frequency of reference 2
F tracked 3	Tracked frequency of reference 3
ISup	Current measurement module voltage supply supervision (CT card 1)
ISup"	Current measurement module voltage supply supervision (CT card 2)
USup	Voltage measurement module voltage supply supervision (VT card 2)
IL1""	Phase current I_{L1} (CT card 3)
IL2""	Phase current I_{L2} (CT card 3)
IL3""	Phase current I_{L3} (CT card 3)
I01""c	Residual current I_{01} coarse* (CT card 3)
I01""f	Residual current I_{01} fine* (CT card 3)
I02""c	Residual current I_{02} coarse* (CT card 3)
I02""f	Residual current I_{02} fine* (CT card 3)
ISup_3	Current measurement module voltage supply supervision (CT card 3)
UL1(2)VT2	Line-to-neutral U_{L1} or line-to-line voltage U_{12} (VT card 2)
UL2(3)VT2	Line-to-neutral U_{L2} or line-to-line voltage U_{23} (VT card 2)
UL3(1)VT2	Line-to-neutral U_{L3} or line-to-line voltage U_{31} (VT card 2)
U0(SS)VT2	Zero sequence voltage U_0 or synchrocheck voltage U_{SS} (VT card 2)
USup_2	Voltage measurement module voltage supply supervision (VT card 2)

***NOTE:** There are two signals for each residual current channel in the disturbance recorder: coarse and fine. A coarse signal is capable of sampling in the full range of the current channel but suffers a loss of accuracy at very low currents. A fine signal is capable of sampling at very low currents and with high accuracy but cuts off at higher currents. Table below lists performance of both channels with fine and coarse gain.

Table. 5.5.6 - 248. Residual current channel performance with coarse or residual gain.

Channel	Coarse gain range	Fine gain range	Fine gain peak
I01	0...150 A	0...10 A	15 A
I02	0...75 A	0...5 A	8 A

Table. 5.5.6 - 249. Digital recording channels – Measurements.

Signal	Description	Signal	Description
Currents			
Pri.Pha.curr.ILx	Primary phase current ILx (IL1, IL2, IL3)	Pha.curr.ILx TRMS Pri	Primary phase current TRMS (IL1, IL2, IL3)
Pha.angle ILx	Phase angle ILx (IL1, IL2, IL3)	Pos./Neg./Zero seq.curr.	Positive/Negative/Zero sequence current
Pha.curr.ILx	Phase current ILx (IL1, IL2, IL3)	Sec.Pos./Neg./Zero seq.curr.	Secondary positive/negative/zero sequence current
Sec.Pha.curr.ILx	Secondary phase current ILx (IL1, IL2, IL3)	Pri.Pos./Neg./Zero seq.curr.	Primary positive/negative/zero sequence current
Pri.Res.curr.I0x	Primary residual current I0x (I01, I02)	Pos./Neg./Zero seq.curr.angle	Positive/Negative/Zero sequence current angle
Res.curr.angle I0x	Residual current angle I0x (I01, I02)	Res.curr.I0x TRMS	Residual current TRMS I0x (I01, I02)
Res.curr.I0x	Residual current I0x (I01, I02)	Res.curr.I0x TRMS Sec	Secondary residual current TRMS I0x (I01, I02)
Sec.Res.curr.I0x	Secondary residual current I0x (I01, I02)	Res.curr.I0x TRMS Pri	Primary residual current TRMS I0x (I01, I02)
Pri.cal.I0	Primary calculated I0	Pha.Lx ampl. THD	Phase Lx amplitude THD (L1, L2, L3)
Sec.calc.I0	Secondary calculated I0	Pha.Lx pow. THD	Phase Lx power THD (L1, L2, L3)
calc.I0	Calculated I0	Res.I0x ampl. THD	Residual I0x amplitude THD (I01, I02)
calc.I0 Pha.angle	Calculated I0 phase angle	Res.I0x pow. THD	Residual I0x power THD (I01, I02)
Pha.curr.ILx TRMS	Phase current TRMS ILx (IL1, IL2, IL3)	P-P curr.ILx	Phase-to-phase current ILx (IL1, IL2, IL3)
Pha.curr.ILx TRMS Sec	Secondary phase current TRMS (IL1, IL2, IL3)	P-P curr.I0x	Phase-to-phase current I0x (I01, I02)
Voltages			
Ux Volt p.u.	Ux voltage in per-unit values (U1, U2, U3, U4)	System volt ULxx mag	Magnitude of the system voltage ULxx (UL12, UL23, UL31)
Ux Volt pri	Primary Ux voltage (U1, U2, U3, U4)	System volt ULxx mag(kV)	Magnitude of the system voltage ULxx in kilovolts (UL12, UL23, UL31)
Ux Volt sec	Secondary Ux voltage (U1, U2, U3, U4)	System volt ULxx ang	Angle of the system voltage ULxx (UL12, UL23, UL31)
Ux Volt TRMS p.u.	Ux voltage TRMS in per-unit values (U1, U2, U3, U4)	System volt ULx mag	Magnitude of the system voltage ULx (U1, U2, U3, U4)
Ux Volt TRMS pri	Primary Ux voltage TRMS (U1, U2, U3, U4)	System volt ULx mag(kV)	Magnitude of the system voltage ULx in kilovolts (U1, U2, U3, U4)
Ux Volt TRMS sec	Secondary Ux voltage TRMS (U1, U2, U3, U4)	System volt ULx ang	Angle of the system voltage ULx (U1, U2, U3, U4)
Pos./Neg./Zero seq.Volt.p.u.	Positive/Negative/Zero sequence voltage in per-unit values	System volt U0 mag	Magnitude of the system voltage U0
Pos./Neg./Zero seq.Volt.pri	Primary positive/negative/zero sequence voltage	System volt U0 mag(kV)	Magnitude of the system voltage U0 in kilovolts
Pos./Neg./Zero seq.Volt.sec	Secondary positive/negative/zero sequence voltage	System volt U0 mag(%)	Magnitude of the system voltage U0 in percentages
Ux Angle	Ux angle (U1, U2, U3, U4)	System volt U0 ang	Angle of the system voltage U0

Signal	Description	Signal	Description
Pos./Neg./Zero Seq volt.Angle	Positive/Negative/Zero sequence voltage angle	Ux Angle difference	Ux angle difference (U1, U2, U3)
Resistive and reactive currents			
ILx Resistive Current p.u.	ILx resistive current in per-unit values (IL1, IL2, IL3)	Pos.seq. Resistive Current Pri.	Primary positive sequence resistive current
ILx Reactive Current p.u.	ILx reactive current in per-unit values (IL1, IL2, IL3)	Pos.seq. Reactive Current Pri.	Primary positive sequence reactive current
Pos.Seq. Resistive Current p.u.	Positive sequence resistive current in per-unit values	I0x Residual Resistive Current Pri.	Primary residual resistive current I0x (I01, I02)
Pos.Seq. Reactive Current p.u.	Positive sequence reactive current in per-unit values	I0x Residual Reactive Current Pri.	Primary residual reactive current I0x (I01, I02)
I0x Residual Resistive Current p.u.	I0x residual resistive current in per-unit values (I01, I02)	ILx Resistive Current Sec.	Secondary resistive current ILx (IL1, IL2, IL3)
I0x Residual Reactive Current p.u.	I0x residual reactive current in per-unit values (I01, I02)	ILx Reactive Current Sec.	Secondary reactive current ILx (IL1, IL2, IL3)
ILx Resistive Current Pri.	Primary resistive current ILx (IL1, IL2, IL3)	I0x Residual Resistive Current Sec.	Secondary residual resistive current I0x (I01, I02)
ILx Reactive Current Pri.	Primary reactive current ILx (IL1, IL2, IL3)	I0x Residual Reactive Current Sec.	Secondary residual reactive current I0x (I01, I02)
Power, GYB, frequency			
Lx PF	Lx power factor (L1, L2, L3)	Curve x Input	Input of Curve x (1, 2, 3, 4)
POW1 3PH Apparent power (S)	Three-phase apparent power	Curve x Output	Output of Curve x (1, 2, 3, 4)
POW1 3PH Apparent power (S MVA)	Three-phase apparent power in megavolt-amperes	Enablebasedfunctions(VT1)	Enable frequency-based functions
POW1 3PH Active power (P)	Three-phase active power	Track.sys.f.	Tracked system frequency
POW1 3PH Active power (P MW)	Three-phase active power in megawatts	Sampl.f. used	Used sample frequency
POW1 3PH Reactive power (Q)	Three-phase reactive power	Tr f CH x	Tracked frequency (channels A, B, C)
POW1 3PH Reactive power (Q MVar)	Three-phase reactive power in megavars	Alg f Fast	Fast frequency algorithm
POW1 3PH Tan(phi)	Three-phase tangent phi	Alg f avg	Average frequency algorithm
POW1 3PH Cos(phi)	Three-phase cosine phi	Frequency based protections blocked	When true ("1"), all frequency-based protections are blocked.
3PH PF	Three-phase power factor	f atm. Protections (when not measurable returns to nominal)	Frequency at the moment. If the system nominal is set to 50 Hz, this will show "50 Hz".
Neutral conductance G (Pri)	Primary neutral conductance	f atm. Display (when not measurable is 0 Hz)	Frequency at the moment. If the frequency is not measurable, this will show "0 Hz".

Signal	Description	Signal	Description
Neutral susceptance B (Pri)	Primary neutral susceptance	f meas qlty	Quality of tracked frequency
Neutral admittance Y (Pri)	Primary neutral admittance	f meas from	Indicates which of the three voltage or current channel frequencies is used by the relay.
Neutral admittance Y (Ang)	Neutral admittance angle	SS1.meas.frqs	Synchrocheck – the measured frequency from voltage channel 1
I01 Resistive component (Pri)	Primary resistive component I01	SS2.meas.frqs	Synchrocheck – the measured frequency from voltage channel 2
I01 Capacitive component (Pri)	Primary capacitive component I01	Enable f based functions	Status of this signal is active when frequency-based protection functions are enabled.

Table. 5.5.6 - 250. Digital recording channels – Binary signals.

Signal	Description	Signal	Description
Dlx	Digital input 1...11	Timer x Output	Output of Timer 1...10
Open/close control buttons	Active if buttons 1 or 0 in the unit's front panel are pressed.	Internal Relay Fault active	If the unit has an internal fault, this signal is active.
Status PushButton x On	Status of Push Button 1...12 is ON	(Protection, control and monitoring event signals)	(see the individual function description for the specific outputs)
Status PushButton x Off	Status of Push Button 1...12 is OFF	Always True/False	"Always false" is always "0". Always true is always "1".
Forced SG in use	Stage forcing in use	OUTx	Output contact statuses
SGx Active	Setting group 1...8 active	GOOSE INx	GOOSE input 1...64
Double Ethernet LinkA down	Double ethernet communication card link A connection is down.	GOOSE INx quality	Quality of GOOSE input 1...64
Double Ethernet LinkB down	Double ethernet communication card link B connection is down.	Logical Input x	Logical input 1...32
MBIO ModA Ch x Invalid	Channel 1...8 of MBIO Mod A is invalid	Logical Output x	Logical output 1...64
MBIO ModB Ch x Invalid	Channel 1...8 of MBIO Mod B is invalid	NTP sync alarm	If NTP time synchronization is lost, this signal will be active.
MBIO ModC Ch x Invalid	Channel 1...8 of MBIO Mod C is invalid	Ph.Rotating Logic control 0=A-B-C, 1=A-C-B	Phase rotating order at the moment. If true ("1") the phase order is reversed.



NOTE!

Digital channels are measured every 5 ms.

Recording settings and triggering

Disturbance recorder can be triggered manually or automatically by using the dedicated triggers. Every signal listed in "Digital recording channels" can be selected to trigger the recorder.

The device has a maximum limit of 100 for the number of recordings. Even when the recordings are very small, their number cannot exceed 100. The number of analog and digital channels together with the sample rate and the time setting affect the recording size. See calculation examples below in the section titled "Estimating the maximum length of total recording time".

Table. 5.5.6 - 251. Recorder control settings.

Name	Range	Step	Default	Description
Recorder enabled	0: Enabled 1: Disabled	-	0: Enabled	Enables and disables the disturbance recorder function.
Recorder status	0: Recorder ready 1: Recording triggered 2: Recording and storing 3: Storing recording 4: Recorder full 5: Wrong config	-	-	Indicates the status of recorder.
Clear record+	0...2 ³² -1	1	-	Clears selected recording. If "1" is inserted, first recording will be cleared from memory. If "10" is inserted, tenth (10th) recording will be cleared from memory.
Manual trigger	0: - 1: Trig	-	0: -	Triggers disturbance recording manually. This parameter will return back to "-" automatically.
Clear all records	0: - 1: Clear	-	0: -	Clears all disturbance recordings.
Clear newest record	0: - 1: Clear	-	0: -	Clears the newest stored disturbance recording.
Clear oldest record	0: - 1: Clear	-	0: -	Clears the oldest stored disturbance recording.
Max. number of recordings	0...100	1	-	Displays the maximum number of recordings that can be stored in the device's memory with settings currently in use. The maximum number of recordings can go up to 100.
Max. length of a recording	0.000...1800.000s	0.001s	-	Displays the maximum length of a single recording.
Max. location of the pre-trigger	0.000...1800.000s	0.001s	-	Displays the highest pre-triggering time that can be set with the settings currently in use.
Recordings in memory	0...100	1	-	Displays how many recordings are stored in the memory.

Table. 5.5.6 - 252. Recorder trigger setting.

Name	Description
Recorder trigger	Selects the trigger input(s). Clicking the "Edit" button brings up a pop-up window, and checking the boxes enable the selected triggers.

Table. 5.5.6 - 253. Recorder settings.

Name	Range	Step	Default	Description
Recording length	0.100...1800.000s	0.01s	1s	Sets the length of a recording.

Name	Range	Step	Default	Description
Recording mode	0: FIFO 1: Keep olds	-	0: FIFO	Selects what happens when the memory is full. "FIFO" (= first in, first out) replaces the oldest stored recording with the latest one. "Keep olds" does not accept new recordings.
Analog channel samples	0: 64s/c 1: 32s/c 2: 16s/c 3: 8s/c	-	0: 64s/c	Selects the sample rate of the disturbance recorder in samples per cycle. The samples are saved from the measured wave according to this setting.
Digital channel samples	5ms (fixed)	-	5 ms(fixed)	The fixed sample rate of the recorded digital channels.
Pretriggering time	0.2...15.0s	0.1s	0.2s	Sets the recording length before the trigger.
Analog recording CH1...CH20	0...8 freely selectable channels	-	-	Selects the analog channel for recording. Please see the list of all available analog channels in the section titled "Analog and digital recording channels".
Automatically get recordings	0: Disabled 1: Enabled	-	0: Disabled	Enables and disables the automatic transfer of recordings. The recordings are taken from the relay's protection CPU and transferred to the relay's FTP directory in the communication CPU; the FTP client then automatically loads the recordings from the relay and transfers them further to the SCADA system. Please note that when this setting is enabled, all new disturbance recordings will be pushed to the FTP server of the relay. Up to six (6) recordings can be stored in the FTP at once. Once those six recordings have been retrieved and removed, more recordings will then be pushed to the FTP. When a recording has been sent to the FTP server of the relay, it is no longer accessible through setting tools <i>Disturbance recorder</i> → <i>Get DR files</i> command.
Recorder digital channels	0...95 freely selectable channels	-	-	Selects the digital channel for recording. Please see the list of all available digital channels in the section titled "Analog and digital recording channels".

NOTE!



The disturbance recorder is not ready unless the "Max. length of a recording" parameter is showing some value other than zero. At least one trigger input has to be selected in the "Recorder Trigger" setting to fulfill this term.

Estimating the maximum length of total recording time

Once the disturbance recorder's settings have been made and loaded to the relay, the device automatically calculates and displays the total length of recordings. However, if the user wishes to confirm this calculation, they can do so with the following formula. Please note that the formula assumes there are no other files in the FTP that share the 64 MB space.

$$\frac{\text{Total sample reserve}}{(f_n * (Ch_{an} + 1) * SR) + (200 \text{ Hz} * Ch_{dig})}$$

Where:

- total sample reserve = the number of samples available in the FTP when no other files are saved; calculated by dividing the total number of available bytes by 4 bytes (=the size of one sample); e.g. 64 306 588 bytes/4 bytes = 16 076 647 samples.
- f_n = the nominal frequency (Hz).

- Ch_{an} = the number of analog channels recorded; "+ 1" stands for the time stamp for each recorded sample.
- SR = the selected sample rate (s/c).
- 200 Hz = the rate at which digital channels are always recorded, i.e. 5 ms.
- Ch_{dig} = the number of digital channels recorded.

For example, let us say the nominal frequency is 50 Hz, the selected sample rate is 64 s/c, nine (9) analog channels and two (2) digital channels record. The calculation is as follows:

$$\frac{16\,076\,647 \text{ samples}}{(50 \text{ Hz} * (9 + 1) * 64) + (200 \text{ Hz} * 2)} \approx 496 \text{ s}$$

Therefore, the maximum recording length in our example is approximately 496 seconds.

Application example

This chapter presents an application example of how to set the disturbance recorder and analyze its output. The recorder is configured by using the setting tool software or relay HMI, and the results are analyzed with the AQviewer software (is automatically downloaded and installed with AQtivate). Registered users can download the latest tools from the Arcteq website (arcteq.fi/downloads/).

In this example, we want the recordings to be made according to the following specifications:

- the recording length is 6.0 s
- the sample rate is 64 s/c (therefore, with a 50 Hz system frequency a sample is taken every 312.5 μ s)
- the analog channels 1...8 are used
- digital channels are tracked every 5 ms
- the first activation of the overcurrent stage trip ($I > TRIP$) triggers the recorder
- the pre-triggering time is 5 (ie. how long is recorded before the $I > TRIP$ signal) and the post-triggering time is 1 s

The image below shows how these settings are placed in the setting tool.

Figure. 5.5.6 - 226. Disturbance recorder settings.

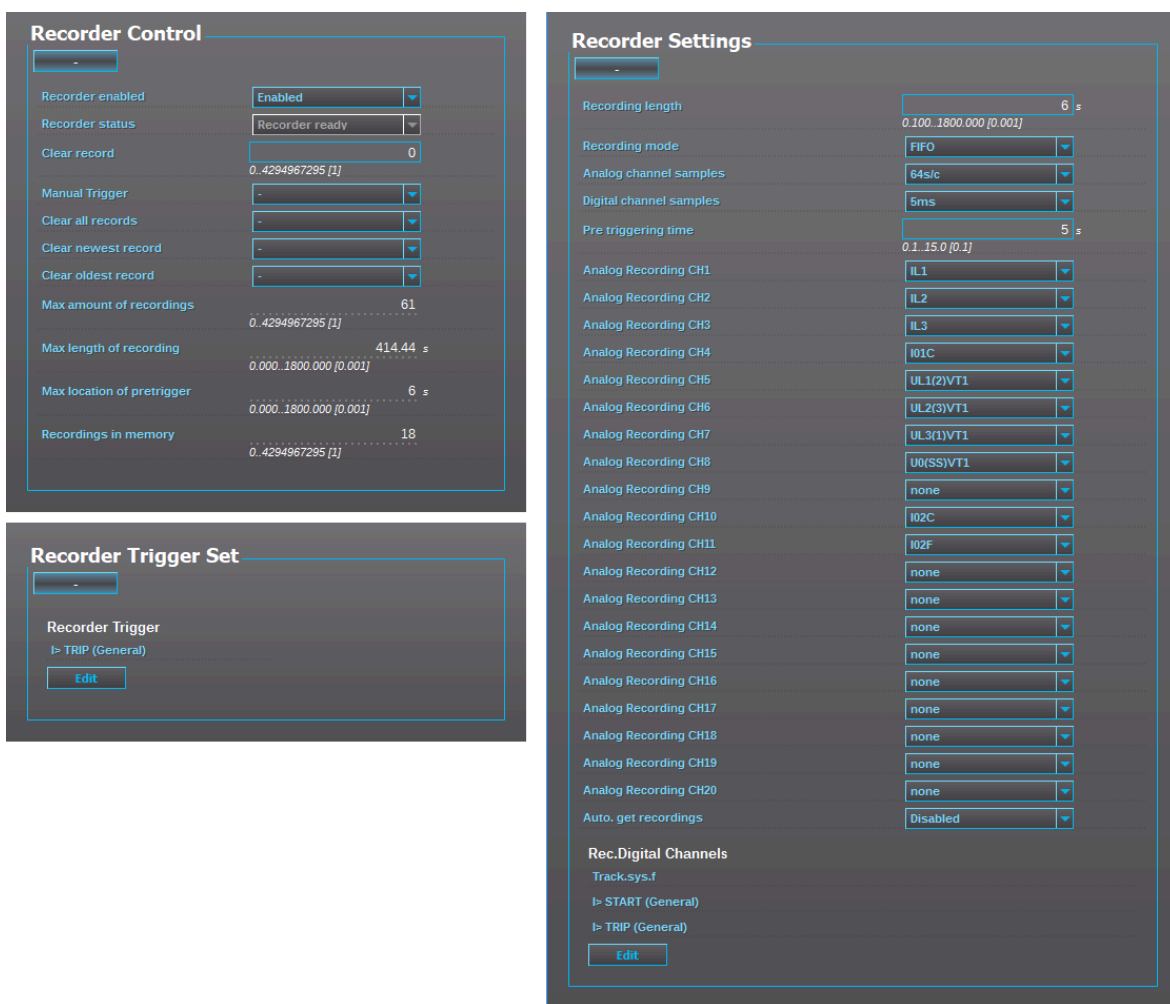
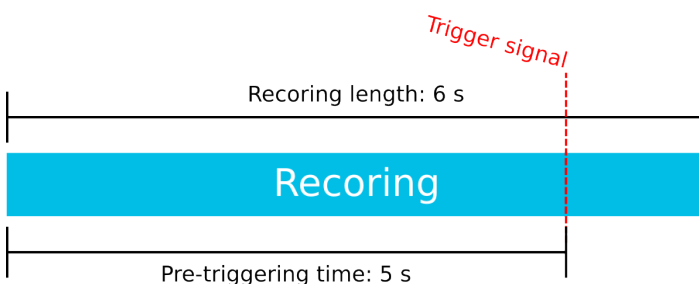
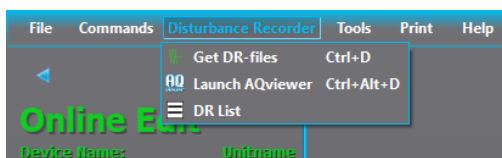

Figure. 5.5.6 - 227. Effects of recording length and pre-triggering time signals. This example is based on the settings shown above.



When there is at least one recording in the device's memory, that recording can be analyzed by using the AQviewer software (see the image below). However, the recording must first be made accessible to AQviewer. The user can read it from the device's memory (*Disturbance recorder* → *Get DR-files*). Alternatively, the user can load the recordings individually (*Disturbance recorder* → *DR List*) from a folder in the PC's hard disk drive; the exact location of the folder is described in *Tools* → *Settings* → *DR path*.



The user can also launch the AQviewer software from the *Disturbance recorder* menu.

AQviewer

Opening folders

Disturbance recordings can be opened by clicking on the "Open folder" icon or by going to *File* → *Open* (see the image below). The recordings are packed COMTRADE files; a -zip file includes *.cfg and *.dat files. AQviewer can open both original packed .zip files and COMTRADE files directly as they are located in same directory.

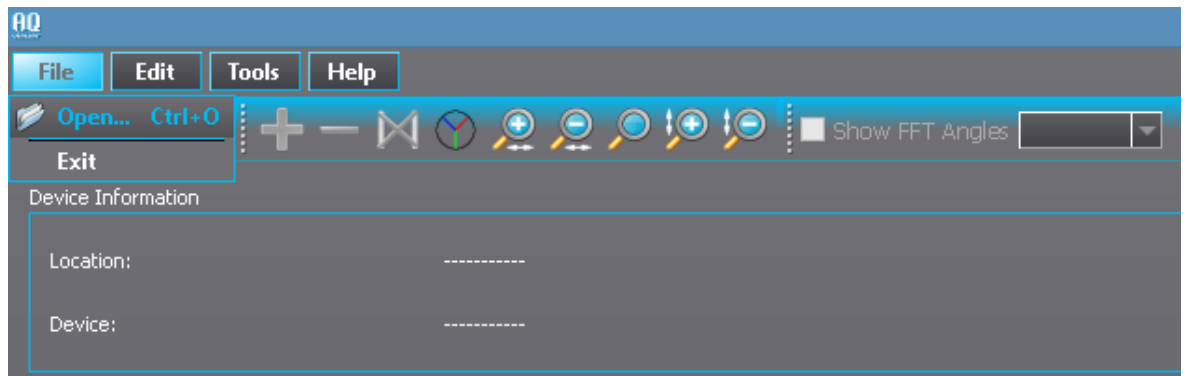

Adding signals to plotters

By default, the default plotter is empty. Choose the measured signals ("Analog channels") on the left to move them to the plotter. In the image below (on the left) the phase currents IL1, IL2 and IL3 are selected; AQViewer color-codes them automatically. If you want to add another plotter, choose the blue "+" icon (in the main toolbar on the top). Please note that the "Add plotter" text appears when you move the cursor on top of the icon. Once clicked, the "Add graph" pop-up window appears (see the image below on the right). In the example the line-to-neutral voltages UL1, UL2 and UL3 are selected and moved to the window on the right. Confirm the selection by clicking the "OK" button.

Figure. 5.5.6 - 228. Adding another plotter

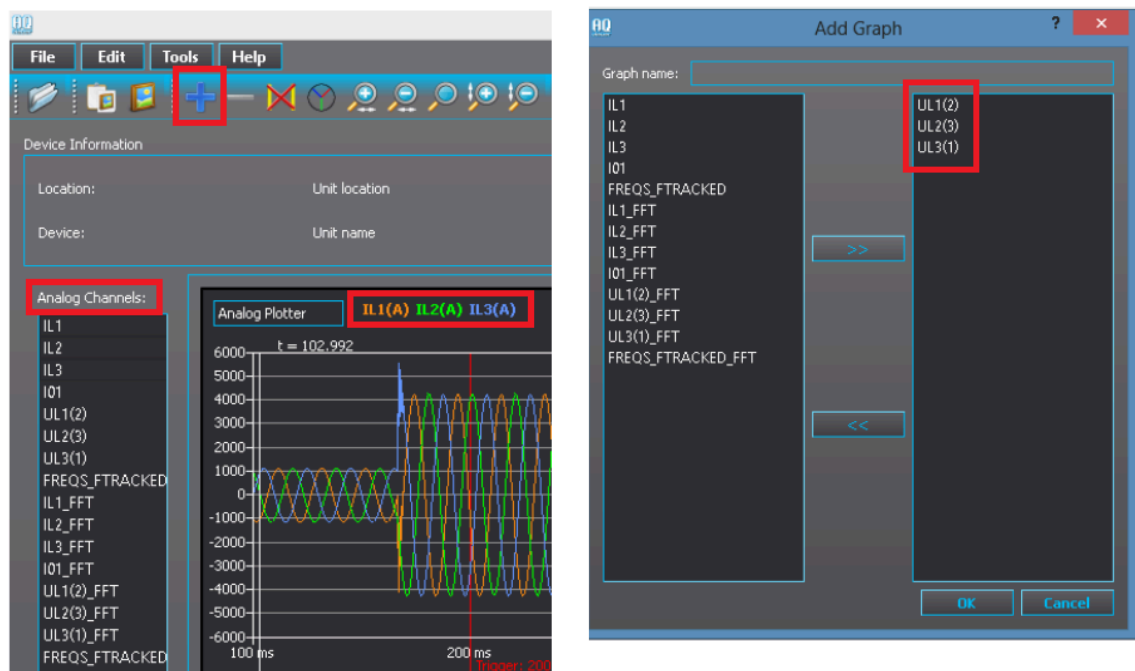

General use and zooming

1. You can remove plotters individually by using the red "—" icon (numbered "1" in the image below). Please note that the "Remove plotters" text appears when you move the cursor on top of the icon.
2. You can add cursors to measure time by staying on top of any plotter and double-clicking the left mouse button. You can add up to five (5) cursors simultaneously. You can remove cursors by clicking on the icon (numbered "2" in the image below). Please note that the "Remove all cursors" text appears when you move the cursor on top of the icon.
3. You can zoom in manually by placing the cursor on top of a plotter, holding down the left mouse button and moving the cursor to create the area you want to zoom in. You can also zoom in (and out) by using the horizontal and vertical magnifying glass "+" and "—" icons (numbered "3" in the image below). If you want to reset the zooming, click on the middle magnifying glass icon. You can also zoom in and out the amplitude of individual plotters by holding down **Shift** and scrolling the mouse wheel up and down, respectively.
4. You can toggle between primary (P) and secondary (S) signals (numbered "4" in the image below).

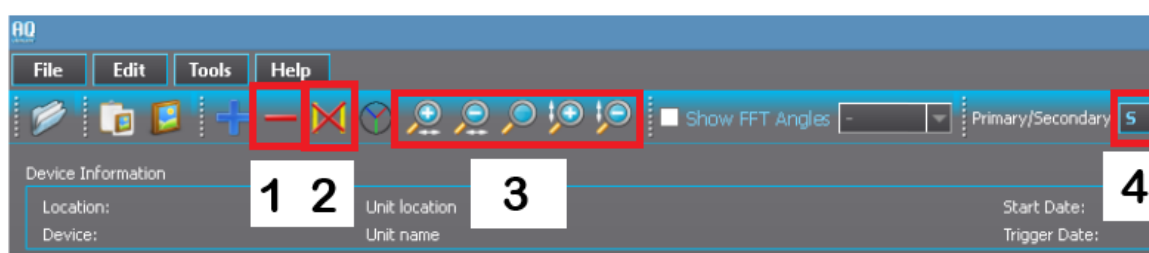

Events

The disturbance recorder function (abbreviated "DR" in event block names) generates events and registers from the status changes of the function: the recorder generates an event each time it is triggered (manually or by dedicated signals). Events cannot be masked off. The user can select which event messages are stored in the main event buffer: ON, OFF, or both.

Table. 5.5.6 - 254. Event codes.

Event number	Event channel	Event block name	Event code	Description
4096	64	DR1	0	Recorder triggered ON
4097	64	DR1	1	Recorder triggered OFF
4098	64	DR1	2	Recorder memory cleared
4099	64	DR1	3	Oldest record cleared
4100	64	DR1	4	Recorder memory full ON
4101	64	DR1	5	Recorder memory full OFF
4102	64	DR1	6	Recording ON
4103	64	DR1	7	Recording OFF
4104	64	DR1	8	Storing recording ON
4105	64	DR1	9	Storing recording OFF
4106	64	DR1	10	Newest record cleared

5.5.7 Measurement recorder

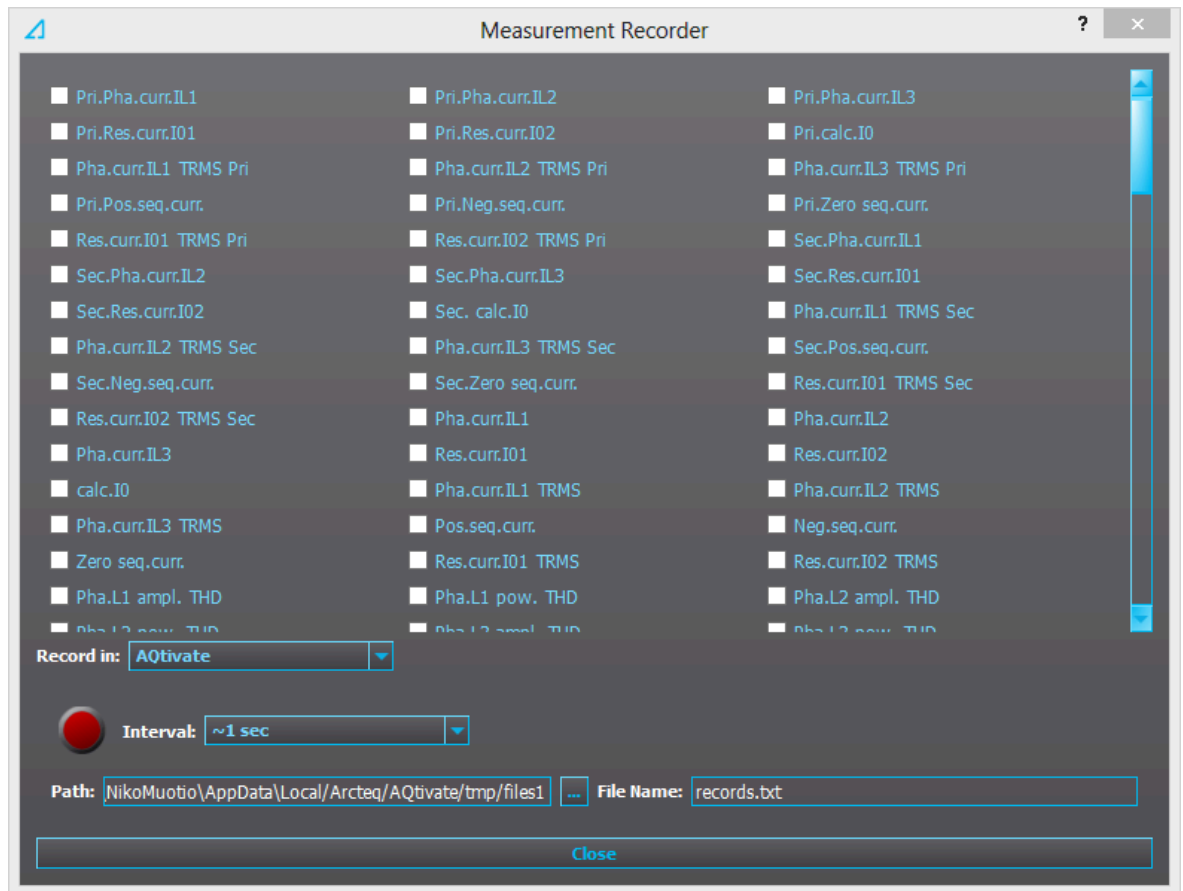

Measurements can be recorded to a file with the measurement recorder. The chosen measurements are recorded at selected intervals. In the "Measurement recorder" window, the measurements the user wants to be recorded can be selected by checking their respective check boxes. In order for the measurement recorder to activate, a connection to a relay must be established via the setting tool software and its Live Edit mode must be enabled (see the AQtivate 200 manual for more information). Navigate to the measurement recorder through *Tools* → *Miscellaneous tools* → *Measurement recorder*. The recording interval can be changed from the "Interval" drop-down menu. From the "Record in" drop-down menu the user can also choose whether the measurements are recorded in the setting tool or in the relay.

If the recording is done in the setting tool, both the setting tool software and its Live Edit mode have to be activated. The user can change the recording file location by editing the "Path" field. File names can also be changed with the "File name" field. Hitting the "Record" button (the big red circle) starts the recorder. Please note that closing the "Measurement recorder" window does not stop the recording; that can only be done by hitting the "Stop" button (the big blue circle).

If the recording is done in the relay, only the recording interval needs to be set before recording can be started. The setting tool estimates the maximum recording time, which depends on the recording interval. When the measurement recorder is running, the measurements can be viewed in graph form with the AQtivate PRO software (see the image below).

Figure. 5.5.7 - 229. Measurement recorder values viewed with AQtivate PRO.



Table. 5.5.7 - 255. Available analog signals.

Current measurements	P-P Curr.I"L3	L1 Imp.React.Ind.E.Mvarh
Pri.Pha.Curr.IL1	P-P Curr.I"01	L1 Imp.React.Ind.E.kvarh
Pri.Pha.Curr.IL2	P-P Curr.I"02	L1 Exp/Imp React.Ind.E.bal.Mvarh
Pri.Pha.Curr.IL3	Pha.angle I"L1	L1 Exp/Imp React.Ind.E.bal.kvarh
Pri.Res.Curr.I01	Pha.angle I"L2	L2 Exp.Active Energy MWh
Pri.Res.Curr.I02	Pha.angle I"L3	L2 Exp.Active Energy kWh
Pri.Calc.I0	Res.Curr.angle I"01	L2 Imp.Active Energy MWh
Pha.Curr.IL1 TRMS Pri	Res.Curr.angle I"02	L2 Imp.Active Energy kWh
Pha.Curr.IL2 TRMS Pri	Calc.I"0.angle	L2 Exp/Imp Act. E balance MWh
Pha.Curr.IL3 TRMS Pri	I" Pos.Seq.Curr.angle	L2 Exp/Imp Act. E balance kWh
Pri.Pos.Seq.Curr.	I" Neg.Seq.Curr.angle	L2 Exp.React.Cap.E.Mvarh
Pri.Neg.Seq.Curr.	I" Zero.Seq.Curr.angle	L2 Exp.React.Cap.E.kvarh
Pri.Zero.Seq.Curr.	Voltage measurements	L2 Imp.React.Cap.E.Mvarh
Res.Curr.I01 TRMS Pri	U1Volt Pri	L2 Imp.React.Cap.E.kvarh
Res.Curr.I02 TRMS Pri	U2Volt Pri	L2 Exp/Imp React.Cap.E.bal.Mvarh
Sec.Pha.Curr.IL1	U3Volt Pri	L2 Exp/Imp React.Cap.E.bal.kvarh
Sec.Pha.Curr.IL2	U4Volt Pri	L2 Exp.React.Ind.E.Mvarh
Sec.Pha.Curr.IL3	U1Volt Pri TRMS	L2 Exp.React.Ind.E.kvarh
Sec.Res.Curr.I01	U2Volt Pri TRMS	L2 Imp.React.Ind.E.Mvarh
Sec.Res.Curr.I02	U3Volt Pri TRMS	L2 Imp.React.Ind.E.kvarh
Sec.Calc.I0	U4Volt Pri TRMS	L2 Exp/Imp React.Ind.E.bal.Mvarh
Pha.Curr.IL1 TRMS Sec	Pos.Seq.Volt.Pri	L2 Exp/Imp React.Ind.E.bal.kvarh

Pha.Curr.IL2 TRMS Sec	Neg.Seq.Volt.Pri	L3 Exp.Active Energy MWh
Pha.Curr.IL3 TRMS Sec	Zero.Seq.Volt.Pri	L3 Exp.Active Energy kWh
Sec.Pos.Seq.Curr.	U1Volt Sec	L3 Imp.Active Energy MWh
Sec.Neg.Seq.Curr.	U2Volt Sec	L3 Imp.Active Energy kWh
Sec.Zero.Seq.Curr.	U3Volt Sec	L3 Exp/Imp Act. E balance MWh
Res.Curr.I01 TRMS Sec	U4Volt Sec	L3 Exp/Imp Act. E balance kWh
Res.Curr.I02 TRMS Sec	U1Volt Sec TRMS	L3 Exp.React.Cap.E.Mvarh
Pha.Curr.IL1	U2Volt Sec TRMS	L3 Exp.React.Cap.E.kvarh
Pha.Curr.IL2	U3Volt Sec TRMS	L3 Imp.React.Cap.E.Mvarh
Pha.Curr.IL3	U4Volt Sec TRMS	L3 Imp.React.Cap.E.kvarh
Res.Curr.I01	Pos.Seq.Volt.Sec	L3 Exp/Imp React.Cap.E.bal.Mvarh
Res.Curr.I02	Neg.Seq.Volt.Sec	L3 Exp/Imp React.Cap.E.bal.kvarh
Calc.I0	Zero.Seq.Volt.Sec	L3 Exp.React.Ind.E.Mvarh
Pha.Curr.IL1 TRMS	U1Volt p.u.	L3 Exp.React.Ind.E.kvarh
Pha.Curr.IL2 TRMS	U2Volt p.u.	L3 Imp.React.Ind.E.Mvarh
Pha.Curr.IL3 TRMS	U3Volt p.u.	L3 Imp.React.Ind.E.kvarh
Pos.Seq.Curr.	U4Volt p.u.	L3 Exp/Imp React.Ind.E.bal.Mvarh
Neg.Seq.Curr.	U1Volt TRMS p.u.	L3 Exp/Imp React.Ind.E.bal.kvarh
Zero.Seq.Curr.	U2Volt TRMS p.u.	Exp.Active Energy MWh
Res.Curr.I01 TRMS	U3Volt p.u.	Exp.Active Energy kWh
Res.Curr.I02 TRMS	U4Volt p.u.	Imp.Active Energy MWh
Pha.L1 ampl. THD	Pos.Seq.Volt. p.u.	Imp.Active Energy kWh
Pha.L2 ampl. THD	Neg.Seq.Volt. p.u.	Exp/Imp Act. E balance MWh
Pha.L3 ampl. THD	Zero.Seq.Volt. p.u.	Exp/Imp Act. E balance kWh
Pha.L1 pow. THD	U1Volt Angle	Exp.React.Cap.E.Mvarh
Pha.L2 pow. THD	U2Volt Angle	Exp.React.Cap.E.kvarh
Pha.L3 pow. THD	U3Volt Angle	Imp.React.Cap.E.Mvarh
Res.I01 ampl. THD	U4Volt Angle	Imp.React.Cap.E.kvarh
Res.I01 pow. THD	Pos.Seq.Volt. Angle	Exp/Imp React.Cap.E.bal.Mvarh
Res.I02 ampl. THD	Neg.Seq.Volt. Angle	Exp/Imp React.Cap.E.bal.kvarh
Res.I02 pow. THD	Zero.Seq.Volt. Angle	Exp.React.Ind.E.Mvarh
P-P Curr.IL1	System Volt UL12 mag	Exp.React.Ind.E.kvarh
P-P Curr.IL2	System Volt UL12 mag (kV)	Imp.React.Ind.E.Mvarh
P-P Curr.IL3	System Volt UL23 mag	Imp.React.Ind.E.kvarh
P-P Curr.I01	System Volt UL23 mag (kV)	Exp/Imp React.Ind.E.bal.Mvarh
P-P Curr.I02	System Volt UL31 mag	Exp/Imp React.Ind.E.bal.kvarh
Pha.angle IL1	System Volt UL31 mag (kV)	Other measurements
Pha.angle IL2	System Volt UL1 mag	TM> Trip expect mode
Pha.angle IL3	System Volt UL1 mag (kV)	TM> Time to 100% T

Res.Curr.angle I01	System Volt UL2 mag	TM> Reference T curr.
Res.Curr.angle I02	System Volt UL2 mag (kV)	TM> Active meas curr.
Calc.I0.angle	System Volt UL3 mag	TM> T est.with act. curr.
Pos.Seq.Curr.angle	System Volt UL3 mag (kV)	TM> T at the moment
Neg.Seq.Curr.angle	System Volt U0 mag	TM> Max.Temp.Rise All.
Zero.Seq.Curr.angle	System Volt U0 mag (kV)	TM> Temp.Rise atm.
Pri.Pha.Curr.I"L1	System Volt U1 mag	TM> Hot Spot estimate
Pri.Pha.Curr.I"L2	System Volt U1 mag (kV)	TM> Hot Spot Max. All
Pri.Pha.Curr.I"L3	System Volt U2 mag	TM> Used k for amb.temp
Pri.Res.Curr.I"01	System Volt U2 mag (kV)	TM> Trip delay remaining
Pri.Res.Curr.I"02	System Volt U3 mag	TM> Alarm 1 time to rel.
Pri.Calc.I"0	System Volt U3 mag (kV)	TM> Alarm 2 time to rel.
Pha.Curr.I"L1 TRMS Pri	System Volt U4 mag	TM> Inhibit time to rel.
Pha.Curr.I"L2 TRMS Pri	System Volt U4 mag (kV)	TM> Trip time to rel.
Pha.Curr.I"L3 TRMS Pri	System Volt UL12 ang	S1 Measurement
I" Pri.Pos.Seq.Curr.	System Volt UL23 ang	S2 Measurement
I" Pri.Neg.Seq.Curr.	System Volt UL31 ang	S3 Measurement
I" Pri.Zero.Seq.Curr.	System Volt UL1 ang	S4 Measurement
Res.Curr.I"01 TRMS Pri	System Volt UL2 ang	S5 Measurement
Res.Curr.I"02 TRMS Pri	System Volt UL3 ang	S6 Measurement
Sec.Pha.Curr.I"L1	System Volt U0 ang	S7 Measurement
Sec.Pha.Curr.I"L2	System Volt U1 ang	S8 Measurement
Sec.Pha.Curr.I"L3	System Volt U2 ang	S9 Measurement
Sec.Res.Curr.I"01	System Volt U3 ang	S10 Measurement
Sec.Res.Curr.I"02	System Volt U4 ang	S11 Measurement
Sec.Calc.I"0	Power measurements	S12 Measurement
Pha.Curr.I"L1 TRMS Sec	L1 Apparent Power (S)	Sys.meas.frqs
Pha.Curr.I"L2 TRMS Sec	L1 Active Power (P)	f atm.
Pha.Curr.I"L3 TRMS Sec	L1 Reactive Power (Q)	f meas from
I" Sec.Pos.Seq.Curr.	L1 Tan(phi)	SS1.meas.frqs
I" Sec.Neg.Seq.Curr.	L1 Cos(phi)	SS1f meas from
I" Sec.Zero.Seq.Curr.	L2 Apparent Power (S)	SS2 meas.frqs
Res.Curr.I"01 TRMS Sec	L2 Active Power (P)	SS2f meas from
Res.Curr.I"02 TRMS Sec	L2 Reactive Power (Q)	L1 Bias current
Pha.Curr.I"L1	L2 Tan(phi)	L1 Diff current
Pha.Curr.I"L2	L2 Cos(phi)	L1 Char current
Pha.Curr.I"L3	L3 Apparent Power (S)	L2 Bias current
Res.Curr.I"01	L3 Active Power (P)	L2 Diff current
Res.Curr.I"02	L3 Reactive Power (Q)	L2 Char current

Calc.I"0	L3 Tan(phi)	L3 Bias current
Pha.Curr.I"L1 TRMS	L3 Cos(phi)	L3 Diff current
Pha.Curr.I"L2 TRMS	3PH Apparent Power (S)	L3 Char current
Pha.Curr.I"L3 TRMS	3PH Active Power (P)	HV I0d> Bias current
I" Pos.Seq.Curr.	3PH Reactive Power (Q)	HV I0d> Diff current
I" Neg.Seq.Curr.	3PH Tan(phi)	HV I0d> Char current
I" Zero.Seq.Curr.	3PH Cos(phi)	LV I0d> Bias current
Res.Curr.I"01 TRMS	Energy measurements	LV I0d> Diff current
Res.Curr.I"02 TRMS	L1 Exp.Active Energy MWh	LV I0d> Char current
Pha.IL"1 ampl. THD	L1 Exp.Active Energy kWh	Curve1 Input
Pha.IL"2 ampl. THD	L1 Imp.Active Energy MWh	Curve1 Output
Pha.IL"3 ampl. THD	L1 Imp.Active Energy kWh	Curve2 Input
Pha.IL"1 pow. THD	L1 Exp/Imp Act. E balance MWh	Curve2 Output
Pha.IL"2 pow. THD	L1 Exp/Imp Act. E balance kWh	Curve3 Input
Pha.IL"3 pow. THD	L1 Exp.React.Cap.E.Mvarh	Curve3 Output
Res.I"01 ampl. THD	L1 Exp.React.Cap.E.kvarh	Curve4 Input
Res.I"01 pow. THD	L1 Imp.React.Cap.E.Mvarh	Curve4 Output
Res.I"02 ampl. THD	L1 Imp.React.Cap.E.kvarh	Control mode
Res.I"02 pow. THD	L1 Exp/Imp React.Cap.E.bal.Mvarh	Motor status
P-P Curr.I"L1	L1 Exp/Imp React.Cap.E.bal.kvarh	Active setting group
P-P Curr.I"L2	L1 Exp.React.Ind.E.Mvarh	
	L1 Exp.React.Ind.E.kvarh	

5.5.8 Measurement value recorder

The measurement value recorder function records the value of the selected magnitudes at the time of a pre-defined trigger signal. An typical application is the recording of fault currents or voltages at the time of the breaker trips; it can also be used to record the values from any trigger signal set by the user. The user can select whether the function records per-unit values or primary values. Additionally, the user can set the function to record overcurrent fault types or voltage fault types. The function operates instantly from the trigger signal.

The measurement value recorder function has an integrated fault display which shows the current fault values when the tripped by one of the following functions: I> (non-directional overcurrent), Idir> (directional overcurrent), I0> (non-directional earth fault), I0dir> (directional earth fault), f< (underfrequency), f> (overfrequency), U< (undervoltage), U> (overvoltage), U1/U2 >/< (sequence voltage) or U0> (residual voltage). When any of these functions trip, the fault values and the fault type are displayed in the Mimic view. The view can be enabled by activating the "VREC Trigger on" setting (*Tools* → *Events and logs* → *Set alarm events*). The resetting of the fault values is done by the input selected in the *General* menu.

Measured input

The function block uses analog current and voltage measurement values. Based on these values, the relay calculates the primary and secondary values of currents, voltages, powers, and impedances as well as other values.

The user can set up to eight (8) magnitudes to be recorded when the function is triggered. An overcurrent fault type, a voltage fault type, and a tripped stage can be recorded and reported straight to SCADA.

NOTE!



The available measurement values depend on the relay type. If only current analog measurements are available, the recorder can solely use signals which only use current. The same applies, if only voltage analog measurements are available.

Currents	Description
IL1 (ff), IL2 (ff), IL3 (ff), I01 (ff), I02 (ff)	The fundamental frequency current measurement values (RMS) of phase currents and of residual currents.
IL1TRMS, IL2TRMS, IL3TRMS, I01TRMS, I02TRMS	The TRMS current measurement values of phase currents and of residual currents.
IL1,2,3 & I01/I02 2 nd h., 3 rd h., 4 th h., 5 th h., 7 th h., 9 th h., 11 th h., 13 th h., 15 th h., 17 th h., 19 th h.	The magnitudes of phase current components: Fundamental, 2 nd harmonic, 3 rd harmonic, 4 th harmonic, 5 th harmonic 7 th , harmonic 9 th , harmonic 11 th , harmonic 13 th , harmonic 15 th , harmonic 17 th , harmonic 19 th harmonic current.
I1, I2, I0Z	The positive sequence current, the negative sequence current and the zero sequence current.
I0CalcMag	The residual current calculated from phase currents.
IL1Ang, IL2Ang, IL3Ang, I01Ang, I02Ang, I0CalcAng, I1Ang, I2Ang	The angles of each measured current.
Voltages	Description
UL1Mag, UL2Mag, UL3Mag, UL12Mag, UL23Mag, UL31Mag U0Mag, U0CalcMag	The magnitudes of phase voltages, of phase-to-phase voltages, and of residual voltages.
U1 Pos.seq V mag, U2 Neg.seq V mag	The positive sequence voltage and the negative sequence voltage.
UL1Ang, UL2Ang, UL3Ang, UL12Ang, UL23Ang, UL31Ang U0Ang, U0CalcAng	The angles of phase voltages, of phase-to-phase voltages, and of residual voltages.
U1 Pos.seq V Ang, U2 Neg.seq V Ang	The positive sequence angle and the negative sequence angle.
Powers	Description
S3PH, P3PH, Q3PH	The three-phase apparent, active and reactive powers.
SL1, SL2, SL3, PL1, PL2, PL3, QL1, QL2, QL3	The phase apparent, active and reactive powers.
tanfi3PH, tanfiL1, tanfiL2, tanfiL3	The tan (φ) of three-phase powers and phase powers.
cosfi3PH, cosfiL1, cosfiL2, cosfiL3	The cos (φ) of three-phase powers and phase powers.
Impedances and admittances	Description
RL12, RL23, RL31 XL12, XL23, XL31, RL1, RL2, RL3 XL1, XL2, XL3 Z12, Z23, Z31 ZL1, ZL2, ZL3	The phase-to-phase and phase-to-neutral resistances, reactances and impedances.
Z12Ang, Z23Ang, Z31Ang, ZL1Ang, ZL2Ang, ZL3Ang	The phase-to-phase and phase-to-neutral impedance angles.

Currents	Description
Rseq, Xseq, Zseq RseqAng, XseqAng, ZseqAng	The positive sequence resistance, reactance and impedance values and angles.
GL1, GL2, GL3, G0 BL1, BL2, BL3, B0 YL1, YL2, YL3, Y0	The conductances, susceptances and admittances.
YL1angle, YL2angle, YL3angle Y0angle	The admittance angles.
Others	Description
System f.	The tracking frequency in use at that moment.
Ref f1	The reference frequency 1.
Ref f2	The reference frequency 2.
M thermal T	The motor thermal temperature.
F thermal T	The feeder thermal temperature.
T thermal T	The transformer thermal temperature.
RTD meas 1...16	The RTD measurement channels 1...16.
Ext RTD meas 1...8	The external RTD measurement channels 1...8 (ADAM module).

Reported values

When triggered, the function holds the recorded values of up to eight channels, as set. In addition to this tripped stage, the overcurrent fault type and the voltage fault types are reported to SCADA.

Table. 5.5.8 - 256. Reported values.

Name	Range	Step	Description
Tripped stage	0: - 1: l> Trip 2: l>> Trip 3: l>>> Trip 4: l>>>> Trip 5: lDir> Trip 6: lDir>> Trip 7: lDir>>> Trip 8: lDir>>>> Trip 9: U> Trip 10: U>> Trip 11: U>>> Trip 12: U>>>> Trip 13: U< Trip 14: U<< Trip 15: U<<< Trip 16: U<<<< Trip 17: lO> TRIP 18: lO>> Trip 19: lO>>> Trip 20: lO>>>> Trip 21: lODir> Trip 22: lODir>> Trip 23: lODir>>> Trip 24: lODir>>>> Trip 25: f> Trip 26: f>> Trip 27: f>>> Trip 28: f>>>> Trip 29: f< Trip 30: f<< Trip 31: f<<< Trip 32: f<<<< Trip 33: P> Trip 34: P< Trip 35: Prev> Trip 36: T> Trip 37: l2> Trip 38: l2>> Trip 39: l2>>> Trip 40: l2>>>> Trip 41: U1/2 > Trip 42: U1/2 >> Trip 43: U1/2 >>> Trip 44: U1/2 >>>> Trip 45: U0> Trip 46: U0>> Trip 47: U0>>> Trip 48: U0>>>> Trip	-	The tripped stage.
Overcurrent fault type	0: - 1: A-G 2: B-G 3: A-B 4: C-G 5: A-C 6: B-C 7: A-B-C	-	The overcurrent fault type.

Name	Range	Step	Description
Voltage fault type	0: - 1: A(AB) 2: B(BC) 3: A-B(AB-BC) 4: C(CA) 5: A-C(AB-CA) 6: B-C(BC-CA) 7: A-B-C 8: - 9: Overfrequency 10: Underfrequency 11: Overpower 12: Underpower 13: Reversepower 14: Thermal overload 15: Unbalance 16: Harmonic overcurrent 17: Residual overvoltage	-	The voltage fault type.
Magnitude 1...8	0.000...1800.000 A/V/p.u.	0.001 A/V/p.u.	The recorded value in one of the eight channels.

Events

The measurement value recorder function (abbreviated "VREC" in event block names) generates events from the function triggers. The user can select which event messages are stored in the main event buffer: ON, OFF, or both.

Table. 5.5.8 - 257. Event codes.

Event number	Event channel	Event block name	Event code	Description
9984	156	VREC1	0	Recorder triggered ON
9985	156	VREC1	1	Recorder triggered OFF

6 System integration

6.1 Communication protocols

6.1.1 NTP

When enabled, the NTP (Network Time Protocol) service can use external time sources to synchronize the device's system time. The NTP client service uses an Ethernet connection to connect to the NTP time server. NTP can be enabled by setting the primary time server and the secondary time server parameters to the address of the system's NTP time source(s).

Table. 6.1.1 - 258. Server settings.

Name	Range	Description
Primary time server address	0.0.0.0...255.255.255.255	Defines the address of the primary NTP server. Setting this parameter at "0.0.0.0" means that the server is not in use.
Secondary time server address	0.0.0.0...255.255.255.255	Defines the address of the secondary (or backup) NTP server. Setting this parameter at "0.0.0.0" means that the server is not in use.

Table. 6.1.1 - 259. Client settings.

Name	Range	Description
IP address	0.0.0.0...255.255.255.255	Defines the address of the NTP client. NOTE: This address must be different than the relay's IP address.
Netmask	0.0.0.0...255.255.255.255	Defines the client's netmask.
Gateway	0.0.0.0...255.255.255.255	Defines the client's gateway.
MAC address	-	Displays the MAC address of the client.
Network status	0: Running 1: IP error 2: NM error 3: GW error	Displays the status or possible errors of the NTP (client) settings.

Table. 6.1.1 - 260. Status.

Name	Range	Description
NTP quality for events	0: No sync 1: Synchronized	Displays the status of the NTP time synchronization at the moment. NOTE: This indication is not valid if another time synchronization method is used (external serial).
NTP-processed message count	0...2 ³² -1	Displays the number of messages processed by the NTP protocol.

NOTE!



A unique IP address must be reserved for the NTP client. The relay's IP address cannot be used.

Additionally, the time zone of the relay can be set by connecting to the relay and the selecting the time zone at *Commands* → *Set time zone* (AQtivate).

6.1.2 Modbus/TCP and Modbus/RTU

The device supports both Modbus/TCP and Modbus/RTU communication. Modbus/TCP uses the Ethernet connection to communicate with Modbus/TCP clients. Modbus/RTU is a serial protocol that can be selected for the available serial ports.

The following Modbus function types are supported:

- Read multiple holding registers (function code 3)
- Write single holding register (function code 6)
- Write multiple holding registers (function code 16)
- Read/Write multiple registers (function code 23)

The following data can be accessed using both Modbus/TCP and Modbus/RTU:

- Device measurements
- Device I/O
- Commands
- Events
- Time

Once the configuration file has been loaded, the user can access the Modbus map of the relay via the AQtivate software (*Tools* → *Communication* → *Modbusmap*). Please note that holding registers start from 1. Some masters might begin numbering holding register from 0 instead of 1; this will cause an offset of 1 between the relay and the master.

Table. 6.1.2 - 261. Modbus/TCP settings.

Parameter	Range	Description
Enable Modbus/TCP	0: Disabled 1: Enabled	Enables and disables the Modbus/TCP on the Ethernet port.
IP port	0...65 535	Defines the IP port used by Modbus/TCP. The standard port (and the default setting) is 502.
Event read mode	0: Get oldest available 1: Continue previous connection 2: New events only	0: Get oldest event possible (Default and current implementation) 1: Continue with the event idx from previous connection 2: Get only new events from connection time and forward

Table. 6.1.2 - 262. Modbus/RTU settings.

Parameter	Range	Description
Slave address	1...247	Defines the Modbus/RTU slave address for the unit.

Additionally, the user can adjust the measurement update interval with the following parameters (found at *Measurement* → *Measurement update*). These parameters do not affect the operating times of protection functions, only the frequency of measurement reporting to Modbus.

Table. 6.1.2 - 263. Settings for measurement update interval.

Name	Range	Step	Default	Description
Current measurement update interval	500...10 000ms	5ms	2 000ms	Defines the measurement update interval of all current-related measurements.
Voltage measurement update interval	500...10 000ms	5ms	2 000ms	Defines the measurement update interval of all voltage-related measurements.

Name	Range	Step	Default	Description
Power measurement update interval	500...10 000ms	5ms	2 000ms	Defines the measurement update interval of all power-related measurements.
Impedance measurement update interval	500...10 000ms	5ms	2 000ms	Defines the measurement update interval of all impedance-related measurements.

6.1.3 Modbus I/O

The Modbus I/O protocol can be selected to communicate on the available serial ports. The Modbus I/O is actually a Modbus/RTU master implementation that is dedicated to communicating with serial Modbus/RTU slaves such as RTD input modules. Up to three (3) Modbus/RTU slaves can be connected to the same bus polled by the Modbus I/O implementation. These are named I/O Module A, I/O Module B and I/O Module C. Each of the modules can be configured using parameters in the following two tables.

Table. 6.1.3 - 264. Module settings.

Name	Range	Description
I/O module X address	0...247	Defines the Modbus unit address for the selected I/O Module (A, B, or C). If this setting is set to "0", the selected module is not in use.
Module x type	0: ADAM-4018+ 1: ADAM-4015	Selects the module type.
Channels in use	Channel 0...Channel 7 (or None)	Selects the number of channels to be used by the module.

Table. 6.1.3 - 265. Channel settings.

Name	Range	Step	Default	Description
T.C. type	0: +/- 20mA 1: 4...20mA 2: Type J 3: Type K 4: Type T 5: Type E 6: Type R 7: Type S	-	1: 4...20mA	Selects the thermocouple or the mA input connected to the I/O module. Types J, K, T and E are nickel-alloy thermocouples, while Types R and S are platinum/rhodium-alloy thermocouples.
Input value	-101.0...2 000.0	0.1	-	Displays the input value of the selected channel.
Input status	0: Invalid 1: OK	-	-	Displays the input status of the selected channel.

6.1.4 IEC 61850

The user can enable the IEC 61850 protocol in device models that support this protocol at *Communication* → *Protocols* → *IEC61850*. AQ-21x frame units support Edition 1 of IEC 61850. AQ-25x frame units support both Edition 1 and 2 of IEC61850. The following services are supported by IEC 61850 in Arcteq devices:

- Up to six data sets (predefined data sets can be edited with the IEC 61850 tool in AQtivate)
- Report Control Blocks (both buffered and unbuffered reporting)
- Control ('Direct operate with normal security', 'Select before operate with normal security', 'Direct with enhanced security' and 'Select before operate with enhanced security' control sequences)
- Disturbance recording file transfer
- GOOSE

- Time synchronization

The device's current IEC 61850 setup can be viewed and edited with the IEC61850 tool (*Tools* → *Communication* → *IEC 61850*). By browsing the 61850 tree one can see the full list of available logical nodes in the Arcteq implementation.

Settings.

The general setting parameters for the IEC 61850 protocol are visible both in AQtivate and in the local HMI. The settings are described in the table below.

Table. 6.1.4 - 266. General settings.

Name	Range	Step	Default	Description
Enable IEC 61850	0: Disabled 1: Enabled	-	0: Disabled	Enables and disables the IEC 61850 communication protocol.
IP port	0...65 535	1	102	Defines the IP port used by the IEC 61850 protocol. The standard (and default) port is 102.
General deadband	0.1...10.0%	0.1%	2%	Determines the general data reporting deadband settings.
Active energy deadband	0.1...1000.0kWh	0.1kWh	2kWh	Determines the data reporting deadband settings for this measurement.
Reactive energy deadband	0.1...1000.0kVar	0.1kVar	2kVar	Determines the data reporting deadband settings for this measurement.
Active power deadband	0.1...1000.0kW	0.1kW	2kW	Determines the data reporting deadband settings for this measurement.
Reactive power deadband	0.1...1000.0kVar	0.1kVar	2kVar	Determines the data reporting deadband settings for this measurement.
Apparent power deadband	0.1...1000.0kVA	0.1kVA	2kVA	Determines the data reporting deadband settings for this measurement.
Power factor deadband	0.01...0.99	0.01	0.05	Determines the data reporting deadband settings for this measurement.
Frequency deadband	0.01...1.00Hz	0.01Hz	0.1Hz	Determines the data reporting deadband settings for this measurement.
Current deadband	0.01...50.00A	0.01A	5A	Determines the data reporting deadband settings for this measurement.
Residual current deadband	0.01...50.00A	0.01A	0.2A	Determines the data reporting deadband settings for this measurement.
Voltage deadband	0.01...5000.00V	0.01V	200V	Determines the data reporting deadband settings for this measurement.
Residual voltage deadband	0.01...5000.00V	0.01V	200V	Determines the data reporting deadband settings for this measurement.
Angle measurement deadband	0.1...5.0deg	0.1deg	1deg	Determines the data reporting deadband settings for this measurement.
Integration time	0...10 000ms	1ms	0ms	Defines the integration time of the protocol. If this parameter is set to "0 ms", no integration time is in use.
Reconfigure GOOSE	0: - 1: Reconfigure	-	0: -	Reconfigures the GOOSE.
Enable GOOSE subscriber	0: Disabled 1: Enabled	-	0: Disabled	Enabled and disables the GOOSE subscriber.

For more information on the IEC 61850 communication protocol support, please refer to the conformance statement documents (www.arcteq.fi/downloads/ → AQ-200 series → Resources).

6.1.5 GOOSE

Arcteq relays support both GOOSE publisher and GOOSE subscriber. GOOSE subscriber is enabled with the "GOOSE subscriber enable" parameter at *Communication* → *Protocols* → *IEC 61850/GOOSE*. The GOOSE inputs are configured using either the local HMI or the AQtivate software.

There are up to 64 GOOSE inputs available for use. Each of the GOOSE inputs also has a corresponding input quality signal which can also be used in internal logic. The quality is good, when the input quality is low (that is, when the quality is marked as "0"). The value of the input quality can increase as a result of a GOOSE time-out or a configuration error, for example. The status and quality of the various logical input signals can be viewed at the *GOOSE IN status* and *GOOSE IN quality* tabs at *Control* → *Device I/O* → *Logical signals*.

GOOSE input settings

The table below presents the different settings available for all 64 GOOSE inputs.

Table. 6.1.5 - 267. GOOSE input settings.

Name	Range	Step	Default	Description
In use	0: No 1: Yes	-	0: No	Enables and disables the GOOSE input in question.
Application ID ("AppID")	0x0...0x3FFF	0x1	0x0	Defines the application ID that will be matched with the publisher's GOOSE control block.
Configuration revision ("ConfRev")	1...2 ³² -1	1	1	Defines the configuration revision that will be matched with the publisher's GOOSE control block.
Data index ("DataIdx")	0...99	1	-	Defines the data index of the value in the matched published frame. It is the status of the GOOSE input.
NextIdx is quality	0: No 1: Yes	-	0: No	Selects whether or not the next received input is the quality bit of the GOOSE input.
Data type	0: Boolean 1: Integer 2: Unsigned 3: Floating point	-	0: Boolean	Selects the data type of the GOOSE input.

Setting the publisher

The configuration of the GOOSE publisher is done using the IEC 61850 tool in AQtivate (*Tools* → *Communication* → *IEC 61850*). Refer to *AQtivate-200 Instruction manual* for more information on how to set up GOOSE publisher.

6.1.6 IEC 103

IEC 103 is the shortened form of the international standard IEC 60870-5-103. The AQ-200 series units are able to run as a secondary (slave) station. The IEC 103 protocol can be selected for the serial ports that are available in the device. A primary (master) station can then communicate with the Arcteq device and receive information by polling from the slave device. The transfer of disturbance recordings is not supported.

NOTE: Once the configuration file has been loaded, the IEC 103 map of the relay can be found in the AQtivate software (*Tools* → *IEC 103 map*).

The following table presents the setting parameters for the IEC 103 protocol.

Name	Range	Step	Default	Description
Slave address	1...254	1	1	Defines the IEC 103 slave address for the unit.
Measurement interval	0...60 000ms	1ms	2000ms	Defines the interval for the measurements update.

6.1.7 DNP3

DNP3 is a protocol standard which is controlled by the DNP Users Group (www.dnp.org). The implementation of a DNP3 slave is compliant with the DNP3 subset (level) 2, but it also contains some functionalities of the higher levels. For detailed information please refer to the DNP3 Device Profile document (www.arcteq.fi/downloads/ → AQ-200 series → Resources).

Settings

The following table describes the DNP3 setting parameters.

Table. 6.1.7 - 268. Settings.

Name	Range	Step	Default	Description
Enable DNP3 TCP	0: Disabled 1: Enabled	-	0: Disabled	Enables and disables the DNP3 TCP communication protocol when the Ethernet port is used for DNP3. If a serial port is used, the DNP3 protocol can be enabled from <i>Communication</i> → <i>DNP3</i> .
IP port	0...65 535	1	20 000	Defines the IP port used by the protocol.
Slave address	1...65 519	1	1	Defines the DNP3 slave address of the unit.
Master address	1...65 534	1	2	Defines the address for the allowed master.
Link layer time-out	0...60 000ms	1ms	0ms	Defines the length of the time-out for the link layer.
Link layer retries	1...20	1	1	Defines the number of retries for the link layer.
Diagnostic - Error counter	0...2 ³² -1	1	-	Counts the total number of errors in received and sent messages.
Diagnostic - Transmitted messages	0...2 ³² -1	1	-	Counts the total number of transmitted messages.
Diagnostic - Received messages	0...2 ³² -1	1	-	Counts the total number of received messages.

Default variations

Table. 6.1.7 - 269. Default variations.

Name	Range	Default	Description
Group 1 variation (BI)	0: Var 1 1: Var 2	0: Var 1	Selects the variation of the binary signal.
Group 2 variation (BI change)	0: Var 1 1: Var 2	1: Var 2	Selects the variation of the binary signal change.
Group 3 variation (DBI)	0: Var 1 1: Var 2	0: Var 1	Selects the variation of the double point signal.

Name	Range	Default	Description
Group 4 variation (DBI change)	0: Var 1 1: Var 2	1: Var 2	Selects the variation of the double point signal.
Group 20 variation (CNTR)	0: Var 1 1: Var 2 2: Var 5 3: Var 6	0: Var 1	Selects the variation of the control signal.
Group 22 variation (CNTR change)	0: Var 1 1: Var 2 2: Var 5 3: Var 6	2: Var 5	Selects the variation of the control signal change.
Group 30 variation (AI)	0: Var 1 1: Var 2 2: Var 3 3: Var 4 4: Var 5	4: Var 5	Selects the variation of the analog signal.
Group 32 variation (AI change)	0: Var 1 1: Var 2 2: Var 3 3: Var 4 4: Var 5 5: Var 7	4: Var 5	Selects the variation of the analog signal change.

Setting the analog change deadbands

Table. 6.1.7 - 270. Analog change deadband settings.

Name	Range	Step	Default	Description
General deadband	0.1...10.0%	0.1%	2%	Determines the general data reporting deadband settings.
Active energy deadband	0.1...1000.0kWh	0.1kWh	2kWh	Determines the data reporting deadband settings for this measurement.
Reactive energy deadband	0.1...1000.0kVar	0.1kVar	2kVar	Determines the data reporting deadband settings for this measurement.
Active power deadband	0.1...1000.0kW	0.1kW	2kW	Determines the data reporting deadband settings for this measurement.
Reactive power deadband	0.1...1000.0kVar	0.1kVar	2kVar	Determines the data reporting deadband settings for this measurement.
Apparent power deadband	0.1...1000.0kVA	0.1kVA	2kVA	Determines the data reporting deadband settings for this measurement.
Power factor deadband	0.01...0.99	0.01	0.05	Determines the data reporting deadband settings for this measurement.
Frequency deadband	0.01...1.00Hz	0.01Hz	0.1Hz	Determines the data reporting deadband settings for this measurement.
Current deadband	0.01...50.00A	0.01A	5A	Determines the data reporting deadband settings for this measurement.
Residual current deadband	0.01...50.00A	0.01A	0.2A	Determines the data reporting deadband settings for this measurement.
Voltage deadband	0.01...5000.00V	0.01V	200V	Determines the data reporting deadband settings for this measurement.
Residual voltage deadband	0.01...5000.00V	0.01V	200V	Determines the data reporting deadband settings for this measurement.
Angle measurement deadband	0.1...5.0deg	0.1deg	1deg	Determines the data reporting deadband settings for this measurement.
Integration time	0...10 000ms	1ms	-	Displays the integration time of the protocol.

6.1.8 IEC 101/104

The standards IEC 60870-5-101 and IEC 60870-5-104 are closely related. Both are derived from the IEC 60870-5 standard. On the physical layer the IEC 101 protocol uses serial communication whereas the IEC 104 protocol uses Ethernet communication. The IEC 101/104 implementation works as a slave in the unbalanced mode.

For detailed information please refer to the IEC 101/104 interoperability document (www.arcteq.fi/downloads/ → AQ-200 series → Resources → "AQ-200 IEC101 & IEC104 interoperability").

IEC 101 settings

Table. 6.1.8 - 271. IEC 101 settings.

Name	Range	Step	Default	Description
Common address of ASDU	0...65 534	1	1	Defines the common address of the application service data unit (ASDU) for the IEC 101 communication protocol.
Common address of ASDU size	1...2	1	2	Defines the size of the common address of ASDU.
Link layer address	0...65 534	1	1	Defines the address for the link layer.
Link layer address size	1...2	1	2	Defines the address size of the link layer.
Information object address size	2...3	1	3	Defines the address size of the information object.
Cause of transmission size	1...2	1	2	Defines the cause of transmission size

IEC 104 settings

Table. 6.1.8 - 272. IEC 104 settings.

Name	Range	Step	Default	Description
IEC 104 enable	0: Disabled 1: Enabled	-	0: Disabled	Enables and disables the IEC 104 communication protocol.
IP port	0...65 535	1	2404	Defines the IP port used by the protocol.
Common address of ASDU	0...65 534	1	1	Defines the common address of the application service data unit (ASDU) for the IEC 104 communication protocol.

Measurement scaling coefficients

The measurement scaling coefficients are available for the following measurements, in addition to the general measurement scaling coefficient:

- Active energy
- Reactive energy
- Active power
- Reactive power
- Apparent power
- Power factor
- Frequency

- Current
- Residual current
- Voltage
- Residual voltage
- Angle

The range is the same for all of the scaling coefficients. By default, there is no scaling.

- No scaling
- 1/10
- 1/100
- 1/1000
- 1/10 000
- 1/100 000
- 1/1 000 000
- 10
- 100
- 1000
- 10 000
- 100 000
- 1 000 000

Deadband settings.

Table. 6.1.8 - 273. Analog change deadband settings.

Name	Range	Step	Default	Description
General deadband	0.1...10.0%	0.1%	2%	Determines the general data reporting deadband settings.
Active energy deadband	0.1...1000.0kWh	0.1kWh	2kWh	Determines the data reporting deadband settings for this measurement.
Reactive energy deadband	0.1...1000.0kVar	0.1kVar	2kVar	Determines the data reporting deadband settings for this measurement.
Active power deadband	0.1...1000.0kW	0.1kW	2kW	Determines the data reporting deadband settings for this measurement.
Reactive power deadband	0.1...1000.0kVar	0.1kVar	2kVar	Determines the data reporting deadband settings for this measurement.
Apparent power deadband	0.1...1000.0kVA	0.1kVA	2kVA	Determines the data reporting deadband settings for this measurement.
Power factor deadband	0.01...0.99	0.01	0.05	Determines the data reporting deadband settings for this measurement.
Frequency deadband	0.01...1.00Hz	0.01Hz	0.1Hz	Determines the data reporting deadband settings for this measurement.
Current deadband	0.01...50.00A	0.01A	5A	Determines the data reporting deadband settings for this measurement.
Residual current deadband	0.01...50.00A	0.01A	0.2A	Determines the data reporting deadband settings for this measurement.
Voltage deadband	0.01...5000.00V	0.01V	200V	Determines the data reporting deadband settings for this measurement.
Residual voltage deadband	0.01...5000.00V	0.01V	200V	Determines the data reporting deadband settings for this measurement.
Angle measurement deadband	0.1...5.0deg	0.1deg	1deg	Determines the data reporting deadband settings for this measurement.
Integration time	0...10 000ms	1ms	-	Displays the integration time of the protocol.

6.1.9 SPA

The device can act as a SPA slave. SPA can be selected as the communication protocol for the COM B port (RS-485 port in the CPU module). When the device includes a serial RS-232 card connector, the SPA protocol can also be selected as the communication protocol for the COM E and COM F ports. Please refer to the chapter "Construction and installation" in the device manual to see the connections for these modules.

The data transfer rate of SPA is 9600 bps, but it can also be set to 19 200 bps or 38 400 bps. As a slave the device sends data on demand or by sequenced polling. The available data can be measurements, circuit breaker states, function starts, function trips, etc. The full SPA signal map can be found in AQtivate (*Tools* → *SPA map*).

The SPA event addresses can be found at *Tools* → *Events and logs* → *Event list*.

NOTE!



To access SPA map and event list, an .aqs configuration file should be downloaded from the relay.

6.2 Analog fault registers

At *Communication* → *General I/O* → *Analog fault registers* the user can set up to twelve (12) channels to record the measured value when a protection function starts or trips. These values can be read in two ways: locally from this same menu, or through a communication protocol if one is in use.

The following table presents the setting parameters available for the 12 channels.

Table. 6.2 - 274. Fault register settings.

Name	Range	Step	Default	Description
Select record source	0: Not in use 1...12: l>, l>>, l>>>, l>>>> (IL1, IL2, IL3) 13...24: Id>, Id>>, Id>>>, Id>>>> (IL1, IL2, IL3) 25...28: I0>, I0>>, I0>>>, I0>>>> (I0) 29...32: I0d>, I0d>>, I0d>>>, I0d>>>> (I0) 33: FLX	-	0: Not in use	Selects the protection function and its stage to be used as the source for the fault register recording. The user can choose between non-directional overcurrent, directional overcurrent, non-directional earth fault, directional earth fault, and fault locator functions.
Select record trigger	0: TRIP signal 1: START signal 2: START and TRIP signals	-	0: TRIP signal	Selects what triggers the fault register recording: the selected function's TRIP signal, its START signal, or either one.
Recorded fault value	- 1000 000.00...1 000 000.00	0.01	-	Displays the recorded measurement value at the time of the selected fault register trigger.

6.3 Real-time measurements to communication

With the *Real-time signals to communication* menu the user can report to SCADA measurements that are not normally available in the communication protocols mapping. Up to eight (8) magnitudes can be selected. The recorded value can be either a per-unit value or a primary value (set by the user).

Measurable values

Function block uses analog current and voltage measurement values. The relay uses these values as the basis when it calculates the primary and secondary values of currents, voltages, powers, impedances and other values.

Table. 6.3 - 275. Available measured values.

Signals	Description
Currents	
IL1 (ff), IL2 (ff), IL3 (ff), IO1 (ff), IO2 (ff)	Fundamental frequency (RMS) current measurement values of phase currents and residual currents.
IL1 (TRMS), IL2 (TRMS), IL3 (TRMS), IO1 (TRMS), IO2 (TRMS)	TRMS current measurement values of phase currents and residual currents.
IL1, IL2, IL3, IO1, IO2 & 2 nd h., 3 rd h., 4 th h., 5 th h., 7 th h., 9 th h., 11 th h., 13 th h., 15 th h., 17 th h., 19 th h.	Magnitudes of the phase current components: 2 nd harmonic, 3 rd harmonic, 4 th harmonic, 5 th harmonic, 7 th harmonic, 9 th harmonic, 11 th harmonic, 13 th harmonic, 15 th harmonic, 17 th harmonic, 19 th harmonic current.
I1, I2, IOZ	Positive sequence current, negative sequence current and zero sequence current.
IOCalcMag	Residual current calculated from phase currents.
IL1Ang, IL2Ang, IL3Ang, IO1Ang, IO2Ang, IOCalcAng, I1Ang, I2Ang	Angles of each measured current.
Voltages	
UL1Mag, UL2Mag, UL3Mag, UL12Mag, UL23Mag, UL31Mag, U0Mag, U0CalcMag	Magnitudes of phase voltages, phase-to-phase voltages and residual voltages.
U1 Pos.seq V mag, U2 Neg.seq V mag	Positive and negative sequence voltages.
UL1Ang, UL2Ang, UL3Ang, UL12Ang, UL23Ang, UL31Ang, U0Ang, U0CalcAng	Angles of phase voltages, phase-to-phase voltages and residual voltages.
U1 Pos.seq V Ang, U2 Neg.seq V Ang	Positive and negative sequence angles.
Powers	
S3PH, P3PH, Q3PH	Three-phase apparent, active and reactive power.
SL1, SL2, SL3, PL1, PL2, PL3, QL1, QL2, QL3	Phase apparent, active and reactive powers.
tanfi3PH, tanfiL1, tanfiL2, tanfiL3	Tan (φ) of three-phase powers and phase powers.
cosfi3PH, cosfiL1, cosfiL2, cosfiL3	Cos (φ) of three-phase powers and phase powers.
Impedances and admittances	
RL12, RL23, RL31, XL12, XL23, XL31, RL1, RL2, RL3, XL1, XL2, XL3, Z12, Z23, Z31, ZL1, ZL2, ZL3	Phase-to-phase and phase-to-neutral resistances, reactances and impedances.

Signals	Description
Z12Ang, Z23Ang, Z31Ang, ZL1Ang, ZL2Ang, ZL3Ang	Phase-to-phase and phase-to-neutral impedance angles.
Rseq, Xseq, Zseq RseqAng, XseqAng, ZseqAng	Positive sequence resistance, reactance and impedance values and angles.
GL1, GL2, GL3, G0 BL1, BL2, BL3, B0 YL1, YL2, YL3, Y0	Conductances, susceptances and admittances.
YL1angle, YL2angle, YL3angle, Y0angle	Admittance angles.
Others	
System f.	Used tracking frequency at the moment.
Ref f1	Reference frequency 1.
Ref f2	Reference frequency 2.
M thermal T	Motor thermal temperature.
F thermal T	Feeder thermal temperature.
T thermal T	Transformer thermal temperature.
RTD meas 1...16	RTD measurement channels 1...16.
Ext RTD meas 1...8	External RTD measurement channels 1...8 (ADAM module).

Settings

Table. 6.3 - 276. Settings.

Name	Range	Step	Default	Description
Measurement value recorder mode	0: Disabled 1: Activated	-	0: Disabled	Activates and disables the real-time signals to communication.
Scale current values to primary	0: No 1: Yes	-	0: No	Selects whether or not values are scaled to primary.
Slot X magnitude selection	0: Currents 1: Voltages 2: Powers 3: Impedance (ZRX) and admittance (YGB) 4: Others	-	0: Currents	Selects the measured magnitude category of the chosen slot.
Slot X magnitude	Described in table above ("Available measured values")	-	-	Selects the magnitude in the previously selected category.
Magnitude X	-10 000 000.000...10 000 000.000	0.001	-	Displays the measured value of the selected magnitude of the selected slot. The unit depends on the selected magnitude (either amperes, volts, or per-unit values).

7 Connections and application examples

7.1 Connections of AQ-F213

Figure. 7.1 - 230. AQ-F213 variant without add-on modules.

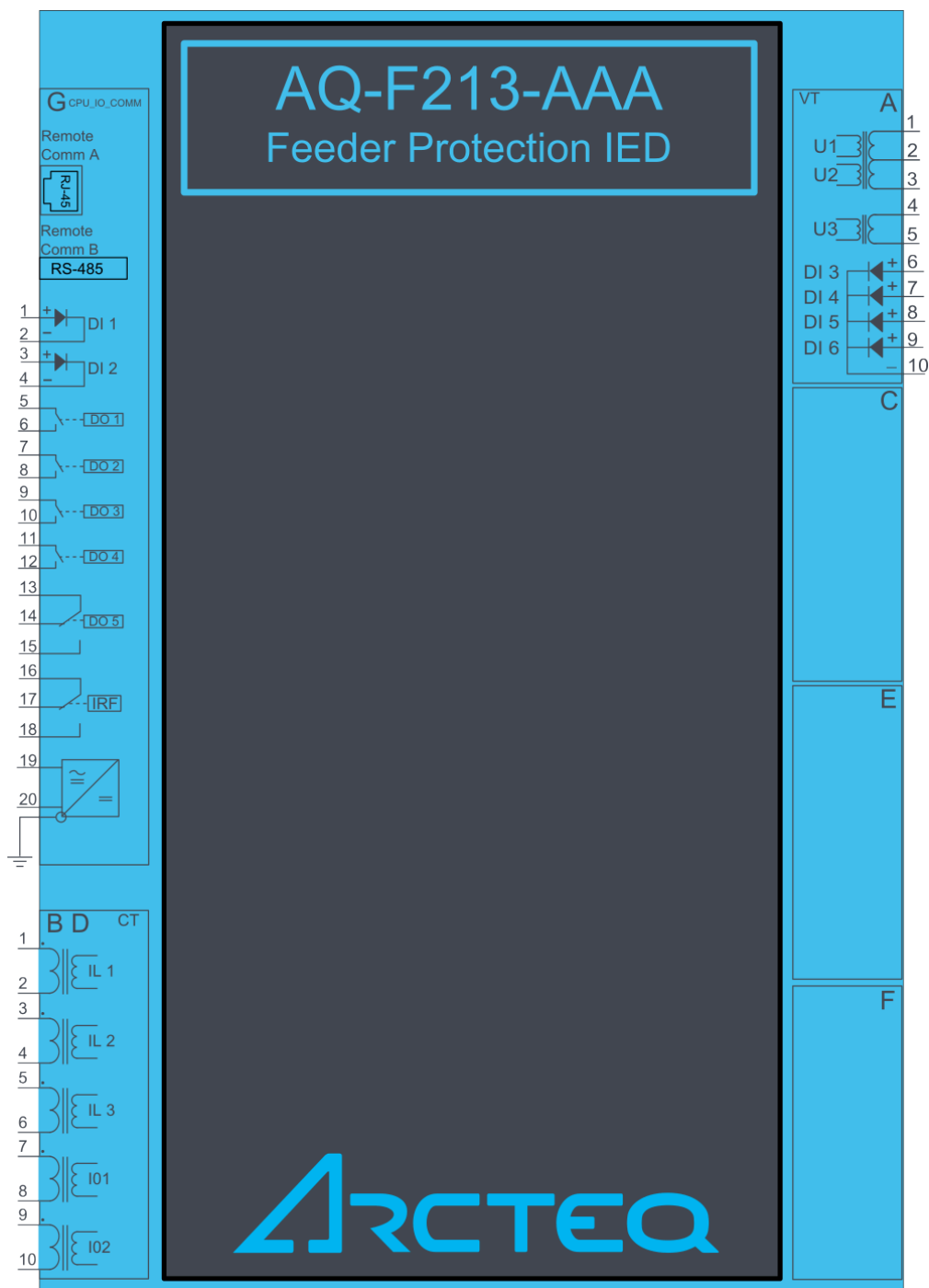

Figure. 7.1 - 231. AQ-F213 variant with digital input and output modules.

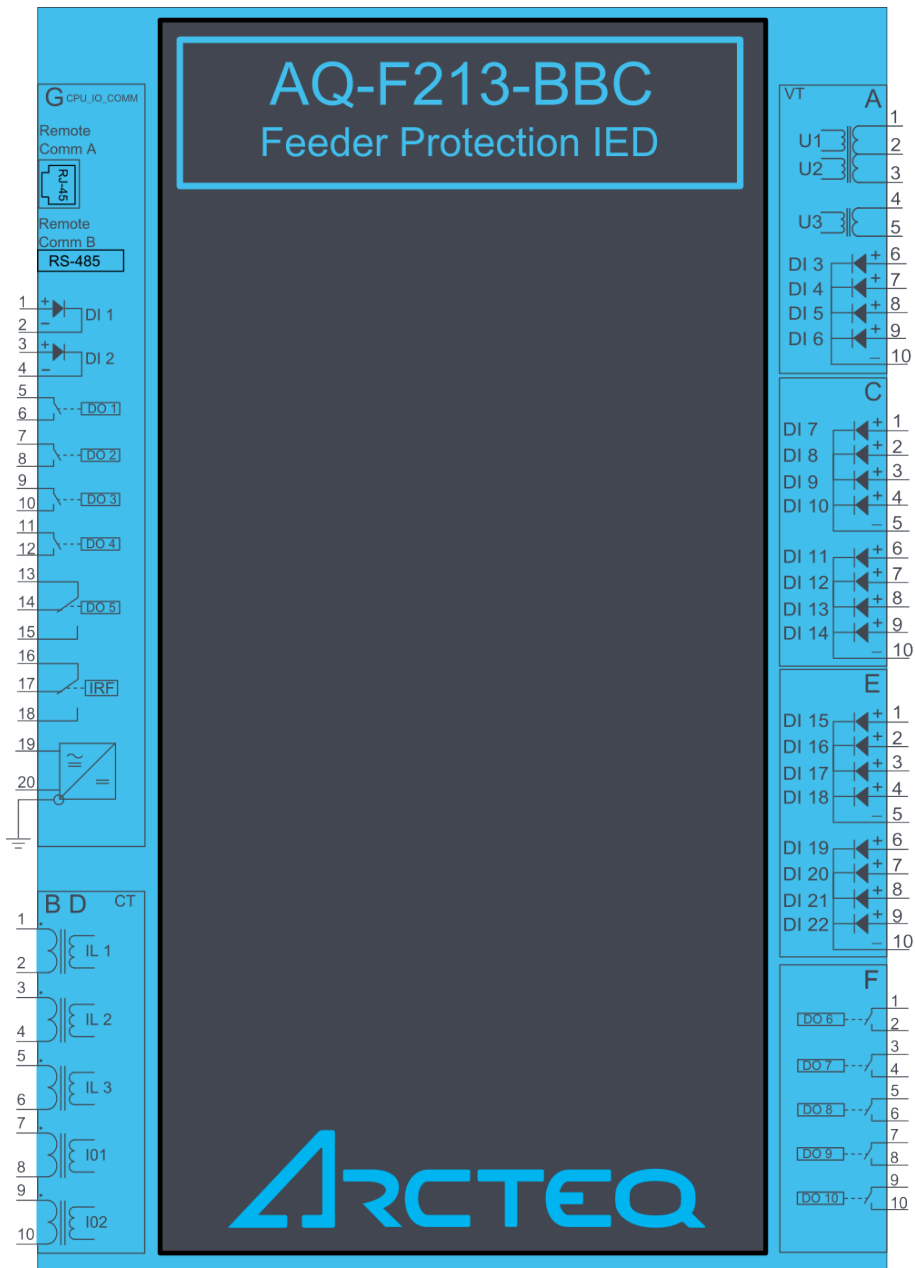
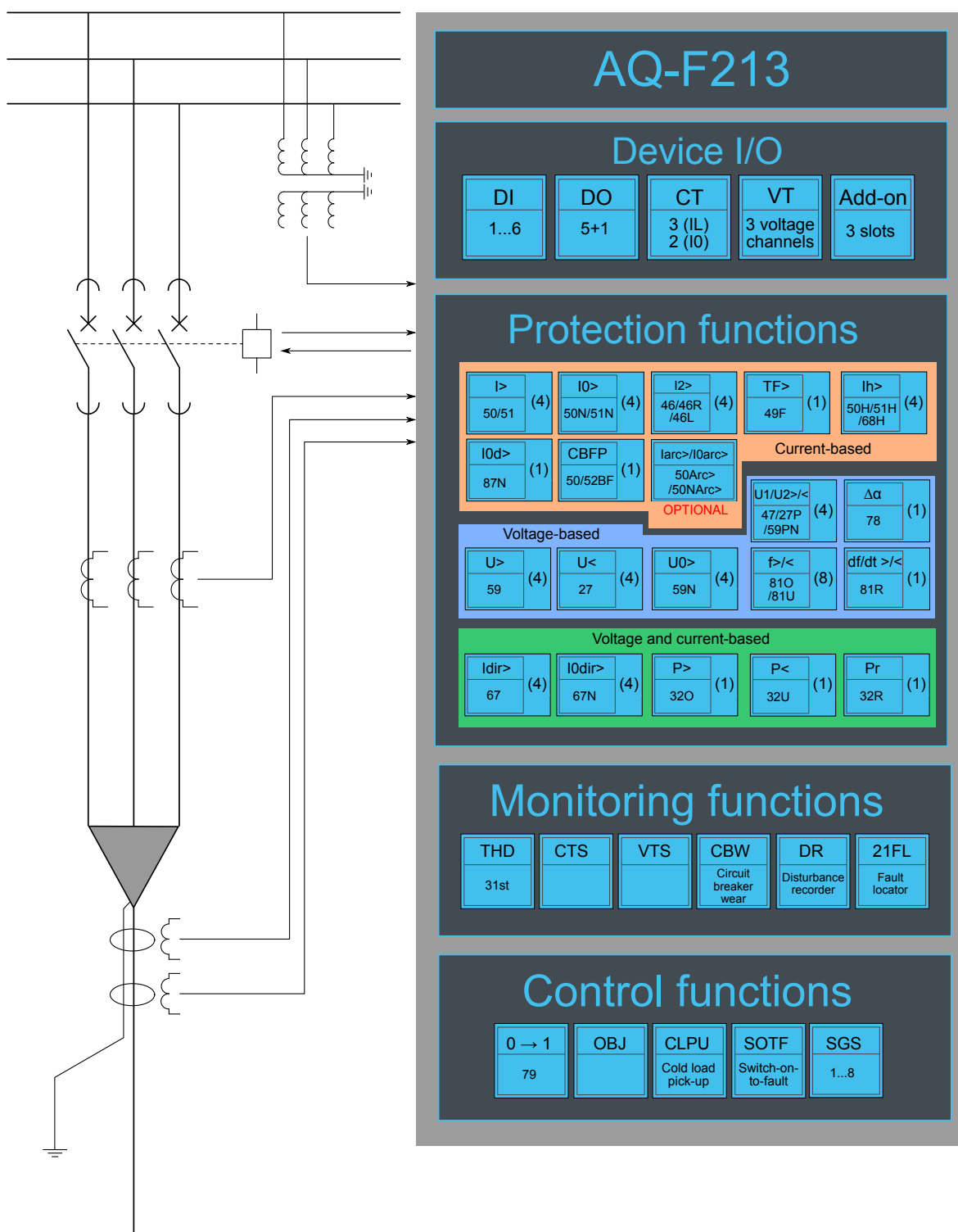

Figure. 7.1 - 232. AQ-F213 application example with function block diagram.



7.2 Application example and its connections

This chapter presents an application example for the feeder protection IED.

Since two line-to-line voltages and the zero sequence voltage (U3) are connected, this application uses the voltage measurement mode "2LL+U0" (see the image below). Additionally, the three phase currents and the residual current (I01) are also connected. The digital inputs are connected to indicate the breaker status, while the digital outputs are used for breaker control.

Figure. 7.2 - 233. Application example and its connections.

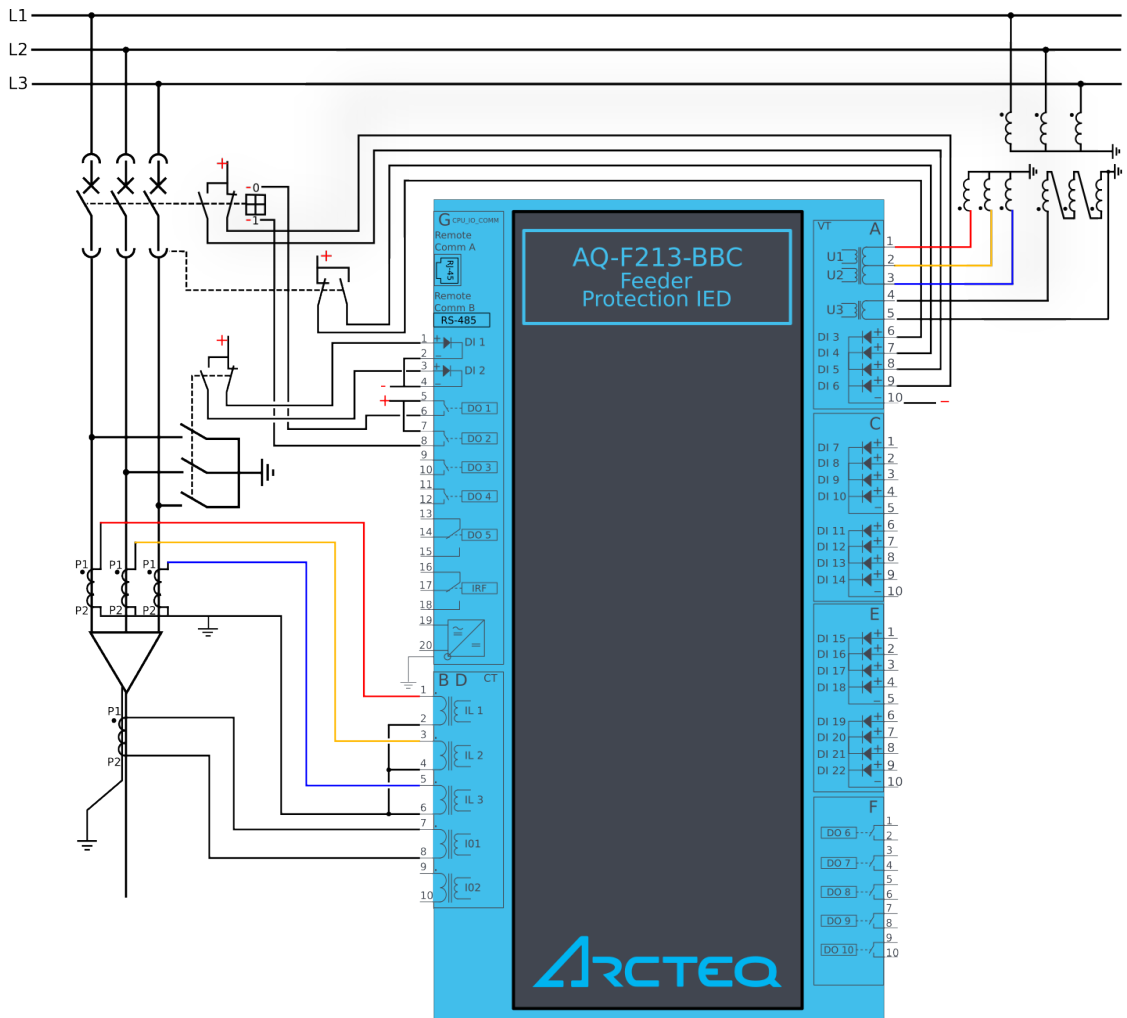

7.3 Two-phase, three-wire ARON input connection

This chapter presents the two-phase, three-wire ARON input connection for any AQ-200 series IED with a current transformer. The example is for applications with protection CTs for just two phases. The connection is suitable for both motor and feeder applications.

Figure. 7.3 - 234. ARON connection.

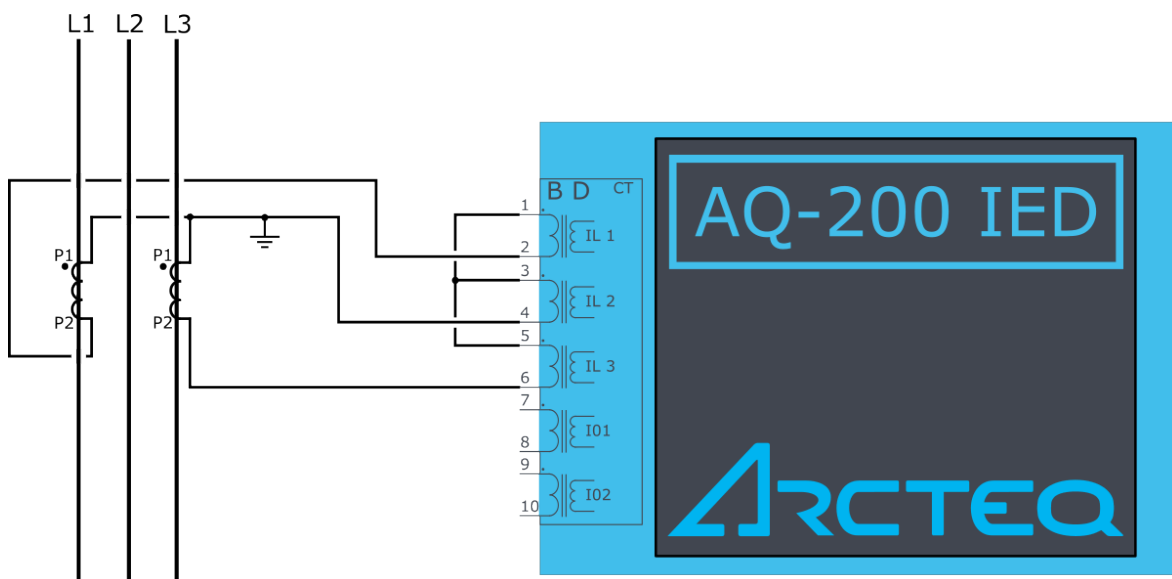

The ARON input connection can measure the load symmetrically despite the fact that one of the CTs is missing from the installation. Normally, Phase 2 does not have a current transformer installed as an external fault is much more likely to appear on Lines 1 or 3.

A fault between Line 2 and the earth cannot be detected when the ARON input connection is used. In order to detect an earth fault in Phase 2, a cable core CT must be used.

7.4 Trip circuit supervision (95)

Trip circuit supervision is used to monitor the wiring from auxiliary power supply, through the IED's digital output, and all the way to the open coil of the breaker. It is recommended to supervise the health of the trip circuit when breaker is closed.

Trip circuit supervision with one digital input and one non-latched trip output

The figure below presents an application scheme for trip circuit supervision with one digital input and a non-latched trip output. With this connection the current keeps flowing to the open coil of the breaker via the breaker's closing auxiliary contacts (52b) even after the circuit breaker is opened. This requires a resistor which reduces the current: this way the coil is not energized and the relay output does not need to cut off the coil's inductive current.

Figure. 7.4 - 235. Trip circuit supervision with one DI and one non-latched trip output.

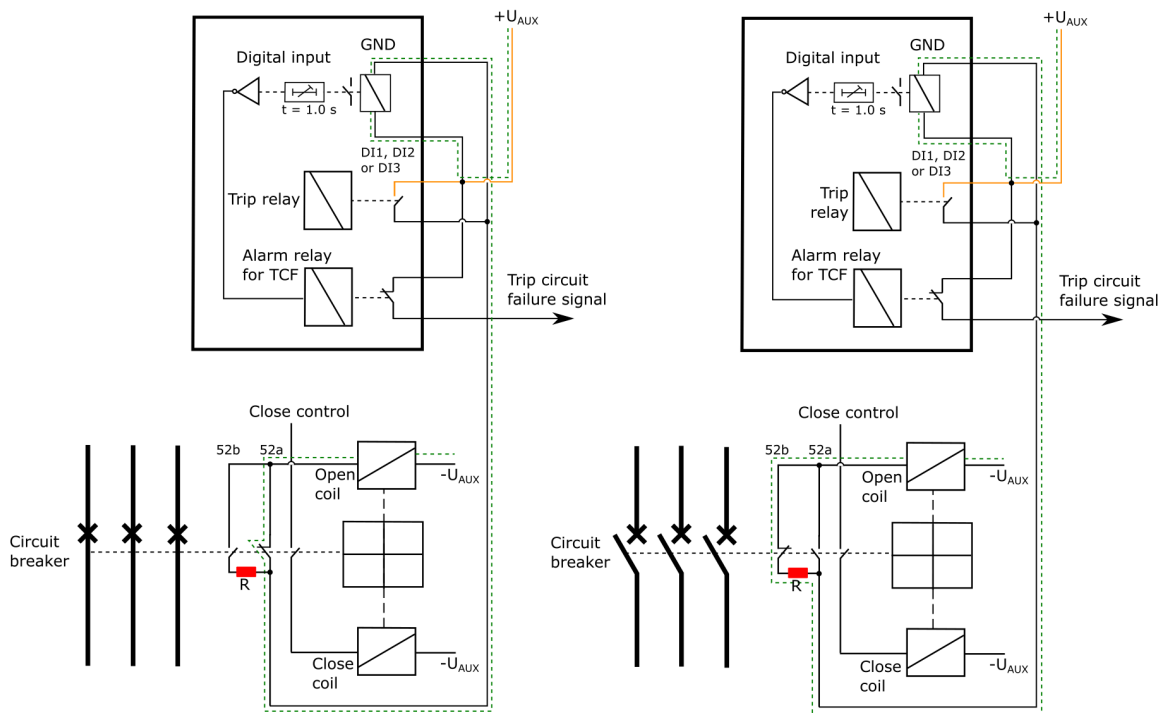

Note that the digital input that monitors the circuit is normally closed, and the same applies to the alarm relay if one is used. For monitoring and especially trip circuit supervision purposes it is recommended to use a normally closed contact to confirm the wiring's condition. An active digital input generates a less than 2 mA current to the circuit, which is usually small enough not to make the breaker's open coil operate.

When the trip relay is controlled and the circuit breaker is opening, the digital input is shorted by the trip contact as long as the breaker opens. Normally, this takes about 100 ms if the relay is non-latched. A one second activation delay should, therefore, be added to the digital input. An activation delay that is slightly longer than the circuit breaker's operations time should be enough. When circuit breaker failure protection (CBFP) is used, adding its operation time to the digital input activation time is useful. The whole digital input activation time is, therefore, $t_{DI} = t_{CB} + t_{IEDrelease} + t_{CBFP}$.

The image below presents the necessary settings when using a digital input for trip circuit supervision. The input's polarity must be NC (normally closed) and a one second delay is needed to avoid nuisance alarm while the circuit breaker is controlled open.

Figure. 7.4 - 236. Settings for a digital input used for trip circuit supervision.

Non-latched outputs are seen as hollow circles in the output matrix, whereas latched contacts are painted. See the image below of an output matrix where a non-latched trip contact is used to open the circuit breaker.

Figure. 7.4 - 237. Non-latched trip contact.

Inputs	OUT1	OUT2	OUT3	OUT4	OUT5
I> START (General)					
I> START(A)					
I> START(B)					
I> START(C)					
I> TRIP (General)	○				
I> TRIP(A)					
I> TRIP(B)					
I> TRIP(C)					
I> BLOCKED					

When the auto-reclosing function is used in feeder applications, the trip output contacts must be non-latched. Trip circuit supervision is generally easier and more reliable to build with non-latched outputs.

The open coil remains energized only as long as the circuit breaker is opened and the IED output releases. This takes approximately 100 ms depending on the size and type of the breaker. When the breaker opens, the auxiliary contacts open the inductive circuit; however, the trip contact does not open at the same time. The IED's output relay contact opens in under 50 ms or after a set release delay that takes place after the breaker is opened. This means that the open coil is energized for a while after the breaker has already opened. The coil could even be energized a moment longer if the circuit breaker failure protection has to be used and the incomer performs the trip.

Trip circuit supervision with one digital input and one connected, non-latched trip output

There is one main difference between non-latched and latched control in trip circuit supervision: when using the latched control, the trip circuit (in an open state) cannot be monitored as the digital input is shorted by the IED's trip output.

Figure. 7.4 - 238. Trip circuit supervision with one DI and one latched output contact.

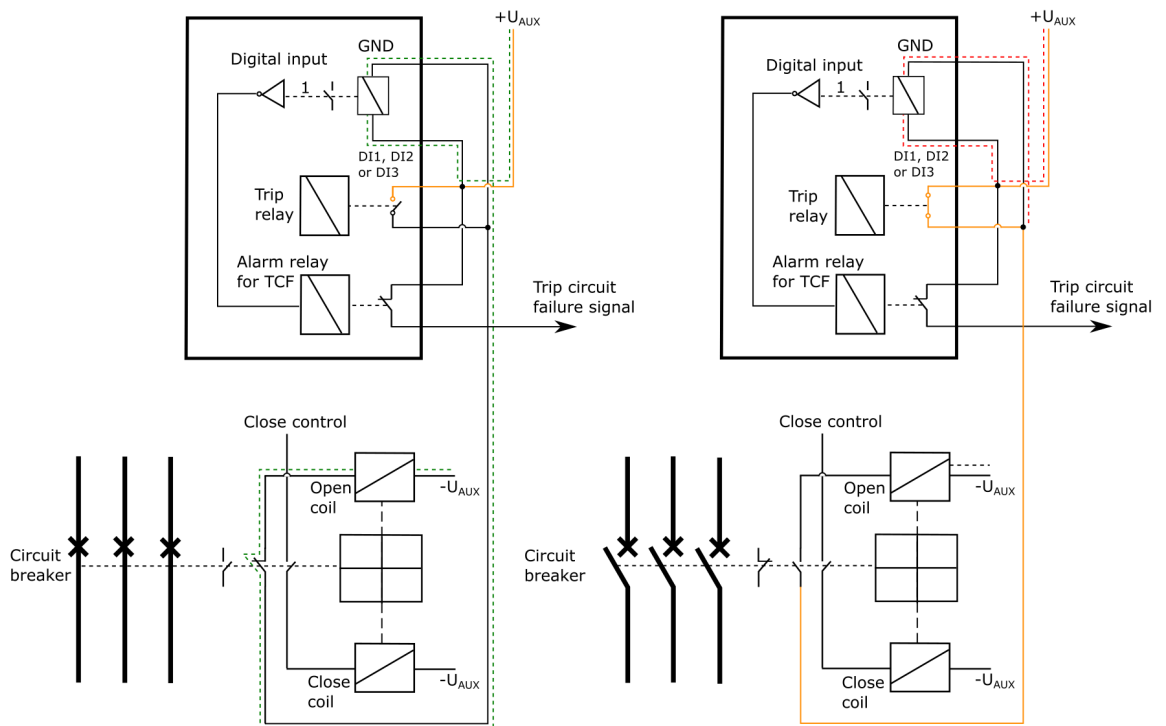

The trip circuit with a latched output contact can be monitored, but only when the circuit breaker's status is "Closed". Whenever the breaker is open, the supervision is blocked by an internal logic scheme. Its disadvantage is that the user does not know whether or not the trip circuit is intact when the breaker is closed again.

The following logic scheme (or similar) blocks the supervision alarm when the circuit breaker is open. The alarm is issued whenever the breaker is closed and whenever the inverted digital input ("TCS") activates. A normally closed digital input activates only when there is something wrong with the trip circuit and the auxiliary power goes off. Logical output can be used in the output matrix or in SCADA as the user wants.

The image below presents a block scheme when a non-latched trip output is not used.

Figure. 7.4 - 239. Example block scheme.

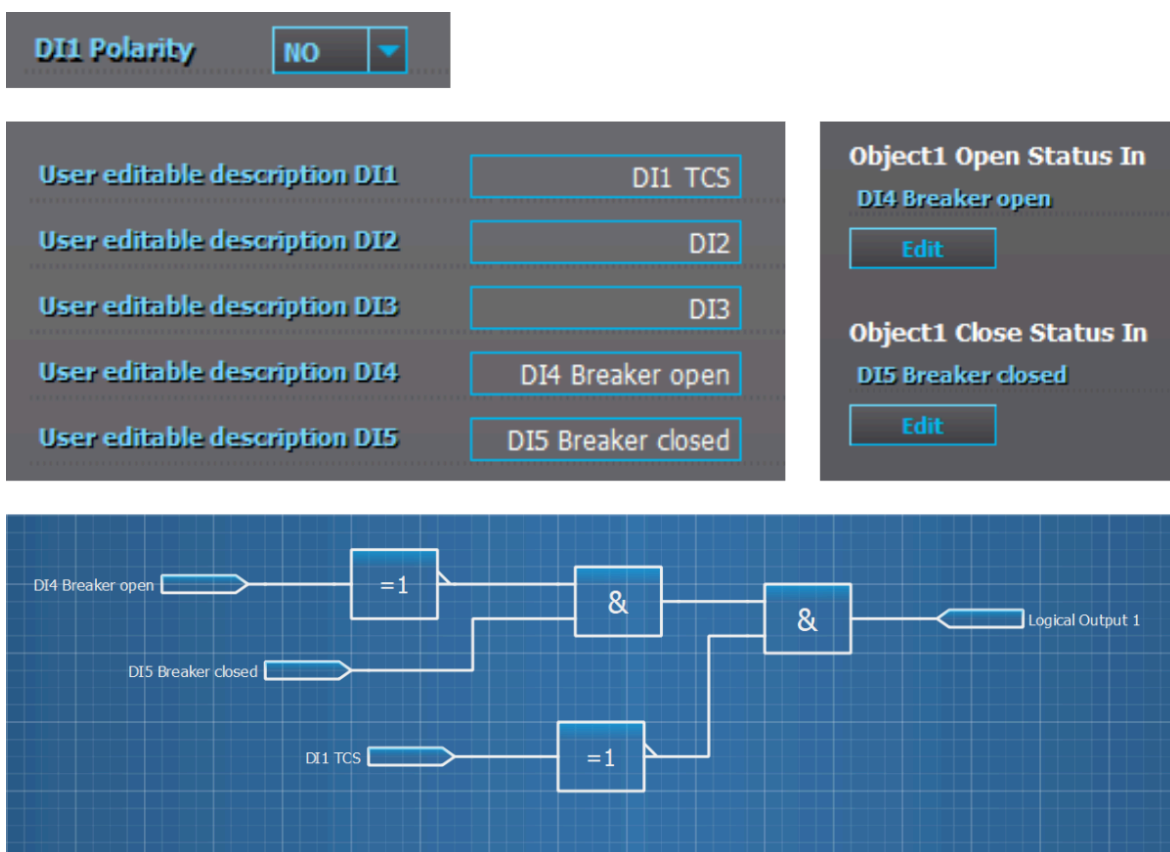

8 Construction and installation

8.1 Construction

AQ-X213 is a member of the modular and scalable AQ-200 series, and it includes three (3) configurable and modular add-on card slots. As a standard configuration the device includes the CPU module (which consists of the CPU, a number of inputs and outputs, and the power supply) as well as one separate current measurement module and one module that combines three voltage measurement channels and four digital input channels.

The images below present the modules of both the non-optional model (AQ-X213-XXXXXXX-AAA, on the left) and the fully optional model (AQ-X213-XXXXXXX-BBC, on the right).

Figure. 8.1 - 240. Modular construction of AQ-X213.

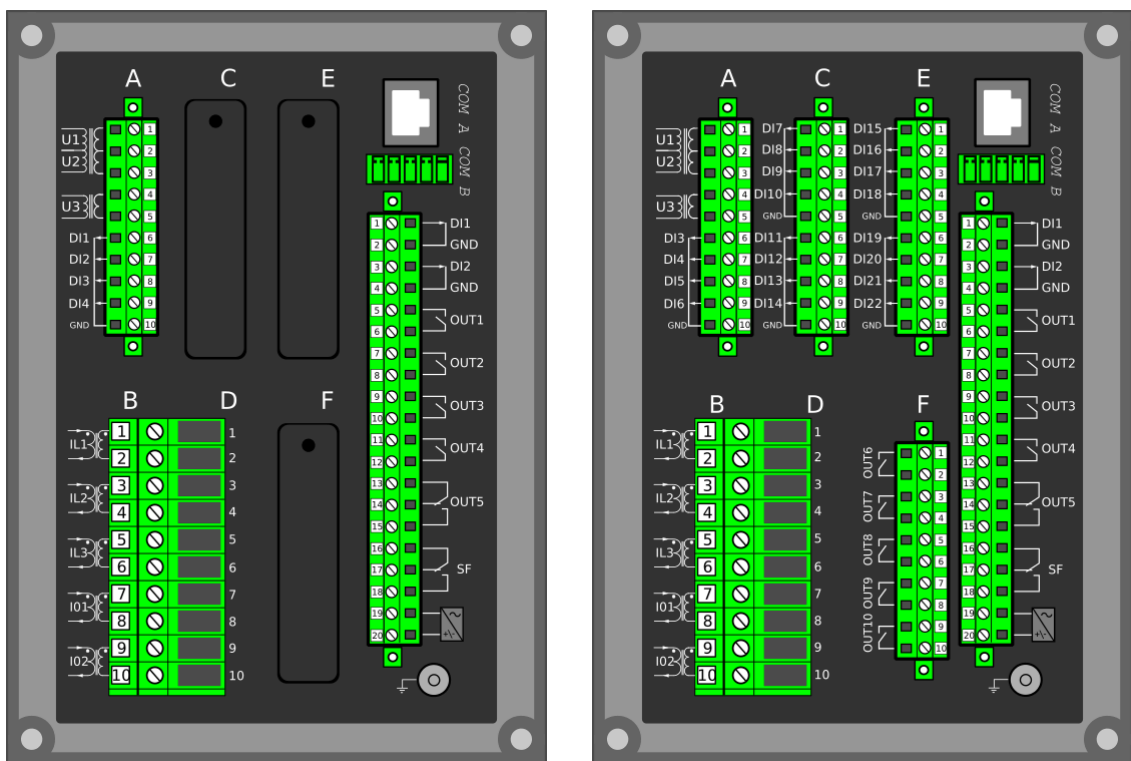

The modular structure of AQ-X213 allows for scalable solutions for different application requirements. In non-standard configurations Slots C, E and F accept all available add-on modules, such as digital I/O modules, integrated arc protection or another special module. The only difference between the slots affecting device scalability is that Slots E and F also support communication options.

When an add-on module is inserted into the device, the start-up scan searches for modules according to their type designation code. If the module location or content is not what the device expects, the IED does not take additional modules into account and instead issues a configuration error message. In field upgrades, therefore, the add-on module must be ordered from Arcteq Relays Ltd. or its representative who can then provide the module with its corresponding unlocking code to allow the device to operate correctly once the hardware configuration has been upgraded. This also means that the module's location in the device cannot be changed without updating the device configuration data which, again, requires the unlocking code.

When an I/O module is inserted into the device, the module location affects the naming of the I/O. The I/O scanning order in the start-up sequence is as follows: the CPU module I/O, Slot C, Slot E, Slot F. This means that the digital input channels DI1 and DI2 as well as the digital output channels OUT1, OUT2, OUT3, OUT4 and OUT5 are always located in the CPU module. If additional I/O cards are installed, their location and card type affect the I/O naming.

The figure below presents the start-up hardware scan order of the device as well as the I/O naming principles.

Figure. 8.1 - 241. AQ-X213 hardware scanning and I/O naming principles.

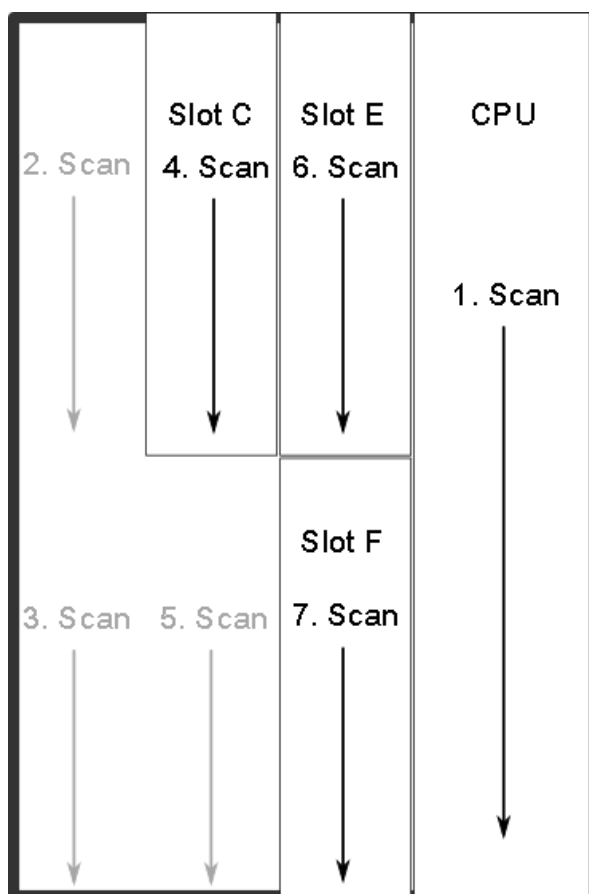

1. Scan
The start-up system; detects and self-tests the CPU module, voltages, communication and the I/O; finds and assigns "DI1", "DI2", "OUT1", "OUT2", "OUT3", "OUT4" and "OUT5".
2. Scan
Scans Slot A and finds the VT module and the DI4 module with three voltage channels and four digital inputs (fixed for AQ-X213). Assigns "DI3", "DI4", "DI5", "DI6". If the VTM is not found, the device issues an alarm.
3. Scan
Scans Slot B, which should always remain empty in AQ-X213 devices. If it is not empty, the device issues an alarm.
4. Scan
Scans Slot C, and moves to the next slot if Slot C is empty. If the scan finds an 8DI module (that is, a module with eight digital inputs), it reserves the designations "DI7", "DI8", "DI9", "DI10", "DI11", "DI12", "DI13" and "DI14" to this slot. If the scan finds a DO5 module (that is, a module with five digital outputs), it reserves the designations "OUT6", "OUT7", "OUT8", "OUT9" and "OUT10" to this slot. The I/O is then added if the type designation code (e.g. AQ-P215-PH0AAAA-BBC) matches with the existing modules in the device. If the code and the modules do not match, the device issues and alarm. An alarm is also issued if the device expects to find a module here but does not find one.

5. Scan
Scans Slot D and finds the five channels of the CT module (fixed for AQ-X213). If the CTM is not found, the device issues an alarm.
6. Scan
Scans Slot E, and moves to the next slot if Slot E is empty. If the scan finds an 8DI module, it reserves the designations "DI7", "DI8", "DI9", "DI10", "DI11", "DI12", "DI13" and "DI14" to this slot. If Slot C also has an 8DI module (and therefore has already reserved these designations), the device reserves the designations "DI15", "DI16", "DI17", "DI18", "DI19", "DI20", "DI21" and "DI22" to this slot. If the scan finds a 5DO module, it reserves the designations "OUT6", "OUT7", "OUT8", "OUT9" and "OUT10" to this slot. Again, if Slot C also has a 5DO and has therefore already reserved these designations, the device reserves the designations "OUT11", "OUT12", "OUT13", "OUT14" and "OUT15" to this slot. If the scan finds an arc protection module, it reserves the sensor channels ("S1", "S2", "S3", "S4"), the high-speed outputs ("HSO1", "HSO2") and the digital input channel ("ArcBI") to this slot.
7. Scan
A similar operation to Scan 6 (checks which designations have been reserved by modules in previous slots and numbers the new ones accordingly).

Thus far this document has only explained the installation of I/O add-on cards to the option module slots. This is because all other module types are treated in a same way. For example, when an additional communication port is installed into the upper port of the communication module, its designation is Communication port 3 or higher, as Communication ports 1 and 2 already exist in the CPU module (which is scanned, and thus designated, first). After a communication port is detected, it is added into the device's communication space and its corresponding settings are enabled.

The fully optioned example case of AQ-X213-XXXXXXX-BBC (the first image pair, on the right) has a total of 22 digital input channels available: two (DI1...DI2) in the CPU module, four (DI3...DI6) in the voltage measurement module, and the rest in Slots C and E in groups of eight. It also has a total of 10 digital output channels available: five (DO1...DO5) in the CPU module, and five (DO6...DO10) in Slot F. These same principles apply to all non-standard configurations in the AQ-X213 IED family.

8.2 CPU module

Figure. 8.2 - 242. CPU module.

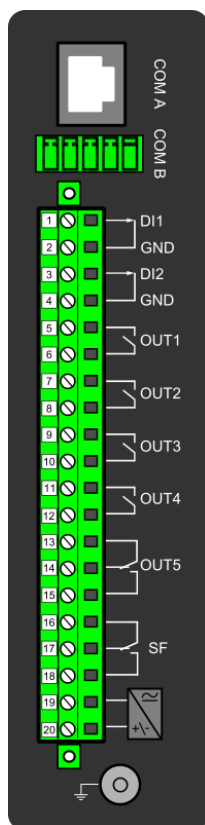

Table. 8.2 - 277. Module connectors.

Connector	Description
COM A:	Communication port A, or the RJ-45 port. Used for setting tool connection and for IEC 61850, Modbus/TCP, IEC 104, DNP3 and station bus communications.
COM B:	Communication port B, or the RS-485 port. Used for the SCADA communications for the following protocols: Modbus/RTU, Modbus I/O, SPA, DNP3, IEC 101 and IEC 103. The pins have the following designations: Pin 1 = DATA +, Pin 2 = DATA -, Pin 3 = GND, Pins 4 & 5 = Terminator resistor enabled by shorting.
X 1	Digital input 1, nominal threshold voltage 24 V, 110 V or 220 V.
X 2	GND for digital input 1.
X 3	Digital input 2, nominal threshold voltage 24 V, 110 V or 220 V.
X 4	GND for digital input 2.
X 5:6	Output relay 1, with a normally open (NO) contact.
X 7:8	Output relay 2, with a normally open (NO) contact.
X 9:10	Output relay 3, with a normally open (NO) contact.
X 11:12	Output relay 4, with a normally open (NO) contact.
X 13:14:15	Output relay 5, with a changeover contact.
X 16:17:18	System fault's output relay, with a changeover contact. Pins 16 and 17 are closed when the unit has a system fault or is powered OFF. Pins 16 and 18 are closed when the unit is powered ON and there is no system fault.
X 19:20	Power supply IN. Either 85...265 VAC/DC (model A; order code "H") or 18...75 DC (model B; order code "L"). Positive side (+) to Pin 20.
GND	The relay's earthing connector.

By default, the CPU module (combining the CPU, the I/O and the power supply) includes two standard communication ports and the relay's basic digital I/O.

The current consumption of the digital inputs is 2 mA when activated, while the range of the operating voltage is 24 V/110 V/220 V depending on the ordered hardware. All digital inputs are scanned in 5 ms program cycles, and their pick-up and release delays as well as their NO/NC selection can be set with software. The digital output controls are also set by the user with software. By default, the digital outputs are controlled in 5 ms program cycles. All output contacts are mechanical. The rated voltage of the NO/NC outputs is 250 VAC/DC.

The auxiliary voltage is defined in the ordering code: the available power supply models available are A (85...265 VAC/DC) and B (18...75 DC). For further details, please refer to the "Auxiliary voltage" chapter in the "Technical data" section of this document.

Settings and scanning cycle of digital inputs

The settings described in the table below can be found at *Control* → *Device I/O* → *Digital input settings* in the relay settings.

Table. 8.2 - 278. Digital input settings.

Name	Range	Step	Default	Description
Dlx Polarity	0: NO (Normally open) 1: NC (Normally closed)	-	0: NO	Selects whether the status of the digital input is 1 or 0 when the input is energized.
Dlx Activation delay	0.000...1800.000 s	0.001 s	0.000 s	Defines the delay for the status change from 0 to 1.
Dlx Drop-off time	0.000...1800.000 s	0.001 s	0.000 s	Defines the delay for the status change from 1 to 0.
Dlx AC mode	0: Disabled 1: Enabled	-	0: Disabled	Selects whether or not a 30-ms deactivation delay is added to account for alternating current.

Scanning cycle

All digital inputs are scanned in a 5 ms cycle, meaning that the state of an input is updated every 0...5 milliseconds. When an input is used internally in the device (either in setting group change or logic), it takes additional 0...5 milliseconds to operate. Theoretically, therefore, it takes 0...10 milliseconds to change the group when a digital input is used for group control or a similar function. In practice, however, the delay is between 2...8 milliseconds about 95 % of the time. When a digital input is connected directly to a digital output (T1...Tx), it takes an additional 5 ms round. Therefore, when a digital input controls a digital output internally, it takes 0...15 milliseconds in theory and 2...13 milliseconds in practice.



NOTE!

The mechanical delay of the relay is not included in these approximations!

8.3 Current measurement module

Figure. 8.3 - 243. Module connections with standard and ring lug terminals.

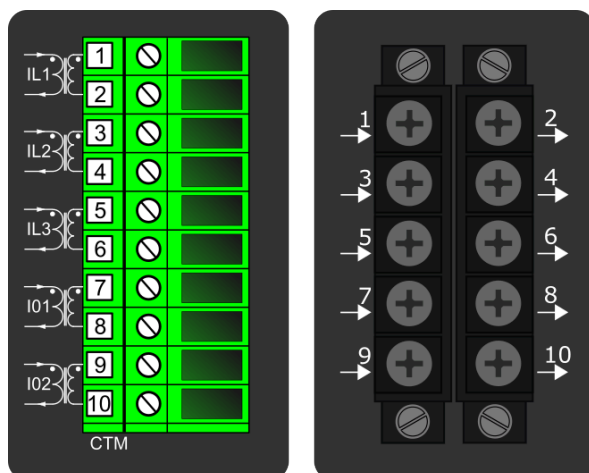

Connector	Description
CTM 1-2	Phase current measurement for phase L1 (A).
CTM 3-4	Phase current measurement for phase L2 (B).
CTM 5-6	Phase current measurement for phase L3 (C).
CTM 7-8	Coarse residual current measurement IO1.
CTM 9-10	Fine residual current measurement IO2.

A basic current measurement module with five channels includes three-phase current measurement inputs as well as coarse and fine residual current inputs. The CT module is available with either standard or ring lug connectors.

The current measurement module is connected to the secondary side of conventional current transformers (CTs). The nominal current for the phase current inputs is 5 A. The input nominal current can be scaled for secondary currents of 1... 10 A. The secondary currents are calibrated to nominal currents of 1 A and 5 A, which provide $\pm 0.5\%$ inaccuracy when the range is $0.005...4 \times I_n$.

The measurement ranges are as follows:

- Phase currents 25 mA...250 A (RMS)
- Coarse residual current 5 mA...150 A (RMS)
- Fine residual current 1 mA...75 A (RMS)

The characteristics of phase current inputs are as follows:

- The angle measurement inaccuracy is less than ± 0.2 degrees with nominal current.
- The frequency measurement range of the phase current inputs is 6...1800 Hz with standard hardware.
- The quantization of the measurement signal is applied with 18-bit AD converters, and the sample rate of the signal is 64 samples/cycle when the system frequency ranges from 6 Hz to 75 Hz.

For further details please refer to the "Current measurement" chapter in the "Technical data" section of this document.

8.4 Voltage measurement module

Figure. 8.4 - 244. Voltage measurement module.

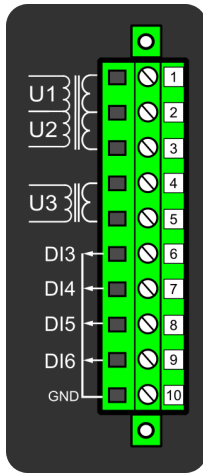

Connector	Description
X 1-2-3	Configurable voltage measurement inputs U1 and U2.
X 4-5	Configurable voltage measurement input U3.
X 6	Digital input 3
X 7	Digital input 4
X 8	Digital input 5
X 9	Digital input 6
X 10	Common earthing for the digital inputs 3...6.

The three-channel voltage measurement module has three voltage measurement inputs that can be configured freely. It also has four digital inputs. As the main processor module comes with two digital inputs, the first digital input in the voltage measurement module is designated "DI3".

The voltage measurement module is connected to the secondary side of conventional voltage transformers (VTs) or directly to low-voltage systems secured by fuses. The nominal voltage can be set between 0.2...120.0 V. Voltages are calibrated in a range of 0...250 V, which provides $\pm 1\%$ inaccuracy in the same range.

The voltage input characteristics are as follows:

- The measurement range is 1...250 V per channel.
- The angle measurement inaccuracy is less than ± 1.0 degrees within the nominal range.
- The frequency measurement range of the voltage inputs is 6...1800 Hz with standard hardware.
- The quantization of the measurement signal is applied with 18-bit AD converters, and the sample rate of the signal is 64 samples/cycle when the system frequency ranges from 6 Hz to 75 Hz.

For further details please refer to the "Voltage measurement" chapter in the "Technical data" section of this document.

8.5 Digital input module (optional)

Figure. 8.5 - 245. Digital input module (DI8) with eight add-on digital inputs.

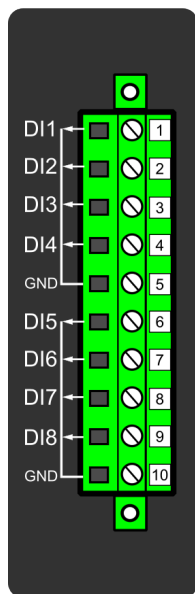

Connector	Description (x = the number of digital inputs in other modules that precede this one in the configuration)
X 1	Dlx + 1
X 2	Dlx + 2
X 3	Dlx + 3
X 4	Dlx + 4
X 5	Common earthing for the first four digital inputs.
X 6	Dlx + 5
X 7	Dlx + 6
X 8	Dlx + 7
X 9	Dlx + 8
X 10	Common earthing for the other four digital inputs.

The DI8 module is an add-on module with eight (8) galvanically isolated digital inputs. This module can be ordered directly to be installed into the device in the factory, or it can be upgraded in the field after the device's original installation when required. The properties of the inputs in this module are the same as those of the inputs in the main processor module. The current consumption of the digital inputs is 2 mA when activated, while the range of the operating voltage is from 0...265 VAC/DC. The activation and release thresholds are set in the software and the resolution is 1 V. All digital inputs are scanned in 5 ms program cycles, and their pick-up and release delays as well as their NO/NC selection can be set with software.

For the naming convention of the digital inputs provided by this module please refer to the chapter titled "Construction and installation".

For technical details please refer to the chapter titled "Digital input module" in the "Technical data" section of this document.

Setting up the activation and release delays

The settings described in the table below can be found at *Control* → *Device I/O* → *Digital input settings* in the relay settings.

Table. 8.5 - 279. Digital input settings of DI8 module.

Name	Range	Step	Default	Description
Dlx Polarity	0: NO (Normally open) 1: NC (Normally closed)	-	0: NO	Selects whether the status of the digital input is 1 or 0 when the input is energized.
Dlx Activation threshold	16.0...200.0 V	0.1 V	88 V	Defines the activation threshold for the digital input. When "NO" is the selected polarity, the measured voltage exceeding this setting activates the input. When "NC" is the selected polarity, the measured voltage exceeding this setting deactivates the input.
Dlx Release threshold	10.0...200.0 V	0.1 V	60V	Defines the release threshold for the digital input. When "NO" is the selected polarity, the measured voltage below this setting deactivates the input. When "NC" is the selected polarity, the measured voltage below this setting activates the input.
Dlx Activation delay	0.000...1800.000 s	0.001 s	0.000 s	Defines the delay when the status changes from 0 to 1.
Dlx Drop-off time	0.000...1800.000 s	0.001 s	0.000 s	Defines the delay when the status changes from 1 to 0.
Dlx AC Mode	0: Disabled 1: Enabled	-	0: Disabled	Selects whether or not a 30-ms deactivation delay is added to take the alternating current into account. The "Dlx Release threshold" parameter is hidden and forced to 10 % of the set "Dlx Activation threshold" parameter.
Dlx Counter	0...2 ³² -1	1	0	Displays the number of times the digital input has changed its status from 0 to 1.
Dlx Clear counter	0: - 1: Clear	-	0: -	Resets the Dlx counter value to zero.

The user can set the activation threshold individually for each digital input. When the activation and release thresholds have been set properly, they will result in the digital input states to be activated and released reliably. The selection of the normal state between normally open (NO) and normally closed (NC) defines whether or not the digital input is considered activated when the digital input channel is energized.

The diagram below depicts the digital input states when the input channels are energized and de-energized.

Figure. 8.5 - 246. Digital input state when energizing and de-energizing the digital input channels.

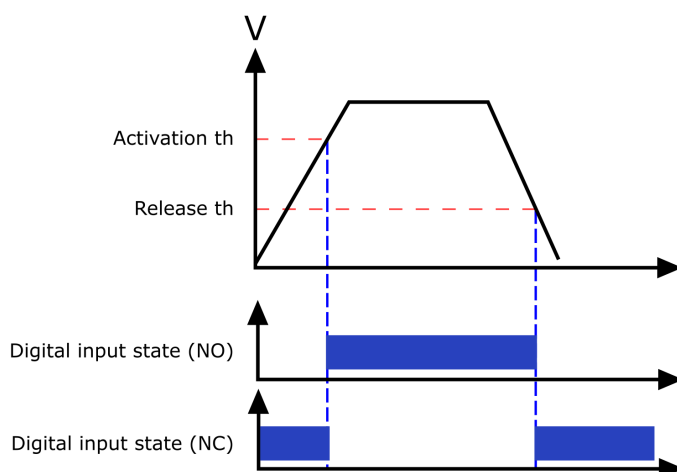

Digital input voltage measurements

Digital input option card channels measure voltage on each channel. The measured voltage can be seen at *Control* → *Device IO* → *Digital inputs* → *Digital input voltages*.

Table. 8.5 - 280. Digital input channel voltage measurement.

Name	Range	Step	Description
Dlx Voltage now	0.000...275.000 V	0.001 V	Voltage measurement of a digital input channel.

8.6 Digital output module (optional)

Figure. 8.6 - 247. Digital output module (DO5) with five add-on digital outputs.

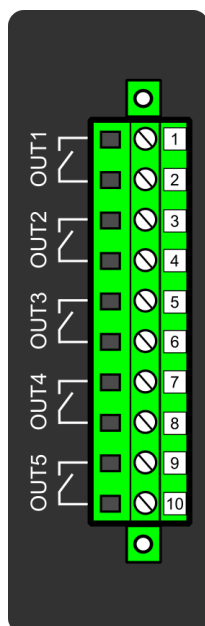

Connector	Description
X 1-2	OUTx + 1 (1 st and 2 nd pole NO)
X 3-4	OUTx + 2 (1 st and 2 nd pole NO)

Connector	Description
X 5-6	OUTx + 3 (1 st and 2 nd pole NO)
X 7-8	OUTx + 4 (1 st and 2 nd pole NO)
X 9-10	OUTx + 5 (1 st and 2 nd pole NO)

The DO5 module is an add-on module with five (5) digital outputs. This module can be ordered directly to be installed into the device in the factory, or it can be upgraded in the field after the device's original installation when required. The properties of the outputs in this module are the same as those of the outputs in the main processor module. The user can set the digital output controls with software. All digital outputs are scanned in 5 ms program cycles, and their contacts are mechanical in type. The rated voltage of the NO/NC outputs is 250 VAC/DC.

For the naming convention of the digital inputs provided by this module please refer to the chapter titled "Construction and installation".

For technical details please refer to the chapter titled "Digital output module" in the "Technical data" section of this document.

8.7 Arc protection module (optional)

Figure. 8.7 - 248. Arc protection module.

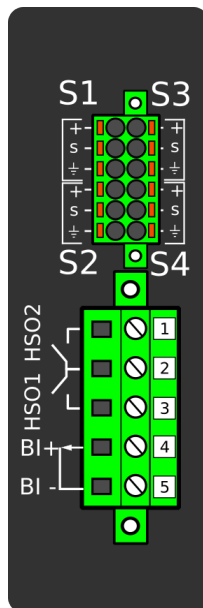

Table. 8.7 - 281. Module connections.

Connector	Description
S1	Light sensor channels 1...4 with positive ("+"), sensor ("S") and earth connectors.
S2	
S3	
S4	
X 1	HSO2 (+, NO)
X 2	Common battery positive terminal (+) for the HSOs.
X 3	HSO1 (+, NO)

Connector	Description
X 4	Binary input 1 (+ pole)
X 5	Binary input 1 (– pole)

The arc protection module is an add-on module with four (4) light sensor channels, two (2) high-speed outputs and one (1) binary input. This module can be ordered directly to be installed into the device in the factory, or it can be upgraded in the field after the device's original installation when required. If even one of the sensor channels is connected incorrectly, the channel does not work. Each channel can have up to three (3) light sensors serially connected to it. The user can choose how many of the channels are in use.

The high-speed outputs (HSO1 and HSO2) operate only with a DC power supply. The battery's positive terminal (+) must be wired according to the drawing. The NO side of the outputs 1 or 2 must be wired through trip coil to the battery's negative terminal (–). The high-speed outputs can withstand voltages up to 250 VDC. The operation time of the high-speed outputs is less than 1 ms. For further information please refer to the chapter titled "Arc protection module" in the "Technical data" section of this manual.

The rated voltage of the binary input is 24 VDC. The threshold picks up at ≥ 16 VDC. The binary input can be used for external light information or for similar applications. It can also be used as a part of various ARC schemes. Please note that the binary input's delay is 5...10ms.

NOTE!



BI1, HSO1 and HSO2 are not visible in the *Binary inputs* and *Binary outputs* menus (*Control* → *Device I/O*), they can only be programmed in the arc matrix menu (*Protection* → *Arc protection* → *I/O* → *Direct output control* and *HSO control*).

8.8 RTD input module (optional)

Figure. 8.8 - 249. RTD input module connectors.

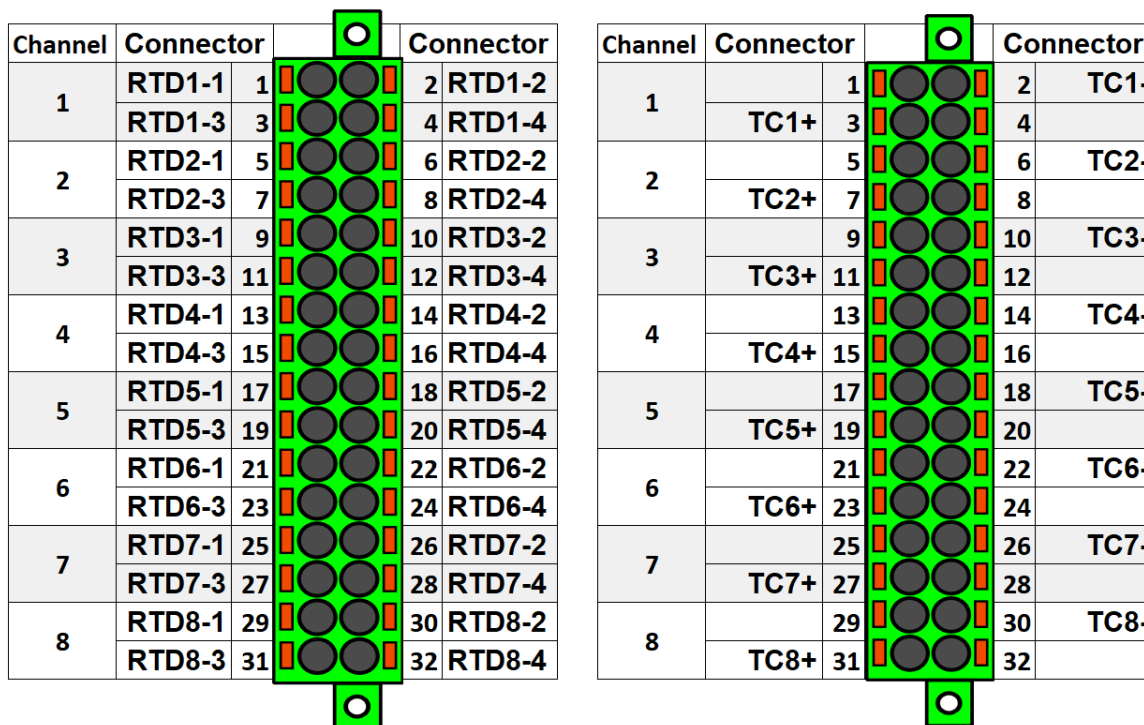

The RTD input module is an add-on module with eight (8) RTD input channels. Each input supports 2-wire, 3-wire and 4-wire RTD sensors as well as thermocouple (TC) sensors. The sensor type can be selected with software for two groups, four channels each. The supported sensor types are as follows:

- Supported RTD sensors: Pt100, Pt1000
- Supported thermocouple sensors: type K (NiCh/NiAl), type J (Fe/constantan), type T (Cu/constantan) and type S (Cu/CuNi compensating).

Figure. 8.8 - 250. Different sensor types and their connections.

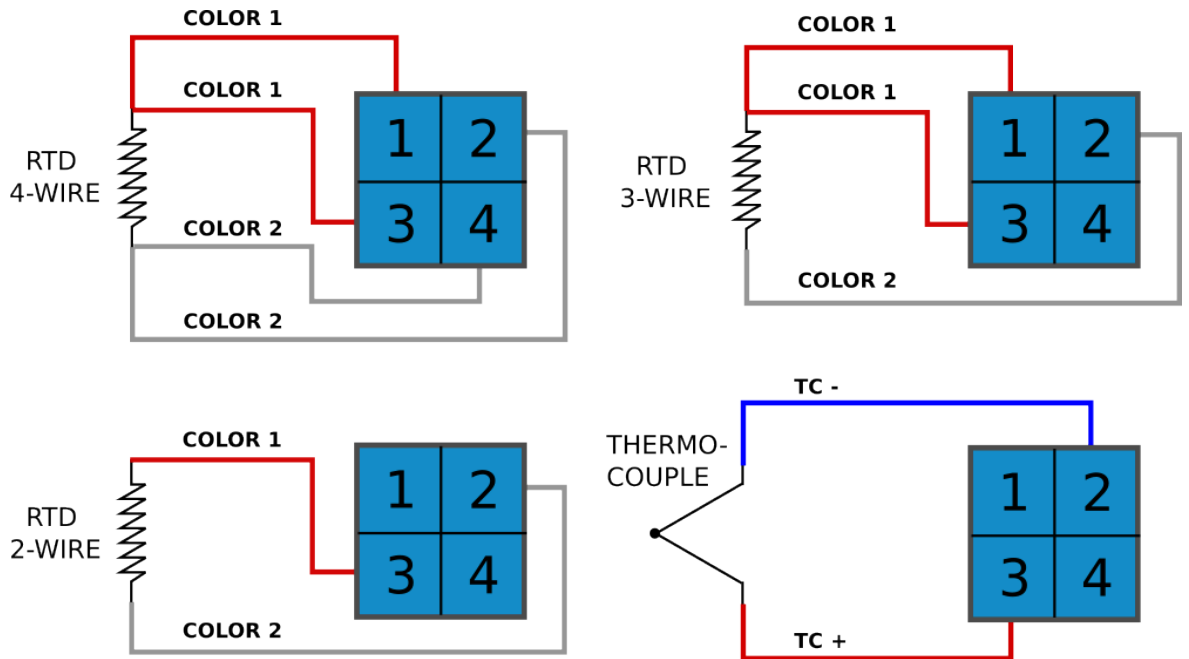

8.9 Serial RS-232 communication module (optional)

Figure. 8.9 - 251. Serial RS-232 module connectors.

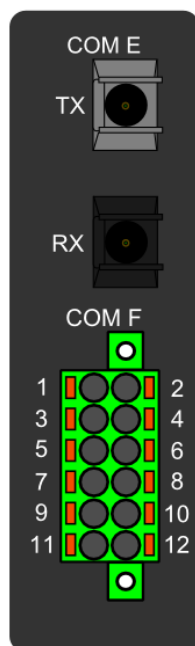

Connector	Name	Description
COM E	Serial fiber (GG/ PP/GP/PG)	<ul style="list-style-type: none"> • Serial-based communications • Wavelength 660 nm • Compatible with 50/125 μm, 62.5/125 μm, 100/140 μm, and 200 μm Plastic-Clad Silica (PCS) fiber • Compatible with ST connectors
COM F – Pin 1	+24 V input	Optional external auxiliary voltage for serial fiber
COM F – Pin 2	GND	Optional external auxiliary voltage for serial fiber
COM F – Pin 3	-	-
COM F – Pin 4	-	-
COM F – Pin 5	RS-232 RTS	Serial based communications
COM F – Pin 6	RS-232 GND	Serial based communications
COM F – Pin 7	RS-232 TX	Serial based communications
COM F – Pin 8	RS-232 RX	Serial based communications
COM F – Pin 9	-	-
COM F – Pin 10	+3.3 V output (spare)	Spare power source for external equipment (45 mA)
COM F – Pin 11	-	-
COM F – Pin 12	-	-

The option card includes two serial communication interfaces: COM E is a serial fiber interface with glass/plastic option, COM F is an RS-232 interface.

8.10 LC 100 Mbps Ethernet communication module (optional)

Figure. 8.10 - 252. LC 100 Mbps Ethernet module connectors.

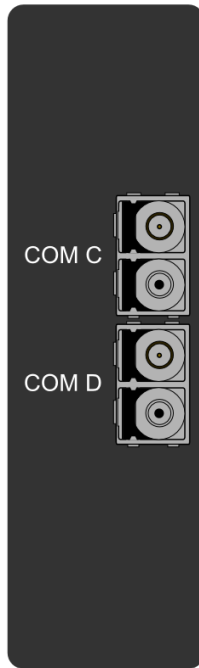

Connector	Description
COM C:	<ul style="list-style-type: none">• Communication port C, LC fiber connector.• 62.5/125 μm or 50/125 μm multimode (glass).• Wavelength 1300 nm.
COM D:	<ul style="list-style-type: none">• Communication port D, LC fiber connector.• 62.5/125 μm or 50/125 μm multimode (glass).• Wavelength 1300 nm.

The optional LC 100 Mbps Ethernet card supports both HSR and PRP protocols. The card has two PRP/HSR ports, which are 100 Mbps fiber ports.

8.11 Double ST 100 Mbps Ethernet communication module (optional)

Figure. 8.11 - 253. Double ST 100 Mbps Ethernet communication module connectors.

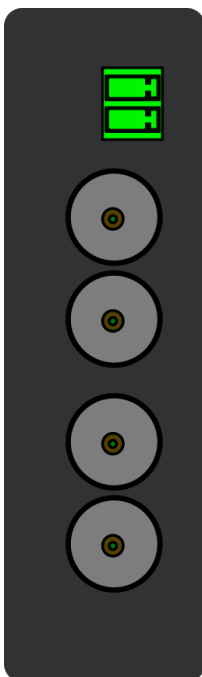

Connector	Description
Two-pin connector	<ul style="list-style-type: none"> • IRIG-B input
ST connectors	<ul style="list-style-type: none"> • Duplex ST connectors (IRIG-B input) • 62.5/125 μm or 50/125 μm multimode fiber • Transmitter wavelength: 1260...1360 nm (nominal: 1310 nm) • Receiver wavelength: 1100...1600 nm • 100BASE-FX • Up to 2 km

This option cards supports redundant ring configuration and multidrop configurations. Redundant communication can be implemented by Ethernet switches that support Rapid Spanning Tree Protocol (RSTP). Please note that each ring can only contain AQ-200 series devices, and any third party devices must be connected to a separate ring.

For other redundancy options, please refer to the option card "LC 100 Mbps Ethernet communication module".

The images below present two example configurations: the first displays a ring configuration (note how the third party devices are connected in a separate ring), while the second displays a multidrop configuration.

Figure. 8.11 - 254. Example of a ring configuration.

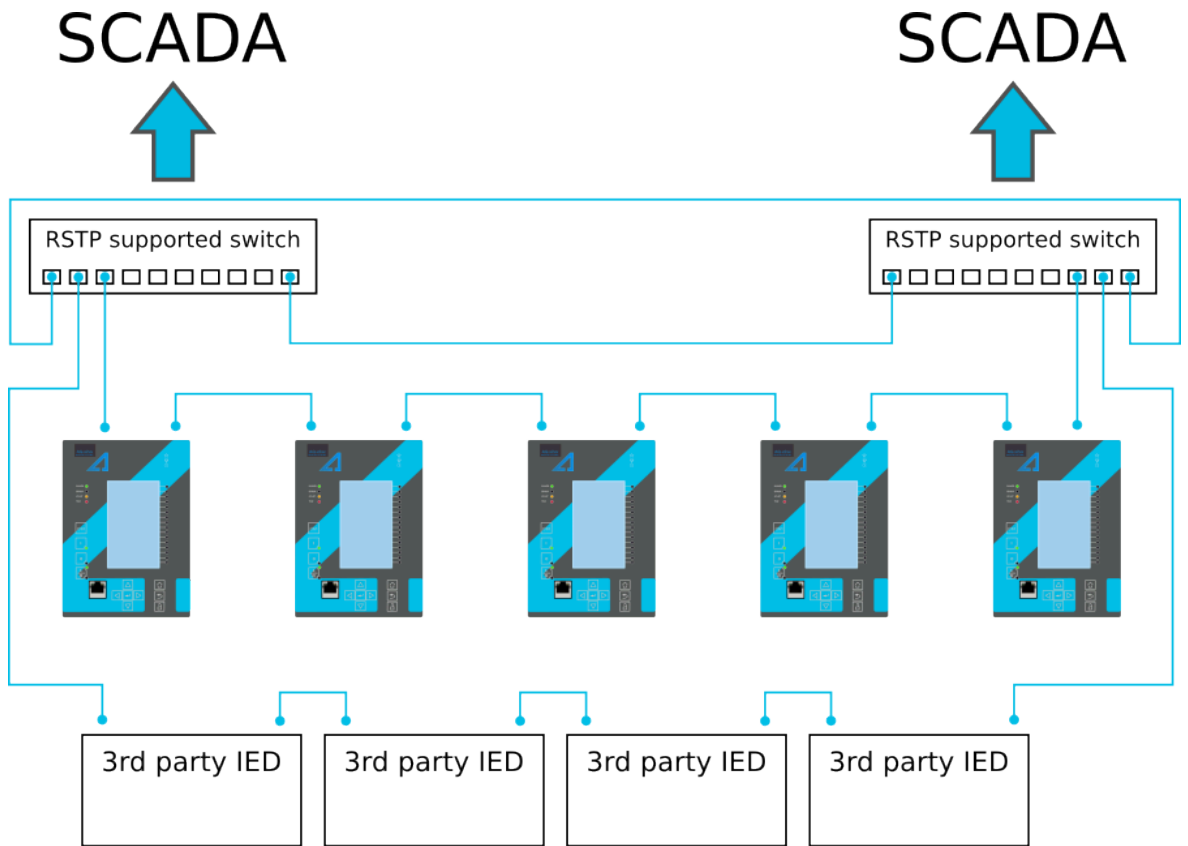
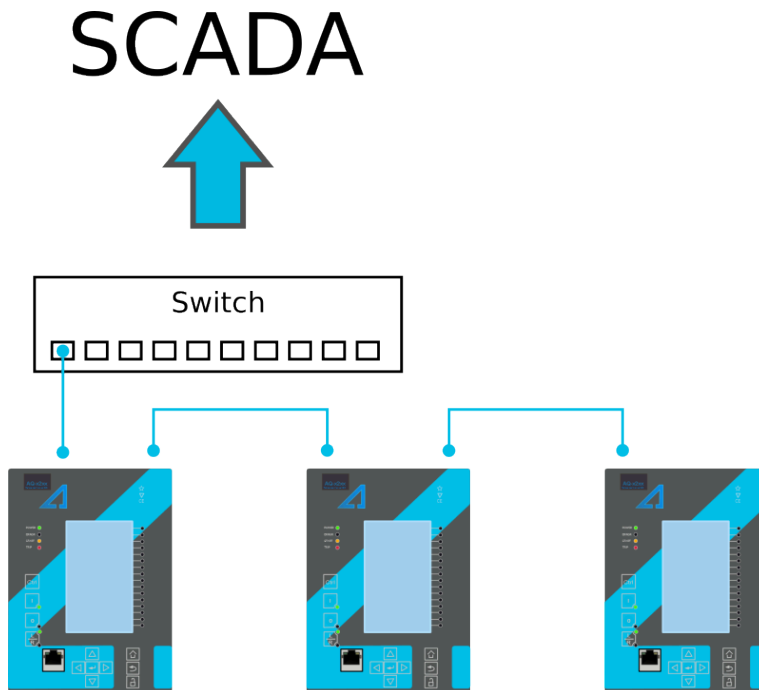

Figure. 8.11 - 255. Example of a multidrop configuration.



8.12 Double RJ-45 10/100 Mbps Ethernet communication module (optional)

Figure. 8.12 - 256. Double RJ-45 10/100 Mbps Ethernet communication module.



Connector	Description
Two-pin connector	<ul style="list-style-type: none"> • IRIG-B input
RJ-45 connectors	<ul style="list-style-type: none"> • Two Ethernet ports • RJ-45 connectors • 10BASE-T and 100BASE-TX

This option card supports multidrop configurations.

For other redundancy options, please refer to the option card "LC 100 Mbps Ethernet communication module".

The images below present two example configurations: the first displays a ring configuration (note how the third party devices are connected in a separate ring), while the second displays a multidrop configuration.

Figure. 8.12 - 257. Example of a ring configuration.

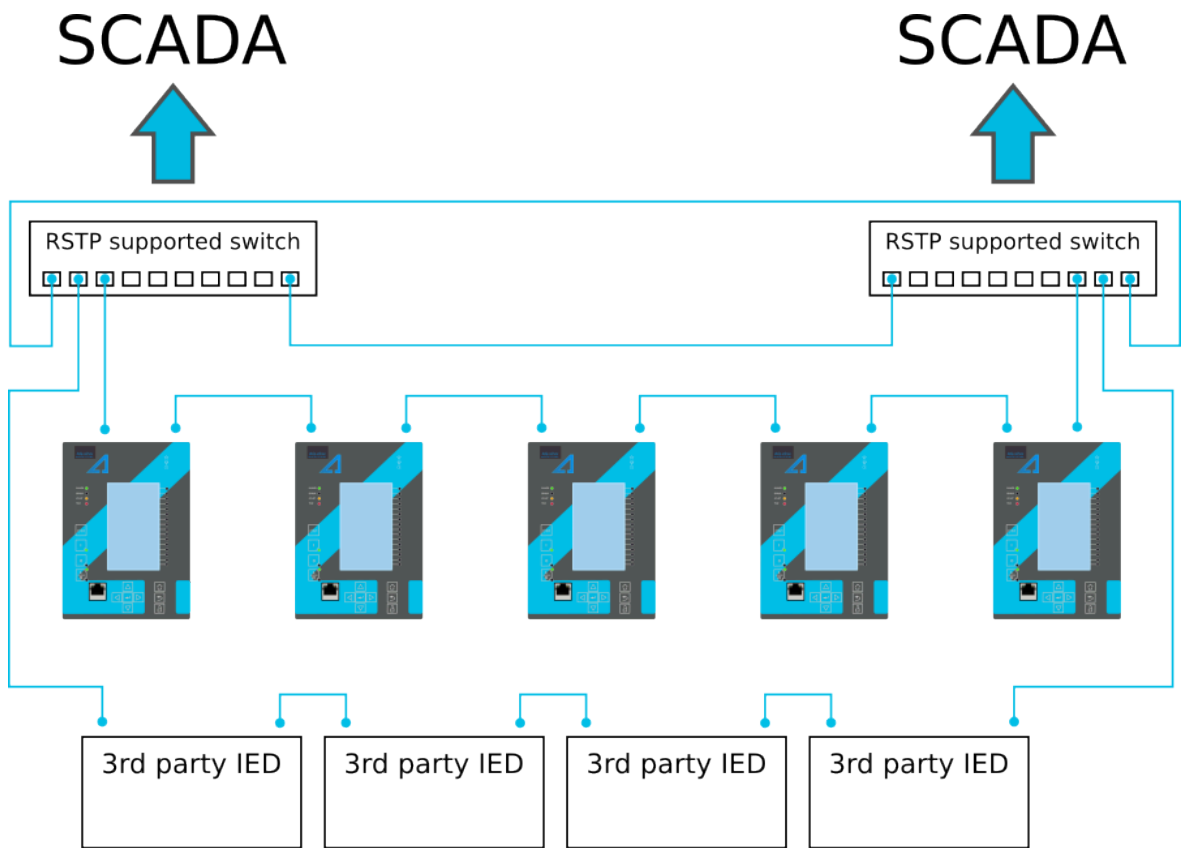
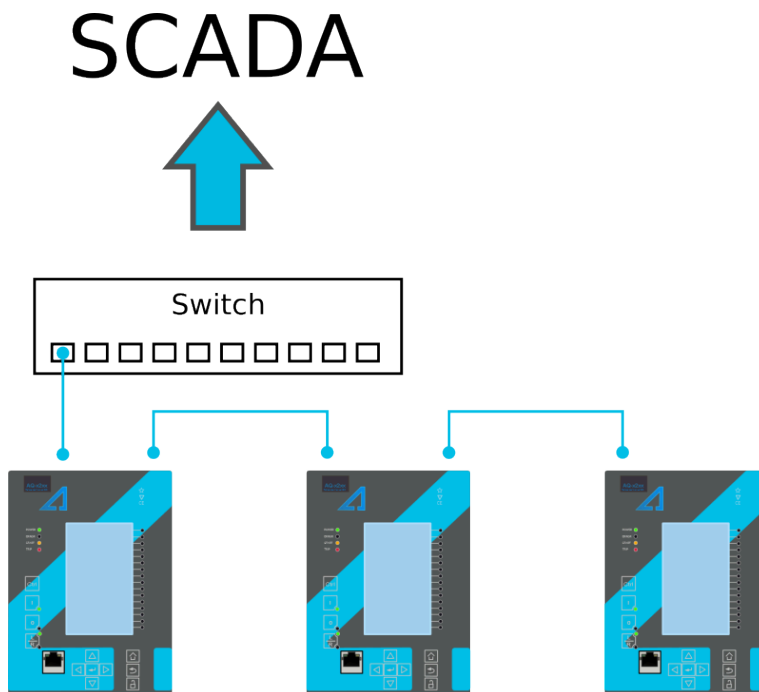
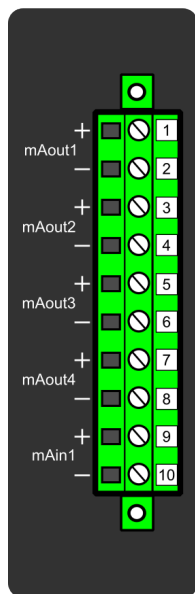

Figure. 8.12 - 258. Example of a multidrop configuration.



8.13 Milliampere (mA) I/O module (optional)

Figure. 8.13 - 259. Milliampere (mA) I/O module connections.



Connector	Description
Pin 1	mA OUT 1 + connector (0...24 mA)
Pin 2	mA OUT 1 – connector (0...24 mA)
Pin 3	mA OUT 2 + connector (0...24 mA)
Pin 4	mA OUT 2 – connector (0...24 mA)
Pin 5	mA OUT 3 + connector (0...24 mA)
Pin 6	mA OUT 3 – connector (0...24 mA)
Pin 7	mA OUT 4 + connector (0...24 mA)
Pin 8	mA OUT 4 – connector (0...24 mA)
Pin 9	mA IN 1 + connector (0...33 mA)
Pin 10	mA IN 1 – connector (0...33 mA)

The milliampere (mA) I/O module is an add-on module with four (4) mA outputs and one (1) mA input. Both the outputs and the input are in two galvanically isolated groups, with one pin for the positive (+) connector and one pin for the negative (–) connector.

This module can be ordered directly to be installed into the device in the factory, or it can be upgraded in the field after the device's original installation when required.

The user sets the mA I/O with the mA outputs control function. This can be done at *Control* → *Device I/O* → *mA outputs* in the relay configuration settings.

8.14 Dimensions and installation

The device can be installed either to a standard 19" rack or to a switchgear panel with cutouts. The desired installation type is defined in the order code. When installing to a rack, the device takes a quarter (¼) of the rack's width, meaning that a total of four devices can be installed to the same rack next to one another.

The figures below describe the device dimensions (first figure), the device installation (second), and the panel cutout dimensions and device spacing (third).

Figure. 8.14 - 260. Device dimensions.

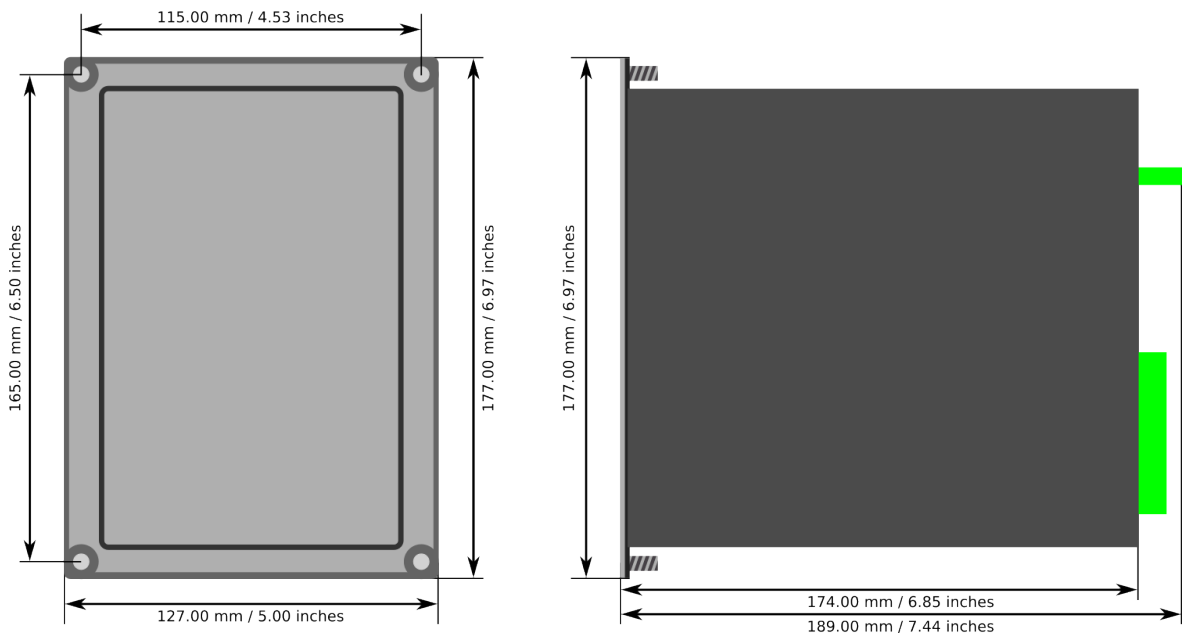

Figure. 8.14 - 261. Device installation.

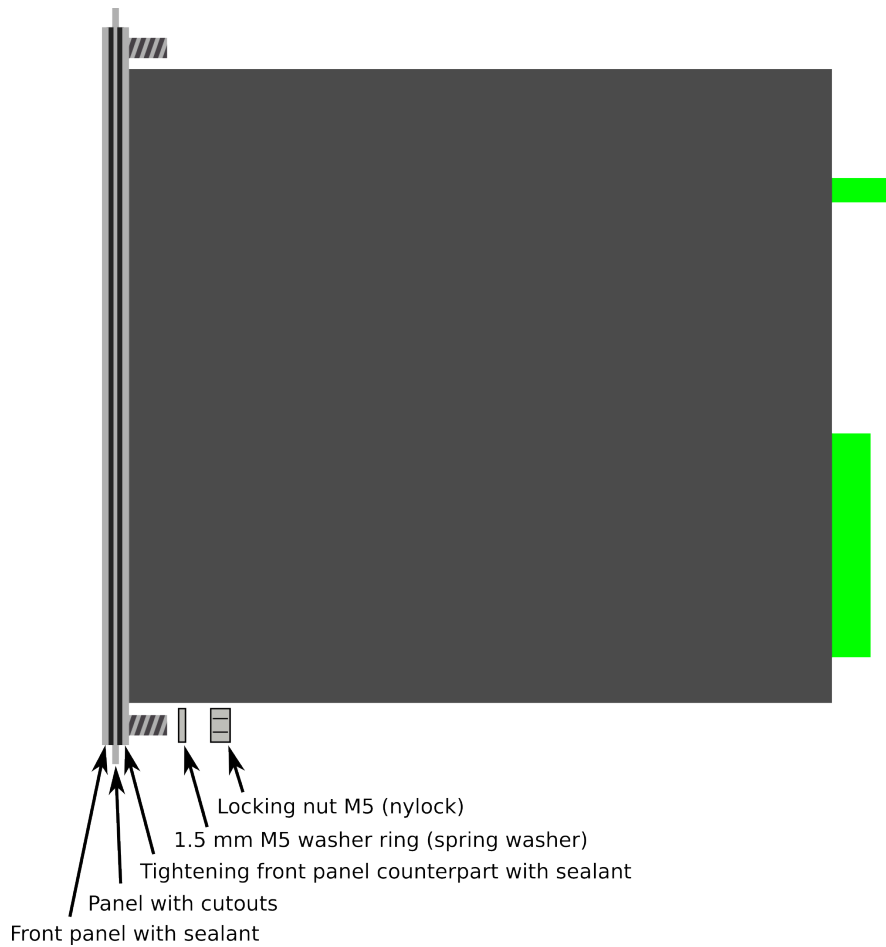
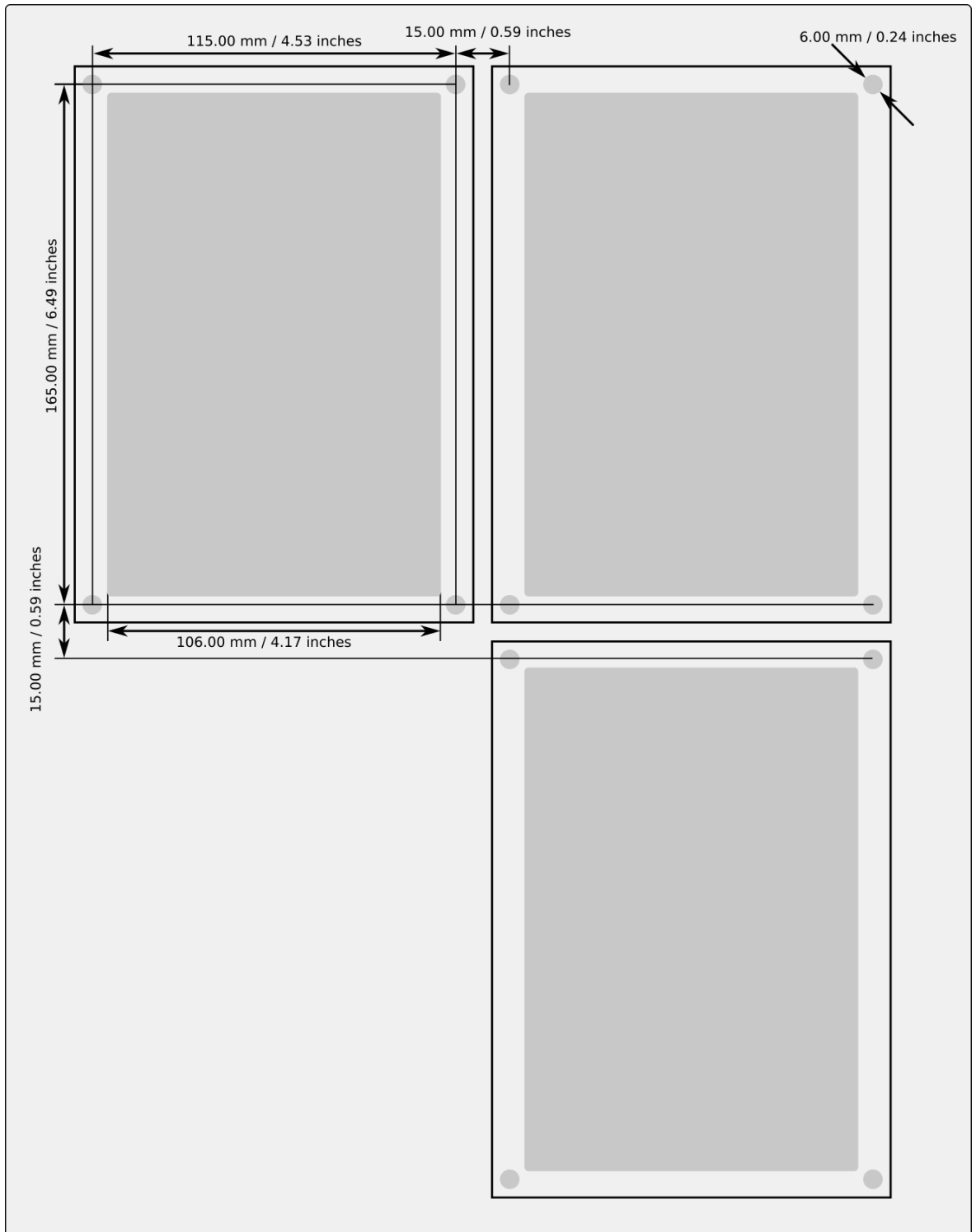

Figure. 8.14 - 262. Panel cutout dimensions and device spacing.



9 Technical data

9.1 Hardware

9.1.1 Measurements

9.1.1.1 Current measurement

Table. 9.1.1.1 - 282. Technical data for the current measurement module.

Connections	
Measurement channels/CT inputs	Three phase current inputs: IL1 (A), IL2 (B), IL3 (C) Two residual current inputs: Coarse residual current input I01, Fine residual current input I02
Phase current inputs (A, B, C)	
Sample rate	64 samples per cycle in frequency range 6...75Hz
Rated current I_N	5 A (configurable 0.2...10 A)
Thermal withstand	30 A (continuous) 100 A (for 10 s) 500 A (for 1 s) 1250 A (for 0.01 s)
Frequency measurement range	From 6...75Hz fundamental, up to the 31 st harmonic current
Current measurement range	25 mA...250 A (RMS)
Current measurement inaccuracy	0.005...4.000 × I_N < ±0.5 % or < ±15 mA 4...20 × I_N < ±0.5 % 20...50 × I_N < ±1.0 %
Angle measurement inaccuracy	< ±0.2° ($I > 0.1$ A) < ±1.0° ($I \leq 0.1$ A)
Burden (50/60 Hz)	<0.1 VA
Transient overreach	<8 %
Coarse residual current input (I01)	
Rated current I_N	1 A (configurable 0.1...10 A)
Thermal withstand	25 A (continuous) 100 A (for 10 s) 500 A (for 1 s) 1250 A (for 0.01 s)
Frequency measurement range	From 6...75 Hz fundamental, up to the 31 st harmonic current
Current measurement range	5 mA...150 A (RMS)
Current measurement inaccuracy	0.002...10.000 × I_N < ±0.5 % or < ±3 mA 10...150 × I_N < ±0.5 %

Angle measurement inaccuracy	< $\pm 0.2^\circ$ ($I > 0.05$ A) < $\pm 1.0^\circ$ ($I \leq 0.05$ A)
Burden (50/60Hz)	<0.1 VA
Transient overreach	<5 %
Fine residual current input (I02)	
Rated current I_N	0.2 A (configurable 0.001...10 A)
Thermal withstand	25 A (continuous) 100 A (for 10 s) 500 A (for 1 s) 1250 A (for 0.01 s)
Frequency measurement range	From 6...75 Hz fundamental, up to the 31 st harmonic current
Current measurement range	1 mA...75 A (RMS)
Current measurement inaccuracy	$0.002...25.000 \times I_N < \pm 0.5 \%$ or $< \pm 0.6$ mA $25...375 \times I_N < \pm 1.0 \%$
Angle measurement inaccuracy	< $\pm 0.2^\circ$ ($I > 0.01$ A) < $\pm 1.0^\circ$ ($I \leq 0.01$ A)
Burden (50/60Hz)	<0.1 VA
Transient overreach	<5 %
Terminal block connection	
Terminal block	Phoenix Contact FRONT 4-H-6,35
Solid or stranded wire	
Maximum wire diameter	4 mm ²



NOTE!

Current measurement accuracy has been verified with 50/60 Hz.

The amplitude difference is 0.2 % and the angle difference is 0.5 degrees higher at 16.67 Hz and other frequencies.

9.1.1.2 Voltage measurement

Table. 9.1.1.2 - 283. Technical data for the voltage measurement module.

Connection	
Measurement channels/VT inputs	3 separate VT inputs
Measurement	
Sample rate	64 samples per cycle in frequency range 6...75Hz
Voltage inputs	U1, U2, U3
Voltage measuring range	1.00...250.00 V (RMS)
Frequency measurement range	6...75 Hz
Voltage measurement inaccuracy	1.00...250 V $< \pm 1 \%$

Angle measurement inaccuracy	< ±1.0 degrees
Terminal block connection	
Terminal block	Phoenix Contact MSTB 2,5/5-ST-5,08
Solid or stranded wire	
Maximum wire diameter	4 mm ²
Burden (50/60 Hz)	<0.02 VA
Thermal withstand	300 V _{RMS} (continuous)

9.1.1.3 Power and energy measurement

Table. 9.1.1.3 - 284. Power and energy measurement accuracy.

Power measurements (P, Q, S)	
Frequency range	6...75 Hz
Inaccuracy	0.3 % <1.2 × I _N or 3 VA of secondary 1.0 % >1.2 × I _N or 3 VA of secondary
Energy measurement	
Frequency range	6...75 Hz
Energy and power metering inaccuracy	0.5 S (50/60Hz) as standard

9.1.1.4 Frequency measurement

Table. 9.1.1.4 - 285. Frequency measurement accuracy.

Frequency measurement performance	
Frequency measuring range	6...75 Hz fundamental, up to the 31 st harmonic current or voltage
Inaccuracy	10 mHz

9.1.2 CPU & Power supply

9.1.2.1 Auxiliary voltage

Table. 9.1.2.1 - 286. Power supply model A

Rated values	
Rated auxiliary voltage	85...265 V (AC/DC)
Power consumption	< 7 W < 15 W
Maximum permitted interrupt time	< 60 ms with 110 VDC
DC ripple	< 15 %
Terminal block connection	
Terminal block	Phoenix Contact MSTB 2,5/5-ST-5,08
Solid or stranded wire	
Maximum wire diameter	2.5 mm ²

Table. 9.1.2.1 - 287. Power supply model B

Rated values	
Rated auxiliary voltage	18...72 VDC
Power consumption	< 7 W < 15 W
Maximum permitted interrupt time	< 90 ms with 24 VDC
DC ripple	< 15 %
Terminal block connection	
Terminal block	Phoenix Contact MSTB 2,5/5-ST-5,08
Solid or stranded wire	
Maximum wire diameter	2.5 mm ²

9.1.2.2 CPU communication ports

Table. 9.1.2.2 - 288. Front panel local communication port.

Port	
Port media	Copper Ethernet RJ-45
Number of ports	1
Port protocols	PC-protocols FTP Telnet
Features	
Data transfer rate	100 MB
System integration	Cannot be used for system protocols, only for local programming

Table. 9.1.2.2 - 289. Rear panel system communication port A.

Port	
Port media	Copper Ethernet RJ-45
Number of ports	1
Features	
Port protocols	IEC 61850 IEC 104 Modbus/TCP DNP3 FTP Telnet
Data transfer rate	100 MB
System integration	Can be used for system protocols and for local programming

Table. 9.1.2.2 - 290. Rear panel system communication port B.

Port	
------	--

Port media	Copper RS-485
Number of ports	1
Features	
Port protocols	Modbus/RTU IEC 103 IEC 101 DNP3 SPA
Data transfer rate	65 580 kB/s
System integration	Can be used for system protocols

9.1.2.3 CPU digital inputs

Table. 9.1.2.3 - 291. CPU model-isolated digital inputs, with thresholds defined by order code.

Rated values	
Rated auxiliary voltage	265 V (AC/DC)
Nominal voltage	Order code defined: 24, 110, 220 V (AC/DC)
Pick-up threshold Release threshold	Order code defined: 19, 90, 170 V Order code defined: 14, 65, 132 V
Scanning rate	5 ms
Settings	
Pick-up delay	Software settable: 0... 1800 s
Polarity	Software settable: Normally On/Normally Off
Current drain	2 mA
Terminal block connection	
Terminal block	Phoenix Contact MSTB 2,5/5-ST-5,08
Solid or stranded wire Maximum wire diameter	2.5 mm ²

9.1.2.4 CPU digital outputs

Table. 9.1.2.4 - 292. Digital outputs (Normally Open)

Rated values	
Rated auxiliary voltage	265 V (AC/DC)
Continuous carry	5 A
Make and carry 0.5 s Make and carry 3 s	30 A 15 A
Breaking capacity, DC (L/R = 40 ms) at 48 VDC at 110 VDC at 220 VDC	1 A 0.4 A 0.2 A
Control rate	5 ms
Settings	

Polarity	Software settable: Normally On/Normally Off
Terminal block connection	
Terminal block	Phoenix Contact MSTB 2,5/5-ST-5,08
Solid or stranded wire Maximum wire diameter	2.5 mm ²

Table. 9.1.2.4 - 293. Digital outputs (Change-Over)

Rated values	
Rated auxiliary voltage	265 V (AC/DC)
Continuous carry	5 A
Make and carry 0.5 s Make and carry 3 s	30 A 15 A
Breaking capacity, DC (L/R = 40 ms) at 48 VDC at 110 VDC at 220 VDC	1 A 0.4 A 0.2 A
Control rate	5 ms
Settings	
Polarity	Software settable: Normally On/Normally Off
Terminal block connection	
Terminal block	Phoenix Contact MSTB 2,5/5-ST-5,08
Solid or stranded wire Maximum wire diameter	2.5 mm ²

9.1.3 Option cards

9.1.3.1 Digital input module

Table. 9.1.3.1 - 294. Technical data for the digital input module.

Rated values	
Rated auxiliary voltage	5...265 V (AC/DC)
Current drain	2 mA
Scanning rate Activation/release delay	5 ms 5...11 ms
Settings	
Pick-up threshold Release threshold	Software settable: 16...200 V, setting step 1 V Software settable: 10...200 V, setting step 1 V
Pick-up delay	Software settable: 0...1800 s
Drop-off delay	Software settable: 0...1800 s
Polarity	Software settable: Normally On/Normally Off
Terminal block connection	
Terminal block	Phoenix Contact MSTB 2,5/5-ST-5,08
Solid or stranded wire Maximum wire diameter	2.5 mm ²

9.1.3.2 Digital output module

Table. 9.1.3.2 - 295. Technical data for the digital output module.

Rated values	
Rated auxiliary voltage	265 V (AC/DC)
Continuous carry	5 A
Make and carry 0.5 s Make and carry 3 s	30 A 15 A
Breaking capacity, DC (L/R = 40 ms) at 48 VDC at 110 VDC at 220 VDC	1 A 0.4 A 0.2 A
Control rate	5 ms
Settings	
Polarity	Software settable: Normally On/Normally Off
Terminal block connection	
Terminal block	Phoenix Contact MSTB 2,5/5-ST-5,08
Solid or stranded wire Maximum wire diameter	2.5 mm ²

9.1.3.3 Arc protection module

Table. 9.1.3.3 - 296. Technical data for the arc protection module.

Connections	
Input arc point sensor channels	S1, S2, S3, S4 (pressure and light, or light only)
Sensors per channel	3
Performance	
Pick-up light intensity	8, 25 or 50 kLx (the sensor is selectable in the order code)
Inaccuracy: - Point sensor detection radius	180 degrees
Start and instant operating time (light only)	Typically <5 ms (dedicated semiconductor outputs) Typically <10 ms (regular output relays)

Table. 9.1.3.3 - 297. High-Speed Outputs (HSO1...2)

Rated values	
Rated auxiliary voltage	250 VDC
Continuous carry	2 A
Make and carry 0.5 s Make and carry 3 s	15 A 6 A
Breaking capacity, DC (L/R = 40 ms)	1 A/110 W
Control rate	5 ms
Operation delay	<1 ms
Polarity	Normally Off
Contact material	Semiconductor
Terminal block connection	

Terminal block	Phoenix Contact MSTB 2,5/5-ST-5,08
Solid or stranded wire	2.5 mm ²
Maximum wire diameter	

Table. 9.1.3.3 - 298. Binary input channel

Rated values	
Voltage withstand	265 VDC
Rated auxiliary voltage	24 VDC
Pick-up threshold	≥16 VDC
Release threshold	≤15 VDC
Scanning rate	5 ms
Polarity	Normally Off
Current drain	3 mA
Terminal block connection	
Terminal block	Phoenix Contact MSTB 2,5/5-ST-5,08
Solid or stranded wire	2.5 mm ²
Maximum wire diameter	

NOTE! Polarity has to be correct.

9.1.3.4 Milliampere module (mA out & mA in)

Table. 9.1.3.4 - 299. Technical data for the milliampere module.

Signals	
Output magnitudes	4 × mA output signal (DC)
Input magnitudes	1 × mA input signal (DC)
mA input	
Range (hardware)	0...33 mA
Range (measurement)	0...24 mA
Inaccuracy	±0.1 mA
Update cycle	5...10 000 ms, setting step 5 ms
Response time @ 5 ms cycle	~ 15 ms (13...18 ms)
Update cycle time inaccuracy	Max. +20 ms above the set cycle
mA input scaling range	0...4000 mA
Output scaling range	-1 000 000.0000...1 000 000.0000, setting step 0.0001
mA output	
Inaccuracy @ 0...24 mA	±0.01 mA
Response time @ 5 ms cycle [fixed]	< 5 ms
mA output scaling range	0...24 mA, setting step 0.001 mA
Source signal scaling range	-1 000 000.000...1 000 000.0000, setting step 0.0001

9.1.3.5 RTD input module

Table. 9.1.3.5 - 300. Technical data for the RTD input module.

Channels 1-8	
2/3/4-wire RTD and thermocouple sensors	
Pt100 or Pt1000	
Type K, Type J, Type T and Type S	
Channels 7 & 8 support mA measurement	

9.1.3.6 RS-232 & serial fiber communication module

Table. 9.1.3.6 - 301. Technical data for the RS-232 & serial fiber communication module.

Ports	
RS-232	
Serial fiber (GG/PP/GP/PG)	
Serial port wavelength	
660 nm	
Cable type	
1 mm plastic fiber	

9.1.3.7 Double LC 100 Mbps Ethernet communication module

Table. 9.1.3.7 - 302. Technical data for the double LC 100 Mbps Ethernet communication module.

Protocols	
Protocols	HSR and PRP
Ports	
Quantity of fiber ports	2
Communication port C & D	LC fiber connector Wavelength 1300 nm
Fiber cable	50/125 µm or 62.5/125 µm multimode (glass)

9.1.4 Display

Table. 9.1.4 - 303. Technical data for the HMI LCD display.

Dimensions and resolution	
Number of dots/resolution	320 x 160
Size	84.78 × 49.90 mm (3.34 × 1.96 in)
Display	
Type of display	LCD
Color	Monochrome

9.2 Functions

9.2.1 Protection functions

9.2.1.1 Non-directional overcurrent protection ($I >$; 50/51)

Table. 9.2.1.1 - 304. Technical data for the non-directional overcurrent function.

Measurement inputs	
Current inputs	Phase current inputs: I_{L1} (A), I_{L2} (B), I_{L3} (C)
Current input magnitudes	RMS phase currents TRMS phase currents Peak-to-peak phase currents
Pick-up	
Pick-up current setting	$0.10 \dots 50.00 \times I_n$, setting step $0.01 \times I_n$
Inrush 2nd harmonic blocking	$0.10 \dots 50.00 \% I_{fund}$, setting step $0.01 \% I_{fund}$
Inaccuracy: - Current - 2 nd harmonic blocking	$\pm 0.5 \% I_{set}$ or $\pm 15 \text{ mA}$ ($0.10 \dots 4.0 \times I_{set}$) $\pm 1.0 \%$ -unit of the 2 nd harmonic setting
Operation time	
Definite time function operating time setting	$0.00 \dots 1800.00 \text{ s}$, setting step 0.005 s
Inaccuracy: - Definite time: I_m/I_{set} ratio > 3 - Definite time: I_m/I_{set} ratio = $1.05 \dots 3$	$\pm 1.0 \%$ or $\pm 20 \text{ ms}$ $\pm 1.0 \%$ or $\pm 30 \text{ ms}$
IDMT setting parameters: - k Time dial setting for IDMT - A IDMT constant - B IDMT constant - C IDMT constant	$0.01 \dots 25.00$, step 0.01 $0 \dots 250.0000$, step 0.0001 $0 \dots 5.0000$, step 0.0001 $0 \dots 250.0000$, step 0.0001
Inaccuracy: - IDMT operating time - IDMT minimum operating time	$\pm 1.5 \%$ or $\pm 20 \text{ ms}$ $\pm 20 \text{ ms}$
Retardation time (overshoot)	$< 30 \text{ ms}$
Instant operation time	
Start time and instant operation time (trip): - I_m/I_{set} ratio > 3 - I_m/I_{set} ratio = $1.05 \dots 3$	$< 35 \text{ ms}$ (typically 25 ms) $< 50 \text{ ms}$
Reset	
Reset ratio	97 % of the pick-up current setting
Reset time setting Inaccuracy: Reset time	$0.010 \dots 10.000 \text{ s}$, step 0.005 s $\pm 1.0 \%$ or $\pm 50 \text{ ms}$
Instant reset time and start-up reset	$< 50 \text{ ms}$

Note!

- The release delay does not apply to phase-specific tripping.

9.2.1.2 Non-directional earth fault protection ($I_{0>}$; 50N/51N)

Table 9.2.1.2 - 305. Technical data for the non-directional earth fault function.

Measurement inputs	
Current input (selectable)	Residual current channel I_{01} (Coarse) Residual current channel I_{02} (Fine) Calculated residual current: I_{L1} (A), I_{L2} (B), I_{L3} (C)
Current input magnitudes	RMS residual current (I_{01} , I_{02} or calculated I_0) TRMS residual current (I_{01} or I_{02}) Peak-to-peak residual current (I_{01} or I_{02})
Pick-up	
Used magnitude	Measured residual current I_{01} (1 A) Measured residual current I_{02} (0.2 A) Calculated residual current I_{0Calc} (5 A)
Pick-up current setting	$0.0001 \dots 40.00 \times I_n$, setting step $0.0001 \times I_n$
Inaccuracy: - Starting I_{01} (1 A) - Starting I_{02} (0.2 A) - Starting I_{0Calc} (5 A)	$\pm 0.5 \% I_{0Set}$ or ± 3 mA ($0.005 \dots 10.0 \times I_{Set}$) $\pm 1.5 \% I_{0Set}$ or ± 1.0 mA ($0.005 \dots 25.0 \times I_{Set}$) $\pm 1.0 \% I_{0Set}$ or ± 15 mA ($0.005 \dots 4.0 \times I_{Set}$)
Operating time	
Definite time function operating time setting	$0.00 \dots 1800.00$ s, setting step 0.005 s
Inaccuracy: - Definite time: I_m/I_{Set} ratio > 3 - Definite time: I_m/I_{Set} ratio = $1.05 \dots 3$	$\pm 1.0 \%$ or ± 20 ms $\pm 1.0 \%$ or ± 30 ms
IDMT setting parameters: - k Time dial setting for IDMT - A IDMT constant - B IDMT constant - C IDMT constant	$0.01 \dots 25.00$, step 0.01 $0 \dots 250.0000$, step 0.0001 $0 \dots 5.0000$, step 0.0001 $0 \dots 250.0000$, step 0.0001
Inaccuracy: - IDMT operating time - IDMT minimum operating time	$\pm 1.5 \%$ or ± 20 ms ± 20 ms
Retardation time (overshoot)	< 30 ms
Instant operation time	
Start time and instant operation time (trip): - I_m/I_{Set} ratio > 3.5 - I_m/I_{Set} ratio = $1.05 \dots 3.5$	< 50 ms (typically 35 ms) < 55 ms
Reset	
Reset ratio	97 % of the pick-up current setting
Reset time setting Inaccuracy: Reset time	$0.010 \dots 10.000$ s, step 0.005 s $\pm 1.0 \%$ or ± 50 ms
Instant reset time and start-up reset	< 50 ms

Note!

- The operation and reset time accuracy does not apply when the measured secondary current in I_{02} is $1 \dots 20$ mA. The pick-up is tuned to be more sensitive and the operation times vary because of this.

9.2.1.3 Directional overcurrent protection ($I_{dir} > 67$)

Table 9.2.1.3 - 306. Technical data for the directional overcurrent function.

Measurement inputs	
Current inputs	Phase current inputs: I_{L1} (A), I_{L2} (B), I_{L3} (C)
Current input magnitudes	RMS phase currents TRMS phase currents Peak-to-peak phase currents
Current measurement calculation	Positive sequence current angle
Voltage inputs	U_{L1} , U_{L2} , U_{L3} U_{L12} , $U_{L23} + U_0$
Voltage input calculation	Positive sequence voltage angle
Pick-up	
Characteristic direction	Directional, non-directional
Operating sector center	-180.0...180.0 deg, setting step 0.1 deg
Operating sector size (+/-)	1.00...180.00 deg, setting step 0.10 deg
Pick-up current setting	$0.10...40.00 \times I_n$, setting step $0.01 \times I_n$
Inaccuracy: - Current - $U1/I1$ angle ($U > 15$ V) - $U1/I1$ angle ($U = 1...15$ V)	$\pm 0.5 \% I_{set}$ or ± 15 mA ($0.10...4.0 \times I_{set}$) $\pm 0.4^\circ$ $\pm 3.0^\circ$
Operation time	
Definite time function operating time setting	0.00...1800.00 s, setting step 0.005 s
Inaccuracy: - Definite time: I_m/I_{set} ratio > 3 - Definite time: I_m/I_{set} ratio 1.05...3	$\pm 1.0 \%$ or ± 20 ms $\pm 1.0 \%$ or ± 35 ms
IDMT setting parameters: - k Time dial setting for IDMT - A IDMT constant - B IDMT constant - C IDMT constant	0.01...25.00, step 0.01 0...250.0000, step 0.0001 0...5.0000, step 0.0001 0...250.0000, step 0.0001
Inaccuracy: - IDMT operating time - IDMT minimum operating time	$\pm 1.5 \%$ or ± 20 ms ± 20 ms
Instant operation time	
Start time and instant operation time (trip): - I_m/I_{set} ratio > 3 - I_m/I_{set} ratio = 1.05...3	<35 ms (typically 25 ms) <50 ms
Reset	
Reset ratio: - Current - $U1/I1$ angle	97 % of the pick-up current setting 2.0°
Reset time setting Inaccuracy: Reset time	0.010...10.000 s, step 0.005 s $\pm 1.0 \%$ or ± 50 ms
Instant reset time and start-up reset	<50 ms

Note!

- The minimum voltage for direction solving is 1.0 V secondary. During three-phase short-circuits the angle memory is active for 0.5 seconds in case the voltage drops below 1.0 V.

9.2.1.4 Directional earth fault protection (I_{0dir} ; 67N/32N)

Table 9.2.1.4 - 307. Technical data for the directional earth fault function.

Measurement inputs	
Current input (selectable)	Residual current channel I_{01} (Coarse) Residual current channel I_{02} (Fine) Calculated residual current: I_{L1} (A), I_{L2} (B), I_{L3} (C)
Current input magnitudes	RMS residual current (I_{01} , I_{02} or calculated I_0) TRMS residual current (I_{01} or I_{02}) Peak-to-peak residual current (I_{01} or I_{02})
Voltage input (selectable)	Residual voltage from U_3 voltage channel Residual voltage calculated from U_{L1} , U_{L2} , U_{L3}
Voltage input magnitudes	RMS residual voltage U_0 Calculated RMS residual voltage U_0
Pick-up	
Characteristic direction	Unearthed (Varmetric 90°) Petersen coil GND (Wattmetric 180°) <i>Earthed</i> (Adjustable sector)
When the <i>earthed</i> mode is active: - Tripping area center - Tripping area size (+/-)	0.00...360.00 deg, setting step 0.10 deg 45.00...135.00 deg, setting step 0.10 deg
Pick-up current setting Pick-up voltage setting	0.005...40.00 × I_n , setting step 0.001 × I_n 1.00...50.00 % U_{0n} , setting step 0.01 % U_{0n}
Inaccuracy: - Starting I_{01} (1 A) - Starting I_{02} (0.2 A) - Starting I_{0Calc} (5 A) - Voltage U_0 and U_{0Calc} - U_0/I_0 angle ($U > 15$ V) - U_0/I_0 angle ($U = 1...15$ V)	±0.5 % I_{0Set} or ±3 mA (0.005...10.0 × I_{Set}) ±1.5 % I_{0Set} or ±1.0 mA (0.005...25.0 × I_{Set}) ±1.5 % I_{0Set} or ±15 mA (0.005...4.0 × I_{Set}) ±1.0 % I_{0Set} or ±30 mV ±0.2° ($I_{0Calc} \pm 1.0^\circ$) ±1.0°
Operation time	
Definite time function operating time setting	0.00...1800.00 s, setting step 0.005 s
Inaccuracy: - Definite time (I_m/I_{Set} ratio 1.05→)	±1.0 % or ±30 ms
IDMT setting parameters: - k Time dial setting for IDMT - A IDMT constant - B IDMT constant - C IDMT constant	0.01...25.00, step 0.01 0...250.0000, step 0.0001 0...5.0000, step 0.0001 0...250.0000, step 0.0001
Inaccuracy: - IDMT operating time - IDMT minimum operating time	±1.5 % or ±25 ms ±20 ms
Instant operation time	
Start time and instant operation time (trip): - I_m/I_{Set} ratio > 3 - I_m/I_{Set} ratio = 1.05...3	<55 ms (typically 45 ms) <65 ms
Reset	
Reset ratio: - Current and voltage - U_0/I_0 angle	97 % of the pick-up current and voltage setting 2.0°
Reset time setting Inaccuracy: Reset time	0.000...150.000 s, step 0.005 s ±1.0 % or ±45 ms
Instant reset time and start-up reset	<50 ms

Note!

- While the U0 direction is 180°, the I0 current injected to the +90° angle is considered to be of a negative sine value (inductive).

9.2.1.5 Negative sequence overcurrent/ phase current reversal/ current unbalance protection (I2>; 46/46R/46L)

Table. 9.2.1.5 - 308. Technical data for the current unbalance function.

Measurement inputs	
Current inputs	Phase current inputs: I _{L1} (A), I _{L2} (B), I _{L3} (C)
Current input calculations	Positive sequence current (I1) Negative sequence current (I2)
Pick-up	
Used magnitude	Negative sequence component I2pu Relative unbalance I2/I1
Pick-up setting	0.01...40.00 × I _n , setting step 0.01 × I _n (I2pu) 1.00...200.00 %, setting step 0.01 % (I2/I1)
Minimum phase current (at least one phase above)	0.01...2.00 × I _n , setting step 0.01 × I _n
Inaccuracy: - Starting I2pu - Starting I2/I1	±1.0 %-unit or ±100 mA (0.10...4.0 × I _n) ±1.0 %-unit or ±100 mA (0.10...4.0 × I _n)
Operating time	
Definite time function operating time setting	0.00...1800.00 s, setting step 0.005 s
Inaccuracy: - Definite time (I _m /I _{set} ratio > 1.05)	±1.5 % or ±60 ms
IDMT setting parameters: - k Time dial setting for IDMT - A IDMT Constant - B IDMT Constant - C IDMT Constant	0.01...25.00, step 0.01 0...250.0000, step 0.0001 0...5.0000, step 0.0001 0...250.0000, step 0.0001
Inaccuracy: - IDMT operating time - IDMT minimum operating time	±2.0 % or ±30 ms ±20 ms
Retardation time (overshoot)	<5 ms
Instant operation time	
Start time and instant operation time (trip): - I _m /I _{set} ratio > 1.05	<70 ms
Reset	
Reset ratio	97 % of the pick-up setting
Reset time setting Inaccuracy: Reset time	0.010...10.000 s, step 0.005 s ±1.5 % or ±60 ms
Instant reset time and start-up reset	<55 ms

9.2.1.6 Harmonic overcurrent protection (Ih>; 50H/51H/68H)

Table. 9.2.1.6 - 309. Technical data for the harmonic overcurrent function.

Measurement inputs	
--------------------	--

Current inputs	Phase current inputs: I _{L1} (A), I _{L2} (B), I _{L3} (C) Residual current channel I ₀₁ (Coarse) Residual current channel I ₀₂ (Fine)
Pick-up	
Harmonic selection	2 nd , 3 rd , 4 th , 5 th , 6 th , 7 th , 9 th , 11 th , 13 th , 15 th , 17 th or 19 th
Used magnitude	Harmonic per unit ($\times I_N$) Harmonic relative (I _h /I _L)
Pick-up setting	0.05...2.00 $\times I_N$, setting step 0.01 $\times I_N$ ($\times I_N$) 5.00...200.00 %, setting step 0.01 % (I _h /I _L)
Inaccuracy: - Starting $\times I_N$ - Starting $\times I_h/I_L$	<0.03 $\times I_N$ (2 nd , 3 rd , 5 th) <0.03 $\times I_N$ tolerance to I _h (2 nd , 3 rd , 5 th)
Operation time	
Definite time function operating time setting	0.00...1800.00 s, setting step 0.005 s
Inaccuracy: - Definite time (I _M /I _{SET} ratio >1.05)	± 1.0 % or ± 35 ms
IDMT setting parameters: k Time dial setting for IDMT A IDMT constant B IDMT constant C IDMT constant	0.01...25.00, step 0.01 0...250.0000, step 0.0001 0...5.0000, step 0.0001 0...250.0000, step 0.0001
Inaccuracy: - IDMT operating time - IDMT minimum operating time	± 1.5 % or ± 20 ms ± 20 ms
Instant operation time	
Start time and instant operation time (trip): I _M /I _{SET} ratio >1.05	<50 ms
Reset	
Reset ratio	95 % of the pick-up setting
Reset time setting Inaccuracy: Reset time	0.010...10.000 s, step 0.005 s ± 1.0 % or ± 35 ms
Instant reset time and start-up reset	<50 ms

Note!

- Harmonics generally: The amplitude of the harmonic content has to be least $0.02 \times I_N$ when the relative mode (I_h/I_L) is used.
- Blocking: To achieve fast activation for blocking purposes with the harmonic overcurrent stage, note that the harmonic stage may be activated by a rapid load change or fault situation. An intentional activation lasts for approximately 20 ms if a harmonic component is not present. The harmonic stage stays active if the harmonic content is above the pick-up limit.
- Tripping: When using the harmonic overcurrent stage for tripping, please ensure that the operation time is set to 20 ms (DT) or longer to avoid nuisance tripping caused by the above-mentioned reasons.

9.2.1.7 Circuit breaker failure protection (CBFP; 50BF/52BF)

Table. 9.2.1.7 - 310. Technical data for the circuit breaker failure protection function.

Measurement inputs

Current inputs	Phase current inputs: I_{L1} (A), I_{L2} (B), I_{L3} (C) Residual current channel I_{01} (Coarse) Residual current channel I_{02} (Fine)
Current input magnitudes	RMS phase currents RMS residual current (I_{01} , I_{02} or calculated I_0)
Pick-up	
Monitored signals	Digital input status, digital output status, logical signals
Pick-up current setting: - $I_{L1} \dots I_{L3}$ - I_{01} , I_{02} , I_{0Calc}	$0.10 \dots 40.00 \times I_N$, setting step $0.01 \times I_N$ $0.005 \dots 40.00 \times I_N$, setting step $0.005 \times I_N$
Inaccuracy: - Starting phase current (5A) - Starting I_{01} (1 A) - Starting I_{02} (0.2 A) - Starting I_{0Calc} (5 A)	$\pm 0.5 \% I_{SET}$ or ± 15 mA ($0.10 \dots 4.0 \times I_{SET}$) $\pm 0.5 \% I_{0SET}$ or ± 3 mA ($0.005 \dots 10.0 \times I_{SET}$) $\pm 1.5 \% I_{0SET}$ or ± 1.0 mA ($0.005 \dots 25.0 \times I_{SET}$) $\pm 1.0 \% I_{0SET}$ or ± 15 mA ($0.005 \dots 4.0 \times I_{SET}$)
Operation time	
Definite time function operating time setting	$0.050 \dots 1800.000$ s, setting step 0.005 s
Inaccuracy: - Current criteria (I_M/I_{SET} ratio $1.05 \rightarrow$) - DO or DI only	± 1.0 % or ± 55 ms ± 15 ms
Reset	
Reset ratio	97 % of the pick-up current setting
Reset time	<50 ms

9.2.1.8 Low-impedance or high-impedance restricted earth fault/ cable end differential protection ($I_{0d} >$; 87N)

Table. 9.2.1.8 - 311. Technical data for the restricted earth fault/cable end differential function.

Measurement inputs	
Current inputs	Phase current inputs: I_{L1} (A), I_{L2} (B), I_{L3} (C) Residual current channel I_{01} (Coarse) Residual current channel I_{02} (Fine)
Current input calculations	Calculated bias and residual differential currents
Pick-up	
Operating modes	Restricted earth fault Cable end differential
Characteristics	Biased differential with 3 settable sections and 2 slopes
Pick-up current sensitivity setting Slope 1 Slope 2 Bias (Turnpoint 1 & 2)	$0.01 \dots 50.00 \% (I_N)$, setting step 0.01% $0.00 \dots 150.00 \%$, setting step 0.01% $0.00 \dots 250.00 \%$, setting step 0.01% $0.01 \dots 50.00 \times I_N$, setting step $0.01 \times I_N$
Inaccuracy - Starting	$\pm 3\%$ of the set pick-up value $> 0.5 \times I_N$ setting. ± 5 mA $< 0.5 \times I_N$ setting
Operation time	
Instant operation time $1.05 \times I_{SET}$	<30 ms
Reset	
Reset ratio	No hysteresis
Reset time	<40 ms

9.2.1.9 Overvoltage protection ($U >$; 59)

Table 9.2.1.9 - 312. Technical data for the overvoltage function.

Measurement inputs	
Voltage inputs	U_{L1}, U_{L2}, U_{L3} $U_{L12}, U_{L23} + U_0$
Voltage input magnitudes	RMS line-to-line or line-to-neutral voltages
Pick-up	
Pick-up terms	1 voltage 2 voltages 3 voltages
Pick-up setting	50.00...150.00 % U_N , setting step 0.01 % U_N
Inaccuracy: - Voltage	$\pm 3.5\% U_{SET}$
Operating time	
Definite time function operating time setting	0.00...1800.00 s, setting step 0.005 s
Inaccuracy: - Definite time (U_M/U_{SET} ratio 1.05 \rightarrow)	$\pm 1.0\%$ or ± 35 ms
IDMT setting parameters: k Time dial setting for IDMT A IDMT constant B IDMT constant C IDMT constant	0.01...25.00, step 0.01 0...250.0000, step 0.0001 0...5.0000, step 0.0001 0...250.0000, step 0.0001
Inaccuracy: - IDMT operating time - IDMT minimum operating time	$\pm 1.5\%$ or ± 20 ms ± 20 ms
Instant operation time	
Start time and instant operation time (trip): - U_M/U_{SET} ratio 1.05 \rightarrow	<50 ms
Reset	
Reset ratio	97 % of the pick-up voltage setting
Reset time setting Inaccuracy: Reset time	0.010...10.000 s, step 0.005 s $\pm 1.0\%$ or ± 35 ms
Instant reset time and start-up reset	<50 ms

9.2.1.10 Undervoltage protection ($U <$; 27)

Table 9.2.1.10 - 313. Technical data for the undervoltage function.

Input signals	
Voltage inputs	U_{L1}, U_{L2}, U_{L3} $U_{L12}, U_{L23} + U_0$
Voltage input magnitudes	RMS line-to-line or line-to-neutral voltages
Pick-up	
Pick-up terms	1 voltage 2 voltages 3 voltages
Pick-up setting	20.00...120.00 % U_N , setting step 0.01 % U_N
Inaccuracy: - Voltage	$\pm 3.5\% U_{SET}$

Low voltage block	
Pick-up setting	0.00...80.00 %U _N , setting step 0.01 %U _N
Inaccuracy: - Voltage	±3.5 %U _{SET}
Operation time	
Definite time function operating time setting	0.00...1800.00 s, setting step 0.005 s
Inaccuracy: - Definite time (U _M /U _{SET} ratio 1.05→)	±1.0 % or ±35 ms
IDMT setting parameters: k Time dial setting for IDMT A IDMT constant B IDMT constant C IDMT constant	0.01...25.00, step 0.01 0...250.0000, step 0.0001 0...5.0000, step 0.0001 0...250.0000, step 0.0001
Inaccuracy: - IDMT operating time - IDMT minimum operating time	±1.5 % or ±20 ms ±20 ms
Instant operation time	
Start time and instant operation time (trip): - U _M /U _{SET} ratio 1.05→	<65 ms
Retardation time (overshoot)	<30 ms
Reset	
Reset ratio	103 % of the pick-up voltage setting
Reset time setting Inaccuracy: Reset time	0.010...10.000 s, step 0.005 s ±1.0 % or ±45 ms
Instant reset time and start-up reset	<50 ms

Note!

- The low-voltage block is not in use when its pick-up setting is set to 0 %. The undervoltage function is in trip stage when the LV block is disabled and the device has no voltage injection.
- After the low voltage blocking condition, the undervoltage stage does not trip unless the voltage exceeds the pick-up setting first.

9.2.1.11 Neutral overvoltage protection (U₀>; 59N)

Table. 9.2.1.11 - 314. Technical data for the neutral overvoltage.

Measurement inputs	
Voltage inputs (selectable)	Residual voltage from U ₃ voltage channel Residual voltage calculated from U _{L1} , U _{L2} , U _{L3}
Voltage input magnitudes	RMS residual voltage U ₀ Calculated RMS residual voltage U ₀
Pick-up	
Pick-up voltage setting	1.00...50.00 %U _{0N} , setting step 0.01 × I _N
Inaccuracy: - Voltage U ₀ - Voltage U ₀ Calc	±3.5 %U _{0SET} or ±30 mV ±400 mV
Operation time	
Definite time function operating time setting	0.00...1800.00 s, setting step 0.005 s

Inaccuracy: - Definite time (U_0/U_{SET} ratio 1.05→)	$\pm 1.0\%$ or ± 35 ms
IDMT setting parameters: k Time dial setting for IDMT A IDMT constant B IDMT constant C IDMT constant	0.01...25.00, step 0.01 0...250.0000, step 0.0001 0...5.0000, step 0.0001 0...250.0000, step 0.0001
Inaccuracy: - IDMT operating time - IDMT minimum operating time	$\pm 1.5\%$ or ± 20 ms ± 20 ms
Instant operation time	
Start time and instant operation time (trip): - U_0/U_{SET} ratio 1.05→	<50 ms
Reset	
Reset ratio	97 % of the pick-up voltage setting
Reset time setting Inaccuracy: Reset time	0.000...150.000 s, step 0.005 s $\pm 1.0\%$ or ± 35 ms
Instant reset time and start-up reset	<50 ms

9.2.1.12 Sequence voltage protection ($U_1/U_2 > / <$; 47/27P/59NP)

Table 9.2.1.12 - 315. Technical data for the sequence voltage function.

Measurement inputs	
Voltage inputs	U_{L1}, U_{L2}, U_{L3} $U_{L12}, U_{L23}, U_{L31}$ (+ U_0)
Voltage input calculations	Positive sequence voltage (I1) Negative sequence voltage (I2)
Pick-up	
Pick-up setting	5.00...150.00 % U_N , setting step 0.01 % U_N
Inaccuracy: - Voltage	$\pm 1.5\%U_{SET}$ or ± 30 mV
Low voltage block	
Pick-up setting	1.00...80.00 % U_N , setting step 0.01 % U_N
Inaccuracy: -Voltage	$\pm 1.5\%U_{SET}$ or ± 30 mV
Operation time	
Definite time function operating time setting	0.00...1800.00 s, setting step 0.005 s
Inaccuracy -Definite Time (U_M/U_{SET} ratio 1.05→)	$\pm 1.0\%$ or ± 35 ms
IDMT setting parameters: k Time dial setting for IDMT A IDMT constant B IDMT constant C IDMT constant	0.01...25.00, step 0.01 0...250.0000, step 0.0001 0...5.0000, step 0.0001 0...250.0000, step 0.0001
Inaccuracy: - IDMT operating time - IDMT minimum operating time	$\pm 1.5\%$ or ± 20 ms ± 20 ms
Instant operation time	
Start time and instant operation time (trip): - U_M/U_{SET} ratio <0.95/1.05→	<65 ms

Reset	
Reset ratio	97 or 103 % of the pick-up voltage setting
Reset time setting Inaccuracy: Reset time	0.010...10.000 s, step 0.005 s ±1.0 % or ±35 ms
Instant reset time and start-up reset	<50 ms

9.2.1.13 Overfrequency and underfrequency protection ($f > / <$; 81O/81U)

Table. 9.2.1.13 - 316. Technical data for the overfrequency and underfrequency function.

Input signals	
Sampling mode	Fixed Tracking
Frequency reference 1 Frequency reference 2 Frequency reference 3	CT1IL1, CT2IL1, VT1U1, VT2U1 CT1IL2, CT2IL2, VT1U2, VT2U2 CT1IL3, CT2IL3, VT1U3, VT2U3
Pick-up	
$f >$ pick-up setting $f <$ pick-up setting	10.00...70.00 Hz, setting step 0.01 Hz 7.00...65.00 Hz, setting step 0.01 Hz
Inaccuracy (sampling mode): - Fixed - Tracking	±20 mHz (50/60 Hz fixed frequency) ±20 mHz ($U > 30$ V secondary) ±20 mHz ($I > 30$ % of rated secondary)
Operation time	
Definite time function operating time setting	0.00...1800.00 s, setting step 0.005 s
Inaccuracy: - Definite time (I_M/I_{SET} ratio +/- 50 mHz)	±1.5 % or ±50 ms (max. step size: 100 mHz)
Instant operation time	
Start time and instant operation time (trip): - I_M/I_{SET} ratio +/- 50 mHz (Fixed) - I_M/I_{SET} ratio +/- 50 mHz (Tracking)	<70 ms (max. step size: 100 mHz) <3 cycles or <60 ms (max. step size: 100 mHz)
Reset	
Reset ratio	0.020 Hz
Instant reset time and start-up reset: - I_M/I_{SET} ratio +/- 50 mHz (Fixed) - I_M/I_{SET} ratio +/- 50 mHz (Tracking)	<110 ms (max. step size: 100 mHz) <3 cycles or <70 ms (max. step size: 100 mHz)

Note!

- The secondary voltage must exceed 2 volts or the current must exceed 0.25 amperes (peak-to-peak) in order for the function to measure frequency.
- The frequency is measured two seconds after a signal is received.
- The fixed frequency mode: When the fixed mode is used, the system's nominal frequency should be set to 50 or 60 Hz.
- The tracked frequency mode: When tracked mode is used, the system's nominal frequency can be anything between 7...75 Hz.

9.2.1.14 Rate-of-change of frequency protection ($df/dt > / <$; 81R)

Table. 9.2.1.14 - 317. Technical data of the rate-of-change of frequency function.

Input signals

Sampling mode	Fixed Tracking
Frequency reference 1 Frequency reference 2 Frequency reference 3	CT1IL1, CT2IL1, VT1U1, VT2U1 CT1IL2, CT2IL2, VT1U2, VT2U2 CT1IL3, CT2IL3, VT1U3, VT2U3
Pick-up	
Df/dt>/< pick-up setting	0.15...1.00 Hz/s, setting step 0.01 Hz
f> limit	10.00...70.00 Hz, setting step 0.01 Hz
f< limit	7.00...65.00 Hz, setting step 0.01 Hz
Pick-up inaccuracy	
Df/dt	±5.0 %I _{SET} or ±20 mHz/s
Frequency	±15 mHz (U > 30 V secondary) ±20 mHz (I > 30 % of rated secondary)
Operation time	
Definite time function operating time setting	0.00...1800.00 s, setting step 0.005 s
Inaccuracy: - Definite time (I _M /I _{SET} ratio +/- 50 mHz)	±1.5 % or ±110 ms (max. step size: 100 mHz)
Start time and instant operation time (trip):	
f _M /f _{SET} ratio +/- 20 mHz (overreach)	<180 ms
f _M /f _{SET} ratio +/- 200 mHz (overreach)	<90 ms
Reset	
Reset ratio (frequency limit)	0.020 Hz
Instant reset time and start-up reset - f _M /f _{SET} ratio +/- 50 mHz	<2 cycles or <60 ms (max. step size: 100 mHz)

Note!

- The frequency is measured two seconds after a signal is received.

9.2.1.15 Line thermal overload protection (TF>; 49F)

Table. 9.2.1.15 - 318. Technical data for the line thermal overload protection function.

Measurement inputs	
Current inputs	Phase current inputs: I _{L1} (A), I _{L2} (B), I _{L3} (C)
Current input magnitudes	TRMS phase currents (up to the 31 st harmonic)
Settings	
Time constants τ	1
Time constant value	0.0...500.00 min, step 0.1 min
Service factor (maximum overloading)	0.01...5.00 × I _N , step 0.01 × I _N
Thermal model biasing	- Ambient temperature (Set -60.0...500.0 deg, step 0.1 deg and RTD) - Negative sequence current
Thermal replica temperature estimates	Selectable between °C and °F
Outputs	

- Alarm 1 - Alarm 2 - Thermal trip - Trip delay - Restart inhibit	0...150 %, step 1 % 0...150 %, step 1 % 0...150 %, step 1 % 0.000...3600.000 s, step 0.005 s 0...150 %, step 1 %
Inaccuracy	
- Starting - Operating time	±0.5 % of the set pick-up value ±5 % or ± 500 ms

9.2.1.16 Overpower (P>; 32O), underpower (P<; 32U) and reverse power (Pr; 32R) protection

Table. 9.2.1.16 - 319. Technical data for the power protection functions.

Measurement inputs	
Current inputs	Phase current inputs: I _{L1} (A), I _{L2} (B), I _{L3} (C)
Voltage inputs	U _{L1} , U _{L2} , U _{L3} U _{L12} , U _{L23} (+ U ₀)
Calculated measurement	Three-phase active power
Pick-up	
P>	0.10...150 000.00 kW, setting step 0.01 kW
Prev>	-15 000.00...-1.00 kW, setting step 0.01 kW
P< Low-power blocking P _{SET<}	0.00...150 000.00 kW, setting step 0.01 kW 0.00...100 000.00 kW, setting step 0.01 kW
Inaccuracy: - Active power	Typically <3.0 %P _{SET}
Operation time	
Definite time function operating time setting	0.00...1800.00 s, setting step 0.005 s
Inaccuracy: - Definite time (P _M /P _{SET} ratio 1.05→)	±1.0 % or ±35 ms
Instant operation time	
Start time and instant operation time (trip): - P _M /P _{SET} ratio 1.05→	<50 ms
Reset	
Reset ratio	97 or 103 %P _{SET}
Reset time setting Inaccuracy: Reset time	0.000...150.000 s, step 0.005 s ±1.0 % or ±35 ms
Instant reset time and start-up reset	<50 ms

Note!

- Voltage measurement starts from 0.5 V and current measurement from 50 mA. In case either or both are missing the power measurement is forced to 0 kW. If the settings allow it (low-power blocking = 0 kW), the P< might be in the trip state during this condition. The trip is released when the voltage and the current are begin to be measured.
- When the low-power blocking is set to zero, it is not in use. Also, all power measurements below 1.00 kW are forced to zero ("P< blocked").

9.2.1.17 Resistance temperature detectors

Table. 9.2.1.17 - 320. Technical data of the resistance temperature detectors.

Inputs	
Resistance input magnitudes	Measured temperatures measured by RTD sensors
Alarm channels	12 individual alarm channels
Settable alarms	24 alarms available (two per each alarm channel)
Pick-up	
Alarm setting range Inaccuracy Reset ratio	101.00...2000.00 deg, setting step 0.1 deg (either < or > setting) ±3 % of the set pick-up value 97 % of the pick-up setting
Operation	
Operating time	Typically <500 ms

9.2.1.18 Arc fault protection (IArc>/IOArc>; 50Arc/50NArc) (optional)

Table. 9.2.1.18 - 321. Technical data for the arc fault protection function.

Measurement inputs	
Current inputs	Phase current inputs: I _{L1} (A), I _{L2} (B), I _{L3} (C) Residual current channel I ₀₁ (Coarse) Residual current channel I ₀₂ (Fine)
Current input magnitudes	Sample-based phase current measurement Sample-based residual current measurement
Arc point sensor inputs	Channels S1, S2, S3, S4 (pressure and light sensor, or light-only sensor) Up to four (4) sensors per channel
System frequency operating range	6.00...75.00 Hz
Pick-up	
Pick-up current setting (phase current) Pick-up current setting (residual current) Pick-up light intensity	0.50...40.00 × I _N , setting step 0.01 × I _N 0.10...40.00 × I _N , setting step 0.01 × I _N 8, 25 or 50 kLx (the sensor is selected in the order code)
Starting inaccuracy (IArc> and IOArc>)	±3 % of the set pick-up value > 0.5 × I _N setting. 5 mA < 0.5 × I _N setting.
Point sensor detection radius	180 degrees
Operation time	
Light only: - Semiconductor outputs HSO1 and HSO2 - Regular relay outputs	Typically 7 ms (3...12 ms) Typically 10 ms (6.5...15 ms)
Light + current criteria (zone 1...4): - Semiconductor outputs HSO1 and HSO2 - Regular relay outputs	Typically 10 ms (6.5...14 ms) Typically 14 ms (10...18 ms)
Arc BI only: - Semiconductor outputs HSO1 and HSO2 - Regular relay outputs	Typically 7 ms (2...12 ms) Typically 10 ms (6.5...15 ms)
Reset	
Reset ratio for current	97 % of the pick-up setting
Reset time	<35 ms

Note!

- The maximum length of the arc sensor cable is 200 meters.

9.2.1.19 Voltage memory

Table 9.2.1.19 - 322. Technical data for the voltage memory function.

Measurement inputs	
Voltage inputs	U_{L1}, U_{L2}, U_{L3} $U_{L12}, U_{L23}, U_{L31} + U_0$
Current inputs (back-up frequency)	Phase current inputs: I_{L1} (A), I_{L2} (B), I_{L3} (C)
Pick-up	
Pick-up voltage setting Pick-up current setting (optional)	2.00...50.00 % U_N , setting step $0.01 \times \%U_N$ $0.01...50.00 \times I_N$, setting step $0.01 \times I_N$
Inaccuracy: - Voltage - Current	$\pm 1.5 \%U_{SET}$ or ± 30 mV $\pm 0.5 \%I_{SET}$ or ± 15 mA ($0.10...4.0 \times I_{SET}$)
Operation time	
Angle memory activation delay	<20 ms (typically 5 ms)
Maximum active time	0.020...50.000 s, setting step 0.005 s
Inaccuracy: - Definite time (U_M/U_{SET} ratio >1.05)	$\pm 1.0 \%$ or ± 35 ms
Angle memory	
Angle drift while voltage is absent	$\pm 1.0^\circ$ per 1 second
Reset	
Reset ratio: - Voltage memory (voltage) - Voltage memory (current)	103 % of the pick-up voltage setting 97 % of the pick-up current setting
Reset time	<50 ms

Note!

- Voltage memory is activated only when all line voltages fall below set pick-up value.
- Voltage memory activation captures healthy situation voltage angles, one cycle before actual activation (50Hz/20ms before “bolted” fault)

9.2.2 Control functions

9.2.2.1 Setting group selection

Table 9.2.2.1 - 323. Technical data for the setting group selection function.

Settings and control modes	
Setting groups	8 independent, control-prioritized setting groups
Control scale	Common for all installed functions which support setting groups
Control mode	
Local	Any digital signal available in the device
Remote	Force change overrule of local controls either from the setting tool, HMI or SCADA
Operation time	
Reaction time	<5 ms from receiving the control signal

9.2.2.2 Object control and monitoring

Table. 9.2.2.2 - 324. Technical data for the object control and monitoring function.

Signals	
Input signals	Digital inputs Software signals
Output signals	Close command output Open command output
Operation time	
Breaker traverse time setting	0.02...500.00 s, setting step 0.02 s
Max. close/open command pulse length	0.02...500.00 s, setting step 0.02 s
Control termination time out setting	0.02...500.00 s, setting step 0.02 s
Inaccuracy: - Definite time operating time	±0.5 % or ±10 ms
Breaker control operation time	
External object control time	<75 ms
Object control during auto-reclosing	See the technical sheet for the auto-reclosing function.

9.2.2.3 Auto-reclosing (0 → 1; 79)

Table. 9.2.2.3 - 325. Technical data for the auto-reclosing function.

Input signals	
Input signals	Software signals (protection, logics, etc.) Binary inputs
Requests	
REQ1-5	5 priority request inputs; can be set parallel as signals to each request
Shots	
1-5 shots	5 independent or scheme-controlled shots in each AR request
Operation time	
Operating time settings: - Lockout after successful AR - Object close reclaim time - AR shot starting delay - AR shot dead time delay - AR shot action time - AR shot specific reclaim time	0.000...1800.000 s, setting step 0.005 s 0.000...1800.000 s, setting step 0.005 s 0.000...1800.000 s, setting step 0.005 s 0.000...1800.000 s, setting step 0.005 s 0.000...1800.000 s, setting step 0.005 s 0.000...1800.000 s, setting step 0.005 s
Inaccuracy	
AR starting (from a protection stage's START signal)	±1.0 % or ±30 ms (AR delay)
AR starting (from a protection stage's TRIP signal)	Trip delay inaccuracy +25 ms (Protection + AR delay)
Dead time	±1.0 % or ±35 ms (AR delay)
Action time	±1.0 % or ±30 ms (AR delay)
Instant starting time	
Instant operation time	Protection activation delay + 15 ms (Protection + AR delay)

9.2.2.4 Cold load pick-up (CLPU)

Table 9.2.2.4 - 326. Technical data for the cold load pick-up function.

Measurement inputs	
Current inputs	Phase current inputs: IL1 (A), IL2 (B), IL3 (C)
Current input magnitudes	RMS phase currents
Pick-up	
Pick-up current setting - LOW/HIGH/OVER	0.01...40.00 × I _N , setting step 0.01 × I _N
Reset ratio	97 % of the pick-up current setting
Inaccuracy: - Current	±0.5 % I _{SET} or ±15 mA (0.10...4.0 × I _{SET})
Operation time	
Definite time function operating time settings: - t _{SET} - t _{MAX} - t _{MIN}	0.000...1800.000 s, setting step 0.005 s 0.000...1800.000 s, setting step 0.005 s 0.000...1800.000 s, setting step 0.005 s
Inaccuracy: - Definite time (I _M /I _{SET} ratio = 1.05/0.95)	±1.0 % or ±45 ms
Instant operation time	
CLPU activation and release	<45 ms (measured from the trip contact)

Note!

- A single-phase current (IL1, IL2 or IL3) is enough to prolong or release the blocking during an overcurrent condition.

9.2.2.5 Switch-on-to-fault (SOTF)

Table 9.2.2.5 - 327. Technical data for the switch-on-to-fault function.

Initialization signals	
SOTF activate input	Any IED blocking input signal (Object closed signal, etc.)
Pick-up	
SOTF function input	Any IED blocking input signal (I> or similar)
SOTF activation time	
Activation time	<40 ms (measured from the trip contact)
SOTF release time	
Release time setting	0.000...1800.000 s, setting step 0.005 s
Inaccuracy: - Definite time	±1.0 % or ±30 ms
SOTF instant release time	<40 ms (measured from the trip contact)

9.2.2.6 Vector jump ($\Delta\phi$; 78)

Table 9.2.2.6 - 328. Technical data for the vector jump protection function.

Measurement inputs

Voltage inputs	U_{L1}, U_{L2}, U_{L3} $U_{L12}, U_{L23}, U_{L31} + U_0$
Monitored voltages	Any or all system line-to-line voltage(s) Any or all system line-to-neutral voltage(s) Specifically chosen line-to-line or line-to-neutral voltage U4 channel voltage
Pick-up	
Pick-up setting	0.05...30.00°, setting step 0.01°
Inaccuracy: - Voltage angle	±30% overreach or 1.00 °
Low-voltage blocking	
Pick-up setting	0.01...100.00 % U_N , setting step 0.01 % U_N
Inaccuracy: - Voltage	±1.5 % U_{SET} or ±30 mV
Instant operation time	
Alarm and trip operation time: - (I_M/I_{SET} ratio > ±30% overreach or 1.00 °)	<40 ms (typically 30 ms) 50/60 Hz <50 ms (typically 40 ms) 16.67 Hz
Reset	
Trip pulse	~5-10ms

9.2.3 Monitoring functions

9.2.3.1 Current transformer supervision

Table. 9.2.3.1 - 329. Technical data for the current transformer supervision function.

Measurement inputs	
Current inputs	Phase current inputs: I_{L1} (A), I_{L2} (B), I_{L3} (C) Residual current channel I_{01} (Coarse) (optional) Residual current channel I_{02} (Fine) (optional)
Current input magnitudes	RMS phase currents RMS residual current (I_{01}, I_{02}) (optional)
Pick-up	
Pick-up current settings: - I_{SET} high limit - I_{SET} low limit - I_{SUM} difference - I_{SET} ratio - I_2/I_1 ratio	0.10...40.00 × I_N , setting step 0.01 × I_N 0.10...40.00 × I_N , setting step 0.01 × I_N 0.10...40.00 × I_N , setting step 0.01 × I_N 0.01...100.00 %, setting step 0.01 % 0.01...100.00 %, setting step 0.01 %
Inaccuracy: - Starting I_{L1}, I_{L2}, I_{L3} - Starting I_2/I_1 - Starting I_{01} (1 A) - Starting I_{02} (0.2 A)	±0.5 % I_{SET} or ±15 mA (0.10...4.0 × I_{SET}) ±1.0 % I_2/I_1 or ±100 mA (0.10...4.0 × I_N) ±0.5 % I_{0SET} or ±3 mA (0.005...10.0 × I_{SET}) ±1.5 % I_{0SET} or ±1.0 mA (0.005...25.0 × I_{SET})
Time delay for alarm	
Definite time function operating time setting	0.00...1800.00 s, setting step 0.005 s
Inaccuracy_ - Definite time (I_M/I_{SET} ratio > 1.05)	±2.0 % or ±80 ms
Instant operation time (alarm): - I_M/I_{SET} ratio > 1.05	<80 ms (<50 ms in differential protection relays)

Reset	
Reset ratio	97/103 % of the pick-up current setting
Instant reset time and start-up reset	<80 ms (<50 ms in differential protection relays)

9.2.3.2 Voltage transformer supervision (60)

Table. 9.2.3.2 - 330. Technical data for the voltage transformer supervision function.

Measurement inputs	
Voltage input	U_{L1}, U_{L2}, U_{L3} U_{L12}, U_{L23}
Voltage input magnitudes	RMS line-to-line or line-to-neutral voltages
Pickup	
Pickup settings: - Voltage (low pick-up) - Voltage (high pick-up) - Angle shift limit	0.05...0.50 × U_N , setting step 0.01 × U_N 0.50...1.10 × U_N , setting step 0.01 × U_N 2.00...90.00 deg, setting step 0.10 deg
Inaccuracy: - Voltage - U angle ($U > 1 V$)	±4.0 % U_{SET} ±3.0°
External line/bus side pickup (optional)	0 → 1
Time delay for alarm	
Definite time function operating time setting	0.00...1800.00 s, setting step 0.005 s
Inaccuracy: - Definite time (U_M/U_{SET} ratio > 1.05/0.95)	±1.0 % or ±35 ms
Instant operation time (alarm): - U_M/U_{SET} ratio > 1.05/0.95	<50 ms
VTS MCB trip bus/line (external input)	<50 ms
Reset	
Reset ratio	97/103 % of the pick-up voltage setting
Reset time setting Inaccuracy: Reset time	0.010...10.000 s, step 0.005 s ±1.0 % or ±35 ms
Instant reset time and start-up reset	<50 ms
VTS MCB trip bus/line (external input)	<50 ms

Note!

- When turning on the auxiliary power of an IED, the normal condition of a stage has to be fulfilled before tripping.

9.2.3.3 Circuit breaker wear monitoring

Table. 9.2.3.3 - 331. Technical data for the circuit breaker wear monitoring function.

Pick-up	
Breaker characteristics settings: - Nominal breaking current - Maximum breaking current - Operations with nominal current - Operations with maximum breaking current	0.00...100.00 kA, setting step 0.001 kA 0.00...100.00 kA, setting step 0.001 kA 0...200 000 operations, setting step 1 operation 0...200 000 operations, setting step 1 operation
Pick-up setting for Alarm 1 and Alarm 2	0...200 000 operations, setting step 1 operation

Inaccuracy	
Inaccuracy for current/operations counter: - Current measurement element - Operation counter	$0.1 \times I_N > I < 2 \times I_N \pm 0.2\%$ of the measured current, rest 0.5 % $\pm 0.5\%$ of operations deducted

9.2.3.4 Total harmonic distortion

Table. 9.2.3.4 - 332. Technical data for the total harmonic distortion function.

Input signals	
Current inputs	Phase current inputs: I_{L1} (A), I_{L2} (B), I_{L3} (C) Residual current channel I_{Q1} (Coarse) Residual current channel I_{Q2} (Fine)
Current input magnitudes	Current measurement channels (FFT result) up to the 31 st harmonic component.
Pick-up	
Operating modes	Power THD Amplitude THD
Pick-up setting for all comparators	0.10...200.00 % , setting step 0.01 %
Inaccuracy	$\pm 3\%$ of the set pick-up value $> 0.5 \times I_N$ setting; $5 \text{ mA} < 0.5 \times I_N$ setting.
Time delay	
Definite time function operating time setting for all timers	0.00...1800.00 s, setting step 0.005 s
Inaccuracy: - Definite time operating time - Instant operating time, when I_M/I_{SET} ratio > 3 - Instant operating time, when I_M/I_{SET} ratio $1.05 < I_M/I_{SET} < 3$	$\pm 0.5\%$ or $\pm 10 \text{ ms}$ Typically $< 20 \text{ ms}$ Typically $< 25 \text{ ms}$
Reset	
Reset time	Typically $< 10 \text{ ms}$
Reset ratio	97 %

9.2.3.5 Fault locator (21FL)

Table. 9.2.3.5 - 333. Technical data for the fault locator function.

Input signals	
Current inputs	Phase current inputs: I_{L1} (A), I_{L2} (B), I_{L3} (C)
Voltage inputs	U_{L1} , U_{L2} , U_{L3} U_{L12} , U_{L23} , U_{L31} + U_0
Calculated reactance magnitudes when line-to-neutral voltages available	XL_{12} , XL_{23} , XL_{31} , XL_1 , XL_2 , XL_3
Calculated reactance magnitudes when line-to-line voltages available	XL_{12} , XL_{23} , XL_{31}
Pick-up	
Trigger current $>$	$0.00 \dots 40.00 \times I_N$, setting step $0.01 \times I_N$
Inaccuracy: - Triggering	$\pm 0.5\% I_{SET}$ or $\pm 15 \text{ mA}$ ($0.10 \dots 4.0 \times I_{SET}$)
Reactance	
Reactance per kilometer	$0.000 \dots 5.000 \text{ s}$, setting step $0.001 \text{ } \Omega/\text{km}$

Inaccuracy: - Reactance	±5.0 % (typically)
Operation (Triggering)	
Activation	From the trip signal of any protection stage
Minimum operation time	At least 0.040 s of stage operation time required

9.2.3.6 Disturbance recorder

Table. 9.2.3.6 - 334. Technical data for the disturbance recorder function.

Recorded values	
Recorder analog channels	0...20 channels Freely selectable
Recorder digital channels	0...95 channels Freely selectable analog and binary signals 5 ms sample rate (FFT)
Performance	
Sample rate	8, 16, 32 or 64 samples/cycle
Recording length	0.000...1800.000 s, setting step 0.001 s The maximum length is determined by the chosen signals.
Number of recordings	0...100, 60 MB of shared flash memory reserved The maximum number of recordings according to the chosen signals and operation time setting combined

9.3 Tests and environmental

Electrical environment compatibility

Table. 9.3 - 335. Disturbance tests.

All tests	CE-approved and tested according to EN 60255-26
Emissions	
Conducted emissions: EN 60255-26 Ch. 5.2, CISPR 22	150 kHz...30 MHz
Radiated emissions: EN 60255-26 Ch. 5.1, CISPR 11	30...1 000 MHz
Immunity	
Electrostatic discharge (ESD): EN 60255-26, IEC 61000-4-2	Air discharge 15 kV Contact discharge 8 kV
Electrical fast transients (EFT): EN 60255-26, IEC 61000-4-4	Power supply input 4 kV, 5/50 ns, 5 kHz Other inputs and outputs 4 kV, 5/50 ns, 5 kHz
Surge: EN 60255-26, IEC 61000-4-5	Between wires 2 kV, 1.2/50 µs Between wire and earth 4 kV, 1.2/50 µs
Radiated RF electromagnetic field: EN 60255-26, IEC 61000-4-3	f = 80...1 000 MHz, 10 V/m

Conducted RF field: EN 60255-26, IEC 61000-4-6	f = 150 kHz...80 MHz, 10 V (RMS)
---	----------------------------------

Table. 9.3 - 336. Voltage tests.

Dielectric voltage test	
EN 60255-27, IEC 60255-5, EN 60255-1	2 kV (AC), 50 Hz, 1 min
Impulse voltage test	
EN 60255-27, IEC 60255-5	5 kV, 1.2/50 µs, 0.5 J

Physical environment compatibility

Table. 9.3 - 337. Mechanical tests.

Vibration test	
EN 60255-1, EN 60255-27, IEC 60255-21-1 Class 1	2...13.2 Hz, ± 3.5 mm 13.2...100 Hz, ± 1.0 g
Shock and bump test	
EN 60255-1, EN 60255-27, IEC 60255-21-2 Class 1	20 g, 1 000 bumps/direction.

Table. 9.3 - 338. Environmental tests.

Damp heat (cyclic)	
EN 60255-1, IEC 60068-2-30	Operational: +25...+55 °C, 93...97 % (RH), 12+12h
Dry heat	
EN 60255-1, IEC 60068-2-2	Storage: +70 °C, 16 h Operational: +55 °C, 16 h
Cold test	
EN 60255-1, IEC 60068-2-1	Storage: -40 °C, 16 h Operational: -20 °C, 16 h

Table. 9.3 - 339. Environmental conditions.

IP classes	
Casing protection class	IP54 (front) IP21 (rear)
Temperature ranges	
Ambient service temperature range	-35...+70 °C
Transport and storage temperature range	-40...+70 °C
Other	
Altitude	<2000 m
Overvoltage category	III
Pollution degree	2

Casing and package

Table. 9.3 - 340. Dimensions and weight.

Without packaging (net)	
Dimensions	Height: 117 mm (4U) Width: 127 mm (¼ rack) Depth: 174 mm (no cards & connectors)
Weight	1.5 kg
With packaging (gross)	
Dimensions	Height: 170 mm Width: 242 mm Depth: 219 mm
Weight	2 kg

10 Ordering information

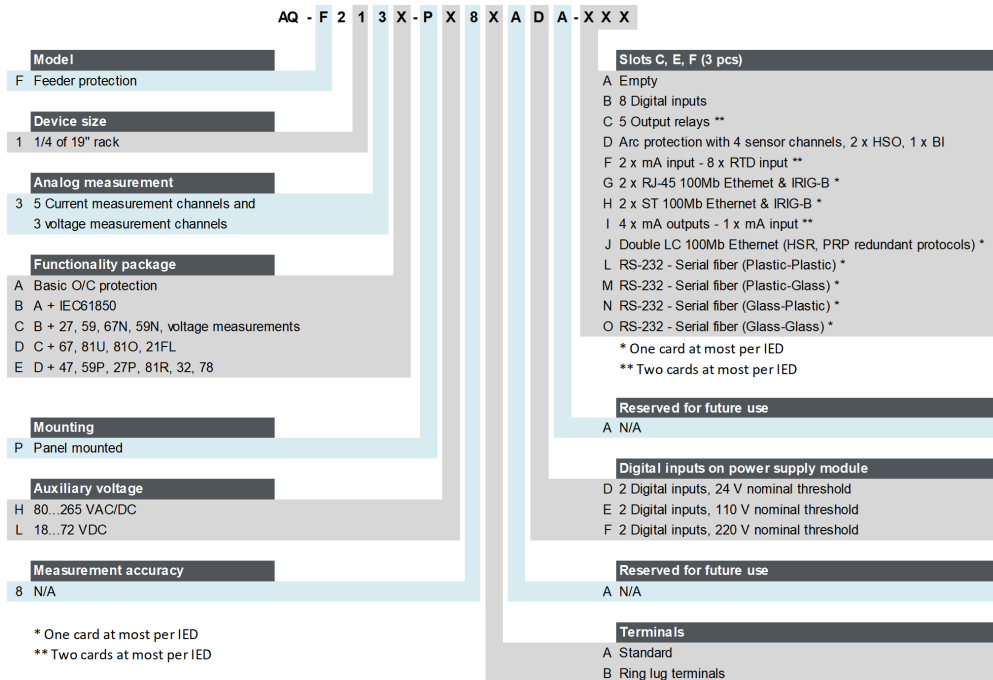

Accessories

Order code	Description	Note	Manufacturer
ADAM-4015-CE	External 6-channel 2 or 3 wires RTD Input module, pre-configured	Requires an external power module	Advanced Co. Ltd.
ADAM-4018+-BE	External 8-ch Thermocouple mA Input module, pre-configured	Requires an external power module	Advanced Co. Ltd.
AQX033	Raising frame 87 mm		Arcteq Ltd.
AQX070	Raising frame 40 mm		Arcteq Ltd.
AQX069	Combiflex frame		Arcteq Ltd.
AQX097	Wall mounting bracket		Arcteq Ltd.
AQ-01A	Light point sensor unit (8,000 lux threshold)	Max. cable length 200 m	Arcteq Ltd.
AQ-01B	Light point sensor unit (25,000 lux threshold)	Max. cable length 200 m	Arcteq Ltd.
AQ-01C	Light point sensor unit (50,000 lux threshold)	Max. cable length 200 m	Arcteq Ltd.
AQ-02A	Pressure and light point sensor unit (8,000 lux threshold)	Max. cable length 200 m	Arcteq Ltd.
AQ-02B	Pressure and light point sensor unit (25,000 lux threshold)	Max. cable length 200 m	Arcteq Ltd.
AQ-02C	Pressure and light point sensor unit (50,000 lux threshold)	Max. cable length 200 m	Arcteq Ltd.

11 Contact and reference information

Manufacturer

Arcteq Relays Ltd.

Visiting and postal address

Kvartsikatu 2 A 1

65300 Vaasa, Finland

Contacts

Phone:	+358 10 3221 370
Fax:	+358 10 3221 389
Website (general):	arcteq.fi
Website (technical support):	support.arcteq.fi
E-mail (sales):	sales@arcteq.fi