

# x930 Series

Gigabit Layer 3 Ethernet Switches  
AlliedWare Plus™ v5.5.1-2

AT-x930-28GTX

AT-x930-28GPX

AT-x930-28GSTX

AT-x930-52GTX

AT-x930-52GPX

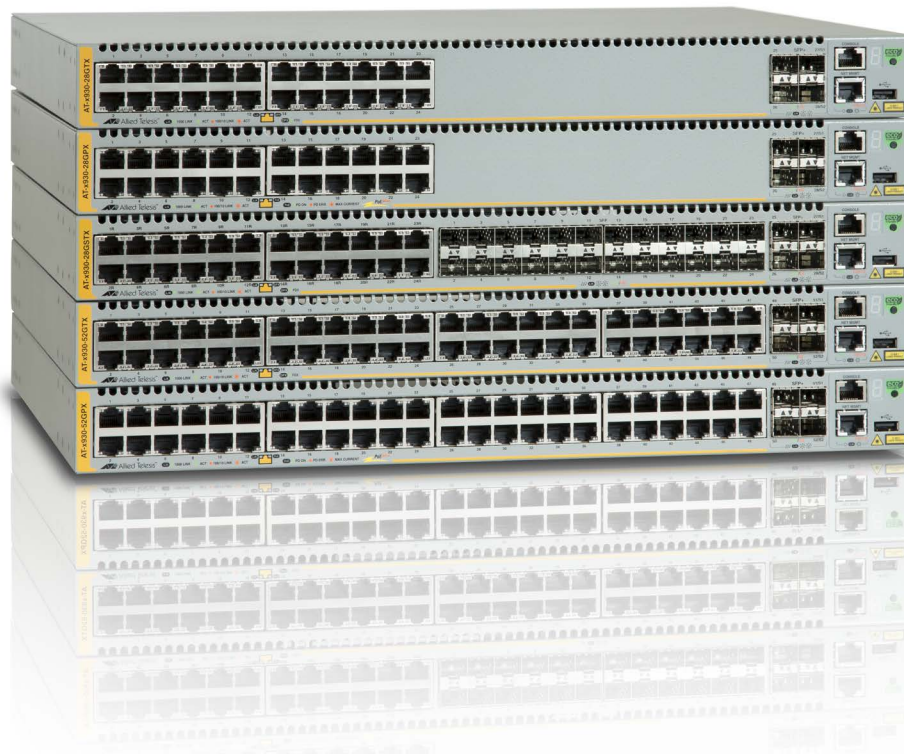

## Installation Guide for VCStack™

Copyright © 2022 Allied Telesis, Inc.

All rights reserved. No part of this publication may be reproduced without prior written permission from Allied Telesis, Inc.

Allied Telesis, VCStack, and the Allied Telesis logo are trademarks of Allied Telesis, Incorporated. All other product names, company names, logos or other designations mentioned herein are trademarks or registered trademarks of their respective owners.

Allied Telesis, Inc. reserves the right to make changes in specifications and other information contained in this document without prior written notice. The information provided herein is subject to change without notice. In no event shall Allied Telesis, Inc. be liable for any incidental, special, indirect, or consequential damages whatsoever, including but not limited to lost profits, arising out of or related to this manual or the information contained herein, even if Allied Telesis, Inc. has been advised of, known, or should have known, the possibility of such damages.

# Electrical Safety and Emissions Standards

---

This product meets the following standards.

## U.S. Federal Communications Commission

### Radiated Energy

Note: This equipment has been tested and found to comply with the limits for a Class A digital device pursuant to Part 15 of FCC Rules. These limits are designed to provide reasonable protection against harmful interference when the equipment is operated in a commercial environment. This equipment generates, uses, and can radiate radio frequency energy and, if not installed and used in accordance with this instruction manual, may cause harmful interference to radio communications. Operation of this equipment in a residential area is likely to cause harmful interference in which case the user will be required to correct the interference at his own expense.

Note: Modifications or changes not expressly approved of by the manufacturer or the FCC, can void your right to operate this equipment.

## Industry Canada

This Class A digital apparatus complies with Canadian ICES-003.

Cet appareil numérique de la classe A est conforme à la norme NMB-003 du Canada.

RFI Emissions: FCC Class A, EN55022 Class A, EN61000-3-2, EN61000-3-3, VCCI Class A, C-TICK, CE

**Warning:** In a domestic environment this product may cause radio interference in which case the user may be required to take adequate measures.

EMC (Immunity): EN55024

Electrical Safety: EN60950-1 (TUV), UL 60950-1 (cUL<sub>US</sub>)



Laser Safety

EN60825

## Translated Safety Statements

---

**Important:** Safety statements that have the  symbol are translated into multiple languages in the *Translated Safety Statements* document at [www.alliedtelesis.com/support](http://www.alliedtelesis.com/support).

**Remarque:** Les consignes de sécurité portant le symbole  sont traduites dans plusieurs langues dans le document *Translated Safety Statements*, disponible à l'adresse [www.alliedtelesis.com/library](http://www.alliedtelesis.com/library).

# Contents

---

<b>Preface</b> .....	13
Document Conventions .....	14
Contacting Allied Telesis .....	15
<b>Chapter 1: Overview</b> .....	17
Models .....	18
Front and Back Panels .....	19
Features .....	22
x930 Models .....	22
10/100/1000 Mbps Copper Ports .....	22
Power Over Ethernet .....	22
SFP Ports .....	23
SFP+ Ports .....	23
SFP+ S1 and S2 Stacking Ports .....	24
LEDs .....	24
Installation Options .....	24
MAC Address Table .....	24
Management Software and Interfaces .....	24
Management Methods .....	25
Power Supplies .....	25
Management Panel .....	26
Power Supplies .....	27
System-Only Power Supplies .....	27
System and PoE+ Power Supplies .....	28
Guidelines .....	29
10/100/1000Base-T Copper Ports .....	31
Speed .....	31
Duplex Mode .....	31
Wiring Configuration .....	31
Maximum Distance .....	32
Cable Requirements .....	32
Port Pinouts .....	32
Power Over Ethernet .....	33
PoE Standards .....	33
Powered Device Classes .....	33
Power Budget .....	34
Port Prioritization .....	36
Wiring Implementation .....	37
SFP Ports .....	38
SFP+ Ports .....	39
S1 and S2 SFP+ Ports .....	40
Ethernet Management Port (NET MGMT) .....	41
NET MGMT LEDs .....	41
eco-friendly Button .....	42
LEDs .....	43
LEDs for the Copper Ports .....	43
LEDs for the SFP Ports .....	46
LEDs for the SFP+ Ports .....	47
LEDs for the Stacking Ports .....	48
Switch ID LED .....	49

USB Port .....	51
Console Port .....	52
AT-StackQS and AT-x9EM/XT4 Cards .....	53
AT-StackQS Card .....	53
AT-x9EM/XT4 Card .....	55
<b>Chapter 2: Virtual Chassis Stacking</b> .....	<b>57</b>
Overview .....	58
Stack Trunks .....	59
.....	59
Trunks of Ports S1 and S2 .....	60
Trunks of AT-StackQS Cards .....	64
Trunks of Copper 10/100/1000Mbps Ports .....	67
Trunks of SFP Ports on AT-x930-28GSTX Switches .....	69
General Stacking Guidelines .....	72
Master and Member Switches .....	73
Selection of the Master Switch .....	73
Switch ID Numbers .....	74
Feature Licenses .....	75
Specifying Ports in the Command Line Interface .....	76
Stack Worksheet .....	78
<b>Chapter 3: Beginning the Installation</b> .....	<b>83</b>
Reviewing Safety Precautions .....	84
Choosing a Site for the Switch .....	89
Unpacking the Switch .....	90
<b>Chapter 4: Installing the Power Supplies</b> .....	<b>93</b>
Installing the Power Supplies .....	94
Installing a Blank Power Supply Slot Cover .....	100
<b>Chapter 5: Installing AT-StackQS and AT-x9EM/XT4 Cards</b> .....	<b>103</b>
Guidelines .....	104
Installing the Card .....	105
<b>Chapter 6: Installing the Switch on a Table</b> .....	<b>113</b>
<b>Chapter 7: Installing the Switch in an Equipment Rack</b> .....	<b>115</b>
Required Items .....	116
Installing the Switch in an Equipment Rack .....	117
<b>Chapter 8: Installing the Switch on a Wall</b> .....	<b>121</b>
Switch Orientation on the Wall .....	122
Recommended Minimum Wall Area Dimensions .....	123
Plywood Base for a Wall with Wooden Studs .....	125
Installation Guidelines .....	127
Tools and Material .....	127
Installing the Plywood Base .....	129
Installing the Switch on the Plywood Base .....	130
Installing the Switch on a Concrete Wall .....	133
<b>Chapter 9: Wiring the DC Connector on the AT-PWR250-80 Power Supply</b> .....	<b>137</b>
<b>Chapter 10: Displaying the AlliedWare Plus Version Number</b> .....	<b>141</b>
Starting a Local Management Session .....	142
Displaying the Hardware Status and AlliedWare Plus Version Number .....	145
<b>Chapter 11: Building the Stack with SFP+ Ports S1 and S2</b> .....	<b>147</b>
Introduction .....	148
Designating SFP+ Ports S1 and S2 as the Stack Trunk .....	149
Powering On the Switches Sequentially .....	152
Powering On the Switches Simultaneously .....	154
Verifying the Stack and Assigning Priority Numbers .....	156

<b>Chapter 12: Building the Stack with AT-StackQS Cards</b> .....	159
Introduction .....	160
Powering On the Switches Sequentially .....	161
Powering On the Switches Simultaneously .....	163
<b>Chapter 13: Building the Stack with Copper or SFP Gigabit Ports</b> .....	165
Introduction .....	166
Command Summary .....	167
STACK ENABLE Command .....	167
STACKPORT Command .....	167
STACK PRIORITY Command .....	167
STACK RENUMBER Command .....	169
SWITCH PROVISION Command .....	169
Configuring the Master Switch .....	170
General Steps for the Master Switch .....	170
Configuring the Master Switch - Part I .....	171
Configuring the Master Switch - Part II .....	173
Verifying the Master Switch .....	174
What to Do Next .....	176
Configuring the Member Switches .....	177
General Steps for the Member Switches .....	177
Configuring Member Switches - Part I .....	178
Configuring Member Switches - Part II .....	179
Verifying Member Switches .....	181
What to Do Next for Member Switches .....	183
Powering on the Stack .....	184
<b>Chapter 14: Cabling the Networking Ports</b> .....	185
Cabling Copper Ports .....	186
Installing SFP and SFP+ Transceivers .....	188
Installing AT-SP10TW Direct Connect Cables .....	192
Cabling the AT-StackQS Card with AT-QSFPICU Cables .....	194
Cabling the AT-StackQS Card with Fiber Optic Transceivers .....	196
<b>Chapter 15: Troubleshooting</b> .....	197
<b>Appendix A: Technical Specifications</b> .....	203
Physical Specifications .....	204
Environmental Specifications .....	206
Power Specifications .....	207
Certifications .....	209
RJ-45 Copper Port Pinouts .....	210
RJ-45 Style Serial Console Port Pinouts .....	212
Stacking Transceivers .....	213





# Figures

---

Figure 1: Front Panels of the AT-x930-28GTX and AT-x930-28GPX Switches .....	19
Figure 2: Front Panels of the AT-x930-28GSTX, AT-x930-52GTX, and AT-x930-52GPX Switches.....	20
Figure 3: Back Panel of the AT-x930-28GTX, AT-x930-28GSTX, and AT-x930-52GTX Switches .....	21
Figure 4: Back Panel of the AT-x930-28GPX and AT-x930-52GPX Switches .....	21
Figure 5: Management Panel .....	26
Figure 6: AT-PWR150, AT-PWR250, and AT-PWR250-80 Power Supplies.....	27
Figure 7: AT-PWR800 and AT-PWR1200 Power Supplies .....	28
Figure 8: LEDs for the 10/100/1000Base-T Ports on the AT-x930-28GTX, AT-x930-28GSTX, and AT-x930-52GTX Switches .....	43
Figure 9: LEDs for the 10/100/1000Base-T Ports on the AT-x930-28GPX and AT-x930-52GPX Switches .....	45
Figure 10: SFP Port LEDs .....	46
Figure 11: SFP+ Port LEDs .....	47
Figure 12: Switch ID LED .....	49
Figure 13: Switch ID LED .....	50
Figure 14: Switch ID LEDs in the Low Power Mode.....	50
Figure 15: AT-StackQS Card.....	53
Figure 16: Copper Breakout Cable.....	53
Figure 17: AT-x9EM/XT4 Card .....	55
Figure 18: Trunk of Ports S1 and S2 for a Stack of Two Switches.....	61
Figure 19: Trunk of Ports S1 and S2 for a Stack of Four Switches .....	62
Figure 20: Trunk of Ports S1 and S2 for a Stack of Eight Switches .....	63
Figure 21: Trunk of AT-StackQS Cards for a Stack of Two Switches .....	65
Figure 22: Trunk of AT-StackQS Cards for a Stack of Four Switches.....	65
Figure 23: Trunk of AT-StackQS Cards for a Stack of Eight Switches .....	66
Figure 24: Trunk of Copper Gigabit Ports for a Stack of Two Switches .....	67
Figure 25: Trunk of Copper Gigabit Ports for a Stack of Three Switches.....	68
Figure 26: Trunk of Copper Gigabit Ports for a Stack of Four Switches.....	68
Figure 27: Trunk of SFP Gigabit Ports for a Stack of Two AT-x930-28GSTX Switches.....	70
Figure 28: Trunk of SFP Gigabit Ports for a Stack of Three AT-x930-28GSTX Switches .....	70
Figure 29: Trunk of SFP and Copper Gigabit Ports for a Mixed Stack of Four Switches .....	71
Figure 30: PORT Parameter in the Command Line Interface.....	76
Figure 31: Accessory Kit.....	90
Figure 32: Pre-installed Items.....	91
Figure 33: Removing the Blank Panel .....	95
Figure 34: Power Supply Accessory Items .....	96
Figure 35: Installing a Power Supply .....	97
Figure 36: Improper Installation of a Power Supply.....	98
Figure 37: Tightening the Captive Screws on the Power Supply.....	98
Figure 38: Installing the Power Cord Retaining Clip.....	99
Figure 39: Installing a Blank Panel on a Power Supply Slot.....	100
Figure 40: Tightening the Captive Screws on the Blank Panel for the Power Supply Slot.....	101
Figure 41: Loosening the Two Captive Screws on the AT-FAN09 Module .....	106
Figure 42: Removing the AT-FAN09 Module.....	106
Figure 43: Loosening the Captive Screw on the AT-FAN09ADP Module.....	107
Figure 44: Removing the AT-FAN09ADP Module .....	107
Figure 45: Removing the Card from the Anti-static Bag .....	108
Figure 46: Aligning the Card in the Slot.....	109
Figure 47: Seating the Card in the Switch .....	109
Figure 48: Tightening the Captive Screw on the Card.....	110

Figure 49: Aligning the AT-FAN09 Module in the Slot.....	110
Figure 50: Tightening the Two Captive Screws on the AT-FAN09 Module .....	111
Figure 51: Storing the AT-FAN09ADP Module in an Anti-static Bag .....	111
Figure 52: Installing the Bumper Feet.....	113
Figure 53: Attaching the Equipment Rack Brackets .....	118
Figure 54: Attaching the Equipment Rack Brackets (Continued).....	119
Figure 55: Installing the Switch in an Equipment Rack.....	120
Figure 56: Positions of the Switch on the Wall.....	122
Figure 57: Minimum Wall Area Dimensions with the Front Panel on the Left.....	123
Figure 58: Minimum Wall Area Dimensions with the Front Panel on the Right .....	124
Figure 59: Switch on the Wall with a Plywood Base .....	125
Figure 60: Steps to Installing the Switch with a Plywood Base.....	126
Figure 61: Installing the Brackets to the Switch for Wall Installation.....	130
Figure 62: Mounting Holes.....	131
Figure 63: Securing the Switch to the Plywood Base .....	132
Figure 64: Marking the Locations of the Bracket Holes on a Concrete Wall.....	134
Figure 65: Installing the Switch on a Concrete Wall .....	135
Figure 66: On/Off Switch on AT-PWR250-80 Power Supply .....	138
Figure 67: DC Terminal Block.....	138
Figure 68: Stripped Wire .....	139
Figure 69: Connecting the Ground Wire to the DC Terminal Block .....	139
Figure 70: Management Cable Included with Switch.....	142
Figure 71: VT-Kit3 Management Cable .....	142
Figure 72: Management Workstation, VT-Kit3 Management Cable, and Switch.....	143
Figure 73: Connecting the Management Cable to the Console Port .....	144
Figure 74: User Exec Mode Prompt.....	144
Figure 75: SHOW STACK Command.....	156
Figure 76: Moving to the Global Configuration Mode with the ENABLE and CONFIGURE TERMINAL Commands.....	157
Figure 77: Returning to the Privileged Exec Mode .....	158
Figure 78: Saving the Priority Values with the WRITE Command .....	158
Figure 79: SHOW STACK Command with New Switch Priority Numbers .....	158
Figure 80: SHOW STACK Command on the Master Switch .....	174
Figure 81: SHOW RUNNING-CONFIG INTERFACE Command on the Master Switch .....	175
Figure 82: SHOW STACK Command for a Member Switch .....	181
Figure 83: SHOW RUNNING-CONFIG INTERFACE Command for Member Switches.....	182
Figure 84: Removing the Dust Plug from an SFP+ Port.....	189
Figure 85: Installing SFP+ Transceivers.....	189
Figure 86: Removing the Dust Cover from an SFP or SFP+ Transceiver .....	190
Figure 87: Positioning the SFP or SFP+ Handle in the Upright Position .....	190
Figure 88: Connecting a Fiber Optic Cable to an SFP or SFP+ Transceiver .....	191
Figure 89: Removing the Dust Cover from the AT-SP10TW Cable.....	192
Figure 90: Installing AT-SP10TW Cables .....	193
Figure 91: Removing the Dust Cover from Port 1.....	194
Figure 92: Installing the AT-QSFPICU Cable in Port 1 .....	195
Figure 93: RJ-45 Socket Pin Layout (Front View).....	210

# Tables

---

Table 1: Models and Basic Features .....	18
Table 2: IEEE Powered Device Classes .....	34
Table 3: Power Supply Budgets of the Power Supplies .....	34
Table 4: Power Budgets of the AT-PWR800 Power Supply .....	35
Table 5: Power Budgets of the AT-PWR1200 Power Supply .....	35
Table 6: NET MGMT Port LED .....	41
Table 7: LEDs on the 10/100/1000Base-T Ports on the AT-x930-28GTX, AT-x930-28GSTX and AT-x930-52GTX Switches .....	44
Table 8: LEDs on the 10/100/1000Base-T Ports on the AT-x930-28GPX and AT-x930-52GPX Switches .....	45
Table 9: SFP Port LEDs on the AT-x930-28GSTX Switch .....	47
Table 10: SFP+ Port LEDs .....	48
Table 11: Stacking Port LEDs .....	49
Table 12: AT-StackQS Card LEDs .....	54
Table 13: AT-StackQS Card LEDs with 10Gbps Breakout Cables .....	54
Table 14: Copper Cables for the AT-x9EM/XT4 Card .....	55
Table 15: AT-x9EM/XT4 Card LEDs .....	56
Table 16: PORT Parameter Format .....	76
Table 17: Stack Worksheet .....	78
Table 18: Stacking Worksheet Columns .....	80
Table 19: Power Supply Accessory Items .....	96
Table 20: Hardware Options and Management Software Versions .....	146
Table 21: Designating SFP+ Ports S1 and S2 as the Stack Trunk in Switches Containing AT-StackQS Cards .....	150
Table 22: Configuring the Master Switch to Use Gigabit Ports as the Stack Trunk - Part I .....	171
Table 23: Configuring the Master Switch to Use Gigabit Ports as the Stack Trunk - Part II .....	173
Table 24: Configuring Member Switches - Part I .....	178
Table 25: Configuring Member Switches - Part II .....	179
Table 26: Product Dimensions .....	204
Table 27: Product Weights .....	204
Table 28: Ventilation Requirements .....	205
Table 29: Environmental Specifications .....	206
Table 30: Maximum Power Consumptions with the AT-PWR150, AT-PWR250, or AT-PWR250-80 Power Supply .....	207
Table 31: Maximum Power Consumptions with the AT-PWR800 Power Supply .....	207
Table 32: Maximum Power Consumptions with the AT-PWR1200 Power Supply .....	207
Table 33: Input Voltages of the Power Supplies .....	208
Table 34: Product Certifications .....	209
Table 35: Pin Signals for 10 and 100 Mbps .....	210
Table 36: Pin Signals for 1000 Mbps .....	210
Table 37: RJ-45 Style Serial Console Port Pin Signals .....	212
Table 38: AT-QSFPSR Transceiver Operating Specifications .....	213
Table 39: AT-QSFPLR4 Transceiver Operating Specifications .....	213



# Preface

---

This guide contains the installation instructions for the x930 Series of Layer 3, Gigabit Ethernet switches. This preface contains the following sections:

- “Document Conventions” on page 14
- “Contacting Allied Telesis” on page 15

---

**Note**

This guide explains how to build a stack of up to eight switches with the Virtual Chassis Stacking (VCStack™) feature. For instructions on how to install the switches as standalone units, refer to the *x930 Series Installation Guide for Standalone Switches*.

---

## Document Conventions

---

This document uses the following conventions:

---

**Note**

Notes provide additional information.

---



---

**Caution**

Cautions inform you that performing or omitting a specific action may result in equipment damage or loss of data.

---



---

**Warning**

Warnings inform you that performing or omitting a specific action may result in bodily injury.

---

## Contacting Allied Telesis

---

For assistance with this product, you can contact Allied Telesis technical support on the Support & Services section of the Allied Telesis web site at **[www.alliedtelesis.com/support](http://www.alliedtelesis.com/support)**. You can find links for the following services on the page:

- ❑ 24/7 Online Support — Enter our interactive support center to search for answers to your product questions in our knowledge database, to check support tickets, to learn about RMAs, and to contact Allied Telesis technical experts.
- ❑ USA and EMEA phone support — Select the phone number that best fits your location and customer type.
- ❑ Hardware warranty information — Learn about Allied Telesis warranties and register your product online.
- ❑ Replacement Services — Submit a Return Merchandise Authorization (RMA) request via our interactive support center.
- ❑ Documentation — View the most recent installation and user guides, software release notes, white papers, and data sheets for your products.
- ❑ Software Downloads — Download the latest software releases for your managed products.

For sales or corporate information, go to **[www.alliedtelesis.com/purchase](http://www.alliedtelesis.com/purchase)** and select your region.





# Chapter 1

# Overview

---

This chapter contains the following sections:

- “Models” on page 18
- “Front and Back Panels” on page 19
- “Features” on page 22
- “Management Panel” on page 26
- “Power Supplies” on page 27
- “10/100/1000Base-T Copper Ports” on page 31
- “Power Over Ethernet” on page 33
- “SFP Ports” on page 38
- “SFP+ Ports” on page 39
- “S1 and S2 SFP+ Ports” on page 40
- “Ethernet Management Port (NET MGMT)” on page 41
- “eco-friendly Button” on page 42
- “LEDs” on page 43
- “USB Port” on page 51
- “Console Port” on page 52
- “AT-StackQS and AT-x9EM/XT4 Cards” on page 53

---

### **Note**

This guide explains how to build a stack of multiple switches with the Virtual Chassis Stacking (VCStack™) feature. For instructions on how to install the switches as standalone units, refer to the *x930 Series Installation Guide for Standalone Switches*.

---

## Models

---

Table 1 lists the models and basic features of the x930 Series of stackable Gigabit Layer 3 switches.

Table 1. Models and Basic Features

Model	10/100/ 1000Mbps Copper Ports	100/ 1000Mbps SFP Ports	1000Mbps/ 10GbE SFP+ Ports	PoE+	VCStack
AT-x930-28GTX	24	0	4	No	Yes
AT-x930-28GPX	24	0	4	Yes	Yes
AT-x930-28GSTX	24	24	4	No	Yes
AT-x930-52GTX	48	0	4	No	Yes
AT-x930-52GPX	48	0	4	Yes	Yes

Additional information is listed here:

- ❑ The switches do not come with power supplies. Power supplies must be ordered separately. For more information, refer to “Power Supplies” on page 27.
- ❑ The power budgets of the AT-x930-28GPX and AT-x930-52GPX Switches for PoE+ powered devices depend on the number and types of power supplies installed in the units. For more information, refer to “Power Budget” on page 34.
- ❑ You may use the VCStack feature to stack the switches with the S1 and S2 ports, the optional AT-StackQS card, or the 10/100/1000Mbps front panel ports. For more information, refer to Chapter 2, “Virtual Chassis Stacking” on page 57.
- ❑ The copper ports and SFP ports on AT-x930-28GSTX Switch are paired together. Only one port in a pair can be operational at a time. For more information, refer to “SFP Ports” on page 38.

## Front and Back Panels

The front panels of the x930 Series switches are shown in Figure 1 and Figure 2 on page 20.

**AT-x930-28GTX**

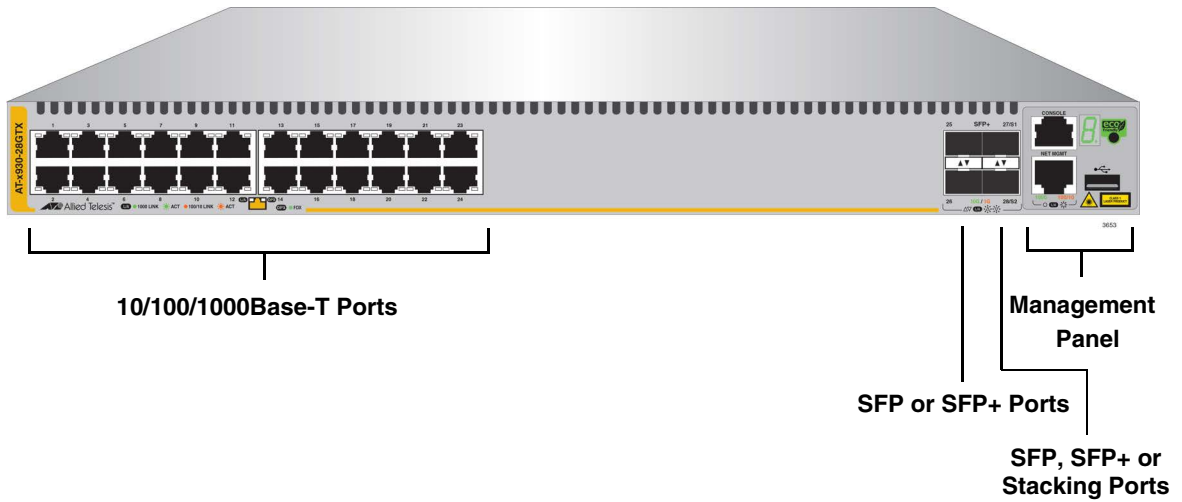

**AT-x930-28GPX**

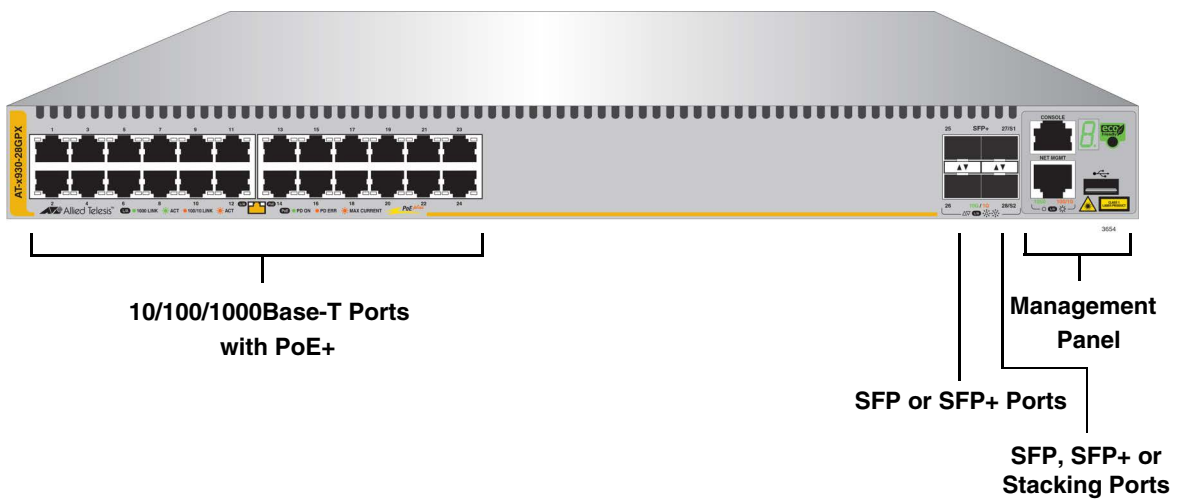
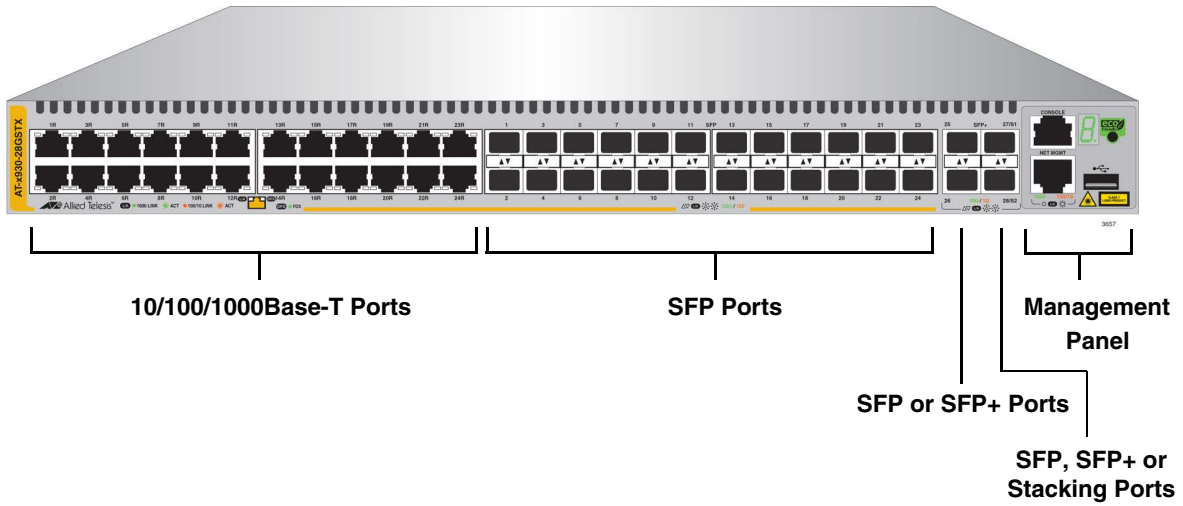
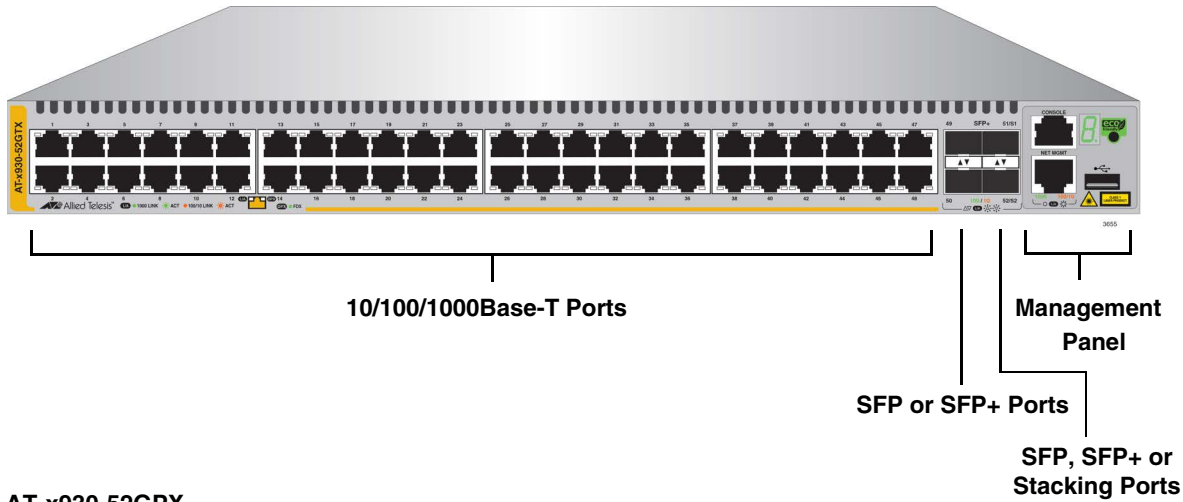

Figure 1. Front Panels of the AT-x930-28GTX and AT-x930-28GPX Switches

**AT-x930-28GSTX**



**AT-x930-52GTX**



**AT-x930-52GPX**

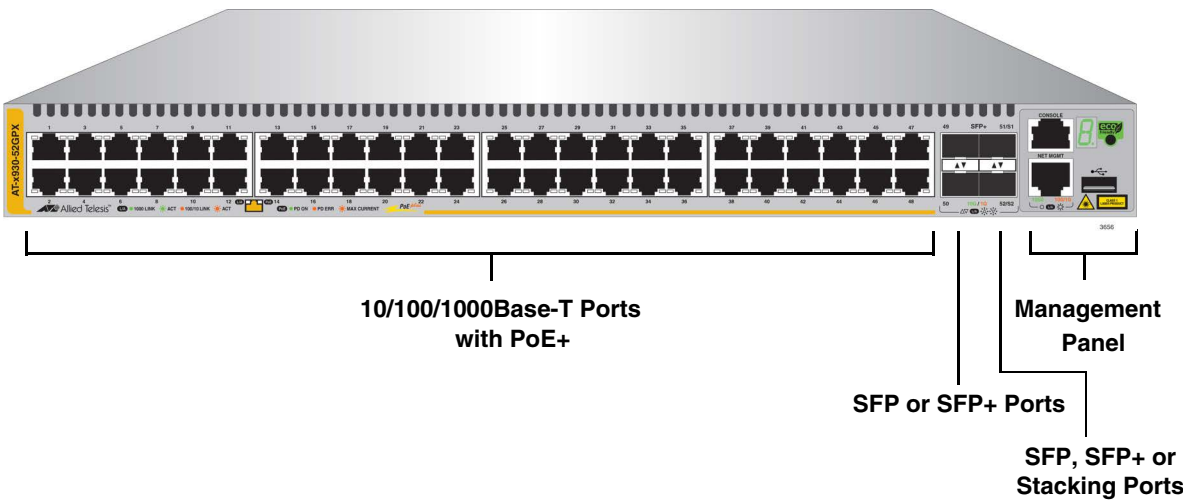

Figure 2. Front Panels of the AT-x930-28GSTX, AT-x930-52GTX, and AT-x930-52GPX Switches

Figure 3 shows the back panel of the non-PoE AT-x930-28GTX, AT-x930-28GSTX, and AT-x930-52GTX Switches. The back panel has these pre-installed components:

- ❑ AT-FAN09ADP module
- ❑ AT-FAN09 fan module
- ❑ AT-PNL250 blank panel

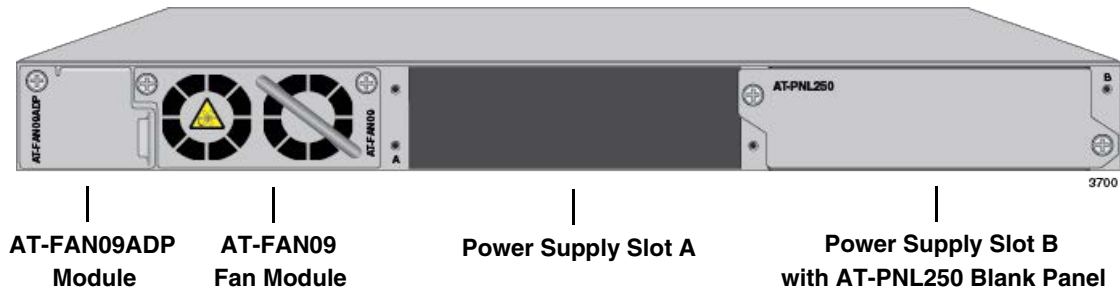

Figure 3. Back Panel of the AT-x930-28GTX, AT-x930-28GSTX, and AT-x930-52GTX Switches

Figure 4 shows the back panel of the PoE AT-x930-28GPX and AT-x930-52GPX Switches. The back panel has these pre-installed components:

- ❑ AT-FAN09ADP module
- ❑ AT-FAN09 fan module
- ❑ AT-PNL800/1200 blank panel

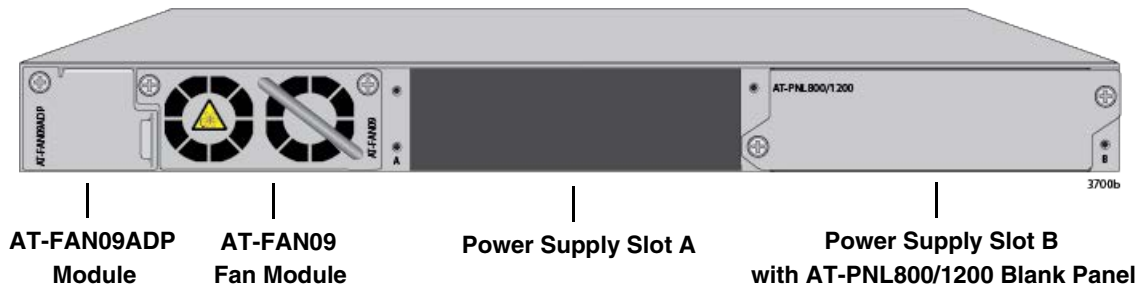

Figure 4. Back Panel of the AT-x930-28GPX and AT-x930-52GPX Switches

## Features

---

Here are the switches and their features:

### **x930 Models**

Here are the switches in the x930 Series:

- ❑ AT-x930-28GTX
- ❑ AT-x930-28GPX
- ❑ AT-x930-28GSTX
- ❑ AT-x930-52GTX
- ❑ AT-x930-52GPX

### **10/100/1000 Mbps Copper Ports**

Here are the basic features of the 10/100/1000 Mbps copper ports:

- ❑ 24 or 48 ports per switch
- ❑ 10Base-T, 100Base-TX, and 1000Base-T compliant
- ❑ IEEE 802.3u Auto-Negotiation compliant
- ❑ Auto-MDI/MDIX
- ❑ 100 meters (328 feet) maximum operating distance
- ❑ IEEE 802.3x flow control in 10/100Base-TX full-duplex mode
- ❑ IEEE 802.3x backpressure in 10/100Base-TX half-duplex mode
- ❑ IEEE 802.3ab 1000Base-T
- ❑ Layer 2 and Layer 3 jumbo frames up to 13KB and 9KB, respectively
- ❑ RJ-45 connectors

### **Power Over Ethernet**

Here are the basic features of Power over Ethernet (PoE) on the copper ports on the AT-x930-28GPX and AT-x930-52GPX Switches:

- ❑ Supported on ports 1 to 24 on the AT-x930-28GPX Switch and ports 1 to 48 on the AT-x930-52GPX Switch
- ❑ Supports PoE (15.4 watts maximum) and PoE+ (30 watts maximum) at the switch ports
- ❑ Supports powered device classes 0 to 4
- ❑ Port prioritization
- ❑ Mode A wiring

**SFP Ports** The AT-x930-28GSTX Switch supports the following types of transceivers in its twenty four SFP ports:

- ❑ 100Base-FX, 1000Base-T, and 1000Base-SX/LX SFP transceivers
- ❑ Single-port BiDi 100Base-FX and 1000Base-LX SFP transceivers
- ❑ 1000Base-ZX SFP transceivers

---

**Note**

The SFP ports and copper ports on the AT-x930-28GSTX Switch are paired together. Only one port in a pair can be active at a time. For more information, refer to “SFP Ports” on page 38.

---



---

**Note**

SFP transceivers must be purchased separately. For a list of supported transceivers, refer to the product’s data sheet on the Allied Telesis website.

---

**SFP+ Ports** The four SFP+ ports support the following types of transceivers:

- ❑ SFP 1000Base-SX/LX SFP transceivers
- ❑ SFP single-port BiDi 1000Base-LX transceivers
- ❑ SFP 1000Base-ZX transceivers
- ❑ SFP+ 10Gbps, 10GBase-SR/LR fiber optic transceivers
- ❑ SFP+ 10Gbps AT-SP10TW direct connect twinax cables with SFP+ transceiver-style connectors

---

**Note**

The SFP+ ports do not support 100Mbps 100Base-FX transceivers.

---



---

**Note**

The port support full-duplex mode only. They do not support half-duplex mode.

---



---

**Note**

SFP and SFP+ transceivers must be purchased separately. For a list of supported transceivers, refer to the product’s data sheet on the Allied Telesis web site.

---

---

**Note**

SFP+ ports 27/S1 and 28/S2 on the 28-port switches and ports 51/S1 and 52/S2 on the 52-port switches are initially configured as stacking ports for the VCStack feature. You can use them as regular Ethernet ports by disabling VCStack or by using other switch ports for the stack trunk. For more information, refer to Chapter 2, “Virtual Chassis Stacking” on page 57.

---

**SFP+ S1 and S2 Stacking Ports**

SFP+ ports 27/S1 and 28/S2 on the 28-port switches and ports 51/S1 and 52/S2 on the 52-port switches can be used either as regular networking ports or as the trunk in the VCStack feature to build a stack of up to eight switches. For more information, refer to the Chapter 2, “Virtual Chassis Stacking” on page 57.

**LEDs**

Here are the port LEDs:

- Link/activity and duplex mode LEDs for the copper ports on non-PoE switches
- Link/activity and PoE status LEDs for the copper ports on PoE switches
- Link/activity LEDs for SFP and SFP+ ports
- Stack ID number LED
- eco-friendly button turns off the LEDs to conserve electricity

**Installation Options**

Here are the installation options for the switches:

- 19-inch equipment rack
- Desk or tabletop
- Wall

**MAC Address Table**

Here are the basic features of the MAC address tables of the switches:

- Storage capacity of 64K dynamic and static entries
- Automatic learning and aging

**Management Software and Interfaces**

Here are the management software and interfaces:

- AlliedWare Plus Management Software
- Command line interface
- Web browser interface



## **Management Methods**

Here are the methods for managing the switches:

- Local management through the Console port
- Remote Telnet and Secure Shell management
- Remote HTTP and HTTPS web browser management
- SNMPv1, v2c, and v3
- Allied Telesis Autonomous Management Framework (AMF)
- AT-Vista Manager mini
- Autonomous Wireless Control (AWC)

## **Power Supplies**

Here are the power supplies:

- AT-PWR150
- AT-PWR250
- AT-PWR250-80
- AT-PWR800
- AT-PWR1200

# Management Panel

Figure 5 identifies the components in the management panel on the x930 Series switches.

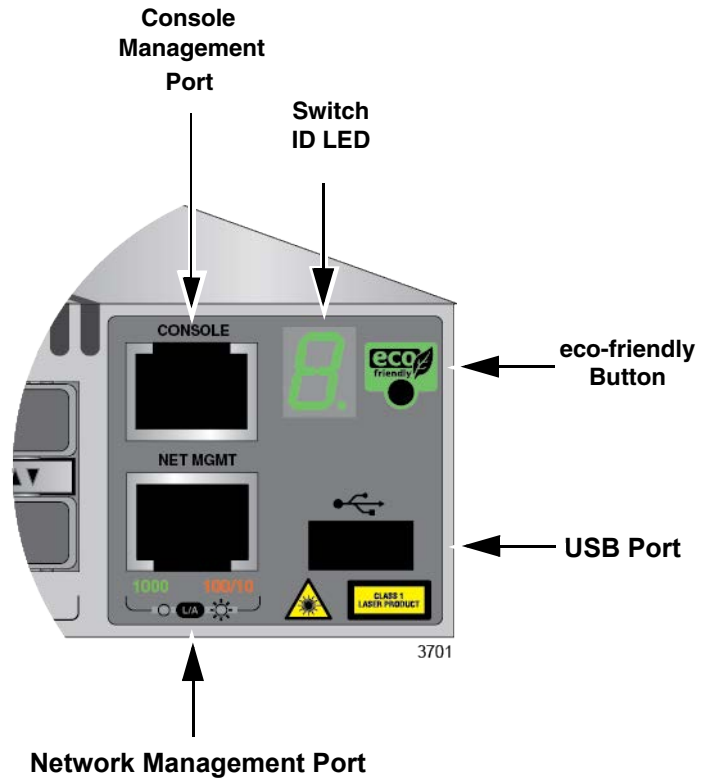

Figure 5. Management Panel

## Power Supplies

Here are the five power supplies for the x930 Switches:

- ❑ AT-PWR150
- ❑ AT-PWR250
- ❑ AT-PWR250-80
- ❑ AT-PWR800
- ❑ AT-PWR1200

### System-Only Power Supplies

The AT-PWR150, AT-PWR250, and AT-PWR250-80 Power Supplies are shown in Figure 6. They provide system power only. They are primarily intended for the non-PoE AT-x930-28GTX, AT-x930-28GSTX, and AT-x930-52GTX Switches. The AT-x930-28GTX and AT-x930-28GSTX Power Supplies have AC connectors. The AT-PWR250-80 Power Supply has a DC connector for DC wiring environments.

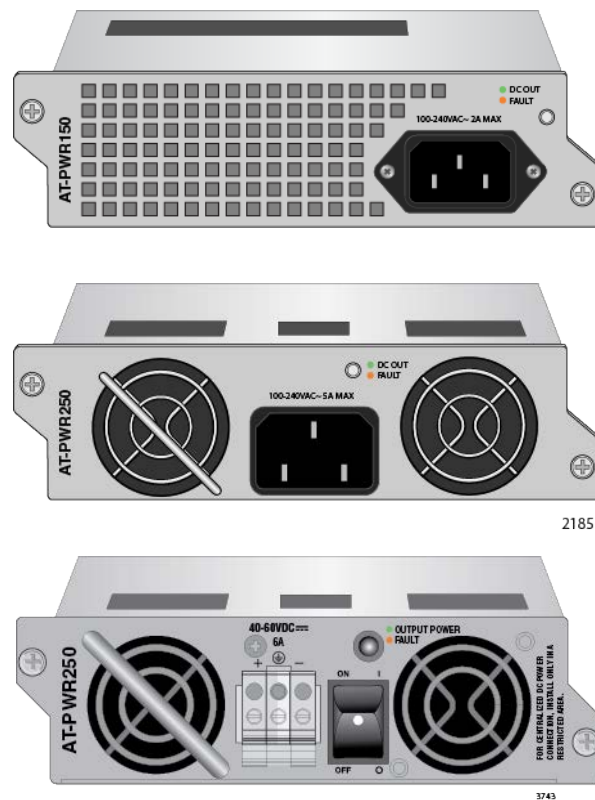

Figure 6. AT-PWR150, AT-PWR250, and AT-PWR250-80 Power Supplies

Here are the operating characteristics:

- ❑ The power supplies provide system power only. They do not support PoE+ devices.
- ❑ A single power supply can power an entire switch.

- ❑ Installing two power supplies adds power redundancy.
- ❑ The power supplies are not recommended for the PoE+ AT-x930-28GPX and AT-x930-52GPX Switches because they do not supply power for PoE+ devices. You may install them into PoE+ switches, but the switches will not support powered devices.

## System and PoE+ Power Supplies

The AT-PWR800 and AT-PWR1200 Power Supplies provide both system power and power for PoE+ devices on AT-x930-28GPX and AT-x930-52GPX Switches. Refer to Figure 7.



Figure 7. AT-PWR800 and AT-PWR1200 Power Supplies

A PoE+ switch with one AT-PWR800 Power Supply has the following power characteristics:

- ❑ Full system power
- ❑ 380 watts of PoE+ power

A PoE+ switch with two AT-PWR800 Power Supplies has these power characteristics:

- ❑ Full system power and redundant system power
- ❑ Either 740 watts of PoE+ power or 380 watts of active PoE+ power and 380 watts of redundant PoE+ power.

A PoE+ switch with one AT-PWR1200 Power Supply has the following power characteristics:

- ❑ Full system power
- ❑ 740 watts of power for PoE devices

A PoE+switch with two AT-PWR1200 Power Supplies has these power characteristics:

- ❑ Full system power and redundant system power
- ❑ Either 1440 watts of PoE power or 740 watts of active PoE power and 740 watts of redundant PoE power.

## Guidelines

Please review the following guidelines concerning power supplies:

- ❑ The x930 Series Switches do not come with power supplies. Power supplies must be ordered separately.
- ❑ If you install two power supplies in the switch, they must both be the same model. For example, you may install two AT-PWR800 Power Supplies or two AT-PWR1200 Power Supplies in a switch. You may not install two different power supply models in the switch.
- ❑ The non-PoE AT-x930-28GTX, AT-x930-28GSTX, and AT-x930-52GTX Switches require only one power supply for full operations. Installing a second power supply adds power redundancy, which protects against interruptions to network operations in the event a power supply loses power or fails. Power redundancy is available only when both AC or DC connectors on the switch are connected to power sources.
- ❑ The PoE AT-x930-28GPX and AT-x930-52GPX Switches also require only one power supply for network operations, excluding PoE+. The switches can continue to operate even if one power supply fails or loses power. Adding a second power supply in the PoE+ switches either increases the amount of power for powered devices or adds PoE+ redundancy. For further information, refer to “Power Budget” on page 34.
- ❑ You may install AT-PWR800 and AT-PWR1200 Power Supplies in non-PoE x930 Switches. The power supplies will provide system power only.
- ❑ The DC wires for the AT-PWR250-80 DC Power Supply should be routed from a DC load center containing appropriate overcurrent branch protection for each DC feed, as required by the cognizant local electrical authority.

Refer to “Technical Specifications” on page 203 for the input voltage ranges.



### Warning

Power cord is used as a disconnection device. To de-energize equipment, disconnect the power cord. ⚡ E3

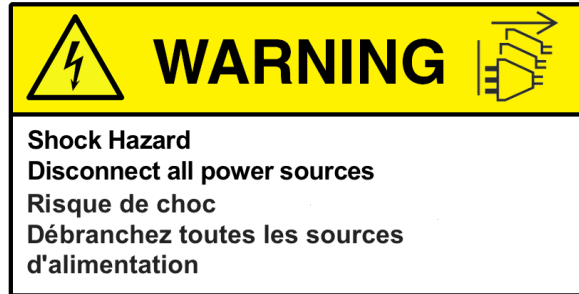

---

**Warning**

This unit might have more than one power cord. To reduce the risk of electric shock, disconnect all power cords before servicing the unit.  E30

---

---

**Note**

The AT-PWR150, AT-PWR250, AT-PWR800, and AT-PWR1200 Power Supplies are powered on or off by connecting or disconnecting the power cords. The AT-PWR250-80 Power Supply is powered on or off with its On/Off power switch or by deactivating the DC circuit.

---

## 10/100/1000Base-T Copper Ports

---

The copper ports on the switches are described in this section.

**Speed** The ports can operate at 10, 100, or 1000 Mbps. The speeds may be set manually using the management software or automatically with Auto-Negotiation (IEEE 802.3u), the default setting.

---

**Note**

The ports must be set to Auto-Negotiation to function at 1000 Mbps and are not compatible with devices that are not IEEE 802.3u compliant.

---

**Duplex Mode** The copper ports can operate in either half- or full-duplex mode. The duplex mode of a port, like port speed, may be set manually using the management software or automatically with Auto-Negotiation (IEEE 802.3u), the default setting.

The speed and duplex mode settings of a port may be set independently of each other. For example, a port may be configured such that its speed is set manually while its duplex mode is established through Auto-Negotiation.

---

**Note**

A switch port should not use Auto-Negotiation to set its duplex mode if it is connected to a network device that does not support Auto-Negotiation for 10 or 100 Mbps operation and has a fixed duplex mode of full-duplex. Otherwise, a duplex-mode mismatch may occur in which a switch port and a network device operate at different duplex modes. The duplex modes of switch ports that are connected to network devices that do not support Auto-Negotiation should be set manually through the management software.

---

**Wiring Configuration** The wiring configuration of a port operating at 10 or 100 Mbps can be MDI or MDI-X. The wiring configurations of a switch port and a network device connected with straight-through copper cabling have to be opposite, such that one device is using MDI and the other MDI-X. For instance, a switch port has to be set to MDI-X if it is connected to a network device set to MDI.

You may set the wiring configurations of the ports manually or let the switch configure them automatically with auto-MDI/MDI-X (IEEE 802.3ab-compliant). This feature enables the switch to automatically negotiate with network devices to establish their proper settings.

The MDI and MDI-X settings do not apply when ports are operating at 1000 Mbps.

**Maximum Distance**

The ports have a maximum operating distance of 100 meters (328 feet).

**Cable Requirements**

Here are the cable requirements:

- ❑ 10 or 100Mbps - Standard TIA/EIA 568-B-compliant Category 3 unshielded cabling
- ❑ 1000Mbps - Standard TIA/EIA 568-A-compliant Category 5 or TIA/EIA 568-B-compliant Enhanced Category 5 (Cat 5e) unshielded cabling.

---

**Note**

For the cable requirements for the ports on the AT-x930-28GPX and AT-x930-52GPX Switches for PoE devices, refer to “Cable Requirements” on page 32.

---

**Port Pinouts**

Refer to Table 35 on page 210 and Table 36 on page 210 for the port pinouts of the 10/100/1000Base-T copper ports.



## Power Over Ethernet

---

The AT-x930-28GPX and AT-x930-52GPX Switches feature Power over Ethernet (PoE) on the 10/100/1000Base-T ports. PoE is used to supply power to network devices over the same copper cables that carry the network traffic.

The main advantage of PoE is that it can make it easier to install a network. The selection of a location for a network device is often limited by whether there is a power source nearby. This often limits equipment placement or requires the added time and cost of having additional electrical sources installed. But with PoE, you can install PoE-compatible devices wherever they are needed without having to worry about whether there are power sources nearby.

A device that provides PoE to other network devices is referred to as *power sourcing equipment (PSE)*. The AT-x930-28GPX and AT-x930-52GPX Switches act as PSE units by adding DC power to the network cable, thus functioning as a central power source for other network devices.

Devices that receive their power from a PSE are called *powered devices (PD)*. Examples include wireless access points, IP telephones, webcams, and even other Ethernet switches.

The switch automatically determines whether or not a device connected to a port is a powered device. Ports that are connected to network nodes that are not powered devices (that is, devices that receive their power from another power source) function as regular Ethernet ports, without PoE. The PoE feature remains activated on the ports but no power is delivered to the devices.

### PoE Standards

The AT-x930-28GPX and AT-x930-52GPX Switches support these PoE standards:

- ❑ PoE (IEEE 802.3af): This standard provides up to 15.4 watts at the switch port to support powered devices that require up to 12.95 watts.
- ❑ PoE+ (IEEE 802.3at): This standard provides up to 30.0 watts at the switch port to support powered devices that require up to 25.5 watts.

### Powered Device Classes

Powered devices are grouped into the five classes listed in Table 2 on page 34. The classes are based on the amount of power the devices require. The switches support all five classes.

Table 2. IEEE Powered Device Classes

Class	Maximum Power Output from a Switch Port	PD Power Range
0	15.4W	0.44W to 12.95W
1	4.0W	0.44W to 3.84W
2	7.0W	3.84W to 6.49W
3	15.4W	6.49W to 12.95W
4	30.0W	12.95W to 25.5W

## Power Budget

The power budget defines the maximum amount of power the switch can supply to the powered devices on its ports. The higher the budget, the more PoE devices the switch can support at one time.

The power budgets for the AT-x930-28GPX and AT-x930-52GPX Switches depend on several factors. The first is the power supply model. The power budgets of the five power supplies are listed in Table 3.

Table 3. Power Supply Budgets of the Power Supplies

Power Supply	Power Budget for PoE Devices
AT-PWR150	0 watts
AT-PWR250	0 watts
AT-PWR250-80	0 watts
AT-PWR800	380 watts
AT-PWR1200	740 watts

### Note

The AT-PWR150, AT-PWR250 and AT-PWR250-80 Power Supplies are intended for the non-PoE AT-x930-28GTX, AT-x930-28GSTX, and AT-x930-52GTX Switches. They are not intended for the AT-x930-28GPX and AT-x930-52GPX Switches because they do not provide power for PoE + devices. You may install them in the PoE+ switches, but the switches will not support PoE devices.

Another factor that determines the power budget of the switch is the number of PoE power supplies in the device. The power budget of a PoE switch that has only one PoE power supply is equal to the budget of the power supply. For example, a switch that has one AT-PWR1200 Power Supply has a power budget of 740W for powered devices.

A PoE switch with two AT-PWR800 or AT-PWR1200 Power Supplies has either redundant PoE power or nearly double the power budget. This is controlled by the power boost feature, which has a status of either enabled or disabled. When the power boost feature is enabled, a PoE switch with two power supplies actively uses the PoE power from both supplies to increase its available power budget. When the feature is disabled, the switch uses the PoE power of only one of its power supplies and keeps the other in reserve in case the primary power supply should fail or lose power. The default setting of power boost is disabled.

As an example, assume that a PoE switch has one AT-PWR1200 Power Supply, which has a power budget of 740W for powered devices. Thus, the switch would have a total power budget of 740W. Now assume the switch has two AT-PWR1200 Power Supplies. When the power boost mode is enabled, the switch uses the PoE power from both supplies, for a total power budget of 1440W. When the power boost mode is disabled, the switch has an active PoE power of 740W and a redundant budget of the same amount. The switch activates the redundant power budget only if the power supply providing the active power budget fails or loses power.

Table 4 lists the power budgets for the switch with one or two AT-PWR800 Power Supplies and the power boost mode.

Table 4. Power Budgets of the AT-PWR800 Power Supply

<b>Number of Power Supplies in the Switch</b>	<b>State of Power Boost</b>	<b>Power Budget of the Switch</b>	<b>Redundant Power</b>
One	NA	380 watts	0 watts
Two	Enabled	740 watts	0 watts
Two	Disabled	380 watts	380 watts

Table 5 lists the power budgets for the switch with one or two AT-PWR1200 Power Supplies and the power boost mode.

Table 5. Power Budgets of the AT-PWR1200 Power Supply

<b>Number of Power Supplies in the Switch</b>	<b>State of Power Boost</b>	<b>Power Budget of the Switch</b>	<b>Redundant Power</b>
One	NA	740 watts	0 watts
Two	Enabled	1440 watts	0 watts
Two	Disabled	740 watts	740 watts

The maximum number of PoE devices the switch can support at one time is determined by its power budget and the power requirements of the devices. The switch can supply power to all of the devices as long as their total power requirements is less than its power budget. If the switch determines that the power requirements of the devices exceed its power budget, it denies power to one or more ports using a mechanism referred to as port prioritization.

To determine whether the power requirements of the PoE devices you plan to connect to the switch exceed its power budget, refer to their documentation for their power requirements and add the requirements together. The switch should be able to power all of the devices simultaneously as long as the total is below its power budget. If the total exceeds the available power budget, you should consider reducing the number of PoE devices so that all of the devices receive power. Otherwise, the switch powers a subset of the devices, based on port prioritization.

The switch can handle different power requirements on different ports. This enables you to connect different classes of PoE equipment to the ports on the switch.

## **Port Prioritization**

If the power requirements of the powered devices exceed the switch's power budget, the switch denies power to some ports based on a system called port prioritization. You may use this mechanism to ensure that powered devices critical to the operations of your network are given preferential treatment by the switch in the distribution of power should the demands of the devices exceed the available capacity.

There are three priority levels:

- Critical
- High
- Low

Ports set to the Critical level, the highest priority level, are guaranteed power before any of the ports assigned to the other two priority levels. Ports assigned to the other priority levels receive power only if all the Critical ports are receiving power. Ports that are connected to your most critical powered devices should be assigned to this level. If there is not enough power to support all the ports set to the Critical priority level, power is provided to the ports based on port number, in ascending order.

The High level is the second highest level. Ports set to this level receive power only if all the ports set to the Critical level are already receiving power. If there is not enough power to support all of the ports set to the High priority level, power is provided to the ports based on port number, in ascending order.

The lowest priority level is Low. This is the default setting. Ports set to this

level only receive power if all of the ports assigned to the other two levels are already receiving power. As with the other levels, if there is not enough power to support all of the ports set to the Low priority level, power is provided to the ports based on port number, in ascending order.

Power allocation is dynamic. Ports supplying power to powered devices may cease power transmission if the switch's power budget is at maximum usage and new powered devices, connected to ports with higher priorities, become active.

## **Wiring Implementation**

The IEEE 802.3af standard defines two methods for the delivery of DC power over copper cable from a switch to the powered devices. These methods, known as modes A and B, identify the wires within the cable that carry the DC power from the switch to a powered device.

Copper cabling typically consists of eight wires. With 10Base-T and 100Base-TX devices, the wires connected to pins 1, 2, 3, and 6 on the RJ-45 connectors carry the network traffic while the wires connected to pins 4, 5, 7, and 8 are unused. With 1000Base-T devices, all eight wires are used to carry network data.

It takes four wires to deliver DC power to a PD. With Mode A, the power is delivered on pins 1, 2, 3, and 6. These are the same pins in 10Base-T and 100Base-TX devices that carry the network data. With mode B, the power is provided over the spare wires.

The ports on the AT-x930-28GPX and AT-x930-52GPX Switches deliver the power using pins 1, 2, 3, and 6, which corresponds to mode A in the IEEE 802.3af standard. Powered devices that comply with the IEEE 802.3af standard are required to support both power delivery methods. Legacy devices that do not comply with the standard will work with the switch if they are powered on pins 1, 2, 3, and 6.

## SFP Ports

---

The twenty four ports on the AT-x930-28GSTX Switch support the following types of SFP transceivers:

- ❑ 100Base-FX, 1000Base-T, and 1000Base-SX/LX SFP transceivers
- ❑ Single-port BiDi 100Base-FX and 1000Base-LX SFP transceivers
- ❑ 1000Base-ZX SFP transceivers

The SFP ports are paired with the twenty four 10/100/1000Base-T copper ports. SFP port 1 is paired with copper port 1R, port 2 with copper port 2R, and so on. Only one port in a pair can be active at a time. For example, if you install a transceiver in SFP port 3 and connect it to an active network device, the switch deactivates copper port 3R.

Please review the following guidelines for using the SFP ports on the AT-x930-28GSTX Switch:

- ❑ Each SFP port is paired with a copper port.
- ❑ You may not change the port pairings.
- ❑ Only one port in a pair can be active at a time.
- ❑ The copper port is the default active port of a pair.
- ❑ An SFP port automatically becomes active when you install and connect an SFP transceiver to an active network device.
- ❑ The switch automatically reactivates the copper port of a pair when the transceiver in the corresponding SFP port loses its link to a remote network device. For example, the switch reactivates copper port 4R if you disconnect the fiber optic cable from a transceiver in SFP port 4.
- ❑ The letter “R” in the numbering of the copper ports on the front of the switch refers to the “redundant” function of the ports. The copper ports are only available when their corresponding SFP ports are empty or the SFP transceivers have not established links with network devices.

## SFP+ Ports

---

The switches have four SFP+ ports that support the following types of SFP 1000Mbps and SFP+ 10Gbps transceivers:

- ❑ 1000Base-SX/LX SFP transceivers
- ❑ Single-port BiDi 1000Base-LX SFP transceivers
- ❑ 1000Base-ZX SFP transceivers
- ❑ 10Gbps, 10GBase-SR/LR fiber optic transceivers
- ❑ 10Gbps AT-SP10TW direct connect twinax cables with SFP+ transceiver-style connectors
- ❑ 10Gbps AT-SP10TW1 and AT-SP10TW3 1- and 3-meter SFP+ direct attach cables

You may use the ports and transceivers to connect switches to other network devices over large distances, build high-speed backbone networks between network devices, or connect high-speed devices, such as servers, to your network.

The switches support a variety of short and long distance SFP and SFP+ modules. For a list of supported SFP modules, refer to the product's data sheet on the Allied Telesis website.

---

**Note**

The SFP+ ports do not support 100Mbps 100Base-FX transceivers.

---

---

**Note**

The ports support full-duplex mode only. They do not support half-duplex mode.

---

---

**Note**

SFP and SFP+ transceivers must be purchased separately.

---

---

**Note**

SFP+ ports 27/S1 and 28/S2 on the AT-x930-28GTX, AT-x930-28GSTX, and AT-x930-28GPX Switches and ports 51/S1 and 52/S2 on the AT-x930-52GTX and AT-x930-52GPX Switches are initially configured as stacking ports for the VCStack feature. You can use them as regular Ethernet ports by disabling VCStack or by using other switch ports for the stack trunk. Refer to Chapter 2, "Virtual Chassis Stacking" on page 57 for more information.

---

## S1 and S2 SFP+ Ports

---

SFP+ ports 27/S1 and 28/S2 on the front panels of the 28-port switches and 51/S1 and 52/S2 on the 52-port switches can be used either as regular Ethernet networking ports or as the trunk in a stack of up to eight switches with the VCStack feature. The switches of a VCStack act as a single virtual unit, synchronizing their actions so that switching operations, like spanning tree protocols, virtual LANs, and static port trunks, span across all of the units and ports. For more information, refer to Chapter 2, “Virtual Chassis Stacking” on page 57.

---

**Note**

For a list of supported transceivers, refer to the product’s data sheet on the Allied Telesis web site.

---

---

**Note**

The S1 and S2 ports are the default stack trunk ports if the switch does not contain the AT-StackQS Card. To use the ports as regular Ethernet networking ports, you must disable VCStack or use other switch ports for the stack trunk. The ports on the AT-StackQS Card are the default stack trunk ports if the card is installed.

---



## Ethernet Management Port (NET MGMT)

---

The NET MGMT port in the management panel of the switch is a separate routed eth0 interface. The interface is not part of the switching matrix of the Ethernet line cards, but the CPU on the controller card can route traffic in or out of the port.

Here are the guidelines to using the port:

- ❑ The port should only be used for initial configuration and maintenance access to the chassis.
- ❑ The NET MGMT port has a standard RJ-45 8-pin connector and operates at 10, 100, or 1000 Mbps in either half- or full-duplex mode.
- ❑ The cable requirements for the port are the same as the ports on the AT-x930-28GTX Switch, listed in “Cable Requirements” on page 32. For the port pinouts, refer to “RJ-45 Copper Port Pinouts” on page 210.
- ❑ The default setting for the port is Auto-Negotiation, which sets the speed and duplex mode automatically. You may disable Auto-Negotiation and configure the port manually.
- ❑ The wiring configuration of the NET MGMT port is set automatically with automatic MDIX detection. You may disable automatic MDIX detection and set the wiring configuration manually.
- ❑ The port is referred to as eth0 in the management software.

For instructions on how to configure the NET MGMT port, refer to the Software Reference for x930 Series Switches.

### NET MGMT LEDs

The Network Management (NET MGMT) port on the switch has two Status LEDs, described in Table 6.

Table 6. NET MGMT Port LED

LED	State	Description
Left LED	Solid Green	The port has a valid 1000 Mbps link.
	Flashing Green	The port is transmitting or receiving data at 1000 Mbps.
Right LED	Solid Amber	The port has a valid 10 or 100 Mbps link.
	Flashing Amber	The port is transmitting or receiving data at 10 or 100 Mbps.

## eco-friendly Button

---

The eco-friendly button on the front panel of the switch is used to toggle the port LEDs on or off. You might turn off the LEDs to conserve electricity when you are not monitoring the device. You can also toggle the LEDs with the ECOFRIENDLY LED and NO ECOFRIENDLY LED commands in the Global Configuration mode of the command line interface. The switch is said to be operating in a low power mode when the LEDs are turned off.

Operating the switch in the low power mode with the LEDs turned off does not interfere with the network operations of the device.

The management software on the switch has a command that blinks the LEDs so that you can quickly and easily identify a specific unit among the devices in an equipment rack. It is the FINDME command. The command works on the switch even if you turned off the LEDs with the eco-friendly button or NO ECOFRIENDLY LED command.

The Switch ID LED is always on, but it displays different information depending on whether the LEDs are on or off. When the LEDs are on, the ID LED displays the ID number of the switch. When the switch is operating in the low power mode with the LEDs off, the ID LED indicates whether the switch is a stand-alone unit or the master or member switch of a VCStack, as detailed in Figure 14 on page 50.

---

### **Note**

Before checking or troubleshooting the network connections to the ports on the switch, you should always check to be sure that the LEDs are on by either pressing the eco-friendly button or issuing the ECOFRIENDLY LED and NO ECOFRIENDLY LED commands in the Global Configuration mode of the command line interface.

---

## LEDs

Here are descriptions of the LEDs.

### LEDs for the Copper Ports

The copper ports on the AT-x930-28GTX, AT-x930-28GSTX, and AT-x930-52GTX Switches have two LEDs that display link, activity and duplex mode information. The LEDs are shown in Figure 8.

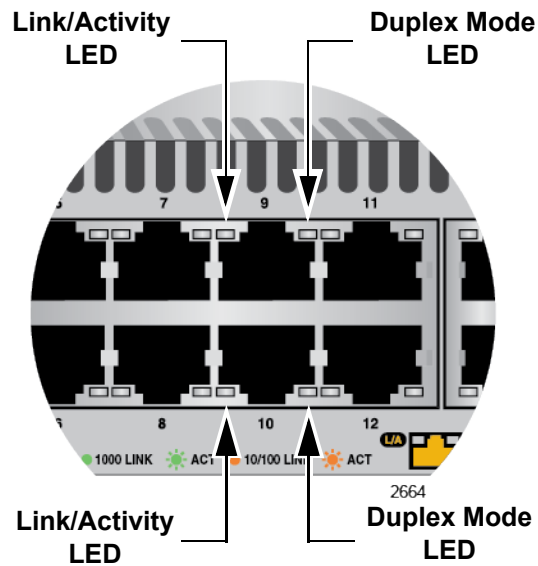

Figure 8. LEDs for the 10/100/1000Base-T Ports on the AT-x930-28GTX, AT-x930-28GSTX, and AT-x930-52GTX Switches

The LEDs are described in Table 7 on page 44.

Table 7. LEDs on the 10/100/1000Base-T Ports on the AT-x930-28GTX, AT-x930-28GSTX and AT-x930-52GTX Switches

LED	State	Description
Link/ Activity LED	Solid Green	A port has established a 1000 Mbps link to a network device.
	Flashing Green	A port is transmitting or receiving data at 1000 Mbps.
	Solid Amber	A port has established a 10 or 100 Mbps link to a network device.
	Flashing Amber	A port is transmitting or receiving data at 10 or 100 Mbps.
	Off	A port has not established a link with another network device or the LEDs are turned off. To turn on the LEDs, use the eco-friendly button.
Duplex Mode LED	Green	A port is operating in full duplex mode.
	Amber	A port is operating in half-duplex mode at 10 or 100 Mbps. (Half-duplex mode does not apply to 1000 Mbps operation.)
	Flashing Amber	Collisions are occurring on a port operating at 10 or 100 Mbps.

The copper ports on the AT-x930-28GPX and AT-x930-52GPX Switches have two LEDs that display link, activity and PoE information. The LEDs are shown in Figure 9 on page 45.

---

**Note**

You can view the duplex mode information for the ports on the AT-x930-28GPX and AT-x930-52GPX Switches with the management software.

---

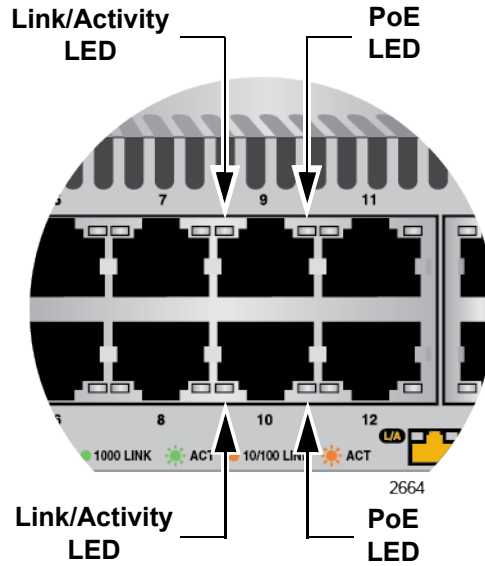

Figure 9. LEDs for the 10/100/1000Base-T Ports on the AT-x930-28GPX and AT-x930-52GPX Switches

The LEDs are described in Table 8.

Table 8. LEDs on the 10/100/1000Base-T Ports on the AT-x930-28GPX and AT-x930-52GPX Switches

LED	State	Description
Link/ Activity LED	Solid Green	A port has established a 1000 Mbps link to a network device.
	Flashing Green	A port is transmitting or receiving data at 1000 Mbps.
	Solid Amber	A port has established a 10 or 100 Mbps link to a network device.
	Flashing Amber	A port is transmitting or receiving data at 10 or 100 Mbps.
	Off	A port has not established a link with another network device or the LEDs are turned off. To turn on the LEDs, use the eco-friendly button.

Table 8. LEDs on the 10/100/1000Base-T Ports on the AT-x930-28GPX and AT-x930-52GPX Switches (Continued)

LED	State	Description
PoE	Green	The switch detects a powered device (PD) on the port and is delivering power to it.
	Solid Amber	The switch has shut down PoE+ on the port because of a fault condition.
	Flashing Amber	The switch detects a PD on the port but is not delivering power to it because it has reached its maximum power budget.
	Off	This LED state can result from the following conditions: <ul style="list-style-type: none"> <li><input type="checkbox"/> The port is not connected to a PD.</li> <li><input type="checkbox"/> The PD is powered off.</li> <li><input type="checkbox"/> The port is disabled in the management software.</li> <li><input type="checkbox"/> PoE is disabled on the port.</li> <li><input type="checkbox"/> The LEDs on the Ethernet line cards are turned off. To turn on the LEDs, use the eco-friendly button.</li> </ul>

**LEDs for the SFP Ports**

The LEDs for the twenty four SFP ports on the AT-x930-28GSTX Switch are located between the ports. Refer to Figure 10. Each SFP port has one LED. The left-hand LED is for the top port and the right-hand LED is for the bottom port.

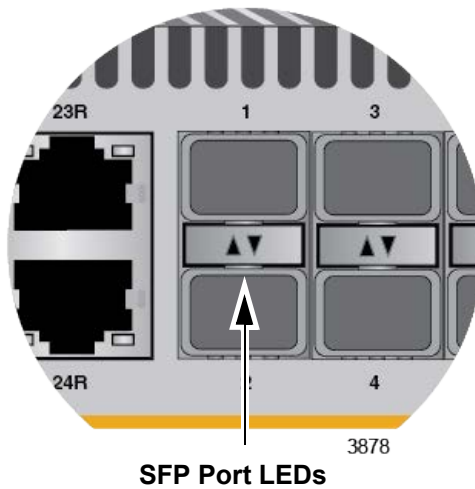

Figure 10. SFP Port LEDs

The possible states of the LEDs for the SFP ports are described in Table 9.

Table 9. SFP Port LEDs on the AT-x930-28GSTX Switch

LED	State	Description
Link/Activity	Solid green	The SFP transceiver in the port has established a link at 1000 Mbps to a network device.
	Flashing green	The SFP transceiver is receiving or transmitting packets to a network device at 1000 Mbps.
	Solid amber	The SFP transceiver in the port has established a link at 100 Mbps to a network device.
	Flashing amber	The SFP transceiver is receiving or transmitting packets to a network device at 100 Mbps.
	Off	The port is empty, the SFP transceiver has not established a link to a network device, or the LEDs are turned off. To turn on the LEDs, use the eco-friendly button.

### LEDs for the SFP+ Ports

The LEDs for the SFP+ ports are located between the ports, as shown in Figure 11. Each SFP+ port has one LED. The left LED is for the top port and the right LED is for the bottom port.

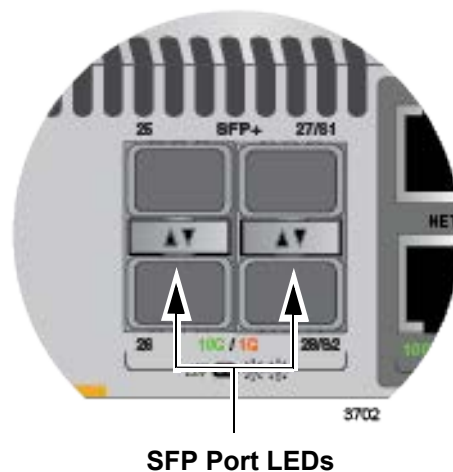

Figure 11. SFP+ Port LEDs

The LEDs are described in Table 10.

Table 10. SFP+ Port LEDs

LED	State	Description
Link/Activity	Solid green	The SFP+ transceiver in the port has established a link at 10 Gbps to a network device.
	Flashing green	The SFP+ transceiver is receiving or transmitting packets to a network device at 10 Gbps.
	Solid amber	The SFP transceiver in the port has established a link at 1000 Mbps to a network device.
	Flashing amber	The SFP transceiver is receiving or transmitting packets to a network device at 1000 Mbps.
	Off	The port is empty, the SFP or SFP+ transceiver has not established a link to a network device, or the LEDs are turned off. To turn on the LEDs, use the eco-friendly button.

**LEDs for the Stacking Ports**

SFP+ ports 27/S1 and 28/S2 on the 28-port switches and ports 51/S1 and 52/S2 on the 52-port switches may be used as stacking ports to build a VCStack of up to eight switches at 10Gbps speeds or four switches at 1000M speeds. For background information, refer to Chapter 2, “Virtual Chassis Stacking” on page 57. Table 11 on page 49 defines the LED states when the ports are used to build a stack of switches.



Table 11. Stacking Port LEDs

LED	State	Description
Link/Activity	Off	The port is empty, the stacking transceiver has not established a link to a network device, or the LEDs are turned off. To turn on the LEDs, use the eco-friendly button.
	Solid green	The stacking transceiver has established a 10Gbps link to another switch in the stack.
	Flashing green	The stacking transceiver is receiving or transmitting packets.
	Solid amber	The stacking transceiver in the port has established a link at 1Gbps to a network device.
	Flashing amber	The stacking transceiver is receiving or transmitting packets to a network device at 1Gbps.

**Switch ID LED**

The Switch ID LED, shown in Figure 12, displays the ID number of the switch. A stand-alone switch has the ID number 0. Switches in a VCStack have the numbers 1 to 8.

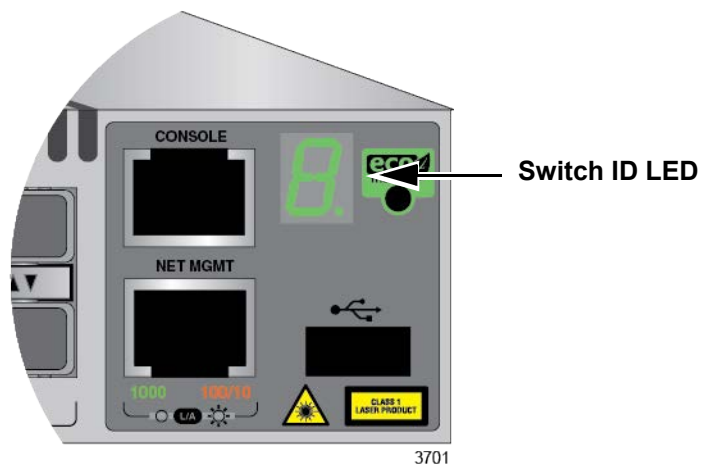

Figure 12. Switch ID LED

The states of the LED when the switch is not operating in the low power mode are shown in Figure 13.

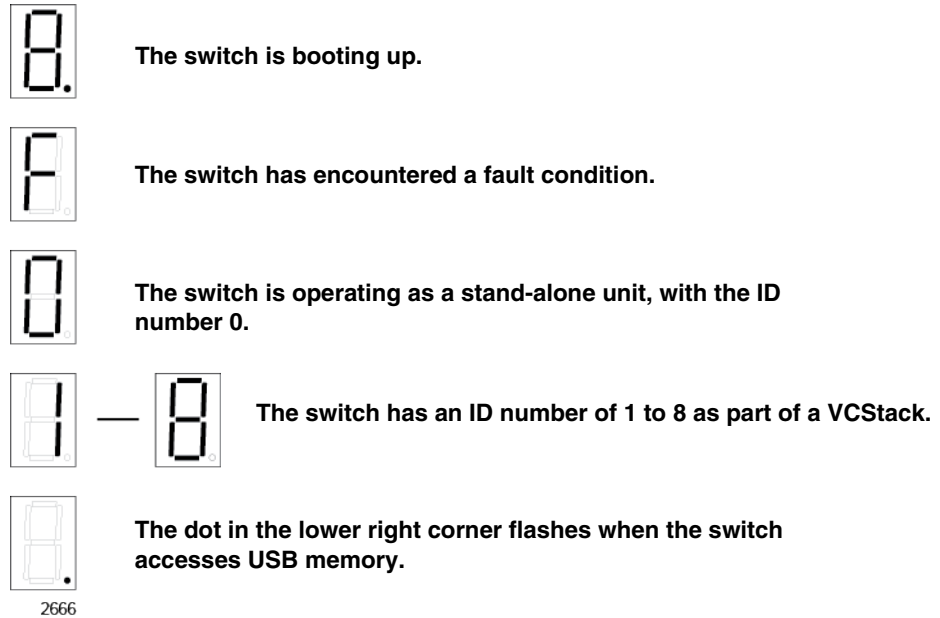

Figure 13. Switch ID LED

The switch displays the letter “F” for fault on the ID LED if it detects one of the following problems:

- A cooling fan has failed.
- The internal temperature of the switch has exceeded the normal operating range and the switch may shut down.

**Note**

You can use the SHOW SYSTEM ENVIRONMENT command in the command line interface to identify the source of the problem.

The states of the LED when the switch is operating in the low power mode are shown in Figure 14.

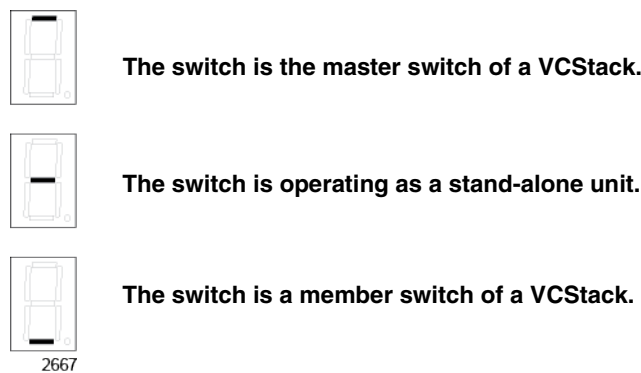

Figure 14. Switch ID LEDs in the Low Power Mode

## USB Port

---

The management panel has a USB port. You may use the port to store configuration files on flash drives or to restore configuration files to switches whose settings have been lost or corrupted, or to quickly configure replacement units. You may also use the port and flash drives to update the management firmware on the switch.

The port is USB2.0 compatible.

## Console Port

---

You use the Console port to manage the switch and configure its features and parameter settings. This type of management uses serial RS-232 and is commonly referred to as local management because it is not conducted over your network. To perform local management, you must be at the location of the switch and use the management cable included with the device.

To establish a local management session with the switch, connect a terminal or a personal computer with a terminal emulation program to the Console port, which has an RJ-45 style (8P8C) connector, using the provided management cable. The cable has RJ-45 style (8P8C) and DB-9 (D-sub 9-pin) connectors.

To connect a laptop/desktop computer and a network device, such as a switch, you can use the AT-VT-Kit3 management cable. The cable is a USB-to-Serial converter with a USB-A male connector on one end and an RJ-45 female receptor on the other end.

---

### Note

To use the AT-VT-Kit3 management cable, you must install the driver software onto your Windows system. For installation instructions, refer to Allied Telesis *Quick Installation Guide AT-VT-Kit3 Management Cable*.

---

The Console port is set to the following specifications:

- Default baud rate: 9600 bps (Range is 9600 to 115200 bps)
- Data bits: 8
- Parity: None
- Stop bits: 1
- Flow control: None

---

### Note

These settings are for a DEC VT100 or ANSI terminal, or an equivalent terminal emulation program.

---

## AT-StackQS and AT-x9EM/XT4 Cards

This section describes the two optional cards for the x930 Series:

- ❑ AT-StackQS Card
- ❑ AT-x9EM/XT4 Card

### AT-StackQS Card

The AT-StackQS Card has two ports for 40Gbps transceivers and a bandwidth of 160Gbps. You install it in the back panel of the switch, replacing the AT-FAN09ADP Module. Refer to Figure 15.

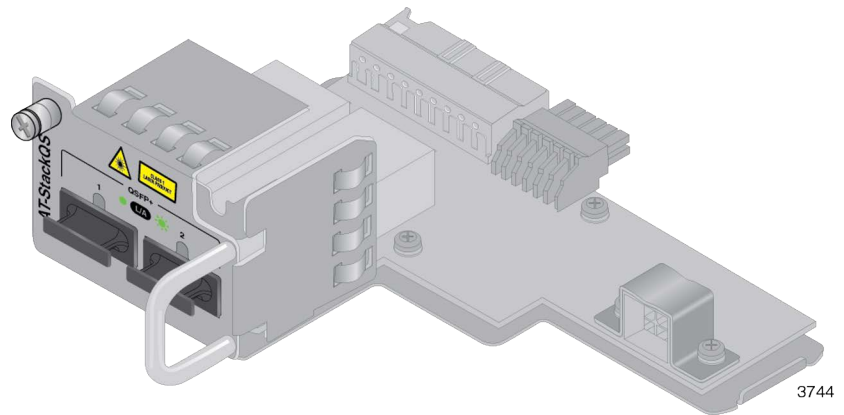

Figure 15. AT-StackQS Card

The card has three functions:

- ❑ The ports can be used as 40Gbps networking ports.
- ❑ The ports can be used as the stack trunk in a VCStack of up to eight switches. Refer to “Trunks of AT-StackQS Cards” on page 64.
- ❑ Each port can be converted from one 40Gbps port into four 10Gbps ports with breakout cables of 1 and 3 meters in length. Refer to Figure 16.

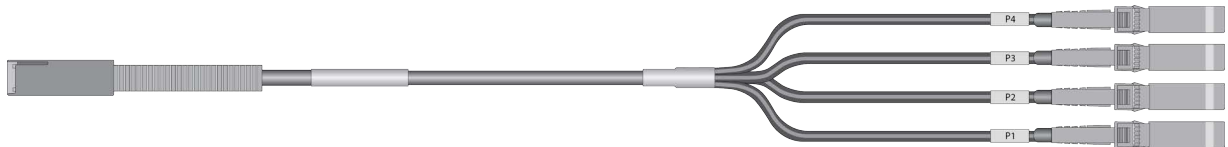

Figure 16. Copper Breakout Cable

**Note**

Breakout cables are supported in 26-port x930 Switches. They are not supported in 52-port switches.

Each transceiver port has one LED. The states of the LED are defined in Table 12.

Table 12. AT-StackQS Card LEDs

LED	State	Description
L/A (Link/Activity)	Off	The port is not connected to another network device, the device is not powered on, or the LEDs are turned off. To turn on the LEDs, use the eco-friendly button.
	Solid green	The port has established a 40Gbps link to network device.
	Flashing green	The port is transmitting or receiving network packets.

The LED states for breakout cables are described in Table 13.

Table 13. AT-StackQS Card LEDs with 10Gbps Breakout Cables

State	Description
Solid Amber	At least one of the four ports on the breakout cable has established a 10Gbps link to a network device.
Flashing Amber	At least one of the four ports on the breakout cable is sending or receiving data.
Off	<p>Possible causes of this state are listed here:</p> <ul style="list-style-type: none"> <li>- The transceiver port is empty.</li> <li>- None of the ports on the breakout cable have established links to network devices.</li> <li>- The LEDs are turned off. To turn on the LEDs, use the eco-friendly button.</li> </ul>

## AT-x9EM/XT4 Card

This card adds four additional networking ports to the switch. The ports can operate at either 1Gbps or 10Gbps and have RJ-45 connectors for copper cables. Refer to Figure 17.

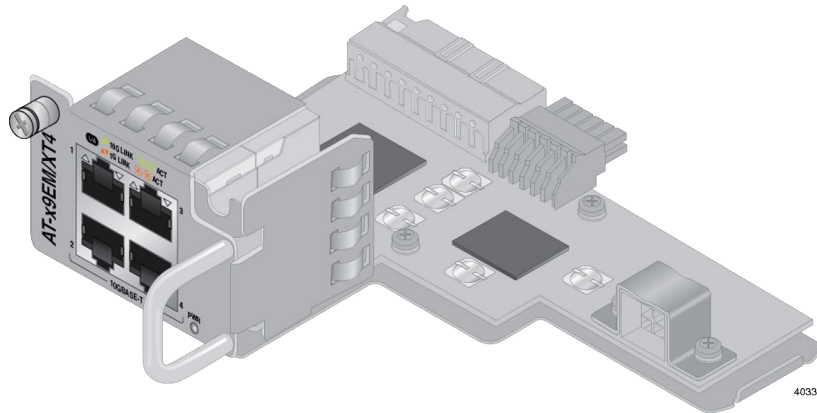

Figure 17. AT-x9EM/XT4 Card

### Note

The card requires version 5.4.5-2 or later of the management software. The instructions in “Displaying the Hardware Status and AlliedWare Plus Version Number” on page 145 explain how to determine the version number of the software on the switch.

The cable requirements for the ports are given in Table 14.

Table 14. Copper Cables for the AT-x9EM/XT4 Card

Port Speed	Cable Type	Maximum Operating Distance
1Gbps	Standard TIA/EIA 568-A-compliant Category 5 or TIA/EIA 568-B-compliant Enhanced Category 5 (Cat 5e) shielded or unshielded cabling	100 m (328 ft)
10Gbps	Standard TIA/EIA-568-C.1 compliant Category 6a (Cat 6a) shielded or unshielded cabling	100 m (328 ft)

Each port has one LED. The states of the LED are defined in Table 15 on page 56.

Table 15. AT-x9EM/XT4 Card LEDs

LED	State	Description
L/A (Link/ Activity)	Off	The port is not connected to another network device, the device is not powered on, or the LEDs are turned off. To turn on the LEDs, use the eco-friendly button.
	Solid green	The port has established a 10Gbps link to a network device.
	Flashing green	The port is transmitting or receiving network traffic at 10Gbps.
	Solid amber	The port has established a 1Gbps link to a network device.
	Flashing amber	The port is transmitting or receiving network traffic at 1Gbps.

You can install only one AT-x9EM/XT4 Card in the switch. It replaces the AT-FAN09ADP Module in the back panel. The installation instructions are provided in Chapter 5, “Installing AT-StackQS and AT-x9EM/XT4 Cards” on page 103.



## Chapter 2

# Virtual Chassis Stacking

---

The sections in this chapter are listed here:

- “Overview” on page 58
- “Stack Trunks” on page 59
- “Trunks of Ports S1 and S2” on page 60
- “Trunks of AT-StackQS Cards” on page 64
- “Trunks of Copper 10/100/1000Mbps Ports” on page 67
- “Trunks of SFP Ports on AT-x930-28GSTX Switches” on page 69
- “General Stacking Guidelines” on page 72
- “Master and Member Switches” on page 73
- “Switch ID Numbers” on page 74
- “Feature Licenses” on page 75
- “Specifying Ports in the Command Line Interface” on page 76
- “Stack Worksheet” on page 78

---

### **Note**

For more information on VCStack, refer to the *Stacking Introduction and Stacking Commands* chapters in the *Software Reference for x930 Series Switches, AlliedWare Operating System* from [www.alliedtelesis.com](http://www.alliedtelesis.com).

---

## Overview

---

The Virtual Chassis Stacking (VCStack) feature allows multiple x930 Switches to function as a single networking unit. Benefits of the VCStack feature include:

- ❑ Simplifies management - You can manage the devices of the stack as a single unit, rather than individually. Your local and remote management sessions automatically give you management access to all the devices.
- ❑ Reduces IP addresses - A stack requires only one IP address for remote management access, thereby reducing the number of IP addresses you have to assign to network devices. The one address gives you management access to all the units.
- ❑ Adds network redundancy - You can add redundancy to your network topology by distributing functions across multiple switches. For instance, static port trunks on standalone switches have to consist of ports from the same switch. In contrast, static port trunks in a stack can have ports from different switches.
- ❑ Reduces protocol requirements - Creating a stack might eliminate your need to configure some protocols, such as the Virtual Router Redundancy Protocol and Spanning Tree Protocol.

## Stack Trunks

---

The switches in a stack are connected by a trunk that consists of two or more ports on each device. The x930 Switches support the following four types of trunks:

- ❑ “Trunks of Ports S1 and S2” on page 60
- ❑ “Trunks of AT-StackQS Cards” on page 64
- ❑ “Trunks of Copper 10/100/1000Mbps Ports” on page 67
- ❑ “Trunks of SFP Ports on AT-x930-28GSTX Switches” on page 69

The front-panel ports S1 and S2 are the default trunk ports, except if the switches contain AT-StackQS Cards, in which case their ports are the default trunk ports.

## Trunks of Ports S1 and S2

---

Front-panel ports S1 and S2 are the default trunk ports on x930 Switches, except for switches containing AT-StackQS Cards, in which case their ports are the default trunk ports. The ports are 27/S1 and 28/S2 on 28-port switches and 52/S1 and 52/S2 on 52-port x930 Switches. Here are the guidelines:

- ❑ Stacks with trunks of ports S1 and S2 can have up to eight x930 Switches.
- ❑ Stacks can have both 28- and 52-port switches.
- ❑ Ports S1 and S2 support a variety of short and long distance fiber optic SFP+ transceivers and direct connect cables. You may use any of the supported transceivers for the trunk. Refer to the product's data sheet on the Allied Telesis web site for a list of supported transceivers. Transceivers are purchased separately.
- ❑ The SFP+ transceivers or direct connect cables must be from Allied Telesis. Switches with transceivers from other network equipment providers might not form the stack.
- ❑ The cables must crossover to different ports in the switches of the stack. Port S1 in one switch has to crossover to port S2 in the next switch. Additionally, the ports on the cards in the first and last switches of the stack have to be connected together to form a loop in the trunk.
- ❑ You can use ports S1 and S2 as regular networking ports by disabling VCStack or selecting other ports as the stack trunk.
- ❑ For switches that have AT-StackQS Cards, you have to perform the `STACK ENABLE BUILTIN PORTS` command to use ports S1 and S2 as the trunk ports.
- ❑ The bandwidth of the trunk is 40Gbps.

For instructions, refer to Chapter 11, "Building the Stack with SFP+ Ports S1 and S2" on page 147.

An example of a stack trunk for two switches is illustrated in Figure 18 on page 61.

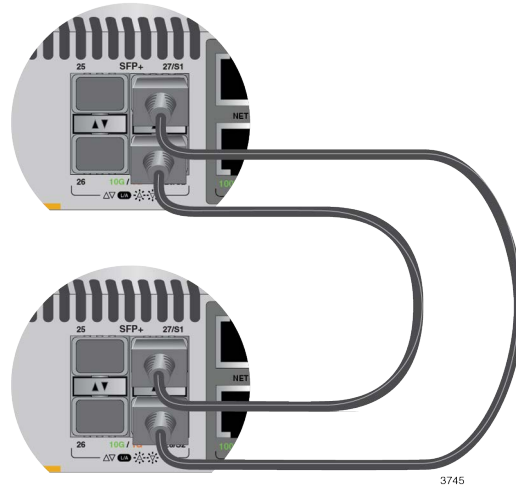

Figure 18. Trunk of Ports S1 and S2 for a Stack of Two Switches



**Caution**

The stack will not function if the connections to ports S1 and S2 do not crossover on the switches. The switches will instead operate as stand-alone devices. *E78*

An example of a stack trunk for four switches is illustrated in Figure 19.

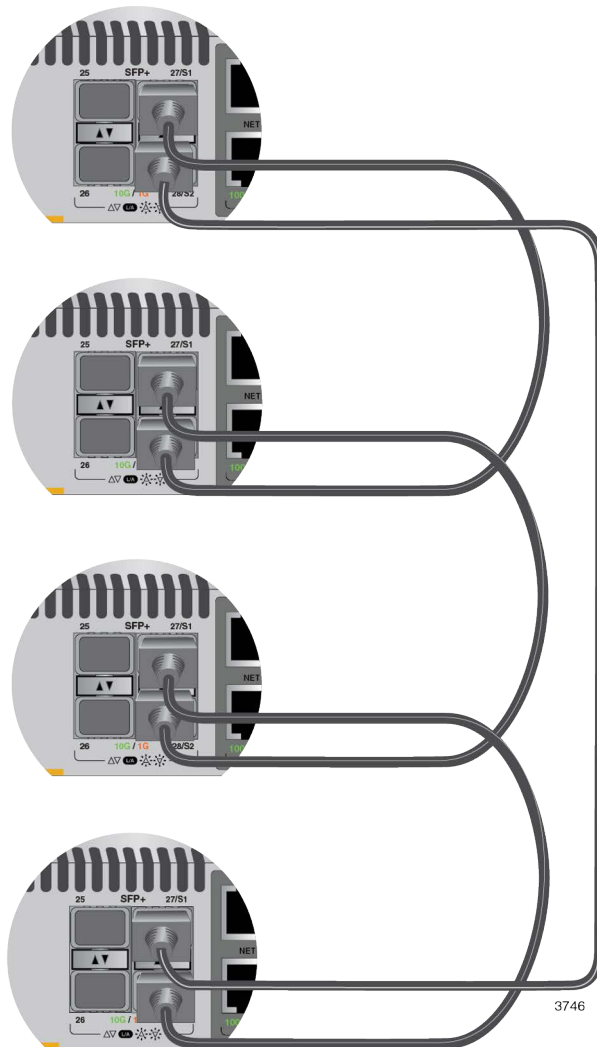

Figure 19. Trunk of Ports S1 and S2 for a Stack of Four Switches

A stack of eight switches is shown in Figure 20.

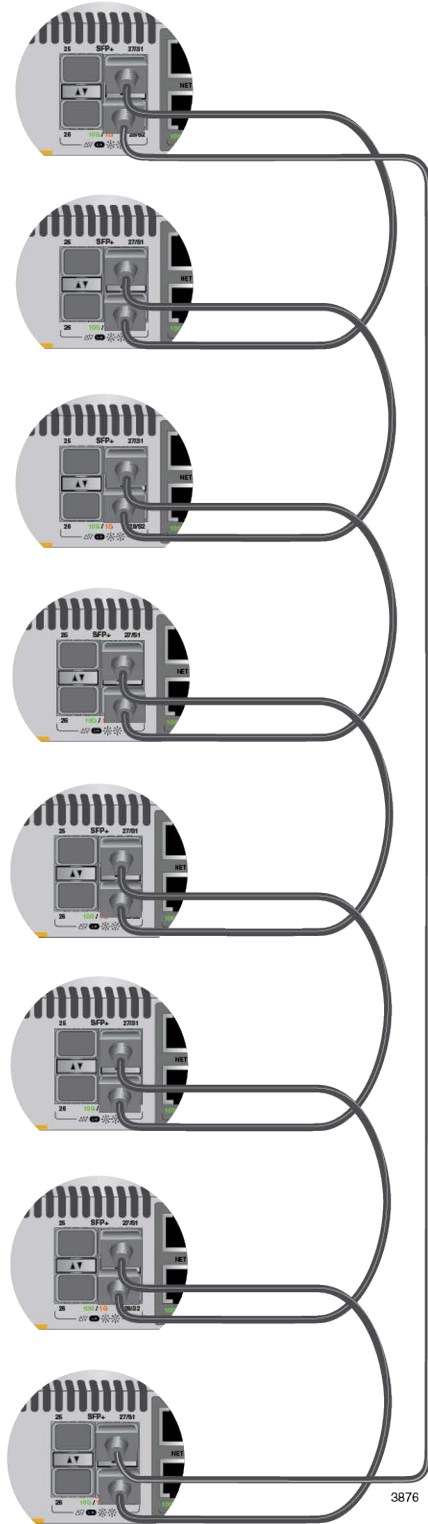

Figure 20. Trunk of Ports S1 and S2 for a Stack of Eight Switches

## Trunks of AT-StackQS Cards

---

If you want to reserve ports S1 and S2 on the x930 Switches for other network functions or need a faster trunk for the stack, you can build a trunk with AT-StackQS Cards. They support 40Gbps QSFP+ transceivers in their two ports. Refer to Figure 15 on page 53. Here are the guidelines for a trunk of AT-StackQS Cards:

- ❑ Stacks can have up to eight x930 Switches.
- ❑ Stacks can have both 28- and 52-port switches.
- ❑ You must install AT-StackQS Cards in all the switches of the stack.
- ❑ You must use QSFP+ transceivers from Allied Telesis. Switches with transceivers from other network equipment providers might not be able to form the stack. For a list of supported transceivers, refer to the product's data sheet on the Allied Telesis web site. Transceivers are purchased separately.
- ❑ The two ports on the AT-StackQS Cards are the default trunk ports. (For switches without AT-StackQS Cards, ports S1 and S2 are the default trunk ports.)
- ❑ The cables have to crossover to different ports on the cards in the switches of the stack. Port 1 on the card in one switch has to crossover to port 2 on the card in the next switch. Additionally, the ports on the cards in the first and last switches of the stack have to be connected together to form a loop in the trunk.
- ❑ To use the ports on AT-StackQS Cards as regular networking ports, you can disable VCStack or select other ports as the trunk.
- ❑ The bandwidth of the trunk is 160Gbps.

For instructions, refer to Chapter 12, "Building the Stack with AT-StackQS Cards" on page 159.

Here are examples of stack trunks of AT-StackQS Cards. Figure 21 on page 65 illustrates a stack of two x930 Switches.



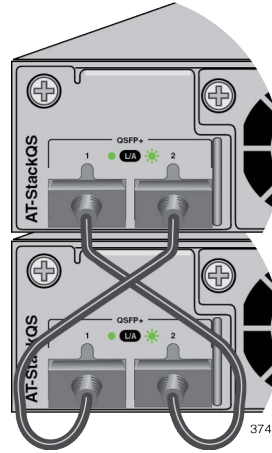

Figure 21. Trunk of AT-StackQS Cards for a Stack of Two Switches

The stack in Figure 22 has four switches.

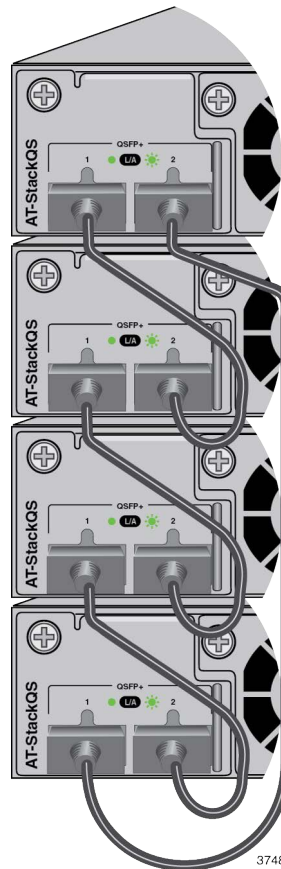

Figure 22. Trunk of AT-StackQS Cards for a Stack of Four Switches

Figure 23 is a stack of eight switches.

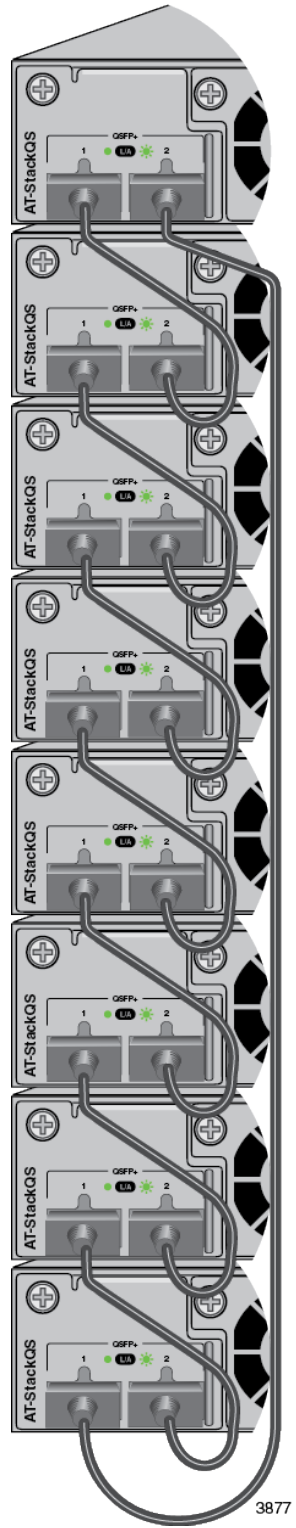

Figure 23. Trunk of AT-StackQS Cards for a Stack of Eight Switches

## Trunks of Copper 10/100/1000Mbps Ports

---

You can use the copper Gigabit ports on the front panels as the trunks for stacks of x930 Switches. Here are the guidelines:

- ❑ Stacks can have up to four switches.
- ❑ Stacks can have both 28-port and 52-port x930 Switches.
- ❑ Trunks can have up to eight copper Gigabit ports per switch.
- ❑ For 52-port switches, use only ports in the range 1 to 24 for the trunk ports.
- ❑ You should try to use the same Gigabit ports as the trunk on all the switches in the stack. This can make managing and troubleshooting stacks easier.
- ❑ You have to configure the master and member switches of the stack by designating the Gigabit ports of the trunk with the `STACK ENABLE FRONT-PANEL-PORTS` and `STACKPORT` commands, and adding the members switches to the master switch as provisioned switches.
- ❑ The Gigabit ports of the trunk have to be at their default settings. You cannot change the settings of trunk ports.

---

### Note

Trunks of copper Gigabit ports require AlliedWare Plus version 5.5.1-2.1 or later.

---

For instructions, refer to Chapter 13, “Building the Stack with Copper or SFP Gigabit Ports” on page 165

Here are examples of stacks with trunks of copper Gigabit ports. Figure 24 is of a stack of two switches. The trunk uses ports 1 to 4 on both switches. (The maximum is eight ports per switch.) This is not a requirement, but managing the stack will be easier if you select the same ports as the trunk on all the switches and connect the same ports together, when possible.

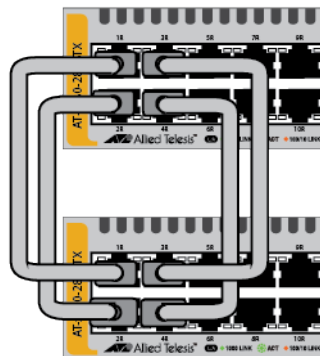

Figure 24. Trunk of Copper Gigabit Ports for a Stack of Two Switches

Here is an example of a stack of three switches.

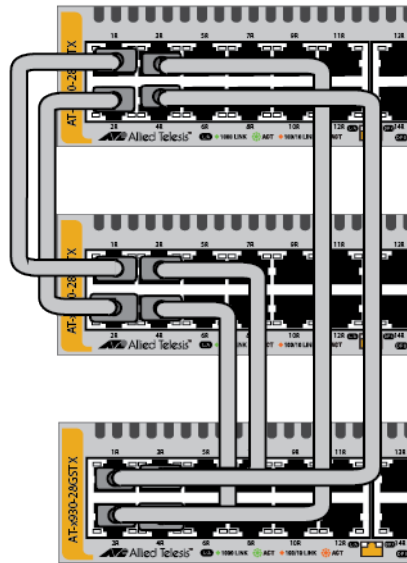

Figure 25. Trunk of Copper Gigabit Ports for a Stack of Three Switches

Figure 26 is an example of a stack of four switches.

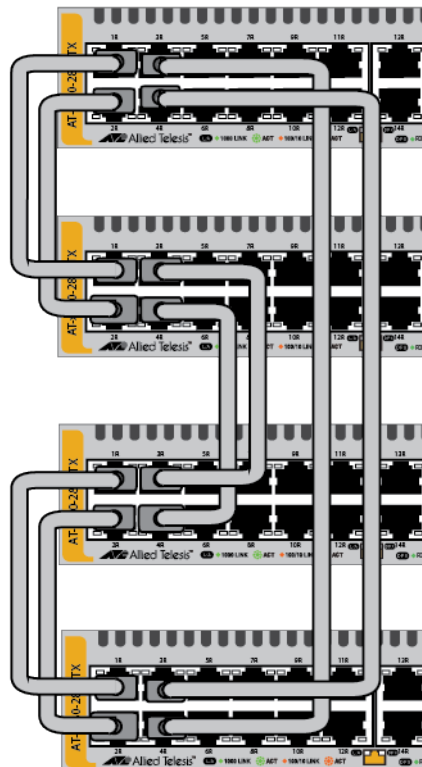

Figure 26. Trunk of Copper Gigabit Ports for a Stack of Four Switches

## Trunks of SFP Ports on AT-x930-28GSTX Switches

---

AT-x930-28GSTX Switches have 24 Gigabit copper ports numbered 1R to 24R and 24 SFP ports numbered 1 to 24 on the front panels. As explained in “SFP Ports” on page 38, the ports are paired together. Copper port 1R and SFP port 1 are one pair, copper port 2R and SFP port 2 are another pair, and so on. Only one port in a pair can be active at a time. The copper Gigabit port is the active port when its companion SFP port is unused. The SFP port is the active port when an SFP transceiver is installed and linked to a network device.

You can use the copper ports or SFP Gigabit ports on AT-x930-28GSTX Switches as trunk ports. For directions on using copper Gigabit ports, refer to “Trunks of Copper 10/100/1000Mbps Ports” on page 67. Here are the guidelines to using SFP Gigabit ports as trunks:

- ❑ Stacks can have up to four switches.
- ❑ Trunks can have up to eight SFP ports per switch.
- ❑ Trunks can have both copper Gigabit ports and Gigabit SFP ports.
- ❑ Stacks can have both 28- and 52-port switches.
- ❑ You have to configure the master and member switches of the stack by designating the Gigabit ports of the trunk with the `STACK ENABLE FRONT-PANEL-PORTS` and `STACKPORT` commands, and adding the members switches to the master switch as provisioned switches.
- ❑ The SFP ports of the trunk have to be at their default settings. You cannot change the settings of trunk ports.
- ❑ The SFP transceivers must be from Allied Telesis. Switches might not form the stack with SFP transceivers from other network equipment providers. For a list of supported transceivers, refer to the product’s data sheet on the Allied Telesis web site.

---

### Note

Trunks of SFP transceivers require AlliedWare Plus version 5.5.1-2.1 or later.

---

For instructions, refer to Chapter 13, “Building the Stack with Copper or SFP Gigabit Ports” on page 165.

Here are examples of trunks of SFP Gigabit ports for stacks of AT-x930-28GSTX Switches. The example in Figure 27 on page 70 is a stack of two AT-x930-28GSTX Switches. The trunk consists of SFP ports 1 to 4 on both switches. (The maximum number of trunk ports per switch is eight ports.) As with trunks of copper Gigabit ports, managing the stack will be easier if you select the same ports as the trunk on the switches and connect the same ports together, when possible.

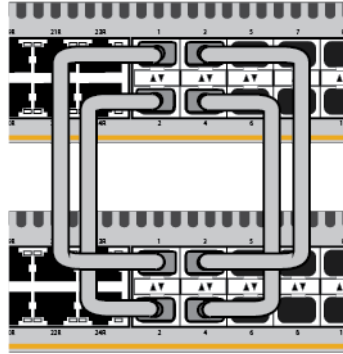

Figure 27. Trunk of SFP Gigabit Ports for a Stack of Two AT-x930-28GSTX Switches

The example in Figure 28 is a stack of three AT-x930-28GSTX Switches. As in the previous example, the trunk contains SFP Gigabit ports 1 to 4.

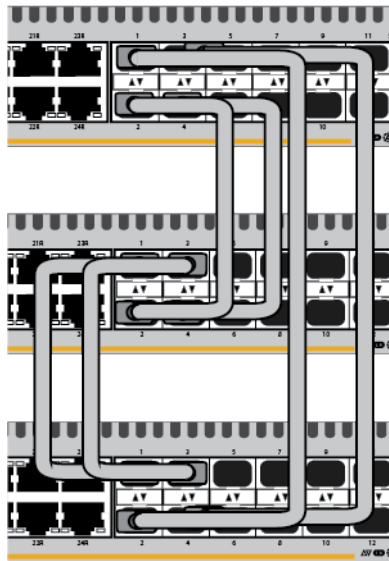

Figure 28. Trunk of SFP Gigabit Ports for a Stack of Three AT-x930-28GSTX Switches

For mixed stacks of AT-x930-28GSTX Switches and other x930 Switches, trunks can have both Gigabit copper ports and SFP ports. In Figure 29 on page 71, the trunk for the stack of two AT-x930-28GSTX Switches and two other x930 Switches has both Gigabit copper and SFP ports. The trunk ports on the AT-x930-28GSTX Switches are copper ports 21R and 22R, and SFP ports 1 and 2. The trunk ports on the other switches are copper ports 21 to 24.

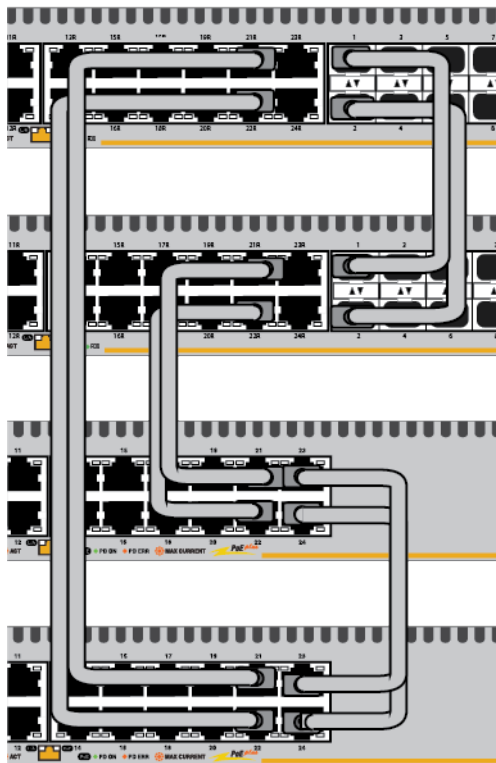

Figure 29. Trunk of SFP and Copper Gigabit Ports for a Mixed Stack of Four Switches

## General Stacking Guidelines

---

Here are additional stacking guidelines:

- ❑ Stacking is enabled by default on x930 Switches.
- ❑ VCStack comes standard with the AlliedWare Plus software for x930 Switches. No additional software or licenses are required.
- ❑ The switches must all have the same version of AlliedWare Plus software.
- ❑ The switches can be the same or different x930 models.
- ❑ Any x930 Switch can be the master switch of a stack.
- ❑ A stack of x930 Switches cannot contain other stacking switches, such as x600 or x610 Switches.
- ❑ In stacks of three or more switches, all the switches must have the same number of trunk ports.
- ❑ Do not configure switch features, such as virtual LANs and routing protocols, before building the stack. Switches might discard the settings when the stack is powered on for the first time.
- ❑ Trunk ports must be directly linked together. There cannot be any intermediary devices, such as media converters, routers, or other switches, between trunk ports.
- ❑ Trunks cannot have different types of trunk ports. For example, a trunk cannot have both Gigabit copper ports and ports S1 and S2.



## Master and Member Switches

---

Stacks have a master switch. Some of its functions include:

- Coordinate and monitor stack operations.
- Verify that the switches are using the same version of management software.
- Verify that the switches have different ID numbers. It automatically assigns new ID numbers to resolve situations where two or more switches have the same ID number.
- Verify that the stacking transceivers that connect the switches together are cabled correctly.

The other switches are called member switches. A member switch can automatically transition to the master role if the current master switch is removed from the stack or powered off. This ensures continued operations of the stack even if the master switch stops operating.

### Selection of the Master Switch

The switches of the stack designate the master switch during the initialization process that they perform whenever they are powered on or reset. They select the master switch based on the following parameters:

- Stack priority numbers
- MAC addresses

The stack priority number is an adjustable value of 0 to 255, where the lower the number, the higher the priority. Typically, the switch with the lowest priority number (highest priority) becomes the master switch of a stack. The default priority value is 128.

If the switches have the same priority values, they select the master switch based on their MAC addresses. As with the priority value, the lower the MAC address, the higher the priority. The switch with the lowest MAC address becomes the master switch.

If you power on the switches of the stack simultaneously without adjusting the priority values, they select the master switch based on their MAC addresses. If you power on the switches one at a time, the master switch is the first switch to be powered on.

After the stack is established and operating, you may change the priority settings on the individual units and so control which switch will be the master switch the next time you reboot or power on the stack.

## Switch ID Numbers

---

Each switch must be assigned an ID number. The range is 1 to 8 for a stack with a trunk of AT-StackQS modules or the S1 and S2 ports. The range is 1 to 4 when the stack trunk consists of the 1Gbps front panel ports. The default is 1. The ID numbers are displayed on the ID LEDs on the front panels of the units. You may assign the numbers yourself or let the master switch assign the numbers automatically when you initially power on the stack.

You use the ID numbers to identify the individual ports and switches when you configure the devices with the commands in the management software. For further information, refer to “Specifying Ports in the Command Line Interface” on page 76.

The ID numbers are also used to identify the parameter settings that are stored in the configuration file. When the stack is reset or power cycled, the ID numbers identify the devices to which the parameter settings belong.



### Caution

You should not change the ID numbers of the switches after you start to configure the parameter settings. Otherwise, the parameter settings might be applied to the wrong devices when you reset or power cycle the stack. *E79*

---

The switches do not use their ID numbers to select the master switch. The selection of the master switch is based on their priority numbers and MAC addresses, as previously explained.

## Feature Licenses

---

The x930 Switches comes with the AlliedWare Plus operating system and a base set of features that are available as soon as you install the devices. Allied Telesis provides additional features in the AlliedWare Plus software for the switches, but they have to be unlocked before you can use them. They are unlocked with feature licenses from Allied Telesis. Refer to the product's data sheet on the Allied Telesis web site for the list of licenses.

Here are the guidelines to feature licenses for a stack of x930 Series switches:

- ❑ The VCStack feature is part of the base features of the switches. It does not require a feature license.
- ❑ You may install feature licenses while the switches are operating as stand-alone units or as a stack.
- ❑ Depending on the feature license, you might have to order one license for each switch or one license for the entire stack.
- ❑ The switches will form a stack even if they have different feature licenses. However, the additional features are only available on those switches that have the necessary licenses. The stack generates a warning message if it detects that the switches do not have the same optional feature licenses.

## Specifying Ports in the Command Line Interface

The individual ports on the switches of the stack are specified in the command line interface with the PORT parameter. The format of the parameter is shown in Figure 30.

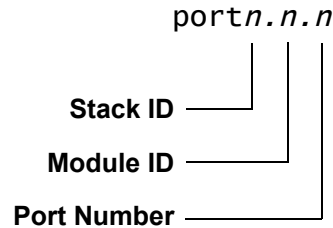

Figure 30. PORT Parameter in the Command Line Interface

The three parts of the PORT parameter are described in Table 16.

Table 16. PORT Parameter Format

Number	Description
Stack ID	Designates a switch's ID number. This number designates a switch in the stack. The switches display their ID numbers on their Switch ID LEDs. You can also view the ID numbers with the SHOW STACK command in the command line interface. You may specify only one ID number in the PORT parameter.
Module ID	Designates the module number of a port. The possible values are listed here:  - Enter 0 for the module ID to designate a port on the front panel of a switch.  - Enter 1 to designate a port on an optional AT-StackQS or AT-x9EM/XT4 Card.
Port Number	Designates a port number.

This example of the PORT parameter uses the INTERFACE command to enter the Port Interface mode for ports 15 and 17 on the switch with the ID number 1:

```
awplus> enable
awplus# configure terminal
awplus(config)# interface port1.0.15,port1.0.17
```

This example enters the Port Interface mode for ports 1 and 2 on the optional AT-x9EM/XT4 Card on the switch with the ID number 3:

```
awplus> enable
awplus# configure terminal
awplus(config)# interface port3.1.1-port3.1.2
```

For instructions on the command line interface and the PORT parameter, refer to the *Software Reference for x930 Series Switches, AlliedWare Operating System*.

## Stack Worksheet

---

The worksheet in Table 17 can assist you in configuring and maintaining a stack.

Table 17. Stack Worksheet

	Switch/ Location	Switch ID	Prior- ity	Firmware Version Number <sup>1</sup>	Trunk Ports	Transceiver	StackQS or x9EM/XT4 Card
Master		1	1			25   49:  26   50  27 /S1   51/S1  28 /S2   52/S2	
Member		2	2			25   49:  26   50  27 /S1   51/S1  28 /S2   52/S2	
Member		3	3			25   49:  26   50  27 /S1   51/S1  28 /S2   52/S2	
Member		4	4			25   49:  26   50  27 /S1   51/S1  28 /S2   52/S2	

Table 17. Stack Worksheet

	Switch/ Location	Switch ID	Prior- ity	Firmware Version Number <sup>1</sup>	Trunk Ports	Transceiver	StackQS or x9EM/XT4 Card
Member		5	5			25   49: 26   50 27 /S1   51/S1 28 /S2   52/S2	
Member		6	6			25   49: 26   50 27 /S1   51/S1 28 /S2   52/S2	
Member		7	7			25   49: 26   50 27 /S1   51/S1 28 /S2   52/S2	
Member		8	8			25   49: 26   50 27 /S1   51/S1 28 /S2   52/S2	

1. AlliedWare Plus version number.

The worksheet columns are described in Table 18.

Table 18. Stacking Worksheet Columns

Column	Description
Switch/Location	Use this column to record the model names and physical locations of the switches, such as their buildings or equipment rooms. The information can be useful in identifying and locating the switches if they are in different locations.
Switch ID	Each switch in a stack has to have a unique ID number, in the range of 1 to 4. They display the numbers on the ID LEDs on the front panels and you use the numbers to configure the individual ports. Allied Telesis recommends assigning the ID 1, the default value, to the master switch. You should decide on the ID assignments of the switches before beginning the configuration procedures.
Priority	<p>When the switches of a stack are reset or powered on, they perform an initialization process that involves, in part, choosing the master switch. The selection is based on their priority numbers and MAC addresses. The former is an adjustable parameter with a range of 0 to 255 and a default value of 128. The lower the value, the higher the priority. Thus, the switch with the lowest value becomes the stack master.</p> <p>If switches have the same priority number, the master is selected based on their MAC addresses. Again, as with priority numbers, the lower the MAC address, the higher the priority.</p> <p>Allied Telesis recommends setting each switch's priority value to match its ID value. This is to ensure that the switch you have chosen to be the master unit will indeed function in that role. It will also make it possible for you to know the order in which the switches assume the master role if the primary master should fail or be powered off.</p>



Table 18. Stacking Worksheet Columns (Continued)

<b>Column</b>	<b>Description</b>
Firmware Version Number	Use this column to record the version numbers of the AlliedWare Plus management software on the switches. The switches might not be able to form the stack if they have different versions. Switches that have different versions should be updated to the most recent release before you build the stack. The configuration instructions explain how to view the version numbers.
Trunk Ports	Use this column to enter the trunk ports. You should choose the ports before beginning the configuration procedures. Refer to “Stack Trunks” on page 59.
Transceivers	Used this column to record the types of transceivers in ports 25, 26, 27/S1, and 28/S2 of 28-port switches and ports 49, 50, 51/S1, and 52/S2 of 52-port switches.
AT-x9EM/XT4 or AT-StackQS Card	Use this column to enter the names of expansion cards in the switches.



## Chapter 3

# Beginning the Installation

---

The chapter contains the following sections:

- “Reviewing Safety Precautions” on page 84
- “Choosing a Site for the Switch” on page 89
- “Unpacking the Switch” on page 90

## Reviewing Safety Precautions

---

Please review the following safety precautions before beginning the installation procedure.

---

### Note

Safety statements that have the  symbol are translated into multiple languages in the *Translated Safety Statements* document at [www.alliedtelesis.com/support](http://www.alliedtelesis.com/support).

---



---

### Warning

Class 1 Laser product.  L1

---



---

### Warning

Laser Radiation.  
Class 1M Laser product.

---



---

### Warning

Do not stare into the laser beam.  L2

---



---

### Warning

Do not look directly at the fiber optic ends or inspect the cable ends with an optical lens.  L6

---



---

### Warning

To prevent electric shock, do not remove the cover. No user-serviceable parts inside. This unit contains hazardous voltages and should only be opened by a trained and qualified technician. To avoid the possibility of electric shock, disconnect electric power to the product before connecting or disconnecting the LAN cables.  E1

---



---

### Warning

Do not work on equipment or cables during periods of lightning activity.  E2

---



**Warning**

Power cord is used as a disconnection device. To de-energize equipment, disconnect the power cord. ⚡ E3

---



**Warning**

Class I Equipment. This equipment must be earthed. The power plug must be connected to a properly wired earth ground socket outlet. An improperly wired socket outlet could place hazardous voltages on accessible metal parts. ⚡ E4

---

---

**Note**

Pluggable Equipment. The socket outlet shall be installed near the equipment and shall be easily accessible. ⚡ E5

---



**Caution**

Air vents must not be blocked and must have free access to the room ambient air for cooling. ⚡ E6

---



**Warning**

Operating Temperatures. All the switches are designed for a maximum ambient temperature of 45° degrees C. ⚡ E52

---

---

**Note**

All Countries: Install product in accordance with local and National Electrical Codes. ⚡ E8

---



**Warning**

When installing this equipment, always ensure that the frame ground connection is installed first and disconnected last. ⚡ E11

---



**Warning**

Only trained and qualified personnel are allowed to install or replace this equipment. ⚡ E14

---



**Caution**

Circuit Overloading: Consideration should be given to the connection of the equipment to the supply circuit and the effect that overloading of circuits might have on overcurrent protection and supply wiring. Appropriate consideration of equipment nameplate ratings should be used when addressing this concern. *⌘* E21

---



**Caution**

Risk of explosion if battery is replaced by an incorrect type. Replace only with the same or equivalent type recommended by the manufacturer. Dispose of used batteries according to the manufacturer's instructions.

**Attention:** Le remplacement de la batterie par une batterie de type incorrect peut provoquer un danger d'explosion. La remplacer uniquement par une batterie du même type ou de type équivalent recommandée par le constructeur. Les batteries doivent être éliminées conformément aux instructions du constructeur. *⌘* E22

---



**Warning**

Mounting of the equipment in the rack should be such that a hazardous condition is not created due to uneven mechanical loading. *⌘* E25

---



**Warning**

The chassis may be heavy and awkward to lift. Allied Telesis recommends that you get assistance when mounting the chassis in an equipment rack. *⌘* E28

---

---

**Note**

Use dedicated power circuits or power conditioners to supply reliable electrical power to the device. *⌘* E27

---



**Warning**

This unit might have more than one power cord. To reduce the risk of electric shock, disconnect all power cords before servicing the unit. *⌘* E30

---

---

**Note**

If installed in a closed or multi-unit rack assembly, the operating ambient temperature of the rack environment may be greater than the room ambient temperature. Therefore, consideration should be given to installing the equipment in an environment compatible with the manufacturer's maximum rated ambient temperature (T<sub>mra</sub>).  E35

---



---

**Caution**

Installation of the equipment in a rack should be such that the amount of air flow required for safe operation of the equipment is not compromised.  E36

---



---

**Warning**

Reliable earthing of rack-mounted equipment should be maintained. Particular attention should be given to supply connections other than direct connections to the branch circuits (e.g., use of power strips).  E37

---



---

**Warning**

To reduce the risk of electric shock, the PoE ports on this product must not connect to cabling that is routed outside the building where this device is located.  E40

---



---

**Warning**

This product may have multiple AC power cords installed. To de-energize this equipment, disconnect all power cords from the device.  E41

---



---

**Caution**

An Energy Hazard exists inside this equipment. Do not insert hands or tools into open chassis slots or plugs.  E44

---



---

**Warning**

This equipment shall be installed in a Restricted Access location.  E45

---



**Caution**

The unit does not contain serviceable components. Please return damaged units for servicing.  E42

---



**Warning**

The temperature of an operational SFP or SFP+ transceiver may exceed 70° C (158° F). Exercise caution when removing or handling a transceiver with unprotected hands.  E43

---



## Choosing a Site for the Switch

---

Observe these requirements when planning the installation of the switch.

- If you plan to install the switch in an equipment rack, check to be sure that the rack is safely secured so that it will not tip over. Devices in a rack should be installed starting at the bottom, with the heavier devices near the bottom of the rack.
- If you plan to install the switch on a table, check to be sure that the table is level and stable.
- The power outlet should be located near the switch and be easily accessible.
- The site should allow for easy access to the ports on the front of the switch, so that you can easily connect and disconnect cables, and view the port LEDs.
- The site should allow for adequate air flow around the unit and through the cooling vents on the front and rear panels. (The ventilation direction in units that have a cooling fan is from front to back, with the fan on the back panel drawing the air out of the unit.)
- The site should not expose the switch to moisture or water.
- The site should be a dust-free environment.
- The site should include dedicated power circuits or power conditioners to supply reliable electrical power to the network devices.
- Do not install the switch in a wiring or utility box because it will overheat and fail from inadequate airflow.



### Warning

Switches should not be stacked on a table or desktop because that could present a personal safety hazard if you need to move or replace switches. *E91*

---

## Unpacking the Switch

---

Figure 31 lists the items in the accessory kit that comes with the switch. If any item is missing or damaged, contact your Allied Telesis sales representative for assistance.

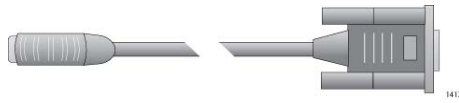

One 2 m (6.6 ft) local management cable with RJ-45 (8P8C) and DB-9 (D-sub 9-pin) connectors.

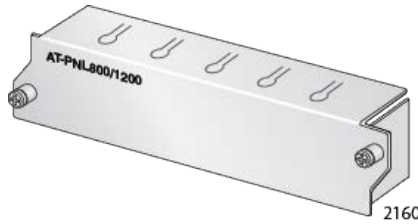

One AT-PNL800/1200 blank panel

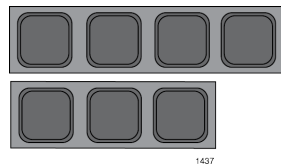

Seven bumper feet



Sixteen bracket screws

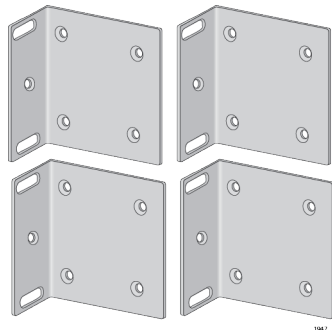

Four equipment rack or wall mounting brackets

Figure 31. Accessory Kit

Figure 32 lists the items that come pre-installed in the switch.



Four dust covers in the SFP+ ports on the front panel

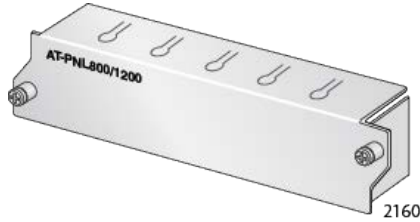

One AT-PNL800/1200 or AT-PNL250 blank panel on the back panel

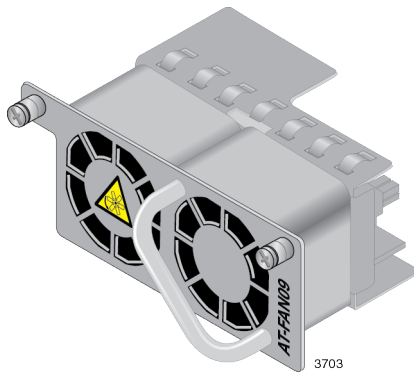

One AT-FAN09 Fan Module in the back panel

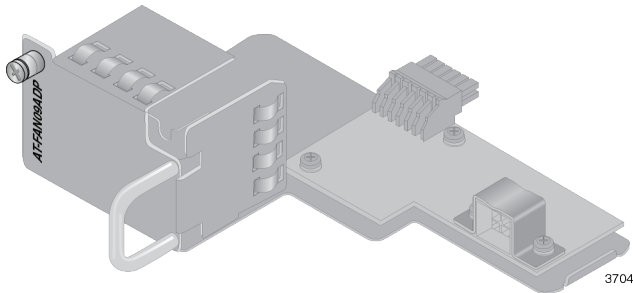

One AT-FAN09ADP Module in the back panel

Figure 32. Pre-installed Items

---

**Note**

You should retain the original packaging material in the event you need to return the unit to Allied Telesis.

---

---

**Note**

The product does not come with power supplies. Power supplies must be ordered separately.

---



## Chapter 4

# Installing the Power Supplies

---

The sections in this chapter are listed here:

- “Installing the Power Supplies” on page 94
- “Installing a Blank Power Supply Slot Cover” on page 100

## Installing the Power Supplies

---

This section contains the procedure for installing the power supplies in the switch. If you are planning to install the switch in an equipment rack or on a wall, it may be easier to install the power supplies first.



**Caution**

The device can be damaged by electrostatic discharge (ESD). Be sure to follow standard ESD protection procedures, such as wearing a wrist or foot strap, when installing the device. *ES* E106

---



**Caution**

The switch is heavy. Always ask for assistance when moving or lifting the device so as to avoid injuring yourself or damaging the equipment.

---

The illustrations in the following procedure show the AT-PWR800 Power Supply. The procedure is the same for all power supplies.

To install the power supplies, perform the following procedure:

1. Place the switch on a level, secure table or desk.

---

**Note**

If you are installing only one power supply, skip step 2.

---

2. Use a cross-head screwdriver to loosen the two captive screws on the blank panel covering power supply slot B on the back panel and remove it from the switch. Refer to Figure 33 on page 95.

---

**Note**

Allied Telesis recommends removing the blank panel from slot B even if you are installing only one power supply. You reinstall the panel later in the procedure.

---

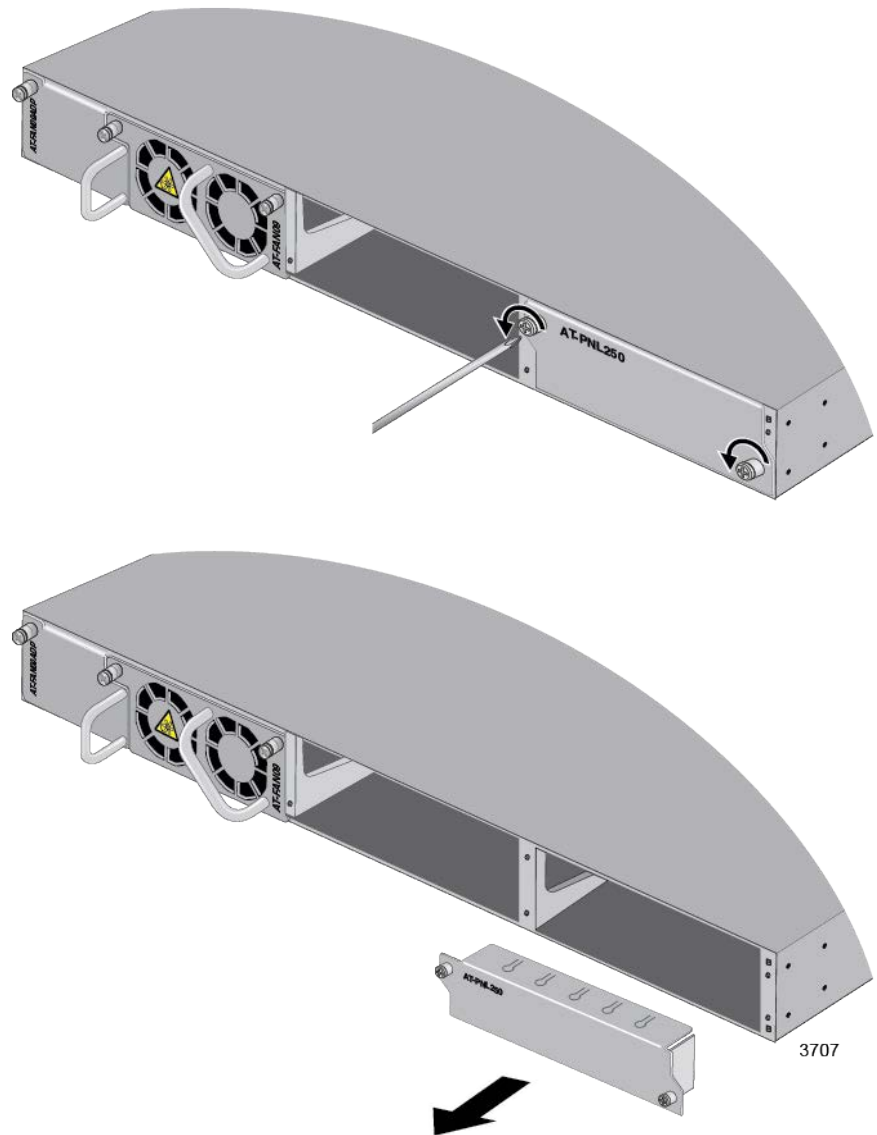

Figure 33. Removing the Blank Panel

3. Unpack the power supply from its shipping container.



**Caution**

The device is heavy. Use both hands to lift it. You might injure yourself or damage the device if you drop it. ⚡ E94

4. Check the shipping container for the accessory items.

Refer to Table 19 on page 96 to determine the accessory items that come with your power supply.

Table 19. Power Supply Accessory Items

Power Supply	One Power Cord Retaining Clip	One Power Cord
AT-PWR150	Yes	Yes
AT-PWR250	Yes	Yes
AT-PWR250-80	No	No
AT-PWR800	Yes	Yes
AT-PWR1200	No	Yes

The items are shown in Figure 34 on page 96.

Power Cord Retaining Clip



Power Cord



Figure 34. Power Supply Accessory Items

**Note**

The power cord that comes with the AT-PWR1200 Power Supply for installations in North America has a 20 Amp, 125 V NEMA 5-20P plug that is only compatible with an NEMA 5-20R receptacle.

- Slide the new power supply into slot A in the back panel of the switch. Refer to Figure 35 on page 97.

Please review the following guidelines before installing the module:

- The handle on the power supply should be on the left as you install the module. Refer to Figure 35 on page 97.
- When installed, the AT-PWR1200 Power Supply extends 5.6 cm (2.2 in.) from the back panel of the switch.



- ❑ The power supply is fully installed in the slot when the tabs with the captive screws are flush with the back panel of the switch. Light pressure may be required to properly seat the module on the power connector inside the chassis.

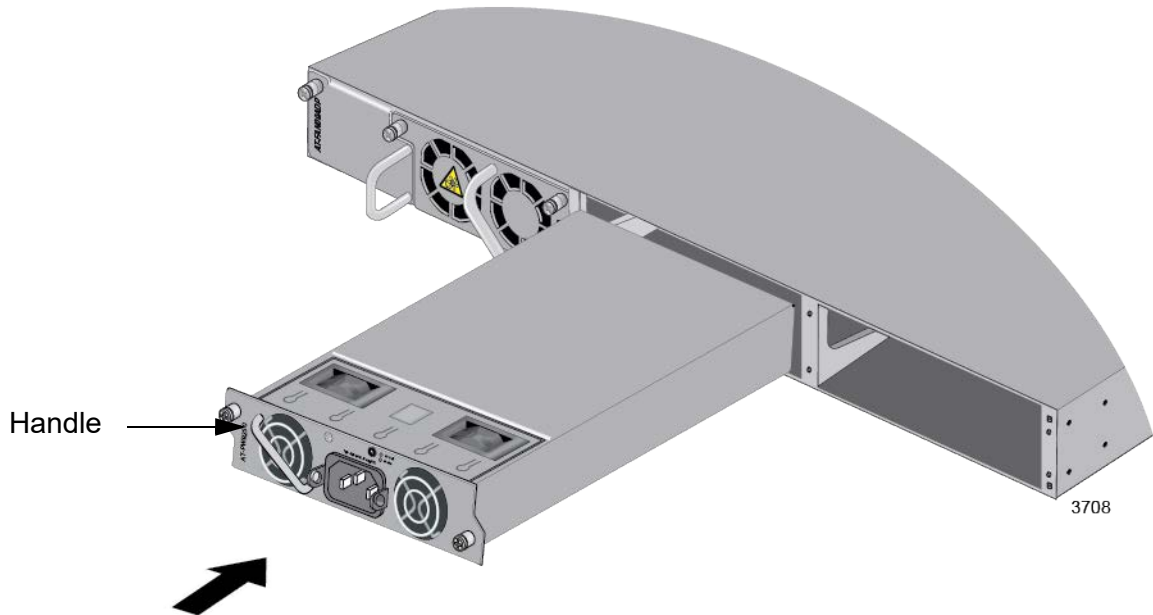

Figure 35. Installing a Power Supply



**Caution**

Do not use excessive force when seating the module, because this may damage the system or the module. If the module resists seating, remove it from the system, realign it, and try again. *E47*



**Caution**

The power supply is not hot-swappable. It might be damaged if it is installed in the switch while it is powered on. Refer to Figure 36 on page 98.

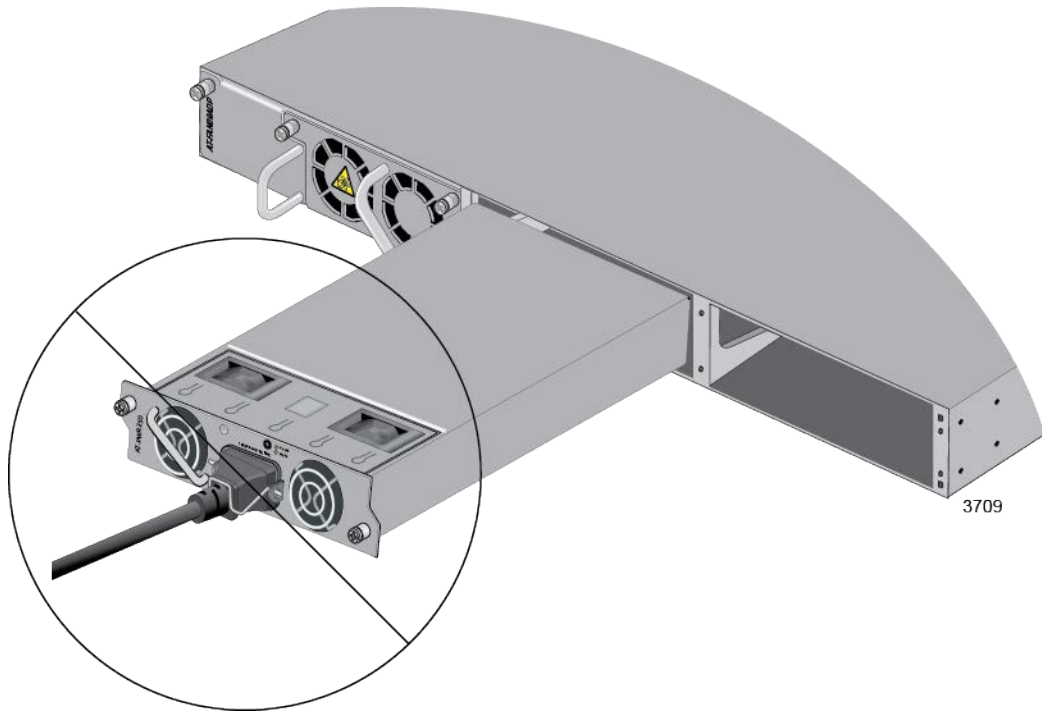

Figure 36. Improper Installation of a Power Supply

6. Secure the power supply to the chassis by tightening the two captive screws with a cross-head screwdriver. Refer to Figure 37.

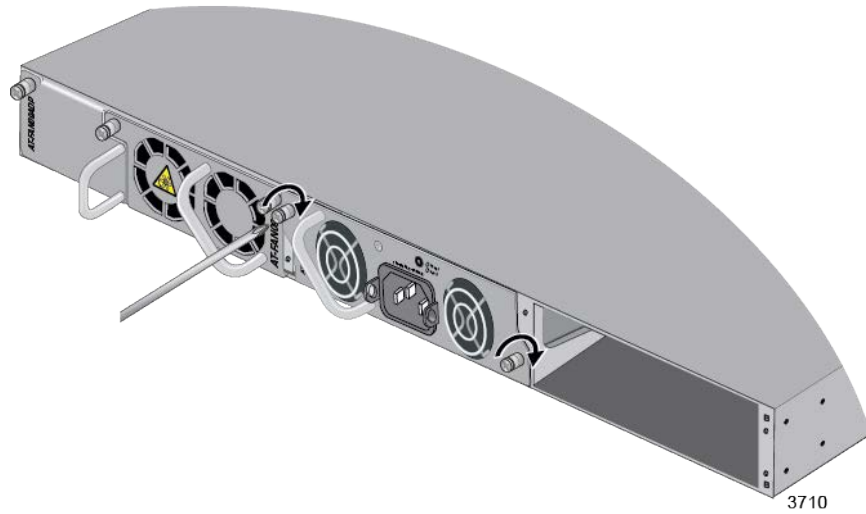

Figure 37. Tightening the Captive Screws on the Power Supply

7. If you installed the AT-PWR150, AT-PWR250 or AT-PWR800 Power Supply, install the power cord retaining clip on the AC plug. Press the sides of the clip inward and insert the two ends into the holes on the AC socket. Refer to Figure 38.

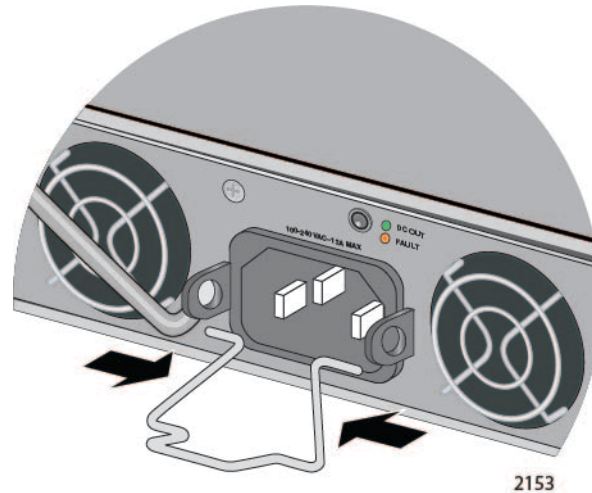

Figure 38. Installing the Power Cord Retaining Clip

---

**Note**

The AT-PWR250-80 and AT-PWR1200 Power Supplies do not come with a retaining clip.

---

8. To install a second power supply, repeat this procedure, starting with step 3.
9. If you installed only one power supply, perform the procedure in “Installing a Blank Power Supply Slot Cover” on page 100.
10. Do one of the following:
  - To install an optional module, refer to Chapter 5, “Installing AT-StackQS and AT-x9EM/XT4 Cards” on page 103.
  - To install the switch on a table, go to Chapter 6, “Installing the Switch on a Table” on page 113.
  - To install the switch in an equipment rack, refer to Chapter 7, “Installing the Switch in an Equipment Rack” on page 115.
  - To install the switch on a wall, refer to Chapter 8, “Installing the Switch on a Wall” on page 121.

## Installing a Blank Power Supply Slot Cover

---

If you installed only one power supply in the switch, install a blank panel over the empty power supply slot. To install a blank cover, perform the following procedure:

1. Position the appropriate blank panel over the slot.
  - ❑ Use the AT-PNL250 Blank Panel if the switch has only one AT-PWR150, AT-PWR250, or AT-PWR250-80 Power Supply.
  - ❑ Use the AT-PNL800/1200 Blank Panel if the switch has only one AT-PWR800 or AT-PWR1200 Power Supply. Refer to Figure 39.

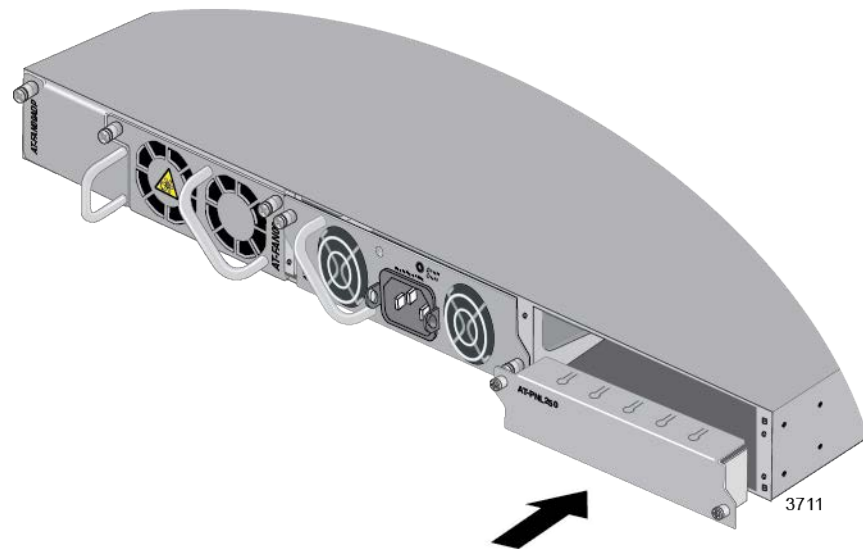

Figure 39. Installing a Blank Panel on a Power Supply Slot

2. Tighten the two captive screws with a cross-head screwdriver to secure the panel to the switch. Refer to Figure 40 on page 101.



Figure 40. Tightening the Captive Screws on the Blank Panel for the Power Supply Slot

3. Do one of the following:
  - To install an optional module, refer to Chapter 5, “Installing AT-StackQS and AT-x9EM/XT4 Cards” on page 103.
  - To install the switch on a table, go to Chapter 6, “Installing the Switch on a Table” on page 113.
  - To install the switch in an equipment rack, refer to Chapter 7, “Installing the Switch in an Equipment Rack” on page 115.
  - To install the switch on a wall, refer to Chapter 8, “Installing the Switch on a Wall” on page 121.



## Chapter 5

# Installing AT-StackQS and AT-x9EM/ XT4 Cards

---

This chapter contains the installation instructions for AT-StackQS and AT-x9EM/XT4 Cards. For descriptions, refer to “AT-StackQS Card” on page 53 and “AT-x9EM/XT4 Card” on page 55. The sections are listed here:

- “Guidelines” on page 104
- “Installing the Card” on page 105

## Guidelines

---

Please observe the following guidelines when handling AT-StackQS and AT-x9EM/XT4 Cards.

- Wear an anti-static device when handling the card.



### Caution

The device can be damaged by electrostatic discharge (ESD). Be sure to follow standard ESD protections procedures, such as wearing a wrist or foot strap, when installing the device. *ES* E106

---

- Hold the card by its faceplate or edges.
- Never touch the electronic components on the top or bottom of the card.
- Do not remove the card from its anti-static bag until you are ready to install it in the switch.
- If you need to remove the card from the switch, immediately return it in its anti-static bag and packaging container.



## Installing the Card

---

This section contains the procedure for installing AT-StackQS and AT-x9EM/XT4 Cards in x930 Switches. The illustrations show the AT-StackQS Card. The procedure is the same for the AT-x9EM/XT4 Card.

---

**Note**

Although the cards are hot-swappable, Allied Telesis recommends powering off the switch before installing them because the installation procedure requires temporarily removing the AT-FAN09 Fan Module.

---

---

**Note**

If the switch is powered on, power it off by performing step 1. If the switch is already powered off, start with step 2.

---

To install the AT-StackQS or AT-x9EM/XT4 Card, perform the following procedure:

1. If the switch is powered on, power it off by doing one of the following:
  - ❑ For the AC AT-PWR150, AT-PWR250, AT-PWR800, or AT-PWR1200 Power Supply, disconnect the power cord from the AC power source.
  - ❑ For the DC AT-PWR250-80 Power Supply, either turn Off the power switch on the power supply or power off the DC circuit.

**Warning**

This unit might have more than one power cord. To reduce the risk of electric shock, disconnect all power cords before servicing the unit. ⚡ E30

---

2. Place the switch on a table, with the back panel facing you.
3. Loosen the two captive screws on the AT-FAN09 Fan Module with a cross-head screwdriver. Refer to Figure 41 on page 106.

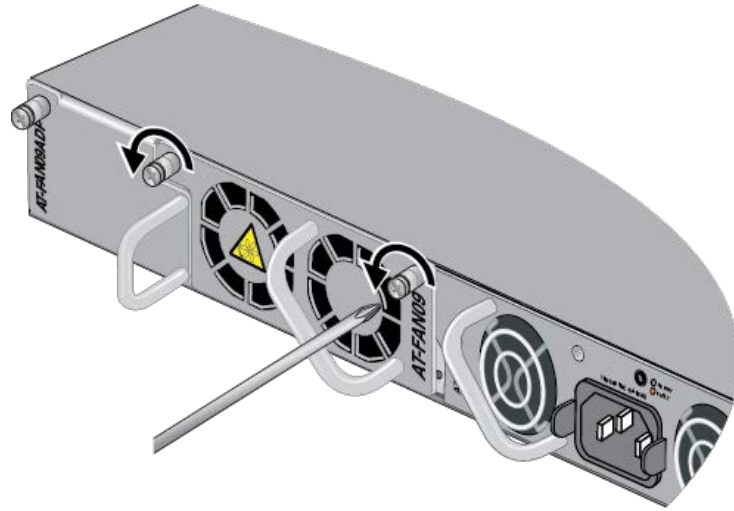

Figure 41. Loosening the Two Captive Screws on the AT-FAN09 Module

4. Carefully pull the AT-FAN09 Module from the switch. Refer to Figure 42.

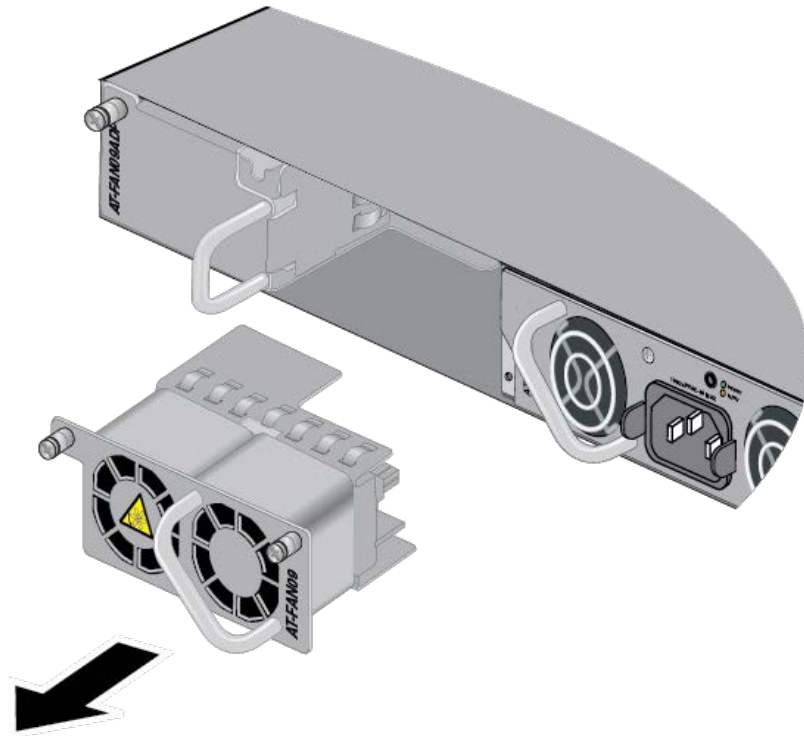

Figure 42. Removing the AT-FAN09 Module

5. Use a cross-head screwdriver to loosen the captive screw on the AT-FAN09ADP Module. Refer to Figure 43.

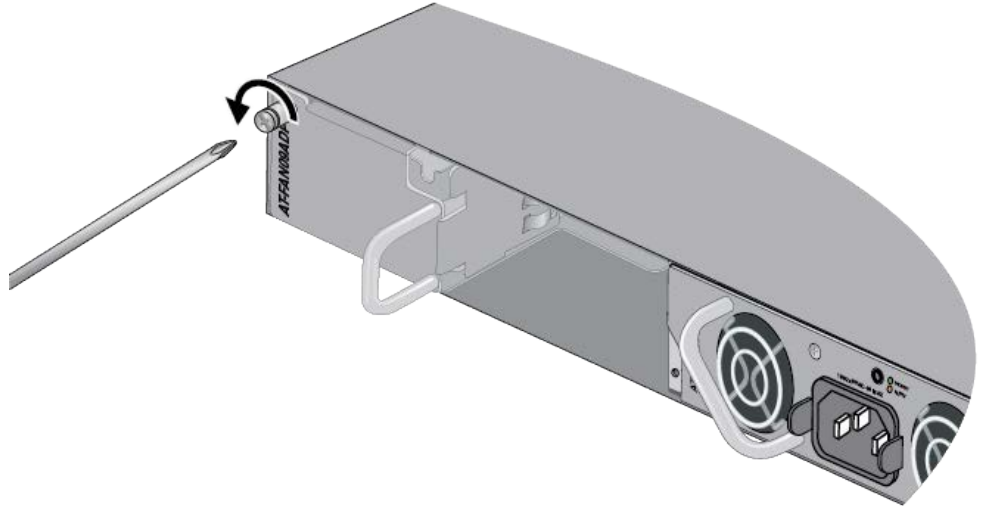

Figure 43. Loosening the Captive Screw on the AT-FAN09ADP Module

6. Carefully pull the AT-FAN09ADP Module from the switch. Refer to Figure 44.

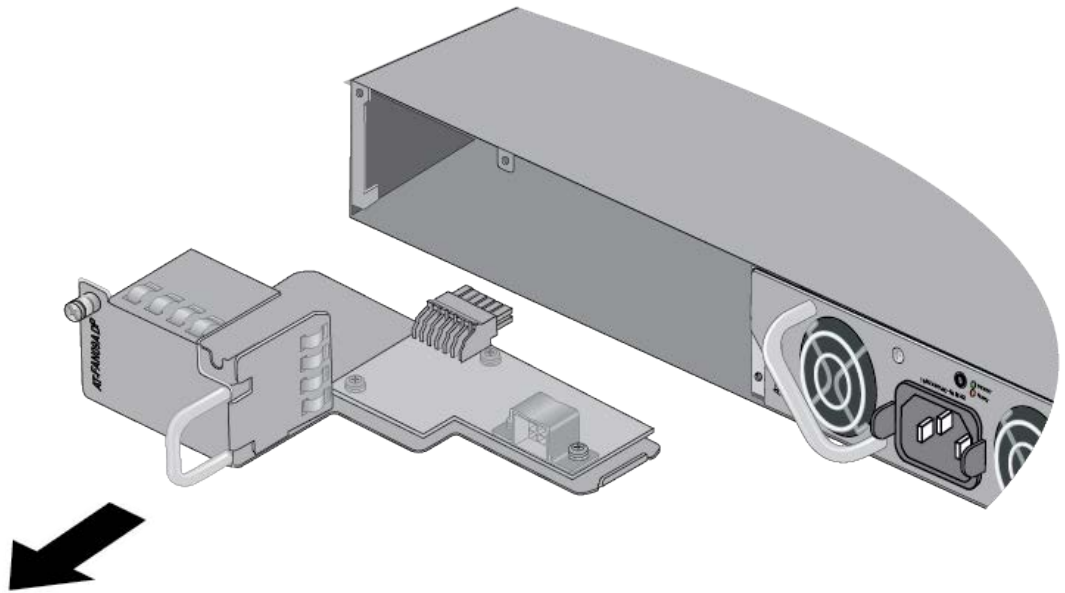

Figure 44. Removing the AT-FAN09ADP Module

7. Remove the AT-StackQS or AT-x9EM/XT4 Card from the anti-static bag. Refer to Figure 45.

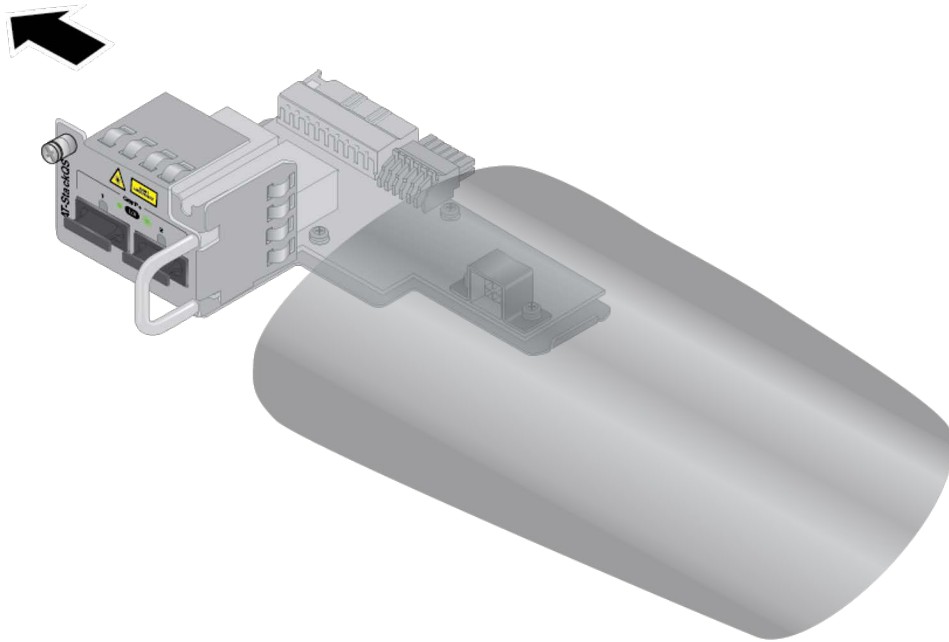

Figure 45. Removing the Card from the Anti-static Bag

8. Carefully align the card in the slot and slide it into the switch. The left edge of the card fits into the slot in the bottom corner of the switch. Refer to Figure 46 on page 109.

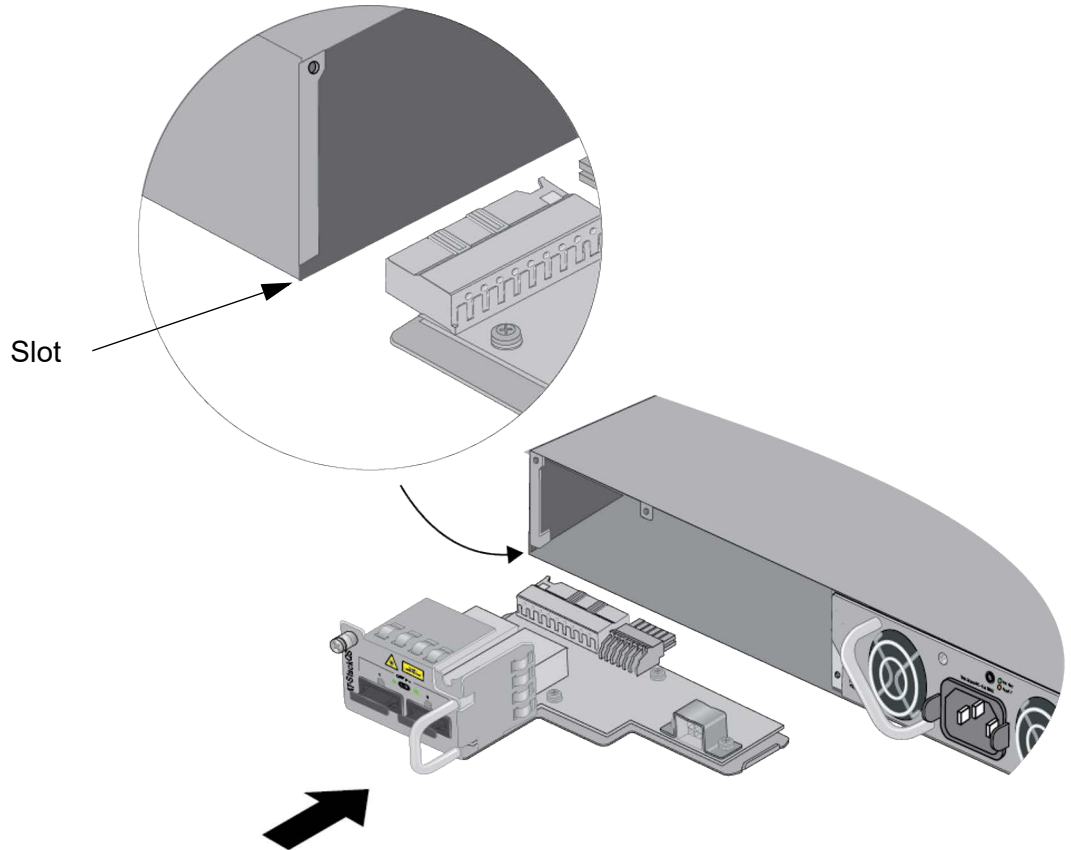

Figure 46. Aligning the Card in the Slot

9. When you feel the card make contact with the connector inside the switch, gently press on the handle to seat it on the connector. Refer to Figure 47.

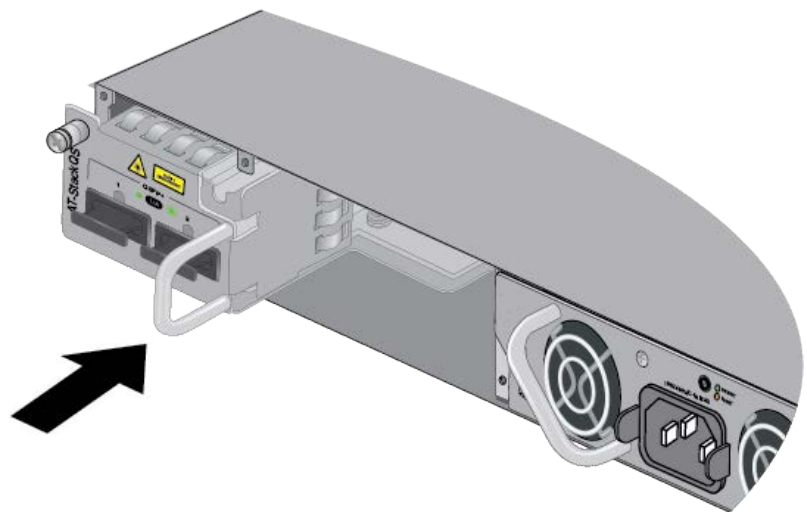

Figure 47. Seating the Card in the Switch

10. Tighten the captive screw to secure the card in the switch. Refer to Figure 48.

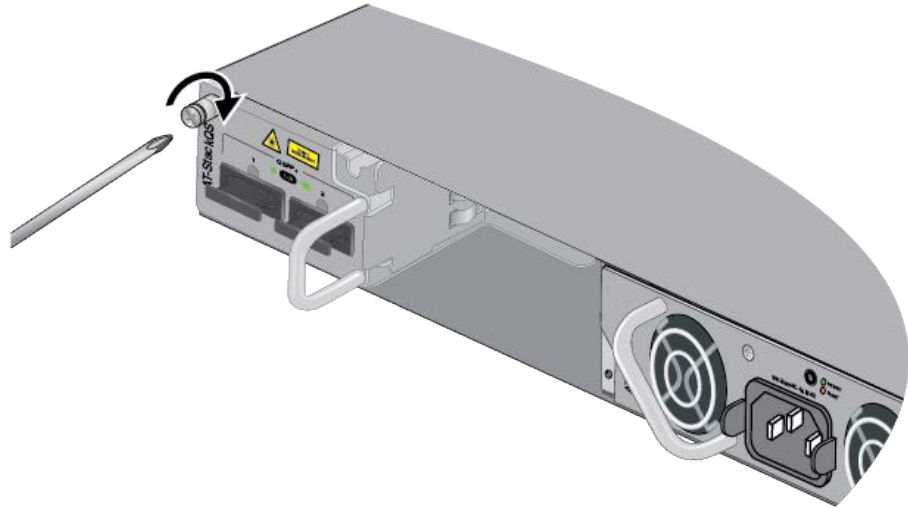

Figure 48. Tightening the Captive Screw on the Card

11. Align the AT-FAN09 Module in the slot and carefully slide it into the switch. Refer to Figure 49.

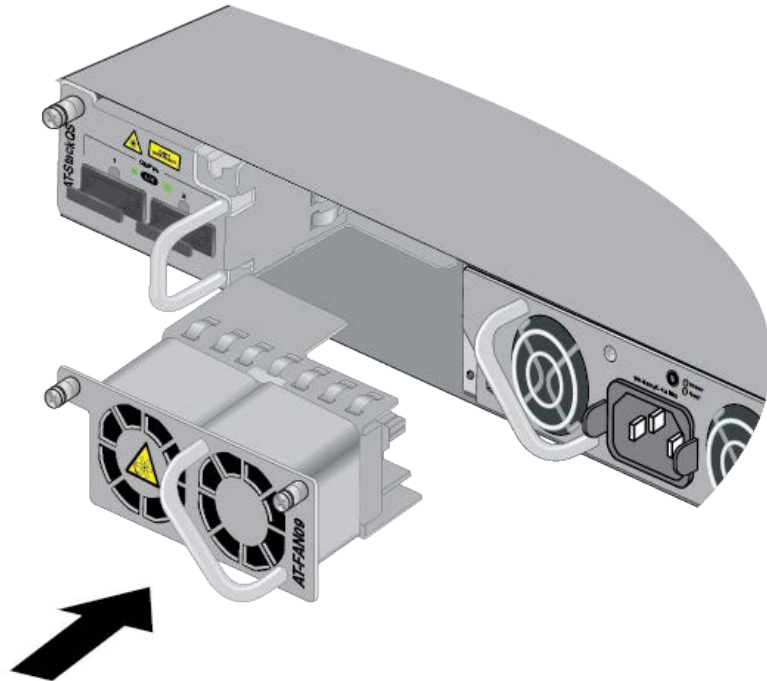

Figure 49. Aligning the AT-FAN09 Module in the Slot

12. Tighten the two captive screws on the AT-FAN09 Module to secure it to the switch. Refer to Figure 50.

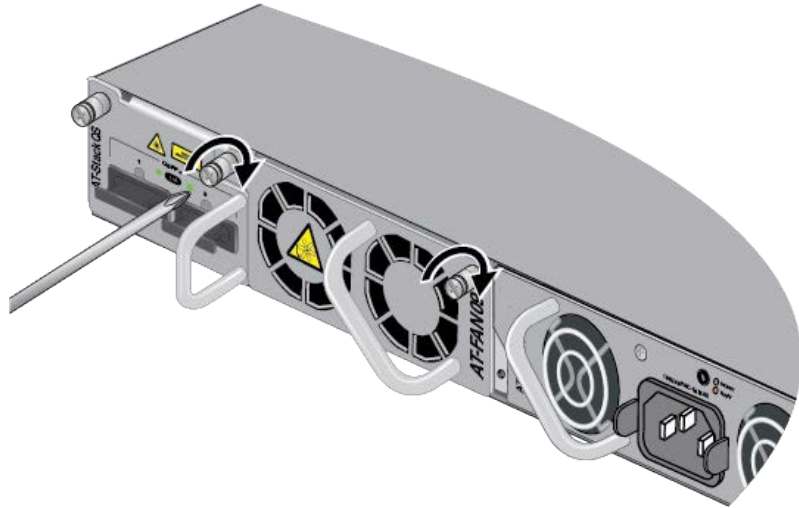

Figure 50. Tightening the Two Captive Screws on the AT-FAN09 Module

13. Store the AT-FAN09ADP Module in an anti-static bag and place it in a safe location. Refer to Figure 51.

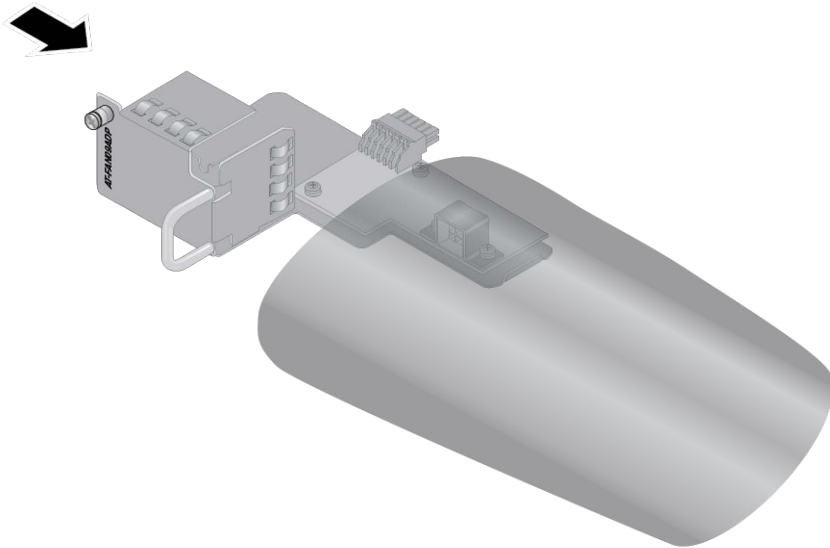

Figure 51. Storing the AT-FAN09ADP Module in an Anti-static Bag

14. If you purchased AT-StackQS Cards for other sx930 Switches, repeat this procedure to install the cards.

15. Do one of the following:

- To install the switch on a table, go to Chapter 6, “Installing the Switch on a Table” on page 113.
- To install the switch in an equipment rack, refer to Chapter 7, “Installing the Switch in an Equipment Rack” on page 115.
- To install the switch on a wall, refer to Chapter 8, “Installing the Switch on a Wall” on page 121.



## Chapter 6

# Installing the Switch on a Table

To install the switch on a table, perform the following procedure:



### Warning

Switches should not be stacked on a table or desktop because that could present a personal safety hazard if you need to move or replace units. E91



### Warning

The switch is heavy. Always ask for assistance when moving or lifting the device so as to avoid injuring yourself or damaging the equipment.

1. Review the procedure in “Choosing a Site for the Switch” on page 89 to verify that the selected site is suitable for the unit.
2. Check to be sure that the table or desk is strong enough to support the weight of the switch.
3. Check to be sure that all of the appropriate components are included in the shipping container. Refer to “Unpacking the Switch” on page 90.
4. Place the switch upside down on a level, secure table or desk.
5. Install the seven bumper feet to the bottom of the switch. Refer to Figure 52.

Three bumper feet should be installed along the front edge of the bottom panel and four feet along the rear edge.

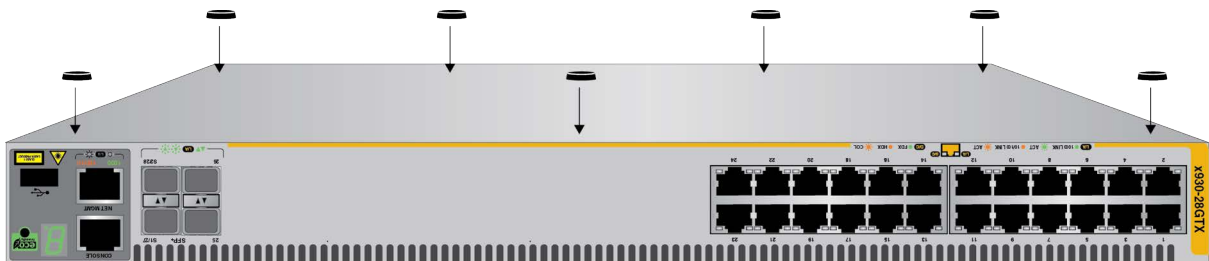

3706

Figure 52. Installing the Bumper Feet

---

**Note**

The bumper feet are only to be used if you are installing the switch on a table or desk. Do not install the bumper feet if you are installing the unit in an equipment rack or on a wall.

---

6. Turn the chassis over.
7. Repeat this procedure on any other switches that are to be installed on a table or desktop.
8. Do one of the following:
  - ❑ If any of the switches have the AT-PWR250-80 DC Power Supply, go to Chapter 9, “Wiring the DC Connector on the AT-PWR250-80 Power Supply” on page 137.
  - ❑ Otherwise, go to Chapter 10, “Displaying the AlliedWare Plus Version Number” on page 141.

## Chapter 7

# Installing the Switch in an Equipment Rack

---

This chapter contains instructions for installing the switch in an equipment rack. The sections in the chapter are listed here:

- “Required Items” on page 116
- “Installing the Switch in an Equipment Rack” on page 117

## Required Items

---

This procedure requires the following items:

- Two equipment rack brackets (included with the switch)
- Eight bracket screws (included with the switch)
- Cross-head screwdriver (not provided)
- Four standard equipment rack screws (not provided)

---

### **Note**

The switch comes with four equipment rack brackets and sixteen screws. Two brackets and eight screws are used to install the unit in an equipment rack. The extra brackets and screws are for installing the device on a wall.

---

## Installing the Switch in an Equipment Rack

---

To install the switch in a 19-inch equipment rack, perform the following procedure:



---

**Caution**

The chassis may be heavy and awkward to lift. Allied Telesis recommends that you get assistance when mounting the chassis in an equipment rack. *ES* E28

---

---

**Note**

The x930 Series switches can be installed in an equipment rack with the AT-RKMT-SL01 Sliding Rack Mount Kit. For instructions, refer to the AT-RKMT-SL01 Sliding Rack Mount Kit Installation Guide.

---

1. Place the unit on a level, secure surface.
2. Attach two of the rack mount brackets to the sides of the switch using eight of the bracket screws included with the unit. Figure 53 on page 118 and Figure 54 on page 119 illustrate the four possible bracket positions.



Figure 53. Attaching the Equipment Rack Brackets

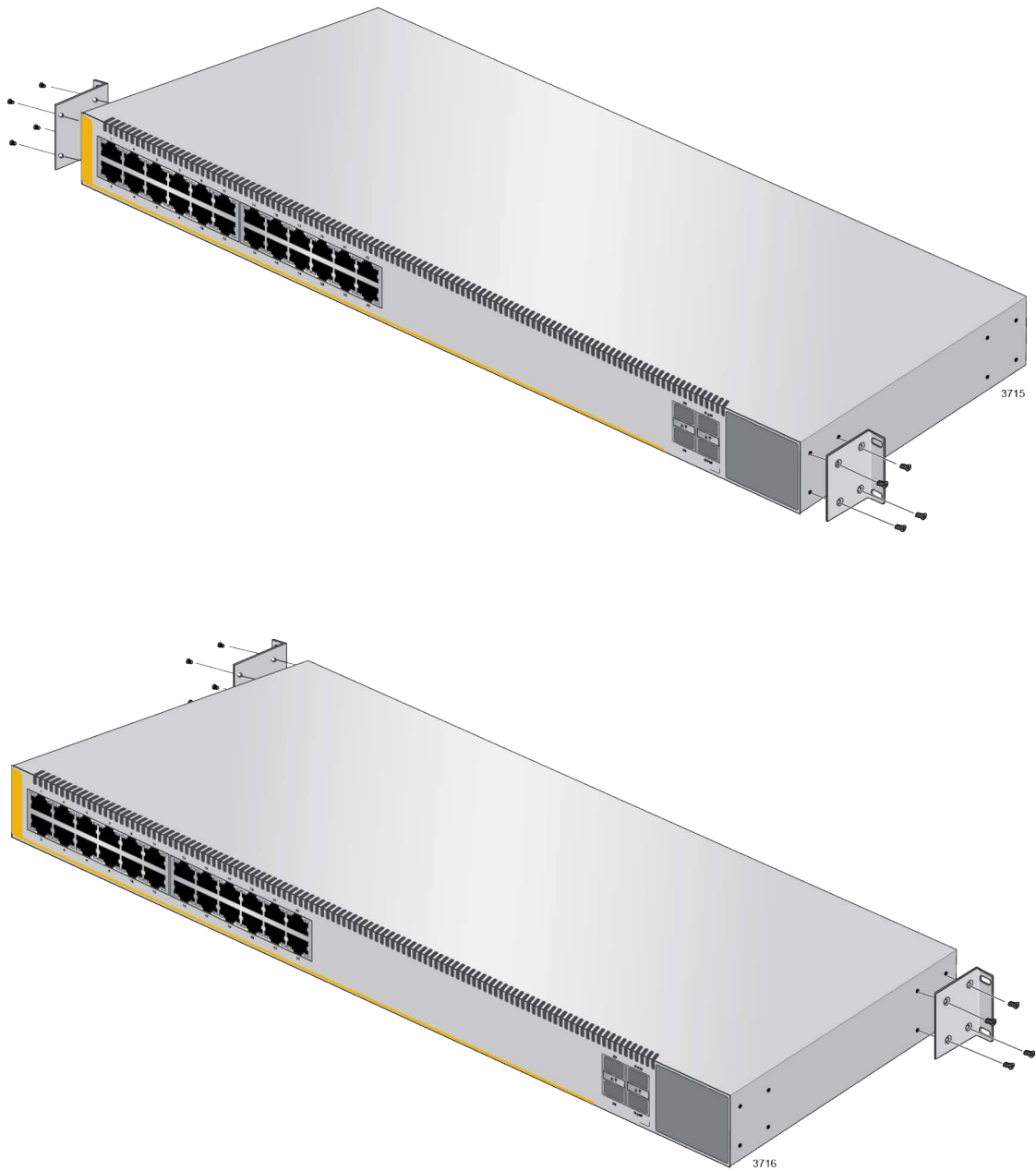

Figure 54. Attaching the Equipment Rack Brackets (Continued)

3. Have two people hold the switch in the equipment rack while you secure it using standard equipment rack screws (not provided). Refer to Figure 55 on page 120.



Figure 55. Installing the Switch in an Equipment Rack

4. Repeat this procedure if there are other switches to be installed in an equipment rack.
5. Do one of the following:
  - If you have not installed the power supplies yet, go to Chapter 4, “Installing the Power Supplies” on page 93.
  - If any of the switches contain the AT-PWR250-80 DC Power Supply, go to Chapter 9, “Wiring the DC Connector on the AT-PWR250-80 Power Supply” on page 137.
  - Otherwise, go to Chapter 10, “Displaying the AlliedWare Plus Version Number” on page 141.



## Chapter 8

# Installing the Switch on a Wall

---

The procedures in this chapter are listed here:

- “Switch Orientation on the Wall” on page 122
- “Recommended Minimum Wall Area Dimensions” on page 123
- “Plywood Base for a Wall with Wooden Studs” on page 125
- “Installation Guidelines” on page 127
- “Installing the Plywood Base” on page 129
- “Installing the Switch on the Plywood Base” on page 130
- “Installing the Switch on a Concrete Wall” on page 133

## Switch Orientation on the Wall

---

You may install the switch on a wall with the front panel facing to the left or right, as shown in Figure 56. You may not install it with the front panel facing to the top or bottom.

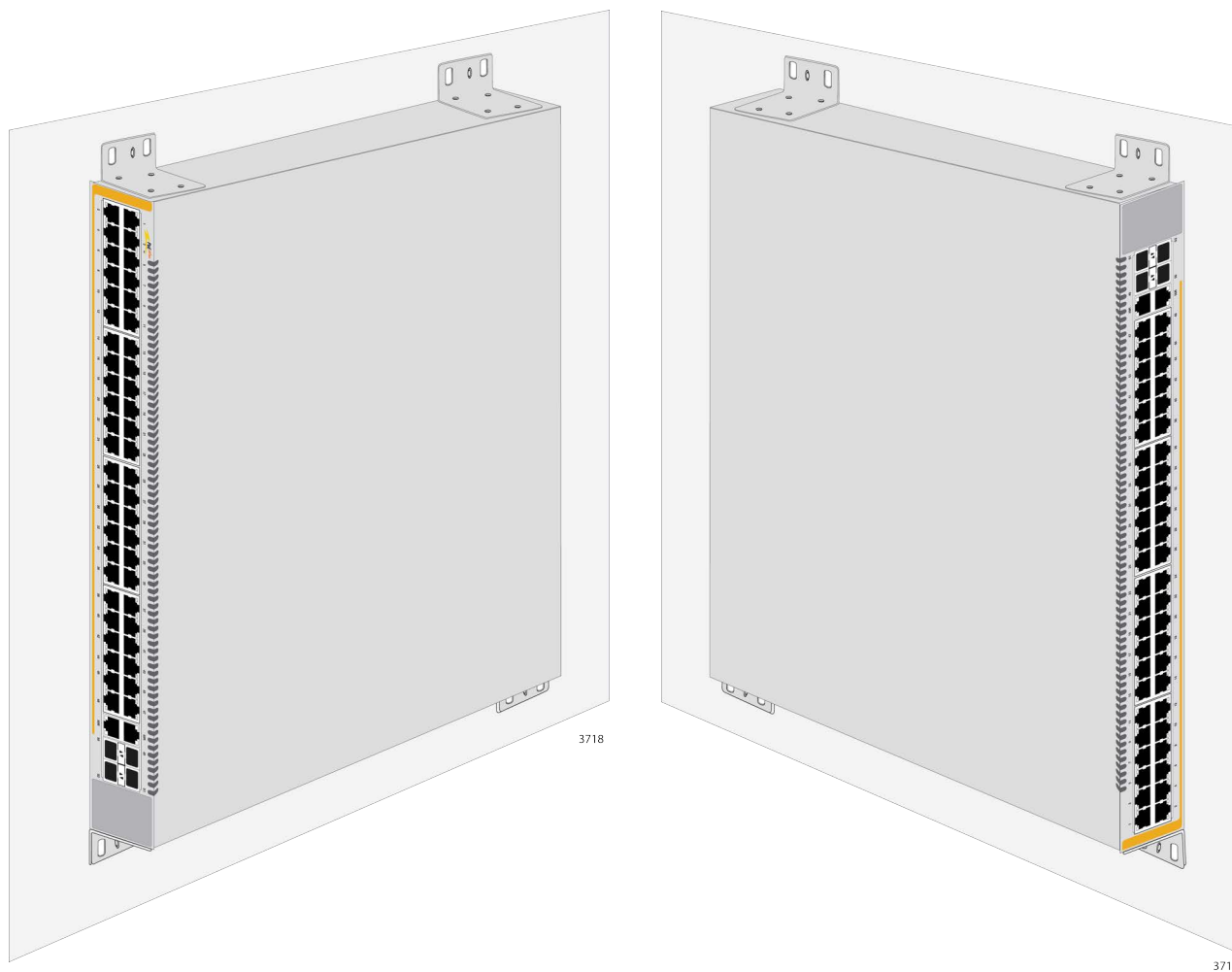

Figure 56. Positions of the Switch on the Wall

## Recommended Minimum Wall Area Dimensions

The recommended minimum dimensions for the reserved wall area for the switch are listed here:

- Width: 68.0 centimeters (27 inches)
- Height: 58.4 centimeters (23 inches)

You should position the switch in the reserved wall area such that the front panel has more space than the rear panel. This may make it easier for you to service and maintain the unit. Figure 57 and Figure 58 on page 124 illustrate the recommended positions of the switch in the reserved area when the front panel is on the left and right, respectively.

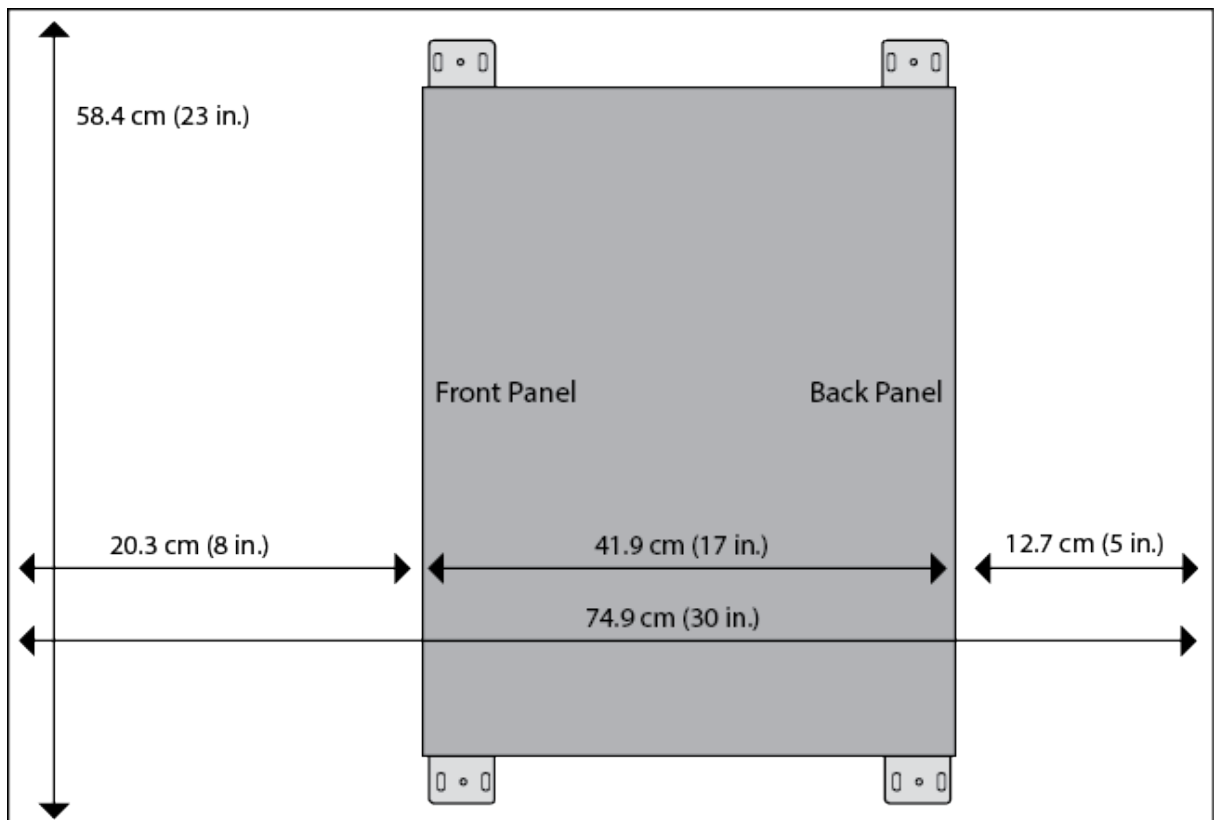

3720

Figure 57. Minimum Wall Area Dimensions with the Front Panel on the Left

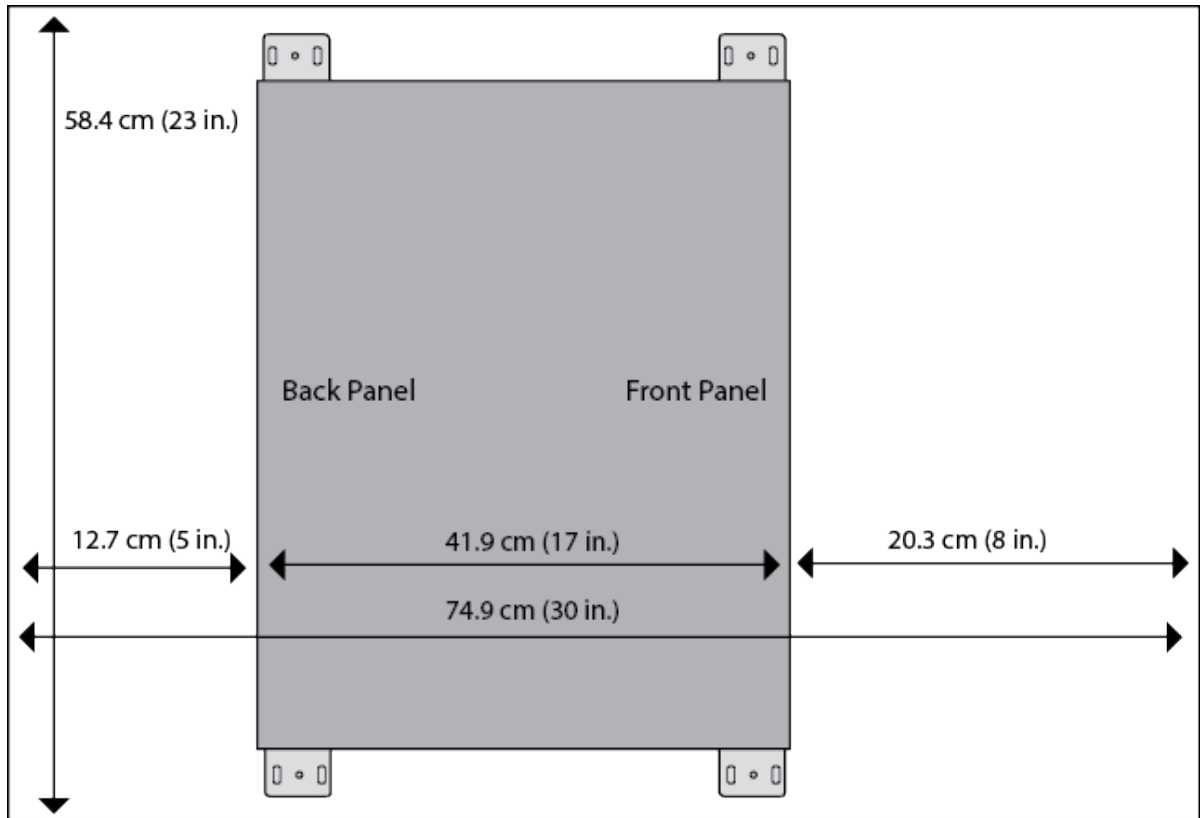

3721

Figure 58. Minimum Wall Area Dimensions with the Front Panel on the Right

## Plywood Base for a Wall with Wooden Studs

If you are installing the switch on a wall that has wooden studs, Allied Telesis recommends using a plywood base to attach the device to the wall. (A plywood base is not required for a concrete wall.) Refer to Figure 59.

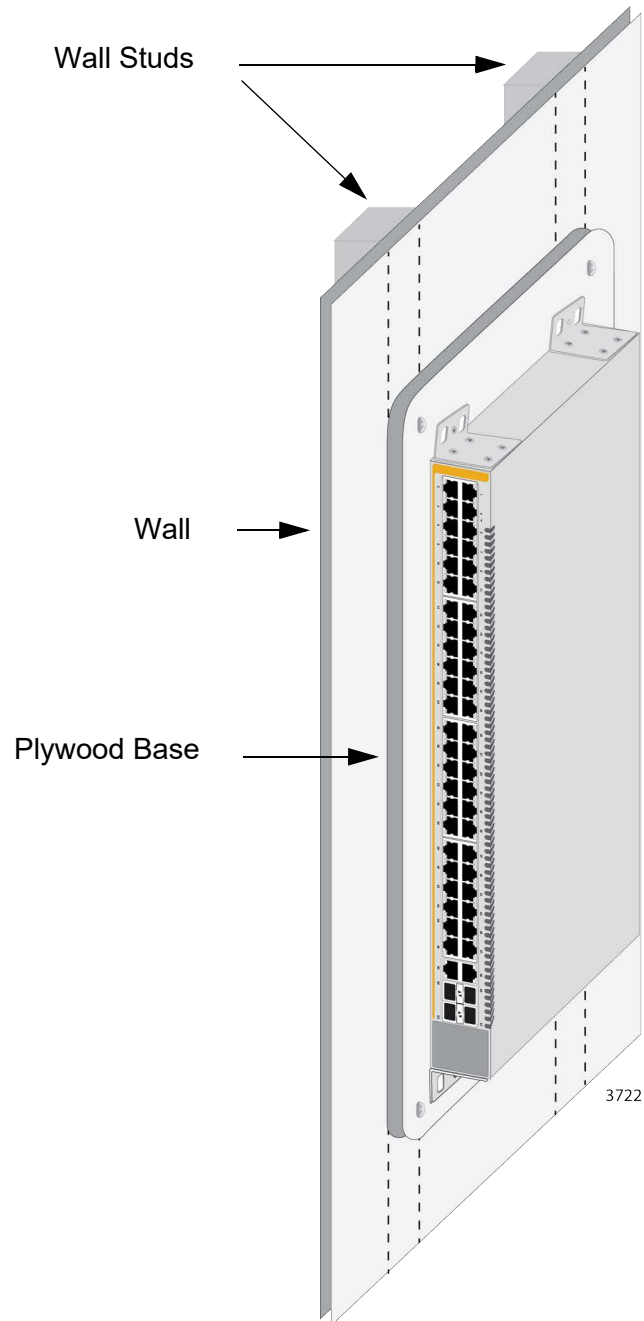

Figure 59. Switch on the Wall with a Plywood Base

The plywood base allows you to mount the switch on two wall studs. If you install the switch without the base, you could attach only one side to a stud. This is because the standard distance between two studs in a wall is 41 centimeters (16 inches) while the distance between the left and right brackets on the switch is 36.2 centimeters (14 1/4 inches).

The recommended minimum dimensions of the plywood base are listed here:

- ❑ Width: 58.4 centimeters (23 inches)
- ❑ Height: 55.9 centimeters (22 inches)
- ❑ Thickness: 5.1 centimeters (2 inches)

The dimensions assume the wall studs are 41 centimeters (16 inches) apart. You may need to adjust the width of the base if the distance between the studs in your wall is different than the industry standard.

You should install the plywood base to the wall and then install the switch on the base. Refer to Figure 60.

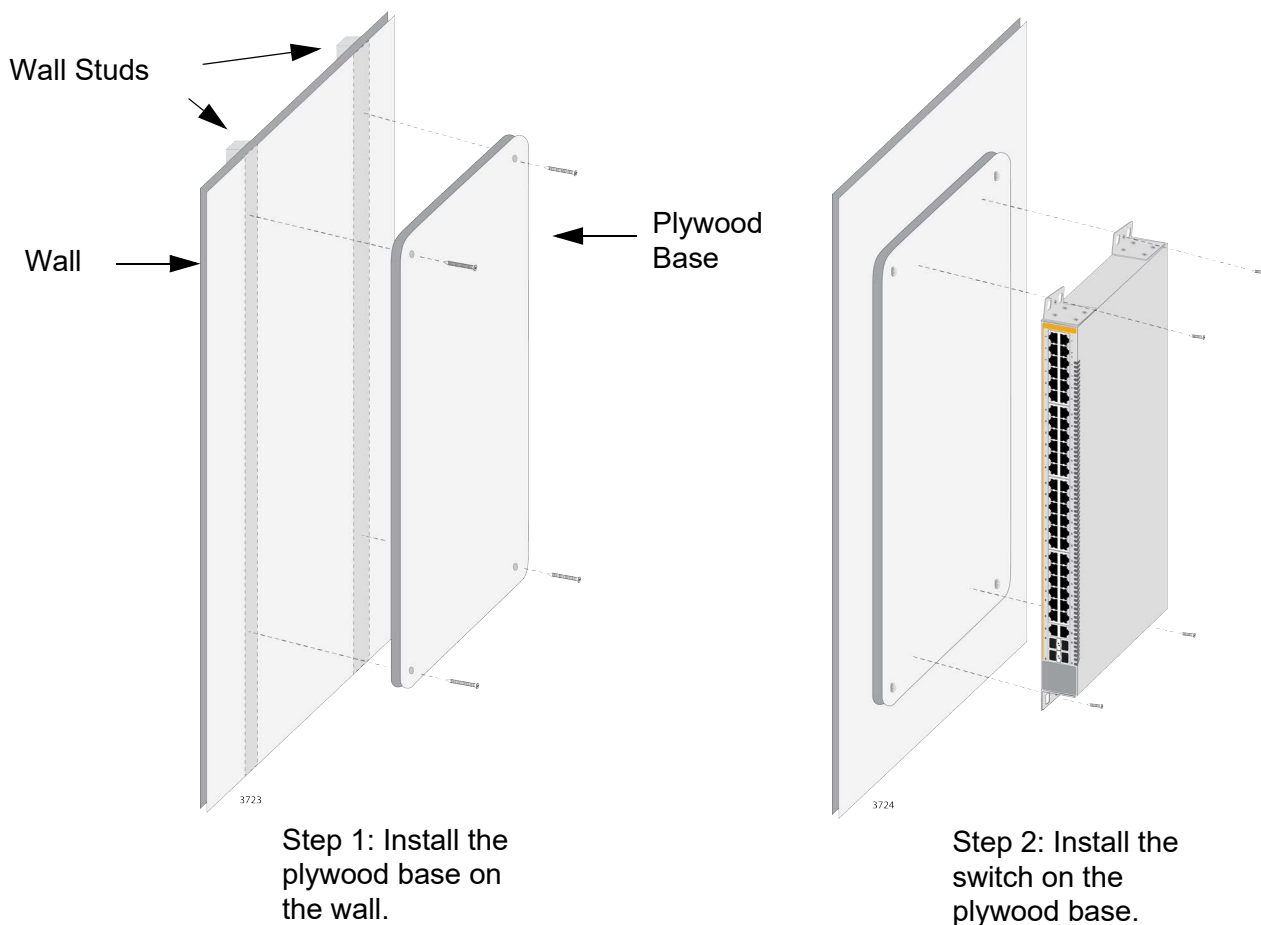

Figure 60. Steps to Installing the Switch with a Plywood Base

## Installation Guidelines

---

Here are the guidelines to installing the switch on a wall:

- You may install the switch on a wall that has wooden studs.
- You may install it on a concrete wall.
- If you are installing the switch on a wall with wooden studs, you should use a plywood base to support the switch. For more information, refer to “Plywood Base for a Wall with Wooden Studs” on page 125. A plywood base is not required for a concrete wall.
- You should not install the switch on a wall that has metal studs. Metal studs may not be strong enough to safely support the device.
- You should not install the switch only on sheetrock or similar material. Sheetrock is not strong enough to safely support the device.
- You should install the power supplies before installing the switch on a wall. For instructions, refer to Chapter 4, “Installing the Power Supplies” on page 93.



### Warning

The device is heavy. Always ask for assistance before moving or lifting it to avoid injuring yourself or damaging the equipment.

---



### Warning

The device should be installed on a wall by a qualified building contractor. Serious injury to yourself or others or damage to the equipment may result if it is not properly fastened to the wall.  E105

---

## Tools and Material

Here are the required tools and material for installing the switch on a wall:

- Sixteen bracket screws (included with the switch)
- Four wall or equipment rack brackets (included with the switch)
- Four wall screws (included with the switch)
- Four anchors for a concrete wall (included with the switch)
- Cross-head screwdriver (not provided)
- Stud finder for a wooden wall, capable of identifying the middle of wall studs and hot electrical wiring (not provided)
- Drill and 1/4” carbide drill bit for a concrete wall (not provided)

- ❑ Plywood base if you are installing the switch on a wall with wooden studs (not provided.) Refer to “Plywood Base for a Wall with Wooden Studs” on page 125 for illustrations.
- ❑ Four screws and anchors for attaching the plywood base to the wall (not provided)



**Caution**

The supplied screws and anchors may not be appropriate for all walls. A qualified building contractor should determine the proper hardware requirements for your wall prior to installing the equipment.  E88

---



## Installing the Plywood Base

---

A plywood base is recommended when installing the switch on a wall that has wooden studs. Refer to “Plywood Base for a Wall with Wooden Studs” on page 125. Consult a qualified building contractor for installation instructions for the plywood base. The installation guidelines are listed here:

- ❑ You should use a stud finder to identify the middle of studs and hot electrical wiring in the wall.
- ❑ You should attach the base to two wall studs with a minimum of four screws.
- ❑ The selected wall location for the base should adhere to the recommendations in “Choosing a Site for the Switch” on page 89 and “Recommended Minimum Wall Area Dimensions” on page 123.

## Installing the Switch on the Plywood Base

---

This procedure assumes that the plywood base for the switch is already installed on the wall. Please review “Reviewing Safety Precautions” on page 84 and “Choosing a Site for the Switch” on page 89 before performing this procedure. Allied Telesis recommends a minimum of three people for this procedure.



### Caution

The device is heavy. Always ask for assistance before moving or lifting it to avoid injuring yourself or damaging the equipment.

---



### Caution

The device should be installed on a wall by a qualified building contractor. Serious injury to yourself or others or damage to the equipment may result if it is not properly fastened to the wall. *ES*  
E105

---

To install the switch on the plywood base, perform the following procedure:

1. Place the switch in a table.
2. Install the four brackets with the sixteen screws that come with the switch to the sides of the unit, as shown in Figure 61.



Figure 61. Installing the Brackets to the Switch for Wall Installation

The sides of the switch have two sets of holes. One set is for installing the switch on a wall with the brackets and the other set is for the AT-RKMT-SL01 Rack Mounting Kit. The holes for the brackets are identified in Figure 62.

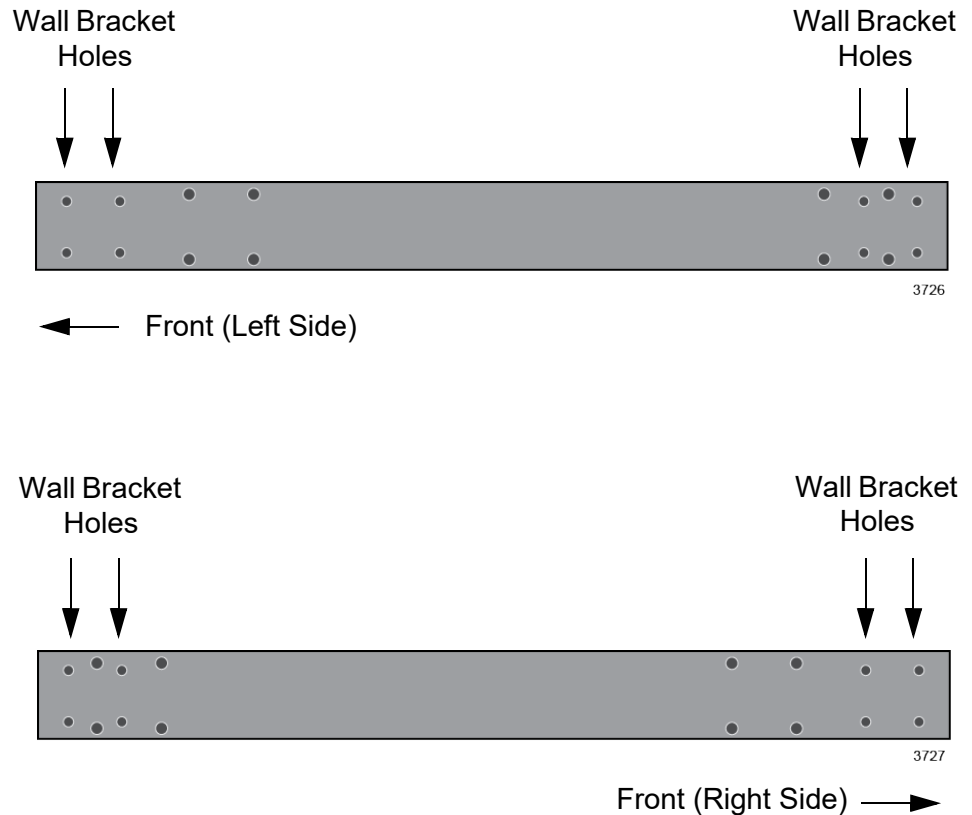

Figure 62. Mounting Holes

3. After attaching the brackets to the side of the switch, have two people hold the switch on the plywood base on the wall while you secure it with the four provided screws. Refer to Figure 63 on page 132.

Please follow these guidelines as you position the switch on the wall:

- Position the switch so that the front panel faces to the left or the right. Refer to Figure 56 on page 122. You may not install the switch with the front panel facing up or down.
- Leave sufficient space from other devices or walls so that you can access the front and back panels. Refer to “Recommended Minimum Wall Area Dimensions” on page 123.

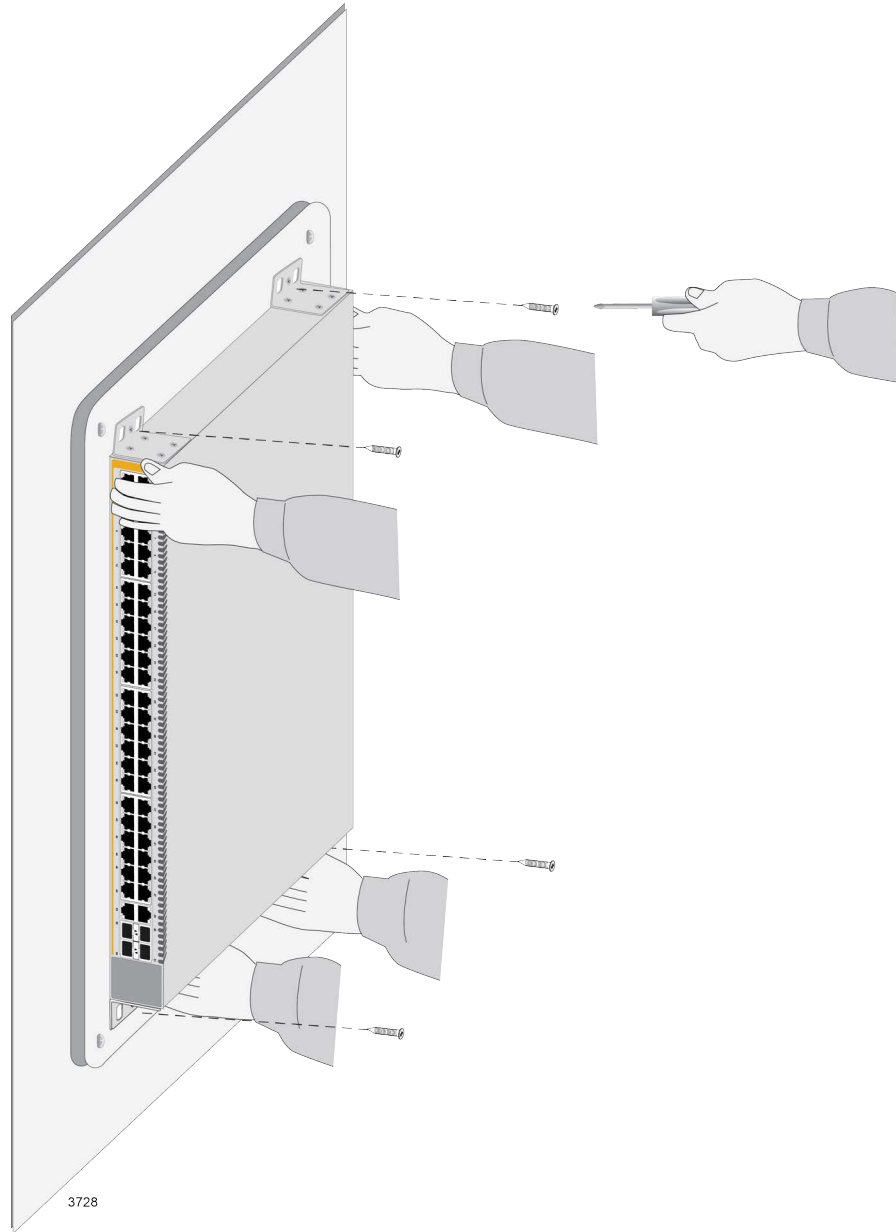

Figure 63. Securing the Switch to the Plywood Base

4. Repeat this procedure to install other switches on a wall.
5. Do one of the following:
  - ❑ If any of the switches contain the AT-PWR250-80 DC Power Supply, go to Chapter 9, “Wiring the DC Connector on the AT-PWR250-80 Power Supply” on page 137.
  - ❑ Otherwise, go to Chapter 10, “Displaying the AlliedWare Plus Version Number” on page 141.

## Installing the Switch on a Concrete Wall

---

Allied Telesis recommends a minimum of three people for this procedure. To install the switch on a concrete wall, perform the following procedure:

**Caution**

The switch is heavy. Always ask for assistance before moving or lifting the device so as to avoid injuring yourself or damaging the equipment.

---

**Caution**

The switch should be installed on a wall by a qualified building contractor. Serious injury to yourself or others or damage to the equipment may result if the switch is not properly secured to the wall. *GE* E105

---

1. Place the switch in a table.
2. Install the four brackets with sixteen screws that come with the switch to the sides of the unit, as shown in Figure 61 on page 130 and Figure 62 on page 131.
3. Have two people hold the switch on the concrete wall at the selected location for the device while you use a pencil or pen to mark the wall with the locations of the four screw holes in the four brackets. Refer to Figure 64 on page 134.

Please follow these guidelines as you position the switch on the wall:

- Position the switch so that the front panel faces the left or the right. Refer to Figure 56 on page 122. You may not install the switch with the front panel facing up or down.
- Leave sufficient space from other devices or walls so that you can access the front and back panels. Refer to “Recommended Minimum Wall Area Dimensions” on page 123.

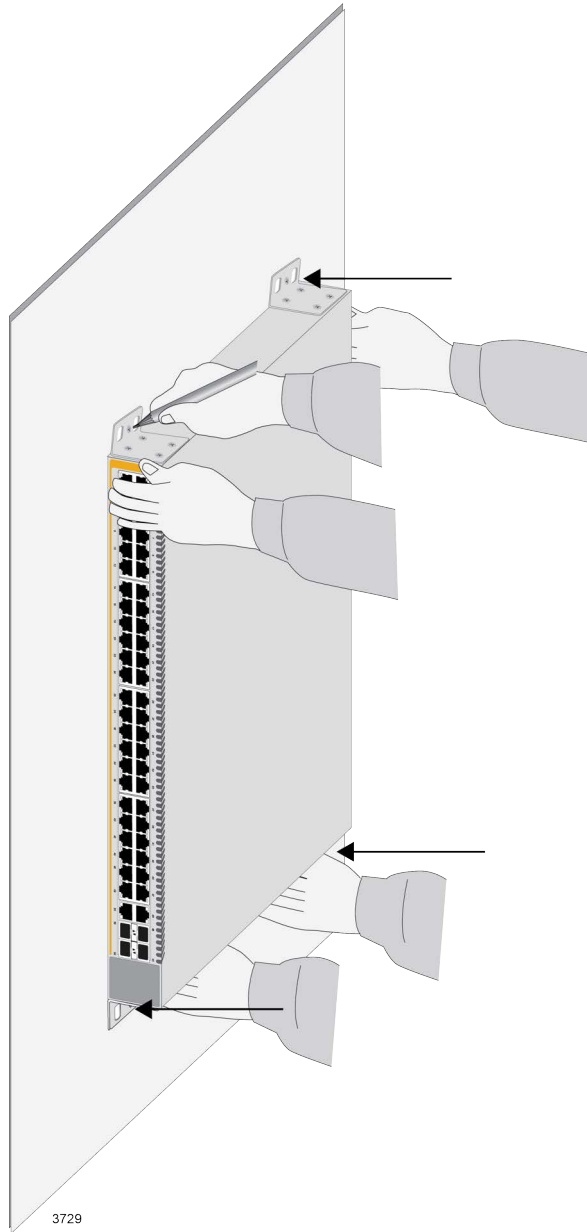

Figure 64. Marking the Locations of the Bracket Holes on a Concrete Wall

4. Place the switch on a table or desk.
5. Use a drill and a 1/4" carbide drill bit to pre-drill the four holes you marked in step 3. Please review the following guidelines:
  - ❑ Prior to drilling, set the drill to hammer and rotation mode. The modes break up the concrete and clean out the hole.
  - ❑ Allied Telesis recommends cleaning out the holes with a brush or compressed air.

6. Insert the four anchors into the holes.
7. Have two people hold the switch at the selected wall location while you secure it with the four provided screws. Refer to Figure 65.

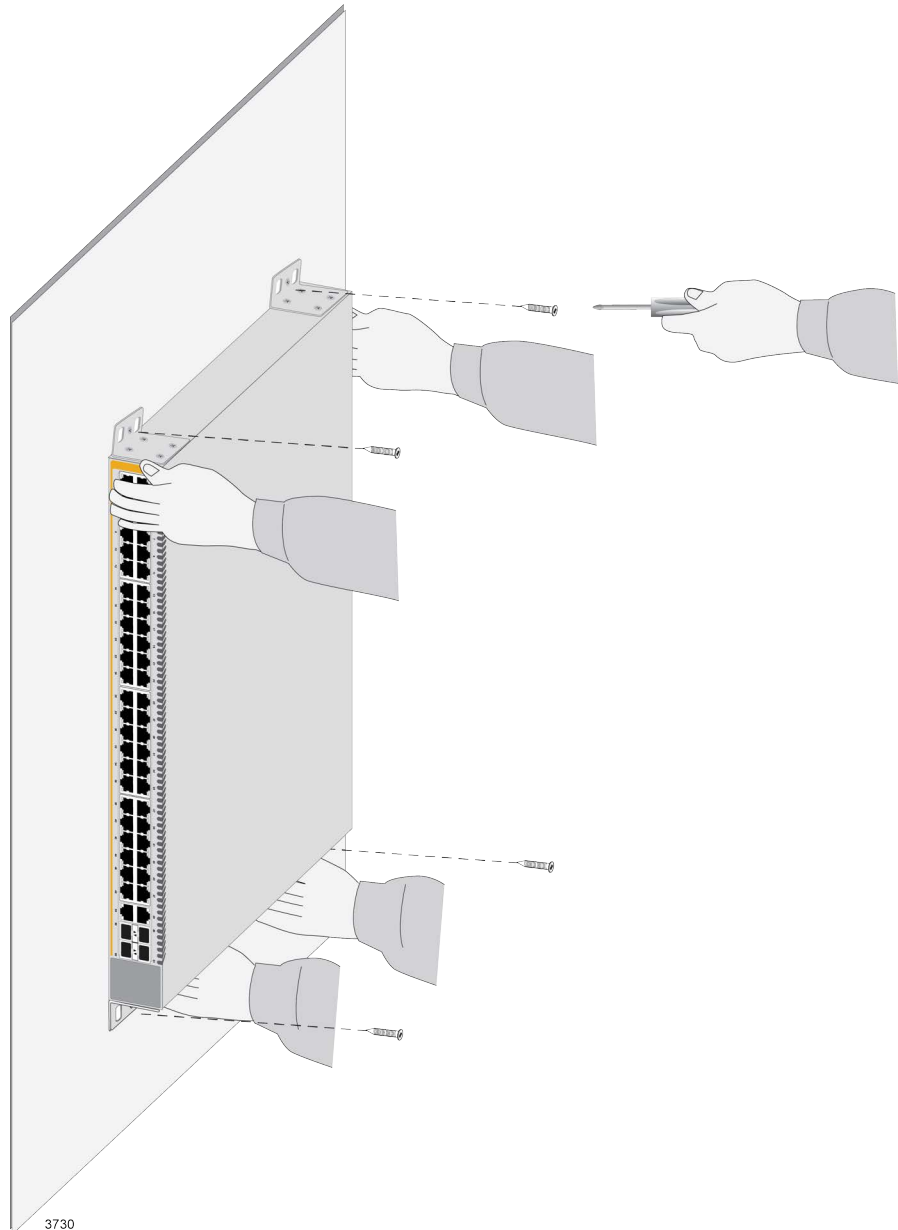

Figure 65. Installing the Switch on a Concrete Wall

8. Repeat this procedure for any other switches that are to be installed on concrete walls.

9. Do one of the following:
  - ❑ If any switches contain the AT-PWR250-80 DC Power Supply, go to Chapter 9, “Wiring the DC Connector on the AT-PWR250-80 Power Supply” on page 137.
  - ❑ Otherwise, go to Chapter 10, “Displaying the AlliedWare Plus Version Number” on page 141.



## Chapter 9

# Wiring the DC Connector on the AT-PWR250-80 Power Supply

---

This chapter contains instructions on how to wire the DC connector on the AT-PWR250-80 DC power supply.



---

**Warning**

As a safety precaution, install a circuit breaker with a minimum value of 15 Amps between the equipment and the DC power source.

*↪* E9

---



---

**Warning**

Always connect the wires to the LAN equipment first before connecting them to the circuit breaker. Do not work with HOT feeds to avoid the danger of physical injury from electrical shock. Always verify that the circuit breaker is in the OFF position before connecting the wires to the circuit breaker. *↪* E9

---



---

**Warning**

For centralized DC power connection, install only in a restricted access area. *↪* E23

---



---

**Warning**

This equipment must be installed in a Restricted Access location. *↪* E45

---

---

**Note**

A tray cable is required to connect the power source if the unit is powered by centralized DC power. The tray cable must be a UL listed Type TC tray cable and rated at 600 V and 90 degrees C, with three conductors, minimum 14 AWG. *↪* E24

---

To wire the DC connector on the AT-PWR250-80 DC Power Supply, perform the following procedure:

1. Power off the DC circuit to which the switch will be connected.

2. Verify that the On/Off switch on the power supply is in the Off position. Refer to Figure 66 on page 138.

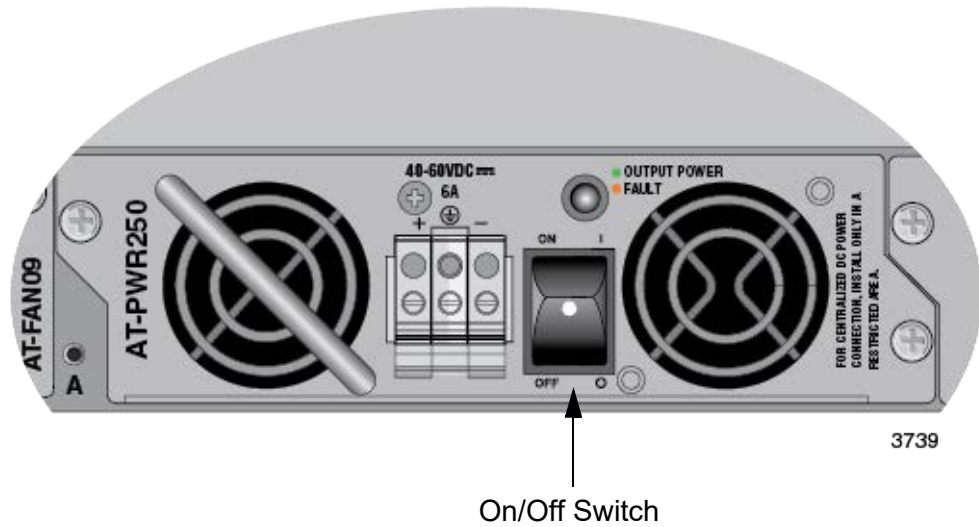

Figure 66. On/Off Switch on AT-PWR250-80 Power Supply

3. Use the legend above the terminal block to identify the terminals. The terminals are **positive**, **power supply ground** and **negative**, from left to right. Refer to Figure 67.

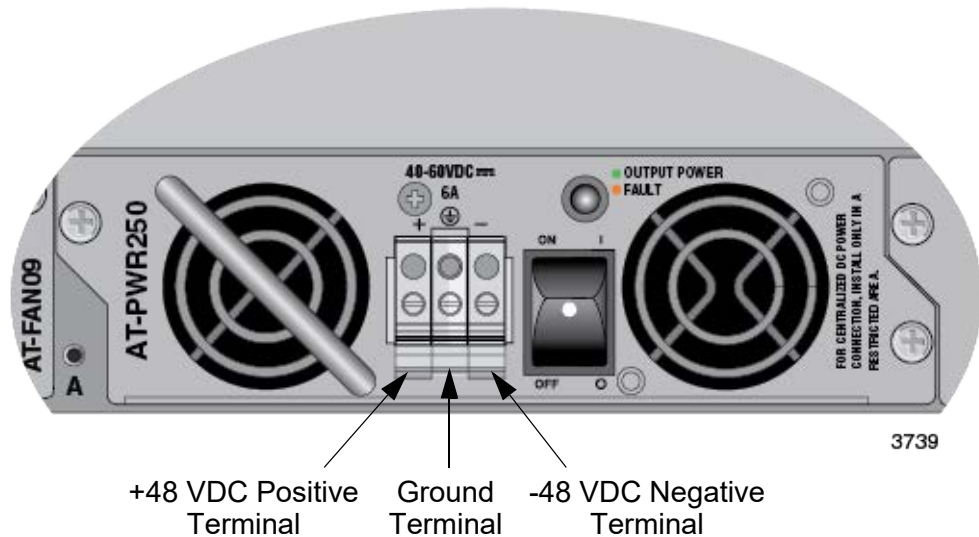



Figure 67. DC Terminal Block

4. With a 14-gauge wire-stripping tool, strip the three wires in the tray cable coming from the DC input power source to  $8\text{mm} \pm 1\text{mm}$  ( $0.31\text{ in.} \pm 0.039\text{ in.}$ ), as shown in Figure 68 on page 139.



### Warning

Do not strip more than the recommended amount of wire. Stripping more than the recommended amount can create a safety hazard by leaving exposed wire on the terminal block after installation.  E10

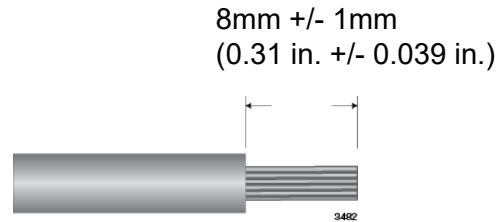

Figure 68. Stripped Wire

5. Insert the power supply ground wire into the middle connector of the DC terminal and tighten the connection with a flathead screwdriver. Refer to Figure 69.



### Warning

When installing this equipment, always ensure that the power supply ground connection is installed first and disconnected last.  E11



Figure 69. Connecting the Ground Wire to the DC Terminal Block

6. Connect the +48 VDC (RTN) feed wire to the terminal block marked + (plus).
7. Connect the -48 VDC feed wire to the terminal block marked - (minus).



**Warning**

Check to see if there are any exposed copper strands coming from the installed wires. When this installation is done correctly there should be no exposed copper wire strands extending from the terminal block. Any exposed wiring can conduct harmful levels of electricity to persons touching the wires. *ES* E12

---

8. Secure the tray cable near the rack framework using multiple cable ties to minimize the chance of the connections being disturbed by casual contact with the wiring. Use at least four cable ties, separated four inches apart. Locate the first one within six inches of the terminal block.

---

**Note**

This system will work with a positive grounded or negative grounded DC system. *ES* E13

---

9. Verify that the circuit breaker is in the OFF position.
10. Connect the supply-cable wires to the circuit breaker.

---

**Note**

Do not power on the switch at this time.

---

11. If the switch has two AT-PWR250-80 Power Supplies, repeat this procedure to wire the second DC connector.
12. Repeat this procedure to wire the DC connectors on the AT-PWR250-80 Power Supplies in the other switches of the stack.
13. After wiring all of the AT-PWR250-80 Power Supplies, go to Chapter 10, “Displaying the AlliedWare Plus Version Number” on page 141.



**Warning**

This unit might have more than one power source. To reduce the risk of electric shock, disconnect all power cords before servicing the unit. *ES* E30

---

## Chapter 10

# Displaying the AlliedWare Plus Version Number

---

The procedures in this section explain how to verify the hardware status of the switch and display the version number of the AlliedWare Plus software, Allied Telesis recommends performing these procedures on each switch individually before building the stack. Here are the procedures:

- ❑ “Starting a Local Management Session” on page 142
- ❑ “Displaying the Hardware Status and AlliedWare Plus Version Number” on page 145

## Starting a Local Management Session

---

The switch supports the following types of management:

- ❑ Local management: Local management is performed through the Console port on the management panel of the switch. The switch does not require an IP address for local management.
- ❑ Remote network: You can also manage the switch over your network from your workstations. For this, the switch requires a IPv4 or IPv6 address. The switch can obtain its address automatically from a DHCP server on your network because it has both DHCPv4 and DHCPv6 clients. The default setting for the clients is enabled. If the switch does not receive a response to its queries for an IP address, it uses the default IPv4 address 169.254.42.42/16.

This section explains how to start a local management session on the Console port on the front panel of the switch with the management cable included with the device. The management cable requires a computer or terminal with a DB-9 (D-sub 9-pin) connector. Refer to Figure 70.

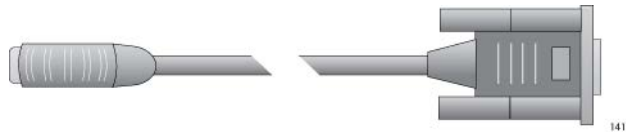

Figure 70. Management Cable Included with Switch

For computers without a DB-9 connector, such as laptop computers, Allied Telesis offers the VT-Kit3 management cable. It has a male UB connector that connects to a USB port on your workstation. Refer to Figure 71.



Figure 71. VT-Kit3 Management Cable

You connect the cable to the Console port on the switch with a standard, straight-through Ethernet cable. Refer to Figure 72 on page 143. The VT-Kit3 management cable and its software driver are sold separately.

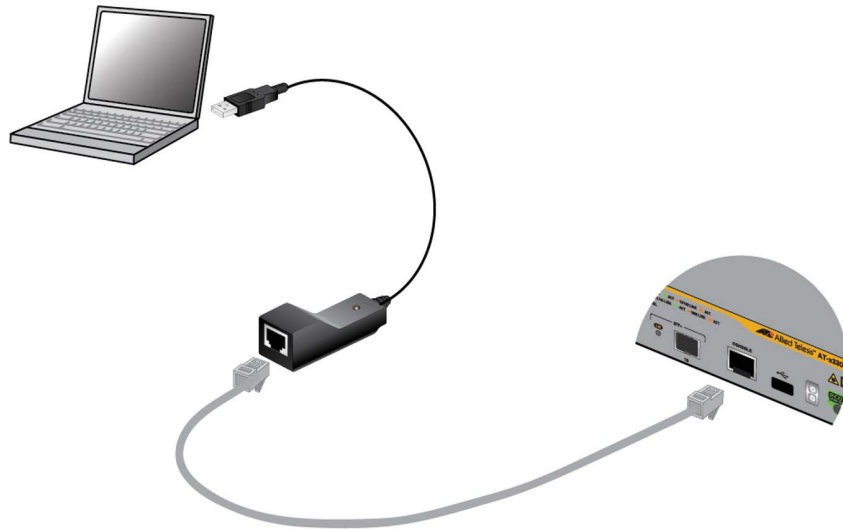

Figure 72. Management Workstation, VT-Kit3 Management Cable, and Switch

This procedure explains how to start a local management session on the switch with the management cable included with the device. For instructions on how to start a remote management session, refer to the *x330 Series Software Reference for AlliedWare Plus Operating System*.

To start a local management session using the management cable provided with the switch, perform the following procedure:

1. Power on one of the switches by doing one of the following:
  - ❑ If the switch has an AC power supply, connect the AC power cord to the power supply on the back panel and to an AC power source. If the switch has two power supplies, you need to power on only one of them for this procedure.
  - ❑ If the switch has the DC AT-PWR250-80 Power Supply, power on the DC circuit and the On/Off switch on the power supply. (If you have not yet wired the DC connector on the power supply, refer to Chapter 9, “Wiring the DC Connector on the AT-PWR250-80 Power Supply” on page 137.)
2. Wait one minute for the switch to initialize its management software.
3. Connect the RJ-45 connector on the management cable to the Console port on the front panel of the switch. Refer to Figure 73 on page 144.

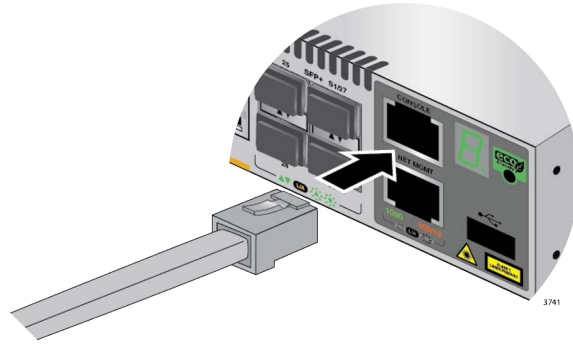

Figure 73. Connecting the Management Cable to the Console Port

4. Connect the other end of the cable to an RS-232 port on a terminal or PC with a terminal emulator program.
5. Configure the terminal or terminal emulator program as follows:
  - Baud rate: 9600 bps (The baud rate of the Console Port is adjustable from 1200 to 115200 bps. The default is 9600 bps.)
  - Data bits: 8
  - Parity: None
  - Stop bits: 1
  - Flow control: None

---

**Note**

The port settings are for a DEC VT100 or ANSI terminal, or an equivalent terminal emulator program.

---

6. Press Enter.

You are prompted for a user name and password.

7. If this is the initial management session of the switch, enter “manager” as the user name and “friend” as the password. The user name and password are case sensitive.

The local management session starts when the User Exec mode prompt, shown in Figure 74. is displayed.

```
awplus>
```

Figure 74. User Exec Mode Prompt

The User Exec mode is the first level in the command mode interface. For complete information on the modes and commands, refer to the *Software Reference for x930 Series Switches, AlliedWare Plus Operating System*.



## **Displaying the Hardware Status and AlliedWare Plus Version Number**

---

This section contains the procedure for displaying the version number of the AlliedWare Plus software on the switch. This procedure is important if the switches contain the AT-StackQS or AT-x9EM/XT4 Card, or you plan to use copper or SFP Gigabit ports for the trunk. The procedure verifies that the version of the software supports the hardware features.

To verify support for the hardware features, perform the following procedure:

1. Power on one of the switches by doing one of the following:
  - ❑ If the switch has an AC power supply, connect the AC power cord to the power supply on the back panel and to an AC power source. If the switch has two power supplies, you need to power on only one of them for this procedure.
  - ❑ If the switch has the DC AT-PWR250-80 Power Supply, power on the DC circuit and the On/Off switch on the power supply. (If you have not yet wired the DC connector on the power supply, refer to Chapter 9, “Wiring the DC Connector on the AT-PWR250-80 Power Supply” on page 137.)
2. Wait one minute for the switch to initialize its management software.
3. Start a local management session on the switch. For instructions, refer to “Starting a Local Management Session” on page 142.
4. In the User Exec or Privileged Exec mode, enter the SHOW SYSTEM ENVIRONMENT command to display hardware status. Check the Status column. All components should have the “OK” status.
5. In the User Exec mode, enter either the SHOW SYSTEM or SHOW VERSION command.
6. Compare the Software Version field in the command with the information in Table 20 on page 146 to determine whether the switch supports the hardware options and whether you need to update its software. For example, if you are building a VCStack with AT-StackQS Cards and AT-QSFPSR Transceivers, you need to update the software if it is earlier than 5.4.5-1.

Table 20. Hardware Options and Management Software Versions

Optional Hardware	Minimum Version of Operating System
AT-StackQS Card and AT-QSFPICU Cables	5.4.5
AT-StackQS Card and AT-QSFPSR Transceivers	5.4.5-1
AT-StackQS Card and AT-QSFPLR4 Transceivers	5.4.5-2
AT-x9EM/XT4 Card	5.4.5-2
Stack trunks of copper or SFP Gigabit ports	5.5.1-2.1

7. Do one of the following:
  - If you need to upgrade the software on the switch, refer to the *Software Reference for x930 Series Switches, AlliedWare Operating System* from [www.alliedtelesis.com](http://www.alliedtelesis.com).
  - If you do not have to update the software, repeat the procedures in this chapter on the remaining switches of the stack.
8. If there are no further switches, power off all the switches.
9. Go to one of the following chapters:
  - Chapter 11, “Building the Stack with SFP+ Ports S1 and S2” on page 147
  - Chapter 12, “Building the Stack with AT-StackQS Cards” on page 159
  - Chapter 13, “Building the Stack with Copper or SFP Gigabit Ports” on page 165

## Chapter 11

# Building the Stack with SFP+ Ports S1 and S2

---

This chapter explains how to build a stack of x930 Switches with a trunk of SFP+ ports S1 and S2. The chapter contains the following procedures:

- ❑ “Introduction” on page 148
- ❑ “Designating SFP+ Ports S1 and S2 as the Stack Trunk” on page 149
- ❑ “Powering On the Switches Sequentially” on page 152
- ❑ “Powering On the Switches Simultaneously” on page 154
- ❑ “Verifying the Stack and Assigning Priority Numbers” on page 156

## Introduction

---

This chapter contains instructions on how to build a stack of up to eight x930 Switches with SFP+ ports S1 and S2 as the stack trunk. Review the following information before performing the procedures:

- ❑ No configuration procedures are required if the x930 Switches are at their default settings and do not contain AT-StackQS Cards. VcStack is enabled by default and the SFP+ ports S1 and S2 are the default trunk ports. You can power on the switches of the stack either individually to control the assignment of the switch ID numbers yourself or simultaneously to allow the switches to assign the numbers automatically. Refer to “Powering On the Switches Sequentially” on page 152 or “Powering On the Switches Simultaneously” on page 154.
- ❑ For x930 Switches containing AT-StackQS Cards, you must perform “Designating SFP+ Ports S1 and S2 as the Stack Trunk” on page 149 before cabling the trunk ports and building the stack. As explained in the procedure, you have to explicitly set the SFP+ ports S1 and S2 as the stack trunk with the `STACK ENABLE BUILTIN PORTS` command on switches containing AT-StackQS Cards.

For background information on switch ID numbers, refer to “Switch ID Numbers” on page 74.



### Caution

Do not change switch ID numbers after beginning to configure the parameter settings of the stack. Otherwise, the stack might assign configuration settings to the wrong switches the next time you reboot or power on the stack.

---

## Designating SFP+ Ports S1 and S2 as the Stack Trunk

---

This procedure designates the SFP+ ports S1 and S2 ports as the trunk ports on switches containing AT-StackQS Cards. Review the following information before performing the command:

- ❑ The SFP+ ports S1 and S2 are the default trunk ports in switches that are at the default settings and do not contain AT-StackQS Cards. If none of the switches for the stack contains the card, you can skip this procedure and go to “Powering On the Switches Sequentially” on page 152 or “Powering On the Switches Simultaneously” on page 154.
- ❑ For switches containing AT-StackQS Cards, the default trunk ports are the two 40Gbps ports on the cards. To use the front panel SFP+ ports S1 and S2 as the stack trunk instead, you have perform the `STACK ENABLE BUILTIN-PORTS` command, as explained in the following procedure. The command designates the SFP+ ports S1 and S2 as the trunk ports and redefines the 40Gbps ports on the cards as regular networking ports.
- ❑ You must also perform this command if you designated front panel Gigabit ports as the trunk, but later decide to use the SFP+ ports S1 and S2 instead.
- ❑ You should disconnect all cables from the SFP+ ports S1 and S2 and AT-StackQS Cards before performing the procedure.

This procedure assumes the following:

- ❑ You performed the procedures in Chapter 10, “Displaying the AlliedWare Plus Version Number” on page 141.
- ❑ There are no cables connected to the SFP+ ports S1 and S2.
- ❑ For switches with DC AT-PWR250-80 Power Supplies, you have already wired the DC connectors. For instructions, refer to Chapter 9, “Wiring the DC Connector on the AT-PWR250-80 Power Supply” on page 137

After performing this procedure on all switches containing AT-StackQS Cards, do the following:

1. Power off all the switches that will be in the stack.
2. Cable the SFP+ ports S1 and S2 for the trunk. Refer to “Installing SFP and SFP+ Transceivers” on page 188 and “Installing AT-SP10TW Direct Connect Cables” on page 192.

3. Power on the switches of the stack either individually to control the assignment of the ID numbers yourself or simultaneously to allow the switches to assign the numbers automatically. Refer to “Powering On the Switches Sequentially” on page 152 or “Powering On the Switches Simultaneously” on page 154.
4. Verify the operations of the stack by performing “Verifying the Stack and Assigning Priority Numbers” on page 156.

To designate the SFP+ ports S1 and S2 ports as the trunk ports in switches containing AT-StackQS Cards, perform the procedure in Table 21.

Table 21. Designating SFP+ Ports S1 and S2 as the Stack Trunk in Switches Containing AT-StackQS Cards

Step	Description and Command
1	Power on the switch and start a local management session. Refer to “Starting a Local Management Session” on page 142.
2	Enter the ENABLE and CONFIGURE TERMINAL commands to move to the Global Configuration mode.  awplus> enable awplus# configure terminal Enter configuration commands, one per line. End with CNTL/Z.
3	Enter the STACK ENABLE BUILTIN PORTS command to designate the SFP+ ports S1 and S2 as the trunk ports for the switch:  awplus(config)# stack enable builtin-ports
4	Enter the EXIT command to return to the Privileged Exec mode.  awplus(config)# exit
5	Enter the WRITE command to save your change.  awplus# write Building configuration ... [OK]
6	Restart the switch with the REBOOT command.  awplus# reboot reboot system? (y/n):
7	Type “Y” for yes.
8	Wait one minute for the switch to start the AlliedWare Plus software.
9	Start a new local management session on the switch.

Table 21. Designating SFP+ Ports S1 and S2 as the Stack Trunk in Switches Containing AT-StackQS Cards (Continued)

Step	Description and Command
10	<p>Enter the SHOW RUNNING-CONFIG command to display the switch's configuration. Check the configuration for the STACK ENABLE BUILTIN PORTS command. If the command is present in the configuration, go to the next step. Otherwise, repeat this procedure:</p> <pre>awplus&gt; show running-config</pre>
11	<p>Enter the exit command to end your management session.</p> <pre>awplus&gt; exit</pre>
12	Power off the switch.
13	Repeat this procedure on all x930 Switches containing AT-StackQS Cards.
14	Cable the SFP+ ports S1 and S2 for the trunk. Refer to "Installing SFP and SFP+ Transceivers" on page 188 or "Installing AT-SP10TW Direct Connect Cables" on page 192
15	Power on the switches of the stack either individually to control the assignment of the ID numbers yourself or simultaneously to allow the switches to assign the numbers automatically. Refer to "Powering On the Switches Sequentially" on page 152 or "Powering On the Switches Simultaneously" on page 154.
16	Verify the stack by performing "Verifying the Stack and Assigning Priority Numbers" on page 156.

## Powering On the Switches Sequentially

---

This procedure explains how to control the assignment of the ID numbers of the switches by powering on the units one at a time during the first power-on sequence. The first switch is assigned ID number 1, the next unit ID number 2, and so on. This procedure is useful when the switches are installed in the same equipment rack. You can number them in sequence, such as from top to bottom, to make them easier to identify.

In this procedure the first switch powered on becomes the master switch of the stack. If you do not change the priority values of the switches and later reset or power cycle the stack, the switches will select the master based on their MAC addresses. This could result in a different switch becoming the master. However, this does not change their ID numbers, the stack configuration, or the manner in which you manage the stack.

This procedure assumes the following:

- You performed “Displaying the Hardware Status and AlliedWare Plus Version Number” on page 145 to confirm that all the switches have the same version of the AlliedWare Plus software.
- You performed “Designating SFP+ Ports S1 and S2 as the Stack Trunk” on page 149 on any switches containing AT-StackQS Cards.
- This is the first power-on of the stack.
- The switches are at their default settings.
- The switches are powered off.

After performing this procedure, go to “Verifying the Stack and Assigning Priority Numbers” on page 156. You can monitor the power-on sequence by connecting a terminal or PC with a terminal emulator program to the Console port on the switch you power on first. Refer to “Starting a Local Management Session” on page 142 for the terminal settings.

---

### Note

Refer to “Power Specifications” on page 207 for the power specifications of the switches.

---

To control the assignment of the switch ID numbers, perform the following procedure:

1. Cable the SFP+ ports S1 and S2 on all the switches of the stack. For guidelines and examples, refer to “Trunks of Ports S1 and S2” on page 60. For cabling instructions, refer to “Installing SFP and SFP+ Transceivers” on page 188.



2. Power on the switch you want assigned ID number 1:
  - ❑ For switches with AC power supplies, connect the AC power cords to the power supplies on the back panels and to AC power sources.
  - ❑ For switches with DC AT-PWR250-80 Power Supplies, power on the DC circuits and the On/Off switches on the power supply. (For wiring instructions, refer to Chapter 9, “Wiring the DC Connector on the AT-PWR250-80 Power Supply” on page 137.)



---

**Warning**

Power cord is used as a disconnection device. To de-energize equipment, disconnect the power cord. *⚡* E3

---

3. Wait one minute for the switch to start the AlliedWare Plus software.

The switch displays the number 1 on its ID LED and is now the master switch.
4. Power on the switch to be assigned ID number 2.
5. Wait two minutes for the new switch to join the stack as a member.

The new switch automatically boots up twice before joining the stack as a new member, once with the default ID number 1 and again with the next available number, which is 2.
6. If there is a third switch, power it on and wait two minutes for it to join the stack as a member with the ID number 3.
7. Repeat step 6 until all the switches are powered on.

The stack is now operational. The switches retain their ID numbers even when reset or powered off.
8. Go to “Verifying the Stack and Assigning Priority Numbers” on page 156.

## Powering On the Switches Simultaneously

---

This procedure powers on the switches simultaneously so that they assign their ID numbers automatically by performing the following steps:

1. They start the AlliedWare Plus software.
2. They compare their switch priority numbers over the stack trunk.
3. Since they all have the same priority number, the default 128, they compare MAC addresses.
4. The switch with the lowest MAC address becomes the master switch.
5. The master switch assigns itself the ID number 1.
6. The master switch assigns ID numbers in the range of 2 to 8 to the other switches.
7. The other switches reboot the AlliedWare Plus software with their new ID numbers.

This procedure assumes the following:

- You performed “Displaying the Hardware Status and AlliedWare Plus Version Number” on page 145 to confirm that all the switches have the same version of the AlliedWare Plus software.
- You performed “Designating SFP+ Ports S1 and S2 as the Stack Trunk” on page 149 on any switches containing AT-StackQS Cards.
- This is the first power-on of the stack.
- The switches are at their default settings.
- The switches are powered off.

You can monitor the power-on sequence by connecting a terminal or PC with a terminal emulator program to the Console port on any of the switches. For the terminal settings, refer to “Starting a Local Management Session” on page 142.

---

### Note

Refer to “Power Specifications” on page 207 for the power specifications of the switches.

---

After performing this procedure, go to “Verifying the Stack and Assigning Priority Numbers” on page 156.

To have the switches assign the ID numbers automatically, perform the following procedure:

1. Cable the SFP+ ports S1 and S2 ports on the switches of the stack. For guidelines and examples, refer to “Trunks of Ports S1 and S2” on page 60. For cabling instructions, refer to Chapter 14, “Cabling the Networking Ports” on page 185.
2. Power on all the switches of the stack simultaneously:
  - ❑ For switches with AC power supplies, connect the AC power cords to the power supplies on the back panels and to AC power sources.
  - ❑ For switches with DC AT-PWR250-80 Power Supplies, power on the DC circuits and the On/Off switches on the power supply. (For wiring instructions, refer to Chapter 9, “Wiring the DC Connector on the AT-PWR250-80 Power Supply” on page 137.)

**Warning**

Power cord is used as a disconnection device. To de-energize equipment, disconnect the power cord. ⚡ E3

---

3. Wait three minutes for the switches to select the master switch and for the master switch to assign ID numbers to the member switches.

The stack is now operational. The switches retain their ID numbers even when reset or powered off.

4. Go to “Verifying the Stack and Assigning Priority Numbers” on page 156.

## Verifying the Stack and Assigning Priority Numbers

To verify the stack and assign priority numbers, perform the following procedure:

1. Start a local management session on any switch in the stack. For instructions, refer to “Starting a Local Management Session” on page 142.
2. From the User Exec mode, enter the SHOW STACK command:

```
awplus> show stack
```

An example of a stack of four switches is shown in Figure 75.

```
awplus> show stack
Virtual Chassis Stacking summary information
ID      Pending ID  MAC address      Priority  Status  Role
1       -            nnnn:nnnn:nnnn  128     Ready  Active Master
2       -            nnnn:nnnn:nnnn  128     Ready  Backup Member
3       -            nnnn:nnnn:nnnn  128     Ready  Backup Member
4       -            nnnn:nnnn:nnnn  128     Ready  Backup Member
Operational Status      Normal operations
Stack MAC address       nnnn:nnnn:nnnn
awplus(config)#
```

Figure 75. SHOW STACK Command

Review the following items:

- ❑ The command should list all the switches in the stack. If the list is incomplete, refer to Chapter 15, “Troubleshooting” on page 197.
- ❑ The Operational Status field displays “Normal operations” when the stacking ports are cabled in the loop topology and all stacking ports are operating normally.
- ❑ The Operational Status field displays “Not all stack ports are up” if the S1 and S2 trunk ports are in the chain topology or trunk ports are unable to establish links with their local or remote counterparts. Refer to Chapter 15, “Troubleshooting” on page 197.
- ❑ The switches will have the priority value 128, the default value, if you powered on the stack with the procedures in this chapter.
- ❑ The master switch will have the priority value 1 if you performed Chapter 13, “Building the Stack with Copper or SFP Gigabit Ports” on page 165.

- ❑ Depending on how you power on or reboot the stack in the future, the switches might select a different master. That does not change their ID numbers, their configurations, or the manner in which you manage the stack.
3. Do one of the following:
    - ❑ To set the switch priority values, continue with the next step. Setting priority numbers is optional. Assigning switches unique priority numbers can protect the configuration of the stack when adding new switches, as well as establish the order in which member switches become the master switch, if necessary. For background information, refer to the “STACK PRIORITY Command” on page 167.
    - ❑ Otherwise, go to Chapter 14, “Cabling the Networking Ports” on page 185, to complete the installation.
  4. Enter the ENABLE and CONFIGURE TERMINAL commands to move to the Privileged Exec mode: Refer to Figure 76.

```
awplus> enable
awplus# configure terminal
Enter configuration commands, one per line. End with CNTL/Z.
awplus(config)#
```

Figure 76. Moving to the Global Configuration Mode with the ENABLE and CONFIGURE TERMINAL Commands

5. Enter the STACK PRIORITY command to set the priority numbers. The command has this format:

```
stack ID_number priority priority
```

You can change the priority number of only one switch at a time. The parameters are as follows:

- ❑ The ID\_NUMBER parameter is the ID number of the switch whose priority value you are setting. The range is 1 to 8. Switches display their ID numbers on the ID LEDs on the front panels.
- ❑ The PRIORITY parameter is the new priority value for the switch. The range is 0 to 255. The default is 128. The lower the number, the higher the priority.

The stack will be easier to manage if the priority number of a switch is the same as its switch ID. Here are two examples. To assign the priority value 1 to the switch with the ID number 1, you enter:

```
awplus(config)# stack 1 priority 1
```

To assign the priority value to 2 to the switch with the ID number 2, you enter:

```
awplus(config)# stack 2 priority 2
```

6. After setting the priority values, enter the EXIT command to return to the Privileged Exec mode. Refer to Figure 77.

```
awplus(config)# exit
awplus#
```

Figure 77. Returning to the Privileged Exec Mode

7. Enter the WRITE command to save your changes in the configuration file of the stack. The switch displays the confirmation prompt in Figure 78.

```
awplus# write
Building configuration ...
[OK]
awplus#
```

Figure 78. Saving the Priority Values with the WRITE Command

8. Enter the SHOW STACK command to verify the new priority numbers. Figure 79 is an example of a stack of four switches:

```
awplus# show stack
Virtual Chassis Stacking summary information
ID      Pending ID  MAC address      Priority  Status  Role
1       -            nnnn:nnnn:nnnn  1        Ready  Active Master
2       -            nnnn:nnnn:nnnn  2        Ready  Backup Member
3       -            nnnn:nnnn:nnnn  3        Ready  Backup Member
4       -            nnnn:nnnn:nnnn  4        Ready  Backup Member
Operational Status      Normal operations
Stack MAC address       nnnn:nnnn:nnnn
```

Figure 79. SHOW STACK Command with New Switch Priority Numbers

9. To end the management session, enter the EXIT command.
10. Go to Chapter 14, “Cabling the Networking Ports” on page 185, to complete the installation.

## Chapter 12

# Building the Stack with AT-StackQS Cards

---

This chapter explains how to build a stack of x930 Switches with the two 40Gbps ports on AT-StackQS Cards as the trunk. The chapter contains the following procedures:

- ❑ “Introduction” on page 160
- ❑ “Powering On the Switches Sequentially” on page 161
- ❑ “Powering On the Switches Simultaneously” on page 163

## Introduction

---

This chapter explains how to build a stack of up to eight x930 Switches with a stack trunk of 40Gbps transceivers in AT-StackQS Cards. There are no configuration procedures. The stacking feature is enabled by default on the switches and the ports on the AT-StackQS Cards are the default trunk ports. To build the stack, you install the AT-StackQS Cards in the switches, install 40Gbps transceivers, cable the transceiver ports, and power on the switches either sequentially or simultaneously.

Here are the two procedures for powering on the stack with AT-StackQS Cards as the stack trunk:

- ❑ To control the assignment of the switch ID numbers yourself, perform “Powering On the Switches Sequentially” on page 161. The numbers are assigned in the order in which you power on the units.
- ❑ To have the switches assign the ID numbers automatically, perform “Powering On the Switches Simultaneously” on page 163.



### Caution

Do not change switch ID numbers after beginning to configure the parameter settings of the stack. Otherwise, the stack might assign configuration settings to the wrong switches the next time you reboot or power on the stack.

---

For background information and guidelines, refer to “Trunks of AT-StackQS Cards” on page 64.



## Powering On the Switches Sequentially

---

This procedure explains how to control the assignment of the ID numbers of the x930 Switches by powering on the devices one at a time during the first power-on sequence. The first switch is assigned ID number 1, the next unit ID number 2, and so on. This procedure is useful when the switches are installed in the same equipment rack. You can number them in sequence, such as from top to bottom, to make them easier to identify.

In this procedure the first switch powered on becomes the master switch of the stack. If you do not change the priority values of the switches and later reset or power cycle the stack, the switches will select the master based on their MAC addresses. This could result in the selection of a different switch as the master. However, this does not change their ID numbers, the stack configuration, or the manner in which you manage the stack.

The procedure assumes the following:

- ❑ You installed the AT-StackQS Cards in the switches. Refer to Chapter 5, “Installing AT-StackQS and AT-x9EM/XT4 Cards” on page 103.
- ❑ You installed 40Gbps transceivers in the AT-StackQS Cards and cabled the ports. For trunk examples, refer to “Trunks of AT-StackQS Cards” on page 64. For cabling instructions, refer to “Cabling the AT-StackQS Card with AT-QSFICU Cables” on page 194 and “Cabling the AT-StackQS Card with Fiber Optic Transceivers” on page 196.
- ❑ The switches are at their default settings.
- ❑ You performed “Displaying the Hardware Status and AlliedWare Plus Version Number” on page 145 to confirm that all the x930 Switches have the same version of the AlliedWare Plus software.
- ❑ This is the first power-on of the stack.
- ❑ The switches are powered off.

After performing this procedure, go to “Verifying the Stack and Assigning Priority Numbers” on page 156.

You can monitor the power-on sequence by connecting a terminal or PC with a terminal emulator program to the Console port on the switch you power on first. For the terminal settings, refer to “Starting a Local Management Session” on page 142.

---

### Note

Refer to “Power Specifications” on page 207 for the power specifications of the switches.

---

To control the assignment of the switch ID numbers, perform the following procedure:

1. Power on the x930 Switch you want assigned ID number 1:
  - ❑ If the switch has AC power supplies, connect the AC power cords to the power supplies on the back panel and to AC power sources.
  - ❑ If the switch has DC AT-PWR250-80 Power Supplies, power on the DC circuits and the On/Off switches on the power supply. (For wiring instructions, refer to Chapter 9, “Wiring the DC Connector on the AT-PWR250-80 Power Supply” on page 137.)



**Warning**

Power cord is used as a disconnection device. To de-energize equipment, disconnect the power cord. ⚡ E3

---

2. Wait one minute for the switch to start the AlliedWare Plus software.

The switch displays the number 1 on its ID LED and is now the master switch.
3. Power on the x930 Switch you want assigned ID number 2.
4. Wait two minutes for the new switch to join the stack as a member.

The new switch automatically boots up twice before joining the stack as a new member, once with the default ID number 1 and again with the next available number, which is 2.
5. If there is a third switch, power it on and wait two minutes for it to join the stack as a member with the ID number 3.
6. Repeat step 5 until all the switches are powered on.

The stack is now operational. The switches retain their ID numbers even when reset or powered off.
7. To continue with the installation, go to “Verifying the Stack and Assigning Priority Numbers” on page 156.

## Powering On the Switches Simultaneously

---

This procedure powers on the x930 Switches simultaneously. They assign their ID numbers automatically by performing the following steps:

1. They start the AlliedWare Plus software.
2. They compare their switch priority numbers over the stack trunk.
3. Because they all have the same priority number, the default 128, they compare MAC addresses.
4. The switch with the lowest MAC address becomes the master switch.
5. The master switch assigns itself the ID number 1.
6. The master switch assigns ID numbers in the range of 2 to 8 to the other switches.
7. The other switches reboot the AlliedWare Plus software with their new ID numbers.

The procedure assumes the following:

- You installed the AT-StackQS Cards in the switches. Refer to Chapter 5, “Installing AT-StackQS and AT-x9EM/XT4 Cards” on page 103.
- You cabled the ports on the AT-StackQS Cards. For trunk examples, refer to “Trunks of AT-StackQS Cards” on page 64. For cabling instructions, refer to “Cabling the AT-StackQS Card with AT-QSFPICU Cables” on page 194 and “Cabling the AT-StackQS Card with Fiber Optic Transceivers” on page 196.
- The switches are at their default settings.
- You performed “Displaying the Hardware Status and AlliedWare Plus Version Number” on page 145 to confirm that all the x930 Switches have the same version of the AlliedWare Plus software.
- This is the first power-on of the stack.
- The switches are powered off.

After performing this procedure, go to “Verifying the Stack and Assigning Priority Numbers” on page 156.

You can monitor the power-on sequence by connecting a terminal or PC with a terminal emulator program to the Console port on any of the switches. For the terminal settings, refer to “Starting a Local Management Session” on page 142.

---

**Note**

Refer to “Power Specifications” on page 207 for the power specifications of the switches.

---

To have the switches assign the ID numbers automatically, perform the following procedure:

1. Power on all the x930 Switches of the stack simultaneously:
  - ❑ For switches with AC power supplies, connect the AC power cords to the power supplies on the back panels and to AC power sources.
  - ❑ For switches with DC AT-PWR250-80 Power Supplies, power on the DC circuits and the On/Off switches on the power supply. (For wiring instructions, refer to Chapter 9, “Wiring the DC Connector on the AT-PWR250-80 Power Supply” on page 137.)

**Warning**

Power cord is used as a disconnection device. To de-energize equipment, disconnect the power cord. *See* E3

---

2. Wait three minutes for the x930 Switches to select the master switch and for the master switch to assign ID numbers to the member switches.

The stack is now operational. The switches retain their ID numbers when reset or powered off.

3. To continue with the installation, go to “Verifying the Stack and Assigning Priority Numbers” on page 156.

## Chapter 13

# Building the Stack with Copper or SFP Gigabit Ports

---

This chapter explains how to build a stack of x930 Switches using front panel copper or SFP Gigabit ports as the trunk. The chapter contains the following sections:

- ❑ “Introduction” on page 166
- ❑ “Command Summary” on page 167
- ❑ “Configuring the Master Switch” on page 170
- ❑ “Configuring the Member Switches” on page 177
- ❑ “Powering on the Stack” on page 184

## Introduction

---

This chapter contains instructions on how to build a stack with a trunk of Gigabit ports on the front panels of the x930 Switches. For background information and examples, refer to “Trunks of Copper 10/100/1000Mbps Ports” on page 67 and “Trunks of SFP Ports on AT-x930-28GSTX Switches” on page 69. Here are the main steps:

1. Fill in the “Stack Worksheet” on page 78.
2. Review “Command Summary” on page 167.
3. “Configuring the Master Switch” on page 170.
4. “Configuring the Member Switches” on page 177.
5. “Powering on the Stack” on page 184
6. “Verifying the Stack and Assigning Priority Numbers” on page 156

Review the following information before performing the instructions:

- The procedures should be performed in the order presented here.
- The master switch can be any x930 Switch. Refer to “Master and Member Switches” on page 73.
- If network cables are connected to the Gigabit ports that will be the trunk, disconnect them before continuing. You should configure the switches before cabling the trunk ports.

---

### Note

Cabling the ports of the stack trunk before configuring the switches may result in loops in your network topology, which can cause poor network performance.

---

## Command Summary

---

This section describes the AlliedWare Plus commands for configuring master and member switches to use front panel Gigabit ports as the stack trunk. For further instructions, refer to the *Software Reference for x930 Switch, AlliedWare Plus Operating System*. After reviewing the commands, start the configuration procedures by performing “Configuring the Master Switch” on page 170.

### **STACK ENABLE Command**

You use this command in the Global Configuration mode of the AlliedWare Plus software to enable and disable the VCStack feature on the switch. It has these formats:

- STACK ENABLE BUILTIN-PORTS:** This command enables VCStack on the switch and designates the SFP+ S1 and S2 ports as the stack trunk. This is the default setting for x930 Switches that do not have AT-StackQS Cards.
- STACK ENABLE EXPANSION-PORTS:** This command enables VCStack on the switch and designates the ports on AT-StackQS Cards as the stack trunk. This is the default setting for x930 Switches that have AT-StackQS Cards.
- STACK ENABLE FRONT-PANEL-PORTS:** This command enables VCStack on switches and designates Gigabit ports on the front panels as the stack trunk.
- NO STACK ENABLE:** This command disables VCStack. You can use the switch as a standalone unit when the feature is disabled.

### **STACKPORT Command**

You use this command in the port interface modes of the AlliedWare Plus software to add and remove ports from the stack trunk. Here are its two forms:

- STACKPORT:** You use this command to add ports to the stack trunk.
- NO STACKPORT:** You use this command to remove ports from the stack trunk and return them to regular Ethernet networking ports.

### **STACK PRIORITY Command**

This command is used to set a switch’s priority value. Every switch in a stack has a priority value. The range is 0 to 255. The default is 128. The lower the number, the higher the priority. Switches use their priority settings for the following functions:

- Select the master switch when the switches are powered on or rebooted simultaneously.

- ❑ Designate the order in which they become the master switch if the active master switch stops responding. If the switches have the same priority value, they use their MAC addresses to select the master. The lower the MAC address, the higher the priority.

Allied Telesis recommends setting the priority numbers to match the switch ID numbers. For example, the switch with ID 1 should be assigned priority 1, switch with ID 2 should be assigned priority 2, and so on. This is not a requirement, but it can make managing and troubleshooting the stack easier.

You can set the priority number on the master switch before building the stack, but you have to wait until the member switches are part of the stack before setting their priority values.

---

**Note**

Setting the priority values can protect the stack's configuration if you later add a new switch that has a lower MAC address than the active master while the stack is powered off. If the priority values of the switches are at the default value when you power on the stack, the new switch might become the master, possibly resulting in the loss of the stack's configuration.

---

The command has this format:

```
stack switch_ID priority priority_number
```

The variables are defined here:

- ❑ *switch\_ID* - This is the ID number of the switch. The ID number is displayed on the ID LED on the front panel. The range is 1 to 6. You can specify only one ID number.
- ❑ *priority\_number* - This is the new priority number for the switch. The range is 0 to 255. The default is 128. You can specify only one number.

This example assigns the priority 1 to the switch with ID 1:

```
awplus(config)# stack 1 priority 1
```

This example assigns the priority 2 to the switch with ID 2:

```
awplus(config)# stack 2 priority 2
```



## STACK RENUMBER Command

Every switch in the stack must have a unique ID number. They display their numbers on the ID LEDs on the front panels. The range is 1 to 8 or 1 to 4, depending on the stack trunk. The default is 1. You use the numbers to identify switches in the command line interface of the AlliedWare Plus software. Refer to “Switch ID Numbers” on page 74.

The master switch can assign the ID numbers automatically during the first power-on of the stack, or you can use this command to set them either before or immediately after building the stack. The command, which is found in the Global Configuration mode, has this format.

```
stack current_switch_ID renumber new_switch_ID
```

The variables are defined here:

- ❑ *current\_switch\_ID* - This is the current ID number of the switch. You can specify only one ID number.
- ❑ *new\_switch\_ID* - This is the new ID number for the switch. The range is 1 to 6. The default is 1. You can specify only one number.

Changing the ID number requires resetting the switch.

This example changes a switch’s current ID from 1, the default, to 2:

```
awplus(config)# stack 1 renumber 2
```

---

### Note

Switches use their priority numbers and MAC addresses, not their ID numbers, to select the master switch. Consequently, the master switch of the stack might not have the ID number 1.

---

## SWITCH PROVISION Command

You use this command to add member switches to the configuration of the master switch before powering on the stack for the first time. Here is the format of the command:

```
switch switch_ID provision x930
```

This example adds a provisioned member switch with the ID 2 to the master switch:

```
awplus(config)# switch 2 provision x930
```

You can add one member switch at a time with the command.

## Configuring the Master Switch

---

This section contains the procedures for configuring x930 Switches to be the master switch of a stack. The procedures designate the Gigabit ports of the trunk and add the member switches as provisioned switches to the configuration of the master switch.

---

**Note**

Any x930 Switch can be the master switch of the stack.

---

Here are the procedures:

- ❑ “General Steps for the Master Switch,” next
- ❑ “Configuring the Master Switch - Part I” on page 171
- ❑ “Configuring the Master Switch - Part II” on page 173
- ❑ “Verifying the Master Switch” on page 174
- ❑ “What to Do Next” on page 176

The procedures should be performed in the order presented here.

---

**Note**

The procedures require resetting the switch. Some network traffic will be lost if its ports are connected to active networks.

---

Allied Telesis recommends filling out the “Stack Worksheet” on page 78 before building the stack.

### General Steps for the Master Switch

There are two parts to configuring the master switch for a stack trunk of Gigabit ports. Here are the main steps to Part I:

1. Start a local management session on the switch.
2. Designate Gigabit front panel ports to be trunk ports with the `STACK ENABLE FRONT-PANEL-PORTS` command in the Global Configuration mode. You have to perform this command before designating the actual Gigabit ports of the trunk.
3. Designate up to eight Gigabit ports to be the stack trunk with the `STACKPORT` command in the port interface modes.
4. Assign the master switch the priority 1 with the `STACK PRIORITY` command in the Global Configuration mode to designate it as master switch of the stack. This step is optional.

5. Save your changes with the WRITE command in the Privilege Exec mode.

Here are the main steps to Part II:

1. Add the member switches as provisioned units to the configuration of the master switch, with the SWITCH PROVISION command.
2. Designate up to eight Gigabit ports on the provisioned member switches to be the stack trunk with the STACKPORT command in the port interface modes.
3. Save your changes to the master switch with the WRITE command in the Privilege Exec mode.
4. Reboot the master switch with the REBOOT command.
5. Start a new local management session.
6. Verify the changes on the master switch with the SHOW STACK and SHOW RUNNING-CONFIG INTERFACE command.

### Configuring the Master Switch - Part I

To configure Gigabit ports on the master switch as the stack trunk, start by performing the procedure in Table 22.

Table 22. Configuring the Master Switch to Use Gigabit Ports as the Stack Trunk - Part I

Step	Description and Command
1	Power on the switch to be the master switch and start a local management session. Any x930 Switch can be the master switch of a stack. Refer to “Starting a Local Management Session” on page 142.
2	Enter the ENABLE and CONFIGURE TERMINAL commands to move to the Global Configuration mode.  awplus> enable awplus# configure terminal Enter configuration commands, one per line. End with CNTL/Z. awplus(config)#
Step 3 designates Gigabit ports as the stack trunk with the STACK ENABLE FRONT-PANEL-PORTS command.	
3	Enter the STACK ENABLE FRONT-PANEL-PORTS command in the Global Configuration mode to designate Gigabit ports as the stack trunk. You have to perform this command before designating the actual trunk ports:  awplus(config)# stack enable front-panel-ports

Table 22. Configuring the Master Switch to Use Gigabit Ports as the Stack Trunk - Part I (Continued)

Step	Description and Command
Steps 4 and 5 designate the Gigabit ports of the trunk.	
4	Enter the port interface modes of the Gigabit ports to be the stack trunk. The trunk can have up to eight ports per switch. If you filled out the Stack Worksheet, refer there for the ports. This example assumes ports 1 to 8 will be the trunk:  <pre>awplus(config)# interface port1.0.1-1.0.8 awplus(config-if)#</pre>
5	Enter the STACKPORT command to designate the Gigabit ports as the stack trunk:  <pre>awplus(config-if)# stackport</pre> % Save the config and restart the system for this change to take effect.
Steps 6 and 7 assign the switch the priority 1 with the STACK PRIORITY command to designate it as the master unit of the stack. These steps are optional.	
6	Enter the EXIT command to return to the Global Configuration mode.  <pre>awplus(config-if)# exit</pre>
7	Enter the STACK PRIORITY command to assign priority 1 to the switch.  <pre>awplus(config)# stack 1 priority 1</pre>
The remaining steps save your changes.	
8	Enter the EXIT command to return to the Privileged Exec mode.  <pre>awplus(config)# exit</pre>
9	Enter the WRITE command to save your changes.  <pre>awplus# write Building configuration ... [OK]</pre>
10	Go to “Configuring the Master Switch - Part II,” next.

## Configuring the Master Switch - Part II

In Part II you add the member switches to the configuration of the master switch and designate their Gigabit ports of the trunk. This is referred to as provisioning the master switch. The procedure assumes you are continuing directly from the previous procedure.

Table 23. Configuring the Master Switch to Use Gigabit Ports as the Stack Trunk - Part II

Step	Description and Command
Steps 1 to 2 add the member switches as provisioned switches to the master switch.	
1	<p>Enter the CONFIGURE TERMINAL command to move to the Global Configuration mode.</p> <pre>awplus# configure terminal Enter configuration commands, one per line. End with CNTL/Z. awplus(config)#</pre>
2	<p>Enter the SWITCH PROVISION command to add up to three member switches as provisioned switches to the configuration of the master switch. (A stack with a trunk of Gigabit ports can have up to four switches total.) Assign each unit a unique ID number in the range of 2 to 4. These examples add two 28-port switches and one 52-port switch as provisioned member switches on the master switch, with the IDs 2 to 4:</p> <pre>awplus(config)# switch 2 provision x930-28 awplus(config)# switch 3 provision x930-28 awplus(config)# switch 4 provision x930-52</pre>
Steps 3 and 4 designate the Gigabit ports that will be the trunk ports on the member switches.	
3	<p>Enter the port interface modes of the Gigabit ports on the provisioned member switches to be the stack trunk. The trunk can have up to eight ports per switch. If you filled out the Stack Worksheet, refer there for the ports. This example assumes the member switches will use Gigabit ports 1 to 8 as the stack trunk:</p> <pre>awplus(config)# interface port2.0.1-2.0.8,port3.0.1-3.0.8,port4.0.1-4.0.8 awplus(config-if)#</pre>
4	<p>Enter the STACKPORT command to designate the selected Gigabit ports as the stack trunk:</p> <pre>awplus(config-if)# stackport % Save the config and restart the system for this change to take effect.</pre>
The remaining steps save your changes and reboot the master switch.	
5	<p>Enter the EXIT command twice to return to the Privileged Exec mode.</p> <pre>awplus(config-if)# exit awplus(config)# exit</pre>

Table 23. Configuring the Master Switch to Use Gigabit Ports as the Stack Trunk - Part II

Step	Description and Command
6	Enter the WRITE command to save your changes.  awplus# write Building configuration ... [OK]
7	Restart the switch with the REBOOT command.  awplus# reboot reboot system? (y/n):
8	Type “Y” for yes.
9	Wait one minute for the switch to start the AlliedWare Plus software.
10	Go to “Verifying the Master Switch” on page 174.

**Verifying the Master Switch**

To confirm the configuration of the master switch, perform the following steps:

1. Start a new local management session on the master switch. Refer to “Starting a Local Management Session” on page 142.
2. Move to the Privileged Exec mode with the ENABLE command.

```
awplus> enable
awplus#
```

3. Enter the SHOW STACK command. Figure 80 is an example of a master switch with three provisioned member switches:

```
awplus# show stack
Virtual Chassis Stacking summary information
ID Pending ID MAC address Priority Status Role
1 - nnnn.nnnn.nnnn 1 Ready Active Master
2 - - - - - Provisioned
3 - - - - - Provisioned
4 - - - - - Provisioned
Operational status Standalone unit
Stack MAC address nnnn.nnnn.nnnn
```

Figure 80. SHOW STACK Command on the Master Switch

4. Check the display for the following:
  - ❑ Switch ID 1 is the master switch.
  - ❑ The other ID entries are the provisioned member switches. There should be one entry for each member switch that will be in the stack. If the table does not include these fields, perform the SWITCH PROVISION command in “Configuring the Master Switch - Part II” on page 173.
  - ❑ The master switch should have the priority 1 if you performed the STACK PRIORITY command in “Configuring the Master Switch - Part I” on page 171.
5. Enter the SHOW RUNNING-CONFIG INTERFACE command to view the port configurations on the master switch and provisioned member switches. Confirm that the correct Gigabit ports have the STACKPORT command, designating them as the stack trunk:

```

awplus# show running-config interface
interface port1.0.1-1.0.23
  switchport
  switchport mode access

stack enable front-panel-ports
!
interface port1.0.1-1.0.8   Trunk ports on the
  stackport                master switch
!
interface port1.0.27-1.0.28
  switchport
  switchport mode access
!
interface port2.0.1-2.0.23
  switchport
  switchport mode access
!
interface port2.0.1-2.0.8   Trunk ports on a
  stackport                provisioned member
                          switch
!
interface port2.0.27-2.0.28
  switchport
  switchport mode access
.
.

```

Figure 81. SHOW RUNNING-CONFIG INTERFACE Command on the Master Switch

6. Go to “What to Do Next,” next.

**What to Do Next** After configuring the master switch, do the following:

1. Power off the switch. For AC power supplies, disconnect the AC power cords from the AC power sources. For DC power supplies, turn off the ON/OFF switch on the power supplies or power off the DC power circuits.
2. Configure the member switches. Refer to “Configuring the Member Switches” on page 177.
3. After configuring the master switch and all member switches, build the stack by cabling the trunk Gigabit ports on the switches. Refer to “Cabling Copper Ports” on page 186 or “Installing SFP and SFP+ Transceivers” on page 188.
4. Power on the master and member switches of the stack. Refer to “Powering on the Stack” on page 184.
5. Verify that the switches formed the stack by performing “Verifying the Stack and Assigning Priority Numbers” on page 156.
6. Cable the networking ports. Refer to Chapter 14, “Cabling the Networking Ports” on page 185.



## Configuring the Member Switches

---

This section contains the procedures for configuring the member switches of the stack by assigning them ID numbers and designating Gigabit ports as the stack trunk: Here are the procedures:

- ❑ “General Steps for the Member Switches” on page 177
- ❑ “Configuring Member Switches - Part I” on page 178
- ❑ “Configuring Member Switches - Part II” on page 179
- ❑ “Verifying Member Switches” on page 181
- ❑ “What to Do Next for Member Switches” on page 183

You have to perform the procedures on each member switch individually, before connecting the trunk Gigabit ports. The procedures should be performed in the order presented here.

---

### Note

The procedures require resetting member switches. Some network traffic will be lost if the ports are connected to an active network.

---

### General Steps for the Member Switches

Configuring the member switches has two parts. Part I has these main steps:

1. Start a local management session on the switch.
2. Assign an ID number in the range of 2 to 4 to the member switch with the SWITCH RENUMBER command in the Global Configuration mode.
3. Save your changes with the WRITE command in the Privilege Exec mode.
4. Restart the switch with the REBOOT command.

Part II has these main steps:

1. Start a new local management session with the switch.
2. Designate Gigabit front panel ports to be the trunk ports with the STACK ENABLE FRONT-PANEL-PORTS command in the Global Configuration mode. You have to perform this command before designating the actual Gigabit ports of the trunk.
3. Designate up to eight Gigabit ports to be the stack trunk with the STACKPORT command in the port interface modes.

4. Save your changes with the WRITE command in the Privilege Exec mode.
5. Restart the switch with the REBOOT command.
6. Start a new local management session.
7. Verify your changes with the SHOW STACK and SHOW RUNNING-CONFIG INTERFACE commands.

**Configuring Member Switches - Part I**

Perform Part I in Table 24 to configure a member switch.

Table 24. Configuring Member Switches - Part I

Step	Description and Command
1	Power on a member switch and start a local management session. Refer to “Starting a Local Management Session” on page 142.
2	Enter the ENABLE and CONFIGURE TERMINAL commands to move to the Global Configuration mode:  <pre>awplus&gt; enable awplus# configure terminal</pre> Enter configuration commands, one per line. End with CNTL/Z. <pre>awplus(config)#</pre>
Step 3 sets the member switch’s ID number.	
3	Set the ID number of the member switch with the STACK RENUMBER command. Each switch must have a unique ID number. The default value is 1. The range is 1 to 4. If you are using the worksheet on “Stack Worksheet” on page 78, refer there for the ID numbers. This example changes the switch’s ID number from the default value 1 to the new value 2.  <pre>awplus(config)# stack 1 renumber 2 % warning: the new ID will not become effective until the stack-member reboots. % warning: the boot configuration may now be invalid.</pre>
The remaining steps reboot the unit. (You do not have to update the configuration file with the WRITE command after changing a switch’s ID number.)	
4	Enter the EXIT command to return to the Privileged Exec mode.  <pre>awplus(config)# exit</pre>

Table 24. Configuring Member Switches - Part I (Continued)

Step	Description and Command
5	Restart the switch with the REBOOT command.  awplus# reboot reboot system? (y/n): awplus#
6	Type "Y" for yes.
7	Wait one minute for the switch to start the AlliedWare Plus software.
8	Check the ID LED on the front panel. Do one of the following: - If the ID LED is displaying the switch's new ID number, go to "Configuring Member Switches - Part II," next. - If the ID LED is displaying the wrong number, repeat this procedure.

### Configuring Member Switches - Part II

Part II has these actions:

- Designate the trunk type to be Gigabit front panel ports with the STACK ENABLE FRONT-PANEL-PORTS command in the Global Configuration mode.
- Designate the Gigabit ports of the trunk with the STACKPORT command in the port interface modes.
- Reboot the switch.

Perform the procedure in Table 25.

Table 25. Configuring Member Switches - Part II

Step	Description and Command
1	Start a new local management session on the member switch. Refer to "Starting a Local Management Session" on page 142.
2	Enter the ENABLE and CONFIGURE TERMINAL commands to move to the Global Configuration mode.  awplus> enable awplus# configure terminal Enter configuration commands, one per line. End with CNTL/Z. awplus(config)#

Table 25. Configuring Member Switches - Part II (Continued)

Step	Description and Command
Step 3 identifies the trunk type to be Gigabit ports.	
3	Enter the STACK ENABLE FRONT-PANEL-PORTS command in the Global Configuration mode to indicate that the trunk will be Gigabit ports. You have to perform this command before designating the Gigabit ports:  <pre>awplus(config)# stack enable front-panel-ports</pre>
Steps 4 and 5 designate the Gigabit ports of the trunk on the member switch.	
4	Enter the port Interface modes of the Gigabit ports that are to be the trunk on the member switch. This example assumes the member switch has the ID 2 and the trunk will have ports 1 to 8. Remember to change the switch ID number in the PORT parameter as you configure each member switch:  <pre>awplus(config)# interface port2.0.1-2.0.8 awplus(config-if)#</pre>
5	Designate the ports as the stack trunk with the STACKPORT command.  <pre>awplus(config-if)# stackport</pre> % Save the config and restart the system for this change to take effect.
The remaining steps save your changes and reboot the switch.	
6	Enter the EXIT command twice to return to the Privilege Exec mode.  <pre>awplus(config-if)# exit awplus(config)# exit awplus#</pre>
7	Save your changes with the WRITE command.  <pre>awplus# write Building configuration ... [OK]</pre>
8	Reboot the switch.  <pre>awplus# reboot reboot system? (y/n):</pre>
9	Type "Y" for yes.
10	Wait one minute for the switch to start the AlliedWare Plus software.
11	Go to "Verifying Member Switches," next.

## Verifying Member Switches

Perform this procedure to verify the configuration of a member switch.

1. Start a new local management session on the switch. Refer to “Starting a Local Management Session” on page 142.
2. Move to the Privileged Exec mode with the ENABLE command.

```
awplus> enable
awplus#
```

3. Enter the SHOW STACK command. Figure 80 is an example of a member switch with the ID number 2.:

```
awplus# show stack
Virtual Chassis Stacking summary information
ID Pending ID  MAC address          Priority  Status  Role
1  -             -                -        -       Provisioned
2  -             nnnn.nnnn.nnnn  128     Ready   Active Master
Operational Status          Standalone unit
Stack MAC address           nnnn.nnnn.nnnn
```

Figure 82. SHOW STACK Command for a Member Switch

4. Check the display for the following:
  - The values for the ID 1 row should be blank. This default provisioned entry will be used by the master switch when you power on the stack.
  - The member’s Switch ID should be the number you assigned it in Part I.
5. Enter the SHOW RUNNING-CONFIG INTERFACE command to display the port configuration on the member switch. Confirm that the correct Gigabit ports on the member switch have the STACKPORT command, designating them as the trunk: Refer to Figure 83 on page 182 for an example.

```

awplus# show running-config interface
interface port1.0.1-1.0.26
  switchport
  switchport mode access
!
stack enable front-panel-ports
!
interface port1.0.27-1.0.28 1
  stackport
!
interface port2.0.1-2.0.24
  switchport
  switchport mode access
!
interface port2.0.1-2.0.8 2
  stackport
!
interface port2.0.27-2.0.28
  switchport
  switchport mode access
!
awplus#

```

Figure 83. SHOW RUNNING-CONFIG INTERFACE Command for Member Switches

Note the following:

- ❑ 1 - These lines designate the stack ports for the default provisioned switch. You can ignore these lines on member switches.
- ❑ 2 - These lines designate the trunk ports for the member switch you are configuring. The switch ID number in the PORT parameter should match the ID number of the switch and the port numbers should be the Gigabit ports of the trunk. Repeat the procedure if the display does not include these lines.

6. Go to “What to Do Next for Member Switches” on page 183.

## **What to Do Next for Member Switches**

After configuring the member switch, do the following:

1. Power off the member switch.
2. Repeat these procedures to configure all member switches, assigning each one a unique ID number and identifying the Gigabit ports of the trunk.
3. If you have not already configured the master switch, perform “Configuring the Master Switch” on page 170.
4. Power off the master and all member switches.
5. Cable the Gigabit ports of the trunk on the master and member switches. Refer to “Cabling Copper Ports” on page 186. For trunks of SFP ports on AT-x930-28GSTX Switches, refer to “Installing SFP and SFP+ Transceivers” on page 188. For cabling examples, refer to “Trunks of Copper 10/100/1000Mbps Ports” on page 67 and “Trunks of SFP Ports on AT-x930-28GSTX Switches” on page 69.
6. Perform “Powering on the Stack” on page 184.
7. Perform “Verifying the Stack and Assigning Priority Numbers” on page 156 to confirm that the switches formed the stack.
8. Cable the networking ports, as explained in Chapter 14, “Cabling the Networking Ports” on page 185.

## Powering on the Stack

---

After configuring the master and member switches for Gigabit ports as the trunk, you are ready to cable the trunk ports and power on the stack. You can monitor the power-on sequence by connecting a terminal or computer with a terminal emulator program to the Console port on the master switch. The terminal settings are listed in “Starting a Local Management Session” on page 142.

To power on the stack for the first time, perform the following procedure:

1. Verify that the master and member switches are powered off.
2. Cable the Gigabit ports of the stack trunk on the switches. Refer to “Cabling Copper Ports” on page 186 or “Installing SFP and SFP+ Transceivers” on page 188 for trunks containing SFP ports on AT-x930-28GSTX Switches, For cabling examples, refer to “Trunks of Copper 10/100/1000Mbps Ports” on page 67 and “Trunks of SFP Ports on AT-x930-28GSTX Switches” on page 69.
3. Power on the master switch.

Refer to “Power Specifications” on page 207 for the power specifications of the switches.



### Warning

Power cord is used as a disconnection device. To de-energize equipment, disconnect the power cord. *GS* E3

---

### Note

Pluggable Equipment. The socket outlet shall be installed near the equipment and shall be easily accessible. *GS* E5

---

4. Wait one minute for the master switch to start the AlliedWare Plus software.
5. Power on the member switches either sequentially or simultaneously.
6. Wait one minute for the member switches to join the stack.
7. Go to “Verifying the Stack and Assigning Priority Numbers” on page 156.



## Chapter 14

# Cabling the Networking Ports

---

This chapter contains the following procedures:

- ❑ “Cabling Copper Ports” on page 186
- ❑ “Installing SFP and SFP+ Transceivers” on page 188
- ❑ “Installing AT-SP10TW Direct Connect Cables” on page 192
- ❑ “Cabling the AT-StackQS Card with AT-QSFICU Cables” on page 194
- ❑ “Cabling the AT-StackQS Card with Fiber Optic Transceivers” on page 196

## Cabling Copper Ports

---

Here are the guidelines to cabling the 10/100/1000Base-T copper ports:

- ❑ The cable specifications for the ports are listed in “Cable Requirements” on page 32.
- ❑ The connectors on the cables should fit snugly into the ports, and the tabs should lock the connectors into place.
- ❑ The default setting for the wiring configurations is auto-MDI/MDI-X. The default setting is appropriate for switch ports that are connected to 10/100Base-TX network devices that also support auto-MDI/MDI-X.
- ❑ The default auto-MDI/MDI-X setting is not appropriate for switch ports that are connected to 10/100Base-TX network devices that do not support auto-MDI/MDI-X and have a fixed wiring configuration. For switch ports connected to those types of network devices, you should disable auto-MDI/MDI-X and set the wiring configurations manually.
- ❑ The appropriate MDI/MDI-X setting for a switch port connected to a 10/100Base-TX network device with a fixed wiring configuration depends on the setting of the network device and whether the switch and network device are connected with straight-through or crossover cable. If you are using straight-through copper cable, the wiring configurations of a port on the switch and a port on a network device must be opposite each other, such that one port uses MDI and the other MDI-X. For example, if a network device has a fixed wiring configuration of MDI, you must disable auto-MDI/MDI-X on the corresponding switch port and manually set it to MDI-X. If you are using crossover copper cable, the wiring configurations of a port on the switch and a port on a network device must be the same.
- ❑ The default speed setting for the ports is Auto-Negotiation. This setting is appropriate for ports connected to network devices that also support Auto-Negotiation.
- ❑ The default speed setting of Auto-Negotiation is not appropriate for ports connected to 10/100Base-TX network devices that do not support Auto-Negotiation and have fixed speeds. For those switch ports, you should disable Auto-Negotiation and set the port’s speed manually to match the speeds of the network devices.
- ❑ The 10/100/1000Base-T ports must be set to Auto-Negotiation, the default setting, to operate at 1000Mbps.
- ❑ The default duplex mode setting for the ports is Auto-Negotiation. This setting is appropriate for ports connected to network devices that also support Auto-Negotiation for duplex modes.

- ❑ The default duplex mode setting of Auto-Negotiation is not appropriate for ports connected to network devices that do not support Auto-Negotiation and have a fixed duplex mode. You should disable Auto-Negotiation on those ports and set their duplex modes manually to avoid the possibility of duplex mode mismatches. A switch port using Auto-Negotiation defaults to half-duplex if it detects that the end node is not using Auto-Negotiation, which can result in a mismatch if the end node is operating at a fixed duplex mode of full-duplex.
- ❑ Do not attach cables to ports of static or LACP port trunks until after you have configured the trunks on the switch. Otherwise, the ports will form network loops that can adversely affect network performance.

## Installing SFP and SFP+ Transceivers

---

This section contains instructions for installing SFP and SFP+ transceivers in the ports on the switch.

---

### Note

Refer to the product's data sheet on the Allied Telesis web site for a list of supported transceivers.

---

Here are the guidelines:

- ❑ Ports 25 to 28 on 28-port x930 switches and ports 49 to 52 on 52-port switches support 1000Mbps SFP and 10Gbps SFP+ transceivers. They do not support 100Mbps SFP transceivers.
- ❑ Ports 1 to 24 on the AT-x930-28GSTX Switch support 100/1000Mbps SFP transceivers. They do not support 10Gbps SFP+ transceivers.
- ❑ If you are using SFP+ ports S1 and S2 as the VCStack trunk, review the guidelines in “Trunks of Ports S1 and S2” on page 60 before performing this procedure.
- ❑ SFP and SFP+ transceivers are hot-swappable. You may install them while the switch is powered on.
- ❑ The operational specifications and fiber optic cable requirements of the transceivers are provided in the documents included with the devices.
- ❑ You should install a transceiver before connecting the fiber optic cable.
- ❑ Fiber optic transceivers are dust sensitive. Always keep the plug in the optical bores when a fiber optic cable is not installed, or when you store the transceiver. When you do remove the plug, keep it for future use.
- ❑ Unnecessary removal and insertion of a transceiver can lead to premature failure.



### Warning

Transceivers can be damaged by static electricity. Be sure to observe all standard electrostatic discharge (ESD) precautions, such as wearing an anti-static wrist strap, to avoid damaging the devices. *ES* E86

---

The illustrations in the procedure show the installation of a transceiver in port 25 of a 28-port switch. The procedure is the same for all SFP and SFP+ ports. The transceiver in the illustrations has a duplex LC connector. Your transceivers may have different connectors.

To install transceivers, perform the following procedure:

1. If the transceiver port has a dust plug, remove it. Refer to Figure 84.



Figure 84. Removing the Dust Plug from an SFP+ Port

2. Remove the transceiver from its shipping container and store the packaging material in a safe location.
3. If you are installing the transceiver in a top port, position the transceiver with the Allied Telesis label facing up. If you are installing the transceiver in a bottom port, position the transceiver with the label facing down.
4. Slide the transceiver into the port until it clicks into place. Refer to Figure 85.

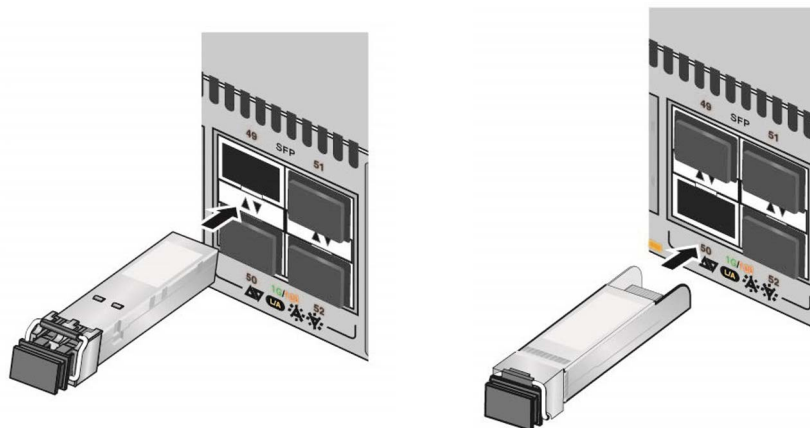

Figure 85. Installing SFP+ Transceivers

---

**Note**

If you are ready to attach the fiber optic cable to the transceiver, continue with the next step. Otherwise, repeat steps 1 to 4 to install the remaining transceivers in the switch.

---

5. Remove the dust cover from the transceiver. Refer to Figure 86.

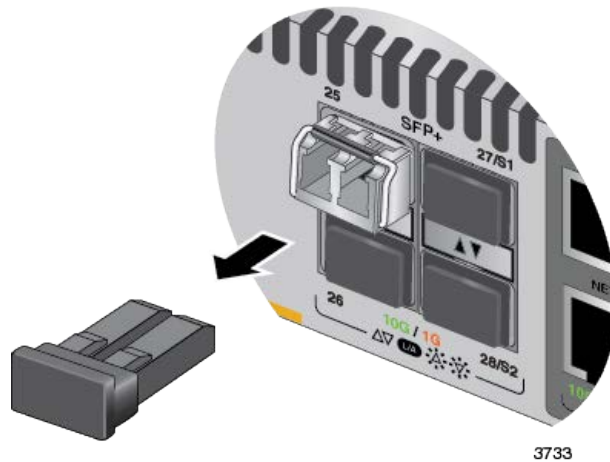

Figure 86. Removing the Dust Cover from an SFP or SFP+ Transceiver

6. Verify the position of the handle on the transceiver. If the transceiver is in a top port, the handle should be in the upright position, as shown in Figure 87. If the transceiver is in a bottom port, the handle should be in the down position.

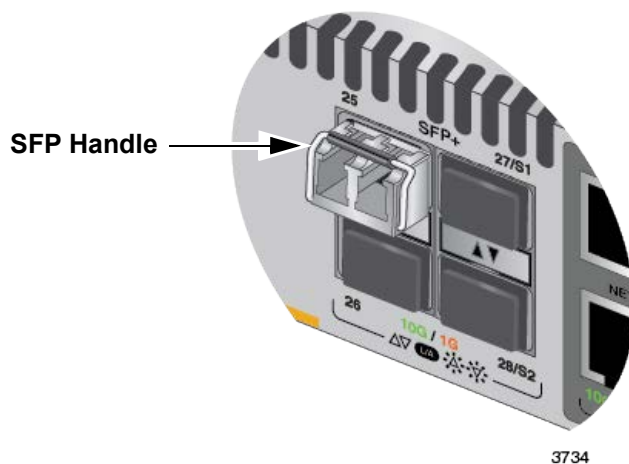

Figure 87. Positioning the SFP or SFP+ Handle in the Upright Position

7. Connect the fiber optic cable to the transceiver, as shown in Figure 88 on page 191. The connector on the cable should fit snugly into the port, and the tab should lock the connector into place.

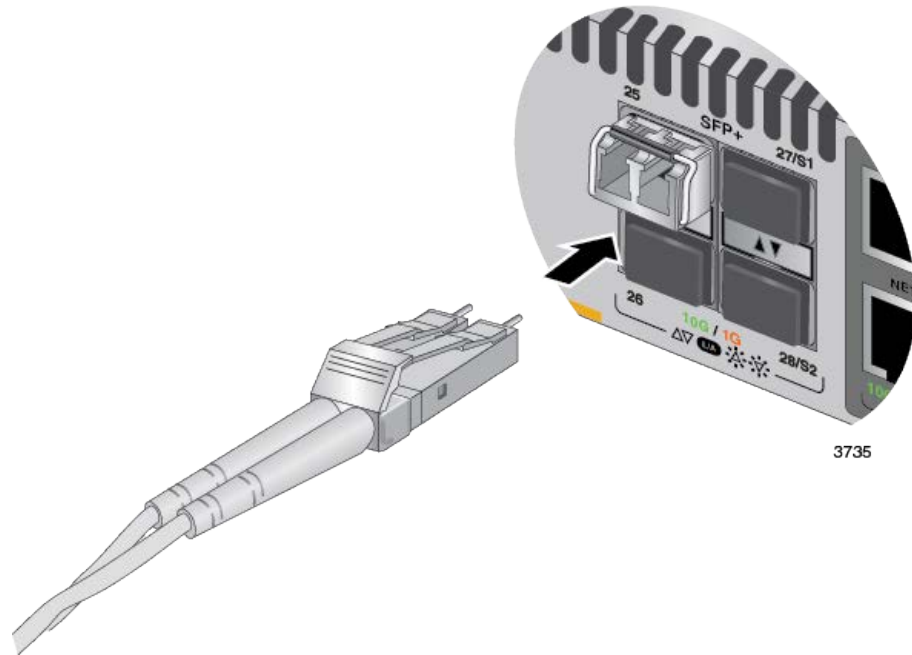

Figure 88. Connecting a Fiber Optic Cable to an SFP or SFP+ Transceiver

8. Repeat this procedure to install and cable additional transceivers.
9. If you are using SFP+ ports as the VCStack trunk, go to Chapter 11, “Building the Stack with SFP+ Ports S1 and S2” on page 147 after cabling all the switches.

## Installing AT-SP10TW Direct Connect Cables

---

This section contains the procedure for installing AT-SP10TW direct connect cables in SFP+ ports. Here are the guidelines:

- ❑ The cables are supported in ports 25 to 28 on 28-port x930 Switches and ports 49 to 52 on 52-port switches.
- ❑ If you are using SFP+ ports S1 and S2 as the VCStack trunk, review the guidelines in “Trunks of Ports S1 and S2” on page 60 before performing this procedure.
- ❑ The cables are hot-swappable. You may install them while the switch is powered on.



### Warning

A transceiver can be damaged by static electricity. Be sure to observe all standard electrostatic discharge (ESD) precautions, such as wearing an anti-static wrist strap, to avoid damaging the device. *⚡* E92

---

To install AT-SP10TW direct connect cables, perform the following procedure:

1. If the SFP+ port has a dust cover, remove it. Refer to Figure 86 on page 190.
2. Remove the AT-SP10TW direct connect cable from its shipping container and store the packaging material in a safe location.
3. Remove the dust cap from a connector on the cable. Refer to Figure 89.

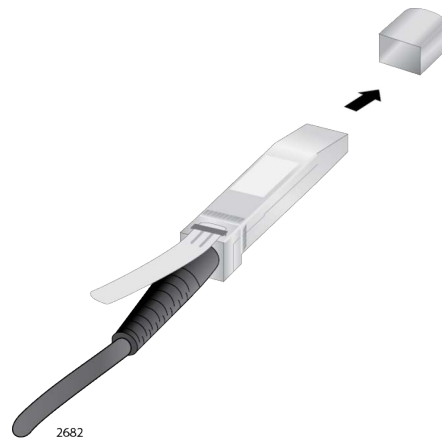

Figure 89. Removing the Dust Cover from the AT-SP10TW Cable



4. Slide the connector into the port. The release tab on the connector must be on top when installed in a top SFP+ port and on the bottom when installed in a bottom SFP+ port. Refer to Figure 90.



Figure 90. Installing AT-SP10TW Cables

5. Install the other end of the cable in a compatible port on another network device. To use SFP+ ports as the VCStack trunk, the connections must crossover on the switches. The connection on port S1 in one switch must crossover to port S2 in the next switch.
6. Repeat this procedure to cable other SFP+ ports.
7. If you are using SFP+ ports as the VCStack trunk, go to Chapter 11, “Building the Stack with SFP+ Ports S1 and S2” on page 147 after cabling all the switches.

## Cabling the AT-StackQS Card with AT-QSFPICU Cables

---

This section contains the procedure for cabling AT-StackQS Cards with copper AT-QSFPICU Cables. For installation instructions on installing the card, refer to Chapter 5, “Installing AT-StackQS and AT-x9EM/XT4 Cards” on page 103

If you are using the ports on the card for the VCStack trunk, review the guidelines in “Trunks of AT-StackQS Cards” on page 64 before performing this procedure.

To cable AT-StackQS Cards with AT-QSFPICU Cables, perform the following procedure:

1. Remove the dust cover from a port on the AT-StackQS Card. Refer to Figure 91.

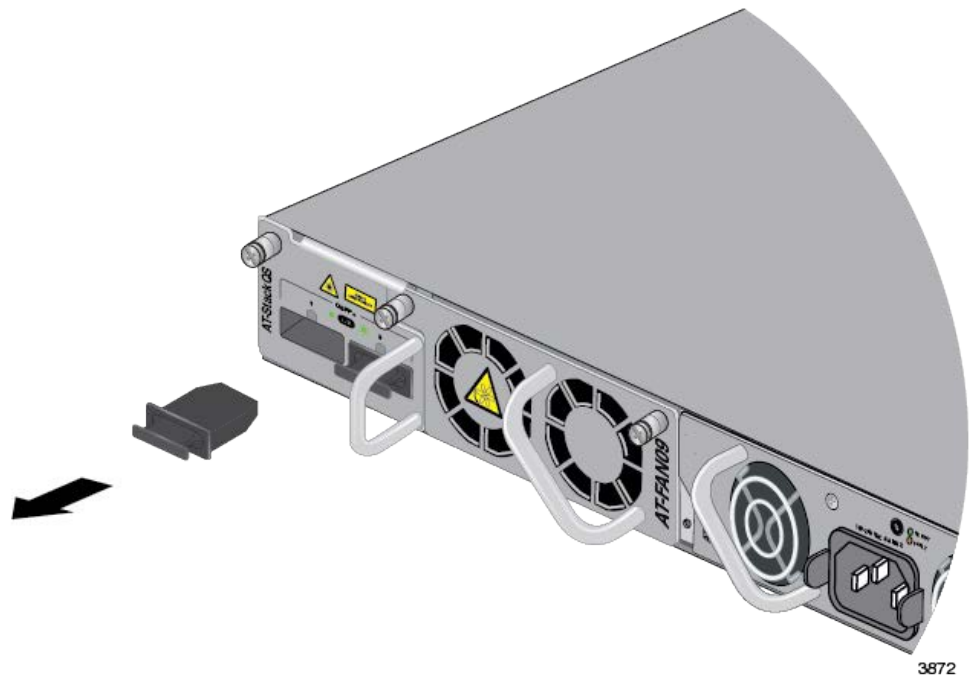

Figure 91. Removing the Dust Cover from Port 1

2. Slide the connector on the AT-QSFPICU Cable into the port until it clicks into place. Refer to Figure 92 on page 195.

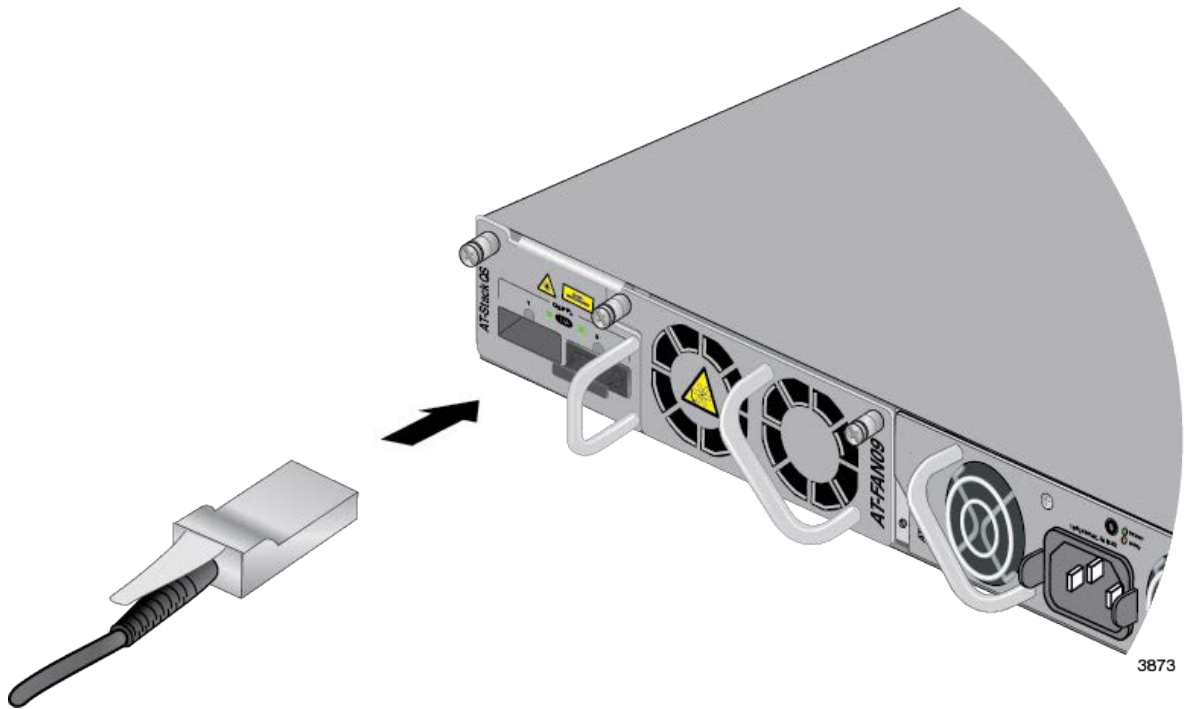

Figure 92. Installing the AT-QSFPICU Cable in Port 1

3. Install the other end of the cable into a compatible port on another networking device. If you are using the cards for the VCStack trunk, the connections must crossover on the switches. Port 1 on the card in one switch must be connected to port 2 in the next switch.
4. Repeat this procedure to install and cable a transceiver in the second port.
5. If you are using the cards for the VCStack trunk, install and cable cards in the other switches of the stack.
6. If you are using the cards for the VCStack trunk, go to Chapter 12, “Building the Stack with AT-StackQS Cards” on page 159 after cabling all the switches.

## Cabling the AT-StackQS Card with Fiber Optic Transceivers

---

This section contains the procedure for cabling AT-StackQS Cards with AT-QSFPSR and AT-QSFPLR4 Transceivers. For instructions on installing the cards in switches, refer to Chapter 5, “Installing AT-StackQS and AT-x9EM/XT4 Cards” on page 103

If you are using the ports on the card for the VCStack trunk, review the guidelines in “Trunks of AT-StackQS Cards” on page 64 before performing this procedure.

For the maximum operating distances and cable requirements of the transceivers, refer to the *x930 Data Sheet* on the Allied Telesis website for the list of supported transceivers for the AT-StackQS card.

The transceivers are hot-swappable. You can install them while the switches are powered on.

To cable the AT-StackQS Cards with fiber optic transceivers, perform the following procedure:

1. Remove the dust cover from one of the ports on the AT-StackQS Card.
2. Slide a transceivers into the port until it clicks into place.
3. Attach a fiber optic cable to the transceiver.
4. Repeat this procedure to install and cable a transceiver in the second port.
5. If you are using the cards for the VCStack trunk, install and cable cards in the other switches of the stack. The connections must crossover on the switches. Port 1 on the card in one switch must be connected to port 2 in the next switch.
6. If you are using the cards for the VCStack trunk, go to Chapter 12, “Building the Stack with AT-StackQS Cards” on page 159 after cabling all the switches.

## Chapter 15

# Troubleshooting

---

This chapter contains suggestions on how to troubleshoot the switch if a problem occurs.

---

**Note**

For further assistance, please contact Allied Telesis Technical Support at [www.alliedtelesis.com/support](http://www.alliedtelesis.com/support).

---

**Problem 1:** All of the port LEDs and the Switch ID LED are off, and the fans are not operating.

**Solutions:** The unit is not receiving power. If the switch has an AC power supply, try the following:

- Verify that the power cord is securely connected to the power source and to the AC connector on the back panel of the switch.
- Verify that the power outlet has power by connecting another device to it.
- Try connecting the unit to another power source.
- Try a different power cord.
- Verify that the voltage from the power source is within the required levels for your region.

If the switch has the DC AT-PWR250-80 Power Supply, try the following:

- Verify that the DC circuit is powered on.
- Verify that the On/Off switch on the power supply is in the On position.
- Verify that the positive, negative, and ground wires are properly connected to the AT-PWR250-80 Power Supply and DC circuit. Refer to “Wiring the DC Connector on the AT-PWR250-80 Power Supply” on page 137.
- Try connecting the switch to another DC circuit.
- Try replacing the positive, negative, and ground wires.

**Problem 2:** All of the port LEDs are off even though the ports are connected to active network devices.

**Solution:** The switch may be operating in the low power mode. To toggle on the LEDs, press the eco-friendly button on the front panel of the switch. You may also toggle the LEDs off and on with the ECOFRIENDLY LED and NO ECOFRIENDLY LED commands in the command line interface.

**Problem 3:** A copper port on the switch is connected to a network device but the port's LINK/ACT LED is off.

**Solutions:** The port is unable to establish a link to a network device. Try the following:

- ❑ Verify that the port is connected to the correct copper cable. This is to eliminate the possibility that the port is connected to the wrong network device.
- ❑ Verify that the network device connected to the port is powered on and is operating properly.
- ❑ Try connecting another network device to the port with a different cable. If the port is able to establish a link, then the problem is with the cable or the other network device.
- ❑ Verify that the copper cable does not exceed 100 meters (328 feet).
- ❑ Verify that you are using the appropriate category of copper cable. The cable types are listed in "Cable Requirements" on page 32 for the 10/100/1000Base-T ports.
- ❑ Verify that the companion SFP port of the copper port is empty. This applies only to the AT-x930-28GSTX Switch. For example, if copper port 2R is connected to an active network device but cannot establish a connection to it, verify that SFP port 2 is empty. For more information, refer to "SFP Ports" on page 38.

---

**Note**

A 1000Base connection may require five to ten seconds to establish a link.

---

**Problem 4:** The LINK/ACT LED for an SFP or SFP+ transceiver is off.

**Solutions:** The fiber optic port on the transceiver is unable to establish a link to a network device. Try the following:

- ❑ Verify that the remote network device connected to the fiber optic port is operating properly.
- ❑ Check that the transceiver is fully inserted in the port.
- ❑ Verify that the fiber optic cable is securely connected to the port on the SFP or SFP+ module and to the port on the remote device.

- ❑ Verify that the operating specifications of the fiber optic ports on the transceiver and remote network device are compatible.
- ❑ Verify that the correct type of fiber optic cabling is being used.
- ❑ Verify that the port is connected to the correct fiber optic cable. This is to eliminate the possibility that the port is connected to the wrong remote network device.
- ❑ Try connecting another network device to the fiber optic port using a different cable. If the port is able to establish a link, then the problem is with the cable or with the other network device.
- ❑ Use the switch's management software to verify that the port is enabled.
- ❑ If the remote network device is a managed device, use its management firmware to determine whether its port is enabled.
- ❑ Test the attenuation of both directions on the fiber optic cable with a fiber optic tester to determine whether the optical signal is too weak (sensitivity) or too strong (maximum input power).

**Problem 5:** The SHOW STACK command is not displaying all the switches in the stack.

**Solutions:** One or more switches cannot join the stack. If the switches are stacked with the S1 and S2 ports, try the following:

- ❑ Verify that you are using only Allied Telesis SFP+ transceivers or AT-SPI0TW direct connect cables. The switches will not form a stack with any other type of transceiver or cable.
- ❑ Verify that the SFP+ transceivers or direct connect cables are fully inserted into the S1 and S2 ports.
- ❑ Verify that the fiber optic cables are securely connected to the ports on the SFP+ transceivers.
- ❑ Verify that the transceivers or cables are properly cabled. The cables must crossover to different ports on the switches. Port S1 on one switch must crossover to port S2 on another switch.
- ❑ Verify that VCStack is activated on the switches. For instructions, refer to Chapter 10, "Displaying the AlliedWare Plus Version Number" on page 141.

If the switches are stacked with AT-StackQS Cards and AT-QSFPICU Cables, try the following:

- ❑ Verify that the AT-StackQS Cards are fully seated in the slots of the back panels of the switches.
- ❑ Verify that the AT-QSFPICU Cables are fully seated in the ports in the AT-StackQS Cards.

- ❑ Verify that the AT-QSFICU Cables are from Allied Telesis. The trunk will not work with cables from another network equipment manufacturer.
- ❑ Verify that the ports on the AT-StackQS Cards are properly cabled. The cables must crossover to different ports on the cards. Port 1 on the AT-StackQS Card in one switch must crossover to port 2 on the card in another switch.
- ❑ Verify that VCStack is activated on the switches. For instructions, refer to Chapter 10, “Displaying the AlliedWare Plus Version Number” on page 141.

If the switches are stacked with AT-StackQS Cards and AT-QSFPSR or AT-QSFPLR4 Transceivers, try the following:

- ❑ Verify that the AT-StackQS Cards are fully seated in the slots of the back panels of the switches.
- ❑ Verify that the transceivers are fully seated in the ports in the AT-StackQS Cards.
- ❑ Verify that the transceivers are from Allied Telesis. The trunk will not work with transceivers from another network equipment manufacturer.
- ❑ For AT-QSFPSR Transceivers, verify that you are using 12-strand OM4 fiber optic cable and that the cables are not longer than 150 m (492 ft).
- ❑ For AT-QSFPLR4 Transceivers, verify that you are using SMF cables and that the cables are in range of 2 m (6.6 ft) to 10 km (6.2 mi).
- ❑ For AT-QSFPSR Transceivers, verify that the switches have version 5.4.5-1 or later of the x930 operating system. For instructions, refer to “Displaying the Hardware Status and AlliedWare Plus Version Number” on page 145.
- ❑ For AT-QSFPLR4 Transceivers, verify that the switches have version 5.4.5-2 or later of the x930 operating system. For instructions, refer to “Displaying the Hardware Status and AlliedWare Plus Version Number” on page 145.
- ❑ Verify that the ports on the AT-StackQS Cards are properly cabled. The cables must crossover to different ports on the cards. Port 1 on the AT-StackQS Card in one switch must crossover to port 2 on the card in another switch. For background information, refer to “Trunks of AT-StackQS Cards” on page 64.
- ❑ Verify that VCStack is activated on the switches. For instructions, refer to Chapter 10, “Displaying the AlliedWare Plus Version Number” on page 141.



**Problem 6:** Network performance between a copper port on the switch and a network device is slow.

**Solution:** There might be a duplex mode mismatch between the port and the network device. This can occur when a copper port using Auto-Negotiation is connected to a remote device that has a fixed speed of 10 or 100 Mbps and a fixed duplex mode of full duplex. If this is the cause of the problem, adjust the duplex mode of the port on the network device or switch so that both ports are using the same duplex mode. You can use either the LEDs or management software on the switch to determine the duplex mode settings of the ports. The LEDs are described in Table 7 on page 44.

**Problem 7:** The switch functions intermittently.

**Solutions:** Check the system hardware status through the management software:

- ❑ Use the SHOW SYSTEM ENVIRONMENT command in the Privileged Exec mode to verify that the input voltage from the power source to the switch is stable and within the approved operating range. The unit will shut down if the input voltage fluctuates above or below the approved operating range.
- ❑ Use the SHOW SYSTEM ENVIRONMENT command in the Privileged Exec mode to verify that the fan is operating correctly.
- ❑ Verify that the location of the switch allows for adequate airflow. The unit will shut down if it is in danger of overheating.

**Problem 8:** The Switch ID LED on the front of the switch is flashing the letter “F.”

**Solutions:** One or more of the following problems has occurred:

- ❑ A cooling fan has failed.
- ❑ The internal temperature of the switch has exceeded the normal operating range and the switch may shut down.

Contact your Allied Telesis sales representative for assistance.

**Problem 9:** A port on the AT-x930-28GPX or AT-x930-52GPX Switch is not providing power to a PoE device.

**Solutions:** Try the following:

- ❑ Review the PD’s documentation to confirm that the device supports Mode A of the IEEE 802.3at standard. Mode A is one of two modes that define the connector pins that deliver the power from the port in the switch to the powered device. In Mode A, the power is carried on pins 1, 3, and 6 on the RJ-45 port, the same pins that carry the network traffic. The second mode, Mode B, defines pins

4, 5, 7, and 8 as the power carriers. The AT-x930-28GPX and AT-x930-52GPX Switches do not support Mode B. Most powered devices are designed to accept power by either mode, but some legacy devices may only support one mode. This can be verified by reviewing the device's documentation or data sheet. Legacy devices that only support Mode B will not work with the switches.

- ❑ Check that the device's power requirements do not exceed 30 W. This can be verified by reviewing the device's documentation or data sheet.
- ❑ Verify that you are using the appropriate category of copper cable by referring to "Cable Requirements" on page 32.
- ❑ Use the management software on the switch to determine whether PoE is enabled on the port. The default setting for PoE is enabled.
- ❑ Use the management software on the switch to determine whether the PoE power setting for the port has been reduced to a value below the power requirements of the device.
- ❑ Try connecting the device to a different port on the switch.

**Problem 10:** One or more ports on the optional AT-x9EM/XT Card cannot establish connections to network devices or do not forward traffic.

**Solutions:** Try the following:

- ❑ Verify that the switch has version 5.4.5-2 or later of the x930 operating system. Earlier versions of the management software do not support the card. For instructions, refer to "Displaying the Hardware Status and AlliedWare Plus Version Number" on page 145.
- ❑ Check that the cables do not exceed 100 m (328 ft).
- ❑ Verify that you are using UTP or STP Cat. 5e for 1Gbps links and UTP or STP Cat. 6e cable for 10Gbps links.
- ❑ Verify that the port is connected to the correct copper cable. This is to eliminate the possibility that the port is connected to the wrong network device.
- ❑ Verify that the network device connected to the port is powered on and is operating properly.
- ❑ Try connecting another network device to the port with a different cable. If the port is able to establish a link, then the problem is with the cable or the other network device.
- ❑ Verify that the copper cable does not exceed 100 meters (328 feet).

## Appendix A

# Technical Specifications

---

This appendix contains the following sections:

- "Physical Specifications" on page 204
- "Environmental Specifications" on page 206
- "Power Specifications" on page 207
- "Certifications" on page 209
- "RJ-45 Copper Port Pinouts" on page 210
- "RJ-45 Style Serial Console Port Pinouts" on page 212
- "Stacking Transceivers" on page 213

## Physical Specifications

---

### Dimensions (H x W x D)

Table 26 lists the dimensions of the switches and power supplies.

Table 26. Product Dimensions

AT-x930-28GTX	4.4 cm x 44.0 cm x 42.0 cm (1.7 in. x 17.3 in. x 16.5 in.)
AT-x930-28GPX	4.4 cm x 44.0 cm x 42.0 cm (1.7 in. x 17.3 in. x 16.5 in.)
AT-x930-28GSTX	4.4 cm x 44.0 cm x 42.0 cm (1.7 in. x 17.3 in. x 16.5 in.)
AT-x930-52GTX	4.4 cm x 44.0 cm x 42.0 cm (1.7 in. x 17.3 in. x 16.5 in.)
AT-x930-52GPX	4.4 cm x 44.0 cm x 42.0 cm (1.7 in. x 17.3 in. x 16.5 in.)
AT-PWR150	4.2 cm x 14.8 cm x 25.2 cm (1.7 in. x 5.8 in. x 9.8 in.)
AT-PWR250	4.2 cm x 14.8 cm x 25.2 cm (1.7 in. x 5.8 in. x 9.8 in.)
AT-PWR250-80	4.2 cm x 14.8 cm x 25.2 cm (1.7 in. x 5.8 in. x 9.8 in.)
AT-PWR800	4.2 cm x 14.8 cm x 25.2 cm (1.7 in. x 5.8 in. x 9.8 in.)
AT-PWR1200	4.2 cm x 14.8 cm x 30.7 cm (1.7 in. x 5.8 in. x 12.1 in.)

### Weights

Table 27 lists the weights of the switches and power supplies.

Table 27. Product Weights

AT-x930-28GTX	5.1 kg (11.2 lb.)
AT-x930-28GPX	5.1 kg (11.2 lb.)
AT-x930-28GSTX	5.1 kg (11.2 lb.)
AT-x930-52GTX	5.1 kg (11.2 lb.)

Table 27. Product Weights (Continued)

AT-x930-52GPX	5.2 kg (11.5 lb.)
AT-PWR150	1.3 kg (2.8 lb)
AT-PWR250	1.5 kg (3.3 lb.)
AT-PWR250-80	1.5 kg (3.3 lb.)
AT-PWR800	1.8 kg (4.0 lb.)
AT-PWR1200	2.2 kg (4.9 lb.)

The weights of the switches do not include the power supplies.

### Ventilation

Table 28 lists the ventilation requirements.

Table 28. Ventilation Requirements

Recommended Minimum Ventilation on All Sides	10 cm (4.0 in)
--	----------------

## Environmental Specifications

---

Table 29 lists the environmental specifications of the switches.

Table 29. Environmental Specifications

Operating Temperature	0° C to 45° C (32° F to 113° F)
Storage Temperature	-25° C to 70° C (-13° F to 158° F)
Operating Humidity	5% to 90% noncondensing
Storage Humidity	5% to 95% noncondensing
Maximum Operating Altitude	3,000 m (9,842 ft)
Maximum Nonoperating Altitude	4,000 m (13,100 ft)

## Power Specifications

---

This section contains the maximum power consumption values and input voltages.

### Maximum Power Consumption

Table 30, Table 31, and Table 32 list the maximum power consumptions of the switches with the different power supplies.

Table 30. Maximum Power Consumptions with the AT-PWR150, AT-PWR250, or AT-PWR250-80 Power Supply

AT-x930-28GTX	83.6 watts
AT-x930-28GPX	83.8 watts
AT-x930-28GSTX	96.5 watts
AT-x930-52GTX	94.6 watts
AT-x930-52GPX	96.8 watts

Table 31. Maximum Power Consumptions with the AT-PWR800 Power Supply

AT-x930-28GTX	83.8 watts
AT-x930-28GPX	564.2 watts
AT-x930-28GSTX	96.6 watts
AT-x930-52GTX	96.6 watts
AT-x930-52GPX	577.0 watts

Table 32. Maximum Power Consumptions with the AT-PWR1200 Power Supply

AT-x930-28GTX	86.8 watts
AT-x930-28GPX	808.4 watts
AT-x930-28GSTX	97.9 watts
AT-x930-52GTX	98.5 watts
AT-x930-52GPX	880.0 watts

### Input Voltages

Table 33 lists the input voltages for the five power supplies.

Table 33. Input Voltages of the Power Supplies

AT-PWR150	100-240 VAC~, 2.0A maximum, 50/60 Hz
AT-PWR250	100-240 VAC~, 5.0A maximum, 50/60 Hz
AT-PWR250-80	40-60 VDC, 6.0A maximum
AT-PWR800	100-240 VAC~, 10.0A maximum, 50/60 Hz
AT-PWR1200	100-240 VAC~, 15.0-7A maximum, 50/60 Hz



## Certifications

---

Table 34 lists the product certificates.

Table 34. Product Certifications

EMI (Emissions)	FCC Class A, EN55022 Class A, EN61000-3-2, EN61000-3-3, VCCI Class A, CISPR Class A, C-TICK, CE
EMC (Immunity)	EN55024
Electrical and Laser Safety	EN60950-1 (TUV), UL 60950-1 (CULUS), EN60825
Compliance Marks	CE, CULUS, TUV, C-Tick

## RJ-45 Copper Port Pinouts

Figure 93 illustrates the pin layout of the RJ-45 connectors and ports.

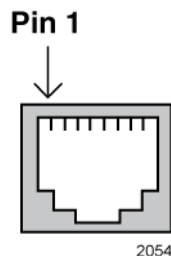

Figure 93. RJ-45 Socket Pin Layout (Front View)

Table 35 lists the pin signals for 10 and 100 Mbps.

Table 35. Pin Signals for 10 and 100 Mbps

Pin	MDI Signal	MDI-X Signal
1	TX+	RX+
2	TX-	RX-
3	RX+	TX+
4	Not used	Not used
5	Not used	Not used
6	RX-	TX-
7	Not used	Not used
8	Not used	Not used

Table 36 lists the pin signals when a port operating at 1000 Mbps.

Table 36. Pin Signals for 1000 Mbps

Pinout	Pair
1	Pair 1 +
2	Pair 1 -
3	Pair 2 +
4	Pair 3 +

Table 36. Pin Signals for 1000 Mbps (Continued)

5	Pair 3 -
6	Pair 2 -
7	Pair 4 +
8	Pair 4 -

## RJ-45 Style Serial Console Port Pinouts

---

Table 37 lists the pin signals of the RJ-45 style serial Console port.

Table 37. RJ-45 Style Serial Console Port Pin Signals

<b>Pin</b>	<b>Signal</b>
1	Looped to pin 8.
2	Looped to pin 7.
3	Transmit Data
4	Ground
5	Ground
6	Receive Data
7	Looped to pin 2.
8	Looped to pin 1.

## Stacking Transceivers

---

Table 38 lists the operating specifications for the AT-QSFPSR Transceiver.

Table 38. AT-QSFPSR Transceiver Operating Specifications

Specification	Value
Wavelength	850nm
Transmitter - maximum power	-1.0dBm
Transmitter - minimum power	-7.6dBm
Receiver - saturation	-2.4dBm
Receiver - sensitivity	-9.5dBm

Table 39 lists the operating specifications for the AT-QSFPLR4 Transceiver.

Table 39. AT-QSFPLR4 Transceiver Operating Specifications

Specification	Value
Wavelengths	1271nm 1291nm 1311nm 1331nm
Transmitter - maximum total average power	8.3dBm
Transmitter - minimum average power, each lane	-7dBm
Transmitter - maximum average power, each lane	2.3dBm
Receiver - saturation	3.3dBm
Receiver - sensitivity, each lane	-11.5dBm

