

# Secure Ethernet Network Adapters

---

AT-2712FX/SC  
AT-2712LX20/SC  
AT-2912T

## Installation and User's Guide

Copyright © 2010 Allied Telesis, Inc.

All rights reserved. No part of this publication may be reproduced without prior written permission from Allied Telesis, Inc. Allied Telesis and the Allied Telesis logo are trademarks of Allied Telesis, Incorporated. Broadcom® and the pulse logo are among the trademarks of Broadcom Corporation. All other product names, company names, logos or other designations mentioned herein are trademarks or registered trademarks of their respective owners.

# Electrical Safety and Emissions Standards

This product meets the following standards.

U.S. Federal Communications Commission	
<b>Declaration of Conformity</b>	
Manufacturer Name: Allied Telesis, Inc.	
Declares that the product: <b>Secure Ethernet Adapter</b>	
Model Numbers: <b>AT-2712FX/SC, AT-2712LX20/SC, and AT-2912T</b>	
This product complies with FCC Part 15B, Class B Limits:	
This device complies with part 15 of the FCC Rules. Operation is subject to the following two conditions: (1) This device must not cause harmful interference, and (2) this device must accept any interference received, including interference that may cause undesired operation.	
<b>Radiated Energy</b>	
Note: This equipment has been tested and found to comply with the limits for a Class B digital device pursuant to Part 15 of FCC Rules. These limits are designed to provide reasonable protection against harmful interference in a residential installation. This equipment generates, uses and can radiate radio frequency energy and, if not installed and used in accordance with instructions, may cause harmful interference to radio or television reception, which can be determined by turning the equipment off and on. The user is encouraged to try to correct the interference by one or more of the following measures:	
<ul style="list-style-type: none"><li>- Reorient or relocate the receiving antenna.</li><li>- Increase the separation between the equipment and the receiver.</li><li>- Connect the equipment into an outlet on a circuit different from that to which the receiver is connected.</li><li>- Consult the dealer or an experienced radio/TV technician for help.</li></ul>	
Changes and modifications not expressly approved by the manufacturer or registrant of this equipment can void your authority to operate this equipment under Federal Communications Commission rules.	

Industry Canada	
This Class B digital apparatus complies with Canadian ICES-003.	
Cet appareil numérique de la classe B est conforme à la norme NMB-003 du Canada.	

European Union Restriction of the Use of Certain Hazardous Substances (RoHS) in Electrical and Electronic Equipment	
This Allied Telesis RoHS-compliant product conforms to the European Union Restriction of the Use of Certain Hazardous Substances (RoHS) in Electrical and Electronic Equipment. Allied Telesis ensures RoHS conformance by requiring supplier Declarations of Conformity, monitoring incoming materials, and maintaining manufacturing process controls.	

RFI Emissions	FCC Class B, EN55022 Class B, EN61000-3-2, EN61000-3-3, VCCI Class B, C-TICK, CE
Immunity	EN55024
Electrical Safety	EN60950 (TUV), UL 60950 (cUL <sub>US</sub> )
 Laser Safety	EN60825

## Translated Safety Statements

---

**Important:** The  indicates that a translation of the safety statement is available in a PDF document titled “Translated Safety Statements” on the Allied Telesis website at [www.alliedtelesis.com/support/software](http://www.alliedtelesis.com/support/software). After you have accessed this website, enter the model number in the **Search by Product Name** box and then click **Find** to view the current list of documents.

# Contents

---

<b>Preface</b> .....	11
Safety Symbols Used in this Document .....	12
Where to Find Management Software Updates and Product Information .....	13
Contacting Allied Telesis .....	14
Online Support .....	14
Email and Telephone Support .....	14
Returning Products .....	14
For Sales Information .....	14
Warranty .....	14
<b>Chapter 1: Introducing the Secure Ethernet Network Adapters</b> .....	15
Functional Descriptions .....	16
AT-2712FX/SC and AT-2712LX20/SC Adapters .....	16
AT-2912T Adapter .....	18
Supported Operating Systems and Features .....	19
<b>Chapter 2: Installing the Hardware</b> .....	21
Reviewing Safety Precautions .....	22
Reviewing the Contents of Your Shipment .....	24
Pre-Installation Checklist .....	25
Replacing the Bracket .....	26
Replacing the Low-Profile Bracket .....	26
Replacing the Standard Bracket .....	28
Installing a Network Adapter Card .....	29
Connecting the Network Cables .....	33
<b>Chapter 3: Installing Windows Server 2003 and Windows XP Driver Software</b> .....	35
Installing the Driver Software .....	36
Using the Driver Installer .....	36
Updating the Adapter Software .....	39
Modifying Configuration Properties .....	43
Uninstalling the Driver Software .....	45
<b>Chapter 4: Installing the Windows Vista and Windows 7 Driver Software</b> .....	47
Installing the Driver Software .....	48
Uninstalling the Driver Software .....	54
<b>Chapter 5: Setting Advanced Properties</b> .....	57
Accessing the Advanced Tab .....	58
Selecting the Advanced Tab in Windows Server 2003 or Windows XP .....	58
Selecting the Advanced Tab in Windows 7 .....	61
Selecting the Advanced Tab in Windows Vista .....	63
Modifying Advanced Properties .....	65
Updating the Ethernet@WireSpeed Property .....	66
Updating the Flow Control Property .....	66
Updating the Interrupt Moderation Property .....	68
Updating the Checksum Offload Property .....	69
Updating the Large Send Offload Property .....	70
Updating the Jumbo MTU Property .....	71
Updating the Network Address Property .....	72
Updating the RSS Queues Property .....	73
Updating the Priority & VLAN Property .....	74

Updating the Receive Buffers Property .....	75
Updating the Receive Side Scaling Property .....	75
Updating the Speed & Duplex Mode Property .....	76
Updating the TCP Connection Offload Properties .....	78
Updating the Transmit Buffers Property .....	79
Updating the VLAN ID Property .....	79
Updating the WOL Speed .....	80
<b>Chapter 6: Enabling LINUX</b> .....	<b>81</b>
Introduction .....	82
Limitations .....	82
Packaging .....	82
Installing LINUX TG3 File .....	83
Installing the Source RPM Package .....	83
Building the Driver from the Source TAR File .....	84
Driver Settings .....	85
Driver Default Settings .....	86
Unloading and Removing the Driver .....	88
Driver Messages .....	89
<b>Appendix A: Specifications</b> .....	<b>91</b>
Physical Specifications .....	91
Environmental Specifications .....	91
Power Specifications .....	92
Performance Specifications .....	92
Quality and Reliability .....	92
Operating Specifications .....	92
10/100/1000Base-T Twisted-Pair Port Connectors .....	93
<b>Appendix B: Cleaning Fiber Optic Connectors</b> .....	<b>95</b>
Using a Cartridge-Type Cleaner .....	96
Using a Swab .....	98

# Figures

---

Figure 1. AT-2712FX/SC Adapter.....	16
Figure 2. AT-2712FX/SC Faceplate .....	17
Figure 3. AT-2912T Adapter .....	18
Figure 4. AT-2912T Faceplate.....	18
Figure 5. Removing the Low-Profile Bracket .....	26
Figure 6. Fastening Screws onto Standard Bracket .....	27
Figure 7. Removing the Standard Bracket.....	28
Figure 8. Fastening Screws onto Low-Profile Bracket.....	28
Figure 9. Removing the PC Cover.....	30
Figure 10. Removing the Faceplate From PCI Slot.....	30
Figure 11. Inserting the Adapter with a High-profile Bracket .....	31
Figure 12. Securing the Adapter with a High-profile Bracket.....	32
Figure 13. Welcome to the Found New Hardware Wizard Window.....	37
Figure 14. Found New Hardware Wizard Window: Search and Installation Options.....	38
Figure 15. Windows Server 2003 Start Window .....	40
Figure 16. Run Window .....	40
Figure 17. Device Manager Window (Network adapter folder is collapsed).....	41
Figure 18. Welcome to Hardware Update Wizard Window .....	42
Figure 19. Hardware Update Wizard Window .....	42
Figure 20. System Properties Dialog Box.....	44
Figure 21. Windows 7 Search Box .....	49
Figure 22. Windows Vista Start Menu .....	50
Figure 23. Windows Vista Run Window.....	50
Figure 24. Device Manager Window.....	51
Figure 25. Device Manager Window: Ethernet Controller .....	52
Figure 26. Update Driver Software - Ethernet Controller Window .....	52
Figure 27. Update Driver Software: Ethernet Controller: Browse.....	53
Figure 28. Update Driver Software - Confirmation Window.....	53
Figure 29. System Properties Dialog Box.....	59
Figure 30. Advanced Tab .....	60
Figure 31. Windows 7 Search Box .....	61
Figure 32. Device Manager Window.....	62
Figure 33. Windows Vista Start Menu .....	63
Figure 34. Windows Vista Run Window.....	63
Figure 35. RJ-45 Connector and Port Pin Layout.....	93
Figure 36. Ferrule in an SC Connector Plug.....	95
Figure 37. Unclean and Clean Ferrule.....	95
Figure 38. Cartridge Cleaner .....	96
Figure 39. Rubbing the Ferrule Tip on the Cleaning Surface.....	96
Figure 40. Lint-Free and Alcohol-Free Swabs.....	98
Figure 41. Cleaning a Recessed Ferrule.....	98





# Tables

---

Table 1: Safety Symbols .....	12
Table 2: Fiber Optic Port 100 LED Status .....	17
Table 3: Twisted-Pair Port LED Status .....	18
Table 4: 1000BASE-SX Fiber Optic Cable Specifications .....	33
Table 5: Ethtool Utility Examples .....	86
Table 6: Linux Driver Settings .....	86
Table 7: MDI Pin Signals (10Base-T or 100Base-TX) .....	93
Table 8: MDI-X Pin Signals (10Base-T or 100Base-TX) .....	94
Table 9: RJ-45 1000Base-T Connector Pinouts .....	94



# Preface

---

This guide contains instructions on how to install the AT-2712FX/SC, AT-2712LX20/SC, and AT-2912T Secure Ethernet Network adapters and configure the adapters using the driver software.

The Preface contains the following sections:



- ❑ “Safety Symbols Used in this Document” on page 12
- ❑ “Where to Find Management Software Updates and Product Information” on page 13
- ❑ “Contacting Allied Telesis” on page 14

## Safety Symbols Used in this Document

---

This document uses the safety symbols defined in Table 1.

Table 1. Safety Symbols

Symbol	Meaning	Description
	Caution	Performing or omitting a specific action may result in equipment damage or loss of data.
	Warning	Performing or omitting a specific action may result in electrical shock.

## Where to Find Management Software Updates and Product Information

---

New releases of management software are on the Allied Telesis web site. In addition, the installation and user guides are available for all Allied Telesis products in portable document format (PDF) on our web site. Both the management software and the product documentation are available at **[www.alliedtelesis.com/support/software/](http://www.alliedtelesis.com/support/software/)**.

Once you access the web site, enter the hardware product model in the **Search by Product Name** field. For example, enter "AT-2912T" and then click **Find**. You can download the management software. In addition, you can view the documents online or download them onto your local workstation or server.

## Contacting Allied Telesis

---

This section provides Allied Telesis contact information for technical support as well as sales or corporate information.

### **Online Support**

You can request technical support online by accessing the Allied Telesis Knowledge Base: [www.alliedtelesis.com/support/kb.aspx](http://www.alliedtelesis.com/support/kb.aspx). You can use the Knowledge Base to submit questions to our technical support staff and review answers to previously asked questions.

### **Email and Telephone Support**

For Technical Support via email or telephone, refer to the Support section of the Allied Telesis web site: [www.alliedtelesis.com/support](http://www.alliedtelesis.com/support).

### **Returning Products**

Products for return or repair must first be assigned a return materials authorization (RMA) number. A product sent to Allied Telesis without an RMA number will be returned to the sender at the sender's expense. For instructions on how to obtain an RMA number, go to the Support section on our web site at [www.alliedtelesis.com/support/rma.aspx](http://www.alliedtelesis.com/support/rma.aspx).

### **For Sales Information**

You can find the contact information for Allied Telesis sales offices or valued resellers listed on our web site at [www.alliedtelesis.com/purchase](http://www.alliedtelesis.com/purchase). To purchase Allied Telesis products directly, contact one of our sales representatives or one of our valued resellers.

### **Warranty**

Go to [www.alliedtelesis.com/support/warranty](http://www.alliedtelesis.com/support/warranty) for the specific terms and conditions of the warranty and for warranty registration for the AT-2712FX/SC, AT-2712LX20/SC, and AT-2912T adapters.

## Chapter 1

# Introducing the Secure Ethernet Network Adapters

---

This chapter provides an introduction to the Allied Telesis AT-2712FX/SC, AT-2712LX20/SC, and AT-2912T Secure Ethernet Network Adapters and contains the following sections:

- ❑ “Functional Descriptions” on page 16
- ❑ “Supported Operating Systems and Features” on page 19

## Functional Descriptions

---

The AT-2712FX/SC, AT-2712LX20/SC, and AT-2912T adapters feature in-built cryptographic processors that take over a number of data encryption and decryption functions within the hardware, releasing the host CPU to perform other tasks. This ensures the highest possible speeds when transmitting or receiving secure data, without compromising data security or host system performance.

As part of the company's green range, all three adapters are engineered to reduce power consumption. They incorporate centralized power management features that automatically place idle circuitry into a lower power mode to save energy and battery life in a laptop.

The following sections provide functional descriptions of the AT-2712FX/SC, AT-2712LX/20SC, and AT-2912T adapters.

### **AT-2712FX/SC and AT-2712LX20/SC Adapters**

Both the AT-2712FX/SC and AT-2712LX20/SC adapters connect a PCIe compliant server or workstation to a Fast Ethernet network using fiber optic cabling and a connector. In addition, both adapters operate at speeds of 100 Mbps in full-duplex and half-duplex modes. The two adapters are identical in appearance. The AT-2712FX/SC adapter is shown in Figure 1.

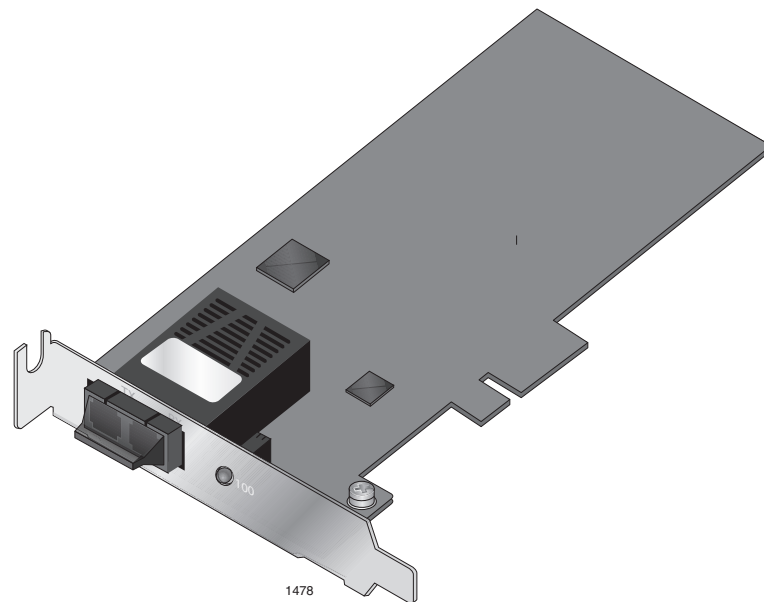

Figure 1. AT-2712FX/SC Adapter

Both the AT-2712FX/SC and AT-2712LX20/SC adapters have one SC connector. The AT-2712FX/SC adapter uses a connector that meets 62.5/125  $\mu\text{m}$  or 50/125  $\mu\text{m}$  multimode specifications. AT-2712LX20/SC adapter uses a connector that meets 9/125  $\mu\text{m}$  single-mode specifications.



The difference between the two adapters is their cable length requirements. The AT-2712FX/SC is designed for multimode operation using cables of up to 275 meters (902 feet) in length. The AT-2712LX20/SC adapter is designed for single mode operation using cables of up to 10 kilometers (6.123 miles) in length. For more information about the cables, see Table 3 on page 33.

### AT-2712FX/SC and AT-2712LX20/SC Adapters Physical Descriptions

The faceplate on the AT-2712FX/SC and AT-2712LX20/SC adapters provides two fiber optic connectors for attaching the adapter to a compatible link partner. See Figure 2 for an illustration of the adapter's faceplate.

Both the AT-2712FX/SC and AT-2712LX20/SC adapters have one fiber port and one LED, as shown in Figure 2 and described in Table 1.

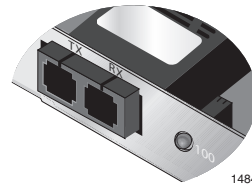

Figure 2. AT-2712FX/SC Faceplate

Table 1. Fiber Optic Port 100 LED Status

State	Description
Green	The port is operating at 100 Mbps and has a valid link.
Flashing	The port is receiving or transmitting network packets at 100 Mbps.

## AT-2912T Adapter

The AT-2912T adapter is a Gigabit Ethernet secure PCIe NIC featuring on-board encryption. It is fully compatible with other secure IPsec as well as non-IPsec NICs. This adapter operates at speeds of 10/100/1000T Mbps in both full-duplex and half-duplex modes.

The AT-2912T adapter has one twisted-pair connector, as shown in Figure 3.

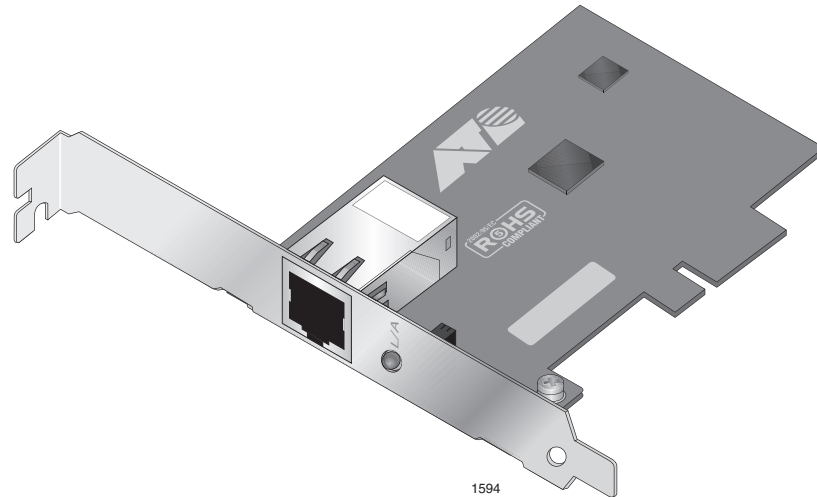

Figure 3. AT-2912T Adapter

### AT-2912T Adapter Physical Description

The faceplate on the AT-2912T adapter provides one twisted-pair connector for attaching the adapter to a compatible link partner. See Figure 4 for an illustration of the adapter’s faceplate.

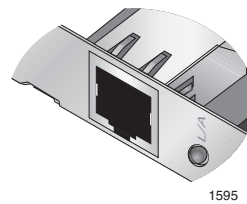

Figure 4. AT-2912T Faceplate

The AT-2912T adapter has one LED as described in Table 2.

Table 2. Twisted-Pair Port LED Status

State	Description
Green	The port is operating at 10/100/1000 Mbps and has a valid link.
Flashing	The port is receiving or transmitting network packets at 10/100/1000 Mbps

## Supported Operating Systems and Features

---

The Secure Ethernet Network adapters are shipped from the factory with the default Broadcom software driver installed. You can download the latest version of the software driver and our configuration from the Allied Telesis website at [www.alliedtelesis.com/support/software](http://www.alliedtelesis.com/support/software). After you have accessed this website, enter the model number in the **Search by Product Name** box and then click **Find**.

The Secure Ethernet Network adapters have software support for the following operating systems:

- Microsoft Windows Server 2003 (32-bit and 64-bit extended)
- Microsoft Windows XP (32-bit and 64-bit extended)
- Microsoft Windows Vista (32-bit and 64-bit extended)
- Microsoft Windows 7 (32-bit and 64-bit extended)
- Linux (32-bit and 64-bit extended)

The following list of features for the AT-2712FX/SC, AT-2712LX20/SC, and AT-2912T adapters applies to all of the supported operating systems:

- PCI Express x1 interface
- Flow Control (IEEE 802.1x)
- Layer 2 Priority Encoding (802.1p)
- TCP checksum RX/TX support
- 72 KB packet buffer
- PXE remote root support
- Wake on LAN (WOL)
- IPSec



## Chapter 2

# Installing the Hardware

---

This chapter provides installation procedures for the adapters. It contains the following sections:

- ❑ “Reviewing Safety Precautions” on page 22
- ❑ “Reviewing the Contents of Your Shipment” on page 24
- ❑ “Pre-Installation Checklist” on page 25
- ❑ “Replacing the Bracket” on page 26
- ❑ “Installing a Network Adapter Card” on page 29
- ❑ “Connecting the Network Cables” on page 33

## Reviewing Safety Precautions

---

Please review the following safety precautions before you begin to install a network adapter card.

---

### Note

The  indicates that a translation of the safety statement is available in a PDF document titled “Translated Safety Statements” on the Allied Telesis website at [www.alliedtelesis.com/support/software](http://www.alliedtelesis.com/support/software). After you have accessed this website, enter the model number in the **Search by Product Name** box and then click **Find** to view the current list of documents.

---



---

### Warning

This is a “Class 1 LED product”.  L1

---



---

### Warning

Do not stare into the laser beam.  L2

---



---

### Warning

**Warning:** Do not look directly at the fiber optic cable ends or inspect the cable ends with an optical lens.  E29

---



---

### Warning

Do not work on this equipment or cables during periods of lightning activity.  E2

---



---

### Warning

Operating Temperature: This product is designed for a maximum ambient temperature of 40 degrees C.  E7

---

---

### Note

All Countries: Install this product in accordance with local and National Electric Codes.  E8

---



---

### Warning

The adapter is being installed in a system that operates with voltages that can be lethal. Before you remove the cover of your system, you must observe the following precautions to protect yourself and to prevent damage to the system components.

- Remove any metallic objects or jewelry from your hands and wrists.
  - Make sure to use only insulated or nonconducting tools.
  - Verify that the system is powered OFF and unplugged before accessing internal components.
  - Installation or removal of adapters must be performed in a static-free environment. The use of a properly grounded wrist strap or other personal antistatic devices and an antistatic mat is strongly recommended.  E39
-

## Reviewing the Contents of Your Shipment

---

The following items are included with your adapter:

- ❑ Antistatic bag (used for protecting the adapter when stored or shipped). Keep the adapter in its packaging until ready for installation.
- ❑ Low-profile bracket (attached to the AT-2712FX/SC and AT-2712LX20/SC adapters)
- ❑ Standard bracket (attached to the AT-2912T adapter)

Inform your network supplier of any missing or damaged items. If you need to return the adapter, you must pack it in the original (or equivalent) packing material or the warranty will be voided. See “Returning Products” on page 14.

The installation and user guides for all Allied Telesis products are available in PDF format on our web site at **[www.alliedtelesis.com/support/software](http://www.alliedtelesis.com/support/software)**. For further instructions, see “Where to Find Management Software Updates and Product Information” on page 13.



## Pre-Installation Checklist

---

Before you install an adapter card, check the following list:

1. Verify that your system is using the latest BIOS.

---

**Note**

If you acquired the adapter software from the Allied Telesis support website, download the software drivers and then enter the path to where the adapter driver files reside on your system. For instructions that describe how to download the software, see “Where to Find Management Software Updates and Product Information” on page 13.

---

2. If your system is active, shut it down.
3. When the system shut down is complete, power OFF and unplug your system.
4. Holding the adapter card by the edges, remove it from its shipping package and place it on an antistatic surface.
5. Check the adapter for visible signs of damage, particularly on the card's edge connector.

**Caution**

Do not attempt to install a damaged adapter. If the adapter is damaged, report it to Allied Telesis. See “Contacting Allied Telesis” on page 14.

---

## Replacing the Bracket

---

Depending on your PC, you may need to replace the bracket attached to your adapter. The AT-2712FX/SC and AT-2712LX20/SC adapters are shipped with the low-profile bracket attached to the adapter. The AT-2912T adapter is shipped with the standard bracket attached to the adapter.

The following procedures describe how to replace a bracket:

- ❑ “Replacing the Low-Profile Bracket” on page 26
- ❑ “Replacing the Standard Bracket” on page 28

In both procedures, the AT-2712FX/SC adapter is shown in the illustrations. However, you can perform the procedures on all three adapters.

### Replacing the Low-Profile Bracket

To replace the low-profile bracket with the standard bracket, perform the following procedure:

1. Remove the screws that attach the bracket to the adapter. See Figure 5.

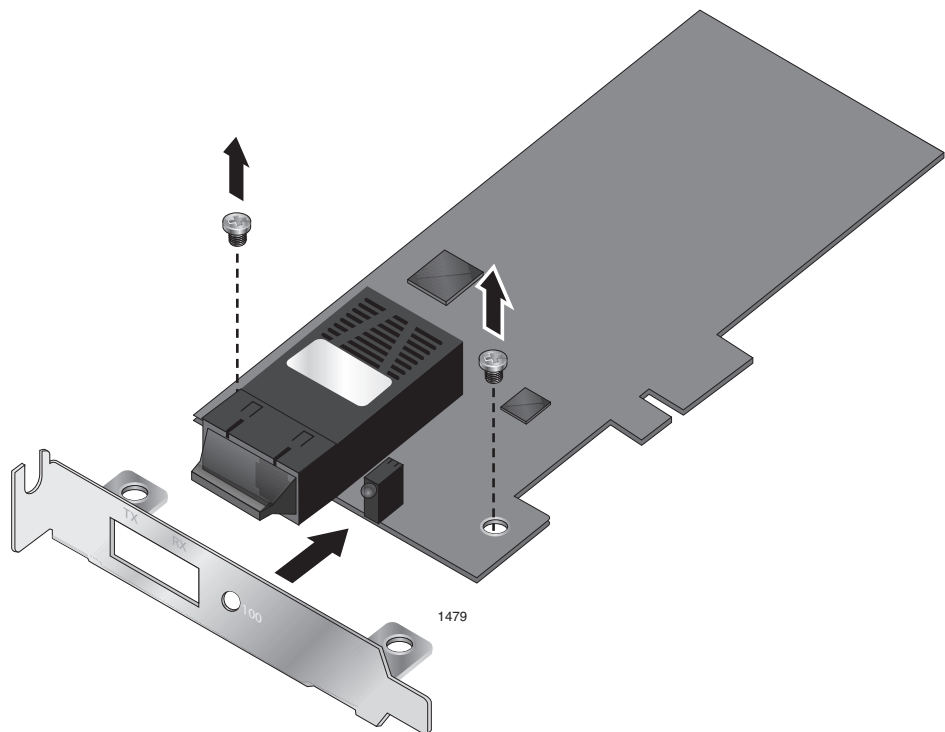

Figure 5. Removing the Low-Profile Bracket

2. Align the tabs of the standard bracket with the holes on the adapter and fasten the screws onto the adapter. See Figure 6.

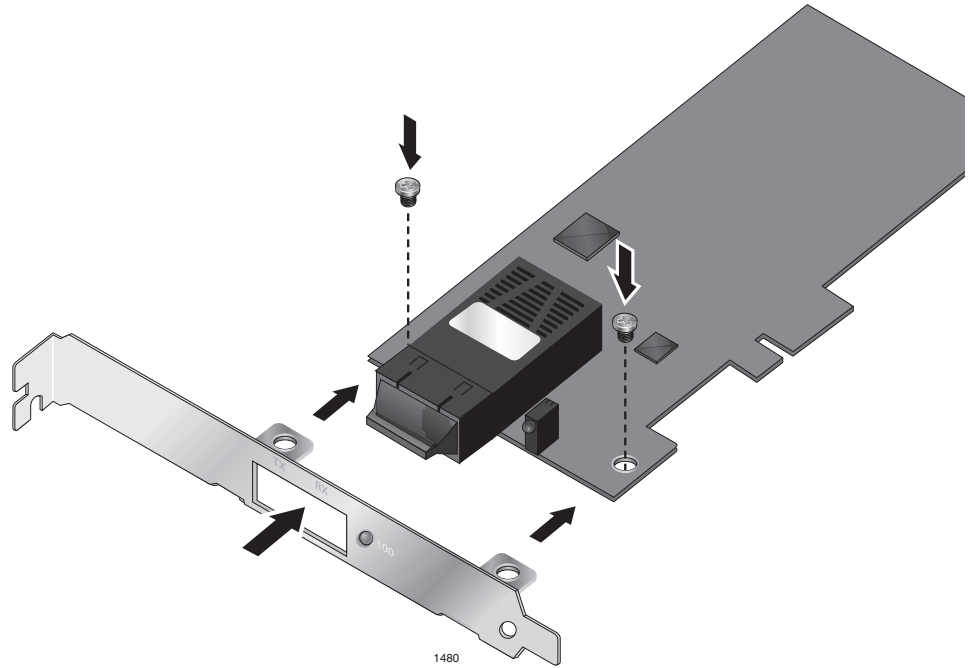

Figure 6. Fastening Screws onto Standard Bracket

## Replacing the Standard Bracket

To replace the standard bracket with the low-profile bracket, perform the following procedure:

1. Remove the screws that attach the bracket to the adapter. See Figure 7.

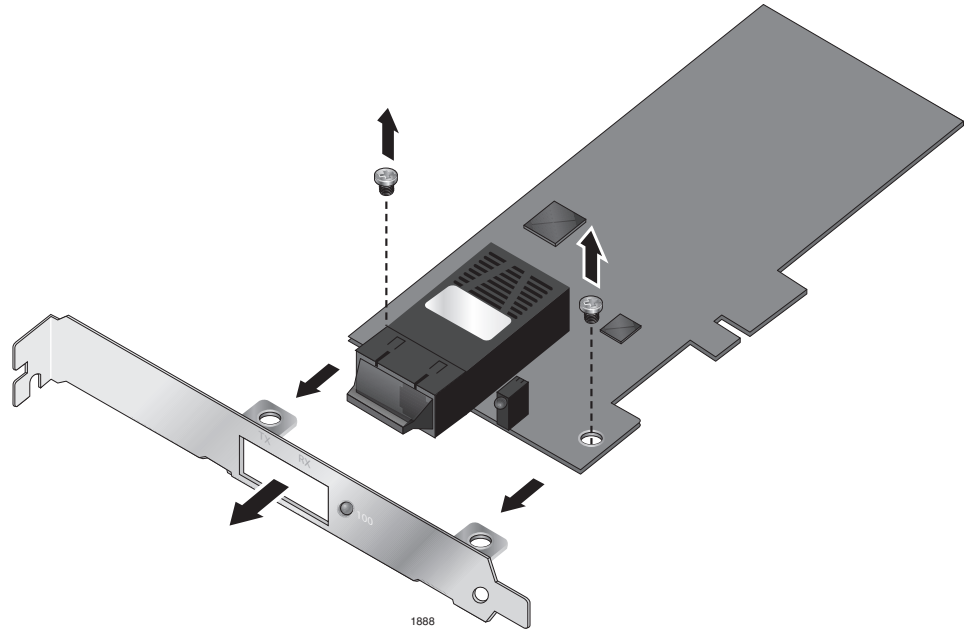

Figure 7. Removing the Standard Bracket

2. Align the tabs of the low-profile bracket with the holes on the adapter and fasten the screws onto the adapter. See Figure 8.

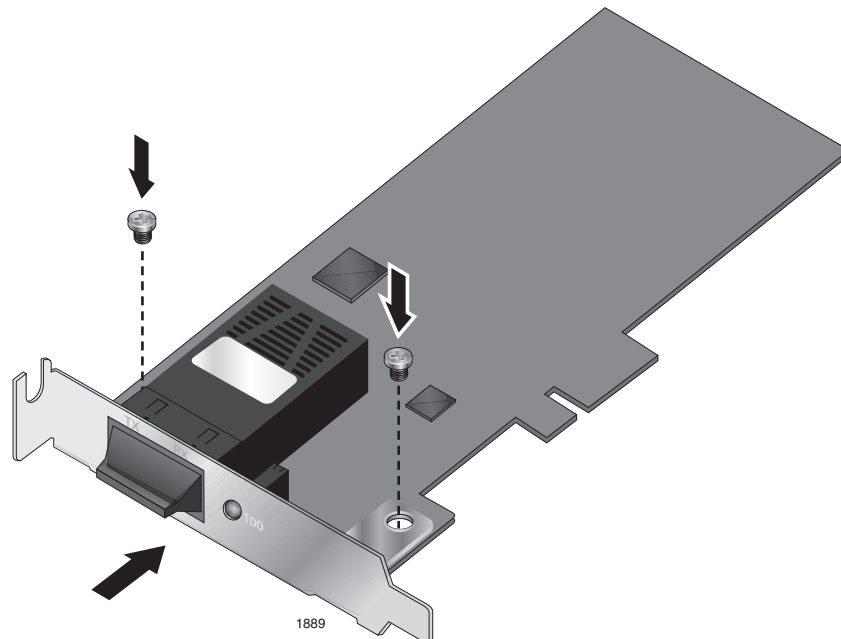

Figure 8. Fastening Screws onto Low-Profile Bracket

## Installing a Network Adapter Card

---

The following instructions apply to installing the AT-2712FX/SC, AT-2712LX20/SC, and AT-2912T adapters in most systems. For details about performing these tasks on your particular system, refer to the manuals that were supplied with your system.

---

**Note**

To perform this procedure, you need to provide one Phillips-head screw.

---

To install an adapter, perform the following procedure:

1. Review the “Pre-Installation Checklist” on page 25 and “Reviewing Safety Precautions” on page 22.

Before installing the adapter, ensure the system power is OFF and unplugged from the power outlet, and that proper electrical grounding procedures have been followed.

**Warning**

High voltage inside the system presents a safety hazard. Make sure the power is off before removing the cover.

---

2. Remove the system cover and select any appropriate empty PCI slot. See Figure 9 on page 30.

If you do not know how to identify an appropriate PCI slot, refer to your system documentation.

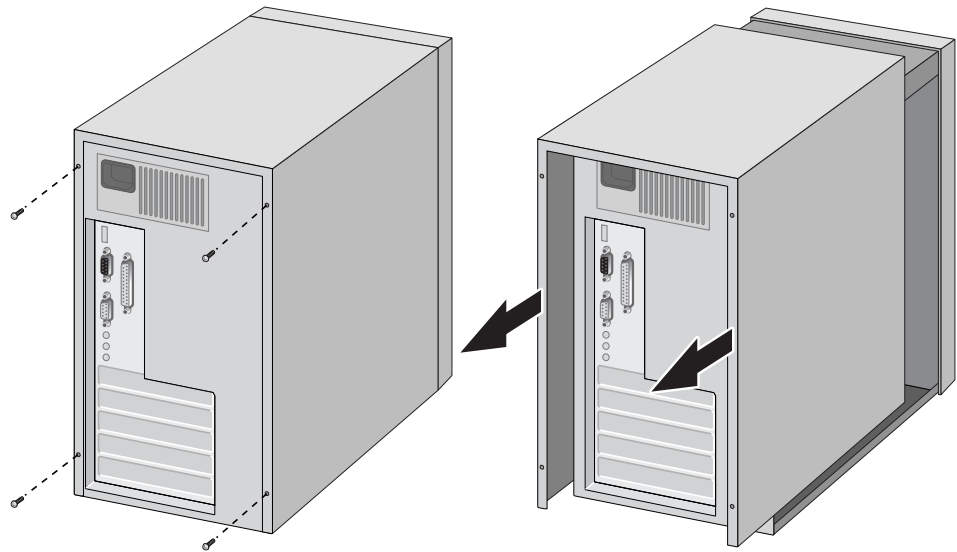

Figure 9. Removing the PC Cover

3. Select an empty, non-shared PCI slot and remove the faceplate.

Keep the faceplate in a safe place. You may need it for future use. See Figure 10.

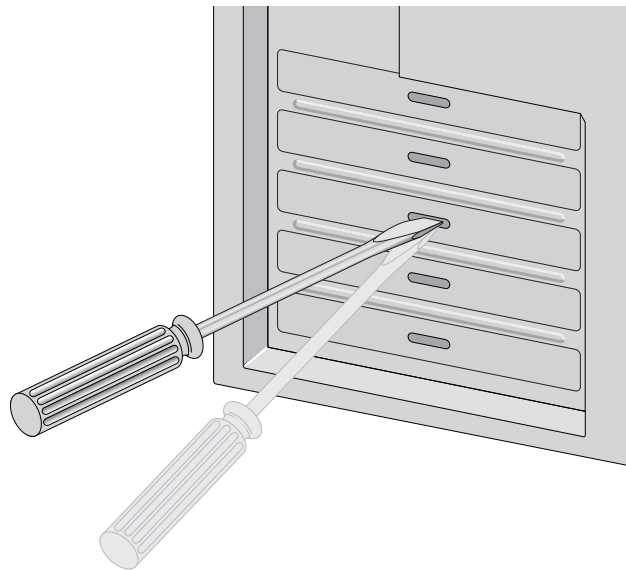

Figure 10. Removing the Faceplate From PCI Slot

---

**Note**

If you cannot locate or do not know how to find an appropriate PCI slot, refer to the documentation that came with your system.

---

4. Remove the network adapter card from the shipping package and store the packaging material in a safe location.

**Caution**

Wear a grounding device and observe electrostatic discharge precautions when installing the network adapter card in a system. Failure to observe this caution could result in damage to the card.

---

5. Applying even pressure at both corners of the card, push the adapter card until it is firmly seated in the appropriate PCI slot.

Make sure the card is securely seated. To insert the network adapter card, see Figure 11.

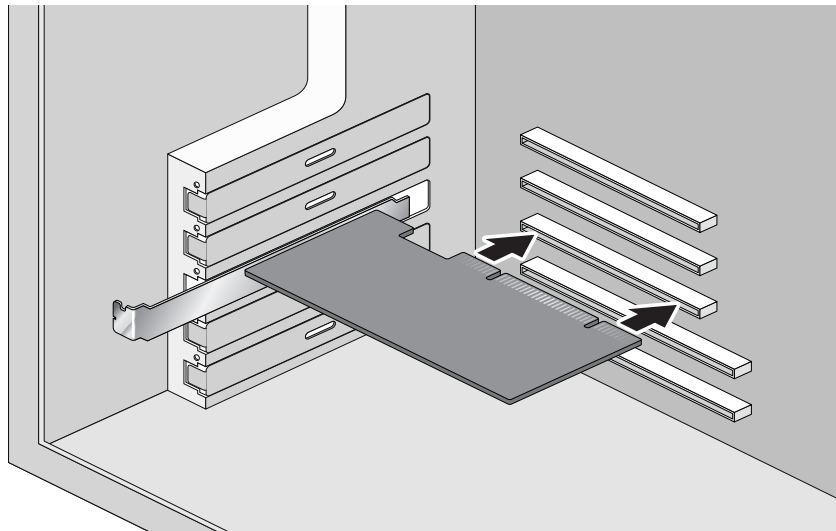

Figure 11. Inserting the Adapter with a High-profile Bracket

**Caution**

Do not use excessive force when seating the card, because this may damage the system or the adapter. If the card resists seating, remove it from the system, realign it, and try again.

---

6. Secure the network adapter card to the chassis with a Phillips-head screw (not provided). See Figure 12 on page 32.

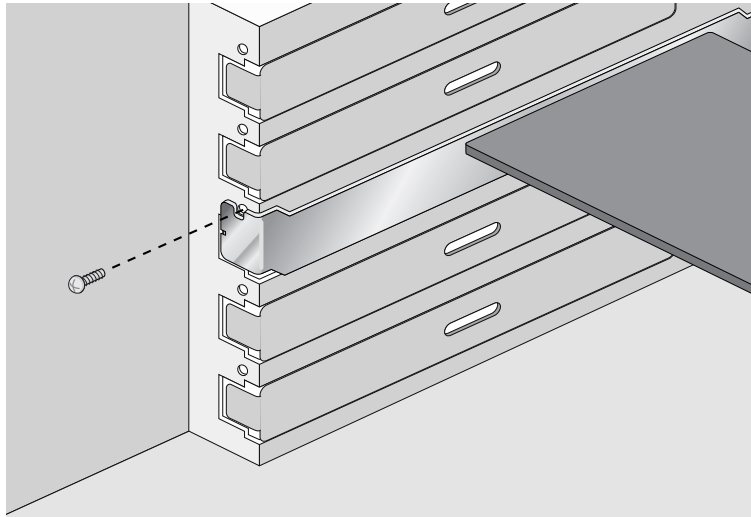

Figure 12. Securing the Adapter with a High-profile Bracket

7. Replace the system's cover and secure it with the screws removed in Step 2.
8. Disconnect any personal antistatic devices.
9. Power the system on.

Once the system returns to proper operation, the adapter hardware is fully installed. Next, connect the network cables. See "Connecting the Network Cables" on page 33.



## Connecting the Network Cables

---

The AT-2712FX/SC and AT-2712LX20/SC adapters have two fiber optic connectors (transmit and receive) for attaching the system to a compatible link partner or an IEEE 802.3z compliant Fast Ethernet switch. Both adapters require a fiber optic cable.

The AT-2912T adapter has one twisted-pair connector which requires a twisted-pair cable. For pin signals and pinout information, see "10/100/1000Base-T Twisted-Pair Port Connectors" on page 93.

To connect a network cable to the adapter, perform the following procedure:



### Warning

The fiber optic ports contain a Class 1 LED device. When the ports are disconnected, always cover them with the provided plug. Exposed ports may cause skin or eye damage.

1. Connect one end of the cable to the adapter:
  - For the AT-2912T adapter, connect one end of the twisted-pair cable to the adapter.
  - For the AT-2712FX/SC and AT-2712LX20/SC adapters, prepare a fiber optic cable according to the specifications in Table 3. Connect one end of the cable to the adapter.

Table 3. 1000BASE-SX Fiber Optic Cable Specifications

Port Type	Connector	Media	Maximum Distance	Wavelength
1000BASE-SX	Fiber Optic	62.5 $\mu$ m multimode 850 nm	275 meters (853 feet)	1310 nm
1000BASE-LX	Fiber Optic	9.125 $\mu$ m single mode 1310 nm	10 kilometer (6.213 miles)	1310 nm

2. Connect the other end of the cable:
  - For the AT-2912T adapter, connect the other end of the cable to another twisted pair port.
  - For the AT-2712FX/SC and AT-2712LX20/SC adapters, connect the other end of the cable to the appropriate Ethernet fiber optic port.

---

**Note**

After the cable is properly connected at both ends, the adapter port LEDs is functional. For descriptions of LED operation, see “AT-2712FX/SC and AT-2712LX20/SC Adapters Physical Descriptions” on page 17 or “AT-2912T Adapter Physical Description” on page 18.

---

After you connect the system to the network and power is supplied, the AT-2712FX/SC and AT-2712LX20/SC adapters attempt to establish the connection at 100 Mbps full-duplex. The AT-2912T uses Autonegotiation to determine the connection settings.

## Chapter 3

# Installing Windows Server 2003 and Windows XP Driver Software

---

This chapter describes how to install the Windows Server 2003 and Windows XP driver software. This chapter contains the following sections:

- “Installing the Driver Software” on page 36
- “Uninstalling the Driver Software” on page 45

After you install the driver software, you can modify the configuration properties as described in see Chapter 5, “Setting Advanced Properties” on page 57.

## Installing the Driver Software

---

When a Windows Server 2003 or Windows XP system first boots up after installing a new Secure Ethernet Network adapter, the system automatically detects the new hardware and prompts you to install the driver software for that device.

There are three installation procedures:

- ❑ “Using the Driver Installer” on page 36
- ❑ “Updating the Adapter Software” on page 39
- ❑ “Modifying Configuration Properties” on page 43

---

**Note**

The adapter must be physically installed in your system before installing the driver software. See Chapter 2, “Installing the Hardware” on page 21 for details.

---

---

**Note**

If the Windows Server 2003 or Windows XP system detects an adapter and installs a default driver, update the driver as described in “Updating the Adapter Software” on page 39.

---

---

**Note**

If there is an onboard Broadcom network interface, the native Broadcom driver may load. You can use this driver, or the latest driver supplied by Allied Telesis.

---

### Using the Driver Installer

When you boot up either operating system after installing the adapter card, a series of *Found New Hardware* windows are displayed. You must have Administrator privileges to install the driver software.

---

**Note**

Before beginning this procedure, verify that the Windows Server 2003 or Windows XP system has been upgraded to the latest version with the latest service pack applied.

---

---

**Note**

If you have a Windows XP system, the window in Figure 13 on page 37 opens. Start with step 1. If you have a Windows Server 2003 system, the window in Figure 14 on page 38 opens. Start with step 3 on the same page.

---

To install the adapter software on a Windows Server 2003 or Windows XP system, do the following:

1. Click **Install from a list or specific location (Advanced)**.

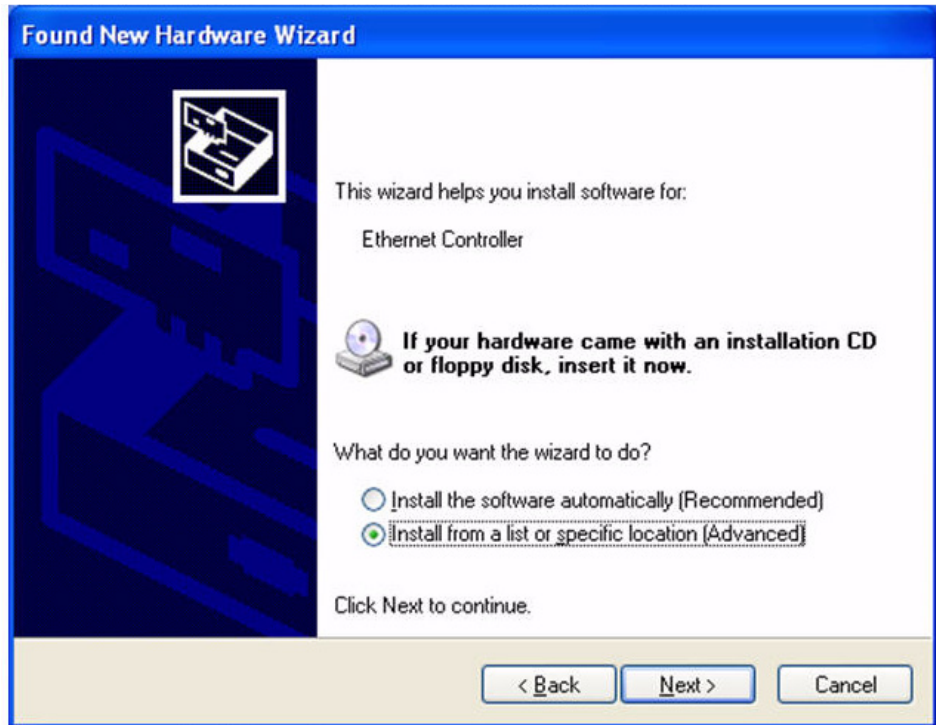

Figure 13. Welcome to the Found New Hardware Wizard Window

2. Click **Next**.

The second Welcome to the Found New Hardware Wizard Window is shown in Figure 14 on page 38.

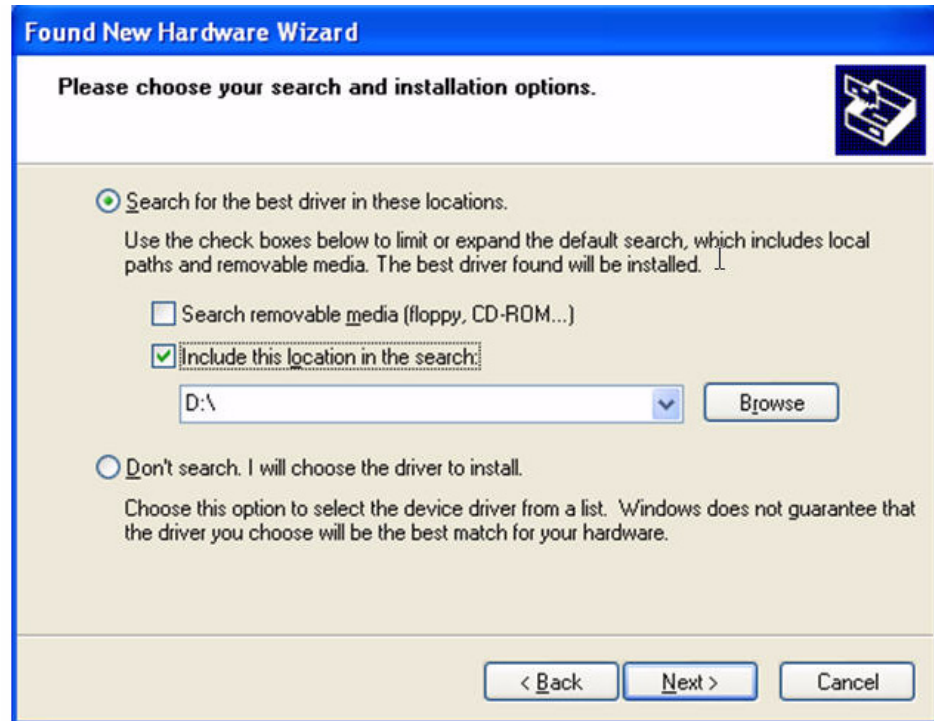

Figure 14. Found New Hardware Wizard Window: Search and Installation Options

3. Click **Include this location in the search**.
4. Click **Browse** and locate the path of the software driver.
5. Click **Next**.
6. When the software installation is complete, click **Finish** to close the wizard and complete the software installation.

## Updating the Adapter Software

This section provides a procedure for updating the adapter software for the Windows Server 2003 or Windows XP systems. To obtain the latest version of an Secure Ethernet Network adapter software drivers, download it from the Allied Telesis website. For instructions, see “Where to Find Management Software Updates and Product Information” on page 13.

---

**Note**

You may need to reboot your system after completing the driver update to properly load the new drivers.

---

When you update the adapter software on existing devices, the Advanced Property settings may not be updated unless you remove the existing device by following the instructions in “Uninstalling the Driver Software” on page 45. Then perform a scan for hardware changes in the device manager followed by reinstalling the device with the current adapter software as described in “Installing the Driver Software” on page 36.

---

**Note**

Before uninstalling a device, capture all of the Advanced Property settings because the properties will be lost.

---

### Updating the Windows Server 2003 or Windows XP Driver Software

To update the adapter software on a Windows Server 2003 or a Windows XP system, perform the following procedure.

---

**Note**

Update all adapters by repeating the following steps on each device.

---

1. Start either a Windows Server 2003 or a Windows XP system and log in.

You must have Administrator privileges to update the driver software.

2. On the desktop, open the **Start** menu.

See Figure 15 on page 40 for an example of the Start menu.

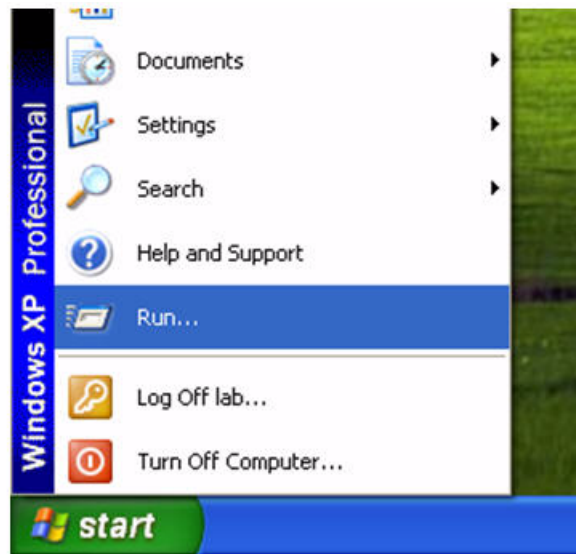

Figure 15. Windows Server 2003 Start Window

3. Select **Run** from the menu and enter the following command:

`devmgmt.msc`

See Figure 16 for an example of the Run Window.

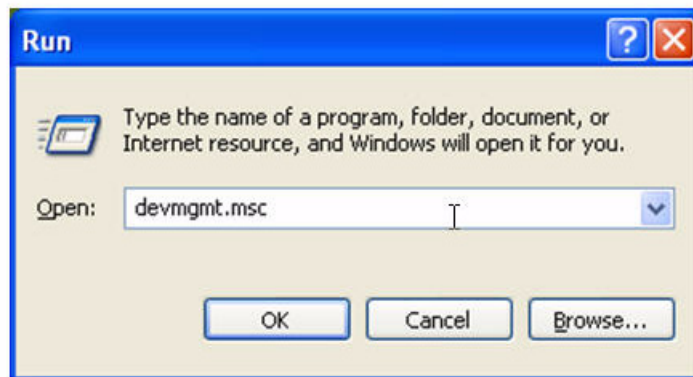

Figure 16. Run Window



The Device Manager Window is shown in Figure 17.

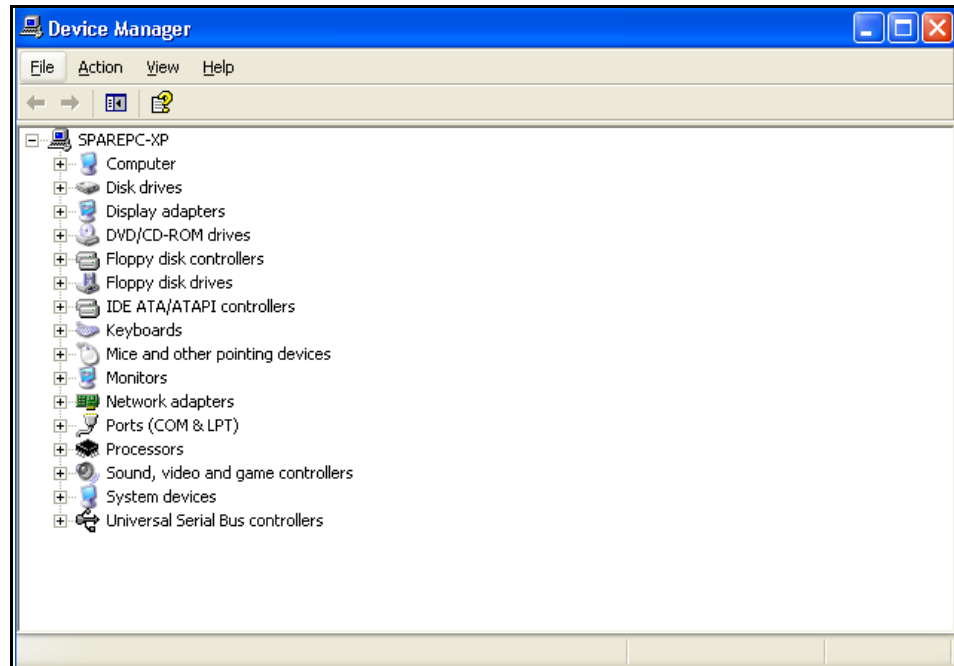

Figure 17. Device Manager Window (Network adapter folder is collapsed)

4. In the Device Manager window, click the + next to the Network adapters folder.

The selection expands to show the list of installed network adapter cards.

5. Right click on one of the following the adapters:

- Allied Telesis AT-2712FX/SC
- Allied Telesis AT-2912T

---

**Note**

Select “AT-2712FX/SC” to update the drivers for either the AT-2712FX/SC or the AT-2712LX20/SC adapter.

---

6. Select **Update Driver**.

The Hardware Update Wizard Window opens, as shown in Figure 18.



Figure 18. Welcome to Hardware Update Wizard Window

7. For a Windows Server 2003 system, skip to step 10. For a Windows XP system, click **No, not this time** to copy the driver software from your PC.
8. Click **Next**.

The Second New Found Hardware Wizard Window opens, as shown in Figure 19.

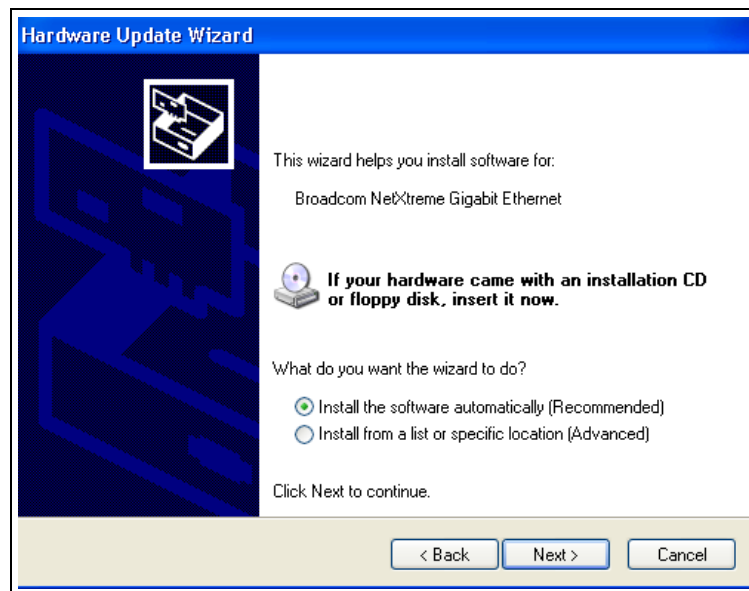

Figure 19. Hardware Update Wizard Window

9. Click **Install from a list or specified location (Advanced)**.
10. Click **Next**.
11. If you are prompted to specify the location of the software driver, click **Browse** (do not use the text field) and locate the path.

After you install the driver software, you can modify the configuration properties. See Chapter 5, "Setting Advanced Properties" on page 57.

## **Modifying Configuration Properties**

Although the default values are appropriate in most cases, you can change any of the available options to meet the requirements of your specific system. After the adapter driver software has been installed, you can use this procedure to access the System Property Dialog box which provides access to the Advanced Properties on the Advanced Tab.

To access the System Properties Dialog box, perform the following procedure:

1. Start either a Windows Server 2003 or a Windows XP system and log in.

You must have Administrator privileges to update the driver software.

2. On the desktop, right click **My Computer**.

The My Computer window opens.

3. Select **Properties** from the menu.

The System Properties Dialog box opens, as shown in Figure 20 on page 44.

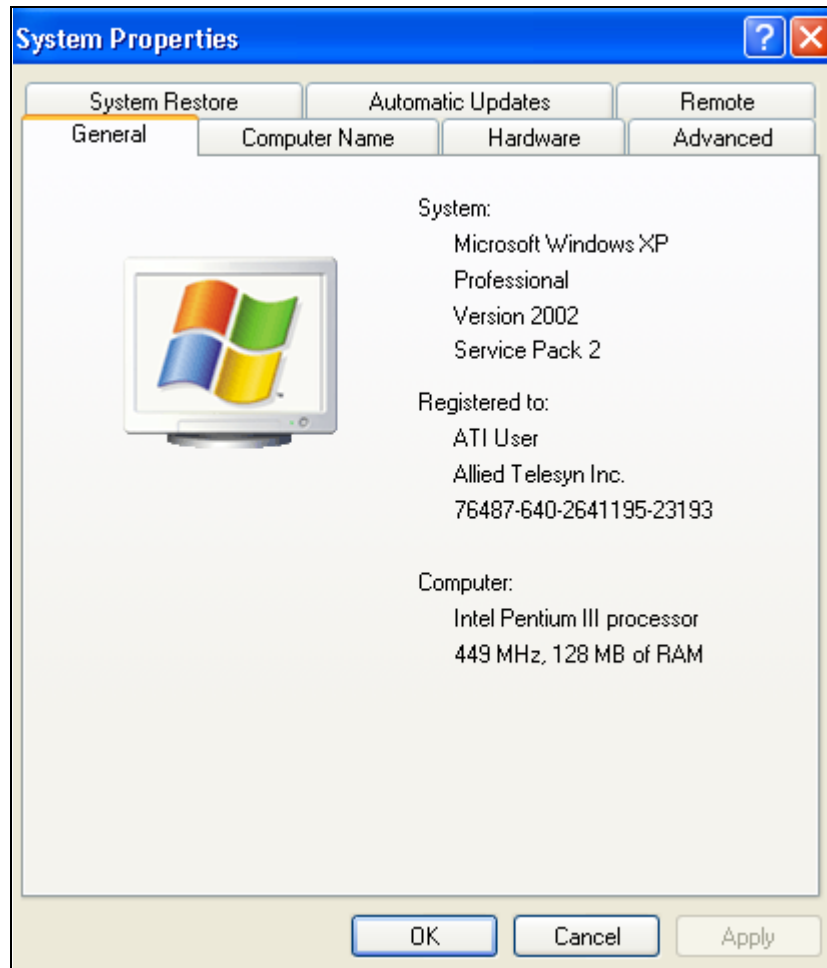

Figure 20. System Properties Dialog Box

For instructions that describe how to set the Advanced Properties, see Chapter 5, "Setting Advanced Properties" on page 57.

## Uninstalling the Driver Software

---

Before physically removing an adapter from your system, you must uninstall the adapter driver software.



---

**Caution**

Before uninstalling the Allied Telesis device, be sure to capture all Advanced Property settings because the properties are lost during the uninstall process.

---

To uninstall the adapter software from your system, perform the following procedure:

1. Start Windows Server 2003 or Windows XP and log in.

---

**Note**

You must have Administrator privileges to remove the driver software.

---

2. Choose from the following:

- If you have a Windows Server 2003 Server system, click **Start**. Then select the **Control Panel** from the menu. Double-click the **System** icon.
- If you have a Windows XP system, right click on **My Computer**. Then select **Properties** from the menu.

The Device Manager Window opens. It is shown in Figure 17 on page 41.

3. In the Device Manager window, click the **+** next to the Network adapters folder.

The selection expands to show the list of installed network adapter cards.

4. Right-click on the adapter to be removed. Select from the following:

- Allied Telesis AT-2712FX/SC
- Allied Telesis AT-2912T

---

**Note**

Select "AT-2712FX/SC" to update the drivers for either the AT-2712FX/SC or the AT-2712LX20/SC adapter.

---

5. Select **Uninstall**.

A Confirm Device Removal window opens.

6. Click **OK** to complete the uninstall.

---

**Note**

Not all driver files are removed as part of this procedure.

---

## Chapter 4

# Installing the Windows Vista and Windows 7 Driver Software

---

This chapter describes how to install the Windows Vista and Windows 7 driver software on a Secure Ethernet Network adapter. The installation procedures are identical for both the 32-bit and 64-bit Windows Operating systems.

This chapter contains the following sections:

- “Installing the Driver Software” on page 48
- “Uninstalling the Driver Software” on page 54

---

**Note**

To set Advanced Properties, see Chapter 5, “Setting Advanced Properties” on page 57.

---

## Installing the Driver Software

---

After you install a Secure Ethernet Network adapter, the system detects the new hardware and creates an entry in the Device Manager when the Windows operating system first boots up. Shortly after you log in, you need to install the driver software for the Secure Ethernet Network adapter. To install or update the driver software, you must have administrative privileges.

To obtain the latest Secure Ethernet Network adapter software drivers, go to the Allied Telesis website at [www.alliedtelesis.com/support/software](http://www.alliedtelesis.com/support/software). For further instructions, see “Where to Find Management Software Updates and Product Information” on page 13.

To install the Windows Vista or Windows 7 Operating System driver software, do the following:

---

**Note**

The adapter must be physically installed in your system before you install the driver software. See Chapter 2, “Installing the Hardware” on page 21 for instructions.

---

1. Start a Windows operating system and log in.
2. Open the Device Manager.

For instructions on how to open the Device Manager, see one of the following procedures:

- To open the Device Manager in the Windows 7 Operating System, follow steps 3 and 4.
- To open the Device Manager in the Windows Vista Operating System, follow steps 5 through 7.



3. To select the Device Manager in the Windows 7 Operating System, select the Start button. The Windows 7 Search Box is displayed. See Figure 21.

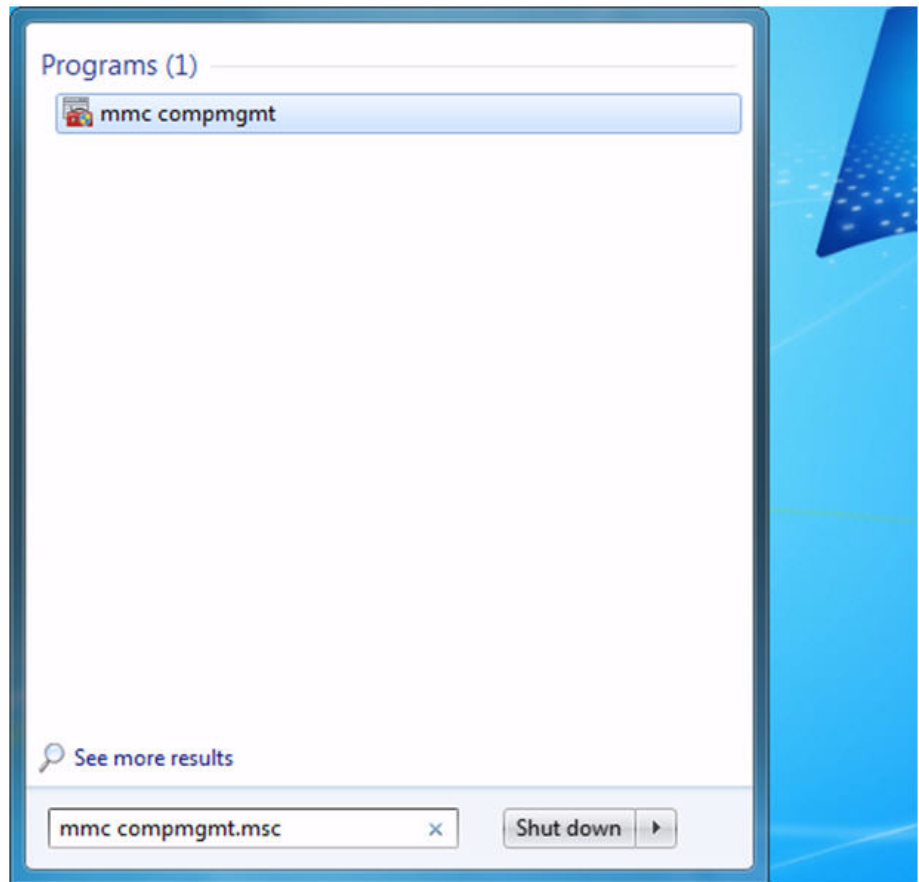

Figure 21. Windows 7 Search Box

4. Enter the following command:

```
mmc compmgmt.msc
```

The Device Manager window is displayed. For an example of the Device Manager window, see Figure 24 on page 51.

5. To select the Device Manager in the Windows Vista Operating System, select the Start menu.

See Figure 22 for an example of the Windows Vista Start menu.

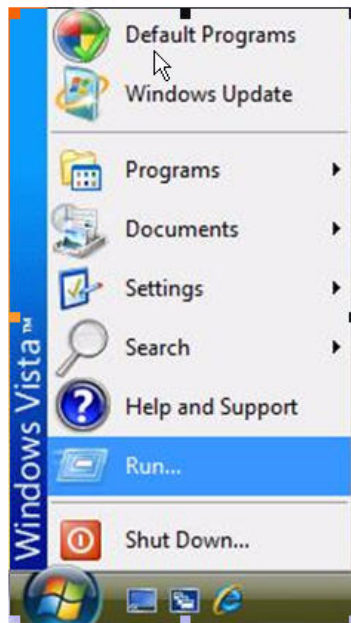

Figure 22. Windows Vista Start Menu

6. From the Start Menu, select **Run**.

The Windows Vista Run window is displayed. See Figure 23.

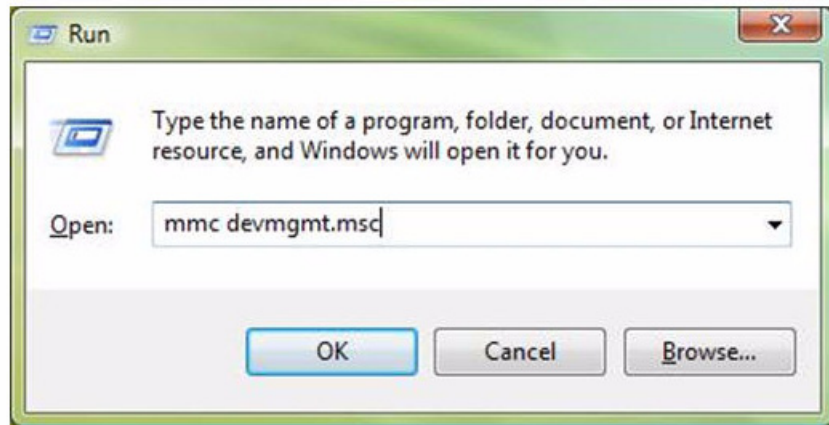

Figure 23. Windows Vista Run Window

7. Enter the following command in the Run window:

`mmc devmgmt.msc`

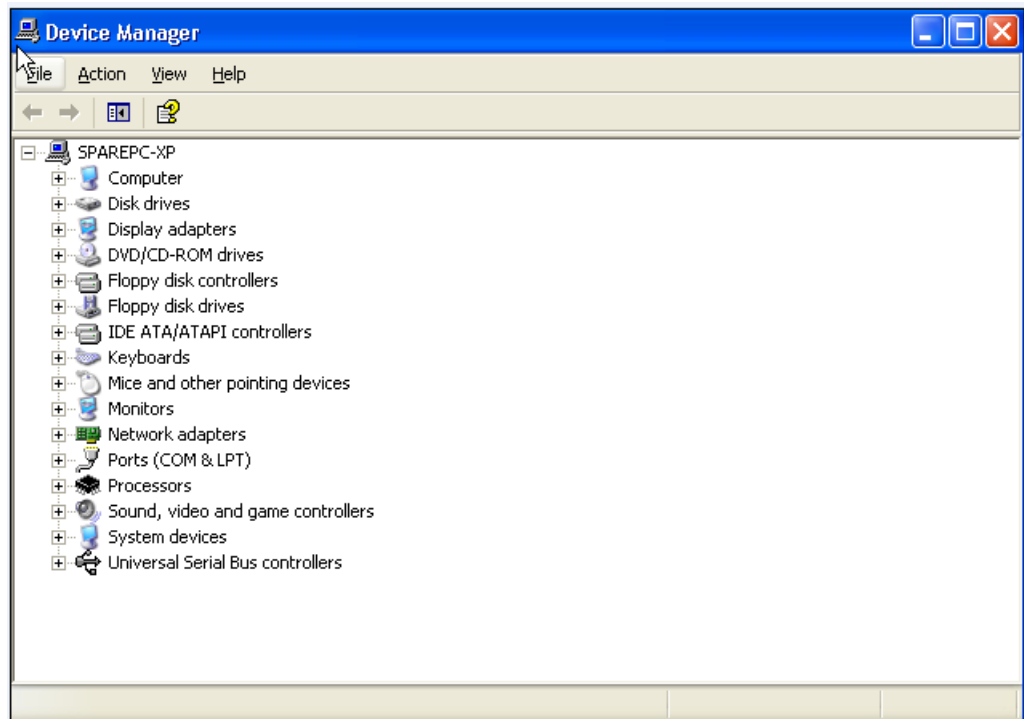

Figure 24. Device Manager Window

8. Open the Network Adapters folder.

The list of installed adapters is displayed.

9. Right click on the Secure Network Ethernet adapter.

The adapter window is displayed.

10. In the Device Manager window, click the + next to the Network adapters folder.

The selection expands to show the list of installed network adapter cards installed on your PC.

11. Right click on one of the following adapters:

- Allied Telesis AT-2712FX/SC**
- Allied Telesis AT-2912T**

---

**Note**

Select “AT-2712FX/SC” to update the software drivers on either the AT-2712FX/SC adapter or the AT-2712LX20/SC adapter.

---

12. Right click **Ethernet Controller** and select **Update Driver Software**.

See Figure 25 for an example of the Device Manger window with Ethernet Controller selected.

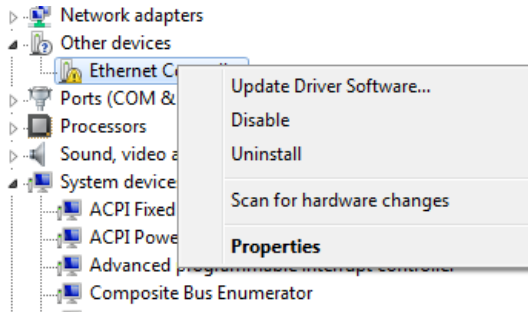

Figure 25. Device Manager Window: Ethernet Controller

13. Select Update Driver Software.

The Update Driver Software - Ethernet Controller Window is displayed. See Figure 26.

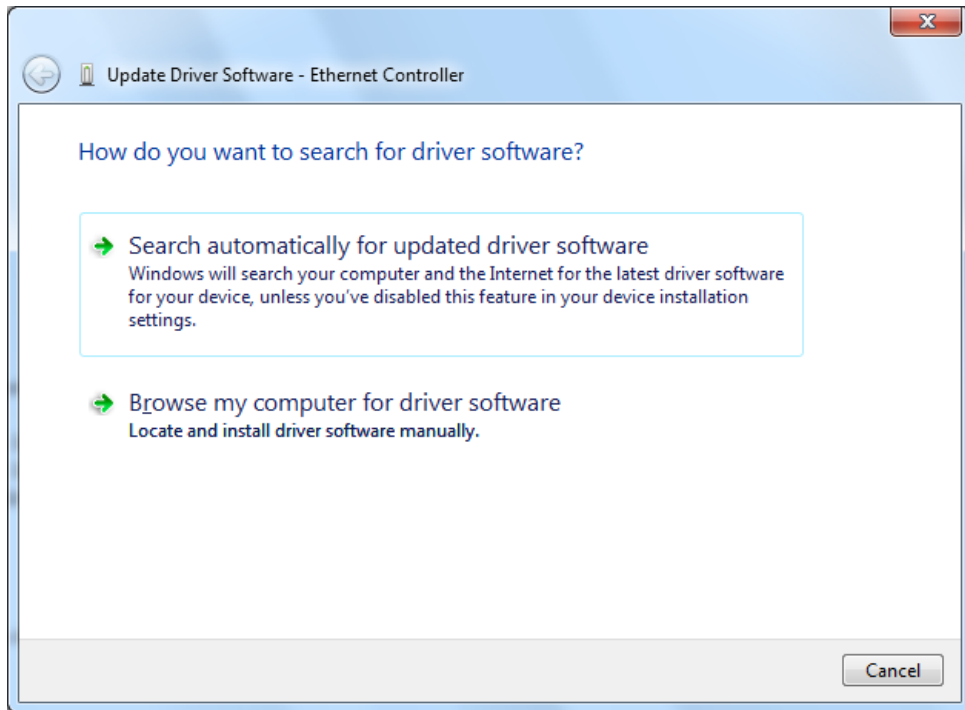

Figure 26. Update Driver Software - Ethernet Controller Window

14. Click **Browse my computer for driver software**.

The Update Driver Software - Ethernet Controller: Browse for Driver Software Window is displayed. See Figure 27 on page 53.

15. Click **Browse** to search your computer for the location of the driver software. See Figure 27.

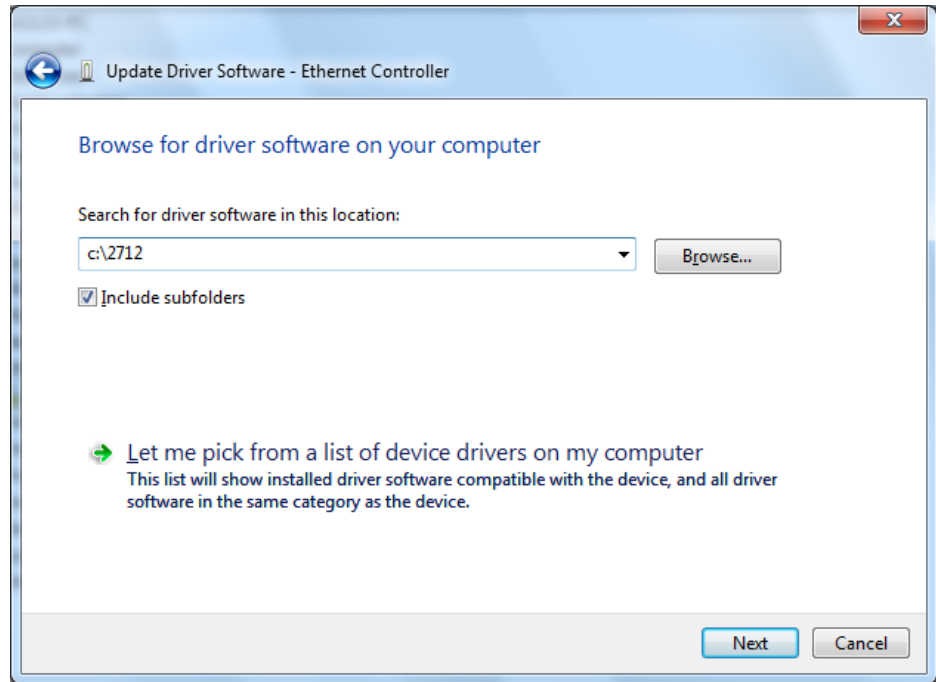

Figure 27. Update Driver Software: Ethernet Controller: Browse

16. Click **Next**. A confirmation message is displayed. See Figure 28.

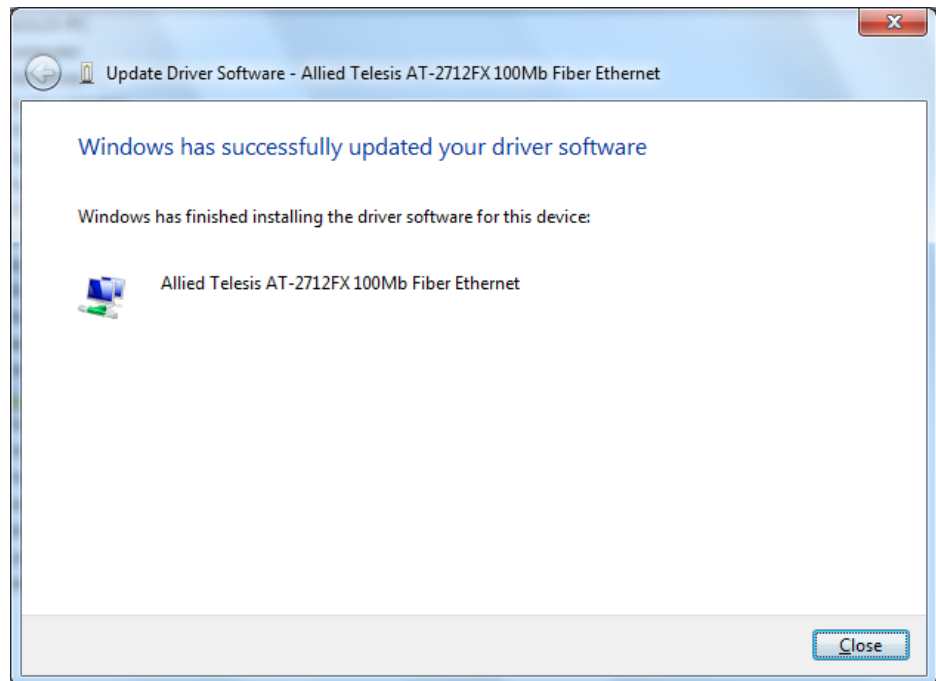

Figure 28. Update Driver Software - Confirmation Window

## Uninstalling the Driver Software

---

Before physically removing an adapter from your system, you need to uninstall the driver software first. The procedure in this section describes how to uninstall the driver software.

---

### Note

You must have Administrator privileges to remove the driver software.

---



---

### Caution

Before uninstalling the Allied Telesis device, be sure to capture all of the Advanced Property settings because the properties are lost during the uninstall process.

---

To uninstall the driver software from your system, do the following:

1. Start a Windows Vista or Windows 7 Operating System on your laptop and log in.
2. Open the **Device Manager**.

For instructions on how to open the Device Manager, see the following:

3. Open the Device Manager:
  - To open the Device Manager in the Windows 7 Operating System, follow steps 3 and 4.
  - To open the Device Manager in the Windows Vista Operating System, follow steps 5 through 7.
4. To select the Device Manager in the Windows 7 Operating System, select the Start button. See Figure 21 on page 49.

5. Enter the following command:

```
mmc compmgmt.msc
```

The Device Manager window is displayed. For an example of the Device Manager window, see Figure 24 on page 51.

6. To select the Device Manager in the Windows Vista Operating System, select the Start menu.

The Windows 7 Search Box is displayed. See Figure 22 on page 50.

7. From the Start Menu, select **Run**.

The Windows Vista Run window is displayed. See Figure 23 on page 50.

8. Enter the following command in the Run window:

```
mmc devmgmt.msc
```

The Device Manager Window is shown in Figure 24 on page 51.

9. In the Device Manager window, click the **+** next to the Network adapters folder.

The selection expands to show the list of installed network adapter cards.

10. Right click on one of the following adapters:

- Allied Telesis AT-2712FX/SC**
- Allied Telesis AT-2912T**

---

**Note**

Select "AT-2712FX/SC" to remove the software drivers on either the AT-2712FX/SC adapter or the AT-2712LX20/SC adapter.

---

The adapter window is displayed.

11. Select **Uninstall**.

A Confirm Device Removal window opens.

12. Click **OK** to complete the uninstall.

---

**Note**

Not all of the driver files are removed as a result of this procedure. You can remove additional drivers and installation files by selecting the checkbox to remove these files.

---





## Chapter 5

# Setting Advanced Properties

---

For all of the Windows operating systems, you access the Windows Advanced Properties from the Advanced Tab. Although the default values of the Advanced Properties are appropriate in most cases, you can change any of the available options to meet the requirements of your system.

This chapter discusses the following topics:

- “Accessing the Advanced Tab” on page 58
- “Modifying Advanced Properties” on page 65

## Accessing the Advanced Tab

---

To modify the configuration properties of the Windows Operating systems, you must access the Advanced Tab. Depending on your operating system, there are several ways to do this. See the following procedures:

- ❑ “Selecting the Advanced Tab in Windows Server 2003 or Windows XP” on page 58
- ❑ “Selecting the Advanced Tab in Windows 7” on page 61
- ❑ “Selecting the Advanced Tab in Windows Vista” on page 63

### Selecting the Advanced Tab in Windows Server 2003 or Windows XP

After you have installed the adapter driver software, you can use this procedure to access the System Property Dialog box which provides access to the Advanced Properties on the Advanced Tab.

To access the System Properties Dialog box, do the following:

1. Start a Windows Server 2003 or Windows XP system and log in.

You must have Administrator privileges to update the driver software.

2. On the desktop, right click **My Computer**.

The My Computer window opens.

3. Select **Properties** from the menu.

The System Properties Dialog box opens, as shown in Figure 29 on page 59.

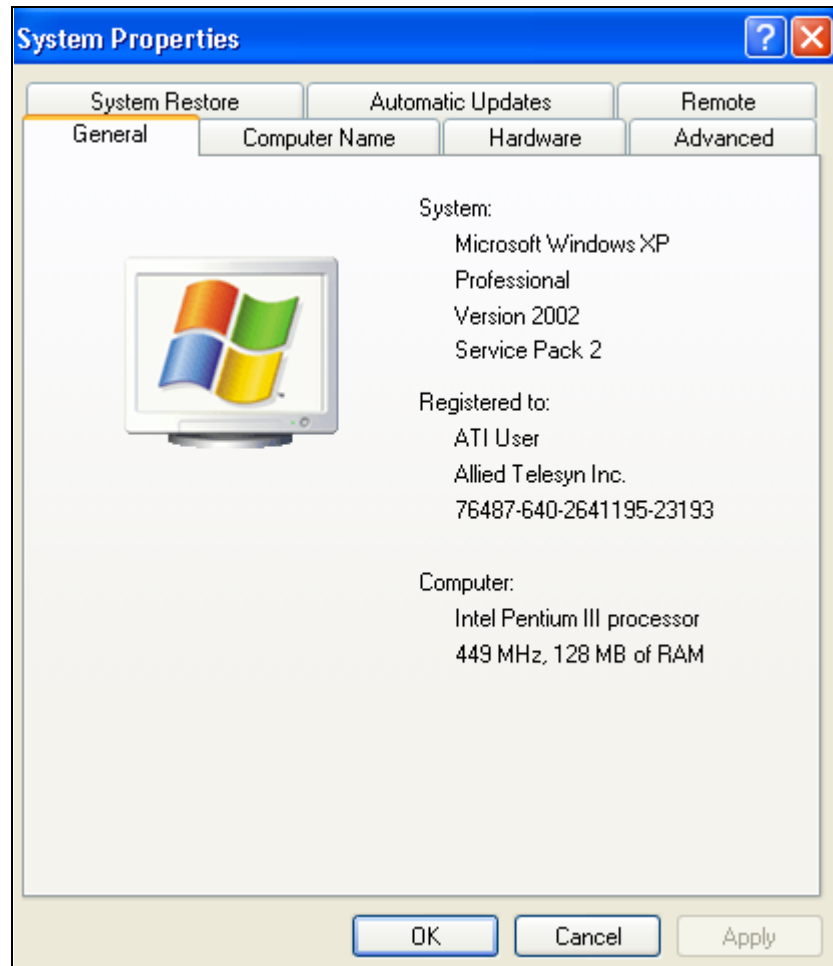

Figure 29. System Properties Dialog Box

4. Click on the **Advanced** tab on the System Properties Dialog Box which is located at the top of the window.

The Advanced tab is shown in Figure 30.

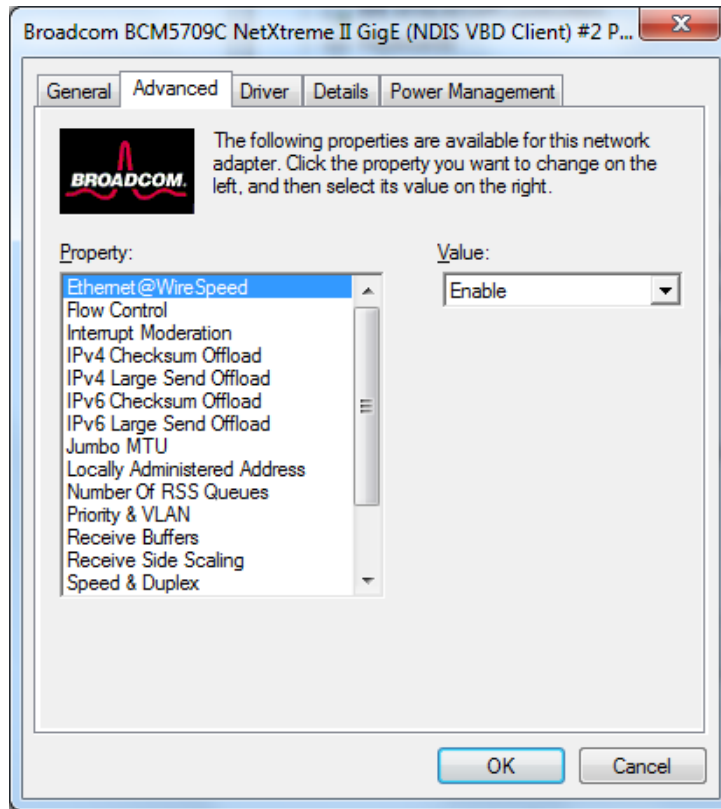

Figure 30. Advanced Tab

## Selecting the Advanced Tab in Windows 7

To select the Advanced Tab in Windows 7 Operating systems, do the following:

1. Select the Start button. See Figure 31.

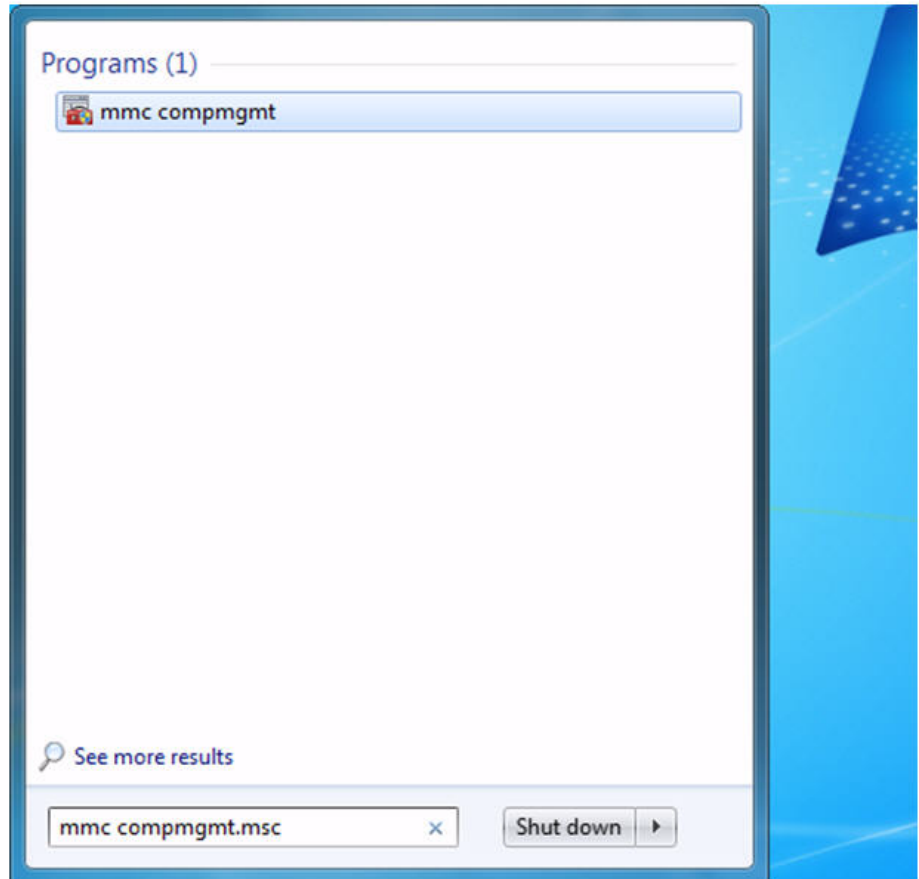

Figure 31. Windows 7 Search Box

2. Enter the following command:

```
mmc compmgmt.msc
```

The Device Manager window is displayed. See Figure 32 on page 62.

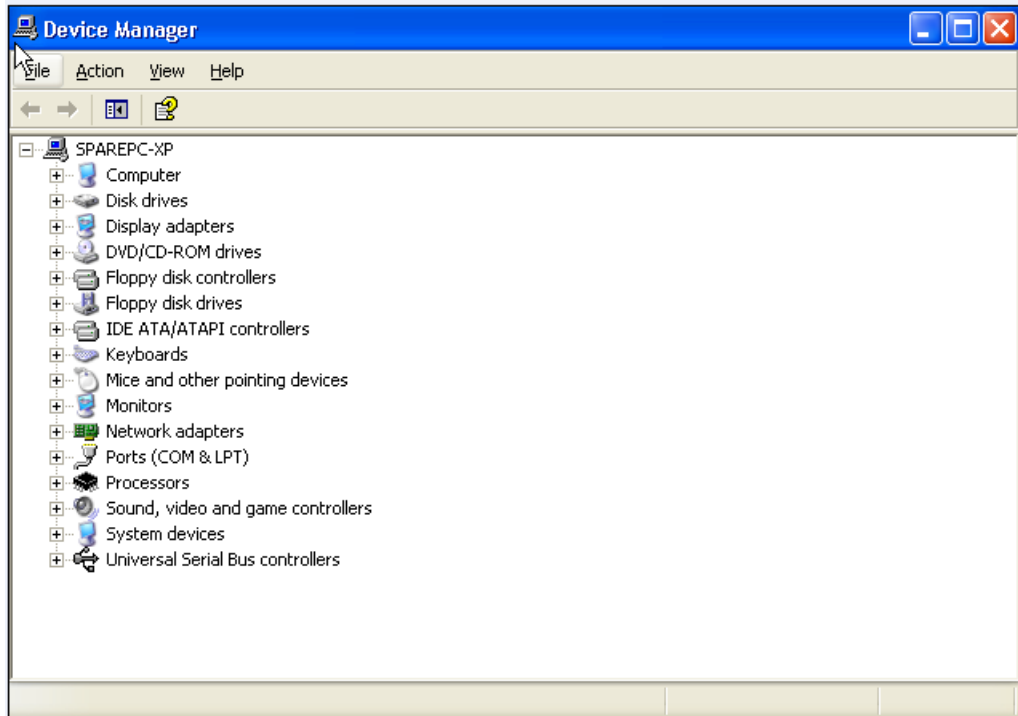

Figure 32. Device Manager Window

3. Open the Network Adapters folder.

The list of installed adapters is displayed.

4. Right click on one of the following adapters:

- Allied Telesis AT-2712FX/SC**
- Allied Telesis AT-2912T**

---

**Note**

Select "AT-2712FX/SC" to indicate either the AT-2712FX/SC adapter or the AT-2712LX20/SC adapter.

---

The adapter window is displayed.

5. Select the **Advanced** tab.

The Advanced tab is shown in Figure 30 on page 60.

## Selecting the Advanced Tab in Windows Vista

In the Windows Vista Operating System, you access the Advanced Tab through the Device Manager.

To select the Device Manager in the Windows Vista Operating System, do the following:

1. Select the Start menu.

See Figure 33 for an example of the Windows Vista Start menu.

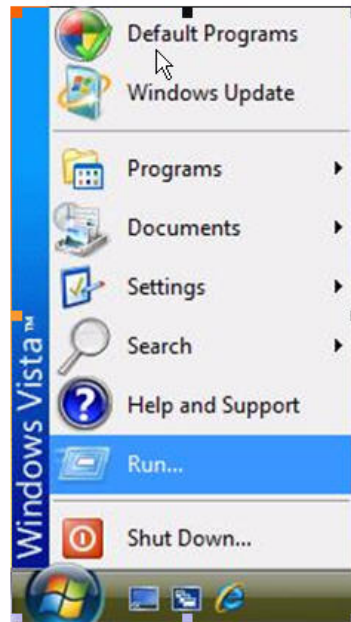

Figure 33. Windows Vista Start Menu

2. From the Start Menu, select **Run**.

The Windows Vista Run window is displayed. See Figure 34.

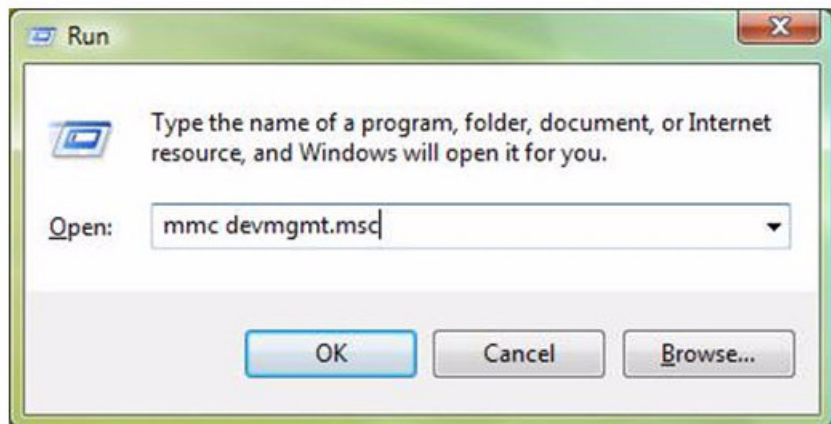

Figure 34. Windows Vista Run Window

3. Enter the following command in the Run window:

```
mmc devmgmt.msc
```

4. From the Computer Management Window, select Device Manager in the left panel.

The Device Manager window is displayed. See Figure 32 on page 62.

5. Open the Network Adapters folder.

The list of installed adapters is displayed.

6. Right click on one of the following adapters:

- Allied Telesis AT-2712FX/SC**
- Allied Telesis AT-2912T**

---

**Note**

Select “AT-2712FX/SC” to indicate either the AT-2712FX/SC adapter or the AT-2712LX20/SC adapter.

---

The adapter window is displayed.

7. Select the **Advanced** tab.

The Advanced tab is shown in Figure 30 on page 60.



## Modifying Advanced Properties

---

After you have installed the driver software, you can use the following procedures to verify or change the adapter properties:

- ❑ “Updating the Ethernet@ WireSpeed Property” on page 66
- ❑ “Updating the Flow Control Property” on page 66
- ❑ “Updating the Interrupt Moderation Property” on page 68
- ❑ “Updating the Checksum Offload Property” on page 69
- ❑ “Updating the Large Send Offload Property” on page 70
- ❑ “Updating the Jumbo MTU Property” on page 71
- ❑ “Updating the Network Address Property” on page 72
- ❑ “Updating the RSS Queues Property” on page 73
- ❑ “Updating the Priority & VLAN Property” on page 74
- ❑ “Updating the Receive Buffers Property” on page 75
- ❑ “Updating the Receive Side Scaling Property” on page 75
- ❑ “Updating the Speed & Duplex Mode Property” on page 76
- ❑ “Updating the TCP Connection Offload Properties” on page 78
- ❑ “Updating the Transmit Buffers Property” on page 79
- ❑ “Updating the VLAN ID Property” on page 79
- ❑ “Updating the WOL Speed” on page 80

---

**Note**

After you upgrade the driver software, the Advanced Properties may change.

---

---

**Note**

The procedures in the sections listed above may differ slightly if the “Classic Start Menu” is set on your computer.

---

## Updating the Ethernet@WireSpeed Property

The Ethernet@Wirespeed property enables a Secure Ethernet Network adapter to establish a link at a lower speed when only two pairs of wires are available in the cabling plant. By default, the Ethernet@Wirespeed property is enabled.

To enable or disable the Ethernet@WireSpeed property, do the following:

1. Access the **Advanced** tab:
  - For Windows Server 2003 Operating systems, see “Selecting the Advanced Tab in Windows Server 2003 or Windows XP” on page 58.
  - For Windows 7 Operating systems, see “Selecting the Advanced Tab in Windows 7” on page 61.
  - For Windows Vista Operating systems, see “Selecting the Advanced Tab in Windows Vista” on page 63.

The Advanced tab is shown in Figure 30 on page 60.

2. From the Property list on the Advanced tab, select **Ethernet@Wirespeed**.
3. From the Value list on the Advanced tab, select one of the following:
  - Enable** - Enables Ethernet@Wirespeed. This is the default.
  - Disable** - Disables Ethernet@Wirespeed.
4. Click **OK**.
5. If you are prompted to restart your computer, click **Yes**.

Although it is not necessary to reboot the system for new adapter properties to take effect, Allied Telesis recommends rebooting recommended to reinitialize all of the registers.

6. Verify that the adapter port LEDs are operating correctly. See one of the following descriptions:
  - “AT-2712FX/SC and AT-2712LX20/SC Adapters Physical Descriptions” on page 17
  - “AT-2912T Adapter Physical Description” on page 18

## Updating the Flow Control Property

The Flow Control property allows you to enable or disable the receipt or transmission of PAUSE frames which, in turn, allows the adapter and the switch to control the transmit rate. The port side that receives the PAUSE frame momentarily stops transmitting. The recommended selection is Disable, which configures the adapter to ignore PAUSE frames. By default, the Flow Control property is disabled.

To change the Flow Control property, do the following:

1. Access the **Advanced** tab:

- For Windows Server 2003 Operating systems, see “Selecting the Advanced Tab in Windows Server 2003 or Windows XP” on page 58.
- For Windows 7 Operating systems, see “Selecting the Advanced Tab in Windows 7” on page 61.
- For Windows Vista Operating systems, see “Selecting the Advanced Tab in Windows Vista” on page 63.

The Advanced tab is shown in Figure 30 on page 60.

2. From the Property list on the Advanced tab, select **Flow Control**.

3. From the Value list on the Advanced tab, select one of the following:

- Auto** - (default) PAUSE frame receipt and transmission is optimized.
- Disable** - PAUSE frame receipt and transmission is disabled (recommended).
- Rx PAUSE** - PAUSE frame receipt is enabled.
- Rx/Tx PAUSE** - PAUSE frame receipt and transmission is enabled.
- Tx PAUSE** - PAUSE frame transmission is enabled.

4. Click **OK**.

5. If prompted to restart your computer, click **Yes**.

Although it is not necessary to reboot the system for new adapter properties to take effect, rebooting is recommended to reinitialize all of the registers.

6. Verify that the port LED operates correctly. See one of the following descriptions:

- “AT-2712FX/SC and AT-2712LX20/SC Adapters Physical Descriptions” on page 17
- “AT-2912T Adapter Physical Description” on page 18

## Updating the Interrupt Moderation Property

Interrupt moderation enables adaptive interrupt coalescing, which limits the rate of interrupt to the CPU during packet transmission and packet reception. The disabled option allows one interrupt for every packet transmission and packet reception. The default value is Enabled.

To change the Interrupt Moderation setting, do the following:

1. Access the **Advanced** tab:
  - For Windows Server 2003 Operating systems, see “Selecting the Advanced Tab in Windows Server 2003 or Windows XP” on page 58.
  - For Windows 7 Operating systems, see “Selecting the Advanced Tab in Windows 7” on page 61.
  - For Windows Vista Operating systems, see “Selecting the Advanced Tab in Windows Vista” on page 63.

The Advanced tab is shown in Figure 30 on page 60.

2. From the Property list on the Advanced tab, select **Interrupt Moderation**.

For an example of the Advanced tab, see Figure 30 on page 60.

3. From the Value list on the Advanced tab, select one of the following:
  - Enabled**
  - Disabled**

4. Click **OK**.

5. If prompted to restart your computer, click **Yes**.

Although it is not necessary to reboot the system for new adapter properties to take effect, Allied Telesis recommends rebooting to reinitialize all of the registers.

6. Verify that the port LED operates correctly. See one of the following descriptions:
  - “AT-2712FX/SC and AT-2712LX20/SC Adapters Physical Descriptions” on page 17
  - “AT-2912T Adapter Physical Description” on page 18

## Updating the Checksum Offload Property

Usually, the Checksum Offload function is computed by the protocol stack. By selecting one of the Checksum Offload properties, the adapter can compute the checksum.

To change the Checksum Offload setting, do the following:

1. Access the **Advanced** tab:
  - For Windows Server 2003 Operating systems, see “Selecting the Advanced Tab in Windows Server 2003 or Windows XP” on page 58.
  - For Windows 7 Operating systems, see “Selecting the Advanced Tab in Windows 7” on page 61.
  - For Windows Vista Operating systems, see “Selecting the Advanced Tab in Windows Vista” on page 63.

The Advanced tab is shown in Figure 30 on page 60.

2. From the Property list under the Advanced tab, select **IPv4 Checksum Offload** or **IPv6 Checksum Offload**.
3. From the Value list on the Advanced tab, select one of the following:
  - None** - Disables checksum offloading.
  - Rx TCP/IP Checksum** - Enables receive TCP, IP, and UDP checksum offloading.
  - Tx TCP/IP Checksum** - Enables transmit TCP, IP, and UDP checksum offloading.
  - Tx/Rx TCP/IP Checksum** (default) - Enables transmit and receive TCP, IP, and UDP checksum offloading.
4. Click **OK**.
5. If prompted to restart your computer, click **Yes**.

Although it is not necessary to reboot the system for new adapter properties to take effect, rebooting is recommended to reinitialize all registers.

6. Verify that the port LED operates correctly. See one of the following descriptions:
  - “AT-2712FX/SC and AT-2712LX20/SC Adapters Physical Descriptions” on page 17
  - “AT-2912T Adapter Physical Description” on page 18

## Updating the Large Send Offload Property

Normally, the protocol stack performs TCP segmentation. When you enable the Large Send Offload property, the network adapter does the TCP segmentation. There are several Large Send Offload properties to choose from, depending on the TCP/IP version you are using on your PC. You can select IPV4, IPV4 version 2, or IPv6 version 2. By default, the Large Send Offload Property is disabled.

To change the Large Send Offload property, do the following:

1. Access the **Advanced** tab:
  - For Windows Server 2003 Operating systems, see “Selecting the Advanced Tab in Windows Server 2003 or Windows XP” on page 58.
  - For Windows 7 Operating systems, see “Selecting the Advanced Tab in Windows 7” on page 61.
  - For Windows Vista Operating systems, see “Selecting the Advanced Tab in Windows Vista” on page 63.

The Advanced tab is shown in Figure 30 on page 60.

2. From the Property list on the Advanced tab, select one of the following:
  - IPv4 Large Send Offload**
  - IPv6 Large Send Offload**
3. From the Value list on the Advanced tab, select one of the following:
  - Enable** - Enables the Large Send Offload property.
  - Disable** - Disables the Large Send Offload property. This is the default.
4. Click **OK**.
5. If prompted to restart your computer, click **Yes**.

Although it is not necessary to reboot the system for new adapter properties to take effect, rebooting is recommended to reinitialize all registers.

6. Verify that the port LED operates correctly. See one of the following descriptions:
  - “AT-2712FX/SC and AT-2712LX20/SC Adapters Physical Descriptions” on page 17
  - “AT-2912T Adapter Physical Description” on page 18

## Updating the Jumbo MTU Property

The Jumbo MTU property allows the adapter to transmit and receive oversized Ethernet frames that are greater than 1,514 bytes but less than 9,000 bytes in length. Note that this property requires a switch that is able to process large frames. By default, the Jumbo MTU property is set to 1500 bytes.

To increase the size of the received frames, do the following:

1. Access the **Advanced** tab:
  - For Windows Server 2003 Operating systems, see “Selecting the Advanced Tab in Windows Server 2003 or Windows XP” on page 58.
  - For Windows 7 Operating systems, see “Selecting the Advanced Tab in Windows 7” on page 61.
  - For Windows Vista Operating systems, see “Selecting the Advanced Tab in Windows Vista” on page 63.

The Advanced tab is shown in Figure 30 on page 60.

2. From the Property list on the Advanced tab, select **Jumbo MTU**.
3. From the Value list on the Advanced tab, select the byte quantity in 500-byte increments.
4. Click **OK**.
5. If prompted to restart your computer, click **Yes**.

Although it is not necessary to reboot the system for new adapter properties to take effect, rebooting is recommended to reinitialize all registers.

6. Verify that the adapter port LEDs are operating correctly. See one of the following descriptions:
  - “AT-2712FX/SC and AT-2712LX20/SC Adapters Physical Descriptions” on page 17
  - “AT-2912T Adapter Physical Description” on page 18

## Updating the Network Address Property

The Network Address is a user-defined address that is used to replace the MAC address that was originally assigned to the adapter. In some operating systems, this property is called Locally Administered Address. The network address consists of a 12-digit hexadecimal number.

To change the Network Address property, do the following:

1. Access the **Advanced** tab:
  - For Windows Server 2003 Operating systems, see “Selecting the Advanced Tab in Windows Server 2003 or Windows XP” on page 58.
  - For Windows 7 Operating systems, see “Selecting the Advanced Tab in Windows 7” on page 61.
  - For Windows Vista Operating systems, see “Selecting the Advanced Tab in Windows Vista” on page 63.

The Advanced tab is shown in Figure 30 on page 60.

2. From the Property list on the Advanced tab, select **Network Address**.
3. In the Value list on the Advanced tab, enter the Locally Administered Address. Here are some guidelines:
  - The range is 0000 0000 0001 to FFFF FFFF FFFD.
  - Do not use a multicast address (least significant bit of the high byte = 1).
  - Do not use all 0's or all F's.
4. If you are prompted to restart your computer, click **Yes**.

Although it is not necessary to reboot the system for new adapter properties to take effect, rebooting is recommended to reinitialize all registers.

5. Verify that the port LEDs are operating correctly. See one of the following descriptions:
  - “AT-2712FX/SC and AT-2712LX20/SC Adapters Physical Descriptions” on page 17
  - “AT-2912T Adapter Physical Description” on page 18



## Updating the RSS Queues Property

The number of RSS queues varies depending on the adapter. For 1 Gbps network adapters, the RSS queue options are 1, 2, 4, and 8. The default is 8 RSS queues. For 10 Gbps network adapters, the RSS queue options are Auto, 1, 2, 4, 8, and 16. The default value is Auto queues.

To set the number of RSS Queues property, do the following:

1. Access the **Advanced** tab:
  - For Windows Server 2003 Operating systems, see “Selecting the Advanced Tab in Windows Server 2003 or Windows XP” on page 58.
  - For Windows 7 Operating systems, see “Selecting the Advanced Tab in Windows 7” on page 61.
  - For Windows Vista Operating systems, see “Selecting the Advanced Tab in Windows Vista” on page 63.

The Advanced tab is shown in Figure 30 on page 60.

2. From the Property list on the Advanced tab, select **Number of RSS Queues**.
3. From the Value list on the Advanced tab, select one of the following:
  - 1, 2, 4, or 8** (for 1 Gbps adapters)
  - Auto, 1, 2, 4, 8, or 16** (for 10 Gbps adapters)
4. Click **OK**.
5. If prompted to restart your computer, click **Yes**.

Although it is not necessary to reboot the system for new adapter properties to take effect, rebooting is recommended to reinitialize all registers.

6. Verify that the port LED operates correctly. See one of the following descriptions:
  - “AT-2712FX/SC and AT-2712LX20/SC Adapters Physical Descriptions” on page 17
  - “AT-2912T Adapter Physical Description” on page 18

## Updating the Priority & VLAN Property

Priority allows you to prioritize traffic or limit bandwidth instead of treating all traffic in the same manner. A Virtual Local Area Network (VLAN) is a logical area network that extends beyond a traditional LAN to a group of logical LANs. By default, this property is enabled.

To set the port priority and assign a VLAN ID, do the following:

1. Access the **Advanced** tab:
  - For Windows Server 2003 Operating systems, see “Selecting the Advanced Tab in Windows Server 2003 or Windows XP” on page 58.
  - For Windows 7 Operating systems, see “Selecting the Advanced Tab in Windows 7” on page 61.
  - For Windows Vista Operating systems, see “Selecting the Advanced Tab in Windows Vista” on page 63.

The Advanced tab is shown in Figure 30 on page 60.

2. From the Property list on the Advanced tab, select “**Priority & VLAN.**”
3. From the Value list on the Advanced tab, select one of the following:
  - Priority & VLAN Disabled**
  - Priority & VLAN Enabled**
  - Priority Enabled**
  - VLAN Enabled**
4. Click **OK**.
5. If prompted to restart your computer, click **Yes**.

Although it is not necessary to reboot the system for new adapter properties to take effect, rebooting is recommended to reinitialize all registers.

6. Verify that the port LEDs are operating correctly. See one of the following descriptions:
  - “AT-2712FX/SC and AT-2712LX20/SC Adapters Physical Descriptions” on page 17
  - “AT-2912T Adapter Physical Description” on page 18

## Updating the Receive Buffers Property

Receive Buffers are data segments that allow the network adapter to allocate receive packets to memory. For 1 Gbps adapters, the range of valid receive buffers is 50 to 2,000 in increments of 1. The default value is 750 receive buffers.

To set the Receive Buffers property, do the following:

1. Access the **Advanced** tab:
  - For Windows Server 2003 Operating systems, see “Selecting the Advanced Tab in Windows Server 2003 or Windows XP” on page 58.
  - For Windows 7 Operating systems, see “Selecting the Advanced Tab in Windows 7” on page 61.
  - For Windows Vista Operating systems, see “Selecting the Advanced Tab in Windows Vista” on page 63.

The Advanced tab is shown in Figure 30 on page 60.

2. From the Property list on the Advanced tab, select **Receive Buffers**.
3. From the Value list on the Advanced tab, enter a value between 50 and 2,000.
4. Click **OK**.
5. If prompted to restart your computer, click **Yes**.

Although it is not necessary to reboot the system for new adapter properties to take effect, rebooting is recommended to reinitialize all registers.

6. Verify that the port LED operates correctly. See one of the following descriptions:
  - “AT-2712FX/SC and AT-2712LX20/SC Adapters Physical Descriptions” on page 17
  - “AT-2912T Adapter Physical Description” on page 18

## Updating the Receive Side Scaling Property

The Receive Side Scaling (RSS) feature configures RSS queues from 1 to 4. The available options are RSS 1 Queue, RSS 2 Queue, and RSS 4 Queue. By default, RSS is enabled.

To set RSS, do the following:

1. Access the **Advanced** tab:
  - For Windows Server 2003 Operating systems, see “Selecting the Advanced Tab in Windows Server 2003 or Windows XP” on page 58.

- For Windows 7 Operating systems, see “Selecting the Advanced Tab in Windows 7” on page 61.
- For Windows Vista Operating systems, see “Selecting the Advanced Tab in Windows Vista” on page 63.

The Advanced tab is shown in Figure 30 on page 60.

2. From the Property list on the Advanced tab, select **Receive Side Scaling**.
3. From the Value list on the Advanced tab, select one of the following:
  - Enabled**
  - Disabled**
4. Click **OK**.
5. If prompted to restart your computer, click **Yes**.

Although it is not necessary to reboot the system for new adapter properties to take effect, rebooting is recommended to reinitialize all registers.

6. Verify that the port LED operates correctly. See one of the following descriptions:
  - “AT-2712FX/SC and AT-2712LX20/SC Adapters Physical Descriptions” on page 17
  - “AT-2912T Adapter Physical Description” on page 18

## Updating the Speed & Duplex Mode Property

The Speed & Duplex Mode property allows you to set the speed of the copper adapters as well as the change the duplex mode from full to half. By default, the duplex mode is set to a speed of 1000 Mb in full duplex mode.

To change the speed and duplex mode of a copper-based adapter, do the following:

1. Access the **Advanced** tab:
  - For Windows Server 2003 Operating systems, see “Selecting the Advanced Tab in Windows Server 2003 or Windows XP” on page 58.
  - For Windows 7 Operating systems, see “Selecting the Advanced Tab in Windows 7” on page 61.

- For Windows Vista Operating systems, see “Selecting the Advanced Tab in Windows Vista” on page 63.

The Advanced tab is shown in Figure 30 on page 60.

2. From the Property list on the Advanced tab, select **Speed & Duplex**.
3. From the Value list on the Advanced tab, select one of the following:
  - 10 Mb Full**
  - 10 Mb Half**
  - 100 Mb Full**
  - 100 Mb Half**
  - Auto**

The Auto setting is a speed of 1000 Mb in full duplex mode. This is the default setting for the adapters.

4. Click **OK**.
5. If prompted to restart your computer, click **Yes**.

Although it is not necessary to reboot the system for new adapter properties to take effect, rebooting is recommended to reinitialize all registers.

6. Verify that the port LEDs are operating correctly. See one of the following descriptions:
  - “AT-2712FX/SC and AT-2712LX20/SC Adapters Physical Descriptions” on page 17
  - “AT-2912T Adapter Physical Description” on page 18

## Updating the TCP Connection Offload Properties

There are two types of TCP Connection Offload properties. The TCP Connection Offload (IPv4) property enables or disables TOE offload when the IPv4 protocol is in use. The TCP Connection Offload (IPv6) property enables or disables TOE offload when the IPv6 protocol is in use. By default, this property is enabled for both the IPv4 and IPv6 versions.

To set TCP Connection Offload for both the IPv4 and IPv6 properties, do the following:

1. Access the **Advanced** tab:
  - For Windows Server 2003 Operating systems, see “Selecting the Advanced Tab in Windows Server 2003 or Windows XP” on page 58.
  - For Windows 7 Operating systems, see “Selecting the Advanced Tab in Windows 7” on page 61.
  - For Windows Vista Operating systems, see “Selecting the Advanced Tab in Windows Vista” on page 63.

The Advanced tab is shown in Figure 30 on page 60.

2. From the Property list on the Advanced tab, select **TCP Connection Offload (IPv4)** or **TCP Connection Offload (IPv6)**.
3. From the Value list on the Advanced tab, select one of the following:
  - Enabled**
  - Disabled**
4. Click **OK**.
5. If prompted to restart your computer, click **Yes**.

Although it is not necessary to reboot the system for new adapter properties to take effect, rebooting is recommended to reinitialize all registers.

6. Verify that the port LED operates correctly. See one of the following descriptions:
  - “AT-2712FX/SC and AT-2712LX20/SC Adapters Physical Descriptions” on page 17
  - “AT-2912T Adapter Physical Description” on page 18

## Updating the Transmit Buffers Property

Transmit buffers are data segments that allow the network adapter to monitor transmit packets in the system memory. The default value is 1500.

To set the Transmit Buffers property, do the following:

1. Access the **Advanced** tab:
  - For Windows Server 2003 Operating systems, see “Selecting the Advanced Tab in Windows Server 2003 or Windows XP” on page 58.
  - For Windows 7 Operating systems, see “Selecting the Advanced Tab in Windows 7” on page 61.
  - For Windows Vista Operating systems, see “Selecting the Advanced Tab in Windows Vista” on page 63.

The Advanced tab is shown in Figure 30 on page 60.

2. From the Property list on the Advanced tab, select **Transmit Buffers**.
3. From the Value list on the Advanced tab, enter a number between 0 and 2,500.
4. Click **OK**.
5. If prompted to restart your computer, click **Yes**.

Although it is not necessary to reboot the system for new adapter properties to take effect, rebooting is recommended to reinitialize all registers.

6. Verify that the port LED operates correctly. See one of the following descriptions:
  - “AT-2712FX/SC and AT-2712LX20/SC Adapters Physical Descriptions” on page 17
  - “AT-2912T Adapter Physical Description” on page 18

## Updating the VLAN ID Property

The VLAN ID specifies the VLAN identifier. It is the number of the VLAN where the port is an untagged member. You must assign a VLAN ID to a VLAN. The range is 1 to 4094. The default VLAN has a VLAN ID of 0.

To assign a VLAN ID, do the following:

1. Access the Advanced Tab:
  - For Windows Server 2003 Operating systems, see “Selecting the Advanced Tab in Windows Server 2003 or Windows XP” on page 58.

- ❑ For Windows 7 Operating systems, see “Selecting the Advanced Tab in Windows 7” on page 61.
- ❑ For Windows Vista Operating systems, see “Selecting the Advanced Tab in Windows Vista” on page 63.

The Advanced tab is shown in Figure 30 on page 60.

2. Under Property list on the Advanced tab, select **VLAN ID**.
3. From the Value list on the Advanced tab, choose a VLAN ID from 1 to 4094.

---

**Note**

The default VLAN has a VLAN ID of 0.

---

4. Click **OK**.
5. If prompted to restart your computer, click **Yes**.

Although it is not necessary to reboot the system for new adapter properties to take effect, rebooting is recommended to reinitialize all registers.

6. Verify that the port LEDs are operating correctly. See one of the following descriptions:
  - ❑ “AT-2712FX/SC and AT-2712LX20/SC Adapters Physical Descriptions” on page 17
  - ❑ “AT-2912T Adapter Physical Description” on page 18

## Updating the WOL Speed

The WOL Speed property sets the speed at which the network adapter connects to the network while the network adapter is in Wake on LAN (WOL) mode. By default, the WOL Speed property is set to Auto. You cannot change this setting.



## Chapter 6

# Enabling LINUX

---

This chapter describes how to enable the LINUX System on the AT-2712FX/SC, AT-2712LX20/SC, and AT-2912T adapters. This chapter contains the following sections:

- ❑ “Introduction” on page 82
- ❑ “Installing LINUX TG3 File” on page 83
- ❑ “Unloading and Removing the Driver” on page 88
- ❑ “Driver Messages” on page 89

## Introduction

---

This chapter describes the tg3 Linux driver for the Broadcom NetXtreme PCI/PCI-X/PCI Express Ethernet Network Controllers.

The most recent driver is in the latest 2.6 Linux kernel. You can download the driver from [www.broadcom.com](http://www.broadcom.com) as a source package. However, it is generally not necessary to do so if you are using the latest 2.6 upstream kernel from [www.kernel.org](http://www.kernel.org) or one of the latest vendor kernels from Red Hat, SuSE, or other vendors.

The tg3 driver from the Broadcom package is almost identical to the tg3 driver in the latest 2.6 upstream Linux kernel. It includes some additional kernel-compatible code to allow it to compile on older 2.6 kernels and some 2.4 kernels. The version number is similar but generally has a one-letter suffix, for example 3.55b, to distinguish it from the in-kernel tg3 driver.

### Limitations

The current version of the driver has been tested on the 2.4x kernels starting from 2.4.24 and all 2.6.x kernels.



#### Caution

The driver may not compile on kernels older than version 2.4.24.

---

Testing is concentrated on i386 and x86\_64 CPU architectures. Only limited testing has been done on some other architectures such as PowerPC and SPARC64.

On some kernels, you may need to make minor changes to some source files and the Makefile.

### Packaging

To replace an older previously installed or in-kernel tg3 driver, follow the instructions in “Installing LINUX TG3 File” on page 83.

The driver package from [www.broadcom.com](http://www.broadcom.com) is released in two packaging formats: source RPM and compressed tar formats. The file names for the two packages are tg3<version>.src.rpm and tgs<version>.tar.gz respectively. Identical source files to build the driver are included in both packages.

## Installing LINUX TG3 File

---

There are two procedures to install the Linux TG3 file:

- “Installing the Source RPM Package” on page 83
- “Building the Driver from the Source TAR File” on page 84

### Installing the Source RPM Package

Here are general guidelines for installing the Source RPM Package:

1. Install the source RPM package by enter the following command:

```
rpm -ivh tg3<version>.src.rpm
```

2. Change directory to the RPM path and build the binary driver for your kernel. Enter one of the following commands:

```
cd /usr/src/{redhat, openLinux, turbo, packages, rpm..}
```

or

```
rpmbuild -bb SPECS/tg3.spec (for RPM version 4.x.x)
```

---

#### Note

The RPM path is different for specific Linux distributions.

---

3. By default, the driver is compiled for the running kernel. To build the driver for a kernel different from the running kernel, specify the kernel by defining it in KVER. If this is not necessary, skip to step 4. Enter the following command:

```
rpmbuild -bb SPECS/tg3.spec --define "KVER <kernel_version>
```

where <kernel\_version> in the form of 2.x.y-z is the version number of another kernel that is installed on the system.

4. To install the newly-built package (driver and man page), enter the following command:

```
rpm -ivh RPMS/<arch>/tg3-<version>.<arch>.rpm
```

where <arch> is the architecture of the machine such as i386. For example:

```
rpm -ivh RPMS/i386/tg3-<version>.i386.rpm
```

---

**Note**

The force option may be needed on some Linux distributions if conflicts are reported.

---

Depending on the kernel, the driver is installed in one of the following directories:

2.4.x kernels:

```
/lib/modules/<kernel_version>/kernel/drivers/net/  
tg3.o
```

2.6.x kernels:

```
/lib/modules/<kernel_version>/kernel/drivers/net/  
tg3.ko
```

5. To load the driver, enter one of the following commands:

```
insmod tg3.o
```

or

```
insmod tg3.ko (on 2.6 kernels)
```

or

```
modprobe tg3
```

To configure the network protocol and address, refer to the Linux version-specific documentation.

## **Building the Driver from the Source TAR File**

To build the LINUX driver from the source TAR file, do the following:

1. Create a directory, called `tg3 - version`, and extract the TAR files to the directory. Enter the following command:

```
tar xvzf tg3-version.tar.gz
```

2. Build the driver `tg3.o` or `tg3.ko` as a loadable module for the running kernel. Enter the following commands:

```
cd src  
make
```

3. The driver is compiled for the running kernel by default. To build the driver for a kernel different from the one running, specify the kernel by defining it in `KVER`. If this is not necessary, skip to step 4.

Enter the following command:

```
make KVER=<kernel_version>
```

where `<kernel_version>` in the form of `2.x.y-z` is the version of another kernel that is installed on the system.

4. Test the driver by loading it. Enter the following commands:

```
insmod tg3.o
```

or

```
insmod tg3.ko (on 2.6 kernels)
```

or

```
modprobe tg3
```

5. Install the driver by entering the following command:

```
make install
```

See “Installing the Source RPM Package” on page 83 for the location of the installed driver.

To configure the network protocol and address, refer to the Linux version-specific documentation.

## Driver Settings

It is important to configure the speed and duplex settings for the AT-2712FX/SC and AT-2712LX20/SC adapters. By default, the Linux driver is configured for autonegotiation which is not supported with an 100 FX operation. Driver settings can be queried and changed using the `ethtool` utility. Download the latest `ethtool` from the following web site:

<http://sourceforge.net/projects/gkernel>

See Table 4 on page 86 for examples that describe how to use the `ethtool` utility. In addition, see the `ethtool` man page for more information about this utility.

The `ethtool` settings do not persist across reboot or module reload. However, you can place the `ethtool` commands in a startup script such as `/etc/rc.local` to preserve the settings across a reboot.

On Red Hat distributions, you can specify “ethtool -s” parameters in the ifcfg-ethx scripts using the ETHTOOL\_OPTS keyword. The specified ethtool parameters are set up during ifup. For example, go to the following directory:

/etc/sysconfig/network-scripts/ifcfg-eth0

Add the following line to the script:

ETHTOOL\_OPTS="wol g speed 100 duplex half autoneg off"

Table 4. Ethtool Utility Examples

Action	Commands
Display current speed, duplex, and link status	ethtool eth0
Change speed, duplex mode, and autonegotiation status to 100Mbps half duplex, and no autonegotiation	ethtool -s eth0 speed 100 duplex half autoneg off
Change speed, duplex mode, and autonegotiation status to 100Mbps full duplex mode, and no autonegotiation	ethtool -s eth0 speed 100 duplex full autoneg off
Display flow control settings	ethtool -a eth0
Turn off flow control	ethtool -A eth0 autoneg off rx off tx off
Display offload settings	ethtool -k eth0
Turn off TCP Segmentation Offload (TSO)	ethtool -K eth0 tso off
Display statistics	ethtool -S eth0
Perform a self-test on an interface that is up and running	ethtool -t eth0

### Driver Default Settings

Table 5 lists the default settings of the Linux driver.

Table 5. Linux Driver Settings

Feature	Default Setting
Speed	Autonegotiation with all speeds advertised
Flow control	Autonegotiation with Rx and Tx advertised
MTU	1500 (range 46 - 9000)

Table 5. Linux Driver Settings (Continued)

<b>Feature</b>	<b>Default Setting</b>
Rx Ring Size	200 (range 0 - 511)
Rx Jumbo Ring Size	100 (range 0 - 255)
Tx Ring Size	511 (range (MAX_SKB_FRAGS+1) - 511)
Coalesce Rx usecs	20 (range 0 - 1023)
Coalesce Rx usecs irq	20 (range 0 - 255)
Coalesce Rx frames	5 (range 0 1023)
Coalesce Rx frames irq	5 (range 0 - 255)
Coalesce Tx usecs	72 (range 0 - 1023)
Coalesce Tx usecs irq	20 (range 0 - 255)
Coalesce Tx frames	53 (range 0 - 1023)
Coalesce Tx frames irq	5 (range 0 - 255)
Coalesce stats usecs	1000000 (approximately 1 second) Some coalescing parameters are not used or have different defaults on some chips
MSI	Enabled if supported by the chip and passes the interrupt test
TSO	Enabled on newer chips that support TCP segmentation offload in hardware
WoL (Wake on LAN)	Disabled

## Unloading and Removing the Driver

---

To unload the driver, use the `ifconfig` command to bring down all `eth#` interfaces opened by the driver. Then enter the following command:

```
rmmod tg3
```

---

**Note**

On all 2.6 kernels, you do not need to bring down the `eth#` interfaces before unloading the driver module.

---

If the driver was installed using `rpm`, enter the following command to remove it:

```
rpm -e tg3
```

If the driver was installed using the `make install` command from the tar file, you need to manually delete the driver `tg3.o` (or `tg3.ko`) from the system. Refer to “Installing the Source RPM Package” on page 83 for the location of the installed driver.



## Driver Messages

---

The following messages are the most common sample messages that are logged in the `/var/log/messages` file. Use the `dmesg -n<level>` command to control the level at which messages appear on the console. Most systems are set to level 6 by default. To see all messages, set the level higher than 6.

### Driver Signon

```
tg3.c:v3.92n (September 29, 2008)
```

### NIC Detected

```
eth0: Tigon3 [partno(BCM95704A6) rev 2003 PHY(5704)
(PCIX:100MHz:64-bit)
10/100/1000BaseT Ethernet 00:10:18:04:3f:36
eth0: RXcsums[1] LinkChgREG[0] MIirq[0] ASF[0]
wirespeed[1] TSOcap[1]
eth0: dma_rwctrl[769f4000] dma_mask[64-bit]
```

### Link Up and Speed Indication

```
tg3: eth0: Link is up at 1000 Mbps, full duplex.
tg3: eth0: Flow control is on for TX and on for RX.
```

### Link Down Indication

```
tg3: eth#: Link is down.
```



# Appendix A

# Specifications

---

## Physical Specifications

---

This section provides the dimensions and weight of the adapters.

Dimensions: AT-2712FX/SC: 11.59 cm x 6.89 cm (4.56 in. x 2.71 in.)  
AT-2712LX20/SC: 11.59 cm x 6.89 cm (4.56 in. x 2.71 in.)  
AT-2912T: 8.18 cm x 6.89 cm (3.22 in. x 2.71 in.)

Weight: AT-2712FX/SC: 45.36 g (.10 lbs.)  
AT-2712LX20/SC: 45.36 g (.10 lbs.)  
AT-2912T: 45.36 g (.10 lbs.)

## Environmental Specifications

---

The following environmental specifications apply to the AT-2712FX/SC, AT-2712LX20/SC, and AT-2912T adapters:

Operating Temperature: 0°C to 40°C (+32°F to +104°F)  
Storage Temperature: -20°C to +70°C (-4°F to +158°F)  
Operating Humidity: 30% to 80% (noncondensing)  
Storage Humidity: 10% to 95% (noncondensing)  
Maximum Operating Altitude: 10,000  
Maximum Storage Altitude 35,000 ft.

## Power Specifications

---

The following power specifications apply to the AT-2712FX/SC, AT-2712LX20/SC, and AT-2912T adapters.

Operating Voltage: 3.3V

Power Consumption: AT-2712FX/SC: 3.22 Watts, @ +3.3V Avg  
AT-2712LX20/SC: 3.22 Watts, @ +3.3V Avg  
AT-2912T: 2.05 Watts, @ +3.3V Avg

## Performance Specifications

---

The following performance specifications apply to the AT-2712FX/SC, AT-2712LX20/SC, and AT-2912T adapters:

PCI clock: 33/66 MHz max

PCI-X clock: 66 to 133 MHz

PCI or PCI-X Data/Address: AT-2712FX/SC 32-bit

## Quality and Reliability

---

The MTBF values for the Secure Ethernet Network Adapters are:

AT-2712FX/SC: 3,600,000 hours

AT-2712LX20/SC: 800,000 hours

AT-2912T: 5,670,000 hours

## Operating Specifications

---

The following operating specifications apply to the AT-2712FX/SC and AT-2712LX20/SC adapters.

AT-2712FX/SC Operating Specifications:

Output Optical Power: -9.5 dBm minimum to -4 dBm maximum

Input Optical Power: -18 dBm to 0 dBm maximum

Receive Sensitivity:           -12.5 dBm with 62.5 um fiber or  
   -13.5 dBm with 50 um fiber

AT-2712LX20/SC Operating Specifications:

Output Optical Power:       -15 dBm minimum to -5 dBm maximum

Input Optical Power:        -3 dBm maximum

Receive Sensitivity:         -34 dBm typical

## 10/100/1000Base-T Twisted-Pair Port Connectors

---

This section lists the pin signals for the 10/100/1000Base-T twisted-pair ports for the AT-2912T adapter. Figure 35 illustrates the pin layout to an RJ-45 connector and port.

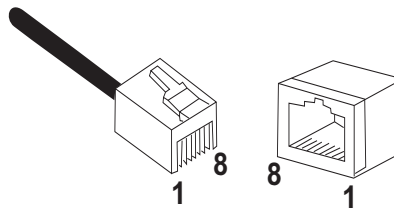

Figure 35. RJ-45 Connector and Port Pin Layout

Table 6 lists the RJ-45 pin signals when a twisted-pair port is operating in the MDI configuration.

Table 6. MDI Pin Signals (10Base-T or 100Base-TX)

Pin	Signal
1	TX+
2	TX-
3	RX+
6	RX-

Table 7 lists the RJ-45 port pin signals when a twisted-pair port is operating in the MDI-X configuration.

Table 7. MDI-X Pin Signals (10Base-T or 100Base-TX)

<b>Pin</b>	<b>Signal</b>
1	RX+
2	RX-
3	TX+
6	TX-

Table 8 lists the RJ-45 connector pin and their signals when a 1000Base-T port is operating at 1000 Mbps.

Table 8. RJ-45 1000Base-T Connector Pinouts

<b>Pin</b>	<b>Pair</b>	<b>Signal</b>
1	1	TX and RX+
2	1	TX and RX-
3	2	TX and RX+
4	3	TX and RX+
5	3	TX and RX-
6	2	TX and RX-
7	4	TX and RX+
8	4	TX and RX-

## Appendix B

# Cleaning Fiber Optic Connectors

---

The fiber optic connector consists of a fiber optic plug and its adapter. The end of the fiber optic cable is held in the core of the ferrule in the plug. Light signals are transmitted through the core of the fiber. Even minor smudges or dirt on the end face of the fiber, completely invisible to the naked eye, can disrupt light transmission and lead to failure of the component or of the entire system. Therefore, it is of utmost importance to clean all fiber optic connectors before use.

Figure 36 shows the ferrule in an SC connector.

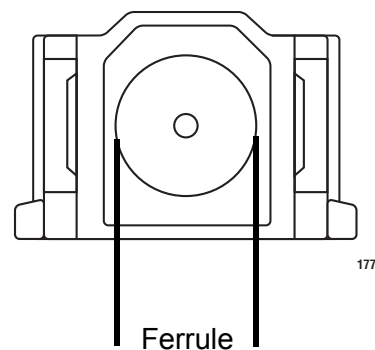

Figure 36. Ferrule in an SC Connector Plug

Figure 37 shows part of the end face of an unclean and clean ferrule.

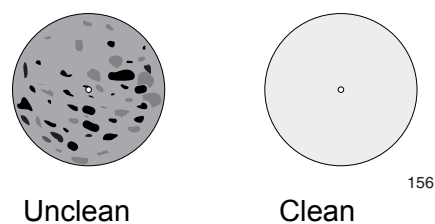

Figure 37. Unclean and Clean Ferrule

This appendix provides the following procedures

- ❑ "Using a Cartridge-Type Cleaner" on page 96
- ❑ "Using a Swab" on page 98

## Using a Cartridge-Type Cleaner

---

Fiber optic cartridge cleaners are available from many vendors and are typically called “cartridge cleaners,” as shown in Figure 38.



Figure 38. Cartridge Cleaner

---

**Note**

Do not use compressed air or aerosol air to clean a fiber optic connector.

---

To clean a fiber optic connector using a cartridge cleaner, perform the following procedure.

1. With one hand, hold the cartridge cleaner and push the lever on the cleaning cartridge in the direction of the arrow to expose the cleaning surface, as shown in Figure 39.

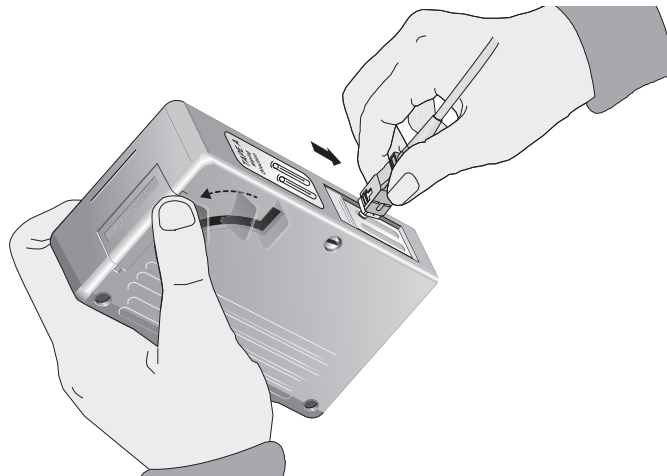

Figure 39. Rubbing the Ferrule Tip on the Cleaning Surface



---

**Note**

Rub the ferrule tip on the cleaning surface in one direction only.

---

2. Place the ferrule tip on the exposed cleaning surface and rub the ferrule in a downward direction, as shown in Figure 39 on page 96.
3. When you reach the end of the cleaning surface, pick up the ferrule tip, rotate and place it at the top and rub downwards at least 2 times.



---

**Caution**

Failing to pick up the ferrule tip when you reach the bottom of the cleaning surface can result in static electricity that can damage the fiber optic cable.

---

4. If desired, repeat steps 3 and 4.
5. If a fiber inspection scope is available, use the scope to inspect the ferrule end face to make sure that it is clean.
6. Reconnect the cable to the port or protect the ferrule tip with a dust cap.

---

**Note**

Always keep a dust cap on a fiber optic cable when it is not in use.

---

---

**Note**

Do not touch the end face of the ferrule in the connector.

---



---

**Warning**

Do not stare into the laser beam. ⚠ L2

---



---

**Warning**

Do not look directly at the cable ends or inspect the cable ends with an optical lens. ⚠ E29

---

## Using a Swab

---

Specially treated swabs, known as stick cleaners, are available for cleaning inside connector adapters or hard-to-reach ferrule tips. These swabs, often referred to as “lint free” or “alcohol free” swabs, are available from many vendors, as shown in Figure 40. Stick cleaners are available in both 2.5 mm and 1.25 mm sizes for use on SC and MU connectors respectively.

---

**Note**

NEVER use a household cotton swab and/or alcohol to clean a fiber optic connector. This may leave a residue on the ferrule tip.

---

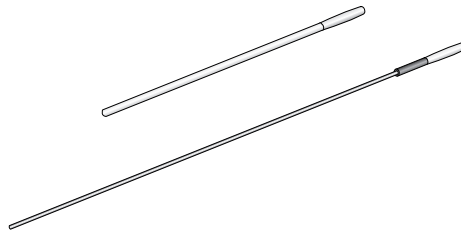

Figure 40. Lint-Free and Alcohol-Free Swabs

---

**Note**

Do not use compressed air or aerosol air to clean a fiber optic connector.

---

To clean a recessed ferrule using a swab, perform the following procedure.

1. Insert the swab into the adapter as shown in Figure 39 and rub the ferrule tip with the swab.

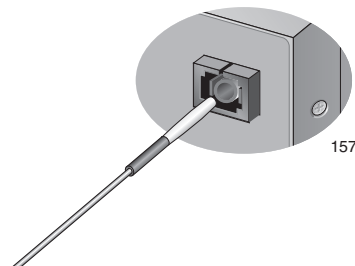

Figure 41. Cleaning a Recessed Ferrule

2. If desired, repeat step 1.

3. If a fiber inspection scope is available, use the scope to inspect the connector to make sure that it is clean and to check for scratches, pits, or other problems that may affect performance.

---

**Note**

Always keep a dust cap on a fiber optic cable when it is not in use.

---



---

**Warning**

Do not stare into the laser beam. ⚠ L2

---



---

**Warning**

Do not look directly at the cable ends or inspect the cable ends with an optical lens. ⚠ E29

---

