

ITAS DRYFLAMEPACK MODEL DFP01 TECHNICAL DATASHEET (METRIC)

Basic burner parameters	Value
Maximum Capacity input [kW _{lhv}]	125
Minimum Capacity input [kW _{lhv}]	10
High fire combustion air [Nm ³ /h]	150 ($\lambda = 1,2$)
Air pressure at burner inlet [mbar]	10
Flame dimensions [mm] <i>(Measured from outlet of combustor)</i>	Length: 400 Diameter: 150
Gas and air control	On ratio via integrated gas- and air control valves
Ignition	Direct ignition by spark rod
Installation position	Horizontal
Burner model	ITAS DF0250
Weight burner with valves and combustor [kg]	13

Notes:

- All data are based on net calorific values = lhv
- All information is based on common practice for gas and air pipe design. Contact Fives ITAS S.p.A. for any further support.
- All inputs are based on laboratory testing at neutral chamber conditions
- Natural gas: lhv = 9,97 kWh/Nm³; d=0,56
- Propane: lhv = 26,3 kWh/Nm³; d=1,58

Burner configuration options:

Fuel options	N: Natural gas	L: LPG
Nozzle selection	Natural gas	LPG
Factory settings gas – and air valves	Natural gas	LPG

Combustor options	S: Standard Alloy	E: Extended Alloy
Combustor length [mm]	220	320
Diameter [mm]	152	152
Material	AISI 310	AISI 310

Flame supervision options	I: Ionization rod	U: UV-interrupted	U: UV-continuous
Connection on burner body [inch]	3/4	3/4	3/4
Model	ITAS standard	QRA10	QRA73
Voltage [V/Hz]	110 (50/60 Hz) or 230 (50/60 Hz)	110 (50/60 Hz) or 230 (50/60 Hz)	110 (50/60 Hz) or 230 (50/60 Hz)

Combustion air configuration options:

The blower selection depends on a variety of choices to be made:

Position of the combustion air inlet to the burner and the position of the blower motor.

T: Combustion air inlet on top

L: Motor left

R: Motor right

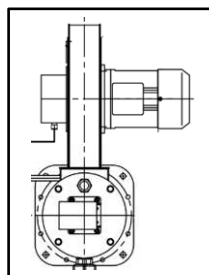
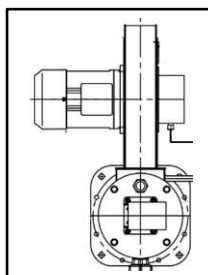

B: Combustion air inlet on bottom

L: Motor left

R: Motor right

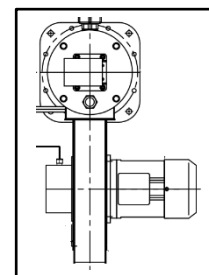
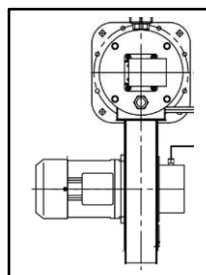

Fan supply voltage	Backpressure: -5 to 1.5 mbar	Max 5 mbar
16: Single-phase 110 V - 60 Hz	VAP252	VAP252
25: Single-phase 230 V - 50 Hz	VAP252	VAP252

Blower properties	VAP252
Motor power [kW]	0,37
Protection grid	Standard
Cylindrical Filter	Optional (replaces grid)
Air switch setting [mbar]*	5
Weight [kg]	14

Notes:

* Based on neutral chamber conditions

Gas train configuration options:

All gas trains are designed to meet IP54 protection class and up to 350 mbar inlet pressure. The installation direction of the gas train is related to the blower motor installation. Motor left is gas train left and motor right is gas train right.

A packaged gas valve train consists of:

- Manual ball valve
- Compensator
- Manometer
- Minimum gas pressure switch
- GasMultiblock with dirt trap, double safety shut of valves and pressure reducer
- Maximum gas pressure switch

The selection of the gas train components is a result of multiple selections made, such as fuel type and auxiliary supply voltage.

Fuel options	N: Natural gas	L: LPG
Gas pressure at valvetrain [mbar]	50 to 350	50 to 350
Gas train connection [inch]	1/2	1/2
Max. gas switch setting [mbar]*	60	
Min. gas switch setting [mbar]*	10	
Voltage [V/Hz]	110/60 or 230/50	110/60 or 230/50
Weight gas valve train [kg]	~3,5	~3,5

Notes:

* Based on neutral chamber conditions

Burner Management configuration options:

	Basic BMS		Programmable BMS	
Operation	Interrupted		Interrupted	Continuous
Burner relay	LME21		LME73	LME75
Flame scanner	Ionization		Ionization or UV	
Failure messaging	No		Display	
External setpoint	Client signal directly to servomotor		Burner relay receives either 4-20mA or 3-pnt step or 0-10v from client	
Signal to the control-motor	3-pnt step to SQN31	4-20mA to SQM4x	3-pnt step signal from burner relay to SQN31 motor	
Manual/ remote switch	No		Yes	
Panel installation	On burner (Plastic box)		Junction box (Plastic) on burner + Panel (steel) for wall installation (including 5m cable and connector)	
Temp. limit switch	No		Optional	
Space reserve	No		10% (when no high temp switch)	
Burner on/off switch	No		Yes	
Signal lamps	Single lamp burner “failure/ in operation”		Separate lamps for “burner failure” and “burner in operation”	
Weight [kg]	...		20	

For all panels:

- Completely pre-assembled and tested
- Ignition transformer is supplied with the panel (installed on support outside the panel)
- Available for supply voltage 110V/60Hz or 230V/ 50Hz
- Protection class is IP54
- Language on name plates is English
- System purging by client
- Excluding leak test
- No flame signal indication
- No wiring numbering
- Including main switch
- Including reset button
- Including blower motor starter



DIMENSIONS

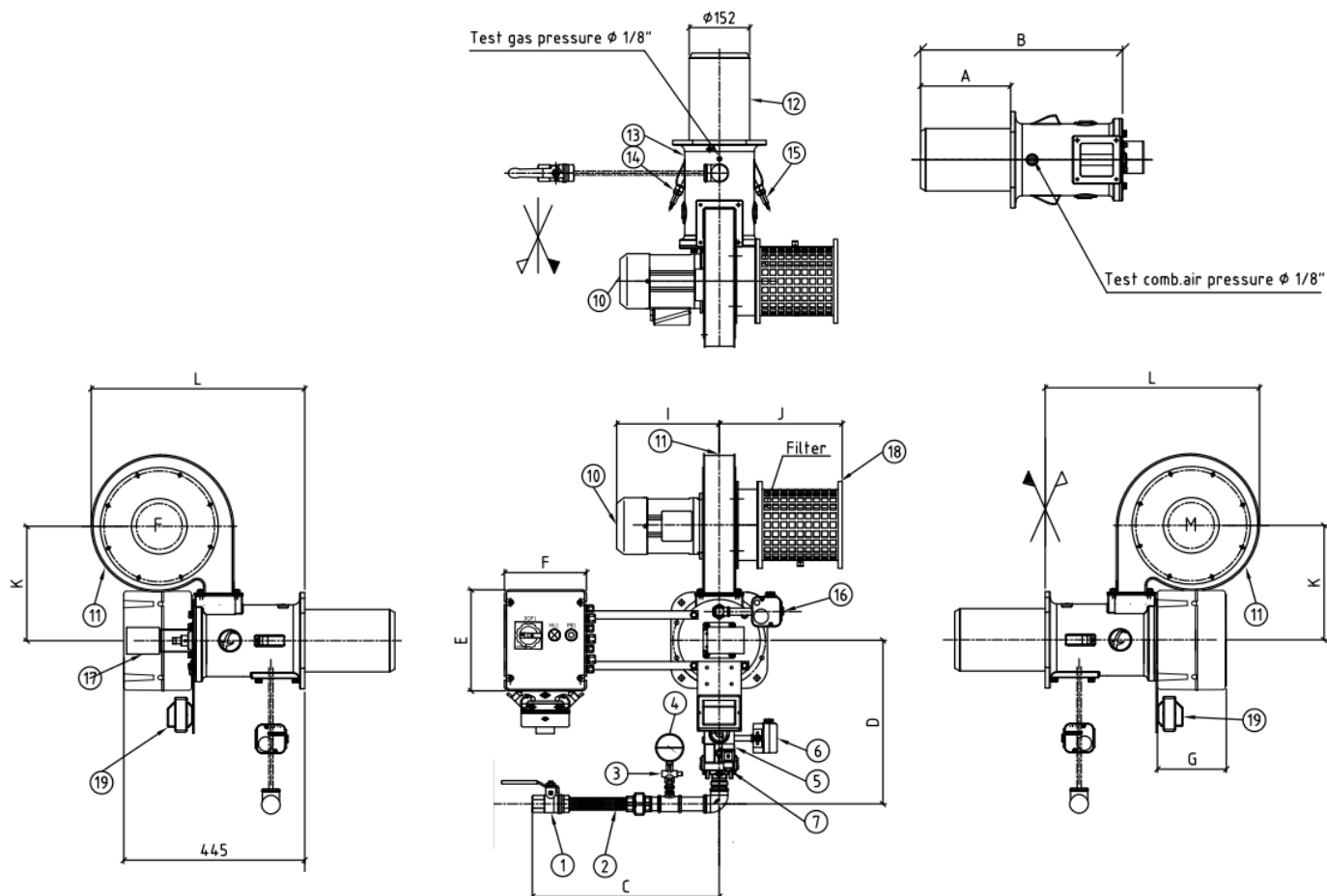

Combustor	Standard	Extended
A	220	300
B	495	575

Fuel	NG	LPG
C	345	345
D	355	355

Panel	LME21	LME7*
E	247	400
F	200	300
G	168	200

Blower	VAP252
I	250
J	300
K	280
L	521

Pos.	Instrumentation list
01	Ball valve
02	Flexible/ compensator
03	Manometer valve
04	Manometer 0-600 mbar
05	Double safety shut-off
06	Max. gas pressure switch
07	Min. gas pressure switch
08	Gas pressure regulator
09	3-way solenoid valve
10	Electric motor
11	Combustion air fan
12	Combustor tube
13	ITAS Dryflame burner head
14	Spark plug
15	Flame rod
16	Combustion air pressure switch
17	Servomotor for gas/air regulation
18	Combustion air filter
19	Ignition transformer

* LME 7 panel is supplied as loose part including cable and connector. Components are wired to a terminal strip installed in a box (same sizes as LME21 box).