

U·S·S  
STRUCTURAL SECTIONS



UNITED STATES STEEL

St. Louis, Missouri  
April 27, 1940

It has been noticed an error occurred in the printing of our new  
USS Structural Sections Book.

Upon referring to the heading, "Section Index and Nominal Size,"  
you will note the section number of the 14" sections at the top of  
Page 43 reads "CBP-146". This should read "CBP-145" and we would thank  
you to so correct your book.

CARNEGIE-ILLINOIS STEEL CORPORATION

Robt. Korsan, Jr., Manager of Sales.

Wm.S.Gray-MH.

USS STRUCTURAL SECTIONS BOOK

There are attached two new sheets for insertion in each Structural Sections Book sent you - one is an errata sheet which includes all corrections to date, and the other covers CB-51 and is to be inserted between Pages 24 and 25.

To insert these sheets you simply lay in correct position in the book and press the perforations into position with any blunt instrument.

CARNEGIE-ILLINOIS STEEL CORPORATION

*R. Koran Jr.*  
Manager of Sales

Wm. S. Gray-MH.

Enclosures.

# ERRATA

## U·S·S STRUCTURAL SECTIONS

### CORRECTION

PAGE

- 13 Under Section Index CB 362 the nominal depth should be 36 in. instead of 30 in.  
 25 The following corrections should be made in columns 5, 6, and 7:

		<u>Flange Th.</u>	<u>Web Th.</u>	<u>Web <math>\frac{1}{2}</math> Th.</u>
CBL 12	22 lbs.....	$\frac{3}{16}$	$\frac{1}{4}$	$\frac{1}{8}$
CBL 12	19 lbs.....	$\frac{3}{8}$	$\frac{1}{4}$	$\frac{1}{8}$
CBL 10	19 lbs.....	$\frac{3}{8}$	$\frac{1}{4}$	$\frac{1}{8}$
CBL 10	17 lbs.....	$\frac{5}{16}$	$\frac{1}{4}$	$\frac{1}{8}$
CBL 8	15 lbs.....	$\frac{5}{16}$	$\frac{1}{4}$	$\frac{1}{8}$
CBL 6	16 lbs.....	$\frac{3}{8}$	$\frac{1}{4}$	$\frac{1}{8}$

- 28 Under Section Index 6" B14, insert P.C.B. opposite 17.25 lbs.; and add S. to 14.75 lbs.  
 28 Remove bracket from 5" B15.  
 30 Nominal size of H 4 should be 8 x 8 instead of 8 x 18.  
 32 Under Section Index C 2, Axis 1-1 S, the figure 2.14 in the fifth line should be 21.4.  
 37 Under Section Index A 7,  $\frac{1}{8}$  in. thickness, change weight per foot from 2.48 lbs. to 2.50 lbs.  
 41 Under Section Index A 26,  $\frac{1}{4}$ " thickness, change weight per foot from 6.1 lbs. to 6.2 lbs.  
 42 Under Section Index A 29,  $\frac{3}{8}$  in. thickness, change weight per foot from 3.7 lbs. to 3.71 lbs.  
 42 Under Section Index A 35, the entire last line,  $\frac{3}{8}$  in. thickness, belongs with Section Index A 48, the group immediately following; and the District Rolled column should show C.S. instead of S.  
 43 Section Index CBP 146 should be CBP 145.  
 56 Section Index C 27 is shown to be rolled in Pittsburgh and Birmingham. This should be Pittsburgh only.  
 58 Section Index C 28 is shown to be rolled in Pittsburgh, Chicago, and Birmingham. This should be Pittsburgh and Chicago only.  
 58 Section Index C 31 should be shown as rolled "P" only for all four weights.  
 58 Under Section Index C 74 the entire line following 15.6 lbs. should appear below 16.5 lbs. to conform with C 74 on page 59.  
 66 Section Index A 547 should be A 645.  
 94 On sketch of floor plate M 41, dimension  $1\frac{1}{8}$ " should be  $\frac{3}{8}$ ", and dimension  $2\frac{1}{8}$ " should be  $1\frac{1}{8}$ ".  
 108 The seventh line of the right-hand group of figures shows a diameter of  $\frac{1}{2}$  in. This should be  $\frac{3}{4}$  in.  
 112 The sub-heading (1 axis 1-1 and 2-2 =  $\frac{d^4}{12} = .08333 d^4$ ), should be (1 axis 1-1 =  $\frac{d^4}{12} = .08333d^4$ ).

B134

# U·S·S

## STRUCTURAL SECTIONS

INFORMATION AND TABLES  
FOR ENGINEERS AND DESIGNERS  
AND OTHER DATA  
PERTAINING TO STRUCTURAL STEEL



CARNEGIE-ILLINOIS STEEL CORPORATION • *Pittsburgh and Chicago*

COLUMBIA STEEL COMPANY • *San Francisco*

TENNESSEE COAL, IRON & RAILROAD COMPANY • *Birmingham*

UNITED STATES STEEL EXPORT COMPANY  
*New York - Export Distributors*

★

SCULLY STEEL PRODUCTS COMPANY  
*Chicago - Warehouse Distributors*

# UNITED STATES STEEL

Copyright 1940 by

CARNEGIE-ILLINOIS STEEL CORPORATION  
Pittsburgh, Pa. Chicago, Ill.

TENNESSEE COAL, IRON AND RAILROAD COMPANY  
Birmingham, Ala.

COLUMBIA STEEL COMPANY  
San Francisco, Cal.

## Foreword

THIS publication presents those sections available for use for steel construction generally, including bridges, buildings, car and ship construction, and gives detailed data relative to dimensions and properties essential to their use. It supersedes and cancels all previous publications relating to structural sections.

This edition is issued jointly by

CARNEGIE-ILLINOIS STEEL CORPORATION  
TENNESSEE COAL, IRON AND RAILROAD COMPANY  
COLUMBIA STEEL COMPANY

Each company sells all the products listed, regardless of where produced.

The following symbols used with the sections indicate in which district or districts they are produced.

- P. Produced in Pittsburgh district of Carnegie-Illinois Steel Corporation.
- C. Produced in Chicago district of Carnegie-Illinois Steel Corporation.
- B. Produced in Birmingham district by Tennessee Coal, Iron and Railroad Company.
- S. Produced in Pacific Coast district by Columbia Steel Company.

# METHOD OF INCREASING SECTION AREAS

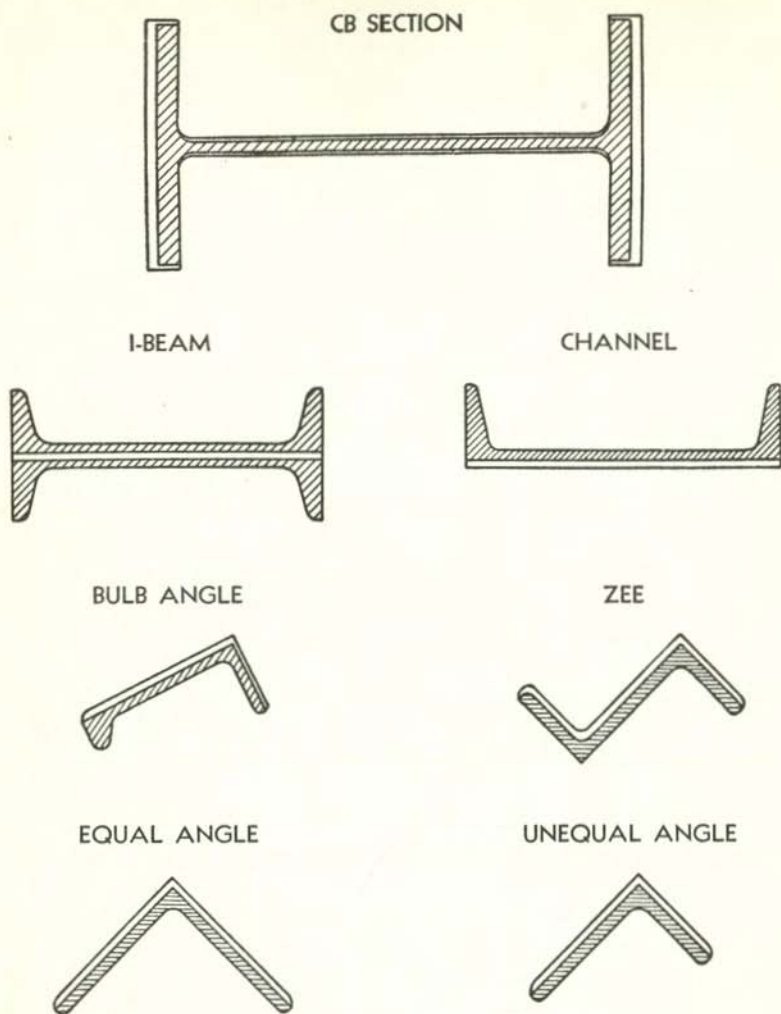

The above figures show the method of increasing the sectional areas and weights of structural steel shapes. Cross hatched portions represent the minimum sections and the blank portions the added areas.

In the case of Channels and Standard Beams the enlargement of the section adds an equal amount to the thickness of the web and the width of the flanges. In the case of CB Sections equal thicknesses of metal are added to the web thickness and flange width and proportional additions to the flange thickness. In the case of Angles and Zees, the effect of spreading the rolls is to increase slightly the length of the legs. In the case of Ship Building Bulb Angles, as a rule each increase or decrease in web thickness carries with it about one-half that increase or decrease in the flange thickness.

Inasmuch as the roll passes are modified in the wear of the rolls, the actual dimensions will not always conform to the theoretical, even in the case of the minimum weight sections. Provision should be made for such variations in designing and detailing.



# Rolling Tolerances

## Cambering

### Removal of Surface Imperfections

### Method of Computation of

### Weights and Properties

**I**N the rolling of structural shapes, factors like roll wear and subsequent roll dressing, temperature variations, etc., cause the finished sections to vary from theoretical published profiles. To meet such variations, standard rolling tolerances have been established which the rolling mills are able to meet. These tolerances are shown on pages 6 and 7 and are in accordance with manufacturers' standard practice.

The limitations as to the cambering of rolled beams as a mill operation are shown on page 9. Cambering requirements for any sizes not shown may be submitted to the mill to determine whether or not they can be met.

The methods and limitations on the correction of surface imperfections as published by the American Society for Testing Materials are shown on page 8.

In computing the weights and properties of rolled steel shapes, the following method, in accordance with the practice adopted by the Association of American Steel Manufacturers, is used: For CB wide flange shapes, CB light beams, stanchions, and joists the fillets are included for both weights and properties; for weights of standard I beams, channels and shipbuilding bulb angles the fillets and roundings are included; for the weights of angles, tees, zees, and car building bulb angles the fillets and roundings are not included; for the properties of shipbuilding bulb angles, the fillets and roundings are included; for the properties of standard I beams and channels and for all angles, tees, zees, and car building bulb angles the fillets and roundings are not included.

# HOT ROLLED CARBON STEEL

STRUCTURAL BEAMS, CHANNELS, ANGLES, BULB ANGLES, TEES, ZEES

All dimensions in inches unless otherwise noted

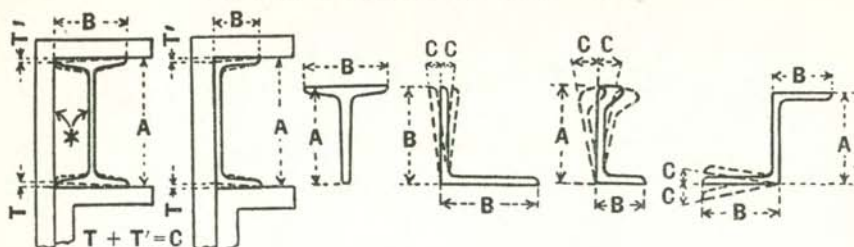

\*Back of square and web to be parallel when measuring for out-of-square.

## DEPTH, WIDTH, WEIGHT AND OUT-OF-SQUARE

Table 1

Section	Specified Size (Longer Leg of an Unequal Angle Determines Size for Variations)	Variations from Specified Size and Weight					
		A, Depth		B, Flange Width or Leg Length		C, Out-of-Square or Parallel per Inch of B	Weight, Per Cent, Over or Under
		Over	Under	Over	Under		
Beams . . . . .	3 to 7	$\frac{3}{32}$	$\frac{1}{16}$	$\frac{1}{8}$	$\frac{1}{8}$	$\frac{1}{32}$	$2\frac{1}{2}$
	Over 7 to 14	$\frac{1}{8}$	$\frac{3}{32}$	$\frac{5}{32}$	$\frac{5}{32}$	$\frac{1}{32}$	$2\frac{1}{2}$
	Over 14 to 24	$\frac{3}{16}$	$\frac{1}{8}$	$\frac{3}{16}$	$\frac{3}{16}$	$\frac{1}{32}$	$2\frac{1}{2}$
Channels . . . . .	3 to 7	$\frac{3}{32}$	$\frac{1}{16}$	$\frac{1}{8}$	$\frac{1}{8}$	$\frac{1}{32}$	$2\frac{1}{2}$
	Over 7 to 14	$\frac{1}{8}$	$\frac{3}{32}$	$\frac{1}{8}$	$\frac{5}{32}$	$\frac{1}{32}$	$2\frac{1}{2}$
	Over 14	$\frac{3}{16}$	$\frac{1}{8}$	$\frac{1}{8}$	$\frac{3}{16}$	$\frac{1}{32}$	$2\frac{1}{2}$
Tees . . . . .	3 to 7	$\frac{3}{32}$	$\frac{1}{16}$	$\frac{1}{8}$	$\frac{1}{8}$	$\frac{1}{32}$	$2\frac{1}{2}$
Angles, Bulb Angles, and Zees . . . . .	3 to 4	$\frac{1}{8}$	$\frac{1}{16}$	$\frac{1}{8}$	$\frac{3}{32}$	$1\frac{1}{2}^\circ$ or $3/128$	$2\frac{1}{2}$
	Over 4 to 6	$\frac{1}{8}$	$\frac{1}{16}$	$\frac{1}{8}$	$\frac{1}{8}$	$1\frac{1}{2}^\circ$ or $3/128$	$2\frac{1}{2}$
	Over 6	$\frac{1}{8}$	$\frac{1}{16}$	$\frac{3}{16}$	$\frac{1}{8}$	$1\frac{1}{2}^\circ$ or $3/128$	$2\frac{1}{2}$

## LENGTH

Table 2

Section	Variations from Specified Length for Lengths Given							
	30' and Under		Over 30' to 40', incl.		Over 40' to 50', incl.		Over 50'	
	Over	Under	Over	Under	Over	Under	Over	Under
Beams, Channels . . . . .	$\frac{3}{8}$	$\frac{3}{8}$	$\frac{5}{8}$	$\frac{3}{8}$	$\frac{7}{8}$	$\frac{3}{8}$	1	$\frac{3}{8}$
Angles, Bulb Angles, Tees, Zees . . . . .	$\frac{3}{4}$	0	1	0	$1\frac{1}{4}$	0	$1\frac{1}{4}$	0

## ENDS OUT-OF-SQUARE

Beams, Channels, Tees:  $\frac{1}{64}$ " per inch of depth.  
 Angles, Bulb Angles:  $1\frac{1}{2}^\circ$  or  $3/128$ " per inch of leg length.  
 Zees:  $1\frac{1}{2}^\circ$  or  $3/128$ " per inch of the sum of the lengths of both legs.

## CAMBER

$$\frac{1}{8}'' \times \frac{\text{Number of feet of length}}{5}$$

# HOT ROLLED CARBON STEEL

## WIDE FLANGE STRUCTURAL SECTIONS

All dimensions in inches unless otherwise noted

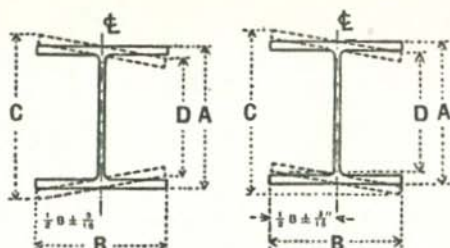

### DEPTH, WIDTH, WEIGHT AND OUT-OF SQUARE

Table 3

Nominal Size, Depth	Variations from Specified Size							
	A, Depth		B, Flange Width		C, Max. Depth at any Point	C minus D, Out-of-Square or Parallel	Web off Center Respect to -ϕ	Weight, Per Cent
	Over	Under	Over	Under	Over Normal	Not Over	Not Over	Over or Under
12 or Under	1/8	1/8	1/4	3/16	1/4	3/16	3/16	2 1/2
Over 12	1/8	1/8	1/4	3/16	1/4	1/4	3/16	2 1/2

### LENGTH

Table 4

Nominal Size, Depth	Variations from Specified Length for Lengths Given			
	30 Feet and Under		Over 30 Feet	
	Over	Under	Over	Under
Beams 8 to 24	3/8	3/8	3/8, plus 1/16 for each additional 5' or fraction thereof	3/8
Beams over 24 and all Columns	1/2	1/2	1/2, plus 1/16 for each additional 5' or fraction thereof	1/2

When variations are specified to be all over, the sum of the over and under variations shall apply.

### ENDS OUT-OF-SQUARE

1/4" per inch of depth or of flange width if it is greater than the depth.

### CAMBER OR SWEEP

Beams:  $\frac{1}{8}'' \times \frac{\text{Number of feet of length}}{10}$

When ordered as columns:

Lengths up to 45':  $\frac{1}{8}'' \times \frac{\text{Number of feet of length}}{10}$  but not over 3/8"

Lengths over 45':  $\frac{3}{8}'' + \frac{1}{8}'' \times \frac{\text{Number of feet of length minus 45}}{10}$

## SURFACE FINISH

A.S.T.M. SPECIFICATIONS: SHOWN UNDER FINISH CLAUSE OF A7-36, A9-36 AND A94-36

Surface imperfections that do not affect the full utility of the piece, shall not be considered as injurious defects in structural shapes  $\frac{3}{8}$  inch or more in thickness. Such pieces shall be processed by the following methods in order to give them a workmanlike finish:

(1) When surface imperfections are less than  $\frac{1}{16}$  inch in depth, they may be removed by grinding.

(2) When the surface imperfections are  $\frac{1}{16}$  inch or more in depth, the pieces may be subjected to chipping and welding under limiting conditions as follows:

The cross-sectional area of any piece shall not be reduced more than  $1\frac{1}{2}$  per cent at any point, nor shall the total area of the chipped surface of any piece exceed 2 per cent of the total surface area of that piece.

After any imperfection has been completely removed, the maximum depth of depression shall not exceed the following:

Thickness of Material Inches	Depth of Depression Max. Inches
$\frac{3}{8}$ up to $\frac{1}{2}$	$\frac{1}{16}$
$\frac{1}{2}$ up to 1	$\frac{1}{8}$
1 up to $1\frac{1}{4}$	$\frac{3}{16}$
$1\frac{1}{4}$ up to $2\frac{1}{4}$	$\frac{1}{4}$
$2\frac{1}{4}$ up to $3\frac{1}{2}$	$\frac{3}{8}$

An experienced mill inspector shall inspect the work after chipping operation to see that the defects have been completely removed and that the limitations specified above have not been exceeded. The inspector representing the purchaser shall be given full opportunity to make this same inspection. All welding shall be done by qualified welders using suitable coated welding rods. The welds shall be sound, the weld metal being thoroughly fused on all surfaces and edges, without undercutting or over-lap. Weld metal shall project at least  $\frac{1}{16}$  inch above the rolled surface after welding, and the projecting metal shall be removed by grinding or by chipping and grinding to make it flush with the rolled surface and produce a workmanlike finish. Chisel marks shall be removed, leaving a smooth surface.

## CAMBERING OF ROLLED BEAMS

The following information covers the limitations upon cold cambering of deep beams at the mill, as offered by the American Mills which produce wide flange sections.

Maximum length for cambering is 100 feet.

Maximum camber, measured at mid-length, and minimum length for given cambers, is shown in table below.

Section	Minimum Length for Given Camber								
	5" Camber	4½" Camber	4" Camber	3½" Camber	3" Camber	2½" Camber	2" Camber	1½" Camber	1" Camber
24" Wide Flange and Over.....	85'	75'	65'	55'	50'	45'	40'	35'	30'
21" Wide Flange 24" Standard.....	80'	70'	60'	50'	45'	40'	35'	30'	25'

Camber will approximate a simple regular curve from end to end (nearly) of beam, or between any two points on beam as specified. Reverse or other compound curves will not be undertaken. Camber shall be specified by the ordinate at mid-length of the portion specified to be curved. Ordinates at other points shall not be specified. The cambered ordinate may vary from that specified by ½ inch over, nothing under.

# GENERAL NOTATION

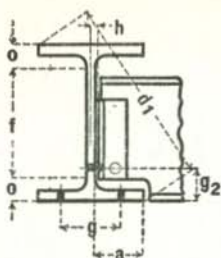

CB SECTION

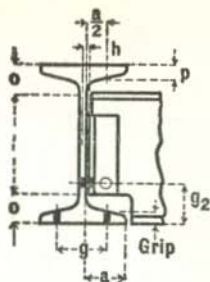

I-BEAM

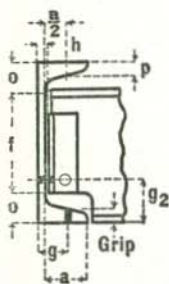

CHANNEL

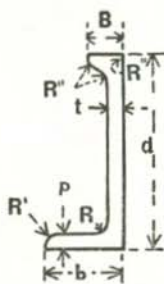

BULB ANGLE

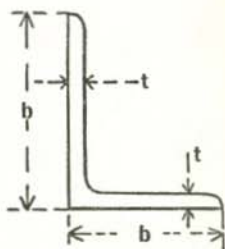

ANGLE

## DIMENSIONS

- a—Normal distance from near face of web to toe of flange, inches.
- B—Width of bulb, inches.
- b—Flange width, inches.
- d—Depth of section, inches.
- d<sub>1</sub>—Diagonal dimension, inches.
- f—Tangent distance on web between fillets, inches.
- g—Usual distance between gauge lines of flange, inches.
- g<sub>2</sub>—Distance from outside face of flange to nearest allowable hole on web, inches.
- h—Minimum distance from end of beam connection to center line of web, inches.
- o—Distance from point of tangent of fillet on web to outside face of flange, inches.
- p—Flange thickness, inches.
- R—Radius of fillet at root, inches.
- R', R''—Radius of roundings, inches.
- T—Thickness of bulb at root, inches.
- t—Web thickness, inches.
- t'—Thickness of bulb at toe, inches.

## PROPERTIES

- I—Moment of inertia about center of gravity, inches<sup>4</sup>.
- PI—Polar moment of inertia, inches<sup>4</sup>.
- r—Radius of gyration, inches.
- S—Section modulus, inches<sup>3</sup>.
- x, y—Distance from neutral axis to extreme fiber, inches.

Any deviation from the above notation is noted at the points of exception.

## REGULAR SHAPES

**S**TRUCTURAL SHAPES shown in this section, for which there is a popular and constant demand, may be secured promptly from frequent rollings. Designers should keep this in mind when making up their specification, to avoid unnecessary delay.



# WIDE FLANGE

## CB SECTIONS

1940

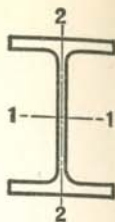

### PROPERTIES OF SECTIONS

District Rolled	Section Index and Nominal Size	Depth of Section In.	Wt. per Foot Lbs.	Area of Section In. <sup>2</sup>	Flange		Web Thickness In.	Axis 1-1			Axis 2-2		
					Width In.	Thick-ness In.		I In. <sup>4</sup>	S In. <sup>3</sup>	r In.	I In. <sup>4</sup>	S In. <sup>3</sup>	r In.
P. C.	36" WF	36.72	300	88.17	16.655	1.680	.945	20290.2	1105.1	15.17	1225.2	147.1	3.73
	CB 362	36.50	280	82.32	16.595	1.570	.885	18819.3	1031.2	15.12	1127.5	135.9	3.70
	36 x 16 1/2	36.24	260	76.56	16.555	1.440	.845	17233.8	951.1	15.00	1020.6	123.3	3.65
	R=1.02	36.12	250	73.49	16.525	1.380	.815	16465.9	911.7	14.97	969.6	117.4	3.63
		36.00	240	70.60	16.500	1.320	.790	15724.0	873.6	14.92	920.1	111.5	3.61
	35.88	230	67.73	16.475	1.260	.765	14988.4	835.5	14.88	870.9	105.7	3.59	
P. C.	36" WF	36.48	194	57.11	12.117	1.260	.770	12103.4	663.6	14.56	355.4	58.7	2.49
	CB 361	36.32	182	53.54	12.072	1.180	.725	11281.5	621.2	14.52	327.7	54.3	2.47
	36 x 12	36.16	170	49.98	12.027	1.100	.680	10470.0	579.1	14.47	300.6	50.0	2.45
	R=.80	36.00	160	47.09	12.000	1.020	.653	9738.8	541.0	14.38	275.4	45.9	2.42
		35.84	150	44.16	11.972	.940	.625	9012.1	502.9	14.29	250.4	41.8	2.38
P. C.	33" WF	33.50	240	70.52	15.865	1.400	.830	13585.1	811.1	13.88	874.3	110.2	3.52
	CB 332	33.25	220	64.73	15.810	1.275	.775	12312.1	740.6	13.79	782.4	99.0	3.48
	33 x 15 3/4	33.12	210	61.78	15.783	1.210	.748	11664.5	704.4	13.74	735.6	93.2	3.45
	R=.96	33.00	200	58.79	15.750	1.150	.715	11048.2	669.6	13.71	691.7	87.8	3.43
P. C.	33" WF	33.50	152	44.71	11.565	1.055	.635	8147.6	486.4	13.50	256.1	44.3	2.39
	CB 331	33.31	141	41.51	11.535	.960	.605	7442.2	446.8	13.39	229.7	39.8	2.35
	33 x 11 1/2	33.15	132	38.84	11.510	.880	.580	6856.8	413.7	13.29	207.8	36.1	2.31
	R=.75	33.00	125	36.78	11.500	.805	.570	6354.7	385.1	13.14	188.2	32.7	2.26
P. C.	30" WF	30.38	210	61.78	15.105	1.315	.775	9872.4	649.9	12.64	707.9	93.7	3.38
	CB 302	30.25	200	58.76	15.070	1.250	.740	9340.5	617.6	12.61	665.7	88.3	3.37
	30 x 15	30.12	190	55.90	15.040	1.185	.710	8825.9	586.1	12.57	624.6	83.1	3.34
	R=.91	30.00	180	52.89	15.000	1.125	.670	8328.2	555.2	12.55	585.6	78.1	3.33
		29.88	172	50.65	14.985	1.065	.655	7891.5	528.2	12.48	550.1	73.4	3.30
P. C.	30" WF	30.30	132	38.83	10.551	1.000	.615	5753.1	379.7	12.17	185.0	35.1	2.18
	CB 301	30.16	124	36.45	10.521	.930	.585	5347.1	354.6	12.11	169.7	32.3	2.16
	30 x 10 1/2	30.00	116	34.13	10.500	.850	.564	4919.1	327.9	12.00	153.2	29.2	2.12
	R=.70	29.82	108	31.77	10.484	.760	.548	4461.0	299.2	11.85	135.1	25.8	2.06

For key to symbols in first column, refer to page 3.



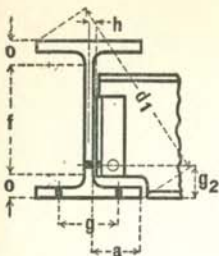

# WIDE FLANGE CB SECTIONS



## DIMENSIONS OF SECTIONS FOR DETAILING

Section Index and Nominal Depth	Weight per Foot	Depth of Section	Flange		Web		Distance					Usual Gage $\sigma$	
			Width	Thick-ness	Thick-ness	Half Thick-ness	$\alpha$	f	o	$d_1$	Min. $g_2$		Clear. h
36" WF CB 362 30 x 16 1/2 R = 1.02	300	36 3/4	16 5/8	1 1/16	1 5/16	1/2	7 7/8	31 1/8	2 13/16	40 3/8	4	3/16	5 1/2
	280	36 1/2	16 5/8	1 1/16	1 7/8	1/2	7 7/8	31 1/8	2 11/16	40 1/8	4	1/2	5 1/2
	260	36 1/4	16 1/2	1 7/16	1 7/8	1/2	7 7/8	31 1/8	2 9/16	39 7/8	3 3/4	1/2	5 1/2
	250	36 1/8	16 1/2	1 3/8	1 13/16	1/2	7 7/8	31 1/8	2 1/2	39 3/4	3 3/4	1/2	5 1/2
	240	36	16 1/2	1 5/16	1 13/16	1/2	7 7/8	31 1/8	2 1/16	39 5/8	3 3/4	1/2	5 1/2
230	35 7/8	16 1/2	1 1/4	1 3/4	3/8	7 7/8	31 1/8	2 3/8	39 1/2	3 1/2	7/16	5 1/2	
36" WF CB 361 36 x 12 R = .80	194	36 1/2	12 3/8	1 1/4	1 13/16	3/8	5 5/8	32 1/4	2 1/8	38 1/2	3 1/4	7/16	5 1/2
	182	36 3/8	12 3/8	1 3/16	1 3/4	3/8	5 5/8	32 1/4	2 1/16	38 3/8	3 3/4	7/16	5 1/2
	170	36 1/8	12	1 1/8	1 11/16	3/8	5 5/8	32 1/4	1 15/16	38 1/8	3 3/4	7/16	5 1/2
	160	36	12	1	1 11/16	5/16	5 5/8	32 1/4	1 7/8	38	3	3/8	5 1/2
	150	35 7/8	12	1 5/16	1 5/8	5/16	5 5/8	32 1/4	1 13/16	37 7/8	3	3/8	5 1/2
33" WF CB 332 33 x 15 3/4 R = .96	240	33 1/2	15 7/8	1 3/8	1 7/8	3/8	7 1/2	28 5/8	2 7/16	37 1/8	3 3/4	1/2	5 1/2
	220	33 1/4	15 3/4	1 1/4	1 13/16	3/8	7 1/2	28 5/8	2 5/16	36 7/8	3 1/2	7/16	5 1/2
	210	33 1/8	15 3/4	1 3/16	1 3/4	3/8	7 1/2	28 5/8	2 1/4	36 3/4	3 1/2	7/16	5 1/2
	200	33	15 3/4	1 1/8	1 3/4	3/8	7 1/2	28 5/8	2 3/16	36 5/8	3 1/2	7/16	5 1/2
33" WF CB 331 33 x 11 1/2 R = .75	152	33 1/2	11 5/8	1 1/16	1 5/8	5/16	5 1/2	29 3/4	1 7/8	35 1/2	3	3/8	5 1/2
	141	33 1/4	11 1/2	1 5/16	1 5/8	5/16	5 1/2	29 3/4	1 3/4	35 1/4	3	3/8	5 1/2
	132	33 1/8	11 1/2	1 7/8	1 5/8	5/16	5 1/2	29 3/4	1 11/16	35 1/8	3	3/8	5 1/2
	125	33	11 1/2	1 13/16	1 9/16	5/16	5 1/2	29 3/4	1 5/8	35	2 3/4	3/8	5 1/2
30" WF CB 302 30 x 15 R = .91	210	30 3/8	15 1/8	1 5/16	1 13/16	3/8	7 1/8	25 3/4	2 5/16	34	3 1/2	7/16	5 1/2
	200	30 1/4	15 5/8	1 1/4	1 3/4	3/8	7 1/8	25 3/4	2 1/4	33 7/8	3 1/2	7/16	5 1/2
	190	30 1/8	15	1 3/16	1 3/4	3/8	7 1/8	25 3/4	2 3/16	33 3/4	3 1/2	7/16	5 1/2
	180	30	15	1 1/8	1 11/16	3/8	7 1/8	25 3/4	2 1/8	33 5/8	3 1/4	7/16	5 1/2
	172	29 7/8	15	1 1/16	1 11/16	5/16	7 1/8	25 3/4	2 1/16	33 1/2	3 1/4	3/8	5 1/2
30" WF CB 301 30 x 10 1/2 R = .70	132	30 1/4	10 1/2	1	1 5/8	5/16	5	26 7/8	1 11/16	32 1/8	3	3/8	5 1/2
	124	30 1/8	10 1/2	1 5/16	1 5/8	5/16	5	26 7/8	1 5/8	31 7/8	3	3/8	5 1/2
	116	30	10 1/2	1 7/8	1 9/16	5/16	5	26 7/8	1 9/16	31 3/4	2 3/4	3/8	5 1/2
	108	29 7/8	10 1/2	1 3/4	1 9/16	5/16	5	26 7/8	1 1/2	31 5/8	2 3/4	3/8	5 1/2

Gages  $g_2$  are based on 1 1/4" edge distance (3/8" maximum rivet).

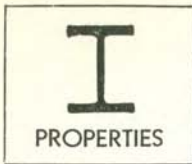

# WIDE FLANGE CB SECTIONS

1940

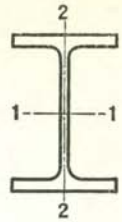

## PROPERTIES OF SECTIONS

District Rolled	Section Index and Nominal Size	Depth of Section In.	Weight per Foot Lbs.	Area of Section In. <sup>2</sup>	Flange		Web Thickness In.	Axis 1-1			Axis 2-2		
					Width In.	Thick-ness In.		I In. <sup>4</sup>	S In. <sup>3</sup>	r In.	I In. <sup>4</sup>	S In. <sup>3</sup>	r In.
P. C.	27" WF	27.31	177	52.10	14.090	1.190	.725	6728.6	492.8	11.36	518.9	73.7	3.16
	CB 272	27.12	163	47.93	14.035	1.095	.670	6141.5	452.9	11.32	468.7	66.8	3.13
	27 x 14	27.00	154	45.30	14.000	1.035	.635	5775.8	427.8	11.29	437.6	62.5	3.11
	R = .86	26.88	145	42.68	13.965	.975	.600	5414.3	402.9	11.26	406.9	58.3	3.09
P. C.	27" WF	27.28	114	33.53	10.070	.932	.570	4080.5	299.2	11.03	149.6	29.7	2.11
	CB 271	27.14	106	31.17	10.035	.862	.535	3761.2	277.2	10.98	136.1	27.1	2.09
	27 x 10	27.00	98	28.82	10.000	.792	.500	3446.5	255.3	10.94	122.9	24.6	2.07
	R = .64	26.84	91	26.77	9.983	.712	.483	3129.2	233.2	10.81	109.0	21.8	2.02
P. C.	24" WF	24.72	160	47.04	14.091	1.135	.656	5110.3	413.5	10.42	492.6	69.9	3.23
	CB 243	24.56	150	44.10	14.063	1.055	.628	4733.5	385.5	10.36	452.5	64.3	3.20
	24 x 14	24.41	140	41.16	14.029	.980	.594	4376.1	358.6	10.31	414.5	59.1	3.17
	R = .70	24.25	130	38.21	14.000	.900	.565	4009.5	330.7	10.24	375.2	53.6	3.13
P. C.	24" WF	24.31	120	35.29	12.088	.930	.556	3635.3	299.1	10.15	254.0	42.0	2.68
	CB 242	24.16	110	32.36	12.042	.855	.510	3315.0	274.4	10.12	229.1	38.0	2.66
	24 x 12	24.00	100	29.43	12.000	.775	.468	2987.3	248.9	10.08	203.5	33.9	2.63
	R = .70												
P. C.	24" WF	24.29	94	27.63	9.061	.872	.516	2683.0	220.9	9.85	102.2	22.6	1.92
	CB 241	24.16	87	25.58	9.025	.807	.480	2467.8	204.3	9.82	92.9	20.6	1.91
	24 x 9	24.00	80	23.54	9.000	.727	.455	2229.7	185.8	9.73	82.4	18.3	1.87
	R = .54	23.87	74	21.77	8.975	.662	.430	2033.8	170.4	9.67	73.8	16.5	1.84
P. C.	21" WF	21.46	142	41.76	13.132	1.095	.659	3403.1	317.2	9.03	385.9	58.8	3.04
	CB 213	21.31	132	38.81	13.087	1.020	.614	3141.6	294.8	9.00	353.8	54.1	3.02
	21 x 13	21.16	122	35.85	13.040	.945	.567	2883.2	272.5	8.97	322.1	49.4	3.00
	R = .65	21.00	112	32.93	13.000	.865	.527	2620.6	249.6	8.92	289.7	44.6	2.96
P. C.	21" WF	21.29	103	30.27	9.071	1.010	.608	2268.0	213.1	8.66	119.9	26.4	1.99
	CB 212	21.14	96	28.21	9.038	.935	.575	2088.9	197.6	8.60	109.3	24.2	1.97
	21 x 9	21.00	89	26.15	9.000	.865	.537	1919.2	182.8	8.57	99.4	22.1	1.95
	R = .65	20.86	82	24.10	8.962	.795	.499	1752.4	168.0	8.53	89.6	20.0	1.93
P. C.	21" WF	21.24	73	21.46	8.295	.740	.455	1600.3	150.7	8.64	66.2	16.0	1.76
	CB 211	21.13	68	20.02	8.270	.685	.430	1478.3	139.9	8.59	60.4	14.6	1.74
	21 x 8 1/4	21.00	63	18.52	8.250	.620	.410	1343.6	128.0	8.52	53.8	13.0	1.70
	R = .54	20.91	59	17.36	8.230	.575	.390	1246.8	119.3	8.47	49.2	12.0	1.68

For key to symbols in first column, refer to page 3.

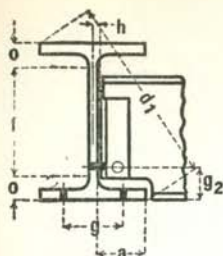

# WIDE FLANGE CB SECTIONS

## DIMENSIONS OF SECTIONS FOR DETAILING

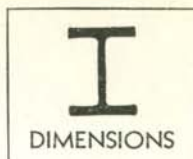

Section Index and Nominal Depth	Weight per Foot	Depth of Section	Flange		Web		Distance						Usual Gage g
			Width	Thick-ness	Thick-ness	Half Thick-ness	a	f	o	d <sub>1</sub>	Min. g <sub>2</sub>	Clear. h	
27" WF	177	27 3/4	14 1/8	1 3/16	3/4	3/8	6 3/4	23	2 1/8	30 3/4	3 1/4	7/16	5 1/2
CB 272	163	27 7/8	14	1 1/8	1 1/16	3/8	6 3/4	23	2 1/16	30 5/8	3 1/4	7/16	5 1/2
27 x 14	154	27	14	1 1/16	5/8	5/16	6 3/4	23	2	30 1/2	3 1/4	3/8	5 1/2
R = .86	145	26 7/8	14	1	5/8	5/16	6 3/4	23	1 15/16	30 3/8	3 1/4	3/8	5 1/2
27" WF	114	27 1/4	10 1/8	1 5/16	9/16	5/16	4 3/4	24	1 5/8	29 1/8	2 3/4	3/8	5 1/2
CB 271	106	27 3/8	10	7/8	9/16	5/16	4 3/4	24	1 9/16	29	2 3/4	3/8	5 1/2
27 x 10	98	27	10	1 3/16	1/2	1/4	4 3/4	24	1 1/2	28 7/8	2 3/4	5/16	5 1/2
R = .64	91	26 7/8	10	1 1/16	1/2	1/4	4 3/4	24	1 7/16	28 3/4	2 3/4	5/16	5 1/2
24" WF	160	24 3/4	14 1/8	1 1/8	1 1/16	5/16	6 3/4	20 3/4	2	28 1/2	3 1/4	3/8	5 1/2
CB 243	150	24 1/2	14 1/8	1 1/16	5/8	5/16	6 3/4	20 3/4	1 7/8	28 1/4	3 1/4	3/8	5 1/2
24 x 14	140	24 3/8	14	1	5/8	5/16	6 3/4	20 3/4	1 13/16	28 1/8	3	3/8	5 1/2
R = .70	130	24 1/4	14	7/8	9/16	5/16	6 3/4	20 3/4	1 3/4	28	3	3/8	5 1/2
24" WF	120	24 1/4	12 1/8	1 5/16	9/16	5/16	5 3/4	20 7/8	1 11/16	27 1/8	3	3/8	5 1/2
CB 242	110	24 3/8	12	7/8	1/2	1/4	5 3/4	20 7/8	1 5/8	27	2 3/4	5/16	5 1/2
24 x 12	100	24	12	3/4	1/2	1/4	5 3/4	20 7/8	1 9/16	26 7/8	2 3/4	5/16	5 1/2
R = .70													
24" WF	94	24 1/4	9	7/8	9/16	1/4	4 1/4	21 3/8	1 7/16	25 7/8	2 3/4	5/16	5 1/2
CB 241	87	24 3/8	9	1 3/16	1/2	1/4	4 1/4	21 3/8	1 3/8	25 3/4	2 3/4	5/16	5 1/2
24 x 9	80	24	9	3/4	1/2	1/4	4 1/4	21 3/8	1 5/16	25 5/8	2 1/2	5/16	5 1/2
R = .54	74	23 7/8	9	1 1/16	7/16	1/4	4 1/4	21 3/8	1 1/4	25 1/2	2 1/2	5/16	5 1/2
21" WF	142	21 1/2	13 1/8	1 1/8	1 1/16	3/8	6 1/4	17 3/4	1 7/8	25 1/4	3	7/16	5 1/2
CB 213	132	21 1/4	13 3/8	1	5/8	5/16	6 1/4	17 3/4	1 3/4	25	3	3/8	5 1/2
21 x 13	122	21 3/8	13	1 5/16	9/16	5/16	6 1/4	17 3/4	1 11/16	24 7/8	3	3/8	5 1/2
R = .65	112	21	13	7/8	9/16	1/4	6 1/4	17 3/4	1 5/8	24 3/4	3	5/16	5 1/2
21" WF	103	21 1/4	9 1/8	1	5/8	5/16	4 1/4	18	1 5/8	23 3/8	3	3/8	5 1/2
CB 212	96	21 3/8	9	1 5/16	9/16	5/16	4 1/4	18	1 9/16	23	2 3/4	3/8	5 1/2
21 x 9	89	21	9	7/8	9/16	5/16	4 1/4	18	1 1/2	22 7/8	2 3/4	3/8	5 1/2
R = .65	82	20 7/8	9	1 3/16	1/2	1/4	4 1/4	18	1 7/16	22 3/4	2 3/4	5/16	5 1/2
21" WF	73	21 1/4	8 1/4	3/4	1/2	1/4	4	18 5/8	1 5/16	22 7/8	2 1/2	5/16	5 1/2
CB 211	68	21 3/8	8 3/4	1 1/16	7/16	1/4	4	18 5/8	1 1/4	22 3/4	2 1/2	5/16	5 1/2
21 x 8 1/4	63	21	8 1/4	5/8	7/16	1/4	4	18 5/8	1 3/16	22 5/8	2 1/2	5/16	5 1/2
R = .54	59	20 7/8	8 1/4	9/16	3/8	5/16	4	18 5/8	1 1/8	22 1/2	2 1/2	1/4	5 1/2

Gages g<sub>2</sub> are based on 1/4" edge distance (1/8" maximum rivet).



WIDE FLANGE

CB SECTIONS 1940

PROPERTIES OF SECTIONS

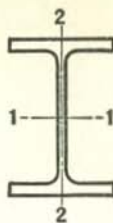

District Rolled	Section Index and Nominal Size	Depth of Section In.	Weight per Foot Lbs.	Area of Section In. <sup>2</sup>	Flange			Axis 1-1			Axis 2-2		
					Width In.	Thickness In.	Web Thickness In.	I In. <sup>4</sup>	S In. <sup>3</sup>	r In.	I In. <sup>4</sup>	S In. <sup>3</sup>	r In.
P. C.	18" WF	18.64	124	36.45	11.889	1.071	.651	2227.1	239.0	7.82	281.9	47.4	2.78
	CB 183	18.48	114	33.51	11.833	.991	.595	2033.8	220.1	7.79	255.6	43.2	2.76
	18 x 11 3/4	18.32	105	30.86	11.792	.911	.554	1852.5	202.2	7.75	231.0	39.2	2.73
	R = .60	18.16	96	28.22	11.750	.831	.512	1674.7	184.4	7.70	206.8	35.2	2.71
P. C.	18" WF	18.32	85	24.97	8.838	.911	.526	1429.9	156.1	7.57	99.4	22.5	2.00
	CB 182	18.16	77	22.63	8.787	.831	.475	1286.8	141.7	7.54	88.6	20.2	1.98
	18 x 8 3/4	18.00	70	20.56	8.750	.751	.438	1153.9	128.2	7.49	78.5	17.9	1.95
	R = .60	17.87	64	18.80	8.715	.686	.403	1045.8	117.0	7.46	70.3	16.1	1.93
P. C.	18" WF	18.12	55	16.19	7.532	.630	.390	889.9	98.2	7.41	42.0	11.1	1.61
	CB 181	18.00	50	14.71	7.500	.570	.358	800.6	89.0	7.38	37.2	9.9	1.59
	18 x 7 1/2	17.90	47	13.81	7.492	.520	.350	736.4	82.3	7.30	33.5	9.0	1.56
P. C.	16" WF	16.64	114	33.51	11.629	1.035	.631	1642.6	197.4	7.00	254.6	43.8	2.76
	CB 163	16.48	105	30.87	11.582	.955	.584	1497.5	181.7	6.96	230.7	39.8	2.73
	16x11 1/2	16.32	96	28.22	11.533	.875	.535	1355.1	166.1	6.93	207.2	35.9	2.71
	R = .60	16.16	88	25.87	11.502	.795	.504	1222.6	151.3	6.87	185.2	32.2	2.67
P. C.	16" WF	16.32	78	22.92	8.586	.875	.529	1042.6	127.8	6.74	87.5	20.4	1.95
	CB 162	16.16	71	20.86	8.543	.795	.486	936.9	115.9	6.70	77.9	18.2	1.93
	16x8 1/2	16.00	64	18.80	8.500	.715	.443	833.8	104.2	6.66	68.4	16.1	1.91
	R = .60	15.86	58	17.04	8.464	.645	.407	746.4	94.1	6.62	60.5	14.3	1.88
P.C.	16" WF	16.25	50	14.70	7.073	.628	.380	655.4	80.7	6.68	34.8	9.8	1.54
	CB 161	16.12	45	13.24	7.039	.563	.346	583.3	72.4	6.64	30.5	8.7	1.52
	16 x 7	16.00	40	11.77	7.000	.503	.307	515.5	64.4	6.62	26.5	7.6	1.50
	R = .43	15.85	36	10.59	6.992	.428	.299	446.3	56.3	6.49	22.1	6.3	1.45

For key to symbols in first column, refer to page 3.

# WIDE FLANGE CB SECTIONS

## DIMENSIONS OF SECTIONS FOR DETAILING

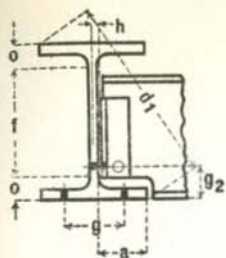
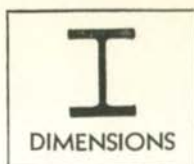

Section Index and Nominal Depth	Weight per Foot	Depth of Section	Flange		Web		Distance					Usual Gage $\sigma$	
			Width	Thick-ness	Thick-ness	Half Thick-ness	$a$	$f$	$o$	$d_1$	Min. $\sigma_2$		Clear. $h$
	Lbs.	In.	In.	In.	In.	In.	In.	In.	In.	In.	In.	In.	In.
18" WF	124	18 $\frac{5}{8}$	11 $\frac{7}{8}$	1 $\frac{1}{16}$	1 $\frac{1}{16}$	5 $\frac{1}{16}$	5 $\frac{5}{8}$	15 $\frac{1}{8}$	13 $\frac{3}{4}$	22 $\frac{1}{8}$	3	3 $\frac{3}{8}$	5 $\frac{1}{2}$
CB 183	114	18 $\frac{1}{2}$	11 $\frac{7}{8}$	1	1	5 $\frac{5}{8}$	5 $\frac{5}{8}$	15 $\frac{1}{8}$	11 $\frac{11}{16}$	22	3	3 $\frac{3}{8}$	5 $\frac{1}{2}$
18 x 11 $\frac{3}{4}$	105	18 $\frac{3}{8}$	11 $\frac{3}{4}$	1 $\frac{5}{16}$	1 $\frac{5}{16}$	5 $\frac{1}{16}$	5 $\frac{5}{8}$	15 $\frac{1}{8}$	15 $\frac{5}{8}$	21 $\frac{7}{8}$	2 $\frac{3}{4}$	3 $\frac{3}{8}$	5 $\frac{1}{2}$
R = .60	96	18 $\frac{1}{8}$	11 $\frac{3}{4}$	1 $\frac{3}{16}$	1 $\frac{1}{2}$	1 $\frac{1}{4}$	5 $\frac{5}{8}$	15 $\frac{1}{8}$	13 $\frac{1}{2}$	21 $\frac{3}{4}$	2 $\frac{3}{4}$	3 $\frac{5}{16}$	5 $\frac{1}{2}$
18" WF	85	18 $\frac{3}{8}$	8 $\frac{7}{8}$	1 $\frac{5}{16}$	1 $\frac{5}{16}$	1 $\frac{1}{4}$	4 $\frac{1}{8}$	15 $\frac{3}{8}$	11 $\frac{1}{2}$	20 $\frac{3}{8}$	2 $\frac{3}{4}$	3 $\frac{5}{16}$	5 $\frac{1}{2}$
CB 182	77	18 $\frac{1}{8}$	8 $\frac{3}{4}$	1 $\frac{3}{16}$	1 $\frac{1}{2}$	1 $\frac{1}{4}$	4 $\frac{1}{8}$	15 $\frac{3}{8}$	13 $\frac{3}{8}$	20 $\frac{1}{8}$	2 $\frac{3}{4}$	3 $\frac{5}{16}$	5 $\frac{1}{2}$
18 x 8 $\frac{3}{4}$	70	18	8 $\frac{3}{4}$	1 $\frac{3}{4}$	1 $\frac{1}{16}$	1 $\frac{1}{4}$	4 $\frac{1}{8}$	15 $\frac{3}{8}$	13 $\frac{1}{16}$	20	2 $\frac{3}{4}$	3 $\frac{5}{16}$	5 $\frac{1}{2}$
R = .60	64	17 $\frac{7}{8}$	8 $\frac{3}{4}$	1 $\frac{1}{16}$	1 $\frac{1}{16}$	1 $\frac{1}{16}$	4 $\frac{1}{8}$	15 $\frac{3}{8}$	13 $\frac{1}{4}$	20	2 $\frac{1}{2}$	3 $\frac{1}{4}$	5 $\frac{1}{2}$
18" WF	55	18 $\frac{1}{8}$	7 $\frac{1}{2}$	1 $\frac{5}{8}$	1 $\frac{3}{8}$	1 $\frac{3}{16}$	3 $\frac{5}{8}$	15 $\frac{7}{8}$	11 $\frac{1}{8}$	19 $\frac{5}{8}$	2 $\frac{1}{2}$	3 $\frac{1}{4}$	3 $\frac{1}{2}$
CB 181	50	18	7 $\frac{1}{2}$	1 $\frac{9}{16}$	1 $\frac{3}{8}$	1 $\frac{3}{16}$	3 $\frac{5}{8}$	15 $\frac{7}{8}$	11 $\frac{1}{16}$	19 $\frac{1}{2}$	2 $\frac{1}{4}$	3 $\frac{1}{4}$	3 $\frac{1}{2}$
18 x 7 $\frac{1}{2}$	47	17 $\frac{7}{8}$	7 $\frac{1}{2}$	1 $\frac{1}{2}$	1 $\frac{3}{8}$	1 $\frac{3}{16}$	3 $\frac{5}{8}$	15 $\frac{7}{8}$	1	19 $\frac{3}{8}$	2 $\frac{1}{4}$	3 $\frac{1}{4}$	3 $\frac{1}{2}$
R = .43													
16" WF	114	16 $\frac{5}{8}$	11 $\frac{5}{8}$	1 $\frac{1}{16}$	1 $\frac{5}{8}$	1 $\frac{5}{16}$	5 $\frac{1}{2}$	13 $\frac{1}{8}$	13 $\frac{3}{4}$	20 $\frac{3}{8}$	3	3 $\frac{3}{8}$	5 $\frac{1}{2}$
CB 163	105	16 $\frac{1}{2}$	11 $\frac{5}{8}$	1 $\frac{3}{16}$	1 $\frac{5}{8}$	1 $\frac{5}{16}$	5 $\frac{1}{2}$	13 $\frac{1}{8}$	11 $\frac{11}{16}$	20 $\frac{1}{4}$	3	3 $\frac{3}{8}$	5 $\frac{1}{2}$
16 x 11 $\frac{1}{2}$	96	16 $\frac{3}{8}$	11 $\frac{1}{2}$	1 $\frac{3}{8}$	1 $\frac{9}{16}$	1 $\frac{5}{16}$	5 $\frac{1}{2}$	13 $\frac{1}{8}$	13 $\frac{5}{8}$	20	2 $\frac{3}{4}$	3 $\frac{3}{8}$	5 $\frac{1}{2}$
R = .60	88	16 $\frac{1}{8}$	11 $\frac{1}{2}$	1 $\frac{3}{16}$	1 $\frac{1}{2}$	1 $\frac{1}{4}$	5 $\frac{1}{2}$	13 $\frac{1}{8}$	11 $\frac{1}{2}$	19 $\frac{7}{8}$	2 $\frac{3}{4}$	3 $\frac{5}{16}$	5 $\frac{1}{2}$
16" WF	78	16 $\frac{3}{8}$	8 $\frac{5}{8}$	1 $\frac{7}{8}$	1 $\frac{9}{16}$	1 $\frac{1}{4}$	4	13 $\frac{3}{8}$	11 $\frac{1}{2}$	18 $\frac{1}{2}$	2 $\frac{3}{4}$	3 $\frac{5}{16}$	5 $\frac{1}{2}$
CB 162	71	16 $\frac{1}{8}$	8 $\frac{1}{2}$	1 $\frac{3}{16}$	1 $\frac{1}{2}$	1 $\frac{1}{4}$	4	13 $\frac{3}{8}$	13 $\frac{3}{8}$	18 $\frac{1}{4}$	2 $\frac{3}{4}$	3 $\frac{5}{16}$	5 $\frac{1}{2}$
16 x 8 $\frac{1}{2}$	64	16	8 $\frac{1}{2}$	1 $\frac{11}{16}$	1 $\frac{1}{16}$	1 $\frac{3}{4}$	4	13 $\frac{3}{8}$	13 $\frac{1}{16}$	18 $\frac{1}{8}$	2 $\frac{1}{2}$	3 $\frac{5}{16}$	5 $\frac{1}{2}$
R = .60	58	15 $\frac{7}{8}$	8 $\frac{1}{2}$	1 $\frac{5}{8}$	1 $\frac{1}{16}$	1 $\frac{1}{4}$	4	13 $\frac{3}{8}$	13 $\frac{1}{4}$	18	2 $\frac{1}{2}$	3 $\frac{5}{16}$	5 $\frac{1}{2}$
16" WF	50	16 $\frac{1}{4}$	7 $\frac{3}{8}$	1 $\frac{5}{8}$	1 $\frac{3}{8}$	1 $\frac{3}{16}$	3 $\frac{3}{8}$	14	11 $\frac{1}{8}$	17 $\frac{3}{4}$	2 $\frac{1}{2}$	3 $\frac{1}{4}$	3 $\frac{1}{2}$
CB 161	45	16 $\frac{1}{8}$	7	1 $\frac{9}{16}$	1 $\frac{3}{8}$	1 $\frac{3}{16}$	3 $\frac{3}{8}$	14	11 $\frac{1}{16}$	17 $\frac{5}{8}$	2 $\frac{1}{4}$	3 $\frac{1}{4}$	3 $\frac{1}{2}$
16 x 7	40	16	7	1 $\frac{1}{2}$	1 $\frac{5}{16}$	1 $\frac{3}{16}$	3 $\frac{3}{8}$	14	1	17 $\frac{1}{2}$	2 $\frac{1}{4}$	3 $\frac{1}{4}$	3 $\frac{1}{2}$
R = .43	36	15 $\frac{7}{8}$	7	1 $\frac{1}{16}$	1 $\frac{5}{16}$	1 $\frac{3}{16}$	3 $\frac{3}{8}$	14	1 $\frac{15}{16}$	17 $\frac{3}{8}$	2 $\frac{1}{4}$	3 $\frac{1}{4}$	3 $\frac{1}{2}$

Gages  $g_2$  are based on 1 $\frac{1}{4}$ " edge distance ( $\frac{7}{8}$ " maximum rivet).

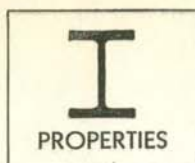

WIDE FLANGE  
CB SECTIONS  
PROPERTIES OF SECTIONS

1940

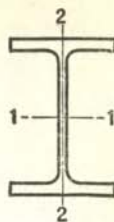

District Rolled	Section Index and Nominal Size	Depth of Section In. <sup>2</sup>	Weight per Foot Lbs.	Area of Section In. <sup>2</sup>	Flange		Web Thickness In.	Axis 1-1			Axis 2-2		
					Width In.	Thick-ness In.		I In. <sup>4</sup>	S In. <sup>3</sup>	r In.	I In. <sup>4</sup>	S In. <sup>3</sup>	r In.
P. C.	14" WF CB 146 14 x 16 R = .60	18.69	426	125.25	16.695	3.033	1.875	6610.3	707.4	7.26	2359.5	282.7	4.34
		18.50	412	121.15	16.645	2.938	1.825	6309.7	682.1	7.22	2264.9	272.1	4.32
		18.31	398	116.98	16.590	2.843	1.770	6013.7	656.9	7.17	2169.7	261.6	4.31
		18.12	384	112.93	16.540	2.748	1.720	5727.5	632.2	7.12	2078.1	251.3	4.29
		17.94	370	108.78	16.475	2.658	1.655	5454.2	608.1	7.08	1986.0	241.1	4.27
		17.75	356	104.68	16.420	2.563	1.600	5179.4	583.6	7.03	1895.7	230.9	4.26
		17.56	342	100.59	16.365	2.468	1.545	4911.5	559.4	6.99	1806.9	220.8	4.24
		17.38	328	96.43	16.295	2.378	1.475	4656.1	535.8	6.95	1718.5	210.9	4.22
		17.19	314	92.30	16.235	2.283	1.415	4399.4	511.9	6.90	1631.4	201.0	4.20
		17.00	300	88.20	16.175	2.188	1.355	4149.5	488.2	6.86	1546.0	191.2	4.19
		16.81	287	84.37	16.130	2.093	1.310	3912.1	465.5	6.81	1466.5	181.8	4.17
		16.62	273	80.22	16.065	1.998	1.245	3673.2	442.0	6.77	1382.9	172.2	4.15
		16.50	264	77.63	16.025	1.938	1.205	3526.0	427.4	6.74	1331.2	166.1	4.14
		16.37	255	74.98	15.990	1.873	1.170	3372.6	412.0	6.71	1278.1	159.9	4.13
		16.25	246	72.33	15.945	1.813	1.125	3228.9	397.4	6.68	1226.6	153.9	4.12
		16.12	237	69.69	15.910	1.748	1.090	3080.9	382.2	6.65	1174.8	147.7	4.11
		16.00	228	67.06	15.865	1.688	1.045	2942.4	367.8	6.62	1124.8	141.8	4.10
		15.87	219	64.36	15.825	1.623	1.005	2798.2	352.6	6.59	1073.2	135.6	4.08
		15.75	211	62.07	15.800	1.563	.980	2671.4	339.2	6.56	1028.6	130.2	4.07
		15.63	202	59.39	15.750	1.503	.930	2538.8	324.9	6.54	979.7	124.4	4.06
15.50	193	56.73	15.710	1.438	.890	2402.4	310.0	6.51	930.1	118.4	4.05		
15.38	184	54.07	15.660	1.378	.840	2274.8	295.8	6.49	882.7	112.7	4.04		
15.25	176	51.73	15.640	1.313	.820	2149.6	281.9	6.45	837.9	107.1	4.02		
15.12	167	49.09	15.600	1.248	.780	2020.8	267.3	6.42	790.2	101.3	4.01		
15.00	158	46.47	15.550	1.188	.730	1900.6	253.4	6.40	745.0	95.8	4.00		
14.88	150	44.08	15.515	1.128	.695	1786.9	240.2	6.37	702.5	90.6	3.99		
14.75	142	41.85	15.500	1.063	.680	1672.2	226.7	6.32	660.1	85.2	3.97		
14.61	*320	94.12	16.710	2.093	1.890	4141.7	492.8	6.63	1635.1	195.7	4.17		
P. C.	14" WF CB 145 14 x 14 1/2 R = .60	14.75	136	39.98	14.740	1.063	.660	1593.0	216.0	6.31	567.7	77.0	3.77
		14.62	127	37.33	14.690	.998	.610	1476.7	202.0	6.29	527.6	71.8	3.76
		14.50	119	34.99	14.650	.938	.570	1373.1	189.4	6.26	491.8	67.1	3.75
		14.37	111	32.65	14.620	.873	.540	1266.5	176.3	6.23	454.9	62.2	3.73
		14.25	103	30.26	14.575	.813	.495	1165.8	163.6	6.21	419.7	57.6	3.72
		14.12	95	27.94	14.545	.748	.465	1063.5	150.6	6.17	383.7	52.8	3.71
		14.00	87	25.56	14.500	.688	.420	966.9	138.1	6.15	349.7	48.2	3.70

\*Column Core Section.  
For key to symbols in first column, refer to page 3.

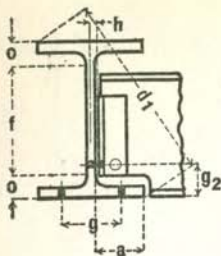

# WIDE FLANGE CB SECTIONS

## DIMENSIONS OF SECTIONS FOR DETAILING

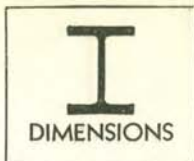

Section Index and Nominal Depth	Weight per Foot	Depth of Section	Flange		Web		Distance					Usual Gage g	
			Width	Thick-ness	Thick-ness	Half Thick-ness	a	f	o	d <sub>1</sub>	Min. g <sub>2</sub>		Clear. h
	Lbs.	In.	In.	In.	In.	In.	In.	In.	In.	In.	In.	In.	In.
	426	18 <sup>3</sup> / <sub>4</sub>	16 <sup>3</sup> / <sub>4</sub>	3 <sup>1</sup> / <sub>16</sub>	1 <sup>7</sup> / <sub>8</sub>	1 <sup>5</sup> / <sub>16</sub>	7 <sup>3</sup> / <sub>8</sub>	11 <sup>3</sup> / <sub>8</sub>	3 <sup>5</sup> / <sub>8</sub>	25 <sup>1</sup> / <sub>8</sub>	5	1	
	412	18 <sup>1</sup> / <sub>2</sub>	16 <sup>5</sup> / <sub>8</sub>	2 <sup>15</sup> / <sub>16</sub>	1 <sup>13</sup> / <sub>16</sub>	1 <sup>9</sup> / <sub>16</sub>	7 <sup>3</sup> / <sub>8</sub>	11 <sup>3</sup> / <sub>8</sub>	3 <sup>9</sup> / <sub>16</sub>	24 <sup>7</sup> / <sub>8</sub>	4 <sup>3</sup> / <sub>4</sub>	1	
	398	18 <sup>1</sup> / <sub>4</sub>	16 <sup>5</sup> / <sub>8</sub>	2 <sup>13</sup> / <sub>16</sub>	1 <sup>13</sup> / <sub>16</sub>	7 <sup>7</sup> / <sub>8</sub>	7 <sup>3</sup> / <sub>8</sub>	11 <sup>3</sup> / <sub>8</sub>	3 <sup>7</sup> / <sub>16</sub>	24 <sup>3</sup> / <sub>4</sub>	4 <sup>3</sup> / <sub>4</sub>	1 <sup>5</sup> / <sub>16</sub>	
	384	18 <sup>1</sup> / <sub>8</sub>	16 <sup>1</sup> / <sub>2</sub>	2 <sup>3</sup> / <sub>4</sub>	1 <sup>3</sup> / <sub>4</sub>	7 <sup>5</sup> / <sub>8</sub>	7 <sup>3</sup> / <sub>8</sub>	11 <sup>3</sup> / <sub>8</sub>	3 <sup>3</sup> / <sub>8</sub>	24 <sup>5</sup> / <sub>8</sub>	4 <sup>3</sup> / <sub>4</sub>	1 <sup>5</sup> / <sub>16</sub>	
	370	18	16 <sup>1</sup> / <sub>2</sub>	2 <sup>1</sup> / <sub>16</sub>	1 <sup>11</sup> / <sub>16</sub>	1 <sup>13</sup> / <sub>16</sub>	7 <sup>3</sup> / <sub>8</sub>	11 <sup>3</sup> / <sub>8</sub>	3 <sup>1</sup> / <sub>4</sub>	24 <sup>3</sup> / <sub>8</sub>	4 <sup>1</sup> / <sub>2</sub>	7 <sup>7</sup> / <sub>8</sub>	
	356	17 <sup>3</sup> / <sub>4</sub>	16 <sup>5</sup> / <sub>8</sub>	2 <sup>9</sup> / <sub>16</sub>	1 <sup>5</sup> / <sub>8</sub>	1 <sup>13</sup> / <sub>16</sub>	7 <sup>3</sup> / <sub>8</sub>	11 <sup>3</sup> / <sub>8</sub>	3 <sup>9</sup> / <sub>16</sub>	24 <sup>1</sup> / <sub>4</sub>	4 <sup>1</sup> / <sub>2</sub>	7 <sup>7</sup> / <sub>8</sub>	
	342	17 <sup>1</sup> / <sub>2</sub>	16 <sup>3</sup> / <sub>8</sub>	2 <sup>7</sup> / <sub>16</sub>	1 <sup>9</sup> / <sub>16</sub>	1 <sup>13</sup> / <sub>16</sub>	7 <sup>3</sup> / <sub>8</sub>	11 <sup>3</sup> / <sub>8</sub>	3 <sup>1</sup> / <sub>16</sub>	24	4 <sup>1</sup> / <sub>4</sub>	7 <sup>7</sup> / <sub>8</sub>	
	328	17 <sup>3</sup> / <sub>8</sub>	16 <sup>1</sup> / <sub>4</sub>	2 <sup>5</sup> / <sub>8</sub>	1 <sup>1</sup> / <sub>2</sub>	3 <sup>4</sup> / <sub>8</sub>	7 <sup>3</sup> / <sub>8</sub>	11 <sup>3</sup> / <sub>8</sub>	3	23 <sup>7</sup> / <sub>8</sub>	4 <sup>1</sup> / <sub>4</sub>	1 <sup>13</sup> / <sub>16</sub>	
	314	17 <sup>1</sup> / <sub>4</sub>	16 <sup>1</sup> / <sub>4</sub>	2 <sup>5</sup> / <sub>16</sub>	1 <sup>7</sup> / <sub>16</sub>	3 <sup>4</sup> / <sub>8</sub>	7 <sup>3</sup> / <sub>8</sub>	11 <sup>3</sup> / <sub>8</sub>	2 <sup>7</sup> / <sub>8</sub>	23 <sup>3</sup> / <sub>4</sub>	4 <sup>1</sup> / <sub>4</sub>	1 <sup>13</sup> / <sub>16</sub>	
	300	17	16 <sup>1</sup> / <sub>2</sub>	2 <sup>9</sup> / <sub>16</sub>	1 <sup>3</sup> / <sub>8</sub>	1 <sup>11</sup> / <sub>16</sub>	7 <sup>3</sup> / <sub>8</sub>	11 <sup>3</sup> / <sub>8</sub>	2 <sup>13</sup> / <sub>16</sub>	23 <sup>1</sup> / <sub>2</sub>	4	3 <sup>4</sup> / <sub>8</sub>	
	287	16 <sup>3</sup> / <sub>4</sub>	16 <sup>1</sup> / <sub>8</sub>	2 <sup>1</sup> / <sub>16</sub>	1 <sup>5</sup> / <sub>16</sub>	1 <sup>11</sup> / <sub>16</sub>	7 <sup>3</sup> / <sub>8</sub>	11 <sup>3</sup> / <sub>8</sub>	2 <sup>11</sup> / <sub>16</sub>	23 <sup>3</sup> / <sub>8</sub>	4	3 <sup>4</sup> / <sub>8</sub>	
	273	16 <sup>5</sup> / <sub>8</sub>	16 <sup>1</sup> / <sub>8</sub>	2	1 <sup>1</sup> / <sub>4</sub>	5 <sup>8</sup> / <sub>8</sub>	7 <sup>3</sup> / <sub>8</sub>	11 <sup>3</sup> / <sub>8</sub>	2 <sup>5</sup> / <sub>8</sub>	23 <sup>1</sup> / <sub>8</sub>	4	1 <sup>11</sup> / <sub>16</sub>	
14" WF	264	16 <sup>1</sup> / <sub>2</sub>	16	1 <sup>15</sup> / <sub>16</sub>	1 <sup>1</sup> / <sub>4</sub>	5 <sup>8</sup> / <sub>8</sub>	7 <sup>3</sup> / <sub>8</sub>	11 <sup>3</sup> / <sub>8</sub>	2 <sup>9</sup> / <sub>16</sub>	23	3 <sup>3</sup> / <sub>4</sub>	1 <sup>11</sup> / <sub>16</sub>	
CB 146	255	16 <sup>3</sup> / <sub>8</sub>	16	1 <sup>7</sup> / <sub>8</sub>	1 <sup>13</sup> / <sub>16</sub>	5 <sup>8</sup> / <sub>8</sub>	7 <sup>3</sup> / <sub>8</sub>	11 <sup>3</sup> / <sub>8</sub>	2 <sup>1</sup> / <sub>2</sub>	23	3 <sup>3</sup> / <sub>4</sub>	1 <sup>11</sup> / <sub>16</sub>	
14 x 16	246	16 <sup>1</sup> / <sub>4</sub>	16	1 <sup>13</sup> / <sub>16</sub>	1 <sup>1</sup> / <sub>8</sub>	9 <sup>16</sup> / <sub>16</sub>	7 <sup>3</sup> / <sub>8</sub>	11 <sup>3</sup> / <sub>8</sub>	2 <sup>7</sup> / <sub>16</sub>	22 <sup>7</sup> / <sub>8</sub>	3 <sup>3</sup> / <sub>4</sub>	5 <sup>8</sup> / <sub>8</sub>	
R = .60	237	16 <sup>1</sup> / <sub>8</sub>	15 <sup>7</sup> / <sub>8</sub>	1 <sup>3</sup> / <sub>4</sub>	1 <sup>1</sup> / <sub>8</sub>	9 <sup>16</sup> / <sub>16</sub>	7 <sup>3</sup> / <sub>8</sub>	11 <sup>3</sup> / <sub>8</sub>	2 <sup>5</sup> / <sub>8</sub>	22 <sup>3</sup> / <sub>4</sub>	3 <sup>3</sup> / <sub>4</sub>	5 <sup>8</sup> / <sub>8</sub>	
	228	16	15 <sup>7</sup> / <sub>8</sub>	1 <sup>11</sup> / <sub>16</sub>	1 <sup>1</sup> / <sub>16</sub>	9 <sup>16</sup> / <sub>16</sub>	7 <sup>3</sup> / <sub>8</sub>	11 <sup>3</sup> / <sub>8</sub>	2 <sup>5</sup> / <sub>16</sub>	22 <sup>5</sup> / <sub>8</sub>	3 <sup>1</sup> / <sub>2</sub>	5 <sup>8</sup> / <sub>8</sub>	
	219	15 <sup>7</sup> / <sub>8</sub>	15 <sup>7</sup> / <sub>8</sub>	1 <sup>9</sup> / <sub>8</sub>	1	1 <sup>1</sup> / <sub>2</sub>	7 <sup>3</sup> / <sub>8</sub>	11 <sup>3</sup> / <sub>8</sub>	2 <sup>1</sup> / <sub>4</sub>	22 <sup>1</sup> / <sub>2</sub>	3 <sup>1</sup> / <sub>2</sub>	9 <sup>16</sup> / <sub>16</sub>	
	211	15 <sup>3</sup> / <sub>4</sub>	15 <sup>3</sup> / <sub>4</sub>	1 <sup>9</sup> / <sub>16</sub>	1	1 <sup>1</sup> / <sub>2</sub>	7 <sup>3</sup> / <sub>8</sub>	11 <sup>3</sup> / <sub>8</sub>	2 <sup>9</sup> / <sub>16</sub>	22 <sup>3</sup> / <sub>8</sub>	3 <sup>1</sup> / <sub>2</sub>	9 <sup>16</sup> / <sub>16</sub>	
	202	15 <sup>5</sup> / <sub>8</sub>	15 <sup>3</sup> / <sub>4</sub>	1 <sup>1</sup> / <sub>2</sub>	1 <sup>15</sup> / <sub>16</sub>	1 <sup>1</sup> / <sub>2</sub>	7 <sup>3</sup> / <sub>8</sub>	11 <sup>3</sup> / <sub>8</sub>	2 <sup>1</sup> / <sub>8</sub>	22 <sup>1</sup> / <sub>4</sub>	3 <sup>1</sup> / <sub>2</sub>	9 <sup>16</sup> / <sub>16</sub>	
	193	15 <sup>1</sup> / <sub>2</sub>	15 <sup>3</sup> / <sub>4</sub>	1 <sup>7</sup> / <sub>16</sub>	7 <sup>8</sup> / <sub>8</sub>	7 <sup>16</sup> / <sub>16</sub>	7 <sup>3</sup> / <sub>8</sub>	11 <sup>3</sup> / <sub>8</sub>	2 <sup>1</sup> / <sub>16</sub>	22 <sup>1</sup> / <sub>8</sub>	3 <sup>1</sup> / <sub>4</sub>	1 <sup>1</sup> / <sub>2</sub>	
	184	15 <sup>3</sup> / <sub>8</sub>	15 <sup>5</sup> / <sub>8</sub>	1 <sup>9</sup> / <sub>8</sub>	7 <sup>8</sup> / <sub>8</sub>	7 <sup>16</sup> / <sub>16</sub>	7 <sup>3</sup> / <sub>8</sub>	11 <sup>3</sup> / <sub>8</sub>	2	22	3 <sup>1</sup> / <sub>4</sub>	1 <sup>1</sup> / <sub>2</sub>	
	176	15 <sup>1</sup> / <sub>4</sub>	15 <sup>5</sup> / <sub>8</sub>	1 <sup>9</sup> / <sub>16</sub>	1 <sup>13</sup> / <sub>16</sub>	7 <sup>16</sup> / <sub>16</sub>	7 <sup>3</sup> / <sub>8</sub>	11 <sup>3</sup> / <sub>8</sub>	1 <sup>15</sup> / <sub>16</sub>	21 <sup>7</sup> / <sub>8</sub>	3 <sup>1</sup> / <sub>4</sub>	1 <sup>1</sup> / <sub>2</sub>	
	167	15 <sup>1</sup> / <sub>8</sub>	15 <sup>5</sup> / <sub>8</sub>	1 <sup>1</sup> / <sub>4</sub>	1 <sup>13</sup> / <sub>16</sub>	5 <sup>8</sup> / <sub>8</sub>	7 <sup>3</sup> / <sub>8</sub>	11 <sup>3</sup> / <sub>8</sub>	1 <sup>7</sup> / <sub>8</sub>	21 <sup>3</sup> / <sub>4</sub>	3 <sup>1</sup> / <sub>4</sub>	7 <sup>16</sup> / <sub>16</sub>	
	158	15	15 <sup>1</sup> / <sub>2</sub>	1 <sup>3</sup> / <sub>16</sub>	3 <sup>4</sup> / <sub>8</sub>	3 <sup>8</sup> / <sub>8</sub>	7 <sup>3</sup> / <sub>8</sub>	11 <sup>3</sup> / <sub>8</sub>	1 <sup>13</sup> / <sub>16</sub>	21 <sup>5</sup> / <sub>8</sub>	3	7 <sup>16</sup> / <sub>16</sub>	
	150	14 <sup>7</sup> / <sub>8</sub>	15 <sup>1</sup> / <sub>2</sub>	1 <sup>1</sup> / <sub>8</sub>	1 <sup>11</sup> / <sub>16</sub>	3 <sup>8</sup> / <sub>8</sub>	7 <sup>3</sup> / <sub>8</sub>	11 <sup>3</sup> / <sub>8</sub>	1 <sup>3</sup> / <sub>4</sub>	21 <sup>1</sup> / <sub>2</sub>	3	7 <sup>16</sup> / <sub>16</sub>	
	142	14 <sup>3</sup> / <sub>4</sub>	15 <sup>1</sup> / <sub>2</sub>	1 <sup>1</sup> / <sub>16</sub>	1 <sup>11</sup> / <sub>16</sub>	3 <sup>8</sup> / <sub>8</sub>	7 <sup>3</sup> / <sub>8</sub>	11 <sup>3</sup> / <sub>8</sub>	1 <sup>11</sup> / <sub>16</sub>	21 <sup>1</sup> / <sub>2</sub>	3	7 <sup>16</sup> / <sub>16</sub>	
	+320	16 <sup>3</sup> / <sub>4</sub>	16 <sup>3</sup> / <sub>4</sub>	2 <sup>1</sup> / <sub>16</sub>	1 <sup>7</sup> / <sub>8</sub>	1 <sup>13</sup> / <sub>16</sub>	7 <sup>3</sup> / <sub>8</sub>	11 <sup>3</sup> / <sub>8</sub>	2 <sup>11</sup> / <sub>16</sub>	23 <sup>3</sup> / <sub>4</sub>	4	1	
14" WF	136	14 <sup>3</sup> / <sub>4</sub>	14 <sup>3</sup> / <sub>4</sub>	1 <sup>1</sup> / <sub>16</sub>	1 <sup>1</sup> / <sub>16</sub>	3 <sup>8</sup> / <sub>8</sub>	7	11 <sup>3</sup> / <sub>8</sub>	1 <sup>11</sup> / <sub>16</sub>	20 <sup>7</sup> / <sub>8</sub>	3	7 <sup>16</sup> / <sub>16</sub>	5 <sup>1</sup> / <sub>2</sub>
CB 145	127	14 <sup>5</sup> / <sub>8</sub>	14 <sup>3</sup> / <sub>4</sub>	1	5 <sup>8</sup> / <sub>8</sub>	5 <sup>16</sup> / <sub>16</sub>	7	11 <sup>3</sup> / <sub>8</sub>	1 <sup>5</sup> / <sub>8</sub>	20 <sup>3</sup> / <sub>4</sub>	3	3 <sup>8</sup> / <sub>8</sub>	5 <sup>1</sup> / <sub>2</sub>
14 x 14 <sup>1</sup> / <sub>2</sub>	119	14 <sup>1</sup> / <sub>2</sub>	14 <sup>5</sup> / <sub>8</sub>	1 <sup>15</sup> / <sub>16</sub>	9 <sup>16</sup> / <sub>16</sub>	5 <sup>16</sup> / <sub>16</sub>	7	11 <sup>3</sup> / <sub>8</sub>	1 <sup>9</sup> / <sub>16</sub>	20 <sup>5</sup> / <sub>8</sub>	2 <sup>3</sup> / <sub>4</sub>	3 <sup>8</sup> / <sub>8</sub>	5 <sup>1</sup> / <sub>2</sub>
R = .60	111	14 <sup>3</sup> / <sub>8</sub>	14 <sup>5</sup> / <sub>8</sub>	7 <sup>8</sup> / <sub>8</sub>	9 <sup>16</sup> / <sub>16</sub>	5 <sup>16</sup> / <sub>16</sub>	7	11 <sup>3</sup> / <sub>8</sub>	1 <sup>1</sup> / <sub>2</sub>	20 <sup>1</sup> / <sub>2</sub>	2 <sup>3</sup> / <sub>4</sub>	3 <sup>8</sup> / <sub>8</sub>	5 <sup>1</sup> / <sub>2</sub>
	103	14 <sup>1</sup> / <sub>4</sub>	14 <sup>5</sup> / <sub>8</sub>	1 <sup>13</sup> / <sub>16</sub>	1 <sup>1</sup> / <sub>2</sub>	7 <sup>4</sup> / <sub>4</sub>	7	11 <sup>3</sup> / <sub>8</sub>	1 <sup>7</sup> / <sub>16</sub>	20 <sup>1</sup> / <sub>2</sub>	2 <sup>3</sup> / <sub>4</sub>	5 <sup>16</sup> / <sub>16</sub>	5 <sup>1</sup> / <sub>2</sub>
	95	14 <sup>1</sup> / <sub>8</sub>	14 <sup>1</sup> / <sub>2</sub>	3 <sup>4</sup> / <sub>4</sub>	1 <sup>1</sup> / <sub>2</sub>	7 <sup>4</sup> / <sub>4</sub>	7	11 <sup>3</sup> / <sub>8</sub>	1 <sup>3</sup> / <sub>8</sub>	20 <sup>1</sup> / <sub>4</sub>	2 <sup>3</sup> / <sub>4</sub>	5 <sup>16</sup> / <sub>16</sub>	5 <sup>1</sup> / <sub>2</sub>
	87	14	14 <sup>1</sup> / <sub>2</sub>	1 <sup>11</sup> / <sub>16</sub>	7 <sup>16</sup> / <sub>16</sub>	7 <sup>4</sup> / <sub>4</sub>	7	11 <sup>3</sup> / <sub>8</sub>	1 <sup>9</sup> / <sub>16</sub>	20 <sup>1</sup> / <sub>4</sub>	2 <sup>1</sup> / <sub>2</sub>	5 <sup>16</sup> / <sub>16</sub>	5 <sup>1</sup> / <sub>2</sub>

3-513-3

\*Column Core Section.

Gages g<sub>2</sub> are based on 1<sup>1</sup>/<sub>4</sub>" edge distance (7<sup>8</sup>/<sub>8</sub>" maximum rivet).

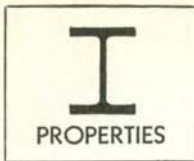

# WIDE FLANGE CB SECTIONS

1940

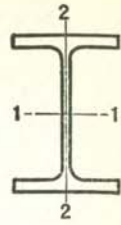

## PROPERTIES OF SECTIONS

District Rolled	Section Index and Nominal Size	Depth of Section In.	Weight per Foot Lbs.	Area of Section In. <sup>2</sup>	Flange			Web Thickness In.	Axis 1-1			Axis 2-2		
					Width In.	Thick-ness In.	I		S	r	I	S	r	
														In. <sup>4</sup>
P. C.	14" WF	14.18	84	24.71	12.023	.778	.451	928.4	130.9	6.13	225.5	37.5	3.02	
	CB 144	14.06	78	22.94	12.000	.718	.428	851.2	121.1	6.09	206.9	34.5	3.00	
	14 x 12 R = .60													
P. C.	14" WF	14.19	74	21.76	10.072	.783	.450	796.8	112.3	6.05	133.5	26.5	2.48	
	CB 143	14.06	68	20.00	10.040	.718	.418	724.1	103.0	6.02	121.2	24.1	2.46	
	14 x 10 R = .60	13.91	61	17.94	10.000	.643	.378	641.5	92.2	5.98	107.3	21.5	2.45	
P. C.	14" WF	14.06	58	17.06	8.098	.718	.406	597.9	85.0	5.92	63.7	15.7	1.93	
	CB 142	13.94	53	15.59	8.062	.658	.370	542.1	77.8	5.90	57.5	14.3	1.92	
	14 x 8	13.81	48	14.11	8.031	.593	.339	484.9	70.2	5.86	51.3	12.8	1.91	
	R = .60	13.68	43	12.65	8.000	.528	.308	429.0	62.7	5.82	45.1	11.3	1.89	
P. C.	14" WF	14.24	42	12.34	6.801	.573	.338	432.2	60.7	5.92	28.1	8.3	1.51	
	CB 141	14.12	38	11.17	6.776	.513	.313	385.3	54.6	5.87	24.6	7.3	1.49	
	14 x 6 3/4	14.00	34	10.00	6.750	.453	.287	339.2	48.5	5.83	21.3	6.3	1.46	
	R = .43	13.86	30	8.81	6.733	.383	.270	289.6	41.8	5.73	17.5	5.2	1.41	
P. C.		14.38	190	55.86	12.670	1.736	1.060	1892.5	263.2	5.82	589.7	93.1	3.25	
		14.12	176	51.79	12.615	1.606	1.005	1712.5	242.6	5.75	538.4	85.4	3.22	
		13.88	161	47.38	12.515	1.486	.905	1541.8	222.2	5.70	486.2	77.7	3.20	
		13.62	147	43.24	12.450	1.356	.840	1374.4	201.8	5.64	436.8	70.2	3.18	
	12" WF	13.38	133	39.11	12.365	1.236	.755	1221.2	182.5	5.59	389.9	63.1	3.16	
	CB 124	13.12	120	35.31	12.320	1.106	.710	1071.7	163.4	5.51	345.1	56.0	3.13	
	12 x 12	12.88	106	31.19	12.230	.986	.620	930.7	144.5	5.46	300.9	49.2	3.11	
	R = .60	12.75	99	29.09	12.190	.921	.580	858.5	134.7	5.43	278.2	45.7	3.09	
		12.62	92	27.06	12.155	.856	.545	788.9	125.0	5.40	256.4	42.2	3.08	
		12.50	85	24.98	12.105	.796	.495	723.3	115.7	5.38	235.5	38.9	3.07	
		12.38	79	23.22	12.080	.736	.470	663.0	107.1	5.34	216.4	35.8	3.05	
		12.25	72	21.16	12.040	.671	.430	597.4	97.5	5.31	195.3	32.4	3.04	
		12.12	65	19.11	12.000	.606	.390	533.4	88.0	5.28	174.6	29.1	3.02	
	P. C.	12" WF	12.31	64	18.83	10.060	.701	.405	528.3	85.8	5.29	119.0	23.7	2.51
CB 123		12.19	58	17.06	10.014	.641	.359	476.1	78.1	5.28	107.4	21.4	2.51	
12 x 10 R = .60		12.06	53	15.59	10.000	.576	.345	426.2	70.7	5.23	96.1	19.2	2.48	
P. C.	12" WF	12.19	50	14.71	8.077	.641	.371	394.5	64.7	5.18	56.4	14.0	1.96	
	CB 122	12.06	45	13.24	8.042	.576	.336	350.8	58.2	5.15	50.0	12.4	1.94	
	12 x 8 R = .60	11.94	40	11.77	8.000	.516	.294	310.1	51.9	5.13	44.1	11.0	1.94	
P. C.	12" WF	12.24	36	10.59	6.565	.540	.305	280.8	45.9	5.15	23.7	7.2	1.50	
	CB 121	12.12	32	9.41	6.533	.480	.273	246.8	40.7	5.12	20.6	6.3	1.48	
	12 x 6 1/2	12.00	28	8.23	6.500	.420	.240	213.5	35.6	5.09	17.5	5.4	1.46	
	R = .37	11.87	25	7.39	6.500	.355	.240	183.4	30.9	4.98	14.5	4.5	1.40	

For key to symbols in first column, refer to page 3.



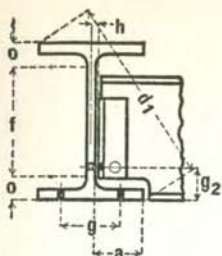

# WIDE FLANGE CB SECTIONS

## DIMENSIONS OF SECTIONS FOR DETAILING

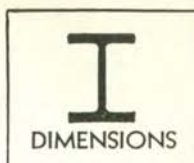

Section Index and Nominal Depth	Weight per Foot	Depth of Section	Flange		Web		Distance						Usual Gage g
			Width	Thick-ness	Thick-ness	Half Thick-ness	a	f	o	d <sub>1</sub>	Min. g <sub>2</sub>	Clear, h	
14" WF	84	14 1/8	12	3/4	7/16	1/4	5 3/4	11 3/8	1 3/8	18 5/8	2 3/4	5/16	5 1/2
CB 144	78	14	12	11/16	7/16	1/4	5 3/4	11 3/8	1 5/16	18 1/2	2 1/2	5/16	5 1/2
R = .60													
14" WF	74	14 1/4	10 1/8	13/16	7/16	1/4	4 3/4	11 3/8	1 3/8	17 1/2	2 3/4	5/16	5 1/2
CB 143	68	14	10	1 1/16	7/16	1/4	4 3/4	11 3/8	1 5/16	17 1/4	2 1/2	5/16	5 1/2
R = .60													
14 x 10	61	13 7/8	10	5/8	3/8	3/16	4 3/4	11 3/8	1 1/4	17 1/8	2 1/2	1/4	5 1/2
14" WF	58	14	8 1/8	1 1/16	7/16	3/16	3 7/8	11 3/8	1 5/16	16 1/4	2 1/2	1/4	5 1/2
CB 142	53	14	8	1 1/16	3/8	3/16	3 7/8	11 3/8	1 1/4	16 1/8	2 1/2	1/4	5 1/2
14 x 8	48	13 3/4	8	9/16	3/8	3/16	3 7/8	11 3/8	1 3/16	16	2 1/2	1/4	5 1/2
R = .60													
14" WF	43	13 5/8	8	1/2	5/16	3/16	3 7/8	11 3/8	1 1/8	15 7/8	2 1/2	1/4	5 1/2
14" WF	42	14 1/4	6 3/4	9/16	3/8	3/16	3 1/4	12 1/8	1 1/16	15 3/4	2 1/4	1/4	3 1/2
CB 141	38	14 1/8	6 3/4	1/2	5/16	3/16	3 1/4	12 1/8	1	15 3/4	2 1/4	1/4	3 1/2
14 x 6 3/4	34	14	6 3/4	7/16	5/16	3/16	3 1/4	12 1/8	1 5/16	15 5/8	2 1/4	1/4	3 1/2
R = .43													
	30	13 7/8	6 3/4	3/8	5/16	1/8	3 1/4	12 1/8	7/8	15 1/2	2 1/4	3/16	3 1/2
	190	14 3/8	12 5/8	1 3/4	1 1/16	9/16	5 3/4	9 3/4	2 5/16	19 1/4	3 3/4	5/8	5 1/2
	176	14 1/8	12 5/8	1 5/8	1	1 1/2	5 3/4	9 3/4	2 9/16	19	3 1/2	3/16	5 1/2
	161	13 7/8	12 1/2	1 1/2	1 5/16	7/16	5 3/4	9 3/4	2 1/16	18 3/4	3 1/2	1/2	5 1/2
	147	13 5/8	12 1/2	1 3/8	7/8	7/16	5 3/4	9 3/4	1 15/16	18 1/2	3 1/4	1/2	5 1/2
12" WF	133	13 3/8	12 3/8	1 1/4	3/4	3/8	5 3/4	9 3/4	1 13/16	18 1/4	3 1/4	7/16	5 1/2
CB 124	120	13 1/8	12 3/8	1 1/8	3/4	3/8	5 3/4	9 3/4	1 11/16	18	3	7/16	5 1/2
12 x 12	106	12 7/8	12 1/4	1	5/8	5/16	5 3/4	9 3/4	1 9/16	17 7/8	3	3/8	5 1/2
R = .60													
	99	12 3/4	12 1/4	1 5/16	5/8	5/16	5 3/4	9 3/4	1 1/2	17 3/4	2 3/4	3/8	5 1/2
	92	12 5/8	12 1/8	7/8	9/16	5/16	5 3/4	9 3/4	1 7/16	17 1/2	2 3/4	3/8	5 1/2
	85	12 1/2	12 1/8	13/16	1/2	1/4	5 3/4	9 3/4	1 3/8	17 1/2	2 3/4	5/16	5 1/2
	79	12 3/8	12 1/8	3/4	1/2	1/4	5 3/4	9 3/4	1 5/16	17 3/8	2 3/4	5/16	5 1/2
	72	12 1/4	12	1 1/16	7/16	1/4	5 3/4	9 3/4	1 1/4	17 1/4	2 1/2	5/16	5 1/2
	65	12 1/8	12	5/8	3/8	3/16	5 3/4	9 3/4	1 3/16	17 1/8	2 1/2	1/4	5 1/2
12" WF	64	12 3/4	10	1 1/16	7/16	3/16	4 7/8	9 3/4	1 5/16	15 7/8	2 1/2	1/4	5 1/2
CB 123	58	12 1/4	10	5/8	3/8	3/16	4 7/8	9 3/4	1 1/4	15 7/8	2 1/2	1/4	5 1/2
12 x 10	53	12	10	9/16	3/8	3/16	4 7/8	9 3/4	1 3/16	15 5/8	2 1/2	1/4	5 1/2
R = .60													
12" WF	50	12 3/4	8 1/8	5/8	3/8	3/16	3 7/8	9 3/4	1 1/4	14 5/8	2 1/2	1/4	5 1/2
CB 122	45	12	8	9/16	3/8	3/16	3 7/8	9 3/4	1 3/16	14 1/2	2 1/2	1/4	5 1/2
12 x 8	40	12	8	1/2	5/16	3/16	3 7/8	9 3/4	1 1/8	14 3/8	2 1/2	1/4	5 1/2
R = .60													
12" WF	36	12 3/4	6 5/8	9/16	5/16	3/16	3 1/8	10 3/8	1 5/16	14	2 1/4	1/4	3 1/2
CB 121	32	12 1/8	6 1/2	1/2	3/16	1/8	3 1/8	10 3/8	7/8	13 3/4	2 1/4	3/16	3 1/2
12 x 6 1/2	28	12	6 1/2	7/16	1/4	1/8	3 1/8	10 3/8	1 3/16	13 3/4	2 1/4	3/16	3 1/2
R = .37													
	25	11 7/8	6 1/2	3/8	1/4	1/8	3 1/8	10 3/8	3/4	13 5/8	2 1/4	3/16	3 1/2

Gages g<sub>2</sub> are based on 1/4" edge distance (7/8" maximum rivet).



# WIDE FLANGE CB SECTIONS 1940

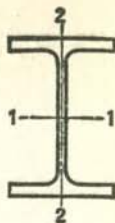

## PROPERTIES OF SECTIONS

District Rolled	Section Index and Nominal Size	Depth of Section	Weight per Foot	Area of Section	Flange		Web Thickness	Axis 1-1			Axis 2-2		
					Width	Thickness		I	S	r	I	S	r
					In.	In.		In. <sup>4</sup>	In. <sup>3</sup>	In.	In. <sup>4</sup>	In. <sup>3</sup>	In.
P.C.	10" WF CB 103 10 x 10 R = .50	11.88	136	40.03	10.575	1.498	.915	917.2	154.4	4.79	295.9	56.0	2.72
		11.62	124	36.46	10.505	1.368	.845	813.1	139.9	4.72	264.8	50.4	2.69
		11.38	112	32.92	10.415	1.248	.755	718.7	126.3	4.67	235.4	45.2	2.67
		11.12	100	29.43	10.345	1.118	.685	625.0	112.4	4.61	206.6	39.9	2.65
		10.88	89	26.19	10.275	.998	.615	542.4	99.7	4.55	180.6	35.2	2.63
		10.62	77	22.67	10.195	.868	.535	457.2	86.1	4.49	153.4	30.1	2.60
		10.50	72	21.18	10.170	.808	.510	420.7	80.1	4.46	141.8	27.9	2.59
		10.38	66	19.41	10.117	.748	.457	382.5	73.7	4.44	129.2	25.5	2.58
		10.25	60	17.66	10.075	.683	.415	343.7	67.1	4.41	116.5	23.1	2.57
P.C.	10" WF CB 102 10 x 8 R = .50	10.12	54	15.88	10.028	.618	.368	305.7	60.4	4.39	103.9	20.7	2.56
		10.00	49	14.40	10.000	.558	.340	272.9	54.6	4.35	93.0	18.6	2.54
		10.12	45	13.24	8.022	.618	.350	248.6	49.1	4.33	53.2	13.3	2.00
		10.00	41	12.06	8.000	.558	.328	222.4	44.5	4.29	47.7	11.9	1.99
P.C.	10" WF CB 101 10 x 5 3/4 R = .32	9.88	37	10.88	7.978	.498	.306	196.9	39.9	4.25	42.2	10.6	1.97
		9.75	33	9.71	7.964	.433	.292	170.9	35.0	4.20	36.5	9.2	1.94
		10.22	29	8.53	5.799	.500	.289	157.3	30.8	4.29	15.2	5.2	1.34
		10.12	26	7.65	5.769	.450	.259	139.7	27.6	4.27	13.4	4.6	1.32
P.C.	8" WF CB 83 8 x 8 R = .40	10.00	23	6.77	5.750	.390	.240	120.6	24.1	4.22	11.3	3.9	1.29
		9.90	21	6.19	5.750	.340	.240	106.3	21.5	4.14	9.7	3.4	1.25
		9.00	67	19.70	8.287	.933	.575	271.8	60.4	3.71	88.6	21.4	2.12
		8.75	58	17.06	8.222	.808	.510	227.3	52.0	3.65	74.9	18.2	2.10
		8.50	48	14.11	8.117	.683	.405	183.7	43.2	3.61	60.9	15.0	2.08
		8.25	40	11.76	8.077	.558	.365	146.3	35.5	3.53	49.0	12.1	2.04
P.C.	8" WF CB 82 8 x 6 1/2 R = .40	8.12	35	10.30	8.027	.493	.315	126.5	31.1	3.50	42.5	10.6	2.03
		8.06	33	9.70	8.012	.463	.300	117.9	29.3	3.49	39.7	9.9	2.02
		8.00	31	9.12	8.000	.433	.288	109.7	27.4	3.47	37.0	9.2	2.01
		8.03	27	7.93	6.528	.448	.273	94.1	23.4	3.44	20.8	6.4	1.62
P.C.	8" WF CB 81 8 x 5 1/4 R = .32	7.93	24	7.06	6.500	.398	.245	82.5	20.8	3.42	18.2	5.6	1.61
		8.19	21	6.18	5.272	.403	.252	73.8	18.0	3.45	9.13	3.5	1.22
		8.09	19	5.59	5.264	.353	.244	64.7	16.0	3.40	7.87	3.0	1.19
		8.00	17	5.00	5.250	.308	.230	56.4	14.1	3.36	6.72	2.6	1.16

For key to symbols in first column, refer to page 3.

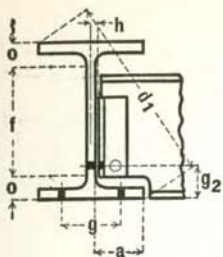

WIDE FLANGE  
CB SECTIONS

DIMENSIONS OF SECTIONS  
FOR DETAILING

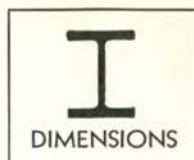

Section Index and Nominal Depth	Weight per Foot	Depth of Section	Flange		Web		Distance					Usual Gage g	
			Width	Thickness	Thickness	Half Thickness	α	f	o	d <sub>1</sub>	Min. g <sub>2</sub>		Clear. h
			In.	In.	In.	In.	In.	In.	In.	In.	In.		In.
10" WF CB 103 10 x 10 R = .50	136	11 7/8	10 5/8	1 1/2	15/16	1/2	47/8	77/8	2	16	3 1/4	9/16	5 1/2
	124	11 5/8	10 1/2	1 3/8	7/8	7/16	47/8	77/8	1 7/8	15 3/4	3 3/4	1/2	5 1/2
	112	11 3/8	10 3/8	1 1/4	3/4	3/8	47/8	77/8	1 3/4	15 1/2	3	7/16	5 1/2
	100	11 1/8	10 3/8	1 1/8	11/16	3/8	47/8	77/8	1 5/8	15 1/4	3	7/16	5 1/2
	89	10 7/8	10 1/4	1	5/8	5/16	47/8	77/8	1 1/2	15	2 3/4	3/8	5 1/2
	77	10 5/8	10 1/4	7/8	9/16	5/16	47/8	77/8	1 3/8	14 3/4	2 3/4	3/8	5 1/2
	72	10 1/2	10 1/8	13/16	1/2	1/4	47/8	77/8	1 5/16	14 3/8	2 3/4	5/16	5 1/2
	66	10 3/8	10 1/8	3/4	7/16	1/4	47/8	77/8	1 1/4	14 1/2	2 1/2	5/16	5 1/2
	60	10 1/4	10 1/8	11/16	7/16	1/4	47/8	77/8	1 3/16	14 3/8	2 1/2	5/16	5 1/2
	54	10 1/8	10	5/8	3/8	3/16	47/8	77/8	1 1/8	14 1/4	2 1/2	1/4	5 1/2
49	10	10	9/16	3/8	3/16	47/8	77/8	1 1/16	14 1/8	2 1/2	1/4	5 1/2	
10" WF CB 102 10 x 8 R = .50	45	10 1/8	8	5/8	3/8	3/16	37/8	77/8	1 1/8	13	2 1/2	1/4	5 1/2
	41	10	8	9/16	5/16	3/16	37/8	77/8	1 1/16	12 7/8	2 1/2	1/4	5 1/2
	37	9 7/8	8	1/2	5/16	3/16	37/8	77/8	1	12 3/4	2 1/4	1/4	5 1/2
	33	9 3/4	8	7/16	5/16	3/16	37/8	77/8	1 5/16	12 5/8	2 1/4	1/4	5 1/2
10" WF CB 101 10 x 5 3/4 R = .32	29	10 1/4	5 3/4	1/2	5/16	3/16	2 3/4	8 1/2	7/8	11 3/4	2 1/4	1/4	2 3/4
	26	10 1/8	5 3/4	7/16	1/4	1/8	2 3/4	8 1/2	1 1/16	11 3/4	2 1/4	3/16	2 3/4
	23	10	5 3/4	3/8	1/4	1/8	2 3/4	8 1/2	3/4	11 5/8	2 1/4	3/16	2 3/4
	21	9 7/8	5 3/4	5/16	1/4	1/8	2 3/4	8 1/2	1 1/16	11 1/2	2	3/16	2 3/4
8" WF CB 83 8 x 8 R = .40	67	9	8 1/4	1 5/16	9/16	5/16	37/8	6 3/8	1 5/16	12 1/4	2 3/4	3/8	5 1/2
	58	8 3/4	8 1/4	1 3/16	1/2	1/4	37/8	6 3/8	1 3/16	12	2 1/2	5/16	5 1/2
	48	8 1/2	8 1/8	1 1/16	7/16	3/16	37/8	6 3/8	1 1/16	11 7/8	2 1/2	1/4	5 1/2
	40	8 1/4	8 1/8	9/16	3/8	3/16	37/8	6 3/8	1 5/16	11 5/8	2 1/4	1/4	5 1/2
	35	8 1/8	8	1/2	5/16	3/16	37/8	6 3/8	7/8	11 1/2	2 1/4	1/4	5 1/2
	33	8	8	7/16	5/16	3/16	37/8	6 3/8	7/8	11 3/8	2 1/4	1/4	5 1/2
31	8	8	7/16	5/16	3/16	37/8	6 3/8	1 3/16	11 3/8	2 1/4	1/4	5 1/2	
8" WF CB 82 8 x 6 1/2 R = .40	27	8	6 1/2	7/16	5/16	1/8	3 1/8	6 3/8	7/8	10 3/8	2 1/4	3/16	3 1/2
	24	7 7/8	6 1/2	3/8	1/4	1/8	3 1/8	6 3/8	1 3/16	10 1/4	2 1/4	3/16	3 1/2
8" WF CB 81 8 x 5 1/4 R = .32	21	8 1/4	5 1/4	3/8	1/4	1/8	2 1/2	6 3/4	3/4	9 3/4	2 1/4	3/16	2 3/4
	19	8 1/8	5 1/4	3/8	1/4	1/8	2 1/2	6 3/4	1 1/16	9 5/8	2 1/4	3/16	2 3/4
	17	8	5 1/4	5/16	1/4	1/8	2 1/2	6 3/4	5/8	9 5/8	2 1/4	3/16	2 3/4

Gages g<sub>2</sub> are based on 1 1/4" edge distance (3/8" maximum rivet).



WIDE FLANGE

1940

LIGHT BEAMS, STANCHIONS AND JOISTS

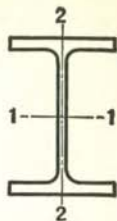

PROPERTIES OF SECTIONS

District Rolled	Section Index and Nominal Size	Depth of Section In.	Weight per Foot Lbs.	Area of Section In. <sup>2</sup>	Flange		Web Thickness In.	Axis 1-1			Axis 2-2		
					Width In.	Thick-ness In.		I In. <sup>4</sup>	S In. <sup>3</sup>	r In.	I In. <sup>4</sup>	S In. <sup>3</sup>	r In.
<b>LIGHT BEAMS</b>													
P.C.	CBL 12 12 x 4 R = .30	12.31	22	6.47	4.030	.424	.260	155.7	25.3	4.91	4.55	2.26	0.84
		12.16	19	5.62	4.010	.349	.240	130.1	21.4	4.81	3.67	1.83	0.81
		12.00	16½	4.86	4.000	.269	.230	105.3	17.5	4.65	2.79	1.39	0.76
P.C.	CBL 10 10 x 4 R = .38	10.25	19	5.61	4.020	.394	.250	96.2	18.8	4.14	4.19	2.08	0.86
		10.12	17	4.98	4.010	.329	.240	81.8	16.2	4.05	3.45	1.72	0.83
		10.00	15	4.40	4.000	.269	.230	68.8	13.8	3.95	2.79	1.39	0.80
P.C.	CBL 8 8 x 4 R = .30	8.12	15	4.43	4.015	.314	.245	48.0	11.8	3.29	3.30	1.65	0.86
		8.00	13	3.83	4.000	.254	.230	39.5	9.88	3.21	2.62	1.31	0.83
P.C.	CBL 6 6 x 4 R = .25	6.25	16	4.72	4.030	.404	.260	31.7	10.1	2.59	4.32	2.14	0.96
		6.00	12	3.53	4.000	.279	.230	21.7	7.24	2.48	2.89	1.44	0.90
<b>STANCHIONS</b>													
P.	CBS 6	6.46	27½	8.09	6.112	.500	.352	59.7	18.5	2.71	19.1	6.2	1.53
		6.37	25	7.35	6.080	.456	.320	53.5	16.8	2.69	17.1	5.6	1.52
		6.28	22½	6.61	6.050	.411	.290	47.4	15.1	2.67	15.2	5.0	1.51
		6.20	20	5.88	6.018	.367	.258	41.7	13.4	2.66	13.3	4.4	1.50
		6.11	18	5.29	6.010	.322	.250	36.4	11.9	2.62	11.7	3.9	1.48
		6.00	15½	4.59	6.000	.269	.240	30.3	10.1	2.56	9.69	3.2	1.45
<b>JOISTS</b>													
P.C.	CBJ 12 12 x 4 R = .30	11.91	14	4.14	3.970	.224	.200	88.2	14.8	4.61	2.25	1.13	0.74
P.C.	CBJ 10 10 x 4 R = .30	9.87	11½	3.39	3.950	.204	.180	51.9	10.5	3.92	2.01	1.02	0.77
P.C.	CBJ 8 8 x 4 R = .30	7.90	10	2.95	3.940	.204	.170	30.8	7.79	3.23	1.99	1.01	0.82
P.C.	CBJ 6 6 x 4 R = .25	5.83	8½	2.50	3.940	.194	.170	14.8	5.07	2.43	1.89	0.96	0.87

For key to symbols in first column, refer to page 3.  
This sheet replaces pages 23-24, "USS Structural Sections."



# WIDE FLANGE LIGHT BEAMS, STANCHIONS AND JOISTS

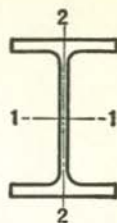

## PROPERTIES OF SECTIONS

District Rolled	Section Index and Nominal Size	Depth of Section In.	Weight per Foot Lbs.	Area of Section In. <sup>2</sup>	Flange		Web Thickness In.	Axis 1-1			Axis 2-2		
					Width In.	Thickness In.		I	S	r	I	S	r
P.	CB 51	5.12	18.5	5.45	5.025	.420	.265	25.4	9.94	2.16	8.89	3.54	1.28
	5 x 5	5.00	16	4.70	5.000	.360	.240	21.3	8.53	2.13	7.51	3.00	1.26
	R = .3	4.86	13.5	3.98	4.990	.292	.230	17.1	7.02	2.07	6.05	2.43	1.23

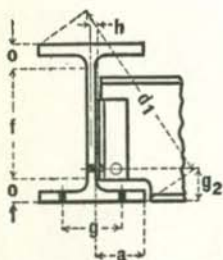

## DIMENSIONS OF SECTIONS FOR DETAILING

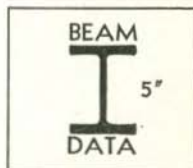

Section Index and Nominal Size	Weight per Foot Lbs.	Depth of Section In.	Flange		Web		Distance						Usual Gage In.
			Width In.	Thickness In.	Thickness In.	1/2 Thickness In.	a	f	o	d <sup>1</sup>	Min. g <sub>2</sub>	Clear h	
CB 51	18.5	5 1/8	5	7/16	1/4	1/8	2 3/8	3 11/16	11/16	7 1/8	2 3/4	3/16	3
5 x 5	16	5	5	3/8	1/4	1/8	2 3/8	3 11/16	5/8	7	2 3/4	3/16	3
R = .3	13.5	4 7/8	5	5/16	1/4	1/8	2 3/8	3 11/16	9/16	7	2 3/4	3/16	3

Addition, to be inserted between pages 24 and 25 U-S-S Structural Sections Hand Book.

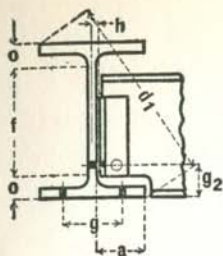

WIDE FLANGE  
LIGHT BEAMS, STANCHIONS  
AND JOISTS  
DIMENSIONS OF SECTIONS  
FOR DETAILING

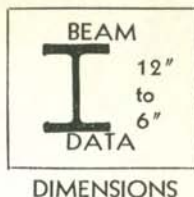

Section Index and Nominal Size	Weight per Foot Lbs.	Depth of Section In.	Flange		Web		Distance					Usual Gage $\sigma$ In.	
			Width In.	Thick-ness In.	Thick-ness In.	$\frac{1}{2}$ Thick-ness In.	$\alpha$ In.	f In.	$\sigma$ In.	$d_1$ In.	Min. $g_2$ In.		Clear. h In.
<b>LIGHT BEAMS</b>													
CBL 12 12 x 4 R = .30	22 19 16 $\frac{1}{2}$	12 $\frac{3}{4}$ 12 $\frac{1}{8}$ 12	4 4 4	$\frac{1}{4}$ $\frac{1}{4}$ $\frac{1}{4}$	$\frac{3}{16}$ $\frac{3}{8}$ $\frac{1}{4}$	$\frac{1}{4}$ $\frac{3}{16}$ $\frac{1}{8}$	$1\frac{7}{8}$ $1\frac{7}{8}$ $1\frac{7}{8}$	$10\frac{3}{4}$ $10\frac{3}{4}$ $10\frac{3}{4}$	$\frac{3}{4}$ $1\frac{1}{16}$ $\frac{5}{8}$	13 12 $\frac{3}{4}$ 12 $\frac{5}{8}$	2 2 1 $\frac{3}{4}$	$\frac{5}{16}$ $\frac{1}{4}$ $\frac{3}{16}$	$2\frac{1}{4}$ $2\frac{1}{4}$ $2\frac{1}{4}$
CBL 10 10 x 4 R = .38	19 17 15	10 $\frac{1}{4}$ 10 $\frac{1}{8}$ 10	4 4 4	$\frac{1}{4}$ $\frac{1}{4}$ $\frac{1}{4}$	$\frac{3}{8}$ $\frac{5}{16}$ $\frac{1}{4}$	$\frac{3}{16}$ $\frac{3}{16}$ $\frac{1}{8}$	$1\frac{7}{8}$ $1\frac{7}{8}$ $1\frac{7}{8}$	$8\frac{7}{8}$ $8\frac{7}{8}$ $8\frac{7}{8}$	$1\frac{1}{16}$ $\frac{5}{8}$ $\frac{9}{16}$	11 10 $\frac{7}{8}$ 10 $\frac{3}{4}$	2 2 1 $\frac{3}{4}$	$\frac{1}{4}$ $\frac{1}{4}$ $\frac{3}{16}$	$2\frac{1}{4}$ $2\frac{1}{4}$ $2\frac{1}{4}$
CBL 8 8 x 4 R = .30	15 13	8 $\frac{1}{8}$ 8	4 4	$\frac{1}{4}$ $\frac{1}{4}$	$\frac{5}{16}$ $\frac{1}{4}$	$\frac{3}{16}$ $\frac{1}{8}$	$1\frac{7}{8}$ $1\frac{7}{8}$	$6\frac{7}{8}$ $6\frac{7}{8}$	$\frac{5}{8}$ $\frac{9}{16}$	9 9	2 1 $\frac{3}{4}$	$\frac{1}{4}$ $\frac{3}{16}$	$2\frac{1}{4}$ $2\frac{1}{4}$
CBL 6 6 x 4 R = .25	16 12	6 $\frac{1}{4}$ 6	4 4	$\frac{1}{4}$ $\frac{1}{4}$	$\frac{3}{8}$ $\frac{1}{4}$	$\frac{3}{16}$ $\frac{1}{8}$	$1\frac{7}{8}$ $1\frac{7}{8}$	$4\frac{7}{8}$ $4\frac{7}{8}$	$1\frac{1}{16}$ $\frac{9}{16}$	$7\frac{3}{8}$ 7 $\frac{1}{4}$	2 1 $\frac{3}{4}$	$\frac{1}{4}$ $\frac{3}{16}$	$2\frac{1}{4}$ $2\frac{1}{4}$
<b>STANCHIONS</b>													
CBS 6 6 x 6 R = .25	27 $\frac{1}{2}$ 25 22 $\frac{1}{2}$ 20 18 15 $\frac{1}{2}$	6 $\frac{1}{2}$ 6 $\frac{3}{8}$ 6 $\frac{1}{4}$ 6 6 6	6 $\frac{1}{8}$ 6 6 6 6 6	$\frac{1}{2}$ $\frac{1}{2}$ $\frac{7}{16}$ $\frac{3}{8}$ $\frac{5}{16}$ $\frac{1}{4}$	$\frac{3}{8}$ $\frac{5}{16}$ $\frac{5}{16}$ $\frac{1}{4}$ $\frac{3}{16}$ $\frac{1}{4}$	$\frac{3}{16}$ $\frac{3}{16}$ $\frac{3}{16}$ $\frac{3}{16}$ $\frac{1}{8}$ $\frac{1}{4}$	$2\frac{7}{8}$ $2\frac{7}{8}$ $2\frac{7}{8}$ $2\frac{7}{8}$ $2\frac{7}{8}$ $2\frac{7}{8}$	$4\frac{7}{8}$ $4\frac{7}{8}$ $4\frac{7}{8}$ $4\frac{7}{8}$ $4\frac{7}{8}$ $4\frac{7}{8}$	$1\frac{3}{16}$ $\frac{3}{4}$ $1\frac{1}{16}$ $1\frac{1}{16}$ $\frac{5}{8}$ $\frac{9}{16}$	$8\frac{7}{8}$ $8\frac{7}{8}$ $8\frac{3}{4}$ $8\frac{5}{8}$ $8\frac{1}{2}$ $8\frac{1}{2}$	$2\frac{1}{4}$ $2\frac{1}{4}$ 2 2 2 2	$\frac{1}{4}$ $\frac{1}{4}$ $\frac{1}{4}$ $\frac{3}{16}$ $\frac{3}{16}$ $\frac{3}{16}$	$3\frac{1}{2}$ $3\frac{1}{2}$ $3\frac{1}{2}$ $3\frac{1}{2}$ $3\frac{1}{2}$ $3\frac{1}{2}$
<b>JOISTS</b>													
CBJ 12 12 x 4 R = .30	14	11 $\frac{7}{8}$	4	$\frac{3}{16}$	$\frac{1}{4}$	$\frac{1}{8}$	$1\frac{7}{8}$	$10\frac{3}{4}$	$\frac{9}{16}$	12 $\frac{1}{2}$	1 $\frac{3}{4}$	$\frac{3}{16}$	$2\frac{1}{4}$
CBJ 10 10 x 4 R = .30	11 $\frac{1}{2}$	9 $\frac{7}{8}$	4	$\frac{3}{16}$	$\frac{3}{16}$	$\frac{1}{8}$	$1\frac{7}{8}$	$8\frac{7}{8}$	$\frac{1}{2}$	10 $\frac{5}{8}$	1 $\frac{3}{4}$	$\frac{3}{16}$	$2\frac{1}{4}$
CBJ 8 8 x 4 R = .30	10	7 $\frac{7}{8}$	4	$\frac{3}{16}$	$\frac{3}{16}$	$\frac{1}{8}$	$1\frac{7}{8}$	$6\frac{7}{8}$	$\frac{1}{2}$	$8\frac{7}{8}$	1 $\frac{3}{4}$	$\frac{3}{16}$	$2\frac{1}{4}$
CBJ 6 6 x 4 R = .25	8 $\frac{1}{2}$	5 $\frac{7}{8}$	4	$\frac{3}{16}$	$\frac{3}{16}$	$\frac{1}{8}$	$1\frac{7}{8}$	5	$\frac{7}{16}$	7	1 $\frac{3}{4}$	$\frac{3}{16}$	$2\frac{1}{4}$

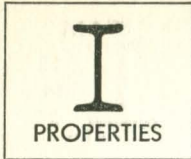

# BEAMS

## AMERICAN STANDARD

1940

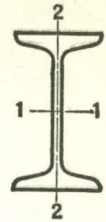

### PROPERTIES OF SECTIONS

District Rolled	Section Index and Nominal Size	Depth of Beam In.	Weight per Foot Lbs.	Area of Section In. <sup>2</sup>	Width of Flange In.	Web Thickness In.	Axis 1-1			Axis 2-2		
							I In. <sup>4</sup> *	S In. <sup>3</sup>	r In.	I In. <sup>4</sup>	S In. <sup>3</sup>	r In.
P.C.	24" I	24	120.0	35.13	8.048	.798	3010.8	250.9	9.26	84.9	21.1	1.56
	B 18		115.0	33.67	7.987	.737	2940.5	245.0	9.35	82.8	20.7	1.57
	24 x 7 <sup>7</sup> / <sub>8</sub>		110.0	32.18	7.925	.675	2869.1	239.1	9.44	80.6	20.3	1.58
	R = .60		105.9	30.98	7.875	.625	2811.5	234.3	9.53	78.9	20.0	1.60
P.C.	24" I	24	100.0	29.25	7.247	.747	2371.8	197.6	9.05	48.4	13.4	1.29
	B 1		95.0	27.79	7.186	.686	2301.5	191.8	9.08	47.0	13.0	1.30
	24 x 7		90.0	26.30	7.124	.624	2230.1	185.8	9.21	45.5	12.8	1.32
	R = .60		85.0	24.84	7.063	.563	2159.8	180.0	9.33	44.2	12.5	1.33
			79.9	23.33	7.000	.500	2087.2	173.9	9.46	42.9	12.2	1.36
P.C.	20" I	20	100.0	29.20	7.273	.873	1648.3	164.8	7.51	52.4	14.4	1.34
	B 2		95.0	27.74	7.200	.800	1599.7	160.0	7.59	50.5	14.0	1.35
	20 x 7		90.0	26.26	7.126	.726	1550.3	155.0	7.68	48.7	13.7	1.36
	R = .70		85.0	24.80	7.053	.653	1501.7	150.2	7.78	47.0	13.3	1.38
			81.4	23.74	7.000	.600	1466.3	146.6	7.86	45.8	13.1	1.39
P.C.	20" I	20	75.0	21.90	6.391	.641	1263.5	126.3	7.60	30.1	9.4	1.17
	B 3		70.0	20.42	6.317	.567	1214.2	121.4	7.71	28.9	9.2	1.19
	20 x 6 <sup>1</sup> / <sub>4</sub>		65.4	19.08	6.250	.500	1169.5	116.9	7.83	27.9	8.9	1.21
P.C.B.	18" I	18	70.0	20.46	6.251	.711	917.5	101.9	6.70	24.5	7.8	1.09
	B 4		65.0	18.98	6.169	.629	877.7	97.5	6.80	23.4	7.6	1.11
	18 x 6		60.0	17.50	6.087	.547	837.8	93.1	6.92	22.3	7.3	1.13
	R = .56		54.7	15.94	6.000	.460	795.5	88.4	7.07	21.2	7.1	1.15
P.C.	15" I	15	75.0	21.85	6.278	.868	687.2	91.6	5.61	30.6	9.8	1.18
	B 6		70.0	20.38	6.180	.770	659.6	87.9	5.69	28.8	9.3	1.19
	15 x 6		65.0	18.91	6.082	.672	632.1	84.3	5.78	27.2	8.9	1.20
	R = .69		60.8	17.68	6.000	.590	609.0	81.2	5.87	26.0	8.7	1.21
P.C.B.	15" I	15	55.0	16.06	5.738	.648	508.7	67.8	5.63	17.0	5.9	1.03
	B 7		50.0	14.59	5.640	.550	481.1	64.2	5.74	16.0	5.7	1.05
	15 x 5 <sup>1</sup> / <sub>2</sub>		45.0	13.12	5.542	.452	453.6	60.5	5.88	15.0	5.4	1.07
	R = .51		42.9	12.49	5.500	.410	441.8	58.9	5.95	14.6	5.3	1.08

For key to symbols in first column, refer to page 3.

# BEAMS

## AMERICAN STANDARD

### DIMENSIONS OF SECTIONS FOR DETAILING

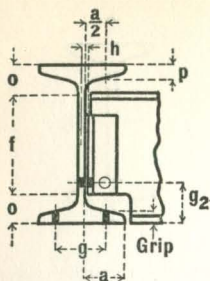
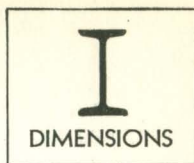

Section Index and Depth	Weight per Foot	Flange		Web		Distance							Max. Flange Rivet
		Width	Thick-ness, P	Thick-ness	Half Thick-ness	a	f	o	Min. g <sub>2</sub>	Clear. h	Gage g	Grip	
24" I B 18 R = .60	120.0	8	1 3/8	13/16	7/16	3 5/8	20 1/8	1 15/16	3 1/4	1 1/2	4	1 1/8	1
	115.0	8	1 1/8	3/4	3/8	3 5/8	20 1/8	1 15/16	3 1/4	7/16	4	1 1/8	1
	110.0	7 7/8	1 1/8	1 1/16	3/8	3 5/8	20 1/8	1 15/16	3 1/4	7/16	4	1 1/8	1
	105.9	7 7/8	1 1/8	5/8	5/16	3 5/8	20 1/8	1 15/16	3 1/4	3/8	4	1 1/8	1
24" I B 1 R = .60	100.0	7 1/4	7/8	3/4	3/8	3 1/4	20 3/4	1 5/8	3	7/16	4	7/8	1
	95.0	7 1/8	7/8	1 1/16	3/8	3 1/4	20 3/4	1 5/8	3	7/16	4	7/8	1
	90.0	7 1/8	7/8	5/8	5/16	3 1/4	20 3/4	1 5/8	3	3/8	4	7/8	1
	85.0	7 1/8	7/8	9/16	5/16	3 1/4	20 3/4	1 5/8	3	3/8	4	7/8	1
	79.9	7	7/8	1/2	1/4	3 1/4	20 3/4	1 5/8	3	5/16	4	7/8	1
20" I B 2 R = .70	100.0	7 1/4	15/16	7/8	7/16	3 1/4	16 1/2	1 3/4	3 1/4	1/2	4	15/16	1
	95.0	7 1/4	15/16	13/16	7/16	3 1/4	16 1/2	1 3/4	3 1/4	1/2	4	15/16	1
	90.0	7 1/8	15/16	3/4	3/8	3 1/4	16 1/2	1 3/4	3 1/4	7/16	4	15/16	1
	85.0	7	15/16	1 1/16	5/16	3 1/4	16 1/2	1 3/4	3 1/4	3/8	4	7/8	1
	81.4	7	15/16	5/8	5/16	3 1/4	16 1/2	1 3/4	3 1/4	3/8	4	7/8	1
20" I B 3 R = .60	75.0	6 3/8	13/16	5/8	5/16	2 7/8	16 7/8	1 9/16	3	3/8	3 1/2	13/16	7/8
	70.0	6 3/8	13/16	9/16	5/16	2 7/8	16 7/8	1 9/16	3	3/8	3 1/2	13/16	7/8
	65.4	6 1/4	13/16	1/2	1/4	2 7/8	16 7/8	1 9/16	3	5/16	3 1/2	3/4	7/8
18" I B 4 R = .56	70.0	6 1/4	1 1/16	3/4	3/8	2 3/4	15 1/4	1 3/8	2 3/4	7/16	3 1/2	1 1/16	7/8
	65.0	6 1/8	1 1/16	5/8	5/16	2 3/4	15 1/4	1 3/8	2 3/4	3/8	3 1/2	1 1/16	7/8
	60.0	6 1/8	1 1/16	9/16	5/16	2 3/4	15 1/4	1 3/8	2 3/4	3/8	3 1/2	1 1/16	7/8
	54.7	6	1 1/16	1/2	1/4	2 3/4	15 1/4	1 3/8	2 3/4	5/16	3 1/2	1 1/16	7/8
15" I B 6 R = .69	75.0	6 1/4	13/16	7/8	7/16	2 3/4	11 3/4	1 5/8	3	1/2	3 1/2	13/16	7/8
	70.0	6 1/8	13/16	13/16	3/8	2 3/4	11 3/4	1 5/8	3	7/16	3 1/2	13/16	7/8
	65.0	6 1/8	13/16	1 1/16	3/8	2 3/4	11 3/4	1 5/8	3	7/16	3 1/2	13/16	7/8
	60.8	6	13/16	5/8	5/16	2 3/4	11 3/4	1 5/8	3	3/8	3 1/2	13/16	7/8
15" I B 7 R = .51	55.0	5 3/4	5/8	1 1/16	3/16	2 1/2	12 1/2	1 1/4	2 3/4	3/8	3 1/2	5/8	3/4
	50.0	5 5/8	5/8	9/16	5/16	2 1/2	12 1/2	1 1/4	2 3/4	3/8	3 1/2	9/16	3/4
	45.0	5 1/2	5/8	7/16	1/4	2 1/2	12 1/2	1 1/4	2 3/4	5/16	3 1/2	9/16	3/4
	42.9	5 1/2	5/8	7/16	1/4	2 1/2	12 1/2	1 1/4	2 3/4	5/16	3 1/2	9/16	3/4

Gages g<sub>2</sub> are based on 1/4" edge distance (7/8" maximum rivet).





# BEAMS

1940

## AMERICAN STANDARD

### PROPERTIES OF SECTIONS

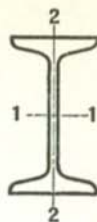

District Rolled	Section Index and Nominal Size	Depth of Beam In.	Weight per Foot Lbs.	Area of Section In. <sup>2</sup>	Width of Flange In.	Web Thickness In.	Axis 1-1			Axis 2-2		
							I	S	r	I	S	r
							In. <sup>4</sup>	In. <sup>2</sup>	In.	In. <sup>4</sup>	In. <sup>2</sup>	In.
P.C.	12" I	12	55.0	16.04	5.600	.810	319.3	53.2	4.46	17.3	6.2	1.04
	B 8		50.0	14.57	5.477	.687	301.6	50.3	4.55	16.0	5.8	1.05
	12 x 5 1/4		45.0	13.10	5.355	.565	284.1	47.3	4.66	14.8	5.5	1.06
	R = .56		40.8	11.84	5.250	.460	268.9	44.8	4.77	13.8	5.3	1.08
P.C.B.	12" I	12	35.0	10.20	5.078	.428	227.0	37.8	4.72	10.0	3.9	0.99
	B 9		31.8	9.26	5.000	.350	215.8	36.0	4.83	9.5	3.8	1.01
	12 x 5 R = .45											
P.C.B.	10" I	10	40.0	11.69	5.091	.741	158.0	31.6	3.68	9.4	3.7	0.90
	B 10		35.0	10.22	4.944	.594	145.8	29.2	3.78	8.5	3.4	0.91
	10 x 4 5/8		30.0	8.75	4.797	.447	133.5	26.7	3.91	7.6	3.2	0.93
	R = .41		25.4	7.38	4.660	.310	122.1	24.4	4.07	6.9	3.0	0.97
P.C.B.	9" I	9	35.0	10.22	4.764	.724	111.3	24.7	3.30	7.3	3.0	0.84
	B 11		30.0	8.76	4.601	.561	101.4	22.5	3.40	6.4	2.8	0.85
	9 x 4 3/8		25.0	7.28	4.437	.397	91.4	20.3	3.54	5.6	2.5	0.88
	R = .39		21.8	6.32	4.330	.290	84.9	18.9	3.67	5.2	2.4	0.90
P.C.B.	8" I	8	25.5	7.43	4.262	.532	68.1	17.0	3.03	4.7	2.2	0.80
	B 12		23.0	6.71	4.171	.441	64.2	16.0	3.09	4.4	2.1	0.81
	8 x 4		20.5	5.97	4.079	.349	60.2	15.1	3.18	4.0	2.0	0.82
	R = .37		18.4	5.34	4.000	.270	56.9	14.2	3.26	3.8	1.9	0.84
P.C.B.	7" I	7	20.0	5.83	3.860	.450	41.9	12.0	2.68	3.1	1.6	0.74
	B 13		17.5	5.09	3.755	.345	38.9	11.1	2.77	2.9	1.6	0.76
	7 x 3 3/8 R = .35		15.3	4.43	3.660	.250	36.2	10.4	2.86	2.7	1.5	0.78
P.C.B.	6" I	6	17.25	5.02	3.565	.465	26.0	8.7	2.28	2.3	1.3	0.68
B 14	14.75		4.29	3.443	.343	23.8	7.9	2.36	2.1	1.2	0.69	
P.C.B.S. 6 x 3 3/8 R = .33	12.5		3.61	3.330	.230	21.8	7.3	2.46	1.8	1.1	0.72	
P.C.	5" I	5	14.75	4.29	3.284	.494	15.0	6.0	1.87	1.7	1.0	0.63
P.C.S.	B 15		12.25	3.56	3.137	.347	13.5	5.4	1.95	1.4	0.91	0.63
P.C.S.	5 x 3 R = .31		10.0	2.87	3.000	.210	12.1	4.8	2.05	1.2	0.82	0.65

For key to symbols in first column, refer to page 3.

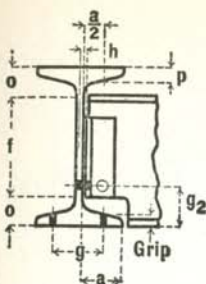

# BEAMS

## AMERICAN STANDARD

### DIMENSIONS OF SECTIONS

### FOR DETAILING

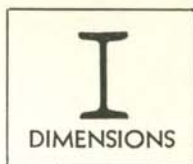

Section Index and Depth	Weight per Foot	Flange		Web		Distance							Max. Flange Rivet
		Width	Thick-ness, p	Thick-ness	Half Thick-ness	a	f	o	Min. g <sub>2</sub>	Clear. h	Gage g	Grip	
		Lbs.	In.	In.	In.	In.	In.	In.	In.	In.	In.	In.	
12" I B 8 R = .56	55.0	5 <sup>5</sup> / <sub>8</sub>	1 <sup>1</sup> / <sub>16</sub>	1 <sup>3</sup> / <sub>16</sub>	7 <sup>1</sup> / <sub>16</sub>	2 <sup>3</sup> / <sub>8</sub>	9 <sup>3</sup> / <sub>8</sub>	1 <sup>5</sup> / <sub>16</sub>	2 <sup>3</sup> / <sub>4</sub>	1 <sup>1</sup> / <sub>2</sub>	3	5 <sup>8</sup> / <sub>16</sub>	3 <sup>4</sup> / <sub>16</sub>
	50.0	5 <sup>1</sup> / <sub>2</sub>	1 <sup>1</sup> / <sub>16</sub>	1 <sup>1</sup> / <sub>16</sub>	3 <sup>8</sup> / <sub>16</sub>	2 <sup>3</sup> / <sub>8</sub>	9 <sup>3</sup> / <sub>8</sub>	1 <sup>5</sup> / <sub>16</sub>	2 <sup>3</sup> / <sub>4</sub>	7 <sup>1</sup> / <sub>16</sub>	3	5 <sup>8</sup> / <sub>16</sub>	3 <sup>4</sup> / <sub>16</sub>
	45.0	5 <sup>3</sup> / <sub>8</sub>	1 <sup>1</sup> / <sub>16</sub>	9 <sup>1</sup> / <sub>16</sub>	5 <sup>1</sup> / <sub>16</sub>	2 <sup>3</sup> / <sub>8</sub>	9 <sup>3</sup> / <sub>8</sub>	1 <sup>5</sup> / <sub>16</sub>	2 <sup>3</sup> / <sub>4</sub>	3 <sup>8</sup> / <sub>16</sub>	3	5 <sup>8</sup> / <sub>16</sub>	3 <sup>4</sup> / <sub>16</sub>
	40.8	5 <sup>1</sup> / <sub>4</sub>	1 <sup>1</sup> / <sub>16</sub>	1 <sup>1</sup> / <sub>2</sub>	1 <sup>1</sup> / <sub>4</sub>	2 <sup>3</sup> / <sub>8</sub>	9 <sup>3</sup> / <sub>8</sub>	1 <sup>5</sup> / <sub>16</sub>	2 <sup>3</sup> / <sub>4</sub>	5 <sup>1</sup> / <sub>16</sub>	3	5 <sup>8</sup> / <sub>16</sub>	3 <sup>4</sup> / <sub>16</sub>
12" I B 9 R = .45	35.0	5 <sup>1</sup> / <sub>8</sub>	3 <sup>1</sup> / <sub>16</sub>	7 <sup>1</sup> / <sub>16</sub>	1 <sup>1</sup> / <sub>4</sub>	2 <sup>3</sup> / <sub>8</sub>	9 <sup>3</sup> / <sub>4</sub>	1 <sup>1</sup> / <sub>8</sub>	2 <sup>1</sup> / <sub>2</sub>	5 <sup>1</sup> / <sub>16</sub>	3	1 <sup>1</sup> / <sub>2</sub>	3 <sup>4</sup> / <sub>16</sub>
	31.8	5	3 <sup>1</sup> / <sub>16</sub>	3 <sup>8</sup> / <sub>16</sub>	3 <sup>1</sup> / <sub>16</sub>	2 <sup>3</sup> / <sub>8</sub>	9 <sup>3</sup> / <sub>4</sub>	1 <sup>1</sup> / <sub>8</sub>	2 <sup>1</sup> / <sub>2</sub>	1 <sup>1</sup> / <sub>4</sub>	3	1 <sup>1</sup> / <sub>2</sub>	3 <sup>4</sup> / <sub>16</sub>
10" I B 10 R = .41	40.0	5 <sup>1</sup> / <sub>8</sub>	1 <sup>1</sup> / <sub>2</sub>	3 <sup>4</sup> / <sub>16</sub>	3 <sup>8</sup> / <sub>16</sub>	2 <sup>1</sup> / <sub>8</sub>	8	1	2 <sup>1</sup> / <sub>2</sub>	7 <sup>1</sup> / <sub>16</sub>	2 <sup>3</sup> / <sub>4</sub>	1 <sup>1</sup> / <sub>2</sub>	3 <sup>4</sup> / <sub>16</sub>
	35.0	5	1 <sup>1</sup> / <sub>2</sub>	5 <sup>8</sup> / <sub>16</sub>	5 <sup>1</sup> / <sub>16</sub>	2 <sup>1</sup> / <sub>8</sub>	8	1	2 <sup>1</sup> / <sub>2</sub>	3 <sup>8</sup> / <sub>16</sub>	2 <sup>3</sup> / <sub>4</sub>	1 <sup>1</sup> / <sub>2</sub>	3 <sup>4</sup> / <sub>16</sub>
	30.0	4 <sup>3</sup> / <sub>4</sub>	1 <sup>1</sup> / <sub>2</sub>	7 <sup>1</sup> / <sub>16</sub>	1 <sup>1</sup> / <sub>4</sub>	2 <sup>1</sup> / <sub>8</sub>	8	1	2 <sup>1</sup> / <sub>2</sub>	5 <sup>1</sup> / <sub>16</sub>	2 <sup>3</sup> / <sub>4</sub>	1 <sup>1</sup> / <sub>2</sub>	3 <sup>4</sup> / <sub>16</sub>
	25.4	4 <sup>5</sup> / <sub>8</sub>	1 <sup>1</sup> / <sub>2</sub>	3 <sup>1</sup> / <sub>16</sub>	3 <sup>1</sup> / <sub>16</sub>	2 <sup>1</sup> / <sub>8</sub>	8	1	2 <sup>1</sup> / <sub>2</sub>	1 <sup>1</sup> / <sub>4</sub>	2 <sup>3</sup> / <sub>4</sub>	1 <sup>1</sup> / <sub>2</sub>	3 <sup>4</sup> / <sub>16</sub>
9" I B 11 R = .39	35.0	4 <sup>3</sup> / <sub>4</sub>	5 <sup>8</sup> / <sub>16</sub>	3 <sup>4</sup> / <sub>16</sub>	3 <sup>8</sup> / <sub>16</sub>	2 <sup>1</sup> / <sub>16</sub>	7 <sup>1</sup> / <sub>16</sub>	1	2 <sup>1</sup> / <sub>2</sub>	1 <sup>3</sup> / <sub>16</sub>	2 <sup>1</sup> / <sub>2</sub>	1 <sup>1</sup> / <sub>2</sub>	3 <sup>4</sup> / <sub>16</sub>
	30.0	4 <sup>9</sup> / <sub>16</sub>	5 <sup>8</sup> / <sub>16</sub>	9 <sup>1</sup> / <sub>16</sub>	5 <sup>1</sup> / <sub>16</sub>	2 <sup>1</sup> / <sub>16</sub>	7 <sup>1</sup> / <sub>16</sub>	1	2 <sup>1</sup> / <sub>2</sub>	5 <sup>8</sup> / <sub>16</sub>	2 <sup>1</sup> / <sub>2</sub>	1 <sup>1</sup> / <sub>2</sub>	3 <sup>4</sup> / <sub>16</sub>
	25.0	4 <sup>7</sup> / <sub>16</sub>	5 <sup>8</sup> / <sub>16</sub>	7 <sup>1</sup> / <sub>16</sub>	1 <sup>1</sup> / <sub>4</sub>	2 <sup>1</sup> / <sub>16</sub>	7 <sup>1</sup> / <sub>16</sub>	1	2 <sup>1</sup> / <sub>2</sub>	1 <sup>1</sup> / <sub>2</sub>	2 <sup>1</sup> / <sub>2</sub>	1 <sup>1</sup> / <sub>2</sub>	3 <sup>4</sup> / <sub>16</sub>
	21.8	4 <sup>5</sup> / <sub>16</sub>	5 <sup>8</sup> / <sub>16</sub>	5 <sup>1</sup> / <sub>16</sub>	3 <sup>1</sup> / <sub>16</sub>	2 <sup>1</sup> / <sub>16</sub>	7 <sup>1</sup> / <sub>16</sub>	1	2 <sup>1</sup> / <sub>2</sub>	3 <sup>8</sup> / <sub>16</sub>	2 <sup>1</sup> / <sub>2</sub>	1 <sup>1</sup> / <sub>2</sub>	3 <sup>4</sup> / <sub>16</sub>
8" I B 12 R = .37	25.5	4 <sup>1</sup> / <sub>4</sub>	7 <sup>1</sup> / <sub>16</sub>	9 <sup>1</sup> / <sub>16</sub>	1 <sup>1</sup> / <sub>4</sub>	1 <sup>7</sup> / <sub>8</sub>	6 <sup>1</sup> / <sub>4</sub>	7 <sup>8</sup> / <sub>16</sub>	2 <sup>1</sup> / <sub>4</sub>	5 <sup>1</sup> / <sub>16</sub>	2 <sup>1</sup> / <sub>4</sub>	7 <sup>1</sup> / <sub>16</sub>	3 <sup>4</sup> / <sub>16</sub>
	23.0	4 <sup>1</sup> / <sub>8</sub>	7 <sup>1</sup> / <sub>16</sub>	7 <sup>1</sup> / <sub>16</sub>	1 <sup>1</sup> / <sub>4</sub>	1 <sup>7</sup> / <sub>8</sub>	6 <sup>1</sup> / <sub>4</sub>	7 <sup>8</sup> / <sub>16</sub>	2 <sup>1</sup> / <sub>4</sub>	5 <sup>1</sup> / <sub>16</sub>	2 <sup>1</sup> / <sub>4</sub>	7 <sup>1</sup> / <sub>16</sub>	3 <sup>4</sup> / <sub>16</sub>
	20.5	4 <sup>1</sup> / <sub>8</sub>	7 <sup>1</sup> / <sub>16</sub>	3 <sup>8</sup> / <sub>16</sub>	3 <sup>1</sup> / <sub>16</sub>	1 <sup>7</sup> / <sub>8</sub>	6 <sup>1</sup> / <sub>4</sub>	7 <sup>8</sup> / <sub>16</sub>	2 <sup>1</sup> / <sub>4</sub>	1 <sup>1</sup> / <sub>4</sub>	2 <sup>1</sup> / <sub>4</sub>	7 <sup>1</sup> / <sub>16</sub>	3 <sup>4</sup> / <sub>16</sub>
	18.4	4	7 <sup>1</sup> / <sub>16</sub>	3 <sup>1</sup> / <sub>16</sub>	1 <sup>1</sup> / <sub>8</sub>	1 <sup>7</sup> / <sub>8</sub>	6 <sup>1</sup> / <sub>4</sub>	7 <sup>8</sup> / <sub>16</sub>	2 <sup>1</sup> / <sub>4</sub>	3 <sup>1</sup> / <sub>16</sub>	2 <sup>1</sup> / <sub>4</sub>	7 <sup>1</sup> / <sub>16</sub>	3 <sup>4</sup> / <sub>16</sub>
7" I B 13 R = .35	20.0	3 <sup>7</sup> / <sub>8</sub>	3 <sup>8</sup> / <sub>16</sub>	7 <sup>1</sup> / <sub>16</sub>	1 <sup>1</sup> / <sub>4</sub>	1 <sup>3</sup> / <sub>4</sub>	5 <sup>3</sup> / <sub>8</sub>	1 <sup>3</sup> / <sub>16</sub>	2	5 <sup>1</sup> / <sub>16</sub>	2 <sup>1</sup> / <sub>4</sub>	3 <sup>8</sup> / <sub>16</sub>	5 <sup>8</sup> / <sub>16</sub>
	17.5	3 <sup>3</sup> / <sub>4</sub>	3 <sup>8</sup> / <sub>16</sub>	3 <sup>8</sup> / <sub>16</sub>	3 <sup>1</sup> / <sub>16</sub>	1 <sup>3</sup> / <sub>4</sub>	5 <sup>3</sup> / <sub>8</sub>	1 <sup>3</sup> / <sub>16</sub>	2	1 <sup>1</sup> / <sub>4</sub>	2 <sup>1</sup> / <sub>4</sub>	3 <sup>8</sup> / <sub>16</sub>	5 <sup>8</sup> / <sub>16</sub>
	15.3	3 <sup>5</sup> / <sub>8</sub>	3 <sup>8</sup> / <sub>16</sub>	1 <sup>1</sup> / <sub>4</sub>	1 <sup>1</sup> / <sub>8</sub>	1 <sup>3</sup> / <sub>4</sub>	5 <sup>3</sup> / <sub>8</sub>	1 <sup>3</sup> / <sub>16</sub>	2 <sup>1</sup> / <sub>4</sub>	3 <sup>1</sup> / <sub>16</sub>	2 <sup>1</sup> / <sub>4</sub>	3 <sup>8</sup> / <sub>16</sub>	5 <sup>8</sup> / <sub>16</sub>
6" I B 14 R = .33	17.25	3 <sup>5</sup> / <sub>8</sub>	3 <sup>8</sup> / <sub>16</sub>	1 <sup>1</sup> / <sub>2</sub>	1 <sup>1</sup> / <sub>4</sub>	1 <sup>1</sup> / <sub>2</sub>	4 <sup>1</sup> / <sub>2</sub>	3 <sup>4</sup> / <sub>16</sub>	2	5 <sup>1</sup> / <sub>16</sub>	2	3 <sup>8</sup> / <sub>16</sub>	5 <sup>8</sup> / <sub>16</sub>
	14.75	3 <sup>1</sup> / <sub>2</sub>	3 <sup>8</sup> / <sub>16</sub>	3 <sup>8</sup> / <sub>16</sub>	3 <sup>1</sup> / <sub>16</sub>	1 <sup>1</sup> / <sub>2</sub>	4 <sup>1</sup> / <sub>2</sub>	3 <sup>4</sup> / <sub>16</sub>	2	1 <sup>1</sup> / <sub>4</sub>	2	3 <sup>8</sup> / <sub>16</sub>	5 <sup>8</sup> / <sub>16</sub>
	12.5	3 <sup>3</sup> / <sub>8</sub>	3 <sup>8</sup> / <sub>16</sub>	1 <sup>1</sup> / <sub>4</sub>	1 <sup>1</sup> / <sub>8</sub>	1 <sup>1</sup> / <sub>2</sub>	4 <sup>1</sup> / <sub>2</sub>	3 <sup>4</sup> / <sub>16</sub>	2	3 <sup>1</sup> / <sub>16</sub>	2	3 <sup>1</sup> / <sub>16</sub>	5 <sup>8</sup> / <sub>16</sub>
5" I B 15 R = .31	14.75	3 <sup>1</sup> / <sub>4</sub>	5 <sup>1</sup> / <sub>16</sub>	1 <sup>1</sup> / <sub>2</sub>	1 <sup>1</sup> / <sub>4</sub>	1 <sup>3</sup> / <sub>8</sub>	3 <sup>5</sup> / <sub>8</sub>	1 <sup>1</sup> / <sub>16</sub>	2	5 <sup>1</sup> / <sub>16</sub>	1 <sup>3</sup> / <sub>4</sub>	5 <sup>1</sup> / <sub>16</sub>	1 <sup>1</sup> / <sub>2</sub>
	12.25	3 <sup>1</sup> / <sub>8</sub>	5 <sup>1</sup> / <sub>16</sub>	3 <sup>8</sup> / <sub>16</sub>	3 <sup>1</sup> / <sub>16</sub>	1 <sup>3</sup> / <sub>8</sub>	3 <sup>5</sup> / <sub>8</sub>	1 <sup>1</sup> / <sub>16</sub>	2	1 <sup>1</sup> / <sub>4</sub>	1 <sup>3</sup> / <sub>4</sub>	5 <sup>1</sup> / <sub>16</sub>	1 <sup>1</sup> / <sub>2</sub>
	10.0	3	3 <sup>1</sup> / <sub>16</sub>	1 <sup>1</sup> / <sub>4</sub>	1 <sup>1</sup> / <sub>8</sub>	1 <sup>3</sup> / <sub>8</sub>	3 <sup>5</sup> / <sub>8</sub>	1 <sup>1</sup> / <sub>16</sub>	2	3 <sup>1</sup> / <sub>16</sub>	1 <sup>3</sup> / <sub>4</sub>	5 <sup>1</sup> / <sub>16</sub>	1 <sup>1</sup> / <sub>2</sub>

Gages g<sub>2</sub> are based on 1 1/4" edge distance (3/4" maximum rivet).



# BEAMS

1940

## AMERICAN STANDARD PROPERTIES OF SECTIONS

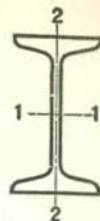

District Rolled	Section Index and Nominal Size	Depth of Beam In.	Weight per Foot Lbs.	Area of Section In. <sup>2</sup>	Width of Flange In.	Web Thickness In.	Axis 1-1			Axis 2-2		
							I In. <sup>4</sup>	S In. <sup>3</sup>	r In.	I In. <sup>4</sup>	S In. <sup>3</sup>	r In.
P.C.	4" I	4	10.5	3.05	2.870	.400	7.1	3.5	1.52	1.00	0.70	0.57
P.C.B.	B16		9.5	2.76	2.796	.326	6.7	3.3	1.56	0.91	0.65	0.58
P.C.B.S.	4 x 2 $\frac{5}{8}$		8.5	2.46	2.723	.253	6.3	3.2	1.60	0.83	0.61	0.58
P.C.B.S.	R = .29		7.7	2.21	2.660	.190	6.0	3.0	1.64	0.77	0.58	0.59
P.C.B.	3" I	3	7.5	2.17	2.509	.349	2.9	1.9	1.15	0.59	0.47	0.52
P.C.B.S.	B 17		6.5	1.88	2.411	.251	2.7	1.8	1.19	0.51	0.43	0.52
P.C.B.S.	3 x 2 $\frac{3}{8}$		5.7	1.64	2.330	.170	2.5	1.7	1.23	0.46	0.40	0.53
P.C.B.S.	R = .27											

### H-BEAMS

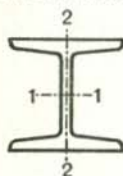

District Rolled	Section Index and Nominal Size	Depth of Beam In.	Weight per Foot Lbs.	Area of Section In. <sup>2</sup>	Width of Flange In.	Web Thickness In.	Axis 1-1			Axis 2-2		
							I In. <sup>4</sup>	S In. <sup>3</sup>	r In.	I In. <sup>4</sup>	S In. <sup>3</sup>	r In.
P.C.	H 4	8	37.7	11.00	8.125	.500	120.8	30.2	3.31	36.9	9.1	1.83
	8 x 18		34.3	10.00	8.000	.375	115.5	28.9	3.40	35.1	8.8	1.87
	R = .313		32.6	9.50	7.938	.313	112.8	28.2	3.45	34.2	8.6	1.90
P.C.	H 3a	6	27.5	8.08	6.063	.438	49.3	16.4	2.47	16.0	5.3	1.41
	6 x 6 R = .313		25.0	7.33	5.938	.313	47.0	15.7	2.53	14.9	5.0	1.43
P.C.	H 3	6	22.5	6.61	6.063	.375	41.0	13.7	2.49	12.2	4.0	1.36
	6x6 R = .313		20.0	5.86	5.938	.250	38.8	12.9	2.57	11.4	3.8	1.39
P.C.	H 2	5	18.9	5.47	5.000	.313	23.8	9.5	2.08	7.8	3.1	1.20
P.C.S.	H 1	4	13.8	3.99	4.000	.313	10.7	5.3	1.64	3.6	1.8	0.95
	4 x 4 R = .313											

For key to symbols in first column, refer to page 3.

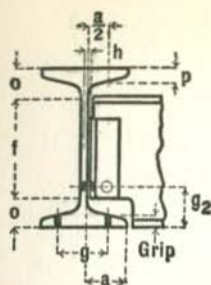

# BEAMS

## AMERICAN STANDARD

### DIMENSIONS OF SECTIONS FOR DETAILING

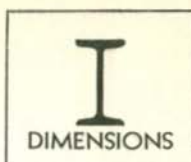

Section Index and Depth	Weight per Foot	Flange		Web		Distance						Max. Flange Rivet	
		Width	Thick-ness, p	Thick-ness	Half Thick-ness	a	f	o	Min. g <sub>2</sub>	Clear. h	Gage g		Grip
		Lbs.	In.	In.	In.	In.	In.	In.	In.	In.	In.		In.
4" I B 16 R = .29	10.5	27/8	5/16	7/16	3/16	1 1/4	2 3/4	5/8	2	1/4	1 1/2	5/16	1/2
	9.5	2 3/4	5/16	5/16	3/16	1 1/4	2 3/4	5/8	2	1/4	1 1/2	5/16	1/2
	8.5	2 3/4	5/16	1/4	1/8	1 1/4	2 3/4	5/8	2	3/16	1 1/2	5/16	1/2
	7.7	2 5/8	5/16	3/16	1/8	1 1/4	2 3/4	5/8	2	3/16	1 1/2	5/16	1/2
3" I B 17 R = .27	7.5	2 1/2	1/4	3/8	3/16	1 1/8	1 7/8	9/16	.....	1/4	1 1/2	1/4	3/8
	6.5	2 3/8	1/4	1/4	1/8	1 1/8	1 7/8	9/16	.....	3/16	1 1/2	1/4	3/8
	5.7	2 3/8	1/4	3/16	1/8	1 1/8	1 7/8	9/16	.....	3/16	1 1/2	1/4	3/8

Gages g<sub>2</sub> are based on 1 1/4" edge distance (3/8" maximum rivet).

## H-BEAMS

Section Index and Depth	Weight per Foot	Flange		Web		Distance						Max. Flange Rivet
		Width	Thick-ness, p	Thick-ness	Half Thick-ness	a	f	o	Min. g <sub>2</sub>	Gage g	Grip	
		Lbs.	In.	In.	In.	In.	In.	In.	In.	In.	In.	
H 4 8 R = .313	37.7	8 1/8	7/16	1/2	1/4	3 13/16	6 1/4	7/8	2 1/4	5	7/16	7/8
	34.3	8	7/16	3/8	3/16	3 13/16	6 1/4	7/8	2 1/4	5	7/16	7/8
	32.6	8	7/16	5/16	3/16	3 13/16	6 1/4	7/8	2 1/4	5	7/16	7/8
H 3a 6 R = .313	27.5	6 1/8	1/2	7/16	3/4	2 13/16	4 1/4	7/8	2 1/4	3 1/2	1/2	7/8
	25.0	6	1/2	5/16	3/16	2 13/16	4 1/4	7/8	2 1/4	3 1/2	1/2	7/8
H 3 6 R = .313	22.5	6 1/8	3/8	3/8	3/16	2 7/8	4 7/16	3/4	2	3 1/2	3/8	7/8
	20.0	6	3/8	1/4	1/8	2 7/8	4 7/16	3/4	2	3 1/2	3/8	7/8
H 2 5 R = .313	18.9	5	7/16	5/16	3/16	2 3/8	3 3/8	13/16	2	2 3/4	7/16	3/4
H 1 4 R = .313	13.8	4	3/8	5/16	3/16	1 7/8	2 1/2	3/4	2	2 1/4	3/8	5/8

Gages g<sub>2</sub> are based on 1 1/4" edge distance (3/8" maximum rivet).

# CHANNELS

## AMERICAN STANDARD

### PROPERTIES OF SECTIONS

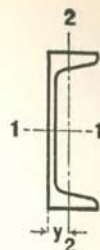

District Rolled	Section Index and Nominal Size	Depth of Channel In.	Weight per Foot Lbs.	Area of Section In. <sup>2</sup>	Width of Flange In.	Web Thickness In.	Axis 1-1			Axis 2-2			
							I	S	r	I	S	r	y
							In. <sup>4</sup>	In. <sup>3</sup>	In.	In. <sup>4</sup>	In. <sup>3</sup>	In.	In.
P.C.	†C 60 18 x 4 R = .625	18	58.0	16.98	4.200	.700	670.7	74.5	6.29	18.5	5.6	1.04	0.88
			51.9	15.18	4.100	.600	622.1	69.1	6.40	17.1	5.3	1.06	0.87
			45.8	13.38	4.000	.500	573.5	63.7	6.55	15.8	5.1	1.09	0.89
			42.7	12.48	3.950	.450	549.2	61.0	6.64	15.0	4.9	1.10	0.90
P.C.			55.0	16.11	3.814	.814	429.0	57.2	5.16	12.1	4.1	0.87	0.82
P.C.B.			50.0	14.64	3.716	.716	401.4	53.6	5.24	11.2	3.8	0.87	0.80
P.C.B.	C 1 15 x 3 <sup>3</sup> / <sub>8</sub> R = .50	15	45.0	13.17	3.618	.618	373.9	49.8	5.33	10.3	3.6	0.88	0.79
P.C.B.			40.0	11.70	3.520	.520	346.3	46.2	5.44	9.3	3.4	0.89	0.78
P.C.B.			35.0	10.23	3.422	.422	318.7	42.5	5.58	8.4	3.2	0.91	0.79
P.C.B.			33.9	9.90	3.400	.400	312.6	41.7	5.62	8.2	3.2	0.91	0.79
P.C.			50.0	14.66	4.412	.787	312.9	48.1	4.62	16.7	4.9	1.07	0.98
P.C.	C 20 13 x 4 R = .48	13	45.0	13.18	4.298	.673	292.0	44.9	4.71	15.3	4.6	1.08	0.97
P.C.			40.0	11.71	4.185	.560	271.4	41.7	4.82	13.9	4.3	1.09	0.97
P.C.B.			37.0	10.82	4.117	.492	258.9	39.8	4.89	13.0	4.2	1.10	0.98
P.C.B.			35.0	10.24	4.072	.447	250.7	38.6	4.95	12.5	4.0	1.10	0.99
P.C.B.			31.8	9.30	4.000	.375	237.5	36.5	5.05	11.6	3.9	1.11	1.01
P.C.B.	C 2 12 x 3 R = .38	12	40.0	11.73	3.415	.755	196.5	32.8	4.09	6.6	2.5	0.75	0.72
			35.0	10.26	3.292	.632	178.8	29.8	4.18	5.9	2.3	0.76	0.69
			30.0	8.79	3.170	.510	161.2	26.9	4.28	5.2	2.1	0.77	0.68
			25.0	7.32	3.047	.387	143.5	23.9	4.43	4.5	1.9	0.79	0.68
			20.7	6.03	2.940	.280	128.1	2.14	4.61	3.9	1.7	0.81	0.70
P.C.B.			35.0	10.27	3.180	.820	115.2	23.0	3.34	4.6	1.9	0.67	0.69
P.C.B.	C 3 10 x 2 <sup>5</sup> / <sub>8</sub> R = .34	10	30.0	8.80	3.033	.673	103.0	20.6	3.42	4.0	1.7	0.67	0.65
P.C.B.			25.0	7.33	2.886	.526	90.7	18.1	3.52	3.4	1.5	0.68	0.62
P.C.B.S.			20.0	5.86	2.739	.379	78.5	15.7	3.66	2.8	1.3	0.70	0.61
P.C.B.S.			15.3	4.47	2.600	.240	66.9	13.4	3.87	2.3	1.2	0.72	0.64
P.C.B.	C 4 9 x 2 <sup>1</sup> / <sub>2</sub> R = .33	9	25.0	7.33	2.812	.612	70.5	15.7	3.10	3.0	1.4	0.64	0.61
			20.0	5.86	2.648	.448	60.6	13.5	3.22	2.4	1.2	0.65	0.59
			15.0	4.39	2.485	.285	50.7	11.3	3.40	1.9	1.0	0.67	0.59
			13.4	3.89	2.430	.230	47.3	10.5	3.49	1.8	0.97	0.67	0.61

†C 60 is not an American standard channel.  
For key to symbols in first column, refer to page 3.

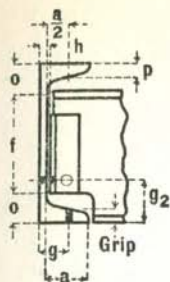

# CHANNELS

## AMERICAN STANDARD

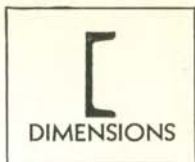

### DIMENSIONS OF SECTIONS FOR DETAILING

Section Index and Depth	Weight per Foot	Flange		Web		Distance						Max. Flange Rivet	
		Width	Thick-ness, p	Thick-ness	Half Thick-ness	a	f	o	Min. g <sub>2</sub>	Clear. h	Gage g		Grip
†C 60 18 R = .625	58.0	4 1/4	5/8	11/16	3/8	3 1/2	15 3/8	1 5/16	2 3/4	3/4	2 1/2	5/8	1
	51.9	4 1/8	5/8	5/8	5/16	3 1/2	15 3/8	1 5/16	2 3/4	11/16	2 1/2	5/8	1
	45.8	4	5/8	1/2	1/4	3 1/2	15 3/8	1 5/16	2 3/4	9/16	2 1/2	5/8	1
	42.7	4	5/8	7/16	1/4	3 1/2	15 3/8	1 5/16	2 3/4	1/2	2 1/2	5/8	1
C 1 15 R = .50	55.0	3 7/8	5/8	13/16	7/16	3	12 3/8	1 5/16	2 3/4	7/8	2 1/4	11/16	1
	50.0	3 3/4	5/8	3/4	3/8	3	12 3/8	1 5/16	2 3/4	13/16	2 1/4	5/8	1
	45.0	3 5/8	5/8	5/8	5/16	3	12 3/8	1 5/16	2 3/4	11/16	2 1/4	5/8	1
	40.0	3 1/2	5/8	9/16	1/4	3	12 3/8	1 5/16	2 3/4	5/8	2	5/8	1
	35.0	3 3/8	5/8	7/16	1/4	3	12 3/8	1 5/16	2 3/4	1/2	2	5/8	1
33.9	3 3/8	5/8	7/16	3/16	3	12 3/8	1 5/16	2 3/4	1/2	2	5/8	1	
C 20 13 R = .48	50.0	4 3/8	5/8	13/16	7/16	3 5/8	10 3/8	1 5/16	2 3/4	7/8	2 1/2	5/8	1
	45.0	4 1/4	5/8	11/16	3/8	3 5/8	10 3/8	1 5/16	2 3/4	3/4	2 1/2	5/8	1
	40.0	4 1/8	5/8	9/16	5/16	3 5/8	10 3/8	1 5/16	2 3/4	5/8	2 1/2	9/16	1
	37.0	4 1/8	5/8	1/2	1/4	3 5/8	10 3/8	1 5/16	2 3/4	9/16	2 1/2	9/16	1
	35.0	4 1/8	5/8	7/16	1/4	3 5/8	10 3/8	1 5/16	2 3/4	1/2	2 1/2	9/16	1
31.8	4	5/8	3/8	3/16	3 5/8	10 3/8	1 5/16	2 3/4	7/16	2 1/2	9/16	1	
C 2 12 R = .38	40.0	3 3/8	1/2	3/4	3/8	2 5/8	9 7/8	1 1/16	2 1/2	13/16	2	1/2	7/8
	35.0	3 1/4	1/2	5/8	5/16	2 5/8	9 7/8	1 1/16	2 1/2	11/16	2	1/2	7/8
	30.0	3 3/8	1/2	1/2	1/4	2 5/8	9 7/8	1 1/16	2 1/2	9/16	1 3/4	1/2	7/8
	25.0	3	1/2	3/8	3/16	2 5/8	9 7/8	1 1/16	2 1/2	7/16	1 3/4	1/2	7/8
	20.7	3	1/2	5/16	1/8	2 5/8	9 7/8	1 1/16	2 1/2	3/8	1 3/4	1/2	7/8
C 3 10 R = .34	35.0	3 1/8	7/16	13/16	7/16	2 3/8	8 1/8	1 5/16	2 1/2	7/8	1 3/4	1/2	3/4
	30.0	3	7/16	11/16	3/8	2 3/8	8 1/8	1 5/16	2 1/2	3/4	1 3/4	7/16	3/4
	25.0	2 7/8	7/16	9/16	1/4	2 3/8	8 1/8	1 5/16	2 1/2	5/8	1 3/4	7/16	3/4
	20.0	2 3/4	7/16	3/8	3/16	2 3/8	8 1/8	1 5/16	2 1/2	7/16	1 1/2	7/16	3/4
	15.3	2 5/8	7/16	1/4	1/8	2 3/8	8 1/8	1 5/16	2 1/2	5/16	1 1/2	7/16	3/4
C 4 9 R = .33	25.0	2 3/4	7/16	5/8	5/16	2 1/4	7 1/4	7/8	2 1/2	11/16	1 1/2	7/16	3/4
	20.0	2 5/8	7/16	7/16	1/4	2 1/4	7 1/4	7/8	2 1/2	1/2	1 1/2	7/16	3/4
	15.0	2 1/2	7/16	5/16	3/16	2 1/4	7 1/4	7/8	2 1/2	3/8	1 3/8	7/16	3/4
	13.4	2 3/8	7/16	1/4	1/8	2 1/4	7 1/4	7/8	2 1/2	7/16	1 3/8	7/16	3/4

Gages g<sub>2</sub> are based on 1 1/4" edge distance (7/8" maximum rivet).  
†C 60 is not an American standard channel.

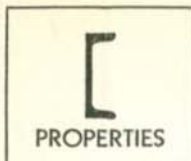

# CHANNELS

## AMERICAN STANDARD

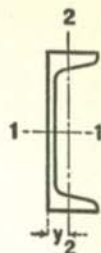

### PROPERTIES OF SECTIONS

District Rolled	Section Index and Nominal Size	Depth of Channel	Weight per Foot	Area of Section	Width of Flange	Web Thickness	Axis 1-1			Axis 2-2			
							I	S	r	I	S	r	y
							In. <sup>4</sup>	In. <sup>3</sup>	In.	In. <sup>4</sup>	In. <sup>3</sup>	In.	In.
P.C.B.			21.25	6.23	2.619	.579	47.6	11.9	2.77	2.20	1.10	0.60	0.59
P.C.B.	C 5		18.75	5.49	2.527	.487	43.7	10.9	2.82	2.00	1.00	0.60	0.57
P.C.B.S.	8 x 2 3/4	8	16.25	4.76	2.435	.395	39.8	9.9	2.89	1.80	0.94	0.61	0.56
P.C.B.S.	R = .32		13.75	4.02	2.343	.303	35.8	9.0	2.99	1.50	0.86	0.62	0.56
P.C.B.S.			11.50	3.36	2.260	.220	32.3	8.1	3.10	1.30	0.79	0.63	0.58
P.C.			19.75	5.79	2.509	.629	33.1	9.4	2.39	1.80	0.96	0.56	0.58
P.C.B.	C 6		17.25	5.05	2.404	.524	30.1	8.6	2.44	1.60	0.86	0.56	0.55
P.C.B.S.	7 x 2	7	14.75	4.32	2.299	.419	27.1	7.7	2.51	1.40	0.79	0.57	0.53
P.C.B.S.	R = .31		12.25	3.58	2.194	.314	24.1	6.9	2.59	1.20	0.71	0.58	0.53
P.C.B.S.			9.80	2.85	2.090	.210	21.1	6.0	2.72	0.98	0.63	0.59	0.55
P.C.B.	C 7		15.50	4.54	2.279	.559	19.5	6.5	2.07	1.30	0.73	0.53	0.55
P.C.B.S.	6 x 2	6	13.00	3.81	2.157	.437	17.3	5.8	2.13	1.10	0.65	0.53	0.52
P.C.B.S.	R = .30		10.50	3.07	2.034	.314	15.1	5.0	2.22	0.87	0.57	0.53	0.50
P.C.B.S.			8.20	2.39	1.920	.200	13.0	4.3	2.34	0.70	0.50	0.54	0.52
P.C.B.S.	C 8		11.50	3.36	2.032	.472	10.4	4.1	1.76	0.82	0.54	0.49	0.51
P.C.B.S.	5 x 1 3/4	5	9.00	2.63	1.885	.325	8.8	3.5	1.83	0.64	0.45	0.49	0.48
			6.70	1.95	1.750	.190	7.4	3.0	1.95	0.48	0.38	0.50	0.49
P.C.B.S.	C 9	4	7.25	2.12	1.720	.320	4.5	2.3	1.47	0.44	0.35	0.46	0.46
			6.25	1.82	1.647	.247	4.1	2.1	1.50	0.38	0.32	0.45	0.46
P.C.B.S.	4 x 1 5/8		5.40	1.56	1.580	.180	3.8	1.9	1.56	0.32	0.29	0.45	0.46
P.C.B.S.	R = .28												
P.C.B.	C 10		6.00	1.75	1.596	.356	2.1	1.4	1.08	0.31	0.27	0.42	0.46
P.C.B.S.	3 x 1 1/2	3	5.00	1.46	1.498	.258	1.8	1.2	1.12	0.25	0.24	0.41	0.44
P.C.B.S.			4.10	1.19	1.410	.170	1.6	1.1	1.17	0.20	0.21	0.41	0.44

For key to symbols in first column, refer to page 3.

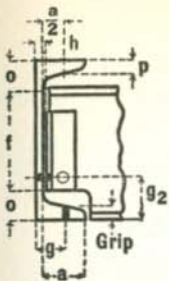

# CHANNELS

## AMERICAN STANDARD

### DIMENSIONS OF SECTIONS FOR DETAILING

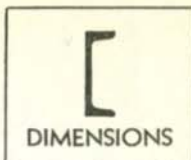

Section Index and Depth	Weight per Foot	Flange		Web		Distance						Max. Flange Rivet	
		Width	Thick-ness, p	Thick-ness	Half Thick-ness	a	f	o	Min. g <sub>2</sub>	Clear. h	Gage g		Grip
		Lbs.	In.	In.	In.	In.	In.	In.	In.	In.	In.		In.
C 5 8 R = .32	21.25	2 5/8	3/8	5/8	5/16	2	6 3/8	13/16	2 1/4	1 1/16	1 1/2	3/8	3/4
	18.75	2 1/2	3/8	1/2	1/4	2	6 3/8	13/16	2 1/4	9/16	1 1/2	3/8	3/4
	16.25	2 3/8	3/8	7/16	3/16	2	6 3/8	13/16	2 1/4	1/2	1 1/2	3/8	3/4
	13.75	2 3/8	3/8	5/16	3/16	2	6 3/8	13/16	2 1/4	3/8	1 3/8	3/8	3/4
	11.5	2 1/4	3/8	1/4	1/8	2	6 3/8	13/16	2 1/4	5/16	1 3/8	3/8	3/4
C 6 7 R = .31	19.75	2 1/2	3/8	5/8	5/16	1 7/8	5 3/8	13/16	2	1 1/16	1 1/2	3/8	5/8
	17.25	2 3/8	3/8	9/16	1/4	1 7/8	5 3/8	13/16	2	5/8	1 1/2	3/8	5/8
	14.75	2 1/4	3/8	7/16	1/4	1 7/8	5 3/8	13/16	2	1/2	1 1/4	3/8	5/8
	12.25	2 1/4	3/8	5/16	3/16	1 7/8	5 3/8	13/16	2	3/8	1 1/4	3/8	5/8
	9.8	2 1/8	3/8	1/4	1/8	1 7/8	5 3/8	13/16	2	5/16	1 1/4	3/8	5/8
C 7 6 R = .30	15.5	2 1/4	3/8	9/16	5/16	1 3/4	4 1/2	3/4	2	5/8	1 3/8	3/8	5/8
	13.0	2 1/8	3/8	7/16	1/4	1 3/4	4 1/2	3/4	2	1/2	1 3/8	3/16	5/8
	10.5	2	3/8	5/16	3/16	1 3/4	4 1/2	3/4	2	3/8	1 3/8	3/8	5/8
	8.2	1 7/8	3/8	3/16	1/8	1 3/4	4 1/2	3/4	2	1/4	1 1/8	3/16	5/8
C 8 5 R = .29	11.5	2	5/16	1/2	1/4	1 1/2	3 5/8	1 1/16	2	9/16	1 1/8	5/16	1/2
	9.0	1 7/8	5/16	5/16	3/16	1 1/2	3 5/8	1 1/16	2	3/8	1 1/8	5/16	1/2
	6.7	1 3/4	5/16	3/16	1/8	1 1/2	3 5/8	1 1/16	2	1/4	1 1/8	3/16	1/2
C 9 4 R = .28	7.25	1 3/4	5/16	5/16	3/16	1 3/8	2 3/4	5/8	2	3/8	1	5/16	1/2
	6.25	1 5/8	5/16	1/4	1/8	1 3/8	2 3/4	5/8	2	5/16	1	5/16	1/2
	5.4	1 5/8	5/16	3/16	1/8	1 3/8	2 3/4	5/8	2	1/4	1	1/4	1/2
C 10 3 R = .27	6.0	1 5/8	1/4	3/8	3/16	1 1/4	1 3/4	5/8	.....	7/16	7/8	5/16	1/2
	5.0	1 1/2	1/4	1/4	1/8	1 1/4	1 3/4	5/8	.....	5/16	7/8	1/4	1/2
	4.1	1 3/8	1/4	3/16	1/8	1 1/4	1 3/4	5/8	.....	1/4	7/8	1/4	1/2

Gages g<sub>2</sub> are based on 1/4" edge distance (3/8" maximum rivet).



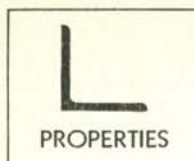

# EQUAL ANGLES

## PROPERTIES OF SECTIONS

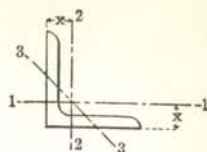

District Rolled	Section Index	Size	Thickness	Weight per Foot	Area of Section	Axis 1-1 and Axis 2-2				Axis 3-3		
						I	S	x	x	x min.		
						In. <sup>4</sup>	In. <sup>3</sup>	In.	In.	In.		
P.C.B.	A 1 R = 5/8	8 x 8	1 1/8	56.9	16.73	98.0	17.5	2.42	2.41	1.55		
			1 1/16	54.0	15.87	93.5	16.7	2.43	2.39	1.56		
			1	51.0	15.00	89.0	15.8	2.44	2.37	1.56		
			15/16	48.1	14.12	84.3	14.9	2.44	2.34	1.56		
			7/8	45.0	13.23	79.6	14.0	2.45	2.32	1.56		
			13/16	42.0	12.34	74.7	13.1	2.46	2.30	1.57		
			3/4	38.9	11.44	69.7	12.2	2.47	2.28	1.57		
			11/16	35.8	10.53	64.6	11.2	2.48	2.25	1.58		
			5/8	32.7	9.61	59.4	10.3	2.49	2.23	1.58		
			9/16	29.6	8.68	54.1	9.3	2.50	2.21	1.58		
			1/2	26.4	7.75	48.6	8.4	2.51	2.19	1.58		
P.			1 1/16	39.6	11.62	37.2	9.0	1.79	1.89	1.16		
P.C.B.			1	37.4	11.00	35.5	8.6	1.80	1.86	1.16		
P.C.B.			15/16	35.3	10.37	33.7	8.1	1.80	1.84	1.16		
P.C.B.			7/8	33.1	9.73	31.9	7.6	1.81	1.82	1.17		
P.C.B.			13/16	31.0	9.09	30.1	7.2	1.82	1.80	1.17		
P.C.B.S.			3/4	28.7	8.44	28.2	6.7	1.83	1.78	1.17		
P.C.B.S.	A 2 R = 1/2	6 x 6	11/16	26.5	7.78	26.2	6.2	1.83	1.75	1.17		
P.C.B.S.			5/8	24.2	7.11	24.2	5.7	1.84	1.73	1.17		
P.C.B.S.			9/16	21.9	6.43	22.1	5.1	1.85	1.71	1.18		
P.C.B.S.			1/2	19.6	5.75	19.9	4.6	1.86	1.68	1.18		
P.C.B.S.			7/16	17.2	5.06	17.7	4.1	1.87	1.66	1.19		
P.C.B.S.			3/8	14.9	4.36	15.4	3.5	1.88	1.64	1.19		
P.S.			*9/16	12.6	3.66	13.0	3.0	1.89	1.61	1.19		
P.C.					1	30.6	9.00	19.6	5.8	1.48	1.61	0.96
P.C.					15/16	28.9	8.50	18.7	5.5	1.48	1.59	0.96
P.C.					7/8	27.2	7.98	17.8	5.2	1.49	1.57	0.96
P.C.			13/16	25.4	7.47	16.8	4.9	1.50	1.55	0.97		
P.C.B.S.			3/4	23.6	6.94	15.7	4.5	1.50	1.52	0.97		
P.C.B.S.	A 3 R = 1/2	5 x 5	11/16	21.8	6.40	14.7	4.2	1.51	1.50	0.97		
P.C.B.S.			5/8	20.0	5.86	13.6	3.9	1.52	1.48	0.97		
P.C.B.S.			9/16	18.1	5.31	12.4	3.5	1.53	1.46	0.98		
P.C.B.S.			1/2	16.2	4.75	11.3	3.2	1.54	1.43	0.98		
P.C.B.S.			7/16	14.3	4.18	10.0	2.8	1.55	1.41	0.98		
P.C.B.S.			3/8	12.3	3.61	8.7	2.4	1.56	1.39	0.99		
P.C.B.S.			*9/16	10.3	3.03	7.4	2.0	1.56	1.36	0.99		
P.C.B.S.			*1/4	8.3	2.44	6.0	1.6	1.57	1.34	0.99		

\*Special gage taking a special extra.  
For key to symbols in first column, refer to page 3.

# EQUAL ANGLES



## PROPERTIES OF SECTIONS

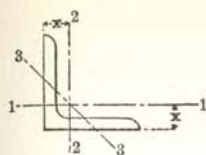

District Rolled	Section Index	Size	Thickness	Weight per Foot	Area of Section	Axis 1-1 and Axis 2-2				Axis 3-3		
						I	S	r	x	r min.		
		In.	In.	Lbs.	In. <sup>2</sup>	In. <sup>4</sup>	In. <sup>3</sup>	In.	In.	In.		
P.C.	A 4 R = 3/8	4 x 4	13/16	19.9	5.84	8.1	3.0	1.18	1.29	0.77		
P.C.B.S.			3/4	18.5	5.44	7.7	2.8	1.19	1.27	0.77		
P.C.B.			11/16	17.1	5.03	7.2	2.6	1.19	1.25	0.77		
P.C.B.S.			5/8	15.7	4.61	6.7	2.4	1.20	1.23	0.77		
P.C.B.S.			9/16	14.3	4.18	6.1	2.2	1.21	1.21	0.78		
P.C.B.S.			1/2	12.8	3.75	5.6	2.0	1.22	1.18	0.78		
P.C.B.S.			7/16	11.3	3.31	5.0	1.8	1.23	1.16	0.78		
P.C.B.S.			3/8	9.8	2.86	4.4	1.5	1.23	1.14	0.79		
P.C.B.S.			5/16	8.2	2.40	3.7	1.3	1.24	1.12	0.79		
P.C.B.S.			*3/4	6.6	1.94	3.0	1.0	1.25	1.09	0.79		
P.			*3/16	5.0	1.46	2.3	0.80	1.26	1.07	0.79		
P.C.	A 5 R = 3/8	3 1/2 x 3 1/2	13/16	17.1	5.03	5.3	2.3	1.02	1.17	0.67		
P.C.B.			3/4	16.0	4.69	5.0	2.1	1.03	1.15	0.67		
P.C.B.			11/16	14.8	4.34	4.7	2.0	1.04	1.12	0.67		
P.C.B.			5/8	13.6	3.98	4.3	1.8	1.04	1.10	0.68		
P.C.B.S.			9/16	12.4	3.62	4.0	1.6	1.05	1.08	0.68		
P.C.B.S.			1/2	11.1	3.25	3.6	1.5	1.06	1.06	0.68		
P.C.B.S.			7/16	9.8	2.87	3.3	1.3	1.07	1.04	0.68		
P.C.B.S.			3/8	8.5	2.48	2.9	1.2	1.07	1.01	0.69		
P.C.B.S.			5/16	7.2	2.09	2.5	0.98	1.08	0.99	0.69		
P.C.B.S.			1/4	5.8	1.69	2.0	0.79	1.09	0.97	0.69		
P.C.S.			*3/16	4.4	1.28	1.6	0.61	1.10	0.95	0.69		
P.C.B.	A 7 R = 5/16	3 x 3	5/8	11.5	3.36	2.6	1.3	0.88	0.98	0.57		
P.C.B.			9/16	10.4	3.06	2.4	1.2	0.89	0.95	0.58		
P.C.B.S.			1/2	9.4	2.75	2.2	1.1	0.90	0.93	0.58		
P.C.B.S.			7/16	8.3	2.43	2.0	0.95	0.91	0.91	0.58		
P.C.B.S.			3/8	7.2	2.11	1.8	0.83	0.91	0.89	0.58		
P.C.B.S.			5/16	6.1	1.78	1.5	0.71	0.92	0.87	0.59		
P.C.B.S.			1/4	4.9	1.44	1.2	0.58	0.93	0.84	0.59		
P.C.B.S.			*3/16	3.71	1.09	0.96	0.44	0.94	0.82	0.59		
P.C.			*1/8	2.48	0.73	0.66	0.30	0.96	0.80	0.59		
P.C.B.			†A 9 R = 1/4	2 1/2 x 2 1/2	1/2	7.7	2.25	1.2	0.73	0.74	0.81	0.47
P.C.B.					7/16	6.8	2.00	1.1	0.65	0.75	0.78	0.48
P.C.B.S.	3/8	5.9			1.73	0.98	0.57	0.75	0.76	0.48		
P.C.B.S.	5/16	5.0			1.47	0.85	0.48	0.76	0.74	0.49		
P.C.B.S.	1/4	4.1			1.19	0.70	0.39	0.77	0.72	0.49		
P.C.B.S.	3/16	3.07			0.90	0.55	0.30	0.78	0.69	0.49		
P.C.B.S.	1/8	2.08			0.61	0.38	0.20	0.79	0.67	0.50		

†Subject to bar card extra.

\*Special gage taking a special extra.

For key to symbols in first column, refer to page 3.



# EQUAL ANGLES

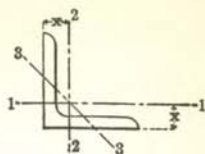

## PROPERTIES OF SECTIONS

District Rolled	Section Index	Size	Thickness	Weight per Foot	Area of Section	Axis 1-1 and Axis 2-2				Axis 3-3
						I	S	x	x	x min.
		In.	In.	Lbs.	In. <sup>2</sup>	In. <sup>4</sup>	In. <sup>3</sup>	In.	In.	In.
P.C.B.	†A 11 R = 1/4	2 x 2	7/16	5.3	1.56	0.54	0.40	0.59	0.66	0.39
P.C.B.S.			3/8	4.7	1.36	0.48	0.35	0.59	0.64	0.39
P.C.B.S.			5/16	3.92	1.15	0.42	0.30	0.60	0.61	0.39
P.C.B.S.			1/4	3.19	0.94	0.35	0.25	0.61	0.59	0.39
P.C.B.S.			3/16	2.44	0.71	0.28	0.19	0.62	0.57	0.40
P.C.B.S.			1/8	1.65	0.48	0.19	0.13	0.63	0.55	0.40
P.C.B.S.	†A 12 R = 1/4	1 3/4 x 1 3/4	3/8	3.99	1.17	0.31	0.26	0.51	0.57	0.34
			5/16	3.39	1.00	0.27	0.23	0.52	0.55	0.34
			1/4	2.77	0.81	0.23	0.19	0.53	0.53	0.34
			3/16	2.12	0.62	0.18	0.14	0.54	0.51	0.35
			1/8	1.44	0.42	0.13	0.10	0.55	0.48	0.35
P.C.S.	†A 13 R = 3/16	1 1/2 x 1 1/2	3/8	3.35	0.98	0.19	0.19	0.44	0.51	0.29
P.C.B.S.			5/16	2.86	0.84	0.16	0.16	0.44	0.49	0.29
P.C.B.S.			1/4	2.34	0.69	0.14	0.13	0.45	0.47	0.29
P.C.B.S.			3/16	1.80	0.53	0.11	0.10	0.46	0.44	0.29
P.C.B.S.			1/8	1.23	0.36	0.08	0.07	0.46	0.42	0.30
P.C.	†A 15 R = 3/16	1 1/4 x 1 1/4	5/16	2.33	0.68	0.09	0.11	0.36	0.42	0.24
P.C.B.S.			1/4	1.92	0.56	0.08	0.09	0.37	0.40	0.24
P.C.B.S.			3/16	1.48	0.43	0.06	0.07	0.38	0.38	0.24
P.C.B.S.			1/8	1.01	0.30	0.04	0.05	0.38	0.35	0.25
P.C.B.S.	†A 16 R = 1/8	1 x 1	1/4	1.49	0.44	0.04	0.06	0.29	0.34	0.19
			3/16	1.16	0.34	0.03	0.04	0.30	0.32	0.19
			1/8	0.80	0.23	0.02	0.03	0.31	0.30	0.19

†Subject to bar card extra.

For key to symbols in first column, refer to page 3.

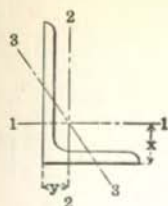

# UNEQUAL ANGLES



## PROPERTIES OF SECTIONS

District Rolled	Section Index	Size	Thick-ness	Weight per Foot	Area of Section	Axis 1-1				Axis 2-2				Axis 3-3		
						I	S	x	z	I	S	x	y	r min.		
						in. <sup>4</sup>	in. <sup>3</sup>	in.	in.	in. <sup>4</sup>	in. <sup>3</sup>	in.	in.	in.		
P.	A18 R = 1/2	8 x 6	1 1/8	49.3	14.48	88.9	16.8	2.48	2.70	42.5	9.9	1.71	1.70	1.28		
P.			1 1/16	46.8	13.75	84.9	15.9	2.48	2.68	40.7	9.4	1.72	1.68	1.28		
P.C.B.			1	44.2	13.00	80.8	15.1	2.49	2.65	38.8	8.9	1.73	1.65	1.28		
P.C.B.			15/16	41.7	12.25	76.6	14.3	2.50	2.63	36.8	8.4	1.73	1.63	1.28		
P.C.B.			7/8	39.1	11.48	72.3	13.4	2.51	2.61	34.9	7.9	1.74	1.61	1.28		
P.C.B.			13/16	36.5	10.72	67.9	12.5	2.52	2.59	32.8	7.4	1.75	1.59	1.29		
P.C.B.			3/4	33.8	9.94	63.4	11.7	2.53	2.56	30.7	6.9	1.76	1.56	1.29		
P.C.B.			11/16	31.2	9.15	58.8	10.8	2.54	2.54	28.6	6.4	1.77	1.54	1.29		
P.C.B.			5/8	28.5	8.36	54.1	9.9	2.54	2.52	26.3	5.9	1.77	1.52	1.30		
P.C.B.			9/16	25.7	7.56	49.3	8.9	2.55	2.50	24.0	5.3	1.78	1.50	1.30		
P.C.B.			1/2	23.0	6.75	44.3	8.0	2.56	2.47	21.7	4.8	1.79	1.47	1.30		
P.C.B.			7/16	20.2	5.93	39.2	7.1	2.57	2.45	19.3	4.2	1.80	1.45	1.30		
P.C.			A50 R = 1/2	8 x 4	1	37.4	11.00	69.6	14.1	2.52	3.05	11.6	3.9	1.03	1.05	0.85
					15/16	35.3	10.37	66.1	13.3	2.52	3.02	11.1	3.7	1.03	1.02	0.85
	7/8	33.1			9.73	62.4	12.5	2.53	3.00	10.5	3.5	1.04	1.00	0.85		
	13/16	31.0			9.09	58.7	11.7	2.54	2.98	10.0	3.3	1.05	0.98	0.85		
	3/4	28.7			8.44	54.9	10.9	2.55	2.95	9.4	3.1	1.05	0.95	0.85		
	11/16	26.5			7.78	51.0	10.0	2.56	2.93	8.7	2.8	1.06	0.93	0.85		
	5/8	24.2			7.11	46.9	9.2	2.56	2.91	8.1	2.6	1.07	0.91	0.86		
	9/16	21.9			6.43	42.8	8.4	2.58	2.88	7.4	2.4	1.07	0.88	0.86		
	1/2	19.6			5.75	38.5	7.5	2.59	2.86	6.7	2.2	1.08	0.86	0.86		
	7/16	17.2			5.06	34.1	6.6	2.60	2.83	6.0	1.9	1.09	0.83	0.87		
P.C.	A60 R = 1/2	7 x 4	1	34.0	10.00	47.7	10.8	2.18	2.60	11.2	3.9	1.06	1.10	0.85		
			15/16	32.1	9.44	45.4	10.3	2.19	2.58	10.7	3.7	1.07	1.08	0.86		
			7/8	30.2	8.86	42.9	9.7	2.20	2.55	10.2	3.5	1.07	1.05	0.86		
			13/16	28.2	8.28	40.4	9.0	2.21	2.53	9.6	3.2	1.08	1.03	0.86		
			3/4	26.2	7.69	37.8	8.4	2.22	2.51	9.1	3.0	1.09	1.01	0.86		
			11/16	24.2	7.09	35.1	7.8	2.23	2.49	8.5	2.8	1.09	0.99	0.86		
			5/8	22.1	6.49	32.4	7.1	2.24	2.46	7.8	2.6	1.10	0.96	0.86		
			9/16	20.0	5.88	29.6	6.5	2.24	2.44	7.2	2.4	1.11	0.94	0.87		
			1/2	17.9	5.25	26.7	5.8	2.25	2.42	6.5	2.1	1.11	0.92	0.87		
			7/16	15.8	4.63	23.7	5.1	2.26	2.39	5.8	1.9	1.12	0.89	0.88		
3/8	13.6	3.99	20.6	4.4	2.27	2.37	5.1	1.6	1.13	0.87	0.88					

For key to symbols in first column, refer to page 3.



# UNEQUAL ANGLES

## PROPERTIES OF SECTIONS

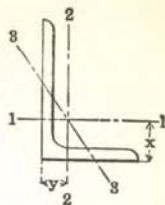

District Rolled	Section Index	Size in.	Thickness in.	Weight per Foot Lbs.	Area of Section In. <sup>2</sup>	Axis 1-1				Axis 2-2				Axis 3-3		
						I	S	r	x	I	S	r	y	r min.		
						In. <sup>4</sup>	In. <sup>3</sup>	In.	In.	In. <sup>4</sup>	In. <sup>3</sup>	In.	In.	In.		
P.C.	A 20 R = 1/2	6 x 4	1	30.6	9.00	30.8	8.0	1.85	2.17	10.8	3.8	1.09	1.17	0.85		
P.C.			15/16	28.9	8.50	29.3	7.6	1.86	2.14	10.3	3.6	1.10	1.14	0.85		
P.C.B.			7/8	27.2	7.98	27.7	7.2	1.86	2.12	9.8	3.4	1.11	1.12	0.86		
P.C.B.			13/16	25.4	7.47	26.1	6.7	1.87	2.10	9.2	3.2	1.11	1.10	0.86		
P.C.B.S.			3/4	23.6	6.94	24.5	6.2	1.88	2.08	8.7	3.0	1.12	1.08	0.86		
P.C.B.S.			11/16	21.8	6.40	22.8	5.8	1.89	2.06	8.1	2.8	1.13	1.06	0.86		
P.C.B.S.			5/8	20.0	5.86	21.1	5.3	1.90	2.03	7.5	2.5	1.13	1.03	0.86		
P.C.B.S.			9/16	18.1	5.31	19.3	4.8	1.90	2.01	6.9	2.3	1.14	1.01	0.87		
P.C.B.S.			1/2	16.2	4.75	17.4	4.3	1.91	1.99	6.3	2.1	1.15	0.99	0.87		
P.C.B.S.			7/16	14.3	4.18	15.5	3.8	1.92	1.96	5.6	1.8	1.16	0.96	0.87		
P.C.B.S.			3/8	12.3	3.61	13.5	3.3	1.93	1.94	4.9	1.6	1.17	0.94	0.88		
P.C.			*5/16	10.3	3.03	11.4	2.8	1.94	1.92	4.2	1.4	1.17	0.92	0.88		
C.			A 21 R = 1/2	6 x 3 1/2	1	28.9	8.50	29.2	7.8	1.85	2.26	7.2	2.9	0.92	1.01	0.74
P.C.					15/16	27.3	8.03	27.8	7.4	1.86	2.24	6.9	2.7	0.93	0.99	0.74
P.C.	7/8	25.7			7.55	26.4	7.0	1.87	2.22	6.6	2.6	0.93	0.97	0.75		
P.C.	13/16	24.0			7.06	24.9	6.6	1.88	2.20	6.2	2.4	0.94	0.95	0.75		
P.C.B.	3/4	22.4			6.56	23.3	6.1	1.89	2.18	5.8	2.3	0.94	0.93	0.75		
P.C.B.	11/16	20.6			6.06	21.7	5.6	1.89	2.15	5.5	2.1	0.95	0.90	0.75		
P.C.B.	5/8	18.9			5.55	20.1	5.2	1.90	2.13	5.1	1.9	0.96	0.88	0.75		
P.C.B.	9/16	17.1			5.03	18.4	4.7	1.91	2.11	4.7	1.8	0.96	0.86	0.75		
P.C.B.	1/2	15.3			4.50	16.6	4.2	1.92	2.08	4.3	1.6	0.97	0.83	0.76		
P.C.B.	7/16	13.5			3.97	14.8	3.7	1.93	2.06	3.8	1.4	0.98	0.81	0.76		
P.C.B.	3/8	11.7			3.42	12.9	3.3	1.94	2.04	3.3	1.2	0.99	0.79	0.77		
P.C.B.	*9/16	9.8			2.87	10.9	2.7	1.95	2.01	2.9	1.0	1.00	0.76	0.77		
B.	*1/4	7.9			2.31	8.9	2.2	1.96	1.99	2.5	0.91	1.01	0.74	0.77		
B.	A 22 R = 3/16	5 x 4			3/4	21.1	6.19	14.6	4.4	1.54	1.66	8.5	2.9	1.14	1.16	0.78
			11/16	19.5	5.72	13.6	4.1	1.54	1.64	7.9	2.7	1.15	1.14	0.78		
			5/8	17.8	5.23	12.4	3.7	1.55	1.62	7.3	2.5	1.16	1.12	0.78		
			9/16	16.2	4.75	11.6	3.4	1.56	1.60	6.6	2.2	1.17	1.10	0.79		
			1/2	14.5	4.25	10.5	3.1	1.57	1.57	6.0	2.0	1.18	1.07	0.79		
			7/16	12.8	3.75	9.3	2.7	1.58	1.55	5.3	1.8	1.19	1.05	0.79		
P.C.B.	A 23 R = 3/16	5 x 3 1/2	3/8	22.7	6.67	15.7	4.9	1.53	1.79	6.2	2.5	0.96	1.04	0.75		
			13/16	21.3	6.25	14.8	4.6	1.54	1.77	5.9	2.4	0.97	1.02	0.75		
			3/4	19.8	5.81	13.9	4.3	1.55	1.75	5.6	2.2	0.98	1.00	0.75		
			11/16	18.3	5.37	13.0	4.0	1.56	1.72	5.2	2.1	0.98	0.97	0.75		
			5/8	16.8	4.92	12.0	3.7	1.56	1.70	4.8	1.9	0.99	0.95	0.75		
			9/16	15.2	4.47	11.0	3.3	1.57	1.68	4.4	1.7	1.00	0.93	0.75		
			1/2	13.6	4.00	10.0	3.0	1.58	1.66	4.0	1.6	1.01	0.91	0.75		
			7/16	12.0	3.53	8.9	2.6	1.59	1.63	3.6	1.4	1.01	0.88	0.76		
			3/8	10.4	3.05	7.8	2.3	1.60	1.61	3.2	1.2	1.02	0.86	0.76		
			9/16	8.7	2.56	6.6	1.9	1.61	1.59	2.7	1.0	1.03	0.84	0.76		
P.C.	*1/4	7.0	2.06	5.4	1.6	1.61	1.56	2.2	0.83	1.04	0.81	0.76				

\*Special gage taking a special extra.  
For key to symbols in first column, refer to page 3.

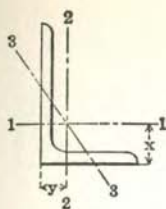

# UNEQUAL ANGLES

## PROPERTIES OF SECTIONS



District Rolled	Section Index	Size	Thick-ness	Weight per Foot	Area of Section	Axis 1-1				Axis 2-2				Axis 3-3
						I		S		I		S		r min.
						in. <sup>4</sup>	in. <sup>3</sup>	in.	in.	in. <sup>4</sup>	in. <sup>3</sup>	in.	in.	
P.C.	A 24 R = 3/8	5 x 3	13/16	19.9	5.84	14.0	4.5	1.55	1.86	3.7	1.7	0.80	0.86	0.64
P.C.B.			3/4	18.5	5.44	13.2	4.2	1.55	1.84	3.5	1.6	0.80	0.84	0.64
P.C.B.			11/16	17.1	5.03	12.3	3.9	1.56	1.82	3.3	1.5	0.81	0.82	0.64
P.C.B.S.			5/8	15.7	4.61	11.4	3.5	1.57	1.80	3.1	1.4	0.81	0.80	0.64
P.C.B.S.			9/16	14.3	4.18	10.4	3.2	1.58	1.77	2.8	1.3	0.82	0.77	0.65
P.C.B.S.			1/2	12.8	3.75	9.5	2.9	1.59	1.75	2.6	1.1	0.83	0.75	0.65
P.C.B.S.			7/16	11.3	3.31	8.4	2.6	1.60	1.73	2.3	1.0	0.84	0.73	0.65
P.C.B.S.			3/8	9.8	2.86	7.4	2.2	1.61	1.70	2.0	0.89	0.84	0.70	0.65
P.C.B.S.			5/16	8.2	2.40	6.3	1.9	1.61	1.68	1.8	0.75	0.85	0.68	0.66
C.S.			1/4	6.6	1.94	5.1	1.5	1.62	1.66	1.4	0.61	0.86	0.66	0.66
P.C.	A 26 R = 3/8	4 x 3 1/2	13/16	18.5	5.43	7.8	2.9	1.19	1.36	5.5	2.3	1.01	1.11	0.72
P.C.			3/4	17.3	5.06	7.3	2.8	1.20	1.34	5.2	2.1	1.01	1.09	0.72
P.C.			11/16	16.0	4.68	6.9	2.6	1.21	1.32	4.9	2.0	1.02	1.07	0.72
P.C.			5/8	14.7	4.30	6.4	2.4	1.22	1.29	4.5	1.8	1.03	1.04	0.72
P.C.B.			9/16	13.3	3.90	5.9	2.1	1.23	1.27	4.2	1.7	1.03	1.02	0.72
P.C.B.			1/2	11.9	3.50	5.3	1.9	1.23	1.25	3.8	1.5	1.04	1.00	0.72
P.C.B.			7/16	10.6	3.09	4.8	1.7	1.24	1.23	3.4	1.3	1.05	0.98	0.72
P.C.B.			3/8	9.1	2.67	4.2	1.5	1.25	1.21	3.0	1.2	1.06	0.96	0.73
P.C.B.			5/16	7.7	2.25	3.6	1.3	1.26	1.18	2.6	1.0	1.07	0.93	0.73
P.C.B.			1/4	6.1	1.81	2.9	1.0	1.27	1.16	2.1	0.81	1.07	0.91	0.73
P.	3/16	4.6	1.36	2.2	0.78	1.29	1.13	1.6	0.62	1.09	0.89	0.73		
P.C.	A 27 R = 3/8	4 x 3	13/16	17.1	5.03	7.3	2.9	1.21	1.44	3.5	1.7	0.83	0.94	0.64
P.C.			3/4	16.0	4.69	6.9	2.7	1.22	1.42	3.3	1.6	0.84	0.92	0.64
P.C.			11/16	14.8	4.34	6.5	2.5	1.22	1.39	3.1	1.5	0.84	0.89	0.64
P.C.B.S.			5/8	13.6	3.98	6.0	2.3	1.23	1.37	2.9	1.4	0.85	0.87	0.64
P.C.B.S.			9/16	12.4	3.62	5.6	2.1	1.24	1.35	2.7	1.2	0.86	0.85	0.64
P.C.B.S.			1/2	11.1	3.25	5.0	1.9	1.25	1.33	2.4	1.1	0.86	0.83	0.64
P.C.B.S.			7/16	9.8	2.87	4.5	1.7	1.25	1.30	2.2	1.0	0.87	0.80	0.64
P.C.B.S.			3/8	8.5	2.48	4.0	1.5	1.26	1.38	1.9	0.87	0.88	0.78	0.64
P.C.B.S.			5/16	7.2	2.09	3.4	1.2	1.27	1.26	1.7	0.74	0.89	0.76	0.65
P.C.B.S.			1/4	5.8	1.69	2.8	1.0	1.28	1.24	1.4	0.60	0.89	0.74	0.65
P.	3/16	4.4	1.28	2.1	0.77	1.29	1.21	1.1	0.46	0.91	0.71	0.65		
P.C.	A 28 R = 3/8	3 1/2 x 3	13/16	15.8	4.62	5.0	2.2	1.04	1.23	3.3	1.7	0.85	0.98	0.62
P.C.			3/4	14.7	4.31	4.7	2.1	1.04	1.21	3.1	1.5	0.85	0.96	0.62
P.C.			11/16	13.6	4.00	4.4	1.9	1.05	1.19	3.0	1.4	0.86	0.94	0.62
P.C.			5/8	12.5	3.67	4.1	1.8	1.06	1.17	2.8	1.3	0.87	0.92	0.62
P.C.B.			9/16	11.4	3.34	3.8	1.6	1.07	1.15	2.5	1.2	0.87	0.90	0.62
P.C.B.S.			1/2	10.2	3.00	3.5	1.5	1.07	1.13	2.3	1.1	0.88	0.88	0.62
P.C.B.S.			7/16	9.1	2.65	3.1	1.3	1.08	1.10	2.1	0.98	0.89	0.85	0.62
P.C.B.S.			3/8	7.9	2.30	2.7	1.1	1.09	1.08	1.8	0.85	0.90	0.83	0.62
P.C.B.S.			5/16	6.6	1.93	2.3	0.96	1.10	1.06	1.6	0.72	0.90	0.81	0.63
P.C.B.S.			1/4	5.4	1.56	1.9	0.78	1.11	1.04	1.3	0.58	0.91	0.79	0.63
P.C.	3/16	4.0	1.18	1.5	0.59	1.12	1.01	1.0	0.45	0.93	0.76	0.63		

\*Special gage taking a special extra.  
For key to symbols in first column, refer to page 3.



# UNEQUAL ANGLES

## PROPERTIES OF SECTIONS

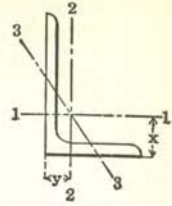

District Rolled	Section Index	Size	Thickness	Weight per Foot	Area of Section	Axis 1-1				Axis 2-2				Axis 3-3
						I	S	x	x	I	S	x	y	r min.
						In. <sup>4</sup>	In. <sup>3</sup>	In.	In.	In. <sup>4</sup>	In. <sup>3</sup>	In.	In.	In.
P.C.	A 29 R = 5/16	3 1/2 x 2 1/2	1/16	12.5	3.65	4.1	1.9	1.06	1.27	1.7	0.99	0.69	0.77	0.53
P.C.B.			5/8	11.5	3.36	3.8	1.7	1.07	1.25	1.6	0.92	0.69	0.75	0.53
P.C.B.			3/16	10.4	3.06	3.6	1.6	1.08	1.23	1.5	0.84	0.70	0.73	0.53
P.C.B.			1/2	9.4	2.75	3.2	1.4	1.09	1.20	1.4	0.76	0.70	0.70	0.53
P.C.B.			7/16	8.3	2.43	2.9	1.3	1.09	1.18	1.2	0.68	0.71	0.68	0.54
P.C.B.S.			3/8	7.2	2.11	2.6	1.1	1.10	1.16	1.1	0.59	0.72	0.66	0.54
P.C.B.S.			5/16	6.1	1.78	2.2	0.93	1.11	1.14	0.94	0.50	0.73	0.64	0.54
P.C.B.S.			1/4	4.9	1.44	1.8	0.75	1.12	1.11	0.78	0.41	0.74	0.61	0.54
P.C.B.S.			3/16	3.7	1.09	1.4	0.58	1.13	1.09	0.60	0.32	0.74	0.59	0.55
P.C.B.			9/16	9.5	2.78	2.3	1.2	0.91	1.02	1.4	0.82	0.72	0.77	0.52
P.C.B.	1/2	8.5	2.50	2.1	1.0	0.91	1.00	1.3	0.74	0.72	0.75	0.52		
P.C.B.	A 32 R = 5/16	3 x 2 1/2	7/16	7.6	2.21	1.9	0.93	0.92	0.98	1.2	0.66	0.73	0.73	0.52
P.C.B.S.			3/8	6.6	1.92	1.7	0.81	0.93	0.96	1.0	0.58	0.74	0.71	0.52
P.C.B.S.			5/16	5.6	1.62	1.4	0.69	0.94	0.93	0.90	0.49	0.74	0.68	0.53
P.C.B.S.			1/4	4.5	1.31	1.2	0.56	0.95	0.91	0.74	0.40	0.75	0.66	0.53
P.C.B.S.			3/16	3.39	1.00	0.91	0.43	0.95	0.89	0.58	0.31	0.76	0.64	0.53
P.C.B.			1/2	7.7	2.25	1.9	1.0	0.92	1.08	0.67	0.47	0.55	0.58	0.43
P.C.B.			7/16	6.8	2.00	1.7	0.89	0.93	1.06	0.61	0.42	0.55	0.56	0.43
P.C.B.S.	A 33 R = 5/16	3 x 2	3/8	5.9	1.73	1.5	0.78	0.94	1.04	0.54	0.37	0.56	0.54	0.43
P.C.B.S.			5/16	5.0	1.47	1.3	0.66	0.95	1.02	0.47	0.32	0.57	0.52	0.43
P.C.B.S.			1/4	4.1	1.19	1.1	0.54	0.95	0.99	0.39	0.26	0.57	0.49	0.43
P.C.B.S.			3/16	3.07	0.90	0.84	0.41	0.97	0.97	0.31	0.20	0.58	0.47	0.44
P.C.B.			1/2	6.8	2.00	1.1	0.70	0.75	0.88	0.64	0.46	0.56	0.63	0.42
P.C.B.	† A 35 R = 1/4	2 1/2 x 2	7/16	6.1	1.78	1.0	0.62	0.76	0.85	0.58	0.41	0.57	0.60	0.42
P.C.B.S.			3/8	5.3	1.55	0.91	0.55	0.77	0.83	0.51	0.36	0.58	0.58	0.42
P.C.B.S.			5/16	4.5	1.31	0.79	0.47	0.78	0.81	0.45	0.31	0.58	0.56	0.42
P.C.B.S.			1/4	3.62	1.06	0.65	0.38	0.78	0.79	0.37	0.25	0.59	0.54	0.42
P.C.B.S.			3/16	2.75	0.81	0.51	0.29	0.79	0.76	0.29	0.20	0.60	0.51	0.43
P.C.B.S.			1/8	1.86	0.55	0.35	0.20	0.80	0.74	0.20	0.13	0.61	0.49	0.43
S.			3/8	4.7	1.36	0.82	0.52	0.78	0.92	0.22	0.20	0.40	0.42	0.32
P.C.S.	† A 48 R = 1/4	2 1/2 x 1 1/2	5/16	3.92	1.15	0.71	0.44	0.79	0.90	0.19	0.17	0.41	0.40	0.32
P.C.S.			1/4	3.19	0.94	0.59	0.36	0.79	0.88	0.16	0.14	0.41	0.38	0.32
P.C.S.			3/16	2.44	0.72	0.46	0.28	0.80	0.85	0.13	0.11	0.42	0.35	0.33
P.C.S.	† A 37 R = 1/4	2 x 1 1/2	3/8	3.99	1.17	0.43	0.34	0.61	0.71	0.21	0.20	0.42	0.46	0.32
P.C.B.S.			5/16	3.39	1.00	0.38	0.29	0.62	0.69	0.18	0.17	0.42	0.44	0.32
P.C.B.S.			1/4	2.77	0.81	0.32	0.24	0.62	0.66	0.15	0.14	0.43	0.41	0.32
P.C.B.S.			3/16	2.12	0.62	0.25	0.18	0.63	0.64	0.12	0.11	0.44	0.39	0.32
P.C.B.S.			1/8	1.44	0.42	0.17	0.13	0.64	0.62	0.09	0.08	0.45	0.37	0.33
P.C.	† A 39 R = 1/4	1 3/4 x 1 1/4	1/4	2.34	0.69	0.20	0.18	0.54	0.60	0.09	0.10	0.35	0.35	0.27
P.C.			3/16	1.80	0.53	0.16	0.14	0.55	0.58	0.07	0.08	0.36	0.33	0.27
P.C.			1/8	1.23	0.36	0.11	0.09	0.56	0.56	0.05	0.05	0.37	0.31	0.27

\*Special gage taking a special extra.  
For key to symbols in first column, refer to page 3.

†Subject to bar card extra.

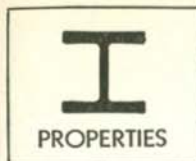

# BEARING PILES

## WIDE FLANGE CB SECTIONS

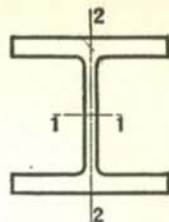

### PROPERTIES OF SECTIONS

District Rolled	Section Index and Nominal Size	Depth of Section In.	Weight per Foot Lbs.	Area of Section In. <sup>2</sup>	FLANGE		Web Thickness In.	Axis 1-1			Axis 2-2		
					Width In.	Thick-ness In.		I	S	r	I	S	r
								In. <sup>4</sup>	In. <sup>3</sup>	In.	In. <sup>4</sup>	In. <sup>3</sup>	In.
P.C.	145 CBP 146 14 x 14 1/2	14.234	117	34.44	14.885	.805	.805	1228.5	172.6	5.97	443.1	59.5	3.59
		14.032	102	30.01	14.784	.704	.704	1055.1	150.4	5.93	379.6	51.3	3.56
		13.856	89	26.19	14.696	.616	.616	909.1	131.2	5.89	326.2	44.4	3.53
		13.636	73	21.46	14.586	.506	.506	733.1	107.5	5.85	261.9	35.9	3.49
P.C.	CBP 124 12 x 12	12.122	74	21.76	12.217	.607	.607	566.5	93.5	5.10	184.7	30.2	2.91
		11.780	53	15.58	12.046	.436	.436	394.8	67.0	5.03	127.3	21.2	2.86
P.C.	CBP 103 10 x 10	10.012	57	16.76	10.224	.564	.564	294.7	58.9	4.19	100.6	19.7	2.45
		9.760	44	12.95	10.098	.438	.438	221.9	45.5	4.14	75.3	14.9	2.41
		9.720	42	12.35	10.078	.418	.418	210.8	43.4	4.13	71.4	14.2	2.40
P.C.	CBP 83 8 x 8	8.026	36	10.60	8.158	.446	.446	119.8	29.9	3.36	40.4	9.9	1.95

Complete data regarding these sections will be found in a separate publication entitled "Steel Bearing Piles."

For key to symbols in first column, refer to page 3.

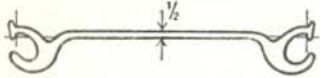
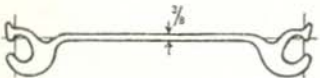
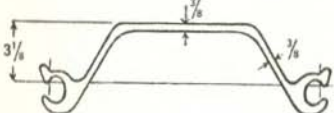
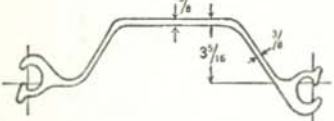
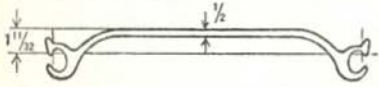
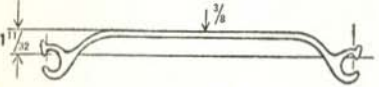
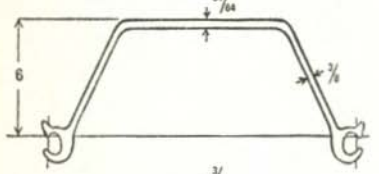
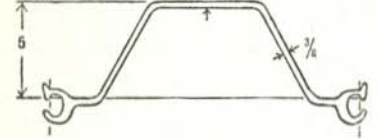
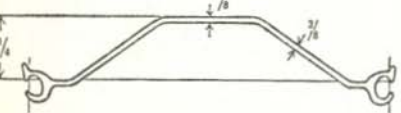

# STEEL SHEET PILING SECTIONS

Profile	District Rolled	Section Index	Driving Distance per Pile	Weight		Web Thickness	Section Modulus	
				Per Foot	Per Square Foot of Wall		Per Pile	Per Foot of Wall
				In.	Lbs.		Lbs.	In. <sup>3</sup>
	P.	M 108	15	43.8	35.0	1/2	3.8	3.1
	P.	M 107	15	38.8	31.0	3/8	3.7	3.0
	P.	M 106	14	36.2	31.0	3/8	10.3	8.9
	C.	M 117	15	38.8	31.0	3/8	8.9	7.1
INTERLOCK WITH EACH OTHER								
	P.	M 113	16	37.3	28.0	1/2	3.3	2.5
	P.C.	M 112	16	30.7	23.0	3/8	3.2	2.4
	P.	M 110	16	42.7	32.0	31/64	20.4	15.3
	P.C.	M 116	16	36.0	27.0	3/8	14.3	10.7
	P.C.	M 115	19 5/8	36.0	22.0	3/8	8.8	5.4

For key to symbols in first column, refer to page 3.

# STEEL SHEET PILING SECTIONS— Z PILES

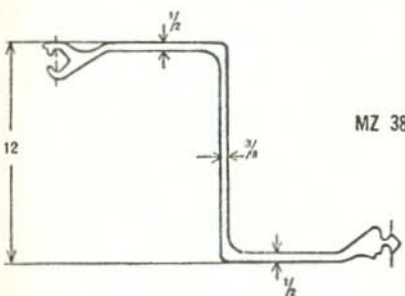
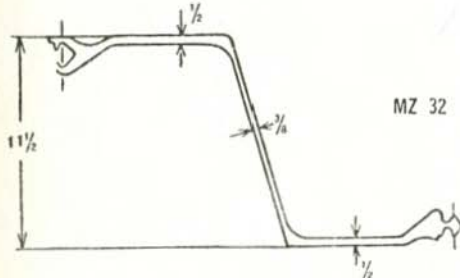
Profile	District Rolled	Weight		Web Thickness	Section Modulus		
		Driving Distance per Pile	Per Foot		Per Square Foot of Wall	Per Pile	Per Foot of Wall
		In.	Lbs.	Lbs.	In.	In. <sup>3</sup>	In. <sup>3</sup>
	P.	18	57.0	38.0	$\frac{3}{8}$	70.2	46.8
	P.	21	56.0	32.0	$\frac{3}{8}$	67.0	38.3

Complete data regarding these sections will be found in a separate publication entitled "Steel Sheet Piling."

For key to symbols in first column, refer to page 3.

## STRUCTURAL TEES

In addition to sections of rolled tees the following series include sections produced by shearing or gas cutting either standard beams or CB sections.

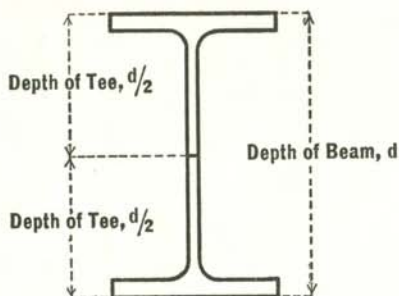

The following tolerances, over or under, apply to the depth  $d/2$  of the tee which is one-half of the beam depth:

Beams 8" to 15" incl. . . . . $\frac{3}{16}$ "	Beams 21" to 24" incl. . . . . $\frac{5}{16}$ "
Beams 16" to 20" incl. . . . . $\frac{1}{4}$ "	Beams over 24" . . . . . $\frac{3}{8}$ "

The above tolerances for depth of tees include the allowable tolerances in depth for the beams before splitting. Tolerances both for dimensions and straightness, as set up for the beams from which these tees are cut, will apply.

These sections should be ordered either in pairs or so as to utilize all of the beam from which they are produced.

All structural tees are produced in Pittsburgh District only.

# STRUCTURAL TEES

CUT FROM  
CB SECTIONS

PROPERTIES OF SECTIONS

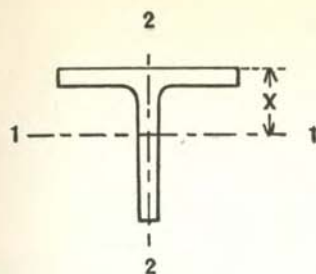

District Produced	Section Index	Weight per Foot	Depth of Tee	Flange		Stem Thickness	Area of Section	Axis 1-1				Axis 2-2			
				Width	Thick-ness			I	S	r	x	I	S	r	
															Lbs.
P.	T18 WF	150	18.36	16.655	1.680	.945	44.09	1222.7	85.9	5.27	4.13	612.6	73.6	3.73	
	TCB 18	140	18.25	16.595	1.570	.885	41.16	1133.3	79.9	5.25	4.07	563.7	67.9	3.70	
	(CB 362)	130	18.12	16.555	1.440	.845	38.28	1059.2	75.4	5.26	4.07	510.3	61.6	3.65	
		125	18.06	16.525	1.380	.815	36.74	1014.6	72.4	5.25	4.04	484.8	58.7	3.63	
		120	18.00	16.500	1.320	.790	35.30	975.0	69.8	5.26	4.03	460.0	55.8	3.61	
115	17.94	16.475	1.260	.765	33.86	935.8	67.2	5.26	4.02	435.5	52.9	3.59			
P.	(CB 361)	T18 WF	97	18.24	12.117	1.260	.770	28.56	904.0	67.3	5.63	4.81	177.7	29.3	2.49
		TCB 18	91	18.16	12.072	1.180	.725	26.77	844.0	63.0	5.61	4.77	163.9	27.1	2.47
		85	18.08	12.027	1.100	.680	24.99	784.7	58.8	5.60	4.74	150.3	25.0	2.45	
		80	18.00	12.000	1.020	.653	23.54	741.0	56.0	5.61	4.76	137.7	22.9	2.42	
		75	17.92	11.972	.940	.625	22.08	696.7	53.0	5.62	4.79	125.2	20.9	2.38	
P.	(CB 332)	T16 WF	120	16.75	15.865	1.400	.830	35.26	822.5	63.2	4.83	3.73	437.2	55.1	3.52
		TCB16.5	110	16.63	15.810	1.275	.775	32.36	754.1	58.4	4.83	3.71	391.2	49.5	3.48
		105	16.56	15.783	1.210	.748	30.89	720.3	56.0	4.83	3.70	367.8	46.6	3.45	
		100	16.50	15.750	1.150	.715	29.40	683.6	53.3	4.82	3.67	345.8	43.9	3.43	
P.	(CB 331)	T16 WF	76	16.75	11.565	1.055	.635	22.35	591.9	47.4	5.15	4.26	128.1	22.1	2.39
		TCB16.5	70.5	16.66	11.535	.960	.605	20.76	551.8	44.7	5.16	4.30	114.9	19.9	2.35
		66	16.58	11.510	.880	.580	19.42	518.5	42.4	5.17	4.33	103.9	18.1	2.31	
		62.5	16.50	11.500	.805	.570	18.39	495.7	41.0	5.19	4.42	94.1	16.4	2.26	
P.	(CB 302)	T15 WF	105	15.19	15.105	1.315	.775	30.89	578.0	48.7	4.33	3.31	354.0	46.9	3.38
		TCB 15	100	15.13	15.070	1.250	.740	29.38	545.2	46.0	4.31	3.28	332.8	44.2	3.37
		95	15.06	15.040	1.185	.710	27.95	520.4	44.1	4.31	3.26	312.3	41.5	3.34	
		90	15.00	15.000	1.125	.670	26.45	488.6	41.4	4.30	3.21	292.8	39.0	3.33	
		86	14.94	14.985	1.065	.655	25.32	471.0	40.2	4.31	3.23	275.1	36.7	3.30	
P.	(CB 301)	T15 WF	66	15.15	10.551	1.000	.615	19.41	420.7	37.4	4.66	3.90	92.5	17.5	2.18
		TCB 15	62	15.08	10.521	.930	.585	18.22	394.8	35.3	4.65	3.90	84.8	16.1	2.16
		58	15.00	10.500	.850	.564	17.07	371.8	33.6	4.67	3.94	76.6	14.6	2.12	
		54	14.91	10.484	.760	.548	15.88	349.5	32.1	4.69	4.03	67.6	12.9	2.06	
P.	(CB 272)	T13 WF	88.5	13.655	14.090	1.190	.725	26.05	391.8	36.7	3.88	2.97	259.4	36.8	3.16
		TCB13.5	81.5	13.56	14.035	1.095	.670	23.96	358.7	33.7	3.87	2.92	234.4	33.4	3.13
		77	13.50	14.000	1.035	.635	22.65	337.4	31.8	3.86	2.89	218.8	31.3	3.11	
		72.5	13.44	13.965	.975	.600	21.34	316.3	29.9	3.85	2.85	203.5	29.1	3.09	

Section Index in parentheses refers to beam from which tee is cut.  
For key to symbols in first column, refer to page 3.

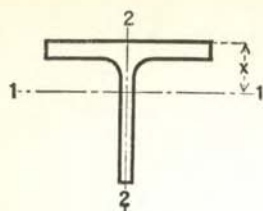

# STRUCTURAL TEES

CUT FROM  
CB SECTIONS

## PROPERTIES OF SECTIONS

District Produced	Section Index	Weight per Foot	Depth of Tee	Flange		Stem Thickness	Area of Section	Axis 1-1				Axis 2-2		
				Width	Thickness			I	S	r	x	I	S	r
		Lbs.	In.	In.	In.	In.	In. <sup>2</sup>	In. <sup>4</sup>	In. <sup>2</sup>	In.	In.	In. <sup>4</sup>	In. <sup>2</sup>	In.
P.	T13 WF	57	13.64	10.070	.932	.570	16.77	288.9	28.3	4.15	3.42	74.8	14.9	2.11
	TCB13.5	53	13.57	10.035	.862	.535	15.59	267.9	26.3	4.14	3.40	68.1	13.6	2.09
	(CB 271)	49	13.50	10.000	.792	.500	14.41	247.2	24.4	4.14	3.38	61.5	12.3	2.07
		45.5	13.42	9.983	.712	.483	13.38	231.9	23.2	4.16	3.44	54.5	10.9	2.02
P.	T12 WF	80	12.36	14.091	1.135	.656	23.54	271.6	27.6	3.40	2.51	246.3	35.0	3.23
	TCB 12	75	12.28	14.063	1.055	.628	22.07	255.6	26.1	3.40	2.50	226.2	32.2	3.20
	(CB 243)	70	12.21	14.029	.980	.594	20.60	238.4	24.5	3.40	2.48	207.3	29.5	3.17
		65	12.13	14.000	.900	.565	19.13	222.6	23.1	3.41	2.47	187.6	26.8	3.13
P.	T12 WF	60	12.155	12.088	.930	.556	17.64	213.6	22.4	3.48	2.62	127.0	21.0	2.68
	TCB 12	55	12.08	12.042	.855	.510	16.18	195.2	20.5	3.47	2.57	114.5	19.0	2.66
	(CB 242)	50	12.00	12.000	.775	.468	14.71	176.7	18.7	3.46	2.54	101.8	17.0	2.63
P.	T12 WF	47	12.145	9.061	.872	.516	13.81	185.9	20.3	3.67	2.99	51.1	11.3	1.92
	TCB 12	43.5	12.08	9.025	.807	.480	12.79	171.3	18.8	3.66	2.96	46.5	10.3	1.91
	(CB 241)	40	12.00	9.000	.727	.455	11.77	158.4	17.6	3.67	2.98	41.2	9.2	1.87
		37	11.94	8.975	.662	.430	10.88	147.0	16.4	3.67	2.99	36.9	8.2	1.84
P.	T10 WF	71	10.73	13.132	1.095	.659	20.89	177.3	20.8	2.91	2.18	193.0	29.4	3.04
	TCB10.5	66	10.655	13.087	1.020	.614	19.43	161.9	19.0	2.89	2.14	176.9	27.0	3.02
	(CB 213)	61	10.58	13.040	.945	.567	17.95	149.1	17.6	2.88	2.09	161.0	24.7	3.00
		56	10.50	13.000	.865	.527	16.48	136.4	16.2	2.88	2.06	144.8	22.3	2.96
P.	T10 WF	51.5	10.645	9.071	1.010	.608	15.14	147.5	18.3	3.12	2.57	60.0	13.2	1.99
	TCB10.5	48	10.57	9.038	.935	.575	14.11	137.1	17.1	3.11	2.55	54.7	12.1	1.97
	(CB 212)	44.5	10.50	9.000	.865	.537	13.07	126.4	15.8	3.11	2.51	49.7	11.0	1.95
		41	10.43	8.962	.795	.499	12.05	115.4	14.5	3.09	2.48	44.8	10.0	1.93
P.	T10 WF	36.5	10.62	8.295	.740	.455	10.73	110.2	13.7	3.21	2.60	33.1	7.98	1.76
	TCB10.5	34	10.57	8.270	.685	.430	10.01	102.8	12.9	3.20	2.59	30.2	7.30	1.74
	(CB 211)	31.5	10.50	8.250	.620	.410	9.26	95.7	12.1	3.21	2.61	26.9	6.52	1.70
		29.5	10.46	8.230	.575	.390	8.68	89.8	11.5	3.22	2.61	24.6	5.98	1.68
P.	T9 WF	62	9.32	11.889	1.071	.651	18.24	113.7	15.4	2.50	1.91	140.9	23.7	2.78
	TCB 9	57	9.24	11.833	.991	.595	16.77	102.6	13.9	2.47	1.85	127.8	21.6	2.76
	(CB 183)	52.5	9.16	11.792	.911	.554	15.45	93.9	12.8	2.47	1.82	115.5	19.6	2.73
		48	9.08	11.750	.831	.512	14.13	85.3	11.7	2.46	1.78	103.4	17.6	2.71
P.	T9 WF	42.5	9.16	8.838	.911	.526	12.49	84.4	11.9	2.60	2.05	49.7	11.3	2.00
	TCB 9	38.5	9.08	8.787	.831	.475	11.32	75.3	10.6	2.58	1.99	44.3	10.1	1.98
	(CB 182)	35	9.00	8.750	.751	.438	10.28	68.1	9.67	2.57	1.96	39.2	8.97	1.95
		32	8.935	8.715	.686	.403	9.40	61.8	8.82	2.56	1.93	35.2	8.07	1.93

Section index in parentheses refers to beam from which tee is cut.  
For key to symbols in first column, refer to page 3.

# STRUCTURAL TEES

CUT FROM

CB SECTIONS

PROPERTIES OF SECTIONS

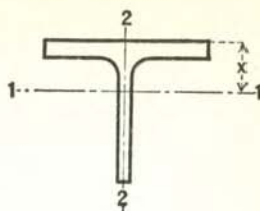

District Produced	Section Index	Weight per Foot	Depth of Tee	Flange		Stem Thickness	Area of Section	Axis 1-1				Axis 2-2		
				Width	Thickness			I	S	r	x	I	S	r
P.	T 9 WF	27.5	9.06	7.532	.630	.390	8.09	59.6	8.63	2.71	2.16	21.0	5.57	1.61
	TCB 9	25	9.00	7.500	.570	.358	7.35	53.9	7.85	2.71	2.14	18.6	4.96	1.59
	(CB 181)	23.5	8.95	7.492	.520	.350	6.91	51.3	7.57	2.72	2.18	16.8	4.48	1.56
P.	T 8 WF	57	8.32	11.629	1.035	.631	16.77	78.9	11.9	2.17	1.66	127.3	21.9	2.76
	TCB 8	52.5	8.24	11.582	.955	.584	15.45	71.8	10.8	2.16	1.62	115.4	19.9	2.73
	(CB 163)	48	8.16	11.533	.875	.535	14.13	64.7	9.82	2.14	1.57	103.6	18.0	2.71
		44	8.08	11.502	.795	.504	12.95	59.5	9.11	2.14	1.55	92.6	16.1	2.67
P.	T 8 WF	39	8.16	8.586	.875	.529	11.46	60.0	9.45	2.28	1.81	43.8	10.2	1.95
	TCB 8	35.5	8.08	8.543	.795	.486	10.43	54.0	8.57	2.28	1.77	38.9	9.11	1.93
	(CB 162)	32	8.00	8.500	.715	.443	9.40	48.3	7.71	2.27	1.73	34.2	8.05	1.91
		29	7.93	8.464	.645	.407	8.52	43.6	7.00	2.26	1.70	30.2	7.14	1.88
P.	T 8 WF	25	8.125	7.073	.628	.380	7.35	42.2	6.77	2.40	1.89	17.4	4.92	1.54
	TCB 8	22.5	8.06	7.039	.563	.346	6.62	37.8	6.10	2.39	1.87	15.2	4.33	1.52
	(CB 161)	20	8.00	7.000	.503	.307	5.88	33.2	5.37	2.37	1.82	13.3	3.79	1.50
		18	7.93	6.992	.428	.299	5.30	30.7	5.10	2.41	1.90	11.1	3.17	1.45
P.		105.5	7.875	15.800	1.563	.980	31.04	102.2	16.2	1.81	1.57	514.3	65.1	4.07
		101	7.815	15.750	1.503	.930	29.70	95.7	15.2	1.80	1.53	489.8	62.2	4.06
		96.5	7.75	15.710	1.438	.890	28.36	90.1	14.4	1.78	1.49	465.1	59.2	4.05
	T 7 WF	92	7.69	15.660	1.378	.840	27.04	83.9	13.4	1.76	1.45	441.4	56.4	4.04
	TCB 7	88	7.625	15.640	1.313	.820	25.87	80.2	12.9	1.76	1.42	418.9	53.6	4.02
		(CB 146)	83.5	7.56	15.600	1.248	.780	24.55	75.0	12.1	1.75	1.39	395.1	50.7
		79	7.50	15.550	1.188	.730	23.24	69.3	11.3	1.73	1.34	372.5	47.9	4.00
		75	7.44	15.515	1.128	.695	22.04	64.9	10.6	1.72	1.31	351.3	45.3	3.99
		71	7.375	15.500	1.063	.680	20.92	62.1	10.2	1.72	1.29	330.1	42.6	3.97
		68	7.375	14.740	1.063	.660	19.99	60.0	9.89	1.73	1.31	283.9	38.5	3.77
		63.5	7.31	14.690	.998	.610	18.67	54.7	9.04	1.71	1.26	263.8	35.9	3.76
T 7 WF	59.5	7.25	14.650	.938	.570	17.49	50.4	8.36	1.70	1.22	245.9	33.6	3.75	
TCB 7	55.5	7.185	14.620	.873	.540	16.33	46.7	7.80	1.69	1.19	227.4	31.1	3.73	
	(CB 145)	51.5	7.125	14.575	.813	.495	15.13	42.4	7.10	1.67	1.15	209.9	28.8	3.72
		47.5	7.06	14.545	.748	.465	13.97	39.1	6.58	1.67	1.12	191.9	26.4	3.71
		43.5	7.00	14.500	.688	.420	12.78	34.9	5.88	1.65	1.08	174.8	24.1	3.70

Section Index in parentheses refers to beam from which tee is cut.  
For key to symbols in first column, refer to page 3.

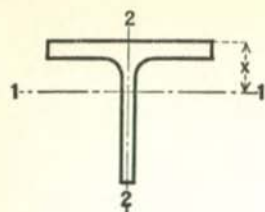

# STRUCTURAL TEES

## CUT FROM CB SECTIONS PROPERTIES OF SECTIONS

District Produced	Section Index	Weight per Foot	Depth of Tee	Flange		Stem Thickness	Area of Section	Axis 1-1				Axis 2-2		
				Width	Thickness			I	S	r	x	I	S	r
P.	T 7 WF	42	7.09	12.023	.778	.451	12.36	37.4	6.36	1.74	1.21	112.7	18.8	3.02
	TCB 7	39	7.03	12.000	.718	.428	11.47	34.8	5.96	1.74	1.19	103.5	17.2	3.00
	(CB 144)													
P.	T 7 WF	37	7.095	10.072	.783	.450	10.88	36.1	6.26	1.82	1.32	66.7	13.3	2.48
	TCB 7	34	7.03	10.040	.718	.418	10.00	33.0	5.74	1.81	1.29	60.6	12.1	2.46
	(CB 143)	30.5	6.955	10.000	.643	.378	8.97	29.2	5.13	1.80	1.25	53.6	10.7	2.45
P.	T 7 WF	29	7.03	8.098	.718	.406	8.53	30.8	5.49	1.90	1.42	31.8	7.85	1.93
	TCB 7	26.5	6.97	8.062	.658	.370	7.79	27.7	4.95	1.88	1.38	28.8	7.14	1.92
	(CB 142)	24	6.905	8.031	.593	.339	7.06	24.9	4.49	1.88	1.35	25.6	6.38	1.91
		21.5	6.84	8.000	.528	.308	6.32	22.2	4.02	1.87	1.33	22.6	5.64	1.89
P.	T 7 WF	21	7.12	6.801	.573	.338	6.17	25.9	4.67	2.05	1.57	14.0	4.13	1.51
	TCB 7	19	7.06	6.776	.513	.313	5.59	23.5	4.27	2.05	1.56	12.3	3.64	1.49
	(CB 141)	17	7.00	6.750	.453	.287	5.00	21.1	3.86	2.05	1.55	10.6	3.15	1.46
		15	6.93	6.733	.383	.270	4.41	19.0	3.55	2.08	1.59	8.77	2.61	1.41
P.		80.5	6.94	12.515	1.486	.905	23.69	62.6	11.5	1.63	1.47	243.1	38.9	3.20
		73.5	6.81	12.450	1.356	.840	21.62	55.7	10.3	1.61	1.41	218.4	35.1	3.18
		66.5	6.69	12.365	1.236	.755	19.56	48.4	9.03	1.57	1.33	195.0	31.5	3.16
		60	6.56	12.320	1.106	.710	17.65	43.4	8.22	1.57	1.28	172.5	28.0	3.13
	T 6 WF	53	6.44	12.230	.986	.620	15.59	36.7	7.01	1.53	1.20	150.4	24.6	3.11
	TCB 6	49.5	6.375	12.190	.921	.580	14.54	33.7	6.46	1.52	1.16	139.1	22.8	3.09
	(CB 124)	46	6.31	12.155	.856	.545	13.53	31.0	5.98	1.51	1.13	128.2	21.1	3.08
		42.5	6.25	12.105	.796	.495	12.49	27.8	5.38	1.49	1.08	117.7	19.5	3.07
		39.5	6.19	12.080	.736	.470	11.61	25.8	5.02	1.48	1.06	108.2	17.9	3.05
		36	6.125	12.040	.671	.430	10.58	23.1	4.53	1.48	1.02	97.6	16.2	3.04
		32.5	6.06	12.000	.606	.390	9.55	20.6	4.06	1.47	.98	87.3	14.6	3.02
	P.	T 6 WF	32	6.155	10.060	.701	.405	9.42	21.7	4.28	1.52	1.08	59.5	11.8
TCB 6		29	6.095	10.014	.641	.359	8.53	19.0	3.75	1.49	1.03	53.7	10.7	2.51
(CB 123)		26.5	6.03	10.000	.576	.345	7.80	17.7	3.54	1.51	1.02	48.0	9.60	2.48

Section Index in parentheses refers to beam from which tee is cut.  
For key to symbols in first column, refer to page 3.

# STRUCTURAL TEES

CUT FROM  
CB SECTIONS

PROPERTIES OF SECTIONS

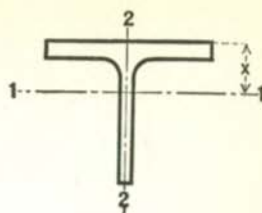

District Produced	Section Index	Weight per Foot	Depth of Tee	Flange		Stem Thickness	Area of Section	Axis 1-1				Axis 2-2		
				Width	Thickness			I	S	r	x	I	S	r
				In.	In.			In. <sup>4</sup>	In. <sup>2</sup>	In.	In.	In. <sup>4</sup>	In. <sup>2</sup>	In.
P.	T 6 WF	25	6.095	8.077	.641	.371	7.36	18.7	3.80	1.60	1.17	28.2	6.98	1.96
	TCB 6	22.5	6.03	8.042	.576	.336	6.62	16.6	3.40	1.59	1.13	25.0	6.20	1.94
	(CB 122)	20	5.97	8.000	.516	.294	5.89	14.4	2.94	1.56	1.08	22.0	5.50	1.94
P.	T 6 WF	18	6.12	6.565	.540	.305	5.29	15.3	3.14	1.70	1.26	11.9	3.62	1.50
	TCB 6	16	6.06	6.533	.480	.273	4.71	13.4	2.77	1.69	1.22	10.3	3.15	1.48
	(CB 121)	14	6.00	6.500	.420	.240	4.12	11.6	2.41	1.68	1.19	8.76	2.70	1.46
		12.5	5.935	6.500	.355	.240	3.69	11.0	2.35	1.72	1.26	7.27	2.24	1.40
P.	T 6 WF	11	6.16	4.030	.424	.260	3.24	11.7	2.58	1.90	1.63	2.27	1.13	.84
	TCBL 6	9.5	6.08	4.010	.349	.240	2.81	10.2	2.32	1.91	1.67	1.84	.92	.81
	(CBL 12)	8.25	6.00	4.000	.269	.230	2.43	9.02	2.13	1.93	1.76	1.39	.70	.76
P.	T 6 WF													
	TCBJ 6	7.00	5.96	3.970	.224	.200	2.07	7.66	1.83	1.92	1.76	1.13	.57	.74
P.		68	5.94	10.575	1.498	.915	20.01	38.2	8.33	1.38	1.36	147.9	28.0	2.72
		62	5.81	10.505	1.368	.845	18.23	33.5	7.41	1.36	1.29	132.4	25.2	2.69
		56	5.69	10.415	1.248	.755	16.46	28.8	6.42	1.32	1.21	117.7	22.6	2.67
		50	5.56	10.345	1.118	.685	14.72	24.8	5.62	1.30	1.14	103.3	20.0	2.65
	T 5 WF	44.5	5.44	10.275	.998	.615	13.09	21.3	4.88	1.28	1.07	90.3	17.6	2.63
	TCB 5	38.5	5.31	10.195	.868	.535	11.33	17.7	4.10	1.25	1.00	76.7	15.1	2.60
	(CB 103)	36	5.25	10.170	.808	.510	10.59	16.4	3.83	1.24	.97	70.9	13.9	2.59
		33	5.19	10.117	.748	.457	9.70	14.5	3.39	1.22	.92	64.6	12.8	2.58
		30	5.125	10.075	.683	.415	8.83	12.8	3.02	1.21	.88	58.2	11.6	2.57
		27	5.06	10.028	.618	.368	7.94	11.2	2.64	1.18	.84	51.95	10.4	2.56
		24.5	5.00	10.000	.558	.340	7.20	10.1	2.40	1.18	.81	46.5	9.30	2.54

Section Index in parentheses refers to beam from which tee is cut.  
For key to symbols in first column, refer to page 3.



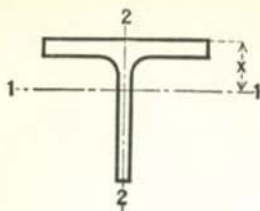

# STRUCTURAL TEES

CUT FROM  
CB SECTIONS

## PROPERTIES OF SECTIONS

District Produced	Section Index	Weight per Foot	Depth of Tee	Flange		Stem Thickness	Area of Section	Axis 1-1				Axis 2-2		
				Width	Thickness			I	S	r	x	I	S	r
P.	T 5 WF	22.5	5.06	8.022	.618	.350	6.62	10.3	2.48	1.25	.91	26.6	6.63	2.00
	TCB 5	20.5	5.00	8.000	.558	.328	6.03	9.38	2.28	1.25	.89	23.8	5.95	1.99
	(CB 102)	18.5	4.94	7.978	.498	.306	5.44	8.49	2.09	1.25	.87	21.1	5.29	1.97
		16.5	4.875	7.964	.433	.292	4.85	7.80	1.95	1.27	.88	18.2	4.58	1.94
P.	T 5 WF	14.5	5.11	5.799	.500	.289	4.27	8.38	2.07	1.40	1.05	7.61	2.62	1.34
	TCB 5	13	5.06	5.769	.450	.259	3.82	7.40	1.83	1.39	1.02	6.68	2.32	1.32
	(CB 101)	11.5	5.00	5.750	.390	.240	3.38	6.62	1.66	1.40	1.02	5.66	1.97	1.29
		10.5	4.95	5.750	.340	.240	3.10	6.31	1.62	1.43	1.06	4.87	1.69	1.25
P.	T 4 WF	33.5	4.50	8.287	.933	.575	9.85	10.94	3.07	1.05	.94	44.3	10.7	2.12
	TCB 4	29	4.375	8.222	.808	.510	8.53	9.11	2.60	1.03	.87	37.50	9.10	2.10
	(CB 83)	24	4.25	8.117	.683	.405	7.06	6.92	2.00	.99	.78	30.45	7.50	2.08
		20	4.125	8.077	.558	.365	5.88	5.80	1.71	.99	.74	24.50	6.05	2.04
		17.5	4.06	8.027	.493	.315	5.15	4.88	1.45	.97	.69	21.25	5.30	2.03
		16.5	4.03	8.012	.463	.300	4.85	4.56	1.36	.97	.68	19.85	4.95	2.02
	15.5	4.00	8.000	.433	.288	4.56	4.31	1.30	.97	.67	18.50	4.60	2.01	
P.	T 4 WF	13.5	4.015	6.528	.448	.273	3.97	4.03	1.22	1.01	.72	10.4	3.18	1.62
	TCB 4	12	3.965	6.500	.398	.245	3.53	3.53	1.08	1.00	.70	9.10	2.80	1.61
(CB 82)														
P.	T 4 WF	10.5	4.095	5.272	.403	.252	3.09	3.80	1.16	1.11	.82	4.56	1.73	1.22
	TCB 4	9.5	4.045	5.264	.353	.244	2.79	3.53	1.10	1.12	.83	3.93	1.49	1.19
	(CB 81)	8.5	4.00	5.250	.308	.230	2.50	3.21	1.01	1.13	.84	3.36	1.28	1.16

Section Index in parentheses refers to beam from which tee is cut.  
For key to symbols in first column, refer to page 3.

# STRUCTURAL TEES

CUT FROM

## STANDARD BEAMS

### PROPERTIES OF SECTIONS

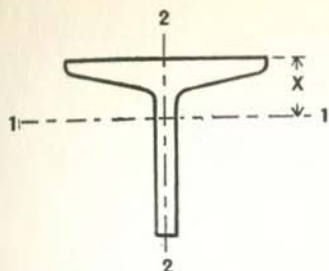

District Produced	Section Index	Weight per Foot	Depth of Tee	Flange		Stem Thickness	Area of Section	Axis 1-1				Axis 2-2		
				Width	Thick-ness			I	S	r	x	I	S	r
P.	TB 6 (B 8)	27.5	6.00	5.600	.660	.810	8.09	28.3	6.98	1.87	1.95	8.52	3.04	1.03
		25	6.00	5.477	.660	.687	7.35	25.2	6.05	1.85	1.84	7.85	2.87	1.03
		22.5	6.00	5.355	.660	.565	6.62	21.9	5.10	1.82	1.71	7.25	2.71	1.05
		20.4	6.00	5.250	.660	.460	5.99	18.8	4.26	1.77	1.57	6.77	2.58	1.06
P.	TB 6 (B 9)	17.5	6.00	5.078	.544	.428	5.14	17.2	3.95	1.83	1.65	4.93	1.94	.98
		15.9	6.00	5.000	.544	.350	4.67	14.9	3.31	1.78	1.51	4.68	1.87	1.00
P.	TB 5 (B 10)	20	5.00	5.091	.491	.741	5.88	14.6	4.39	1.58	1.67	4.67	1.83	.89
		17.5	5.00	4.944	.491	.594	5.15	12.5	3.63	1.56	1.56	4.18	1.69	.90
		15	5.00	4.797	.491	.447	4.41	10.2	2.84	1.52	1.40	3.75	1.56	.92
		12.7	5.00	4.660	.491	.310	3.73	7.81	2.05	1.45	1.20	3.39	1.46	.95
P.	TB 4 (B 12)	12.75	4.00	4.262	.425	.532	3.75	5.75	2.08	1.24	1.24	2.33	1.09	.79
		11.5	4.00	4.171	.425	.441	3.38	5.03	1.77	1.22	1.15	2.15	1.03	.80
		10.25	4.00	4.079	.425	.349	3.01	4.24	1.44	1.19	1.05	1.99	.98	.81
		9.2	4.00	4.000	.425	.270	2.70	3.50	1.14	1.14	.94	1.86	.93	.83
P.	TB 3.5 (B 13)	10	3.50	3.860	.392	.450	2.94	3.36	1.36	1.07	1.04	1.58	.82	.73
		8.75	3.50	3.755	.392	.345	2.57	2.77	1.08	1.04	.93	1.44	.77	.75
		7.65	3.50	3.660	.392	.250	2.24	2.18	.81	.99	.81	1.32	.72	.77
P.	TB 3 (B 14)	8.625	3.00	3.565	.359	.465	2.53	2.13	1.02	.92	.91	1.15	.65	.67
		7.375	3.00	3.443	.359	.343	2.17	1.71	.78	.89	.82	1.02	.59	.69
		6.25	3.00	3.330	.359	.230	1.83	1.27	.55	.83	.69	.93	.56	.71

Section index in parentheses refers to beam from which tee is cut.  
For key to symbols in first column, refer to page 3.

# STRUCTURAL TEES

## CUT FROM

## LIGHT BEAMS

### PROPERTIES OF SECTIONS

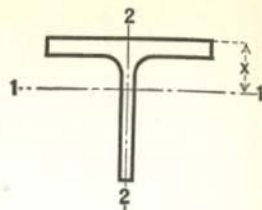

District Produced	Section Index	Weight per Foot	Depth of Tee	Flange		Stem Thickness	Area of Section	Axis 1-1				Axis 2-2		
				Width	Thick-ness			I	S	r	x	I	S	r
				In.	In.			In. <sup>4</sup>	In. <sup>3</sup>	In.	In.	In. <sup>3</sup>	In.	In.
P.	TCBL 5 (CBL 10)	9.50	5.13	4.020	.394	.250	2.80	6.70	1.74	1.55	1.28	2.09	1.04	.86
		8.50	5.06	4.010	.329	.240	2.49	6.07	1.62	1.56	1.32	1.73	.86	.83
		7.50	5.00	4.000	.269	.230	2.20	5.46	1.50	1.57	1.37	1.39	.70	.80
P.	TCBJ 5 (CBJ 10)	5.75	4.94	3.950	.204	.180	1.69	4.15	1.16	1.57	1.35	1.00	.51	.77
P.	TCBL 4 (CBL 8)	7.50	4.06	4.015	.314	.245	2.22	3.29	1.07	1.22	1.00	1.65	.82	.86
		6.50	4.00	4.000	.254	.230	1.91	2.90	.98	1.23	1.03	1.31	.66	.83
P.	TCBJ 4 (CBJ 8)	5.00	3.95	3.940	.204	.170	1.48	2.15	.72	1.21	.96	1.00	.51	.82
P.	TCBL 3 (CBL 6)	8.00	3.13	4.030	.404	.260	2.36	1.66	.68	.84	.67	2.16	1.07	.96
		6.00	3.00	4.000	.279	.230	1.77	1.30	.56	.86	.67	1.44	.72	.90
P.	TCBJ 3 (CBJ 6)	4.25	2.92	3.940	.194	.170	1.25	.90	.40	.85	.64	.94	.48	.87

Section index in parentheses refers to beam from which tee is cut.  
For key to symbols in first column, refer to page 3.

## **SPECIAL SECTIONS**

**STRUCTURAL SHAPES** in this group are, due to a fluctuating demand, rolled only at irregular intervals, and then generally after special arrangements have been made with the mill.

Unless the tonnage of any one size is sufficient in itself to warrant a rolling, a "Regular" structural shape should be specified if possible. Where "Special" shapes must be used the matter should be referred to the nearest district office for information as to deliveries.

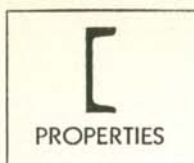

# CHANNELS

## CAR BUILDING AND SHIPBUILDING

### PROPERTIES OF SECTIONS

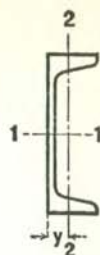

District Rolled	Section Index and Nominal Size	Depth of Channel In.	Weight per Foot Lbs.	Area of Section In. <sup>2</sup>	Width of Flange In.	Web Thickness In.	Axis 1-1			Axis 2-2			
							I	S	r	I	S	r	y
							In. <sup>4</sup>	In. <sup>2</sup>	In.	In. <sup>4</sup>	In. <sup>3</sup>	In.	In.
P.C.	C 60 18 x 4 R = .625	18	58.0	16.98	4.200	.700	670.7	74.5	6.29	18.5	5.6	1.04	0.88
			51.9	15.18	4.100	.600	622.1	69.1	6.40	17.1	5.3	1.06	0.87
			45.8	13.38	4.000	.500	573.5	63.7	6.55	15.8	5.1	1.09	0.89
			42.7	12.48	3.950	.450	549.2	61.0	6.64	15.0	4.9	1.10	0.90
P.C.	C 20 13 x 4 R = .48	13	50.0	14.66	4.412	.787	312.9	48.1	4.62	16.7	4.9	1.07	0.98
P.C.			45.0	13.18	4.298	.673	292.0	44.9	4.71	15.3	4.6	1.08	0.97
P.C.			40.0	11.71	4.185	.560	271.4	41.7	4.82	13.9	4.3	1.09	0.97
P.C.B.			37.0	10.82	4.117	.492	258.9	39.8	4.89	13.0	4.2	1.10	0.98
P.C.B.			35.0	10.24	4.072	.447	250.7	38.6	4.95	12.5	4.0	1.10	0.99
P.C.B.			31.8	9.30	4.000	.375	237.5	36.5	5.05	11.6	3.9	1.11	1.01
P.C.	C 170 12 x 4 R = .50	12	50.0	14.64	4.135	.835	268.1	44.7	4.28	17.8	5.8	1.10	1.06
P.C.			48.6	14.22	4.100	.800	263.0	43.8	4.30	17.3	5.7	1.10	1.05
P.C.			46.6	13.62	4.050	.750	255.8	42.6	4.33	16.6	5.5	1.11	1.05
P.C.B.			44.5	13.02	4.000	.700	248.6	41.4	4.37	16.0	5.4	1.11	1.05
P.C.B.			40.0	11.70	3.890	.590	232.8	38.8	4.46	14.5	5.1	1.12	1.05
P.C.B.			35.0	10.23	3.767	.467	215.1	35.8	4.59	12.9	4.8	1.12	1.07
P.	C 21 12 x 4 R = .625	12	44.7	13.05	4.200	.725	245.0	40.8	4.33	16.8	5.3	1.14	1.04
			40.6	11.85	4.100	.625	230.6	38.4	4.41	15.5	5.1	1.15	1.04
			36.5	10.65	4.000	.525	216.2	36.0	4.51	14.2	4.8	1.16	1.06
			34.5	10.05	3.950	.475	209.0	34.8	4.57	13.5	4.7	1.16	1.07
P.	C 171 12 x 3 1/2 R = .60	12	41.1	12.00	3.700	.700	217.8	36.3	4.26	11.3	4.0	0.97	0.89
			37.0	10.80	3.600	.600	203.4	33.9	4.34	10.3	3.8	0.98	0.89
			32.9	9.60	3.500	.500	189.0	31.5	4.44	9.4	3.6	0.99	0.89
			30.9	9.00	3.450	.450	181.8	30.3	4.50	8.9	3.5	0.99	0.90
P.	C 26 10 x 4 R = .575	10	37.0	10.81	4.200	.675	146.3	29.3	3.68	14.9	4.8	1.18	1.10
			33.6	9.81	4.100	.575	138.0	27.6	3.75	13.7	4.6	1.18	1.11
			30.2	8.81	4.000	.475	129.7	25.9	3.84	12.5	4.3	1.19	1.13
			28.5	8.31	3.950	.425	125.5	25.1	3.89	11.8	4.2	1.19	1.15
P.B.	C 27 10 x 3 1/2 R = .575	10	35.1	10.23	3.700	.675	133.6	26.7	3.61	10.4	3.8	1.01	0.95
			31.7	9.23	3.600	.575	125.2	25.0	3.69	9.5	3.6	1.01	0.95
			28.3	8.23	3.500	.475	116.9	23.4	3.77	8.6	3.4	1.02	0.96
			26.6	7.73	3.450	.425	112.7	22.5	3.82	8.1	3.3	1.02	0.97
			24.9	7.23	3.400	.375	108.6	21.7	3.88	7.6	3.2	1.03	0.98

For key to symbols in first column, refer to page 3.

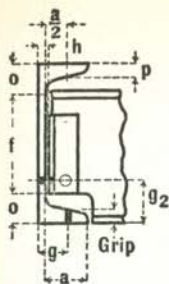

# CHANNELS

## CAR BUILDING AND SHIP BUILDING

### DIMENSIONS OF SECTIONS FOR DETAILING

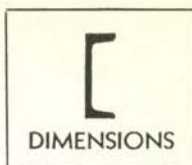

Section Index and Depth	Weight per Foot	Flange		Web		Distance						Max. Flange Rivet	
		Width	Thick-ness, p	Thick-ness	Half Thick-ness	a	f	o	Min. g <sup>2</sup>	Clear. h	Gage g		Grip
		Lbs.	In.	In.	In.	In.	In.	In.	In.	In.	In.		In.
C 60 18 R = .625	58.0	4 1/4	5/8	11/16	3/8	3 1/2	15 3/8	15 1/16	2 3/4	3/4	2 1/2	5/8	1
	51.9	4 1/8	5/8	5/8	5/16	3 1/2	15 3/8	15 1/16	2 3/4	11/16	2 1/2	5/8	1
	45.8	4	5/8	1/2	1/4	3 1/2	15 3/8	15 1/16	2 3/4	9/16	2 1/2	5/8	1
	42.7	4	5/8	7/16	1/4	3 1/2	15 3/8	15 1/16	2 3/4	1/2	2 1/2	5/8	1
C 20 13 R = .48	50.0	4 3/8	5/8	1 3/16	7/16	3 5/8	10 3/8	15 1/16	2 3/4	7/8	2 1/2	5/8	1
	45.0	4 1/4	5/8	11/16	3/8	3 5/8	10 3/8	15 1/16	2 3/4	3/4	2 1/2	5/8	1
	40.0	4 1/8	5/8	9/16	5/16	3 5/8	10 3/8	15 1/16	2 3/4	5/8	2 1/2	9/16	1
	37.0	4 1/8	5/8	1/2	1/4	3 5/8	10 3/8	15 1/16	2 3/4	9/16	2 1/2	9/16	1
	35.0	4 1/8	5/8	7/16	1/4	3 5/8	10 3/8	15 1/16	2 3/4	1/2	2 1/2	9/16	1
31.8	4	5/8	3/8	3/16	3 5/8	10 3/8	15 1/16	2 3/4	7/16	2 1/2	9/16	1	
C 170 12 R = .50	50.0	4 1/8	11/16	7/8	7/16	3 3/8	9 1/2	1 1/4	2 1/2	15/16	2 1/2	11/16	1
	48.6	4 1/8	11/16	1 3/16	7/16	3 3/8	9 1/2	1 1/4	2 1/2	7/8	2 1/2	11/16	1
	46.6	4	11/16	3/4	3/8	3 3/8	9 1/2	1 1/4	2 1/2	1 3/16	2 1/2	11/16	1
	44.5	4	11/16	11/16	3/8	3 3/8	9 1/2	1 1/4	2 1/2	3/4	2 1/2	11/16	1
	40.0	3 7/8	11/16	5/8	5/16	3 3/8	9 1/2	1 1/4	2 1/2	11/16	2 1/2	11/16	1
35.0	3 3/4	11/16	1/2	1/4	3 3/8	9 1/2	1 1/4	2 1/2	9/16	2 1/2	11/16	1	
C 21 12 R = .625	44.7	4 1/4	5/8	3/4	3/8	3 1/2	9 3/8	15 1/16	2 1/2	1 3/16	2 1/2	5/8	1
	40.6	4 1/8	5/8	5/8	5/16	3 1/2	9 3/8	15 1/16	2 1/2	11/16	2 1/2	5/8	1
	36.5	4	5/8	9/16	1/4	3 1/2	9 3/8	15 1/16	2 1/2	5/8	2 1/2	5/8	1
	34.5	4	5/8	1/2	1/4	3 1/2	9 3/8	15 1/16	2 1/2	9/16	2 1/2	5/8	1
C 171 12 R = .60	41.1	3 3/4	5/8	11/16	3/8	3	9 1/2	1 1/4	2 1/2	3/4	2 1/4	5/8	7/8
	37.0	3 5/8	5/8	5/8	5/16	3	9 1/2	1 1/4	2 1/2	11/16	2 1/4	5/8	7/8
	32.9	3 1/2	5/8	1/2	1/4	3	9 1/2	1 1/4	2 1/2	9/16	2 1/4	9/16	7/8
	30.9	3 1/2	5/8	7/16	1/4	3	9 1/2	1 1/4	2 1/2	1/2	2 1/4	9/16	7/8
C 26 10 R = .575	37.0	4 1/4	9/16	11/16	3/8	3 1/2	7 1/2	1 1/4	2 1/2	3/4	2 1/2	9/16	7/8
	33.6	4 1/8	9/16	9/16	5/16	3 1/2	7 1/2	1 1/4	2 1/2	5/8	2 1/2	9/16	7/8
	30.2	4	9/16	1/2	1/4	3 1/2	7 1/2	1 1/4	2 1/2	9/16	2 1/2	9/16	7/8
	28.5	4	9/16	7/16	1/4	3 1/2	7 1/2	1 1/4	2 1/2	1/2	2 1/2	9/16	7/8
C 27 10 R = .575	35.1	3 3/4	9/16	11/16	3/8	3	7 5/8	1 3/16	2 1/2	3/4	2	9/16	7/8
	31.7	3 5/8	9/16	9/16	5/16	3	7 5/8	1 3/16	2 1/2	5/8	2	9/16	7/8
	28.3	3 1/2	9/16	1/2	1/4	3	7 5/8	1 3/16	2 1/2	9/16	2	9/16	7/8
	26.6	3 1/2	9/16	7/16	1/4	3	7 5/8	1 3/16	2 1/2	1/2	2	9/16	7/8
	24.9	3 3/8	9/16	3/8	3/16	3	7 5/8	1 3/16	2 1/2	7/16	2	9/16	7/8

Gages g are usual standard gages, but may be varied if conditions require.  
Gages g<sub>2</sub> are based on 1 1/4" edge distance (3/8" maximum rivet).

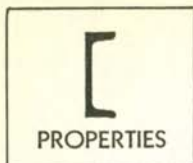

# CHANNELS

## CAR BUILDING AND SHIP BUILDING

### PROPERTIES OF SECTIONS

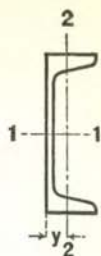

District Rolled	Section Index and Nominal Size	Depth of Channel In.	Weight per Foot Lbs.	Area of Section In. <sup>2</sup>	Width of Flange In.	Web Thickness In.	Axis 1-1			Axis 2-2			
							I	S	r	I	S	r	y
							In. <sup>4</sup>	In. <sup>3</sup>	In.	In. <sup>4</sup>	In. <sup>3</sup>	In.	In.
P.C.B.	C 28 10 x 3½ R = .50	10	25.3	7.38	3.550	.425	106.0	21.2	3.79	7.9	3.0	1.04	0.94
			23.6	6.88	3.500	.375	101.8	20.4	3.85	7.5	2.9	1.04	0.96
			21.9	6.38	3.450	.325	97.6	19.5	3.91	7.0	2.8	1.05	0.98
P.C. P.C. P.C. P.	C 31 9 x 4 R = .575	9	34.7	10.13	4.200	.675	113.0	25.1	3.34	14.5	4.8	1.20	1.15
			31.7	9.23	4.100	.575	106.9	23.8	3.40	13.3	4.5	1.20	1.16
			28.6	8.33	4.000	.475	100.9	22.4	3.48	12.1	4.3	1.20	1.18
			27.1	7.88	3.950	.425	97.8	21.7	3.52	11.4	4.2	1.20	1.20
P.	C 32 9 x 3½ R = .55	9	31.6	9.21	3.700	.650	99.4	22.1	3.29	9.7	3.6	1.03	0.98
			28.5	8.31	3.600	.550	93.4	20.7	3.35	8.8	3.4	1.03	0.98
			25.4	7.41	3.500	.450	87.3	19.4	3.43	8.0	3.2	1.04	1.00
			23.9	6.96	3.450	.400	84.3	18.7	3.48	7.5	3.1	1.04	1.01
P.	C 36 8 x 3½ R = .525	8	28.2	8.23	3.700	.625	71.8	18.0	2.95	9.0	3.4	1.05	1.02
			25.5	7.43	3.600	.525	67.6	16.9	3.02	8.2	3.2	1.05	1.02
			22.8	6.63	3.500	.425	63.3	15.8	3.09	7.4	3.0	1.05	1.04
			21.4	6.23	3.450	.375	61.2	15.3	3.13	6.9	2.9	1.05	1.05
P.B.	C 37 8 x 3 R = .50	8	25.5	7.43	3.225	.600	62.6	15.6	2.90	5.8	2.5	0.89	0.86
			22.7	6.63	3.125	.500	58.3	14.6	2.97	5.3	2.3	0.89	0.85
			20.0	5.83	3.025	.400	54.0	13.5	3.05	4.7	2.2	0.90	0.86
			19.3	5.63	3.000	.375	53.0	13.2	3.07	4.5	2.1	0.90	0.87
P.C.B.	C 211 7 x 4 R = .38	7	18.8	5.48	4.000	.350	42.9	12.2	2.80	8.3	3.0	1.23	1.23
			25.5	7.43	3.225	.600	62.6	15.6	2.90	5.8	2.5	0.89	0.86
			22.7	6.63	3.125	.500	58.3	14.6	2.97	5.3	2.3	0.89	0.85
			20.0	5.83	3.025	.400	54.0	13.5	3.05	4.7	2.2	0.90	0.86
P.C.	C 41 7 x 3½ R = .50	7	25.0	7.30	3.700	.600	49.9	14.3	2.62	8.3	3.2	1.07	1.06
			22.7	6.60	3.600	.500	47.1	13.5	2.67	7.5	3.0	1.07	1.07
			20.3	5.90	3.500	.400	44.2	12.6	2.74	6.7	2.8	1.07	1.09
			19.1	5.55	3.450	.350	42.8	12.2	2.78	6.3	2.7	1.07	1.11
P.	C 42 7 x 3 R = .475	7	20.0	5.82	3.100	.475	40.2	11.5	2.63	4.7	2.1	0.90	0.88
			17.6	5.12	3.000	.375	37.3	10.7	2.70	4.2	2.0	0.90	0.90
			16.4	4.77	2.950	.325	35.9	10.2	2.74	3.9	1.9	0.90	0.91
C.	C 74 7 x 3⅝ R = .35	7	15.6	4.59	3.313	.313	35.1	10.0	2.77	4.8	2.1	1.02	1.01
			18.6	5.47	3.438	.438	38.7	11.1	2.66	5.6	2.3	1.01	0.97
			16.5	4.85	3.350	.350	36.2	10.3	2.73	5.1	2.2	1.02	0.99

For key to symbols in first column, refer to page 3.

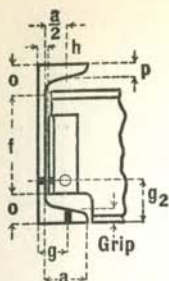

# CHANNELS

## CAR BUILDING AND SHIP BUILDING



### DIMENSIONS OF SECTIONS FOR DETAILING

Section Index and Depth	Weight per Foot	Flange		Web		Distance						Max. Flange Rivet	
		Width	Thick-ness, p	Thick-ness	Half Thick-ness	a	f	o	Min. g <sub>1</sub>	Clear. h	Gage g		Grip
C 28	25.3	3 1/2	1/2	7/16	3/4	3 1/8	7 7/8	1 1/16	2 1/2	1/2	2	1/2	7/8
10	23.6	3 1/2	1/2	3/8	3/16	3 1/8	7 7/8	1 1/16	2 1/2	7/16	2	1/2	7/8
R = .50	21.9	3 1/2	1/2	5/16	3/16	3 1/8	7 7/8	1 1/16	2 1/2	3/8	2	1/2	7/8
C 31	34.7	4 1/4	9/16	11/16	3/8	3 1/2	6 1/2	1 3/4	2 1/2	3/4	2 1/2	9/16	7/8
9	31.7	4 1/8	9/16	9/16	9/16	3 1/2	6 1/2	1 3/4	2 1/2	5/8	2 1/2	9/16	7/8
R = .575	28.6	4	9/16	1/2	1/4	3 1/2	6 1/2	1 3/4	2 1/2	9/16	2 1/2	9/16	7/8
	27.1	4	9/16	7/16	3/4	3 1/2	6 1/2	1 3/4	2 1/2	1/2	2 1/2	9/16	7/8
C 32	31.6	3 3/4	9/16	11/16	5/16	3	6 3/4	1 1/8	2 1/2	3/4	2	9/16	7/8
9	28.5	3 5/8	9/16	9/16	5/16	3	6 3/4	1 1/8	2 1/2	5/8	2	9/16	7/8
R = .55	25.4	3 1/2	9/16	7/16	1/4	3	6 3/4	1 1/8	2 1/2	1/2	2	9/16	7/8
	23.9	3 1/2	9/16	7/16	3/16	3	6 3/4	1 1/8	2 1/2	1/2	2	9/16	7/8
C 36	28.2	3 3/4	1/2	5/8	5/16	3 1/8	5 7/8	1 1/16	2 3/4	1 1/16	2	1/2	7/8
8	25.5	3 5/8	1/2	9/16	1/4	3 1/8	5 7/8	1 1/16	2 3/4	5/8	2	1/2	7/8
R = .525	22.8	3 1/2	1/2	7/16	1/4	3 1/8	5 7/8	1 1/16	2 3/4	1/2	2	1/2	7/8
	21.4	3 1/2	1/2	3/8	3/16	3 1/8	5 7/8	1 1/16	2 3/4	7/16	2	1/2	7/8
C 37	25.5	3 1/4	1/2	5/8	5/16	2 5/8	5 7/8	1 1/16	2 1/4	1 1/16	1 3/4	1/2	7/8
8	22.7	3 1/8	1/2	1/2	1/4	2 5/8	5 7/8	1 1/16	2 1/4	9/16	1 3/4	1/2	7/8
R = .50	20.0	3	1/2	7/16	3/16	2 5/8	5 7/8	1 1/16	2 1/4	1/2	1 3/4	1/2	7/8
	19.3	3	1/2	3/8	3/16	2 5/8	5 7/8	1 1/16	2 1/4	7/16	1 3/4	1/2	7/8
	18.7	3	1/2	3/8	3/16	2 5/8	5 7/8	1 1/16	2 1/4	7/16	1 3/4	1/2	7/8
C 211	18.8	4	7/16	3/8	3/16	3 5/8	5 1/4	7/8	2 3/4	7/16	2 1/2	3/8	7/8
R = .38													
C 41	25.0	3 3/4	1/2	5/8	5/16	3 1/8	4 7/8	1 1/16	2 3/4	1 1/16	2	1/2	7/8
7	22.7	3 5/8	1/2	1/2	1/4	3 1/8	4 7/8	1 1/16	2 3/4	9/16	2	1/2	7/8
R = .50	20.3	3 1/2	1/2	7/16	3/16	3 1/8	4 7/8	1 1/16	2 3/4	1/2	2	1/2	7/8
	19.1	3 1/2	1/2	3/8	3/16	3 1/8	4 7/8	1 1/16	2 3/4	7/16	2	1/2	7/8
C 42	20.0	3 1/8	1/2	1/2	1/4	2 5/8	5	1	2 3/4	9/16	1 3/4	1/2	7/8
7	17.6	3	1/2	3/8	3/16	2 5/8	5	1	2 3/4	7/16	1 3/4	1/2	7/8
R = .475	16.4	3	1/2	5/16	3/16	2 5/8	5	1	2 3/4	3/8	1 3/4	1/2	7/8
C 74	18.6	3 1/2	3/8	7/16	3/16	3	5 7/16	3/4	2 3/4	1/2	2	1/2	7/8
7	16.5	3 3/8	3/8	3/8	3/16	3	5 7/16	3/4	2 3/4	7/16	2	1/2	7/8
R = .35	15.6	3 1/4	3/8	5/16	3/16	3	5 7/16	3/4	2 3/4	3/8	2	1/2	7/8

Gages, g are usual standard gages but may be varied if conditions require.  
Gages, g<sub>2</sub> are based on 1/4" edge distance (7/8" maximum rivet).



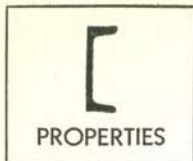

# CHANNELS

## CAR BUILDING AND SHIP BUILDING

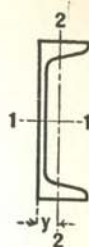

### PROPERTIES OF SECTIONS

District Rolled	Section Index and Nominal Size	Depth of Channel	Weight per Foot	Area of Section	Width of Flange	Web Thick- ness	Axis 1-1			Axis 2-2			
							I	S	r	I	S	r	y
							In. <sup>4</sup>	In. <sup>2</sup>	In.	In. <sup>4</sup>	In. <sup>2</sup>	In.	In.
P.	C 46 6 x 3½ R=.475	6	22.0	6.42	3.700	.575	33.0	11.0	2.27	7.6	2.9	1.09	1.12
			20.0	5.82	3.600	.475	31.2	10.4	2.32	6.9	2.8	1.09	1.13
			18.0	5.22	3.500	.375	29.4	9.8	2.38	6.1	2.6	1.08	1.15
			16.9	4.92	3.450	.325	28.5	9.5	2.41	5.7	2.5	1.08	1.17
C. C. P.C.	C 56 6 x 3½ R=.385	6	19.0	5.56	3.681	.521	28.6	9.5	2.27	6.3	2.4	1.07	1.03
			17.5	5.10	3.604	.444	27.2	9.1	2.31	5.8	2.3	1.07	1.04
			16.9	4.92	3.575	.415	26.7	8.9	2.33	5.7	2.2	1.07	1.05
			15.3	4.48	3.500	.340	25.3	8.4	2.38	5.1	2.1	1.08	1.08
P.B.	C 47 6 x 3 R=.475	6	16.3	4.75	3.000	.375	25.8	8.6	2.33	4.0	1.9	0.91	0.95
			15.1	4.37	2.938	.313	24.7	8.2	2.38	3.6	1.8	0.91	0.97
P.	C 48 6 x 2½ R=.375	6	13.3	3.90	2.563	.375	19.7	6.6	2.25	2.1	1.2	0.74	0.71
			12.0	3.52	2.500	.313	18.6	6.2	2.30	2.0	1.1	0.75	0.72
P.	C 200 4 x 2½ R=.28	4	13.8	4.00	2.500	.500	8.8	4.4	1.49	2.2	1.4	0.74	0.86
P.	*		10.3	3.02	2.250	.625	3.4	2.3	1.06	1.16	0.76	0.62	0.73
P.	C 192	3	9.0	2.64	2.125	.500	3.1	2.1	1.09	0.97	0.68	0.61	0.71
P.	C 193		7.1	2.08	1.938	.313	2.7	1.8	1.14	0.71	0.56	0.58	0.68
C.	C 21		6.5	1.89	1.875	.250	2.6	1.7	1.17	0.63	0.52	0.58	0.67
P.	3 x 1⅞ R=.19		5.8	1.68	1.805	.180	2.4	1.6	1.20	0.53	0.47	0.56	0.68

\*C 193 and C 21 are identical with C 192 except flanges are flared outward to 3⅞" at the toe of flanges. C 21 not rolled to 5.8 lb.

For key to symbols in first column, refer to page 3.

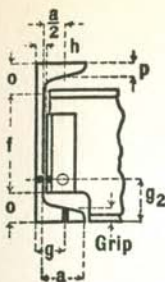

# CHANNELS

## CAR BUILDING AND SHIP BUILDING

### DIMENSIONS OF SECTIONS FOR DETAILING

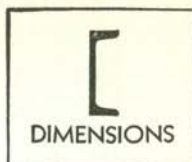

Section Index and Depth	Weight per Foot	Flange		Web		Distance							Max. Flange Rivet
		Width	Thick-ness, p	Thick-ness	Half Thick-ness	a	f	o	Min. g <sup>2</sup>	Clear. h	Gage g	Grip	
		Lbs.	In.	In.	In.	In.	In.	In.	In.	In.	In.	In.	
C 46 6 R = .475	22.0	3 3/4	1/2	9/16	5/16	3 1/8	4	1	2 1/4	5/8	2	1/2	7/8
	20.0	3 5/8	1/2	1/2	1/4	3 1/8	4	1	2 1/4	9/16	2	1/2	7/8
	18.0	3 1/2	1/2	3/8	3/16	3 1/8	4	1	2 1/4	7/16	2	1/2	7/8
	16.9	3 1/2	1/2	5/16	3/16	3 1/8	4	1	2 1/4	3/8	2	1/2	7/8
C 56 6 R = .385	19.0	3 3/4	3/8	1/2	1/4	3 1/8	4 3/8	1 3/16	2	9/16	2	3/8	7/8
	17.5	3 5/8	3/8	7/16	1/4	3 1/8	4 3/8	1 3/16	2	1/2	2	3/8	7/8
	16.9	3 5/8	3/8	7/16	1/4	3 1/8	4 3/8	1 3/16	2	1/2	2	3/8	7/8
	15.3	3 1/2	3/8	3/8	3/16	3 1/8	4 3/8	1 3/16	2	7/16	2	3/8	7/8
C 47 6 R = .475	16.3	3	1/2	3/8	3/16	2 5/8	4	1	2 1/4	7/16	1 3/4	1/2	3/4
	15.1	3	1/2	5/16	3/16	2 5/8	4	1	2 1/4	3/8	1 3/4	1/2	3/4
C 48 6 R = .375	13.3	2 5/8	3/8	3/8	3/16	2 1/8	4 1/2	3/4	2	7/16	1 1/2	3/8	5/8
	12.0	2 1/2	3/8	5/16	3/16	2 1/8	4 1/2	3/4	2	3/8	1 1/2	3/8	5/8
C 200 4 R = .28	13.8	2 1/2	1/2	1/2	1/4	2	2 3/8	1 3/16	2	9/16	1 1/2	1/2	5/8
* C 192	10.3	2 1/4	3/8	5/8	5/16	1 5/8	1 7/8	9/16	...	1 1/16	...	..	..
C 193	9.0	2 1/8	3/8	1/2	1/4	1 5/8	1 7/8	9/16	...	9/16	...	..	..
C 21	7.1	2	3/8	5/16	3/16	1 5/8	1 7/8	9/16	...	3/8	...	..	..
3	6.5	1 7/8	3/8	1/4	1/8	1 5/8	1 7/8	9/16	...	5/16	...	..	..
R = .19	5.8	1 3/4	3/8	3/16	1/8	1 3/8	1 7/8	9/16	...	1/4	...	..	..

Gages g are usual standard gages, but may be varied if conditions require.

Gages g<sub>2</sub> are based on 1 1/4" edge distance (1/8" maximum rivet).

\*C 193 and C 21 are identical with C 192 except flanges are flared out to 3 1/8" at toe of flanges. C 21 not rolled to 5.8 lb.

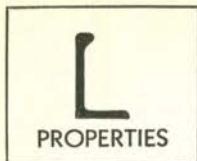

# BULB ANGLES

## SHIP BUILDING

### PROPERTIES OF SECTIONS



District Rolled	Section Index and Nominal Size	Thickness		Weight per Foot	Area of Section	Axis 1-1				Axis 2-2			
		Web	Flange			I	S	r	x	I	S	r	y
		In.	In.										
P.	BA 313 10 x 3½	.70	.64	34.7	10.20	125.6	23.4	3.51	4.69	6.8	2.4	0.81	0.79
		.64	.61	32.3	9.49	118.1	22.1	3.53	4.69	6.2	2.2	0.81	0.77
		.58	.58	29.9	8.78	110.7	20.9	3.55	4.70	5.6	2.0	0.80	0.75
		.52	.485	27.2	7.98	102.9	19.6	3.59	4.80	5.1	1.8	0.80	0.72
		.46	.455	24.8	7.28	95.4	18.4	3.62	4.82	4.6	1.6	0.80	0.70
		.40	.425	22.4	6.57	88.0	17.2	3.66	4.85	4.1	1.5	0.79	0.68
P.	BA 312 9 x 3½	.68	.62	30.8	9.03	90.1	18.2	3.16	4.11	6.3	2.2	0.83	0.80
		.62	.59	28.6	8.38	84.6	17.2	3.18	4.10	5.7	2.1	0.83	0.78
		.56	.56	26.4	7.74	79.0	16.1	3.20	4.10	5.2	1.9	0.82	0.75
		.50	.465	23.8	7.00	73.3	15.1	3.24	4.19	4.7	1.7	0.82	0.72
		.44	.435	21.6	6.35	67.7	14.1	3.27	4.21	4.2	1.5	0.82	0.70
		.38	.405	19.4	5.70	62.2	13.1	3.30	4.22	3.7	1.4	0.81	0.68
P.	BA 311 8 x 3½	.58	.55	24.3	7.14	57.0	12.7	2.83	3.53	5.2	1.9	0.85	0.78
		.52	.52	22.3	6.55	53.0	11.8	2.85	3.52	4.7	1.7	0.84	0.76
		.46	.43	20.0	5.87	48.9	11.1	2.89	3.61	4.2	1.5	0.85	0.72
		.40	.40	18.0	5.28	44.9	10.2	2.92	3.61	3.7	1.3	0.84	0.70
		.34	.37	16.0	4.70	40.9	9.4	2.95	3.62	3.3	1.2	0.84	0.69
P.	BA 310 8 x 3	.58	.55	23.3	6.85	53.9	12.4	2.80	3.67	3.4	1.4	0.70	0.68
		.52	.52	21.4	6.28	50.1	11.5	2.82	3.66	3.0	1.3	0.70	0.66
		.46	.43	19.2	5.64	46.2	10.8	2.86	3.74	2.8	1.1	0.70	0.63
		.40	.40	17.3	5.07	42.4	10.0	2.89	3.75	2.4	1.0	0.69	0.61
		.34	.37	15.4	4.50	38.5	9.2	2.92	3.77	2.1	0.90	0.69	0.59
P.	BA 309 7 x 3½	.56	.54	21.1	6.19	37.5	9.2	2.46	2.95	4.8	1.8	0.88	0.80
		.50	.51	19.3	5.67	34.7	8.6	2.48	2.93	4.3	1.6	0.87	0.78
		.44	.41	17.1	5.03	32.0	8.0	2.52	3.03	3.9	1.4	0.88	0.74
		.38	.38	15.3	4.50	29.2	7.3	2.55	3.02	3.4	1.2	0.87	0.72
		.32	.35	13.6	3.98	26.4	6.7	2.58	3.01	3.0	1.1	0.87	0.71
P.	BA 308 7 x 3	.56	.54	20.2	5.91	35.4	9.0	2.45	3.08	3.1	1.3	0.72	0.69
		.50	.51	18.4	5.40	32.8	8.3	2.46	3.07	2.8	1.2	0.72	0.67
		.44	.41	16.4	4.81	30.2	7.8	2.50	3.15	2.5	1.0	0.72	0.64
		.38	.38	14.7	4.30	27.5	7.1	2.53	3.15	2.2	0.93	0.72	0.62
		.32	.35	12.9	3.79	24.9	6.5	2.56	3.15	1.9	0.82	0.71	0.60
P.	BA 307 6 x 3½	.52	.49	17.4	5.12	22.7	6.3	2.10	2.42	4.3	1.6	0.92	0.82
		.46	.46	15.9	4.65	20.8	5.8	2.12	2.40	3.9	1.4	0.91	0.80
		.40	.365	13.9	4.06	19.0	5.3	2.16	2.47	3.4	1.2	0.91	0.76
		.34	.335	12.3	3.60	17.2	4.8	2.19	2.46	3.0	1.1	0.91	0.74
		.28	.305	10.7	3.13	15.3	4.4	2.21	2.45	2.6	0.94	0.91	0.73

For key to symbols in first column, refer to page 3.

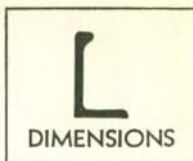
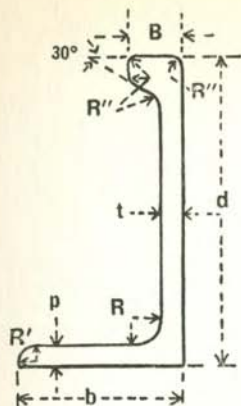

# BULB ANGLES

## SHIP BUILDING

### DIMENSIONS OF SECTIONS FOR DETAILING

Section Index and Nominal Size	Weight per Foot	Flange		Web		Width of Bulb B	Radius of Fillet R	Radii of Roundings	
		Width b	Thickness p	Depth d	Thickness t			R'	R''
		Lbs.	In.	In.	In.			In.	In.
BA 313 10 x 3 1/2	34.7	3 3/4	5/8	10	1 1/16	2	.54	.27	.40
	32.3	3 3/4	5/8	10	5/8	1 15/16	.54	.27	.40
	29.9	3 5/8	9/16	10	9/16	1 7/8	.54	.27	.40
	27.2	3 5/8	1/2	10	1/2	1 13/16	.54	.27	.40
	24.8	3 1/2	7/16	10	7/16	1 3/4	.54	.27	.40
	22.4	3 1/2	7/16	10	3/8	1 11/16	.54	.27	.40
BA 312 9 x 3 1/2	30.8	3 3/4	5/8	9	1 1/16	1 7/8	.54	.27	.36
	28.6	3 3/4	9/16	9	5/8	1 15/16	.54	.27	.36
	26.4	3 5/8	9/16	9	9/16	1 3/4	.54	.27	.36
	23.8	3 5/8	7/16	9	1/2	1 11/16	.54	.27	.36
	21.6	3 1/2	7/16	9	7/16	1 5/8	.54	.27	.36
	19.4	3 1/2	3/8	9	3/8	1 1/16	.54	.27	.36
BA 311 8 x 3 1/2	24.3	3 5/8	9/16	8	9/16	1 5/8	.54	.27	.32
	22.3	3 5/8	1/2	8	1/2	1 13/16	.54	.27	.32
	20.0	3 1/2	7/16	8	7/16	1 1/2	.54	.27	.32
	18.0	3 1/2	3/8	8	3/8	1 7/16	.54	.27	.32
	16.0	3 1/2	3/8	8	9/16	1 3/8	.54	.27	.32
	23.3	3 1/8	9/16	8	9/16	1 5/8	.48	.24	.32
BA 310 8 x 3	21.4	3 1/8	1/2	8	1/2	1 9/16	.48	.24	.32
	19.2	3	7/16	8	7/16	1 1/2	.48	.24	.32
	17.3	3	3/8	8	3/8	1 7/16	.48	.24	.32
	15.4	3	3/8	8	5/16	1 3/8	.48	.24	.32
BA 309 7 x 3 1/2	21.1	3 5/8	9/16	7	9/16	1 1/2	.54	.27	.28
	19.3	3 5/8	1/2	7	1/2	1 7/16	.54	.27	.28
	17.1	3 1/2	7/16	7	7/16	1 3/8	.54	.27	.28
	15.3	3 1/2	3/8	7	3/8	1 5/16	.54	.27	.28
	13.6	3 1/2	3/8	7	5/16	1 1/4	.54	.27	.28
BA 308 7 x 3	20.2	3 1/8	9/16	7	9/16	1 1/2	.48	.24	.28
	18.4	3 1/8	1/2	7	1/2	1 7/16	.48	.24	.28
	16.4	3	7/16	7	7/16	1 3/8	.48	.24	.28
	14.7	3	3/8	7	3/8	1 5/16	.48	.24	.28
	12.9	3	3/8	7	5/16	1 1/4	.48	.24	.28
	17.4	3 3/4	1/2	6	1/2	1 5/16	.54	.27	.24
BA 307 6 x 3 1/2	15.9	3 5/8	7/16	6	7/16	1 1/4	.54	.27	.24
	13.9	3 5/8	3/8	6	3/8	1 3/16	.54	.27	.24
	12.3	3 1/2	9/16	6	5/16	1 1/8	.54	.27	.24
	10.7	3 1/2	5/16	6	1/4	1 1/16	.54	.27	.24

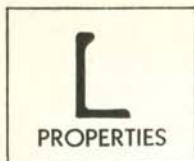

# BULB ANGLES

## SHIP BUILDING

### PROPERTIES OF SECTIONS

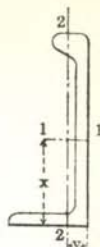

District Rolled	Section Index and Nominal Size	Thickness		Weight per Foot	Area of Section	Axis 1-1				Axis 2-2			
		Web	Flange			I	S	r	x	I	S	r	y
		In.	In.			In. <sup>4</sup>	In. <sup>3</sup>	In.	In.	In. <sup>4</sup>	In. <sup>3</sup>	In.	In.
P.	BA 306 6 x 3	.52	.49	16.6	4.86	21.4	6.1	2.10	2.53	2.8	1.2	0.76	0.70
		.46	.46	15.0	4.41	19.7	5.6	2.11	2.51	2.5	1.1	0.75	0.68
		.40	.365	13.2	3.87	17.9	5.2	2.15	2.59	2.2	0.91	0.75	0.64
		.34	.335	11.7	3.42	16.2	4.7	2.18	2.58	1.9	0.80	0.75	0.63
		.28	.305	10.1	2.97	14.5	4.3	2.21	2.58	1.6	0.70	0.74	0.61
P.	BA 305 5 1/2 x 3	.50	.46	14.9	4.37	16.1	4.9	1.92	2.27	2.6	1.1	0.78	0.71
		.44	.43	13.4	3.94	14.7	4.5	1.93	2.25	2.3	1.0	0.77	0.69
		.38	.345	11.7	3.44	13.4	4.1	1.97	2.31	2.0	0.85	0.77	0.65
		.32	.315	10.3	3.02	12.0	3.7	2.00	2.30	1.8	0.75	0.77	0.63
		.26	.285	8.9	2.60	10.6	3.3	2.02	2.28	1.5	0.65	0.76	0.62
P.	BA 303 5 x 2 1/2	.48	.44	12.6	3.68	11.1	3.8	1.74	2.12	1.5	0.75	0.63	0.61
		.42	.41	11.3	3.30	10.1	3.5	1.75	2.10	1.3	0.67	0.63	0.58
		.36	.33	9.8	2.88	9.1	3.1	1.78	2.06	1.1	0.56	0.63	0.55
		.30	.30	8.5	2.50	8.1	2.7	1.81	2.03	0.97	0.49	0.62	0.53
		.24	.27	7.3	2.13	7.1	2.4	1.83	2.01	0.81	0.42	0.62	0.51

# BULB ANGLES

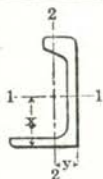

# CAR BUILDING

District Rolled	Section Index and Nominal Size	Thickness		Weight per Foot	Area of Section	Axis 1-1				Axis 2-2			
		Web	Flange			I	S	r	x	I	S	r	y
		In.	In.			In. <sup>4</sup>	In. <sup>3</sup>	In.	In.	In. <sup>4</sup>	In. <sup>3</sup>	In.	In.
P.C.	BA 125 5 x 4 1/2 R = 3/8	.438	.438	19.1	5.64	20.8	7.9	1.91	2.39	7.9	2.4	1.18	1.23
P.C.B.	BA 124 5 x 3 1/2 R = 3/8	.375	.375	13.0	3.82	13.5	4.9	1.88	2.22	3.3	1.2	0.92	0.86
P.	BA 122 4 x 3 1/2 R = 3/8	.500	.500	14.3	4.21	8.7	3.7	1.44	1.65	3.9	1.5	0.96	0.99
P.C.B.	BA 123 4 x 3 1/2 R = 3/8	.375	.375	11.9	3.48	7.9	3.5	1.50	1.77	3.1	1.2	0.94	0.94

For key to symbols in first column, refer to page 3.

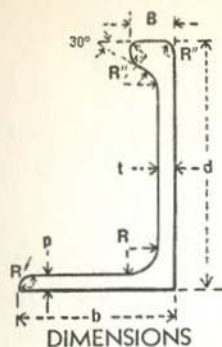

# BULB ANGLES

## SHIP BUILDING

### DIMENSIONS OF SECTIONS FOR DETAILING

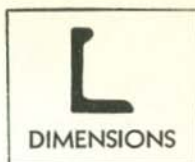

Section Index and Nominal Size	Weight per Foot Lbs.	Flange		Web		Width of Bulb B	Radius of Fillet R	Radii of Roundings	
		Width b	Thickness p	Depth d	Thickness t			R'	R''
		In.	In.	In.	In.			In.	In.
BA 306 6 x 3	16.6	3 1/8	1/2	6	1/2	1 5/16	.48	.24	.24
	15.0	3 1/8	7/16	6	7/16	1 1/4	.48	.24	.24
	13.2	3	3/8	6	3/8	1 3/16	.48	.24	.24
	11.7	3	5/16	6	5/16	1 1/8	.48	.24	.24
	10.1	3	3/16	6	1/4	1 1/16	.48	.24	.24
BA 305 5 1/2 x 3	14.9	3 1/8	7/16	5 1/2	1/2	1 3/16	.48	.24	.22
	13.4	3 1/8	7/16	5 1/2	7/16	1 1/8	.48	.24	.22
	11.7	3	3/8	5 1/2	3/8	1 1/16	.48	.24	.22
	10.3	3	5/16	5 1/2	5/16	1	.48	.24	.22
	8.9	3	3/16	5 1/2	1/4	1	.48	.24	.22
BA 303 5 x 2 1/2	12.6	2 5/8	7/16	5	1/2	1 1/8	.42	.21	.20
	11.3	2 5/8	7/16	5	7/16	1 1/16	.42	.21	.20
	9.8	2 1/2	5/16	5	3/8	1	.42	.21	.20
	8.5	2 1/2	5/16	5	5/16	1 5/16	.42	.21	.20
	7.3	2 1/2	1/4	5	1/4	7/8	.42	.21	.20

# BULB ANGLES

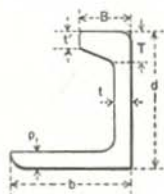

# CAR BUILDING

Section Index and Nominal Size	Weight per Foot Lbs.	Flange		Web		Bulb		
		Width b	Thickness p	Depth d	Thickness t	Width B	Thickness t'	Thickness at Root T
		In.	In.	In.	In.	In.	In.	In.
BA 125 5 x 4 1/2 R = 3/8	19.1	4 1/2	7/16	5	7/16	2 1/4	9/16	1 9/32
BA 124 5 x 3 1/2 R = 3/8	13.0	3 1/2	3/8	5	3/8	1 1/2	7/16	1 1/16
BA 122 4 x 3 1/2 R = 3/8	14.3	3 1/2	1/2	4	1/2	1 1/2	1/2	29/32
BA 123 4 x 3 1/2 R = 3/8	11.9	3 1/2	3/8	4	3/8	1 1/2	1/2	1 5/16



# SPECIAL ANGLES

## EQUAL AND UNEQUAL

### PROPERTIES OF SECTIONS

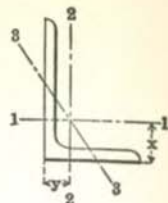

District Rolled	Section Index	Size	Thick-ness	Weight per Foot	Area of Section	Axis 1-1				Axis 2-2				Axis 3-3				
						I		S		x		I		S		y		r min.
						In. <sup>4</sup>	In. <sup>2</sup>	In.	In.	In. <sup>4</sup>	In. <sup>2</sup>	In.	In.	In. <sup>4</sup>	In. <sup>2</sup>	In.	In.	In.
P.			1/2	8.5	2.50	1.67	.89	.82	.87	1.67	.89	.82	.87	.54				
P.			3/16	7.6	2.21	1.51	.79	.83	.85	1.51	.79	.83	.85	.54				
P.			3/8	6.6	1.92	1.33	.69	.83	.82	1.33	.69	.83	.82	.54				
P.C.	†A 8	2 3/4 x 2 3/4	3/16	5.6	1.62	1.15	.59	.84	.80	1.15	.59	.84	.80	.54				
P.C.	R = 1/4		1/4	4.5	1.31	.95	.48	.85	.78	.95	.48	.85	.78	.54				
P.C.			3/16	3.39	1.00	.73	.37	.86	.76	.73	.37	.86	.76	.55				
P.C.			1/8	2.28	.67	.51	.25	.87	.73	.51	.25	.87	.73	.55				
P.			1/2	6.8	2.00	.87	.58	.66	.74	.87	.58	.66	.74	.44				
P.B.			3/16	6.1	.178	.79	.52	.67	.72	.79	.52	.67	.72	.44				
P.C.B.			3/8	5.3	.155	.70	.45	.67	.70	.70	.45	.67	.70	.44				
P.C.B.	†A 10	2 1/4 x 2 1/4	3/16	4.5	1.31	.61	.39	.68	.68	.61	.39	.68	.68	.44				
P.C.B.	R = 1/4		1/4	3.62	1.06	.50	.32	.69	.65	.50	.32	.69	.65	.44				
P.C.B.			3/16	2.75	.81	.39	.24	.70	.63	.39	.24	.70	.63	.44				
P.C.B.			1/8	1.86	.55	.27	.17	.71	.61	.27	.17	.71	.61	.45				
B.			1/4	1.70	.50	.054	.072	.33	.37	.054	.072	.33	.37	.22				
P.B.	†A 508	1 1/8 x 1 1/8	3/16	1.32	.39	.044	.057	.34	.35	.044	.057	.34	.35	.22				
P.B.	R = 1/8		1/8	.91	.27	.032	.040	.34	.33	.032	.040	.34	.33	.22				
P.B.	A 81 R = 1/8	7/8 x 7/8	3/16	1.00	.29	.019	.033	.26	.29	.019	.033	.26	.29	.17				
			1/8	.69	.20	.014	.023	.26	.26	.014	.023	.26	.26	.17				
B.			1/4	1.06	.31	.014	.030	.21	.28	.014	.030	.21	.28	.15				
P.C.B.	†A 17	3/4 x 3/4	3/16	.84	.25	.012	.024	.22	.25	.012	.024	.22	.25	.15				
P.C.B.S.	R = 1/8		1/8	.59	.17	.009	.017	.22	.23	.009	.017	.22	.23	.15				
P.	†A 547 R = 1/4	2 x 1 1/4	1/4	2.55	.75	.30	.23	.63	.71	.089	.097	.34	.33	.27				
			3/16	1.96	.57	.23	.18	.64	.69	.071	.075	.35	.31	.27				
S.	†SS9 R = 1/4	1 3/8 x 1 1/4	1/8	1.06	.31	.06	.06	.43	.41	.045	.050	.38	.34	.23				
P.C.	†A 40 R = 1/8	1 3/8 x 7/8	3/16	1.32	.39	.071	.081	.43	.49	.022	.035	.24	.24	.19				
			1/8	.91	.27	.051	.056	.44	.47	.017	.026	.25	.22	.20				
P.C.	†A 42 R = 1/8	1 x 5/8	1/8	.64	.19	.018	.029	.31	.35	.006	.012	.17	.17	.13				

†Subject to Bar Card Extra.  
For key to symbols in first column, refer to page 3.

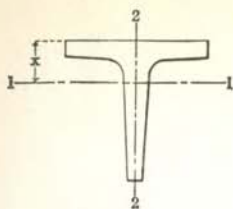

PROPERTIES

# TEES

## EQUAL AND UNEQUAL

### PROPERTIES OF SECTIONS AND DIMENSIONS

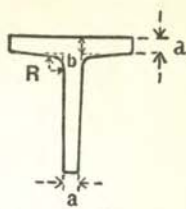

DIMENSIONS

District Rolled	Section Index	Size					Weight per Foot	Area of Section	Axis 1-1				Axis 2-2		
		Flange	Stem	Thickness		Radius of Fillet R			I	S	r	x	I	S	r
				Toe a	Root b										

### EQUAL TEES

P.	T 40	6½	6½	.40, .45	.55, .45	.40	19.8	5.80	23.5	5.0	2.01	1.76	10.1	3.1	1.32
P.C.	T 1	4	4	½	⅞	½	13.5	3.97	5.7	2.0	1.20	1.18	2.8	1.4	0.84
P.C.	T 2	4	4	⅜	⅞	½	10.5	3.09	4.5	1.6	1.21	1.13	2.1	1.1	0.83
C.	T 3	3½	3½	½	⅞	⅜	11.7	3.44	3.7	1.5	1.04	1.05	1.9	1.1	0.74
C.	T 4	3½	3½	⅜	⅞	⅜	9.2	2.68	3.0	1.2	1.05	1.01	1.4	0.81	0.73
P.C.	T 8	3	3	⅜	⅞	⅝	7.8	2.27	1.8	0.86	0.90	0.88	0.90	0.60	0.63
P.C.	T 9	3	3	⅝	⅞	⅝	6.7	1.95	1.6	0.74	0.90	0.86	0.75	0.50	0.62
P.C.	T 10	2½	2½	⅜	⅞	¼	6.4	1.87	1.0	0.59	0.74	0.76	0.52	0.42	0.53
P.C.	T 11	2½	2½	⅝	⅞	¼	5.5	1.60	0.88	0.50	0.74	0.74	0.44	0.35	0.52
P.C.	T 12	2¼	2¼	⅝	⅞	¼	4.9	1.43	0.65	0.41	0.67	0.68	0.33	0.29	0.48
P.C.	T 13	2¼	2¼	¼	⅝	¼	4.1	1.19	0.52	0.32	0.66	0.65	0.25	0.22	0.46
P.C.	T 14	2	2	⅝	⅞	¼	4.3	1.26	0.44	0.31	0.59	0.61	0.23	0.23	0.43
P.C.	T 15	2	2	¼	⅝	¼	3.56	1.05	0.37	0.26	0.59	0.59	0.18	0.18	0.42

### UNEQUAL TEES

P.	T 50	5	3⅛	½, ⅜	⅜, ⅜	⅞, ⅞	⅜	13.6	4.00	2.7	1.1	0.82	0.76	5.2	2.1	1.14
		5	3	⅜, ⅜	⅜, ⅜	⅞, ⅞	⅜	11.5	3.37	2.4	1.1	0.84	0.76	3.9	1.6	1.10
P.C.	T 57	4	5	½	⅞	½	15.3	4.50	10.8	3.1	1.55	1.56	2.8	1.4	0.79	
P.C.	T 58	4	5	⅜	⅞	½	11.9	3.49	8.5	2.4	1.56	1.51	2.1	1.1	0.78	
P.	T 59	4	4½	½	⅞	½	14.4	4.23	7.9	2.5	1.37	1.37	2.8	1.4	0.81	
P.	T 60	4	4½	⅜	⅞	½	11.2	3.29	6.3	2.0	1.39	1.31	2.1	1.1	0.80	
P.C.	T 61	4	3	⅜	⅞	⅜	9.2	2.68	2.0	0.90	0.86	0.78	2.1	1.1	0.89	
P.	T 44	4	3	⅝	⅞	⅜	7.8	2.29	1.7	0.77	0.87	0.75	1.8	0.88	0.88	
P.	T 62	4	2½	⅜	⅞	⅜	8.5	2.48	1.2	0.62	0.69	0.62	2.1	1.0	0.92	
P.	T 63	4	2½	⅝	⅞	⅜	7.2	2.12	1.0	0.53	0.69	0.60	1.8	0.88	0.91	
P.C.	T 79	3	2½	⅝	⅞	⅝	6.1	1.77	0.94	0.52	0.73	0.68	0.75	0.50	0.65	
P.C.	T 83	2½	3	⅝	⅞	⅜	6.1	1.77	1.5	0.72	0.92	0.92	0.44	0.35	0.50	

\*Where two dimensions are shown, the first is for the flange, the second for the stem.

For key to symbols in first column, refer to page 3.



# SPECIAL TEE SECTION

WALL ARMOR TEE

DIMENSIONS OF SECTION

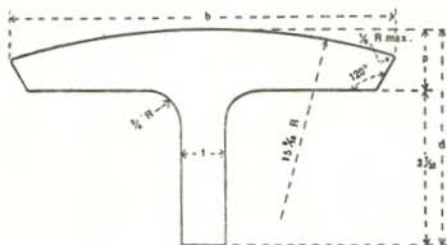

District Rolled	Section Index	Depth	Weight per Foot	Area of Section	Flange		Stem Thickness
					Width	Thickness	
		d	Lbs.	In. <sup>2</sup>	b	p	t
P.	T 41	$4\frac{7}{16}$	29.2	8.585	$7\frac{3}{4}$	1	$\frac{5}{8}$

For key to symbols in first column, refer to page 3.

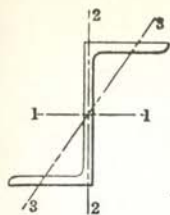

# ZEES

## PROPERTIES OF SECTIONS AND DIMENSIONS



District Rolled	Section Index	Size			Weight per Foot	Area of Section	Axis 1-1			Axis 2-2			Axis 3-3
		Depth	Flange	Thickness			I	S	r	I	S	r	r min.
		In.	In.	In.			In. <sup>4</sup>	In. <sup>3</sup>	In.	In. <sup>4</sup>	In. <sup>3</sup>	In.	In.
P.C.	Z 3 R = 5/16	6 1/8	3 5/8	7/8	34.6	10.17	50.2	16.4	2.22	19.2	6.0	1.37	0.83
		6 1/16	3 9/16	1 1/16	32.0	9.40	46.1	15.2	2.22	17.3	5.5	1.36	0.82
		6	3 1/2	3/4	29.4	8.63	42.1	14.0	2.21	15.4	4.9	1.34	0.81
P.C.	Z 2 R = 5/16	6 1/8	3 5/8	1 1/16	28.1	8.25	43.2	14.1	2.29	16.3	5.0	1.41	0.84
		6 1/16	3 9/16	5/8	25.4	7.46	38.9	12.8	2.28	14.4	4.4	1.39	0.82
		6	3 1/2	9/16	22.8	6.68	34.6	11.5	2.28	12.6	3.9	1.37	0.81
P.C.	Z 1 R = 5/16	6 1/8	3 5/8	1/2	21.1	6.19	34.4	11.2	2.36	12.9	3.8	1.44	0.84
		6 1/16	3 9/16	7/16	18.4	5.39	29.8	9.8	2.35	11.0	3.3	1.43	0.83
		6	3 1/2	3/8	15.7	4.59	25.3	8.4	2.35	9.1	2.8	1.41	0.83
P.C.	Z 6 R = 5/16	5 1/8	3 3/8	1 3/16	28.4	8.33	28.7	11.2	1.86	14.4	4.8	1.31	0.76
		5 1/16	3 9/16	3/4	26.0	7.64	26.2	10.3	1.85	12.8	4.4	1.30	0.74
		5	3 1/4	1 1/16	23.7	6.96	23.7	9.5	1.84	11.4	3.9	1.28	0.73
P.C.	Z 5 R = 5/16	5 1/8	3 3/8	5/8	22.6	6.64	24.5	9.6	1.92	12.1	3.9	1.35	0.76
		5 1/16	3 9/16	9/16	20.2	5.94	21.8	8.6	1.91	10.5	3.5	1.33	0.75
		5	3 1/4	1/2	17.9	5.25	19.2	7.7	1.91	9.1	3.0	1.31	0.74
P.C.	Z 4 R = 5/16	5 1/8	3 3/8	7/16	16.4	4.81	19.1	7.4	1.99	9.2	2.9	1.38	0.77
		5 1/16	3 9/16	3/8	14.0	4.10	16.2	6.4	1.99	7.7	2.5	1.37	0.76
		5	3 1/4	5/16	11.6	3.40	13.4	5.3	1.98	6.2	2.0	1.35	0.75
P.C.	Z 9 R = 5/16	4 1/8	3 3/16	3/4	23.0	6.75	15.0	7.3	1.49	11.2	4.0	1.29	0.68
		4 1/16	3 1/8	1 1/16	20.9	6.14	13.5	6.7	1.48	10.0	3.6	1.27	0.67
		4	3 1/16	5/8	18.9	5.55	12.1	6.1	1.48	8.7	3.2	1.25	0.66
P.C.	Z 8 R = 5/16	4 1/8	3 3/16	9/16	18.0	5.27	12.7	6.2	1.55	9.3	3.2	1.33	0.68
		4 1/16	3 1/8	1/2	15.9	4.66	11.2	5.5	1.55	8.0	2.8	1.31	0.67
		4	3 1/16	7/16	13.8	4.05	9.7	4.8	1.55	6.7	2.4	1.29	0.66
P.C.B.	Z 7 R = 5/16	4 1/8	3 3/16	3/8	12.5	3.66	9.6	4.7	1.62	6.8	2.3	1.36	0.69
		4 1/16	3 1/8	5/16	10.3	3.03	7.9	3.9	1.62	5.5	1.8	1.34	0.68
		4	3 1/16	1/4	8.2	2.41	6.3	3.1	1.62	4.2	1.4	1.33	0.67
P.C.	Z 12 R = 5/16	3 1/16	2 3/4	9/16	14.3	4.18	5.3	3.4	1.12	5.7	2.3	1.17	0.54
		3	2 1 1/16	1/2	12.6	3.69	4.6	3.1	1.12	4.9	2.0	1.15	0.53
P.C.B.	Z 11 R = 5/16	3 1/16	2 3/4	7/16	11.5	3.36	4.6	3.0	1.17	4.8	1.9	1.19	0.55
		3	2 1 1/16	3/8	9.8	2.86	3.9	2.6	1.16	3.9	1.6	1.17	0.54
P.C.B.	Z 10 R = 5/16	3 1/16	2 3/4	5/16	8.5	2.48	3.6	2.4	1.21	3.6	1.4	1.21	0.56
		3	2 1 1/16	1/4	6.7	1.97	2.9	1.9	1.21	2.8	1.1	1.19	0.55

For key to symbols in first column, refer to page 3.

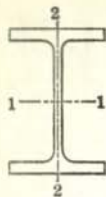

WIDE FLANGE  
CB SECTIONS  
FOR SUBWAY COLUMNS

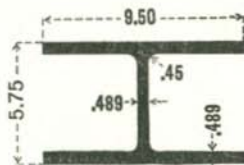
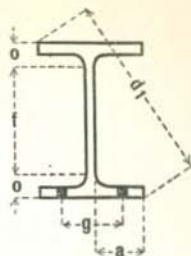

**CB 61** 5 $\frac{3}{4}$  x 9 $\frac{1}{2}$

PROPERTIES OF SECTIONS

District Rolled	Section Index and Nominal Size	Depth of Section In.	Weight per Foot Lbs.	Area of Section In. <sup>2</sup>	Flange		Web	Axis 1-1			Axis 2-2		
					Width	Thick-ness	Thick-ness	I	S	r	I	S	r
					In.	In.	In.	In. <sup>4</sup>	In. <sup>3</sup>	In.	In. <sup>4</sup>	In. <sup>3</sup>	In.
P.	5 $\frac{3}{4}$ " WF CB 61 5 $\frac{3}{4}$ x 9 $\frac{1}{2}$	6.842	88	25.87	10.046	1.035	1.035	187.3	54.7	2.69	175.4	34.9	2.60
		6.666	80	23.52	9.959	.947	.948	164.9	49.5	2.65	156.3	31.4	2.58
		6.444	70	20.58	9.846	.836	.835	138.7	43.0	2.60	133.3	27.1	2.54
		6.216	60	17.63	9.733	.722	.722	113.9	36.7	2.54	111.1	22.8	2.51
		5.986	50	14.70	9.617	.607	.606	91.0	30.4	2.49	90.1	18.7	2.48
		5.750	40	11.76	9.500	.489	.489	69.6	24.2	2.43	69.9	14.7	2.44

DIMENSIONS FOR DETAILING

Section Index and Nominal Depth	Weight per Foot Lbs.	Depth of Section In.	Flange		Web		Distance				Usual Gage g In.
			Width	Thick-ness	Thick-ness	Half Thick-ness	a	f	o	d <sub>1</sub>	
			In.	In.	In.	In.	In.	In.	In.	In.	
5 $\frac{3}{4}$ " WF CB 61 5 $\frac{3}{4}$ x 9 $\frac{1}{2}$	88	6 $\frac{7}{8}$	10	1 $\frac{1}{16}$	1 $\frac{1}{16}$	$\frac{3}{16}$	4 $\frac{1}{2}$	3 $\frac{7}{8}$	1 $\frac{1}{2}$	12 $\frac{1}{4}$	5 $\frac{1}{2}$
	80	6 $\frac{5}{8}$	10	1 $\frac{3}{16}$	1 $\frac{3}{16}$	$\frac{1}{2}$	4 $\frac{1}{2}$	3 $\frac{7}{8}$	1 $\frac{3}{8}$	12	5 $\frac{1}{2}$
	70	6 $\frac{1}{2}$	9 $\frac{7}{8}$	1 $\frac{3}{16}$	$\frac{7}{8}$	$\frac{1}{16}$	4 $\frac{1}{2}$	3 $\frac{7}{8}$	1 $\frac{5}{16}$	11 $\frac{7}{8}$	5 $\frac{1}{2}$
	60	6 $\frac{1}{4}$	9 $\frac{3}{4}$	$\frac{3}{4}$	$\frac{3}{4}$	$\frac{3}{8}$	4 $\frac{1}{2}$	3 $\frac{7}{8}$	1 $\frac{3}{16}$	11 $\frac{5}{8}$	5 $\frac{1}{2}$
	50	6	9 $\frac{5}{8}$	$\frac{5}{8}$	$\frac{5}{8}$	$\frac{5}{16}$	4 $\frac{1}{2}$	3 $\frac{7}{8}$	1 $\frac{1}{16}$	11 $\frac{3}{8}$	5 $\frac{1}{2}$
	40	5 $\frac{3}{4}$	9 $\frac{1}{2}$	$\frac{1}{2}$	$\frac{1}{2}$	$\frac{1}{4}$	4 $\frac{1}{2}$	3 $\frac{7}{8}$	1 $\frac{5}{16}$	11 $\frac{1}{8}$	5 $\frac{1}{2}$

For key to symbol in first column, refer to page 3.

# MISCELLANEOUS CAR BUILDING SECTIONS

## CENTER SILL SECTION

## CENTER SILL SECTION

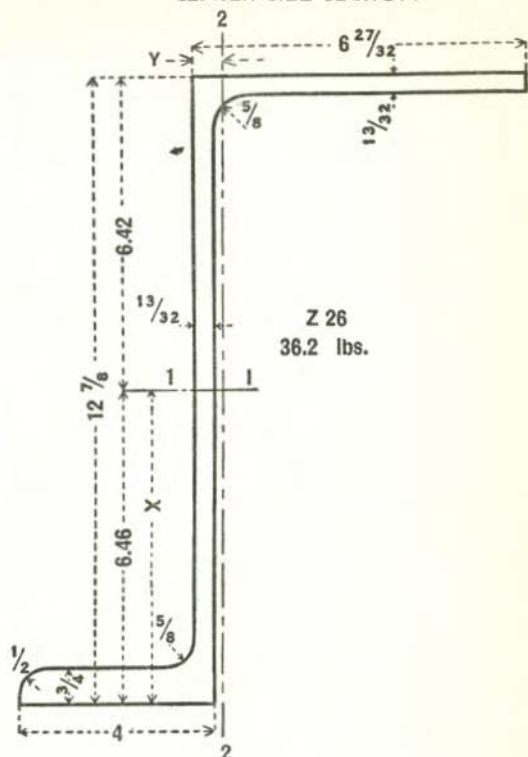
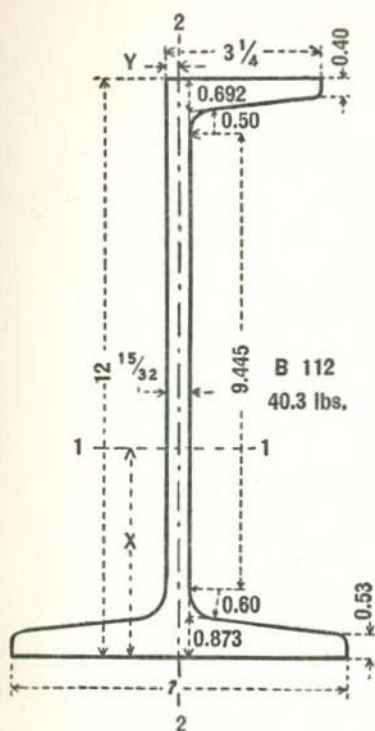

District Rolled	Section Index	Depth In.	Weight per Foot Lbs.	Area In <sup>2</sup>	Width of Flange In.	Thick- ness of Web In.	Axis 1-1				Axis 2-2			
							I In. <sup>4</sup>	S In. <sup>3</sup>	r In.	x In.	I In. <sup>4</sup>	S In. <sup>3</sup>	r In.	y In.

### CENTER SILL SECTION B112

P.C.	B 112	12	40.3	11.72	3 1/4, 7	15/32	238.1	31.9	4.51	4.54	21.8	5.9	1.36	0.43
------	-------	----	------	-------	----------	-------	-------	------	------	------	------	-----	------	------

### CENTER SILL SECTION Z26

P.C.	Z 26	12 15/16	41.2	12.12	6 29/32, 4 1/16	15/32	308.0	47.5	5.04	6.59	59.2	9.4	2.21	0.62
		12 7/8	36.2	10.65	6 27/32, 4	13/32	276.1	42.8	5.09	6.46	51.4	8.2	2.20	0.56
		12 13/16	31.3	9.20	6 25/32, 3 15/16	11/32	240.9	38.1	5.12	6.31	43.8	7.0	2.18	0.48

### COMPLETE SILL Z26

P.C.	Z 26	12 15/16	82.4	24.24	13 13/16	15/32	616.0	95.0	5.04	6.59	981.2	93.4	8.99	6.91
		12 7/8	72.4	21.30	13 11/16	13/32	552.2	85.5	5.09	6.46	945.3	90.6	9.42	6.84
		12 13/16	62.6	18.40	13 9/16	11/32	481.7	76.3	5.12	6.31	818.1	78.9	9.43	6.78

For key to symbols in first column, refer to page 3.

# MISCELLANEOUS CAR BUILDING SECTIONS

## W SIDE PLATE SECTION

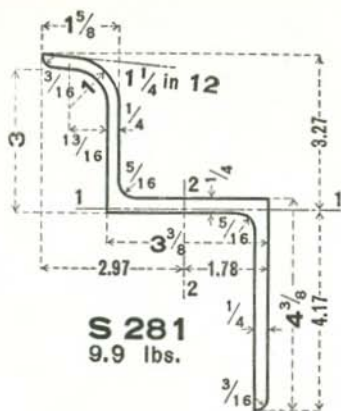

## SIDE POST SECTION

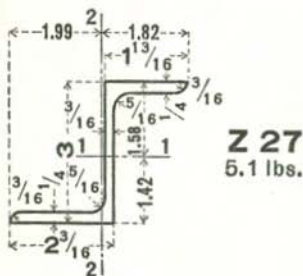

## SIDE PLATE SECTION

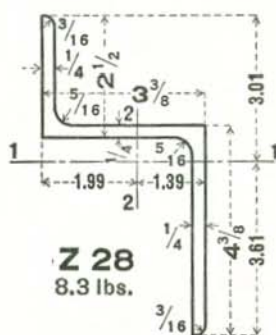

District Rolled	Section Index	Depth	Weight per Foot	Area	Axis 1-1		Axis 2-2	
					I	S	I	S
					In. <sup>4</sup>	In. <sup>3</sup>	In. <sup>4</sup>	In. <sup>3</sup>
C.	S 281	7 1/16	9.9	2.89	11.26	2.70	6.94	2.34
C.B.	Z 27	3	5.10	1.50	2.13	1.34	1.16	0.58
C.	Z 28	3 3/8	8.30	2.44	6.53	1.81	4.48	2.25

For key to symbols in first column, refer to page 3.

# MISCELLANEOUS CAR BUILDING SECTIONS

## CAR DOOR TRACK SECTIONS

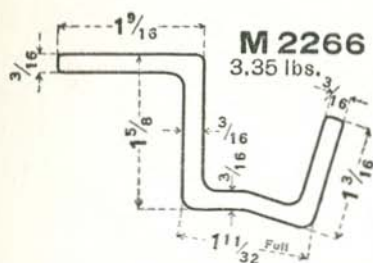

Rolled in Pittsburgh District

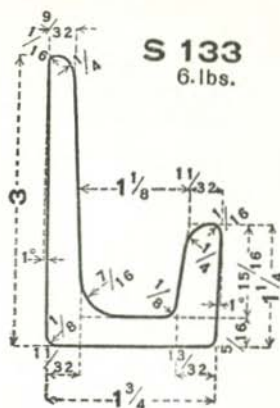

Rolled in Chicago District

## DOOR SPREADER SECTION

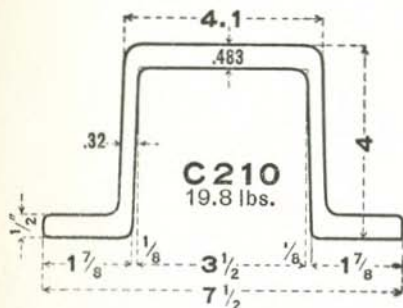

Rolled in Pittsburgh District

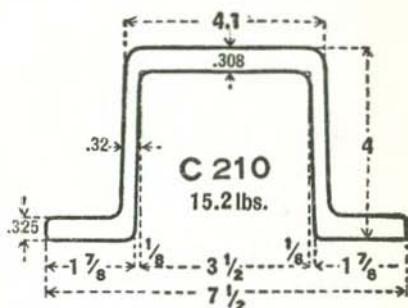

Rolled in Pittsburgh District

## BELT RAIL SECTIONS

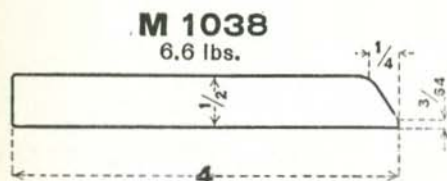

Rolled in Pittsburgh District

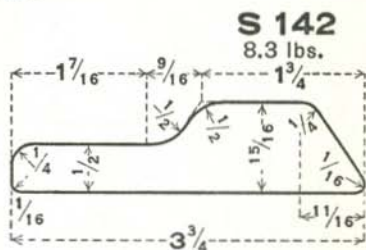

Rolled in Chicago District

PROFILES SHOW DIMENSIONS IN INCHES

# MISCELLANEOUS CAR BUILDING SECTIONS

## DRAW BAR AND DRAFT KEY SECTIONS

**M 2625**  
37.9 lbs.

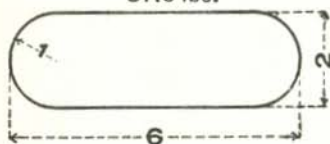

Rolled in Pittsburgh District

**M 2150**  
29.0 lbs.

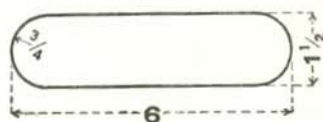

Rolled in Pittsburgh District

**M 1850**  
18.2 lbs.

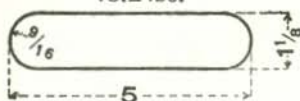

Rolled in Pittsburgh District

**M 2626**  
20.1 lbs.

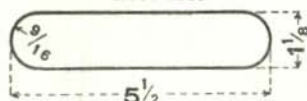

Rolled in Pittsburgh District

**S 170**  
13.6 lbs.

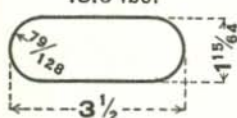

Rolled in Chicago District

**M 1851**  
16.3 lbs.

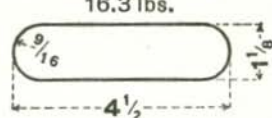

Rolled in Pittsburgh District

PROFILES SHOW DIMENSIONS IN INCHES

# COLD FORMED SECTIONS

## ANGLES

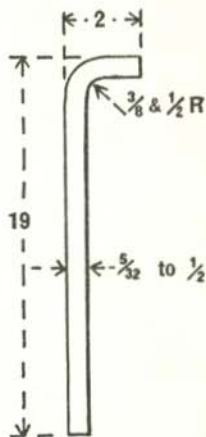
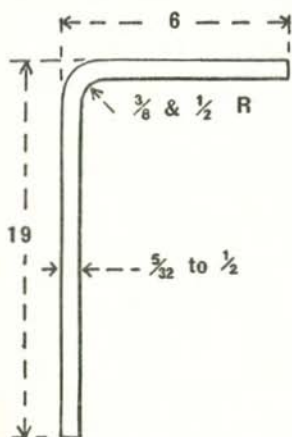

MAXIMUM AND MINIMUM HORIZONTAL LEGS FOR MAXIMUM VERTICAL LEG 19 INCHES

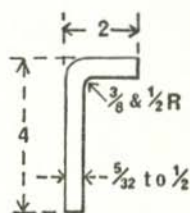
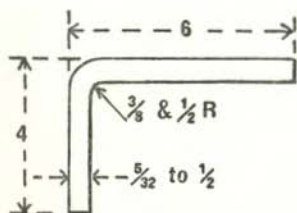

MAXIMUM AND MINIMUM HORIZONTAL LEGS FOR MINIMUM VERTICAL LEG 4 INCHES

Any combination of vertical leg dimensions (4" to 19") and horizontal leg dimensions (2" to 6") can be supplied within thickness limits from  $\frac{5}{32}$ " to  $\frac{1}{2}$ " in structural grade carbon steel.

All sections have fillet radii of  $\frac{3}{8}$ " or  $\frac{1}{2}$ " and rounded corners opposite fillets. Sharp corners opposite fillets cannot be furnished.

The maximum length which can be furnished is 80'. Dimensional, squareness and cutting tolerances, same as applicable to hot rolled sections of comparable size. Sections can be furnished in U-S-S Cor-Ten, U-S-S Man-Ten or regular structural grades of carbon steels.

All cold formed sections rolled only in Chicago District.



# MEMORANDA

# COLD FORMED SECTIONS

## ZEEES

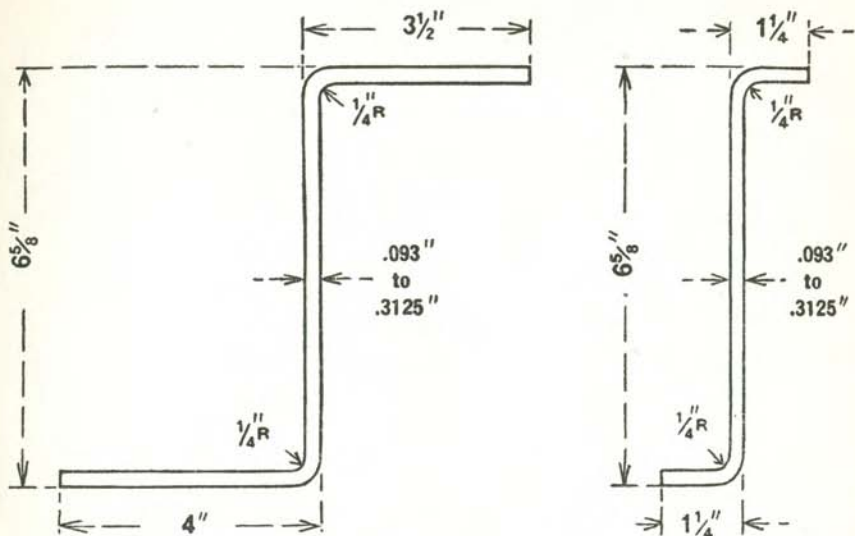

MAXIMUM AND MINIMUM PROFILES FOR MAXIMUM DEPTH  $6\frac{5}{8}$  INCHES

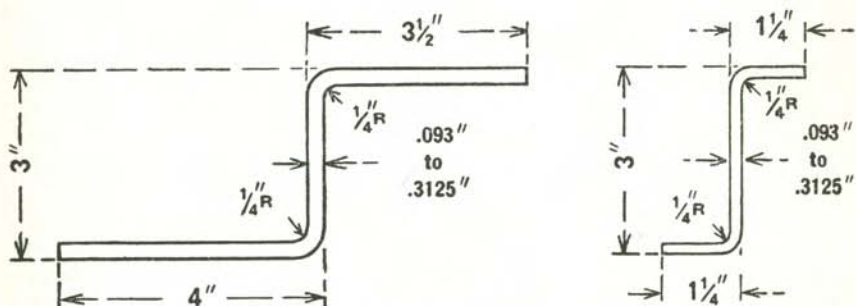

MAXIMUM AND MINIMUM PROFILES FOR MINIMUM DEPTH 3 INCHES

Any combination of web dimensions (3" to  $6\frac{5}{8}$ ") and flange dimensions ( $1\frac{1}{4}$ " to  $3\frac{1}{2}$ " for one flange and  $1\frac{1}{4}$ " to 4" for other flange) can be supplied within thickness limits from .093" to .3125".

All sections have fillet radii of  $\frac{1}{4}$ " and rounded corners opposite fillets. Sharp corners opposite fillets cannot be furnished.

The maximum length which can be furnished is 80'. Dimensional, squareness and cutting tolerances, same as applicable to hot rolled sections of comparable size. Sections can be furnished in U.S.S. Cor-Ten, U.S.S. Man-Ten or regular structural grades of carbon steels.

All cold formed sections rolled in Chicago District.

# COLD FORMED SECTIONS MISCELLANEOUS CAR BUILDING SECTIONS

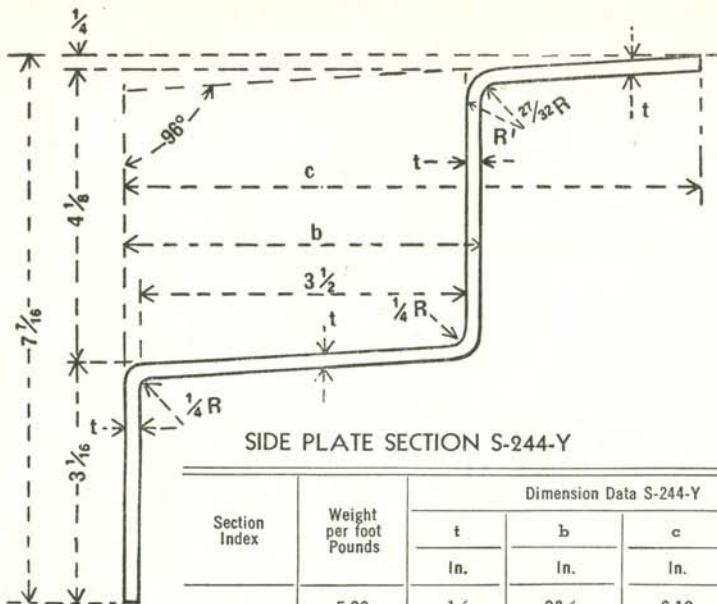

SIDE PLATE SECTION S-244-Y

Section Index	Weight per foot Pounds	Dimension Data S-244-Y			
		t	b	c	R <sup>1</sup>
		In.	In.	In.	In.
S-244-Y	5.20	1/8	3 3/4	6.12	3 1/32
	6.50	5/32	3 13/16	6.18	1
	7.96	3/16	3 7/8	6.16	1 1/32

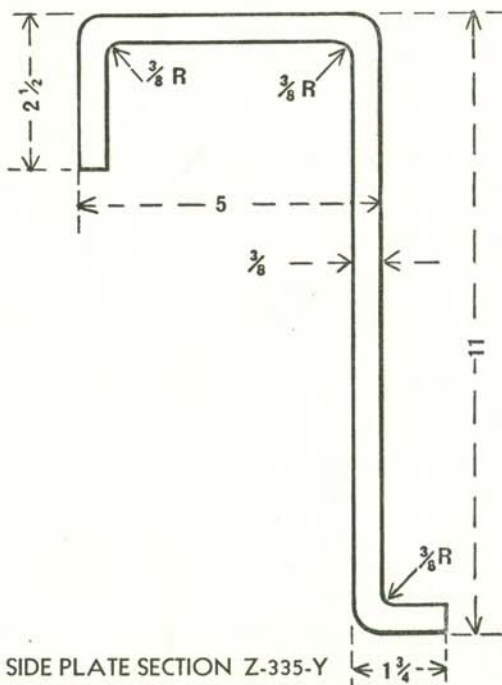

SIDE PLATE SECTION Z-335-Y

All cold formed sections rolled only in Chicago District.

## MISCELLANEOUS MATERIAL AND DATA

ON the following pages are listed rolled steel column bases, plates, floor plates, crane rails, crane rail splices, fastenings, and clamps, steel cross ties.

Also listed is useful data regarding cover-plated wide flange beams, areas and weights of rectangular sections, properties of plates, properties of round and square bars, bolts, nuts, structural rivets, pipe columns.

On pages 136-138 is shown a table of economy of CB beams by section modulus which enables the designer to select the most economical section for the given conditions of required strength and depth.

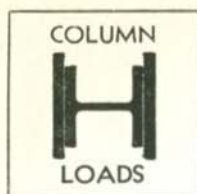

# CB SECTIONS

## COLUMNS WITH COVER PLATES

### 14-INCH CORE

### PROPERTIES

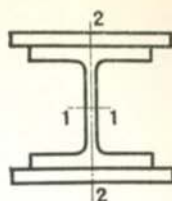

Cover Plates		Total Depth	Total Weight per Foot	Total Area	Axis 1-1				Axis 2-2			
Width	Thickness				I	S	r	Bending Factor	I	S	r	Bending Factor
In.	In.	In.	Lbs.	Sq. In.	In. <sup>4</sup>	In. <sup>3</sup>	In.	A ÷ S	In. <sup>4</sup>	In. <sup>3</sup>	In.	A ÷ S
<b>CORE SECTION - C B 146 - 320 LBS.</b>												
24	3 5/8	24.06	912	268.1	22497	1870	9.16	.143	9987	832	6.10	.322
	3 1/2	23.81	891	262.1	21638	1818	9.09	.144	9699	808	6.08	.324
	3 3/8	23.56	871	256.1	20797	1765	9.01	.145	9411	784	6.06	.327
	3 1/4	23.31	850	250.1	19973	1714	8.94	.146	9123	760	6.04	.329
	3 3/8	23.06	830	244.1	19166	1662	8.86	.147	8835	736	6.02	.332
	3	22.81	810	238.1	18377	1611	8.79	.148	8547	712	5.99	.334
23	3	22.81	789	232.1	17784	1559	8.75	.149	7719	671	5.77	.346
	2 7/8	22.56	770	226.4	17044	1511	8.68	.150	7465	649	5.74	.349
	2 3/4	22.13	750	220.6	16321	1463	8.60	.151	7212	627	5.72	.352
22	2 3/4	22.31	731	215.1	15791	1416	8.57	.152	6515	592	5.50	.363
	2 5/8	22.06	713	209.6	15115	1370	8.49	.153	6294	572	5.48	.366
	2 1/2	21.81	694	204.1	14453	1325	8.41	.154	6072	552	5.45	.370
	2 3/8	21.56	675	198.6	13806	1281	8.34	.155	5850	532	5.43	.373
	2 1/4	21.31	657	193.1	13175	1236	8.26	.156	5628	512	5.40	.377
	2 1/8	21.06	638	187.6	12558	1193	8.18	.157	5406	491	5.37	.382
	2	20.81	619	182.1	11955	1149	8.10	.159	5184	471	5.34	.387
	1 7/8	20.56	601	176.6	11367	1106	8.02	.160	4963	451	5.30	.391
	1 3/4	20.31	582	171.1	10792	1063	7.94	.161	4741	431	5.26	.397
	1 5/8	20.06	563	165.6	10232	1020	7.86	.162	4519	411	5.22	.403
	1 1/2	19.81	544	160.1	9686	978	7.78	.164	4297	391	5.18	.410
20	1 1/2	19.81	524	154.1	9182	927	7.72	.166	3635	364	4.86	.424
	1 3/8	19.56	507	149.1	8697	889	7.64	.168	3468	347	4.82	.430
	1 1/4	19.31	490	144.1	8225	852	7.55	.169	3302	330	4.79	.436
18	1 1/4	19.11	473	139.1	7817	810	7.50	.172	2850	317	4.53	.439
	1 3/8	19.06	458	134.6	7403	777	7.42	.173	2729	303	4.50	.444
	1	18.81	442	130.1	6999	744	7.33	.175	2607	290	4.48	.449

NOTE: Weights do not include rivets. Properties are for gross section.

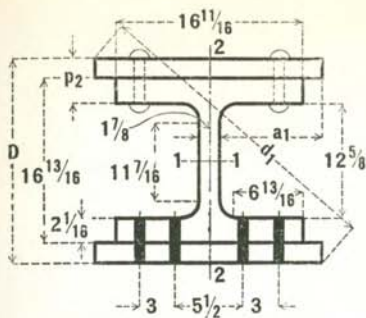

CB SECTIONS  
 COLUMNS WITH  
 COVER PLATES  
 14-INCH CORE  
 DIMENSIONS



Cover Plates		Column Dimensions				Total Weight per Foot
Width	Thickness	Depth	Grip	Diagonal	Distance	
In.	In.	D	P <sub>2</sub>	a <sub>1</sub>	α <sub>1</sub>	Lbs.

CORE SECTION - CB 146 - 320 LBS.

24	3 5/8	24 1/16	5 11/16	34	11 1/16	912
	3 1/2	23 13/16	5 9/16	33 13/16	11 1/16	891
	3 3/8	23 9/16	5 7/16	33 5/8	11 1/16	871
	3 1/4	23 5/16	5 5/16	33 1/16	11 1/16	850
	3 1/8	23 1/16	5 3/16	33 3/16	11 1/16	830
	3	22 13/16	5 1/16	33 1/8	11 1/16	810
23	3	22 13/16	5 1/16	32 3/8	10 9/16	789
	2 7/8	22 9/16	4 15/16	32 3/16	10 9/16	770
	2 3/4	22 5/16	4 13/16	32 1/16	10 9/16	750
22	2 3/4	22 5/16	4 13/16	31 5/16	10 1/16	731
	2 5/8	22 1/16	4 11/16	31 1/8	10 1/16	713
	2 1/2	21 13/16	4 9/16	31	10 1/16	694
	2 3/8	21 9/16	4 7/16	30 13/16	10 1/16	675
	2 1/4	21 5/16	4 5/16	30 5/8	10 1/16	657
	2 1/8	21 1/16	4 3/16	30 7/16	10 1/16	638
	2	20 13/16	4 1/16	30 5/16	10 1/16	619
	1 7/8	20 9/16	3 15/16	30 1/8	10 1/16	601
	1 3/4	20 5/16	3 13/16	29 15/16	10 1/16	582
	1 5/8	20 1/16	3 11/16	29 3/4	10 1/16	563
1 1/2	19 13/16	3 9/16	29 5/8	10 1/16	544	
20	1 1/2	19 13/16	3 9/16	28 1/8	9 1/16	524
	1 3/8	19 9/16	3 7/16	28	9 1/16	507
	1 1/4	19 5/16	3 5/16	27 13/16	9 1/16	490
18	1 1/4	19 5/16	3 5/16	26 3/8	8 1/16	473
	1 1/8	19 1/16	3 3/16	26 3/16	8 1/16	458
	1	18 13/16	3 1/16	26 1/16	8 1/16	442

## ROLLED STEEL PLATES FOR COLUMN BASES

The following rolled widths and thicknesses are standard sizes of rolled steel plates for use as column bases. Selections from these sizes will facilitate manufacture and delivery.

### ROLLED SIZES

All dimensions are given in inches

14 x $1\frac{1}{4}$	28 x 3	44 x 5
14 x $1\frac{1}{2}$	28 x $3\frac{1}{2}$	44 x $5\frac{1}{2}$
16 x $1\frac{1}{2}$	32 x $3\frac{1}{2}$	48 x $5\frac{1}{2}$
16 x 2	32 x 4	48 x 6
20 x 2	36 x 4	48 x $6\frac{1}{2}$
20 x $2\frac{1}{2}$	36 x $4\frac{1}{2}$	52 x 6
20 x 3	40 x $4\frac{1}{2}$	52 x $6\frac{1}{2}$
24 x 2	40 x 5	56 x $6\frac{1}{2}$
24 x $2\frac{1}{2}$		56 x 7
24 x 3		56 x 8

All plates are of open hearth steel.

## PLATES

ON the following pages are shown tables of sizes of carbon steel plates in rectangular and circular sheared, universal mill, heavy rectangular over 2 inches in thickness, and floor plates.

Plate requirements in excess of dimensions shown may be submitted for special consideration.



PLATES ROLLED IN PITTSBURGH DISTRICT  
EXTREME SIZES OF RECTANGULAR UNIVERSAL PLATES

CARBON STEEL — STRUCTURAL GRADE — 72,000 LBS. MAXIMUM T. S.

Thickness Inches	Lbs. per Sq. Ft.	WIDTHS IN INCHES												LENGTHS IN INCHES											
		Over 47 Incl.	Over 45 Incl.	Over 43 Incl.	Over 41 Incl.	Over 39 Incl.	Over 37 Incl.	Over 36 Incl.	Over 33 Incl.	Over 31 Incl.	Over 29 Incl.	Over 27 Incl.	Over 25 Incl.	Over 23 Incl.	Over 21 Incl.	Over 19 Incl.	Over 17 Incl.	Over 15 Incl.	Over 13 Incl.	Over 11 Incl.	Over 9 Incl.	Over 8 Incl.	Over 7 Incl.	Over 6 Incl.	
1/4	10.20	1200	1200	1200	1200	1260	1320	1320	1320	1320	1320	1320	1320	1320	1320	1320	1320	1320	1320	1320	1320	1320	1320	1320	1320
5/16	12.75	1500	1500	1500	1500	1500	1500	1500	1500	1500	1500	1500	1500	1500	1500	1500	1500	1500	1500	1500	1500	1500	1500	1500	1500
3/8	15.30	1500	1500	1500	1500	1500	1500	1500	1500	1500	1500	1500	1500	1500	1500	1500	1500	1500	1500	1500	1500	1500	1500	1500	1500
7/16	17.85	1500	1500	1500	1500	1500	1500	1500	1500	1500	1500	1500	1500	1500	1500	1500	1500	1500	1500	1500	1500	1500	1500	1500	1500
1/2	20.40	1500	1500	1500	1500	1500	1500	1500	1500	1500	1500	1500	1500	1500	1500	1500	1500	1500	1500	1500	1500	1500	1500	1500	1500
9/16	22.95	1500	1500	1500	1500	1500	1500	1500	1500	1500	1500	1500	1500	1500	1500	1500	1500	1500	1500	1500	1500	1500	1500	1500	1500
5/8	25.50	1500	1500	1500	1500	1500	1500	1500	1500	1500	1500	1500	1500	1500	1500	1500	1500	1500	1500	1500	1500	1500	1500	1500	1500
3/4	30.60	1364	1392	1452	1500	1500	1500	1500	1500	1500	1500	1500	1500	1500	1500	1500	1500	1500	1500	1500	1500	1500	1500	1500	1500
7/8	35.70	1169	1193	1247	1304	1367	1438	1500	1500	1500	1500	1500	1500	1500	1500	1500	1500	1500	1500	1500	1500	1500	1500	1500	1500
1	40.80	1023	1044	1091	1142	1197	1258	1327	1363	1498	1500	1500	1500	1500	1500	1500	1500	1500	1500	1500	1500	1500	1500	1500	1500
1 1/8	45.90	910	927	970	1014	1064	1119	1180	1211	1323	1407	1470	1476	1485	1494	1500	1500	1500	1500	1500	1500	1500	1500	1500	1500
1 1/4	51.00	819	835	873	913	957	1006	1061	1091	1190	1267	1323	1328	1336	1344	1355	1366	1382	1052	1215	1435	372	396	432	504
1 3/8	56.10	744	759	794	830	870	915	965	991	1082	1151	1202	1208	1215	1222	1232	1242	1256	956	1104	1305	348	360	384	444
1 1/2	61.20	682	696	726	761	797	838	884	908	991	1056	1102	1107	1114	1120	1129	1139	1152	876	1012	1195	312	336	360	408
1 5/8	66.30	629	643	671	702	736	775	816	838	915	974	1018	1022	1028	1034	1042	1051	1063	934	1103	288	300	336	384	
1 3/4	71.40	584	597	623	652	684	719	758	776	850	904	945	949	954	961	968	976	987	867	1025	264	276	300	360	
1 7/8	76.50	545	556	581	608	638	671	707	726	793	844	882	886	891	896	904	912	921	701	809	955	240	264	276	
2	81.60	511	522	545	571	598	629	663	681	744	791	826	830	835	840	847	854	863	657	759	897	228	264	264	

Plates of greater dimensions than shown may be submitted for special consideration.

**PLATES ROLLED IN PITTSBURGH DISTRICT  
EXTREME SIZES OF RECTANGULAR AND CIRCULAR SHEARED PLATES  
CARBON STEEL — STRUCTURAL GRADE — 72,000 LBS. MAXIMUM T. S.**

Thickness Inches	Weight Pounds per Sq. Ft.	WIDTHS IN INCHES												Maximum Diameter Inches							
		128	126	120	114	108	102	96	90 $\frac{3}{4}$	90	84	78	72		66	60	54	48	42	36	30
#12 Ga.	4.375									240	240	240	240	240	240	360	360	360	360	360	84
#11 Ga.	5.000									360	360	360	360	360	360	500	500	500	500	500	84
#10 Ga.	5.625									480	480	480	480	480	480	500	500	500	500	500	90
#9 Ga.	6.250									480	480	480	480	480	480	500	500	500	500	500	90
#8 Ga.	6.875									600	600	600	600	600	600	600	600	600	600	600	90
#7 Ga.	7.500									600	600	600	600	600	600	600	600	600	600	600	90
$\frac{3}{16}$	7.65									900	900	900	900	900	900	900	900	900	900	900	96
$\frac{1}{4}$	10.20									900	900	900	900	900	900	900	900	900	900	900	120
$\frac{5}{16}$	12.75									948	1080	1128	1176	1224	1272	1272	1320	1368	1368	1368	126
$\frac{3}{8}$	15.30	252	300	420	450	460	470	520	560	948	1080	1128	1176	1224	1272	1320	1368	1368	1368	130	
$\frac{7}{16}$	17.85	252	330	400	420	440	470	530	580	948	1080	1128	1176	1224	1272	1320	1368	1368	1368	130	
$\frac{1}{2}$	20.40	300	360	450	470	500	530	570	630	948	1080	1128	1176	1224	1272	1320	1368	1368	1368	130	
$\frac{9}{16}$	22.95	300	360	420	460	480	510	550	620	948	1068	1068	1124	1224	1272	1320	1368	1368	1368	130	
$\frac{5}{8}$	25.50	340	360	430	480	500	530	600	650	924	948	948	1024	1224	1272	1320	1368	1368	1368	130	
$\frac{11}{16}$	28.05	340	360	430	480	500	530	600	650	816	864	864	864	1188	1272	1320	1368	1368	1368	130	
$\frac{3}{4}$	30.60	340	360	420	450	480	520	580	620	744	792	792	792	1080	1188	1320	1332	1332	1332	130	
$\frac{13}{16}$	33.15	340	360	410	440	480	510	550	620	620	670	740	760	760	760	760	760	760	760	130	
$\frac{7}{8}$	35.70	340	360	410	440	480	520	550	600	600	650	720	760	760	760	720	720	640	600	550	130
1	40.80	330	360	430	470	520	540	580	630	630	680	740	760	760	760	720	700	640	600	530	130
$1\frac{1}{8}$	45.90	360	390	400	440	480	510	550	590	590	640	700	750	760	760	720	640	640	600	500	130
$1\frac{1}{4}$	51.00	340	360	390	410	430	470	500	540	540	580	620	680	700	700	700	640	640	580	480	130
$1\frac{3}{8}$	61.20	260	300	336	350	370	400	420	450	490	530	570	600	600	600	600	640	620	480	450	130
$1\frac{3}{4}$	71.40	250	260	290	300	320	340	360	390	390	430	460	500	540	570	620	620	620	480	420	130
2	81.60	210	220	250	260	280	300	320	330	330	380	410	450	470	500	550	580	580	440	420	130

\*Plates ordered over 90" to 96" wide inclusive and  $\frac{3}{16}$ " thick, must be specified to thickness only. Cannot be furnished to weight per sq. ft.  
 Plates 36" wide and narrower by  $\frac{3}{8}$ " thick and heavier; also plates up to 48" wide by  $\frac{3}{16}$ " and heavier, can be rolled on Universal Mill. For greater length and Universal Mill sizes, see Universal Mill plate table.  
 Plates of greater dimensions than shown may be submitted for special consideration. Sizes above heavy line are sheet sizes that can be rolled on sheared plate mill.

PLATES ROLLED IN PITTSBURGH DISTRICT

EXTREME SIZES OF RECTANGULAR PLATES  
OVER 2 INCHES THICK

CARBON STEEL—STRUCTURAL GRADE—72,000 LBS. MAXIMUM T. S.

Thickness Inches	WIDTHS IN INCHES																		
	Over 126 to 128 Incl.	Over 120 to 126 Incl.	Over 114 to 120 Incl.	Over 108 to 114 Incl.	Over 102 to 108 Incl.	Over 96 to 102 Incl.	Over 90 to 96 Incl.	Over 84 to 90 Incl.	Over 78 to 84 Incl.	Over 72 to 78 Incl.	Over 66 to 72 Incl.	Over 60 to 66 Incl.	Over 54 to 60 Incl.	Over 48 to 54 Incl.	Over 47 to 48 Incl.	Over 45 to 47 Incl.	Over 43 to 45 Incl.	Over 41 to 43 Incl.	Over 39 to 41 Incl.
	LENGTHS IN INCHES																		
2 1/4	155	178	222	241	254	269	286	305	327	352	381	416	457	508	435	444	463	485	508
2 1/2	140	160	200	217	229	242	257	275	294	317	343	374	412	458	392	400	417	437	458
3	130	135	170	180	191	202	214	229	245	264	286	312	343	380	325	333	347	364	381
3 1/2	...	130	147	155	163	173	183	196	210	226	245	267	294	327	284	286	298	312	327
4	...	...	128	135	143	151	161	171	184	198	214	234	257	286	243	250	260	273	286
4 1/2	...	...	114	121	128	133	142	151	162	176	190	207	228	254	218	222	231	243	254
5	...	...	...	108	114	121	128	137	147	158	171	187	206	229	196	200	208	218	229
5 1/2	...	...	...	...	104	109	117	125	134	143	156	170	187	207	178	183	190	200	209
6	...	...	...	...	...	101	107	114	122	132	143	156	171	190	162	166	173	182	190
6 1/2	...	...	...	...	...	...	98	105	112	122	131	143	158	176	152	154	161	169	176
7	...	...	...	...	...	...	91	98	105	113	122	133	147	163	142	143	149	156	163
7 1/2	...	...	...	...	...	...	...	91	97	106	114	125	137	152	130	132	138	144	152
8	...	...	...	...	...	...	...	85	92	99	107	117	128	143	121	125	130	136	143
8 1/2	...	...	...	...	...	...	...	...	86	93	100	110	121	134	115	117	122	128	134
9	...	...	...	...	...	...	...	...	81	88	95	104	114	127	109	111	115	121	127
9 1/2	...	...	...	...	...	...	...	...	...	83	90	98	108	120	103	105	110	115	120
10	...	...	...	...	...	...	...	...	...	79	85	93	103	114	98	100	104	109	114
10 1/2	...	...	...	...	...	...	...	...	...	75	81	89	97	108	93	95	99	104	109
11	...	...	...	...	...	...	...	...	...	72	77	85	93	104	89	91	95	100	104
11 1/2	...	...	...	...	...	...	...	...	...	...	74	81	89	99	85	87	90	95	99
12	...	...	...	...	...	...	...	...	...	...	71	78	86	95	81	83	86	91	95
12 1/2	...	...	...	...	...	...	...	...	...	...	68	75	82	91	78	80	83	87	91
13	...	...	...	...	...	...	...	...	...	...	...	72	79	87	76	77	80	84	88
13 1/2	...	...	...	...	...	...	...	...	...	...	...	69	76	84	73	74	77	81	84
14	...	...	...	...	...	...	...	...	...	...	...	66	73	81	70	71	74	78	81
14 1/2	...	...	...	...	...	...	...	...	...	...	...	64	71	78	68	69	72	75	79
15	...	...	...	...	...	...	...	...	...	...	...	62	68	76	65	66	69	72	76

Sizes over 6" to 48" wide inclusive based on furnishing with rolled edges.

Sizes over 48" wide based on furnishing from sheared plate mills flame cut to width. All sizes must be flame cut to length.

Lengths as shown are based on maximum width as shown in each increment of width as grouped above.

Plates of greater dimensions than shown may be submitted for special consideration.

PLATES ROLLED IN PITTSBURGH DISTRICT

EXTREME SIZES OF RECTANGULAR PLATES  
OVER 2 INCHES THICK

CARBON STEEL—STRUCTURAL GRADE—72,000 LBS. MAXIMUM T. S.

Thickness Inches	WIDTHS IN INCHES																		
	Over 37 to 39 Incl.	Over 35 to 37 Incl.	Over 33 to 35 Incl.	Over 31 to 33 Incl.	Over 29 to 31 Incl.	Over 27 to 29 Incl.	Over 25 to 27 Incl.	Over 23 to 25 Incl.	Over 21 to 23 Incl.	Over 19 to 21 Incl.	Over 17 to 19 Incl.	Over 15 to 17 Incl.	Over 13 to 15 Incl.	Over 11 to 13 Incl.	Over 10 to 11 Incl.	Over 9 to 10 Incl.	Over 8 to 9 Incl.	Over 7 to 8 Incl.	Over 6 to 7 Incl.
	LENGTHS IN INCHES																		
2¼	535	564	596	632	675	704	708	711	716	722	729	736	561	646	764	741	824	252	276
2½	481	507	536	568	606	634	637	640	644	649	656	662	505	582	688	667	741	240	252
3	401	423	447	474	506	528	531	533	537	541	546	552	420	485	573	556	618	228	228
3½	344	362	383	406	433	453	455	457	460	464	468	473	360	415	491	476	529	...	...
4	300	317	335	355	379	396	398	400	403	406	410	414	315	363	430	417	463	...	...
4½	267	282	298	316	337	352	354	355	358	361	364	368	280	323	382	370	...	...	...
5	240	253	268	284	303	317	318	320	322	325	328	331	252	291	343	...	...	...	...
5½	220	232	245	260	278	288	289	291	293	295	298	301	229	264	...	...	...	...	...
6	200	211	223	237	253	264	265	266	268	270	273	276	210	...	...	...	...	...	...
6½	186	196	207	220	234	244	245	246	248	250	252	254	194	...	...	...	...	...	...
7	172	181	191	203	216	226	227	226	230	232	234	236	...	...	...	...	...	...	...
7½	160	168	178	188	202	211	212	213	215	216	218	220	...	...	...	...	...	...	...
8	150	158	167	177	189	198	199	200	201	203	205	...	...	...	...	...	...	...	...
8½	141	149	157	167	178	186	187	188	189	191	192	...	...	...	...	...	...	...	...
9	133	141	149	158	168	176	177	178	179	180	...	...	...	...	...	...	...	...	...
9½	126	133	141	149	159	167	167	168	169	170	...	...	...	...	...	...	...	...	...
10	120	127	134	142	152	158	159	160	161	...	...	...	...	...	...	...	...	...	...
10½	114	120	127	135	144	151	151	152	153	...	...	...	...	...	...	...	...	...	...
11	109	115	122	129	138	144	144	145	...	...	...	...	...	...	...	...	...	...	...
11½	104	110	116	123	132	137	138	139	...	...	...	...	...	...	...	...	...	...	...
12	100	105	111	118	126	132	132	...	...	...	...	...	...	...	...	...	...	...	...
12½	96	101	107	114	121	126	127	...	...	...	...	...	...	...	...	...	...	...	...
13	93	98	103	110	117	122	...	...	...	...	...	...	...	...	...	...	...	...	...
13½	89	94	99	105	112	117	...	...	...	...	...	...	...	...	...	...	...	...	...
14	86	90	95	101	108	...	...	...	...	...	...	...	...	...	...	...	...	...	...
14½	83	87	92	98	104	...	...	...	...	...	...	...	...	...	...	...	...	...	...
15	80	84	89	94	...	...	...	...	...	...	...	...	...	...	...	...	...	...	...

Sizes over 6" to 48" wide inclusive based on furnishing with rolled edges.

Sizes over 48" wide based on furnishing from sheared plate mills flame cut to width. All sizes must be flame cut to length. Lengths as shown are based on maximum width as shown in each increment of width as grouped above.

Plates of greater dimensions than shown may be submitted for special consideration.



PLATES ROLLED IN CHICAGO DISTRICT  
**EXTREME SIZES OF RECTANGULAR AND CIRCULAR SHEARED PLATES**  
 CARBON STEEL — STRUCTURAL GRADE — 72,000 LBS. MAXIMUM T. S.

Thickness Inches	Weight Pounds per Sq. Ft.	WIDTHS IN INCHES												Diameter, Maximum Inches										
		150	144	138	132	126	120	114	108	102	96	90	84		54	53	49	24 to 48						
		LENGTHS IN INCHES																						
5/8	6.53																240	240	720	720	720	720	84	
3/4	7.65																							84
1/4	10.20																							146
5/16	12.75	360	400	440	460	480	500	520	540	580	610	660	720	720	720	720	720	720	720	720	720	720	720	153
3/8	15.30	360	480	520	560	600	620	640	700	740	780	840	840	840	840	840	840	840	840	840	840	840	840	153
7/16	17.85	360	540	560	680	620	640	680	720	780	780	840	840	840	840	840	840	840	840	840	840	840	840	153
1/2	20.40	360	540	580	600	630	660	700	740	780	840	840	840	840	840	840	840	840	840	840	840	840	840	153
9/16	22.95	380	540	580	600	630	660	700	740	780	840	840	840	840	840	840	840	840	840	840	840	840	840	153
5/8	25.50	400	525	580	600	630	660	700	740	780	840	840	840	840	840	840	840	840	840	840	840	840	840	153
11/16	28.05	400	525	580	600	645	680	710	760	780	840	840	840	840	840	840	840	840	840	840	840	840	840	153
3/4	30.60	400	525	630	660	675	700	740	780	840	840	840	840	840	840	840	840	840	840	840	840	840	840	153
13/16	33.15	400	525	630	660	675	700	740	780	840	840	840	840	840	840	840	840	840	840	840	840	840	840	153
15/16	35.70	400	600	630	660	690	720	760	800	840	840	840	840	840	840	840	840	840	840	840	840	840	840	153
1	40.80	400	540	610	640	670	705	745	780	800	840	840	840	840	840	840	840	840	840	840	840	840	840	153
1 1/16	45.90	400	510	600	630	660	690	730	770	780	800	840	840	840	840	840	840	840	840	840	840	840	840	153
1 1/4	51.00	400	580	610	610	640	670	710	740	780	780	780	780	780	780	780	780	780	780	780	780	780	780	153
1 1/2	61.20	400	480	510	540	595	625	665	660	700	740	780	820	820	820	820	820	820	820	820	820	820	820	153
1 3/4	71.40	360	445	475	500	520	550	575	610	645	685	735	780	820	820	820	820	820	820	820	820	820	820	153
2	81.60	360	390	415	435	455	480	505	530	560	600	640	680	820	820	820	820	820	820	820	820	820	820	153

Sizes above heavy line are sheet sizes that can be rolled on sheared plate mill.  
 Plates of greater dimensions than shown may be submitted for special consideration.

PLATES ROLLED IN CHICAGO DISTRICT

EXTREME SIZES OF RECTANGULAR PLATES  
OVER 2 INCHES THICK

CARBON STEEL—STRUCTURAL GRADE—72,000 LBS. MAXIMUM T. S.

Thickness Inches	WIDTHS IN INCHES														
	146	138	131	125	120	115	111	107	103	100	97	95	92	90	88
	LENGTHS IN INCHES														
2½	420	450	473	497	520	542	563	583	608	610	612	622	646	660	677
3	342	367	391	407	426	442	460	477	500	503	506	512	530	542	557
3½	290	310	330	345	360	377	392	407	425	428	430	436	452	462	474
4	260	280	294	309	324	339	351	367	380	385	390	394	406	416	427
4½	218	235	249	262	275	287	300	310	324	327	330	334	346	354	364
5	192	208	219	230	243	254	265	275	287	290	292	295	306	314	323
5½	172	186	197	208	218	228	238	247	258	264	266	268	277	283	291
6	155	167	177	187	196	206	215	224	234	237	239	242	250	255	263
6½	140	152	162	171	179	188	196	204	214	216	218	220	228	234	241
7	...	140	147	156	164	171	179	187	195	197	200	202	209	214	220
7½	...	...	140	143	151	158	165	172	180	182	184	186	193	198	204
8	...	...	...	140	144	147	152	159	167	169	171	173	179	183	189
8½	...	...	...	135	141	144	146	148	156	158	160	163	167	171	177
9	...	...	...	...	138	141	143	144	145	147	149	151	156	160	165
9½	...	...	...	...	...	139	141	142	143	144	144	144	150	154	158
10	...	...	...	...	...	...	139	140	141	142	142	143	146	145	148
10½	...	...	...	...	...	...	...	...	140	140	141	141	143	144	146
11	...	...	...	...	...	...	...	...	...	...	140	140	142	143	144
11½	...	...	...	...	...	...	...	...	...	...	...	...	140	141	142
12	...	...	...	...	...	...	...	...	...	...	...	...	...	140	141
12½	...	...	...	...	...	...	...	...	...	...	...	...	...	...	...
13	...	...	...	...	...	...	...	...	...	...	...	...	...	...	...
13½	...	...	...	...	...	...	...	...	...	...	...	...	...	...	...
14	...	...	...	...	...	...	...	...	...	...	...	...	...	...	...
14½	...	...	...	...	...	...	...	...	...	...	...	...	...	...	...
15	...	...	...	...	...	...	...	...	...	...	...	...	...	...	...

Sizes over 6½" to 30" wide inclusive based on furnishing with rolled edges.

Sizes over 30" wide based on furnishing from sheared plate mills flame cut to width. All sizes must be flame cut to length.

Plates of greater dimensions than shown may be submitted for special consideration.

PLATES ROLLED IN CHICAGO DISTRICT

EXTREME SIZES OF RECTANGULAR PLATES  
OVER 2 INCHES THICK

CARBON STEEL—STRUCTURAL GRADE—72,000 LBS. MAXIMUM T. S.

Thickness Inches	WIDTHS IN INCHES															
	86	84	80	70	60	50	40	30½	30	25	20	15	10	8	7	6½
	LENGTHS IN INCHES															
2½	690	712	730	800	820	820	820	820	460	460	460	460	450	450	410	360
3	570	587	602	687	760	750	820	820	360	380	380	380	360	375	340	300
3½	486	500	512	487	650	645	780	780	320	330	340	340	320	320	300	265
4	436	450	460	527	588	550	670	670	280	280	300	300	280	280	260	230
4½	372	382	392	450	500	490	600	600	245	245	255	255	250	250	...	...
5	330	340	349	400	442	445	535	535	210	210	210	210	220	220	...	...
5½	297	307	315	362	402	400	485	485	195	195	195	195	200	200	...	...
6	270	278	286	330	366	365	440	440	185	185	185	185	185	185	...	...
6½	247	254	261	301	335	340	410	410	...	...	...	...	...	...	...	...
7	226	233	240	277	309	316	383	383	...	...	...	...	...	...	...	...
7½	209	215	221	256	286	293	355	355	...	...	...	...	...	...	...	...
8	194	200	206	238	266	275	330	330	...	...	...	...	...	...	...	...
8½	181	187	193	223	250	255	310	310	...	...	...	...	...	...	...	...
9	169	175	180	209	233	243	295	295	...	...	...	...	...	...	...	...
9½	162	167	172	200	223	230	280	280	...	...	...	...	...	...	...	...
10	152	156	161	187	209	216	264	264	...	...	...	...	...	...	...	...
10½	149	152	157	177	198	205	250	250	...	...	...	...	...	...	...	...
11	147	149	154	167	187	195	239	239	...	...	...	...	...	...	...	...
11½	144	146	149	163	178	185	226	226	...	...	...	...	...	...	...	...
12	142	143	145	158	174	175	216	216	...	...	...	...	...	...	...	...
12½	...	140	142	154	168	168	205	205	...	...	...	...	...	...	...	...
13	...	...	140	150	163	160	198	198	...	...	...	...	...	...	...	...
13½	...	...	...	146	157	154	190	190	...	...	...	...	...	...	...	...
14	...	...	...	143	152	148	183	183	...	...	...	...	...	...	...	...
14½	...	...	...	142	148	143	175	175	...	...	...	...	...	...	...	...
15	...	...	...	140	145	137	170	170	...	...	...	...	...	...	...	...

Sizes over 6½" to 30" wide inclusive based on furnishing with rolled edges.  
 Sizes over 30" wide based on furnishing from sheared plate mills flame cut to width. All sizes must be flame cut to length.  
 Plates of greater dimensions than shown may be submitted for special consideration.



PLATES ROLLED IN BIRMINGHAM DISTRICT  
EXTREME SIZES OF RECTANGULAR UNIVERSAL PLATES

CARBON STEEL — STRUCTURAL GRADE — 72,000 LBS. MAXIMUM T. S.

Thickness Inches	Weight Pounds per Sq. Ft.	WIDTHS IN INCHES										LENGTHS IN INCHES									
		Over 40 to 42 Incl.	Over 38 to 40 Incl.	Over 36 to 38 Incl.	Over 34 to 36 Incl.	Over 32 to 34 Incl.	Over 30 to 32 Incl.	Over 28 to 30 Incl.	Over 26 to 28 Incl.	Over 24 to 26 Incl.	Over 22 to 24 Incl.	Over 20 to 22 Incl.	Over 18 to 20 Incl.	Over 16 to 18 Incl.	Over 14 to 16 Incl.	Over 12 to 14 Incl.	Over 10 to 12 Incl.				
1/4	10.20	720	720	720	720	720	720	720	720	720	720	720	720	720	720	720	720				
5/16	12.75	1200	1200	1200	1200	1200	1200	1200	1200	1200	1200	1200	1200	1200	1200	1200	1200				
3/8	15.30	1200	1200	1200	1200	1200	1200	1200	1200	1200	1200	1200	1200	1200	1200	1200	1200				
7/16	17.85	1200	1200	1200	1200	1200	1200	1200	1200	1200	1200	1200	1200	1200	1200	1200	1200				
1/2	20.40	1200	1200	1200	1200	1200	1200	1200	1200	1200	1200	1200	1200	1200	1200	1200	1200				
9/16	22.95	1200	1200	1200	1200	1200	1200	1200	1200	1200	1200	1200	1200	1200	1200	1200	1200				
5/8	25.50	1200	1200	1200	1200	1200	1200	1200	1200	1200	1200	1200	1200	1200	1200	1200	1200				
3/4	28.05	1165	1165	1170	1170	1170	1170	1170	1170	1175	1175	1175	1180	1185	1190	1200	1200				
13/16	30.60	1065	1070	1070	1070	1070	1070	1075	1075	1075	1075	1080	1080	1090	1095	1100	1110				
7/8	33.15	985	985	985	985	990	990	990	990	995	995	1000	1000	1005	1010	1015	1020				
1	35.70	915	915	915	915	915	920	920	920	920	925	925	930	930	935	940	950				
1 1/8	40.80	795	795	800	800	800	800	800	800	805	805	805	810	810	815	820	830				
1 1/8	45.90	705	705	705	705	710	710	710	710	710	710	715	720	720	725	725	735				

Plates of greater dimensions than shown may be submitted for special consideration.

PLATES ROLLED IN BIRMINGHAM DISTRICT  
EXTREME SIZES OF RECTANGULAR AND CIRCULAR SHEARED PLATES

CARBON STEEL — STRUCTURAL GRADE — 72,000 LBS. MAXIMUM T. S.

Thickness Inches	Weight Pounds per Sq. Ft.	WIDTHS IN INCHES												Maximum Diameter Inches				
		96	90	84	78	72	66	60	54	50	48	42	36		30	24		
3/16	7.65	360	400	440	480	480	480	480	480	480	480	480	480	480	480	480	96	
	10.20	480	480	550	600	600	600	600	600	600	600	600	600	600	600	600	600	96
1/4	12.75	480	520	550	600	600	600	600	600	600	600	600	600	600	600	600	96	
5/16	15.30	480	550	600	600	600	600	600	600	600	600	600	600	600	600	600	96	
3/8	17.85	480	550	600	600	600	600	600	600	600	600	600	600	600	600	600	96	
7/16	20.40	480	500	600	600	600	600	600	600	600	600	600	600	600	600	600	96	
1/2	22.95	480	530	600	600	600	600	600	600	600	600	600	600	600	600	600	96	
9/16	25.50	480	530	600	600	600	600	600	600	600	600	600	600	600	600	600	96	
5/8	28.05	480	560	600	600	600	600	600	600	600	600	600	600	600	600	600	96	
11/16	30.60	480	540	560	600	600	600	600	600	600	600	600	600	600	520	600	96	
3/4	33.15	480	500	550	600	600	600	600	600	600	600	600	600	600	600	600	96	
13/16	35.70	480	520	540	580	600	600	600	600	600	600	600	600	600	600	600	96	
7/8	40.80	480	500	540	580	580	600	600	600	600	600	600	600	580	580	540	96	
1	45.90	480	450	500	520	580	600	600	600	600	600	600	600	600	600	600	96	
1 1/8		480	500	520	580	580	600	600	600	600	600	600	600	600	580	580	580	96

Plates of greater dimensions than shown may be submitted for special consideration.

**FLOOR PLATES**  
**EXTREME SIZES OF RECTANGULAR AND CIRCULAR FLOOR PLATES**  
**CARBON STEEL — SECTION M41**

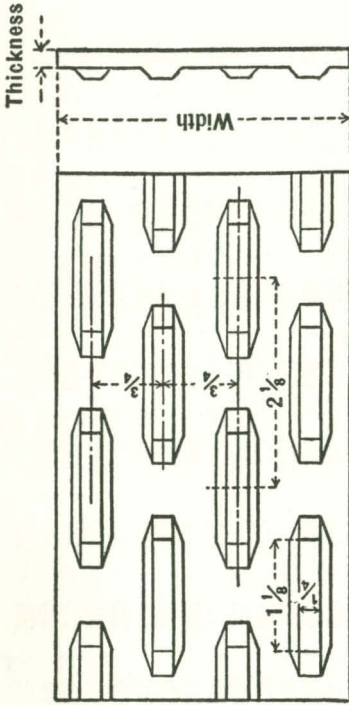

Thickness Inches	Weight Pounds per Sq. Ft.	WIDTHS IN INCHES						LENGTHS IN INCHES						Maximum Diameter, Inches		
		Over 84 to 90 Incl.	Over 72 to 84 Incl.	Over 60 to 72 Incl.	Over 30 to 60 Incl.	Over 24 to 30 Incl.	Over 18 to 24 Incl.	Over 360 to 480 Incl.	Over 600 to 600 Incl.	Over 600 to 600 Incl.	Over 600 to 600 Incl.	Over 600 to 600 Incl.	Over 600 to 600 Incl.		Over 600 to 600 Incl.	
1/8	6.50															60
3/16	8.70															90
1/4	11.25															90
5/16	13.80															90
3/8	16.35															90
7/16	18.90															90
1/2	21.45															90
5/8	26.55															120
3/4	31.65															120
1	41.85															120

Pittsburgh District Only

FLOOR PLATES  
 EXTREME SIZES OF RECTANGULAR AND CIRCULAR FLOOR PLATES  
 CARBON STEEL — SECTION S300

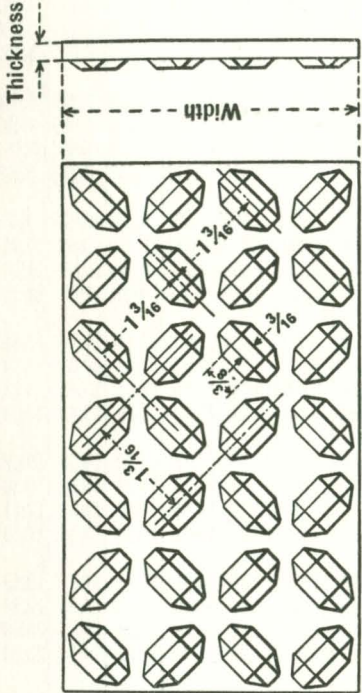

Thickness Inches	Weight Pounds per Sq. Ft.	WIDTHS IN INCHES						LENGTHS IN INCHES						Maximum Diameter, Inches
		Over 72 Incl.	Over 60 72 Incl.	Over 48 60 Incl.	Over 30 48 Incl.	Over 24 30 Incl.	Over 18 24 Incl.	Over 18 24 Incl.	Over 12 18 Incl.	Over 6 12 Incl.	Over 18 24 Incl.	Over 12 18 Incl.	Over 6 12 Incl.	
1/2	6.15							240	240	240	180	180	144	48
5/8	8.70	600						600	600	360	300	300	144	84
3/4	11.25	600	600					600	600	360	300	300	144	84
7/8	13.80	600	600	600				600	600	360	300	300	144	84
1	16.35	600	600	600	600			600	600	360	300	300	144	84
1 1/8	18.90	600	600	600	600	600		600	600	360	300	300	120	72
1 1/4	21.45	600	600	600	600	600	600	600	600	360	300	300	120	72
1 1/2	26.55	600	600	600	600	600	600	600	600	360	300	300	120	72
1 3/4	31.65	600	600	600	600	600	600	600	600	360	300	300	120	72

Chicago and Pittsburgh Districts

# WEIGHTS OF RECTANGULAR SECTIONS

## POUNDS PER LINEAL FOOT

Width, Inches	Thickness, Inches															
	1/16	1/8	3/16	1/4	5/16	3/8	7/16	1/2	9/16	5/8	11/16	3/4	13/16	7/8	15/16	1
1/4	.053	.106	.159	.213	.266	.319	.372	.425	.478	.531	.584	.638	.691	.744	.797	.850
1/2	.106	.213	.319	.425	.531	.638	.744	.850	.956	1.063	1.169	1.275	1.381	1.488	1.594	1.700
3/4	.159	.319	.478	.638	.797	.956	1.116	1.275	1.434	1.594	1.753	1.913	2.072	2.231	2.391	2.550
1	.213	.425	.638	.850	1.063	1.275	1.488	1.700	1.913	2.125	2.338	2.550	2.763	2.975	3.188	3.400
1 1/4	.266	.531	.797	1.063	1.328	1.594	1.859	2.125	2.391	2.656	2.922	3.188	3.453	3.719	3.984	4.250
1 1/2	.319	.638	.956	1.275	1.594	1.913	2.231	2.550	2.869	3.188	3.506	3.825	4.144	4.463	4.781	5.100
1 3/4	.372	.744	1.116	1.488	1.859	2.231	2.603	2.975	3.347	3.719	4.091	4.463	4.834	5.206	5.578	5.950
2	.425	.850	1.275	1.700	2.125	2.550	2.975	3.400	3.825	4.250	4.675	5.100	5.525	5.950	6.375	6.800
2 1/4	.478	.956	1.434	1.913	2.391	2.869	3.347	3.825	4.303	4.781	5.259	5.738	6.216	6.694	7.172	7.650
2 1/2	.531	1.063	1.594	2.125	2.656	3.188	3.719	4.250	4.781	5.313	5.844	6.375	6.906	7.438	7.969	8.500
2 3/4	.584	1.169	1.753	2.338	2.922	3.506	4.091	4.675	5.259	5.844	6.428	7.013	7.597	8.181	8.766	9.350
3	.638	1.275	1.913	2.550	3.188	3.825	4.463	5.100	5.738	6.375	7.013	7.650	8.288	8.925	9.563	10.20
3 1/4	.691	1.381	2.072	2.763	3.453	4.144	4.834	5.525	6.216	6.906	7.597	8.288	8.978	9.669	10.36	11.05
3 1/2	.744	1.488	2.231	2.975	3.719	4.463	5.206	5.950	6.694	7.438	8.181	8.925	9.669	10.41	11.16	11.90
3 3/4	.797	1.594	2.391	3.188	3.984	4.781	5.578	6.375	7.172	7.969	8.766	9.563	10.36	11.16	11.95	12.75
4	.850	1.700	2.550	3.400	4.250	5.100	5.950	6.800	7.650	8.500	9.350	10.20	11.05	11.90	12.75	13.60
4 1/4	.903	1.806	2.709	3.613	4.516	5.419	6.322	7.225	8.128	9.031	9.934	10.84	11.74	12.64	13.55	14.45
4 1/2	.956	1.913	2.869	3.825	4.781	5.738	6.694	7.650	8.606	9.563	10.52	11.48	12.43	13.39	14.34	15.30
4 3/4	1.009	2.019	3.028	4.038	5.047	6.056	7.066	8.075	9.084	10.09	11.10	12.11	13.12	14.13	15.14	16.15
5	1.063	2.125	3.188	4.250	5.313	6.375	7.438	8.500	9.563	10.63	11.69	12.75	13.81	14.88	15.94	17.00
5 1/4	1.116	2.231	3.347	4.463	5.578	6.694	7.809	8.925	10.04	11.16	12.27	13.39	14.50	15.62	16.73	17.85
5 1/2	1.169	2.338	3.506	4.675	5.844	7.013	8.181	9.350	10.52	11.69	12.86	14.03	15.19	16.36	17.53	18.70
5 3/4	1.222	2.444	3.666	4.888	6.109	7.331	8.553	9.775	11.00	12.22	13.44	14.66	15.88	17.11	18.33	19.55
6	1.275	2.550	3.825	5.100	6.375	7.650	8.925	10.20	11.48	12.75	14.03	15.30	16.58	17.85	19.13	20.40
6 1/4	1.328	2.656	3.984	5.313	6.641	7.969	9.297	10.63	11.95	13.28	14.61	15.94	17.27	18.59	19.92	21.25
6 1/2	1.381	2.763	4.144	5.525	6.906	8.288	9.669	11.05	12.43	13.81	15.19	16.58	17.96	19.34	20.72	22.10
6 3/4	1.434	2.869	4.303	5.738	7.172	8.606	10.04	11.48	12.91	14.34	15.78	17.21	18.65	20.08	21.52	22.95
7	1.488	2.975	4.463	5.950	7.438	8.925	10.41	11.90	13.39	14.88	16.36	17.85	19.34	20.83	22.31	23.80
7 1/4	1.541	3.081	4.622	6.163	7.703	9.244	10.78	12.33	13.87	15.41	16.95	18.49	20.03	21.57	23.11	24.65
7 1/2	1.594	3.188	4.781	6.375	7.969	9.563	11.16	12.75	14.34	15.94	17.53	19.13	20.72	22.31	23.91	25.50
7 3/4	1.647	3.294	4.941	6.588	8.234	9.881	11.53	13.18	14.82	16.47	18.12	19.76	21.41	23.06	24.70	26.35
8	1.700	3.400	5.100	6.800	8.500	10.20	11.90	13.60	15.30	17.00	18.70	20.40	22.10	23.80	25.50	27.20
8 1/4	1.753	3.506	5.259	7.013	8.766	10.52	12.27	14.03	15.78	17.53	19.28	21.04	22.79	24.54	26.30	28.05
8 1/2	1.806	3.613	5.419	7.225	9.031	10.84	12.64	14.45	16.26	18.06	19.87	21.68	23.48	25.29	27.09	28.90
8 3/4	1.859	3.719	5.578	7.438	9.297	11.16	13.02	14.88	16.73	18.59	20.45	22.31	24.17	26.03	27.89	29.75
9	1.913	3.825	5.738	7.650	9.563	11.48	13.39	15.30	17.21	19.13	21.04	22.95	24.86	26.78	28.69	30.60
9 1/4	1.966	3.931	5.897	7.863	9.828	11.79	13.76	15.73	17.69	19.66	21.62	23.59	25.55	27.52	29.48	31.45
9 1/2	2.019	4.038	6.056	8.075	10.09	12.11	14.13	16.15	18.17	20.19	22.21	24.23	26.24	28.26	30.28	32.30
9 3/4	2.072	4.144	6.216	8.288	10.36	12.43	14.50	16.58	18.65	20.72	22.79	24.86	26.93	29.01	31.08	33.15
10	2.125	4.250	6.375	8.500	10.63	12.75	14.88	17.00	19.13	21.25	23.38	25.50	27.63	29.75	31.88	34.00

# AREAS OF RECTANGULAR SECTIONS

## SQUARE INCHES

Width, Inches	Thickness, Inches															
	1/16	1/8	3/16	1/4	5/16	3/8	7/16	1/2	9/16	5/8	11/16	3/4	13/16	7/8	15/16	1
1/4	.016	.031	.047	.063	.078	.094	.109	.125	.141	.156	.172	.188	.203	.219	.234	.250
1/4	.031	.063	.094	.125	.156	.188	.219	.250	.281	.313	.344	.375	.406	.438	.469	.500
3/4	.047	.094	.141	.188	.234	.281	.328	.375	.422	.469	.516	.563	.609	.656	.703	.750
1	.063	.125	.188	.250	.313	.375	.438	.500	.563	.625	.688	.750	.813	.875	.938	1.000
1 1/4	.078	.156	.234	.313	.391	.469	.547	.625	.703	.781	.859	.938	1.016	1.094	1.172	1.250
1 1/2	.094	.188	.281	.375	.469	.563	.656	.750	.844	.938	1.031	1.125	1.219	1.313	1.406	1.500
1 3/4	.109	.219	.328	.438	.547	.656	.766	.875	.984	1.094	1.203	1.313	1.422	1.531	1.641	1.750
2	.125	.250	.375	.500	.625	.750	.875	1.000	1.125	1.250	1.375	1.500	1.625	1.750	1.875	2.000
2 1/4	.141	.281	.422	.563	.703	.844	.984	1.125	1.266	1.406	1.547	1.688	1.828	1.969	2.109	2.250
2 1/2	.156	.313	.469	.625	.781	.938	1.094	1.250	1.406	1.563	1.719	1.875	2.031	2.188	2.344	2.500
2 3/4	.172	.344	.516	.688	.859	1.031	1.203	1.375	1.547	1.719	1.891	2.063	2.234	2.406	2.578	2.750
3	.188	.375	.563	.750	.938	1.125	1.313	1.500	1.688	1.875	2.063	2.250	2.438	2.625	2.813	3.000
3 1/4	.203	.406	.609	.813	1.016	1.219	1.422	1.625	1.828	2.031	2.234	2.438	2.641	2.844	3.047	3.250
3 1/2	.219	.438	.656	.875	1.094	1.313	1.531	1.750	1.969	2.188	2.406	2.625	2.844	3.063	3.281	3.500
3 3/4	.234	.469	.703	.938	1.172	1.406	1.641	1.875	2.109	2.344	2.578	2.813	3.047	3.281	3.516	3.750
4	.250	.500	.750	1.000	1.250	1.500	1.750	2.000	2.250	2.500	2.750	3.000	3.250	3.500	3.750	4.000
4 1/4	.266	.531	.797	1.063	1.328	1.594	1.859	2.125	2.391	2.656	2.922	3.188	3.453	3.719	3.984	4.250
4 1/2	.281	.563	.844	1.125	1.406	1.688	1.969	2.250	2.531	2.813	3.094	3.375	3.656	3.938	4.219	4.500
4 3/4	.297	.594	.891	1.188	1.484	1.781	2.078	2.375	2.672	2.969	3.266	3.563	3.859	4.156	4.453	4.750
5	.313	.625	.938	1.250	1.563	1.875	2.188	2.500	2.813	3.125	3.438	3.750	4.063	4.375	4.688	5.000
5 1/4	.328	.656	.984	1.313	1.641	1.969	2.297	2.625	2.953	3.281	3.609	3.938	4.266	4.594	4.922	5.250
5 1/2	.344	.688	1.031	1.375	1.719	2.063	2.406	2.750	3.094	3.438	3.781	4.125	4.469	4.813	5.156	5.500
5 3/4	.359	.719	1.078	1.438	1.797	2.156	2.516	2.875	3.234	3.594	3.953	4.313	4.672	5.031	5.391	5.750
6	.375	.750	1.125	1.500	1.875	2.250	2.625	3.000	3.375	3.750	4.125	4.500	4.875	5.250	5.625	6.000
6 1/4	.391	.781	1.172	1.563	1.953	2.344	2.734	3.125	3.516	3.906	4.297	4.688	5.078	5.469	5.859	6.250
6 1/2	.406	.813	1.219	1.625	2.031	2.438	2.844	3.250	3.656	4.063	4.469	4.875	5.281	5.688	6.094	6.500
6 3/4	.422	.844	1.266	1.688	2.109	2.531	2.953	3.375	3.797	4.219	4.641	5.063	5.484	5.906	6.328	6.750
7	.438	.875	1.313	1.750	2.188	2.625	3.063	3.500	3.938	4.375	4.813	5.250	5.688	6.125	6.563	7.000
7 1/4	.453	.906	1.359	1.813	2.266	2.719	3.172	3.625	4.078	4.531	4.984	5.438	5.891	6.344	6.797	7.250
7 1/2	.469	.938	1.406	1.875	2.344	2.813	3.281	3.750	4.219	4.688	5.156	5.625	6.094	6.563	7.031	7.500
7 3/4	.484	.969	1.453	1.938	2.422	2.906	3.391	3.875	4.359	4.844	5.328	5.813	6.297	6.781	7.266	7.750
8	.500	1.000	1.500	2.000	2.500	3.000	3.500	4.000	4.500	5.000	5.500	6.000	6.500	7.000	7.500	8.000
8 1/4	.516	1.031	1.547	2.063	2.578	3.094	3.609	4.125	4.641	5.156	5.672	6.188	6.703	7.219	7.734	8.250
8 1/2	.531	1.063	1.594	2.125	2.656	3.188	3.719	4.250	4.781	5.313	5.844	6.375	6.906	7.438	7.969	8.500
8 3/4	.547	1.094	1.641	2.188	2.734	3.281	3.828	4.375	4.922	5.469	6.016	6.563	7.109	7.656	8.203	8.750
9	.563	1.125	1.688	2.250	2.813	3.375	3.938	4.500	5.063	5.625	6.188	6.750	7.313	7.875	8.438	9.000
9 1/4	.578	1.156	1.734	2.313	2.891	3.469	4.047	4.625	5.203	5.781	6.359	6.938	7.516	8.094	8.672	9.250
9 1/2	.594	1.188	1.781	2.375	2.969	3.563	4.156	4.750	5.344	5.938	6.531	7.125	7.719	8.313	8.906	9.500
9 3/4	.609	1.219	1.828	2.438	3.047	3.656	4.266	4.875	5.484	6.094	6.703	7.313	7.922	8.531	9.141	9.750
10	.625	1.250	1.875	2.500	3.125	3.750	4.375	5.000	5.625	6.250	6.875	7.500	8.125	8.750	9.375	10.000

# WEIGHTS OF RECTANGULAR SECTIONS

## POUNDS PER LINEAL FOOT

Width, Inches	Thickness, Inches															
	$\frac{1}{16}$	$\frac{1}{8}$	$\frac{3}{16}$	$\frac{1}{4}$	$\frac{5}{16}$	$\frac{3}{8}$	$\frac{7}{16}$	$\frac{1}{2}$	$\frac{9}{16}$	$\frac{5}{8}$	$\frac{11}{16}$	$\frac{3}{4}$	$\frac{13}{16}$	$\frac{7}{8}$	$\frac{15}{16}$	1
10 $\frac{1}{4}$	2.178	4.356	6.534	8.713	10.89	13.07	15.25	17.43	19.60	21.78	23.96	26.14	28.32	30.49	32.67	34.85
10 $\frac{1}{2}$	2.231	4.463	6.694	8.925	11.16	13.39	15.62	17.85	20.08	22.31	24.54	26.78	29.01	31.24	33.47	35.70
10 $\frac{3}{4}$	2.284	4.569	6.853	9.138	11.42	13.71	15.99	18.28	20.56	22.84	25.13	27.41	29.70	31.98	34.27	36.55
11	2.338	4.675	7.013	9.350	11.69	14.03	16.36	18.70	21.04	23.38	25.71	28.05	30.39	32.73	35.06	37.40
11 $\frac{1}{4}$	2.391	4.781	7.172	9.563	11.95	14.34	16.73	19.13	21.52	23.91	26.30	28.69	31.08	33.47	35.86	38.25
11 $\frac{1}{2}$	2.444	4.888	7.331	9.775	12.22	14.66	17.11	19.55	21.99	24.44	26.88	29.33	31.77	34.21	36.66	39.10
11 $\frac{3}{4}$	2.497	4.994	7.491	9.988	12.48	14.98	17.48	19.98	22.47	24.97	27.47	29.96	32.46	34.96	37.45	39.95
12	2.550	5.100	7.650	10.20	12.75	15.30	17.85	20.40	22.95	25.50	28.05	30.60	33.15	35.70	38.25	40.80
12 $\frac{1}{2}$	2.656	5.313	7.969	10.63	13.28	15.94	18.59	21.25	23.91	26.56	29.22	31.88	34.53	37.19	39.84	42.50
13	2.763	5.525	8.288	11.05	13.81	16.58	19.34	22.10	24.86	27.63	30.39	33.15	35.91	38.68	41.44	44.20
13 $\frac{1}{2}$	2.869	5.738	8.606	11.48	14.34	17.21	20.08	22.95	25.82	28.69	31.56	34.43	37.29	40.16	43.03	45.90
14	2.975	5.950	8.925	11.90	14.88	17.85	20.83	23.80	26.78	29.75	32.73	35.70	38.68	41.65	44.62	47.60
14 $\frac{1}{2}$	3.081	6.163	9.244	12.33	15.41	18.49	21.57	24.65	27.73	30.81	33.89	36.98	40.06	43.14	46.22	49.30
15	3.188	6.375	9.563	12.75	15.94	19.13	22.31	25.50	28.69	31.88	35.06	38.25	41.44	44.63	47.81	51.00
15 $\frac{1}{2}$	3.294	6.588	9.881	13.18	16.47	19.76	23.06	26.35	29.64	32.94	36.23	39.53	42.82	46.11	49.41	52.70
16	3.400	6.800	10.20	13.60	17.00	20.40	23.80	27.20	30.60	34.00	37.40	40.80	44.20	47.60	51.00	54.40
16 $\frac{1}{2}$	3.506	7.013	10.52	14.03	17.53	21.04	24.54	28.05	31.56	35.06	38.57	42.08	45.58	49.09	52.59	56.10
17	3.613	7.225	10.84	14.45	18.06	21.68	25.29	28.90	32.51	36.13	39.74	43.35	46.96	50.58	54.19	57.80
17 $\frac{1}{2}$	3.719	7.438	11.16	14.88	18.59	22.31	26.03	29.75	33.47	37.19	40.91	44.63	48.34	52.06	55.78	59.50
18	3.825	7.650	11.48	15.30	19.13	22.95	26.78	30.60	34.43	38.25	42.08	45.90	49.73	53.55	57.38	61.20
18 $\frac{1}{2}$	3.931	7.863	11.79	15.73	19.66	23.59	27.52	31.45	35.38	39.31	43.24	47.18	51.11	55.04	58.97	62.90
19	4.038	8.075	12.11	16.15	20.19	24.23	28.26	32.30	36.34	40.38	44.41	48.45	52.49	56.53	60.56	64.60
19 $\frac{1}{2}$	4.144	8.288	12.43	16.58	20.72	24.86	29.01	33.15	37.29	41.44	45.58	49.73	53.87	58.01	62.16	66.30
20	4.250	8.500	12.75	17.00	21.25	25.50	29.75	34.00	38.25	42.50	46.75	51.00	55.25	59.50	63.75	68.00
20 $\frac{1}{2}$	4.356	8.713	13.07	17.43	21.78	26.14	30.49	34.85	39.21	43.56	47.92	52.28	56.63	60.99	65.34	69.70
21	4.463	8.925	13.39	17.85	22.31	26.78	31.24	35.70	40.16	44.63	49.09	53.55	58.01	62.48	66.94	71.40
21 $\frac{1}{2}$	4.569	9.138	13.71	18.28	22.84	27.41	31.98	36.55	41.12	45.69	50.26	54.83	59.39	63.96	68.53	73.10
22	4.675	9.350	14.03	18.70	23.38	28.05	32.73	37.40	42.08	46.75	51.43	56.10	60.78	65.45	70.13	74.80
22 $\frac{1}{2}$	4.781	9.563	14.34	19.13	23.91	28.69	33.47	38.25	43.03	47.81	52.59	57.38	62.16	66.94	71.72	76.50
23	4.888	9.775	14.66	19.55	24.44	29.33	34.21	39.10	43.99	48.88	53.76	58.65	63.54	68.43	73.31	78.20
23 $\frac{1}{2}$	4.994	9.988	14.98	19.98	24.97	29.96	34.96	39.95	44.94	49.94	54.93	59.93	64.92	69.91	74.91	79.90
24	5.100	10.20	15.30	20.40	25.50	30.60	35.70	40.80	45.90	51.00	56.10	61.20	66.30	71.40	76.50	81.60
25	5.313	10.63	15.94	21.25	26.56	31.88	37.19	42.50	47.81	53.13	58.44	63.75	69.06	74.38	79.69	85.00
26	5.525	11.05	16.58	22.10	27.63	33.15	38.68	44.20	49.73	55.25	60.78	66.30	71.83	77.35	82.88	88.40
27	5.738	11.48	17.21	22.95	28.69	34.43	40.16	45.90	51.64	57.38	63.11	68.85	74.59	80.33	86.06	91.80
28	5.950	11.90	17.85	23.80	29.75	35.70	41.65	47.60	53.55	59.50	65.45	71.40	77.35	83.30	89.25	95.20
29	6.163	12.33	18.49	24.65	30.81	36.98	43.14	49.30	55.46	61.63	67.79	73.95	80.11	86.28	92.44	98.60
30	6.375	12.75	19.13	25.50	31.88	38.25	44.63	51.00	57.38	63.75	70.13	76.50	82.88	89.25	95.63	102.0
31	6.588	13.18	19.76	26.35	32.94	39.53	46.11	52.70	59.29	65.88	72.46	79.05	85.64	92.23	98.81	105.4
32	6.800	13.60	20.40	27.20	34.00	40.80	47.60	54.40	61.20	68.00	74.80	81.60	88.40	95.20	102.0	108.8

# AREAS OF RECTANGULAR SECTIONS

## SQURE INCHES

Width Inches	Thickness, Inches															
	1/16	1/8	3/16	1/4	5/16	3/8	7/16	1/2	9/16	5/8	11/16	3/4	13/16	7/8	15/16	1
10 1/4	.641	1.281	1.922	2.563	3.203	3.844	4.484	5.125	5.766	6.406	7.047	7.688	8.328	8.969	9.609	10.25
10 1/2	.656	1.313	1.969	2.625	3.281	3.938	4.594	5.250	5.906	6.563	7.219	7.875	8.531	9.188	9.844	10.50
10 3/4	.672	1.344	2.016	2.688	3.359	4.031	4.703	5.375	6.047	6.719	7.391	8.063	8.734	9.406	10.08	10.75
11	.688	1.375	2.063	2.750	3.438	4.125	4.813	5.500	6.188	6.875	7.563	8.250	8.938	9.625	10.31	11.00
11 1/4	.703	1.406	2.109	2.813	3.516	4.219	4.922	5.625	6.328	7.031	7.734	8.438	9.141	9.844	10.55	11.25
11 1/2	.719	1.438	2.156	2.875	3.594	4.313	5.031	5.750	6.469	7.188	7.906	8.625	9.344	10.06	10.78	11.50
11 3/4	.734	1.469	2.203	2.938	3.672	4.406	5.141	5.875	6.609	7.344	8.078	8.813	9.547	10.28	11.02	11.75
12	.750	1.500	2.250	3.000	3.750	4.500	5.250	6.000	6.750	7.500	8.250	9.000	9.750	10.50	11.25	12.00
12 1/2	.781	1.563	2.344	3.125	3.906	4.688	5.469	6.250	7.031	7.813	8.594	9.375	10.16	10.94	11.72	12.50
13	.813	1.625	2.438	3.250	4.063	4.875	5.688	6.500	7.313	8.125	8.938	9.750	10.56	11.38	12.19	13.00
13 1/2	.844	1.688	2.531	3.375	4.219	5.063	5.906	6.750	7.594	8.438	9.281	10.13	10.97	11.81	12.66	13.50
14	.875	1.750	2.625	3.500	4.375	5.250	6.125	7.000	7.875	8.750	9.625	10.50	11.38	12.25	13.13	14.00
14 1/2	.906	1.813	2.719	3.625	4.531	5.438	6.344	7.250	8.156	9.063	9.969	10.88	11.78	12.69	13.59	14.50
15	.938	1.875	2.813	3.750	4.688	5.625	6.563	7.500	8.438	9.375	10.31	11.25	12.19	13.13	14.06	15.00
15 1/2	.969	1.938	2.906	3.875	4.844	5.813	6.781	7.750	8.719	9.688	10.66	11.63	12.59	13.56	14.53	15.50
16	1.000	2.000	3.000	4.000	5.000	6.000	7.000	8.000	9.000	10.00	11.00	12.00	13.00	14.00	15.00	16.00
16 1/2	1.031	2.063	3.094	4.125	5.156	6.188	7.219	8.250	9.281	10.31	11.34	12.38	13.41	14.44	15.47	16.50
17	1.063	2.125	3.188	4.250	5.313	6.375	7.438	8.500	9.563	10.63	11.69	12.75	13.81	14.88	15.94	17.00
17 1/2	1.094	2.188	3.281	4.375	5.469	6.563	7.656	8.750	9.844	10.94	12.03	13.13	14.22	15.31	16.41	17.50
18	1.125	2.250	3.375	4.500	5.625	6.750	7.875	9.000	10.13	11.25	12.38	13.50	14.63	15.75	16.88	18.00
18 1/2	1.156	2.313	3.469	4.625	5.781	6.938	8.094	9.250	10.41	11.56	12.72	13.88	15.03	16.19	17.34	18.50
19	1.188	2.375	3.563	4.750	5.938	7.125	8.313	9.500	10.69	11.88	13.06	14.25	15.44	16.63	17.81	19.00
19 1/2	1.219	2.438	3.656	4.875	6.094	7.313	8.531	9.750	10.97	12.19	13.41	14.63	15.84	17.06	18.28	19.50
20	1.250	2.500	3.750	5.000	6.250	7.500	8.750	10.00	11.25	12.50	13.75	15.00	16.25	17.50	18.75	20.00
20 1/2	1.281	2.563	3.844	5.125	6.406	7.688	8.969	10.25	11.53	12.81	14.09	15.38	16.66	17.94	19.22	20.50
21	1.313	2.625	3.938	5.250	6.563	7.875	9.188	10.50	11.81	13.13	14.44	15.75	17.06	18.38	19.69	21.00
21 1/2	1.344	2.688	4.031	5.375	6.719	8.063	9.406	10.75	12.09	13.44	14.78	16.13	17.47	18.81	20.16	21.50
22	1.375	2.750	4.125	5.500	6.875	8.250	9.625	11.00	12.38	13.75	15.13	16.50	17.88	19.25	20.63	22.00
22 1/2	1.406	2.813	4.219	5.625	7.031	8.438	9.844	11.25	12.66	14.06	15.47	16.88	18.28	19.69	21.09	22.50
23	1.438	2.875	4.313	5.750	7.188	8.625	10.06	11.50	12.94	14.38	15.81	17.25	18.69	20.13	21.56	23.00
23 1/2	1.469	2.938	4.406	5.875	7.344	8.813	10.28	11.75	13.22	14.69	16.16	17.63	19.09	20.56	22.03	23.50
24	1.500	3.000	4.500	6.000	7.500	9.000	10.50	12.00	13.50	15.00	16.50	18.00	19.50	21.00	22.50	24.00
25	1.563	3.125	4.688	6.250	7.813	9.375	10.94	12.50	14.06	15.63	17.19	18.75	20.31	21.88	23.44	25.00
26	1.625	3.250	4.875	6.500	8.125	9.750	11.38	13.00	14.63	16.25	17.88	19.50	21.13	22.75	24.38	26.00
27	1.688	3.375	5.063	6.750	8.438	10.13	11.81	13.50	15.19	16.88	18.56	20.25	21.94	23.63	25.31	27.00
28	1.750	3.500	5.250	7.000	8.750	10.50	12.25	14.00	15.75	17.50	19.25	21.00	22.75	24.50	26.25	28.00
29	1.813	3.625	5.438	7.250	9.063	10.88	12.69	14.50	16.31	18.13	19.94	21.75	23.56	25.38	27.19	29.00
30	1.875	3.750	5.625	7.500	9.375	11.25	13.13	15.00	16.88	18.75	20.63	22.50	24.38	26.25	28.13	30.00
31	1.938	3.875	5.813	7.750	9.688	11.63	13.56	15.50	17.44	19.38	21.31	23.25	25.19	27.13	29.06	31.00
32	2.000	4.000	6.000	8.000	10.00	12.00	14.00	16.00	18.00	20.00	22.00	24.00	26.00	28.00	30.00	32.00



# WEIGHTS OF RECTANGULAR SECTIONS

POUNDS PER LINEAL FOOT

Width Inches	Thickness, Inches															
	1/16	1/8	3/16	1/4	5/16	3/8	7/16	1/2	9/16	5/8	11/16	3/4	13/16	7/8	15/16	1
33	7.013	14.03	21.04	28.05	35.06	42.08	49.09	56.10	63.11	70.13	77.14	84.15	91.16	98.18	105.2	112.2
34	7.225	14.45	21.68	28.90	36.13	43.35	50.58	57.80	65.03	72.25	79.48	86.70	93.93	101.2	108.4	115.6
35	7.438	14.88	22.31	29.75	37.19	44.63	52.06	59.50	66.94	74.38	81.81	89.25	96.69	104.1	111.6	119.0
36	7.650	15.30	22.95	30.60	38.25	45.90	53.55	61.20	68.85	76.50	84.15	91.80	99.45	107.1	114.8	122.4
37	7.863	15.73	23.59	31.45	39.31	47.18	55.04	62.90	70.76	78.63	86.49	94.35	102.2	110.1	117.9	125.8
38	8.075	16.15	24.23	32.30	40.38	48.45	56.53	64.60	72.68	80.75	88.83	96.90	105.0	113.1	121.1	129.2
39	8.288	16.58	24.86	33.15	41.44	49.73	58.01	66.30	74.59	82.88	91.16	99.45	107.7	116.0	124.3	132.6
40	8.500	17.00	25.50	34.00	42.50	51.00	59.50	68.00	76.50	85.00	93.50	102.0	110.5	119.0	127.5	136.0
41	8.713	17.43	26.14	34.85	43.56	52.28	60.99	69.70	78.41	87.13	95.84	104.6	113.3	122.0	130.7	139.4
42	8.925	17.85	26.78	35.70	44.63	53.55	62.48	71.40	80.33	89.25	98.18	107.1	116.0	125.0	133.9	142.8
43	9.138	18.28	27.41	36.55	45.69	54.83	63.96	73.10	82.24	91.38	100.5	109.7	118.8	127.9	137.1	146.2
44	9.350	18.70	28.05	37.40	46.75	56.10	65.45	74.80	84.15	93.50	102.9	112.2	121.6	130.9	140.3	149.6
45	9.563	19.13	28.69	38.25	47.81	57.38	66.94	76.50	86.06	95.63	105.2	114.8	124.3	133.9	143.4	153.0
46	9.775	19.55	29.33	39.10	48.88	58.65	68.43	78.20	87.98	97.75	107.5	117.3	127.1	136.9	146.6	156.4
47	9.988	19.98	29.96	39.95	49.94	59.93	69.91	79.90	89.89	99.88	109.9	119.9	129.8	139.8	149.8	159.8
48	10.20	20.40	30.60	40.80	51.00	61.20	71.40	81.60	91.80	102.0	112.2	122.4	132.6	142.8	153.0	163.2
49	10.41	20.83	31.24	41.65	52.06	62.48	72.89	83.30	93.71	104.1	114.5	125.0	135.4	145.8	156.2	166.6
50	10.63	21.25	31.88	42.50	53.13	63.75	74.38	85.00	95.63	106.3	116.9	127.5	138.1	148.8	159.4	170.0
51	10.84	21.68	32.51	43.35	54.19	65.03	75.86	86.70	97.54	108.4	119.2	130.1	140.9	151.7	162.6	173.4
52	11.05	22.10	33.15	44.20	55.25	66.30	77.35	88.40	99.45	110.5	121.6	132.6	143.7	154.7	165.8	176.8
53	11.26	22.53	33.79	45.05	56.31	67.58	78.84	90.10	101.4	112.6	123.9	135.2	146.4	157.7	168.9	180.2
54	11.48	22.95	34.43	45.90	57.38	68.85	80.33	91.80	103.3	114.8	126.2	137.7	149.2	160.7	172.1	183.6
55	11.69	23.38	35.06	46.75	58.44	70.13	81.81	93.50	105.2	116.9	128.6	140.3	151.9	163.6	175.3	187.0
56	11.90	23.80	35.70	47.60	59.50	71.40	83.30	95.20	107.1	119.0	130.9	142.8	154.7	166.6	178.5	190.4
57	12.11	24.23	36.34	48.45	60.56	72.68	84.79	96.90	109.0	121.1	133.2	145.4	157.5	169.6	181.7	193.8
58	12.33	24.65	36.98	49.30	61.63	73.95	86.28	98.60	110.9	123.3	135.6	147.9	160.2	172.6	184.9	197.2
59	12.54	25.08	37.61	50.15	62.69	75.23	87.76	100.3	112.8	125.4	137.9	150.5	163.0	175.5	188.1	200.6
60	12.75	25.50	38.25	51.00	63.75	76.50	89.25	102.1	114.8	127.5	140.3	153.0	165.8	178.5	191.3	204.0
61	12.96	25.93	38.89	51.85	64.81	77.78	90.74	103.7	116.7	129.6	142.6	155.6	168.5	181.5	194.4	207.4
62	13.18	26.35	39.53	52.70	65.88	79.05	92.23	105.4	118.6	131.8	144.9	158.1	171.3	184.5	197.6	210.8
63	13.39	26.78	40.16	53.55	66.94	80.33	93.71	107.1	120.5	133.9	147.3	160.7	174.0	187.4	200.8	214.2
64	13.60	27.20	40.80	54.40	68.00	81.60	95.20	108.8	122.4	136.0	149.6	163.2	176.8	190.4	204.0	217.6
65	13.81	27.63	41.44	55.25	69.06	82.88	96.69	110.5	124.3	138.1	151.9	165.8	179.6	193.4	207.2	221.0
66	14.03	28.05	42.08	56.10	70.13	84.15	98.18	112.2	126.2	140.3	154.3	168.3	182.3	196.4	210.4	224.4
67	14.24	28.48	42.71	56.95	71.19	85.43	99.66	113.9	128.1	142.4	156.6	170.9	185.1	199.3	213.6	227.8
68	14.45	28.90	43.35	57.80	72.25	86.70	101.2	115.6	130.1	144.5	159.0	173.4	187.9	202.3	216.8	231.2
69	14.66	29.33	43.99	58.65	73.31	87.98	102.6	117.3	132.0	146.6	161.3	176.0	190.6	205.3	219.9	234.6
70	14.88	29.75	44.63	59.50	74.38	89.25	104.1	119.0	133.9	148.8	163.6	178.5	193.4	208.3	223.1	238.0
71	15.09	30.18	45.26	60.35	75.44	90.53	105.6	120.7	135.8	150.9	166.0	181.1	196.1	211.2	226.3	241.4
72	15.30	30.60	45.90	61.20	76.50	91.80	107.1	122.4	137.7	153.0	168.3	183.6	198.9	214.2	229.5	244.8

# AREAS OF RECTANGULAR SECTIONS

## SQUARE INCHES

Width, Inches	Thickness, Inches															
	$\frac{1}{16}$	$\frac{1}{8}$	$\frac{3}{16}$	$\frac{1}{4}$	$\frac{5}{16}$	$\frac{3}{8}$	$\frac{7}{16}$	$\frac{1}{2}$	$\frac{9}{16}$	$\frac{5}{8}$	$\frac{11}{16}$	$\frac{3}{4}$	$\frac{13}{16}$	$\frac{7}{8}$	$\frac{15}{16}$	1
33	2.063	4.125	6.188	8.250	10.31	12.38	14.44	16.50	18.56	20.63	22.69	24.75	26.81	28.88	30.94	33.00
34	2.125	4.250	6.375	8.500	10.63	12.75	14.88	17.00	19.13	21.25	23.38	25.50	27.63	29.75	31.88	34.00
35	2.188	4.375	6.563	8.750	10.94	13.13	15.31	17.50	19.69	21.88	24.06	26.25	28.44	30.63	32.81	35.00
36	2.250	4.500	6.750	9.000	11.25	13.50	15.75	18.00	20.25	22.50	24.75	27.00	29.25	31.50	33.75	36.00
37	2.313	4.625	6.938	9.250	11.56	13.88	16.19	18.50	20.81	23.13	25.44	27.75	30.06	32.38	34.69	37.00
38	2.375	4.750	7.125	9.500	11.88	14.25	16.63	19.00	21.38	23.75	26.13	28.50	30.88	33.25	35.63	38.00
39	2.438	4.875	7.313	9.750	12.19	14.63	17.06	19.50	21.94	24.38	26.81	29.25	31.69	34.13	36.56	39.00
40	2.500	5.000	7.500	10.00	12.50	15.00	17.50	20.00	22.50	25.00	27.50	30.00	32.50	35.00	37.50	40.00
41	2.563	5.125	7.688	10.25	12.81	15.38	17.94	20.50	23.06	25.63	28.19	30.75	33.31	35.88	38.44	41.00
42	2.625	5.250	7.875	10.50	13.13	15.75	18.38	21.00	23.63	26.25	28.88	31.50	34.13	36.75	39.38	42.00
43	2.688	5.375	8.063	10.75	13.44	16.13	18.81	21.50	24.19	26.88	29.56	32.25	34.94	37.63	40.31	43.00
44	2.750	5.500	8.250	11.00	13.75	16.50	19.25	22.00	24.75	27.50	30.25	33.00	35.75	38.50	41.25	44.00
45	2.813	5.625	8.438	11.25	14.06	16.88	19.69	22.50	25.31	28.13	30.94	33.75	36.56	39.38	42.19	45.00
46	2.875	5.750	8.625	11.50	14.38	17.25	20.13	23.00	25.88	28.75	31.63	34.50	37.38	40.25	43.13	46.00
47	2.938	5.875	8.813	11.75	14.69	17.63	20.56	23.50	26.44	29.38	32.31	35.25	38.19	41.13	44.06	47.00
48	3.000	6.000	9.000	12.00	15.00	18.00	21.00	24.00	27.00	30.00	33.00	36.00	39.00	42.00	45.00	48.00
49	3.063	6.125	9.188	12.25	15.31	18.38	21.44	24.50	27.56	30.63	33.69	36.75	39.81	42.88	45.94	49.00
50	3.125	6.250	9.375	12.50	15.63	18.75	21.88	25.00	28.13	31.25	34.38	37.50	40.63	43.75	46.88	50.00
51	3.188	6.375	9.563	12.75	15.94	19.13	22.31	25.50	28.69	31.88	35.06	38.25	41.44	44.63	47.81	51.00
52	3.250	6.500	9.750	13.00	16.25	19.50	22.75	26.00	29.25	32.50	35.75	39.00	42.25	45.50	48.75	52.00
53	3.313	6.625	9.938	13.25	16.56	19.88	23.19	26.50	29.81	33.13	36.44	39.75	43.06	46.38	49.69	53.00
54	3.375	6.750	10.13	13.50	16.88	20.25	23.63	27.00	30.38	33.75	37.13	40.50	43.88	47.25	50.63	54.00
55	3.438	6.875	10.31	13.75	17.19	20.63	24.06	27.50	30.94	34.38	37.81	41.25	44.69	48.13	51.56	55.00
56	3.500	7.000	10.50	14.00	17.50	21.00	24.50	28.00	31.50	35.00	38.50	42.00	45.50	49.00	52.50	56.00
57	3.563	7.125	10.69	14.25	17.81	21.38	24.94	28.50	32.06	35.63	39.19	42.75	46.31	49.88	53.44	57.00
58	3.625	7.250	10.88	14.50	18.13	21.75	25.38	29.00	32.63	36.25	39.88	43.50	47.13	50.75	54.38	58.00
59	3.688	7.375	11.06	14.75	18.44	22.13	25.81	29.50	33.19	36.88	40.56	44.25	47.94	51.63	55.31	59.00
60	3.750	7.500	11.25	15.00	18.75	22.50	26.25	30.00	33.75	37.50	41.25	45.00	48.75	52.50	56.25	60.00
61	3.813	7.625	11.44	15.25	19.06	22.88	26.69	30.50	34.31	38.13	41.94	45.75	49.56	53.38	57.19	61.00
62	3.875	7.750	11.63	15.50	19.38	23.25	27.13	31.00	34.88	38.75	42.63	46.50	50.38	54.25	58.13	62.00
63	3.938	7.875	11.81	15.75	19.69	23.63	27.56	31.50	35.44	39.38	43.31	47.25	51.19	55.13	59.06	63.00
64	4.000	8.000	12.00	16.00	20.00	24.00	28.00	32.00	36.00	40.00	44.00	48.00	52.00	56.00	60.00	64.00
65	4.063	8.125	12.19	16.25	20.31	24.38	28.44	32.50	36.56	40.63	44.69	48.75	52.81	56.88	60.94	65.00
66	4.125	8.250	12.38	16.50	20.63	24.75	28.88	33.00	37.13	41.25	45.38	49.50	53.63	57.75	61.88	66.00
67	4.188	8.375	12.56	16.75	20.94	25.13	29.31	33.50	37.69	41.88	46.06	50.25	54.44	58.63	62.81	67.00
68	4.250	8.500	12.75	17.00	21.25	25.50	29.75	34.00	38.25	42.50	46.75	51.00	55.25	59.50	63.75	68.00
69	4.313	8.625	12.94	17.25	21.56	25.88	30.19	34.50	38.81	43.13	47.44	51.75	56.06	60.38	64.69	69.00
70	4.375	8.750	13.13	17.50	21.88	26.25	30.63	35.00	39.38	43.75	48.13	52.50	56.88	61.25	65.63	70.00
71	4.438	8.875	13.31	17.75	22.19	26.63	31.06	35.50	39.94	44.38	48.81	53.25	56.69	62.13	66.56	71.00
72	4.500	9.000	13.50	18.00	22.50	27.00	31.50	36.00	40.50	45.00	49.50	54.00	58.50	63.00	67.50	72.00

# WEIGHTS OF RECTANGULAR SECTIONS

## POUNDS PER LINEAL FOOT

Width, Inches	Thickness, Inches															
	$\frac{1}{16}$	$\frac{1}{8}$	$\frac{3}{16}$	$\frac{1}{4}$	$\frac{5}{16}$	$\frac{3}{8}$	$\frac{7}{16}$	$\frac{1}{2}$	$\frac{9}{16}$	$\frac{5}{8}$	$1\frac{1}{16}$	$\frac{3}{4}$	$1\frac{1}{8}$	$\frac{7}{8}$	$1\frac{1}{2}$	1
73	15.51	31.03	46.54	62.05	77.56	93.08	108.6	124.1	139.6	155.1	170.6	186.2	201.7	217.2	232.7	248.2
74	15.73	31.45	47.18	62.90	78.63	94.35	110.1	125.8	141.5	157.3	173.0	188.7	204.4	220.2	235.9	251.6
75	15.94	31.88	47.81	63.75	79.69	95.63	111.6	127.5	143.4	159.4	175.3	191.3	207.2	223.1	239.1	255.0
76	16.15	32.30	48.45	64.60	80.75	96.90	113.1	129.2	145.4	161.5	177.7	193.8	210.0	226.1	242.3	258.4
77	16.36	32.73	49.09	65.45	81.81	98.18	114.5	130.9	147.3	163.6	180.0	196.4	212.7	229.1	245.4	261.8
78	16.58	33.15	49.73	66.30	82.88	99.45	116.0	132.6	149.2	165.8	182.3	198.9	215.5	232.1	248.6	265.2
79	16.79	33.58	50.36	67.15	83.94	100.7	117.5	134.3	151.1	167.9	184.7	201.5	218.2	235.0	251.8	268.6
80	17.00	34.00	51.00	68.00	85.00	102.0	119.0	136.0	153.0	170.0	187.0	204.0	221.0	238.0	255.0	272.0
81	17.21	34.43	51.64	68.85	86.06	103.3	120.5	137.7	154.9	172.1	189.3	206.6	223.8	241.0	258.2	275.4
82	17.43	34.85	52.28	69.70	87.13	104.6	122.0	139.4	156.8	174.3	191.7	209.1	226.5	244.0	261.4	278.8
83	17.64	35.28	52.91	70.55	88.19	105.8	123.5	141.1	158.7	176.4	194.0	211.7	229.3	246.9	264.6	282.2
84	17.85	35.70	53.55	71.40	89.25	107.1	125.0	142.8	160.7	178.5	196.4	214.2	232.1	249.9	267.8	285.6
85	18.06	36.13	54.19	72.25	90.31	108.4	126.4	144.5	162.6	180.6	198.7	216.8	234.8	252.9	270.9	289.0
86	18.28	36.55	54.83	73.10	91.38	109.7	127.9	146.2	164.5	182.8	201.0	219.3	237.6	255.9	274.1	292.4
87	18.49	36.98	55.46	73.95	92.44	110.9	129.4	147.9	166.4	184.9	203.4	221.9	240.3	258.8	277.3	295.8
88	18.70	37.40	56.10	74.80	93.50	112.2	130.9	149.6	168.3	187.0	205.7	224.4	243.1	261.8	280.5	299.2
89	18.91	37.83	56.74	75.65	94.56	113.5	132.4	151.3	170.2	189.1	208.0	227.0	245.9	264.8	283.7	302.6
90	19.13	38.25	57.38	76.50	95.63	114.8	133.9	153.0	172.1	191.3	210.4	229.5	248.6	267.8	286.9	306.0
91	19.34	38.68	58.01	77.35	96.69	116.0	135.4	154.7	174.0	193.4	212.7	232.1	251.4	270.7	290.1	309.4
92	19.55	39.10	58.65	78.20	97.75	117.3	136.9	156.4	176.0	195.5	215.1	234.6	254.2	273.7	293.3	312.8
93	19.76	39.53	59.29	79.05	98.81	118.6	138.3	158.1	177.9	197.6	217.4	237.2	256.9	276.7	296.4	316.2
94	19.98	39.95	59.93	79.90	99.88	119.9	139.8	159.8	179.8	199.8	219.7	239.7	259.7	279.7	299.6	319.6
95	20.19	40.38	60.56	80.75	100.9	121.1	141.3	161.5	181.7	201.9	222.1	242.3	262.4	282.6	302.8	323.0
96	20.40	40.80	61.20	81.60	102.0	122.4	142.8	163.2	183.6	204.0	224.4	244.8	265.2	285.6	306.0	326.4
97	20.61	41.23	61.84	82.45	103.1	123.7	144.3	164.9	185.5	206.1	226.7	247.4	268.0	288.6	309.2	329.8
98	20.83	41.65	62.48	83.30	104.1	125.0	145.8	166.6	187.4	208.3	229.1	249.9	270.7	291.6	312.4	333.2
99	21.04	42.08	63.11	84.15	105.2	126.2	147.3	168.3	189.3	210.4	231.4	252.5	273.5	294.5	315.6	336.6
100	21.25	42.50	63.75	85.00	106.3	127.5	148.8	170.0	191.3	212.5	233.8	255.0	276.3	297.5	318.8	340.0
102	21.68	43.35	65.03	86.70	108.4	130.1	151.7	173.4	195.1	216.8	238.4	260.1	281.8	303.5	325.1	346.8
104	22.10	44.20	66.30	88.40	110.5	132.6	154.7	176.8	198.9	221.0	243.1	265.2	287.3	309.4	331.5	353.6
106	22.53	45.05	67.58	90.10	112.6	135.2	157.7	180.2	202.7	225.3	247.8	270.3	292.8	315.4	337.9	360.4
108	22.95	45.90	68.85	91.80	114.8	137.7	160.7	183.6	206.6	229.5	252.5	275.4	298.4	321.3	344.3	367.2
110	23.38	46.75	70.13	93.50	116.9	140.3	163.6	187.0	210.4	233.8	257.1	280.5	303.9	327.3	350.6	374.0
112	23.80	47.60	71.40	95.20	119.0	142.8	166.6	190.4	214.2	238.0	261.8	285.6	309.4	333.2	357.0	380.8
114	24.23	48.45	72.68	96.90	121.1	145.4	169.6	193.8	218.0	242.3	266.5	290.7	314.9	339.2	363.4	387.6
116	24.65	49.30	73.95	98.60	123.3	147.9	172.6	197.2	221.9	246.5	271.2	295.8	320.5	345.1	369.8	394.4
118	25.08	50.15	75.23	100.3	125.4	150.5	175.5	200.6	225.7	250.8	275.8	300.9	326.0	351.1	376.1	401.2
120	25.50	51.00	76.50	102.0	127.5	153.0	178.5	204.0	229.5	255.0	280.5	306.0	331.5	357.0	382.5	408.0

# AREAS OF RECTANGULAR SECTIONS

## SQUARE INCHES

Width, Inches	Thickness, Inches															
	1/16	1/8	3/16	1/4	5/16	3/8	7/16	1/2	9/16	5/8	11/16	3/4	13/16	7/8	15/16	1
73	4.563	9.125	13.69	18.25	22.81	27.38	31.94	36.50	41.06	45.63	50.19	54.75	59.31	63.88	68.44	73.00
74	4.625	9.250	13.88	18.50	23.13	27.75	32.38	37.00	41.63	46.25	50.88	55.50	60.13	64.75	69.38	74.00
75	4.688	9.375	14.06	18.75	23.44	28.13	32.81	37.50	42.19	46.88	51.56	56.25	60.94	65.63	70.31	75.00
76	4.750	9.500	14.25	19.00	23.75	28.50	33.25	38.00	42.75	47.50	52.25	57.00	61.75	66.50	71.25	76.00
77	4.813	9.625	14.44	19.25	24.06	28.88	33.69	38.50	43.31	48.13	52.94	57.75	62.56	67.38	72.19	77.00
78	4.875	9.750	14.63	19.50	24.38	29.25	34.13	39.00	43.88	48.75	53.63	58.50	63.38	68.25	73.13	78.00
79	4.938	9.875	14.81	19.75	24.69	29.63	34.56	39.50	44.44	49.38	54.31	59.25	64.19	69.13	74.06	79.00
80	5.000	10.00	15.00	20.00	25.00	30.00	35.00	40.00	45.00	50.00	55.00	60.00	65.00	70.00	75.00	80.00
81	5.063	10.13	15.19	20.25	25.31	30.38	35.44	40.50	45.56	50.63	55.69	60.75	65.81	70.88	75.94	81.00
82	5.125	10.25	15.38	20.50	25.63	30.75	35.88	41.00	46.13	51.25	56.38	61.50	66.63	71.75	76.88	82.00
83	5.188	10.38	15.56	20.75	25.94	31.13	36.31	41.50	46.69	51.88	57.06	62.25	67.44	72.63	77.81	83.00
84	5.250	10.50	15.75	21.00	26.25	31.50	36.75	42.00	47.25	52.50	57.75	63.00	68.25	73.50	78.75	84.00
85	5.313	10.63	15.94	21.25	26.56	31.88	37.19	42.50	47.81	53.13	58.44	63.75	69.06	74.38	79.69	85.00
86	5.375	10.75	16.13	21.50	26.88	32.25	37.63	43.00	48.38	53.75	59.13	64.50	69.88	75.25	80.63	86.00
87	5.438	10.88	16.31	21.75	27.19	32.63	38.06	43.50	48.94	54.38	59.81	65.25	70.69	76.13	81.56	87.00
88	5.500	11.00	16.50	22.00	27.50	33.00	38.50	44.00	49.50	55.00	60.50	66.00	71.50	77.00	82.50	88.00
89	5.563	11.13	16.69	22.25	27.81	33.38	38.94	44.50	50.06	55.63	61.19	66.75	72.31	77.88	83.44	89.00
90	5.625	11.25	16.88	22.50	28.13	33.75	39.38	45.00	50.63	56.25	61.88	67.50	73.13	78.75	84.38	90.00
91	5.688	11.38	17.06	22.75	28.44	34.13	39.81	45.50	51.19	56.88	62.56	68.25	73.94	79.63	85.31	91.00
92	5.750	11.50	17.25	23.00	28.75	34.50	40.25	46.00	51.75	57.50	63.25	69.00	74.75	80.50	86.25	92.00
93	5.813	11.63	17.44	23.25	29.06	34.88	40.69	46.50	52.31	58.13	63.94	69.75	75.56	81.38	87.19	93.00
94	5.875	11.75	17.63	23.50	29.38	35.25	41.13	47.00	52.88	58.75	64.63	70.50	76.38	82.25	88.13	94.00
95	5.938	11.88	17.81	23.75	29.69	35.63	41.56	47.50	53.44	59.38	65.31	71.25	77.19	83.13	89.06	95.00
96	6.000	12.00	18.00	24.00	30.00	36.00	42.00	48.00	54.00	60.00	66.00	72.00	78.00	84.00	90.00	96.00
97	6.063	12.13	18.19	24.25	30.31	36.38	42.44	48.50	54.56	60.63	66.69	72.75	78.81	84.88	90.94	97.00
98	6.125	12.25	18.38	24.50	30.63	36.75	42.88	49.00	55.13	61.25	67.38	73.50	79.63	85.75	91.88	98.00
99	6.188	12.38	18.56	24.75	30.94	37.13	43.31	49.50	55.69	61.88	68.06	74.25	80.44	86.63	92.81	99.00
100	6.250	12.50	18.75	25.00	31.25	37.50	43.75	50.00	56.25	62.50	68.75	75.00	81.25	87.50	93.75	100.0
102	6.375	12.75	19.13	25.50	31.88	38.25	44.63	51.00	57.38	63.75	70.13	76.50	82.88	89.25	95.63	102.0
104	6.500	13.00	19.50	26.00	32.50	39.00	45.50	52.00	58.50	65.00	71.50	78.00	84.50	91.00	97.50	104.0
106	6.625	13.25	19.88	26.50	33.13	39.75	46.38	53.00	59.63	66.25	72.88	79.50	86.13	92.75	99.38	106.0
108	6.750	13.50	20.25	27.00	33.75	40.50	47.25	54.00	60.75	67.50	74.25	81.00	87.75	94.50	101.3	108.0
110	6.875	13.75	20.63	27.50	34.38	41.25	48.13	55.00	61.88	68.75	75.63	82.50	89.38	96.25	103.1	110.0
112	7.000	14.00	21.00	28.00	35.00	42.00	49.00	56.00	63.00	70.00	77.00	84.00	91.00	98.00	105.0	112.0
114	7.125	14.25	21.38	28.50	35.63	42.75	49.88	57.00	64.13	71.25	78.38	85.50	92.63	99.75	106.9	114.0
116	7.250	14.50	21.75	29.00	36.25	43.50	50.75	58.00	65.25	72.50	79.75	87.00	94.25	101.5	108.8	116.0
118	7.375	14.75	22.13	29.50	36.88	44.25	51.63	59.00	66.38	73.75	81.13	88.50	95.88	103.3	110.6	118.0
120	7.500	15.00	22.50	30.00	37.50	45.00	52.50	60.00	67.50	75.00	82.50	90.00	97.50	105.0	112.5	120.0

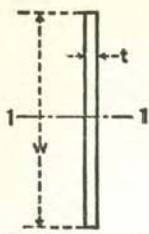

# PLATES

## WEIGHTS, AREAS, AND MOMENTS OF INERTIA

$$I = \frac{tw^3}{12}$$

Width w	Thickness t, Inch														
	1/4			5/16			3/8			7/16			1/2		
	Wt. per Foot	Area	I <sub>1-1</sub>	Wt. per Foot	Area	I <sub>1-1</sub>	Wt. per Foot	Area	I <sub>1-1</sub>	Wt. per Foot	Area	I <sub>1-1</sub>	Wt. per Foot	Area	I <sub>1-1</sub>
In.	Lb.	In. <sup>2</sup>	In. <sup>4</sup>	Lb.	In. <sup>2</sup>	In. <sup>4</sup>	Lb.	In. <sup>2</sup>	In. <sup>4</sup>	Lb.	In. <sup>2</sup>	In. <sup>4</sup>	Lb.	In. <sup>2</sup>	In. <sup>4</sup>
6	5.10	1.50	4.5	6.38	1.88	5.6	7.65	2.25	6.8	8.93	2.63	7.9	10.2	3.0	9.0
7	5.95	1.75	7.2	7.44	2.19	8.9	8.93	2.63	10.7	10.41	3.06	12.5	11.9	3.5	14.3
8	6.80	2.00	10.7	8.50	2.50	13.3	10.20	3.00	16.0	11.90	3.50	18.7	13.6	4.0	21.3
9	7.65	2.25	15.2	9.56	2.81	19.0	11.48	3.37	22.8	13.39	3.94	26.6	15.3	4.5	30.4
10	8.50	2.50	20.8	10.63	3.13	26.0	12.75	3.75	31.3	14.88	4.38	36.5	17.0	5.0	41.7
11	9.35	2.75	27.7	11.69	3.44	34.7	14.03	4.13	41.6	16.36	4.81	48.5	18.7	5.5	55.5
12	10.20	3.00	36.0	12.75	3.75	45.0	15.30	4.50	54.0	17.85	5.25	63.0	20.4	6.0	72.0
13	11.05	3.25	45.8	13.81	4.06	57.2	16.58	4.88	68.7	19.34	5.69	80.1	22.1	6.5	91.5
14	11.90	3.50	57.2	14.88	4.38	71.5	17.85	5.25	85.8	20.83	6.13	100	23.8	7.0	114
15	12.75	3.75	70.3	15.94	4.69	87.9	19.13	5.63	106	22.31	6.56	123	25.5	7.5	141
16	13.60	4.00	85	17.00	5.00	107	20.40	6.00	128	23.80	7.00	149	27.2	8.0	171
17	14.45	4.25	102	18.06	5.31	128	21.68	6.38	154	25.29	7.44	179	28.9	8.5	205
18	15.30	4.50	122	19.13	5.63	152	22.95	6.75	182	26.78	7.88	213	30.6	9.0	243
19	16.15	4.75	143	20.19	5.94	179	24.23	7.13	214	28.26	8.31	250	32.3	9.5	286
20	17.00	5.00	167	21.25	6.25	208	25.50	7.50	250	29.75	8.75	292	34.0	10.0	333
21	17.85	5.25	193	22.31	6.56	241	26.78	7.88	289	31.24	9.19	338	35.7	10.5	386
22	18.70	5.50	222	23.38	6.88	277	28.05	8.25	333	32.73	9.63	388	37.4	11.0	444
23	19.55	5.75	254	24.44	7.19	317	29.33	8.63	380	34.21	10.06	444	39.1	11.5	507
24	20.40	6.00	288	25.50	7.50	360	30.60	9.00	432	35.70	10.50	504	40.8	12.0	576
25	21.25	6.25	326	26.56	7.81	407	31.88	9.38	488	37.19	10.94	570	42.5	12.5	651
26	22.10	6.50	366	27.63	8.13	458	33.15	9.75	549	38.68	11.38	641	44.2	13.0	732
27	22.95	6.75	410	28.69	8.44	513	34.43	10.13	615	40.16	11.81	718	45.9	13.5	820
28	23.80	7.00	457	29.75	8.75	572	35.70	10.50	686	41.65	12.25	800	47.6	14.0	915
29	24.65	7.25	508	30.81	9.06	635	36.98	10.88	762	43.14	12.69	889	49.3	14.5	1016
30	25.50	7.50	563	31.88	9.38	703	38.25	11.25	844	44.63	13.13	984	51.0	15.0	1125
31	26.35	7.75	621	32.94	9.69	776	39.53	11.63	931	46.11	13.56	1086	52.7	15.5	1241
32	27.20	8.00	683	34.00	10.00	853	40.80	12.00	1024	47.60	14.00	1195	54.4	16.0	1365
33	28.05	8.25	749	35.06	10.31	936	42.08	12.38	1123	49.09	14.44	1310	56.1	16.5	1497
34	28.90	8.50	819	36.13	10.63	1024	43.35	12.75	1228	50.58	14.88	1433	57.8	17.0	1638
35	29.75	8.75	893	37.19	10.94	1117	44.63	13.13	1340	52.06	15.31	1563	59.5	17.5	1787
36	30.60	9.00	972	38.25	11.25	1215	45.90	13.50	1458	53.55	15.75	1701	61.2	18.0	1944
37	31.45	9.25	1055	39.31	11.56	1319	47.18	13.88	1583	55.04	16.19	1847	62.9	18.5	2111
38	32.30	9.50	1143	40.38	11.88	1429	48.45	14.25	1715	56.53	16.63	2001	64.6	19.0	2286
39	33.15	9.75	1236	41.44	12.19	1545	49.73	14.63	1854	58.01	17.06	2163	66.3	19.5	2472
40	34.00	10.00	1333	42.50	12.50	1667	51.00	15.00	2000	59.50	17.50	2333	68.0	20.0	2667
41	34.85	10.25	1436	43.56	12.81	1795	52.28	15.38	2154	60.99	17.94	2513	69.7	20.5	2872
42	35.70	10.50	1544	44.63	13.13	1929	53.55	15.75	2315	62.48	18.38	2701	71.4	21.0	3087
43	36.55	10.75	1656	45.69	13.44	2071	54.83	16.13	2485	63.96	18.81	2899	73.1	21.5	3313
44	37.40	11.00	1775	46.75	13.75	2218	56.10	16.50	2662	65.45	19.25	3106	74.8	22.0	3549
45	38.25	11.25	1898	47.81	14.06	2373	57.38	16.88	2848	66.94	19.69	3322	76.5	22.5	3797
46	39.10	11.50	2028	48.88	14.38	2535	58.65	17.25	3042	68.43	20.13	3549	78.2	23.0	4056
47	39.95	11.75	2163	49.94	14.69	2704	59.93	17.63	3245	69.91	20.56	3785	79.9	23.5	4326
48	40.80	12.00	2304	51.00	15.00	2880	61.20	18.00	3456	71.40	21.00	4032	81.6	24.0	4608
49	41.65	12.25	2451	52.1	15.31	3064	62.5	18.38	3677	72.9	21.44	4289	83.3	24.5	4902
50	42.50	12.50	2604	53.1	15.63	3255	63.8	18.75	3906	74.4	21.88	4557	85.0	25.0	5208
51	43.35	12.75	2764	54.2	15.94	3454	65.0	19.13	4145	75.9	22.31	4836	86.7	25.5	5527
52	44.20	13.00	2929	55.3	16.25	3662	66.3	19.50	4394	77.4	22.75	5126	88.4	26.0	5859

# PLATES

## WEIGHTS, AREAS, AND MOMENTS OF INERTIA

$$I = \frac{tw^3}{12}$$

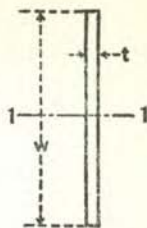

Width w In.	Thickness t, Inch														
	1/16			5/8			3/4			7/8			1		
	Wt. per Foot Lb.	Area In. <sup>2</sup>	I <sub>1-1</sub> In. <sup>4</sup>	Wt. per Foot Lb.	Area In. <sup>2</sup>	I <sub>1-1</sub> In. <sup>4</sup>	Wt. per Foot Lb.	Area In. <sup>2</sup>	I <sub>1-1</sub> In. <sup>4</sup>	Wt. per Foot Lb.	Area In. <sup>2</sup>	I <sub>1-1</sub> In. <sup>4</sup>	Wt. per Foot Lb.	Area In. <sup>2</sup>	I <sub>1-1</sub> In. <sup>4</sup>
6	11.48	3.375	10.1	12.75	3.750	11.3	15.30	4.500	13.5	17.85	5.250	15.8	20.4	6.0	18.0
7	13.39	3.938	16.1	14.88	4.375	17.9	17.85	5.250	21.4	20.83	6.125	25.0	23.8	7.0	28.6
8	15.30	4.500	24.0	17.00	5.000	26.7	20.40	6.000	32.0	23.80	7.000	37.3	27.2	8.0	42.7
9	17.21	5.063	34.2	19.13	5.625	38.0	22.95	6.750	45.6	26.78	7.875	53.2	30.6	9.0	60.8
10	19.13	5.625	46.9	21.25	6.250	52.1	25.50	7.500	62.5	29.75	8.750	72.9	34.0	10.0	83.3
11	21.04	6.188	62.4	23.38	6.875	69.3	28.05	8.250	83.2	32.73	9.625	97.1	37.4	11.0	111
12	22.95	6.750	81.0	25.50	7.500	90.0	30.60	9.000	108.0	35.70	10.500	126	40.8	12.0	144
13	24.86	7.313	103	27.63	8.125	114	33.15	9.750	137	38.68	11.38	160	44.2	13.0	183
14	26.78	7.875	129	29.75	8.750	143	35.70	10.500	172	41.65	12.25	200	47.6	14.0	229
15	28.69	8.438	158	31.88	9.375	176	38.25	11.25	211	44.63	13.13	246	51.0	15.0	281
16	30.60	9.000	192	34.00	10.000	213	40.80	12.000	256	47.60	14.000	299	54.4	16.0	341
17	32.51	9.563	230	36.13	10.63	256	43.35	12.75	307	50.58	14.88	358	57.8	17.0	409
18	34.43	10.13	273	38.25	11.25	304	45.90	13.500	365	53.55	15.75	425	61.2	18.0	486
19	36.34	10.69	322	40.38	11.88	357	48.45	14.25	429	56.53	16.63	500	64.6	19.0	572
20	38.25	11.25	375	42.50	12.500	417	51.00	15.000	500	59.50	17.500	583	68.0	20.0	667
21	40.16	11.81	434	44.63	13.13	482	53.55	15.75	579	62.48	18.38	675	71.4	21.0	772
22	42.08	12.38	499	46.75	13.75	555	56.10	16.500	666	65.45	19.25	776	74.8	22.0	887
23	43.99	12.94	570	48.88	14.38	634	58.65	17.25	760	68.43	20.13	887	78.2	23.0	1014
24	45.90	13.50	648	51.00	15.000	720	61.20	18.000	864	71.40	21.000	1008	81.6	24.0	1152
25	47.81	14.06	732	53.13	15.63	814	63.75	18.75	977	74.38	21.88	1139	85.0	25.0	1302
26	49.73	14.63	824	55.25	16.25	915	66.30	19.500	1099	77.35	22.75	1282	88.4	26.0	1465
27	51.64	15.19	923	57.38	16.88	1025	68.85	20.25	1230	80.33	23.63	1435	91.8	27.0	1640
28	53.55	15.75	1029	59.50	17.500	1143	71.40	21.000	1372	83.30	24.500	1601	95.2	28.0	1829
29	55.46	16.31	1143	61.63	18.13	1270	73.95	21.75	1524	86.28	25.38	1778	98.6	29.0	2032
30	57.38	16.88	1266	63.75	18.75	1406	76.50	22.500	1688	89.25	26.25	1969	102.0	30.0	2250
31	59.29	17.44	1397	65.88	19.38	1552	79.05	23.25	1862	92.23	27.13	2172	105.4	31.0	2483
32	61.20	18.00	1536	68.00	20.000	1707	81.60	24.000	2048	95.20	28.000	2389	108.8	32.0	2731
33	63.11	18.56	1685	70.13	20.63	1872	84.15	24.75	2246	98.18	28.88	2620	112.2	33.0	2995
34	65.03	19.13	1842	72.25	21.25	2047	86.70	25.500	2457	101.2	29.75	2866	115.6	34.0	3275
35	66.94	19.69	2010	74.38	21.88	2233	89.25	26.25	2680	104.1	30.63	3126	119.0	35.0	3573
36	68.85	20.25	2187	76.50	22.500	2430	91.80	27.000	2916	107.1	31.500	3402	122.4	36.0	3888
37	70.76	20.81	2374	78.63	23.13	2638	94.35	27.75	3166	110.1	32.38	3693	125.8	37.0	4221
38	72.68	21.38	2572	80.75	23.75	2858	96.90	28.500	3430	113.1	33.25	4001	129.2	38.0	4573
39	74.59	21.94	2781	82.88	24.38	3090	99.45	29.25	3707	116.0	34.13	4325	132.6	39.0	4943
40	76.50	22.500	3000	85.00	25.000	3333	102.0	30.000	4000	119.0	35.000	4667	136.0	40.0	5333
41	78.41	23.06	3231	87.13	25.63	3590	104.6	30.75	4308	122.0	35.88	5026	139.4	41.0	5743
42	80.33	23.63	3473	89.25	26.25	3859	107.1	31.500	4631	125.0	36.75	5402	142.8	42.0	6174
43	82.24	24.19	3727	91.38	26.88	4141	109.7	32.25	4969	127.9	37.63	5797	146.2	43.0	6626
44	84.15	24.75	3993	93.50	27.500	4437	112.2	33.000	5324	130.9	38.500	6211	149.6	44.0	7099
45	86.06	25.31	4272	95.63	28.13	4746	114.8	33.75	5695	133.9	39.38	6645	153.0	45.0	7594
46	87.98	25.88	4563	97.75	28.75	5070	117.3	34.500	6084	136.9	40.25	7097	156.4	46.0	8111
47	89.89	26.44	4867	99.88	29.38	5407	119.9	35.25	6489	139.8	41.13	7570	159.8	47.0	8652
48	91.80	27.00	5184	102.0	30.000	5760	122.4	36.000	6912	142.8	42.000	8064	163.2	48.0	9216
49	93.7	27.56	5515	104.1	30.63	6128	125.0	36.75	7353	145.8	42.88	8579	166.6	49.0	9804
50	95.6	28.13	5859	106.3	31.25	6510	127.5	37.500	7813	148.8	43.75	9115	170.0	50.0	10417
51	97.5	28.69	6218	108.4	31.88	6909	130.1	38.25	8291	151.7	44.63	9673	173.4	51.0	11054
52	99.5	29.25	6591	110.5	32.500	7323	132.6	39.000	8788	154.7	45.500	10253	176.8	52.0	11717

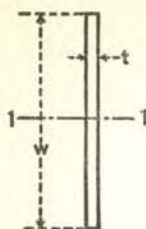

# PLATES

## WEIGHTS, AREAS, AND MOMENTS OF INERTIA

$$I = \frac{tw^3}{12}$$

Width w		Thickness t, Inch														
		1/4			5/16			3/8			7/16			1/2		
In.	Lb.	In. <sup>2</sup>	In. <sup>4</sup>	Lb.	In. <sup>2</sup>	In. <sup>4</sup>	Lb.	In. <sup>2</sup>	In. <sup>4</sup>	Lb.	In. <sup>2</sup>	In. <sup>4</sup>	Lb.	In. <sup>2</sup>	In. <sup>4</sup>	
53	45.05	13.25	3102	56.3	16.56	3877	67.6	19.88	4652	78.8	23.19	5428	90.1	26.5	6203	
54	45.90	13.50	3281	57.4	16.88	4101	68.9	20.25	4921	80.3	23.63	5741	91.8	27.0	6561	
55	46.75	13.75	3466	58.4	17.19	4333	70.1	20.63	5199	81.8	24.06	6066	93.5	27.5	6932	
56	47.60	14.00	3659	59.5	17.50	4573	71.4	21.00	5488	83.3	24.50	6403	95.2	28.0	7317	
57	48.45	14.25	3858	60.6	17.81	4823	72.7	21.38	5787	84.8	24.94	6752	96.9	28.5	7716	
58	49.30	14.50	4065	61.6	18.13	5081	74.0	21.75	6097	86.3	25.38	7114	98.6	29.0	8130	
59	50.15	14.75	4279	62.7	18.44	5348	75.2	22.13	6418	87.8	25.81	7488	100.3	29.5	8557	
60	51.00	15.00	4500	63.8	18.75	5625	76.5	22.50	6750	89.3	26.25	7875	102.0	30.0	9000	
62	52.70	15.50	4965	65.9	19.38	6207	79.1	23.25	7448	92.2	27.13	8689	105.4	31.0	9930	
64	54.40	16.00	5461	68.0	20.00	6827	81.6	24.00	8192	95.2	28.00	9557	108.8	32.0	10923	
66	56.10	16.50	5990	70.1	20.63	7487	84.2	24.75	8984	98.2	28.88	10482	112.2	33.0	11979	
68	57.80	17.00	6551	72.3	21.25	8188	86.7	25.50	9826	101.2	29.75	11464	115.6	34.0	13101	
70	59.50	17.50	7146	74.4	21.88	8932	89.3	26.25	10719	104.1	30.63	12505	119.0	35.0	14292	
72	61.20	18.00	7776	76.5	22.50	9720	91.8	27.00	11664	107.1	31.50	13608	122.4	36.0	15552	
74	62.90	18.50	8442	78.6	23.13	10553	94.4	27.75	12663	110.1	32.38	14774	125.8	37.0	16884	
76	64.60	19.00	9145	80.8	23.75	11432	96.9	28.50	13718	113.1	33.25	16004	129.2	38.0	18291	
78	66.30	19.50	9887	82.9	24.38	12358	99.5	29.25	14830	116.0	34.13	17301	132.6	39.0	19773	
80	68.00	20.00	10667	85.0	25.00	13333	102.0	30.00	16000	119.0	35.00	18667	136.0	40.0	21333	
82	69.70	20.50	11487	87.1	25.63	14359	104.6	30.75	17230	122.0	35.88	20102	139.4	41.0	22974	
84	71.40	21.00	12348	89.3	26.25	15435	107.1	31.50	18522	125.0	36.75	21609	142.8	42.0	24696	
86	73.10	21.50	13251	91.4	26.88	16564	109.7	32.25	19877	127.9	37.63	23190	146.2	43.0	26502	
88	74.80	22.00	14197	93.5	27.50	17747	112.2	33.00	21296	130.9	38.50	24845	149.6	44.0	28395	
90	76.50	22.50	15188	95.6	28.13	18984	114.8	33.75	22781	133.9	39.38	26578	153.0	45.0	30375	
92	78.20	23.00	16223	97.8	28.75	20278	117.3	34.50	24334	136.9	40.25	28390	156.4	46.0	32445	
94	79.90	23.50	17304	99.9	29.38	21630	119.9	35.25	25956	139.8	41.13	30282	159.8	47.0	34608	
96	81.60	24.00	18432	102.0	30.00	23040	122.4	36.00	27648	142.8	42.00	32256	163.2	48.0	36864	
98	83.30	24.50	19608	104.1	30.63	24510	125.0	36.75	29412	145.8	42.88	34314	166.6	49.0	39216	
100	85.00	25.00	20833	106.3	31.25	26042	127.5	37.50	31250	148.8	43.75	36458	170.0	50.0	41667	
102	86.70	25.50	22109	108.4	31.88	27636	130.1	38.25	33163	151.7	44.63	38690	173.4	51.0	44217	
104	88.40	26.00	23435	110.5	32.50	29293	132.6	39.00	35152	154.7	45.50	41011	176.8	52.0	46869	
106	90.10	26.50	24813	112.6	33.13	31016	135.2	39.75	37219	157.7	46.38	43423	180.2	53.0	49626	
108	91.80	27.00	26244	114.8	33.75	32805	137.7	40.50	39366	160.7	47.25	45927	183.6	54.0	52488	
110	93.50	27.50	27729	116.9	34.38	34661	140.3	41.25	41594	163.6	48.13	48526	187.0	55.0	55458	
112	95.20	28.00	29269	119.0	35.00	36587	142.8	42.00	43904	166.6	49.00	51221	190.4	56.0	58539	
114	96.90	28.50	30866	121.1	35.63	38582	145.4	42.75	46298	169.6	49.88	54105	193.8	57.0	61731	
116	98.60	29.00	32519	123.3	36.25	40648	147.9	43.50	48778	172.6	50.75	56908	197.2	58.0	65037	
118	100.3	29.50	34230	125.4	36.88	42787	150.5	44.25	51345	175.5	51.63	59902	200.6	59.0	68460	
120	102.0	30.00	36000	127.5	37.50	45000	153.0	45.00	54000	178.5	52.50	63000	204.0	60.0	72000	
122	103.7	30.50	37830	129.6	38.13	47288	155.6	45.75	56745	181.5	53.38	66203	207.4	61.0	75660	
124	105.4	31.00	39721	131.8	38.75	49652	158.1	46.50	59582	184.5	54.25	69512	210.8	62.0	79443	
128	108.8	32.00	43691	136.0	40.00	54613	163.2	48.00	65536	190.4	56.00	76459	217.6	64.0	87381	
132	112.2	33.00	47916	140.3	41.25	59895	168.3	49.50	71874	196.4	57.75	83853	224.4	66.0	95832	
136	115.6	34.00	52405	144.5	42.50	65507	173.4	51.00	78608	202.3	59.50	91709	231.2	68.0	104811	
140	119.0	35.00	57167	148.8	43.75	71458	178.5	52.50	85750	208.3	61.25	100042	238.0	70.0	114333	
144	.....	.....	.....	153.0	45.00	77760	183.6	54.00	93312	214.2	63.00	108864	244.8	72.0	124416	
148	.....	.....	.....	157.3	46.25	84422	188.7	55.50	101306	220.2	64.75	118190	251.6	74.0	135075	
152	.....	.....	.....	161.5	47.50	91453	193.8	57.00	109744	226.1	66.50	128035	258.4	76.0	146325	

# PLATES

## WEIGHTS, AREAS, AND MOMENTS OF INERTIA

$$I = \frac{tw^3}{12}$$

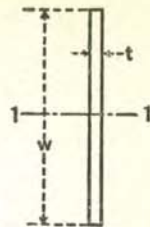

Width w	Thickness t, Inch														
	1/16			5/8			3/4			7/8			1		
	Wt. per Foot	Area	I <sub>1-1</sub>	Wt. per Foot	Area	I <sub>1-1</sub>	Wt. per Foot	Area	I <sub>1-1</sub>	Wt. per Foot	Area	I <sub>1-1</sub>	Wt. per Foot	Area	I <sub>1-1</sub>
In.	Lb.	In. <sup>2</sup>	In. <sup>4</sup>	Lb.	In. <sup>2</sup>	In. <sup>4</sup>	Lb.	In. <sup>2</sup>	In. <sup>4</sup>	Lb.	In. <sup>2</sup>	In. <sup>4</sup>	Lb.	In. <sup>2</sup>	In. <sup>4</sup>
53	101.4	29.81	6979	112.6	33.13	7754	135.2	39.75	9305	157.7	46.38	10856	180.2	53.0	12406
54	103.3	30.38	7381	114.8	33.75	8201	137.7	40.50	9842	160.7	47.25	11482	183.6	54.0	13122
55	105.2	30.94	7799	116.9	34.38	8665	140.3	41.25	10398	163.6	48.13	12132	187.0	55.0	13865
56	107.1	31.50	8232	119.0	35.00	9147	142.8	42.00	10976	166.6	49.00	12805	190.4	56.0	14635
57	109.0	32.06	8681	121.1	35.63	9646	145.4	42.75	11575	169.6	49.88	13504	193.8	57.0	15433
58	110.9	32.63	9146	123.3	36.25	10162	147.9	43.50	12195	172.6	50.75	14227	197.2	58.0	16259
59	112.8	33.19	9627	125.4	36.88	10697	150.5	44.25	12836	175.5	51.63	14976	200.6	59.0	17115
60	114.8	33.75	10125	127.5	37.50	11250	153.0	45.00	13500	178.5	52.50	15750	204.0	60.0	18000
62	118.6	34.88	11172	131.8	38.75	12413	158.1	46.50	14896	184.5	54.25	17378	210.8	62.0	19861
64	122.4	36.00	12288	136.0	40.00	13653	163.2	48.00	16384	190.4	56.00	19115	217.6	64.0	21845
66	126.2	37.13	13476	140.3	41.25	14974	168.3	49.50	17969	196.4	57.75	20963	224.4	66.0	23958
68	130.1	38.25	14739	144.5	42.50	16377	173.4	51.00	19652	202.3	59.50	22927	231.2	68.0	26203
70	133.9	39.38	16078	148.8	43.75	17865	178.5	52.50	21438	208.3	61.25	25010	238.0	70.0	28583
72	137.7	40.50	17496	153.0	45.00	19440	183.6	54.00	23328	214.2	63.00	27216	244.8	72.0	31104
74	141.5	41.63	18995	157.3	46.25	21105	188.7	55.50	25327	220.2	64.75	29548	251.6	74.0	33769
76	145.4	42.75	20577	161.5	47.50	22863	193.8	57.00	27436	226.1	66.50	32009	258.4	76.0	36581
78	149.2	43.88	22245	165.8	48.75	24716	198.9	58.50	29660	232.1	68.25	34603	265.2	78.0	39546
80	153.0	45.00	24000	170.0	50.00	26667	204.0	60.00	32000	238.0	70.00	37333	272.0	80.0	42667
82	156.8	46.13	25845	174.3	51.25	28717	209.1	61.50	34461	244.0	71.75	40204	278.8	82.0	45947
84	160.7	47.25	27783	178.5	52.50	30870	214.2	63.00	37044	249.9	73.50	43218	285.6	84.0	49392
86	164.5	48.38	29815	182.8	53.75	33128	219.3	64.50	39754	255.9	75.25	46379	292.4	86.0	53005
88	168.3	49.50	31944	187.0	55.00	35493	224.4	66.00	42592	261.8	77.00	49691	299.2	88.0	56789
90	172.1	50.63	34172	191.3	56.25	37969	229.5	67.50	45563	267.8	78.75	53156	306.0	90.0	60750
92	176.0	51.75	36501	195.5	57.50	40557	234.6	69.00	48668	273.7	80.50	56779	312.8	92.0	64891
94	179.8	52.88	38934	199.8	58.75	43260	239.7	70.50	51912	279.7	82.25	60563	319.6	94.0	69215
96	183.6	54.00	41472	204.0	60.00	46080	244.8	72.00	55296	285.6	84.00	64512	326.4	96.0	73728
98	187.4	55.13	44118	208.3	61.25	49020	249.9	73.50	58825	291.6	85.75	68629	333.2	98.0	78433
100	191.3	56.25	46875	212.5	62.50	52083	255.0	75.00	62500	297.5	87.50	72917	340.0	100	83333
102	195.1	57.38	49744	216.8	63.75	55271	260.1	76.50	66326	303.5	89.25	77380	346.8	102	88434
104	198.9	58.50	52728	221.0	65.00	58587	265.2	78.00	70304	309.4	91.00	82021	353.6	104	93739
106	202.7	59.63	55829	225.3	66.25	62032	270.3	79.50	74439	315.4	92.75	86845	360.4	106	99251
108	206.6	60.75	59049	229.5	67.50	65610	275.4	81.00	78732	321.3	94.50	91854	367.2	108	104976
110	210.4	61.88	62391	233.8	68.75	69323	280.5	82.50	83188	327.3	96.25	97052	374.0	110	110917
112	214.2	63.00	65856	238.0	70.00	73173	285.6	84.00	87808	333.2	98.00	102443	380.8	112	117077
114	218.0	64.13	69447	242.3	71.25	77164	290.7	85.50	92597	339.2	99.75	108029	387.6	114	123462
116	221.9	65.25	73167	246.5	72.50	81297	295.8	87.00	97556	345.1	101.5	113815	394.4	116	130075
118	225.7	66.38	77017	250.8	73.75	85575	300.9	88.50	102690	351.1	103.3	119804	401.2	118	136919
120	229.5	67.50	81000	255.0	75.00	90000	306.0	90.00	108000	357.0	105.0	126000	408.0	120	144000
122	233.3	68.63	85118	259.3	76.25	94575	311.1	91.50	113491	363.0	106.8	132406	414.8	122	151321
124	237.2	69.75	89373	263.5	77.50	99303	316.2	93.00	119164	368.9	108.5	139025	422.5	124	158885
126	241.8	72.00	98304	272.0	80.00	109227	326.4	96.00	131072	380.8	112.0	152917	435.2	128	174763
132	252.5	74.25	107811	280.5	82.50	119790	336.6	99.00	143748	392.7	115.5	167706	448.8	132	191664
136	260.1	76.50	117912	289.0	85.00	131013	346.8	102.0	157216	404.6	119.0	183419	462.4	136	209621
140	267.8	78.75	128625	297.5	87.50	142917	357.0	105.0	171500	416.5	122.5	200083	476.0	140	228667
144	275.4	81.00	139968	306.0	90.00	155520	367.2	108.0	186624	428.4	126.0	217728	489.6	144	248832
148	283.1	83.25	151959	314.5	92.50	168843	377.4	111.0	202612	440.3	129.5	236381	503.2	148	270149
152	290.7	85.50	164616	323.0	95.00	182907	387.6	114.0	219488	452.2	133.0	256069	516.8	152	292651





# ROUND BARS

## WEIGHTS, AREAS, AND PROPERTIES

$$I = .049087 d^4$$

$$S = .098175 d^3$$

$$r = \frac{d}{4}$$

Diam-eter d	Weight per Foot	Area of Section	Properties			Polar Moment of Inertia PI	Diam-eter d	Weight per Foot	Area of Section	Properties			Polar Moment of Inertia PI
			I	S	r					I	S	r	
In.	Lb.	In. <sup>2</sup>	In. <sup>4</sup>	In. <sup>3</sup>	In.	In. <sup>4</sup>	In.	Lb.	In. <sup>2</sup>	In. <sup>4</sup>	In. <sup>3</sup>	In.	In. <sup>4</sup>
0							0						
1/4	.167	.0491	.00019	.00153	.0625	.00038	3/4	1.502	.4418	.0155	.0414	.188	.0311
17/64	.188	.0554	.00024	.00184	.0664	.00048	49/64	1.565	.4604	.0169	.0441	.191	.0337
9/32	.211	.0621	.00031	.00218	.0703	.00061	25/32	1.630	.4794	.0183	.0468	.195	.0366
19/64	.235	.0692	.00038	.00257	.0742	.00076	51/64	1.696	.4987	.0198	.0497	.199	.0396
5/16	.261	.0767	.00047	.00300	.0781	.00094	13/16	1.763	.5185	.0214	.0527	.203	.0428
21/64	.288	.0846	.00057	.00347	.0820	.00114	53/64	1.831	.5386	.0231	.0558	.207	.0462
11/32	.316	.0928	.00069	.00399	.0859	.00137	17/32	1.901	.5591	.0249	.0590	.211	.0498
23/64	.345	.1014	.00082	.00456	.0898	.00164	55/64	1.972	.5800	.0268	.0623	.215	.0536
3/8	.376	.1104	.00097	.00518	.0938	.00194	7/8	2.044	.6013	.0288	.0658	.219	.0576
25/64	.407	.1198	.00114	.00585	.0977	.00229	57/64	2.118	.6230	.0309	.0694	.223	.0618
13/32	.441	.1296	.00134	.00658	.102	.00267	29/32	2.193	.6450	.0331	.0731	.227	.0662
27/64	.475	.1398	.00156	.00737	.106	.00311	59/64	2.270	.6675	.0355	.0769	.231	.0709
7/16	.511	.1503	.00180	.00822	.109	.00360	15/16	2.347	.6903	.0379	.0809	.234	.0758
29/64	.548	.1613	.00207	.00913	.113	.00414	61/64	2.426	.7135	.0405	.0850	.238	.0810
15/32	.587	.1726	.00237	.0101	.117	.00474	31/32	2.506	.7371	.0432	.0893	.242	.0865
31/64	.627	.1843	.00270	.0112	.121	.00540	63/64	2.587	.7610	.0461	.0936	.246	.0922
1/2	.668	.1963	.00307	.0123	.125	.00614	1	2.670	.7854	.0491	.0982	.250	.0982
33/64	.710	.2088	.00347	.0135	.129	.00694	1/64	2.754	.8101	.0522	.103	.254	.104
17/32	.754	.2217	.00391	.0147	.133	.00782	1/32	2.840	.8353	.0555	.108	.258	.111
35/64	.799	.2349	.00439	.0161	.137	.00878	3/64	2.927	.8608	.0590	.113	.262	.118
9/16	.845	.2485	.00491	.0175	.141	.00983	1/16	3.014	.8866	.0626	.118	.266	.125
37/64	.893	.2625	.00548	.0190	.145	.0110	5/64	3.104	.9129	.0663	.123	.270	.133
19/32	.941	.2769	.00610	.0206	.148	.0122	3/32	3.194	.9396	.0703	.128	.273	.141
39/64	.992	.2916	.00677	.0222	.152	.0135	7/64	3.286	.9666	.0744	.134	.277	.149
5/8	1.043	.3068	.00749	.0240	.156	.0150	1/8	3.379	.9940	.0786	.140	.281	.157
41/64	1.096	.3223	.00827	.0258	.160	.0165	9/64	3.474	1.0218	.0831	.146	.285	.166
21/32	1.150	.3382	.00910	.0278	.164	.0182	5/32	3.570	1.0500	.0877	.152	.289	.175
43/64	1.205	.3545	.0100	.0298	.168	.0200	11/64	3.667	1.0786	.0926	.158	.293	.185
11/16	1.262	.3712	.0110	.0319	.172	.0219	3/16	3.766	1.1075	.0976	.164	.297	.195
45/64	1.320	.3883	.0120	.0341	.176	.0240	13/64	3.865	1.1369	.103	.171	.301	.206
23/32	1.379	.4057	.0131	.0365	.180	.0262	7/32	3.966	1.1666	.108	.178	.305	.217
47/64	1.440	.4236	.0143	.0389	.184	.0286	15/64	4.069	1.1967	.114	.185	.309	.228

# ROUND BARS

## WEIGHTS, AREAS, AND PROPERTIES

$$I = .049087 d^4$$

$$S = .098175 d^3$$

$$r = \frac{d}{4}$$

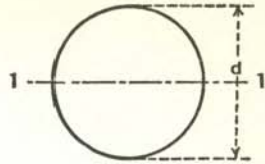

Diameter d	Weight per Foot	Area of Section	Properties			Polar Moment of Inertia PI	Diameter d	Weight per Foot	Area of Section	Properties			Polar Moment of Inertia PI
			I	S	r					I	S	r	
In.	Lb.	In. <sup>2</sup>	In. <sup>4</sup>	In. <sup>3</sup>	In.	In. <sup>4</sup>	In.	Lb.	In. <sup>2</sup>	In. <sup>4</sup>	In. <sup>3</sup>	In.	In. <sup>4</sup>
1							1						
1/4	4.173	1.227	.120	.192	.313	.240	3/4	8.178	2.405	.460	.526	.438	.921
17/64	4.277	1.258	.126	.199	.316	.252	49/64	8.325	2.448	.477	.540	.441	.954
9/32	4.384	1.289	.132	.206	.320	.265	25/32	8.473	2.492	.494	.555	.445	.988
19/64	4.491	1.321	.139	.214	.324	.278	51/64	8.622	2.536	.512	.570	.449	1.023
5/16	4.600	1.353	.146	.222	.328	.291	13/16	8.773	2.580	.530	.585	.453	1.060
21/64	4.710	1.385	.153	.230	.332	.305	53/64	8.924	2.625	.548	.600	.457	1.097
11/32	4.822	1.418	.160	.238	.336	.320	27/32	9.078	2.670	.567	.615	.461	1.135
23/64	4.935	1.451	.168	.247	.340	.335	55/64	9.232	2.715	.587	.631	.465	1.173
3/8	5.049	1.485	.175	.255	.344	.351	7/8	9.388	2.761	.607	.647	.469	1.213
25/64	5.164	1.519	.184	.264	.348	.367	57/64	9.545	2.807	.627	.663	.473	1.254
13/32	5.281	1.553	.192	.273	.352	.384	29/32	9.704	2.854	.648	.680	.477	1.296
27/64	5.399	1.588	.201	.282	.356	.401	59/64	9.863	2.901	.670	.697	.481	1.339
7/16	5.518	1.623	.210	.292	.359	.419	15/16	10.024	2.948	.692	.714	.484	1.383
29/64	5.639	1.658	.219	.301	.363	.438	61/64	10.187	2.996	.714	.731	.488	1.429
15/32	5.761	1.694	.228	.311	.367	.457	31/32	10.350	3.044	.737	.749	.492	1.475
31/64	5.884	1.731	.238	.321	.371	.477	63/64	10.515	3.093	.761	.767	.496	1.522
1/2	6.008	1.767	.249	.331	.375	.497	2	10.681	3.142	.785	.785	.500	1.571
33/64	6.134	1.804	.259	.342	.379	.518	1/64	10.849	3.191	.810	.804	.504	1.620
17/32	6.261	1.842	.270	.352	.383	.540	1/32	11.018	3.241	.836	.823	.508	1.671
35/64	6.390	1.879	.281	.363	.387	.562	3/64	11.188	3.291	.862	.842	.512	1.723
9/16	6.520	1.918	.293	.375	.391	.585	1/16	11.359	3.341	.888	.861	.516	1.777
37/64	6.650	1.956	.304	.386	.395	.609	5/64	11.532	3.392	.916	.881	.520	1.831
19/32	6.783	1.995	.317	.397	.398	.633	3/32	11.706	3.443	.943	.901	.523	1.887
39/64	6.916	2.034	.329	.409	.402	.659	7/64	11.882	3.495	.972	.921	.527	1.944
5/8	7.051	2.074	.342	.421	.406	.685	1/8	12.058	3.547	1.001	.942	.531	2.002
41/64	7.188	2.114	.356	.434	.410	.711	9/64	12.236	3.599	1.031	.963	.535	2.061
21/32	7.325	2.155	.369	.446	.414	.739	5/32	12.416	3.652	1.061	.984	.539	2.122
43/64	7.464	2.195	.384	.459	.418	.767	11/64	12.596	3.705	1.092	1.006	.543	2.184
11/16	7.604	2.237	.398	.472	.422	.796	3/16	12.778	3.758	1.124	1.028	.547	2.248
45/64	7.746	2.278	.413	.485	.426	.826	13/64	12.961	3.812	1.156	1.050	.551	2.313
23/32	7.889	2.320	.428	.498	.430	.857	7/32	13.146	3.866	1.190	1.072	.555	2.379
47/64	8.033	2.363	.444	.512	.434	.888	15/64	13.332	3.921	1.223	1.095	.559	2.447

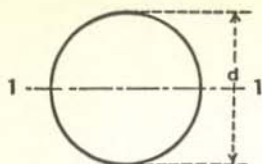

# ROUND BARS

## WEIGHTS, AREAS, AND PROPERTIES

$$I = .049087 d^4$$

$$S = .098175 d^3$$

$$r = \frac{d}{4}$$

Diameter d	Weight per Foot	Area of Section	Properties			Polar Mo- ment of Inertia PI	Diameter d	Weight per Foot	Area of Section	Properties			Polar Mo- ment of Inertia PI
			I	S	r					I	S	r	
In.	Lb.	In. <sup>2</sup>	In. <sup>4</sup>	In. <sup>3</sup>	In.	In. <sup>4</sup>	In.	Lb.	In. <sup>2</sup>	In. <sup>4</sup>	In. <sup>3</sup>	In.	In. <sup>4</sup>
2							2						
1/4	13.519	3.976	1.258	1.118	.563	2.516	3/4	20.195	5.940	2.807	2.042	.688	5.615
17/64	13.707	4.032	1.293	1.142	.566	2.587	49/64	20.425	6.007	2.872	2.077	.691	5.743
9/32	13.897	4.087	1.329	1.166	.570	2.659	25/32	20.656	6.075	2.937	2.112	.695	5.874
19/64	14.088	4.144	1.366	1.190	.574	2.732	51/64	20.889	6.144	3.004	2.148	.699	6.007
5/16	14.280	4.200	1.404	1.214	.578	2.808	15/16	21.123	6.213	3.071	2.184	.703	6.143
21/64	14.474	4.257	1.442	1.239	.582	2.884	53/64	21.358	6.282	3.140	2.221	.707	6.281
11/32	14.669	4.314	1.481	1.264	.586	2.962	27/32	21.595	6.351	3.210	2.258	.711	6.420
23/64	14.865	4.372	1.521	1.289	.590	3.042	55/64	21.833	6.421	3.281	2.295	.715	6.563
3/8	15.062	4.430	1.562	1.315	.594	3.124	7/8	22.072	6.492	3.354	2.333	.719	6.707
25/64	15.261	4.489	1.603	1.341	.598	3.207	57/64	22.313	6.563	3.427	2.371	.723	6.854
13/32	15.461	4.548	1.646	1.368	.602	3.291	29/32	22.555	6.634	3.502	2.410	.727	7.004
27/64	15.663	4.607	1.689	1.395	.606	3.378	59/64	22.798	6.705	3.578	2.449	.731	7.156
7/16	15.866	4.666	1.733	1.422	.609	3.466	15/16	23.042	6.777	3.655	2.488	.734	7.310
29/64	16.070	4.726	1.778	1.449	.613	3.555	61/64	23.288	6.849	3.733	2.528	.738	7.467
15/32	16.275	4.787	1.823	1.477	.617	3.647	31/32	23.535	6.922	3.813	2.569	.742	7.626
31/64	16.482	4.848	1.870	1.505	.621	3.740	63/64	23.783	6.995	3.894	2.610	.746	7.788
1/2	16.690	4.909	1.917	1.534	.625	3.835	3	24.033	7.069	3.976	2.651	.750	7.952
33/64	16.899	4.970	1.966	1.563	.629	3.932	1/16	25.045	7.366	4.318	2.820	.766	8.636
17/32	17.110	5.032	2.015	1.592	.633	4.030	1/8	26.078	7.670	4.681	2.996	.781	9.363
35/64	17.321	5.095	2.065	1.622	.637	4.131	3/16	27.131	7.980	5.067	3.179	.797	10.13
9/16	17.535	5.157	2.117	1.652	.641	4.233	1/4	28.206	8.296	5.477	3.370	.813	10.95
37/64	17.749	5.220	2.169	1.682	.645	4.337	5/16	29.301	8.618	5.910	3.568	.828	11.82
19/32	17.965	5.284	2.222	1.713	.648	4.443	3/8	30.417	8.946	6.369	3.774	.844	12.74
39/64	18.182	5.348	2.276	1.744	.652	4.551	7/16	31.554	9.281	6.854	3.988	.859	13.71
5/8	18.400	5.412	2.331	1.776	.656	4.661	1/2	32.71	9.621	7.366	4.209	.875	14.73
41/64	18.620	5.477	2.387	1.808	.660	4.773	9/16	33.89	9.968	7.907	4.439	.891	15.81
21/32	18.841	5.542	2.444	1.840	.664	4.887	5/8	35.09	10.321	8.476	4.677	.906	16.95
43/64	19.063	5.607	2.502	1.873	.668	5.003	11/16	36.31	10.680	9.076	4.923	.922	18.15
11/16	19.287	5.673	2.561	1.906	.672	5.121	3/4	37.55	11.045	9.707	5.177	.938	19.41
45/64	19.512	5.739	2.621	1.939	.676	5.242	13/16	38.81	11.416	10.37	5.440	.953	20.74
23/32	19.738	5.805	2.682	1.973	.680	5.364	7/8	40.10	11.793	11.07	5.712	.969	22.14
47/64	19.966	5.872	2.744	2.007	.684	5.488	15/16	41.40	12.177	11.80	5.993	.984	23.60

# ROUND BARS

## WEIGHTS, AREAS, AND PROPERTIES

$$I = .049087 d^4$$

$$S = .098175 d^3$$

$$r = \frac{d}{4}$$

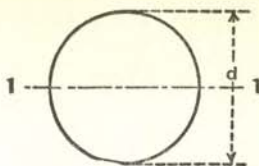

Diameter d	Weight per Foot	Area of Section	Properties			Polar Mo- ment of Inertia PI	Diam- eter d	Weight per Foot	Area of Section	Properties			Polar Mo- ment of Inertia PI
			I	S	r					I	S	r	
In.	Lb.	In. <sup>2</sup>	In. <sup>4</sup>	In. <sup>3</sup>	In.	In. <sup>4</sup>	In.	Lb.	In. <sup>2</sup>	In. <sup>4</sup>	In. <sup>3</sup>	In.	In. <sup>4</sup>
4	42.73	12.566	12.57	6.283	1.000	25.13	6	121.67	35.785	101.9	30.19	1.688	203.8
1/16	44.07	12.962	13.37	6.582	1.016	26.74	7/8	126.22	37.122	109.7	31.90	1.719	219.3
1/8	45.44	13.364	14.21	6.891	1.031	28.42	7	130.85	38.485	117.9	33.67	1.750	235.7
3/16	46.83	13.772	15.09	7.209	1.047	30.19	1/8	135.56	39.871	126.5	35.51	1.781	253.0
1/4	48.23	14.186	16.02	7.536	1.063	32.03	3/4	140.36	41.282	135.6	37.41	1.813	271.2
5/16	49.66	14.607	16.98	7.874	1.078	33.96	3/8	145.24	42.718	145.2	39.38	1.844	290.4
3/8	51.11	15.033	17.98	8.221	1.094	35.97	1/2	150.21	44.179	155.3	41.42	1.875	310.6
7/16	52.58	15.466	19.03	8.579	1.109	38.07	5/8	155.26	45.664	165.9	43.52	1.906	331.9
1/2	54.08	15.904	20.13	8.946	1.125	40.26	3/4	160.39	47.173	177.1	45.70	1.938	354.2
9/16	55.59	16.349	21.27	9.324	1.141	42.54	7/8	165.60	48.707	188.8	47.95	1.969	377.6
5/8	57.12	16.800	22.46	9.713	1.156	44.92	8	170.90	50.266	201.1	50.27	2.000	402.1
11/16	58.68	17.257	23.70	10.11	1.172	47.40							
3/4	60.25	17.721	24.99	10.52	1.188	49.98							
13/16	61.85	18.190	26.33	10.94	1.203	52.66							
7/8	63.46	18.665	27.72	11.37	1.219	55.45							
15/16	65.10	19.147	29.17	11.82	1.234	58.35							
5	66.76	19.635	30.68	12.27	1.250	61.36							
1/16	68.44	20.129	32.24	12.74	1.266	64.49							
1/8	70.14	20.629	33.86	13.22	1.281	67.73							
3/16	71.86	21.135	35.55	13.70	1.297	71.09							
1/4	73.60	21.648	37.29	14.21	1.313	74.58							
5/16	77.15	22.691	40.97	15.25	1.344	81.94							
1/2	80.78	23.758	44.92	16.33	1.375	89.84							
5/8	84.49	24.850	49.14	17.47	1.406	98.29							
3/4	88.29	25.967	53.66	18.66	1.438	107.32							
7/8	92.17	27.109	58.48	19.91	1.469	116.96							
6	96.13	28.274	63.62	21.21	1.500	127.24							
1/8	100.18	29.465	69.09	22.56	1.531	138.17							
1/4	104.31	30.680	74.90	23.97	1.563	149.80							
3/8	108.52	31.919	81.08	25.44	1.594	162.15							
1/2	112.82	33.183	87.62	26.96	1.625	175.25							
5/8	117.20	34.472	94.56	28.55	1.656	189.12							

# SQUARE BARS

## WEIGHTS, AREAS, AND PROPERTIES

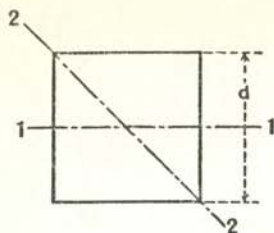

$$I \text{ axis 1-1 and 2-2} = \frac{d^4}{12} = .08333 d^4$$

$$S \text{ axis 1-1} = \frac{d^3}{6} = .166667 d^3$$

$$S \text{ axis 2-2} = \frac{d^3}{6\sqrt{2}} = .117851 d^3$$

$$r \text{ axis 1-1 and 2-2} = \frac{d}{\sqrt{12}} = .288675 d$$

Size d	Weight per Foot	Area of Section A	AXIS 1-1		AXIS 2-2		Polar Moment of Inertia $PI = \frac{d^4}{6}$
			I	S	S	r	
In.	Lb.	In. <sup>2</sup>	In. <sup>4</sup>	In. <sup>3</sup>	In. <sup>3</sup>	In.	In. <sup>4</sup>
0							
$\frac{1}{4}$	.213	.0625	.00033	.00260	.00184	.0722	.00066
$\frac{9}{32}$	.269	.0791	.00052	.00371	.00262	.0812	.00104
$\frac{3}{16}$	.332	.0977	.00079	.00509	.00360	.0902	.00158
$\frac{11}{32}$	.402	.1182	.00116	.00677	.00479	.0992	.00232
$\frac{3}{8}$	.478	.1406	.00165	.00879	.00621	.108	.00330
$\frac{13}{32}$	.561	.1650	.00227	.0112	.00790	.117	.00454
$\frac{7}{16}$	.651	.1914	.00305	.0140	.00987	.126	.00610
$\frac{15}{32}$	.747	.2197	.00402	.0172	.0121	.135	.00804
$\frac{1}{2}$	.850	.2500	.00521	.0208	.0147	.144	.0104
$\frac{17}{32}$	.960	.2822	.00664	.0250	.0177	.153	.0133
$\frac{9}{16}$	1.076	.3164	.00834	.0297	.0210	.162	.0167
$\frac{19}{32}$	1.199	.3525	.01036	.0349	.0247	.171	.0207
$\frac{5}{8}$	1.328	.3906	.0127	.0407	.0288	.180	.0254
$\frac{21}{32}$	1.464	.4307	.0155	.0471	.0333	.189	.0309
$\frac{11}{16}$	1.607	.4727	.0186	.0542	.0383	.199	.0372
$\frac{23}{32}$	1.756	.5166	.0222	.0619	.0438	.208	.0445
$\frac{3}{4}$	1.913	.5625	.0264	.0703	.0497	.217	.0527
$\frac{25}{32}$	2.075	.6104	.0310	.0795	.0562	.226	.0621
$\frac{13}{16}$	2.245	.6602	.0363	.0894	.0632	.235	.0726
$\frac{27}{32}$	2.420	.7119	.0422	.100	.0708	.244	.0845
$\frac{7}{8}$	2.603	.7656	.0489	.112	.0790	.253	.0977
$\frac{29}{32}$	2.792	.8213	.0562	.124	.0877	.262	.112
$\frac{15}{16}$	2.988	.8789	.0644	.137	.0971	.271	.129
$\frac{31}{32}$	3.191	.9385	.0734	.152	.107	.280	.147
1	3.400	1.0000	.0833	.167	.118	.289	.167
$\frac{1}{16}$	3.838	1.1289	.106	.200	.141	.307	.212
$\frac{1}{8}$	4.303	1.2656	.133	.237	.168	.325	.267
$\frac{3}{16}$	4.795	1.4102	.166	.279	.197	.343	.331

# SQUARE BARS

## WEIGHTS, AREAS, AND PROPERTIES

$$I \text{ axis } 1=1 \text{ and } 2-2 = \frac{d^4}{12} = .08333 d^4$$

$$S \text{ axis } 1=1 = \frac{d^3}{6} = .166667 d^3$$

$$S \text{ axis } 2=2 = \frac{d^3}{6\sqrt{2}} = .117851 d^3$$

$$r \text{ axis } 1=1 \text{ and } 2=2 = \frac{d}{\sqrt{12}} = .288675 d$$

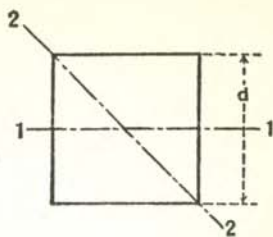

Size d	Weight per Foot	Area of Section A	AXIS 1-1		AXIS 2-2		Polar Moment of Inertia PI = $\frac{d^4}{6}$
			I	S	S	r	
In.	Lbs.	In. <sup>2</sup>	In. <sup>4</sup>	In. <sup>3</sup>	In. <sup>3</sup>	In.	In. <sup>4</sup>
1							
1/4	5.313	1.5625	.203	.326	.230	.361	.407
5/16	5.857	1.7227	.247	.377	.266	.379	.495
3/8	6.428	1.8906	.298	.433	.306	.397	.596
7/16	7.026	2.0664	.356	.495	.350	.415	.712
1/2	7.650	2.2500	.422	.563	.398	.433	.844
9/16	8.301	2.4414	.497	.636	.450	.451	.993
5/8	8.978	2.6406	.581	.715	.506	.469	1.162
11/16	9.682	2.8477	.676	.801	.566	.487	1.352
3/4	10.413	3.0625	.782	.893	.632	.505	1.563
13/16	11.170	3.2852	.899	.992	.702	.523	1.799
7/8	11.953	3.5156	1.030	1.099	.777	.541	2.060
15/16	12.763	3.7539	1.174	1.212	.857	.559	2.349
2	13.600	4.0000	1.333	1.333	.943	.577	2.667
1/16	14.463	4.2539	1.508	1.462	1.034	.595	3.016
1/8	15.353	4.5156	1.699	1.599	1.131	.613	3.398
3/16	16.270	4.7852	1.908	1.745	1.234	.632	3.816
1/4	17.213	5.0625	2.136	1.898	1.342	.650	4.271
5/16	18.182	5.3477	2.383	2.061	1.457	.668	4.766
3/8	19.178	5.6406	2.651	2.233	1.579	.686	5.303
7/16	20.201	5.9414	2.942	2.414	1.707	.704	5.883
1/2	21.250	6.2500	3.255	2.604	1.841	.722	6.510
9/16	22.326	6.5664	3.593	2.804	1.983	.740	7.186
5/8	23.428	6.8906	3.957	3.015	2.132	.758	7.913
11/16	24.557	7.2227	4.347	3.235	2.288	.776	8.694
3/4	25.713	7.5625	4.766	3.466	2.451	.794	9.532
13/16	26.895	7.9102	5.214	3.708	2.622	.812	10.428
7/8	28.103	8.2656	5.693	3.961	2.801	.830	11.387
15/16	29.338	8.6289	6.205	4.225	2.987	.848	12.410
3	30.600	9.0000	6.750	4.500	3.182	.866	13.500

# CRANE RAILS

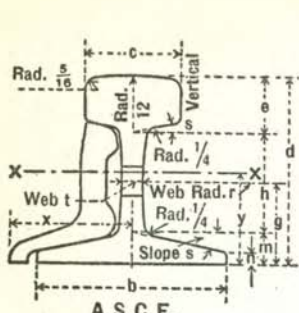

A.S.C.E.

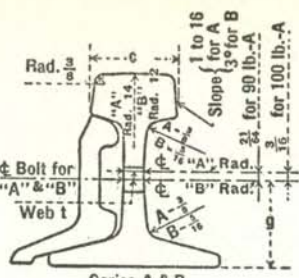

Series A & B  
A.R.A.

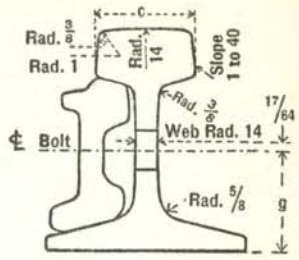

A.R.E.A.-100 lb.

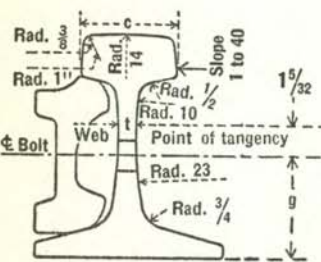

A.R.E.A.-131 lb.

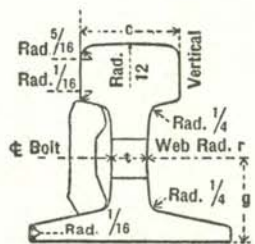

C.I.S. 105 lb.

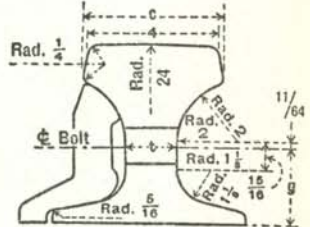

C.I.S. 175 lb.

District Rolled	Weight per Yd. and Type	Section Index	Dimensions, Inches											Properties			
			Depth	Base Width	Minimum Web	Web Radius	Head Width	Head Depth	Web Depth	Base Thickness		Slope	Gage	Gross Area	Axis x-x		
										m	n				I	S	N.A. from base y
d	b	t	r	c	e	h	m	n	a	g	In. <sup>2</sup>	In. <sup>4</sup>	In. <sup>3</sup>	In.			
P.C.B.	30 lb. A.S.C.E.	3040	3 1/8	3 1/8	2 1/64	12	1 1/16	7/8	1 3/32	17/32	1 1/64	13°	1 25/64	3.00	4.1	2.5	1.52
P.C.	40 lb. A.S.C.E.	4040	3 1/2	3 1/2	2 5/64	12	1 7/8	1 1/64	1 55/64	5/8	7/32	13°	1 7 1/2 128	3.94	6.6	3.6	1.68
P.C.B.	50 lb. A.S.C.E.	5040	3 7/8	3 7/8	7/16	12	2 1/8	1 1/8	2 1/16	1 1/16	1 5/64	13°	1 23 3/32	4.87	9.9	5.0	1.88
P.C.B.	60 lb. A.S.C.E.	6040	4 1/4	4 1/4	3 1/64	12	2 3/8	1 1/32	2 1/4	49/64	9/32	13°	1 11 5/128	5.93	14.6	6.6	2.05
P.C.	70 lb. A.S.C.E.	7040	4 5/8	4 5/8	3 3/64	12	2 7/16	1 11/32	2 19/32	13/16	9/32	13°	2 3/64	6.81	19.7	8.2	2.22
C.	80 lb. A.R.A.-B.	8030	4 15/16	4 7/16	3 5/64	12	2 7/16	1 11/32	2 15/32	1	31/64	13°	2 15/64	7.91	25.1	9.4	2.27
P.C.B.	80 lb. A.S.C.E.	8040	5	5	3 5/64	12	2 1/2	1 1/2	2 5/8	7/8	1 9/64	13°	2 3/16	7.86	26.4	10.1	2.38
P.C.B.	85 lb. A.S.C.E.	8540	5 3/8	5 3/8	9/16	12	2 9/16	1 35/64	2 3/4	57/64	1 9/64	13°	2 17/64	8.33	30.1	11.1	2.47
P.C.B.	90 lb. A.R.A.-A.	9020	5 5/8	5 1/8	9/16	14	2 9/16	1 15/32	3 3/32	1	23/64	14°	2 37/64	8.82	38.7	12.6	2.54
P.C.B.	90 lb. A.R.A.-B.	9030	5 1 5/8	4 49/64	9/16	12	2 9/16	1 39/64	2 5/8	1 1/32	31/64	13°	2 1 3/32	8.87	32.3	11.5	2.44
P.C.	90 lb. A.S.C.E.	9040	5 3/8	5 3/8	9/16	12	2 5/8	1 19/32	2 55/64	59/64	1 9/64	13°	2 45 1/2 128	8.83	34.4	12.2	2.55
P.C.	100 lb. A.R.A.-A.	10020	6	5 1/2	9/16	14	2 3/4	1 9/16	3 3/8	1 1/16	3/8	14°	2 3/4	9.84	48.9	15.0	2.75
P.C.B.	100 lb. A.R.E.A.	10025	6	5 5/8	9/16	14	2 11/16	1 21/16	3 3/8	1 1/16	25/64	14°	2 45/64	9.95	49.0	15.1	2.75
P.C.B.	100 lb. A.R.A.-B.	10030	5 4 1/64	5 9/64	9/16	12	2 21/32	1 45/64	2 55/64	1 3/64	31/64	13°	2 65 1/2 128	9.85	41.3	13.7	2.63
P.C.	100 lb. A.S.C.E.	10040	5 3/4	5 3/4	9/16	12	2 3/4	1 45/64	3 5/64	3 1/32	5/16	13°	2 55 1/2 128	9.84	44.0	14.6	2.73
P.	105 lb. C.I.S.	10551	5 3/8	5 1/8	1 9/16	12	2 9/16	1 25/32	2 15/32	1	1 3/32	13°	2 13/64	10.30	34.4	12.4	2.41
P.C.B.	131 lb. A.R.E.A.	13128	7 1/8	6	2 1/32	Sketch	3	1 3/4	4 3/16	1 3/16	7/16	14°	3 3/32	12.82	88.5	22.6	3.20
P.	175 lb. C.I.S.	175-418	6	6	1 1/2	Sketch	4 1/4	1 3/4	3 3/4	1 1/2	1 1/2	12°	2 21/32	17.15	71.5	23.7	3.02

For key to symbols in first column, refer to page 3.

# CRANE RAIL SPLICES

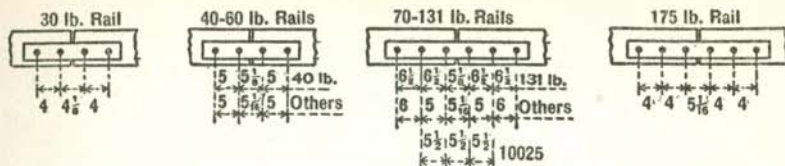

Rail gage for splice bars shown on page 114.

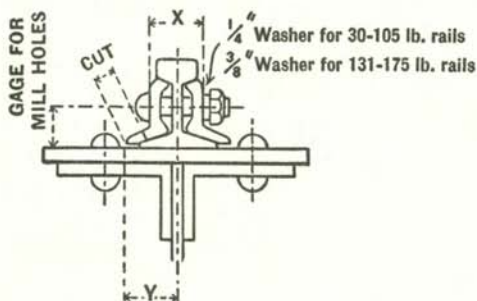

Standard splice-bars are used for crane rails and should be cut to clear rivets, if necessary.

Girder gage for rivets is given on page 117.

Rail gage for hook bolts is given on page 116.

RAIL		JOINT BAR				BOLTS		
Section	Section	Lg.	Holes	Y	Cut	Diam.	X	Lg.
3040	S 3040	16 1/8	1 1/16 x 3 1/32	2	9/16	5/8	1 11/16	2 3/4
4040	S 4040	20	1 3/16 x 1 1/8	2 3/16	9/16	3/4	1 15/16	3 1/4
5040	S 5040	24	1 3/16 x 1 1/8	2 7/16	5/8	3/4	2 1/4	3 1/2
6040	S 6040	24	1 3/16 x 1 1/8	2 11/16	1 1/16	3/4	2 19/32	3 7/8
7040	S 7040	34	1 3/16 x 1 1/8	2 15/16	3/4	3/4	2 27/32	4 1/8
8030	S 7040	34	1 5/16 x 1 1/4	2 19/16	1 3/16	7/8	2 27/32	4 1/8
8040	S 8040	34	1 5/16 x 1 1/4	3 3/16	1 3/16	7/8	3 1/16	4 1/2
8540	S 8540	34	1 5/16 x 1 1/4	3 11/32	7/8	7/8	3 3/32	4 1/2
9020	S 9020	34	1 1/16 x 1 13/32	3 19/16	1 3/8	1	3 9/16	4 7/8
9030	S 9030	34	1 1/16 x 1 13/32	3 8 5/128	1 13/32	1	3 7/16	4 7/8
9040	S 9040	34	1 1/16 x 1 13/32	3 7/16	7/8	1	3 1/4	4 3/4
10020	S 10020	34	1 1/16 x 1 13/32	4 1/16	1 7/16	1	3 7/16	4 7/8
10025	R 10025E	24	1 1/16 x 1 13/32	2 9/16	....	1	3 5/8	5 1/4
10030	S 10030C	34	1 1/16 x 1 13/32	4	1 9/16	1	3 3/8	4 7/8
10040	S 10040	34	1 1/16 x 1 13/32	3 5/8	7/8	1	3 7/16	4 7/8
10551	S 7040	34	1 5/16 x 1 1/4	....	....	7/8	3 3/32	4 1/2
13128	R 13125G	36	1 1/16 x 1 13/32	2 15/16	....	1	4 9/8	6 3/8
175-418	418	26	1 3/16	4 1/32	1 1/4	1 1/8	4 3/4	6 1/2



# CRANE RAIL FASTENINGS

## HOOK BOLTS

### AMERICAN BRIDGE COMPANY STANDARD

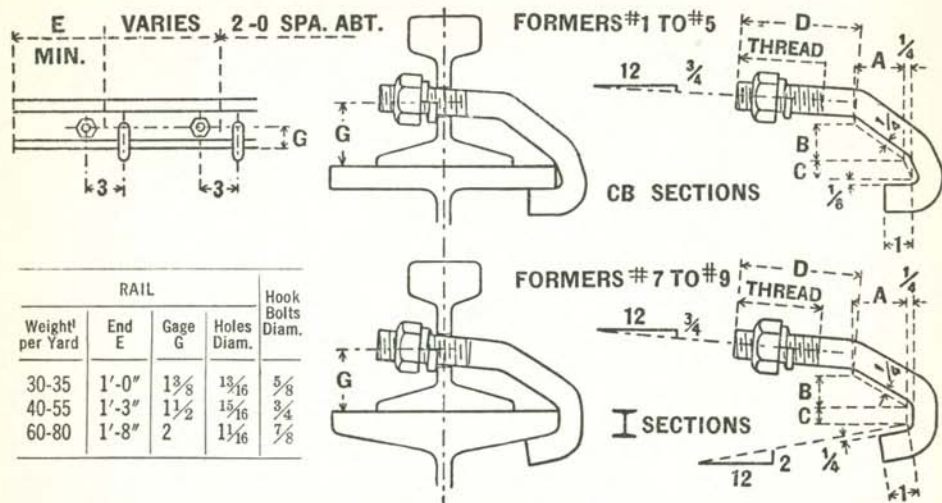

Weight <sup>1</sup> per Yard	RAIL			Hook Bolts Diam.
	End E	Gage G	Holes Diam.	
30-35	1'-0"	1 3/8	1 3/16	5/8
40-55	1'-3"	1 1/2	1 3/16	3/4
60-80	1'-8"	2	1 1/16	7/8

BEAM			HOOK BOLTS			STANDARD HOOK BOLTS										
Type	Nom. Depth	Weight per Foot	RAILS			Type	Diam.	No.	A	B	C	Thread	D	Length	Mark	
			30	40	50											60
WF C.B.	12	25-36	11	21	41	WF C.B.	5/8	1	1 1/2	3/8	5/8	3	3 3/4	8 1/2	11	
		40-50	12	22	42								4 1/2	9 1/4	12	
		53-64	12	22	42								4	9	21	
	14	30-42	11	21	41			3/4	2	1 1/2	7/16	5/8	3 1/4	4 3/4	9 3/4	22
		43-58	12	22	42									3 3/8	10	31
		61-74	12	22	42									3 3/8	10	31
	16	37-45	11	21	41			7/8	4	1 3/4	1	5/8	3 1/4	3 7/8	9 1/2	41
		50-68	12	22	42									4 9/8	10 1/4	42
		61-74	12	22	42									3 7/8	10 1/2	51
	18	47-57	12	22	42			5/8	5	2 3/4	1 1/16	3/4	3 1/4	3 7/8	10 1/2	52
		64-77	31	51	3 1/4									11	52	
		47-57	12	22	42									3 1/4	11	52
21	58-73	12	32	42	Am. Std.	7	1 1/4	1/2	1/2	2 1/2	3	7 1/2	71			
	77-89	31	51	3 1/2							8	72				
	96	31	52	2 3/4							3 3/8	8	81			
24	70-81		31	51	3/4	8	1 1/8	5/8	1/2	3 1/4	3 3/4	4 7/8	82			
	85, 93		31	52							3	3 1/2	9	91		
	70-81		31	51							3 1/4	4 7/8	9 1/2	83		
Am. Std.	12	31.8-55	71	81	7/8	9	1 3/4	1	1/2	3 1/4	3 1/2	4 1/2	9	91		
	15	42.9-55	71	81							3 1/4	4 1/2	10	92		
	60.8-75	71	81													
	54.7-70	72	82	91												
	75.6-90	72	82	92												
20	65.4-75	72	82	91												
81.4-100	72	82	92													
24	79.9-120	72	83	92												

Hook Bolts are used only where width of flange will not allow rail clamps.

Hook Bolts spaced about 2'-00" centers, and not over 3'-4" at rail splices.

Hook Bolts are made by standard formers, and only distance "D" can vary.

Hook Bolts to have hexagon nuts, and nut locks.

Hook Bolts allow rail adjustment of  $\pm 1/2$ ".

# CRANE RAIL CLAMPS

## AMERICAN BRIDGE COMPANY STANDARD

Clamp plates furnished flat and bent in field by tightening bolts.

Clamps in pairs about 3'-00" centers. Not over 4'-00" at splices.

Fillers turned to bear against toe of rail after rail is aligned.

Filler No. 1. Provides for an adjustment of  $\pm \frac{3}{16}$ ", varying by  $\frac{1}{8}$ ".

Filler No. 2. Provides for an adjustment of  $\pm \frac{3}{8}$ ", varying by  $\frac{1}{4}$ ".

For runways 200 ft. long (and under) order full quota of fillers No. 1, but no fillers No. 2.

For runways over 200 ft. long (and all export work) order full quota of fillers No. 1, and in addition, 30 per cent of fillers No. 2.

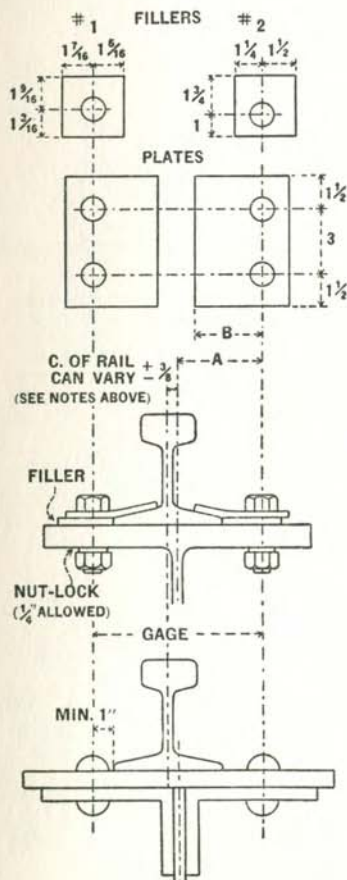

Section	RAIL		FILLERS	Gage	A	B	PLATES			BOLTS
	Half Base	Toe					Size	Lg.	Mark	
3040	$1\frac{9}{16}$	$\frac{3}{16}$	$\frac{3}{16}$	6	3	$2\frac{1}{4}$	$3\frac{1}{2}$	RC 1	} $\frac{3}{4}$	
4040	$1\frac{3}{4}$	$\frac{3}{16}$	$\frac{3}{16}$	$6\frac{1}{4}$	$3\frac{1}{8}$	$2\frac{3}{8}$	$3\frac{5}{8}$	RC 2		
5040	$1\frac{15}{16}$	$\frac{1}{4}$	$\frac{1}{4}$	$6\frac{3}{4}$	$3\frac{3}{8}$	$2\frac{5}{8}$	$3\frac{7}{8}$	RC 4		
6040	$2\frac{1}{8}$	$\frac{1}{4}$	$\frac{1}{4}$	7	$3\frac{1}{2}$	$2\frac{5}{8}$	$3\frac{7}{8}$	RC 4		
7040	$2\frac{5}{16}$	$\frac{3}{16}$	$\frac{1}{4}$	$7\frac{1}{2}$	$3\frac{3}{4}$	$2\frac{3}{4}$	4	RC 6	} $\frac{7}{8}$	
8030	$2\frac{1}{4}$	$\frac{1}{2}$	$\frac{1}{2}$	$7\frac{1}{4}$	$3\frac{5}{8}$	$2\frac{3}{4}$	4	RC 6		
8040	$2\frac{1}{2}$	$\frac{3}{16}$	$\frac{1}{4}$	$7\frac{3}{4}$	$3\frac{7}{8}$	3	$4\frac{1}{4}$	RC 7		
8540	$2\frac{5}{8}$	$\frac{3}{16}$	$\frac{1}{4}$	8	4	3	$4\frac{1}{4}$	RC 7		
9020	$2\frac{9}{16}$	$\frac{3}{8}$	$\frac{3}{8}$	8	4	3	$4\frac{1}{4}$	RC 7		
9030	$2\frac{9}{8}$	$\frac{1}{2}$	$\frac{1}{2}$	$7\frac{1}{2}$	$3\frac{3}{4}$	$2\frac{3}{4}$	4	RC 6		
9040	$2\frac{11}{16}$	$\frac{3}{16}$	$\frac{1}{4}$	$8\frac{1}{4}$	$4\frac{1}{8}$	$3\frac{1}{4}$	$4\frac{1}{2}$	RC 8		
10020	$2\frac{3}{4}$	$\frac{3}{8}$	$\frac{3}{8}$	$8\frac{1}{4}$	$4\frac{1}{8}$	} $3$	} $6 \times \frac{1}{2}$	} $4\frac{1}{2}$ RC 9 1		
10025	$2\frac{11}{16}$	$\frac{3}{8}$	$\frac{3}{8}$	$8\frac{1}{4}$	$4\frac{1}{8}$					
10030	$2\frac{9}{16}$	$\frac{1}{2}$	$\frac{1}{2}$	8	4					
10040	$2\frac{7}{8}$	$\frac{3}{16}$	$\frac{1}{4}$	$8\frac{1}{2}$	$4\frac{1}{4}$					
10551	$2\frac{5}{8}$	$\frac{3}{8}$	$\frac{3}{8}$	8	4					
13128	3	$\frac{1}{2}$	$\frac{1}{2}$	$8\frac{3}{4}$	$4\frac{3}{8}$					
175-418	3	$\frac{1}{2}$	$\frac{1}{2}$	$8\frac{3}{4}$	$4\frac{3}{8}$					

Holes in structural members to be located without regard to splices. If splice bars are found to interfere at any point, additional holes are to be drilled in field so that spacing of clamps does not exceed 4 ft.

# CROSS TIES

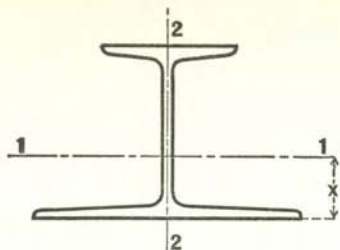

District Rolled	Section Index	Depth of Section In.	Weight per Foot Lbs.	Area of Section In. <sup>2</sup>	Width of Flange		Thickness of Web In.	Axis 1-1				Axis 2-2		
					Top	Bottom		I	S	r	x	I	S	r
					In.	In.		In. <sup>4</sup>	In. <sup>3</sup>	In.	In.	In. <sup>4</sup>	In. <sup>3</sup>	In.
P.	M29	5.50	24.0	7.01	5.0	8.0	.375	35.4	11.3	2.25	2.38	16.8	4.2	1.55
P.	M21	5.50	20.0	5.71	4.5	8.0	.250	30.9	9.7	2.33	2.33	14.9	3.7	1.62
P.	M25	4.25	14.5	4.10	4.0	6.0	.250	13.0	5.5	1.78	1.88	6.1	2.0	1.22
P.	M24	3.00	9.4	2.77	3.0	4.5	.203	4.2	2.5	1.24	1.32	2.9	1.3	1.03

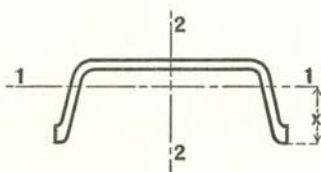

District Rolled	Section Index	Depth of Section In.	Weight per Foot Lbs.	Area of Section In. <sup>2</sup>	Width of Section		Thickness of Web In.	Axis 1-1				Axis 2-2		
					Top	Bottom		I	S	r	x	I	S	r
					In.	In.		In. <sup>4</sup>	In. <sup>3</sup>	In.	In.	In. <sup>4</sup>	In. <sup>3</sup>	In.
P.	M27A	2.39	12.4	3.65	5.5	7.0	.391	1.63	0.93	0.67	1.75	20.8	5.9	2.39
P.	M27	2.25	9.0	2.62	5.5	7.0	.250	1.28	0.79	0.70	1.62	16.8	4.8	2.53
P.	M20	2.00	6.0	1.72	4.5	6.0	.188	0.71	0.51	0.64	1.41	8.4	2.8	2.22
P.	M18	1.50	4.2	1.21	3.4	5.0	.156	0.31	0.31	0.50	1.00	3.6	1.5	1.73

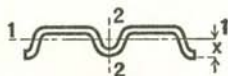

District Rolled	Section Index	Depth of Section In.	Weight per Foot Lbs.	Area of Section In. <sup>2</sup>	Width of Section In.	Thickness In.	Axis 1-1				Axis 2-2		
							I	S	r	x	I	S	r
							In. <sup>4</sup>	In. <sup>3</sup>	In.	In.	In. <sup>4</sup>	In. <sup>3</sup>	In.
P.	M26A	$1\frac{3}{16}$	3.25	0.95	$4\frac{3}{4}$	.141	0.068	0.136	0.27	0.50	1.94	0.82	1.43
P.	M19A	$1\frac{1}{16}$	2.50	0.74	$4\frac{1}{4}$	.125	0.034	0.077	0.21	0.44	1.23	0.58	1.29

For key to symbols in first column, refer to page 3.

# RAIL CLIPS

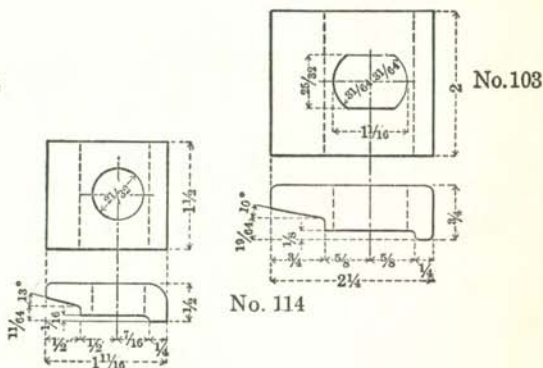
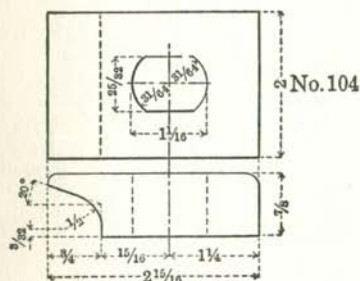
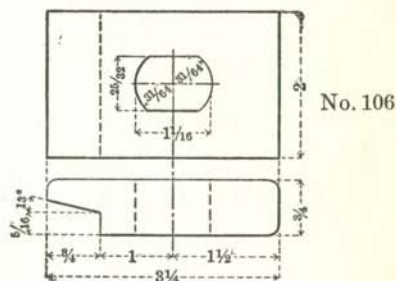
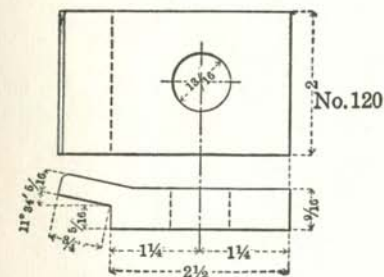
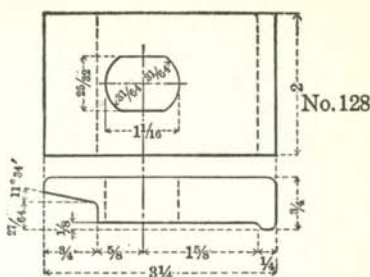
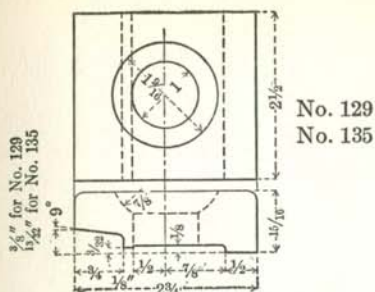

District Rolled	Clip Number	Weight per Foot, Pounds	Weight, Finished, Pounds	CLIPS FOR	
				Tie Sections	Rail Sections
C.	135	7.3	1.27	M 21, M 25, M 29	Girder Rails, Screw Spikes
P.	129	7.3	1.27	M 21, M 25, M 29	Girder Rails, Screw Spikes
P.	128	6.0	0.87	M 21, M 25, M 29	100 to 60 lbs. A. R. A.-B.
P.	120	5.6	0.81	M 18, M 20, M 27	50 to 25 lbs. A. S. C. E. and A. R. A.
P.	106	7.2	1.05	M 21, M 25, M 29	100 to 60 lbs. A. S. C. E.
P.	104	7.2	1.02	M 21, M 25, M 29	100 to 60 lbs. Angle Bars
P.	103	4.3	0.58	M 21, M 25, M 29	100 to 55 lbs. A. S. C. E.
P.	114	2.24	0.24	M 24	50 to 20 lbs. A. S. C. E.

Clips can be furnished with standard  $\frac{25}{32}$ " diameter holes or with holes of any size consistent with section, but unless specifically ordered clips will be furnished as shown.

For key to symbols in first column, refer to page 3.

# MEMORANDA

# DIMENSIONS OF STRUCTURAL RIVETS

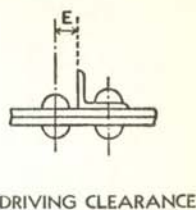
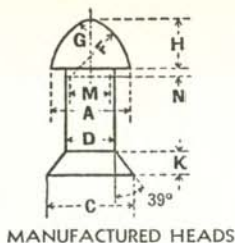
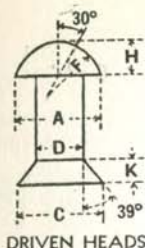

High Button (Acorn) Heads: American Standards Association, 1936

		Dia of Rivet, Inches										
		1/2	5/8	3/4	7/8	1	1 1/8	1 1/4	1 3/8	1 1/2		
Driven Head Inches	Full	A	1.5D + 1/8	7/8	1 1/16	1 1/4	1 1/16	1 5/8	1 13/16	2	2 3/16	2 3/8
		H	.425 A	3/8	7/16	9/16	5/8	11/16	3/4	7/8	1 5/16	1
		F	1.5 H	9/16	1 1/16	1 3/16	29/32	1 1/32	1 5/32	1 9/32	1 13/32	1 1/2
Manufactured Head Inches	Full	A	1.5 D + 1/32	1 3/16	1	1 3/16	1 3/8	1 3/4	1 15/16	2 1/4	2 1/8	2 5/16
		H	.75 D + 1/8	1/2	5/8	1 1/16	1 3/16	7/8	1	1 1/16	1 3/16	1 1/4
		F	.75 D + 9/32	23/32	3/4	27/32	15/16	1 1/32	1 1/8	1 7/32	1 5/16	1 11/32
Die, In.	B	M	.50	1/2	1/2	1/2	1/2	1/2	1/2	1/2	1/2	1/2
		N	.093	3/32	3/32	3/32	3/32	3/32	3/32	3/32	3/32	3/32
		G	.75 D - 9/32	9/32	3/16	9/32	3/8	19/32	9/16	21/32	3/4	27/32
Driving Clearance Inches	E (min.) E (pref.)	C	.5 D	1 1/8	1 1/4	1 1/2	1 3/4	2	2 1/4	2 1/2	2 3/4	
		K	1/4	5/16	3/8	7/16	1/2	9/16	5/8	1 1/16	3/4	
		B	1 3/4	2	2 1/4	2 1/2	2 3/4	3	3 1/4	3 1/2	3 3/4	

## CONVENTIONAL SIGNS FOR RIVETING

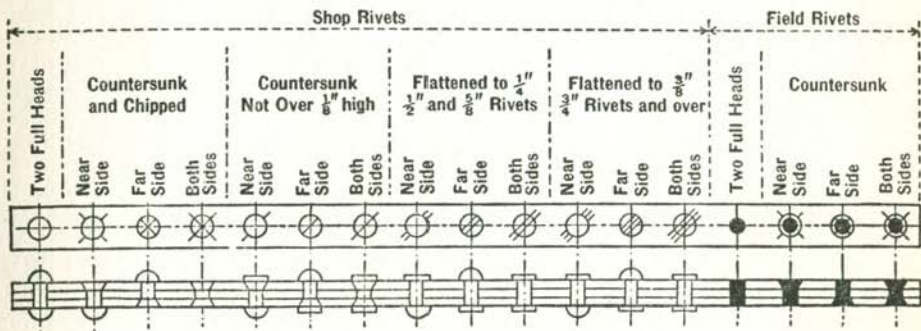

USUAL GAGES FOR ANGLES, INCHES												CRIMPS			
Leg	8	7	6	5	4	3 1/2	3	2 1/2	2	1 3/4	1 1/2	1 3/8	1 1/4	1	b = t + 1 1/2" Min. = 2"
g	4 1/2	4	3 1/2	3	2 1/2	2	1 3/4	1 3/8	1 1/8	1	7/8	7/8	3/4	5/8	
g1	3	2 1/2	2 1/4	2											
g2	3	3	2 1/2	1 3/4											

# LENGTH OF STRUCTURAL RIVETS

LENGTH OF UNDRIVEN RIVETS, IN INCHES, FOR VARIOUS GRIPS

AMERICAN INSTITUTE OF STEEL CONSTRUCTION STANDARD

American Bridge Company practice varies slightly and should be checked against these standards by the user.

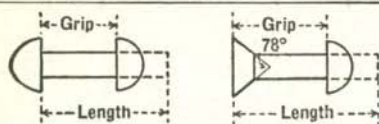

BUTTON HEAD

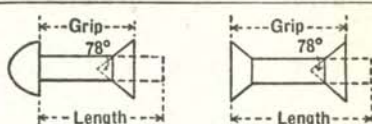

COUNTERSUNK

Grip Inches	Diameter of Rivet, Inches						
	1/2	5/8	3/4	7/8	1	1 1/8	1 1/4
1/2	1 1/8	1 7/8	1 7/8	2	2 1/8		
5/8	1 3/4	2	2	2 1/8	2 1/4		
3/4	1 7/8	2 1/8	2 1/8	2 3/4	2 3/8		
7/8	2	2 1/4	2 1/4	2 3/8	2 1/2		
1	2 1/4	2 3/8	2 3/8	2 1/2	2 5/8	2 3/4	2 7/8
1 1/8	2 5/8	2 1/2	2 1/2	2 5/8	2 3/4	2 3/8	3
1 1/4	2 1/2	2 5/8	2 5/8	2 3/4	2 7/8	3	3 1/8
3/8	2 5/8	2 3/4	2 3/4	2 7/8	3	3 1/8	3 1/4
1 1/2	2 7/8	3	3	3 1/8	3 1/4	3 3/8	3 1/2
5/8	3	3 1/8	3 1/8	3 3/4	3 3/8	3 3/4	3 5/8
3/4	3 1/8	3 1/4	3 1/4	3 1/2	3 5/8	3 3/4	3 7/8
7/8	3 1/4	3 3/8	3 3/8	3 5/8	3 3/4	3 7/8	4
2	3 1/2	3 1/2	3 5/8	3 3/4	3 7/8	4	4 1/8
1 1/8	3 5/8	3 5/8	3 3/4	3 7/8	4	4 1/8	4 1/4
1 1/4	3 3/4	3 7/8	3 7/8	4	4 1/8	4 1/4	4 3/8
3/8	4	4	4	4 1/8	4 1/4	4 3/8	4 1/2
1 1/2	4 1/8	4 1/8	4 1/8	4 1/4	4 3/8	4 1/4	4 5/8
5/8	4 1/4	4 1/4	4 1/4	4 3/8	4 1/2	4 5/8	4 3/4
3/4	4 3/8	4 3/8	4 3/8	4 1/2	4 5/8	4 3/4	4 7/8
7/8	4 5/8	4 5/8	4 5/8	4 3/4	4 7/8	4 5/8	5
3	...	4 3/4	4 3/4	4 7/8	5	5 1/8	5 1/4
1 1/8	...	4 7/8	4 7/8	5	5 1/8	5 1/4	5 3/8
1 1/4	...	5	5	5 1/8	5 1/4	5 3/8	5 1/2
3/8	...	5 1/8	5 1/8	5 1/4	5 3/8	5 1/2	5 5/8
1 1/2	...	5 3/8	5 3/8	5 1/2	5 3/8	5 5/8	5 3/4
5/8	...	5 1/2	5 1/2	5 1/2	5 5/8	5 3/4	5 7/8
3/4	...	5 5/8	5 5/8	5 3/4	5 7/8	6	6
7/8	...	5 3/4	5 3/4	5 3/4	5 7/8	6	6 1/8
4	...	...	5 7/8	6	6 1/8	6 1/4	6 1/2
1 1/8	...	...	6	6 1/8	6 3/8	6 1/2	6 5/8
1 1/4	...	...	6 1/8	6 1/4	6 3/8	6 1/2	6 5/8
3/8	...	...	6 3/8	6 1/2	6 1/2	6 3/4	6 3/4
1 1/2	...	...	6 1/2	6 5/8	6 5/8	6 3/4	6 7/8
5/8	...	...	6 5/8	6 3/4	6 3/4	6 7/8	7
3/4	...	...	6 3/4	6 7/8	6 7/8	7	7 1/8
7/8	...	...	6 7/8	7	7	7 1/8	7 1/4
5	...	...	...	7 1/8	7 1/8	7 1/4	7 3/8
1 1/8	...	...	...	7 3/4	7 1/4	7 3/8	7 1/2
1 1/4	...	...	...	7 5/8	7 3/8	7 1/2	7 5/8
3/8	...	...	...	7 5/8	7 5/8	7 3/4	7 3/4
1 1/2	...	...	...	7 3/4	7 3/4	7 5/8	7 7/8
5/8	...	...	...	7 7/8	7 7/8	8	8
3/4	...	...	...	8	8	8 1/8	8 1/8
7/8	...	...	...	8 1/8	8 1/8	8 1/4	8 1/4

Grip Inches	Diameter of Rivet, Inches						
	1/2	5/8	3/4	7/8	1	1 1/8	1 1/4
1/2	1	1	1 1/8	1 1/4	1 1/4		
5/8	1 1/8	1 1/4	1 1/4	1 3/8	1 3/8		
3/4	1 3/8	1 3/8	1 3/8	1 1/2	1 1/2		
7/8	1 1/2	1 1/2	1 1/2	1 5/8	1 5/8		
1	1 5/8	1 5/8	1 5/8	1 3/4	1 3/4	1 7/8	1 7/8
1 1/8	1 3/4	1 3/4	1 7/8	1 7/8	1 7/8	2	2
1 1/4	2	2	2	2	2	2 1/8	2 1/8
3/8	2 1/8	2 1/8	2 1/8	2 1/4	2 1/4	2 3/8	2 3/8
1 1/2	2 1/4	2 1/4	2 1/4	2 3/8	2 3/8	2 1/2	2 1/2
5/8	2 5/8	2 5/8	2 5/8	2 1/2	2 1/2	2 5/8	2 5/8
3/4	2 3/4	2 3/4	2 3/4	2 3/4	2 3/4	2 3/4	2 3/4
7/8	2 3/4	2 3/4	2 3/4	2 3/4	2 3/4	2 3/4	2 3/4
2	2 7/8	2 7/8	2 7/8	2 7/8	2 7/8	3	3
1 1/8	3 1/8	3	3	3	3	3 1/8	3 1/8
1 1/4	3 3/4	3 1/8	3 1/8	3 1/8	3 1/4	3 1/4	3 1/4
3/8	3 3/8	3 3/8	3 3/8	3 3/8	3 3/8	3 3/8	3 3/8
1 1/2	3 1/2	3 1/2	3 1/2	3 1/2	3 1/2	3 5/8	3 5/8
5/8	3 3/4	3 5/8	3 5/8	3 5/8	3 5/8	3 3/4	3 3/4
3/4	3 7/8	3 3/4	3 3/4	3 3/4	3 3/4	3 7/8	3 7/8
7/8	4	3 7/8	3 7/8	3 7/8	3 7/8	4	4
3	...	4 1/8	4 1/8	4 1/8	4 1/8	4 1/8	4 1/8
1 1/8	...	4 1/4	4 1/4	4 1/4	4 1/4	4 1/4	4 1/4
1 1/4	...	4 3/8	4 3/8	4 3/8	4 3/8	4 3/8	4 3/8
3/8	...	4 1/2	4 1/2	4 1/2	4 1/2	4 1/2	4 1/2
1 1/2	...	4 5/8	4 5/8	4 5/8	4 5/8	4 5/8	4 5/8
5/8	...	4 3/4	4 3/4	4 3/4	4 3/4	4 3/4	4 3/4
3/4	...	5	5	5	5	5	5
7/8	...	5 1/8	5 1/8	5 1/8	5 1/8	5 1/8	5 1/8
4	...	...	5 1/4	5 1/4	5 1/4	5 1/4	5 1/4
1 1/8	...	...	5 3/8	5 3/8	5 3/8	5 3/8	5 3/8
1 1/4	...	...	5 1/2	5 1/2	5 1/2	5 1/2	5 1/2
3/8	...	...	5 5/8	5 5/8	5 5/8	5 5/8	5 5/8
1 1/2	...	...	5 3/4	5 3/4	5 3/4	5 3/4	5 3/4
5/8	...	...	6	6	6	6	6
3/4	...	...	6 1/8	6 1/8	6 1/8	6 1/8	6 1/8
7/8	...	...	6 1/4	6 1/4	6 1/4	6 1/4	6 1/4
5	...	...	...	6 3/8	6 3/8	6 3/8	6 3/8
1 1/8	...	...	...	6 1/2	6 1/2	6 1/2	6 1/2
1 1/4	...	...	...	6 5/8	6 5/8	6 5/8	6 5/8
3/8	...	...	...	6 3/4	6 3/4	6 3/4	6 3/4
1 1/2	...	...	...	6 7/8	6 7/8	6 7/8	6 7/8
5/8	...	...	...	7	7	7	7
3/4	...	...	...	7 1/4	7 1/4	7 1/4	7 1/4
7/8	...	...	...	7 3/8	7 3/8	7 3/8	7 3/8

# WEIGHT OF STRUCTURAL RIVETS

## AMERICAN BRIDGE COMPANY STANDARD

### WEIGHT WITH ONE HIGH BUTTON (ACORN) MANUFACTURED HEAD IN POUNDS PER 100

Length Inches	Diameter of Rivet, Inches							Length Inches	Diameter of Rivet, Inches						
	1/2	5/8	3/4	7/8	1	1 1/8	1 1/4		1/2	5/8	3/4	7/8	1	1 1/8	1 1/4
								5	..	50	74	104	138	180	226
								1/8	..	51	76	106	141	183	230
								1/4	..	52	78	108	144	187	234
								3/8	..	53	79	110	147	190	239
1 1/4	11							1/2	..	54	81	113	149	194	243
3/8	12							5/8	..	55	82	115	152	197	247
1/2	12	20	31	45	60	81	104	3/4	..	57	84	117	155	201	252
13	21	32	47	63	85	108		7/8	..	58	85	119	158	204	256
14	22	33	49	66	88	113									
3/4	14	23	35	51	69	92	117								
7/8	14	23	35	51	69	92	117								
2	15	24	37	53	72	95	122	6	..	..	87	121	161	208	261
1/8	16	25	39	55	74	99	126	1/8	..	..	89	123	163	212	265
1/4	17	26	40	57	77	102	130	1/4	..	..	90	125	166	215	269
3/8	17	27	42	59	80	106	135	3/8	..	..	92	127	169	219	274
1/2	18	28	43	62	83	109	139	1/2	..	..	93	130	172	222	278
5/8	19	29	45	64	85	113	143	5/8	..	..	95	132	174	226	282
3/4	19	31	46	66	88	116	148	3/4	..	..	96	134	177	229	287
7/8	20	32	48	68	91	120	152	7/8	..	..	98	136	180	233	291
3	21	33	50	70	94	123	156	7	..	..	100	138	183	236	295
1/8	21	34	51	72	97	127	161	1/8	..	..	101	140	186	240	300
1/4	22	35	53	74	99	131	165	1/4	..	..	103	142	188	243	304
3/8	23	36	54	76	102	134	169	3/8	..	..	104	144	191	247	308
1/2	23	37	56	79	105	138	174	1/2	..	..	106	147	194	250	313
5/8	24	38	57	81	108	141	178	5/8	..	..	107	149	197	254	317
3/4	25	39	59	83	110	145	182	3/4	..	..	109	151	199	257	321
7/8	26	40	60	85	113	148	187	7/8	..	..	110	153	202	261	326
4	26	41	62	87	116	152	191	8	..	..	..	155	205	264	330
1/8	27	42	64	89	119	155	195	1/8	..	..	..	157	208	268	334
1/4	28	44	65	91	122	159	200	1/4	..	..	..	159	211	271	339
3/8	28	45	67	93	124	162	204	3/8	..	..	..	161	213	275	343
1/2	29	46	68	96	127	166	208	1/2	..	..	..	164	216	278	347
5/8	30	47	70	98	130	169	213	5/8	..	..	..	166	219	282	352
3/4	30	48	71	100	133	173	217	3/4	..	..	..	168	222	285	356
7/8	31	49	73	102	135	176	221	7/8	..	..	..	170	224	289	360

### WEIGHT WITH ONE COUNTERSUNK HEAD IN POUNDS PER 100

For Countersunk Rivets, use weight given above with following deductions	Diameter of Rivet, Inches						
	1/2	5/8	3/4	7/8	1	1 1/8	1 1/4
Deduction, Lb.	3	4	7	12	18	26	36

### WEIGHT OF HIGH BUTTON (ACORN) HEADS AFTER DRIVING

Diameter of Rivet, Inches	1/2	5/8	3/4	7/8	1	1 1/8	1 1/4
Weight per 100 Heads, Lb.	4	7	12	18	26	36	48



# WEIGHT OF BOLTS

WITH SQUARE HEADS AND HEXAGON NUTS  
IN POUNDS PER 100

Length Under Head Inches	Diameter of Bolt in Inches											
	1/4	5/16	3/8	7/16	1/2	5/8	3/4	7/8	1	1 1/8	1 1/4	
1	2.7	5.0	7.2	11.2	14.9	28	43					
1 1/4	3.1	5.5	8.0	12.2	16.3	30	46	68				
1 1/2	3.4	6.1	8.8	13.3	17.7	32	49	73	103	144	190	
1 3/4	3.8	6.6	9.6	14.4	19.0	35	52	77	109	151	199	
2	4.1	7.2	10.4	15.4	20.4	37	55	81	115	158	208	
2 1/4	4.5	7.7	11.1	16.5	21.8	39	58	85	120	165	216	
2 1/2	4.8	8.2	11.9	17.5	23.2	41	61	90	126	172	225	
2 3/4	5.2	8.8	12.7	18.6	24.6	43	64	94	131	179	234	
3	5.5	9.3	13.5	19.7	26.0	45	68	98	137	187	242	
3 1/4	5.9	9.9	14.3	20.7	27.4	48	71	102	142	194	251	
3 1/2	6.2	10.4	15.1	21.8	28.8	50	74	107	148	201	260	
3 3/4	6.6	11.0	15.8	22.9	30.2	52	77	111	153	208	268	
4	6.9	11.5	16.6	23.9	31.6	54	80	115	159	215	277	
4 1/4	7.3	12.0	17.4	25.0	33.0	56	83	119	165	222	286	
4 1/2	7.6	12.6	18.2	26.1	34.4	58	86	124	170	229	294	
4 3/4	8.0	13.1	19.0	27.1	35.7	61	89	128	176	236	303	
5	8.3	13.7	19.8	28.2	37.1	63	93	132	181	243	312	
5 1/4	8.6	14.2	20.5	29.3	38.5	65	96	136	187	250	321	
5 1/2	9.0	14.8	21.3	30.3	39.9	67	99	141	192	257	329	
5 3/4	9.3	15.3	22.1	31.4	41.3	69	102	145	198	264	338	
6	9.7	15.9	22.9	32.4	42.7	71	105	149	204	271	347	
6 1/4	10.0	16.4	23.7	33.5	44.1	74	108	153	209	278	355	
6 1/2	10.4	16.9	24.5	34.6	45.5	76	111	158	215	285	364	
6 3/4	10.7	17.5	25.2	35.6	46.9	78	114	162	220	292	373	
7	11.1	18.0	26.0	36.7	48.3	80	118	166	226	299	381	
7 1/4	11.4	18.6	26.8	37.8	49.7	82	121	170	231	306	390	
7 1/2	11.8	19.1	27.6	38.8	51.1	84	124	175	237	313	399	
7 3/4	12.1	19.7	28.4	39.9	52.4	87	127	179	242	320	407	
8	12.5	20.2	29.2	41.0	53.8	89	130	183	248	327	416	
8 1/2	.....	21.3	30.7	43.1	56.6	93	136	192	259	341	434	
9	.....	22.4	32.3	45.2	59.4	98	143	200	270	356	451	
9 1/2	.....	23.5	33.9	47.4	62.2	102	149	209	281	370	468	
10	.....	24.6	35.4	49.5	65.0	106	155	217	293	384	486	
10 1/2	.....	.....	37.0	51.6	67.8	111	161	226	304	398	503	
11	.....	.....	38.6	53.7	70.5	115	168	234	315	412	520	
11 1/2	.....	.....	40.1	55.9	73.3	119	174	243	326	426	538	
12	.....	.....	41.7	58.0	76.1	124	180	251	337	440	555	
12 1/2	.....	.....	.....	60.1	78.9	128	186	260	348	454	573	
13	.....	.....	.....	62.3	81.7	132	193	268	359	468	590	
13 1/2	.....	.....	.....	64.4	84.5	137	199	277	370	482	607	
14	.....	.....	.....	66.5	87.2	141	205	285	382	496	625	
14 1/2	.....	.....	.....	.....	90.0	145	211	294	393	510	642	
15	.....	.....	.....	.....	92.8	150	218	302	404	525	660	
15 1/2	.....	.....	.....	.....	95.6	154	224	311	415	539	677	
16	.....	.....	.....	.....	98.4	158	230	320	426	553	694	
Per Inch additional	1.4	2.2	3.1	4.3	5.6	8.7	12.5	17.0	22.3	28.2	34.8	

# WEIGHT OF BOLTS

## SPECIAL CASES IN POUNDS PER 100

### VARIATIONS IN HEADS OR NUTS

As stated on page 124, usual practice is Square Head and Hexagon Nut, "American Standard Regular." For other combinations of head and nut, or for "American Standard Heavy," make the appropriate deductions and additions of weights of heads and nuts as tabulated below, from the weights per 100 found on page 124.

Weight of 100 Each		Diameter of Bolt, Inches										
		¼	⅝	⅜	7/16	½	⅝	¾	7/8	1	1⅛	1¼
Regular	Square Heads	.7	1.4	2.2	3.2	5.1	10	18	29	42	60	84
	Hexagon Heads	.6	1.2	1.9	2.8	4.5	9	15	25	36	52	73
	Square Nuts	.81	1.7	2.3	4.1	5.6	10	14	23	35	49	67
	Hexagon Nuts	.64	1.4	1.9	3.7	4.2	9	12	18	28	42	54
Heavy	Square Heads	...	...	...	...	9.5	17	28	42	61	84	112
	Hexagon Heads	...	...	...	...	8.2	14	24	36	53	73	94
	Square Nuts	...	...	...	...	7.9	14	23	35	50	66	92
	Hexagon Nuts	...	...	...	...	6.6	11	19	28	41	56	73

### HEAVY BOLTS

Weights of bolts over 1¼ inches in diameter may be calculated from the following data. Standard practice is "American Standard Regular" head with "American Standard Regular" or "Heavy" nut, as specified.

Weight of 100 Each		Diameter of Bolt, Inches										
		1½	1¾	2	2¼	2½	2¾	3	3¼	3½	3¾	4
Regular	Square Heads	143	226	343	484	660	881	1148	1452	1830	2241	2710
	Hexagon Heads	124	196	297	419	577	764	994	1257	1585	1941	2350
	Square Nuts	116	184	276	391	539	666	874	...	...	...	...
	Hexagon Nuts	102	162	231	337	472	606	825	...	...	...	...
Heavy	Square Heads	190	295	432	608	825	1087	1401	1775	2115	2715	3312
	Hexagon Heads	162	254	377	538	727	890	1214	1526	1906	2344	2845
	Square Nuts	154	242	355	496	674	831	1082	1767	2043	2303	2969
	Hexagon Nuts	123	208	303	422	573	742	1008	1196	1485	1789	2184
Pounds per linear inch of Shank		.5007	.6815	.8900	1.127	1.391	1.683	2.003	2.348	2.723	3.126	3.556

# BOLT HEADS AND NUTS

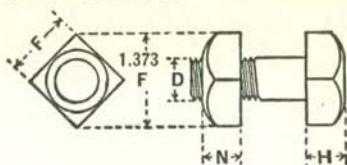
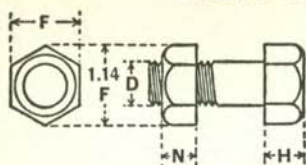

HEADS AND NUTS		American Standard Regular	American Standard Heavy
HEAD	Height, H	$\frac{3}{8} D$	$\frac{3}{4} D + \frac{1}{16}''$
	Short Dia., F	$1\frac{1}{2} D$	$1\frac{1}{2} D + \frac{1}{16}''$
NUT	Height, N	$\frac{3}{8} D$	D
	Short Dia., F	$1\frac{1}{2} D + \frac{1}{16}''$ (D = $\frac{3}{8}''$ or less) $1\frac{1}{2} D$ (D greater than $\frac{3}{8}''$ )	$1\frac{1}{2} D + \frac{1}{8}''$

American Standard Bolt and Nut dimensions rounded to the nearest  $\frac{1}{16}$  inch, are those adopted by American Institute of Bolt, Nut and Rivet Manufacturers and approved by American Standards Association, March, 1933. "American Standard Regular" formerly called Manufacturers Standard, American Standard, etc. "American Standard Heavy" formerly called United States Standard. Some fabricators have standard heads and nuts differing only slightly from the table. For bolts with countersunk heads the included angle is 78 degrees, the same as for rivets. See page 121 for dimensions.

## STANDARD DIMENSIONS

Diam. of Bolt In.	Series	HEAD					Diam. of Bolt In.	Series	NUT				
		Hexagon		Height In.	Square				Hexagon		Height In.	Square	
		Diameter, In.			Diameter, In.				Diameter, In.			Diameter, In.	
		Long	Short		Long	Short			Long	Short		Long	Short
$\frac{1}{4}$	American Standard Regular	$\frac{7}{16}$	$\frac{3}{8}$	$\frac{3}{16}$	$\frac{1}{2}$	$\frac{3}{8}$	$\frac{1}{4}$	$\frac{1}{2}$	$\frac{7}{16}$	$\frac{1}{4}$	$\frac{5}{8}$	$\frac{7}{16}$	
$\frac{3}{8}$		$\frac{5}{8}$	$\frac{9}{16}$	$\frac{1}{4}$	$\frac{3}{4}$	$\frac{9}{16}$	$\frac{3}{8}$	$\frac{11}{16}$	$\frac{5}{8}$	$\frac{5}{16}$	$\frac{7}{8}$	$\frac{5}{8}$	
$\frac{1}{2}$		$\frac{7}{8}$	$\frac{3}{4}$	$\frac{5}{16}$	1	$\frac{3}{4}$	$\frac{1}{2}$	$\frac{15}{16}$	$\frac{13}{16}$	$\frac{7}{16}$	$\frac{11}{8}$	$\frac{13}{16}$	
$\frac{5}{8}$		$\frac{11}{16}$	$\frac{15}{16}$	$\frac{7}{16}$	$\frac{15}{16}$	$\frac{15}{16}$	$\frac{5}{8}$	$1\frac{1}{8}$	1	$\frac{9}{16}$	$\frac{13}{8}$	1	
$\frac{3}{4}$		$\frac{15}{16}$	$1\frac{1}{8}$	$\frac{1}{2}$	$\frac{19}{16}$	$1\frac{1}{8}$	$\frac{3}{4}$	$\frac{15}{16}$	$1\frac{1}{8}$	$\frac{11}{16}$	$\frac{19}{16}$	$1\frac{1}{8}$	
$\frac{7}{8}$		$1\frac{1}{2}$	$\frac{15}{16}$	$\frac{9}{16}$	$1\frac{13}{16}$	$\frac{15}{16}$	$\frac{7}{8}$	$1\frac{1}{2}$	$\frac{15}{16}$	$\frac{3}{4}$	$1\frac{13}{16}$	$\frac{15}{16}$	
1		$\frac{11}{16}$	$\frac{11}{2}$	$\frac{5}{8}$	$\frac{21}{16}$	$1\frac{1}{2}$	1	$\frac{11}{16}$	$\frac{11}{2}$	$\frac{7}{8}$	$\frac{21}{16}$	$1\frac{1}{2}$	
$1\frac{1}{8}$		$\frac{11}{16}$	$\frac{11}{16}$	$\frac{3}{4}$	$\frac{25}{16}$	$\frac{11}{16}$	$1\frac{1}{8}$	$\frac{11}{16}$	$\frac{11}{16}$	1	$\frac{25}{16}$	$\frac{11}{16}$	
$1\frac{1}{4}$	$\frac{21}{8}$	$1\frac{7}{8}$	$\frac{13}{16}$	$\frac{29}{16}$	$1\frac{7}{8}$	$1\frac{1}{4}$	$\frac{21}{8}$	$1\frac{7}{8}$	$1\frac{1}{8}$	$\frac{29}{16}$	$1\frac{7}{8}$		
$1\frac{3}{8}$	American Standard Heavy	$\frac{23}{8}$	$\frac{21}{16}$	$\frac{15}{16}$	$\frac{21}{16}$	$\frac{21}{16}$	$1\frac{3}{8}$	$2\frac{1}{2}$	$\frac{29}{16}$	$1\frac{3}{8}$	3	$\frac{23}{16}$	
$1\frac{1}{2}$		$\frac{29}{16}$	$\frac{21}{4}$	1	$\frac{31}{16}$	$\frac{21}{4}$	$1\frac{1}{2}$	$\frac{21}{16}$	$\frac{29}{8}$	$1\frac{1}{2}$	$\frac{31}{4}$	$\frac{29}{8}$	
$1\frac{5}{8}$		$\frac{23}{4}$	$\frac{27}{16}$	$\frac{11}{16}$	$\frac{33}{8}$	$\frac{27}{16}$	$1\frac{5}{8}$	$\frac{21}{16}$	$\frac{29}{16}$	$1\frac{5}{8}$	$\frac{31}{2}$	$\frac{29}{16}$	
$1\frac{3}{4}$		3	$\frac{25}{8}$	$\frac{13}{16}$	$\frac{35}{8}$	$\frac{25}{8}$	$1\frac{3}{4}$	$\frac{31}{8}$	$\frac{23}{4}$	$1\frac{3}{4}$	$\frac{33}{4}$	$\frac{23}{4}$	
$1\frac{7}{8}$		$\frac{39}{16}$	$\frac{21}{16}$	$\frac{11}{4}$	$\frac{37}{8}$	$\frac{21}{16}$	$1\frac{7}{8}$	$\frac{39}{8}$	$\frac{21}{16}$	$1\frac{7}{8}$	$\frac{41}{16}$	$\frac{21}{16}$	
2		$\frac{37}{16}$	3	$\frac{15}{16}$	$\frac{41}{8}$	3	2	$\frac{39}{16}$	$\frac{31}{8}$	2	$\frac{45}{16}$	$\frac{31}{8}$	
$2\frac{1}{4}$		$\frac{37}{8}$	$\frac{33}{8}$	$\frac{11}{2}$	$\frac{45}{8}$	$\frac{33}{8}$	$2\frac{1}{4}$	4	$\frac{31}{2}$	$\frac{21}{4}$	$\frac{41}{16}$	$\frac{31}{2}$	
$2\frac{1}{2}$		$\frac{41}{4}$	$\frac{33}{4}$	$\frac{11}{16}$	$\frac{51}{8}$	$\frac{33}{4}$	$2\frac{1}{2}$	$\frac{47}{16}$	$\frac{37}{8}$	$\frac{21}{2}$	$\frac{55}{16}$	$\frac{37}{8}$	
$2\frac{3}{4}$	$\frac{41}{16}$	$\frac{41}{8}$	$\frac{11}{16}$	$\frac{51}{16}$	$\frac{41}{8}$	$2\frac{3}{4}$	$\frac{47}{8}$	$\frac{41}{4}$	$\frac{23}{4}$	$\frac{51}{16}$	$\frac{41}{4}$		
3	American Standard Heavy	$\frac{51}{8}$	$\frac{41}{2}$	2	$\frac{63}{16}$	$\frac{41}{2}$	3	$\frac{51}{4}$	$\frac{45}{8}$	3	$\frac{63}{8}$	$\frac{45}{8}$	
$3\frac{1}{4}$		$\frac{59}{16}$	$\frac{47}{8}$	$\frac{23}{16}$	$\frac{61}{16}$	$\frac{47}{8}$	$\frac{31}{4}$	$\frac{51}{16}$	5	$\frac{31}{4}$	$\frac{67}{8}$	5	
$3\frac{1}{2}$		6	$\frac{51}{4}$	$\frac{25}{16}$	$\frac{73}{16}$	$\frac{51}{4}$	$\frac{31}{2}$	$\frac{61}{8}$	$\frac{53}{8}$	$\frac{31}{2}$	$\frac{73}{8}$	$\frac{53}{8}$	
$3\frac{3}{4}$		$\frac{67}{16}$	$\frac{55}{8}$	$\frac{21}{2}$	$\frac{73}{4}$	$\frac{55}{8}$	$\frac{33}{4}$	$\frac{69}{16}$	$\frac{53}{4}$	$\frac{33}{4}$	$\frac{77}{8}$	$\frac{53}{4}$	
4		$\frac{67}{8}$	6	$\frac{21}{16}$	$\frac{81}{4}$	6	4	7	$\frac{61}{8}$	4	$\frac{87}{16}$	$\frac{61}{8}$	
$4\frac{1}{4}$		$\frac{71}{4}$	$\frac{63}{8}$	$\frac{21}{16}$	$\frac{83}{4}$	$\frac{63}{8}$	$\frac{41}{4}$	$\frac{71}{16}$	$\frac{61}{2}$	$\frac{41}{4}$	$\frac{81}{16}$	$\frac{61}{2}$	
$4\frac{1}{2}$		$\frac{71}{16}$	$\frac{63}{4}$	3	$\frac{91}{4}$	$\frac{63}{4}$	$\frac{41}{2}$	$\frac{71}{16}$	$\frac{67}{8}$	$\frac{41}{2}$	$\frac{91}{16}$	$\frac{67}{8}$	
$4\frac{3}{4}$		$\frac{81}{8}$	$\frac{71}{8}$	$\frac{33}{16}$	$\frac{91}{16}$	$\frac{71}{8}$	$\frac{43}{4}$	$\frac{81}{4}$	$\frac{71}{4}$	$\frac{43}{4}$	$\frac{91}{16}$	$\frac{71}{4}$	
5	American Standard Heavy	$\frac{89}{16}$	$\frac{71}{2}$	$\frac{35}{16}$	$\frac{105}{16}$	$\frac{71}{2}$	5	$\frac{81}{16}$	$\frac{75}{8}$	5	$\frac{101}{2}$	$\frac{75}{8}$	
$5\frac{1}{4}$		9	$\frac{77}{8}$	$\frac{31}{2}$	$\frac{103}{16}$	$\frac{77}{8}$	$\frac{51}{4}$	$\frac{91}{8}$	8	$\frac{51}{4}$	11	8	
$5\frac{1}{2}$		$\frac{93}{8}$	$\frac{81}{4}$	$\frac{31}{16}$	$\frac{113}{16}$	$\frac{81}{4}$	$\frac{51}{2}$	$\frac{99}{16}$	$\frac{83}{8}$	$\frac{51}{2}$	$\frac{111}{2}$	$\frac{83}{8}$	
$5\frac{3}{4}$		$\frac{91}{16}$	$\frac{85}{8}$	$\frac{31}{16}$	$\frac{113}{16}$	$\frac{85}{8}$	$\frac{53}{4}$	10	$\frac{83}{4}$	$\frac{53}{4}$	12	$\frac{83}{4}$	
6		$10\frac{1}{4}$	9	4	$\frac{123}{8}$	9	6	$10\frac{3}{8}$	$\frac{91}{8}$	6	$\frac{121}{2}$	$\frac{91}{8}$	

# TURNBUCKLES AND SLEEVE NUTS

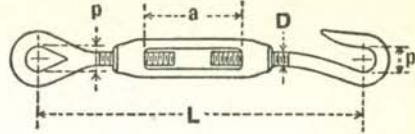
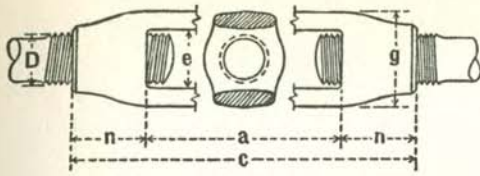

125—

Thread: American Standard Free Fit—Class 2

Size D In.	Standard Turnbuckles					Weight of Turnbuckles, Lbs.						Eye and Hook Stubs				
	Dimensions, Inches					Length, a, Inches						Std. P In.	(av.) for a=6"	Weight, Lb.		
	a	n	c	e	g	6	9	12	18	24	36			48	Eye	Hook
3/8	6	9/16	7 1/8	9/16	1 1/32	.41							3/4	19	.30	.25
1/2	6	3/4	7 1/2	1 1/16	1 5/16	.70	.75	1.00					1	19	.61	.48
5/8	6	29/32	7 13/16	1 3/16	1 1/2	.89	1.38	1.50					1 1/4	19 1/2	1.07	.95
3/4	6	1 1/16	8 1/8	1 5/16	1 29/32	1.20	1.63	2.13	3.06	4.38			1 1/2	21	1.70	1.52
7/8	6	1 1/8	8 7/16	1 3/8	1 7/8	1.46		2.83	4.33	5.47			1 3/4	23 1/4	2.44	2.19
1	6	1 5/8	8 3/4	1 3/2	2 1/8	2.27		3.80	4.13	4.45	5.12		2	24 1/2	3.42	3.10
1 1/8	6	1 9/16	9 1/8	1 13/32	2 3/8	2.72		4.00	7.25	9.15	12.95		2 1/4	26 3/4	4.92	4.50
1 1/4	6	1 3/4	9 1/2	1 19/32	2 17/32	3.58		4.70	7.13	12.11	16.75		2 1/2	28	6.35	5.82
1 3/8	6	1 15/16	9 7/8	1 11/16	2 3/4	4.13							2 3/4	30	8.42	7.79
1 1/2	6	2 1/8	10 1/4	1 27/32	3 1/8	5.25		8.00	9.13	11.75	17.75	24.00	3	32	10.83	10.08
1 5/8	6	2 1/4	10 1/2	1 31/32	3 3/8	5.88							3 1/4	34	13.91	12.94
1 3/4	6	2 1/2	11	2 3/8	3 9/16	7.05			15.00	21.59	29.35	37.85	3 1/2	35	17.40	16.38
1 7/8	6	2 3/4	11 1/2	2 5/8	4	9.95							3 3/4	37 1/2	20.62	19.45
2	6	2 3/4	11 1/2	2 5/8	4	9.95		15.23		28.35	37.95	48.45	4	40 1/2	25.45	24.13
2 1/4	6	3 3/8	12 3/4	2 11/16	4 5/8	18.00				37.80	51.00	63.95	4 1/2	43 1/2	39.02	37.35
2 1/2	6	3 3/4	13 1/2	3	5	23.25				49.38	65.30	82.50	5	50	57.02	54.94
2 3/4	6	4 1/8	14 1/4	3 1/4	5 5/8	31.50							5 1/2	55	81.80	79.28
3	6	4 1/2	15	3 3/8	6 1/8	39.50							6	60	106.06	103.06
3 1/4	6	5 1/4	16 1/2	3 7/8	6 3/4	61.00	70.00									
3 1/2	6	5 1/4	16 1/2	3 7/8	6 3/4	61.00	70.00					203.00				
3 3/4	6	6	18	4 3/4	8 1/2	89.00										
4	6	6	18	4 3/4	8 1/2	89.00						314.00				
4 1/4	9	6 3/4	22 1/2	5 1/4	9 3/4		152.00									
4 1/2	9	6 3/4	22 1/2	5 1/4	9 3/4		152.00									
4 3/4	9	6 3/4	22 1/2	5 1/4	9 3/4		152.00									
5	9	7 1/2	24	6	10		200.00									

Weights and dimensions of Turnbuckles, Eyes and Hooks are Cleveland City Forge Company Standard.  
Similar products of other companies are essentially the same.

## SLEEVE NUTS

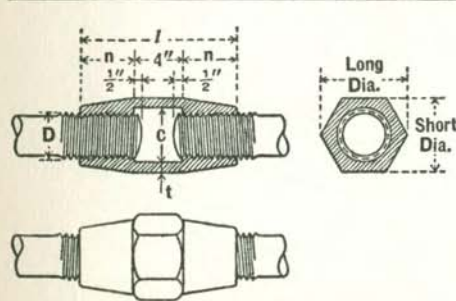

Thread: American Standard Free Fit—Class 2  
Material: Cast Steel

Diam. of Screw D	Long Diam.	Nut n	Clear c	Short Diam.	Thick- ness t	Length l	Wt.
4	7 1/16	4 1/2	4 1/8	6 1/8	1	13	55
4 1/4	7 1/2	4 3/4	4 3/8	6 1/2	1 1/16	13 1/2	65
4 1/2	7 13/16	5	4 3/4	6 7/8	1 1/16	14	75
4 3/4	8 3/8	5 1/4	5	7 1/4	1 1/8	14 1/2	98
5	8 7/8	5 1/2	5 1/4	7 5/8	1 3/16	15	110
5 1/4	9 1/4	5 3/4	5 1/2	8	1 1/4	15 1/2	122
5 1/2	9 3/4	6	5 3/4	8 3/8	1 3/16	16	142
5 3/4	10 1/8	6 1/4	6	8 3/4	1 3/8	16 1/2	157
6	10 5/8	6 1/2	6 1/4	9 1/8	1 7/16	17	176

# UPSET SCREW ENDS FOR SQUARE BARS

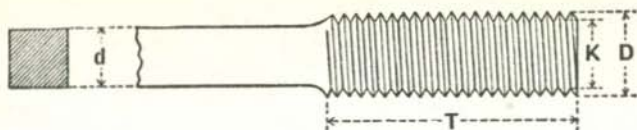

Thread: American Standard Free Fit—Class 2

BAR			UPSET					
Side of Square d Inches	Area Sq. In.	Weight per Foot Lb.	Diameter D Inches	Length T Inches	Additional Length for Upset +10% Inches	Diameter at Root of Thread K Inches	Area	
							At Root of Thread Sq. In.	Excess Over Area of Bar %
* 3/4	0.563	1.91	1 1/8	4	4	0.939	0.693	23.2
* 7/8	0.766	2.60	1 1/4	4	4	1.064	0.890	16.2
1	1.000	3.40	1 1/2	4	4	1.283	1.294	29.4
1 1/8	1.266	4.30	1 5/8	4	3 1/2	1.389	1.515	19.7
1 1/4	1.563	5.31	1 7/8	4 1/2	4 1/2	1.615	2.049	31.1
1 3/8	1.891	6.43	2	4 1/2	4	1.711	2.300	21.7
1 1/2	2.250	7.65	2 1/4	5	5	1.961	3.021	34.3
1 5/8	2.641	8.98	2 3/8	5	4 1/2	2.086	3.419	29.5
1 3/4	3.063	10.41	2 1/2	5 1/2	4 1/2	2.175	3.716	21.3
1 7/8	3.516	11.95	2 3/4	5 1/2	5	2.425	4.619	31.4
2	4.000	13.60	2 7/8	6	5	2.550	5.108	27.7
2 1/8	4.516	15.35	3	6	4 1/2	2.629	5.428	20.2
2 1/4	5.063	17.21	3 1/4	6 1/2	5 1/2	2.879	6.509	28.6
2 3/8	5.641	19.18	3 1/2	7	6 1/2	3.100	7.549	33.8
2 1/2	6.250	21.25	3 3/4	7	7	3.317	8.641	38.3
2 5/8	6.891	23.43	3 3/4	7	5 1/2	3.317	8.641	25.4
2 3/4	7.563	25.71	4	7 1/2	6 1/2	3.567	9.993	32.1
2 7/8	8.266	28.10	4 1/4	8	7 1/2	3.798	11.330	37.1
3	9.000	30.60	4 1/4	8	6	3.798	11.330	25.9
3 1/8	9.766	33.20	4 1/2	8 1/2	7	4.028	12.741	30.5
3 1/4	10.563	35.91	4 3/4	8 1/2	7 1/2	4.255	14.221	34.6

\*Upsets are special.

# UPSET SCREW ENDS FOR ROUND BARS

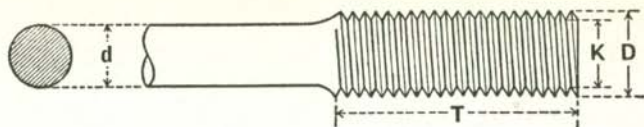

Thread: American Standard Free Fit—Class 2

BAR			UPSET					
Diameter d Inches	Area Sq. In.	Weight per Foot Lbs.	Diameter D Inches	Length T Inches	Additional Length for Upset +10% Inches	Diameter at Root of Thread K Inches	Area	
							At Root of Thread Sq. In.	Excess Over Area of Bar %
* 3/4	0.442	1.50	1	4	5	0.838	0.551	24.7
* 7/8	0.601	2.04	1 1/4	4	5 1/2	1.064	0.890	48.0
1	0.785	2.67	1 3/8	4	4	1.158	1.054	34.2
1 1/8	0.994	3.38	1 1/2	4	4	1.283	1.294	30.2
1 1/4	1.227	4.17	1 5/8	4	4	1.389	1.515	23.5
1 3/8	1.485	5.05	1 3/4	4	4	1.490	1.744	17.5
1 1/2	1.767	6.01	2	4 1/2	4 1/2	1.711	2.300	30.2
1 5/8	2.074	7.05	2 1/8	4 1/2	4	1.836	2.649	27.7
1 3/4	2.405	8.18	2 1/4	5	4	1.961	3.021	25.6
1 7/8	2.761	9.39	2 3/8	5	4	2.086	3.419	23.8
2	3.142	10.68	2 1/2	5 1/2	4	2.175	3.716	18.3
2 1/8	3.547	12.06	2 5/8	5 1/2	3 1/2	2.300	4.156	17.2
2 1/4	3.976	13.52	2 7/8	6	4 1/2	2.550	5.108	28.4
2 3/8	4.430	15.06	3	6	4 1/2	2.629	5.428	22.5
2 1/2	4.909	16.69	3 1/4	6 1/2	5 1/2	2.879	6.509	32.6
2 5/8	5.412	18.40	3 1/4	6 1/2	4 1/2	2.879	6.509	20.3
2 3/4	5.940	20.19	3 1/2	7	5 1/2	3.100	7.549	27.1
2 7/8	6.492	22.07	3 3/4	7	6	3.317	8.641	33.1
3	7.069	24.03	3 3/4	7	5	3.317	8.641	22.2
3 1/8	7.670	26.08	4	7 1/2	6	3.567	9.993	30.3
3 1/4	8.296	28.21	4	7 1/2	5	3.567	9.993	20.5
3 3/8	8.946	30.42	4 1/4	8	5 1/2	3.798	11.330	26.6
3 1/2	9.621	32.71	4 1/4	8	5	3.798	11.330	17.8
3 5/8	10.321	35.09	4 1/2	8 1/2	5 1/2	4.028	12.741	23.4
3 3/4	11.045	37.55	4 3/4	8 1/2	6	4.255	14.221	28.8
3 7/8	11.793	40.10	4 3/4	8 1/2	5 1/2	4.255	14.221	20.6

\*Upsets are special.

# LOOP RODS AND STUB ENDS

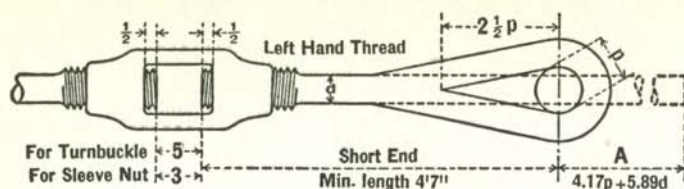

Thread: American Standard Free Fit—Class 2

Pin Diam. p Inches	LENGTH "A" FOR ONE LOOP IN FEET AND INCHES										
	Size of Square or Round Bar, d, in Inches										
	3/4	7/8	1	1 1/8	1 1/4	1 3/8	1 1/2	1 5/8	1 3/4	1 7/8	2
1 1/8	0- 9 1/2	0-10	0-11	0-11 1/2	.....	.....	.....	.....	.....	.....	.....
1 1/4	0-10	0-10 1/2	0-11 1/2	1- 0	1- 1	1- 2	1- 2 1/2	.....	.....	.....	.....
1 1/2	0-11	0-11 1/2	1- 0 1/2	1- 1	1- 2	1- 3	1- 3 1/2	1- 4 1/2	1- 5	1- 6	.....
1 3/4	1- 0	1- 0 1/2	1- 1 1/2	1- 2	1- 3	1- 3 1/2	1- 4 1/2	1- 5	1- 6	.....	.....
2	1- 1	1- 1 1/2	1- 2 1/2	1- 3	1- 4	1- 4 1/2	1- 5 1/2	1- 6	1- 7	1- 7 1/2	1- 8 1/2
2 1/4	1- 2	1- 3	1- 3 1/2	1- 4 1/2	1- 5	1- 5 1/2	1- 6 1/2	1- 7	1- 8	1- 8 1/2	1- 9 1/2
2 1/2	1- 3	1- 4	1- 4 1/2	1- 5 1/2	1- 6	1- 7	1- 7 1/2	1- 8	1- 9	1- 9 1/2	1-10 1/2
2 3/4	1- 4	1- 5	1- 5 1/2	1- 6 1/2	1- 7	1- 8	1- 8 1/2	1- 9 1/2	1-10	1-11	1-11 1/2
3	1- 5	1- 6	1- 6 1/2	1- 7 1/2	1- 8	1- 9	1- 9 1/2	1-10 1/2	1-11	2- 0	2- 0 1/2
*3 1/4	1- 6	1- 7	1- 7 1/2	1- 8 1/2	1- 9	1-10	1-10 1/2	1-11 1/2	2- 0	2- 1	2- 1 1/2
3 1/2	1- 7 1/2	1- 8	1- 8 1/2	1- 9 1/2	1-10	1-11	1-11 1/2	2- 0 1/2	2- 1	2- 2	2- 2 1/2
*3 3/4	1- 8 1/2	1- 9	1-10	1-10 1/2	1-11	2- 0	2- 0 1/2	2- 1 1/2	2- 2	2- 3	2- 3 1/2
4	1- 9 1/2	1-10	1-11	1-11 1/2	2- 0 1/2	2- 1	2- 2	2- 2 1/2	2- 3	2- 4	2- 4 1/2
*4 1/4	.....	1-11	2- 0	2- 0 1/2	2- 1 1/2	2- 2	2- 3	2- 3 1/2	2- 4 1/2	2- 5	2- 6
4 1/2	.....	2- 0	2- 1	2- 1 1/2	2- 2 1/2	2- 3	2- 4	2- 4 1/2	2- 5 1/2	2- 6	2- 7
*4 3/4	.....	2- 1	2- 2	2- 2 1/2	2- 3 1/2	2- 4	2- 5	2- 5 1/2	2- 6 1/2	2- 7	2- 8
5	.....	2- 2 1/2	2- 3	2- 3 1/2	2- 4 1/2	2- 5	2- 6	2- 6 1/2	2- 7 1/2	2- 8	2- 9
*5 1/4	.....	.....	2- 4	2- 5	2- 5 1/2	2- 6	2- 7	2- 7 1/2	2- 8 1/2	2- 9	2-10
5 1/2	.....	.....	2- 5	2- 6	2- 6 1/2	2- 7 1/2	2- 8	2- 9	2- 9 1/2	2-10	2-11
*5 3/4	.....	.....	2- 6	2- 7	2- 7 1/2	2- 8 1/2	2- 9	2-10	2-10 1/2	2-11 1/2	3- 0
6	.....	.....	2- 7	2- 8	2- 8 1/2	2- 9 1/2	2-10	2-11	2-11 1/2	3- 0 1/2	3- 1
*6 1/4	.....	.....	.....	2- 9	2- 9 1/2	2-10 1/2	2-11	3- 0	3- 0 1/2	3- 1 1/2	3- 2
6 1/2	.....	.....	.....	2-10	2-10 1/2	2-11 1/2	3- 0	3- 1	3- 1 1/2	3- 2 1/2	3- 3
*6 3/4	.....	.....	.....	2-11	3- 0	3- 0 1/2	3- 1	3- 2	3- 2 1/2	3- 3 1/2	3- 4
7	.....	.....	.....	3- 0	3- 1	3- 1 1/2	3- 2 1/2	3- 3	3- 3 1/2	3- 4 1/2	3- 5

\*Pins are special.

Maximum shipping length of long end = 35 feet.

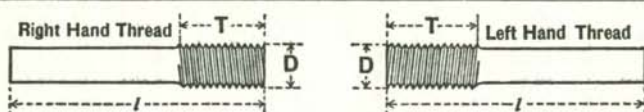

Diameter of Round, In.	3/4	.....	7/8	1	1 1/8	1 1/4	1 3/8	.....	1 1/2	1 5/8	1 3/4	1 7/8	2
Side of Square, In.....	.....	3/4	7/8	.....	1	1 1/8	.....	1 1/4	1 3/8	.....	1 1/2	1 5/8	1 3/4
Diameter of Upset, D, In.	1	1 1/8	1 1/4	1 3/8	1 1/2	1 5/8	1 3/4	1 7/8	2	2 3/8	2 1/4	2 3/8	2 1/2
Length of Upset, T, In.	4	4	4	4	4	4	4	4 1/2	4 1/2	4 1/2	5	5	5 1/2
Length, I, In.....	9 1/2	9 1/2	10	10 1/2	10 1/2	11	11 1/2	11 1/2	11 1/2	11 1/2	12	12 1/2	13

# CLEVISES

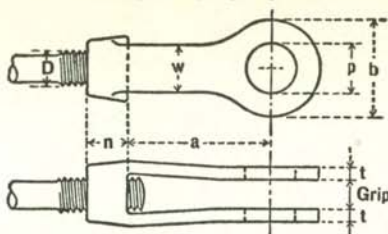

Thread: American Standard Free Fit—Class 2

Grip = thickness plate + 1/4"

Clevise Number	Dimensions, Inches							Weight Pounds
	Max. D	Max. p	b	n	a	w	t	
2 1/2	7/8	1 1/4	2 1/2	1	5	1 1/4	3/8	2.5
3	1 1/4	1 1/2	3	1 1/4	5	1 1/2	1/2	4.0
3 1/2	1 1/2	1 3/4	3 1/2	1 1/2	6	1 3/4	1/2	6.0
4	1 3/4	2	4	1 3/4	6	2	1/2	8.0
5	2 1/8	2 1/2	5	2 1/4	7	2 1/2	5/8	16.0
6	2 5/8	3	6	2 3/4	8	3	3/4	26.0
7	3	3 1/2	7	3	9	3 1/2	7/8	36.0
8	4	4 1/4	8	4	10	4	1 1/4	71.0

## CLEVIS NUMBERS FOR VARIOUS RODS AND PINS

Upset Rods Nominal Size		Diameter of Tap D	Diameter of Pin, Inches															
Round	Square		7/8	1	1 1/4	1 1/2	1 3/4	2	2 1/4	2 1/2	2 3/4	3	3 1/4	3 1/2	3 3/4	4	4 1/4	
		5/8	2 1/2	2 1/2	2 1/2													
		3/4	2 1/2	2 1/2	2 1/2													
		7/8	2 1/2	2 1/2	2 1/2													
3/4		1	...	3	3	3	3 1/2											
	3/4	1 1/8	...	3	3	3	3 1/2											
7/8	7/8	1 1/4	...	3	3	3	3 1/2	4										
1		1 3/8	...	...	3 1/2	3 1/2	3 1/2	4	4									
1 1/8	1	1 1/2	...	...	3 1/2	3 1/2	4	4	5									
1 1/4	1 1/8	1 5/8	...	...	...	4	4	5	5	5								
1 3/8		1 3/4	...	...	...	4	5	5	5	5								
	1 1/4	1 7/8	...	...	...	5	5	5	5	5								
1 1/2	1 3/8	2	...	...	...	5	5	5	5	6	6							
1 5/8		2 1/8	...	...	...	5	5	5	6	6	6	6						
1 3/4	1 1/2	2 1/4	...	...	...	...	...	6	6	6	6	6	7	7	7			
1 7/8	1 5/8	2 3/8	...	...	...	...	...	6	6	6	6	6	7	7	7	8		
2	1 3/4	2 1/2	...	...	...	...	...	6	6	6	7	7	7	7	7	8		
2 1/8		2 5/8	...	...	...	...	...	...	...	7	7	7	7	7	7	8		
	1 7/8	2 3/4	...	...	...	...	...	...	...	7	7	7	7	7	8	8		
2 1/4	2	2 7/8	...	...	...	...	...	...	...	7	7	7	7	8	8	8	8	
2 3/8	2 1/8	3	...	...	...	...	...	...	...	7	7	8	8	8	8	8	8	
		3 1/8	...	...	...	...	...	...	...	...	8	8	8	8	8	8	8	
2 1/2-2 5/8	2 1/4	3 1/4	...	...	...	...	...	...	...	...	8	8	8	8	8	8	8	
		3 3/8	...	...	...	...	...	...	...	...	8	8	8	8	8	8	8	
2 3/4	2 3/8	3 1/2	...	...	...	...	...	...	...	...	8	8	8	8	8	8	8	
		3 5/8	...	...	...	...	...	...	...	...	8	8	8	8	8	8	8	
2 7/8-3	2 1/2-2 5/8	3 3/4	...	...	...	...	...	...	...	...	8	8	8	8	8	8	8	
		3 7/8	...	...	...	...	...	...	...	...	8	8	8	8	8	8	8	
3 1/8-3 1/4	2 3/4	4	...	...	...	...	...	...	...	...	8	8	8	8	8	8	8	

Weights and dimensions of clevises are Cleveland City Forge Co. Standard. Similar products of other manufacturers are essentially the same.



# RECESSED PIN NUTS AND COTTER PINS

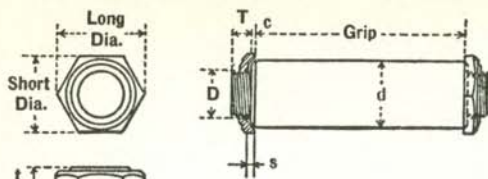

Thread  
Shape: American Standard  
Free Fit—Class 2  
Pitch: 6 per inch

Material: Pressed Steel

Diameter of Pin d	PIN			Thick- ness t	NUT				Diameter Rough Hole	Weight Pounds	
	Thread				Diameter		Recess				
	D	T	c		Short Diam.	Long Diam.	Rough Diam.	s			
2	2 1/4	1 1/2	1	1/8	7/8	3	3 3/8	2 5/8	1/4	1 1/4	1
2 1/2	2 3/4	2	1 1/8	1/8	1	3 5/8	4 1/8	3 1/8	1/4	1 3/4	2
3	3 1/4	2 1/2	1 3/4	1/8	1 1/8	4 3/8	5	3 7/8	3/8	2 1/4	3
	3 3/4	3	1 5/8	1/4	1 1/4	4 7/8	5 5/8	4 3/8	3/8	2 3/4	4
4 1/4	4 1/2	3 1/2	1 1/2	1/4	1 3/8	5 3/4	6 5/8	5 1/4	1/2	3 1/4	5
	5	4	1 5/8	1/4	1 1/2	6 1/4	7 1/4	5 3/4	1/2	3 3/4	6
5 1/2	5 3/4	4 1/2	1 3/4	1/4	1 5/8	7	8 1/8	6 1/2	5/8	4 1/4	8
	6 1/4	5	1 7/8	3/8	1 3/4	7 5/8	8 7/8	7	5/8	4 3/4	10
	6 3/4	5 1/2	2	3/8	1 7/8	8 1/8	9 3/8	7 1/2	3/4	5 1/4	12
	7 1/4	5 1/2	2	3/8	1 7/8	8 5/8	10	8	3/4	5 1/4	14
7 3/4	8	6	2 1/4	3/8	2 1/8	9 3/8	10 7/8	8 3/4	3/4	5 3/4	19
8 1/2	8 3/4	6	2 1/4	3/8	2 1/8	10 1/4	11 7/8	9 5/8	3/4	5 3/4	24
	9 1/4	6	2 3/8	3/8	2 1/4	11 1/4	13	10 5/8	3/4	5 3/4	32
	9 3/4	6	2 3/8	3/8	2 1/4	11 1/4	13	10 5/8	3/4	5 3/4	32

\*Special Sizes

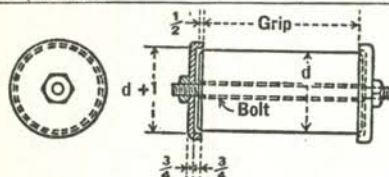

TYPICAL PIN CAP DETAIL FOR PINS  
OVER 10 INCHES IN DIAMETER  
Dimensions shown are approximate.

Recessed Pin Nuts similar to those listed above are available, in cast steel, for pins up to 24 inches in diameter.

For pins over 10 inches in diameter, however, the preferred practice is a detail similar to that shown at the left, in which the pin is held in place by a recessed cap at each end and secured by a bolt passing completely through the caps and pin. Suitable provision must be made for attaching pilots and driving nuts.

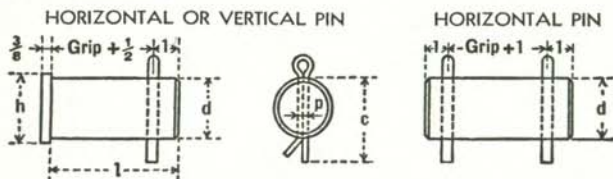

l = Length of Pin, in inches.

Pin Diam. d	PINS WITH HEADS		COTTER			Pin Diam. d	PINS WITH HEADS		COTTER		
	Head Diam. h	Weight of One. Lb.	Length c	Diam. p	Weight per 100. Lb.		Head Diam. h	Weight of One. Lb.	Length c	Diam. p	Weight per 100. Lb.
1 1/4	1 1/2	.19 + .35l	2	1/4	2.64	2 3/4	3 1/8	.82 + 1.68l	4	3/8	11.4
1 1/2	1 3/4	.26 + .50l	2 1/2	1/4	3.10	3	3 1/2	1.02 + 2.00l	5	1/2	28.5
1 3/4	2	.33 + .68l	2 3/4	1/4	3.50	3 1/4	3 3/4	1.17 + 2.35l	5	1/2	28.5
2	2 3/8	.47 + .89l	3	3/8	9.00	3 1/2	4	1.34 + 2.73l	6	1/2	33.8
2 1/4	2 5/8	.58 + 1.13l	3 1/4	3/8	9.40	3 3/4	4 1/4	1.51 + 3.13l	6	1/2	33.8
2 1/2	2 7/8	.70 + 1.39l	3 3/4	3/8	10.9						

# EYE BARS

## AMERICAN BRIDGE COMPANY STANDARD

EYE BAR

ADJUSTABLE EYE BAR



Minimum length, L, for short end is 6'-6", preferably 7'-0". Left thread.  
Thread: American Standard Free Fit—Class 2

HEADS FOR ALL BARS						SCREW ENDS FOR ADJUSTABLE BARS										
Size of Bar			Head			Add. Material A Ft. In.	Size of Bar			Upset End				Add. Material B Ft. In.		
Width In.	Thickness		Diam. b In.	Max. Pin In.	Excess Head over Bar %		Width In.	Min. Thickness In.	Area In. <sup>2</sup>	Diam. D In.	Lgth. T In.	Thds. per Inch	At Root of Thread			
	Max. In.	Min. In.										Diam. In.	Area In. <sup>2</sup>	Excess over Bar %		
2	1	1/2	4 1/2	1 3/4	37.5	0-10 1/2	2	* 5/8	1.25	1 3/4	4	5	1.49	1.74	39.6	1-0
			5 1/2	2 3/4		1- 2 1/2		3/4	1.50	1 7/8	5	1.62	2.05	36.6	1-0	
			* 6 1/2	3 3/4		1- 7 1/2		7/8	1.75	2	4 1/2	1.71	2.30	31.4	0-11	
2 1/2	1	5/8	6	2 1/2	40.0	1- 1 3/4	2 1/2	* 3/4	1.88	2 1/8	4 1/2	4 1/2	1.84	2.65	41.2	1-0
			7	3 1/2		1- 5 3/4		7/8	2.19	2 1/4	5	1.96	3.02	38.1	1-0	
			* 8	4 1/2		1-10 3/4		1	2.50	2 3/8	5	2.09	3.42	36.7	1-0	
3	1 1/2	5/8	7 1/2	3 1/4	41.7	1- 4 1/2	3	* 3/4	2.25	2 1/2	5	4 1/2	1.96	3.02	34.3	1-0
			8 1/2	4 1/4		1- 9 1/2		7/8	2.63	2 1/2	5 1/2	2.18	3.72	41.6	1-1	
			* 9 1/2	5 1/4		2- 2 1/2		1	3.00	2 1/2	5 1/2	2.18	3.72	23.9	1-1	
4	1 3/4	7/8	10	4 1/2	37.5	1-9	4	* 3/4	3.00	2 1/2	5 1/2	4	2.18	3.72	23.9	1-1
			11	5 1/2		2- 3		7/8	3.50	2 3/4	5 1/2	2.43	4.62	32.0	0-11	
			1	6 1/2		2- 8		1	4.00	3	6	2.63	5.43	35.7	1-1	
5	2	3/4	12	5 1/4	35.0	1-10 1/2	5	* 3/4	3.75	2 7/8	6	3 1/2	2.55	5.11	36.2	1-0
			13 1/2	6 3/4		2- 6		7/8	4.38	3	6	2.63	5.43	24.1	0-11	
			* 15	8 1/4		3- 3		1	5.00	3 1/4	6 1/2	2.88	6.51	30.2	1-0	
6	2	1	14	5 3/4	37.5	2- 1	6	* 1	6.00	3 1/2	7	3 1/4	3.10	7.55	34.2	1-1
			14 3/4	6 1/2		2- 4		1 1/8	6.25	3 3/4	7	3.32	8.64	38.3	1-2	
			* 16 1/2	8 1/4		3- 2		1 1/4	7.50	4	7 1/2	3	3.57	9.99	33.2	1-1
7	2	1 1/8	16 1/2	7	35.7	2- 6 1/2	7	1 1/8	7.88	4 1/4	8	2 7/8	3.80	11.3	37.1	1-2
			17 1/2	8		2-11		1 1/4	8.75	4 1/2	8	3.57	9.99	33.2	1-1	
			* 18 1/2	9		3- 4		1 3/8	8.25	4 1/4	8	3.80	11.3	37.1	1-2	
8	2	1 1/8	18	7	37.5	2- 7 1/2	8	* 1 1/8	7.88	4 1/4	7 1/2	3	3.57	9.99	26.9	1-0
			19	8		2- 9 1/2		1 1/4	8.75	4 1/2	8	3.80	11.3	29.5	1-1	
			* 20	9		3- 4		1 3/8	9.63	4 1/2	8 1/2	4.03	12.7	32.4	1-2	
9	2	1 1/8	20	7 1/2	38.9	2- 8 1/2	9	1 1/2	10.5	4 3/4	8 1/2	2 7/8	4.26	14.2	35.4	1-2
			22	9 1/2		3- 4 1/2		1 1/4	10.0	4 1/2	8 1/2	4.03	12.7	27.4	1-2	
			22 1/2	9		3- 2 1/2		1 3/8	11.0	4 3/4	8 1/2	4.26	14.2	29.3	1-2	
10	2	1 1/4	24	10 1/2	35.0	3- 9	10	1 1/2	12.0	5	9	2 1/2	4.48	15.8	31.4	1-2
			25	11 1/2		4- 1		1 5/8	13.0	5 1/4	9 1/2	4.73	17.6	35.2	1-3	
			26 1/2	10		3- 6		1 3/8	12.4	5	9 1/4	4.48	15.8	28.3	1-2	
12	2	1 3/8	28	11 1/2	37.5	4- 2	12	1 3/8	13.5	5 1/4	9 1/4	2 1/2	4.73	17.6	30.2	1-1
			29 1/2	13		4- 8		1 5/8	14.6	5 1/2	9 3/4	4.95	19.3	31.7	1-1	
			31	12		4- 3		1 5/8	13.8	5 1/4	9 1/4	4.73	17.6	27.8	1-1	
14	2	1 1/2	33	14	35.7	4-10	14	1 1/2	15.0	5 1/2	9 3/4	2 3/8	4.95	19.3	28.9	1-1
			34	15		5- 5		1 5/8	16.3	5 3/4	10	5.20	21.3	30.8	1-1	
			31	12		4- 3		1 1/2	18.0	6	10 1/2	5.42	23.1	28.3	1-1	
16	2	1 3/4	36	14	37.5	4- 9	16	1 3/4	19.5	6 1/4	10 3/4	2 1/4	5.73	25.8	29.6	1-1
			37 1/2	16		5- 4		1 3/4	21.0	6 1/2	11	5.89	27.3	29.7	1-1	
			37 1/2	16		5- 4		1 3/4	21.0	6 1/2	11	5.89	27.3	29.7	1-1	

Pin holes to be deducted in estimating weight. \*Bars are special.  
NOTE: For Bars 14" x 1 3/4" (and thicker) with 33" head add material "A" = 4'-5 3/4".

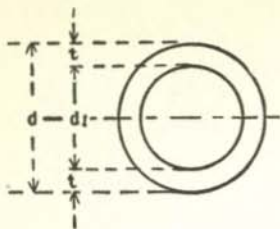

# PIPE COLUMNS

## STANDARD PIPE

Nominal Diameter	DIAMETERS				Thick-ness t	Weight per Foot	Area of Section	I	S	r
	Outside d		Inside d <sub>i</sub>							
	Fractions	Decimals	Fractions	Decimals						
In.	In.	In.	In.	In.	Lb.	In. <sup>2</sup>	In. <sup>4</sup>	In. <sup>3</sup>	In.	
1	1 <sup>3</sup> / <sub>16</sub>	1.315	1 <sup>1</sup> / <sub>16</sub>	1.049	.133	1.678	.494	.087	.133	.42
1 <sup>1</sup> / <sub>2</sub>	1 <sup>7</sup> / <sub>8</sub>	1.900	1 <sup>5</sup> / <sub>8</sub>	1.610	.145	2.717	.800	.310	.326	.62
2	2 <sup>3</sup> / <sub>8</sub>	2.375	2 <sup>1</sup> / <sub>16</sub>	2.067	.154	3.652	1.075	.666	.561	.79
2 <sup>1</sup> / <sub>2</sub>	2 <sup>7</sup> / <sub>8</sub>	2.875	2 <sup>1</sup> / <sub>2</sub>	2.469	.203	5.793	1.704	1.530	1.064	.95
3	3 <sup>1</sup> / <sub>2</sub>	3.500	3 <sup>1</sup> / <sub>16</sub>	3.068	.216	7.575	2.228	3.017	1.724	1.16
4	4 <sup>1</sup> / <sub>2</sub>	4.500	4	4.026	.237	10.790	3.174	7.233	3.214	1.51
4	4 <sup>1</sup> / <sub>2</sub>	4.500	3 <sup>13</sup> / <sub>16</sub>	3.826	.337	14.983	4.407	9.610	4.271	1.48
4	4 <sup>1</sup> / <sub>2</sub>	4.500	3 <sup>1</sup> / <sub>8</sub>	3.152	.674	27.541	8.101	15.28	6.793	1.37
5	5 <sup>9</sup> / <sub>16</sub>	5.563	5 <sup>1</sup> / <sub>16</sub>	5.047	.258	14.617	4.300	15.16	5.451	1.88
5	5 <sup>9</sup> / <sub>16</sub>	5.563	4 <sup>13</sup> / <sub>16</sub>	4.813	.375	20.778	6.112	20.67	7.431	1.84
5	5 <sup>9</sup> / <sub>16</sub>	5.563	4 <sup>1</sup> / <sub>16</sub>	4.063	.750	38.552	11.34	33.63	12.09	1.72
6	6 <sup>5</sup> / <sub>8</sub>	6.625	6 <sup>1</sup> / <sub>16</sub>	6.065	.280	18.974	5.581	28.14	8.496	2.25
6	6 <sup>5</sup> / <sub>8</sub>	6.625	5 <sup>3</sup> / <sub>4</sub>	5.761	.432	28.573	8.405	40.49	12.22	2.20
6	6 <sup>5</sup> / <sub>8</sub>	6.625	4 <sup>7</sup> / <sub>8</sub>	4.897	.864	53.160	15.64	66.33	20.02	2.06
8	8 <sup>5</sup> / <sub>8</sub>	8.625	8 <sup>1</sup> / <sub>16</sub>	8.071	.277	24.696	7.265	63.35	14.69	2.95
8	8 <sup>5</sup> / <sub>8</sub>	8.625	8	7.981	.322	28.554	8.399	72.49	16.81	2.94
8	8 <sup>5</sup> / <sub>8</sub>	8.625	7 <sup>5</sup> / <sub>8</sub>	7.625	.500	43.388	12.76	105.7	24.51	2.88
8	8 <sup>5</sup> / <sub>8</sub>	8.625	6 <sup>7</sup> / <sub>8</sub>	6.875	.875	72.424	21.30	162.0	37.56	2.76
10	10 <sup>3</sup> / <sub>4</sub>	10.750	10 <sup>9</sup> / <sub>16</sub>	10.192	.279	31.201	9.178	125.9	23.42	3.70
10	10 <sup>3</sup> / <sub>4</sub>	10.750	10 <sup>1</sup> / <sub>8</sub>	10.136	.307	34.240	10.07	137.4	25.57	3.69
10	10 <sup>3</sup> / <sub>4</sub>	10.750	10	10.020	.365	40.483	11.91	160.7	29.90	3.67
10	10 <sup>3</sup> / <sub>4</sub>	10.750	9 <sup>3</sup> / <sub>4</sub>	9.750	.500	54.735	16.10	212.0	39.43	3.63
12	12 <sup>3</sup> / <sub>4</sub>	12.750	12 <sup>1</sup> / <sub>16</sub>	12.090	.330	43.773	12.88	248.5	38.97	4.39
12	12 <sup>3</sup> / <sub>4</sub>	12.750	12	12.000	.375	49.562	14.58	279.3	43.82	4.38
12	12 <sup>3</sup> / <sub>4</sub>	12.750	11 <sup>3</sup> / <sub>4</sub>	11.750	.500	65.415	19.24	361.5	56.71	4.34

## EXPLANATION OF TABLE OF ECONOMY OF CB BEAMS BY SECTION MODULUS

The tables on following pages list CB Sections for the given section modulus in the order of the most economical sections for various depths. Efficiencies decrease from left to right across the page.

The section modulus in the first column is the maximum for the beams listed in that line. When a desired section modulus lies between two adjacent values shown in the table, use the line of higher value.

Only the most economical shape of equal or higher section modulus is shown for any given depth. No depth is given whose most economical shape is surpassed in economy by a beam of less depth. In general, the shapes given under the heading "First Selection" are the most economical. There are, however, cases in which deeper beams of equal economy are available. If the "First Selection" is too deep for framing, use the next selection in that line which has a suitable depth. It will be the most economical CB Section for the given conditions of required strength and depth.

**EXAMPLE:** Select a beam for section modulus of 150 with depth not over 17 inches.

In the table, opposite the next higher section modulus, namely 150.6, we find that CB 211 x 73 is the most economical section but since the depth must be less than 17 inches, we find under column "Third Selection" that CB 163 x 88 is the proper one to use. The actual depth of this section is 16.16 inches and the section modulus 151.3 inches<sup>3</sup>.

All beams are to be secured against lateral deflection.

# ECONOMY OF CB BEAMS BY SECTION MODULUS

Section Modulus Inches <sup>3</sup>	CB SECTION—INDEX AND WEIGHT PER FOOT					
	First Selection	Second Selection	Third Selection	Fourth Selection	Fifth Selection	Sixth Selection
1105.1	CB 362 x 300					
1031.2	CB 362 x 280					
951.1	CB 362 x 260					
911.7	CB 362 x 250					
873.6	CB 362 x 240					
835.5	CB 362 x 230					
811.1	CB 362 x 230	CB 332 x 240				
740.6	CB 332 x 220					
704.4	CB 332 x 210					
669.6	CB 332 x 200					
663.6	CB 361 x 194	CB 332 x 200				
649.9	CB 361 x 194	CB 332 x 200	CB 302 x 210			
621.2	CB 361 x 182	CB 332 x 200	CB 302 x 210			
617.6	CB 361 x 182	CB 332 x 200	CB 302 x 200			
586.1	CB 361 x 182	CB 302 x 190				
579.1	CB 361 x 170	CB 302 x 190				
555.2	CB 361 x 170	CB 302 x 180				
541.0	CB 361 x 160	CB 302 x 180				
528.2	CB 361 x 160	CB 302 x 172				
502.9	CB 361 x 150	CB 302 x 172				
492.8	CB 361 x 150	CB 302 x 172	CB 272 x 177			
486.4	CB 361 x 150	CB 331 x 152	CB 302 x 172	CB 272 x 177		
452.9	CB 361 x 150	CB 331 x 152	CB 272 x 163			
446.8	CB 331 x 141	CB 272 x 163				
427.8	CB 331 x 141	CB 272 x 154				
413.5	CB 331 x 132	CB 272 x 154	CB 243 x 160			
402.9	CB 331 x 132	CB 272 x 145	CB 243 x 160			
385.5	CB 331 x 132	CB 272 x 145	CB 243 x 150			
385.1	CB 331 x 125	CB 272 x 145	CB 243 x 150			
379.7	CB 331 x 125	CB 301 x 132	CB 272 x 145	CB 243 x 150		
358.6	CB 331 x 125	CB 301 x 132	CB 243 x 140			
354.6	CB 301 x 124	CB 243 x 140				
330.7	CB 301 x 124	CB 243 x 130				
327.9	CB 301 x 116	CB 243 x 130				
317.2	CB 301 x 116	CB 243 x 130	CB 213 x 142			
299.1	CB 301 x 108	CB 271 x 114	CB 242 x 120	CB 213 x 142		
294.8	CB 301 x 108	CB 271 x 114	CB 242 x 120	CB 213 x 132		
277.2	CB 271 x 106	CB 242 x 120	CB 213 x 132			
274.4	CB 271 x 106	CB 242 x 110	CB 213 x 132			
272.5	CB 271 x 106	CB 242 x 110	CB 213 x 122			
255.3	CB 271 x 98	CB 242 x 110	CB 213 x 122			
249.6	CB 271 x 98	CB 242 x 110	CB 213 x 112			
248.9	CB 271 x 98	CB 242 x 100	CB 213 x 112			
239.0	CB 271 x 98	CB 242 x 100	CB 213 x 112	CB 183 x 124		
233.2	CB 271 x 91	CB 242 x 100	CB 213 x 112	CB 183 x 124		
220.9	CB 271 x 91	CB 241 x 94	CB 213 x 112	CB 183 x 124		
220.1	CB 271 x 91	CB 241 x 94	CB 213 x 112	CB 183 x 114		
216.0	CB 271 x 91	CB 241 x 94	CB 213 x 112	CB 183 x 114	CB 145 x 136	
213.1	CB 271 x 91	CB 241 x 94	CB 212 x 103	CB 183 x 114	CB 145 x 136	
204.3	CB 241 x 87	CB 212 x 103	CB 183 x 114	CB 145 x 136		
202.0	CB 241 x 87	CB 212 x 103	CB 183 x 105	CB 145 x 127		
197.4	CB 241 x 87	CB 212 x 96	CB 183 x 105	CB 163 x 114	CB 145 x 127	

# ECONOMY OF CB BEAMS BY SECTION MODULUS

CB SECTION—INDEX AND WEIGHT PER FOOT

Section Modulus Inches <sup>3</sup>	First Selection	Second Selection	Third Selection	Fourth Selection	Fifth Selection	Sixth Selection
189.4	CB 241 x 87	CB 212 x 96	CB 183 x 105	CB 163 x 114	CB 145 x 119	
185.8	CB 241 x 80	CB 212 x 96	CB 183 x 105	CB 163 x 114	CB 145 x 119	
184.4	CB 241 x 80	CB 212 x 96	CB 183 x 96	CB 163 x 114	CB 145 x 119	
182.8	CB 241 x 80	CB 212 x 89	CB 183 x 96	CB 163 x 114	CB 145 x 119	
181.7	CB 241 x 80	CB 212 x 89	CB 183 x 96	CB 163 x 105	CB 145 x 119	
176.3	CB 241 x 80	CB 212 x 89	CB 183 x 96	CB 163 x 105	CB 145 x 111	
170.4	CB 241 x 74	CB 212 x 89	CB 183 x 96	CB 163 x 105	CB 145 x 111	
168.0	CB 241 x 74	CB 212 x 82	CB 183 x 96	CB 163 x 105	CB 145 x 111	
166.1	CB 241 x 74	CB 212 x 82	CB 183 x 96	CB 163 x 96	CB 145 x 111	
163.4	CB 241 x 74	CB 212 x 82	CB 183 x 96	CB 163 x 96	CB 145 x 103	CB 124 x 120
156.1	CB 241 x 74	CB 212 x 82	CB 182 x 85	CB 163 x 96	CB 145 x 103	CB 124 x 120
151.3	CB 241 x 74	CB 212 x 82	CB 182 x 85	CB 163 x 88	CB 145 x 103	CB 124 x 120
150.6	CB 211 x 73	CB 182 x 85	CB 163 x 88	CB 145 x 95	CB 124 x 120	
144.5	CB 211 x 73	CB 182 x 85	CB 163 x 88	CB 145 x 95	CB 124 x 106	
141.7	CB 211 x 73	CB 182 x 77	CB 163 x 88	CB 145 x 95	CB 124 x 106	
139.9	CB 211 x 68	CB 182 x 77	CB 163 x 88	CB 145 x 95	CB 124 x 106	
138.1	CB 211 x 68	CB 182 x 77	CB 145 x 87	CB 124 x 106		
134.7	CB 211 x 68	CB 182 x 77	CB 145 x 87	CB 124 x 99		
130.9	CB 211 x 68	CB 182 x 77	CB 144 x 84	CB 124 x 99		
128.2	CB 211 x 68	CB 182 x 70	CB 144 x 84	CB 124 x 99		
127.8	CB 211 x 63	CB 182 x 70	CB 162 x 78	CB 144 x 84	CB 124 x 99	
125.0	CB 211 x 63	CB 182 x 70	CB 162 x 78	CB 144 x 84	CB 124 x 92	
121.1	CB 211 x 63	CB 182 x 70	CB 162 x 78	CB 144 x 78	CB 124 x 92	
119.3	CB 211 x 59	CB 182 x 70	CB 162 x 78	CB 144 x 78	CB 124 x 92	
117.0	CB 211 x 59	CB 182 x 64	CB 162 x 78	CB 144 x 78	CB 124 x 92	
115.7	CB 211 x 59	CB 182 x 64	CB 162 x 71	CB 144 x 78	CB 124 x 85	
112.3	CB 211 x 59	CB 182 x 64	CB 162 x 71	CB 143 x 74	CB 124 x 85	CB 103 x 100
107.1	CB 211 x 59	CB 182 x 64	CB 162 x 71	CB 143 x 74	CB 124 x 79	CB 103 x 100
104.2	CB 211 x 59	CB 182 x 64	CB 162 x 64	CB 143 x 74	CB 124 x 79	CB 103 x 100
103.0	CB 211 x 59	CB 182 x 64	CB 162 x 64	CB 143 x 68	CB 124 x 79	CB 103 x 100
99.7	CB 211 x 59	CB 182 x 64	CB 162 x 64	CB 143 x 68	CB 124 x 79	CB 103 x 89
98.2	CB 181 x 55	CB 162 x 64	CB 143 x 68	CB 124 x 79	CB 103 x 89	
97.5	CB 181 x 55	CB 162 x 64	CB 143 x 68	CB 124 x 72	CB 103 x 89	
94.1	CB 181 x 55	CB 162 x 58	CB 143 x 68	CB 124 x 72	CB 103 x 89	
92.2	CB 181 x 55	CB 162 x 58	CB 143 x 61	CB 124 x 72	CB 103 x 89	
89.0	CB 181 x 50	CB 162 x 58	CB 143 x 61	CB 124 x 72	CB 103 x 89	
88.0	CB 181 x 50	CB 162 x 58	CB 143 x 61	CB 124 x 65	CB 103 x 89	
86.1	CB 181 x 50	CB 162 x 58	CB 143 x 61	CB 124 x 65	CB 103 x 77	
85.8	CB 181 x 50	CB 162 x 58	CB 143 x 61	CB 123 x 64	CB 103 x 77	
85.0	CB 181 x 50	CB 162 x 58	CB 142 x 58	CB 123 x 64	CB 103 x 77	
82.3	CB 181 x 47	CB 162 x 58	CB 142 x 58	CB 123 x 64	CB 103 x 77	
80.7	CB 181 x 47	CB 161 x 50	CB 142 x 58	CB 123 x 64	CB 103 x 77	
80.1	CB 181 x 47	CB 161 x 50	CB 142 x 58	CB 123 x 64	CB 103 x 72	
78.1	CB 181 x 47	CB 161 x 50	CB 142 x 58	CB 123 x 58	CB 103 x 72	
77.8	CB 181 x 47	CB 161 x 50	CB 142 x 53	CB 123 x 58	CB 103 x 72	
73.7	CB 181 x 47	CB 161 x 50	CB 142 x 53	CB 123 x 58	CB 103 x 66	
72.4	CB 161 x 45	CB 142 x 53	CB 123 x 58	CB 103 x 66		
70.7	CB 161 x 45	CB 142 x 53	CB 123 x 53	CB 103 x 66		
70.2	CB 161 x 45	CB 142 x 48	CB 123 x 53	CB 103 x 66		
67.1	CB 161 x 45	CB 142 x 48	CB 123 x 53	CB 103 x 60		
64.7	CB 161 x 45	CB 142 x 48	CB 122 x 50	CB 103 x 60		
64.4	CB 161 x 40	CB 142 x 48	CB 122 x 50	CB 103 x 60		

# ECONOMY OF CB BEAMS BY SECTION MODULUS

Section Modulus Inches <sup>3</sup>	CB SECTION—INDEX AND WEIGHT PER FOOT					
	First Selection	Second Selection	Third Selection	Fourth Selection	Fifth Selection	Sixth Selection
62.7	CB 161 x 40	CB 142 x 43	CB 122 x 50	CB 103 x 60		
60.7	CB 161 x 40	CB 141 x 42	CB 122 x 50	CB 103 x 60		
60.4	CB 161 x 40	CB 141 x 42	CB 122 x 50	CB 103 x 54	CB 83 x 67	
58.2	CB 161 x 40	CB 141 x 42	CB 122 x 45	CB 103 x 54	CB 83 x 67	
56.3	CB 161 x 36	CB 141 x 42	CB 122 x 45	CB 103 x 54	CB 83 x 67	
54.6	CB 161 x 36	CB 141 x 38	CB 122 x 45	CB 103 x 49	CB 83 x 67	
51.9	CB 161 x 36	CB 141 x 38	CB 122 x 40	CB 103 x 49	CB 83 x 58	
49.1	CB 161 x 36	CB 141 x 38	CB 122 x 40	CB 102 x 45	CB 83 x 58	
48.5	CB 141 x 34	CB 122 x 40	CB 102 x 45	CB 83 x 58		
45.9	CB 141 x 34	CB 121 x 36	CB 102 x 45	CB 83 x 58		
44.5	CB 141 x 34	CB 121 x 36	CB 102 x 41	CB 83 x 58		
43.2	CB 141 x 34	CB 121 x 36	CB 102 x 41	CB 83 x 48		
41.8	CB 141 x 30	CB 121 x 36	CB 102 x 41	CB 83 x 48		
40.7	CB 141 x 30	CB 121 x 32	CB 102 x 41	CB 83 x 48		
39.9	CB 141 x 30	CB 121 x 32	CB 102 x 37	CB 83 x 48		
35.5	CB 121 x 28	CB 102 x 37	CB 83 x 40			
35.0	CB 121 x 28	CB 102 x 33	CB 83 x 40			
31.1	CB 121 x 28	CB 102 x 33	CB 83 x 35			
30.8	CB 121 x 25	CB 101 x 29	CB 83 x 35			
29.3	CB 121 x 25	CB 101 x 29	CB 83 x 33			
27.6	CB 121 x 25	CB 101 x 26	CB 83 x 33			
27.4	CB 121 x 25	CB 101 x 26	CB 83 x 31			
27.0	CB 121 x 25	CB 101 x 26	CB 83 x 31			
25.3	CBL 12 x 22	CB 101 x 26	CB 83 x 31			
24.1	CBL 12 x 22	CB 101 x 23	CB 83 x 31			
23.4	CBL 12 x 22	CB 101 x 23	CB 82 x 27			
21.4	CBL 12 x 19	CB 101 x 21	CB 82 x 27			
20.8	CBL 12 x 19	CB 101 x 21	CB 82 x 24			
19.8	CBL 12 x 19	CB 101 x 21	CB 82 x 24			
18.8	CBL 12 x 19	CBL 10 x 19	CB 82 x 24			
18.0	CBL 12 x 19	CBL 10 x 19	CB 81 x 21			
17.5	CBL 12 x 16½	CBL 10 x 19	CB 81 x 21			
16.4	CBL 12 x 16½	CBL 10 x 19	CB 81 x 21			
16.2	CBL 12 x 16½	CBL 10 x 17	CB 81 x 21			
16.0	CBL 12 x 16½	CBL 10 x 17	CB 81 x 19			
14.8	CBL 12 x 16½	CBL 10 x 17	CB 81 x 19			
14.1	CBL 12 x 16½	CBL 10 x 17	CB 81 x 17			
13.8	CBL 10 x 15	CB 81 x 17				
13.1	CBL 10 x 15	CB 81 x 17				
11.8	CBL 10 x 15	CBL 8 x 15				
11.5	CBL 10 x 15	CBL 8 x 15				
10.1	CBL 10 x 15	CBL 8 x 15	CBL 6 x 16			
9.94	CBL 10 x 15	CBL 8 x 15	CBL 6 x 16			
9.88	CBL 8 x 13	CBL 6 x 16				
9.7	CBL 8 x 13					
8.53	CBL 8 x 13					
7.24	CBL 6 x 12					
7.02	CBL 6 x 12					
5.45	CBL 6 x 12					

# DECIMAL OF AN INCH AND OF A FOOT

Fractions of Inch or Foot		Inch Equivalents to Foot Fractions	Fractions of Inch or Foot		Inch Equivalents to Foot Fractions	Fractions of Inch or Foot		Inch Equivalents to Foot Fractions
1/64	.0052	1/16	.2552	31/16	.5052	61/16	.7552	91/16
	.0104	1/8	.2604	31/8	.5104	61/8	.7604	91/8
	.015625	3/16	.265625	33/16	.515625	63/16	.765625	93/16
	.0208	1/4	.2708	31/4	.5208	61/4	.7708	91/4
1/32	.0260	3/16	.2760	33/16	.5260	63/16	.7760	93/16
	.03125	3/8	.28125	33/8	.53125	63/8	.78125	93/8
	.0365	7/16	.2865	37/16	.5365	67/16	.7865	97/16
	.0417	1/2	.2917	31/2	.5417	61/2	.7917	91/2
3/64	.046875	9/16	.296875	39/16	.546875	69/16	.796875	99/16
	.0521	5/8	.3021	35/8	.5521	65/8	.8021	95/8
	.0573	11/16	.3073	311/16	.5573	611/16	.8073	911/16
	.0625	3/4	.3125	33/4	.5625	63/4	.8125	93/4
1/16	.0677	13/16	.3177	313/16	.5677	613/16	.8177	913/16
	.0729	7/8	.3229	37/8	.5729	67/8	.8229	97/8
	.078125	15/16	.328125	315/16	.578125	615/16	.828125	915/16
	.0833	1	.3333	4	.5833	7	.8333	10
3/32	.0885	11/16	.3385	41/16	.5885	71/16	.8385	101/16
	.09375	11/8	.34375	41/8	.59375	71/8	.84375	101/8
	.0990	13/16	.3490	43/16	.5990	73/16	.8490	103/16
	.1042	11/4	.3542	41/4	.6042	71/4	.8542	101/4
7/64	.109375	13/16	.359375	45/16	.609375	75/16	.859375	105/16
	.1146	13/8	.3646	43/8	.6146	73/8	.8646	103/8
	.1198	17/16	.3698	47/16	.6198	77/16	.8698	107/16
	.1250	11/2	.3750	41/2	.6250	71/2	.8750	101/2
1/8	.1302	13/8	.3802	43/8	.6302	73/8	.8802	103/8
	.1354	13/8	.3854	43/8	.6354	73/8	.8854	103/8
	.140625	111/16	.390625	411/16	.640625	711/16	.890625	1011/16
	.1458	13/4	.3958	43/4	.6458	73/4	.8958	103/4
5/32	.1510	113/16	.4010	413/16	.6510	713/16	.9010	1013/16
	.15625	17/8	.40625	47/8	.65625	77/8	.90625	107/8
	.1615	113/16	.4115	413/16	.6615	713/16	.9115	1013/16
	.1667	2	.4167	5	.6667	8	.9167	11
11/64	.171875	21/16	.421875	51/16	.671875	81/16	.921875	111/16
	.1771	21/8	.4271	51/8	.6771	81/8	.9271	111/8
	.1823	23/16	.4323	53/16	.6823	83/16	.9323	113/16
	.1875	21/4	.4375	51/4	.6875	81/4	.9375	111/4
3/16	.1927	23/16	.4427	53/16	.6927	83/16	.9427	113/16
	.1979	23/8	.4479	53/8	.6979	83/8	.9479	113/8
	.203125	27/16	.453125	57/16	.703125	87/16	.953125	117/16
	.2083	23/2	.4583	51/2	.7083	81/2	.9583	111/2
7/32	.2135	29/16	.4635	59/16	.7135	89/16	.9635	119/16
	.21875	25/8	.46875	55/8	.71875	85/8	.96875	115/8
	.2240	211/16	.4740	511/16	.7240	811/16	.9740	1111/16
	.2292	23/4	.4792	53/4	.7292	83/4	.9792	113/4
15/64	.234375	213/16	.484375	513/16	.734375	813/16	.984375	1113/16
	.2396	27/8	.4896	57/8	.7396	87/8	.9896	117/8
	.2448	215/16	.4948	515/16	.7448	815/16	.9948	1115/16
	.2500	3	.5000	6	.7500	9	1.0000	12



# INDEX

## A

American standard beams, properties and dimensions of.....	26-31
American standard beams, rolling and cutting tolerances.....	6
American standard channels, properties and dimensions of.....	32-35
Angles, cold formed.....	75
Angles, equal legs, properties and dimensions of.....	36-38
Angles, unequal legs, properties and dimensions of.....	39-42
Angles, special, equal and unequal legs, properties and dimensions of.....	66
Angles, usual gages for.....	121
Areas, methods of increasing.....	4
Areas, of sections: see properties.	
Areas, weights, and properties of round bars.....	108-111
Areas, weights, and properties of square bars.....	112-113

## B

Bars, dimensions and weights of upset screw ends for square and round.....	128-129
Bars, table of properties and weights of round.....	108-111
Bars, table of properties and weights of square.....	112-113
Bases, rolled steel column.....	82
Beams, properties and dimensions of American standard.....	26-31
Beams, properties and dimensions of CB wide flange.....	12-25
Beams, Table of economy of CB beams by section modulus.....	136-138
Bearing piles, properties and dimensions of CB.....	43
Bolt and nut dimensions.....	126
Bolts, weight of.....	124-125
Bulb angles, car building, properties and dimensions of.....	64-65
Bulb angles, shipbuilding, properties and dimensions of.....	62-65
Bulb angles, rolling and cutting tolerances.....	6

## C

Cambering of CB wide flange shapes.....	9
Car building bulb angles, properties and dimensions of.....	64-65
Car building channels, properties and dimensions of.....	56-61
Car building cold formed sections, dimensions of.....	75-78
Car building miscellaneous sections.....	71-74
CB beams: See CB wide flange shapes.	
CB H bearing piles, properties and dimensions of.....	43
CB joists, properties and dimensions of.....	24-25
CB light beams, properties and dimensions of.....	24-25
CB stanchions, properties and dimensions of.....	24-25
CB steel sheet piling, properties and dimensions of.....	44-45
CB structural (split beam) tees, notes on.....	46
CB structural (split beam) tees, properties and dimensions of.....	47-54
CB wide flange shapes, cambering of.....	9
CB wide flange shapes, properties and dimensions of.....	12-25
CB wide flange shapes, rolling and cutting tolerances.....	7
Center of gravity of sections: See properties.	
Channels, properties and dimensions of American standard.....	32-35
Channels, properties and dimensions of car building and shipbuilding.....	56-61
Channels, rolling and cutting tolerances.....	6
Circular sheared plates, tables of sizes.....	85, 89, 93
Clevises, dimensions and weights of.....	131

Cold formed sections, angles.....	75
Cold formed sections, zeos.....	77
Column bases, rolled steel.....	82
Columns, cover-plated CB wide flange shapes.....	80-81
Columns, properties and dimensions of subway.....	70
Columns, properties and dimensions of pipe.....	134
Cotter pins and pin nuts, diameter and weights of recessed.....	132
Cover-plated CB wide flange shapes, properties and dimensions of.....	80-81
Crane rail clamps, table of.....	117
Crane rail fastenings, table of.....	116
Crane rail splices, table of.....	115
Crane rails, table of properties and dimensions.....	114
Cross ties, properties and dimensions of.....	118
Cutting and rolling tolerances: See tolerances.	

## D

Decimals of an inch and of a foot.....	139
Dimensions, bolt and nut.....	126
Dimensions, and properties of sections: See properties.	
Dimensions, for detailing American standard beams.....	29, 31
Dimensions, for detailing American standard channels.....	33, 35
Dimensions, for detailing CB light beams, stanchions, joists.....	25
Dimensions, for detailing CB wide flange shapes.....	13, 15, 17, 19, 21, 23, 25
Dimensions, for detailing cover-plated CB wide flange shapes.....	80-81
Dimensions, for detailing crane rails.....	114
Dimensions, for detailing crane rail splices.....	115
Dimensions, for detailing crane rail fastenings.....	116
Dimensions, for detailing crane rail clamps.....	117
Dimensions, for detailing bulb angles, car building.....	65
Dimensions, for detailing bulb angles, shipbuilding.....	63, 65
Dimensions, for detailing miscellaneous car building sections.....	71-74
Dimensions, for detailing channels, car building and shipbuilding.....	57, 59, 61
Dimensions, for detailing rol'ed tees.....	67-68
Dimensions, for detailing subway columns.....	70
Dimensions, for detailing zeos.....	69
Dimensions of bolt head and nuts.....	126
Dimensions of loop rods and stub ends.....	130
Dimensions of structural rivets.....	121
Dimensions and weights of clevises.....	131
Dimensions of recessed pin nuts and cotter pins.....	132
Dimensions of turnbuckles and sleeve nuts.....	127
Dimensions of upset screw ends for round bars.....	129
Dimensions of upset screw ends for square bars.....	128
Districts, symbols for.....	3
Draft key and draw bar sections.....	74

## E

Economy of CB beams by section modulus.....	136-138
Economy table, notes on.....	135
Eye bars, dimensions of.....	133

## F

Fastenings, table of crane rail.....	116
Finish, A. S. T. M. specifications on surface.....	8
Floor plates, tables of sizes.....	94-95
Foreword.....	3

## G

- Gage for angles, usual . . . . . 121  
Gravity of sections: See properties.  
Gyration of sections: See properties.

## H

- H beams, properties and dimensions of . . . . . 30-31  
H bearing piles, properties and dimensions of CB . . . . . 43  
Heads of rivets, weights of . . . . . 123  
Heavy bolts . . . . . 125  
Heavy rectangular plates, table of . . . . . 86-87, 90-91

## I

- Increasing areas and weights of structural shapes . . . . . 4

## J

- Joists, properties and dimensions of CB . . . . . 24-25

## L

- Lengths of structural rivets . . . . . 122  
Light beams, properties and dimensions of CB . . . . . 24-25  
Loop rods and stub ends, dimensions of . . . . . 130

## M

- Miscellaneous car building sections . . . . . 71-74  
Miscellaneous material, notes on . . . . . 79  
Modulus of sections: See properties.  
Moment of inertia of sections: See properties.

## N

- Notation, general . . . . . 10  
Notes on structural tees . . . . . 46  
Notes on cambering . . . . . 5  
Notes on column base plates . . . . . 82  
Notes on plates . . . . . 83  
Notes on surface finish . . . . . 5  
Notes on table of economy of CB beams by section modulus . . . . . 135  
Nut and bolt dimensions . . . . . 126  
Nuts and cotter pins, dimensions . . . . . 132  
Nuts, sleeve, weights and dimensions of . . . . . 127

## P

- Piling, properties and dimensions of CB bearing piles . . . . . 43  
Piling, properties and dimensions of CB steel sheet . . . . . 44-45  
Pin nuts and cotter pins, dimensions and weights of recessed . . . . . 132

Pipe columns, dimensions and properties of.....	134
Plates, tables of properties of.....	104-107
Plates, tables of sizes of floor.....	94-95
Plates, tables of sizes of rectangular and circular sheared.....	85, 89, 93
Plates, tables of sizes of rectangular heavy plates.....	86-87, 90-91
Plates, tables of sizes of universal.....	84, 88, 92
Properties and dimensions of American standard beams.....	26-31
Properties and dimensions of American standard channels.....	32-35
Properties and dimensions of angles, equal legs.....	36-38
Properties and dimensions of angles, unequal legs.....	39-42
Properties and dimensions of CB H bearing piles.....	43
Properties and dimensions of CB steel sheet piling.....	44-45
Properties and dimensions of CB joists, stanchions, light beams.....	24-25
Properties and dimensions of CB structural (split beam) tees.....	47-54
Properties and dimensions of CB wide flange shapes.....	12-25
Properties and dimensions of cover plated CB wide flange shapes.....	80-81
Properties and dimensions of crane rails.....	114
Properties and dimensions of special angles, equal and unequal.....	66
Properties and dimensions of special bulb angles car building.....	64-65
Properties and dimensions of special bulb angles shipbuilding.....	62-65
Properties and dimensions of miscellaneous car building sections.....	71-74
Properties and dimensions of special channels, car and shipbuilding.....	56-61
Properties and dimensions of special rolled tees, equal and unequal.....	67-68
Properties and dimensions of special subway columns.....	70
Properties and dimensions of special zeos.....	69
Properties and weights of round bars.....	108-111
Properties and weights of square bars.....	112-113

## R

Radius of gyration of sections: See properties.....	
Rail clips.....	119
Rails, properties and dimensions of crane.....	114
Rectangular and circular sheared plates, tables of sizes and weights of.....	85, 89, 93
Rectangular sections, table of weights and areas of.....	96-103
Rectangular sections, table of moment of inertia of.....	104-107
Rectangular universal plates, tables of sizes and weights of.....	84, 88, 92
Regular shapes, notes on.....	11
Removal of surface imperfections, notes on.....	5
Riveting, conventional signs for.....	121
Rivets, dimensions of structural.....	121
Rivets, lengths of structural.....	122
Rivets, weights.....	123
Rolled steel plates for column bases.....	82
Rolling and cutting tolerances: See tolerances.....	
Round bars, weights, areas, and properties of.....	108-111

## S

Screw ends for round and square bars, dimensions and weights for upset.....	128-129
Section modulus of sections: See properties.....	
Shapes, regular, notes on.....	11
Shapes, special, notes on.....	55
Sheared plates, tables of sizes of rectangular and circular.....	85, 89, 93
Shipbuilding bulb angles, properties and dimensions of.....	62-65
Shipbuilding channels, properties and dimensions of.....	56-61
Signs for riveting.....	121
Sleeve nuts, dimensions and weights of.....	127
Special sections, notes on.....	55

Square bars, weights, areas and properties of . . . . .	112-113
Stanchions, properties and dimensions of CB . . . . .	24-25
Steel sheet piling, properties and dimensions of . . . . .	44-45
Stub ends and loop rods, dimensions of . . . . .	130
Subway columns, properties and dimensions of . . . . .	70
Surface finish, A. S. T. M. specification . . . . .	8
Symbols for riveting . . . . .	121

## T

Tees, notes on structural (split beam) . . . . .	46
Tees, properties and dimensions of structural (split beam) . . . . .	47-54
Tees, properties and dimensions of special rolled . . . . .	67-68
Tees, rolling and cutting tolerances . . . . .	6
Ties, properties and dimensions of steel cross . . . . .	118
Tolerances for structural rolled shapes . . . . .	6, 7
Turnbuckles and sleeve nuts, dimensions and weights of . . . . .	127

## U

Universal plates, tables of sizes and weights . . . . .	84, 88, 92
Upset screw ends for round and square bars, dimensions and weights of . . . . .	128-129

## W

Weights of bolt heads and nuts . . . . .	124-125
Weights of clevises . . . . .	131
Weights of plates . . . . .	104-107
Weights of rectangular sections . . . . .	96-103
Weights of sleeve nuts . . . . .	127
Weights of structural rivets and heads . . . . .	123
Weights of turnbuckles . . . . .	127
Weights of upset screw ends for round and square bars . . . . .	128-129
Wide flange CB shapes, rolling and cutting tolerances . . . . .	7
Wide flange CB shapes and Standard Beams, cambering of . . . . .	9
Wide flange CB shapes, properties and dimensions of . . . . .	12-25

## Z

Zees, cold formed sections . . . . .	77
Zees, properties and dimensions of rolled . . . . .	69
Zees, rolling and cutting tolerances . . . . .	6
Z piling, properties and dimensions of CB steel sheet . . . . .	45

# PRINCIPAL SUBSIDIARY MANUFACTURING COMPANIES OF UNITED STATES STEEL CORPORATION

## CARNEGIE-ILLINOIS STEEL CORPORATION

Pittsburgh, Pa.

Chicago, Ill.

### ROLLED, FORGED, FABRICATED AND CAST STEEL PRODUCTS

Wide Flange CB Sections	Rails, Heavy and Light
Structural Shapes	U-S-S Controlled Steels
Plates	U-S-S Abrasion Resisting Steel
Bars	GEO Track Material
Concrete Reinforcing Bars	Splice Bars
Flats	Tie Plates
Slack Barrel Hoop	Track Bolts
Strip	Track Spikes
Column Base Plates	Cross Ties
Floor Plates	Axles and Forgings
I-Beam-Lok Floor Construction	Wheels, Car and Locomotive
T-Tri-Lok Floor Construction	U-S-S Carilloy (Alloy) Steels
Steel Sheet Piling	U-S-S Stainless and
CBP Bearing Piles	Heat-Resisting Steels
Steel Mine Timbers	U-S-S High Tensile Steels

### SHEET AND TIN MILL PRODUCTS

Black Sheets—	Galvanized Sheets—
Hot Rolled	U-S-S Galvanized
Cold Rolled	U-S-S Copper Steel Galvanized
Strip Steel	U-S-S Galvanized Paint Bond
Hot Rolled	U-S-S Galvanized Culvert Sheets
U-S-S Electrical Sheets	Corrugated Sheets
U-S-S Vitrenamel	Black and Galvanized
U-S-S Stainless and	Formed Roofing and Siding Products
Heat Resisting Steel Sheets	Bright Tin Plates—
U-S-S High Tensile Steel Sheets	Cokes
Blued Sheets—	Charcoals
Copper Steel Wellsville Polished	Terne Plates—
Blued Stove Pipe and Elbow Stock	Ternes
Superblue	Old Style Ternes
Long Terne Sheets	U. S. Eagle Ternes
Copper Steel Roofing Long Ternes	Fire Door Ternes
Galvannealed Sheets	Long and Short Ternes
	Tin Mill Black

### LORAIN DIVISION

Johnstown, Pa.

Special Track Work and Accessories	Forged Steel Grinding Balls
Girder Rails	Carbon Steel Castings
Industrial and Mine Cars	Manganese Steel Castings
Coal Conveyors	Alloy Steel Castings
Mine Jacks	Grey Iron Castings

# PRINCIPAL SUBSIDIARY MANUFACTURING COMPANIES OF UNITED STATES STEEL CORPORATION—Continued

## COLUMBIA STEEL COMPANY

General Offices: Russ Building, San Francisco, Cal.

### ROLLED, CAST AND DRAWN STEEL PRODUCTS

Structural Shapes	Wire—
Bars and Small Shapes	Manufacturers Wires
Concrete Reinforcement Bars	Plain or Galvanized
Strip under 1/4"	Barbed
Tie Plates	Spring
Sheets—	Wire Nails
Black	Wire Fence
Blue Annealed	Wire Rope
Galvanized	Wire Rods
Semi-Finished Material	Wire Strand
	Wire Tacks
	Steel Castings

Also distributors for Pacific Coast territory of products of  
all subsidiary manufacturing companies of United States Steel Corporation

## TENNESSEE COAL, IRON AND RAILROAD COMPANY

General Offices: Brown-Marx Building, Birmingham, Ala.

### ROLLED, FORGED AND DRAWN STEEL PRODUCTS

Structural Shapes	Axles	Sheets—
Plates	Forgings	Hot Rolled
Bars	Rails	Hot Rolled Annealed
Small Shapes	Rail Accessories	Galvanized
Hot Rolled Strip	Semi-Finished Material	Wire and Wire Products
Cotton Ties	Pig Iron	

## AMERICAN BRIDGE COMPANY

General Offices: Frick Building, Pittsburgh, Pa.

### STEEL STRUCTURES OF ALL CLASSES

Bridges	Dams	Towers
Buildings	Crane Runways	Poles
Viaducts	Buckle Plates	Sub-Stations
Subway Structures	Barges	Tanks
Ferry Aprons	Hulls	Eyebars
Ore Docks	Turntables	Electric Furnaces (Heroult)

# PRINCIPAL SUBSIDIARY MANUFACTURING COMPANIES OF UNITED STATES STEEL CORPORATION—Continued

## AMERICAN STEEL AND WIRE COMPANY

General Offices: Rockefeller Building, 614 Superior Ave., N.W., Cleveland, Ohio

### WIRE AND WIRE PRODUCTS

Aerial Tramways	Netting	Tacks
Bale Ties	Piano Wire	Telegraph Wire
Barbed Wire	Plain Wire	Telephone Wire
Cold Rolled Strip Steel	Rail Bonds	Trolley Wire
Concrete Reinforcement	Screw Stock	Welding Wire
Electrical Wires	Spikes	Wire Fabric
Flat Wire	Springs	Wire Fence
Hoops	Steel Gates	Wire Rope
Manufacturing Wires	Steel Posts	Wire for Manufacturing Purposes
Nails	Strand	U-S-S Stainless and Heat Resisting Steels

## CYCLONE FENCE COMPANY

General Offices: Waukegan, Ill.

### ORNAMENTAL AND PROTECTIVE FENCE

Chain Link Protective Fence	Chain Link Conveyor Belting
Chain Link Road Guard	Screen Cloth
Ornamental Iron Fence	Hardware Cloth
Ornamental Lawn Fence	Woven Wire Partitions
	Wire Baskets (Rubbish Burners)

## FEDERAL SHIPBUILDING AND DRY DOCK COMPANY

General Offices: Lincoln Highway, Kearny, N. J.

### SHIPS AND STEEL FABRICATION

Builders and Repairers of—	Heavy Machine Work
Merchant Ships	Steel Fabrication
Barges, Dredges, Lighters	



# PRINCIPAL SUBSIDIARY MANUFACTURING COMPANIES OF UNITED STATES STEEL CORPORATION—Concluded

---

## NATIONAL TUBE COMPANY

General Offices: Frick Building, Pittsburgh, Pa.

### WELDED AND SEAMLESS STEEL TUBULAR PRODUCTS

Standard Pipe	Boiler Tubes
Copper Steel Pipe	Seamless Mechanical Tubing
Line Pipe, Casing	Aircraft Tubing
Oil Well Tubing	Seamless Alloy Tubing
Drive Pipe	Trolley Poles, Line Poles
Rotary Drill Pipe	Cylinders, Seamless Couplings
Galvanized Pipe	U·S·S Stainless and
Special Dipped and Coated Pipe	Heat Resisting Pipes and Tubes
Duoline (cement lined) Pipe	

## OIL WELL SUPPLY COMPANY

General Offices: Dallas, Texas

### OIL FIELD DRILLING AND PUMPING MACHINERY AND AUXILIARY EQUIPMENT

"Oilwell," "Imperial," "Wilson-Snyder" and "Erie Ball" Products	
General Machine Products	Locomotive Type Boilers
Drop and Light Hammer Forgings	Swaged Nipples and Bull Plugs
Steel and Iron Castings	Special Fittings
Erie Ball Steam Engines	Wilson-Snyder Pumping Machinery

## UNIVERSAL ATLAS CEMENT COMPANY

General Offices: 135 East 42nd Street, New York, N.Y.

Atlas Portland Cement	Atlas White Portland Cement
Universal Portland Cement	Atlas Lumnite Cement
Atlas Waterproofed White Portland Cement	

# CARNEGIE-ILLINOIS STEEL CORPORATION

## General Offices

PITTSBURGH DISTRICT, Pittsburgh, Pa.....	Carnegie Building
CHICAGO DISTRICT, Chicago, Ill.....	208 South La Salle Street
LORAIN DIVISION, Johnstown, Pa.....	545 Central Avenue

# TENNESSEE COAL, IRON & RAILROAD COMPANY

## General Offices

BIRMINGHAM, ALA.....	Brown-Marx Building
----------------------	---------------------

---

## DISTRICT SALES OFFICES

BIRMINGHAM.....	Brown-Marx Building, 2000 First Avenue North
BOSTON.....	Statler Office Building, 20 Providence Street
CHICAGO.....	208 South La Salle Street
CINCINNATI.....	Union Trust Building, Fourth and Walnut Streets
CLEVELAND.....	Rockefeller Building, 614 Superior Avenue, N. W.
DENVER.....	First National Bank Building, 17th and Stout Streets
DETROIT.....	General Motors Building
HOUSTON.....	P. O. Box 159
INDIANAPOLIS.....	Chamber of Commerce Building, 320 North Meridian St.
MILWAUKEE.....	Bankers Building, 208 East Wisconsin Avenue
NEW YORK.....	71 Broadway
PHILADELPHIA.....	Broad Street Station Building, 1617 Pennsylvania Boulevard
PITTSBURGH.....	Frick Building, 437 Grant Street
ST. LOUIS.....	Mississippi Valley Trust Building, 506 Olive Street
ST. PAUL.....	First National Bank Building, 334 Minnesota Street
WASHINGTON.....	703 Normandy Bldg., 1626 K Street, N. W.

## LORAIN DIVISION

BIRMINGHAM.....	Brown-Marx Building, 2000 First Avenue North
CHICAGO.....	208 South La Salle Street
DENVER.....	First National Bank Building, 17th and Stout Streets
HOUSTON.....	P. O. Box 159
JOHNSTOWN.....	545 Central Avenue
NEW YORK.....	71 Broadway

# COLUMBIA STEEL COMPANY

## General Offices

SAN FRANCISCO.....	Russ Building, 235 Montgomery Street
--------------------	--------------------------------------

## District Sales Offices

LOS ANGELES.....	2087 East Slauson Street
PORTLAND.....	2345 N. W. Nicolai Street
SALT LAKE CITY.....	Walker Bank Building
SEATTLE.....	Fourth Avenue South and Connecticut Street

## Export Distributors:

### UNITED STATES STEEL EXPORT COMPANY

NEW YORK.....	Hudson Terminal Building, 30 Church Street
---------------	--

MEMORANDA

