

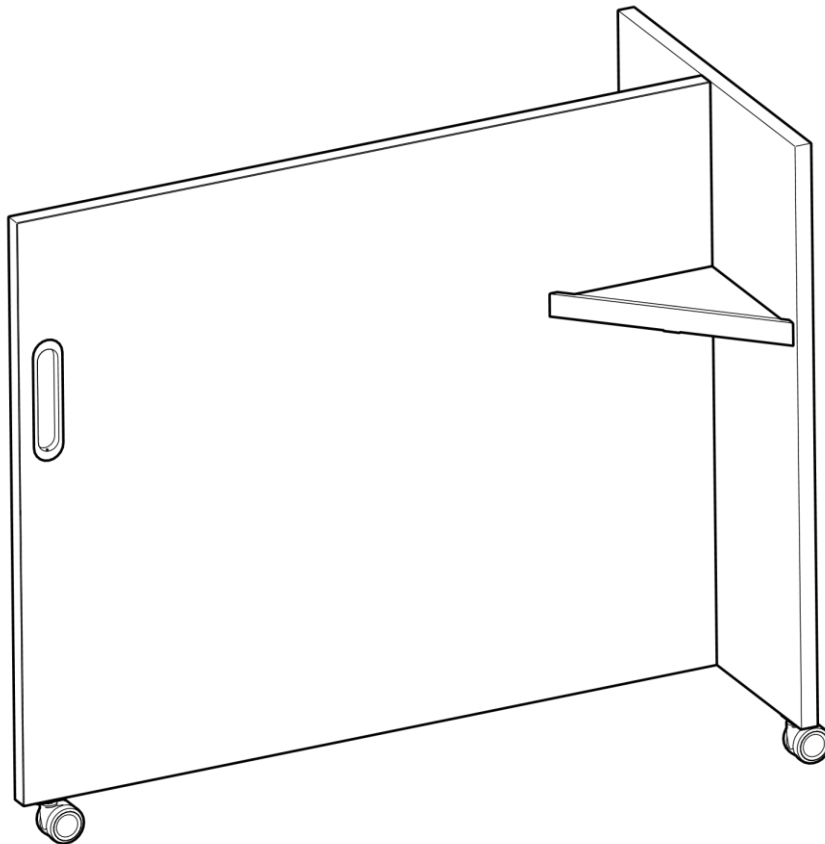





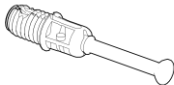

Tri-Wheel Mobile Dividers

Date	Page No.	Description of change	Name
2/19/2020	1-5	Released	P. Fortin
2/25/2020	5	Insert pg 5 for Inset Handle	P. Fortin
5/20/2021	2, 8-11	Pg 2: Added parts list Pg 8-11: Added Lexan screen installation	S. Powers

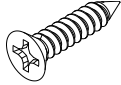
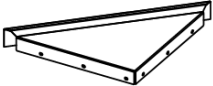

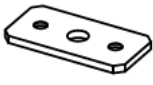
Tri-Wheel Mobile Dividers

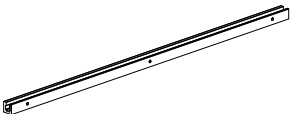
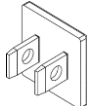
Parts List

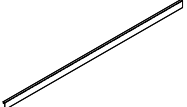
Item	Replacement Part number	Circle Sheet Part Number	Description	Image
P1	RH-DU325-I	RH-DU325-I	Pin	
P2	RH-0079485-I	RH-0079485-I	Cam	
P3	RH-QS0978	RH-QS0978	Flat Head Screw #9 x 7/8" Long	
P4	RA-TWWBTRAY	RA-TWWBTRAY	Tri-Wheel Tray	
P5	RH-UK570.202X3	RH-UK570.202X3	Caster 60mm 3/8-16 x 5/8" Non-locking	
P6	RA-MWBTP	RA-MWBTP	Thread Plate	
P7	RH-SMZFP102B	RH-SMZFP102B	Flat Head Sheet Metal Screw #10 x 2" long	
P8	RH-HN200SH	RH-HN200SH	Inset Handle	
P9	VL-RGExx xx = 36-96 (6in increments)	VL-RGExx xx = 36-96 (6in increments)	Channel	
P10	OX-TFBEEC	OX-TFBEEC	End Cap	
P11	RH-SHSS142814	RH-SHSS142814	Set Screw 1/4-28 x 1/4" long	
P12	OX-TFBExx xx = 222 (for 24D) xx = 228 (for 30D)	OX-TFBExx xx = 222 (for 24D) xx = 228 (for 30D)	Cover	

Tri-Wheel Mobile Dividers

Step 1: With the divider in the upside-down position, install the cams and pins

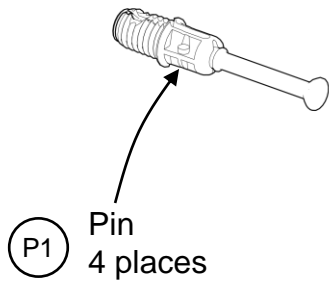
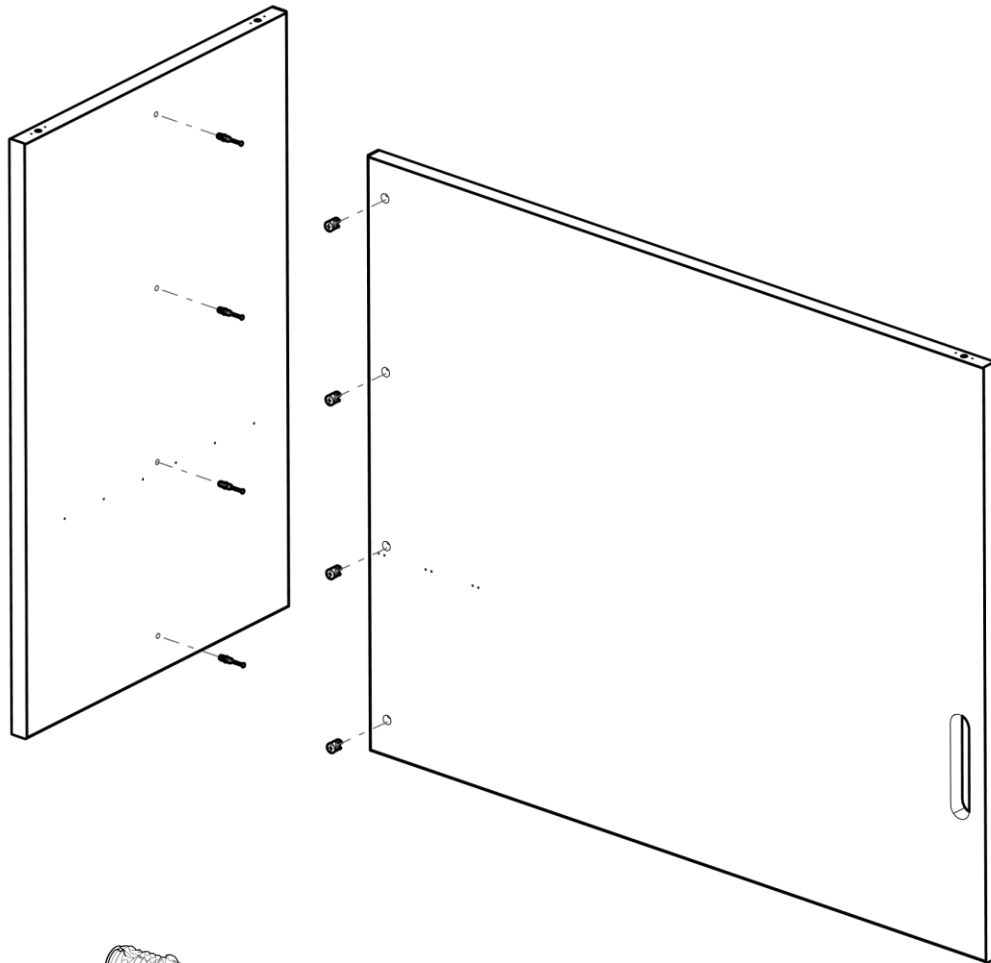

P1 Pin
4 places

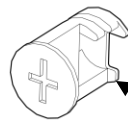

P2 Cam
4 places

Tri-Wheel Mobile Dividers

Step 2: Install the trays on both sides of the divider with #9 x 7/8" flat head wood screws

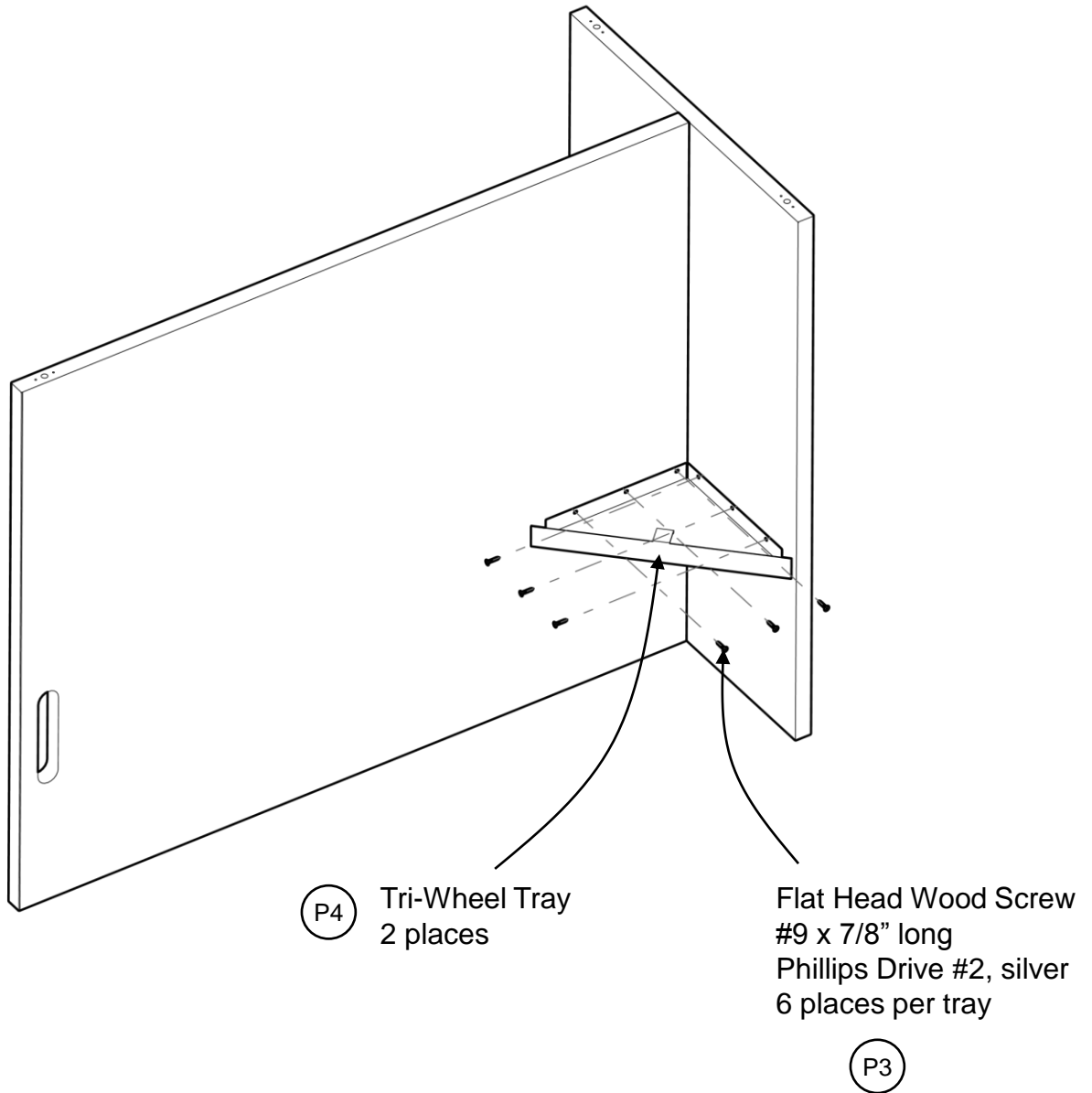

Tri-Wheel Mobile Dividers

Step 3: Install the casters to the divider using the #10 x 2" flat head screws and thread plates.

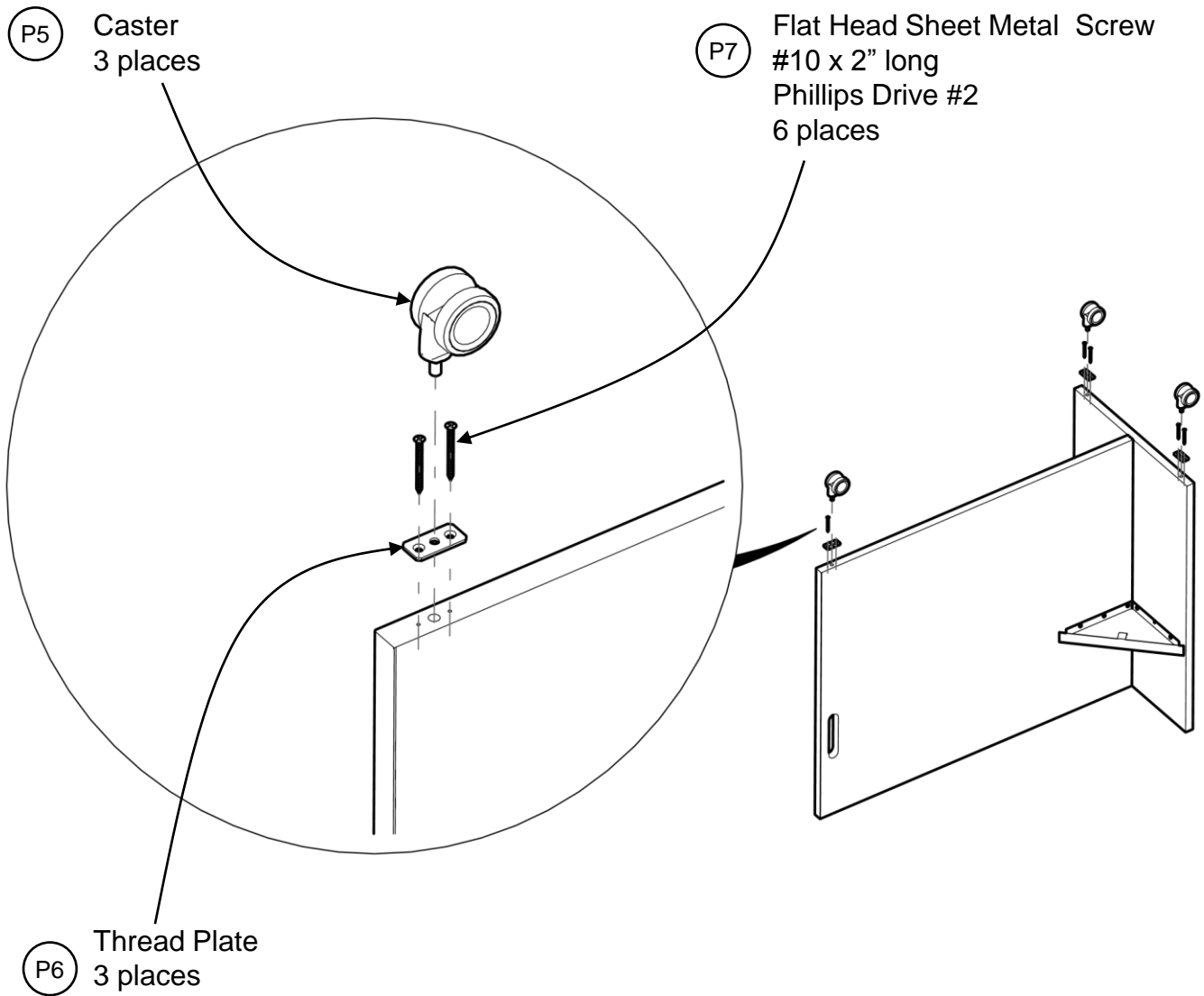

Tri-Wheel Mobile Dividers

Step 4: Install the handles with the nails provided in the handle kit.

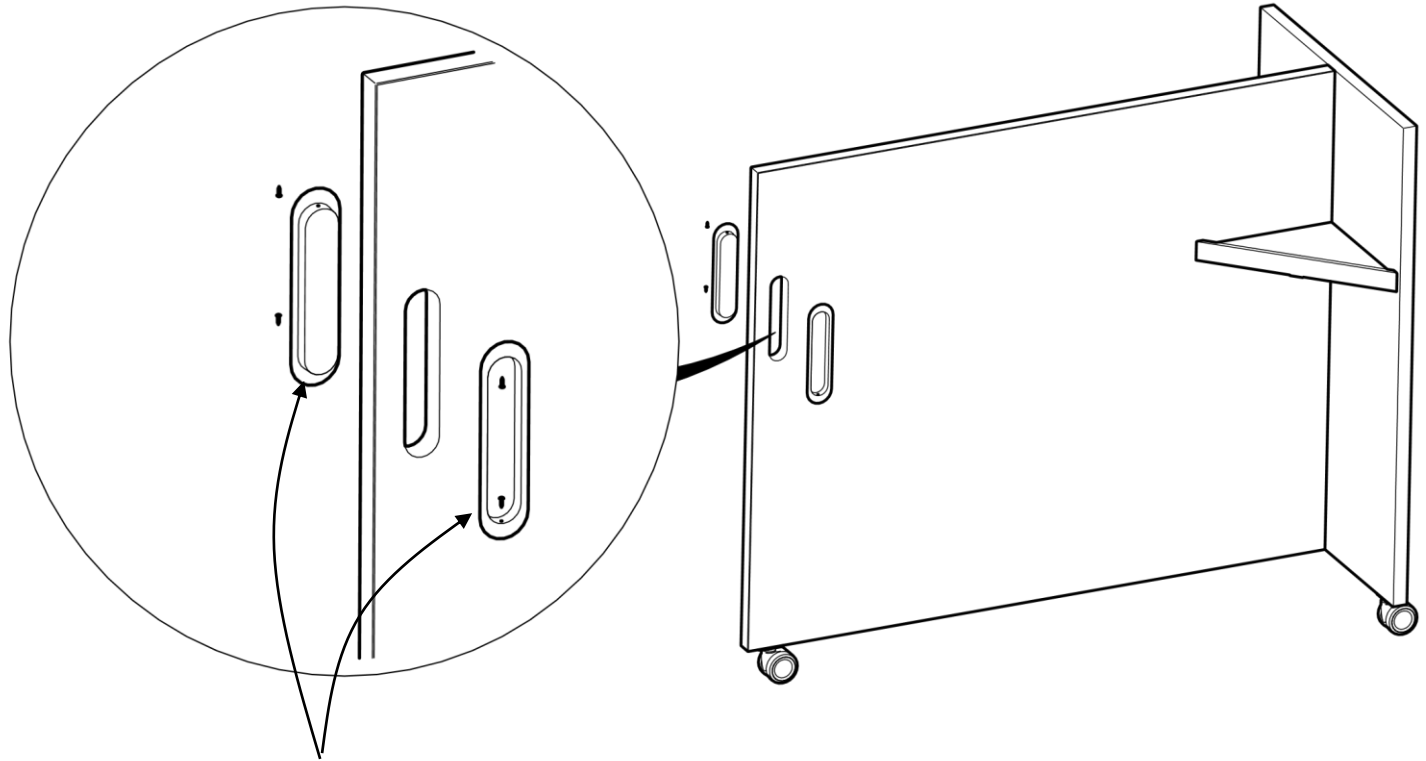

(P8) Handle Kit
(nails included)

Tri-Wheel Mobile Dividers

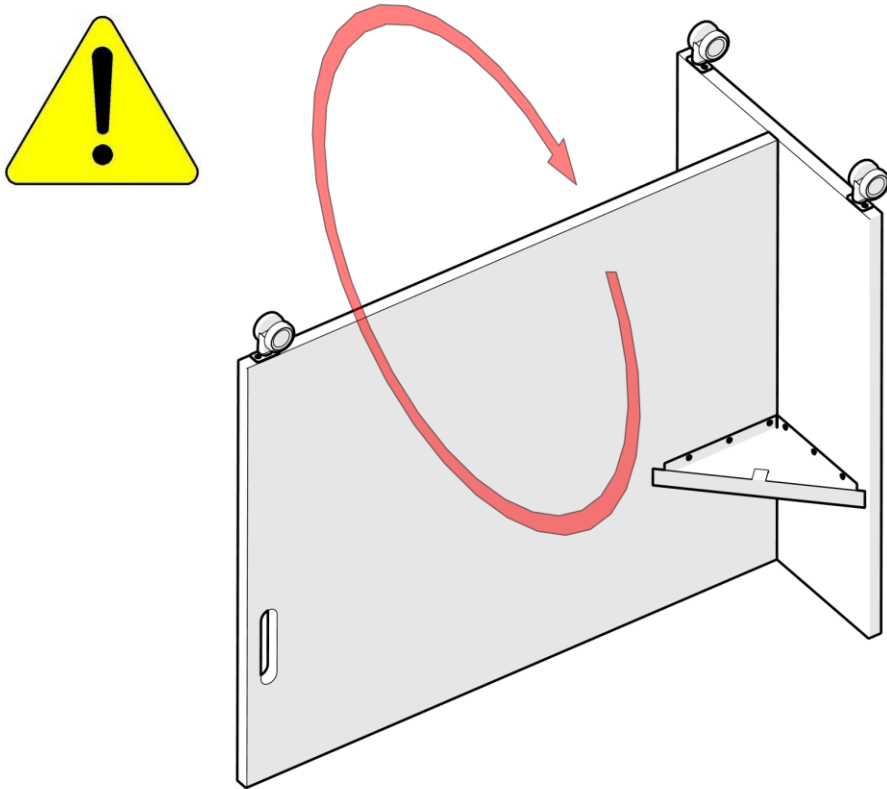

With assistance, flip over the whiteboard.

Caution: these units can be very heavy, and doing so without assistance may cause injury or damage to the whiteboard.

Tri-Wheel Mobile Dividers - Lexan Screens

Step 1: Install one endcap into the end of the channel.

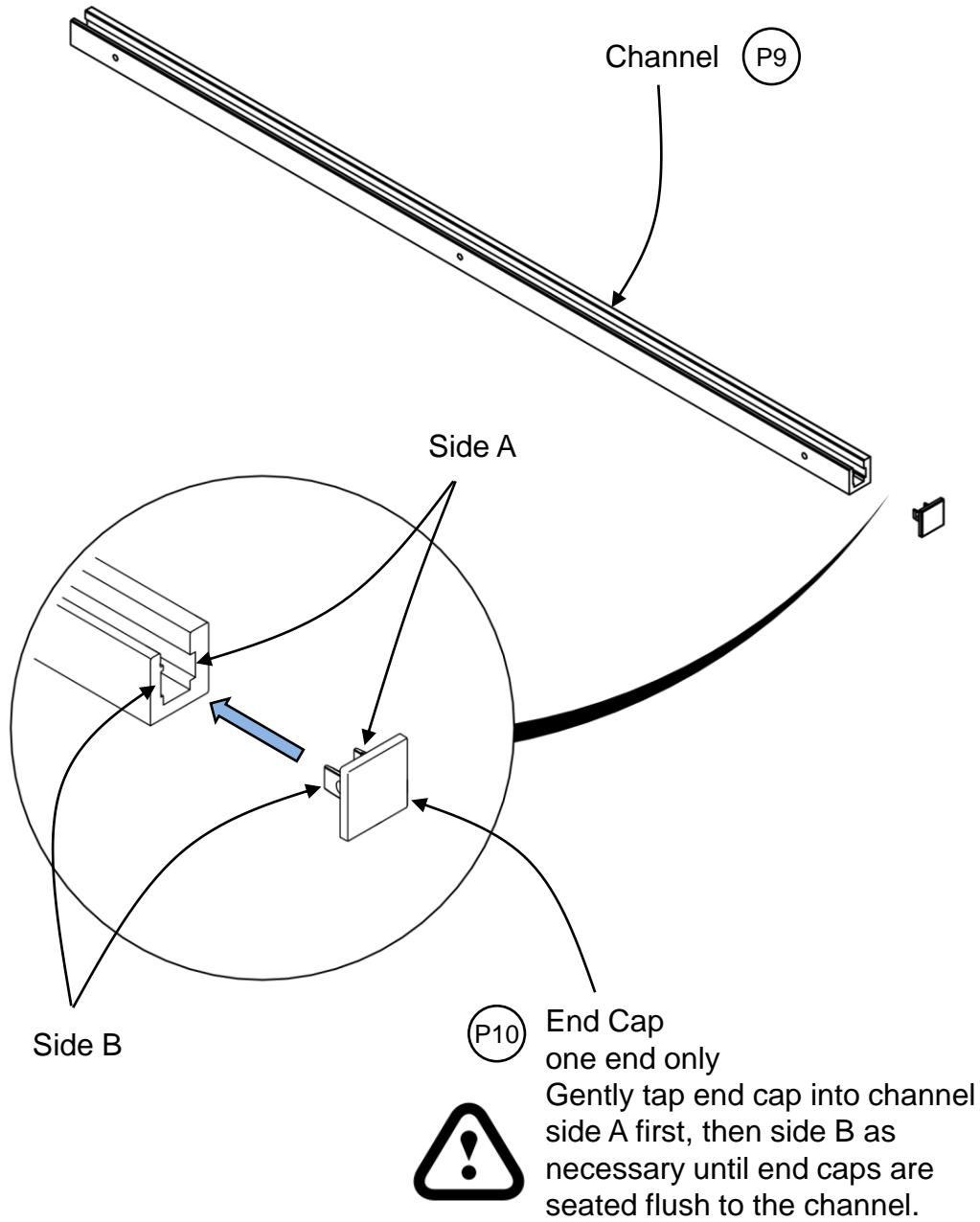

Tri-Wheel Mobile Dividers - Lexan Screens

Step 2: Attach the channel to the divider using the #9 x 7/8" flat head screws.

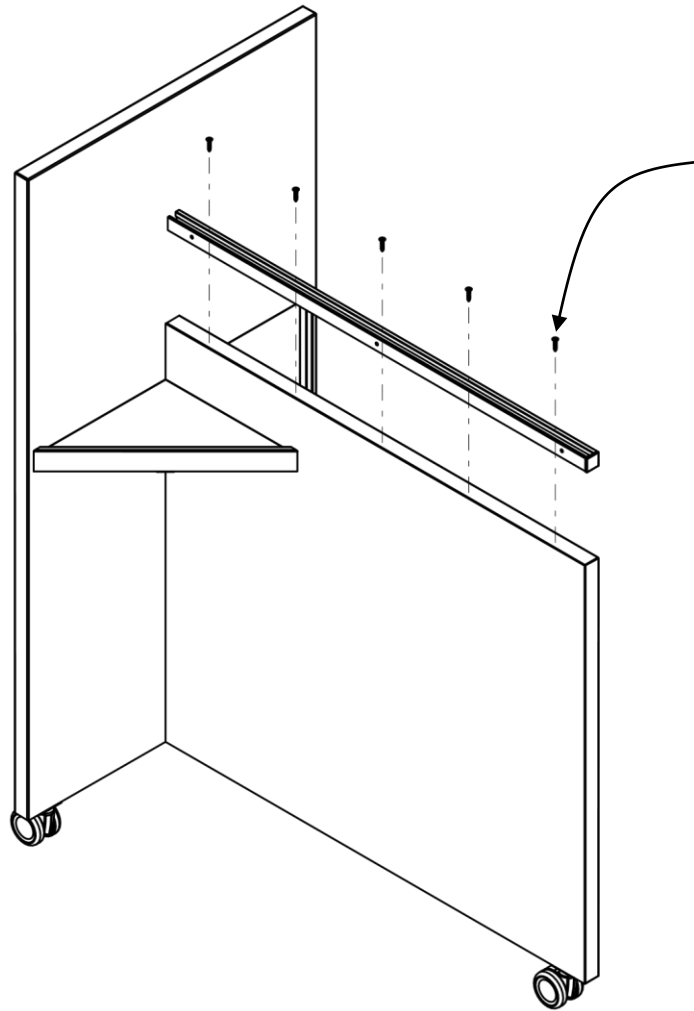

P3

Flat Head Wood Screw
#9 x 7/8" long
Phillips Drive #2, silver
3 places (sizes 36-42)
5 places (sizes 48+)

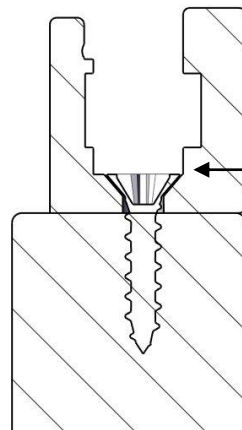

Screw must be flush or
below channel bottom

Tri-Wheel Mobile Dividers - Lexan Screens

Step 3: Place the Lexan screen into the channel and secure in place using the 1/4-28 x 1/4" long set screws.

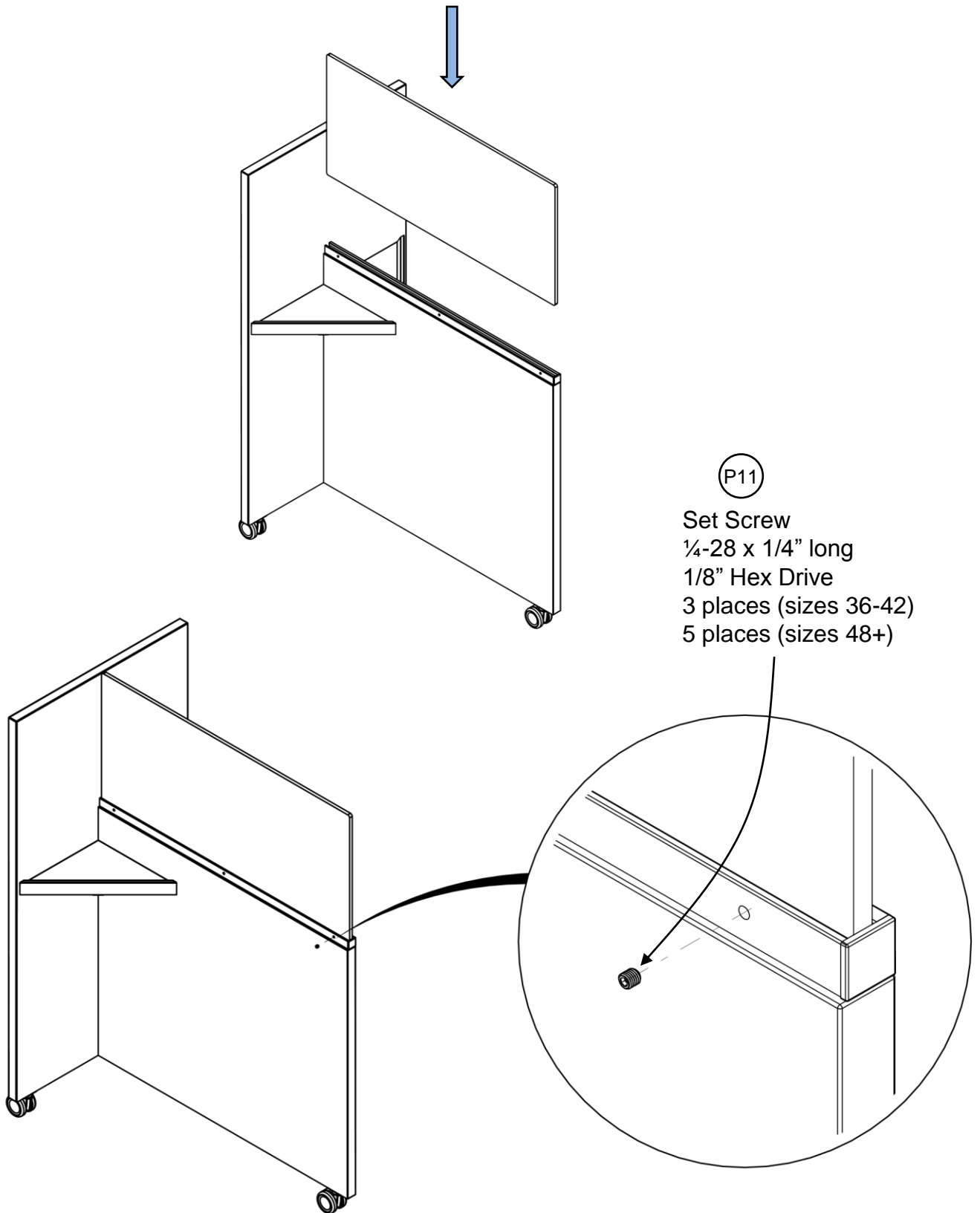

Tri-Wheel Mobile Dividers - Lexan Screens

Step 4: Install the cover.

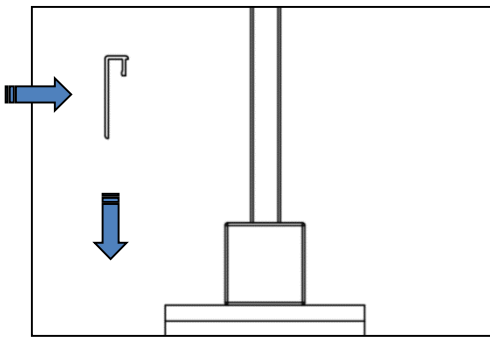
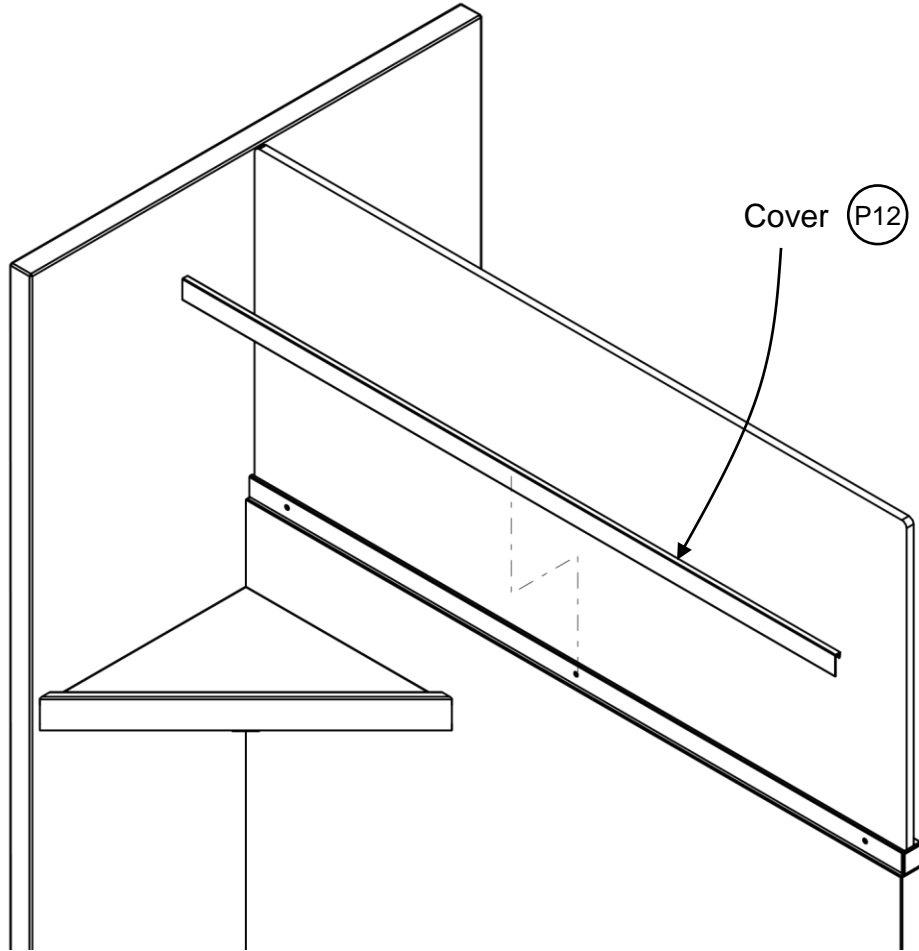

- Snap rail cover down onto rail from above using block of wood with soft mallet.
- Ensure Rail Cover is properly seated

