

Glossary:

➤ Page 2 Tapered Engine Shaft (J609A/J609B) Guide

1) For simple tapered engine shafts, reference page 2 dimensions to identify your engine's J609A or J609B tapered shaft and proceed through checkout. Additional shaft types are available at checkout dropdown menu.



OR

➤ Page 3 S.A.E. Flywheel Coupling Diameter Guide

➤ Page 4 S.A.E. Flywheel Housing Diameter Guide

1) Download and/or print pages 3 & 4 guides to identify your flywheel coupling and housing specs.

2) Complete all dimensions/data specification questions on blanks provided.

3) Save a copy and email to: sales@absolutesuppliers.com.

4) Use information on blanks during checkout or call 888-264-2189 for further assistance.

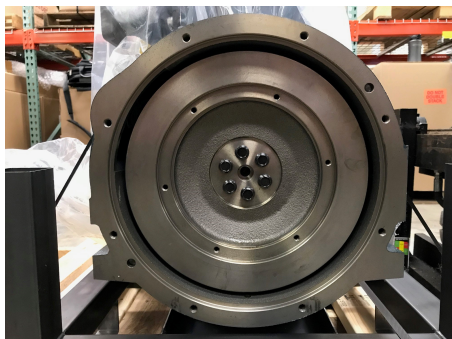

Tapered Engine Shaft Guide (J609A/J609B)

J609A

V-type

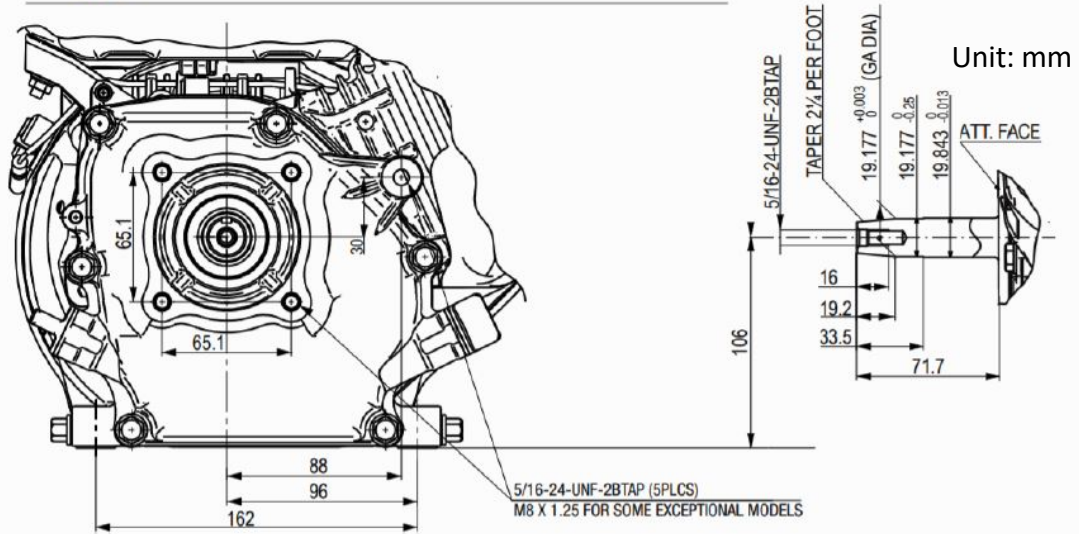

J609B

V Type

Unit: mm (in)

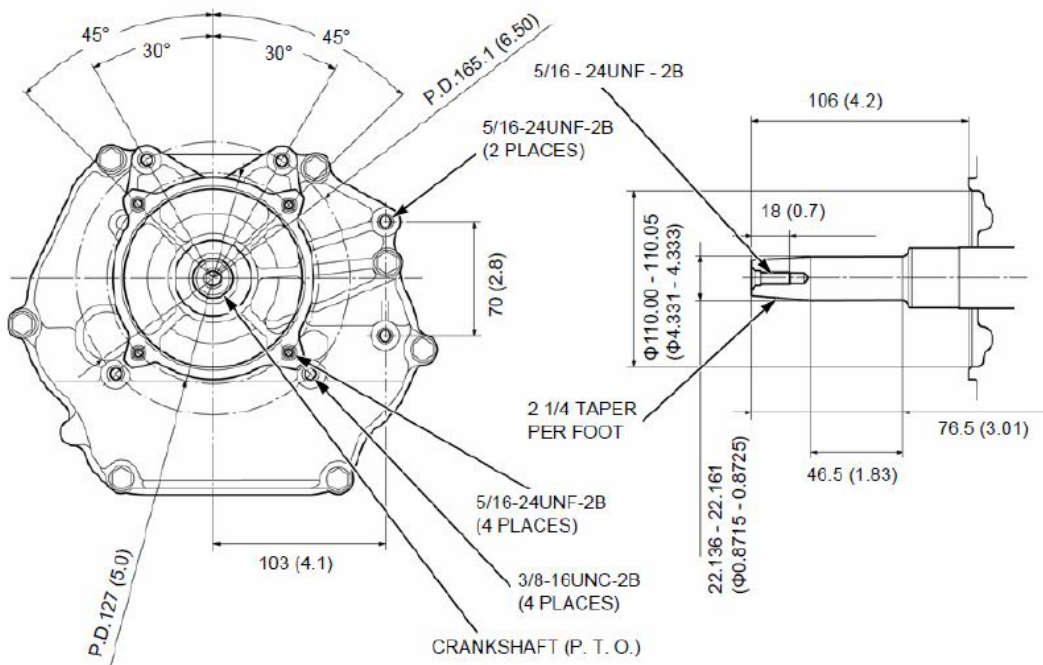

S.A.E. Flywheel Coupling Diameter Guide

Generator End

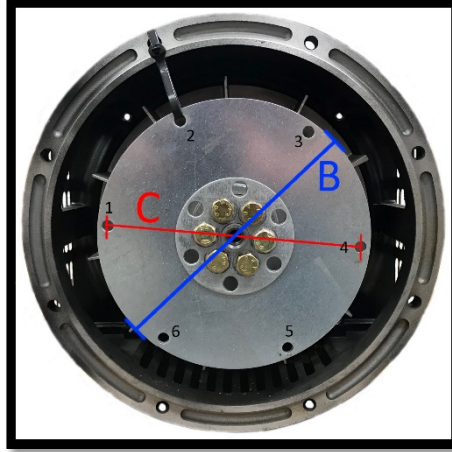

FLYWHEEL COUPLING

1. Flywheel Coupling Pilot Size (**Dimension B**): _____ Inches. Measure the pilot diameter (recess) in the flywheel where the coupling will be mounted (outside diameter of S.A.E. Disc Coupling)
2. Flywheel Coupling Size (**Dimension C**): _____ Inches. Measure the distance from the bolt hole center to center (measuring across the center line of the crank shaft).
3. S.A.E. Disc Coupling Holes: _____ ea. Count number of drilled and tapped holes on your S.A.E. Disc Coupling perimeter (*Ex. in the above picture there are 6 numbered holes*).
4. Flywheel Coupling #: _____. Based on the answers 1-3, choose from chart below your Flywheel Coupling (*Ex. Dim. B 12 3/8, Dim. C 11 5/8, & 8 Holes = # 10.*)

S. A. E. Flywheel Dimensions (in)

Flywheel	A	B	C	XG	Holes	Size
21	23	26.5	25.25	0	12	5/8-11
18	19 5/8	22.5	21 3/8	5/8	6	5/8-11
14	16 1/8	18 3/8	17.25	1	8	1/2-13
11 1/2	12.375	13 7/8	13.125	1 9/16	8	3/8-16
10	10 7/8	12 3/8	11 5/8	2 1/8	8	3/8-16
8	8 7/8	10 3/8	9 5/8	2 7/16	6	3/8-16
7 1/2	8 1/8	9 1/2	8.75	1 3/16	8	5/16-18
6 1/2	7.25	8 1/2	7 7/8	1 3/16	6	5/16-18
17.75 D	--	17.75	15.5	.72	8	5/8-11
15.50 D	--	15.50	13 7/8	.72	8	5/8-11
12.75 D	--	12.75	11	0	4	1/2-13

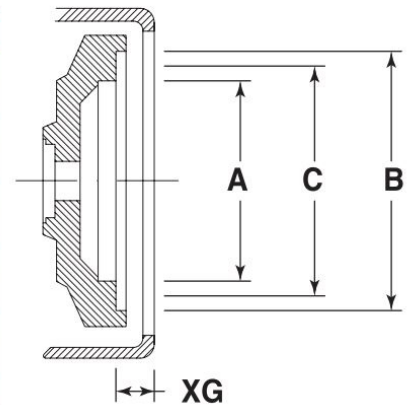

S.A.E. FLYWHEEL HOUSING DIAMETER GUIDE

Engine End

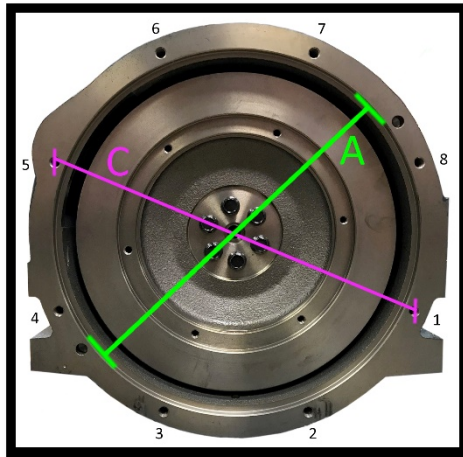

FLYWHEEL HOUSING

5. Flywheel Housing Pilot Bore Size (**Dimension A**): _____ Inches. Measure the pilot bore diameter (inside machined diameter) in the housing where the mounting plate will be mounted.
6. Flywheel Housing Size (**Dimension C**) _____ Inches. Measure the distance from bolt hole center to center (measuring across the center line of the crank shaft).
7. Flywheel Housing Perimeter Holes _____ ea. Count number of drilled and tapped holes on your housing perimeter (Ex. *in the above picture there are 8 numbered holes*).
8. S.A.E. Adaptor # _____. Based on the answers 5-7, choose from chart below.

SAE DIMENSIONS/ MOUNTING ARRANGEMENTS

S. A. E. Flywheel Housing Dimensions (in)

S.A.E. No.	A	B	C	Holes	Size
00	31	34.75	33.5	16	1/2-13
0	25.5	28	26.75	16	1/2-13
1/2	23	25.5	24 3/8	12	1/2-13
1	20 1/8	21.75	20 7/8	12	7/16-14
2	17 5/8	19.25	18 3/8	12	3/8-16
3	16 1/8	17.75	16 7/8	12	3/8-16
4	14.25	15 7/8	15	12	3/8-16
5	12 3/8	14	13 1/8	8	3/8-16
6	10.5	12 1/8	11.25	8	3/8-16

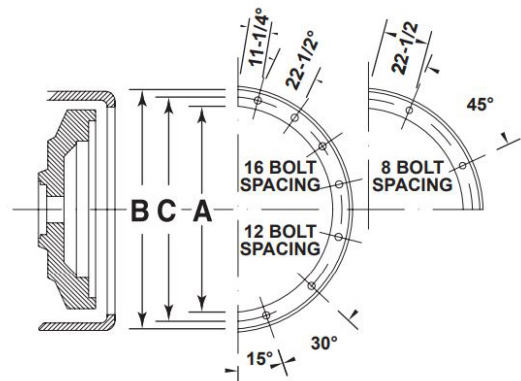

CONTACT INFO:

First Name: _____

Last Name: _____

Company Name: _____

Phone: _____ Email: _____

SKU/Model Of Generator Your Are Considering To Purchase: _____/_____