

**EverFocus**<sup>®</sup>

**1/3" CCD Color Day/Night  
plus Wide Dynamic Range  
Outdoor Vandal Dome Camera**

Operation Instructions  
Model No. **ED610**

Please read this manual first for correct installation and operation. This manual should be retained for future reference. The information in this manual was current when published. The manufacturer reserves the right to revise and improve its products. All specifications are therefore subject to change without notice.

### **PRECAUTIONS**

- 1. Do not install the camera near electric or magnetic fields.**  
Install the camera away from TV/radio transmitters, magnets, electric motors, transformers and audio speakers since the electromagnetic fields generated from these devices may distort the video image.
- 2. Never disassemble the camera beyond the recommendations in this manual nor introduce materials other than those recommended herein.**  
Improper disassembly or introduction of corrosive materials may result in equipment failure or other damage.
- 3. Try and avoid facing the camera toward the sun.**  
In some circumstances, direct sunlight may cause permanent damage to the sensor and/or internal circuits.
- 4. Keep the power cord away from water and other liquids and never touch the power cord with wet hands.**  
Touching a wet power cord with hands or touching the power cord with wet hands may result in electric shock.
- 5. Never install the camera in areas exposed to oil, gas or solvents.**  
Oil, gas or solvents may result in equipment failure, electric shock or, in extreme cases, fire.
- 6. Cleaning**  
Do not touch the surface of the sensor directly with the hands. Use a damp soft cloth to remove any dirt from the camera body. Use lens tissue or a cotton tipped applicator and ethanol to clean the sensor and the camera lens. Please do not use complex solvents, corrosive or abrasive agents for cleaning.
- 7. Do not operate the camera beyond the specified temperature, humidity or power source ratings.**  
Use the camera at temperatures within -10°C ~ 50°C (14°F~122°F) and in an IP66 compliant environment; this device is not rated as submersible. The input power source is 12VDC/24VAC.

## TABLE OF CONTENTS

|   |    |
|---|----|
| 1. PRODUCT OVERVIEW .....   | 3  |
| 1.1 Main Features .....   | 3  |
| 1.2 Content List.....   | 3  |
| 1.3 Specifications .....  | 5  |
| 1.4 Dimensions.....   | 6  |
| 1.5 Camera Component Description .....                              | 7  |
| 1.6 Front and Back Panel Layout.....                                | 8  |
| 1.7 Related Products .....  | 9  |
| 2. INSTALLATION .....   | 10 |
| 2.1 Mounting Camera.....  | 10 |
| 2.1.1 Drill the Holes .....   | 10 |
| 2.1.2 Mounting .....  | 11 |
| 2.2 Adjusting Camera .....  | 13 |
| 2.2.1 Adjusting Camera Position .....                               | 13 |
| 2.2.2 Adjusting Zoom and Focus.....                                 | 14 |
| 2.2.3 Camera Setting .....  | 16 |
| 2.2.3.1 OSD User Setup Menu .....                                   | 16 |
| 2.2.4 Close the Camera Cover (after installation is complete) ..... | 16 |
| 3. OSD MENU & CONFIGURATION.....                                    | 18 |
| 3.1 Access the user setup menu screen.....                          | 18 |
| 3.2 ED610 Menu Tree.....  | 19 |
| 3.3 LENS.....   | 22 |
| 3.4 EXPOSURE .....  | 22 |
| 3.4.1 SHUTTER.....  | 22 |

|                                    |    |
|------------------------------------|----|
| 3.4.2 AGC (Auto Gain Control)..... | 22 |
| 3.4.3 SENSE-UP.....                | 22 |
| 3.4.4 BLC.....                     | 23 |
| 3.4.5 HSBLC.....                   | 24 |
| 3.4.6 D-WDR.....                   | 24 |
| 3.4.7 Return.....                  | 24 |
| 3.5 WHITE BALANCE CONTROL.....     | 25 |
| 3.6 DAY NIGHT.....                 | 25 |
| 3.7 3DNR.....                      | 26 |
| 3.8 SPECIAL.....                   | 26 |
| 3.8.1 CAM TITLE.....               | 26 |
| 3.8.2 D-EFFECT.....                | 27 |
| 3.8.3 MOTION.....                  | 28 |
| 3.8.4 PRIVACY.....                 | 29 |
| 3.8.5 SYNC.....                    | 29 |
| 3.8.6 LANGUAGE.....                | 29 |
| 3.8.7 RETURN.....                  | 29 |
| 3.9 ADJUST.....                    | 29 |
| 3.9.1 SHARPNESS.....               | 29 |
| 3.9.2 BLUE.....                    | 30 |
| 3.9.3 RED.....                     | 30 |
| 3.9.4 RETURN.....                  | 30 |
| 3.10 RESET.....                    | 30 |
| 3.10.1 FACTORY RESET.....          | 30 |
| 3.10.2 RETURN.....                 | 30 |
| 3.11 EXIT.....                     | 30 |

## 1. PRODUCT OVERVIEW

Amazing *color* low light sensitivity of .05 lux *before* the added benefits of digital signal processing technology, delivered by a 1/3" Sony Super HAD II sensor, is just the beginning with the new EverFocus ED610. Get **color without compromise**: 560TVL resolution, your choice of full motion color *or* true day/night images in low light without ghosting, plus 120dB Digital Wide Dynamic Range to handle the most challenging of bright or unbalanced scene lighting conditions. Vandal resistant, IP66, with varifocal auto iris lens, 3-axis positioning, dual voltage operation and a full suite of OSD Menu and DSP functions (3D-DNR to save DVR HDD space, privacy masking, 32X digital zoom, mirroring and rotation, 256X sens-up to a max of .0002 lux, and much more) this is the camera you have been waiting for, and might be the only camera you'll ever need.

### 1.1 Main Features

- Super HAD II sensor at .05 lux has *5X better native light sensitivity before* DSP low light boost
- Color without compromise: your choice of full motion color or true day/night images in low light without ghosting
- True Day/Night with ICR module
- Starlight super high sensitivity of 0.0002 Lux/F=1.2 is achieved through a sensitivity increase setting of up to 256x
- Digital Wide Dynamic Range expansion to deliver properly exposed images despite bright light sources, deep shadows and/or unbalanced lighting in the same scene
- Provides 3D-Noise Reduction to improve picture clarity while enabling DVRs to improve disk storage utilization
- 3 axis positioning for wall or ceiling mounting with flexible angle viewing
- Easy to use OSD setup menu
- Motion detection for 4 configurable zones
- Privacy mask function for 8 configurable zones
- Provides digital zoom up to 32x
- Dual voltage (12VDC/24VAC) with line lock to AC supply

### 1.2 Content List



Please be careful when you unpack the box and the electronic devices inside. Check and make sure that you have all the items listed below inside the original box:

Camera Unit x 1

This Operation Manual x 1

Mounting kit includes:

- Long Screws x 3 (for mounting the base)
- Expanding Anchors x 3
- Washers x 3

Installation Template Sticker x 1

Video Test Cable x 1



Power Adapter Cable x 1



Desiccant Pack x 1



Focus Aiding Lens Cap (for 9~22mm models only) x 1



**Please Note:** If an item appears to have been damaged in shipment, replace it properly in its carton and notify the shipper. If any items are missing, notify your EverFocus Electronics Corp. Sales Representative or Customer Service. The shipping carton is the safest container in which the unit may be transported. Save it for possible future use.

### 1.3 Specifications

| Items                 | Parameter  |
|-----------------------|--|
| Pickup Device         | 1/3" SONY Super HAD II CCD   |
| Video Format          | NTSC or PAL  |
| Scanning System       | NTSC:525 TVL, 60 fields/sec<br>PAL:625 TVL, 50 fields/sec                    |
| Picture Elements      | 768 x 494(NTSC); 752 x 582 (PAL)   |
| Horizontal Resolution | 560 TVL  |
| Sensitivity           | 0.05Lux/F=1.2(AGC ON); 0.0002Lux/F=1.2(Sens-up 256x)                         |
| S/N Ratio             | Over 52dB (AGC off)  |
| Electronic Shutter    | 1/50 (1/60) ~1/100,000   |
| Video Outputs         | 1. BNC 1.0 Vp-p ,75ohm<br>2. Additional testing video output 1.0 Vp-p, 75ohm |
| Gamma Correction      | 0.45   |
| Lens Type             | Vari-focal lens, Auto Iris, 2.8-10mm (MVB), 9-22mm (MV2)                     |
| Back Light Comp.      | OFF, BLC, HSBLC Selectable   |
| Auto Gain Control     | Off/Low/Middle/High Selectable   |
| White Balance         | ATW/AWB/AWC/Manual/Indoor/Outdoor Selectable                                 |
| Sync. Mode            | Internal/Line lock external sync.  |
| Day & Night           | Yes, (Auto, Color, B/W,EXT)  |
| OSD Menu              | Yes  |
| 3DNR                  | Off/On switchable  |
| D-WDR                 | Outdoor, Indoor  |
| Digital Slow Shutter  | Sens-Up ~ 256x   |
| Mirror                | Off/Mirror/V-Flip/Rotate Selectable  |
| Digital Zoom          | Off/On switchable (up to 32X)  |
| Motion Detection      | Off/On for 4 Zones   |
| Privacy Mask          | Off/On for 8 Zones   |
| Weatherproof          | IP66   |
| Vandal Resistant      | Yes  |
| Power Source          | 12VDC/24VAC  |
| Power Consumption     | 12VDC:3W max.<br>24VAC:3W max.   |
| Operating Temperature | -10°C~50°C ; 14°F~122°F  |
| Weatherproof          | IP66   |
| Dimensions            | 123mm(O.D.) x 107.8mm (H) ; 4.8" (O.D.) x 4.2" (H)                           |
| Weight                | 0.74 kg / 1.6 lbs  |
| Certifications        | CE/FCC   |

## 1.4 Dimensions

123mm x 107.8mm ; 4.8" x 4.2"

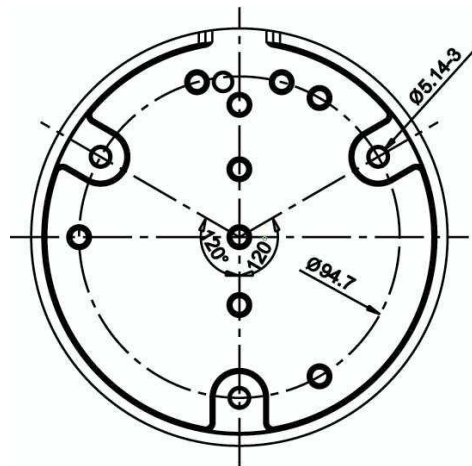
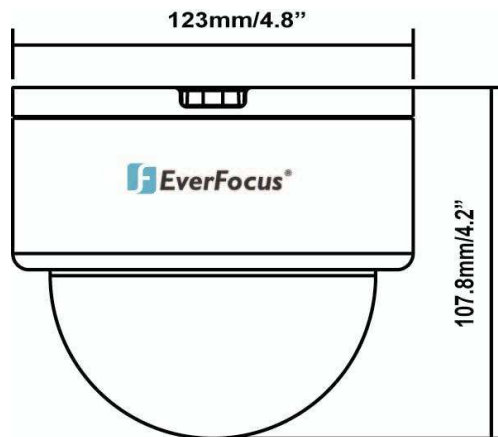

$\varnothing 5.143\text{mm}/0.2''$   
 $\varnothing 94.7\text{mm}/3.78''$

## 1.5 Camera Component Description

### Exterior view



### Interior view





## 1.6 Front and Back Panel Layout

### Front Panel Layout:

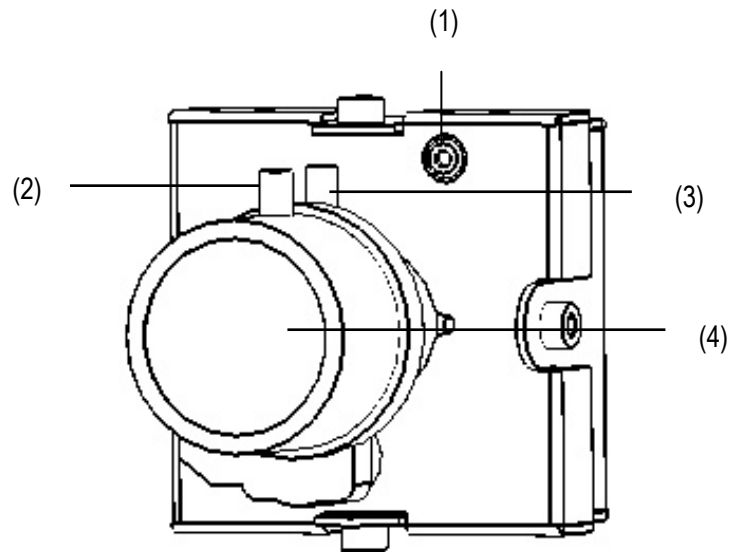

### Back Panel Layout:

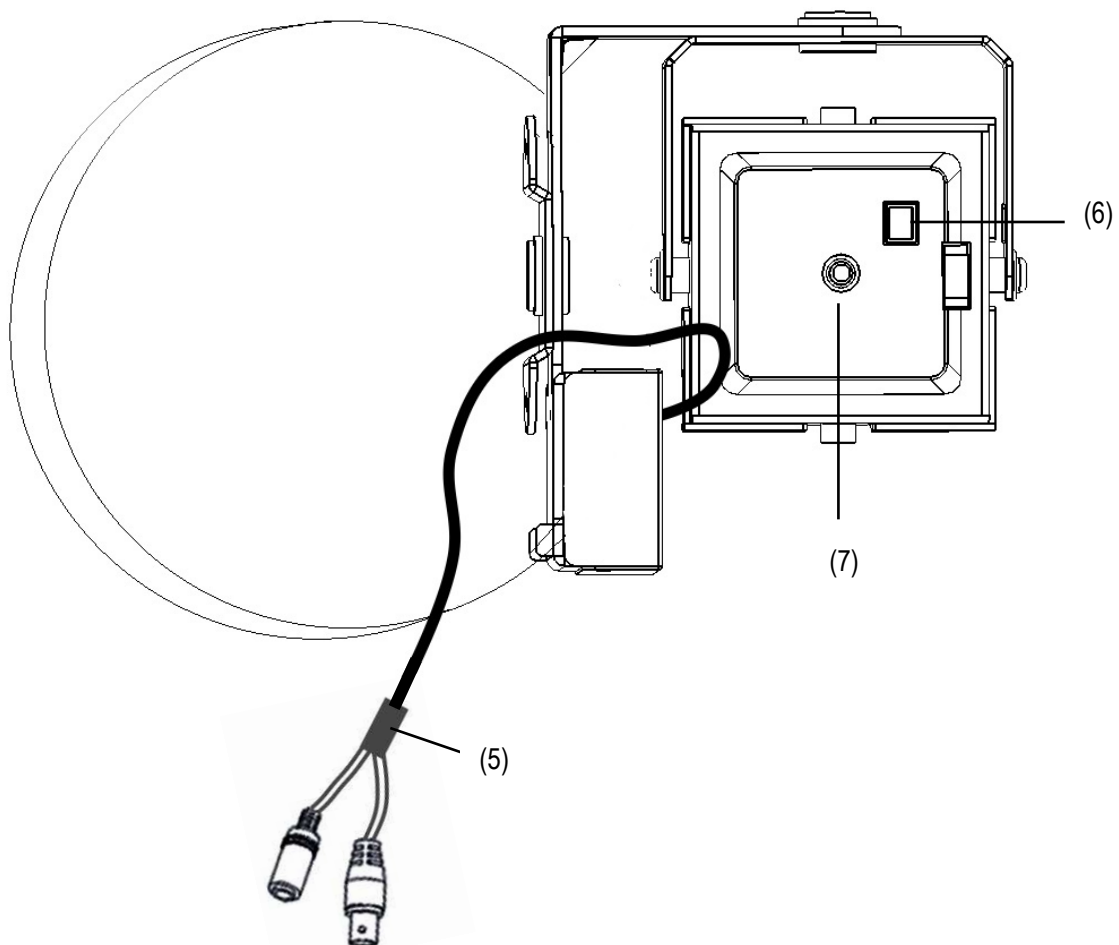

### (1) External Light Sensor

External Light sensor is used to detect the lighting level the environment. (The light sensor is “down” when the internal camera module is properly positioned).

### (2) Focus Ring

To set the focus, and loosen the focus ring knob, and turn the ring toward <F> or <N> as necessary, and re-tighten when the adjustment is complete.

### (3) Zoom Ring

To adjust the viewing angle, loosen the zoom ring knob. Turn the ring toward <W> to Zoom out or <T> to Zoom in as necessary, and re-tighten when the adjustment is complete.

### (4) Lens

The included vari-focal, DC iris lens allows manual adjustment of the field of view (zoom & focus). The choices for focal length range are:

- 2.8-10mm
- 9-22mm

### (5) Power & Video pigtail cable

Connect power and video to pigtail cable

### (6) Test Video Output Connector

When installing the camera, you can use this video connector to connect a portable monitor. This will allow you to easily adjust camera’s field of view and focus.

(7) **OSD Menu joystick:** Use the joystick to move the cursor Upwards/Downwards. This is used to select the item to be set.

Tilt the stick to the right or left. This is used to select or adjust the parameters of the selected item.

Press in on the stick to enter the setup menu. If the item has its own setting menu (sign ), press the stick again to display the sub- menu.

## 1.7 Related Products

In addition, you may order the following EverFocus products which are recommended for use with the camera to achieve the best performance:

L Type Bracket: BA-EDMS



EN220 5.6 inch LCD Test Monitor



## 2. INSTALLATION

This chapter will describe, in general terms, how to install the ED610 camera.

STEPS:

2.1. Mounting Camera:

1. Drill the Holes. See 2.1.1
2. Mounting: See 2.1.2

2.2. Adjusting Camera:

1. Adjust the camera position. See 2.2.1
2. Adjusting Zoom and Focus See 2.2.2
3. Camera Setting. See 2.2.3
4. How to close camera cover after installation. See 2.2.4

### Warning

- To prevent electrical shock, turn off the electrical power before making electrical connections.
- Do not expose the camera to water or moisture while open during installation, nor try to operate it while open in wet areas. Once properly installed and sealed, the dome is IP66 rated against water infiltration.

### 2.1 Mounting Camera

#### 2.1 .1 Drill the Holes

1. Paste the drilling template on the ceiling or wall
2. Drill 4 holes, 1 for the power/video cable, 3 for screws A, B and C.

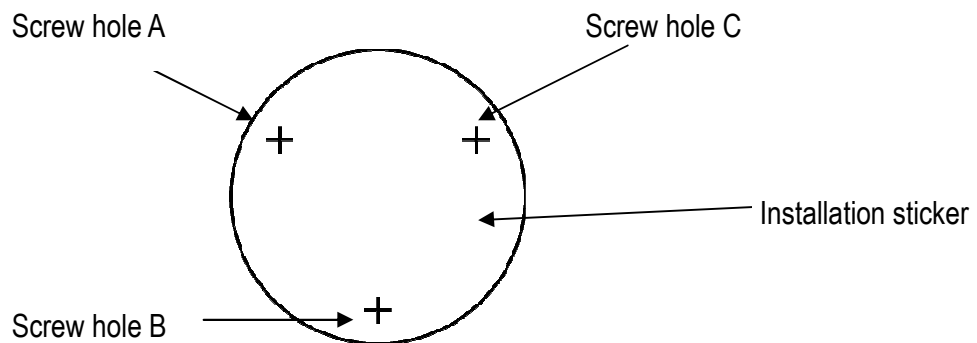

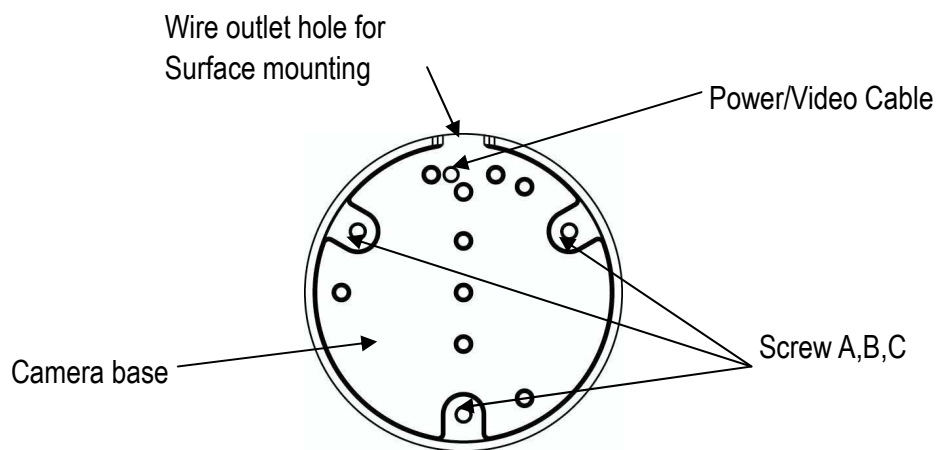

### 2.1.2 Mounting

1. Take off camera's cover by rotating the cover counter clockwise.

Loose outer cover ring first

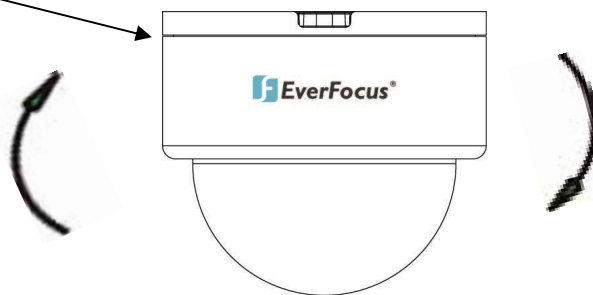

Take off camera's cover

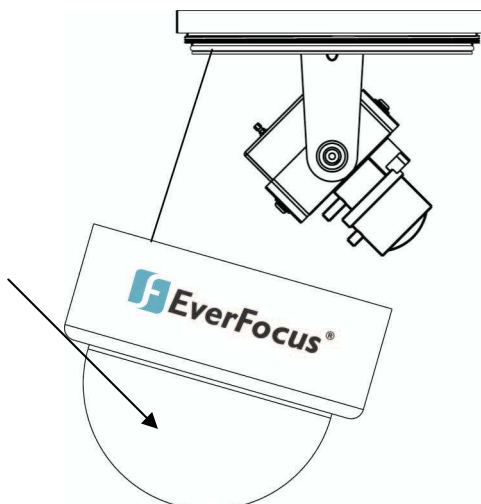

2. Pull the cables to be connected to the power and video cables from the ceiling or wall.

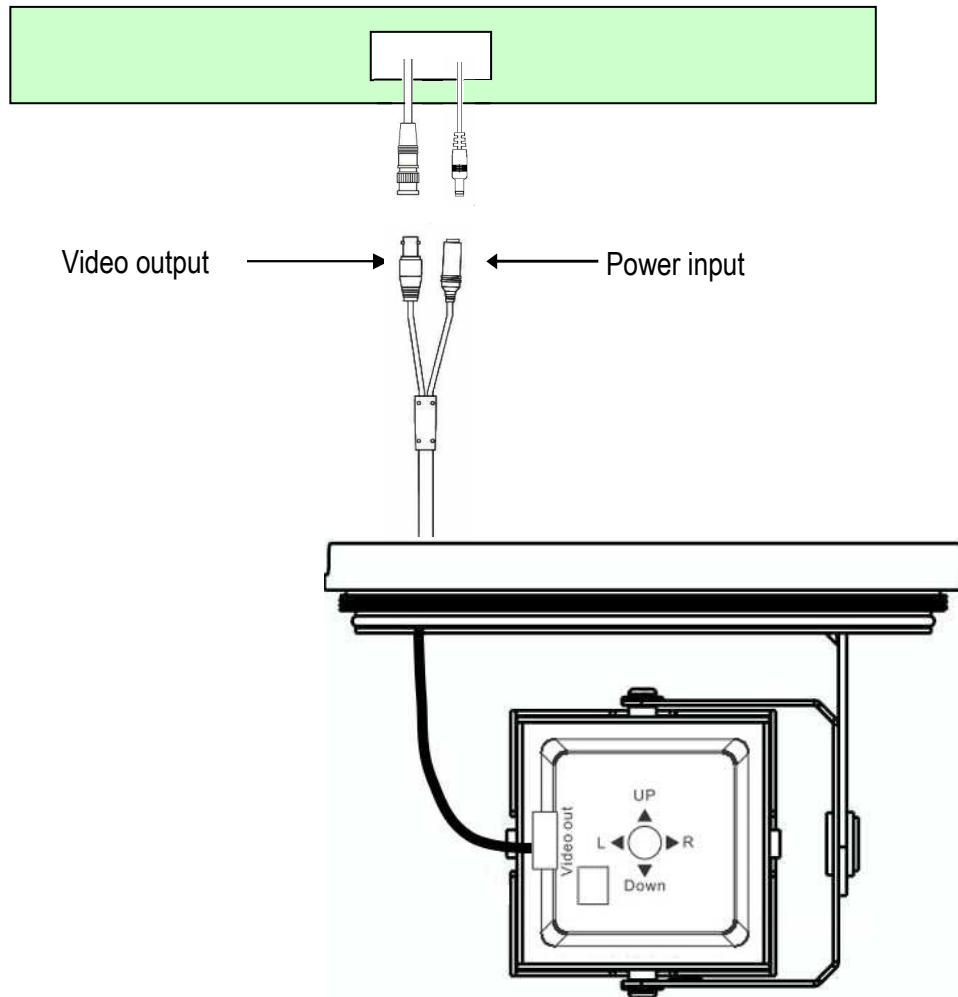

3. Fix the camera base to ceiling or wall by using 3 screws and washers. The washers are used to create the IP66 seal and must be used.

**Ceiling Mount:**

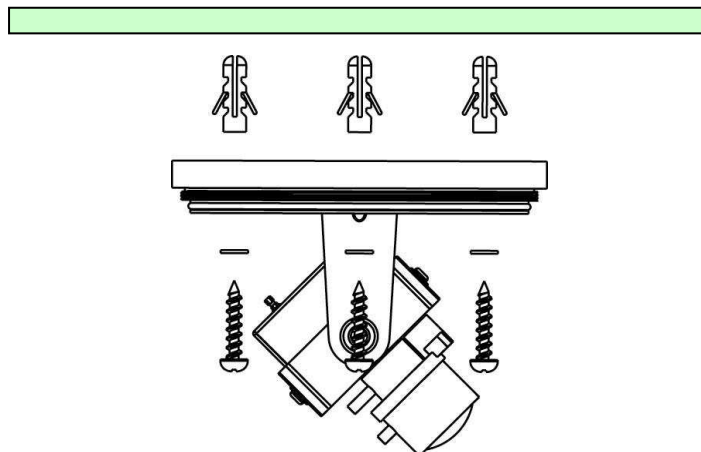

**Wall Mount:**

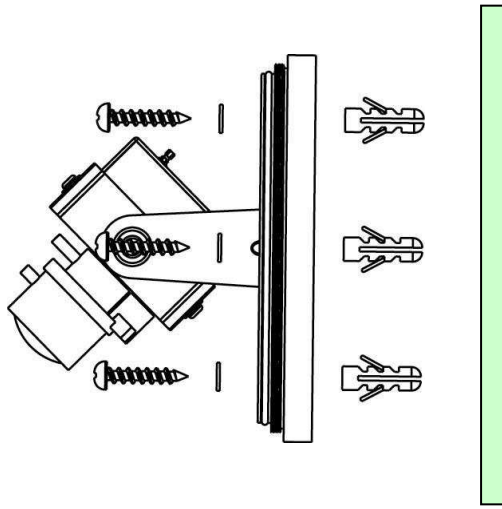

**2.2 Adjusting Camera**

**2.2.1 Adjusting Camera Position**

Adjust the camera to best angle for viewing.

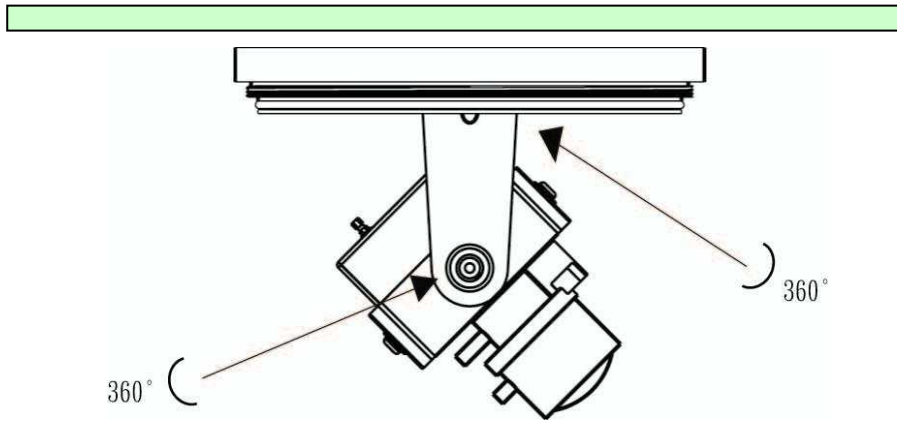

When you install on the ceiling, change angle of view by turning these joints.

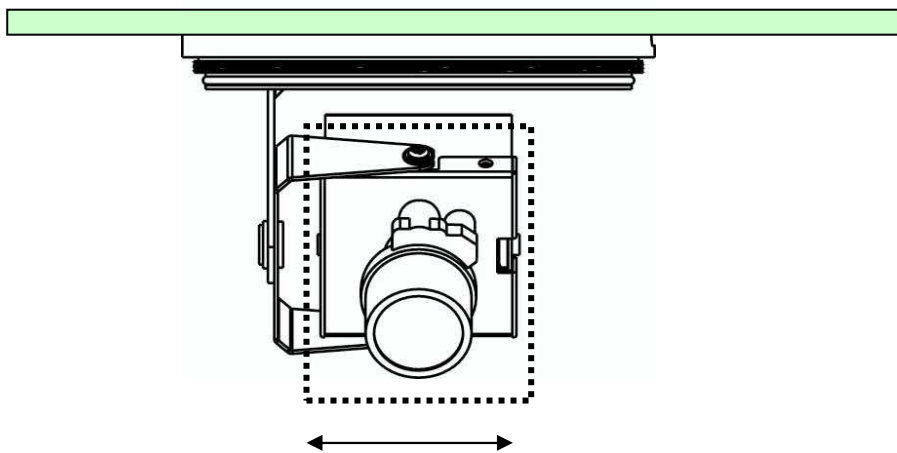

Module can be adjusted up and down

## 2.2.2 Adjusting Zoom and Focus

It is highly recommended to use an EverFocus Test Monitor to set up the camera. Find the Video test connection on the back of the camera module. Connect using the video cable included in the package.

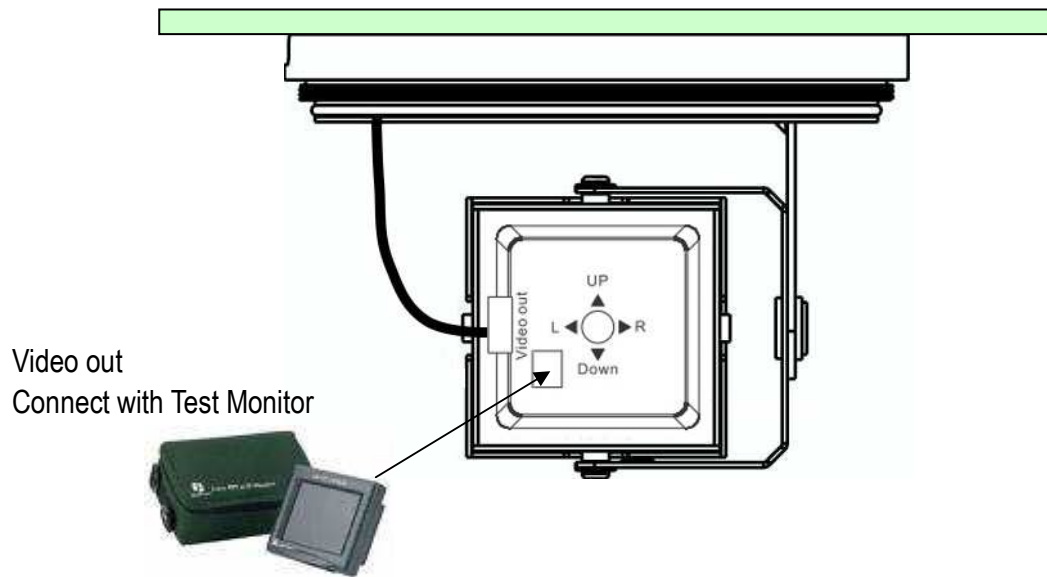

1. Loosen the zoom ring knob, and then turn the ring towards <W> or <T> as necessary to obtain the desired view angle.  
W side (Zoom out)  
The viewing range will be wider and the subject is smaller.  
T side (Zoom in)  
The viewing range will be smaller and the subject is larger.
2. Loosen the focus ring knob, then turn the ring towards <∞> or <N> as necessary to obtain a clear video image.
3. Repeat steps 1 and 2 until the best image is obtained. Once the lens setting is complete, tighten the zoom and focus ring knobs.

### Important Note when focusing a 9-22mm Lens

To adjust lens zoom and focus, if using the 9~22mm lens model ED610 camera, the focus aiding lens cap must be used to simulate the dome being closed. Follow the steps below to ensure that camera will stay in focus when the dome is installed.

- Step 1 Take the included focus aiding lens cap (shown below) from its small plastic bag.



Step 2 Open the dome cover and place the Focus aiding lens cap on the lens, making sure that the cap's notch is resting on the zoom knob.

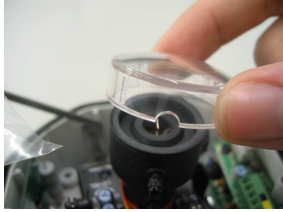

Step 3 With cap on, adjust the focus and zoom rings by loosening the knobs and turning the rings until subject is in focus. Retighten the knobs when done.

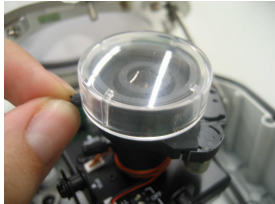

Step 4 When finished adjusting focus and zoom, remove the focus aiding cap from the camera lens, replace the dome cover and secure the cover by turning it clockwise. See Section 2.2.4 below for additional information.

**NOTE:** It is recommended to put the desiccant pack under the bracket. Or, use a cable tie to secure it before placing the cover back on the camera.



## 2.2.3 Camera Setting

### 2.2.3.1 OSD User Setup Menu

This camera utilizes an On Screen Display (OSD) user setup menu.

Please refer to Chapter 3 OSD Menu & Configuration, to get more details about OSD menu usage.

### 2.2.4 Close the Camera Cover (after installation is complete)

The ED610 is specially designed with one inner cover and one outer cover ring for water-proofing and ease of installation. Please follow these instructions for closing the camera cover.

1. Align the window in the cover with the lens



2. Push the interior cover toward the base, until it completely covers the whole red gasket and is lined up parallel with camera base. (The cover must be aligned with the camera base or it cannot be closed. Then turn the outer cover ring clockwise to secure it tightly to the camera base.

Push the inner cover and cover the whole red gasket



Outer cover ring

**Correct**



**Wrong (not aligned)**



3. If the lens is not aligned with the window, loosen the outer cover, adjust the inner cover so that the lens aimed exactly at the window.

Slightly adjust the cover



4. Tighten the outer cover ring until it is firmly secured.

Turn the external ring



### 3. OSD MENU & CONFIGURATION

This chapter introduces how to configure the camera OSD menu.

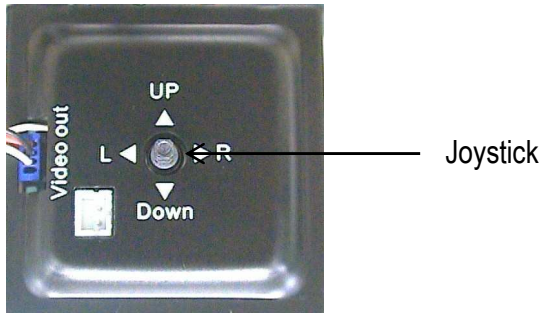

#### 3.1 Access the user setup menu screen

- I. **Press inward on the end of the joystick**  
The menu screen will appear on the monitor.
- II. **Navigating with the joystick**  
Angle the joystick ▲ or ▼ to move the cursor up or down. Angle the joystick ◀ or ▶ to adjust the mode or value of a setting.
- III. **Switching to sub-menu screens**  
When an item with sub-menu is selected, press inward on the end of the joystick to switch to the sub-menu for further settings.

**NOTE:**

For those selected items with “◀■” sign at the end, there is a sub-menu for further settings.

- IV. **Return to previous page**  
Press the **SET** button to return to previous page if the choice displayed is RETURN.
- V. **Close the menu screen**  
Press the **SET** button to exit the menu system if the choice displayed is END (sub-menu) or EXIT (main menu only).

### 3.2 ED610 Menu Tree

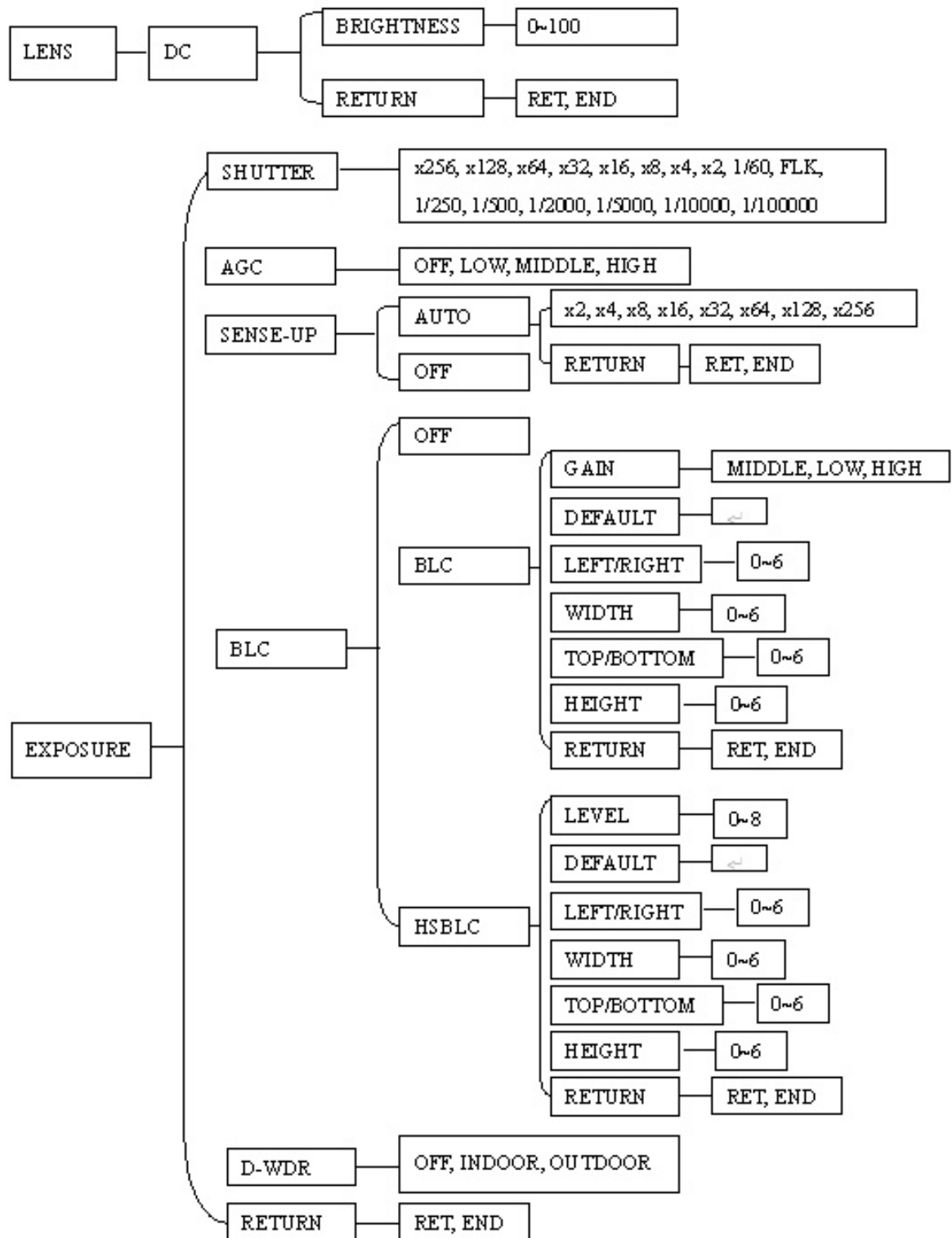

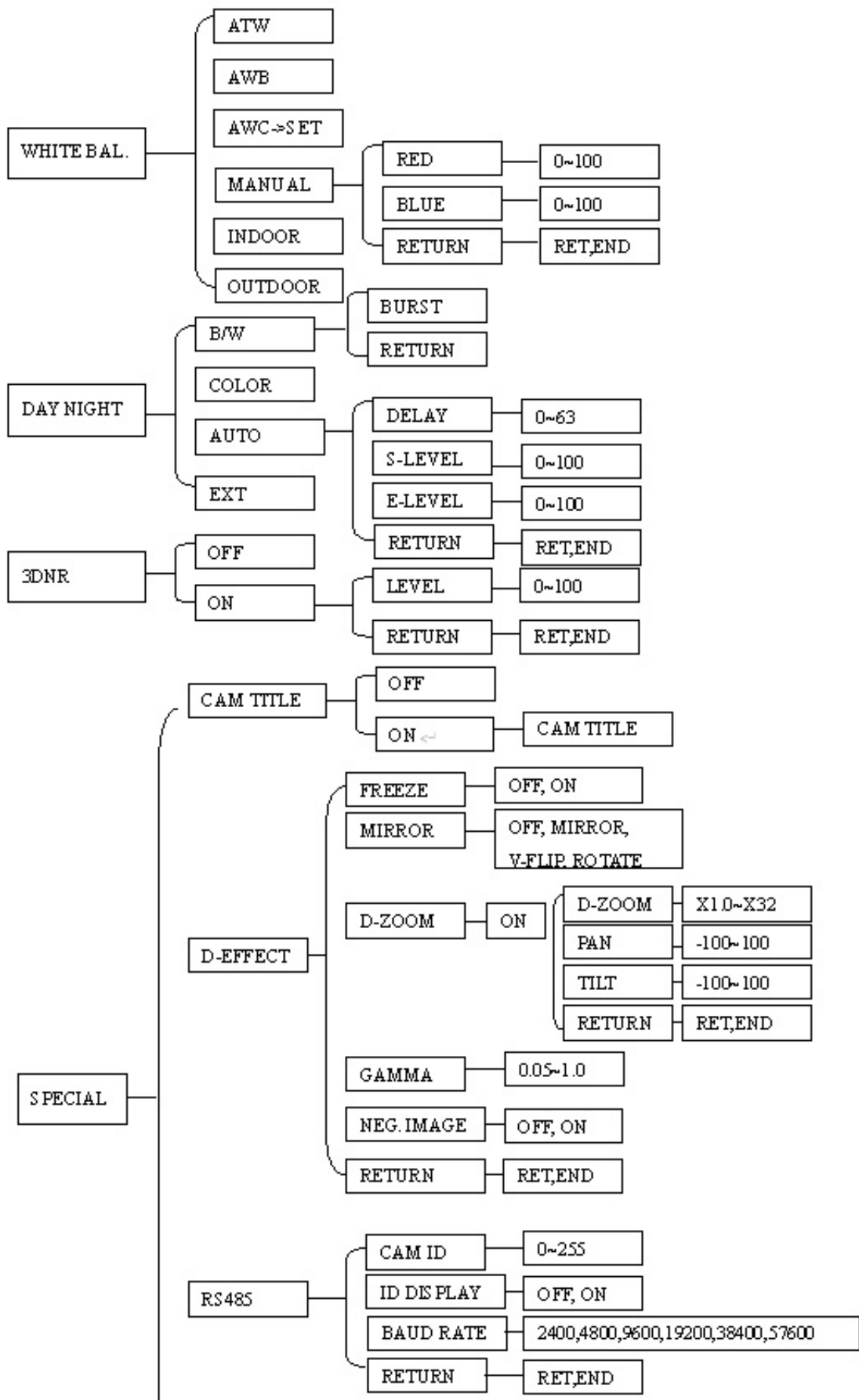

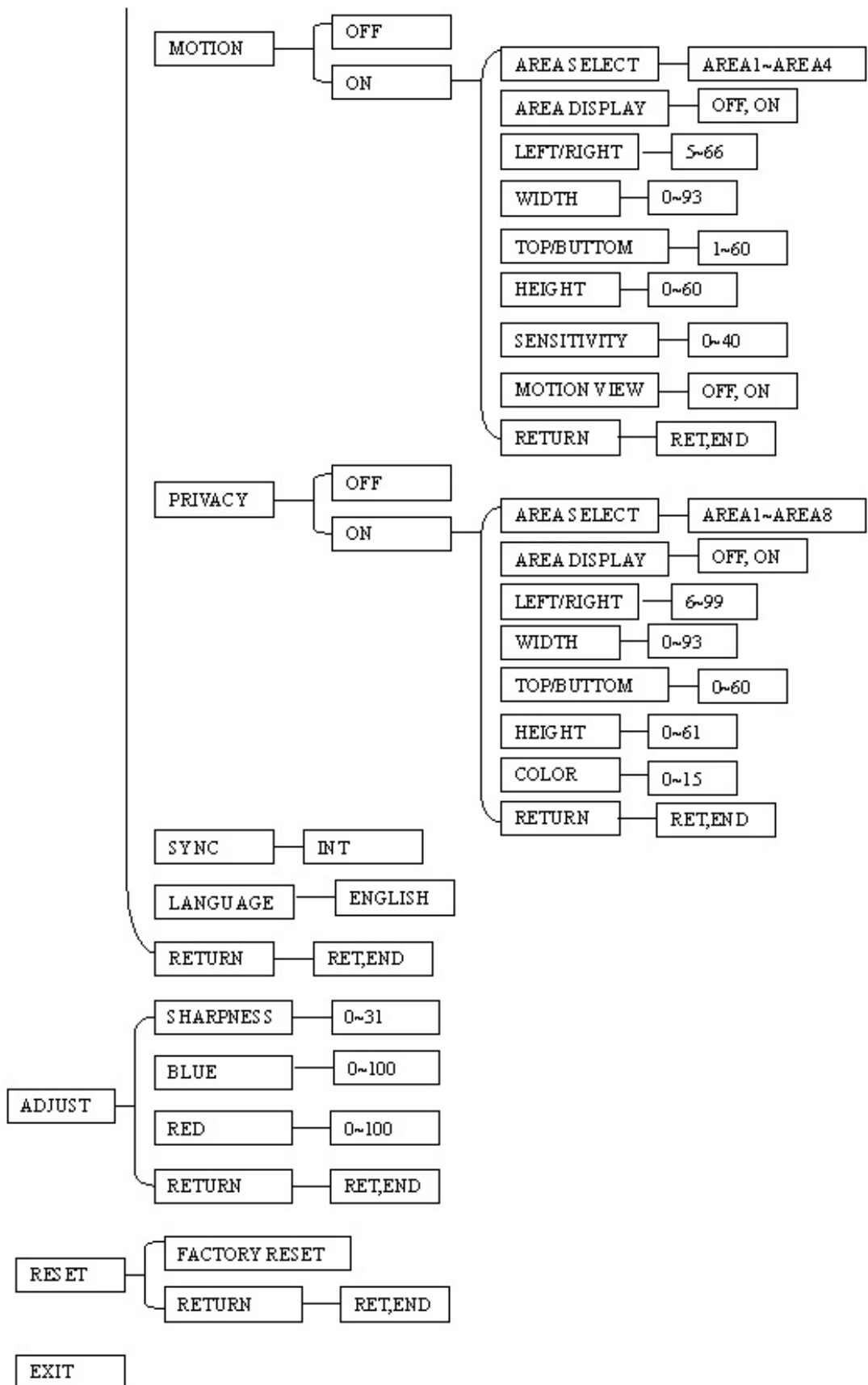

### 3.3 LENS

1. When the SETUP menu is displayed on the screen, please direct the arrow to point to "LENS" by moving the joystick UP and DOWN.

**NOTE:**

The brightness of the screen can be adjusted in the BRIGHTNESS sub menu. The level can be adjusted from 0 to 100.

2. Select "RET" to save all settings in the LENS menu and returns to the previous menu.  
Select "END" to save all the menu settings and exit from the OSD menu.

### 3.4 EXPOSURE

When the SETUP menu is displayed, direct the arrow to EXPOSURE and press in on the joystick.

#### 3.4.1 SHUTTER

1. When the EXPOSURE menu is displayed on the screen, please direct the arrow to point "SHUTTER" by moving the joystick UP or DOWN.
2. Select the shutter mode by moving the joystick LEFT or RIGHT.  
Select from x256, x128, x64, x32, x16, x8, x4, x2, 1/60, FLK, 1/125, 1/500, 1/2000, 1/5000, 1/10000, 1/00000.

FLK:

Please select "FLK" mode if flickering occurs on the screen, because of an irregular balance between illumination and scan frequency. NTSC model: 1/100, PAL model: 1/120.

#### 3.4.2 AGC (Auto Gain Control)

1. Please direct the arrow to point to "AGC" by moving the joystick UP and DOWN.
2. Select the mode you would like to operate by moving the joystick LEFT or RIGHT. The more the level of gain increases, the brighter the screen; however, the level of noise increases as well. Please select from HIGH, MIDDLE, LOW and OFF.

#### 3.4.3 SENSE-UP

SENSE-UP is used to keep a brilliant, vivid screen image by automatically detecting changes in the level of light under low light level conditions.

1. Please direct the arrow to point to "SENSE-UP" by moving the joystick UP and DOWN.
2. Select the mode you would like to operate by moving the joystick LEFT or RIGHT.

AUTO:

Low light level auto mode.

OFF:

The function is disabled.

**NOTES:**

- ① The maximum amplification in low light level situations can be adjusted by pressing the SETUP button in "AUTO" mode. This sets an upper limit on the 'boost'.
- ② The image becomes brighter when the setting increases; however, the after image increases as well. Due to the increased light sensitivity of the Super Had II chip, far less DSP 'boost' is needed, resulting in color or B/W images in low light with minimal ghosting.
- ③ Please note that spots and noise may appear if light amplification increases when SENSE-UP is operating. This is a normal phenomenon, controllable with DNR.

**3.4.4 BLC**

Video gain can be adjusted automatically to correct the exposure of subjects that are in front of a bright light source.

1. Please direct the arrow to point to "BLC" by moving the joystick UP and DOWN.
2. Select the BLC mode by pressing the LEFT or RIGHT button. Then make adjustments as below:

**GAIN:**

Select from High, Middle and Low.

**DEFAULT:**

Set the factory default values for BLC.

**LEFT/RIGHT:**

Set the Left/Right side of an area for the BLC to be adjusted. The value adjustable is 0~6.

**WIDTH:**

Set the width of an area for the BLC to be adjusted. The value adjustable is 0~6.

**TOP/BOTTOM:**

Set the Top/Bottom side of an area for the BLC to be adjusted. The value adjustable is 0~6.

**HEIGHT:**

Set the height of an area for the BLC to be adjusted. The value adjustable is 0~6.

Select "RET" to save all settings in this menu and returns to the previous menu.

Select "END" to save all the menu settings and exit.



### 3.4.5 HSBLC

HSBLC (Highlight Suppression BLC) is used to reduce the brightness of light sources in a specific area. It is activated only in a low illumination environment to minimize the effects of glare from bright lights such as spotlights, street lights or headlights in the field of view. Where 'traditional' BLC can increase the exposure of a dark area surrounded by a brighter area, HSBLC can decrease the exposure of bright areas surrounded by darker areas.

1. Please direct the arrow to point to "BLC" by using the UP and DOWN buttons.
2. Select the HSBLC mode by pressing the LEFT or RIGHT button. Then make adjustments as below:

LEVEL: Adjust the sensitivity level for HSBLC from 0 to 8.

DEFAULT: Set the factory default values for HSBLC.

LEFT/RIGHT: Set the Left/Right side of an area for the HSBLC to be adjusted. The value adjustable is 0~6.

WIDTH: Set the width of an area for the HSBLC to be adjusted. The value adjustable is 0~6.

TOP/BOTTOM: Set the Top/Bottom side of an area for the HSBLC to be adjusted. The value adjustable is 0~6.

HEIGHT: Set the height of an area for the HSBLC to be adjusted. The value adjustable is 0~6.

Select "RET" to save all settings in HSBLC menu and returns to the previous menu.

Select "END" to save all the menu settings and exit from the OSD menu.

### 3.4.6 D-WDR

When there are both bright and dark areas at same time, this function can make both areas properly exposed.

1. Please direct the arrow to point to "D-WDR" by using the UP and DOWN buttons.
2. Select the mode you would like to operate by moving the joystick LEFT or RIGHT.

OFF: Disables D-WDR function

INDOOR: Select this option if you are in an indoor environment.

OUTDOOR: Select this option if you are in an outdoor environment.

### 3.4.7 Return

Select "RET" to save all settings in the EXPOSURE menu and returns to the previous menu.

Select "END" to save all the menu settings and exit from the OSD menu.

### 3.5 WHITE BALANCE CONTROL

The screen color can be adjusted by using the WHITE BALANCE function.

1. Please direct the arrow to point to "WHITE BAL" by moving the joystick UP and DOWN.
2. Please select the mode you would like to operate by moving the joystick LEFT or RIGHT.

Please select one of the 6 modes below:

ATW (Auto Tracking White Balance):

This mode can be used within the color temperature range from 5,500°K to 6,000°K (eg, fluorescent light, outdoor, sodium vapor lamp or inside tunnels).

AWB:

This mode can be used within the color temperature range from 2,500°K to 10,000°K.

AWC->SET: To find the optimal setting for the current luminance environment in this mode, point the camera toward a sheet of white paper, and press middle of joystick. If the environment changes, you have to readjust it.

MANUAL: The manual adjustment mode enables a more precise adjustment. Please select ATW or AWC first. Then change to manual adjustment mode and press middle of joystick. Set the suitable color temperature, and increase or decrease the red and blue color values at the same time while checking the color changes of the objects in view.

Select "RET" to save all settings in this menu and returns to the previous menu.

Select "END" to save all the menu settings and exit.

INDOOR:

Select this option when the color temperature is 5,600°K.

OUTDOOR:

Select this option when the color temperature is 3,300°K.

Press "RET" to save all settings in this menu and returns to the previous menu.

Press "END" to save all the menu settings and exit

### 3.6 DAY NIGHT

These settings control the operation of the camera when the illumination level changes. Choices are Color at all times; B/W at all times; or color when illumination is bright, switching to B/W in low light.

⇒ B/W: The picture is always displayed in B/W.

BURST: OFF/ON.

ON: Retains the color burst information; minor color noises may appear when ambient illumination is low.

OFF: With color burst signal off, picture will be pure B/W.

Return: Press "RET" to save all settings in the DAY/NIGHT menu and returns to the previous menu.

Press "END" to save all the menu settings and exit.

- ⇒ COLOR: The picture is always displayed in color, even at low light levels.
- ⇒ AUTO: The picture switches to color in a normal (bright) environment and switches to B/W when the ambient illumination is low. The switching point is determined by the AGC level.

**Note: AGC selection must be set as middle or high in order to employ the auto switching function.**

Delay: Set the switchover delay time from 0~63 seconds.

S-Level: Set the start level from 0~100.

E-Level: Set the end level from 0~100.

#### EXT:

The picture switches to color in a normal environment and switches to B/W when the ambient illumination is low. The switching condition is determined by the light sensor alongside the lens.

### 3.7 3DNR

3DNR reduces the background noise in a low luminance environment.

#### OFF:

Disables 3DNR to keep the same amount of noise.

#### ON:

Enables 3DNR to reduce the noise.

- Level: adjust noise reduction level from 0~100.
- Return: Select "RET" to save all settings in 3DNR menu and returns to the previous menu.  
Select "END" to save all the menu settings and exit from the OSD menu.

### 3.8 SPECIAL

In this section, user can control special settings including Cam Title, D-Effect, Motion, Privacy, Sync, Language and Return.

1. Please direct the arrow to point to "SPECIAL" on the SETUP menu by moving the joystick UP and DOWN.
2. Select the mode you would like to operate by moving the joystick LEFT or RIGHT.

#### 3.8.1 CAM TITLE

Input a camera title and it will be displayed on the monitor.

- 1) Please direct the arrow to point to "CAMERA" by moving the joystick UP or DOWN.
- 2) Select "ON" by moving the joystick LEFT or RIGHT.
- 3) Press in on the joystick.
- 4) Maximum 15 letters can be used for the ID.
  - Moving the joystick UP and DOWN position the cursor on the letter to be chosen.
  - Press in on the joystick to lock in the letters. Repeat as necessary.
- 5) Once a name has been selected, please choose a position where you would like to display the name.
  - Move the cursor onto "POS" and press in on the joystick.
  - The name will appear at the top left hand corner.
  - Angle the joystick in any direction to select the desired position to display the name. Press in on the joystick to lock in the position.



ON:

- D-Zoom: Select digital zoom from X1.0 up to X32.

To control the portion of the magnified image in view (0 is the center of the image):

- Pan: Select pan digital zoom from -100 to 100.
- Tilt: Select tilt digital zoom from -100 to 100.
- Return: Select “RET” to save all settings in D-ZOOM menu and returns to the previous menu.
- Select “END” to save all the menu settings and exit from the OSD menu.

#### 3.8.2.4 GAMMA

To adjust displayed brightness from 0.05 up to 1.0.

#### 3.8.2.5 NEG. IMAGE

Allows user to create a negative of the original image. A negative image is a tonal inversion of a positive image, in which light areas appear dark and vice versa. A negative color image is additionally color reversed, with red areas appearing cyan, greens appearing magenta and blues appearing yellow.

#### 3.8.2.6 RETURN

Select “RET” to save all settings in D-EFFECT menu and returns to the previous menu.

Select “END” to save all the menu settings and exit from OSD menu.

### 3.8.3 MOTION

This camera enables you to observe movements of objects in 4 different areas on the screen, and the message “MOTION DETECTED” appears on the screen when movement is detected; this may help to improve operational efficiency. The camera detects an object’s movement by sensing changes in the pixels displayed.

-OFF: Disables the MOTION function.

-ON:

- AREA SELECT: Please select the area you would like to detect from the 4 areas in AREA SELECT mode
- AREA DISPLAY: Select “ON” to use the motion area selected in sensitivity. Select “OFF” to disable this function.
- LEFT/RIGHT: Set the coordinate of the horizontal axis 5~66.
- WIDTH: Set the size of horizontal area 0~93.
- TOP/BOTTOM: Set the coordinate of the vertical axis 1~60.
- HEIGHT: Set the size of vertical area 0~60.
- SENSITIVITY: Set the sensitivity level for the motion trigger by selecting from 0~40. When the sensitivity value is high, motion detection sensitivity increases to sense very small movements and vice versa.
- MOTION VIEW: Select “ON” to display motion detection pixels in the live view.
- Select “RET” to save all settings in MOTION menu and returns to the previous menu.  
Select “END” to save all the menu settings and exit from OSD menu.

### 3.8.4 PRIVACY

This mode covers the areas you do not want to see on the screen.

#### OFF:

Disable the PRIVACY function.

#### ON:

- AREA SELECT: Please select the area you would like to hide from the 8 areas in AREA SELECT mode
- AREA DISPLAY: Select "ON" to use the area selected in the AREA SELECT. Select "OFF" to disable this function.
- LEFT/RIGHT: Set the coordinate of the horizontal axis 6~98.
- WIDTH: Set the size of horizontal area 0~93.
- TOP/BOTTOM: Set the coordinate of the vertical axis 0~60.
- HEIGHT: Set the size of vertical area 0~61.
- COLOR: Set area color. It is selectable from 0 to 15.
- Select "RET" to save all settings in PRIVACY menu and returns to the previous menu.  
Select "END" to save all the menu settings and exit from OSD menu.

### 3.8.5 SYNC

There are two SYNCHRONIZATION modes: INTERNAL and EXTERNAL LINE-LOCK. In LINE-LOCK mode, the video signal is synchronized to the frequency of the incoming AC power. The Line-Lock synchronization can only be used when the supply power is 24VAC/60Hz (NTSC models) or 50Hz (PAL models).

#### INT:

Internal synchronization

#### L/L:

External line-lock synchronization

### 3.8.6 LANGUAGE

Select OSD language. ED610 camera supports multiple languages.

### 3.8.7 RETURN

Select "RET" to save all settings in SPECIAL menu and returns to the previous menu.

Select "END" to save all the menu settings and exit from OSD menu.

## 3.9 ADJUST

Adjust sharpness, Blue and Red level in this section.

### 3.9.1 SHARPNESS

The contour of the video image becomes cleaner and more easily distinguished as the level of SHARPNESS increases. If the level is set too high it may affect the video image and cause noise. The available range of level is 0~31.

### **3.9.2 BLUE**

Adjust image's blue level. The available range of level is 0~100.

### **3.9.3 RED**

Adjust image's red level. The available range of level is 0~100.

### **3.9.4 RETURN**

Select "RET" to save all settings in ADJUST menu and returns to the previous menu.

Select "END" to save all the menu settings and exit from OSD menu.

## **3.10 RESET**

### **3.10.1 FACTORY RESET**

Reset to the default settings.

### **3.10.2 RETURN**

Select "RET" to save all settings in RESET menu and returns to the previous menu.

Select "END" to exit from OSD menu.

## **3.11 EXIT**

Save all the menu settings and exit.

#### **NOTE:**

If you quit the Menu without pressing EXIT, all the settings you previously modified will NOT be saved.

## **EverFocus Electronics Corp.**

### **Headquarter Office**

12F, No.79 Sec.1 Shin-Tai Wu Road,  
Hsi-Chi, Taipei, Taiwan  
Tel: +886-2-26982334  
Fax: +886-2-26982380

### **Beijing office**

Room 609, Technology Trade Building,  
Shangdi Information Industry Base,  
Haidian District, Beijing China  
Tel: +86-10-62971096  
Fax: +86-10-62971423

### **European Office**

Albert-Einstein-Strasse 1,  
D-46446 Emmerich, Germany  
Tel: +49-2822-9394-0  
Fax: +49-2822-939495

### **Japan Office**

1809 WBG Marive East 18F,  
2-6 Nakase, Mihama-ku,  
Chiba city 261-7118, Japan  
Tel: +81-43-212-8188  
Fax: +81-43-297-0081

### **USA California Office**

1801 Highland Ave. Unit A  
Duarte, CA 91010 ,U.S.A  
Tel: +1-626-844-8888  
Fax: +1-626-844-8838

### **USA New York Office**

415 Oser Ave Unit S  
Hauppauge, NY 11788  
Sales: +1-631-436-5070  
Fax: +1-631-436-5027

|   |  |  |
|---|--|--|
|  | <p>Your EverFocus product is designed and manufactured with high quality materials and components which can be recycled and reused. This symbol means that electrical and electronic equipment, at their end-of-life, should be disposed of separately from your household waste. Please, dispose of this equipment at your local community waste collection/recycling centre. In the European Union there are separate collection systems for used electrical and electronic product. Please, help us to conserve the environment we live in!</p> | <p>Ihr EverFocus Produkt wurde entwickelt und hergestellt mit qualitativ hochwertigen Materialien und Komponenten, die recycelt und wieder verwendet werden können. Dieses Symbol bedeutet, dass elektrische und elektronische Geräte am Ende ihrer Nutzungsdauer vom Hausmüll getrennt entsorgt werden sollen. Bitte entsorgen Sie dieses Gerät bei Ihrer örtlichen kommunalen Sammelstelle oder im Recycling Centre. Helfen Sie uns bitte, die Umwelt zu erhalten, in der wir leben!</p> |
|---|--|--|



**EverFocus®**

P/N: MED6G00100