

PIC32MZ DA Curiosity User Guide

Preface

The Microchip PIC32MZ DA Curiosity Development Board (EV87D54A) includes an integrated programmer and debugger, which requires no additional hardware to get started. Users can expand functionality through MikroElektronika mikroBUS™ Click™ adapter boards, add Ethernet connectivity with the Microchip PHY daughter board, add Wi-Fi® connectivity capability using the Microchip expansions boards, and add audio input and output capability with Microchip audio daughter boards. With or without expansion boards, the Curiosity PIC32MZ DA development board provides the freedom to develop a variety of applications, including Bluetooth® audio, CAN, graphics/UI, Internet of Things (IoT), robotics development, and proof-of-concept designs. The following figure shows the PIC32MZ DA Curiosity development Board.

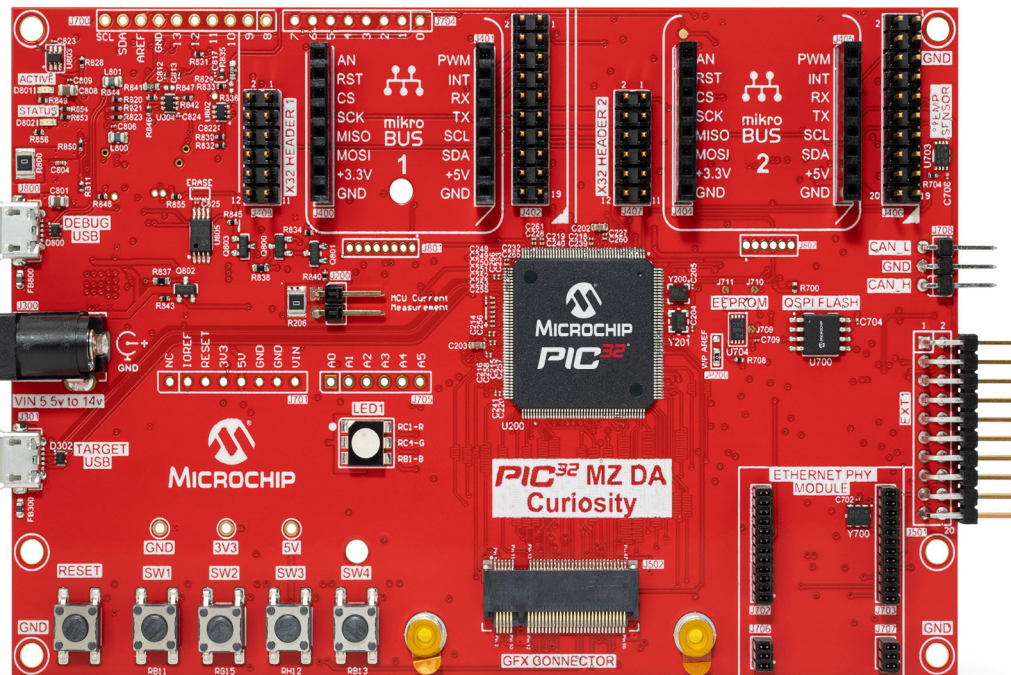

Table of Contents

Preface.....	1
1. Introduction.....	3
1.1. PIC32MZ DA Curiosity Features.....	3
1.2. Kit Contents.....	3
2. Development Board Functionality and Features.....	4
2.1. Development Board Feature Location.....	4
2.2. System Block Diagram.....	6
2.3. Power Block Diagram.....	6
2.4. PICKit™ On-Board 4.....	7
2.5. X32 Audio Interface.....	9
2.6. mikroBUS™.....	12
2.7. Control Area Network (CAN) Bus Interface.....	13
2.8. Ethernet.....	14
2.9. Xplained Pro Standard Extension Header.....	15
2.10. Graphics Connector or GFX Card Interface.....	17
2.11. I ² C Temperature Sensor MCP9808.....	19
2.12. I ² C MAC48 EEPROM.....	20
2.13. QSPI/SQI Flash Memory.....	22
2.14. Buttons and LEDs.....	22
2.15. Micro SD Card.....	23
2.16. USB.....	23
3. Hardware.....	25
3.1. Schematics.....	25
3.2. Schematics.....	33
3.3. Bill of Materials.....	33
3.4. Board Dimensions.....	37
4. Revision History.....	38
The Microchip Website.....	39
Product Change Notification Service.....	39
Customer Support.....	39
Microchip Devices Code Protection Feature.....	39
Legal Notice.....	39
Trademarks.....	40
Quality Management System.....	40
Worldwide Sales and Service.....	41

1. Introduction

The PIC32MZ DA Curiosity Development Board (EV87D54A) includes an integrated programmer and debugger. Additional hardware is not required to get started. Users can expand functionality through MikroElektronika mikroBUS™ Click™ adapter boards, add Ethernet connectivity with the Microchip PHY Daughter Board, add Wi-Fi™ connectivity capability using the Microchip expansion boards, and add audio input/output capability with Microchip audio daughter boards.

With or without expansion boards, the PIC32MZ DA Curiosity Development Board provides the freedom to develop for a variety of applications, including Bluetooth® Audio, CAN, Graphics/UI, Internet of Things (IoT), robotics development, and proof-of-concept designs.

1.1 PIC32MZ DA Curiosity Features

The following are key features of the PIC32MZ DA Curiosity Development Board:

- PIC32MZ2064DAR176-I/2J, 200 MHz, 2 MB Flash, 640 KB SRAM, 32 MB DDR2
- On-board debugger (PKoB4)
 - Real time programming and debugging
 - Virtual COM port (VCOM)
- Two mikroBUS™ interfaces
- Two X32 audio interfaces supporting Bluetooth and audio
- Ethernet interface
- Graphics interface
- Explained pro extension compatible interface
- CAN interface
- User buttons
- User RGB LED
- 8 MB QSPI memory
- I²C EEPROM MAC, AT24MAC402 (external)
- I²C Temperature Sensors, MCP9808 (external)
- Arduino Uno R3 compatible interface

1.2 Kit Contents

The kit contains the following:

- One PIC32 MZ DA Curiosity Development Board (EV87D54A)
- One 24-bit pass through Graphics Card (AC320213)

Note: If any part of a kit is missing, contact a Microchip sales office for assistance. A list of Microchip offices for sales and service is provided on the last page of this document.

2. Development Board Functionality and Features

2.1 Development Board Feature Location

Figure 2-1. PIC32MZ DA Curiosity Development Board Layout (Top View)

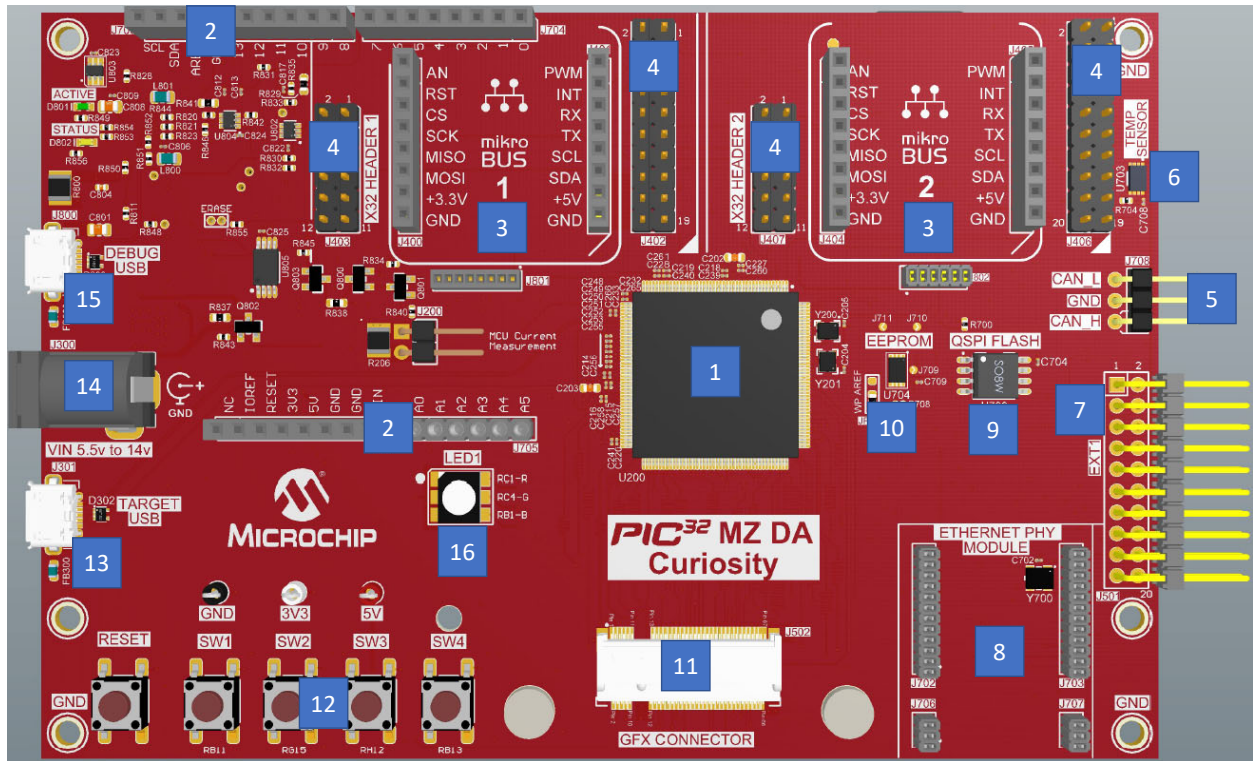

Figure 2-2. PIC32MZ DA Curiosity Development Board Layout (Bottom View)

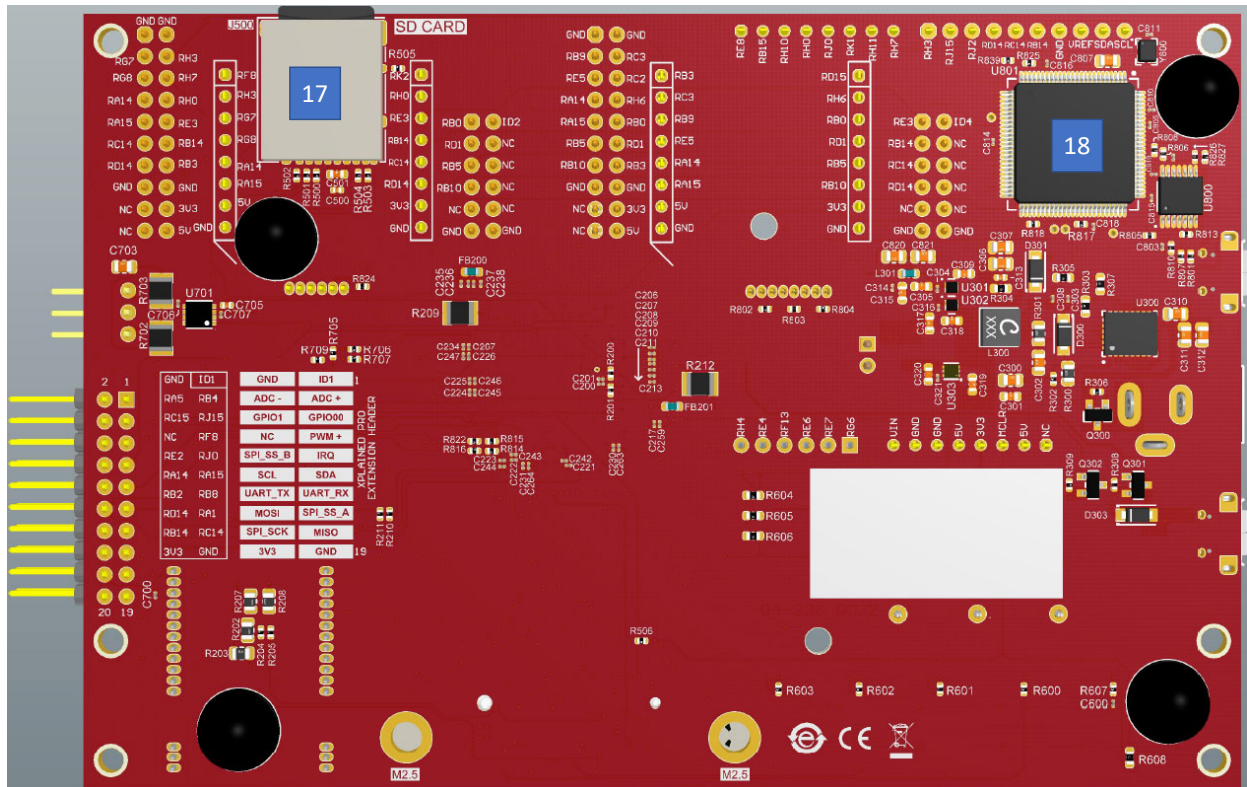

Table 2-1. Development Board Features and Location

Number	Description of item
1	PIC32MZ2064DAR176-I/2J
2	Arduino Uno interface. Headers not populated
3	mikroBUS™ Click™ interface. Two per board
4	X32 Audio interface. Two per board. Bluetooth and Audio CODECs sold separately
5	CAN interface
6	I ² C Temperature Sensor, MCP9808
7	Xplained pro expansion compatible interface
8	Ethernet interface (RMII, SPI, GPIO). Ethernet PHY not included.
9	Quad SPI Memory 8 MB (64 Mb)
10	I ² C EEPROM, AT24MAC402
11	Graphics Interface
12	Programmable user buttons
13	USB to PIC32MZ DA
14	2.5 mm barrel jack power input
15	USB to PKoB4 for debugging, power, virtual COM port
16	User Programmable RGB LED
17	Micro SD card socket

.....continued

Number	Description of item
18	PIC Kit On-Board 4 (PKoB4)

2.2 System Block Diagram

The following figure shows a high-level block diagram with the major data bus routing.

Figure 2-3. System Block Diagram

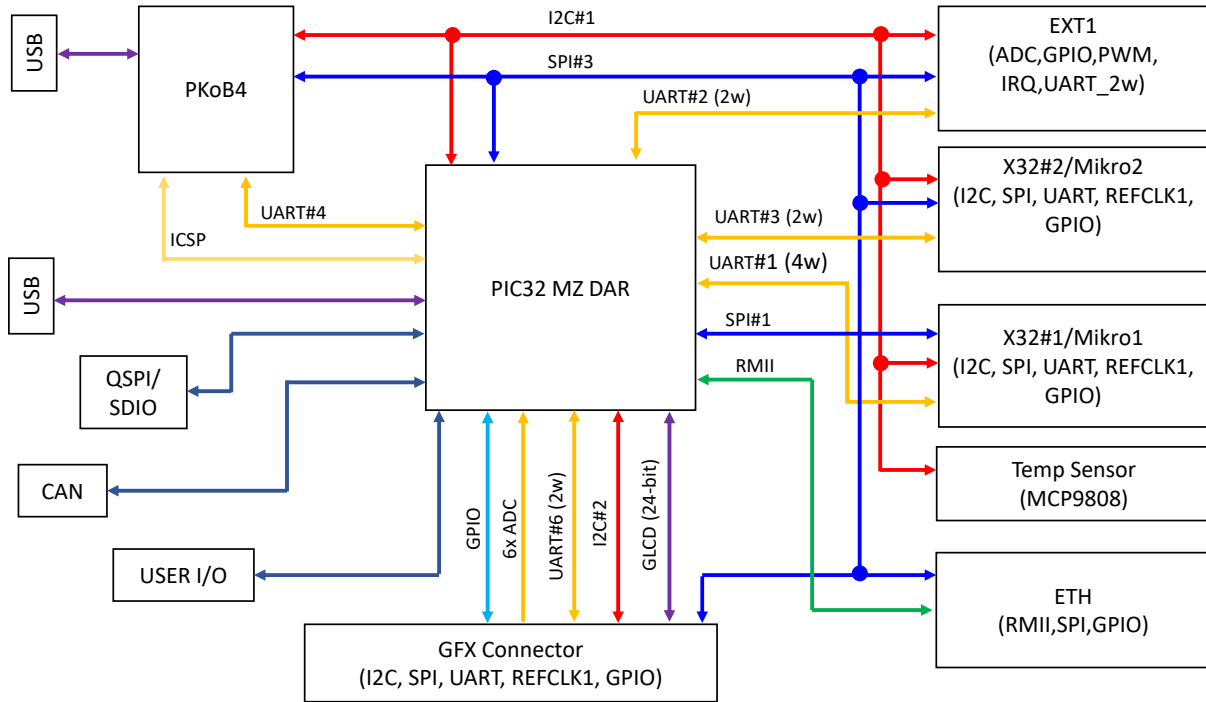

2.3 Power Block Diagram

The following figure is a high-level block diagram of the power system on the PIC32MZ DA Curiosity board. The PIC32MZ DA Curiosity board has several power sub systems that allow it to accept up to 16V. The barrel jack is a 2.1 mm center positive connector. The power can also be connected through the Arduino header, this input is before the reverse voltage protection.

Figure 2-4. Power Block Diagram

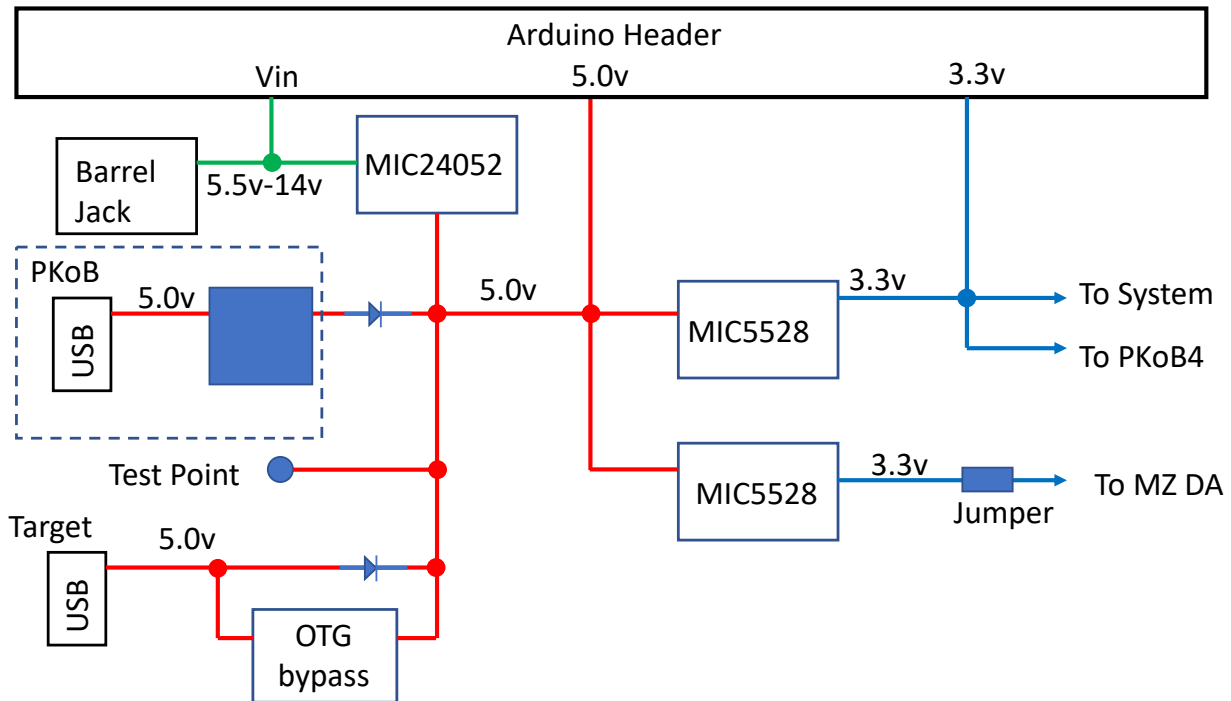

2.4 PICKit™ On-Board 4

MPLAB® PICKit™ On-Board 4 (PKoB4) is a new generation of in-circuit debugger. The MPLAB PKoB4 programs faster than its predecessor and is designed to use a high-speed 2.0 USB interface providing a feature rich debugging experience through one USB cable. The PKoB4 is intended to support programming, debugging, and Data Gateway interface.

The MPLAB PKoB4 In-Circuit Debugger is compatible with these platforms:

- Microsoft Windows® 7 or later
- Linux®
- macOS™

The MPLAB PKoB4 In-Circuit Debugger system provides the following advantages:

Features/Capabilities:

- Connects to computer through high-speed USB 2.0 (480 Mbits) cable
- Programs devices using MPLAB X IDE or MPLAB X IPE
- Supports multiple hardware and software breakpoints, stopwatch, and source code file debugging
- Debugs the application in real time
- Sets breakpoints based on internal events
- Monitors internal file registers
- Debugs at full speed
- Configures pin drivers
- Field-upgradeable through an MPLAB X IDE firmware download
- Adds new device support and features by installing the latest version of MPLAB X IDE (available as a free download at <https://www.microchip.com/mplabx/>)
- Indicates debugger status through on-board LEDs

Performance/Speed:

- More and faster memory
- A Real-Time Operating System (RTOS)
- No firmware download delays incurred when switching devices
- A 32-bit MCU running at 300 MHz

2.4.1 Recovery Method

When PKoB4 becomes unresponsive, users can recover the tool by following these recovery process.

1. With the PIC32MZ DA Curiosity Development board still powered, short the 2 pads for approximately 10 seconds.

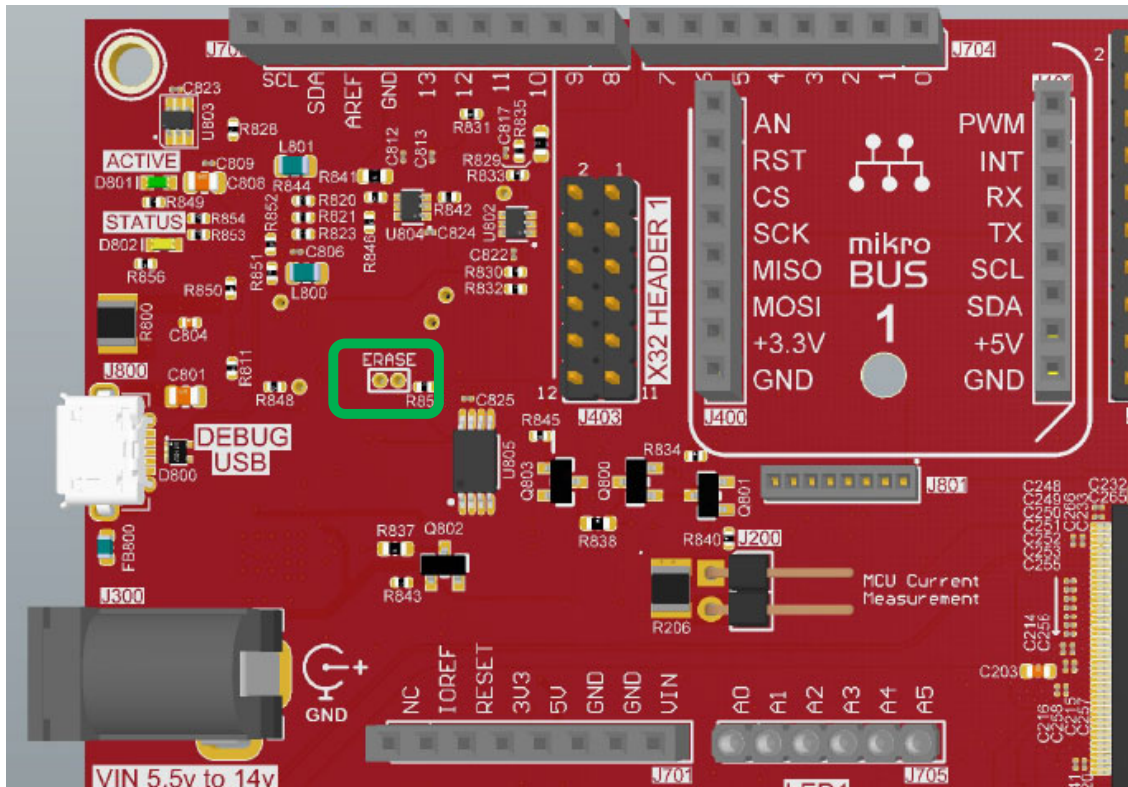

2. Open the latest version of MPLAB X IDE.
3. Select *Debug > Hardware Tool Emergency Boot Firmware Recovery*.

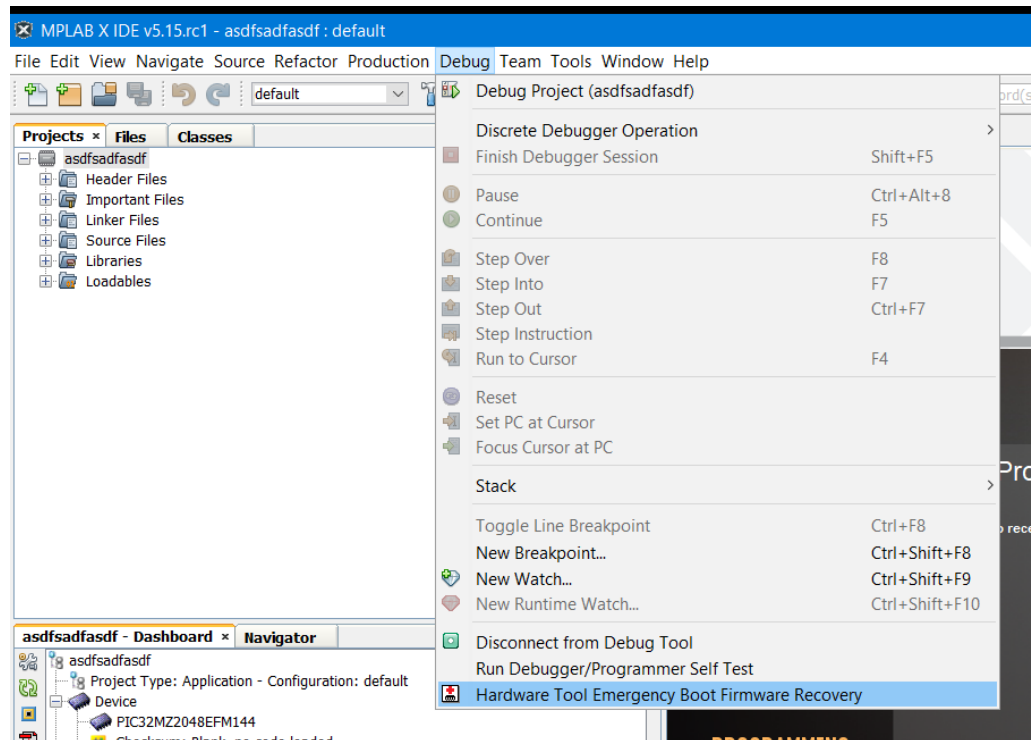

4. Follow the instructions displayed on the screen to bring the tool back to factory condition.

For additional information on PKoB4, refer to the MPLAB PICKit™ 4 User Guide: <http://ww1.microchip.com/downloads/en/DeviceDoc/MPLAB%20PICKit%20ICD%20Users%20Guide%20DS50002751C.pdf>

2.5 X32 Audio Interface

There are two X32, 32-pin interfaces to the board to support audio CODEC/DACs and Bluetooth radios. This interface has audio supply I²S as well as other control lines and data interfaces.

2.5.1 Block Diagram

The PIC32MZ DA Curiosity board has two X32 interfaces that share two I²S signals. The following figure shows the relation between the I²S signals and the X32 daughter board interface.

Figure 2-5. Block Diagram

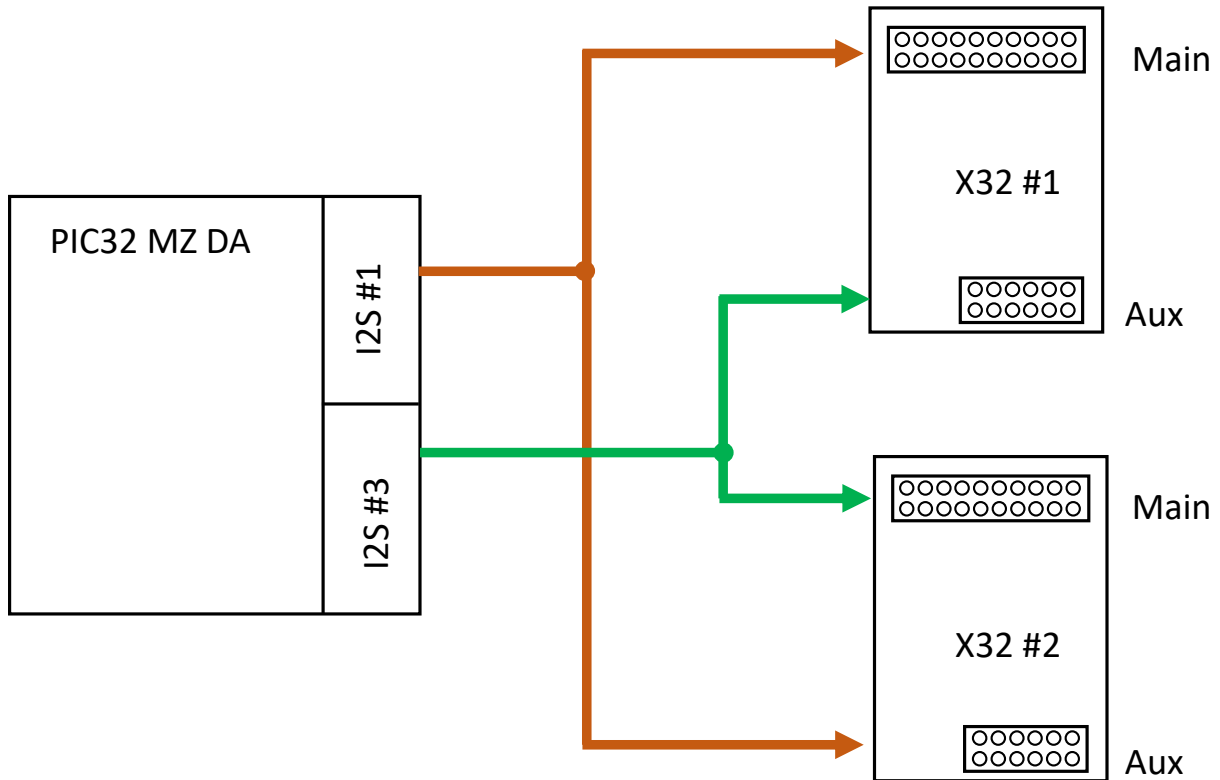

2.5.2 Pinout

The following table describes the pinout for the X32 Audio interface. Refer to the [Schematics](#) for additional information.

Table 2-2. X32 Audio Interface Pinout

Pin Number	Name	Description	Interface
1	GND	Ground	Power
2	GND	Ground	Power
3	UART RX	UART RX, receive to MCU from DB	UART
4	UART CTS	UART Clear to send	UART
5	UART TX	UART TX, transmit from MCU to DB	UART
6	UART RTS	UART Ready to send	UART
7	I2C SCL	Clock line for I ² C interface.	I ² C
8	STBY/RST	Standby/Reset control	GPIO
9	I2C SDA	Data line for I ² C interface.	I ² C
10	Audio WS/LRCLK	Audio Word Select/ Left Right Clock	I ² S
11	Audio In	Audio into MCU, out from CODEC	I ² S
12	Audio CLK	Audio clock	I ² S
13	Audio out	Audio out of MCU, in to CODEC/DAC	I ² S

.....continued			
Pin Number	Name	Description	Interface
14	REFCLK/MCK	Reference clock #1	REFCLK
15	GND	Ground	Power
16	GND	Ground	Power
17	NC	Legacy hold over	-
18	+3.3v	VDD	Power
19	NC	Legacy hold over	-
20	+5.0v	VDD	Power
21 (1)	Audio WS/ Audio LRCLK	Audio Word Select/ Left Right Clock	I ² S
22 (2)	ADC/Card ID pin	Analog-to-Digital Converter to read voltage on the daughter card	ADC
23 (3)	Audio CLK	Audio Clock	I ² S
24 (4)	NC		
25 (5)	Audio IN	Audio into MCU, out from CODEC	I ² S
26 (6)	NC		
27 (7)	Audio OUT	Audio out of MCU, in to CODEC/DAC	I ² S
28 (8)	NC		
29 (9)	REFCLK2/MCK2	Reference clock #2	REFCLK
30 (10)	NC		
31 (11)	GND	Ground	Power
32 (12)	GND	Ground	Power

2.5.3 Port Connections

The following table shows the port and connections to the X32 Audio interface. The I²S signals listed are the main signals, both signals are available at each interface, see the X32 [Block Diagram](#) for clarification.

Table 2-3. Port Connections

Interface	X32#1	X32#2
UART RX	RPB9	RPG7
UART TX	RPE5	RPG8
UART RTS	RPC2	RPH7 ⁽¹⁾
UART CTS	RPC3	RPH3 ⁽¹⁾
I ² C SDA	RA15	RA15
I ² C SCL	RA14	RA14
Reset	RH6	RH0
REFCLK	RPB3	RPB3
SPI SCK (I ² S Clock)	RPD1	RPB14
SPI MOSI (I ² S Audio Out)	RPB10	RPD14

.....continued		
Interface	X32#1	X32#2
SPI MISO (I ² S Audio In)	RPB5	RPC14
SPI CS (I ² S LRCLK)	RPB0	RPE3
ADC	AN33	AN11

Note:

1. Implemented as GPIO only.

2.6 mikroBUS™

The mikroBUS™ interface allows for the use of additional click™ boards. For additional information and to see the boards which can be used with this development board, visit <https://www.mikroe.com/>.

Table 2-4. Pin Description

Pin Number	Name	Function
1	GND	Ground
2	+5V	+5.0V
3	SDA	I ² C SDA
4	SCL	I ² C SCL
5	TX	UART TX transmit from MCU to DB
6	RX	UART RX receive to MCU from DB
7	INT	Interrupt request line
8	PWM	Pulse width modulation
9	GND	Ground
10	+3.3V	Ground
11	MOSI	MOSI line of serial peripheral interface.
12	MISO	MISO line of serial peripheral interface.
13	SCK	Clock for serial peripheral interface
14	CS	Chip Select for serial peripheral interface (Active low)
15	RST	Reset
16	AN	Analog-to-digital converter.

2.6.1 Port Connections

The following table shows the port and connections for the mikroBUS interface. The mikroBUS is nested inside of the X32 Audio interface, due to mechanical interference either a mikroBUS or Audio interface can be used in the same socket. The mikroBUS interface shares signals with the X32 Audio interface. Refer to the [Pinout](#) for pinout or signal probing.

Table 2-5. Port and Connections

Interface	mikroBUS #1	mikroBUS #2
UART RX	RPB9	RPG7
UART TX	RPE5	RPG8

.....continued		
Interface	mikroBUS #1	mikroBUS #2
INT/IRQ	RPC3	RPH3
I2C SDA	RA15	RA15
I2C SCL	RA14	RA14
Reset	RH6	RH0
PWM	RPB3	RPF8
SPI Clock	RPD1	RPB14
SPI MOSI	RPB10	RPC14
SPI MISO	RPB5	RPD14
SPI SS	RPB0	RPE3
ADC	AN33	AN11

2.7 Control Area Network (CAN) Bus Interface

The PIC32MZ DA Curiosity board provides access to a CAN interface that is post transceiver. The on-board CAN transceiver is an ATA6561, allowing the application to be used with any CAN bus compliant interface.

Table 2-6. CAN Pin Description

Pin Number	Name	Description	Port
1	CAN_H	CAN High Signal	-
2	GND	Ground	-
3	CAN_L	CAN Low Signal	-
-	CAN2_TX	CAN Transmit	RPF2
-	CAN2_RX	CAN Receive	RPE2

2.7.1 Schematic

Figure 2-6. Can Interface

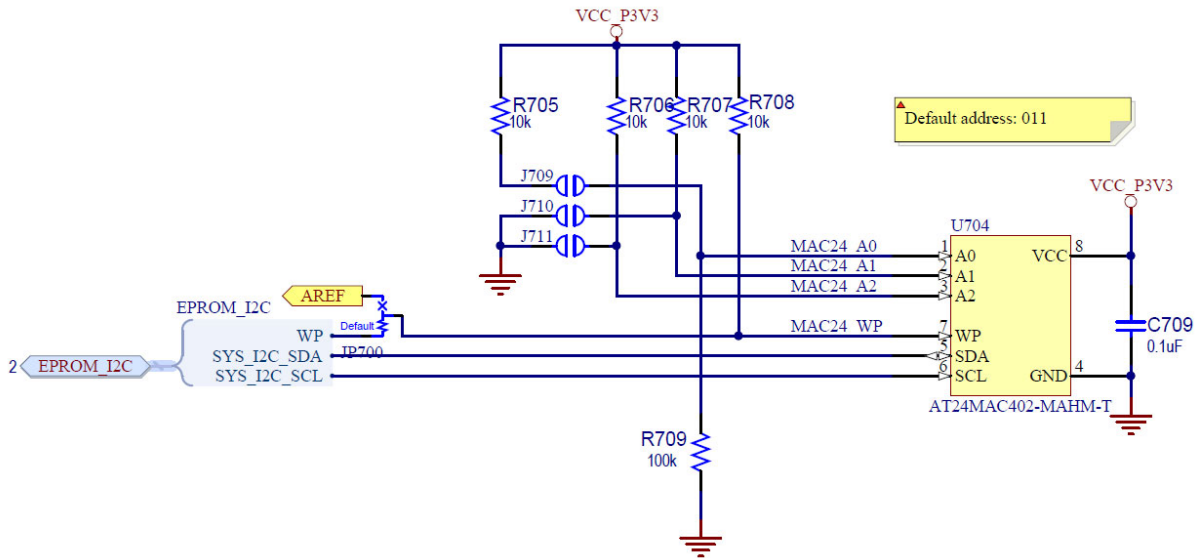

2.8 Ethernet

The PIC32MZ DA Curiosity board has a modular Ethernet PHY system that allows for different PHYs to be plugged into the board. This interface is set up to use a Reduced Media-independent interface (RMII interface) as well as a SPI bus interface with GPIO.

Figure 2-7. Ethernet PHY Header Configuration

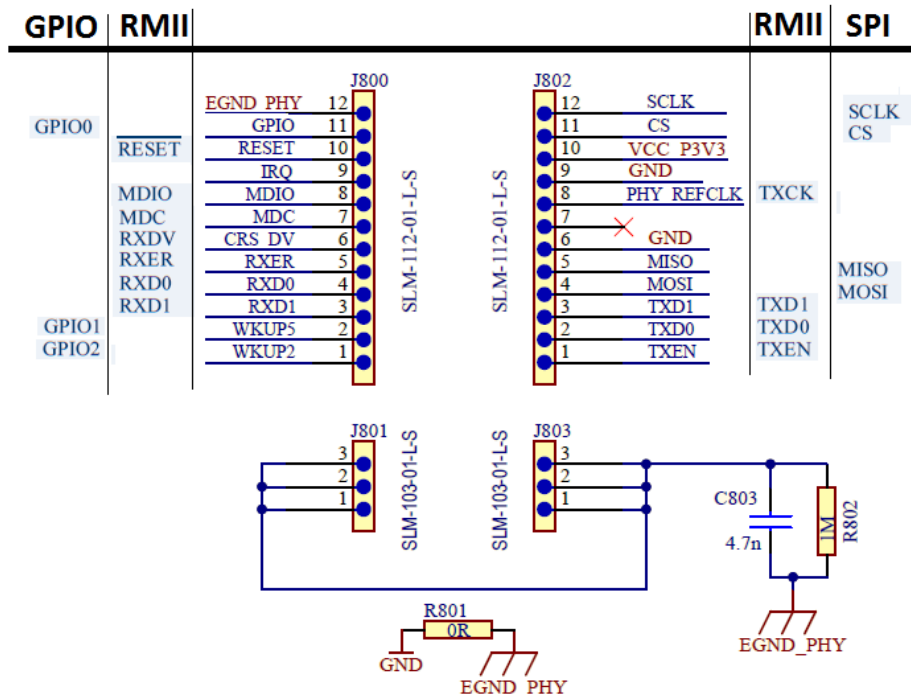

Table 2-7. Pinout and Description of the Ethernet Interface

Pin Number	Name	Description	Port
1	GPIO	General purpose I/O	RK1
2	GPIO	General purpose I/O	RD7
3	RXD1	Receive Data 1	RH5
4	RXD0	Receive Data 0	RH8
5	RXER	Receive Error	RF3
6	RXDV	Receive Data Valid	RH13
7	MDC	Ethernet Management Data Clock	RD11
8	MDIO	Ethernet Management Data	RJ1
9	IRQ	Interrupt request line	RJ2
10	RESET	Reset control to the Ethernet PHY	RJ0
11	GPIO	General purpose I/O	RH11
12	EGND	Shield Ground	-
13 (1)	TXEN	Transmit Enable	RD6
14 (2)	TXD0	Transmit Data	RJ8
15 (3)	TDX1	Transmit Data	RJ9
16 (4)	MOSI	MOSI line of serial peripheral interface.	RD14
17 (5)	MISO	MISO line of serial peripheral interface	RC14
18 (6)	GND	Ground	-
19 (7)	NC	No Connect	-
20 (8)	REFCLK (in)	Reference Clock input (50MHz)	RJ11
21 (9)	GND	GND	-
22 (10)	+3.3v VDD	+3.3V VDD	-
23 (11)	CS	Chip Select for serial peripheral interface	RJ2
24 (12)	SCK	Clock for serial peripheral interface	RB14
25 -30	EGND	Shield Ground	-

2.9 Xplained Pro Standard Extension Header

The PIC32MZ DA Curiosity board has an Xplained Pro compatible interface that allows for the use of existing expansion boards. This interface consists of a dual row, 20-pin, 100 mil, 90 degree extension male headers, while Xplained Pro extensions have their female counterparts. The extension headers can be used to connect a variety of Xplained Pro extension boards or to access the pins of the target MCU directly.

Note: All pins are not always connected.

Figure 2-8. Explained Pro Pins

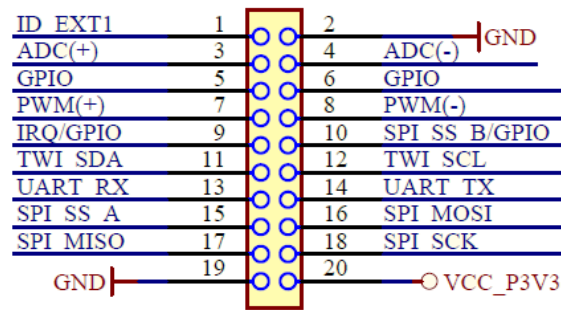

All connected pins follow the defined pinout description in the following table.

Table 2-8. Pinout

Pin number	Name	Description	Port
1	ID	Communication line to the ID chip on an extension board	Connected to PKoB4
2	GND	Ground	-
3	ADC(+)	Analog-to-digital converter, alternatively positive part of differential ADC	RB4/AN2
4	ADC(-)	Analog-to-digital converter, alternatively negative part of differential ADC	RA5/AN7
5	GPIO1	General purpose I/O	RJ15
6	GPIO2	General purpose I/O	RC15
7	PWM(+)	Pulse width modulation, alternatively positive part of differential PWM	RF8
8	PWM(-)	Pulse width modulation, alternatively negative part of differential PWM	No Connect
9	IRQ/INT/GPIO	Interrupt request line and/or general purpose I/O	RJ0
10	SPI \overline{SS} B/GPIO	SPI Select or General purpose I/O	RE2
11	I2C SDA	Data line for I ² C interface. Always implemented, bus type	RA15
12	I2C SCL	Clock line for I ² C interface. Always implemented, bus type.	RA14
13	UART RX	Receiver line of target device UART	RPB1
14	UART TX	Transmitter line of target device UART.	RPB2
15	SPI \overline{SS} A/GPIO	SPI Select or General purpose I/O	RA1
16	SPI MOSI	MOSI line of serial peripheral interface. Always implemented, bus type.	RPD14
17	SPI MISO	MISO line of serial peripheral interface. Always implemented, bus type.	RPC14
18	SPI SCK	Clock for serial peripheral interface. Always implemented, bus type	RPB14
19	GND	Ground	-
20	VCC	Power for extension boards (3.3V)	-

2.10 Graphics Connector or GFX Card Interface

The PIC32MZ DA Curiosity board has a new graphics interface to allow for use with different graphics cards to support different graphic support models. The PIC32MZ DA is intended to drive a 24-bit RGB panel natively with the internal LCD controller and GPU.

Table 2-9. Pinout

Pin Number	Name	Description	Port
1	GND	Ground	-
2	GND	Ground	-
3	MCLR	Master Clear, controlled by the debugger, allows for a complete system reboot.	-
4	IRQ1 (LCD Touch)	Interrupt request line for cap touch device.	RH14
5	5.0v VCC	5.0v	-
6	IRQ2 (Q Touch)	Interrupt request line for Q touch devices.	RH1
7	LCDEN	LCD Data Enable	RJ7
8	IRQ3 (Display Controllers)	Interrupt request line for external display controllers.	RH9
9	LCDHSYNC	LCD Horizontal Sync	RJ5
10	IRQ4 (Resistive touch)	Interrupt request line for resistive touch controllers.	No Connect
11	LCDVSYNC	LCD Vertical Sync or Write enable (active low)	RJ4
12	5.0v VCC	+5.0v	-
13	LCDPCK	LCD pixel Clock or Read Enable (active low)	RJ6
14	I2C SDA	Data line for I ² C interface. Always implemented, bus type.	RA3
15	LCD D16	LCD Data bit 16	RF5
16	I2C SCL	Clock line for I ² C interface. Always implemented, bus type.	RA2
17	LCD D17	LCD Data bit 17	RF4
18	SPI SCK	Clock for serial peripheral interface. Always implemented, bus type.	RB14
19	LCD D18	LCD Data bit 18	RJ10
20	SPI MOSI	MOSI line of serial peripheral interface.	RD14
21	LCD D19	LCD Data bit 19	RK7
22	SPI MISO	MISO line of serial peripheral interface.	RC14
23	LCD D20	LCD Data bit 20	RJ3
24	SPI SS	SPI Select	RB12
25	LCD D21	LCD Data bit 21	RH15
26	UART RX	Receiver line of target device (from MCU to GFX card).	RE8
27	LCD D22	LCD Data bit 22	RD13

.....continued			
Pin Number	Name	Description	Port
28	UART TX	Transmitter line of target device UART (from MCU to GFX card).	RB15
29	LCD D23	LCD Data bit 23	RK0
30	UART RTS	UART Ready To Send (from MCU to GFX card), (Not Implemented on this design).	No Connect
31	LCD D8	LCD Data bit 8	RJ14
32	UART CTS	UART Clear To Send (from MCU to GFX card), (Not Implemented on this design).	No Connect
333	LCD D9	LCD Data bit 9	RJ12
34	LCD PWM	LCD PWM back light control	RD0/OC?
35	LCD D10	LCD Data bit 10	RD2
36	PWM2	Pulse width modulation	RB3
37	LCD D11	LCD Data bit 11	RD3
38	GPIO1	General purpose I/O	RKH11
39	LCD D12	LCD Data bit 12	RK3
40	GPIO2	General purpose I/O	RK1
41	LCD D13	LCD Data bit 13	RK4
42	GPIO3	General purpose I/O	RH10
43	LCD D14	LCD Data bit 14	RK5
44	STBY/RST/GPIO4	Standby/reset or General purpose I/O. For resetting devices attached to the GFX connector.	RD10
45	LCD D15	LCD Data bit 15	RK6
46	STBY/RST/GPIO5	Standby2/Reset2 or General purpose I/O(not Implemented on this design).	No Connect
47	LCD D0	LCD Data bit 0	RJ13
48	ID pin	Communication line to the ID chip on an extension board.	Connected to PKoB4
49	LCD D1	LCD Data bit 1	RA4
50	ADC 0	Analog-to-digital converter to MCU.	AN14
51	LCD D2	LCD Data bit 2	RD9
52	ADC1	Analog-to-digital converter to MCU.	AN15
53	LCD D3	LCD Data bit 3	RG0
54	ADC2	Analog-to-digital converter to MCU.	AN16
55	LCD D4	LCD Data bit 4	RG1
56	ADC3	Analog-to-digital converter to MCU.	AN17
57	LCD D5	LCD Data bit 5	RF1
58	ADC4	Analog-to-digital converter to MCU.	AN18

.....continued			
Pin Number	Name	Description	Port
59	LCD D6	LCD Data bit 6	RF0
60	ADC5	Analog-to-digital converter to MCU.	AN20
61	LCD D7	LCD Data bit 7	RD12
62	ADC6	Analog-to-digital converter to MCU (Not Implemented on this design).	No Connect
63	3.3V VCC	+3.3V VCC	-
64	ADC7	Analog-to-digital converter to MCU (Not Implemented on this design).	No Connect
65	GND	Ground	-
66	3.3V VCC	+3.3V VCC	-
67	GND	Ground	-
68	GND TAB	Mounting Tab	-
69	GND TAB	Mounting Tab	-

2.11 I²C Temperature Sensor MCP9808

The PIC32MZ DA Curiosity board has a Microchip MCP9808 I²C temperature sensor on board. This sensor is attached to the I²C bus and has a dedicated IRQ pin. The behavior of this pin can be programmed through the I²C by following the data sheet of this device.

Table 2-10. Function and Port

Function	Description	Type	Port
Alert IRQ	Notifies the PIC32 MZ DA curiosity that a I ² C message or event is ready	Input	RA9
SYS_I2C_SDA	System I ² C Data	Bidirectional	RA15
SYS_I2C_SCL	System I ² C Clock	Clock	RA14

The MCP9808 on the PIC32MZ DA Curiosity has a fixed address as shown in the following table:

Table 2-11. Fixed Address

Device	Address Code				Client Address		
	A6	A5	A4	A3	A2	A1	A0
MCP9808	0	0	1	1	0	0	0

For more information on this device, refer to the *MCP9808 Data sheet* which is available for download at <https://www.microchip.com/wwwproducts/en/en556182>.

2.11.1 Schematic

Figure 2-9. Temperature Sensor

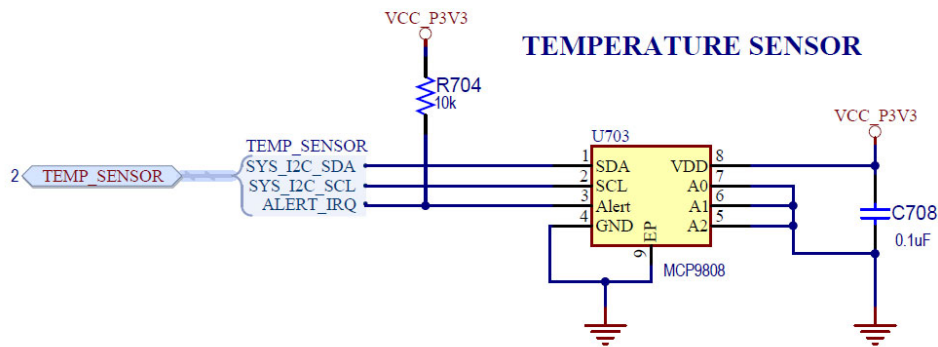

2.12 I²C MAC48 EEPROM

The PIC32MZ DA Curiosity Board has an on board I²C Serial EEPROM with a unique 48-bit MAC address. This device is located on the system I²C bus.

Table 2-12. Port and Function

Function	Description	Type	Port
Write Protect	Write protect pin, a high value (logic 1) protects the device from write. A low value (logic 0) means normal read/write	Output	RA10
SYS_I2C_SDA	System I ² C Data	Bidirectional	RA15
SYS_I2C_SCL	System I ² C Clock	Clock	RA14

The PIC32MZ DA Curiosity Board provides the ability to change the I²C client address through the solder pads. The default address for user stored information is as follows:

Device	Address Code				Client Address (default)		
	A6	A5	A4	A3	A2	A1	A0

AT24MAC402 (Standard User space)	1	0	1	0	1	1	0
----------------------------------	---	---	---	---	---	---	---

Device	Address Code				Client Address (default)		
	A6	A5	A4	A3	A2	A1	A0
AT24MAC402 (Extended space, read only)	1	0	1	1	1	1	0

2.12.1 EUI-48

The EUI-48 address is stored in the last six bytes of the AT24MAC402's extended memory block as shown in the table below. This is a read only address.

	48-Bit EUI					
	24-bit OUI			24-bit Extended ID		
Memory Address (Hex)	9A	9B	9C	9D	9E	9F
EUI Value (Hex)	FC	C2	3D	Byte 1	Byte 2	Byte 3

The first three bytes of the EUI read-only address field are called the Organizationally Unique Identifier (OUI) and the IEEE[®] Registration Authority has assigned FCC23Dh as the Microchip/Atmel, OUI.

Following the OUI, the remaining bytes are called the Extension Identifier and will be either three bytes or five bytes depending on if it is an EUI-48 address (AT24MAC402). Microchip/Atmel generates this unique 24-bit data value along with the OUI to guarantee a globally unique EUI address value and programs it at the factory before permanently locking the extended memory region.

The unique 128-bit serial number is located in the extended range of the part, this unique information starts at the register 0x80 (0x80-0x8F).

For more information, visit <https://www.microchip.com/wwwproducts/en/AT24MAC402>.

Changing the default I²C address can be done by electrically shorting the exposed pads on the board.

Figure 2-10. Board Location

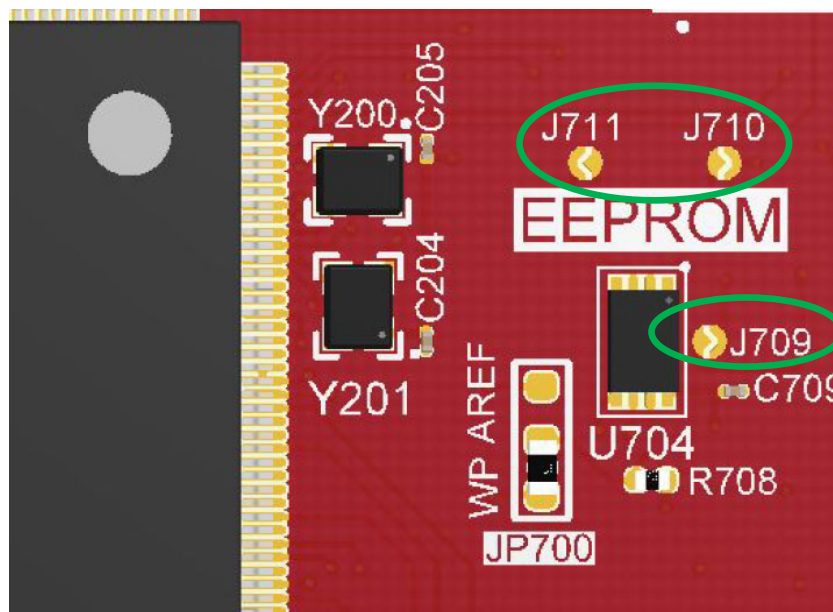

2.12.2 Schematic

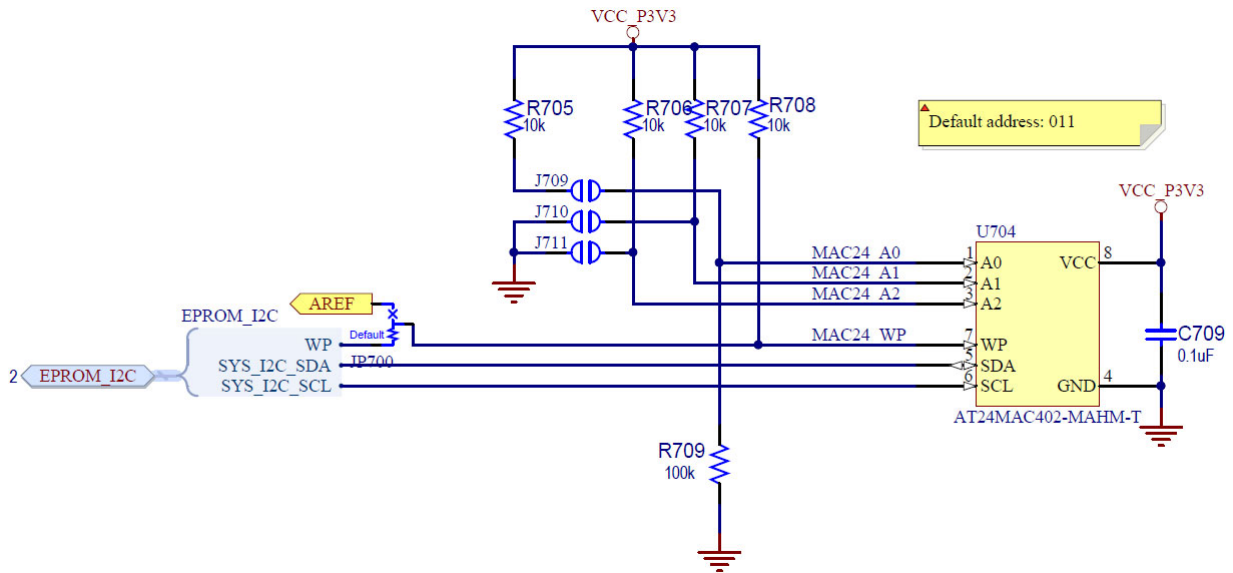

2.13 QSPI/SQI Flash Memory

The PIC32MZ DA Curiosity has an on-board 8 megabyte (64 megabit) Flash memory for users to store information or project assets in. The device is a SST26VF064BA.

For more information, visit <https://www.microchip.com/wwwproducts/en/SST26VF064BA>.

Figure 2-11. Schematic

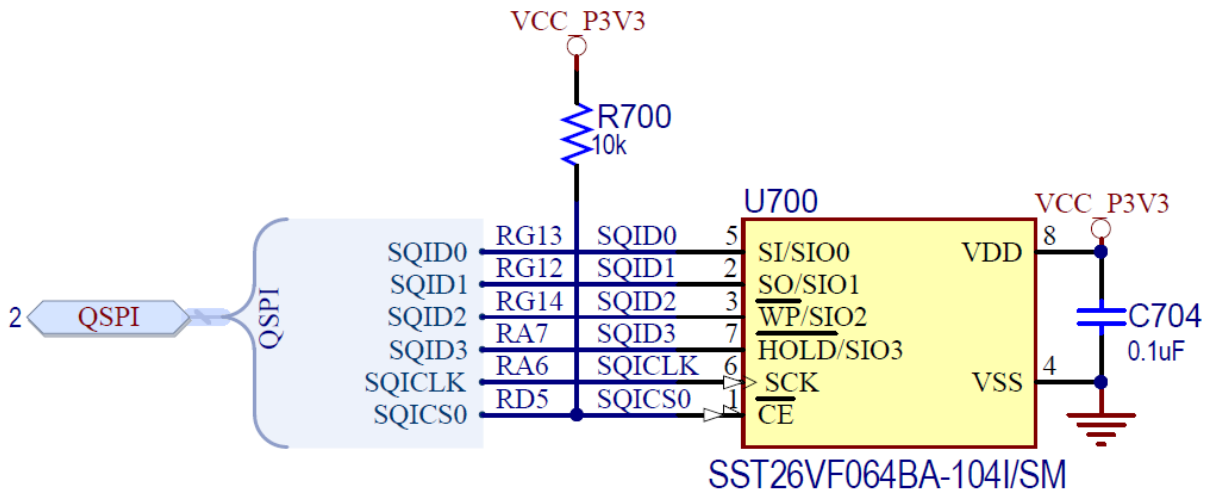

2.14 Buttons and LEDs

The PIC32MZ DA Curiosity Board offers several user buttons and LEDs. Some of the LEDs can be used with PWM (Output Compare). The following table shows the function, description, and port on the MCU.

Table 2-13. Function and Port

Function	Description	Type	Port
SW1	Users switch	Input	RB11
SW2	Users switch	Input	RG15
SW3	Users switch	Input	RH12
SW4	Users switch	Input	RB13
RESET	Hard reset of the PIC32	Input	MCLR
LED4 (Red)	RGB LED Red channel	GPIO or PWM	RPC1 or OC
LED4 (Green)	RGB LED Green Channel	GPIO or PWM	RPC4 or OC
LED4 (Blue)	REB LED Blue Channel	GPIO or PWM	RPB1 or OC

2.15 Micro SD Card

The PIC32MZ DA Curiosity provides an on-board SD card interface that is connected to the PIC32MZ DA internal SDIO interface. This bus is shared with the QSPI/SQI interface. Each device has its own chip select to allow for simultaneous use in the user application.

Table 2-14. Function and Port

Function	Description	Port
SDCD	SD Card Card Detect, High (logic 1) = no Card present. Low (Logic 0) = card present	RA0
SDCK	SD Card Clock	RA6
SDCMD	SD Card Command	RD4
SDDATA0	SD Card Data 0	RG13
SDDATA1	SD Card Data 1	RG12
SDDATA2	SD Card Data 2	RG14
SDDATA3	SD Card Data 3	RA7

Figure 2-12. Micro SD card Schematic

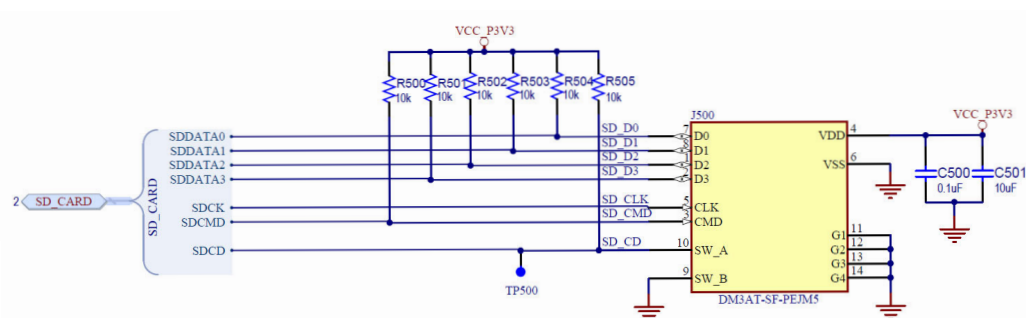

2.16 USB

The PIC32MZ DA Curiosity Board has a high-speed USB 2.0 connection. This port can act as either a device class or host class.

For Device class use the USB cable which can be plugged into the target USB. Refer to [Board Feature Location](#) for the location.

For Host device class operation, a USB OTG cable is needed. To enable power from the PIC32MZ DA Curiosity Board the user must control the VBUS Enable pin.

The PIC32MZ DA Curiosity Board must be powered through the PKoB4, and one of the following power sources:

- Barrel jack
- External source
- Vin

Table 2-15. Function and Port

Function	Description	Port
VBUS Enable	Enable power control to USB devices attached to the PIC32MZ DA Curiosity board	RJ13

3. Hardware

3.1 Schematics

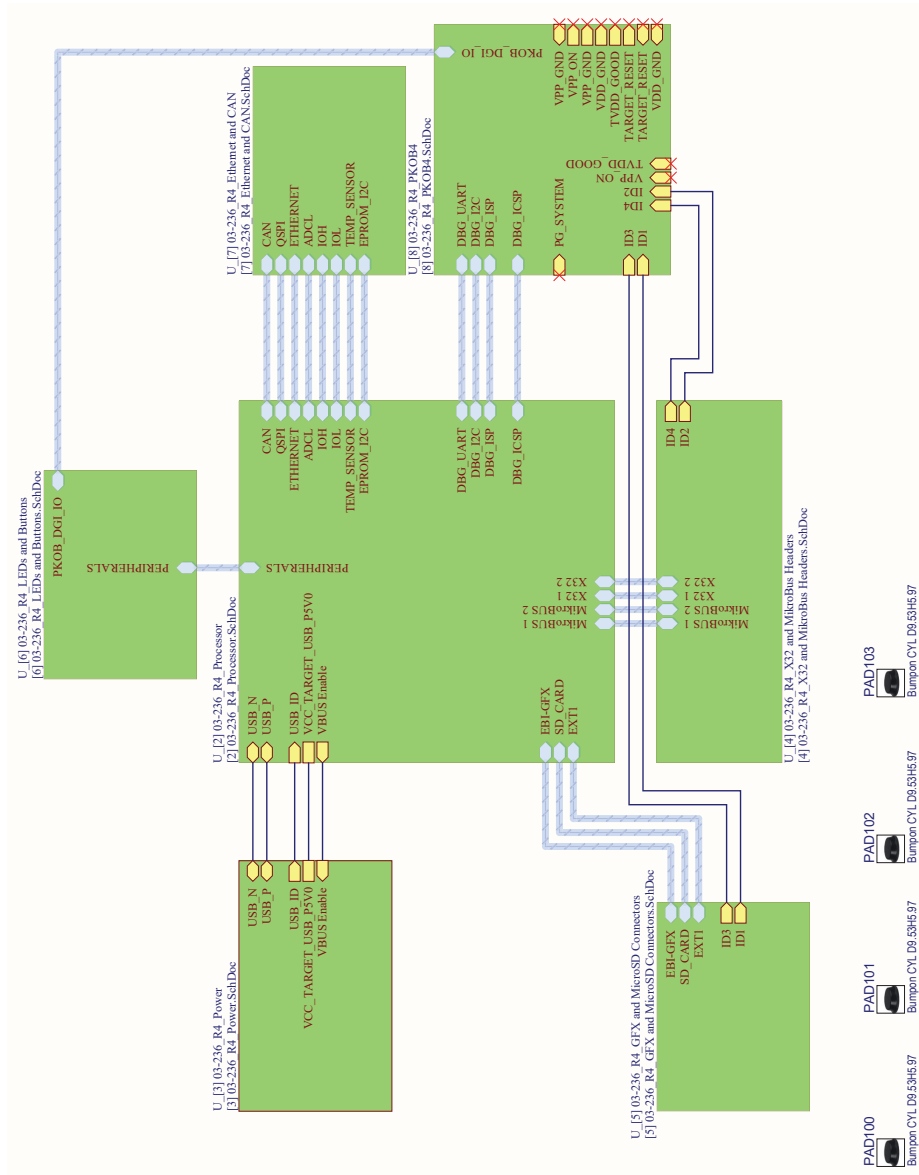

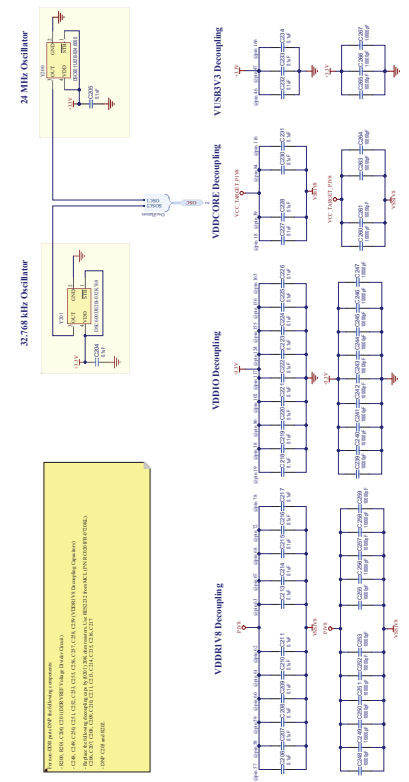
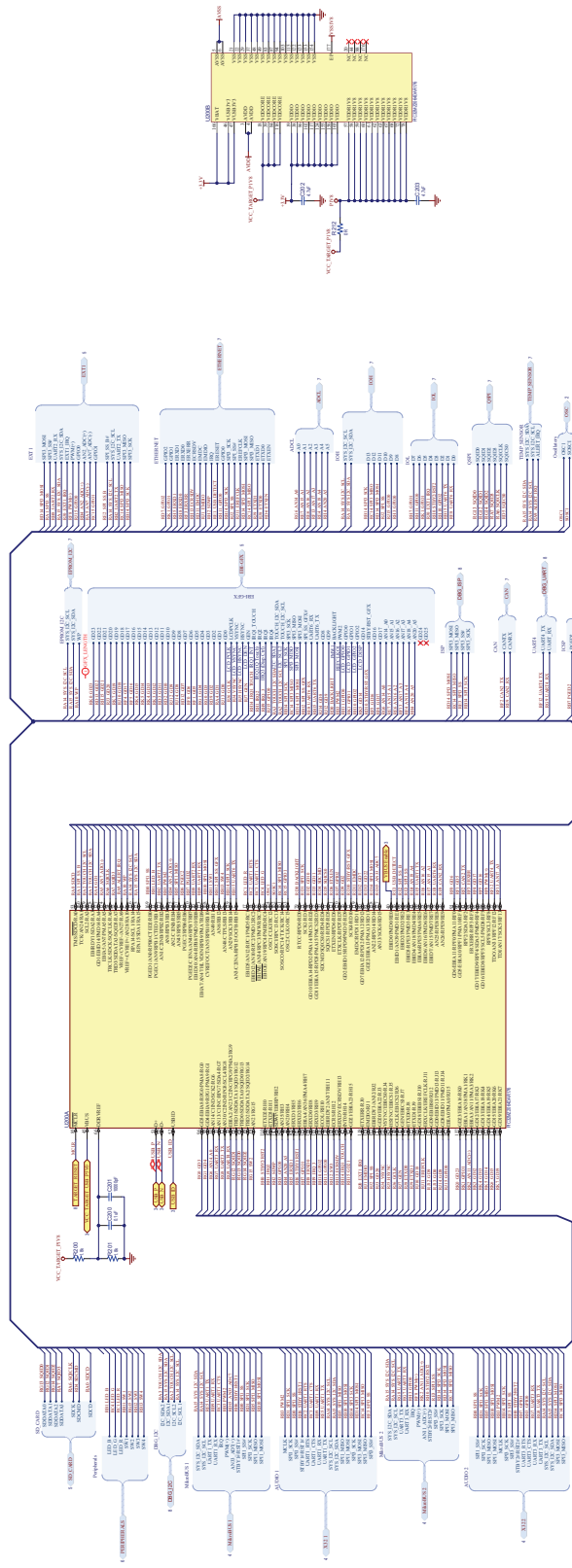

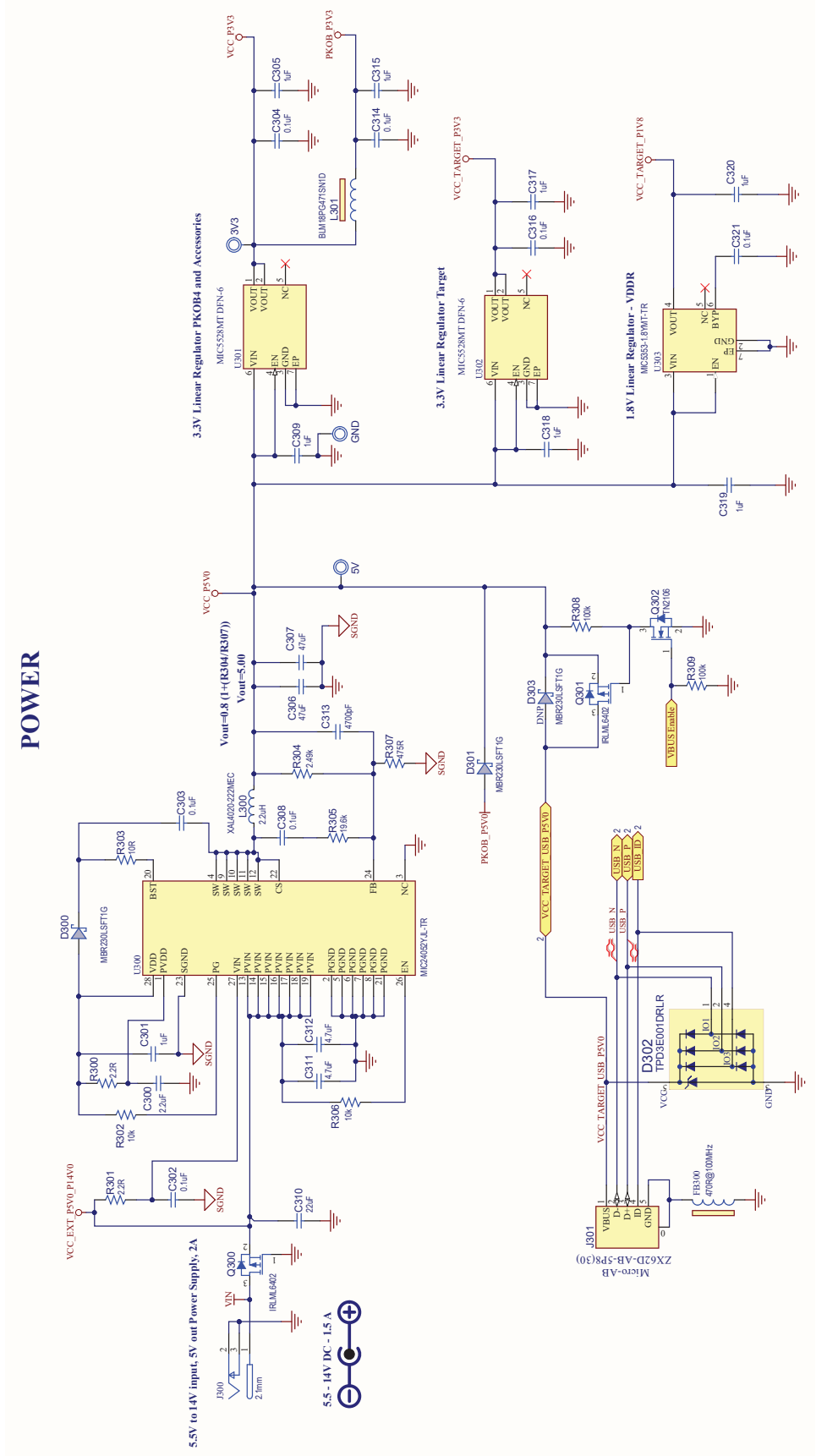

MikroBus Header #1

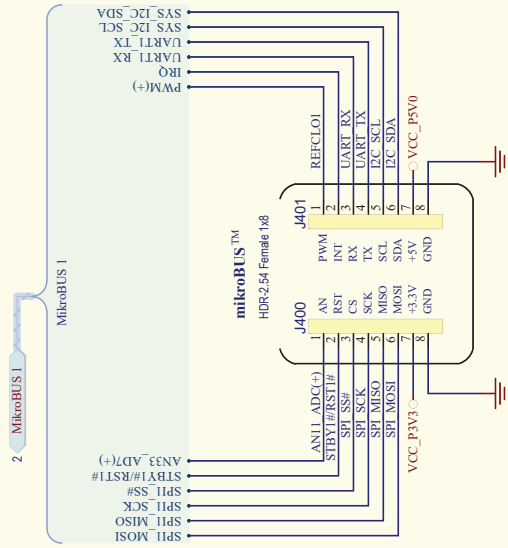

X32 HEADER #1

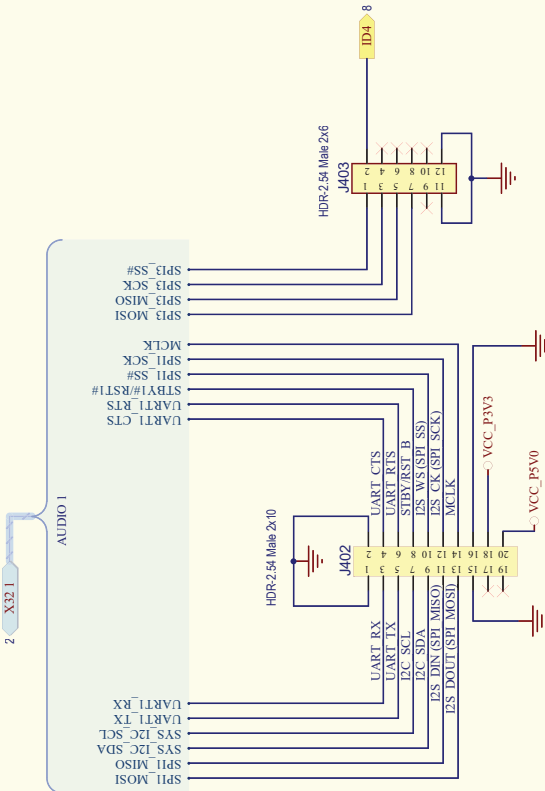

MikroBus Header #2

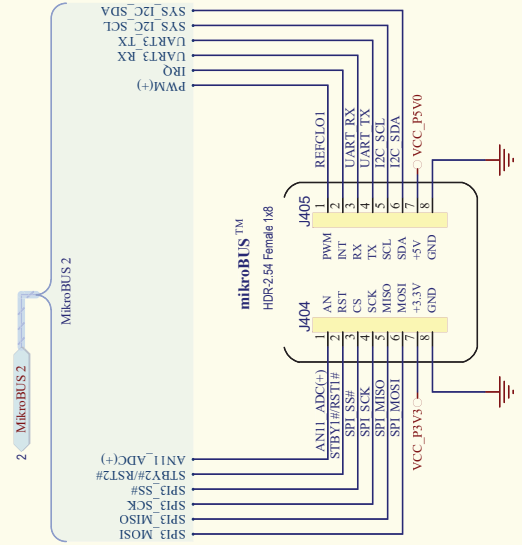

X32 HEADER #2

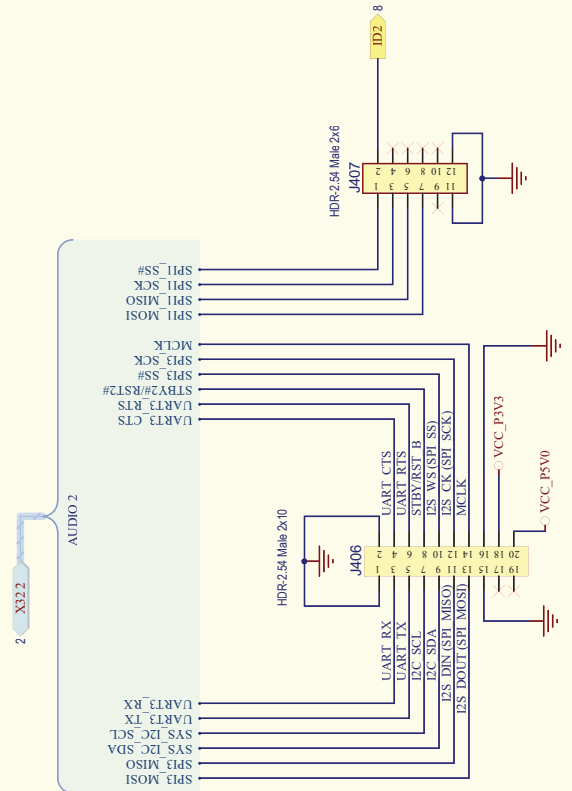

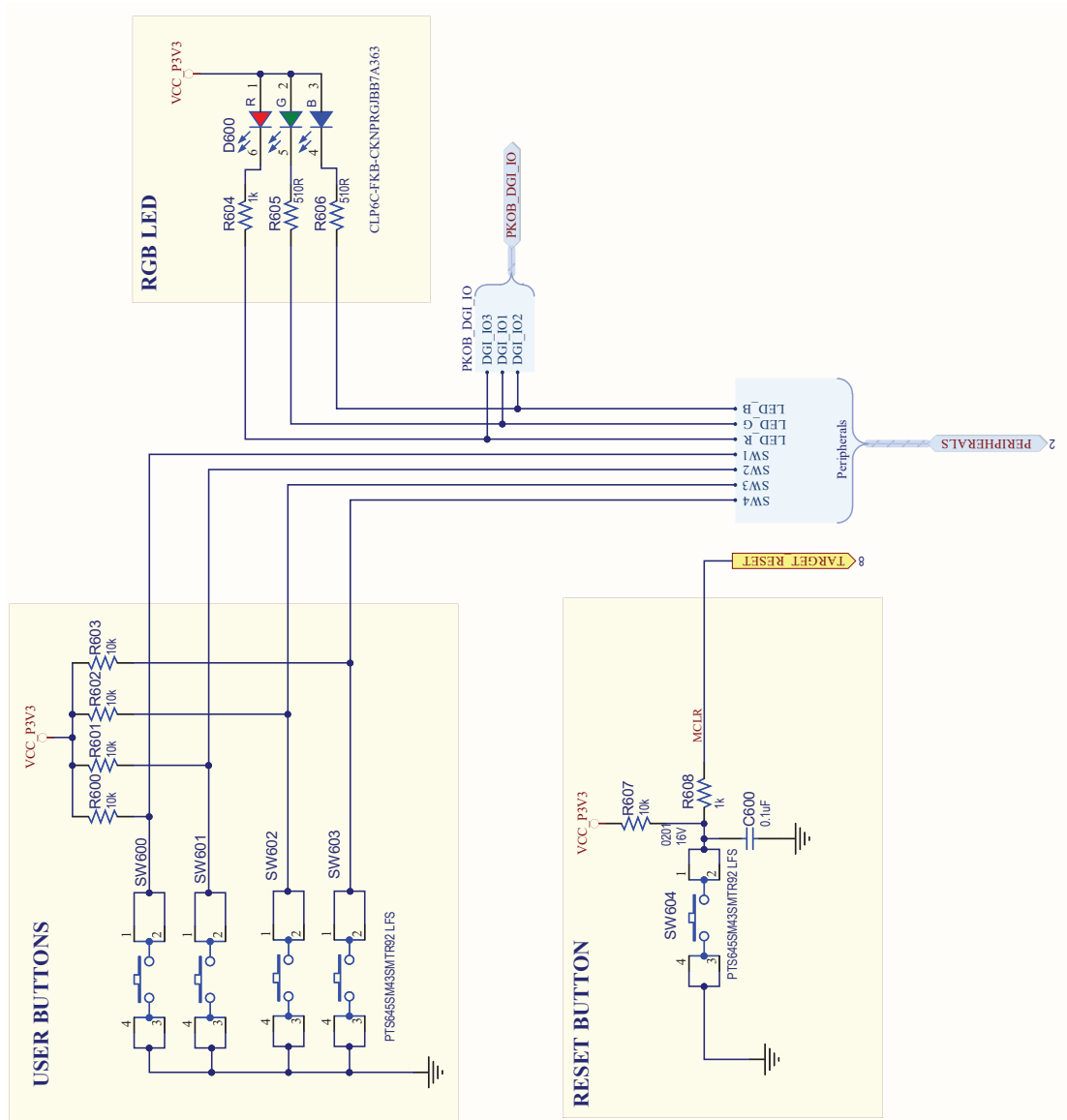

PICKIT on Board 4

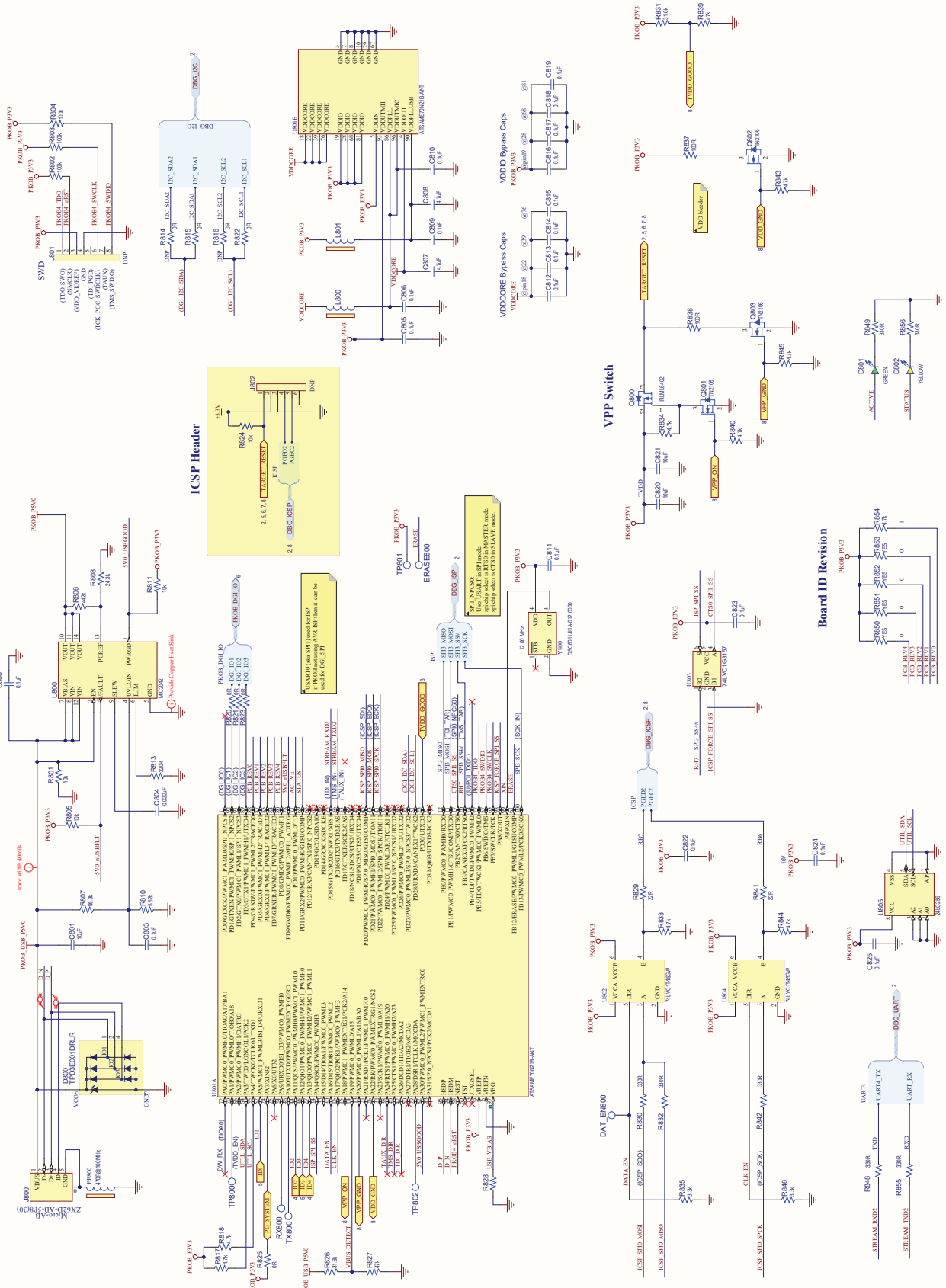

3.2 Schematics

Figure 3-1. Graphics card schematics

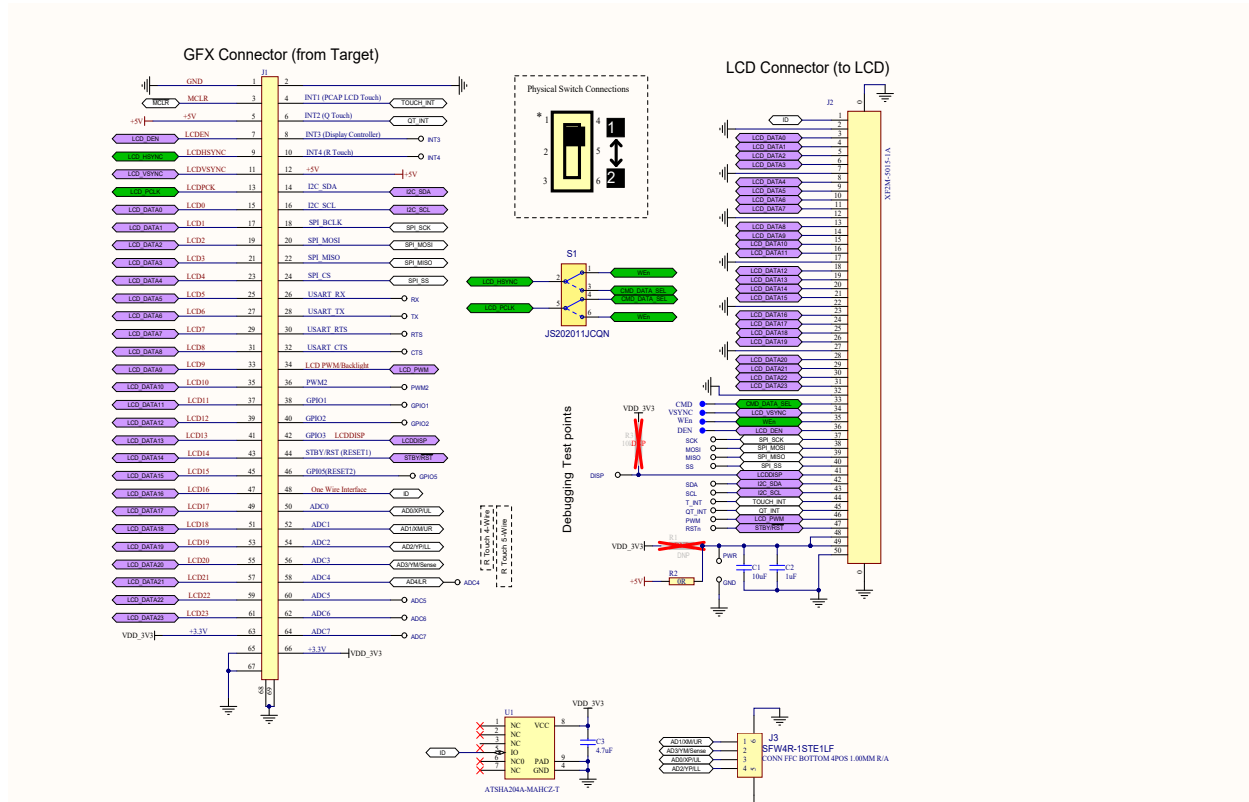

3.3 Bill of Materials

Quantity	Designator	Description	Manufacturer	Manufacturer Part Number
30	C201, C235, C238, C239, C240, C241, C242, C243, C244, C245, C246, C247, C248, C249, C250, C251, C252, C253, C255, C256, C257, C258, C259, C260, C261, C263, C264, C265, C266, C267	CAP CER 10000pF 10V 10% X7R SMD 0201	Murata	490-3194-2-ND
2	C202, C203	CAP CER 4.7uF 10V 10% X7S SMD 0603	Murata Electronics	GRM188C71A475KE11D
1	C300	CAP CER 2.2uF 16V 10% X7R SMD 0805	Murata	GRM21BR71C225KA12L
8	C301, C305, C309, C315, C317, C318, C319, C320	CAP CER 1uF 16V 10% X7R SMD 0603	Würth Electronics Inc	885012206052
1	C302	CAP CER 0.1uF 50V X7R 0805	KEMET	C0805C104K5RACTU
2	C306, C307	CAP CER 47uF 10V 20% X5R SMD 0805	TDK Corporation	C2012X5R1A476M125AC
1	C310	CAP CER 22uF 25V 20% X5R SMD 0805	Murata Electronics North America	GRT21BR61E226ME13L
5	C311, C312, C703, C807, C808	CAP CER 4.7uF 25V X7R 0805	TDK Corporation	C2012X7R1E475K125AB
1	C313	CAP CER 4700pF 50V 10% X7R SMD 0402	Murata Electronics North America	GRM155R71H472KA01J

EV87D54A

Hardware

.....continued

Quantity	Designator	Description	Manufacturer	Manufacturer Part Number
1	C500	CAP CER 0.1uF 16V 10% X7R SMD 0402	Würth Electronics Inc	885012205037
1	C501	CAP CER 10uF 10V 10% X5R SMD 0603	Samsung Electro-Mechanics	CL10A106KP8NNNC
1	C705	CAP CER 15pF 50V 5% NP0 SMD 0402	Murata	GRM1555C1H150JA01D
3	C801, C820, C821	CAP CER 10uF 25V 10% X5R SMD 0805	TDK Corporation	C2012X5R1E106K125AB
1	C804	CAP CER 0.022uF 16V 10% X7R SMD 0402	Samsung Electro-Mechanics America, Inc	CL05B223KO5NNNC
2	D300, D301	DIO SCKY MBR230LSFT1G 430mV 2A 30V SMD SOD-123FL	ON Semiconductor	MBR230LSFT1G
2	D302, D800	TVS DIODE LOW-CAP 3-CH ESD	Texas Instruments	TPD3E001DRLR
1	D600	DIO LED TRI RGB 2V 3.2V 3.2V 50mA 50mA 50mA SMD PLCC-6	Cree Inc.	CLP6C-FKB-CM1Q1H1BB7R3R3
1	D801	DIO LED GREEN 2V 30mA 35mcd Clear SMD 0603	Lite-On Inc	LTST-C191KGKT
1	D802	DIO LED YELLOW 2.1V 20mA 6mcd Clear SMD 0603	Lite-On	LTST-C190YKT
2	FB200, FB201	FERRITE BEAD 120 OHM 0603 1LN	Murata	BLM18PG121SN1D
3	FB300, FB800, L301	FERRITE 470R@100MHz 1A SMD 0603	Murata Electronics North America	BLM18PG471SN1D
1	J200	CON HDR-2.54 Male 1X2 Gold 6mm MH TH R/A	Würth Electronics Inc.	61300211021
1	J300	CON POWER 2.1mm 5.5mm Switch Slotted TH R/A	MPD (Memory Protection Devices)	EJ508A
2	J301, J800	CON USB2.0 Micro-AB Female ZX62D-AB-5P8(30) TOP MOUNT TH R/A	Hirose Connector	ZX62D-AB-5P8(30)
4	J400, J401, J404, J405	CON HDR-2.54 Female 1x8 Tin TH VERT	Sullins	PPTC081LFBN-RC
2	J402, J406	CON HDR 2.54 MALE 2x10 3u" GOLD IN CONTACT AREA MATTE TIN ON TAIL 5.84MH TH VERT	Samtec	TSW-110-07-F-D
2	J403, J407	CON HDR-2.54 Male 2x6 Gold 5.84MH TH VERT	Samtec	TSW-106-07-G-D
1	J500	CONN MICRO SD CARD PUSH-PUSH R/A	Hirose Electric Co Ltd	DM3AT-SF-PEJM5
1	J501	CON HDR-2.54 Male 2x10 Gold 5.84MH TH R/A	Samtec	TSW-110-08-S-D-RA
1	J502	CONN EDGE DUAL FEMALE 67POS 0.020	TE Connectivity	2199230-3
2	J702, J703	CON STRIP-1.27 Female 1x12 Gold TH VERT	Samtec	SLM-112-01-L-S
2	J706, J707	CON STRIP-1.27 Female 1x3 Gold TH VERT	Samtec	SLM-103-01-G-S
1	J708	CON HDR-2.54 Male 1x3 Tin 6.2MH TH R/A	Molex Inc	0022288030
1	JP200	MECH HW JUMPER 1.27mm 1x2 GOLD	Sullins Connector Solutions	NPB02SVAN-RC
1	JP700	RES TKF 0R SMD 3P JUMPER 0603	Panasonic	ERJ-3GEY0R00V
1	L300	INDUCTOR 2.2uH 5.5A 20% SMD L4W4H2.1	Coilcraft	XAL4020-222MEC
2	L800, L801	FERRITE 2A 600R SMD 0805	TDK Corporation	MPZ2012S601AT000
2	MH500, MH501	RND STNDFF M2.5X0.45 STEEL 2.5MM	Würth Elektronik	9774025151R
3	Q300, Q301, Q800	TRANS FET P-CH IRLML6402 -20V -3.7A 1.3W SOT-23-3	International Rectifier	IRLML6402TRPBF
6	R200, R201, R204, R205, R210, R211	RES TKF 1.8k 1% 1/10W SMD 0402	Panasonic Electronic Components	ERJ-2RKF1801X
2	R202, R207	RES TKF 0R 1/16W SMD 0805	Stackpole Electronics Inc	RMCF 1/10 0 R
2	R206, R209	RES TKF 0R 1/3W SMD 1210	Stackpole Electronics Inc.	RMCF1210ZT0R00
1	R212	RES SMD 0 OHM JUMPER 1/2W 1210	Vishay Dale	CRCW12100000Z0EA
2	R300, R301	RES TKF 2.2R 1% 1/8W SMD 0805 AEC-Q200	Vishay Dale	CRCW08052R20FKEA

EV87D54A

Hardware

.....continued

Quantity	Designator	Description	Manufacturer	Manufacturer Part Number
24	R302, R306, R500, R501, R502, R503, R504, R505, R506, R600, R601, R602, R603, R607, R700, R704, R705, R706, R707, R708, R801, R805, R811, R824	RES TKF 10k 1% 1/10W SMD 0402	Panasonic	ERJ-2RKF1002X
1	R303	RES 10 OHM 1% 1/10W 0603	Stackpole Electronics Inc	RMCF0603FT10R0
1	R304	RES TKF 2.49k 1% 1/10W SMD 0603	Panasonic	ERJ-3EKF2491V
1	R305	RES TKF 19.6k 1% 1/10W SMD 0603	Yageo	RC0603FR-0719K6L
1	R307	RES TKF 475R 1% 1/10W SMD 0603	Panasonic Electronic Components	ERJ-3EKF4750V
6	R308, R309, R709, R802, R803, R804	RES TKF 100k 1% 1/10W SMD 0402	Panasonic	ERJ-2RKF1003X
2	R604, R608	RES TKF 1k 1% 1/10W SMD 0603	Panasonic	ERJ-3EKF1001V
2	R605, R606	RES TKF 510R 1% 1/10W SMD 0603	Vishay Dale	CRCW0603510RFKEA
2	R702, R703	RES TKF 62R 1% 1/2W SMD 1210 AEC-Q200	Panasonic	ERJ-14NF62R0U
1	R806	RES SMD 442K OHM 1% 1/10W 0402	Panasonic Electronic Components	ERJ-2RKF4423X
1	R807	RES TKF 95.3k 1% 1/16W SMD 0402	Rohm Semiconductor	MCR01MRTF9532
1	R808	RES TKF 24.3k 1% 1/16W SMD 0402	Samsung	RC1005F2432CS
2	R810, R828	RES TKF 5.62k 1% 1/16W SMD 0402	Vishay Dale	CRCW04025K62FKED
1	R813	RES TKF 220R 1% 1/16W SMD 0402	Yageo	RC0402FR-07220RL
6	R815, R820, R821, R822, R823, R825	RES TKF 0R 1/16W SMD 0402	Yageo	RC0402JR-070RL
13	R817, R818, R833, R834, R840, R843, R844, R845, R850, R851, R852, R853, R854	RES TKF 4.7k 1% 1/16W SMD 0402	Yageo	RC0402FR-074K7L
2	R826, R831	RES TKF 31.6k 1% 1/10W SMD 0402	Panasonic	ERJ-2RKF3162X
2	R827, R839	RES TKF 47k 5% 1/10W SMD 0402	Panasonic	ERJ-2GEJ473X
2	R829, R841	RES TKF 22 OHM 1% 1/10W SMD 0603	Yageo	RC0603FR-0722RL
7	R830, R832, R842, R848, R849, R855, R856	RES TKF 330R 1% 1/16W SMD 0402	Yageo	RC0402FR-07330RL
2	R835, R846	RES TKF 3.3k 5% 1/10W SMD 0402	Panasonic - ECG	ERJ-2GEJ332X
2	R837, R838	RES TKF 100R 5% 1/10W SMD 0603	Vishay	CRCW0603100RJNEA
5	SW600, SW601, SW602, SW603, SW604	SWITCH TACT SPST 12V 50mA PTS645SM43SMTR92 LFS SMD	Würth Electronics Inc	430182043816
2	U802, U804	IC TRANSCEIVER 74LVC1T45GW Single Bit Voltage Translator SOT-363	NXP USA Inc.	74LVC1T45GW,125
1	U803	IC SWITCH SPDT 74LVC1G3157 SC-70-6	Texas Instruments	SN74LVC1G3157DCKR
4	Q302, Q801, Q802, Q803	MCHP ANALOG MOSFET N-CH TN2106 60V 280mA 360mW 2.5R SOT23-3	Microchip Technology	TN2106K1-G
1	U200	MCHP MCU 32-BIT 200MHz 1024kB 640kB PIC32MZ1064DAA176-I/2J LQFP-176	Microchip Technology	PIC32MZ2064DAR176-I/2J
1	U300	MCHP ANALOG SWITCHER Buck 12V 6A MIC24052YJL-TR QFN-28	Microchip Technology	MIC24052YJL-TR
2	U301, U302	MCHP ANALOG LDO 3.3V MIC5528-3.3YMT-TR 6-TDFN	Microchip Technology	MIC5528-3.3YMT-TR
1	U303	MCHP ANALOG LDO 1.8V 500mA MIC5353-1.8YMT-TR MLF-6	Microchip Technology	MIC5353-1.8YMT-TR
1	U700	MCHP SERIAL FLASH SST26VF064BA-104I SOIJ-8	Microchip Technology	SST26VF064BA-104I/SM

EV87D54A

Hardware

.....continued

Quantity	Designator	Description	Manufacturer	Manufacturer Part Number
1	U701	MCHP INTERFACE CAN ATA6563-GBQW1 VDFN-8	Microchip Technology	ATA6563-GBQW1
1	U703	MCHP ANALOG TEMPERATURE SENSOR -40C to +125C MCP9808T-E/MC DFN-8	Microchip Technology	MCP9808T-E/MC
1	U704	IC EEPROM 2K I2C 1MHZ 8UDFN	Microchip Technology	AT24MAC402-MAHM-T
1	U800	MCHP ANALOG POWER SWITCH 5.5V 3A MIC2042-1YTS TSSOP-14	Microchip Technology	MIC2042-1YTS
1	U801	MCHP MCU 32-BIT 300MHz 2MB 384kB ATSAME70N21B-ANT LQFP-100	Microchip Technology	ATSAME70N21B-ANT
1	U805	MCHP MEMORY SERIAL EEPROM 256k I2C 24LC256T-E/ST TSSOP-8	Microchip Technology	24LC256T-E/ST
1	Y200	MCHP CLOCK OSCILLATOR SINGLE 24.000MHZ DSC6011JI2B-024.0000 VLGA	Microchip Technology	DSC6011JI2B-024.0000
1	Y800	MCHP CLOCK OSCILLATOR SINGLE 12.000MHZ DSC6011JI1A-012.0000 VLGA	Microchip Technology	DSC6011JI1A-012.0000
1	Y201	MCHP CLOCK OSCILLATOR SINGLE 32.768KHz DSC6003JE2B-032K768 SMD VLGA	Microchip Technology	DSC6003JE2B-032K768
1	Y700	MCHP CLOCK OSCILLATOR 50MHz DSC1001CI2-050.0000T DFN-4	Microchip Technology	DSC1001CI2-050.0000T
4	PAD100, PAD101, PAD102, PAD103	MECH HW RUBBER PAD CYLINDRICAL D9.53H5.97	3M 3M	SJ61A2
DNP	3V3	MISC, TEST POINT MULTI PURPOSE MINI WHITE	Keystone	5002
DNP	5V	MISC, TEST POINT MULTI PURPOSE MINI RED	Keystone	5000
DNP	C200, C204, C205, C206, C207, C208, C209, C210, C211, C213, C214, C215, C216, C217, C218, C219, C220, C221, C222, C223, C224, C225, C226, C227, C228, C230, C231, C232, C233, C234, C236, C237, C303, C304, C308, C314, C316, C321, C600, C700, C702, C704, C706, C707, C708, C709, C800, C803, C805, C806, C809, C810, C811, C812, C813, C814, C815, C816, C817, C818, C819, C822, C823, C824, C825	CAP CER 0.1µF 16V 10% X5R SMD 0201	Murata Electronics North America	GRM033R61C104KE84D
DNP	D303	DIO SCKY MBR230LSFT1G 430mV 2A 30V SMD SOD-123FL	ON Semiconductor	MBR230LSFT1G
DNP	GND	MISC, TEST POINT MULTI PURPOSE MINI BLACK	Keystone	5001
DNP	J701, J704	CON HDR-2.54 Female 1x8 Tin TH VERT	Sullins	PPTC081LFBN-RC
DNP	J700	CON HDR-2.54 Female 1x10 Gold TH VERT	Sullins Connector Solutions	PPPC101LFBN-RC
DNP	J705	CON HDR-2.54 Female 1x6 Gold TH	Sullins Connector Solutions	801-43-006-10-001000
DNP	J801	CON HDR-1.27 Female 1x8 TH VERT	Greenconn	FSEA120-0802A002B1AB
DNP	J802	CON HDR-1.27 Female 1x6 Gold TH VERT	Samtec	SLM-106-01-G-S
DNP	R203, R208	RES TKF 0R 1/16W SMD 0805	Stackpole Electronics Inc	RMCF 1/10 0 R
DNP	R814, R816	RES TKF 0R 1/16W SMD 0402	Yageo	RC0402JR-070RL

3.4 Board Dimensions

The PIC32MZ DA Curiosity board has the following dimensions and mounting holes. These units are in imperial units (mil).

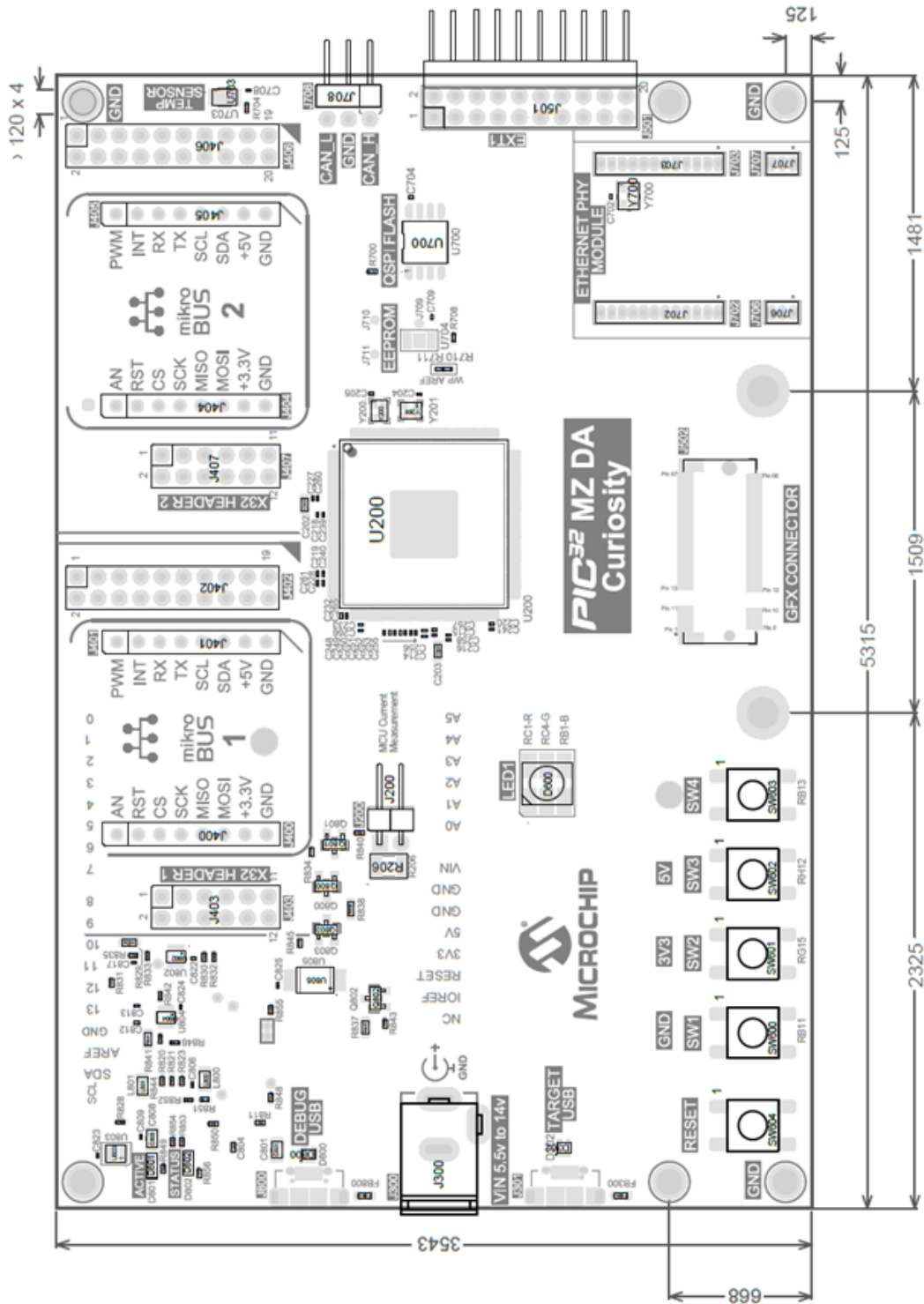

4. Revision History

Revision B (06/2021)

The terminology used in this document may not match with the contents of the current revision of the device data sheet or other Microchip documentation and collateral. If there are any questions or concerns regarding terminology, contact a Microchip support or sales representative.

Throughout this document all references of “Master” were changed to “Host”, and “Slave” was changed to “Client”, where applicable.

The following updates were added in this revision:

- Updated the Pinout table, [Graphics Connector / GFX Card Interface](#), with new values for the name, description and port

Revision A - 08/2020

This is the initial released version of this document.

The Microchip Website

Microchip provides online support via our website at www.microchip.com/. This website is used to make files and information easily available to customers. Some of the content available includes:

- **Product Support** – Data sheets and errata, application notes and sample programs, design resources, user's guides and hardware support documents, latest software releases and archived software
- **General Technical Support** – Frequently Asked Questions (FAQs), technical support requests, online discussion groups, Microchip design partner program member listing
- **Business of Microchip** – Product selector and ordering guides, latest Microchip press releases, listing of seminars and events, listings of Microchip sales offices, distributors and factory representatives

Product Change Notification Service

Microchip's product change notification service helps keep customers current on Microchip products. Subscribers will receive email notification whenever there are changes, updates, revisions or errata related to a specified product family or development tool of interest.

To register, go to www.microchip.com/pcn and follow the registration instructions.

Customer Support

Users of Microchip products can receive assistance through several channels:

- Distributor or Representative
- Local Sales Office
- Embedded Solutions Engineer (ESE)
- Technical Support

Customers should contact their distributor, representative or ESE for support. Local sales offices are also available to help customers. A listing of sales offices and locations is included in this document.

Technical support is available through the website at: www.microchip.com/support

Microchip Devices Code Protection Feature

Note the following details of the code protection feature on Microchip devices:

- Microchip products meet the specification contained in their particular Microchip Data Sheet.
- Microchip believes that its family of products is one of the most secure families of its kind on the market today, when used in the intended manner and under normal conditions.
- There are dishonest and possibly illegal methods used to breach the code protection feature. All of these methods, to our knowledge, require using the Microchip products in a manner outside the operating specifications contained in Microchip's Data Sheets. Most likely, the person doing so is engaged in theft of intellectual property.
- Microchip is willing to work with the customer who is concerned about the integrity of their code.
- Neither Microchip nor any other semiconductor manufacturer can guarantee the security of their code. Code protection does not mean that we are guaranteeing the product as "unbreakable."

Code protection is constantly evolving. We at Microchip are committed to continuously improving the code protection features of our products. Attempts to break Microchip's code protection feature may be a violation of the Digital Millennium Copyright Act. If such acts allow unauthorized access to your software or other copyrighted work, you may have a right to sue for relief under that Act.

Legal Notice

Information contained in this publication regarding device applications and the like is provided only for your convenience and may be superseded by updates. It is your responsibility to ensure that your application meets with

your specifications. MICROCHIP MAKES NO REPRESENTATIONS OR WARRANTIES OF ANY KIND WHETHER EXPRESS OR IMPLIED, WRITTEN OR ORAL, STATUTORY OR OTHERWISE, RELATED TO THE INFORMATION, INCLUDING BUT NOT LIMITED TO ITS CONDITION, QUALITY, PERFORMANCE, MERCHANTABILITY OR FITNESS FOR PURPOSE. Microchip disclaims all liability arising from this information and its use. Use of Microchip devices in life support and/or safety applications is entirely at the buyer's risk, and the buyer agrees to defend, indemnify and hold harmless Microchip from any and all damages, claims, suits, or expenses resulting from such use. No licenses are conveyed, implicitly or otherwise, under any Microchip intellectual property rights unless otherwise stated.

Trademarks

The Microchip name and logo, the Microchip logo, Adaptec, AnyRate, AVR, AVR logo, AVR Freaks, BesTime, BitCloud, chipKIT, chipKIT logo, CryptoMemory, CryptoRF, dsPIC, FlashFlex, flexPWR, HELDO, IGLOO, JukeBlox, KeeLoq, Kleer, LANCheck, LinkMD, maXStylus, maXTouch, MediaLB, megaAVR, Microsemi, Microsemi logo, MOST, MOST logo, MPLAB, OptoLyzer, PackeTime, PIC, picoPower, PICSTART, PIC32 logo, PolarFire, Prochip Designer, QTouch, SAM-BA, SenGenuity, SpyNIC, SST, SST Logo, SuperFlash, Symmetricom, SyncServer, Tachyon, TempTrackr, TimeSource, tinyAVR, UNI/O, Vectron, and XMEGA are registered trademarks of Microchip Technology Incorporated in the U.S.A. and other countries.

APT, ClockWorks, The Embedded Control Solutions Company, EtherSynch, FlashTec, Hyper Speed Control, HyperLight Load, IntelliMOS, Libero, motorBench, mTouch, Powermite 3, Precision Edge, ProASIC, ProASIC Plus, ProASIC Plus logo, Quiet-Wire, SmartFusion, SyncWorld, Temux, TimeCesium, TimeHub, TimePictra, TimeProvider, Vite, WinPath, and ZL are registered trademarks of Microchip Technology Incorporated in the U.S.A.

Adjacent Key Suppression, AKS, Analog-for-the-Digital Age, Any Capacitor, AnyIn, AnyOut, BlueSky, BodyCom, CodeGuard, CryptoAuthentication, CryptoAutomotive, CryptoCompanion, CryptoController, dsPICDEM, dsPICDEM.net, Dynamic Average Matching, DAM, ECAN, EtherGREEN, In-Circuit Serial Programming, ICSP, INICnet, Inter-Chip Connectivity, JitterBlocker, KleerNet, KleerNet logo, memBrain, Mindi, MiWi, MPASM, MPF, MPLAB Certified logo, MPLIB, MPLINK, MultiTRAK, NetDetach, Omniscient Code Generation, PICDEM, PICDEM.net, PICkit, PICtail, PowerSmart, PureSilicon, QMatrix, REAL ICE, Ripple Blocker, SAM-ICE, Serial Quad I/O, SMART-I.S., SQL, SuperSwitcher, SuperSwitcher II, Total Endurance, TSHARC, USBCheck, VariSense, ViewSpan, WiperLock, Wireless DNA, and ZENA are trademarks of Microchip Technology Incorporated in the U.S.A. and other countries.

SQTP is a service mark of Microchip Technology Incorporated in the U.S.A.

The Adaptec logo, Frequency on Demand, Silicon Storage Technology, and Symmcom are registered trademarks of Microchip Technology Inc. in other countries.

GestIC is a registered trademark of Microchip Technology Germany II GmbH & Co. KG, a subsidiary of Microchip Technology Inc., in other countries.

All other trademarks mentioned herein are property of their respective companies.

© 2020, Microchip Technology Incorporated, Printed in the U.S.A., All Rights Reserved.

ISBN: 978-1-5224-8401-1

Quality Management System

For information regarding Microchip's Quality Management Systems, please visit www.microchip.com/quality.

Worldwide Sales and Service

AMERICAS	ASIA/PACIFIC	ASIA/PACIFIC	EUROPE
<p>Corporate Office 2355 West Chandler Blvd. Chandler, AZ 85224-6199 Tel: 480-792-7200 Tel: 480-792-7277 Technical Support: www.microchip.com/support Web Address: www.microchip.com</p> <p>Atlanta Duluth, GA Tel: 678-957-9614 Fax: 678-957-1455</p> <p>Austin, TX Tel: 512-257-3370</p> <p>Boston Westborough, MA Tel: 774-760-0087 Fax: 774-760-0088</p> <p>Chicago Itasca, IL Tel: 630-285-0071 Fax: 630-285-0075</p> <p>Dallas Addison, TX Tel: 972-818-7423 Fax: 972-818-2924</p> <p>Detroit Novi, MI Tel: 248-848-4000</p> <p>Houston, TX Tel: 281-894-5983</p> <p>Indianapolis Noblesville, IN Tel: 317-773-8323 Fax: 317-773-5453 Tel: 317-536-2380</p> <p>Los Angeles Mission Viejo, CA Tel: 949-462-9523 Fax: 949-462-9608 Tel: 951-273-7800</p> <p>Raleigh, NC Tel: 919-844-7510</p> <p>New York, NY Tel: 631-435-6000</p> <p>San Jose, CA Tel: 408-735-9110 Tel: 408-436-4270</p> <p>Canada - Toronto Tel: 905-695-1980 Fax: 905-695-2078</p>	<p>Australia - Sydney Tel: 61-2-9868-6733</p> <p>China - Beijing Tel: 86-10-8569-7000</p> <p>China - Chengdu Tel: 86-28-8665-5511</p> <p>China - Chongqing Tel: 86-23-8980-9588</p> <p>China - Dongguan Tel: 86-769-8702-9880</p> <p>China - Guangzhou Tel: 86-20-8755-8029</p> <p>China - Hangzhou Tel: 86-571-8792-8115</p> <p>China - Hong Kong SAR Tel: 852-2943-5100</p> <p>China - Nanjing Tel: 86-25-8473-2460</p> <p>China - Qingdao Tel: 86-532-8502-7355</p> <p>China - Shanghai Tel: 86-21-3326-8000</p> <p>China - Shenyang Tel: 86-24-2334-2829</p> <p>China - Shenzhen Tel: 86-755-8864-2200</p> <p>China - Suzhou Tel: 86-186-6233-1526</p> <p>China - Wuhan Tel: 86-27-5980-5300</p> <p>China - Xian Tel: 86-29-8833-7252</p> <p>China - Xiamen Tel: 86-592-2388138</p> <p>China - Zhuhai Tel: 86-756-3210040</p>	<p>India - Bangalore Tel: 91-80-3090-4444</p> <p>India - New Delhi Tel: 91-11-4160-8631</p> <p>India - Pune Tel: 91-20-4121-0141</p> <p>Japan - Osaka Tel: 81-6-6152-7160</p> <p>Japan - Tokyo Tel: 81-3-6880-3770</p> <p>Korea - Daegu Tel: 82-53-744-4301</p> <p>Korea - Seoul Tel: 82-2-554-7200</p> <p>Malaysia - Kuala Lumpur Tel: 60-3-7651-7906</p> <p>Malaysia - Penang Tel: 60-4-227-8870</p> <p>Philippines - Manila Tel: 63-2-634-9065</p> <p>Singapore Tel: 65-6334-8870</p> <p>Taiwan - Hsin Chu Tel: 886-3-577-8366</p> <p>Taiwan - Kaohsiung Tel: 886-7-213-7830</p> <p>Taiwan - Taipei Tel: 886-2-2508-8600</p> <p>Thailand - Bangkok Tel: 66-2-694-1351</p> <p>Vietnam - Ho Chi Minh Tel: 84-28-5448-2100</p>	<p>Austria - Wels Tel: 43-7242-2244-39 Fax: 43-7242-2244-393</p> <p>Denmark - Copenhagen Tel: 45-4485-5910 Fax: 45-4485-2829</p> <p>Finland - Espoo Tel: 358-9-4520-820</p> <p>France - Paris Tel: 33-1-69-53-63-20 Fax: 33-1-69-30-90-79</p> <p>Germany - Garching Tel: 49-8931-9700</p> <p>Germany - Haan Tel: 49-2129-3766400</p> <p>Germany - Heilbronn Tel: 49-7131-72400</p> <p>Germany - Karlsruhe Tel: 49-721-625370</p> <p>Germany - Munich Tel: 49-89-627-144-0 Fax: 49-89-627-144-44</p> <p>Germany - Rosenheim Tel: 49-8031-354-560</p> <p>Israel - Ra'anana Tel: 972-9-744-7705</p> <p>Italy - Milan Tel: 39-0331-742611 Fax: 39-0331-466781</p> <p>Italy - Padova Tel: 39-049-7625286</p> <p>Netherlands - Drunen Tel: 31-416-690399 Fax: 31-416-690340</p> <p>Norway - Trondheim Tel: 47-72884388</p> <p>Poland - Warsaw Tel: 48-22-3325737</p> <p>Romania - Bucharest Tel: 40-21-407-87-50</p> <p>Spain - Madrid Tel: 34-91-708-08-90 Fax: 34-91-708-08-91</p> <p>Sweden - Gothenberg Tel: 46-31-704-60-40</p> <p>Sweden - Stockholm Tel: 46-8-5090-4654</p> <p>UK - Wokingham Tel: 44-118-921-5800 Fax: 44-118-921-5820</p>