

1/6

*The*

# SHORTWAVE

*Magazine*



**EXCLUSIVELY FOR THE  
SHORT WAVE LISTENER  
EXPERIMENTER AND  
TRANSMITTING AMATEUR**

**VOL. IV No. 5 JULY 1946**

# WEBB'S

are pleased to introduce the

## EDDYSTONE

### "504"

#### COMMUNICATION RECEIVER



The new British made "504" Receiver embodying refinements and technique resulting from close contact with wartime research.

Unique unit construction gives great mechanical rigidity. Precision type tuning mechanism, free from back-lash, effective scale length of tuning dial is 36 inches per band. For A.C. operation, 40 to 60 cycles, 110 and 200/240 volts.

PRICE: **£48 10s.**  
(PLUS PURCHASE TAX £10:8:6)

We are registering orders for delivery August and September. Supplies will be in strict rotation and early booking is desirable.

Write for details of our registration arrangements, also brochure giving full technical data on the "504"

Some salient features :-

- Nine valves.
- Two R.F. and two I.F. stages.
- Crystal Filter.
- Noise Limiter.
- B.F.O.
- Five switched bands.
- Continuous coverage 30,000 to 600 Kc/s.
- Sensitivity better than 2 microvolts.
- "S" meter.

A specimen Receiver is on show and demonstration at our Soho Street address.

#### ● TUNING COILS AND PACKS

"U.C.L." Kit for the construction of a modern 3 waveband superhet, comprising the essential components :-

1. 3 waveband coil pack, assembled with coils, switch, padders and trimmers mounted on sub-chassis, wired and tested for assembly into the receiver chassis. Wave-range 16.8 to 51, 200 to 550 and 800 to 2,000 metres.
2. A pair of 465 Kc/s. I.F. Transformers.
3. Two-gang tuning condenser.
4. A glass tuning scale with correct calibrations for three bands.

Box complete with circuit diagram of complete receiver ... .. Price **£4:17:6**  
(including tax)

"Amateur Radio." Four Band Coil Unit, assembled on sub-chassis with 4 coils, trimmers and wave-change switch. Complete with circuit details for assembly into an efficient two-valve "straight" receiver. Wave range 9.7 to 208 metres.

Price of Coil Unit **£1:10:0**

#### ● TRANSMITTING VALVES

Direct replacement equivalents of popular U.S.A. types.

- Type 807 (S.T.C. 5B/250A) ... .. **£1:10:5**
- Type 866/866A (S.T.C. 2V/400A) ... .. **£1: 7:6**
- Type RU34 (S.T.C. 4074A) ... .. **£1:10:0**
- Type 83 (S.T.C. 22V/310A) ... .. **15:0**
- Type S.T.C. 4274A—a new full-wave vacuum rectifier, 1000 volts, 200 m.a., filament 5v. 2 amps. ... .. **£1: 0:0**

#### ● AERIAL RELAYS

Stocks now available of new double-pole Aerial change-over relay. Approximate size 3" x 2 3/8" x 1 3/8" high, low-loss construction. Contacts take 4 amps. RF. Coil operation 4 to 6 volts A.C. ... .. **£2:17:6**

#### ● HIGH VOLTAGE CONDENSERS

- Unrepeatable at price, U.S.A. "Aerovox" metal can type with mounting clips.
- 8 mfd. 600v. size, 3 3/8" x 1 1/4" x 3 3/8" high ... .. **5:0**
- 4 mfd. 1000v. size, 2 1/2" x 1 1/4" x 4 1/2" ... .. **7:6**

# WEBB'S

Write, phone or call—  
Our shop hours are 9 a.m. to 5 p.m.  
(Saturdays 9 a.m. to 1 p.m.)

# RADIO

14 SOHO ST. LONDON, W.1

Telephone: GERRARD 2089

# Getting Down to it!

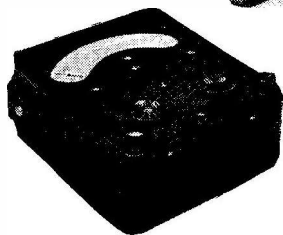

The 50-range Model 7 Universal AvoMeter is the leader of the world-famed range of "Avo" Electrical Measuring Instruments which are appreciated for their compact portability, dependability, and a steadfast accuracy which is often used as a standard by which other instruments are judged. Fully descriptive pamphlet available on application.

OF course you don't have to take us too literally, but we assure our innumerable friends that we *are* pressing on with the production of all the well-known "Avo" Testing Instruments with a view to speeding up delivery dates as time goes on.

Meanwhile, we have not neglected to use the advances perfected during the war years, and the several new Instruments scheduled for early production will measure up to the traditional "Avo" standards of accuracy and reliability.



(Regd. Trade Mark)

**ELECTRICAL TESTING INSTRUMENTS**

SOLE MANUFACTURERS  
**THE AUTOMATIC COIL WINDER & ELECTRICAL EQUIPMENT CO. LTD.**  
 WINDER HOUSE · DOUGLAS STREET · LONDON · S.W.1 · TELEPHONE VICTORIA 3100/1

# A NEW PUBLICATION TO INTEREST YOU!

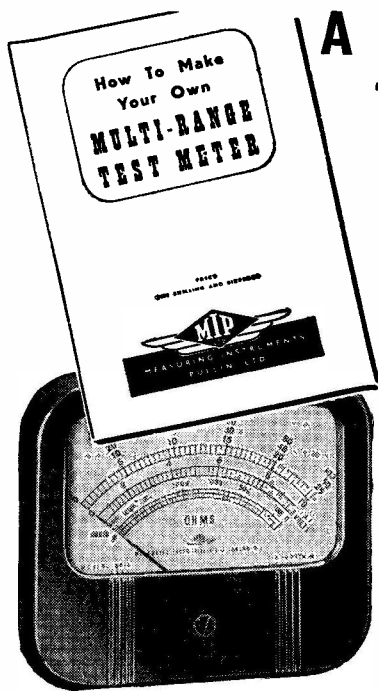

This well illustrated book enables any Amateur Constructor or Service Engineer to make a successful multi-range test instrument which is accurate, modern, and of pleasing appearance, at a most reasonable cost.

Available from the M.I.P. authorised distributors listed below.  
(Price 1/6d. 1/9d. post free).



Authorised distributors

A.C.S. RADIO LTD., 44, Widmore Rd., Bromley, Kent.  
CUSSINS & LIGHT LTD., King's Square, York.  
HOLIDAY & HEMMERDINGER LTD.,  
74-78, Hardman St., Manchester, 3.  
RADIO-MART G5NI (Birmingham) LTD.,  
48, Holloway Rd., Birmingham, 1.  
TELE-RADIO (1943) LTD., 177, Edgware Rd., London, W.2.  
C. WEBB LTD., Carrs Lane, Birmingham.  
WEBBS RADIO, 14 Soho St., London, W.1.  
WELWORTH WIRELESS & ELEC. CO.,  
8, Withy Grove, Manchester, 4.

Measuring Instruments (Pullin) Ltd., Phoenix Works,  
Great West Road, Brentford, Middlesex.

## ELECTRADIX OFFERS!

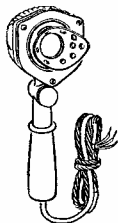

**MICROPHONES.** The Lesdix No. 11A hand mike is again available; a carbon inset in solid brass case, the sensitive diaphragm protected by a perforated metal panel, 8/6. Metal clad inset only 5/-. Pedestal mikes for desk or pulpit, 25/-. High radio transformer, 4/6 extra. Recording and announcer's hand mikes, multi-carbon, metal clad, service type, by Tannoy and Truvox, with neat switch in handle, 21/- (as illustrated). Special high ratio transformer, 7/6.

**HEADPHONES.** Single low resistance headphone, as new, surplus G.P.O. stock type S.G.B., light weight, bakelite case and cap with headband and cord, 8/6. High resistance double headphones, type S.G.B., with headband and cord, light weight, as new, 22/6.

**BUZZERS.** Transmitter buzzers, new, G.P.O. polarised type, battery and line terminals, 2 contacts adjustable, on bakelite base, 8/6.

**SWITCHES.** Dewar key switches, new, C.O. type, 7 contacts, 5 make, 2 C.O., 7/6.

**SEND-RECEIVE HAND COMS.** All-metal field hand coms. for portable or fixed stations. The famous No. 16 Govt. type used in field telephones: mike and earpiece with damaged finger switch easily repaired. 7/6 (no cords supplied.)

**G.P.O. HAND COM.** Telephones, new, with switch in handle and long 4-way cord, 15/-.

**SPARK COILS.** Ex G.P.O. with S.W. helix for model control, 55/-. Spark coil only, for 1/2 in. to 1/2 in. spark, operated from 6/12 volt accumulator, 25/- each.

**FANS.** D.C. 110 and 220 volt table fans, in new condition, with 10-12 in. blade and guard by G.E.C., Verity and other well-known makers, 35/-. Oscillating type, 45/-. Fan motors only, heavy bulkhead type, 110/220 volt D.C., 25/-. 24 volt D.C. table fans, 6 in. blade and guard, 25/- each.

**RELAYS.** We have just taken delivery of a consignment of new Siemens relays, 500-1,000 ohms, 2 makes, 10/-; 2 makes, 1 S.P.C.O., 12/6; 3 makes, 1 break, 12/6; 500-500 ohms S.P.C.O., 10/-; 200 ohms, 1 break, 1 S.P.C.O. slugged, 12/6; 10,000 ohm S.P.C.O., 21/-. Send for special leaflet. Relay contact assembly, thermal action, 12/6. Siemen's high-speed relays in heavy brass case, £3 5s. Telephone type No. 6, 2-coil polarised, S.P.C.O., 6 volts, 25 m.a., 325 ohms, 8/6. No. 1A S.P. on-off, 2 volts, 40 m.a., 5/-. Relay movements, 1,000 ohms, less blade and contact, 2/6. Moving coil relays by Weston, Elliott and Sullivan.

**MAGNETS.** Midget ALNI perm. steel disc magnets, 3/8 in. dia. with centre hole 1/8 in. dia. of tremendous magnetic force; unlimited uses, 3/6 each. Horse shoe permanent steel magnets, various sizes, from 3/6 each.

**TRANSFORMERS.** 3 kW Crypto 230 v. to 115 v. shrouded, £9 10s.; 3kW Metvick 50 cy. 400 v. to 600 v., £9 10s.; 500 watts, Foster 50 cy., 440 v. to 110 v. 5 amps., £4 15s.; 230 v. 50 cy. to 20 volts 2 amps, 30/-; 230 v. 50 cy. to 12 v. 3 amps., 32/6.

**AUTO-TRANSFORMERS.** 5 watts H.T. test transformers, 110/220 v. to 1,000 v. 5 m.a., 10/-; 230 volts to 110 volts, 50 cy. 80 watts, 25/-; 150 watts, 35/-; 300 watts, 60/-; 350 watts, 65/-; 900/1,000 watts, £7 10s.

When ordering, please mention the "S.W.M."

**ELECTRADIX RADIOS**

214 QUEENSTOWN RD., LONDON, S.W.8  
Telephone MACaulay 2159.

# Two items from the NEW EDDYSTONE CATALOGUE

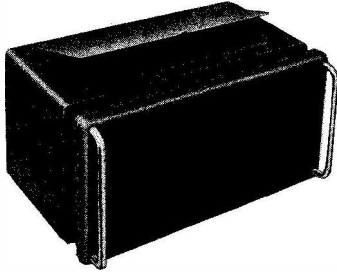

## METAL CABINETS

Two sizes available. One measures 16 $\frac{3}{4}$ " long, 8" wide, 8 $\frac{3}{4}$ " deep; the other 10 $\frac{1}{2}$ " long, 6" wide, 7" deep. Both have hinged lids in the top. Finish is ripple black.

Order from  
your Eddystone  
Agent

# EDDYSTONE

SUPPORT THE BRITISH MANUFACTURER

EDDYSTONE WORKS · ALVECHURCH RD · BIRMINGHAM 31

## TRANSMITTING RACKS

Ideal for that new transmitter, this rack comprises uprights, top and bottom frames, top plate, side brackets, front panel and chassis. The dimensions conform to international standards, the chassis measuring 17" x 10" x 2", whilst the uprights are 63" in length. Holes punched out in all members to facilitate assembly. Mild steel construction. Finish is glossy black, except panels which are ripple black on the outside. Panels are available in four sizes, ranging from 3 $\frac{1}{2}$ " to 10 $\frac{1}{2}$ ". All items sold separately.

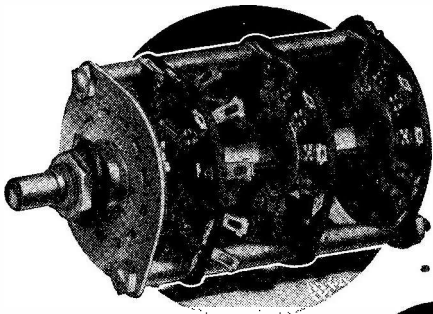
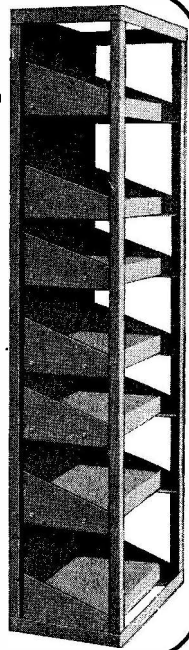

for  
SWITCHES

... the name is

# DANK

BRITISH N.S.F. CO. LTD.

KEIGHLEY · YORKS · Phone: Keighley 4221/4  
Grams: Enesef, Keighley

London Office: 25 Manchester Sq., W.1. Tele: Welbeck 7941/6

SOLE LICENSEES OF THE OAK MANUFACTURING CO. LTD., CHICAGO

British N.S.F. Sub-Licensees: Plessey Co. Ltd., A.B. Metal Products Ltd

Other British N.S.F. Products include PAPER CAPACITORS,  
SILVERED MICA CAPACITORS, WIRE WOUND RESISTORS  
AND VOLUME CONTROLS — Write for full details.



*A red letter day in the History  
of the Radio Industry*



*... on this date  
as frequently announced*

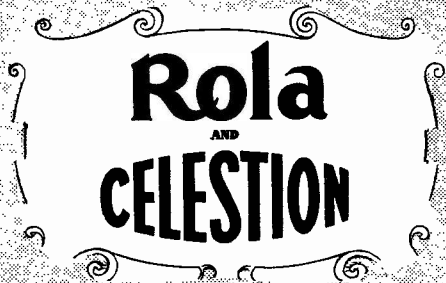

*finally join forces in the interests of greater  
Speaker Production for the Radio Industry*

**BRITISH ROLA LTD.,**  
Georgian House, Bury St., St. James's, S.W.1  
Factories: Thames Ditton & Devises.

**CELESTION LTD.,**  
Kingston-upon-Thames, Surrey.

# The Reason why



Type "A"

Details of all types of S. G. Brown headphones are given in Brochure "S.W." Free on request.

the reception from S. G. Brown, Type "A" (Adjustable Reed Movement) headphones is so fine, is because a steel reed is introduced, capable of the utmost sensitivity, in place of the usual flat diaphragm which by its nature is limited.

The reed is held in extremely sensitive suspension by the pull of a powerful 35% Cobalt Steel magnet in one direction, and its own elasticity in the other. When in use, the reed, in response to the minutest impulses, activates the rigid cone disc which merely sets the air in motion without calling into play any vibratory properties of its own.

YOUR LOCAL DEALER CAN SUPPLY

Type "A." Adjustable Reed Movement 57/6  
 Type "F." Featherweight, 23/- Type "D1," 32/6

## S.G. Brown, Ltd.

VICTORIA RD., NORTH ACTON, LONDON, W.3 'Phone : ACOrn 5021

### A.C.S. RADIO

We wish we could list the full range of our components below, but space allows us to mention only a few items. However, our new list will be sent free on application and contains hundreds of items of interest to the short-wave enthusiast.

**CRYSTALS.** A good selection of HAMRAD 7 mc/s Crystal Units in stock, suitable for 7, 14 and 28 mc/s. In enclosed holder, standard spacing—£1/10/-. Processed to your exact specification (about 2 weeks)—£1/15/-.

**AERIAL WIRE**—Hard drawn, enamelled copper.  
 14 S.W.G. 12 S.W.G.  
 75 ft.—3/6 100 ft.—7/3  
 100 ft.—4/6 140 ft.—10/-  
 140 ft.—6/3

**TRANSMITTING VALVES.** In addition to the range of Transmitting Valves by Standard Telephones and Cables, we have a few American Valves, including HYTRON HY-60—£1/13/6 ; EIMAC 100TL—£4/17/6 ; RAYTHEON RK-20—£4/15/0 ; RAYTHEON RK-100—£1/15/0.

**METERS.** A full range of Meters by Measuring Instruments (Pullin) Ltd. Details on request.

**44 WIDMORE RD BROMLEY, KENT**  
 'Phone RAVensbourne 0156

### "Cydon" Transmitting Capacitors

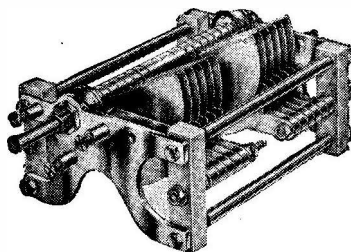

TYPE SSTR.	SQUARE LAW
Max. Capacity	List Price
100 pF.....	£1:7:6
150 ,, .....	£1:12:0
200 ,, .....	£1:15:0
250 ,, .....	£2:0:0
300 ,, .....	£2:10:0

**SYDNEY S. BIRD & SONS, LTD.**  
 Cambridge Arterial Road, Enfield, Middx

## AMATEUR CHASSIS

The following are of aluminium ; very light in weight, very rigid, very easy to work. Fitted with stout steel straps (plated) for extra rigidity, and tapped 2 B.A. for cabinet fixing. All undrilled, perfectly plain.

Owing to increased manufacturing costs we regret the following slight increases.

7 in. by 7 in. by 2 in. deep	...	...	4/-
5½ in. by 9½ in. by 2 in. deep	...	...	4/3
11 in. by 7 in. by 2 in. deep	...	...	5/-
17 in. by 10 in. by 2 in. deep	...	...	6/-
12 by 9 by 3 in. deep, ...	...	...	6/6

Also midget radio type, 10 by 5½ by 2 in., punched for 6½ in. speaker and seven valves (or five valves and two IF transformers) ... 5/-

Any quantity available from stock, despatch at once. Packing and postage 1/- each extra.

## WIRELESS SUPPLIES UNLIMITED

264-266 Old Christchurch Road,  
BOURNEMOUTH, HANTS.

# AERIALS

## "EXSTAT" SHORT WAVE TELEVISION CAR RADIO

Sold by all the leading  
dealers

## ANTIFERRECE LIMITED

PLENDER PL., PLENDER ST.

LONDON, N.W.1

\*Phone EUSton 5613-4-5

# PREMIER RADIO

(MORRIS AND CO. (RADIO) LTD.)

ALL POST ORDERS TO: JUBILEE WORKS,  
167, LOWER CLAPTON RD., LONDON, E.S.  
(Amherst 4723)

CALLERS TO: 169, FLEET ST., E.C.4. (Central  
2833)

1946 LIST now available; hundreds of new lines.  
*Terms of Business:* Cash with order or C.O.D. over £1. All enquiries must be accompanied by a 2½d. stamp.

BRAND NEW GOVERNMENT SURPLUS, Etc.  
MANY ITEMS AT PRE-WAR PRICES.

**ELECTROLYTIC CONDENSERS.** 8 mfd., 500 v.w., 3/-; 16 mf., 500 v.w., 4/-; 50 mf., 12 v.w., or 25 mf., 25 v.w., 2/3; 50 v., 50 v.w., 3/-; 500 mf., 12 v.w., 4/6.

**MIDGET RADIO KITS.** Complete with drilled chassis, valves and loudspeaker, only cabinet required, medium and long wave t.r.f. size 10×6×6, 4 valve, inc. rect., tone control, AC/DC operation, 200/250 v. Circuit and Constructional Details supplied. Price including tax 46/17/6.

**MOTOR GENERATORS.** Input 6 v. DC. Output 220 v. DC, 50 mA. with smoothing. 43/10/0.

**ROTARY TRANSFORMERS.** DC to DC. Input 12 or 18 volts. Output with 12 v. input; HT 200 v. 60 mA, and 8 v. 2 a, with 18 v. input; HT 300 v., 70 mA and 12 v. 2 a, £2. Smaller model, input 12 or 18 volts, with 12 v. input HT 180 v., 30 mA. LT 4 v. 3a, with 18 v. input; HT 300 v., 30 mA; LT 6.5 v. 3 a., 10/-; Input 24/28 v. Output 1,000-1,200 v., 70 mA, £2.

**VIBRATOR POWER UNITS.** Input 6 v. Output 120 v., 15 mA. £2/0/0. Input 12 v. Output 240 v., 100 mA, 6 v. 10 a., £3/10/0.

**CO-AXIAL CABLE.** Super quality, single screened, weatherproof, 1/6 yd.

**SUPER QUALITY OIL-FILLED PAPER (MANSBRIDGE TYPE) CONDENSERS** 2 mfd., 1,000 v.w., 2/6 each or £1 per doz.; 2 mfd. 600 v.w., 1/3 each or 10/- per doz.; 1 mfd. 600 v.w., 1/- each or 8/- per doz.

**LOUDSPEAKERS.** Rola sin., P.M., 21/6; 6½in. P.M., 22/6; 8in. P.M., 24/-; 2½in. P.M., 25/-; 3½in. P.M., 30/- 9in., 7 watt., 15 ohm., V.C., P.M., 38/-.

**SUPERHET TUNING KIT,** comprising 9 midget coils for H.F. Aerial and Osc. covering 16-47, 200-557 and 700-2,000 m., suitable switch, all padders and trimmers, 38/10. Worth double. Also available a suitable 3 gang condenser with complete S.M. drive and dial, 30/-.

**FIRST-GRADE METERS.** 3½in. diameter, 1 milliamp, £2/12/0; 500 microamps, £2/18/6. 4½in., 1 milliamp, £3/5/0; 500 microamps, £3/11/6. Westinghouse Meter Rectifier for either type, 10/-; Multiple shunts, 10, 100, 500 mA, 10/-; Any value multiplier, 2/6 each.

**SIGNAL GENERATORS.** B.P.L., 1946 model, £21. Send for descriptive leaflet.

**AC/DC AMPLIFIERS,** 5 watts output, high gain, three-stage feedback, £8/8/0.

**PLAYING DESKS.** A super quality electric gramophone motor with magnetic pick-up and automatic start-stop. Mounted on a substantial metal base 200-250 v. A/C, £6/17/6.

**MAINS TRANSFORMERS,** 300+300 v., 60 mA, three 4 v. 2-3 a. windings, 25/-; 350+350 100 mA, 5 v., 2 a., 6.3 v., 2-3 a., 29/-; 350+350 100 mA, three 4 v. 2-3 a. windings, 29/-; 350+350 150 mA, 4 v., 2-3 a., 4 v. 3-6 a., 4 v. 1-2 a., 4 v. 1-2 a., windings, 39/-; 350+350 150 mA, 5 v. 2 a., 6.3 v. 2 a., 6.3 v. 2 a., 36/-; 500×500 250 mA, 5 v. 3 a., 6.3 v. 2 a., 6.3 v. 4 a., 65/-; 425+425 200 mA, 4 v. 2-3 a., 4 v. 2-3 a., 4 v. 3-6 a., 47/-; 350+350 150 mA, 4 v., 1-2 a., 4 v. 2-3 a., 4 v. 3-4 a., 36/-; 500+500, 150 mA four 4 v., 2-3 a., LT windings, 47/-.



# QUARTZ CRYSTAL UNITS

## FOR YOUR TRANSMITTER

### TYPE 2 LOW TEMPERATURE COEFFICIENT PLATES

3.50/3.75 Mc/s or 7.00/7.50 Mc/s for the  
30 Mc/s band.

3.66/3.75 Mc/s or 7.32/7.50 Mc/s for the  
60 Mc/s band.

#### PRICES:—

Random frequency in either band . . . £1 - 10 - 0  
Specified frequency in either band . . . £1 - 16 - 0

**AVAILABLE FOR IMMEDIATE DELIVERY**



## FOR YOUR FREQUENCY STANDARD

### TYPE JCF/200 LOW TEMPERATURE COEFFICIENT BAR

Frequency . . . 100 Kc/s

Accuracy . . .  $\pm 0.1\%$

Price . . . . £2 - 15 - 0

Vacuum mounted for optimum stability.  
A high precision unit of extreme stability,  
the crystal being nodally mounted on fine  
wires soldered to the bar.

**DELIVERY FROM STOCK**

**SALFORD ELECTRICAL INSTRUMENTS LTD.**

PEEL WORKS, SALFORD 3

Telephones: BLACKfriars 6688 (6 lines).

Telegrams and Cables: "SPARKLESS, MANCHESTER"

Proprietors: **THE GENERAL ELECTRIC Co. Ltd., of England**

USE **Varley**  
TRADE MARK  
PRODUCTS  
for  
**QUALITY and RELIABILITY**

*Mains Transformers*  
*A.F. Transformers*  
*Smoothing Chokes*  
*Thermal Delay  
Switches*  
*Power Resistances*

**OLIVER PELL CONTROL LTD.** TELEPHONE  
CAMBRIDGE ROW, WOOLWICH. S.E.18 WOOLWICH-1422

---



---

## SOUND EQUIPMENT

**MODEL A36.** A.C. Amplifier De Luxe. 7 valve. Using KT66's in AB1, 36 watts. Stabilized voltage, with high gain mic. stage, electronic mixing.

Ready for use. £22 10s. 0d.

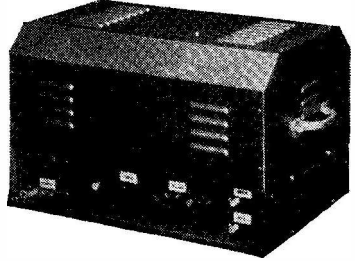

Three other Amplifiers of interest :—

**A18.** Gramo. amplifier, 15w. £11 15s. 0d.

**A23.** P.A. amplifier, 20w. £15 10s. 0d.

**A18.** PEC. Film proj. amplifier. £12 5s. 0d.

**Speakers** for use with above equipments : 10 in. 15 ohm, 37/6. 12-in., £6 10s. 0d.

Call on your local dealer or write for illustrated literature

**RADIO INSTRUMENT CO.**

294 BROADWAY, BEXLEYHEATH, KENT

---



---

## Wot!—No Coils?

is a question we are frequently being asked !

We are doing our best to complete existing orders as soon as possible, but average delivery is six weeks.

A great demand, and shortage of incoming materials, are the chief reasons for delay.

On our other components the situation is rather better, and average delivery is two weeks.

*Catalogue 6d.*

**DENCO (CLACTON) LTD., OLD ROAD, CLACTON, ESSEX**

# WODEN *... the Hall-mark of a Good Transformer*

## MULTIMATCH MODULATION TRANSFORMERS

Woden engineers have developed a special range of Multimatch modulation transformers for Amateur Transmitting use, details of which are given below. The transformers are vacuum impregnated and fitted in compound-filled steel pots giving reliable and silent working.

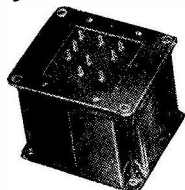

Primary impedances, 2,000/18,000 ohms. Secondary impedances, 200/20,000 ohms.  
 TYPE U.M.1. Suitable for 30 watts Audio. Max. Sec. current, 120 m/a 35/-  
 TYPE U.M.2. Suitable for 60 watts Audio. Max. Sec. current, 200 m/a 46/9  
 TYPE U.M.3. Suitable for 125 watts Audio. Max. Sec. current, 250 m/a 67/-  
 Larger sizes to order.

## DE LUXE TYPE TRANSFORMERS AND CHOKES

This entirely new range of transformers and chokes housed in streamlined die-cast cases enable equipment to be constructed setting a standard not hitherto attained. Full details are given in our lists and a representative range is given below.

### MAINS TRANSFORMERS

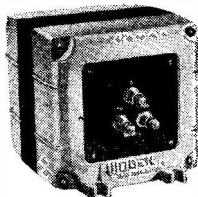

D.T.M.11. 250-0-250 60 m/a 29/9	D.T.M.16. 650-0-650 200 m/a 62/2
D.T.M.12. 275-0-275 120 m/a 42/11	D.T.M.17. 750-0-750 250 m/a 90/3
D.T.M.13. 350-0-350 120 m/a 46/3	D.T.M.18. 1250-1000-0-1000-1250 300 m/a 137/6
D.T.M.14. 425-0-425 150 m/a 53/8	D.T.M.19. 1500-0-1500 350 m/a 155/2
D.T.M.15. 500-0-500 150 m/a 53/8	D.T.M.20. 2000-0-2000 350 m/a 176/-

### FILAMENT TRANSFORMERS



D.T.F.11. 2.5 v. 5 amp. C.T. 24/9	D.T.F.17. 7.5 v. 5 amp. C.T. 28/2
D.T.F.12. 2.5 v. 10 amp. C.T. 31/11	D.T.F.18. 5 v. 3 amp. C.T. 29/2
D.T.F.13. 4 v. 10 amp. C.T. 33/7	6.3 v. 4 amp. C.T. 29/2
D.T.F.14. 5 v. 4 amp. C.T. 24/9	D.T.F.19. 4 v. 2.5 amp. C.T. 29/2
D.T.F.15. 6.3 v. 4 amp. C.T. 24/9	4 v. 6 amp. C.T. 29/2
D.T.F.16. 4 v. 6 amp. C.T. 24/9	D.T.F.20. 10 v. 10 amp. C.T. 47/4

### SMOOTHING CHOKES

D.C.S. 11. 12 Hy 60 m/a. D.C. Resist. 550 ohms 16/4
D.C.S. 12. 12 Hy 150 m/a. D.C. Resist. 190 ohms 22/11
D.C.S. 13. 12 Hy 250 m/a. D.C. Resist. 180 ohms 47/4
D.C.S. 14. 12 Hy 350 m/a. D.C. Resist. 60 ohms 86/11
D.C.S. 15. 12 Hy 500 m/a. D.C. Resist. 80 ohms 94/8
D.C.S. 16. 12 or 60 Hy 100 or 50 m/a. D.C. Resist. 250 ohms or 1,100 ohms 22/11

Obtainable from Messrs. Webbs Radio, Soho Street, London, W.1, or direct from  
**WODEN TRANSFORMER CO., LTD · BILSTON · STAFFS**  
 Phone: Bilston 41959

# hallicrafters

**FAMOUS COMMUNICATION RECEIVERS  
AND TRANSMITTERS ARE NOW BEING  
MANUFACTURED IN ENGLAND —**

**by McElroy Adams Group**

Here is Model 40, which replaces the well-known S-20-R, and which is scheduled first on production line.

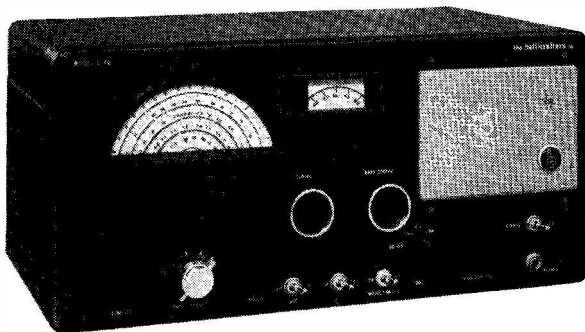

There is a range of some 15 new 1946 instruments, including Panoramic receivers, VHF transmitters and receivers, VHF Converters, Amateur-band Exciters and Speech Amplifiers.

Deliveries will not commence for some months, but you must take **BRITISH MADE HALLICRAFTERS** into your new amateur scheme.

**McELROY ADAMS GROUP**  
**IMPERIAL BUILDINGS, KINGSWAY**  
**LONDON, W.C.2**

Cables : REGADAM, LONDON.

Telephone : HOLborn 3908

---

---

---

---

---

# SHORT WAVE MAGAZINE

FOR THE RADIO AMATEUR AND AMATEUR RADIO

Vol. IV.

JULY 1946

No. 5

---

---

## C O N T E N T S

	<i>Page</i>
Editorial .....	269
Five Metres, <i>by A. J. Devon</i> .....	270
Franklin for VFO, <i>by J. Hum (G5UM)</i> .....	273
Amateur Operating, Part II, <i>by "The Old Timer"</i> .....	279
A Break-In Key and Relay Control, <i>by N. P. Spooner (G2NS)</i> .....	282
Modulating the Carrier, <i>by L. H. Thomas, M.B.E. (G6QB)</i> .....	286
DX Commentary—On the Amateur Bands, <i>by H. A. M. Whyte (G6WY)</i> .....	291
Calls Heard .....	296
Rotary Beam Mounting, <i>by Constance Hall (G8LY)</i> .....	297
British Amateur Valve Types ( <i>Transmitting, Modulating and Rectifying</i> ).....	298
An Automatic Keyer, <i>by Hilton O'Heffernan (G5BY)</i> .....	300
Modulation on the Auxiliary Grid, <i>by J. Ingram Myers, B.Sc. (G4HM)</i> .....	302
Here and There.....	308
G9BF Calling .....	309
How Things Happen.....	310
Getting Going on 7 and 14 mc .....	312
New QRAs .....	313
Month with the Clubs, <i>from Reports</i> .....	314

---

---

Editor : AUSTIN FORSYTH, O.B.E.

Advertising Manager : P. H. FALKNER

*Published on the first Wednesday in each month at 49 Victoria Street, London, S.W.1  
Telephone : Abbey 2279. Annual subscription : Inland 20s. Abroad 22s. post paid.*

### AUTHORS' MSS.

*Articles submitted for Editorial consideration must be typed double-spaced with wide margins, on one side only of quarto sheets, with diagrams shown separately. Photographs should be clearly identified on the back. Payment is made for all material used, and a figure quoted in the letter of acceptance. A large stamped addressed envelope should be enclosed for the return of MSS. not found suitable for publication.*

---

---

# **E.M.I.**

## **AND THE RADIO AMATEUR**



**R**ecognising the achievements of the radio amateur in peace and war, it is the intention of E.M.I. to make available from time to time items of specialised equipment of particular value to the radio amateur at home and overseas. Detailed information will appear in due course in the Short Wave Magazine and other amateur periodicals.

**ELECTRIC & MUSICAL INDUSTRIES LTD.**

**HAYES, MIDDLESEX**

## EDITORIAL

## Surplus

Having last month discussed the production costs of new equipment, we might profitably consider this time the disposal of surplus radio apparatus—a matter in which there is naturally much interest.

All three Services used radio on a scale and to an extent far surpassing anything that could have been expected before the war. After 1939, our home radio industry commenced an expansion to much beyond its pre-war size, and probably reached its peak of production about September, 1944, a few months before the end of the war in Europe. The net result is that, stacked up in various parts of the country, are tremendous quantities of every kind of radio equipment. Our lowest estimate suggests that there cannot be less than five million valves in types covering all possible requirements in the field of Amateur Radio alone!

Consider, then, the problems facing the authorities: Are they to release all this equipment, involving the radio trade in the worst kind of deflation, crippling and stifling it for years, and incidentally, retarding progress and development? Or are they to try and discriminate between who is to have it and who not? Is this practicable, and if so, could racketeering be prevented? Or must they embark upon the expensive and complicated business of breaking down, classifying, pricing and retailing such enormous stocks? In this case, would the potential market justify the cost and effort involved? Alternatively, should they simply try and job off piles of rotting junk impartially to all comers? Would this be fair to those who cannot make a personal choice?

Taking the long view, and considering every aspect of what is in truth a very difficult problem, we feel the answer to these questions must be an emphatic No. The right place for all this surplus is the bottom of the North Sea—and that as soon as possible.

*Arthur Griffiths*

## Five Metres

### *Band Opens for Europe Six Days in June —The G5BY/G6LK Link—American Notes*

**A**S suggested in these notes last month—"the prediction is that sporadic-E effects will get more and more frequent"—the band opened for Europe on June 3, 4, 5, 7, 8 and 16. G2XC (Portsmouth), G5BD and G5LL (Mablethorpe), G5BY (Thurlestone), G5MP (Hythe) and G6CW (Nottingham) were there to take advantage of it.

G5BD and G6CW worked F3JB on June 3, G2XC and G5LL worked him on June 4 (when G5LL also got I1FA) and on June 16 G5BY worked I1DA and I1FA. On this latter date, G6CW heard I1BR, F3JB and an unidentified F. On June 4 G5MP received the Italian end of the I1FA-G2XC contact.

Every report comments upon the great strength of the DX—"louder than the locals," in most cases. All contacts were on 'phone, for the sufficient reason that the foreigners can only work MCW or telephony. On June 3 and 4, the active periods were roughly 1700-1900 BST, and on June 16, 1300-1445, with the final fade-out at about 1700. On the other occasions (the afternoons and early evenings of June 5, 7 and 8) when the band was wide open, apparently the only station on was G5BY, who called in vain, but heard nothing except harmonics.

The Italians are using self-excited transmitters and (presumably) super-regenerative receivers, though F3JB has a 6V6 ECO into an 807 driving a pair of RL12P35's to 100 watts input; his receiver is 955-6J5-6V6 super-regen., and, by the way, his full QRA is Victor Biancheri, 4 Quai du Port, Bandol, Var.

These particular European stations are, it seems, regularly active on 58 mc, working one another on 'phone when the band is not open for DX. The following Swiss stations are also known

to be on: HB1DC, 9CO, 9DW, 9DZ, 9EC, 9ER, 9G, 9MH and 9S. They are working each other successfully, but at the time of writing (June 20) the only DX achieved has been the reception of G5BY by HB9G (reported here last month).

#### Inter-G DX

In this month's "Calls Heard" appear the recent logs of G6CW and G6LK. From G5BY's carefully set out and fully documented masterpiece—we say "masterpiece" because it includes not only the usual RST, time and date information, but also full details of barometer, wind direction and speed, sun condition, maximum and minimum temperatures, weather at time of contact, and period of QSO to the nearest minute—the following is extracted for the present record: Between May 20 and June 16, he had 29 DX contacts, no less than 17 of them being with G6LK (Cranleigh, 156 miles); up to June 15, they had succeeded in working on eleven consecutive nights. This is a splendid effort, and once again bears out one of our earlier predictions.

New stations worked by G5BY are G5WP (Woking) and G8BD (Portsmouth), while further contacts have been obtained with G5MA (Ashted, Surrey), G5MQ (Liverpool) and G8RS (Reading); G2MV (Coulsdon) was heard RST-339 at 2312 on June 8.

#### General Notes

G6LK, who is using 6L6-807-T40-HK24's into a 3-element beam 35 ft. high, has a 4-element job under construction. His receiver is a converter into an HRO, and by dint of regular operation, he has become one of the more reliable signals at DX. He finds



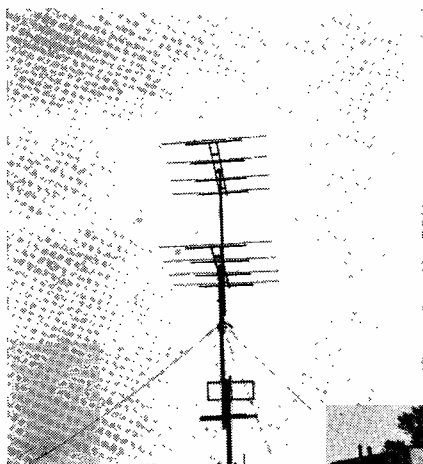

An 8-element rotary beam for 58 mc. The aerial system used by G5BY (South Devon) for recent DX contacts, including the Europeans and G5MQ (Liverpool, 215 miles).

G2BMZ (Torquay) and G5BY the most consistent DX stations to him, but has had S8-9 contacts with G5MQ (188 miles).

G6CW, reporting generally on the month's doings, remarks upon the effect the DX conditions of June 16 had upon medium-distance signals. He started with G5TX (180 miles) early in the evening, with the latter's 'phone at S5. By 2320 it had built up to S8. G6CW has now changed his feeder line from 600 ohms (see drawing on p. 206, June) to 100 ohms, with greatly improved results on both transmission and reception; the reason is that the low-impedance feeder is far less susceptible to wet weather. This is a point worth bearing in mind. In the Nottingham district, there are now five local stations active on 58 mc.

G5BD and G5LL plough a lonely furrow up at Mablethorpe, in Lincolnshire. G5BD is using his all-band transmitter, which has been "persuaded" on to 58 mc; the T55 in the final has a 1-turn grid coil! His receiver is a home-built superhet, with 956, 954 RF's, EF39 mixer, 955 oscillator and two 6K7 IF's on 465 kc. The aerial is a species of long wire,

only 16 ft. high, pending the erection of masts. G5LL is on parallel lines to G5BD and, generally speaking, they share whatever happens to be going, like G5MQ and G6YQ.

G6VX, who has been away most of the month, was putting out a tremendous signal off the 4-element rotary, of which a photograph appears here, with dimensions. It is 50 ft. high. As at June 2, he had had 5-metre contacts with 57 stations.

### Predictions

Wearing a very small halo, may it be said that so far every prediction made in this column since we reopened in March has materialised, and to time.

The results of the work of the last few months make it clear how the band is shaping up. Well-equipped stations, able to work regularly, will obtain consistent results over distances up to 200 miles. With activity a little further afield—or if north of the Border there was anyone working on the band—this distance might extend to 300 miles or more. *Anyone* on the band, anywhere, and with any sort of equipment (almost) will be able to work DX when conditions are right, that is to say, when sporadic-E effects are producing these "louder than local" European signals.

The behaviour of 28 mc is a reliable indication of the condition of 58 mc (there is nothing new about this) and if the co-operation materialises—which is another way of saying "if W's and VE's listen in our band under sporadic-E conditions"—contacts across the water should be fairly easy, with signals as good as they are when 28 mc is hot for North America.

VK and ZL are not quite outside the bounds of possibility, but due to (a) the low level of activity out there, (b) the watchfulness called for, (c) the time factor, and (d) the highly unstable nature of the path even when signals are coming down, they are not really very likely, except by sheer luck. The other approach to this particular problem would be for a G and a VK to keep schedule every day for a year.

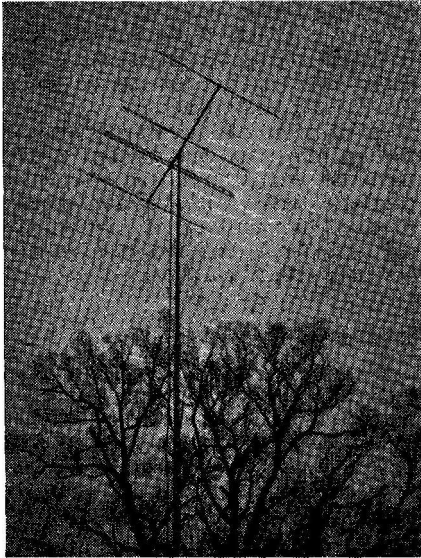

The four-element 58 mc rotary beam at G6VX (Hayes, Kent). The reflector is 100 in. long, the radiator 98 in., first director 92 in., and second director 91 in. Spacings are: Reflector-radiator 30 in., radiator-first director 20 in., and radiator-second director 60 in. The feeder is 100 ohms.

### Trans-Atlantic Working

But it does seem reasonable to plan for W/VE contacts. They know where we are, and we know that they can be found in the 50-54 mc band, with FM signals in the 52.5-54 mc area; the Americans are mainly high-powered, and all have directional radiating systems. Among themselves, they are getting excellent results—the post-war two-way record on 50 mc is 1,100 miles, made on April 23 this year by WILSN-W9DWU. On this same evening, which was the big night over there, many good inter-State contacts were obtained. Tests for directivity suggested that there was a general “scatter” effect during this period, with signals “raining down from overhead,” to quote W1HDQ in this month’s *QST*.

Well, we are now right into the expected 58 mc DX period. Hot up the gear, keep active, watch 28 mc, listen around the American (50-54 mc) band when things seem lively, and let

us have your story by the 22nd of the month, even if nothing has happened by then.

We will happily present a year’s free subscription and some nice bits of equipment to choice (within reason) to the G who makes the first confirmed 58-50 mc contact with W or VE, any time from now on. This is not so much an inducement as a small reward; the reward itself will be the achieving of the contact.

### Test Periods

In view of the changing conditions on 58 mc and the approach of the “little DX season” we feel that scheduled Test Periods are of no practical value for the time being. They have, in any case, served their immediate purpose by helping to focus and increase activity on the band.

Write A. J. Devon, c/o *The Short Wave Magazine*, 49 Victoria Street, London, S.W.1, with your notes for next month’s issue—if you have something really exciting, like trans-Atlantic DX, wire Abbey 2279. Reports by July 22, please.

### LATE FLASH

G5BY worked SA8B, North Africa, 2125 BST June 24, RST579 both ways. A first contact.

*Errata—Page 272*

LATE FLASH—read FA8B

### RESERVE ORGANISATIONS

The Americans appear to be a jump ahead in this respect. It seems that the U.S. Navy has great plans for the enrolment, training and equipping of radio amateurs in the United States, who will be taken care of by a headquarters formation created specially for the purpose. Since a good deal of money is said to be involved, a vote for supply will have to be extracted from Congress before anything practical can be done.

We also hear that the Royal Canadian Air Force Amateur Radio System is now forming, and is to operate on 3.5 mc.

## Franklin for VFO

### *Discussing the Merits of the Franklin Drive Oscillator, and its Application as a VFO*

By J. H. HUM (G5UM)

*(We make no apology for presenting yet another of these VFO designs. We consider that in the interests of all concerned, every experienced amateur transmitter regularly on the air should give serious thought to the possibility of adapting his station for break-in, single-channel working, in order to economise on precious frequencies in the DX communication bands. On the other hand, we also feel that absolute beginners should remain crystal-controlled until they have acquired some actual experience of amateur operating. QRM will be no worse for them, and if all G stations accept our suggestions, should be much less, since the VFO's would naturally tend to avoid settling on CC stations signing new calls.—Ed.)*

AT the moment of writing this article about 3,000 British amateurs will be re-licensed and back on the air. In a year perhaps there will be as many as 10,000 of them. These figures tell more about the nature of the interference problem of the future than can any amount of lurid forecasting.

What are the answers?

Obviously, the use of lower power inputs and much less telephony. In a democratic country where amateurs can do pretty well as they please, such developments are unlikely unless a great deal more self discipline is imposed than exists at present.

Two further remedies—technical ones this time—are possible. One is the universal employment of single-signal superhets, which so effectively cut one side of a signal that the amount of space in the band is in effect doubled. Prolonged listening on such a receiver is always a discomfort, and it is unsatisfactory for telephony reception. Anyway, such receivers are not easily obtainable.

The other alternative is a very much more practical one, and has already been discussed by G6QB in the May and June issues of this *Magazine*. It

envisages the use of variable frequency oscillators by a majority of amateurs, and the eventual development of Amateur Radio to the stage where two stations in contact use the same frequency; and secondly, of the much wider use of multi-way contacts, again all on the same frequency.

The advantages of such a development are apparent from a little arithmetic: If 50 stations on 7 mc work 50 other stations, all on different frequencies, 100 stations are thus causing interference during any given period. Now if these 50 stations park on the frequencies of the other 50 whom they are working, the amount of interference will be halved and the potential occupancy of the band doubled.

To achieve this desirable state of affairs variable frequency oscillators of exceptional stability must become universal. Numerous types of ECO are described in the various amateur handbooks, but, strangely enough, the smallest amount of space is generally devoted to one of the best master oscillators, namely, the Franklin. Properly built, the Franklin Oscillator can be as stable as a crystal oscillator and can possess comparable frequency drift. And properly adjusted it can give a T9 note every time.

**Basic Franklin Oscillator**

Fig. 1 shows the basic circuit diagram of the Franklin oscillator. Its operation is simple: V2 is coupled back to the grid of V1 and the whole circuit rings round. The frequency at which it does so will be determined by the size of the coil and condenser in the grid circuit of the first valve.

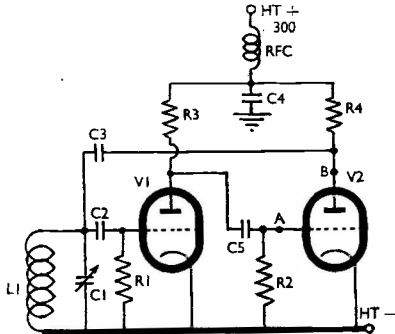

Fig. 1. The basic Franklin high-stability oscillator circuit.

That is all there is to it. The only point to watch is to keep condensers C2 and C3 small enough to make the circuit just oscillate and no more.

The inherent stability of the Franklin oscillator arises from these facts: Circuit variations appear in series with the two small condensers C2 and C3 and are, therefore, unnoticeable in the tuned circuit. Secondly, if the capacity of C1 is made large enough, any such variations appearing in series with C2 and C3 represent such a small proportion of the capacity of C1 as to cause no change in it. Put more simply, the tuned circuit C1/L1 is isolated from the outside world by C2 and C3 and is effectively protected from its buffetings.

**Output Coupling**

Having derived our basic oscillator of two valves we must next decide how to couple it to succeeding stages in order to obtain some drive for a transmitter. Numerous methods of doing this have been outlined from time to time. Commonly, a buffer stage is added, as in Fig. 2, and the output taken from its anode. In the writer's experience a buffer valve is superfluous and output can quite safely be taken direct from the oscillator itself, as is indeed done in a well-known type of commercial transmitter. In this transmitter the output is simply taken from the anode of V2 and fed through a low capacity direct to the grid of a frequency doubler.

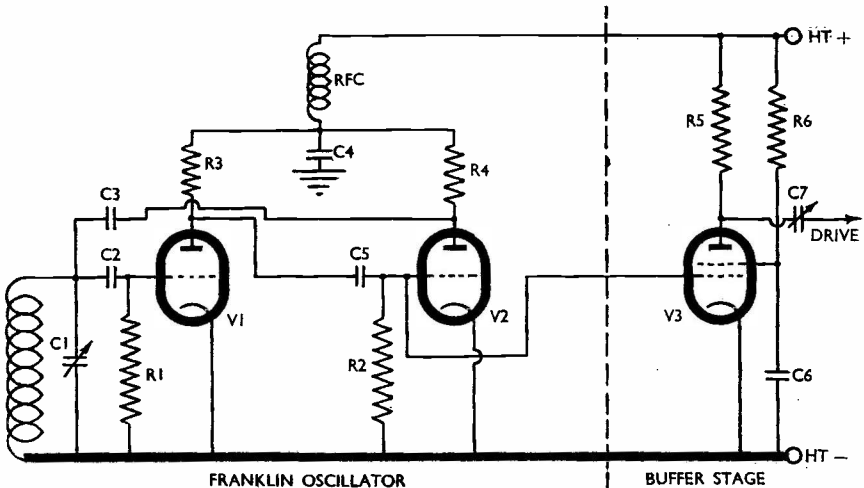
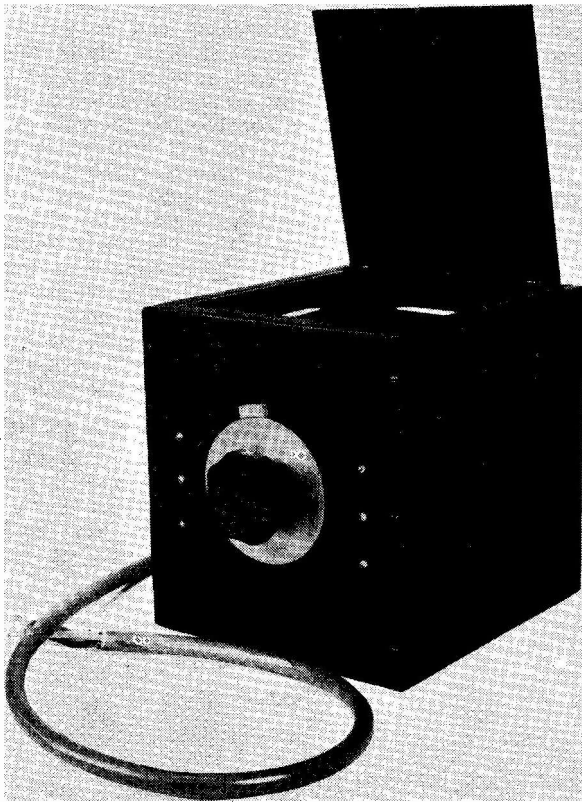

Fig. 2. A derivative of the basic Franklin circuit, with a buffer stage V3.



*The Muirhead dial can be read to a tenth of a degree, and the oscillator can be calibrated against crystals of known frequency. Output is taken from a plug at the side of the cabinet and the on-off switch and keying jack are at the rear. A 4-way cable feeds in the power.*

Some users of the Franklin oscillator declare that if the output is taken from V2 anode it will be directly coupled *via* the feed-back condenser to the tuned circuit in the grid of V1; hence, they argue that output is taken preferably from the *grid* of V2 at the point marked A in Fig. 1, thus placing a valve between the output lead and the tuned circuit.

A moment's consideration will show the fallacy of this reasoning, for the grid of V2 is coupled to the tuned circuit in the grid of V1 *via* the capacity of C5 and the self-capacity of V1.

Experiments have been conducted to determine the relative effectiveness of taking the output either from point A or B in Fig. 1, and it can be stated categorically that there is nothing to choose between them. Measurements showed that exactly the same amount of drive was obtainable from either, and the character of the note remained unchanged whichever was used.

#### Value of Coupling Condenser

We have now decided that our basic oscillator shall be as in Fig. 1, with

the output taken from V2 anode. In a practical design this output was taken to the last point on a 7-position switch. To the other 6 points on this switch crystals of different frequencies were connected so that crystal control or VFO control could be had simply by moving the switch to the proper position. It will be obvious from these remarks that the Franklin oscillator is intended to feed direct into the grid of the CO stage.

In the commercial design referred to earlier, the Franklin's output is taken through two  $25 \mu\text{F}$  condensers in series. The oscillator functions on approximately 400 metres, and, as has already been said, feeds into the frequency doubler stage. Two  $25 \mu\text{F}$  condensers in series might seem to be rather a small capacity at this comparatively low frequency; the reason for the use of such a low capacity is that the commercial oscillator in question is run fairly hard and therefore the minimum amount of coupling to the FD is provided.

In an amateur design, where a Franklin oscillator is run at say 200 to 300 volts, the value of the coupling condenser can safely be increased. Practical tests show that with the oscillator working on 1.8 mc, its value can go up to as much as  $100 \mu\text{F}$ , with a considerable increase in drive to the CO or FD into which it feeds, and with no deterioration of note.

This brings us now to deciding for which frequency we should build our oscillator, bearing in mind (a) that the Franklin oscillator is reputed to be useless on high frequencies, and (b) that if we can make it oscillate on higher frequencies, we shall probably need to reduce that coupling condenser to considerably less than  $100 \mu\text{F}$ .

### Franklin Oscillator on HF

To attempt to make a Franklin oscillator function on higher frequencies it was decided to use a well-known VHF valve, namely the RK34 twin-triode, connected up as shown in Fig. 3.

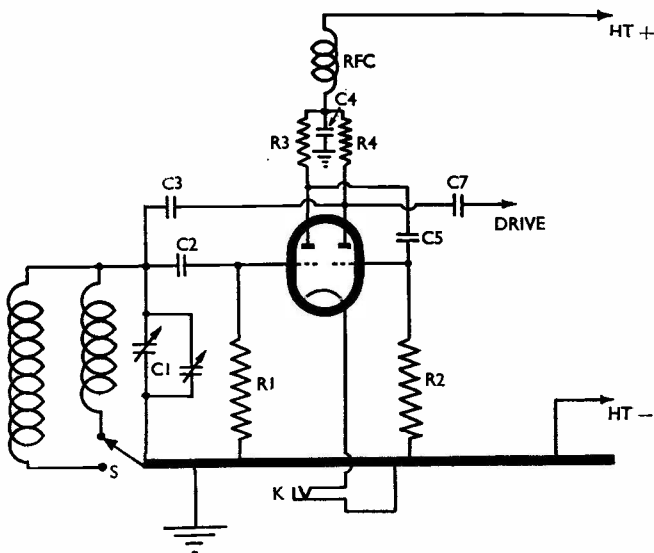

Fig. 3. The circuit as developed by GSUM. The valve is an RK-34 (the DET19 and 4074A are exactly similar) and the oscillator will give good output with a high degree of stability on 1.8, 3.5 and 7 mc. Switch S selects the frequency ranges, the two lower being covered on the same coil. K is the keying point, in the cathode of the twin-triode. The circuit is discussed in the text and all values given in the table.

Using 400 volts on this valve and with a 25-turn coil on a 1½ in. former and 250  $\mu\mu\text{F}$  across it, as much output was obtained on 7 mc as was given with a standard 7 mc crystal. And an 807 valve on 28 mc could be driven to full output (*via* the usual frequency doublers) just as effectively as it could be driven by the more usual crystal. The value of coupling condenser between the Franklin and the 7 mc stage was only 10  $\mu\mu\text{F}$ .

These results encouraged an attempt to persuade the oscillator to function at even higher frequencies. With a 6-turn coil and the same condenser, steady oscillation was obtained up to 20 mc, after which the RK34 began to squegg, probably due to insufficient standing capacity across the first grid. Output at these high frequencies dropped considerably as compared with that obtained on 7 mc, and the conclusion reached was that the Franklin oscillator should be reserved as a frequency meter rather than a source of drive at frequencies higher than 7 mc.

The frequency of 7 mc was obtained with the 250  $\mu\mu\text{F}$  condenser about two-thirds out. At that frequency the standing combined plate currents totalled 16 mA at 400 volts. Little, if any, change in standing current is discernible when the output is connected into the following stage, i.e., when the load is on.

### Valves to Use

One of the charms of the Franklin oscillator is that almost any type of triode can be employed for it. In a commercial design two ML6 valves were used, but as these are not at all easy to obtain, their four-volt equivalent—the ML4—may be mentioned as a perfectly reasonable alternative. Equally the well-known 6J5 functions excellently in this circuit.

In general the Franklin appears to like a fairly docile type of valve. Attempts made to persuade high-slope television pentodes of the EF50 or SP41 types to work as triodes in the Franklin oscillator were not successful, probably due to the fact that the

smallest amount of feed-back capacity set them into uncontrollable oscillation of the squegging type.

### A Practical Design

Sufficient has been said by now to give potential users of the Franklin oscillator practically all the information they need to build up such a variable frequency oscillator for themselves.

Circuit? As in Fig. 1. Valves? Either ML4 or 6J5. Output? Off the anode of V2—but wait a moment; do you want to run the oscillator on 1·8 or 7 mc? Upon that decision will rest the choice of value of coupling condenser.

All right, let us design our oscillator to function on both frequencies. If we use a coil of 40 turns on a 1½ in. former, we shall obtain the 160-metre band with a 250  $\mu\mu\text{F}$  condenser full in, and the 80-metre band with the condenser two-thirds out. And if we put in a coil of 25 turns, we shall find 7 mc with the condenser two-thirds out. Stability improves if we allow as much capacity as possible at C1, so let us use 20 turns for 7 mc so that the vanes of our condenser will be slightly more fully meshed.

Now, if we take our 20-turn and 40-turn coils to a switch, we can select the particular band we require.

The observant will have noticed by now that a capacity of 250  $\mu\mu\text{F}$  is much too large to be put on a condenser scale if really accurate frequency measurement is required. We were coming to that. *The 250  $\mu\mu\text{F}$  condenser is merely a band setter.* In parallel with it should be connected a 6-24  $\mu\mu\text{F}$  air-spaced trimmer, rotated by means of a Muirhead or other type of dial which permits extremely accurate reading.

Calibration is then carried out by band setting the oscillator against crystals of known frequency and arranging that the LF end of the band appears on one end of the scale when the trimmer is fully meshed and the HF end of it at the other when the trimmer is full out. No attempt must be made to use a Franklin oscillator until calibration has been completed.

Moreover, by the terms of the transmitting licence, a crystal controlled frequency standard must be available if a non-crystal type oscillator is used to drive the transmitter.

We still do not seem to have decided on the value of that coupling condenser to connect our Franklin to our switchable crystal oscillator—or to our frequency doubler, whichever we prefer. It has already been said that its value should be about  $10\ \mu\mu\text{F}$  for 7 mc, but as much as  $100\ \mu\mu\text{F}$  for 1.8 mc. In this position, therefore, we connect one of the excellent Eddystone "Microdensers," the minimum capacity of which is about  $5\ \mu\mu\text{F}$ ; the maximum capacity can be selected to taste. A  $100\ \mu\mu\text{F}$  Microdenser is a good size to choose. When adjusting a Franklin it is rotated to secure the required drive—and of course for a T9 note. All adjustments should be checked by listening on a monitor.

Keying? There could be only one place and that is in the cathode of VI. In some designs the key is shown in the screen of a buffer stage, which is not such good practice as keying VI cathode, which cuts off oscillation completely and permits break-in working.

### Design Points

Another question that may occur to readers at this point is: Why this insistence on condenser coupling? Cannot link couplings be employed? The answer is that link coupling can quite easily be taken from a buffer or succeeding stage, but it possesses the considerable disadvantage that a "passenger valve" must be put in order to provide it, and secondly, it gives no extra drive anyway! Certainly, the output condenser so far specified is "hot," but in practice a screened lead taken from it to an adjoining transmitter could be as much as 4 ft. long with no drop in output nor undesirable local pick up. If the Franklin can be built into an existing transmitter to keep the output lead short, all the better.

A final reminder to those embarking on this practical design: Wire up everything as rigidly as possible, use sub-assemblies in preference to hanging components in the wiring, and wind the two coils so that their turns will never move again, i.e. well shellaced. Connect an on/off switch in the HT lead so that the VFO can be switched off when not required.

### Table of Values

*(All circuit designations are common to each diagram)*

C1 = $250\ \mu\mu\text{F}$ variable, with parallel 6-24 $\mu\mu\text{F}$ bandsread trimmer.	R1, R2 = 80,000 ohm grid resistors.
C2, C3 = 3 or 5 $\mu\mu\text{F}$ ceramic-cup feed-back condensers.	R3, R4 = 25,000 ohm anode decoupling resistors (oscillator valves).
C4 = .01 $\mu\text{F}$ mica HT by-pass condenser.	R5 = 25,000 ohm anode decoupling resistor (buffer valve).
C5 = $100\ \mu\mu\text{F}$ coupling condenser.	R6 = 47,000 ohm screen decoupling resistor (buffer valve).
C6 = .01 $\mu\text{F}$ screen decoupling condenser.	V1, V2 = ML4 or 6J5 oscillator valves.
C7 = $100\ \mu\mu\text{F}$ coupling condenser (see text). Can be $10\ \mu\mu\text{F}$ for 7 mc only.	V3 = AC/SG, MS4 or 6J7 buffer.
	Valve in Fig. 3 = 6N7 or RK34.



# Amateur Operating

## *The DX Sense—Procedure—How to Call and When to Listen*

By THE OLD TIMER

*(We commend this article, the first part of which appeared last month, to all those who wish to hear themselves spoken of as good operators.—Ed.)*

**I**N last month's article we dealt with three of the main headings set down as the basis of good operating. We now come to the fourth: Ability to "winkle out" weak signals from other stations and interference. This, if it can be termed an art, is a difficult art to acquire, but probably the one that contributes most of all to the success of the enthusiastic chaser after DX.

You may have a nice station; you may have worked Australia and New Zealand and South Africa and South America; you may with just pride say that your transmitter puts its signals all over the world. And yet you are mystified when you hear G6\*\* announce that he has worked Portuguese Guinea, Tristan da Cunha, South Georgia, Pitcairn Island and Seychelles—none of which you have even heard! There's only one answer—you haven't been listening.

Of course, it's not everyone who wants to join in the furious race for "new countries"; it doesn't really get you anywhere, although, if you are the type, it is undoubtedly good fun. If you are *not* the type, then you probably pass over numerous weak signals without really hearing them. The super-DX-fiend simply lives on that sort of thing, and rarely even listens to the stronger station that you would call. And this same super-DX-fiend is most probably not a man with a particularly efficient transmitter and receiver—he has simply acquired, by long practice, the ability to single out these interesting weak signals and to

hold on to them, bulldog-fashion, through thick and thin, vacuum-cleaner and motor-car, CW and spark!

There is no correspondence course which will teach you how to do this. The only answer is practice, and lots of it. You must simply freeze on to that S2 signal and not be distracted even by a full symphony orchestra playing your favourite music. Anyone speaking to you will not be heard; you will be late for meals or even for work. You will be practising a very intense form of concentration. And without this you will never appear high up in the list of countries worked.

Well, there it is—either you are that type or you are not. If you are not, but would like to be, you have a lot of hard work in front of you.

### Telephony Procedure

One would think that the average amateur would experience no difficulty with 'phone operation, even if his CW technique were a bit weak. Many amateurs, however, do very strange things when on 'phone, and must lose many good contacts through their sloppy method of operating. There is no need to be a potential BBC announcer, but a clear speaking voice is essential; and equally essential is a good modulation system. Since our theme is "operating" we will assume that the gear passes muster—don't spoil the characteristics of your modulator by speaking too far from, or too close to, the microphone. Study the characteristics of your modulation

equipment on a monitor and speak at the right distance. Those who fondle the microphone with their moustaches, even if they do not suffer from over-modulation, often create a nasty "splash" on sibilants, particularly when using crystal microphones.

When you call a station who has just finished a CQ, do so as if you mean it—not too slowly and not too fast. Probably the best formula is "Calling G7XX, G7XX, G7XX . . . Calling G7XX, G7XX, G7XX . . . this is G7YY, G7YY calling you." The other method, "Hullo G7XX, hullo G7XX, hullo G7XX . . . etc." wastes about 50 per cent of the time on useless "Hullo's" which do not tell anyone a thing and are a dead loss. Do not repeat the other man's call too often without giving your own; he may hear you but pass on to someone else in exasperation. Use the correct phonetic alphabet, and cut out those terrible place names; the Americans have been told to do it, officially, and we should not lag behind in these matters. Place names, of all the possible words to use, are the most confusing.

Use plain language in your 'phone contacts and don't look on them as a transcribed form of Morse. If static is the trouble, say "Static"—not "QRN" or, worst of all, the frightful, childish, nauseous "QR Norway"! If you have to use a phonetic alphabet to get abbreviations over, then they are no longer abbreviations, and it is shorter to use the word for which they stand. Which is easier at both ends—"Jamming," or "QR Madagascar"? Perhaps someone will carry the thing to its limits and announce "Your sigs are QS Antimacassar 5, Rhododendron 7, but with QR Madagascar and QR Norway and a little QS Baltimore." It's so obvious that it's not worth saying any more. Either you do or you don't!

Don't use needless Americanisms of the Hollywood variety (unless you really think they are clever). When you finish what you have to say, it is perfectly effective to say "G7YY over to G7XX," or "G7XX, this is G7YY standing by," or, in the snappiest

form, "G7XX, G7YY by." And when you are thinking of finishing off, there is not much point in using the grand phrase "Over, off and clear" unless you realise what it means (which, so far as we can see, is exactly nothing). If you are going "over," you are not "off"; and what the "clear" means, if you have already intimated that you are switching off, we wouldn't know. Only two things can happen when you reach for that switch—either you are "over and standing-by (or listening)", or else you are "over and then switching off." If you are still working the other fellow, you are over and standing-by for him. If you have finished with him you are over and listening on the band, or else you are just switching off and going to lunch (or the local, or the police station, or somewhere). So we suggest three possible terminations: (1) "Over to you"; (2) "Over, and tuning the band"; (3) "Closing down." So far as we can argue with ourselves, "Over, off and clear" might mean any of these or all three at once!

One final commentary on telephony operation—speak distinctly and fairly slowly and don't repeat everything you say unless the other fellow asks for it, or makes it obvious by his report that it is necessary.

#### THE AMATEUR BANDS

Following are the bands now open for amateur operation:

1800-2000 kc	10 watts (A) and (B)
7150-7300 kc	25 watts (A), 150 watts (B)
14100-14300 kc	25 watts (A), 150 watts (B)
28000-30000 kc	25 watts (A), 100 watts (B)
58500-60000 kc	25 watts (A) and (B)

Note that the two sections of the 7 and 14 mc bands allotted are not in harmonic relation. It is proposed that telephony operation on these bands be confined to the areas 7200-7300 and 14200-14300 kc. "A" licenses are all three-letter calls issued post-war, and are for CW operation only; licensees in this category are not normally allowed the use of telephony and full power till they have had twelve months' experience. Class "B" licensees are holders of reissued pre-war two-letter call signs, and are allowed the unrestricted use of CW, MCW and Phone with power as given above.

## Understanding Your Gear

This heading is perhaps unimportant; but it is essential that you should know, from theory or experience or both, something of the manner in which your aerial system should operate. For instance, if you have a half-wave dipole orientated North-South you will (or should) know where its main lobes land and will not tear everything apart because you receive consistently weak reports (if any) from South Africa. It goes even further back and affects the choice of an aerial system to begin with; if it *must* run East-West, for instance, and you are desperately keen to work the United States a lot, you will put up a full-wave rather than a half-wave, and so on.

Having arrived at something permanent, you will find out from your results and your log if it is working as might be expected, and this will affect your operating thereafter, because you will know where your best signals normally go.

## Considerate Operating

This is one of the factors that will make it plain to the world whether you really are a good operator or not. Do you tune up a newly-built transmitter (complete with parasitics) on the 28 mc band when the whole world is coming through on a Sunday afternoon? Do you work telephony with your nearest neighbour when the band is full of DX? Do you steal a QSO from someone else by dumping your ECO right on top of him and calling the DX station before the QSO has finished? Do you introduce heavy ripple into your T9x note so as to "cut through"? If the answer to these questions is "Yes," you had better not read on—you are probably so thick-skinned that nothing here will strike you as applying to yourself.

A considerate operator is like an unselfish motorist—he gets there just the same, but without leaving a trail of profanity and irritation behind him. There is a type of person who will never make a good driver, simply because, although normal in other

ways, he becomes short-tempered as soon as he gets at the wheel, and everyone else on the road is in the wrong. That type will likewise never make a good amateur. We hate to bring in the much misused word "gentleman," but it seems to fit here. As we said before, either you are or you aren't.

## That Sixth Sense

This is perhaps the most difficult aspect of good operating about which to write. But it is a fact that a good operator with years of practice behind him acquires something like an instinct which tells him whether he has a chance of raising some interesting station or not; whether the fellow who has just finished a QSO is still listening to the other station's "final" or tuning the band; whether it is better to call "CQ" or to continue listening round for something interesting. It can't be taught, but it can be learnt. Probably the biggest single factor concerned is listening experience.

If you are the type that continually calls "CQ" and just takes what comes back, it is obvious that you never hear anything else. If, on the other hand, you control your itching fingers for a while and simply sit back and listen, you will invariably pick up all sorts of little tit-bits of information; you will hear that rare DX station working someone else and thus be aware of his frequency; you will notice, perhaps, that he is fading out, and therefore, instead of waiting in the queue to call him, you will get on with something else and have a go at him next day.

It is surprising how often one happens to bear one's own call mentioned by other people, too. We have often heard a DX station tell someone else that we were coming in "fb" the previous morning, although perhaps we didn't know that ourselves. You will hear other stations telling of their great deeds and will learn from this what DX is about—at what time and on what frequency. All this huge information bureau is lost to the "CQ-hound." It pays to listen.

*(Conclusion)*

# A Break-in Key and Relay Control

Ingenious Idea and a Useful Discussion

By N. P. SPOONER (G2NS)

Strange as the statement may seem, an old GPO sounder makes an ideal straight key for controlling a complete break-in system, and has the additional advantages of light action, fine spring-tension adjustment and solid keying contacts equivalent to those fitted to the Post Office single-current key. Its weight ensures that it "stays put" without screwing down, and its position in the scheme of things obviates the sudden arrival of any "packets" when bare metal parts are touched.

Upon examining the sounder, which should be of the relaying type originally used in telegraph repeater circuits, it will be found that a plain flat contact is fixed to the upper face of the square spring-tensioned armature lever. This is held against an adjustable screw contact that points downwards from the centre of a large arch immediately overhead. Through the armature lever itself, and pointing downwards below it, is another adjustable screw contact. Immediately below this is a plain flat contact set in the centre of a smaller arch. Normally, the upper pair of contacts are closed while the lower pair are open.

Here then, and all ready to hand, is a very effective and extremely simple means of controlling a full break-in system. If the upper closed contacts operate a receiver muting relay and the lower open pair are connected to a CO back-biasing relay, then we have the receiver (at the end of a separate receiving aerial) alive and the transmitter dead. If the contact positions are reversed, then the receiver becomes dead and the transmitter alive.

## Modifying the Sounder

All that is needed is a simple means of making the reversal and of isolating the lower and the upper contacts electrically. A short length of square brass bar with an ebonite knob will effect the former and two cuts with a hack-saw blade the latter.

To turn the sounder into a break-in Morse key, therefore, its two unwanted coils complete with their cores are first removed. A 4½-in. length of ¼-in. square brass bar is then bent to the shape shown in the sketch and screwed at the end remote from the fulcrum to the underside

of the armature lever. The lower end of this bar takes the conventional Morse key ebonite disc and knob. The contacts can next be electrically isolated by making a hack-saw cut between the two arches in the brass baseplate of the sounder. Another hack-saw cut close to the fulcrum arch will isolate the armature lever.

To complete the job, simple re-wiring is carried out by removing the covering plate from the underside of the heavy ebonite base and exposing the terminal screws, soldering pins and original wiring by cleaning the wax from the grooves. If the sounder has two unmarked terminals in front and three at the rear marked S, T and M respectively (referring originally to "spacer," "tongue," and "marker"), then it will be found convenient after taking out the old wiring to use three only of the five for upper positive contact A, lower positive contact B, and a negative connection to the moving armature lever itself, with its two attached contacts A1 and B1.

## CW or 'Phone

This completes the key, and wiring up to the two relays only consists of running a lead from contact A terminal to positive *via* the receiver muting relay, which may be arranged either to short the receiver input to earth, open the RF cathodes, and cut the entire HT if the heaters are separately fed, or switch the HT at the send-receive panel position. So much for CW.

For telephony, hold the key down while speaking or slip a visiting card between A and A1, using a manual SPDT switch wired across the key terminals with its pole connected to negative. If foot operation is preferred, use the visiting card and SPDT bathroom ceiling-switch with cord and pedal.

And here, too, it might be added that ordinary types of sounder could no doubt be converted if some ingenuity is displayed in isolating the "contacts" electrically and substituting decent solid keying pairs for the usual metal screws.

The modern station deserves something better than the old multiplicity of switches that took so long to throw and often bewildered even the proud operator who had

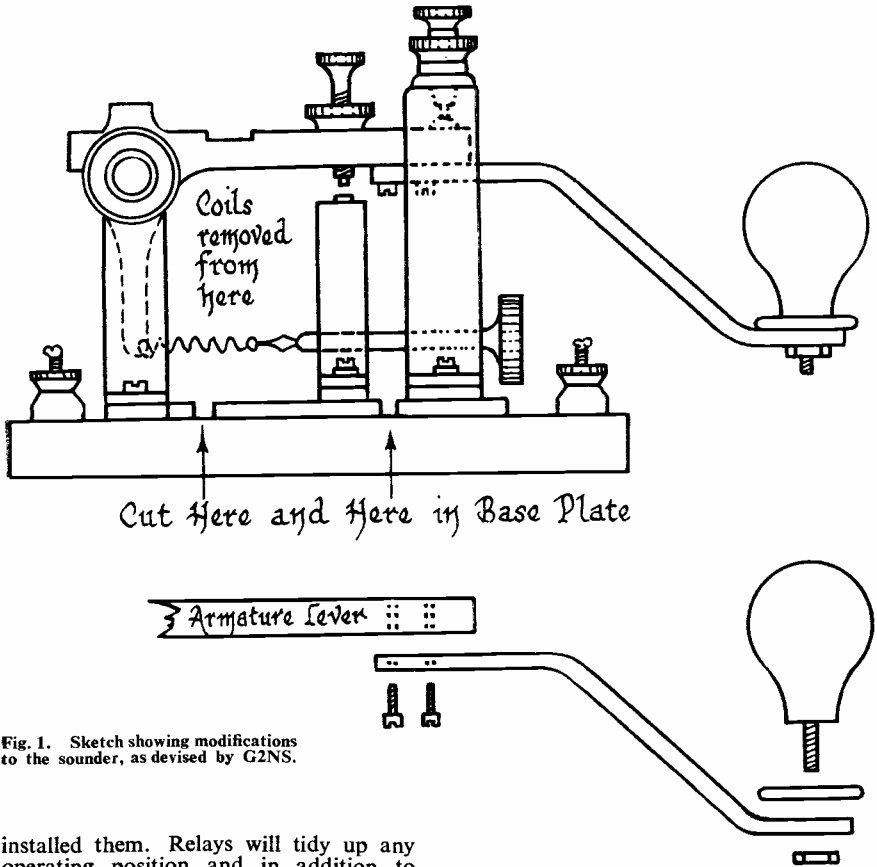

Fig. 1. Sketch showing modifications to the sounder, as devised by G2NS.

installed them. Relays will tidy up any operating position, and in addition to remote control and transmitter keying, one of the most useful jobs they can nowadays perform is complete change-over and semi-break-in working without keying the oscillator stage.

Straight types of multi-contact relays can be controlled manually by a SPDT switch placed near the key and used for CW send-receive, or telephony switch-to-talk-listen. If a relay with a "slug" fitted\* to the end of the coil remote from the armature is employed, the whole operation can be performed entirely automatically and can be controlled by a small pair of light auxiliary contacts added to the key, the main contacts of which are free for any desired stage of the transmitter.

The action will then be as follows: Upon the closing of the key, its auxiliary

(\*This is a method of obtaining delayed action.—Ed.)

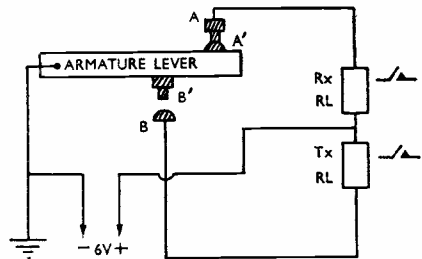
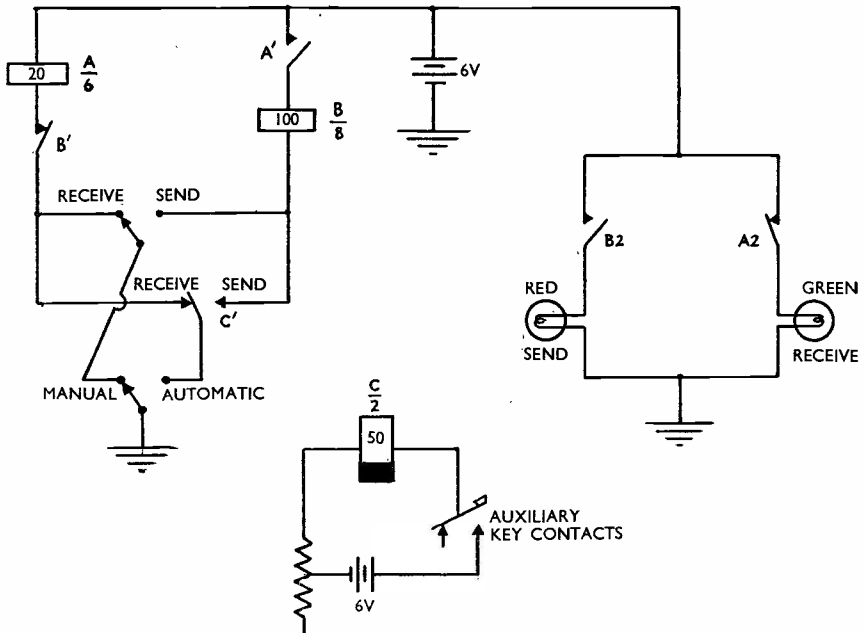

Fig. 2. Schematic of the re-wired sounder. The relays (RL) are energized from a 6-volt source, but the supply used will depend upon the type of relay employed; they are nowadays obtainable for a wide range of AC and DC voltages.



Example of a Detached Circuit Diagram to show the wiring of a set of relays and switches, performing a particular function which it may not be necessary to illustrate. The symbols are explained in the text. For instance, relay  $\frac{A}{6}$  is of 20 ohms resistance and has six pairs of contacts; it is energised by one set of contacts of relay B, which can control eight circuits and is of 100 ohms resistance. In this example, the send-receive indicator lights are also energised by relays B and A, respectively. A circuit of this kind is not easy to follow at first, but when understood it is no more difficult than any other.

contacts close and the slugged relay is energised. The contacts of the latter in turn actuate a second and straight-type relay which puts the entire station on the air. The slugging or slowed release of the first relay holds everything in the "send" position during normal keying speeds, but upon pausing with the key open the slugged relay shortly afterwards becomes de-energised and the second relay thereupon reverses the entire station back to the "receive" position.

After the opened-key pause the time elapsing before the change-over takes place can within limits be additionally shortened or lengthened by a variable resistor that increases or decreases the energising voltage. In the writer's case, the relay will hold with keying speeds as slow as 5 w.p.m.

There is, however, one point not to be overlooked. Listening on a monitor will indicate that upon closing the key to go on "send" from the "receive" position, the initial signal is lost owing to the energisa-

tion time-factor. This can be overcome by sending a longer-than-usual commencing signal to put the station on the air, or if already in QSO a long dash. Another way is to go on the air manually and come off automatically by fitting across the key auxiliary contacts a push-button or a foot-operated pressel switch. When either one is pressed the transmitter crystal oscillator stage will very shortly afterwards be heard in the monitor, and keying can be commenced at once without signal loss.

Thereafter, the return to the "receive" position is left for the relays to carry out, automatically by themselves. Should the monitor wander badly on 28 mc, audible monitoring can be done by a buzzer in series with the energising voltage source and a second small auxiliary pair of light contacts added to the key. The best position in which to fit these and the already mentioned first pair is beneath the button.

#### Relay Detached Contact Diagram

Alternatively, without use of monitor

or buzzer, transmitter keying can be commenced upon the lighting of the red ("send") indicator lamp shown in the conventional detached contact diagram (example herewith). This gives individual relays an identification letter, with a fractional number to show how many separate switching operations each will perform when energised. The resistance of each coil is given inside the symbol and the hatched square of slugged relay C in this diagram indicates "slow to release." Together with their relay letters contacts are numbered from one upwards, and are shown in their actual circuit positions but for simplicity detached from their parent relays.

It will be seen that interlocking ensures that the transmitter cannot be switched on until loaded by its aerial system and after the receiver is off and muted. The energising voltage is obtained from a suitable 6-volt source and with the exception of aerial relay "A" and 28/56 mc converter HT switching relay "F" (not shown), all are energised upon "send."

"A" is an old 20-ohm GPO sounder with added contacts. Relay "B" is a straight type 3000 with a 4-make and 4-break

spring-set. Relay "C," used only for automatic change-over, has SPDT or change-over contacts, is slugged, and in appearance similar to the type 3000. Other relays not shown are one of 150 ohms for the 28/56 mc converter HT switching, made in this case from an old car cut-out, and a 50-ohm cut-out for receiver muting; this can be done by opening the RF stage cathodes and/or earthing the receiver input. The transmitter HT switching relay is a 100-ohm straight Type 3000 relay that will handle 4 stages (or 3 stages and a modulator).

If when looking at the diagram the current path is followed from positive through the relays, contacts and hand-switches down to negative the entire operation will be easily understood. The reverse positions to those shown will of course hold true for "send." The amateur use of relays will in practice be found perfectly straightforward, and the fact that one can sit back and allow them to do most of the work will be pronounced as decidedly stimulating after the old tedious method of throwing numerous switches and becoming generally tied up in trailing hay-wire!

#### WORD OF WARNING

A correspondent sends us the following, cut from one of the women's weeklies: "My husband's fanatic affection for his hobby, Amateur Radio, is threatening to break up our marriage, which is only one year old. I know a man should have a hobby, but surely one that uses up every spare evening and is of interest only to him is not conducive to a happy married life. I am wondering if other wives have to put up with this sort of thing.—Mrs. J. L., London."

It's not funny. He is becoming far too absorbed in Amateur Radio, in which she does not even try to be interested.

The thing for him to remember is that Amateur Radio is not the only thing in life; he should, therefore, ration his time accordingly. She, on the other hand, should try to take an interest in it; after all, there are at least a dozen of her sex in this country who hold full licences in their own right. There are hundreds more, wives and sisters, who have taken the

trouble to sort out the difference between the transmitter and the receiver, know what DX and QSL mean, and are quite prepared to co-operate when the bands are hot, or amateur friends are visiting. The best of these wonderful women have even learnt to operate the station, even if they do not quite understand what they are doing!

Amateur Radio is a hobby, not a penance. It should be taken easily, not as a life and death matter. There is always tomorrow, and the DX comes round every year. The amateur who is a credit to Amateur Radio is *not* the man who devotes himself to it to the exclusion of all else, but who uses his hobby as a stimulus to make himself a more useful citizen.

We have no use for the 100 per cent. ham fiend. He is a menace to himself and everyone around him. Take it easy. And wives, take an interest, and be thankful it's something that keeps him at home!

---

*Mention the Magazine when writing to Advertisers—It Helps You, Helps Them and Helps Us.*

---

# Modulating the Carrier

## *The First of Two Practical Articles on Telephony Working*

By L. H. THOMAS, M.B.E. (G6QB)

**A**LTHOUGH the writer has always had a soft spot for the CW school, in company with many other amateurs, old and new, it has to be admitted that Morse communication is a primitive business compared with telephony. Logically, it should be confined to those occasions when, on account of interference or weak signals, telephony is not practicable. But CW is, by comparison with 'phone, so little trouble that a good operator, to whom Morse comes quite automatically, can derive just as much pleasure from it as from a 'phone conversation, and in many cases even more.

The fact remains that no amateur station is complete until it is rigged for really good quality telephony, and the problem of the choice of gear is the first one confronting the new amateur after he has served his CW apprenticeship. The various handbooks all contain excellent treatises on the theory of modulation and also much constructional information on audio equipment; this article must therefore be different, and it is hoped that it will serve to fill some of the gaps in the excellent material already published.

It is assumed, therefore, that G2ZZZ has completed his twelve months' work on CW, and therefore has a reasonable sort of PA stage with an input of 25 watts, which he would now like to see beautifully modulated so that he can work, on 'phone, most of the stations that he has already contacted on CW. For this very reason it is proposed to start being unconventional right here and to suggest that the correct approach is to work, not forwards from a microphone, but backwards from the PA stage.

For the moment we will leave grid modulation out of account, because,

although it is economical from the point of view of the amount of audio needed, it is far more tricky to adjust than other forms, and in the hands of a beginner may easily produce dire results.

### Anode Modulation

Assuming your PA stage to be a smallish triode, we will consider anode modulated. If the PA should be a tetrode, the same remarks apply, except that the anode and screen are both modulated. The fundamentals, briefly, are these:

(i) 100 per cent. modulation implies doubling the carrier-wave amplitude at times and reducing it to zero at others. (Fig. 1.)

(ii) The instantaneous carrier-power on peaks is four times that of the unmodulated carrier wave.

(iii) The *average* power in a carrier modulated by a sine-wave is  $1\frac{1}{2}$  times that in the same carrier unmodulated.

(iv) From (iii) it is obvious that the modulator has got to be capable of supplying watts (of audio) to the tune of the extra 50 per cent. of power required.

Always remember those four simple points and you will not go far wrong in the fundamentals of modulation.

We may now start the "working back" process from the PA. Dealing with inputs (since the RF output tends to be rather a nebulous quantity) we have stated that to modulate your licensed 25 watts fully you will need a modulator which will give you, in round figures, 12 watts of audio output. This, of course, assumes that you desire 100 per cent. modulation; in passing, we may as well mention that you can attain 75 per cent. modulation with about 7 watts of audio, and 50



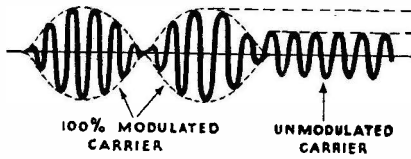

Fig. 1. What the carrier should look like, electrically, under modulated and non-modulated conditions. Compare with the oscillogram Fig. 30 on p. 215, June, which there represents 38 per cent. modulation.

per cent. with about 3, all on a 25 watt carrier. We will, however, take 100 per cent. as the goal throughout.

You are going to use anode modulation; in other words, you propose swinging the normal anode voltage of your PA from zero to twice its normal value. This means, at once, that you cannot use a similar valve to your PA and running at the same anode voltage, as a modulator; the anode swing available would not be sufficient, as the distortionless value is bound to be less than the anode voltage applied. This leads us to consider the simplest of all modulation circuit arrangements (Fig. 2). Here you have the same type of valve for your modulator as you

have for your PA, but operating at a higher voltage; the PA voltage has been dropped by a heavy-duty resistor R, thus enabling you to use the same power pack. The condenser C is there to pass the speech frequencies across the resistor.

**Choke Control**

This system was in common use 25 years ago, and was invariably known as "choke control"; the purpose of the iron-core choke is, of course, to provide a high impedance to all audio frequencies and keep them out of the power supply. As we are "working backwards" we will leave details for the time being and proceed in that direction.

This modulator valve will now give the necessary control over the anode volts of your PA when it is delivering the required amount of audio output. The latter condition is dependent upon what we do to the input side of that valve. So, to take the simplest possible case, we feed an audio amplifier into its grid circuit; and we feed the output of a microphone (or gramophone pickup, or sine-wave generator) into the audio amplifier.

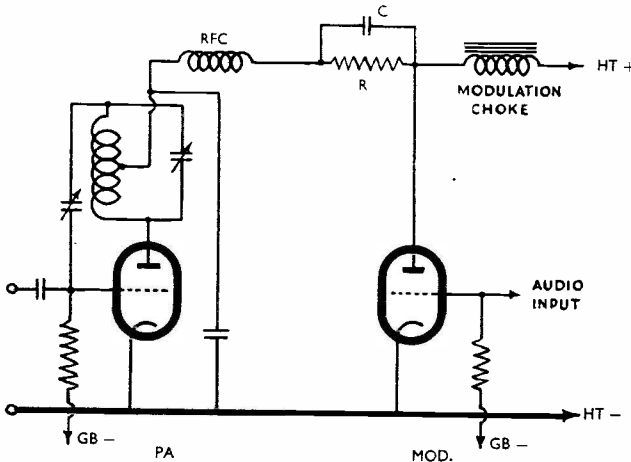

Fig. 2. Essentials of the well-known, well-tried, practical and effective choke-control system of modulation. The working of the circuit is discussed in the text.

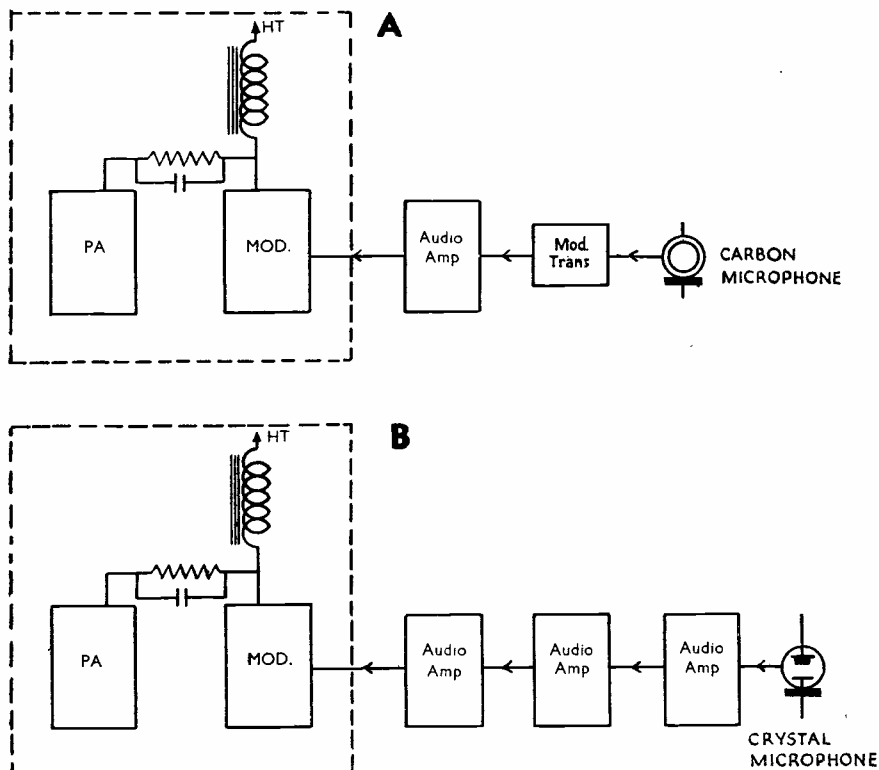

Fig. 3. (A) Units involved when using a carbon microphone. (B) The same with the better quality but far less sensitive crystal microphone.

Fig. 3A, then, shows a completely modulated PA in block form. A carbon microphone, feeding into a modulation transformer of fairly high ratio (50 : 1 is frequently quoted) applies some 10-20 volts of audio into the grid circuit of a triode (ML4, 6J5 or similar type); this is resistance or transformer-coupled to a larger triode (PX 25, or similar type); and the output of this latter valve modulates the anode voltage applied to your PA stage.

Simple enough, but basically you have a perfect modulation system here, and although many minor variations made be made—such as the use of transformer instead of choke-coupling between the modulator and the PA—you have a system which, from the point of view of audible results,

cannot easily be improved upon. We will go into circuit details and changes such as the use of a Class-B modulator later.

Now, we hope, you begin to see the point of working backwards. If you decide that a carbon microphone is not going to be good enough for GZZZZ, then you will not have to rend the whole thing asunder and build a new modulator. You will simply remove everything before the grid of your first triode (in this case the carbon microphone and its transformer) and substitute a further amplifier, going back to your moving-coil, or ribbon, or crystal microphone (Fig. 3B).

#### Layout of Telephony Equipment

Now let us digress and talk about station design as a whole for a moment.

There are two ways of looking on the problem of designing a telephony transmitter. One school of thought starts with a microphone; builds round it a speech amplifier and modulator, all on one big chassis, and applies the output of this to the transmitter. This is sound enough, but not exactly flexible, for the entire design depends upon the type of transmitter and the power to be used. If you build a most beautiful and compact speech-amplifier-cum-modulator designed to work with, say, a single 807, using 25 watts in the PA, then you will have a very nice permanent job—as long as

and the modulation is taken care of in the transmitter itself.

In such a case a rebuild for higher power will merely mean a change of modulator valve—part of the rebuild—and a subsequent turning-up of the gain control in the speech amplifier. There should really be no need to keep rebuilding the latter, which ought to be regarded as part of the microphone—a glorified “head-amplifier,” in fact.

At the writer's own station this layout is used. The microphone and its amplifier are quite separate from the transmitter proper; they are

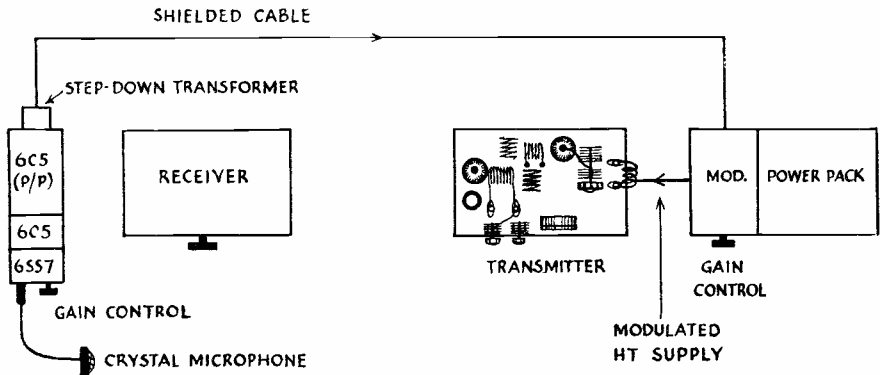

Fig. 4. One way of laying out the various units of the complete station. Note that the speech or “head” amplifier is adjacent to the receiver, with the modulator stage proper incorporated in the power pack. The arguments for this arrangement are given in the text.

you use your 807 and 25 watts. But when the great day arrives and you decide that push-pull 807's and 100 watts are desirable, then you will probably have to scrap your modulation equipment and start again.

The other school of thought (to which we are, perhaps vainly, trying to recruit you) suggests that the *modulator* valve should be part of the transmitter; and that the speech amplifier itself may be entirely separate. Or, putting it in an even simpler fashion, that your transmitter, when you build it, has somewhere on its chassis two little terminals into which audio is injected, whether this be from one stage after a carbon microphone or four stages after a crystal microphone;

easily at hand when the operator sits in front of the receiver. Thus, the gain control is always quite accessible. The output from the speech amplifier is a push-pull step-down transformer; on one side push-pull 6C5's—on the other a length of shielded cable. This cable finds its way across the room and eventually plugs into the modulator panel, where it is stepped up through another transformer to the grids of the modulator valves, which, in effect, form part of the power-pack supplying the PA stage (Fig. 4). After all, the job of an anode modulator is to supply a speech-modulated voltage to the anode (and screen) of the PA, so why not make it part of the power-pack?

This system has more than one advantage. The microphone and gain-control are right beside the receiver. That bugbear of all modulation systems using a low-output microphone, RF pick-up in the mike leads, is settled by this means. Many a neat "speech-amplifier-cum-modulator-cum-power-pack" has been ripped to pieces by the exasperated owner because of RF feedback troubles; and it seems that when feedback is present (as evidenced by squeals at various frequencies before the gain control is turned up high enough for full modulation), in nine cases out of ten the microphone leads and/or the first valve may be blamed for it. In such a case when the writer was rebuilding, it was found that the substitution of a 6SJ7 for a 6J7 cured the entire trouble; although the 6J7 was under a screen, the extra length of grid lead involved was enough to make the whole amplifier "touchy." At all events, it became completely tame with the substitution of the single-ended valve, with the grid lead reduced in length to about  $\frac{1}{4}$  in. and that under the chassis.

#### The Flexibility Factor

Yet another argument for the suggested system is that the entire method of modulation may be altered without a major rebuild. If the PA is changed, for instance, to a pentode of the PT15 class, suppressor-grid modulation may be tried with the minimum of trouble; the modulator itself is simply put on one side and the speech-amplifier output fed to the suppressor. Grid modulation in its various forms may also be put into use by the same method.

So far, then, we have arrived at these conclusions:

- (i) According to the PA of your choice, a modulator stage may be built to suit it, and built either integral with the transmitter or with the main power-pack;
- (ii) Into this is fed a speech-amplifier suitable for the particular microphone it is desired to use;
- (iii) Anode modulation is preferable for the beginner; at a later stage he may well settle down to experiment with other systems.

(iv) A good carbon microphone with a fairly high output saves an enormous amount of trouble in the early stages.

Next month we will consider various systems in more detail and go into the choice of modulator valves.



#### AMATEUR RADIO IN CZECHOSLOVAKIA

On May 5, OK licences were restored, the first actually to receive them being 17 pre-war amateurs who had survived their sufferings in prison or concentration camp, including OK1AA and OK2FL. The next batch issued were to those who, in the words of our good friend OK1AQ, were "illegal active members of C.A.V." (the Czechoslovak Amateur Radio Society). The third issue will be to amateurs who held a call prior to 1935. After that, applications will be granted on the merits of the case. Frequencies authorised are 1.8, 28 and 58 mc, with 50 watts on the HF bands.

Very little equipment has been left to our OK colleagues; there is nothing to be bought and there are no imports of British or American parts. The enemy (see "Amateur Radio in Holland," May issue) gathered up all he could find in the way of radio gear. As OK1AQ puts it, they have to rely on the "O-V-1/2 historical type" for their receivers, and on the transmitting side they are busy trying to adapt German military equipment.

On March 23, the first post-war amateur gathering was held at Brno, with representatives from all over the Republic. The membership of C.A.V. is now about 3,000, and new officers were elected at this meeting, with OK1SC (Prague) as President. With the agreement of the authorities, it was decided that the call-signs of the 14 OK's who gave their lives in the struggle against the Germans should not be reallotted unless applied for in years to come by their children.

C.A.V. is publishing a monthly journal, and its headquarters station OK1CAV has been specially licensed for amateur news broadcast operation on 3,600 kc; transmissions are every Thursday between 2100 and 2200 Central European time, on both CW and 'phone, and consist of news of C.A.V. branches and affiliated societies, notification of new authorisations, and so on.

Finally, OK1AQ reports that stations signing OK1AB, OK1FB, OK3AA and OK3RS are unlicensed, and may or may not be on Czechoslovak territory.

# DX COMMENTARY

## ON CALLS HEARD, WORKED & QSL'd

By H. A. M. WHYTE (G6WY)

This is being written before the great activity starts on 14 mc, so we cannot express any first hand knowledge of the QRM to be expected. Last month it was recommended that all G's should endeavour to keep their telephony transmissions within the bands 7,200-7,300 and 14,200-14,300 kc, and it is hoped that this will be followed in the interests of all concerned.

Reports still come in of unofficial activity on 7 mc by British amateurs. The opening of the 7 mc band will at least do away with this illegal operation, but we can only say we regret that it should have happened, as the action of a few might well have jeopardised the future use of the band. This is what happened in Denmark, because certain OZ's worked on 3.5 mc before permission was given and were severely warned.

We must support the authorities, who know best, and are very favourably inclined to British amateurs.

### VFO's

As so many VFO's are now in use, we have some comments to make. First, be very careful that you do not go outside the frequency allocation limits on 7 and 14 mc. This will be very easy to do as other Europeans will be operating over the whole range 14,000-14,400 and 7,000-7,300 kc, and carelessness may put the VFO near a station working outside *our* limits. It has often been noticed that G's have wandered on the wrong side of 28,000 kc, so please be careful that your frequency is at all times within the bands. Secondly, it has been V-ery F-requently O-berved that VFO's do not necessarily produce a good note ! This is not confined to 28 mc, but has been most noticeable on 1.8 mc. An unstable note obviously takes up more room on our very crowded bands, and from the owner's point of view it is a disadvantage because his signals will not be so easily received on modern selective receivers. A crystal filter just does not like an unstable signal.

### Handles

Many adverse comments have come in on this inane business of using "handles."

We were inclined at first to go a bit slow in voicing an opinion, but *QST*, the official organ of the American Radio Relay League, now comes out with the remark that "handle" is the most distasteful word in all the language of Amateur Radio. We could not agree more, and we are sure that we shall have the vast majority of British amateurs behind us in helping to stamp out this absurd and puerile business. If you are asked for your "handle," either ignore it, which you can do without causing offence, or explain that you have a call sign and that's good enough. Things have got to such a pass that just recently we have heard "Bill turning it over to Charlie," with no mention of call signs !

### How to Sign

Another direction in which greater care is needed is in signing when changing over to the other man. Calls are often gabbed in such a way that there is no possibility of recognising them. May we emphasise strongly that call signs should be clearly enunciated at all times, especially when changing over and finishing a QSO. Apart from anything else, it is one of the conditions of the licence. The new regulations for American amateurs lay it down that the caller shall always sign *last*; e.g., if G6FO works G6WY, then he says "G6WY, this is G6FO changing over—over." Or, to make it snappier for this restless age, "G6WY from G6FO—over." Remember the "over." We put this forward as the suggested procedure to be adopted by all British amateurs. Stations have often been heard changing over in this cryptic fashion "G6WY G6FO." Now what can that mean? Who is changing over to whom? No mention is made that the transmission is ceasing—it just stops after two call signs have been spoken !

G2BVN (Romford) remarks that many G's when working CW send the text of their transmission at 10/12 w.p.m., but then sign over at 20/25 w.p.m. This practice shows the same mentality as the use of "handles."

### BCL Interference

There is not the space in this column to deal with the age-old problem of broadcast interference, but GW6OK (Colwyn Bay) mentions that certain frequencies in the 1.8-2 mc band beat with a harmonic of the oscillator in the domestic superhet receiver and produce a wipe-out effect on the broadcast bands. This is especially so when the IF frequency is around 460 kc, as used by most commercial receivers. It may be necessary to avoid certain frequencies, so that the image produced in the BC set does not fall on a BBC transmission. This trouble is very common on the long wave broadcasting frequencies, and can be recognised as it is a tunable signal.

### 28 MC DX

The band has lived up to expectations in producing workable Europeans during the month, as well as DX on other days. Signals from GI, GM, F, PA, D2, D4, OZ, SM and LA have come through in the South of England, and have given us some good contacts.

Perhaps the most interesting European stations have been ZB2A and EA1D. The former is now giving his QRA as c/o C.S.O., R.A.F. Gibraltar, while the latter asks for cards to be sent to his home,

VS3JH when using portable on the mainland of North Borneo. You will remember that normally he is located on Labuan I. PK4DA is in Palembang, Sumatra, and requests QSLs via VERON, Box 400, Rotterdam. Do *not* QSL direct.

A few KA's and VK's came through in the middle of June to round things off. VU2WP in New Delhi put over some nice suppressor grid modulated 'phone, and VQ4MSN and 4ERR put Kenya on the map. South America was always a possibility with PY6AG, 2OE and CX1FY.

In the line of countries worked, G6QB (Bexhill) now has 61 in the log; all these are, of course, post-war contacts, obtained on either CW or 'phone with 90-100 watts to a pair of 807's in push-pull, feeding a Windom. The receiver is an HRO.

### Calls Heard Lists

An SWL reader has complained that his log sent in for the last 1.8 mc SLP was not published! The log was a very good one, most carefully compiled, but obviously we cannot guarantee to publish all the good logs we receive; in fact, only a small percentage of all logs received do appear, but we try to give all regular (and reliable) correspondents a chance. We feel sure

---

## ON THE AMATEUR BANDS

---

QRA—John Mohn, 306 North Willomet, Dallas, Texas. OK1AA was active, giving many a new post-war country, and XA's in Italy were there, including XAAN, XAAJ, XABC, XABZ, XACO, XABF, XAZO and G6HB/I. The Italian nationals have been on and we understand that they are making application for official recognition by the new government.

Burnia made a surprising appearance with XZ2AB and XZ2DN, while Iraq was much sought after in Y12XG (G2FON) and Y12AC, both at R.A.F., Habbaniya, Iraq. Northern Rhodesia popped up at odd times with VQ2FR, 2WP and 2PL, while ZS1T takes the palm for the loudest signal from South Africa. ZD4AC is still active on 'phone, and we understand that G2VV (Hampton) worked ZD4AA, who was using 3 watts only. ET6MI in Ethiopia has caused great excitement with his weak, chirpy signals at the LF end of 28 mc. He is VQ6MI working over the border from British Somaliland—and he QSL's. G6LZ (Croydon) reports working

that everyone will agree that this is the fairest way. One of the purposes of the SLP's is to focus attention on one particular band at a given time—thus a whole army of operators are on the watch, not only for DX, but for rotten operating. We publish a selection of the logs as a matter of general information and interest. Let us have no rift in this particular lute!

### Apology

Last month P. Harris, of West Byfleet, Surrey, reported reception of KA1ABA. We said that there were no three-letter KA's. This station *is* in Manila and quite genuine. He was also heard in QSO with G8PO by BRS-12,165 (Barnes) and QRA's were exchanged. We still await the full address. Apologies are therefore due to our correspondent, who was correct.

### General

On 14 mc C. A. Woad (Warrington) heard LZ1XX in Sofia, Bulgaria, who is quite genuine, and was LZ1ID (un-

licensed) before the war; we have his pre-war card. This correspondent wants to know why the F reporting code for telephony is not used. We think the reason is that, whereas the T code supplies a definite need for CW, and is the fastest way of transmitting the information, on telephony normal speech can explain reception much more easily than a formal code.

C. A. Woad heard AC3SS giving his QRA as "The Himalayas" when in QSO

QRA of CE3CX as Box 761, Santiago. BRS 10588 (Bradford) supplies some useful QRA's: LU6AJ, 1573 Santa Fe Av., Buenos Aires; YV5ABY and 5ABX, Box 1247, Caracas; YV5AN, Box 1666, Caracas; CX2CO, Box 37, Montevideo; CO2BA, Box 1049, Havana; PZ1A, Box 679, Para Maribo, Surinam; HC1FG, Box 881, Quito; PY6AG, Box 533, Bahia. He tells us that ZC1AR is run by British Service personnel in Transjordan, and that TR1P in Tripoli refuses to dis-



Danish OZ7BP, of Gilleleje, who has an ECO-PA transmitter and a 1-V-1 receiver.

with EP1C at Abadan, Persia. The latter is W9SAJ, who should have left by now.

Lieut. T. D. Aldwell, on board H.M.S. *Sussex* in the Mediterranean, also received AC3SS on 14 mc CW, as well as HZ1AA and VS9RP. We await further details of these unusual calls. Lieut. Aldwell forwards an interesting list of 1.8 mc G's heard by him in the Mediterranean; see "Calls Heard" this issue.

XZ4AR mentioned last month is operated by the signals staff of R.A.F. H.Q. in Rangoon—G2CNT is one of the operators. J. Collinge, BSWL 1887, who is with the B.A.O.R., heard HB9BB working J6MX on 14 mc 'phone. The Americans are officially authorised to operate amateur stations when on active service in the Pacific area, as is the case in Germany and other parts of the world. Patrick Masterson (Derby) logged ZC1AR, UA3AM and FA8C on 14 mc and reports

close his full QRA over the air. We hope the latter will QSL when he gets back to the States. LI3AR is another elusive one in Libya.

BRS-9326 (Angmering-on-Sea) forwards the full QRA's of seven LU's who have been mentioned in the "DX Commentary." Here they are (names omitted for brevity): LU8AK, Blanco Encalada 3769; LU7CD Centenera 260; LU3AX, Tte. Gral. Donato Alvarez 2539; LU7AZ, Pedro Goyena 1333; LUICA, San Eduardo 674, and LU5CK, Galvan 3074; *add* Buenos Aires to *all these*. For LU8EE, it is Belgrano 834, Olavarria.

I. Bates (Perth), who makes some very useful suggestions regarding "Calls Heard," supplies FA8C, *via* HB9AG; PY1ABS, Rua Canuto Saraiva 32, Tijuca, Rio de Janeiro; and UA3CA, Box 88, Moscow. He also lists CR9AG on 14,045, CM2BA

on 14,130 and K6FC on 14,030 kc. There is an odour of suspicion about the latter.

### The Top Band

Activity has fallen off slightly, and it has been possible to breathe again sometimes when there are not too many 'phones on. D4ABJ and D2DI in Hamburg have been obliging many 10 watt G's with a 'phone contact with Germany. Their signals have been amazing. Many D2's are there, and G6HB/I was on from Rome during June. May we again request the greatest possible discretion when using 'phone during the crowded hours? See suggestions on p. 232, June issue.

GM6XI (Edinburgh) remarks that many G's appear to be using excessive power on 1.8 mc; the GM's are relatively DX and have a good opportunity of judging conditions in this respect. With his own 10 watts he has worked G, GW, EI, GI, GC, LA and D.

### Set Listening Periods—July

July 13, 1800-2000 BST, 14 mc.

July 14, 2200-2400 BST, 7 mc.

Unless you happen to be an overseas reader, cut out all G's. Europeans can be

reported, but what we are really after is the DX. Please forward all logs *as soon as possible* after the SLP.

### Monthly DX Forecasts

During the last few months, many correspondents have asked for the revival of what in pre-war days we called the monthly DX forecast. This was an

*Our contributor is not usually able to reply by post to readers' letters, owing to the heavy correspondence involved in the preparation of the "DX Commentary." He will, however, always discuss in it matters of general interest raised by readers, who will thus receive a reply in print. G6WY welcomes a large volume of incoming mail, which should be posted to reach him c/o "Short Wave Magazine," 49 Victoria Street, London, S.W.1, as early as possible in the month.*

attempt to indicate what was likely to be heard on different bands at various times, and from what parts of the world. Accuracy cannot, of course, be guaranteed, but with this month's "DX Commentary" appear our predictions for July. The DX

### DX FORECAST FOR JULY 1946 (All times GMT)

	7mc	14 mc	28 mc
<b>NORTH AMERICA :</b>			
Eastern and			
Central American States ..	2200-0600	1800-0800	1300-2200 (or later)
<b>SOUTH AMERICA .. ..</b>	2359-0600	2000-0800	1300-2400
<b>AFRICA :</b>			
(North of Cancer) .. ..	1400-0900	All Day	0800-2100
(South of Cancer) .. ..	1900-0600	1600-2300	0700-2100
<b>ASIA :</b>			
West of 75°E. .. ..	2000-0600	1200-2300	0700-2100
East of 75°E. .. ..	2200-0700	1500-2200	0700-2100
<b>OCEANIA :</b>			
VK, ZL .. ..	0400-0700	0300-0900 1900-2000	0800-1200
<b>PK, KA, KB6, Pacific Area ..</b>	2200-0700	1500-2200	0700-2100

**NOTE** Signals from the continents listed above may be heard at times other than forecast, but in general they may be expected as shown here.



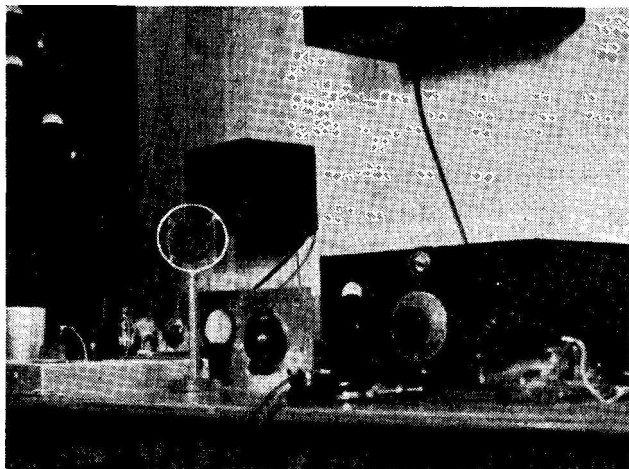

Swedish SM7UC of Malmo, whose receiver is a home-built superhet.

Forecast is based entirely upon (a) previous experience, and (b) reasonable probabilities as suggested by the trends in the behaviour of the reflecting layers.

#### Footnotes

The Swiss National Mountain Day (NMD) will be held again, the first time after the war, and takes place on Sunday, August 11. All portables participating in this event will be operating from QRA's at least 3,300 ft. above sea level. By the way, when operating portable the Swiss stations use the prefix HB1; the letters following remain the same. The NMD starts at 0700 and will be closed at 1100 GMT; only the 3.5 mc band will be used. Reports sent to USKA, Post Box 196, Berne-Transit, will be very much appreciated.

Here are a few stations worked by HB9J on 14 mc: HH5PA, Box 16, Port au Prince, Haiti; PZ1A, P.O. Box 679, Paramaribo, Surinam; I6AA Sicily (says he will soon be licensed with XA call), ZC1AR (phone) Transjordanian, and ZC6CK.

G6WY had a long QSO with LA5XY on June 18 on 1.8 mc and cleared up the mystery surrounding him. LA5XY is *not* in Norway but is using that call to cover his activity on 1.8 mc, as his government has not permitted their amateurs to use

this frequency yet. He gives his QRA as "Southern Scandinavia," which is correct. He used to work many G's on 1.75 mc before the war. In fact, "LA5XY" referred to a QSO he had with G6WY on 1.75 mc in 1931, and a check in the log disclosed the real Scandinavian call of "LA5XY."

#### THE QRP SOCIETY

The proposal to revive the F.O.C. is mentioned elsewhere. Another suggestion which has been put forward is that the *Magazine* should sponsor a QRP Society, to be composed of readers either genuinely interested in low-power working for its own sake, or who are compelled, due to lack of mains or other reasons, to operate with inputs of less than ten watts.

We were, in fact, on the point of launching a QRP society just before war broke out, so that we are now, as then, quite prepared to support, encourage and assist such a society if the necessary response is forthcoming. As the efficient organisation of any such society is an exacting business which requires much self-sacrificing effort, the first need is for a secretary; preferably, he should have a full call and some years' practical experience. Suggestions on this point, as well as an indication from among readers generally as to possible interest in such an organisation, will be welcome.

*Join Your Local Radio Society*

# CALLS HEARD

Please arrange all logs strictly in the form given here, in numerical and alphabetical order and on separate sheets under appropriate band headings, with call sign or SWL number and address on each sheet.

## MAGAZINE SET

### LISTENING PERIOD

7 mc

June 13, 2100-2359 BST

BR5-7905, 4 Kangley Bridge Road, Lower Sydenham, London, S.E.26.

'Phone: EI9L. CW: EI3B, F8ARA, FA8P, HB9FG, IIRN, LA9Q, ON4EFA, 4H, 4MAL, 4TP, 4X, 4XU, OZ7PAX.

I. Bates, 37 Craigie Road, Craigie, Perth, Scotland.

'Phone: EI9L, F3CBAK I1AR, ON4ADI, 4BAC. CW: IIRN, LA3EA, 3OA, 9Q, OZ7PAX, ON4EFA, 4FA, 4MAL, 4X, PAØRF, PY2QL.

## GENERAL

### 1.8 mc CW and 'Phone

Lieut. D. W. Aldwell, H.M.S. "Sussex," c/o G.P.O., London.

G2BI (45), 2HFO (34), 2KO (55), 2NJ (44), 5PJ (44), 5RP (44), 6LB (34), 6TR (34), 6UC (45), 6ZH (45), 8KH (45), 8ML (34), 8PX (44). All heard off Tunis; RS values in brackets. G2JL (33) heard in harbour at Malta.

### 1.8 mc 'Phone

W. Watson, 46 Torphichen Street, Edinburgh, 3.

D2DF, 2SC, 4ABJ, 4ALX, G2AK, 2BG, 2FM, 2HB, 2HN, 2JB, 3BU, 3Y, 3JG, 3OZ, 3PW, 3VO, 3WQ, 6AB, 6GL, 6GO, 6UX, 6WS, 8MU, 8OC, PAUF. 'Phone only, June 9-14 inclusive.

### 3.5 mc CW and 'Phone

BR5-9326, South View, Upper Drive, Angmering - on - Sea, Sussex.

'Phone: W1MQH (0337), 2HGA (0445), 3FBG (0351), 3FBG (0351), 3FH (0405), 4CPP (0347) 4HBH (0417), 8MMJ (0355), 8QSZ (0344), 8QXM (0341), 8ZGQ (0400). CW: W1AQ (0333), 2JGG (0331), 2JUC (0328), KP4AB (0410). All times GMT, June 8 and 9 only.

### 14 mc 'Phone

BR5-10588, 1 Jer Lane, Horton Bank Top, Bradford, Yorks.

AC3SS, CE1AK, 1AO, 1AR, 1BE, 3AJ, 3CI, 3CT, 3FG, CM2X, CO2AS, 2BA, 2CQ, 2CV, 2DQ, 2DV, 2FA, 2JJ, 2KL, 2LY, 2MA, 2SV, 2UP, 6BD, 7DS, 7RL, 8AY, 8MP, 8RL,

CX2CO, 3BL, 3CL, 3CN, EP1C, FASAB, 8AB, HC1FG, HK1AC, 1AF, 1HC, 4AF, HP1A, HZ2YY, LU1CX, IJC, 1DJU, 2BG, 2CO, 3AQ, 3FB, 4HI, 6AJ, 0A4H, 0A4M, PR1AA, PY1AB, 1AO, 1ACE, 1AEB, 1AEJ, 1CK, 1FO, 1GL, 2AC, 2AJ, 2AY, 2HV, 4BK, 4BV, 4BY, 4CU, 4NB, 6AG, 7AK, 7AN, PZ1A, SU1CK, 1CX, 1KE, 1USA, 8MS, SV1GY, TG9RV, TI2AB, 2CA, 2OA, 2PZ, 2RC, 3LR, TR1P, VP3LF, XE2MA, 3AB, 3BK, YR5M, 5USA, YV1AB, IRE, 1AU, 5AB, 5AE, 5AG, 5AN, 5ABE, 5ABQ, 5 ABW, 5ABX, 5ABY, 5ACE, 5ACU, 5AVG, 5OL.

## FIVE METRES

G6CW, St. Ann's, Bramcote Lane, Wollaston, Notts.

Worked: F3JB, G2AK (46), 3IS (52), 5LJ (42), 5TX (180), 6GF (26), 6SL (48), 6VM (128), 8IG (126). Heard: G2MR (120), 2MV (124), 2WS (126), 3PD (75), 6LK (130), 6YQ (85), 6YU (48), I1BR. F3JB worked June 3 and 11BR heard June 16.

G6LK, Warham Lodge, Bridge Road, Cranleigh, Guildford.

Worked: G2AK(108), 2BB, 2BMZ (134), 2LC, 2MC, 2MR, 2NH, 2XC, 3CQ, 3FD, 3FU, 3KP, 3NR, 3OO, 3SU, 4CG, 4CI, 4IG, 5AS, 5BY(156), 5FK, 5KH, 5MA, 5MQ(188), 5OJ, 5OO, 5RD, 5TP, 5TX, 5WP, 6CW(128), 6FO, 6NA, 6VX, 6YQ(188), 6YU(98), 8CK, 8DV, 8GV, 8IG, 8LY, 8OS, 8RS, 8SK. Heard: 5LJ(114), 6RA, 6TL(200), 8DX, 8QY. Distances of DX stations in brackets.

## FIRST-CLASS OPERATORS' CLUB

It has been suggested that the *Magazine* should undertake the revival of the F.O.C., now understood to be defunct. Our issue of September, 1939—the last before the war—carried details of the aims and objects of this society which, as its title suggests, were to improve and maintain operating standards. The main qualifications for membership were good operating ability and technique (with all it implies), and Morse speeds around 25 w.p.m., sending and receiving. The Club was managed by a small committee, and had 70 members at the time of which we write.

The *Magazine* is fully prepared to

support, in the general interest, a revived F.O.C. This support would extend to providing such facilities as publicity, space for regular notes, and other services of a like nature as may from time to time be required. It is, however, considered that the actual management of the Club should not be a *Magazine* responsibility, but should remain in the hands of an elected committee.

Enquiries from interested readers, and a nomination for the onerous duty of provisional organising secretary, would be welcome. Depending upon the reaction, a decision can then be taken as to the next steps.

## ROTARY BEAM MOUNTING

Idea by CONSTANCE HALL (G8LY)

A very simple and inexpensive beam aerial was constructed by the writer late in 1939 (in this case for 56 mc) and placed on a small area of flat roof 18 in. wide, with one supporting bracket 6 ft. from the base. The pole was a 25-footer, beam three element, and height above ground to flat roof, 21 ft. This beam survived a series of gales before being dismantled, as it gave the house an "Enemy objective" look!

### Construction

A 10-gallon oil drum with top removed, and an old piece of piping, an inch larger in diameter than the base of the pole, were obtained. Rough-cast concrete (mixture : 1 cement, 2½ sand, 5 coarse gravel) was poured into the drum to a depth of 3 in. to form a solid base.

The piping was then held vertically and quite upright in the drum, and the remainder of the drum filled with rough-cast cement. It was then allowed to harden absolutely for two or three days, and the piping watched for the first few hours to make sure it kept quite vertical (which it did!).

While this hardening was taking place the beam was constructed, a matter of individual requirements, so not given in detail now. Before attaching the aerial to the top of the pole, a metal ring (see sketch) was passed over and down the pole, just large enough to allow the pole to rotate without much side-play; this was fitted about 6 ft. above the base.

### Points of Detail

Before placing the pole in the pipe, a piece of metal was screwed to its base, the diameter of this metal "pad" being the same as that of the pole.

Four bagatelle balls were dropped down the piping and the pole, with beam attached, inserted and the whole thing raised vertically. The ring was then fixed to the wall, for support, so that no stay wires were required.

A piece of old inner tubing was tacked round the pole and over the top of the piping, to stop rain trickling down. A rear-lamp cycle reflector was screwed to the side of the pole, with the beam facing north, so that in the dark one could illuminate it even with a feeble torch; it is always helpful to beam in the desired direction!

Another point—use a piece of wood to wedge the pole into the piping when the beam is aligned, but the wedge *must* be attached to a cord or a piece of wire, otherwise it may drop down the piping and then the rotary beam will become a permanent fixture instead of a movable one!

This beam mounting, if constructed to smaller dimensions, is ideal for portable work where a car is available for transport.

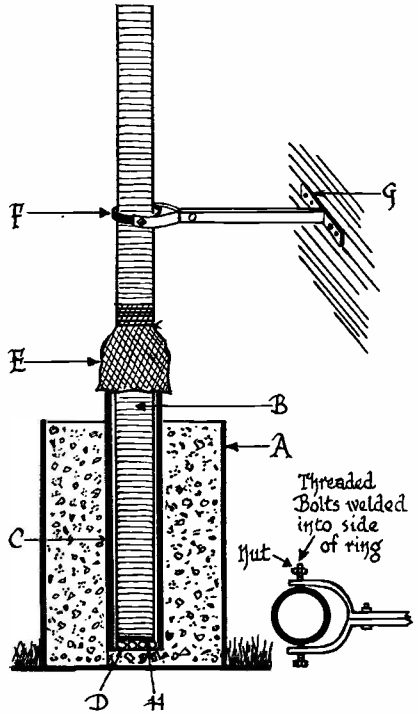

G8LY'S ingenious beam aerial mounting. The 10-gallon size drum A is filled with concrete, in which is set the closed-end pipe C. The pole B, with a steel end-piece H, rotates in this pipe, and is carried on the steel balls D at the bottom of the pipe. The steadying ring F provides additional support and can be fixed at a convenient height above the drum, which can simply rest on any suitable flat surface. The ring F should be secured to a firm support by means of brackets, G, shaped and cut to fit. The rubber hood E prevents rain getting into the pipe. Give the whole thing a coat of green paint, and it would look well in any garden.

## BRITISH AMATEUR VALVE TYPES—

Showing main characteristics,

Maker	Designation	Type	Service	Fil. or H'ter		Maximum Plate	
				Volts	Amps	Volts	Current
E.M.I.	KT8c	Beam Tetrode	RF	6.3 H	1.27	600	95
	DET19	Twin Triode	RF	6.3 H	0.8	300	40
G.E.C. (Osram)	KT66	Tetrode	AF/RF	6.3 H	1.27	400	80
	KT8						
	DET19	details as for KT8c and DET19 (E.M.I.) types					
	DET20	Triode	RF	6.3 H	0.2	300	25
	DA41	Triode	AF	7.5 F	2.5	1000	280
	PT15	Pentode	RF	6.0 F	1.3	1250	80
	U18/20	F.W.	Rect.	4.0 F	3.75	500	250
U52	F.W.	Rect.	5.0 F	3.0	500	250	
	U23	H.W.	Rect.	4.0 F	3.3	1750	125
MULLARD	QVO4-7	Tetrode	RF	6.3 H	0.6	300	40
	QVO4-20	Double Tetrode	RF	6.3 H	1.6	400	180
	TZ05-20	Triode	RF	6.0 F	1.1	400	85
	PVO6-25	Pentode	RF	6.3 H	1.3	600	120
	PV1-35	Pentode	RF	12.0 H	0.9	1000	150
	QY2-100	Tetrode	RF	10.0 F	5.0	2000	170
	EL-37	Pentode	AF/RF	6.3 H	1.3	400	80
	MZ1-75	Triode	AF	10.0 F	1.1	1000	75
	RZ1-150	F.W.	Rect.	4.0 F	4.0	1000	150
	RZ1-250	H.W.	Rect.	6.0 F	2.0	2000	250
	RG1-240A	H.W.	MV. Rect.	4.0 F	2.7	1250	250
	RG3-250	H.W.	MV. Rect.	2.5 F	5.0	1000	250
	FW4-500	F.W.	Rect.	4.0 F	3.0	500	250
	FW4-800	F.W.	Rect.	4.0 F	3.0	850	125
	STANDARD	4033L	Triode	AF/RF	6.0 H	1.4	600
4052A		Pentode	RF	7.5 F	3.0	1250	80
4061A		Pentode	RF	6.3 H	0.8	500	55
4069A		Pentode	RF	10.0 F	5.4	2000	140
4074A		Twin Triode	RF	6.3 H	0.8	300	80
4274A		F.W.	Rect.	5.0 F	2.0	1000	200
4282B		Tetrode	RF	10.0 F	3.0	1000	100
4300A		Triode	AF	5.0 F	1.2	450	80
4304CA		Triode	RF	7.5 F	3.3	1000	100
4356A		Triode	RF	5.0 F	5.0	1500	100
2V/400A		H.W.	MV. Rect.	2.5 F	5.0	1000	250
3A/147J		G.G.T.O.	RF	4.0 H	0.65	350	28
3B/401J		Special UHF Triode	RF	6.3 F	2.0	1000	100
5B/250A		Beam Tetrode	RF	6.3 H	0.9	600	100
5C/100A		Pentode	RF	10.0 F	5.0	2000	180

## NOTES

- (1) "H" indicates indirectly-heated; "F" directly-heated filament. MV. is mercury vapour.
- (2) Ratings are maxima throughout. RF power output stated may not be obtainable at highest frequencies given. In general, ratings must be reduced for safe operation at upper frequency limit.
- (3) Column "Output Watts" refers to RF, AF or DC output, as appropriate to valve described.

**TRANSMITTING, MODULATING & RECTIFYING**

American equivalents and current list prices.

Output Watts	Freq. Range or Limit	American Equivalent	List Price	Remarks	
12-38	1.8-60 mc	807, RK25	25s.	Ceramic-based. Two in push-pull can be run at 100 watts input on 28 mc. Can be parallel connected; cathodes are separate. Plate current stated is per anode	
8-16	250 mc	RK34	22s. 6d.		
7	—	6L6G	15s.	Two in Class-AB1 push-pull will give 35 watts audio output. Valve is suitable for all 6L6 positions.	
4	480 mc	none	20s.	Grid plate connections brought out to top caps Ratings are for two valves in Class-B push-pull. Valve designed for zero grid bias operation. Ceramic based. Valve can be operated at up to 100 watts input on 28 mc. Two in push-pull give 150 watts RF on 7 mc.	
175	—	TZ40	15s.		
42-82	1.8-60 mc	RK20	32s. 6d.	Vacuum (83 is MV. type) type rectifiers (816 is MV. type).	
125	—	83	15s.		
125	—	83	15s.		
220	—	816	25s.		
6	150 mc	none	25s.	Heaters can be connected series or parallel. Valve is direct replacement for 815.  Can be operated under conditions similar to PT15. Valve is direct replacement for 813. Suitable for all 6L6 positions. Ratings for single valve as Class-A amplifier. Two in Class-AB push-pull will give 110 watts audio.  MV. type 83 is nearer for rating.	
44	200 mc	815	62s. 6d.		
21	30 mc	801	24s. 6d.		
45	20-60 mc	807, RK25	35s.		
73	20-60 mc	RK20A	110s.		
260	30-60 mc	813	170s.		
7	—	6L6G	15s.		
20	—	211	65s.		
150	—	none	69s.		
250	—	none	70s.		
300	—	866 Jr.	15s.		
250	—	866A	45s.		
125	—	83V	15s.		
100	—	none	15s.		
55	—	none	35s.		Can be operated under conditions similar to PT 15.  Directly interchangeable with DET19 and RK34.
64	20-60 mc	RK20	142s. 6d.		
24	60 mc	RK25	40s.		
200	20 mc	RK28	140s.		
14	200 mc	RK34	30s.		
200	—	WE. 274	20s.		
67	1.8-20 mc	WE. 282	90s.		
12	—	WE. 300	30s.		
70	100-300 mc	304B	77s. 6d.		
100	100-250 mc	356A	70s.		
250	—	866A	27s. 6d.		
2	750 mc	none	30s.		
6-20	600-800 mc	none	150s.		
24-37	60-125 mc	807	25s.	Directly interchangeable with 807.	
260	1.8-20 mc	813	145s.	Directly interchangeable with 813.	

- (4) The American equivalents given are either exact, or near enough to ensure comparable performance. The types are not always interchangeable without alteration of valve socket, except where stated.  
(5) Socket connections of all types given here will be published separately.  
(6) Detailed information on all valves listed is obtainable from the manufacturers concerned.  
(7) The list is complete to July, 1946, and prices given are current at that date.

# An Automatic Keyer

## *Details of a Practical Design*

By HILTON O'HEFFERNAN (G5BY)

**T**HIS automatic keyer can be offered as a time-proven device, since it had at least eight years' continuous operation before the war and is now in full use again.

It allows for two CQ's, band identification, and two station call signs to be continuously repeated. An alternative band identification or the "DX" sign can be brought into operation by setting a switch to the appropriate position. Actually, two entirely different series of Morse characters could be used; for example, one to call CQ and the other—idea specially recommended to G9BF—switched in directly a contact is established, to send something like "RRRR ur sigs RST599 fb hr in Balkans pse QSL 73 SK"!

### The Drum

Most of the constructional details will be clear from the drawings, but there are one or two points—especially the choice of drum size—which require explanation. The drum diameter *can* be reduced if difficulty is experienced in getting one of the size given turned up on a lathe, but this will in turn mean that the size of the Morse characters, cut out of copper foil, will have to be made proportionately smaller. They will, therefore, be more difficult to cut accurately and be fragile in use. The chief objection to the employment of a smaller drum is, however, the loss of the flywheel effect; this is of the greatest importance in keeping the speed constant and, by so doing, allowing the use of cheap gearing devices—such as the train of Meccano gear wheels shown.

It is absolutely essential that the drum should turn freely and be accurately balanced. When the Morse strips are in position, but before the brushes are fixed, throw the large gear wheel on the drum spindle out of mesh, so that the drum is perfectly free. It

should spin easily and run for some time. When stopped it should, if perfectly balanced, remain stationary in any position. Failure to do so means that it must be balanced up. This is done by noting the position in which it comes to rest and then fixing a small strip of lead on the side and near the top. Keep on checking balance and fixing counterweights until the drum runs perfectly.

### The Morse Strips

The width of the drum being 2 in, the Morse characters are cut out of copper foil 2 in. wide—see sketch—which is placed round the circumference and held in position by drawing pins in the  $\frac{1}{4}$  in. wide strip left for this purpose. The "open" ends of the characters are securely held under a  $\frac{1}{4}$  in. wide band of copper foil running right round the circumference and also held in position by drawing pins. Clean the copper foil well with metal polish when finally in position, and then smear with a thin layer of vaseline; this will ensure a good and lasting electrical contact with the brushes, shown as AC-BA in the drawing.

These brushes can be constructed from springy copper foil, or strips from old 'phone jacks can be utilised. The two outside ones A-A and either B or C (as selected) complete the keying circuit; the extra brush A helps to make this circuit certain, since the A brushes have to ride over the heads of the drawing pins. The A brushes can be eliminated by running a wire from the copper foil, down the flat side of the drum, and connecting it to the metal bearing of the drum spindle.

Any fractional-H.P. motor—preferably incorporating a speed reduction gear—will be quite suitable as the driving source. A suggested wiring arrangement is indicated, giving choice of two speeds, with a fine adjustment of speed on each.

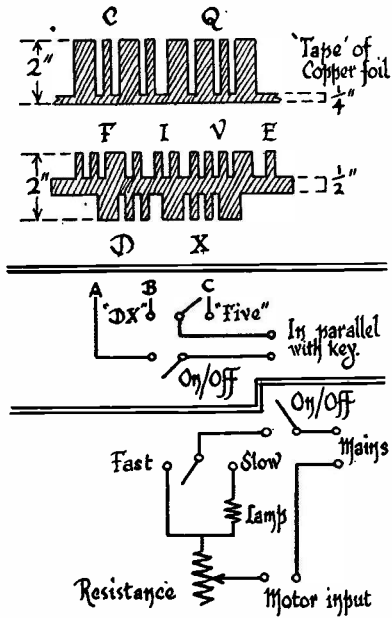
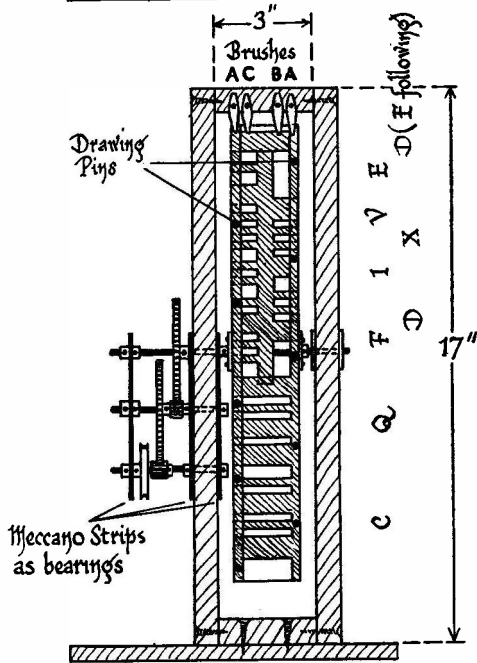
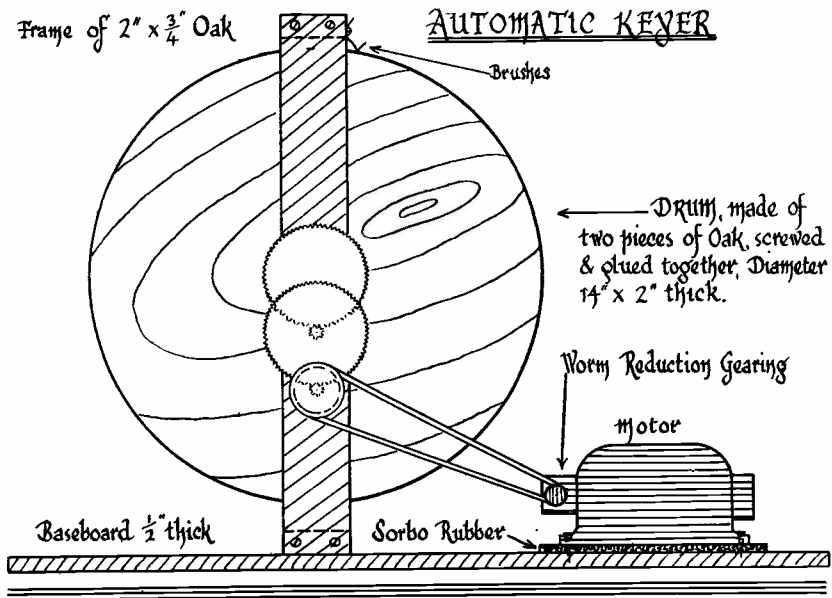

**THE GSBY AUTOMATIC KEY**

These drawings give full mechanical and electrical details of the keying unit. The particular form of construction adopted can be varied to suit individual requirements, but an essential feature is the large diameter drum.

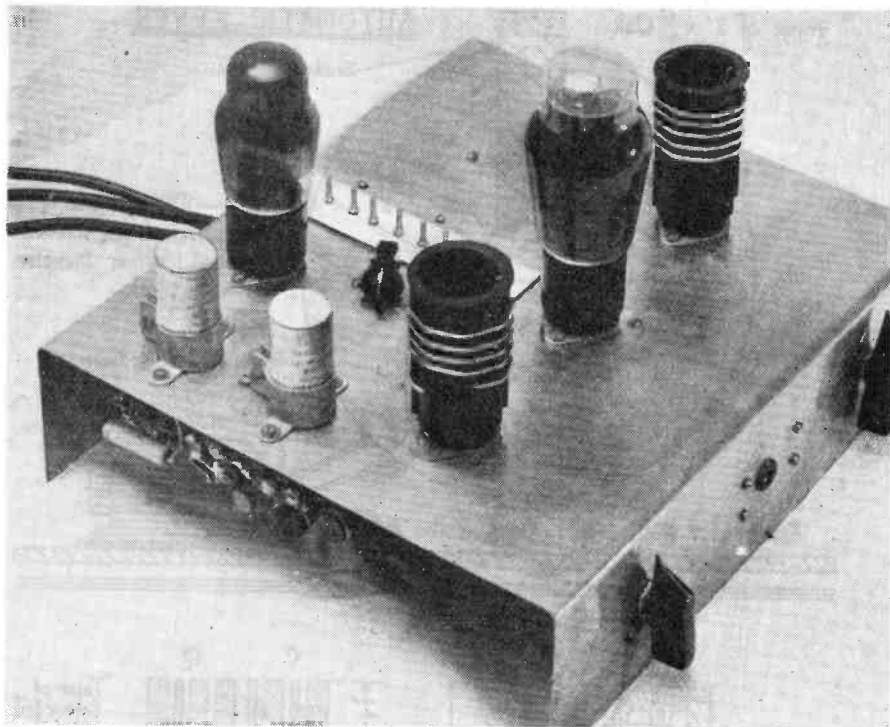

## Modulation on the Auxiliary Grid

*An Effective Method for Low-Power 'Phone Operation*

By J. INGRAM MYERS, B.Sc. (G4HM)

**T**HE stage power gain of a beam tetrode RF amplifier is governed, if other factors remain constant, by the auxiliary, or screen, grid volts. Over the range between zero and an experimentally determined voltage, the ratio stage power gain to auxiliary grid voltage is sufficiently constant for modulation to be carried out.

The system about to be described has produced consistently good reports of quality during many QSO's. Due to its suitability for remote control, it enabled the author to be very active on 28 mc while in bed with 'flu!

### Application

This system of modulation has several advantages over other types. It does not affect the stability of the PA with which it works, and 100 per cent. modulation is easily obtained using audio powers of less than 4 per cent. of the modulated RF output. Consequently, a high gain and high output audio-frequency amplifier is not required—a big economy in expensive components. It works well with several types of beam tetrodes; 6L6, 6V6, EL37 and 807 have all been used.

The design given here has been



adapted for use with a 6L6G. Care has been taken to use only components which are easily obtainable and the layout and construction are quite simple.

The RF side of the circuit may be used either as PA, doubler or buffer, and requires 0.2 volt RF drive on 28 mc. The HT power consumption is 12 watts on 'phone and 24 watts on CW, the RF outputs being  $7\frac{1}{2}$  watts and 15 watts respectively. The modulator valve is a 6V6G mounted on the same chassis—this requires only a 76, L63 or 6C5 as a pre-amplifier, when a moving coil microphone is used.

The unit as described here is intended to be operated with a system of remote control which enables the PA

and clearly is applicable to any RF stage making use of a beam tetrode. The circuit diagram of the system as applied at G4HM is given in Fig. 2; there is no fundamental difference between Figs. 1 and 2, but the latter provides for connecting in the remote-control unit and also covers the circuit of the actual PA-Modulator assembly which is described and illustrated here.

Experienced readers would have no difficulty in adapting the basic idea to their own particular circumstances, should they not wish to construct the actual equipment illustrated.

### Circuit Details

The PA is intended to be link-coupled to the driver unit and the tank

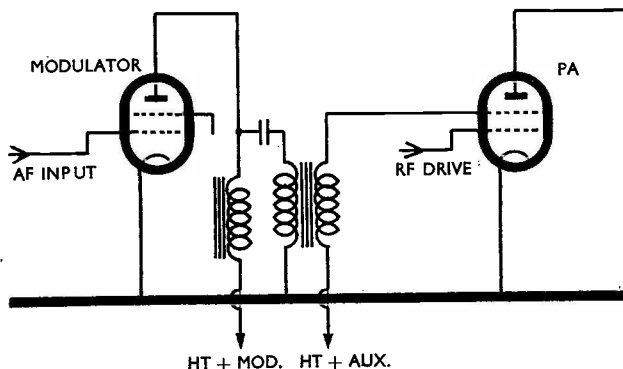

Fig. 1. The essentials of a simple system of auxiliary grid modulation. With a 6L6 in the PA position,  $7\frac{1}{2}$  watts RF output can be obtained on 'phone.

to be keyed, modulated and switched from a distant control point. This is coupled to the amplifier-modulator unit by two unshielded leads of any length (5 amp. cab-tyre is used). Three GPO relays are mounted on the unit itself, while the speech pre-amplifier is mounted in the control unit. The aerial is automatically switched to the Rx (used near the control unit) along the control lines when the PA is switched off. A single send-receive switch is used. The terminal strip on the top of the chassis is to facilitate the introduction of the relay unit, already mentioned, and which is to be described later.

The basic circuit is shown in Fig. 1,

circuit is directly connected to an 80-ohm coaxial cable or matched line. The bias for the 6L6G is derived partly from the R1 and partly from the R2 and C5. Terminals V and W are included so that plate current may be measured. This is carried out in the anode circuit to allow a low-grade moving iron meter (0 = 100 mA) to be used. It is better to avoid cathode metering with this type of instrument. Terminals X and Y permit grid current measurement. Modulation is obtained by superimposing an audio voltage in series with the DC voltage applied to the auxiliary grid from the HT supply. An ordinary LF transformer (ratio 3-1) is used in a parallel fed circuit to

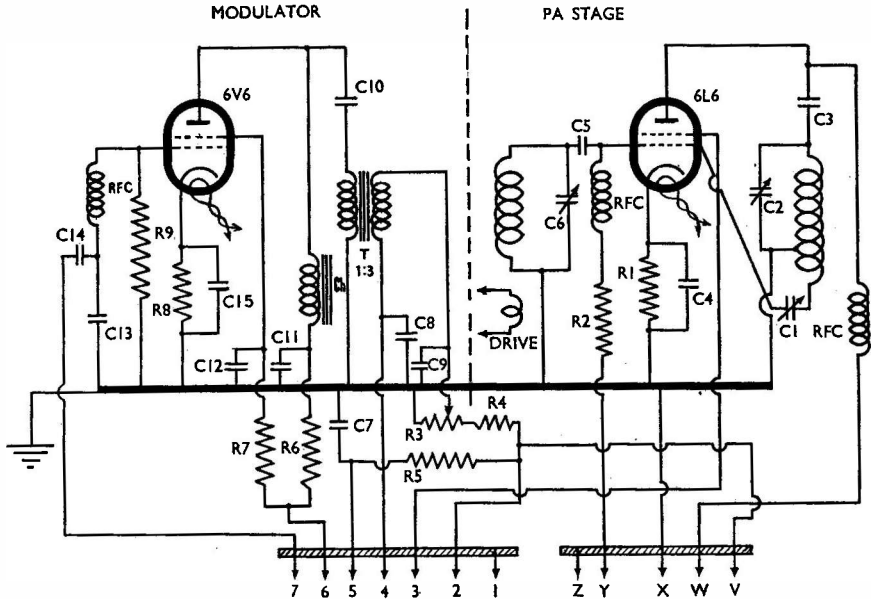

Fig. 2. The system as applied to G4HM's transmitter, illustrated here, showing circuit details of PA and modulator. Terminals V-Z and 1-7 indicate connections brought out to panel strips. No. 1 is HT+, and No. 7 audio input, while V-W give HT metering for the PA, and X-Y read PA grid current. These terminations provide connecting points for the relays of a remote-control arrangement. A form of plate neutralisation is shown (C1), but the system of modulation is of course in no way dependent upon this. Any beam tetrode suitable for use as a PA, whether neutralised or not, should work equally well.

avoid the standing plate current of the 6V6G. A 30-henry LF choke, 50 mA working, provides the series load for the 6V6G. C13 and the associated RF choke form a filter to remove stray RF from the control grid of the modulator.

**Constructional Data**

The chassis is constructed from 18-gauge tinned plated mild steel; a single sheet 12 in. by 16 in. is used. This should be marked out as indicated. The 1 in. holes should be cut with a circular hacksaw tank cutter, or if this is not available a 1 in. wood centre bit with the cutting edge removed will serve. The slots are made by drilling 1/4-in. holes and then removing the material between with a cold chisel. The chassis should then be bent to form 3 in. flanges back and front. This will provide ample mechanical strength.

The condensers, valve and coil

holders and other main components should now be mounted. The RF chokes are placed near each coil socket on the under-side of the chassis. The small LF components are mounted on a support strip along the back of the chassis, held 1/2 in. away from the chassis by ebonite collars.

The grounded components in the PA should be taken to a common lead, itself connected to the chassis at a point half-way between the tuning condensers.

The terminal strip containing terminals 1-7 is composed of a piece of 1/8 in. paxolin 1 in. wide and 5 in. long. The terminals are made up from 1/4 in. cheese-head 6 BA bolts, nuts and washers. This strip is mounted under the chassis over the slot provided. The strip containing terminals V-Z is of the same size and is placed over the slot at the rear of the chassis.

The neutralising condenser is supported on 1/2 in. ceramic stand-off

insulators in such a way that it may be adjusted by a screwdriver through the centre hole in the front of the chassis. A rubber grommet is placed in this hole and also in the hole at the rear of the chassis where the HT and LT leads are taken out.

The PA coils are wound with 18-gauge tinned copper wire on  $1\frac{1}{2}$  in. octal-based coil formers. The grid coil has 4 turns, and a 1-turn coupling coil placed at the earthy end; the anode coil has 5 turns. These are, of course, values for 28 mc, which would have to be increased for 7 or 14 mc, to which the design as a whole is equally applicable. The grid-tuning condenser and coil are on the left of the chassis and the anode tuning condenser and coil are on the right viewed from the front. R3 is mounted in the  $\frac{3}{8}$ -in. hole on the top of the chassis.

#### Tests and Adjustments

The HT at 350 volts should be connected up and terminals 1 and 2 shorted. Terminals 3 and 5 must also be connected. The tank circuit should be tuned to minimum plate current and the RF output checked with a loop light or preferably with an artificial aerial. Plate current should be about 72 mA at resonance—under load—or

20 mA off load, rising to 90 mA when the tank circuit is detuned.

A milliammeter should be inserted at the earthy end of R2 and the grid current measured. This should be 3-4 mA—thus the cathode safety bias *plus* that developed across the grid leak will ensure that the valve is working under Class-C conditions. The HT should now be removed from both screen and anode while the drive is still being applied. Neutralisation may now be checked. If, when the tank circuit is swung over resonance, a dip in grid current occurs, then neutralising is required and must be adjusted until no change in grid mA reading results when C2 is varied about the resonance setting.

The connection to terminal 5 should now be transferred to terminal 4. A voltmeter of high internal resistance is then connected between auxiliary grid and earth and the HT applied. The voltage on the auxiliary grid is now varied by the potentiometer R3, and if the voltage is reduced to zero RF output should fall to zero. If this does not happen, the neutralising is not correct. The auxiliary grid voltage should now be adjusted to approximately 100 volts. When modulation is applied, by audio input to terminal 7, the auxiliary grid volts should be

#### Table of Values

R1 = 700 ohms, 2-watt	C4 = .01 $\mu$ F paper
R2 = 20,000 ohms, 1-watt	C5 = .002 $\mu$ F mica
R3 = 50,000 ohms, 2-watt, wirewound potentiometer	C6 = 60 $\mu$ F
R4 = 25,000 ohms, 2-watt	C7 = .01 $\mu$ F, tubular
R5 = 20,000 ohms, 2-watt	C8 = .002 $\mu$ F, mica
R6 = 2,200 ohms, 10-watt	C9 = 1 $\mu$ F
R7 = 20,000 ohms, 2-watt	C10 = 0.5 $\mu$ F, tubular
R8 = 240 ohms, 1-watt	C11 = 8 $\mu$ F, electrolytic
R9 = 52,000 ohms, $\frac{1}{2}$ -watt	C12 = 1 $\mu$ F
C1 = 5 $\mu$ F	C13 = .001 $\mu$ F, mica
C2 = 60 $\mu$ F	C14 = 0.1 $\mu$ F, tubular
C3 = .002 $\mu$ F mica	C15 = 50 $\mu$ F, electrolytic, 25-v.
	RFC = RF chokes, any good make



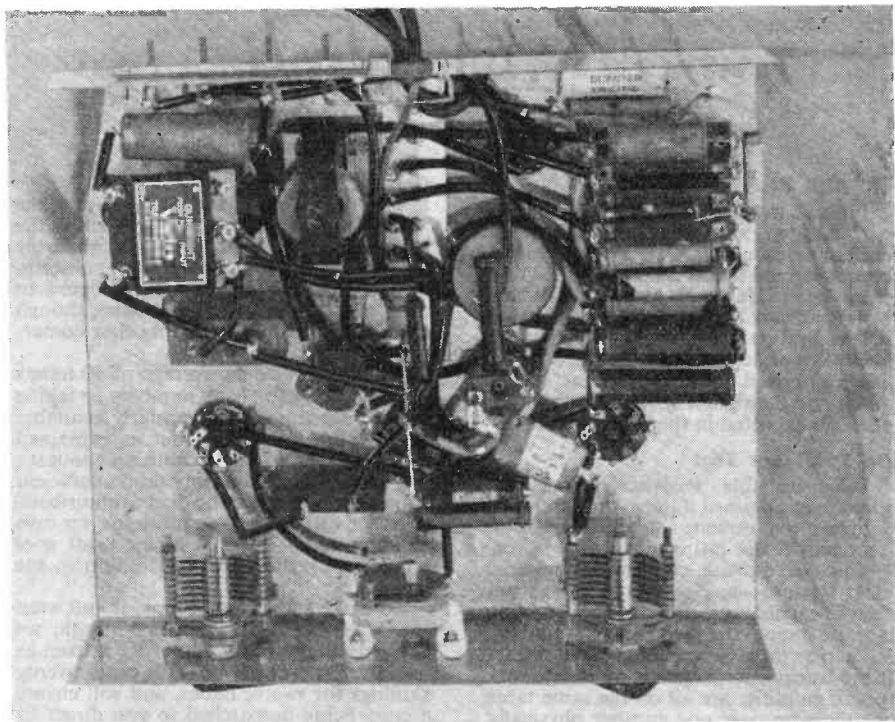

Underneath the chassis of G4HM's PA-Modulator unit. The condenser midway between the two tuning condensers is C1, the neutralising condenser, adjusted by means of a screwdriver through the grommeted hole

possible to vary the output power up to this maximum from zero merely by varying the screen volts between 0 and 100 and the audio input in proportion.

**Three Common Faults**

(1) If a loop light held near the tank circuit shows a *diminution* in brilliance when speaking into the microphone,

then the auxiliary grid voltage is too *high*.

(2) If the light increases very greatly, then the voltage is too low.

(3) If an high impedance AC voltmeter across the secondary of the LF coupling transformer reads more than 71 per cent. (on peaks of modulation) of the DC voltage applied to the auxiliary grid, then overmodulation is taking place.

**TABLE OF OPERATING DATA**

6L6 PA Stage	Anode Volts Va.	Screen Volts Vs.	Anode Current Ia.	Screen Current Is.	Grid Volts Vg.	Grid Current Ig.	Input DC RF watts	RF Output watts
CW 'Phone	350	250	72 mA	5 mA	— 90	3.4 mA	24	15
	350	100	33 mA	2.3 mA	— 90	3.4 mA	12	7½-8
6V6 Mod.	250	250	4.5 mA	4.5 mA	— 12.5	<b>Total Current</b>		
						CW=	77mA:	'Phone =

# Here and There

## The Call Book

Further to the note which appeared on p. 248, June, anent the obtaining of the current issue of the Call Book, we have been informed that it can be supplied from stock by B. Hayes, 8 Althorpe Crescent, New Bradwell, Bletchley, Bucks. The price is 10s., and only a limited supply is available. We understand the Board of Trade has authorised the bulk import of this particular consignment, and further supplies are expected in the next few weeks.

## Do You Know That

Uncontrollable feedback effects are sometimes obtained if the microphone lead happens to resonate at the transmitter frequency? For instance, a lead 4 ft. long—which is quite a convenient length in most stations—is  $\frac{1}{4}$ -wave on 28 mc, and even if carried in earthed metal braiding, is quite capable of producing modulated RF across the first amplifier input circuit. If the transmitter, receiver, modulator and speech amplifier are all on the same table, or otherwise near one another physically, the microphone lead should be kept as short as possible, and in any case to a non-resonant length.

## "BKS"

The Editorial in June *QST* discusses in some detail the pros and cons of single-channel working, and with us advocates its general adoption, using VFO control. The approach is, however, a little different from ours in the April and May issues of the *Magazine*, in that K. B. Warner suggests that at the first answering stage the VFO should be tuned not on, but *slightly off*, the called station's frequency; this would enable all concerned to hear the called station's reply to the caller of his choice. Thereafter, the caller would move right on to the called station's frequency, both then proceeding with break-in, single-channel working.

As K.B.W. suggests, what we need now is a thorough testing of the procedure. It looks quite sound, and is no trouble to try. It might help us all a great deal. So before criticising the theory, give BKS a thorough trial. Then let us know, as a result of your practical experience, how you find it.

## Getting the Magazine

The March, April and May issues of the *Magazine* have been sold out since the middle of May, and June will probably be gone when this appears. New subscriptions can therefore only be accepted to start with the next (August) issue, though it may be possible to supply first comers with a June copy.

We still receive an average of 40 letters a week asking for back numbers or telling us the *Magazine* is not regularly available locally. We know this, but as explained on p. 185 (May), can do nothing about it; out of each issue, we only retain sufficient copies for posting to the direct subscribers, together with a small quantity for our own counter sales. The rest of the print goes to the wholesalers for distribution in the usual way.

To make sure of your copy, if you want the *Magazine* regularly every month, we can only suggest that you order it from us on direct subscription. This costs twenty shillings for twelve issues, and will ensure a copy being despatched to you direct by post monthly on publishing day—the first Wednesday of the month. Write the Circulation Manager, *The Short Wave Magazine*, 49 Victoria Street, London, S.W.1.

## Foto fer Foto?

Acknowledgments to the unknown readers in Warrington, Lancs, and Liverpool who produced well - designed "MO1FFI" and "PX9OL" QSL cards, sending them to G9BF, c/o the Office. Our poor friend says he knew he would get some sooner or later!

## 'PHONE C/W AREAS

Help rationalise the use of the 7 and 14 mc bands by keeping 'phone in the 7,200-7,300 kc and 14,200-14,300 kc areas. New 3-letter G's and CW operators, please choose your crystals to give working points in the 7,150-7,200 kc and 14,100-14,200 kc areas.

## American Item

The W's now have the whole of the 3.5 mc band (3,900-4,000 kc 'phone) and are also allowed to play with pulse on amateur allocations above 1,215 mc. From 30,000 *megacycles* upwards, there are no restrictions of any kind!

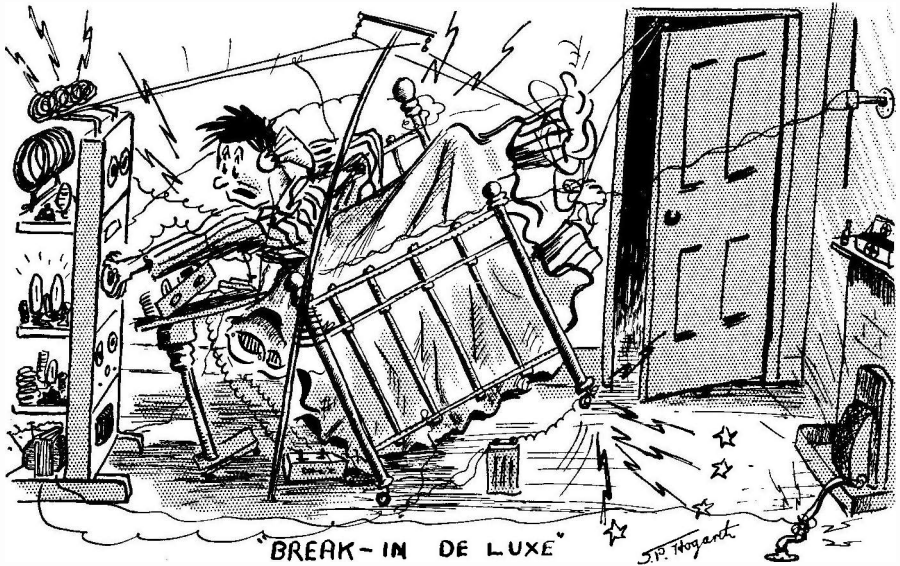

## G9BF Calling

(Sorry, but he's here again.—Ed.)

Received two cards this month. One from old pal MO1FFI and another saying "Pse put out appelle general on 7400 kc 'phone 1600 Sunday will be listening 88's Susie." Do not know any YL with call-sign SUSIE but am prepared all eventualities so decide keep sked irrespective. Am of course well known for quality 'phone, so not surprised being asked for sked.

Sunday arrives, have bath, brush hair, clean collar and borrow French dictionary from old pal GX7XX (sometimes signing PX9YL) down road. He surprised about French dictionary, but tell him am studying for GPO licence exam. He still more surprised. Look at dictionary a bit, realise why most French hams prefer talk English. Decide will talk English for sked.

Come on 1530 testing Tx. No trouble at all finding 7400 as have absorption freq. meter calibrated from 6000 to 16000 kc (about) using .0005 condenser and five-turn coil. Do not recommend coil-changing with delicate measuring equipment. Check calibration by tuning Rx to dial setting old pal GX7EE. ECO on about 7150 to 7175 or thereabouts.

Tx perking fine on CW; bags RF up spout with usual 150 watts to T20. Put out snappy 5-minute CQ on key, back

comes old pal MO1FFI. Give him "Ur sigs usual RST599 om tnx card whats QRA nw es hw?" He replies "Ur sigs fb S9 om see postmark fer QRA but note vy ruff tho fb fer DX." This puzzling, as now have 2  $\mu$ F smoothing condenser in power pack. Decide try 'phone.

Switch on modulator and notice steady flicker on all meters including hot-wire in aerial. This curious as mike not switched in. Switch in mike. Loud howl from direction modulator-speech amplifier. Howl persists no matter what adjustment gain control, mod bias, aerial coupling, PA drive or ECO setting. All meter readings very high and aerial current doubled; first time aerial ammeter registering since operating 'phone, so modulator working better than usual.

Switch off and think, first principles first. Obviously instability somewhere. Always recommend methodical checking so start with ECO and work towards PA and back again. Howl still there. Then try modulator. Still no joy. Time now long past 1630, so sked missed. Tea missed too. At 1830, decide to check speech amplifier. Find grid resistor across input to first valve fallen off and wire to grid cap touching panel.

Wonder if SUSIE will QSL.

(We'd like to know.—Ed.)

## HOW THINGS HAPPEN

## APOLOGIA

The processes through which a drawing must go involve at least seven checks before it can appear in print. One might, in fact, suppose that the system is as near proof against error as any that could be devised. But it is not.

Attention has already been drawn to some mistakes which were made in the "Principles of Short Wave Reception." Here are three diagrams which, appearing in that series, successfully concealed small errors which were brought in at different stages and have only come to light as the result of a re-check on the March, April and May issues. These drawings are now shown here as they should have appeared in the first place. We apologise for these mistakes and while so doing, draw attention to a few others in the same series that may or may not have been noticed by readers.

In the diagram of Fig. 2, p. 147 (May), shown here corrected, R4 should be 25,000 ohms; it is not given in the original caption. In Fig. 3, p. 148 (May)—the oscillator section only of which is redrawn here with the correction to L3/L4—the lack of a by-pass condenser for the BFO reaction winding in the plate of V3 in the original circuit has been criticised by G3PL (Hull). The reply from A. A. Mawse is that "when using the recommended IF of 1.6 mc and employing a reaction winding as described, there are in practice sufficient stray capacities to make the by-pass condenser unnecessary. If one is required, try 100  $\mu\text{F}$  between the RFC end of the winding and earth." In the caption to Fig. 4 on p. 150 (May), a valve type is given as "7G711232"; this should be 7G7/1232. The coil values for this circuit are shown not in the table, as says the caption, but in the text (p. 149, "A 58 mc Unit").

So much for the "Principles of Short Wave Reception" in the March, April and May issues.

### Tidying up June

In June, p. 225, in the panel headed "The Amateur Bands," the 14 mc range should read 14,100-14,300 kc. And on p. 240, June (a very small one this), switches S1 and S2 in the circuit diagram should have been shown closed. The working of the circuit is then much clearer, though the argument is in no way affected.

In G5BY's article in the June issue, the coil former drawing on p. 231 shows it as octal-based with key, whereas in fact Eddystone standard six-pin formers were used.

That seems to be all in the way of errors that have so far crept in. Even though they are relatively unimportant, and in most cases obvious, mistakes, our face is still red, and we apologise to anyone who has been led into difficulties because of them.

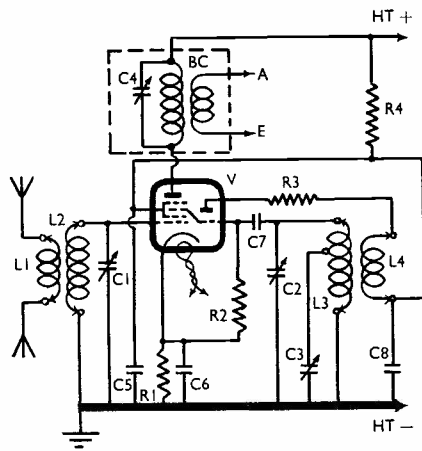

The diagram of Fig. 2, p. 147, May issue, corrected.

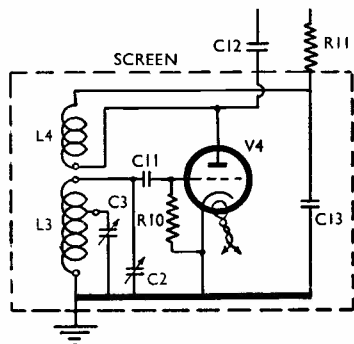

The diagram of Fig. 3, p. 148, May issue, corrected.



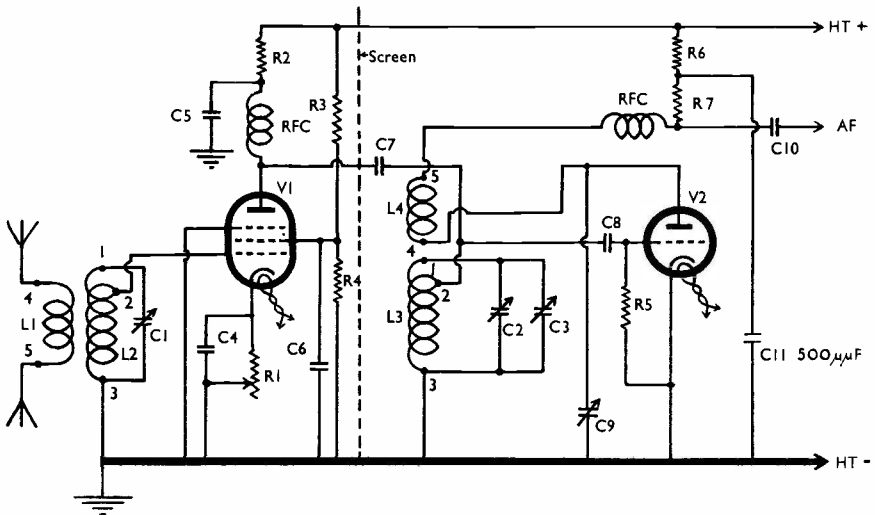

The diagram of Fig. 3, p. 82, April issue, corrected.

**British Amateur Valve Types**

Elsewhere in this issue appears the first comprehensive list of British transmitting valves suitable for Amateur Radio yet published in this country.

Sufficient information is given for a valve for any particular purpose to be quickly chosen, with its equivalents, main characteristics and current list price. We have not attempted to show every detail of all types, since to have done so would have resulted in a mass of indigestible data. Having selected a valve, the necessary detailed operating data will normally be supplied with it.

Looking over the list, one cannot fail to be impressed by the wide range of British types available, and their favourable cost in comparison with present ruling prices of their American equivalents in this country. As to suitability, in every case they are at least as good as the corresponding American types.

The stocks of American transmitting valves are running very low, and may not be replenished for a long time. Hence, like so many other things, they now have a scarcity value. From the data we give this month, you can choose a valve for any stage of a transmitter on any band and, in general, pay rather less for it than you would for the American equivalent.

**RADIO VALVE VADE MECUM**

This is a remarkable publication, probably the only one of its kind yet attempted. It seeks to list full data on all valves extant—and very nearly succeeds. The compass of the book covers not only all British and American types, but every Continental make as well, including Russian, of which there are no less than 130 varieties listed! Full details as to characteristics, base connections and interchangeability are given, and in glancing through the index one notices such species as the Record, Marathon, Radiotech, Telefunken, Vatea, Adzam, Castilla, Celsior and Visseaux, to mention only a few taken at random.

The working details given of the various types are extraordinarily complete, including as they do such factors as the cathode bias resistor, input peak voltage and mean oscillator plate current, where data of this kind are appropriate.

There is also a most useful section, compiled from information supplied by the Allied Inter-Services Technical Valve Committee, which correlates Service and commercial types, giving the VR/VT/VU and CV numbers corresponding to the manufacturers' normal markings.

The book "Radio Valve Vade-Mecum" is a Dutch publication by P. H. Brans, runs to over 200 pages, is printed in four languages, including English, and costs 12s. 6d. of the sole agents, Messrs. Ritchie Vincent & Telford, Ltd., 176 High Street, Acton, London, W.5.

## Getting Going on 7 & 14 mc

*Discussing a Simple Transmitter Design  
Using Modern Valves*

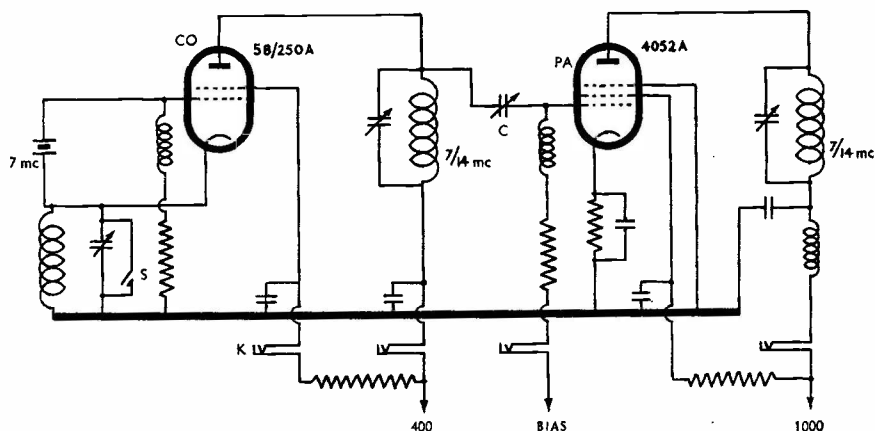

Elements of the design discussed in the text. For 7 mc working, S converts the first stage to a straight CO: for 14 mc, the 5B/250A is in tritode, with its tank tuned to twice the crystal frequency. The PA is a straight un-neutralized amplifier on either band. Condenser C controls the grid excitation, and K is the keying point. PA inputs of 80 to 90 watts are easily obtainable on both bands.

**W**ITH the resumption of hostilities imminent on 7 and 14 mc, many readers will be thinking about a suitable rig, especially for CW working.

The circuit given here shows the essentials of a good modern design, which is at once simple and easy both to construct and get going. The discussion this month is concerned only with the general features of the transmitter as a design—the set as finally constructed will appear next month, with all circuit details and the necessary operating data.

### Circuit

The drive side consists of an STC 5B/250A beam tetrode (similar to the KT8c and 807), which can be operated either as a straight CO on 7 mc or as a tritode for producing output on 14 mc. This change is quite easily obtained by means of switch S, which when made converts from tritode to CO. This stage is keyed in the screen—jack K in the diagram. The PA, which is a straight un-neutralized

RF amplifier on both bands, is an STC 4052A (like the PT15 and RK20), which is capable of producing large RF outputs with comparatively insignificant driving power.

The drive into the grid of the PA is controlled by the series condenser C, a simple variation of the standard direct-coupled CO-PA circuit; such an arrangement is always useful with these very sensitive valves, as it enables the PA grid current to be adjusted accurately. With the more robust and far less sensitive triodes of the T20 species, one usually adjusts for full drive. With pentodes and beam tetrodes, this is nearly always the very thing to avoid if the valve is to work efficiently and have a useful life. They simply will not stand being over-driven.

### General Points

There is nothing either clever or unusual about this design. It is a sound basic circuit with a few slight frills which will be found to make it

flexible and easy to control. The PA can be modulated either on the suppressor—for relatively low-power 'phone—or on plate-and-screen for full-power operation.

At the moment we are working out a band-switch arrangement for the CO and PA tank circuits, in order to try and obtain good efficiency on

both bands without having to change coils or fiddle with taps. The difficulty is to find a switch which will stand up to the RF current circulating in the output tank.

We hope to produce some more ideas on the whole outfit next month, when we shall be illustrating the built-up job.

### NEW QRA's

*Only those which have changed since the appearance of the September, 1939, issue of the Call Book or were not included in it for fully licensed operation, or are now licensed for the first time, can be published here. All that do appear in this column will automatically be included in the next Call Book, now in preparation. The number of QRAs we can print each month depends upon space available. QRAs are inserted as they are received, up to the limit of the space allowance. Please write clearly and address to QRA Section.*

EI3P	W. L. Watts, 1 Kill Avenue, Durr Laoghaire, Co. Dublin, Eire.	G3BU	H. G. Smith, 15 Abbeymead Road Abbey Lane, Leicester. (Tel.: Leicester 62053).
G2ATU	B. A. Wilbraham, 1 Rochester Avenue, Sedgley Park, Prestwich, Manchester.	G3OO	D. T. Bennett, 1 Manor Drive, Southgate, London, N.14. (Tel.: ENTenterprise 2462.)
G2BLA	F/O M. A. Pyle, 66 Gracefield Gardens, Streatham, London, S.W.16. (Tel.: Streatham 0691.)	G3PZ	R. R. Waite, 157 Tuffley Avenue, Gloucester.
G2BRJ	R. Jones, Clowne, Nr. Chesterfield, Derbyshire.	G3SS	E. F. Lawden, 345 Stockfield Road, South Yardley, Birmingham 25.
G2BYK	J. C. Payne, Welton Manor, Welton, Nr. Daventry, Northants.	GM4AN	W. G. Hopcroft, 3 McKenzie Street, Sinclairtown, Kirkcaldy, Fife.
G2CKA	F/O F. W. S. Kempton, Avonhurst, 28 Baronsmead, Whitkirk, Leeds.	G4AP	J. G. Rooke, 72 Goddard Avenue, Swindon, Wilts.
G2CLL	G. F. Eglesfield, 60 Buckingham Avenue, Feltham, Middlesex.	G4AR	A. E. Dowdeswell, 11 Kingsbridge Road, North Kensington, London, W.10.
G2CQO	G. Harrison, 21 Alnwick Avenue, Whitley Bay, Northumberland.	G4BH	A. Norwiche, 5A Victoria Road, Surbiton, Surrey.
G2CUZ	N. Horrocks, 32 Sandbrook Road, Ainsdale, Southport, Lancs.	G4JK	G. R. Whiteside, "Highways," Oxenholme Road, Kendal, Westmorland. (Tel.: Kendal 85.)
G2DFH	H. Griffiths, Pendennis, St. Erth, Hayle, Cornwall.	G4KN	H. A. Thomson, Brenton, New Road, Watchet, Somerset.
G2DTA	R. Bowes, 10 Blackgate, Coxhoe, via Ferryhill, Co. Durham.	G5AC	A. Cogdon, 16 Greta Terrace, Sunderland, Co. Durham.
G2FAQ	C. E. Pellatt, 101 Boundary Road, Chatham, Kent.	G5BB	A. H. Bruce, 2 Albemarle Mansions, Heath Drive, Hampstead, London, N.W.3.
G2FUU	T. Knight, Caxton House, High Street, Hoddesdon, Herts.	G5LH	R. Mitchell, Croft House, Horbury, nr. Wakefield, Yorks.
G2FXI	H. S. Jewitt, 95 Rock Avenue, Gillingham, Kent.	G5XD	B. C. Christian, 8 Woodkind Hey, Bebbington, Wirral, Cheshire.
G2FYG	Capt. E. J. Devaney, R.A.S.C., 12 Colville Street, Derby.	G6AD	N. Kellett, 16 Melton Road, Asfordby Hill, nr. Melton Mowbray, Leics.
G2FZJ	W. Bell, 16 Middlebrooke Lane, Thorne, nr. Doncaster, Yorks.	G6NG	A. N. Harris, 4A Lessington Avenue, Romford, Essex.
G2HAX	S. P. Shackelford, 20 Coniston Drive, Tilehurst, Reading, Berks.	G6VS	W. H. G. Metcalfe, 128 Stamfordham Drive, Liverpool, 19.
G2HG	J. Egremont, New Cottage, Colden Common, Winchester, Hants.	G8AO	Capt. E. Clarke, M.B.E., 175 Marsden Road, South Shields, Durham. (Tel.: South Shields 218.)
G2HLF	R. J. Lee, 9 Theobalds Green, Heathfield, Sussex.	G8FM	J. H. Shankland, B.Sc., BM/SHANK, London, W.C.1 (Station at Rugby).
G2RK	C. A. Reddick, 7 Rosedene Gardens, Ilford, Essex.		
G2VBM	K. H. Pearce, 14 South Avenue, Oldfield Park, Bath, Somerset.		
G2WD	G. McLean Wilford, The End House, Hilderstone Road, Rough Close, Stoke-on-Trent, Staffs.		
G3BR	S. T. Hall, 140 Sinclair Road, London, W.14.		

# THE MONTH WITH THE CLUBS

## FROM REPORTS

Twenty-two clubs are represented here this month, all the notes having been received by the due date—thank you, secretaries! None are included which arrived after it, since this column is written and set on the closing date. For the next (August) issue, please let us have your material by July 22 *certain*.

Of the twenty-two, nine appear for the first time in these pages; we look forward to seeing their notes regularly. As some readers have observed, the space given to this feature has increased considerably since our first issue, and as space is at a premium, the Editor is beginning to talk about "two pages maximum." We should, therefore, like to have secretaries' views as to the future presentation of "Month with the Clubs."

Should we continue in the present style (which has many advantages) or should we try and write the feature as a continuous general-interest narrative? This might mean that some Clubs, reporting only briefly, would not be mentioned in the body of the article.

We are now getting frequent letters from readers asking "Is there a Club in my district?" We are at the moment dealing with these enquiries individually, but at an early date propose publishing main details from our Register of Active Clubs. This now contains information on nearly 50 local societies, the majority making Amateur Radio their chief interest. It will, however, mean a whole page out of "Month with the Clubs."

The current reports follow. Names and addresses of the secretaries of all Clubs mentioned appear as usual at the end of the article—and please remember July 19 or 20 (for July 22).

**Bradford Short Wave Club.**—Meeting weekly on Mondays and membership still increasing, sums up the story here. They are always pleased to see visitors and prospective members.

**Hounslow and District Radio Society.**—With a present total of 31 members (good going in less than two months), the average attendance is 22 at the meetings. Straight and superhet type receivers have been demonstrated and discussed, and a Morse class formed; a club library is under consideration.

**West Sussex Short Wave and Television Society.**—They meet fortnightly at the Punchbowl Hotel, Chichester, under the presidency of Mr. Gerald Marcuse, G2NM, the G.O.M. of Amateur Radio. Recent lecturers have been G6OT on "Radar" and "Negative Feed Back," and G2AAH on "A 5-metre Converter." Many readers will remember him for his pre-war 56 mc activities. A permanent club-room is being sought, and new members (not necessarily holders of radiating licences) will be welcomed. West Sussex committee members include G2PF, G5CM and G8RO.

**HI-Q Club, Giffnock.**—Members are active on all amateur bands; on 1.8 mc, they hear stations in Southern England working one another and complaining of poor conditions when their signals are S4 in Scotland. GM2FZT has been working Europeans on 28 mc with 5 watts to an FD and an indoor doublet. The secretary would like to have information on vertical dipoles, field strength meters, the R.A.F. 1154B transmitter and radar interference with reception (curing, methods of?)

**Grafton Radio Society.**—The current series of lectures includes "Radio in War Time," by F/Lt. Bernard Randell, B.Sc., G.I.E.E., and SPIHH of Tele-Radio (1943) demonstrated his midget VHF 'phone transmitter and receiver at a recent meeting. Grafton's "Practical Section" is under way with the building of two transmitters, and superhet and 1-V-1 receivers. It is hoped shortly to be in operation on all amateur bands. The SWL section is expanding rapidly, and good progress is being made by the Morse classes. The ex-Service membership includes a preponderance from the R.A.F.—they would like to see a few more from the Navy and Army. Meetings are every Monday, Thursday and Friday, 7.30-9.30 p.m., at the Grafton L.C.C. School, Eburne Road, Holloway, N.7.

**Northern Radio Club.**—There are three active calls among their 25 members, and code classes and lectures are in full swing; the object is to try and cover the syllabus for the Radio Amateurs' Examination. Recent visits have included the BBC's Newcastle studios and the Staghead transmitter.

**Birmingham and District Short Wave Society.**—The next meeting is on August 12, when the concluding part of a lecture on aërials will be given; the event of immediate interest is the Club DX competition, reported last month. It is hoped that the results will be out in time for our August issue.

**Hull.**—There are about 110 keen amateurs in the area, and the local group hold regular monthly meetings in their own club-room at 30, Prince's Avenue, the attendance averaging 30. Some 15 members are fully licensed, and it is expected that this number will increase considerably very shortly. There is some interest in 58 mc working, and one or two members have receivers on the band. It is proposed to open the club-room two nights per week, with full meetings once each month; the next is on July 22. An elementary radio course is to be given every Friday night, a library is being collected, and a club station is planned. Altogether, an active and enterprising centre of Amateur Radio interest.

**Whitefield and District Radio Society.**—The regular weekly meetings are every Monday at 7.30 p.m., at the Stand Grammar School, Higher Lane, Whitefield. G6GV has been appointed technical adviser; he will be giving a series of lectures on Amateur Radio subjects. Morse instruction is a regular feature. All interested in radio are invited to the meetings.

**South Shields Amateur Radio Club.**—They have resumed activities, and meet every Friday at 7.0 p.m. in the St. Paul's School Rooms; the first hour of the evening is devoted to Morse practice. An interesting programme has been mapped out, new members are invited and visitors are welcomed. Officers of the club are G8VV and G8IF, who have given several lectures and demonstrations.

**Coventry Amateur Radio Society.**—With 50 members, they meet fortnightly at John Hough's Mission, Room 8, on Mondays at 7.30 p.m. Here again, Morse instruction is featured. Special lectures and visits are arranged—the last was to the G.E.C. Telephone Works—and G6DC has given a talk on "Radio in Burma."

**Slade Radio.**—Membership continues to grow, with abundant enthusiasm displayed in all matters pertaining to radio. Enquiries are being made about portable facilities, and plans are in hand for a D/F outing.

**Sunderland and District.**—The notice convening a meeting to consider the formation of an Amateur Radio club in the Sunderland district was unfortunately too late for publication in our last issue. However, we hope readers interested will get in touch with G2TG, whose address appears at the end of this article.

**Bournemouth and District Amateur Radio Club.**—With the arrival of G2DBF, lately secretary of the Maidenhead group, a club was formed in Bournemouth on May 9. About 30 have joined, and meetings are held fortnightly on Thursdays in the Lodge Room of the Branksome Towers, Commercial Road; the next are on July 4 and 18. Twelve members hold licences, Morse classes have been started with G2NS as instructor, and application has been made for a club transmitting licence. The idea is to get a permanent club-room, so that a station can be built. As well as all this, a crystal register has been started and a library is being formed—very good going for less than two months' work. G2DBF says that he would like to hear from other club secretaries with a view to exchanging ideas and visits. Any amateur who happens to be in Bournemouth on holiday will be welcome at the meetings.

**West Cornwall Radio Club.**—At present, most of the members are active transmitters, but new applications from anyone interested in Amateur Radio will be gladly received, and it is intended to arrange a programme to suit all tastes. Meetings are held alternately in Penzance (The Dolphin Hotel, Quay) and Falmouth, on the first and third Thursdays, respectively, every month. The president is G2WW, the secretary G2JL and the assistant secretary (Falmouth) G6LV.

**Edware and District Radio Society.**—After nine years, G2AI has had to give up the presidency on leaving the district. A member who took the Radio Amateur Examination discussed the questions and his answers at a recent meeting—the point of this is that he is a real amateur, in the sense being a non-professional who was not in the Services. Two visits have been arranged to a well-known station, and G2IM has lectured on aërials.

**Salisbury and District Short Wave Club.**—First formed in 1936, with the late Sir Oliver Lodge as its patron, Salisbury had to close down during the war years. It has now been re-formed, with all Amateur Radio activities well in hand. They have applied for a club licence (transmitting,

not the other kind) and a modern type of superhet is in course of construction. Various groups are undertaking to cover transmitter and aerial design, receivers, modulators and amplifiers, VHF work, including television, a Morse class and a beginners' section. Active members include G5DZ (ex-VS7MB) and G2FIX. The meetings are every Tuesday and Thursday at 7.30 p.m., but the club workshop is available to members any day.

**Manchester and District Radio Society.**—This is another club which has recently been re-formed, under the chairmanship of Ian Auchterlonie, G6OM, with G5CP as secretary and G2WQ as treasurer. Their meetings are monthly, at the College of Technology, Sackville Street, and the secretary would like to hear from prospective members.

**Stourbridge and District Radio Society.**—Twenty-five members attended the last meeting, when it was agreed to commence a local monitoring service for the benefit of transmitting members who wish to conduct special tests. The next meeting, on July 2, is to consist of talks by members experienced in portable work; future talks will cover aeriels, power distribution, 28 mc and radar.

**Midland Amateur Radio Society.**—At the meeting on May 21, when 68 members and visitors were present, 58 mc converters formed the subject for discussion. G5BJ opened the meeting, and G2AK and G2BKZ also contributed to the discussion. G2RQ summed up and drew attention to the high standard of workmanship of the converters on view. The next meeting of M.A.R.S. is on July 16, at the Chamber of Commerce, New Street, Birmingham, and visitors are always welcome.

**Reading and District Radio Club.**—Converters will also figure at their next meeting, on July 27. The Lewis Cup will be awarded for the best piece of home-constructed apparatus; judging will take place on September 28, and a good entry is expected. G8RS has been lecturing on 5-metre equipment and radar.

**Liverpool and District Short Wave Club.**—They now have 40 members and there is a high level of activity in all branches. Several members will be taking the next G.P.O. examination, in connection with which the Morse classes are being well supported. The club workshop is open on Monday and Saturday evenings, and new members are enrolled at every meeting.

Following are the names and addresses of the secretaries of the clubs mentioned this month. They will be pleased to give every assistance to prospective members.

**BIRMINGHAM.** G. Hodgkiss, BSWL-1938, 30 Towyn Road, Moseley, Birmingham, 13.  
**BOURNEMOUTH.** J. F. Squires, M.B.E., G2DBF, 80 Victoria Road, Bournemouth.  
**BRADFORD.** V. W. Soven, G2BYC, 6 West View, Eldwick, Bingley, Yorks.  
**COVENTRY.** T. Taylor, 19 Anthony Way, Stoke, Coventry.  
**EDGWARE.** P. A. Thorogood, G4KD, 35 Gibbs Green, Edgware.  
**GRAFTON.** W. H. C. Jennings, A.M.I.R.E., 82 Craven Park Road, London, N.15. (Tel. : Stamford Hill 3891).  
**HI-Q CLUB.** J. D. Gillies, GM2FZT, 3 Berridale Avenue, Glasgow, S.4.  
**HOUNSLOW.** A. H. Pottle, 11 Abinger Gardens, Isleworth, Middlesex.  
**HULL.** A. Bell, G2XA, 22 Orchard Road, Hull.  
**LIVERPOOL.** T. W. Carney, G4QC, 9 Gladeville Road, Aigburth, Liverpool, 17.  
**MANCHESTER.** C. R. Plant, G5CP, 33 Manley Road, Sale, Manchester. (Tel. : Sale 3816).  
**M.A.R.S.** W. J. Vincent, G4OI, 342 Warwick Road, Solihull. (Tel. : Solihull 0413).  
**NORTHERN.** A. Robson, 522 Denton Road, Newcastle-on-Tyne, 5.  
**READING.** R. J. Nash, BRS-4873, 9 Holybrook Road, Reading.  
**SALISBURY.** C. A. Harley, 85 Fisherton Street, Salisbury, Wilts.  
**SLADE.** L. A. Griffiths, 47 Welwyndale Road, Sutton Coldfield, Birmingham.  
**SOUTH SHIELDS.** W. Denny, 12 South Frederick Street, South Shields.  
**STOURBRIDGE.** D. Rock, G8PR, Sandhurst, Vicarage Road, Amblecote, Stourbridge.  
**SUNDERLAND.** W. Stockburn, G2TG, 40 Nertherburn Road, Sunderland.  
**WEST CORNWALL.** R. V. Allbright, G2JL, Greenacre Cottage, Lidden, Penzance.  
**WEST SUSSEX.** L. Frost, G5PF, Old Timbers, Boxgrove, Nr. Chichester.  
**WHITEFIELD.** E. Fearn, 4 Partington Street, Newton Heath, Manchester, 10.

*For the Best Information on the Latest News,  
read the Short Wave Magazine regularly*

# CATALOGUE EXTRACTS

## AERIAL EQUIPMENT

	£	s.	d.
75' coil 14 SWG enamelled copper wire	3	6	
100' coil 14 SWG enamelled copper wire	4	6	
150' coil 14 SWG enamelled copper wire	6	6	
100' coil 12 SWG enamelled copper wire	7	3	

**Feeder cable**—150 watt, close space  
80 ohms impedance, Polythene insulation,  $\cdot 27$  DB/100 ft. at 1 megacycle,  
Per yard 9

**Twin screened**, Polythene insulation  
80-100 ohms, 1.8 DB/100 ft. at 30 megacycles... Per yard 2 0

## STANDARD RACKS, CHASSIS & PANELS

**Racks**

31½" steel rack, grey or black...	2	0	0
63" steel rack, grey or black...	2	10	0

**Chassis**, 17" x 10" x 2", grey or black ... 8 6

**Panels**—steel, black or grey crinkle finish.

19" x 10½"	7	6	
19" x 8½"	6	6	
19" x 7"	5	6	
19" x 5½"	4	6	
19" x 3½"	3	6	

## METERS

Measuring Instruments (Pullin) Ltd.,  
B.S.I. accuracy—

2½" square dial, flush mounting, 0-50 ma., 0-100 ma., 0-250 ma., D.C.	2	5	0
2½" square dial Thermo-couples. R.F. 0-100 ma. 0-250 ma. 0-500 ma.	95/8	89/-	80/8
3½" rectangular dial, flush mounting. 0-1 ma. D.C., with Multi Range Scale for constructing Universal Test Meter	4	9	0

"HOW TO MAKE your own Multi-Range Test Meter," by A. Stephenson, of Measuring Instruments (Pullin) Ltd. £ s. d. (post free) 1 9

## CONDENSERS

Paper—oil impregnated.

4 mfd. 1,000 V wkg. ...	15	0
4 mfd. 2,000 V wkg. ...	1	0
2 mfd. 2,000 V wkg. ...	15	0
4 mfd. 650 V wkg. ...	7	3

## TRANSFORMERS by Partridge.

600-500-400-0-400-500-600V, 180ma. 5 volt, 3 amp. ; 6.3 volt, 5 amp. ...	3	15	0
2.5 volt, 10 amp. (2K volt insulation) ...	18	6	
375-0-375 volt, 150 ma., 4 volt, 4 amp. ; 4 volt, 6 amp. C.T., 4 volt, 2 amp. C.T.	2	15	0

## MODULATION TRANSFORMERS—by Partridge.

10,000 ohms C.T., tapped at 6,600 and 3,800 ohms. Secondary 15,000 ohms tapped at 10,000 and 5,000.		
25 watts suitable for 50 watt carrier...	2	5
50 watts suitable for 100 watt carrier...	3	7
75 watts suitable for 150 watt carrier...	4	6

## VALVES

866—27/6 ; 83 (British made)—15/- ; 807—30/5 ; 6L6—18/3 ; VR150/30—15/- ; VR105/30—15/-.

## Q.C.C. CRYSTALS

X Cut—in 1.7 ; 3.5 or 7 megacycle bands.

Taken from our own stock ... each	1	12	6
Ground to your own specified frequency ...	1	17	6
100 kc. frequency sub-standards, .01% ...	2	5	0

## CRYSTAL MICROPHONE

Rothermel Crystal. DB. 104 ... 5 5 0

## SCREENED MICROPHONE CABLE

Single, per yard ...	9
Twin " " ...	1 6

## OUR NEW 24 PAGE CATALOGUE

is now being printed ; distribution will be completed this month. **If you have not ordered yours**, please send 2½d. stamp for postage.



**TELE-RADIO (1943) LTD.**

177 EDGWARE ROAD, LONDON, W.2

Telephone : PADDINGTON 6116



**A QUART INTO A PINT POT**

If we were to attempt to list all the items of Amateur apparatus we have in stock, we would need considerably more space than is available at the present time; may we suggest that you either visit our showrooms and make a personal inspection, or let us have your enquiries. We will willingly forward a quotation upon receipt of details. We give below a selection of items we have in stock at the time of going to press.

**VALVES.** S.T. & C., equivalents of RK25, RK34, 866, 83, etc., also 6L6, 6V6, 6K8, 6K7, etc.

**CONDENSERS.** Transmitting variables, up to 5,000 volt working. Raymart ceramic variable condensers. Oil-immersed high voltage smoothing (4 mfd. 1,000 or 2,000 volt). Large range of metallised mica condensers. Special line of high voltage mica condensers (.002 mfd. 2,000 volt working).

**RESISTORS.** All types and values from  $\frac{1}{2}$  watt to 50 watt ratings.

**TRANSFORMERS.** Complete range with outputs from 250 volts to 2,000 volts, or constructed to your specification. Modulation transformers (multi-ratio) 60 and 100 watt. These are being specially made for us by Vortexion Ltd. W/V Quality Multi-ratio Output transformers (15 watt).

**RADIOCRAFT LTD.**

11 Church Road, Upper Norwood, London, S.E.19.

(One minute from Crystal Palace (HL) Southern Railway Station and bus terminus).  
Open all day Saturday.

## THE PARTRIDGE ORGANIZATION

is again at your service.

For six years we have been supplying the Services with our iron cored components. We are now once more accepting orders for ordinary commercial and domestic needs.

Our technical department will again be pleased to assist you in your transformer problems.

We look forward to hearing from our old friends, and welcome enquiries from newcomers.

May we send you our 1946 price list? This details a comprehensive range of components that can now be despatched from stock.

Telephor.e:

Abbey 2244

**PARTRIDGE**  
**TRANSFORMERS LTD**  
76-8, PETTY FRANCE, LONDON, S.W.1

## A MOVING COIL MICROPHONE SPECIALLY SUITED TO AMATEUR USE

Adequate frequency response: 70-8,500 c.p.s. approx.; low impedance, giving maximum protection against both R.F. and L.F. feedback. No polarising current required; no background; robustness; high sensitivity and no pronounced resonances are characteristics of this microphone.

Inevitable minute variations from model to model make it impossible to publish figures which are 100% correct in every case. We can, however, guarantee that these variations are small enough not to affect the performance.

Price.....£5 15s. 0d.  
TRANSFORMER 15s. 0d.

**FILM INDUSTRIES LTD., 60 PADDINGTON ST., W.1**

Telegrams: Troosound, Wesdo, London.

Telephone: Welbeck 2385/6

Managing Director: D. T. BENNETT (G.300)

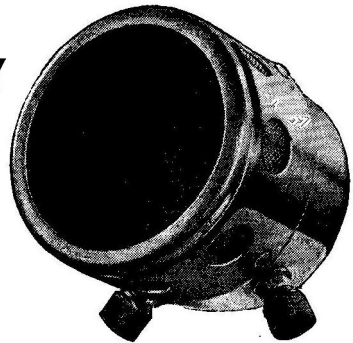

**THE F.I. TYPE M.5**

Diameter, 3 in.  
Depth, 2½ in.  
Weight, 2 lbs.  
Coil impedance, 6 ohms at 400 c.p.s.  
Average impedance, 50-10,000 c.p.s., 8.9 ohms.  
Finish: Nickel plate.  
Output for normal close speech across transformer with 250,000 secondary load; 0.20 volts.



THE FINEST CORED SOLDER IN THE WORLD

**ERSIN  
MULTICORE**

Multicore Solder contains 3 cores of extra active non-corrosive Ersin Flux. No extra flux is required and joints can be readily made on oxidised surfaces. The three cores of Ersin Multicore ensure rapid melting and flux continuity, thus speeding up soldering operations and eliminating waste.

NOMINAL 1-lb. REELS HIGH TIN CONTENT PRE-WAR QUALITY.				
Catalogue Reference No.	Alloy Tin-Lead	S.W.G.	Approx. Length per nominal 1-lb. reel.	Price per nominal 1-lb. reel (subject)
16014	60/40	14	84 feet	5/-
16018	60/40	18	128 feet	6/9

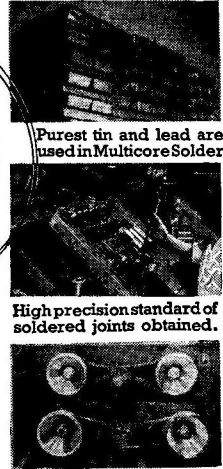
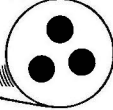
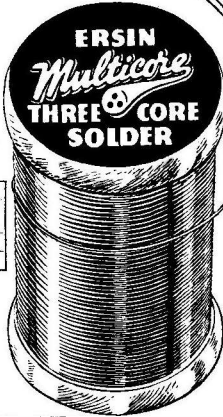

**MULTICORE SOLDERS LTD.**  
**MELLIER HOUSE, ALBEMARLE STREET, LONDON, W.1**  
 Tel. REGent 1411 (P.B.X. 4 lines)

Multicore being made in gauges between 10 & 22 S.W.G.

**FOR BAND CHECKING**

**CAN BE  
 SUPPLIED  
 SINGLY  
 OR IN  
 SETS OF FIVE  
 1.5—70 m/cs**

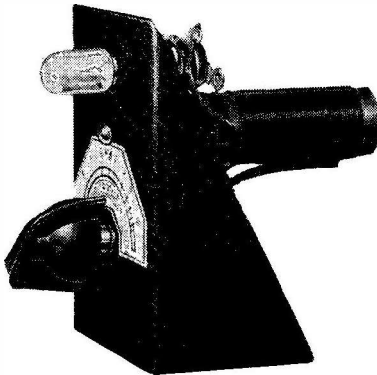

**ABSORPTION  
 WAVE-  
 METERS  
 SMALL  
 NEAT  
 EFFICIENT**

Tele :  
 2494  
 (2 Lines)

**LABGEAR**  
 WILLOW PLACE  
**CAMBRIDGE**

Grams :  
 LABGEAR  
 CAMBRIDGE

**MANUFACTURERS OF HIGH CLASS COMMUNICATIONS EQUIPMENT**

## LASKY'S RADIO

EVERYTHING FOR THE HOME SET  
CONSTRUCTOR, AMATEUR RADIO  
EXPERIMENTER, AND SERVICEMAN.

**ELECTROLYTIC CONDENSERS, 500v. WORKING.**—8 mfd., 3/-, 16 mfd., 4/9 ; 8 x 8 mfd., 5/6 ; 8 x 16, 6/9 ; 16 x 16, 7/9.

**HIGH VOLTAGE OIL-FILLED CONDENSERS.**—8 mfd., 600 v.w., 5/- ; 4 mfd., 1,000 v.w., 7/- ; 10 mfd., 600 v.w., 7/- ; 2 mfd., 1,000 v.w., 4/6 ; 4 mfd., 450 v.w., 3/9 ; 1 mfd., 1,000 v.w., 3/6 ; 4 mfd., 400 v.w., 3/3 ; 1 mfd., 750 v.w., 3/- . All with china stand-off insulators and fixing clip (feet). 0.1 mfd., at 8,000 v.w. (tubular), 10/6 ; 0.5 mfd., 6,000 v.w., 10/-.

**YAXLEY TYPE SWITCHES.**—4-pole, 3-way 2/6 ; 2-pole, 5-way (Midget), 2/3.

**COILS.**—Medium and long-wave with reaction and circuit, 8/6 per pair. **Whearite** "P" coils from 2/3 each. I.F. Trans., 465 kc/s., 15/- pair. **Whearite Midget I.F.T.'s** 460 Kc/s., 10/6 each. **L.M. & S.Wave, A.E. and O.S.C.**, 465 Kc/s with superhet circuit 10/6 pair. **Weymouth** all-wave coil pack with all switches, padder trimmers, and circuit, 38/6.

**MAINS TRANS. ALL TYPES.**—350-0-350 120 m.a., 6.3 and 5v. (Tapped at 4v.) input 200-250v., with mains tapping board and fixing feet, 37/6. 350-0-350, 80 m.a., 6.3 and 5v. or 4v. and 4v. 29/6.

**RADIO VALVES.**—English and U.S.A. types, 6,000 at B.O.T. prices. A few examples : CL4, CL33, PP35, PEN383, R3, APV4, MS/PEN., PENA4, VP4B, EF9, EF39, AZ31, CY31, CY1, UR3C, AZ1, etc., etc. 45Z5, 25Z5, 25Z6, 50L6, 35L6, 25Z6, 12SK7, 12SA7, 6SA7, 14A7, 12B7, 7A7, 7B7, 12SQ7, 25Y5, 25A6, 12SJ7, 6K7, 6J7, 6U7, 6K8, 6F6, 6V6, 6L6g, etc., etc., etc.

**ENERGISED SPEAKERS WITH O/TRANS.**—8in., 2,000 $\Omega$  Field, 35/- ; 6 $\frac{1}{2}$ in., 2,000 $\Omega$  Field, 32/6 ; 10in., 5,000 $\Omega$  Field, 45/-.

**P.M. SPEAKERS, LESS O/TRANS.**—2 $\frac{1}{2}$ in., 27/- ; 3 $\frac{1}{2}$ in., 29/6 ; 5in., 22/- ; 6 $\frac{1}{2}$ in., 23/6 ; 8in., 21/- . With trans., 6 $\frac{1}{2}$ in., 27/6 ; 8in., 27/6 ; 10in., 39/6. **Goodmans**, 10in., 39/6 ; 12in., £6 15/- . **Midget Chokes**, 5/9 ; **Midget O/Trans.**, 4/10 $\frac{1}{2}$ . **Universal O/Trans. Multiratio**, 7/6.

SPACE IS NOT AVAILABLE TO  
ADVERTISE ALL OUR GOODS. SEND ID.  
FOR OUR CURRENT LIST. ALL OUR  
PRODUCTS ARE GUARANTEED. WE  
AIM TO GIVE SATISFACTION AND  
VALUE.

TERMS.—CASH WITH ORDER C.O.D., or  
pro forma.

## LASKY'S RADIO

370, Harrow Road, Paddington, W.9  
(Opposite Paddington Hospital).

Phone: Cunningham 1979

## YOUR CRYSTAL IS NOT MASS PRODUCED WHEN MADE BY BROOKES

DURING 20 YEARS OF MANUFACTURING  
EACH UNIT HAS RECEIVED INDIVIDUAL  
ATTENTION FROM SKILLED CRAFTSMEN,  
AND EVERY HOLDER IS A PRECISION  
BUILT ENGINEERING JOB.

IN OUR POSITION AS PIONEERS OF  
CRYSTAL MAKING WE KNOW THAT  
ONLY IN THIS WAY CAN THE MAXIMUM  
EFFICIENCY BE OBTAINED.

1-8 and 7 mc/s, £1 12s. 6d. and £2, from stock.  
1-8 and 7 mc/s, £1 17s. 6d. and £2 7s. 6d. spec.  
frequency.

100 Kc/s Reference Units, £2 10s.

100/1,000 Kc/s Dual Frequency, £3.

4-Way Crystal Selector, 13/6.

Complete Oscillator Units.

Electronic Apparatus made to order.

### BROOKES CRYSTALS LTD.

51/53 Greenwich Church Street, London,  
S.E.10. 'Phone: GREENWICH 1828

## UNSURPASSED for SHORT WAVE WORK



Ericsson Supersensitive Telephones simply  
annihilate distance. Perfect in tone. Really  
comfortable in wear. British made. All  
good dealers 25/- or direct

# Ericsson

**SUPERSENSITIVE  
TELEPHONES.**

56 Kingsway, London, W.C.1  
HOLborn 6936

**CATHODYNE RADIO SERVICES**

181, Upper Richmond Road, Putney, S.W.15  
PUTney 0628

**TERMS:** Cash with order. C.O.D. (Under three pounds postage and packing charged to addressee).

Obtain your **EDDYSTONE** supplies locally! As more products become available we shall increase our range.

Listed below are a few of the lines we have of interest to home constructors. No matter what your requirements are, the more unusual the greater the interest; let us know, we desire to serve you.

**COMPLETE KITS OF PARTS AND CHASSIS SUPPLIED**

**ALUMINIUM CHASSIS.** 16 gauge polished aluminium  $10'' \times 4\frac{1}{2}'' \times 2''$ , drilled for 4 valves and 5" speaker cut-out. 5/6

**ELECTROLYTIC CONDENSERS.**

Miniature Dry Aluminium Can types: 8 mfd. 500 v. 2" high 1" diameter, 3/-; 16 mfd. 500 v. 2" high 1" diameter, 4/6; 8-8 mfd. 500v. 2" high  $1\frac{1}{2}''$  diameter, 5/6 Bias types, cardboard cases, tubular; 25 mfd. 25v., 2/3; 50 mfd. 60v., 3/0. Ferranti cardboard case tubular; 8 mfd. 500v. peak, 3/6

**PAPER CONDENSERS.** Sprague

Aluminium CASES: 0-001 mfd. 1,000v. D.C., 0-002 mfd. 1,000v. D.C., 0-01 mfd. 1,000v. D.C., 0-02 mfd. 750v. D.C., 0-1 mfd. 500v. D.C., 0-25 mfd. 500v. D.C., 0-5 mfd. 500v. D.C., 4/6 doz. all values.

**RESISTORS.**  $\frac{1}{2}$ ,  $\frac{1}{4}$  and 1 watt types. 4/- doz

**MAINS TRANSFORMERS.** Upright or

Sub-Chassis mounting. Flying leads, mains tapping panel 200-250v, 350v. C.T., 4v 2 amp. C.T., 4v. 4 amp. 60-80 mills, 350v. C.T. 60-80 mills, 6-3v. 3 amp. 5v. 2 amp. C.T. Chromium plated lamination shrouds. 32/6 each.

**TERMINALS.** 4 B.A. Black ebonite insulation,  $\frac{1}{8}''$  hole required for insulation clearance. 7/6 doz.

**VALVE HOLDERS.** International Octal Paxolin Wafer type, 4d. each; Mazda Octal Paxolin Wafer type, 6d. each; International Octal 'Amphenol' type, 6d. each; 6-pin UX Paxolin Wafer type, 6d. each

**WAVECHANGE SWITCHES.** Single Bank: 3 circuit 4 position, 5/- each; 4 circuit, 3 position, 5/- each; 2 circuit, 6 position, 3/- each.

**KNOBS.** Black pointers, Brown pointers, Black round, Brown round, 9d. each.

**VOLUME CONTROLS.**  $\frac{1}{2}$  and  $\frac{1}{4}$  meg with switch, 4/6 each.

**VIBRATORS.** 6 and 12 volt Non-synchronous 4-pin UX, 15/- each.

**THIS MONTH'S BARGAINS**

**ALUMINIUM CAN TUBULAR CONDENSERS.**—0.1mfd 1000 v. 1/9, .02mfd 750 v. 1/3, .1mfd 1000 v. 1/-.

**TINNED COPPER WIRE.**—16, 18, 20 and 22 S.W.G. on 1 lb. reels, 4/- lb.

**LINE CORD.**—3 amp. 60-70 ohms per foot. Per yard 2-way 1/4, 3-way 1/7.

**VOLUME CONTROLS.**—Less switch 2/6, with switch 3/6. Wire-wound, less switch, 3/9.

**"WALKIE TALKIE" RECEIVER TRANSMITTERS.**—Special offer of the R58 Walkie Talkie now being extensively advertised. The complete job, including spare kit of valves, 2 microphones, 2 pairs headphones, aeriels, accumulators, vibrator unit, etc. In Makers' Sealed Cartons. A few only at £15/10/- carriage paid, C.W.O.

Post Orders only. The Cheapest Mail Order House in the Trade. C.W.O. or C.O.D. over £1. Carriage paid on orders over £1. Send S.A.E. for New Summer Price List. Country Dealers send for particulars of our "Country Dealer Service."

**U.E.I. CORP.,**

32 St. Gabriels Road, London, N.W.2

**IMMEDIATE DELIVERY!**

**V55R COMMUNICATION RECEIVER**

**Specification:**  
9 Valves, A.V.C. B.F.O.  
3½ Watts Output  
5 Switched Bands  
Price Complete  
£32-10-0

Write for illustrated literature

COMMUNICATION RECEIVER

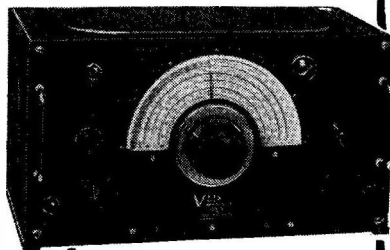

An All-British Designed and Modified Superheterodyne  
**VOICE & VISION CO.**  
58-60 RUTLAND STREET,  
LEICESTER, ENG.

**LONDEX for RELAYS****AERIAL CHANGE-OVER RELAY**

for Radio Frequency  
Type A.E.C.O. 4.

3 V.A. Coil Consumption, especially designed for Transmitters, High Frequency Heating, Amateur Stations, etc. Ask for leaflet 112/SVV.

**LONDEX LTD**

MANUFACTURERS OF RELAYS

207 ANERLEY ROAD, LONDON S.E.20

## RESULTS -

reported by Candler students who enrolled for the Junior Morse Code Course.

Ref. No. 3048.

"I am pleased to report excellent progress and many Hams have said with what ease they can copy my sending."

Ref. No. 2521. (Completed first five lessons.)

"I commenced actively in January and seem to have progressed very satisfactorily since I took my G.P.O. Morse test on February 26th, and know I passed well. I made no errors in receiving at 12 words per minute, and sent at 14 words per minute. . . I found lesson five most helpful from the point of view of training the sub-conscious faculty for faster receiving and ease of receiving, too."

Ref. No. 2245. (Complete all ten lessons.)

"I am glad to announce that I recently passed the P.M.G. Special Exam., and as you will see on my report, my speeds are now far ahead of the speeds needed in the examination. I therefore walked through the telegraphy part."

NOTE : Speeds were Sending 23 w.p.m., Receiving Code 19 and Plain language 24 w.p.m.

**THERE ARE CANDLER MORSE CODE COURSES FOR BEGINNERS AND OPERATORS**

Full details are given in the Candler "BOOK OF FACTS," sent post free on request.

**THE CANDLER SYSTEM CO. (555.W.)**  
121 Kingsway, London, W.C.2.

Candler System Co., Denver, Colorado, U.S.A.

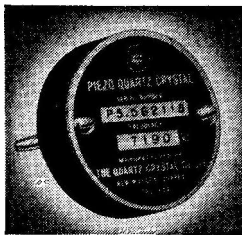

## Q.C.C. TYPE P5 QUARTZ CRYSTAL UNIT

This unit uses the well-known Q.C.C. Power type crystal, which is undoubtedly the most rugged and active crystal cut available for amateur use. The crystal is mounted in our type U dust proof holder, with standard  $\frac{1}{8}$  in. pin spacing, as illustrated above.

The P5 unit has a temperature Co-efficient of 20 cycles per megacycle per degree Centigrade temperature change. Used with a 6V6 or 6L6 type beam tetrode, it will give up to 5 watts r.f. output on the fundamental frequency, and approximately 3 watts on the second harmonic in the Tritet circuit.

Available in the 1.8 to 2.0 Mc. band for fundamental use, and in the 3.5 Mc. band and 7 Mc. band for frequency multiplying to the 28 and 58 Mc. bands. An official certificate of calibration is sent with each P5 unit, giving the frequency under stated operating conditions to an accuracy of 0.025%.

**PRICES :** Ground to your specified frequency in the above bands ... £1.17.6

Or ground to a frequency not specified by you but taken from our stock ... £1.12.6

Please note that all the leading dealers in amateur equipment now carry stocks of the P5 crystal unit. **THE QUARTZ CRYSTAL CO., LTD.** (Directors: E. A. Dedman, G2NH., N. H. R. Munday, G5MA., W. J. Thompson, G2MR.), 63/71 Kingston Road, **NEW MALDEN, SURREY.** Telephone : **MALden 0334**

# M.O.S.

**MAIL ORDER SUPPLY CO.**  
24 NEW ROAD, LONDON, E.1  
STEPNEY GREEN 2760

**THIS MONTH WE OFFER GOVERNMENT SURPLUS BARGAINS AS FOLLOWS:—**

★ **2I VALVE SPECIAL RADAR CHASSIS**

containing a host of scarce and valuable components worth £30. These include over 150 Resistors and Condensers of good assorted Values, Electrolytics, Relays, Intervalve Transformers, Filament Transformer, Loktal Ceramic and Octal Valveholders, Diode Valves, 5 Wirewound Potentiometers as detailed below, 6-watt Wirewound Resistors, etc., etc. **ONLY £2 19s. 6d.** (carriage 2s. 6d.)

★ **VALVEHOLDER ASSEMBLY**

containing 5 Loktal 9-pin Ceramic Valveholders, and 4 Amphenol Octal Valveholders mounted on aluminium sub-panel. **ONLY 2s. 3d.** (postage 7d.).

★ **POTENTIOMETER ASSEMBLY**

containing 5 wirewound Potentiometers mounted on panel. Values : 2 50,000 $\Omega$ , 2 20,000 $\Omega$  and 1 5 Meg $\Omega$ . In addition 2 .1 mfd. Tubular Condensers are assembled on this panel. **ONLY 8s. 11d.** (postage 8d.).

★ **BLACK MOULDED FLUTED INSTRUMENT KNOBS**

Instrument Knobs with skirt. Indicating line engraved on each knob. 2 in. skirt, 1½ in. knob, made by Raymart, with provision for dial assembly. **ONLY 1s. 2d.** each or 12s. dozen.

S.A.E. with all enquiries please. Postage under £1 C.W.O.

## Short Wave Coil Unit

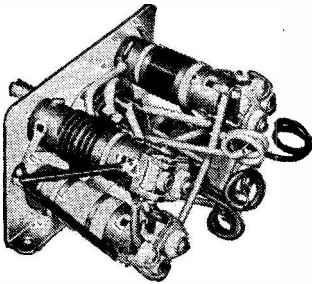

**30/-**  
Complete  
(as illustrated)

4 COILS already wired and switched, each coil consists of aerial, grid and reaction windings. Ranges covered with 160 mmfd. tuning condenser.

SWR 1. 9-83 metres to 24 metres. SWR 2. 18-7 metres to 45-4 metres. SWR 3. 38-4 metres to 95 metres. SWR 4. 92-3 metres to 206 metres.

Coil Unit complete with blue-print of 2 valve (Battery) S.W. receiver for above Unit 30/- Blue-prints only, 1/6. Individual coils 3/3 each.

Also available : 5 and 10 metre Tank Coil, R.F. Chokes, Aerial. Oscill. and H.F. coils for all wavebands.

**AMATEUR RADIO PRODUCTS**  
50 GLASSLYN ROAD, CROUCH END,  
LONDON, N.8. Phone :—Mountview 4745.

## CONTINENTAL RADIO BOOKS

**Radio Valve Vade Mecum** (5th Edn.) P. H. Brans, International valve characteristics and data (over 7,000) Continental, British, American, Russian and Services types, equivalents, etc. 12s. 6d.

**La Radio Revue.** Continental monthly for amateurs and service engineers. (French or Dutch editions.) Subscription, 20s. 0d. per annum.

Publishers : Algemeene en Technische, Boekhandel, Antwerp.

**Methode Dynamique de Depannage et de Mise au Point** (French). Aisberg and Nissen. A novel method of point-to-point test and servicing with constant output as opposed to constant input. 7s. 6d.

**La Modulation de Frequence et ses Applications** (2nd Edn.) E. Aisberg. (French.) Frequency Modulation and its applications. 10s. 6d.  
Publishers : Societe des Editions Radio, Paris.

**Radio/Television Dictionary.** A. Strabel. (English-Dutch, Dutch-English.) Some 2,000 most used words and phrases. 4s. 0d.

Publishers : Oceanic Exchange Co. of New York, U.S.A. Europe office : Hilversum.

Obtainable through :—Sole Agents for British territories :

**RITCHIE VINCENT & TELFORD LTD.**  
136a Kenton Road, Harrow, Middlesex  
(Tel : WORDSWORTH 3970.)

Continental Office :  
Lijsterbeslaan 35, Hilversum, Holland.  
P.O. Box 40.

## SEND YOUR "WANTS" TO VALLANCE'S

Test Equipment. Delivery from Stock. Universal, AvoMinor, 22 ranges, £8 10s. ; Taylor 90A, 1,000 ohms/volt, A.C. and D.C., 40 ranges £15 15s. ; E.I.C. Universal, 1,000 ohms/volt A.C./D.C., £8 10s. ; Walsall, Model 845, 2,000 ohms/volt, with low ohms range, £14 6s. 8d. ; Taylor, 120A Junior A.C./D.C., 21 range, 1,000 ohms/volt, £8 10s. ; Hunts, C. and R. Bridge, 0-00001 mfd.-50 mfd., power factor 50%, 50 ohms to 5 meg., insulation test, £18 18s. ; Taylor, C. and R. Bridge, 110A, capacity measurements up to 120 mfd., resistance 120 ohms-12 meg., power factor measurements on all capacity ranges, £14 14s. Mullard C. and R. Bridge, 10 m.mfd.-10 mfd. and 10 ohms-10 meg. power factor, 15 gns.

B.P.L. Signal Generators.—Frequency ranges, 100-250, 250-650, 650-1,600 kc/s ; 1-6-4-5, 4-5-12, 12-30 mc/s ; accuracy of calibration, 1% ; internal modulation, 400 cycles ; 6-step multiplier and attenuator, £21. A.C. mains 200/250 volts or 105-115 volts. 50/60 cycles.

Transmitting Valves.—RK34, Twin Triode, 300v. 10 watts anode dissipation, 6-3v. 0-8 amp, £1 10s. ; RK25, Pentode, 500v. 10 watts anode dissipation, 6-3v. 0-9 amp, £2 ; 807, Beam Power Tetrode, 750v. 30 watts anode dissipation, 6-3v. 0-9 amp., £1 10s. 5d. ; 866, Rectifier (mercury vapour) 10,000v. inverse peak 1,000 m.a., half wave 2-5v. 5 amp, £1 7s. 6d. ; 35T, Triode, 2,000v. 150 m.a. 70 watts anode dissipation, 5v. 4 amp, £2 15s. ; 6L6 (metal) Beam Power Tetrode, 500v. 21 watts anode dissipation, 6.3v. 0-9 amp, 18/3.

Telcothene 72 ohm Feeder, 10½d. per yard. Aerial Strain Insulators, long leakage path (glass), 1/- each.

Transposition Blocks, 4½d.

Aerial T. Pieces, 1/2.

H.M.V. Anti-Static Aerial comprises : 100 ft. Shielded Twin Feeder Cable ; 1 only Aerial Anti-Static Transformer ; 1 only Receiver Anti-Static Transformer ; 1 only Receiver A.S. Transformer clamp and screws, 57/6 complete (boxed).

Finest quality Peribraid Sleeving at 6d. per yard. 1 mm. blue, 1-5 mm. green or yellow, 2 mm. yellow, 3 mm. green.

Instrument Wire.—Finest hard drawn enamelled copper, 36 S.W.G.—in 1-lb. reels, only 3/6 per lb. Single Rayon—enamelled.—42 S.W.G. 4 oz. reels only, 5/3 per reel.

Condensers.—4 mfd. 500 volt working, TCC Tubular, 2/5 ; B1 Paper Block, 2/10 ; Dubilier Dry Elec. Tubular, 3/3 ; metal cased Paper Block, 4/6. 4 mfd. 1,000 v. working, TCC oil immersed, 18/9. 4 mfd. 2,000 v. working, TCC paper, 15/-.

4+4 mfd. 500v. working, B.I. Block Elec., 6/- 8 mfd. 500 v. working, B.I. Tubular Elec., 3/2 ; B.I. Block, 3/6 ; TCC Mini-pack, 4/6 ; Dubilier Drylytic, 4/- ; B.I. Can, 4/6 ; TCC Oil Immersed, 19/9. 8+4 mfd. 500 v. working, B.I. Cardboard Block, 6/- 16 mfd. 500 v. working, B.I. Block, 4/6 ; TCC Tubular, 4/9 ; B.I. Can Elec., 5/3. 16-8 mfd. 500 v. working, B.I. Block, 7/9. 8-8 mfd. 500 v. working, B.I. Block, 5/3 ; B.I. Can Elec., 7/3 ; Dubilier Can Drylytic, 6/6.

Also large stocks of bias and by-pass Condensers by best makers ; Mains Transformers with standard inputs and outputs, or with special windings to your specification ; Output Transformers, small or heavy duty types ; Speakers PM or ME, Coils, Coil assemblies—in fact, everything you want for transmitter, receiver, amplifier, or experimental work.

Immediate attention to all orders and enquiries. Goods sent C.O.D. or against C.W.O. whichever best suits you. When sending C.W.O. please include sufficient for packing and postage.

**VALLANCE'S**  
144 BRIGGATE, LEEDS, I.

**NEW DUAL TESTSCOPE**

Ideal for  
High and Low  
Voltage Testing; 1/30  
100/850 A.C. and D.C. Allowance made  
on old models. Send for interesting leaflet  
L34 on Electrical and Radio Testing,  
from all Dealers or direct.

**RUNBAKEN MANCHESTER-I****H.A.C.****Short-Wave Equipment**

Noted for over 15 years for  
Short-Wave Receivers and Kits of quality

One Valve Kit, Model "C" Price 20/-  
Two " " " "E" " 43/-

These kits are complete with all components,  
accessories, and full instructions. The  
prices are inclusive of postage and packing.  
Send stamped addressed envelope for  
descriptive catalogue

A. L. BACCHUS, 109 Hartington Road,  
London, S.W.8

### TRADE ADVERTISEMENTS

**AMATEUR REQUIREMENTS.**—Our staff now released from the services, we can accept again mail orders. Send 2½d. for catalogue of over 500 lines.—Southern Radio and Electrical Supplies, 85 Fisherton Street, Salisbury, Wilts.

**CHASSIS, Racks, Cabinets, Panels, Aluminium Sheet, 16 and 18 gauge. S.A.E. lists.**—Amateur Radio Service G6HP, Canning Street, Burnley.

**CHASSIS, all sizes, plain or punched to your requirements, from 3s. 9d.**—Details: Ead, 13 Bence Lane, Darton, Yorkshire.

**G6VS (Ex-VU2EU) for Ham Gear.** '00035 mfd. 3-Gang 6/9; Carbon Microphones with Transformer 7/6; Pullin Meters; Eddystone Components. S.A.E. for Lists. Goods despatched return post. G6VS, Carlton Music Salon, West Kirby, Cheshire.

**HARMONY HOUSE (Prop. G2IN) for radio frequency cable.** One Shilling per yard. Send 6d. in stamps for sample. Eddystone and Raymart stockist.—116 Cambridge Road, Southport.

WE HAVE THE LARGEST STOCK OF ENGLISH AND AMERICAN RADIO BOOKS IN THE COUNTRY, INCLUDING MANY NOW OUT OF PRINT. Write or call for list.—The Modern Book Co., 19-23 Praed Street (Dept. V), London, W.2. Pad. 4185.

"XTALS" Genuine "Standard Radio" Quartz 1,000 k/c Xtals mounted in pressure holders. For frequency meters, etc. (Circuit free.) Will grind to 1.8 m/c, 3.5 m/c or 7 m/c bands. No station or service man complete without one. Only 10/- each or 3 for 25/- carr. paid. Limited quantity available. —Mortimer, Dore, Sheffield.

### READERS' ADVERTISEMENTS

20 COPIES *Short Wave Magazine*, Feb. '38 to Sept. '39 inclusive. Best offer over 7s.—Allen, Holbrook A., Hampton Park, Hereford.

**MICROAMMETER 0-30.** Moving Coil. 4 in. mirror scale. Square case. Lovely instrument. £4 15s.—Pattullo, Pendle, Coldharbour Lane, Bushey, Herts.

**S M A L L   A D V E R T I S E M E N T S**

There is a differentiation between small Trade insertions and Readers' small advertisements. *Trade Advertisements* : 9d. per word, minimum charge 12s. *Readers' Small Advertisements* : 3d. per word, minimum charge 5s. Add 25 per cent. for bold face (heavy type) insertions in either section. All charges are payable with order and no series discounts are allowed on small advertisements. Matter of radio interest only is accepted, and all copy should be in hand by the 15th of the month previous to publication.

Write the

Advertisement Manager,

*The Short Wave Magazine*, 49 Victoria Street, London, S.W.1

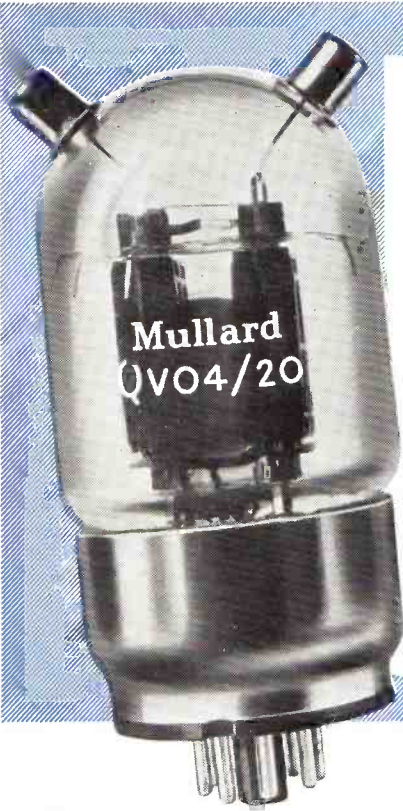

**THIS**  
*Double*  
**BEAM**  
**TETRODE**

will be popular  
with Amateurs

**H**ERE is a valve with ideal characteristics for amateur transmitters. Low anode voltage and high frequency of operation are outstanding features. It is one of a complete range of Mullard transmitting valves available to amateurs.

QV04-20 DOUBLE BEAM TETRODE	
Vf	6.3 or 12.6 V.
If	1.6 or 0.8 A.
Va	400 V.
Vg2	145 V.
Wa	2 x 10 W.
Wo(CW)	44 W.
Driving Power	0.23 W.
Max. Freq. for full ratings	125 Mc/s.
Max. Freq. for reduced ratings	200 Mc/s.

Write for details of Mullard Transmitting Valves for Amateurs.

**Mullard**



**CQ**  
**ALL 'HAMS'**  
 de  
**G6MB**  
**G8RN**  
**G2CIN**

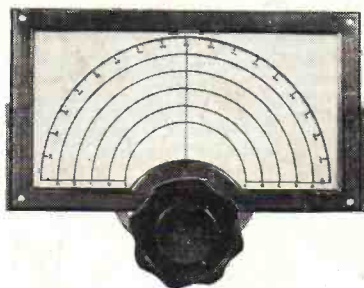

If you want a tube for that new P.A. stage—a complete tank coil and condenser unit—a soldering tag or just a “rag chew” —come along and have a personal QSO.

We are always glad to renew old contacts and make new ones, and we can probably help you with that rebuild.

We are specialists in S.W. equipment, and if it's something new in Ham gear, we are sure to have it.

73s es hpe CUL.

**THE 'Q' MAX SLOW MOTION DIAL FOR INDIVIDUAL CALIBRATION** is illustrated above.

- 9-1 Slow Motion Drive.
- Five Blank Scales and one Scale engraved 0-180°
- Escutcheon glass (6½" × 3½") and Fluted Knob.

**15/6**



**THE 'Q' MAX CHASSIS CUTTER** (illustrated at left) ends all your tiresome drilling and scraping.

For Octal holes 1⅛".

**10/6**

**BERRY'S**  
**(SHORT WAVE) LTD.**

**25 HIGH HOLBORN, LONDON, W.C.1**  
 (Opposite Chancery Lane), Telephone : HOLborn 6231