

FOR THE RADIO ENTHUSIAST...

JANUARY 1981

Practical Wireless

Australia \$1.15
New Zealand \$1.25
Malaysia \$4.00

65p

8 EXTRA PAGES OF PROJECTS & FEATURES

tape-slide controller

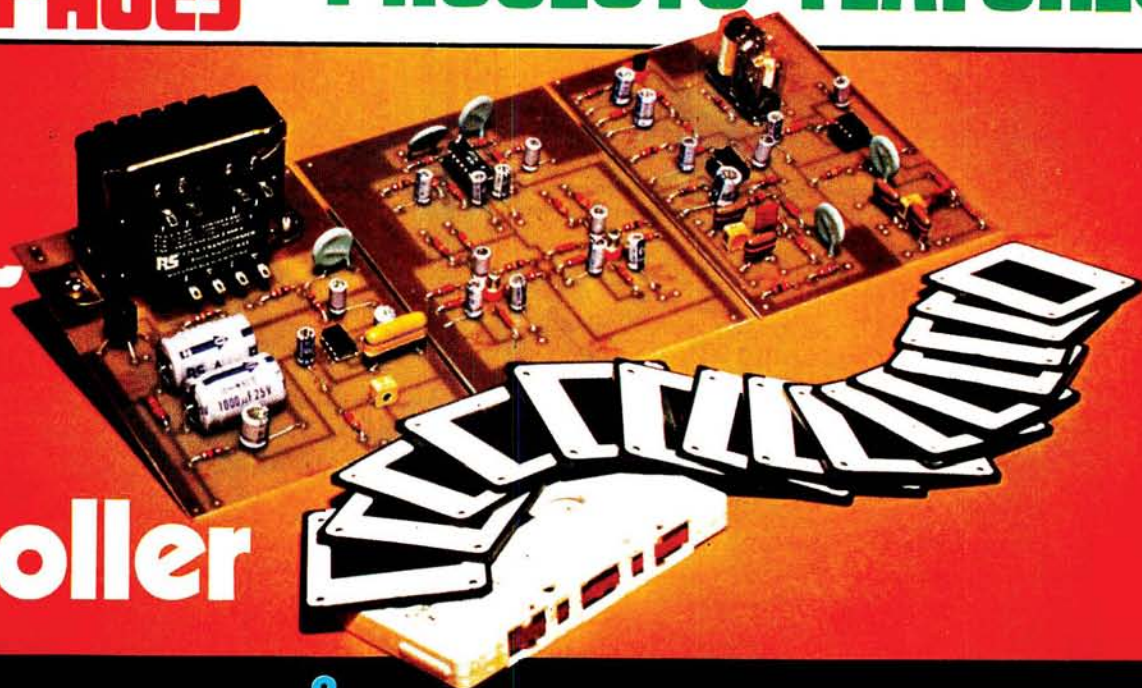

&
DXTV
The Basics



PLUS { **Pw** 'NIMBUS' Scanning Module
Back-up Power Supply for a Portable Radio

AS REVIEWED THIS ISSUE
 TRY OUR TR 7800
 IN OUR SHOWROOM NOW!



Bredhurst electronics

HIGH ST., HANDCROSS, W. SUSSEX O444 400786



This month we thought we would use some of our expensive space to send a seasonal message to all our customers both past and future. Although we are newer than some other dealers in the amateur radio market, we have always "Tried Harder" to give all customers the best advice and service possible. We would like to thank you all for your custom, and we hope to meet many more

of you in the coming year.

Best 73 and Merry Xmas from

Richard G30QT

Bob G3VXJ

Graham G8YYQ



THE IC2E "POCKET PORTABLE"



- Fully synthesized – covering 144-145.995 in 5KHz steps.
- 1.5W power output with 9V battery as supplied.
- Optional 6V or 12V packs for lower or higher power.
- BNC antenna output socket for helical or external antenna.
- Weight – only 450 grams, with supplied battery pack and helical.
- Send/battery indicator – indicates transmit until time for battery recharge.
- Duplex/Simplex switch – Hi/Low power switch.
- Optional external speaker microphone available now.
- Full 12 months guarantee for all rigs bought from Bredhurst Electronics.

£159

inc. VAT & CARRIAGE

YAESU FT 480R 2M MULTI-MODE

£359, inc. VAT & CARRIAGE



ICOM IC260E 2M MULTI-MODE

£339, inc. VAT & CARRIAGE



TRIO TR9000 2M MULTI-MODE

£345, inc. VAT & CARRIAGE



FDK MULTI 750E 2M MULTI-MODE

£299, inc. VAT & CARRIAGE



TRANSCEIVERS

H.F.	
TRIO TS130V	£404.00
TRIO TS130S	£491.00
TRIO TS250SE	£437.00
YAESU FT707	£499.00
YAESU FT101Z	£488.00
YAESU FT101ZD	£569.00
TRIO TS830S	£639.00
TRIO TS180S (with DFC)	£679.00
YAESU FT107M	£690.00
2.M. MOBILES	
FDK Multi 700EX	£199.00
STANDARD C8800	£250.00
ICOM IC255E	£255.00
TRIO TR7800	£265.00
HANDHELDS	
FDK PALM II	£99.00
ICOM IC2E	£159.00
FDK PALM IV	£159.00
AOR AR245A	£178.00
TRIO TR2300	£166.00
YAESU FT207R	£199.00
TRIO TR2400	£198.00
2.M. MULTIMODES	
FDK Multi 750E	£299.00
ICOM IC260E	£339.00
TRIO TR9000	£345.00
YAESU FT480	£359.00
ICOM IC251E	£479.00

RECEIVERS

H.F.	
LOWE SRX30	£158.00
YAESU FRG7	£199.00
TRIO R1000	£285.00
YAESU FRG7700	£309.00
2.M. F.M.	
SEARCH 9	£45.00
A.O.R. AR22	£83.00
FDK TM56B	£79.00
BEARCAT 220FB	£258.00
MARINE V.H.F.	
SEARCH 9	£45.00
S.R. 11 (+ scan)	£55.00
FDK TM56B	£79.00
BEARCAT 220FB	£258.00

Contact Bredhurst to order the latest H.F. Receiver from Yaesu FRG7700. £309.00 or £389.00 with memories.

"SAFETY"

KEEP BOTH HANDS ON THE WHEEL
 USING THE LATEST IN MOBILE MICROPHONES
 These consist of a high quality condenser microphone used in conjunction with an F.E.T. preamplifier with approx. 12dB gain. Fix the boom microphone to a convenient point such as the sun visor. Position the amplifier and TX/RX switch on the gear lever. Connect the mic plug and power lead and its ready for use.

MM202S £20.95 inc. VAT (carriage 50p)
 MM202H – Head band £28.00 inc. VAT (carriage 50p)

ACCESSORIES

KEYERS HK707 (Up/down)	£74.00 (—)
KEYERS HK704 (Squeeze)	£4.50 (£0.25)
KEYERS EK150 (Semi/fully auto with monitor) 240V/12V	£4.50 (£0.25)
HELICAL BNC – 2 metres	£6.00 (£0.30)
HELICAL PL259 – 2 metres	£21.95 (£0.75)
DUMMY LOAD DL20	£22.95 (£0.75)
DUMMY LOAD T80	£32.00 (£0.75)
DUMMY LOAD T100	£34.00 (£0.75)
DUMMY LOAD T150	£34.00 (£0.75)
DUMMY LOAD T200	£34.00 (£0.75)
MOBILE SPEAKERS YAESU 8 ohm 6W	£9.95 (£0.75)
POWER SUPPLIES 13.8V 4A	£22.95 (£1.00)
POWER SUPPLIES 13.8V 6A	£29.95 (£1.50)
POWER SUPPLIES 13.8V 25A	£92.00 (£0.00)
MICROPHONES, ADONIS desk compressor	£39.95 (—)
MICROPHONES, ADONIS 3 output desk compressor	£59.95 (—)
MICROPHONES, YAESU YD148 dual imp.	£20.95 (£0.75)
WORLD CLOCK QTR24	£18.40 (£0.75)
WORLD CLOCK QTR24D (Quartz)	£24.50 (£0.75)
LOW PASS FILTERS TRIO LF30A	£18.40 (£0.75)
LOW PASS FILTER YAESU FF501DX	£19.95 (£0.75)
LISTENERS A.T.U. MIZUHO KX2	£29.95 (£0.75)
AUDIO PROCESSOR MIZUHO AP-MI	£33.00 (£0.75)
DIP METER TRIO DM-800	£1.00 (£0.75)
WAVE METER FX1	£28.00 (£0.75)
SWR25	£13.00 (£0.50)
SWR110	£35.00 (£0.50)
SWR CN620 (2M)	£52.00 (£0.50)
SWR CN630 (70cm)	£71.00 (£0.50)
7MHz TRAPS (pair)	£6.95 (£0.50)
FERRITE RINGS 2 OFF	£0.80 (£0.20)

TRY OUR
MAIL ORDER SERVICE

VISIT OUR
RETAIL PREMISES
 MON-SAT 9-5.30

BUDGET ACCOUNT – ACCESS – BARCLAYCARD – PART EXCHANGE

MID SUSSEX HOUSE · HIGH ST. · HANDCROSS · WEST SUSSEX RH17 6BW
 MAIL ORDER TEL: 0444 400786 9am-5.30pm RETAIL CALLERS

TO ORDER ANY OF THE ABOVE ITEMS SIMPLY WRITE, ENCLOSING A CHEQUE OR PHONE YOUR CREDIT CARD NUMBER

EDITORIAL OFFICES
Practical Wireless
Westover House
West Quay Road
Poole, Dorset BH15 1JG
☎ Poole 71191

Geoff Arnold G3GSR
Editor

Dick Ganderton C.Eng., MIERE, G8VFN
Assistant Editor

Peter Metalli
Art Editor

John Fell G8MCP
Technical Editor

Alan Martin G8ZPW
News & Production Editor

Elaine Howard
Technical Sub-Editor

Rob Mackie
Technical Artist

Keith Woodruff
Assistant Art Editor

Sylvia Barrett, Sharron Breeze
Secretarial

ADVERTISEMENT OFFICES
Practical Wireless
King's Reach Tower
Stamford Street
London SE1 9LS
Telex: 915748 MAGDIV-G

Dennis Brough
Advertisement Manager
☎ 01-261 6636

Roger Hall G8TNT (Sam)
Ad. Sales Executive
☎ 01-261 6807

Claire Gerrish
Secretary
☎ 01-261 6636

Colin R. Brown
Classified Advertisements
☎ 01-261 5762

Dave Kerindi
Make-up & Copy
☎ 01-261 6570

COPYRIGHT

© IPC Magazines Limited 1981. Copyright in all drawings, photographs and articles published in *Practical Wireless* is fully protected and reproduction or imitation in whole or in part is expressly forbidden. All reasonable precautions are taken by *Practical Wireless* to ensure that the advice and data given to our readers are reliable. We cannot however guarantee it and we cannot accept legal responsibility for it. Prices are those current as we go to press.

Practical Wireless

JANUARY 1981 VOL. 57 NO. 1 ISSUE 886

contents

- 20 Tape/Slide Controller—1**
Fred Judd
- 24 Kindly Note**
PW Tamar, Sept 1980
PW Nimbus Charger/p.s.u., Oct 1980
- 25 The Basics of TV DXing—1**
Roger Bunney
- 31 Air Test**
Sommerkamp TS-802 Hand-held
- 32 PW "Twynham" Digital/Analogue Multimeter—2**
M. Tooley & D. Whitfield
- 39 Introducing RTTY—5**
Jeff Maynard G4EJA
- 44 PW "Helford" HF SSB Transceiver—3**
Vic Goom G4AMW
- 50 Special Product Report**
RTVC 12 + 12W Amplifier Kit
- 52 PW "Nimbus" 2m System—8 (16-channel Scanner)**
M. Tooley G8CKT & D. Whitfield G8FTB
- 60 Back-up Power Supply Unit for Portable Radios**
Keith Cummins
- 66 Radio Special Product Report**
Trio TR-7800 2m f.m. Mobile
- 70 PW "Sherborne" Synthesised Tuner—4**
W. S. Poel
- 103 Advert Index**
- 63 Binders**
- 17 Comment**
- 24 Kindly Note**
- 42 Letters**
- 43 Mods**
- 18 News**
- 51 Next Month**
- 77 On the Air**
- 36 Production Lines**
- 17 Services**
- 49 Sketchbook**
- 59 Uncle Ed**
- 62 YL Column**

Pure ind

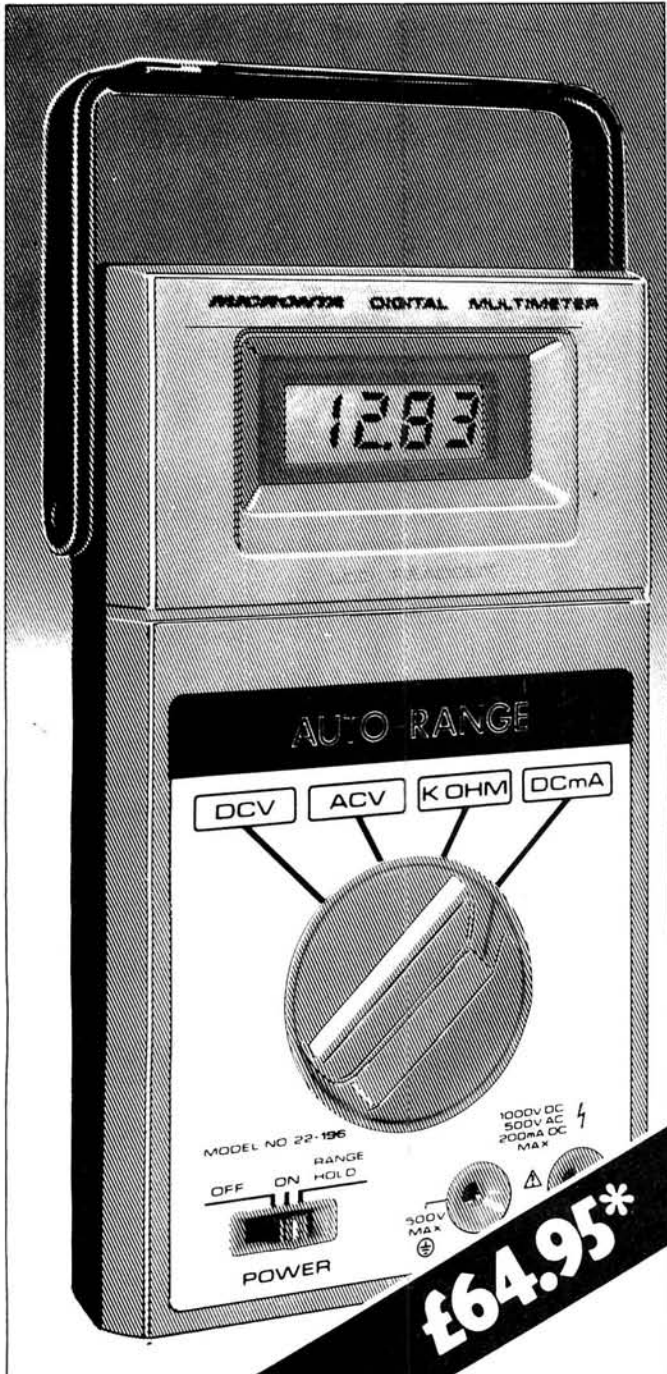

£64.95*

Micronta Auto Range Multimeter Gives you correct polarity, range and measurement — every time. Single function switch lets you choose DC 4 ranges; AC 4 ranges; DC current resistance. 4 ranges. LCD readout. Exclusive range hold facility. 22-196

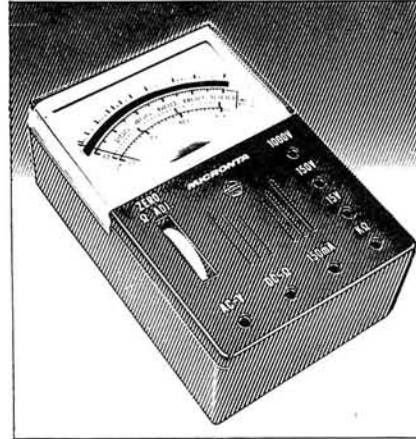

£6.95*

Micronta 1000 Ohms/Volt Multitester Very compact at 89 x 59 x 32 mm. Easy to read colour meter, pin jacks for all 8 ranges. Reads AC V, DC current and ohms. Mirrored scale. 20-027



£9.95*

Micronta Transistorized Signal Tracer Spot circuit troubles, check RF, IF and audio signals from aerial to speaker on all audio equipment. It has built in 5 cm speaker with volume control. 50 x 143 x 38 mm. 22-010

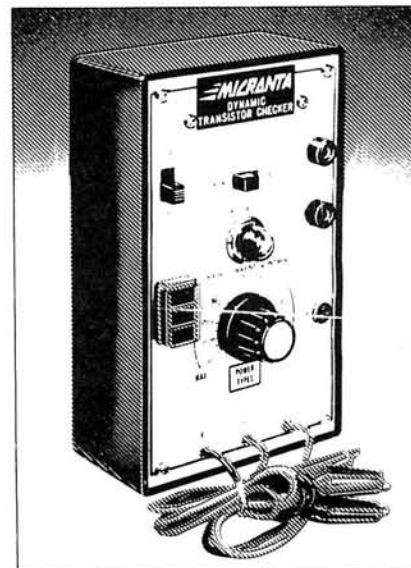

£9.95*

Micronta Dynamic Transistor Checker Shows current gain and electrode open and short circuit. Tests low medium or high power PNP or NPN types. Go/no-go tests from 5-50 mA on power types. "Quick-check" sockets. 22-024

Wigence.

Realistic Direct Entry Programmable Scanning Receiver Hear real-life drama on six exciting bands. With direct access to all frequencies, you can punch in actual frequencies for monitoring, storing in the computer's memory or just exploring. Big fluorescent display. Phase locked loop security. 20-9111

TRS-80 Model I C.P.U.'s Ready to run from your TV monitor. Plug in and start computing. Contains 4096 bytes of user memory and can be expanded to 16K. 26-9051

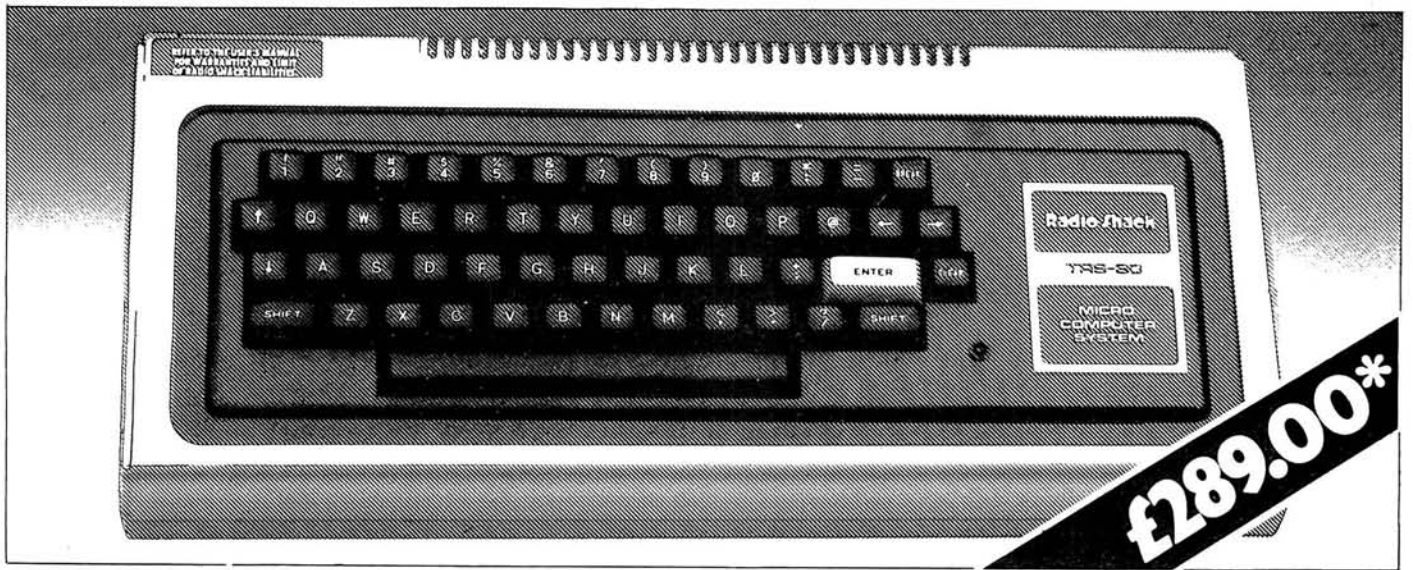
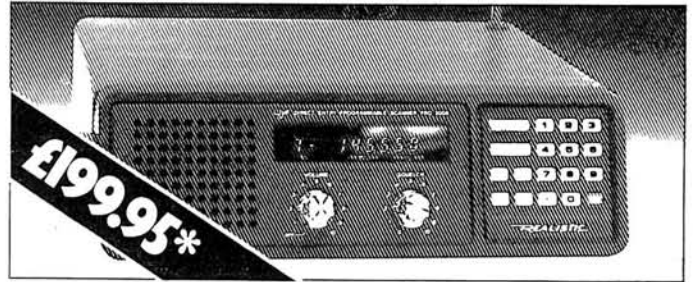

- | | | | | | | | |
|---|--|---|--|---|--|--|--|
| <p>ACCRINGTON
17 Union Street</p> <p>ALDRIDGE
15 Central Area Development</p> <p>BARNLEY
58 Market Street</p> <p>BASINGSTOKE
22 London Street</p> <p>BIRKENHEAD
Kwik Save Centre, Prenton</p> <p>BRADFORD COMPUTER CENTRE
2-4, Forster Square</p> <p>BIRMINGHAM AREA</p> <p>BULL RING
528 Bridge Link Shopping Centre</p> <p>CAPE HILL
44-46, Cape Hill</p> <p>CITY CENTRE
57-58 Dale End</p> <p>CORPORATION STREET
80, Corporation Street</p> <p>DALE END
57-58, Dale End</p> <p>EDGBASTON COMPUTER CENTRE
Edgbaston Shopping Centre</p> <p>ERDINGTON
218 High Street</p> <p>HALESOWEN
5-7, Queensway</p> <p>NORTHFIELD
749 Bristol Road South</p> | <p>PERRY BARR
23 Linton Square</p> <p>SHELDON
2268 Coventry Road</p> <p>SMETHWICK
44-46 Cape Hill</p> <p>WARD END
887 Washwood Heath Road</p> <p>WEDNESBURY
Bilston Road</p> <p>BOLTON
5 Nelson Square</p> <p>BOSCOMBE
548 Christchurch Road</p> <p>BOURNEMOUTH
132-4 Commercial Road</p> <p>BRADFORD
9 Petergate</p> <p>BRIGHTON
70 London Road</p> <p>BRISTOL AREA</p> <p>BISHOPSTON
13 Gloucester Road</p> <p>BRISTOL COMPUTER CENTRE
Colston Centre</p> <p>CLIFTON
146 Wheelies Road</p> <p>DOWNEND
5 Edmonnton Road</p> <p>KNOWLE
Broadwalk Shopping Centre</p> <p>YATE
4 North Parade</p> | <p>BROMSGROVE
6-8 St. John Street</p> <p>BROWNHILLS
60 High Street</p> <p>BURY (Lancs)
91 The Rock</p> <p>CARDIFF
9 Wood Street</p> <p>CHELTENHAM
31 Cambray Place</p> <p>CHESTER
Kwik Save Centre</p> <p>COVENTRY
Sealand Road</p> <p>CREWE
4 Miles Street</p> <p>DARLINGTON
12 Market Street</p> <p>DARLINGTON
15-16 Prestgate</p> <p>DERBY
33 Victoria Street</p> <p>DONCASTER
32-34 Kingsgate</p> <p>DUDLEY
Trindie Road Roundabout</p> <p>EASTBOURNE
Langley Shopping Centre</p> <p>EXETER
13 Paris Street</p> <p>GRIMSBY
Riverhead Centre</p> <p>HARROGATE
The Colonnades</p> <p>OXFORD STREET
34 Oxford Street</p> | <p>HUDDERSFIELD
Pachnose Shopping Centre</p> <p>HULL
23 Catford Broadway</p> <p>LEAMINGTON SPA
83 Warwick Street</p> <p>LEEDS
72 Merrion Centre</p> <p>LEEDS
3 Eastgate</p> <p>LEICESTER
Market Street</p> <p>LEITCHWORTH
25 Commerce Way</p> <p>LINCOLN
High Street</p> <p>LIVERPOOL AREA</p> <p>ALLERTON
90 Ailsdon Road</p> <p>ENFIELD
23 North Mall</p> <p>ENFIELD
10 Colman Parade</p> <p>HAMMERSMITH
142-4 King Street</p> <p>HENDON
24 Sentinel Square</p> <p>ORPINGTON
5 The Walrus</p> <p>PILMERS GREEN
378 Green Lanes</p> <p>ROMFORD
27 Green Lane</p> <p>SEACOL LANE
1-2, Seacool Lane</p> | <p>STREATHAM
254 Streatham High Road</p> <p>TOTTENHAM
455 High Road</p> <p>WALTHAMSTOW
123 High Street</p> <p>WALWORTH
279 Wai worth Road</p> <p>WANDSWORTH
107-9 High Street</p> <p>WELLING
7 Embassy Court</p> <p>WIMBLEDON
124-6 The Broadway</p> <p>LUTON
157 Dunstable Road</p> <p>MANCHESTER AREA</p> <p>BRAMHALL
14-15 The Centre</p> <p>CHADDERTON
67 High Street</p> <p>CHEADLE
67 High Street</p> <p>DEANSGATE COMPUTER CENTRE
36 Market Place</p> <p>HYDE
4-8 The Mall</p> <p>RADCLIFFE
25 Blackburn Street</p> <p>SALE
The Mill</p> | <p>CITY CENTRE
Arncliffe Centre</p> <p>STRETFORD
Arncliffe Centre</p> <p>NEWBURY
14 Bartholomew Street</p> <p>NORTHAMPTON
Weston Favel Shopping Centre</p> <p>NOTTINGHAM AREA</p> <p>ARNOLD
126 B Front Street</p> <p>BEESTON
30 The Square</p> <p>NUNEATON
1 Church Street</p> <p>OXFORD
9-10 St. Clements</p> <p>PAIGNTON
35 Hilde Road</p> <p>PLYMOUTH
64 Royal Parade</p> <p>PORT TALBOT
Aberfan Centre</p> <p>READING
18 The Butts Shopping Centre</p> <p>RUGBY
25 Church Street</p> <p>RUNCORN
120 Runcorn Shopping City</p> <p>SCUNTHORPE
140 High Street</p> | <p>SHREWSBURY
20 Shop Latch</p> <p>SITTINGBOURNE
20 The Forum Shopping Centre</p> <p>SLOUGH
233 High Street</p> <p>SOUTHAMPTON
East St. Centre</p> <p>STAFFORD
6 Sherdan Shopping Centre</p> <p>ST. HELENS
Emergent Centre</p> <p>STOKE-ON-TRENT
Hanley 16 Charles Street</p> <p>SUNDERLAND
4 Fawcett Street</p> <p>SURREY
26x High Street</p> <p>SUTTON (Surrey)
206 High Street</p> <p>TORQUAY
134 Union Street</p> | <p>TYNE AND WEAR AREA</p> <p>NEWCASTLE
23 Newgate Centre</p> <p>SHEFFIELD
19-20, Hallsborough Shopping Centre</p> <p>SHIELDS ROAD
184-6 Shields Road</p> <p>WASHINGTON NEW TOWN
Galleries Shopping Centre</p> <p>WAKEFIELD
Kirkgate Shopping Centre</p> <p>WALSALL
74 Bradford Street</p> <p>WALLASEY
The Precinct</p> <p>WORCESTER
8 St. Nicholas Street</p> <p>WORKSOP
7-9 Bridge Place</p> <p>YORK
5 Church Street</p> |
|---|--|---|--|---|--|--|--|

*All prices include VAT.

IT'S POSSIBLE, ONLY AT Tandy
Better Equipment. Lower Prices. No Middlemen!

Technical Training in Radio, Television and Electronics

ICS have helped thousands of ambitious people to move up into higher paid, more secure jobs in the field of electronics—now it can be your turn. Whether you are a newcomer to the field or are already working in the industry, ICS can provide you with the specialised training so essential to success.

Personal Tuition and Guaranteed Success

The expert and personal guidance by fully qualified tutors, backed by the ICS guarantee of tuition until successful is the key to our outstanding record in the technical training field. You study at the time and pace that suits you best and in your own home. In the words of one of our many successful students: "Since starting my course, my salary has trebled and I am expecting a further increase when my course is completed."

City and Guilds Certificates

Excellent job prospects await those who hold one of these recognised certificates. ICS can coach you for:

Telecommunications Technicians
Radio, TV Electronics Technicians
Technical Communications
Radio Servicing Theory
Radio Amateurs
Electrical Installation Work
Also MPT Radio Communications Certificate

Diploma Courses

Colour TV Servicing
Electronic Engineering and Maintenance
Computer Engineering and Programming
Radio, TV and Audio, Engineering and Servicing
Electrical Engineering, Installations and Contracting

Qualify for a New Career

Home study courses for leading professional examinations and diploma courses for business and technical subjects:—

G.C.E.	Engineering	Purchasing
60 subjects	Farming	Sales
at "O" & "A" levels	Heating	Storekeeping
Accountancy	Industrial	Work Study
Air	Management	
Conditioning	Mechanical	
Building		

POST OR PHONE TODAY FOR FREE BOOKLET.

ICS To: International Correspondence Schools

SINCE 1890
Dept. 276D Intertext House, London
SW8 4UJ or telephone 622 9911

Subject of Interest

Name

Address

Telephone Number

DIGITAL VOLTMETER MODULE



Fully built and tested, ONLY

£11.95 - VAT

- * Reads positive and negative voltages with a sensitivity of 0 - +999mV and 0 - -99mV
- * Requires only single supply between 7 & 12 volts (220mA)
- * High accuracy +0.1% +1 digit
- * Large bright 0.43" high efficiency displays
- * 4 readings per second sampling rate
- * Size only 41 x 95 x 10mm
- * Supplied with full data & applications information

This brand new, quality module manufactured by Autona Limited (who are one of the U.K.'s largest module manufacturers) means you can build accurate test equipment, multi-meters, thermometers, etc. easily and at a fraction of the cost of ready-made equipment. Full details are provided showing how to measure A.C. voltage, current, resistance and temperature.

Send your cheque or P.O. (£11.95 + £1.79 V.A.T. + 50pp. & p. = £14.24) now to:—

Dept. P.W.3
RISCOMP LIMITED
21 Duke Street
Princes Risborough
Bucks. HP17 0AT

BUCKINGHAMSHIRE'S NEW ELECTRONICS CENTRE
8 miles off the M40
50 minutes from London
Telephone: (084 44) 6326

EX-STOCK DELIVERY

INTERESTED IN ELECTRONICS?

TRY A ZEDPACK!
COMPONENTS AT A PRICE EVERYONE CAN AFFORD

- Z1 300 mixed $\frac{1}{2}$ and $\frac{1}{4}$ watt resistors £1-95
Z2 150 mixed 1 and 2 watt resistors £1-50
Z3 300 mixed capacitors, most types £3-95
Z4 100 mixed electrolytics £2-20
Z5 100 mixed polystyrene caps £2-20
Z6 300 mixed printed circuit components £1-95
Z7 300 mixed printed circuit resistors £1-45
Z8 100 mixed high wattage resistors, wire-wound etc. £2-75
Z9 100 mixed miniature ceramic and plate caps £1-20
Z10 25 assorted pots. £1-50
Z11 25 assorted presets, skeleton etc. £1
Z12 20 assorted vdr's and thermistors £1-20
Z13 11b mixed hardware. Nuts, bolts self-lappers, sleeving, etc. £1-20
Z14 100 mixed, new and marked, full spec. transistors. Pack includes:— BC148, BF154, BF274, BC212L, BC238, BC184L, MEO412 and, or lots of similar types £4-95
Z15 100 mixed diodes including:—zener, power, bridge, signal, germanium, silicon etc. All full spec. £4-95
Z16 20 1N4148 £1
Z17 20 1N4003/10D2 £1
Z18 20 assorted zeners, 1 watt and 400mw £1-50
Z19 25 high voltage pulse caps, etc. £1-25
Z20 20 Assorted Switches. P/B, slide, toggle, multipole, reed etc., etc. £2-45
TBA 800 Audio I.C. £1 ea. 3 for £2-50.
BD181 (78V, 15A, TO3) 3 for £1.
12V 1-3W ZENERS 12 for £1
Plastic BC108's 12 for £1
BC154 12 for £1, BC183L 12 for £1
200 μ A Miniature level/batt. meters, as fitted to many cassette recorders. 90p
Deluxe FIBREGLASS printed circuit etching kits. 10 for £1
Includes 100 sq ins. of copperclad F/G board, 1lb ferric chloride, (made for U.S. army to MIL, SPEC.), 1 dalo etch resist pen, abrasive cleaner, etch resist dish and instructions. **OUR PRICE £4-95**

1lb of FeCl. £1-25. 5lb. £5.
150 sq. ins. single sided board. £2-20
150 sq. ins. double sided board. £3-30
Dalo pen. £1

UHF Transistors T.V. TUNER with slow motion drive, A.E.skt. and leads £1-95
100 Miniature reed switches. £3-30

P/B SWITCH BANKS
These cost a fortune! Were made for various music centres. Includes independent and interdependent latching types multi pole c/o etc. Can be modified. Can't be repeated. 3 Banks for £1.
KNOBBS for Switch Banks 10 for £1. Chrome or spun aluminium finish.

MINIATURE MAINS TRANSFORMERS
Top quality. Split bobbin construction will give 4 5V-0-4 5V at 250MA. 1 $\frac{1}{2}$ " x 1 $\frac{1}{2}$ " x 1 $\frac{1}{2}$ ", all sorts of uses. **ONLY 90p**
3 for £2-20
1000 μ f, 100V, Radial, 1 $\frac{1}{2}$ " x 2". **ONLY 70p.** 3 for £1-50. 2,200 μ f 40v. 60p. 3 for £1-50. 4,700 μ f 40v. 80p. 3 for £2.
Don't Let Your Environment Dehydrate You!

Buy our Honeywell Humidity Controller. Membrane actuated, very sensitive, 1" shaft, 250V, 3-75A Contacts. Ideal for greenhouses, centrally heated homes, offices etc. Build your own humidifiers or alarms. Fraction of original cost 90p ea. 3 for £2.

VERNITRON FM4 10-7MHz
Ceramic filters. 50p each. 3 for £1.
R.C. SUPPRESSORS. 250V.
1" x 3" x 1". Ideal for car and home. Suppresses. Fluorescent lights, motors, contacts, useful for Snubber networks. 3 for £1.

ALTERNATOR RECTIFIERS
Make lovely 60 amp bridges. Ideal for High Power Battery Chargers. Type 4AFI. Set of 4 (2 neg. case + 2 pos. case) £2.

Special Purchase enables us to offer Mullard C280 Polyester Capacitors (Liquorice Allsorts) at the unbeatable price of £2 for 100 mixed, £15 for 1000. These consist of factory clearance lots i.e. spillages, floor sweepings, cosmetic rejects etc. Also Mullard miniature electrolytics 100 mixed £1-50, 1000 for £10. Pack of each £3. 1000 of each £30.

To: **"GEMINI ELECTRONIC COMPONENTS"**
"THE WAREHOUSE" SPEEDWELL ST. LONDON S.E.8.
Please Quote ZED Code. Where shown. Send Cheque* or Postal Order. Plus 50p P.A.P.
*Schools etc. SEND OFFICIAL ORDER
ZED PACKS now available for Callers at 50 Deptford Broadway, London, S.E.8.

The NEW

VIDEOTONE

YOU CANNOT BUY CHEAPER - YOU CAN ONLY GET LESS FOR YOUR MONEY!

Introduces DIRECT SELLING - the Ultimate Discount!!!

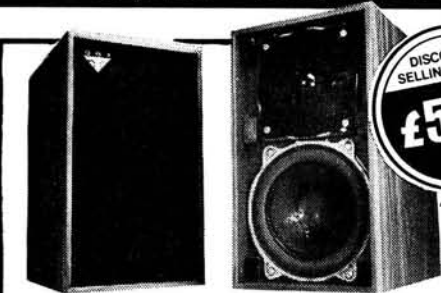

DISCOUNT SELLING PRICE
£50.00

LOUDSPEAKERS

The complete fully reviewed range of Videotone Speakers which dominate within their class. Now at lowest ever prices.

D 100	£38
Minimax 11	£44
GB3	£50
GB2	£60
GBS	£207
D 93	£40



DISCOUNT SELLING PRICE
£68.00

DISCOUNT SELLING PRICE
£75.00

ELECTRONICS

This new range of Electronics from Videotone redefines the words quality and value for money to a new high.

30 watt amp MC input SA4120	£75.00
Stereo Tuner ST4120	£68.00
Cassette full features SC3200	£98.00
50 Watt amplifier WA7700	£77.00
20 Watt amplifier LA2020	£58.00



DISCOUNT SELLING PRICE
£9.69

HEADPHONES

HP 90 Headphone	£12.65
HP 80 Headphone	£9.69

Superbly made with top flight performance.

CORAL CARTRIDGES

Fast becoming one of the top names



MOVING COIL
UK's No. 1 Cartridge

MC 81	£48.87
777EX	£35
777E	£25

HEAD AMP

H300	£51.75
T100	£24.75

MOVING MAGNET

555SX	£7.28
555E	£14.22
666E	£32.48

HEADSHELLS

S100	£6
S101	£7
S200	£4

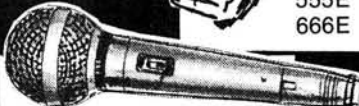

MICROPHONES

MU 105-22	£29.30
MU 105-12	£22.25
MU 25 C	£17.39

TURNTABLES

Sansui SR222 Mk2	£69.00
JVC LA 11	£64.00
JVC SLQ 3	£140.00

A MESSAGE FROM VIDEOTONE

Dear Customer

SPECIAL OFFER

This month with a copy of this advertisement from PRACTICAL WIRELESS GB2 speakers £39.50 a pair instead of the regular £60.00.

**Please Note:*

If required by Mail Order, postage and packing £7.00.

Videotone

SEND FOR OUR LATEST FREE BROCHURE AND DETAIL LIST OF LOCAL SALES OUTLETS IN THE U.K.



VIDEOTONE
98 CROFTON PARK ROAD,
CROFTON PARK, LONDON SE4
Tel: 01-690 8511/2

Please send me your Direct Selling Brochure and list of sales outlets.

Name _____

Address _____

PW1/81

VIDEOTONE

ALL PRODUCTS ON DISPLAY & CONTINUOUS DEMONSTRATIONS

ALL PRICES INCLUDE VAT

Marshall's

A. Marshall (London) Ltd., Kingsgate House,
Kingsgate Place, London NW6 4TA
Industrial Sales: 01-328 1009
Mail Order: 01-624 8582 24hr. service
Also retail shops: 325 Edgware Road, London W2
40 Cricklewood Broadway, London NW2 85 West Regent St. Glasgow
108A Stokes Croft, Bristol

We now supply the extremely reliable and cost conscious LEADER range of testgear.

SINGLE TRACE OSCILLOSCOPES		
LBO 510A 5" 4MHz 20mV		£125.00
LBO 512A 5" 10MHz 10mV		£170.00
LBO 513A 5" 10MHz 10mV		£215.00
LBO 507A 5" 20MHz 10mV		£239.00

DUAL TRACE OSCILLOSCOPES		
LBO 308S 3" 20MHz 2mV		£419.00
LBO 508A 5" 20MHz 10mV		£299.00
LBO 520A 5" 35MHz 5mV		£475.00
LBO 514 5" 10MHz 5mV		£256.00

T.V. RADIO TEST GEAR		
LSG 16 Signal Generator		£ 39.00
LSG 231 FM Stereo Signal Generator		£169.00
LCG 392U PAL B Pattern Generator		£189.00

AUDIO TEST GEAR		
LAC 26 Audio Generator		£ 60.00
LAC 170A Audio Generator		£119.00
LUM 17D Distortion Meter		£225.00
LFM 39A Wow/Flutter Meter (Dist)		£249.00
LFM 39A Wow/Flutter Meter (Dist)		£299.00
LAV 191 Audio Tester		£249.00
LAC 125 Low Distortion Audio Generator		£229.00

GENERAL TEST GEAR		
LCH 740 LCR Bridge		£135.00
LTC 906A Transistor Checker		£ 90.00
LVT 72 FET Transistor Checker		£119.00
LTC 907 Transistor Checker		£139.00
LAT 47 Attenuator		£135.00
LAT 45 Attenuator		£ 75.00
LFI 1300 Sweep Function Generator		£299.00

AMATEUR RADIO		
LUM 815 DIP Meter		£ 43.00
LIM 870A Antenna Impedance Meter		£ 41.00
LPM 880 HF Power Meter		£ 69.00
LPM 885 SWR Watt Meter		£ 34.00
LAC 895 Antenna Coupler		£ 85.00
LAC 896 Antenna Coupler		£ 41.00
LAC 897 Antenna Coupler		£ 41.00

Please send large SAE for special catalogue. All prices exclusive VAT/carriage.

The new Marshall's 80/81 catalogue is now available. A veritable treasure house of components, test gear, tools, etc.



Lots of old friends, but also many new products including leader test gear, Crimson Hi Fi Modules, Rechargeable Ni Cad batteries and chargers (very competitive). More components including SN74ALS series, new tools etc. Available by post, UK 75p post paid: Europe 95p post paid: Rest of world £1.35 post paid.

SINCLAIR INSTRUMENTS

Digital Multimeter		
"	PDM35	£ 34.50
"	DM235	£ 52.50
"	DM350	£ 72.50
"	DM450	£ 99.00
Digital Frequency Meter		
	PFM200	£ 49.80
Low Power Oscilloscope		
	SC110	£139.00

NEW

TF200	Frequency Meter	
		£145.00
TGF105	Pulse Generator	
		£ 85.00

CRIMSON ELEKTRIK HI FI MODULES

CE608	Power Amp	£20.09
CE1004	"	£23.43
CE1008	"	£26.30
CE1704	"	£33.48
CE1708	"	£33.48
CPS1	Power Unit	£19.52
CPS3	"	£23.52
CPS6	"	£30.00
CPR1	Pre Amp	£32.17
CPR1S	Pre Amp	£42.52

All Prices + VAT + postage/packaging
Don't forget! We also carry an impressive range of semi-conductors, passive components, electro-mechanical components, tools etc.



Wilmslow Audio

THE firm for speakers!

SEND 50p FOR THE WORLD'S BEST CATALOGUE OF SPEAKERS, DRIVE UNITS, KITS, CROSSOVERS ETC. AND DISCOUNT PRICE LIST.

AUDAX ● AUDIOMASTER ● BAKER ● BOWER & WILKINS ● CASTLE ● CELESTION ● CHARTWELL ● COLES ● DALESFORD ● DECCA ● EAGLE ● ELAC ● EMI ● FANE ● GAUSS ● GOODMAN'S ● HARBETH ● ISOPHON ● I.M.F. ● JORDAN ● JORDAN WATTS ● KEF ● LOWTHER ● McKENZIE ● MISSION ● MONITOR AUDIO ● MOTOROLA ● PEERLESS ● RADFORD ● RAM ● ROGERS ● RICHARD ALLAN ● SEAS ● SHACKMAN ● STAG ● TANNOY ● VIDEOTONE ● WHARFEDALE ●

WILMSLOW AUDIO (Dept. P.W.)

33/39 CHURCH STREET, WILMSLOW,
CHESHIRE SK9 1HF

Tel: 0625 529599

FOR MAIL ORDER & EXPORT OF DRIVE UNITS, KITS ETC.

Tel: 0625 526213

(SWIFT OF WILMSLOW) FOR HI-FI & COMPLETE SPEAKERS

PCB'S FOR PRACTICAL WIRELESS PROJECTS

Jan. 80.	Nimbus Radio Control Encoder	WR061	Price £2.28 30 pence p&p.
Jan. 80.	Nimbus Radio Control Rec.	WR064	Price £2.92 30 pence p&p.
Jan. 80.	A.F. Speech Processor	WR068	Price £2.28 30 pence p&p.
Jan. 80.	Wide Band Pre Amp.	WR067	Price £0.70 30 pence p&p.
Jan. 80.	Nimbus Radio Control T.X.	WR062	Price £2.26 30 pence p&p.
April 80	Signal Generator	WR070	Price £2.71 30 pence p&p.
April 80.	P.W. Nimbus Relay	WR075	Price £0.55 30 pence p&p.
April 80.	P.W. Nimbus Modulator	WR074	Price £0.70 30 pence p&p.
April 80.	Nimbus Transceiver	WR073	Price £5.30 30 pence p&p.
May 80.	Hundred Second Photo Timer	WR078	Price £2.48 30 pence p&p.
June 80.	Audio Limiter Main Board	WK076	Price £2.00 30 pence p&p.
June 80.	Audio Limiter	WK077	Price £1.15 30 pence p&p.
June 80.	Audio Limiter RF Input Board	WR079	Price £1.30 30 pence p&p.
June 80.	VHF/UHF Repeater Timer Main	WR080	Price £1.90 30 pence p&p.
June 80	P.W. Nimbus Base Station Adpt.	WR083	Price £2.60 30 pence p&p.
June 80.	Acoustic Flash Trigger	WRK84	Price £1.25 30 pence p&p.
Aug. 80	Model Railway Controller	WR085	Price £2.17 30 pence p&p.
Sept. 80	Transceiver Power Unit	WR095	Price £0.62 30 pence p&p.
Sept. 80	P.W. Nimbus Tonedurst/Timer Module	WR096	Price £1.85 30 pence p&p.
Sept. 80	Beginners 2m Converter	WAD634	Price £1.08 30 pence p&p.
Sept. 80	P.W. Tamar Board 1	WR086	Price £0.80 30 pence p&p.
Sept. 80	P.W. Tamar Board 2	WR087	Price £1.50 30 pence p&p.
Sept. 80	P.W. Tamar Board 3	WR088	Price £1.71 30 pence p&p.
Sept. 80	P.W. Tamar Board 4	WR089	Price £1.71 30 pence p&p.
Oct. 80	P.W. Tamar Board 5	WR090	Price £3.70 30 pence p&p.
Oct. 80	P.W. Tamar Board 6	WR091	Price £3.70 30 pence p&p.
Oct. 80	P.W. Nimbus 7 Mains PSU/Charger	WR097	Price £0.80 30 pence p&p.
Oct. 80	Direct Conversion Receiver	WR082	Price £1.40 30 pence p&p.
Nov. 80	Linear Scale Resistance Meter	WAD641	Price 90p 30 pence p&p
Nov. 80	Model Radio Control Field Test Unit	WK100	Price 90p 30 pence p&p
Nov. 80	M.R.C.F. T.V.	WK101	Price 90p 30 pence p&p

FULL RANGE OF RS COMPONENTS AVAILABLE

C. BOWES ELECTRONICS
252A Stockport Road, Cheadle Heath,
Stockport, Cheshire SK3 0LX.
Tel: 061-428 4497

Please enclose cheque or postal order with order.

Master Electronics the new Practical way.

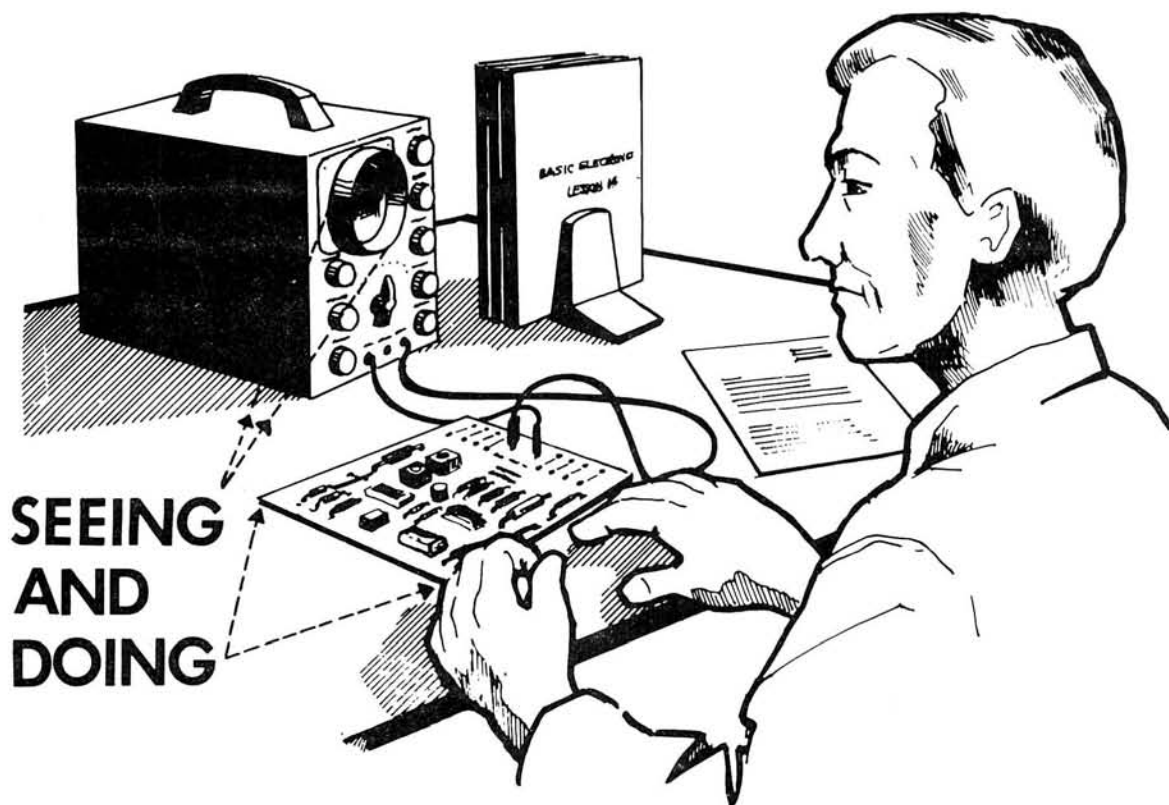

**SEEING
AND
DOING**

Conquer the 'Chip' — Easy-Fast-Exciting!

AND MASTER ALL THE NEW TECHNIQUES
IN MODERN ELECTRONICS.

- Build an Oscilloscope.
- Carry out over 40 full experiments including work on Digital Electronic Circuits.
- Recognition of Electronic Components.
- Understand and draw Circuit Diagrams.
- Experience with handling Solid State Circuits and "Chips".
- Testing and Servicing of Radio, T.V., Hi-Fi and all types of modern computerised equipment.

Colour Brochure — without any obligation. Post to :-

PW/1/812

BRITISH NATIONAL RADIO & ELECTRONICS SCHOOL
4 Cleveland Road, Jersey, Channel Islands.

Name

Address

.....

.....

BLOCK CAPS PLEASE

BRN



I.L.P. Toroidal

**TRANSFORMERS
IN A RANGE OF
75
TYPES**

We use advanced winding technology to make our toroidal transformers. They have only half the weight and height of their laminated equivalents and are appreciably more efficient. Our toroids cost virtually the same as the older types which they are rapidly replacing. Induced hum is reduced by a factor of ten. Supplied with rigid mounting kit with centre bolt, steel and neoprene washers.

30VA 70mm dia. x 30mm
Weight 0.45 Kg **£4.71**
(+£1.00 p.p. + 0.86 VAT)

TYPE	SECONDARY RMS VOLTS	SECONDARY RMS CURRENT
1X010	6 + 6	2.50
1X011	9 + 9	1.66
1X012	12 + 12	1.25
1X013	15 + 15	1.00
1X014	18 + 18	0.83
1X015	22 + 22	0.68
1X016	25 + 25	0.60
1X017	30 + 30	0.50

50VA 80mm dia. x 35mm
Weight 0.9 Kg **£5.19**
(+£1.10 p.p. + 0.94 VAT)

2X010	6 + 6	4.16
2X011	9 + 9	2.77
2X012	12 + 12	2.08
2X013	15 + 15	1.66
2X014	18 + 18	1.38
2X015	22 + 22	1.13
2X016	25 + 25	1.00
2X017	30 + 30	0.83
2X028	110	0.45
2X029	220	0.22
2X030	240	0.20

80VA 90mm dia. x 30mm
Weight 1 Kg **£5.76**
(+£1.20 p.p. + £1.04 VAT)

3X010	6 + 6	6.64
3X011	9 + 9	4.44
3X012	12 + 12	3.33
3X013	15 + 15	2.66
3X014	18 + 18	2.22
3X015	22 + 22	1.81
3X016	25 + 25	1.60
3X017	30 + 30	1.33
3X028	110	0.72
3X029	220	0.36
3X030	240	0.33

120VA 90mm dia. x 40mm
Weight 1.2 Kg **£6.72**
(+£1.30 p.p. + £1.20 VAT)

4X011	9 + 9	6.66
4X012	12 + 12	5.00
4X013	15 + 15	4.00
4X014	18 + 18	3.33
4X015	22 + 22	2.72
4X016	25 + 25	2.40
4X017	30 + 30	2.00
4X028	110	1.09
4X029	220	0.54
4X030	240	0.50

160VA 110mm dia. x 40mm
Weight 1.8 Kg **£8.88**
(+£1.40 p.p. + £1.54 VAT)

TYPE	SECONDARY RMS VOLTS	SECONDARY RMS CURRENT
5X012	12 + 12	6.66
5X013	15 + 15	5.33
5X014	18 + 18	4.44
5X015	22 + 22	3.63
5X016	25 + 25	3.20
5X017	30 + 30	2.66
5X018	35 + 35	2.28
5X028	110	1.45
5X029	220	0.72
5X030	240	0.66

225VA 110mm dia. x 45mm
Weight 2.2 Kg **£10.59**
(+£1.50 p.p. + £1.81 VAT)

6X014	18 + 18	6.25
6X015	22 + 22	5.11
6X016	25 + 25	4.50
6X017	30 + 30	3.75
6X018	35 + 35	3.21
6X026	40 + 40	2.81
6X028	110	2.04
6X029	220	1.02
6X030	240	0.93

300VA 110mm dia. x 50mm
Weight 2.6 Kg **£12.27**
(+£1.60 p.p. + £2.08 VAT)

7X016	25 + 25	6.00
7X017	30 + 30	5.00
7X018	35 + 35	4.28
7X026	40 + 40	3.75
7X025	45 + 45	3.33
7X028	110	2.72
7X029	220	1.36
7X030	240	1.25

500VA 140mm dia. x 60mm
Weight 4 Kg **£16.35**
(+£1.70 p.p. + £2.71 VAT)

8X017	30 + 30	8.33
8X018	35 + 35	7.14
8X026	40 + 40	6.25
8X025	45 + 45	5.55
8X033	50 + 50	5.00
8X028	110	4.54
8X029	220	2.27
8X030	240	2.08

• I.L.P. TOROIDAL TRANSFORMERS ARE GUARANTEED FOR 5 YEARS

CHOICE OF 3 PRIMARY INPUTS

I.L.P. Toroidal Transformers are available in choice of 110V, 220V, 240V, coded as follows: (Secondaries can be connected in series or parallel)

For 110V Primary insert 0 in place of "X" in type number.
For 220V Primary (Europe) insert 1 in place of "X" in type number.
For 240V Primary (U.K.) insert 2 in place of "X" in type number.

Example - 120VA 240V 15 + 15V. 4A = 42013.

• CUSTOMER DESIGN ENQUIRIES INVITED.
QUANTITY PRICE LIST AVAILABLE.

FREEPOST facility. (U.K. only).

Simply address envelope to **FREEPOST** to address below. NO STAMP REQUIRED.

TO ORDER Enclose cheque/Postal Order/Money Order payable to I.L.P. Electronics Ltd or quote your ACCESS or BARCLAYCARD account No. To pay C.O.D. add £1 extra to TOTAL value of order. Also available from ELECTROVALUE and MARSHALLS.



I.L.P. TRANSFORMERS
A division of I.L.P. ELECTRONICS LTD.

**FREEPOST T1 GRAHAM BELL HOUSE ROPER CLOSE
CANTERBURY CT2 7EP
Phone (0227) 54778 Technical (0227) 64723 Telex 965 780**

PM COMPONENTS LTD

VALVE & COMPONENT SPECIALISTS
CONINGSBY HOUSE, WROTHAM RD.,
MEOPHAM, KENT.

VALUES	PL509	2.30	6080	4.20	BC213L	0.09	BU108	1.69	
DY86	0.55	PL802	2.50	6146A	4.45	BC214	0.09	BU205	1.30
DY802	0.60	PV88	0.72	6146B	4.85	BC214L	0.09	BU208	1.39
E180F	5.65	PY500A	1.35	7025	1.50	BC237	0.09	BU208A	1.52
EABC80	0.56	PY801	0.60	7360	7.50	BC238	0.08	MJ340	0.40
EBF89	0.70	QV02-6	8.25	7591	2.35	BC307	0.09	OC71	0.22
ECC81	0.55	QV03-20A				BC327	0.10	R2008B	1.70
ECC82	0.55		12.25			BC337	0.10	R2010B	1.70
ECC83	0.60	QV06-40A				BC461	0.30	R2540	2.48
ECC85	0.60		13.95			BC126	0.22	BC478	0.20
ECC88	0.65	QV03-12	3.25	AC127	0.22	BC547	0.10	TIP29C	0.42
ECC807	1.30	TB2.5/300		AC128	0.28	BC548	0.10	TIP30C	0.42
ECCF80	0.65		42.00	AC141K	0.34	BC549A	0.08	TIP31C	0.43
ECCF82	0.60	TY2-125A	30.00	AC176	0.22	BC557	0.07	TIP32C	0.42
ECH81	0.58	U19	11.95	AC176K	0.31	BC558	0.07	TIP41C	0.45
ECL82	0.58	UCH81	0.70	AC187	0.26	BD131	0.32	TIP42C	0.47
ECL83	1.13	UCL82	0.70	AC187K	0.28	BD132	0.35	TIP47	0.65
ECL86	0.74	UL84	0.78	AC188	0.22	BD133	0.40	TIP2955	0.84
EF80	0.48	UY85	0.70	AD149	0.70	BD135	0.30	TIP3055	0.60
EF86	0.70	Z759	9.00	AD161	0.39	BD136	0.30	TIS91	0.20
EF89	0.65	2D21	1.60	AD161/2	1.04	BD137	0.28	2N3054	0.59
EF91	1.22	4CX250B	21.75	AD162	0.39	BD138	0.30	2N3055	0.59
EF93	0.65	5R4GY	1.25	AF127	0.32	BD139	0.28	2N3702	1.12
EF94	0.65	5U4G	0.90	AF139	0.42	BD140	0.30	2N3703	0.12
EF95	0.78	6GK6	2.50	AF239	0.42	BD144	1.20	2N3704	0.12
EF183	0.56	6J8	0.65	BC107	0.10	BF115	0.35	2N3705	0.12
EF184	0.56	6J56C	5.00	BC107B	0.10	BF167	0.24	2N3706	0.12
EL34	1.54	6K06	4.50	BC108	0.10	BF179	0.34	2N3708	0.12
EL84	0.60	6L6GC	1.75	BC108C	0.10	BF180	0.29	2N5294	0.38
EM84	0.65	6LD20	0.60	BC109B	0.10	BF183	0.29	2N5296	0.48
EZ80	0.48	6L06	6.50	BC140	0.31	BF194	0.11	2N5298	0.38
EZ81	0.56	6SN7GT	0.90	BC141	0.25	BF195	0.11	I.C.'s	1.15
GZ32	0.76	6V6GT	1.05	BC142	0.21	BF196	0.11	MC1307	1.00
GZ33	1.81	7S7	2.00	BC143	0.24	BF197	0.10	MC1350	1.00
GZ34	2.00	12AT7	0.60	BC147	0.09	BF198	0.10	MC1495	3.00
KT61	3.50	12AU7	0.60	BC148	0.09	BF199	0.14	MC1495	3.00
KT66	4.00	12AX7	0.65	BC149	0.09	BF200	0.30	SN76003N	1.65
KT77	5.00	12BA6	0.80	BC157	0.10	BF257	0.28	SN76013N	1.15
KT88	6.00	12BE6	1.05	BC158	0.09	BF258	0.25	SN76013ND	1.15
N78	8.90	12BH7	0.95	BC159	0.09	BF259	0.26	SN76023N	1.35
OA2	0.78	12HG7	3.50	BC160	0.28	BF336	0.34	SN76033N	1.35
PCF80	0.72	85A2	1.20	BC170B	0.10	BFX29	0.30	SN76227N	1.05
PCF802	0.66	90C1	1.69	BC171	0.08	BFX84	0.26	SN76131N	1.30
PCF808	1.48	807	1.09	BC172	0.08	BFX85	0.28	SN76227N	1.05
PCL82	0.68	811A	9.00	BC173B	0.10	BFX86	0.30	SN76660N	0.60
PCL84	0.72	813	11.30	BC182	0.09	BFX88	0.25	TA86B1B	1.20
PCL86	0.75	833A	47.85	BC183	0.09	BFY50	0.21	TBA1205	7.00
PCL805	0.80	866A	2.50	BC184LA	0.09	BFY51	0.21	TBA540	1.25
PFL200	1.13	2050A	3.90	BC212	0.09	BFY52	0.25	TBA550Q	1.55
PL504	1.13	5763	3.20	BC212L	0.09	BFY90	0.73	TBA641-B11	1.90
PL509	1.48	5814A	2.75	BC213	0.09	BU105	1.22		

Prices exclude VAT
Please add 15%
P&P 50p per order

Many other types available
including vintage valves.
PHONE 0474 813225



P.W. KITS

P. W. NIMBUS

Transceiver (PCB & all components except channel xtals) **£46.00**
Modulator (PCB & all components) **£4.50**
General Assembly (Aerial, mike, box, speakers etc.) **£32.50**
Complete Kit (if all parts purchased) **£80.00**

ADD ON BASE UNIT

Complete Kit **£38.00**

Many other P.W. kits available including:-

Wideband RF Pre-Amp **£7.50** AF Speech Processor **£17.00**
Beginners 2m Converter **£15.00** Model Railway Controller **£21.50**
VHF/UHF Repeater Station Timer (main board only) **£22.50**
Linear Frequency Meter Tone burst and Timer Module.
Also: Philips 5" Scope Tubes (CV2191/DG132) **£12.50**.

We also stock Kits for projects published in most magazines. Personal callers welcome - but please phone first to check availability.

All Prices include post and VAT.

T. POWELL 306 St. Paul's Road, Highbury Corner,
London N1. Telephone: 01-226 1489.

ACCESS/VISA ACCEPTED
Shop open: Mon. to Fri. 9-5.30. Sat. 9-4.30.

It's on it's way . . .
the brand new **1981** edition of the
World Radio TV Handbook.

The *only* directory of International Broadcasting!
The standard reference of DXer's, SWL's and professionals!

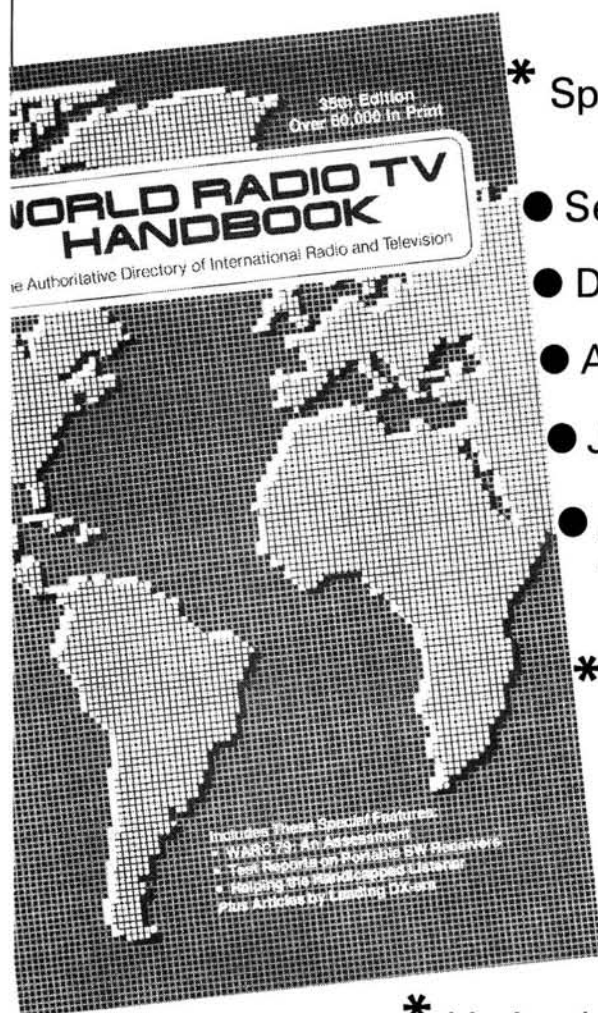

* Special articles will include:-

- Selected previews of New Receivers
- DX Clubs and their Activities
- Aspects of propagation
- Jamming and its problems
- A variety of features covering the main interests of DXer's/SWL's

* Completely updated reference section with frequencies, times, languages, addresses, and details of all known SW, and most MW stations

* UK price only £9.50

* Listing by frequency of the worlds SW/MW/LW stations, and *essential* information for the active listener

W.R.T.H. will be published 5th January 1981

Available from your bookseller or direct from:-

UK
Billboard Ltd
7 Carnaby Street
London W1
439 9411

UK TRADE
Argus Books Ltd
14 St. James Rd.
Watford
Herts.

USA
Billboard Publications
Watson Guptill
One Astor Plaza
New York 10036

EUROPE
J. Frost
Soliljevej 44
2650 Hvidovre
Denmark

SUPERSOUND 13 HI-FI MONO AMPLIFIER

A superb solid state audio amplifier. Brand new components throughout. 5 silicon transistors plus 2 power output transistors in push-pull. Full wave rectification. Output approx. 13 watts r.m.s. into 8 ohms. Frequency response 12Hz-30KHz ± 3db. Fully integrated pre-amplifier stage with separate Volume, Bass boost and Treble cut controls. Suitable for 8-15 ohm speakers. Input for ceramic or crystal cartridge. Sensitivity approx. 40mV for full output. Supplied ready built and tested, with knobs, escutcheon panel, input and output plugs. Overall size 3" high x 6 1/2" wide x 7 1/2" deep. AC 200/250V. PRICE £18-40, P. & P. £1-60.

HARVERSON MODEL P.A. TWO ZERO

An advanced solid state general purpose mono amplifier suitable for Public Address system, Disco, Guitar, Gram, etc. Features 3 individually controlled inputs (each input has a separate 2 stage pre-amp.). Input 1, 15mV into 47k. Input 2, 15mV into 47k (suitable for use with mic. or guitar etc.). Input 3, 200mV into 1 meg. suitable for gram, tuner, or tape etc. Full mixing facilities with full range bass & treble controls. All inputs plug into standard jack sockets on front panel. Output socket on rear of chassis for an 8 ohm or 16 ohm speaker. Output in excess of 30 watts music power. Very attractively finished purpose built cabinet made from black vinyl covered steel, with a brushed anodised aluminium front escutcheon. For ac mains operation 200/240 volts. Size approx. 12 1/2" wide x 5 1/2" high x 7 1/2" deep. Special price £29-00 + £3-00 carriage and packing.

"POLY PLANAR" WAFER-TYPE, WIDE RANGE ELECTRO-DYNAMIC SPEAKER

Size 11 1/2" x 14 1/2" x 1 1/2" deep. Weight 19oz. Power handling 20W r.m.s. (40W peak). Impedance 8 ohm only. Response 40Hz-20KHz. Can be mounted on ceilings, walls, doors, under tables, etc., and used with or without baffle. Send S.A.E. for full details. Only £9-20 each + p. & p. (one £1-20, two £1-50).

A brand new 22 transistor hi-fi stereo amplifier

of superior design made by a well-known British manufacturer, for a now cancelled contract order. The unit is supplied new & tested on a printed circuit panel size approx. 6 1/2" x 4 1/2" x 1 1/2" h. using high grade discrete components. Brief specification: 15 watts r.m.s. per channel O/P into 8 ohms. (o/p stages fully protected against s/c) I/P 60mV, for ceramic cartridge. Provision for tape i/p & o/p. Only requires the addition of a 40 volt @ 2 amp. power supply & the bass, treble, balance & vol. control. (standard types). FULL Circuit diagram & connection details supplied. Price with edge connectors. Only £9-00 + 80p p. & p. *Suitable 2 stage pre-amp. for mag. cart. RIAA corrected can be supplied @ £2-50 if ordered with amplifier. Suitable components for power supply can be supplied if ordered with amplifier—mains transformer, rectifier, smoothing condenser. £4-00 + £1-80 p. & p.

MAINS OPERATED SOLID STATE AM/FM STEREO TUNER



200/240V Mains operated Solid State FM AM Stereo Tuner. Covering M.W. A.M. 540-1605 KHz VHF/FM 88-108 MHz. Built-in Ferrite rod aerial for M.W. Full AFC and AGC on AM and FM. Stereo Beacon Lamp

Indicator. Built in Pre-amps with variable output voltage adjustable by pre-set control. Max o/p Voltage 600mV RMS into 20K. Simulated Teak finish cabinet. Will match almost any amplifier. Size 8 1/2" x 4" x 9 1/4" deep.

LIMITED NUMBER ONLY at £29-00 + £2-00 P. & P.

10/14 WATT HI-FI AMPLIFIER KIT

A stylishly finished monaural amplifier with an output of 14 watts from 2 EL84s in push-pull. Super reproduction of both music and speech with negligible hum. Separate inputs for mike and gram allow records and announcements to follow each other. Fully shrouded section wound output transformer to match 3-15 Ω speaker and 2 independent volume controls, and separate bass and treble controls are provided giving good lift and cut. Valve line-up 2 EL84s, ECC83, EF86 and E280 rectifier. Simple instruction booklet 50p + SAE (Free with parts). All parts sold separately. ONLY £18-40, P. & P. £2-00. Also available ready built and tested £22-50, P. & P. £2-00.

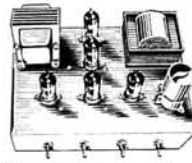

STEREO DECODER MK.II

SIZE 1 1/2" x 2 5/16" x 1" ready built. Pre-aligned and tested for 10-16V neg. earth operation. Can be fitted to almost any FM VHF radio or tuner. Stereo beacon light can be fitted if required. Full details and instructions supplied £7-00 plus 25p P. & P. Stereo beacon light if required 40p extra.

Mullard LP1159 RF IF module 470kHz £2-50 + P. & P. 40p. Full specification and connection details supplied. Pye VHF FM Tuner Head covering 88-108MHz 10-7 MHz I.F. output. 7-8V + earth. Supplied pre-aligned, with full circuit diagram with precision-gear F.M. gang and 323PF + 323PF A.M. Tuning gang only £3-40 + P. & P. 60p.

STEREO MAGNETIC PRE-AMP. Sens. 3mV in for 100mV out. 15 to 35V neg. earth. Equ. ± 1dB from 20Hz to 20KHz. Input impedance 47K. Size 1 1/2" x 2 1/2" x 1/2" H. £3-20 + 22p P. & P.

HARVERSON SUPERSOUND 10 + 10 STEREO AMPLIFIER KIT

A really first-class Hi-Fi Stereo Amplifier Kit. Uses 14 transistors including Silicon Transistors in the first five stages on each channel resulting in even lower noise level with improved sensitivity. Integral pre-amp with Bass, Treble and two Volume Controls. Suitable for use with Ceramic or Crystal cartridges. Very simple to modify to suit magnetic cartridge—instructions included. Output stage for any speakers from 8 to 15 ohms. Compact design, all parts supplied including drilled metalwork, high quality ready drilled printed circuit board with component identification clearly marked, smart brushed anodised aluminium front panel with matching knobs, wire, solder, nuts, bolts—no extras to buy. Simple step by step instructions enable any constructor to build an amplifier to be proud of. Brief specification: Power output: 14 watts r.m.s. per channel into 5 ohms. Frequency response: ± 3dB 12-30,000 Hz Sensitivity: better than 80mV into 1M Ω. Full power bandwidth: ± 3dB 12-15,000 Hz. Bass boost approx. to ± 12dB. Treble cut approx. to -16dB. Negative feedback 18dB over main amp. Power requirements 35v. at 1.0 amp. Overall Size 12" x 8" x 2 1/2". Fully detailed 8 page construction manual and parts list free with kit or send 50p plus large S.A.E. AMPLIFIER KIT £14-95 P. & P. £1-20 (Magnetic input components 33p extra) POWER PACK KIT £6-20 P. & P. £1-50 CABINET £6-20 P. & P. £1-50

SPECIAL OFFER—only £25-80 if all 3 items ordered at one time plus £2-80 P. & P.

Full after sales service Also avail. ready built and tested £32-20, P. & P. £2-80.

HARVERSON STEREO 44

A solid state stereo amplifier chassis, with an output of 3-4 watts per channel into 8 ohm speakers. Using the latest high technology integrated circuit amplifiers with built in short term thermal overload protection. All components including rectifier smoothing capacitor, fuse, tone control, volume controls, 2 pin din speaker sockets & 5 pin din tape rec. play socket are mounted on the printed circuit panel, size approx. 9 1/2" x 2 1/2" x 1" max. depth. Supplied brand new & tested, with knobs, brushed anodised aluminium 2 way escutcheon (to allow the amplifier to be mounted horizontally or vertically) at only £10-40 plus 90p P. & P. Mains transformer with an output of 17v a/c at 500m/a can be supplied at £2-15 + 70p P. & P. if required. Full connection details supplied.

All prices and specifications correct at time of press and subject to alteration without notice.

PLEASE NOTE: P. & P. CHARGES QUOTED APPLY TO U.K. ONLY. SEND SAE WITH ALL ENQUIRIES.

HARVERSON SURPLUS CO. LTD. (Dept. P.W.) 170 MERTON HIGH ST., LONDON, S.W.19. Tel.: 01-540 3985
A few minutes from South Wimbledon Tube Station. ACCESS/BARCLAYCARD WELCOME
Open 9.30-5.30 Mon. to Fri. 9.30-5 Sat. Closed Wed.

The facts of the case

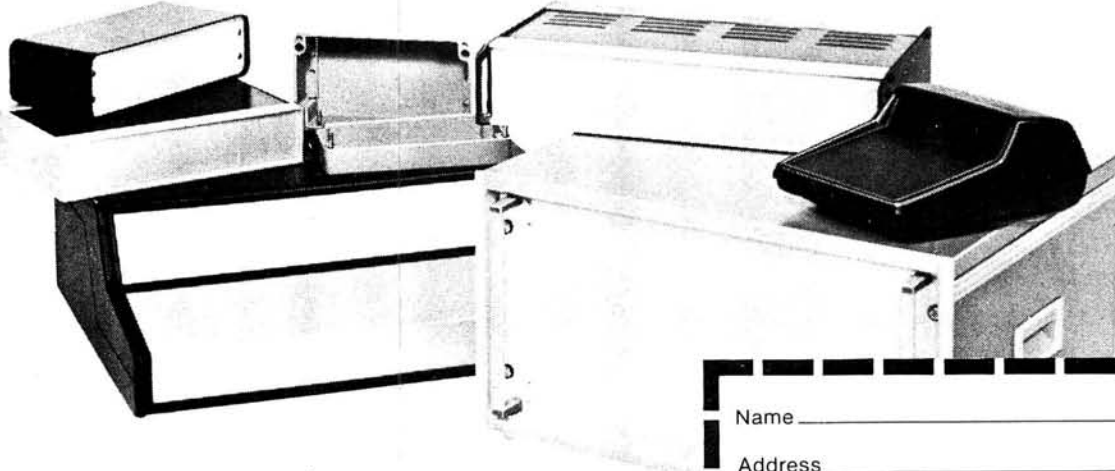

West Hyde have one aim in life, to provide a practical solution to the problem of electronic packaging. The fact of the matter is that we have an ideal case for almost every project featured in this magazine. In this advertisement it is impossible to show you our whole range of nearly 1,000 different instrument cases, or our extensive collection of tools and accessories. Please complete the coupon and, in turn, we will send you our free 80-page catalogue and price list.

Name _____
Address _____

WEST HYDE

West Hyde Developments Limited, Unit 9, Park Street Industrial Estate, Aylesbury, Bucks., HP20 1ET
Telephone: Aylesbury (0296) 20441/5

At these sensational prices you can afford to give

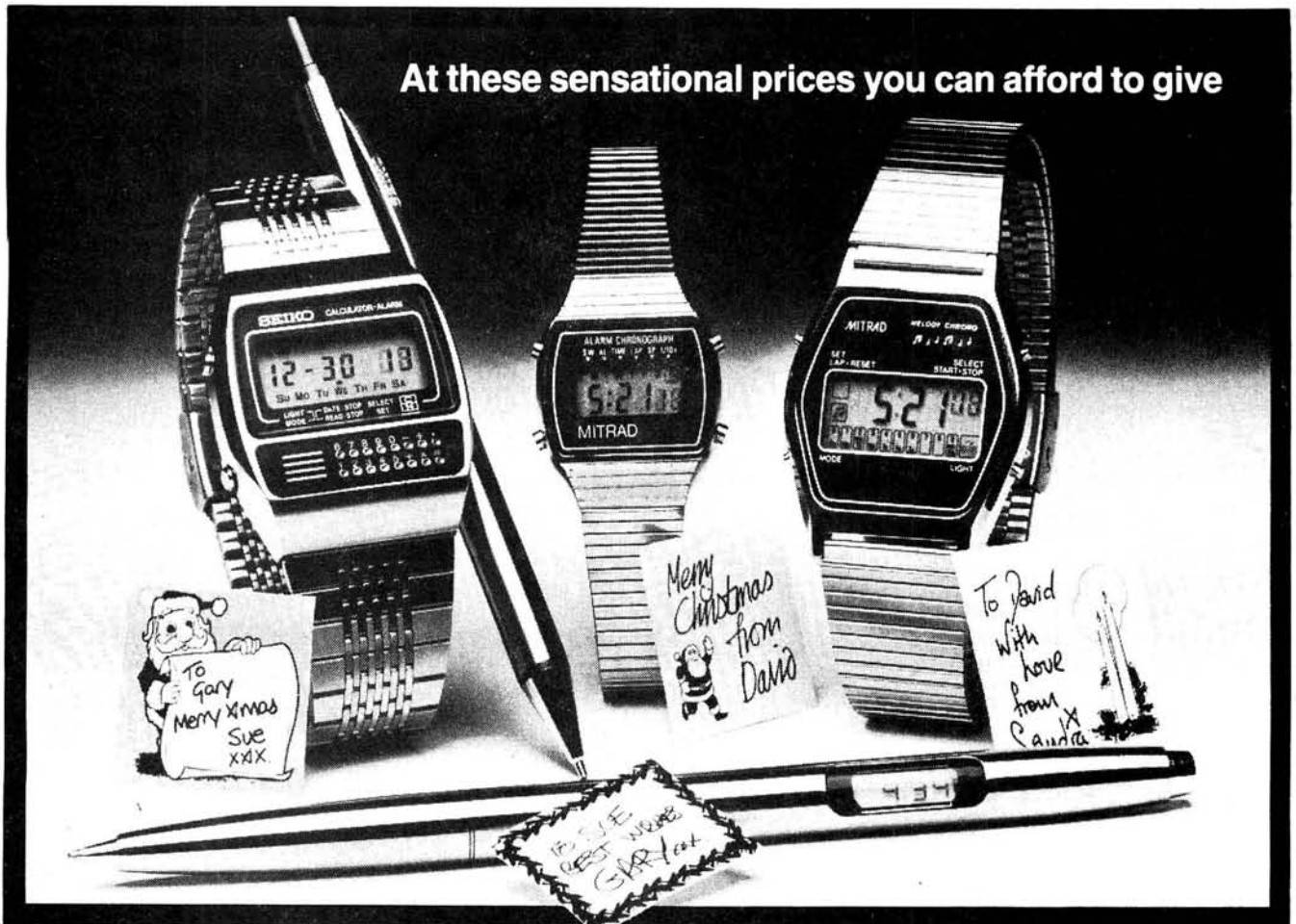

CHRISTMAS TIME PRESENTS

Great gifts at giveaway prices. For your family. Your friends. Or yourself.

SEIKO QUARTZ CALCULATOR/ALARM

Only £49.95 + 85p p&p

Continuous display of hours, minutes, seconds with day, alarm indicators. Optional display: month, date, AM/PM with day indicator. Calculator (16 key) performs arithmetic, percentage, constant and power calculations. 12 hour alarm with AM/PM indication, rings twice a second for 10 seconds, then four times a second for 10 seconds. Display flashes as battery life nears end. Back light. Water resistant. Adjustable stainless steel strap.

MITRAD MD605 QUARTZ LADIES MUSICAL ALARM

CHRONO Only £11.95 + 85p p&p

Continuous display of hours, minutes, seconds. Optional display: day, date, month. Auto calendar. Chronograph with lap timing facilities to 1/10 sec. 24 hour alarm plays 30 seconds of Beethoven's 'Für Elise'. Back light. Infinitely adjustable stainless steel strap.

MITRAD MD610 QUARTZ GENTLEMAN'S MELODY

ALARM Only £16.95 + 85p p&p

Case thickness only 5mm. Continuous display of hours, minutes, seconds with date and mode indications. 'Running horse' chronograph to 1/10 sec. 12 hour alarm plays 30 seconds of 'Yellow Rose of Texas'. Back light. Infinitely adjustable stainless steel strap.

MITRAD PEN WATCH Only £11.15 + 85p p&p

Elegant stainless steel ballpoint pen combined with a quartz precision timepiece. The five function LCD watch displays hours, minutes, seconds, month and date and has a computerised four year date memory. In presentation case with spare pen refill.

From the collection of 12 month guaranteed leading make products offered through Mitrad's 7 day distribution system and backed by Mitrad's own service organisation. For complete product range, ring or write for catalogue. Trade price list available for bulk buyers.

MITRAD The Premier mail order house specialising in quality products and superior after-sales care.

To: Mitrad, 68-70 High Street, Kettering, Northants. Please send me:

- Seiko Calculator/Alarm at £50.80 inc p&p MD605 at £12.80 inc p&p
 MD610 at £17.80 inc p&p Pen Watch(es) at £12.00 inc p&p

Total value of my order £ _____

I enclose cheque/PO or debit my Access/Barclaycard



No. _____ Signature _____

Name _____ (block letters please)

Address _____

☎ Credit card holders may telephone (0536) 522024 24 hours a day stating card number for immediate attention. All orders despatched within 7 days. Delivery subject to availability. Full refund if not completely satisfied. Mitrad. Registered in England No. 2554356. Code: PW 12/80



Mitrad, 68-70 High Street, Kettering, Northants.

COMMUNICATIONS RECEIVERS made by Murphy Radio for Navy, high grade Rx covering 60 to 560Kc in two bands & 1.5 to 30Mc/s in 3 bands, uses 13 B7g type valves as 2 RF stages, 3x IF stages at 800Kc, Det, N.Lim, AVC, 2x AF stages, BFO & 800Kc crystal Cal. the O/P stage matches to 100 ohm phones or 2 watts into 600 ohm. Controls, Main Tune, Band Sel, RF gain, LF gain, Phone gain, AVC On/off, Selectivity at 8, 3, 1Kc or 200c/s, the 1Kc sel uses Bandpass Crystal filter the 200c uses Crystal plus Audio Filter, the BFO can be swt to upper or lower beat i.e. 801 or 799Kc int set, also 800Kc for tune. There are two O/P jacks for phones & one for spk. on front panel, provision for 75 ohm Ae I/P or long wire. Complete in steel case size 13x14" front 14" deep, Note these Rx require external power supply giving 250v 100Ma & 150v Stab DC 6.3v AC at 4 amps. There is room inside the case to build an internal P.U. Supplied tested with circ & 40 page handbook. **£115.**

VIDEO RECORDERS Philips type LDL1000 portable monochrome 625 line reel to reel type 1/2" tape 75 ohm I/P & O/P 1v sig. 4v Vid ext size 42x34x20 Cm weight 12Kg 240v 50c I/P supplied in good cond with 80 page handbook untested with 2x tapes fuller spec on request. **£185.**

TEST SET CT373 Audio bench test set Osc 17c to 170Kc, AF VTVM, Dist meas set new cond with book full spec on request. **£80.**

HELIPOT DIALS Colvern 10 turn type **£1.50.** Beckman 15 turn **£2.50.**

COAX RELAYS coil 24v DC as 1p c/o RF plus c/o aux contacts 50 ohm with connectors okay VHF small size ex new equip **£5.**

SELECTIVE CALLING UNITS contains LV mains P.U. 500 Ua meter, telephone dial, selection of trasis boards, 12v relays, rot swts, in new cond **£25.**

SOLARTRON ENCH P.U. 240v I/P gives 0 to 500v DC at 100Ma up to 350v also 6.3v AC at 3 amps, fitted Volt/Ma meter in table case size 13x8x13" supplied tested with circ **£22.**

POWER UNIT INVERTOR contains 6x pot cores, 3x HV TO. 3 power swt transis 4x3 amp diodes, 2x thyristors, 10x misc transis, 3x 20 mm fuse holders, res, elec conds etc on case size 9x3 1/2 x 4" with circ. **£4.50, 2 for £8, 10 for £25.**

CRYSTALS mostly 10Xj types in range 5 to 8Mc/s 20 mixed for **£2.30.**

TRANS UNIT small battery operated unit crystal controlled with two valves for use on 2 to 8 Mc/s CW with circ **£5.50.**

MAINS FILTERS Plessey 240v at 1.5 amps size 2 1/2 x 1 1/4 x 1" new **£2.20.**

MAINS TRANS 200/250v Sec 340-250-0-250-340v at 210Ma plus LTs 6.3v 5 amps twice & 5v 5 amps Ct new few only left. **£10.50.**

AUTO TRANS 200/250v to 115v 560 watts fully enclosed term conn new cond **£13.50.**

RADIO STATION KIT contains small Morse key, 100ft Ae wire, special high resis head set, haversack etc new cond **£5.50.**

ROTARY SWTS all new 2p 11 way **85p** larger type 2p 23way 3 & 8p 12 way **£3.**

FILM RECORDERS contains 24v DC motor, good selection of gears, prism ass, 16 mm cassettes etc good cond **£7.50.**

INFRA RED light & heat units lamp only no fittings rated 115v 500 watts ex 7" dai new 2 for **£5.40.**

HEADPHONES low res type DLR.5 can be used for sound powered intercomm link **£3.50** pair two for **£6** also new boxed at **£4.50** pair.

HAND GENERATORS for use with MK.123 TR O/P 115v 100c 40 watts and 80 watts int, new cond in fitted case with accs. **£25.**

MIRRORS searchlight, silvered, steel backed 20 1/2" dai 3 1/2" deep at centre with hole 3 3/4" dia may have some scratch marks due to handling **£25.**

PHOTO TRANSIS Fairchild type FPT120 end viewing new with data 60p ea two for **£1.**

DIODES Stud mt type new rated 10 amps 600 PIV 4 for **£2** or 1 Kv PIV 4 for **£2.75.**

H.D. SLIDE RES panel mt rated 1 ohm 12 amps **£4.50.**

TECH HANDBOOKS we can obtain photostats on most of the old Service Radio gear, plus some test equip about 14 days.

Above prices include carr/postage & VAT. Goods ex equipment unless stated new 2x10p stamps for list 25/1.

A. H. SUPPLIES
122 HANDSWORTH ROAD,
SHEFFIELD S9 4AE. Phone: 444278 (0742).

WOOD & DOUGLAS

With the winter evenings approaching, the constructional season for radio amateurs is about to begin. If you are undecided on your winter project perhaps you can find something in our range of over 30 kits and modules to suit you.

70FM05TR In case you missed October's review of this single channel FM transceiver for 70 cms here are a few details. The receiver sensitivity is typically 0.4µV and uses dual gate MOSFETS and a high quality crystal filter. The audio output drives an 8Ω speaker. The transmitter gives 500mW of RF and has a modulator on the pcb. Both boards use readily available crystals and measure a very compact 6" by less than 1 1/4".

Kit RX **£38.50** Assembled RX **£47.25**
TX **£17.80** TX **£25.95**

70MC06TR When one channel is not enough then by adding this two pcb set you will have 6 channels on tx/rx. This includes a toneburst for repeaters and a scanner to ease monitoring.

Kit RX **£18.60** Assembled RX **£26.05**
TX **£11.30** TX **£18.10**

144SY25B An FM synthesiser for 25KHz steps at 144-146MHz. The output frequencies are 5.5, 11, 22 or 45MHz on receive and 6, 12 or 24MHz on transmit. This will feed most commercial radio telephones and also the PW NIMBUS. So for the cost of ten crystal channels you get full band coverage, crystal controlled toneburst, repeater ±600KHz offset, out of lock inhibit and channel selection by channel number.

Kit **£50.95** Assembled **£69.70**

INTERESTED? If you would like further details of these and our many other products then send a large SAE (please!) for the latest lists. The above prices include VAT at the current rate but please add 60p p&p on the total order. The prices include all items to make a working pcb module. We do not supply external hardware such as boxes or switches etc. This leaves you free to use the modules in whatever configuration you wish and yet have confidence that the electronics will perform well. We will gladly service any of our products providing it has been built as directed. We make a small charge for this facility depending on complexity. Kits when in stock are return of post otherwise 10-14 days. Assembled items 10-20 days.

**9 HILLCREST, TADLEY
BASINGSTOKE, HANTS RG26 6JB**



LOW PROFILE I.C. SOCKETS				TRANSFORMERS (ALL 240V Primary)			
1+ 100+	1+ 100+	6-0-6 = 100ma	£1.00	15-0-15 = 1A	£2.90		
6 pin 7p 5.5p	20 pin 16p 14p	6-0-6 = 250ma	£1.60	6.3V = 1.5A	£2.38		
8 pin 8p 6p	22 pin 18p 18p	9-0-9 = 75ma	£1.00	6-0-6 = 1.5A	£2.88		
14 pin 10p 8.5p	24 pin 20p 18p	12-0-12 = 50ma	£1.00	9-0-9 = 2A	£4.47		
16 pin 11p 9.5p	28 pin 28p 20p	12-0-12 = 100ma	£1.50	12-0-12 = 2A	£4.54		
18 pin 13p 11.6p	40 pin 32p 31p	9-0-9 = 1A	£2.40	30-0-30 = 2A	£6.28		
		12-0-12 = 1A	£2.86	14V = 2A	£3.50		
BRIDGE RECTIFIERS				400mw Zener Diodes			
1.5A	2.0A	50V	38p	50V	50p	100A	£2.25
100V	38p	100V	43p	100V	73p	100V	£2.34
200V	41p	200V	44p	200V	76p	200V	£2.60
400V	43p	400V	51p	400V	84p	400V	£2.79
600V	47p	600V	58p	600V	95p	600V	£3.54
800V	54p	800V	65p				£4.75
				Wholesale/Quantity prices available			
				1 Watt Zener Diodes			
2.7v, 3v, 3.3v, 3.6v, 3.9v, 4.3v, 4.7v, 5.1v, 5.6v, 6.2v, 6.8v,	3.3v, 3.6v, 3.9v, 4.3v, 4.7v, 5.1v, 5.6v, 6.2v, 6.8v, 7.5v,	7.5v, 8.2v, 9.1v, 10v, 11v, 12v, 13v, 13.5v, 15v, 16v, 18v,	20v, 22v, 24v, 27v, 30v, 33v, 36v, 39v, 43v, 47v, 51v,	62v, 68v, 75v, 82v, 91v, 100v, 110v, 120v, 130v, 150v,	160v, 180v, 200v,		
PRICE: 8p each, 75p/10. Any 100 for £6. BA154 4p, BA156 9p, BY126 12p, OA10 35p, BY127 12p, OA90 10p, OA91 10p, OA200 5p.	PRICE: 15p each. Any 100 £12.50.						
				WIREWOUND RESISTORS			
2.5 Watt 5% Values: 0.22 ohm to 270 ohm				PRICE: 18p each			
5 Watt 5% Values: 10 ohm to 12K				PRICE: 21p each			
10 Watt 5% Values: 15 ohm to 25K				PRICE: 24p each			
4 Watt 5% & 10% Values: 1 ohm to 10K (Flameproof)				PRICE: 22p each			
7 Watt 5% & 10% Values: 0.47 ohm to 22K (Flameproof)				PRICE: 24p each			
11 Watt 5% & 10% Values: 1 ohm to 22K (Flameproof)				PRICE: 28p each			
17 Watt 5% & 10% Values: 1 ohm to 22K (Flameproof)				PRICE: 35p each			
				SPECIAL OFFER: METAL SLIDER POTENTIOMETERS			
				Length of track 60mm: 500 ohm LIN			
				Mono 30p, 50K, 100 Stereo 40p			
				100K LIN Stereo 40p, 1 Meg LOG Stereo 40p. ALL PRICES INCLUDE FREE KNOBS TO FIT			
MARCUS TRADING, Dept. PW5, The Old School, Edataston, WEM, Shropshire, SY4 5RJ.							

L.B. ELECTRONICS

SPECIAL OFFER: - 5" LED displays. FND500 Full spec. 50p each, larger quantities P.O.A. P/P 25p.
ASTEC UM1111 E36 Modulators (Pull Outs) 65p each. P/P 25p.
JUST ARRIVED: Battery eliminator 6V 200mA, brand new 95p each. P/P 35p. 5K Multi turn trim pots. PCB Mounting, pack of 14 **£2.50.** P/P 25p.
CAPACITOR SCOOP: 1600uf at 10V, 160uf at 25V axial lead 24 at **£1.00** (mixed). P/P 25p.
GIVE AWAY: 22 pin low profile Dill socket, gold plated 12p each. 10 at **£1.00.** P/P 25p.
PEWEC: Mini fans 80mm - 80mm approx. 115V **£4.50.** P/P **£1.00.**
TANTALUM CAPACITORS: 4.7uf at 25V, 14 for **£1.00.** P/P 25p.
LEDS: - 2" Red 12p, TIL209 10p, OCP70 25p, 2114 (45ONS) **£4.50,** 2526 (Character Generator) **£2.95.** 2716 Eprom (single rail full spec.) **£9.95** P/P 25p.

ALL I.C.'s POSTAGE AND PACKING 25p
ALL PRICES INCLUSIVE OF V.A.T.
MANY SURPLUS COMPUTER BARGAINS
ACCESS AND BARCLAYCARD ACCEPTED

L.B. ELECTRONICS

11 Hercies Road, Hillingdon, Middlesex UB10 9LS.
Telephone: (89) 55399.

EXPERIMENTOR BREADBOARDS

FROM **CSC**

No soldering breadboards. Simply plug components in and out of letter number identified. Nickel-silver contact holes. Start small and simply snap-lock boards together to build a breadboard of any size.

All EXP Breadboards have two bus-bars as an integral part of the board. If you need more than two buses, simply snap on 4 more bus-bars with the aid of an EXP 48.

EXP 325 The ideal breadboard for 1 chip circuits. Accepts 8, 14, 16 and up to 22-pin IC's. **ONLY £3-84**

EXP 350 270 contact points with two 20-point bus-bars. **ONLY £3-62**

EXP 300 550 contacts with two 40-point bus-bars. **ONLY £6-61**

EXP 650 For Micro-processors. **ONLY £4-14**

EXP 48 **ONLY £2-65**

EXP 600 As EXP 300 but accepts 24 pin DIL and over. **ONLY £7-25**

All EXP 300 Breadboards mix and match with 600 series.

ANTEX IRONS

1943 15 watt quality soldering iron with 3/32" bit **£5-12**

1947 Replacement element for 1943 **£2-33**

1944 Iron coated bit 3/32" for 1943 **£0-58**

1945 Iron coated bit 1/8" for 1943 **£0-58**

1946 Iron coated bit 3/16" for 1943 **£0-58**

1948 18 watt iron with iron coated bit **£5-12**

1952 Replacement element for 1948 **£2-22**

1949 Iron coated bit 3/32" for 1948 **£0-58**

1950 Iron coated bit 1/8" for 1948 **£0-58**

1951 Iron coated bit 3/16" for 1948 **£0-58**

1931 X25 25 watt iron, ceramic shaft and another shaft of stainless steel to ensure strength **£6-12**

1935 Replacement element for 1931 **£2-05**

1932 Iron coated bit 1/8" for 1931 **£0-58**

1933 Iron coated bit 2/16" for 1931 **£0-58**

1934 Iron coated bit 3/32" for 1931 **£0-58**

1953 SK1 soldering Kit - contains 15 watt soldering iron with 3/16" bit plus two spare bits, a reel of solder, heat-sink and a booklet 'How to Solder' **£7-28**

1939 ST3 iron stand made from high grade bakelite chrom plated steel spring, suit all models - includes accommodation for six bits and two sponges to keep the iron bits clean **£1-89**

1724 Model MLX as X25 iron but 12 volts **£5-59**

CASES AND BOXES

VERO plastic case box. These boxes consist of top and bottom sections which include fixings points for horizontal mounting PC boards/chassis plates, the two sections are held together by four screws which enter through the base and are concealed by plastic feet.

No.	Length	Width	Height	Price
170	140mm	40mm	205mm	£4-35
171	140mm	75mm	205mm	£4-85
172	140mm	110mm	205mm	£6-30

INSTRUMENT CASES in two sections vinyl covered top and sides, aluminium bottom, front and back.

No.	Length	Width	Height	Price
155	3in	5 1/2in	2in	£2.01
156	11in	6in	3in	£3.10
157	6in	4 1/2in	1 1/2in	£1.93
158	9in	5 1/2in	2 1/2in	£2.59

ALUMINIUM BOXES made from bright all, folded construction each box complete with half inch deep lid and screws.

No.	Length	Width	Height	Price
159	4in	2 1/2in	1 1/2in	£0.98
160	4in	4in	1 1/2in	£0.98
161	4in	2 1/2in	1 1/2in	£0.98
162	5 1/2in	4in	1 1/2in	£1.10
163	4in	2 1/2in	2in	£0.98
164	3in	2in	1in	£0.67
165	7in	5in	2 1/2in	£1.54
166	8in	6in	3in	£1.98
167	6in	4in	2in	£1.32

SLOPE front aluminium boxes with black vinyl base and sides & aluminium back, top & front - strong construction easily accessible.

No.	Length	Width	Height	Price
169	2 1/2in	5 1/2in	2 1/2in	£5-45
168	2 1/2in	7in	4in	£8-21

AUDIO MODULES

AMPLIFIERS

AL10	3 watt Audio Amplifier Module 22-32v supply	£3-63
AL20	5 watt Audio Amplifier Module 22-32v supply	£4-11
AL30A	7-10 watt Audio Amplifier Module 22-32v supply	£4-78
AL60	15-25 watt Audio Amplifier Module 30-50v supply	£5-92
AL80	35 watt Audio Amplifier Module 40-60v supply	£9-28
AL120	50 watt Audio Amplifier Module 50-70v supply	£15-11
AL250	125 watt Audio Amplifier Module 50-80v supply	£22-54

STEREO PRE-AMPLIFIERS

PA12	Supply voltage 22-32v input sensitivity 300mv suit. AL10/AL20/AL30	£9-83
PA100	Supply voltage 24-36v inputs:- Tape, Tuner, Mag P.U., Suit: AL60/AL80	£20-30
PA200	Supply voltage 35-70v inputs:- Tape, Tuner, Mag P.U., Suit: AL80/AL120/AL250	£20-98

MONO PRE-AMPLIFIERS

MM100	Supply voltage 40-65v inputs: Mag, P.U., Tape Microphone Max. output 500mv	£14-29
MM100G	Supply voltage 40-65v inputs: 2 Guitars, Microphones Max. output 500mv	£14-29

POWER SUPPLIES

PS12	24v Supply suit 2 - AL10, 2 - AL20, 2 - AL30 & PA12/S450	£1-90
SPM80	33v Stabilised supply - suit 2 - AL60, PA100 to 15 watts	£5-57
SPM120/45	45v Stabilised supply - suit 2 - AL60, PA100 to 25 watts	£7-34
SPM120/55	55v Stabilised supply - suit 2 - AL80, PA200	£7-34
SPM120/65	65v Stabilised supply - suit 2 - AL120, PA200, 1 - AL250, PA200	£7-34
SG30	15-0-15 Stabilised power supply for 2 - GE100MKII	£4-37

MISCELLANEOUS

MPA30	Stereo Magnetic Cartridge Pre-Amplifier - input 3.5mv Output 100mv	£3-76
S. 450	Stereo FM Tuner Supply Voltage 20-30v - Varicapped tuning	£29-39
STEREO30	Complete 7 watt per Channel Stereo Amplifier Board - includes amps, pre-amp, power supply, front panel, knobs etc. - requires 2050 Transformer	£24-25
BP124	5 watt 12v max. - Siren Alarm Module	£4-43
GE100MKII	10 channel mono-graphic equaliser complete with sliders and knobs	£26-45
VPS30	Variable regulated stabilised power supply 2-30v 0-2 amps	£8-74

TRANSFORMERS

No.	Description	P&P
2034	1.7 amp 35v suit SPM80	£6.21 £1.21
2035	2 amp 55v	£7.30 £1.47
2036	750mA 1v suit PS12	£3.68
2040	1.5 amp 0-45v-55v suit SPM120/45 SPM120/55v	£5.98 £1.21
2041	2 amp 0-55v-65v suit SPM120/55, SPM120/65v	£7.82 £1.47
2050	1 amp 0-20v suit Stereo 30	£3.74 £0.75
1725	150mA 15-0-15v suit SG30	£2.04

ACCESSORIES

139	Teak Cabinet suit Stereo 30, 320 - 235 - 81mm	£8-05
140	Teak Cabinet suit STA15 425 - 290 - 95mm	£9-78
FP100	Front Panel for PA100 & PA200	£2-07
BP100	Back Panel for PA100 & PA200	£1-84
GE100FP	Front Panel for one GE100MKII	£2-05
2240	Kit of parts including Teak Cabinet chassis sockets, knobs to build 15 watt stereo amplifier (Does not include modules)	£22-94

SPECIAL OFFERS

MINIDRILL 12v hand held battery-operated mini drill, 7.500 r.p.m. Collet chuck. Ideal for drilling printed circuits or model making. No. 1402. Complete with two drills - 1, 15. **£6.33**

TRANSFORMER 240v Primary 0-20v - 2A Secondary. By removing 5 turns for each volt from the secondary winding, any voltage up to 20v = 2A is obtainable. Ideal for the experimenter. No. 2042. **£1-50** + 86p. P & P

ANTEX MLX Soldering Iron. Sturdy 25 watt iron complete with: 4 1/2 metres of 2-core cable. Works off a 12 volt battery. Ideal for Car Boat, Caravan, No.1724. **£5-29**

METAL FOIL CAPACITOR PAKS

16204 - Containing 50 metal foil capacitor like Mullard C280 series - Mixed values ranging from 01uf - 2.2uf. Complete with identification sheet **£1-38**

TRIACS

2 amp	T05 case	Price	10 amp	Price	
100	No. 100	£0-36	100	TR110A/100	£0-88
200	TR12A/200	£0-59	200	TR110A/200	£1-06
400	TR12A/400	£0-82	400	TR110A/400	£1-29

6 amp	10 amp	Price
100	TR16A/100	£0-59
200	TR16A/200	£0-70
400	TR16A/400	£0-88

DIACS

BR100	£0-23	032	£0-23
-------	-------	-----	-------

SILICON RECTIFIERS

200mA	IS920 50V	£0-07	3 Amp	IN5400 50V	£0-16
	IS921 100V	£0-08		IN5401 100V	£0-17
	IS922 150V	£0-09		IN5402 200V	£0-18
	IS923 200V	£0-10		IN5404 400V	£0-20
	IS924 300V	£0-12		IN5406 600V	£0-24
				IN5407 800V	£0-29
				IN5408 1000V	£0-35

1 Amp	IN4001 50V	£0-051	10 Amp	IS10 50 50V	£0-22
	IN4002 100V	£0-06		IS10 100 100V	£0-24
	IN4003 200V	£0-07		IS10 200 200V	£0-26
	IN4004 400V	£0-08		IS10 400 400V	£0-40
	IN4005 600V	£0-09		IS10 600 600V	£0-48
	IN4006 800V	£0-10		IS10 800 800V	£0-59
	IN4007 1000V	£0-12		IS10 1000 1000V	£0-69
				IS10 1200 1200V	£0-79

1.5 Amp	IS015 50V	£0-10	30 Amp	IS30 50 50V	£0-64
	IS020 100V	£0-12		IS30 100 100V	£0-75
	IS021 200V	£0-13		IS30 200 200V	£1-07
	IS023 400V	£0-15		IS30 400 400V	£1-44
	IS025 600V	£0-16		IS30 600 600V	£2-02
	IS027 800V	£0-18		IS30 800 800V	£2-33
	IS029 1000V	£0-23		IS30 1000 1000V	£2-66
	IS031 1200V	£0-29		IS30 1200 1200V	£3-31

60 Amp	IS70 50 50V	£0-86		IS70 400 400V	£2-01
	IS70 100 100V	£0-97		IS70 600 600V	£2-59
	IS70 200 200V	£1-38		IS70 800 800V	£2-88
				IS70 1000 1000V	£3-45

THYRISTORS

600ma	TO 18 Case	Price	7 amp	TO 48 Case	Price
10 THY800/10	50 THY7A/50	£0-17	100 THY7A/100	50 THY10A/50	£0-55
20 THY800/20	100 THY7A/100	£0-18	200 THY7A/200	100 THY10A/100	£0-59
30 THY800/30	400 THY7A/400	£0-23	600 THY7A/600	800 THY7A/800	£0-66
50 THY800/50	800 THY7A/800	£0-25			£0-71
100 THY800/100		£0-29			£0-90
200 THY800/200		£0-44			£1-06
400 THY800/400		£0-51			

1 amp	TO 66 Case	Price	10 amp	TO 48 Case	Price
50 THY1A/50	50 THY10A/50	£0-30	100 THY10A/100	50 THY10A/50	£0-59
100 THY1A/100	200 THY10A/200	£0-32	200 THY10A/200	100 THY10A/100	£0-66
200 THY1A/200	400 THY10A/400	£0-37	400 THY10A/400	600 THY10A/600	£0-81
400 THY1A/400	800 THY1A/800	£0-44	600 THY10A/600	800 THY10A/800	£1-14
600 THY1A/600		£0-52			£1-40
800 THY1A/800		£0-67			

3 amp	TO 66 Case	Price	30 amp	TO 94 Case	Price
50 THY3A/50	50 THY30A/50	£0-32	100 THY30A/100	50 THY30A/50	£1-38
100 THY3A/100	100 THY30A/100	£0-35	200 THY30A/200	100 THY30A/100	£1-64
200 THY3A/200	200 THY30A/200	£0-38	400 THY30A/400	200 THY30A/200	£1-87
400 THY3A/400	400 THY30A/400	£0-48	600 THY30A/600	400 THY30A/400	£2-06
600 THY3A/600	600 THY30A/600	£0-58	800 THY30A/800	600 THY30A/600	£2-43
800 THY3A/800		£0-75			

5 amp	TO 66 Case	Price	No.	Price
50 THY5A/50	100 THY5A/100	£0-41	BT	



SIMPLY AHEAD
and staying there

The range grows bigger... better...

New Profile Amplifiers - Two New Series

MOSFET

CHOOSE AN I.L.P. MOSFET POWER AMP when it is advantageous to have a faster slew rate, lower distortion at higher frequencies, enhanced thermal stability, the ability to work with complex loads without difficulty and complete absence of crossover distortion. I.L.P.'s exclusive encapsulation technique within fully adequate heatsinks has been taken a stage further with specially developed copper MOSFETs. These ensure optimum operating efficiency and reliability. Connections are via five pins on the underside. **THESE MOSFETS ARE IDENTICAL IN PERFORMANCE TO THE CHEAPEST AMPLIFIERS IN THIS EXCITING NEW CATEGORY BUT ARE ONLY A FRACTION OF PRICES CHARGED ELSEWHERE.**

Model	Output Power RMS	Distortion Typical at 1KHz	Slew Rate	Rise Time	Signal/Noise Ratio DIN AUDIO	Price & VAT
MOS120	60W into 4-8Ω	0.005%	20V/μs	3μs	100dB	£25.88 + £3.88
MOS200	120W into 4-8Ω	0.005%	20V/μs	3μs	100dB	£33.46 + £5.02

BIPOLAR

CHOOSE AN I.L.P. BIPOLAR POWER AMP where power and price are first consideration while maintaining optimum performance with hi-fi quality and wide choice of models. From domestic hi-fi to disco and P.A., for instrument amplification, there is an I.L.P. Bipolar to fill the bill, and as with our new Mosfets, we have encapsulated Bipolars within our New Profile extrusions with their computer-verified thermal efficiency and improved mounting shoulders. Connections are simple, via five pins on the underside and with our newest pre-amps and power supply units, it becomes easier than ever to have a system layout housed the way you want it.

Model	Output Power RMS	Distortion Typical at 1KHz	Slew Rate	Rise Time	Signal/Noise Ratio DIN AUDIO	Price & VAT
HY30	15W into 4-8Ω	0.015%	15V/μs	5μs	100dB	£6.34 + 95p
HY60	30W into 4-8Ω	0.015%	15V/μs	5μs	100dB	£7.24 + £1.09
HY120	60W into 4-8Ω	0.01%	15V/μs	5μs	100dB	£15.20 + £2.28
HY200	120W into 4-8Ω	0.01%	15V/μs	5μs	100dB	£18.44 + £2.77
HY400	240W into 4Ω	0.01%	15V/μs	5μs	100dB	£27.68 + £4.15

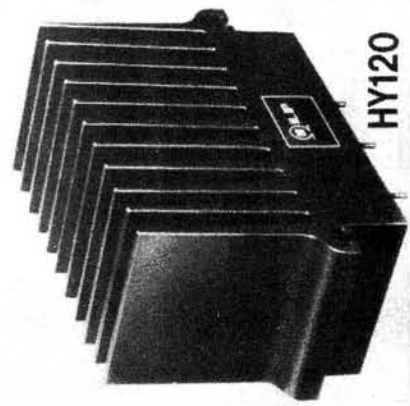

I.L.P. POWER AMPS ARE ENCAPSULATED FOR THERMAL STABILITY AND LONGER LIFE

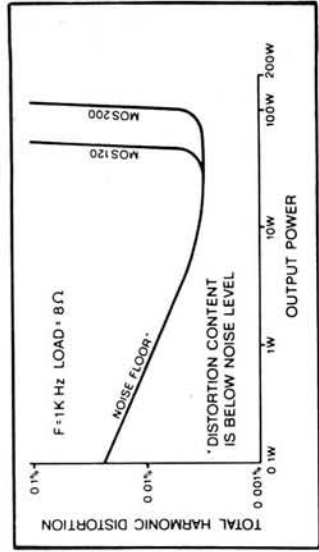

Load impedance both models 4Ω-∞ Input sensitivity both models 100KΩ
4Ω-∞ Input sensitivity both models 15Hz-100KHz-3dB

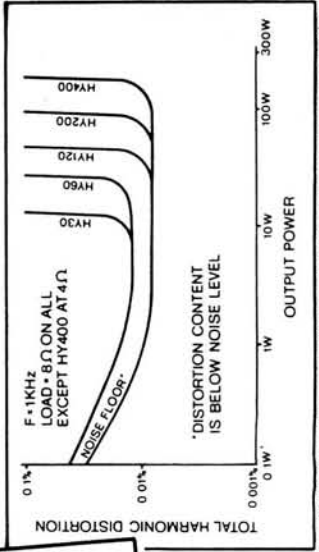

Load impedance all models 4Ω-∞ Input impedance all models 100KΩ
Input sensitivity all models 500mV Frequency response all models 15Hz-50KHz-3dB

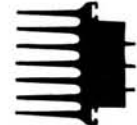

THE NEW PROFILE EXTRUSIONS
The introduction of standard heatsink extrusion for all I.L.P. power amplifiers achieves many advantages: - Research shows they provide optimum thermal dissipation and stability. Slotted shoulders allow easy mounting; standardisation enables us to keep our prices competitive. Surfaces are matt black, anodised for lower thermal conductivity. Extrusions vary in size according to module number.

NEW PRE-AMPS

HY6 (mono) and HY66 (stereo) are new to I.L.P.'s range of advanced audio modules. Their improved characteristics and styling ensure their being compatible with all I.L.P. power-amps, both MOSFET and BIPOLAR, giving you a chance to get the best possible reproduction from your equipment. HY6 and HY66 pre-amps are protected against short circuit and wrong polarity. Full assembly instructions are provided. Mounting boards are available as below.

Sizes - HY6 - 45 x 20 x 40 mm. HY66 - 90 x 20 x 40 mm. Active Tone Control circuits provide ± 12 dB cut and boost. Inputs Sensitivity - Mag. P.U. - 3mV; Mic - selectable 1-12mV; All others 100mV. Tape O/P - 100mV; Main O/P - 500mV; Frequency response - D.C. to 100KHz - 3dB.

HY6 mono £5.60 + 84p VAT Connectors included

HY66 stereo £10.60 + £1.59 VAT Connectors included

B6 Mounting Board for one HY6 78p + 12p VAT

B66 Mounting Board for one HY66 99p + 15p VAT

NEW POWER SUPPLY UNITS

Of the eleven power supply units which comprise our current range, nine have toroidal transformers made in our own factory. Thus these I.L.P. power supply units are space-saving, more efficient and their better overall design helps enormously when assembly building. All models in the range are compatible with all I.L.P. amps and pre-amps with types to match whatever I.L.P. power amps you choose.

PSU30 ± 15 V at 100mA to drive up to 12 x HY6 or 6 x HY66 £4.50 + 0.68p VAT

PSU36 for use with 1 or 2 HY30's £8.10 + £1.22 VAT

PSU50 for use with 1 or 2 HY60's £9.75 + £1.46 VAT

PSU60 for use with 1 HY120 £9.75 + £1.46 VAT

PSU65 for use with 1 MOS120 £13.61 + £2.04 VAT

PSU70 for use with 1 or 2 HY120's £13.61 + £2.04 VAT

PSU75 for use with 1 or 2 MOS120 £14.75 + £2.21 VAT

PSU95 for use with 1 HY200 £23.02 + £3.45 VAT

PSU180 for use with 1 HY400 or 2 HY200 £24.20 + £3.63 VAT

PSU185 for use with 1 or 2 MOS200

★ Freepost facility

When ordering or writing about I.L.P. products, you do not need to stamp the envelope. Mark it FREEPOST plus the code shown in the address below. We pay the postage for you.



TO ORDER Send cheque or money order payable to I.L.P. Electronics Ltd and crossed. Or pay by ACCESSOR/BARCLAYCARD. Cash payments must be in registered envelope; if C.O.D. payment is wanted, please add £1.00 to TOTAL value of order.

ELECTRONICS LTD.

FREEPOST 1 Graham Bell House, Roper Close, Canterbury, Kent CT2 7EP.
Telephone (0227) 54778 [Technical (0227) 64723] Telex 965780

Available also from MARSHALLS, WATFORD ELECTRONICS and certain other selected retailers

COMPATIBLE WITH ALL I.L.P. MODULES

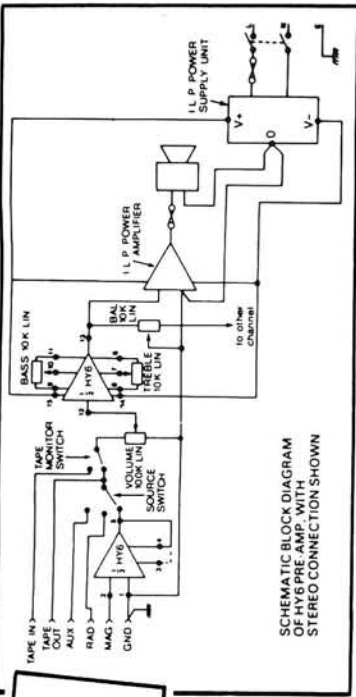

SCHEMATIC BLOCK DIAGRAM OF HY6 PRE-AMP WITH STEREO CONNECTION SHOWN

- DISTORTION TYPICALLY 0.005%
- S/N RATIO - 90dB (Mag. P.U. - 68 dB)
- 38 dB overload margin on Mag. P.U.
- LATEST DESIGN HIGH QUALITY CONNECTORS
- ONLY POTS, SWITCHES AND PLUGS/SOCKETS NEED ADDING
- NEEDS ONLY UNREGULATED POWER SUPPLY ± 15 to ± 60 V

IN A RANGE OF 11 MODELS USING LATEST TOROIDAL TRANSFORMERS

1971-1980 TEN YEARS OF PLANNED PROGRESS

When, in 1971, Ian L. Potts founded his now world-famous company, he saw the need for a different and more rational approach to exploiting to the full, the potential that lay in modular construction. New thinking was badly needed. The result was a range of modules revolutionary in concept. The rightness of this new thinking is shown by the size of the company today, its new factory, its vast exports, its acceptance by constructors as the modules to build with. The range grows bigger and better. Exciting new lines (in no way conflicting with existing ones) are well past drawing board stage. This is why I.L.P. are simply ahead and staying there.

BRITAIN'S FASTEST GROWING MODULE SUPPLIERS

To: I.L.P. ELECTRONICS LTD. CANTERBURY CT2 7EP

Please supply.....

Total purchase price £.....

I enclose Cheque Postal Orders International Money Order

Please debit my Access/Barclaycard Account No.....

NAME.....

ADDRESS.....

Signature.....

ALL UK ORDERS DESPATCHED POST FREE

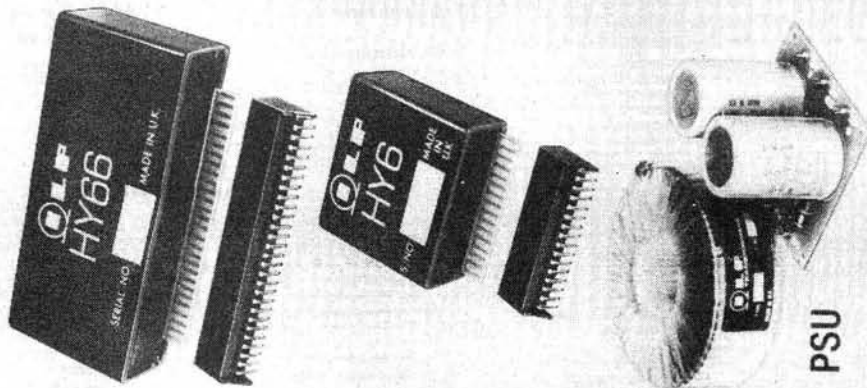

NO QUIBBLE 5 YEAR GUARANTEE
7-DAY DESPATCH ON ALL ORDERS
BRITISH DESIGN AND MANUFACTURE
FREEPOST SERVICE



NEW

PRACTICAL ELECTRONICS PROJECT 125 WATT POWER AMP KIT

SPECIFICATIONS.

Max. Output power 125 watt RMS
 Operating voltage (DC) 50-80 Max.
 Loads 4-16 ohms
 Frequency response Measured at 100 watts 25Hz-20kHz
 Sensitivity for 100 watts 400mV @ 47K
 Typical T.H.D. @ 50 watts load 0.1 %
 Dimensions 205 x 90 and 190 x 36 mm

The P.E. power amp kit is a module for high power applications—disco units, guitar amplifiers, public address systems and even high power domestic systems. The unit is protected against short circuiting of the load and is safe in an open circuit condition. A large safety margin exists by use of generously rated components, the

output stage uses four 115 watt transistors normally only two would be used, result, a high powered rugged unit. The PC Board is backprinted, etched and ready to drill for ease of construction, and the aluminium chassis is preformed and ready to use, supplied with all parts and circuit diagrams.



AS FEATURED IN PRACTICAL ELECTRONICS OCTOBER ISSUE

£9.50 plus £1.00 p&p
 125 watt power amp kit

ACCESSORIES
 Suitable L.S. coupling electrolytic **£1.00** plus 20p p&p

Suitable Mains Power Supply Unit sufficient for one power amp **£7.50** plus £2.75 p&p

DIY STEREO BARGAIN PACKS FEATURING FAMOUS BUILT MULLARD PREAMP MODULES

MULLARD STEREO PREAMP MODULES AND TWO 12 WATT POWER AMP KITS.

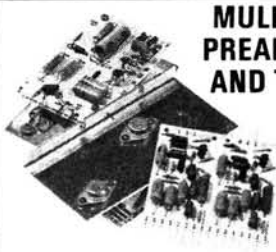

In easy to build form P.C.B.s backprinted, etched and drilled ready to use.

BUILD A 12 WATTS PER CHANNEL STEREO AMPLIFIER ACCESSORIES AND L.S. KIT EXTRA (not available separately) £6.00

DIY PACK 1 2 x power amp kits LP1182/ preamp module, suitable for ceramic and auxiliary inputs. **£6.00** plus £1.10 p&p

DIY PACK 2 2 x power amp kits LP1184 preamp module suitable for magnetic ceramic and auxiliary inputs. **£8.50** plus £1.15 p&p

DIY SPEAKER KIT Two 8" x 5" approx. 4 ohm bass. **£3.50** plus £1.70 p&p

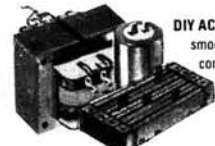

DIY ACCESSORIES Mains transformer smoothing capacitor rectifier 4 x slider controls, for base, treble and volume. **£3.00** plus £1.60 p&p

ACCESSORIES: Available only at time of purchase of Bargain Packs

12 + 12 WATT AMPLIFIER KIT NOTE: for use with 4 to 8 ohms speakers.

With up-to-the-minute features. To complete you just supply screws, connecting wire and solder. Features include din input sockets for ceramic cartridge, microphone, tape or tuner. Outputs—tape, speakers and headphones. By the press of a button it transforms into a 24 watt mono disco amplifier with twin deck mixing. The kit incorporates a Mullard LP1183 pre-amp module, plus 2 power amplifier assembly kits and mains power supply. Also featured 4 slider level controls, rotary bass and treble controls and 6 push button switches. Silver finish fascia panel with matching knobs. Easy to assemble teak simulate cabinet and ready made metal work. For further information instructions are available price 50p. Free with kit. Size 9 1/4" x 8 3/4" x 4" approx.

£13.95 plus £2.55 p&p

NOTE: for use with 4 to 8 ohms speakers.

BSR chassis record deck with manual set down and return, complete with stereo ceramic cartridge



£8.50 plus £2.75 p&p when purchased with amplifier. Available separately **£10.50** plus £2.75 p&p.

8" SPEAKER KIT. 2 Phillips 8" approx. speakers. **£4.75** per stereo pair plus £1.50 p&p when purchased with amplifier. Available separately **£6.75** plus £1.50 p&p.

STEREO MAGNETIC PRE-AMP CONVERSION KIT all components including P.C.B. to convert your ceramic input on the 12 + 12 amp to magnetic. **£2.00** when purchased with kit featured above. **£4.00** separately inc p&p.

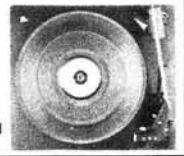

BSR Manual single play record deck with auto return and cueing lever. Fitted with stereo ceramic cartridge 2 speeds with 45 rpm spindle adaptor ideally suited for home or disco use.



£12.25 OUR PRICE plus £2.75 p&p Size approx 13" x 11"

PHILLIPS RECORD PLAYER DECK GC037



Hi Fi record player deck, 2 speed, damped cueing, auto shut-off, belt drive with floating sub chassis to minimise acoustic feedback. Complete with GP401 stereo magnetic cartridge—LIMITED STOCK. UNBEATABLE OFFER AT

£27.50 complete plus £2.75 p&p

OFFER! SAVE MONEY by purchasing 12 + 12 amp kit, BSR record deck and speaker kit together for only **£25.50** p&p £4.50.

PRACTICAL ELECTRONICS CAR RADIO KIT **£10.50** plus £1.75 p&p

(Constructors pack 7)



2 WAVE BAND MW LW
 * Easy to build * 5 push button tuning
 * Modern styling design * All new unused components
 * 6 watt output * Ready etched & punched P.C.B.
 * Incorporates suppression circuits * Now with tape input socket

All the electronic components to build the radio, you supply only the wire and solder as featured in the Practical Electronics March issue. Features: Pre-set tuning with five push button options, black illuminated tuning scale, with matching rotary control knobs, one, combining on/off volume and tone-control, the other for manual tuning, each set on wood simulated fascia. The P.E. Traveller has a 6 watts output, neg ground and incorporates an integrated circuit output stage, a Mullard IF module LP1181 ceramic filter type, pre-aligned and assembled and a Bird pre-aligned push button tuning unit. The radio fits easily in or under dashboards. Complete with instructions.

CONSTRUCTORS PACK 7A
 Suitable stainless steel fully retractable locking aerial and speaker (approx. 6" x 4") is available as a kit complete **£1.95** per pack plus £1.00 p&p
 Pack 7A may only be purchased at the same time as Pack 7.
 NOTE: Constructor's pack 7A sold complete with radio kit **£15.20** including p&p.
FEATURED PROJECT IN PRACTICAL ELECTRONICS.



30 + 30 WATT STEREO AMPLIFIER BUILT AND TESTED

Viscount IV unit in teak simulate cabinet silver finished rotary controls and pushbuttons with matching fascia, red mains indicator and stereo jack socket. Functions switch for mic magnetic and crystal pickups, tape and auxiliary. Rear panel features fuse holder, DIN speaker and input socket 30 + 30 watts. RMS 60 + 60 watts peak for use with 4 to 8 ohm speakers. Size 14 1/4" x 10" approx.

READY TO PLAY **£32.90** plus £3.30 p&p



323 EDGWARE ROAD, LONDON W2 21C HIGH STREET, ACTON W3 6NG

ACTON: Mail Order only. No callers
ALL PRICES INCLUDE VAT AT 15%
 All items subject to availability. Price correct at 1.11.80 and subject to change without notice.
 For further information send for instructions 20p plus stamped addressed envelope.

NOTE: Persons under 16 years not served without parent's authorisation.

BARGAIN OFFER!!



ARISTON PICK UP
 Ariston pick-up arm manufactured in Japan. Complete with headshell. Listed price over £30.00. **£11.95** plus £2.50 p&p

100 WATT MONO DISCO AMPLIFIER



Brushed aluminium fascia and rotary controls. Size approx 14" x 4" x 10 1/4". Five vertical slide controls, master volume, tape level, mic level, deck level, PLUS INTER DECK FADER for perfect graduated change from record deck No. 1 to No. 2, or vice versa. Pre fade level controls (PRL) lets YOU hear next disc before fading it in. VU meter monitors output level. Output 100 watts RMS 200 watts peak. **£76.00** plus £4.00 p&p

50 WATT MONO DISCO AMPLIFIER

Size approx 13 1/4" x 5 1/4" x 6 3/4". 50 watts rms. 100 watts peak output. Big features include two disc inputs, both for ceramic cartridges, tape input and microphone input. Level mixing controls fitted with integral push-pull switches. Independent bass and treble controls and master volume. **£30.60** plus £3.20 p&p





comment...

Inferior Beings?

AS I mentioned last month, the number of candidates for the May 1980 Radio Amateurs' Examination was a record, as was the number of passes. In fact, the number of candidates had virtually doubled compared with two years' previously. The most interesting statistic to emerge from an analysis of the past six years' figures is that the pass rate, i.e., the percentage of candidates who were successful in each exam, has remained almost constant during that period.

This would seem to refute the disturbing view expressed in some parts of the amateur radio fraternity, that new licensees who have passed the multiple-choice form of the RAE are inferior beings, simply because the number of passes has gone up, "therefore the pass-mark must have been lowered." Here I make what I think to be a fair assumption—that it would be untrue to say that only about a thousand people in the UK can be trained sufficiently well to pass the Radio Amateurs' Examination each May/June. (I have to confine my comments to the summer exams, because it is only for these that statistics are available.)

Obviously, it is statistically possible for a candidate with no knowledge whatsoever of radio, to pass the multiple choice RAE merely by choosing answers at random. However, we calculate the

probability of anyone doing this to be around one chance in 10^{30} !

The reasons behind the dramatic rise in the number of candidates are probably many. Undoubtedly, some of them must be frustrated CBers looking for a legitimate or a more flexible form of radio pastime. Others will be people who were frightened off by the previous written examinations. But you do not have to be literate to enjoy, nor to contribute to, the hobby of amateur radio. Neither does the ability to express yourself in writing automatically guarantee a sane and considerate attitude towards your fellow amateurs when on the air. It has been my experience in life that there are as big fools around with university degrees as without!

I think that it would be for the benefit of amateur radio as a whole if the newly licensed were welcomed by the old hands (and the not so old) whether individually or in clubs, and encouraged to get involved in experimenting, regardless of what sort of exam they passed. After all, that's what the hobby is supposed to be all about.

Geoff Arnold

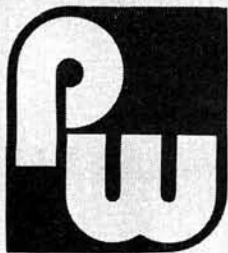

services

QUERIES

While we will always try to assist readers in difficulties with a *Practical Wireless* project, we cannot offer advice on modifications to our designs, nor on commercial radio, TV or electronic equipment. Please address your letters to the **Editor, "Practical Wireless", Westover House, West Quay Road, Poole, Dorset BH15 1JG**, giving a clear description of the problem and enclosing a stamped self-addressed envelope. Only one project per letter please.

Components for our projects are usually available from advertisers. For more difficult items, a source will be suggested in the "Buying Guide" box included in each constructional article.

PROJECT COST

The approximate cost quoted in each constructional article includes the box or case used for the prototype. For some projects the type of case may be critical; if so this will be mentioned in the Buying Guide.

CONSTRUCTION RATING

Each constructional project will in future be given a rating, to guide readers as to its complexity:

Beginner

A project that can be tackled by a beginner who is able to identify components and handle a soldering iron fairly competently. Generally this category will be used for simple projects, but sometimes for more complicated ones of wide appeal. In this case, construction and wiring will be dealt with in some detail.

Intermediate

A project likely to appeal to a wide range of constructors, and requiring only basic test equipment to complete any tests and adjustments. A fair degree of experience in building electronic or radio projects is assumed.

Advanced

A project likely to appeal to an experienced constructor, and often requiring access to workshop facilities and test equipment for construction, testing and alignment. Constructional information will generally be limited to the more critical aspects of the project. Definitely not recommended for a beginner to tackle on his own.

SUBSCRIPTIONS

Subscriptions are available to both home and overseas addresses at £11.80 per annum, from "**Practical Wireless**" **Subscription Department, Room 2613, King's Reach Tower, Stamford Street, London SE1 9LS**. Airmail rates for overseas subscriptions can be quoted on request.

BACK NUMBERS AND BINDERS

Limited stocks of some recent issues of *PW* are available at 95p each, including post and packing to addresses at home and overseas.

Binders are available (Price £4.30 to UK addresses and overseas, including post and packing) each accommodating one volume of *PW*. Please state the year and volume number for which the binder is required.

Send your orders to **Post Sales Department, IPC Magazines Ltd., Lavington House, 25 Lavington Street, London SE1 0PF**. All prices include VAT where appropriate.

Please make cheques, postal orders, etc., payable to IPC Magazines Limited.

NEWS NEWS NEWS

The 1980 Girl Technician Engineer of the Year

The 1980 Girl Technician Engineer of the Year is Miss Fenella Hume, age 23, a Development Project Leader from Cambridge. At a ceremony in London, on 31 October 1980, HRH The Prince of Wales presented her with a prize of £250 and an inscribed rose bowl. A special award was also made to the runner-up, Miss Sally Buswell, 25, an Assistant Instrument Engineer from Pinner, Middlesex.

Sponsored by The Caroline Haslett Memorial Trust and The Institution of Electrical and Electronics Technician Engineers, this Award aims to focus attention on electrical and electronic engineering as a worthwhile professional career for women.

Fenella Hume holds the position of Development Project Leader with Kent Industrial Measurements Ltd. at Eaton Socon, St Neots, Cambridgeshire. She is responsible for the organisation of design projects, including the allocation of work to technicians and apprentices, and for the detailed design of



controller indicators and chart recorders. Fenella finds satisfaction in being able to use her knowledge and experience to create a well-engineered and marketable product, to prove continually the basic principles of elec-

tronics whilst designing and testing, and to train her mind to think logically.

The Institution of Electrical and Electronics Technician Engineers, 2 Savoy Hill, London WC2R 0BS. Tel: 01-836 3357.

New Book Company

A new company, ZL Communications, has recently been formed to supply technical books to the public on a mail order basis.

Subjects covered will include, amateur radio, audio (Hi-Fi and tape recording), CB radio, computers and microprocessors, electronics, radio and television.

For catalogue and further information contact: *ZL Communications, 35 Burnt House Road, Cantley, Nr Norwich, Norfolk NR13 3RT. Tel: Freethorpe (049 370) 821.*

G9BRY—Mayday, SOS, 10-62, Help

In the October 1980 edition of "10-4", the official newsletter of the Citizens' Band Association, it was announced that the Home Office had issued the CBA with a transmitting licence for 941-975MHz, with the callsign G9BRY.

The purpose of issuing the licence was to enable the CBA to evaluate the

possibilities of 900MHz CB or Open Channel. The licence is valid until 30 November 1980, the last day for comment on the Green Paper.

I understand from James Bryant, President of the CBA, that the CBA has met with a major problem—they cannot obtain any equipment for the frequency.

A search has been mounted for a pair of rigs and James assures me that the search has not only covered the UK, indeed, they have sought assistance on a world-wide scale, without success. At the time of going to press (early November) this was still the situation.

Contrary to general opinion, it would seem that 900MHz equipment is unobtainable!

Spreading Out

Amplicon Micro Systems Ltd., the micro computer marketing company of Amplicon Electronics Ltd. have recently opened a new office at Kingston House, Stephenson Way, Three

Bridges, Crawley, to provide demonstration facilities and after sales service for the Commodore range of low-cost business systems for use in business, industry, education and the home.

The Commodore PET range of products are available for demonstration, as are the new 8000 series of computers.

Further information from: *Amplicon, Richmond Road, Brighton, East Sussex BN2 3RL. Tel: (0273) 608331.*

Tools Catalogue

TRI-tronic Marketing Ltd. has produced a 12-page catalogue listing tools and hardware for the home constructor.

All the tools are professional quality and supplied at discount prices. An accompanying price list gives prices inclusive of VAT and p&p.

The catalogue is available free-of-charge from: *TRI-tronic Marketing Ltd., 75 Albert Street, Rugby, Warwickshire CV21 2SN. Tel: (0788) 73328.*

NEWS NEWS NEWS

Club News

The Wisbech Radio and Electronics Club inform me that they have changed their meeting nights from Mondays to Thursdays.

The meetings kick-off at 1930hrs, at the address below, on alternate weeks, starting Thursday, 16 October 1980.

The club extend a welcome to anyone interested in amateur radio, short-wave listening, electronics generally or passing the RAE.

Further details can be obtained from: *The Secretary, D. Dunn G8RZN, Five Bells, Parson Drove, Nr Wisbech, Cambs. Tel: (094 574) 231.*

Bye Bye 405

The Home Secretary, in a written reply in the House of Commons earlier this year, made a detailed statement about the closure of the 405-line television services and the further extension of the 625-line service.

His statement began: "The 405-line v.h.f. television services of the BBC and the IBA transmit BBC-1 and ITV in black and white only and are now substantially duplicated by the 625-line u.h.f. services which transmit BBC-1, BBC-2 and ITV in colour, and which will in due course transmit the fourth channel service. Phase II of the current u.h.f. engineering programme for extending the 625-line services to communities with populations of 500 or more (over 99% of the population) should be completed by about 1984.

"The need to close the 405-line services in the early 1980s was recognised by the Pilkington Committee and the Annan Committee on the Future of Broadcasting. The manufacture of sets capable of receiving the 405-line services ceased some years ago and the transmitting equipment is rapidly nearing the end of its useful life. Substantial capital expenditure would be required to extend its life beyond the next few years and such expenditure on a duplicate and obsolescent service could not be justified.

"I have, therefore, agreed with the broadcasting authorities on a timetable for the closure of the 405-line services. Closure will begin in 1982 and will be phased over a period of about 4 years."

The BBC and the IBA are co-operating closely in the implementa-

tion of these engineering programmes in order to minimise any inconvenience to the public. As far as possible they plan to close down their 405-line services in Bands I and III at the same time in particular areas, although this will not be possible everywhere since the BBC have 110 transmitters on 405-lines while the IBA have 47.

Stations to be closed earlier in the programme will be those in areas where there is good coverage from the u.h.f. 625-line services. The last stations to be closed will be some of the high-power main stations in areas where 625-line coverage is less complete.

BBC Engineering Publicity, Room 707A, Henry Wood House, Broadcasting House, London W1A 1AA. Tel: 01-580 4468 ext. 5434.

On the Move

Ace Mailtronix has moved into larger premises. The company specialises in electronics components for magazine projects in addition to its electronic component catalogue listing approximately 1000 items available ex-stock by mail order.

The catalogue is available now, priced 30p to mail order customers. This is refundable with subsequent orders over £5.00. Callers are welcome during normal working hours, Monday to Friday and on Saturday mornings, to whom the catalogue is free.

The new premises are at: *3A Commercial Road, Batley, West Yorks. WF17 5HJ. Tel: (0924) 441129.*

Business News

Lascar Electronics, the Essex-based instrument manufacturers have appointed Audio Electronics as their Central London stockists.

All their most popular instruments will be stocked at: *Audio Electronics, 301 Edgware Road, London W2. Tel: 01-724 3564.*

Sinclair Electronics Ltd., has been appointed the sole importer for the UK and Eire for Leader Electronics Corp. of Japan.

Leader manufactures a wide range of competitively priced, high quality test equipment, including single and dual trace oscilloscopes with

bandwidths up to 35MHz, and a comprehensive selection of items covering most test requirements in the fields of TV, Video, Audio, Amateur Radio and CB.

Leader products will be stocked in the UK by Sinclair and a few select distributors will be appointed.

Sinclair also markets a rapidly expanding range of portable test equipment, manufactured by them in the UK, under the trade name Thandar.

Sinclair Electronics Ltd., London Road, St Ives, Huntingdon, Cambs PE17 4HJ. Tel: (0480) 64646.

Coals to Tokyo

Following upon last year's State of the Art award for the Quad electrostatic loudspeaker comes the news that the Quad 44 control unit has been voted a "State of the Art" award for 1980 by Japan's foremost audio magazine "Stereo Sound". Products are selected for the award by a panel consisting of eight leading Japanese audio critics.

In Japan the opinion of the audio critics has enormous influence upon the market and the accolade given to the Quad 44 will have significant commercial benefits as well as being a source of pride to the design team at Quad. Fifteen per cent of the Quad 44 production is earmarked for airfreight to Tokyo each month to satisfy demand.

The Acoustical Manufacturing Co. Ltd., Huntingdon PE18 7DE. Tel: (0480) 52561.

Can I Help You!

Are you the secretary, organiser or general dog's body of your local radio club or any other group whose functions may interest readers of *PW*. If so, let me know and I will endeavour to publicise your rally, get-together whatever, through this column. Remember though, we compile the magazine some time ahead of publication day (e.g. this note was written in November), so, the earlier I can have details, the better.

Alan Martin

More on page 90 ▶▶▶

tape//slide controller

PART 1

Fred JUDD

Automatic control of slide projectors from magnetic tape can be done quite easily with audio signal pulses on one track of a stereo tape-recorder leaving the remaining track available for commentary, music and sound effects. With a reel-to-reel recorder a similar function can also be carried out by means of adhesive foil strips on the tape that are used to operate a relay which in turn will actuate the projector slide change mechanism. An electro-optical system could also be used.

However, if one wishes to use the now much more popular cassette deck, most of which are two-channel (stereo) then there is no alternative but to use one track for slide change pulses and the other for music and commentary which prevents having normal stereo recording and reproduction.

The controller described in this article enables automatic slide change to be carried out and yet allows one to retain the full stereo record and replay facility with any cassette or reel recorder. It can also be used with any mono (single track) cassette or reel machine. The slide projector must have the facility for automatic slide change and for this purpose must have a 2-pin connection for the external control. If this is not provided, but the projector has a remote control button, then connection can be made to this.

The controller operates on the principle that music and commentary, etc., can be recorded in stereo as normal, together with projector control impulses on one of the tracks. On replay the pulse is separated from the music, etc., and vice-versa, with the pulse being used to operate a relay. The relay has two contacts (normally open) which are connected to the auto slide change socket on the projector. The controller also incorporates dual channel mixing for stereo microphones and high level input signals, a facility that few cassette decks have, so one has provision for mixing commentary, music and sound effects, or background sound whilst recording and simultaneously programming the slide changes.

The Circuit

With the aid of the block diagram (Fig. 1) the general function of the unit can be followed. About 300mV r.m.s. of 50Hz signal is obtained from the secondary winding of the power supply transformer and fed to the pulse gate, a button-operated "electronic attenuator" i.e. giving a very clean pulse free from switching spikes which would produce audible clicks.

The pulse signal is recorded, as required for a change of slide, together with the left-hand channel audio signals



The completed Tape/Slide Controller ready to be connected to the tape-recorder and automatic slide projector

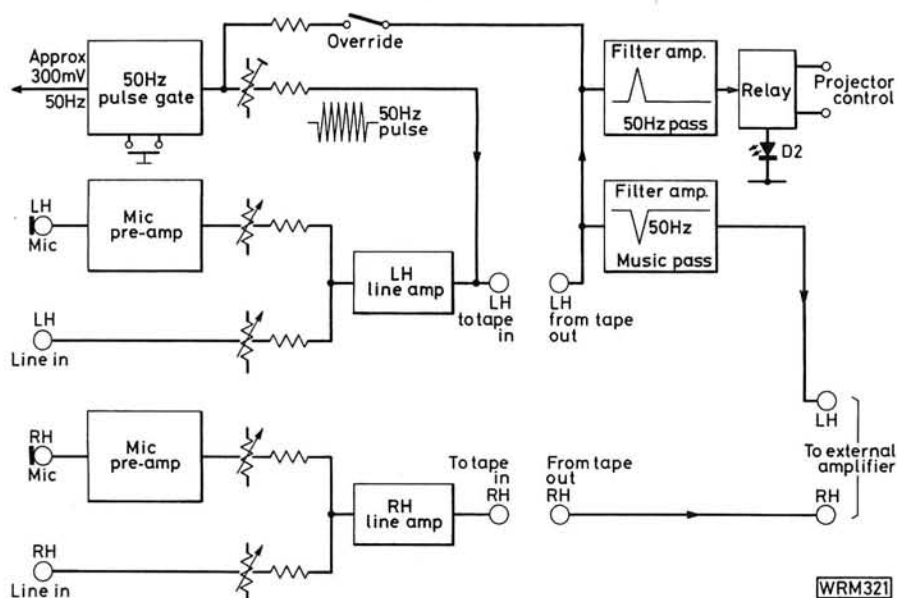

Fig. 1: Block diagram of the Tape/Slide Controller

from the microphone or high level inputs (music, etc.) onto the left-hand channel of the tape-recorder (TO LH TAPE IN). On replay these signals are returned from the left-hand channel of the recorder (FROM LH TAPE OUT). The 50Hz pass filter rejects music signals, even bass notes that might occur at 50Hz, as there is a time delay in the rectifier circuit from which d.c. is obtained (from the pulse) to actuate the relay. Music signals are passed through the 50Hz reject filter (music pass) and then to the output socket for the external amplifier. Signals for the right-hand channel, mic or high level, go to the tape-recorder via "TO RH TAPE IN" and from the tape-recorder through "FROM RH TAPE OUT" and the direct link to the external amplifier.

Most cassette and reel-to-reel recorders have a through monitoring arrangement in which case the slide projector will be automatically operated as a pulse is recorded. One can therefore prepare a commentary and music script marked with the right places for a change of slide. With the slides to be shown loaded in the correct order it is simply a matter of pressing the pulse button at the right moment whilst recording the commentary, etc. On replay (with slides reloaded) the programme is then repeated automatically. Should the recorder not have through monitoring, then the override switch can be used so that slides will still be changed whilst the pulses are being recorded. An example of how to make up a programme and operate the controller will be given later.

The full circuit is given in Figs. 2 and 3. IC1 operates as left- and right-hand channel microphone pre-amp. stages the outputs each being taken to a passive mixer circuit (R5-R8 (RH) and R27-R30 (LH)) which also takes in the left- and right-hand channels for high level signals. The output from each passive mixer section is taken to an output amplifier, one for the left-hand and one for right-hand channel to the tape-recorder. These are together on circuit board 1.

The 50Hz slide control pulse is taken from the i.c. "electronic attenuator" via R55 and coupled to the left-hand channel output of the mixer circuit. Note also that the left-hand mixing circuit IC1b and Tr2 has a reduced bass response so that any strong bass signals very close to 50Hz, from music sources being recorded, are sufficiently attenuated to prevent accidental triggering of the slide control relay. This reduction in bass response is obtained by the use of a low value by-pass capacitor (C18) in series with

R35 in the emitter return of Tr2. This does not detract from the overall bass response as most bass signals in stereo are fairly equal on both channels. The right-hand channel response is of course normal.

Signals returned from the left-hand channel of the recorder on replay include the 50Hz pulse which now has to be separated from music and commentary. This is done by a twin-T filter in negative feedback with IC3 (741 op. amp.) which also amplifies the pulse so that about 2V r.m.s. at 50Hz is available at its output. This is rectified by D1 and the d.c. used to turn on Tr3 to operate the relay. Only the relay specified should be used as the circuit design has been optimised for this.

Commentary and music signals (left-hand channel) are taken via IC2 a 741 op. amp. which passes all signals except those very close to 50Hz and also has unity gain so that signals going to the external amplifier are equalised with those from the right-hand channel. Signals for the

CONSTRUCTION RATING Intermediate

BUYING GUIDE

Readers should have no difficulty in obtaining the components for this project. The relay specified is an RS Components type and can be obtained from several of our regular advertisers who offer RS Components parts. Printed circuit boards will also be available from those advertisers specialising in this service. You are advised to study the advertisement pages for the components for this project.

APPROXIMATE COST £35

Fig. 2: Circuit diagram of the power supply for the Tape/Slide Controller

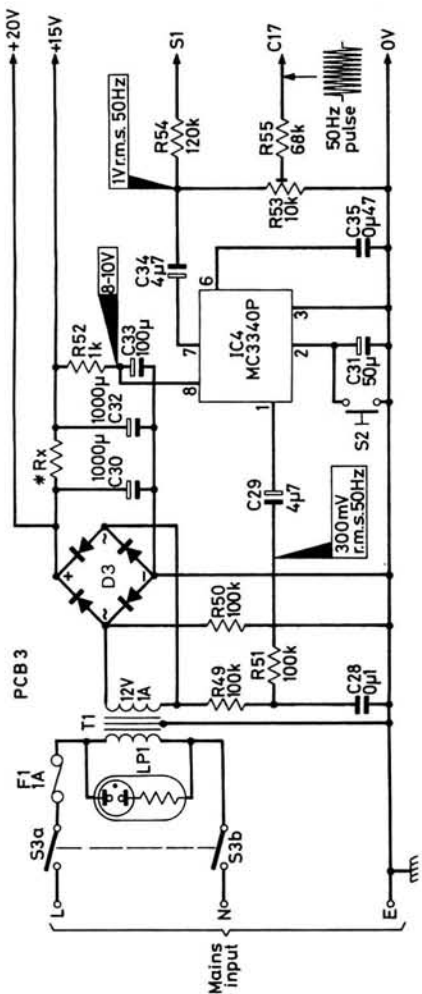
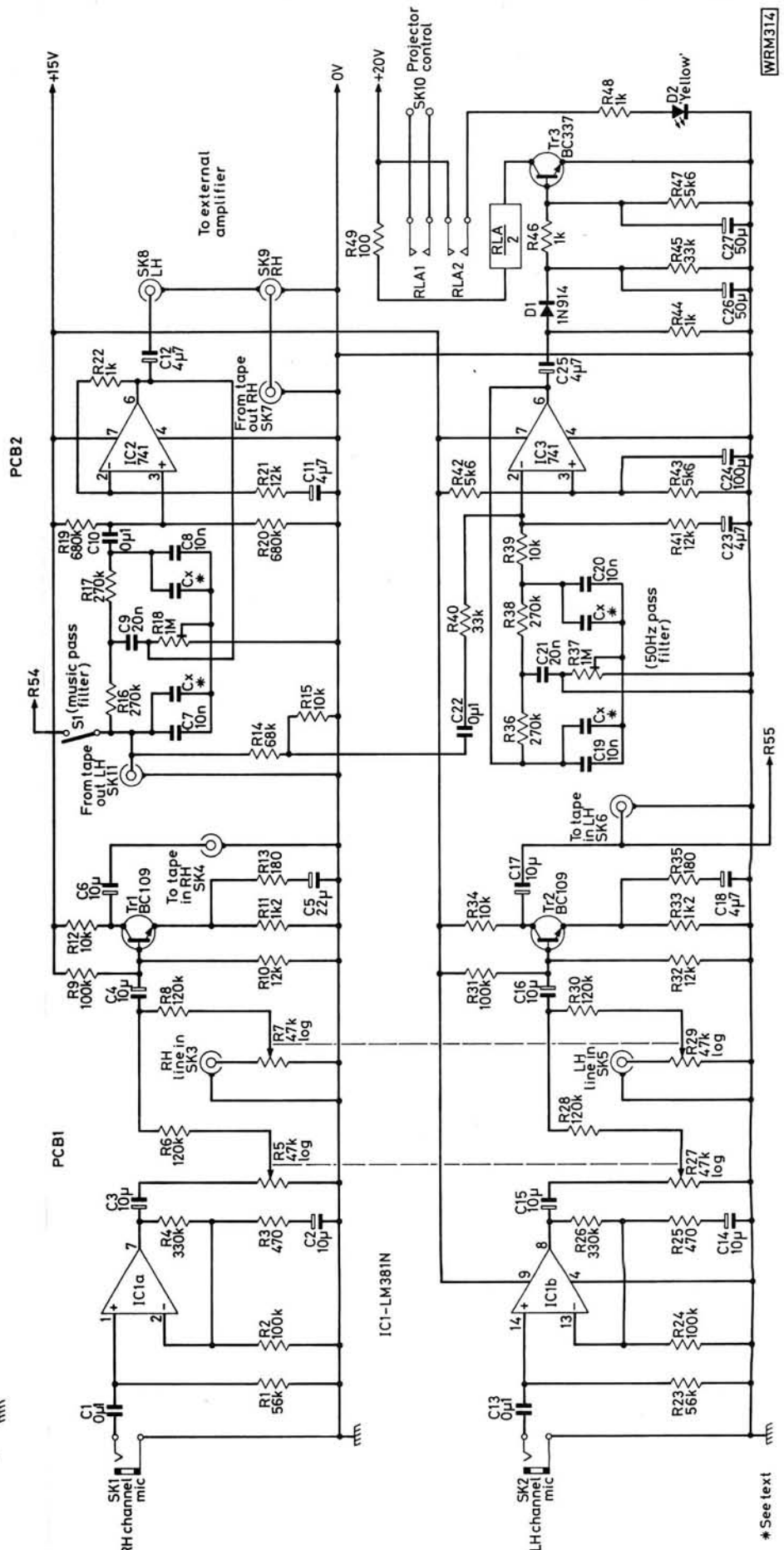

Fig. 3: Circuit diagram of the Tape/Slide Controller



* See text

WRM314

★ components

Resistors

$\frac{1}{4}$ W 5% carbon film

100Ω	1	R56
180Ω	2	R13,35
470Ω	2	R3,25
1kΩ	5	R22,44,46,48,52
1.2kΩ	2	R11,33
5.6kΩ	3	R42,43,47
10kΩ	4	R12,15,34,39
12kΩ	4	R10,21,32,41
33kΩ	2	R40,45
56kΩ	2	R1,23
68kΩ	2	R14,55
100kΩ	7	R2,9,24,31,49,50,51
120kΩ	5	R6,8,28,30,54
270kΩ	4	R16,17,36,38
330kΩ	2	R4,26
680kΩ	2	R19,20

$\frac{1}{2}$ W 5%

270Ω	1	Rx (see text)
------	---	---------------

Capacitors

Disc ceramic

10nF	4	C7,8,19,20
0.1μF	5	C1,10,13,22,28

Polyester

0.47μF	1	C35
--------	---	-----

Electrolytic p.c.b. type

4.7μF 16V	7	C11,12,18,23,25,29,34
10μF 16V	8	C2,3,4,6,14,15,16,17
22μF 16V	1	C5
50μF 16V	3	C26,27,31
100μF 16V	2	C24,33
1000μF 25V	2	C30,32

Potentiometers

Side adjusting cermet

10kΩ	1	R53
1MΩ	2	R18,37

Tandem ganged

50 + 50kΩ		
log	2	R5 + 27,7 + 29

Semiconductors

Diodes

1N914	1	D1
50V, 1A bridge	1	D3
Red l.e.d.	1	D2

Transistors

BC109	2	Tr1,2
BC337	1	Tr3

Integrated circuits

741	2	IC2,3
LM381N	1	IC1
MC3340P	1	IC4

Miscellaneous

Relay 12V 250Ω (RS349-658); Min. toggle switch s.p.s.t. (1); d.p.d.t. (1); Phono sockets, Red (4), Black (4); $\frac{1}{4}$ inch jack sockets (2); 240V panel neon; Knobs (2); 14-pin d.i.l. socket (1); 8-pin d.i.l. sockets (3); Mains transformer 12V 12VA; Min. push-button switch (1); Verobox 75-1412K (205 × 140 × 110mm); Set of three p.c.b.s; 1A fuse; Panel mounting fuseholder; Self-adhesive p.c.b. guides.

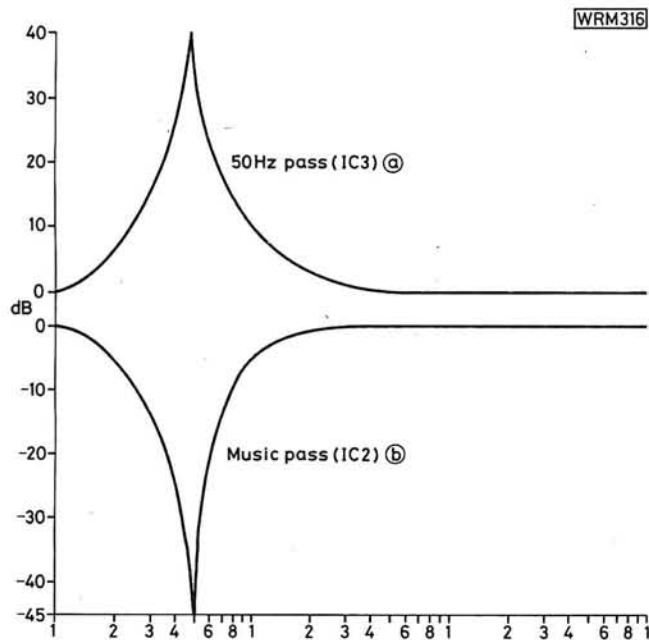

right-hand channel (to external amplifier) are taken straight through from the recorder output via the linked sockets marked "FROM TAPE OUT RH" and "EXT AMPLIFIER RH". The two filter circuits IC2 and IC3 and the relay amplifier Tr3 are contained on circuit board 2.

The remaining part of the circuitry is that of the power supply which is quite conventional but contains the electronic attenuator i.c. A 50Hz voltage for the pulse is obtained from the network R49, R50, C28, R51, which provides a sine-wave of about 300mV to the i.c. via C2. In normal operation the push-button is depressed for about 1 second to provide a long enough pulse to actuate the projector control relay. The required pulse level, as will be explained later, is obtained by the pre-set R53.

General Performance

The audio mixing section has a performance comparable with top grade domestic cassette and reel-to-reel recorders. Signal-to-noise, referenced to 0.775V r.m.s.

Fig. 4: The filters provide maximum acceptance or rejection of over 40dB at a frequency of 50Hz as shown in these response curves

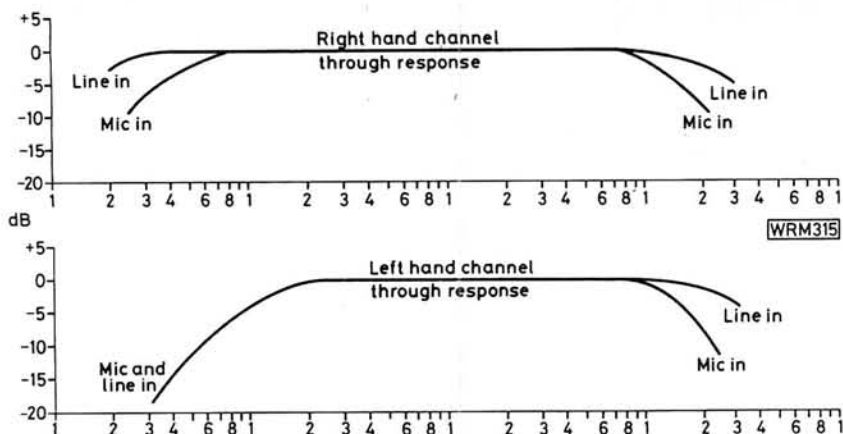
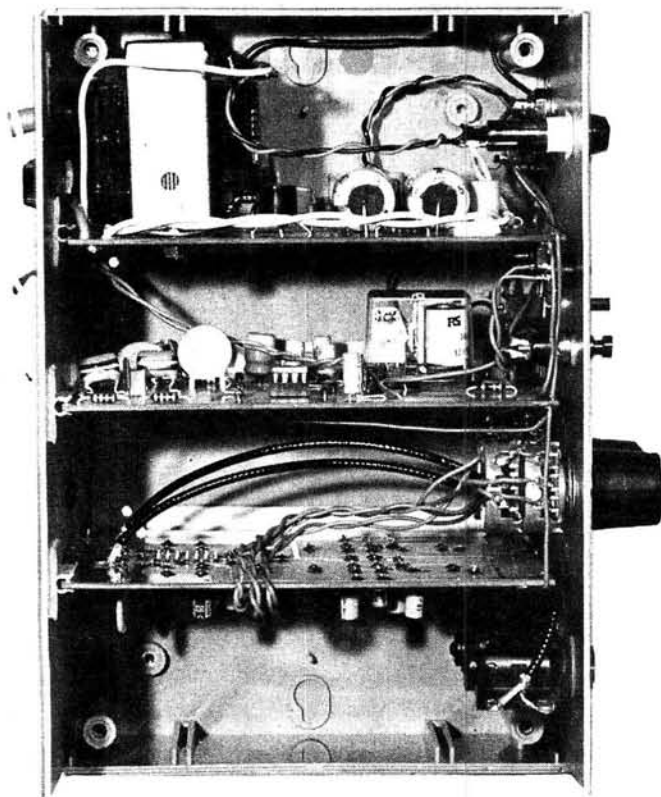

Fig. 5: The overall frequency response for each channel is shown in this diagram. It can be seen that the left-hand response has a reduced bass response



output, is 70dB for the line inputs and 55dB for the microphone inputs and t.h.d. from either inputs is less than 0.1 per cent. The microphone input sensitivity is 0.5mV for 0.775V output and at the line inputs it is 200mV for 0.775V output. The microphone inputs are suitable for impedances of 200Ω or higher. Very low impedance microphones, 25–30Ω, should have a suitable matching transformer.

Frequency Response

The overall frequency response for each channel is shown in Fig. 5 but as already mentioned the left-hand channel has a reduced bass response. The filter responses are shown in Fig. 4 and provide maximum acceptance and/or rejection at 50Hz to about 40dB. Each filter is tuneable to 50Hz by means of a preset potentiometer and the procedure will be dealt with later.

The second part will deal with construction and use of the unit.

kindly note!

PW "Tamar" 28MHz Transverter Driver, September 1980.

The specifications for RFC6 on the power supply board are:

36 turns of 23 or 24 s.w.g. enamelled copper wire evenly spaced on a 12.5mm diameter toroid. The toroid should be mounted vertically and secured to the p.c.b. with epoxy resin adhesive.

PW "Nimbus" Charger/p.s.u., Oct 1980

There are two minor discrepancies between the circuit diagram and the p.c.b. layout in the p.s.u. charger. The circuit diagram should be taken to be the definitive version. The p.c.b. should be corrected as follows, remove R3 lead from the junction with R1 and reconnect to the track adjacent to C3 positive end. Make a link from the p.c.b. location, vacated by R3 (directly below D2), to BR1 positive track pad.

the things
people say



"No, I can't hear you on the input, but that's probably because I'm only running 10 watts here."

... Brighton & District RS Newsletter

Have you heard any (printable) comments, funny peculiar or funny ha-ha? If so, why not send them in to our Editorial offices at Poole. We will pay for every one published.

The BASICS of TV DXing

Part I Roger BUNNEY



Our heading photograph shows a test card received via single-hop Sporadic E propagation from ORF-Austria by N. E. Parkes, Co. Antrim, using a simple indoor dipole at his home in a block of flats

As the name suggests, DXTV is the art of receiving distant television signals, which in this context are those signals intended for domestic viewing in areas far from the receiving location. Although the broadcasting authorities take great care to engineer transmitter characteristics to minimise interference to other transmitters operating in the same spectrum but at distances far removed from the originating site, under certain propagation conditions those very signals can be carried over hundreds and perhaps thousands of miles, and be received on relatively simple equipment. The purpose of this article is to explain briefly the mechanism by which these signals travel, and to suggest the basic requirements for a receiving installation.

It may be instructive at this stage to consider the television signal itself, since across the European land-mass several transmission systems are in use. The actual vision signal is amplitude modulated onto the carrier but with one sideband partially suppressed. This is known as vestigial sideband modulation (v.s.b.). The modulation may be either negative- or positive-going, Fig. 1 will clearly show the differences. Negative-going video is employed with the UK 625-line u.h.f. transmissions—tuning onto a blank channel will reveal a greyish background with black dots of noise; positive-going video is used on the more elderly 405-line v.h.f. transmissions, a blank channel will show a very dark background with bright white noise dots. The various types of transmission used in Europe are detailed in Table 1, and with few exceptions it will be noted that negative-going vision has been adopted. Sound modulation with negative-going vision signals is generally f.m., those countries still using positive-going vision always have a.m. modulated sound. In passing, it should be mentioned that the TV transmissions that have been received from experimental satellites and those for the future will employ f.m. video modulation; such reception is of rather a specialised nature and will not be pursued further in this article.

Broadcasting of television signals is carried out in certain frequency bands and at the time of writing are as follows: Band I, 40–70MHz; Band III, 162–230MHz; Bands IV/V (u.h.f.) 470–860MHz. Decisions passed at the recent WARC '79 will mean slight alterations to those frequencies, perhaps most significantly in Band I. Study of Table 1 will clearly show that different transmission

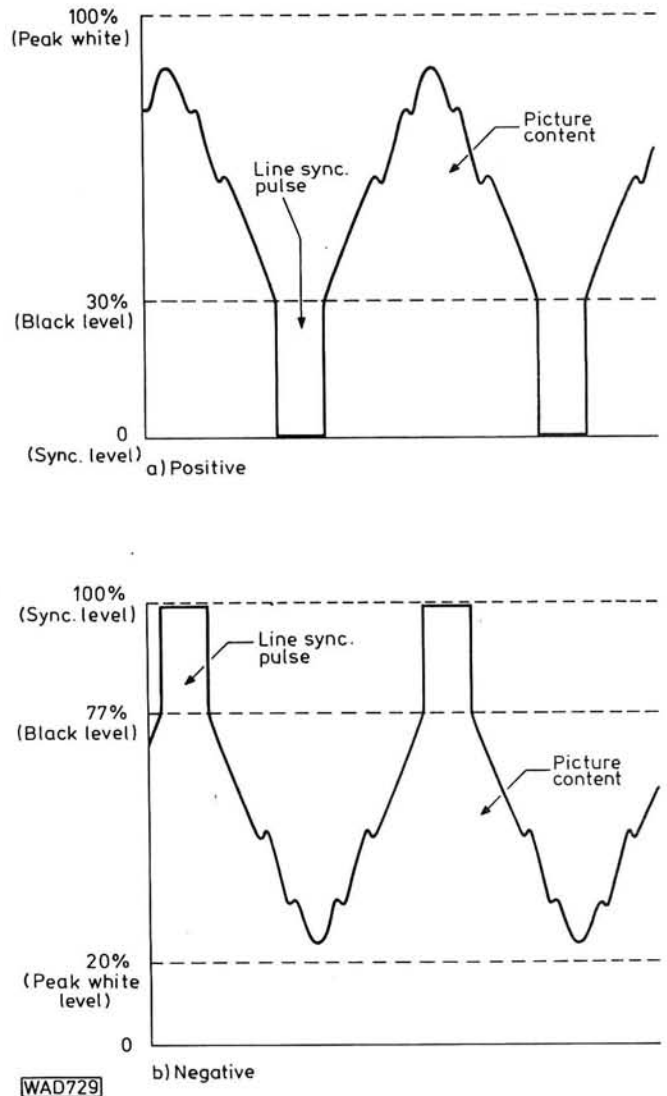

Fig. 1: Vision waveforms for: (a) positive modulation, and (b) negative modulation

Table 1
European TV Systems

System	No. of Lines	Overall Channel Bandwidth (MHz)	Vision Bandwidth (MHz)	Sound/Vision Spacing (MHz)	Vision Modulation	Sound Modulation
A	405	5	3	- 3.5	+	a.m.
B	625	7	5	+ 5.5	-	f.m.
D	625	8	6	+ 6.5	-	f.m.
E	819	14	10	± 11.15	+	a.m.
G/H	625	8	5	+ 5.5	-	f.m.
I	625	8	5.5	+ 6	-	f.m.
L	625	8	6	+ 6.5	+	a.m.

- A = UK — e.g., Ch. B3
- B = Western Europe — e.g., Ch. E2 (v.h.f.)
- D = Eastern Europe — e.g., Ch. R1 (Not East Germany)
- E = France (v.h.f.) — e.g., Ch. F2
- G/H = As for System B but u.h.f.
- I = UK — u.h.f.
- L = France/Luxembourg u.h.f. — e.g., Ch. E21

systems have varying overall channel bandwidths, the 405-line channels on System A have a much smaller bandwidth than 625-line channels. Thus it follows that in a given television band, a greater number of channels can be packed in if the overall transmission bandwidth is small. The vision frequencies used in Band I are detailed in Fig. 2 and whereas five UK 405-line channels are used, only three System B 625-line channels can be employed. In point of fact the latter System B channels extend to 48MHz and no lower, if an extension was made down to 40MHz only one extra channel would result. Band I vision frequencies have been shown, since this particular band does allow quite spectacular reception with the minimum of equipment. A free booklet from the IBA, Engineering Information Service, Crawley Court, Winchester, Hants SO21 2QA, details the UK Band III and the main u.h.f. carrier frequencies for each channel now used throughout Europe—the booklet is called *Transmitting Stations, A Pocket Guide*.

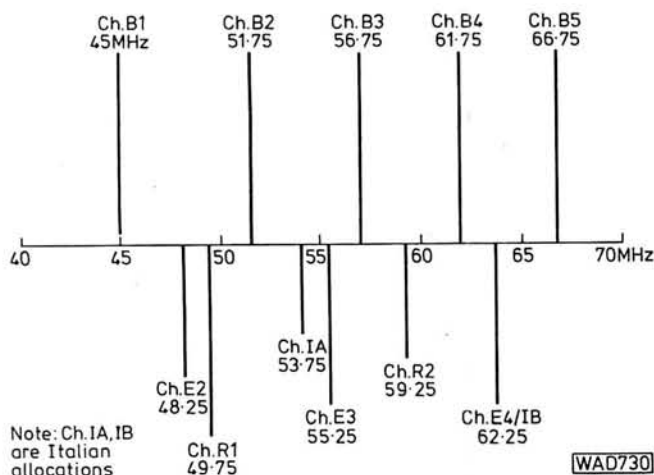

Fig. 2: Vision frequencies in Band I, 40-70MHz

Signal Propagation

Having described briefly the different types of signal waveform used for television transmission, and before going on to suggest the means to receive such elusive signals, it may be wise to detail how the signal arrives by two different modes, that of "weather assisted" or Tropospheric propagation, and that of "Ionospheric assisted" or Sporadic E propagation. There are other types of signal propagation, but for simplicity it seems best to concentrate on the more familiar types and leave the more esoteric forms of signal propagation to further study and experiment at a later stage. I am sure that most viewers have been aware that during certain types of weather condition, interference arises on the "local" TV programmes, if nothing more than an announcement suggesting that viewers may be experiencing difficulties and "do not adjust your set".

The more inquisitive of us may—possibly by accident—whilst tuning between local programmes happen upon weaker signals, perhaps of another ITV programme or if near the coast a foreign programme/test card, etc. During such conditions a glance at the weather map may disclose that the UK is under the influence of a slow-moving high-pressure system (Anti-cyclone). Reception conditions will start to build up particularly if the system is virtually stationary. Usually towards evening, as the sun falls and ground temperatures drop, an inversion may occur, caused by the different rates at which the air and surface temperatures fall. This is particularly marked during clear cloudless summer days followed with equally clear nights. During such conditions, TV signals will be propagated at both v.h.f. and u.h.f. at distances of up to 1000 miles, and certainly until such transmissions close down for the night. As they open up the next morning it will often be found that the signals are still present, but as the sun rises and temperatures rise again so conditions will fall.

This diurnal characteristic is such that an effect known as "ducting" can occur, whereby a distant v.h.f./u.h.f. signal can put an exceptionally strong signal into the UK, but stations in the same direction and at lesser distances are poorly received. The Brocken TV transmitter in East Germany is a favourite for this to be observed on Ch. E6 (Band III) and Ch. E34 (u.h.f.) when no other DX signals are present! In this instance the transmitter is located high in the mountains and literally transmits its signals directly into the duct.

High-pressure systems can also produce spectacular reception, particularly during the autumn/winter months, and foggy conditions often manifest many distant signals. At times a high-pressure system may remain for some days with no apparent improvement in DXTV, but as the system slowly moves away and the high-pressure starts to fall then signals may rise from the noise. Signals can be received along the advancing wavefront of (for example) a fast-moving cold front, where we have an abrupt temperature gradient, similar to a temperature inversion, which can give signal reception up to several hundreds of miles. Such conditions however may be present for an hour or less depending upon the speed and "sharpness" of the front.

Sporadic E

High above the Earth's surface are the various layers of the Ionosphere that support signal reception at medium and short waves, such reflection relating to the time of

day, part of the year and prevailing Solar activity. At around the 70 mile height is the E layer. I am sure many readers will recall the (happy?) days for 405-lines when during the summer months BBC1 was regularly shattered with Continental interference. That interference is or was the result of Sporadic E. Normally the E layer will not support v.h.f. signal reflection, it being transparent to signals above about 7-10MHz (this latter figure is very approximate and will vary according to the conditions as noted at the beginning of this section). Certainly for u.h.f. TV in Band I and above, the E layer is just not there during normal conditions. At times however, intense ionisation of a localised nature happens within the E layer and such patches are capable of supporting signal reflection at frequencies in Band I, often Band II (f.m.) and on very rare occasions even at the low end of Band III (I once noted Ch. E7 vision via Sporadic E at 190MHz!). The causes of such ionisation are not confirmed, although recent work by radio amateurs does show a definite connection between Meteor Showers and Sporadic E. However the net result for the DXTV enthusiast is that during the generalised period of early May to late August one can experience "Sporadic E openings".

Such openings produce strong or very strong Band I TV signals from one or more stations or countries in either a very localised area or a more widespread tract of Europe, usually via a single hop of 500 miles or more, up to perhaps 1500 miles. Often double hop occurs, giving up to 3000 mile distances; an example that is received on Ch. E3 is the Amman, Jordan transmitter. To receive single-hop signals under 500 miles calls for very intense ionisation, and although this can happen it is very rare.

Sporadic E enjoys a "season" as indicated during the summer months, although as its name implies it can occur anywhere, anytime. Often a mid-winter peak of Sporadic E is noted. Signals, unlike the "fringe" type of the Tropospheric with its slow fading, are spectacular, ranging from a few microvolts to several millivolts and across a time span of seconds. Due to the strength of signals, quite simple equipment can be employed. I recall some years ago experimenting with a dipole array on a 9ft pole in the garden, and comparing the Ch. E2 Madrid signals with those coming down from a 4-element Band I array at 50ft. Signal levels were measured reaching to nearly 3mV and at times similar strength signals were noted from both aerials.

Sporadic E is certainly dramatic, the newcomer to DXTV can easily equip himself with basic apparatus and successfully receive foreign Band I signals, and once having gained experience in receiver and propagation requirements, can advance himself to the other and more difficult forms of signal reception. I personally advise enthusiasts to follow this route since if the knowledge/experience is available to convert an older receiver, minimal financial outlay results and the technical experience thus gained is invaluable for future construction, modification and experimental work. For the non-technical enthusiast such DX is possible even without removing the rear cover of his receiver, by employing a standard u.h.f. domestic TV set.

Equipment

I have been active in DXTV for nearly 20 years, and have written the DXTV column in our companion magazine *Television* since the early '70s. During this time I have encountered most problems likely to beset the newcomer to this hobby. Of course in the 1960's, prior to the 625-line service, any person wishing to undertake serious DXTV operation would have to modify his 405-line set to

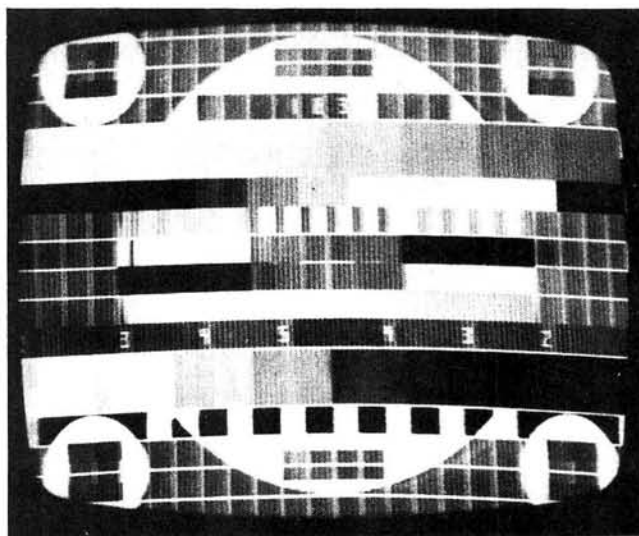

An example of single-hop SpE reception, showing the USSR test card on Ch. R2 (59.25MHz) as seen by Gareth Price in Lowestoft

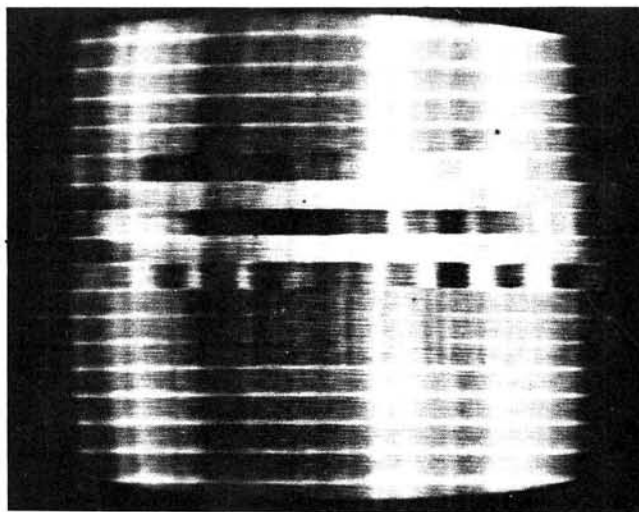

Trans-Equatorial F2 reception of Ch. R1 Vladivostok in Perth, Western Australia by Anthony Mann. Note the characteristic smearing and multiple image effects

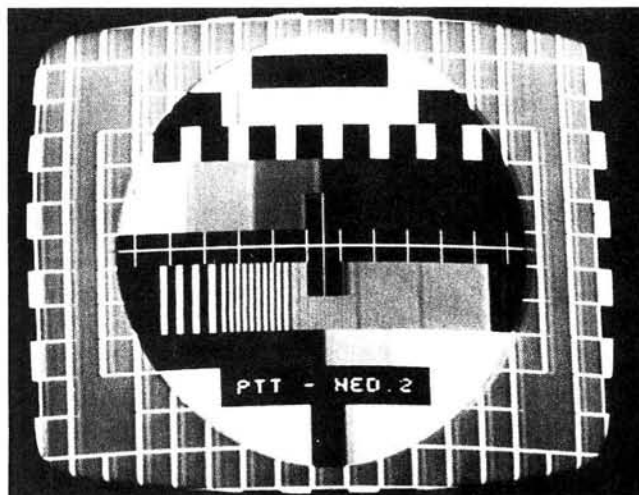

Good-quality Tropospheric u.h.f. reception of the Philips 5544 test card from Lopik, Holland on Ch. E27 by Gareth Price, Lowestoft

receive the 625-line negative-going video signals used across Europe (with the exception of France). In these days, with the adoption of 625-lines, little modification is necessary, there are even receivers available that already have v.h.f./u.h.f. tuners fitted and just a few of these may incorporate 5.5/6MHz sound intercarrier switching to enable the sound of the UK u.h.f. and West European v.h.f./u.h.f. services to be resolved. So, for a price, DXTV watching can be extremely easy—the dealer may even wire on the 3-pin mains plug! Unfortunately problems can result with the use of such receivers, which will be expanded on shortly. At this stage consideration of how to receive Sporadic E in Band I must be given, since this provides the easiest means of DXTV operation and at lowest cost (both in terms of labour and finance!).

As already mentioned, the enthusiast can contact his local discount warehouse or TV dealer, establish which receivers have 625-line v.h.f. coverage, possibly with 5.5/6MHz switching, and simply write out a cheque. The question of aerials will be dealt with later. The second way of achieving v.h.f. coverage is to make use of the standard u.h.f.-only receiver, preferably with a continuous tuner (i.e., one marked with Chs. 21–68 on a rotary scale), since push-button tuning—unless there are about 10 buttons—is operationally inconvenient and clumsy. The receiver in its unmodified form can be used directly for u.h.f. Tropospheric DXing, but with the inclusion into the system of a device known as a v.h.f./u.h.f. up-converter, the receiver then can be tuned over Band I and Band III. The up-converter is a small transistorised frequency converter that transfers the 40–250MHz spectrum to an equivalent slot in the u.h.f. bands, often in the Ch. 30 to Ch. 60 region. Therefore, by plugging a Band I aerial into the converter, connecting the output of the converter to the u.h.f. aerial socket of the TV receiver, and tuning the latter over the appropriate u.h.f. channels, Band I will be resolved on the u.h.f. receiver—simple but effective. The up-converter unit will normally be fitted with a wideband r.f. amplifier stage and give a throughput gain of up to 4dB. The noise figure is typically around 6dB but experience has shown that these converters can be used successfully for DXTV operation even on weak Band III Tropospheric signals.

A third means of receiving DXTV signals is by obtaining and modifying an earlier dual-standard (405/625-line) receiver. This does call for a degree of skill in the enthusiast, since modifications will entail separating the video detectors from the i.f. strip, the object being to utilise the narrow i.f. bandwidth (System A) but with the negative detector. The benefits are improved selectivity and higher gain with lower noise. For such work either the existing receiver's v.h.f. tuner can be replaced with a modern varicap equivalent, or the original tuner can be used as an i.f. pre-amplifier stage and tuning carried out with an external varicap tuner unit. The advantage of the latter method is that i.f. shaping and limiting circuits can be fitted in the i.f. feed to the main receiver, such circuits again being aimed at the improvement of weak signal working and rejection of adjacent interference. When such work is undertaken the sound signal accompanying the received video will be lost, since we are working with reduced i.f. bandwidths. With intercarrier sound this signal proceeds along the vision i.f. strip and is then taken into the sound i.f. strip at the video detector/video amplifier. Restriction of the vision i.f. bandpass down to around 3MHz will mean the sound is lost.

At this point I feel that great stress must be placed on the problems of i.f. selectivity. I am aware that many readers will be using imported v.h.f./u.h.f. receivers intended for reception of sound and vision. A glance at the Band I vision allocations will show that in many cases

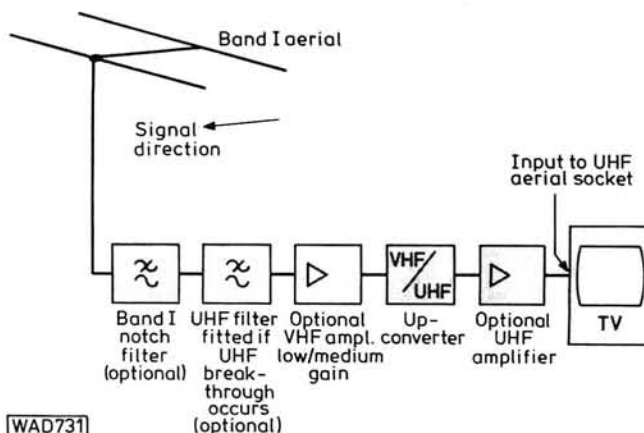

Fig. 3: Using an up-converter to provide v.h.f. coverage on a u.h.f.-only receiver

(assuming a 6MHz sound/vision separation for the UK standard) if a receiver is tuned to, say, Ch. E2 vision at 48.25MHz, the i.f. bandpass of that receiver will be capable of passing incident signals (other than the desired) if they fall within the spectrum of 48.25MHz to 54.25MHz. Indeed if above the 6MHz limit we have a strong "local" Band I station, there is every likelihood of it "splashing down" into the i.f. bandpass. Certainly if such a receiver is used at my home for receiving Ch. R1 video at 49.75MHz, the local Ch. B3 sound at 53.25MHz will all but render Ch. R1 useless, except for very strong signals, by producing "sound splatter". The problem is often made worse by the enthusiast using a high-gain aerial amplifier (pre-amplifier) whereas the correct course of action should be to notch-filter out Ch. B3 sound and then amplify. Even if there is no strong "local" to produce problems, in the first good Sporadic E opening Ch. E2 vision and Ch. R1 vision will tend to overlap and "float" over each other—such are the problems of the wide i.f. bandpass receiver.

Those enthusiasts in London living within 15 miles of the Crystal Palace Ch. B1 transmitter unfortunately tend to suffer badly with the 45MHz vision spreading up into Chs. E2/R1 vision. Again a simple notch filter on 45MHz will remove the problem, but of course the i.f. characteristics are preset, and given conditions when several strong signals are present (such as a Sporadic E opening) the problem will obviously recur. The answer is to use/modify the i.f. strip into the reduced bandwidth state, and this course is usually taken by the serious enthusiast. Such restriction can easily be incorporated by using the Philips G8 Selectivity Panel, a small active filter that has four tuned circuits capable of being "peaked up" and inserted in series with the feed from the tuner to the main i.f. strip. For exceptional selectivity it has been known for two such filters to be connected in series.

A final word if searching for an early receiver to modify. It must have very good field sync (i.e., frame locking on a weak signal) and flywheel line sync is essential. The Bush TV125/TV161 receivers are ideal for DX work and usually can be obtained at nominal cost.

For enthusiasts intending to modify an early receiver, it will almost certainly use a.c./d.c. technique—that is it will have a live chassis if connected to the mains the wrong way round. Ensure that you have a "dead" chassis, no connections go between chassis and other external units unless via isolation capacitors and always remember that death is permanent—240V will and does kill. So if in doubt—don't!

In Part 2, next month, we deal with aerials and aerial amplifiers for DXing.

Lee Electronics Ltd



Londons Leading Stockists Of:
STANDARD YAESU ICOM FDK KDK MICROWAVE MODULES LUNAR SST SHURE HI-MOUND CDE STOLLE
TELECOMM ANTENNAE J-BEAM SWAN KATSUMI ETC.

INTRODUCING THE YAESU FRG7700



- * One-touch frequency selection from long wave to short wave with 12 channels capable direct memory circuitry. (With memory type only).
- * 150kHz to 29.999MHz full coverage high stability dual PLL system.
- * Strong for cross modulation.
- * Automatic band pass filter selection.
- * 3 filters for AM reception.
- * 2 steps of AGC . . . fast/slow.
- * Narrow band FM reception capability.
- * Timer facility.
- * Back up battery.
- * Sinpo coded signal strength meter.
- * Receiver noise blanker circuitry.
- * 12 kinds of attenuator.
- * High quality audio sound.
- * Dimmer control.
- * AC + DC operation.

BASIC UNIT £309
MEMORY UNIT ONLY £83.95
FRG7700 WITH MEMORY £389

Just a small selection from our comprehensive range of accessories.

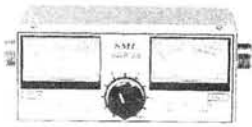

SWR25: This ever-popular twin SWR and Power meter covers 3.5-150MHz at **£12.65** inc. VAT. P&P 50p.



DL-30 Dummy load 25W DC-150 MHz **£6.35** inc. VAT. P&P 25p.

T-100 80W Dummy load DC-500 MHz **£24.10** inc. VAT. P&P 25p.

T-200 150W Dummy load DC-500 MHz **£35.60** inc. VAT. P&P 25p.



SWR200B swr/power meter covering 3-200MHz 50/75 Ohm power range 3-30MHz, 20/200/2kW, VHF 2/20/200W **£40.20**. P&P £1.00.

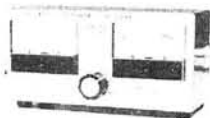

T-435: VHF/UHF swr and power meter with 2/20/120 watt through line power measurement **£34.45** inc. VAT. P&P 75p.



CT-1 Coax Toggle 3 SO239's **£6.85** inc. VAT. P&P 25p.
CT-2 Coax Toggle 2 SO239's 1 PL259 **£6.85** inc. VAT. P&P 25p.



PX402 13-8V DC 3 amp continuous 4 amp max fully stabilized power supply with overload protection **£22.95** inc. VAT. P&P £2.00.
Also available:
PH5000, 5A continuous, 7A surge. **EP2500**, 25A continuous, 30A surge.

We are London's Largest Stockist of Microwave Modules products.

TRANSVERTERS:

MMT28/144	(10m linear transverter)	
MMT144/28	(2m linear transverter)	
MMT432/28-S	(70cm linear transverter)	
MMT432/144-R	(70cm linear transverter)	
MMT70/28	(4m linear transverter)	
MMT70/144	(4m linear transverter)	
MMT1296/144	(23cm linear transverter)	

LINEAR AMPLIFIERS:

MML144/25	(2m 25 watt linear amplifier)	
MML144/100	(2m 100 watt linear amplifier)	
MML144/40	(2m 40 watt linear amplifier)	
MML432/20	(70cm 20 watt linear amplifier)	
MML432/50	(70cm 50 watt linear amplifier)	
MML432/100	(70cm 100 watt linear amplifier)	

RECEIVE CONVERTERS:

MM2000	(RTTY to TV converter)	
MMC28/144	(10m converter)	
MMC50/28	(6m converter)	
MMC50/28L0	(6m converter)	
MMC70/28	(4m converter)	
MMC70/28L0	(4m converter)	

Price £ inc. VAT	Post Rate			
90.85	B	MMC144/28	(2m converter)	24.90 A
99.00	B	MMC144/28L0	(2m converter)	26.90 A
136.85	B	MMC432/28-S	(70cm converter)	29.90 A
173.65	B	MMC432/144-S	(70cm converter)	29.90 A
115.00	B	MMC1296/28	(23cm converter, 10m output)	32.20 A
115.00	B	MMC1296/144	(23cm converter, 2m output)	59.80 B
184.00	C			
48.30	B			
142.60	D			
69.00	B			
69.00	B			
113.85	D			
228.65	D			
169.00	B			
24.90	A			
24.90	A			
26.90	A			
24.90	A			
26.90	A			
69.00	A			
69.00	A			
34.50	A			
27.60	A			
5.75	A			

THE ABOVE PRICES ARE INCLUSIVE OF VAT BUT NOT POSTAGE. PLEASE ADD POSTAGE TO THE ABOVE PRICES AT THE FOLLOWING RATES:
UNITS 'A': £0.675 UNITS 'B': £1.75 UNITS 'C': £2.25 UNITS 'D': £2.75

400 EDGWARE ROAD
LONDON W2
01-723 5521 Tlx: 298765



INSTANT H.P.
& P/EX. WELCOME

Send 25p for
full details
of our range.

SOMMERKAMP AT ARROW



CHECK THE SPECIFICATIONS – YOU'LL SEE SOMMERKAMP IS YOUR BEST BUY!!
MODEL TS-802

2m VHF FM handy-talky

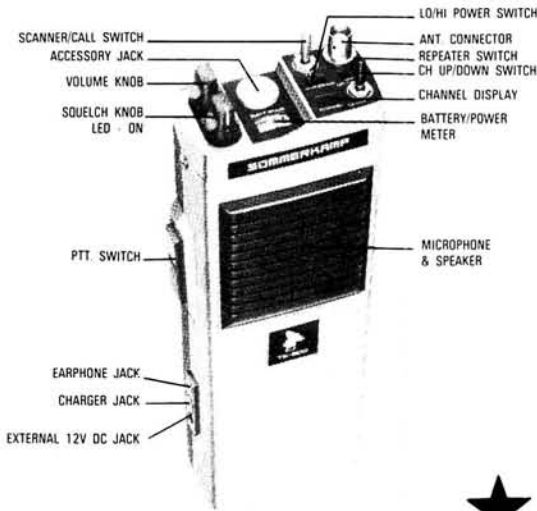

SPECIFICATIONS FOR MODEL TS-802

GENERAL

Frequency Range: 144.025 ~ 146.000 (1ch ~ 80ch) in 25KHz steps with repeater (R0 ~ R9)
 Frequency Control: Digitally synthesized PLL system
 Frequency Stability: 3×10^{-6} at 25°C
 8×10^{-6} at $\times 10^\circ\text{C}$ to +50°C
 Semiconductor Compliments: 17 Transistors, 5 FETs, 12 ICs, 44 Diodes
 Modulation Type: Frequency Modulation
 Supply Voltage: 12V DC
 Current Drain: Transmit: 0.4 A Receive: 0.025 A
 Antenna Impedance: 50 Ohms unbalanced
 Size: 230mm x 78mm x 43.5mm

TRANSMITTER:

Frequency Control: Phase Locked Loop Synthesizer
 Modulation: FM
 Power Output: HI.....2W LOW.....0.1W
 Spurious/Harmonic Output: Less than -60 dB
 Microphone: Condenser microphone

RECEIVER

Frequency Scheme: Superheterodyne with 10.67MHz
 Sensitiveity: 0.5µV for 12dB sinad
 0.5µV squelch threshold
 Spurious/Image Response: -70 dB
 Selectivity: 15KHz -3dB, 25KHz -70dB
 Audio Output Power: 250mW at 8 ohm 10% THD

★ NEW LOW PRICE £129 ALL IN!
ARROW ELECTRONICS LTD.
 Leader House, Coptfold Road, Brentwood, Essex CM14 4BN.
 Tel. Brentwood 219435 & 226470

LISTEN TO VHF MARINE or AMATEUR BAND with an SR9 RECEIVER



FROM **Catronics**

The SR-9 represents the finest value-for-money ever offered in the FM monitor receiver market. Giving fully tunable coverage of the 2 metre amateur band from 144-146 MHz, or Marine Band from 156-162 MHz, the SR-9 also incorporates the facility for installing optional crystals which will provide up to ELEVEN fixed channels for the most popular frequencies – mobile calling channel, local repeater channels, distress channel etc. The SR-9 is completely self contained, even to the loudspeaker, and needs only 12 volts dc (negative earth) at approx. 200 mA to operate. Mounting hardware is provided for installation.

SR9 Receiver £46 (+£1.50 carr.) – State Amateur or Marine version.
 Special Package Deal No. 1: SR9 + Mains Power Supply + Amateur Band Loft/Roof Aerial for £66 (+ £2 carr.)
 Special Package Deal No. 2: SR9 + Car Gutter Clip Aerial for £51 (+ £1.50 carr.)

TRIO R1000 RX at a VERY SPECIAL PRICE!

As featured in May issue of P.W. 200KHz-30MHz. PLL synthesizer. Digital readout plus analog display for easy accurate tuning. 240Vac/12Vdc supply £285 (+ £5.50 carr.)

PW 'HELFDOR' TX/RX

Components and kits available to build this SSB Tx/Rx inc. PCB, SL1600 i.c.'s etc.

Ask for details and prices.

ALL OUR PRICES INCLUDE VAT

EASY TERMS available. Access and Barclaycards welcome

CATRONICS LTD. (Dept. 181) COMMUNICATIONS HOUSE,
 20 WALLINGTON SQUARE,
 WALLINGTON, SURREY SM6 8RG.

Phone: 01-669 6700. Mon.-Fri. 9 a.m.-5.30 p.m. Sats. 1 p.m.

TR7800

READ THE REVIEW IN THIS ISSUE,
 AND THEN COME ALONG AND
 TRY IT FOR YOURSELF AT

M.R.S.
COMMUNICATIONS LTD.
 76 Park Road, Whitchurch,

CARDIFF

Tel: Cardiff (0222) 616936

OPEN
 9 am to 5 pm
 6 Days



air test

USER REPORTS ON SETS AND SUNDRIES

SOMMERKAMP TS-802 2m Hand-held Transceiver

Recently introduced into the UK market is the TS-802 2m v.h.f. f.m. handy-talky, the latest in an expanding range of equipment from the Swiss Sommerkamp Co.

As supplied the rig has a scannable frequency range from 144.025MHz to 146.000MHz in channelised 25kHz steps derived from a phase-locked-loop synthesiser.

Received frequency is indicated on a miniaturised 2-digit, 7-segment red l.e.d. display which takes the form of channel numbers from 1 to 80 and R0 to R9 when repeater mode is selected (600kHz up-shift). The unfortunate result of this method of presentation is that display readings have to be decoded by the operator. For example, display channel 60 = 145.500MHz = S.20. However, until practice makes perfect, a look-up table, on the back panel, can be referred to giving display readings against true frequency.

Scanning of the available channels can be accomplished by manual step-through using the UP/DOWN toggle switch, or continuously by activating the scanning switch. The scan will cease when a signal above the preset reference level is detected.

The receiver circuit incorporates a conventional single-conversion superhetrodyne with an i.f. of 10.67MHz. The sensitivity quoted by the manufacturers is 0.5µV for 12dB SINAD (0.35µV p.d.), with a SQUELCH threshold of 0.5µV (0.1µV).

Selectivity given at 15kHz and 25kHz are -3dB and -70dB respectively. Italic figures given in brackets are those measured during our test evaluation.

The audio stage develops an output of 250mW into an 8Ω speaker with a specified 10% total harmonic distortion.

On the transmit side, the TS-802 produces 2W (1.7W) of f.m. in the HI position and 0.1W (0.3W) in the LOW. Spurious harmonic outputs are quoted as -60dB. An internally mounted, front panel capacitor microphone is supplied for normal hand-held use, but various optional handsets and "fist" microphones are available. These are interfaced via the multi-pin socket fitted into the top panel (normally hidden by the circular aluminium blanking plate).

Top-panel features, which are of necessity closely grouped, include separate VOLUME and SQUELCH, combined BATTERY STATE and "S" METER, SCANNER/REPEATER 1750Hz tone switch, SIMPLEX/REPEATER selector and UP/DOWN channel switch. The remaining feature is a BNC connector to take the supplied $\frac{1}{4}$ λ flexible rubber antenna. Side-mounted sockets are provided for earphone, charging line and external 12V d.c. supply.

Results

The initial impression of the TS-802 is made by its "chunky" solidarity. This is enhanced by an all-up weight of



1.14 kg. Being physically larger at 80 x 45 x 235mm, than equivalent hand-held rigs it was a surprise to find a conventional sized pack of 10 AA-size NiCad cells. The increased depth is required to house the large complement of on-board logic system integrated circuits (on the single-sided p.c.b.).

In operation the receiver section sensitivity proved adequate for the available power output, and in practice would probably complement a 10W outboard power amplifier if used in a mobile installation. Normal hand-held operation consists of holding the front grille close to the mouth and depressing the side-mounted p.t.t. switch bar. After transmissions in excess of several minutes a "two-handed" technique was adopted to preserve the reviewer's right arm muscles for the application of vocal chord lubrication!

Modulation characteristics of the evaluation sample produced low-level muffled response reports from stations worked, indicating the need for an increase in audio-drive level. Repeater working with manual toneburst, such as that fitted to this rig, is a confirmed "two-handed" affair and for operational convenience auto-tone would be much preferred. Display legibility, in anything but dull ambient light, was found to be poor, caused by a combination of the small character size and lack of brilliance. With economising circuits designed in, an adequate drive level for the displays should not deplete the available power reserves that much.

Included in the basic transceiver package is a carrying case and shoulder strap, earphone and instruction booklet giving outline specification, circuit diagram and basic driving procedures. Detailed service information is not included.

The TS-802 is currently being offered by **Arrow Electronics, 7 Coptfold Road, Brentwood, Essex CM14 4BN. Tel: 0277-226470**, at £129 including VAT and carriage, and at this price merits serious consideration by anyone contemplating purchase of a 2m hand-held. Our thanks to Arrow for the loan of the review unit.

PW 'TWHYNHAM'

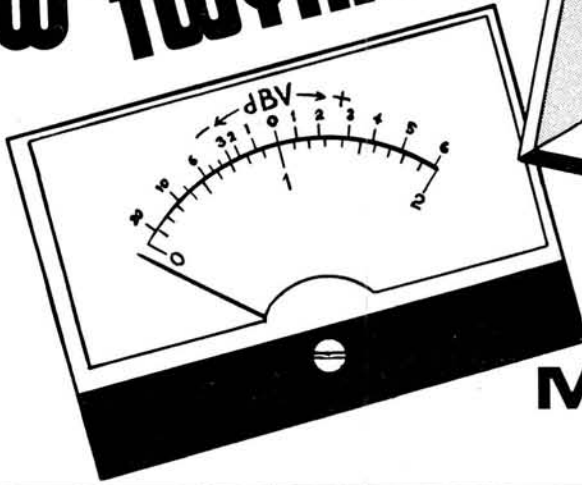

DIGITAL/ANALOGUE MULTIMETER PART 2

Michael TOOLEY BA & David WHITFIELD MA MSc

With the exception of the input connectors and displays all the components are mounted on a single-sided printed circuit board. The copper-track pattern and associated component layouts are shown in Figs. 18 and 19.

It is essential that the described layout is followed closely since any deviation from the published design may give rise to spurious readings caused by hum and noise.

The components should preferably be fitted to the p.c.b. in the following order: links (10 off); terminal pins (6 off); i.c. sockets; fixed and variable resistors; transistors, diodes and regulators; capacitors; rotary switch unit with the transformer being fitted last.

Switches

The switch assembly can take two forms, either printed circuit board mounting (RS Components 327-311; 6 off 327-591 and 1 pk. 327-327) or a conventional rotary type. The former, although considerably more expensive than the normal type, is much more convenient since the p.c.b. has been designed to mate directly with the pins of the switch wafers, each of which incorporates a small

"daughter" p.c.b., thereby eliminating all wiring from the switch to the p.c.b.

Details for assembling the printed circuit switch assembly are shown in Fig. 13. Before assembling the wafers it is first essential to ensure that they are set to position 7, identified by viewing each wafer/p.c.b. assembly from the wafer side and setting the rotating contact to the lower isolated static contact as shown in Fig. 14. Prepare the shafting assembly to accept the wafers as follows: Remove the control nut, lock washer and rotation stop limit from the shafting assembly. Turn the control shaft to the extreme anti-clockwise position (position 1) and then rotate the shaft clockwise counting the stops from position 1 to position 7. Carefully slide the wafers and spacers onto the shafting assembly checking the alignment of each as it is inserted. Note that only 3.2mm miniature spacers are suitable since they define the ultimate wafer pin spacing at the p.c.b.

Carefully insert the completed switch assembly into the p.c.b. pressing down gently starting at the front (first wafer) of the switch. Do not force the assembly as this may damage the pins!

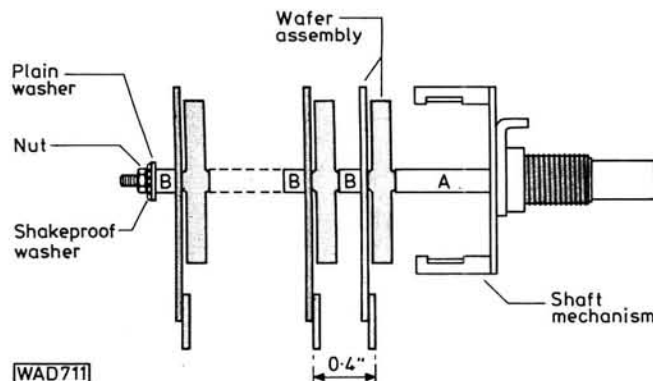
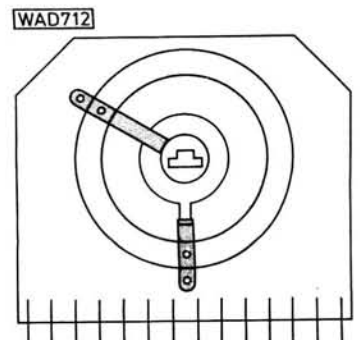

Fig. 13 (left): Details of the printed circuit type of rotary switch Fig. 14 (Right): Ensure that the switch wafers are positioned as shown before assembly



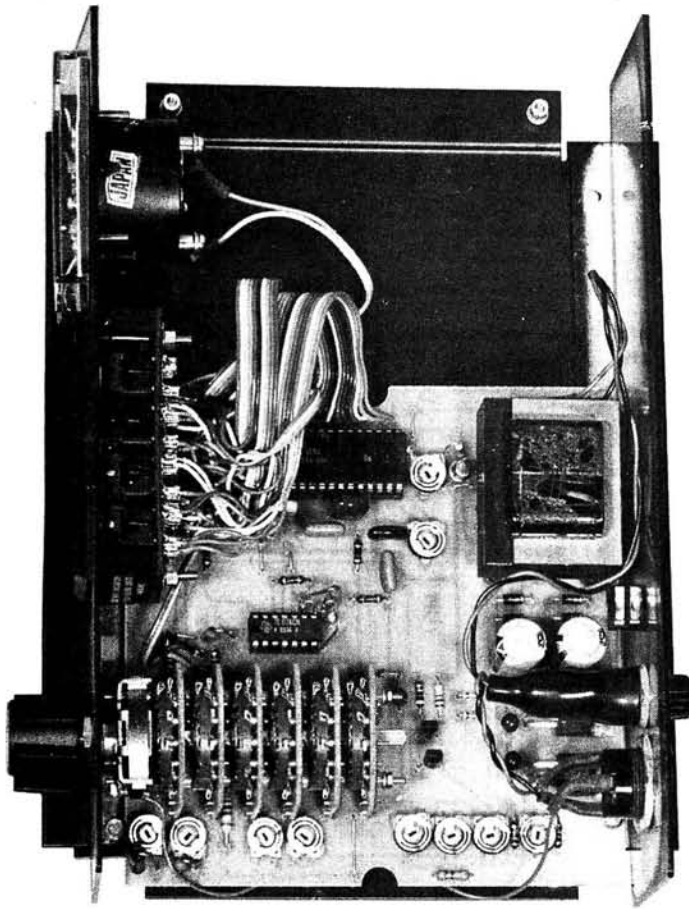
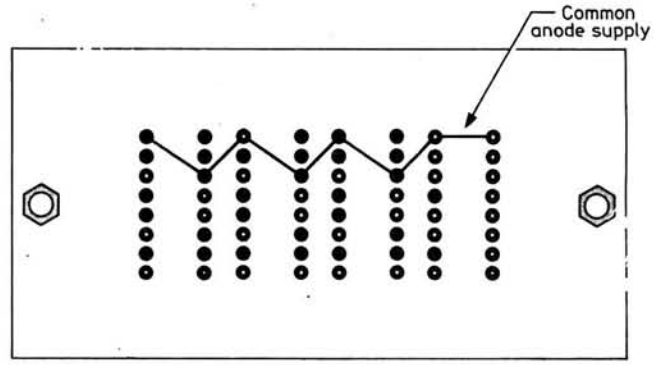

Fig. 15 (below): The pin connections for the 7107 integrated circuit. The photograph above shows the internal layout of the instrument



● Not connected
 ● Connected to main p.c.b. (see figure 19 for pin details)
 — Link

WAD714

Fig. 16 (above): The wiring on the back of the display bezel. The bottom row of pins is not used

Fig. 17 (below): Connections to the displays

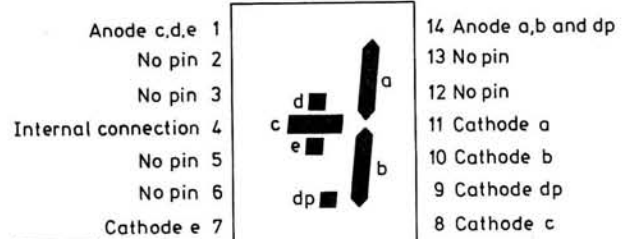
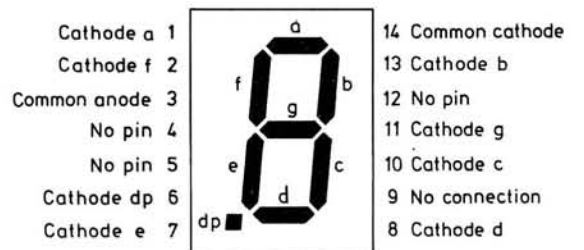

WAD710

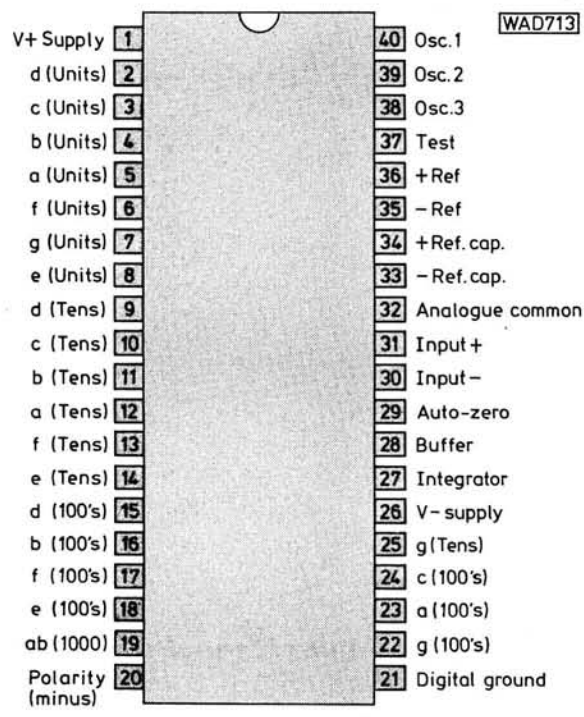

Wired Rotary Switch

Care should similarly be taken to ensure the correct alignment of wafers when a conventional rotary switch is used. In this case, however, the spacing between wafers is not so critical. The switch wafers will need to be wired to the p.c.b. but note that, since not all the switch positions are used on some wafers, it will only be necessary to make a limited number of connections and some further economy is also possible by linking tags directly on the wafer rather than running all tags to the p.c.b.

In either case, check that the switch does not foul any of the components previously soldered to the p.c.b. and, in particular, it is wise to check that the variable resistors can be rotated throughout their travel. If this is not the case then the offending components can be eased slightly to clear the switch wafers.

Earth Link

When the p.c.b. is complete, carefully check the underside of the board for dry joints and links between tracks, then solder the copper braid link as shown in Fig. 19. This link is essential to eliminate a small (2-3mV) voltage drop

Fig. 18: The copper-track pattern of the p.c.b. shown full size. The component placement diagram, Fig. 17, is shown on the next page

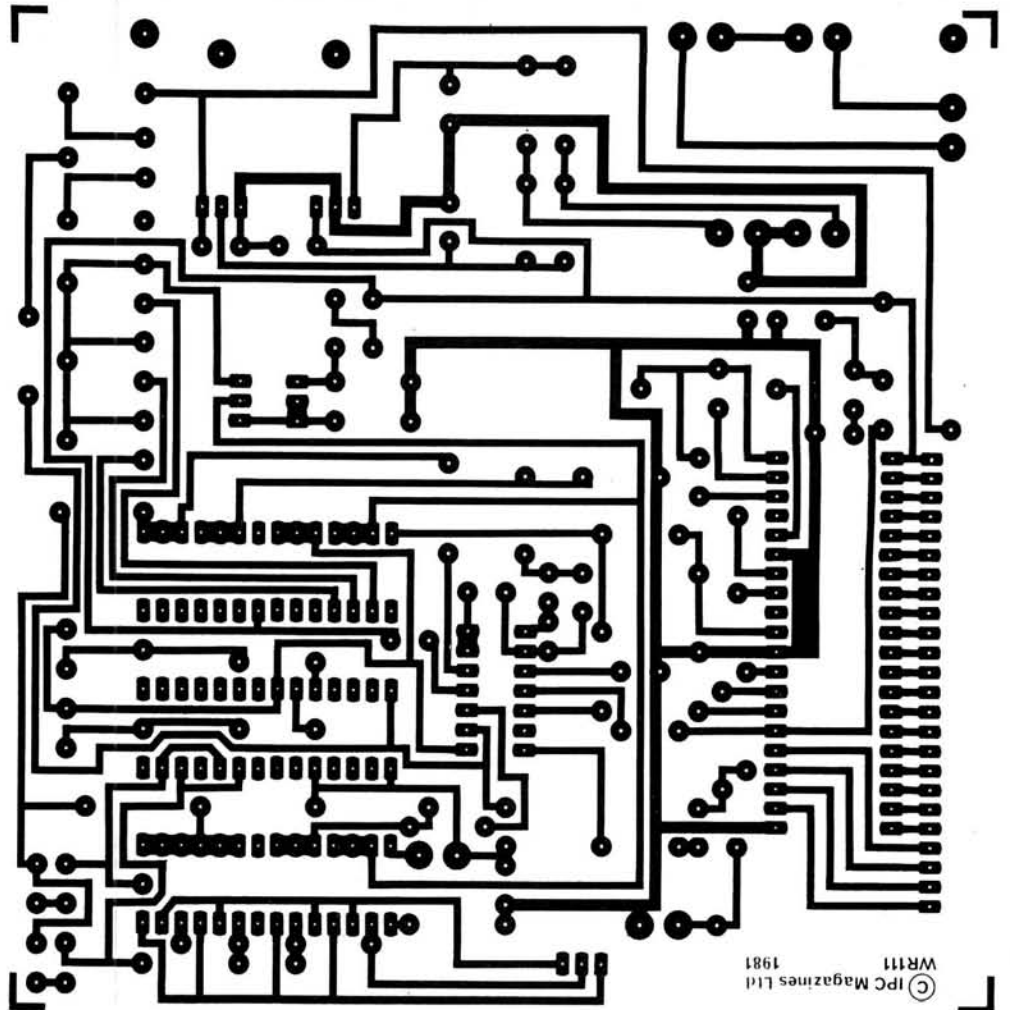

© IPC Magazines Ltd
WR111
1981

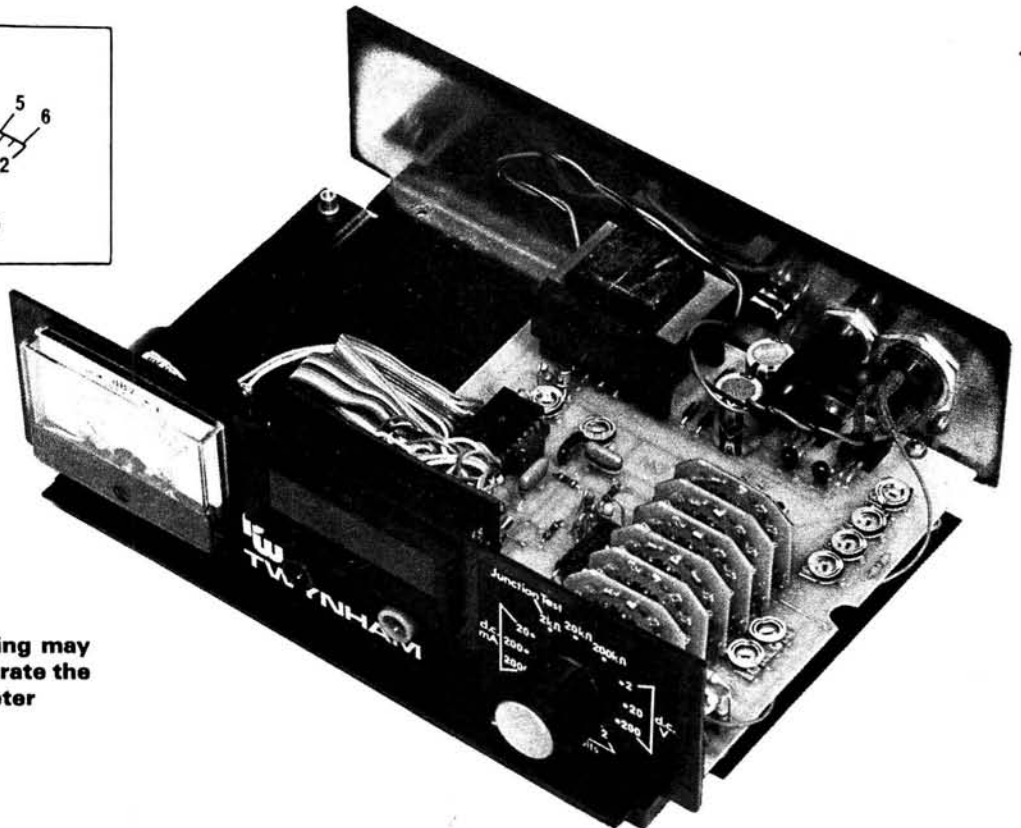
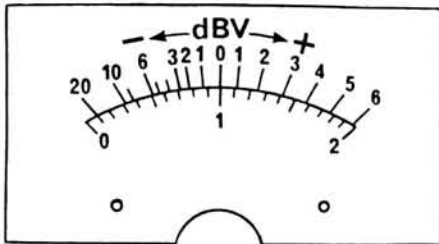
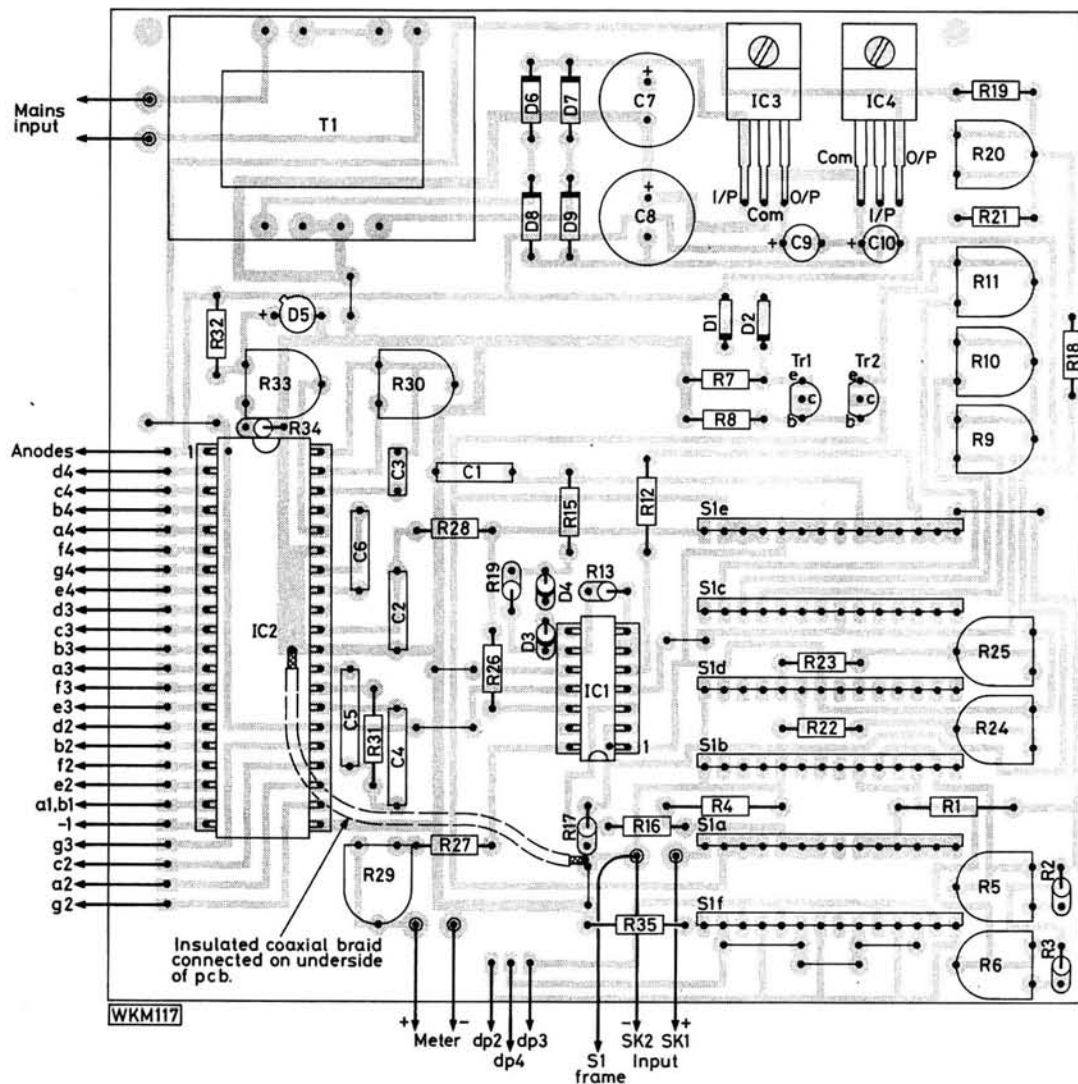

Fig. 20 (above): This drawing may be cut out and used to calibrate the dial of the analogue meter



which appears along the common 0V rail of the p.c.b. between the input terminal and the input pins of the 7107. The link should be as short and direct as possible and should be sleeved in order to prevent short-circuits. A length of coaxial cable would be ideal, with the inner conductor and insulation removed to leave just the braid and outer sleeve.

Finally connect the display to the p.c.b. using two short lengths of 20-way ribbon cable. The pin connections of the common anode i.e.d. displays are shown in Fig. 17, together with the rear of the display module wiring shown in Fig. 16.

Initial Checks

When the wiring is complete the integrated circuits (7107 and LF347) should be inserted in their holders—checking carefully that the pin-orientation is correct! The mains supply should then be connected via the fuse specified in the components list. The i.e.d. display should immediately become illuminated. If a digital frequency meter is available the frequency of the 7107's internal oscillator should be set to 50kHz (R30 set to approximately mid-position). The range switch should then be set to the 2V d.c. position with the input terminals short-circuited by means of a short jumper lead. The display should read

“000” (the first digit being suppressed). If the last digit is “1” rather than “0” this usually indicates either the presence of a small common mode voltage or the pick-up of hum and/or noise from the surrounding wiring.

When the short-circuiting link is removed from the input terminals a reading will appear on the display due to static charge accumulating on the input of the 7107. (This is due to the exceptionally high input impedance of the 2V range.) Switch to the 20V and 200V d.c. ranges and the display should read “0.00” and “00.0” respectively. Next check the over-range indication by switching to the three ohms ranges. On each of these ranges the leading digit “1” should be illuminated and the last three digits should be suppressed.

Part 3 will deal with the final calibration and use of the PW Twynham.

The following corrections should be made to the text in Part One.

- P20: R1 should read R31; C1, C6 and C2, C5.
- P21: VR1 should read R5; VR2, R6; VR11, R20; VR3, R9; VR4, R10 and VR5, R11
- P23: R10 should read R15; VR9, R30; VR10, R33; R22, R31; R23, R32; R24, R34. R35 was omitted from the components list and is $150\Omega \frac{1}{4}W$. R32 in Fig. 11 is shown as R23 and R30 should be a preset.

PRODUCTION LINES

ALAN MARTIN G8ZPW

4-metre Equipment

Microwave Modules Ltd. have recently introduced a new series of their popular all-mode transverters for the 4-metre band.

Originally only the MMT70/144 was available to down-convert from 144MHz to 70MHz. However, this new series of 70MHz equipment now includes the MMT70/28, which allows 28MHz transceivers to be used on 4-metres.

These new transverters feature the usual high quality construction techniques, with the following features; 10 watts r.f. output from rugged p.a. transistor; linear all-mode operation; low-noise receive converter (2dB noise figure) and r.f. VOX change-over.

The development of the MMT70/144, which was originally a single conversion device, has resulted in an improved design, built around a double conversion principle, which down-converts the 144MHz signal before the second conversion up to 70MHz. This development has also formed the basis for the MMT70/28.

To complement this transverter range, Microwave Modules have also announced two linear power amplifiers for 70MHz, which will provide 40 watts output (MML70/40) and 100 watts output (MML70/100), both for 10 watts input. (Prospective f.m. operators please note 50 watt power restriction on this band.)

The MMT70/28 and MMT70/144 each cost £115 inc. VAT, plus £1.75 p&p, the MML70/40 costs £69 inc. VAT, plus £1.75 p&p and the MML70/100 costs £142.60 inc. VAT, plus £2.75 p&p.

The transverter range could be of particular interest to Class B licence holders, should the UK Authorities ratify the recommendations made at WARC 1979 in Geneva, which will allow them to enjoy the freedom of working the 4-metre band.

Further details and advice regarding these units may be obtained by contacting: *Microwave Modules Ltd., Brookfield Drive, Aintree, Liverpool L9 7AN. Tel: 051-523 4011.*

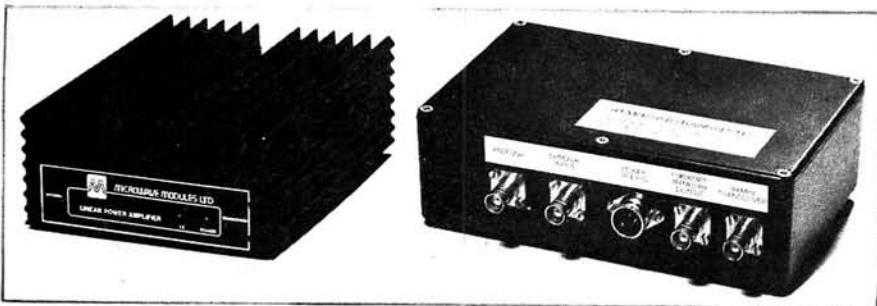

Hand-held Box

A pocket size, hand-held box, ideal for housing remote control handsets, instruments, etc., is the latest addition to the Vero range of plastic enclosures.

It incorporates a 20 x 50mm cut-out slot which may be used for fitting a display panel or switches and a 12 x 35mm recessed panel for labelling. A 71 x 107mm p.c.b. can be accommodated in the top section of the two part body by the use of four self-tapping screws, whilst the bottom section will house a 56 x 105mm p.c.b. The two sections snap together and are secured by four screws which enter through the base.



There is an integral battery compartment which will accept a PP3 battery and has a slide-off cover allowing easy access.

This attractively styled enclosure (order No. 652996H) costs £2.90, which includes VAT and p&p, is available from: *Vero Electronics Ltd., Industrial Estate, Chandler's Ford, Eastleigh, Hants SO5 3ZR. Tel: (04215) 66300.*

More on page 64▶▶▶

Light Bender

Edward Fletcher and Partners announce the availability of a new British-made product, the Light Probe.

Comprising a small hand-held torch and 230mm of 3mm diameter flexible fibre optic light guide, the Light Probe can be used for illumination and inspection in inaccessible areas, or where a direct light source will not penetrate. By using fibre optics, the light from the torch can be "bent" around corners as required. The fibre optic light guide can be detached and the torch used conventionally.

Main users might include the handyman, garage mechanic, electrical or electronics enthusiast and model maker. The Light Probe would make an ideal gift or novelty item, and also serve as an introduction to the new technology of fibre optics.

The price of the Light Probe is £1.99, which includes VAT and p&p (two HP7 batteries, not included), and is available only from the manufacturers: *Edward Fletcher & Partners, 25 West Park Road, Kew, Richmond, Surrey TW9 4DB. Tel: 01-876 2204.*



DEMAND THE "ORIGINAL"

SPECIAL QUOTES!
ON 27 TO 1000 MHz
FIBREGLASS ANTENNAS
ANYWHERE IN THE WORLD!



NOW IN SIX COLOURS!

- SILVER-GREY
- RED
- WHITE
- BLACK
- SPUN GOLD
- CLEAR

THE No. 1 HELICALLY WIRE WOUND AND MOST COPIED ANTENNA IN THE WORLD!

CB • 2 METRE • MARINE TELE • LAND MOBILE TELE

- TRUE HIGH dB GAIN ANTENNAS
- LOW ANGLE OF RADIATION
- $\frac{5}{8}$ and $\frac{3}{4}$
- LOW SWR PROVEN
- POWER RATED UP TO 1400 WATTS
- RUGGED SHATTER-PROOF FIBREGLASS
- FACTORY PRE-TUNED
- THE ULTIMATE PERFORMERS

SERVING THE CB AND COMMUNICATIONS MARKET WITH 27-1000 MHz EQUIPMENT SINCE 1962
'FIRESTIK' ANTENNA COMPANY • 2614 EAST ADAMS • PHOENIX, ARIZONA 85034 U.S.A.

DISTRIBUTED IN THE
UNITED KINGDOM BY:



103 High Street, Shepperton, Middlesex
Tel: Walton-on-Thames 48145

TRIO — YAESU — SOMMERKAMP

**MERSEYSIDE
AMATEUR
RADIO
SUPPLIES**

**IN STOCK
NOW
SOMMERKAMP
TS802
AND
TRIO TR7800**

ANTENNAS AND ACCESSORIES
PART EXCHANGE WELCOME

WRITE, CALL OR PHONE WITH YOUR
REQUIREMENTS TO

**MERSEYSIDE AMATEUR
RADIO SUPPLIES**

112 OXFORD RD, WATERLOO,
LIVERPOOL L22

ACCESS • 051 920 7483 • BARCLAYCARD

Western

THE COMMUNICATIONS SPECIALISTS
EVERYTHING FOR THE RADIO AMATEUR

**ANTENNAS . . .
FOR THE HF BANDS**

BRITISH MADE BY **Western**

TRAP DIPOLES (3 types)

TD1/10-80	10, 40 and 80m	£34.44
TD1/15-80	15, 20, 40 and 80m	£34.44
TD-P	Portable type with winding spools	£30.48

(TD1 are of 14 gauge copper; TD-P is copper/terylene braid)

VERTICAL

DX-5V	10-80 metres; approx 26ft high; slimline	£89.00
-------	--	--------

BEAM ANTENNAS (and Rotary Dipole)

DX-31	Rotary dipole for 10, 15, 20m	£46.00
DX-32	2-element beam for 10, 15, 20m	£80.50
DX-33	3- " " " " " "	£121.90
DX-34	4- " " " " " "	£161.00
DX-103	3-element monoband beam for 10m	£74.75
DX-105	5- " " " " " "	£97.75

★ Other Antenna Accessories available – see our Price List ★

ALL PRICES INCLUDE VAT (15%) AND FREE DELIVERY UK.

Send large SAE for further details of this and other equipment – or use
our Answerphone after hours.

Western Electronics (UK) Ltd

HEAD OFFICE (All Mail/Enquiries)

FAIRFIELD ESTATE

LOUTH, Lincs, LN11 0JH

Tel: Louth (0507) 604955/6/7

ACCESS
VISA
H.P.



MICROWAVE MODULES LTD

4 FOR 81??

To get the New Year off to a tremendous start, we are pleased to announce a new range of products for 4 metres, which includes both linear transverters and amplifiers.

These Units have been developed as a result of pressure from our customers, indicating a great demand and requirement for such equipment.

Originally we produced the MMT70/144, which allowed 2 metre multimode transceivers to be operated on the 4 metre band.

This popular Unit has now been superseded by an improved, double conversion, unit which down converts the 2 metre signal to 28MHz, before the second conversion up to 4 metres.

The development of this Unit has also formed the basis for the **NEW MMT70/28**, which is a straightforward 10 metre to 4 metre linear transverter (single conversion).

4 METRE LINEAR TRANSVERTERS

MMT70/144

MMT70/28

Both the MMT70/28 and MMT70/144 have the following features:-

- * 10 watts RF output from rugged PA.
- * Linear all mode operation.
- * Sensitive, low-noise receive converter
- * RF Vox changeover.
- * 12 month Guarantee - including PA devices.

Frequency coverage	70-70.7MHz	
Input frequency range	144-144.7MHz	28-28.7MHz
Input modes	SSB, FM, AM, CW	
Input drive required	10 watts	5-500mW
Output power	10 watts continuous rating	
Level of spurious output	-60dB	
Conversion principle	Double	Single
Receive converter gain	30dB typical	
Receive converter noise figure	2.0dB maximum	
Power required	12.5 volts + 2.1 amps	
Price	£115 inc VAT (p&p £1.75)	£115 inc VAT (p&p £1.75)

4 METRE LINEAR AMPLIFIERS

MML70/40

MML70/100

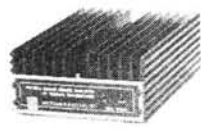

MMT70/144

This new range of 4 metre linear amplifiers is intended for use with our 4 metre transverters. Also they may be used with any other 4 metre equipment, having an output power of up to 14 watts maximum.

This unit will boost 10 watts input drive to 40 watts minimum output. It also includes a receive preamp which will generally improve reception.
GREAT VALUE AT £69 inc. VAT (p&p £1.75).

This unit is ideal for both fixed station and mobile/portable use. It provides a 10dB power gain, and requires 12.5 volts + 12 amps maximum.

- Features include:**
- * Linear all-mode operation.
 - * RF Vox changeover.
 - * Supplied with all connectors.
- £142.60 inc. VAT (p&p £2.75)**



MML70/40

BARCLAYCARD AND ACCESS WELCOME



MICROWAVE MODULES
BROOKFIELD DRIVE, AINTREE, LIVERPOOL L97AN, ENGLAND
TELEPHONE: 051 5234011 TELEX: 628608 MICRO G

CALLERS ARE WELCOME, PLEASE TELEPHONE FIRST

HOURS:
MONDAY-FRIDAY
9-12.30, 1-4.30

COMPARE THESE FEATURES

- ★ MICROPROCESSOR CONTROLLED 32,000 CHANNELS
- ★ AM & FM ALL BANDS
- ★ WIDER COVERAGE: 26-58, 58-88, 108-180, 380-514MHz; includes 10m, 4m, 2m, & 70cm Amateur bands.
- ★ 5kHz & 12½kHz FREQUENCY INCREMENTS
- ★ 16 MEMORY CHANNELS WITH DIRECT ACCESS
- ★ SELECTIVE PRIORITY CHANNELS WITH LOCKOUT
- ★ 2 SPEED SCAN SCAN DELAY CONTROL
- ★ 2 SPEED SEARCH UP AND DOWN
- ★ SEARCH BETWEEN PRESET LIMITS UP AND DOWN
- ★ 3 SQUELCH MODES inc. CARRIER & AUDIO
- ★ Dx & LOCAL CONTROL
- ★ RELAY OUTPUT FOR Aux. CONTROL
- ★ INTERNAL SPEAKER
- ★ EXTERNAL SPEAKER & TAPE OUTPUTS
- ★ LARGE GREEN DIGITRON DISPLAY BRIGHT/DIM
- ★ AM-PM CLOCK DISPLAY
- ★ 12v DC, 230V AC OPERATION

**"SCAN-X" VHF/UHF BROADBAND
FIXED STATION AERIAL £19.90.**

Ideal for SX-200 and other VHF/UHF receivers.

U.K. IMPORTERS & DISTRIBUTORS:
REVCO ELECTRONICS LTD.
POUNDWELL STREET
MODBURY, DEVON, PL21 0RQ.
Tel: Modbury (0548) 830665
Dealer enquiries invited

SX200 THE ULTIMATE SCANNER



£241.50 INC. VAT Delivered

MAIN SERVICE & SALES AGENTS:
GAREX ELECTRONICS
7 NORVIC ROAD
MARSWORTH, TRING
HERTS HP23 4LS
Tel: Cheddington (0296) 668684



introducing

RTTY

part 5

Jeff MAYNARD G4EJA

The microprocessor has brought quite a revolution to RTTY. The equipment from Hal outlined in the previous part of this series is only possible because of the microprocessor. Also possible is the use of an existing microprocessor-based system for RTTY purposes. So the Pet or Apple, or home-brew system, can be used to decode and display or originate RTTY. The advantages are numerous and include domestic acceptability (how many XYLs appreciate a Creed 7B thumping away in the attic?), availability and versatility. It is the latter that this article will concentrate upon.

Reception

First, the reception of RTTY by home computer. Before a program can start to examine any potential RTTY signals, it is necessary to convert the incoming tones into a suitable (i.e., TTL-compatible) signal. This is easiest to achieve with a p.l.l. as shown in Fig. 36 (Part 2 of this series should be consulted for a full description of p.l.l. demodulators and alignment details for the circuit shown).

With this interface the user can feed TTL-level Baudot code (plus noise, QRM, c.w.), etc., to an auxiliary input port. It is possible of course, to convert the Baudot to parallel form via a UART (universal asynchronous receiver transmitter) and change from a serial- to a

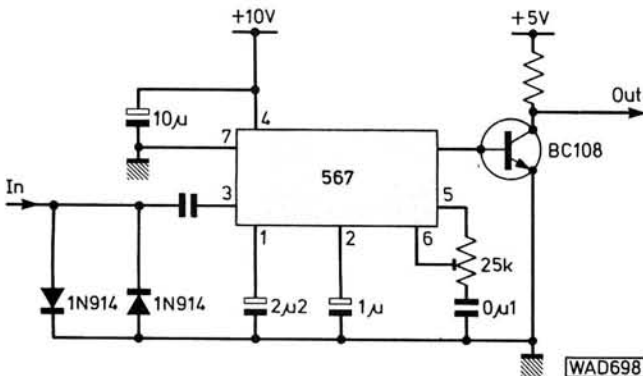

Fig. 36: A TTL interface for the home computer

parallel-type interface. However, use of a serial interface avoids the need for additional hardware and allows the conversion, when necessary, to be done by software.

In the no-signal condition the RTTY input sits at mark (TTL level high or 1). A new character is always signified by a change from mark-to-space (high to low) for 22 milliseconds. This is of course followed by further mark/space transitions but we can return to these later.

The simplest way to identify RTTY by software is as follows: The program will wait until a mark-to-space transition first occurs; if this space is still present 11ms later it can be taken as a mark. The signal is then examined at 22ms intervals from this mid-point—i.e., in the middle of each expected element—and a mark or a space registered. Following the fifth data bit, the signal should revert to mark for at least 33ms (1½ stop bits). This procedure is shown in the flow diagram of Fig. 37. The output of this routine is a 5-bit representation of each incoming Baudot character. For example, the letter A would be 11000 where 1 is a mark and 0 a space. It is possible to be more selective in the acceptance of incoming RTTY by sampling the character elements more often. For example each element could be examined, say, seven times—every 3 milliseconds—and a decision made as to whether it was a mark or a space by majority. This technique can eliminate

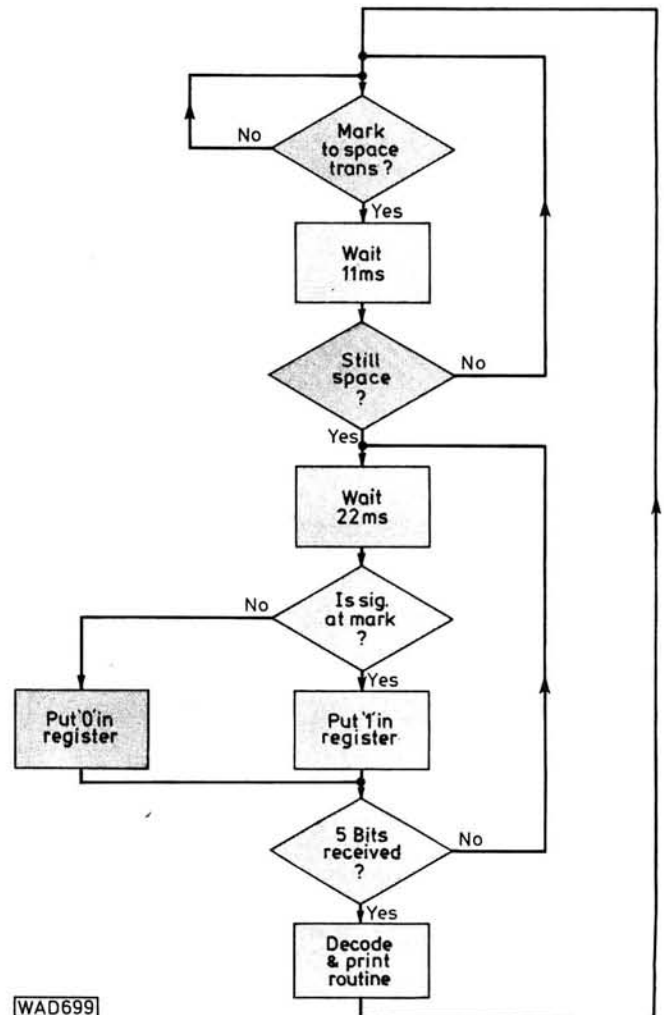
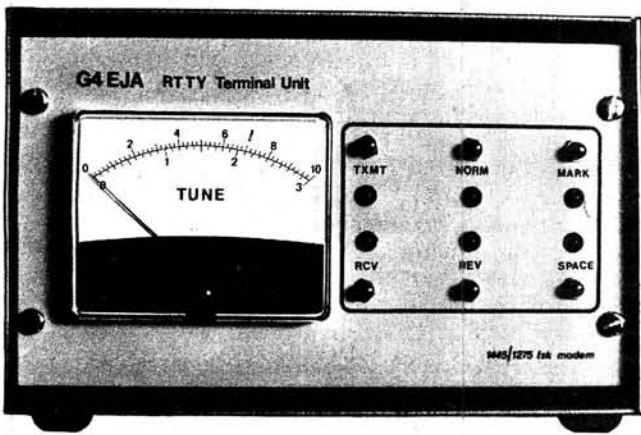

Fig. 37: RTTY to Binary conversion flow diagram



The Terminal Unit of the author's RTTY equipment

some of the problems of short noise bursts that coincide with a sampling point. Some scope for experimentation in respect of sampling frequency is clearly available.

Whichever method is adopted, the next problem is to fill in the box labelled "decode and print routine". The binary pattern (shown overleaf) is a representation of a Baudot character and as such is not directly compatible with an ASCII-based computer. To convert from Baudot to ASCII is quite simple—the Baudot code can be taken as a binary value. For example the letter T is 00001, carriage return is 00010, the letter O is 00011 and so on. Thus if the Baudot code is used as an offset to a table arranged in order of binary value, the appropriate character can be extracted directly. As another example consider the letter L, which having the code 01001 or binary 9 would have the ninth place in the table or list. Baudot codes of course represent two different characters depending on the shift being letter (lower) or figures (upper)—see Part 1. The look-up routine must take account of this by keeping a shift flag and referring to the appropriate table.

There are a number of refinements that can be inserted into a program between the decoding—as outlined above—and the printing or display of the characters. Some of these are discussed below.

Some home computers—such as the Pet—have a screen width less than that normally found on an RTTY machine. It is necessary therefore to insert carriage returns at appropriate places, taking care of course not to split a word.

To overcome the effects of QRM, it is often helpful to force the output to letter shift each time a space character is encountered. The program should include the facility to change shift from the keyboard whilst decoding is taking place.

Logging by program can be done by searching for key words such as "your call sign" DE . . . but more of this later when discussing transmitting by software. The s.w.l. can finish at this point, being unconcerned with the problems of transmitting, and can concentrate on finding the DX. There are a number of awards available for RTTY including those from BARTG, SARTG (Scandinavia), CARTG (Canadian), DARC (German) and RTTY magazine. A number of other awards—available to listeners and licensed stations—can be endorsed for RTTY. In this category is the Cheshire Award, administered by the author, for which no RTTY claims have yet been made.

Transmission

To transmit RTTY from a home computer requires first a reversal of the reception procedure. Individual ASCII characters must be converted to Baudot—the simplest method is to use the ASCII absolute value as the offset for a table look-up. The Baudot can be transmitted by switching an auxiliary output off for 22ms for each required space, remembering to leave mark for at least 33ms after the last bit and to precede the bits with a 22ms space. Suitable TTL to AFSK converters to drive the station transmitter have been described earlier in this series.

Note that the Baudot character is extracted bit by bit from the micro word by ANDing with 0000 0001 and then shifting right one bit (assuming that the Baudot representation has the signal bit 1 to the right). Incidentally, readers having difficulty following the programming techniques described might like to read the author's *Computer Programming Made Simple*, published in London by W. H. Allen and recently extensively revised to encompass the latest techniques and technology.

Transcribing from ASCII to Baudot and then to TTL is the simplest of the transmitting options. The greatest scope is in data and message manipulation—the limit being set only by the user's imagination (and perhaps system memory capacity!). Baudot uses figure- and letter-shift characters to assign alternate meanings to codes. Since this is not the case in ASCII, the user's RTTY program will need to insert shift characters as appropriate. A sequence such as shown in Fig. 38 will prove adequate. Many RTTY users find it useful to send a down shift (letter shift) each time a space is encountered.

Letter- or down-shift characters can also be sent during idle periods. For example a program could detect the fact that a key has not been depressed for, say, two seconds and start to send shifts. If text is being sent line by line—i.e., text output only commenced when a carriage return is keyed—the program can automatically send down shifts (this is known as "diddling").

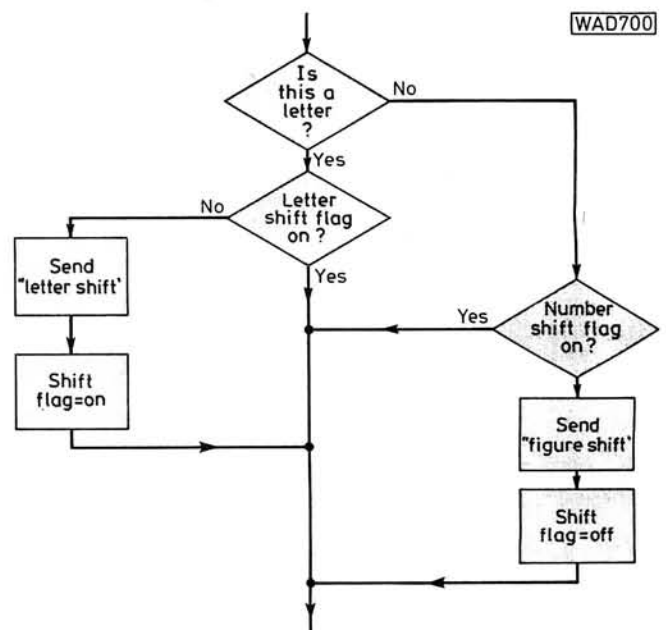

Fig. 38: A flow diagram for shift characters

A single ASCII code will indicate carriage return and line feed (CR/LF) but in Baudot these must be sent separately. It is useful—to the mechanical-based receiving station—if two carriage returns are sent; the inclusion of a down shift is another good idea. Thus, when the user presses “return” on his ASCII keyboard the Baudot sequence:

CR CR LF Let

should be generated.

Generating “standard” messages from a single key is—from the author’s own experience—one of the most useful features of a software-controlled RTTY station. A character with no Baudot equivalent—such as \$—can be selected to initiate standard messages. Thus the user could introduce ten such messages, for example:

```
$0 CQ CQ CQ CQ
$1 CQ TEST CQ TEST
$2 CQ DX CQ DX CQ
$3 RYRYRYRYRYRY
$4 THE QUICK BROWN FOX . . .
$5 DE G4EJA G4EJA
$6 IN WIDNES CHESHIRE UK
$7 YOUR REPORT IS RST
$8 PSE QSL VIA BUREAU
$9 DD/MM/YY 00:00 GMT
```

In the case of \$9, the program would of course insert the current date and the time of day. Clearly the user can extend this principle to a comprehensive range of messages including a station description (a popular RTTY topic). Again the limiting factor is imagination and memory capacity. The recording of time and date will be useful for log keeping if a hard copy is available. This is particularly the case in a contest where, to obtain maximum points, the operator must spend a minimum amount of time on clerical work whilst the contest is running. A word of caution though for those without hard copy. If log keeping information is held by software for later entry into the station log, the user must make provision for retrieving the information in case of mains or program (or any other) failure. Regular dumps to disc or cassette should be made just in case.

Reversing the mark/space tones (by inverting the TTL output) and changing the baud rate are two other useful add-ons to an RTTY program. Such is the importance of these parameters that a program-activated alarm (for a second or two) should accompany them.

Buying Software

If the inexperienced programmer finds the work required to achieve the above a little daunting (the more so because assembler language will be required to achieve the necessary processing speed) there is no cause for alarm. Ready-made systems are available for most popular home computers. A supplier of one range of amateur radio software is Nicomtech of Stephens Road, Saltash, Cornwall who has systems for TRS-80, Exidy Sorcerer, Apple and Pet hardware.

RTTY (and Morse) systems (produced by Macrotronics Inc. of California) are available for TRS-80, Exidy Sorcerer and Pet at £96.60, £96.60 and £67 respectively. These prices include a simple (phase-locked loop-based) terminal unit together with the necessary hardware interface for the computer system in question. The manual does point out that, in marginal reception conditions, a better t.u. will be desirable. Output from the

terminal unit is polar or +12 volts. Output for transmission is via a transistor (together with sidetone for Morse) which can be used to directly key a c.w. transmitter. For RTTY, however, an AFSK unit will have to be built. Any of the designs described earlier in this series will be suitable.

A package for Apple II users is also available from Nicomtech at £17.82. This provides only the necessary software and the user must construct a terminal unit and the necessary interface circuitry (diagram supplied with the software). From the same source are Apple SSTV programs and satellite prediction and logging for the Pet.

Copying RTTY QSOs on a video is just like reading the c.w. or phone parts of the band as regards format and terminology and so on. Stations will usually be found calling CQ on 20 metres (around 14.090MHz), and a typical RTTY QSO might go like this (author’s transmissions underlined):

```
CQ CQ CQ CQ DE W1ABC
CQ CQ CQ CQ DE W1ABC
CQ CQ CQ CQ DE W1ABC
PSE KKK
W1ABC DE G4EJA G4EJA G4EJA
W1ABC DE G4EJA IN WIDNES
PSE K
G4EJA DE W1ABC
OK OM TNX FOR THE CALL
UR RST HERE IS 579 579 579
NAME IS BOB AND QTH IS NY
SO HOW COPY??
G4EJA DE W1ABC PSE K
W1ABC DE G4EJA
OK BOB, ALL 100% HERE
UR SIG IS FB AT RST 599 599
NAME IS JEFF AND QTH IS WIDNES
RIG IS ATLAS 210 AND 2 ELE TRIBANDER
AT 40 FT. TU IS HOME BREW TO VDU
WITH 8K RAM
W1ABC DE G4EJA KKK
G4EJA DE W1ABC
OK, JEFF ALL COPY GOOD SIG FROM YOUR
ATLAS. RIG HERE IS TR7 FEEDING
3 ELE MONOBANDER AT 60 FT. RTTY IS
DS-3000 FROM HAL.
WX TODAY IS SUNNY AND WARM
THANKS FOR QSO AND QSL IS OK VIA
THE BURO. 73'S FOR NOW JEFF AND
CUAGN. G4EJA DE W1ABC AR SK
W1ABC DE G4EJA OK BOB, WX HERE
NOT SO GOOD. QSL IS OK AND WILL LOOK
FOR YOU IN THE CONTEST NEXT WEEK
73 73 73 DE G4EJA
BI BI
```

The final line would probably also contain a couple of bell characters. Contest QSOs are similar to those in other modes with the emphasis being on speed of course, although the exchange of information is very important. “Rag-chewing” is also popular on RTTY; the author has been known to chat to a state-side RTTY station for almost two hours, and has a regular sked with a Swedish club station.

RTTY has its adherents, as do the various other facets of amateur radio, and it is for the individual to decide whether RTTY is the mode to follow. The shortage of RTTY in some countries can give a new twist to DX; the author recently worked a station in OX (Greenland) only to be told that he was one of only two RTTY stations currently active in that country!

Letters to the Editor intended for publication must be original, and not duplicated to or copied from other publications. We reserve the right to shorten or edit them if necessary.

Letters

CB South Africa

Sir: I read your editorial of the September 1980 issue with more than the usual interest, simply because the situation of CB in your country reminds one of the pre-legalisation period of the same in South Africa a mere sixteen months ago. It started with CB sets being smuggled in from the USA, and "converted" amateur equipment. Within a few months the movement gathered momentum and got so out of hand the government was virtually forced to legalise CB. At that stage there was still the possibility of creating a civilised CB service, because the only way in which the latter can be established, is if the authorities stay one ahead of Cbers and the regulations keep pace with technology.

Unfortunately the South African lawmakers did not learn from the American experience, but blundered on the same path bound for chaos—and no excuse, they virtually copied part of the FCC rules. Only nine channels were given, which was the quickest road to frequency congestion and operator frustration. Since most sets were 40-channel, imported from the USA, everyone soon said goodbye to 9-channel CB by pulling out pins and removing hastily-added limiting circuits. With no s.s.b.-only and a.m.-only channels, we just as quickly inherited the American a.m. versus s.s.b. struggle. Unity gain omni-directional antennas were supposed to protect local communication, but eventually simply added to the congestion, which might have been relieved by directional arrays. Foreign DX was forbidden, but apparently the authorities had no knowledge of the sunspot cycle, and even worse, they gave us CB right in the explosion of a monster called Cycle 21.

Anyway, everyone soon got used to the novelty of doing their thing the legal way, and no-one was complaining, least of all the GPO who netted a tidy one million Rands (that's about £550 000) from licence fees within seven months. But then the Cbers grew tired of the mess, and after a period of pleading from one side and warnings from the other, the whole thing started falling apart. Forty per cent sold their sets, 30 per cent continued as before, and the rest erected beams and quads, installed linear amplifiers and converted their sets to 11 metre h.f. transceivers.

Right now the whole of the 11 metre band, from 26 to 28MHz, is lost for ever as far as government control is concerned, and the only hope for a truce between circling GPO vans and sneaking pirate stations is the drop of m.u.f. to its lowest readings. So, apparently the formula for establishing CB with some hope for future control, will be to legalise such

a service before John Citizen learns that he can key a mike: to give him the whole of the 11m band before he takes it himself: to give separate s.s.b. and a.m. frequencies: to legalise international DX; and to allow virtually any other technical conversion John C can do on his set—e.g., extended clarification on both receive and transmit, which gives more space.

A CB service somewhere in the v.h.f. bands is not going to eliminate illegal operation, and simply because of two factors; cost and lack of DX. A 27MHz system on the other hand gives much greater ground-wave range in relation to money invested. Even if a v.h.f./u.h.f. service is legalised in the UK, the pirate on 27MHz will not simply disappear. Once the "good buddy" operator moves up to the legal band, either because the GPO is getting too hot or because he can afford the more costly equipment, the only one to remain will be the DX operator on s.s.b. He is the backbone of the pirate movement, and being the more careful and clever operator, appears only when "skip is running". I have yet to meet the GPO official who tracks down his man when S9 signals are bombing in from all over the globe.

From what I hear and read, it seems your government is well on their way to contributing heavily to the growth of the international 11m movement. All I can say, is, keep on trying GPO hunters, patience radio amateurs, patience TV owners, patience all of you relying on communications in civil services, and happy DX UK pirates.

I have worked the world on 25 watts with a sloppy quarter-wave groundplane from Channel 1 to 99, and it was fun while it lasted. Fortunately I heard about amateur radio somewhere along the road, and being a sucker for DX and tinkering with resistors and such, found that there is a safer way in which to enjoy radio electronics. The final crunch came some months ago when the final amplifier stage went up in smoke. I am now converting it to a 10 metre set for the day when I may legally enter the world of amateur radio. But then no regrets about the "old days"—it taught me more than just the wonders of transmitters and receivers, and it's the poor man's amateur radio after all.

*The former Tango 7 and others,
Lutzville,
South Africa.
(Name and address supplied)*

CB Northern Ireland

Sir: I am writing in reply to your item *Making Haste Slowly* in *PW*, September 1980. I myself run two of these illegal transceiver units known as Citizens' Band Radios, along with at least 13000 other registered "good buddies" in Northern Ireland, and God knows how many others who are not registered.

I have to say that these illegal sets are the best thing ever to happen to Northern Ireland. As everyone is aware, the community in Belfast is divided by both political and religious differences, and there are certain parts of the city where it is unwise to go unless you live there. The CB radio has however broken down these barriers, and the whole community can "modulate" with each other without even caring what religious or political views each other hold. I myself have made several "good buddies" in West Belfast, who I would otherwise never have met as I live in the South Belfast area. The growth of CB radio has done more for the community in one year than all the politicians have been able to do in eleven years!

*"Big Muff"
(Name and address supplied)*

MODS

IMPORTANT—The ideas presented here are suggestions only, and as they are untried by this magazine, we cannot accept responsibility for any resultant damage, however caused. Before alterations are attempted, care should be taken to ensure that any guarantee is not invalidated, and it should also be borne in mind that modifications usually have an adverse effect on resale prices. In cases where specialist skills or equipment are needed, most dealers will undertake the work for a reasonable fee.

Roger Hall G8TNT(Sam)

No. 3

Judging from the response I have received, modifying equipment is a popular pastime amongst amateurs, and I would like to thank all of you who have already contacted me with material. As this column depends on feedback from readers, please continue to write in if you have any tips to pass on.

In reply to queries regarding the simplicity of the mod for increasing the frequency range of the Trio TR-2400 that appeared in the November issue, it really is as easy as it seems. Just by cutting and resoldering one wire the TR-2400 can be made to cover 143.900–148.495MHz.

For other readers who have said that their TR-2400 is still under guarantee, and who are understandably reluctant to delve inside with a soldering iron, here is a way to “trick” the microprocessor into covering the extended frequency range without modifying the set in any way.

The first step is to hold down the REV REPT button and then key in 5500. Now release the button and the display will change to 6100 (145.500 + 600 = 146.100).

The transceiver can now be tuned between 146 and 148.495MHz by using the UP/DOWN buttons on the front of the set. When the display runs past 148.495MHz it will jump to 143.900. When this happens, only the UP button is effective, because pressing the DOWN button makes the display revert to 145MHz. Any frequency in the 146–148MHz range can be held in a memory for future use, and if one is, it is not necessary to repeat the procedure with the REV REPT button. To get back into the 146–148MHz range just recall this frequency from the memory and then move up or down with the appropriate button.

This “trick” only seems to work with early models and they can be recognised easily because their REV REPT buttons will not lock in the down position, whereas they will in the later models.

The major disadvantage with using this technique is that frequencies cannot be entered directly through the keypad.

I would like to thank Lowe Electronics for that idea, and for the following mod for the Trio R-1000.

Some keen DX a.m. listeners have said that they would like the selectivity to be narrower than the standard 12kHz (WIDE) and 6kHz (NARROW). This very simple mod will change it to 6kHz (WIDE) and 2.7kHz (NARROW) whilst leaving the 12kHz filter fitted in the set so that the mod can be reversed whenever required.

First remove the top cover and find J3, which is alongside the i.f. filters (Fig. 1). Then cut the brown/white and red/white wires and re-connect them as in Fig. 2. That's all, the mod is now done. Should 6kHz prove to be too narrow, connecting the wires as in Fig. 3 will give 12kHz (WIDE) and 2.7kHz (NARROW). With both versions of this mod the bandwidth on s.s.b. is 2.7kHz.

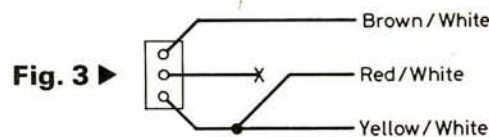
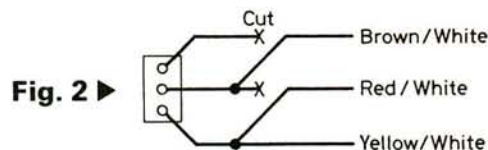
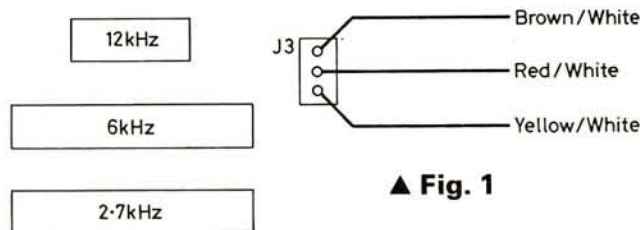

WAM 022

Mr Colin Coker G4FCN, has written in with a little-known piece of information about Yaesu Musen and Sommerkamp equipment. Many of the receivers manufactured by these companies have 600Ω tapping on their output transformers, as well as the more usual 8Ω connections. This should be of interest to the many who are interested in RTTY, SSTV, etc.

It should be a very simply job either to fit an additional socket to the rear of the set and to wire it up to the 600Ω tapping, or to remove the wires from the existing extension speaker socket, solder them together and insulate them, and then to connect this socket to the 600Ω tapping. If the latter method is used, it does, of course, mean that an 8Ω extension speaker can no longer be plugged in.

Thanks for the very useful tip Colin.

Wanted

There must be many amateurs who want to modify their rigs, but don't know how. With this in mind, I would like to use this corner to publish requests from readers for mods that they would like to do, in the hope that someone, somewhere, will be able to enlighten them.

One request that I have received “on the air” from several people is for a mod to extend the frequency range of the Trio TR-9000. Can anyone help? If you can, or if you know any other mods, or if you would like to find out about a specific mod, please write to: R. S. Hall, Practical Wireless, King's Reach Tower (Hatfield House), Stamford Street, London SE1 9LS.

73's
Sam G8TNT



HF SSB TRANSCEIVER

Vic Goom G4AMW

The Preselector circuits are simple filters which are tuneable over the bands selected. Two separate filters are used, the required one being selected by the rotary switch S101.

To match into the G4CLF board a 50Ω port is needed. This is provided by the tap on L103 and L101. The basic impedance of each filter is 1kΩ and this matches into the Transmitter Pre-amplifier. When in the Receive mode the Preselector is connected to the aerial via RLB/1 and S101b and needs an input impedance of 50Ω. Again this is provided by the tap on L102 and L104, these acting as auto-transformers to give the desired impedance transformation.

The four coils, L101–104 are wound on Neosid A6 coil formers which should have 900 grade iron powder screw cores and aluminium screening cans (Table 1).

The preselector circuits are built up on a simple p.c.b. and it is recommended that the alignment is checked before the screening cans are permanently fitted to the board.

The four-gang variable capacitor (Jackson Type 5318/4/102) is fitted with a reduction drive having a 10:1 reduction ratio (Jackson Type 5870/3). The four leads connecting the preselector to the four-gang capacitor (C103,104,105,106) should be as short and direct as possible and pass through the four holes provided in the p.c.b. for this purpose.

Table 1

Band	Turns	Wire	50ΩPort	Former	Core
20m	20	26 s.w.g.	4T	Neosid A6	900
80m	60	30 s.w.g.	8T	Neosid A6	900

Small coaxial cable (RG174A/U or Uniradio 95) should be used for the connections to the 50Ω ports while the plain wire connection to the tops of L102 and L104 should be tucked around the side of the box as low down as possible.

★ components

PRESELECTOR BOARD

Capacitors

Ceramic

1pF	1	C102
33pF	1	C101

Variable, air spaced, 4 gangs

10 to 102pF	1	C103,104,105,106 (see text)
-------------	---	-----------------------------

Inductors

Wound on Neosid A6 formers (see Table 1)

20T tap at 4T	2	L103,104
60T tap at 8T	2	L101,102

Miscellaneous

Printed circuit board; 3p2w rotary switch; Neosid A6 coil formers and cans (4); Reduction drive (see text).

Tx Pre-amplifier

The Transmitter Pre-amplifier is at the front-end of a very high gain, wide bandwidth chain. To cope with this the Plessey SL610 i.c. was used rather than the cheaper 1600 series version.

The input impedance of the pre-amplifier is around 1k Ω and this matches the preselector output impedance.

Adjustment of the transmitter output power is made by varying R205. The output can be varied from zero to full power by this simple means and R205 is mounted on the front panel so as to allow the operator maximum flexibility and economy of battery power.

★ components

PRE-AMPLIFIER BOARD

Resistors

$\frac{1}{4}$ W 5% High Stability Carbon film

100 Ω	2	R202,203
1k Ω	1	R201
2k Ω	1	R204

Potentiometers

4.7k Ω	1	R205
---------------	---	------

Capacitors

Ceramic

4.7nF	1	C203
10nF	2	C201,202
0.1 μ F	1	C204

Inductors

2T on FX1115 ferrite bead	1	RFC201
---------------------------	---	--------

Semiconductors

Integrated Circuits

SL610	1	IC201
-------	---	-------

Miscellaneous

Printed circuit board; Relay 6V, 2p changeover (RS349-642); FX1115 Ferrite bead;

Constructional Details

The Tx Pre-amplifier is constructed on a simple p.c.b. which will be mounted on 6mm spacers. All component leads should be as short as possible with the body of each part close to the surface of the p.c.b.

Small coaxial cable is used to connect the output of the pre-amplifier to the input of the Tx First Amplifier.

The Tx Pre-amplifier board also carries the additional relay (RLB/2) which is used to disconnect the preselector aerial input and short-out the coaxial aerial lead from the aerial relay RLA/2.

RFC201, and RFC301 in the Tx First Amplifier supply line, are simply 2T of 22 s.w.g. enamelled copper wire wound through an FX1115 ferrite bead.

TRANSMITTER FIRST AMPLIFIER BOARD

Resistors

$\frac{1}{4}$ W 2% Metal Oxide

2.2 Ω	2	R302,303
10 Ω	1	R304
47 Ω	1	R305
470 Ω	1	R301

Capacitors

Ceramic disc

0.1 μ F	1	C302
-------------	---	------

Tantalum bead

22 μ F 16V	1	C301
----------------	---	------

Inductors

2T on FX1115	1	RFC301
2T: 2 + 2T on Ferrite core	2	T301,302 (see text)

Semiconductors

Diodes

IN4002	1	D301
--------	---	------

Transistors

2N4427	2	Tr301,302
--------	---	-----------

Miscellaneous

Printed circuit board; FX1115 Ferrite bead; 2-hole Ferrite core (2); Terminal pins (10).

Readers who intend to operate the Helford should be in possession of the appropriate licence issued by the Home Office to those who have passed the City and Guilds Radio Amateurs' Examination. Details may be obtained from: The Home Office, Radio Regulatory Department, Amateur Licensing Section, Waterloo Bridge House, Waterloo Road, London SE1 8UA.

Tx First Amplifier

This stage uses a pair of 2N4427 transistors in a push-pull configuration to provide the required level of drive to the r.f. driver stages.

The output from this stage can be increased by reducing R304 from the design value of 10 Ω . This will enable you to run the driver stage to 25W output which in a lot of cases will probably satisfy the operator.

continued on page 63 ►►►

AMATEUR RADIO EXCHANGE



Brenda (G8 SXY) and Bernie (G4 AOG) invite you to the only shop in London where you can see and try all the leading makes of Amateur Radio Equipment under one roof . . . YAESU, ICOM, TRIIO, STANDARD . . . compare them all . . . and have a cup of Brenda's coffee too!



GET AWAY FROM IT ALL!

Why not get away from it all, to the clean, fresh pastures of 70cm where there's more room to talk to the contacts you really want. 1981 sees the announcement of two great new 70cm rigs from YAESU, the FT-404R handheld (left) and the FT-780R mobile (below). Both have all the features you could wish PLUS that YAESU built-in extra . . . reliability.

FT-404R The handy format of the **FT-202R** with similar 6-channel capability and 1 watt output.

FT-780R The first-ever all-mode 70cm mobile transceiver with full coverage between 430 and 440 MHz on FM/CW/USB/LSB. Special features include 2 VFOs, 4 memories, digital clarifier (RIT), band and memory scan controlled from mic, priority channel, and crystal controlled access tone.



HERE!! NOW!! YAESU'S LATEST RECEIVER - THE SUPERB FRG-7700. The one with all the features including FM right across the band and 12-memory option.

★ General coverage 150KHz-30MHz ★ Digital and analogue read-out ★ Fine tune ★ Attenuator ★ Noise blanker ★ Fast or slow AGC ★ Digital clock and automatic ON/OFF timer ★ Three AM filters, 12KHz, 6KHz and 2.7KHz ★ 12v or mains ★ Receives in LSB, USB, AM and FM ★ Optional 12-memory facility enabling you to store your favourite frequencies for recall at the touch of a button . . . and our FRG-7700's come complete with exclusive HELSICAN aerial worth £15 . . . FREE!



★ PHONE FOR LATEST PRICE DETAILS ON ALL YAESU EQUIPMENT ★

Compare our two fantastic new scanning receivers

Bearcat 220FB from the USA

- ★ Covers three amateur bands plus aircraft, marine and public service bands on these frequencies: 66-88MHz, 118-136MHz, 144-148MHz, 148-174MHz and 420-512MHz.
- ★ Scans between any two pre-set channels, and also offers a priority-channel signal-finder and a lock-out facility.
- ★ Operates on mains or 12V, so use at home, in the car or on the boat.



£258^{.95} inc. VAT

SX-200 from Japan



£240 inc. VAT

- ★ Scans VHF and UHF bands in both AM and FM modes throughout its frequency ranges, 26 to 88MHz, 108 to 180MHz and 380 to 514MHz ★ 16 memories ★ Memory bank programmable to scan frequencies in any band ★ Display automatically reverts to time/day/date ★ 2-speed scan ★ 3 watts audio out ★ Sensitivity 0.5 v 20db S/N ★ Supplied with AC mains adaptor for 12V operation.

CLOSED WEDNESDAY, BUT USE OUR 24-HOUR ANSAPHONE SERVICE, OR RING MARTIN (G4HKS) ON 01-575 5291 FOR EVENING SALES ENQUIRIES.

LICENSED CREDIT BROKERS - Ask for written quotation.
INSTANT HP FOR LICENSED AMATEURS AND 6-MONTH NO-INTEREST
HP TERMS AVAILABLE.



CREDIT SALES
BY TELEPHONE



2 NORTHFIELD ROAD, EALING, LONDON W13 9SY. Tel: 01-579 5311
So easy for Overseas Visitors - Northfields Station is just seven stops from Heathrow on the Piccadilly Line.

TRIO



Photo Acoustics Ltd

MICRO COMMUNICATIONS DIVISION

AUTHORISED



DEALER

RADIO COMMUNICATIONS—AUDIO—VIDEO
AND COMPUTER SALES AND SERVICE

TRIO		
TS520SE	160-10m 200w transmitter	£437.00
TS-180S	160-10m 200w transmitter	£679.65
TS120S	80-10m mobile 200W transmitter	£432.40
TS120V	80-10m mobile 20W transmitter	£347.30
TS830S	160-10m transmitter (includes new bands, various I.F. options, digital display, 2x 6146 PA plus many other features)	£639.52
	2M/70cm multimode base station	£763.60
TS770E	2m multimode mobile/base station	£345.00
TR9000	2m 25W mobile/base station	£268.00
TR2300	2m handheld (80 channels)	£166.75
TR2400	2m synthesised handheld	£198.00
Full range of Trio accessories and oscilloscopes available.		
RECEIVERS		
R1000	0.2-30MHz	£285.00
R820	Simply the best amateur receiver	£690.00
SRX30	SSB/AM/CW 0.5-30MHz	£158.00
SR9	144-146 or 156-162MHz tunable or xtal	£46.00
AMR217B	Marine or amateur scanner with 8 x tals	£120.75
FS10	10 channel pocket scanner	£82.00
FRG7	Aircraft Receivers from With batteries and charger	£12.50
AP12	With 12 x tals	£89.70
RS12	Air band scanner-litted 5 channels	£118.45
RS17	Air band portable-tunable and xtal	£49.45
	Extra xtals for the above, each	£2.80
SK200	Scanner 26-514MHz and AM/FM	£235.00

ICOM		
IC2E	2m handheld	£159.00
IC240	2m 10W mobile	£169.00
IC255E	2m 25W scanning mobile	£255.00
IC260E	2m multimode mobile	£339.00
IC251E	2m multimode base station	£479.00
IC215E	With S20, 22, RD-9, inc.	£149.00
IC402	70cm sst portable	£242.00
IC202S	2m sst portable	£169.00
IC720	HF 0.1-30MHz 100W transmitter	£680.00
All Icom accessories available - 12 months guarantee, including PA transistors.		

AERIALS		
Full range of J Beans - Revco - Ascot - Hokushin - G-Whip - G20YM - Trio etc.		

ROTATORS		
AR40	For Mini Eiams	£59.80
DR7500X	For 3 element HF beams. Preset controller	£98.04
DR7500R	For 3 element HF beams. Round controller	£107.98
DR7600X	Takes up to 2 element 40m beam. Preset controller	£135.00
DR7600R	Takes up to 2 element 40m beam. Round controller	£144.90
KR400	Kenpro rotator	£105.00
5 core-6 core cable-UR43-UR67 twin feeder P.O.A.		

ACCESSORIES		
CN1001A	Automatic ATU and SWR	£129.95
CN620	Cross pointer SWR. 1.8-150MHz	£52.81
CN630	Cross pointer 140-450MHz	£71.00
CN650	Cross pointer 1.2-2.5GHz	£95.00
T3170L	3.5-150MHz	£12.94
FS7	SWR/power meter	£33.00
RW151D	Watt meter 0.150W, 0-500MHz	£69.00

Full range of MICROWAVE MODULES and S.E.M. products available
Power supplies - microphones, plugs, sockets, dummy loads, lightning arresters etc. all available.

PET		
NEW CBM 8032	- 80 column - 24k Rom	£1029.25
NEW CBM 8050	storage dual drive	£1029.25
CBM 2001-8	- 8k including cassette	£435.88
CBM 3008	- 8k Overlay keyboard	£467.70
CBM 3016	- 16k Green screen	£569.25
CBM 3032	- 32k Green screen	£718.75
CBM 3022	- 80 column dot matrix printer	£440.45
CBM 3040	- Dual drive mini floppy	£718.75
C2N	- Cassette deck	£56.83
KIM 1	- The ideal teaching aid	£106.95
KIM 3B	- ram board	£110.40
KIM 4S	Mother board	£47.75
All PET leads and accessories available including manuals.		

NASCOM		
System 80	- no RAM - FREE ROM	£258.75

Graphics board with 3k RAM	£103.50
Keyboard cases NAS 1/2	£4.03
16k RAM board 'S' will take 48k	£161.00
Power supplies NAS-PEN Zeap 2	P.O.A.
IMP printer	£373.75

ATARI TV GAMES AND CARTRIDGES VIDEO GENIE	
EG3003 Tandy level 2 compatible, with 16k RAM integral cassette boxed and ready to go only	£333.00

DOLPHIN	
BD80P PET/EEC Parallel or RS232C high quality matrix printer	£458.85
Ricoh RP1500 Daisy wheel inc. interface	£1828.00
BASE 2 Super print 800 friction or tractor feed inc. 3 standard interfaces	£373.75

CONSUMABLES - SOFTWARE	
Mini Disks - Box of 10	£22.94
C15 Cassettes - high quality - Box of 10	£4.50
80 Column tractor feed paper - per 100 sheets	£9.66
Labels - per 1000	£8.95
Printer Ribbons	£2.53
Petsoft - Commodore - BSF - Monitor. Everything from Space Invaders to a complete Business System. Large range of books in stock	

PLEASE PHONE FOR QUOTATION ON ANY ITEMS NOT LISTED

ALL PRICES INCLUDE VAT

WE ALSO SUPPLY FROM OUR AV DIVISION - VIDEO RECORDERS - TAPE RECORDERS - COPIERS - MIXERS - TELETXT RECEIVERS - AUDIO - AMPLIFIERS ETC. BY REVOX, UHER, AKAI, SONY, NEAL, MARANTZ, TANDBERG, SHARP, ASSMANN, NATIONAL PANASONIC, ETC.

Have a day out, take the XYL and Harmonics to the superb new shopping centre at Milton Keynes and come and visit our new Showrooms 5 minutes away in the High Street of Newport Pagnell, and have a cup of Steve's tea! Contact Derek, G3TGE, Steve G8PWS or Judy.

MAIL ORDER SECURICOR DELIVERY

Ask for details of our Credit Card Scheme - £750 instant credit could be available to you now! APR 34.5%
MONDAY-SATURDAY 9.30am-5.30pm

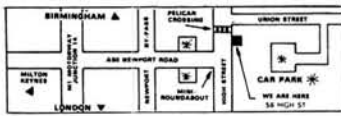

We may be a new name in Amateur Communications but we have 12 years of service to the Broadcasting and Recording Industry - Educational and Governmental Depts.

HIRE PURCHASE PART EXCHANGE

APR 39.60
or let us sell your rig for you - no commission charged if you purchase new rig from us.
MONDAY-SATURDAY 9.30am-5.30pm

58 HIGH STREET, NEWPORT PAGNELL, BUCKS. • TEL. 0908 610625

NORTHERN COMMUNICATIONS

AMATEUR • COMMERCIAL • MARINE

Merry Christmas from Richard G3UGF

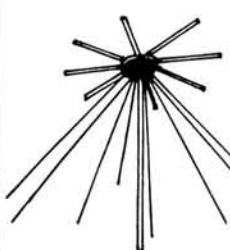

NORCONE 512 (66-512 MHz)
It's here! A no compromise, precision made, full 16 element discone antenna, made in Britain. Standard SO239 connector, with cover. Supplied with 1" diameter, 30" mounting support mast and complete instructions.
An ideal partner for the "Bearcat" and other scanning receivers. It may also be used for transmission and in particular where antenna space is limited.
Full coverage of 70.144,432MHz Amateur bands plus Aircraft, Marine and Commercial bands.
£24.95 p.p. £1.50
NCMK-1. In line vertical mounting kit for 1" to 2" mast.
£2.45 p.p. £0.50

ZL-12 COMPACT YAGI
13db gain, compact 2 metre Yagi. 10'6" boom, lightweight rugged design. Hundreds of this award winning antenna already in use. Send for details.
£28.75 p.p. £1.50

ZL-8 SUPER COMPACT YAGI
9db gain, super compact 2 metre Yagi. 6'0" boom, lightweight rugged design. Ideal for limited spaces and portable operation.
£17.25 p.p. £1.50

YAESU FT480R. FDK 750E MULTIMODES
Both of these new 2 metre multimodes transceivers are amongst our full range of Amateur Radio equipment and accessories. Ring or call for complete information:

NEW - FRG7700
As reviewed in this issue - come in and try it for yourself. **£309.00**

299-303, Clarendon Road, Halifax HX3 6AW, West Yorkshire. G3UGF.

Tues-Sat. 9.45am-5.30pm. Telephone (0422) 40792.



FREQUENCY DISPLAY UNITS

INTERNAL OR EXTERNAL
FOR **FRG7** £44.77
SRX30 £44.77

10% OFF UNTIL 31st DECEMBER
£40.29

(All prices inclusive of postage and V.A.T.)
B. BROOKES ELECTRONICS, 69 Leicester Street, NORWICH NR2 2DZ, ENGLAND.
Tel: 0603-24573.

STEPHENS-JAMES LIMITED

COMMUNICATION ENGINEERS

47 WARRINGTON ROAD, LEIGH WN7 3EA

ENGLAND
Telephone (0942) 676790

Everything for the Short Wave Listener.

We stock receivers and listening aids by most of the world's leading manufacturers. Full range of VHF receivers-transceivers. Mobile equipment pre-selectors-filters-antennas. Stabilised power supplies from 2 to 20 Amp. Antenna switches-converters. Aluminium masts-clamps. Antenna rotators.

Trio R1000 Receiver
Digital readout general coverage receiver covering 200kHz to 30MHz with a P.L.L. synthesiser. Also incorporating quartz digital clock. £285.20.

Trio R820
Amateur Band Receiver £690.00.
Send for full specifications of our full range of receivers covering from 200kHz to 520MHz. Our secondhand equipment changes daily. Send SAE for up to date lists. Part exchange welcome. Good clean Equipment bought for cash.

We have a good range of secondhand equipment at all times. Send large S.A.E. for details or telephone. Open 6 days a week.

Bearcat 220FB Receiver
Scanning Receiver. 66-88MHz-118-136MHz. 144-148MHz-144-148MHz. 420-450MHz-450-470MHz. 470-512MHz £258.75.
Send S.A.E. for details of our range Aircraft Band Receivers.

CONSTRUCTOR'S SKETCHBOOK

RADIO FREQUENCY CHOKES

USED EXTENSIVELY IN SUCH PROJECTS AS THE P.W. HELFORD TO BLOCK r.f.

COMMERCIAL RANGES ARE AVAILABLE BUT THE TYPES SHOWN HERE ARE SIMPLE TO MAKE.

A FEW TURNS OF ENAMELLED COPPER WIRE WOUND THROUGH A SMALL FERRITE BEAD WILL KEEP r.f. OFF THE SUPPLY LINES. THESE BEADS ARE ALSO USED TO SUPPRESS PARASITIC OSCILLATIONS. JUST THREAD THE BEAD ONTO THE LEAD CONCERNED.

A FERRITE TOROID CAN ALSO BE USED PARTICULARLY WHERE TWO OR MORE WINDINGS ARE REQUIRED.

AIR CORED CHOKES NEED A SIMPLE FORMER. A LARGE VALUE CARBON COMPOSITION RESISTOR IS IDEAL. USE A 1W VERSION WITH A VALUE OF AROUND 150K Ω OR HIGHER. OCCASIONALLY A LOW VALUE RESISTOR (50 Ω) WILL BE SPECIFIED TO ACT AS A PARASITIC STOPPER AND DAMP THE CHOKE.

THE ENDS OF THE WINDING ARE SOLDERED TO THE RESISTOR LEADS - OF COURSE.

WRM324

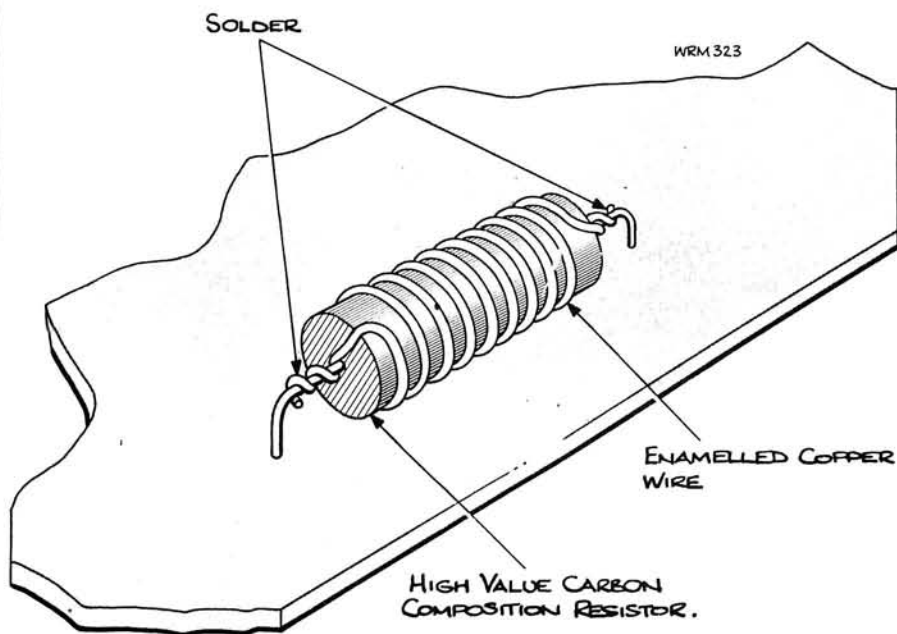
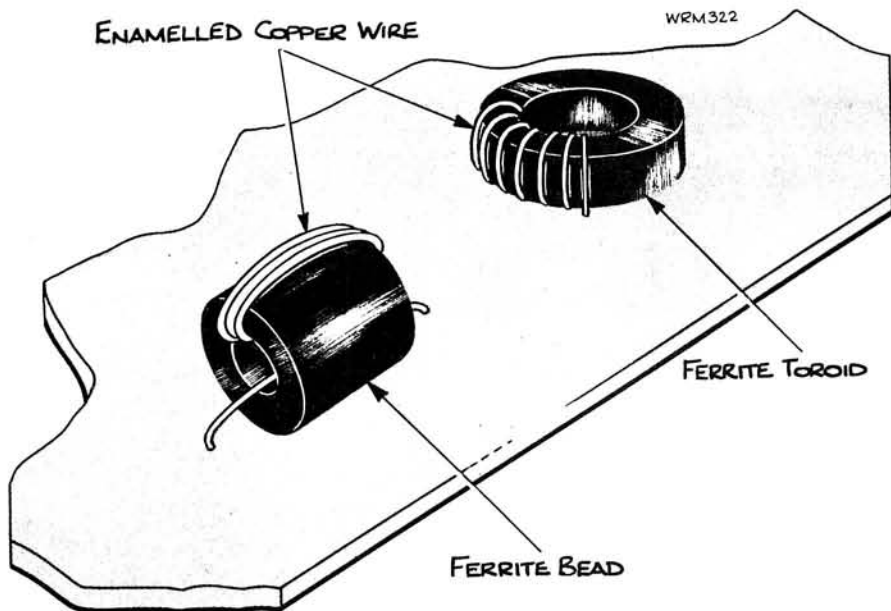

**SPECIAL
PRODUCT
REPORT**

RTVC

**DISCO
AMPLIFIER
12+12**

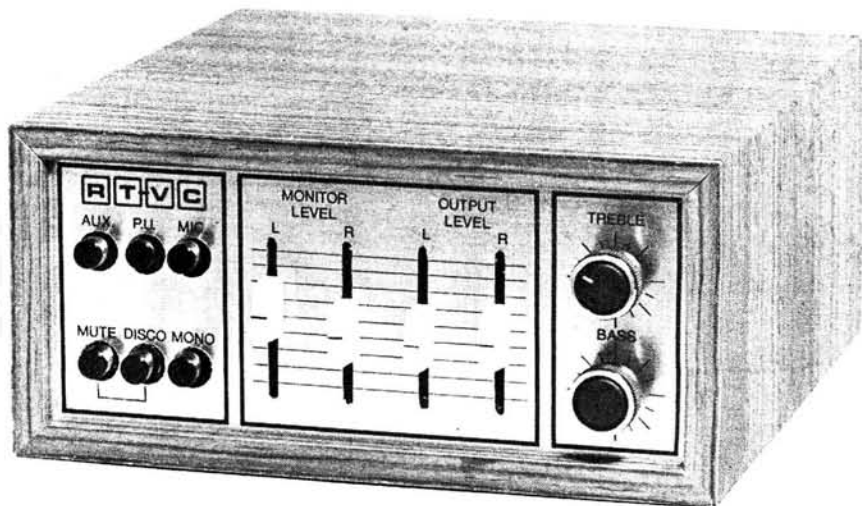

In these days when equipment designs are getting ever more exotic and expensive, it is often forgotten that for some applications, a very acceptable standard of performance can be obtained by far less sophisticated means.

The 12 + 12 Stereo Amplifier Kit from RTVC, although by no stretch of the imagination using "state-of-the-art" techniques, will no doubt appeal to anyone looking for a very inexpensive way of listening to music or running a small p.a. or disco system.

Assembling the Kit

The pre-amplifier/tone control function is taken care of by a Mullard LP1183 module, which is a p.c.b. with 22 pins for external connections of inputs, outputs and controls, and using all discrete components. Two components have to be changed in each channel, and it is essential that desoldering braid is available for this operation, since the p.c.b. track lifts very easily if the soldering iron is applied for too long. (Time taken: 15 minutes including adding power supply links.)

The two power amplifiers have to be assembled from components and p.c.b.s provided. The complementary output transistors are mounted on an aluminium heatsink which doubles as the amplifier mounting bracket, and are connected to the p.c.b. by flying leads. The board is roller-tinned, but unfortunately all the holes have been drilled very much over-size so that mounting components is a very solder-thirsty operation. (Time taken: two hours for two amplifiers.)

All the controls (four slider and two rotary potentiometers, plus two 3-button switch assemblies) are mounted on the front panel, with the pre-amp. board stood off with long screws and spacers. Connecting up this lot is a long tedious process, and a goodly selection of different coloured wires (I used 14) is almost essential if mistakes are to be avoided. (Time taken to assemble and wire, excluding screened leads to input sockets: 2½ hours.)

The rear panel carries DIN input and loudspeaker sockets, stereo headphone socket and the selenium bridge rectifier and low voltage fuse holder for the power supply. There are also holes punched for optional mains on/off switch and neon indicator (not supplied). No hole was drilled for the fuse holder locating pin, and the rectifier mounting hole was

under-size. (Time taken to assemble and partly wire: 1¼ hours.)

The chipboard base of the amplifier provides a mounting for the front and rear panels, the two power amplifiers, the amplifier output capacitors, the mains transformer and the supply reservoir capacitor. The woodscrews required for fixing are not included in the kit, but must be supplied, along with wire, solder and glue for the cabinet assembly, by the constructor. The transformer weighs around 1½kg (3¼lb), and I personally would not like to risk fixing it with ½in or ⅝in chipboard screws. Instead, I used 4BA screws and nuts. Placing of the various parts is fairly critical, to allow clearance around everything, so check carefully before screwing down, not forgetting the four screened twin cables which will be required to link the input sockets at the rear with the selector switches at the front.

A "star" solder-tag is provided for the multiplicity of earthing connections, and this is fixed to one of the transformer mounting screws. This tag proved to be completely unsolderable, and reminded me of ones with similar properties which were around in the nineteen-forties and fifties. You can just imagine how popular they were in labs and on production lines! The remedy is to painstakingly file, scrape

★ **specification**

Power output:	12W r.m.s. per channel into 3Ω, or 24W mono with 2-channel mixing
Load impedance:	3-15Ω
Input sensitivity:	MIC; 2mV into 18kΩ PU; 150mV into 2.2MΩ AUX; 150mV into 2.2MΩ
Tone controls:	Bass; ±12dB at 60Hz Treble; ±12dB at 10Hz
Distortion:	0.1% at 5W at 1kHz
Hum:	Typically -55dB
Power requirements:	220-250V 50Hz a.c.

or glasspaper away every vestige of the plating around the component-lead holes before fitting the tag.

After mounting all the parts on the baseboard, the remainder of the wiring can be completed, and the front fascia fitted before putting on all the control knobs. The shafts on the two rotary potentiometers are too long and have to be cut down. The push-button knobs have a tendency to fly off, which can be either hilarious or annoying, depending upon the circumstances and your frame of mind. A drop of glue in each does the trick.

The cabinet top cover, which is also in plastics-veneered chipboard, is supplied ready mitred, and simply glues together. The recommended method of fixing the cover to the baseboard is by screwing through the mitred edges, but there is very little "meat" there, and I feel that a more secure way would be to use some form of tapped angle brackets.

Final assembly and wiring took a total of 4½ hours, making a grand total for the project (including 30 minutes checking off the components supplied against the list) of 11 hours.

The instruction leaflet is fairly easy to follow, except for the drawing of the input selector switch wiring, which was not too clear. No circuit diagram is given for the LP1183 pre-amp. module.

Results

The completed amplifier performed well except that noise emanating from the pre-amps was a little troublesome. This could possibly be improved by experimenting with different transistor types. The mains transformer runs very hot, and I would recommend adding some ventilation to the cabinet for continuous use.

Separate MONITOR fader controls set the output level to the TAPE OUT/MONITOR socket, which is combined with the AUX input socket. A MUTE button allows the power amplifiers to be muted, during recording, etc.

A MONO button allows the right and left pre-amplifiers to be paralleled at their inputs, whilst depressing the DISCO and MUTE buttons together parallels the power amplifier inputs, so that the right and left OUTPUT LEVEL faders then operate as a two-channel mixer.

Because of the design of the unit, construction time is fairly long, as there are a lot of connections to be made. If you have plenty of time to spare, then this kit is good value for money at £13.95 including VAT, plus £2.55 postage and packing if buying by mail order. See the RTVC advertisement in this issue for their addresses for personal shoppers and mail order.

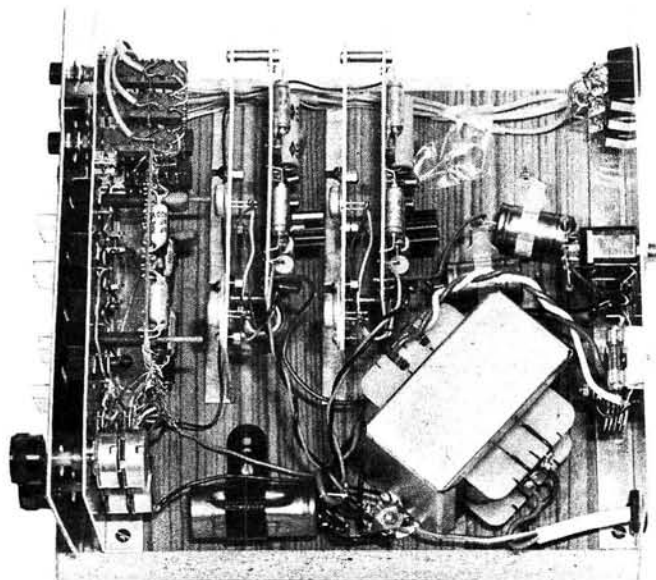

Next month in **Pw**

again

8 Extra Pages OF PROJECTS & FEATURES

On
Sale
2 JAN



morse tutor

Struggling to pass the Morse Test? Build our Morse Tutor and master the c.w. This project fires random Morse at you for practice singly, or groups of five characters, mixed or plain letters

Accented Metronome

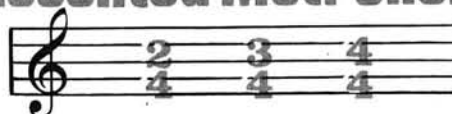

This device uses a distinct lowering in pitch to accentuate the pre-selected second, third or fourth beat. Using few components this is an ideal beginners project

Beginning new series

UNDERSTANDING RECEIVER PARAMETERS





NIMBUS

Modular 2m Transceiver System

16-Channel Scanner

(Part 8)

Michael TOOLEY BA G8CKT
&
David WHITFIELD BA MSc G8FTB

There are two main functional modules, the control logic and the channel oscillators. The control logic provides the means by which the operator's requirements are used to select any of the 16 channels at any given moment, utilising digital logic elements.

The channel oscillators consist of two banks of up to 16 electronically switched crystal oscillators, one each for transmit and receive, employing analogue r.f. circuits.

Operating Facilities

The Nimbus Autoscanner has two main modes of operation, MANUAL and AUTO. In the AUTO mode there are a number of operational sub-modes, and a range of optional features. A diagrammatic representation of the total range of control facilities is shown in Fig. 2, and detailed descriptions follow.

Manual Mode

In MANUAL mode the user selects the active channel directly by means of a hexadecimal-coded thumbwheel switch. Any change of switch setting, however, is ignored whilst the transceiver is in TRANSMIT mode. When the transceiver reverts to RECEIVE, the selected channel is updated to the new setting and continues to follow the switch setting until the mode again changes.

Auto Mode

In AUTO mode there are three operational sub-modes available, with a range of additional facilities, which may be used to tailor the Nimbus Autoscanner to the user's exact requirements. The sub-modes are as follows:

(1) SCAN causes the autoscanner to sweep through each of the 16 channels in turn. The time spent on each channel may be selected by the operator. In the unit

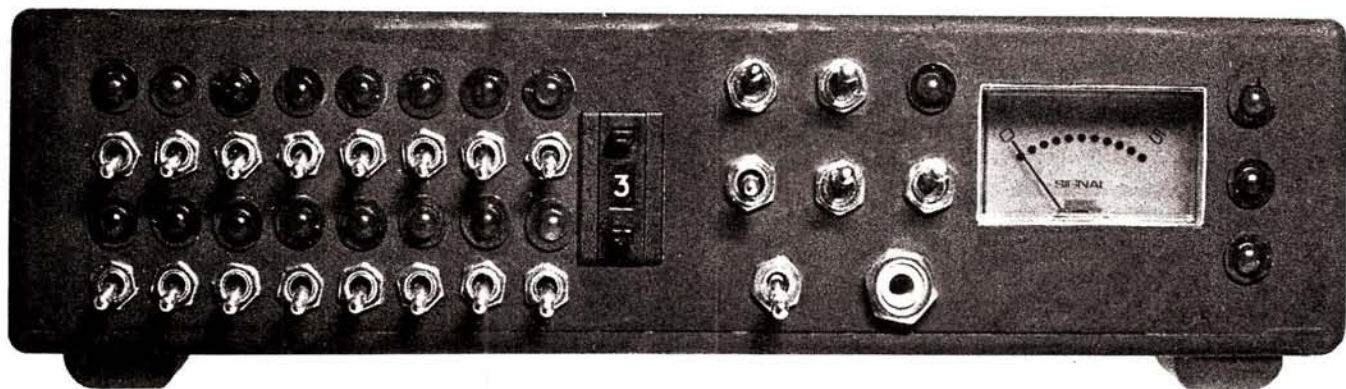

To further complement the Nimbus range of 2 metre equipment, the design presented here will expand the basic portable rig into a fully-fledged base station. It gives the user 16 additional channels that can be "interrogated" in several selectable modes including an intelligent scanning capability. As with the other items in the range, autoscanner may readily be used with similar v.h.f. equipment.

System Description

An outline block diagram of the autoscanner is shown in Fig. 1. The unit to be described either replaces or supplements the four manually switched channels provided in the Nimbus portable transceiver.

described, there are two switch-selected preset intervals of half second and two seconds. The user may also decide, at any time, to ignore any of the 16 channels without affecting either the order of the sweep or the time spent on each of the remaining channels in the sweep. Thus, for example, the autoscanner may be set up to spend two seconds on each of the channels 1-5-6-8-B-F in turn, repeating the sequence every twelve seconds. A further optional feature is the ability to sweep either continuously as just described, or to halt the sweep when an active channel above a predetermined "S" level is encountered. This is useful when monitoring a group of "vacant" channels, waiting for a signal.

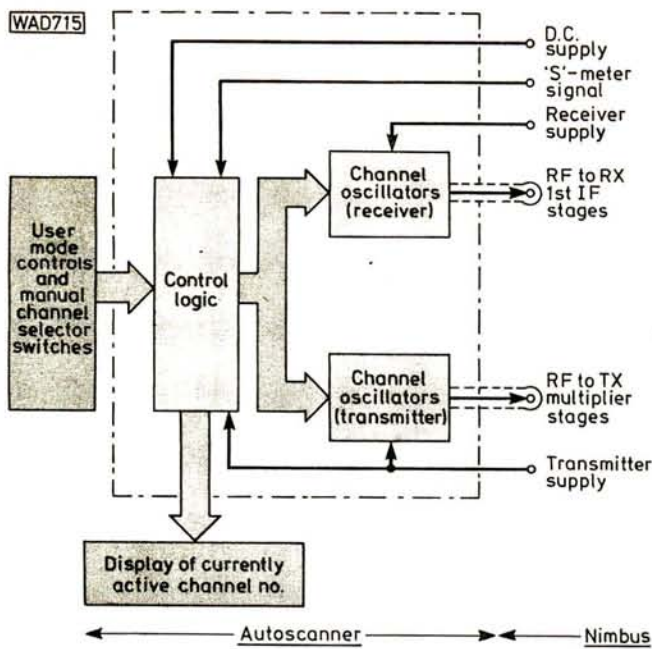
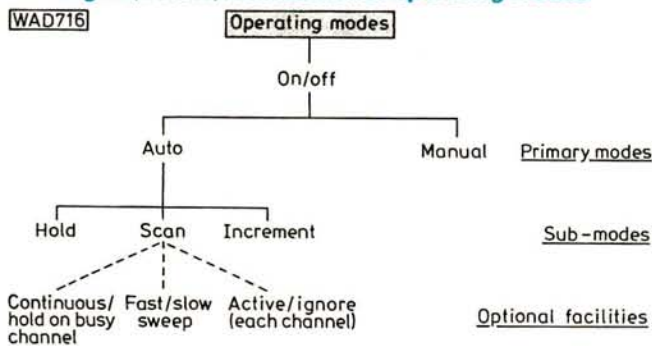

Fig. 1 (above): Block diagram of the PW Nimbus Autoscanner

Fig. 2 (below): Autoscanner operating modes



(2) HOLD causes the sweep to halt. This is useful when the hold-on-busy-channel facility in the SCAN sub-mode encounters the required signal.

(3) INCREMENT allows the user to step through each of the 16 channels in turn under manual control.

Channel Change Inhibit

In all modes and sub-modes, with the exception of INCREMENT, channel changing can only occur while the transceiver is in RECEIVE mode. The INCREMENT sub-mode allows channel change during transmission for test and alignment purposes, while making accidental channel change unlikely. At all times, the user is provided with a visual i.e.d. display of the currently selected channel.

Control Logic

The control logic determines which of the possible 16 channels is active at any given time, and thus it may be likened to an electronic channel switch. The different operating modes have already been described, and the mode selected is interpreted by the control logic to enable

the appropriate channel at the appropriate time(s). In all cases, only one channel may be active at any given moment, but the manner and the order of selection may be varied at will by the operator. The control logic also provides the operator with a constant i.e.d. indication of the currently selected channel.

A block diagram for the control logic is shown in Fig. 3. There are three main modules: the timing generator, sequencing logic and the channel selector. The logic is essentially TTL and occupies two printed circuit boards: one for the timing generator and sequencing logic and the other for the channel selector.

Timing Generator

The timing generator module provides the autoscanner sequencing logic with a number of related clock signals which are required for timing and control purposes. The idealised waveforms for these signals are illustrated in Fig. 7. In practice, the mark:space ratios will vary according to the scan rate selected, i.e., FAST or SLOW.

The circuit used to generate the timing waveforms is shown in Fig. 4. A precision timer, IC1, is used in an astable configuration to generate the master timing reference signal. The frequency of oscillation is set by R1 (only on SLOW scan rate), R2, R3 and C1. In SCAN mode, the control system is designed such that a new channel is selected for every 32 astable cycles that elapse. Switching R1 in/out of circuit, therefore, allows the sweep rate to be decreased/increased as required. The values specified for the frequency-determining components give sweep rates of approximately one new channel per half second (FAST), and one new channel per two seconds (SLOW). Constructors wishing to employ different sweep rates may use the formulae below to calculate alternative component values.

$$\text{Fast rate} = 0.0222(R2 + 2R3)C1 \text{ seconds/channel}$$

$$\text{Slow rate} = 0.0222(R1 + R2 + 2R3)C1 \text{ seconds/channel}$$

Resistances in kΩ
Capacitance in μF

CONSTRUCTION RATING Advanced

BUYING GUIDE

All components required for the PW Nimbus Autoscanner are readily available from suppliers advertising in PW. Printed circuit boards can be obtained from usual sources. The cost quoted below is for a fully crystallised, 16-channel unit.

APPROXIMATE COST £190 (FULLY CRYSTALLLED)

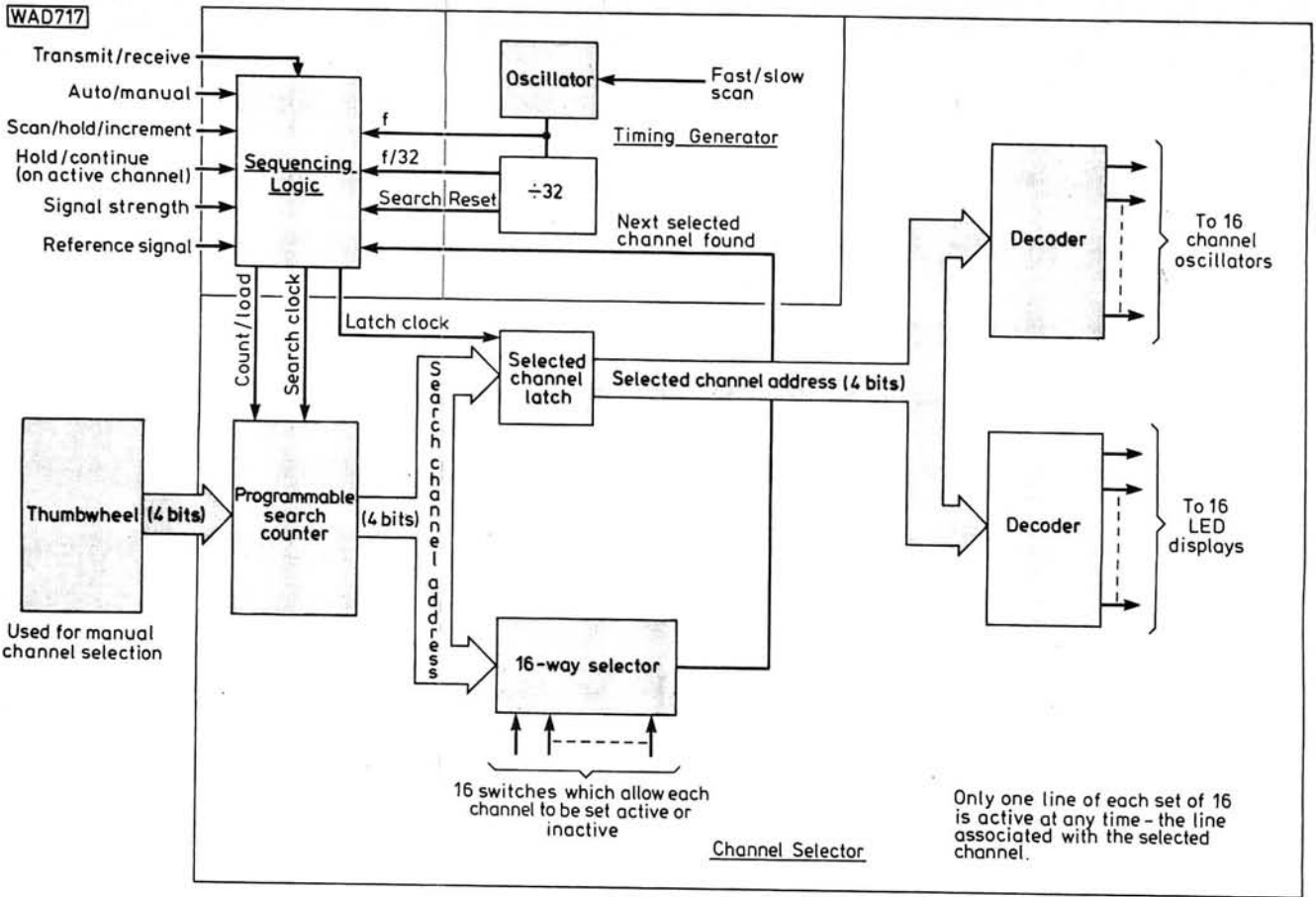
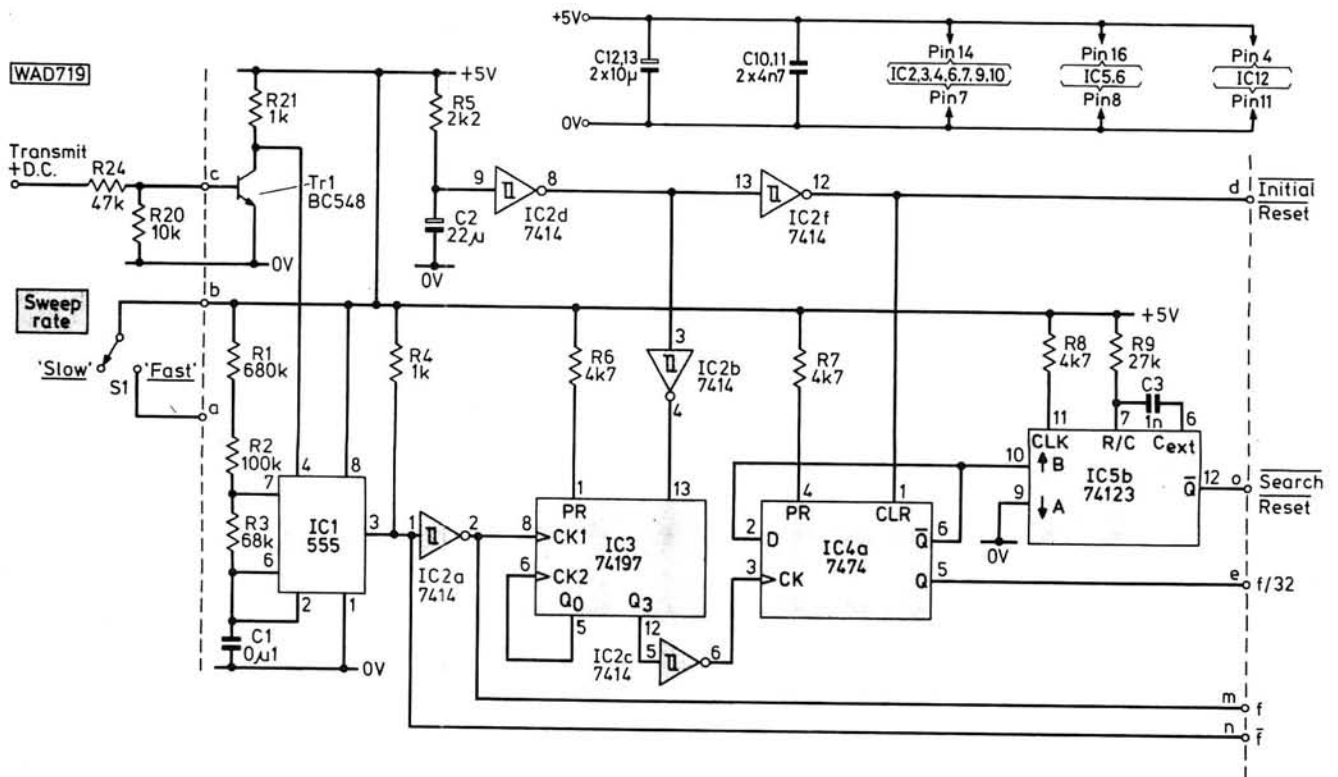

Fig. 3 (above): Block diagram for the control logic

Fig. 4 (below): Circuit diagram for the timing generator and associated power supply rails



If preferred, R1 and R2 may be replaced by a fixed resistor, to set the fastest sweep rate, in series with a potentiometer whose value will set the slowest sweep rate. Typically, a 2.2MΩ potentiometer in series with a 47kΩ resistor will provide a useful range of control.

The remaining timing and control signals are all derived from the astable oscillator output. The original reference (\bar{f}) is inverted to produce a second clock phase (f). A binary counter, IC3, and a D-type flip-flop, IC4a, are then used to divide-by-32 to produce the signal $f/32$. A monostable, IC5b, is arranged to use the falling edge of $f/32$ to generate a 10μsec negative-going reset pulse after every 32 astable cycles. The pulse duration of this reset is determined by R9 and C3.

The arrangement of R5, C2 and IC2d is used to provide a "power-on-reset" function whenever d.c. power is newly applied to the autoscanner logic. By this means, the control system is always initialised to a known state at switch-on.

The \bar{Reset} input on IC1 is used to override the

autoscanner control logic and prevent any inadvertent change of channel while the transceiver is in TRANSMIT mode. The TRANSMIT d.c. supply rail is sensed by R20/R21, and turns on Tr1. The collector potential falls to near 0V, which provides a logic LOW to the \bar{Reset} input of the 555. This inhibits the master clock, and prevents any change of channel in either the MANUAL or the AUTO/SCAN modes. For test purposes, change of channel while in TRANSMIT mode is still possible by means of the AUTO/INCREMENT facility.

Sequencing Logic

The sequencing logic uses inputs from the timing generator and from the user control switches to produce the \bar{Reset} , Search Clock, Latch Clock, and Manual signals used by the channel selector board to determine which of the 16 channels is selected at any time. The circuit diagram for the sequencing logic is shown in Fig. 5.

Fig. 5: Circuit diagram for the sequencing logic

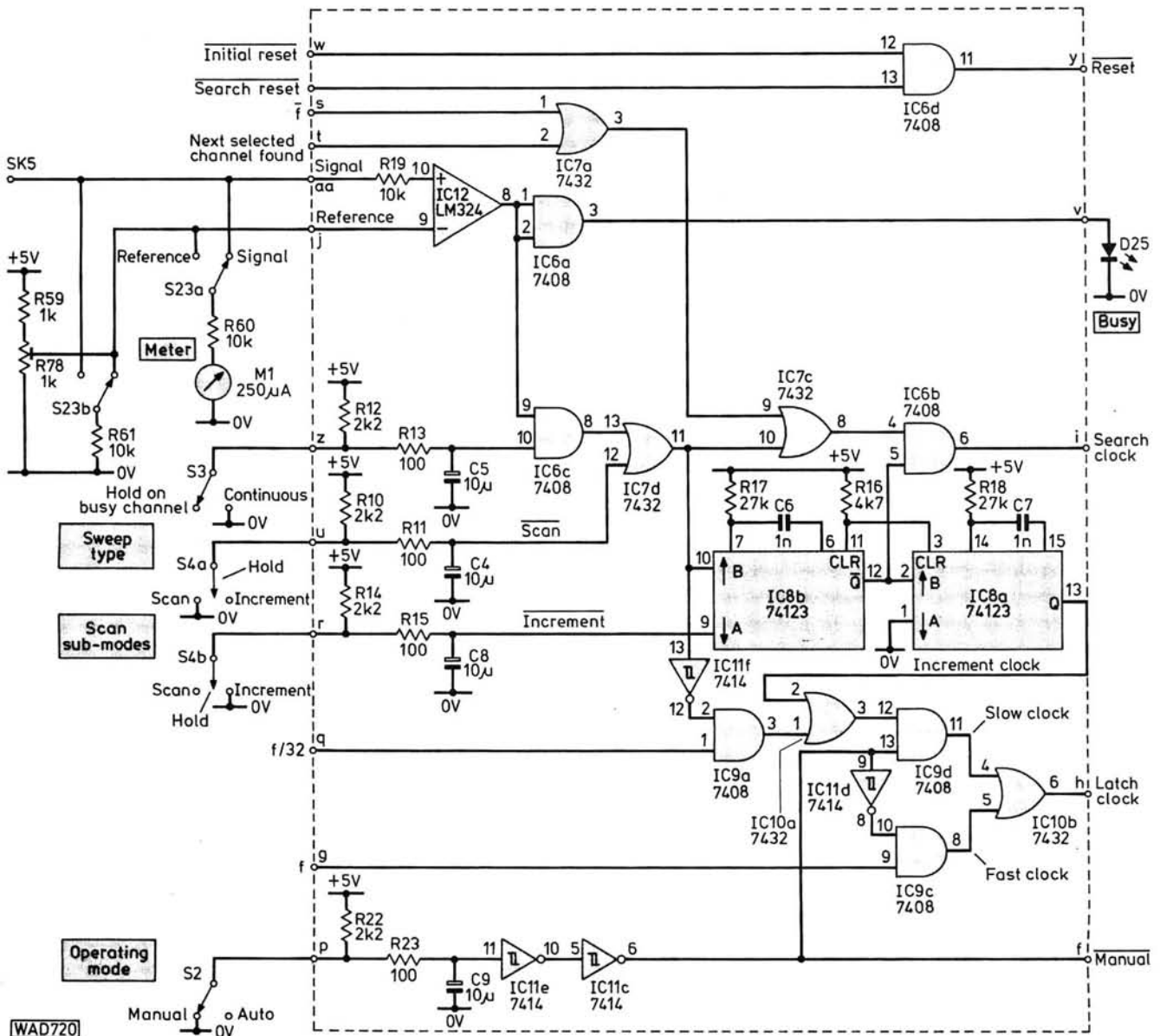

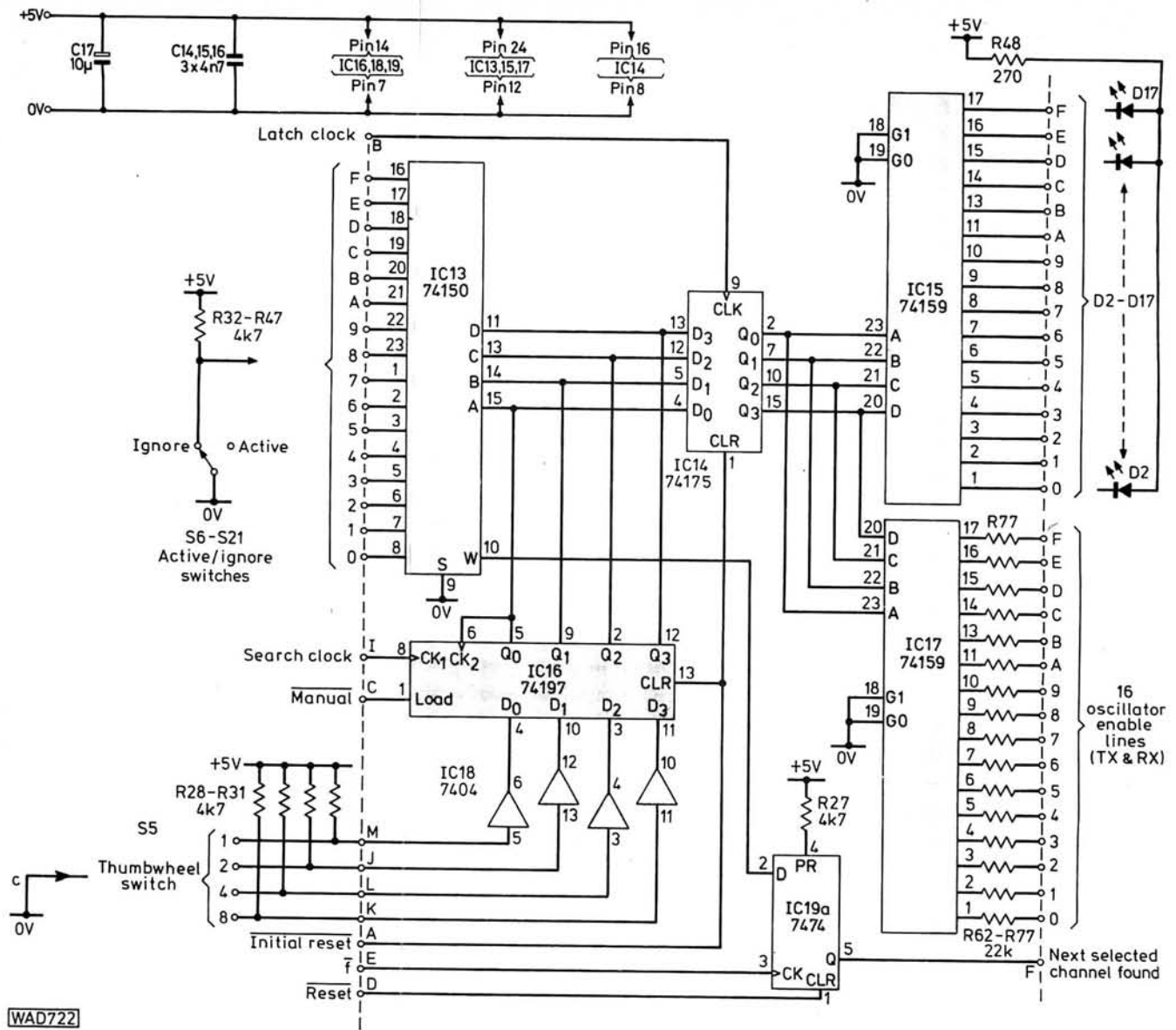

Fig. 6: Channel selector circuit diagram and associated power supply rails

The operating mode for the autoscanner is set to AUTO or MANUAL by S2. The arrangement of R22, R23 and C9, in conjunction with the Schmitt-input gate IC11e, is used to "debounce" the switch. This prevents multiple triggering due to contact bounce when the toggle switch changes over. After buffering, the level selected by S2 (Manual) is sent to the channel selector board for use as the primary mode control line and to the on-board Latch Clock steering logic.

The Latch Clock steering logic uses the Manual signal to determine whether the FAST Clock or the SLOW Clock is used to provide the clock function. In MANUAL mode, the FAST Clock (frequency = f) is used, while in AUTO mode, the SLOW Clock ($f/32$ or INCREMENT Clock, depending on whether the sub-mode is SCAN or INCREMENT, respectively) is used.

The AUTO sub-mode selection is performed by the two-pole three-position toggle switch S4. This switch has a centre-off position, used for HOLD, and is spring-biased-to-centre, used for INCREMENT, in one of the two remaining positions.

The HOLD sub-mode is selected by default by the centre-off position on S4. In this position, the INCREMENT logic is disabled by holding the A-input HIGH on IC8b by means of R14, while the search and latch clocks are disabled by R10 holding the Inhibit Clock line HIGH.

INCREMENT is the sub-mode which provides the means to advance from the channel selected by the HOLD sub-mode. Operating the spring-loaded position on S4 initiates a sequence of pulses which has the effect of stepping the autoscanner on to the next channel. The pulse sequence illustrated in Fig. 8 uses two $1\mu\text{s}$ monostables, IC8b and IC8a, to advance the search counter by one, and then update the channel latch on the channel selector board. In this way, the user may step through the 16 channels one at a time in either RECEIVE or TRANSMIT operating mode.

In the SCAN sub-mode, \bar{f} drives the Search Clock line until the Next Selected Channel Found line indicates that the channel selector search counter has advanced to the next selected (i.e., not set to "ignore") channel. The Search Clock is then inhibited for the duration, and the next rising edge of the Latch Clock causes this channel to be enabled.

In this way, the frequency of the Latch Clock determines the rate of sweep; one search-and-enable sequence occurring for each clock cycle.

An alternative to the continuous sweep described above is provided by S3 and IC12. Operation of S3 allows the sweep to be halted when the receiver's sweep sequence encounters an occupied channel. This "busy" channel is then held for as long as the signal remains. IC12 is used to compare the received signal strength with the pre-determined reference level (see later), and IC6c uses the comparator output to override the sweep whenever a signal above the threshold is encountered. Where not required, or where no signal strength line is available from the receiver, the HOLD-ON-BUSY-CHANNEL facility may be omitted by replacing S3, R12, R13, C5, IC12 and IC6c by a link between pins 12 and 13 on IC7d.

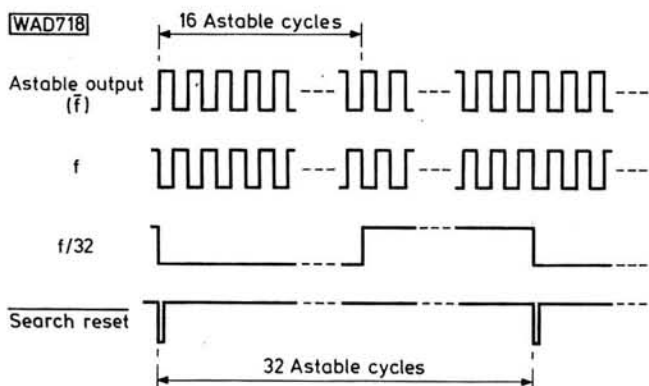

Fig. 7 (above): Timing generator signal waveform

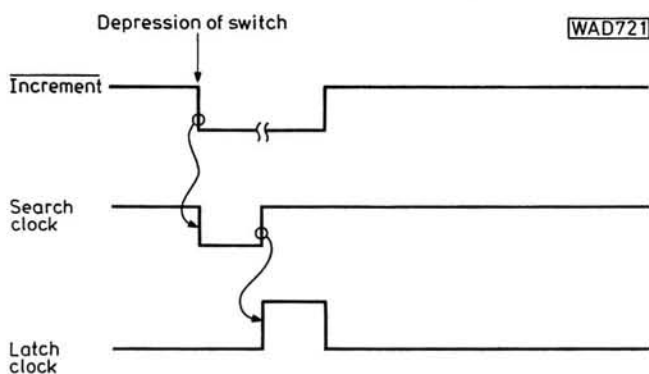

Fig. 8 (below): Pulse sequence for increment mode

Readers who intend to operate the *PW* Nimbus should be in possession of the appropriate licence issued by the Home Office to those who have passed the City and Guilds Radio Amateurs' Examination. Details may be obtained from: The Home Office, Radio Regulatory Department, Amateur Licensing Section, Waterloo Bridge House, Waterloo Road, London SE1 8UA.

★ components

TIMING GENERATOR AND SEQUENCING LOGIC BOARD

Resistors

$\frac{1}{4}$ W 5% Carbon

100 Ω	4	R11,13,15,23
1k Ω	3	R4,21,59
2.2k Ω	5	R5,10,12,14,22
4.7k Ω	4	R6,7,8,16
10k Ω	4	R19,20,60,61
27k Ω	3	R9,17,18
47k Ω	1	R24
68k Ω	1	R3
100k Ω	1	R2
680k Ω	1	R1

Pre-set cermet multiturn

1k Ω	1	R78
-------------	---	-----

Capacitors

Ceramic

1nF	3	C3,6,7
4.7nF	2	C10,11
0.1 μ F	1	C1

Tantalum 10V

10 μ F	6	C4,5,8,9,12,13
22 μ F	1	C2

Semiconductors

Integrated Circuits

555	1	IC1
7408	2	IC6,9
7414	2	IC2,11
7432	2	IC7,10
7474	1	IC4
74123	2	IC5,8
74197 or 74177	1	IC3
LM324	1	IC12

Diodes

0.2in l.e.d. (green)	1	D25
----------------------	---	-----

Transistors

BC548	1	Tr1
-------	---	-----

Miscellaneous

Sub-miniature toggle switch s.p.d.t. (3); Centre-off spring-biased one way sub-miniature d.p.d.t. toggle switch; Sub-miniature spring-biased d.p.d.t. toggle switch; Panel mounting for D25; Panel mounting hardware for R78; 250 μ A f.s.d. meter (Maplin LB80B).

CHANNEL SELECTOR BOARD

Resistors

<i>1/4W 5% Carbon</i>		
270Ω	1	R48
4.7kΩ	21	R27-47
22kΩ	16	R62-77

Semiconductors

Diodes

0.2in I.e.d.	16	D2-17
--------------	----	-------

Integrated Circuits

7404 or 7414	1	IC18
7474	1	IC19
74150	1	IC13
74159	2	IC15,17
74175	1	IC14
74197 or 74177	1	IC16

Capacitors

Ceramic

4.7nF	3	C14,15,16
-------	---	-----------

Tantalum 15V

10μF	1	C17
------	---	-----

Miscellaneous

3 off 24-pin d.i.l. sockets; 3 off 14-pin d.i.l. sockets; 1 off 16-pin d.i.l. socket; Sub-miniature hexadecimal thumbwheel edge switch module (RS337-431); Pair of end cheeks (RS337-419); Ultra miniature s.p.s.t. toggle switches (16 off); Mounting hardware for I.e.d.s.

POWER SUPPLIES

Resistors

<i>1/4W 5% Carbon</i>		
1kΩ	3	R56,57,58

Semiconductors

Integrated Circuits

UA7805KC	1	IC20 (TO3 can 5V 1.5A regulator)
----------	---	----------------------------------

Diodes

1N4001	3	D19,21,23
0.2in I.e.d. (red)	1	D20
0.2in I.e.d. (green)	1	D22
0.2in I.e.d. (orange)	1	D24

Capacitors

Ceramic

4.7nF	4	C24,25,26,28
-------	---	--------------

Polyester

100nF	1	C27
-------	---	-----

Electrolytic

10μF 10V	1	C29 (axial lead)
----------	---	------------------

Sockets

4mm insulated (red)	3	SK1,2,3
4mm insulated (black)	1	SK4

Miscellaneous

Four-pole double-throw toggle switch (RS316-995 miniature toggle); 4 off anti-parasite beads; 3 off I.e.d. mounting hardware; Die-cast box approximately 220 x 145 x 55mm.

The Nimbus transceiver's signal strength output is connected to SK5 on the Autoscanner, and then via R19 to the non-inverting input of the comparator, IC12. The reference, which is applied to the inverting input of the comparator, is variable from 0 to +2.5 volts, and is derived from the +5V supply rail. The reference level is set by a screwdriver-adjustable panel mounted multiturn trimmer, R62. The signal strength meter, M1, may be used to display either the Nimbus receiver signal strength or the preset reference level. The selector switch, S23, is spring-biased to show the receiver signal strength as the normal setting. The output of the signal comparator is displayed on the I.e.d., D25, i.e., this I.e.d. is illuminated when the signal strength exceeds the reference level.

The final section of the sequencing logic comprises a single gate, IC6d. This gate provides the Reset line for the channel selector board by combining the Initial Reset and the Search Reset signals from the timing generator.

Channel Selector

The channel selector is the module which is responsible for implementing the channel selection, and as such forms the "heart" of the autoscanner. A block diagram is included in Fig. 3, and a detailed circuit diagram is shown in Fig. 6.

The operation of the channel selector is in one of two modes, depending on whether the primary autoscanner mode is MANUAL or AUTO. The MANUAL line from the sequencing logic is used to control the programmable 4-bit search counter, IC16. In AUTO mode, this counter is clocked by Search Clock, and increments by one for each High-to-Low transition. In MANUAL mode, the counter outputs, Q₀ to Q₃, follow the data presented at the data inputs, irrespective of the state of the clock. The output therefore reflects the current setting of the thumbwheel switch, S5. A change of mode from AUTO to MANUAL holds the last setting of the thumbwheel switch until the next HIGH-to-LOW clock transition.

In AUTO mode, the search counter output drives the 16-way selector, IC13. During a sweep cycle, this selector looks at one of the 16 active/ignore switches (S6 to S21) at a time. The search counter increments until a switch is found which is set "active", i.e., the W output from IC13 goes HIGH. The flip-flop, IC19a, is then set, causing the sequencing logic to freeze Search Clock for the remainder of the sweep cycle, i.e., until the start of the next 32 astable cycles. The saved counter value selects the next channel in the scan sequence when this is updated at the rising edge of Latch Clock. At this edge, the counter output is transferred to the selected channel latch, IC14, and the flip-flop is reset. This new value of selected channel is held in the latch while the Search Clock is re-started and the sweep cycle repeats. The latch output is used to drive two 4-to-16 line decoders, IC17 and IC15, which enable the selected channel oscillator, and illuminate the corresponding channel-selected I.e.d. indicator, respectively.

In MANUAL mode, the Latch Clock frequency is 32 times higher than in the AUTO mode. The thumbwheel switch setting thus appears to the operator to have been implemented immediately, whereas in practice there will be a slight delay of typically 30ms.

Next Instalment

In Part 2 we will be dealing with the channel oscillators, power supplies and full constructional details.

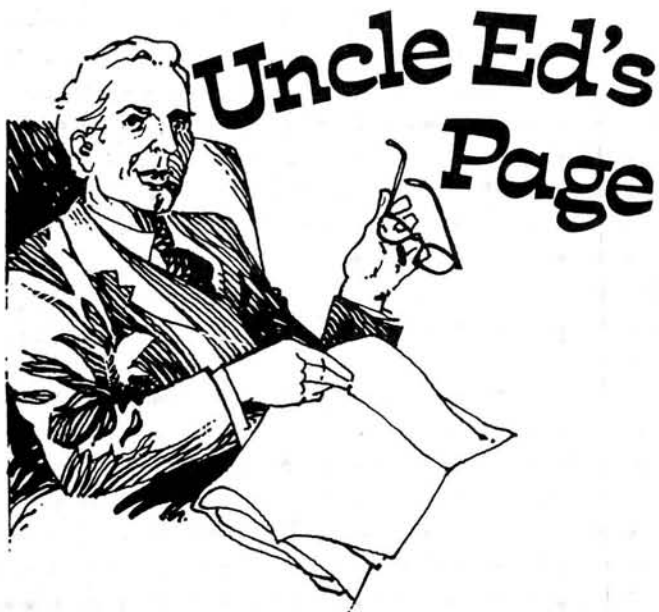

A monthly look at some aspect of the radio/electronics hobby that seems to bug the beginner, or occasionally a more advanced topic seen from an unusual angle.

DIODES

For what is basically a pretty straightforward component, the diode causes a lot of headaches for the newcomer to electronics. The diode is a device which allows current to flow in one direction only, and blocks it in the reverse direction. (This ignores the small reverse leakage current, and the large reverse current that can flow if a critical breakdown voltage is exceeded, as in Zener diodes. I'll talk about these some other time.)

Here we come against our first stumbling block—which is the forward direction and which is reverse? The answer is, it all depends; on whether you're talking about "conventional" current flow or electron flow. While we're on the subject, let me declare myself here and now as an electron-flow man, basically because I like to be able to visualise a problem, and I can "see" those negatively-charged electrons rushing

around the circuit towards the positive terminal of the power supply (attraction of opposites). "Conventional" current flow is from the positive side of the power supply to the negative, and was chosen to be that way round in the early days of electrical engineering, before it was discovered that current in a conductor was a flow of free electrons.

Unfortunately, the circuit symbol for the "solid-state" diode, which in those days would have been a copper-oxide type, was laid down to be an arrow and a bar (Fig. 1), with the arrow-head pointing in the direction of conventional current flow. The arrow-head is called the anode (a) and the bar the cathode (k).

If a battery or other source of d.c. voltage is connected across a diode, with its positive terminal to the anode and its negative terminal to the cathode (Fig. 2) a heavy current will flow—I've included the resistor to limit that current, and so stop the diode being burnt out. So, forward current flow in a diode is into the anode and out of the cathode if you're talking about conventional current, or into the cathode and out of the anode if you prefer electron flow. In either case, it happens when the anode is connected to the positive side of the supply, and the cathode to the negative. Reverse the battery and the current flow is blocked.

The bottom end of the resistor in Fig. 2 is connected to the negative terminal of the supply, and the top end is connected (via the diode) to the positive terminal. Looked at another way, there's a current flowing in the circuit, and we've said that electrons flow towards the more positive part of the circuit. Electrons are flowing left to right through the diode, so they must be flowing upwards through the resistor. Therefore the top end of the resistor must be positive compared to its bottom end, as shown.

The circuit of Fig. 2 doesn't really do anything very useful, but you could replace the battery by a source of alternating voltage, such as a transformer with its primary connected to the a.c. mains (Fig. 3). The diode would then pass current when the voltage of the source had the same polarity as the battery in Fig. 2, but block it when the polarity of the source reversed. Current flow through the resistor would be intermittent, but always in the same direction. In this application the diode is being used as a rectifier, producing a pulsating d.c. supply from an a.c. source.

This brings us nicely on to another perennial question from the beginner: "Why is the cathode of a diode circuit symbol often labelled with a cross, when everyone knows that a cathode is a negative electrode?" Well, Fig. 3 gives a clue to the answer to this one, because so far as the resistor R is concerned, the cathode of the diode is what it sees as the positive side of the supply. In fact, it is just convention that the cathode of a diode is identified with a cross because it has a positive voltage produced on it when used as a rectifier.

Yet more conventions apply to the physical appearance of real diodes. First, that on diodes with cylindrical bodies, the cathode end is marked with a band. This band can be black, red, white or sky-blue pink, but it is always at the cathode end. Second, on the larger diodes which are bolted to a heat-sink or chassis by means of a threaded stud, the stud end is (almost) always the cathode. Exceptions (well, most conventions have some exceptions) are: (a) some diodes are marked with the diode circuit symbol; (b) a few stud-mounted diodes are stud anode—sometimes these can be identified by an "R" at the end of the type number, as they are known as reverse polarity package types.

Although I'm not dealing with thyristors (s.c.r.s) here, it is worth mentioning that they are, by convention, normally stud anode, though a few aren't. People do believe in making life complicated, don't they?

I've tried to summarise these conventions in Fig. 4, with a valve diode as well, for comparison. I'll continue the diode saga next month.

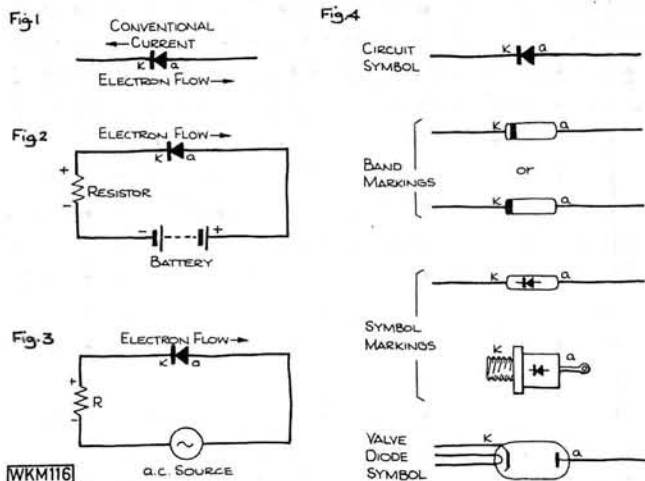

WKMT16



BACK-UP POWER SUPPLY UNIT FOR PORTABLE RADIOS

Keith CUMMINS

It is a well-known fact that the better quality portable radios, with respectable output stages, are somewhat heavy on batteries. Because the radio has sufficient power capability to rise above such ambient noises as washing machines, food mixers, etc., the battery life tends to be very short should the kitchen be the radio's usual location.

My wife owns a Bush TR130 radio which falls into the above category. Its usual working area is the kitchen, but nevertheless it spends a fair amount of time in other parts of the house, where the demand for high volume is much reduced. The last thing the lady of the house is interested in is trailing a power unit around with the radio. Therefore it was considered sensible to install a power unit in the kitchen where the power requirement is greatest. Another point to be taken into account is the ease of operation. The power unit is tucked away in a cupboard, and a flying lead emerges where the radio is used; the lead being electrically dead until the radio is connected to it. When the radio is connected and switched on, power from the battery is used to switch the power supply unit, which then takes over from the battery.

It is necessary to modify the radio circuit, and an l.e.d. was fitted to indicate correct operation of the power supply. The modification is simple and straightforward, the most difficult part being the addition of a 3 pin DIN socket to accept the external power.

Because use of this unit will involve modifications to existing equipment, and also necessitate the wiring of incoming mains via a relay, we emphasise that the project should not be undertaken by anyone who is not confident of what he is doing!

**CONSTRUCTION
RATING** **Beginner**

BUYING GUIDE

Readers should have little difficulty in obtaining the components. The metal box came from Zaerix Electronics Ltd., type-Minibox 521-563.

**APPROXIMATE
COST** **£10**

The layout is quite uncritical, and for this reason, the experienced constructor can devise his own. We would recommend that the unit be built into an earthed metal box, for safety reasons, since it will be permanently con-

★ components

Resistors

10% 1/4W

33Ω	1	R6
220Ω	1	R8
1kΩ	1	R1
2.2kΩ	1	R5
4.7kΩ	1	R4
10kΩ	2	R2,7
22kΩ	1	R3

Semiconductors

Diodes

BY164	1	D1
1N4001	3	D3,5,6
6.2V 400mW	1	D2
Yellow l.e.d.	1	D4

Transistors

TIP31	1	Tr1
BC109	1	Tr2
BFY50	1	Tr3

Capacitors

Electrolytic

2200μF 25V	1	C1
22μF 15V	1	C2
47μF 15V	1	C3

Miscellaneous

RLA s.p. make 40Ω coil; T1 240V primary, 14V 1A secondary; F1 100mA antisurge with fuseholder to suit; PL1 3-pin DIN plug; SK1 3-pin DIN socket; Minibox 521-563 (154 × 104 × 60mm). Zaerix Electronics Ltd.

nected to the mains. A nasty fault, though most unlikely, will then blow the fuse, with any fire risk rendered negligible.

Figs. 1 and 2 show the power supply circuit and the input modifications required by the radio. The two circuits need to be considered together, and for this reason the component numbers run sequentially from Fig. 1 to Fig. 2.

It is best to first consider battery operation of the radio; the power supply will not be plugged in, so nothing is connected to pins 1, 2 and 3. When S1 is turned on, +9V from the battery is conveyed via D6 and the switch to the remainder of the radio. Due to the voltage drop across the diode, the radio circuits are supplied with +8.4V.

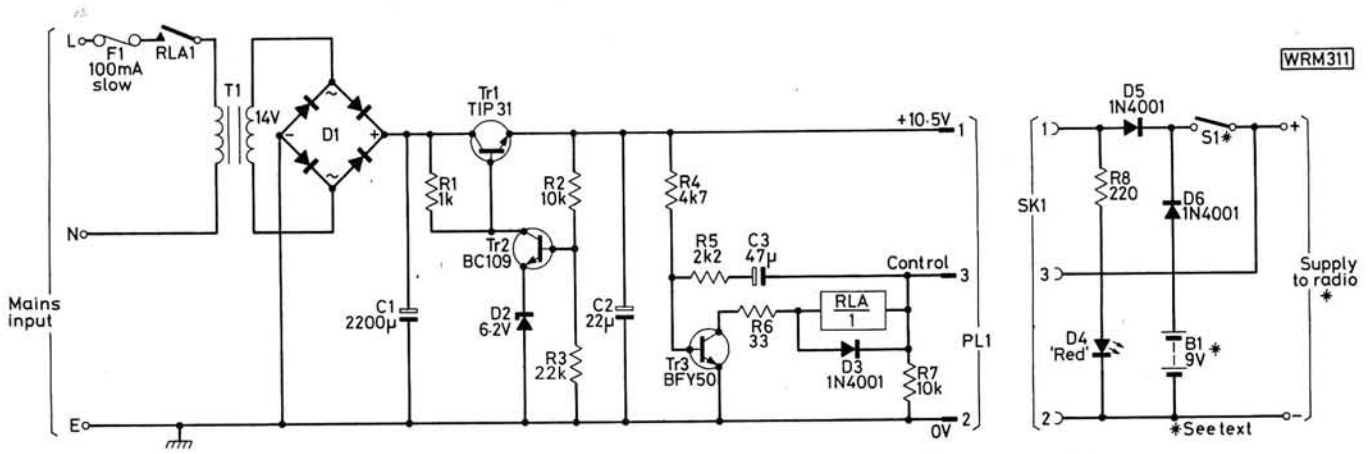
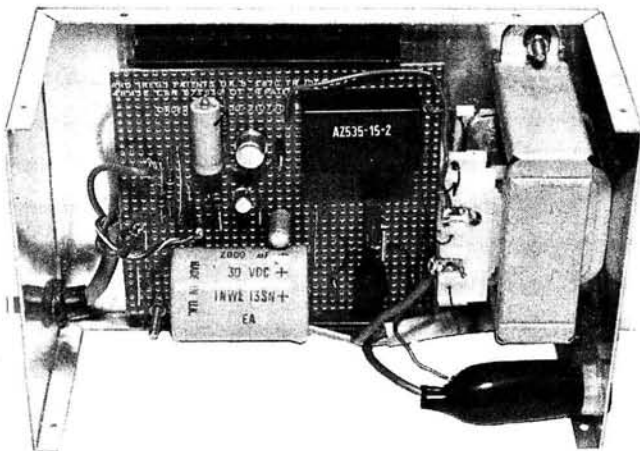

Fig. 1 and Fig. 2: Power supply circuit with the internal input modifications of the radio

If the power supply is connected, or closing S1 (or plugging in while the radio is playing) will apply 8.4V to the control line into the power supply. C3 charges up R5 and the base of Tr3, therefore the transistor turns on, and RLA placed in its collector circuit, (and also fed from the control line), energises. Mains power is applied to T1, resulting in a regulated output of +10.5V appearing at pin 1, this lights D4 indicating mains power available. D5 conducts, and lifts the supply to the radio from 8.4V to 9.9V. D6 is now reverse biased, so no current flows from the battery. R4 in the power unit maintains the base current of Tr3, so ensuring that RLA remains energised even though C3 is charged. The reader will now see the reason for including Tr3; if no mains power is available, RLA energises only for the duration of the charging time of C3. Since no maintaining current flows through R4, the relay drops out again. This ensures that in the event of power failure, or a fault in the power supply, this not left draining the battery.



Internal view of the power supply

Another point worth noting is that the power unit cannot be switched on if the battery is flat. This ensures that a weak, leaking battery cannot be left in the radio while it is running from the power supply unit.

The regulator part of the p.s.u. (Power Supply Unit), consisting of Tr1 and Tr2 and associated components follows a basically classical design. Tr2 is the error amplifier, with voltage reference Zener D2 connected in its emitter, while Tr1 is the series regulator. C2 provides h.f. decoupling to ensure stability.

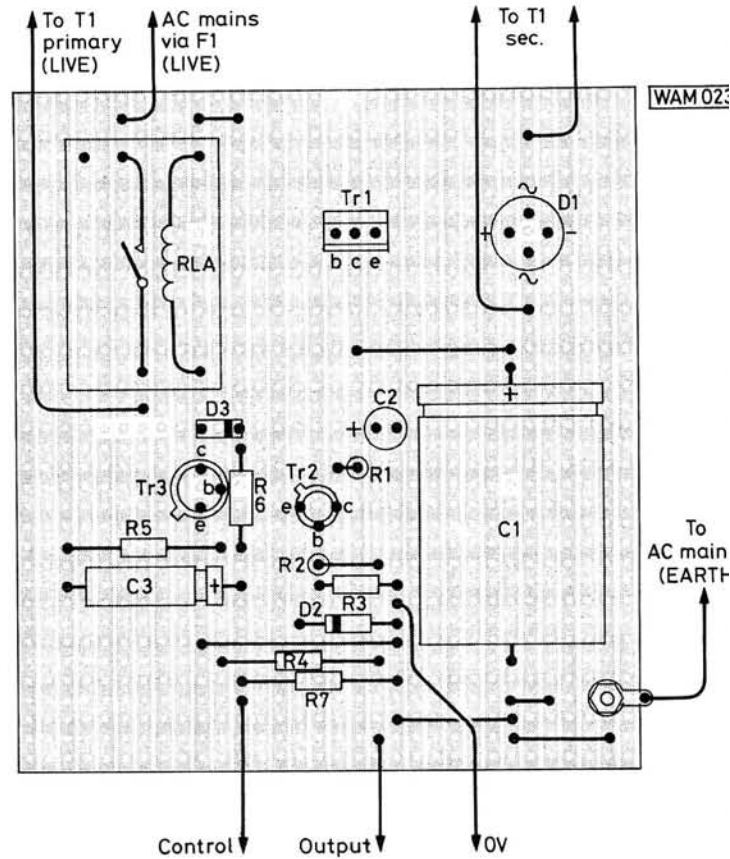

Fig. 3: Prototype Veroboard layout diagram

Choice of Relay

The relay should provide adequate insulation between contacts and frame, since mains is being handled. The resistance is not too critical, the important thing is that it should actuate at about 7V to ensure reliable operation. The relay used in the prototype was a 5 volt, 40 ohms type, hence the use of R6—this component may be omitted where a higher voltage relay is used. R7 is included to provide a discharge path for C3 if the p.s.u. is unplugged from the radio while in use, while D3 is a back-e.m.f. quenching diode.

Care has been taken to ensure that there are no "do's"

continued on page 68 ▶▶▶

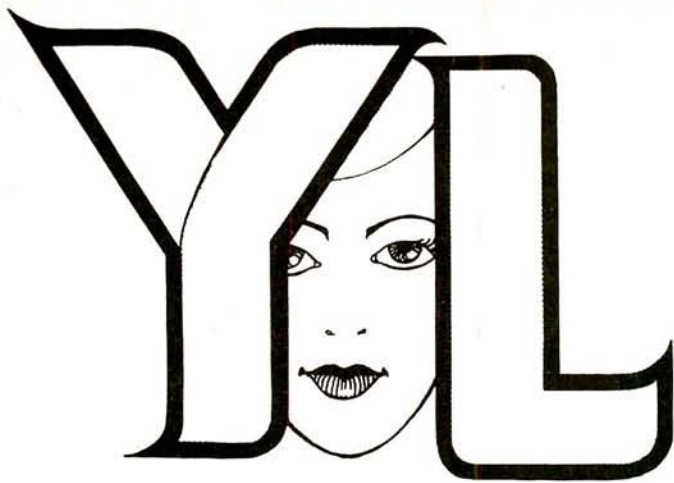

the



Elaine HOWARD

Hello, and welcome to the very first YL column. Let me firstly introduce myself. After originally training as a Marine Radio Officer and being unable to get a job at sea, I started work as a Test Engineer on a Defence Project. It was after this that I decided to change to journalism, and joined *Practical Wireless* back in September. Although I am not a Licensed Amateur as of yet, I sat the Morse exam in the summer and the RAE in December, so hopefully I will be on the air very soon.

Although there are still not many licensed YLs and XYLs in comparison with the total number of licensed amateurs, at least the number is growing. There is an association called BYLARA (British Young Ladies Amateur Radio Association), which brings together like minded YLs from all around the world. They are affiliated to the RSGB and they are open to licensed and non-licensed YLs and OMs wishing to join. When I wrote to the Secretary of BYLARA, G4EZI, she sent me some very interesting information about the group. It's best to start at the beginning of the story, and this is some of the letter she sent to me:

"Now as to the history of BYLARA. The idea for a YL club in Britain was first mooted in 1977, and a meeting took place at the Drayton Manor Rally of that year, chaired by Barbara, G4EKX. This earlier effort met with failure, as it was felt that there were not enough interested YLs at that time to make forming a YL club a possibility.

Nothing was then done until 1979, when Rita, G3NOB, wrote to Mary, G4GAJ, and myself, suggesting that there were so many newly licensed YLs on the band, the time would be right to suggest the starting of a YL club again. Both Mary and I were quite enthusiastic about the idea, and we decided that this time our approach would be different. The earlier effort we feel, met with failure because the approach was: "Should we form a YL club?"—this time, we decided to be more positive about the procedure and the message to put across was: "We are forming a YL club—would you like to join us?"

So the three of us put the word around that there would be a meeting of interested YLs at the Drayton Manor Rally to discuss the proposed formation of a new YL club. At that initial meeting on the 29 April 1979, there were eight YLs present. Mary acted as chairman, and informally proposed the formation of the club, and invited anyone else who was interested to join us. It was all very informal in those days—the aims of the club, newsletter,

subscriptions, etc., were all suggested, and Mary, Rita and I agreed to fulfill the duties of chairman, treasurer and secretary, just to get the club started.

After the meeting I, as secretary, wrote to about 50 YLs to tell them about the club, and invite them to join us. Subscriptions began to roll in. Rita unfortunately was unable to continue as treasurer and was succeeded by Judith G4IAQ.

From thence the club went from strength to strength, with the admission of OMs and DX YLs as associate members.

A formal business meeting took place at Leicester (The Leicester Exhibition, 10 November 1979), to thrash out a formal constitution as the club had expanded so rapidly, and already had over 100 members.

1980 saw BYLARA displays at many radio rallies, including the Leeds White Rose Rally in March. April 1980 at Drayton Manor saw our first AGM and the election of a committee, and in May 1980 we were invited to put on a display at the RSGB Exhibition at Alexandra Palace.



Illustration courtesy of the BYLARA June newsletter



Currently, we have a membership of well over 100 members, run a weekly net on 80m, have meetings at radio rallies, have an attractive YL award and a quarterly newsletter."

So as you can see there is a very active YL community in the world of amateur radio. I was at the Ally Pally rally and I was very impressed by the stand that BYLARA had. They had collected blank QSL cards from their members and made them into a very colourful display.

If anyone has any comments to make about YLs in Amateur Radio then I would be pleased to hear them.

For further information in BYLARA please contact: Mrs D. Hughes G4EZI, 3 Primley Park Crescent, Leeds LS17 7HY.



Bind it

It's so easy and tidy with the Easibind binder to file your copies away. Each binder is designed to hold approximately 12 issues and is attractively bound and blocked with the PRACTICAL WIRELESS logo. Gold Letra-set supplied for self blocking of volume numbers and years.

Price £4.30 including postage, packing and VAT. Why not place your order now and send the completed coupon below with remittance to: IPC Magazines Ltd., Post Sales Dept., Lavington House, 25 Lavington Street, London SE1 0PF.

it's easy with **EASIBIND**

✂

Order form PRACTICAL WIRELESS

I enclose P.O./cheque value
for.....binders

Years required
(BLOCK LETTERS PLEASE)

Name

Address

.....

Date

PW HELFORD—3

▶▶▶ continued from page 46

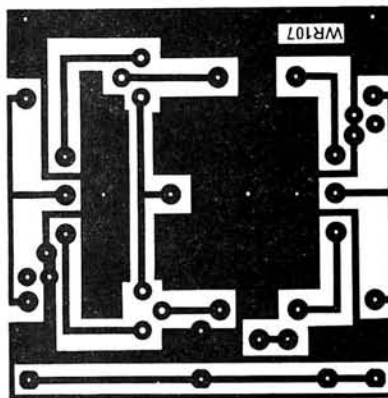
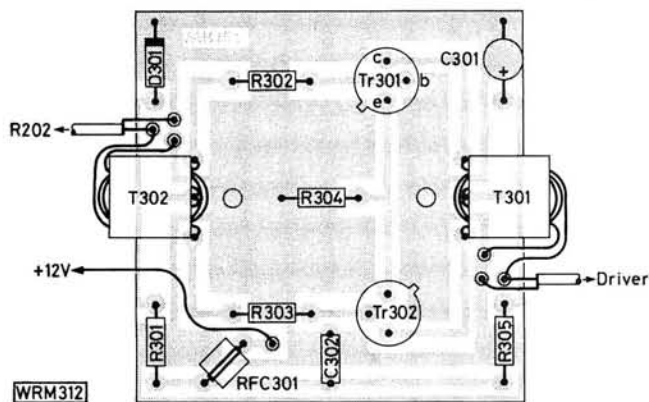

Fig. 12 (far left): The component placement drawing for the Tx First Amplifier board. Fig. 13 (left): The copper-track pattern for the Tx First Amplifier p.c.b. shown full size

Construction

Again this circuit is built on a simple p.c.b. and like the previously described boards all component leads should be kept as short as possible. When the final mechanical assembly of the completed transceiver is carried out this board will be mounted onto a removable screen using 6mm stand-offs. The output from the First Amplifier to the driver stage is made with miniature coaxial cable.

The input and output transformers are wound onto double aperture ferrite cores using 22 s.w.g. enamelled copper wire and taking care not to scratch the insulation. The cores are then fixed to the p.c.b. using epoxy adhesive and the ends of the windings taken to the appropriate pins on the p.c.b.

Table 2

	Primary	Secondary
T301	2T + 2T 22 s.w.g.	2T 22 s.w.g.
T302	2T 22 s.w.g.	2T + 2T 22 s.w.g.

First Trials

It should now be possible to carry out the first tests on the transmitting side of the *PW* Helford, albeit with only a low power output.

In Part 2, C702 was not fully specified. It must have a negative temperature coefficient.

Next month we will describe the r.f. driver amplifier.

PRODUCTION LINES

ALAN MARTIN G8ZPW

Mini TV

Hitachi have just launched a brand new product, the K2300, which is a very compact lightweight monochrome television with combined digital clock.

The set has a 4½ in tube and receives both u.h.f. and v.h.f. bands, selected at the touch of a button. Tuning has been simplified by using a vertical line on the screen, which indicates the channel being received and is cancelled by a button once tuned-in correctly. A built-in telescopic aerial is supplied, but for poor reception areas, an external aerial socket is provided. The quartz digital clock can also be set to switch the set on or off at any predetermined time.

Powered by either a.c. mains, car battery, its own internal batteries or an optional battery pack, the K2300 is also fitted with an audio recording jack and earphone socket.

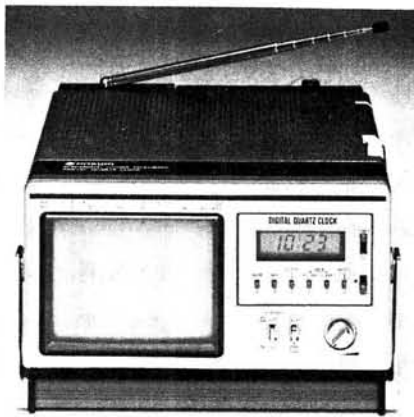

Priced at £115, which includes VAT, the K2300 is available through normal retail outlets.

Economy Keyboard Case

West Hyde Developments Ltd., the instrument case specialists have added a purpose-designed keyboard enclosure to their Princess range of cases for calculators, data input terminals and microprocessors.

Made in Britain, the enclosure is vacuum-formed in two halves which are clipped then screwed together for rigidity in final assembly. The ABS plastic is easy to drill, punch and clean and the base contains a series of mounting ribs.

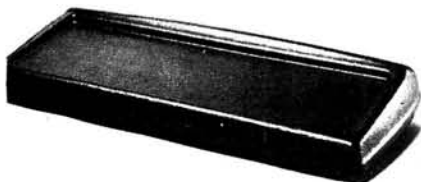

The Princess keyboard costs £10.75 plus VAT and overall measurements are 435 x 205 x 70mm high. The 380 x 130mm recessed area allows plenty of room for cutting out apertures to take the keyboard assembly.

West Hyde Developments operate an efficient 24-hour response, mail order service and also a sales desk at: Unit 9, Park Street, Industrial Estate, Aylesbury, Bucks HP20 1ET. Tel: (0296) 20441.

Cassette Accessory

An answer to the perennial problem of tangled cassette tapes, faced by anyone interested in recording or recordings, is provided by Fixotape, a new device just launched by Jorephani Exports.

Simple to use, Fixotape snap-fixes to any table edge or shelf, the cassette is then fitted with the tape fed through a guide, and at the turn of a handle the tangled, twisted, creased or knotted tape is freed.

Fixotape is being marketed through normal retail outlets, particularly hi-fi and record shops, but in the event of difficulty, can be obtained, price £1.99, which includes VAT and p&p, direct from: Jorephani Exports, Park Lane, Corsham, Wilts. Tel: (0249) 714855.

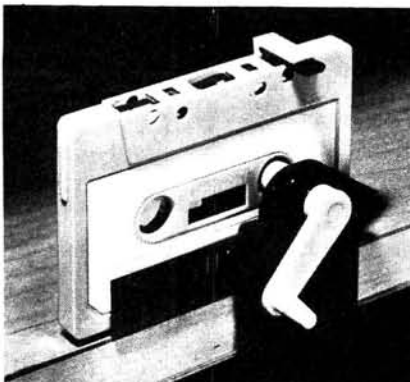

UHF/TV Aerial Amp.

Antiference announce the introduction of "XtraBoost" XB1U, a new u.h.f./TV aerial amplifier for indoor use.

Designed to improve reception in difficult areas, the unit is particularly attractive for the DIY enthusiast as it is easy to install and operate.

Specification for the XB1U amplifier is: Bandwidth, 470-860MHz; Gain, 10dB (3 times); Maximum output (4 u.h.f. channels), 30dBmV 31.5mV; Input/output impedance (nominal), 75 ohms; Noise figure <4dB. Powered by a.c. mains, fused at 3A and housed in a brilliant white high-impact plastic case should cost £14.40 plus VAT.

Further information from: Antiference Ltd., Aylesbury, Bucks HP19 3BJ. Tel: (0296) 82511.



Cutting Comment

Once in a while a tool is launched on the market which is labelled "universal", "all-purpose", etc., but rarely does it live up to its name.

One that does is the All Purpose Cutter from Vero Electronics. Having had one on trial for several months, its ability to cut just about anything has been proved on paper, cloth, cardboard, 22 s.w.g. aluminium sheet, cotton, string, wire and p.c.b. stock. It will even prune the roses! And after all that it still cuts paper cleanly.

The All Purpose Cutter is made from stainless steel, with plastics coated handles, and is available from Vero stockists, priced at around £4.30 including VAT.





FRG7700 COMMUNICATIONS RECEIVER

IT IS RATHER UNUSUAL TO HAVE SO MUCH SMALL PRINT IN AN ADVERTISEMENT LAUNCHING A NEW RECEIVER, BUT THEN THIS IS RATHER AN UNUSUAL RECEIVER!

General Coverage

From 30MHz to 150KHz (and at reduced spec down past 60Khz to almost DC!) in 1MHz bands selected by a 40 way rotary switch calibrated 0-29 (plus 1, 3, 7, 10, 14, 18, 21, 24, 28 and 29 for easy amateur band changes).

All Modes

SSB, (USB and LSB), CW, AM and FM. The inclusion of a N.B.F.M. detector and squelch opens new horizons. On 10m FM Simplex plus repeaters, and with a convertor, Marine, P.M.R. Lab use, and of course, the VHF/UHF amateur bands, where the high quality noise blanker will be found to be most efficient.

Selectivity

4 filters fitted as standard! SSB, 2.7KHz and FM 15KHz. For AM, 3 positions! Narrow 2.7KHz, Medium 6KHz and Wide 12KHz, which with the tone control, and switchable AGC provides the operating flexibility demanded by discriminating BCL's in today's crowded bands.

Sensitivity

Fraction of a microvolt sensitivity provided by the latest 3SK73 mosfet RF stage makes the best use of inefficient aerials for those difficult locations. A 20dB switchable attenuator and a continuous RF attenuator on the front panel minimises problems with very powerful stations.

Ease of use

No preselectors! The use of the latest up conversion circuits with a 48MHz first IF and professional grade crystal filter plus dual PLL system provides automatic selection of the input band-pass filter direct from the band sector or memory.

The VFO has both a pleasing bright, but dimmable digital readout and a back illuminated analogue scale. It is tuned by a comfortable 1 $\frac{3}{4}$ " knob with a 'fast tune finger tip recess' through a zero backlash slow motion drive. The front panel is remarkably uncluttered, clearly labelled and the controls in logical positions. The illuminated meter is calibrated in both conventional 'S' units (0-9 +20, +40, +60dB) and in SIMPO 1-5 for broadcast station reporting.

Antennas

On the rear panel a SO239 coax socket provides a 50 ohm input (2-30MHz) for resonant antennas and convertors. In parallel, and in addition, are posts, for Earth, and for 500 ohm antenna input (up to 2MHz).

Timer

An inbuilt quartz clock/timer is featured. Time is displayed in 12 hour format (with AM/PM indicators) on the digital frequency readout, ideal for accurate log keeping. In the event of a mains failure the clock will continue to run (but does not of course, display) on the memory back up cells. For use with a tape recorder:- 3.5mm jack provides 100mV of audio (irrespective of the

position of the AF gain control) and relay contacts (15V @ 1A max) provide remote control. This relay is switched by the timer which may be programmed for switch on/switch off (and snooze - allows up to 59 minutes of listening after switch off).

Memory (option)

12 frequencies *anywhere* within the tuning range may be stored by simply touching the M button and then recalled by pressing the MR button, no preselector adjustment, no range switch adjustment. The memory is tunable by ± 1 KHz and is kept alive year long by 3 'AA' dry cells. The memory may be used for storing all the frequencies of a particular broadcast station, and with a convertor, the common marine channels, 2m FM channels (switch between the VFO and memory for repeater input/output) etc.

World Wide Portability

Power:- Mains 240-220 VAC easy adjustment 100-120V, 50/60Hz and 12 VDC external supply.

Size:- 13" x 5" x 9"

Weight:- 14lbs (with carrying handle)

Speaker:- Inbuilt 8 ohms, 1.5W of AF, External 4-16 ohm unit. $\frac{1}{4}$ " phone jack for personal listening or winking out the weak ones.

Memory:- Going on a trip? Store Radio 4 and all the BBC World Services in the memory and keep in touch with the news.

FRG7700 £309.00
PRICES INCLUDE VAT @ 15%

FRG7700M £389.00
FREE SECURICOR DELIVERY

MEMORY £83.95
2 YEAR DISTRIBUTOR WARRANTY



SOUTH MIDLANDS COMMUNICATIONS LIMITED

S. M. HOUSE, OSBORNE ROAD, TOTTON, SOUTHAMPTON, SO4 4DN, ENGLAND
Tel: Totton (0703) 867333, Telex: 477351 SMCOMM G, Telegram: "Aerial" Southampton



S.M.C. (Jack Tweedy) LTD
Roger Baines, G3YBO
79 Chatsworth Road,
Chesterfield, Derbyshire
Chesterfield (0246) 34982
9-6: Tuesday-Saturday

NORTHERN (Leeds) BRANCH
Colin Thomas, G3PSM
257 Otley Road,
Leeds 16, Yorkshire.
Leeds (0532) 782326
9-5.30 Monday-Saturday

S.M.C. (Jack Tweedy) LTD
Jack Tweedy, G 3ZY
150 Horncastle Road,
Woodhall Spa, Lincolnshire
Woodhall Spa (0526) 52793
9-5: Tuesday-Sat (- appointments)



GW3TMP Howarth Pontybodkin (035287) 846/324
GI3KDR John Bangor (0247) 55162

GW8EBB Swansea (0792 872525)
G3ZUL Brian Stourbridge (03843) 5917

GM8GEC Jack Edinburgh (031665) 2420
GI3WWY Mervyn Tantragee (0762) 84056



TRIO
TR-7800

2m FM TRANSCEIVER



Trio's 2 metre mobile f.m. transceiver, the TR-7800 is the latest in a long line of well engineered, high performance rigs. Its external appearance of solid construction is further enhanced by the available facilities which to date have only been obtainable from the more expensive "multi-modes". At last a manufacturer has realised the potentially suicidal nature of mobile operation and applied a design philosophy allowing operational simplicity.

The evaluation sample arrived soundly packed, complete with mobile mounting bracket, scanning microphone, comprehensive instruction manual and approximately four metres of heavy connecting cable, a welcome change from the previous minimal allocation, which allows direct routing to the battery in most vehicles. The incorporation of in-line fusing is an example of basic installation protection, often left (and forgotten) to the unsuspecting consumer.

This report is based on considerable experience gained over a period of two months under mobile and base station operation. Manufacturers' statistics are quoted for reference in the specifications with measured parameters in italics.

Features

Referring to the accompanying photograph of the front panel, starting at the top left-hand corner, we have standard concentric volume and squelch controls. The squelch is easy to adjust, even with arms length operation it proved to be very precise with minimal closing delay. Audio output in excess of 2W is more than adequate for mobile situations and in most vehicles the internal lid mounted 75mm diameter speaker will suffice. An external 3.5mm jack socket is provided on the rear panel for connecting the optional SP.40 speaker pod.

The frequency display uses a four-digit 7-segment red l.e.d. device for keyboard entered readout and a similar 2-segment device for memorised channels. On-air transmit and busy indication is provided by respective yellow and red

l.e.d. devices as is the "S" meter which follows the current bar l.e.d. formation.

Selection of output power is accomplished by the HI-LOW latching push-button at the top right-hand corner. Low power is user-adjustable by accessible rear panel pot and can be set anywhere in the range, up to 15W. A 1750Hz repeater access tone is available by latching the TONE button. Subsequent tones are generated automatically when the microphone p.t.t. switch is depressed.

When operating in repeater mode, input monitoring is accomplished by pressing the REV button, which is of the non-latching variety.

Frequency Control

Keyboard operation of a rig is, in the reviewer's opinion, best kept to base station mode. With this concept in mind the split personality of the TR-7800 becomes apparent. By use of the KEY or MEMORY SELECT button it is possible to select frequency either via the keyboard pad, or the large rotary switch knob for access to the 15 memorised channels. All normal memory programming is conducted via the key pad.

In practice, memory programming is easy to accomplish and is comparable to operating a basic calculator. If you do make an error the displayed characters can be removed by pressing the "C" (clear) button. Inbuilt lockout will inhibit transmission if an attempt is made to enter out-of-band frequencies. Non-standard offset can be provided by using channels 13 and 14 allowing any choice of "in band" splits. This feature is useful when transverting to 70cm where repeater shifts of 1.6MHz are required.

When in keyboard mode it is possible to select frequency via the microphone UP-DOWN shift. By pressing the appropriate button once, the displayed frequency will shift 25 or 5kHz dependent on STEP selection.

In either keyboard or memory mode, holding the microphone UP-DOWN button down, or pressing the keyboard button marked SC, will cause continuous scanning of either the full 2MHz bandwidth or pre-memorised channels. If a

Test equipment

Bird model 43 Thru-line wattmeter and 50Ω dummy load;
 Marconi TF2370 spectrum analyser with TF2373 frequency extender;
 Racal 9081 synthesised signal generator;
 Marconi TF2011 v.h.f. f.m. signal generator.
 The test measurements are shown in italics

★ specifications

GENERAL

Frequency range: 144.000 to 145.995MHz
Frequency synthesiser: Digitally controlled, phase locked v.c.o.
Mode: FM (F3)
Antenna impedance: 50 ohms
Supply requirements: 13.8V d.c. \pm 15% negative earth
Operating temperature: -20°C to $+50^{\circ}\text{C}$
Current consumption: 0.4A in receive mode, squelch closed
 6A in HI transmit
 2.5A in low transmit
 Memory back-up 3mA
Dimensions: 175 x 64 x 206mm
Weight: 2.1kg

RECEIVER

Sensitivity: Better than $0.5\mu\text{V}$ for 30dB S/N
 Better than $0.2\mu\text{V}$ for 12dB SINAD
 ($0.11\mu\text{V p.d.}$ for 12dB SINAD constant across bandwidth)
Selectivity: 12kHz (-6dB)
 24kHz (-60dB)
Adjacent channel Intermodulation response: (-88dB)
 (-78dB)

"S" Meter

calibration:
I.e.d. No. 1 ($-4\text{dB}\mu\text{V}$)
I.e.d. No. 2 ($0\text{dB}\mu\text{V}$)
I.e.d. No. 3 ($+5\text{dB}\mu\text{V}$)
I.e.d. No. 4 ($+11\text{dB}\mu\text{V}$)
I.e.d. No. 5 ($+15\text{dB}\mu\text{V}$)
Squelch sensitivity: $0.16\mu\text{V}$ (threshold)
 ($0.06\mu\text{V p.d.}$)
Audio output: 2W into 8Ω load (2.6W 10% dist. 1.7W at onset of clipping)

TRANSMITTER

RF output power into 50Ω load: (13.8V d.c. supply)
HI: 25W min. (32W)
 (25W at 12V)
LOW: 5W (adjustable) (5W)
 (5W at 12V)
Modulation: Variable reactance direct shift
Frequency tolerance: Better than $\pm 20 \times 10^{-6}$ over temperature range
Spurious output: HI: Less than -60dB (Better than 65dB down on carrier 0-1250MHz)
 LOW: Less than -53dB (Better than 60dB down)
Deviation (max.): $\pm 5\text{kHz}$
RPT. Tone-burst frequency: 1750Hz
Microphone: Dynamic 500Ω with p.t.t. and UP/DOWN switches

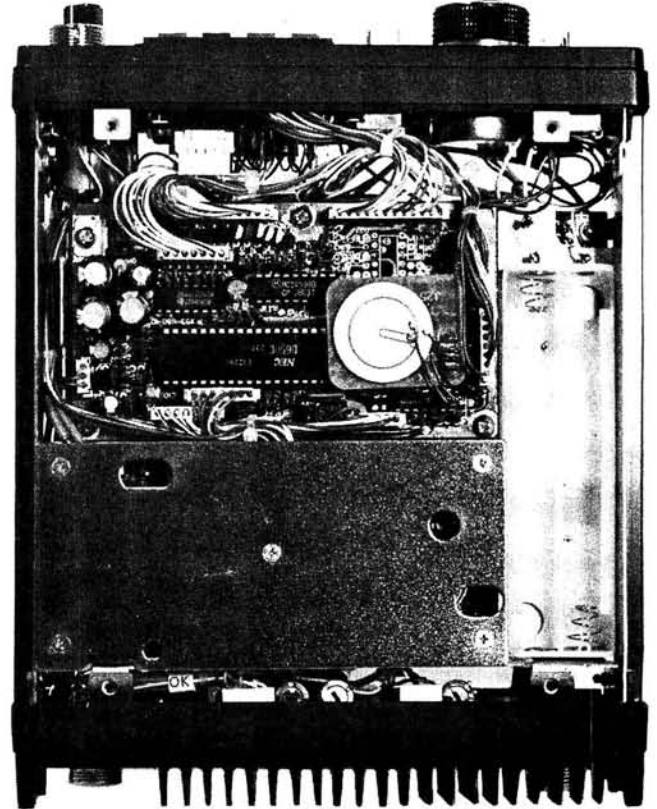
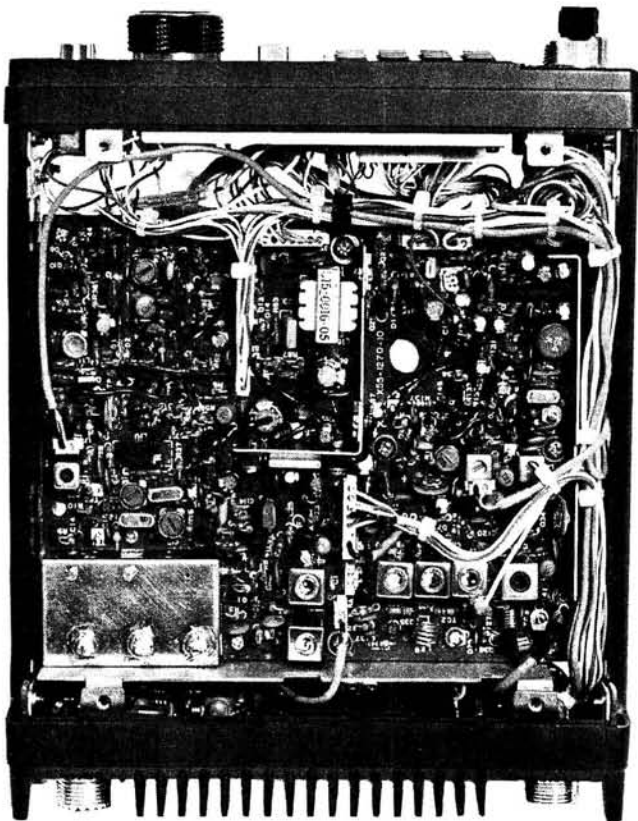

busy frequency is located the scan will stop automatically for five seconds. Scanning is terminated by pressing the p.t.t. switch or either of the UP-DOWN buttons.

Further features are provided in conjunction with the scanning section. When ALERT is latched in, the selected frequency memorised in channel 14 is checked at 6-second intervals, accompanied by an audible tone "blip", regardless of currently displayed frequency. By pressing the button marked OPER an instant QSY is made to memory channel 14.

Internal construction and layout follows the common Trio format of two separate circuit boards mounted back to back. This affords good access to all components which are clearly identifiable by screen printed lettering. From the r.f. point of view the TR-7800 incorporates conventional phase-locked-loop frequency synthesis, the receiver section being a double-conversion superheterodyne with a first i.f. of 10.695MHz and second i.f. of 455kHz. One interesting constructional feature is the incorporation of a final-stage power amplifier module. As this device is fully integrated all variable matching components associated with discrete final drive stages are made unnecessary, and are factory matched for life.

Operating Impressions

After carefully reading the instruction manual and relating it to the controls, operation became straightforward. Initially the hardest area to grasp was concerned with channel programming but even this soon became instinctive.

Reports received during many QSOs indicated clean, normal levels of transmitted audio with no evidence of excessive tonal colouration. The only adjustments found necessary were to the factory-set, two-second duration and amplitude level of the tone-burst generator. By removing the appropriate side cover the relevant board was easily located and adjustment made. On receive the exceptionally sensitive front-end performance was found to more than complement the rig's 25W-plus high power output. Even operating during crowded "lift" conditions produced no discernible adjacent-channel or cross-modulation effects.

For serious mobile working over distances in excess of 30 miles the transceive compatibility offered by the TR-7800 was found to be ideal, ensuring access to repeaters when audible. As a basic guide, it has been found that a transceiver with a receiver section sensitivity of 0.22 μ V, for 12dB SINAD, requires a matching output power of 25 watts.

As the rig was used in mobile and base-station modes it was found well worth while fitting the optional four AA size NiCad cells to the internal tray. This provided a power supply back-up, claimed by the manufacturers to last up to five days without recharging. Whilst connected to the mobile supply or base p.s.u., internally generated float charging of the cells is provided. For base station use only, a supply can be provided from a standard NiCad charger connected to the rear-mounted socket marked BACK-UP.

Also located at the rear of the rig is the UHF SO239 aerial connection and a further pair of user accessible potentiometers for the adjustment of the r.f. level metering and p.a. module protection circuit. This last facility progressively reduces the output power level delivered by the final stage when a mismatched condition is detected. The clarity of the display sections was found to be adequate for all light levels encountered.

In conclusion, the TR-7800 offers to the base station/mobile user state-of-the-art facilities on 2 metres f.m. at a price of £268.

The Trio 7800 is available from **Lowe Electronics Ltd., Chesterfield Road, Matlock, Derbys. Tel: 0629-2817** to whom we offer our thanks for the loan of the review unit.

BACK UP PSU FOR PORTABLE RADIOS

▶▶▶ continued from page 61

and "don'ts" concerning the operation of this unit. It can be plugged into and unplugged from the radio, whilst the latter is playing, without damage. As soon as the plug is removed, the "latching-up" collapses, the plug becomes totally dead, and the mains transformer in the p.s.u. is de-energised.

Other Voltages

It is possible to make the p.s.u. supply a nominal 6V instead of 9V, R3 should be omitted in this case. Also, R6 should be shorted out if RLA is being energised from a PP6 source.

Modification of the Radio

To simplify the modification of the TR130 radio, its car aerial input socket was removed (it is never used in the writer's car). This made way for the 3 pin DIN socket which was easily fitted after filing out the hole in the chassis. The two halves of the cabinet needed the file treatment as well.

The l.e.d. can be conveniently fitted at the lower right hand corner of the radio dial (in the case in question, just below the "Bush" motif). A hole has to be drilled, and the l.e.d. pushed through. The dial backplate is plastic, so the l.e.d. can be a push fit.

For other radios, the circuit will be the same, but of course, the constructor will need to devise his own layout.

Bearing in mind the cost of batteries these days, a power unit would not take very long to off-set the cost of construction. *Electrical and Radio Trading* journal quoted Ever Ready prices as:

PP3	0.55p
PP9	0.99p
HP2	0.29p
HP11	0.27p

Having trouble getting your copy of PW each month?

Why not place a regular order with your newsagent, or take out a subscription?

LOWE ELECTRONICS LTD

PART OF THE



TRIO LINE

A SUPERB GENERAL COVERAGE RECEIVER

**R1000 £285.20 inc VAT
carriage by Securicor £4.50**



The R-1000 is a high class general coverage receiver covering 30 bands between 200KHz and 30MHz with a PLL synthesizer that incorporates all of Trio's sophisticated electronic technology developed over recent years.

Both digital display readout (1KHz resolution) and analog display (10KHz resolution) are provided for easy and accurate tuning.

The R-1000 also includes a quartz digital clock with timer, three IF filters, RF ATT and tone control, etc. to ensure the best receiving conditions for each mode.

Due consideration has been given to innovative design and compactness, making the R-1000 an incomparable station receiver for amateur radio operators, professionals, BCL's and SWL's, etc.

THE 2 METRE FM MOBILE TRANSCEIVER

**TR7800 £268 inc VAT
carriage by Securicor £4.50**



The new TR7800 is the only 2 metre FM mobile transceiver. Its performance both in your car and shack has to be experienced to be believed. Power output is 25 watts, a needle bending signal. The rig has keyboard entry for fixed station use and for programming the 15 memories. When used with the up/down shift switch on the mike the 15 memories, each having a repeater shift facility, make mobile operation a sheer pleasure. The scan facility, both on memory and 25/5Kc on keyboard means no missed contacts. Five second hold on each occupied channel gives you time to identify the station before the rig moves on to the next QSO, press the mike switch and the scan instruction is cancelled. Add the priority facility and you have it, the only 2 metre FM mobile rig.

THE HF SSB TRANSCEIVER

**TS520SE £437 inc VAT
carriage by Securicor £4.50**



In the face of ever increasing complexity in amateur radio equipment, it's comforting to know that the TS520SE is still in volume production. Radio amateurs all over the world (and dealers too) have voted the TS520SE "my favourite transceiver" because of its astounding reputation for reliability, high sensitivity receiver, and of course the unequalled Trio audio quality coming from the transmitter. The TS520SE incorporates all of the features demanded by today's amateur, and at an outstandingly low price. No wonder it's top of the list in popularity, and comparison with other transceivers will convince you that the TS520SE is the best value for money on the market today.

Of course, the bare figures cannot tell you just how nice the TS520SE feels in use, nor can they tell you the pleasure of hearing other operators saying "never heard better audio OM, what rig are you using?"

**THE ABOVE REPRESENTS A SMALL PART OF
THE TRIO LINE. SEND 48p FOR FULL DETAILS**

HEAD OFFICE AND SERVICE CENTRE

CHESTERFIELD ROAD, MATLOCK, DERBSY. TEL 0629-2817 or 2430 OPEN 9-5.30 TUES-SAT. PHONE 9-9

For personal attention on the South Coast contact John, G3JYG, 16 Harvard Road, Ringmer, Lewes, Sussex. Ringmer 812071.

For equally helpful attention in Scotland contact Sim, GM3SAN, 19 Ellismuir Road, Baillieston, Nr. Glasgow. 041-771 0364.

FOR ALL THAT'S BEST IN HAM RADIO CONTACT US AT MATLOCK.

THE **PW**

'SHERBORNE'

**SYNTHESISED
AM/FM TUNER**

PART 4

W.S.POEL

In this, the final part of the *PW* "Sherborne" series, we deal with the construction of the tuner modules, plus testing of the complete system.

Construction of the Tuner Modules

The f.m. tuner heads are presented as entirely prefabricated and pre-aligned units, so this part of the text will concern only the f.m. i.f./a.m. tuner system, and the stereo decoder.

The a.m./f.m. system p.c.b. layout is shown in Fig. 31. It is very densely packed in comparison to most enthusiast constructional projects, and if you feel this is beyond your skills, this item is also available as a prefabricated module from Ambit International. The unit is designed to fit into a proprietary set of metal work, with push-fit lids, to ensure full screening of the i.f. from any external r.f.i. and vice-versa. There is realistically very little hope of successfully contriving to produce a home-made p.c.b. of this complexity.

The i.c. can be fitted using a socket, although unless you use a Zetronix low-profile type, the fit can be impossibly tight. Care should be exercised in the selection of the correct varicap diodes for the tuned circuits; only the Toko KV1215/1235 types are suited to this application by virtue of their inherent matching. The fact that each tuned circuit is provided with its own individual varicap relaxes the requirement for absolute accuracy of matching of the tuning elements.

The choice of the other components is not very critical in terms of stability considerations. The use of disc or plate capacitors much larger than 5–7mm diameter/section is a nuisance in such a tightly packed environment, and will inevitably lead to untidy construction with unhelpful side effects on the behaviour of the system. The size and complexity of the projects demands that only trustworthy components should be used. Temptations to dip into the junk box should be resisted. The printed circuit board layouts of the ferrite rod antenna switching/tuning arrangements (Fig. 32) and Stereo Decoder module (Fig. 33) are less crowded, and should not present any difficulties.

The design work in producing the circuit of the a.m./f.m. module is as much contained in the physical layout as in the actual diagrammatic representation of the circuit elements, so whilst you are welcome to try to adapt the circuit to incorporate any of your own ideas and innovations, it is as well to start with the basic item as

shown, since it is far easier to work from a starting point of a known and proven circuit.

One final point—although it may seem unlikely to those not versed in r.f. techniques, it is really quite important to note the way in which components are fitted, since certain stand-up resistors have a polarity in terms of a "hot" and a "cold" (earthy) end with respect to r.f. considerations.

Take, for example, R14 in Fig. 14 (Part 2). The upper end is decoupled to earth via C13 and can therefore be considered to be earthed from an r.f. point of view. This is the "cold" end. As R14 is the collector load for Tr1 (a 10.7MHz i.f. amplifier), the amplified output from Tr1 is developed across it, and the lower end of the resistor is therefore the point of maximum r.f. potential in the circuit. This is the "hot" end.

In all such cases, the lead at the "hot" end of the resistor should be kept as short as possible. The earthy end is then the longer end.

The careful placement of resistors in audio sections is also advised, since it will then be possible to use the end standing up to connect test probes to check signal path continuity.

Testing

We have now completed construction of the various sections of the complete tuner. Some brief setting up information has been given for the synthesiser section, but for complete checking, the radio must be fully assembled and used in conjunction with all the features of the synthesiser.

Although various aspects of the system are interactive, the synthesiser and radio modules can be used independently if so desired, so the setting up and testing of the radio section should be treated separately in the first instance. This way, faults in the radio construction will not mislead the constructor when a complete system check in conjunction with the synthesiser is attempted.

The f.m. front end can be assumed to be working on arrival, but if you take the lid off to look inside, make sure that you put it back the same way, as the lids are not entirely symmetrical in the UM1181, and can cause the underside track to be shorted out.

The f.m. i.f./a.m. tuner module can likewise be assumed to be working on arrival, but in case you have decided to make it yourself, a few details are included below. You should not attempt to make this section unless you have a signal generator and frequency counter, and are familiar with using them in conjunction with radio fault-finding and alignment.

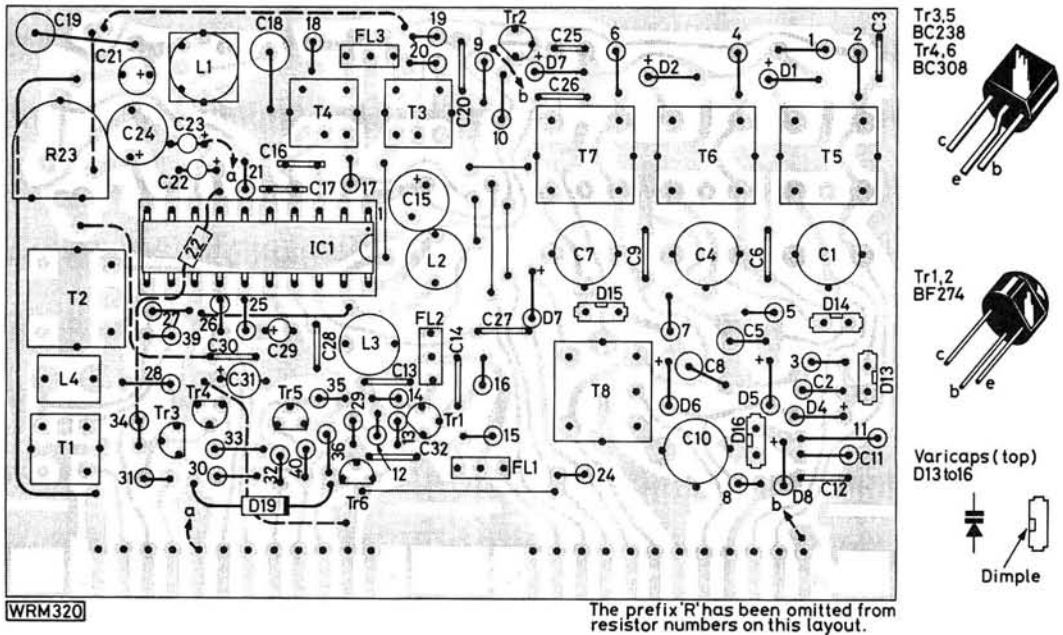
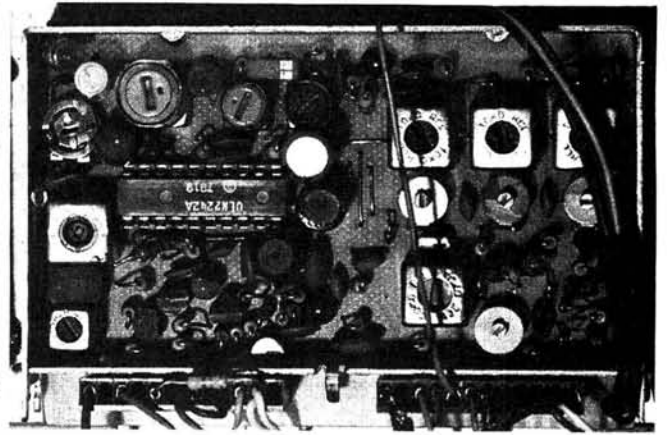
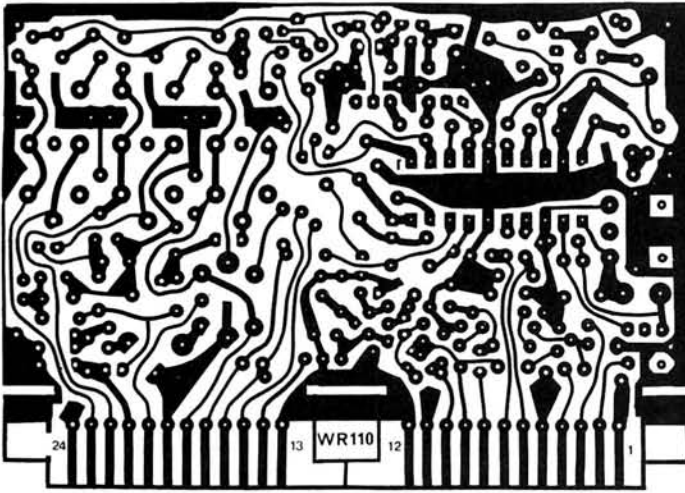

Fig. 31: FM IF and AM Tuner module, showing the p.c.b. pattern (full size) and component layout (approximately 1-3 times full size). The photograph shows a prototype version of the module, which differs in some minor respects from the one in the drawings. The leads to the ferrite rod antenna assembly are connected underneath the board

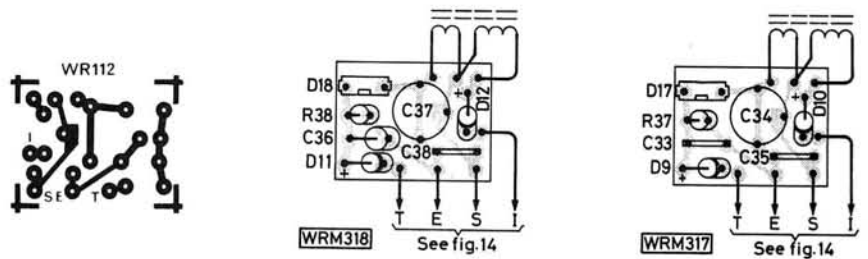
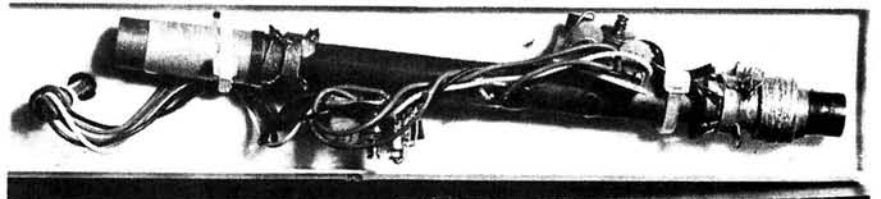

Fig. 32: The ferrite rod antenna p.c.b. pattern and component layouts for the medium-wave and long-wave switching/tuning boards, all shown full size. The photograph shows the completed antenna assembly



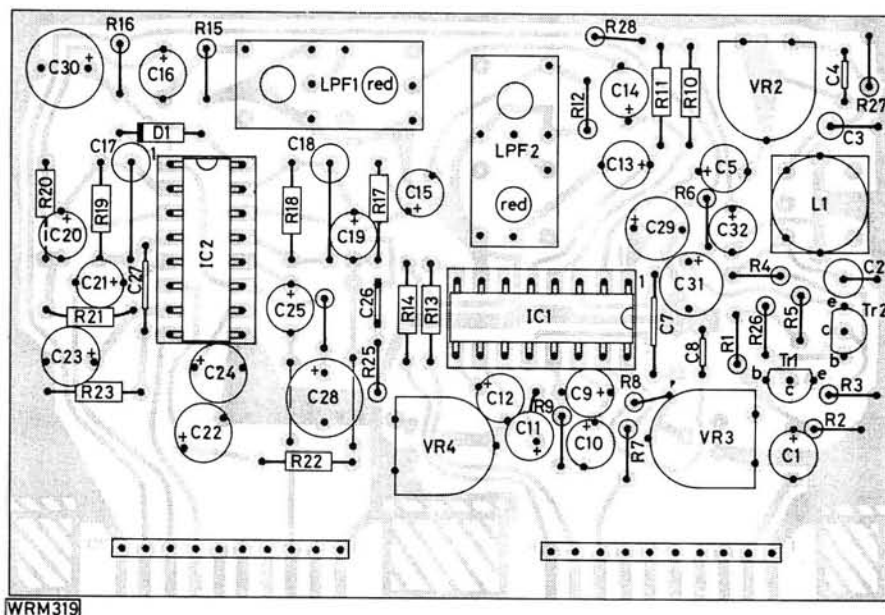
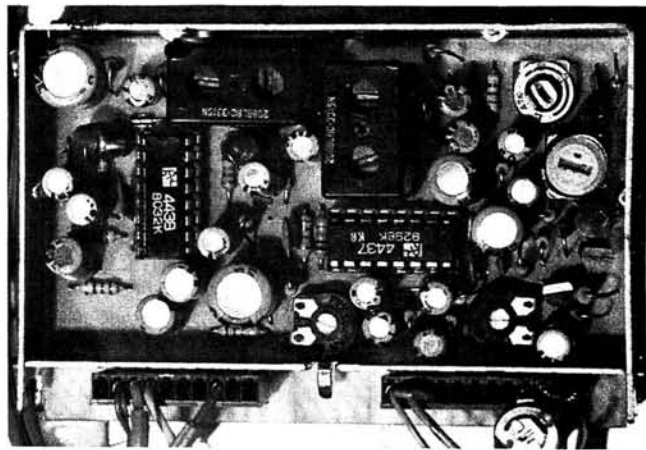
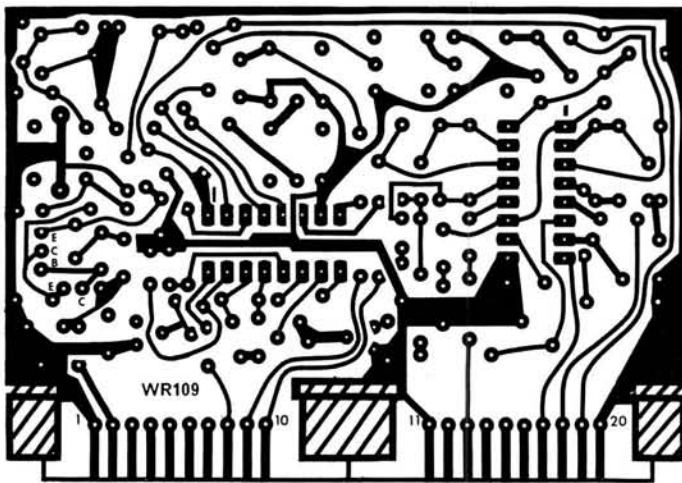

Fig. 33: The Stereo Decoder and Muting Pre-amp module, showing the p.c.b. pattern (full size) and component layout (approximately 1-3 times full size). The photograph shows the completed module

WRM319

Aligning the FM IF and AM Tuner

This section should be tested first as an f.m. i.f. and detector, and then as an a.m. radio when the f.m. function is established and working. The unit should be connected up as an f.m. i.f. in the first instance, with an i.f. feed from the tuner head—using a stable 12V tuning supply or a battery. With tuning bias of 2-4 volts, the majority of the local Band II f.m. broadcast stations should be audible. (Remember an antenna!)

The initial switch-on condition should provide smooth white noise at the audio output—with the muting system completely defeated for the time being. (Ground pin 5 of the module.) If the sound is crackling and broken up, then check to make certain that all decoupling capacitors are in place.

A centre-zero meter should be placed across the a.f.c. output (pin 3) and the a.f.c. reference (pin 11), and the detector coil T2 should be rotated for zero offset. If you use a metal trimming tool for this operation, check that the results are the same when you take it out—as it may be necessary to compensate by turning the core a fraction further clockwise before removing the tool. It should be possible to cause the meter to swing from one extreme to

the other, with the noise at the centre zero position being the characteristic smooth sound of an f.m. tuner "off station". At either extreme, the heavy d.c. offset in the audio path will cause the signal to be limited on one side, leading to clipping distortion.

An ordinary 12V d.c. meter should be connected between pin 10 and earth, as this is the output of the deviation mute detector. The output should go low when the tuning is swung through the centre of the tuning meter—but remember to disconnect the short from pin 5 to ground to re-enable the mute output, and take pin 8 to ground to disable the effects of the noise mute circuit.

The remaining parts of the muting circuit can be checked by tuning to a station and checking the output at pin 6 of the module. This output is usually high, but goes low when a signal is tuned. The very high gain front end used in this design may possess sufficient noise in the output to cause the mute to operate on inter-station noise alone. In the final system, this is not of too much concern, since the MPU is responsible for the muting whilst tuning is being carried out. However, to establish that this section is working correctly, the mute should go high when the i.f. input is shorted, or the connection from the front end is removed.

Once the noise mute function has been verified, it can be added to the deviation mute by connecting pin 6 to pin 8—or in the case of high-gain front ends, by connecting the a.g.c. output on pin 7 to pin 8, since this output goes low only after some 1000 μ V of input signal. If the detector persists in displaying a large d.c. offset, check that no part of the a.m. detector transformer secondary is earthed (see Part 2 of this article for a detailed explanation of the mechanism of this problem).

The a.m. section can be checked out by simply leaving pin 15 of the module open-circuit, and grounding the desired band selector. Start with the Long Wave, and tune for approximately 200kHz by adjusting the tuning voltage and then the core of the oscillator coil. See Table 2 for approximate voltage/frequency values. The antenna coil on the rod should be peaked by shifting its position.

Unlike many designs, the Medium Wave is completely independent of any Long-Wave trimming, and so may be treated as an entirely separate entity. Tune and trim at the points shown in Table 2 using the coil at the l.f. end, and the capacitor at the h.f. end with a bit of both in the middle.

Short Wave requires the attachment of a wire antenna at pin 20 of the module. A 10–20pF capacitor should be placed in series at this point, or the loading effect on the SW tuning is too severe for the stage to be tracked with the oscillator. If desired, the SW coils can be substituted by a MW coil for a long-wire type of MW antenna if you are after serious medium wave DX, but then an extra tuned circuit or two in the form of a preselector is a good idea to avoid overload and image breakthrough. A careful design can use the same tuning and switching voltages and still retain its tracking, with maybe a simple “peaking” trimming adjustment for optimisation. In fact, the same basic idea can be carried through to any extension of the front end of such a varicap-tuned radio system.

The major points to watch for when testing this module are simple and obvious things—like the correct orientation of the varicaps and switching diodes. Despite the apparent complexity of the system, a correctly constructed and connected unit can be made to work with the minimum of fuss—provided you have the test equipment mentioned earlier. Playing it by ear can be a lot more long-winded.

The Stereo Decoder

The input birdy filter may be omitted, since this function is carried out by the output filter of the i.f. strip. If correctly assembled, the stereo decoder phase-locked-loop v.c.o. trimming can be carried out by simply tuning to a stereo f.m. signal, and adjusting the preset VR3 until the l.e.d. lights up.

The stereo decoder can be made from component parts with minimal bother, but if you have an oscilloscope and access to alignment equipment, then so much the better. The main alignment consideration here is the accurate setting of the pilot cancel notch, which may be achieved by simply looking at the audio output whilst listening to a stereo transmission, and adjusting the pilot cancel preset VR4 for minimum 19kHz. You will see the 19kHz sawtooth disappear completely at the absolute null point. Since this is a phase adjustment, the correct adjustment of the preceding birdy filter will be interactive, and the birdy filter can only be accurately set up with a sweep generator and spectrum analyser—or by listening for the stereo test tones, and setting the core for maximum separation. A stereo generator could also be used for the purpose if required.

If you are listening to a.m. and there are loud whistles coming through, then remember to use the v.c.o. defeat

Table 2

Approx. Tuning Voltage	Typical Frequency			
	LW kHz	MW kHz	SW MHz	FM MHz
1.0	—	558	—	—
2.0	—	612	—	90.0
3.0	155	666	—	94.5
4.0	173	738	—	98.0
5.0	191	828	6.2	101.0
6.0	227	999	6.9	104.0
7.0	263	1224	7.8	106.0
8.0	290	1332	8.8	108.0
9.0	317	1476	9.3	—
10.0	335	1557	9.7	—
11.0	353	1611	—	—

facility to prevent this problem occurring. Simply using the enforced mono pin will not actually disable the v.c.o. action.

Test the muting action of the output pre-amplifier by placing 4V or so on the muting pin of the module—this effect will be swift and totally silent.

Connecting Up

If you have persevered this far through the project, then the moment of complete assembly is at hand. If your synthesiser section is working as far as you can tell from the functions that are independent of radio “feedback”, then connect up the entire system as shown in Fig. 10, in Part 2.

Start the final alignment session with at least three hours to spare, and plenty of patience! Things like the correct voltages from the power supply section, the certainty of a working set of tuner modules, etc., are taken for granted. This is no time to start debugging these minor elements of the overall system.

First switch on, see if everything is quite happy, and that there is no nasty “cooking” smell from anywhere. Select MW from the synthesiser control and press the manual tune button until you reach a known local frequency—such as 909kHz. Strong signals should be coming through, and if so, keep going through the band until something goes wrong.

The most likely problem is the loss of lock signal, causing the mute to stay shut at the extremes of the band. This is because it is possible to align the tuner module over a span of tuning voltages so that although on a manual test, the complete 520kHz to 1620kHz range may be covered, the more limited range of tuning voltage available from the synthesiser output may not be enough. Say the unit covers the entire desired frequency span with 1–13V bias, yet the synthesiser tuning voltage is 12.5V maximum. After 12.5V has been reached, the synthesiser will step on, but it will lose lock as the a.m. local oscillator cannot quite squeeze to the necessary frequency.

Adjust the trimmer of the MW oscillator coil until the synthesiser can reach 1620kHz with the voltage output available. The synthesiser will then “go over” and start from 520kHz again. If you find it necessary to do this a couple of times to get the tuning range spot on, load the top and bottom frequencies of each band into the tuning memory (first getting ENABLE to light up—which requires

a signal to be present and locked in anyway), and then the adjustment is quite easily performed by recalling each end of the band in turn. You should have no problems with f.m., where the entire tuning span is comfortably within the range of the synthesiser output.

If you get no success at all on a.m., then check the local oscillator output from the module and its connection to the synthesiser. If you continue to draw a blank, move on to the f.m. section to try to determine if the rest of the system such as bandswitching and MPU control connections are in order.

If nothing happens on f.m. either, and you cannot obtain any "locked-on signal", then check that the prescaler supply voltage is being switched on by the switching logic—and make certain the connection is getting through to the prescaler. If you still cannot obtain any working signals on f.m., check the output of the prescaler (the input is a better place, assuming that you have the necessary 100MHz bandwidth scope). It is a fairly ragged 10MHz (approx) squarewave, and if it is actually being driven from the f.m. local oscillator, then the frequency will vary if you disconnect the f.m. tuning bias voltage, and reconnect it to a manual tuning system. The low-pass filter at the prescaler output can sometimes be too severe, and if the output of the prescaler after the l.p.f. is heavily attenuated, this can cause problems for the p.l.l. The filter can be bypassed at this stage of the test procedure to see if this is contributing to the problem, although at a later stage, you should refit it (or a slightly less severe version, with reduced turns on the choke), to prevent spurious radiation of harmonics causing birdies in Band II.

If you tune the f.m. to a known Band II frequency, and then set the synthesiser to the same value—check to see if the output of the phase detector of the p.l.l. i.c. indicates a signal that is trying to lock. If there is still nothing doing, but you are getting all the right readings on the display, and the prescaler output seems to indicate that all is getting as far as the p.l.l. input, then the synthesiser control lines to the p.l.l. i.c. may be faulty (bad soldering, bridged joint, etc.). If there is nothing getting to the prescaler, then check the l.o. buffer amplifier stage very carefully.

You will eventually reach a stage when all bands are working—and the last item to sort out is the function of the automatic tuning/scanning. Push the button and see what happens, starting with f.m. The scan stop signal from the i.f. should cause the MPU to stop exactly on station. There is no other preset adjustment for the f.m. scanning, and the only problems that arise can be caused by the incorrect setting of the detector coil. If this is so, set the synthesiser to a known local Band II transmission, and check the centre-zero tuning voltage with a meter, as described in connection with the initial testing of this module. The detector should then be trimmed for an absolute null, leading to the deviation mute signal going low exactly on channel.

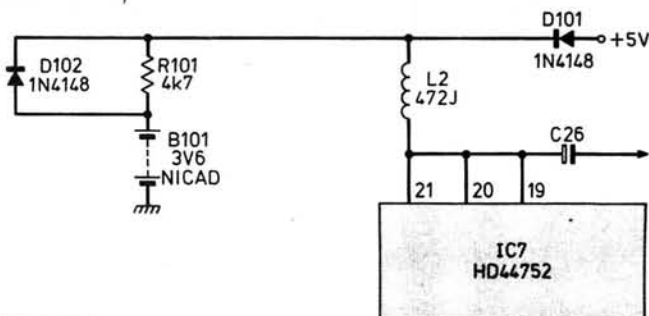

WAD728

Fig. 34: A simple modification to add battery back-up to the synthesiser station memory

The a.m. scan stop signal is slightly different, and can be preset to stop only on signals above a certain signal level. The preset should be set by experimentation under average listening conditions so that relatively noise-free signals only will cause the scanning to stop. Remember that the MPU will only scan whilst a signal is in lock—so when the scan reaches a band end, and starts from the other end again, it pauses a few seconds while the various filter components on the tuning bias line charge/discharge. Likewise, if the tuner goes out of lock, the scan will stop, and the mute stay shut. The manual tuning controls will still advance the display, but the system will not in fact be doing anything more than changing the readout numbers.

For any additional information on the system or components thereof, you should refer to the manufacturers' data sheets and information. Despite the length and scope of this feature, there is much left still unsaid about other aspects of the system that the more adventurous might like to delve into. For example, the auto rotating m.w./l.w. ferrite antenna, the s.w. converter, etc.

Memory Back-up

For constructors who prefer to switch off their tuner at the mains when not in use, Fig. 34 shows a way of adding a back-up battery to retain frequency and band information for the eight memory channels at all times. It is not possible to keep the clock going since this is controlled by a signal from the p.l.l. i.c. reference divider chain.

The added components are those with reference numbers in the 100 series. Diodes D101 (inserted in the +5V supply line to pins 19, 20 and 21 of IC7) and D102 form a simple gate which connects the higher of the two voltage sources to the MPU. Resistor R101 provides a charging current of around 500µA for B101 so long as the mains supply is connected to the tuner.



Your national radio society

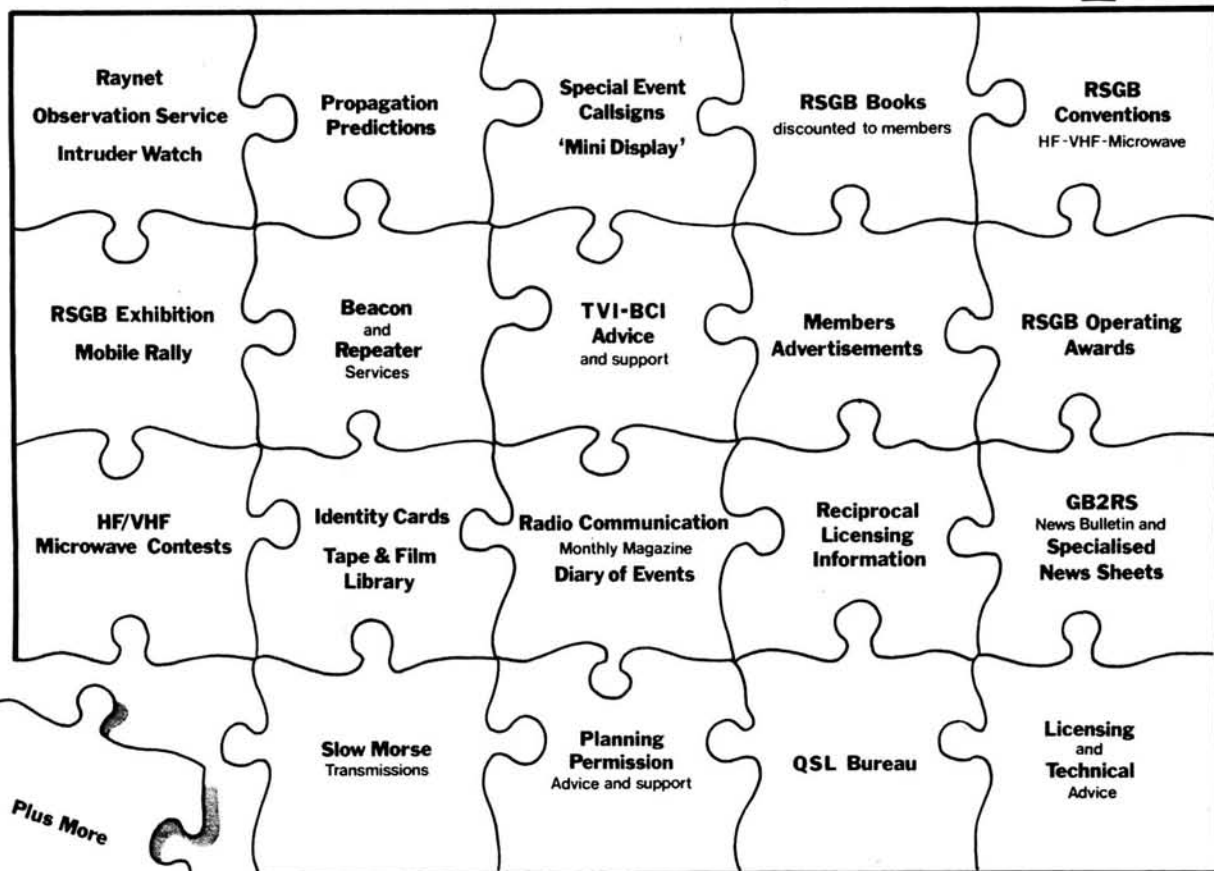

The Radio Society of Great Britain provides a complete range of services and benefits to radio amateurs and listeners, including the vital national and international liaison essential for the well-being of amateur radio.

For full details of the Society, send a post card with your name and address to:-

Radio Society of Great Britain, Dept PW1,
35 Doughty Street, London WC1N 2AE.

Discover the world of

• **AMATEUR RADIO** •

with RSGB

SOUND ADVICE – SOUND VALUE

A GOOD START is essential to short wave listening and expert advice is important in achieving this – So here's some – If you've made up your mind to buy a receiver you should be aware it will perform only as well as the antenna it sees. The old adage regarding wire antennas "As long and as high as you can" is still good, but at best is only good for PEAK PERFORMANCE on one or two frequencies, at worst none.

Whichever frequency you tune your receiver to, for PEAK PERFORMANCE on all frequencies you need good matching between your Receiver and Antenna to hear the best from it. If you plan to listen on the high frequency bands up to 30MHz then you know you can't have an antenna for every frequency! Or can you? – Well Not quite! BUT we can offer you MUCH IMPROVED PERFORMANCE from your receiver by using an antenna tuning unit, that will electrically change the length of your antenna to match the frequency you select – In other words – A MATCH AT ALL FREQUENCIES.

You'll see many antennas being advertised under gimmicky names, but when it comes down to it they're only random wires or odd configurations. At the end of the day, if you're expecting the performance the manufacturers want you to have, you'll still have to buy an antenna tuning unit.

Tell you what we'll do – we'll prove it to you – we'll give you one ABSOLUTELY FREE when you buy your FRG 7 or FRG 7000 and we'll give you complete advice on an antenna to suit your available space, which should only cost you a couple of pounds!

So let's put the offer in big print for you!

Yaesu FRG 7 + Amtech 200	199.00
Yaesu FRG 7000 + Amtech 200	£299.00
Trio R1000 + Amtech 200	£299.00
Yaesu FRG 7700S + Amtech 300	£309.00

Yaesu FRG 7700S with 2 metres	£315.00
Yaesu FRG 7700M + Amtech 300	£389.00
Yaesu FRG 7700M with 2 metres	£399.00
VAT included	Carriage £3.00

What's the difference between the Amtech 200 and Amtech 300? Well both will tune any random length of wire but the Amtech 300 will do a little extra – it will also match co-axial fed antennas – Their normal selling price, The Amtech 300 £39.95 – The Amtech 200 £25.95 – What can you lose?

So get cracking MAKE A GOOD START! HAVE PEAK PERFORMANCE FROM THE OFF.

JAYBEAM – HYGAIN – BANTECH – AMTECH – CUSHCRAFT – SWAN – ATLAS
and 50 other major lines – all ex stock.



AMCOMM SERVICES

194A NORTHOLT ROAD, SOUTH HARROW, MIDDX. Tels: 01-864 1166 & 01-422 9585

OPENING HOURS: Tues-Sat 9.00-5.30 Sunday by appointment.



INSTRUMENT CASES AND BOXES

a comprehensive, top quality range of products.

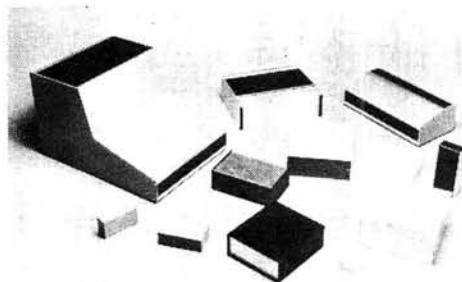

Minibox 521 – 563 as used in
PRACTICAL WIRELESS

Back-up power supply for a
PORTABLE RADIO

Retail supplies are available from—

ELECTRO TECH COMPONENTS LTD.,
364 Edgware Road,
London, W.2.
Tel. 01-723 5667

Minibox 521-563 £3.00 each incl. VAT P&P



**Zaerix
Electronics
Limited**
46 Westbourne Grove,
London, W2 5SF, England.
Telephone: 01-727 5641/2/3
Cables: Zaero, London, W2.
Telex: 261306



CB AND AMATEUR RADIO ●

ANTENNAS ● ACCESSORIES

● MAIL ORDER

➔ NEW ● NEW ● NEW ◀

SUPER SLIM JIM – 2 metre omni (LJ2). An even slimmer version of the famous SLIM JIM. An entirely new design by F. C. Judd G2BCX, even more efficient than the original. Only 44 inches long, can be used for BASE STATION or MOBILE OPERATION. Imp: 50 ohms. Completely enclosed and waterproof. Gain 3dB (EIA). Fittings for mast mounting, mobile magnetic or gutter mounting available extra. LJ2 price **£16.00** including VAT, postage and packing.

THE BIG JIM – 27MHz omni – BJ27. An entirely new design – base station antenna for CB radio. Only 9 feet long – no radials. Gain 3dB (EIA). Low angle radiation for local or DX. Two-way 27MHz contacts between the UK and USA have produced 59 plus signals and 10-4 copy. Mast or wall mounting fittings extra. Also tunable for 10M Amateur band. BJ27 price **£67.00** including vat, postage and packing.

THE RED ALERT – VHF antenna checker and RF sensor (ZLS1). Will check any antenna for radiation, correct voltage and current distribution. Repeating audible bleep and visual indication in presence of radiation. Operates any frequency 20-1000MHz. Supplied complete with probe antenna. ZLS1 price **£12.00** including VAT, postage and packing.

THE PERSUADER – Speech Processor (SP15). Increase your talk power by up to 32 times. Average effective speech power gain 15dB. Fully automatic in operation. Red and green indicators show correct operational setting. Operates for SSB, AM or FM. Tailored response for greater readability and harmonic filtering. Suitable all standard mics and rigs. SP15 price **£36.18** including VAT, postage and packing.

DUMMY LOAD – Self indicating (ZL50). Check TX power without radiating. Check coaxial cable runs and antenna match by comparison. Useable with all VSWR meters. Built in LED power indicator. Automatic sensing insures impedance of 50 ohms to within better than 0.5 ohm. Useable power up to 20 watts continuous or 100 watts intermittent. Self VSWR 1 to 1. Frequency limit 200MHz. ZL50 price **£9.00** including VAT, postage and packing.

SAE for further details of above.

CASH WITH ORDERS ONLY.** Cheques, Postal Orders etc., payable to ZL COMMUNICATIONS.

Wide selection of books on CB Radio, Electronics, Amateur Radio etc. Also CB T-Shirts, badges, car stickers and unique LEARN ALL ABOUT CB cassette tape etc. Send 20p stamp (not SAE) with name and address for full catalogue and accessories list.

ZL COMMUNICATIONS

CANTLEY, NR. NORWICH, NORFOLK, NR13 3RT.
Tel: 049 370 821 (9-5.30 Monday to Friday only).
Callers by appointment only.

IMPORTANT NOTICE

Notice is hereby given that antennas for 2 metre operation called the ZL SPECIAL (series) and the SLIM JIM, which are currently being advertised in various journals as manufactured products, are NOT repeat NOT produced by ZL COMMUNICATIONS. Neither are these antennas approved in any way whatsoever by F. C. Judd (G2BCX), Director of ZL Communications, and who was responsible for their design in the first instance as published in various issues of Practical Wireless and the book "Two Metre Antenna Handbook".

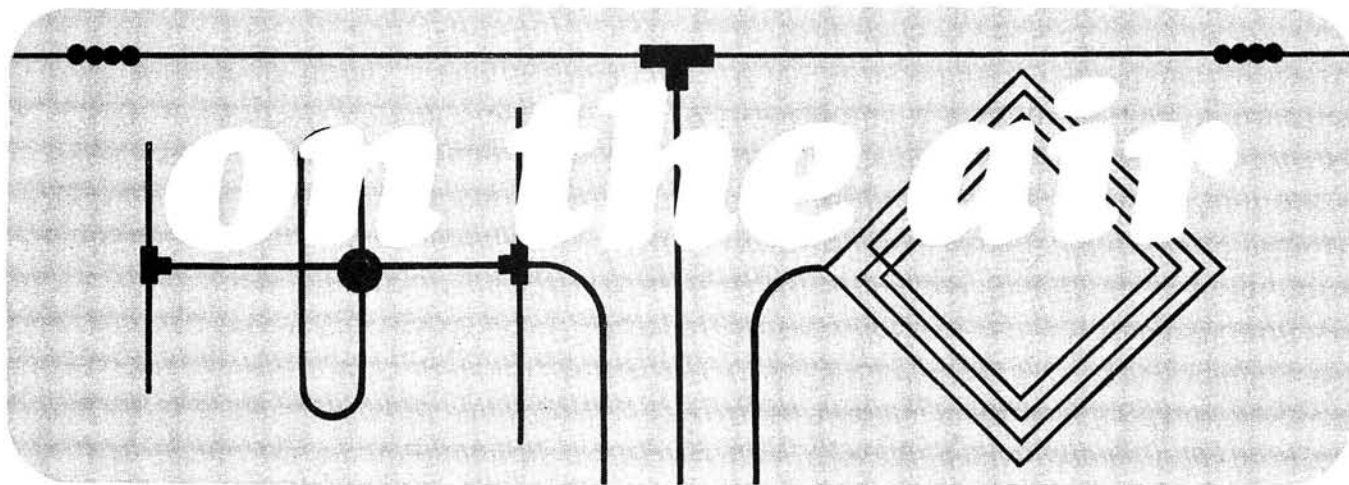

Amateur Bands

by Eric Dowdeswell G4AR

Reports to: Eric Dowdeswell G4AR
Silver Firs, Leatherhead Road,
Ashted, Surrey KT21 2TW.
Logs by bands in alphabetical order.

The current debate on the future, or otherwise, of Citizens' Band radio in the UK crops up frequently in letters from readers, opinions usually crystallising into two principal points of view. First, that of younger people, mostly new to the world of radio communications who have, somehow, been led to believe that CB is some miraculous system that will enable them to talk around the world without the bother of having to take and pass an examination.

The second aspect is that of the reader who has experience of short-wave listening and amateur radio, who realises that he is not going to be able to get something for nothing and is prepared to sit the RAE.

The Green Paper issued by the Home Office on the subject of CB, or Open Channel as the HO prefers to call it, suggests frequencies above the u.h.f. TV band, above 928MHz or so. I am personally quite convinced that OC will never be permitted below that frequency and the various CB associations and movements might as well accept this (if the money-grabbing interests will let them). They could then get on with the campaign aimed at getting the Government to implement OC as soon as possible following the November deadline on public comment set in the Green Paper. Let us know soon the precise frequency for the proposed 40 channels, and the mode, not specifically mentioned, but assumed to be f.m.

Clubs and Clubs

Seems this feature does get read by some, judging by the several clubs reporting in this month for the first time. Apart from being a source of knowledge on amateur radio matters generally, a club is often the foundation of lasting friendships and a centre of allied social activities for all the

members of a family. It is also the means of avoiding being completely dedicated to the hobby to the extent of neglecting one's family and social responsibilities.

Ipswich RC. Exciting news for members, with the acquisition of a clubroom at the Rose & Crown, Norwich Road, Ipswich, with meetings on the second and last Weds of every month around 8pm. The previous HQ in a school imposed severe restrictions on club activities. However the school will still be used on other Weds for less formal meetings and for code classes. Incidentally, the new clubroom is separate from the bars of the pub so juniors need not fear if they want to barge in and join the club. Contact: Jack Tootill G4IFF, 76 Fircroft Road, Ipswich IP1 6PX, or ring him on 0473 44047. Club magazine *QUA* lists an interesting talk on assembling an amateur radio station, by G4GVW on Dec 10.

Wolverhampton ARS. In the list for the first time, meets every Monday, 8pm, at Neachells Cottage, Stockwell End, Tettenhall. Club station is G8TA. Unusual activity for 2m addicts is a regular DF hunt run on Sundays. All you want to know from John Cook G8EDG, 75 Windmill Lane, Castlecroft, Wolverhampton WV3 8HN.

Mid Lanark ARS. Friday nights at 7.30 finds the club in session at the Wrangholm Hall, Community Centre, Jerviston Street, New Stevenson, Motherwell, with club station GM3PXX. Maybe in time (if *PW* is early), is the bring, buy and swap night on Dec 5, with the 19th being devoted to a film night. Try club Sec Doug Smillie GM4FKD at the club QTH.

Exmoor RC. Now has club call G8SSS, 15 licensed members and six passes out of seven candidates in the last December RAE, the lazy fellow passing in May. Mike Jemison G8RZE runs the club RAE courses, obviously very well indeed, while XYL Pat, taking the next RAE, is club Sec at Homedale, Brayford, North Devon. Dare she **not** pass?! Oh, yes. Club meets 7.30pm every Thursday at Loughrigg, East Street, South Molton with ladies in particular being especially welcome.

Stevenage & District RS. RAE classes already under way, one for absolute beginners and the other for those with a fair knowledge of electronics. What a good idea! Other clubs please copy! After the bigheads have passed their RAE the beginners move up to the advanced class and so on. Worthy of mention are Frank Collet G3OVT organiser, with help from Pat Higham G8JLM and Cliff Barber G4BGP. Meetings Tuesdays 7.30pm at British Aerospace Dynamics Ltd., Plant B, Staff Canteen. Membership costs a mere £3 a year which can't be bad value for money. Trevor Tugwell G8KMV, 11 The Dell, Stevenage, Herts will help further.

Verulam ARC. Lovely to hear from Mary Claytensmith G4JKS, 115 Monshalswich Lane, St Albans, Herts AL1 4UU about the club which meets fourth Tuesday of each month at the Charles Morris Memorial Hall, Tyttenhanger Green, Tyttenhanger near St Albans at 7.30pm. December 16 is AGM and Christmas Social, in that order! Informal meetings on second Tuesdays at the RAFA Club, Victoria Street, St Albans.

Bournemouth RS. Club call now G2BRS and not G3FVU. Meets in the clubroom of the Dolphin Hotel, Holdenhurst Road, Bournemouth at 7.30pm with next meeting on Dec 7 being a skittles event versus South Dorset RS. Radio controlled ones, of course! Very interesting will be a sale of equipment on behalf of the RAIBC coffers which "may take several sessions," says their Newsletter. Not to be missed. Recent change of secretary means writing to Glenn Lloyd, 4 Gorleston Road, Parkstone, Poole, Dorset. I've heard of Poole before, somewhere!

Edgware & District RS. Meets second and fourth Thursdays 8pm at Watling Community Centre, 145 Orange Hill, Burnt Oak, Edgware with other activities like a club net on 160m, slow Morse practice, also on Top Band from G3ASR, the club station call, plus code classes before each meeting at speeds to suit those present. Coming up is a junk sale or, to put it a little more delicately, a sale of equipment surplus to requirements. It's surprising what bargains one can find at a junk sale! This one is on Dec 11. Very sorry to learn from the *Edgware Ham News* of the death of Doug Findlay G3BZG, long standing supporter of the club and RSGB president in 1957. More info on the club from: Howard Drury G4HMD, 39 Wemborough Road, Stanmore, Middx or try 01-952 6462.

RAIBC. Not a local club as are others reported in this column but a national one for the blind and/or invalid amateur or s.w.l., plus its many supporters, like Audrey, the XYL of Eric Payne G4FHE, who has recorded onto tape the whole of the *Guide to Amateur Radio*, to be copied for the benefit of blind members aspiring to a licence or for beginners to the hobby. This item culled from *Radial*, the club's magazine. Club Secretary is Frances Woolley G3LWY, 9 Rannoch Court, Adelaide Road, Surbiton, Surrey KT6 4TE.

Meirion ARS. New this year, the club has an excellent programme organised right through to next April with the annual dinner on Dec 13. So it's the first Thursday of the month at the Ship Inn, Dolgellau at 7.30pm. New members and visiting folk most welcome. PRO is Dave Morgan GW8PKA, Penybont, Gellilydan, Blaenau Ffestiniog, Gwynedd or ring Maentwrog 341.

Wirral ARS. First and third Weds, 7.45pm, Sports Centre, Grange Road West, Birkenhead, but regret that excellent newsletter does not give events for December. PRO Gordon Lees G3UJX, 30 Manor Drive, Upton will be glad to fill you in, or ring 677 1518.

Hastings Electronics & RC. Active again in recent years after long absence, now with club call G6HH (you've guessed it! Happy Hastings!) and interests covering all aspects of electronics besides amateur radio. Membership no less than 130 which speaks well for the efforts of chairman Terry Ransom G4FET. Own club premises at 479 Bexhill Road, St Leonards, but size of membership means meetings third Wednesday of the month, 8pm, at West Hill Community Centre, Croft Road, Hastings. If you want to play around with the rig then its Bexhill Road every Friday evening. Try Secretary Derek Edwards G8RYG, 214 Hillside Road, Hastings for latest news of events. Should mention club has well-written and properly printed leaflet about the club for intending members, plus ditto monthly magazine *Vital Spark*, which all helps to swell the numbers.

DX Time

The SRX-30 plus dipoles of **Basil Woodcock** BRS44266 (Leeds) seems to have been working overtime, especially on 10m where the log showed the VP8SB and VP8SU, FP0FXP, VQ9TT, VS6CT, S79MC, 3B8CF, 3B6CD, ZE1AR and 9K2EW. Three goodies on 20m were 5V4HD, 8R1RBF, and 8SVT whose QTH I'd like to know. In Chadderton, Lancs, 14-year-old **Mark Ryder** BRS43580 concentrated on 20m to find FG0FIS/FS7, FK8DH, FO0CT, HV3SJ, P29CH, S8AAP (there it is again!), VK2AGT/LH (Lord Howe Is), VK9NC, VK0KH, VP2AZE, VP8PP, 6W8FZ, 8P6BX plus 9X5DR. Nice ones on 10m were HH2FH, HK0FBF, VK5RD/VK8 and YS9RVE. Bravely, Mark says he will forego the December RAE because of schoolwork. All the better to ensure a pass OM!

A *PW* amateur bands' receiver plus preselector fed from a G5RV aerial enabled **Paul Flatman** (Ipswich) to dig deep on 21MHz and 28MHz rather than 14MHz which he found patchy. So 21 looked like D68AP (Comoro Is), HS1AMM, FG0FIS/FS7 (QSL K6LPL), J3AH (QSL W2GHK), J6LFH, T1AJ, TU4AT, VP5TCI, XT2AW (QSL KN1DPS), YB0CR and YC1GJ. Obliging on 28 were C5AAJ, FM7AV (QSL F6BFH), VP2MPB (QSL W5STI), ZS3KC, 5N8THG and 9J2BO.

Just 200 yards away from Mark Ryder, mentioned above, lives **Mike Howard** with his DX-160 and "XJK" aerial, said to be related to the W8JK (Info please! he screamed) which got plenty of DX on 20m like FH8OM, H44SH, KS6BK, P29CH, TR8DX, VK0KH, VQ9PA, T3AC (Kiribati Is), 3D2FJ and 8Q7BB on the Maldives. On 15m it was FO8EM, TU4AT, ZF1MA, 5N2LED, with A22AJ, VS6GC and YS9TE on the 10m band. Mike reckons the BV2A heard on 14 175kHz is a phoney, so be careful.

Complaints of the confusion over American call signs are well founded and the only answer is to listen well and get the QTH! I really must try to publish a list of the present situation over there, as those who are using old call books to check calls are in a right mess!

Allan Stevens (Crowthorne, Berks) is still toying with the idea of a commercial up-converter, but used his regular set to copy AI5P/SV5 in the Dodecanese (that's a W!) on 10m for a very rare one plus VP2KAQ, VP2SAM, ZP5CPE, 7X4MD on 15m. **Dave Coggins** in Knutsford, Cheshire, persisted with his phased verticals and FRG-7 to find CE9AF, FP0FXP, FR7BP/T for an excellent one on Tromelin Is, VP8JB, YJ8NPS and 3B8DB on 28MHz; H44JB, KC4USV on McMurdo Base in Antarctica, T2AAA on Tuvalu Is, plus XYL op T2XYL, TR8DX, and VK9NNW on Norfolk Is, copied on 21MHz, not to mention HL9WP, KC4USV again and VK0KH on 14MHz. Down to 7MHz where C31LU, EP2TY, FM7AV and VK3XI appeared, the last around 7095kHz. Yet lower to 3.5MHz to catch UA9AZO and 4X4VE.

As he knew I was holidaying, **Bill Rendell** of Truro kindly kept his log to two entries this month. How kind! But I'm glad you didn't all do that. They were VP8SB on 20m whose c.w. was "very crisp and very, very fast," says Bill, and FR0FLO on Reunion Is, which was a new prefix and new island captured on 15m. A continuous process of updating his HRO keeps Bill pretty busy. In Hull, **Colin Frankland** was satisfied with his month's listening on his Trio 9R59DS with indoor dipoles and Codar PR30 preselector netting EA9IE, J6LDZ on St Lucia, 3D6BP, 5H3FW and 9G1JX on 21MHz while 14MHz produced FP0FXP, J6LDB, PA0FM/PJ3 and XE2AX.

Between swotting for the RAE and copying the slow Morse from G4RS, **Robert Heeley** of Mansfield, Notts, has managed to copy some DX on his FRG-7 to which he has fitted a Microwave Modules 2m converter but we'll ignore that! 10m came up with C5ABK, SU1AL, 3B8LH, and H44WH and AM, with TG9NR for 40m. Problem for Robert is lack of space for a decent aerial so has got down to wire wound on broom handles but it works, he says, aided and abetted by an a.t.u.

Dave Duglas GM4ELV of Arrochar, Strathclyde, kindly left his Argonaut QRP rig alone long enough to drop me a line on his DXing achievements with a couple of watts or so, but is very disappointed at lack of any reports from G-land on his c.w. He has abandoned his s.s.b. gear and concentrates entirely on QRP c.w., like CM2ER, CP6EL, CX5CH, HI8VBR, lots of Ws, LU3EEG, PY1HQ, VE1HK, VK6LK, VP2AZG, VP8QG, KB2DF/VP9, YV1DOB, ZP5CD, 4Z4DX, 5B4PA, 6W8AR and 9G1EL, **all on 40m** which is an amazing performance in two-way communication. Dave's YL is studying for the RAE and Dave is off to university to gather up a BA. Best wishes to them both.

A family bereavement has kept **Bernard Hughes** BRS25901 of Worcester away from his receiver for a while. Our condolences OM. 80m came up with some nice catches indeed such as A9XCE, A35TW, CE5BYZ and OX3CO. Up to 40m for FM0FJE, FM7AV, TR8DX and 7X4MD, jumping up to 10m for CE9AF, FR0FLO/T, HK0FBF, K5LBU/ST0, 8Q7BB and lastly 9U5AY.

In General

Quite a few notes and telephone messages from regulars who had passed their May RAE and had been eagerly awaiting their calls. Like **John Dainty** of West Wickham, Kent, who studied on his own for around a year and is an invalid to boot. He is now on 2m with his new call G8YLF, and code practice is under way for a G4 before long.

Arthur White of Aisby near Grantham, Lincs, is an excited G8XYX who has already reached a code speed enough to qualify for a G4. Seems Arthur's teacher G3ZOA is delighted to have got his XYL through the RAE, too, and she is now G4KOA! How about that! For the moment Arthur has a KDK FM-2016E on 2m with a four-element beam at 40ft. Like many others, Arthur complained bitterly at the three months wait before hearing the RAE results followed by a further two months before his licence came along.

In Talgarth, Brecon, Powys **Rod Williams** BRS43353 became GW8YPR and started by charging around the local mountainside with his hand-held Icom IC-2E working people all over the place. From home, using a Slim Jim aerial, Rod has been accessing a repeater 70 miles away.

Located in Haverfordwest, Dyfed, **Royston Price** had waited six weeks for his call at the time of writing, his Trio 7600 all ready to go on 2m. He suggested the RSGB should have sent some of its staff to help out the Home Office staff in issuing the licences!

Getting his feet wet on 20m with an f.e.t./i.c. super-regen receiver, 15-year-old **Stephen Pratt** of Abingdon, Oxon, calls himself a relative newcomer to amateur radio, so welcome to the club. The RAE in December is the next target for Stephen so best wishes OM. **Jeremy Pursall** of the North Bristol ARC writes for the first time although he has been DXing around for four years. Being a trainee communications engineer he does not anticipate any trouble with the RAE very soon. Set-up now is a DX-300 but comments: "Bristol is an amateur radio drop-out when it comes to decent shops", so please note, any retailer thinking of a new market for his bits and pieces!

From **G. A. Cartwright** in Wolverhampton comes a very interesting description of his adventures in YU-land, where he accidentally came across a couple of their clubs where he was made most welcome. Anyone wanting further info, perhaps going there next year, should contact G.A.C. at 1 Patshull Road, Albrighton, Wolverhampton.

A personal appeal. I love getting all your letters and logs but **please** put your full name and QTH on every letter because if you do not I have to go wading through past files to locate the info. I manage to remember those who have been writing for many months past but as someone is reputed to have said: "there's an end to it". Ta!

Letters and logs on DX, etc., by the 15th of the month, general letters any time. Time to say "Happy Christmas" to you all and your families, who, hopefully, will get into the festive spirit and come up with plenty of nice gear for the shack. Now for my favourite Christmas joke! Wife bought the OM two RSGB ties for Christmas. He came down Christmas morning proudly wearing one, "and what's wrong with the other one?" she asked!

**Medium Wave
Broadcast
Band DX**

by **Charles Molloy G8BUS**

Reports to: **Charles Molloy G8BUS**
132 Segars Lane, Southport PR8 3JG.

Interference from broadcasting stations is the main obstacle to successful medium wave DXing. The loop aerial offers one solution to the problem but there are occasions when it doesn't help. If the interference (QRM) is coming from the same direction as the DX or from the exact opposite direction, then it will not be possible to null-out the QRM and leave the DX. A loop has two nulls 180 degrees apart! What can be done then? One possibility is to listen for DX in those parts of the band where it can be found in-between European stations, and a quick look at the 1978 Geneva Plan will reveal where they are.

Channel Spacing

In North America the channel spacing is 10kHz starting with 540kHz and ending at 1600kHz. This is the system in use at the moment and it is in operation in Central and South America as well, including the Caribbean (ITU Region 2).

The Geneva Plan starts at 531kHz with 9kHz spacing between stations and it continues right up to 1602kHz, yielding a total of 119 channels against the 106 in Region 2. The two systems co-incide every 90kHz starting at 540kHz, then 630kHz, 720kHz and so on up to 1530kHz.

DX Slots

There are also pairs of frequencies across the band where channels of the two systems are farthest apart, the

maximum frequency difference possible being 4kHz. These too, occur at intervals of 90kHz beginning with 580kHz/590kHz, then 670/680, 760/770, etc., to 1570/1580. These are the DX slots where Region 2 broadcasts may be heard reasonably clear of interference from European all-nighters, and there are surprisingly, 24 of them. Not every one will yield DX or be free of QRM, but you will greatly increase your chances if you investigate them.

What to Listen For

The following is a selection of what can be heard, starting with two powerhouses; WNEW in New York City on 1130kHz and WCAU in Philadelphia on 1210kHz. Search for VOXM St John's Newfoundland on 590kHz, WJR Detroit on 760, WABC New York 770, WHDH Boston 850, CBH Halifax 860, CBM Montreal 940, WBZ Boston 1030, WERE Cleveland 1300, WLOB Portland 1310, WEGP Presque Isle 1390, CKLM Laval Quebec 1570 (in French).

Among the many Latin Americans around are Radio Jornal in Rio de Janeiro on 940kHz in Portuguese, Radio Vision in Caracas on 950 and Radio Coro 1210 (both in Venezuela), three Colombians, Radio Vision Barranquilla 1220, Radio Vision Bogota 1310 and Radio Universal Barranquilla 1400, and the lone Fort-de-France in Martinique which is on 1310kHz in French.

All this may sound rather complicated and the newcomer might well feel that it is just as easy to tune around the band. DX can be heard that way but it will be time-consuming if you are going to investigate every weak signal, and your rare North American might turn out to be AFN in West Germany.

To be successful the medium wave DXer has to be persistent and ingenious, but there is some satisfaction to be had when one "beats the odds". There are other ways of doing this such as listening early in the morning, but more about that next time.

Loops

There are still a few experimenters about, one of whom is **Andy Small** of Barking. He modified the standard "40 inch" loop aerial with rather surprising results. He writes: "The single inductance turn has been omitted and a length of wire is taken from the earth side of the tuning capacitor to the aerial socket on the receiver—it takes only a few minutes to modify your existing loop. The signal strength is far superior to that from the inductance winding and the tuning is equally sharp. The null works very well also and I would say that this is like having a long wire antenna with all the properties of a loop aerial." Andy then invites my comments on the set up, which is shown in Fig. 1.

The "aerial" consists of the loop together with the new single wire lead to the receiver. The latter will still pick up signal when the loop's null is pointed towards QRM and the overall effect will be to degrade the null i.e. it will be impossible to null-out a station completely though it may be feasible to reduce its strength to a lowish value especially if the lead is kept short. If you are nulling out a station to get better reception from another one on the same frequency then the residual pick-up by the "downlead" may not be noticeable. It is worth noting however that the additional pick-up required to give the increase in signal strength must be coming from the downlead so you are faced with a compromise between a stronger signal and an inferior null.

Readers often write to me asking what sort of results will be obtained from various aerial configurations. My answer is always the same—try it and see. Theory is only there as a guide and if we could predict exactly how equip-

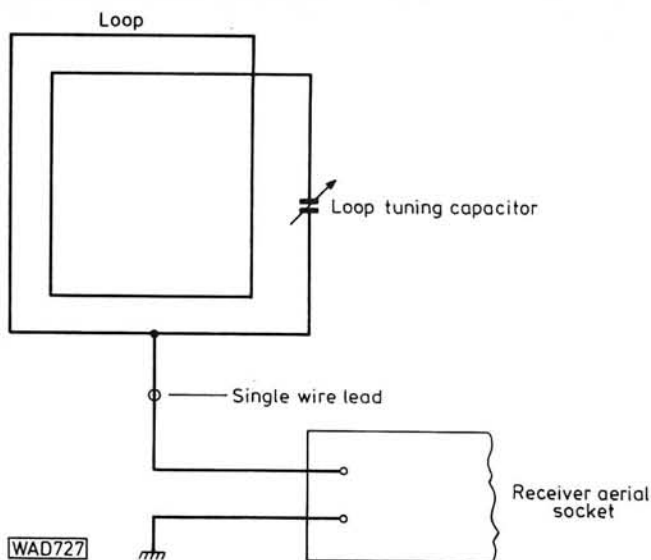
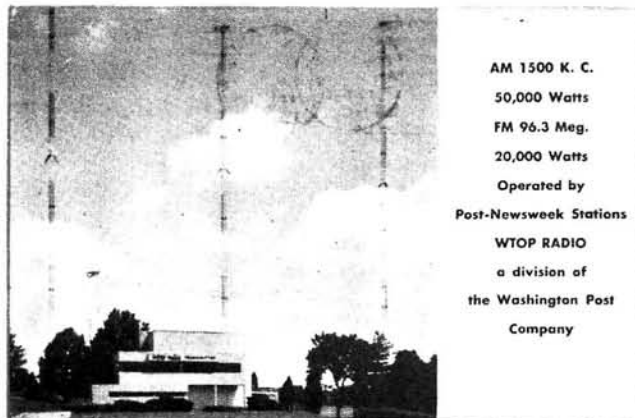

Fig. 1: The direct-coupled loop arrangement proposed by Andy Small



The QSL card of WHN New York City



Station WOTP, Washington DC's QSL card

ment will perform or what propagation will be like on any particular date then a lot of the fun would go out of DXing on the medium waves.



YOUR
SOMMERKAMP
IMPORTER

1 Railway Road, Blackburn, Lancs.
Telephone: 51842.
(Telephone Evenings:
Bolton 592929 G4GHE).



A brand new handy transceiver covering 144.025-146 MHz in 25 KHz steps by means of a PLL synthesizer. IF of 10.7 MHz with Xtal filter, MOSFET in RF & mixer stages. Features include electronic channel selection, switchable reverse scan, 'busy' channel search, switchable repeater shift, tone burst, digital readout on channel selection. Transmitter output 2 watts or switchable down to 0.2 watts. Price includes aerial, leather case, tone burst circuit and a free battery charger.

OUR 1981 PRICE
£129.00

SOMMERKAMP TS 280 FM.
80 channels 2 FM Mobile Transceiver

A deservedly popular rig for the car. Quick and easy channel change with illuminated read out, frequency range 144 to 145.975 MHz in 25 KHz steps. Comes complete with mobile mount and microphone (which also incorporates a volume control). Two versions available - 50 W output, switchable down to 2 watts at **£199 inc. VAT** - 10 W output switchable down to 1 watt at **£159 inc. VAT**.

- Sommerkamp FRG7 receiver **£188**
- Sommerkamp FRG7700 receiver **P.O.A.**
- Sommerkamp TS788DX 10 metre multimode transceiver **£325 inc. VAT**
- Sommerkamp FT277ZD 160 metre-10 metre transceiver **£589 inc. VAT**
- Sommerkamp FT767 80-10 metre mobile transceiver **£499 inc. VAT**

We also stock genuine Sommerkamp accessories: Power supplies, SWR bridges, 2 metre aerials etc.

Send for details and prices.

All prices include VAT. Barclaycard and Access, part exchange, etc.

LAR
THE SHORT WAVE WIZARDS



TRIO R1000 PLL SWL
Receiver 200 kHz to
30 MHz £297.85

(Securicor delivery arranged if required)

Trio R1000 C&L SWL Communications Receiver 200 KHz to 30MHz.

TRIO EQUIPMENT

- R820 The ultimate SWL receiver. **£690.00**
 - SP820 Matching Extension Speaker. **£37.95**
 - HS5 Communications Headphones. **£21.85**
 - HS4 Communications Headphones. **£10.35**
- Full range of Trio Transceivers in stock.

COMMUNICATIONS RECEIVERS

- Lowe SRX30 still the best value. **£158.00**
 - YAESU FRG7 General Coverage. **£199.00**
 - YAESU FRG7000 Digital Readout. **£359.00**
- All YAESU Transceivers available.

ICOM AMATEUR EQUIPMENT

LAR are Yorkshires largest stockists of the full ICOM range of transceivers.

VHF AMATEUR RECEIVERS

- Search SR9 VFO for crystal control 2M FM 144 to 146 MHz. **£46.00**
- (Marine 156 to 162 MHz also available).
- AMR 2178 2M FM Scanner 144-146 MHz. Fitted 8 crystals battery/mains.
- The best and most popular 2m. monitor. **£120.00**
- Extra crystals for the above receiver. **£2.50**

TUNERS, SWITCHES AND SHACK CLOCKS

- Kx2 SWL Antenna Tuner 500 KHz to 30 MHz. **£29.90**
- LAR Omni Match (HF, VHF, Mobile & Linear, send 20p for details).
- Cx/3 SWL 3 Way Antenna Switch. **£5.60**
- LAR 1 kW PEP Feeder Switch (switch to quality). **£16.95**
- COPAL 24 Hour Digital Clock, mains operated. **£12.95**

AIR BAND RECEIVERS

- Sharp Fx213 AU hand held portable. **£16.00**
- SILY ACE R517 VFO and crystal control. **£49.50**
- SIGNAL R512 Scanner fitted 5 channels. **£138.00**
- Crystals for R517 or R512. **£2.80**
- Regency Digital flight scan (no crystals required). **£230.00**
- BEARCAT 220 FB. Scanner 66 to 512 MHz. **£258.75**
- SX200 Programmable Scanner 26 to 514 MHz. **£239.00**

(All prices include VAT. Securicor delivery arranged on request.)

Buy by post or phone your Barclaycard, Access, or LAR Creditcard number. Alternatively, call in for a chat. The shop is just 10 minutes from Leeds City Station, and there's easy parking if you travel by car. *Instant HP for licensed amateurs. *Extended Credit Terms Available.

Send 50p for Catalogue and Price List.



Leeds Amateur Radio
27 Cookridge Street, Leeds LS2 3AG.
Tel: 782224

TRIO DISTRIBUTOR. LAR are area distributors for Jay Beams, Antenna Specialists, Hilomast Icom and Microwave Modules and Ascot products.

YAESU MUSEN – FRG-7700

A NEW BREAKTHROUGH IN RECEIVER TECHNOLOGY

Yes indeed, the exciting new FRG-7700 GENERAL COVERAGE RECEIVER from YAESU MUSEN, the world's largest manufacturer of Amateur Radio equipment, will satisfy the demands of the most critical Short Wave Listener or Licensed Operator with it's superb performance and incredible specification – just consider the following condensed details:

Frequency coverage 150 KHz–29.999 MHz.

Modes

AM (fitted Narrow, Medium and Wide Filters).
 USB, LSB, CW and FM.
 Memory option with twelve channels and automatic band selection.
 CPU Digital Clock and Timer.
 State-of-the-Art Noise Blanker.
 FM Squelch Control.
 Mains or Battery operation.
 Digital and Analogue read-out.

FRG-7700.....£309
 FRG-7700 (Fitted Memory)£389



Send today for full details of the new FRG-7700 or if you would like the full Yaesu catalogue as well 36 pence in stamps will bring you this together with our credit voucher for £3.60 – a 10 to 1 winning offer!

FULL DETAILS AND THE NEW LOW FACTORY PRICE LIST FROM
BRITAIN'S NO. 1 IMPORTER
 EX-STOCK – INSTANT CREDIT – FREE SECURICOR DELIVERY

AMATEUR ELECTRONICS UK



508-516 ALUM ROCK ROAD 021-327 1497
BIRMINGHAM 8 6313
 Telex 337045



AH ELECTRONICS

20 BARBY LANE, HILLMORTON,
 RUGBY, WARWICKSHIRE CV22 5QJ.
 TEL: 76473 EVE 71066.

Mail Order Only or callers by appointment.
 All prices include VAT but add 50p post & packing.

VHF RF. POWER TRANSISTORS:-

Type	Gain (db)	Output (watts)	Volts	Freq.	Price
2N6083	5.7	30w.	12	175MHz	£6.50
BLY87A	9	8	12	175	£4.00
SD1212-6	8.2	3	12	175	£2.50
BLW16A	10	12	12	175	£0.75
PT4236A	10	1 min.	12	175	£0.75
PT4555	8	25	12	80	£4.00
PT4556C	7	40	12	80	£5.00
2N5070	13	25(pep)	24	30	£5.00

MDA800 8 amp 50 volt bridge rectifier OK for 12v PSU etc. 65p. 2 for £1.15.
DUAL-GATE MOSFETS 3N204 £1.25, 3SK51 (40673) 80p, BFR84 75p.
FETs E5565 (2N3819) 30p, TIS88A 40p, BF256C 40p, 2N4381 40p.
BIPOLARS:- BF576. pnp VHF RF amp. FT1200 MHz 20p, 2N4957 pnp VHF/UHF RF amp nf only 3½db - 1GHz 30p, BF180 30p, BF166 VHF RF amp 25p, BFY90 UHF RF amp 95p, BF152 VHF mix/osc. 15p.
RF SWITCHING DIODES for switching oscillators etc. BA143 (VHF) 20p, BA144 (UHF) 25p.

AUDIO AMP IC. TBA1010 6 watt output adjustable to 3 watt. + 14 volt single-line type & ideal for transceivers, receivers, record players, cassette players etc. BARGAIN OFFER ONLY £1.35 two for £2.40. Supplied with data sheet showing construction of stereo amp, full data sheet (19 pages) 20p.

27-30 MHz RECEIVER PRE-AMP. Have you a tired or old receiver with poor performance above 25MHz then one of our super pre-amps is what you want:- 50 ohm imp. in & out 25db gain with better than 1db nf. ready built on PCB 60mmx40mm, adjustable gain control, only £8.00 or built into grey hammer finish die cast box with BNC sockets £12.50.

10.7 MHz CRYSTAL FILTER for AM/FM 12½ KHz channel spacing ±3½ KHz - only new & unused small size 38mmx18mmx15mm 200 ohm imp. give away PRICE ONLY £4.00 each two for £7.00.

10.7 MHz CRYSTAL FILTER for AM/FM 12½ KHz channel spacing +3½ KHz = 3db ITT type 024DE/923L. £7.00 ea.

MOTOROLA CAR RADIO PCBs complete less vol. cont. tuner etc. with circuit 80p ea. four for £3.00.

CAR RADIO 470 KHz IF AMPS with stereo pre-amp IC. with circuit 65p.

CAR RADIO/CASSETTE PLAYER stereo amps 5 watt/chan. with multigang pot. matching amp to above IF amp board. Contains 2 TA7205P ICs, with circuit £2.75.

BAG MIXED ELECTROLYTIC CAPACITORS 2.2mf - 1000Mfd 100 £1.60.

BAG OF MIXED RESISTORS ½ watt carbon film pre-formed type all with long leads plus some ¼ watt std types 250 for £1.60.

FEEDTHROUGH CAPACITORS 1000pf 500v solder in type ¼" dia. 10 for 28p.

FERRITE RINGS 12mm dia 10p ea. **FERRITE BEADS** FX1115 10 for 20p.

PRICE LIST 15p STAMP – FREE WITH ORDER.

HOME BRU RADIO

(Mail order only)

G4CLF. P.C.B. SPECIAL OFFER. Set of I.C.s and P.C.B. to include: 2 off. SL1612. 1 off. SL1621. 1 off. SL6270. 2 off. SL1640. 1 off. SL6310. £18 incl. VAT + P&P 30p.

G4CLF P.C.B.	£4.24
SL1612	£1.56
SL1621	£2.07
SL6270	£2.51
SL1640	£2.07
SL6310	£2.51
2N5771	.31p
BA182	.36p
78L06	.59p
J304	.54p
J310	.87p
FX2249 (per pair)	.60p
SBL-1 = (MD108)	£4.90
+ P&P 30p	

"HELFDORD" TROUBLESHOOTING

(A service by the designers)

Any query we receive providing it is accompanied with a S.A.E. and one of our Invoice Numbers, we will do our best to answer.

HOME BRU RADIO

(Mail order only)

55, Ashley Road, Parkstone,
 Poole BH14 9BT.

DX Heard

A good log of North American DX comes from Andy Small who used his Hammarlund SP600JX and modified loop to hear CBM in Montreal on 940kHz, CHER in Sydney, Nova Scotia on 950, WHN New York City on 1050 WEGP Presque Isle in Maine on 1390, CFGO Ottawa 1440, WTOP Washington DC on 1500 and WITS Boston on 1510kHz. Andy has now logged a total of 24 North Americans since making his debut on the medium waves one year ago.

Reader **Bernt Erfjord** of Kvinesdal in Norway has been trying his luck with UK local radio DXing. He reports hearing both Radio Metro and Radio Clyde on 1152kHz and Radio Tees on 1172kHz. The receiver is an FRG-7 with long wire antenna and Bernt has been at the controls now for some two years.

From Malaysia comes a log from 18-year-old **Jeffrey Seow** who "put a few turns" round the ferrite rod aerial of his portable receiver. Stations heard included the Voice of America on approximately 1400kHz at 1310 GMT, the BBC on approx 1190kHz at 2250 and the VOA again on approx 1099 at 1138. Jeff wonders if anyone can suggest what he was listening to. Well, the BBC broadcasts from Cyprus on 1413kHz and from Oman on 1296kHz, but even allowing for poor receiver calibration we are a long way from 1190kHz. So far as I know the VOA does not broadcast near 1400kHz or 1099kHz.

It is risky interfering with the ferrite rod aerial as many receivers are designed to operate with the pick up from this alone. If you apply a larger signal than normal to the aerial circuit there is a risk of overloading and spurious responses. Suggest you try to get hold of a crystal calibrator Jeff so that you can get a more accurate estimate of frequency. Jeff would love to hear from readers of his own age; his address is: 1 North Avenue, Fettes Park, Penang, Malaysia.

A good opening to North America occurred between September 27 and October 3. **Nick Hall-Patch** of Victoria BC on the west coast of Canada reports hearing the BBC on 648 and 882kHz and West Germany on 756kHz. A tape of an unidentified station on 1017kHz logged at 0321 GMT on October 3 and sent to me for information is certainly Istanbul, which really is a good catch from Nick's QTH. An excellent start for North America for this winter.

Short Wave Broadcast Bands

by **Charles Molloy G8BUS**

Reports: as for medium wave DX,
but please keep separate.

Until recently one of the problems facing the short wave listener was how to find the station he wanted to listen to. It is possible to pick up a broadcast on the medium and

long waves just by setting the pointer to its frequency or wavelength as marked on the tuning scale. Many scales indeed have station names printed on them. Things are very different on the short waves. Many more stations are packed into the tuning scale so that the unfortunate listener will be lucky if he manages to get within 100kHz of the channel he is looking for.

Tuning Aids

Broadcasters are aware of the problem and some of them put out a distinctive interval signal for a few minutes before the start of a programme. All the listener has to do is to tune across the correct band until this signal is heard. Set manufacturers too try to help. Bandspread scales are provided on some receivers which spread out each international s.w. band. Others have logging scales from which the s.w.l. can prepare graphs of frequency against log scale readings if he is keen, or more likely, just keep a note of the log readings of stations that interest him.

Digital readout of course solves the problem completely, but at the moment it is only the more expensive modern receivers that have it. What can be done to help the owners of the large numbers of receivers still in use that do not have digital readout? A crystal calibrator will go a long way to easing the problem. Although not as convenient to use, the calibrator, which is an accessory and can be used with any receiver, will provide results just as accurate as digital readout.

Crystal Calibrator

This device is really a miniature crystal-controlled radio transmitter whose output is rich in harmonics so that it generates "marker pips" right across the short waves. The calibrator is connected to the set in place of the aerial and it may even contain a switch to enable this to be done easily. A simple calibrator with an output of 100kHz would produce markers at 100kHz intervals across the bands up to and perhaps beyond 30MHz. These will be picked up by the receiver where they will appear as unmodulated carriers, or if the calibrator is modulated, by a carrier with an audible tone on it.

A calibrator with a single output is of limited value. It is more useful to have one with several outputs, like the one offered by Cambridge Kits, who advertise in *PW*, which has separate outputs of 1MHz, 100kHz and 25kHz. When the 1MHz output is used there will be markers on every MHz, i.e. 2MHz, 3MHz and so on across the scale. If the 100kHz output is used there will be markers at 100kHz intervals and the 25kHz output will generate markers at 25kHz intervals right across the spectrum.

Using the Calibrator

How is the calibrator used? Suppose you want to set the receiver onto 9750kHz in the 31m band. Use the calibrator's 1MHz output and locate the 9MHz marker using the receiver tuning scale. It ought to be accurate enough for that! Now switch in the 100kHz output and tune to the 9100, 9200 markers in turn, continuing until you reach 9700. Now turn on the 25kHz output and tune past 9725 to 9750kHz and there you are. If you are looking for Radio Bagdad (reader **R Edwards** please note), then you are only 5kHz away from it and if you tune back slightly you should find this station easily.

It would of course be more convenient to locate 10MHz and then tune down in frequency until you come to 9750, and this is probably what most people would do once they have had a little practice using the device. Similarly, if you want to know the frequency of the station

you are listening to, simply switch in the calibrator, locate the nearest 25kHz marker, then the nearest 100kHz and 1MHz markers and you can work it out. A little more complicated than setting the receiver on a chosen frequency but again, a little practice is required to get the feel of using a calibrator.

I used a calibrator with outputs of 1MHz, 100kHz and 10kHz for a number of years but confusion can arise when using the 10kHz output as there are so many markers. Some users prefer 25kHz to 10kHz for the lowest output as it should not be too difficult to estimate frequency between two 25kHz marker pips.



A rather attractive QSL from Tahiti

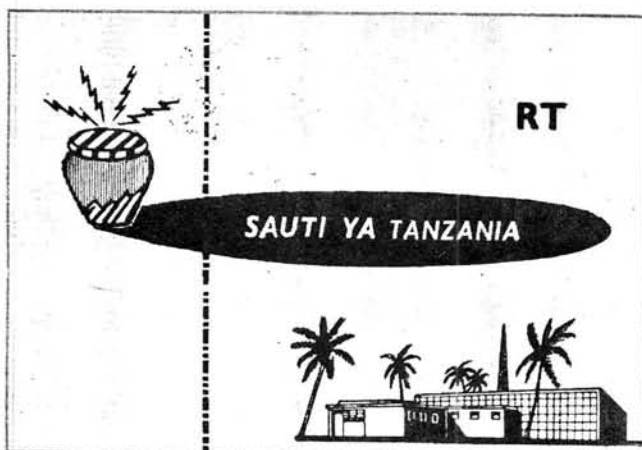

Radio Tanzania issues this QSL card



The long-awaited QSL from Uganda

Time Signal Stations

The 9th edition of a *List of Time Signal Stations* has just come to hand. It is a 50-page illustrated booklet written in English which contains lists of time signal stations in frequency order and also by country where details of the "programme" are given. The introduction is rather interesting as it explains the different time scales in use such as Ephemeris Time, Atomic Time and Sidereal Time, as well as the definition of such an unlikely quantity as a leap second. Copies are obtainable from Gerd Klawitter, D-4430 Steinfurt, Ochtrupper Str 138, Federal Republic of Germany for 6DM or 7 International Reply Coupons (available in main post offices).

Radio New Zealand

RNZ is coming in well on 15 485kHz in the early morning. **Bernt Erfjord** (Norway) picked it up at 0600 with his FRG-7 and long wire antenna, **Alex Dowie** (Hove) heard it between 0540 and 0700 on his Lowe SRX-30 plus 66ft long wire and **David Appleyard** of Uppsala in Sweden logged it at 0500 with his Panasonic DR49 and 25ft long wire. David also heard it between 1800 and 2000 with a lot of QRM from Radio Pakistan. **Simon Baird** (Taynuilt Scotland) lay in bed listening to a RNZ sports report on his Panasonic RF2200 and telescopic antenna. "Even the XYL who could not be described as an enthusiast, was impressed." How to live dangerously at 0630 on a Sunday morning!

Tony King of RNZ tells me that 15 485 has been providing quite phenomenal reception in Europe around 0400 to 0600. "The beam in this schedule will be via Australia on this frequency."

DX Heard

The time signal station BPV at Shanghai is reported on 10MHz by reader **B. S. Robertson** of Oxford, who heard it at 2000 on September 22. The identification came verbally in English and as "BPV" in Morse. Two other exotic catches heard were Tahiti on 11 825kHz at 0630 and Tanzania on 5050kHz. Tahiti was heard on a number of occasions early in the day last winter on this frequency; QRM permitting, this is the time to get a QSL from the South Pacific. Listen for the interval signal on the hour. It is quite distinctive, being a Tahitian flute with drums. Many thanks to our reader for lending his QSLs from these stations for publication.

Our Norwegian reader **Bernt Erfjord** picked up the Singapore Broadcasting Corporation on 5052kHz in English at 1600 until close down at 1630. Also heard were a number of Latin Americans around 0300, the most conspicuous being Ecos del Torbes in Venezuela on 4980 and Radio Sutatenza in Colombia on 5095kHz. Alex Dowie asks about Western Samoa, but unfortunately this country does not broadcast on either the short waves or the tropical bands. The final word is from **B. S. Robertson**, who much to his surprise received a QSL from Radio Uganda (15 325) after some 13 months, which he reckons is even longer than from Chile.

VHF Bands

by Ron Ham BRS15744

Reports to: Ron Ham BRS15744
Faraday, Greyfriars, Storrington,
Sussex RH20 4HE.

Among the many fascinations of operating during a v.h.f. opening is wondering whether the other bands are better from a DX point of view than the one you are using, and how best to determine the geographical extent of the prevailing disturbance. Such was the case on October 3, when, for a few hours during a lengthy spell of good tropospheric conditions, both the v.h.f. and u.h.f. bands really opened up, a situation duly exploited by most of my readers.

Solar

Cmdr Henry Hatfield, Sevenoaks and I recorded a 3-minute burst of solar radio noise, Fig. 1, at 136 and 143 MHz respectively, during the midday observation on September 30, and earlier in the morning, Henry, using his spectrohelioscope, saw a large flare take place on the west limb of the sun. We also recorded small bursts of radio noise on October 3, 8, 12, 13, 14 and 17 and mild noise storms on days 9, 14 and 16. On the 9th, Henry observed six sunspot groups. The one near the east limb had about 20 spots, while another was a long chain with about 18 spots. At 1124 he watched a triple flare occur in one group and 16 minutes later the radio noise storm began. Ted Waring, at his observatory in Bristol, counted 32 sunspots on September 26, 37 on the 29th, 19 on October 3rd and 50 on the 15th. There is little wonder that, with solar activity like this, the BBC World Service reported ionospheric disturbances during the early hours of October 5 and 12.

The 10m Band

On September 23, 24 and 25, Harold Brodribb, St Leonards-on-Sea, heard many s.s.b. signals from stations in Canada and the USA, and at 1030 on the 24th he listened to both sides of a QSO between VK6HPF and W4TFB. With the band open again, Harold identified a variety of harmonics between 28 and 31MHz coming from lower frequency broadcast stations in Alma Ata and Moscow. Like myself, Ted Waring received signals on most days between September 20 and October 15, from the International Beacon Project stations in Bahrain A9XC, Bermuda VP9BA, Cyprus 5B4CY and the two South Africans ZS6DN and ZS6PW. On October 7, Harold Goble G4FDQ, Lancing, worked into Guam on s.s.b. and at 1437 on the 10th he contacted a station in Albuquerque, New Mexico, commemorating an International Balloon Festival.

While mobile on October 1, Stan Williams G3LQI/M, using a TS-120S, a G3RVM Iambic keyer and a helical "G" whip aerial mounted on the boot of his car, worked N4BP who was running 5 watts from a solar-powered rig. Stan's main interest is h.f. c.w. mobile, and between October 1 and 11 he worked several stations in the USA, one in Alaska and a VP8. On Sunday the 12th, he parked his car outside the radio building at the Chalk Pits Museum in



Fig. 1: A solar burst recorded by the author during the mid-day observation on September 30

Fig. 2: G3LQI/M operating c.w. at the Chalk Pits Museum

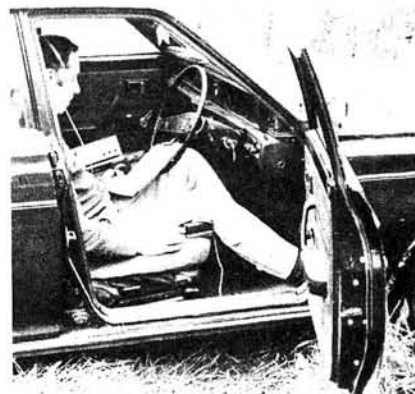

Fig. 3: G3WMU watches his son Pete G4ESC operating at the Chalk Pits Museum



Sussex and made c.w. contacts with five JAs on 15m and three Ws and a VE on 10m, Fig. 2.

The Brownlow family were also at the museum on the 12th and once again delighted the visitors by showing them how an amateur radio station, G3WMU/P can communicate with other parts of the world, Fig. 3.

Tropospheric

The atmospheric pressure rose sharply from 30.1in (1019mb) at midday on September 28 to 30.3in (1026mb)

Fig. 4: Barograph chart recorded by the author, showing the change in pressure that caused the extensive tropospheric disturbance on October 3



at noon on the 29th and then rose a little more to 30.4in (1029mb) during the evening of the 30th where it hovered, giving good v.h.f. conditions, until about 0200 on October 3. Then a gradual fall began and as expected, there was an extensive tropospheric opening, mainly affecting the u.h.f. bands, between about 1600 on the 3rd and 0300 on the 4th, Fig. 4.

For most of the time from September 28 to around midnight on October 3, I received signals averaging 529 from the 70cm beacon at Sutton Coldfield GB3SUT, with only a dipole feeding my receiver. This signal peaked to 559 at 0740 on October 1 and 599, during the peak of the opening, at 1920 on the 3rd. Throughout the period I heard signals at varying strengths from the Bristol Channel GB3BC R6 and Birmingham GB3BM R5, repeaters. and periodically a selection of continental broadcast stations in Band II. **George Grzebieniak**, London, heard 2m signals from F and PA0 on September 28 and 29, HB9ARI on October 2 and OE2CAL on the 3rd. Between 0500 and 0700 on the 4th, **T. Amp**, using a National Panasonic DR49 with an indoor aerial, heard eight French and nine other continental broadcast stations in Band II, several of them being stronger than the BBC signals.

At 1623 on September 26, Harold Brodribb heard strong signals from several French stations between 88 and 100MHz, and on the 29th another Sussex station, **Mick Senior** G4EFO, Horsham, worked into Belgium, France and Holland on 70cm and heard strong signals from the Sutton Coldfield beacon. Mick also worked G8OUU in Peterborough, via the Peterborough repeater GB3PB, RB10. This contact was of special interest to Mick because he built the original PB aeriels. Another Horsham reader, **Ken Smith** BRS20001, heard French and Dutch stations in Band II: one Dutch station, said Ken "was in full stereo". **John Hill** G8HUY, Hayling Island, Hants, told me that from midday on September 30 to early on October 5, he received signals from the beacons in Switzerland, HB9HB on 2m and HB9F on 70cm. John is a very keen 70cm operator and with 6 watts from his Icom 260E, a Microwave Modules transverter and a home-brew 27-element quad loop aerial, he worked stations in 11 countries, DL, F, G, GJ, GU, GW, HB9, OE, OK, ON and PA0 on October 3.

In nearby Portsmouth, G8HND worked an SP near Russia on 70cm and an OK on 23 cm, and **Geoff Stone** G3FZL, told me that several London stations also worked into OK on 23cm. Around 1400 on October 1, **Alan Baker** G4GNX, Newhaven, heard G8WWU work a French station on the Swiss border through the Brighton repeater GB3SR, R3, and between 2100 and midnight on the 3rd Alan worked DF1CF, near Austria, DF6LN east of Denmark, OK1XW/P (Alan's 21st country on 2m) and DF5DL on 2m c.w. and heard part of an SP's call sign on

s.s.b. Along the coast in Lancing, **Barry Ainsworth** G4GPW, also worked into OK on 2m, and **John Cooper** G8NGO, Cowfold, had a wonderful time. On September 27 he worked five PA0s and an OZ, 28th two ONs and seven PA0s, 29th four DLs, five Fs, two PA0s, and G5KW/P in the Scilly Isles "was a fantastic signal," said John. On September 30 he worked 12 Fs and three HB9s, October 1 eight Fs, 2nd three Fs and three HB9s and between 1700 and 2300 on the 3rd he worked five Fs, a GW, five HB9s, four OEs, an OK and 94 West Germans on 2m s.s.b.

Cross Band 10m to 6m

At 1356 on October 16, **John Branegan** GM4IHJ, Fife, heard Bob Billings VE1AVX, Nova Scotia with his automatic keyer on 50.005MHz. Although John did not complete a cross-band QSO with him this time, DK1ITZ did make it, so, to use John's words "6m is officially back in business".

News Items

Within the first fortnight some 45 people had enrolled for the RAE class run on behalf of the Brighton and District Radio Society, by Nigel Hewitt G8JFT, BSc, on Thursdays at 1930, at 47 Cromwell Rd., Hove, Sussex.

Finally, I would like to thank my readers, the Editor and editorial staff of *PW* and my many friends in amateur radio who gave their support to the highly successful Wireless Day at the Chalk Pits Museum on October 5.

TV

by Ron Ham BRS15744

Reports: as for VHF Bands,
but please keep separate.

Thanks to the continued support from my readers, we will in future have a column devoted to DXTV, and although this will be specialised, as far as unusual propagation is concerned, the subject will be closely allied to my v.h.f. column.

Drake R-7 Synthesized, General Coverage Receiver

Model 1240



Full general coverage reception, 0-30 MHz, with no gaps or range crystals required.

Continuous tuning all the way from vlf thru hf. Superb state-of-the-art performance on a-m, ssb, RTTY, and cw —and it transceives with the Drake TR-7.

Price — £989 inc. vat.

100% solid state broadband design, fully synthesized with a permeability tuned oscillator (PTO) for smooth, continuous tuning.

Covers the complete range 0 to 30 MHz with no gaps in frequency coverage. Both digital and analog frequency readout.

Special front-end circuitry employing a high level double balanced mixer and 48 MHz "up-converted" 1st i-f for superior general coverage, image rejection and strong signal handling performance.

Complete front-end bandpass filters are included that operate from hf thru vlf. External vlf preselectors are not required.

10 dB pushbutton-controlled broadband preamp can be activated on all ranges above 1.5 MHz. Low noise design.

Various optional selectivity filters for cw, RTTY and a-m are switch-selected from the front panel. Ssb filter standard.

Special new low distortion "synchro-phase" a-m detector provides superior international shortwave broadcast reception. This new technique permits 3 kHz a-m sideband response with the use of a 4 kHz filter for better interference rejection.

Tunable i-f notch filter effectively reduces heterodyne interference from nearby stations.

The famous Drake full electronic passband tuning system is employed, permitting the passband position

to be adjusted for any selectivity filter. This is a great aid in interference rejection.

Three agc time constants plus "Off" are switch-selected from the front panel.

Complete transceive/separate functions when used with the Drake TR-7 transceiver are included, along with separate R-7 R.I.T. control.

Special multi-function antenna selector/50 ohm splitter is switch-selected from the front panel, and provides simultaneous dual receive with the TR-7. This makes possible the reception of two different frequencies at the same time. Main and alternate antennas and vhf/uhf converters may also be selected with this switching network.

The digital readout of the R-7 may be used as a 150 MHz counter, and is switched from the front panel. Access thru rear panel connector.

The built-in power supply operates from 100, 120, 200, 240 V-ac, 50/60 Hz, or nominal 13.8 V-dc.

The R-7 includes a built-in speaker, or an external Drake MS-7 speaker may be used.

Built-in 25 kHz calibrator for calibration of analog dial.

Low level audio output for tape recorder.

Up to eight crystal controlled fixed channels can be selected. (With Drake Aux-7 installed.)

Optional Drake NB-7A Noise Blanker available. Provides true impulse type noise blanking performance.

Optional accessories available

- Model 1531 Drake MS-7 Speaker
- Model 7021 Drake SL-300 Cw Filter, 300 Hz
- Model 7022 Drake SL-500 Cw Filter, 500 Hz
- Model 7023 Drake SL-1800 Ssb/RTTY Filter, 1800 Hz
- Model 7024 Drake SL-6000 A-m Filter, 6.0 kHz
- Model 7026 Drake SL-4000 A-m Filter, 4.0 kHz
- Model 1532 Drake NB-7A Noise Blanker
- Model 1536 Drake Aux-7 Range Program/Fixed-Frequency Board

And RADIO SHACK for TRIO, including the



TR 7800

(As reviewed in this issue)

£268.00 inc. Vat.



RADIO SHACK LIMITED,
TELEX 23718

188 BROADHURST GARDENS, LONDON, NW6 3AY
TELEPHONE 01-624 7174

Make sure of your Heathkit catalogue... write now.

HEATHKIT
QUALITY ELECTRONICS YOU CAN BUILD

**New
Winter 1980/81
catalogue out now.**

Keep up to date with the world's finest electronic kits—with the Heathkit catalogue. 48 product packed pages contain photographs and specifications of the widest possible range of kits. Everything from doorbells to digital clocks, multimeters to microcomputers.

Heathkit make it easy to build, easy on your pocket, and as with 13 million Heathkit builders over 34 years, your success is guaranteed.

Make sure of your copy of the Heathkit catalogue. Send the coupon today, plus 25p in stamps and beat the demand.

To: Heath Electronics (U.K.) Limited, Dept (PW1), Bristol Road, Gloucester, GL2 6EE.

Please send me a copy of the Heathkit catalogue. I enclose 25p in stamps.

Name _____

Address _____

Soldering
Iron offer
FREE

N.B. If you are already on the Heathkit mailing list you will automatically receive a copy of the Heathkit catalogue without having to use this coupon. When you receive your catalogue you will get details of this free offer.



HEATHKIT

HEATH
ZENITH

From the World-Record Joystick People! A REVOLUTIONARY ANTENNA THEY CALLED "IMPOSSIBLE" THE JOYFRAME (Patent Applied for)

Amateur Bands 3.5-30 Mhz.

The ultimate in small package, poor QTH, versatile antennas. Comes in easily assembled package which makes up to a 21" x 21" x 21" (inches) triangle. The unit JUST STANDS ON TOP OF TX/RX! Two knob control — and is rotated by hand for directivity on 80m, is omni-directional on higher freq.'s and for many SW BC stations. Incredible low angle radiation. Tested at 2 watts (only) CW at our works — world wide contacts! "Soak test" with G2VF using only 30 watts has satisfactorily filled his log with world wide QSO's. Loop TRANSMISSION performance with such a small unit has, we believe, never been seriously contemplated before, but rather written off as "impossible". Years of research from the firm that produced the JOYSTICK VFA and related systems now offers the JOYFRAME to the amateur fraternity and is the answer to the "maidens prayer" to everyone with a space problem. All the benefits of JOYSTICK products: substantially harmonic-free, low angle, efficiency, compact.

COMPLETE (incl. ATU) £60.00

ANTENNAS (our regular lines)

THE JOYSTICK VFA (Variable Freq. Antenna)

- Only 230cm long, easily assembled and installed.
- Continuous tuning 0.5-30Mhz ● Omni-directional
- Substantially harmonic-FREE

SYSTEM "A" For the SWL or 160m. Tx. £48.55

THE JOYMASTER SUPERMATCH SYSTEM

- Newer development for higher power, improved performance and even greater capability in the awkward QTH! O Includes matching ATU O Amateur Bands (Incl. 'new' bands) 3.5-30Mhz. O 500 w.p.e.p.

NEW SUPERMATCH

SYSTYEM with 13' Joyradial 5 band radial £82.00

SUPERMATCH ATU

available to improve performance of existing antennas. Impressive, versatile, try it! **£50.00**

JOYRADIAL (3.5-30Mhz) £6.90

RECEIVERS

Get out on the air in seconds!

- FRG7700 £309 (£380 with memory) ● FRG7 + free wire aerial ONLY £187.00 ● FRG7000 + free wire aerial £299.00
- Package "R.1" (FRG7 + ATU + World Record VFA and FREE HEADPHONES) £218 ● Package "R.2." (FRG7000 + ATU + World Record VFA and FREE HEADPHONES) £331.00.

TRANSCEIVERS ETC.

We reckon we're offering the

LOWEST YAESU PRICES

Try phoning us for your PERSONALISED quote with or without Partridge antennas. For example: ● FT101ZD — only £559 ● FT901DM — only £795 ● FT7B — only £395.



G3CED
G3VFA

JUST TELEPHONE YOUR CARD NUMBER

0843 62535 (ext 5) (62839 after office hours) or send 14p stamp for FREE literature. Prices correct as at press. NOTE our prices are always INCLUSIVE OF VAT, carriage. Prompt service too, goods usually despatched WITHIN 48 HOURS!

5 Partridge House,
Prospect Road, Broadstairs, Kent CT10 1LD
(Callers by appointment).

PARTRIDGE
BROADSTAIRS KENT ENGLAND
ELECTRONIC LTD



Fig. 1: Picture received north of Leicester by Bruno Perfect in 1947



Fig. 2: An Austrian programme received by Michael Hahn in 1930 on October 3



Fig. 3: A sports programme from Belgium received by Michael Hahn on October 3



Fig. 4: A west German news programme seen by Michael Hahn on October 3



Fig. 5: SSTV picture received from Japan by Sam Faulkner at 0850 on September 28

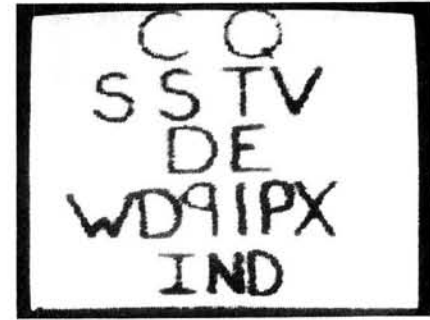

Fig. 6: SSTV picture received by Sam Faulkner at 1745 on September 27

An Early DXer

Although a limited television service operated from Alexandra Palace, London, between November 1936 and the outbreak of war in 1939, large-scale production of sets and the expansion of the service did not begin until transmissions re-started in June, 1946, and the radio factories returned to peace-time work. I well remember those early post-war days when a Channel 1 "H" aerial, a 9in screen, programmes daily from 2030 to 2200, plus an hour on Wednesday afternoons for the ladies, were all we had. For fringe area viewers, like myself, sets were souped up and pre-amplifiers fitted but even then, under normal conditions the pictures were often poor.

One of the early enthusiasts, **Bruno Perfect**, told me that in 1947, when he was living about 10 miles north of Leicester and using a pre-war receiver, an "H" aerial and a home-brew two-stage pre-amp with selected low noise SP61 valves, he received a picture from London, Fig. 1, at that awfully high frequency of 45MHz. Now with worldwide television, Band I, 40–60 MHz approximately, is a happy hunting ground for long-distance television as **Sam Faulkner**, Burton-on-Trent, found between 1730 and 1930 on September 20 when he watched *Bugs Bunny* cartoons and the American TV series *The Love Boat* from RTVE, Spain on Channels E2 and E3.

Band I

During a sporadic E disturbance from 1300 to 1630 on October 10, I received strong pictures from Russia on Ch. R1 49.75MHz and the associated sound on 56.25MHz. At 1318 a clock appeared showing 1618, followed by a YL announcer and a caption with Russian writing. At 1314 I counted 16 very strong east-European f.m. broad-

cast signals between 66 and 73MHz. Between 0800 and 0850 on October 14 I watched strong, unsteady pictures, with multiple blurred images on Ch. R1 similar to the F2 disturbances last year. **John Branegan** GM4IHJ, Fife, reports a "dreadfully smeared picture" from Central Asian Russian TV, on Ch. R1 at 0730 on the 16th, so keep your eyes on R1, it could produce some interesting results this winter.

UHF

There were signs of the approaching good tropospheric conditions on September 28 when **George Grzebieniak**, London, received Westward ITV from Huntshaw Cross on Ch. 59 and on the 29th, both Ken Smith, Horsham and I received strong, negative-image, pictures from France on Ch. 21. While heavy patterning was building up on the BBC and ITV signals, I was also receiving a strong picture from the IBA transmitter at Lichfield, Ch. 8, with a dipole feeding the receiver. George Grzebieniak and **T. Ampì**, also from London, were among the many readers I met on the Wireless Communications Day at the Chalk Pits Museum, Houghton, Sussex, on October 5. George and T. Ampì have become good friends and are in the process of modifying equipment at T. Ampì's station.

"On September 29 and October 3, I received good u.h.f. signals from Crystal Palace," writes **Simon Hamer**, from Presteigne, Wales. Simon uses a Bush 176 receiver with a 26-element, Group "A" aerial from a QTH 500ft a.s.l. with a gap in the hills in the south-east. He also has Grundig "Melody-Boy" and "Satellit" receivers and a Pioneer SX450 for Band II. During a visit to a Science Museum in Denmark recently, Simon saw, among the vintage items, a 1952 Bush TV receiver which had been converted from 405 to 625 lines by a Danish enthusiast.

Between 1930 and 2130 on October 3, **Michael Hahn** G4JRB, Rainham, Essex, received strong u.h.f. pictures from Continental stations and watched a programme similar to our *Police 5* from Austria, Fig. 2, sport with interviews with footballers from Belgium, Fig. 3, and a news bulletin from W-Germany, Fig. 4. For most of September 28, Michael received weak pictures from BRT-RTB, Belgium and NED-2 Holland, and at 1700 on the 30th he saw the evening's programmes from BRT start with *Paulus The Gnome* and then watched other items periodically throughout the evening.

T. Ampì first noticed the good conditions on September 26 when he received colour pictures from NED-2 on Ch. 27 and Germany WDR1, Ch. 30 on the 27th. He received further colour pictures from Holland, Ch. 27 on the 29th, four Swiss stations on Channels 29, 31, 32 and 34 between 0640 and 1015 on October 1 and Belgium and Germany on the 3rd. French stations were predominant with T. Ampì from 1015 on the 1st, when he received pictures from Antenne 2 on Channels 21, 25 and 34, and what looked like Ceefax on 57. On Ch. 34 the French station was fighting with the Swiss station +PTT TSI for predominance. On the 3rd he identified many Continental

signals between Channels 21 and 69, and at one time he saw BRTF on top of the IBA signal from Bluebell Hill on Ch. 43 and Ch. 44 he saw *Es folgt un 1800 Uhr*.

SSTV

"With excellent conditions on 10m during the latter half of September, my KW202 receiver with Robot 400 was rarely far away from the SSTV calling channel, 28 680kHz" writes Sam Faulkner. "SSTV activity really peaked during September 27 and 28 with pre-fixes W1 to W0 logged between 1540 and 2030 on the 27th" continued Sam, who also received his first colour CQ card (in mono) from W7KPW in Arizona while he was in QSO with WB3KOJ. Between September 23 and October 7 Sam received pictures from LA, JA and many from the USA (Figs. 5 and 6) and ZS. "SSTV from ZS land has been very much in evidence, with ZS6AM and particularly ZS6BFU replaying the video he was copying from the States at 1730 on the 27th," writes Sam, who concluded his letter with "The incredible SSTV QRM at times is an indication of the fantastic popularity this mode now enjoys, especially in Europe and the United States".



New Mini Computer

One of the smallest computers on the market, the new Tandy TRS-80 Pocket Computer, was launched in the UK in October.

The computer is battery powered which means that a number of programmes can be loaded and retained for up to 300 hours (the life of the battery) even when the power is switched off, and also makes it a highly mobile unit that can be used almost anywhere. The TRS-80 measures only 175 x 70 x 15mm and will sell for £119 (including VAT).

There are already eight packages of software available to cover varying needs. These include civil engineering, aviation, maths drill, business statistics, real estate, personal finance and a games package. These too, will be in the shops in late autumn at prices ranging from £8.95 to £13.95 (including VAT).

The TRS-80 has a 4-bit CPU consisting of two microprocessors. It can carry 1.9K of user memory (RAM) and a total of 11K of ROM-7K for BASIC interpreter and approximately 4K for the monitor.

Using the cassette interface (£17.95), multiple programmes can be loaded from cassette tape without the previous programme being erased.



Each programme in RAM can be executed selectively by a simple key input.

The machine has a display screen and a 57-key alpha-numeric keyboard. A user manual is included.

Tandy Corporation (UK) Ltd., see advertisement pages of your telephone directory for your local branch.

Zaerix Acquires Mazda

Zaerix Electronics recently announced the acquisition, from Thorn Brimar Ltd., of the radio valves and tubes marketing

and distribution business based at Rochester. With effect from 1 October 1980, Zaerix will be the exclusive licensed distributors of Mazda valves, and on the same date the business will be transferred to their London HQ.

Zaerix will be taking over the complete valve stock, together with the testing facilities of the Rochester operation. Customer service and quality control procedures will be maintained.

Further information from: *Zaerix Electronics Ltd., 46 Westbourne Grove, London W2 5SF. Tel: 01-727 5641/7774.*



The biggest name in solder worldwide

Products that help you make a better job of it.



Arax Multicore Solder.

Economy pack for general non-electrical use. Replaces solid wire and stick solder. (B.S. 219 Grade L). Econopak 200g reel of 3mm dia. Size 16A. £4.14 per reel.



- | Handy Dispensers | | Per pack |
|------------------|--|----------|
| PC115 | for printed circuits. | £1.15 |
| SV130 | for radio and TV repairs. | £1.61 |
| AR140 | for non-electrical applications, except aluminium | £1.38 |
| SS160 | for stainless steel and silver jewellery. | £2.53 |
| 19A | for printed circuit boards – non-corrosive. | 96p |
| AL150 | for aluminium. | £1.93 |
| BCA16 | solder cream for stainless steel, jewellery and household products (non-electrical). | £3.22 |
| BCR10 | solder cream for electronic and electrical use. | £1.38 |
| BCA14 | all purpose solder cream, non-electrical jointing and repairing. | £1.38 |

Tip Kleen.
Multicore Tip Kleen. Soldering-iron tip wiping pad. Replaces wet sponges. (Should not be used above 350°C). 81p per pack.



Econopak.

Ersin Multicore 5-core solder. Contains non-corrosive flux for electrical applications. 1.2mm dia. 200g Econopak. Size 13A. £4.14 per reel.



Metal Soldering.

Arax Multicore 4-acid-core solder for metal fabrication (not aluminium) and repairs. 40/60 tin/lead. 1.6mm dia. Size 11. £3.91 per reel.



TV and Radio Soldering. Savbit Multicore for radio, TV and similar work. Reduces copper erosion. 1.2mm dia. Size 5. 90p per handy dispenser. Econopak. General purpose solder suitable for all electrical joints. 40/60 alloy 1.2mm dia. Size 6. 58p per handy plastic dispenser.



Toolbox Reels.

Multicore 5-core solder for general use. Suitable for electrical joints (B.S. 219 Grade C). 40/60 tin/lead. 1.6mm dia. Size 3. £3.91 per reel.

Savbit.

Multicore 5-core solder for radio, TV and similar work. Reduces copper erosion. Suitable for service engineers and manufacturers using small quantities of solder. 1.2mm dia. Size 12. £3.91 per reel.



Multicore Wick.

Multicore solder-wick for removing solder from virtually any joint. 17mm dia. Size AB10. £1.38 per reel.



Aluminium Soldering.

Alu-Sol Multicore 4-core solder for soldering most types of aluminium. No extra flux needed. 1.6mm dia. Size 4. £11.50 per reel.



Soldering Flux Pastes.

Multicore soldering flux paste. Extra fast, non-corrosive, rosin-flux for electrical and general purpose soldering.

Rosin R.F.10. 35g net. 69p per pack.

Multicore soldering flux paste for soft metals (except aluminium) and stainless steel. Non-electrical. Arax A.F.14. 35g. 69p per pack.

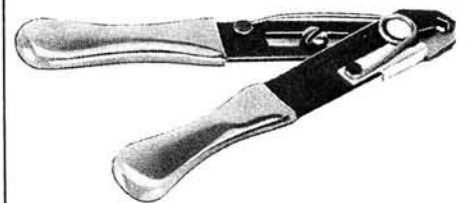

Wire Stripper and cutter.

Wire stripper and cutter with precision ground and hardened steel jaws. Adjustable to most wire sizes. With handle locking-catch and easy-grip plastic covered handles.

Ref: 9. £2.69 per pair.

Bib Hi-Fi Accessories Ltd., (Solder Division), Kelsey House, Wood Lane End, Hemel Hempstead, Hertfordshire HP2 4RQ. Telephone: (0442) 61291.

All recommended retail prices shown are inclusive of VAT. If you have difficulty in obtaining any of these products send direct with 40p for postage and packing. For free colour brochure send S.A.E.

Here



NOW

ELECTROVALUE CATALOGUE '81

as included FREE with December issue of
PRACTICAL ELECTRONICS

It's work-bench size for keeping alongside your favourite journal for instant reference to stock and technical data.



With more to choose from than ever - all the items you have learned to depend on being obtainable from Electrovalue PLUS MANY NEW ONES to bring Catalogue '81 bang up to date. The V.A.T. inclusive price list that goes with it will hold for at least 4 months before the next one is issued.

Yes - you will enjoy dealing with Electrovalue - prices are keen - service is tops.



Write, phone or call if you haven't yet got Catalogue '81 - and you will receive yours by return. (We pay postage).

AND YOU GET BONUS DISCOUNTS AND FREE U.K. POSTAGE TOO, WHEN YOU BUY FROM ELECTROVALUE.

ELECTROVALUE LTD., (Dept.) 28 St. Judes Rd, Englefield Green, Egham, Surrey TW20 0HB. Telephone: (STD 0784) (London 87) 33603 Telex: 264475

Please send me my FREE COPY OF ELECTROVALUE CATALOGUE '81.

Name

Address

J. BIRKETT

(Partners: J. H. Birkett, J. L. Birkett)

Radio Component Suppliers

25 The Strait, Lincoln. LN2 1JF

Telephone: 20767





- UHF POWER AMPLIFIER MODULE** 50 mW Input 2.5 Watt Out 13 Volt 420 To 480 MHz 50 ohm Type BGY 22C - £12.50.
BLY 34 2 WATT 13 VOLT 175 MHz TRANSISTORS - 75p.
HF-VHF POWER TRANSISTORS Type 5878LY SSB-FM 27 To 80 MHz, 40 Watts, 28 Volt with data - £3.
BLY 85 175 MHz 4 Watt 13 Volt with data - £2.50.
BLY 97 24 Volt 175 MHz 4 Watt with data - £3.
BFR 64 470 MHz 13 Volt 3 Watt with data - £4.
UNMARKED GOOD 2N 3866 VHF TRANSISTORS at 3 for 75p.
H.P. HOT CARRIER DIODES 5800-2800 - 40p each.
R.F. SIGNAL TRANSISTORS 2N 918 - 25p, 2N 5179, 2N 5180 Both 50p.
EDDYSTONE TRANSMITTING VARIABLE 30 - 30pf (60pt) - £2.20.
VHF-UHF STRIPLINE FET 2N 4417 with data - £2.20.
VHF R.F. CHOKES 25 - 25pf - 50p, 38 - 38pf - 60p.
BUTTERFLY PRE-SET VARIABLES 25 - 25pf - 50p, 38 - 38pf - 60p.
2 GHz STRIPLINE NPN TRANSISTORS - £1 each.
5 GHz STRIPLINE NPN LOW NOISE TRANSISTORS - £3 each.
FERRITE BEADS FX 1115 - 15p doz. Long Type 3/8" 6 for 10p.
10.7 MHz VERNITRON FILTERS at 50p, 3 for £1.
VHF FETS BF 256C - 4 for 75p, E304 - 30p, 4 for £1.
WIRE ENDED VHF AERIAL SWITCHING PIN DIODES with data at 40p each.
STRIPLINE TRANSISTORS NPN BF 362, PNP BF 679 Both at 25p.
X BAND GUNN DIODES with data - £1.65.
X BAND TUNING VARACTOR DIODES 1 To 2 pf or 2 To 4pf, Both £1.65.
MINIATURE CERAMIC TRIMMERS 2.5 To 6pf, 3 To 10pf 4.7 To 20pf, 6 To 35f, 10 To 40pf All 15p each.
VARIABLE CAPACITORS Direct Drive. 5pf - 75p, 10pf - 75p, 125 - 125pf - 60p, 100 - 200pf - 60p, 250 - 250pf (500pf) - 85p, 10 - 10 - 10pf - 75p.
3/16" COIL FORMERS with core at 6 for 25p.
SUB-MINIATURE CERAMIC TUBULAR TRIMMERS 0.5pf To 3pf - 15p.
MURATA 455 KHz FILTERS - 50p each.
MINIATURE 10pf AIRSPACED TRIMMERS at 20p each.
SOLDER-IN FEED THRU'S 6 Spf, 27pf, 300pf, 1000pf All 20p doz.
ERIE RED CAP MINIATURE DISCS 01uf 100v.w. at 5p each.
ELECTROLYTIC CAPACITORS 1500uf 63v.w. Size Approx. 3" x 1" - 3 for £1.
20 ASSORTED BRANDED 250 mW ZENERS for 60p.
9 VOLT ITRON 9 DIGIT SEVEN SEGMENT DISPLAY Type FG95A - £1.80.
TRANSFORMERS 240 Volt Input. Type 1. 24 Volt Tapped at 14 Volt 1 Amp - £1.30 (P&P 25p). Type 2. 30-0-30 Volt 500 mA - £1.30 (P&P 25p). Type 9. 12 Volt 1 Amp - £1.60 (P&P 25p).
HOUSE CODED TTL 7400, 7410, 74L00, 7453, 7430 All at 6 for 50p.
TTL I.C.'s 74H00 - 15p, 74H10 - 15p, 74H30 - 15p, 74H50 - 15p, 74H51 - 15p, 74H61 - 15p, 74H106 - 25p, 74S05 - 15p, 74S10 - 22p, 74S51 - 22p, 74S64 - 22p, 74S158 - 60p.
6 To 12 Volt MINIATURE RELAYS 5 Amp SPCO Contacts - 60p.
WIRE ENDED HF TO VHF PIN SWITCHING DIODES untested 25 for £1.50.

Please add 20p for post and packing on U.K. orders under £2. Overseas postage charged at cost.

NEED ENCLOSING?

Now, CSC are really in the hardware business, with a series of plastic cases ideally suited to applications ranging from hand-held probes to hi-fi equipment. CSC cases are moulded in robust plastic and come with all the necessary screws, covers and, where appropriate, battery compartments, connectors and transparent panels for displays. And CSC can provide customer-specified variations for large-quantity orders. Fill in the coupon for more details.

CSC (UK) Ltd, Unit 1, Shire Hill Industrial Estate, Saffron Walden, Essex CB11 3AQ. Telephone: (0799) 21682. Telex: 817477.

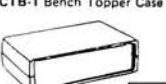
CTP- Probe Case  (£3.30 Nett) £3.50 Qty	DMC-2 Design-Mate Case  (£3.85 Nett) £5.29 Qty	CBP-1 Portable Case  (£5.75 Nett) £7.76 Qty
CTH-1 Handheld Case  (£3.00 Nett) £4.31 Qty	DMC-1 Design-Mate Case  (£4.25 Nett) £5.75 Qty	CTB-1 Bench Topper Case  (£7.15 Nett) £9.37 Qty

Bold prices include P & P and 15% VAT. Please deduct £1 postage from each additional order.

I enclose cheque/PO for £
 or debit my Barclaycard, Access, American Express card
 No Exp. date
 or Tel: (0799) 21682 with your card number and your order will be in the post immediately.

NAME

ADDRESS

CONTINENTAL SPECIALTIES CORPORATION



FREE catalogue tick box

Continental Specialties Corporation (UK) Limited, Dept. 6MM
 Unit 1, Shire Hill Industrial Estate, Saffron Walden, Essex CB11 3AQ.

TOMORROW'S TOOLS TODAY

AND THERE'S MORE WHERE THIS CAME FROM

It's a long time since one of our adverts was presented in 'list' form - but simply because we do not try to squeeze this lot in every time doesn't mean that it's not available. Our new style price list (now some 40 pages long) includes all this and more, including quantity prices and a brief description. The kits, modules and specialized RF components - such as TOKO coils, filters etc. are covered in the general price list - so send now for a free copy (with an SAE please). Part 4 of the catalogue is due out now (incorporating a revised version of pt.1).

LINEAR ICs - NUMERIC LISTINGS

TBA1205	1.00	KB4413	1.95
L200	1.95	KB4417	1.80
U237B	1.28	TD4420	2.25
U247B	1.28	KB4420B	1.09
U257B	1.28	KB4423	2.30
U267B	1.28	KB4424	1.65
LM301H	0.67	KB4431	1.95
LM301N	0.30	KB4432	1.95
LM308H	0.96	KB4433	1.52
LM308N	0.65	KB4436	2.53
LM339N	0.66	KB4437	1.75
LM348N	1.86	KB4438	2.22
LF351N	0.38	KB4441	1.35
LF353N	0.76	KB4445	1.29
LM374N	1.75	KB4446	2.75
LM380N-14	3.00	KB4448	1.65
LM380N-8	1.00	NE5044N	2.26
LM381N	1.81	NE5532N	1.85
ZN419CE	1.95	SO6000	3.75
NE5544N	1.80	SL6270	2.03
NE555N	0.30	SL6310	2.03
NE5556N	0.50	SL6600	3.75
NE560N	3.50	SL6690	2.75
NE562N	4.05	SL6700	2.35
NE564N	4.29	SL6700	2.35
NE565N	1.00	ICL8038CC	4.50
NE566N	1.60	MSL9362	1.75
NE570N	3.85	MSL9363	1.75
SL624	3.28	HAI1211	1.95
TBA651	1.81	HAI1223	2.15
UA709HC	0.64	HAI1225	1.45
UA709PC	0.36	HAI2002	1.45
UA710HC	0.65	HAI2017	0.80
UA710PC	0.59	HAI2402	1.95
UA741CH	0.66	HAI2411	1.20
UA741CN	0.27	HAI2412	1.55
UA747CN	0.70	LF13741	0.33
UA748CN	0.36	SN76660N	0.80
UA753	2.44		
UA758	2.35		
TBA810AS	1.09		
TBA820M	0.75		
TC9490E	1.80		
TD1028	2.11		
TD1029	2.11		
TD1054	1.45		
TD1062	1.95		
TD1072	2.64		
TD1074A	5.09		
TD1083	1.95		
TD1090	3.05		
HAI137	1.20		
HAI196	2.00		
HAI197	1.40		
TD1220	1.40		
LM1303	0.99		
LM1307	1.55		
LM1310P	1.90		
LM1330	1.20		
LM1350	1.20		
LM1370	1.90		
LM1388	2.75		
TD1490	1.86		
MC1496P	1.25		
SL1610P	1.60		
SL1611P	1.60		
SL1612P	1.60		
SL1613P	1.89		
SL1620P	2.17		
SL1621P	2.17		
SL1623P	2.24		
SL1624C	3.28		
SL1625P	2.17		
SL1626P	2.44		
SL1630P	1.62		
SL1640P	1.89		
SL1641P	1.89		
TD2002	1.25		
TD2020	3.00		
UA2242A	3.05		
UA2283B	1.00		
CA3080E	0.70		
CA3089E	1.84		
CA3090AQ	3.35		
CA3123E	1.40		
CA3130E	0.80		
CA3130T	0.90		
CA3140E	0.46		
CA3189E	2.20		
MC3357P	2.35		
LM3900N	0.60		
LM3900N	0.68		
LM3914N	4.02		
LM3915N	2.80		
KB4400	0.80		
KB4406	0.60		
KB4412	1.95		

TTL N and LSN

7400N	0.13	7443N	1.15	74LS112	0.38	74LS169	2.00
74LS00	0.20	7444N	1.12	74LS113	0.38	74170N	2.30
7401N	0.13	7445N	0.94	74LS114	0.38	74LS170	2.00
74LS01	0.20	7446N	0.94	74188N	0.83	74LS174	1.20
7402N	0.14	7447N	0.89	74120N	1.15	74175N	0.87
74LS02	0.20	7448N	0.56	74120N	1.15	74175N	1.10
7403N	0.14	7449N	0.99	74121N	0.46	74176N	0.75
74LS03	0.20	74LS49	0.99	74123N	0.73	74177N	0.78
7404N	0.14	7451N	1.17	74LS124	1.75	74181N	1.65
74LS04	0.24	74LS51	0.24	74125N	0.38	74LS181	3.50
7405N	0.18	7453N	0.17	74LS125	0.44	74LS183	2.10
74LS06	0.26	7454N	0.17	74LS126	0.57	74184N	1.35
7407N	0.38	7460N	0.17	74LS127	0.73	74185N	1.34
7408N	0.17	74LS63	1.24	74LS132	0.78	74LS190	0.92
74LS08	0.24	7470N	0.28	74LS136	0.40	74192N	1.05
7409N	0.17	7472N	0.28	74LS138	0.60	74LS193	1.80
74LS10	0.15	7473N	0.32	74141N	0.56	74194N	1.05
74LS101	0.24	74LS73	0.38	74142N	0.65	74196N	0.99
74LS11	0.20	7474N	0.27	74143N	3.12	74LS196	1.10
74LS111	0.24	74LS74	0.28	74144N	3.12	74LS197	1.10
74LS11N	0.20	7475N	0.38	74LS145	0.97	74198N	1.50
74121N	0.24	7476N	0.37	74147N	1.75	74199N	1.60
7412N	0.17	74LS76	0.38	74148N	1.09	74LS247	0.93
7413N	0.30	74LS78	0.38	74148N	1.09	74LS257	1.08
7414N	0.51	7480N	0.48	74150N	0.99	74LS260	1.53
74LS15	0.24	7481N	0.86	74151N	0.55	74LS279	0.52
7416N	0.30	7482N	0.69	74LS152	0.84	74LS283	1.20
7417N	0.30	7485N	1.04	74LS153	0.64	74LS293	0.95
7420N	0.16	74LS85	0.99	74LS153	0.54	74LS365	0.49
74LS20	0.24	74LS86	0.40	74154N	0.96	74LS366	0.49
7421N	0.29	7489N	2.05	74LS155	0.54	74LS367	0.43
74LS21	0.24	7490N	3.03	74LS155	1.10	74LS368	0.49
7423N	0.27	74LS90	0.90	74156N	0.80	74LS374	1.80
7425N	0.27	7491N	0.76	74157N	0.67	74LS377	1.95
7427N	0.27	74LS91	1.10	74LS157	0.55	74LS379	1.30
74LS27	0.44	7492N	0.38	74LS158	0.60	74LS393	1.40
7428N	0.35	74LS92	0.78	74159N	2.10		
UA753	2.44	7493N	0.32	74160N	0.82		
7430N	0.17	74LS93	0.99	74LS160	1.30		
74LS30	0.24	7494N	0.28	74161N	0.92		
7432N	0.25	7495N	0.65	74LS161	0.78		
74LS32	0.24	74LS95	1.14	74LS162	1.30		
7437N	0.40	7496N	0.58	74163N	0.92		
7438N	0.33	74LS96	1.20	74LS163	0.78		
74LS38	0.24	7497N	1.85	74164N	1.04		
7440N	0.17	74LS107	0.38	74LS164	1.30		
74LS40	0.24	74109N	0.63	74165N	1.05		
7441N	0.74	74LS109	0.70	74LS165	1.04		
7442N	0.70	74110N	0.54	74167N	2.50		
74LS42	0.99	74111N	0.68				

FREQUENCY DISPLAY & SYNTHESIZER ICs

SAAL056	3.75
SAAL058	3.35
SAAL059	3.35
11C900C	14.00
LNL232	19.00
LNL242	19.00
MSL2318	3.84
MSM5523	11.30
MSM5524	11.30
MSM5525	7.85
MSM5526	7.85
MSM5527	9.75
MSM55271	9.75
ICM7106CP	9.55
ICM7216B	19.25
ICM7217A	9.50
SP8629	3.85
SP8647	6.00
95H90PC	6.00
HDL0551	2.45
HD44015	4.45
HDL2009	6.00
HD44752	8.00

CMOS 4000 SERIES

4001	0.17
4000	0.17
4002	0.23
4008	0.80
4009	0.58
4010B	0.58
4011AE	0.20
4011B	0.20
4012	0.55
4013	0.55
4015	0.95
4016	0.52
4017	0.80
4019	0.60
4020B	0.93
4021	0.82
4022	0.90
4023	0.17
4024	0.76
4025	0.17
4026	1.80
4028	0.72
4029	1.00
4030	0.58
4035	1.20
4040	0.83
4042	0.85

VOLTAGE REGULATORS

78series	0.95
79series	1.00
78Mseries	0.65
78Lseries	0.35
79L05	0.85
78MGT2C	1.75
79MGT2C	1.75
723CN	0.65
L200	1.95
TD1412	0.75
NE5553N	1.25
LM317MP	1.48
LM337MP	1.48

MICROMARKET

8080A/2	7.50
8212	2.30
8214	3.50
8216	1.95
8224	3.50
8251	6.25
8255	5.40
6800P	7.50
6810	5.95
6820	7.45
6850	4.90
6852	4.85
MC2708	7.50
2114	6.50
4027	5.78
2102	1.70
2112	3.40
2513	7.54
IM4716	4.50
81LS97	1.25

CRYSTAL FILTER PRODUCTS

10.7MHz 2 POLE TYPES:	
LM15A 15KHz BW 2.49	
10.7MHz 8 POLE TYPES:	
LM441 15KHz BW 14.50	
H4402 7.5KHz BW 15.50	
LM222D 2.4KHz SSB 17.20	
HF FIRST FILTERS:	
B34F8A 34.5MHz HF 32.00	

RADIO CONTROL CRYSTALS

(No splits available)	
AM TX:	
3rd OT 30pF HC25U 1.65	
AM/PM RX:	
3rd OT 30pF HC25U 1.65	
FM TX:	
3rd OT 30pF HC25U 1.85	
Pairs FM	3.25
Pairs AM	3.10

CRYSTALS

32.768 kHz	2.70
100kHz	3.85
455kHz	5.00
1.0MHz	3.00
3.2768MHz	2.70
4.000MHz	2.00
4.19439MHz	2.30
6.5536MHz	2.10
10.0MHz	2.50
10.6985MHz	2.50
10.7015MHz	2.50
10.245MHz	2.50
10.7MHz	3.00
11.52MHz	2.50
100MHz	3.00

VARICAP TUNING DIODES

BA102	0.30
BA121	0.30
ITT210	0.30
BB204B	0.36
BB105B	0.36
BB109	0.27
MM125	1.05
BB212	1.95
KV1210	2.45
KV1211	1.75
KV1226	1.95
KV1225	2.75
KV1215	2.55
KV1225	2.75

SWITCHING AND PIN DIODES

LN6263	0.62
BA182	0.19
BA244	0.17
BA379	0.35
TM1061	0.95

SHOTTKY DIODES

1N4148	0.06
1N4001	0.06
1N4002	0.07
1N5402	1.15
CA91	0.07
AA112	0.25

LEDs

3MM RED	0.12
3MM RED CLEAR	0.15
3MM RED	0.15
2.5 X 5MM RED	0.17
3MM GREEN	0.15
3MM GN CLEAR	

"THE ALL IN ONE RF MEASURING UNIT"

50MHz Frequency Counter, with provision for 455KHz offset, R.F. power and S.W.R. ratio meter in 2 ranges, field strength meter, complete with mini whip aerial and test lead, S.O. 239 sockets fitted for power and S.W.R. measurements.

SPECIFICATION

Freq. Counter = 1KHz-50MHz.
 5 Digit LED Readout,
 Sensitivity = 20mV-20V,
 Input Imp = 1M OHM at 20PF,
 Power Supply Input 12V DC,
 S.W.R. Range 1-1.3 Calibrated,
 R.F. Power and
 S.W.R. Range 0-10
 Watts - 0-100 Watts,
 Imp 50 OHM,
 Field Strength Range 0-10dB
 Size = 6 $\frac{1}{4}$ "W 3 $\frac{1}{4}$ "H 4 $\frac{1}{2}$ "D

£49.50 INC VAT
 Post & Packing £1.00
 Trade enquiries welcome.

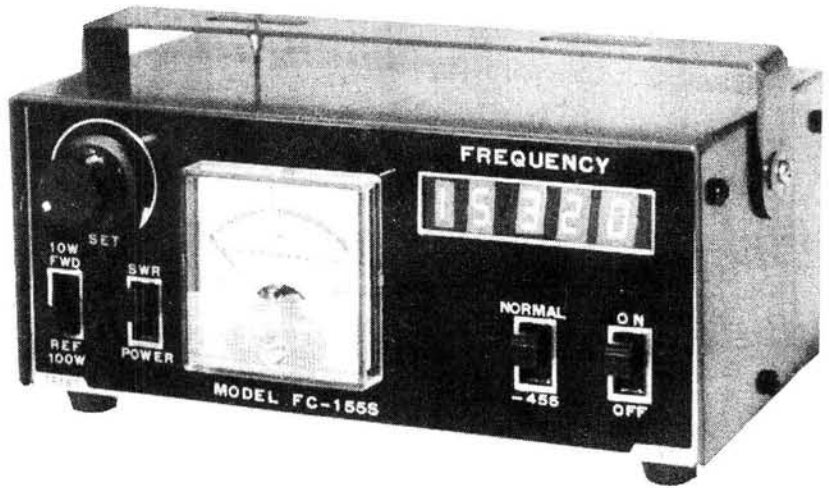

OPEN CHANNEL U.K. LIMITED

7, HUGHENDEN ROAD, HASTINGS, SUSSEX TN34 3TG.
 Tel. 0424-428131, TELEX: 95281.



QUALITY QUARTZ CRYSTALS QUICKLY

10 kHz 50 kHz 100 kHz 500 kHz 1MHz 100MHz 250MHz 270MHz

Webster Electronics

ILMINSTER, SOMERSET TA19 9QA, ENGLAND
 Telephone (046 05) 4261/2 Telex 46571 FRQNCY G

**Please Mention PRACTICAL WIRELESS when
 replying to advertisements.**



SAFGAN Presents DT-400 series from £159 + VAT

**HIGH QUALITY DUAL TRACE OSCILLOSCOPES
 AT PRICES EVERYONE CAN AFFORD**

Model DT-410	4" CRT	5mv/div	10MHz	@ £159 + VAT
Model DT-412	4" CRT	5mv/div	12MHz	@ £172 + VAT
Model DT-415	4" CRT	5mv/div	15MHz	@ £185 + VAT

SPECIFICATION FOR ALL MODELS

- | | |
|--|--|
| <ul style="list-style-type: none"> ★ CH1, CH2: 5mv/div-20v/div in 12 cal steps ★ BANDWIDTH: 10MHz (DT-410), 12MHz (DT-412), 15MHz (DT-415) ★ TIME BASE: 0.5us/div-200ms/div in 18 cal steps
 ×5 Expansion to 100ns/div
 ×5 Multiplier to 1s/div ★ XY FACILITY: Matched inputs X=CH1, Y=CH2 | <ul style="list-style-type: none"> ★ TRIGGER: Level Control, ± slope
 Bright Line AUTO, NORMAL, TV Triggering CH1, CH2 0.5 div; EXT Trig 100mv ★ Z Modulation ★ Graticule blue ruled 8 × 10 div (6.4 × 8cm²) ★ Size: H215mm W165mm D280mm Weight 4.5kg
 PROBE (X1-REF-X10) £11.50 + VAT |
|--|--|

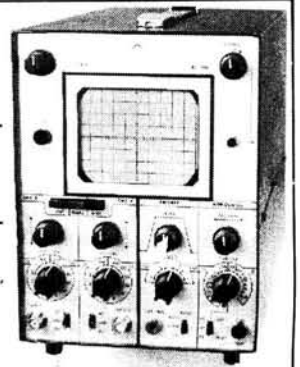

ORDERS TO: **SAFGAN ELECTRONICS LTD.** (Goods +15% + £3 P&P)
56 BISHOPS WOOD, ST. JOHNS, WOKING, SURREY GU21 3QB
 OFFICIAL GOVERNMENT AND EDUCATIONAL ORDERS ACCEPTED

TEL: WOKING 66836
 OR WOKING 69560



DT-400 SERIES

OFF THE SHELF DELIVERY ON THESE



BRAND NEW FROM FLUKE... NOW AVAILABLE THE 8024A HAND HELD DMM

This model incorporates all the features of the 8020A but in addition has:
A peak hold switch which can be used in AC or DC for volts and current functions.
Audible continuity testing and level detection for sensing logic levels.
A temperature (°C) range for use with a thermocouple.

£135

Carriage and Insurance £3

The following accessories are in stock now

- Y8008 Touch and Hold Probe..... £18.00
- 80K-40 High Voltage Probe..... £45.00
- 81RF RF Probe to 100 MHz..... £32.00
- 80T-150C Temperature Probe (C)..... £55.00
- 801-600 Clamp-on AC Current Probe £55.00

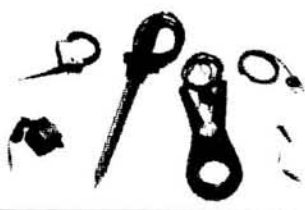

HERE IT IS... THE EVER POPULAR 8022A HAND-HELD DMM

Consider the following features:
6 resistance ranges from 200 ohm-20 ohms.
8 current ranges from 2mA-2A AC/DC.
10 voltage ranges from 200 mv-1000v DC-200 mc-750V AC.
Pocket size - weighing only 370 gms.
Full overload protection - will withstand 6kv spikes.
Rugged construction - virtually indestructible.
Meets tough military specs - drop proof.
In line, pushbutton operation for single-handed useage.
Incorporates low power CMOS chip for low power consumption.
All this plus a 2-year full guarantee.



For only £89
Carriage and Insurance £3

Soft carrying case £7 extra

Even more sophisticated the Fluke 8020A.
Identical in most respects to the 8022A but in addition incorporates a conductance range from 2mS-200nS.

Price £112

Carriage and Insurance £3.00

A handsome soft carrying case is included (this model only)

OFF THE SHELF DELIVERY ON THESE

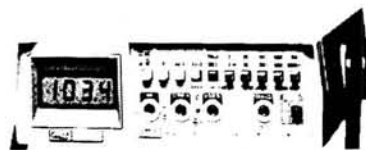

8010A AND 8012A BENCH MODEL D.M.M.s

The 8010A is a general purpose, bench/portable digital multimeter with more functions and features than ever offered for such a low price. Its companion, the 8012A, has identical characteristics except that it has two additional low resistance ranges, 2Ω and 20Ω to replace the 8010A's 10 ampere current range.

The 8010A and 8012A feature:
10 voltage ranges from 200mv-1000v dc, 200mv-75v ac.
3 conductance ranges from 2mS-200nS.
6 resistance ranges from 200Ω-20MΩ - the 8012A has two additional resistance ranges 2Ω and 20Ω.
10 current ranges from 200μA-2A AC/DC - the 8010A has two additional current ranges 10A AC and 10A DC.

8010A £159 8012A £199
Carriage and Insurance £3.

The 8010A is also available with two rechargeable Nicad size C batteries installed in option -01 a+ £179.00.

PLEASE ADD 15% VAT TO ALL ORDERS except where items marked "VAT Included". CALLERS WELCOME.

We are open 9 a.m.-6 p.m. Monday-Saturdays. We carry a very large selection of electronic components and electro-mechanical items. Special quotations on quantities.

ELECTRO-TECH COMPONENTS LTD.

364 EDGWARE ROAD, LONDON, W.2. TEL: 01-723 5667

OHIO SUPERBOARD II



Improved 50Hz guard band models with full 32 x 32 display. Black and white £159 15% vat post free. Colour £225 + 15% Vat. Special offer:- if bought with either Superboard these items are at the reduced prices shown first. Also sold separately at the bracketed prices. Add 15% vat. Guard band kit £9 (£8). Modulator and power supply kit £7.95 (£25). 4K extra ram £20 (£24). Display expansion kit approx 30 lines x 54 characters £15 (£20). Case £23 (£26). Colour conversion board £65 (£65). CEGMON improved monitor rom poa.

SINCLAIR PRODUCTS
PFM200 £51.95, case £2.07, adaptor £4.20, connector kit £13.95. Microvision TV £89, mains adaptor £6.88, PDM35 £34.23, adaptor £4.20, case £2.07, DM350 £76.70, DM450 £102.17. DM235 £55.55.
Accessories for all 3 models:- rechargeable batteries £8, adaptor/charger £4.20, case £8.90, Enterprise prog calculator £19.95, New SC110 10 MHz oscilloscope £144.95.
COMPUTER GAMES
Chess champion £49.95, Chess challenger £7.99, Sensory Chess Champion £119, Star chess £62, Atari Videocomputer £107, Cartridges £14.85.
TV GAMES
AY-3-8550 chip £4, kit £5.28, Stunt cycle AY-3-8785 chip £14.00, kit £6.95, 10 game paddle 2 AY-3-8600 chip £9.95, kit £7.03, Modified shoot kit £5.28, Colour generator kit £9.95.

MAINS TRANSFORMERS
6.0-6V 100ma 96p, 1.1a £3.12, 9.0-9V 75ma 96p, 1a £2.85, 2a £4.73, 12.0-12V 100ma £1.20, 1a £3.50, 15.0-15V 1a £3.78.

JC12 AND JC20 AMPLIFIERS
Integrated circuit audio amplifier chips with data and printed circuits. JC12 6 watts £2.50, JC20 10 watts £3.50.
CONTINENTAL SPEC. PRODUCTS
EXP300 £6.61, EXP350 £3.62, EXP325 £1.84, EXP650 £4.14, EXP48 £2.64.

PRINTED CIRCUIT MATERIALS

PC etching kits:- economy £2.72, standard £5.06, 40 sq ins pcb 50p, 1 lb FeCl £1.60, etch resist pens:- economy 50p, dalo 90p drill bits 1/32" or 1mm 35p, etching dish 92p, laminate cutter £1.30.

BI-PAK AUDIO MODULES
AL30A £4.53 PA12 £9.31, PS12 £1.75, T538 £2.70, S450 £27.90, AL60 £5.62, PA100 £19.24, SPM80 £5.26, BMT80 £6.08, Stereo 30 £23.94, AL80 £8.56.
S-DECS AND T-DECS
S-Dec £3.79, T-Dec £4.59, 16 dil adaptor £2.31.

BATTERY ELIMINATORS
3-way types with switched output and 4 way multi-jack:- 3/4/6v 100ma £2.94, 6/7/9/300ma £3.45, 100ma radio types with press stud connectors 9v £4.77, 6v £4.77, 4.5v £4.77, 9+9v £5.99, 6+6v £5.99, 4/4/4v £5.99. Fully stabilized model 3/6/7/9/400ma £6.95 car converters 12v dc input, output 3/4/6/7/9/12v 800ma £3.04.

BATTERY ELIMINATOR KITS
100ma radio types with press-stud connectors 4.5v £1.64, 6v £1.64, 9v £1.64, 4/4/4v £2.30, 6+6v £2.30, 9+9v £2.30. Heavy duty 13 Way types 4/6/7/8/11/13/14/17/21/25/28/34/42v 1A £6.62, 2A £10.56. Car converter input 12v dc, output 6/7/9/3v 1A stabilized £1.62. Stabilized TTL computer supply 5V 2A £8.18, 5v 4A £13.86. Stabilized 8-way types 3/4/6/7/9/12/15/18v 100ma £3.12, 1A £7.80, 2A £11.81. Stabilized variable voltage models 2-18v 100ma £3.12, 1-30v 1A £8.10, 1-30v 2A £14.52.

COMPONENTS
1N4148 0.9p, 1N4002 3.7p, 741 8dil 20p, bc182, bc184, bc212, bc214, bc547, bc549 6.1p, tip41c 48p, bd132 32p, fuses 20mm x5mm cartridge 15, 25, .5, 1, 2, 3, 5A quickblow 2p, resistors 5% 1W £12 100 to 10M 1.5p, 0.8 for 50- of one value, polyester capacitors 160v .015, .068mf 2.6p, .1mf 4.0p, .01mf 3.0p, .022, .033mf 3.3p, .047mf 4.0p, .15, .33mf 4.9p, .47mf 6.0p, polystyrene capacitors £12 63v 10 to 1000pf 4p, 1n2 to 10n 5p, ceramic capacitors 50v E6 22pf to 17n 2.5p, electrolytic capacitors 50v .5, 1, 2mf 6p, 25v 5, 10mf 6p, 15v 22, 33mf 6p, 47, 68mf 5p, 100mf 7p, 330, 470mf 9p, 1000mf 11p, zeners 400mv E24 2v7 to 33v 7p, preset pots subminiature 0.1W horiz or vert 100 to 4M7 8p, red LEDs 11p, ic sockets 8 dil 8.7p, 14dil 10.1p, 16 dil 12p.

SWANLEY ELECTRONICS

DEPT PW, 32 Gosdell Rd., Swanley, Kent BR8 8EZ.

Mail order only. Please add 35p postage. Prices include VAT unless stated. Lists 27p post free. Overseas customers deduct 13%. Official credit orders welcome.

MIGHTY NINETY PACKS

SUPER VALUE PACKS ALL AT 90p EACH POSTAGE 15p PER PACK UP TO FOUR PACKS FIVE OR MORE POST FREE BUY SIX PACKS AND GET A SEVENTH PACK FREE!

- MN1.** 300 1/2-watt Resistors pre-formed for P&C Mtg.
- MN2.** 200 1/2 AND 1/4-watt Resistors.
- MN3.** 100 1/2 & 2-watt Resistors.
- MN4.** 50 Wirewound Resistors.
- MN5.** 100 metal oxide Resistors. 1%, 2% and 5%.
- MN6.** 12 asstd. potentiometers.
- MN7.** 25 asstd. skeleton pre-set Resistors.
- MN8.** 50 asstd. Electrolytic Capacitors.
- MN9.** 100 asstd. Ceramic Capacitors. Plite, disc, tub and monolithic etc.
- MN10.** 100 mixed capacitors. Polyester, Polystyrene, Metallised, Radial and Axial types.
- MN11.** 20 asstd. Silver Mica Capacitors
- MN12.** 8 Tantalum Bead Capacitors (useful values).
- MN13.** 20 asstd. Transistors. BC, 2N Series + Power etc.
- MN14.** 40 1N4148 Diodes.
- MN15.** 5 Light Sensitive Devices.
- MN16.** 20 min. wire-ended Neons.
- MN17.** 2 12-volt Relays. Ex nearly new equip.
- MN18.** 3 Encapsulated Reed Relays, 9-12v. coil, 6-pole and t-pole.
- MN19.** 2 24-volt Relays. Ex nearly new equip.
- MN20.** 1 240-110 to 12-volt, 100ma Transformer.
- MN21.** 1 240-110 to 24-volt 100ma Transformer.
- MN22.** 8 .2" Led's with clips, 4 red, 2 yellow, 2 green.
- MN23.** 116 asstd. screws, nuts, washers, self-tappers etc.
- MN24.** 100 asstd. small springs.
- MN25.** 50 asstd. pop rivets.
- MN26.** 50 asstd. insulated crimps.
- MN27.** 200 items, grommets, spacers, cable markers, plastic screws, sleeving, tie wraps etc.
- MN28.** 20 asstd. fuses. 1 1/2" 20mm etc.
- MN29.** 75mts equipment, wire, asstd. colours and sizes.
- MN30.** 3 x 2m length, 3 core, mains cable.
- MN31.** 12 asstd. trimmer capacitors, compression film, Air-spaced etc.
- MN32.** 15 30pP Beehive trimmers.
- MN33.** 20 coil formers, ceramic, plastic, reed relay etc.
- MN34.** 25 min. glass reed switch.
- MN35.** 10 asstd. switches, toggle, slide, micro, etc.
- MN36.** 10 ex equipment panel lamps (no rubbish).
- MN37.** 10 asstd. audio connectors. Din phone etc.
- MN38.** 1 PCB with triac control IC data inc.
- MN39.** 1 oscillator PCB loads of components (no data).
- MN40.** 50 Polystyrene Capacitors.
- MN41.** 10 assorted T.T.L. I/Cs.
- MN42.** 10 BC107 Transistors.
- MN43.** 10 BC108 Transistors.
- MN44.** 10 screw fix S.P. C.O. min. slide switch.

PLEASE QUOTE NO. OF PACKS WHEN ORDERING

CHORDGATE LTD.

75 FARINGTON ROAD, SWINDON, WILTS. Tel. Swindon (0793) 33877. Retail shop at above address.

TTLs BY TEXAS			LINEAR I.C.s			TRANSISTORS			TI/P41C			DIODES		
7400 11p	7497 180p	74221 160p	74LS192 140p	74C157 250p	MC1496 100p	AC127/8 20p	BFY51/2 22p	TIP41C 78p	2N3866 90p	DIODES				
7401 12p	74100 130p	74251 140p	74LS193 140p	74C160 155p	MC3340 120p	AD149 70p	BFY52 33p	TIP42A 70p	2N3903/4 18p	BY127 12p				
7402 14p	74104 65p	74259 250p	74LS195 140p	74C161 155p	MC3360 120p	AD161/2 45p	BFY90 90p	TIP42C 82p	2N3905/6 20p	OA47 9p				
7403 14p	74105 65p	74285 90p	74LS196 120p	74C162 155p	MC5039 75p	BC107/8 11p	BFY30 90p	TIP3055 70p	2N4058/9 12p	OA81 15p				
7404 14p	74107 34p	74278 290p	74LS200 140p	74C163 155p	NE531 100p	BC147/8 9p	BU105 190p	TIS43 34p	2N4060 12p	OA90 9p				
7405 18p	74109 55p	74283 190p	74LS201 140p	74C173 120p	NE543K 225p	BC149 10p	BU108 250p	TI893 30p	2N4062/2 18p	OA91 9p				
7406 32p	74110 55p	74284 400p	74LS242 175p	74C174 160p	NE555 25p	BC157/8 10p	BU205 220p	ZTX108 12p	2N4123/4 22p	OA95 9p				
7407 32p	74111 70p	74285 400p	74LS243 175p	74C175 210p	NE556 70p	BC159 11p	BU208 240p	ZTX109 12p	2N4125/6 22p	OA200 9p				
7408 18p	74116 200p	74290 150p	74LS244 180p	74C192 150p	NE561 70p	BC169C 12p	BU406 145p	ZTX502 18p	2N4401/3 27p	IN914 4p				
7409 18p	74118 130p	74293 150p	74LS245 180p	74C193 150p	NE562B 425p	BC172 12p		ZTX504 30p	2N4427 90p	IN916 7p				
7410 15p	74119 210p	74294 150p	74LS246 180p	74C194 150p	NE565 155p	BC177/8 17p			2N4871 60p	1N4148 4p				
7411 24p	74120 110p	74298 200p	74LS257 175p	74C195 110p	NE566 175p	BC181/2 10p			2N5087 27p	1N4001/2 5p				
7412 20p	74121 25p	74365 150p	74LS259 175p	74C221 175p	NE567 175p	BC184 11p			2N5089 27p	1N4003/4 6p				
7413 30p	74122 48p	74366 150p	74LS298 249p	4000 SERIES		BC187 30p			2N5172 27p	1N4005 6p				
7414 60p	74123 48p	74367 150p	74LS373 195p	CA3130E 100p	CA3140E 70p	BC212/3 11p			2N5179 27p	1N4006/7 7p				
7415 27p	74125 55p	74368 150p	74LS374 195p	CA3160E 75p	CA3160E 75p	BC214 12p			2N5191 83p	1N5401/3 14p				
7416 27p	74126 60p	74390 200p	74LS376 195p	CA3048 225p	CA3048 225p	BC214 12p			2N5194 90p	1N5404/7 19p				
7417 27p	74127 60p	74393 200p	81LS96 140p	CA3080E 72p	CA3080E 72p	BC214 12p			2N5245 40p	ZENERs				
7420 17p	74128 75p	74490 225p	81LS97 140p	CA3090A 375p	CA3090A 375p	BC214 12p			2N5296 55p	2.7V-33V				
7421 40p	74132 75p	74490 225p	81LS98 140p	ICL7105 925p	ICL7105 925p	BC214 12p			2N5401 50p	400 mW 9p				
7422 22p	74136 60p	74490 225p	81LS99 140p	LM301A 38p	LM301A 38p	BC214 12p			2N5457/8 40p	1 W 15p				
7423 34p	74141 70p	SERIES		LM312 190p	LM312 190p	BC214 12p			2N5459 40p	OFFERS				
7425 30p	74142 200p	74LS00 14p	74LS00 14p	LM318 200p	LM318 200p	BC214 12p			2N5460 40p	100+ 741				
7426 40p	74145 90p	74LS02 18p	74LS02 18p	LM324 70p	LM324 70p	BC214 12p			2N5465 44p	£16				
7427 34p	74147 190p	74LS04 14p	74LS04 14p	LM339 90p	LM339 90p	BC214 12p			2N5472 27p	1N4006/7 7p				
7428 30p	74148 150p	74LS08 22p	74LS08 22p	LM348 95p	LM348 95p	BC214 12p			2N5478 18p	1N4006/7 7p				
7430 17p	74150 100p	74LS10 20p	74LS10 20p	LM377 175p	LM377 175p	BC214 12p			2N5484 44p	1N4006/7 7p				
7432 30p	74151A 70p	74LS13 38p	74LS13 38p	LM380 70p	LM380 70p	BC214 12p			2N5485 44p	1N4006/7 7p				
7433 40p	74153 70p	74LS14 7p	74LS14 7p	LM381A 150p	LM381A 150p	BC214 12p			2N5485 44p	1N4006/7 7p				
7437 35p	74154 100p	74LS20 22p	74LS20 22p	LM389N 140p	LM389N 140p	BC214 12p			2N5485 44p	1N4006/7 7p				
7438 35p	74155 90p	74LS22 28p	74LS22 28p	LM709 35p	LM709 35p	BC214 12p			2N5485 44p	1N4006/7 7p				
7440 17p	74157 70p	74LS30 22p	74LS30 22p	LM710 50p	LM710 50p	BC214 12p			2N5485 44p	1N4006/7 7p				
7442A 60p	74159 190p	74LS47 90p	74LS47 90p	LM733 100p	LM733 100p	BC214 12p			2N5485 44p	1N4006/7 7p				
7443 112p	74160 100p	74LS55 30p	74LS55 30p	LM741 25p	LM741 25p	BC214 12p			2N5485 44p	1N4006/7 7p				
7444 112p	74161 100p	74LS73 50p	74LS73 50p	LM747 70p	LM747 70p	BC214 12p			2N5485 44p	1N4006/7 7p				
7445 100p	74162 100p	74LS74 40p	74LS74 40p	LM748 35p	LM748 35p	BC214 12p			2N5485 44p	1N4006/7 7p				
7446A 90p	74163 100p	74LS75 50p	74LS75 50p	LM3900 70p	LM3900 70p	BC214 12p			2N5485 44p	1N4006/7 7p				
7447A 70p	74164 100p	74LS83 110p	74LS83 110p	LM3911 130p	LM3911 130p	BC214 12p			2N5485 44p	1N4006/7 7p				
7448 80p	74165 130p	74LS85 100p	74LS85 100p	LM4136 120p	LM4136 120p	BC214 12p			2N5485 44p	1N4006/7 7p				
7450 17p	74166 100p	74LS86 40p	74LS86 40p	MC1301P 150p	MC1301P 150p	BC214 12p			2N5485 44p	1N4006/7 7p				
7451 17p	74167 200p	74LS90 60p	74LS90 60p	MC1458 40p	MC1458 40p	BC214 12p			2N5485 44p	1N4006/7 7p				
7453 17p	74170 240p	74LS93 60p	74LS93 60p	MC1485 40p	MC1485 40p	BC214 12p			2N5485 44p	1N4006/7 7p				
7454 17p	74172 220p	74LS107 45p	74LS107 45p	VOLTAGE REGULATORS		BC214 12p			2N5485 44p	1N4006/7 7p				
7460 17p	74173 120p	74LS112 100p	74LS112 100p	Fixed Plastic TO-220		BC214 12p			2N5485 44p	1N4006/7 7p				
7470 36p	74174 95p	74LS123 75p	74LS123 75p	1A +ve 1A -ve	5V 7805 60p	BC214 12p			2N5485 44p	1N4006/7 7p				
7472 30p	74175 85p	74LS132 90p	74LS132 90p	12V 7812 60p	12V 7912 70p	BC214 12p			2N5485 44p	1N4006/7 7p				
7473 34p	74176 90p	74LS133 60p	74LS133 60p	15V 7815 60p	15V 7915 80p	BC214 12p			2N5485 44p	1N4006/7 7p				
7474 30p	74177 90p	74LS138 60p	74LS138 60p	18V 7818 90p	18V 7918 90p	BC214 12p			2N5485 44p	1N4006/7 7p				
7475 30p	74178 160p	74LS139 60p	74LS139 60p	24V 7824 90p	24V 7924 90p	BC214 12p			2N5485 44p	1N4006/7 7p				
7476 35p	74180 90p	74LS151 60p	74LS151 60p	100mA TO-92	100mA TO-92	BC214 12p			2N5485 44p	1N4006/7 7p				
7480 50p	74181 200p	74LS153 60p	74LS153 60p	5V 78L05 35p	5V 78L05 35p	BC214 12p			2N5485 44p	1N4006/7 7p				
7481 100p	74182 90p	74LS157 60p	74LS157 60p	12V 78L12 35p	12V 78L12 35p	BC214 12p			2N5485 44p	1N4006/7 7p				
7482 84p	74184A 150p	74LS158 120p	74LS158 120p	15V 78L15 35p	15V 79L15 80p	BC214 12p			2N5485 44p	1N4006/7 7p				
7483A 90p	74185 100p	74LS160 100p	74LS160 100p	OTHER REGULATORS		BC214 12p			2N5485 44p	1N4006/7 7p				
7484 100p	74186 60p	74LS161 100p	74LS161 100p	LM309K 135p	TBA825B 120p	BC214 12p			2N5485 44p	1N4006/7 7p				
7485 110p	74190 100p	74LS162 140p	74LS162 140p	LM317T 200p	TL430 55p	BC214 12p			2N5485 44p	1N4006/7 7p				
7486 34p	74191 100p	74LS163 100p	74LS163 100p	LM323K 625p	78H05K 675p	BC214 12p			2N5485 44p	1N4006/7 7p				
7489 175p	74192 100p	74LS164 120p	74LS164 120p	LM723 37p	78M52C 140p	BC214 12p			2N5485 44p	1N4006/7 7p				
7490A 30p	74193 100p	74LS165 80p	74LS165 80p	OPTO-ELECTRONICS		BC214 12p			2N5485 44p	1N4006/7 7p				
7491 36p	74194 100p	74LS173 110p	74LS173 110p	2N5777 45p	ORP12 90p	BC214 12p			2N5485 44p	1N4006/7 7p				
7492A 45p	74195 95p	74LS174 110p	74LS174 110p	OCPT71 130p	ORP60 90p	BC214 12p			2N5485 44p	1N4006/7 7p				
7493A 36p	74196 95p	74LS181 320p	74LS181 320p		TIL78 70p	BC214 12p			2N5485 44p	1N4006/7 7p				
7494 36p	74197 100p	74LS190 100p	74LS190 100p			BC214 12p			2N5485 44p	1N4006/7 7p				
7495A 70p	74198 150p	74LS191 100p	74LS191 100p			BC214 12p			2N5485 44p	1N4006/7 7p				
7496 65p	74199 150p	74LS192 100p	74LS192 100p			BC214 12p			2N5485 44p	1N4006/7 7p				

NICKEL CADMIUM BATTERIES

	AA (HP7) 0.5Ahr	SUB 'C' 1.2Ahr	'C' (HP11) 1.65Ahr	'C' (HP11) 2.0Ahr	'D' (HP2) 4.0Ahr	PP3 0.1Ahr
1-24	£0.85	£1.38	£1.89	£2.25	£2.97	£3.79
25-49	£0.82	£1.28	£1.58	£2.10	£2.77	
50-99	£0.80	£1.24	£1.52	£2.02	£2.67	
100 up	£0.70	£1.15	£1.41	£1.87	£2.47	

All cells are brand new full spec devices from reputable mfrs. All Nickel Cadmium cells (except PP3) are supplied complete with solder tags and are 'VENTED' devices suitable for fast charge.

CHARGERS - single or dual O/P to charge PP3, AA or SUB 'C' cells in 12-14 hrs (chargers will charge 'C' and 'D' cells but with longer charging time). Units supplied complete in plug top case with flying leads. Number of cells (10 max) in series and type must be specified for each required O/P when ordering.

SINGLE O/P CHARGER £5.04
DUAL O/P CHARGER £5.72

TRANSFORMERS - as used in chargers, 2 x 12 volt 0.25 amp secondaries 240v primary, tag connections £1.57 each.

Cheques, P.O.'s Mail Order to:-
SOLID STATE SECURITY,
Dept. (PW), Bradshaw Lane,
Parbold, Wigan, Lancs.
Telephone 02576-3018.



This Christmas treat yourself to a HOME RADIO CATALOGUE

- About 2,000 items clearly listed.
- Profusely illustrated throughout.
- Large A-4 size pages.
- Bargain list, order form and 2 coupons each worth 25p if used as directed, all supplied free.

Price £1, plus 50p for post, packing and insurance.
Send cheque or P.O. for £1.50

HOME RADIO Components LTD
Dept. PW, P.O. Box 92, 215 London Road,
Mitcham, Surrey. 01-543 5659

DON'T HANG ABOUT!

Latch on to binding posts with the new HPA-1 package from CSC. Designed to provide a firm foundation for a variety of electronic interconnections, complete with insulating shoulder washers and mounting nuts. Versatile, too - they accept bare wires, banana plugs, alligator clips, spade connectors, and hook connectors. There are five red, five black posts, 20 insulating shoulder washers and 20 hex mounting nuts. And for large quantity orders, CSC can supply other colours. You won't find it a bind to post off the CSC coupon for more details - do it today!

CSC (UK) Ltd, Unit 1, Shire Hill Industrial Estate, Saffron Walden, Essex CB11 3AQ.
Telephone: (0799) 21682. Telex: 817477.

HPA-1 Binding Posts Nett £2.50 Unit price inc P & P 15% VAT £3.73

Please deduct £1 postage from each additional order.

I enclose cheque/PO for £
or debit my Barclaycard, Access, American Express card

No Exp. date
or Tel: (0799) 21682 with your card number and your order will be in the post immediately.

NAME _____

ADDRESS _____
CONTINENTAL SPECIALITIES CORPORATION



Continental Specialities Corporation (UK) Limited, Dept. 6SS
Unit 1, Shire Hill Industrial Estate, Saffron Walden, Essex CB11 3AQ.

TOMORROW'S TOOLS TODAY

FREE catalogue tick box



Receivers and Components

BRAND NEW COMPONENTS BY RETURN

HIGH STABILITY RESISTORS.
 1W Carbon Film E12 Series 1R-10M. (E24 2R-6M2)—1p
 1W 1W & 1W Metal Film E12 Series 10R-2M2—2p
CAPACITORS.
MULLARD Min. Ceramic E12 100V 2% 1.8pf. to 47pf.—3p
 2% 56pf. to 330pf.—4p. 10% 390pf. to 4700pf.—4p
Plate Ceramic 50V Wkg. Vertical Mounting.
 E12, 22pf. to 1000pf. 5% 1K5pf. to 47Kpf.—2p
Miniature Polyester 250V Wkg. Vertical Mounting.
 .01, .015, .022, .033, .047 & 068 mfd.—4p
 0.1—5p. 0.15 & 0.22—6p. 0.33 & 0.47—8p
 0.68—11p. 1.0—15p. 1.5—20p. 2.2—22p
ELECTROLYTIC. Wire Ended (Mfda/Volts).

0.47/50	5p	22/25	5p	100/25	7p	470/25	11p
1.0/50	5p	22/50	8p	100/50	8p	470/40	16p
2.2/50	5p	47/16	5p	220/16	8p	1000/15	15p
4.7/50	5p	47/25	5p	220/25	8p	1000/25	18p
10/50	5p	47/50	8p	220/50	10p	1000/40	35p
22/16	5p	100/16	7p	470/16	11p	2200/16	20p

TANTALUM BEAD SUBMINIATURE ELECTROLYTICS.
 0.1, 0.22, 0.47, 1.0, 2.2 & 35V & 4.7 & 6.3V—14p
 4.7/16V & 25V—15p. 10/16 & 22/6—20p. 10/25—29p
 10/35V, 22/16V, 47/3V, 68/3V & 100/3V—30p
 15/25, 22/25, 47/10—35p. 47/16—80p. 220/16—£1.20
Polystyrene 63V Wkg. E12 Series Long Axial Wires.
 10 pf. to 820 pf.—3p. 1000 pf. to 10,000pf.—4p

TRANSISTORS.
 BC107/8/9 10p BC182L 8p BF197 9p
 BC147/8/9 10p BC184L 8p BFY50/51/52 18p
 BC157/8/9 10p BC212L 8p BFY88 25p
 BC547/8/9/7p BCY70 15p 2N2926 7p
 BC557/8/9/7p BF194 9p 2N3055 50p

8 Pin D.L.L. i.c.'s 741 Op/amp.—18p. 555 Timer—24p
 Holders 8 pin—9p. 14 Pin—12p. 16 Pin—14p. 28 Pin—25p
 40 Pin—30p.
DIODES (p.i.v./amps).
 75/25mA 1N4148 2p 1250/1A BY127 10p
 100/1A 1N4002 4p 400/3A 1N5404 14p
 800/1A 1N4006 6p 80/1.5A 511M1 5p
 1000/1A 1N4007 7p 30/150mA AAY32 12p

ZENER DIODES.
 E24 Series 3V3 to 33V 400mW—8p. 1W—10p
L.E.D.'s 3 mm. & 5 mm. Red—10p. Green, Yellow—14p
 Grommets for 3 mm.—13p. Holders for 5 mm.—2p
FUSES. 20 mm. Glass. 100mA to 5A. O.B.—3p. A/S.—5p
VOLTAGE REGULATORS. 5V, 8V, 12V, 15V 100mA—35p
 5V, 8V, 12V, 15V, 18V & 24V 0.5A—60p. 1A—65p
PRESET POTENTIOMETERS
 50mW & 1W 100R to 1M0.—6p

THE C. R. SUPPLY CO.
 127, Chesterfield Road, Sheffield S8 0RN.
 V.A.T. Inclusive Prices, Postage 15p
 (FREE over £5.00)

8 PAGE LIST FREE. Thousands of different items, all at cut price. Send SAE to PC Electronics, Thornhill, Romsey Road, Whiteparish, Salisbury.

CLEARANCE PARCELS: Transistors, Resistors, Boards, Hardware, 10lbs only £5.80! 1,000 Resistors £4.25, 500 Capacitors £3.75. BC108, BC171, BC204, BC230, 2N5061, CV7497 Transistors, 10 70p, 100 £5.80, 2N 3055, 10 for £3.50, S.A.E. Lists: W.V.E. (1) 15 High Street, Lydney, Gloucestershire.

TUNBRIDGE WELLS COMPONENTS, BALLARD'S, 108 Camden Road, Tunbridge Wells, Tel: 31803. No Lists. Enquiries S.A.E.

Southern Valve Co.,
 2nd Floor, 6 Potters Road, New Barnet, Herts.
 Tel: 01-440 8641 for current prices & availability, all popular valves stocked. **NO CALLERS,** SAE Lists, Cash with order. Same Day Postal Despatch. Telephone afternoons preferred.
 Valves, Tubes, Aerials etc by LEADING-MAKERS. Send SAE Lists or Phone for current prices. Counter or MAIL ORDER. NO COD. Speedy Despatch assured. No order under £1.
Philip Bearman, 6 Potters Road, New Barnet, Herts.
 Tel: 01-449 1934/5 (1934 Recording Machine).
 Telephone for Shop Hours.

INTERESTED IN ELECTRONICS? Do you need components, tools accessories FAST? Yes. Then you need our first class service. Send today for our catalogue 30p refunded on first order. Lightning Electronic Components. Freepost TAMWORTH. Staffs B77 1BR.

SMALL ADS

The prepaid rate for classified advertisements is 28 pence per word (minimum 12 words), box number 60p extra. Semi-display setting £9.50 per single column centimetre (minimum 2.5 cms). All cheques, postal orders etc., to be made payable to Practical Wireless and crossed "Lloyds Bank Ltd". Treasury notes should always be sent registered post. Advertisements, together with remittance should be sent to the Classified Advertisement Manager, Practical Wireless, Room 2337, IPC Magazines Limited, King's Reach Tower, Stamford St., London, SE1 9LS. (Telephone 01-261 5846).

CIRCUIT BOARDS FOR P.W. PROJECTS

Jan 80	Radio Control Enc. £2.00	Apr 80	Nimbus Modulator £0.75
Jan 80	Radio Control Tx £1.50	May 80	Photographic Timer £1.30
Jan 80	Radio Control Rx £1.50	May 80	NBFM Demodulator £1.30
Jan 80	Speech Processor £1.60	Jun 80	Nimbus Base Station £2.50
Jan 80	Wideband Amp £0.70	Aug 80	Railway Controller £1.70
Feb 80	Servo Amp £0.70	Sept 80	Tamar (six boards) £12.00
Mar 80	Servo Controller £0.90	Sept 80	ZM Converter £1.30
Mar 80	Dual Trace Unit £5.70	Sept 80	Nimbus Timeburst £1.80
Apr 80	Signal Generator £2.60	Oct 80	Direct Conversion Rx £1.50
Apr 80	Nimbus Transceiver £4.90	Oct 80	Nimbus Charger £1.00
Apr 80	Stereo Pre Amp £1.00	Nov 80	Linear Resistance Meter £0.70
Apr 80	Stereo Main Board £2.50	Nov 80	R.C. Wavemeter (two boards) £1.50

PRICES INCLUDE VAT, POSTAGE ETC.
 DESIGNERS: We can produce prototype PCB's at realistic prices. Send SAE for details of A/WK requirements etc.
H.T.E. (ELECTRONICS),
 Printed Circuit Boards Div., Dept. P.W.
 50 MILNEFIELD AVENUE, ELGIN, MORAY IV30 3EL

BOURNEMOUTH/BOSCOMBE. Electronic components specialists for 33 years. Forresters (National Radio Supplies) late Holdenhurst Rd. now at 36, Ashley Rd., Boscombe. Tel. 302204. Closed Weds.

TV DX.
 SPECIALISED RECEIVERS and amplifiers supplied.
 Please send SAE for details to:-
H. Cocks, Cripps Corner, Robertsbridge, Sussex.
 Telephone 058083-317.

TONNA (F9FT) AMATEUR ANTENNAS for 2m, 70cm, and 23cm bands. Send 30p for full catalogue. **RANDOM ELECTRONICS (PW),** 12 Conduit Road, Abingdon, Oxon. OX14 1DB.

VALVES
 Radio - T.V. - Industrial - Transmuting Projector Lamps and Semiconductors
 We Dispatch Valves to all parts of the world by return of post, Air or Sea mail, 4000 Types in stock, 1930 to 1976. Obsolete types a speciality. List 50p. Quotations S.A.E. Open to callers Monday to Saturday 9.30 to 5.00 closed Wednesday 1.00. We wish to purchase all types of new and boxed Valves, Projector Lamps and Semiconductors.
COX RADIO (SUSSEX) LTD.
 Dept. P.W. The Parade, East Wittering, Sussex PO28 8BN
 West Wittering 2023 (STD Code 024366)

CRYSTALS MADE TO ORDER within 6 weeks. 4-105MHz, wire or pins. £3.90 each inclusive. **HARTLEY CRYSTALS.** Green Lane, Milford, Godalming, Surrey GU8 5BG.
CRYSTALS Brand new high-precision. You benefit from very large stocks held for industrial supplies. All normal freq standards, baud rates, MPU, and all magazine projects inc: HC33U: 1.0, 1.008, 2.5625 MHz. £3.50, 1.250 MHz. £4.15. HC18U: 4.0, 5.0, 6.0, 7.0, 8.0, 9.0, 10.0, 10.7, 12.0, 15.0, 16.0, 18.0, 20.0, 6-9375, 38-6667 MHz. £3-25. Selected freqs stocked in Glider, Marine and 27 MHz bands. Any freq made to order in 6 weeks from £3-90.
FILTERS Your best source for 6 and 8 pole and monolithics for AM, CW, SSB, FM, on 455 kHz, 1.6, 9.0, 10.7, 21.4 MHz, etc. Prices inc. VAT and UK post. SAE lists.

P. R. GOLLEGE ELECTRONICS
 G3EDW, Marriott, Somerset, TA16 5NS.
 Tel: 0460 73718

WE SUPPLY most Vintage Radio component parts with a friendly service worldwide. British Vintage Radio Components Co., 57, Weldon Park, Weldon, Nr. Corby, Northants. Tel. Corby 61875.

Books and Publications
FULL REPAIR data any named T.V. £5.50, with circuits, layouts, etc., £7. (AUSW) 76 Church Street, Larkhall, Lanarks ML9 1HE.

NOTICE TO READERS

Whilst prices of goods shown in classified advertisements are correct at the time of closing for press, readers are advised to check with the advertiser both prices and availability of goods before ordering from non-current issues of the magazine.

WHY NOT START YOUR OWN BUSINESS REWINDING ELECTRIC MOTORS. A genuine opportunity to success. **LARGE PROFITS.** You can't help but make money if you follow the easy, step by step, instructions in our fully illustrated manual showing how to rewind Electric Motors, Armatures and Field coils as used in Vacuum Cleaners, Electric Drills and Power Tools. **NO PREVIOUS KNOWLEDGE IS REQUIRED,** as the manual covers in 13 chapters, where to obtain all the work you need, materials required, all instructions, rewind charts and how to take data etc. A gold mine of information. How to set up your home workshop and how to cost each job to your customer. £4.50 inclusive of P&P. UK. CWO to: **INDUSTRIAL SUPPLIES,** 102 Parrswood Rd., Withington, Manchester 20. Dept. PW.

RADIO BOOK SERVICE
WORLD RADIO TV HANDBOOK 1980 Edition £9-30
 Radio Stations Guide £1-60
 How to make Walkie-Talkies £1-75
 Beginners Guide to Microprocessors & Computing £1-15
 How to build your own Metal & Treasure Locators £1-15
 How to build Advanced Short Wave Receivers £1-35
 How to build your own Solid State Oscilloscope £1-45
ELEMENTS OF ELECTRONICS
 Book 1, The Simple Electronic Circuit & Components £2-40
 Book 2, Alternating Current Theory £2-40
 Book 3, Semiconductor Tech £2-40
SET OF 3 BOOKS £7-00
PRICES INCLUDE POSTAGE & PACKING.
4 CHILCHESTER COURT, WICKHAM RD, BECKENHAM KEPT BR3 2QW

Build your own P.A., GROUP & DISCO SPEAKERS
 by R. F. C. Stephens
 Save money with this practical guide. Plans for 17 different designs, line source, I.B., Horn and Reflex types, for 8"-18" drive units. £3-95 post free (£5 overseas).
THE INFRA-BASS LOUDSPEAKER
 by G. Holliman
 (full constructional details for versions using 15", 12" and 10" drive units.) £2-95 post free (£5 overseas)
THE DALESFORD SPEAKER BOOK
 by R. F. C. Stephens
 This book is a must for the keen home constructor. Latest technology DIY designs. Plans for I.B., and Reflex designs for 10-100 watts. Also unusual centre-bass system. £2-20 post free (£5 overseas).

VAN KAREN PUBLISHING
 5 SWAN STREET, WILMSLOW, CHESHIRE

Wanted
ELECTRONIC COMPONENTS PURCHASED. All types considered - Must be new. Send detailed list - Offer by return - **WALTONS,** 55A Worcester Street, Wolverhampton.

WANTED. Instruction manual for Taylor Circuit Analyser model 20B in good condition. E. E. Oglivie, 88 Haslemere Road, Thornton Heath, Surrey.

Aerials
ANTI-TVI TRAP DIPOLES
 1981 Range: Shortwave Listener
 Indoor models £14.50 & £27.50
 Outdoor models £30.00 & £36.00
 Lists 10 x 8 in 17p SAE, Aerial Guide 50p
 Indoor and Invisible Aerials £3.50
 Callers Welcome Tel: 03986-215
G2DYM, Uplowman, Tiverton, Devon.

COPPER AERIAL WIRE 14swg hard drawn 70' £3.50, 140' £7.00 inc VAT. Postage £1.75. T.M.P. Electronics, Supplies, Britannia Stores, Leeswood, Nr. Mold, N. Wales.

TV-DX

FM-DX and all domestic reception requirements - Fringe or "Local", Aerials, Amplifiers, Boosters, Filters, Hardware - and the knowledge. Our new 1981 Catalogue costs 40p. SAE all enquiries, please.

SOUTH WEST AERIAL SYSTEMS
10, Old Boundary Road, Shaftesbury, Dorset.
Tel. (0747) 4370.

JAYBEAM AERIALS Mail order service. SAE to Michael Day Ltd., Place Farm Way, Princes Risborough, Bucks.

Courses

COURSES - RADIO AMATEURS EXAMINATION. City & Guilds. Pass this important examination and obtain your G8 licence, with an RRC Home Study Course. For details of this and other courses (GCE, professional examinations etc) write or phone - **THE RAPID RESULTS COLLEGE, DEPT. JX1, Tuition House, London SW19 4DS.** Tel: 01-947 7272 (Careers Advisory Service) or for prospectus requests ring 01-946 1102 (24hr Recordacall).

Educational

CAREERS in Marine Electronics, Courses commencing September and January. Further details, The Nautical College, Fleetwood FY7 8JS. Tel. 03917 79123.

TECHNICAL TRAINING

Get the training you need to move up into a higher paid job. Take the first step now—write or phone ICS for details of ICS specialist homestudy courses on Radio, TV, Audio Eng. and Servicing, Electronics, Computers, also self-build radio kits. Full details from:

ICS SCHOOL OF ELECTRONICS
Dept. 277C Intertex House, London SW8 4UJ
Tel. 01-622 9911 (all hours)
State if under 18

COLOUR TV SERVICING

Learn the techniques of servicing Colour TV sets through new homestudy course approved by leading manufacturers. Covers principles, practice and alignment with numerous illustrations and diagrams. Other courses for radio and audio servicing. Full details from:

ICS SCHOOL OF ELECTRONICS
Dept. 277C Intertex House, London SW8 4UJ
Tel. 01-622 9911 (all hours)
State if under 18

CITY & GUILDS EXAMS

Study for success with ICS. An ICS homestudy course will ensure that you pass your C. & G. exams. Special courses for: Telecoms, Technicians, Electrical Installations, Radio, TV & Electronics Technicians, Radio Amateurs, Full details from:

ICS SCHOOL OF ELECTRONICS
Dept. 277C Intertex House, London SW8 4UJ
Tel. 01-622 9911 (all hours)
State if under 18

Service Sheets

G.T. THE TECHNICAL INFORMATION SERVICE

.76 CHURCH ST., LARKHALL, LANARKS ML9 1HE

Any single service sheet for £1 and large S.A.E.

1000's of different service sheets, service manuals and repair manuals always kept in stock for immediate despatch. S.A.E. brings newsletter; pricelist; bargain offers such as service sheets under 40p; quotations for any requested service sheets/manuals without obligation. Phone 0698 883334.

Save time and money - 2 giant catalogues listing thousands of service sheets/manuals plus £4 worth of vouchers free - send £2 + large S.A.E.

SERVICE SHEETS. Radio, TV etc., 10,000 models. Catalogue 24p. plus S.A.E. with orders, enquiries. TELRAY, 154 Brook Street, Preston PR1 7HP.

BELL'S TELEVISION SERVICES for Service Sheets on Radio, TV etc., £1.00 plus S.A.E. Colour TV Service Manuals on request. S.A.E. with enquiries to B.T.S., 190 Kings Road, Harrogate, N. Yorkshire. Tel. (0423) 55885.

SERVICE SHEETS from 50p and S.A.E. Catalogue 25p and S.A.E. Hamilton Radio, 47 Bohemia Road, St. Leonards, Sussex.

Record Accessories

STYLI, Cartridges for Music Centres, etc. FREE List no. 29 for S.A.E. includes Leads, Mikes, Phones etc. **FELSTEAD ELECTRONICS (PW),** Longley Lane, Gately, Cheadle, Ches. SK8 4EE.

For Sale

OSCILLOSCOPE SOLARTRON CD1016 Dual Beam. Superb condition. £60. Ring Walton on Thames 22323.

D.I.Y. QSL CARDS, just add your own callsign etc. Also listener cards. 50 for £1.70, 100 for £2.75 inc. p+p. Send sae for samples. Also TVI filters, PL259's etc. **Lam Electronics,** 47, Golden Miller Road, Cheltenham, Glos. 24Hr Tel. 0242 43891.

NEW BACK ISSUES OF "PRACTICAL WIRELESS" available 90p each, post free. Cheque or uncrossed P.O. returned if not in stock. **BELL'S TELEVISION SERVICE,** 190 Kings Road, Harrogate, N. Yorks. Tel: (0423) 55885.

MULLARD LP1164 AM/FM I.F. MODULES guaranteed unused £1.50 each or ten for £10. P.P. C.W.O. S.A.E. Lists, Tennex, Stock Road, Southend, Essex.

UK AIRCRAFT FREQUENCIES List £1. UK Marine Frequencies List £1. Including HF VHF. **PLH Electronics,** 20, Vallis Road, Frome, Somerset.

YAESU FRG-7 plus 2M converter, phones. As new, £150. Basingstoke 64688 evenings.

CAPRI TRANSISTOR ORGAN. Eleven treble tones, split keyboard foot pedals. Needs attention. Thirty watt valve amplifier working, sixty watt organ speaker £110. Bromley, Kent. Box No. 151.

Situations Vacant

TESTERS, Test Technicians, Test Engineers - Earn what you're really worth in London Working for a World Leader in Radio & Telecommunications. Phone Len Porter on 01-874 7281 or write - **REDIFON TELECOMUNICATIONS LTD.,** Broomhill Road, Wandsworth, London SW18.

Miscellaneous

LOSING DX?

DIG out the **RARE DX** with a Tunable Audio Notch Filter, between your rx and speaker. **BOOST** your DX/QRM ratio, 40dB notch, £10.90.

TIME EXACT? MSF CLOCK is ALWAYS CORRECT - never gains or loses, self setting at switch-on, 8 digits show Date, Hours, Minutes and Seconds, auto GMT/BST and leap year, also parallel BCD output, receives Rugby 60KHz atomic time signals, built-in antenna, 1000km range, **ABSOLUTE TIME. £54.80.**

V.L.F.? EXPLORE 10-150KHz, Receiver £13.70.

MISSING DX? Get SPOT-ON with a Crystal Calibrator, between your antenna and receiver, 1MHz, 100, 25KHz markers to vhf, £19.80.

Each fun-to-build kit includes all parts, printed circuit, case, instructions, postage etc, money back assurance so GET one NOW.

CAMBRIDGE KITS

45(PN) Old School Lane, Milton, Cambridge.

OUT NOW!! The 1981 Greenweld Components Catalogue. 60p Discount Vouchers, Reply Paid Envelope. Free bargain List & Data Sheet. Only 75p. Greenweld, 443B, Millbrook Road, Southampton SO1 0HX.

C.W.A.S. ALARM. Send now for the latest discount catalogue of Professional Burlar Alarm Equipment. C.W.A.S. Alarm, 11 Denbrook Walk, Bradford BD4 0QS, W. Yorks. Phone 0274 682674.

PRINTED CIRCUITS. Make your own simply, cheaply and quickly! Golden Fotolak Light Sensitive Lacquer - now greatly improved and very much faster. Aerosol cans with full instructions. £2.25. Developer 35p. Ferric Chloride 55p. Clear Acetate sheet for master 14p. Copper-clad Fibre-glass Board approx. 1mm thick £1.70 sq. ft. Post/Packing 60p. White House Electronics, P.O. Box 19, Castle Drive, Penzance, Cornwall.

ORDER FORM PLEASE WRITE IN BLOCK CAPITALS

Please insert the advertisement below in the next available issue of Practical Wireless for insertions

I enclose Cheque/P.O. for £.....

(Cheques and Postal Orders should be crossed Lloyds Bank Ltd. and made payable to Practical Wireless).

NAME.....

ADDRESS.....

Send to: Classified Advertisement Manager

PRACTICAL WIRELESS,
GMG, Classified Advertisement Dept., Rm. 2337,
King's Reach Tower, Stamford Street,
London SE1 9LS Telephone 01-261 5846

Rate
28p per word, minimum 12 words. Box No. 60p extra.

THE SCIENTIFIC WIRE COMPANY

PO Box 30, London E.4
Reg. Office 22 Coningsby Gdns

ENAMELLED COPPER WIRE

SWG	1 lb	8 oz	4 oz	2 oz
10 to 29	3.10	1.86	1.10	.80
30 to 34	3.50	2.00	1.15	.80
35 to 39	3.95	2.36	1.34	.98
40 to 43	5.10	2.97	2.28	1.42
44 to 46	6.00	3.60	2.50	1.91
47	8.37	5.32	3.19	2.50
48 to 49	15.96	9.58	6.38	3.69

SILVER PLATED COPPER WIRE

14 to 22	5.30	3.03	1.85	1.20
24 to 30	6.50	3.75	2.20	1.40

Prices include P&P and VAT.
Orders under £2 please add 20p. SAE for list.
Dealer enquiries welcome.

SEEN MY CAT? 5000 Odds and ends. Mechanical, Electrical. Cat. free. Whiston (Dept. PW) New Mills, Stockport.

KEEP ONE HANDY IN THE WORKSHOP



The unique aerosol treatment for minor burns and scalds. From Boots and other Chemists.

SPLITTER/AMPLIFIER Two Televisions from one Aerial 4DB gain. Send £14.95 or SAE. Michael Day Ltd., Place Farm Way, Princes Risborough, Bucks.

MORSE CODE TUITION AIDS

Cassette A: 1-12 w.p.m. for amateur radio examination.
Cassette B: 12-24 w.p.m. for professional examination preparation. Each Cassette are type C90.
Morse Key and Buzzer unit for sending practice.
Price each Cassette (including booklets) £4-75. Morse Key and Buzzer £4-75.
Prices include postage etc. Overseas Airmail £1-50 extra.

MHEL ELECTRONICS (Dept 2), 12 Longshore Way, Milton, Portsmouth PO4 8LS.

RECHARGEABLE BATTERIES

TRADE ENQUIRIES WELCOME

FULL RANGE AVAILABLE. SAE FOR LISTS. £1.45 for Booklet "Nickel Cadmium Power" plus Catalogue. Write or call, Sandwell Plant Ltd. 2 Union Drive, BOLDMERE, SUTTON COLDFIELD, WEST MIDLANDS. 021 354 9764

If it's a case of making your project look good, then use one of ours.

Simply send a S.A.E. for Details and Prices.

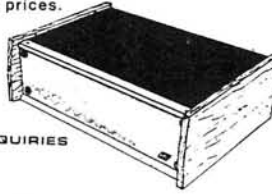

TRADE ENQUIRIES INVITED.

H. M. ELECTRONICS P.W.

271a/275a Fulwood Road.
Broomhill
Sheffield S10 3BD

MICROPROCESSOR CIRCUITS & Programs see Stamtronix. 28, Llanvair Drive, Ascot, Berks. SL5 9HT.

GUITAR/PA/MUSIC AMPLIFIERS

100 watt superb treble/bass overdrive. 12 months guarantee. Unbeatable at £49; 60 watt £42; 200 watt £68; 100 watt twin channel sep. treble/bass per channel £62; 60 watt £52; 200 watt £78; 100 watt four channel sep. treble/bass per channel £75; 200 watt £98; slaves 100 watt £34; 200 watt £56; fuzz boxes, great sound £12.00; bass fuzz £12.90; overdriver fuzz with treble and bass boosters £22; 100 watt combo superb sound overdrive, sturdy construction, castors, unbeatable £98; twin channel £110; bass combo £112; speakers 15in. 100 watt £36; 12in. 100 watt £24; 60 watt £16; microphone Shure Unidyne B £25; 3-Channel sound/light £26.

Send cheque or P.O. to:

WILLIAMSON AMPLIFICATION
62 Thorncliffe Avenue, Dukinfield, Cheshire.
Tel: 061-308 2064

P.W. PROJECT PCB'S

(All Boards to be Pre-paid CWO)
Please add P&P @ 25p to each Board.

Sept. 80	WRO 95	P.S.U.	65p
Sept. 80	WAD 634	2M Converter	1.85p
Sept. 80	WRO 96	Nimbus T.B.	1.85p
Sept. 80	WRO 86	Tamar (1)	65p
Sept. 80	WRO 87	Tamar (2)	2.25p
Sept. 80	WRO 88	Tamar (3)	1.40p
Sept. 80	WRO 89	Tamar (4)	1.30p
Oct. 80	WRO 90	Tamar (5)	4.50p
Oct. 80	WRO 91	Tamar (6)	4.50p
Oct. 80	WRO 97	PSU/Charger	95p
Oct. 80	WRO 82	RX/Driver	2.30p

Fibreglass Strip Boards (3" x 4") 14 strips 60p each
PCB's made to your own specification. Prototypes or production runs. Full photographic facilities.

Details or quotation from:
WINSTON PROMOTIONS (P.W.)
9 HATTON PLACE, LONDON EC1N 8RU
TELEPHONE 01-405 0960/4127

PSYCHOTRONIC GENERATORS, gravity lasers, electrokinesis, electrophotography, skinvision. SAE 4 x 9" Paralab, Downton, Wilts.

NEAT! TIDY! HANDY! 1D 2D 3D 6D
INTERLOCKING PLASTIC STORAGE DRAWERS

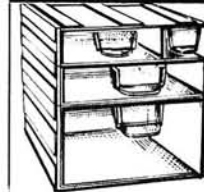

AS SUPPLIED: TO POST OFFICE & GOVT DEPTS

Rigid plastic units interlock together in vertical and horizontal combinations. Transparent plastic drawers have label slots. 1D and 2D have space dividers. Build up any size cabinet for wall, bench or table top.

SINGLE UNITS (1D) 15in x 2 1/2in x 2 1/2in £4.90 DOZEN
DOUBLE UNITS (2D) 15in x 4 1/2in x 2 1/2in £7.50 DOZEN
TREBLE (3D) £7.50 for 8.
DOUBLE TREBLE 2 drawers, in one outer case (6D), £10.90 for 8.
Extra large size (6D1) £8.50 for 8.

Orders over £60, less 5%. Packing/Postage/Coverage: Add £1.30 to all orders under £10. Orders £10 and over, please add 10% carriage.

QUOTATIONS FOR LARGER QUANTITIES
Please add 15% V.A.T. to total remittance.

All prices correct at time of going to press.

FLAIRLINE SUPPLIES

(PW1) 124 Cricklewood Broadway, London N.W.2. Tel: 01-450 4844.

DORAM ELECTRONICS LTD

Fitzroy House, Market Place, Swaffham, Norfolk, PE37 7QH.

New Catalogue



40p

to be refunded with first order

FREE competition entry with catalogue

REF. Dept. PW

Please send me a copy of your new catalogue

NAME

ADDRESS

enclose cheque/postal order for 40p

RST

VALVE MAIL ORDER CO.
Climax House
159 Fallsbrook Road, London SW16 6ED
SPECIAL EXPRESS MAIL ORDER SERVICE

AZ31	1.10	EM87	1.50	PY81	0.84	6AN5	4.74	6Q7	2.20
CL33	2.00	EN91	3.50	PY82	0.80	6AN8A	3.45	6SA7	1.45
DY86/7	0.84	EY51	1.75	PY83	0.70	6A05	0.96	6SC7	1.50
DY802	0.84	EY88	0.84	PY88	0.88	6AR5	1.98	6S7J	1.60
E88CC	3.36	EY500A	1.94	PY800	0.84	6AS6	4.98	6S7K	1.30
E180F	8.40	EZ80	0.84	PY801	0.84	6AS7GA	6.75	6S7GT	2.68
E810F	14.47	EZ81	0.84	QQV02-6	12.56	6AT6	0.85	6SN7GT	1.60
EAB-C80	1.20	EZ82	1.25	QQV03-10	5.80	6AUGT	4.32	6SS7	1.80
EB91	0.82	EZ83	2.75	QQV03-10	5.80	6AUG	1.08	6SG7M	2.50
EBF80	0.50	GZ33	4.00	QQV03-20A	17.50	6AV8A	3.39	6S8	0.80
EBF89	0.85	GZ34	2.50	17.50	688	1.75	6X4	1.20	
EC91	7.56	GZ37	4.00	QQV06-40A	68A6	1.00	6X5GT	0.85	
ECC33	3.50	KT61	3.50	36.34	68A7	5.12	7C5	2.95	
ECC35	3.50	KT66	10.00	QV03-12	4.46	68E6	1.08	7C6	2.25
ECC81	0.88	KT77	8.00	R18	4.25	68H6	1.52	7S7	2.25
ECC82	0.72	KT88	12.00	R19	1.20	68J6	1.08	7AT6	1.20
ECC83	0.88	N78	9.00	SP41	6.00	68N6	1.65	12AT7	0.88
ECC85	1.20	OA2	1.92	SP61	2.00	68Q7A	3.72	12AU7	0.72
ECC88	1.90	OB2	2.55	U19	13.75	68R7	4.00	12AX7	0.88
ECC91	8.93	OC3	1.92	U25	1.16	68R8	1.75	12BA6	2.19
ECF80	1.08	OD3	1.92	U26	1.44	68S7	4.00	12BE6	2.43
ECH35	2.00	PC86	1.40	U37	9.00	68W6	4.00	12BY7	2.70
ECH42	1.15	PC88	1.40	UABC80	1.25	68W7	1.52	12BY7A	2.70
ECH81	1.20	PC92	1.28	UBF89	1.20	6B26	2.37	12HG7	4.17
ECL80	1.00	PC97	1.20	UCH42	1.20	6C4	0.88	30FL1/2	1.12
ECL82	1.00	PC900	1.20	UCH81	2.32	6C6	1.75	30P4	1.20
ECL83	1.50	PCF80	1.00	UCL82	1.04	6CB8A	2.49	30P19	1.20
ECL86	1.20	PCF82	1.00	UCL83	1.44	6CD6GA	5.07	30PL13	1.60
EF37A	3.50	PCF86	1.60	UF89	1.44	6CH6	8.50	30PL14	1.68
EF39	2.75	PCF801	1.60	UL41	2.50	6CL6	3.72	75C1	2.35
EF41	2.00	PCF802	1.90	UL84	1.20	6CW4	7.68	85A2	2.39
EF42	2.00	PCF805	1.60	UY41	1.25	6D6	1.75	90C1	2.44
EF50	1.50	PCF808	1.60	UY85	1.04	6D05	5.94	158Z	3.02
EF54	5.00	PCH200	1.60	VR105/30	1.92	6E48	2.94	50BZ	1.92
EF55	2.50	PCL82	1.00	VR150/30	1.92	6E45	1.85	150C4	2.39
EF80	0.80	PCL83	2.00	Z759	16.80	6F6	1.75	57Z8	27.50
EF86	1.52	PCL84	1.00	Z803U	7.90	6GK6	2.67	805	20.00
EF91	1.80	PCL85	1.08	ZD21	3.50	6H6	1.50	807	3.75
EF92	5.81	PCL86	1.08	3B28	16.80	6H56	3.77	811A	15.93
EF183	0.80	PCL805	1.08	4CX250B	6.5	6J5	2.50	812A	15.88
EF184	0.84	PD500	3.60	27.50	6J6	3.50	813	74.67	
EH90	1.40	PFL200	1.80	5R4GY	2.00	6J7	2.50	866A	8.85
EL32	1.50	PL36	1.20	5U4G	1.52	6JB6A	4.56	872A	18.67
EL33	3.50	PL81	1.20	5V4G	1.52	6JS6C	5.58	931V7	14.76
EL34	2.20	PL82	1.20	5Y3GT	0.85	6K4N	1.25	2050	6.96
EL36	1.60	PL83	2.22	5Z3	1.50	6K6GT	1.30	5763	3.75
EL81	2.50	PL84	1.08	5Z4GT	1.50	6K7	1.50	5814A	3.72
EL84	1.00	PL504	1.40	6/3DL2	1.56	6K8	1.75	5842	12.09
EL86	2.50	PL508	1.80	6AB7	1.80	6KD6	6.36	6080	6.85
EL91	7.14	PL509	3.20	6AH6	4.71	6L6G	2.50	6146A	8.96
EL95	1.32	PL519	3.20	6AK5	3.60	6L6GC	2.50	6146B	7.06
EL360	8.50	PL802	2.96	6AL5	0.82	6L7	2.00	6883B	11.19
EM81	1.00	PY33	1.10	6AM6	1.80	6L6Q	6.72	6973	3.87

Open daily to callers: Mon-Fri 9 a.m.-5 p.m.
Valves, Tubes and Transistors - Closed Saturday
Terms C.W.O. only - Tel. 01-677 2424-7.
Prices excluding VAT add 15%
Quotations for any types not listed S.A.E.
Post and Packing 30p per order
Telex 946708
Prices correct when going to press.

MAINS INTERCOM



NO BATTERIES NO WIRES ONLY
£37.99
PER PAIR
+ VAT £5.70

The modern way of instant 2-way communications. Just plug into power socket. Ready to use. Crystal clear communications from room to room. Range 1/2 mile on the same mains phase. On/off switch. Volume control, with buzzer call and light indicator. Useful as inter-office intercom, between office and warehouse, in surgery and in homes. P. & P. £1.85. Also F.M. 2 channel "touch" model £49.95 + VAT £7.50 + P&P £1.95.

NEW AMERICAN TYPE CRADLE TELEPHONE AMPLIFIER



£18.95
+ VAT £2.85
+ P & P £1.25

Latest transistorised Telephone Amplifier, with detached plug-in speaker. Placing the receiver on to the cradle activates a switch for immediate two-way conversation without holding the handset. Many people can listen at a time. Increase efficiency in office, shop, workshop. Perfect for "conference" calls: leaves the user's hands free to make notes, consult files. No long waiting, saves time with long-distance calls. On/off switch, volume control, conversation recording, model at £20.95 + VAT £3.15. P&P £1.25.

DOOR ENTRY SYSTEM

No house/business/surgery should be without a DOOR ENTRY SYSTEM in this day and age. The modern way to answer the door in safety to unwanted callers. Talk to the caller and admit him only if satisfied by pressing a remote control button which will open the door electronically. A boon for the invalid, the aged, and busy housewife. Supplied complete d.i.y. kit with one internal Telephone, outside Speaker panel, electric door lock release (for Yale type surface latch lock); mains power unit, cable (8-way) to 50 and wiring diagram. Price £59.95 + VAT £9.00 + P&P £1.95. Kit with two Telephone £69.95 + VAT £10.50 + P&P £2.15

10-day price refund guarantee on all items

WEST LONDON DIRECT SUPPLIES (PW1)
169 KENSINGTON HIGH STREET,
LONDON, W8

OSMABET LTD

We make transformers amongst other things.

TRANSFORMERS TO ORDER
We have capacity for the supply of transformers to specification, either one off, or production runs, your enquiries please.
LOW VOLTAGE TRANSFORMERS: Prim 240V ac.
6.3V 1.5A £3.00; 3A £4.15; 6A CT £7.90; 12V 1.5A £3.75; 3A CT £7.90; 6A CT £9.75; 15V 0.5A £3.00; 18V 1.5A CT £7.90; 24V 1.5A CT £7.90; 3A CT £9.75; 5A CT £18.00; 6A CT £29.25; 12A CT £37.50.
MIDGET RECTIFIER TRANSFORMERS: Prim 240V ac.
6.0-6V 1.5A or 9.0-9V 1A £3.40 each; 12.0-12V 1A or 20.0-20V 0.75A £4.15 each; 9.0-9V 0.3A or 12V-0-12V 0.25A or 20V-0-20V 0.15A £3.00 each.
LT TRANSFORMERS TAPED SEC: Prim 240V ac.
0-10-12-14-16-18V 2A £7.50; 4A £9.40; 0-12-15-20-24-30V 2A £8.25; 4A £12.00; 0-20-30-60V 1A £9.00; 2A £12.00; 0-40-50-60-80-100-110V 1A £12.00.
AUTO & ISOLATION TRANSFORMERS 240/110V ac.
30 to 4000 watts, many types ex stock. Lists.

MAINS TRANSFORMERS. SPECIAL OFFER. Prim
240V ac, 300-0-300V 80 Ma; 6.3V 1A CT; 6.3V 1A £5.50; 250-0-250V 50 Ma; 6.3V 1A £3.00; 9V 3A £2.50; 25V 300 Ma 90p; 15-0-15V 0.5A £2.50. 12V 4A £4.00.
LOUDSPEAKERS
1 1/2", 1 1/4", 2 1/4", 2 1/2", 2 3/4" 80 £1.25 each; 3" 35Q 3 1/2" 3, 8, 16, 80Q, 7x4", 3 or 80Q £1.75; 8x5" 25Q £2.50.
Goodman 5" Hi-Fi speaker mid range, C/M 8 25 watt systems £6.50. Goodman 3" Tweeters C/M, 8Q for 25W systems £2.50. 4" 10 watts 8Q £3.50. 8" 25W 8Q £6.00.
"INSTANT" BULK CASSETTE/TAPE ERASER
Instant erasure of cassettes, and any diameter of tape spools, demagnetises tape heads, 200/240V ac. leaflet £8.00.
Tape/Cassette Demagnetisers £3.56.

EDGWISE LEVEL METER FSD 200/µA
Size 19 x 18 x 20mm 8000 £1.50.
CHARGING METERS 1 1/2" diameter
2A or 3A £1.25 each; 5A or 10A £1.50 each.
SINGLE STRANDED WIRE PVC COVERED
32/0.2mm (10A) black or blue. £6.50 100m, 0.5mm £2.50 100m special prices per 1000m and over.

POWER SUPPLY, TWIN OUTPUT Prim 240V ac:
New, British manufacturer, smoothed d.c. output 20V, 1.5A, plus STABILISED output of 15V 100 Ma, plus further 12V ac 0.5A, complete with diagram, £4.50.

O/P TRANSFORMERS FOR VALVE AMPLIFIERS
P.P. Sec. tapped 3-8-15V A-A 6KΩ. 30W £17.50; A-A 3KΩ 50W £22.00; 100W (EL31, K788 etc) £35.00.
G.E.C. MANUAL OF POWER AMPLIFIERS
Covers valve amplifiers 30W to 400W £1.25.

MULTIWAY SCREENED CABLE, PVC COVERED
36 way £1.00; 25 way 75p; 14 way 50p; 6 way 25p.
CONDENSERS AC 50Hz. 4.33/250V; 6/330V, £1.50.
Electrolytic 400 mfd 400V 75p; 2000/30V 30p; 2200/40V 40p; Paper tubular, W/E, 4/160V; 6/160V 30p each, 2mfd 150V 25p, 0.1mfd 2KV 50p.

CARRIAGE EXTRA ON ALL ORDERS
ALL PRICES INCLUDE V.A.T.

Callers by appointment only. S.A.E. Enquiries, Lists.

46, Kenilworth Road, Edgware, Middx.
HA8 8YG. Tel: 01-958 9314

BAKER SPEAKERS "STAR SOUND"

Post £1.50 ea.

GROUP 45-12 £15
12in. 45 watt
4, 8 or 16 ohms.
GROUP 75-12 £22
12in. 75W professional
model, 4, 8 or 16 ohms
Response 30 - 16,000.
With aluminium presence dome.
DISCO 100/12 £26
12 in 100W model
8 or 16 ohm
DISCO 100-15 £29
15in. 100 watt
8 or 16 ohms.
AUDITORIUM 15 £35
Bass woofer 15in.
Special cone
surround. Heavy duty
cone. 60 watts, 20 to 8000 cps.



E.M.I. 1 1/2" x 8in SPEAKER SALE!

With tweeter. And crossover. £9.95
10W. State 3 or 8 ohm.
15W model Post £10.95
8 ohms
GOODMANS 20 Watt Woofer Post £1
Size 12 x 10in. 4 ohms.
Rubber cone surround. £8.50
Hi-Fi Bass unit. Post £2.00
GOODMANS TWIN AXIOM 8
8in. 8 ohm Hi-Fi Twin Cone £9.95 Post
Special unit 15 watts 85p
£8.00
Ditto 15 ohms



EMI MINI MODULE KIT 3-way Loudspeaker System, EMI 5in Bass, 5in Middle, 3in Tweeter, with 3-way Crossover and Ready Cut Baffle. 15 x 8 1/2 in.

Full assembly instructions supplied. Response = 60 to 20,000 cps 12 watt RMS. 8 ohm. £10 per kit. Postage £1.50.

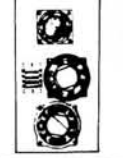

R.C.S. LOUSPEAKER BARGAINS

3 ohm. 6 x 4in. £1.50. 7 x 4in. £1.50. 8 x 5in. £3.00. 6 1/2in. £3.00. 8in. £3.50. 10in. £3.50. 12in. £4.50.
8 ohm. 2 1/2in. £1.50. 3in. £1.50. 5in. £1.50. 10in. £3.50. 12in. £4.50.
16 ohm. 6 x 4in. £1.50. 7 x 4in. £1.50. 5in. £1.50. 8in. £3.50. 12in. £4.50. 10 x 6in. £3.50.

LOW VOLTAGE ELECTROLYTICS

1, 2, 4, 5, 8, 16, 25, 30, 50, 100, 200mF 15V 10p.
500mF 12V 15p; 25V 20p; 50V 30p;
1000mF 12V 20p; 25V 35p; 50V 50p; 1200mF/76V 80p.
2200mF 6V 25p; 25V 42p; 40V 60p; 2000mF/100V £1-20.
2500mF 50V 70p; 3000mF 2.5V 50p; 50V 65p.
3300mF 63V £1-20; 4700mF 63V £1-20; 2700mF/76V £1.
5000mF 35V 85p; 50V 95p; 5600mF 76V £1-75.

HIGH VOLTAGE ELECTROLYTICS

8/350V 35p 8+8/450V 75p 50+ 50/300V 50p
16/350V 45p 8+16/450V 75p 32-32+32/325V 75p
32/500V 75p 20+20/450V 75p 100+100/275V 65p
50/350V 80p 32+32/350V 50p 150+200/275V 70p
50/500V £1-20 50-50/500V £1-80 220/450V 95p

MANY OTHER ELECTROLYTICS IN STOCK

TRIMMERS 10pF, 30pF, 50pF, 5p, 100pF, 150pF, 15p.
CONDENSERS VARIOUS, 1pF to 0.01mF, 3p.
PAPER 350V-0.1 7p; 0.5 13p; 1mF 150V 20p; 2mF 150V 20p
400V-0.001 to 0.05 5p; 0.1-15p; 0.2-25p; 0.4-35p.
MICRO SWITCH SINGLE POLE CHANGEOVER 20p.
SUB-MIN MICRO SWITCH, 25p. Single pole change over.
TWIN GANGS, 385pF £1; 365pF £1; 365pF 25-25pF.
Slow motion drive £1; 25pF 95p; 120V 50p; 3 gang 365p £2.
NEON PANEL INDICATORS £250V, Amber or red 30p.
ILLUMINATED ROCKER SWITCH, Single pole. Red 85p.
RESISTORS, 10Ω to 10M, 1W, 1/2W, 1W, 20% 2p; 2W, 10p.
HIGH STABILITY, 1/2W 2% 10 ohms to 1 meg., 8p.
Ditto 5%. Preferred values 10 ohms to 10 meg., 3p.
ALUMINIUM CHASSIS 18 s.w.g. Undrilled, £1.50, drilled corners; 6 x 4 x 2 1/2in.—£1.20; 8 x 8 x 2 1/2in.—£1.50; 10 x 7in.—£2.40; 12 x 3 x 2 1/2in.—£1.50; 12 x 8 x 2 1/2in.—£2.20; 16 x 10 x 2 1/2in.—£2.70.
ALL ANGLE BRACKET 6 x 1/2 x 1/2in.—25p.
ALUMINIUM PANELS 18 s.w.g. 12 x 12in.—£1.30; 14 x 9in.—£1.20; 6 x 4in.—36p; 12 x 6in.—90p; 10 x 7in.—80p; 8 x 6in.—60p; 14 x 3in.—£2.50; 16 x 6 x 2 1/2in.—£2.40; 12 x 3 x 2 1/2in.—£1.50; 12 x 8 x 2 1/2in.—£2.20; 16 x 10 x 2 1/2in.—£2.70.
Black plastic construction box with brushed aluminium fascia size 6 1/2 x 4 1/2 x 2" £1.50. Many other sizes.
BRIDGE RECTIFIER 200V PIV 1/2 amp 80p. 2 amp £1.00. 4 amp £1.50. 8 amp £2.50.

TOGGLE SWITCHES SP 30p. DPST 40p. DPDT 50p.
MANY OTHER TOGGLES IN STOCK. Please enquire.
BSR STEREO DIAMONDS SC7 medium SC8 High output £2.
SONOTONE 9T AHC Cartridge £3.75. V.100 Magnetic £7.
WIRE-WOUND RESISTORS 5 watt, 10 watt, 15 watt 15p.
CASSETTE MOTOR, 6 volt £1.00.

MAINS TRANSFORMERS

6V, 500mA.....£2.00
12V, 100mA.....£1.75
12V, 750A.....£1.75
10.0-10V 2amp.....£3.00
30V, 5 amp and.....£3.00
17V-0-17V, 2 amp.....£4.00
0, 5, 8, 10, 16V, 1/2 amp.....£2.50
9V, 3 amp.....£3.50
15-0-15V 2 amp.....£3.00
30V, 2 amp.....£3.50
30V, 1 1/2 amp.....£3.30
20V, 40V, 60V, 1 amp.....£4.00

6-0-6V 100mA.....£1.80
9-0-9V 50mA.....£1.50
12V, 3 a, £3.50, 2 a.....£4.00
10V, 30V, 40V, 2 amp.....£3.50
20V, 1 amp.....£3.00
20V-0-20V, 1 amp.....£3.50
2 of 18V, 6 amp, each.....£11.00
12-0-12V, 2 amp.....£3.50
9V, 1/2 amp.....£1.50
28V, 1 amp+28V 1 amp £5.00
32-0-32V 6-5A.....£11.00

Post 50p Access-Barclay-Visa. Lists 20p. Closed Wed.
Radio Components Specialists
337 WHITEHORSE ROAD
CROYDON, SURREY, U.K. TEL. 01-884 1665

F. BROWN & CO.

Kits available:

- KS 100 F.M. Receiver **£5.31.**
- KS 200 F.M. Transmitter **£7.36.**
- KS 240 3x1000W Sound to Light Unit **£13.63.**

Also in stock a wide range of Components, Breadboards, Loudspeakers, Soldering Irons etc.

Stockists for Vero, S.C.S., Ice Meters, Expo Drills, Eagle, Bulgin, Weller, Babani Books.

Prices include VAT, 25p P&P per kit

"SPECIAL OFFER"

250V Mullard Caps, 10 EA .001, .01, .1uf. **70p** incl. P&P.

F. Brown & Co.,
Dept. M.O./P.W.,
45 George IV Bridge,
Edinburgh EH1 1EJ.

MAIL ORDER ADVERTISING

British Code of Advertising Practice
Advertisements in this publication are required to conform to the British Code of Advertising Practice. In respect of mail order advertisements where money is paid in advance, the code requires advertisers to fulfil orders within 28 days, unless a longer delivery period is stated. Where goods are returned undamaged within seven days, the purchaser's money must be refunded. Please retain proof of postage/despatch, as this may be needed.

Mail Order Protection Scheme
If you order goods from Mail Order advertisements in this magazine and pay by post in advance of delivery, PRACTICAL WIRELESS will consider you for compensation if the Advertiser should become insolvent or bankrupt, provided:

- (1) You have not received the goods or had your money returned; and
- (2) You write to the Publisher of PRACTICAL WIRELESS summarising the situation not earlier than 28 days from the day you sent your order and not later than two months from that day.

Please do not wait until the last moment to inform us. When you write, we will tell you how to make your claim and what evidence of payment is required. We guarantee to meet claims from readers made in accordance with the above procedure as soon as possible after the Advertiser has been declared bankrupt or insolvent. This guarantee covers only advance payment sent in direct response to an advertisement in this magazine not, for example payment made in response to catalogues etc, received as a result of answering such advertisements. Classified advertisements are excluded.

TV SPARE PARTS & COMPONENTS

The Practical Wireless TV Sound Tuner. Still unsurpassed! Parts still available. Price List, copy of original article supplied on request. (cost of set of parts £28.40 incl. p/p & VAT)

Callers still welcome at shop premises.

MANOR SUPPLIES

(Tel. 01-794 8751)

172 WEST END LANE, LONDON NW6.

(near W. Hampstead Jubilee and British Rail Stations).

PROGRESSIVE RADIO

ALL ORDERS DESPATCHED BY RETURN POST

SEMICONDUCTORS. 2N5062 (100V 800mA) SCR 18p. BX504 opto isolator 25p. CA3130 95p. TBA800 50p. Tag4443 SCR 45p. Texas R1038 power trans. 50p. TDA1151 25p.

SWITCHES. Min. toggles, SPST 8x5x7mm 42p. DPDT 8x7x7mm 55p. DPDT c/off 12x11x9mm 77p. HEAVY DUTY-DPDT 240VAC 10 Amp 35p. PUSH TYPE, push on 16x6mm 15p, push to break version 17p. 14 pin D.I.L. switch 40p.

DISPLAYS. 4 digit LED clock displays with message centre, 0.6" figures, com. cath. with data £3.25p. NSA1198 8½ digit multiplexed displays, com. cath. with data sheet £1.45p. **SPECIAL OFFER** TIL209 Red LED's 10 for 75p. 0.2" LEDs, red, yellow, green 10p each.

LINEAR I.C.'s. LM300 40p, LM301 55p, LM308 £1.30, LM324 £1.00, LM388 95p, LM358 50p, LM386 90p, LM3900 80p, LM3909 75p, CA1310 £1.70, CA3018 £1.00, CA3028 £1.30, CA3035 £2.20, CA3046 85p, CA3098 95p, CA3130 95p, CA3140 37p, MC1303 £1.40, MC1312 £1.60, MC1330 £1.40, MC1458 40p, NE550 £1.00, NE544 £1.40, NE565 £1.70, NE566 £1.70, TAA550 40p, TAA621 £2.20, NE556 50p, C106D SCR 35p.

GPO TELEPHONE DIALS £1.00 (new). **JACKSONS C804** 50pf var. capacitors 50p each.

TOOLS. 5 piece precision screwdriver sets, individual handles only £1.05 set.

JUMPER TEST LEAD SETS. 10 pairs of leads with insulated crocs each end 90p.

40KHZ TRANSDUCERS, RX/TX £3.50 pair.

STC BREAK GLASS FIRE ALARM UNITS, new with mounting box £1.50p.

MINIATURE SOLID STATE BUZZERS. 33x17x15mm, output at 3 feet 70db, 15ma drain, voltage range 4-15vdc 75p. Mercury switch, 1"x½", 35p.

Cash with order please, official orders welcome from schools etc., please add 30p postage and packing, VAT inclusive. SAE for latest illustrated stock list.

31, CHEAPSIDE, LIVERPOOL L2 2DY

CB -the countdown has begun!

Get ready for CB and two-way radio - with a brand-new magazine that tells you everything you want to know. We show you how CB works and how to use it. We've got a full colour spread on customised American trucks. We offer special deals on CB World sweat shirts, T shirts, caps and badges. And we ask: should we use US Truckspeak or create our own English jargon? And what about the radio amateur - and the aircraft modeller? Tell us what you feel. Get involved - and get this very first issue of CB World.

CB World
First issue out now 60p
Published by IPC - the world's largest publisher of radio and electronic magazines.

INDEX TO ADVERTISERS

A.H. Supplies	12	Golledge Electronics P.R.	98	R.S.T. Valve Mail Order	100
A.J.H. Electronics	82	G T Technical Information Service	99	Radio Book Services	98
Amateur Electronics	82	G2 Dym Aerials	98	Radio Component Specialists	101
Amateur Radio Exchange	47	HM Electronics	100	Radio Shack	87
Ambit International	93	HTE Electronics	98	Radio Society of Great Britain	75
Amcomm Services	76	Harknett Electronics, Maurice	100	Riscomp Ltd (Autona)	4
Arrow Electronics	30	Harverson Surplus Co.	10	R & TV Components	16
		Heath Electronics	88	Safgan Electronics	95
Bib Hi-Fi	91	Homebru Radio	82	Sandwell Plant	100
Bi-Pak	13	Home Radio (components) Ltd	97	Scientific Wire Company	100
Birkett J	92	ICS Intertext	4, 99	Solid State Security	97
Bowes Electronics C	6	ILP Electronics	8, 14, 15	South Midlands Communications Ltd	65
Bredhurst Electronics	Cover II	L.B. Electronics	12	South West Aerials	99
British National Radio & Electronics		Lee Electronics	29	Southern Valve	98
School	7	Leeds Amateur Radio	81	Stephen-James Ltd	48
Brookes B	48	Lowe Electronics	69	Swanley Electronics	96
Brown F	101	Manor Supplies	102	Tandy Corporation (UK) Ltd	2, 3
Burneze Adv	100	Maplin Electronic Supplies	Cover IV	Technomatic Ltd	97
		Marco Trading	12	Tempus	94
C.B. World	103	Marshall A (London) Ltd	6	Thanet Electronics	104, Cover III
Cambridge Kits	99	Mersey Amateur Radio Supplies	37	V & F Smallcraft	94
Catronics Ltd	30	Microwave Modules	38	Van Karen Publishing	98
Chordgate	96	Mitrad	11	Videotone	5
Cocks, Hugh	98	MRS Communications	30	Watford Electronics	102
Colomor (Electronics) Ltd	94	Northern Communications	48	Webster Electronics	95
Continental Specialties Corporation	92, 97	Open Channel U.K. Ltd	95	West London Direct Supplies	101
Cox Radio (Sussex) Ltd	98	Osmabet	101	Western Electronics	37
C.R. Supply Co	98	P.M. Components	8	West Hyde Developments Ltd	10
		Partridge Electronics	88	Williamson Amplifications	100
Doram Electronics	100	Photo Accoustics	48	Willmslow Audio	6
Electro-Tech Components Ltd	96	Powell T	8	Winston Promotions	100
Electrovalve Ltd	92	Progressive Radio	103	Wintjoy Ltd	37
Electronic Mail Order	94			Wood & Douglas	12
				World T.V. Handbook	9
Flairline Supplies	100			Zaerix Electronics Ltd	76
Garex	38			Z.L. Communications	76
Gemini Electronic Components	4				
Gemini Communications	81				

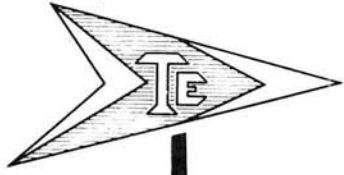

The more you hold it the more you enjoy it the IC-2E Handy Talky £159 INCL.

CHECK THE FEATURES

FULLY SYNTHESIZED — covering 144-145.995 in 400 5kHz steps.
POWER OUTPUT — 1.5W with the 9V rechargeable battery pack as supplied — but lower or higher output available with the optional 6V or 12V packs.
BNC ANTENNA OUTPUT SOCKET — 50 ohms for connecting to another antenna or use the Rubber Duck supplied, supplied.
SEND/BATTERY INDICATOR — Lights during transmit, but when battery power falls below 6V it doesn't light indicating the need for a recharge.
FREQUENCY SELECTION — by thumbwheel switches, indicating the frequency.

+5kHz SWITCH — adds 5kHz to the indicated frequency.
DUPLEX SIMPLEX SWITCH — gives simplex or plus 600kHz or minus 600 kHz Transmit.
HI-LOW SWITCH — reduces power output from 1.5W to 150mW reducing battery drain.
EXTERNAL MICROPHONE JACK — If you do not wish to use the built-in electret condenser mic an optional microphone/speaker with PTT control can be used. Useful for pocket operation.
EXTERNAL SPEAKER JACK — for speaker or earphone.
 This little beauty is supplied ready to go complete with nicad battery pack, charger, rubber duck.

SPECIFICATIONS:

Transistors 4, — FETs 3, ICs 6 Diodes 21.
 Frequency coverage 144-145.995 but will go to 147.995
 Frequency Resolution 5kHz steps.
 Frequency control by digital PLL synthesizer with thumbwheel switches.
 Frequency stability within ± 1.5 kHz.
 Useable temperature -10 degrees C to 60 degrees C.
 Antenna Impedance 50 ohms.
 Power supply requirements DC 8.4V; with attendant battery pack DC 7.2 — 10.8V negative ground is acceptable.
 Current drain at 8.4V

Transmitting:	High 1.5W	Approx 550 MA
	Low 0.15W	Approx 220 MA
Receiving at max audio output		Approx 130 MA
	Squelched	Approx 20 MA

Transmitter output power High 1.5W, Low 0.15W at 8.4V.
 Mode F3, variable reactance frequency modulation, ± 5 kHz.
 Spurious Emissions more than 60dB below carrier.
 Microphone built-in Electret condenser, Optional Speaker Mic can be used.
 Operating Mode, Simplex or Duplex ± 600 kHz from receive frequency.
 Receiver Double Conversion superheterodyne FM.
 Intermediate Frequency 1st 10.695MHz; 2nd 455kHz.
 Sensitivity Better than 0.3uV for 20dB noise quieting.
 Squelch sensitivity — less than 0.3uV.
 Spurious response Rejection ratio more than 60dB.
 Selectivity More than ± 7.5 kHz at -6dB point
 Less than ± 15.0 kHz at -60dB point
 Audio output More than 300mW-8 ohms.
 Tone call Crystal controlled.

It will seduce you in it's own way the ICOM IC 251E £479 INCL. only



AFTER YEARS OF SUCCESS THE IC-211E HAS NOW BEEN REPLACED BY THE IC-251E. NOT JUST A FACE-LIFT, BUT A NUMBER OF IMPORTANT DEVELOPMENTS HAVE BEEN INCORPORATED.

MICROPROCESSOR CONTROL — CPU control with Icom's original programs provides various operating capabilities. No back-lit dial controlled by Icom's unique photo-chopper circuit. Band edge detector and Endless System provides out-of-band protection. No variable capacitors or dial gear, giving problem-free use. The IC251E provides FM, USB, LSB, CW coverage in the 144-146 MHz frequency range. Thus the IC251E can be used for mobile, DX, local calls, and satellite work (easily extended to 148 MHz).
MULTI-PURPOSE SCANNING — Memory Scan allows you to monitor three different memory channels. Program Scan provides scanning between two programmed frequencies. Adjustable scanning speed. Auto-stop stops scanning when a signal is received in all modes.
DUAL VFO's — Two separate VFO's can be used either independently or together for simplex operation, and any desired frequency split in duplex operation. Automatic 600kHz shift available on switch-on.

CONTINUOUS TUNING SYSTEM — Icom's new continuous tuning system features a luminescent display that follows the tuning knob movement and provides an extremely accurate readout. Frequencies are displayed in 7 digits representing 100 MHz to 100 Hz digits.
 Automatic re-cycling restarts the tuning at the bottom of the band when the top is reached — and vice versa. Quick tuning at the bottom of the band when the top is reached in the SSB and CW modes, and 5 KHz steps and 1 KHz steps in the FM mode, is provided for trouble free use.
EASIER OPERATION AND LIGHTER WEIGHT — The most compact, lightest weight all-mode 144 MHz transceiver. First to use a pulse power supply in communication equipment, for lighter weight and cooler running. 50mm-diameter large tuning control knob for smooth and easy tuning.
 Trouble-free controlling knobs for both receiving and transmitting. LED indicator for transmit and receiving modes.
MOST SUITABLE FOR BOTH FIXED AND PORTABLE STATIONS — Built in 240V AC and DC power supplies. Convenient Dial Lock switch for mobile operation. Easy carry handle. Effective Noise Blanking. IC-SM5 high quality stand microphone is suitable for fixed station operation. Powerful audio output 1.5 Watts at 8 ohm, for easy listening even in noisy surroundings.

OUTSTANDING PERFORMANCE — The RF amplifier and first mixer circuits using MOS FETs and other circuits provide excellent Cross Modulation and Two-Signal selectivity characteristics. The IC251E has excellent sensitivity demanded especially for mobile operation, high stability, and with Crystal Filters having high shape factors and exceptional selectivity. The Transmitter uses a balanced mixer in a single conversion system, a band pass filter and a high performance low-pass filter. The system provides distortion-free signals with a minimum spurious radiation level.

SEND FOR MORE DETAILS ON TECHNICAL CHARACTERISTICS.

Thanet for



ICOM

143 RECVLVER RD.,
 BELTINGE,
 HERNE BAY, KENT.
 Tel: 02273/63859



Published on approximately the 7th of each month by IPC Magazines Limited, Westover House, West Quay Road, POOLE, Dorset BH15 1JG. Printed in England by Chapel River Press, Andover, Hants. Sole Agents for Australia and New Zealand—Gordon and Gotch (Asia) Ltd.; South Africa—Central News Agency Ltd. Subscriptions INLAND and OVERSEAS £11.80 payable to IPC Services, Oakfield House, Perrymount Road, Haywards Heath, Sussex. PRACTICAL WIRELESS is sold subject to the following conditions, namely that it shall not, without the written consent of the Publishers first having been given, be lent, resold, hired out or otherwise disposed of by way of Trade at more than the recommended selling price shown on the cover, excluding, first where the selling price is subject to V.A.T. and that it shall not be lent, resold, hired out or otherwise disposed of in a mutilated condition or in any unauthorised cover by way of Trade or affixed to or as part of any publication or advertising, literary or pictorial matter whatsoever.

IC-255E- An experts mobile choice

for only
£255
INCL.

NOW WITH
IMPROVED
FRONT-END



**25 Watts – 5 Memories – Scanning – 600kHz
AND User Selectable Repeater Shift – Full Coverage in 5kHz or 25kHz Steps.**

- Crystal controlled Tone Burst
- Full band coverage – extendable to 148MHz if required
- Four digit LED display
- 25 Watts output or 1W low power
- A superb receiver using grounded gate FET front end
- Scanning over a user programmable range
- Memory scan
- Stop on empty or busy channels
- Tuning in 25kHz or 5kHz steps
- 5 Memories – retained while the power is connected to the rig
- Built-in 600kHz Repeater Shift
- Alternative programmable shift
- Reverse Repeater facilities
- RIT (\pm 3kHz for those off channel stations)
- Scan control from the microphone (optional mic available)
- Good loud audio
- Optically coupled tuning between control knob and CPU
- Multiway 24 pin socket on back for touchpad, computer, or external control
- Rugged modular PA (Guaranteed of course!)
- Mobile mount which can be padlocked
- Up-down scanning microphone available

CAN YOU RESIST SUCH A TEMPTATION

Enjoy VHF mobile at it's best-IC-260E

Replacing the IC-245E, the IC-260E offers such extras as full frequency read out, upper and lower sideband, and scanning as well as FM and CW. Thus, it makes an ideal base station, when used with a DC power supply, as well as a mobile. The use of a microprocessor instead of an LSI chip has enabled Icom to offer this at a lower price than the IC-245E.

144MHz ALL-MODE TRANSCEIVER INCORPORATING A MICRO-COMPUTER – CPU control with Icom's original programs provides various operating capabilities. No backlash dial controlled by Icom's unique photo-chopper circuit. Band edge detector and Endless System provides out-of-band protection. No variable capacitors or dial gear, giving problem-free use. The IC-260E provides FM, USB, LSB, CW coverage in the 144-146MHz frequency range. Thus the IC-260E can be used for mobile, DX, local calls and satellite work. Easily extendable to 144-148.

MULTI PURPOSE SCANNING – Memory scan allows you to monitor three different memory channels. Program Scan provides scanning between two programmed frequencies. Adjustable scanning speed. Auto-stop stops scanning when a signal is received, in all modes.

DUAL VFO'S – Two separate VFO's can be used either independently or together for simplex operation, and any desired frequency split in duplex operation.

CONTINUOUS TUNING SYSTEM – Icom's new continuous tuning system features an LED display that follows the tuning knob movement and provides an extremely accurate readout.



£399 INCL.

Frequencies are displayed in 7 LED digits representing 100MHz to 100Hz digits. When in Duplex and using the tuning-knob the two VFO's track together. Automatic recycling restarts tuning at the top of the band, i.e. 145.999.9 MHz when the dial goes below 144.000.0MHz. Recycling changes 145.999MHz to 144.000.0MHz as well. Quick tuning in 1kHz steps is available, and fine tuning in 100Hz steps in the FM mode, is provided for trouble-free QSO.

OUTSTANDING PERFORMANCE – The RF amplifier and first mixer circuits using MOS FET's and other circuits provide excellent Cross Modulation and Two Signal Selectivity characteristics. The IC-260E has excellent sensitivity demanded especially for mobile operation, high stability and with Crystal Filters having high shape factors and exceptional selectivity. The transmitter uses a balanced mixer in a single conversion system, a band pass filter and a high performance low pass filter. This system provides distortion free signals with a minimum spurious radiation level for an output of 10W or more.

ADDITIONAL CIRCUITS – The IC-260E has a built-in Noise Blanker, CW Break-in CW Monitor, APC and many other circuits for your convenience. The IC-260E has everything you need to really enjoy VHF operation, in an extremely compact rugged transceiver.

Thanet for



ICOM

143 RECVLVER RD.,
BELTINGE,
HERNE BAY, KENT.
Tel: 02273/63859



The new MAPLIN CATALOGUE is out on December 5th

A massive new catalogue from Maplin that's bigger and better than ever before. If you ever buy electronic components this is the one catalogue you must not be without. Over 300 pages, it's a comprehensive guide to electronic components with thousands of photographs and illustrations and page after page of invaluable data. We stock just about every useful component you can think of. In fact, well over 5000 different lines, many of them hard to get from anywhere else. Hundreds and hundreds of fascinating new lines, more data, more pictures and a new layout to help you find things more quickly.

MAPLIN

Maplin Electronic Supplies Ltd.
All mail to: P.O. Box 3, Rayleigh, Essex SS6 8LR.
Telephone: Southend (0702) 554155. Sales (0702) 552911.
Shops:
159-161 King Street, Hammersmith, London W6. Telephone: (01) 748 0926.
284 London Road, Westcliff-on-Sea, Essex. Telephone: Southend (0702) 554000.
Both shops closed Mondays.

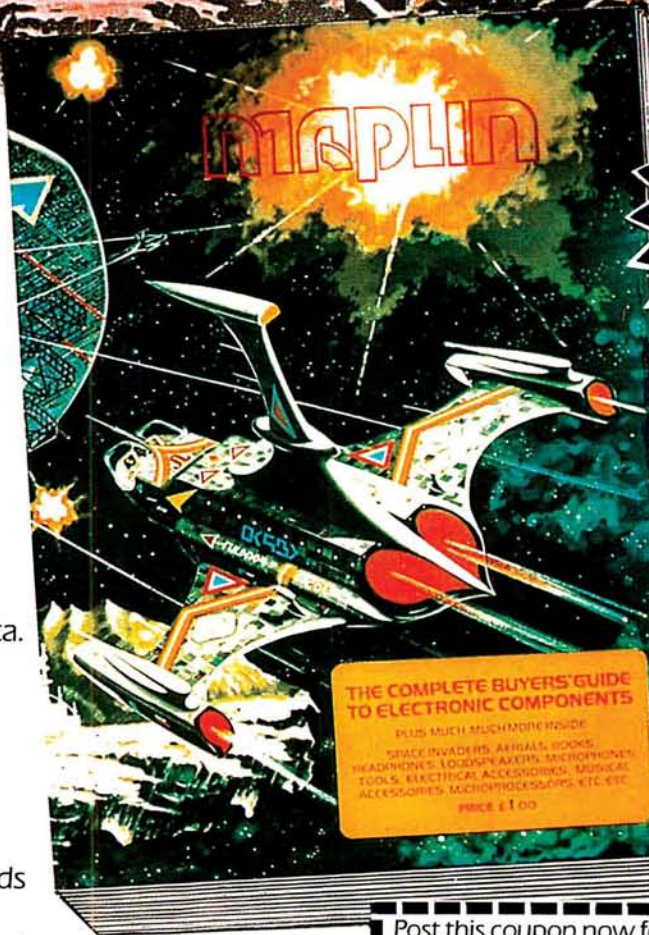

On sale
in all branches
of W H Smith
from Dec 5th
price £1

PLUS LOW PRICES
such as
Resistors from 1½p
Multimeters from £4.25
Ni-Cads from £1.15
Stereo Headphones from £3.49
Radios from £2.95
Over 300 Books
21 Different ranges
of capacitors, etc.,
etc., etc.,

Post this coupon now for your copy of our 1981 catalogue price £1.
Please send me a copy of your 320 page catalogue. I enclose £1 (Plus 25p p&p). If I am not completely satisfied I may return the catalogue to you and have my money refunded. If you live outside the UK send £1.68 or 12 International Reply Coupons.
I enclose £1.25

Name _____

Address _____