

PRACTICAL WIRELESS

AUGUST 1965

2[¢]



SOLAR-POWERED POCKET RECEIVER



ADCOLA

PRODUCTS & SERVICES
(Legal Trade Mark)

SOLDERING INSTRUMENTS AND EQUIPMENT



**DESIGNED FOR
THE AMATEUR'S
RADIO STATION**

ILLUSTRATED
List No. 70 $\frac{1}{8}$ " BIT
IN
**PROTECTIVE
SHIELD**
List No. 68

for catalogue apply direct to:—
Sales and Service Dept.

**ADCOLA PRODUCTS LTD.,
ADCOLA HOUSE,
GAUDEN ROAD, LONDON, S.W.4**

Telephones
MACau ay 4272 & 3101

Telegrams
SOLJOINT LONDON SW4

The SUPER 6 LONG & MEDIUM WAVE TRANSISTOR RADIO



A quality radio available as a kit or ready built. The sparkling performance and superb finish of the completed receiver give you value equivalent to a £12. 12. 0 commercial model.

★ All new parts. ★ 6 transistors and diode. ★ 350mW output. ★ Superhet circuit, Ferrite rod aerial. ★ Weymouth Radio printed circuit board. ★ Component positions and references printed on back of board. ★ Nicely styled wooden cabinet, 11 x 7½ x 3½ in. ★ Vinyl covered in various colours. ★ 6 x 4 in. speaker giving good bass and treble response. ★ Full instruction booklet 2/-. Free with kit. ★ I.F. Frequency 470 kc/s. ★ Lining up service if required. ★ All parts supplied separately. Write for list. S.A.E. please. ★ 9v. battery required. VT9 or P.P.9 (3/9 with kit).

COMPLETE KIT ONLY £4.17.6
PLUS 5/- POST
OR FULLY BUILT £6.17.6 Tax & Carr. Paid

V.H.F. Pre-amplifier with high signal-noise ratio and gain of at least 3:1 under average fringe area conditions. Metal container 3½ x 3½ x 1½ in. high, with strap for eaves, loft or skirting fixing. 9 volt battery operated, using transistor AF114. Covers all British and some Continental stations. 88 to 108 Mc/s. Order with confidence of improved reception.

ELECTRONICS (Camberley) LTD.
15 VICTORIA AVENUE, Camberley, Surrey
Post orders only please

JACKSON



the big name in **PRECISION** components

Precision built radio components are an important contribution to the radio and communications industry. Be sure of the best and buy Jackson Precision Built Components.



BALL-DRIVE DIAL

All the 'works' of this dial are inside the knob. No space is wasted behind the mounting panel, and the dial can be fitted directly to the spindles of one-hole-fixing tuning capacitors and potentiometers. Mounting is simplicity itself, and requires drilling only one 4BA clearance hole. (A template is provided.)

★ Takes standard 0.25in. spindles. ★ 6:1 ratio. ★ Dial 4in. diameter. ★ Scale 0-100 (Type A) or blank (Type B). ★ Powerful: output torque 26oz.—inches min. ★ Low backlash. *Made in England* Price 27/-

JACKSON BROS. (LONDON) LTD.

(DEPT. P.W.) KINGSWAY-WADDON, CROYDON, Surrey.
Phone: Croydon 2754-5 Grams: Walfilco, Souphone, London

FOR PEAK PERFORMANCE AT LOW COST— PICK CODAR AMATEUR RADIO EQUIPMENT

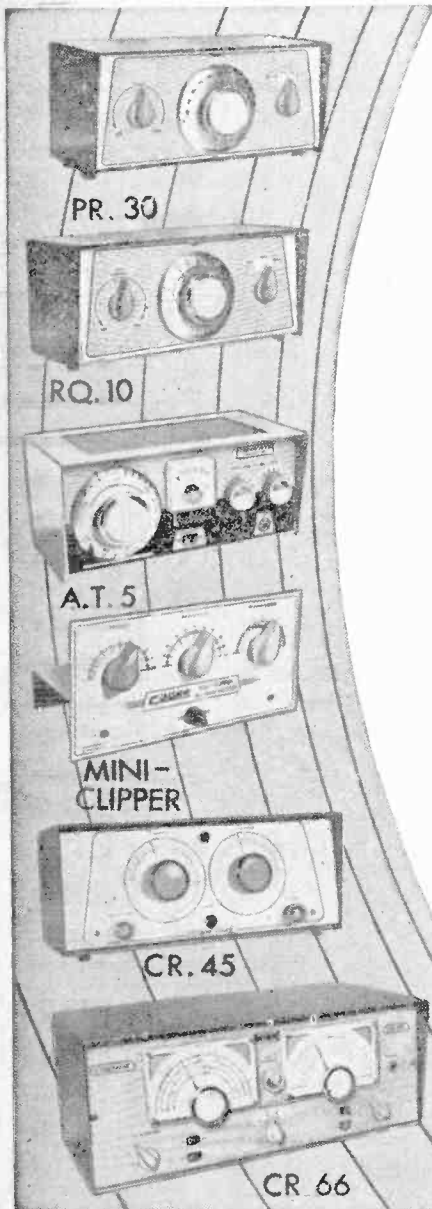

Advanced design and craftsmanship plus an unequalled reputation proved by the many hundreds of testimonials received from CODAR users is your guarantee of complete satisfaction. Only the best is good enough for CODAR—Muller, Brimar, Jackson, Denco, Electronics, Thorn, A.E.I., are just some of the famous names built into CODAR equipment. CODAR-KITS are supplied with clear pictorial diagrams and easy to follow instructions—no technical knowledge or special tools are required for complete success. Build your Short Wave Station with CODAR-KITS and enjoy peak performance and world wide reception previously possible only from much more expensive equipment.

For illustrated leaflets giving fullest details send 6d. in stamps.

CODAR R.F. PRE-SELECTOR. Will considerably improve the performance of any superhet receiver. "Results are amazing." "Well worth the money". **MODEL P.R.30.** Uses EF183 Frame Grid tuned R.F. Amplifier and provides up to 20dB gain plus substantial image rejection, improved signal/noise ratio and selectivity. Selector switch for either dipole or single wire antenna. Power requirements 180-250 volts 12 M/A H.T. 6.3 volts, 3 amp L.T. Size 8 1/2 x 5 x 4 1/2. Ready built, complete with cables, plugs and instructions. £4.19.6. Carr. 3/6. **MODEL P.R.36X.** Self powered version for 200-250v. A.C. and also provides 25 M/A at 200v. H.T. and 6.3v. 1 amp L.T. for other accessories. £7.4.0. Carr. 3/6

CODAR "Q" MULTIPLIER MODEL R.Q.10. For use with any superhet receiver with an I.F. between 450 and 470 Kc/s. Provides considerable increase in selectivity for either peaking or rejecting a signal on AM, CW, or SSB. Both PEAK and NULL functions tunable over receiver I.F. passband. BFO, facility included. Size 8 1/2 x 5 x 4 1/2. Power requirements 180-250v. H.T. at 5 M/A 6.3v. 3 amp L.T. Ready built, complete with cables, plugs and instructions. £6.15.0. Carr. 3/6. **MODEL R.Q.10X.** Self powered version for 200-250v. A.C. and also provides 25 M/A at 200v. H.T. and 6.3v. 1 amp L.T. for other accessories £8.8.0. Carriage 3/6.

CODAR A.T.5, 12 WATT 2 BAND TRANSMITTER. The newest most compact transmitter for fixed or mobile use on 160-80 metres. "The tiny TX with the BIG voice". Size only 8 1/2 x 5 x 4 1/2. (Base area is less than two-thirds of this page!) High stability new type calibrated VFO, 1.8-2.0 Mc/s and 3.5-3.8 Mc/s (up to 4 Mc/s export). Air-spaced CODAR COIL PI-net output, P.A. Plate current meter plus neon indicator. Plate/Screen modulator. AM/CW switch and Panel key jack. Plus changeover for 6 or 12 volts heater supply. Ready built £16.10.0. Carr. 4/-. **A.T.5 POWER SUPPLY KITS.** Type 250/5. For 200/250v. A.C. with Stand-by/Not/Transmit and aerial changeover switching, stabilised VFO supply, neon standby/transmit indicator £8.0.0. Carr. 6/6. Type 12/MS 12 volt solid state power supply unit £11.5.0. Carr. 5/-. Type 12/RC Remote Control and Aerial Switching unit. £2.7.6. Carr. 3/-. (H.P. Terms available).

CODAR-KIT MINI-CLIPPER—OUR FAMOUS SHORT-WAVE RECEIVER. ★Can be built in one evening ready to switch on and bring the World to your fingertips at very low cost. ★Supplied complete with valve, one coil 25-75 metres and 4 page instruction manual. PRICE 39/6. Carr. 3/-. Extra Coils 4/9 each. Instruction Manual only 2/- (credited on order). Electrical Bandsread available. Provision to add 2 transistor amplifier.

CODAR-KIT CR 45 MAINS T.R.F. SHORT-WAVE RECEIVER. World wide reception—North and South America, Russia, India, Australia, Far East, Amateurs, Shippings, etc. ★Separate electrical bandsread. ★3 slow motion vernier drives. ★Low loss polystyrene plug-in coils, factory aligned. ★Dials calibrated in frequencies and degrees. ★Power output 3 watts for 2/3 ohm speaker. ★Valve line-up: ECC81, EL84, E280. **CODAR-KIT CR 45** complete with valves, 3 coils (10-28, 25-75, 60-176 metres) and 11 page instruction manual LESS Cabinet. £7.5.0. Carr. 5/6. **CR 45 CABINET,** 12in. x 5 1/2in. x 7 1/2in. with sliding door for easy coil changing. 35/-. Extra coils 4/9 each. Instruction manual only 4/- (credited on order). (Can now be supplied ready built—price on request). (H.P. terms available).

CODAR-KIT CR 66 COMMUNICATION RECEIVER. The finest superhet kit ever offered. ★Covers 540 Kc/s—30 Mc/s in bands. ★Separate electrical bandsread. ★Factory aligned Coil unit and I.F. Transformers. ★Regenerative I.F. stage for maximum gain and BFO. for C.W. reception. ★Power output 3 watts for 2/3 ohm speaker. ★Panel controls: Aerial Trimmer, A.V.C., Standby Bandswitch, AF Gain, IF Gain, BFO, etc. ★Valve line up: 6CH1, 6BF8, ECC81, EL84, E284. ★Size EM84 16in. x 6 1/2in. x 8 1/2in. **CODAR-KIT CR 66.** Complete with 17 page instruction manual, £19.15.0 (Ready-built £23.0.0). CR 66 "S" Meter Model Kit £22.0.0 (Ready-built £25.0.0). Carr. 7/6 extra on all models (H.P. terms available). Instruction Manual only, 7/6 (credited on order).

CODAR COILS AIR-SPACED INDUCTORS. A complete range of low loss air-spaced inductors developed by CODAR. Over 40 different sizes from 4in. to 2 1/2 in. diameter suitable for all types of circuit application including VFO, P.A. Tank, PI-network-ATU, aerial loading, etc. Full data and prices on request.

CODAR RADIO COMPANY

G31BE G3HGQ

BANK HOUSE, SOUTHWICK SQUARE,
Southwick, Sussex. Tel. 3149

Canada: Codar Radio of Canada Tweed, Ontario



The practical way to Learn Electronics..and save money!

Anyone can build a Heathkit model. The easy-to-follow instruction manuals issued with each kit-set show you how. You will be proud of the professional appearance and performance of your finished model.

A KIT FOR EVERY INTEREST . . . FOR HOME, WORKSHOP, SERVICE & TEST DEPTS.

"AMATEUR" EQUIPMENT

AMATEUR BANDS RECEIVER
Model RA-1. Covers all amateur bands from 160-10 m. Half lattice crystal filter. 8 valve, "S" meter, tuned R.F. amplifier stage.

£39.66 Kit
Assembled £52.10



RA-1

AMATEUR TRANSMITTER. Model DX-100U. Covers all amateur bands 160-10M. 150 w. d.c. input, self contained with power supply. Modulator, VFO

Assembled £104.15.0 £79.10.0 Kit

AMATEUR TRANSMITTER
Model DX-40U. Covers 80-10 m. Power inputs 75 w. C.W., 60 w. peak C.C. phone. Output 40 w. to aerial. Prov. for VFO.

£33.19.0 Kit
Assembled £45.8.0



DX-40U

COMMUNICATIONS TYPE RECEIVER RG-1. A high performance low cost receiver for the discriminating listener. Freq. cov. 600 kc/s-1.5 Mc/s and 1.7 Mc/s to 32 Mc/s. Send for details.

£53.0.0 Assembled £39.16.0 Kit

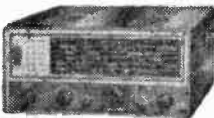

Other kits in the amateur range include: SSB Adaptor SB-10U £39.5.0. Variable freq. Oscillator VF-1U £10.17.6. Balun Coil Unit B-1U £4.15.6. Grid-Dip Meter GD-1U £10.19.6. Q Multiplier QPM-1 £8.10.0. Reflected Power Meter HM-1U £8.5.0. Wide range of models under American Mail Order Scheme.

MONEY BACK GUARANTEE

Daystrom Ltd. unconditionally guarantee that each Heathkit product assembled in accordance with our easy-to-understand instruction manual must meet our published specifications for performance or the purchase price will be cheerfully refunded.

HI-FI SPEAKER SYSTEMS

COTSWOLD STANDARD MODEL
Acoustically designed enclosure "in the white" 26 x 23 x 15 1/2 in. 12in. bass speaker, elliptical middle speaker, 2in. pressure unit. Covers 30-20,000 c/s.

Complete kit with all controls.



MFS SYSTEM

A minimum floor space model for the smaller room. 26in. high x 16 1/2 in. x 14in. deep. Similar performance to standard model.

Price either model £25.12.0 Kit

DAYSTROM LTD

Dept. P.W.-8, GLOUCESTER, ENGLAND

TEST INSTRUMENTS

5in. OSCILLOSCOPE Model 10-12U. Laboratory quality at utility oscilloscope price. Wide band amplifiers essential for T.V. servicing. F.M. alignment, etc. T/B covers 10 c/s-500 kc/s in 5 ranges.

£45.15.0 Assembled £35.17.6 Kit

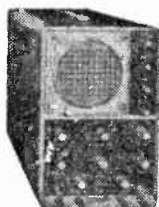

10-12U

PORTABLE 'SCOPE Model OS-1. A compact portable oscilloscope, ideal for servicing and general work. Printed circuit board. Case 7 1/2 x 4 1/2 x 12 1/2 in. long. Wt. only 10 1/2 lbs.

£30.8.0 Assembled £22.18.0 Kit

REGULATED POWER SUPPLY Model IP-20U. Transistorised 0.5-50 v. D.C. Up to 1.5 amps. Compact 9 1/2 x 6 1/2 x 11in.

£47.8.0 Assembled £35.8.0 Kit

VALVE VOLTMETER, Model V-7A. The world's best selling VTVM. Measures up to 1,500 volts (d.c. and r.m.s.) and 4,000 pk. to pk. Res. 0-1Ω 1,000 MΩ. Centre zero dB scale, d.c. input resistance 11MΩ. 4 1/2 in. meter. Complete with test prods, leads and standardising battery.

£19.18.6 Assembled £13.18.6 Kit



V-7A

DE-LUXE 6in. VALVE VOLTMETER, Model 1M-13U. Similar spec. to model V-7A but with improved accuracy. Larger meter. Unique gimbal mount.

£26.18.0 Assembled £18.18.0 Kit

R.F. and H.V. probes available as extras.

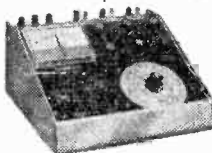

DE - LUXE TRANSISTOR TESTER, Model 1M-30U. Many special features. Provides complete d.c. analysis of PNP, NPN transistors and diodes.

£35.10.0 Assd. £24.18.0 Kit

TV ALIGNMENT GENERATOR, Model HEW-1. Covers 3.6 to 220 Mc/s fundamentals.

£47.10.0 Assembled £37.18.0 Kit

RF SIGNAL GENERATOR, Model RF-1U. Up to 100 Mc/s fundamental, 200 Mc/s harmonics. Up to 100 mV output on all bands.

£19.18.0 Assembled £13.8.0 Kit

MULTIMETER, Model MM-1U. Ranges: 0.15 v. to 1,500 v. a.c. and d.c.; 150μA to 15A d.c.; 0.25Ω to 20MΩ. 4 1/2 in. 50μA meter.

£18.11.6 Assembled £12.18.0 Kit

A wide range of other test instruments available including: R/C Bridge C-3U £10.10.0. AF V/Voltmeter AV-3U £16.10.0. Wattmeters AW-1U, £17.5.0. Capacitance meter CM-1U £15.15.0. Power supplies. Decade boxes etc. Many other instruments available under American Mail Order scheme. Why not send for full details?

LOW-PRICED SPEAKER SYSTEM SSU-1



A practical solution to the problem of a moderately priced speaker suitable for Stereo Mono amplifiers where the equipment has to be compact. Two speakers, balance control, ducted port reflex cabinet.

Horizontal or vertical (with matching legs).

Incl. P.T. £12.12.0 Kit

MODELS FOR HOME, TEST, AND WORKSHOP.
BRITISH HEATHKIT MODELS USE BRITISH COMPONENTS



HI-FI AMPLIFIERS

NEW!! DE-LUXE ALL TRANSISTOR STEREO AMPLIFIER, AA-22U
At last, a British transistor amplifier with high power (20 + 20W) at a reasonable cost, capable of delivering full power at all frequencies in the audio band. Handsome fully finished walnut veneered cabinet. New, compact, professional slim-line styling. Send for full specification of this outstanding amplifier. Kit £43.18.0. Assembled £68.16.0.



6W DE-LUXE STEREO AMPLIFIER, Model S-33H. An inexpensive stereo amplifier with high sensitivity. Suitable for use with Decca Deram cartridge. **£15.17.6** Kit
£21.7.6 Assembled

TAPE RECORD/REPLAY AMPLIFIER KITS. Will operate with most tape decks. Send for details.
TA-1M (Mono), £19.18.0 Kit. TA-1S (Stereo), £25.10.0 Kit.
STEREO CONTROL UNIT, Model USC-1. Ideal for use with MA-12 amplifiers. Kit £19.10.0. Assembled £26.10.0.



S-33

6W STEREO AMPLIFIER Model S-33. 3 w/ch. Inputs for radio, tape and gram. Stereo/Mono ganged controls. Sensitivity 200mV. **£18.18.0 Assembled £13.7.6 Kit**

TRANSISTOR MIXER, Model TM-1. A must for the Tape enthusiast. **£16.17.6 Assembled. £11.16.6 Kit**

5W HI-FI MONO AMPLIFIER, Model MA-5. A low priced amplifier based on the S-33. Printed circuit construction makes it easy to build. **£15.10.0 Assembled £10.19.6 Kit**

HI-FI MONO POWER AMPLIFIER, Model MA-12. Ideal for use with Models USC-1 and UMC-1, 0.1 THD at 10W. Wide frequency range. **£15.18.0 Assembled £11.18.6 Kit**

18W STEREO AMPLIFIER, Model S-99. Ganged controls. Stereo/Mono gram, radio and tape recorder inputs. P/B selection. **£38.9.6 Assembled £28.9.6 Kit**

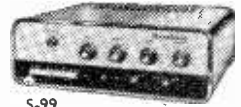

S-99

Send for full spec. of any model.

TRANSISTOR RECEIVERS

"OXFORD" LUXURY TRANSISTOR DUAL WAVEBAND RECEIVER.

The ideal domestic or personal portable receiver. 10 Semi-conductors. Solid leather case. Send for full details. **£14.18.0 Kit**
Incl. P.T.



6 TRANSISTOR PORTABLE, Model UXR-1. Prealigned I.F. transformers. Printed circuit, 7in. x 4in. high flux speaker. Real hide case. Very easy to build.

Incl. P.T. **£12.11.0 Kit**

"MOHICAN" GENERAL COVERAGE RECEIVER, Model GC-1U. Excellent portable or general purpose receiver for "amateur" or short wave listening. See full spec. leaflets. **£37.17.6 Kit**
Assembled £45.17.6



GC-1U

SPEAKERS FOR YOUR OWN ENCLOSURE

- 12" Heavy-duty Bass (Fane 122/12) **£7.7.0.**
- 2" Tweeter (Fane 301) **£3.1.6.**
- (both as used in the Cotswold systems).
- 12" Bass speaker (Audiom-51) **£9.12.5.**
- 8" Goodmans General Purpose G8 **£1.8.6.**
- Two Speakers + Cross-over, System SCM-1.
- (As used in model SSU-1) with details for enclosure **£5.5.0.**

ELECTRONIC WORKSHOP KIT, Model EW-1. An outstanding experimental kit, **£7.13.6** incl. P.T.

A WIDE RANGE OF BOOKS ON ELECTRONICS AND RADIO. PLEASE SEND FOR LISTS OR PRICES.

FREE CATALOGUE of the BRITISH HEATHKIT RANGE
Gladly sent on request

HI-FI TUNERS

Model FM-4U. Tuning range 88-108 Mc/s. Tuning unit (FMT-4U) with 10.7 Mc/s I.F. (£22.15.0 incl. P.T.). I.F. Amp. (FMA-4U) complete with cabinet and valves (£13.13.0). Total **£16.8.0 Kit**



FM-4U

Assembly can be arranged.

AM/FM TUNER. Covers FM 88-108 Mc/s. A.M. 16-50, 200-550, 900-2,000 m. Tuning heart (£4.13.6 incl. P.T.), and I.F. Amp (£22.11.6). Total **£27.5.0 Kit**



Send for leaflets. Assembly can be arranged.

EQUIPMENT CABINETS

A large range, in kit form or assembled and finished, available to meet most needs. Illustrated details on request.

Prices from **£7.15.** to **£44.2.0**

Many other models covering a wide range of equipment for HOME, OFFICE or WORKSHOP
SEND FOR FREE BRITISH CATALOGUE

American Catalogue sent for 1/- post paid

PUBLIC ADDRESS AMPLIFIER, PA-1. 50 w. Amplifier, two heavy duty speakers, variable Tremolo. Ideal for use with guitars, etc. **£54.15.0 Kit**
£74.0.0 Assembled



Legs optional extra 17/6. Set of 4.

50 W POWER AMPLIFIER, MA-50
Ideal for PA work, electronic organs etc. **£27.18.0 Assembled £19.18.0 Kit**

To **DAYSTROM LTD. Dept. P.W.-8, GLOUCESTER ENG.**

Please send me **FREE BRITISH CATALOGUE (Yes/No)**

Full details of model(s).....

NAME

ADDRESS

SURBITON PARK RADIO

MARTIN AUDIOKITS & RECORDAKITS

F.M. TUNER UNITS Nos. 15, 16 and 17 Cash £12.17.6
Or Dep. 51/6 and 12 m. pymts. of 18/10. (H.P. Price £13.17.6)
TRANSISTORISED AMPLIFIER with 5 position input selector, pre-amp and controls, 10 watt amplifier and Power Pack.
 For 3 Ohm Speaker, Cash £14.5.0
Or Dep. 57/- and 12 m. pymts. 20/10. (H.P. Price £15.7/10)
 For 15 Ohm Speaker, Cash £15.3.0
 (H.P. Price £16.12.0)
All above include Front Panels, Knobs and Instructions.
TWO TRACK RECORDAKIT AMP. (Valve) FOR STUDIO DECK, 6 valves, controls, self powered Cash £11.11.0
Or Dep. 47/- and 8 m. pymts. 25/6 (H.P. Price £12.11.0)
COLLARO STUDIO DECK 3 speed latest Two Track Cash £10.18.6
Or Dep. 44/- and 8 m. pymts. 24/6 (H.P. Price £12.0.0)
COMPLETE KIT with case, spkr., tape and mic. Cash £29.19.6
Or Dep. 120/- and 12 m. pymts. 44/- (H.P. Price £32.5.0)
FOUR TRACK AMP. as above Cash £12.12.0
Or Dep. 52/- and 6m. pymts. 27/6 (H.P. Price £13.12.0)
FOUR TRACK COLLARO DECK Marriott "X" Series heads
 Cash £13.19.6
Or Dep. 56/- and 12 m. pymts. 20/6 (H.P. Price £15.2.0)
COMPLETE KIT with case, spkr., tape and mic. Four Track Cash £33.19.6
Or Dep. 136/- and 12 m. pymts. 49/10. (H.P. Price £36.14.0)
TAPE PRE-AMP for Studio Deck, self powered
 Two Track Cash £9/8/0
Or Dep. 34/- and 6 m. pymts. 25/8 (H.P. Price £9/9/0)
 Four Track Cash £9.9.0
Or Dep. 39/- and 6 m. pymts. of 28/4. (H.P. Price £10.9.0)
 We are leading stockists for all Martin Constructional Kits

AMPLIFIERS-TUNERS Selection

ARMSTRONG 223 10-10 watts Stereo Amplifier Cash £27.10.0
Or Dep. 110/- and 12 m. pymts. 40/4 (H.P. Price £29.14.0)
ARMSTRONG 224 F.M. TUNER Powered Cash £22.10.0
Or Dep. 90/- and 12 m. pymts. 33/- (H.P. Price £24.6.0)
ARMSTRONG 223 AM/FM TUNER Powered Cash £28.15.0
Or Dep. 115/- and 12 m. pymts. 42/2. (H.P. Price £31.1.0)
ARMSTRONG 127 MONO 5W with AM/FM Cash £26.10.0
Or Dep. 106/- and 12 m. pymts. 38/10 (H.P. Price £28.12.0)

SURBITON PARK RADIO LTD.

ARMSTRONG 127 STEREO as above Stereo amp. Cash £37.10.0
Or Dep. 150/- and 12 m. pymts. 55/- (H.P. Price £40.10.0)
ARMSTRONG 225 MONO 10W amp. with AM/FM Cash £26.15.0
Or Dep. 147/- and 12 m. pymts. 53/10 (H.P. Price £29.13.0)
ARMSTRONG 227 STEREO as above with Stereo Amp.
 Cash £52.15.0
Or Dep. 211/- and 12 m. pymts. 77/4 (H.P. Price £56.19.0)
ARMSTRONG 226 STEREO as above, but Mag. P.U. Filter
 Cash £61.0.0
Or Dep. 260/- and 12 m. pymts. of 88/- (H.P. Price £65.16.0)
 Teak Cases for all Armstrong Units Cash £29.10.0
ROGERS CADET Mk. 3 10-10 watt Stereo Amp. Mag. P.U.
 Cash £31.17.0
Or Dep. 118/- and 12 m. pymts. of 43/3 (H.P. Price £31.17.0)
CASE MODEL ROGERS CADET Mk. 3 £30.0 extra
LEAK STEREO 30 TRANSISTOR Cash £49.10.0
Or Dep. 198/- and 12 m. pymts. of 72/7 (H.P. Price £53.9.1)

LOUDSPEAKERS Selection

FANE 122/10 heavy Duty 12in. 20 watt Cash £5.5.0
WHARFEDALE SUPER 8/RS/DD Cash £6.14.2
WHARFEDALE SUPER 10/RS/DD Cash £10.18.0
Or Dep. 44/- and 8 m. pymts. of 24/3 (H.P. Price £11.18.0)
GOLDMANS MEXIM Cash £17.16.8
Or Dep. 70/6 and 12 m. pymts. 25/8 (H.P. Price £18.18.6)

MOTORS PICK-UPS Selection

GARRARD SRP10 Mono Cash £5.10.0
GARRARD Model 1000 Mono Cash £5.10.0
GARRARD Model 1200 Mono Large Table Cash £12.10.0
Or Dep. 34/- and 6 m. pymts. 26/- (H.P. Price £19.10.0)
GARRARD Model 3000 Stereo Lightweight arm Cash £11.11.0
Or Dep. 47/- and 8 m. pymts. 25/6 (H.P. Price £12.11.0)
GARRARD S.P.25 Less cart.: Single player Cash £12.10.0
Or Dep. 50/- and 8 m. pymts. of 27/6 (H.P. Price £13.10.0)
GARRARD A.T. 60 Less cart.: Heavy table Cash £13.0.0
Or Dep. 52/- and 12 m. pymts. 19/- (H.P. Price £14.0.0)
GARRARD A 70 De Luxe changer. Less cart. Cash £22.10.0
Or Dep. 90/- and 12 m. pymts. 33/- (H.P. Price £24.6.0)
GARRARD L.A.B. 90 Push button oper., less cart. Cash £27.10.0
Or Dep. 110/- and 12 m. pymts. of 50/4. (H.P. Price £27.14.0)
GARRARD 401 Transcription Table. No arm. Cash £32.10.0
Or Dep. 130/- and 12 m. pymts. 47/8 (H.P. Price £35.2.0)
GOLDRING G66 Mono Single Player Cash £11.11.0
Or Dep. 47/- and 8 m. pymts. 25/6 (H.P. Price £12.11.0)
GOLDRING G17 Less cart. Heavy table, single play Cash £17.1.0
Or Dep. 69/- and 12 m. pymts. 24/11 (H.P. Price £18.8.0)
GOLDRING GL70 trans.: Unit with arm, less cart. Cash £29.18.6
Or Dep. 120/6 and 12 m. pymts. 43/9 (H.P. Price £32.5.6)
 Leaflets available on all items advertised upon receipt of 6d. stamp.

48-50, Surbiton Road, Kingston-on-Thames, Surrey
 Phone KIN. 5549; Hours 9 a.m. to 6 p.m. daily (1 p.m. Weds.)

THE
 PEMBRIDGE
 COLLEGE
 OF ELECTRONICS
 PROVIDES TRAINING
 IN RADIO
 AND TELEVISION

FULL-TIME COLLEGE COURSE IN RADIO AND TELEVISION

Our Course has now been extended to sixteen months' duration to include theoretical and practical instruction on transistor television receivers, U.H.F. television receivers and colour television.
 Next course commences 7th Sept., 1965.
 This Course is recognised by the Radio Trades Examination Board (R.T.E.B.) for the Radio and Television Servicing Certificate examinations.
 Provides excellent practical experience on valve and transistor radio receivers and all well-known makes of television receivers.

To:
 The Pembridge College of Electronics (Dept. P11)
 34a Hereford Road, London, W.2.

Please send, without obligation, details of the Full-time Course in Radio and Television.

Name _____

Address _____

STERN-CLYNE

Electronics Centres throughout Great Britain

HIGH-FIDELITY EQUIPMENT

Ready Built or In Kits of Parts



(1)

(1) Mullard "10 Plus 10" Stereo Amplifier

A High-Fidelity design providing up to 10 watts (per channel).

KIT OF PARTS £20.00
Built and tested £24.0.0 (C. & I. 7/6)

We can also supply the Main Amplifier for operation with our Dual Channel Pre-amplifier.

KIT OF PARTS £27.00
Built and tested £34.0.0 (C. & I. 10/6)



(2)

(2) Mullard Dual Channel Pre-Amplifier

A four-valve design for both Stereophonic and Monophonic operation.

KIT OF PARTS £12.10.0

Built and tested £15.0.0 (C. & I. 5/-)



(3)

(3) The "Twin Three" Stereo Amplifier

Based on a recent design by Mullard Ltd. it is ideally suited for use in Portable Record Players.

Built and tested £9.0.0 (C. & I. 7/6)

To construct a Stereo Portable Record Player, we offer:

Assembled Amplifier with two 8 x 5in Loudspeakers and Portable Case for £16.10.0 (C. & I. 10/-).



(5)

(5) Tudor AM/FM Tuner

Self powered VHF/FM long and medium waves. FM 87.5-108.5 Mc/s. AM/MW 522-1,630 Kcs/s. 1.W 146-270 Kcs/s. Multiplex output.

Built and tested 24 Gns. (P. & P. 7/6)



(6)

(6) Mullard 3-Valve Pre-Amplifier Tone Control

Designed mainly for the Stern/Mullard range of Monophonic Power Amplifiers.

KIT OF PARTS £10.0.0

Built and tested £13.13.0 (C. & I. 5/-)



(8)

(8) Mullard "5-10" Main Amplifier

For use with Mullard 2- or 3-valve pre-amplifiers with which an undistorted power output of up to 10 watts is obtained.

KIT OF PARTS £10.0.0

Built and tested £13.10.0 (C. & I. 8/6)

Above incorporating Partridge Output Transformer £1.8.0 extra.



(9)

(9) Mullard "5-10RC" Amplifier

The popular "5-10" complete incorporating Passive Control Unit providing up to 10 watts high quality reproduction with an input of 600 mV.

KIT OF PARTS £12.0.0

Built and tested £16.0.0 (C. & I. 7/6)

With Partridge Output Transformer £1.8.0 extra.

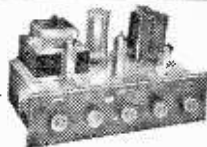

(10)

(10) Mullard "3-3RC"

A high quality Amplifier developed from the very popular 3-watt Mullard "3-3" design.

KIT OF PARTS £8.8.0
Built and tested £11.10.0 (C. & I. 6/6)



(11)

(11) The "Mono-Gram"

A small Amplifier of genuine high quality performance producing up to 3 watts undistorted output.

KIT OF PARTS £4.10.0

Built and tested £8.0.0 (C. & I. 3/6)



(12)

(12) Stereo Tape Pre-Amplifier Model STP-1

For use with current Truvox, Brenson or Collaro "Studio" 1- and 1-track Stereo Decks.

KIT OF PARTS £22.0.0

Built and tested £28.0.0 (C. & I. 8/6)

(13) Mullard Type "C" Tape Pre-Amplifier

Suitable for most 1-track Mono Tape Decks.

KIT OF PARTS £14.0.0

Built and tested £19.10.0 (C. & I. 7/6)



(14)

(14) Mullard Tape Amplifier Model HF/TR3

Based on Mullard's type "A" design and suitable for most 1-track Mono Tape Decks.

KIT OF PARTS £13.13.0

Built and tested £19.0.0 (C. & I. 7/6)

(16) JLI10 Power Amplifier

Incorporates the latest diode/pentode ECL86 valves in push-pull, Partridge ultra linear output transformer. Partridge mains transformer and smoothing choke. 10 watts power output, surplus power output, surplus power available for tuner.

Built and tested £12.12.0 (C. & I. 7/6)

(17) Double Feature Pre-Amplifier

Input for microphone, crystal or magnetic pick-ups, tuner unit, and in addition offers full facilities for tape recording and high fidelity replay. This unique feature means that should you wish to include tape in your hi-fi system at a later date all that is required is a suitable tape deck. Push-button switching for 3 tape speeds actualised.

Built and tested £18.18.0 (C. & I. 5/-)

Prices if both units purchased together:

Built and tested £30.9.0 (C. & I. 10/-)

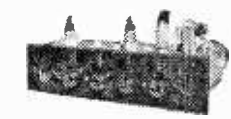

(16)



(17)



(18)

MULLARD 2-VALVE PRE-AMPLIFIER

Employing two EF80 valves and designed to operate with the Mullard AMPLIFIERS but also perfectly suitable for other makes with input up to 250 mV.

★ Equalisation for the latest R.I.A.A. characteristics. ★ Inputs for Cryst. Pickups and variable reluctance magnetic types.



★ Input (a) Direct from High imp. Tape Head. (b) From a Tape Amplifier or Pre-Amplifier. ★ Sensitive Microphone Channel. ★ Wide range BASS and TREBLE Controls. Now with brushed aluminium front panel with contrasting lettering and control knobs.

KIT OF PARTS £6.6.0 BUILT AND TESTED £9.10.0 (Carr. & Ins. 6/-)

Make an ideal combination with the 2-valve Pre-amp. plus our "5-10" main amplifier.

COMBINED PRICE REDUCTIONS

Mullard 5-10 Main Amplifier and 2-valve Pre-amplifier.

KIT £15.16.0 (C. & I. 8/6)

BUILT AND TESTED £21.10.0 (C. & I. 8/6)

Mullard 5-10 Main Amplifier and 3-valve Pre-amplifier.

KIT £19.10.0 (C. & I. 8/6)

BUILT AND TESTED £25.10.0 (C. & I. 9/0)

(Above items with PARTRIDGE Transformer £1.8.0 extra.)

Full descriptive leaflets available on any of the above items.

Instruction Books and Detailed Price Lists are supplied Free with Kits of Parts but may be purchased separately if required.

Items 1, 2 and 14, 3/- each; 6 and 13, 3/8 each; 7, 8, 9, 10, 2/- each; 11, 2/6 each; 12, 3/-. All Post Free.

STERN-CLYNE

Electronics Centres throughout Great Britain

LOUDSPEAKERS

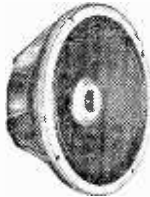

We supply a complete range of Goodmans, Wharfedale, Stentorian, TSL Speaker Units and complete systems. A comprehensive leaflet is available on request this covers technical specifications and prices of

- nearly 60 types including:—
- | | |
|-----------------------------|----------|
| Celestion CX1512 (8lbs.) | £11.10.0 |
| Celestion Model CX2012 | £16.10.0 |
| Stentorian HF 312 5 watts | £3.18.0 |
| Stentorian HF1012 10 watts | £4.12.0 |
| Goodmans Axiote 8 6 watts | £5.10.11 |
| Goodmans Axiom 10 10 watts | £6.5.11 |
| Goodmans Axiom 201 15 watts | £10.17.4 |
| Wharfedale Super 8RS/12/DD | £6.14.2 |
| 6 watts | |
| Wharfedale Golden RS/DD | |
| 8 watts | £7.17.5 |
| 15 watts | |
| Wharfedale RS/12/DD | |
| 15 watts | £11.10.0 |
- Guitar Speakers include:—
- | | |
|------------------------------|----------|
| Wharfedale W12EG 15 watts | £10.10.0 |
| Wharfedale W15EG 20 watts | £17.10.0 |
| Goodmans Audium 51B 15 watts | £9.2.5 |
| Goodmans Axiom 61B 20 watts | £14.7.8 |
- Carr. and Ins. extra.

AMERICAN RECORDING TAPE

- | | |
|--------------------------------|---------|
| 5in. 600ft. Std. Acetate | £/ 8/6 |
| 5in. 900ft. LP Acetate | .. 10/- |
| 5 1/2in. 1,200ft. LP Acetate | .. 12/6 |
| 3 1/2in. 600ft. DP Polyester | .. 11/6 |
| 7in. 1,200ft. Std. Polyester | .. 12/6 |
| 5in. 1,200ft. DP Polyester | .. 15/- |
| 7in. 1,800ft. LP Polyester | .. 20/- |
| 5 1/2in. 1,800ft. DP Polyester | .. 22/6 |
| 7in. 2,400ft. DP Polyester | .. 25/- |
- P. and P. 1/- per Reel. 4 or more Reels POST FREE.

FULLY AUTOMATIC TAPE SPLICER

14/6. P. & P. 1/6.

PLASTIC TAPE SPOOLS

2 1/2in. 1/-; 3in. 1/3; 4in. 2/-; 5in. 2/-; 6 1/2in. 2/3; 7in. 2/6.

PLASTIC SPOOL CONTAINERS.

For spool sizes 5in., 1/6; 5 1/2in., 2/-; 7in., 2/3. Any single item plus 6d. P. & P. Orders over £1 Post Free.

We carry fully comprehensive stocks of Tape Recorders, Decks and Accessories at all Branches or order with confidence by mail.

THE TRAVLER Mk. II CAR RADIO

★ MEDIUM AND LONG WAVES

★ 12 VOLT POSITIVE EARTH

★ Push Button Wave Change

★ SIZE 7 x 2 x 7 inch

★ TRANSISTORISED

ONLY
9 1/2 gns.

P. & P. 5/-



Ready built complete with 7 x 4in. speaker fitted to baffle fixing brackets, filter unit all nuts and bolts and fitting instructions.

Optional Extras: Chromium plated weatherproof telescopic aerials. Type 1, 22in./50in. 19/6. Type 2, 32in./43in. 29/6. Type 3, fully retractable and locking 1in./50in. Depth below wing, 14in. 39/6. all plus P. & P. 2/6 if purchased separately.

The "HIGHWAYMAN" Car Radio to build yourself. Similar in appearance to above but with on/off push button switch. Complete set of parts only £7.19.6. P. & P. 5/-.

RECORD PLAYER BARGAINS

B.S.R. UA. 25

4-speed Autochanger with mono cartridge .. £5.19.6

B.S.R. UA.15

"SUPER SLIM" 4-speed auto-changer with mono cartridge .. £9.19.6

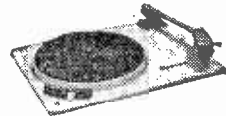

SPECIAL GARRARD OFFERS!

3000 4-speed Autochanger with Sunstone VTA Stereo Cartridge £9.19.6. LAB "A" GCS Mono £15.15.0. LAB "A" on plinth £17.17.0.

OTHER GARRARD MODELS

SRP.10 Single Player £5.9.11. A.1000 with cartridge £8.10.0. SR.25 Single Player £13.10.8. AT.50 with cartridge £14.1.1. 4HP with GCS cartridge £16.17.6. A70 less cartridge £22.11.1. LAB 80 less cartridge £27.10.0. 301 Transcription Unit £25.6.4. 401 Transcription Unit £32.10.0. Carriage and Insurance 5/- extra all models.

TUNER UNITS

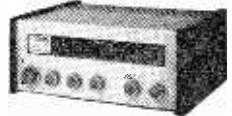

ARMSTRONG
Mono/Tuner Amp. Model 127M £26.10.0
Stereo/Tuner Amp. 127 .. £37.10.0
AM/FM Tuner 223 .. £28.15.0
FM Tuner 224 .. £28.10.0
Carr. and Ins. 7/6.

JASON
FMT1 FM Tuner, Kit of Parts £6.15.0
FMT2 FM Tuner, Kit of Parts £10.12.6
FMT3 FM Tuner for Fringe areas. Kit of Parts .. £12.5.0
FMT4 FM Tuner .. £20.0.4
JTV2/EM.TV Sound, .. £15.15.0
Kit of Parts .. £15.15.0
Carr. and Ins. on above 5/- each.

TRIPLETONE
FM Tuner unpowered .. £18.19.6
FM Tuner self-powered .. £15.14.6
Carr. and Ins. 5/- each.

Descriptive leaflets free on request. Please state model required.

CHASSIS BARGAIN

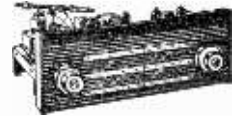

A 6 valve Superhet Radiogram Chassis of outstanding quality covering MW 200/550 Metres. LW 1200-2000 Metres. VHF 87-100 Mc/s. Incorporating internal Ferrite Rod Aerial and the famous Gorrer Tuning Heart for VHF Pick-up input suitable for most modern Record Players. Power output 4 watts, valve line up EZ80, EABC80, EF86, EC117, EL84, EC085. Volume On/Off and Tone Control, attractive black Tuning Dial size 1 1/2 x 5in. with gold lettering and contrasting cream and gold knobs. A.C. 200/250V. Size 1 1/2 x 7 1/2 x 6 1/2in. PRICE 16 Gns. P. & P. 5/- (Terms available.)



NEW LOW PRICE COMMUNICATION RECEIVERS

- | | | |
|--|-----------|--|
| HE 40, 550 Kc/s-30 Mc/s in 4 bands. Carriage 10/-. | £19.19.0. | Starlight 90 Watt Transmitter. |
| HE 30, 530 Kc/s-30 Mc/s in 4 bands. Carriage Paid. | £34.13.0. | Band coverage 80 - 40 - 20 - 15 and 10 Metres. £30.9.0. Carr. 15/- (H.P. Terms available). |

Send S.A.E. for fully descriptive brochure.

LEADING AGENTS FOR

All B & O and SABA Equipment also SONY Tape Recorders

VISIT YOUR NEAREST STERN-CLYNE ELECTRONICS CENTRE

LONDON

18 Tottenham Court Road, W.1. MUSEum 5929/0095. Half Day Saturday.
23 Tottenham Court Road, W.1. MUSEum 3451/2. Half Day Thursday.
309 Edgware Road, W.2. PADdington 6963. Half Day Thursday.
109 Fleet Street, E.C.4. FLEET Street 5812/3. Half Day Saturday.
162 Holloway Road, N.7. NORTH 7941. Half Day Thursday.
9 Camberwell Church Street, S.E.5. RODney 2575. Half Day Thursday.

CROYDON

12 Suffolk House, George Street, MUNICIPAL 3250. Half Day Wednesday.

BRISTOL

26 Merchant Street, BRISTOL 1. BRISTOL 20261. Open 6 days a week.

LIVERPOOL

52 Lord Street, Royal 7450. Open 6 days a week.

MANCHESTER

20/22 Withy Grove, Manchester 4. BLAckfriars 5379/5246.

Open 6 days a week.

SHEFFIELD

125 The Moor, Sheffield, SHEFFIELD 29993. Half Day Thursday.

MAIL ORDERS AND ENQUIRIES TO:

Dept. P.W. 3/6 Eden Grove, Holloway, London N.7. NORTH 8161/8.

Brand new individually checked and guaranteed VALVES

Table listing various vacuum tube types and their specifications, including AC/HL, AC/PA, AL60, etc., with columns for type, quantity, and price.

MANY OTHERS IN STOCK include Cathode Ray Tubes and Special Valves. All U.K. orders below £1. P. & P. 11/-; over £1. 2/-; over £3. P. & P. free.

MARCONI COMMUNICATION RECEIVERS CR. 150. Frequency coverage 2-60 Mc/s in 5 bands. Two lft. 1st 1.600 kc/s, 2nd 463 kc/s. Image signal protecting over 40 dB up to 30 Mc/s and 20-40 dB from 30-60 Mc/s. Self-checking calibration (built-in calibrator). Stabilisation of supply and temperature compensation. Electrical and mechanical indicator Bandpass from 100 c/s to 10 kc/s bandspread. Metering and visual tuning in 5 stages. Acoustic filter associated with 100 c/s. Bandpass position for CW reception. Facilities for diversity reception. Excellent checked condition. £39. Mains P.S.U. by P.C. Radio £4.10.0. Carriage 30/- CR.150/2. Frequency coverage 1.5-22 Mc/s in 4 bands, all other features as in CR.150. Price £31. Carriage 30/-.

P.C. RADIO'S mains P.S.U. for above, 90/-. DHR HIGH RESISTANCE HEADPHONES. New, 14/-, P. & P. 1/6. WIDE RANGE MULLARD VALVE VOLTMETER TYPE E 7555/2. 100mV-500v. D.C. or A.C. peak from 35c to 5mc, additional range 500v. to 15kc D.C. or peak A.C. Frequency response with probe is level from 35c to 100mc. Power supply 110/245v. A.C. Price £19. Carriage £1.

VERY HIGH CLASS COMMUNICATION RECEIVER TYPE BRT 402E. 150 kc/s-385 kc/s., 510 kc/s to 3mc. Fully tested £60. Carriage 30/-. EVERSHED MEGGER CIRCUIT TESTER. 2 ranges 0 to 1,000Ω, 100Ω to 200,000Ω. With test leads, leather carrying case. Tested £4.19.6. P. & P. 3/6.

PANEL METERS (round) table listing meter types and prices: 0-50 microamps, 0-100 microamps, 0-200 microamps, etc.

2 KW ULTRASONIC GENERATOR together with power supply unit for 200-250v. A.C. Complete two chassis with interconnecting cables. Frequency 37 to 43 kc/s adjusted by fine control. Peak output 2kw, average output 500w. Completely new with valves and manual £65. Carriage paid U.K.

R.F. CHOKES. Ideal for vibrators and anti-interference filters. Very low resistance (0.02 Ω). 30μh inductance. 4/3 incl. post.

P.C. RADIO LTD 170 GOLDHAWK ROAD, W.12 Shepherd's Bush 4946 Open 9-5.30 p.m. Thursday 9-1 p.m.

STABILISED POWER SUPPLY UNIT TYPE R.1095 (EDISWAN) with 2 independent outputs. 1. D.C. 120-250V. 50mA metered and regulated. 2. A.C. 6.3v. C.T. 31amps. Stability 0.02%. Price £18.

STABILISED POWER SUPPLY UNIT TYPE R.2001 (EDISWAN) with 2 independent outputs. 1. 0-100v. 50mA metered and regulated by coarse and fine adjustments. 2. 250v. Bias as 5mA. Stability 0.02%. Price £18.

WIDE RANGE MULLARD VALVE VOLT METER TYPE E 7555/2. 100 mV-500 v. D.C. or A.C. peak from 35c to 5 mc. additional range 500 v. to 15 kc. D.C. or peak A.C. Frequency response with probe is level from 35 c to 100 mc. Power supply 110/245 v. A.C. Price £25. Carriage £1.

WIRELESS SET NO. 52 (CANADIAN) Complete station consisting of Transmitter, Receiver, supply unit for 12 v. All contained in special carrier. 1.75-16 mc/s in 3 bands. 813 as output valve. 45-75 v. phone and MCW, 70-100 watt CW. M.O. or crystal. Receiver includes crystal calibrator. Tx can be exactly tuned to Rx frequency. Noise limiter. Sidetone. Loudspeaker on receiver with on/off switch. All brand new with accessories. Export. Price on application.

OUTPUT TRANSFORMERS for push-pull small battery valves (1T4) with output winding for 15 and 600 ohm impedance. 15/- carriage paid.

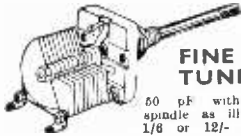

FINE TUNERS

50 pF with long spindle as illus. 1/6 or 12/- dozen.

Microphone Insets

American made. Dynamic type. Real bargain at 2/6, plus 2/- postage.



SELF ENERGISED TELEPHONES

These require no batteries: in fact they have only to be connected by a pair of wires. They can thus be fitted into existing bell circuits. Results are extremely good and maintenance costs are nothing.

Handsets only 15/- each, post etc. 2/6. Two, post free.

Building a 'Scope

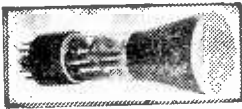

8in. oscilloscope tube. American made type No. 3PPT, 6.3v. 0.6 amp. heater electrostatic deflection. Brand new and guaranteed with circuit diagram of scope 15/- each. Plus 2/6 post and insurance.

Sheet Paxolin

Ideal for transistor projects. Special offer. 12 panels 5 x 8in. 6/-



RELAYS

Totally enclosed in bakelite, this relay has a 24v. coil but can of course be rewound for mains operation. Its contacts are suitable for breaking 20 amps. Price 2/6 each, 24/- doz.



Speaker Bargain

12in. High-fidelity loudspeaker. High flux permanent magnet type with either 8 ohm or 16 ohm speech coil. Will handle up to 10 watts. Brand new by famous maker. Price 2/76 + 3/6 post and insurance.

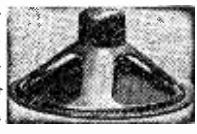

Brayhead Turret Tuner

Complete with Band 1 and Band 3 coils. Less valves 10/- each or with valves 17/6 each. Post 2/6. Knobs 3/6 extra.



Where postage is not definitely stated add 2/- all orders under £3.

SNIPERSCOPE

Famous wartime "cat's eye" used for seeing in the dark. This is an infra-red image converter cell with a silver caesium screen which lights up (like a cathode ray tube) when the electrons released by the infra-red strike it. It follows that as light from an ordinary lamp is rich in infra-red these cells will work burglar alarms, counting circuits, smoke detectors and the hundred and one other devices as will the simpler type of photo cell. Here then is a golden opportunity for some interesting experiments. price 5/- each. Post 2/-. Data will be supplied with cells if requested.

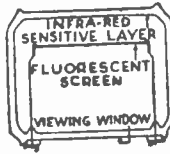

BUILDING AN AMPLIFIER

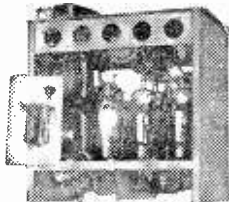

Here is a buy for you. Modulator Unit type 20. Contains parts ideal for building a large output amplifier and all ready set out in metal case. To name a few: Four high output valves Type KT44. Driver valve Type MH41. Iron cored choke for up to 200 milli-amps. Dozens of wire wound and carbon resistors, paper and mica condensers. Terminals and tag panels etc. etc. Three other items of interest to everybody and all ready set out in metal case. To name a few: Transformer Reference 10K/143. This can act as auto-transformer to convert 230 to 110 or 230 to 460, and also as a filament transformer 230 to 6.3 or 230 to 2.5 volts. 2. Miniature Circuit Breaker. For breaking 10 amps A.C. react by pushing knob. 3. Steel Case. With heavy gauge chassis, all ready cut out and fitted valve holders, etc. Price for complete unit is 12/6. Carriage 7/6.

THIS MONTH'S SNIP

TAPE PLAYBACK MACHINE

Made by a very famous British Company to a very exacting specification. This is a really superior machine—the capstan being driven by a synchronous motor and wow and flutter completely eliminated by a very heavy flywheel. Playback is through a full fit tape head which works into a "high fit" amplifier using five modern type valves, EL34 etc., fitted with output transformer needing only a speaker to complete. The machine operates from standard A.C. mains and uses a heavy duty transformer for safety and reliability. Brand new—unused and guaranteed perfect—limited quantity only 55.10.6, plus 7/6 post and ins.

AUTOCHANGER BARGAIN

Garrard Auto-Slim Record Changer

One of the newest record changers that this famous company make—Automatic selection of records which may be turned—may also be played manually. Finger tip adjustment of stylus pressure. Fitted with monohead—but pick-up wired for stereo. Cabinet space required 14 1/2 x 12 1/2 in. with 4 1/2 in. above and 2 1/2 in. below. DON'T MISS THIS SPECIAL SNIP only 25.15.0 (post and insurance, 6/6).

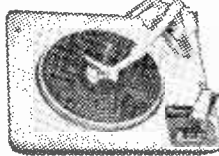

750 mW TRANSISTOR AMPLIFIER

4 transistors including two in push-pull input for crystal or magnetic microphone or pick-up—feed back loops—sensitivity 5 mV.

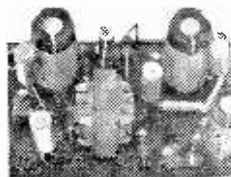

Price 19/6

Post and insurance 2/6. 30 ohm Speaker. 12/6 extra.

Making a Fan Heater

Miniature motor laminated poles. Operates off 20-30v. D.C. Original cost at least £3 each, 8/8 plus 1/6 postage and insurance. Mains model 9/8 plus 2/9 postage and insurance.

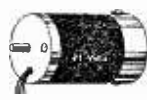

Cabinet Snip

This fine cabinet as illustrated has less control knobs is available this month at a special snip price of 12/6 plus 3/6 post and insurance. Size is 13 1/2 in. x 9 in. x 4 in. and is nicely covered in two tone I.C.I. fabric.



Five Core Cable

Ideal for switching circuits, intercoms, P.A. runs etc. each core flex copper with rubber insulation, cores covered overall in tough rubber or P.V.C. 9d. per yd. or 30 yds. length 15/- plus 5/- post.

Waterproof Heater Wire

16 yds. length 70 watts, self regulating temperature control. 10/-, post free.

THERMOSTATS

Type 'A' 15 amp. for controlling room heaters, greenhouse, airing cupboard. Has spindle for pointer knob quickly adjustable from 30/80°F. 9/6 plus 1/- post. Suitable box for wall mounting. 5/-. P. & P. 1/-. Type 'B' 15 amp. This is a 17 in. long rod type made by the famous Sunvic Co. Spindle adjusts this from 50-550°F. Internal screw alters the setting so this could be adjustable

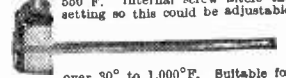

over 30° to 1,000°F. Suitable for controlling furnace, over kiln, immersion heater or to make flamestat or fire alarm. 8/6 plus 2/9 post and insurance.

COMPONENT BARGAINS

485 Kols 15 Transformers. Standard type in aluminium can with trimmers, size 1 1/2 in. square, 1/6 each, 12/- doz. 46 Receiver/Transmitter. Complete except for crystals packed with valves and components. Easily buildable into other gear. 19/8, plus 6/6 carriage and insurance. Output Transformer. Standard pentode type 2/6, 24/- doz. Mullard 510. Amplifier chassis complete with inner screening section, stove enamelled. 7/6, plus 2/9 postage. Precision Wheatstone Bridge. Opportunity to build 100K wire wound pot, 15 watt rating, 5/- only. Also 100K, 100 watt. American made. 15/-, post 2/6. Toggle Panel Switch, 25/30 amp. single pole, 2/6, 24/- dozen. Toggle Switch, 10 amp. double pole, 3/6, 18/- dozen. Electric Lock. 24v. coil but rewindable to other voltages, 4/8; 48/- dozen. Head Phones ideal for short wave listening etc. Low resistance, best makers. 6/-, post 2/6. Sound Powered Inserts (D.L.R.5) as P.E. intercom. as speakers or microphones, 5/6; 54/- dozen.

1 Meg. Potentiometers. Sealed type made. Mergante. among the best ever made. Standard 1 spindle. 1in. long. 6/- dozen. 2 meg. ditto, 6/- doz. 1 meg. ditto, 6/- doz. 100K, ditto 5/8 dozen. 50K, 5/- dozen. M.U Metal Screen for American 5 CPl etc. 6/6 pair for VCR97 and other 6in. tubes. 7/- complete. Ditto for 2.8in. tube, 5/- complete. Trimmer Bank. 5 x 50 pF compression trimmers mounted on metal strip 3 1/2 in. long. Ideal if making pre-set station receiver. ceramic/mica insulation. 2/- each; 18/- doz.

MAINS POWER PACK

Designed to operate transistor sets and amplifiers. Adjustable output 0v-9 to 13 volts for up to 500mA (class B working). Takes the place of any of the following batteries: PPI-PP3-PP4-PP6-PP7-PP9 and others. Kit comprises: mains transformer-rectifier, smoothing and load resistor 5000 and 500 mfd condensers, zener diode and plus 2/6 post.

ELECTRONICS (CROYDON) LTD

Dept. P.W. 266 LONDON ROAD, WEST CROYDON, SURREY
Post orders to: 43 Silverdale Road, Eastbourne, Sussex

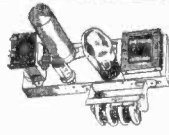
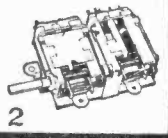

Comprising chassis 8 1/2 x 2 1/4 x 1 1/2 in. Double wound mains transformer, output transformer, volume and tone controls, resistors, condensers etc. Valves 6V6, 6X4 and metal rectifier. Circuit 1 1/2 free with kit 29/6 plus 4/6 P & P

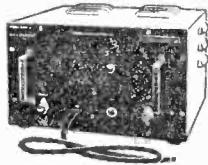
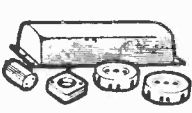
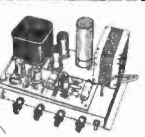
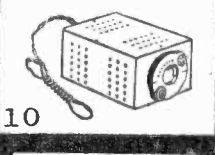
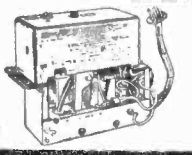
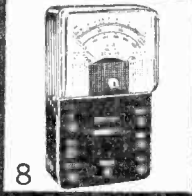
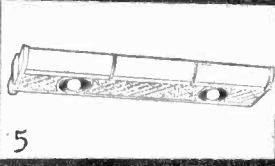
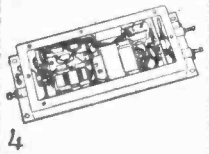

1. **6 VALVE 15 WATT PUSH-PULL AMPLIFIER**, 15 x 7 x 1 1/2 in. A.C. Mains 200-250 volts. 4 inputs with controls for same and bass and treble lift controls. Tapped for 8 and 15 ohm speakers. Extra H.F.T. and L.T. for F.M. Tuner supplies etc. Built and tested. 7 gu. P. & P. 18/6.
2. **CYLDON A.M.F.M. PERMEABILITY TUNERS FOR ALL TRANSISTOR OPERATION**. Size 2 1/2 x 2 1/2 in. approx. By famous manufacturer. A.M. I.F. 470 Kc/s. I.M. I.F. 10.7 Mc/s. A.M. coverage from 1630 Kc/s-325 Kc/s. F.M. coverage 108 Mc/s-88Mc/s. Circuit diagrams 2/6. FREE with Tuner, 1st, 2nd and 3rd A.M. I.F.'s, 1st, 2nd, 3rd and 4th F.M. I.F.'s V.H.F. Osc. choke. A.M. I.F. trap. All the above are the R.F. end of an A.M./F.M. receiver car radio etc. The above items, £2.10.0.
3. **AMPLIFIER KIT**. 3 to 4 watt Amplifier Kit.
4. **TRANSISTOR INVERTOR**. 50 v. D.C. input. Output 240 v. A.C. 40 watts incorporating transformers, choke, condensers and 2 GET373. In solid 16 gauge aluminium case, size 15 x 6 x 2 1/2 in. by famous manufacturer, 19/6, plus 7/- P. & P.
5. **FLOURESCENT LIGHT FITTING**. Twin 40 watt 200/250 v. less tubes. 39/6. P. & P. 7/-.
6. **OSCILLOSCOPE FOR D.C. and A.C. APPLICATIONS**. Push-pull X amplifier. Fly-back suppression. Interval Time-base Scan Wave form available for external use, pulse output available for checking TV line O/P Transformers, etc. Provision for external I.P. and C.R.T. Brightness Modulation. A.C. mains 200/250 v. £18 18.0. P. & P. 10/- FULL 12 MONTHS' GUARANTEE INCLUDING VALVES and TUBE.
7. **A.C. MAINS MOTOR**. Can be used for a variety of purposes, silent running, satisfactory in every way. 250/250v. A.C., 9/6. P. & P. 3/-.
8. **POCKET MULTI-METER**. Size 3 1/2 x 2 1/2 x 1 1/2 in. Meter size 2 1/2 x 1 1/2 in. Sensitivity 1,000 O.P.V. on both A.C. and D.C. A.C. and D.C. volts. 0-15, 0-150, 0-1,000. D.C. current 0-150 mA. Resistance 0-100K Ω Complete with test leads, battery and full instructions, 39/6. P. & P. 2/6. FREE GIFT for limited period only. 20 watt Electric Soldering Iron value 15/- to every purchaser of the Pocket Multi-Meter.
9. **CHANNEL TUNER I.F.** 16-19 Mc/s. Continuously tunable from 174-215 Mc/s. Valves required—PCF80 and POC84 (in series). Cover BBC and ITA ranges. Also Police, Fire and Taxis, etc. Brand new by famous maker, 10/- P. & P. 3/-.
10. **POWER SUPPLY KIT** in metal case, size 3 1/2 x 2 1/2 x 2 in. Incorporating mains transformer, rectifier and condensers. 250/250 A.C. mains Output 5v. 100mA. 10/6 plus 3/- P. & P.
11. **B.S.R. MONARCH UA14 WITH PULL PI HEAD**. 4-speed, plays 10 records, 15in., 10in., or 7in. at 16, 33, 45 or 78 r.p.m. Intermittes 7in., 10in. and 15in. records of the same speed. Has manual play position: colour brown. Dimensions: 12 1/2 x 10 1/2 in. Space required above baseboard 4 1/2 in., below baseboard 2 1/2 in. Fitted with Full Pi turnover crystal head. £5.19.6. P. & P. 7/6.
12. **50 MICRO-AMP METER** movement by world famous manufacturer. Size 3 x 2 1/2 in. 25/-, plus 2/- P. & P.
13. **8-WATT 5-VALVE PUSH-PULL AMPLIFIER & METAL RECTIFIER**. Size: 9 x 8 x 1 1/2 in. A.C. Mains, 200-250v. valves. For use with 8in. or 1.P. records, musical instruments, all makes of pick-ups and tubes. Output 8 watts at 5 per cent total distortion. Separate bass and treble lift controls. Two inputs, with controls for gram. and mike. Output transformer tapped for 5 and 15 ohm speech coils. Built and tested. £8.19.6. P. & P. 8/-.
14. **40W FLOURESCENT LIGHT KIT** incorporating GEC Choke size 8 1/2 x 1 1/2 x 1 1/2 in. 2 bi-pin holders, starter and starter holder, 11/6. P. & P. 4/6. Similar to above: **80W Fluorescent Light Kit** incorporating GEC choke size 11 1/2 x 1 1/2 x 1 1/2 in. 2 bi-pin holders, starter and starter holder 17/6. P. & P. 5/6.
15. **FIRST QUALITY PVC TAPE**.

2 1/2 in. Std. 350ft.	9/-	5 in. D.P. 850ft.	10/6
7 in. Std. 1200ft.	11/6	5 in. T.P. 800ft.	8/-
3 in. L.P. 240ft.	4/-	5 in. T.P. 1800ft.	20/6
6 1/2 in. L.P. 1200ft.	11/6	6 1/2 in. T.P. 2400ft.	27/6
7 in. J.P. 1800ft.	18/6	7 in. T.P. 3600 ft.	37/6

 P. & P. on each 1/6. 4 or more Post Free.
16. **FIXED FREQUENCY SIGNAL GENERATOR**. Crystal controls in metal case, size 10 x 6 x 6 in. Incorporating two PC13 valves, mains transformer, metal rectifier, choke, indicator, lamp, crystal and numerous components. Modulated and unmodulated output socket. Originally used for I.T.V. frequencies. Brand new, 99/0, plus 7/- P. & P. A.C. mains 200-250 volts. **SILICON RECTIFIERS**. 250v. P.I.V. 750 mA. Six for 7/6 post paid.

RADIO & T.V. COMPONENTS (ACTON) LTD.

21b High Street, Acton, London, W.3.

All enquiries S.A.E. Goods not despatched outside U.K. Shop hours 9 a.m.—4 p.m. Early closing Wednesday

SPECIAL OFFER! FROM R. & T.V. LTD.

Elegant Seven
Mk II

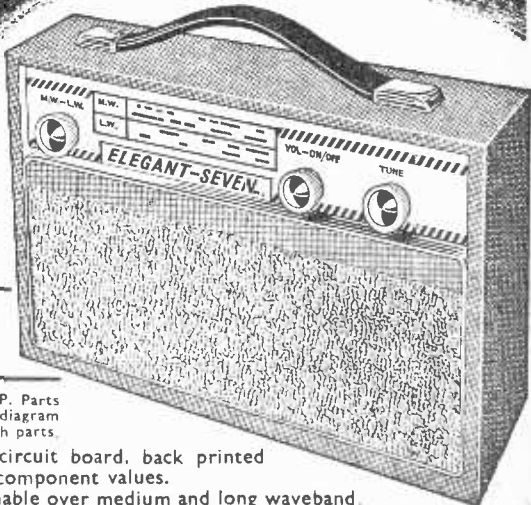

COMBINED PORTABLE & CAR RADIO

The Radio with the STAR features

- ★ 7-transistor superhet. Output 350mW.
- ★ Grey wooden cabinet, fitted handle with silver coloured fittings. Size 12½ x 8½ x 3½ in.
- ★ Horizontal tuning scale, size 11½ x 2½ in. in silver with black lettering.
- ★ All stations clearly marked.
- ★ Ferrite-rod internal aerial.
- ★ I.F. neutralisation on each stage 460 kc/s.
- ★ D.C. coupled output stage with separate A.C. negative feed back.
- ★ All components, ferrite rod and tuning assembly mounted on printed board.
- ★ Operated from PP9 battery.
- ★ Full comprehensive instructions and point-to-point wiring diagrams.

ONLY
£4.4.0

Plus 6/6 P. & P. Parts list & circuit diagram 2/6. FREE with parts.

- ★ Printed circuit board, back printed with all component values.
- ★ Fully tunable over medium and long waveband.
- ★ Car aerial socket. ★ Full after-sale service.

RADIO & TV COMPONENTS (ACTON) LTD 21C High St., Acton, London W3

Open 9 a.m.—6 p.m. including Sats. Early closing Wed. Goods not despatched outside U.K. All enquiries S.A.E. Terms C.W.O.

FREE TO AMBITIOUS ENGINEERS

— THE LATEST EDITION OF ENGINEERING OPPORTUNITIES

Have you sent for your copy?
ENGINEERING OPPORTUNITIES is a highly informative 156-page guide to the best paid engineering posts. It tells you how you can quickly prepare at home for a recognised engineering qualification and outlines a wonderful range of modern Home Study Courses in all branches of Engineering. This unique book also gives full details of the Practical Radio & Electronics Courses, administered by our Specialist Electronics Training Division—the B.I.E.T. School of Electronics, explains the benefits of our Employment Dept. and shows you how to qualify for five years promotion in one year.

SATISFACTION OR REFUND OF FEE

Whatever your age or experience, you cannot afford to miss reading this famous book. If you are earning less than £30 a week, send for your copy of "ENGINEERING OPPORTUNITIES" today—FREE.

WHICH IS YOUR PET SUBJECT?

- Mechanical Eng.,
- Electrical Eng.,
- Civil Engineering,
- Radio Engineering,
- Automobile Eng.,
- Aeronautical Eng.,
- Production Eng.,
- Building, Plastics,
- Draughtsmanship,
- Television, etc.

GET SOME LETTERS AFTER YOUR NAME!

- A.M.I.Mech.E.
- A.M.I.C.E.
- A.M.I.Prod.M.
- A.M.I.M.I.
- A.I.O.B.
- B.Sc.
- A.M.I.E.R.E.
- City & Guilds
- Gen. Cert. of Education
- Etc., etc.

PRACTICAL EQUIPMENT

- Basic Practical and Theoretical Courses for beginners in Radio, T.V., Electronics, Etc., A.M.I.E.R.E. City & Guilds
- Radio Amateurs' Exam. R.T.E.B. Certificate
- P.M.G. Certificate
- Practical Radio
- Radio & Television Services
- Practical Electronics
- Electronics Engineering
- Automation

INCLUDING TOOLS!

The specialist Electronics Division of B.I.E.T. NOW offers you a real laboratory training at home with practical equipment. Ask for details.

B.I.E.T. SCHOOL OF ELECTRONICS



POST COUPON NOW!

Please send me your FREE 156-page "ENGINEERING OPPORTUNITIES"
(Write if you prefer not to cut page)

NAME _____

ADDRESS _____

SUBJECT OR EXAM THAT INTERESTS ME _____ SE/21

BRITISH INSTITUTE OF ENGINEERING TECHNOLOGY
(Dept. SE/21), 29 Wright's Lane, London, W.8

THE B.I.E.T. IS THE LEADING ORGANISATION OF ITS KIND IN THE WORLD

R.S.C. STEREO 20/HIGH FIDELITY AMPLIFIER

PROVIDING 10/14 WATTS ULTRA LINEAR PUSH-PULL OUTPUT ON EACH CHANNEL

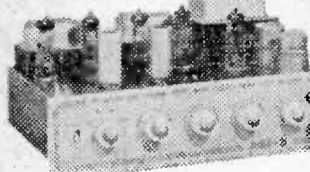

FREQUENCY RESPONSE ± 2 dB. 30-20,000 c.p.s.
HUM LEVEL 65dB down.
SENSITIVITY: 6 millivolts maximum.
HARMONIC DISTORTION (each channel) 0.2%.

SUITABLE for "MIKE", GRAM, RADIO OR TAPE. INTENDED FOR THE HOME OR STUDIO BUT SUITABLE FOR LARGE HALLS OR CLUBS

- * Four-position tone compensation and Input Selector switch.
- * Will amplify direct from Tape Heads.
- * Stereo/Mono switch so that peak monaural output of 28 watts can be obtained.
- * Separate Bass "Lift" and "Cut" and treble "Lift" and "Cut" controls.
- * Neon panel indicator.
- * Handsome Perspex Frontplate.

Based on a current Mullard design and employing valves ECC83, ECL86, ECL84, ECL86, ECL86, ECL86, E281. OUTPUT TRANSFORMERS are high quality sectionally wound to required specification. Output matchings for 3 and 15 ohm speakers on each channel. Complete set of parts with point-to-point wiring diagrams and instructions **13 Gns.** (Carr. 10/-)
or Factory assembled, tested and supplied with our usual 12 months' guarantee for 18 gns. or DEPOSIT 2 gns. and 9 monthly payments of 41/6 (total £20.15.6).

Send S.A.E. for illustrated leaflet.

AUDIOTRINE HI-FI TAPE RECORDER KIT 25 1/2 GNS.

REALISM AT INCREDIBLY LOW COST. CAN BE ASSEMBLED IN AN HOUR
Incorporating the latest Collaro Studio Tape Transcriber. The Audiotrine High Quality Tape Amplifier with negative feedback equalisation for each of 3 speeds. High Flux P.M. Speaker, empty Tape Spool, a Reel of Best Quality Tape and a Handsome Portable Carrying Cabinet tastefully covered in two contrasting shades of Rexine and Vynair. Size 14 1/2 x 16 x 8 1/2 in. high and circuit. Total cost if purchased individually approximately £40. Performance equal to units in the £60-£80 class. S.A.E. for leaflets. TERMS: Deposit 2 gns. and 12 monthly payments of 41/- (Total 23 gns.)



R.S.C. A10 30 WATT ULTRA LINEAR HIGH FIDELITY AMPLIFIER

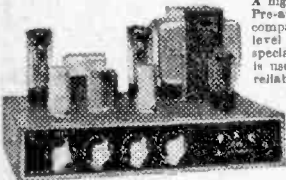

RADIO FEEDER UNIT. An extra input with associated vol. control is provided so that two separate inputs such as Gram and "Mike" can be mixed. 200-250 v. 50 c/s. A.C. Mains output for 3 and 15 ohm speakers. Complete Kit of parts with fully punched chassis and point-to-point wiring diagrams and a Carr. 10/-, instructions. Supplied factory built with EL84 output valves and 12 months' guarantee. for 14 gns. If required perforated cover with carrying handles can be supplied for 15/9. Send S.A.E. for leaflet, also speaker. TERMS: DEPOSIT 34/6 and 9 mthly. payments of 33/6 (Total 16 gns.)

A highly sensitive Push-Pull high output unit with self-contained Pre-amp. Tone Control Stages. Certified performance figures compare equally with most expensive amplifiers available. Hum level 70 dB down. Frequency response ± 3 dB. 30-20,000 c/s. A specially designed sectionally wound ultra linear output transformer is used with 807 output valves. All components are chosen for reliability. Six valves are used EF86, EF86, ECC83, 807, 807. G234 Separate Bass and Treble Controls are provided. Minimum input required for full output is only 12 millivolts so that ANY KIND OF MICROPHONE OR PICK-UP IS SUITABLE. The unit is designed for CLUBS, SCHOOLS, THEATRES, DANCE HALLS or OUTDOOR FUNCTIONS, etc. For use with Electronic ORGAN; BASS, LEAD OR RHYTHM GUITAR, STRING BASS, etc. For standard or long-playing records. OUTPUT SOCKET PROVIDES L.T. and H.T. for records.

ONLY 1 PAIRS OF SOLDERED JOINTS PLUS MAINS

12in. 10 WATT HIGH QUALITY LOUDSPEAKER

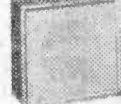

In walnut veneered cabinet. Gauss 12,000 lines. Speech coil 3 ohms or 15 ohms. Only **£4.19.6** Carr. 5/6
Terms: Deposit 11/3 and 9 monthly payments of 11/3 (Total £5.12.6). 12in. 20 WATT HI-FI LOUDSPEAKERS IN CABINETS. Size 18 x 12 x 10in. Finish as above. Only £7.19.6. Terms: Deposit 17/9 and 9 monthly payments of 17/9 (Total £8.17.6). Carr. 8/6.

INTEREST CHARGES REFUNDED

on H.P. and CREDIT SALE Accounts settled in 8 months.

LINEAR TAPE PRE-AMPLIFIER. Type IFL. Switched Equalisation. Positions for Recording at 1in., 3 1/2in., 7 1/2in. per sec., and Playback. EM84 Recording Level Indicator. Designed primarily as the link between a Collaro Tape Deck and Hi-Fi amplifier, suitable almost any Tape Deck. Only 9/6 gns. S.A.E. for leaflet.

HIGH FIDELITY 12-14 WATT AMPLIFIER TYPE A11

PUSH-PULL ULTRA LINEAR OUTPUT "BUILT-IN" TONE CONTROL PRE-AMP STAGES

Two input sockets with associated controls allow mixing of "mike" and gram, as in A10. High sensitivity. Includes 5 valves, ECC83, ECC83, EL84, EL84, E281. High Quality sectionally wound output transformer specially designed for Ultra Linear operation and reliable small condensers of current manufacture. INDIVIDUAL CONTROLS FOR BASS AND TREBLE "Lift" and "Cut". Frequency response ± 3 dB 30-20,000 cfs. Six negative feedback loops. Hum level 60 dB down. ONLY 23 millivolts input required for FULL OUTPUT. Suitable for use with all makes and types of pick-ups and microphones. Comparable with the very best designs for STANDARD or LONG PLAYING RECORDS. For MUSICAL INSTRUMENTS such as STRING BASS, LEAD or RHYTHM GUITARS, etc. OUTPUT SOCKET with plug provides 300v. 30mA, and 6.3v. 1.5a. for supply of a RADIO FEEDER UNIT. Size approx. 12 x 9 x 7 1/2 in. For A.C. mains 200-250v. 50 c.p.s. Output for 3 and 15 ohm speaker. Kit is complete to last nut. Chassis is fully punched. Full instructions and point-to-point wiring diagrams supplied. Only **8 Gns.** Carr. 10/- (Or factory built 51/- extra). If required louvred metal cover with 2 carrying handles can be supplied for 18/9. TERMS ON ASSEMBLED UNITS. DEPOSIT 25/- and 9 monthly payments of 25/- (Total £12.10.0). Send S.A.E. for illustrated leaflet detailing Cabinets, Speakers, Mikes, etc.



R.S.C. JUNIOR BASS REFLEX CABINET. Designed for above speaker, but suitable for any good quality 8in. or 10in. speaker. Acoustically lined and ported. Polished walnut veneer finish. Size 12x12x10in. Strongly made. Handsome appearance. Ensures superb reproduction for only £4.7.8.

R.S.C. STANDARD BASS REFLEX CABINET. For 12in. loudspeaker, acoustically lined and ported. Size 20 x 14 x 13in. Beautiful walnut veneer finish. Recommended for use with Audiotrine Speaker System. £2.19.6.

AUDIOTRINE CORNER CONSOLE CABINETS. Strongly made. Beautiful polished walnut veneered finish. Pleasing design. JUNIOR MODEL. For up to 8in. speaker. Approx. 90x112x18 1/2 in. STANDARD MODEL. To take up to 10in. speaker. Size 27 x 18 x 18in. 5 Gns. Carr. 7/6.



SENIOR MODEL. To take up to 12in. speaker and with Tweeter cut-out. Size approx. 30 x 30 x 18in. (Recommended for use with Audiotrine speaker system). 8 gns. Carr. 8/6. Terms available.

R.S.C. STEREO/TEN HIGH QUALITY AMPLIFIER



Or supplied factory assembled with 12 months' guarantee for £11.7.6. Terms: Deposit 2 gns. and 9 monthly payments of 24/6 (Total £12.19.6).

A complete set of parts for the construction of a stereophonic amplifier giving 5 watts high quality output on each channel (total 10 watts). Sensitivity is 50 millivolts. Suitable for all crystal stereo heads. Ganged Bass and Treble Control give equal variation for "lift" and "cut". Provision is made for use as straight (monaural) 10-watt amplifier. Valve line-up ECC83, ECC83, EL84, EL84, E281. Outputs for 2-3 ohm speakers. Point-to-Point wiring diagrams and instructions supplied. Send S.A.E. for leaflet. **8 Gns.** Carr. 10/- Full constructional details and price list 2/6. Carr. 10/-

S/4 STEREO AMPLIFIER

A complete set of parts to construct a good quality Stereo amplifier with an undistorted output total 8 watts. For A.C. mains input of 200-250 v. Sensitivity 160 m.v. Ganged Volume and Tone Controls. Precise balance control. Full instructions and wiring diagrams supplied **5 Gns.**

Always in Stock at keen prices SINGLE and AUTO RECORD PLAYING UNITS, PICK-UPS, CARTRIDGES, MICROPHONES, VALVES, CABINETS and COMPONENTS too numerous to list.

AUDIOTRINE HI-FI SPEAKER SYSTEMS. Consisting of matched 12in. 12,000 line, 15-ohm high quality speaker; cross-over unit (consisting of a pair of choke, condenser, etc.) and Tweeter. The smooth response and extended frequency range ensure surprisingly realistic reproduction. Standard 10 watt rating. **£4.19.6.** Carr. 5/6 or Senior 24 watt, £8.19.6. Carr. 7/6.

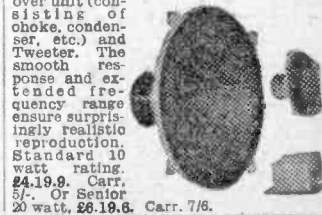



R.S.C. G100 100 Watt AMPLIFIER

TERRIFIC POWER OUTPUT FOR ALL PURPOSES

Addresses on page 292

For **ELECTRONIC ORGAN, LEAD, RHYTHM and BASS GUITAR** and any other musical instrument. **FOR VOCALIST, Gram, RADIO and Tape etc.**
 ★ Incorporating SIX 12in. PLUS TWO 15in. HEAVY DUTY LOUDSPEAKERS.
 Total Rating, 140 watts.

- ★ Housing in 4 substantial Wood Cabinets of pleasing design and covered in contrasting shades of Rexine and Vynair with gold trimmings.
- ★ 4 Jack Inputs in TWO CHANNELS with 4 Independent Volume Controls.
- ★ Separate Bass and Treble Controls on each channel.
- ★ For standard 200-250v. A.C. mains operation.

Fantastic Value at only **89½ Gns.**

Carr. 50/- Or Deposit £11.7.6 and 52 weekly payments of 35/- (Total 97½ Gns.)

Send S.A.E. for full descriptive leaflet or visit one of our many branches and hear this fabulous amplifier.

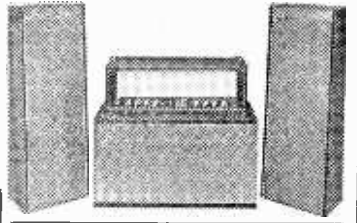

FULL RANGE of MICROPHONES in stock. Most makes. Prices from 12/9 to £50. Credit Terms available over £6 or with other equipment.

R.S.C. BASS-REGENT 50 WATT AMPLIFIER

AN EXCEPTIONALLY POWERFUL HIGH QUALITY ALL-PURPOSE UNIT
 For lead, rhythm, bass guitar and all other musical instruments
 For vocalists, gram, radio, tape and general public address

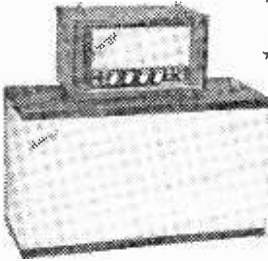

- ★ UNUSUALLY POWERFUL LOUDSPEAKER COMBINATION consisting of a FANE HIGH FLUX 15in. 30 watt unit PLUS A FANE 12in. 20 watt unit with extended frequency response.
- ★ 4 Jack Socket Inputs and two independent Vol. Controls for simultaneous use of up to 4 pick-ups or 'mikes'.
- ★ Separate cabinets fully covered in contrasting tones of Rexine/Vynair with gold trimmings, for speakers and amplifiers.
- ★ Separate Bass and Treble Controls giving 'Boost' and 'Cut'.

47 Carr. 25/- Or deposit £5.11.0 and 12 monthly payments of 24. GNS. (Total 31 Gns.)

HEAVY DUTY SPEAKERS IN CABINETS

TYPE 1001. Two Tone Rexine/Vynair covered Suitable for Bass Guitar. Speaker Unit 15in. High Flux, 15 ohms, 30 watts. Robust cabinet size approx. 24x21x13in.

Only **19½ Gns.**

Or Deposit 5/9 and 9 monthly payments of 44/5 (Total 21½ Gns.)

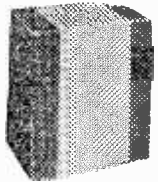

R.S.C. B20 MULTI-PURPOSE AMPLIFIER especially suitable for Bass Guitar

A highly efficient unit incorporating massive 15in. high flux loudspeaker specially constructed to withstand heaviest load conditions. Rating 25 watts. Individual bass and treble controls give ample 'Boost' and 'Cut'. Two jack socket inputs separately controlled. Cabinet is of substantial construction and attractively finished in two contrasting tones of Rexine and Vynair. Size approx. 24 x 21 x 13ins.

Carr. 17/6. Or deposit for S.A.E. **29½ Gns.** £3.4.6 & 12 monthly payments of 51/6. (Total 32½ gns.)

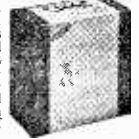

INTEREST CHARGES REFUNDED

ON H.P. ACCOUNTS SETTLED IN 6 MONTHS

R.S.C. COLUMN SPEAKERS



Covered in two-tone Rexine/Vynair. Ideal for vocalists and Public Address. Normally supplied for 15 ohm matching but can be supplied for 100v. line for 35/- extra.
 Type C38, 15-20 watts. Fitted five 8in. high flux speakers. Overall size approx. 42 x 10 x 5in.
12½ Gns. Carr. 10/-
 Or deposit of 29/- and 9 monthly payments 29/- (Total £14.10.0).
 Type C42, 40 watts. Fitted four 12in. 12,000 line 10 watt speakers. Overall size 56 x 14 x 9in. approx.
19½ Gns. Carr. 15/-
 Or deposit of 51/9 and 8 monthly payments of 44/5 (Total 21½ Gns.)

R.S.C. BASS MAJOR

30 WATT MULTI-PURPOSE AMPLIFIER for VOCAL & INSTRUMENTAL GROUPS
 HIGH FIDELITY HIGH OUTPUT

Eminently suitable for lead, rhythm, bass guitar and all other musical instruments

- ★ Incorporating two 12in. 25 watt Heavy Duty High Flux Fane Loudspeakers, one with dual cone for high frequencies.
- ★ Robust, wood cabinet with exceptionally attractive covering of Rexine/Vynair with gold trimmings.
- ★ Four Jack Socket Inputs and two independent Volume Controls for simultaneous connection of up to four Pick-ups or 'Mikes'.
- ★ Separate Bass and Treble Controls. SUPERIOR TO UNITS AT TWICE THE COST. Send S.A.E. for leaflet or call for demonstration at any branch.

39½ Carr. 17/9 Terms: Deposit £3-3-0 and 12 monthly payments of £3-8-4 (Total 43 Gns.)

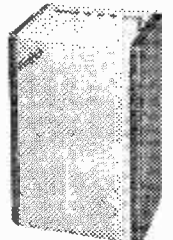

30 WATT HIGH QUALITY AMPLIFIER FOR LEAD RHYTHM AND BASS GUITAR and for Vocal or Instrumental Groups



A Four Input, two volume control Hi-Fi unit with separate Bass and Treble 'Cut and Boost' controls. Designed for vocal or instrumental groups. For Bass, Lead or Rhythm Guitar. Mixture of Brimble type valves. Housed in strong Rexine covered cabinet with twin carrying handles. Attractive black and gold perspex fascia plate. For 200-250v. A.C. mains. Output for 3 or 15 ohm speakers. Send S.A.E. for leaflet.
16½ GNS. Carr. 12/6 or Deposit 2 Gns. and 9 monthly payments of 33/6 (Total 18½ Gns.)

R.S.C. G15 15 WATT AMPLIFIER for Lead or Rhythm Guitar, 'Mike', Gram or Radio

High-fidelity push-pull output. Separate bass and treble 'Cut' and 'Boost' controls. Twin separately controlled inputs so that two instruments or 'mike' and pickups can be used at the same time. Loudspeaker is a heavy duty flux 12in. 20 watt model with cast chassis. Cabinet is covered in contrasting shades of Rexine/Vynair. Size approx. 18 x 18 x 8in.
19 Gns. Carr. 10/- Or DEPOSIT 2 Gns. and 12 monthly payments of 33/3 (Total 21 gns.) Send S.A.E. for leaflet.



LINEAR TREMOLO/PREAMP UNIT Designed for introducing the Tremolo effect to any amplifier which is fitted with a reserve power supply point for smoothed H.T. and 6.3v. A.C. L.T. The unit plugs into power supply point and any input socket or amplifier. Controls are Speed (frequency of interruptions), Depth (for heavy or light effect), Volume and Switch. Three sockets are for two inputs and **4 Gns.** Foot Switch. ONLY

FANE 12" 20W HEAVY DUTY LOUDSPEAKERS 15 ohm voice coil. Suitable Lead or Rhythm Guitar, Vocal and general P.A. purposes. ONLY **5 Gns.**

R.S.C. G5 AMPLIFIER 3 watt high quality output. Incorporating high flux 12in. 10 watt 12,000 line loudspkr. Sensitivity 40 m.v. High impedance jack input. Handsome strongly made cabinet (size 14 x 14 x 7in. approx.) finished in complementary shades of Rexine/Tygan, 200-250v. A.C. mains. Suitable for Lead or Rhythm Guitar in home or small club, etc. £9.19.6 Or DEPOSIT 30/9 and 9 monthly payments of 22/3 (Total 11½ Gns.) Carr. 7/6.

FULL RANGE OF FANE AND GOODMANS SPEAKERS IN STOCK. Credit terms if required.

TRANSISTORISED SOUND MIXER

Enables mixing of up to 4 inputs, i.e. mic., tape, gram., tuner, etc., into single output. Compact and completely self-contained, uses standard 9 volt battery. Four standard jack inputs. PRICE **49/6** Post 3/6.

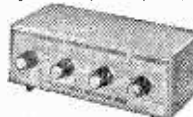

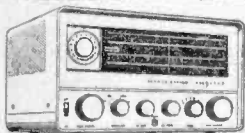

LAFAYETTE HA 63 COMMUNICATION RECEIVER

7 valves + Rectifier. 4 Bands 550 Kc/s—31 Mc/s. 'S' Meter-BFO-ANL-Bandspread Tuning. Built in speaker. 200/250v. A.C. Brand New. 24 Gns. carr. paid.



NEW MODEL! LAFAYETTE HA-230 AMATEUR COMMUNICATIONS RECEIVER

Supersedes model HE-30. 8 valves + rectifier. Continuous coverage on 4 bands. 550 Kc/s—30 Mc/s. Incorporates 1 RF and 2 IF stages. Q Multiplier, BFO ANL, 'S' meter, electrical bandspread, Aerial trimmer, etc. Supplied brand new and guaranteed. 33 Gns. SAE for full details.

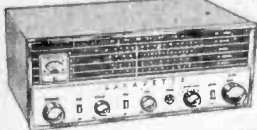

STAR SR 40 COMMUNICATION RECEIVER

4 Bands 550 Kc/s—30 Mc/s. 'S' Meter-BFO-ANL-Bandspread Tuning. Built in speaker. 200/250v. A.C. Brand New. 18 1/2 Gns. Carriage 10/-.

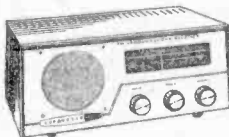

NEW MODEL! LAFAYETTE HA-55 Aircraft Receiver

108—136 Mc/s. High selectivity and sensitivity. Incorporates 2 RF stages including 6CW4 Nuvistor. 8 tubes for 11 tube performance, solid state power supply, adjustable squelch control, slide rule dial, built in 4in. speaker and front panel phone jack. 220/240v. A.C. Supplied brand new and guaranteed. 19 Gns. Carr. 10/-.

OS/BB/U OSCILLOSCOPES

High quality Portable American Oscilloscope. 3in. c.r.t. T/B 3c/s-50 kc/s X Amp: 0-300 kc/s Y Amp: 0-2 Mc/s. Power requirements 105-125v. A.C. Supplied in "as new" condition. Fully tested.

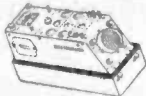

223. Carr. 10/-. Suitable 220/15v. Transformer. 15/6.

TE-22 SINE SQUARE WAVE AUDIO GENERATORS

Sine: 20 p.p.s. to 200 Kc/s on 4 bands. Square: 20 c.p.s. to 25 Kc/s. Output imp. 3000 ohms. 200/240 v. A.C. Brand new Guaranteed. £15. Carr. 7/6.

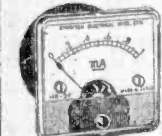
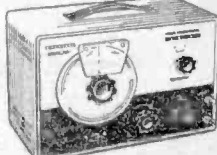

CLEAR PLASTIC PANEL METERS

First grade quality. Moving Coil panel meters, available ex-stock. S.A.E. for illustrated leaflet. Discounts for quantity. Available as follows. Type MR 38P 1 21/32in. square fronts.

2mA ..	22/6	3V. DC ..	22/6
5mA ..	22/6	10V. DC ..	22/6
10mA ..	22/6	20V. DC ..	22/6
20mA ..	22/6	50V. DC ..	22/6
50mA ..	22/6	100V. DC ..	22/6
100mA ..	22/6	150V. DC ..	22/6
150mA ..	22/6	300V. DC ..	22/6
200mA ..	22/6	500V. DC ..	22/6
300mA ..	22/6	750V. DC ..	22/6
600mA ..	22/6	15V. AC ..	22/6
700mA ..	22/6	50V. AC ..	22/6
1-0-1mA ..	22/6	150V. AC ..	22/6
1A. DC ..	22/6	300V. AC ..	22/6
2A. DC ..	22/6	500V. AC ..	22/6
5A. DC ..	22/6	'S' Meter 1mA	22/6

50µA ..	22/6
100µA ..	22/6
200µA ..	22/6
500µA ..	25/-
60-0-60µA ..	22/6
100-0-100µA ..	22/6
500-0-500µA ..	22/6
1mA ..	22/6

POST EXTRA. Larger sizes available—send for lists. ILLUMINATED 'S' METER. 1 1/2in. square front. Cal. in 5 units. 6V. lamp. 22/6. P.P. 1/-. Ditto 2 1/4in. square 32/6. P.P. 1/-.
 223. Carr. 10/-. Suitable 220/15v. Transformer. 15/6.

AVOMETERS



Supplied reconditioned and guaranteed perfect. Model D, £3.10. Model 7, £12.10. Post & Ins 5/-.

ARMY FIELD TELEPHONE TYPE F



General for Bell Ringings. 2 Line Connection. Wood Carry-ing Case. Fits 6 Batteries Supplied Fully Tested, £4.19.6. Pair Carr. 7/6.

ERSKINE TYPE 13 DOUBLE BEAM OSCILLOSCOPES



Timebase 2 o/s.-750 kc/s. Separate Y1 and Y2 amplifiers. Up to 1 Mc/s. cal. lb. at 100 kc/s. and 1 Mc/s. 110/230 v. A.C. Guaranteed perfect. £27.10.0. Carr. 20/-.

MINE DETECTOR No. 4A
 Will detect all types of metals. Fully portable. Complete with instructions, 39/6 each. Carr. 10/- Battery 8/6 extra.

BEST BUY!
 Send 1/- P.O. for full catalogue and lists. Trade supplied. Open 9 a.m. to 6 p.m. Every day, Monday to Saturday.

SILICON RECTIFIERS

200 P.I.V. ..	200mA	2/6
200 P.I.V. ..	6 amp	5/6
1,000 P.I.V. ..	650mA	7/6
800 P.I.V. ..	500mA	5/6
400 P.I.V. ..	3 amp	7/6
400 P.I.V. ..	500mA	3/6
150 P.I.V. ..	15mA	1/-
70 P.I.V. ..	1 amp	3/6
85 P.I.V. ..	8 amp	5/6

Post extra.

AMERICAN TAPES

Best grade quality American Tapes. Brand new and guaranteed. Discounts for quantities.
 3in. 25ft. L.P. acetate 4/-
 3in. 600ft. L.P. mylar 10/-
 5in. 600ft. std. plastic 8/6
 5in. 900ft. L.P. acetate 10/-
 5in. 1200 ft. D.P. mylar 15/6
 5in. 1800ft. L.P. mylar 35/-
 5in. 1200ft. L.P. acetate 12/6
 5in. 1800ft. D.P. mylar 22/6
 5in. 2400ft. T.P. mylar 45/-
 7in. 1200ft. std. mylar 12/6
 7in. 1800ft. L.P. acetate 15/-
 7in. 1800ft. L.P. mylar 20/-
 7in. 2400ft. D.P. mylar 25/-
 7in. 3600ft. T.P. mylar 55/6
 Postage 2/- Over £3 post paid.

TWO-WAY RADIOS

3 Transistor Transceiver. Range up to 1 mile. £9.19.6 per pair complete.
 8 Transistor Transceiver. Range up to 5 miles. £25 per pair complete. Post extra. S.A.E. for full details.



VOLTAGE STABILIZERS

Will stabilize your mains voltage. Ideal for TV Receivers and Industrial equip-ment. Input 100-120 v. and 160-240 v. Constant output 110 v. or 240 v. 250 watts. Brand new guaranteed. £10.10.0 Carr. 7/6.



VARIABLE VOLTAGE TRANSFORMERS

Brand New Guaranteed. Fully Shrouded. Input 230v. 50/60 o/s, output 0-23v.
 1 Amp £4.10.0.
 2.5 Amp £5.17.8.
 5 Amp £9.0.0.
 8 Amp £13.10.0.
 10 Amp £17.0.0.
 12 Amp £19.10.0.
 Metal Case with 2.5 Amp Portable Meter Fuses etc. £9.17.6.



MODEL TE-12
 20,000 O.P.V. 0/06/6/30/120/600/1,200/3,000/6,000 v. D.C. 0/6/30/120/600/1,200 v. A.C. 0/60µA/6/60/600 mA. 0/6K/6/600K/6. Meg/6/600K/6. P.P. 2 MFD. £5.18.6. P. & P. 3/6.

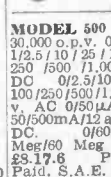

MODEL 500
 30,000 o.p.v. 0/5/1/2.5/10/25/100/250/500/1,000v. DC 0/2.5/10/25/100/250/500/1,000 v. A.C. 0/50µA/5/50/500mA/12 amp D.C. 0/60K/6 Meg/60 Meg 0. £37.6. Post Paid. S.A.E. for full details.



TE-51 NEW 20,000Ω/VOLT MULTI-METER
 0/5/60/120/1,200 v. A.C. 0/30/60/300/600/3,000 v. DC. 0/60µA/12/300 mA, DC. 0/60K/6 Meg. ohm. £4.5.0. Post & pack. 2/6.

Stockists of Nombrex, Codar, Sinclair, and all Electronic Equipment and Components.

C.W. SMITH & CO (RADIO) LIMITED
 Phone: GERRARD 8204/9155.
 Cables: SMITHCLA LESQUARE.
 3-34 LISLE STREET, LONDON, W.C2

THE WHARFEDALE SOUND

stereo/mono

The LINTON is another of the 'new look' loudspeakers developed by Wharfedale and styled by Robert Gutmann, F.S.I.A. The cabinet—made in high density man made timber for reduced panel resonance is superbly veneered. Back radiation is completely eliminated by special internal treatment. A new 8" cast chassis bass unit has been developed by Wharfedale for the Linton. It has a 12,000 oersteds magnet and is fitted with a flexiprene roll surround giving a fundamental open baffle resonance of only 43 c/s. The linear performance is such that the bass distortion is extremely low. A special version of the world famous Super 3 tweeter is combined with a treble control to compliment the 8" bass unit giving an extremely smooth treble response up to very high frequencies. The result

is a well balanced twin speaker system of high performance capable of being driven by relatively small amplifiers to provide adequate volume and fatigue free listening.

Frequency range 40 c/s—15,000 c/s.

Impedance 8-10 ohms.

Power handling capacity 10 watts
(20 watts peak)

Size 19" x 10" x 10" Weight 18 lb.

Finish zebano veneers or walnut
and oiled teak to special order.

£18.7.4

WHARFEDALE WIRELESS WORKS LTD.

IDLE, BRADFORD, YORKSHIRE.

Tel. Idle 1235/6 Grams. 'Wharidel' Bradford

- Treble control.
- Special Wharfedale 3" Tweeter unit.
- Sound absorbent B.A.F. wadding completely eliminates back radiation.
- 8" bass unit with Flexiprene roll surround.
- Cabinet of high density man made timber for reduced panel resonance.

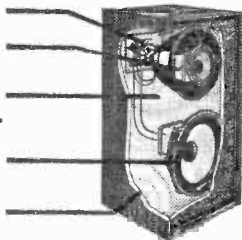

Free technical folder on the Linton from Dept. P.

PRACTICAL WIRELESS

AUGUST 1965
VOL 41 NO 702

REQUIEM FOR A SHOW

IF we had a flag, it would now be at half mast. For the radio and television industry has stood by and doomed to oblivion the 1965 Radio Show, a venture that was hardly allowed to get off the ground.

Since the 1920's the Radio Show has flourished until in recent years it began to flounder, and both public attendance and stand bookings began to decline. No single factor can be pinpointed for the reasons are several, complex and partly intangible.

However, the snowball effect of company mergers progressively reduced the number of potential exhibitors. The increasing cost of buying stand space and of fitting and manning exhibits, also took its toll, and then the broadcasting authorities made less spectacular provision for entertaining the public.

But the death knell for the old-type Radio Show clearly rang out when major exhibitors began staging their own independent trade-only splinter shows. Now this year with most of the big boys opting out, the 1965 Show had little chance.

Whatever the success of these private ventures, however, we do not think they are in the industry's long-term interest. The public may often prove tiresome and exhausting at exhibitions but these are the people who buy the products and keep the manufacturers in business.

Other major industries manufacturing highly competitive consumer goods continue to run successful exhibitions catering for trade and public. The radio industry is the odd man out—and surely it cannot afford to be so insular. Let it have the foresight to organise something worthwhile for 1966.

The Radio Show is dead! Long live the Radio Show!

CONTENTS

	page
News and Comment	297, 330
Solar-powered Pocket Receiver	300
Tape Terminology	303
3 Band Transmitter	307
On the Short Waves	315
Practical Substitutions	317
Two-band Dipoles	322
Photocell Circuits	324
Light Programme Receiver	327
Preparing for the R.A.E.	332
Practically Wireless	341
A Direction Finder for Small Craft—Part 2	342
Books Reviewed	346
A Basic Moullin Voltmeter	349
Club News	354

All correspondence intended for the Editor should be addressed to: The Editor, "Practical Wireless", George Newnes Ltd., Tower House, Southampton Street, London, W.C.2. Phone: TEMple Bar 4363. Telegrams: Newnes Rand London. Subscription rates, including postage: 29s. per year to any part of the world. © George Newnes Ltd., 1965. Copyright in all drawings, photographs and articles published in "Practical Wireless" is specifically reserved throughout the countries signatory to the Berne Convention and the U.S.A. Reproductions or imitations of any of these are therefore expressly forbidden. THE SEPTEMBER ISSUE WILL BE PUBLISHED ON AUGUST 5TH.

Can Anyone Help

PLEASE can anyone help me? I need a small internal switch for a wireless set issued by R.A.P. Ltd., London, 7634. Apart from this component the set appears to be in good condition. R.A.P. appear to have discontinued this model.

W. M. Stanley.

17 Denton Road,
Wokingham,
Berkshire.

C.W. Standards

As an ex-W.T. operator of 20 years' standing I find after months of listening on the amateur bands that the standard of British operators (c.w.) is fast deteriorating compared with other countries. Many of them seem barely able to work at 10 w.p.m.

At a recent R.A.E. examination centre I met a few of the old ex-Service operators who are all eager to do a spot of operating. These men are excellent operators and quite good mechanics, capable of building their own transmitting and receiving equipment. But these men failed the R.A.E. simply because they were unable to memorise a few formulae. Several lads of about 16, however, passed the test, yet they had not a clue how to operate. Consequently they turn to phone working—too scared to work c.w.

If this state of affairs continues there will be very few British operators working on c.w. in a few years' time.

F. Taylor.

Plymouth,
Devon.

Octal Valves Again!

I DISAGREE with R. A. Packer's comments on I.O. valves (May issue). Manufacturers are all for miniaturisation, as we all know, but need constructors follow blindly along the same path?

While I.O. valves are obtainable I consider that the saving in odd shillings far outweighs the sacrifice of that inch or so of not so valuable space.

J. Huot.

Canvey Island,
Essex.

NEWS AND..

404 LOUDSPEAKERS IN WEMBLEY P.A. SYSTEM

The largest public address system in Britain is that of the Wembley Stadium where no less than 404 loudspeakers are installed. Sixty of these are mounted on baffle boards and the remainder in 86 column enclosures.

The p.a. system was recently installed by Rediffusion technicians in time for the F.A. Cup Final in May, but only after they had solved the formidable problem of the Stadium's acoustics which, when it is empty are very different from when it is packed to capacity.

NEW COMPUTER FOR THE MIDLANDS

Businessmen in and around Birmingham requiring computer services can now make use of a new Honeywell 200 machine recently installed by Midlands Computing Centre Ltd.

The new British-made computer is expected to find ready acceptance by Midland-based firms too small to buy their own computer, yet large enough to warrant the analysis of production, sales and costs which modern equipment can provide.

LOW-COST PORTABLE MADE IN BRITAIN

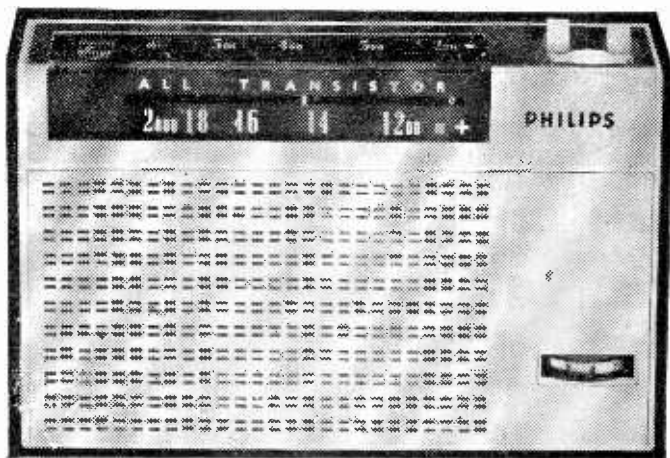

This portable receiver is British made and inexpensive. In fact according to the makers, Philips Electrical Limited, it is the lowest-priced British-made portable radio ever.

Known as the "Popmaster", it has been introduced to combat the ever-growing imports of Hong Kong-manufactured portables into the UK and will sell at £7 19s. 6d.

Each set carries a six months guarantee covering spares and labour and also a world-wide service guarantee valid for any service department of Philips companies throughout the world.

The "Popmaster" covers long and medium wavebands and measures just over 5½ in. x 3½ in. x 1½ in. The 6-transistor circuit is powered by four U7 batteries housed in a sealed compartment in the base of the cabinet. Also contained in the base is a fitted earpiece attachment.

.. COMMENT

OXFORD MOBILE RALLY

On July 11th the Oxford and District Radio Society will hold its tenth anniversary mobile rally. The organisation of this event has been in conjunction with the RSGB.

Talk-in stations on 160m, 80m, 4m and 2m will be operating at the venue in the grounds of the College of Technology, Headington, Oxford. Attractions planned for the day include morris dancing, films, demonstrations, competitions, etc.

TRANSCIVERS FOR NEW POLICE SQUAD



Radio communications is playing a big part in London's new 100-strong police patrol group, which began operations recently. The group has been formed to counteract sudden outbreaks of crime by saturating trouble spots with uniformed police.

Contact between the group's vehicles and Scotland Yard and the P.C.s on foot, is by v.h.f. radio' each constable in the group carrying a light-weight transceiver.

There are just two women P.C.s in the group; one of them is seen here using one of the fully-portable transceivers.

THE '65 SHOW CANCELLED

The '65 Show—this year's planned successor to the National Television and Radio Show—is off due to lack of support.

The organisers of the Show—Industrial and Trade Fairs Ltd.—announced the complete cancellation of the venture after many of the largest companies in the British radio industry had decided not to take part. The commercial TV companies also dropped out.

The exhibition was to have taken on a new appearance this year, with all parts of the radio, television and home entertainment industry represented. This year too, overseas participation was expected for the first time.

GPO TO HAVE SEVEN COMPUTERS

The first of seven English-Electric LEO 326 computers ordered by the GPO has been installed at Charles House, Kensington, London, where it succeeds a LEO 3 machine which has been operating for nearly a year. The work of producing six million telephone bills a year, calculating repayments of National Savings Certificates, preparing experimental route schedules for mail vans and analysing stores and equipment, which the old machine handled, will be carried on by the LEO 326 at much faster speeds and still provide extra computer time for further developments.

A second LEO 326 computer will be installed at Charles House later this year and another two will go to the POs Savings Department at Lytham St. Annes, Lancashire.

When all seven are installed and operating, the GPO will be the largest commercial computer use in Europe.

more News and Comment on

Bottling Acid

SURELY Mr. Ian Gregory (News and Comment, June, 1965) is a little antiquated in his choice of containers for hydro-fluoric acid. In this day and age a polythene bottle would probably be cheaper and more easily obtainable than one of wax or gutta-percha and equally effective.

I. M. Hutchings.

Rugby,
Warwickshire.

Correspondents

I AM 27 years of age and studying radio and television servicing with a correspondence school.

I would like to correspond with radio and television servicemen anywhere in the world.

Ernest Tchakanga.

P.O. Box 357,
Mufulira,
Zambia,
Cent. Africa.

I WOULD like to correspond with anyone in South Africa who is interested in radio and motor-yachts. I am 14 years old.

Ian Thornton.

13 Adshead Close,
Poundswick,
Manchester 23,
Lanca.

I AM a regular subscriber to *Practical Wireless*. In addition to being interested in electronics I am a philatelist and would like to correspond with people in England willing to exchange Indian stamps and first-day-covers for miniature electronic components not available here.

G. H. D'Cruz.

Sugar Factory,
Shimoga,
South India.

The Solo Organ

I HAVE located a small error in the transistor solo organ article (April issue, page 1163). The wire from top right-hand tuning resistance tag should go to the lower arm of VR2 and not to the middle arm as shown.

G. W. Hardy.

Poole,
Dorset.

page 330

THIS is a receiver circuit using the minimum of components, driving a hearing aid type ear-piece, and having as its power supply a solar cell. It requires no external aerial or earth. The final circuit was developed from the somewhat standard receiver circuit of Fig. 1, and it is advisable to build this one up first to test reception conditions in your area. If you have already experimented with one and two transistor circuits of the regenerative and reflex types and you know that you are in a good reception area then the final version may be constructed immediately. Otherwise build up the circuit of Fig. 1 e.g. in a "bread-board" arrangement. This circuit should easily, without external aerial or earth, drive the earpiece on most m.w. stations—the local Home (and possibly Light) should be loud and continentals should be fair. If these conditions are fulfilled then the final Mark 3 version is assured of some success. However, some areas of the country, especially those in deep valleys or below high cliffs, provide very low signal levels (and even a standard six transistor

no single cell had been designed solely as a power supply for an application like this, however it appeared that most could provide sufficient current in average light conditions, all of them appearing to produce a voltage which remained constant at about 0.5V. The type finally chosen was of large (comparatively speaking) surface area: 0.75in. x 0.45in. (1.9cm. x 1.2cm.), designed for both high and low light levels—type MS2A and appears as in Fig. 2.

The current provided by the cell depends on the light intensity, from zero in darkness to about 20mA in bright sunlight on open circuit. Thus the receiver had to be capable of operating from these power conditions. The voltage supply for the design of Fig. 1 was thus reduced to a single dry cell, i.e. 1.5V, and R1 was likewise reduced to approx. 150kΩ in order to keep the same current—of the order of 1mA—flowing in the transistor. Suitable adjustment of TC1 and VR1 then resulted in a fairly similar performance, at slightly reduced volume, to that of the 9V circuit. At this stage the solar cell was substituted for the dry cell, giving

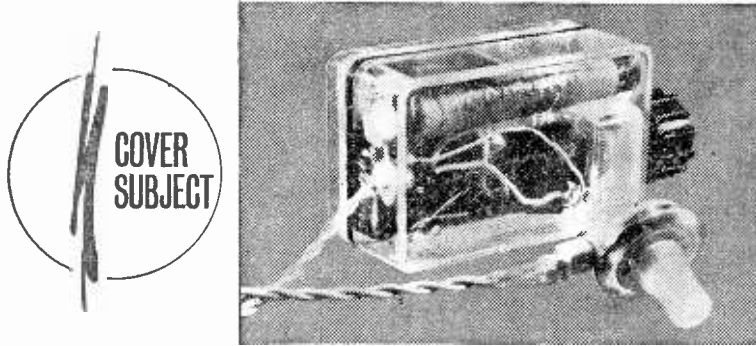

SOLAR-POWERED POCKET RECEIVER

by C. J. Walton

superhet has difficulty in these areas) in which case the circuit of Fig. 1 will receive little if anything and the light powered circuit even less. Thus the disappointment of building something doomed from the start to failure is avoided (and the expense of the solar cell is saved).

Tr1 can be any standard r.f. type for this circuit (in fact a number of accepted "low frequency" transistors will function here, e.g. odd specimens of OC71, XB103, and even an occasional "red spot"—however the recommended r.f. types are necessary for the final circuit) and examples tested were: OC44, XA112, OC171, AF114. Slight variation of R1 may be necessary but the results of this reflexed-regenerative should be good. The coil may need a few turns adding or removing to cover the entire m.w. depending on the characteristics of the components used. It was considered initially that this type of circuit, providing maximum gain at both r.f. and a.f. with separate detection by diodes, would be the most efficient for a light powered receiver.

Then came the choice of a solar cell. Data was obtained from Ferranti Ltd. (Gem Mill, Chadderton, Oldham, Lancs.) and it became obvious that

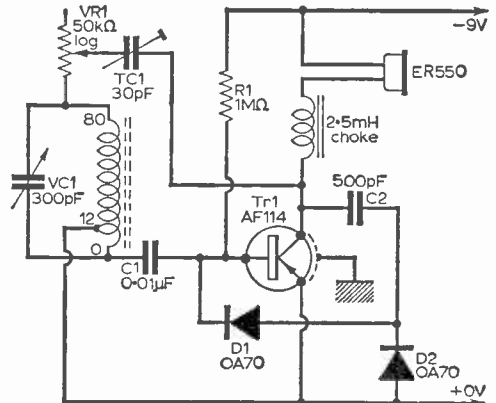

Fig. 1: The circuit of a simple one-transistor reflex receiver which formed the basis of the final design. The coil is wound on a 2in. length of $\frac{3}{16}$ in. diameter ferrite rod using 34s.w.g. d.c.c. wire.

the Mark 1 version of Fig. 3. At this stage it was found that the alloy junction type transistors were not as effective as the alloy diffused types at these low power levels. However the alloy diffused types—OC171, AF114, and a micro alloy type; MAT 121, were all operating quite well. Volume was down from the 1.5V circuit but in my area (Sowerby Bridge near Halifax, in the West Riding of Yorkshire) the Home and Light came through quite well.

With the receiver not tuned to a station as the cell was turned towards a window or other light source, a hissing could be heard in the earpiece signifying that current was flowing in the circuit (and in strong sunlight the hiss was louder than with the 1.5V cell in circuit). Stations became audible just before the hiss commenced, became louder as more light was allowed to fall on the cell, and finally regeneration in the form of whistling was heard. Keeping the light intensity constant and varying R1 the graph of Fig. 4 was obtained. No quantitative measurements were possible, but it can be seen that for regeneration to occur under fairly bright conditions, the optimum value for R1 should be between 10kΩ and 150kΩ approx. A value of 47kΩ was therefore chosen.

Regeneration was, however, difficult to control, occurring either at one end of the band or the

other and was very critical, no matter what adjustment was made to TC1 and VR1 the circuit tended to "plop" in and out of oscillation. To try and alter this unsatisfactory situation and as a further experiment, it was decided to operate the circuit as a regenerative detector, i.e. C2, D1, D2 were removed. The results of this were interesting. Output volume was reduced slightly but regeneration was more easily controllable, far less feedback being required to achieve the same effect. In fact the 30pF trimmer used for TC1 had a too high value even at minimum capacitance (approx. 3pF). VR1 and TC1 were thus removed and a length of insulated (plastic coated) wire was connected to point X and another to point Y (see Fig. 3) and these were twisted together to act as a fine trimmer. This is a very sensitive type of control, the value changing at each twist by only a very small amount.

Finally the effect of removing the r.f. choke (i.e. allowing the earpiece to act as its own choke) was tried. Again there was a reduction in volume but this time regeneration was much easier to control

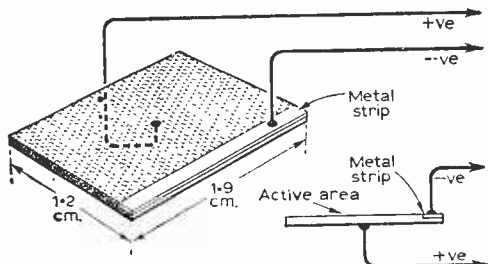

Fig. 2: Physical details of the MS2A solar cell.

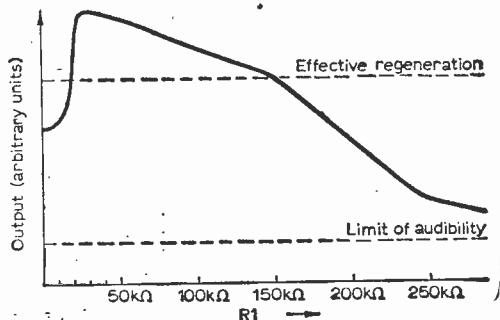

Fig. 4: This graph illustrates the level of sound output with various values of R1, the light intensity kept constant.

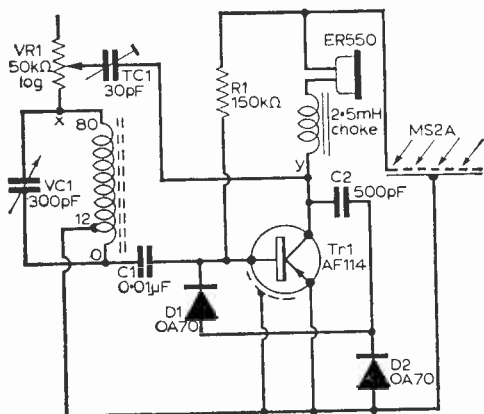

Fig. 3: The basic circuit of Fig. 1 with the solar cell introduced to replace the power supply.

and extended more evenly over the entire band with medium light intensity, tailing off at the low frequency end as the light was reduced. This was the final Mark 3 version shown in Fig. 5. Note that it only uses 8 components altogether. Omitting R1 resulted in very weak reception of the Home Service and nothing else.

Details of Components Used in Final Receiver

Transistors tested included OC171, AF114 (this was the actual transistor used when built into a case) and MAT121. VC1, miniature solid dielectric 300pF tuner.

A small, clear plastic case available from dealers (or from T.S.L., Hudson House, 63 Goldhawk Road, W.12) at 1s., size 2.2in. x 1.4in. x 0.9in. The 2in. length of ferrite rod used as aerial would just fit into the case.

The earpiece used in all the versions is an Ardenite ER550. Any good quality magnetic (not crystal) earpiece would be suitable provided its impedance is > 1kΩ. The chassis is a small piece of perforated eyelet board (cut from a 4½in. x 2½in. piece) which is available, including eyelets, from

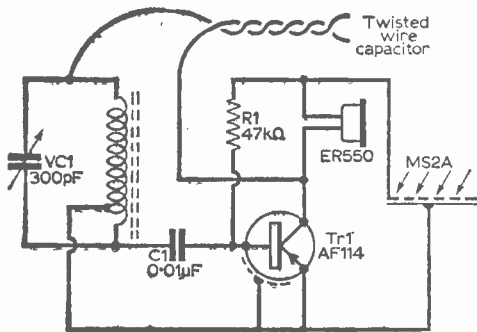
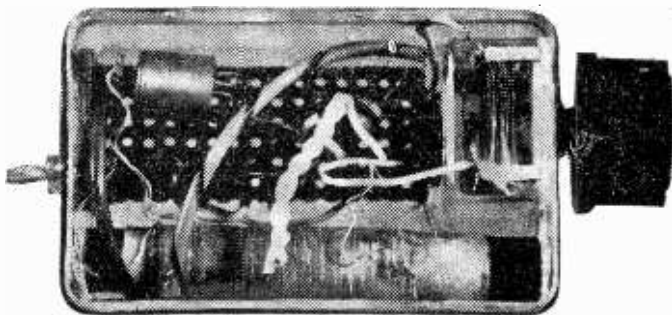

Fig. 5: The final circuit of the receiver.

Right: The finished receiver mounted in its plastic case.



Home Radio (Mitcham), Ltd., 187 London Road, Mitcham, Surrey. The ferrite rod is wound with 32s.w.g. enamelled or silk covered wire. Other details are given in Fig. 6.

The layout of the finished receiver is given in Fig. 6. The cell was stuck with Sellotape to the inside of the case (loss of light through absorption in the plastic is negligible) and its leads sleeved. If an opaque or coloured case is used the cell obviously will have to be stuck on the outside. Feedback was set for dull daylight and if the light intensity should become too high, i.e. a lot of whistling occurring, then the set must be turned away from the light to reduce current rather than changing the feedback.

Fig. 6: These two views of the completed receiver show clearly the construction and wiring.

Further Details of Operation

The circuit does cover the entire m.w. band but obviously local conditions will determine exactly what the performance will be. In Leeds the Home, Light and Third are all at reasonable volume and in the evening the heterodyning whistles of most of the Continentals are heard. Careful tuning in quiet surroundings has brought in Luxembourg, A.F.N. and Berlin

as well as Athlone (Eire) and the northern Caroline. At night some form of artificial light must be used. Any operated from the mains are found to produce an annoying buzz of "mains hum" either at one end of the band or at various points along it as the cell is moved to and from the light source. An ordinary torch is much better, whilst a fluorescent light is useless, producing a continuous buzz. It was found that the set will operate, if held close enough, from a cigarette lighter or even a match. Note that as with all ferrite rod aeriels the set is very directional and sometimes a

—continued on page 338

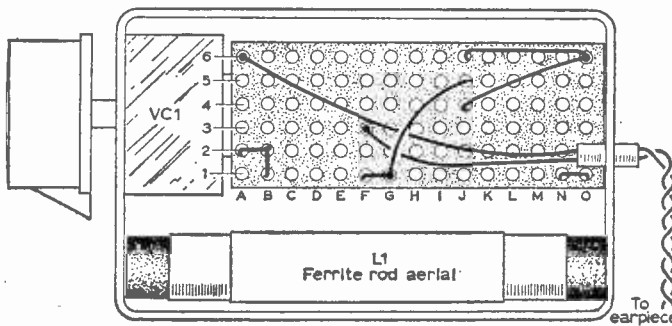
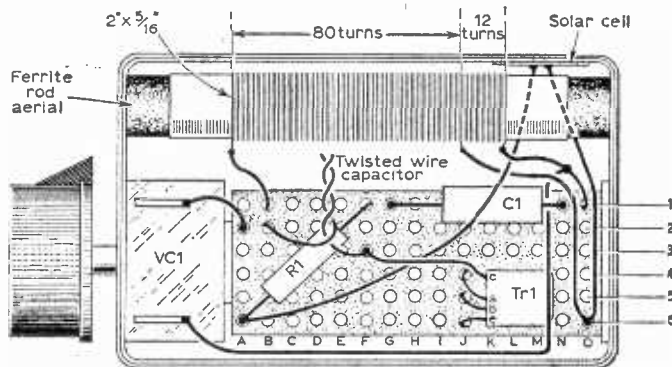

TAPE TAPE TAPE TERMINOLOGY TAPE PART ONE

by H. W. Hellyer

NOWADAYS every branch of art and science carries around with it an enveloping cloak of jargon. Although this may be understood by the coterie of enthusiasts many of the terms are quite incomprehensible to the outsider.

Not least among the "specialist fields" is the art (or science, if you insist) of tape recording. Most readers of this magazine are quite aware of the general idea of tape recording and can interpret most of the terms in everyday use. But now and again the need arises for a more precise definition.

We want to know what a "drop-out" is and how it is caused, not merely be told it exists. More important, when weighing up a possible bargain we want to know just what those impressive specifications mean.

The following notes are compiled, more or less alphabetically, to clear up a few of these vague definitions. This is not a complete glossary of tape terms—which would insult the average readers' intelligence—but an illustrated description of some of the special aspects of tape recording.

AUTOMATIC RECORDING LEVEL

The principle of automatic gain control for radio and television is well known. In tape recording there are special difficulties and special circuits. A portion of the amplified signal is sampled, amplified and fed back as bias to a controlled stage whose gain varies with the applied voltage.

The difficulty lies in the long time constant needed with audio frequency signals. The sampling circuit must react quickly to a loud sound, apply the bias and then retain a comparative level of sounds for a reasonable period.

It is hoped to devote more space to a detailed description of how this is done in a future number of PRACTICAL WIRELESS.

AUTOMATIC STOP

A method of halting the tape transport system when (a) the tape breaks or (b) metal foil leader tape, usually at the end of the reel, completes a relay circuit.

The actual method of stopping the spools varies from the simple interrupter switch in the motor supply to relay-operated solenoid which disengages the head and capstan pressure system, applies the brakes and neutralises the mechanism. Fig. 1 shows typical systems.

AZIMUTH ADJUSTMENT

Setting of record, playback and erase heads to bring the gap into the right position at 90° to the tape length.

Correct positioning is important to allow tapes to be played on different machines and to ensure maximum gain and frequency response. Incorrect azimuth setting of the record/playback head causes loss of high frequencies (see Fig. 2).

Normal method of azimuth adjustment is to replay a pre-recorded signal of constant level (see Test Tape) and adjust the playback head for maximum response.

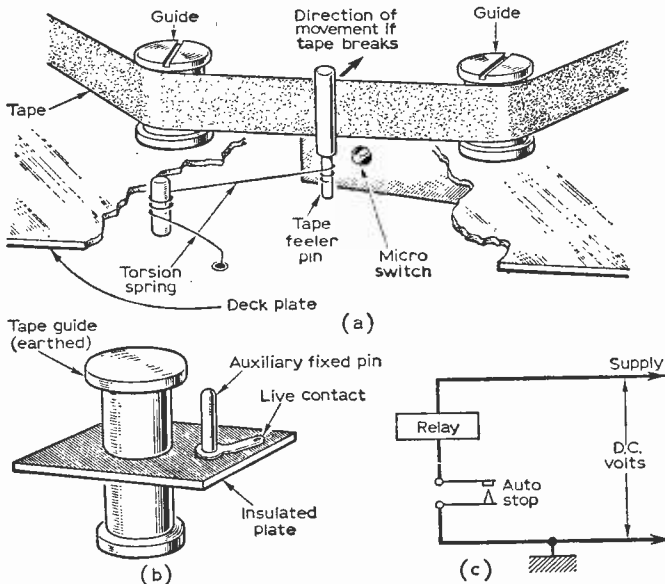

Fig. 1 (a): Micro-switch actuated (open-circuits motor supply) by feeler pin if tape breaks; (b): auto-stop tape guide with separate electrode (alternative may be split-insulated guide); (c): metal foil of tape leader short-circuits contacts to activate relay.

BALANCED INPUT AND OUTPUT

Method of connecting items of equipment by transformer coupling with centre-tapped windings which may be earthed.

Hum and noise are cancelled out to a greater extent by this method and longer leads can thus be used. Normally two-cored screened cable is employed and matching is at low impedance.

BANDWIDTH

In hi-fi work this normally refers to the frequency range covered by the amplifying equipment which is between two extremes that occur where the output is 3dB below that of a standard reference frequency. (Usual reference for this purpose is 1kc/s.)

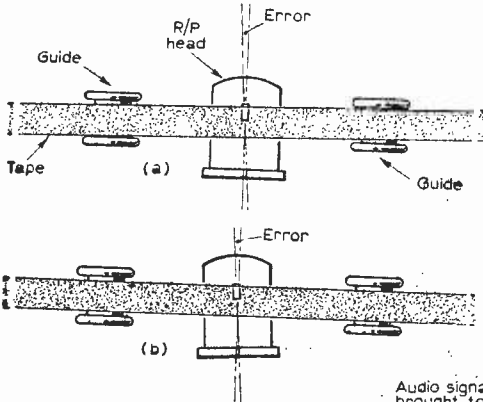

Fig. 2: Off-set guides (a) or head (b) cause h.f. loss.

Fig. 3(a): Signal imposed on bias waveform prevents distortion due to "kink" in magnetisation curve. Optimum bias setting (b) is at value which produces a 3dB drop in output beyond peak.

Where the two limit frequencies only are quoted the above standard is understood. (See also Frequency Response.)

BIAS

The non-linear characteristics of the recording medium are overcome by imposing the audio signal on a high-frequency bias before applying the combined waveform to the recording head (see Fig. 3a).

The frequency of the bias should be as high as possible, allowing for heating losses in the head windings. Normally the bias frequency is about four or five times that of the highest frequency to be recorded; 45 to 70kc/s is the range used in domestic tape recorders.

A bias frequency that is too low will cause shrillness of reproduction of heavily modulated signals.

Bias voltage depends upon the head and tape characteristics and is usually adjustable by a preset control for optimum conditions. Normal adjustment is a little beyond that which produces the maximum output, i.e. over the peak of the curve (see Fig. 3b).

CAPSTAN

Normal method of driving the tape to attain constant speed is by pressing it against a revolving spindle called the capstan. The capstan may be mounted on a flywheel and driven by coupling belts or intermediate wheels from the motor.

The flywheel tends to "iron out" minor speed variations due to its inertia. On some single-motor machines the capstan and flywheel are integral with the motor.

Method of keeping the tape in constant contact with the capstan is by applying a spring-loaded pressure roller or pinch wheel.

CASSETTE

An enclosed spool of tape, usually adapted for automatic loading, either in a complete magazine or as a replacement for a single spool with a free end of tape fed to the take-up spool.

An *endless cassette* contains a long loop of tape which is wound off the outside and back on the inside of the spool for continuous playing.

C.C.I.R.

See Standards.

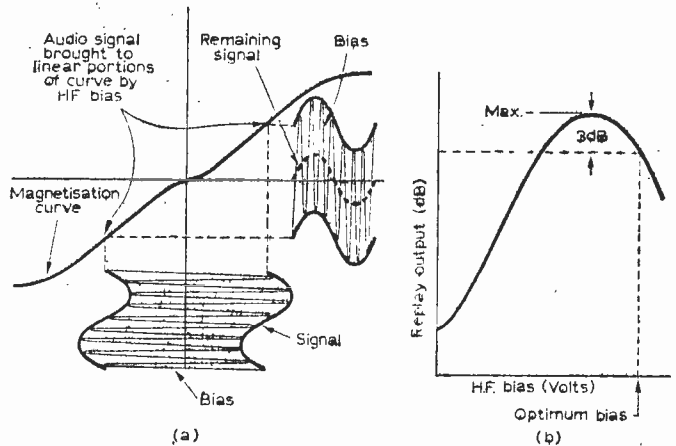

(a)

CHANNEL

In stereo reproduction, one amplifier chain.

CHANNEL SEPARATION

The degree of interference between channels must be reduced below 30dB for stereo systems. Parallel track systems require more stringent separation, greater than 50dB.

CROSSTALK

The above interference is known as crosstalk and may be specified at certain frequencies. It is more noticeable at higher frequencies. Overall separation at all frequencies for tape recording systems should be better than 40dB.

CROSSTRACK

A method of mixing the output from one track with the input to another by which a composite signal can be built up without the need for "super-imposition". Modern tape recorders may incorporate this under the specified terms *multiply* or *sound-on-sound*.

CUEING

Marking of particular places on the tape, visually or aurally. Special controls for "inching" may be fitted to aid cueing.

Dictation machines may use a method of slow wind when required to assist the finding of particular places on the tape. (See also Tape Position Indicator.)

DEFLUXING OR DEGAUSSING

Heads and ferrous metal parts such as supports and guides tend to build up a residual magnetism during use. This causes noisy reproduction when it affects the modulated tape. Method of removing this residual magnetism is to apply a strong and varying field with a *defluxer* and gradually remove this source so that the normal "random" disposition of magnetic "domains" in the metallic parts is resumed.

The construction of a defluxer is generally based on a solenoid with a projecting pole, shaped to be inserted in the tape path mechanism. Regular defluxing should be carried out to reduce background noise. A pronounced hiss is the usual indication of head magnetisation.

Degaussing of the record/play head can be effected by gradually removing the bias voltage. One method is to switch to "Record" and interrupt the mains supply, allowing oscillations to die away. Repeated several times this can keep a recording head degaussed but will not demagnetise other ferrous parts.

DISTORTION

The difference in waveform between input and output of the amplifier as a whole. This is mainly harmonic distortion and may be expressed as a percentage at a specified frequency at full modulation. (e.g. less than 5% at 1kc/s. third harmonic distortion at full modulation, may be stated as $\leq 5\%$.)

The signal-to-noise figure may also be stated as that obtained for a certain distortion factor (see Signal-to-Noise).

DOUBLE GAP

Method of achieving more complete erasure by applying the erase field at two successive places along the tape path. Dimensions are such that the delay from first to second gap is a few milliseconds.

DROP-OUT

Short-term loss of signal which may be caused by discrepancies in tape coating or uneven tracking of tape.

DUOPLAY

Name given to the system of feeding two outputs from a tape recorder into a single channel amplifying system.

DYNAMIC RANGE

The separation, expressed in decibels, between the smallest and the greatest signals the system can handle with specified minimum distortion. The limits are imposed by the loudest sounds received at the input having to be recorded without over-modulating, while the quietest sounds are still above the noise level and the balance between is in proportion.

For a domestic machine the dynamic range may be between 40 and 60dB. In practical terms this means that a 1kc/s signal has a ratio of 10,000 or 1,000,000 to 1. Although the actual dynamic range of a full orchestra may be as much as 70dB the above range is adequate owing to the non-linear relationship between loudness and sound power.

DYNAMIC MICROPHONE

See Moving Coil Microphone.

DUBBING

A term used, mainly in editing, to denote the combining of two or more sound sources into a single recording. Also, in ciné work, the adding of a soundtrack to the film.

ECHO

A signal delay produced by feeding back a replayed signal into the recording channel. The time of delay is determined by the physical separation of the heads and tape speed and may be doubled on two-channel machines by using the second channel as an intermediate stage.

An echo chamber can be either a device similar to the above, to produce the echo effect, or an acoustic method of achieving the same end. Note that echo alone is not effective without *reverberation* for realistic simulation of original sounds.

EDITING

Altering of the signal by cutting and interposing programme material. This can be done physically (see *Splicing*) or by a form of dubbing, using two machines with the first playing back the original programme, the second recording such parts as are required to be used, and halted meanwhile, or with interposed material recorded during the same operation.

ELECTROSTATIC MICROPHONE OR LOUDSPEAKER

A device which depends on capacitor action for its operation. Fig. 4a shows examples.

Basically a diaphragm is held between perforated plates and charged by an external voltage. Sound signals cause vibration and a change in capacity in the former case and in the latter case set up vibrations of the diaphragm to produce the aural output.

The electrostatic loudspeaker is particularly suited to high-frequency reproduction and is often used as a "tweeter".

EQUALISATION

Compensation for the rising frequency response of the tape system and for high-frequency loss which occurs in the playback head. Circuits in the playback amplifier "shape" the response to a

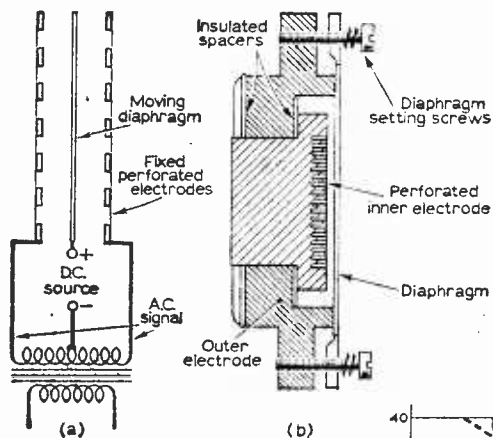

Fig. 4(a): Capacitor loudspeaker and microphone principle; (b): section of capacitor microphone capsule.

recognised standard. For a fuller explanation see *Standards and Pre-emphasis*.

Equalisation is necessary to enable interchange of tapes and tape recorders. It is defined by the time constant of the attenuating section of the circuit. Examples, depending on the speed of the replayed tape are given in Table 1, which also shows the "turnover frequency".

Equalisation standards were revised a year ago and it will be noted that there are three distinct sets of standards, the CCIR, DIN and NARTB. The previous standard, generally accepted, for 3½ in./sec. tape speed was 200 microseconds, now revised to the DIN standard of 140 microseconds, with a turnover frequency at the point where the reactance of the capacitive arm of the attenuator equals the resistance of 1.3kc/s and a low-frequency roll-off of 3.180 microseconds (at 30c/s).

Fig. 5 shows typical equalisation curves. Low-frequency roll-off is generally recognised nowadays as machines in the domestic class rarely reproduce frequencies below this point.

Replaying tapes recorded to one standard on a machine equalised to another will require some modification to the amplifier response to achieve a "level" output. Thus American tapes, recorded to NARTB standards, replayed on European machines, equalised to CCIR standards, will tend to sound over-brilliant and with some bass accentuation.

Conversely CCIR recorded tapes replayed on machines with NARTB standards, having bass and treble cut to compensate for the recording pre-emphasis, will tend to sound weak in both treble and bass.

	Speeds (in./sec.)				
	15	7½	3½	1½	
Time Constant (micro-secs.)	CCIR	35	70	200 (old)	
	NAB	50	50		
	DIN	35	70	140	280
Turnover Frequency (kc/s)	CCIR	4.5	2.6	0.8 (old)	
	NAB	3.2	3.2		
	DIN	4.5	2.6	1.3	0.68

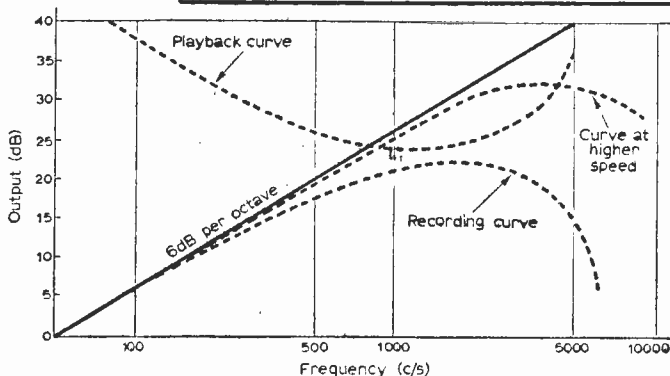

Fig. 5: Recording and playback curves, showing effect of h.f. loss in recording which must be compensated by a boost during playback. At higher speed the loss is less. 6dB octave curve is ideal response.

ERASE

One virtue of the tape recording medium is the possibility of "cleaning off" a tape for re-use. This is termed "erasure" and consists of destroying the pattern of magnetism on the tape and reverting to the normal random disposition of magnetic domains.

Erasure is effected by the application of a strong and varying field as the tape passes a point prior to the recording head.

The method of applying erasure may be by passing the tape across a permanent magnet, or magnets, or by applying the field from the gap of a d.c. or a.c. energised head. The last-mentioned is preferable, as d.c. or permanent magnet erasure tends to build up a unidirectional magnetism, resulting in a hiss.

The waveform should be symmetrical, and is often derived from the common oscillator used to provide the bias waveform.

Bulk erasure is a method of removing the modulation from a tape in one action by inserting the complete spool in a strong field. Special apparatus for this purpose has been developed and is widely used. The applied a.c. field is made to diminish regularly, to prevent residual magnetism leaving a high background level.

PART TWO NEXT MONTH



3 BAND TRANSMITTER

by G30GR

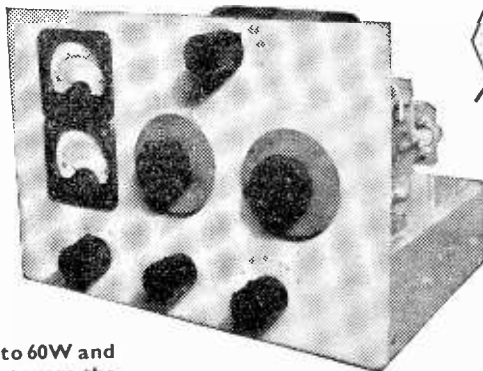

THE 6146 will take an input of up to 60W and the transmitter described here covers the 80, 40 and 20m bands. The building cost is not very great and can be further reduced by simplifications described later if required. The transmitter itself is crystal controlled but it can readily be used with a v.f.o.

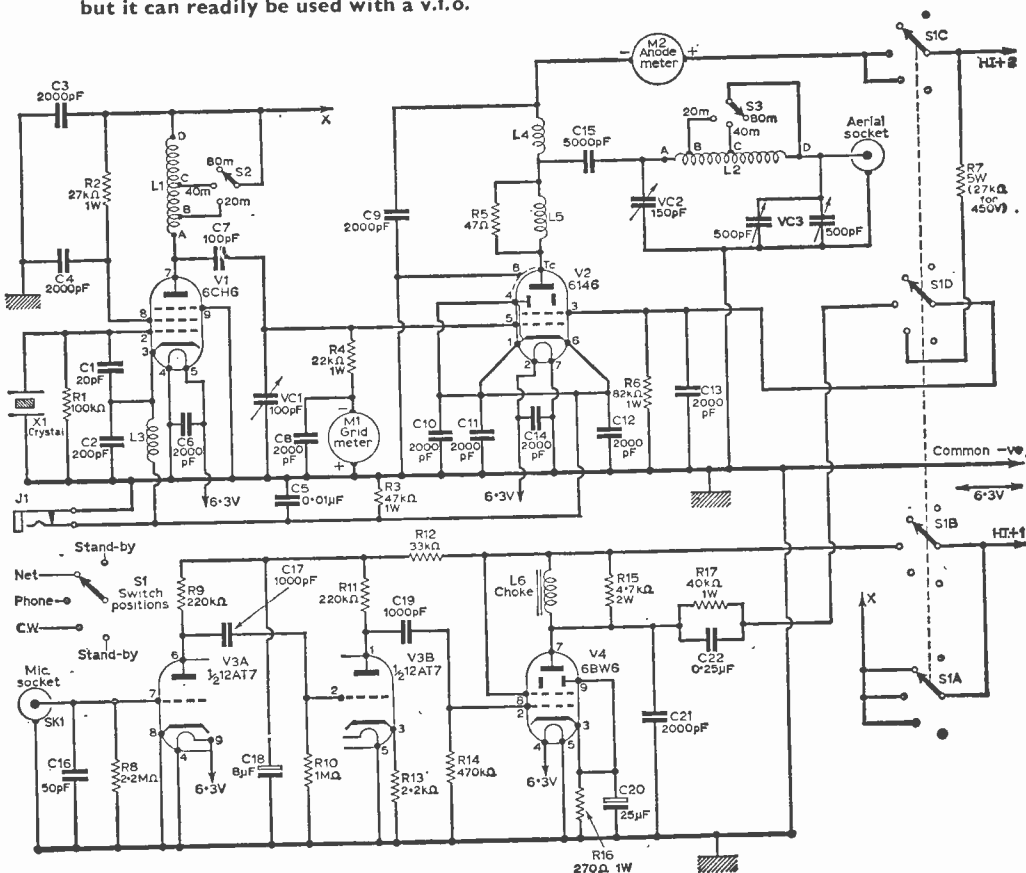

Fig. 1. The transmitter circuit complete except for the power supply.

Fig. 1 shows the transmitter circuit. A 6CH6 is used as an oscillator (V1) which gives high harmonic output when wanted, so that 3.5Mc/s crystals may be used for the 80, 40 and 20m bands. Some 160m band crystals are also satisfactory, especially for 80m.

L1 is the oscillator anode coil switched to cover the 80, 40 and 20m bands and tuned by the 100pF variable capacitor VC1, which also allows grid drive to be adjusted to obtain suitable grid current. It was found that more than sufficient grid current was available on all bands, so this capacitor is normally tuned somewhat off the resonant point. This has no effect on oscillator frequency.

The 6146 (V2) runs with about 2mA to 2.5mA grid current, providing about 40-50V bias developed across the 22kΩ grid resistor R4. This valve has three cathode and beam plate pins each grounded for r.f. by a 2000pF capacitor to chassis (C10-12). For c.w. operation the key plug is inserted in closed-circuit jack J1, the cathodes of both stages being keyed. For 'phone transmission the plug is withdrawn or the key shorted.

L2 is the pi tank coil for three-band coverage and this can work directly into many aeriels. L5 is an anti-parasitic choke. Anode current is checked with the anode meter M2. For a 600V h.t. supply the anode current of the 6146 is listed as 112mA, providing an input of 67W. It is, however, probably as well to restrict the anode current to 100mA. This would give an input of 60W at 600V or 50W at 500V and so on. Good results have been obtained with a 275V h.t. supply or input of 27.5W.

In order to avoid the necessity of providing a large modulator, screen grid modulation is used. A single 6BW6 (V4 in the circuit diagram) will easily supply enough audio power for this type of modulation, excess being dissipated in the 4.7kΩ resistor R15.

When using 'phone it is necessary to reduce the power amplifier (6146) input to about one-half that which can be run on c.w. This is a general rule with screen grid modulated systems. The transmitter thus has an input of up to about 30W on 'phone for average work and 60W on c.w., which is adequate for much DX working.

The modulator section is very straightforward and has enough gain for a crystal microphone of reasonable output. Component values have been chosen to give some treble and bass cut.

Full control switching is furnished by a four-pole, five-way switch S1, the positions of which are shown in Fig. 1. Each "standby" position switches off all circuits but leaves the heaters running. These positions are used while receiving. The second standby position is merely to allow the operator to switch from C.W. to Standby without passing through the 'phone and net positions.

With the switch at "net" h.t. is applied to the oscillator only, allowing tuning up for grid current and netting the receiver on the transmitter frequency. (With a v.f.o. this allows the v.f.o. to be tuned to the receiver frequency also.)

With the switch set for "phone" the modulator is brought into use and h.t. applied to the p.a. anode. Choke modulation of the screen grid is by

the 6BW6, with the d.c. potential derived from the modulator high-tension supply.

When the switch is in the "c.w." position the V2 screen grid is supplied from the high-voltage supply through a dropping resistor chosen to allow full input. This resistor can usually be 27kΩ but is selected as described later.

Metering

As grid and anode currents are very important in setting up, two meters are included. A single meter with grid/anode switching is sometimes employed but the use of separate meters avoids the need for repeated switching from grid to anode circuits and avoids errors such as looking for anode current while the single meter is switched to read grid current.

Two "surplus" meters were used and suitable thermo-couple meters can be purchased at very low cost. When the thermo-couple is removed these instruments usually have a full-scale reading of about 2mA to 5mA. They are thus readily shunted to allow suitable scales to be drawn. The latter can be on thin card cemented to the old dial.

For grid current a 5mA meter is suitable. The one used was 2mA full scale, shunted for 4mA full scale. For anode a 100mA, 150mA or 200mA instrument is suitable or a smaller meter shunted to 150mA or 200mA full scale.

L1... 59 turns 26swg. enamelled

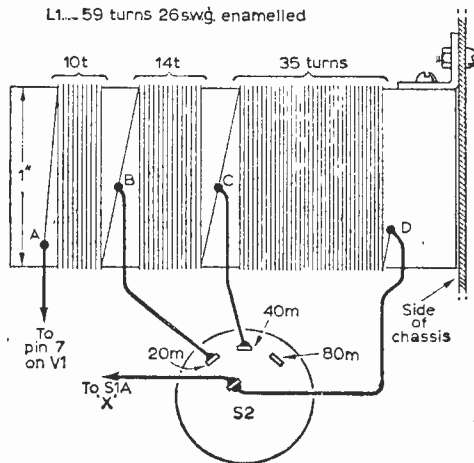

Fig. 2: Winding details of the oscillator anode coil, L1.

Oscillator Stage V1

The oscillator anode coil L1 is shown in Fig. 2 and is wound with 26s.w.g. enamelled wire on a paxolin or similar former 1in. in diameter and 2½in. long. A space of about ¼in. is left between each section. All turns are in the same direction.

Ends A and D are anchored by passing them through holes. Taps B and C are made by baring and twisting the wire and soldering the loop. Switching is so arranged that ten turns are in circuit for 20m, 24 turns for 40m and the whole 59 turns for 80m.

LASKY'S RADIO

Offer the Finest Value to HOME CONSTRUCTORS

We consider our construction parcels to be the finest value on the home constructor market. If on receipt you feel not competent to build the set, you may return it as received within 7 days when the sum paid will be refunded less postage.

THE "SKYROVER" RANGE

GENERAL SPECIFICATION

7 transistor plus 2 diode superhet, 6 waveband portable receiver. Operating from four 1.5 v. torch batteries. The SKYROVER and SKYROVER DE LUXE cover the full Medium Waveband and Short Waveband 31-94 M and also 4 separate switched band-spread ranges, 13M, 16M, 19M and 25M, with Band Spread Tuning for accurate Station Selection. The coil pack and tuning heart is completely factory assembled, wired and tested. The remaining assembly can be completed in under three hours from our easy to follow stage by stage instructions.



NEW—The SKYROVER Mk III

Now supplied with redesigned cabinet, eye-glass controls, black and chrome plastic cabinet. Size 10 x 6 1/2 x 3 1/2 in. with carrying handle.

Can now be built for **£8.19.6** Post 5/-.

H.P. Terms: 20/- dep. and 11 months at 16/6. Total H.P. Price **£12.1.6**.

The SKYROVER DE LUXE

Tone Control Circuit is incorporated with separate Control. In a wood cabinet, size 11 1/2 x 6 1/2 x 3 1/2 in. covered with a washable material with plastic trim and carrying a handle. Car aerial socket fitted.

Can now be built for **£10.19.6** H.P. Terms: 25/- dep. and 11 mths at 20/- Total H.P.P. **£12.5.0**.

A simple additional circuit provides coverage of the 1100/1950M. band (including 1500 M. Licht programme). All components and detailed construction data. **Only 10/- extra** Free This conversion is suitable for both models that have already been constructed.

The "REALISTIC" Seven

★ 7-transistor Superhet. ★ 350 milliwatt output into 4in. high flux speaker.

★ All components mounted on a single printed circuit board ★ Full medium and longwave cover ★ Plastic cabinet with carrying handle, size 7 x 10 x 3 1/2 in. Blue/Grey or all Grey. ★ Socket for car aerial. ★ I.F. frequently 470Kcs.

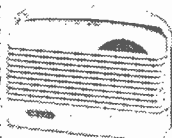

★ Ferrite rod internal aerial. Operates from PP9 or similar battery. ★ Full data supplied. All coils and I.F.'s etc. fully wound ready for immediate assembly. An Outstanding Receiver. **Can be built for £5.19.6** Post 4/6.

PP9 Batt. 3/9. Data and Instructions separately 2/6. Refunded if you purchase the parcel. All parts sold separately.

REALISTIC Seven DE LUXE

With the same specification as standard model—PLUS a superior wood cabinet in contemporary styling with full vision circular dial. **ONLY £1 EXTRA**

SINCLAIR MINIATURES

THE MICRO-6
Self-contained pocket radio. Size only 1 1/2 x 1 1/2 x 1/2 in. Amazing performance. Complete with earphone and detailed construction data. **Can be built for only 59/6** Mercury cell 1/11 extra. All parts sold separately.

THE SLIMLINE
2-transistor pocket radio. Size only 2 1/2 x 1 1/2 x 1 1/2 in. Micro alloy transistors on printed circuit. **CAN BE BUILT FOR 49/6**

THE NEW X30 AMPLIFIER
20 watts P.W.M. amplifier and preamplifier built on single printed circuit size 8 1/2 x 3 1/2 in.—weight only 4 1/2 ozs. built! Imp. sens. 1mV for 20 watts out. Output Imp. 7.5 and 15 ohms. **£7.19.6** Post Free

AVAILABLE READY BUILT AND TESTED. £8.19.6 3 pots. for Vol., bass and treble, 7/6 the 3 extra. mains power pack, if required **£4.19.6**.

THE N10 AMPLIFIER
10 watt power amplifier fitted with integrated pre-amplifier. Requires only 1mV for an output of 10 watts. Only 6 1/2 x 3 1/2 in. **£5.19.6** Post Free

AVAILABLE READY BUILT, TESTED AND GUARANTEED. £8.19.6 Post Free. 3 pots for Volume, Bass and Treble, 7/6 the 3 extra. Mains power pack, if required **54/-**.

RECORD PLAYERS

45 P.P.M. 6 volt Batt. operated. Complete with pick-up fitted crystal cartridge. Size only 7 1/2 in. x 6 in. Fixed auto stop and start. New and perfect. **49/6** Post 2/6



2-speed model for 33 and 45 P.P.M. (as illustrated) **59/6** Post 2/6

Data for Receiver 2/6 extra. Refunded if you purchase the parcel. Four U2 batteries 3/4 extra. All Components Available Separately.

We are pleased to announce the opening of our premises at **42 TOTTENHAM COURT ROAD, LONDON, W.1.** This branch will be devoted exclusively to quality High Fidelity equipment—Tape Recorders, Record Reproducers, Radios, Tuners, etc. Custom built installations will provide balanced comparisons of the best in Hi-Fi in ideal surroundings. Open all day Thursday, early closing Saturday. Tel. LAN 2573.

ELIZABETHAN Type LZ 507 STEREO TAPE RECORDER

High quality 4-track Stereophonic Tape Recorder with unique "solid state" transistor circuit. Brief speech, 4-track recording, mono or stereo, 4 or 2 track replay; 3 speeds—7 1/2, 3 1/2, 1 1/2 I.P.S.; fast forward and rewind; auto tape stop; output 2 watts per channel to two 7in. x 4 in. speakers in detachable enclosures; frequency response 600/4,000 cps. at 7 1/2 I.P.S. Tape position indicator; 2 Vu record level meters; volume and tone controls for each channel; input for 2 mikes and 2 radio/pick-ups. Takes 7in. spools. For 200/250 v. mains use. Overall size 22 x 15 x 7 1/2 in. Brand new and guaranteed. **List Price 49 Gns.**

LASKY'S PRICE 33 Gns. Incl. 2 crystal mics., tape and spool. Carriage & Packing 15/- extra.

TEST METER ADAPTOR

Type P.E. 220. Transistorised device which enables any 50 microamp D.C. Multimeter to be used in place of a valve volt meter. On the 1V. range an impedance of 1 megohm is offered which increases on the 1000 V. range to 100 megohms. 7 ranges immediate connection to Avo 8 but suitable for use with any other 50 microamp meter. Size 6 x 6 x 3 in. New and boxed. **List Price 7 Gns.** **LASKY'S PRICE 39/6**, post 2/6. Set of batteries 7/5 extra.

U.H.F. TUNERS

Only a few available. Complete with PC86 and PC88 valves. We regret no circuit or data is available. Knobs included but not shown.

LASKY'S PRICE 79/6. Post 2/6.



COMMUNICATION RECEIVER KIT—MODEL KT 320

Supplied in sub-assemblies for easy building. Covers range from 540 Kcs to 20 Mc. Ham Band is provided with a scale for direct reading and can also be band spread. Facilities: A.N.L., A.V.C. and M.A.C. Q Multiplier also serves as B.F.O. H.F. stage and two I.F. stages ensure high sensitivity and selectivity. Valve line up 2x6B6, 2x6B6, 2x6AV6, 1x6Q5 and 5Y3. 2 Aerial Sockets, standby position for use with a transmitter. 8 meter fitted, 200-250v. A.C. mains. Steel cabinet, grey crackle finish. Size 15 x 8 x 10 in. Dial 12 x 4 in. All parts new and fully guaranteed. Complete with full construction data and operating manual. **LASKY'S PRICE 25 Gns.** Carriage and Packing FREE.

INTERNATIONAL TAPE

Famous American Brand—Fully Guaranteed

3in. Message tape, 150ft.	3	6	5 1/2 in. Long play, 1,200ft., Acetate base	12	6
3in. Message tape, 225ft.	4	11	5 1/2 in. Standard play, 850ft., PVC base	11	6
3in. Message tape, 300ft.	7	6	5 1/2 in. Triple play, 2,400ft., Mylar base	45	0
3 1/2 in. Triple play 600ft., Mylar base	15	0	7in. Standard play, 1,200ft., Acetate base	10	6
4in. Triple play, 900ft., Mylar base	17	6	7in. Standard play, 1,200ft., Mylar base	12	0
5in. Double play, 1,200ft., Mylar base	15	0	7in. Long play, 1,800ft., Mylar base	19	6
5in. Long play, 900ft., Acetate base	10	0	7in. Double play, 2,400ft., Mylar base	25	0
5in. Standard play, 600ft., PVC base	8	6	7in. Long play, 1,800ft., Acetate base	15	0
5in. Triple play, 1,800ft., Mylar base	35	0	7in. Triple play, 3,600ft., Mylar base	58	6
5 1/2 in. Double play, 1,800ft., Mylar base	22	6	P. & P. 1/- extra per reel; 4 reels and over Post Free.		

207 ELGWARE ROAD, LONDON, W.2
Near Praed St. PADDINGTON 3271/2
BOTH OPEN ALL DAY SAT. Early closing Thurs.,

33 TOTTENHAM COURT ROAD, W.1
Nearest Stn., Gooidge St. MUSEUM 2605
Mail Orders to Dept. X.W., 207 Elgware Rd, W.2.

152/3 FLEET STREET, LONDON, E.C.4
Telephone: Fleet Street 2833
Open all day Thursday, Early closing Sat.

LASKY'S FOR D.V. CONSTRUCTION BARGAINS

RADIONIC

RADIO & ELECTRONIC CONSTRUCTION SYSTEM

YOU NEED RADIONIC

IF YOU ARE A BEGINNER
YOU WISH TO EXPERIMENT
YOU TEACH RADIO OR ELECTRONICS

Unique and brilliantly simple. Hundreds of educational establishments—Universities, Technical Colleges, Schools, the Armed Forces—are already using Radionic for electronic instruction. Enthusiastic owners range from 9 to 82 years of age. Selected by the Council of Industrial Design for all British Design Centres. Featured in Sound and Television broadcasts.

The system is beautifully engineered from top quality British components. No soldering. No mains. No prior knowledge needed. Simply arrange components on perforated transparent panel, position brass connecting strip underneath, fix with 6BA nuts and circuit works with full efficiency. You can then dismantle and build another circuit. Your results are guaranteed by our Technical Department and News Letter Service. All parts available separately for conversion or expansion of sets.

No. 1 Set £5.18.6. 14 Circuits (Earphone)
No. 2 Set £6.19.6. 20 Circuits (Earphone)
No. 3 Set £10.19.6. 22 Circuits (7 x 4in. Loudspeaker output)
No. 4 Set £14.18.6. 26 Circuits (include 6 Transistor and reflex superhets)

Prices (Post Free)

Full details from:

RADIONIC PRODUCTS LIMITED
STEPHENSON WAY, THREE BRIDGES
CRAWLEY, SUSSEX

Tel.: CRAWLEY 28700

Trade Enquiries Invited

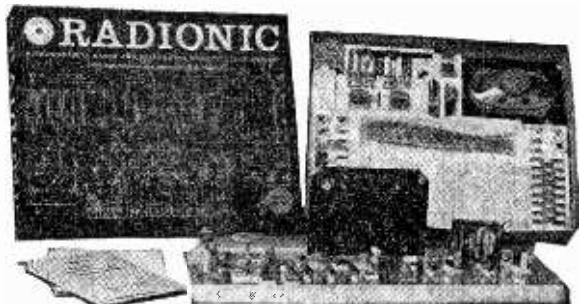

A No. 4 SET and 6-TRANSISTOR SUPERHET

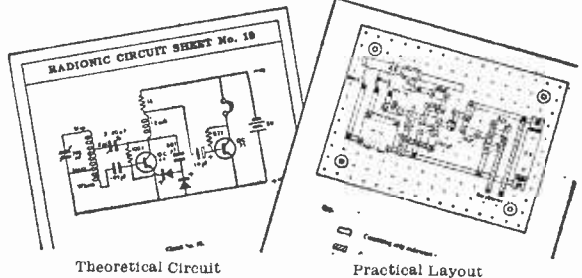

Theoretical Circuit Practical Layout
Our new 'E' Series of basic electronic circuits is also available separately

WEYRAD

TRANSISTOR COILS

The P50 series remain the most popular and widely used components for Medium and Long-wave Transistors Superhets:—

P50/1AC Oscillator Coil for 176 pF tuning	5/4 ea.
P50/2CC 1st & 2nd I.F. Transformers	5/7 ea.
P50/3CC 3rd I.F. Transformers	6/- ea.
All mounted in individual cans $\frac{1}{4}$ in. diam. x $\frac{3}{4}$ in. high.				
RA2W Ferrite Rod Aerial 208 pF Tuning	12/6 ea.
LFDT4 Driver Transformers	9/6 ea.
OPT1A Output Transformers	10/6 ea.
PCAI Printed Circuit Panel	9/6 ea.
Constructor's Booklet	2/- ea.

VALVE RECEIVER COILS

Our individual "H" type iron-cored coils are without equal for the construction of a wide range of receivers. For the simplest T.R.F. sets covering one or more wave-bands the Aerial and H.F. Transformer coils are ideal. The standard superhet circuit using the ever-popular triode-hexode frequency change layout would employ the Aerial and Oscillator coils and the coverage can be selected from 7 different bands ranging from 12.5 to 2,000 metres. For a really high-performance receiver an R.F. stage can be added by using the Aerial, H.F. Transformer and Oscillator Coils and a circuit is provided illustrating such a layout.

H Coils 3/9 each.

PLEASE NOTE OUR CHANGE OF NAME
WEYRAD (ELECTRONICS) LIMITED
REGENT FACTORY, SCHOOL STREET,
WEYMOUTH, DORSET

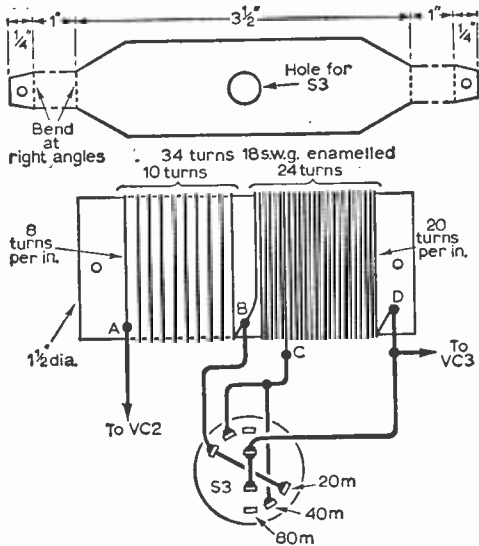

Fig. 3: Winding details of L2, the p.a. tank coil, and dimensions of a bracket to mount it in association with S3.

The maximum effective capacitance across the coil is 50pF and tuning should be correct with the 100pF capacitor nearly open for 20m and 40m and about one-half closed for 80m. If 3.5Mc/s and 7Mc/s crystals are used it is not possible to tune this circuit to unwanted harmonics. L3 is a 2.5mH 60mA r.f. choke.

P.A. Tank Coil L2

This is wound on an insulated tube 3 1/2 in. long and 1 1/2 in. diameter as shown in Fig. 3. Beginning about 1/4 in. from one end, the 18 s.w.g. wire is anchored in hole A and ten turns are wound at eight turns per inch. The wire is secured at B. A further ten turns are then wound and a small loop made at C. After 14 more turns the wire is fixed at D.

The aluminium bracket shown in Fig. 3 holds the coil to the switch. It is cut and bent as shown and fitted to the coil with 6BA bolts, S3 already being in the central hole. Stout connections are then soldered to S3. They are as short as possible. S3 has two three-way sets of contacts and they are used in parallel.

The completed tank coil assembly can be attached to the panel by the securing nut of S3 and short connections taken from A to VC1 and D to VC3.

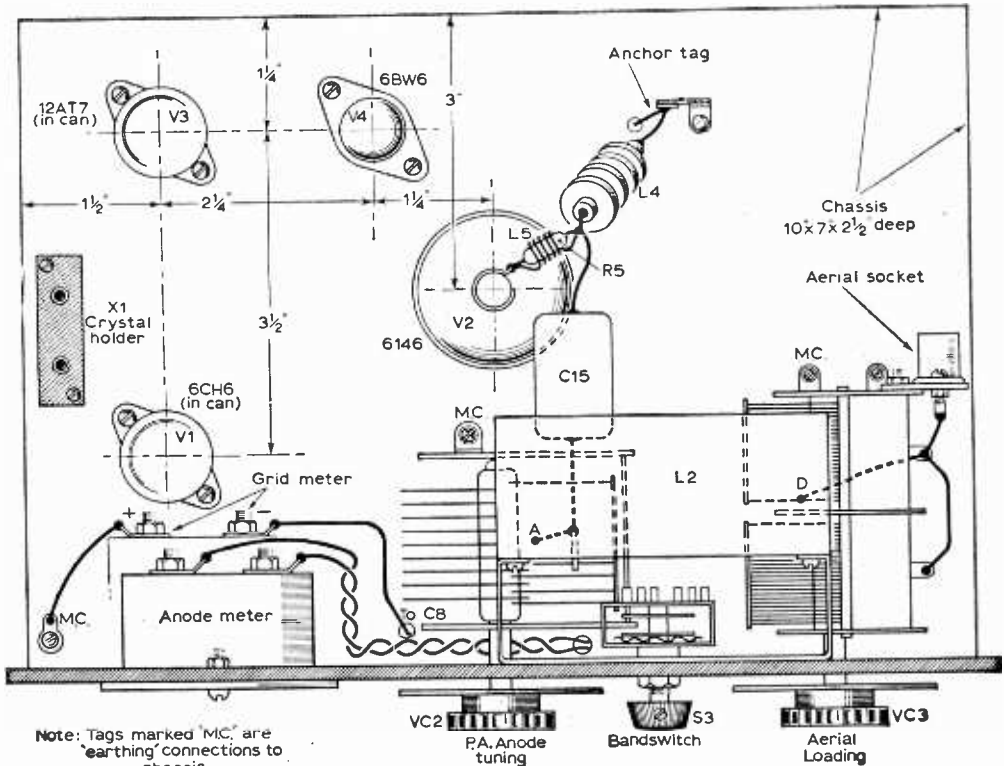

Note: Tags marked 'MC' are earthing connections to chassis

Fig. 4: Above chassis layout where most of the larger components are mounted.

Above Chassis

The chassis measures about 10 x 7 x 2½ in. and the layout is shown in Fig. 4. The crystal holder can be for ½ in. or ¾ in. spacing crystals or both. Valveholders can be located from the dimensions given.

VC2 must have wide spacing to avoid sparking over; a spacing of 0.05 in. between plates is more than adequate for 600V. For 40 and 20m 100pF will suffice but 150pF is required for 80m and 200pF would be better.

VC3 is a receiver type capacitor and should have a total of at least 1,000pF (two-gang 500pF with sections in parallel). For low impedance aerials on 80m 1,500pF is better (three-gang capacitor) but 1,000pF is easily sufficient for the 20 and 40m bands.

Both capacitors are bolted to the chassis and short earth returns provided for their rotor contacts. A small plate carrying a coaxial socket is bolted to the frame of VC3 and allows a coaxial feeder from an aerial to be plugged in. The socket outer sleeve is common to the chassis. This socket is not placed on the rear of the chassis as complete segregation of the p.a. anode and aerial circuit from other wiring would then be difficult.

The front panel measures 10½ x 7½ in. It can be of hardboard or aluminium. Holes are required for the meters, capacitors and S3. S1, S2 and VC1

hold the panel to the chassis. L4 and C15 are wired together and to VC2 (Fig. 4). The assembled tank coil unit can then be fixed by S3 and a short lead taken from A on the coil to VC2 fixed plates. D on the coil is connected to the fixed plates of VC3. L4 is a 2.5mH r.f. choke rated at 150mA d.c.

The anti-parasitic choke L5 consists of five turns of 20 s.w.g. wire with an outside diameter of ½ in. and a total length of ½ in. When the choke is made R5 is placed inside it and connected to choke and anode cap with the shortest possible leads.

Twin twisted leads from the anode current meter pass through a hole nearly under S3 to C9 and the switch. The grid meter is connected from chassis to C8 as in Fig. 4. The lead from L4 goes through the chassis to C9, which is immediately below.

S3 control knob should have band positions marked. It is convenient to use 0-100 or similar dials for p.a. anode tuning and aerial loading (VC2 and VC3) but control knobs without dials are also perfectly satisfactory. Screening cans should be provided for the 12AT7 and 6CH6.

Underside of Chassis

Positions of components and leads are shown in Fig. 5 and the transmitter may conveniently be

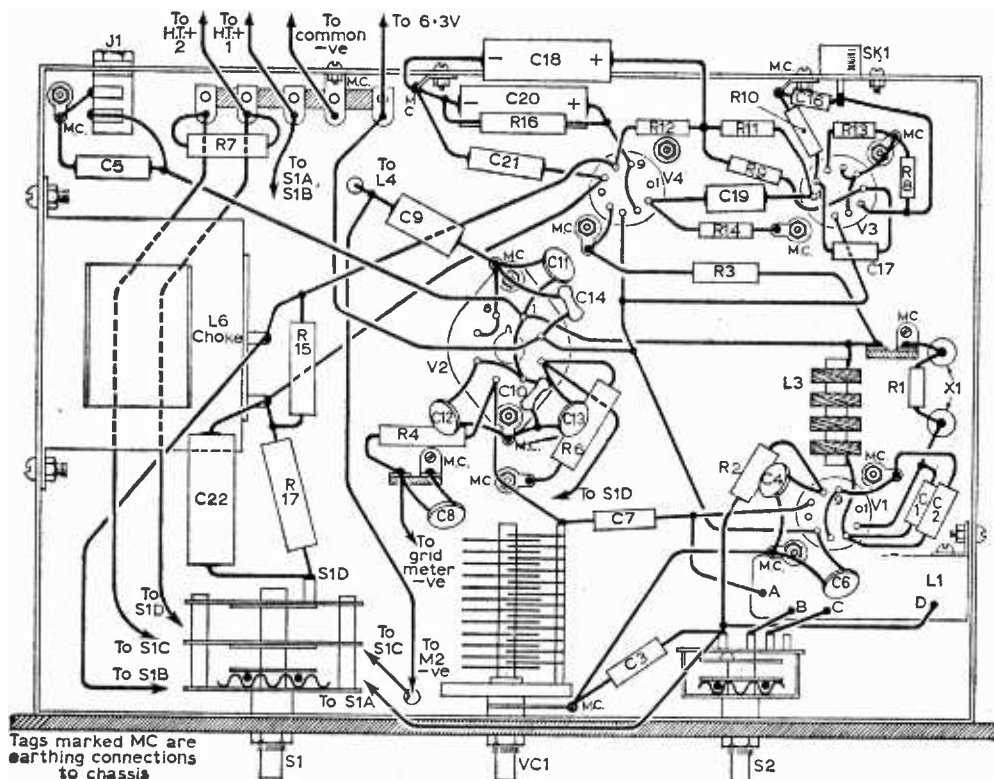

Fig. 5: Complete underchassis wiring, except for the switch, S1.

wired in stages. For r.f. circuits 18 or 20 s.w.g. wire is used. Heater and h.t. wiring should run against the chassis and be adequately insulated. It will be helpful to use sleeving or insulated wire of several colours, especially to identify meter, h.t. and switch circuits.

6CH6 Oscillator

Coil L1 is left until wiring is otherwise finished here. C4 and C6 are disc ceramic capacitors. L3 and R3 are anchored to an insulated tag near the crystal holder. Points MC are tags bolted to the chassis in the usual way.

Connections to C7 and C3 should be as short as possible. L1 is held with a bracket bolted about 1in. from the lower edge of the chassis and 2½in. from the panel.

The oscillator may be tested, if desired, by applying 6.3V a.c. to the heaters and about 250V d.c. to point X (see Fig. 1). With valve and crystal in, current should drop to about 20mA as

for r.f. by C10, C11 and C12, as shown, is necessary to avoid unwanted oscillation.

Double Triode

C17 and C19 should be mica or of equal quality as any slight leakage will upset bias on the second triode section (V3B) or on the 6BW6 (V4). C18 is displaced in Fig. 5 to show connections but lies over R16.

The microphone has the usual screened lead terminating in a coaxial plug. The inexpensive type of general purpose crystal mike should be satisfactory. It may be necessary to keep the microphone and its lead reasonably clear of the aerial.

6BW6 Output

The 6BW6 audio output stage or modulator V4 is very straightforward. For the anode choke L6 a speaker output transformer is most suitable. The type intended for a mains pentode, rated at 60mA or more and probably with a ratio of about 40:1, is ideal. The secondary is not used.

The optimum load of the 6BW6 is about 5kΩ, but the modulating impedance of the screen grid is much higher and not uniform throughout the audio cycle. As more power is available than required a 4.7kΩ resistor R15 is thus added to supply a stable load. The 6BW6 anode connection runs near the back of chassis and tag strip, clear of r.f. circuits, as in Fig. 5.

The modulator may be tested, if required, by temporarily connecting a loudspeaker to the transformer secondary. R15 may be disconnected. Speech should be clear and distinct. The microphone must be well away from the loudspeaker to avoid feedback howling.

Function Switch S1

This is four-pole, five-way, but no circuits have to be completed at either extreme position. Two two-pole, four-way wafers were actually used, assembled on a cut-down spindle from an old switch, and with a stop removed so that a second "off" position was obtained.

Fig. 6 shows the wiring for a new switch, consisting of two wafers, each having two-poles with five-ways. Lengths of coloured flex or other insulated wire can be soldered on before mounting the switch in the chassis.

Switching can be checked without supplies and valves. High tension should reach the 6CH6 anode (pin 7) in all but "standby" positions. With the switch at "phone" h.t.+1 should be connected to pin 8 of the 6BW6 holder and through R17 to pin 3 of the 6146 holder. H.T.+2 also goes to 6146 anode. When the switch is at "c.w." h.t.+2 remains connected to the 6146 anode but pin 3 is now fed through R7 from h.t.+2. In no circumstances must switching be such that screen grid voltage is present on the 6146 when the anode voltage is absent.

Power Supplies

The heaters require 3.2A at 6.3V, so a 3½A or 4A secondary will do well. For h.t.+1 a 250V receiver type power pack is ideal. A supply of about 220V to 270V at 60mA is sufficient.

The voltage applied at h.t.+2 depends on the

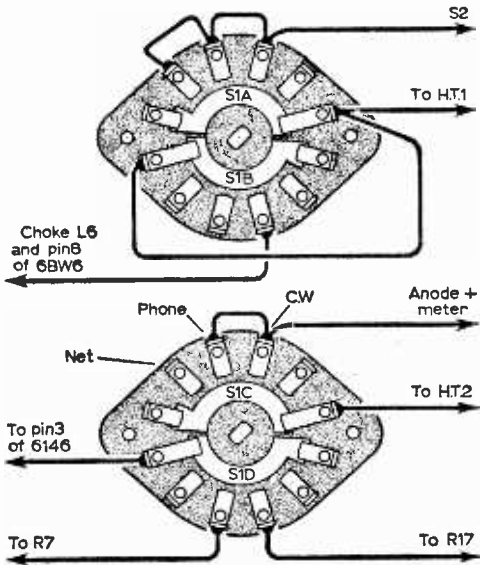

Fig. 6: Connections to the four poles of the function switch, S1.

oscillation commences. The carrier may be detected with a receiver or a tuned wavemeter with bulb indicator will glow if near L1, with S2 and VC1 adjusted for each band.

Power Amplifier

C10, C11, C12 and C13 are disc capacitors connected with very short leads. R4 is clear of the chassis and anchored at a tag providing the grid meter negative connecting point. C8 is a disc capacitor. The meter leads run against the chassis and anode meter leads are clear of the grid meter connections and pass through a separate hole near the function switch S1.

When no plug is inserted in the key jack, L3 and the p.a. cathode circuit are returned to chassis by closing of the jack contacts. Efficient grounding

power supplies which may be available and the input wanted. It is a good plan to make an initial test or tuning up with reduced voltage, such as can be obtained from a 250V supply, or by joining h.t.+2 to h.t.+1.

About 100mA at 450V to 600V falls easily within the rating of a transformer of moderate size and a suitable power supply is shown in Fig. 7. R7 controls the screen grid voltage when working on c.w. and it may be reduced to 10kΩ or less for a 300V supply. The screen voltage of V2 should not exceed 250V or 400V with key open. A screen voltage of about 150V is generally suitable for c.w. current, being about 10mA. Screen dissipation (volts x current) should not exceed 3W.

If there is any doubt the best solution is to begin with a high-value screen grid resistor and reduce this after checking the screen grid voltage and current with a meter. For 'phone the screen voltage is much lower as this is necessary for correct modulation.

Tuning Up

First tests should be made with the switch at "Net". A 3.5Mc/s band crystal can be inserted and adequate grid current should be found on each band by adjusting VC1. Grid current should not be allowed to exceed 3.5mA and should generally be between 2mA and 2.5mA. S2 is always switched to the band upon which output is wanted, so that the final amplifier is not used as a doubler.

A 7Mc/s band crystal is useful to check 14Mc/s tuning to make sure the third harmonic of 3.5Mc/s (10.5Mc/s) is not selected by VC1 in error. Or a bulb indicator meter or receiver can be used. The 14Mc/s band should peak up with VC1 nearly open.

An initial test can be made with power delivered into a 60W household lamp connected to the aerial socket and chassis by a few feet of twin flex. With S2 and S3 at 80 close VC2 and VC3 and tune for grid current at "Net". The function switch is then turned to "Phone" and VC2 is immediately adjusted to find the dip in anode current as shown by the anode meter. The current is increased by opening VC3 and retuning with VC2. VC2 is always tuned for minimum anode current, corresponding to maximum r.f. output.

Grid current is readjusted if necessary by VC1. When the p.a. has been tuned to resonance the switch can be turned to "c.w." if wanted (key closed). As loading progresses in the way described the lamp will light with increasing brilliance. For c.w. the anode current may run up to 100mA.

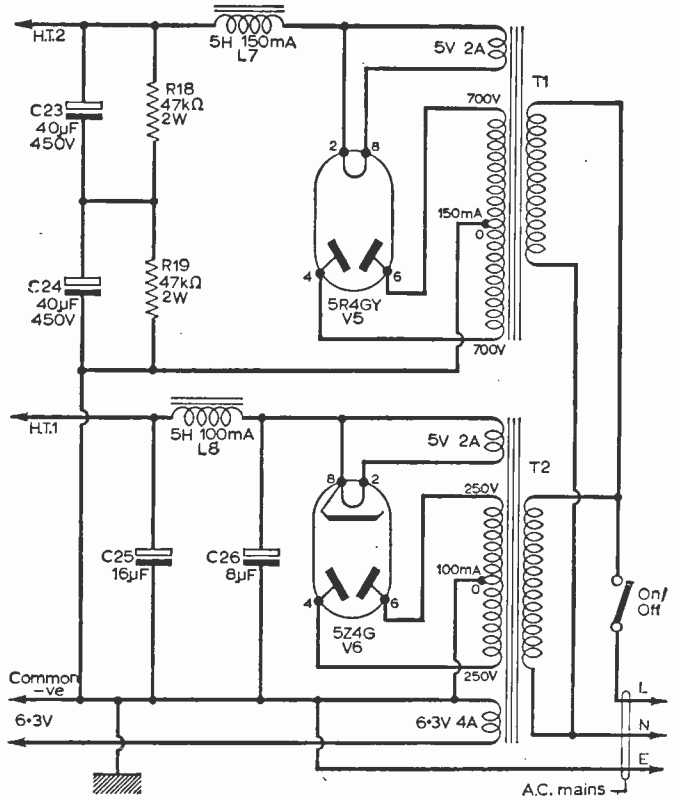

Fig. 7: Circuit of a suitable power supply for the transmitter.

Loading the transmitter into an aerial follows the same method. A coaxial-fed dipole can be fed directly from the transmitter. Various end-fed aeriels can also be used in this way with a good earth to transmitter chassis. For resonant end-fed aeriels some type of aerial tuner placed between aerial and transmitter will be almost essential.

Crystal Frequencies

Crystals with fundamental and harmonics falling within the band limits may be used on all three bands but some crystal frequencies will not supply harmonics within the bands. For 7Mc/s and 14Mc/s, 7Mc/s crystals may be used, while 3.5Mc/s crystals will do for 3.5, 7 and 14Mc/s. Any 1.75 to 1.9Mc/s crystals will do for 3.5-3.8Mc/s also.

'Phone Loading

For best speech quality with screen grid modulation the p.a. must be heavily loaded. To accomplish this the screen voltage of V2 is kept low by R17 and loading with the pi-tank is continued until the dip in anode current on rotating VC2 has become small. An input of about

-continued on page 321

on the Short Waves

MONTHLY NEWS FOR DX LISTENERS

All times are in G.M.T.

All frequencies are in kc/s.

The Broadcast Bands—by John Guttridge

ONE station getting its schedule out well in advance is Radio Moscow. Until the end of August English for Europe is aired at 0700—0730 on 11,830/9,710/9,600/9,480/7,240; 1200—1300 on 15,490/11,930/11,830/11,700/9,780; 1900—1930 on 9,710/9,480/7,340/6,050/1,320; 2000—2030 on 9,710/9,480/7,160/7,340/6,050/1,380; 2100—2200 on 9,710/7,340/7,260/6,050/1,490; 2200—2230 on 9,710/7,340/6,050/1,490/1,380/1,320. In September/October the following changes are made: 0700—0730, 11,830 dropped; 1900—1930, 2000—2030, 7,280/6,170 replace 9,710/9,480; 2100—2230, 7,280 replaces 9,710.

Frequencies used for several English transmissions were changed by *Radio Prague* for its summer schedule. Changes are: 0100—0155, 0330—0425 on 5,930/7,120/7,345/9,795/11,990; 0300—0355 on 15,285/15,448/17,825; 0800—0855 on 6,055/9,503/15,235/15,285/21,450. On its QSL, says D. Hill, date, time and metre band are given.

T. Robinson, Liverpool, reports that *Radio Nederland* (P.O.B. 222, Hilversum) has a DX programme at 1600 on Fridays and a request programme on Saturdays. In London 15,425 gives better reception than 11,730 for the 2100—2150 English transmission but suffers from severe interference from A.F.R.T.S. New York on 15,430.

A. Waddelow, Norwich, has heard the Bonaire relay with Dutch at 2100 on 15,290 giving SINPO 33433. He reports full verification details from *Radio Denmark* (Radio House, Copenhagen V), *Radio Andorra* (Roc des Anelletes, Andorra-la-Vielle, Andorra—return postage required), *Radio Berlin International* (Berlin-Oberschope-weide, Nalepastrasse 18-50, German Democratic Republic), and *Radio Belgrade*.

The 1315—1400 English transmission to South-East Asia from *Emissao Nacional de Radiodifusao* (Rua Sao Marcal, IA, Lisbon) is now on 21,495/17,895. The BBC now has an English transmission to East Africa from 1800—1830 on 15,420.

D. Hill mentions two English transmissions from *Radio Bucharest* (P.O.B. 111, Bucharest) from 1930—2030 on 9,570/9,510/7,225 and 2230—2300 on 7,195/6,190.

Middle Eastern stations reported this month are *Radio Ankara*, *Kol Israel* (Broadcasting House, Jerusalem, Israel), *Radio Baghdad* (Salihiya, Baghdad), *Radio Iran* (Ministry of Information, Meydan Ark, Tehran), and Saudi Arabian Broad-

casting (Ministry of Information, Airport Road, Jeddah). Paul Harris, Elgin, says that English from *Kol Israel* is now from 2045—2115 on 9,009/9,625/9,725. Ankara now has French at 1930—1945 and German at 1800—1815 on 15,160. A. Waddelow reports English on this frequency at 2200—2230 (SINPO 44441).

E. Conduit, Wolverhampton, has had a QSL with date and frequency only from Saudi Arabia and with frequency only from Baghdad, although W. Smith had a yellow card giving date and frequency from Baghdad. Alex Bushby, Glasgow, reports a letter giving no details from Iran.

Two African stations, *Radiodiffusion de la Republique Democratique du Congo* (B.P. 3171, Leopoldville) and the Nigerian Broadcasting Corporation (Broadcasting House, Lagos) are reported by R. Howard, Stockport. The former he has heard between 2030—2200 on 11,795. Nigeria was logged in English between 2130—2205 on 11,900/15,255.

Cairo Radio (U.A.R. Broadcasting and TV, Maspero) has changed the language segments for its transmissions on 17,920 to East and Central Africa. They are now Nianga 1545, Shona 1615, Somali 1645 and English 1745—2030.

According to Paul Harris, *Radiodiffusion Television, Ivoirienne* (B.P. 2261, Abidjan, Ivory Coast), has replaced its International Network frequency of 11,820 by 6,015. He has heard this frequency at 2200—2400 and presumes it carries the 1830—1900 English transmissions on weekdays.

A. Wildsmith, Manchester, advises those who have written to *Radio Ghana* (Broadcasting House, P.O. Box 1633, Accra) and have not received a reply not to despair. He has just received a verification after five months.

Conflicting reports on the QSL of *All India Radio* (P.O. Box 500, New Delhi) from E. Conduit and D. Hill. The former's card had the date only, whilst the latter's had all details.

Finally three reports on *Radio Pyongyang* (Pyongyang, North Korea). Paul Harris has heard English at 1800—1900 on 10,380 and 1900—2000 on 6,540/7,379 with 7,580 being announced as well. According to announcements, he says, other transmissions are 1000—1100, 7,580; 1100—1200, 9,750; 2400—0100, 17,520; 0300—0400, 9,570. M. Clark, Cheltenham, has heard the station on 6,500 at 1900 when it says it is using 7,389/7,595/8,333/10,381. A transmission from 1000—1200 on 6,061/7,353 was also announced.

The Amateur Bands—by David Gibson G3JDG

ONCE more unto the h.f. bands, dear friends, and verily DX shall be thine. Unbelievers should listen on 20m, where thousands of stations from almost everywhere are battling it out.

It is fair to reckon that all those not on 20 are on 15 and this band seems more consistent these days. It stays open for longer and although there is often some QSB it's on the up and up, certainly as regards reliability.

Poor old 10? Not any more—half Europe gets on at the weekends and the African continent shows itself, too. Those with directional antennas on this band should have very full logs.

TWENTY

Let's start with a bang. Here is the pick of the log from **BRS26813**, of Cheltenham, who uses an S640 and HRO5T with a 90ft longwire. All c.w.: AC4H (Tibet), CN8MH, CR4AE, 4BC; EL2AE, 2AM; ET3GO, 3USA; DU1OR (Philippines), FG7XS (Guadeloupe), FM7WH (Martinique), HI4ARM, HK3RQ, HP1BR, HZ3TYQ (Saudi Arabia), JA1BZR, 1FHK, 1DU, 1ZZ, 7AB, 7ARZ; JTIAG, KH6DSW, FLK, JJ, TD, WU; KM6DJ, KP4ARS, LA4EJ/P (Jan Meyen Island), LU2DAW, 8EE; OA4EM, OY7ML (Faroes), PY1BTX, 2ON; PJ2CZ, SU11M, UL7PY, UN1BR, VE8CO, VK2EO, 2OO; VO2NA, VP5BH/MM, 9EP; VU2GW, 2LI; W5IUW/VP9, 6JNX; XE1OE, YV1AD, 4MC, 5AAQ, 5ACP, 5BH; ZD8BC, ZE8TT, ZP5LS, ZS6AJQ, 4U1ITU, 4X4HK, MZ, QA; 5A3TT, 5Z4DW, 6Y5MJ, XG; 7X2ARA, 7X3CT, 9J2GJ.

Which goes to show that if it emits r.f. then it can be found on 14Mc/s and BRS26813 will hear it! Well done, Bob—when do you sleep?

Norman Ponsford (Devon) found these on his t.r.f. CR45 with 60ft longwire, all on a.m.: HB9VW, K3NHL, K2YLM, OE3CL, PY7GV, SV0WBB, WA410, 4X4FA, 5Z4AQ, 5Z4ERR. **W. Langham** (Somerset) got these on a domestic receiver and 75ft longwire: 11BUG, LZ1KBD, PA0PAN, UA9KCF, UO5KBR, YU6BC, 4X4OS, all a.m.

Messrs. **McWhirter** and **Weare** are the ops at Derby School Signals Platoon and pulled in these on an R107 with 200ft longwire: K2ZRK/P, SP4AUQ, UA2KBD, VE4SA, W2RKY, W8HCP (all on a.m.), ET3USA, UA1KIB, UA9MX, UN1BR, UW3FV(?) on c.w.

FIFTEEN

Stephen Beale (London), using the P.W. t.r.f. (May, 1964) and a 66ft. longwire, got these on a.m.: CR6BY, EA8ER, LA4EI, SV1DL, ZC4MO, 4X4QR, 5A1TK, 5A5TE; 5N2KOB, 9G1MR, 9J2DT, 9L1WN, 9Q5DL, 9X5RZ.

D. F. Carrington (Derby) pulled in on his HE30 and 68ft longwire with 14ft vertical whip at far end: CT3AQ (Madeira), EL5CG, EA6GL, PY1NBA, PY1AGP, SV0WO, W9ACU, ZC4KW, 4X4QR, 5A1TK, 9X5WTB and 9Q5's DL, US, AWB, RB, AQ and AD.

Mike Silverstein (London), CR100 and 132ft longwire, hooked. CR6BY, CR7FR, HI8BGA,

JA1GTN, KZ5BE, OA4OS, PY1BYS, VP4LE, VS9ANR, ZE7JR, 9X5RZ.

TEN

Back in circulation! Why, we have even been getting logs!

George Owen (Bristol), using a five-valve t.r.f. and vertical joystick, leads the field with CE4FB, CR4AO, BC; CT1CN, MZ, ILX, IOF, LIM; EA3PA, EL2L, F2SI, HB9FMA, 1ISO, BIW, IYJ, MTO, PAI, WRR; KC4CK, OK1ABN, ZD8JC, ZE1JJ, 5A4HR, 5Z4AA, 9Q5AA.

THE L.F. BANDS

Only the real stalwarts stick at it. On 7Mc/s **Bob Garvy** (Gloucester) had these on his HRO and 90ft longwire, all on c.w.: DJ3ZXA, E19TF, OK4ADX, PY7AOD, SM7ACR, UA1KAL, VP2LZ, ZS6DF.

On 3.5Mc/s **A. Rolfe** (Halstead) got DJ8RS, DL2UZ, DL6VU, F2WW, F3ZK, PA0PAL, SM3YF/MM using an R109 and 12ft whip. And an unsigned log from Preston mentions DJ6QT, DL6ME, E14R, GC2AZ, OZ3IH, SM7WW, VE1IE.

Top band almost abandoned and the only letter we had was from **W. Smith** (Staffs) with a large list of G stations heard.

IN GENERAL

The coat-hanger and cuff-link gang are still at it! **BRS26325** (Dundee) used a fireguard on 21Mc/s for 5A1TK, CT1LJ, 9M4LP, EA8EH. **M. Carter** (North Wales) used a ground-floor window frame into an HRO for 14Mc/s s.s.b.: EP2DS, KH6BK, KR6AAC, MP4BCC, OD5BZ, HV1CN, HB0AFM, HL9PK, KP4CL, VE6TP, W6VPY, W7MK1, ZS6XB, 5N2AAC, 9M2SR. Anybody thought of the little strip of metal foil around cellophane wrapped cigarettes? (Watch it, they resonate at 947Mc/s!)

ZB1 (Malta) is now 9H1 for sure. The Western Carolines and Kure Islands are on and the calls to listen for KC6 and KH6 respectively. 4U1ITU is the headquarters station of the International A.R.C. located in Geneva. Others rumoured to be squirting r.f. about are South Georgia VP8, Christmas Island and Cocos Keeling both VK9, ZD8 on Ascension Island, Crete SV0WGG high end of 20 on s.s.b., Willis Island VK4 and Samoa KS6. For Top-band addicts there is a beacon on 1.801Mc/s in South Africa signing ZE1AZD, reports very much appreciated.

What a lot of field days, British, American and now Korean. The Korean effort will be July 3rd-4th on 80, 40, 20 and 15m. Callsigns to listen for are HM and HL. Other activities on in July are: 4th, 144Mc/s portable contests; 11th, three mobile rallies, tenth anniversary rally, South Shields rally and Torbay mobile rally; 17th-18th, 1.296Mc/s tests (you've just got time to wind a set of coils); 25th, 70Mc/s portable contest and Cornish mobile rally. August 1st, SLADE D/F qualifying event. Good hunting and don't forget to drop me a line on what's coming in at your QTH.



Practical Substitutes

by M. L. Michaelis, M.A.

RESISTOR AND CAPACITOR VALUES

A frequent type of enquiry concerns apparently strange component values, such as "a capacitor of 0.056 μ F". Whilst the familiar sequence of preferred values is quite commonplace for resistors, it is less familiar in Britain for capacitors. However, our example of a 0.056 μ F capacitor simply bears the same relation to a more familiar 0.05 μ F capacitor as does a 56k Ω resistor to an older-type 50k Ω resistor. Such values are mutually interchangeable unless very critical conditions are involved and which the author of an article would point out. Unless otherwise stated, the constructor may assume that a $\pm 20\%$ tolerance is implied for resistor and capacitor component values. This obviously permits mutual interchange of a 0.05 μ F capacitor with a 0.047 μ F or 0.056 μ F preferred-value capacitor. (The 0.05 μ F $\pm 20\%$ could, of course, be anything between 0.04—0.06 μ F.)

If a preferred-value component is outside the tolerance of a near old-type component, one should select a parallel combination of two standard value capacitors to get closer to the specified value. Thus, given $\pm 20\%$ tolerance, the correct substitute for a 0.68 μ F capacitor is a parallel combination of a 0.5 μ F and a 0.2 μ F.

Similarly a 50k Ω resistor can generally replace a 47k Ω or 56k Ω resistor, but a 68k Ω resistor requires either a 75k Ω resistor as substitute, or

THE lists of parts for constructional articles are those found satisfactory in the prototypes and available at the time of publication. Many queries which the editor receives show that many beginners regard a published list of parts as being strictly binding down to the last detail.

Whilst this may be true for special projects a considerable latitude normally exists and the informed constructor can use his discretion regarding substitution of components already in his possession or more readily available.

It is the aim of this article to help readers in making on-the-spot substitute decisions if a dealer does not happen to have the exact item desired in stock. The information given will also serve many other useful practical purposes, such as the selection of modern replacements for defective components in obsolete equipment, or just to make better use of items available in the junkbox instead of making new purchases.

various combinations of two resistors, such as a 50k Ω and a 20k Ω component in series, or two 150k Ω resistors in parallel. Note that the individual wattage ratings of series or parallel combinations of two resistors can be halved only if the individual values are equal or very nearly equal.

In cases where resistor or capacitor substitutions of the kind discussed above lead to a residual discrepancy close to the tolerance limit, e.g. when substituting a 10k Ω resistor for a 12k Ω resistor, it is advisable to measure the actual values. Judicious selection can often lead to a closer approach to the specified value and will avoid additive tolerance errors greater than the tolerance limit. However, a large number of experimental circuits remain uncritical even under the latter circumstances.

The important thing to remember is that, generally speaking, any value within the tolerance of the specified value will be acceptable.

CRITICAL CAPACITOR AND RESISTOR VALUES

Resistor values are frequently more critical when they constitute parts of bleeder networks which determine the operating point of a valve or transistor, or when they are parts of calibrated shunts, multipliers, attenuators or other measuring circuits.

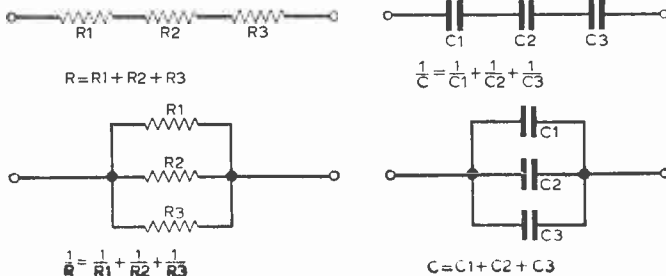

Fig. 1: Series and parallel combinations of resistors and capacitors

Capacitor values are critical in tuned r.f. and i.f. circuits and in oscillator padding positions. Even then, substitutions of combinations of two or even more components in series or parallel to make up the exact specified value are generally permissible.

Note that capacitors in parallel and resistors in series are added whereas capacitors in series and resistors in parallel are equal to the reciprocal of the sum of the individual reciprocals, see Fig. 1.

ELECTROLYTICS

It is normally permissible to substitute non-electrolytic capacitors of the same value for specified electrolytics, if space permits, but electrolytic capacitors cannot be substituted for paper or foil capacitors when insulation and capacitance stability are important factors.

Thus it is usually unsatisfactory to substitute an electrolytic for a paper or metallised foil component in an anode-grid coupling circuit since leakage of the electrolytic would lead to an intolerable displacement of the operating point of the subsequent stage. Very large metallised foil capacitors in long-period high-impedance timing circuits (minutes or hours) cannot be replaced by electrolytics. However, low-impedance transistorised timing equipment does often use low-voltage electrolytics. The accuracy of such circuits, or at least their long-term stability, nevertheless tends to be inferior.

Electrolytic capacitors are relatively coarse, inaccurate components whose capacitance and insulation may vary greatly during the useful lifetime and according to the length of resting time without applied voltage. Thus even if an electrolytic capacitor is found to function satisfactorily in a critical circuit position at some particular time, that circuit cannot in general be relied upon to function satisfactorily with it at all subsequent times. In valve circuitry, electrolytics should normally be confined to smoothing and decoupling functions.

Electrolytics are more widely usable in transistorised circuitry because impedances are generally lower, so that insulation deficiencies are less important. Therefore any slight leakage of electrolytic coupling capacitors leads to much smaller relative displacements of the transistor operating points than in the case of valve circuits.

RF CAPACITORS

It may be unsatisfactory to substitute paper capacitors for ceramic or mica capacitors in r.f. circuits when the operating frequencies are high, although this may not matter so much in long- and medium-wave circuits. On the other hand, ceramic or mica capacitors of adequate voltage rating may be substituted for specified paper ones.

In most r.f. applications it is immaterial whether ceramic or mica types are used. Modern ceramic materials have a greater capacitance in a smaller space, but their voltage ratings are often more limited. Paper capacitors generally have a lower capacitance stability, so that even if they work in local oscillator circuits they should nevertheless be avoided in these stages, otherwise trouble is

likely to be encountered with drift. Mica or ceramic components of good basic stability are most desirable, especially for v.h.f. circuits.

Where an author specifies strange combinations of odd-value capacitors with exact details of manufacturer and type number, and with two or more such capacitors connected in parallel at each position, the intention is to achieve mutual cancellation of the individual temperature coefficients. In such cases it is not possible to make straightforward substitutions of other capacitors without impairing the frequency stability of the circuit.

Forbidden resistor substitutions can arise in circuits where the stray inductance of the resistors plays a significant role. This often means that wirewound resistors cannot be used in place of specified carbon resistors in such circuits as the signal amplifiers of oscilloscopes and wideband a.c. valve voltmeters, or in the video stages of television equipment. However, in these same types of equipment wirewound resistors with a definite inductance used as frequency-correcting peaking inductance may sometimes be found.

If such resistors fail and have to be replaced, simple substitution of a carbon resistor or an arbitrary-inductance wirewound resistor of the same wattage and resistance value may lead to unsatisfactory performance of the equipment (generally reduced bandwidth at the high-frequency end).

POWER SUPPLIES

Due to the lack of standardisation in mains transformers, difficulty in obtaining the exact one specified in an article is a common problem.

Other power supply problems concern rectifier substitutions, in particular the conditions under which valve, metal and silicon rectifiers may or may not be mutually substituted. Finally, readers often query possible interchanges of halfwave, fullwave and bridge rectifier circuits if a specified rectifier arrangement is not available.

There are standard rules of substitution which can be applied to most power supply problems.

MAINS TRANSFORMER SUBSTITUTION

Space permitting, it is always possible to use separate heater transformers, either to cater for all heater requirements independently, or to augment the heater supplies available on the transformer which also carries the h.t. winding. If more than one transformer is used, all primaries should be connected in parallel, but *never* connect secondaries of physically or electrically different transformers in parallel. Series connections of secondaries are always permissible for any combination of transformers, within the insulation ratings, e.g. to obtain higher heater voltages.

If it is possible to obtain a transformer with all the required windings as far as voltages are concerned, but the current ratings are too low, then it is always permissible to wire two such *identical* transformers in parallel.

All primary and secondary connections should be respectively connected in parallel. The current

rating of each composite winding is then twice that of a single transformer. It must be stressed that such connections are possible only for *truly identical* transformers.

If, for example, an h.t. current rating of 150mA is specified, there is no objection to using a transformer with a somewhat higher rating, e.g. a 200mA or even 250mA. However, overloading of h.t. windings in the other direction should be avoided, since it leads to severe overheating. Thus if 150mA h.t. rating is required but only a 100mA transformer type is available, two such identical transformers will have to be connected in parallel.

Fig. 2 shows such a transformer substitution. In the example, a 250-0-250V 200mA transformer with two separate 6.3V 2.5A heater windings has

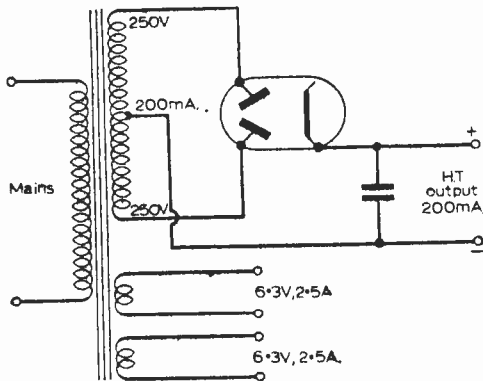

Fig. 2a: Normal full-wave rectifier circuit.

been specified (Fig. 2a). This may be replaced by two smaller transformers, each having a simple 250V 100mA winding for halfwave rectification and a single 6.3V 2.5A heater winding.

Provided that the two transformers are fully identical, there is no objection to feeding the two sections of a full-wave rectifier circuit from separate transformers in the manner shown, and the current rating of each transformer need only be one half of the required rectified h.t. current.

But there is one rather important reservation. The two separate transformers must be of a type specifically intended for halfwave rectification at their full rated current output. Halfwave rectification always passes a d.c. current component through the secondary winding of a transformer, which magnetises the core and lowers the primary inductance. The primary inductive current therefore increases and the transformer gets much hotter than it would otherwise do.

There is no net d.c. magnetisation of the core when the type of full-wave rectification shown in Fig. 2a is employed, with both rectifiers fed from the conventional centre-tapped h.t. winding on a single transformer.

If the two transformers of Fig. 2b are not designed for halfwave rectification, it is better to

change the rectifier arrangement too, using a single transformer with a simple h.t. winding (now rated for the full required h.t. current) feeding a bridge rectifier as shown in Fig. 3.

Provided that the transformer voltages are the same and the rectifier classes of Fig. 2a and Fig. 3 are the same (e.g. in both cases contact-cooled selenium rectifiers, or all silicon diodes), the respective circuits are generally completely interchangeable, whichever one an author should happen to specify.

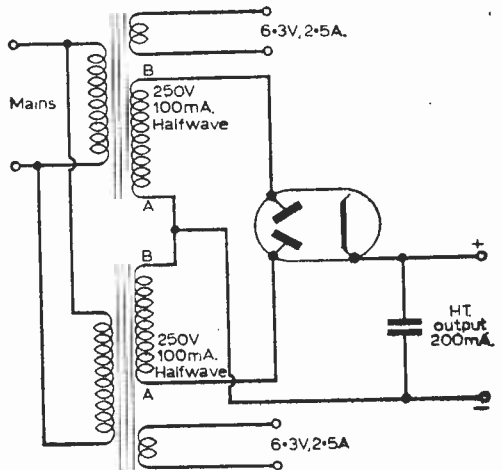

Fig. 2b: Full-wave rectifier circuit with two half-wave transformers.

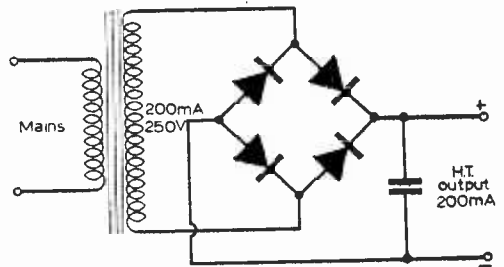

Fig. 3: Bridge h.t. rectifier circuit with simple transformer winding.

PROBLEMS WITH HEATER WINDINGS

Unless two or more transformers are absolutely identical, heater windings should not be connected in parallel, but any form of series connection for obtaining higher voltages is permissible. It is inadvisable to connect two heater windings on the same transformer in parallel, even if the current ratings are identical.

If two or more heater windings are required to meet the demands of all valves in a piece of equipment, it is generally best to "common" one side of each winding to chassis and to connect

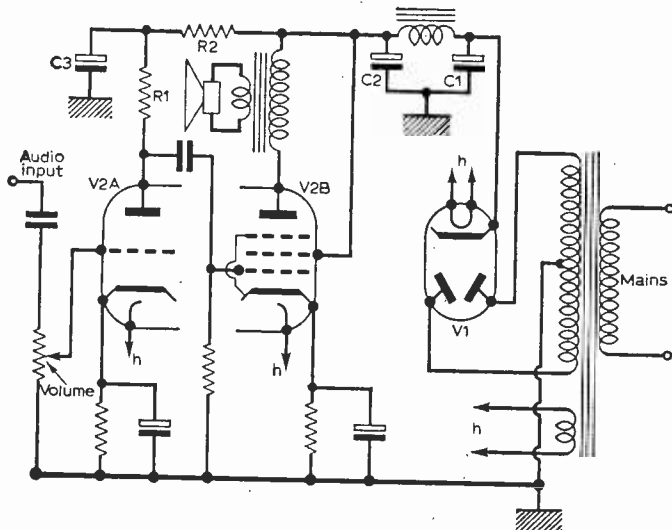

Fig. 4: Surge voltages in electrolytics C1, C2, C3 (see text).

respective groups of valve heaters independently to the other ends. In most cases the specified heater requirements may be redistributed in any manner within reason.

If rectification of the output from a heater winding is required, keep to fullwave or bridge rectification unless the current drain on the d.c. side is only a small fraction of the a.c. current rating. Otherwise d.c. magnetisation of the transformer core can lead to severe overheating and possible burnout.

Whereas h.t. windings may be fairly generously overrated, e.g. there is little objection to loading a 200mA winding with no more than 50mA actual h.t. current drain, such severe underloading is undesirable on heater windings since it can lead to unduly high heater voltages which would endanger valves.

Check with a multimeter and if necessary insert a low-value series resistor (e.g. a coiled length of stout resistance wire determined by experiment or calculation). Adjust for correct voltage reading at heater pins of valves. Alternatively, connect the primary to a higher voltage tap than the prevailing mains voltage. Slight resulting loss of h.t. output voltage is generally tolerable.

RECTIFIER SUBSTITUTIONS

There is little to choose between conventional metal rectifiers, contact-cooled ("flat") selenium rectifiers and silicon rectifiers as far as normal performance in h.t. circuits is concerned, although the efficiency improves in the order given and the heat dissipations and physical sizes decrease accordingly.

The modern silicon h.t. rectifier is undoubtedly the best component in the semiconductor class of h.t. rectifiers and it can serve as a versatile substitute in most cases where specified metal rectifiers

or contact cooled rectifiers are unavailable. Contact cooled selenium rectifiers use a coding such as, for example,

E250 C50=Halfwave (E),
250V a.c. input, d.c. current
(C) 50mA

B450 C200= Bridge (B),
450V a.c. input, d.c. current
(C) 200mA.

Whilst the first example is very common, the second example and similar types often specified for high-power electronic or amplifier designs may be difficult to obtain. Four simple 250V a.c. input silicon h.t. rectifiers connected in a bridge circuit represent a perfect substitute for a B450 C200 and are always easy to obtain.

It is fairly general to use the ubiquitous silicon mains rectifier if any other specified semiconductor rectifier is unobtainable. If the a.c. input does not exceed 250V for non-bridge circuits or 450V for bridge circuits, use a single silicon mains rectifier for each diode section of the substituted rectifier. Otherwise use two silicon rectifiers in series for each diode section if the a.c. input voltage lies between 250V and 500V for non-bridge circuits or between 450V and 900V for bridge circuits.

The silicon mains rectifier has the further advantage that it is generally equally suitable for rectifying low voltages, e.g. heater voltages, although cheaper types with lower inverse voltage ratings are available.

VALVE RECTIFIERS

Whilst it is generally possible to substitute a valve rectifier for a semiconductor h.t. rectifier, if one is willing to go to the trouble of introducing a rectifier heater supply, the converse is not necessarily true. Equipment for which a valve rectifier is specified may well be damaged if a metal rectifier is substituted without due consideration.

Consider the circuit Fig. 4, in which a full-wave valve rectifier circuit feeds a two-stage audio amplifier. If V1 is indirectly heated as shown (e.g. type EZ80), it will not pass any current into the reservoir capacitor C1 until the audio output valve V2b has also warmed up and is able to draw full h.t. output current from C2. The voltage developed across C1 and C2 thus does not rise much above the r.m.s. (a.c.) input voltage from the transformer if the loading is correct.

If a semiconductor rectifier is now substituted for V1, the h.t. voltage builds up immediately across C1 and C2 at switch-on, but there is no output current drain until V2 has warmed up.

The voltage build-up across C1 and C2 will thus initially rise to the peak a.c. input voltage, which is about 1.4 times the r.m.s. input voltage. Electrolytics of correspondingly higher voltage

ratings are then required for C1 and C2.

If the valve rectifier is directly heated (e.g., type 5Y3G), it will deliver h.t. voltage before many of the other valves in the equipment have fully warmed up and are able to draw full h.t. current. The initial h.t. voltage excess will then be less than in the case of semiconductor rectifier circuits, and certainly of shorter duration, but it will often still be significant. Thus beware even of substituting a directly heated rectifier valve for a specified indirectly heated one.

Note that some indirectly heated rectifier valves, e.g. the EZ80, will tolerate the full h.t. output voltage between cathode and heater, so that the rectifier heater may be connected in parallel with the heaters of the other valves, with one side connected to chassis. Other rectifier valves, and of course all directly heated types, will not tolerate this and require a separate rectifier heater winding floating at h.t. voltage on the mains transformer.

If the transformer h.t. winding delivers 250V a.c. or less to the rectifier, a common figure for small amplifiers and receivers, standard 350/380V electrolytics will always be satisfactory for any type of rectifier, whether valve or semiconductor, since this voltage rating withstands the maximum peak voltage which could arise under such conditions. In such equipment there is generally no objection to straightforward substitution of a metal rectifier for a specified valve rectifier.

3 BAND TRANSMITTER

—continued from page 314

50mA should be suitable. If loading is too small speech quality will deteriorate. Excessive loading will reduce r.f. output.

When working with the full anode voltage the p.a. should always be tuned up initially on 'phone, even when c.w. is required, as this helps keep off-tune anode current down. The p.a. stage must not be left operating off tune or without grid current.

V.F.O.

The voltage stabilised v.f.o. originally described for the 160/80m 'phone transmitter is satisfactory*. This v.f.o. operates on 1.75Mc/s. The 160m anode coil is replaced by a slug-tuned coil broadly resonant in the 80m band. Tuning may

The same applies for equipment which derives h.t. voltage by direct rectification of the mains input without a transformer, since the a.c. input voltage is then also below 250V.

Whenever transformer voltages higher than 250V are employed (as in high-power amplifiers and oscilloscopes) care must be exercised if it is desired to replace a specified indirectly heated valve rectifier by a metal rectifier or silicon diode combination.

If any such changes are undertaken, the reservoir (C1) and smoothing (C2) electrolytics, as well as all decoupling electrolytics for individual stages, must be replaced by components of higher voltage rating equal to 1.5 times the a.c. input voltage applied to the rectifier.

The operating voltage across C3 is much lower than that across C1 and C2, because of the large voltage drop across R2 due to anode current of V2a. But until V2 is warm, there is no anode current, so that even C3 charges to the full peak voltage. This will also require replacement.

Apart from such replacements of electrolytics where necessary, a careful check of the complete circuit diagram should be made to see if any other components could be damaged by the higher surge voltages which arise when a metal rectifier is substituted.

PART TWO NEXT MONTH

be done by observing grid current, then leaving the coil alone.

It is necessary to short L3 and C1 may be disconnected. Drive to the 6CH6 is on 3.5Mc/s. for all bands. Any other ordinary v.f.o. is likely to be satisfactory.

Simplifications

If 'phone working only is wanted, R3, C5, C10, C11 and C12 may be omitted, the cathode circuit going directly to chassis. R7 is not wanted, nor the "c.w." switch position. For c.w. only the whole modulator and associated circuits can be omitted. It is also possible to use an 807 as the p.a. with useful results and this type of valve is very inexpensive.

* PRACTICAL WIRELESS, March, 1965.

All this

E.H.T. VOLTMETER FOR OLYMPIC
 ● RECORD PLAYER CONVERSION
 ● IMPROVING SYNC ● MUTUAL
 AND SELF INDUCTANCE BRIDGE
 ● PULSE VOLTAGE TRIPLER plus
 THE LATEST INSTALMENT OF
 "THE OLYMPIC" TRANSISTOR TV
 plus REGULAR SERVICING
 ARTICLES and FEATURES

and more in

Practical Television

August Issue—on sale July 22

TWO-BAND DIPOLES

CONFIGURATED COAX-FED AERIALS by F. G. Rayer

A HALF-WAVE dipole, centre fed with a coaxial or twin line, is one of the simplest aerials which can be used successfully without trouble. Most ready-made, kit and home-built transmitters have a pi-output circuit which allows the transmitter to be loaded directly into a 75Ω or similar coaxial line. This method of working is accordingly very convenient.

An ordinary dipole of this type has two disadvantages which sometimes prevent its use. First it needs to be of particular length and enough space may not be available. Secondly the aerial is generally suitable for one band only, which rather limits operating unless another aerial is also available. Both these difficulties can be overcome to a useful extent.

Dipole Length

Requirements for a single band dipole can best be noted first. An aerial of this kind is shown in Fig. 1. The total length is a half-wave at the operating frequency. This can be found from:

$$\text{Length in feet} = \frac{468}{\text{Mc/s.}}$$

It is usual to cut the aerial for about the middle of the band so that actual coverage includes most of the band. On this basis typical lengths are:

80 metre band ...	128ft.
40 " " ...	66ft. 4in.
20 " " ...	33ft.
15 " " ...	22ft.
10 " " ...	16ft. 3in.

If particular interest lies at the c.w. end of a band, or any other frequency, length can be adjusted to suit.

A 75Ω coaxial feeder is generally used and can be of any length. It may run against roof, walls or elsewhere and is thus easily brought back to the transmitter.

Practical Construction

A suitable method of making the aerial is shown in Fig. 2. A ceramic dipole "T" piece is most convenient at the middle and the overall length is measured as indicated. Hard-drawn 14s.w.g. wire is most suitable but 7/26 aerial wire is lighter and cheaper. The 14s.w.g. wire can be tightly twisted at insulators but the 7/26 needs knotting, soldering or binding.

The coaxial cable outer braiding is separated with a pointed tool and twisted into a pigtail. This is soldered to one aerial wire. The inner lead is soldered to the other wire. Tape holds the feeder to the "T" piece. If moisture enters the coaxial cable this will upset working. Some spacing material can be melted with the soldering iron to seal the end. Or a sealing compound can be used. Ribbed insulators are generally used. For supporting, polythene line is excellent.

If the aerial is not too long, and supports are rigid, the wire can be drawn taut from the ends. But if the aerial is long (say for 80m) an additional pole or other support at or near the centre is useful to help take the weight of the coaxial cable. The latter should run away at right-angles from the aerial.

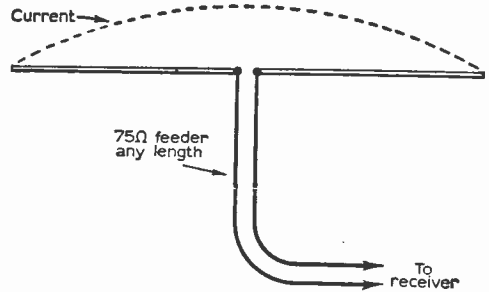

Fig. 1: The usual form for a half-wave dipole.

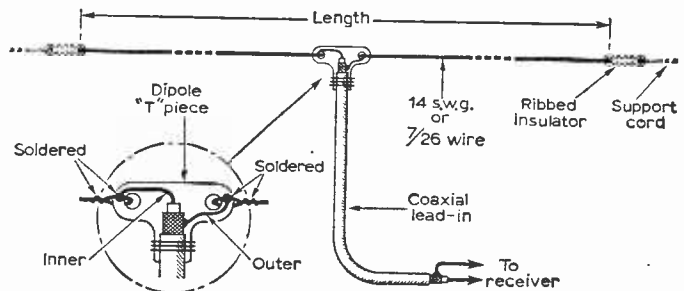

Fig. 2: A practical arrangement for a dipole complete with coaxial feeder.

Two-band Aerial

Distribution of current in the aerial is as shown in Fig. 1 and current is large and impedance low at the centre. This is why the 75Ω feeder is satisfactory.

On any even multiple a high-impedance point will be found near the centre, so the 75Ω feeder is then unsuitable. But on odd harmonics an uneven number of half-waves exist on the aerial, so that the centre is again low impedance. This is shown for three half-waves in Fig. 3.

As a result a 7Mc/s dipole can be used on 21Mc/s. The actual calculated length for three half-waves is:

$$\text{Length in feet} = \frac{492 \times 2.95}{\text{Mc/s.}}$$

It will be found that three half-waves for the 21Mc/s band result in an aerial of about 68ft. Despite this quite good results can be obtained. No other two amateur bands can be covered with a single wire in this way.

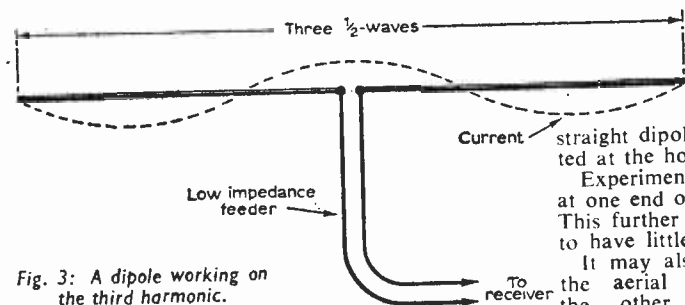

Fig. 3: A dipole working on the third harmonic.

Double Dipole

A dipole for any two chosen bands can be made as in Fig. 4. Length L1 is for the lower frequency band and L2 is for the chosen higher band. One half of L1 is high impedance at even harmonics, so has little effect on the band covered by L2.

In an aerial of this kind made for 3.5Mc/s (80m) and 14Mc/s (20m) bands it was found convenient to suspend the smaller dipole by 6in. ceramic spreaders as used for open-wire lines. L1 was 120ft and L2 33ft. Three spreaders were used each side the centre "T" piece.

On the first day of testing this two-band dipole the best signal report received was strength 8 to 9 from K4QVK, using 120W a.m. Subsequent results in general seemed about the same as those from a single band dipole cut for 20m. On 80m no change in signal strength compared with an 80m dipole could be found.

From these results it appears that the system is

completely practical, though it is clear that the aerial is not one offering any gain in signal strength but merely allowing immediate operating on either of two bands.

It is apparent that if L1 or L2 is operated in the way described for Fig. 3 three-band working is possible. That is, coverage is given for 7Mc/s, 21Mc/s and one other band.

Bent Dipoles

Since the aerial has to be a half-wave this may require a clear span greater than available. This can often be overcome by using some other configuration for the dipole.

Tests show that the conventional arrangement of elements in line can be varied considerably, without much loss of efficiency. A dipole with its two wires at about right angles has almost no directivity. Lengthy tests with such an aerial showed no obvious loss at all, compared with the

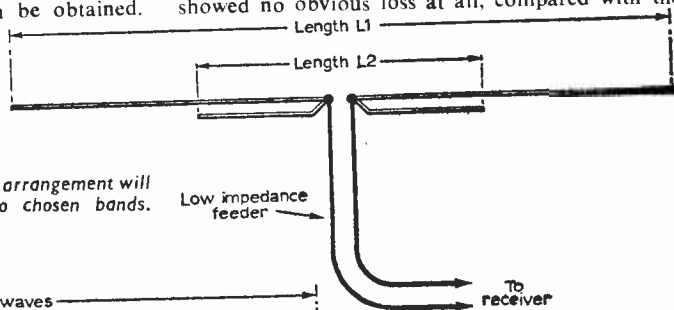

Fig. 4: This dipole arrangement will work for any two chosen bands.

straight dipole. The apex and feeder were supported at the house.

Experiments were made by letting several feet at one end of the horizontal wires drop vertically. This further reduces the space needed, and seems to have little effect on radiation.

It may also be possible to have one half of the aerial in a roof or attic space, with the other half suspended over a short garden. Sloping dipoles were also tried, the angle being from about 30° from vertical to 45° so that 15m and 20m band aeriels could run from a single pole down to an anchor point a few feet from the ground. These all gave good results.

Length Adjustment

When making tests with practical dipoles which were in part near earth or walls, etc., it became apparent that the theoretical length as calculated in the way described was not always best. As a result, it was found that some aeriels would load the transmitter in a satisfactory manner near the low-frequency end of the band, but not near the HF end.

This is cured, if necessary, by pruning the outer ends of the aerial. With a 80m aerial, there will probably be no harm in cutting off 2ft. at each end to begin. But with the higher frequency bands, pruning should be correspondingly less, say about 2 per cent of the total, at a time.

circuits for PHOTOCELLS

FOUR circuits are described, starting with a simple design using the photocell in series with a relay and supply and concluding with a more advanced device using two cells and a transistor logic circuit.

There are several different types of device which are called collectively "photocells". This article is concerned only with one type: the photoconductive cell, which is compact, fairly cheap and suitable for most switching applications. The photoconductive cell is essentially a resistance which changes its value according to the intensity of the light falling on it. Cells are available which give a very large change of resistance with light intensity; a typical change might be from $10M\Omega$ to 300Ω when the cell is exposed to bright, unfocused daylight after being in complete darkness. From this it can be seen that a simple switching circuit need be no more complicated than that shown in Fig. 1.

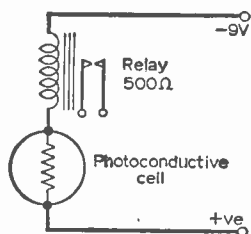

Fig. 1: A simple switching circuit employing a photocell.

With the values given the current in the relay when the cell is illuminated will be a little more than $10mA$ and this should be sufficient to operate many surplus relays.

The values are given simply as an example and are not critical. For instance, the supply voltage could easily be increased to $12V$ if required. The range over which the supply voltage and relay resistance can be changed is limited by three considerations:

(1) The current required in the relay for it to operate. This is determined by the mechanical construction of the relay and will fix an upper limit to the relay resistance for any given supply voltage.

(2) The maximum voltage which the cell can sustain across it. If the voltage across the cell

exceeds a certain value it will "break down" and become permanently damaged. This maximum permissible voltage is usually about $100V$ or above.

(3) The power dissipated in the cell. This is measured in the normal way by the product of the voltage dropped across the cell and the current flowing through it. Photoconductive cells are not usually capable of dissipating much power and this places an upper limit to supply voltages and a lower limit to relay resistance. The maximum power which a cell can dissipate varies according to the type. For the Mullard ORP12 (which is the cell for which Fig. 1 was designed) the value is $200mW$. The circuit must be designed so that this value is not exceeded for any intensity of illumination. The cell is not necessarily dissipating the most power when it is fully illuminated and the current is at a maximum, nor when it is in the dark and the voltage across it is at a maximum. The most power is dissipated when the current flowing is half the value it would have if the cell were short-circuited and the relay placed straight across the supply.

Suppose a circuit is required to operate a $1,000\Omega$ relay which needs $20mA$ to actuate it. Assuming a maximum cell resistance when illuminated of 200Ω then:

Supply voltage = $20 \times (1,000 + 200) = 24V$.

Dissipation in cell = $80mW$ at $20mA$ current and = $144mW$ at $12mA$ (with relay alone $I = 24mA$). Since these values are within the maximum ratings for the cell (ORP12) the circuit will be satisfactory.

The photoconductive cell is not sensitive to the polarity of any voltage across it. Consequently in the simple circuit of Fig. 1 it is not necessary to use a d.c. supply; a.c. is equally satisfactory. It should, however, be remembered that the values given for a.c. voltages are usually r.m.s.; it is important to consider whether the peak supply voltage (r.m.s. $\times \sqrt{2}$) is going to cause the cell to exceed its maximum voltage rating.

If it is desired to make the sensitivity of the circuit adjustable a variable resistance can be put in series with the other components. As the relay is held on when the cell is illuminated it is best to use a relay with changeover contacts, so that the circuit is suitable for such applications as automatic garage door opening by the headlights as well as detecting intruders or counting people passing through doorways.

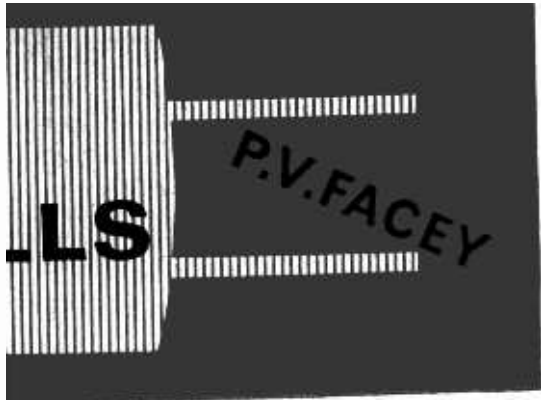

The circuit of Fig. 1, whilst it has the merit of being extremely simple and compact, nevertheless has some disadvantages. If the cell is used so that it is normally illuminated the relay will be held on all the time and battery drain will be high. Also the power limitations of the cell mean that relays requiring currents above 30mA or so cannot be used.

CIRCUIT ONE

Fig. 2 shows a circuit which overcomes these disadvantages and uses an OC83 transistor as a current switch operated by the cell. In this circuit the photocell forms part of a potential divider to which the base of the transistor is tapped. When the cell is illuminated the transistor will be cut off and the total battery drain will be substantially equal to the current flowing in the potential

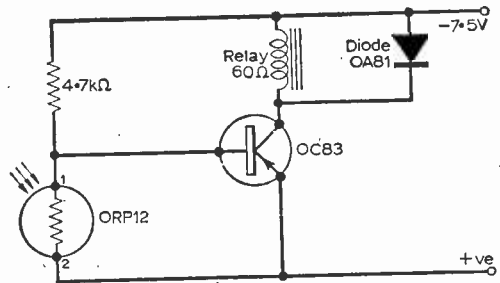

Fig. 2: In this switching circuit the photocell operates the transistor as a current switch.

divider. This is less than 2mA and so photocells with a low power rating can be used provided they give a suitable change in resistance.

The magnitude of the collector current is determined by the supply voltage, the relay resistance, the current gain of the transistor (α) and the base current. With the values given in the figure and assuming $\alpha=90$ we have:

$$I_c = \alpha \times I_b, I_b = 1.5\text{mA approximately.}$$

$$\therefore I_c = 90 \times 1.5 = 135\text{mA.}$$

However, since the maximum voltage across the relay is 7.5V and it has a resistance of 60Ω the current is limited to $7.5/60=125\text{mA}$. Any relay

that will operate at this current or below will do and the coil resistance need not be exactly 60Ω. If a relay with a different coil resistance is used the 4.7kΩ resistor should be changed accordingly to give a suitable base current. The OC83 can carry a maximum collector current of 500mA but for power dissipation reasons it is necessary to limit the current to a maximum value of considerably less. Currents up to about 200mA should be O.K. The OAB1 diode is placed across the relay to short-circuit any induced e.m.f. set up across the relay windings when the transistor switches off. If the diode were not present any induced e.m.f. due to the relay inductance would give rise to a large voltage across the transistor at a time when it is still conducting quite heavily. In other words, the transistor would be called upon to dissipate too much power.

CIRCUIT TWO

Fig. 3 shows a circuit with variable sensitivity using a 100Ω 20mA relay. The circuit can be adjusted to respond to any desired intensity of light above a certain minimum. It will work equally well with a bright focused beam and with the light from a 60mA pea bulb underrun at 40mA from a supply chopped at 10c/s. The

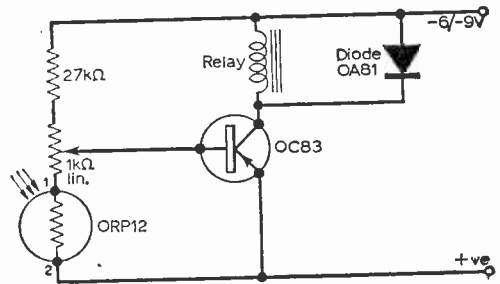

Fig. 3: This circuit, which incorporates a sensitivity control, was found to work well even with an underrun 60mA bulb as the light source.

circuit has been run under these latter conditions for five hours in daylight with the cell unshielded and placed a few centimetres from the flashing bulb. The relay oscillated in sympathy with the light for the whole period in spite of the changing ambient light level. Since the transistor was continually being switched on and off during this time this trial serves as a good test of power stability. The transistor did not heat up at all.

There is much scope for experiment in the circuits of Figs. 2 and 3. Almost any relay to hand may be tried (with due attention to the power handling capacity of the OC83) and the potential divider adjusted to suit any special requirement. Additional sensitivity to dim light may be achieved by connecting point A to a third supply line, positive with respect to the 0V line. (+1.5V, 0V and -7.5V supplies can readily be obtained from a 9V grid bias battery). Different types of screening, lattice windows and coloured filters can also be tried. Photoconductive cells will respond to most of the visible spectrum and

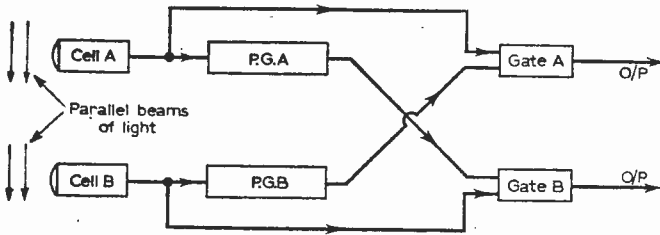

Fig. 4: An arrangement for a device to determine the direction of a body passing two cells.

through the beams in the direction of the arrow and that we call the output of the cells "0" when they are illuminated and "1" when the beam is interrupted. The pulse generator in this circuit is a device that only emits a short output pulse when its input goes 1/0. The gate has output 0 only when both its inputs are 1. Fig. 5 is the practical circuit and 1 indicates a potential of 0V and 0 a potential of -7.5V when related to this circuit.

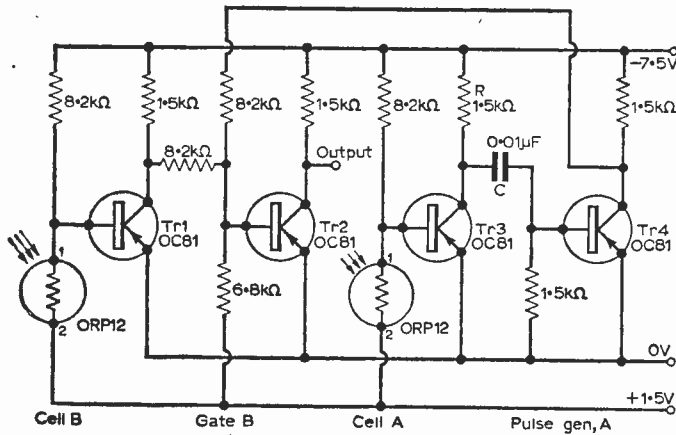

Fig. 5: A practical circuit for the arrangement of Fig. 4.

also to infra-red rays which cannot be seen by the human eye. This is useful for burglar alarms.

the body moves out of beam B, P.G.B. gives a short pulse, but as cell A (Tr3) is at 0 gate A is unaffected.

CIRCUIT THREE

Fig. 4 is a schematic diagram of a device which uses two parallel beams of light across an entrance with two cells and is capable of determining the direction in which any body interrupting the beams is going. Suppose something is travelling

As the circuit (Fig. 4) is symmetrical gate A will produce a pulse when something passes through the beams in the opposite direction. If a body only passes through one beam, or is too thin to interrupt both beams simultaneously, the device gives no output. This may be used to discriminate between persons and arms where it is necessary to prevent people from interfering with a counter by moving their arms through the beams or between pedestrians and vehicles. If it is required to detect objects moving in one direction only, half of the circuit can be removed (i.e. to detect objects moving in the direction of the arrow P.G.B. and gate A can be discarded). Fig. 5 gives the circuit of such a unidirectional device; for bidirectional detection Tr3 and Tr4 should be duplicated with associated components.

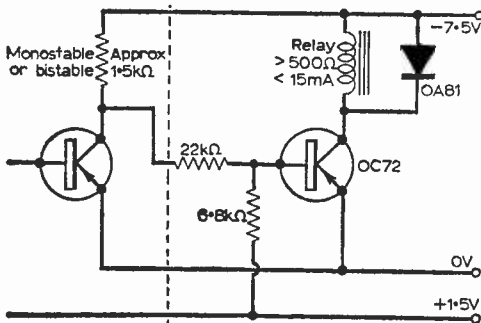

Fig. 6: A relay drive circuit.

The width of the output pulse is determined by the time constant CR and will be less than 1mS with the values given. Such a short pulse cannot be detected on a meter and, unless the device is feeding into further electronic equipment, it is necessary to connect the output to some prolonging circuit such as a monostable. In the case of a unidirectional circuit and if the operation initiated

—continued on page 338

LIGHT PROGRAMME EXTENSION

by V. E. Holley

THE design to be described is essentially a simple inexpensive fixed-tuned Light Programme receiver which is fitted into an extension speaker cabinet. By a system of simple switching either the programme on your main receiver, or on this receiver may be selected at the extension position. Construction is simple and there are no problems of alignment or stability; the less experienced constructor may therefore attempt it with confidence.

Circuit Description

Fig. 1 shows the circuit of the prototype. The ferrite rod aerial fitted with a long wave coil L1, is fixed-tuned by C1 to 200kc/s. V1, an EF91 high gain r.f. pentode, is a most versatile and inexpensive valve. The arrangement of V1 is conventional,

and the stage gain is high and selectivity ample for reception at 200kc/s.

Further r.f. amplification is provided by a second EF91, V2. It must be explained at this stage, that the prototype unit is in service in a locality where the Light Programme is not very well received. In many areas V2 and its associated components will not be required and the amplified signal from V1 may be passed through capacitor C4, direct to the diode detector D1. With only one r.f. stage, the decoupling components R2 and C2 can also be dispensed with. These modifications simplify the receiver considerably. As a guide, the single stage version worked very well in the North-west London area but V2 had to be added for satisfactory results in South-west England.

A GEX34 crystal diode, is used as a detector, and the rectified signal passes via the filter network C7, R8 and C8, and thence to the volume control VR1.

A.F. amplification and output are provided by an ECL82 triode-pentode. Bias for the triode section is obtained through the 10MΩ grid resistor R9, and the cathode can therefore be returned direct to chassis. R10 is the anode load resistor, and C10 couples the audio signal to the grid of the pentode section. R11 and C11 are audio decoupling components. The usual biasing components are included in the pentode cathode circuit, while in the anode circuit, a filter network, comprising R14 and C13 give tone correction. The optimum load for the ECL82 is 9,000Ω and the output transformer should therefore have ratio of about 55:1 for a 3Ω speaker or 25:1 if the speaker is of 15Ω impedance. There will be a voltage drop across the primary winding of the output transformer and resistor R13 ensures that the voltage at the screen grid shall not exceed that at the anode.

Power Supply

The total h.t. current requirement with two r.f. stages is 60mA at 230V, while the valve heaters need 2A at 6.3V. This is provided by a miniature

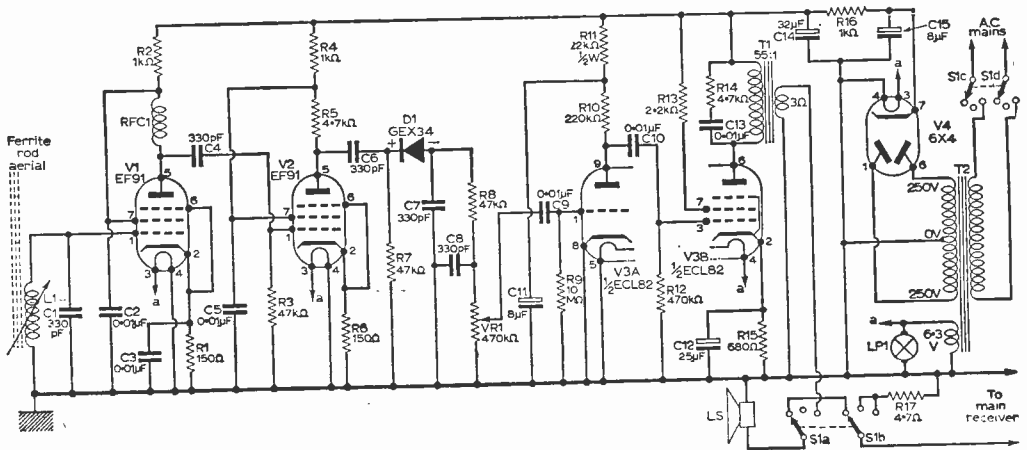

Fig. 1: The Light Programme receiving circuit.

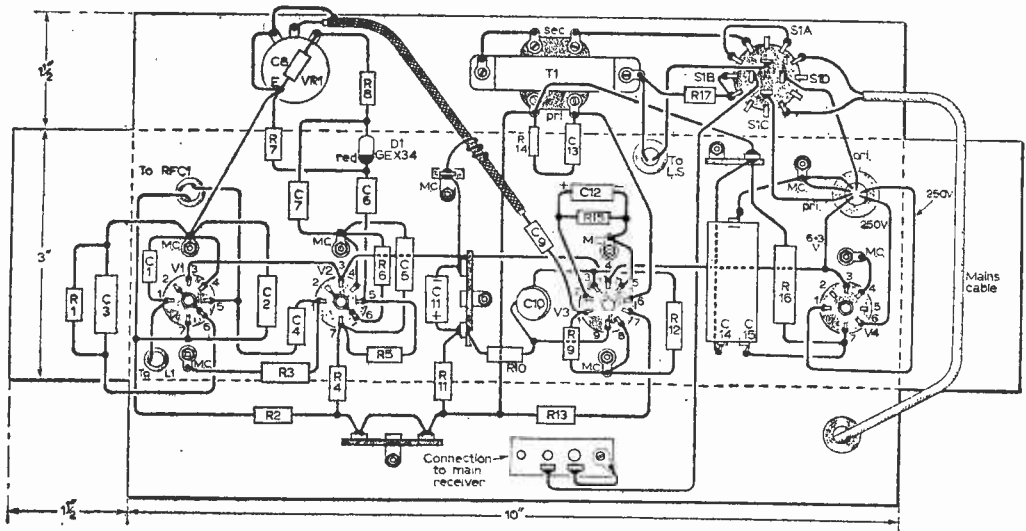

Fig 2: The underchassis wiring of the unit.

mains transformer and a 6X4 valve rectifier. Any other arrangement which provides these currents and voltages will be quite suitable, however, if half-wave rectification is used, it will be necessary to double the value of the reservoir capacitor C15. Smoothing is provided by resistor R16 and capacitor C14. Depending on whether there are one or two r.f. stages and upon the transformer-rectifier combination employed, the value of R16 may need alteration to bring the h.t. line voltage within the range 230–250V. A 6.3V 0.3A pilot light is fitted in any convenient position on the front of the speaker cabinet.

Connection to Main Receiver

Switches S1 a, b, c and d, are the poles of a 4-pole, 3-way switch. This is arranged so that, from a central OFF position, rotation in one direction connects the speaker to the main receiver and in the other, to the internal receiver, at the same time switching the power supply as necessary. Switch S1b introduces a dummy resistive load at the positions where the speaker is not connected to the main receiver, so that the loading of the main output stage will not be upset by operations at the extension. If the extension speaker is of 15Ω impedance, the value of R17 should be increased to

COMPONENTS LIST

Resistors:

R1	150Ω	R10	220kΩ
*R2	1kΩ	R11	22kΩ
*R3	47kΩ	R12	470kΩ
*R4	1kΩ	R13	2.2kΩ
*R5	4.7kΩ	R14	4.7kΩ
*R6	150Ω	R15	680Ω
R7	47kΩ	R16	1kΩ, 5W
R8	47kΩ	R17	4.7Ω
R9	10MΩ		

All 10% 1/4W carbon, unless otherwise stated
VR1 470kΩ potentiometer

Valves:

V1	EF91	V3	ECL82
*V2	EF91	V4	6X4

Inductors:

L1	Dual-wave ferrite rod aerial (Denco FRA2)
RFC1	R.F. choke (Denco RFC7A)
T1	Output transformer. 55:1 ratio for 3Ω speaker; 25:1 ratio for 15Ω speaker
T2	Mains transformer. Secondaries: 250-0-250V, 60mA; 6.3V, 2A

Capacitors:

C1	330pF silver mica 350V
*C2	0.01μF paper 350V
C3	0.01μF paper 350V
C4	330pF silver mica or ceramic 350V
*C5	0.01μF paper 350V
*C6	330pF ceramic 350V
C7	330pF ceramic 350V
C8	330pF ceramic 350V
C9	0.01μF paper 350V
C10	0.01μF ceramic 350V
C11	8μF electrolytic 350V
C12	25μF electrolytic 25V
C13	0.01μF paper 350V
C14	32μF electrolytic 350V
C15	8μF electrolytic 350V

Miscellaneous:

S1	4-pole, 3-way rotary switch
D1	GEX-34 or similar diode
LPI	6.3V, 0.3A pilot lamp
	Three B7G and one B9A valveholders. Lampholder. Tinned copper wire, sleeving, grommets, etc.

*These components are not required if there is to be only one r.f. stage.

about 22Ω . The connection to the extension line is made by way of a non-reversible plug and socket as shown in Fig. 2, the "earthy" side of the line being taken to the larger of the plug pins.

Construction

This is not at all critical and the size and shape of the chassis can be varied to suit the cabinet into which it is to be fitted. For the prototype, an 8in. speaker in a cabinet 12 x 12in. offered a narrow space at the bottom and a chassis 10 x 3 x $1\frac{1}{2}$ in. of 18s.w.g. sheet aluminium was used. Because of the proximity of the aerial, V1 and V2 must be screened and RFC1 must also be enclosed in a screening can. A satisfactory mounting for the aerial can be made from sheet aluminium, cut to shape shown in Fig. 3 and bolted to the rear chassis runner. Fit rubber grommets into the two $\frac{1}{4}$ in. holes and pass the aerial rod through them as shown in the illustration.

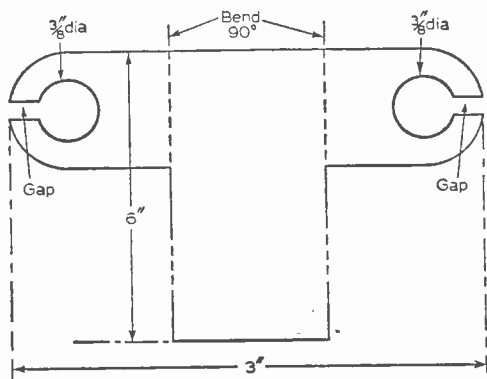

Fig. 2: A suggested addition to the chassis for mounting the ferrite rod aerial.

Fig. 3 shows all the wiring and the approximate positions of the components on the chassis. Tinned copper wire of 22s.w.g. covered with sleeving, is suitable for all the wiring. Work can proceed in any desired order, but it is convenient to deal with the power, output and a.f. stages first and to fit the aerial last, one lead from L1 being earthed at a convenient point above chassis. The ratings for resistors and capacitors are given in the components list. No special components are required but it is convenient to use a disc ceramic for C10.

Testing and Alignment

When all the wiring is complete, check with a meter between C15 and chassis to see that there are no shorts in the h.t. circuits. Now connect the power supply and after allowing a minute or so for warming up, advance the volume control and slide L1 along the ferrite rod until the programme is heard. Accurate tuning is obtained by connecting a high resistance voltmeter, positive to chassis, across V1 and adjusting the position of L1 carefully for maximum indication. Alternatively, the adjustment can be done by ear at very low volume. When the best position for L1 has been found, fix it in position with a little beeswax. ■

NEXT MONTH IN PRACTICAL WIRELESS

THE 'RECORDIO' RADIO TUNER

Designed to be built into a tape recorder for straight-through radio via the recorder amplifier, or the recording of radio programmes.

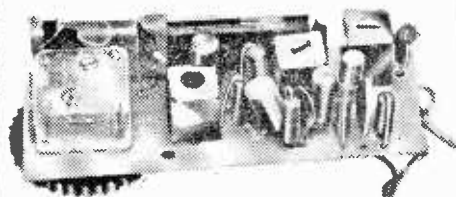

BAND EDGE MARKER

Crystal controlled unit, using a single transistor, giving band edge markers for 80, 40, 20, 15 and 10 metre bands.

THE VERSATILE EF50

Still available for a shilling or two on the surplus market, this valve can be used for a wide number of applications.

TRANSISTOR TWO

Constructional details for a 2-transistor, four-stage reflex receiver for beginners.

SEPTEMBER NUMBER
on sale August 5th

ORDER YOUR COPY NOW!

Wonderful Response

You will, I am sure, be pleased to know that my letter, printed in the May issue of *Practical Wireless*, has more than served its purpose.

I have received a complete set of transformers from a student in Bridlington and a set of slugs from a Londoner. I also received a rather bald request for "the h.f. coil" with no mention of slugs at all! Even then I would have replied, of course, if he had had the goodness to include a s.a.e.

Perhaps the most pleasant result of your publication was a brief note asking me if I was a person the writer knew years ago in . . . I am indeed, so you have found an old friend for me!

Again many thanks and my best wishes for the continued success of P.W.

G. H. Scholey, G3CDR.

Dartford,
Kent.

Like Practical Television

I AM a keen reader of *Practical Wireless* and *Practical Television*. I think that they are both excellent magazines but I would like to see a Test Case relating to radio in *Practical Wireless*. I would also like to see a monthly section on Servicing Radio Receivers set on similar lines to Servicing Television Receivers as in *Practical Television*.

Wm. G. Hall.

Billingham,
Co. Durham.

I would be interested to hear what other readers may have to say on the above subject.—
Editor.

Competent Constructors

WITH reference to Mr. R. A. Packer's letter (News and Comment, May issue). In my view, a competent constructor is one who makes the best possible use of components he *already has in stock*. Or to put it another way, no sensible person would go and buy a new Mini if there was a perfectly good and reliable large car of somewhat older vintage already in the garage.

H. T. Kitchen.

Nuneaton,
Warwicks.

NEWS AND.

SEMICONDUCTOR SUPERMARKET

For the first time in the UK, semiconductor components will soon be available on a self-service basis in a number of centres throughout the country.

Pre-packaged components complete with technical data and information booklets will be displayed in selected retail shops where constructors will be able to help themselves to a range of solar cells, transistors, rectifier diodes, zener diodes, silicon controlled rectifiers, selenium photocells, etc.

The manufacturers of all the products are International Rectifier of Oxted, Surrey, and the first semi-conductor centre opened at Stern-Clyne Ltd. in Holloway Road, London, during May.

All these components have guaranteed performance figures and in the case of such items as transistors, hundreds of American and European equivalents are listed in accompanying literature.

HONG KONG IMPORTS BRITISH RESISTORS

A British electronics firm—Morganite Resistors—is exporting a quarter of a million resistors to Hong Kong every week. According to a recent announcement this is because Japan—a major component supplier to the Hong Kong radio industry—cannot make resistors of the same accuracy within the price range, with a tolerance of better than 10%.

The resistors are mainly used in low-cost transistor receivers.

MINIATURE 18W SOLDERING IRON



This new 18W miniature soldering iron—model "G"—was announced recently by Antex Limited of Grosvenor House, Croydon.

As in all Antex irons, the heat-source of this model is placed inside the actual bit, which is split to prevent "freezing" to the iron. Extra heat storage capacity is achieved with this particular iron in the heavy shank of all the bits designed to fit it. In fact there is a range of four bits (from $\frac{3}{8}$ in. to $\frac{1}{2}$ in.) available for the model "G".

Complete with bit the iron weighs between two and three ounces (according to the bit used) and costs 32s. 6d.

RADIOTELEPHONES FOR TANKER FLEET

The installation of a v.h.f. a.m./f.m. radiotelephone in the S.S. *British Holly* this year brings the number of Redifon v.h.f. equipments now in use aboard B.P.'s fleet of tankers up to one hundred. A similar installation was also made in the 100,000 ton *British Admiral*—the largest tanker ever built in Europe.

Redifon supply two types of v.h.f. radiotelephone—the GR.286 Mk.2 and the GR.289 Mk.2—for use in vessels of all classes. The GR.286 Mk.2 provides complete coverage of all allocated f.m. channels in the International Maritime band of 156–162Mc/s.

The GR.289 Mk.2 radiotelephone provides 11 f.m. channels and covers international distress and safety, inter-ship, port control and radar advice services while also providing public correspondence and private band ship-to-shore channels.

.. COMMENT

IMPROVED WIRE STRIPPERS

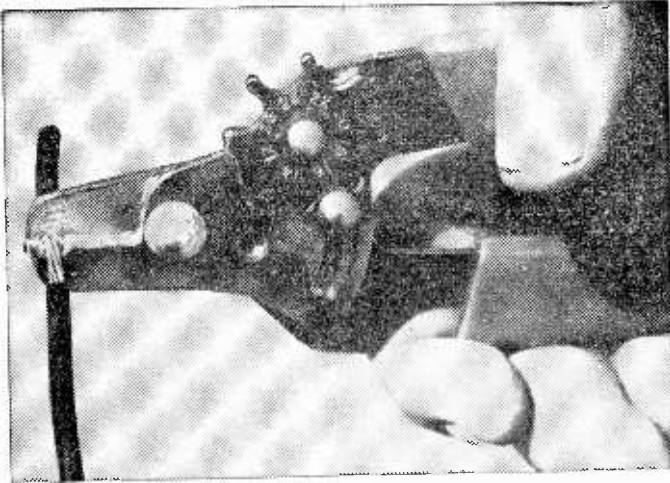

A wire stripper and cutter, more sophisticated than previous models, has been introduced by Multicore Solders Limited (Maylands Avenue, Hemel Hempstead, Herts.).

The tool is in the form of a pair of pliers and is shown in the photograph above. A rotating gauge on the side selects the depth to which the stripper blades cut for any Standard Wire Gauge between 12 and 26, while the blades will also cut through any wire or flex if required. The price is 7s. 6d.

ELECTRICAL ENGINEERS EXHIBITION 1966

Over 30,000 sq. ft. of extra floor space will be available to exhibitors at next year's Electrical Engineers Exhibition.

Already the dates for the Exhibition, to be held once again at Earls Court, London, have been fixed as 23rd to 30th March. Increased overseas participation is expected at the larger show.

RADIO/TV LICENCES TOP 13½ MILLION

The total number of combined sound and television receiving licences in the UK now stands at over 13½ million. The actual figures for April just issued, show an increase during the month of 42,722 to 13,295,767.

The number of sound only licences continues to decrease, the April total being 2,788,405, including 630,191 for sets in cars.

TELEGRAMS VIA EARLY BIRD

During June American telegraph companies and selected customers in Great Britain exchanged pictures and data, telex calls and public telegraph messages via the Early Bird satellite. (Before this Early Bird had been used to relay trans-Atlantic television exchanges).

The telegraph messages transmitted, were ones selected at random from normal "traffic", and were transmitted both by trans-Atlantic cable and by the satellite. Recipients of these received two copies of the telegrams, one clearly marked "Via Early Bird".

BECAUSE OF THE LARGE NUMBER OF "OUTSTANDING" "SELL OR LOAN" REQUESTS NOW HELD BY US, WE REGRET THAT FOR THE NEXT FEW MONTHS WE WILL NOT BE ABLE TO ACCEPT ANY LETTERS FOR THIS COLUMN.

Sir, I would be grateful if any reader could sell or loan me . . .

. . . circuit diagram and/or any information regarding the Holland-made radio Type KY5841E "Nr 3731". I do not know the brand but there is a symbol showing an orchestra conductor on the cabinet.—Lee Soon Eng, 147 Sungei Korok, Aior Star, Kedah, Malaya.

. . . any details for making a bass guitar. The main points I wish to know are: the space measurements between the fret wires and the distance from the junction of head and stem to bridge.—G. Braddock, 36 Liardy's Road, Cleethorpes, Lincs.

. . . modification details (2m) for 19 "b" set.—J. H. Dresner, Paul's Hill, Leigh, Nr. Tonbridge, Kent

. . . manual or any information about Gelsco G209 Receiver.—C. R. Dcherty, 5, Bedford Street North, Liverpool 7

. . . a circuit diagram and/or information about the valves used in the "Packard" A00914 four valve superhet m.w. receiver.—E. Jones, 13 Currie Way, Meadowbridge, Cape, South Africa.

. . . information on the connections to, or any other data on, the c.r.t. type CV1526.—A. F. Young, 56 Church Road Kearsley, Bolton, Lancashire.

. . . the details for a s.s.b. adaptor and a circuit diagram and data of a 60W v.f.o. type transmitter and modulator.

Also, could the reader who very kindly lent me the manual for SX2E please let me have his address.—S. L. Anand, 207 I.I.T. Quarters, Katanpour, Kanpur U.P.

. . . any information on the G.P. receiver R1116A, rel. 100/1322, serial No. 888.—P. Hogarth, 16 Blackett Ave., Norton, Stockton-on-Tees, Co. Durham.

. . . any information on the crystal controlled oscillator section of the Elco v.h.f. receiver unit AP61357—62H, No. 1597, including the type and frequency of crystal required.—P. Neeson, 34 Bangor Road, Holywood, Co. Down, N. Ireland.

. . . circuit diagram and information re Hallcrafters Communications Receiver model 540; frequency range 55Mc/s to 44Mc/s.—Nimal Ratnayake, Royal Ceylon Air Force, China Bay, Ceylon.

. . . any information at all on unit R-3/ARR-2X and/or indicator unit type Z6.—D. Bartle, Rynnmede, 35 Oakland Avenue, West Hartlepool

. . . the handbook or circuit diagram for the wireless set (Canadian) 58 Mk.1.—M. Brereton, 38 Burma Road, Stoke Newington, London, N.16.

. . . a circuit of an o.cilloscope using the "Etel 4EP7" tube.—James P. F. Windle, 57 Victoria Rise, London, S.W.4.

. . . the handbook for the R220.—J. Freer, 83 West End, Kirbymoorside, York.

. . . the handbook for the Globe Scout model 65, by World Radio. Also information as to where a stockist for this company exists in Britain.—Denis McCann, 23 Ochilview, Cowie, Stirlingshire, Scotland.

. . . a service sheet or circuit diagram for Smith's Radiomobile model 4100 or 4200 car radio.—J. Carpenter, 7 Hawkdene, Chingford, London, E.4.

. . . the circuit and servicing manual of the Walter Metropolitan tape recorder.—13 Grange Avenue, Leicester Forest East, Leicester.

. . . any information on the army ser No. 19.—B. Kitcher, 11 Scarborough Road, Blackburn, Lancashire.

PREPARING R.A.E. FOR THE

BRIAN ROBINSON.

10. CRYSTAL OSCILLATORS; FREQUENCY MULTIPLIERS; POWER AMPLIFIERS; TRANSMITTER KEYING; AMPLITUDE MODULATING A TRANSMITTER

10.1 R.F. Oscillator Stability

VARIOUS oscillator circuits were dealt with in a previous article (R.A.E., May, 1965, P.W.) and in each case the frequency of oscillation was determined by an inductance and capacitance combination forming a tuned circuit. (Types of oscillators mentioned included the Tuned Anode-tuned Grid (T.A.T.G.), Colpitts and Hartley.)

In any of these circuits a change in the value of any component in the tuned circuit will result in a change in frequency of the oscillator. For example, if the oscillator valve generates sufficient heat to slightly alter the size of the inductance a gradual frequency drift will occur. Changes in voltages applied to the valve electrodes may also cause frequency changes as different voltages will cause different amounts of heat to be generated. Mechanical vibrations in an oscillator may also cause frequency changes—and can even modulate the oscillator frequency.

An extremely stable oscillator can, however, be constructed which does not use the familiar inductance/capacitance in the grid circuit but instead uses a quartz crystal.

10.2 Crystal Controlled Oscillators

The frequency of an oscillator can be maintained at a constant level by using a quartz crystal as the tuned circuit. The crystal is resonant at a particular fixed frequency and this is determined almost completely by the dimensions of the crystal. In fact the thickness of the crystal is the

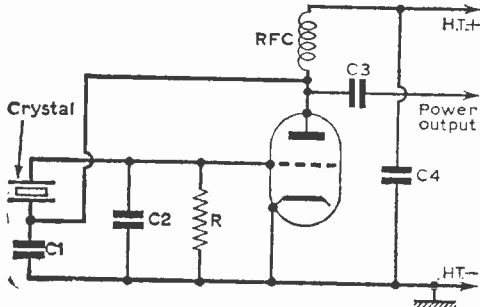

Fig. 88: The Pierce crystal controlled oscillator.

main controlling factor. In order to make a quartz crystal oscillate, however, feedback from the anode to the grid must be facilitated in much the same way as in other types of oscillator mentioned.

When a crystal oscillator is operating, a small current passes through the crystal, this being determined primarily by the amount of feedback applied. If this current becomes too large, heating of the crystal will occur and slight frequency changes will result. It is important to use as low a crystal current as possible—consistent with easily maintained oscillation.

It can be seen that the power output of a crystal controlled oscillator should preferably be kept low and in this respect it is inferior to the inductance/capacitance controlled oscillator.

10.3 Typical Crystal Controlled Oscillator Circuits

In Fig. 88 is shown a very simple crystal controlled oscillator circuit—this is, in fact, a Pierce oscillator.

In Fig. 88 the amount of feedback is controlled by the ratio of the values of C1 and C2. If the circuit is studied carefully it can be seen that C1 is in parallel with the anode/cathode interelectrode capacitance of the valve and that C2 is in parallel with the grid/cathode interelectrode capacitance of the valve. In order to obtain feedback the interelectrode capacitances of the valve are effectively increased. R is a grid leak and may have a value of 20-100,000Ω. R.F.C. is a radio frequency choke and this prevents r.f. power from the oscillator being dissipated in the power supply or from being passed to another circuit through the power supply circuits.

Shown in Fig. 89 is an oscillator circuit which is basically the same as the tuned anode-tuned grid oscillator dealt with previously. In this case the inductance/capacitance in the grid circuit has simply been replaced by a quartz crystal.

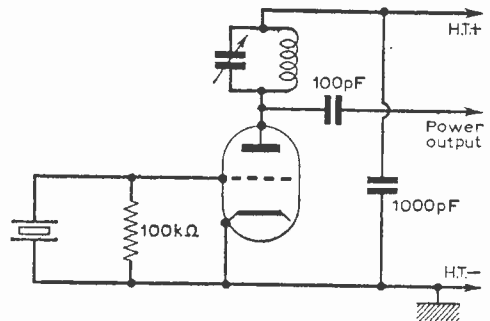

Fig. 89: A grid plate crystal controlled oscillator.

10.4 Frequency Multiplier Circuits

Up to quite recently crystals were only reliable up to a frequency of about 20-30Mc/s, crystals for higher frequencies being very thin and able to operate at very low powers only. Therefore it was found to be comparatively easy to multiply the frequency of operation of a crystal. Frequency

ELECTRONICS

your career . . .
 hobby . . .
 own business . . . ?

The demand for good Electronic Engineers is increasing almost daily throughout the world. Electronics is now the most rapidly expanding of all industries with its applications reaching into almost every sphere of human activity. If you are looking for a new career with new opportunities, then now is the time to choose—Electronics. If you are already employed in this field—then now is the moment to seek high qualifications to secure the top jobs which are waiting to be filled. Most of all, the great potential of electronic development means unlimited scope for the future and will ensure a secure occupation for you—unlikely to be affected by possible future recessions in other industries.

The British National Radio School has had 25 years' experience of HOME STUDY coaching for students wishing to master the fascinating subjects of Electronics—whether the object be career or as a hobby or new interest. The School is entirely independent and specialises ONLY in the teaching of electronic subjects. It employs only fully qualified staff to conduct and supervise each individual course taken by a student and it is this close and personal contact between Tutor and Student which we believe makes possible the successful completion of a course of study.

A special feature of our system is that all courses start right from the beginning and no previous knowledge or experience is necessary or expected. Training is carried out in easy step-by-step stages using the most modern methods of tuition. The great advantage of the home study method is that it provides a complete self-contained course giving everything needed for the subject concerned and enabling work to be done in the comfort of one's own home and over any period of time desired.

EXAMINATION COURSES

- CITY & GUILDS TELECOM. TECHNICIANS CERT.
- CITY & GUILDS FULL TECHNOLOGICAL CERT.
- A.M.Brit.I.R.E. EXAMINATION
- RADIO AMATEURS LICENCE EXAMINATION
- P.M.G. CERTIFICATES FOR RADIO OPERATORS
- R.T.E.B. SERVICING CERTIFICATES

OTHER COURSES

- MATHEMATICS
- TELEVISION
- TRANSISTORS
- SERVO-MECHANISMS
- COMPUTERS
- RADAR & NAVIGATIONAL AIDS

LEARN - THE
 PRACTICAL
 WAY . . .

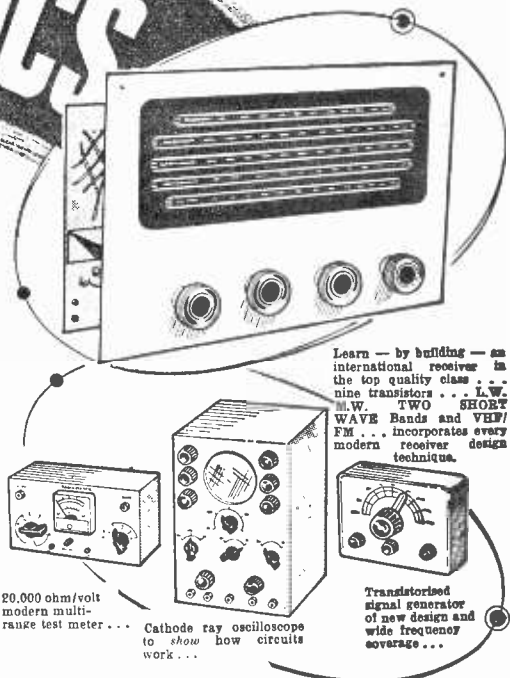

Learn — by building — an international receiver in the top quality class . . . nine transistors . . . L.W. M.W. TWO SHORT WAVE Bands and VHF/FM . . . incorporates every modern receiver design technique.

20,000 ohms/volt modern multi-range test meter . . .

Cathode ray oscilloscope to show how circuits work . . .

Transistorised signal generator of new design and wide frequency coverage . . .



Complete picture way library of theory books and practical manuals NO MATHEMATICS!

BUILD AND EXPERIMENT WITH ALL THE ABOVE—AS—YOU—LEARN . . .

This is a new complete experimental course comprising a mixture of theory and practical work using a very full range of electronic components and apparatus. Starting right from the beginning—or at a later stage if needed—the course enables the student to build up all the basic electronic circuits—amplifier; oscillator; rectifier; detector; etc.—and finally to the design, construction, testing and servicing of a latest design fully transistorised receiver using nine transistors and covering long and medium wave and TWO SHORT WAVE BANDS plus VHF/FM reception. It is of real luxury quality throughout—operates from a 9v. battery and can be used anywhere in the world. Every present-day technique in circuitry is covered and the course also includes multi-range test meter; signal generator and oscilloscope. By the end of the course the student will be able to deal with any type of servicing work with confidence and will also have a very useful workshop of equipment. Nearly 100 interesting and absorbing EXPERIMENTS are carried out during this comprehensive course enabling anyone to gain full mastery of electronics.

FREE



POST NOW

TO: BRITISH NATIONAL RADIO SCHOOL, RADIO HOUSE, READING, BERKS.
 Please send me your free Brochure, giving details of your Courses, without any obligation, to —

NAME

ADDRESS

I am interested in

(We do not employ representatives)

Block Caps Please

courses above PW B/65

British National Radio School

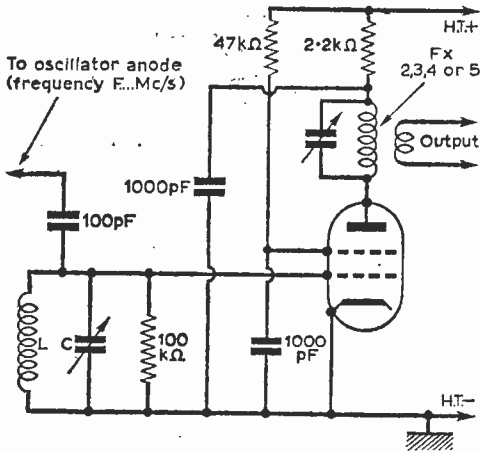

Fig. 90: A frequency multiplier circuit.

multipliers are also of use to enable a single crystal of, say, 3.5Mc/s to be used to obtain output frequencies of 3.5, 7 and 14Mc/s, etc.

In a simple form a frequency multiplier could be as represented in Fig. 90. The tuned circuit in the grid of the valve is resonant at the same frequency as the crystal oscillator and the tuned circuit in the anode may be resonant at two, three, four or five times this frequency. The power output from a frequency multiplier can never be as great as when the stage is used as a straight amplifier. Consequently the greater the number of times the frequency is multiplied the less the power output from the multiplier. Bearing this in mind it is not general to use frequency multipliers which multiply the frequency more than five times.

A simpler frequency multiplier does not use a tuned circuit in the grid but is connected directly to the oscillator anode. This circuit is shown in Fig. 91.

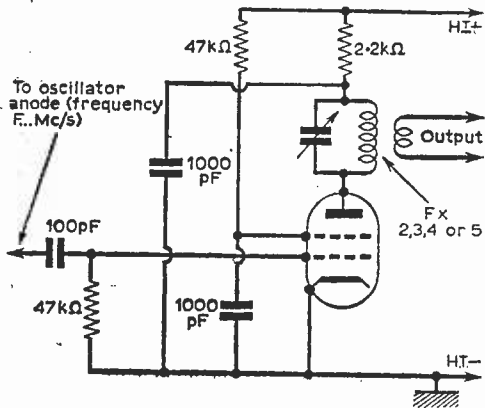

Fig. 91: A simpler frequency multiplier in which the tuned circuit in the grid of Fig. 90 is eliminated.

10.5 R.F. Power Amplifier Circuits

In order to radiate considerable power from a transmitter the signal generated by the oscillator has to be amplified to a very great extent. The function of a power amplifier is, as mentioned, to generate high r.f. powers, but it must also be efficient in respect that harmonic radiation is low. In order to minimise harmonic radiation the Q of the tuned circuits used in a Power Amplifier (p.a.) is made very high.

A simple p.a. is shown in Fig. 92 and L2 may be connected to the aerial or to the next amplifier stage. The load resistance at which the valve operates must be matched to the transmission cable which carries the power to the aerial. For example, the transmission line or feeder may be of, say, 300Ω impedance and, as the p.a. load resistance is usually much higher, L1—L2 constitute a step-down matching transformer.

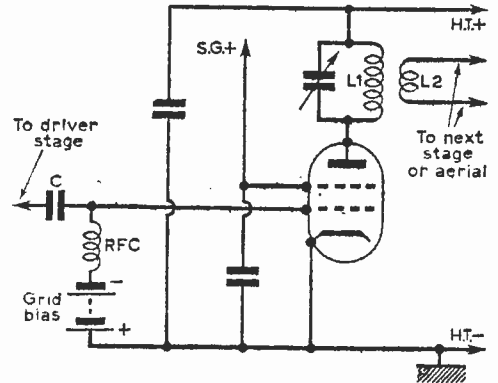

Fig. 92: The circuit of a simple r.f. power amplifier.

In Fig. 92 the r.f.c. is to prevent the power from the driver stage being dissipated in the low impedance bias supply. R.F. power amplifiers are generally operated under Class C or AB conditions. Output circuits will be dealt with further when aerials are discussed.

10.6 Keying a Transmitter

In order to radiate carrier wave (c.w.) signals, using the Morse Code, the output of the transmitter must be reduced to zero after each "dot" and "dash". This is simply a way of saying that in fact the transmitter must be switched on and off in order to radiate the desired signal. This is usually accomplished by using a key. In the interests of safety it is desirable to key the transmitter at a point where high voltages are not present. The key is often placed in the cathode circuit of a crystal controlled oscillator or in the cathode circuit of a buffer amplifier (a buffer amplifier is an amplifier which is used to isolate an oscillator from any higher power amplifier which may follow and it usually operates at the same frequency as the oscillator). In a v.f.o. (variable frequency oscillator) it would be

TECHNICAL TRAINING

in radio television and electronics

Whether you are a newcomer to radio and electronics, or are engaged in the industry and wish to prepare for a recognized examination, ICS can further your technical knowledge and provide the specialized training so essential to success. ICS have helped thousands of ambitious men to move up into higher paid jobs—they can help you too! Why not fill in the coupon below and find out how?

Many diploma and examination courses available, including expert coaching for:

- Institution of Electronics & Radio Engineers (Brit.I.R.E.)
- C. & G. Telecommunication Techns' Certs.
- C. & G. Supplementary Studies
- R.T.E.B. Radio/T.V. Servicing Certificate
- Radio Amateurs' Examination
- P.M.G. Certs in Radiotelegraphy
- General Certificate of Education, etc.

Examination Students Coached until Successful

NEW SELF-BUILD RADIO COURSES

Learn as you build. You can learn both the theory and practice of valve and transistor circuits, and servicing work while building your own 5-valve receiver, transistor portable, signal generator and multi-test meter—all under expert tuition. Transistor portable available as separate course

POST THIS COUPON TODAY

for full details of ICS courses in Radio, T.V. and Electronics.

INTERNATIONAL CORRESPONDENCE SCHOOLS

Dept. 171, Intertext House, Parkgate Road, London, S.W.11

Please send me the ICS prospectus—free and without obligation.

(state Subject or Exams.) _____

NAME _____

ADDRESS _____

8.65

INTERNATIONAL CORRESPONDENCE SCHOOLS

BRAND NEW AM/FM (V.H.F.) RADIO GRAM CHASSIS AT £13.13.0 (Carriage Paid)

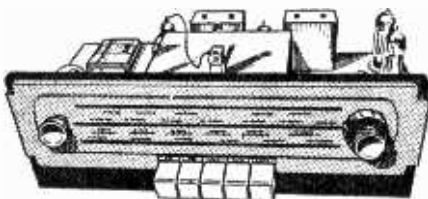

Chassis size 15 x 6 1/2 x 5 1/2 in. high. New manufacture. Dial 1 1/4 x 4 in. in two colours, predominantly cream. 200-250v. A.C. only. Pick-up, Ext. Speaker, Ae. E., and Dipole Sockets. Five pushbuttons—OFF, L.W., M.W., F.M., and Gram. Aligned and tested O.P. Transformer, 1000-1900 M.; 200-350 M.; 85-98 Mc/s. Valves EZ80 rect.; ECH81, EF89, EABC90, EL84, ECC83, 3-ohm speaker required. 10 x 6 in. ELLIPTICAL SPEAKER 25/- to purchasers of this chassis. TERMS: (Chassis) £12.10.0 down and 5 monthly payments of £2.4.0. Cheap Room Dipole for V.H.F., 12/6. Feeder 6d. per yard. ALTERNATIVE DESIGN, L.W. 1000-1900 M.; S.W. (9-15 Mc/s); M.W. 190-475 M.; V.H.F. 87-100 Mc/s. Gram position. Otherwise similar to above chassis. Price £15.15.0 (carr. paid). TERMS: £3.10.0 down and 6 monthly payments of £2.4.0. Total R.P. price £18.14.0. Circuit diagram 2/6.

AMERICAN BRAND TAPE

FULLY GUARANTEED AT RECORD LOW PRICES

MYLAR BASE	
7in. Stand. play, 1,200ft.	12/6
7in. Long play, 1,800ft.	18/6
5in. Double play, 1,200ft.	18/6
5in. Double play, 1,800ft.	22/6
7in. Double play, 2,400ft.	25/-
3in. Triple play, 450ft. (Plain white boxes)	12/6
3in. Triple play, 800ft. (Plain white boxes)	14/-
4in. Triple play, 900ft. (Plain white boxes)	22/6
5in. Triple play, 1,800ft. (Plain white boxes)	42/6
7in. Triple play, 3,600ft. (Unboxed)	75/-

ACETATE BASE		MESSAGE TAPES	
5in. Stand. play, 600ft.	8/-	3in. Stand. play, 150ft.	3/6
7in. Stand. play, 1,200ft.	11/-	3in. Long play, 225ft.	4/11
5in. Long play, 900ft.	10/-	3in. Double play, 300ft.	7/6
5in. Long play, 1,200ft.	12/6	3in. Triple play, 450ft.	12/6
7in. Long play, 1,800ft.	15/-		

SELF-POWERED V.H.F. TUNER CHASSIS

Covering 85-95 Mc/s. Mullard perm.-ability tuner. Dims. 8 x 6 x 6 in. high. Valves ECC85 and 2-EF89's plus 2 diodes with EZ80 rectifier. Mains transformer. Fully wired and tested ONLY £3.17.6 (carr. paid). Room dipole 12/6. Feeder 6d. per yard.



HIGH GAIN PUSH-PULL OUTPUT

AMPLIFIER £5.4.6 (6/- post)

Valves EZ80, ECC83 and 2-ECL 82 giving 8 watts. Chassis 12 x 3 1/2 x 3 1/2 in. With O.P. Trans. for 3 and 16-ohm speaker. Isolated chassis. Bass and treble out. Mike, guitar, radio and crystal pick-up input. Facilities for mixing mike and radio etc. Front panel fixed. Also available as straight 10-watt amplifier with bass, treble and volume controls at £5.5.0. (6/- post). Front panel may be removed on this amp.



4 TRANSISTOR MINIATURE PUSH-PULL AUDIO AMPLIFIER HIGH IMPEDANCE

PRINTED CIRCUIT, 4in. x 2 1/2 in. x 1 1/2 in. over transformers. Output for 3-ohm speaker. Suitable for microphone, record player and intercom 9 volt battery required. Frequency range 100 cps. to 25 Kcps. Push-pull output class B. Instruction sheet provided. Fully wired ready for use. Three types, 200mW 35/-; 600mW 41/-; 1.2W 57/6. (P. & P. 2/6 each).

CM21 CRYSTAL MICROPHONE

With 2.5 mm. Jack plug, 12/6 (Post 1/6). 4 TRANSISTOR BATTERY ALARM. Attractive walnut veneer speaker cabinet 1 1/2 x 8 in. front. Ear piece as mike sensitive at 20ft. x 60ft. Ext. Lead. (P.P.6 battery required)—will last for hundreds of hours. Volume Control and On/Off. Price £3.19.6. (P. & P. 5/-).

GLADSTONE RADIO

66 ELMS ROAD, ALDERSHOT, Hants.

(5 mins. from Station and Buses.) Aldershot 22240
CLOSED WEDNESDAY AFTERNOON
CATALOGUE 6d.

Regret overseas orders cannot be executed.

preferable to key the buffer amplifier rather than the oscillator in order to ensure that the signal does not become "chirpy". A chirpy note results when the keying of the transmitter either directly or indirectly alters the frequency of the oscillator.

When the transmitter key is closed a spark may result; this will generate an r.f. signal but this will only be heard in the immediate vicinity of the transmitter.

When key clicks can be detected on a receiver many miles away they are formed in a different way. When the transmitter is keyed and the carrier wave is interrupted almost instantaneously a key click will result. In order to eliminate the key click the components in the keying circuit must be arranged so that the carrier wave is not interrupted instantaneously but fairly gradually. (The time taken for the signal to reach its peak value is, of course, only measurable in microseconds— μ S.)

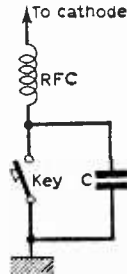

Fig. 93: A typical keying circuit. The r.f. choke and capacitor eliminates key clicks.

A simple keying circuit which could be used in the cathode circuit of a buffer amplifier is shown in Fig. 93. The radio frequency choke and the capacitor act as a filter to eliminate r.f. clicks.

10.6 Amplitude Modulating Transmitter

Modulation is the superimposing of one type of signal on to another, in fact in the cases to be discussed it is the superimposing of an a.f. signal on an r.f. signal.

In Fig. 94a an r.f. signal is represented and in Fig. 94b an a.f. signal is represented. (Scales are not, of course, correct.) If 94a is modulated by 94b the modulated wave will be of the type shown in Fig. 95. The line AB on Fig. 95 represents the mean value of the modulating signal and the ratio of x to y enables the percentage modulation to be calculated, i.e. percentage modulation

$$= \frac{x}{y} \times 100\%$$

Obviously if x equals y the modulation must be 100%. A carrier modulated to 100% is shown in Fig. 96.

If modulation exceeds 100%, distortion will occur as the signal envelope is no longer the same shape as the modulating signal.

When a carrier is modulated the signal which is transmitted does in fact consist of three components, a carrier, an upper sideband and a lower sideband. If a carrier of 100kc/s is modulated by an a.f. signal of 10kc/s the transmitted signal would consist of three components—100kc/s (the carrier), 100kc/s+10kc/s (the upper

sideband) and 100kc/s-10kc/s (the lower sideband). The modulating signal is carried by the sidebands.

10.7 Anode Modulating a Transmitter

A very common method of amplitude modulating a transmitter is anode modulation. The output from an audio amplifier (class A or B and generally push-pull) is passed, via a modulation transformer, to the anode voltage supply of the r.f. power amplifier valve. The modulation of the r.f. amplifier will be 100% when the output of the audio amplifier is such that the voltage appearing at the r.f. amplifier anode varies between 0 and 200% of its d.c. operating voltage.

In order to obtain 100% modulation the sine wave audio power output from the modulator

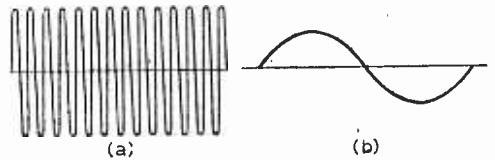

Fig. 94(a): The r.f. signal; (b): the a.f. signal.

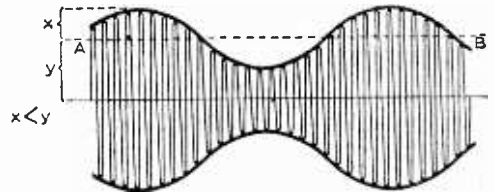

Fig. 95: Here the r.f. signal has been modulated by the a.f.

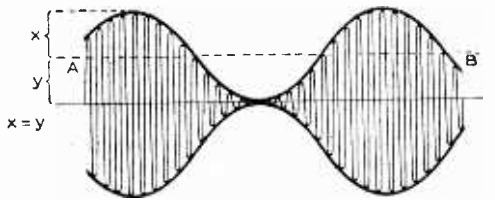

Fig. 96: 100% modulation.

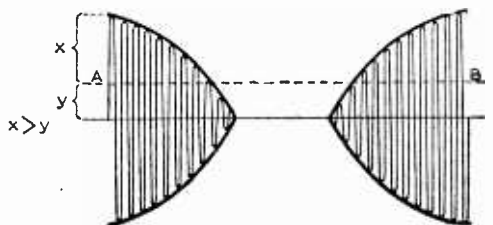

Fig. 97: Modulation in excess of 100%.

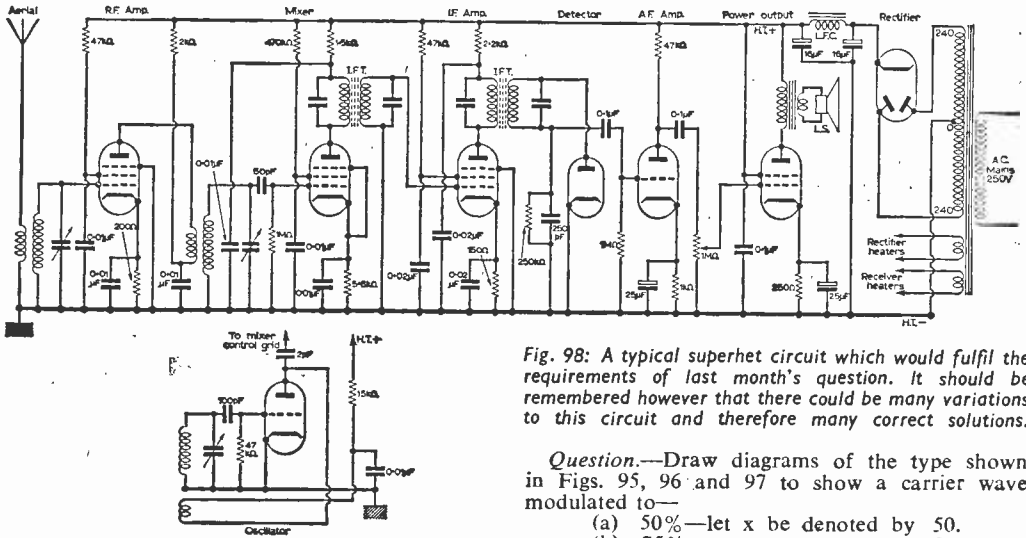

Fig. 98: A typical superhet circuit which would fulfil the requirements of last month's question. It should be remembered however that there could be many variations to this circuit and therefore many correct solutions.

Question.—Draw diagrams of the type shown in Figs. 95, 96 and 97 to show a carrier wave modulated to—

- (a) 50%—let x be denoted by 50.
- (b) 75%— " " " " " 75.
- (c) 150%— " " " " " 150.

Last Month's Question.—A typical answer to this question is as shown in Fig. 98.

PART II NEXT MONTH

must be at least half of the d.c. power input to the r.f. amplifier.

Readers are advised to study also control grid modulation, screen grid modulation and cathode modulation.

SOLAR-POWERED POCKET RECEIVER

—continued from page 302

compromise between the signal direction and the light direction has to be made.

The total cost of the final receiver was about £3, but this may be reduced considerably by using an International Rectifier B2M solar cell, price 15s.

The effect of adding a second transistor was negligible but further experiments may prove

fruitful. The final circuit appears so simple that to many it would appear inconceivable that it works, yet it does. Surely in this circuit the transistor is operating to its capabilities (as they should in all circuits). The field of light operated transistor circuits appears to be almost untouched by experimenters, both amateur and professional (what about Sinclair Radionics Ltd. and others?). The writer would be very interested in receiving details of similar experiments carried out by readers.

PHOTOCELL CIRCUITS

—continued from page 326

by the device has a definite ending (e.g. garage door opening, gate opening, etc.) the output from the gate can be made to set a bistable which controls the opening motor. A limit switch can then be used to reset the bistable when the doors have opened.

No particular transistor is specified for the bulk of the circuit as almost any type will do except surface barrier types.

Fig. 6 shows a suitable relay drive circuit which may be tacked on to any bistable or monostable designed for these supply voltages and with a collector resistance of around 1.5kΩ.

For simple on/off applications the photocell should be mounted in a lightproof box painted matt black inside. A simple lens system using two converging lenses with the cell and lamp filament at the foci will do. The cell lens should be shielded by a tube painted matt black inside so

that light can only enter from sources along the axis of the tube.

The constructor who has some old glass encapsulated transistors which are lightproofed with black paint might like to try making his own photocell by scraping off the paint. The paint can easily be scraped off with a penknife and should be removed from the rounded top end and for about 2mm down the side. The capsule will be filled with blue, white, greyish or transparent grease. Obviously the transparent grease types are best and the blue and white types are no good at all; it is best to repaint them for future use. The scraped transistor will function as a photoconductive cell (emitter +ve) with the base open circuit, but for best results try a resistance between base and emitter. The value will be between 5 and 100kΩ and can be found experimentally. Photocells made in this way will not be as sensitive as proper ones but can be made to work perfectly well by the use of a suitable transistor amplifier stage.

Why

NOT BUILD ONE OF OUR PORTABLE TRANSISTOR RADIOS...

BACKED BY OUR SUPER AFTER SALES SERVICE

ROAMER SEVEN Mk III 5 WAVEBAND PORTABLE OR CAR RADIO

Amazing performance and specification ★ Now with PHILCO MICRO-ALLOY R.F. TRANSISTORS

● 9 stages—7 transistors and 2 diodes
Covers Medium and Long Waves, Trawler Band and two Short Waves to approx. 15 metres. Push-pull output for room filling volume from rich toned heavy "Celestion" speaker. Air spaced ganged tuning condenser. Ferrite rod aerial for M & L waves and telescopic aerial for S Waves. Real leather-look case with gilt trim and shoulder and hand straps. Size 9 x 7 x 4in. approx. The perfect portable and the ideal car radio. (Uses PP7 battery available anywhere.)

Total cost of parts now only £5.19.6 P. & P.
Parts Price List and easy build plans 3/- 5/6

TRANSONA 5 or POCKET 5

● 7 stages—5 transistors and 2 diodes

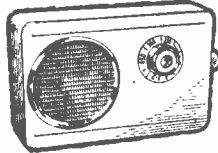

"Transona Five" size 6 1/2 x 4 1/2 in. approx.

Covers M. and L. Waves and Trawler Bands, a feature usually found in only the most expensive radios. On test Home, Light, 208, and many Continental stations were received loud and clear. Designed round supersensitive Ferrite Rod Aerial and new type fine tone super dynamic 2 1/2 in. speaker, attractive plastic cases with red grille.

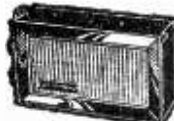

"Pocket Five" size 5 1/2 x 4 x 3 1/2 in.

Total cost of all parts for 42/6 P. & P. 3/6
either type now only (State type required.)
Parts Price List and easy build plans 2/-

TRANSONA SIX

● 8 stages—6 transistors and 2 diodes

This is a top performance receiver covering full Medium and Long Waves and Trawler Band. High-grade approx. 3in. speaker makes listening a pleasure. Ferrite rod aerial. Many stations listed in one evening including Luxembourg loud and clear. Attractive case in grey with red grille. Size 6 1/2 x 4 1/2 x 1 1/2 in. (Uses PP4 battery available anywhere.) Carrying strap 1/- extra.



Total cost of all 59/6 P. & P.
parts now only 3/6.
Parts Price List and easy build plans 1/6



SUPER SEVEN

● 9 stages—7 transistors and 2 diodes

Covers Medium and Long Waves and Trawler Band. The ideal radio for home, car, or can be fitted with carrying strap for outdoor use. Completely portable—has built-in Ferrite rod aerial for wonderful reception. 2 R.F. Stages, push-pull output. 3in. speaker (will drive large speaker). Size 7 1/2 x 5 1/2 x 1 1/2 in. (Uses 9v battery, available anywhere.)

Special circuit incorporating 2 R.F. Stages, push-pull output. 3in. speaker (will drive large speaker). Size 7 1/2 x 5 1/2 x 1 1/2 in. (Uses 9v battery, available anywhere.)
Total cost of all £3.19.6 P. & P. 3/6
Parts Price List and easy build plans 2/-

All components used in our receivers may be purchased separately if desired. Parts price lists and easy build plans available separately at fixed prices stated. Overseas post 10/-

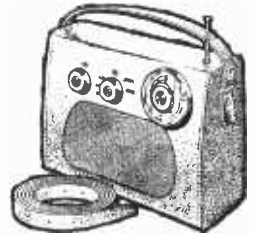

... amazed at volume and performance... has really come up to my expectations!
S. G. Stockton-on-Tees.

MELODY SIX



● 8 stages—6 transistors and 2 diodes
Our latest completely portable transistor radio covering medium and long waves. Incorporates pre-tagged circuit board, 3in. heavy duty speaker, top grade transistors, volume control, tuning condenser, wave change slide switch, sensitive 6in. ferrite rod aerial. Push-pull output. Wonderful reception of B.B.C. Home and Light, 208 and many Continental stations. Handsome leather-look pocket size case, only 6 1/2 x 3 1/2 x 1 1/2 in. approx. with gilt speaker grille and supplied with hand and shoulder straps.
Parts Price List and easy build plans 2/- Total cost of all £3.9.6 P. & P. 3/6

ROAMER SIX NEW!!

NOW WITH PHILCO MICRO-ALLOY R.F. TRANSISTORS
● 6 WAVEBAND !!

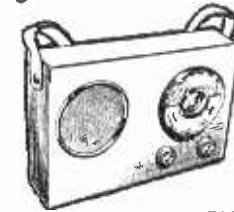

● 8 stages—6 transistors and 2 diodes
Listen to stations half a world away with this 6 waveband portable. Tunable on Medium and Long waves. Trawler band and two Short Waves. Sensitive ferrite rod aerial and telescopic aerial for short waves. Top grade transistors, 3-inch speaker, handsome case with gilt fittings. Size 7 1/2 x 5 1/2 x 1 1/2 in. Carrying strap 1/6 extra.

★ EXTRA BAND FOR EASIER TUNING OF LUX., ETC.
Parts Price List and easy build plans 2/- Total cost of all £3.19.6 P. & P. 3/6

SPECIAL COMPONENT BARGAINS!

- TRANSISTORS, PHILCO MADT (Micro Alloy Diffused). Type 2N503. Maximum frequency of oscillation over 500 Mc/s 15/-
- HEADPHONES, High Fidelity miniature magnetic earpieces (2) on slim band with lead and plug. Easily converted to stereo. American manufacture. 100 ohms impedance. Transformers supplied free for higher impedances 13/6. P. & P. 1/6.
- TUNING CONDENSERS, Air spaced fine quality German manufacture with slow motion drive. 0.0005 with oscillator section 5/-. Post 1/-
- CYLDON PERMEABILITY TUNERS, Full M.W. coverage. Fitted coupling coil, oscillator coil ferrite slugs and slow motion tuning with cursor, etc. GIVE AWAY PRICE 10/- P. & P. 1/-

RADIO EXCHANGE CO.

61, HIGH STREET, BEDFORD. Phone: 2367

Callers side entrance
Barratts Shoe Shop
Open 9—5 p.m.
Sats. 10—12.30 p.m.

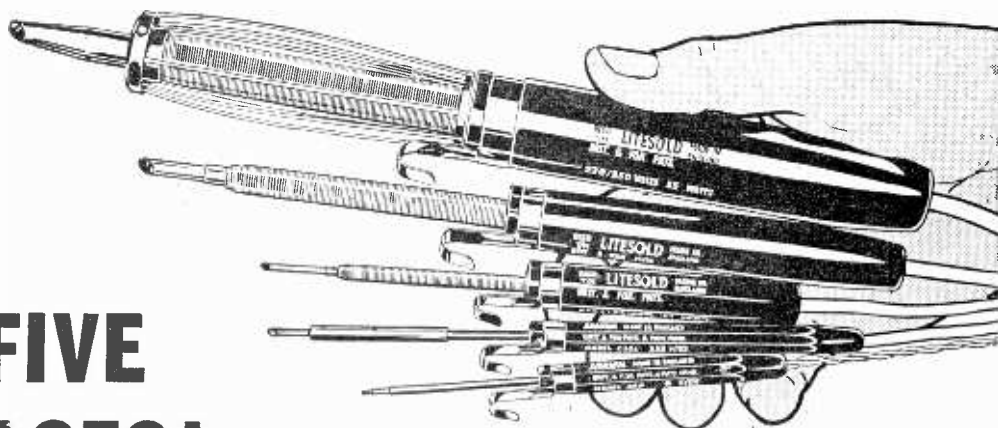

FIVE ACES!

This is a hand that can't be beaten. Five models from our tremendous range of soldering instruments. Superb performance. Amazingly compact. Developed to simplify YOUR soldering. Copper bits for greatest speed. Permatip bits for long life. May we deal you in?

Brochure P.W.10 post free on request

LIGHT SOLDERING DEVELOPMENTS LTD., 28, Sydenham Road, Croydon, Surrey

Telephone: CROydon 8589

NOW ADD F.M. RADIO to your MARTIN AUDIOKIT SET-UP

with only 3 easy-to-assemble prefabricated units

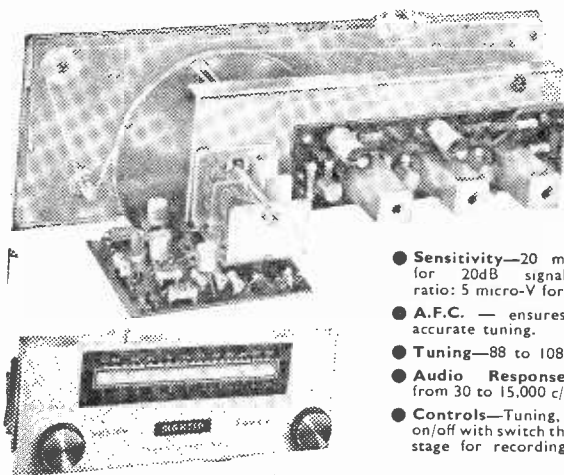

View above shows Units 15, 16 and 17 assembled. Below, the attractive escutcheon.

UNIT 15
F.M. Head
& tuning
condenser

£5.12.6

UNIT 16
I.F. Amp.

£5.7.6

UNIT 17
Mounting drive
escutcheon &
controls.

£1.17.6

SUPERB QUALITY FOR VERY MODEST OUTLAY

From Radio and Hi-Fi Stockists

Trade enquiries invited

MARTIN ELECTRONICS LTD. 154/5 High Street, Brentford, Middlesex ISLeworth 1161/2

The unique and outstandingly successful system developed by Martin Electronics whereby prefabricated transistorised units can be assembled to make your own choice of hi-fi now brings 3 further Units, No. 15, 16 and 17 to enable you to build a modern F.M. Tuner of exceptionally good design and performance. Intended primarily for those who have chosen an Audiokit hi-fi set-up, the Tuner may also be used with other good amplifiers if desired. With a few simple connections, you will have a tuner of excellent appearance to please the most critical ear, yet it is surprisingly inexpensive.

A whole range of Audiokit Units is available which you can assemble to your own choice with ease and complete success. Ask for the Audiokit leaflet.

MARTIN ELECTRONICS

154 High Street, Brentford, Middlesex
F.M. Tuner Leaflet ● Audiokit Leaflet ●
Tick as required

Name

Address.....

P.W.8

A COMMENTARY BY HENRY

PRACTICALLY WIRELESS

No. 12

Little Bittery

THE Radio and Electronic Component Show was held at Olympia from May 18th to 21st.

The old joke about disposable sets—you know, throw it away when the battery runs out—is coming uncomfortably close to reality.

Of the 300 firms exhibiting, more than twenty were making a thing of micro-miniaturisation. Despite the off-hand attitude of one demonstrator, "Needn't bother us, old boy. Thing of the future, what?" I was impressed by the strides recently made by some of the firms we have always regarded as stick-in-the-mud reactionaries. Tiny switches, banks of printed-foil circuits, combination components, and everywhere that with-it word Integration. If a circuit is not integrated nowadays, nobody wants to know.

The ultimate seems to be achieved when our old friends Mullard come up with a three-stage amplifier about the size of a soldered joint. As one critic said: "What's the point if the piece of equipment is smaller than the knob which is being used to control it?"

Whatever the PRO boys may tell you, quoting reliability, efficiency, weight-cost factor, serviceability, etc., it boils down to one essential: is the tiny fellow going to be cheaper to

produce, in quantity than the hand-assembled juggernaut it transplaces? And the answer appears to be Yes. Modern methods have found ways of whittling down capacitors and reducing resistors to strips of etching.

So far, the problem of reducing inductors physically has proved difficult, but the bright lads at Manchester University have been playing about with that one. They have already used computer control on a thin film micro-circuit to prove what can be packed into its 1 square millimetre area and come up with the amazing answer of 100 passive elements. That is equivalent, to save you reaching for the slide rule, to 70,000 per square inch. So, in the space taken up by that coil you can make up practically any R-C combination you wish to supersede it.

Certainly, the modules shown by Eric had quite a few identifiable bits packed into them, and the sub-miniature switches by Elcom and Arrow made one want to hide one's clumsy fingers.

Who makes these things? we wanted to know. How the dickens are they assembled? And the answer, as we might have expected, is that magic word "automation". Cassandra Henry has already commented on the machine that is more reliable than the circuit designer. Here, at Olympia, we saw machines ten times more reliable at fault tracing than any engineer.

Elliott-Automation had an automatic circuit tester that monitors up to 1,000 contact points for continuity and insulation at a rate of ten tests a second. Faster than our apprentice as clocking-off time approaches.

More threatening still, from Solartron we hear of a machine which is programmed to allow



The machine prevents him

the operator to carry out a sequence of tests, or make connections. But if he makes a wrong connection in the sequence, the machine prevents him from making the next move. I was afraid to ask how!

Flexible printed circuits—no, not those from certain portable radios which the makers really intended to be rigid—but genuinely flappable boards, copper-clad laminate that could be bent and shaped without cracks in the foil appearing. That's another thing on the way—as Formica and Electroprints Ltd. showed us. This seems to promise much fun in the workshop.

Yet another aspect of the modern trend is the increasing use of "precious metals". There are firms specialising in the plating of switch contacts with not only silver and platinum, but gold, rhodium and palladium.

With memories of the old days, when circuits were laboriously screwed together by hand, when scraping off a resistor was the accepted method of modification, when the nearest approach to integration were those horrible "blocks" of components covered with shiny black pitch, Henry is not at all sure whether he will be able to bring himself to throw away his radio each time the sun goes in and his solar cell runs down.



Who makes these things?

A DIRECTION
FINDER for
Small Craft
by F. C. Judd
PART TWO

FULL constructional details of this receiver were given in Part 1, together with calibration procedure and notes on the Radio Information Charts which are essential when using the long wave marine radiobeacons. This part deals with a suitable mounting for the receiver and gives further notes on calibration and testing, etc.

Receiver Mounting

The receiver is much easier to handle if it can be rotated through 360° by mounting it on a heavy base as shown in Fig. 8. The base could be made of wood, preferably loaded with brass or lead or, better still, made entirely of brass. A cast-iron

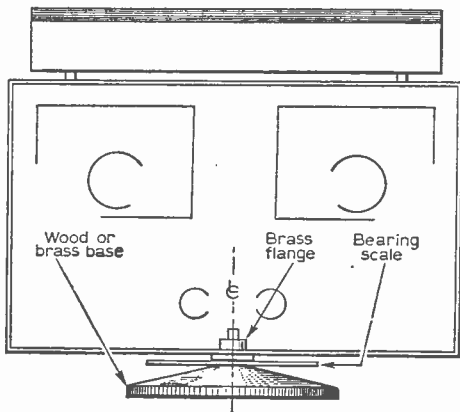

Fig. 8: A suitable mounting arrangement for rotating the receiver on a heavy base.

base could also be used, in fact the one shown in the photograph in Part 1 is cast-iron. In this case, however, careful checks must be carried out to ensure that it does not interfere with the compass. A 360° protractor, obtainable from most large stationers, should be screwed to the top of the base, for this is most useful when working against the heading of a vessel or when there is no alteration in position, i.e. when the vessel is at anchor. A small pointer is attached to the bottom of the receiver case for use with the bearing scale.

The receiver could, of course, be permanently mounted in a vessel providing it (the receiver) can be rotated through 360°. In this case a compass need not be fixed to the receiver but the bearing scale would have to be used in conjunction with the compass on the vessel.

Calibration of the Tuning Dials

The tuning dials, which are small Data Panel Signs (100° type), require pointers which can be attached to the flanges of the Jackson epicyclic ball drives. These pointers can be cut from thin perspex or stout celluloid and shaped and drilled as in Fig. 9. The tuning control knobs can be left to the discretion of the constructor.

The actual calibration of the tuning dials has already been dealt with but as a further guide the diagram in Fig. 10 may prove useful. It is, however, very important that the exact tuning point of each radiobeacon group frequency is known. As it is difficult to mark the actual spot frequencies on the r.f./oscillator dial it is suggested that a separate calibration chart is compiled, this being mounted on stiff card and protected by a celluloid cover.

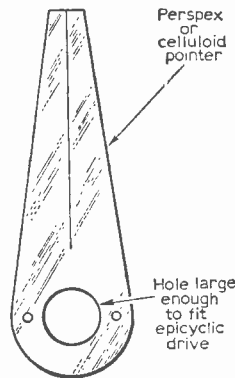

Fig. 9: Two of these perspex tuning dial pointers are required.

Testing the Receiver

Preliminary tests and approximate tuning, etc., can be carried out with a long aerial loosely coupled to the ferrite aerial coil via a small series capacitor. This will allow the radiobeacons to come in quite strongly, but as soon as initial alignment has been completed, close calibration, etc., should be carried out with the band switch in position 3 (d.f.) and any other aerial disconnected. Remember, you may not hear a particular radiobeacon if the ferrite aerial happens to be *end on* (in the null position) to that particular station. When listening for different stations in different

THE LINEAR 'SUPER 30' HIGH FIDELITY PUBLIC ADDRESS AMPLIFIER

TECHNICAL DETAILS

SENSITIVITY FOR 30 WATTS

Gram.—50 millivolts
Mic. 1—5 millivolts
Mic. 2—150 microvolts

FREQUENCY RESPONSE

± 2 dB, 30 c.p.s.—20,000 c.d.

BASS CONTROL

- 15 dB to +15 dB at 50 c.d.

TREBLE CONTROL

+ 12 dB to -12 dB at 10 Kc.

HUM AND NOISE

-60 dB.

HARMONIC DISTORTION

0.5% for 30 watts

VALVES

Mullard ECC83, ECC83, ECC83,
EL34, EL34, GZ34.

NEGATIVE FEEDBACK

20 dB.

DAMPING FACTOR

12.

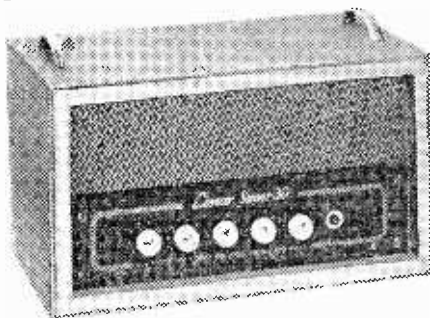

RETAIL PRICE **33 Gns.**

Send S.A.E. for leaflet.

For operation on standard 200-250v.,
50 c.p.s., A.C. mains. 110/120v. models
available for export.

Trade and export enquiries invited.

LINEAR PRODUCTS LTD.
ELECTRON WORKS, ARMLEY, LEEDS

A HIGHLY EFFICIENT
30 WATT GENERAL PURPOSE PUBLIC ADDRESS UNIT

With input mixing facilities and outputs for 3-7.5-15 and 330 ohms (100v line)

A special feature of the 'SUPER 30' is its high degree of stability, ensuring that the longest output leads can be used without fear of the usual troubles associated with instability.

Three high sensitivity standard jack inputs with provision for high and low impedance microphones.

JUST ARRIVED !!



NEW EDITION of the famous **Home Radio Catalogue**

Yes . . . just off the press—Reprint No. 11 of our popular Components Catalogue. It's the *biggest* edition yet . . . an extra 17 pages, listing literally hundreds of new items, plus a supplement! It's *better* than ever too—as you will certainly agree when you examine it. The prices are listed in the separate supplement. Your catalogue will automatically be kept up to date and will thereby have a much longer life than previous editions.

Due to the greatly increased size of this new edition, plus increased costs of printing and paper, we have regretfully had to raise the price a little. It now costs 7/6, plus 1/- for postage and packing . . . but we are retaining the popular feature of including 5 Coupons in the catalogue, each worth 1/- when used as directed. Send off the attached coupon today, enclosing your cheque or P.O. for 8/6.

Please write your name and address in block capitals

NAME.....

ADDRESS.....

HOME RADIO LTD., Dept.PW., 187 LONDON ROAD, MITCHAM

WIRECOMP ELECTRONICS

WIRECOMP'S BARGAIN STORE

48 Tottenham Court Road, London, W.1

Thousands of bargains—Transistor Radios—Record Players—Tape Recorders—Radiograms—Rock Bottom Prices

FAMOUS MAKE TRANSISTOR RADIO THE "STELLA"

7 transistor portable radio. Long, Med. and Short wavebands. Fitted tone switch and sockets for personal earphone and external aerial; chrome telescopic aerial. Uses four 1.5 v. torch batts. Plastic cabinet in beige and red, size 4 x 7 x 1 1/2 in. Excellent tone. 3in. p.m. speaker. Comp. with shoulder strap and external aerial. Full guarantee. List price 17 Gns. **WIRECOMP'S PRICE £9.19.6 P. & P. 5/-**



NEW SUPER MINIATURE POCKET RADIOS

THE SINCLAIR MICRO-6. Self-contained pocket radio. Size only 1 1/4 x 1 3/16 x 1 in. Complete with earphone and detailed construction data. Can be built for only **59/6** Mercury cell 1/11 extra (2 required).

THE SINCLAIR SLIMLINE. The new 2-transistor pocket radio size only 2 1/4 x 1 1/8 x 1 1/8 in. Micro alloy transistorised and printed circuit. All components available separately. Easy to assemble. Can be built for **49/6**

INTERNATIONAL BRAND TAPE—Fully Guaranteed

MYLAR BASE:	ACETATE BASE
3in. Triple play, 600ft. 15/-	3in.—150ft. 3/6
4in. Triple play, 900ft. 17/6	3in.—225ft. 4/11
5in. Double play, 1,200ft. 15/-	3in.—300ft. 7/6
5in. Triple play, 1,800ft. 35/-	5in. Long play, 900ft. 10/-
5in. Double play, 1,800ft. 22/6	5in. Long play, 1,200ft. 12/6
5in. Triple play, 2,400ft. 45/-	7in. Stand. play, 1,200ft. 10/-
7in. Stand play, 1,200ft. 12/6	7in. Long play, 1,800ft. 15/-
7in. Long play, 1,800ft. 19/6	P.V.C. BASE
7in. Double play, 2,400ft. 35/-	5in. Stand. play, 600ft. 8/6
7in. Triple play, 3,000ft. 58/6	5in. Stand. play, 840ft. 11/6

P. & P. 1/- extra per reel. 4 reels and over Post Free.

THE "SKYROVER" RANGE

7 transistor plus 2 diode superhet, 6 waveband portable receiver. Operating from four 1.5 v. torch batteries. Cover the full Medium Waveband and Short Waveband 31-94 M and also 4 separate switched band-spread rangers. 13M, 16M, 19M and 25M, with Band Spread Tuning for accurate Station selection.



NEW—THE "SKYROVER" Mk III
Now supplied with redesigned cabinet, edgewise controls, black and chrome plastic cabinet. Size 10 x 8 1/2 x 3 1/2 in. Can now be **£8.19.6** Post 5/- built for **H.P. Terms: 20/- dep. and 11 months at 18/6. Total H.P. Price £12.1.6.**

THE "SKYROVER" DE LUXE
Tone Control Circuit is incorporated with separate Control. In a wood cabinet, size 11 1/2 x 6 1/2 x 3 1/2 in., covered in a washable material, fitted carrying handle. Can now be **£10.19.6** Post 5/- H.P. Terms: 25/- dep. and 11 months at 20/-. Total H.P.P. £12.5.0.

A simple additional circuit provides coverage of the **ONLY** Post both models that have already been constructed. **10/- Free EXTRA**

Data for Receiver 2/6 extra. Refunded if you purchase the parcel. Four U2 batteries 3/4 extra. All components available separately

PAMPHONIC HI-FI EQUIPMENT

TYPE 3001 Integrated Stereo Amp. List price £38.10.0. **WIRECOMP'S PRICE 23 Gns. C. & P. 10/6**
TYPE 1002A Control Unit. **WIRECOMP'S PRICE £4.19.8. C. & P. 2/6.**
TYPE 1002B Control Unit/Pre-Amp. List Price £25.4.0. **WIRECOMP'S PRICE £8.19.6. C. & P. 2/6.**
TYPE 2001A Pre-Amplifier. **WIRECOMP'S PRICE £5.19.8. C. & P. 3/6.**
TYPE 732A Switched Radio Tuner. **WIRECOMP'S PRICE £5.19.8. C. & P. 7/6**
All fully described in our advertisement in "P.W." April 1965.

323 EDGWARE RD., LONDON, W.2. **AMBASSADOR 7115**

All Branches open all day Saturday Early closing Thursday

378 HARROW RD., LONDON, W.9. **CUNNINGHAM 9530**

Mail Orders to the above address for prompt service

NOMBREX INSTRUMENTATION TRANSISTORISED AUDIO GENERATOR

Model 63 £17.0.9

- ★ Laboratory Specification 10 C/s to 100 Kc/s.
- ★ Direct Calibration. ★ Sine and square output.

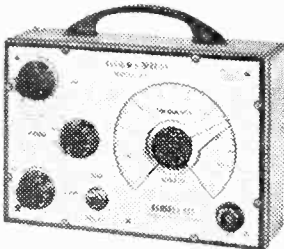

Also available:

- ★ **INDUCTANCE BRIDGE 66** ... **£18. 5.9**
- ★ **POWER SUPPLY UNIT 61** ... **£6.13.6**
- ★ **C.R. BRIDGE 62** ... **£8.10.9**
- ★ **R.F. SIGNAL GENERATOR 27** ... **£9.15.9**

All Prices include Battery, Post and Packing. Prompt delivery

S.A.E. for Technical Leaflets

Trade and Export enquiries invited

NOMBREX LTD.

Phone: 3515

Estuary House, Camperdown Ter., Exmouth, Devon

Any holes in your knowledge of TRANSISTORS?

Whatever your interest in transistor circuitry, you will find the Mullard "Reference Manual of Transistor Circuits" and "Transistor Radios, Circuitry and Servicing Book", valuable sources of reference.

The former describes more than sixty circuits for both domestic and industrial applications.

The latter is an introduction to the subject and describes the basic properties of semiconductors, their function, elementary circuitry and servicing.

REFERENCE MANUAL OF TRANSISTOR CIRCUITS
U.K. PRICE **12/6**
Post extra 1/-

TRANSISTOR RADIOS
Circuitry and Servicing
U.K. PRICE **5/-**
Post extra 8d.



Get your copies from your radio dealer, or send remittance with order to:

MULLARD LTD. MULLARD HOUSE TORRINGTON PLACE LONDON WC1

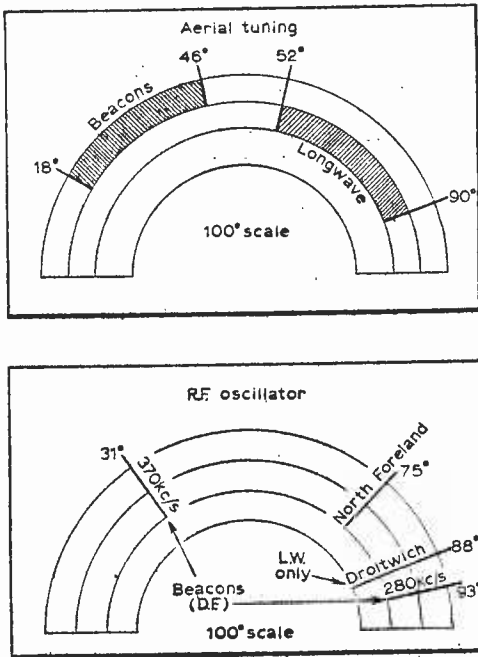

Fig. 10: The aerial and r.f. oscillator tuning dials after calibration.

groups, etc., it is essential to work with the Radio Information Charts, a compass and a protractor, so that whilst calibration is being carried out maximum signals can be maintained with the ferrite aerial *broadside* to the station.

Use of the telescopic aerial will alter the tuning of the ferrite aerial slightly, but remember, *this aerial is only an aid to finding weaker signals and must not be used when direction finding.*

The final calibration of the dials or the making of a calibration chart requires infinite patience, since it may be necessary to wait for each particular group to operate. It is, of course, only necessary to identify one station in a group working on a particular frequency and it does not follow that all the stations in a group will be heard. These stations use quite low power (10 to 20W) and a good deal depends on propagation conditions as to whether they will be received inland.

D.F. and Compass Checks

On no account should d.f. checks be carried out at night as errors may occur through so-called "night conditions" which cause the signals to arrive by different paths. When, and only when, you are satisfied with the calibration, d.f. and compass checks should the receiver be used under

working conditions. **On no account should one blindly rely on a radiobeacon d.f. receiver whether made commercially or home constructed. Radio direction finding is a navigation aid, not a method of navigation.** Like other navigation aids a d.f. receiver is used mainly to confirm position as otherwise plotted by compass and charts.

It is interesting to note that whilst we were carrying out d.f. checks with this receiver in the North Sea and in thick fog at that (see last month's cover), two other small cruisers hailed us to enquire as to where they were. They also requested direction to a particular position on the mainland. This information, confirmed also by our own d.f. fixes, depth finder readings and compass and chart navigation, we were able to give. To our great surprise, however, both cruiser skippers then admitted that *neither had even a compass!* We pointed into the fog and they went thataway! !

The Radio Information Charts

Details of these charts were given earlier, and it must be emphasised that they are not suitable for navigation of any kind. The charts merely show the positions of the radiobeacons on a large scale. The exact position in latitude and longitude of all the radiobeacons is, however, given in the tables printed on the charts. These should be used in conjunction with standard navigation charts. The Radio Information charts also give precise details of frequencies, groups and sequences as well as radiotelephone, British Coastal radio stations and Aircraft beacons. The latter can be received with the d.f. receiver but should be used with caution as most of them are inland which may result in serious bearing errors.

Finally, when using a d.f. receiver, it is necessary to be aware of the various reasons for bearing errors. These can be due to (a) night effects when signals arrive at the receiving aerial by two different propagation paths, (b) reflection from high land, such as cliff faces, (c) reflection from other aeriels or stay wires or even from metal structures on the vessel.

Errors in plotting can also occur, especially when converting magnetic to true bearing or vice versa and in taking into account the heading of the vessel which is usually from magnetic compass. Remember the d.f. aerial will indicate a true bearing and the difference between this and a magnetic compass reading is approximately seven degrees. Up to date navigation charts will show the exact deviation.

Radio on Yachts and Cruisers

The ordinary broadcast receiving licence authorises the reception of programmes sent only from authorised broadcasting stations for general reception. It does *not* permit the reception of messages from coast stations, ship stations, special service stations and radio navigation stations. If reception of messages etc., from these stations is desired (this includes marine radiobeacons) a special "ship" receiving licence is required. This does, however, cover broadcast station reception as well and can be obtained from the Radio Services Department, W.T.S. G.P.O., London, E.C.1. The licence costs £1 per year.

Useful References to Radio Navigation etc.
Admiralty list of Radio Signals and R.D.F. Stations and Beacons
Vol. 2 27s. 6d.
Motor Boat and Yachting Manual 17th Edition 21s.
Temple Press Books

BOOKS REVIEWED

AMATEUR RADIO CIRCUITS BOOK, compiled by G. R. Jessop, A.M.I.E.R.E., G6JP.
Published by the Radio Society of Great Britain.
96 pages. Size 9½in. x 7½in. Price 8s. 6d. post paid.

IF you were asked to find the circuits of a 3.5Mc/s transistor transmitter, a Q-multiplier, a cathode modulator and an electronic T/R switch, it is highly probable that you would have to search through a number of books and sort items of magazines in order to find them.

Amateur Radio Circuits Book is a collection of some 150 circuits liable to prove useful to the average ham. Transmitters, front ends, oscillators, power supplies, noise limiters, and a host of other items. There are circuit diagrams only, for the person who needs just this and values.

At first sight this appears a most excellent book, but a second more detailed reading brings disappointments. For although the drawings score full marks many details are omitted.

The first page depicts an A.T.U. We are shown how the coils are mounted, informed that the diameter should be 2½ and 3 inches and that 14s.w.g. is suitable. But not told how many turns, or even the inductance.

It is this lack of odd bits of information which spoils the ship. A 15W transistor transmitter has all the information except the transistor types. A d.c. amplifier has no transistor type or voltages specified for the two batteries. And so on.

The idea of having all those useful circuits together in one volume is excellent, but it is to be hoped that when second edition time comes around the editor will have filled in the few remaining details.—*F.H.S.*

THE OSCILLOSCOPE, by George Zwick.
Published by Gernsback Library Inc., New York, N.Y.
224 pp. 8½in. x 5½in., paper back. Price 28s.

MANY books have been written about the uses and applications of the oscilloscope. It is a great pity that these are studied only by the committed reader, the experimenter, would-be constructor, student, etc. The man with his cobwebbed 'scope, past its first intriguing fascination, hidden in a corner of his den, seldom finds the book to suit him. And the technician who brings his workshop instrument into occasional use often has no idea of its potentialities.

This book does much to remedy the defect. It first appeared in February, 1963, and has already in March, 1964, come out with a healthy reprint. Its virtue is the method of presentation, rather like an amplified operating manual. As such it should appeal both to the inquiring experimenter and the man at the service bench.

The first four chapters are descriptive. Chapter 1 discusses waveforms, laying the ground for later works. Chapters 2 and 3 cover the theory of the cathode ray tube and the principle of sweep

systems. In Chapter 4 a more practical approach is introduced. Detailed descriptions of both general purpose and laboratory type oscilloscopes are given with 21 diagrams of the vital portions of circuitry.

From this point we enter the field of application. Chapter 5 is a long one, dealing with alignment. Although it is obvious that precise instructions cannot be given because of variations of circuit design a valiant attempt has been made to cover the many possibilities. Chapter 6, on Oscilloscope Techniques, underlines this practice and could profitably have been juxtaposed. There is much useful information in these 24 pages.

More applications are to be found in the next chapter, dealing with tests and measurements. Audio experimenters and students of electronics would find several points of interest; the "hooking-up" details, so often ignored in more technical works, are meticulously outlined. Values of network components, too, are not ignored.

In the final chapter this is carried a step farther by the explicit instruction in 16 useful experiments. We should like to have seen the "hook-up" diagram continued in this chapter but by the time this stage is reached the student should be able to cope.

Both as general reading and as a bench-side reference this book is to be recommended.—*H.W.H.*

**THERE'S
NO DOUBT
ABOUT
IT ...**

with the
August
**PRACTICAL
ELECTRONICS**

**SIMPLE ANALOGUE COMPUTER
TRANSISTOR AND DIODE
TESTER**

ON SALE JULY 15

HERE COMES THE BIG BREAKTHROUGH IN EDUCATIONAL ELECTRONICS - BASIKITS

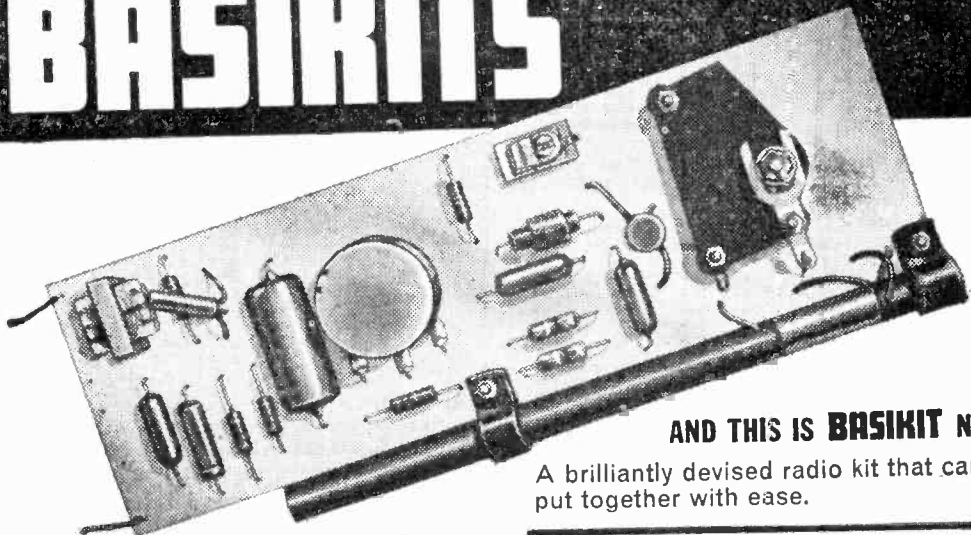

AND THIS IS **BASIKIT No. 1**

A brilliantly devised radio kit that can be put together with ease.

YOUR KEY TO THE FASCINATING WORLD OF ELECTRONICS

All circuits are designed around top quality components, not near equivalents. Full size printed circuits with every component position marked. Makes construction extraordinarily simple. No fiddling with microscopic connections—no inspired guesswork called for. A lavish instruction manual not only tells you how to construct your BasiKit but also advises you on its use and explains exactly how your BasiKit works.

- * VOLUME CONTROL
- * PRECISE TUNING
- * PULLS IN A HOST OF STATIONS
- * MORE THAN TWENTY FULL SIZE HIGH QUALITY COMPONENTS

59/- complete for your biggest and best ever opportunity to learn as you build!

ALSO AVAILABLE: The *BasiKit mains battery Power Unit* which powers all BasiKits. Yours for **42/6**. The *BasiKit Amplifier* that brings real full-voiced power to your BasiKit No. 1 Radio. **57/6** complete.

Watch out for more BasiKits.

ORDER YOUR **BASIKIT** ON THIS COUPON:

TO: BASIKITS DIVISION, K.L.B. ELECTRIC LTD. 335 WHITEHORSE RD, CROYDON

Please supply BK1 Radio @ **59/-**
 BK2 Audio amplifier @ **57/6**
 BK3 Power unit @ **42/6**
 Illustrated leaflet on BasiKits (enclose stamped addressed envelope)

From: **NAME** _____
ADDRESS _____

P.O.
CHEQUE P.W.

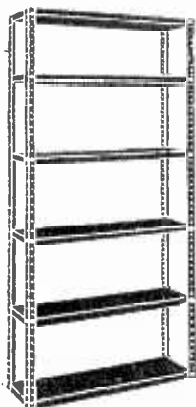

STEEL SHELVING

BRAND NEW

C.W.O. or C.O.D. FREE DELIVERY within 14 days. N. Scotland, Ireland, L.O.M., 10% extra.

65/-

71in. high x 34in. wide 12in. deep with 6 shelves as illustrated.

Each shelf will hold over 3 cwt. Shelves adjustable every 2 in. Stove enamelled dark green. White enamel units 30% extra.

Height	Width	Depth	No. of shelves	Price	3 or more	Extra shelves
71 in.	34 in.	9 in.	6	63/-	61/-	7/-
71 in.	34 in.	12 in.	6	65/-	63/-	8/-
71 in.	34 in.	15 in.	6	74/-	72/-	9/8
71 in.	33½ in.	18 in.	6	86/-	84/-	11/8
86 in.	34 in.	12 in.	6	73/-	71/-	8/-
86 in.	42 in.	12 in.	6	91/-	89/-	11/-

Contractors to H.M. Govt. and United Kingdom Atomic Energy Authority. Exporters of Steel Shelving.

Buy direct from the manufacturers

ROCHDALE METAL PRODUCTS
Dept. P.W. WATERFOOT — LANCS.
Phone: Rossendale 322113

VALVES SAME DAY SERVICE

NEW! TESTED! GUARANTEED!

SETS 1R5, 1R5, 1T4, 3S4, 3V4, DAF91, DF91, DK91, DL92, DL94. Set of 4 for 15/-, DAF96, DF96, DK96, DL96. 4 for 24/8.

1A7GT	7/6	6X3GT	6/3	DAF91	3/9	PCF86	10/9	MU14	5/-	U47	3/8
1H5GT	7/8	7B6	11/9	DAF96	6/0	ECH35	6/0	N18	5/6	U49	9/8
1N5GT	8/0	7B7	7/9	DF90	6/9	ECH42	8/0	N108	7/11	U30	5/3
1R5	4/9	7C5	2/9	DF33	8/0	ECH81	6/8	PC95	6/8	U52	4/6
1R4	4/9	7C9	6/8	DF91	1/9	ECL80	6/8	PC97	7/0	U54	3/9
1R5	3/9	7H1	5/9	DF96	6/0	ECL82	7/6	PC84	5/6	U78	3/9
1T4	1/9	7Y4	5/6	DH76	3/6	ECL86	8/6	PC98	9/6	U91	10/-
2P	1/9	10LD12	7/6	DH77	4/0	EP39	3/9	PCF80	6/11	U281	8/6
3A5	6/9	12AT7	5/9	DH81	12/6	EP41	6/0	PCF82	6/9	U291	9/0
3Q4	5/6	12AU6	5/6	DK32	8/0	EP80	4/9	PCF84	7/9	U301	11/9
3S4	4/9	12AU7	4/9	DK91	4/9	EP85	5/0	PCF86	5/8	U801	15/9
3V4	5/6	12AX7	4/9	DK92	8/0	EP86	7/0	PCF85	9/6	TABC80	5/9
6U4G	4/6	12K7GT	4/3	DK96	6/6	EP89	4/3	PCL82	6/11	UAF42	7/9
5Y3GT	5/3	12K9GT	8/9	DL33	7/9	EP91	2/6	PCL83	9/0	UBC41	6/6
6Z4G/GT	8/0	12Q7GT	4/3	DL35	5/9	EP92	2/6	PU184	8/3	UB81	7/3
6Z9L2	8/9	19B3G6	6/9	DL92	4/9	EP97	7/6	PCL85	5/8	UBP80	6/0
6AL5	2/0	20L1	12/3	DL94	5/6	EP13	7/6	PEN4A	7/6	UBP89	8/0
6A6	2/6	20P4	13/6	DL96	6/0	EL33	6/0	PEN383	8/6	UCC84	8/0
6AQ5	6/0	20P5	11/9	DM70	4/11	EL35	11/9	PEN4VA	10/0	UC85	6/9
6AT6	4/0	25LAGT	4/9	DY86	6/9	EL41	7/9	12/6	UCP80	8/6	8/6
6BA6	4/9	25C10T10	10/6	DY87	8/0	EL84	3/0	PEN3615	10/11	UC14	7/6
6BE6	4/9	30C15	9/6	EAB*80	6/0	EL95	5/6	PL36	3/9	UCH81	7/0
6BG6G	12/6	30P5	8/6	EAB*81	6/0	EL34	6/0	PL81	7/0	ECL82	7/6
6BH6	5/0	30FL1	6/6	EAB41	4/0	FM80	6/3	PL82	5/6	UCL83	9/9
6BJ6	5/6	30L15	10/8	EB91	2/0	FM81	7/3	PL83	6/0	UF41	7/3
6BW6	7/9	30P1	13/6	EB333	5/0	EM83	6/3	PL84	6/3	UCF42	4/6
6F13	3/6	30P19	13/6	EB441	7/3	EM87	7/0	PX23	7/8	UF85	6/8
6F14	9/0	30P1L	9/6	EBF80	6/0	EY51	6/0	PY32	9/0	UF86	6/3
6K7G	1/6	30PL13	10/8	EBF83	7/6	EY86	5/6	PY33	9/0	UL41	7/6
6K8G	4/3	30PL14	11/8	EBF89	6/6	EZ40	6/9	PY80	5/3	UL44	15/0
6K9GT	7/6	35LAGT	6/3	EBL21	10/6	EZ41	6/6	PY61	5/9	UL46	8/6
6P28	9/6	35W4	4/9	EC40	6/9	EZ80	4/0	PY82	5/0	UL84	5/9
6Q7G	4/9	35ZAGT	5/6	EC81	3/9	EZ81	4/6	PY83	5/9	UY41	4/9
6Q7G	7/6	53KU	8/6	EC82	4/9	PW4500	6/3	PY88	7/3	UY85	5/6
68L7GT	4/9	ACVP212	8/6	EC83	7/0	GZ33	14/6	PY800	6/8	VP48	12/6
68N7GT	4/9	B36	4/6	EC84	6/3	GZ37	8/9	TH10C	9/6	W75	3/6
6V90	3/9	CL33	9/6	EC85	5/9	K781	6/6	TH333	7/6	W77	2/6
6V6GT	6/6	CV1	12/6	EC80	7/6	KT76	8/0	U25	3/6	X79	26/0
6X4	3/6	DAC82	7/6	EC82	6/9	ME1400	15/0	U26	8/9	Z77	2/6

READERS RADIO

24 COLBERG PLACE, and at 85 TORQUAY GARDENS STAMFORD HILL REDBRIDGE, ILFORD LONDON, N.16. STA 4587 ESSEX. CRE 7441

Postage on 1 valve 9d. extra. On 2 valves or more postage 6d. per valve extra. Any Parcel Insured against Damage in Transit 6d. extra.



MINIATURE METALLIZED POLYESTER CAPACITORS

Ideally suitable for printed wiring panels and transistorised circuits.

Incorporating a new dielectric material and of unique construction, they are of small physical size and meet the requirements of H.5 D.E.F. 5011 Specification. The windings are virtually non-inductive and the wire terminations are soldered direct to the metal electrodes eliminating contact resistance and ensuring the minimum possible inductance.

Typical 250 volt range

Cap. µF	Dimensions		T.C.C. Type No.
	H.	T.	
0.01	1 1/8" 9mm	1/8" 5.5mm	PM X1
0.022	1 1/8" 9mm	1/8" 5.5mm	PM X2
0.047	1 1/8" 9mm	1/8" 5.5mm	PM X3
0.1	1 1/8" 11mm	1/8" 7.2mm	PM X4

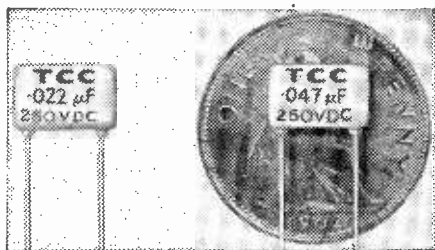
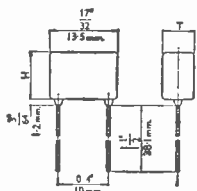

Cap Tolerance ±20%

Insulation Resistance: 10,000 megohms or 2,000 ohm farad which-ever is less.

Terminations: 22 s.w.g. solder-coated parallel wires for vertical mounting.

Power Factor: <0.01 at 1 Kc/s at +20°C.

Temperature Rating: Suitable for working at +85°C. without de-rating.

Finish: Insulated—special non-cracking heat resisting thermosetting compound providing good insulation and good protection against the ingress of moisture.

Details of the full range are given in T.C.C. Bulletin 93, available on request.

THE TELEGRAPH CONDENSER CO. LTD.

Electronics Division • NORTH ACTON • LONDON • W.3 • Tel: ACOOR 0061 • Telex: 261383 also at CHESSINGTON, SURREY and BATHGATE, SCOTLAND

A BASIC MOULLIN VOLTMETER

by G. H.
Meeten

for r.f. resonance indication

THE instrument to be described was intended for use as an indicator of resonance while making r.f. measurements. Its range is 0.1 to 1V peak, approximately, with a high input impedance. It was felt advantageous to use a circuit giving a known scale law so that no calibration of the movement would be necessary, also making the instrument generally more useful. To fulfil these conditions the Moullin or anode-bend circuit was chosen. In this simple, well-known circuit a triode is biased almost to cut-off, and if the V_g-I_a characteristic of the valve is non-linear in this region, partial rectification takes place as shown in Fig. 1.

In particular, if the characteristic can be represented by the relation $I_a = aV_g^2 + bV_g + c$, where a, b, c are constant for a particular value of the anode potential, then analysis shows that when the input e.m.f. to the grid is of the form $v = V_{pk} \sin \omega t$, the mean value of

the increase in anode current is $\frac{a}{2} V_{pk}^2$, where V_{pk} is

the peak e.m.f. Hence a square-law scale can be produced. This means that true r.m.s. values can be read, independent of the input waveform.

CHOOSING A VALVE

The following valves were measured (all pentodes and tetrodes being connected as triodes) to determine the form of the V_g-I_a curve when using 9 volts anode potential. 1T4, EF91, 12AT7, 3S4, CK503AX. The 3S4 and CK503AX gave the most promising

results when plotting $\frac{d I_a}{d V_g}$ against V_g , which should

be a straight line if the V_g-I_a curve is of the required form. The CK503AX is a miniature wire-ended output tetrode. It was decided to use the 3S4 (a battery powered output tetrode) since it is more readily obtainable. The 3S4 filament is tapped and, except where stated, half the filament is unused, the valve taking 50mA at 1.4V.

WORKING POINTS

The basic circuit, shown in Fig. 2, is self-explanatory. The potentiometer across the filament ensures that V_b is the true bias on the grid.

It was stated above that the change of anode current, which will be called ΔI_a , was equal to $\frac{a}{2} V_{pk}^2$, assuming parabolic V_g-I_a characteristics.

In practice there is a best value of V_b for a maximum ΔI_a as the graph of Fig. 3 shows. It was drawn using

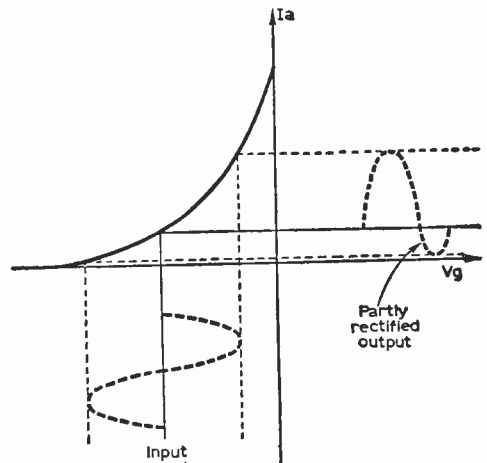

Fig. 1: Partial rectification occurring in the non-linear section of a triode characteristic.

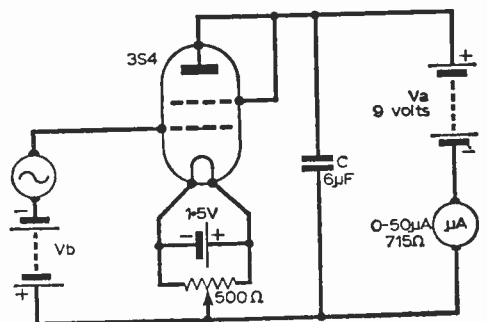

Fig. 2: The basic circuit. A conducting source of e.m.f. is assumed.

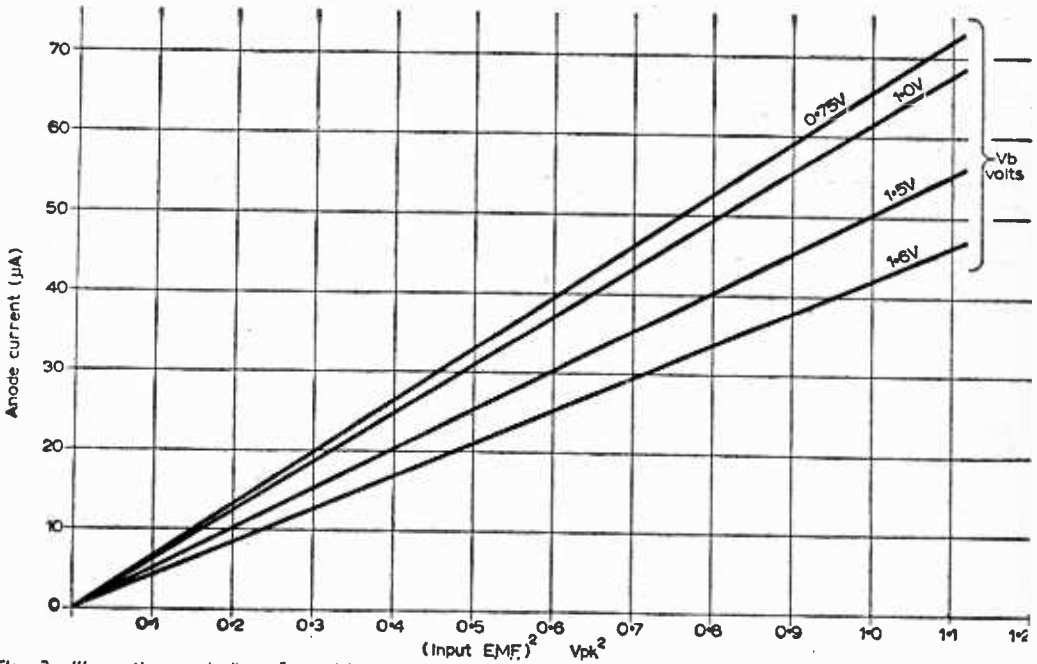

Fig. 3: Illustrating variation of sensitivity and linearity with bias (V_b).

Fig. 4 (right): The complete circuit. Backing-off current is taken from the heater supply cell.

the circuit of Fig. 2 with V_b variable and a source frequency of 50 c/s.

It can be seen from Fig. 3 that although the square-law is true approximately for a range of V_b , it is best when $V_b=1.5V$ or greater, but the sensitivity falls as V_b increases. A bias of $-1.5V$ is a good compromise between sensitivity and linearity and is also the e.m.f. of a single dry cell. A mercury cell could be used with a little loss of linearity and negligible current is drawn.

It was found that if all the filament of the 3S4 was used i.e. 0.1A at 1.4V, then ΔI_a for any given V_b was approximately doubled, but a greater non-square linearity was also incurred. Since the use of dry cells was contemplated the 50mA consumption will be used henceforth.

The complete circuit is shown in Fig. 4. The meter movement is backed off with an equal and opposite current to the standing anode current with no signal which was approximately $80\mu A$. The values of the resistors and capacitors are not at all critical. The following are the components used in the original:

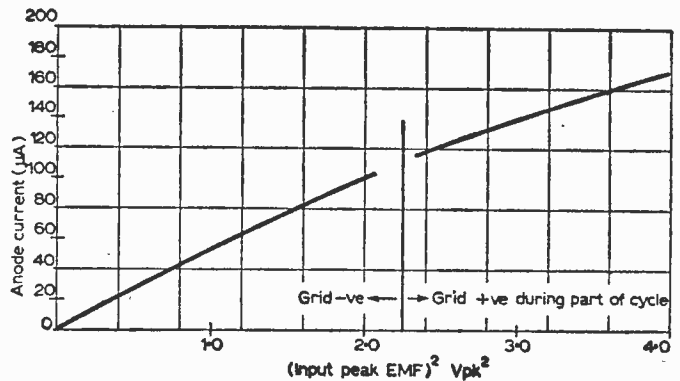
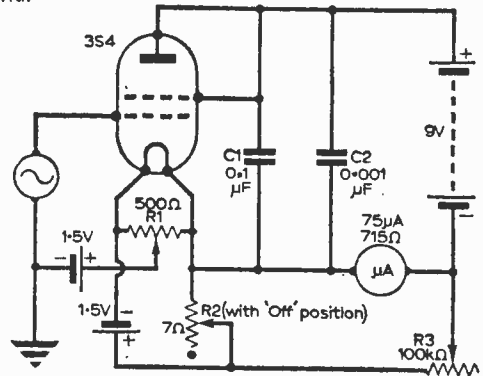

Fig. 5: Large signal characteristics showing the effect of driving the grid positive.

EX-RENTAL TELEVISIONS

14 in. £7.10.0
17 in. £11.10.0



Coloured FREE LIST
Demonstration daily from our large selection
12 months' written guarantee
Channels for all areas
Personal collection advised, or insured Carr., 14in. 20/-; 17in. 30/-

AERIALS. BBC/ITA combined Loft and room aerials—from 25/-, BBC/UHP and colour aerials—from 29/6. SEND FOR FREE LIST.

EX-MAINTENANCE TESTED TUBES

17in.—35/- Most makes and types available. 14in.—15/-
Guaranteed good picture. Carriage 5/- extra.

ONE YEAR GUARANTEED TUBES

21 in. 99/6
17 in. 79/6
15,14 59/6
12 in.



100% REGUNDED
Add 10/- or old tube.
All 110°—99/6 plus 30% refundable on old tube. Carr. 10/6.
14in. Slimline 17 & 19 in. — overseas postage 30/-.

VALVES 6d. each. 1,000's available. Send for List.
CONDENSERS. 100—10/- New. Assorted electrolytics and p.F.s. P. & P. 2/6.
V/CONTROLS. 20—10/- A selection of types and sizes. P. & P. 2/6.
SPEAKERS. 7/8. 6in., 8in., 7 x 4in. and 8 x 3in. Ex. mfd. Salvage. P. & P. 2/3
RESISTANCES. 100, 10/- Mostly "High Stabs". Assorted. P. & P. 2/- (Overseas. P. & P. 3/6).

TELEPHONE HANDSETS

15/6 pair

G.P.O. pattern. House to Workshop. Garage, Inter-Office, etc. Works off any small battery. P. & P. 4/6.

DUKE & CO. (LONDON) LTD.
621/3 Romford Road, Manor Park, E.12
Liverpool St.—Manor Pk.—10 mins.
Phone: ILFord 6001/2/3. Stamp for Free List

An integrated hi-fi turntable unit from only 11 gns?

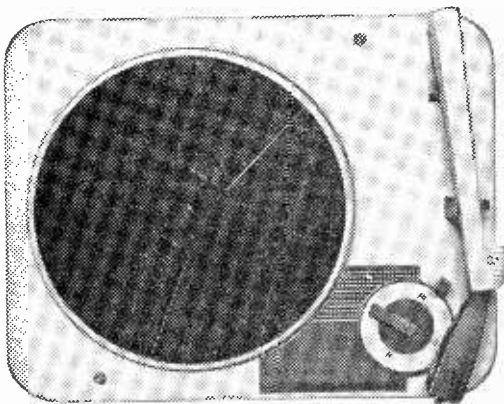

YES!

Only Goldring's 60 years of experience of making gramophone turntables and pick-ups could lead to a unit like this... the ideal integrated turntable, arm and pick-up for do-it-yourself hi-fi aspirants... at such a modest price. Just look at the features of this remarkable G.66 unit:

Silent, specially made Swiss mains motor. Pressed steel turntable on precision bearings evens out mains current fluctuations. Die-cast light alloy arm with full stylus pressure adjustment. Plug-in head shell, wired for mono and stereo, takes alternative pick-up cartridges. Eddy-current speed control (as fitted on some professional units) varies the four standard speeds by $\pm 10\%$. Pick-up raising/lowering device coupled to on/off switch and idler-wheel disengagement mechanism. Deck size 12½" x 10". See the Goldring G.66 at your dealers—or write for descriptive leaflet.

THE GOLDRING G.66

G.66/MX.2 £9.18. 8 + £1.12.4 P.T. £11.11.0
G.66/CS.80 £10.10. 0 + £1.14.2 P.T. £12. 4.2
G.66/CS.90 £12.12.10 + £2. 1.2 P.T. £14.14.0



Goldring Manufacturing Co. (GB) Ltd.,
486-488 High Road, Leytonstone, London E.11
Telephone: Leytonstone 8343

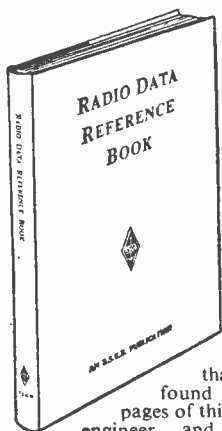

RADIO DATA REFERENCE BOOK

Compiled by
G. R. JESSOP, A.M.I.E.R.E.

Formulae, charts and tables that cannot usually be readily found have been collated into 116 pages of this book for the radio designer, engineer, and especially for the radio amateur. The subjects encompassed range from Ohm's Law to transmission lines, filters, wideband couplers, aerials, transmitter p.a.'s, rectifiers and noise generators. Listed at the rear of the book are numerous tables, amongst which information on FT241 crystal frequencies, insulating materials, units, wire and even the self-resonant frequencies of capacitors may be found.

Price 12s. 6d. from leading booksellers, or 14s. including postage direct from:

R.S.G.B. PUBLICATIONS
Dept. PW, 28 Little Russell Street,
London, W.C.1. HOLborn 7373. 2444.

7 VALVE AM/FM RADIOGRAM CHASSIS

NEW 1965 MODEL NOW AVAILABLE

Valve line-up EOC85, ECH81, EF89, EABC80, EL84, EM81, EZ80.

Three Waveband and Switched Gram positions. Med. 200-550 m. Long 1,000-2,000 m. VHF/FM 88-95 Mc/s Phillips permeability tuning insert on FM and combined AM/FM IF transformers. Latest circuitry including AVC and Neg. Feedback. Three watt output. Sensitivity and reproduction of a very high standard. Chassis size 1 1/2 x 6 1/4 in. Height 7 1/4 in. Illuminated glass dial 1 1/2 x 3 1/4 in. Vertical pointer. Horizontal station names. Gold on brown background. A.C. 200/250 v. operation. Magic-eye tuning. Circuit diagram now available.

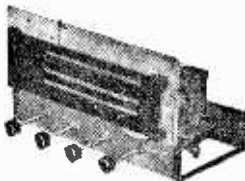

£13.19.6 Carr. & Ins. 7/6

Complete with Tape o/p Socket, ext. spkr. & p/u Sockets, Indoor P.M. aerial and 4 knobs—walnut or ivory to choice. 3 ohm P.M. Speaker only required. Recommended Quality Speakers 10in. R.A., 27/6; 1 1/4 x 5in. E.M.L. "Fidelity" 87/8; 12in. R.A. with conc. Tweeter, 42/6. Carriage 6.

6 VALVE AM/FM TUNER UNIT

Med. and VHF 190 M-550 M, 85 Mc/s-103 Mc/s, 6 valves and metal rectifier. Self contained power unit. AC 200-250 v. operation. Magic eye indicator, 3 push-button controls on/off. Med., VEP diode and high output sockets with gain control. Illuminated 2-col. perspex dial 1 1/2 x 4 in. Chassis 1 1/2 x 4 x 5 1/4 in. Recommended Fidelity Unit for use with Mullard 9/3 8-10 amplifiers. Available only at present as built up units, aligned and tested ready for use. Bargain price £12.10.0, carr. 5/6. We hope to produce this popular unit in kit form very shortly.

NEW BRITISH RECORDING TAPE

Famous Manufacturer Bulk purchase, genuine recommended Tape Bargain. Unconditional guarantee. Fitted Leader and Stop Foils (except 3in). Standard (PVC base) Long Play (PVC base) D'ble Play (Mylar base)

Table with columns for Reel Size, Length, and Price. Includes rows for 5in, 6 1/2in, and 7in reels.

JTY Mercury, 10 gns. 3 valves, 22/6. JTV2 £13.19.6. 4 valves, 28/6.

NEW JASON P.M. HANDBOOK 2/6 Prompt Alignment Services 7/6 plus 2/6.

DE-LUXE RECORD PLAYER



Incorporating 4 Sp. Garrard Auto-Slim unit and Mullard latest 3 watt printed circuit amplifier (ECL 88 and EZ 80), vol., bass and treble controls, with 8 x 5in. 10,000 line speaker. Contemporary styled 2-tone cabinet, charcoal-grey and off-white with matching blue relief. Size 17 1/2 x 15 x 8 1/2. A stylish unit capable of quality reproduction. Circuit and construction details 2/6 (free with kit)

COMPLETE KIT £13.19.6 Carr. and ins. 10/-

Illuminated perspex control panel escutcheon, 7/6 extra. Ready wired 30/- extra. Four contemporary mounting legs (6 or 13in.) 12/6 per set.

CONDENSERS—Silver Mica. All values, 2 pF. to 1,000 pF., 6d. each. PTC ceramics 9d. Tib. 450v. T.C.C. etc. .001 mfd., .01 and 1/350v. 9d. .02-1/500v., 1/2-220 Hunts. 1/6. 5 T.C.C. 1/8. etc. RESISTORS—Modern ratings full range 10 ohms to 10 megohms. 20% 1-w. 3d. ca. ditto 1-w. 6d. ca., 2w. 9d. ca., 10% 1-w. 4d. ca., 5% Hi-stab. 1-w. 6d. ca. (below 100 ohms and over 1 meg. 9d. ca.). 1% Hi-stab., 1-w. 1/6 ca. (below 100 ohms 2/6 ca.).

Table titled 'New Boxed VALVES' with columns for Valve Type, Ratio, and Price. Includes valves like 1T4, 1R5, 185, etc.

Send for detailed bargain lists, 3d. stamp. We manufacture all types Radio Mains Trans., Filters, Chokes, Quality O/P. Transformers. Enquiries invited for Specials, Prototypes for small production runs. Quotations by return.

RETURN-OF-POST ON CASH OR C.O.D. ORDERS

- AMPLIFIER KITS: We have full stocks of all components for the Mullard 510, Mullard 3-3, Mullard 2 and 3 Valve Pre-amp, Mullard Stereo, Mullard Mixer. Fully detailed list on any of these sent upon request. Instruction Manual; All Mullard Audio Circuits in "Circuits for Audio Amplifiers" 9/5 Post Free.
LATEST TEST METERS: AVO Model 8 Mark III, AVO Model 7 Mark II, AVO Multimeter Mark 4, T M K T P 10, T M K T P 55, T M K T P 55, TAYLOR Model 127A, TAYLOR Model 885.

- GRAMOPHONE EQUIPMENT: ALL LATEST MODELS. ALL POST FREE. GRAMMAD CHANGERS, AUTOSLIM Mono, AUTOSLIM AT6 Mono, AUTOSLIM AT8 Stereo/Mono, 3000 LM Stereo/Mono, A70 (with Deram Stereo or Mono Cart), 4HF PLAYER Unit Mono., B.S.R. CHANGERS, UA15 Mono, UA15 Stereo/Mono, UA25 Mono, UA25 Stereo/Mono.

ILLUSTRATED LISTS: Illustrated lists are available on LOUDSPEAKERS, TAPE DECKS, TEST GEAR, GRAMOPHONE EQUIPMENT, AMPLIFIERS. Any will be sent free upon request.

WATTS RADIO (Mail Order) LTD 54 CHURCH STREET, WEYBRIDGE, SURREY

Telephone: Weybridge 47556 Please note: Postal business only from this address (Callers welcome by appointment) CLOSED FOR ANNUAL HOLIDAYS: AUGUST 7th to 30th.

LEARN ELECTRONICS AS YOU BUILD 25 CIRCUITS EXPERIMENTS TEST GEAR

- MINIATURE CATHODE RAY OSCILLOSCOPE
VALVE EXPERIMENTS
BASIC AMPLIFIER
BASIC RECTIFIER
PHOTO ELECTRIC CIRCUIT
TIME DELAY CIRCUIT
SQUARE WAVE GENERATOR
SIMPLE TRANSMITTER
TRANSISTOR EXPERIMENTS
BASIC OSCILLATOR
ELECTRONIC SWITCH
SIGNAL TRACER
BASIC COMPUTER CIRCUIT
BASIC RADIO RECEIVER
MORSE CODE OSCILLATOR
ETC. ETC.

This complete practical course will teach you all the basic facts of electronics by making experiments and building apparatus. You learn how to recognise and handle all types of components—their symbols and how to read a circuit diagram. You see how circuits are built and how they work by USING THE OSCILLOSCOPE PROVIDED. Applications of all the main electronic circuits are demonstrated—radio reception and transmission; photo-electrics; computer basics; timers; control circuits, etc; including servicing techniques. NO MATHS USED OR NEEDED. NO THEORY NEEDED. NO PREVIOUS KNOWLEDGE OR EXPERIENCE NEEDED. Tutor service available. No extras needed—tools provided. Send now for FREE DETAILS without obligation, to address below

TO: LERNAKIT, Dept. K 10, RADIO HOUSE, 40 RUSSELL STREET, READING

POST NOW Please send free details— NAME ADDRESS

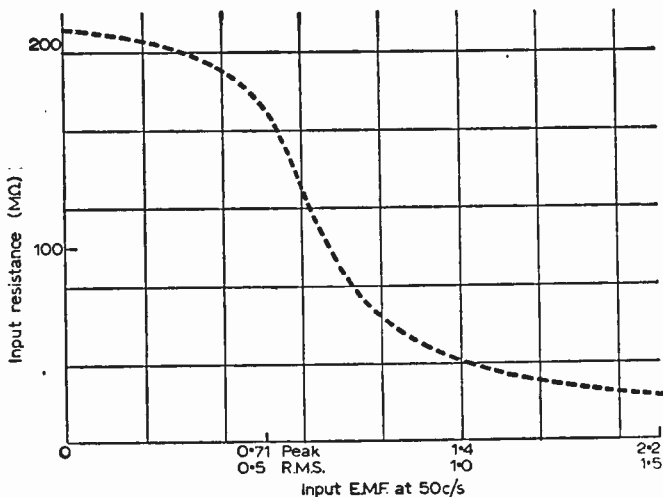

Fig. 6 (left): Illustrating the variation of input resistance with input e.m.f.

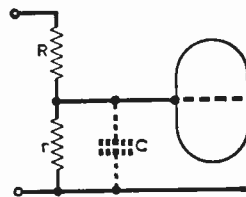

Fig. 7: The input capacitance (dotted) in parallel with the potential divider arm.

- R1 500 Ω wire-wound
- R2 7 Ω wire-wound with filament on/off switch.
- R3 100k Ω carbon
- C1 0.1 μF paper
- C2 0.001 μF ceramic
- Meter 0-75 μA, 715 Ω movement.

If a multi-range instrument is used for the detector it should be of roughly constant input resistance from one range to the next or the sensitivity, i.e. the slope of the $V_{pk}^2 - \Delta I_a$ graph will vary.

SQUARE-LAW LINEARITY

The degree of square-law linearity and the effect of bias upon it is shown in Fig. 3. The effect of driving the grid positive is shown in Fig. 5. The grid is made positive when the peak input signal exceeds the standing bias. When the grid is positive, grid current flows, which is equivalent to saying that not all the electrons from the cathode reach the anode. Hence a lowering of anode current change and sensitivity as Fig. 5 shows. The over-all increase in anode current can be explained by the positive grid now attracting more electrons from the cathode than were formerly emitted. It can be seen that the square-law is not quite true for large input e.m.f. even when the grid is negative.

INPUT IMPEDANCE

If the input of the voltmeter can be assumed to consist of an input resistance R in parallel with an input capacitance C then simple measurements can be made, to arrive at an estimate of R if C is known (or vice-versa). If ΔI_{a1} is the current change when the voltmeter is fed from a low impedance source, and ΔI_{a2} is the reading when the voltmeter grid is con-

nected to the same source by a high resistance R_1 ohms, then it can be shown that:

$$R = \frac{R_1}{\sqrt{[(n-1)^2 + \omega^2 R_1^2 C^2]}}$$

where R and C are defined above, ω is the angular source frequency and $n^2 = \frac{\Delta I_{a1}}{\Delta I_{a2}}$

C includes the capacitance of the wiring in the grid circuit and between the grid and other electrodes. An average value is about 15pF. A graph of input resistance R with input e.m.f. is shown in Fig. 6, in which $C=15pF$ is assumed. The decrease of input resistance is due to the increasing number of electrons reaching the grid as it becomes more positive. The input resistance is however still greater than 30M Ω when the grid is being driven positive during part of the input cycle.

CALIBRATION

It should be stressed that permanent calibration of the instrument is not readily obtainable without voltage stabilisation of the supply power. The square law however is valid over a fairly wide range of battery ageing and for many purposes only the ratio of two e.m.f.'s need be known.

FREQUENCY RANGE

The original instrument was used at all frequencies between 25c/s and 25Mc/s; beyond these limits it was not tested. The Moullin instrument of the 'twenties was stated to be useful up to about 30Mc/s.

—continued on page 354

CLUB

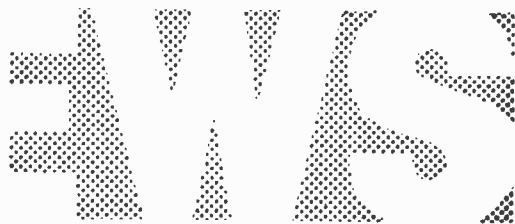

BRADFORD RADIO SOCIETY

Hon. Sec.: J. D. Midgley, G3SAO, 77 Brantwood Road, Bradford 9, Yorkshire.

Meetings are now held in the Bradford Technical College, and the callign G3NN has been issued for the Club station, G3TO.

There was an "Inquest" on the N.F.D. on 22nd June.

COVENTRY AMATEUR RADIO SOCIETY

Hon. Sec.: A. J. Wilkes, G3PQQ, 141 Overslade Crescent, Coundon, Coventry.

The Society will be taking part in the N.F.D. event again after an absence of many years.

DERBY AND DISTRICT AMATEUR RADIO SOCIETY

Hon. Sec.: F. C. Ward, G2CVV, 5 Uplands Avenue, Littleover, Derby.

Raymond F. Street gave a lecture entitled "Introduction to Colour Television" on 23rd June, and on the 30th G. D. Kelsey, B.Sc., discussed the problems of Effluent and its Treatment.

On 3rd-4th July, the 144 Mc/s (portable event) was held, and on 17th July there will be a Garden Party and Exhibition at Heanor Alcegar Secondary School.

HALIFAX AND DISTRICT AMATEUR RADIO SOCIETY

Hon. Sec.: J. Ingham, G3RMQ, Lambert House, Greetland, Halifax, Yorkshire.

On 27th July, G. Drake, G3SJG, will give a talk on Transmitters, and on 24th August, there will be a lecture by F. Nicholls, G3MAX and a visit from the Huddersfield Radio Society.

HUDDERSFIELD AMATEUR RADIO SOCIETY

Hon. Sec.: R. Highton, 5 Brian Avenue, Dalton, Huddersfield, Yorkshire.

Recently the Society held a lecture and demonstration on Oscilloscopes. The Society operating QTH has proved very good with GDX in mind, using a 250ft. dipole.

MID-WARWICKSHIRE AMATEUR RADIO SOCIETY

Hon. Sec.: H. C. Loxley, 5 Guy Street, Warwick.

There will be an open meeting on 12th July, when members will be able to discuss a range of subjects.

Meetings are now held on the top floor of 7 Regent Grove, Leamington Spa. These premises are well situated in the centre of the town, close to main bus routes and with ample car-parking accommodation.

NORTHERN HEIGHTS AMATEUR RADIO SOCIETY

Hon. Sec.: A. Robinson, G3MDW, Candy Cabin, Ogden, Halifax, Yorkshire.

Recent activities of the Club have been a recorded lecture by the late G2SU who was a founder-member; and the first of this year's demonstrations when the Club callign was first used.

A novel innovation this year was a mobile car in the Warley Gala procession which was able to report back to the fixed station on the progress of the parade.

Some future events will include, on 21st July a Ragchew and on 4th August, a lecture on D.F. Equipment by G3LGN.

READING AMATEUR RADIO CLUB

Hon. Sec.: N. C. Taylor, G3TOQ, 83 Stoneham Close, Tilehurst, Reading, Berkshire.

The first Mobile Picnic of the season was held on 20th June, and a good time was had by all. Talk-in stations were operated by G3TOQ on 2 metres and G3EJA on 160 metres.

SALTASH AND DISTRICT AMATEUR RADIO CLUB

Hon. Sec.: D. Bowers, BR5 26760, 95 Grenfell Avenue, Saltash, Cornwall.

A "Mobile Rally" was held at Calstock on Whit Monday, 7th June, and on the 18th, there was a tape and slide lecture which was kindly loaned by Northern Heig: its A.R.S.

An R.S.G.B. Tape Lecture on Receivers was heard on 2nd July. There will be a Treasure Hunt on 16th July.

SOUTH BIRMINGHAM RADIO SOCIETY

Hon. Sec.: J. Rowley, G3TQO, 195 Castle Lane, Solihull.

On 17th June there was a demonstration and display of Heathkit Products and transmitters, receivers and test gear were on show for members to see.

SOUTHGATE, FINCHLEY AND DISTRICT GROUP OF THE R.S.G.B.

Hon. Sec.: R. Wilkinson, G3TXA, 23 Ashridge Gardens, Palmers Green, London, N.13.

The May lecture was given by G3OLE, who spoke about his "hybrid" mobile transmitter. The next meeting will be on 8th July.

SOUTH SHIELDS AND DISTRICT AMATEUR RADIO CLUB

Hon. Sec.: D. Forster, G3KZZ, 41 Marlborough Street, South Shields.

The Club is making preparations for its 6th Mobile Rally which is to be held on Sunday, 11th July at the Bents Park Recreation Ground, Coast Road, South Shields.

Meetings are held weekly on Friday evenings at 7.30 p.m., in Trinity House Social Centre, Laygate Lane, South Shields.

SPEN VALLEY AMATEUR RADIO SOCIETY

Hon. Sec.: N. Pride, 100 Raikes Lane, Birstall, Nr. Leeds.

On 24th June there was an Open and Final Meeting of the season. The A.G.M. of the New Session will be held on 8th July.

Meetings are held at 7.30 p.m. at Heckmondwike Grammar School.

WEST KENT AMATEUR RADIO SOCIETY

Hon. Sec.: H. F. Richards, 17 Reynolds Lane, Tunbridge Wells, Kent.

On 9th July, John Gould will give a talk entitled "Seventy C.M.S.", which is aimed at getting all the Club members on 430 Mc/s.

WIRRAL AMATEUR RADIO SOCIETY

Hon. Sec.: A. Seed, G3FOO, 31 Withert Avenue, Bebington, Wirral, Cheshire.

A Tape Lecture was given on 7th July. Meetings are held at Scout H.Q., Harding House, Park Road West, Cloughton, Birkenhead, at 7.45 p.m. on the first and third Wednesdays in each month.

A BASIC MOULLIN VOLTMETER

—continued from previous page

CONSTRUCTION

No special construction is needed and the constructor may adopt any layout. The only wire that is at all critical is the grid lead. It should be short and well spaced from any other wires to minimise the input capacitance, and very well insulated. The input terminals should be well apart on a panel of insulating material and a ceramic valve-holder should be used. A high input resistance will not be obtained if the above is disregarded although of course the instrument will still work.

RANGE EXTENSION

Although a range of 0.1 to 1V peak is ample for radio-frequency measurements, i.e. measuring Q or self-capacitance of coils, an extension of range would make the instrument more versatile. It is however very difficult to do at high frequencies due to input capacitance. At low frequencies, when the reactance of the input capacitance is considerably less than the resistance of the potential divider in parallel with it, (see Fig. 7) it can be done.

The e.m.f. at the grid is then $\frac{r}{R+r}$ of the applied

e.m.f. If a non-contributory source of e.m.f. is being used then the grid must be given a d.c. path to earth. This can be done with a high resistance, 5MΩ being a suitable value. The input resistance then drops to slightly below 5MΩ, but which is high enough for most purposes.



EQUIPMENT CABINETS OF DISTINCTION



Imperial

- Illustrated in this advertisement are two fine cabinets from the Lewis Radio Range.
- These Cabinets are just two of a really extensive range.
- Each one carefully made by British Craftsmen and soundly constructed from the best materials available.
- Fill in coupon below to obtain FREE catalogue showing this wonderful range of cabinets.



Lowflex

FREE THE NEW LEWIS RADIO CATALOGUE

Designed to assist your choice of Cabinet. The New Lewis Radio Cabinet Catalogue—the most comprehensive ever prepared. Sent absolutely FREE! Please send your FREE 24 page cabinet catalogue.

NAME _____

ADDRESS _____

(Dept. P865)

Capitals please



100 Chase Side, Southgate, London N.14. Tel: Palmers Green 3733/9666

4-STATION INTERCOM



£8/15/0

Solve your communication problems with this latest 4-Station Transistor Intercom system (1 Master and 3 Subs), in de-luxe plastic cabinets for desk or wall mounting. Call/talk/listen from Master to Subs and Subs to Master. Operates on one small 9V battery. On/off switch. Volume control. Ideally suitable to modernize Office, Factory, Workshop, Warehouse, Hospital, Shop etc. for instant inter-departmental contacts. Complete with long connecting wires and other accessories. Nothing else to buy. P. & P. 5/-.
 Modernize your Office, Shop, Warehouse, Workshop, Surgery, Nursery and Home with this latest two-way Transistor Intercom, consisting of two units, Master and Sub, in strong plastic cabinets with chromium stands. Elegantly designed to use as two-way instant communication system call/talk/listen, between two persons anywhere indoors or outdoors. Both units operate on one 9V battery. Pulse transistorized. Complete with accessories. Ready to operate. P. & P. 2/6.

INTERCOM/BABY ALARM



Usualy £5.95—
Our Price ONLY
57'6

Modernize your Office, Shop, Warehouse, Workshop, Surgery, Nursery and Home with this latest two-way Transistor Intercom, consisting of two units, Master and Sub, in strong plastic cabinets with chromium stands. Elegantly designed to use as two-way instant communication system call/talk/listen, between two persons anywhere indoors or outdoors. Both units operate on one 9V battery. Pulse transistorized. Complete with accessories. Ready to operate. P. & P. 2/6.

BATTERY ELIMINATOR & CHARGER, 27/6

Use your Transistor Radio or Intercom from domestic A.C. mains and dry battery PP3 9V this boosts battery's life. Unbeatable value. Save you pounds on batteries. P. & P. 2/6. Complete with Plug, Lead and Snap cord.
 Full price refunded if not satisfied in seven days.
WEST LONDON DIRECT SUPPLIES (PW/11)
 6 Chignell Place, West Ealing, London, W.13.

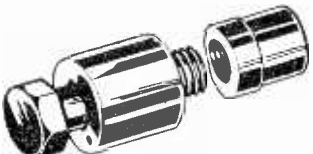

The PUNCH you need!

HOLE PUNCHES

Instant Type	3 1/2" diameter	6/10 ea.
Screw-up Type	3 1/2" diameter	Toggle switch	...	8/6 "
"	"	B7G	...	8/6 "
"	"	B8A, B9A	...	9/6 "
"	"	"	...	10/2 "
"	"	"	...	10/8 "
"	"	"	...	11/8 "
"	1 1/2" diameter	Int. Octal	...	12/4 "
"	"	"	...	12/2 "
"	"	"	...	18/10 "
"	"	B9G	...	21/8 "
"	"	"	...	24/4 "
"	2 3/4" "	Meter	...	33/2 "

Complete Set £9.3.6.

No extra charge for postage and packing in the U.K.

Now supplied by:

TOMPKINS & LONGMAN LTD.
 237 GIPSY ROAD
 WEST NORWOOD, S.E.27
 Tel. Gipsy Hill 5000

NOW ANYONE CAN AFFORD TO TRAIN TO BE AN EXPERT IN RADIO and ELECTRONICS

It's the most exciting news of the year! Just imagine. You can get 35 large, fact-packed lessons for little more than 1/- per lesson! The lessons are crystal clear, practical, easy to master and use. Early lessons make fundamentals clear even to the beginner, while other lessons will give you the practical "know-how" of an expert.

Compare favourably with some courses costing ten times as much. You save because you receive all the lessons at one time and are not required to purchase equipment you do not need. This is a real home-study course that has been bound into one giant 8 x 11 in. 216 page manual. Each page is divided into two columns. A wide column features the text while a narrow column at the side has the instructor's comments, helpful suggestions and additional pictures to simplify the difficult parts. Everyone can benefit from this practical course. No old fashioned (or pseudo modern) methods used here, just straight forward, easy to understand explanations to help you make more money in electronics.

The price! Only 30/6 plus postage 1/6.
 Terms? What of course! See Coupon.

OTHER COURSES AVAILABLE
 RADIO COURSE (22 lessons, price 36/-)
 TELEVISION COURSE (price 36/-)

UNCONDITIONALLY GUARANTEED TO GIVE COMPLETE SATISFACTION

You must be convinced that this is the best value you have ever seen in Electronics, Radio or T.V. Training, otherwise you can return the course (or have your money refunded if sent with order) after you have examined it in your own home for a full seven days. IF YOU SEND CASH WITH ORDER WE WILL INCLUDE A FREE BOOK VALUED 5/-. Tick on the coupon one book for each course ordered with full cash. These free books are authoritative and loaded with information. Would cost at least 5/- each if bought separately—by sending cash you reduce book-keeping and other costs which savings we pass back to you.

— FREE TRIAL OFFER —

Pay only 5/- per week if you wish. Clip coupon right now for this special offer.

To: Sim-Tech Technical Books, Dept. ET78, Gate's Mill, West End, Southampton, Hants.

Please send the following courses for a full seven days' trial:

- No. 1. RADIO COURSE, 37/6, incl. postage.
- No. 2. RADIO & ELECTRONICS COURSE, 41/-, incl. postage.
- No. 3. TELEVISION COURSE, 37/6, incl. postage.

(Free trial customers tick one only please).

If not delighted, I may return the course post-paid without further obligation on my part. Otherwise I will pay cash price of 5/- weekly until paid.

Tick here if enclosing full purchase price.

Please send me

- FREE TRANSISTOR CIRCUITS BOOK.
- FREE OSCILLOSCOPE BOOK.

Amount enclosed £.....

I understand that you will refund this money in full if I am not 100% satisfied. Overseas customers please send full amount (including Ireland).

Name _____
 Address _____

 City _____ County _____



in step with the

20 WATTS R.M.S.
SIZE 8 1/4" x 3 1/4" x 1"

YEARS AHEAD OF ALL OTHER AUDIO SYSTEMS

The Sinclair X-20 enables you to enjoy, for the first time ever the advantages of using a high power, high fidelity audio amplifier truly in step with to-day's space age electronics. No longer does power mean problems of heat and size, for the X-20 requires neither heatsink nor special ventilation. It measures only 8 1/4" x 3 1/4" x 1", weighs 4 1/2 ozs. and will deliver up to 20 watts R.M.S. into a 7 1/2-8 ohms loudspeaker—40 watts output by U.S.A. standards! A 3-stage pre-amplifier of exceptional efficiency is included within the above dimensions to ensure an overall frequency from 20 to 20,000 c/s well within ± 1dB from input to output. With greatly improved transient response, there is corresponding improvement in the results obtained from other equipment used with the X-20 which itself has an energy conversion factor of better than 95% at the output stage. At no point in the circuitry of the X-20 are components over-run, so that the instrument is both stable and assured of indefinite working life—and it is easier to build and install than any amplifier you have ever owned. Best of all it costs far less.

SINCLAIR

Complete kit of parts inc. transistors and X-20 Manual in sealed carton

£7-19-6

Built and tested with X-20 Manual in sealed carton

£9-19-6

X-20 Power Pack sufficient to drive two X-20's

£4-19-6

sinclair

SINCLAIR RADIONICS LTD.
COMBERTON, CAMBRIDGE

Telephone COMBERTON 682

SPACE AGE!

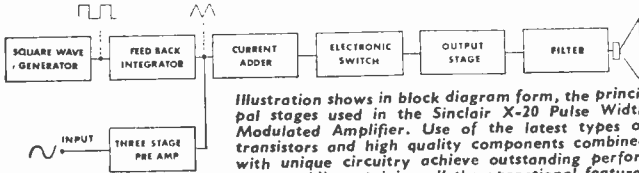

Illustration shows in block diagram form, the principal stages used in the Sinclair X-20 Pulse Width Modulated Amplifier. Use of the latest types of transistors and high quality components combined with unique circuitry achieve outstanding performance whilst retaining all the operational features of conventional quality amplifier design.

ONLY IN THE X-20 WILL YOU FIND ALL THESE IMPORTANT FEATURES

- ★ Easily built in an evening.
- ★ No. of transistors—12
- ★ Output transistors—Silicon epitaxial planars
- ★ Pulse repetition frequency—65 to 75 kc/s
- ★ Energy conversion factor at output—better than 95%
- ★ Frequency response—20 to 20,000 c/s \pm 1 dB
- ★ Total harmonic distortion at 10 watts R.M.S.—0.1%
- ★ Input sensitivity—1 mV into 5-K ohms
- ★ Signal-to-noise ratio—better than 70 dB
- ★ 20 watts R.M.S. music power or 15 watts R.M.S. continuous power into 7.5 ohms
- ★ 15 watts R.M.S. music power or 12 watts R.M.S. continuous power into 15 ohms
- ★ For use with any type of pick-up, microphone, radio tuner, tape pre-amp, etc
- ★ Built-in low pass filter cutting off above 20 Kc/s makes the X-20 widely tolerant of the load connected to it
- ★ Ideal for stereo and P.A.
- ★ Ideal as a guitar amplifier, etc
- ★ Power required—36V d.c. at 700mA
- ★ Superb quality and reliability
- ★ The opportunity to connect your own choice of tone control system

SINCLAIR X-10 P.W.M. SYSTEM

This superb Sinclair integrated P.W.M. amplifier and pre-amp gives you all the advantages of quality and efficiency which makes these Sinclair designs so outstanding in every way, but it has less power than the X-20, and is suited to less spacious listening conditions. Prices are particularly attractive. For 12-15V operation. Tone control system is added to choice.



Complete kit **£5.19.6**
 Ready built **£6.19.6**
 X-10 power supply unit **£2.14.0**

X-20 integrated 20 watt P.W.M. Amplifier and Pre-amplifier

Full service facilities available at all times to all Sinclair customers

GUARANTEE ORDER FORM

Please send me

NAME

ADDRESS

for which I enclose Cash/Cheque/ Money Order

value £.....s.....d.

PW8

Guarantee

Should you not be completely satisfied with your purchase when you receive it from us, your money will be refunded in full and at once without question. Please quote PW.8 should you prefer to write your order instead of cutting out this coupon.

THE WORLD'S SMALLEST MOST PERSONAL RADIO

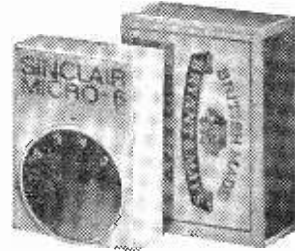

SINCLAIR MICRO-6

Build it now for outdoor days

Smaller than a matchbox, this world-famous receiver brings in stations all over the medium wave band with fantastically good quality and volume. It performs with amazing efficiency in cars, buses, trains and steel-framed buildings, yet measures only 1 1/2 in. x 1 3/16 in. x 1/2 in. complete with self-contained aerial and batteries. The highly stable six-stage circuit has A.G.C. and band-spread for Luxembourg. Building this wonderful set is enjoyable for expert and beginner alike.

All parts inc. transistors, case, lightweight earpiece and instructions come to

59/6

MALLORY MERCURY CELL ZM.312 (2 required), each 1/11. Pack of six, 10/6.

AND A POWER AMPLIFIER

2" x 2"

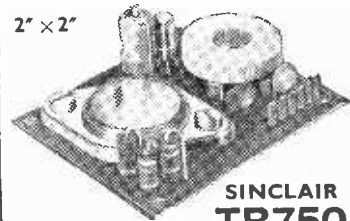

SINCLAIR TR750

With built-in switch and volume control. Output 750mW for feeding into standard 25 to 35 ohm speaker. Input 10mV into 2k Ω . Operates from 9V d.c. Designed principally for use with the Micro-6, with which it will make a car, portable or indoor domestic loudspeaker set, this amplifier will also make a mono or stereo record player, an intercom system, baby alarm, etc.

All parts and instructions **39/6** Ready built and tested **45/-**

RECEIVERS & COMPONENTS

TRANSISTORS, UNMARKED, UNTESTED, 40 for 10/-, p. and p. 1/-, 4 packets post free. Relays, thousands of types special catalogue free. General catalogue of Mechanical and Electrical Gear, Tools, etc., 5,000 items free. **K. R. WHISTON** (Dept. FRW), New Mills, Stockport.

"HEATHKITS" can now be seen in London and purchased on easy terms. Free brochure. **DIRECT TV REPLACEMENTS LTD.**, Dept. PW7/9, 126 Hamilton Road, West Norwood, S.E.27. GIPSY Hill 6166.

SPECIAL OFFER—465kc/s I.P. Strips, 7 Transistors, 5 Diodes, Famous make. Circuit, tested and aligned. 52/6, post paid. **JAMES, "Shalimar"**, Post Office Road, Frettenham, Norfolk.

GUARANTEED NEW & TESTED TRANSISTORS Money returned if not satisfied. XA101, 102, 103, 111, 112, XB103, 1/9 each. XA116, XB102, XA721, 121, 8/9 each. XA191, 1P2, XB113, 5/8 each. XA201, 702, 703, GET 8/9 each. XB104, XC101, 101A, OC189, 3/- each. XC141, 6/- each. OC42, 43, 44, 45, 71, 2/6 each. OC81, 81D, 8/9 each. OC26, 8/- each. General purpose diode, 6d. each. Germanium rectifier GJM 3/- each. Silicon rectifier BY213 3/- each. All previous lists withdrawn. Add 6d. P. & P. on orders under £1.
Transistor Sundries, 6 transistor printed circuit 1/8. 24in. speaker 6/6. Ferrite block 1/-. Edge volume control D.P.S.K. 1/8. T. P. and Osc. coils (set of 4) 6/8 each. Slide switch D.P.T. 1/-. Ganged condenser 6/-. P.P. output transformer 7/6. Driver transformer 7/6. Circuit 1/6.
 All the above made specially and ready for assembly 3/78 post free. Any item supplied separately Add 1/6 P. & P. or order less than 10/-.
CHEVELLYS ELECTRICAL ENGINEERING CO., Bank Chambers, Poulton is Fylde, Lancs.

SPEAKER REPAIRS, cones fitted. Satisfaction guaranteed. **L. S. REPAIRS**, Fluckley, Ashford, Kent.

RESISTORS! You can't resist these! 1,000 assorted wattage and value. Cannot be repeated at £2/10/- per 1,000. **G. F. MILWARD**, 17 Peel Close, Drayton Bassett, Staffs.

TRANSISTORS AT GIVE-AWAY PRICE! NKT 124/5 Switching transistors. Also capable of being used in all stages of a superhet, 6 for 10/-. OC71 equivalent 1/- each. 25 for £1 or £3 per 100. Miniature earphones with plug and lead 5/-. Transistor electrolytics 1/6 each. Brand new 4in. speakers 10/-. Goods under 10/- add 6d. postage please. **G. F. MILWARD**, 17 Peel Close, Drayton Bassett, Staffs.

R & R RADIO & TV SERVICE

Dept. P.W.
MARKET STREET, BACUP, LANC.
 Telephone 465

Closed for local holidays July 29th—August 5th, 1965

SALVAGE VALVES Tested before despatch

6L13	4/6	10P14	5/-	PL82	3/6	30P4	6/6
6L18	4/6	20P5	6/6	U801	7/6	30P16	5/6
EF80	1/8	30P4	7/-	10P1	1/6	PC84	4/6
EC63	3/-	6P16	5/-	20P2	5/3	PCL86	5/-
EC15	3/6	EB91	1/-	30FL1	6/-	PY81	8/6
50F5	5/-	EF85	5/-	PY22	6/-	U301	6/-
PL38	0/-	6301A	4/-	6U49T	5/-	10P13	6/6
PCP38	4/-	20F3	6/-	EC31	2/6	20D1	2/-
PL21	6/-	30FL2	4/-	E001	3/6	30P12	5/6
PY20	5/-	PL8	6/-	EF86	4/-	PY83	5/-
U920	5/-	PCL22	5/-				

Speakers, Kx-TV, 5in. round, 6 x 4in. 3/6; 8in. round, 6/-; post 2/-.

Line Output Transformers available. State set model No.

Turret Transformers, 3/6, post 2/-.

Beam Coils, etc. Quote set model No. with all enquiries and R.A.E. for prompt reply. All goods subject to inspection or money refunded.

RATES: 7/3 per line or part thereof. average five words to line. minimum 2 lines. Box No. 1/- extra. Advertisements must be prepaid and addressed to Advertisement Manager, "Practical Wireless", Tower House, Southampton St., London W.C.2.

RECEIVERS & COMPONENTS (continued)

A1 POST FREE BARGAINS: Guaranteed set tested Valves, EF80, EB91, 6d. each; EOL80, PY31, 2/- each; EC63, PZ30, PY82, 2/8 each; PY80, 2/6; PL83, PL82, PCF80, 3/- each; 20P1, EPF80, PL33, 4/- each; N37, 4/3; 10P13, 5/- S.A.E. for list or enquiries. **A1 RADIO COMPONENTS**, 14 The Borough, Canterbury, Kent.

MARCONI CANADIAN RECEIVER NO.52



Shipping Amateur, & Broadcast. Magnificent 10-valve receiver in three switched bands covering 1.7-17.6 Mc/s. (19 - 170 metres), plus a 3 valve crystal calibrator

employing dual crystal to provide marker check at 10-100-1000 kc/s. One RF and two IF stages. Other refinements: valve, HT, and signal check meter. Internal 3in. speaker and two 6I/9 tube outputs with switched control. R.F.-AF Gain, Noise Limiter, Filter, BFO, Heterodyne pitch control. Wide and Narrow Bandwidth, Man or AVC on CW & RT. Fast and slow tuning with lock. Additional OSC Tuning (plus & minus). Power requirements HT 160v. 60mA; LT 12v. 1 1/2 amps. size 1 1/2 x 1 1/2 in. Fully tested and working. ONLY £9.10.8. Carr. 10/6 or complete with Power supply unit suitable for 115/230v. AC mains and 12v. DC. £12.10.8. Carr. 20/6.

4 VALVE 4 WATT AMPLIFIER

"C" Core transformer
 A.C. Mains 115/230 volts
 600 ohms of high impedance input. Output 3 or 000 ohms (state choice)
 Controls: On/Off switch. (gain control). Indicator light. Valve inspection panel. 19 x 7 x 7in. Brand new in maker's carton. 79/6. Carr. 10/-.
TELESCOPIC AERIAL MASTS. Tubular steel coppered, spray finish, ring cam locking on each section provides for full or any height required. Suitable all fixings and base locations. Bottom section 1 1/2in. diameter. 20ft. (4 section) Closed 5ft. 9in. Weight 10lb. 55/-. Carr. 5/-. 34ft. (6 section) Closed 6ft. 6in. Weight 20lb. 75/-. Carr. 6/-. Further height by adding 3-4ft. Whip sections 13/6. Carr. 4/-. Special price for quantities.

WAVEMETER CLASS D

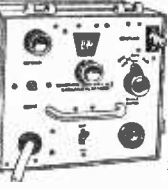

Freq. band 1,900 Kc/s. to 8,000 Kc/s. (168-37.5 metres)
 in two ranges, 900 Kc/s. also 4,000 Kc/s. 8,000 Kc/s. Supply 6 v. D.C. input
 Complete with twin crystal. As new.
PRICE 62/6.
 P. & P. 5/-.

CREED TELEPRINTERS. Price from £15. Carr. 30/-

MOVING COIL HEADPHONES. (BRAND NEW). Chamois padded, complete with jack plug, 15/6. Post 2/-. also available with matching moving coil microphone, 19/6, post 2/-. No. 19 set parts available. Many other bargain S.A.E. all enquiries.

A. J. THOMPSON (Dept P.W.)
 "ELING LODGE"
ODICOTE, HITCHIN, HERTS.
 Phone: ODIDOTE 948

RECEIVERS & COMPONENTS

(continued)

DIRECT TV REPLACEMENTS LTD., largest stocks of TV Components in the UK. Line Output Transformers, Frame Output Transformers, Deflector Coils for most makes. Official sole suppliers for many set makers. Same Day Dispatch Service. Terms C.O.D. or C.W.O. Send S.A.E. for quotes. Day and Night Telephone GIPSY Hill 6166, 126 Hamilton Road, West Norwood, S.E.27.

50 TRANSISTORS, all tested, marked and guaranteed. AP, PF, Silicon and P.N.P. Unobtainable elsewhere at this low price of 35/-, plus p & p 1/- D & W LTD, 224 West Road, Westcliff-on-Sea, Essex.

GUARANTEED BRAND NEW, IN ORIGINAL WOOD PACKING CASE, CANADIAN

MARCONI 52 RECEIVERS

FEW ONLY £10.10s.0d.

Mains Power Unit £2. supplied with outer case and Handbook. circuit set has crystal calibrator, speaker, etc.

Range 1.75-16Mc/s.

J.T. SUPPLY CO.

38 Meadow Lane, Leeds 11, Yorkshire.

TRANSISTORISED SIGNAL INJECTOR. Complete kit of components and circuit of injector for testing amplifier or radio. 10/- only. Post free. **G. F. MILWARD**, 17 Peel Close, Drayton Bassett, Staffs.

HOLLY ELECTRONICS. F.M. Tuner Units. 18 only of these units, chassis, AL1, 3lx2lx1 1/2 in. Permeability tuned, 4in. spindle. Complete with valve, UCC8, I.P. 107 M. but no circuit or details available, un-checked 17/6 each. P.P. Micro Sw, size 1 1/2 x 1 1/2 in. S.F. C/O, first class make, 4/9. Midget Mains Trans., FR1 230V. SEC 10V. 200mA, size 1 1/2 x 1 1/2 in. 5/- Transistors G.E.T. 103, equiv. OC72, 2/- ea. new. Electrolytics, 1000Mf 15V wkg, 1 1/2 x 1 in. tag ended, sleeved, 1/8, 39 + 32mf 25V. wkg., 1 1/2 x 2 1/2 in. clip type. 3/- Volume Controls, 1M. SF, long spindle, dia. 1 1/2 in. 2/8. All items new and P.P. Electrolytics from June issue can still supply. **Holly Electronics**, Holly House, Ford End, Chemsford, Essex.



CANADIAN MARCONI 52 RECEIVERS Superhet Receiver covering 1.75 to 16 Mc/s in 3 bands, 13 valves, crystal calibrator, meter, etc. Requires 150 volts D.C. 60 MA and 12.6 volts D.C. or A.C. Complete with steel outer case. In new condition, packed in original Ministry crates. £10.10.0. Carriage 25/- Reprinted handbook with Circuit etc. Send S.A.E. for leaflet. Transistorised Magnetic Broadcast Receivers, vest pocket size. Battery operated. Fixed frequency. Epoxy resin block construction. 1 x 4in. Ferrite Rod Aerial. No other information. Used, good condition. 5/-. Post 2/9. (Carriage charges apply to England and Wales only)
 Telephone: Worthing 9097



FOR SALE

HAMMER FINISH PAINT. The modern finish for electronics. Can be brushed or sprayed. Blue or Silver 2 1/2oz. tins 3/6, post 8d.; 1/2 pint 7 1/2, post 1/9; 1 pint 15/-, post 2/9. Orders over 30/- post free. Retailers supplied. Write for details. Amazing results! Return of post service. **FLYING AN SPECIALITY PAINTS (P.W.)**, Mickley Square, Stocksfield, Northumberland.

MORSE MADE EASY !

The famous RHYTHM RECORDED COURSE cuts the practice time down to an absolute minimum. One student, aged 20, took only 13 DAYS, and another, aged 71, took only 6 WEEKS to obtain a G.P.O. pass certificate. If you wish to read Morse easily and naturally please enclose 8d. in stamps or two international reply coupons for full explanatory booklet. **To GCHS, 45 GREEN LANE, PURLEY, SURREY**

FIVE-TON FACTORY CLEARANCE: Radio, TV Electrical Components in mixed parcels. Example: 28lb. mixed parcel £1, p.p. 7/6. Speakers, grilles, valves, bases, i.f.s. covers, condensers, etc. Hundred other items. S.A.E. list and postal orders to P. NEWTON, 16 Shalcross Crescent, Hatfield, Herts.

CONDENSER BARGAIN! Miniature Paper Condensers 1/4in. x 1/4in. Ideal for transistor sets. .0001, .001, .002, .005, .02, 4uF. a.s.o small 500uF and 2.2uF Condensers. All 7/6 per 100. £3 per 1,000. G F MILWARD, 17 Peel Close, Drayton Bassett, Staffs

NOW READY!

A modern way of instrument case assembly using our "Die Strip". The strip has been specially made for us at Birmingham on qty production, for low price to the public. It is made of high strength alloy and will enable anyone to assemble an instrument case or cabinet in minutes. Full details of these products will be sent free. Please send large envelope self addressed.

88 set transmitter/receiver. Chassis less valves, 20/- each. Post paid.

Copper Laminate Board, single or double sided, 5/- per square foot panels either type 3ft. by 4ft., 33/-.

High Stab Resistors, 5%, 6d.; 2%, 9d.; 1% 1/-, Every six packed in 7-compartment linen finish component box.

Speakers 3 ohm P.M. 5in., 5/-, 6in., 6/-, 7 x 4in., 7/-, 8in., 8/-, 10in., 12/6.

Please send S.A.E. for full Lists of other goods on offer.

U.K. ONLY

E. R. NICHOLLS
Mail Order and Retail Shop
46 LOWFIELD ROAD
off SHAW HEATH, STOCKPORT
CHESHIRE

FOR SALE

(continued)

TRANSISTORS

1/- each. Red or White Spots.

2/- each. XA101, XA102, XB103, OA90, XA111, XA112, OC430, V10/1S.

3/- each. OC44, OC45, OC70, OC71, OC81, OC81D, XA151, XB104, XC101, XC101A, OC169, OC200.

4/- each. AF114, AF115, AF116, AF117, OC170, OC171, XA103, XA116, XB102, XB105, XC121, XU611.

5/- each. OC139, OC140, OC204, ORP60, XA701, XA703, GET7, GET8, GET9, XC141, BY100, OA211.

10/- each. OC19, OC22, OC25, OC26, OC28, OC35, 2S013.

ZENNER DIODES

4.7v. to 30v., 1/4w. 3/6, 1.5w. 5/-, 7w. 6/- each.

Plus many more. Send 6d. in stamps for full list and eq. chart

B. W. CURSONS

78 BROAD STREET
CANTERBURY, KENT

FOR SALE

(continued)

RADIO Amateur Packing Up. Books, Rad 68, Televisions, etc. Dead cheap or given away. 185 Hewlett Road, Cherttenham, Glou. Tel. 21069.

WANTED

WE BUY New Valves for cash, large or small quantities, old types or the latest. Send details. Quotations by return. **WALTONS WIRELESS STORES**, 15 Church Street, Wolverhampton.

WE BUY New Valves and Transistors, Amplifiers, Short-wave Receivers and Components, etc. A.D.A. MANUFACTURING CO., 116 Alfreton Road, Nottingham.

WANTED VALVES ONLY

Must be new and boxed
Payment by return

WILLIAM CARVIS LTD.

103 North Street, Leeds 7

URGENTLY WANTED, new modern Valves, Transistors, Radios, Cameras, Tape Recorders and Tapes, Watches, Tools, any quantity. S. N. WILLETTTS, 16 New Street, West Bromwich, Staffs. Tel. 2392.

A PROMPT CASH OFFER for your surplus brand new Valves and Transistors. R.H.S., Beverley House, Mannville Terrace, Bradford 7.

MISCELLANEOUS

CONVERT ANY TV SET into an Oscilloscope. Instructions and diagrams 12/6. REDMOND, 42 Dean Close, Portslade, Sussex.

ELECTRONIC MUSIC?

Then how about making yourself an electric organ? Constructional data available—full circuits, drawings and notes! It has 5 octaves, 2 manuals and pedals with 24 stops—uses 41 valves. With its variable attack you can play Classics and Swing.

Write NOW for free leaflet and further details to C. & S., 39 Maude Street, Darlington, Durham. Send 2d. stamp.

METAL WORK

METAL WORK. All types cabinets, chassis racks, etc., to your specifications. PHILPOTTS METAL WORKS LTD., Chapman St., Loughborough.

CABINETS • CASES CHASSIS

Anything in metal. "One-offs" a pleasure. Send your drawing for quote. Stove enamelled in any professional finish

MOSS, WATSON

40 Mount Pleasant Street, Oldham Lancs. MAIN 9400 P.W.

240WATT ELECTRIC POWER ANYWHERE

ANYTIME from 12 VOLT CAR BATTERY

WITH THE AMERICAN DYNAMOTOR UNIT

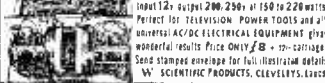

INPUT 12v. output 200-250v. at 150 to 220 watts. Perfect for television. POWER TOOLS and all essential AC ELECTRICAL EQUIPMENT plus wonderful results. Price ONLY £8 + no charge. Send stamped envelope for full illustration details. W. SCIENTIFIC PRODUCTS, CLEVELAND, ENGLAND.

NEW Nombrex Signal Generator, Model 27, £6; Miniature Cathode Ray Oscilloscope with case, 1 1/2in. screen, £12. HULME, 139 Green Lane, Vicars Cross, Chester.

ELECTRIC SOLDERING-IRON



FANTASTIC BARGAIN OFFER

Lightweight Pistol Grip handle 40 watt, 240/250v. A.C. Solid copper bit. Detachable handle forms cover for iron when not in use. With 4ft. Safety 3-core flex. Indispensable for every home handyman. A boon to tinkerers and a necessity for every wireless enthusiast. Offered to you at this new amazing price.

ONLY 9/6

P & P 1/-

C. H. SERVICE, (Dept. P.W.)
Lusted Hall Lane, Tatsfield, Kent.

EDUCATIONAL

RADIO OFFICERS see the world. Seagoing and shore appointments. Our many recent successes provide additional trainee vacancies during 1965/66. Grants available. Day and boarding students. Stamp for prospectus. **WIRELESS COLLEGE**, Colwyn Bay.

THE INCORPORATED PRACTITIONERS IN RADIO AND ELECTRONICS (I.P.R.E.) LTD. Membership Conditions booklet 1/-. Sample copy of I.P.R.E. Official Journal 2/- post free. Secretary, Dept. B, 32 Kidmore Road, Caversham, Reading, Berks.

TRAIN FOR SUCCESS WITH ICS

Study at home for a progressive post in Radio, TV and Electronics. Expert tuition for I.E.R.E., City & Guilds (Telecoms and Radio Amateurs') R.T.E.B., etc. Many unique diploma courses inc. Colour TV, Electronics, Telemetry & Computers. Also self-build kit courses—valve and transistor.

Write for **FREE** prospectus and find out how ICS can help you in your career
ICS DEPT. 541, PARKGATE ROAD, LONDON, S.W. 11.

BECOME "TECHNICALLY QUALIFIED" in your spare time. Guaranteed Diploma and Exam. Home-study Courses in Radio, TV Servicing and Maintenance. **R.T.E.B.**, City and Guilds, etc. Highly informative 120-page Guide — **FREE**. **CHAMBERS COLLEGE (Dept. 263), 148 Holborn, London, E.C.1.**

EDUCATIONAL

(continued)

CITY & GUILDS (electrical, etc.) on "Satisfaction or refund of fee" terms. Thousands of passes. For details of modern courses in all branches of electrical engineering, electronics, radio, T.V., automation, etc. send for 156-page Handbook—**FREE**. **B.I.E.T. (Dept. 242A), 29 Wright's Lane, London, W.8.**

RADIO OFFICERS training courses. Write: Principal, Newport and Monmouthshire College of Technology.

SITUATIONS VACANT

RADIO AND TV Exam. and Courses by Britain's finest Home-study School. Coaching for **Br.I.R.E.**, City and Guild's Amateurs' Licence, **R.T.E.B.**, **P.M.G.** Cert., etc. **FREE** brochure from **BRITISH NATIONAL RADIO SCHOOL**, Russell Street, Reading.

TV & RADIO — **A.M.I.E.R.E.**, City & Guilds, **R.T.E.B.** Cert., etc., on "Satisfaction or refund of fee" terms. Thousands of passes. For details of Exams and Home-training Courses (including practical apparatus) in all branches of radio, TV and electronics, write for 156-page handbook — **FREE**. **B.I.E.T. (Dept. 242G), 29 Wright's Lane, London, W.8.**

A.M.I.MechE., **A.M.I.E.R.E.**, City & Guilds, **G.C.E.**, etc. Become a Technician or Technologist: for high pay and security. Thousands of passes. For details of Exams and Courses in all branches of Engineering, Building, Electronics, etc. write for 156-page handbook—**FREE**. **B.I.E.T. (Dept. 242B), London, W.8.**

TV ENGINEERS for Broadmead branches at Tunbridge Wells, Maidstone and Chatham. Very attractive offers made in salary. Phone: Maidstone 52300.

SOUND RECORDINGS

A UNIQUE BUY. Recording tape, top brand, 7in., 2,400ft., D.P., 25/-; 5 1/2in., 1,200ft., 19/6. P. and p. 1/6 per spool. Bargains in all sizes. **S.A.E.** for list. We repair, buy and sell Records. **E. C. KINGSLEY & CO. LTD.**, 132 Tottenham Court Road, London.

SERVICE SHEETS

SERVICE SHEETS, Radio and Television. 3/6 post paid. **VEST AND EMERY**, 17 Hollgarth St., Durham.

SERVICE SHEETS, Radio, TV, 5,000 models. List 1/- **S.A.E.** inquiries. **TELRAY**, 11 Maudland Bank, Preston.

SERVICE SHEETS for all makes of Radio and TV, 1925-1965. Prices from 1/- with free fault-finding guide. **S.A.E.** inquiries. Catalogue of 6,000 models 1/6. Valves, modern and obsolete. **Radio/TV Books**, **S.A.E.** lists. **HAMILTON RADIO**, Western Road, St Leonards, Sussex.

SERVICE SHEETS (75,000) 4/- each. Callers welcome. Always open. 5 South Street, Oakenshaw, Bradford.

SERVICE SHEETS

4/- ea., plus postage

We have the largest display of Service Sheets for all makes and types of Radios, Televisions, Tape Recorders, etc., in the country. Speedy service.

To obtain the Service Sheet you require please complete the attached coupon.

From: _____
Name: _____

Address: _____

To: S.P. DISTRIBUTORS

44 Old Bond St., London, W.1
Please supply Service Sheets for the following:

Make: _____

Model No..... Radio/TV

Make: _____

Model No..... Radio/TV

Make: _____

Model No.: Radio/TV

I also require list of Service Sheets at 1/6.

(please delete items not applicable)

I enclose remittance of.....

MAIL ORDERS ONLY Au. FW

City and County of Bristol Education Committee

BRISTOL TECHNICAL COLLEGE CAREERS IN RADIO AND RADAR

Marine Radio Officers

2-year, full-time course for young men aged 16 upwards; leading to 1st and 2nd Class P.M.G. Certificates and B.O.T. Radar Maintenance Certificate.

Conversion Course (2nd Class to 1st Class).

R.T. Courses (for Full or Restricted Licence).

Training given on the latest types of Marine and Aircraft Equipment in the newly equipped Laboratories at

THE SCHOOL OF MARINE RADIO AND RADAR

For details write to:

THE REGISTRAR

BRISTOL TECHNICAL COLLEGE ASHLEY DOWN, BRISTOL 7

Licensed Aircraft Radio Engineers

2-year, full-time course for A.R.M.E. Licences, categories A & B, and 6 months' courses for Radar Rating in association with above.

EXPRESS ELECTRONICS

32 SOUTH END, CROYDON, SURREY .

Telephone: Croydon 9186

FOR THE FOLLOWING BRAND NEW UNITS

AMPLIFIERS

TRIPLETONE HI-FI MAJOR	12 watt	£15.18.4
TRIPLETONE CONVERTIBLE	5 watt	£6.19.6
TRIPLETONE GEMINI STEREO	5 watt	£15.15.0
LINEAR	3 watt	£6. 6.0
LINEAR DIATONIC	12 watt	£12.12.0
LINEAR CONCHORD	30 watt	£16.16.0
ADASTRA 3-3	4 watt	£4.19.6
LEAK TL12	14 watt	£18.16.0
LEAK VARISLOPE PRE-AMP	£15.15.0
LEAK TL50	50 watt	£33.12.0
QUAD	15 watt	£22. 1.0
QUAD STEREO/MONO PRE-AMP	£25. 0.0

LOUDSPEAKERS

GOODMANS AXIETTE 8in.	6 watt	£5. 5.0
GOODMANS AXIOM 10in.	10 watt	£6. 6.0
GOODMANS AXIOM 20i	15 watt	£10.15.0

BAKERS 'SELHURST' 3 or 15 ohm

JUNIOR 8in.	8 watt foam	£5. 5.0
STALWART 12in.	15 watt	£5. 5.0
BASS GUITAR 12in.	25 watt	£5. 5.0
STANDARD Heavy Duty 12in.	20 watt	£7. 7.0
BASS Heavy Duty 12in.	25 watt	£12.12.0
AUDITORIUM 15in.	35 watt	£18.18.0

RECORD PLAYERS

GARRARD SRP10 4-speed	£4.19.4
GARRARD AUTOSLIM 4-speed	£6. 7.6
GARRARD AT6 TRANSCRIPTION	£9.17.6
GARRARD 4HF TRANSCRIPTION	£14.17.6
GARRARD A LAB SERIES	£17.10.0
GARRARD 301 LAB SERIES	£19. 5.0
DECCADEC WITH DERAM HEAD	£14.15.0
BSR TAPE-DECKS PD2 Twin Track	£7. 9.6

De-luxe record players with excellent sound reproduction incorporating the latest BSR 4-speed autochanger, independent tone and volume controls, high quality speaker. Not in kit form but factory made and tested. Finished in most attractive two-tone cabinets in blue-grey, red/grey or charcoal/grey with gilt trim. 200-250v. AC. £12.12.0.

Delivered free U.K. S.A.E. enquiries.

GUITAR AMPLIFIERS WITH TREMOLO

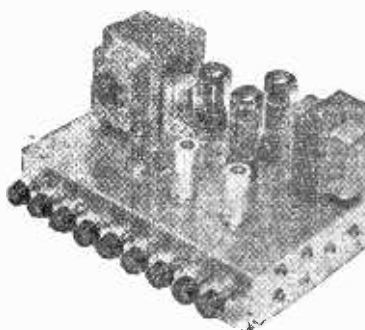

Five jack socket inputs, four with separate tuning volume controls, and one input "straight through". All inputs are of very high sensitivity only 10 millivolts input is required for full output, making them suitable for all types of guitars and microphones. Separate Bass and Treble controls, giving a wide range of Hf

and out. Separate master gain control. Tremolo speed and depth controls. Jack socket for remote tremolo switching. Outputs for 3 and 15 ohms speakers. Valves used in the 30 watt and 50 watt amplifier ECC83, ECC83, EL34, EL34, GZ34. In the 15 watt amplifier ECC83, ECC83, EL84, EL84, E281. An extra valve ECC83 is used in the tremolo circuit. The chassis is complete with base-plate and is solidly made of 18 gauge steel, finished silver grey hammer. size 12 x 8 x 4 1/2 inches high.

PRICES

50 watt with tremolo	£20.10.0
50 watt less tremolo	£19.10.0
30 watt with tremolo	£15.10.0
30 watt less tremolo	£14.10.0
15 watt with tremolo	£12.10.0
15 watt less tremolo	£11.10.0

Add carriage 10/- any amplifier. Send S.A.E. for Descriptive Leaflet. CREDIT TERMS ARRANGED Export Inquiries Invited.

STROUD AUDIO

CASHES GREEN ROAD, STROUD, GLOS.

TRANSISTOR TRANSMITTERS FOR THE AMATEUR

Complete details, including circuit descriptions, construction techniques, parts lists, and operating instructions for 12 useful transistor devices.

by D. L. Stoner

21/- Postage 1/-

INTRODUCTION TO ELECTRONICS, Bureau U.S. Naval Personnel. 8/-, Postage 1/-.

WORLD RADIO TV HANDBOOK 1965. 26/-. Postage 1/-.

DESIGN AND CONSTRUCTION OF TRANSISTOR SUPERHETS by P. H. Warring. 17/6. Postage 1/-.

MAGNETIC RECORDING FOR THE HOBBYIST by A. Zuckerman. 20/-. Postage 1/-.

PRINCIPLES OF TRANSISTOR CIRCUITS by S. W. Amos. 25/-.

THE RADIO AMATEUR'S HANDBOOK 1965. A.R.R.L. 40/-.

Postage 2/6.

RADIO & TELEVISION SERVICING. Special Answers to Inter. Papers, 1961/64 by F. O. M. Bennewitz. 8/6d. Postage 6d.

COMPLETE CATALOGUE 1/-.

THE MODERN BOOK CO.

19-21 PRAED STREET LONDON, W.2

Phone: PADdington 4185 Open 6 days 9-6 p.m.

HALF PRICE OFFER!

THE 'EMPRESS'

HI-FI RADIOGRAM

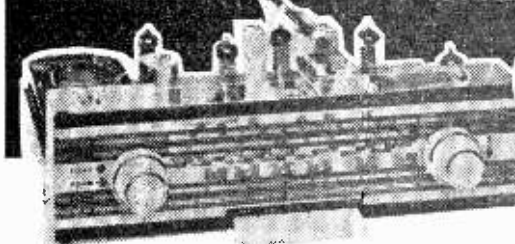

AT ONLY - 23 GNS

Fully Guaranteed for one year!

This magnificent radiogram chassis, complete with 10in. elliptical loudspeaker plus 4 speed auto-changer. At only 23 gns. this is the bargain of the year. Write away for the "Empress" Radiogram today.

- Easily fitted.
- No soldering or technical knowledge necessary.
- Fits almost any cabinet with minimum trouble.
- Modernises your old radiogram.
- Built-in Ferrite rod aerial.
- Piano key switching.
- Luxembourg and Caroline received at full strength.
- Listen to U.S.A., Russia, Africa, Canada and even Australia.
- Unique Lewis Radio 365 day guarantee, even on all the valves.
- All British make.

SPECIAL terms available of £3.12.6 deposit followed by 18 monthly payments of £1.6.7 (total H.P. £27.11.0) plus postage and packing 15/- extra.

INDIVIDUAL CABINETS SUPPLIED ON REQUEST

LEWIS radio LEWIS RADIO, 100, CHASE SIDE, SOUTHGATE LONDON, N.14. Telephone: PAL 3733/9666

10/14 WATT HI-FI AMPLIFIER KIT

A stylish finished modular amplifier with an output of 14 watts from 2 EL34s in push-pull. Super reproduction of both music and speech with negligible hum.

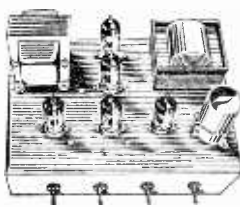

Separate inputs for mike and gram. allow records and announcements to follow each other. Fully shrouded section wound output transformer to match 3-15Ω speaker and independent volume controls and separate bass and treble controls are provided giving good lift and cut. Valve line-up 2 EL34s EC08s EF86 and EZ80 rectifier. Simple instruction booklet 1/6. (Free with parts).

All parts sold separately. ONLY **£6.19.6** P. & P. Also available ready built and tested complete with standard input sockets. **£8.15.0**, P. & P. 8/6. Carrying Case for above **28/6**, P. & P. 7/6.

SPECIAL HARVERSON OFFER !!!

BRAND NEW HEAVY DUTY 12in. SPEAKERS. Response 45 c/s-13 Kc/s. 1 1/2in. voice coil. Available in 3 or 15 ohms. Guaranteed full 15 watts British rating. Heavy cast aluminium frame. These are current production by world famous maker and as they are ordered well below list price we are not permitted to disclose the name. **LIMITED NUMBER ONLY. UNREPEATABLE AT 89/6**, P. & P. 5/- . Also 25 watt Guitar Model available at **25.5.0**.

HIGH GAIN 4-TRANSISTOR PRINTED CIRCUIT AMPLIFIER KIT Type TAI



● Peak output in excess of 1 1/2 watts. ● All standard British components. ● Built on printed circuit panel size 6 x 3in. ● Generous size Driver and Output Transformers. ● Output transformer tapped for 3 ohm and 15 ohm speakers. ● Transistors (GET 114) or 81 Mullard OC81D and matched pair of OC51 o/p ● 9 volt operation. ● Everything supplied wire battery clips solder etc. ● Comprehensive easy to follow instruction and circuit diagram 1/6. (Free with Kit). All parts sold separately. **SPECIAL PRICE 45/-** P. & P. 3/-. Also ready built and tested **52/6**, P. & P. 3/-. A pair of TAI's are ideal for stereo.

HARVERSON'S F.M. TUNER Mk I.

- F.M. tuning head by famous maker.
- Guaranteed non-drit-meability tuning.
- Frequency coverage 88-100 Mc/s
- Balanced diode output.
- Two I.F. stages and discriminator.
- Attractive maroon and gold dial (7 x 3in. glass).
- Self-powered using a good quality mains transformer and valve rectifier.
- Valves used EC08s two EF80's and EZ80 (rectifier).
- Fully drilled chassis.
- Size of completed tuner 8 x 6 1/2in.
- All parts sold separately

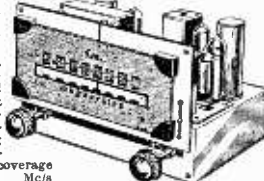

Set of parts if purchased at one time **£5.19.6**, plus 8/6 P. & P. and ins. Circuit diagram and instructions 1/6 post free. Mark II Version as above but complete with magic eye front panel and brackets **£6.12.6**, P. & P. 8/6. Mark III Version as Mark I but with output stage. (EC182) and tone control **£7.7.0**, P. & P. 8/6. Handsome Metal Cabinets. Choice of Black or Green. To fit Mark I, **25/-**, P. & P. 3/-. To fit Mark II, **17/6**, P. & P. 5/-.

SPECIAL PURCHASE TURRET TUNERS

By famous maker. Brand new and unused. Complete with PC084 and PC090 valves 34-38 Mc/s I.F. Biasing for Channels 1 to 5 and 8 and 9. Circuit diagram supplied. **ONLY 25/-** each. P. & P. 3/9.

GORLER F.M. TUNER HEAD
88-100 Mc/s 10.7 Mc/s. L.F. 15/-, plus 2/- P. & P. (OC086 valve, 8/6 extra).

4-SPEED PLAYER UNIT BARGAINS

All Brand New in Maker's Original Packing
SINGLE PLAYERS
GARRARD SRP10 **£5.9.11**, Carr. 5/6
B.S.R. GU7 with auto mounted pick-up arm. **£41.8.8.**, Carr. 5/6

AUTO CHANGERS
LATEST B.S.R. UA26 Super Slim mono. **£6.2.6**
B.S.R. UA15 **£6.19.6**; B.S.R. UA18 **£6.19.6**
LATEST GARRARD AT5..... **£8.8.0**
Standard GARRARD Autoslim..... **£6.10.0**
GARRARD AT6... **£10.10.0**, Carr. 6/6 on each.
All the above units are complete with 7 1/2 mono head and sapphire styli or can be supplied with compatible stereo head for 12/6 extra.

SPECIAL OFFER I

Limited number of
E.M.I. 4-SPEED SINGLE RECORD PLAYER DECKS
with unit mounted pick-ups. Incorporating the following special features: Heavy 8 1/2in. metal turntable. Low flutter performance shaded pole motor for 200/250V. A.C. with 90V tap. Latest ultra lightweight pick-up 15 grammes tracking weight. High output mono ceramic cartridge. Autostop. Overall motorplate size, 12 x 10 x 2 1/2in. below and 2in above.
UNREPEATABLE OFFER AT 89/6
Carr. 5/6

THE NEW HARVERSON KIT FOR THE HOME CONSTRUCTOR

A really excellent all purpose A.C. mains 240V **AMPLIFIER KIT TYPE HSL 'FOUR' 3 VALVE 4 WATT USING EC083, EL86, EZ80, VALVES**
Special features include:
● Heavy duty double-wound mains transformer with electrostatic screen. ● Separate Bass, Treble and Volume controls, giving fully variable boost and cut with minimum insertion loss. ● Heavy negative feedback loop over 2 stages ensure high output at excellent quality with very low distortion factor. ● Suitable for use with guitar, microphone or record player. ● Provision for remote mounting of controls or direct on chassis. ● All this builds onto a chassis size only 7 1/2in. wide x 4in. deep. Overall height 4 1/2in. ● All components and valves are brand new. ● Very clear and concise instructions enable even the inexperienced amateur to construct with 100% success. ● Supplied complete with valves, output transformer (3 ohms only) screened lead, wire, nuts, bolts, solder etc. (No extras to buy).
PRICE 79/6 P. & P. 6/-
Comprehensive circuit diagram, practical layout and parts list 2/6. (Free with Kits).

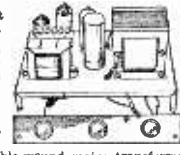

QUALITY RECORD PLAYER AMPLIFIER

A top-quality record player amplifier. Size 7in. w. x 2 1/2in. d. x 6 1/2in. h. This amplifier (which is used in a 29 gm record player) employs heavy duty double wound mains transformer, EC083, EL84, EZ80 valves. Separate bass, treble and volume controls. Complete with output transformer matched for 3 ohm speaker. Ready built and tested
PRICE 69/6 P. & P. 4/9
ALSO AVAILABLE. Mounted on board with output transformer and 6in. speaker ready to fit into cabinet below. **PRICE 89/6** P. & P. 6/9

QUALITY PORTABLE R/PLAYER CABINET

Unset motor board. Will take above amplifier and B.S.R. or GARRARD Autochanger or single Record Player Unit. Size 18 x 14 x 8 1/2in.
PRICE £39.6, Carr. 7/6.

LATEST MODEL B.S.R. TU/12 4-SPEED PLAYER AND PICK-UP ONLY 69/6 Carr. 5/6

7in. metal turntable Low flutter performance. 200/250 v. shaded pole motor with 90 v. tap for valve heaters. High gain crystal pick-up with turnover LP/78 head complete with sapphire styli.



TWO VALVE GRAM AMPLIFIER ON PRINTED CIRCUIT BOARD

(U785, U184). Can be used with 20 v. tap of motor. O.P. Trans. Volume and tone control. Size 6 1/2in wide x 2 1/2in. deep x 3 1/2in. high overall. 0 N L Y 39/6, P. & P. 2/6. Mains dropper res. for filaments if required. 2/6 extra.

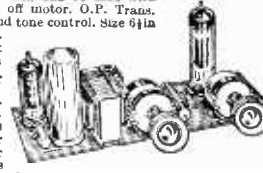

NEW CARTRIDGE BARGAINS

AC08 71-5 single sided crystal cartridge for Stereo and L.P. records. Complete with diamond stylus and universal mounting bracket. List price **£2.6.4**. Our price **18/6**, P. & P. 1/-.
RONETTE STEREO 105 CARTRIDGE. Stereo/LP/78. Complete with two sapphires. Original list price **£7.9**, OUR PRICE **24/-**, P. & P. 1/-.
GARRARD OC92 Mono complete. List price **24/11**. OUR PRICE **12/6**, P. & P. 1/-.

STEREO AMPLIFIERS

Incorporating 2 EC182's and 1 EZ80 heavy duty double-wound mains transformer. Output 4 watts per channel. Full tone and volume controls. Absolutely complete.

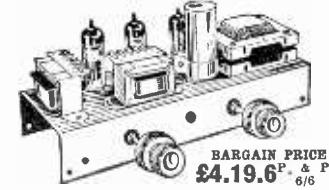

BARGAIN PRICE £4.19.6 P. & P. 6/-
SUPER DE LUXE version of above incorporating EC186 valves separate bass and treble controls and full negative feedback. **8 gns. P. & P. 6/6**.

6 TRANSISTOR AND DIODE SUPERHET

A first-class 2 waveband transistor superhet. ● Printed circuit panel (size 8 1/2 x 2 1/2in.). ● 3 pre-aligned I.F. transformers. ● High-gain Ferrite Rod Aerial. ● All First-grade transistors. ● Car aerial winding. ● Push-pull output. ● All parts supplied with simple instructions. All parts sold separately. Set of parts if purchased at one time **ONLY £4.5.0**, P. & P. 2/6. Circuit diagram 2/- (free with set of parts).

35 OHM SPEAKERS

Suitable for use with above. 2in. Goodman. Ideal replacement for most pocket portables 8/6, 3 1/2in. 12/8; 5in. 17/8; 7 x 4in. 21/-; P. & P. 2/- per speaker.

Portable CABINET

Size approx. 9 1/2 x 6 1/2 x 3 1/2in. Suitable for above using 3 1/2in. speaker 25/-, P. & P. 2/6.

COIL AND TRANSFORMER SET FOR TRANSISTOR SUPERHET

3 I.F. transformers one oscillator coil one driver transformer and wound Ferrite aerial (med. long and car aerial coupling) 32/6 complete post 2/-. 6 transistor printed circuit board to match 8/6. Post 1/-. Circuit diagram 1/6 extra.

SPECIAL BRAND NEW TRANSISTOR BARGAINS

GET 15 (Matched Pair) 15/-; V15/10p. 10/-; OC71 5/-; OC76 8/-; AF117 7/6; ORP12 10/6. Set of Mullard 6 transistors OC34, 7-OC45 OC81D matched pair OC81 25/-, GRP12 Cadmium sulphide Cell, 10/6.

EDISWAM MAZDA

PXA101 6/6; XA103 6/6.
R.F.I. Pack: 1-PXA102 Mixer; 2-PXA101 I.F. Amp. (Equip. OC44 and OC45)..... 30/6
R.F. 2 Pack: 2-PXA101 I.F. 1-PXA102 Osc. 2-PXA102 Mixer..... 20/6
L.F.6 Pack: Consisting of PXB113 Driver Matched pair PX171 mounted complete with heat sinks (Equip. OC81D and OC81)..... 12/6
ALL TRANSISTORS POST FREE.

HARVERSON SURPLUS CO. LTD.

170 HIGH ST., MERTON, S.W.19 Cherrywood 3985
Open all day Saturday Early closing Wed. 1 p.m.

A few minutes from South Wimbledon Tube Station (Please write clearly)
PLEASE NOTE: P. & P. CHARGES QUOTED APPLY TO U.K. ONLY P. & P. ON OVERSEAS ORDERS CHARGED EXTRA.
SEND STAMPED ADDRESSED ENVELOPE WITH ALL ENQUIRIES

SEE RIGHT HAND PAGE FOR MORE ITEMS

3-VALVE AUDIO AMPLIFIER MODEL HA34



Designed for Hi-Fi reproduction of records A.C. Mains operation. Ready built on plated heavy gauge metal chassis size 7 1/2 in. x 4 in. d. x 4 1/2 in. h. Incorporates ECC83, EY154, E250 valves, heavy duty double-wound mains transformer and output transformer matched for 3 ohm speaker, separate bass, treble and volume controls. Negative feedback line. Output 4 1/2 watts. Front panel can be detached and leads extended for remote mounting of controls. The HA34 has been specially designed for us and our quantity order enables us to offer them complete with knobs, valves, £4.5.0 P. & P. etc. wired and tested for only 6/-

BRAND NEW LOUSPEAKERS 5in., 12/6; 6in., 15/-; 8in., 21/-; 10in., 25/-; 12in., 27/6; (12in. 15 ohm, 30/-; 10 in., 28/-; E.M.I. 1 1/2 x 8in. with high flux ceramic magnet, 42/-; 15 ohm, 45/-).

4in. HIGH FLUX TWEETER. 3 ohm or 15 ohm imp. Famous British make, 12/- P. & P. 4 and 6in. 2/-; 8 1/2 and 8in. 2/6; 10 and 12in. 3/6 per speaker.

TAPE DECKS

COLLARO STUDIO DECK. 3 motors, 3 speeds, push button control. Up to 7in. spools. £10 10 0 P. & P. 7/6.

B.S.R. MONARDECK. Single speed. 3 1/2 in. sp. simple control uses 5 1/2 in. spools. £8 15 0 plus 7/6 carr. and insa. Tapes extra on both.

BARGAIN OFFER CORNER

MAINS TRANSFORMERS

Fully shrouded, can be mounted upright or drop through. Tapped per. 110, 200, 250, 240v. Sec. 250v. 1/2 watt at 85 mA and 6.3v. 2 amps. Cf. Stack size 3 x 2 1/2 x 1 1/2 in. PRICE 12/6 P. & P. 3/6. Also semi-shrouded drop thro' type. Pri. 200, 220, 240v. Sec. 250v. 1/2 watt at 70mA and 6.3v. at 1/2 amp. Cf. Stack size 3 x 2 1/2 x 1 1/2 in. PRICE 11/- P. & P. 3/6.

PRECISION 6 MINUTE DELAY ACTION SWITCH Clockwork actuated. Made by Smiths. Separate switching sections at intervals up to 6 mins. Each switch section designed for current loading up to 15 amps at 250 volts. Suitable for photographic timer, sequence switching operations, etc., etc. Brand new and unused units offered at a fraction of their true value. OUR PRICE ONLY 10/- each. P. & P. 1/6 (or more post free). Special quotations for quantity.

HEAVY DUTY NON INDUCTIVE D/P MICRO SWITCH. Conservatively rated 10 amps at 250v. Standard one-hole fixing. Body size 1 1/2 x 1 x 1 in. deep, inc. terminals, 3/- each. P. & P. 1/6 (or more post free).

ROLA CELESTION. Approx. 9 x 6in. 3 ohm Middle register speaker, 10/6 P. & P. 3/6. VYNAIR AND BEKINE SPEAKER AND CABINET FABRICS. Approx. 5 1/2 in. wide. Usually 36/- yard. OUR PRICE 13/6 per yard length. P. & P. 2/6 (min. one yd.) S.A.E. for samples.

ACOS CRYSTAL MIKES. High imp. For desk or hand use. High sensitivity, 18/6 P. & P. 1/6. TSL CRYSTAL STICK MIKE. Listed at 45/- Our price 18/6 P. & P. 1/6.

T.C.C. SUPPRESSOR CONDENSERS. 250v. A.C. .005 + .005 x .1. In tubular can 1 1/2 in. long x 1/2 in. dia. 2 for 3/- Post free.

TRANSISTOR DRIVER AND O/P TRANSFORMERS. (Tapped 3 ohms and 15 ohms output). Plus 4 suitable Transformers giving approx. 1 watt output. 25/- P. & P. 2/6.

2-GANG .0005 TUNING CONDENSERS. 2 1/2 in. h. x 2 1/2 in. d. x 1 1/2 in. w. with built-in trimmer. 4/6 P. & P. 2/6.

MATCHED PAIR OF 2 1/2 WATT TRANSISTOR DRIVER AND OUTPUT TRANSFORMERS. Stack size 1 1/2 x 1 1/2 x 1/2 in. Output trans. tapped for 3 and 15 ohm output, 10/- pair. P. & P. 2/6. BRAND NEW PLESSEY 12v. 4 pin. non-syn. vibrators. Type 12 1.48D. ONLY 8/6 P. & P. 2/6.

1 1/2 IN TELESCOPIC AERIAL. Comprising two 3-section heavily chromed rods. Closed 12in. each extending to 32in. each. Completely adjustable from vertical to horizontal. Supplied complete with universal mounting bracket, coax lead and plug. Suitable for F.M. or T.V. 12/6 P. & P. 2/6. 4-WAY NON-TANGLE TELEPHONE CABLE. Latest spring back coil type, extends 12in. to 5ft. Complete with rubber bushes, 4/6 each. P. & P. 1/6.

Harverson Surplus Co. Ltd.

NEW VALVES!

Guaranteed Set Tested 24-HOUR SERVICE

Table listing various vacuum tube types and their prices, including 1R5, 1S5, 1T4, 354, 3V4, DAF91, DF91, DK91, DL92, DL94, etc.

Postage on 1 valve 9d. extra. On 2 valves or more, postage 6d. per valve extra. Any parcel insured against damage in transit 6d. extra.

Office address, no callers. GERALD BERNARD 83 OSBALDESTON ROAD STONE NEWINGTON LONDON, N.16.

FAMOUS FOR THIRTY YEARS for SHORT-WAVE EQUIPMENT OF QUALITY. H.A.C. SHORT-WAVE KITS. Includes an image of a radio receiver kit.

H.A.C. were the original suppliers of Short-Wave Receiver Kits for the amateur constructor. Over 10,000 satisfied customers including Technical Colleges, Hospitals, Public Schools, R.A.F., Army, Hams, etc. IMPROVED 1965 RANGE 1. Valve model "CX", complete kit, Price 34/6 (customers say: "Definitely the best one-valve S.W. kit available at any price". This kit contains all genuine Short-Wave components, a drilled chassis, accessories and full instructions. Ready to assemble and, of course, as all our products, fully guaranteed. FULL RANGE of other kits still available including the famous model "K", price 77/-.

Before ordering call and inspect a demonstration receiver or send for a descriptive catalogue and order form to— "H.A.C." SHORT-WAVE PRODUCTS (Dept. T.H.), 44 Old Bond St. London W.1

TEST METERS



20,000 O.P.V. MODEL TP 55. Reads voltage up to 1,000 V.A.C. at 20,000 ohms per volt and A.C. at 10,000 O.P.V.; D.C. current to 500mA; Resistance to 10 Mega. Capacitance to 0.1 uF. Deflects from -20 to +80. Size 3 1/2 in. x 2 1/2 in. x 1 1/2 in. £8.19.9.

2,000 O.P.V. MODEL TP 10. Reads A.C. and D.C. Volts up to 1,000; D.C. current to 500mA; Resistance to 1 Meg.; Capacitance to 1 uF; Deflects from -20 to +30; Output Jack for A.C. Measurements. Size 3 1/2 x 5 x 1 1/2 in. £8.19.6.

30,000 OHMS PER VOLT MODEL 500. Reads voltages up to 1,000 V.A.C. at 30,000 ohms per volt and A.C. at 15,000 O.P.V.; D.C. current to 125 mA. Resistance to 60 Mega. Deflects from -20 to +30; Incorporates internal buzzer for audible warning of direct shorts and blocking condenser for A.F. output measurements. Size 3 1/2 x 5 x 1 1/2 in. £8.19.6.

TRANSISTORISED TEST EQUIPMENT. Fully guaranteed, brand new. By NOMBIFEX: 150 Kc/s.—350 Mc/s. Signal Generator. £9.10.0. Resistance-Capacitance Bridge. £5.5.0. 1.5 volts D.C. Power Supply. £6.10.0. Audio Generator 100,000 c/s. £16.15.0. Inductance Bridge. £18.0.0.

SPECIAL OFFER OF AMERICAN VALVE VOLT-METERS. 11 Mega. input. 6 D.C. Voltage ranges to 1,000 V.A.C. voltage ranges to 1,000. 6 Resistance range to 1,000 Megohms. 4in. 200 microamp. meter. For 110/250 volts A.C. operation. With test prods and operating instructions. Manufactured by RCA and Electronic Design. ONLY £7.19.8 Post etc. 3/6.

LINEAR AMPLIFIERS. LC34, 4 watts, size 8 1/2 x 4 1/2 x 2 1/2 in. high. £5.5.0. 1.45 A watts, size 7 x 7 x 5 in. high. £5.19.6. Protective cover 12/9. £15/50 5 watts stereophonic, size 10 1/2 x 8 x 6 in., £12.12.0, cover with carrying handles, 25/-; "Diatonic" 10 watts Hi-Fi Ultra Linear fish-pull size 9 x 7 x 6 1/2 in. high. £12.12.0. 0.5 watts with carrying handles, 19/6. 1 1/16 10 watts Hi-Fi Ultra Linear size 9 x 7 x 5 in. high. £13.13.0. Cover with carrying handles, 19/6. "Combord" 30 watts Hi-Fi Ultra Linear size 12 1/2 x 9 x 7 1/2 in. high. £16.15.0. Cover with carrying handles, 25/-; 130 50 watts Hi-Fi Ultra Linear, size 14 x 10 x 5 in. high. £28.2.0. Cover with carrying handles, 32/6. All amplifiers for normal A.C. mains and ex stock. Details on request.

"Tripletons" Convertible Amplifier. Size 10 x 3 x 4 1/2 in. high. 4 watts output matched for 2-3 ohms. OR 2 amplifiers can be coupled together for STEREO. £8.19.6 each. "Tripleton" F.M. Tuner, size 11 x 6 x 3 in. high. Coverage 90-104 Mc/s. £13.19.6. (unpowered), or £15.14.6 (self-powered). Details on request.

MICROPHONES. Crystal Types. Guitar, 12/6. Desk, with built-in stand, 15/-; ACOS 39/1 Stick, with Table Stand 32/6. Super stick, with heavy Oak stand 49/6. Moving Coil Types. Stick with heavy Desk stand, 59/6. "Slimline" Stick, 50K impedance, with switch, 75/-; Omni-directional chrome plated die-cast frame, 50K with switch, 99/6.

HARRIS ELECTRONICS (London) LTD. 138 GRAY'S INN ROAD, LONDON, W.C.1

Trading hours 9 a.m.—6 p.m., Monday—Friday. Closed Saturday. We are 2 mins. from High Holborn (Chancery Lane Station) and 5 mins. by bus from King's Cross. Please include carriage cost on A.L.I. items. Telephone: TE 6341 7957

Technical Aids to help you earn more!

*Make your choice—
You can examine one of these sets,
by post, FREE for a week.*

1

NEWNES COMPLETE **Lathework**

This lavishly-illustrated set provides all the essential information for operating CENTRE, CAPSTAN, TURRET and AUTOMATIC LATHES. It is designed to help you become highly skilled and fully conversant with various types in present-day use.

Contents include: Differential Threading. Floating-blade reamers. Trepan boring. Back facing. Deep-hole boring. Boring bar cutters. Tool design, multi-cut. Turning universal-joint flange. Camshafts, machining. Gear cutting on lathe. Right-angle lathes. Profile turning. Grinding carbide tools. Chip breakers. Turning compound tapers. Acme threads. Norton quick-change gearbox. End-train. Eccentric turning. High-speed screw-cutting. Designing cams, etc., etc. **SPECIAL FEATURES:** In addition to the wealth of information on setting up and operation, considerable space is devoted to—Lathe Tools, Typical Tooling Arrangements, Multi-cut Lathes, Thread Chasing and Thread Rolling.

2 VOLUMES · 560 PAGES
660 PHOTOS, DRAWINGS
AND DIAGRAMS,
OPERATING DATA, ETC.
PLUS CASE OF:
16 DATA CHARTS



2

NEWNES COMPLETE **Welder**

Written by leading experts it gives you the specialised knowledge that would normally take years to acquire—this means money to you. It explains the theory, methods and techniques used both in repair work and construction.

Electric Welding and Cutting: Equipment, Transformers, Generators, Electrodes, Metal-arc Welding Procedures, Hard Facing, Carbon Arc Welding, Atomic Hydrogen Arc Welding, Inert-gas Arc Welding, Automatic Arc Welding, Stud Welding, Testing Welds, Gas Welding and Cutting Processes, Oxy-Acetylene Welding Equipment and Practice, Welding Iron, Cast Iron, Cast Steel and Alloy Steels, Tube Welding, Hard Facing Processes, Aluminium and Magnesium Welding, Welding Copper and Alloys, Bronze Welding, Flame Brazing, Lead Welding, Oxygen Cutting, Oxy-Acetylene Hand Cutting, Oxygen Cutting by Machine, Tables and Data, Qualification Tests, etc.

2 VOLUMES · 544 PAGES
614 PHOTOS AND
DRAWINGS
139 DIAGRAMS AND TABLES
PLUS CASE OF
14 DATA CHARTS



**Easy no-interest terms if kept
after Free trial**

*Make your
choice here*
POST NOW
No Cost - No Obligation

Without obligation to purchase, please send:

Complete Lathework

Gas & Arc Welding
(Tick your choice)

If you accept this application I will post 10s. deposit 8 days after receipt of the set, then 10/- monthly for 9 months, paying 100s. in all—or return the set. Cash in 8 days, 100s.

Geo. Newnes Ltd. 15-17 Long Acre London W.C.2.
If under 21 your father must fill up this coupon.

Mr. }
Mrs. }
Miss }
Address

Occupation

Signature

(Mr., Mrs., Miss)
(CL/GA)68:67/1475

Tick V where applicable

The address on left is—

My Property	<input type="checkbox"/>
Rented unfurnished	<input type="checkbox"/>
Parents' Home	<input type="checkbox"/>
Furnished Accom.	<input type="checkbox"/>
Temporary Address	<input type="checkbox"/>

Astonishing Radio Bargains from CONCORD

MAKE 5 DIFFERENT TRANSISTOR RADIOS FOR 35/-

NO EXPERIENCE NECESSARY.
No Soldering. Only 8 connections for first radio to work. Just look, you get

A.B.C. Plans, Cabinet, Loudspeaker (alone 1/6), Earphone, 4 Semi-conductors, Coils, Condensers, Resistors, Tuner, Switch, Screws, etc. YF's - EVERYTHING! Loud clear English and Foreign reception. As supplied to Educational Authorities, H.M. Forces, etc. **TESTIMONIALS GALORE.** Mr. R. O'D. of Londonderry, writes: "... I received your components and I must say that I am very satisfied with them. I have it already set up!" **COMPLETE HOME RADIO COURSE.** Originally 28 SHD ONLY 35/- plus 3/6 post, etc.



NEW RADIO ANYONE CAN BUILD IN 2-3 HOURS 19/6

EVEN THE OLDER CHILDREN BUILD THEM!... no soldering—only 16 connections! then hear it reach out bringing in station after station, loud and clear. Palm-of-hand size 4 1/2 x 2 1/2 x 1 1/2 in. Many Testimonials: M.H. of Bradford, writes: "... I have just completed one of your sets successfully, it is the first time I have ever tackled anything like a radio, and I must state here and now, I am amazed how easy it is to a layman like me. Your instructions and plan have obviously been very carefully thought out so that even the most dim can follow them..." **Direct from Manufacturers to You.** Send 19/6 plus 2/6 post, etc.

PARTS AVAILABLE SEPARATELY



AMAZING CIGARETTE RADIO! ONLY 18/6

Yes, a perfectly ordinary packet of cigarettes!—but watch your friends' astonishment on hearing it fetch in station after station, loud and clear! Still holds 10 Cigarettes—yet cleverly conceals highly sensitive, fully transistorised circuit (including tiny battery). Even a young boy can assemble it in under 2 hours. No soldering. No experience necessary. Only 16 connections to make. Ideal for taking to work with You. From our bulging testimonial file. Mr. D.B. of Huddersfield, writes: "... I have fitted the parts in and it is working wonderfully..." **ALL PARTS** including Semi-Conductors, A.B.C. Plans, etc. **ONLY 18/6** plus 2/6 post, etc.

PARTS AVAILABLE SEPARATELY



READ WHAT SATISFIED CUSTOMERS SAY

R.C. of HARRINGAY writes
Received with thanks Skyroma
... Very pleased. Working well.

B.M. of HARRGATE writes
... I would like to thank you ... It is a real bargain.

L.S. of LONDON W.8 writes
... given it a good try out and am very pleased with the results.

S.B. of SOMERSET writes
... delighted with this radio ... glad if you could send one more.

D.R. of GLASGOW writes
... it is a lovely little thing and as clear as a bell.

T.F. of STEVENAGE writes
I would just like to say how pleased any son is with this radio.

J.W. of BRIGHTON writes
... I have recommended your radio to many of my friends.

W.H. of MIDDLESEX writes
Thank you for my dear little radio. It is a real treasure to me.

CONCORD ELECTRONICS

LTD. (Dept. P.W.23) 9 Western Road, Hove, Sussex

RADIO CLEARANCE LTD.

27 TOTTENHAM COURT ROAD, LONDON W.1. Telephone: MUSEum 9188
Trade enquiries invited. The oldest component specialists in the trade. Est. 35 yrs

LOUDSPEAKER BARGAINS STILL AVAILABLE

Enormous purchases of Brand New and Guaranteed Plessey loudspeakers enable us to offer these units at **THE LOWEST PRICES EVER!** Don't miss this golden opportunity to obtain a first-grade permanent-magnet **LOUDSPEAKER** off the production line at **LESS THAN THE MANUFACTURER'S COST!** Read carefully the prepared list below and choose just the right speaker for the job—**COMPARE THE PRICES ANYWHERE! SELLING FAST—STOCKS CHANGING RAPIDLY.**

Size in. inches	Gauss in. lines	Imped. ohms	Price	Size in. inches	Gauss in. lines	Imped. ohms	Price	Size in. inches	Gauss in. lines	Imped. ohms	Price
2	7000	80	8/-	3 1/2	9500	3	10/6	4	9500	25	11/6
2 1/2	7000	35	8/6	3 1/2	9500	8	10/6	5	6000	3	8/-
3 1/2	7000	60	8/6	3 1/2	7000	35	8/6	5	7000	3	8/6
3 1/2	7000	80	9/-	3 1/2	9500	60	10/6	5	7500	3	9/-
3	8500	3	10/-	4	7000	25	11/6	5	8500	3	9/6
3	6000	5	8/6	4	6000	35	10/6	5	9500	3	10/6
3	7000	5	9/-	4	7000	35	11/-	5	9500	15	12/6
3	7000	35	9/-	4	7500	3	9/6	5	8500	25	10/6
3	6500	60	9/6	4	9500	50	11/6	5	9500	35	11/6
3 1/2	6000	15	10/-	4	9500	35	11/6	6 1/2	6000	3	11/-
3 1/2	7000	3	9/6	4	9500	15	12/-	8	9000	15	13/6
5 x 3	6000	3	7/6	7 x 3 1/2	7000	3	9/6	8 x 2 1/2	9500	3	10/-
5 x 3	9000	35	12/6	7 x 3 1/2	3500	3	10/6	8 x 5	8500	3	11/-
5 x 3	7000	3	8/-	7 x 3 1/2	9500	8	11/6	8 x 5	11000	3	13/6
5 x 3	9000	3	8/6	7 x 4	9500	3	11/-	8 x 5	11000	3	13/6
5 x 3	9500	3	9/-	7 x 4	9500	30	12/6	10 x 6	11000	3	22/6
6 x 4	8500	3	9/6	7 x 4	10000	3	12/6	10 x 6	11000	3	22/6
6 x 4	9500	3	10/-	8 x 2 1/2	6000	3	8/6	10 x 6	11000	5	22/6
6 x 4	9500	35	13/6	8 x 2 1/2	7000	5	9/-	10 x 6	11000	5	22/6

ALLOW 2/6 each Speaker for postage and packing and handling charge and please specify the exact requirements—the nearest available will be sent.

SELECTED BARGAINS

Beautifully geared AM/FM 2 gang Condensers, 4/6; AM/FM IFT'S 465 kc/s and 10.7 Mc/s 4/6 pair; Magnavox Crystal Tape Recorder Mikes, 12/6; 3 watt Stereo Amplifiers, complete, ready to switch on, 79/6; Sentercoil rectifiers R3/2D-D3-2-1-Y, 2/6 each. **DIODES**—CA79, OA90, CC46H, GD10, 2/- each. **TRANSISTORS**—OC45 4/6, FXA101, 3/6, AF115, 4/6. Sub. min. Germanium diode 1/3. M1 diode 6d. each. Silicon diodes, 200 p.i.v. 200 mA, 1/- each, 400 p.i.v., 330mA, 2/6 each, please send STAMPED and ADDRESSED envelope with any enquiry. We restre no catalogue—our stocks move too quickly! Kindly make provision for additional postage and package charge to avoid delay. Terms: Cash With Order or C.O.D. on Orders over 10/-.

Roitone



10 WATT MONO AMPLIFIER. Complete with built in pre-amplifier in metal case, plastic veneer covered 6 inputs, 3 each level, with equalisation each input. 1 input switch selected each level with separate vol. control for mixing. Wide range tone controls. Separate Bass and Treble. For use on 220-250V. A.C. mains. Case isolated from mains. ECL86 valves in output for low distortion. Suitable all high impedance Microphones and pick-ups. Size overall including plastic feet: Height 4 1/2 in., Width 11 in., Depth 9 1/2 in.

READY BUILT AND TESTED £14.10.0

POST AND PACKING 5/-

3W+3W STEREO AMPLIFIER. As above amplifier but 2 separate amplifiers giving full 3 watts each channel. Controls: 1 Mono-Stereo, 2 Balance, 3 Left Vol., 4 Right Vol., 5 Bass, 6 Treble, input and output sockets at rear. A.C. mains, 220-250V. Case isolated. **READY BUILT AND TESTED £14.15.0**

POST AND PACKING 5/-

RADIOGRAM CHASSIS. Latest style 3 waveband chassis. Tandem controls through vertical glass dial 6 x 13 1/2 in. Printed Gold on Black. Controls: 1 Waveband, LW, MW, SW, GRAM., 2 Tuning, 3 Vol., 4 Tone on/off, Ferrite Rod Aerial, A.V.C. negative feedback. Full 3 watts output for 3Ω speaker. Pilot Lamp, 220-250V. A.C. mains. Chassis isolated. Overall size: Height 13 1/2 in., Depth 9 in., Width 8 in. Complete with knobs, Dial Aligned and Tested. **£9.15.0**

POST AND PACKING 5/-
TERMS: C.W.O. or C.O.D. 3/6 extra. 7-Day Money Back Guarantee. Mail Order address only.

ROITONE (Dept. P.W.)

61 HIGH STREET, GINDERFORD, GLOUCESTER

Your complete basic guide devoid of mathematics and circuitry

BEGINNER'S GUIDE TO COLOUR TELEVISION

by Terence L. Squires, A.M.Brit.I.R.E.



Explains fully how the signals are created in the television studios, how they are transmitted and the techniques used to receive and display them. Covers: Historical Outline - The Colour Signal - The Chrominance Signal - Colour Transmission - Receiving the Colour Signal - Domestic Aerial Systems - The Receiver Block Diagram - The SECAM Receiver etc.

128 pages, 58 diagrams only 15s. net from all booksellers

... or, in case of difficulty, 16s 3d by post from George Newnes Ltd., Tower House, Southampton Street, London W.C.2.

NEWNES

PADGETTS RADIO STORES

Dept. P.W., OLD TOWN HALL LIVERSEDGE, YORKSHIRE Telephone: Cleckheaton 2866

USA Bomb Computers in original transit case. full of gears, motors, vidior counter, gyro, etc. 37/- carriage 10/-.

PCR. 12 volt Vibrator pack, in original packing case. 25/- carriage 8/-.

RAF Sighting Heads. Complete with lamp, lens, etc. No details. Packed in original metal case. 15/- carriage 10/-.

Single Phase 240 volt. 1,400 r.p.m.. 1/2 h.p. motor with pulley. 28/-, less pulley. 24/-, fully guaranteed. ex washing machine. Carriage 8/6.

One Sixth H.P. Motor. 240 volts 15/-, post 6/9.

New Indicator Unit CRT 100, complete with two tubes, type VCXN393 and VCXN206, plus 21 small valves, relays removed. 67/-, or less valves. 32/- carriage 10/- Sorry no details on the unit.

New 12in. Speakers with built-in tweeter 3 or 15 ohms. 28/6, post paid.

P.M. Speakers, all 5 ohms, ex TV sets. 6in. round 6 x 4in. and 5in., 3/-, post 2/-, 6 for 20/-, post paid. 8in. round. 6/-, post 2/-. 7 x 4in., 5/-, post 2/-.

VALVE LIST

Ex equipment. 3 months guarantee

Table listing various vacuum tube types and their prices, such as EL91 1/8, 20P4 8/6, PCF80 4/-, etc.

Breaking up Mark III Type 19 Sets. Pointer Knobs 7/- doz., post paid. Jack Socket, 1/-, post 6d., doz. 10/-, post paid. Jack 1/6, post 6d. Toggle Switch, metal. 6d., post 6d., doz. 7/6, post paid. Relay type 3000. 1/9, post 1/9, doz. 20/-, post paid. Any other spare send 2/- plus post to cover.

Reclaimed Tubes. 6 months guarantee. 14in. Mullard and Mazda, 17/-, carr. 10/-, 17in., 30/-, carr. 10/-.

"GLOBE-KING"

Amateur Short-Wave Radio

For over twenty years the famous in-comparable "Globe-King" single-valve kits have been used by enthusiasts in almost every country in the world where low cost but high precision standard equipment was essential and demanded. We now take pleasure in announcing the new transistor version. Model TR2—just two transistors giving a tremendous performance. Send s.a.e. today for interesting free literature on this and other equipment. Overseas enthusiasts note: we despatch to all parts of the world via International Postal Services.

JOHNSONS (RADIO) ST. MARTIN'S GATE WORCESTER

Please mention "Practical Wireless" when replying to Advertisements

AMPLIFIERS AND SPEAKERS NORTHCOURT "FIVE" AMPLIFIER

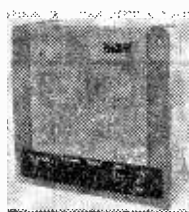

Suitable for guitars, grams and radios. The 5 watt output amplifier incorporates separate volume, treble and bass controls.

Two jack socket inputs are fitted. Twin speakers give exceptionally realistic reproduction and are

built into an attractive cabinet. Size: Length 11 1/2 in. Height 11 1/2 in. Depth 5 1/2 in. Finished in mottle grey with the front cover in Vynair. Mains Voltage 200/250, 50 K/c. Ideal for home use with any guitar. Retail £9.17.6.

P.A. EXTENSION SPEAKER

Suitable for radio and Record Players. Size: Length 10 in. Height 7 in. Depth 5 in. Fitted in durable industrial finished wood cabinet, attractively finished in mottled grey. Speaker front covered in Vynair. Price 29/9 Retail. As above fitted with volume control. 35/9 Retail.

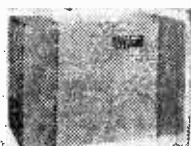

P.A. TWIN EXTENSION SPEAKER

Suitable for all radio and record players (incorporating two speakers 6 x 4 in.). Size: Length 12 in. Height 7 1/2 in. Depth 5 in. Fitted in durable industrial finished wood cabinet, attractively finished in mottled grey. Speaker front covered in Vynair. Price 39/6 Retail. As above fitted with volume control, 43/6 Retail.

FULLY SHROUDED UPRIGHT TRANSFORMERS

350-0-350 100mA 6.3v. 4A C.T. 0-5v. at 3 amp. 29/6 Retail. 300-0-300 100mA 6.3v. 4A C.T. 0-5v. at 3 amp. 29/6 Retail. 250-0-250 100mA 6.3v. 4A C.T. 0-5v. at 3 amp. 29/6 Retail.

All products guaranteed 12 months. Trade supplied. For name of nearest stockist and full accessory brochure, write to:

NORTHCOURT (Electrical Bfd.) LIMITED

Transformer and Coil Manufacturers Dept. P.W. SOUTH PARK MILLS. PUDESEY, Yorks.

NO THE Dewtron

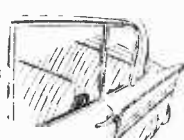

WAVE TRAP gives BOOST to ANY transistor portable radio. IN CAR replaces car aerial; reduces fading. IN HOME boosts distant and PIRATE stations. ON HOLIDAY improves reception in remote areas. A MUST for caravanners. Attaches to any window. Supplied complete with PP3 battery and instructions. Money-back guarantee.

39/6 P. & P. 2/- extra.

D.E.W. Ltd., DEPT. P.W. BINGWOOD ROAD, FERNDOWN, Dorset

Head Office and Warehouse:
44A WESTBOURNE GROVE
LONDON W2
Tel.: PARK 5641/2/3

Z & I AERO SERVICES LTD.

Please send all correspondence and Mail Orders to the Head Office
When sending cash with order, please include 2/6 in £ for postage and handling
MINIMUM CHARGE 2/-. No C.O.D. orders accepted

Retail Shop:
85 TOTENHAM COURT ROAD
LONDON W1
Tel.: LANGHAM 8403

Please write for Catalogue of valves and semiconductor.

Table of electronic components including vacuum tubes (6AN8, 6AR5, etc.), transistors (OC18, OC78, etc.), and semiconductor rectifiers (6AL5, 6AR5, etc.).



LISTEN AND ENJOY THE WORLD'S RADIO AMATEUR AND BROADCAST STATIONS WITH THE GREATEST OF EASE!!!
World Expert Radio Amateur WIBB (U.S.A.) claims the "JOYSTICK" aerial—easier to read stations than with his massive 520' YEE aerial 70' high!!!

ONLY 7' 8" LONG!
"CO" the Radio Amateur's journal claims "JOYSTICK" better for reception than the world popular DIPOLE (four different receivers used to confirm this decision)
YOU CAN BE THE PROUD OWNER OF THE WORLD'S MOST VERSATILE & COMPACT "JOYSTICK" COMPLETE RECEIVING SYSTEM FOR AS LITTLE AS £6.6.6 (Standard system) p. & p. included or the De Luxe system for £7.7.6 p. & p. included.

of X your move!
No doubt you will put your X between the two O's. The machine will then play O on the bottom right hand corner. Play what you will, the machine wins at the next move. This is just one of the games played on our Noughts and Crosses machine. As Brian Truman of Granada TV said, after demonstrating the machine on television on April 12th, "I'm glad I wasn't playing it for money".
One machine that was playing for money, at 3d. a Go, refunded for a drawn game, raised £3 in three hours for charity. Full circuit, wiring diagram and instructions, 3/6d., post free.
PLANET INSTRUMENT CO., 25(W) DOMINION AVE., LEEDS 7

A.R.R.L. RADIO AMATEURS HANDBOOK 1965
New Edition 40/-, Postage 3/3
101 Ways to Use Your Oscilloscope by Middleton. 21/- P. & P. 1/-
Electronics Data Handbook by Clifford. 16/- P. & P. 1/-
Practical Tape Recording by Guy. New ed. 7/6 P. & P. 1/-
Practical Oscilloscope Handbook by Rufus Turner. 25/- P. & P. 1/-
R.S.G.B. Radio Amateur Call Book 1965. 5/- P. & P. 8d.
Semiconductor Circuit Design by Leadham. 7/6 P. & P. 8d.
British Transistor Directory by Bradley. 8/6 P. & P. 8d.
Radio Control for Models by Judd. 15/- P. & P. 1/-
UNIVERSAL BOOK CO.
12 Little Newport Street, London, W.C.2 (adjoining Lisle Street)

BBC2 (625 LINE) TV AERIALS
Mast Mounting Arrays, 9 element 45/-; wide spaced high gain, 11 element 55/-; 14 element 62/6. Wall Mounting with Cranked Arm, 9 element 60/-; wide spaced, high gain, 11 element 67/6; 14 element 75/-. Chimney Arrays Complete, 9 element 72/-; wide spaced high gain, 11 element 80/-; 14 element 87/6. Loft Arrays, 7 element 32/6; wide spaced high gain, 11 element, with Tilting Arm, 62/6; 14 element 70/-. All high gain units have special Multi-rod Reflector. Low loss co-axial cable 1/6 per yard. VHF transistor pre-amps from 75/-.
BBC • ITV • F.M. AERIALS
B.B.C. (Band 1), Telescopic loft 21/-. External S/D 30/-.
I.T.V. (Band 3), 3 Element loft array 25/-. 5 element 35/-. Wall mounting, 3 element 35/-. 5 element 45/-.
Combined B.B.C./I.T.V. L 1 + 3, 41/6; 1 + 5, 48/9; Wall mounting 1 + 3, 56/9; 1 + 5, 63/9; Chimney 1 + 3, 63/9; 1 + 5, 71/3.
VHF transistor pre-amps from 75/-.
F.M. (Band 2), Loft S/D 12/6. "H", 30/-, 3 element, 52/6. External units available. Co-ax cable 8d. yd., Co-ax plugs, 1/3. Outlet boxes 4/6. Diplexer Crossover, Boxes, 12/6. C.W.O. or C.O.D. P. & P. 4/- Send 6d. stamps for illustrated lists.

K.V.A. ELECTRONICS (Dept P.W.)
3b Godstone Road, Kenley, Surrey
CRO 2527

PRACTICAL WIRELESS

blueprints

MOST of these blueprints are drawn full-size and although the issues containing descriptions of these sets are now out of print, constructional details are available free with each blueprint except for those marked thus (*).

Send (preferably) a postal order to cover the cost of the Blueprint (stamps over 6d. unacceptable) to PRACTICAL WIRELESS, Blueprint Dept., George Newnes, Ltd., Tower House, Southampton Street, London W.C.2.

DOUBLE-SIDED BLUEPRINTS

The Strand Amplifier	*
The PW Signal Generator
The Savoy VHF Tuner	*
The Mayfair Pre-amplifier
The Berkeley Loudspeaker Enclosure	*
The Luxembourg Tuner
The PW Troubadour
The PW Everest Tuner
The PW Britannic Two	*
The PW Mercury Six
The PW Regency	*
The PW International Short Wave Two
Beginner's Short Wave Two	*
S.W. Listener's Guide
Beginner's 10-watt Transmitter	*
Transmitting and Aerial Data
P.W. "Sixteen" Multirange Meter	*
Test Meter Applications Chart
The Celeste 7-transistor Portable Radio	*
The Spinette Record Player
The P.W. 35-watt Guitar Amplifier	*
Transistor Radio Mains Unit	*
7 Mc/s Transceiver

RECEIVERS

5/-	The Tutor *	3/-
	The Citizen *	5/-
5/-	Dual-Wave Crystal Diode	PW95	2/6
	Modern One-valver	PW96	2/6
5/-	All-dry Three	PW97	3/6
	Modern Two-valver	PW98	3/6
7/6	A.C. Band-pass Three	PW99	4/-
	A.C. Coronet-4	PW100	4/-
6/-	A.C./D.C. Coronet	PW101	4/-
5/-	The PW Pocket Superhet	5/-

MISCELLANEOUS

5/-	The PW 3-speed Autogram	8/-
	The PW Monophonic Electric Organ	8/-
5/-	The PT Band III TV converter	1/6
5/-	The Mini-amp *	5/-
	The PT Olympic *	7/6
5/-	The PT Multimeter *	5/-

PLEASE NOTE that we can supply no blueprints other than those shown in the above list. Nor are we able to supply service sheets for commercial radio, TV or audio equipment.

QUERY SERVICE

The P.W. Query Service is designed primarily to answer queries on articles published in the magazine and to deal with problems which cannot easily be solved by reference to standard text books. In order to prevent unnecessary disappointment, prospective users of the service should note that:

(a) We cannot undertake to design equipment or to supply wiring diagrams or circuits, to individual requirements.

(b) We cannot undertake to supply detailed information for converting war surplus equipment, or to supply circuitry.

(c) It is usually impossible to supply information on imported domestic equipment owing to the lack of details available.

(d) We regret we are unable to answer technical queries over the telephone.

(e) It helps us if queries are clear and concise.

(f) **We cannot guarantee to answer any query not accompanied by the current query coupon and a stamped addressed envelope.**

QUERY COUPON

This coupon is available until 5th August, 1965 and must accompany all queries in accordance with the rules of our Query Service.

PRACTICAL WIRELESS, AUGUST, 1965

HENRY'S RADIO LTD.

303 EDGWARE RD., LONDON W2

PADdington 1008/9

Open Mon. to Sat. 9-6. Thurs. 1 p.m.
Open all day Saturday**PROVED and TESTED DESIGNS****FULL AFTER SALES SERVICE AND GUARANTEE
UNBEATABLE FOR PERFORMANCE AND VALUE****DETAILED
LEAFLETS
FREE ON
REQUEST****VHF FM TUNER TO BUILD****TOTAL COST TO BUILD £6.19.6**

- ★ 5-transistors, 4-diodes.
- ★ Printed circuit superhet.
- ★ Tuning range 87 to 105 Mc/s
- ★ RF stage and double tuned IFT'S—9 volt 9 mA operated.
- ★ All parts sold separately.
- ★ Output up to 1 volt.
- ★ Size 4 x 3½ x 2½ in.
- P.P. 2/6 (complete with front panel) ★ Cabinet Assembly 20/- extra.

MW/LW POCKET SUPERHET RADIO TO BUILD**TOTAL COST TO BUILD 85/-**

- ★ 6-transistor plus diode.
- ★ Push-pull speaker output.
- ★ Easy printed circuit.
- ★ Slow geared tuning.
- ★ Full MED and long waves.
- ★ Moulded cabinet 5 x 3 x 1½ in.
- P.P. 2/- (Battery 2/6, Phone 5/-)
- ★ Amazing sensitivity and selectivity.

TWO WAVEBAND ALL TRANSISTOR CAR RADIO TO ASSEMBLE**TOTAL COST TO BUILD £3.19.6**

P.P. 3/6.

- ★ Supplied as factory built assemblies—just interconnect.
- ★ 6-transistor push-pull design—double tuned IFT'S.
- ★ Push-button wavechange—full tuning range.
- ★ Size 7 x 4 x 2 in.—fits any car—chromed front dial.
- ★ Units available separately.
- ★ Guaranteed high performance and quality.

PUSH-BUTTON TRANSISTOR PORTABLE TO BUILD**TOTAL COST TO BUILD £7.19.6**P.P. 3/6
(Batteries 6/-)

- ★ 6-transistor superhet design.
- ★ Easy to build printed circuit.
- ★ 8 in. ferrite aerial, and D/T IFT'S.
- ★ Push-button wavechange.
- ★ Full Med./LW geared tuning.
- ★ Attractive sturdy cabinet.
- ★ Size 10 x 7 x 3½ in.
- ★ All parts sold separately.

SENSITIVE SUPERHET PORTABLE**VHF FM TUNER TO ASSEMBLE****TOTAL COST TO BUILD £12.17.6**

(All units available separately). P.P. 2/6

- ★ Supplied as prebuilt and aligned units plus metal work just interconnect.
- ★ 88 to 108 Mc/s. FM tuning.
- ★ 100 mV to 100Kohm output.
- ★ 6-transistor printed circuit. Superhet design.
- ★ Size 9½ x 3½ x 4 in.
- (All units available separately).

Let us quote for Parts for your circuit. Send a list for quick reply.

Fully detailed and illustrated catalogue. Now 96 pages. All types of components and equipment at competitive prices. Price 2/6 post paid.

10 WATT AND 20 WATT AMPLIFIERS**ALL TRANSISTOR PRE-BUILT AND TESTED UNITS**

Unit 1 and 2

- ★ **POWER AMPLIFIERS**
- 10 watts RMS music power output.
- 20 watts peak.
- 6-transistor designs.
- Response 40 c/s to 20 kc/s.
- 100 mV sensitivity.

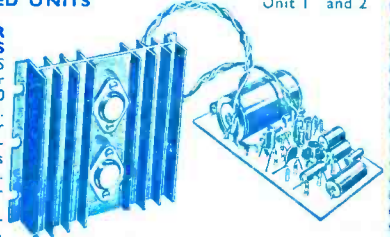
Unit 1. For 12/15 ohm speakers, 40 volt supply. **PRICE BUILT £5.19.6** P.P. 2/6Unit 2. For 3 to 5 ohms. 24 volt. **PRICE BUILT £5.10.0** P.P. 2/6

(Mains units Mono 59/6 Stereo 69/6)

★ PREAMPLIFIERS—MONO AND STEREO VERSIONS.

- 8 inputs, 1½ mV to 300 mV at 1K to 500 Kohm. Response 30 c/s to 20 kc/s. Complete range of controls.



Unit 3. Mono full function preamplifier. Size 9½ x 2½ x 2 in.

(Brown/Gold front panel, 8/6).

Unit 4. Simplified version of Unit 3. Price built 65/- P.P. 1/6

Unit 5. Stereo preamplifier for use with two power amplifiers. Size 9 x 3½ x 1½ in.

PRICE BUILT £10.19.6P.P. 3/6.
(Brown/Gold panel 12/6).Unit 3
PRICE BUILT £5.10.0 P.P. 2/-**★ LOW NOISE—LOW DISTORTION QUALITY DESIGNS**

Enables complete Mono or Stereo equipment to be assembled at a fraction of the cost of a commercial comparable design. Simple to interconnect, outstanding quality.

★ TWO AND FOUR TRACK PORTABLE TAPE RECORDERS TO ASSEMBLE

Prebuilt equipment—6 valves—Collaro studio decks—portable cabinets—8 x 5 in. speakers. Complete recording and playback.

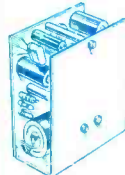
★ Two track deck 10 gns. P.P. 5/-
Amplifier 11 gns. P.P. 3/6
Cabinet with speaker, 5 gns. P.P. 3/6.★ or **SPECIAL PRICE £26**
P.P. 8/6 **TWO TRACK**
★ Four Track deck £13.19.6. P.P. 5/-. Amplifier 12 gns. P.P. 3/6.
Cabinet and speaker 5 gns. P.P. 3/6.★ or **SPECIAL PRICE £30** P.P. 8/6 **FOUR TRACK****★ 4 WATT AND 1½ WATT PACKAGE AMPLIFIERS****PRICES 1½ WATT BUILT 65/-** P.P. 1/6

- ★ 6-transistor push-pull printed circuit designs.
- ★ Peak output 8 watt and 3 watt.
- ★ Size only 2½ x 2 x 1½ in.
- ★ 4 watt, 12/18 volt; 1½ watt, 9/12 volt.
- ★ Output for 3 to 5 ohm speakers.
- ★ 7 mV into 1 Kohm. 40 c/s to 15 kc/s.

4 WATT 79/6 P.P. 1/6