

ANOTHER SHILLING BLUE PRINT FREE

# MODERN WIRELESS

1/6  
MONTHLY

Vol. IX. No. 17.

Edited by  
NORMAN EDWARDS

MAY, 1928.



FREE  
BLUE PRINT  
WITH THIS ISSUE

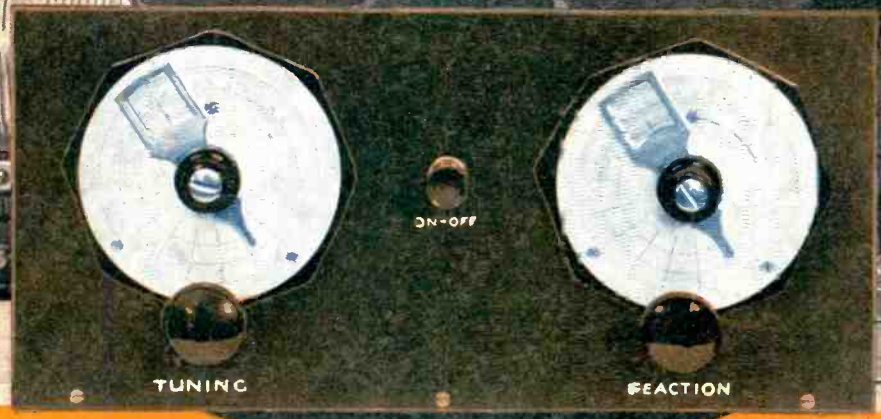



Always the valve with the wonderful Mullard P.M. Filament – that consumes only 0.075 ampere filament current and that for length of life and purity of reception is unequalled, Always then, the valve for improved radio reception in any receiver. Always Mullard.

# Mullard

**THE · MASTER · VALVE**

ADVT. THE MULLARD WIRELESS SERVICE CO., LTD., MULLARD HOUSE, DENMARK ST., LONDON W C 2

# CONTENTS

Vol. IX. No. 17. MODERN WIRELESS MAY, 1928.

	Page		Page
Editorial	475	Imagination and the Listener	521
A Home-Made "Vernier"	476	What Readers Think	523
The Mystery of Radio Personality	477	The "Tetrodyne" Circuit	525
The "All-in" Two	479	Questions Answered	528
Fitting a Screened-Grid Valve	483	In Our Test-Room	529
Aerial Sidelights	487	Television Notes of the Month	531
A Pilot for the Short Waves	489	Radio Abroad	532
The Microscope of Radiation	493	The "Easy-Tune" Four	533
Constant Reaction Control	495	Croydon Calling	540
Practical Constructional Notes	500	My Broadcasting Diary	543
EA J 7	501	America's Television Progress	544
The "Wide-Range" Two	503	Valve Varieties	545
Moving-Coil Loud Speakers	507	A Remedy for Fading	546
Is Your Grid Bias Right?	510	Operating "3 S W"	550
Designing a Portable Set	511	The "M.W." Standardised Coil	552
An Interesting Radio Process	518	Radio and the Gramophone	559
Hints for the Handyman	519	In Passing	562
		Radio Notes and News	562

As some of the arrangements and specialities described in this Journal may be the subject of Letters Patent, the amateur and trader would be well advised to obtain permission of the patentees to use the patents before doing so.

Edited by NORMAN EDWARDS.

Technical Editor: G. V. DOWDING, Grad.I.E.E.

Scientific Adviser: J. H. T. ROBERTS, D.Sc., F.Inst.P.

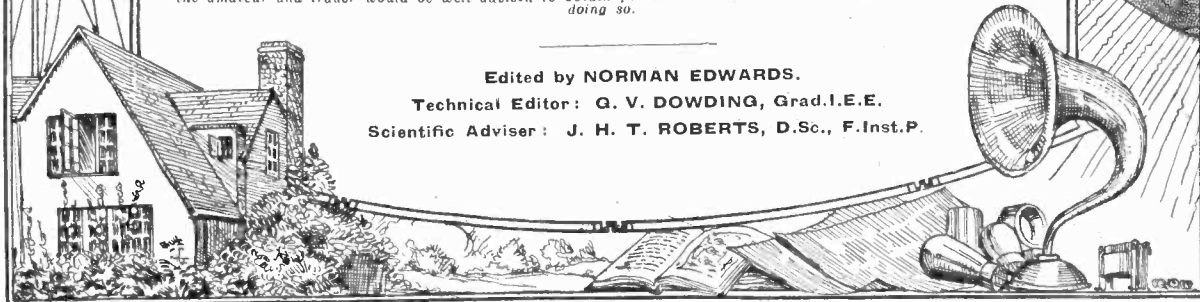

**MAGNUM STANDARD WAVETRAP A NEW MAGNUM PRODUCT**      **MAGNUM NEUTRALISING CONDENSER**      **MAGNUM RAZOR-SHARP WAVEMETER**

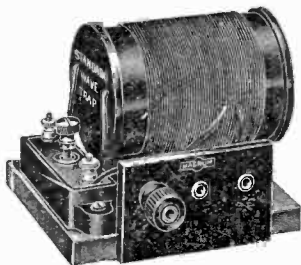

Add selectivity to your set by fitting a Magnum Wavetrap. It can be adapted to any type of set without any alteration in the wiring, and enables you to receive stations hitherto blanketed out by the local station.

As used by Mr. P. W. Harris in "The Business Man's Four," also in the original 1928 "Solodyne."

Price **15/-** complete.

Copper Screening Box can be supplied for the above, price **5/-**.

We specialise in the 1928 "Solodyne," Modernised 1926 "Solodyne" and the 3 "Solodyne" sets described in April issue.

Comprehensive lists will be sent on receipt of stamp.



**Short-Wave Choke.** Specially designed for short-wave work from below 10 metres up to 100 metres. The price is the same as the Magnum Standard Choke, viz.,

**7/6**

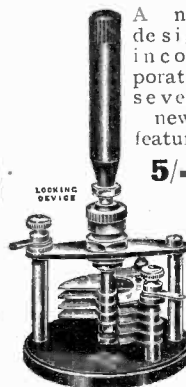

A new design incorporating several new features

**5/-**

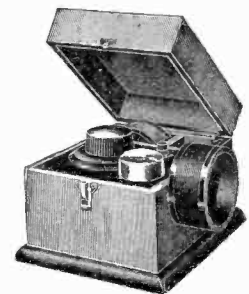

Reduced Prices:

Ready wired, tested and calibrated, £4/15/0.  
Complete set of parts for Home Construction, including coils covering 180/2,000 metres, £4/0/0.  
Coils can be supplied separately:

No. 1.—180/600 metres...	7/6.
No. 2.—600/2,000 metres...	7/6.
Special 3-pin Mount, with Brackets	3/6.

**MAGNUM 6-PIN BASE**

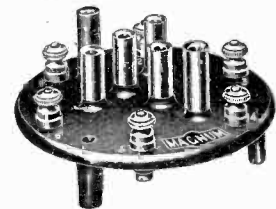

Recommended for all sets employing 6-pin unscreened coils      **2/-**

**BURNE-JONES & CO. LTD.,**  
**MAGNUM HOUSE**  
TELEPHONE: HOP 6257-8  
**288, BOROUGH HIGH ST. LONDON. S. E. I**

# THE "WIDE RANGE" TWO

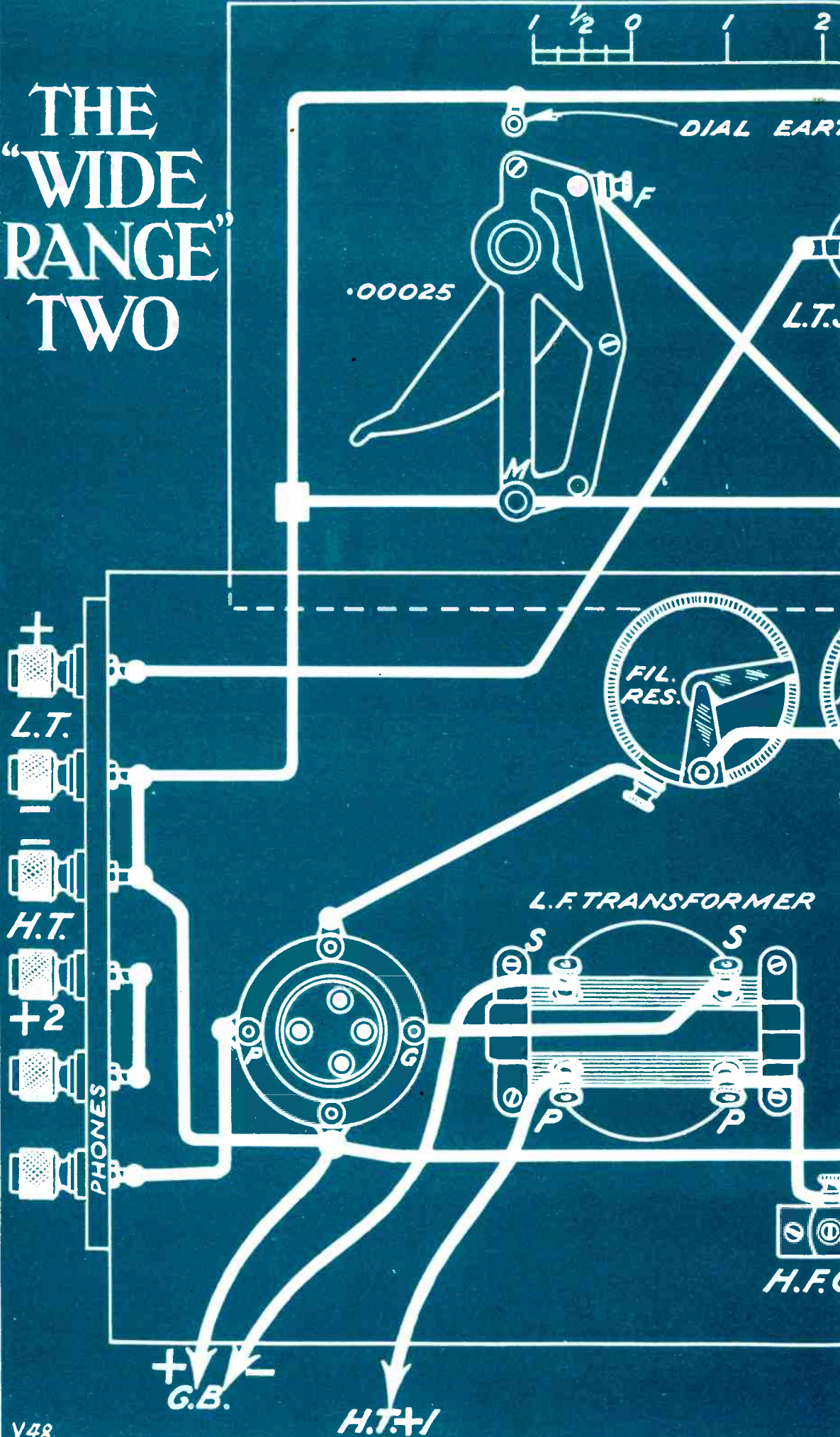

PRICE  
1/-

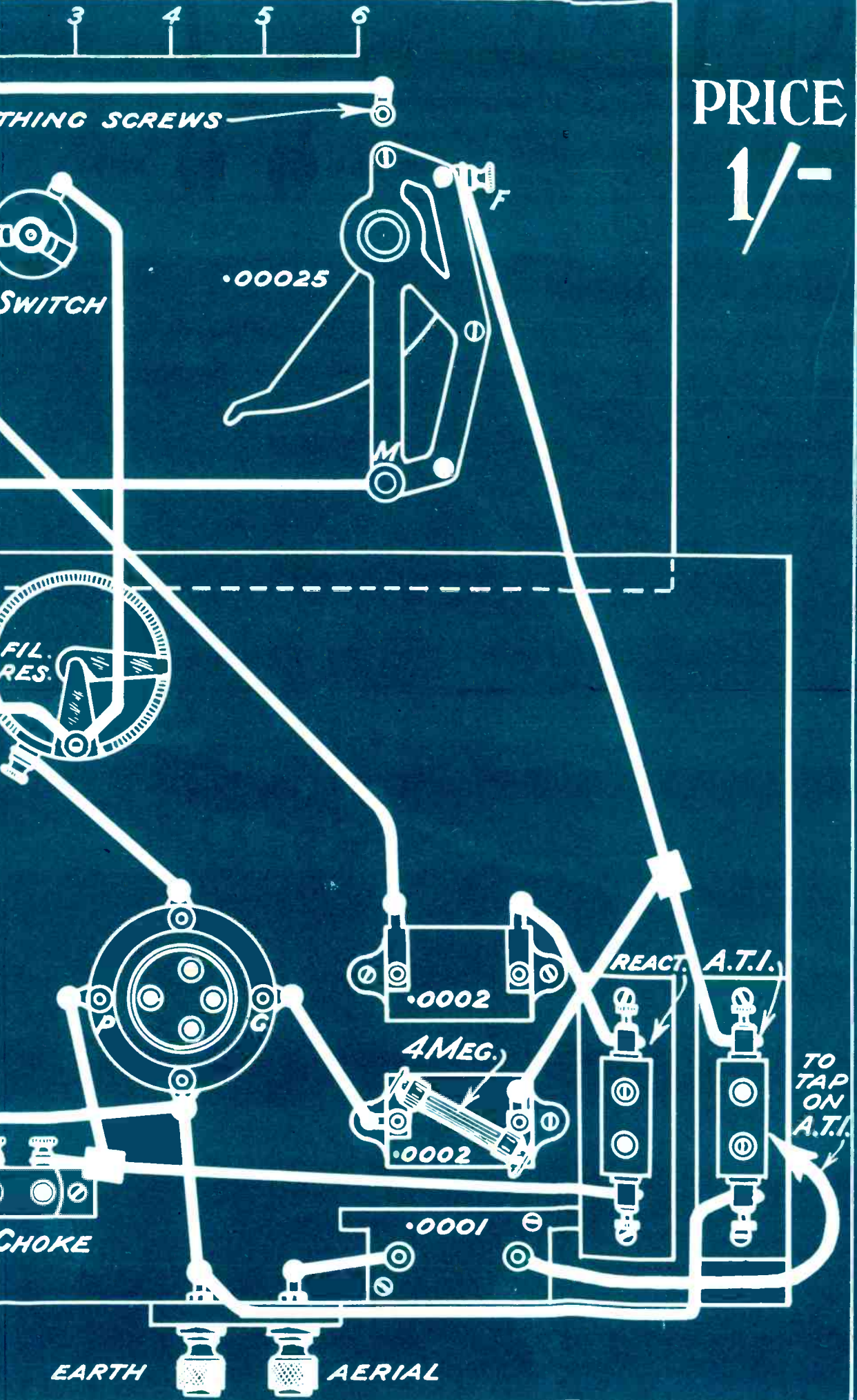



**The Valves which made possible  
Radio Concerts from Seven Countries  
through the wonderful Cossor "MelodyMaker"  
USE THEM IN YOUR SET**

Advt. A. C. Cossor, Ltd., Highbury Grove, London, N.5.

# MODERN WIRELESS

Vol. IX. No. 17.

May, 1928.

*New "M.W." Standardising Policy—Wireless Education—A Tribute to the Amateur.  
By The Editor.*

## New "M.W." Standardising Policy

RECEIVERS specifically designed for the reception of both long and medium waves have, in the past, usually suffered from the drawbacks associated with sets capable of covering a wide band of wave-lengths. Perhaps the chief drawback is in connection with coil-changing—a drawback which, although not bad enough to damn a long-wave-medium-wave set, may truthfully be said to be a real nuisance.

But sets of recent design which do not necessitate coil-changing have shown signs of becoming more and more popular, and consequently the problems associated with the design of suitable loading coils for switching in when changing over from the medium wave-band to the 5 X X and other long-wave bands, are obviously of considerable interest and importance.

In order to facilitate the efforts of our readers who wish to construct such receivers, the MODERN WIRELESS Research Department has produced a standard specification for a loading coil of what may be termed an almost universally useful type.

In the near future constructors will no doubt be able to purchase this coil ready-made, in the same way as they may now purchase one of the "M.W." standard screening boxes or standard wave-traps from several of the firms advertising in this journal, but also the complete specification for the loading coil may be studied in this issue, and it will be seen at once that its construction presents few difficulties and but little expenditure in cash for the necessary materials.

\* \* \*

We hope, from time to time, to give details of other "M.W." standardised components, as we feel sure that in doing so much will be accomplished in facilitating the work of the experimenter and home-constructor.

Further, in next month's issue we shall publish full constructional details of a four-valve set incorporating the new standard loading coil. This set represents a distinct advance in "long-short" receivers, conforming as it does to the highest standards of efficiency, with the latest methods of coil construction and screening, together with a simple system of switching. It is undoubtedly a set which will excite the interest of all MODERN WIRELESS readers.

## Wireless Education

PROPOSALS which may prove far-reaching relating to adult educational broadcasting are made in the B.B.C.'s latest publication, "New Ventures in Broadcasting." A synopsis of this book, and the recommendations made in it by the Hadow Committee, are given elsewhere in this issue.

The publication of the book has, of course, given rise to fresh rumours concerning the B.B.C.'s educational activities, but the recommendations made by the Hadow Committee are not very startling.

In fact, lack of originality is the chief criticism we have to level at the result of the labours of those who, for eighteen months, have been investigating the possibilities of adult education by wireless.

Broadcasting is a versatile medium, but as a means of education (in the strict sense of the word) it will never approach within a hundred miles of the service value of, for example, night schools. Education by broadcasting can, at the best, only be superficial—and "short cuts" in educational matters often do more harm than good.

However, the Hadow Report has now been made: it remains to be seen whether its proposals are adopted, and, if so, whether the listening public will find them of value.

## A Tribute to the Amateur

IT is interesting, and gratifying, to note in a paper read before the Wireless Section of the Institution of Electrical Engineers, by Professor E. V. Appleton, F.R.S., on the subject of fading experiments, carried out at the Peterborough Research Station of the Department of Scientific and Industrial Research, that fading measurements made by amateur observers in different parts of the country gave most valuable information both supplementing and confirming the observations at Peterborough.

We commend this tribute of Professor Appleton's to those gentlemen who represented the British Post Office at the recent Radio Conference at Washington, and who did their best to belittle the work of amateurs and to limit their activities in every possible way.

That they did not succeed was not for want of trying, and that their poor opinion of the value of amateur experimental work in the realm of radio is not shared by gentlemen more qualified to judge is particularly exemplified in the compliment paid to British amateurs by one of the foremost radio scientists in the world.

Mr. Gerald Marcuse—to name but one of many well-known amateurs who have enhanced the prestige of the experimenter in this country—only communicated with us a day ago, enclosing reports from all parts of the world in connection with his short-wave broadcasting service.

It is good news to hear, also, that the service from 2 N M has been extended to June 1st. We can only hope that the Post Office will continue to "extend" 2 N M's licence indefinitely.

# A HOME-MADE VERNIER

*A simple but efficient easy-tuning gadget.*

*By W. J. DELANEY.*

A VERNIER condenser control is a necessity in these days of crowded wave-lengths, and a method which allows of the complete absence of hand-capacity effects is to

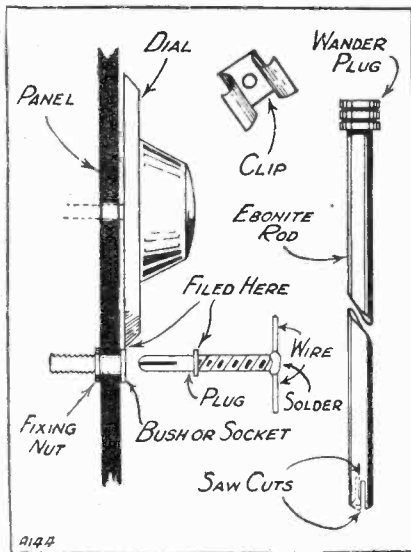

be appreciated. Most vernier dials at present on the market (unless very expensive) suffer from the fact that one's hand must be near the panel when tuning in, with the result that when a station has been found and the hand removed the station disappears.

The following details will enable anyone to construct in about half an hour an efficient anti-hand-capacity vernier control for use with ordinary dials, at a cost of less than one shilling. The only things needed are a panel-mounting plug and socket (preferably nickelled for the sale of appearance) and a piece of ebonite rod about 8 in. long, with an internal bore just a little larger than the outside diameter of the threaded portion of the plug.

The socket is mounted on the panel so that the flange is just level

with the edge of the dial, but below it. To the bottom of the plug a piece of tinned round-section wire (about 16 or 18 gauge) is soldered, allowing about  $\frac{1}{2}$  in. to project on either side. The diagram will make this part of the work clear.

One end of the ebonite rod is then cut out with a thick-bladed hacksaw, for a distance of about  $\frac{3}{4}$  in. The saw-cut should just accommodate the tinned cross-piece of wire. An added refinement is the mounting of a small black wander-plug at the end of the tube. It can either be stuck in with Chatterton's compound, or made to be a driving fit.

A small tool clip (as sold by Hobbies, or any other tool firm, used for holding small tools on work benches) can be fitted either inside the lid of the wireless cabinet or mounted on the panel. The extension handle is clipped in this when not required, and is thus always at hand when wanted.

To prevent the vernier from slipping, a fairly coarse file should be drawn diagonally across the edge of the ebonite dial, and also across the edge of the flange on the plug. The slot in the plug should be opened out so that it turns smoothly in the socket. If the dial is of the 4-in. pattern, a reduction gear of about 16-1 will be obtained with the normal size of plug and socket.

## USEFUL CAPACITIES

By A. V. D. HORT, B.A.

VARIABLE condensers are such handy components that the whole of the experimenter's stock is often well employed in sets or special units. This leaves no surplus for the experimental bench,

and strict economy has to be observed in allotting the condensers which are "at a loose end."

For many purposes the "variable fixed" condenser is almost as useful as the more finely variable instrument. Four fixed condensers connected as in Fig. 1 will give you a wide range of capacities. If you adopt the individual capacity values given in Fig. 1, you will find, in the table appended, the principal values of capacity which are available by different methods of connection. The letters refer to the terminals. Thus, A-B means one connection to A and the other to B, giving .0001 mfd.

"USEFUL CAPACITIES"	
Connections.	Capacity—mfds.
A—BCDE	.001
A—CDE	.0009
A—DEB	.0008
A—DE	.0007
A—BCD	.0006
A—CD	.0005
A—E	.0004
A—D	.0003
CD—EB	.00025
E—BCD	.00024
D—EC	.00023
BC—DE	.00021
A—C	.0002
D—EB	.00019
D—E	.00017
C—DE	.00016
C—E	.00014
C—BD	.00013
C—D	.00012
A—B	.0001
B—CDE	.00009
B—EC	.000085
E—B	.00008
B—D	.000075
B—C	.00007

B—CDE means one lead to B, and the other to C, D, and E, so that three of the capacities are in parallel and the fourth is in series with these. By choosing fixed condensers of other values you can obtain any capacity you want

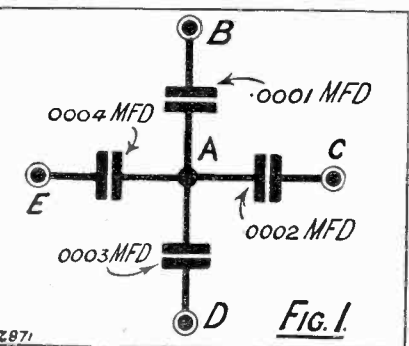





# The MYSTERY OF RADIO PERSONALITY

BY A. CORBETT-SMITH

*"How is it that one man, by radio, will grip his fifty million audience, when another man, of equal or greater distinction, may fail completely?" This fascinating problem is dealt with by the late artistic-director of the B.B.C.*

**Y**ES, and this is a real mystery. No amateur, hothouse "thriller" by a tyro at the game like E. Phillips Oppenheim or Edgar Wallace, to be piled up with clues and neatly solved in the last chapter. The mystery of personality is as old as time. And I doubt whether a debate upon it between, say, Sir Oliver Lodge and the President of the Royal Society would bring us any nearer the solution.

Radio has given us yet another aspect of this mystery, and a most intricate and fascinating one it is. How is it that one man, by radio, will so project a personal magnetism through the ether as to grip the consciousness of his fifty million audience of individuals by his message, when another man, of equal or greater distinction, may fail completely?

For, observe, this is no mere matter of being captured by a voice. It goes far deeper than that. Certain musicians, for example, whose voices we never hear, convey this magnetism. Just as there are a handful of men and

formed I should doubt whether there are even a dozen with the mighty gift of personality for a radio audience. Radio is a stern judge and a ruthless critic. It is impossible to hoodwink the audience, as one may from the stage. Pachmann, in the concert-hall, is not only a fine artist but a compelling personality. By radio I strongly suspect that he might well be a complete failure in the latter sense.

## Two Pianists

Here are two great pianists, Moiseiwitsch and Paderewski. Who shall decide which artist is the greater? Upon the stage and in public life Paderewski has infinitely the more vivid and emotional personality. Yet, by radio, and in comparison with Moiseiwitsch, he was almost flat and

"It is very curious how radio insists upon its own special type of personality. A man may be a magnetic speaker in the Queen's Hall, yet quite unattractive and colourless through the microphone."

colourless. The latter, in a radio recital, had not played four bars of his opening piece before one sensed the undefinable, compelling magnetism.

We hear those artists themselves touch the keys, or a violinist his instrument. Let us take a step deeper into the mystery. What of the orchestral conductors?

Everyone knows the famous "Pomp and Circumstance" March No. 1. A straightforward piece of music, with one performance of it very much like another. But who that heard Sir Edward Elgar conduct it by radio is ever likely to forget it? It was not that he secured more drive, vigour and expression than another conductor. It was the very soul of the composer that went marching on.

We had a similar experience with Sir Hamilton Harty conducting "The Messiah" at Manchester. By radio we could detect the personality of the conductor in every bar. This was far more subtle than any special "reading" of the music. And here is the mystery. In the concert-hall, both Elgar and Harty are lacking in magnetic force upon their audiences.

Why, by radio, are we so vividly conscious, despite ourselves, of the personality of Eugène Goossens and not of Sir Landon Ronald? Of Weingartner and not of Albert Coates? Yet all are in the front rank. I wonder how Sir Thomas Beecham would emerge from the test.



Sir Landon Ronald, the composer and conductor, whose songs have earned world-wide fame.

It is very curious how radio insists upon its own special type of personality. A man may be a magnetic speaker in the Queen's Hall, yet quite unattractive and colourless through the microphone. Or a man may be a superb Hamlet by radio and hopelessly incompetent upon the stage. Very rarely are the two commanding qualities found together.

## A Rare Example

Sir Harry Lauder is one of the rare examples. I can think only of one better. Of Chaliapin, I am not sure. His mighty dramatic power is really too tremendous for the microphone, at least in the studio. It dwarfs judgment. But Mr. Milton Hayes is one,

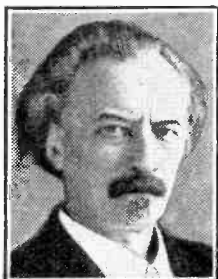

Paderewski, the famous pianist, who has an extremely vivid and emotional personality.

women in history who impressed their personalities upon distant thousands who had never seen nor heard them, nor even a portrait. Horatio Nelson was such a man. And I am sure that Helen of Troy had far more than a pretty face so to set the Old World by the ears.

Now, from the hundreds of radio artists and speakers who have per-

though more magnetic by radio than upon the stage. Mrs. Patrick Campbell? I think not. Her radio personality is more an affair of the curious voice *timbre* and unusual method. But, on the stage, we who have watched her career from old



Sir Thomas Beecham, whose microphone personality can only be guessed at—he has not yet broadcast in this country.

Adelphi days will stoutly maintain that she has no rival.

Three prominent speakers come to mind—Sir Oliver Lodge, Mr. Bernard Shaw and Sir Walford Davies. Each in his own way is singularly attractive. Yet, somehow, I do not feel the real magnetic grip about any one of them. With Sir Oliver we know instinctively that we are listening to one of the great philosophers of the age. And we listen with deep respect. But are we torn out of ourselves? Mr. Shaw is an artist to the fingertips, with a most winning voice and method. Sir Walford is an admirable "popular" speaker with a happy and distinctive "bedside" manner. But do we feel in either the grip of intense personality?

### Charm of Ellen Terry

Of our beloved Ellen Terry we have, alas, no opportunity of judging. But I would be ready to wager a radio triumph. Not so much for her beautiful art and grace of diction, but rather for the radiance of her superb



Albert Coates has conducted for the B.B.C. on many occasions.

womanhood. For Ellen Terry ranks with the historic handful who have compelled over the earth's spaces. Why, even her birthday message of gratitude, though spoken by another, carried an echo of her magnetism.

But, as I have suggested, we must not confuse radio personality with the pleasure we derive from a voice or method. Some of the announcers have graceful and attractive methods and diction. But that is not the personality we are talking about. It is only the captivating *jeune premier* of the stage.

### "Some Mysterious Aura"

To my mind, the most interesting case of to-day for analysis is that of the Prince of Wales. In the Prince we have a man who has, in effect, conquered the world by his personality. Three thousand miles up the Yangtse River no less than on Broadway, New York, they have a strong sense about him. But how much of that personal magnetism is carried across in radio speech if we did not know beforehand who was speaking?

Does any person grip and compel against ourselves? That, I think, is



Sir Harry Lauder, one of the rare examples where stage personality is accompanied by a living microphone personality.

the test question. And, as I have suggested, it is neither voice nor vision, pleasure nor displeasure given, which is the deciding factor. Rather is it some mysterious aura, some setting free and projection of the soul, some thought-photography of the human spirit into space. We need the lore of the ancient Egyptians, with their involved doctrine of the *ka*, or "double," to attempt an explanation.

A mystery, yes! But one of genuine importance in radio work. For it is the compelling power of personality which is most needed, the lack of it the most keenly felt, especially by women. Our men-folk, on the other hand, are inclined to regard the obtrusion of personality as "rather bad form." A typically British attitude towards art.

But it is a very fascinating topic. Here I have attempted no more than a few casual impressions. I wonder if we could possibly persuade Sir Oliver Lodge to develop the theme.

(Copyright in the U.S.A.)

## RADIO ODDS AND ENDS

The expedition which is searching for Col. Fawcett, lost in the Amazonian jungles, is keeping in touch with civilisation by means of two short-wave transmitting sets.

The giant German broadcasting station at Zeesen, near Koenigswusterhausen, transmits an evening concert, from 7 p.m. onwards, on 1,250 metres.

### A Record Breaker

The British beam system of wireless telegraphy has broken the world's records for long-distance telegraphic communication, by exchanging messages for hours on end at a speed of 400 words per minute, with reception too clear for repetition to be necessary.

The Air Ministry's great new wireless station at Croydon works on wave-lengths between 800 and 2,000 metres, and is equipped for Morse, telephony and direction-finding.

Although resistance-capacity-coupling has become really popular only during the last two or three years, it has always been known as an excellent method of coupling, and has been widely used by engineers ever since the valve was used as an amplifier.

### Some Technical Tips

When covered wire is used for connection to a standard screening box, the H.T. positive lead should for safety's sake be protected by Systoflex or some similar additional covering, otherwise accidental strain on the wires may easily cause a very nasty short.

With a crystal set the earth connection is often quite as important as the aerial.

When one soldered joint has to be made close to another one a damp rag wrapped round the latter will tend to prevent it becoming heated and unsoldered.

If reversing the condenser leads does not stop hand-capacity effects it will often be found that one of the grid leads is placed too near to the panel face.

Earthenware jars should not be used as wet-battery containers, as there is much more leakage with these than with glass.

# The "All-In" Two

As you will be able to judge by the photo on the right, this receiver is a **real** portable. Included in the small case are the batteries, frame aerial and space for the telephone receivers. Notwithstanding its exceptionally diminutive nature, the "All-In" is capable of tuning in 5 GB at a distance approaching 100 miles in daylight, while continentals can be heard after dark.

Designed and Described by  
**MARCUS G. SCROGGIE, B.Sc., A.M.I.E.E.**



**T**HE portable receiver has had a rather considerable vogue during the last year or two, and visitors to the Wireless Exhibition at Olympia last autumn could hardly have failed to notice the surprising

under the one name "portable," and before going into constructional details of a particular set it might be worth while considering what purpose portable receivers fulfil.

The majority of those on the

pick up only a very small amount of power from the wireless waves radiated from the station, and hence necessitate considerable magnification to be provided for in the receiver itself; this in turn involves many components, large batteries, heavy weight, bulk, and high cost. In fact, the name portable is notoriously somewhat of a misnomer in its usual application.

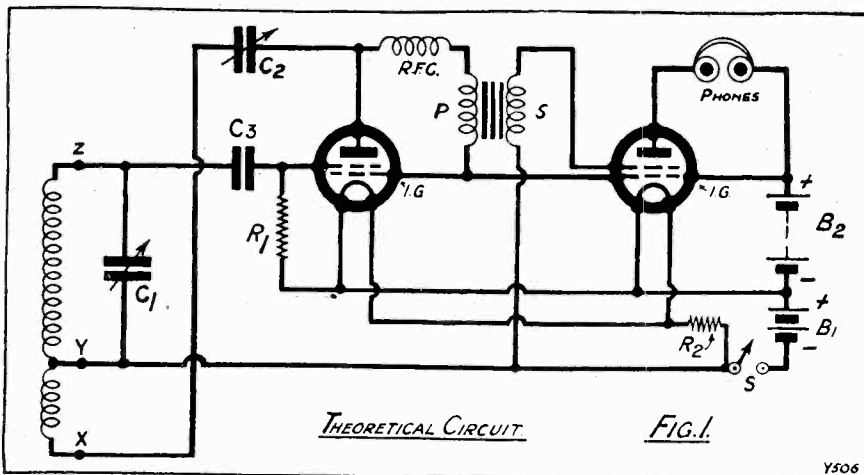

X, Y, and Z are the frame-aerial tapplings; C<sub>1</sub>, '0001-mfd. tuning condenser; C<sub>2</sub>, '0001-mfd. reaction condenser; C<sub>3</sub>, '0003-mfd. grid condenser; R.F.C., radio-frequency choke; R<sub>1</sub>, 3-megohm grid leak; R<sub>2</sub>, 3-ohm fixed resistor; B<sub>1</sub>, L.T. battery; B<sub>2</sub>, 4½-volt dry battery; S, on-off switch; and I.G., inner grid of 4-electrode valve.

number and variety of designs shown there. Constructional articles also have given full attention to such sets.

There are, however, several distinct types of design which are included

market employ four, five, or even more valves in order to work a loud speaker at a reasonable distance from broadcast stations. Using some form of self-contained aerial they inevitably

### Light and Cheap

Comparatively few people really do want to lug about an expensive and heavy piece of apparatus, even when motoring or boating, and the most useful purpose of the majority of so-called portable sets is the avoidance of external wiring and accessories, and the possibility of moving "the wireless" from room to room without trouble.

If one abandons the use of a loud speaker, then it is a comparatively simple matter to produce a little outfit that is light enough not to be a burden, and cheap enough to come within the scope of those who would like an additional receiver that is at the same time somewhat of a novelty with which to amuse friends. It is surprising how many people are quite

### THE COMPONENTS YOU WILL NEED.

- 1 Attache case, 12 in. × 7½ × 4½ in. external dimensions.
- 2 Ormond "Midget" condensers, 0·0001 mfd. variable, with knobs.
- 1 Small on-off switch (Benjamin, Bowyer-Lowe, L. & P., Lissen, Lotus, etc.).
- 1 Small intervalve transformer (Such as Mullard "Permacore," etc.).
- 1 H.F. choke (Edison-Bell, Igranic, or similar flat type).
- 1 3-megohm grid leak and clips or

- holder (Dubilier, Ediswan, Igranic, Lissen, Marconiphone, Mullard, etc.).
- 2 Rigid valve holders (Burndept, Lissen, etc.).
- 1 0·0003-mfd. fixed condenser (Clarke, Dubilier, Lissen, Mullard, T.C.C., etc.).
- 1 3-ohm filament resistor and holder (Burndept in set. Any compact type).
- 2 4-electrode valves (Philips A.141 or Aneloy A.P.412U).
- 1 Siemens size P dry cell or 4-volt

- unspillable accumulator for Aneloy valves.
- 1 4½-volt flash-lamp battery (Ever-ready, Hellesen, Lissen, Siemens).
- 2 Wander plugs (red and black).
- 1 Pair lightweight 'phones (Lissen, or similar type).
- 60 yards 7/35 frame-aerial wire (London Electric Wire Co.).
- Quantity ¾-in. American whitewood, ⅜-in. plywood, or bakelite panel, size to fit; wire, flex, terminals, screws, etc.).

astonished when it is produced, though they may take the ordinary type of receiver for granted. The experimenter finds it instructive to trace the effect of various buildings, etc., in reducing the strength of broadcast, and many curious effects come to light, such as those caused by underground metal, trees, expanses of water, hills, and so forth. A temporary invalid can listen without trouble in any room, and many other uses for such a set will occur to readers.

The "All-In" Two was subjected to searching examinations and tests by the "M.W." Research Dept. before being "passed for publication."

The one to be described, though it utilises 4-electrode valves, is particularly simple both to make and to work, and batteries are reduced to a minimum without loss in efficiency. A wooden frame is wound with the wire which serves both as aerial and tuning coil, and supports inside itself all the remaining components. The frame is held in a miniature attaché case, and may be removed by taking out a couple of screws, when the whole is open to inspection. There is plenty of room in the case for a pair of 'phones.

**The Circuit Used**

The theoretical circuit is illustrated in Fig. 1, which shows a simple detector valve with reaction followed

by a low-frequency amplifying valve. The fourth electrode of each valve, the inner grid, is connected to the positive terminal of a single flash-lamp battery, which replaces the usual high-tension battery. The valves are of the Miniwatt A.141 type, made by Philips, the famous Dutch lamp and valve manufacturers, and are particularly suitable for the present purposes because of the extremely low battery consumption; the filament takes only 0.06 ampere at 1 volt, so two valves can easily be run from a single dry-cell for a very considerable period. The other only battery is, as just mentioned, a six-penny flash-lamp refill.

**Simple Woodwork**

To proceed with the constructional details: The carrying case has external dimensions 12 in. x 7 1/2 in. x 4 1/2 in., and the frame is first constructed of good dry wood, preferably American whitewood, 3/8 in. thick, so as to allow about 1/4 in. all round when dropped into the case. As cases vary in size it will be necessary to exercise care at this stage and alter the dimensions shown in Fig. 2 where necessary, at the same time bearing in mind the space occupied by the various components. The partitions separating the batteries and valves from the control compartment are of the same wood, while the control panel may be of 3/16-in. plywood, or, better still, bakelite sheet. A good plan is to get the batteries and valves into the smallest possible space.

The frame should next be wound, preferably using special stranded copper frame-aerial wire, 7/35 gauge (London Electric Wire Co.), though ordinary D.C.C. wire of about 22 gauge will be fairly satisfactory. Two small holes are drilled in the frame, about 1/4 in. apart, at X (Fig. 2), and the end of the wire looped through to make it fast. This end goes to the reaction condenser.

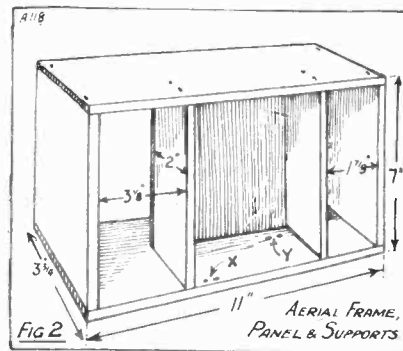

Eighteen turns are then wound on the frame, taking care to keep the wire taut, and a loop of wire is passed through the two holes Y, about 1 in. away from the edge X.

**Fitting the Frame**

This loop forms the tapping which is connected to filament, batteries, etc. The remainder of the wire, another 34 turns, is then wound on, without breaking it at Y, the end made fast at the edge farthest away from X, and brought round to the back to connect to the grid condenser and tuning condenser. The wound frame should now be tried to see that it fits the case without being so tight as to abrade the insulation of the wire. The two valve holders are mounted one behind the other in the right-hand compartment of Fig. 2. The remaining components are fitted to the panel and side cheeks as shown in the rear plan (Fig. 3).

**The Valve Holders**

It should be noted that in this diagram the two valve holders are shown in plan for the sake of clearness instead of the end view of one of them, which would be all that would actually be seen in this position. The two variable condensers, the switch and three terminals are mounted on the panel; the left-hand cheek or panel support is drilled to pass three battery leads and carries the R.F. choke; the right-hand cheek carries the resistor holder, the grid-leak clips (which should be mounted on a strip of ebonite if not bought ready mounted) and the fixed condenser.

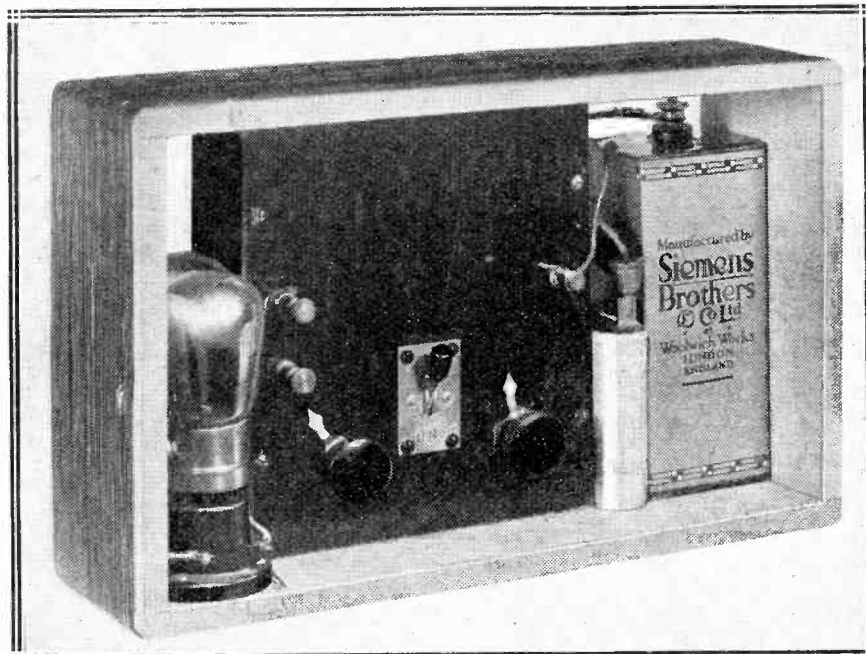

The frame aerial is wound around the wooden framework. The large dry battery supplies current for the dull-smitter 4-electrode valve, while the small 4 1/2-volt "flash-lamp" battery gives all the H.T. that is needed.

The two last-mentioned are situated one behind the other, so the diagram should be examined with care in order to trace the connections. The transformer is secured to the main frame, taking care that the screws do not pass through to the aerial wires.

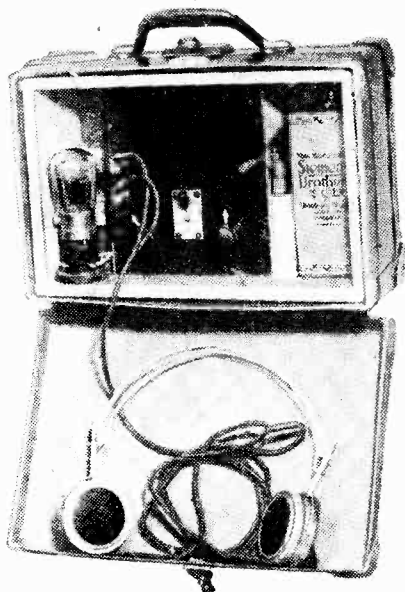

Here is the complete receiver ready for use. An on-off switch is fitted on the panel.

If the transformer is a cheap one it does not matter much in a receiver of this type, as the primary current is small, only a fraction of a milliamp, and will not saturate a small core. The R.F. choke may, if desired, be made by the constructor; it consists of about 1,000 turns of 44 D.S.C. wire wound in a groove 1/16 in. wide and 1/2 in. deep, cut in an ebonite disc 1 3/4 in. in diameter.

**Alternative Valves**

When everything is assembled the wiring is carried out as described in the wiring instructions. Flexible leads for connecting to batteries are taken through holes in one of the side cheeks, using red wire for positive and black for negative. Wander plugs with split pins can be used to connect to the brass strips of the flash-lamp battery, and all the flexible leads should have a knot tied in them on the inner side of the cheek to prevent them being rooted out by a sharp tug.

In using the "Miniwatt" valves note that the inner grid connection takes the form of a terminal on the metal cap. If difficulty is experienced in getting Philips' valves an alternative is the Aneloy 4-electrode valve, of which a number of types are produced. As these valves run at about 3-7

volts, .09 amp. filament current, a very small unspillable 4-volt accumulator must be substituted for the dry cell.

The Aneloy A.P.412U valve is satisfactory in both holders, connected in the same way as the A.141, and with anything from 3 to 6 volts anode battery. Superior results are obtained with these valves if the inner and outer grids are interchanged, that is to say, with the positive battery connections going to the grid socket of each valve holder and the grid connections going to the terminals on the valve caps. If this method is used it is advisable to increase the anode battery to 7 1/2 to 9 volts; two flash-lamp batteries in series, for example. The 3-ohm resistor is about right with these valves, as the filament voltage need not be so high as 3-7 for efficient working.

**Obviating Capacity Effects**

The frame is held in the case by two or more screws through the bottom of the case going into the edge of the wooden frame. Some cases have a metal rim which if left intact puts the receiver out of action, because it acts as a short-circuited turn coupled to the aerial; a gap of 1/4 in. or so should be cut in it, and if it is built up of a number of pieces of metal they should all be soldered together at the joints to prevent noises due to bad contact at these places. Finally, a short piece of wire should be connected between the metal rim and any one of the battery terminals. This is of very valuable assistance in obviating hand-capacity effects, which are usually troublesome

in a receiver which has no definite earth connection, and which is somewhat sharp in tuning.

When the batteries and 'phones are connected and everything is ready the set should be stood up on its side and turned endwise on to the broadcast station, switched on, and if all is well a "plonk" should be heard on moving the reaction condenser over due to the starting of oscillation.

.....  
 "The set tunes from about 330 to 530 metres, and the range of reception, of course, varies greatly with the locality and strength of station, but generally speaking, satisfactory reception should be obtainable within 10 to 15 miles of a main B.B.C. station, 4 to 6 miles from a relay station, and 100 miles from 5 G.B. Out-of-doors these distances are considerably increased."  
 .....

If the tuning condenser is now turned around a whistle indicates that a transmission is being received, and the reaction capacity is carefully reduced until the whistle is resolved into clear reception. Though the likelihood of causing interference through oscillation is small, owing to the low power and small aerial, yet oscillation should not be indulged in too freely because a sensitive receiver is able to pick it up within quite a considerable radius.

**Some Operating Hints**

Tuning is very sharp on distant stations, and a little care is required at first. If less than half the maximum capacity of the reaction

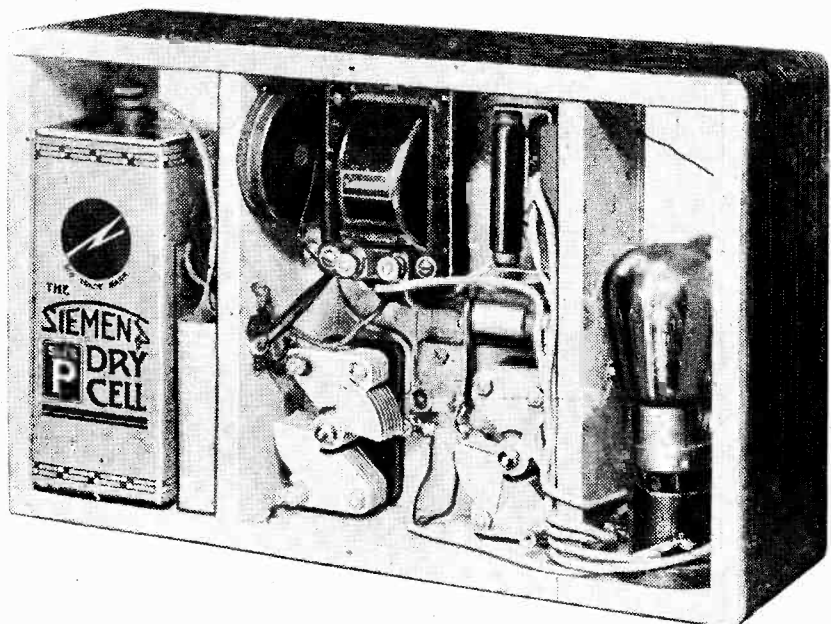

The entire "works" of the set can be lifted bodily out of the small attache case and could be fitted in an ordinary kind of cabinet for use at home during the winter months.

condenser is sufficient to produce oscillation it is advisable to disconnect one of the sets of fixed plates in the reaction condenser.

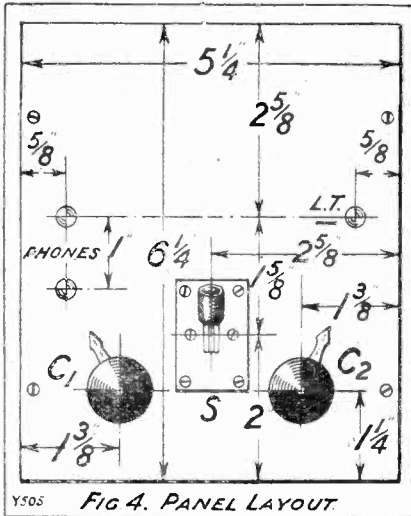

FIG. 4. PANEL LAYOUT.

Also, if it is not desired to tune over such a large band of wave-lengths, the same may be done with the tuning condenser, or to reduce still further the tuning band, and consequently to make the tuning less critical in adjustment, the moving

plates may be left unconnected and the two leads taken to each of the sets of fixed plates. This gives a quarter of the capacity that is obtained by connecting as in the diagram.

ascertain more easily whether it is working or not. Do not stand the receiver on a metal surface, but on a wooden or other insulating table or support.

The set illustrated receives 2 L O

**WIRING INSTRUCTIONS**

Looking at back of panel, as in Fig. 3.  
 Connect nearest end of aerial winding (X) to both sets of fixed plates of reaction condenser, afterwards disconnecting one set if receiver oscillates too easily (see text).  
 Connect aerial tap (Y) to moving plates of tuning condenser, to one terminal of switch, to one terminal of resistor holder, and to I.S. or filament terminal of transformer.  
 Connect far end of aerial winding (Z) to both sets of fixed plates of tuning condenser and to one tag of 0-0003-mfd. fixed condenser.  
 Take red flexible lead from + terminal on dry cell through side cheek, tie knot in lead, and join to one grid-leak clip and to one filament terminal on each valve holder.  
 Take black flexible lead fitted with wander plug (for connection to - strip on flash-lamp battery) through side cheek, tie knot, and solder to red flex just mentioned. Insulate the joint with adhesive black tape.  
 Take red flexible lead fitted with wander

plug (for + strip on flash-lamp battery) to I.P. or + terminal on transformer, to + terminal for 'phones, and to two flexible leads for connection to inner grids (cap terminals) of valves.  
 Join L.T. - terminal on panel (to which - wire of dry cell is made fast) to remaining terminal of switch.  
 Join remaining grid-leak clip and 0-0003-mfd. condenser tag to grid terminal of nearer valve holder.  
 Join remaining resistor holder terminal to remaining filament terminals on valve holders.  
 Join fixed plates of reaction condenser to R.F. choke and to plate terminal of nearer valve holder.  
 Join other terminal of R.F. choke to O.P. or plate terminal of transformer.  
 Join O.S. or grid terminal of transformer to grid terminal of further valve holder.  
 Join plate terminal of further valve holder to remaining 'phone terminal.  
 Join point Y of frame or its direct leads to metal rim of case, if any.

If it is found at all difficult to pick up a station, the end of an ordinary aerial may be laid on the set, which has the effect of greatly increasing the strength and enabling the user to

very strongly in the 'phones, even in fairly shielded buildings at eight miles. The interest and usefulness of a little set like this quite well repay the trouble of making it.

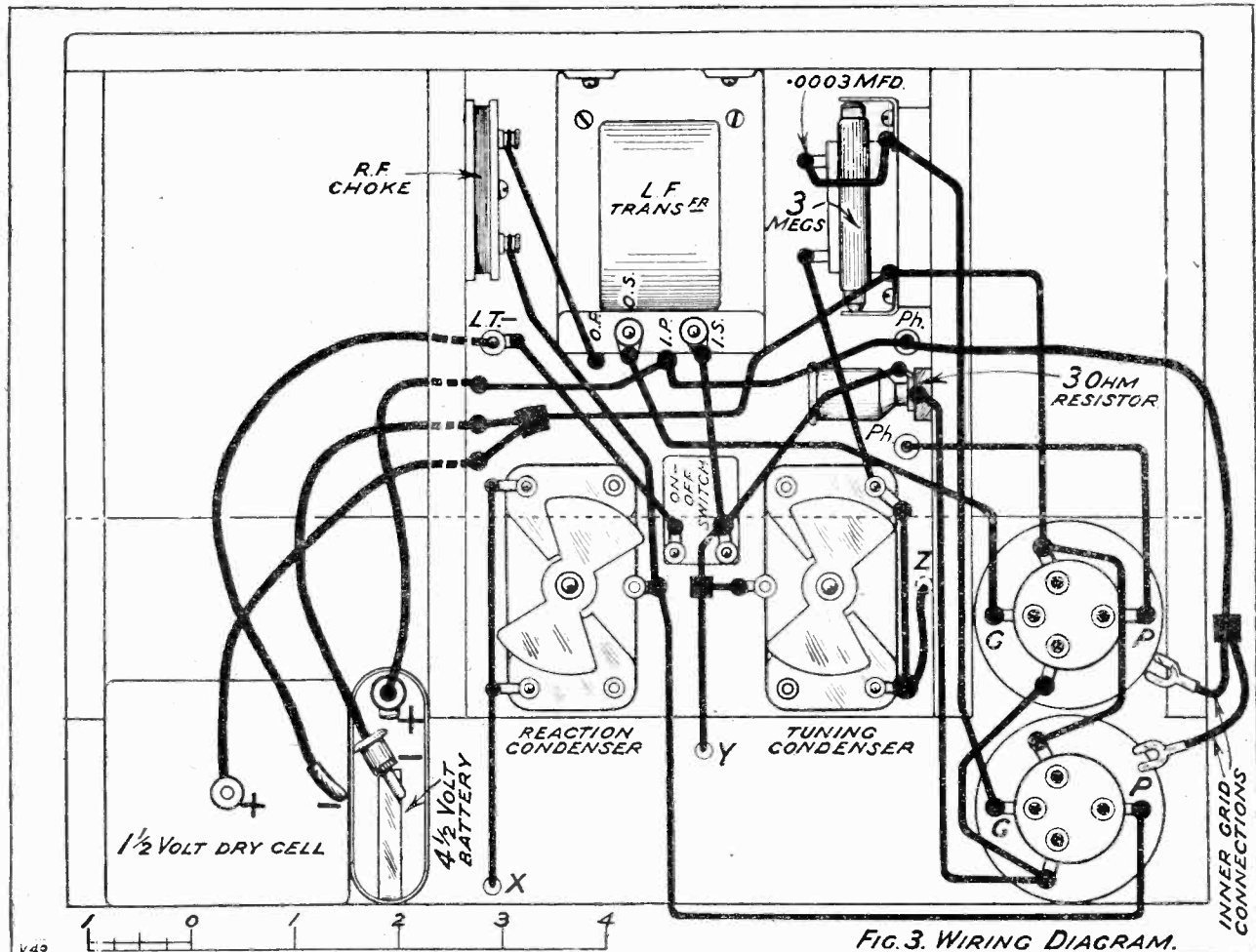

FIG. 3. WIRING DIAGRAM.

# FITTING A SCREENED GRID VALVE

A practical article showing you how you can substitute one of the new and very efficient screened-grid valves for one of the ordinary 3-electrode type in an H.F. stage of an ordinary set.

By F. C. TOPHAM, A.M.I.E.E.

THESE are, perhaps, many readers who are desirous of substituting the screened-grid valve for the ordinary three-electrode valve in the high-frequency amplifying stage of their receivers. They may, however, feel somewhat doubtful as to the

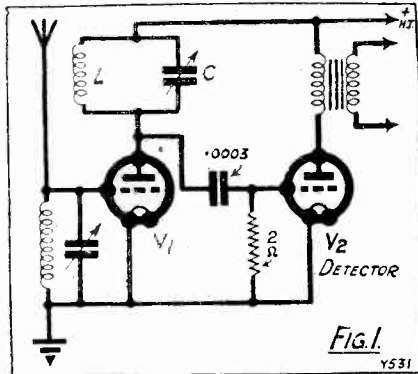

method of doing this, or whether the resulting gain will be sufficient to justify the expense, and it is the purpose of this article to throw some light upon these two points.

Before dealing with the practical side of the matter it may be helpful to outline briefly the main disadvantages of three-electrode valves and in what manner the screened valve overcomes them. For the sake of simplicity consider first the tuned-anode circuit shown in Fig. 1 and which needs no description.

### An Inefficient Circuit

The circuit LC is shunted by the internal resistance of the valve, which may be as low as 14,000 ohms, and this will exercise a heavy damping effect with a consequent loss in selectivity.

To quote an actual example, it was found that with a certain design employing a D.E.L.410 valve having an internal resistance of 14,000 ohms and an amplification factor of 13, the damping due to the valve and added to the circuit LC was no less than 119 ohms, while the overall amplification was reduced to about 6.5.

There is little need to point out that under such conditions it is almost a waste of time to strive after efficiency.

In addition to the above defect the circuit of Fig. 1 may be very unstable, particularly when valves of high amplification factor are used, due to the feed-back of high-frequency energy via the anode-grid capacity.

As scientific design progressed the above faults were greatly diminished by the use of neutralised high-frequency transformers in conjunction with valves of high internal resistance and followed by anode-bend rectification. For the sake of comparison this improved circuit is shown in Fig. 2, but as such receivers have been described in this journal from time to time it is not proposed to go into further details.

### Much Greater Magnification

Now the screened valve has, under proper conditions, a very high internal resistance and amplification factor, but, more important still, its anode-grid capacity is almost negligible. A moment's thought will show that if such a valve is substituted for V1 in Fig. 1 it should be capable of giving us much greater magnification and selectivity without the tendency to oscillate which is inherent with the plain tuned-anode.

In other words, it may be regarded as a kind of "short cut" to the good results achieved by the arrangement

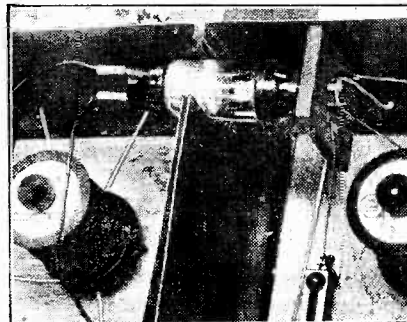

Showing how an S.G. valve should be fixed to provide efficient external screening.

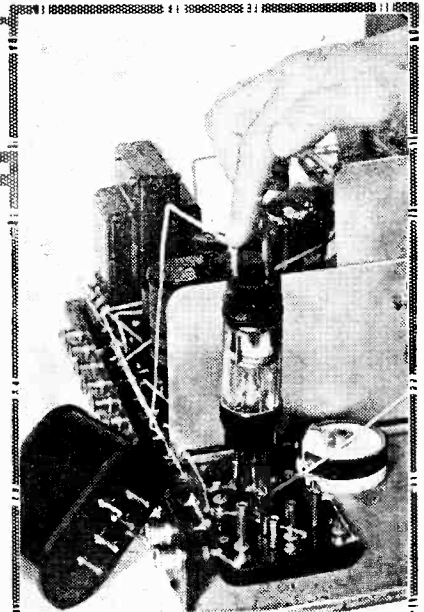

An S.G. valve inserted in an ordinary valve holder with two sockets arranged for its other end. Note the screen.

of Fig. 2, but with certain added advantages.

In what follows it is proposed to describe a short series of experiments (easily undertaken by the reader), having the two-fold object of ascertaining, first, the limitations of the statements contained in the preceding

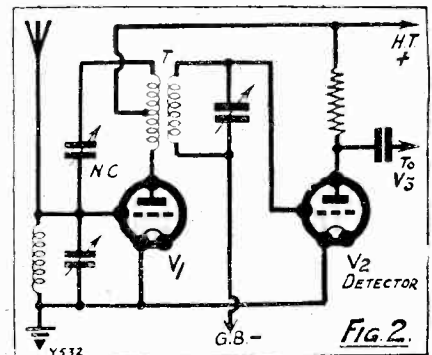

paragraph and, second, the most efficient method of adapting an ordinary receiver to the screened valve. It will be assumed that the reader is already familiar with the general characteristics of this valve.

### To Render Application Wide

The most common type of broadcast receiver is probably that employing one high-frequency stage followed by a detector and one or two stages of low-frequency. In order, therefore, that this article may have as wide an application as possible, it will be confined to the consideration of an instrument having one high-frequency stage and only that part of the receiver will be described.

The original receiver upon which the following experiments were conducted was of the very average type shown in Fig. 2. An unscreened neutralised high-frequency transformer T, having a step-up ratio of about 1 to 4.5, was employed in the anode of the first

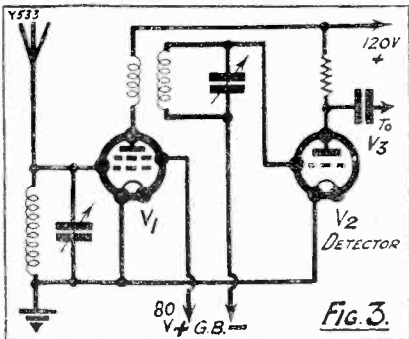

valve. It was of solid wire, giving an overall amplification to the detector of, roughly, 18 to 20, from which it will be seen that the design was open to improvement.

The first experiment was the simple substitution of a screened valve (a Marconi type S.625) for the three-electrode valve  $V_1$  of Fig. 2. To do this it was only necessary to replace the ordinary valve holder by one of a suitable type and to carry an extra lead from the screen-grid terminal to a point on the high-tension battery about 80 volts positive; about 120 volts being applied to the anode.

As the inter-electrode capacity is negligible, the neutralising winding of the transformer T, and the neutralising condenser NC, are no longer required, and hence the circuit became of the simplest form shown in Fig. 3.

### The Transformer Ratio

Upon adjusting the set it was found that the amplification was very little, if any, greater than that given by the original arrangement. Perhaps such a result is contrary to the reader's expectations, but this, together with the fact that there was practically no tendency to oscillation, indicated clearly that the valve was being operated very inefficiently. The reason is not far to seek.

The amplification given by any valve is chiefly dependent upon the ratio of the anode-circuit impedance to the total impedance, the latter including that of the valve. In the case of the screened valve the A.C. resistance is of the order of 175,000 ohms, while the impedance of the few turns constituting the transformer primary was comparatively small—although comparable with the A.C.

resistance of the original three-electrode valve. Hence the greater part of the amplified voltage was expended across the screened valve itself, with the result that the external amplification was small.

The number of turns on the primary was then gradually increased (leaving the secondary unchanged) and, paradoxical as it may seem at first sight, the overall amplification of the system increased although the transformer step-up ratio decreased. This was due to the higher inductance of the primary causing the valve to operate in a more efficient manner. It was found that the maximum amplification to the detector was given when the primary was only a few turns less than the secondary, the ratio being approximately 1 to 1.2.

### Unwanted Coupling

In addition to the increased amplification the tendency of the set to oscillate became more pronounced as the primary turns were increased, not because of inter-electrode capa-

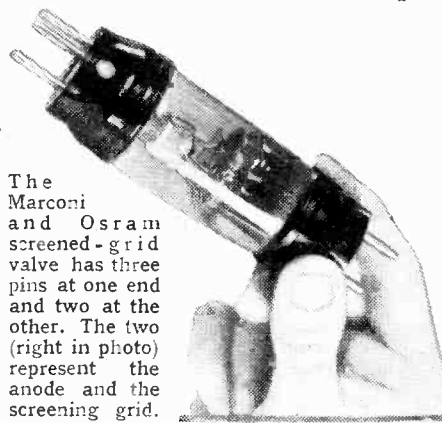

The Marconi and Osram screened-grid valve has three pins at one end and two at the other. The two (right in photo) represent the anode and the screening grid.

city, but owing to the fact that the high amplification caused stray external fields to become troublesome. The most efficient ratio could not be reached, as a matter of fact, until a certain amount of screening (see later) was used.

It is obvious that as the best transformer ratio was only about

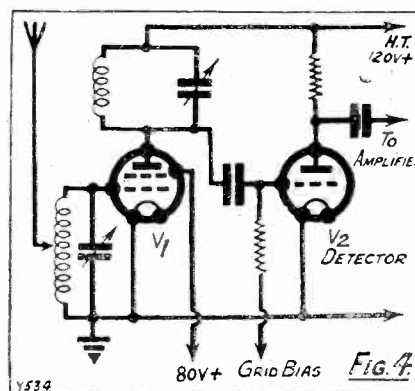

1 to 1.2, we are coming back to the tuned-anode, which can be regarded merely as a transformer with a 1 to 1 ratio. It was decided, therefore, to sacrifice the small extra gain given by the transformer in return for the cheapness and simplicity of the tuned-anode.

### Tuned-Anode Tried

A single-layer coil was constructed, therefore, having 50 turns of No. 24 S.W.G. wire upon a 3-in. diameter former, across which was shunted a 0.0003-mfd. tuning condenser, the

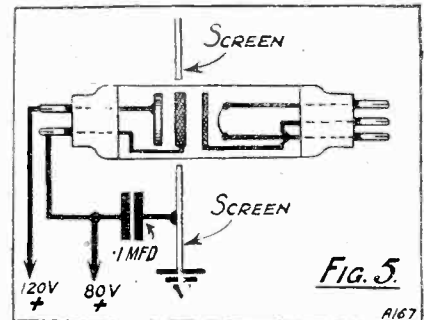

circuit being re-arranged as shown in Fig. 4.

When the valve was adjusted to the correct point, however, the set was found to be quite unworkable, due to instability (remember, no screening was yet employed) caused by the strong field from the anode coil. The simple experiment of altering the relative positions of the grid and anode coils proved that the major part of the trouble was produced by these particular components.

The effect of interposing a flat metal screen about 1 ft. square between the grid and anode circuits was then tried. A hole just large enough to accommodate the valve is cut in the screen, the latter being placed in such a position that the screen grid is in the same plane as the screen (indicated in Fig. 5), the two being "bonded" by a 0.1-mfd. condenser. (Small holes through which it may be necessary to pass connecting wires should be insulated with "Systoflex.")

### The Real Difficulty

The result of the above alteration was not satisfactory, however, as although the tendency to oscillate was diminished it was still troublesome. In other words, the grid and anode fields were still interacting.

We have seen that the above-mentioned interaction is largely due to the coils themselves, and therefore we should expect the substitution of astatic or fieldless coils to effect an



improvement. In order to test the matter a pair of "binocular" coils (of a well-known commercial make) were placed in the grid and anode circuits respectively, with the result that stability could, with care, be maintained by means of the above-described simple flat screen.

Now, the above-mentioned binocular coils had a high-frequency resistance of about 15 ohms at 361 metres, their impedance at resonance being approximately 111,000 ohms in the anode circuit, so that the voltage amplification obtained was about 42.

The overall amplification to the detector was found to be actually 30. This figure was certainly better than that obtained with the three-electrode valve, but, obviously, it should be possible to utilise the peculiar properties of the screened valve to better advantage. An endeavour was then made to improve the efficiency as described under, and this is where the real difficulties began.

### Changing of Coils

A pair of low-loss astatic coils were wound to the design described by Mr. A. Johnson-Randall in MODERN WIRELESS of December last, except that 27/42 Litz wire was used in place of the 9/38 mentioned therein. The reader is referred to that article for further details. These were placed in the grid and anode circuits respectively, and tuned by 0.0003-mfd. condensers, the aerial being connected to the centre of grid coil.

Previous experiments have led us to expect that the above arrangement would be very unstable, unless precautions were taken to completely screen the anode circuit and to prevent high-frequency currents passing to other parts of the receiver, thus influencing the aerial or first grid circuit.

### The Final Circuit

The final circuit is shown in Fig. 6, from which it will be seen that high-frequency chokes  $HFC_1$  and  $HFC_2$  are inserted in the H.T. battery leads to the valves  $V_1$  and  $V_2$ , and by-pass condensers  $C_1$ ,  $C_2$  and  $C_3$ , of 0.1, 0.1 and 0.0001 mfd. respectively, are joined from the points shown to earth (screen).

The anode circuit, including the tuning condenser, choke, etc., is completely enclosed in a metal screening box with lid, the valve projecting through one side as previously described. The best method of constructing such a box is to first line the panel and baseboard with the sheet

metal, and then mount the necessary components thereon, taking the usual precautions with regard to insulation. It is then a simple matter to place the remaining sides of the box in position, taking care that all components, including the lid, are well bonded.

### Simple Screening

Upon trying out the above arrangement, it was found that the amplification and selectivity were greater than those obtained by the solid wire binocular coil, but, although stability could be maintained, the circuit was somewhat difficult to handle, and liable to burst into oscillation.

In a receiver of this type more elaborate screening arrangements are not justified (particularly as the feed-back via the valve is not completely zero), and therefore it was decided to introduce a small amount

under working conditions, and the equivalent anode impedance was 418,500 ohms. The theoretical voltage amplification was 77, but the practical value to the detector valve was about 45, a very satisfactory value.

A few final remarks regarding selectivity may be of interest. It may be contended that an extremely selective anode coil of the type described will cause distortion and loss of the higher frequencies, due to the curtailing of the side-bands of the transmitted wave-band. To some extent this is correct, but the decrease in quality with only one high-frequency stage will not be of great importance. The screened valve is shunted across the tuned-anode and this is equivalent to the introduction of about 9 ohms damping resistance, which is sufficient to prevent undue distortion.

It will now be useful to summarise

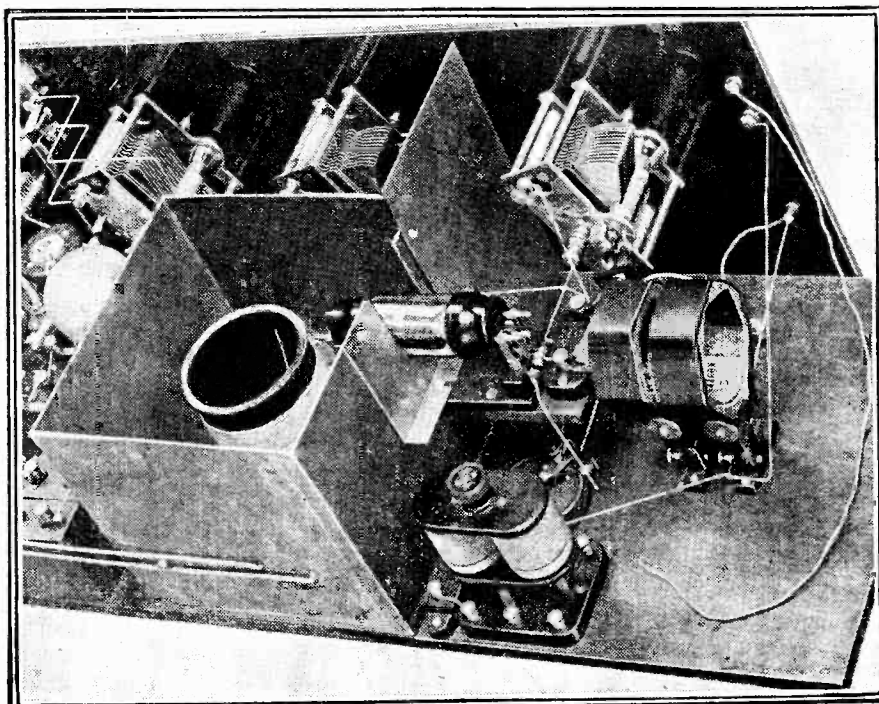

Showing one way a screened-grid valve can be fitted to an "M.W." standard screening box. Alternative methods include fitting the valve through a circular hole cut in the side of the box. The set, a portion of which is illustrated above, is the "Modern Wireless" "Super-Screen" Four.

of damping into the grid circuit by removing the low-loss coil and replacing the binocular coil referred to in the last experiment. All other conditions remained unchanged.

### "Perfectly Stable"

Tests showed that the set as now altered was perfectly stable and easy to handle, even with the maximum amplification obtainable, and hence the arrangement was adopted as final.

The high-frequency resistance of the above anode coil was 5.1 ohms

the chief lessons to be learnt from the experiments.

(1) It is a waste of time to fit a screened valve in an ordinary receiver employing a high-frequency anode transformer designed for three-electrode valves.

(2) If transformer coupling is employed in the anode of a screened valve, the most efficient transformer will be only slightly better than a good tuned-anode. Hence the latter is preferable on the grounds of economy and simplicity, although the

transformer renders screening easier.

(3) Screening is essential, and the higher the magnification the more perfect must this be made.

(4) If low-loss coils are used throughout, the receiver will be probably unstable with plain tuned-anode.



This photo very clearly shows the greater part of the internal construction of the Osram and Marconi S.625. Below is the grid and filament assembly, and above is the screening grid which envelops the anode.

(5) A good form of circuit to use with the screened valve is one having an astatic grid coil of solid wire, an astatic anode coil of the low-loss type, and complete screening of the anode circuit in as large a box as possible. Precautions must also be taken to eliminate high-frequency currents from the low-frequency parts of the instrument.

**PRACTICAL HINTS FOR THE HANDYMAN**  
 Some Grid-Bias Tips—Labelling Battery Leads.

**G**RID bias often gets neglected, probably because the battery is small, seldom renewed, and does not require frequent adjustment. But correct grid bias effects a great saving of H.T. battery current, exercises a marked improvement on quality, and safeguards the set against all sorts of annoying noises which might otherwise mar reception.

If the following hints are observed, much poor reception and many annoying noises will automatically disappear. Make sure that the plugs fit tightly in the sockets and that they are reasonably clean. Cut away frayed ends of flexible wire, for these "whiskers" may give rise to shorting trouble. Long, flexible leads which tend to shake and to move the plug about can easily be held securely if an ordinary elastic band is slipped over the battery, and the plugs are brought under this before being placed in position.

**Avoiding Shorts**

In many batteries the positive socket is set so close to the 1½-volt socket that if the grid bias positive is carelessly adjusted it will bridge the gap between the two and short the 1½-volt cell. This, of course, must be guarded against, as a faulty cell here will affect the functioning of the whole set. Grid-bias batteries which stand upon a baseboard should not be allowed to slide about when the set

is moved, nor be held in place only by their connections.

It is very easy to mount a grid-bias battery securely, and you may save an expensive accident. Many grid-bias batteries have a cardboard lid which protects the sockets from accidental metallic contact whilst the cell is in the dealer's hands. The purchaser very often throws these

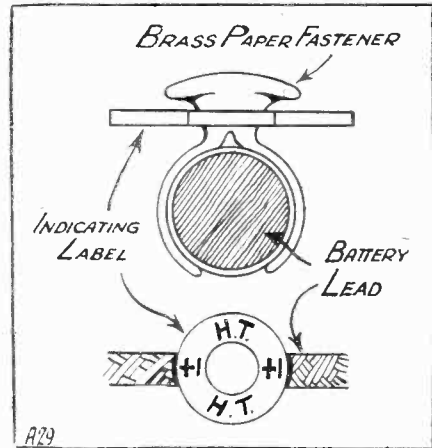

Brass paper-fasteners can easily be used to label battery leads as explained below.

lids away, but if these are turned upside down and screwed direct to the baseboard, they make convenient stands in which the grid-bias battery may be held in position on the baseboard. B. R. P.

**Labelling Battery Leads**

**T**o avoid confusion with battery leads and a possible disastrous result arising from wrong connections, it is advisable always to have some simple means of identifying the individual leads. Using rubber-insulated wire of different colours is one method, or, better still, arrange to mount small indicating tabs actually on the wander plugs themselves with the correct markings shown. If circumstances arise to preclude this latter method, then it is a good plan to employ the small, circular, engraved discs usually supplied for mounting under terminal shanks. These can be readily fastened to the leads through the medium of ordinary brass paper-fasteners. The head of the fastener rests against the disc, and this in turn is held in place by passing the thin brass projections through the disc hole and bending them round the lead as indicated in the above sketch.

It is essential to ensure that the insulation of the lead is not broken in this process, otherwise the metallic connection between fastener and wire will cause a battery short-circuit if the fasteners come in contact with one another at any time.

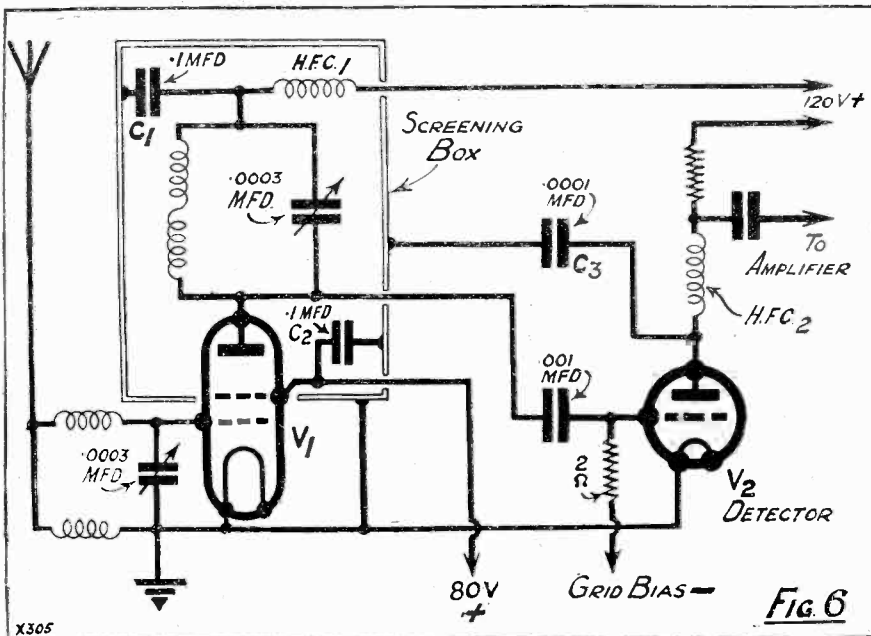

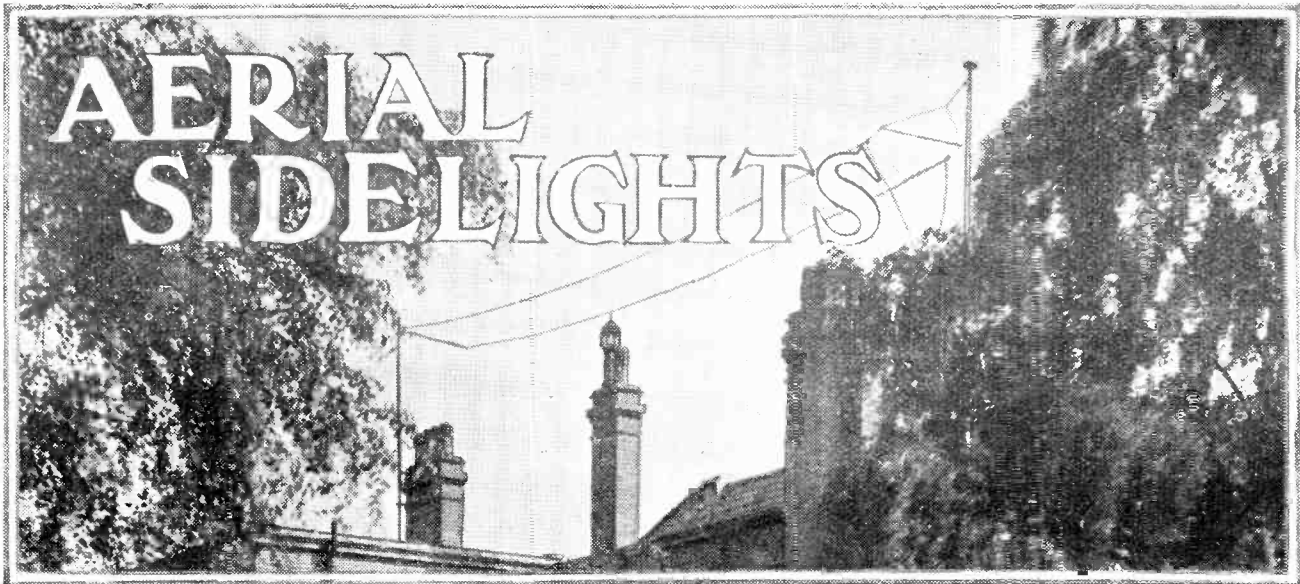

*An article for those who take an interest in How their Wireless Set Works.*

*By P. R. BIRD.*

**D**ID you know that your aerial is really a transformer?

That it is, in fact, a better transformer than either the H.F. or the L.F. variety which may be in your set? For the ordinary high- or low-frequency transformer simply takes one kind of current in its primary and sends out another kind of current in its secondary, but an aerial really does "transform"—it effects a real transmutation, altering one thing into something else.

### The Transformation

It is in your aerial that the most magic metamorphosis in wireless takes place. In some extraordinary fashion of its own the aerial manages to trap and to catch those mysterious and invisible ether waves, and to convert them instantly into that comparatively familiar and well-known form of energy which we call electricity. This is a real transformation—a fundamental alteration of form far more marvellous than anything we ordinarily associate with a mere transformer.

### Input and Output

Like most wireless components, the aerial is really a bit of a dark horse. There is far more in it than meets even the observant optic! And we shall be able to get a better idea of its versatility if we consider it as a transformer, looking separately at its input and its output.

The input to the aerial is not electricity but ether waves; and all that we need say about ether waves

for the moment is that they are electro-magnetic in nature and travel in free space with the speed of light. Electro-magnetic ether waves, like most children of nature, fare best in the wide, free, open spaces, and lose some of their force and vitality if "cribbed, cabined, and confined" by walls or buildings.

Obviously, therefore, our aerial should be hanging free in space, with room to breathe and unhampered by neighbours. All the aerial's length from the lead-in right up to the remotest insulator acts as input, and practically all the electro-magnetic

wave energy that enters the aerial enters it between these points.

### Low Resistance Essential

The aerial's output is not ether waves, like its input, but takes the form of high-frequency electric currents. The currents are exceedingly small, so that the first essential of an aerial is that it should be a good conductor of electricity. If a rope were to be suspended in space beside an aerial, at the same height, of the same length, etc., it would, by virtue of its mere length and position, intercept the ether waves. But its output

In order to minimise high-frequency losses this aerial is stayed right away from the roof, across which it has to pass.

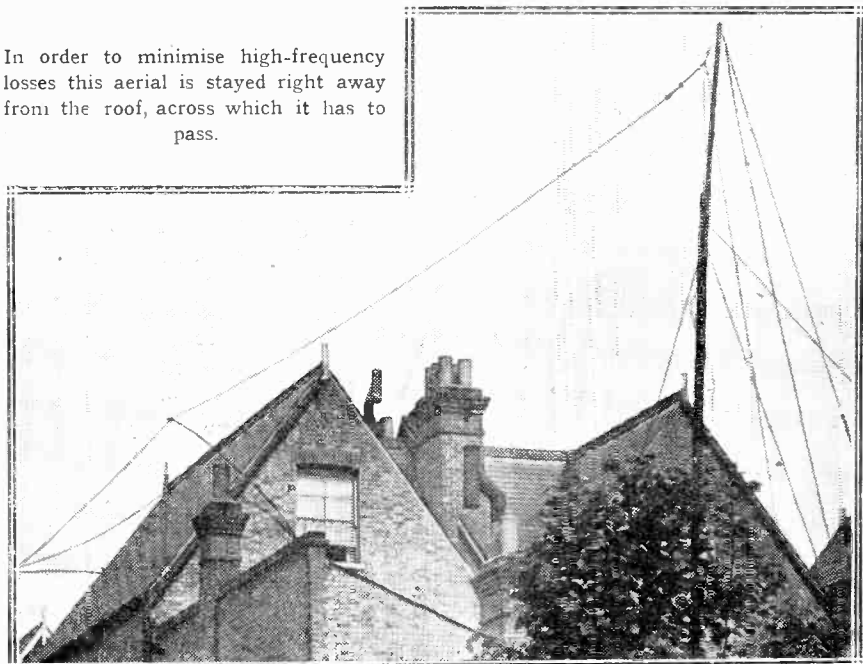

in high-frequency electricity would be nil, because rope is not a conductor of electricity. Owing to the minuteness of the currents the aerial *must* be a good conductor.

A further interesting point to note is that all aerial currents flow only *on the surface* of the wire. So great is the frequency of the current that it does not "sink in," as it were, but travels only on the surface, and therefore travels best on a large wide surface.

### The Wire To Use

It is for this reason that stranded aeri-als with their many surfaces are to be preferred to one single wire, and in order that this surface may be a uniform one, unaffected by changes in temperature, it is an advantage to use insulated stranded wire. Seven-strand No. 22 enamelled wire,

the aerial circuit comprises not only the aerial itself but the lead-in, the aerial coil inside, the set, the earth wire, the buried earth, and also the actual earth itself. There must be a really good contact between the sheet of metal, tin-can, small bath, or whatever it is that forms the buried earth, and the surrounding soil. This is especially true in the summer months. For this reason it is an advantage to bring the earth wire up through a tube, down which water can be poured in dry weather to ensure that the contact around the buried earth plate is really good.

It is a good plan to remember that the aerial and earth actually form a large condenser, the aerial wire being one plate and the earth the other plate. This huge natural condenser is placed across your aerial coil and all the energy in this great

get the maximum output from this point it is important that none of the wires attached to the aerial terminal should be brought close to wires attached to the earth terminal, or to the earth itself (remembering that "the earth" is not only the level ground outside, but walls, gutter-pipes, etc., which make good contact with the earth).

### Importance of Spacing

It is for this reason that the position of the aerial and of the lead-in is so important, for if the aerial runs within, say, an inch of the gutter-pipe, a certain amount of energy will pass across this small space and take a short cut to earth instead of passing through the aerial coil and so helping to work the set. The object in designing a good aerial system should be to induce every particle of current flowing in the aerial circuit to pass through the aerial coil, down the earth lead and to the earth. No short cuts en route, and no possibility of taking a direct cut over a dirty insulator, or across some narrow gap, to a piece of lead piping or other metal which is earthed should be allowed.

### Frequency and Load

One final point about low resistance in the aerial is worth emphasising. Aerial currents are not only necessarily minute, but they are of very high frequency. If the set is tuned to, say, 300 metres, the currents from a station transmitting on that wave-length will race from the aerial, down the lead-in, through the aerial coil, into the earth, back again up the lead-in, through the aerial coil again and back again into the aerial, performing this *double* journey exactly one million times per second! On lower wave-lengths they have to perform this journey much faster, and when one calculates the number of times a current will have to pass across a bad joint or a faulty connection, one can easily see how important it is to get good conductivity in the aerial!

Apart from having to overcome the resistance in the aerial, the high-frequency aerial currents have a certain amount of work to do. The output of the aerial coil is in the form of a definite load upon the energy of the aerial high-frequency currents. If the set is only a crystal set the aerial currents have to energise a tuned circuit with sufficient strength to produce a considerable voltage at the end of the coil. When the crystal

(Continued on page 566.)

### LONDON'S AERIAL VISITORS

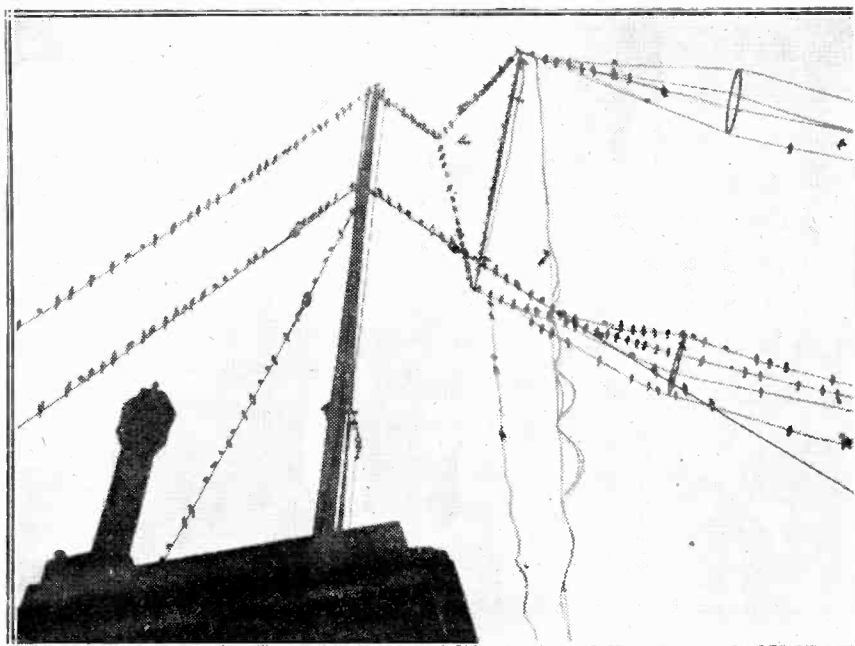

This unusual photograph of a flock of starlings settled upon aerial wires was taken at Marconi House, the London standby station.

whether of copper or phosphor-bronze, is almost ideal for an aerial.

An ordinary aerial wire with its ample surface offers very little resistance to the high-frequency currents flowing in the aerial; but nevertheless the average aerial has a fairly high resistance, much of this being concentrated at the joints in the aerial. It is for this reason that the joints of the lead-in and those on the aerial and earth terminals of the set are important, for if a dirty, rusty-looking film is allowed to form, there is a corresponding reduction in volume of the aerial current.

It must be remembered, too, that

natural condenser is continually rushing backwards and forwards through that coil.

### The Buried Earth

From the further aerial insulator to the aerial terminal is one plate of the condenser, and from the earth terminal of the set to the surface of the ground on which the mast stands is the other plate of the condenser; and the lead-in joint and aerial terminal are no more important for good reception than the earth terminal and the buried contact underground.

The *output* of the aerial is taken from the aerial coil. And in order to

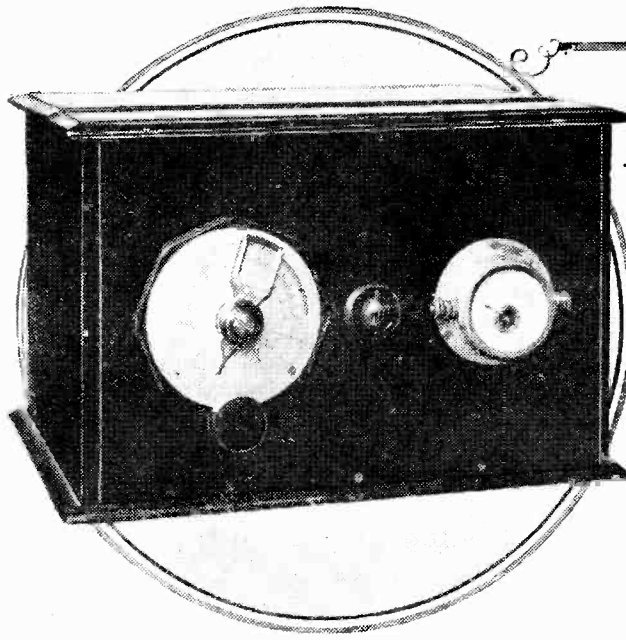

# A PILOT for the SHORT WAVES

*This is a simple wave-meter of the heterodyne variety which, inexpensive to construct, enables one to locate short-wave stations with a high degree of accuracy.*

By L. H. THOMAS (6 Q B)

I HAVE nearly always found that the first lament of the would-be short-wave enthusiast, when he gets his first set working, is that he "doesn't know where he is." This is perfectly excusable and understandable, for one's first dive into the

harder task before him, and it is chiefly to help him that the wave-meter described here has been thought-out and built.

To commence with, one can generally obtain a rough idea of the wavelength on which one is listening simply by consideration of the coil sizes and condenser values. On my own short-wave set, for instance, I know that however I alter the layout and the circuit, within reasonable limits, a nine-turn coil, 3 in. in diameter, with a .0001 variable condenser, will cover a range of approximately 36 metres to 60 metres.

### A Crude Method

It is obviously just too large for 2 X A F, the "W G Y" station working on 32.79 metres, so that one has only to make, say, an eight-turn or seven-turn coil and to search diligently at the appropriate time for a telephony station with an American accent, and one knows where 32.79 metres is to be found!

A pre-calibrated absorption wave-meter is an excellent guide, and is so simple to operate that the veriest novice could hardly fail to grasp the principles within a few moments. Unfortunately, however, the absorption wave-meter can only be calibrated directly from short-wave stations, and one is limited to, say,

Slight variations in the filament or H.T. voltage will not upset the calibration of this instrument, and the design eliminates troublesome hand-capacity effects.

five or six definite calibration points, from which a curve of doubtful accuracy may be drawn. A heterodyne wave-meter may be calibrated without drawing on the supply of short-wave stations at all, and these may afterwards be used to check the curve which has been obtained.

The method I always use is to calibrate the heterodyne wave-meter on the local station (2 L O in my case) and its harmonics, and surprisingly accurate it is. 2 L O's wave-length

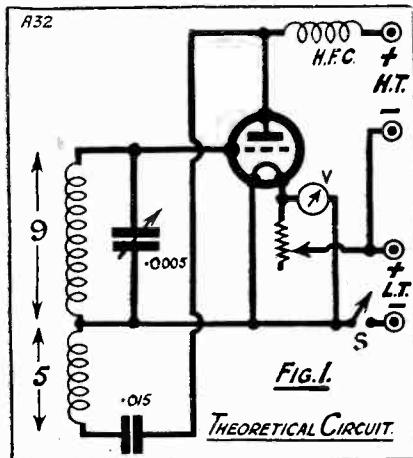

shorter wave-lengths is, it must be confessed, rather a novel experience, and one calculated to make the newcomer feel thoroughly at sea.

### "Finding" Stations

Fortunately there are many stations whose wave-lengths are fixed and well-known, and the fortunate reader who is able to copy Morse code at a good speed should have not the slightest difficulty in finding his whereabouts with the help of a list of some of these stations, such as is printed from time to time. The "telephony-only" man, however (and this probably refers to the majority now that short-wave work has become so universal), has a much

### YOU WILL NEED THESE COMPONENTS

- 1 Panel, 12 in. x 8 in. x 3/16 in. (Radion). (Any good branded material.)
- 1 Cabinet for same, with loose baseboard, 9 in. deep (Carrington). (Arterraft, Bond, Caxton, Makerimport, Pickett, Raymond, etc.)
- 1 .0005 S.L.F. low-loss type condenser, with D.I. type dial (Ormond). (Any good make.)
- 1 Valve holder (Benjamin, Bowyer-Lowe, B.T.H., Burndept, Burne-Jones, Igranic, Lotus, W.B., etc.).
- 1 H.F. choke (Cosmos). (Any good make. Burne-Jones, Bowyer-Lowe, Colvern, Lissen, R.I.-Varley, etc.)
- 1 Baseboard rheostat (Lissen, or similar type).
- 1 .015 fixed condenser (Dubilier). (Clarke, Lissen, Mullard, T.C.C., etc.)
- 1 On-off switch.
- 1 Four-terminal strip.
- 1 Filament voltmeter, reading 0-5, 0-6, or 0-10.
- Wood-screws, terminals, etc., and ebonite strip for coil-mounting, and one threaded ebonite former as described in text.
- Tinned-copper wire.

is always available in "World Radio" or the "Radio Times," and the wave-lengths of the harmonics may easily be calculated after which one has an almost unlimited supply of "stations" from which to calibrate the short-wave wave-meter.

**The Wave-Meter Circuit**

First, however, we must deal with the actual circuit and construction of the wave-meter, after which a few words on the calibration will be better appreciated. The circuit itself is shown in Fig. 1, and, as will at once be seen, it bears a decided resemblance to the "modified Reinartz" receiver circuit. No grid condenser or leak is used. The whole thing is, of course, simply a valve oscillator, or miniature transmitter, whose business it is to radiate feeble waves of any wave-length to which it is set, and, above all, to maintain its accuracy indefinitely. The latter property of constancy of calibration depends as much upon the layout of

It will be noticed that the coil comprises two sections, a grid winding and another for producing reaction. It is most important, if the instrument is to be even moderately accurate, that these two sections should be incorporated in one coil with a tapping at some appropriate point. If one attempts to use two coils with variable coupling the slightest variation of this, accidental or intentional, will upset the whole of the calibration at once. Fixed coupling is, therefore, one essential.

**Important Features**

Other points about the circuit that played their part when its suitability was considered were these:

1. Slight variations in filament voltage do not vary the wave-length to a great enough extent to upset the calibration noticeably.
2. The same applies to the high-tension voltage, which can apparently be varied over as great a range as

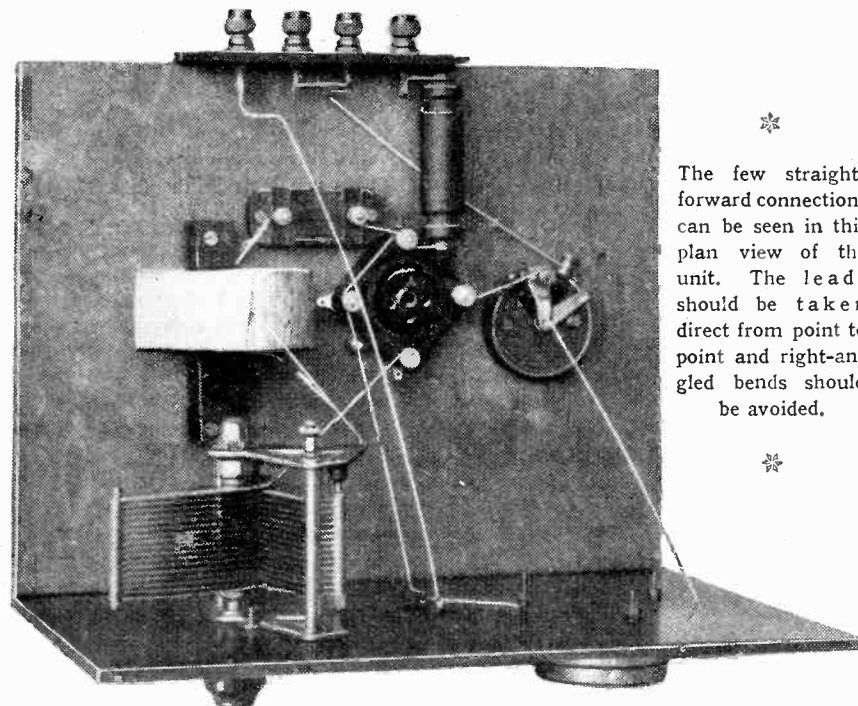

\* The few straight-forward connections can be seen in this plan view of the unit. The leads should be taken direct from point to point and right-angled bends should be avoided.

components and their wiring as on anything else, but there are several factors which come into play.

The wave-meter must, of course, be calibrated with an individual valve, which must always be used thereafter. If one has the misfortune to burn out the favoured valve there is more than a chance that the whole wave-meter will need re-calibration, although another valve of the same type may give identical readings throughout if one is lucky. The best plan is to choose a spare valve and to calibrate with it as well.

30-55 volts without any audible change in the beat-note of the wave-meter taking place.

3. The moving plates of the variable condenser are connected to the L.T., a point at zero high-frequency potential, and hand-capacity effects are, therefore, not present to give trouble in taking readings.

**Reducing Cost**

Points 1 and 2 are rather more important than is realised at first glance, for if one were to employ a circuit the constants of which changed

seriously with every little variation in H.T. and L.T. voltage two precision meters (one for H.T. and the other for L.T.) would at once have to be incorporated in the wave-meter, and each of these costs considerably more than twice as much as the whole instrument does as it stands! The only meter that has been put into use is a cheap filament voltmeter, and if the filament voltage is kept within .25 volt of what it should be there is no trouble from "shifting calibration."

American radio amateurs are asking the Federal radio commission to reserve for them a 10-metre wave-length for experimental transmission and reception.

\* \* \*

One of the largest liners, S.S. Olympic, works on a wave-length of 20 metres, under the call sign G L S Q.

The coil is probably the most important item, and the one used in the wave-meter seen in the photograph was made up as follows:

A threaded ebonite former, 3 in. in diameter and about 1½ in. in length, was first obtained. This is threaded to take about twenty turns of No. 20 wire, and may be obtained from Burne-Jones & Co. Alternatively, a suitable length of threaded ebonite former may be cut off from a whole former such as can be procured almost anywhere. Fourteen turns of No. 20 D.S.C. wire were wound on as tightly as possible, the ends being brought cut through small holes drilled in the former and held securely in place by means of two spots of Chatterton's compound.

**Layout and Wiring**

The sixth turn up was then bared for about ¼ in. (care being taken, of course, not to damage the insulation of adjacent turns) and a short length of tinned copper wire soldered to it. The sixth turn, to avoid errors, is that which leaves five intact turns on the anode side of the tap and eight intact turns on the grid side. The whole coil was now thoroughly wrapped up in Empire tape, with just the two ends and the tap protruding. Some method of remembering which is to be the grid and which the anode end may, of course, be devised, but the Empire tape may actually be marked "A" at one end and "G" the other.

The laying-out and wiring-up of the components may now be carried out, and as the layout shown in the photographs is probably that which requires a minimum amount of wire, the reader might be well advised to copy it.

One point that should not be lost sight of in the wiring is this: That the straight line is the shortest distance between two points, and that if we make all our wires assume this form, no amount of knocking about will be able to shift their positions! This seems obvious when it is pointed out, but there are apparently many who do not realise that pretty right-angled corners and fancy joints are out of place in such a piece of apparatus as a wave-meter, where they do far more harm than good.

### Mounting the Coil

A rheostat is, of course, necessary, in order to adjust the filament voltage to the correct figure, but it is undesirable to have this mounted on the panel. A "baseboard-mounting" type has, therefore, been used, a simple on-off switch being provided on the panel. The filament voltmeter mounted on the panel is, of course, connected directly across the filament terminals of the valve-holder.

The method of mounting the coil is simply to hold the former down to the baseboard by means of a strip of ebonite with a screw through each end. This mounting would not be considered "low-loss" in a short-wave receiver, but there is no harm whatever in using it here, and it does give a firm stand to the coil.

The variable condenser used has all the extremities or "points" of the moving plates bolted together, and this is another desirable feature, for it obviates errors which might be caused by one or more of the moving plates being bent out of shape.

### Calibration

The dial was also considered especially suitable for the purpose, and is one on which very fine readings can be obtained.

So much for the construction of the wave-meter. The most important business is the calibration. I will start by imagining that the local

One easily-overlooked snag in short-wave working is the use of metal panel brackets. If these are placed too near the coils or grid wiring the set may lose considerably in sensitivity and efficiency.

station is 2 L.O. Now, assuming that the same size of condenser and a similar coil have been employed for the reader's wave-meter, it will be safe to assume that the correct reading for 90 metres is in the region of 135 degrees on the scale.

Connect up the H.T. and L.T. to the wave-meter, insert a valve (I used an old D.E.R. type), using about 40 volts of H.T., and tune the wave-meter to about 135 degrees on the scale. Now listen round on the short-wave receiver with about a fifteen-turn coil as A.T.I. The set should be oscillating and the "chirp"

Now tune carefully to the "silent point," treating the harmonic as if it were an ordinary telephony station, but with the receiver oscillating still as it is tuned in, and leave the receiver set there. The wave-meter dial must now be rotated slowly until its beat-note (which should be considerably stronger than 2 L.O's

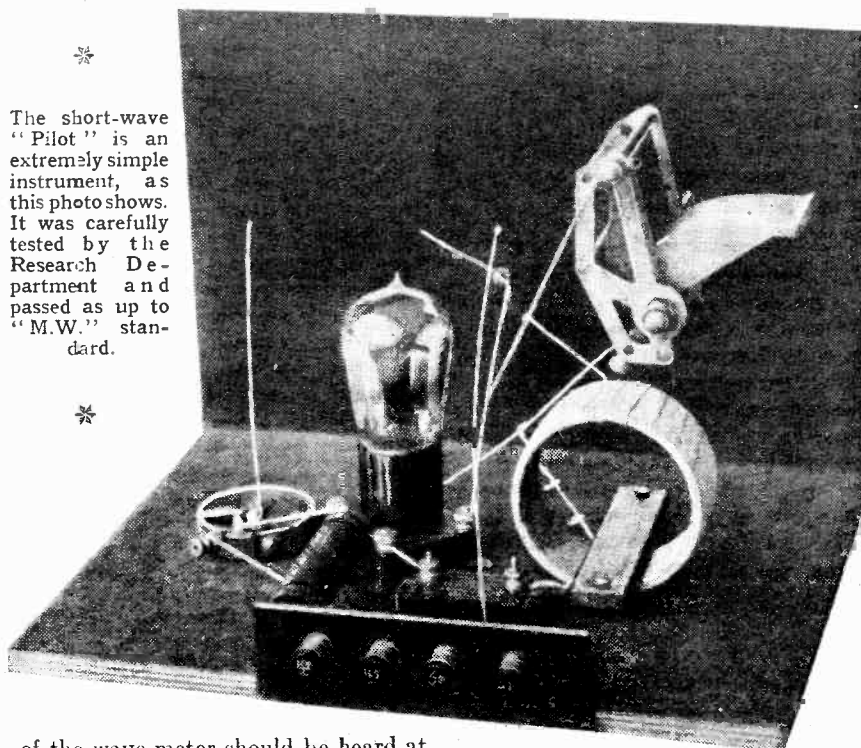

The short-wave "Pilot" is an extremely simple instrument, as this photo shows. It was carefully tested by the Research Department and passed as up to "M.W." standard.

of the wave-meter should be heard at some point on the dial of the receiver. If it is not, rotate the wave-meter dial until its "carrier-wave" is found, as a means of proving that it is oscillating. If the wave-meter does not oscillate, try another valve or a higher H.T. value. When this has been done, try varying the numbers of turns in the receiver coils until the "carrier-wave" with the wave-meter dial set at 135 degrees has been found. Remember that this will not give you exactly 90 metres, but only a very rough approximation. Having found the point, listen round on the short-wave receiver, with aerial and earth connected, very carefully, and if 2 L.O is transmitting at the time, a harmonic of the transmission should be found without difficulty.

### The First Reading

This applies up to distances of thirty miles from 2 L.O, at which distance I can always hear his 90-metre harmonic with a two-valver. 2 L.O's present wave-length being 361.5 metres, the exact wave-length of this harmonic will be 90.375 metres, which may be taken for our purpose as 90.4

harmonic) is heard to come across the weak transmission to which you are tuned in. Tune this also to the "silent point," and carefully note the reading, which will correspond to a wave-length of 90.4 metres.

### Further Settings

Now leave the receiver exactly as it is, but carefully turn the wave-meter dial downwards until a setting of about 36 degrees is reached. At this point the wave-meter is tuned to approximately 45 metres, and the dial should be carefully "searched" until another beat-note, exactly similar to the first but rather weaker, is heard in the receiver. Adjust the wave-meter until this is also tuned to the silent point, and there you will have the reading for 45.2 metres on the wave-meter. What is happening now is that the receiver is tuned to 90.1 metres, while its second harmonic at 45.2 metres, is producing a beat-note with the wave-meter.

All this sounds very complicated, but is really quite simple; and after one or two trials with the wave-meter and receiver you will feel quite competent to tackle the final

calibration. So far, however, it only applies to those to whom 2 L O is the local station. All that the others have to do is to calculate the exact wave-length of the fourth harmonic of their local station (simply taking a quarter of its wave-length) and repeat the foregoing procedure, after making the necessary alterations in the figures. The actual wave-meter described had a minimum wave-length of about 37 metres and a maximum of about 125 metres. Thus, if you want a very rough setting for, say, 100 metres, you will know that it is somewhere in the region of 140 or 145 degrees on the dial.

**An Alternative**

If you cannot find any harmonics of the local station on the short-wave receiver, a simple method of "bringing them up" is to rig up a crystal set on an indoor aerial, tune it carefully to the local station, and then place it somewhere fairly near the short-waver. You will then have no difficulty at all in finding the harmonics. As an alternative, you can tune in the local station during an interval, rotate the wave-meter dial,

90 metres (in the case of 2 L O), and 50 and 100 metres in the case of those whose "local" has a wave-length of 400 metres, and so on, you will know roughly where you are with the short-wave receiver, and be able to finish off the calibration.

**A Reliable Station**

Set the wave-meter to the 45.2-metre reading, change the coils in the short-wave set, and search round until the transmission from the wave-meter is found. It has, of course, already been heard on 90.2 metres, but on 45.2 metres it will be very much stronger.

You will now know where 45.2 metres is on your short-wave set, and if you listen just above this, at any time of the evening, you will hear a powerful station sending automatic Morse, with a very distinctive note sounding like spark, but very sharply tuned. This is S U C, the high-power station at Cairo, and you cannot fail to hear it. At the time of writing, his wave-length is 47.3 metres, and has been so for some months, so that he should make quite a reliable calibration point.

**Easily Completed**

It is now left more or less to the enterprise of the reader to finish off the calibration. One useful method is as follows: You know now where 45.2 metres is. Leave the wave-meter set to this reading, substitute smaller coils in the receiver, and search for half this wave-length—22.6 metres—at which another "chirp" from the wave-meter will be heard. You are now listening to the second harmonic from the wave-meter, and the receiver is tuned to 22.6 metres. Leave the receiver exactly as it is, and rotate the wave-meter dial upwards until yet another "chirp" of about the same intensity is heard. The wave-meter will now be tuned in to 67.8 metres, and you will be listening to its third harmonic on 22.6 metres.

**Wide Range Possible**

You will be able to obtain some half-dozen calibration points on the wave-meter by this method, and a curve may then be drawn roughly. It can be finished off at any time by watching for well-known transmissions of fixed wave-length (and you will now be better qualified to do this, since you will know roughly where to look for them in the first place) and filling in their places on the curve.

The writer takes the useful range

of his wave-meter to be confined between roughly 36 and 135 degrees—45 and 90 metres—and ignores any readings coming outside these limits, for two reasons: the centre portion of the variable condenser and the centre portion of the curve drawn are both likely to be the most accurate portions, and also there is no need to go outside this range, since harmonics can be used. If the fundamental wave-length of the wave-meter can be varied between 45 and 90 metres,

**TWO SHORT-WAVERS.**

The short-wave call-sign of H.M.S. Renown is D S. The wave-length is 36 metres.

The Radio-Vitus (Paris) station now broadcasts on 37 metres on Wednesdays, Fridays and Sundays, from 9 to 10.45 p.m.

then its second harmonic will give a range of 22.5—45 metres—and its third harmonic from 15 to 30 metres, and so on.

By the initial tests you will find out roughly "where you are" on the receiver, and thereafter you will be able to set it roughly to the wave-length of any station wanted and to find the exact reading by the wave-meter. If it is used in this way it is impossible to become confused between its different harmonics.

Three stations that are very useful indeed for checking the calibration are: 2 X A D (telephony) 21.96 metres, 2 X A F (telephony) 32.79 metres, and W I Z (C.W.) 43.15 metres.

**Ready Reckoning**

Incidentally, when the curve has been drawn and finished, the following method may be adopted for measuring the very short waves, especially if one is at sea in the receiver. Simply switch on the wave-meter, rotate the dial until two different "chirps" are found, and take the difference between the readings, which will give you the actual wave on which you are listening. For instance, if you find one beat note on 42 metres and another on 63 metres, it is obvious that you are listening on 21 metres, one of these being the second harmonic and the other the third harmonic of the wave-meter.

It is hoped that this outline of the general method of calibration will prove useful, but no doubt readers will be able to suggest improvements and simplifications to suit their own circumstances.



Here is illustrated the B.B.C.'s ingenious method of broadcasting the sounds of running at athletic meetings. The microphone, which is at the side of the running track, is buried in a pile of gravel.

and note the various points at which "chirps" are heard, which will correspond to the harmonics.

Once you have found these two points, however, at roughly 45 and



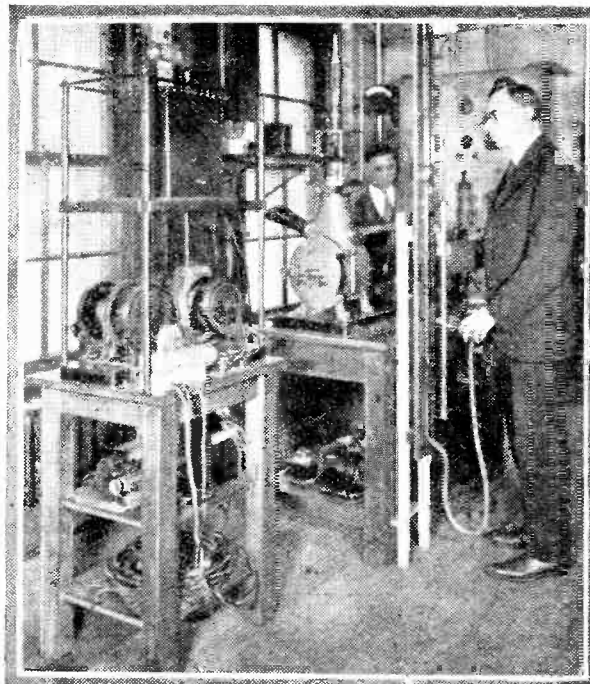

# The MICROSCOPE of RADIATION

*With a remarkable device actual records of electrical waves of very high-frequency can be taken. These are reproduced without appreciable distortion.*

*From a  
Special Correspondent.*

AMERICA, which so often claims to be the leader in scientific research, investigation, and invention, is at last making concessions to the genius of Europe. A striking tribute to the Dufour Cathode-Ray Oscillograph, as a result of what is probably its first application to a really big task, is just to hand.

It was no less than an attempt to record without appreciable distortion electrical waves of frequency one million cycles or higher. This was obviously outside the range of electromagnetic oscillographs, whose limit is about ten thousand cycles a second. America appeared to possess nothing that would make such a study possible.

Even the well-known cathode-ray oscillograph of the Western Electric Company was ruled out as unequal to the task, because it makes no record of a single non-recurring wave. So the American engineers were compelled to fall back upon the instrument which Alexandre Dufour, the celebrated French scientist, created after laborious years of study.

## A Photographic Record

This oscillograph is one of the comparative recent progeny of the classical Braun tube. Dufour first conceived it in 1914, but his researches were interrupted, first, by the world-war and, secondly, by lack of funds, so that it was not until just over five years ago—in 1922—that he was able to produce a machine free enough from troubles to be of general use.

Its outstanding feature is the placing of a photographic film inside the vacuum chamber, so that the cathode stream may impinge directly on the sensitive surface and record its trace photographically with a single traversal.

The oscillograph proper begins with a glass tube holding an aluminium disc cathode and a pierced anode. This tube is fitted by a ground joint to a glass deflection tube, which is in turn fitted into a large bronze chamber that contains the photographic film-holder and a fluorescent viewing screen.

## Six Films Accommodated

The bronze chamber has a carefully fitted door which may be opened to remove the film container, and also a pair of windows through which the viewing screen may be observed. The door has three handles fitted through it that are used for operating the film changer, and for moving aside the viewing screen which also serves as the cover of the film container.

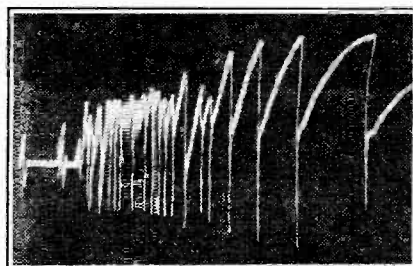

Voltage across a contact in series with the winding of an E-type relay. After the contact opens, twenty-three oscillations take place in about 450 micro-seconds.

The joints between these various parts must be kept sufficiently airtight to hold a pressure of 10 microns—the normal working pressure—for a considerable period, since the pressure is very critical.

Six films about 5 in. square may be placed in the film container and exposed successively. After the container is placed in position, the air must be pumped from the interior of the oscillograph to allow the cathode ray to pass. The Holweck molecular pump, backed by an oil-immersed impellor pump, will produce a sufficient vacuum in about twelve minutes.

## The Electron Stream

The ray consists of a stream of electrons drawn from the cathode by a potential of 50,000 to 60,000 volts. Some of the electrons, moving at 80,000 miles a second, pass in a fine stream through a small hole in the anode and down through the deflecting tube.

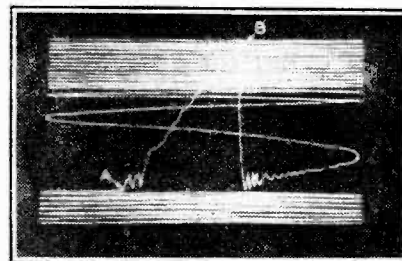

This trace was secured by a second technique. A 500-kilocycle timing wave is swept across the film. At the instant A, a surge was applied to one pair of plates, sweeping the trace up to B. Almost instantly the voltage fell back nearly to zero. An ingenious circuit arrangement then displaced the timing oscillations to leave a clear space on the film.

There the stream is swerved by the electric field between one or more pairs of metal plates, or by the magnetic fields of external coils, or both. Passing on down into the lower chamber, the stream generates its trace by impinging upon either a film or a fluorescent screen. A good trace may be obtained when the

electron stream sweeps across the film as rapidly as 100 miles a second.

Many different techniques have been developed for using this instrument, each particularly suited to some special investigation. The simplest one is that used for a transient wave slow enough to be shown clearly on a rectilinear time scale of the order of 5 micro-seconds per centimetre.

This requires that the cathode stream be given a straight motion or sweep across the film at the rate of about one mile per second. It also requires that the transient be precipitated shortly after the stream strikes the film. In the American tests this was accomplished by a synchronous switching device built in the Bell Telephone Laboratories.

### Synchronous Switching

A synchronous motor drives a switch which applies to the primary of a transformer a single half-wave of 60-cycle alternating current. The transformer has a ratio of 110-60,000; its secondary is connected to the cathode and anode. To the same 60-cycle source is connected a coil which, placed near the deflecting tube, will sweep the stream across the film in any desired time; practical limits are 50 to 500 micro-seconds. An adjustable contact-disc on the

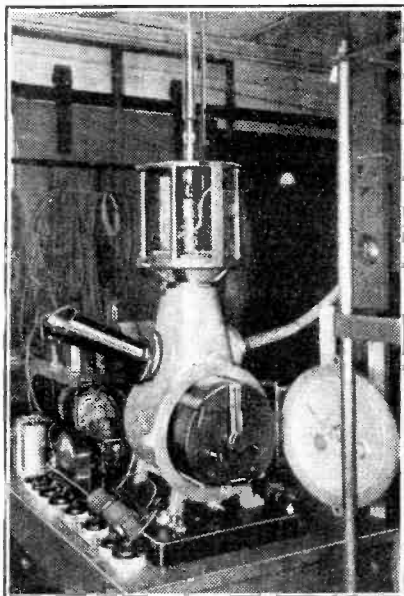

The Dufour Oscillograph with the film container partly withdrawn. Above can be seen the cathode tube, and, inside the housing, the deflection tube.

shaft of the synchronous motor precipitates the transient just as the stream is swept across the film.

For those transients which pass too quickly to be recorded as de-

scribed, the line of traversal is made, not a single straight line across the screen, but a sinusoidal trace. The transient under investigation is then applied in a direction parallel to the axis of the timing wave, so that its zero line is the trace of the timing wave.

Such a record appears rather involved to one accustomed to the usual oscillograms with rectilinear axes, but it may readily be re-plotted to the more familiar coordinates. The timing wave commonly used in the Bell Telephone Laboratory tests has a frequency of 500 kilocycles; a half-cycle, then, is just one micro-second.

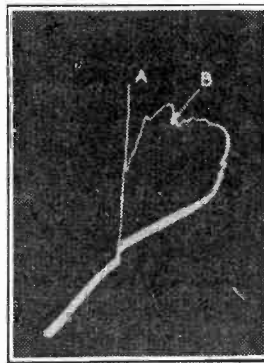

Voltage across a gap (vertically) and current (horizontally). The peak "A" was reached in 0.07 micro-seconds and "B" less than a micro-second later. Rest of patch traversed more slowly.

In a study of the performance of safety gaps the object was to obtain a curve showing the current through a protector plotted against the voltage across the gap. The starting-point of such a curve was located in one corner of the film by the effect of a constant magnetic field.

From this point the stream was swerved in one direction by a coil in series with the current, and in the perpendicular direction by the voltage across the gap applied to a pair of deflector plates. The resultant trace was a closed loop. Time was measured by applying a small "ripple" of 500-kilocycle current to the other pair of plates.

### Has Many Uses

Another technique was used to determine the form of a transient shorter than one micro-second.

As a result of their use of the instrument the American engineers are now loud in its praise. Mr. E. Cole, of the Bell apparatus development department, goes so far as to declare it unrivalled for any study of protective devices when they are subjected to transient electric waves such as might occur on telephone lines during electrical storms. The uses to which the Dufour Oscillograph can be put are many. So versatile and sensitive is it that, in Mr. Cole's

words, it may well be described as the microscope of the electrical sciences.

## USING METERS

IF you would track down and eliminate every possible cause of distortion in your three-, four- or five-valver, you should use at least half a dozen meters, or, shall I say, meters in half a dozen places. You must search for grid current—the bane of a real radio engineer's existence. To merely mention the term in the presence of a group of B.B.C. engineers would be like shouting "fire!" very loudly outside a fire station. To detect grid current, a microammeter in every grid circuit is necessary. A milliammeter must be applied to the anode circuits of all the L.F. valves in order to trace overloading. And the super-enthusiast will not be satisfied until he has a practically stationary needle in each case.

### Voltmeters That Are Essential

Unless you are prepared to go to such lengths, it is well worth asking yourself whether you are going to worry about meters at all. But in this indictment we are not referring to voltmeters used for testing the L.T. and H.T. These are indeed almost essential. Do not get in the way of judging your accumulator as being run down when it fails to "work" the valves. With the present-day dull-emitter this point may indicate a dangerously low level. A 6-volt accumulator should not be allowed to run down below 5.4 volts if it is to have a usefully long life.

### Tracking Overloading

Many so-called 6-volt dull-emitter valves will work quite well at 5 volts, so that the danger of relying upon such an indication of battery condition is apparent.

But if you feel impelled to use a milliammeter do not stick this in the H.T. negative lead and leave it at that. In the main negative H.T. lead you will be able to watch the anode consumption of all the valves together, but kicks of the milliammeter needle may mean the overloading of any one of the L.F. valves, or cumulative overloading of any number of them. You should place the milliammeter in the anode circuit of each of the L.F. valves separately, making all the usual adjustments and getting the needle stable in each case.

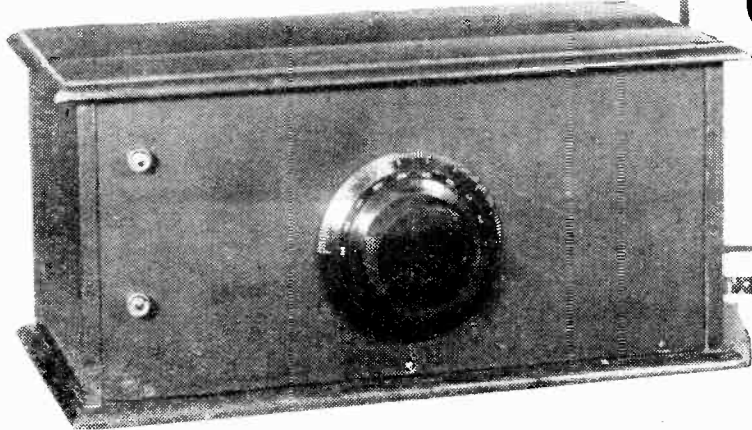

# CONSTANT REACTION CONTROL

A RECEIVER of the nature of the 1928 "Solodyne" makes such good use of high-frequency amplification that detector circuit regenerative effects are almost unnecessary. When, however, we come to the more simple types of set, such as the very popular detector-2 L.F. arrangement or a simple det.-L.F., where there are no modern and efficient stages of H.F. amplification, reaction makes all the difference between the reception of only one or two stations and the tuning-in of a fair number.

And for the reason that reaction is such a vital contribution to sensitivity in the case of the less ambitious kind of receiver, we can take it for granted that it will be with us until, if such ever happens, some entirely new scheme of reception is originated. But, unfortunately, reaction as we know it is a frisky factor in an otherwise perfectly docile equipment. It entails a delicate control and one which necessitates a fairly skilful hand for its entirely successful manipulation.

### That "Instable" Reaction

A three-valve set of the kind I have referred to can become a howling menace to the ether in unskilled hands. The trouble is that reaction, when applied in a straightforward manner, has not a constant effect over the whole tuning range of the receiver. A readjustment is necessary for each station. If the reaction adjustment could be "set" similarly to the filament resistance or H.T. voltage tapings, and the receiver's sensitivity retained at an optimum degree throughout the whole range of tuning, the average det.-2 L.F. and other such sets would immediately become "one-knob" control receivers in the full meaning of the term.

*As the majority of readers will know, one has to operate fairly close to the "edge of reaction" to bring in nine stations on a one-valve set. But the author accomplished this with the set shown above although this has a true "one knob" control. In the following article he describes the series of interesting experiments which led up to the circuit used and others of considerable interest.*

**By G. V. DOWDING, Grad.I.E.E.**  
(Technical Editor).

will no doubt remember the ingenious solution to the problem brought forward by Messrs. Loftin and White.

### An Ingenious Scheme

The latest contribution to radio science in this direction is a very novel scheme, due to Mr. Percy W. Harris. In effect, Mr. Harris takes two well-known principles which work in "opposite" directions, and brings them together in order to obtain a kind of electrical equilibrium. The two effects referred to are ordinary reaction control and resistance-capacity high-frequency amplifier coupling. In the "Harris Circuit" there is an H.F. stage in which is incorporated the so-called Reinartz reaction control. This H.F. stage is coupled to a detector circuit by means of the R.C.C. method. A comparatively small feed-back from the detector circuit to the H.F. valve is arranged. The reaction effect in the H.F. stage decreases as the wave-length tuning increases, but with the increase in wave-length there is

No skill then would be needed to bring in all the stations within the capabilities of the set and there would be a minimum of oscillation to interrupt the nightly programmes. The search for constant reaction has gained the attention of a very large number of technicians for some years past, and MODERN WIRELESS readers

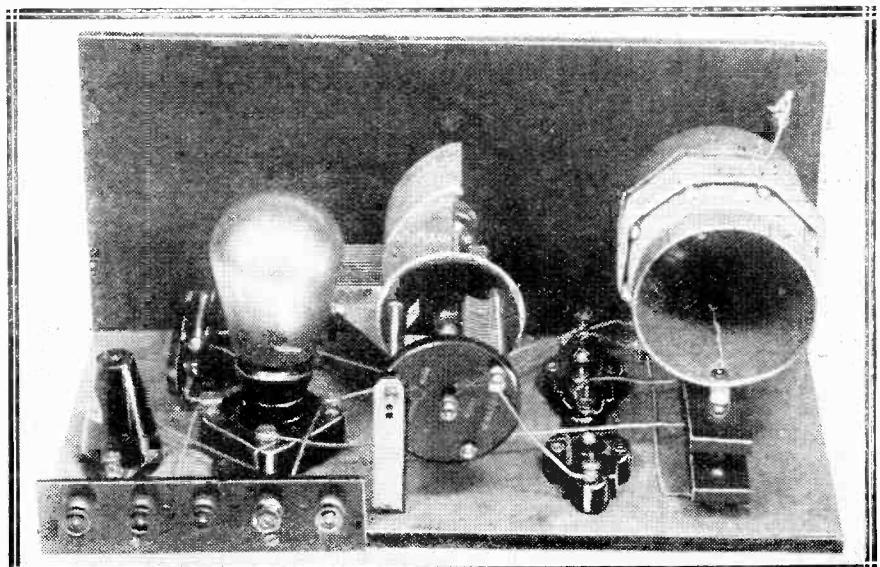

This is the arrangement which introduced a small ganged variable condenser. Although good results were achieved the author did not consider the scheme a particularly practical one.

greater comparative H.F. amplification through the R.C.C. coupling, and a correspondingly greater feed-back via the small capacitive coupling.

In this way a remarkable degree of constancy is preserved, and with skilful initial adjustments of the various components concerned, one

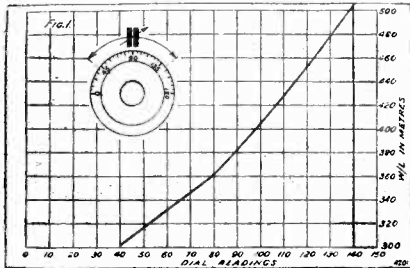

is able to work right on the edge of oscillation throughout the range of the tuning dial with reference to only the one tuning control. For some time I have myself been tentatively experimenting in the intriguing direction of constant reaction. I have not concerned myself so much with the evolution of any particular kind of circuit as to the making uniform of regenerative effects in an ordinary type of receiver. I will leave my readers to judge the value of my researches, and trust they will at least find an account of them of some interest.

**Useful Data Collected**

Actually my investigations occupied much more time than the length of this article might indicate. I pursued several apparently fruitless lines of investigation more or less to the bitter end, owing to the fact that I found that in many such cases I was garnering data which would be useful for other purposes. Much of this, however, I am eliminating for the time being in order to avoid an accusation of irrelevancy.

I happened to have a one-valve receiver on hand in my laboratory. This incorporated the Reinartz

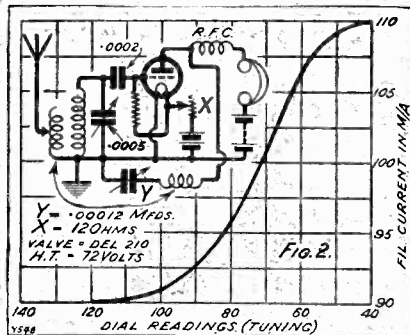

method of reaction control, and seemed to form a useful starting-point for the work. My first step was to connect it up to the aerial and to

calibrate its single tuning dial. The result of this will be seen in Fig. 1. There are two points worth noting.

In the first place, I confined myself to a wave-band of 300 to 500 metres, this being more or less symmetrically placed on the dial. I reasoned that this would facilitate the tabulating of results, and was sufficiently wide an area to commence with. The second point is that the calibration revealed that the set gave practically straight-line wave-length tuning. Some of my readers might reason, and perhaps correctly, that I would have done better to have confined myself to frequency calibration, but of this, more anon.

**The Problem**

There are several things which will effect the regeneration effects of such a receiver, the circuit of this is shown in Fig. 2. If with the aerial tuning condenser turned to any one reading, the reaction condenser Y is adjusted until the set is oscillating, it is a

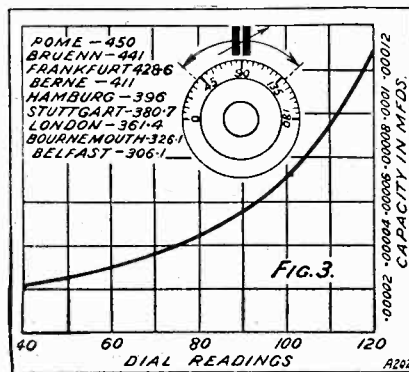

simple matter to cause a cessation of regeneration. One could connect up a much larger aerial, reduce the H.T., reduce the L.T., connect a resistance across the aerial tuning circuit, and so on, but the problem is to so arrange that the set is just on the oscillation point throughout the whole range of movement of the tuning dial, thus keeping the set in its most sensitive condition for reception of any of the stations which come within its tuning range.

**Filament Current Variation**

For some time I ignored the conventional reaction control, the variable condenser Y. I adjusted this at a "set" value which would allow the receiver to oscillate throughout the whole range of the tuning dial movement. I then turned my attention to the filament current supply as being a tractable sort of factor. I found that I could keep the receiver on the edge of oscillation between

300 and 500 metres by varying the filament current between 90 and 110 milliamperes. I did this with the filament resistance already in the set.

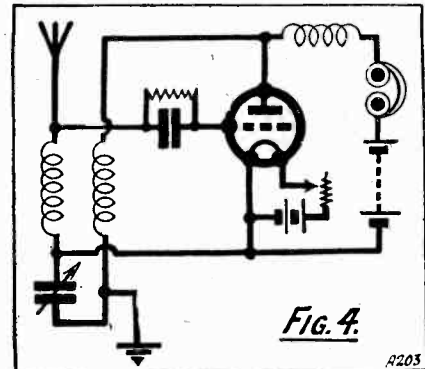

My idea at the moment was that it might be possible to gang a simple secondary filament control with the tuning variable condenser, and reproduce in this way the interesting curve obtained by the ordinary rheostat and which is shown in Fig. 2.

But you will see that it flattens out hopelessly at the bottom and curls suggestively at the top. Similar curve forms were obtained when I varied the conditions, but there appeared to be a suggestive inconstancy in the control, and I could see I would have to turn my attention to other things if I desired to achieved constancy of reaction. A whole range of experiments were then tried, which are, however, only of minor interest. Variable grid condensers, variable grid leaks, a potentiometer control of the grid, a variable damping device across the tuning circuit and across the reaction coil, all gave very intriguing but moderately crude results.

**Calibrating a Condenser**

Eventually I turned my attention to the reaction condenser Y. This was capable of capacity variations of approximately .000018 to .00017 mfd.

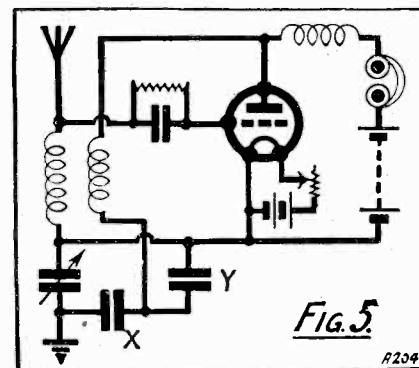

By the way, its rated maximum was .0002 mfd.! I took the capacity curve of this component throughout the range of movement necessary to

keep the receiver in its maximum state of sensitivity between that arbitrary 300 to 500 metres. You will see in Fig. 3, as would be expected, that as the wave-length was increased, more and more reaction condenser capacity had to be brought in. You will also see that if I could have coupled to the variable tuning condenser another condenser which would provide the capacity increase corresponding with the curve in Fig. 3, from about .00002 mfd. to .00012 mfd., then successful constant reaction would ensue. Let me here interpolate that I found that a practically similar form of curve resulted with an entirely new set of conditions. For instance, with an entirely different one-valve receiver I could, by adjusting the coil coupling, obtain a similar curve to that shown in Fig. 3.

**An Interesting Circuit**

That is the problem in a nutshell. Simultaneously with the rotation of the tuning condenser, one needs to increase the capacity of the "feed-

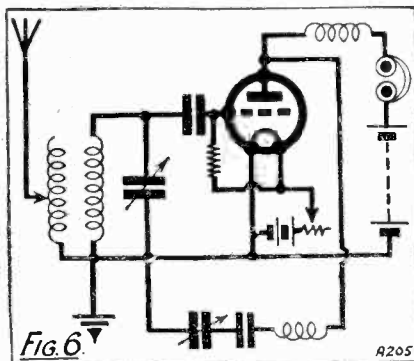

back" or reaction condenser, in a definite manner in order to keep the set in its most sensitive condition. An interesting attempt to do this is illustrated in Fig. 4. Here the tuning condenser is made to operate also as the reaction condenser. But this would be an impossible task in the usual way, for supposing it could be a .0005 mfd. variable, obviously .0005 mfd. would be far too great a capacity for a maximum reaction setting against practically zero for minimum.

**Juggling With Capacities**

By introducing another condenser, X in Fig. 5, the effective capacity in the anode reaction coil feed-back circuit can be reduced to a figure depending upon the value of the added condenser. The minimum also can be brought up to any desired figure by the addition of yet another condenser, shown as Y, but for several reasons the circuit is not a practical

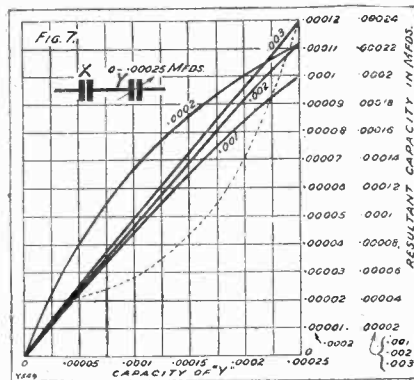

one. To mention only one, it would be difficult to make the capacity curve follow the desired form for both tuning and reaction purposes.

But this business of bringing in additional condensers gave me an idea. I decided to "gang" a reaction condenser with the tuning condenser. I did not use the original reaction condenser, but took another having a maximum of exactly .00025 mfd. For practical purposes I have shown this as having a zero minimum capacity, for its actual minimum value and also the capacity of any of its associated connecting leads, and so on, can be neglected for the time being.

**Effect of Series Condenser**

Now, having fixed this small variable condenser to the tuning condenser, you will see that when this latter was rotated from zero to maximum, the reaction condenser correspondingly brought in a capacity varying from a minimum to .00025 mfd. (plus a small additional capacity

due to leads, and so on). You will see that in the circuit, Fig. 2, I have shown that it is necessary to have a reaction condenser variation from .00002 to .00012 mfd. in order to maintain a constant reaction effect between 40 and 120 on the tuning condenser dial. These were the arbitrary limits I set myself for the time being. Further, you will note that it is not a straight-line capacity variation that is required, but a curve corresponding to Fig. 3.

Now, it is very easy to reduce the maximum capacity of this reaction condenser to .00012 by connecting in series with it a fixed condenser of a certain value. I need hardly point out that when two condensers are in series, the resultant capacity is something less than that of the smaller condenser. The exact rule is that the reciprocal of the two values added together equals the reciprocal of the resultant value.

**The Next Step**

Therefore, my next step was to see exactly what effect this adjustment of the maximum value had on the capacity curve of the condenser. This small condenser, you must understand, had straight-line capacity vanes—that is to say, the capacity increased directly in proportion with the movement of its dial. Ignoring the fact that the capacity variation shown in Fig. 3 was desired only between the 40 and 120 movement of the main dial, let us see how we can obtain a .00002 to .00012 mfd. reaction condenser capacity adjustment for the whole revolution.

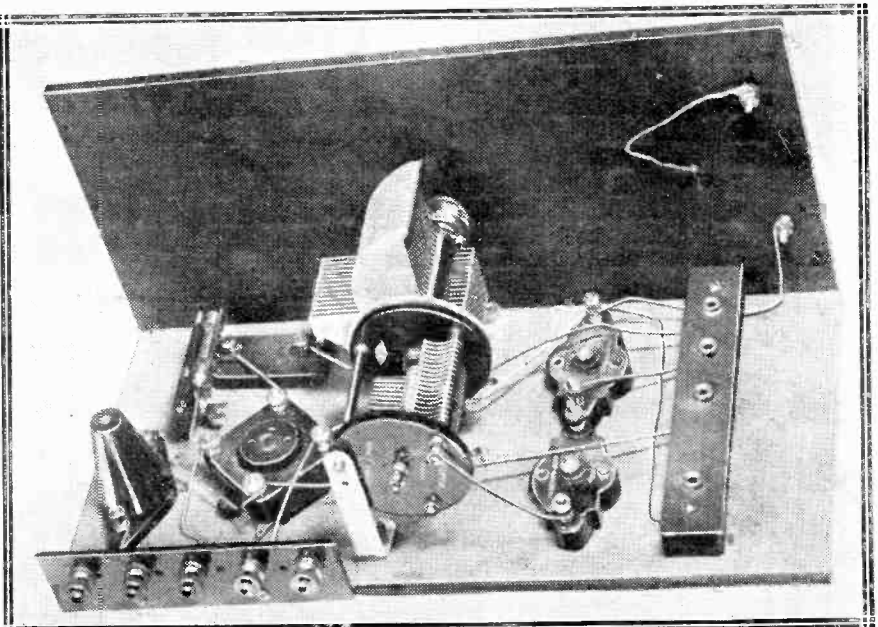

Another view of the one-valve receiver employing the circuit shown in Fig. 2. The two small compression type variable condensers are connected to the ganged reaction condenser, the one in series and the other in parallel, in order to regulate the capacity ranges.

With a fixed condenser of .0002 mfd. (X in Fig. 7), in series with the reaction condenser, the maximum capacity is reduced to .00011 mfd. This drops to an arbitrary zero in a form of the curve shown in Fig. 7. But this curve bends in exactly the opposite way to that of the curve we desire. This latter is shown in a dotted line. Increasing the capacity of the series condenser X increases the maximum resultant capacity and also straightens the curve.

### Paralleled Capacity

With a .001 mfd. the maximum goes up to .0002 mfd., the curve being much straighter, and with a .003 mfd. the maximum is .00024 mfd. and the curve practically straight. But, quite apart from this question of the form of the curve, it is obvious that we are unable to arrange both the minimum and maximum capacities in accordance with our requirements by means of only one additional condenser. By using two, as shown in Fig. 8, one in series in order to regulate the maximum resultant capacity, and another in parallel to regulate the minimum, we can very easily fix our limits.

You will see that whatever the resultant capacity of the variable condenser and the fixed condenser X in series with it, the capacity of the fixed condenser in parallel is an exact addition all the way up the scale.

In effect this means that the whole curve can be shifted up by the added parallel capacity. One can by means of one variable and two fixed con-

densers obtain a capacity variation between any one value and any other value during one complete rotation of the variable condenser dial.

### Compensated Vanes

And if instead of two fixed condensers one variable and one fixed or two variable condensers were used, an extremely wide variation of

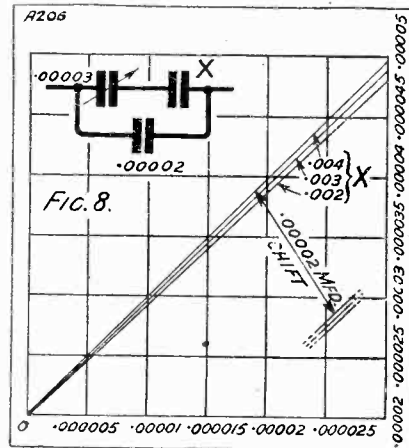

capacity curves could be obtained as shown in Fig. 9. But to get that curve of a shape shown in Fig. 3, the one desired to give us constant reaction in our one valve circuit, it would be necessary to shape the vanes of the main reaction condenser accordingly. Just as the vanes of our tuning condensers are shaped to give us straight-line frequency and log mid-line tuning, so would this small gang variable condenser have to have its vanes shaped in order to

provide us with the capacity variation curve desired.

This is not a difficult matter, as I can prove. I have obtained just the curve of capacity required by reversing the vanes of a small S.L.F. variable condenser. I say "just the curve," but actually it was not quite perfect. However, it was sufficiently satisfactory to give me the stations shown in diagram Fig. 3, on a one-valve receiver at good telephone strength without reference to any other adjustment than that of the main tuning control, which also had coupled to it the ganged reaction.

### A New Idea

My conclusions were, at the end of a fair amount of experimenting, that here was a scheme that might interest a commercial set maker, but one that would hardly commend itself to the amateur constructor. But as a result of all this work another scheme suggested itself of quite a different nature, and one which holds many more possibilities. I arrived at the scheme by reversing my order of thinking. I said to myself—why, instead of endeavouring to make the feed-back better as one increases the wave-length tuning in order to compensate for the falling reaction characteristic, why not get the set just on the edge of oscillation at its maximum tuning and make the conditions worse as the tuning is decreased? Actually, of course, the result is the same!

However, in order to do this I hooked up the circuit shown in Fig. 10. As you will see, in addition to all the ordinary connections, I joined a small variable condenser between the plate of the valve and earth. This small condenser formed a by-pass for the H.F. current between those points. Now the H.F. resistance of this path decreases with increases of frequency (decreases of wave-length). You will also note that increasing the capacity of the reaction condenser will increase the feed-back owing to the decrease of the H.F. resistance of the reaction feed-back circuit. Thus there is the desirable compensating effect.

### The Double Effect

These two variable condensers—the reaction and the by-pass—can be set at certain values so that at the maximum wave-length tuning of the receiver the set is just off the edge of oscillation. Now as the wave-length tuning is decreased so the frequency of the H.F. current increases, the

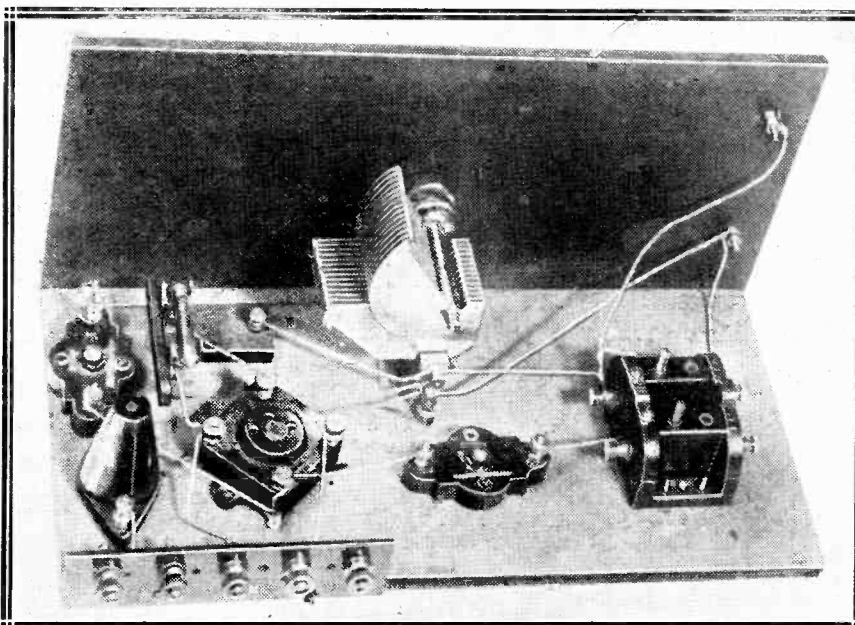

The final arrangement arrived at in the search for a simple system of constant sensitivity. Two small compression type variable condensers replace the usual reaction variable and can be mounted behind the panel of the set.

feed-back or reaction therefore tends to increase in efficiency, but so does the by-pass path. There is another factor to take into consideration. The actual feed-back is via the reaction coil and the grid coil.

**Practical Application**

The efficiency of this coupling decreases with decreasing frequency, but it very kindly follows the square law of the decrease in the capacity impedance. In the practical application

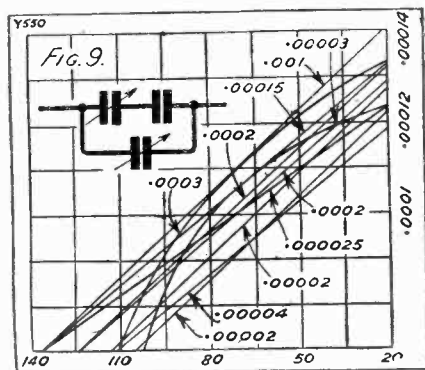

of this circuit, the by-pass and the reaction condensers take the form of the small compression type of variable condensers, and once set they do not require readjustment. And, by the way, the price of two of the compression type of condensers is hardly that of one ordinary variable condenser, so that the circuit is of quite an inexpensive character.

**A Complete Control**

A perfect control of reaction can be obtained with this circuit. If the coupling between the reaction coil and the grid coil is made variable the complete control one has is almost weird. If the small condenser B is reduced to its minimum value, and A set fairly low, the circuit will oscillate over a fair proportion of the lower portion of the tuning dial. By increasing the capacity of A, the oscillation can be spread up and up the dial until the set is oscillating over the whole of the dial.

Then, if a small proportion of the capacity of B is brought in, the set can be made to stop oscillating on the lower portion of the dial and only oscillate on the higher. And as the capacity of B is increased so the oscillation can be pushed farther and farther up the dial until the set is only oscillating on a small area of the upper dial readings. Thus a complete reversal of ordinary conditions can be brought about. And then, by decreasing the coupling between the two coils, it is possible to confine the oscillation area to the centre of the

dial. Further, by various adjustments of the A and B condensers, and the coil coupling, it is possible to obtain a small patch of oscillation at any portion of the dial from the top to the bottom. Needless to say, a condition of no oscillation at any part of the dial is very easily obtainable!

In practice, it is not necessary to have a variable coil coupling, the A and B controls are all that is necessary to set the receiver so that it retains optimum sensitivity over the whole range of the tuning dial. But for maximum results, it is necessary to have a reaction coil size and coupling corresponding with certain values. Curiously enough, I find that the coil unit designed by Mr. G. P. Kendall, for the 1928 "Solodyne," provides approximately the conditions desired. Very shortly I hope to describe the construction of a receiver incorporating the essentials of the circuit shown in Fig. 10. Using only three valves, the set I have in mind, which is already constructed and thoroughly tested, brings in some fifteen or twenty stations at full loud speaker strength, with reference to but one dial on the front of the panel.

**Easily Adjusted**

The reaction is adjusted by means of two compression type variable condensers which are mounted on the baseboard of the set behind the panel. It takes about forty seconds to adjust these, and very little skill is required to do so. Once having set these

little components, the receiver retains its constant sensitivity unimpaired until such drastic alterations as changing the valves, or the aerial, are made. And, curiously enough, it is not at all

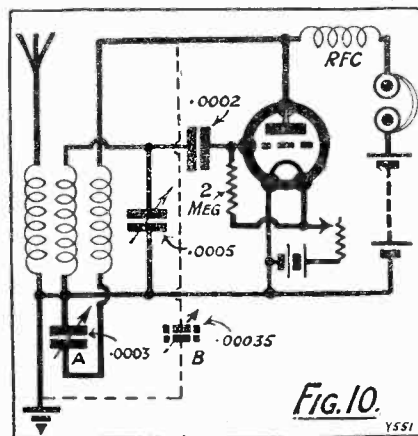

a tricky set to build. Slight variations in the layout and in the wiring do not seem to affect it. I claim no great credit for evolving the circuit, for it is the compression type condenser which has made the scheme a practical one. Had these been available in the past, no doubt a similar sort of arrangement would have occurred to somebody else.

Hitherto, the scheme would have necessitated the use of three ordinary variables instead of two and for this reason would have been an impracticable proposition. I have applied for a patent for this and similar systems, but have no objection at all to its being used by amateur experimenters.

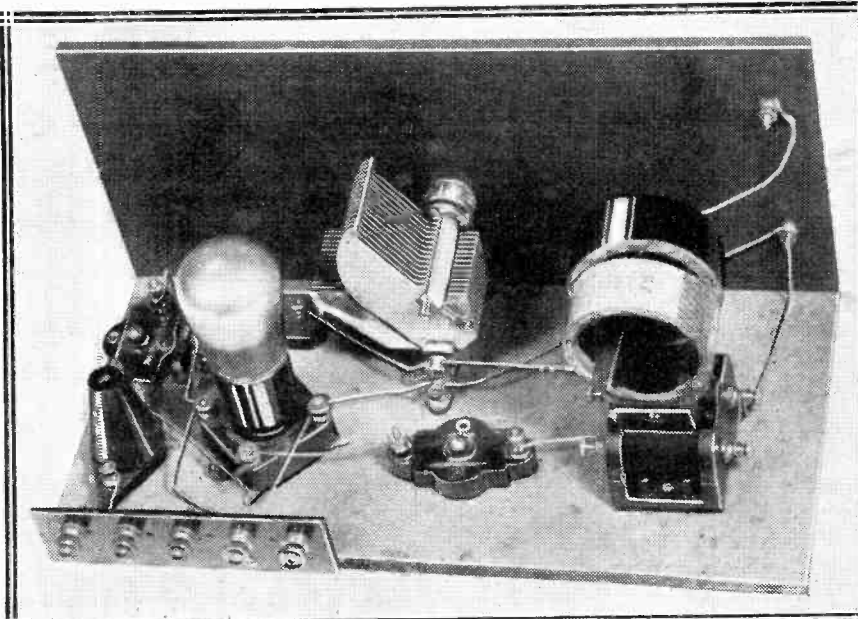

Note the simple nature of the author's "by-passing" scheme which is diagrammatized in Fig. 10. The coils do not have to be variably coupled in practice, a moving coil-holder being used in the above set for experimental purposes. A simple coil unit can be employed instead of two separate plug-in coils.

# Practical Constructional Notes

*A Useful Battery Box—Bent Wood Flares—Rejuvenating Panels—The Centre of a Circle—Interchangeable Spring Clips—Polished Wood Veneer.*

By H. BRAMFORD.

## A Useful Battery Box

**S**mall pocket batteries of the 4½-volt type are still used extensively for high-tension supply. These are satisfactory and economical, but trouble is usually experienced in housing them and connecting them together. I have found it is best first to prepare a box, subdivided for each battery, thus isolating each one from the other. Two dozen batteries, representing 108 volts in all, is a useful number, therefore the box should be divided into twenty-four parts with low, three-plywood divisions. To obviate soldering, the diagram given represents an ebonite panel equipped as shown with Clix sockets. These have been arranged in such a way and to such dimensions as to make direct contact with the battery tags when bent over. The batteries are placed in the box, and the tags bent towards the adjoining batteries. The

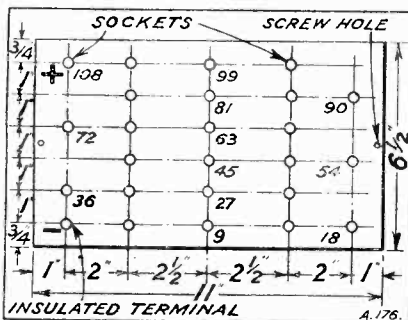

lid is then screwed or clipped on and automatic contact is made at the correct points. The drawing may be considered, therefore, to be a standard reference for the building of such containers. The batteries are arranged in the box, four rows of six in each row. For the negative connection, an insulated terminal is used.

## Bent Wood Flares

**B**ent wood speaker flares may be constructed from wood veneer and perforated zinc, compressed in the order shown in the diagram. A sheet of wood veneer is covered on one side with Seccotine, a similar sized sheet of perforated zinc laid over it, which in turn is covered with more Seccotine, and a final layer of wood veneer placed on. The whole is then placed in a press for

forty-eight hours. The material is now ready for cutting to any desired shape, and may easily be bent into

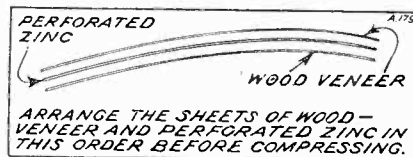

any form without cracking. It also has the advantage of rendering particularly natural tone.

## Rejuvenating Panels

**W**hen panels have been repaired, unwanted holes carefully filled in, etc., a good overall finish may be given by smearing the panel with a lubricating oil and rubbing well with a piece of fine sandpaper in a circular motion. If the sandpaper is not fine scratches will result.

A circular movement will give a better finish than backwards and forwards. Alternatively, fine emery powder and a well-oiled, soft, non-fluffy rag may be used instead. Finish with a good rubbing with a clean rag and a perfectly flush and smooth panel having a dull gloss will result.

## The Centre of a Circle

**I**n marking out it is often necessary to determine or find the exact centre of a given circle. The geometrical method of doing this, which is quite simple, is shown diagrammatically. Consider Z to be the circumference of a circle, the centre of which has to be located. With a pair of compasses strike arcs

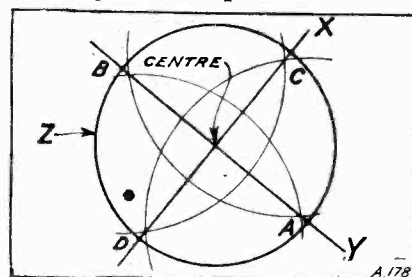

of equal radius at A, B, C, D on the circumference. Draw lines XY through the intersecting points thus made, which will indicate the exact centre.

## Interchangeable Spring Clips

**T**o those amateurs who do a great deal of experimenting, and who use the special spring clip terminals now on the market, the large number of clips required when more than one set or piece of apparatus is used is a source of expense and worry. To obviate this, the writer evolved the following scheme:

To each spring clip is soldered either a valve-leg or a small terminal. Connections to this valve-leg or terminal may be made with flex. In the case of the terminal, the wire is secured to this in the usual way, and if the flex has a valve-pin or "Clix" plug at its end it may be connected to the valve-leg instead. Thus one may use the same clips for several

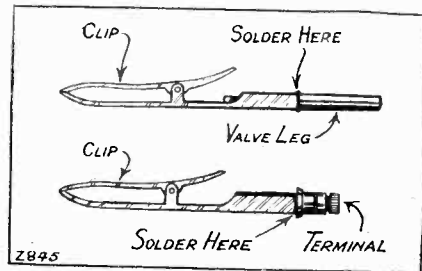

sets by merely fitting valve-pins (or if terminals are used on the clips no pin is necessary) to the connecting leads.

The use of this idea makes a set of clips very flexible in its application to different receivers.

## Polished Wood Veneer

**I**t is possible to obtain wood veneer of any grain, colour or figuring, already polished, giving an appearance equal to any french-polished cabinet. This veneer is of a material which is practically as thin as a piece of paper. It is obvious that a roughly constructed cabinet may be made into a really first-class article by using wood veneer. It is quite easy to cut the veneer with a pair of scissors to the desired shapes.

It is also easy to bend the veneer over and around corners. Seccotine is used when applying the veneer to the cabinet. Air bubbles should be carefully straightened out. This is easily done by using a small needle and pricking the bubble, when it will easily flatten out, the puncture made by the needle being invisible when the cabinet is finished. Large flat surfaces should be kept under pressure for short periods. This material is obtainable from dealers in fretwork supplies, such as Hobbies or Handicrafts.



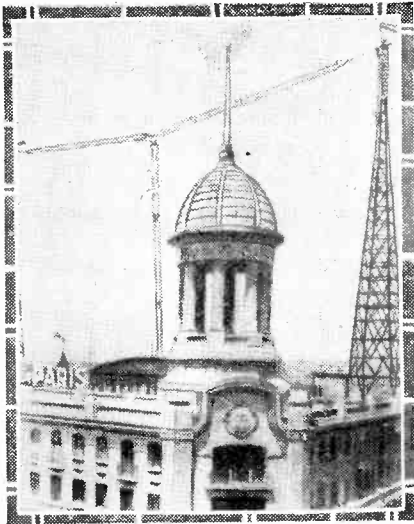

# E A J 7 MADRID'S MUSIC MAKER

One of the most frequently received of all the Continental stations is E A J 7, the Spanish broadcaster of "Old Madrid." Although 840 miles from London it comes over with considerable power and can be picked up in this country on any fairly sensitive set. In the following article some very interesting details of this station are given.

By Our Special Correspondent.

THE radio novice, or rather the amateur who has just got out of his novitiate, and who, with the aid of his first multi-valver, begins to cast off the shackles of the British purveyors of broadcasting, and to stretch his wings, as it were, for his first radio flight around Europe, seldom, if ever, fails to receive the Madrid station at reasonable strength.

Madrid is an "easy" station for most amateurs, despite the fact that it is some 840 miles away from London as the crow flies. Its transmissions are generally clear and perfectly free from "mush," and they can be received at

less broadcasting organisation, the *Radio Madrileña*, appeared as well, with its headquarters in Madrid.

Thus it will be seen that at one stage of the development of radio in Spain a certain amount of chaos seemed inevitable, especially for listeners in the neighbourhood of Madrid, in which city three stations operated on not very widely-separated wave-lengths.

Last year, however, the *Union Radio* reached a friendly agreement with the other groups of Spanish stations, with a result that a much more effective and orderly working of the various stations has been made possible, especially in the immediate neighbourhood of Madrid.

## The Transmitting Gear

Technically, and with regard to its working equipment, the *Union Radio* Station at Madrid, E A J 7, does not differ to any extent from the average present-day broadcasting station operating on medium power. The station transmits on a wave-length of 375 metres (800 kilocycles), and it puts a maximum power of 1.5 kilowatts into its aerial. E A J 7, Madrid, employs a Marconiphone transmitter of the "Q" type—a pattern which appears to be a favourite among Spanish radio engineers, although, let it be said, one or two Spanish stations, notably E A J 1 at Barcelona, are equipped with Western Electric gear.

The Madrid station of the *Union Radio* group utilises a T-aerial, and this it slings between two steel lattice towers which are situated on the roof of one of the highest buildings in the city. The transmitter is earthed by

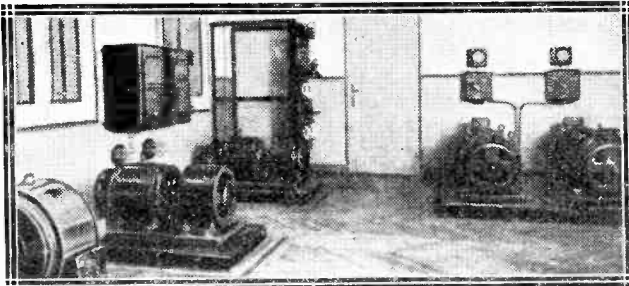

The rotary converters which supply the station's power. The control switches can be seen in the background.

good strength by means of the average efficient three-valve set.

In view of the above facts, it seems rather strange that so little has been written concerning the constitution, equipment, and activities of the Madrid station. Spanish radio activities are interesting enough, even if they are not undertaken on such a large scale as they are in this country, in America, and in other lands.

## National Broadcasting Organisation

Broadcasting in Spain dates back to 1924, in which year the Barcelona station was opened and a national broadcasting organisation formed. "Union Radio," for such is the title of Spain's most important radio organisation, now possesses seven *emisoras*, or broadcasting stations, viz., those at Madrid, Barcelona, Cadiz, Seville, San Sebastian, Bilbao, and Salamanca.

The authorities of the Madrid station, however, have not been without competitors during the past. Some time ago, the *Radio Iberica*, a rival concern run by the *Sociedad Nacional de Radio Diffusion Espanola*, was launched. It had its own station at Madrid, and it also erected other stations up and down Spain. Another wire-

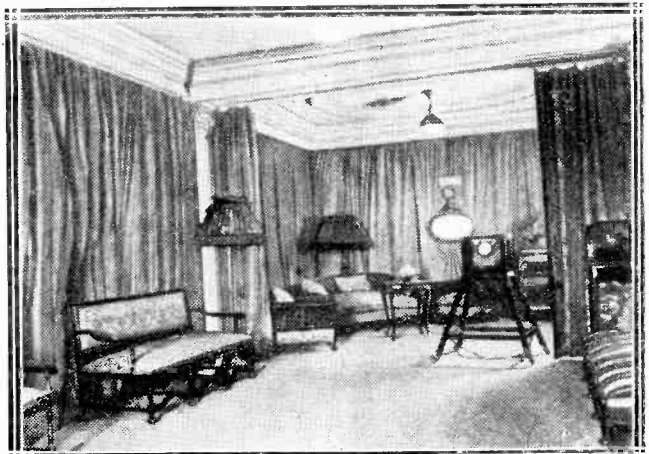

This is the studio. It is interesting to note that it is furnished in the style of a Spanish drawing-room.

means of a symmetrically arranged system of copper plates buried at varying depths directly under the aerial.

The studio of the station, which, incidentally, is only semi-draped in order to provide for the desirable echo effects in the transmissions, and is furnished in the style of an up-to-date Spanish drawing-room, is presided over for the most part by the popular announcer, Signor Luis Medina, who, if he is not altogether responsible for the compilation of the station's programmes, is certainly the "live wire" who effects their smooth working.

### An Interesting "Close Down"

Night after night listeners in this country can hear the voice of Signor Medina giving in sharp staccato-like tones the station's call-sign—*Eh-ah-hota-siete*—E A J 7, after which follows, as many readers will know, a characteristic Spanish radio programme consisting of orchestral music, popular concerts, dance selections, operatic excerpts; the whole being seasoned here and there with a little educational and scientific matter in the form of brief talks which are judiciously introduced.

Station E A J 7 generally begins its evening concert at 7 p.m., although it is "on the air" at frequent intervals from approximately 11.45 a.m. The station does not usually close down until 12.30 a.m., and thus it may be heard over here for a considerable time after the B.B.C. people have closed down for the night. It is rather interesting to hear the closing down of the Madrid station. At the appointed hour, the chimes from a clock situated in the Government Buildings of Madrid are relayed, the Spanish National Anthem is then played, and finally we hear the voice of the studio director and announcer wishing us a cheery *Buenas noches a todos*—Good-night to you all.

### Relayed Programmes

E A J 7 relays its programmes to other Spanish stations on various occasions, and notably to station E A J 9; one of the *Union Radio* group, situated at Bilbao on the north coast of Spain. Amateurs in this country frequently pick up the latter station relaying a programme from Madrid. Under such circumstances it is difficult to distinguish between the stations. Bilbao, however, transmits on a wave-length of 400 metres, which is slightly higher than the wave-length of the Madrid station. Furthermore, the former station has a maximum power of merely .5 kw., which makes its transmissions come in over here usually at a much weaker strength than those of the main Madrid station.

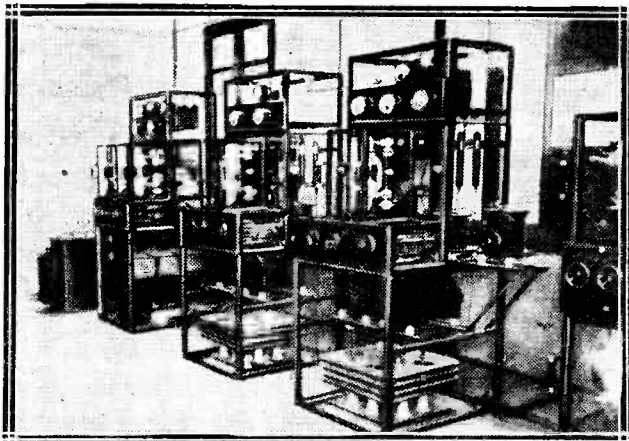

The transmitter at E A J 7 is a "Q" type Marconi outfit, one of the most popular broadcasting assemblies ever made. The same type figures at the majority of British stations.

## ADULT EDUCATION AND BROADCASTING: THE HADOW PROPOSALS

"NEW Ventures in Broadcasting" is the title of one of the latest publications issued by the B.B.C. from Savoy Hill, price 1s. It is a study in adult education as related to broadcasting, and many recommendations are contained in the report of the committee which, under the chairmanship of Sir Henry

Signor Luis Medina, who is announcer and station director at the Madrid station. His is the voice you may have heard giving the call-sign "Eh—Ah—Hota—Siete."

Signor Medina is, according to our correspondent, the "live wire" to whom is due the notably smooth-running programmes.



Hadow, has for some time past been enquiring into the problems of broadcasting and adult education. The principal recommendations in the report are as follow :

1. The provision of recreation and entertainment has been one of the main functions of broadcasting and should be extended and developed.
2. It is impossible, however, to draw a hard-and-fast line between recreation and education. To many recreation includes the best music and drama, the general talks, debates and readings, which keep them in touch with current thought and affairs. This is, in fact, an important form of adult education.

### Specialised Talks

3. There is an impressive and a growing demand that broadcasting should provide facilities also for more specialised adult education, also the fact that broadcasting is a public service strengthens the case for using it in the interests of national education.
4. A much larger proportion of listeners than is commonly supposed have particular interests to which special items could make an appeal. The evidence shows that, in addition to providing a general programme, broadcasting could provide talks which would be welcomed by large sections of the community having their own special interests, e.g. farmers, co-operators, housewives, adolescents, students, etc.
5. Such provision is dependent for its full development on the policy of alternative programmes, which will give a

(Continued on page 576.)



# The "WIDE-RANGE" TWO

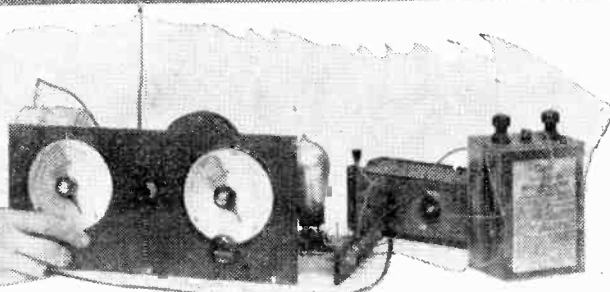

An inexpensive set suitable for the reception of short, medium and long-wave stations.

By  
The "M.W." Technical Staff.

THE lure of short waves has already captured many listeners, and would doubtless capture many more were it not for the fact that a separate set is usually necessary

With the object of introducing those to whom the foregoing remarks particularly apply to the delights of short-wave D.X., the two-valver herein described was evolved ; its advantages

waver, and will bring in K D K A, 2 X A F and 2 X A D with almost monotonous regularity, and can rope in quite a number of lower-powered stations, at distances up to about 3,500 miles, at good 'phone strength.

By substituting broadcast coils for the short-wave type, and short-circuiting the fixed condenser in series with the reaction condenser, the set functions perfectly on the 250-550-metre band, and gives consistently good loud-speaker reception of 2 L O and 5 G B at about 30 miles from the former and 80 miles from the latter.

### LIST OF COMPONENTS

- |   |   |
|---|---|
| <ul style="list-style-type: none"> <li>1 Panel, 14 in. × 7 in. × 1/4 in. (Any good branded material).</li> <li>1 Baseboard, 16 in. × 8 in.</li> <li>2 .00025 variable condensers (Ormond, or other good make). (.0003 mfd. is also a suitable capacity.)</li> <li>2 Slow-motion dials (Ormond, or other good fairly low-g geared type).</li> <li>3 Fixed coil holders (L. &amp; P., Lotus, Peto-Scott, etc.).</li> <li>1 On-off switch (Lissen in set. Any similar type).</li> <li>2 Baseboard rheostats (Lissen, or similar type).</li> <li>2 Fixed condensers, .0002 (Lissen in set. Any good make, Clarke, Dubilier, Igranic, Mullard, T.C.C., etc.).</li> </ul> | <ul style="list-style-type: none"> <li>1 Grid condenser and leak (Mullard in set. Any good make, Dubilier, Igranic, Mullard, etc.).</li> <li>2 Valve holders (Benjamin, Bowyer-Lowe, Burndept, Burne-Jones, B.T.H., Igranic, Lotus, Marconiphone, Pye, W.B., etc.).</li> <li>1 L.F. transformer (R.I. multi-ratio in set. Any good make).</li> <li>1 Terminal strip, 6 in. × 2 in.</li> <li>1 Terminal strip, 2 in. × 2 in.</li> <li>8 Terminals (Belling-Lee, Eelex, Igranic, etc.).</li> <li>1 Bulldog clip.</li> <li>Wire, screws, wander plugs, etc.</li> </ul> |
|---|---|

### "Real Loud-Speaker Strength"

Do not be misled by the term "loud-speaker strength," as in this case this is intended literally, and does not mean that to hear anything from the loud speaker it is necessary to put your ear against the diaphragm ; it is not an exaggeration to say that at times the volume delivered was really too much.

These results were not achieved through the medium of a super-

for the purpose of short-wave reception, and this accounts for the disinclination of the major portion of would-be enthusiasts to take the actual plunge.

The old idea that only amateur transmitters could be heard on wavelengths below 100 metres having been

are numerous, and will appeal immediately to those whose spirits are willing, but whose purses will not stand the strain.

It is a thoroughly efficient short-

A 1/- BLUEPRINT OF THE "WIDE-RANGE" TWO IS PRESENTED FREE WITH THIS ISSUE.

effectually squashed, and a definite knowledge that there are a score or so of powerful telephony transmitters operating on this band, has created an interest which, but for the drawback mentioned previously, would account for the addition of a large number of enthusiasts to the ranks of those who burn the midnight lamp.

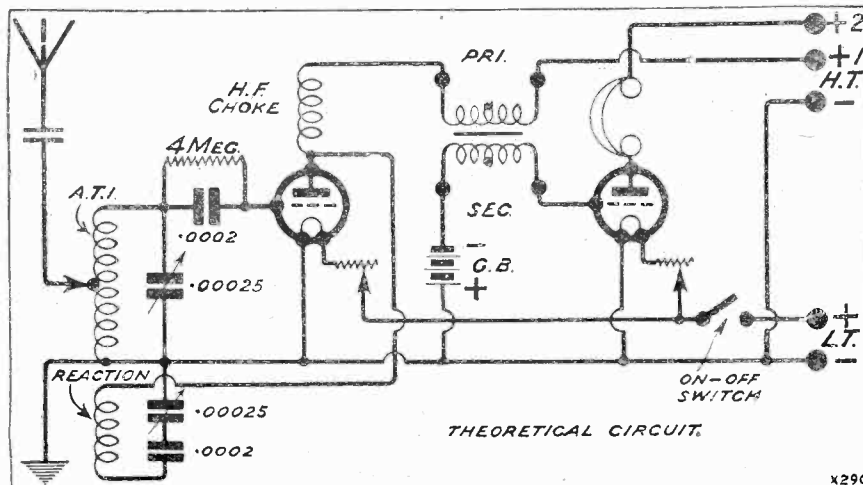

efficient aerial, earth, or valves; the aerial was nothing to cause comment, being about 60 ft. long, and averaging 25 ft. in height. The earth lead was taken to a water-pipe, and the valves were P.M. 2-volters, P.M.1 L.F.

used the holes through which the boss passes must be  $\frac{1}{2}$  in. in diameter, as otherwise the boss on the large nut will project above the face of the panel, and probably cause difficulty in mounting the vernier dials.

in line with the socket of the other.

Adequate spacing of components and wiring is essential if really good results are to be obtained, and in this connection it would be as well to study the photographs showing the disposition of the components behind the panel, and the wiring of those which are connected to the first valve. It will be immediately seen that these leads are as short and straight as it is possible to arrange them, and this, although quite easy, needs care.

There are no points which need mention in the actual mounting of the components, everything being as straightforward as could be desired. It will be noted that the set has a baseboard which overlaps the panel by an inch or so at either end; this will doubtless cause some comment from those who desire to build the set into a cabinet, but it must be remembered that a cabinet detracts slightly from the efficiency of a short-wave receiver, and acts, more or less, as a screen.

**Concerning a Cabinet**

This, however, is not a great matter, and could be overcome by using a 16 in. by 8 in. cabinet, and having a false wooden panel screwed to the ebonite panel of the set, with an oval cut in it to allow the controls to project and showing just a small surface of the ebonite. Such a vignette need only be  $\frac{1}{2}$  in. thick, and would not be likely to affect the fitting of the panel and baseboard to the cabinet.

Another point which would need careful consideration if a cabinet were to be desired is the battery and

as detector, and P.M.2 as the low-frequency amplifier. At no time was there a super-power valve employed, and the H.T., etc., conformed with the instructions given by the manufacturers.

**The Aerial and Earth**

It may be as well to state here that the aerial used for short-wave reception was a single wire about 20 ft. high and 30 ft. long, and instead of an earth a counterpoise was used, which varied from time to time between a length of wire run round the room to a jumbled heap of insulated flex lying on the floor. Both gave good results, and it was not noticeable that there was any difference in the efficiency of the two.

The accompanying diagrams will show that there is nothing very remarkable in the construction or wiring of the set, and reference to the photographs gives some idea of the way in which the latter operation should be carried out. As the set was not originally built with the intention of using it as a loud-speaker receiver, no grid-bias battery was included, and there was no provision made for separate H.T. supply to the detector valve. These additions are included in the blue print, and can be easily built into the set by adding three terminals to the terminal strip and wiring up in the conventional manner.

**Fitting the Panel**

The panel has only six holes drilled in it, three of them are  $\frac{3}{8}$  in. in diameter, the others  $\frac{1}{2}$  in. to take the countersunk headed wood screws which secure it to the baseboard. If the variable condensers specified are

It is advisable to screw the panel to the baseboard before attempting to mount these components, as their weight would make them rather cumbersome if the operation were

"The 'Wide-Range' will bring in KDKA, 2XAF and 2XAD with almost monotonous regularity."

tried after securing them. The remaining components are next fixed to the baseboard in accordance with the blue print and photographs. Remember that the two fixed coil holders which are in juxtaposition must be fitted in the opposite direction, so that the plug of one is

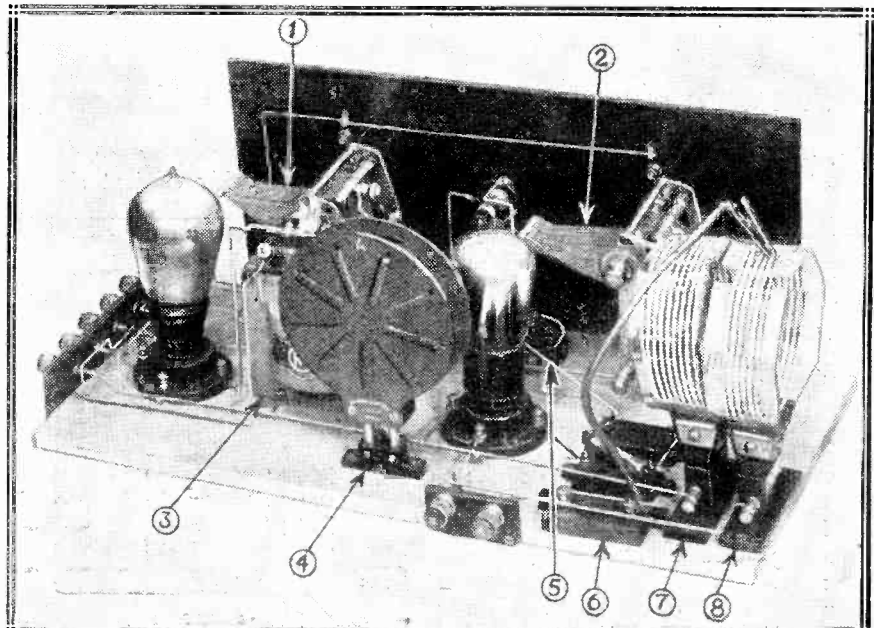
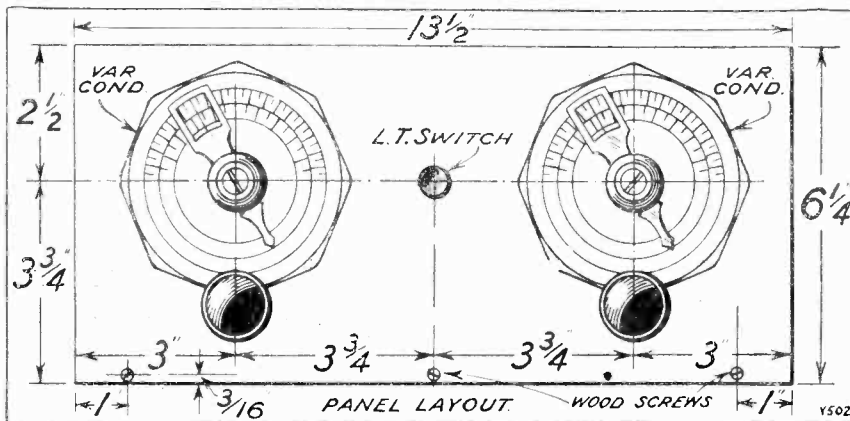

(1) The reaction condenser control; (2) the tuning condenser; (3) the L.F. transformer; (4) plug-in coil used as H.F. choke; (5) filament resistance; (6) fixed condenser which comes in series with aerial; (7) reaction coil; (8) A.T.I.

'phones terminal strip, which is shown mounted at the side of the set, instead of at the back. To get the set into a cabinet with the terminal strip in this position would be impossible, and it would be necessary to mount the strip in the usual place.

This would naturally necessitate a considerable alteration in the wiring, but there should be no trouble in effecting it; the only leads which might need a little extra care are those in the L.T. circuit, which would have to be brought across the base-board to the switch and resistors. The lead joining the filament sockets of the valve holders together remain the same, and the L.T. - lead will be shorter than shown in the diagrams.

**The Series Condenser**

Another thing which is worthy of mention is the inclusion of the .0001 fixed condenser in the aerial circuit. This is intended to be used if the existing aerial is over 30 ft. in length, but is not the full "P.M.G. Standard" 100 ft. In the latter case it would not serve its purpose, that is, to cut down the effective wave-length of the aerial, as the latter would be too large for the condenser to have its full effect.

For anything up to 60 ft. the condenser will solve the problem and will render the erection of an additional aerial unnecessary; but if the existing aerial is of larger dimensions a short one will have to be erected.

Returning to the construction of the set, and assuming that the various points mentioned above have been satisfactorily disposed of, the assembly of the components may be concluded

and the wiring commenced. Decide, first of all, whether the soldering tags fitted on some of the components are to be employed as a means of connection, and if this is the case these should be tinned before proceeding with the wiring proper.

If the constructor realises his limitations where soldering is concerned, the better policy is to make use of the

lot while doing one or two. A really good idea is to cut and bend to shape as many leads as possible, and solder them all in position at once.

By this means a watchful eye can be kept upon the soldering iron, and there need be no trouble over soldering with the iron too hot, or too cool, both of which faults are responsible for a great majority of the dry joints

**WIRING INSTRUCTIONS**

- Join the aerial terminal to one terminal of the .0001 series condenser.
- Join the other terminal of the condenser to the flex lead to which the tapping clip is attached.
- Join the earth terminal to the plug of the aerial coil holder, to one filament terminal of each valve holder, to the L.T. negative, and the H.T. negative terminals, to the moving plates of both variable condensers, and to the earthing terminals of the slow-motion dials.
- Join the L.T. positive terminal to one side of the L.T. switch; the other side of the switch to one terminal of each rheostat, and connect the other terminal of each rheostat to the remaining filament terminal on the corresponding valve holder.
- Join the socket of the aerial coil holder to the fixed plates of the A.T.C., and to one side of the grid leak and condenser; join the other side of the leak and condenser

- to the grid terminal of the first valve holder.
- Join the plate terminal to the socket of the H.F. choke holder, and to the socket of the reaction coil holder. Join the plug of the H.F. choke holder to the P terminal of the L.F. transformer. Join the other P terminal of the L.F. transformer to a flex lead to the H.T. battery.
- Join the plug of the reaction coil holder to one side of the reaction series condenser; the other side of the condenser to the fixed plates of the variable reaction condenser.
- Join one S terminal of the transformer to the grid terminal of the second valve holder; join the other S terminal to the G.B. negative. Join G.B. positive to L.T. negative. (The two G.B. leads are flex.)
- Join the plate terminal of the second valve holder to one 'phone terminal; join the other 'phone terminal to the H.T. positive terminal.
- This completes the wiring

terminals fitted to many of the parts, even the single coil holders having 6 B.A. or even larger terminals as a standard fitment. When it is desired to employ the latter method, it is essential that all these connections should be made with the utmost care, as a single loose contact will cause, if not a total failure of signals, at least a great deal of noise.

**How To Solder**

It is hardly feasible to wire up the whole set without making a single soldered joint, so it is really best to bow to the inevitable, and solder the

which seem invariably to crop up when one is not adept with the iron.

Remember that it is not the quantity of solder applied to the joint which counts, but the heating of the metals to be joined. It is useless to get a large blob of solder on the tip of the iron and hold it hopefully to the terminal shank, trusting that it will spread evenly over the surface of its own accord; in many cases it appears to work as expected, but, nevertheless, such joints are the ones which will give way if subjected to the slightest strain.

**Tips On "Tinning"**

Always hold the iron in such a way that the tinned point is in contact with the parts to be joined, and see that the solder runs freely before removing the iron; should the solder not flow, it is probably due to the parts being dirty, or to the insufficient application of flux. This last, although quite feasible, is seldom the real cause, as the general tendency is to use too much rather than too little. It cannot be too often repeated that the wiring and soldering will make or mar the best of sets, so take care of these final operations, and there need be no cause to check them after completion.

When everything is finished, the set may be connected up to the aerial, earth, and batteries, etc., to be tested out on broadcasting. For this, plug the largest coil you have into the H.F. choke holder.

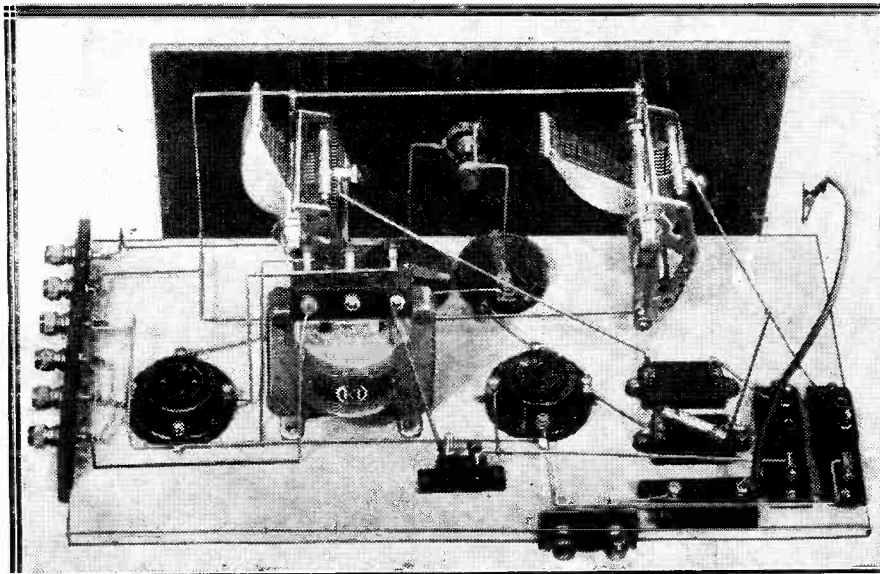

If you are going to use the "Wide-Range" only for the 'phone reception of short-wave stations you will not find either grid bias or separate H.T. pluses essential, but both will be needed if the set is used for normal broadcast reception.

This must, in any case, not be less than 250 turns; the aerial coil will be found to give maximum results when a centre-tapped type is employed. A Gambrell B was excellent, and with the aerial mentioned previously, London and 5GB were easily covered. The reaction coil

on the broadcast band, so that down on the low waves it is easier imagined than described.

In conclusion, the coils to use for the stations just above 20 metres are: aerial 4, tapped as the 6, reaction 6; and I sincerely hope that those who construct this set will

Since two people cannot both speak at once over the transatlantic telephone system, the Rugby station and the Rocky Point station, New York, are able to use the same wave-length for this service.

The number of broadcasting receiving licences held in Australia was nearly doubled during the last twelve months.

The Port of Antwerp is modernising its wireless service for pilots so that ships can enter and leave the Scheldt more expeditiously.

The biggest concentration of broadcast stations in the world is around Chicago, the centre of the U.S. ninth radio district, which has 233 active broadcasting stations in its area.

Several hundred ocean-going ships are now fitted with the new Marconi auto-alarm apparatus for detecting S.O.S. signals.

Using the Mullard valve, a Johannesburg experimenter established wireless communication with a Californian station in daylight, thus setting up a South African record for amateur transmitters.

One feature of the Melbourne station 3LO is an audience hall to which the public are admitted free, in order to provide the necessary atmosphere of an audience for variety turns that are being broadcast.

At the super-receiving station at Belfast, Maine, U.S.A., the aerials for picking up European programmes are each nine miles long and are spaced six miles apart.

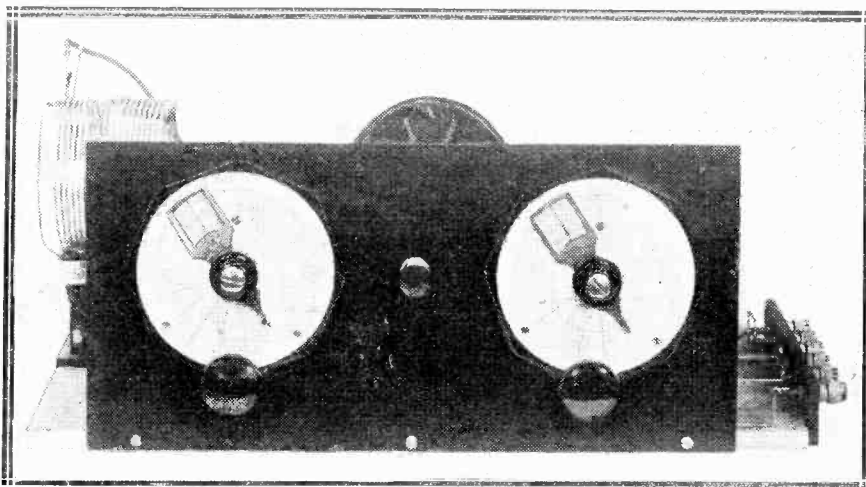

The front panel appearance of the receiver is attractively workmanlike and symmetrical.

may be anything between 30 and 50; the lower the inductance of the coil, the smoother will be the control.

The .0002 fixed condenser in series with the reaction condenser must be short-circuited for use on the broadcast band, as it reduces the effective capacity of the reaction condenser, and if left in circuit would necessitate the use of an oversize coil to obtain reaction. Two clips, as used for tapping the aerial coil, connected by a short piece of flex, will be all that is required for the purpose, and are easily removed when desired.

### Operating Notes

Having tried the set out thoroughly on the 250-550-metre band, it can be considered ready for a short-wave test. The H.F. choke in this case is a standard 25-40 turn coil; the aerial and reaction coils, Igranic short-wave coils Nos. 6 and 9 respectively; with the aerial clip attached to the centre turn of the coil, which should be forced up a little by means of a screwdriver or similar tool. The reaction series condenser may be placed in circuit by removing the shorting wire, and the set is all ready for action. A few trials will show whether the aerial series condenser is necessary, and it can then be left in circuit or discarded as required.

Bear in mind that on the short waves the tuning is not to be rushed, and quick condenser swinging will produce nothing more than a succession of chirps. The set is quite sharp

enjoy the same satisfaction as I did both while constructing and operating it.

C. A. J. M.

### OVERSEAS RADIO ITEMS

The 300-ft. aerial towers of the Belmore broadcasting station, Long Island, New York, are designed to serve as air beacons for aviators. They are painted in 12-ft. bands of black and yellow, and fitted with flood-light equipment to illuminate them at night.

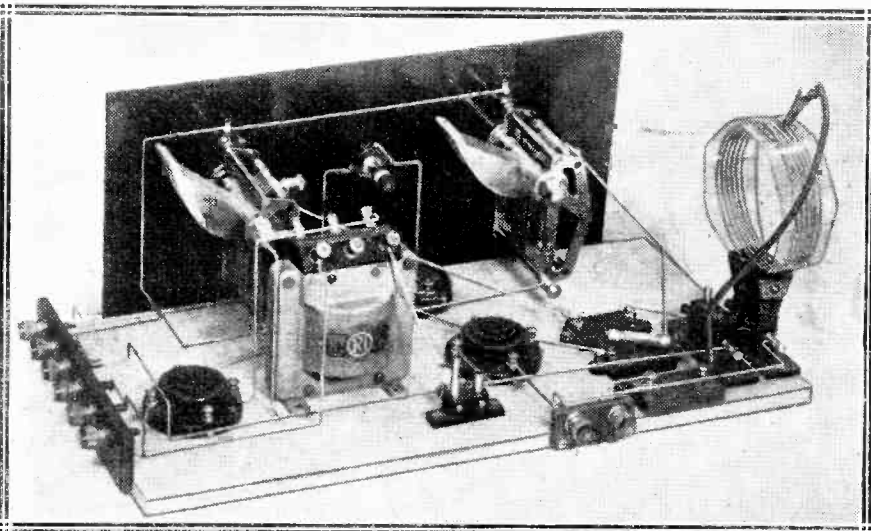

The set can be fitted into a cabinet if the constructor so desires, a handsome effect resulting if a false wooden panel be arranged with an oval cut in it.



*Practical notes on the installation and operation of these instruments are given, together with accounts of experiments undertaken in order to discover methods of achieving the complete faithfulness of reproduction which these speakers render possible.*

By C. P. ALLINSON,  
A.M.I.E.

NUMEROUS articles have appeared dealing with the design and construction of moving-coil loud speakers, so that this aspect of the question has been pretty thoroughly covered, but I do not think that a great deal of attention has been paid to the question of operating and installing this type of

with a moving-coil type of loud speaker for good results to be obtained. A number of alternative expedients are available, all of which give an excellent performance and which allow of the installation of the loud speaker with the greatest ease.

The question of cost being an important one, I propose to deal with the cheapest method of installing this type of loud speaker first. I have used this myself and obtained very excellent results from it, the only addition required apart from the loud speaker itself being a Tate sugar box.

in Fig. 1 shows the method of doing this. By placing the loud speaker to one side, as shown in this sketch, room is left for a special amplifier stage, which I have found to be advisable for use with this type of loud speaker, and the construction of which will be dealt with later on.

With regard to the installation of the speaker in the Tate sugar box, it is important that either one strip of wood be taken out at the back, or a number of large holes be drilled so as to prevent box resonance effects,

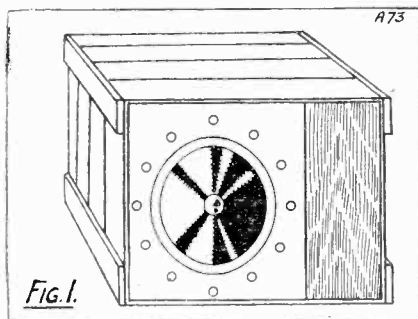

loud speaker so as to obtain the best results.

I have recently been working on a loud speaker of this description and have been conducting a number of experiments with it in connection with various types of receivers.

### Installing the Speaker

I do not intend to deal with such controversial subjects as the use of high- or low-resistance coil windings, the size of the gap in the field, and the use of different materials for suspension. What I am going to deal with is the question of installing the loud speaker and its successful operation with a view to obtaining absolute purity of reproduction.

I know the question of installing has caused quite a lot of worry to many experimenters, especially in view of the fact that it has so frequently been emphasised that a 4-ft. square baffle plate is needed with this type of loud speaker.

This, I think, is a bogey which should be laid at once. It is by no means necessary to use a 4-ft. baffle

### One Method of Mounting

The loud speaker I am using is assembled on a wooden base, and a wooden frame carries the cone and moving coil. The size of this frame is 16 in. square, and it will be found that this will nicely go in a Tate sugar box placed on its long side. It will be found that a gap on either side is left and this can conveniently be closed up with a strip of matching or a piece of 3-ply wood. The sketch

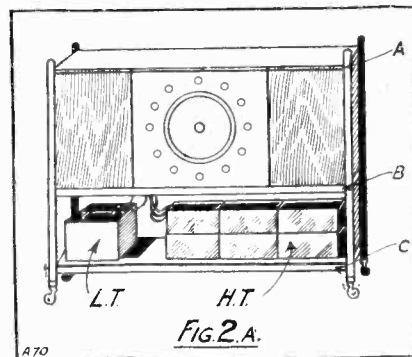

which might otherwise be caused and result in a poor performance being obtained.

Having dealt with the cheapest

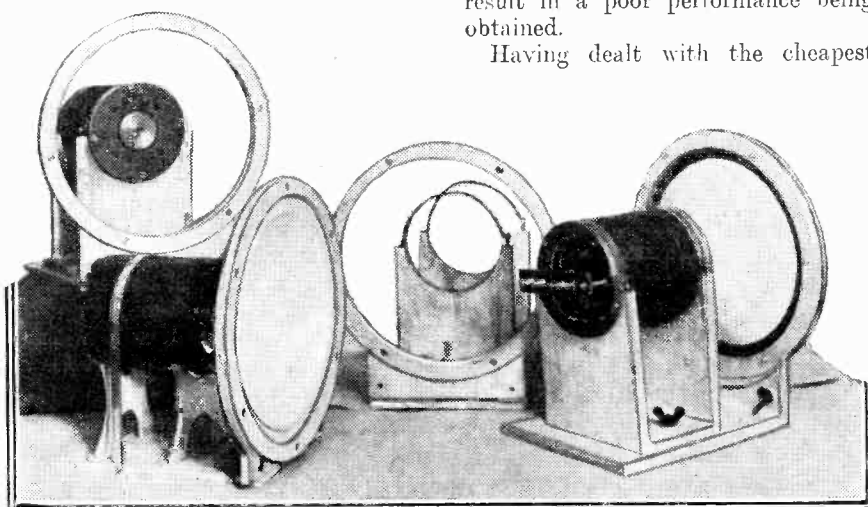

The vital elements of several moving-coil loud speakers are shown above. They are all of the "mains-drive" variety and need current for field magnet purposes.

form of installation, let us now deal with the most convenient. The method which I myself am using is this. I have an old dumb-waiter, which is fitted with three shelves, and by installing the loud speaker into this I can make the whole instrument transportable from one room to another, while the third shelf allows me to incorporate any batteries that I wish to, and cart them about with the complete instrument.

**The Complete Arrangement**

The sketches in Fig. 2 show the complete arrangement. Looking at Fig. A the three shelves are shown at A, B, and C. The underside of the top shelf A was covered with cardboard, so as to make an airtight surface in view of the fact that the shelves are made of wooden slats having appreciable gaps between them. The top of B was covered in the same way, and the loud speaker was slipped in between the two shelves in the centre, as shown.

The openings on either side of the loud speaker were filled up with some thin wood, and since it was desired

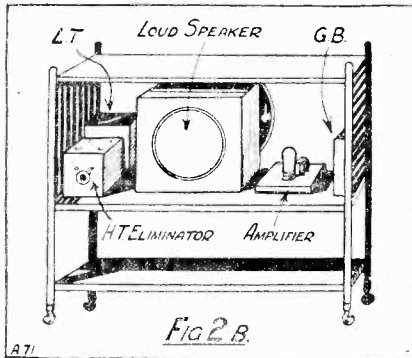

to obtain an absolutely airtight joint, a strip of felt was placed where the wood butted against the wooden frame carrying the cone and moving coil. The two openings on both sides of the shelf were also covered up with thin wood. Match-boarding, 3-ply, or any wood of this description is entirely suitable for the purpose. The back of the shelf, however, was left open so as to prevent any box resonance effects obtaining.

**Another Method**

The bottom shelf C carries the batteries, as shown in the sketch; these consisting of a large 6-volt I.T. accumulator for feeding the field winding, and also providing the filament current for the valve used in the amplifier. H.T. was provided by an accumulator, 180 volts being available.

The amplifier which was used with the loud speaker was fitted on the shelf B at the back.

An alternative arrangement is shown in Fig. 2 at B. In this case, instead of using an H.T. accumulator

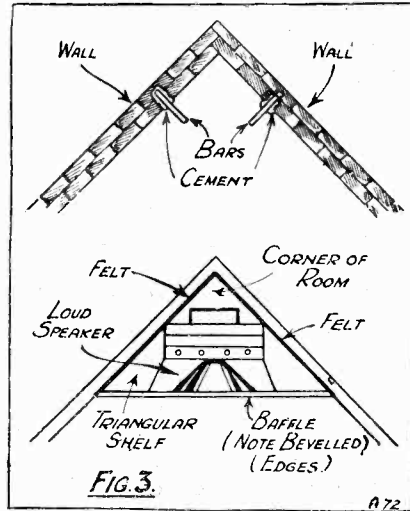

an eliminator was used for supplying the H.T., and since D.C. mains are available the size of the eliminator, of course, is very small. In this case, the layout is a trifle different, the amplifier being placed to one side of the loud speaker, as shown, while the L.T. battery and H.T. eliminator were placed on the other side so that the bottom shelf is empty and can be used either for placing a receiver or any other purpose which is suitable. This arrangement, incidentally, is far more easily transportable than the arrangement in which an H.T. battery is incorporated, in view of the great weight which is added by this component.

**Special Cabinets**

Those who do not desire to use such a rough-and-ready means as the two which I have suggested for installing a moving-coil loud speaker, can get a special cabinet made for the purpose. These are made by a number of different firms, and can be obtained at very reasonable prices if it is not desired to spend a large amount of money on the cabinet.

Another method of mounting this loud speaker, which, of course, is very limited in its application, is mounting it on one side of a door in which a hole is cut so as to coincide with the aperture of the cone. This, of course, is extremely convenient from the point of view of the experimenter himself, but I am afraid it is not always so convenient from the household point of view, and care must be taken to choose a door which is

not much in use. It would be exceedingly awkward if the whole adjustment of the loud speaker were upset by some member of the household banging the door in a fit of temper, for instance.

Another way of mounting the loud speaker which I have employed is also extremely convenient in that it requires the minimum of extra outlay. That is to use a corner of the room. By installing the moving-coil loud speaker in this position the two walls on either side form the continuation of the baffle plate, while if the loud speaker is mounted on a triangular shelf no extension is needed below the loud speaker for a baffle plate, and only a short extension above it.

**The Wall Fixing**

It is important, however, in this case that the walls be sufficiently solid to bear the weight of the loud speaker, since this weighs anything from 30 to 40 lb., depending on the type of construction employed.

Where the two walls forming the angle are brick it is a simple matter to grout a couple of iron bars into the brick or to fix a couple of stout brackets by means of Rawl-plugs, so as to form a perfectly solid support for the loud speaker, which will be quite capable of taking its weight. In order to ensure an airtight joint between the shelf and the baffle and the two walls, felt packing should be used. A sketch for an arrangement of this description is shown in Fig. 3.

I think the above suggestions cover the chief methods of the installation of a moving-coil loud speaker, apart from the use of a 4 ft. baffle, and any variations which may suit particular requirements will, of

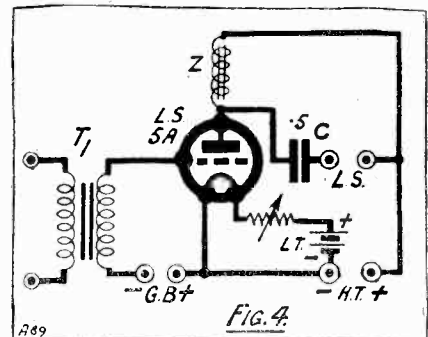

course, suggest themselves to the experimenter.

The moving-coil loud speaker which I have been using has a high-resistance winding, and can therefore be connected practically to any average broadcast receiver providing that a



filter circuit is used. In view of the delicate nature of a high-resistance winding for a moving-coil loud speaker it is most important that this filter circuit be employed, since otherwise the performance of the loud speaker will be considerably affected if the direct current passing the plate circuit of the last valve is allowed to flow through the coil.

### The Output

The decision as to whether to use an output transformer or a filter circuit is largely one of personal preference, both points of view having a large number of adherents. I myself am using a filter circuit.

In using this loud speaker with a number of broadcast receivers I find that it will work perfectly well when connected directly to the receiver as previously stated, but a critical examination of the output led me to consider that the best balance was not being obtained with the use of an ordinary valve, even of the super-power type, in the last stage of the receiver.

On substituting a really low-impedance power valve of the L.S.5A type in the last stage, I found that a marked improvement in the reproduction of the bass notes, especially below 50 or 60 cycles, was observed, while when used with a suitable value of H.T. and grid bias this valve would, of course, handle far greater power without distortion due to bottom bending or grid current than a super-power valve.

I therefore determined to make up a single-stage amplifier which would form part of the loud-speaker installation so that it could be plugged into any receiver, and this amplifier would enable the correct output circuit to be used so as to obtain the best results from the loud speaker itself.

### A Suitable Transformer

The chief difficulty that faced me here was the choice of a suitable transformer for coupling the output from the receiver to the amplifier incorporated in the loud speaker. I did not desire to obtain any appreciable amplification in this stage, but at the same time I wanted to use a transformer which would work perfectly satisfactorily in conjunction with a super-power valve used in the last stage in the receiver itself.

I had by me a Ferranti 1-1 transformer suitable for use with a high-resistance loud speaker, and which was intended for use as an output transformer, and in view of the

characteristics of this component it occurred to me that it would be an excellent coupling transformer to use.

I tried this out and as I expected found that it was all that could be desired. The circuit diagram of the amplifier as built into the loud speaker is shown in Fig. 4.  $T_1$  is the Ferranti output transformer, the secondary of which is connected

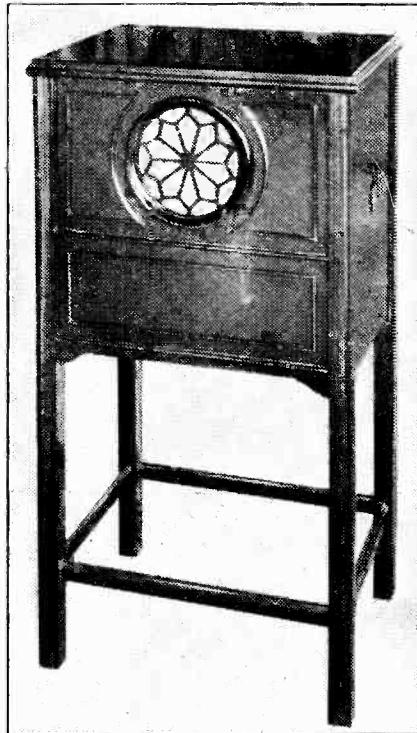

The Rice-Kellogg moving-coil loud speaker, manufactured by the B.T.H. Company, is carefully disposed in a handsome cabinet which provides an ample "baffle" effect. The special B.T.H. amplifier for use with the speaker is also contained in the cabinet.

between grid and filament of an L.S.5A valve. Z is the output filter, the filter condenser C having a value of 5  $\mu$ F.

### H.T. Voltage

The value of the H.T. voltage may be anything up to 400 volts, according to the rating of the valve, and grid bias will be used accordingly. For average broadcast reception, however, I have found that 180 volts H.T. is ample, in conjunction with which 35 to 40 volts grid bias is indicated. The actual amplification given by this stage is small but compensates for the slight lack of sensitivity of the loud speaker which I am using.

It is usually claimed that the moving coil type of loud speaker is extremely insensitive, but this need not be the case. The factors governing the sensitivity of the speaker have

been dealt with elsewhere and need not be repeated here.

In the case of the loud speaker I am using, however, this is very nearly as sensitive as the cone loud speaker which I usually employ, and the small degree of amplification given by this stage just makes up for the difference in sensitivity.

One of the most important things when using this type of loud speaker is to see that the output from your broadcast receiver is absolutely pure and undistorted, for the moving-coil type of loud speaker will show up distortion where no other loud speaker will. Thus, if you are using one of these loud speakers for the first time and you do not think the results are what they should be, do not blame the speaker, but overhaul your set carefully, see that you are using the right values of H.T. and G.B., and the right valves in all cases, and make sure that no overloading is taking place. Once you have got the output from your receiver absolutely pure, you will find that the music given from the moving-coil loud speaker is far and away above any other form of radio reproduction.



### ODD ITEMS

Heat so great that it evaporates steel is developed by a radio-frequency vacuum furnace now in operation in the Westinghouse research laboratory, America. The frequency of the current causing this intense heat is equivalent to a wave-length of 10,000 metres.

\* \* \*

It pays to test the voltage of the grid-bias battery occasionally, as insufficient grid bias means a heavier-than-necessary drain upon H.T.

\* \* \*

If two condensers of equal value are connected in series the total value of the arrangement will be half that of one of the condensers.

\* \* \*

### Parallel Condenser

When two condensers of equal value are connected in parallel, the total capacity of the arrangement will be twice that of either of the condensers.

\* \* \*

When connecting up a strange low-frequency amplifier to the set do not join its H.T. negative terminal to the H.T. battery. (There is no need for this connection, and if it is employed it may result in the shorting of the accumulator.)

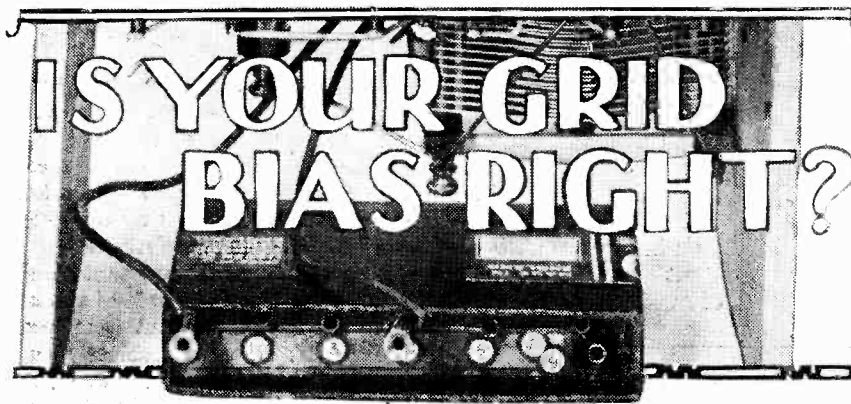

*Some practical notes on a most important subject.  
From a Correspondent.*

**A**LTHOUGH the use of grid bias was disclosed in a patent specification as long ago as 1911, it has only been in general use for the last three years or so, and even nowadays the writer knows from experience that only too often what happens is that the highest H.T. voltage available (often only 60 volts) is connected to the plate of the last L.F. valve and a 4½-volt pocket-lamp battery is connected to give grid bias—because it lengthens the life of the H.T. battery. The finest resistance-capacity coupling in the world would not give distortionless reproduction in such circumstances.

Look at the little picture enclosed in a power-valve box showing the valve's characteristics, or the relation between the voltage on the grid of the valve and the current flowing in the plate circuit when various H.T. voltages are applied.

### Avoiding Distortion

If there is to be no distortion due to overloading the valve it is essential, first, to work on the straight part of the characteristic curve, as only in this way will the changes in the voltage applied to the grid of the L.F. valve (by the detector or previous L.F. valve) be reproduced faithfully by magnified changes in the plate current. Thus if two characteristics are as shown in Fig. 1, the grid must never be allowed to become more than 25 volts negative if there are 120 volts on the plate, or more than 10 volts negative if there are only 60 volts on the plate, because the characteristics then begin to curve.

Secondly, no current must be allowed to flow between the grid and the filament around the circuit connected to them. If grid current is allowed to flow, the amplified changes in the plate current again will not follow exactly the varying voltages

applied to the grid; speech is then "plummy" and a piano sounds wooden. Grid current, of course, will not flow if a grid bias of the right amount is connected to the grid in the opposite direction to that in which the current would tend to flow.

Generally speaking, grid current begins to flow when the grid of a power valve is more positive than about -1 volt. Thus in Fig. 1 we must

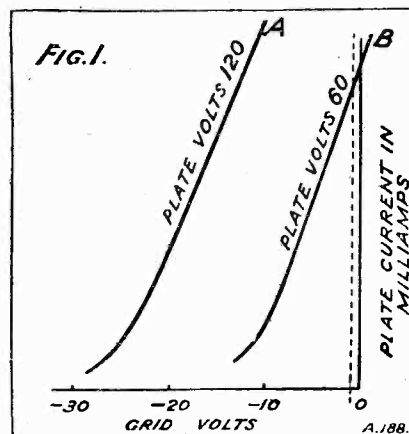

never let the grid voltage go to the right of the dotted line drawn at -1 volt grid potential.

### Grid Swing

Now it has been found by measurement that to obtain really good loud-speaker results for a fair-sized room there must be a voltage variation of about 15 volts on the grid of the last L.F. valve when the set is working. The middle of this swing is 7½ volts, which must be 7½ volts below -1 volt in the case of the last valve; in other words, the steady negative bias to be applied to the grid of the last valve must be not less than 8½ volts or, say, 9 volts, as grid-bias batteries cannot be made with ½-volt tappings.

Having fixed the minimum grid bias for good loud-speaker results,

look again at the picture showing the valve characteristics and find out what curve you must work on or, in other words, what H.T. you must use to have a straight bit of at least 15 volts on the characteristic, the centre of the straight bit being at about -9 volts. In Fig. 1, curve A shows a straight bit of some 21 volts from the dotted line to where the straight bit begins to curve, so that if you used this valve with 120 volts on the plate and a grid bias of 9 volts you would be all right. You could moreover use up to about 12 volts grid bias in this case, so that the valve could deal with a larger input, and by using the 12 volts you would economise in the plate current flowing.

### Fix Bias First

It will be seen then that grid bias is fixed by the input on the grid before the plate voltage is decided upon. To fix it in any other way is to work in the dark. In a two-stage L.F. amplifier the grid swing on the first valve will, of course, be much less than that of the last valve, the exact amount depending on the amplification factor of the valve and the coupling method. The swing may be only ½ volt if the valve and coupler (resistance-capacity or transformer) give an amplification of 30 and a swing of only 15 volts is required on the grid of the last valve.

The D.E.5A type of super-power valve permits a grid swing of about 40 volts with a plate voltage of 120 and 21 volts grid bias.

Remember that valves do not last for ever, and serious distortion may occur if a power valve loses its emission. The writer had a case of this recently. The set had been working splendidly when suddenly the loud speaker began to make nasty buzzes on loud notes, and no amount of juggling with grid bias would keep the milliammeter needle steady.

Finally, the valve was removed from the set, put in a valve holder on the bench, and rough measurements of its plate current taken for various values of grid bias and H.T. voltage.

### Lost Emission

It was thus found that the emission was about one-third what it should have been for a valve of this kind. The filament was worn out, and the smaller number of electrons emitted were insufficient to give a straight characteristic long enough to accommodate the voltage swing on the grid under normal working conditions.



**P**ORTABLE sets, with which many readers of MODERN WIRELESS will now be concerning themselves, present in their design a number of special problems other than that—the most obvious—of portability. One of the most difficult is compactness, which brings with it a whole chain of troubles if not properly tackled. At the same time, as a “portable” which is not really portable fails in its first function, the problems concerned with this aspect of the case will be dealt with first.

Portable sets, for the purpose of this article, are considered to be those which contain in one cabinet the receiver, all batteries and the aerial, as well as the loud speaker (if the set is powerful enough to operate such a device). If, by some means, we could make sets which would operate without high- or low-tension supplies

*The construction of portable receivers necessitates special considerations which do not have to be taken into account where ordinary types of sets are concerned. In this article Mr. Percy Harris discusses some interesting points and gives full details for the construction of two complete receivers.*

By  
**PERCY W. HARRIS, M.I.R.E.**

then weight would scarcely worry us at all, for the parts of the set other than the batteries are comparatively light, particularly when we choose, as we can do, resistance-capacity coupling for the audio-frequency side. Even loud speakers can be made very light, if we choose cone types specially designed for use in portable sets.

For our filament supply we have but two alternatives—dry cells or

accumulators. Two-volt valves are used almost exclusively in portable sets, and therefore we can have either a 2-volt accumulator or two dry cells and an adjustable filament resistance. Nothing smaller than the bell-ringing type of dry cell is of much use for the purpose, and even these are thoroughly unsatisfactory if we want to use them to run a four- or five-valve set.

**Suitable Valves**

I have never had any great fondness for the .06-ampere type of valve, which is now practically obsolete, for there is no doubt that in these efficiency was sacrificed appreciably to obtain the very small filament current of 60 milliamperes. The modern 100-milliamper 2-volt valve is a much more satisfactory proposition in every way. The actual power

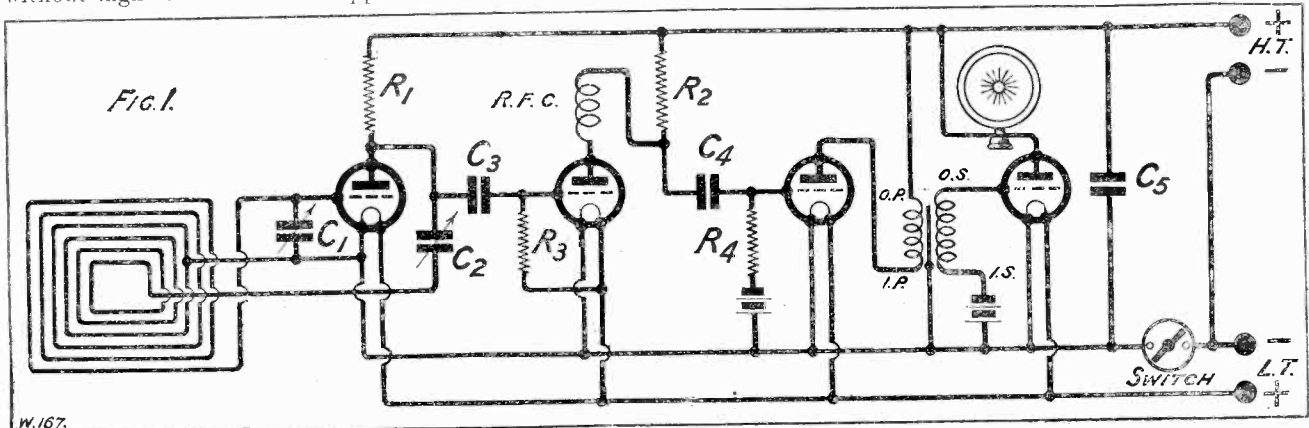

A four-valve circuit that has given extremely good results in portable sets.

absorbed by a 2-volt 100-milliampere filament valve is almost exactly the same as that required by a 60-milliampere  $3\frac{1}{2}$ -volt valve, but whereas with the 60-milliampere type three



An unspillable accumulator takes less space than dry cells, and weighs only one pound more than the dry. Also there is a filament resistance, which, of course, is not needed when the accumulator is employed.

dry cells in series are required, in the 100-milliampere we can use two—a gain in weight in favour of the 100-milliampere type (although the cells will last a shorter time).

It is quite a mistake to imagine, as many people do, that there is a very appreciable saving in weight by using dry cells for filament supply. A good 2-volt unspillable accumulator, charged with acid and with a capacity of 14 ampere hours *actual*, weighs but 1 lb. more than two dry cells of the bell-ringing type, and will give far more satisfactory service in every

way. Furthermore, the space occupied by the unspillable accumulator is less than that of the two cells mentioned.

### Some Interesting Figures

Most of the dry-battery makers supply special dry cells for filament lighting, and there is no question that these give much more satisfactory service than the bell-ringing type; but, on the other hand, a portable set that is taken round the country in a car, or on holidays, will require frequent replenishment of dry batteries, and it is often more convenient to use the bell-ringing type, which is obtainable in practically every village, whereas comparatively few dealers will be found who stock the particular type of filament-lighting dry cell.

Coming to actual figures, the two dry cells of the bell-ringing type illustrated (obtained by the simple expedient of walking into the nearest electrician's and asking for two bell-ringing cells) weigh, together, 3 lb. 2 oz., whereas the unspillable accumulator illustrated weighs exactly 1 lb. more.

The 60-volt dry battery shown, the lowest voltage which will give satisfactory results with most portables, weighs about 4 lb. 6 oz., and we must throw in a few ounces more for a grid-bias battery, so that before we start considering the weight of the set itself we have approximately  $7\frac{3}{4}$  lb. of battery when using dry cells throughout, or  $8\frac{3}{4}$  lb. using an accumulator for L.T. This, by the way, is approx-

imately more than the weight of a good-sized leather attaché case, your morning paper, a few business documents, and a novel.

Any portable set sufficiently powerful to operate a loud speaker must have two stages of note magnification, and it is advisable that there should

### COMPONENTS USED

- 1 Ebonite panel,  $14\frac{1}{2}$  in.  $\times$   $4\frac{1}{2}$  in. (Resistance).
  - 3 Clix sockets and three Clix plugs for same.
  - 1 Variable condenser, .0005 mfd. (Bowyer-Lowe).
  - 1 Variable panel-mounting filament resistance, 10-ohm (C.E. Precision).
  - 1 Panel-mounting micro condenser (Igranite).
  - 1 Single circuit open jack (Lotus).
  - 1 Plug for jack (Lotus).
  - 1 Small vernier dial (Marco, Rothermel or Peto-Scott).
  - 1 .0003-mfd. fixed condenser (Lissen).
  - 1 Grid leak, 4 megohms (Lissen).
  - 1 R.F. choke (Wearite).
  - 2 Valve holders (Lotus).
  - 1 L.F. transformer, 2.5 to 1 ratio (Pye).
  - Few ounces No. 22 D.C.C. for frame.
  - 1 2-volt H.F. type of valve as detector, and 1 2-volt L.F. valve. Both must take the same filament current.
  - 1 60-volt H.T. battery.
  - 2 Bell-ringing dry cells.
  - 1 9-volt grid-bias battery.
  - Stiff wire for wiring up, wander plugs, flexible wire for battery leads.
- Note.—See text re alternatives.

be at least one stage of radio-frequency amplification preceding the detector. For the low-frequency side we can use transformer, choke or resistance-coupling.

### Weight of Components

The last is much the lightest, but requires a higher voltage of high-tension battery, and will not operate satisfactorily on much less than 100 volts. This means, of course, a further addition to the weight of high-tension battery—say, another  $2\frac{1}{2}$  lb. I find the weight of a 100-volt high-tension battery, of the same make and capacity as that previously mentioned, to be 6 lb. 14 oz.

Low-frequency transformers vary considerably in weight. Most, but not all, of the high-grade transformers giving big amplification weigh something in the neighbourhood of two to two and a half pounds. It will thus be seen that the additional weight of battery necessary when using R.C. coupling is much greater than the saving of weight of the transformer—even the heaviest.

Furthermore, if one is prepared to put up with lower amplification

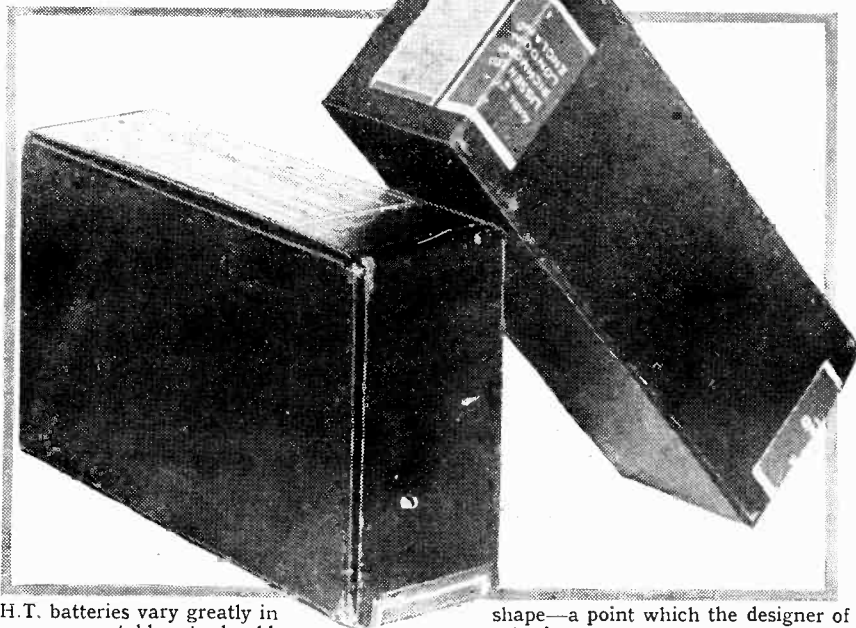

H.T. batteries vary greatly in shape—a point which the designer of portable sets should

take into account.

per stage and not quite such good quality, much smaller and lighter transformers can be obtained. Recently, however, the Mullard Company have brought out a transformer which by use of a new type of core and windings gives first-class quality and high amplification, with a considerable reduction in weight.

There are many problems in connection with frame aerials in all portable sets. Most portables have the frame aerials wound either round the inside of that part of the box containing the set, or in the lid. Electrically, it is generally found more satisfactory to have the frame in the lid, for when it is wound round

eddy currents set up by the parts within the field.

A frame aerial wound with a minimum of solid dielectric in its field is always preferable to one which is wound on solid wood and fixed close up to the casing of a box, which is generally done. If the utmost sensitivity is required for a portable set, it is preferable to use an exterior frame of the folding type. Excellent folding frames can be bought, or can be home-constructed if a suitable wooden framework is used. In one of the photographs accompanying this article there is shown a quite inexpensive framework on which one can wind a folding frame.

### Special Wire Available

Frame aerials of the folding type should be wound with the special flexible frame aerial wire obtained from such firms as the London Electric Wire Co., Ward & Goldstone, Ltd., etc., or with single electric-lighting flex. The former, however, is preferable, as it is very finely stranded and bends as easily as string, whereas the single electric-lighting flex is not quite flexible enough for regular folding.

In practice, there seems to be little to choose between the flat, spiral, diamond type of frame and the type in which all the turns are side by side. The number of turns depends, of course, upon the size of the frame; but as a guide, using a square frame with all the turns touching, and side by side in single-layer formation, about 12 to 14 on a frame measuring 16 in. square will

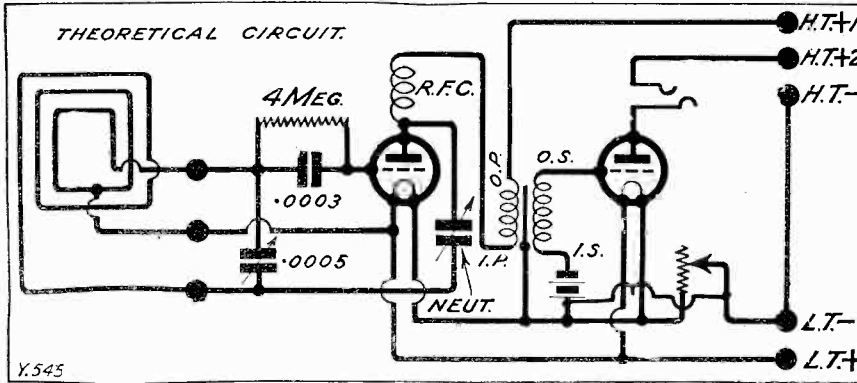

Tuning condensers, valve holders, fixed condensers, grid leaks, etc., are all comparatively light objects, although, when added together, the weights of various components in a complete four or five-valve set total up to quite an appreciable figure. One of the biggest items, however, in a complete portable set is the carrying case itself, and many of those sold are needlessly heavy. An aluminium framework covered with plywood or leather cloth could be made very light, and far below the figure of eight or nine pounds which represents the weight of the case alone of many portable sets.

### Popularity of Portables

To conclude the review of this aspect of the subject, it can be taken that it is a very cleverly designed four- or five-valve portable which, "ready for the road," with adequate batteries in place, weighs much less than thirty pounds.

Portable sets are largely used, not for carrying about on holidays or in the car, but for their great advantages of compactness and independence of aerial or earth wires. This last winter brought considerable prosperity to makers of portable sets, for a large number were sold to flat-dwellers and people who wanted to take the set from one room to another as convenience and fancy dictated. In such cases actually weight is not so important as compactness, so that the use to which a portable set will be put should be carefully borne in mind by anyone attempting to design or choose such an instrument.

the box itself large conducting masses come immediately inside the frame and introduce unwanted damping.

### Frame Aerials

I have carried out a number of experiments in this regard recently, and found enormous differences between different frame aerials and the ways they are wound. For example, in the particular set I have just described, considerably more reaction is required to bring the set into oscillation when the batteries are in their proper position than when they are outside of the box. In this case, however, the additional reaction makes up to a large extent for the losses introduced by the

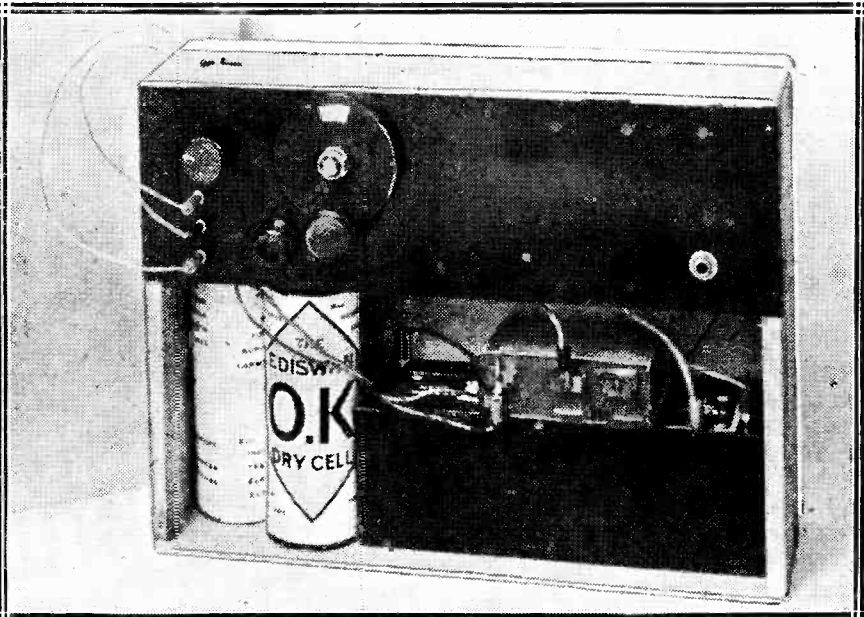

The H.T., L.T. and G.B. batteries can be packed away beneath the panel.

generally be found suitable. On a non-folding frame, single electric-lighting flex will be found very suitable, as the insulation is fairly thick and this spaces the turns advantageously. Reaction windings, if used, can be made of finer wire, such as No. 26 D.C.C.

While the makers of practically all modern valves claim that their productions are "non-microphonic," and while few modern valves give trouble in ordinary sets when the anti-microphonic type of socket is used, when we come to the design of a portable set including the loud speaker (which may be only a few inches from the valves themselves), we come across a lot of troubles which had not previously been noticed.

### Microphonic Valves

Many valves which give no trouble in an ordinary set, become very microphonic when used in such close quarters, and individual specimens of the same make vary considerably among themselves. The troublesome valve is generally that used as detector, the note magnifiers being practically always free from "ponging." The high-frequency valves, too, may give some trouble. It should be remembered that the trouble arises not so much from vibrations which reach the valve through the baseboard—the antiphonic holders generally look after this quite satisfactorily—but to the impinging of air waves from the loud speaker on the glass of the bulb. The best antiphonic holders

are powerless to check this trouble, and the actual position of the valve sockets in a set has an important effect in determining whether you will have trouble or not. (I am speaking now, of course, of sets which have built-in loud speakers.)

particularly effective in portable sets is that shown in Fig. 1, in which reaction on the frame is used as shown and the high-frequency valve is coupled to the detector by means of resistance coupling.

The value of the coupling resistance

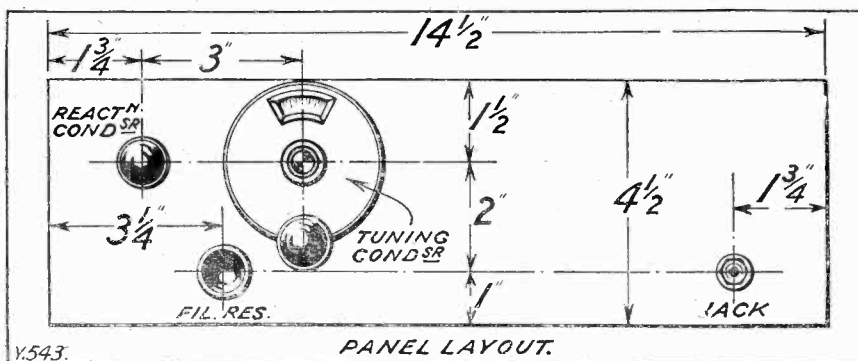

Here are two tips which I have found from practical experience to save a lot of trouble. The first is to glue a length of cotton-wool along the back of the cabinet where the valves are situated—this does a great deal in preventing the reflection of sound waves off the walls of the cabinet—and the other is to take a piece of Plasticine about as big as a small round biscuit and to press it down on top of the valve. This will be found to cure very many obstinate cases.

### A Simple Circuit

If you are making up your own portable set, remember that you will not get good results on anything but a super-heterodyne unless you use reaction on the frame. A very good and simple circuit which I have found

should be about a quarter megohm—a quarter-megohm leak will do—and the grid leak about two megohms. The wiring of such a circuit should be very carefully undertaken, and particularly short leads should be used, otherwise you will get unwanted feedback effects.

The first valve should be one of the R.C. types of valve, and although you will not get so much high-frequency magnification as with a tuned circuit, this particular arrangement enables you to use only one tuning condenser for the whole set—no mean advantage. On the note-magnifying side, one transformer and one resistance can be used. You will require a good 90 or 100-volt high-tension battery.

Finally, when designing your own set, remember that the layout, particularly of those portions of the circuit which carry high-frequency currents, is just as important in a portable set as in any other, and that you must not sacrifice efficiency merely to obtain compactness.

### Shapes of Batteries

Many home-designed portable sets have been found to be unmanageable, due to feedback arising from bad spacing of parts. Start off your design by getting together the batteries you are to use, and arrange these so as to give the maximum space for the rest of the set. Remember, too, that high-tension batteries can be obtained in almost all shapes and sizes.

If your design seems awkward with the particular high-tension battery you have on hand, look around to see if one of a more convenient shape for your purpose can be found. The great difference in the shapes of batteries is illustrated in the photograph in a previous page, and in designing

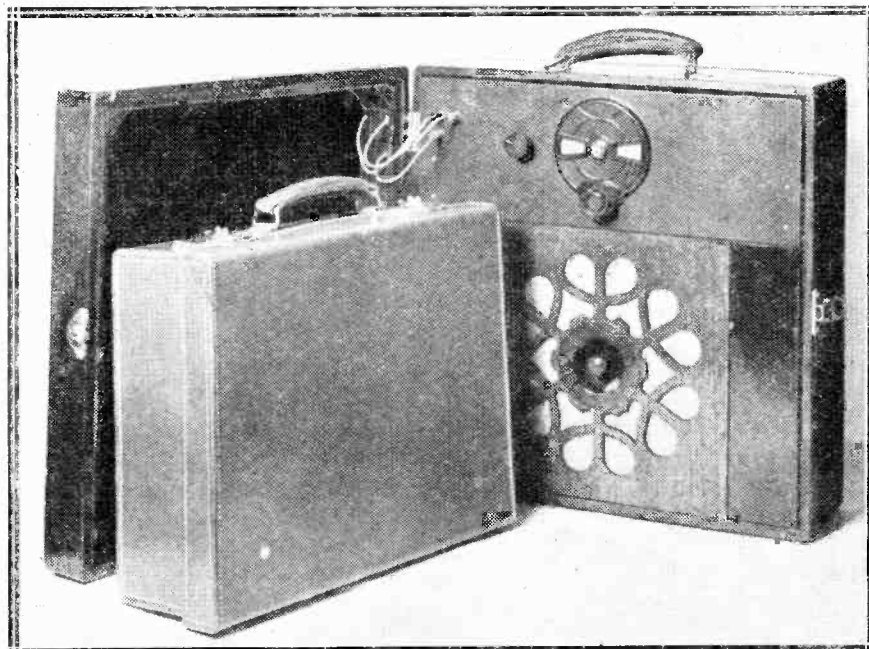

A fairly small case will take a portable to be used with 'phones, but a loud speaker necessitates a much larger one.

my own portable set recently I found a battery which enabled the layout to be entirely redesigned with much greater efficiency.

Do not attempt to cut weight by using a very small high-tension battery. Unless the maker has cheated, which is a very rare occurrence, the heavier the high-tension battery the longer its life. High-tension batteries weighing much less than the figure given in this article will prove an unsatisfactory investment.

### Weighs Only 15 lb

Seeing that hundreds of thousands of listeners live within seven to ten miles of a main station, it occurred to me recently to carry out experiments to see just how simple a portable set could be made, bearing in mind that it would be used for listening to one station only, and that the station would not be situated at a greater distance of ten or fifteen miles. A simple set which would operate one or two pairs of headphones at adequate strength on

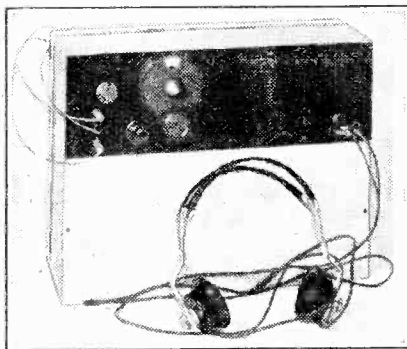

The compactness of the receiver is emphasised by the size of the telephones, and can be judged from this photograph.

signals from the local station would satisfy the requirements of many people, and it was found that a set using a properly designed two-valve circuit could be made up to weigh only 15 lb., inclusive of batteries.

### Completely Self-Contained

The set which is illustrated in the series of photographs accompanying this article measures approximately 15 in. by 11 in. by 5 in., and weighs 15 lb., with a 60-volt H.T. battery, two bell-ringing dry cells, and a grid-bias battery "on board." It gives excellent headphone strength signals from a main station up to about fifteen miles, and, with careful adjustment of reaction, 5 G B can be heard in the London area.

The set is made up for utility rather than appearance, and is not fitted into any carrying case, but as it is completely self-contained, the box,

which has the frame aerial wound around it, can be carried from room to room with great ease and at any angle. At the same time, it is so made

current for both valves, and acts as the on-an-off switch. This is necessary as the voltage given by the dry cells will fall slowly in use, and as we

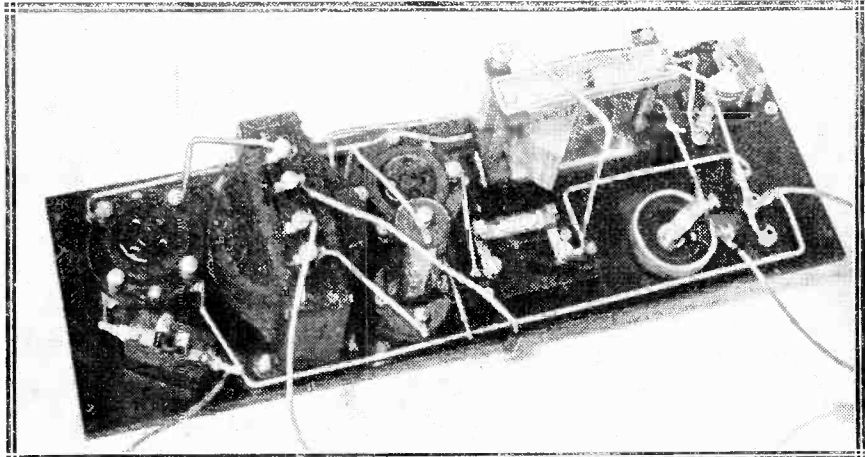

Most of the wiring can be followed in this photograph of the reverse side of the panel.

that it can be dropped into any suitcase for carrying about, and as the whole receiver is quite "dry" in every respect, there is no risk of acid spoiling any articles packed in the same case.

The circuit is given in page 513. The frame aerial is a single winding of 14 turns round the outside of the box, as illustrated, and a tapping is taken from the centre, this being connected, as will be seen, to the positive filament of the detector valve. The tuning condenser is of .0005 mfd. capacity, and is connected across the whole frame. The Hartley type of circuit is used, reaction being controlled by a very small "neutrodyne" type of condenser connected between the moving plates of the tuning condenser and the plate of the valve.

### Filament Rheostat Essential

A radio-frequency choke is interposed between the plate of the valve and the primary of the low-frequency transformer, and a single variable filament resistance controls the

must maintain approximately two volts on the filaments, more and more filament resistance is cut out as the battery gets older.

### When Accumulator Is Used

If a two-volt unspillable accumulator is used, then this variable resistance can be dispensed with, and replaced by a switch, or if it is included it should be turned full on whenever the set is in use, and no harm will be done to the valves. Care should be taken, however, never to turn it full on with new dry batteries, as two together will give approximately three volts, which is exactly a volt more than the maximum which should be used on the valves. By carrying the 10-ohm filament resistance half-way on the valves will be correctly lit with new dry cells.

Telephones are used for reception and are plugged into the set by means of a plug and a jack. This is by far the most convenient method when 'phones are used, as if it is

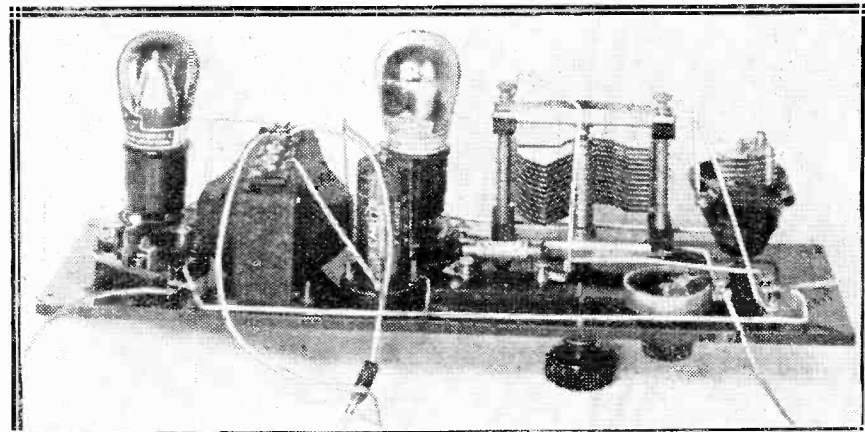

Extreme simplicity is obtained by mounting all the parts on a single panel.

desired to leave the set for a few minutes, or to cross the room, it is much easier to withdraw the plug and move about with the 'phones on the head than to remove them and lay them down. In view of the fact that dry cells are used for filament supply, it was considered inadvisable to use a filament control jack, for this type of jack would switch the current on and off suddenly, and one can easily forget to make the necessary adjustment on the filament resistance when doing this.

**Very Smooth Reaction**

The remarkable sensitivity of this receiver is due to the fact that smooth reaction on to the frame can be obtained; for this, by reducing the effective resistance of the frame, makes it a very sensitive pick-up device. It is, of course, necessary to place the set so that the plane of the frame is in the line connecting the listener with the station, for the set is acutely directional, and nothing will be heard if the frame is situated at right angles to the direction of the station.

The parts needed to make this set are comparatively few.

The framework was home-made from hard wood and actually consists of two side pieces of the thickness shown, a transverse piece of wood, 2 in. by 1 in. (before planing), and thin plywood. The back of the cabinet is left open at the top to enable access to the valves to be obtained, but the rest of the back, front, top and bottom are filled in with thin plywood. The front piece of plywood is held in place by two small wood screws which can be easily taken out when it is desired to change the batteries.

The frame aerial is very simply made. First of all a small hole is

drilled diagonally in the top of the plywood so as to come out at the left-hand side of the case, and the end of the No. 22 D.C.C. wire threaded through this, leaving about a foot

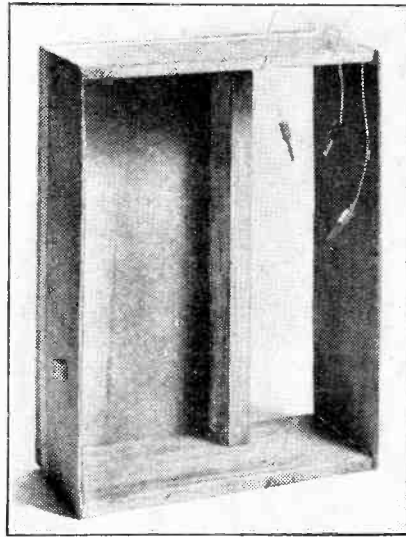

These strong end pieces and a stout transverse stay enable light plywood to be used for the remainder of the casing.

projecting. If a knot is tied in this wire it will prevent it pulling back through the hole, and when fourteen turns are wound on with turns touching, the other end is passed through a similar hole.

**Plugs and Sockets**

The seventh turn is now lifted by means of a knife and a match tucked underneath it to hold it temporarily above the remaining wires. The cotton covering is now removed for about half an inch, the wire tinned, and another foot length soldered on to this. The three wires are then finished with Clix plugs so that they can be quickly fitted into the three sockets on the panel front.

Speaking of plugs and sockets

in connection with portable sets, I would strongly recommend the type of wander plug which grips into the hole in the high-tension battery and grid-bias battery. The Electrolinx people make a spring plug, as also do the Igranic Company, and as the size of sockets in high-tension batteries varies quite appreciably between makes (and sometimes between sockets in the same battery!), the spring or gripping type of plug is a distinct advantage, as it is not likely to jolt out when the set is moved. This applies to all types of portable sets.

**Making the Two-Valver**

The constructional work of the two-valve set is very easy, for all components are mounted on the one panel. The various components are held by 6 B.A. metal screws with countersunk heads, 6 B.A. nuts being used to hold the parts in place. When drilling the panel, you will find it a great improvement in the appearance of the set to countersink the holes rather deeply, and then, when all screws are in place, fill in the tops with black modelling wax, which can be obtained from any toy-shop.

Melt the wax with a match and let it drop into the countersunk holes after the screws are in place. Do not worry about an excess of wax, for when it is quite cold and hard the excess of wax can be sliced off with a sharp knife. If the whole panel is now given a hard rub with a dry duster, a perfectly smooth, uniform surface will be obtained, and you will avoid that spotty appearance which is generally inevitable when a large number of screw heads are showing.

Stiff wire is used for wiring up the set, and flexible leads are taken

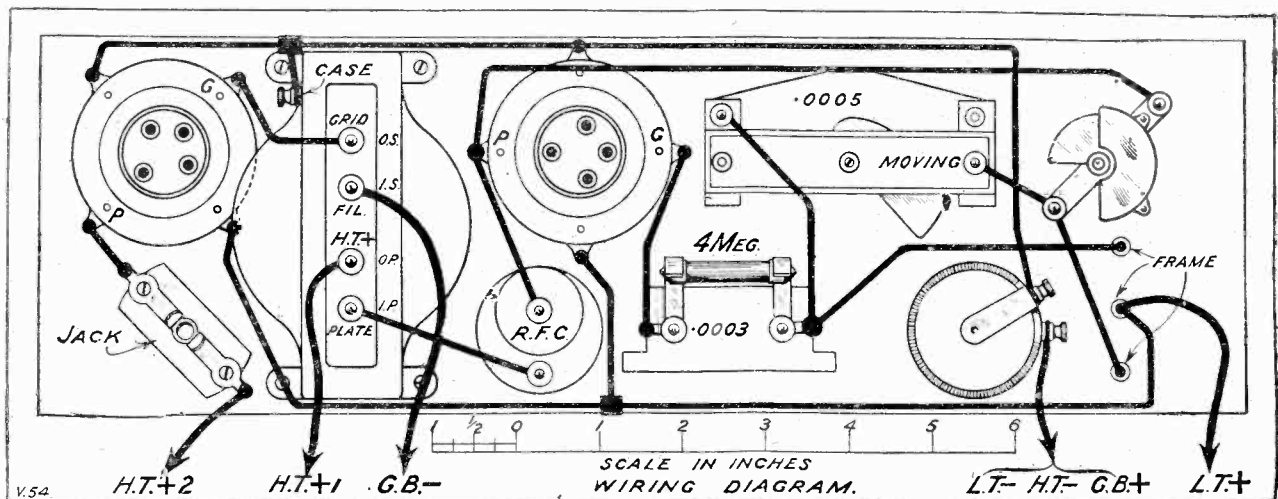



from the centre socket for L.T. positive, from one terminal of the filament resistance for a combination of L.T. negative, grid bias positive, and H.T. negative. A flexible lead is taken from I.S. of the transformer

very useful to bend the end of the negative into a loop, and to screw it underneath a nut behind an ordinary terminal, and then to join the flexible lead from the set between the ordinary gripping screws of the terminal.

vantage, but this procedure, while electrically very good, is rather awkward when it is desired to change the batteries rapidly.

\*\*\*\*\*  
**ITEMS OF INTEREST**  
 \*\*\*\*\*

When connecting your loud speaker to the set be sure (unless a filter circuit is used) that its red terminal is joined to the terminal on the set which is connected to H.T. positive. (If this is not done there is risk of serious damage to the loud speaker.)

\* \* \*  
 Jack Hylton's band has been touring the Continent and has played from several broadcasting stations in France and Germany. Jazz music, as played by this band, has been something of a revelation to both French and German listeners, and has been enthusiastically welcomed.

\* \* \*  
 The Italian broadcasting service has recently been revised and many important extensions are being planned.

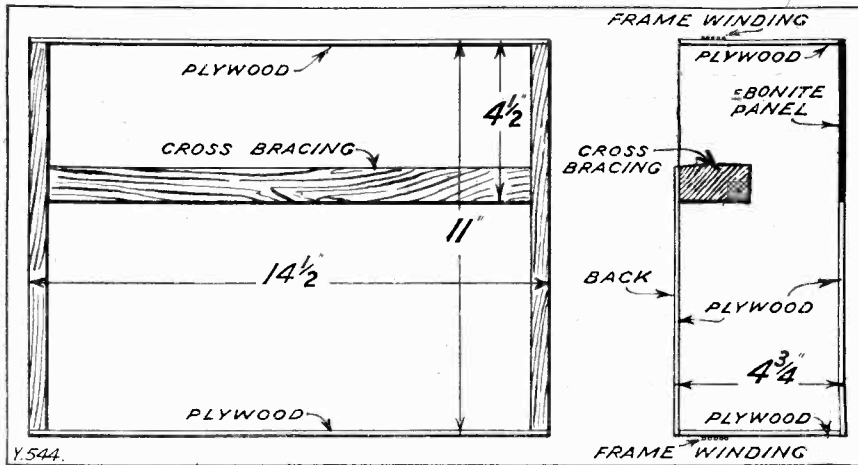

for grid bias negative, and another flexible lead from H.T. positive (or O.P.) terminal of the transformer for H.T. positive 1. Lastly, a flexible lead is taken from one terminal of the jack for H.T. positive 2.

**An Important Connection**

Note particularly that the terminal joined to the core of the transformer is connected to low-tension negative. In most portable sets it will be found a distinct advantage to connect the cores of low-frequency transformers to low-tension negative, even when it is not found of any advantage to do this in ordinary sets.

The operation of this little portable is very simple. About 30 or 40 volts on H.T. positive 1 and the 60-volt on H.T. positive 2 will be found suitable. If the high-tension positive 1 tapping is too high, the reaction will be not quite smooth enough, but around the figure mentioned will be found to suit most valves.

Grid bias should be used according to the specification of the valve makers for the L.F. valve. All of the leading makes of 2-volt valves have been found satisfactory in this set. Tuning is so sharp that a vernier dial is essential, and while any suitable vernier dial or condenser can be used, the size of the panel rather prohibits the larger type.

**The Dry Cells**

The two dry cells used for filament supply are, of course, connected in series, and as one wire of each cell (the negative) is simply a straight, stiff lead, without any terminal or means of connection, it will be found

Alternatively, the flexible wire can be wound round the stiff wire, but this will be found an unsatisfactory method in most cases, and liable to give noises and to slip off at just the wrong time. Of course, the wire can be soldered with ad-

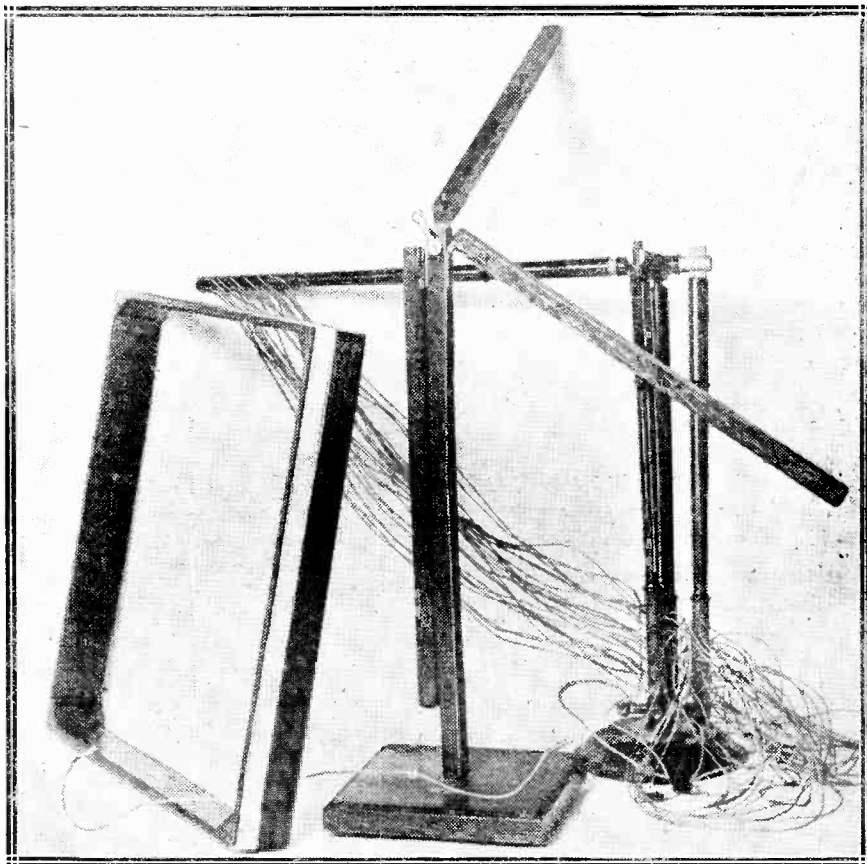

Three types of frame aerial. (Back) A partly folded Bodine frame aerial. (Centre) The Camco aerial for home-constructors. (Left) A useful non-folding frame which fits into the lid of a portable set.

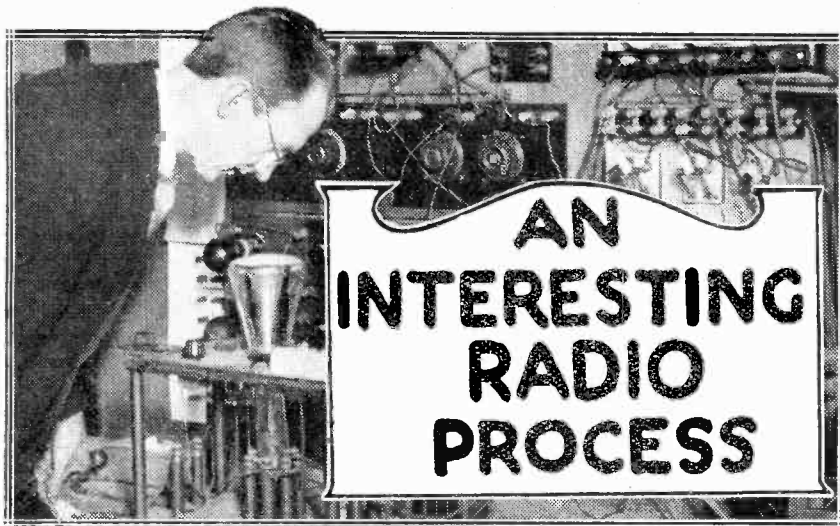

*This article deals with chromium-plating. Does it sound interesting? It is, as you will agree when you have read about it.*

*By C. W. PEARSON.*

ALL amateurs who have at some time or other incorporated an accumulator in the cabinet of the set have noticed that after a few months have elapsed the metallic parts of the set assume a dull, dead appearance. This is due to the acid fumes given off during the process of discharge, which being moist (spray from the electrolyte) are in a very active state to eat into a metal for which they have an affinity. There appears to be no remedy for this when an ordinary lead-acid type accumulator is used, but in the very near future it is highly probable that the metallic parts sold will be plated with a metal that will effectively prevent such corrosion.

**Acidified Atmosphere**

This element is chromium, and research during the last few years has been very intensive and fruitful, so much so that the process that was primarily an academic subject has

**YOUR BATTERIES**

Even if you do not use your accumulators very much during the Spring and Summer, cultivate the habit of having them charged at regular intervals. By doing so you will keep them in good condition and hold sulphation in check. Make your trip to the charging station a monthly duty; it will save you money in the "long run."

been improved and established in industry.

The value of the plating process from a wireless outlook is the complete ability of the metal to withstand corrosive vapours. Irrespective of

the fact that an accumulator may or may not be incorporated in the cabinet of the set in close proximity to the delicate wireless parts, the atmosphere in all large towns contains an appalling amount of acid.

This is not poured out from chemical factories only, but from the domestic fire, so apparently all wireless equipment is liable to corrosion unless efficiently designed to withstand it, or, failing that, unless given careful attention.

**Easily Plated**

It is usually only a matter of a few weeks in a large town before the bright brass parts become dull and lifeless, and as soon as this has happened the set commences to rapidly depreciate in value. Chromium-plating is the only solution to this problem and will double the value (from an appearance view) even after two or three years' use, as a damp rag will bring the surface as bright as new.

The process differs slightly from that of nickel-plating, but the apparatus is almost identical. The solution from which the plate is derived is contained in vessels that are commonly used in other plating processes — asphaltum, stoneware, wood vats with glass or lead linings, or enamelled iron with protective linings of glass.

**Special Dynamo**

Electricity is applied by a plating dynamo especially designed for the task, and its capabilities are a heavy amperage with a low voltage, constant current intensity owing to liberal

dimensions and relatively low speed. The current is controlled by means of a board of accurate measuring instruments. The importance of this cannot be emphasised too strongly, as the characteristics of the electrically deposited chromium are dependent solely upon current intensity and temperature of the solution.

**Extremely Hard**

Some operators take a preference for working with a cold solution, while others persistently adhere to the warm one. The metal obtained from the cold process has a dull grey, granular appearance, and is soft, while the warm bath gives a deposit of a very fine polish (conditionally that the undercoating has been well polished) which is extremely hard.

Softness as spoken of in connection with chromium is in quite a different sense to the term that one uses in iron and steel discussions. In all forms chromium is one of the hardest materials known to man, and as a guidance it may be added that the grey deposit can be only just ground

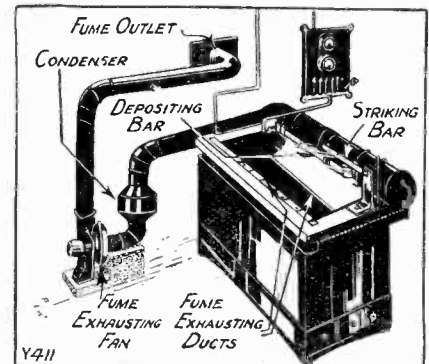

by means of the best quality abrasives, and it is for this reason that nearly all workers adhere to the warm bath process, as the coating is highly polished when the under-coating has been well buffed.

**DISCOVERY DATES**

It was on December 12th, 1901, that Mr. Marconi and his assistant picked up the first transatlantic wireless signals sent out from the Poldhu station, Cornwall. The distance is approximately 1,800 miles.

Radio concert programmes were being sent out on as much as 15 kilowatts from the Marconi Experimental Station at Chelmsford in 1920.

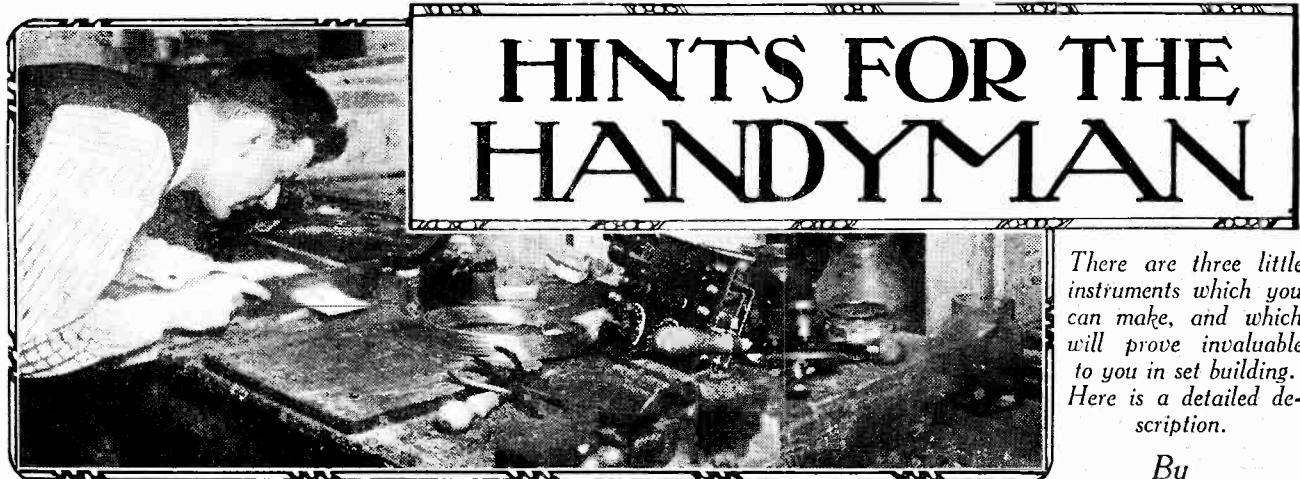

# HINTS FOR THE HANDYMAN

There are three little instruments which you can make, and which will prove invaluable to you in set building. Here is a detailed description.

By  
R. W. HALLOWS.

**H**AVING a little time to spare the other day, I went to my workshop and made up three tools which I had long been thinking about, though somehow an opportunity for turning them out had not occurred. The total cost was insignificant, and the time required for the job was rather less than an hour.

### Saving of Time

Now that I have these tools in use I am wondering how I ever got on without them, for jobs are always turning up in which their time-saving and trouble-saving qualities are demonstrated. I can strongly recommend any reader to make them up for himself, for I am quite sure that he will bless the day when he did so.

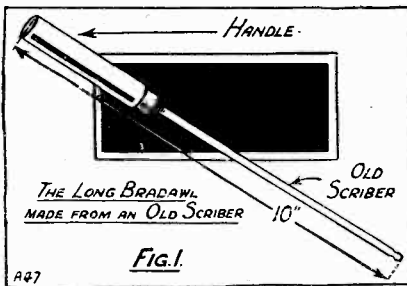

The first of the trio is illustrated in Fig. 1. You know those nasty little jobs that come one's way when an extra baseboard component has to be inserted into a set that is already wired, or when one of the existing components has to be moved to another position. With the ordinary bradawl it is exceedingly hard to make the required screw holes. The "business end" is very short and the stout handle will not allow it to pass through the narrow spaces available.

Even in cases where the point of the bradawl can be brought near the baseboard there is no room for one's hand to grasp the handle. My

bradawl measures 10 in. overall, the blade being 5½ in. in length. It was made simply from a file handle (these are to be purchased cheaply at any good tool shop) and an old broken scriber. Probably most workshop junk boxes contain ancient scribers that are of no further use for their proper purpose, but if one

"Now that I have had these tools in use I am wondering how I ever got on without them."

of these is not available a piece of 5/32 or 3/16-in. steel rod or a stout spoke from a motor cycle or a motor car tangent wheel will answer perfectly well.

The shaft is inserted into the file handle and its end is then ground to bradawl shape by means of the emery wheel. If good steel is used the tool serves a double purpose, for besides acting as a bradawl it forms also an exceedingly useful long-handled screwdriver for dealing with small screws.

### Preventing Shorts

The grinding is done in the following way: First square up the end, then grind two faces opposite one another, and continue the process until the metal is thin enough to form a flat blade with a reasonably fine edge. If an old scriber is used it will be desirable to reduce the diameter of the shaft by means of the grinder for a little distance above the bradawl point so made. When the blade has been ground approximately to shape by means of the emery wheel, it is a matter of a few minutes' work to finish it off with a file.

Another tool, which is even simpler to turn out, is a long screwdriver whose shaft is insulated from handle to blade. It has happened to

most of us to have had to tighten up some screw or other within the set whilst reception was in progress. With the ordinary screwdriver you may have been lucky in ninety-nine cases out of a hundred, but in the hundredth case contact has been made unintentionally by the screwdriver blade between two points at different D.C. potentials with somewhat expensive results.

### Easily Made

If the points happen to be H.T. + and L.T. —, with the batteries wired in series, several perfectly good valves may have gone up in blue flames in a moment. In any case, either accumulator or high-tension battery probably suffered considerably from the short. What is needed to prevent this kind of undesirable adventure is a screwdriver with an insulated shaft, and to make such a tool is a very simple business.

Obtain from any chemist's shop a length of the rubber tubing used for connecting the bulbs and heads of

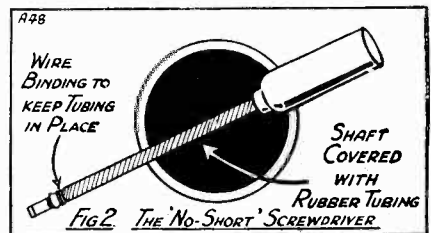

sprays. Cut off a piece as long as the portion of the screwdriver which lies between the handle and the blade, and work it on with the fingers, using, if necessary, a little french chalk as a lubricant.

Once it is in position it can be kept there simply by binding two or three turns of wire tightly round its lower end. The screwdriver so treated may now be used for all kinds of

awkward jobs without the slightest fear that any short-circuit may be caused in a careless moment.

**The "No-Short" Box Spanner**

The third tool is a long box spanner, which is also made so that it cannot effect short-circuits. It often happens that a nut must be tightened up, and that it is inconvenient (or, shall I say, one is too lazy?) to disconnect the batteries whilst this is being done.

.....  
 "What is needed to prevent this kind of undesirable adventure (burn-out valves, etc.) is a screwdriver with an insulated shaft, and to make such a tool is a very simple business."  
 .....

With a short box spanner the process is often not too easy in any event, and with one made simply of unprotected metal a devastating short-circuit is always a possibility. The no-short box spanner is made from a piece of brass tubing some eight or ten inches in length.

**A Simple Job**

A double-ended spanner for 2 B.A. and 4 B.A. may be made from tubing with an internal diameter of 5/16 in., and one for 5 B.A. and 6 B.A. from tubing with 1/4 in. internal diameter. The method of shaping the ends by inserting a nut threaded on to a piece of studding and hammering the tube on to its faces has often been described.

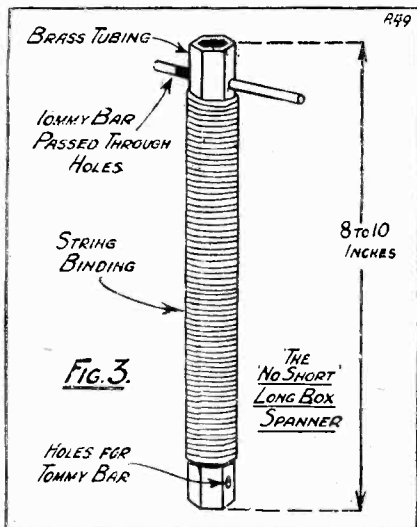

A hole for a tommy-bar, made of a short piece of metal rod, is drilled, as shown in Fig. 3, close to either end. The final process is to bind the tool with twine for the greater part of its length, and to give this a coat of varnish in order to keep it securely in place.

An exceedingly handy box spanner for awkward nuts that cannot be got at either with the ordinary tool or with the long box spanner just described is the "round-the corner" box spanner illustrated in Fig. 4. This is very easily made from a length of the same tubing as was used for the manufacture of the long spanners discussed in a previous paragraph.

**The First Stage**

The first stage is shown at A in the drawing. The end having been shaped to fit nuts of the size for which it is required, the tube is hammered almost flat for a short distance. Should the brass be on the hard side it would be well to anneal the flattened portion by bringing it up to red heat by means of a blow-pipe and then plunging it into cold water.

The business end may be re-hardened later, if necessary, by heating it and allowing it to cool slowly. Now bend the tube carefully round at right angles, and you have a spanner that will enable you to get at nuts which could not otherwise be reached and to tighten them up properly. To avoid all risk of short-circuiting, the shaft of the right-angled box spanner may be whipped with twine like that of the long straight tool.

**Magnetising Screwdrivers**

I have experienced more than once the usefulness of the magnetised screwdriver used in conjunction with steel screws. When it comes to the business of inserting a screw in an awkward spot one uses a steel screw instead of a brass one. The blade of the screwdriver is placed in its nick, and the magnetic attraction between the two enables it to be inserted into places which the fingers cannot get near.

**Exceedingly Useful**

Many people who do not want to buy special screwdrivers have asked whether existing tools cannot be magnetised. The answer is that they can very easily. All that is needed is a fairly powerful bar or horseshoe magnet, such as can be bought from any large toyshop. Rub the screwdriver blade a little over the magnet near one of its poles, and it will soon become permanently magnetised. It should be noted, though, that most screwdrivers are not made of very hard steel so that they tend to lose their magnetism more or less rapidly, a process which is very much accelerated by their being dropped or being knocked about on the workshop bench.

If, however, a permanent magnet is at hand the screwdriver can always be remagnetised in a few moments. Very good little wood-screws for use with the magnetised screwdriver can be bought at Woolworth's. They are made of steel, but as they have a covering of copper they do not rust and they look very well in the set.

**A Connection Tester**

"Atmospherics seem remarkably bad," you say to yourself one evening, for terrific cracklings are produced at

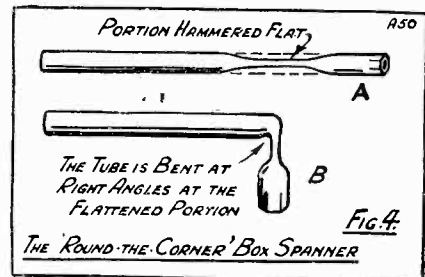

intervals by your telephones or loud speaker. A little later a friend comes in who expresses the utmost surprise on hearing that you have been troubled in this way. His own set, he tells you, was at work when he left his house, and there was not a sign of an atmospheric.

Clearly, then, there is something wrong with your apparatus. You rap sharply the cabinet on the table on which the set stands. The loud speaker responds by firing a broad-side. It is plain that there is a bad connection somewhere. You rock

.....  
 "You rap sharply the cabinet on the table on which the set stands. The loud speaker responds by firing a broad-side. It is plain that there is a bad connection somewhere."  
 .....

each valve in turn by placing the forefinger of the right hand on its bulb, whilst steadying the set with the left hand. The valves and their holders are guiltless. Are the coils to blame? You may try rocking them also, though the equilibrium of the set may quite likely be upset owing to hand-capacity effects if you do so.

We will suppose, however, that you convince yourself that valves, valve holders and coils are in no way responsible. The trouble is either due to a loose wiring connection or to faulty contacts in some "clip-in" component, such as a condenser, a grid leak, or an anode resistance. To locate the seat exactly you require something with which you can prod

(Continued on page 367)



# IMAGINATION AND THE LISTENER

*Do we, as listeners, play our parts in the production of a broadcast thriller?*

*All who are interested in giving Radio Drama a fair chance should read this interesting article.*

*By* NORMAN EDWARDS.

WE hear from time to time of experiments made by members of the B.B.C. in connection with broadcast plays. Sometimes these experiments are of a technical nature, designed for the attainment of greater realism of "effects" in the studio, and sometimes the experiments are in dramatic construction and the production of plays more suitable for broadcasting

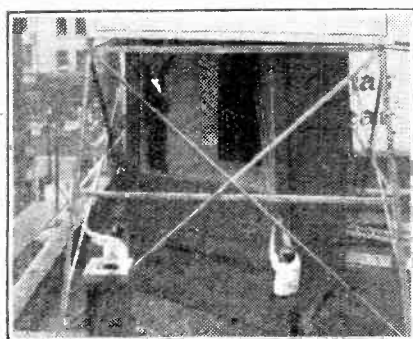

Reputed to be the largest loud speaker in the world, this giant combination of cone and horn weighs over a ton! Where is it?—In America, of course, "atop the broadcast building in Paterson, N.J."

because of their primary appeal to the ear, instead of plays which primarily appeal to vision and are only assisted in that appeal by the incidental dialogue and singing of the players.

### Diversity of Appeal

But although considerable progress has been made in the technique—we may, indeed, say the art—of radio drama, and although the measure of its popularity may be said steadily to increase as more experience is gained in broadcasting methods as a whole, and although its potentialities as a new form of art are becoming more widely perceived, we should be exaggerating the case for radio drama if we said that to-day it was in any way comparable in popularity with the legitimate stage or the cinematograph

Comparisons are not always odious, nor invidious, if they are made in a spirit of constructive criticism. Criticism is essentially intelligent analysis and intelligent comparison, and when we examine the relative appeal of the broadcast play, the stage play, and the cinema play, it becomes obvious that the critical faculty must be dominant because of the very diversity of appeal apparent between these three forms of artistic expression.

### Great Difficulties

And at the very outset of any critical comparison between these three media, it must be obvious that the broadcast play labours under great difficulties, and that, of the three media we have mentioned, there is ample evidence to show that the cinema is to-day the most popular because it makes an appeal to the eye and, in doing so, makes no very great demand upon the intelligence. The legitimate stage would come second in order of popularity for equally obvious reasons; and the broadcast play, although potentially the most intelligent and difficult media, third.

It has been written somewhere that when our judgment ripens our imagination decays; and if we add "sophistication" to judgment, this dicta offers a very good explanation for the difference between the appeal of the cinema and the stage and the appeal of the broadcast play. That difference, we venture to say, constitutes one of the primary troubles which make the B.B.C.'s task so extremely difficult. The Director of Broadcast Programmes has to be versed in the art of psychology if he is to be successful in catering for broadcast listeners satisfactorily.

### Lack of Imagination

Perhaps it may be more adequately expressed if we say that if the progress of civilisation is inevitable it is equally and inevitably at the

expense of imagination. It is lack of public imagination and an excess of public sophistication which constitutes the chief difficulty the B.B.C. has to contend with.

### Too Stolid

It is recorded that in the early days of the Athenian drama, imaginative spectators were furious because Æschylus frightened them out of their wits with his Furies; and Herodotus tells us that when Phrynichus produced his tragedy on the fall of Miletus, he was fined a thousand drachmas for torturing the feelings of his audience!

Can we imagine a modern audience being tortured to such an extent, even by such a fine actress as Miss Sybil Thorndike, that a fine be imposed upon her because of her genius for harrowing the feelings of her audience? And can we imagine the Postmaster-General, as Guardian of the Rights of Listeners and all Licence Payers, fining the B.B.C. for "emotional damage" to the listening audience of to-day?

Theoretically, the idea is conceivable, but practically it is difficult to imagine it under existing conditions, for we live in an age of reason, and in

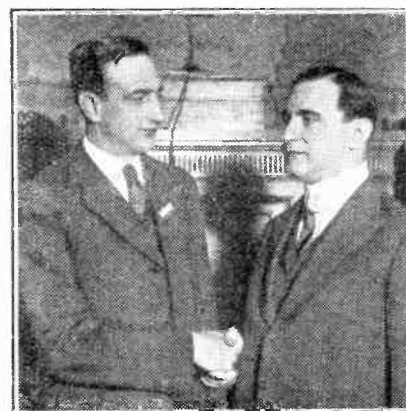

Dr. Alfred Norton Goldsmith (right), the new President of the Institute of Radio Engineers, being welcomed by his predecessor at a New York Convention.

consequence our imagination suffers. To-day, the theatre manager, the film producer, and the B.B.C. producer have to cudgel their brains in order to produce something which will even faintly stimulate the jaded imagination of sophisticated audiences.

The task is rather difficult because audiences know that the promised thrill will be artificial. Its origin is pre-conceived, and the more skilful its origin and however skilful the artistes who interpret it, the spell is broken because the skill is perceived.

any imaginative reaction in us. A child at a party may watch a grown-up of the Olympian world put on an ugly, grotesque mask. It knows that the mask is only a mask, but the child's imagination is too much for its reason, and sometimes it will scream in sheer terror.

### A Famous Case

The analogy may be used in connection with the broadcast listener. He knows that the thrill, like the child's mask, is artificial, but, unlike the child, his reason completely

often different. Perhaps the best instance in the annals of broadcasting was when Father Ronald Knox, quite innocently, broadcast a word-picture of imaginary revolt in London, and succeeded in scaring many thousands of listeners who had not heard the introduction to his fantasy, but only the vivid description of the sack of the Savoy Hotel. Those listeners participated in a very excellent example of how imagination can succeed when reason is dormant, and when sophistication is subordinated to imagination.

The Father Ronald Knox example is analogous to the example of the Athenian dramatist, who was fined for harrowing the feelings of his audience, for many people who were scared out of their wits by Father Ronald Knox's broadcast actually adopted an attitude, after the broadcast, similar to that adopted by the Athenians to *Æschylus*!

### Crude Methods

In our theatres to-day we find imagination run riot—but a raving, ranting imagination, born of an effort designed legitimately, but executed, because of its extreme necessity, in an illegitimate and crude way. Imaginative efforts are made to-day in the London theatres to pierce the stolid, blasé envelope of sophistication which wraps the average London playgoer as completely as the linen bandages swathe an ancient Egyptian mummy.

We find that in many of these plays the appeal to the artistic imagination is nil; but just as the imagination of a child may be so acute that a crude mask worn at a party may stimulate its imagination to the detriment of its reason, so, in many of the crude plays and thrillers of to-day, the sophistication of the audience is so acute that the crudest methods have to be adopted in order to produce the desired effect, namely, the stirring and stimulation of sluggish and atrophied imaginations.

### The Five Senses

This difficulty we conceive to be one of the greatest facing the B.B.C., and it is a difficulty which might well intimidate less adventurous spirits, because broadcasting necessitates a sound knowledge of psychology; and without it no adequate appeal to the most undeveloped of the five senses—that of the sense of hearing—can satisfactorily be made. It is easier, far easier, to stir the imagination by

*(Continued on page 562.)*

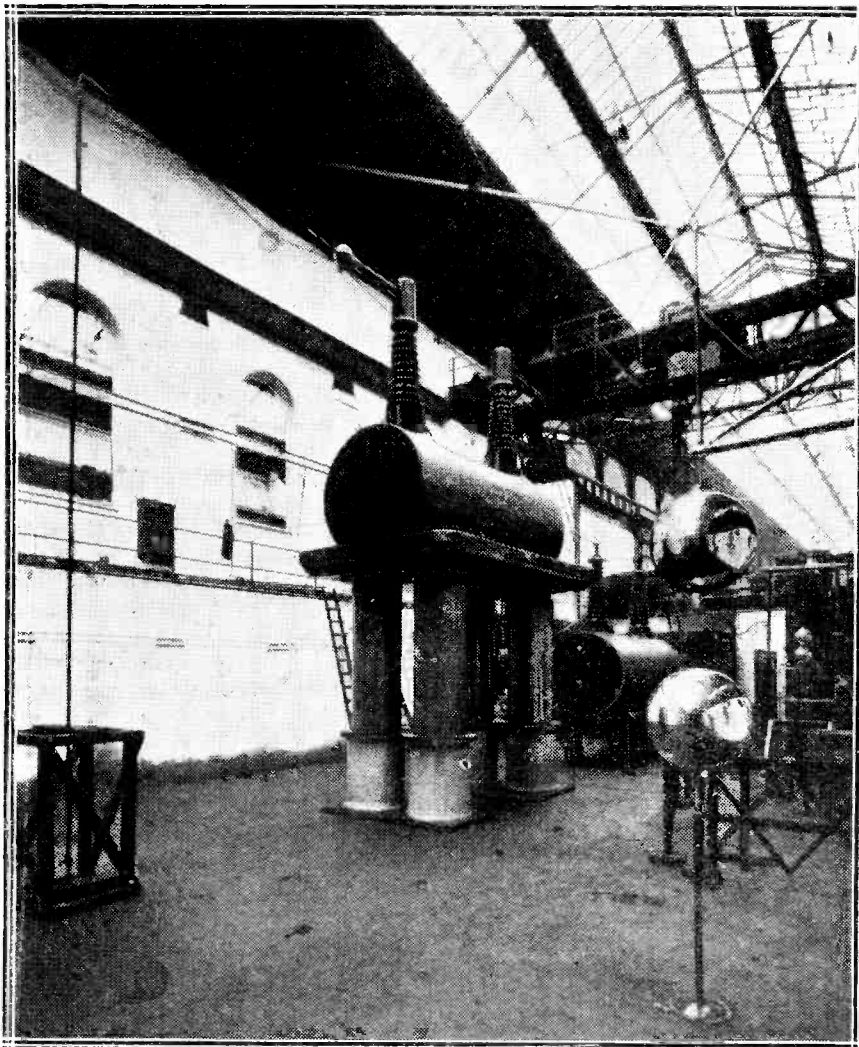

One million volts! Some of the gigantic apparatus recently set up by Ferranti, Ltd., to produce a million-volt arc.

If we could sit in a theatre in such a position that we could see the actors upon the stage, and at the same time watch the machinery of the limelight, of the scene-shifting process, and the many mechanical devices employed for the delusion of the audience, we should be intelligently interested, but it is doubtful whether the actors would produce

subordinates his imagination, so much so, in fact, that it is very rarely indeed that his imagination can give him that sensation which, whether pleasant or harrowing, is essential for an aesthetic and emotional appreciation of a work of art.

But if the listener is caught unprepared, when his armour of sophistication is unbuckled, then the result is

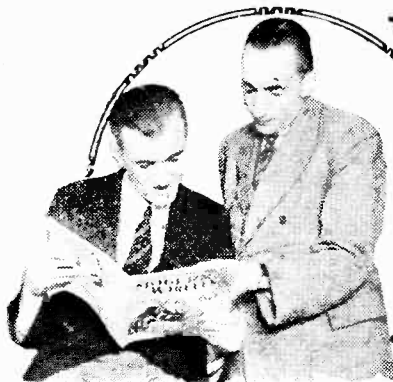

# WHAT READERS THINK

The "Solodyne"—  
The "Straight" Two, etc., etc.

### Can You Beat It?

SIR,—May I take this opportunity of congratulating you on the '28 Solodyne? I have handled many multi-valvers, super-hets. included, and have come to the conclusion this set gets as near perfection as is possible with the components at present available. I completed the set on Sunday last and, so far, have identified 59 stations, which is very creditable as my earth is at present very poor and aerial only moderate.

To come on to another subject: "Is 5 G B Worth While?" Up here there has not been one night this year when the station has been worth listening to!

Wishing you every success.

Yours very truly,

H. MEKLEJOHN (2nd Lieut.),  
Royal Signals Mess,  
Catterick Camp,  
Yorkshire.

### The "Forty-Station Four"

SIR,—I am writing to tell you how pleased I am with the "Forty-Station Four," described by Mr. Allinson in

the November, 1927, issue of MODERN WIRELESS. I constructed the set in December, and since then have had concerts or other entertainments every night from all over Europe. (The parts used were not all the same as those specified, as I had quite a number of spare parts in stock.) The only trouble I have had with the set is cutting out the local station (Dublin), which is only a mile or two away. I solved the problem the other day by constructing the "M.W." Wave-trap and by placing a small fixed condenser in series with the aerial.

I will have no hesitation in recommending this set to anyone wishing to build it.

Yours,

G. C. M. THOMPSON.

Dundrum,  
Co. Dublin.

### The "Straight" Two

SIR,—I have made up the "Straight" two-valver set as designed and described by Mr. L. H. Thomas in your MODERN WIRELESS of October, 1927, and it might interest you to

know of some results which I have had from the set.

I am using coils which I wound myself and Mellard P.M.1 H.F. and P.M.2 valves.

Besides getting most of the stations mentioned by Mr. Thomas, I have also picked up WGY, WEA F, KDKA, WFG, and W.L.W.L, and also a foreign station at 2.30 a.m. on Tuesday morning which I have not yet been able to find out what or where it is.

I have not used condenser or short-wave coils as he mentions in your paper.

I myself do not know much about wireless, and am anxious to know if any other person has had the same results from the same set, and would be grateful if anyone would let me know if he has done so.

MICHAEL BALL.

Stillorgan, Co. Dublin.

### A "Rolls-Royce" at "Ford" Price

SIR,—I have lately returned from the U.S.A., and whilst there I made and used a super-het. according to the enclosed diagram. The results were so fine as regards quality of tone and high selectivity that I wondered if any of your readers would like to make a similar outfit. I may add here that one of my chief reasons for making this set was that I could get a "Rolls-Royce" at a "Ford" price.

To explain:

The intermediate couplers are just bobbins of wood, as per sketch, wound in a little fixture on my worktable with a revolution counter attached. I was, however, fortunate

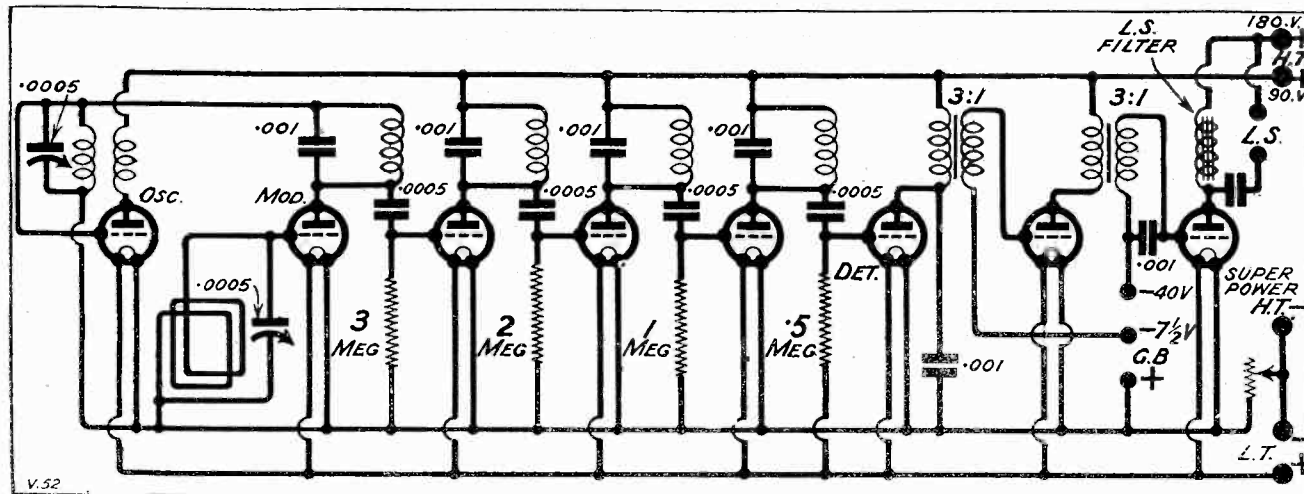

This is the circuit diagram of the super-het. receiver described by Mr. Hulley. Three other diagrams, illustrating sections of its construction, appear in the next page. Frame aerial consists of 125 ft. of stranded wire on largest possible square frame. Oscillator coupler—smoothly wind two layers of No. 30 D.C.C. wire separated by several thicknesses of drawing paper. Then more paper and another layer of wire for plate to H.T. plus 90 winding. In using, reverse plate and H.T. plus 90 terminals if necessary, to get correct polarity for oscillator. Intermediate couplers—900 turns of No. 30 D.C.C. wire, hank wound, with .001-mfd. fixed condenser across the winding.

enough to get them all balanced by a friend of mine; but other people I knew just simply wound the coils very carefully as regards tightness of winding and correct number of turns, and bought the very best fixed condensers they could and stuck them in the set. They seemed to work all right.

An interesting point here was that the windings balanced within a few turns of wire, whilst the fixed condensers were sometimes a long way out. All wire sizes are B. and S. A very compact set can be made by using a long block of wood and mounting the valve sockets on top and boring holes and waxing the coils in the wood itself.

No potentiometer is needed, and there are only three controls—the rheostat and the two variable condenser dials. Of course, a volume control may be fitted and is desirable. I used a 0-100,000-ohm variable resistance across the grid winding of the first L.F. transformer.

I used a fixed loop aerial, 125 ft. of wire fastened round a doorway and pointing E. and W., as that is where most of the best stations are over there. Of course, an aerial and "ground" (earth) can be used by means of a suitable coupler.

The set is not extravagant as regards batteries, although an H.T. eliminator is desirable. Valves with small plates are better, as they reduce any tendency towards howling.

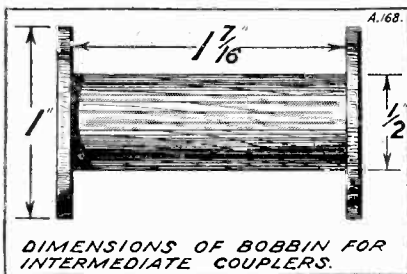

The coils must all lie or stand parallel to each other.

Yours faithfully,  
WALTER H. HULLEY.  
Luton, Beds.

**"Nonsense About Wireless"**

SIR,—I feel that I must write and protest against two points in the article "Nonsense About Wireless," by Mr. St. John Ervine. I should like to point out that with the article as a whole I quite agree, but two remarks made therein struck me as being in very bad taste and certainly ought never to have been written.

Firstly, about Biggleswade. Is

Biggleswade any worse than Kensington, or Llanfairfechan, or Heckmondwyke? And do the inhabitants of Biggleswade necessarily drop their aspirates and talk the sort of balderdash that Mr. St. John Ervine puts into their mouths? It seems to me that in an endeavour to prove his point by ridicule, the pen of "Forked Lightning" (see editorial note) has forked so much that it merely ridicules the writer.

Secondly, his remarks upon jazz. To call the Savoy Orpheans or Jack

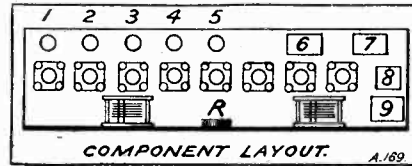

Hylton's Bands, to quote but two examples of broadcasters, a gang of epileptics seems to me to border upon libel.

I would like to ask Mr. St. John Ervine if he really does imagine that all jazz consists of the sort of stuff he quotes. Has he ever heard the Savoy Orpheans play, say, Gershwin's Rhapsody in Blue (H.M.V. record) or, to quote a more modern example, has he heard "Humpty Dumpty" (upon Parlophone) played by Frank Trumbauer and his orchestra? If he has not heard records such as these, to quote his own words, he is, as far as jazz is concerned, "A typical product of a pseudo-democracy which encourages people (I will not write fools) like him to imagine that he who knows nothing at all may criticise and insult (italics mine) men who have given their lives to the study of their subject."

May I suggest to Mr. St. John Ervine that, before he next writes any remarks upon a subject about which he obviously at the moment knows nothing, he acquires, at any rate, a superficial knowledge of jazz which will keep his "Pen of Forked Lightning" more in hand, and prevent it writing the "nonsense" of which it has this time been guilty.

Yours truly,  
G. ATKINSON.

Fulshaw, Wilmslow.

[A copy of Mr. Atkinson's letter was forwarded to Mr. St. John Ervine, whose reply is as follows.—Ed.]

SIR,—Mr. G. Atkinson thinks that two remarks made in my article "Nonsense About Wireless" are "in very bad taste and certainly ought never to have been written." I am

unimpressed by Mr. Atkinson's opinion.

I chose Biggleswade merely because that was the first name that came into my head. As Mr. Atkinson says, any other place would have done equally well.

It appears that he admires jazz. I think that a man who admires jazz ought to be put to a cruel death, on the ground that he is uselessly encumbering a decent earth.

That is all I have to say on the subject: it seems to me to be sufficient.

Yours faithfully,  
ST. JOHN ERVINE.

**From Mr. A. M. Low**

SIR,—I am sure you will not wish to do an injustice to one of your readers, so may I correct an apparent misapprehension concerning my views upon two subjects?

I have often said that wireless cannot, in my opinion, have any noticeable effect upon the weather whatsoever, but that *some* effect, however infinitesimal, probably exists. Surely this cannot be denied?

Is it not ridiculous to lay down the law upon any technical matter without the preface "in my opinion?"

A butterfly upon the free end of a 2-in. diameter 6-ft. steel rod must bend that rod. Very slightly, it is true, but to an extent which could possibly be measured. It would be absurd to say that no bending took place, and I, for one,

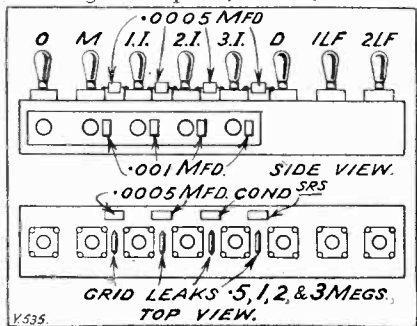

would be interested to know the extent!

Upon the matter of television, I observe you class me with those who look for immediate commercial developments. I happen to have spent time and money on this subject in 1914, and I have frequently stated that with present methods of reproduction it seemed that an almost mathematical degree of selectivity would be necessary before progress could be attained.

I have constantly repeated that, in my humble opinion, it might be  
(Continued on page 370.)



# The "Tetrodyne" Circuit

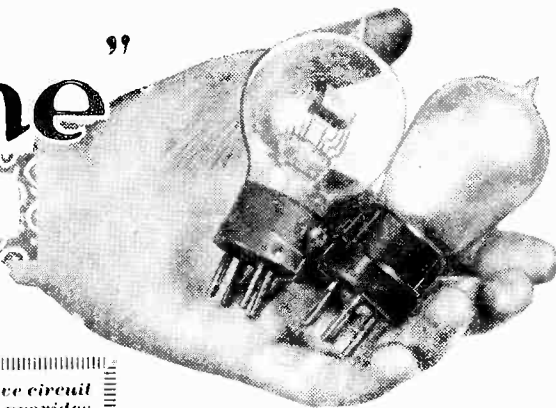

**D**URING the last six months or so considerable attention has been devoted to a special type of tetrode known as the screened-grid valve. This valve, by reason of its greatly reduced grid-anode capacity and its special characteristics, has given rise to the development of H.F. amplifiers of great stability and high amplifying powers.

As many of you are now doubtless aware from your own experiments, these screened-grid valves do give very good results when properly used, even in this more or less early stage of their development. Eventually, such special types of the tetrode will lead to the evolution of more efficient and simpler H.F. amplifiers.

### Considerable H.T. Economy

Although the screened-grid valve looms so largely on the horizon at the present time, we must not let its manifest attractions obscure its lesser brethren. These other forms of the tetrode will yet do much to forward the progress of receiver design. The tetrode can be used with advantage in all the applications of the three-electrode valve.

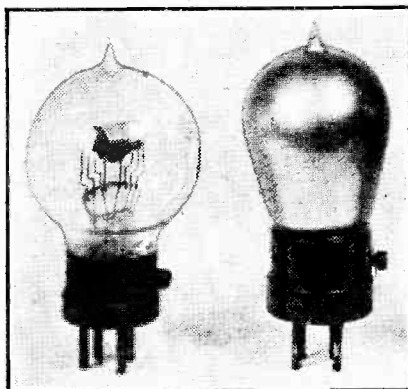

Two typical tetrodes. There are in each case the usual four pins arranged to fit in an ordinary valve holder, the connection to the additional grid being via the small screw terminal on the side of the base

In almost every case a considerably smaller H.T. battery is required, this being an outstanding feature of the tetrode. Some of the most interesting features of this valve are met with when it is used as a detector, and in this article I propose to de-

*A novel four-electrode valve circuit of high efficiency which provides a remarkably smooth control of reaction. Incidentally it is very "tight" on H.T.*

By J. ENGLISH.

scribe a circuit which should be of considerable interest to experimenters and amateurs in general.

The present forms of three-electrode detector circuits have been so tried and tested by constant use and improvement that you may well ask at this juncture whether a tetrode detector constitutes a sufficient improvement to warrant the purchase of a special valve. I will say at once that the tetrode is just such an improvement as to be really worth while.

First of all, it effects a considerable economy in H.T. battery upkeep; no small thing these days, while its efficiency is quite high. Secondly, it provides a degree of reaction remarkable for its smoothness of control, rivalling the best results obtainable with the ordinary valve, but on much less H.T. battery power. This feature of absolutely smooth reaction control is of vital importance in receivers used for D.X. work.

### Selectivity and Sensitivity

The circuit which is the subject of this article possesses these desirable features in full, and, in addition, it embodies a particular method of reaction control which is simplicity itself. Selectivity and sensitivity are of a high order, while the circuit as a detector stage is adaptable to all forms of receivers.

The Tetrodyne circuit is a simple form of regenerative detector which I have developed from an experimental form described in a recent article (Fig. 4, The Tetrode as a Detector), wherein the method and advantages of using the *outer grid* for the purposes of reaction were discussed. The original circuit is reproduced for reference in Fig. 1.

In this circuit the usual form of tuned-grid circuit is used with grid-

condenser rectification, the anode-bend method being equally possible. The outer grid operates as a "space-charge reducer," as is customary in high-magnification tetrode circuits, but with the additional function of supplying the reaction feed-back. This it does by virtue of the conventional H.F. choke and parallel reaction circuit  $L_2 C_2$ , operating like the anode of the ordinary valve. The actual anode circuit of the tetrode is thus in no way concerned with reaction control, and serves merely as the L.F. output of the valve.

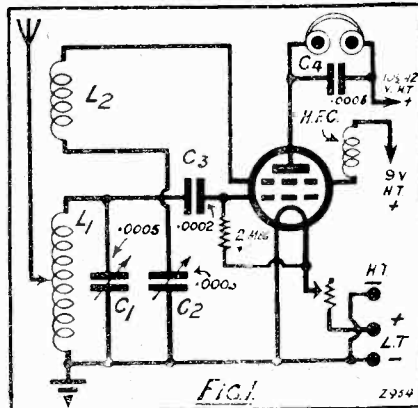

The essential development contained in the new circuit is the particular form of reaction control used. In three-electrode valve circuits, with a parallel reaction circuit like  $L_2 C_2$ , the variable condenser  $C_2$  controls reaction according to its capacity. In this circuit,  $C_2$  is a *fixed* condenser, reaction being controlled by a potentiometer, as in Fig. 2.

### Potentiometer Reaction Control

The great advantage of this form of reaction control is that it has no effect whatever on tuning. In ordinary receivers with capacity-reaction control every adjustment of the reaction condenser tends to upset the tuning, although in cases very slightly, of the grid circuit. This often makes tuning difficult when receiving weak signals on a sensitive set. With this potentiometer control, however, there is no

such effect, so that tuning is very much easier.

As this form of reaction control is somewhat novel, I will give a brief outline of its operation before describing other features of the circuit.

On setting up a receiver to the circuit of Fig. 1, using the values of components indicated therein, but with a fixed condenser for  $C_2$ , it is noticed that the circuit will not oscillate unless the outer grid has a positive potential of a certain definite value below which no reaction effects

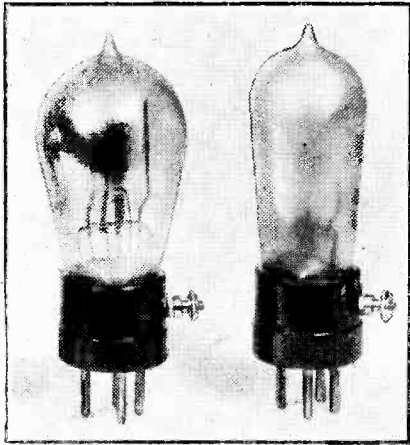

Two more four-electrode valves. There is a very comprehensive range of tetrodes on the market, although at present a large proportion are of French, Dutch and German manufacture.

whatever will take place. The ordinary detector valve acts somewhat similarly in that it refuses to oscillate if the anode voltage is too low. In the case of the tetrode, the outer-grid voltage is much more critical, a volt or so less than the voltage for full reaction causing a complete cessation of signals.

### Fractional Voltage Variation

If the outer grid voltage is maintained at the critical potential, and the anode voltage varied above and below this, the degree of reaction decreases and increases accordingly, an opposite effect to that observed when the outer-grid voltage is varied. Anode voltage variation, however, has not such a marked effect upon reaction as the outer-grid potential changes.

In one experiment with an H.T. battery tapped at every  $1\frac{1}{2}$  volts, setting the outer grid at  $7\frac{1}{2}$  volts caused the receiver to oscillate; 9 volts making oscillation stronger, while 6 volts effectually quenched reaction. Therefore it is imperative for a smooth control of the degree of reaction to find some means of varying this outer-grid potential by

fractions of a volt. Since it is not possible to have a battery with tapings at less than  $1\frac{1}{2}$  volts, the only other method is to use a potentiometer. This, as you know, gives a very exact adjustment of potential to a minute part of a volt.

### Making the Set Sensitive

Accordingly, in this circuit I have connected a potentiometer across the L.T. supply, the H.T. negative lead being taken to the potentiometer slider, as shown in Fig. 2. Moving this slider to either side then produces any desired small variations of the whole H.T. voltage. The effect of this is to give the outer-grid voltage the same variations, thus producing the desired control of reaction in a very simple manner. Many readers will doubtless see in this method a resemblance to the form of potentiometer reaction control used in the Filadyne circuit.

Incidentally, the anode voltage is also varied by a like amount when the potentiometer is adjusted.

With a reliable type of potentiometer the degree of reaction can be controlled within very fine limits. Therefore the receiver can be brought to its most sensitive state very easily without any trouble whatever from backlash or instability.

When working the receiver the potentiometer is set midway, and the outer grid potential increased gradually until oscillation commences. On moving the slider towards negative, reaction decreases, while on moving it towards positive, reaction increases. Once the outer-grid voltage is adjusted all reaction control is done

lightly damped tuned circuit, as when a frame aerial is used. In no case, however, is the reaction control anything but delightfully smooth, even if a large reaction coil is used. Incidentally, the size of this coil is not at all critical, provided it is not too small. The best voltage for the anode is generally a few volts higher than the outer-grid potential, which will be between 6 and 9 volts positive.

It needs an actual trial of this circuit for you to appreciate its advantages as a D.X. receiver; it is so easy to tune, and its efficiency is surprisingly good considering the small battery power required. On a maximum of 9 volts H.T. a large number of stations can be received at good 'phone strength given a good aerial. Also, few components are required so that the set with batteries can be accommodated in quite a small cabinet. In regard to valves to use, several types of tetrode are useful, and some efficient forms are now being introduced by a few leading manufacturers. One type which I have found well suited to the needs of the Tetrodyne circuit is the Aneloy Products' A.P.412-H.F. This valve, which is readily obtainable, has a magnification factor of 28 and is specially designed for high amplification on low H.T. voltages, such as those quoted above.

### High Magnification Tetrodes

In the A.P.412 range the valves have the usual four pins with a small terminal mounted on the side of the moulded base. The outer grid is connected to this terminal in the case

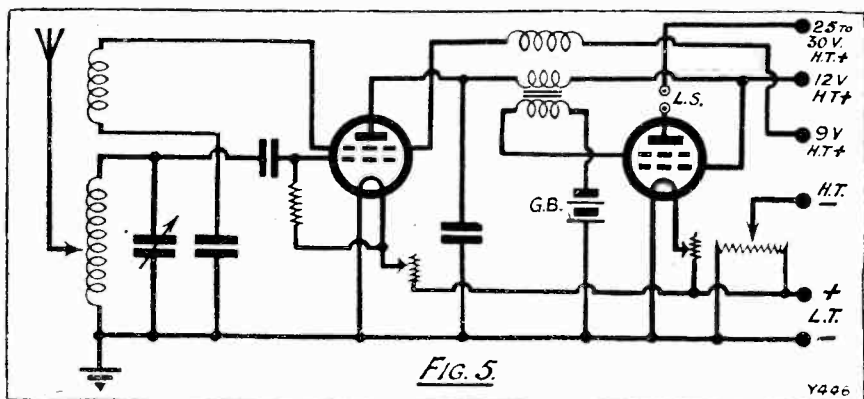

on the potentiometer, a setting being easily found where the set is just on the verge of oscillation, when it is most sensitive to weak signals.

Where there is heavy damping of the grid circuit, due to a big aerial or poor coils, a slightly higher outer-grid voltage is necessary than with a

of high-magnification tetrodes, the ordinary and L.F. types having the terminal connected to the inner grid. With the A.P.412 H.F. the usual valve holder can be used with a flex lead to the outer-grid terminal.

Having tried out this detector circuit, you may begin to consider

the question of adding L.F. amplification. This is quite a simple matter really, for either R.C., choke, or transformer coupling can be used without producing any disturbing effect upon the reaction control. You may perhaps wonder, when the H.T. battery is common to both detector and L.F. stages, whether the potentiometer connected in the H.T. negative lead will give the same control of reaction.

Actually this is the case, and in Fig. 3 we have the diagram for the detector followed by a transformer-coupled L.F. valve. The potentiometer produces the same variation of

.....  
 "It needs an actual trial of this circuit for you to appreciate its advantages as a D.X. receiver; it is so easy to tune and its efficiency is surprisingly good considering the small battery power required."  
 .....

outer-grid potential as before. It also varies the anode potential of the L.F. valve by a like amount, but since this variation is only a very small fraction of its total anode voltage, the effect on that valve is for all practical purposes nil.

This circuit arrangement works quite well and gives loud signals on quite a small aerial.

**Excellent Quality**

The A.P.412 H.F. was found to be the best when using transformer coupling. In this case, seeing that the anode impedance is fairly high, a low-ratio transformer such as the Ferranti 3-1 or similar makes should be used. This results in excellent quality, especially when the two-valve set is used for loud-speaker work fairly near to the local station.

No difficulty arises when choke coupling is used, but when the

detector is R.C. coupled it becomes necessary to increase the present low anode voltage to something like 40 or 50 volts. Using the circuit of Fig. 4 it was found that with the

outer grid be given the right positive potential.

Other forms of tetrode, such as the screened grid, work well as R.C. coupled detectors, but not less than 60 volts

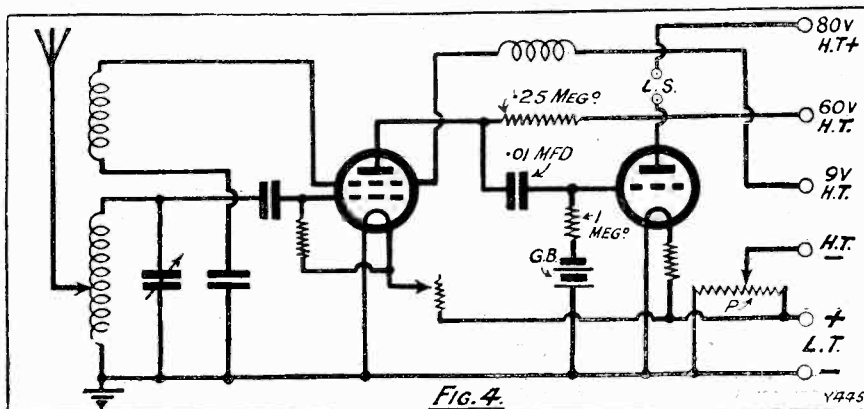

FIG. 4.

A.P.412 H.F. signals were not so strong as with a transformer coupling between detector and L.F. valve. Nevertheless, reaction control was still perfectly smooth, the outer-grid

H.T. must be used for good results. This, in my opinion, is rather a drawback, because one of the essentials of a tetrode detector stage is that it should work on low anode volts.

This, of course, is the case when the Tetrodyne is transformer or choke-coupled, as you will have gathered from the examples cited above. In fact, if a tetrode L.F. amplifier is

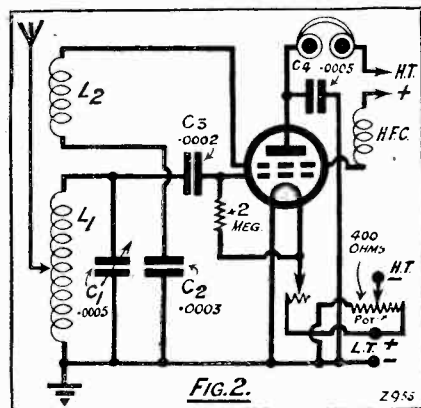

FIG. 2.

potential being round about 10 volts, so that the form of L.F. coupling in the anode circuit has little, if any, effect on the degree and control of reaction. All that matters is that the

.....  
 The Tetrodyne is a development of the circuit shown in Fig. 4 of "The Tetrode as a Detector" ("Modern Wireless," April, 1928).  
 .....

used, the H.T. battery can be reduced to a surprisingly small size and yet give excellent loud-speaker results where the local station is not too far away. A representative circuit is given in Fig. 5.

\*\*\*\*\*  
 \* **BROADCAST JOTTINGS** \*  
 \*\*\*\*\*

The local news broadcast from the Plymouth station now includes weekly information as to the movements of vessels connected with that seaport. The information is obtained by the B.B.C. from the Commander-in-Chief of the Naval Forces, Plymouth.

To connect up the different stations in a recent simultaneous broadcast in the United States, over twelve thousand miles of telephone wire were employed.

The Chinese Government has recently opened a broadcasting station at Tientsin, near Peking, which works on a wave-length of 480 metres.

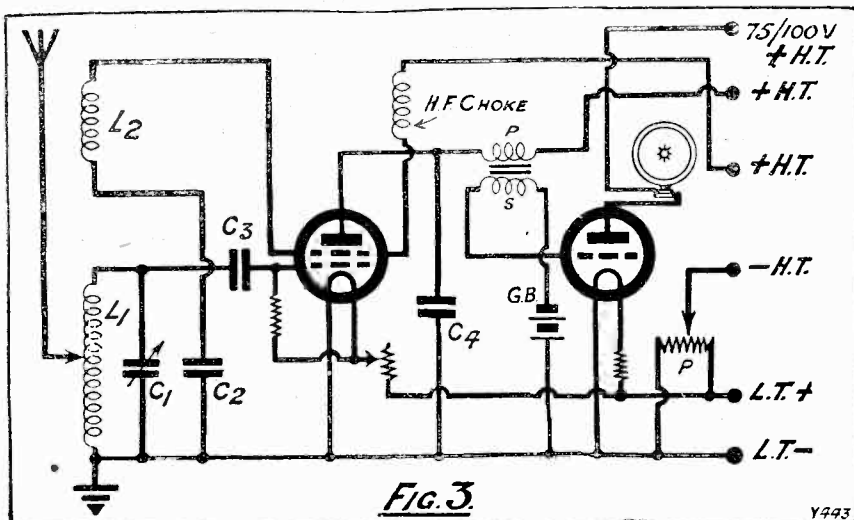

FIG. 3.



# Questions Answered

## Turns For a Frame

T. H. A. (Luton) wishes to know how many turns will be required for a frame-aerial winding suitable for the 250-500-metre broadcast wave-band.

The easiest type of frame to construct is probably the "diamond" type. Two pieces of 1 in. by 1/2 in. oak notched, and united at the centre, can form the actual framework. The outside diameter of the winding is 3 ft. 6 in., and 13 turns of wire are required, spaced 1/2 in. apart.

Six ounces of No. 20 gauge enamelled wire should be sufficient to form the winding.

## Fixed Resistors

M. A. (Birmingham).—"I have a number of 2-volt 1-amp. valves which I wish to utilise. My L.T. battery is of the 4-volt type, and the cells cannot be connected in parallel. Can you give the value in ohms of a suitable resistor to use?"

Assuming that you intend to employ a separate filament resistance for each valve, a suitable value would be 20 ohms. Insert your resistors in the positive filament lead.

## Inadequate Reaction

L. E. R. (Southampton).—"I have built the 'Viking IV' which was described in the December, 1927, issue of MODERN WIRELESS. The receiver seems to work satisfactorily, except for the fact that it is difficult to obtain a sufficient reaction effect unless a very high value of H.T. is applied to the detector valve (H.T.+2).

"The components used are as specified by the author, but I have used a grid-leak type of anode resistance having a value of .5 megohm. Would this account for my failure to obtain adequate reaction?"

Yes, this is quite possibly your trouble. Use an anode resistance having a value not exceeding 250,000 ohms.

With resistances of above this value the anode current is exceedingly small, and very frequently the detector valve will not oscillate unless the

## THE TECHNICAL QUERIES DEPARTMENT

Are you in trouble with your set?

Have you any knotty little Radio problems requiring solution?

The MODERN WIRELESS Technical Queries Department has been thoroughly reorganised and is now in a position to give an unrivalled service. The aim of the department is to furnish really helpful advice in connection with any radio problem, theoretical or practical.

Full details, including the revised and, in cases, considerably reduced scale of charges, can be obtained direct from the Technical Queries Department, MODERN WIRELESS, Fleetway House, Farringdon Street, London, E.C.4.

A postcard will do: on receipt of this all the necessary literature will be sent to you free and post free, immediately. This application will place you under no obligation whatever. Every reader of MODERN WIRELESS should have these details by him. An application form is included which will enable you to ask your questions, so that we can deal with them expeditiously and with the minimum of delay. Having this form you will know exactly what information we require to have before us in order completely to solve your problems.

reaction winding is large. We think that a lower value will probably solve your trouble.

## The M.W. "Station-Getter"

F. C. (Norwich).—"Can the M.W. 'Station-Getter' be used successfully in conjunction with the 'Radio-Gram Four,' and, if so, what are the connections?"

This H.F. unit will give very good results in conjunction with the "Radio-Gram Four." The aerial lead is joined to terminal A on the unit, and X is connected to the aerial terminal on the set. The only modification necessary is the use of a

slightly larger aerial coil in the "Radio-Gram Four." Instead of the 70-turn coil recommended, a coil having the same number of turns as that employed in the anode circuit should be used.

## Moving-Coil Windings

E. W. M. (Morton) asks whether it is possible to use a moving-coil loud speaker without an output transformer, since he has been informed that the latter component is not necessary in all cases.

There are two types of moving coils, viz., low resistance and high resistance. The former consists of comparatively few turns of wire and must be employed in conjunction with a transformer, which usually has a ratio in the neighbourhood of 25-1.

The high-resistance type has a large number of turns of very thin wire and should be used with a choke output circuit, owing to the fact that the delicate winding will probably "burn out" if a heavy anode current is passed through it. In this case a transformer is not necessary. The low-resistance type of coil is more popular, possibly because of its robustness.

## Single-Layer Coils

R. A. (Gravesend).—"Will you please give details of two single-layer coils, one suitable for the 250-500-metre band, and the other to tune from 1,000-2,000 metres.

"How many turns will be required for reaction, assuming the coils to be used in the anode circuit of a screened-grid valve?"

The 250-500-metre coil may consist of 55 turns of No. 24 gauge D.C.C. wound on a 3-in. diameter former, with an additional 25 turns for reaction, laid on as a continuation of the tuned winding and in the same direction.

A .0002 reaction condenser would be suitable.

For 5XX, wind 200 turns of No. 32 D.S.C. on a similar former, with 75 turns for reaction. A good freely-oscillating detector valve of the "H.F." type is advisable.

## Windings For 5XX

O. M. T. (Cardiff) asks a question relating to the turns for the 5XX coils given on page 388 of the April issue.

The turn numbers given represent those necessary for each half of the "astatic" winding.

For instance, the anode coil has 200 turns on each half.



# In Our Test Room

*An Ediswan Accumulator—An Electric Soldering Iron—A Short-Wave Receiver—  
A Ferranti Meter—Igranic Filament Transformer, etc.*

### An Ediswan Accumulator

WE have recently examined a type XW 6-volt Ediswan accumulator having an ampere-hour capacity of twenty. These accumulators are supplied in separate cells, these being linked together by means of stout lead bars. The cells have strong celluloid casings, and robust acid-proof terminal nuts. They are fitted with large vent plugs of the non-siphoning type. The single-cell XW2 of 20 ampere hours' capacity retails at 10s. There is a wide range of other capacity models available.

### An Electric Soldering Iron

The construction of a radio receiver is very greatly facilitated if one has an electric soldering iron. There is not only the advantage of a constantly and evenly heated iron, but also a freedom from the oxidation and other "dirt" which is apt to accumulate on a fire or gas-heated iron.

At one time the possession of an

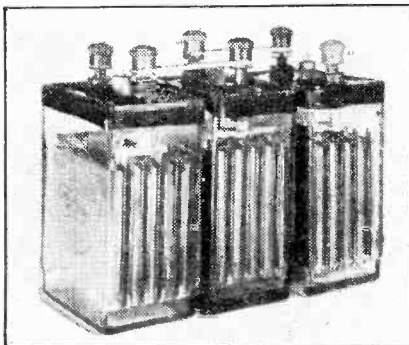

The type XW 6-volt 20-a.h. Ediswan accumulator.

electric soldering-iron savoured of an expensive luxury, but there is now at least one satisfactory make available at a very reasonable price. This is the "K.N.," a product of Knowles

& Son, of 87, Wardour Street, Oxford Street, London, W.1, which retails at 12s. 6d.

It is particularly suitable for radio work, as it is supplied with two bits, one straight and one angle, enabling it to tackle small and awkwardly

Manufacturers and traders are invited to submit for test purposes radio sets, components and accessories to the "Modern Wireless" Test Room at Tallis House. Under the personal supervision of the Technical Editor all tests and examinations are carried out with the strictest of impartiality. Readers can accept the Test Room reports published monthly under the above heading as reliable guides as to the merits and demerits of the various modern productions of the radio industry.

placed wiring and other joints. Five feet of flex and a patent socket adapter complete the outfit.

The "K.N." appears to us to be very cleverly designed, and certainly bears an attractive and clean finish. In operation it is perfectly satisfactory and quite safe. It can be used on either A.C. or D.C. mains, and the fact that it carries a guarantee for a year should make it appeal to the practical and discriminating purchaser.

### A Short-Wave Receiver

We recently had the opportunity of examining and testing a four-valve short-wave receiver due to the Short Wave Communications Development Co., Ltd., of Wickford, Essex. This set covers the following three ranges: 15 to 100, 100 to 550, and 1,000 to 2,000 metres. This, together with other sets due to the above company, was designed by Mr. Gerald Marcuse, the well-known amateur who

is technical adviser to the firm. It incorporates a detector and three resistance-coupled L.F. circuits. Two valves are paralleled in the last stage.

The set is fitted with a metal panel and there is a noticeable absence of hand-capacity effects when in operation. We found it a most interesting receiver to operate. During the first half an hour the set was in use in the latter part of an evening, Australia came in on the loud speaker, whilst dozens of Americans could be heard at greater strength.

On the broadcast band the usual more powerful continentals were receivable with excellent quality. On the long waves some three or four stations came in very well. The price of this receiver is £22 10s.,

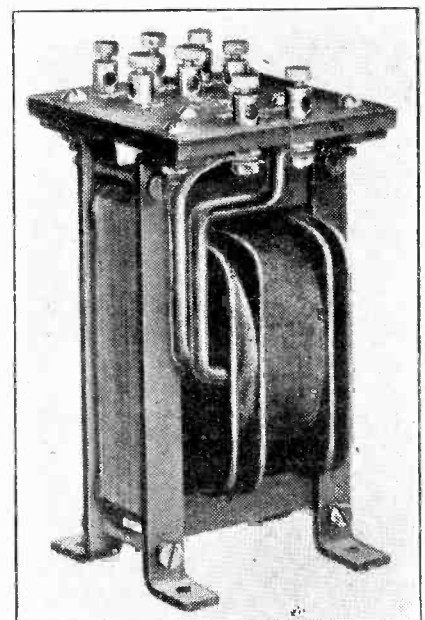

The Metro-Vik transformer for A.C. valves which was recently referred to in these pages.

excluding valves and royalties, but including a complete set of coils and a grid-bias battery

**Dual-Range Rheostat**

We recently received two double-range rheostats from Messrs. Burndept Wireless, Ltd. One, known simply as the Dual Rheostat, has the ranges of from zero to 5 and zero to 30 ohms. The other is called the Super Dual Rheostat, and has zero to 10 and zero to 60-ohm ranges. The construction of these rheostats is carried out practically entirely in metal stampings, there being very little insulation material employed. In an article of this nature this is, of course, a definite advantage. The resistance wire is wound on a flat strip, which is bent around the central metal frame. The contact arm runs smoothly around this wire. The action is smooth and efficient. The component is of the panel-mounting variety, and an aluminium dial and a bakelite knob-pointer are provided. The price of both the above types is 5s. each.

**A Ferranti Meter**

In order to maintain radio receiving equipment in a first-class condition, meters are essential. At intervals the L.T. and H.T. supply voltages must be checked and the grid-bias battery voltage also must be measured in order to ensure that the grids of the valves are being biased at their correct potentials. Also, in order to locate and eliminate valve overloading and other incidental troubles which tend to impair quality of reproduction, anode currents must be checked.

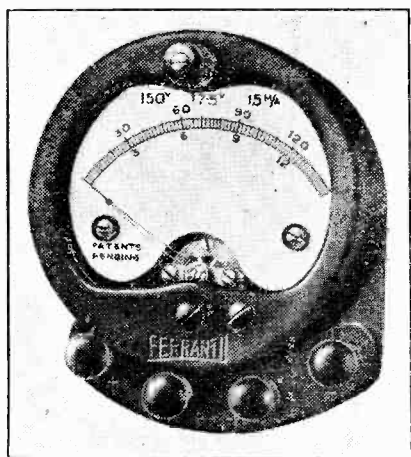

The Ferranti triple-range meter referred to in the accompanying paragraph.

In the ordinary course of events all this measuring necessitates the use of at least three instruments. But there are available several combination meters capable of covering all that work. An excellent example is the

Ferranti P.R.3a, which has three ranges, viz., 15 milliamps, 7.5 volts and 150 volts. Not all combination instruments of this nature are free from moderate error on all ranges, but the Ferranti is throughout a precision instrument and, altogether, a first-class production.

The sample we have tested proved perfectly satisfactory in every respect.

**Trix Valve Holders**

A very cheap anti-microphonic valve holder is the Trix, a product of Eric J. Lever (Trix), Ltd., of Clerkenwell Green, London, E.C.1. It appears to have all the points of a good-class component, and retails at the low price of 1s. 3d. It is fitted with terminals, and the soldering tags are extended and soldered directly to the base of the sockets. These latter are sunk in the holder as a protection against accidental shorts. The insulating moulding appears to be of good quality and is nicely finished. We notice that in the samples sent us valves could be slipped in easily, but were hard to pull out. The makers inform us that this defect will be remedied in all their future deliveries.

**An Oldham Accumulator**

A new Oldham accumulator was recently introduced embodying the same laminated plates which have proved so successful in earlier models. This new Oldham is known as the UVD, and is a large-capacity type suitable for sets using three or more valves. It is contained in a glass case. Its special feature is that it can be charged up quickly and discharged slowly over a long period.

It is, therefore, eminently suitable for the modern types of low-consumption valves. Its design is a sensible one from every point of view. For instance, its glass case is moulded so that it can accommodate a special form of holder. This patent carrier can be fitted very quickly and is both convenient and safe. Amateurs who have experienced trouble with the collapsing of wooden accumulator crates will appreciate this new Oldham device.

**Some Gambrell Components**

Messrs. Gambrell's Neutrovernier condenser, of which it is stated about 60,000 have been sold, has recently been subjected to an improvement. The internal construction of the component has been modified in such a way that it is now able to withstand high voltages at any point of its adjustment without breaking down. The Neutrovernier supplies the capa-

city range of 2 m/mfd. to 38 m/mfd. (approximately). The range is covered in six rotations of the knob, each turn representing approximately 6 m/mfd.

It is a thoroughly well-designed and soundly constructed component, and at the price of 5s. 6d. represents good value for money. It is interesting to note that an indicating dial is available for this Neutrovernier condenser. This dial is attached directly to the condenser, and gives direct readings. The price of this accessory is 1s. 8d. Together with the above-mentioned devices we also recently received several Gambrell coils. These embrace an improvement in the form of a new type of plug.

**Igranic L.F. Choke**

Messrs. Igranic Electric, Ltd., recently sent us one of their type "F" L.F. chokes. This is wound in two sections, which can be connected either series or in parallel. In series a maximum inductance of 73 henries can be obtained. When passing 10 milliamperes of current, 36 henries inductance is given in similar conditions. And at 20 milliamperes the quite respectable inductance of 27 henries is still obtainable.

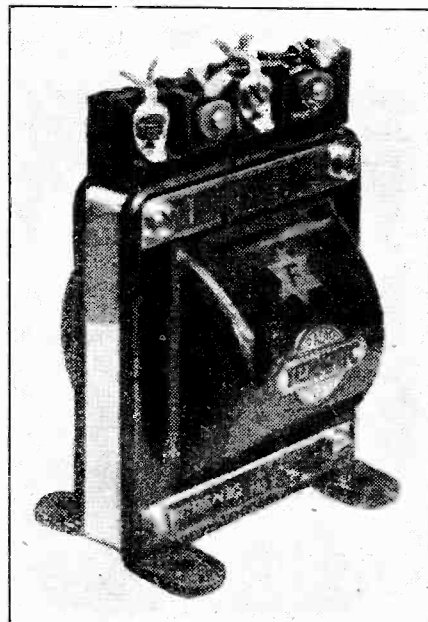

This is the Igranic type "F" L.F. choke.

When the sections are in parallel the ohmic resistance is 240 ohms and 960 ohms when they are in series. It will be seen from this that the choke is a very sound proposition, and we have found it perfectly satisfactory when used either as an inter-valve coupling or in loud-speaker output circuits. There are not too

(Continued on page 572.)

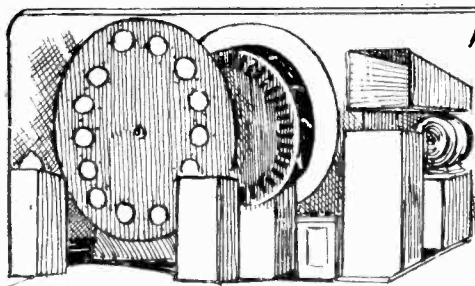

# TELEVISION NOTES OF THE MONTH

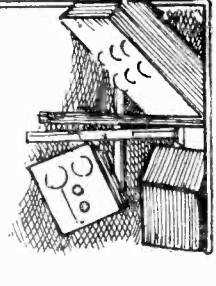

Now we can hope for *intelligent* interest in television. After the flare of "television for the homes," television across the Atlantic, television sets in a general store, and a pan-television periodical, and now, after the sobering effect of the £1,000 challenge and articles giving the truth of television, the public should be left with open and eager minds.

### Watch Dieckmann!

I have a whisper of important developments at the Munich experimental station of Professor Max Dieckmann. When I visited the sunburnt scientist some months ago, he had just scrapped his mirror transmitter—despairing that wagging mirrors or any other mechanism can ever achieve television. With his old transmitter he had managed to send across space the outline of a hand—and that, he said, was the limit. Since, he has been trying to harness cathode rays, or streams of electrons, at his transmitter. News has just come to me from him that he believes he has hit the idea he wanted. Steps are to be taken to try it out—and this must be done before we can pronounce on its value. My part in the developments will ensure that readers of this page will be first to have full and accurate details.

### Is Mechanism Useless?

Baird has explained to me his new idea for a television machine which his engineers are now making. It came as a jolt to me, just as I was settling down to believe that discs and mirrors of any sort are too clumsy and slow ever to achieve television. Mind you, I am not saying that now Baird is going to bring us television of scenes; but he has startlingly shown to me the possibility of a new idea rising from old and well-worn material.

### Baird's New Hope

You will see from my drawing that Baird still holds to spinning discs and lenses. "If I cannot make the discs go fast enough," he told me, "I can

*Below we publish the first of a new monthly series dealing with television progress as noted by our special correspondent who is personally in touch with all the leading television experimenters in the world.*

make them move an image—and an image is light enough to travel at any speed." The first disc, says J.L.B., will cast a series of images of "Bill," the ventriloquist's doll, where I have drawn the first dotted line. These images will be moving off to the right. The lenses of the second disc, on the lower shaft, will take these images and cast them, moving twice as fast, along the second dotted line. By the time the images reach the fifth dotted line they will be moving far faster than mechanism could ever move; and the sixth disc will flash them over the small aperture of the light-sensitive cell.

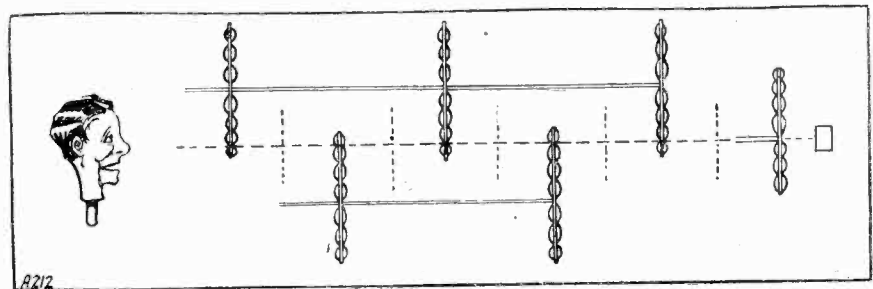

Baird hopes to be able to obtain similar results to that of greatly increasing the speed of rotation of his discs by this multiple disc system. A brief explanation of the idea is given in the accompanying notes.

### Objections

Such is the idea. We shall have to wait to see whether it works. Several difficulties pop up in my mind. Firstly, won't a row of six discs be far too bulky? Secondly, can an image be obtained along a plane, as shown by a dotted line? If you look at your image in a bus window when you are going home at night, you see that the nose of the image is as far in front of the ear of the image as your own nose is in front of your ear. Images cast by lenses have depth in the same way. And, thirdly, how much light will be left to excite the light-sensitive device—Baird says

that his is not a photo-electric cell—after images of an image have been cast through five stages?

I hope these objections may prove only apparent: any technical man knows that practice often achieves things which theory says are impossible. I hope sincerely that Baird is successful with this new machine. It would be fitting, after all that has been told to the world, if Baird were the first one to strike the new principle needed to bring useful television.

### New Television Lamp

One of the difficulties in television has been to find a source of light for the receiver which will change the strength of its glow sufficiently quickly with fluctuations in the current—indicating light and shade—from the transmitter. The lamp used in the General Electric Company's transmission to homes in New York was the neon one, invented by Mr. D.

McFarlan Moore. It will go on and off in a millionth of a second. Mr. C. Francis Jenkins, the Washington inventor, with whom Mr. Moore formerly collaborated, has invented a new lamp. It is gas-filled, and has seven separate filaments. The filaments are made by a rotary switch to glow all at once, alone, or in rapid succession.

### Selenium "Eyes"

Some people still look kindly on the selenium cell, and suggest that amateurs making television experiments should use it. Of selenium cells, some of the best in the world  
(Continued on page 572.)

# RADIO ABROAD

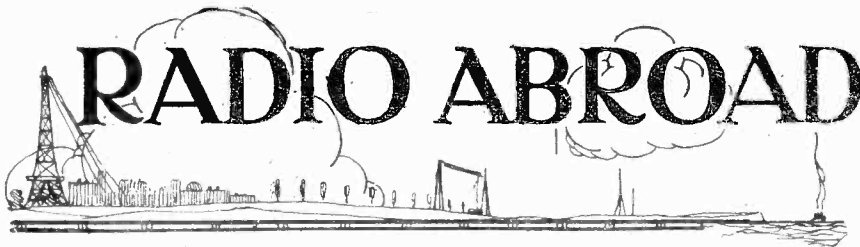

## Airways Radio

THE extent to which the Marconi apparatus used on the Imperial Airways machines flying between Croydon and the Continent is relied upon is shown by the recent experience of Captain A. S. Wilcockson, who flew a Handley-Page Rolls-Royce aeroplane from Paris to Croydon above a fog-bank which obscured the ground practically the whole way. Five minutes after leaving Paris the pilot found himself in dense fog and he had to rise 2,000 ft. to get above it.

At this height it was necessary to fly entirely by compass. The pilot asked for several bearings and positions from Croydon during the journey and these brought him in on a direct line to the Croydon aerodrome.

"I had no difficulty at all in keeping in communication with Croydon at any time, whether I was in the fog, above it, or coming down to the aerodrome, but it would have been impossible to have made the journey without wireless," said Captain Wilcockson.

## What's the Time?

Do you know the time? Of course you do in this country, but when you are searching for foreign stations you want to know the time there, which is quite a different proposition.

A time clock which is universal can very easily be made and will at once show you the time at any part of the world. The Atlas Press Pty., Limited, of Melbourne, publish a very simple cardboard "clock" at 1s. (designed by "Popular Radio Weekly," the well-known Australian radio journal), which tells you the current time in any part of the world. It separates night from day, and by giving universal time it allows you to search for a distant station when that station is operating, and saves you wasting time looking for stations which are not "on the air."

## Picture Reception

Reports are now arriving more and more frequently of experiments and results obtained with the Cooley-Rayfoto apparatus for the reception of broadcast pictures. This machine

has been designed by a very young American experimenter, Austin G. Cooley, and although all kinds of other picture-receiving machines have been produced before, the Cooley-Rayfoto instrument has many points to recommend it.

"It is very simple in construction and is claimed to be just about as nearly foolproof as such a device can be made at the present time. I have seen examples of the pictures received on the Rayfoto machine and they certainly give an excellent representation of the pictures originally broadcast.

## For Home Constructors

The United States radio journals are giving a lot of publicity to the

and the principal manufacturers and suppliers of components are specialising in the requirements of the Rayfoto constructor.

## French Portables

Portable sets are gaining greatly in favour in France, where this type of receiver has lagged behind considerably in popularity as compared with Great Britain. During the special wireless motor-races of last year, the manufacturers as well as the public awoke to the special needs of this class of set. The same thing is true, to a large extent, in Germany, where the portable set has been greatly improved, and some new and interesting portable models were shown at the Berlin Exhibition at the beginning of April.

## Broadcast Publicity

In Great Britain publicity over the broadcast is strictly prohibited, but conditions are otherwise in most other parts of the world where broadcast is in vogue. In the United States, for example, a large number of broadcast stations are actually owned and

## PROGRAMMES FOR THE DEAF

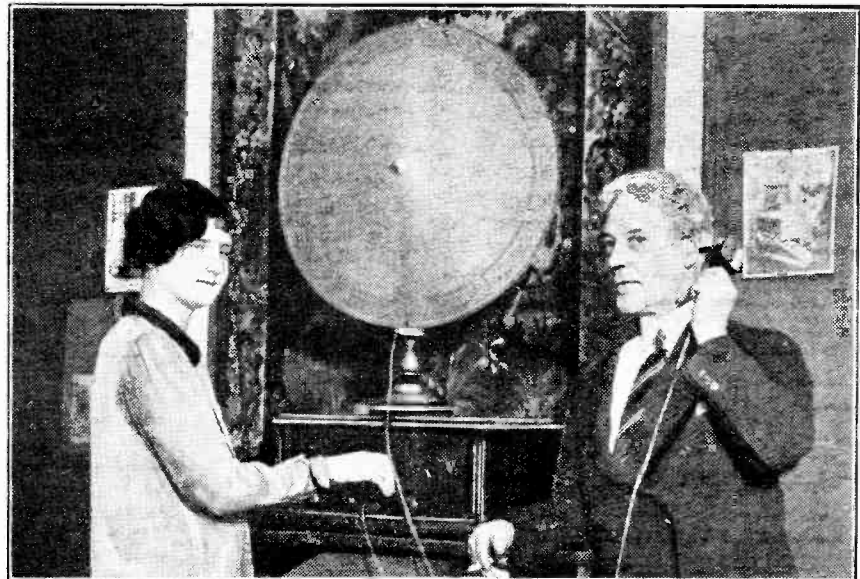

By means of this device, recently perfected in New York, deaf and dumb persons are enabled to "hear" through a unit placed not over the ear, but just behind it. The sensation of sound is then conveyed through the bones of the head.

Cooley system, and the latest development, which is perhaps the most interesting from the point of view of the radio enthusiast, is the placing on the market of all the necessary parts and components for the constructor to build up his own Rayfoto receiver. The essential parts peculiar to the instrument are, of course, standardised, but the "wireless" components (such as condensers, grid leaks, etc.) may be of any reliable make,

operated by business houses, especially the large stores, and naturally the expenditure upon stations is charged to advertising accounts.

In France, broadcasting publicity has for some time been carried on, but it is objected to by listeners, who regard it as a nuisance. The existing state of affairs has made the use of the broadcast service for publicity purposes unavoidable, as there are few

(Continued on page 575)



# The "Easy-Tune" Four

A most successful and simple four-valve receiver which is capable of surprising results.

By  
**C. P. ALLINSON,**  
A.M.I.R.E.



**M**ANY years ago a circuit appeared which had for its main object the simplification of receiver control by giving a more or less constant degree of reaction in the detector circuit. It did not, however, achieve the popularity

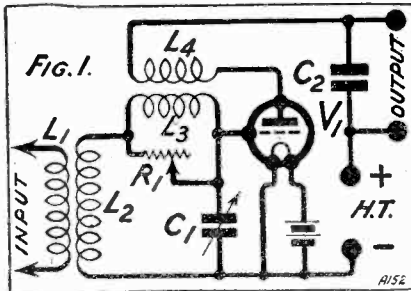

which it deserved, both on theoretical and practical grounds.

This was no doubt largely due to the fact that wireless design was still in its early stages.

I have recently been conducting a number of experiments with this method and have found it peculiarly suitable to present-day requirements, especially as the present-day standard and interchangeability of components has reached such a high pitch.

### Numerous Advantages

As the outcome of my experiments with this circuit I have designed a four-valve receiver which I think is justly named the "Easy-Tune" Four, and which incorporates a number of desirable features which will recommend it alike to the beginner as to the more experienced amateur.

The more I work with this set the more numerous its advantages appear to become, and I find it a little difficult to decide just where to begin in detailing these.

Perhaps I had better start at a point which is quite an important one, and that is the appearance of the receiver and the disposition of the components on the panel.

If you will look at the photographs which have been taken of the set you will see that instead of the conventional dials for controlling the two tuning condensers I have used condensers which are controlled by means of a drum edgewise through the panel. This fact, combined with the elimination of all other components from the panel, bar a small resistance which gives the reaction control, and a switch controlling the number of valves in use, gives the receiver a totally different appearance and strikes an entirely new note.

controlled with the greatest of ease by just one finger. It is also possible, however, not only owing to the design of the condenser used, but also owing to the circuit employed, to control the two tuned circuits simultaneously, and this can very conveniently be done by locking the two drums together with a couple of nuts and bolts passed through slots specially provided for this purpose and, once having found the correct relationship between the two condensers, to lock them permanently and control the receiver with one adjustment only.

### Accurate Ganging

On the other hand, those who feel that they are not obtaining the maximum efficiency from the set by con-

### STATIONS RECEIVED

The following are the stations received during one night's test of the "Easy-Tune" Four :

Karlskrona  
Halsingborg  
Stettin  
Muenster  
Kiel  
Malmo  
Cologne  
Nurnberg  
Belfast  
Newcastle  
Dublin

#### Medium Waves :

Breslau  
Bournemouth  
Petit Parisian  
2 L O  
Stuttgart  
Manchester  
Hamburg  
Glasgow  
Berne  
Kattowitz  
Frankfurt

Seville  
Oslo  
Langenberg  
Berlin  
5 G B  
Brussels  
Vienna  
Munich  
Milan  
Budapest

#### Long Waves :

Kalundborg  
Berlin

5 X X  
Radio Paris

Hilversum  
Huizen

While dealing with the question of the control of these two condensers some further details on this question may be given here. It will be noted that the two drums which control the tuning condensers are adjacent to each other so that they can be

trolling the two circuits simultaneously, need not lock the two condensers together, but can control the two circuits independently.

The circuit employed, however, is one which I have found to give a greater degree of accuracy as regards

ganging purposes than any other circuit which I have ever used.

With regard to the constant reaction circuit which I have used, this employs magnetic reaction, which, as you know, can be made extremely efficient, and on the long waves in particular is usually acknowledged to be more efficient than capacity reaction, although not always so convenient.

**Pure Reproduction**

Another point which has been considered in the design of this receiver is the question of purity of reproduction. It is now generally the practice to use a super-power valve in the second low-frequency stage, especially where strong signals are to be handled. Under these conditions, where switching arrangements are provided so as to enable one or two stages of L.F. amplification to be used, if the loud-speaker is transferred from the plate circuit of the first L.F. valve into that of the super-power valve a difference in tone and balance will result owing to the variation in the ratio of the loud-speaker-valve impedance.

I have therefore so arranged the switching that the loud speaker is always connected in the plate circuit of the super-power valve, while the switch used to enable three or four valves to be employed is further connected so as to form a master switch.

**Results Obtainable**

Before dealing with the circuit of this receiver in further detail I had perhaps better give some idea of the results obtainable with this set, and in order to make the new conditions

for its operation as unfavourable as possible the two tuning controls were locked together and the receiver operated as a gang-controlled set.

Working with an average size aerial at a mile from 2 L.O., with a wave-trap connected in circuit so as to eliminate interference from this transmission, the stations tabulated

When not using a wave-trap it was found that this receiver was considerably more selective than the usual set incorporating one stage only of H.F. amplification, and this, of course, is due to the particular circuit employed.

At the same time it is possible to control the degree of selectivity to a

**COMPONENTS REQUIRED**

- 1 Panel, 24 in. x 7 in. x 3/8 in.
- 1 Cabinet, with baseboard 10 in. deep for same (Original is by Pickett Bros. Also obtainable from Messrs. Aircraft, Bond, Camco, Caxton, Makerimport, Raymond, etc.).
- 1 Drum-control twin condenser (Cydon).
- 1 Fixed condenser, .01 (T.C.C. in set. Any good make, Clarke, Dubilier, Lissen, Mullard, etc.).
- 1 Fixed condenser, .001 (Dubilier in set. See above).
- 2 White-line valve holders for H.F. valves (Bowler-Lowe. See text).
- 1 400-ohm potentiometer, baseboard-mounting type (Igranic, Lissen, etc.).
- 2 6-pin coil bases (Collinson).
- 1 Tapped-grid H.F. transformer for long and short waves (Collinson).
- 2 Featherweight formers, with primaries, for L<sub>2</sub> and L<sub>4</sub> (Collinson).
- 2 Paxolin formers with four-pin mounts for winding L<sub>2</sub> and L<sub>4</sub>, and one base for same (Collinson).
- 1 Variable high-resistance, 6,000 ohms to 1 megohm (W. G. Pye & Co.).
- 1 250,000-ohm wire-wound resistance (R.I.-Varley in set. Any good make).
- 1 .004 and 1 .0001 fixed condensers (Dubilier in set. Any good make, Lissen, etc.).
- 1 1-megohm and 1 .25-megohm grid leaks and clips (Dubilier in set. Any good make, Lissen, etc.).
- 1 L.F. transformer, 6-1 ratio (Marconiphone in set. Any good make).
- 1 3-pole 2-way switch (Utility).
- 1 Double-capacity B.M. neutralising condenser (Peto-Scott).
- 4 Resistances for controlling filaments (L. & P. in original. Any standard baseboard rheostat, Lissen, Igranic, etc.).
- 2 Anti-microphonic valve holders for L.F. valves (Benjamin, Bowyer-Lowe, Burne-Jones, Burndept, B.T.H., Lotus, Marconiphone, Precision, Pye, W.B., etc.).
- 4 Indicating terminals (Aerial, Earth, Output +, Output -). (Belling-Lee, Eelex, Igranic, etc.).
- 1 Set of battery leads (5-way).

in the accompanying tables were received in the course of an evening's test. The majority of them were received at really good loud-speaking strength, while all the tuning was done on the loud speaker, and no headphones were used at all during the test.

certain extent since the aerial and H.F. couplers employ interchangeable primary windings.

Now, if you are not interested in the theoretical diagram of this set you had better skip the next few paragraphs since I am going to deal with one or two of the points in the

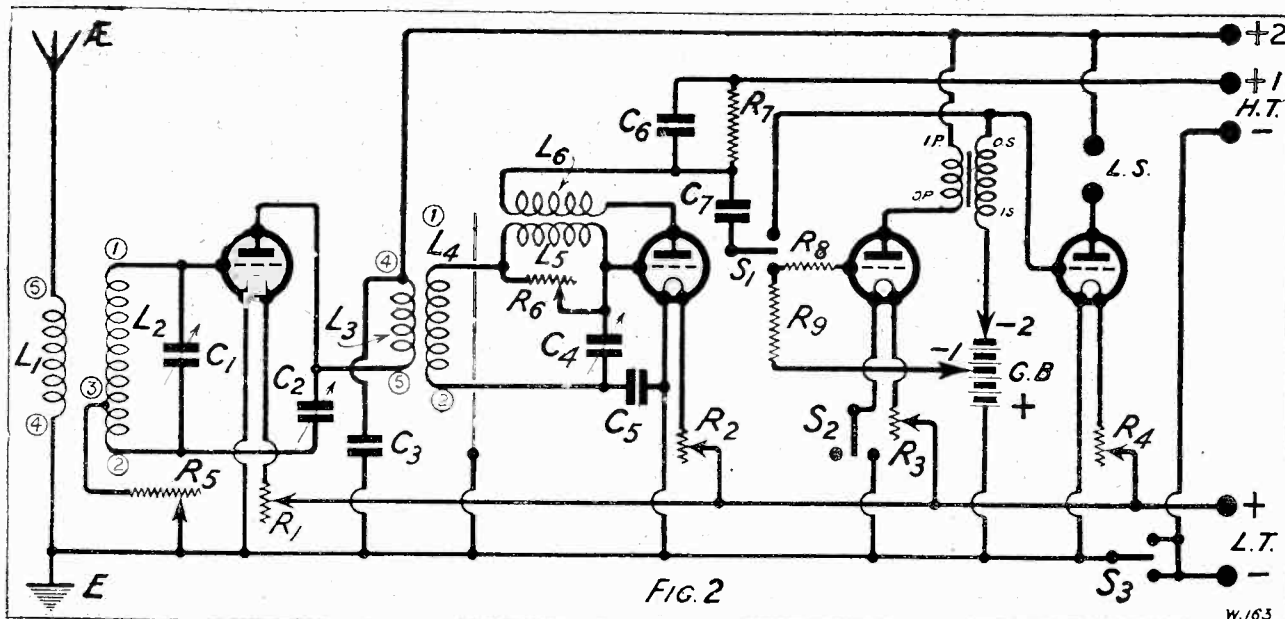

theoretical circuit. The first point is the constant-reaction scheme which I have employed, and this is shown in skeleton form in Fig. 1.

The input inductance  $L_1$  is coupled to only one half of the grid coil, shown at  $L_2$ , the other half  $L_3$  to which the reaction coil  $L_4$  is coupled being shunted by a variable resistance  $R_1$ . The tuning condenser is, of course, connected across the two coils  $L_2$  and  $L_3$ , which are connected between grid and filament of the valve. In view of the fact that magnetic reaction is used, the output, of course, must be shunted by a fixed condenser, the value of which also has a certain effect on the amount of reaction obtained.

**Constant Reaction**

It has been shown on theoretical grounds and proved in actual practice that a circuit of this description gives almost constant reaction over a very wide band of frequencies.

In cases, however, where this arrangement is coupled direct to an aerial and earth system, it is very difficult for any given design to give uniform results owing to the extreme variation of H.F. resistance, capacity and inductance of different aerial and earth systems. If, however, we place a stage of H.F. in front of it, then the aerial and earth damping is removed, and the only damping we have to consider in relation to the circuit is

the damping introduced by the H.F. valve. This, however, does not vary within sufficiently wide limits, providing that a certain type of valve is adhered to, to cause any noticeable variation in the operation of the receiver under differing conditions.

It may be mentioned further that this splitting of the grid coil into two portions, one of which is coupled to

It will be seen from this Fig. that the H.F. valve employs the circuit which I used with such success in the "Forty-Station Four." The aerial is coupled to an interchangeable coil  $L_1$  and to the grid coil  $L_2$ , which is tapped a quarter the way from one end, the tapping going through a 400-ohm potentiometer to L.T. negative. The anode coil  $L_3$ , which is

**AMERICAN STATIONS HEARD**

When tested out between one and two o'clock in the morning, six American stations were tuned-in on the loud speaker, and the carriers of numerous others heard. Only one call-sign was obtained, owing to the long gaps between announcements, but the stations tuned-in on the loud speaker were probably the following :

Station.	Wave-length.	Item.
Detroit	243.6	Religious talk.
Atlantic City (W P G) (call-sign heard)	272.6	Talk on health, followed by dance music and strongly accompanied by ukulele.
Pittsburg (K D K A)	315.6	Musical programme.
Springfield (W B Z)	333.1	Music and talking.
Schenectady (W G Y) (confirmed)	379.5	Peace talk, again followed by light music.
Cleveland (W T A M)	399.8	Musical programme.
New York (W E A F)	491.5	Musical programme.

All the above stations were tuned-in on the loud speaker and, although accompanied by fading, three or four of them gave consistent loud speaking which, incidentally, was heard two rooms away.

the input, the other being coupled to the reaction coil, is a scheme which greatly enhances the selectivity of the receiver, and this assists in giving a very satisfactory degree of selectivity with only one H.F. stage.

The complete theoretical circuit of the "Easy-Tune" Four is shown in Fig. 2.

coupled to  $L_4$ , which is half of the grid inductance in the grid circuit of the detector valve, is also interchangeable, while  $L_5$ , which is shunted by the resistance  $R_6$ , having a value of 6,000 ohms to 1 megohm, is coupled to the reaction winding  $L_6$ .

It will be noticed that the rectifying circuit employed is a free grid

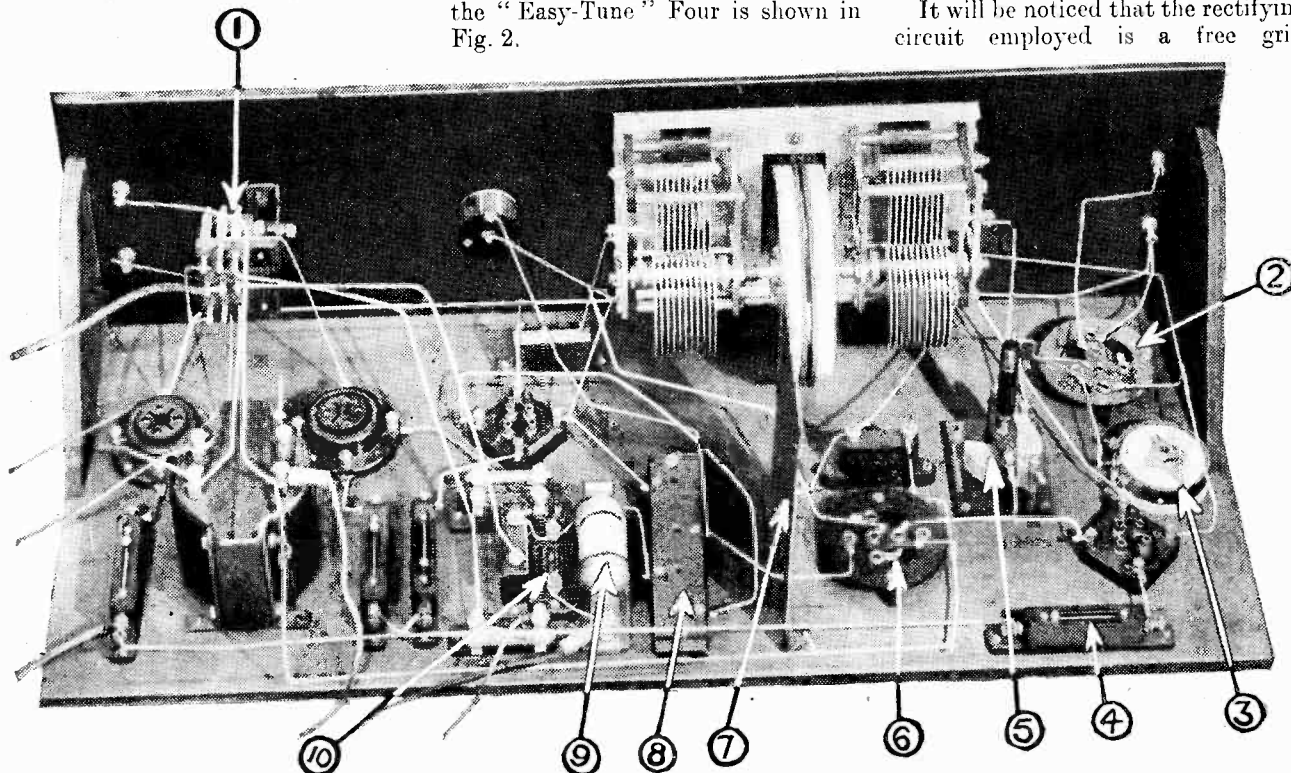

This photograph clearly shows the two condenser drums, fitted closely together to allow of gang-control if desired. The numbers refer to the following components : (1) On-off control jack; (2) aerial coil; (3) grid resistance  $R_5$ ; (4) fil. resistor; (5) neutralising condenser; (6) H.F. transformer; (7) copper screen; (8) reaction-grid coil; (9) anode resistance; (10) by-pass condenser.

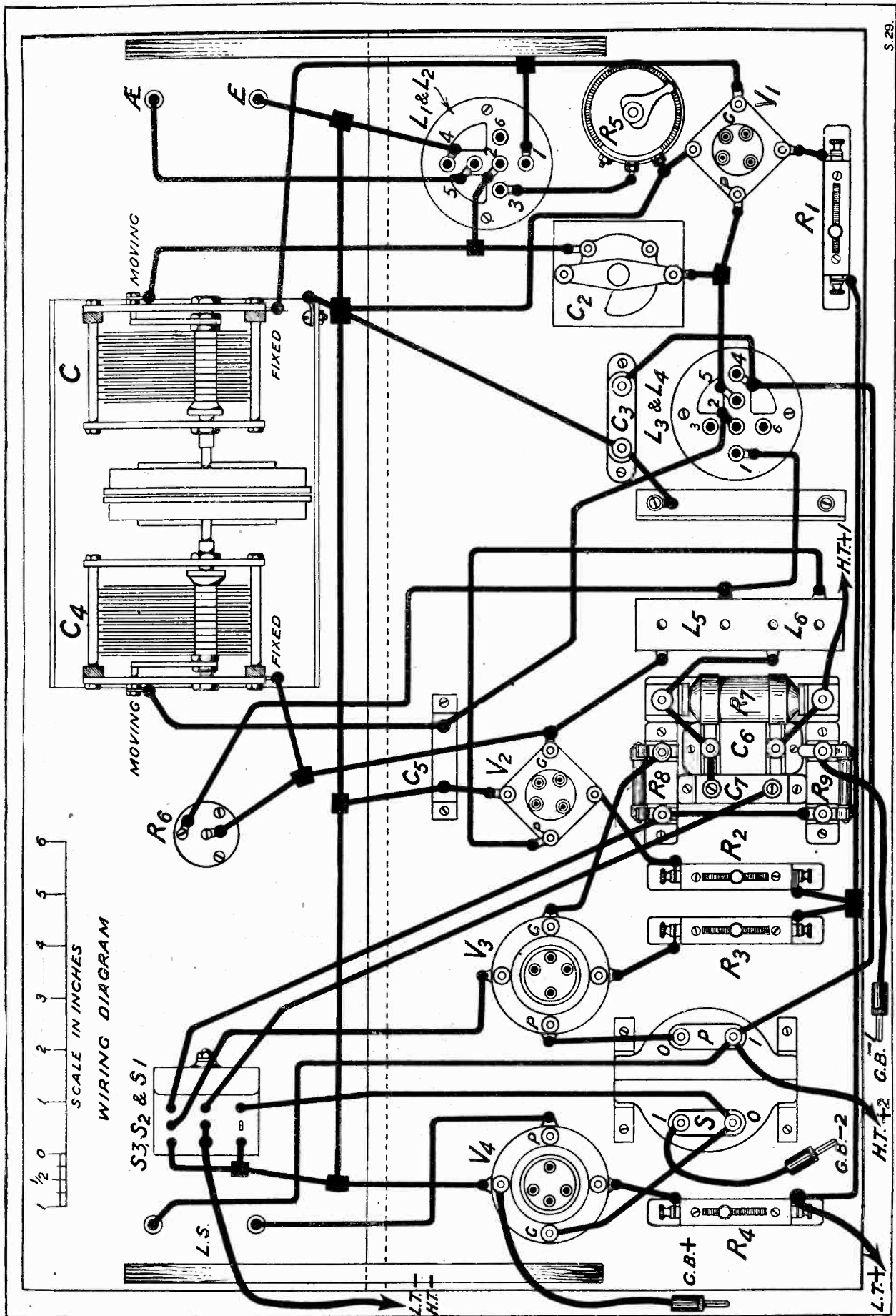

S.28

rectifying circuit, the bottom end of the grid circuit being connected through a fixed condenser  $C_5$  (capacity .001) to L.T. negative, no grid leak being provided. Actually this form of rectification gives the equivalent of anode-bend rectification, and has a number of advantages.

In the latter position the secondary of the L.F. transformer acts as a grid choke, and this is much the simplest method to employ, since it allows of the grid-bias plugs being set and then left correctly adjusted. The arrangement shown further gives a very excellent degree of quality, and in view

many cases where I have used components which only allow of connections being made by soldering, alternatives of other makes can be obtained fitted with terminals, and these, of course, may be employed if desired.

The question of screening was also given careful consideration during the original experiments, and I came to the conclusion that the only screening that was at all necessary was a small-capacity screen between the two inductances  $L_4$  and  $L_5$ , while the inductances have so been mounted as to eliminate practically any possibility of magnetic coupling existing between them. This largely assists in the correct functioning of the receiver.

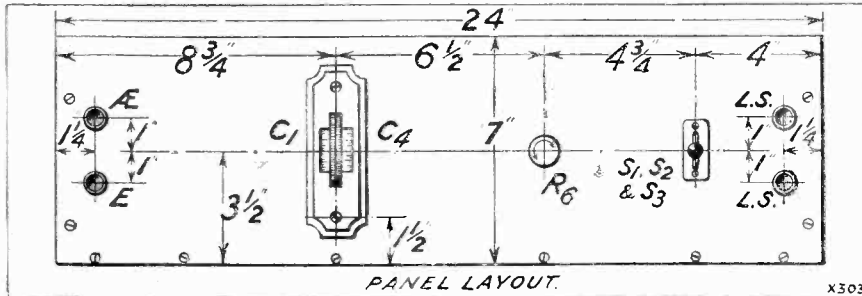

The first and most important advantage is that a far better control of reaction is obtained notwithstanding the use of a high coupling resistance in the position marked  $R_7$ .

### Better Control

By using this free grid type of rectification circuit the gang control of the two tuned circuits becomes a very simple matter, since once the right relationship between the two condensers has been found it does not vary more than a couple of degrees over the whole wave-length range covered by the two condensers.

I have made comparisons as against anode-bend rectification in which bias is applied by a small battery, but with this arrangement I found that the condensers fell out of step.

It is also a self-compensating circuit, since the carrier provides the necessary negative potential. Weak or powerful stations can therefore be received without the necessity for any readjustment of grid potential on the detector, and no choking effects are experienced.

It must be mentioned, however, that this form of rectification is more suitable when used with a high-mu detector valve and a high value of coupling resistance than under other circumstances, and this is a point to bear in mind when constructing the receiver.

### The Switching Arrangement

In order that the loud speaker may remain connected always in the plate circuit of the output valve, the switching shown has been used. It will be seen that the coupling condenser  $C_7$  may be connected either direct to the grid of the first L.F. valve or direct to the grid of the last L.F. valve.

of the fact that the impedance of the grid choke rises with the higher frequencies, it helps to offset any drop in amplification of the higher frequencies that is frequently experienced with resistance-capacity coupling.

The switching is carried out by means of a three-pole three-way switch, the three portions of which are shown at  $S_1$ ,  $S_2$  and  $S_3$ . Actually these are all coupled together and controlled by one knob. This knob appears at the right-hand end of the panel, and is arranged so that when the knob is in the centre position the set is switched off entirely. In the upper position one L.F. only is in use, and when in the lower position two low-frequency stages are in circuit.

### Simple Construction

In the actual construction of the receiver the set has been simplified

### Layout Variation

The wiring up of the receiver has also been facilitated by the use of battery leads instead of a terminal strip at the back.

The layout which I have decided on is suitable for use with the particular condensers which I have used, that is the Cyldon thumb-control gang condenser. If, however, a different type of condenser is used in this position, it may be necessary slightly to alter the layout. Care should be taken to keep the aerial coupler well away from the H.F. transformer, and all leads, especially those to grid and anode, should be kept as short as possible.

In order that the utmost efficiency may be obtained from the H.F. and detector stages, I have used Bowyer-Lowe White-line anti-vibration valve holders on account of their known high efficiency, but there are other makes, no doubt, which would prove

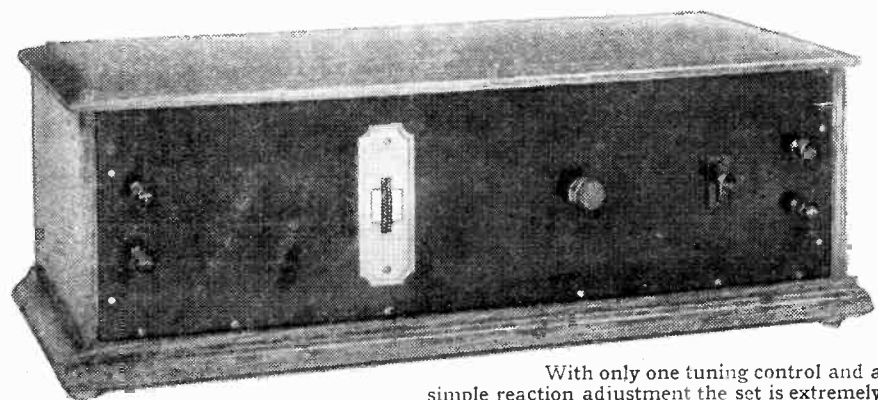

With only one tuning control and a simple reaction adjustment the set is extremely easy to operate, while its high degree of sensitivity makes it an efficient D.X. set.

as far as possible, and there are very few of the components employed which do not enable connections to be made either by means of terminals or nuts if the constructor is not too keen on using a soldering iron. In

equally effective, though, of course, care should be exercised in the choice of valve holders for these positions in order not to introduce unnecessary losses.

For the second L.F. coupling I

have used a 6-1 ratio L.F. transformer, which, by the way, is a Marconi Ideal, since this enables a very satisfactory degree of amplification from the second L.F. stage to be obtained. At the same time the quality is very excellent, but those who wish to obtain the very best possible purity of reproduction may prefer to use a 2.7-1 instead of the 6-1 ratio.

In this case, of course, a slight drop in amplification may result. Care should be taken, however, in the choice of this transformer to make sure that the primary will handle the normal value of plate current passed by the first L.F. valve without approaching saturation, otherwise distortion is liable to be introduced.

### Mounting the Condenser

The only portion of the constructional work which may present any difficulty is the mounting of the twin condenser, since this requires a rather large oblong hole to be cut in the panel. A template is provided by the makers with this condenser, and instructions are given with it as to the manner of cutting this hole.

the slot, and drilling the holes for the fixing screws.

The indicating terminals are mounted by means of  $\frac{5}{16}$ -in. holes, a small V-slot being cut at the bottom in the centre on the front of the panel for the small locating projection.

### The Copper Screen

Having done all the necessary drilling, mount all the components on the panel, and then fix this to the baseboard and the wooden brackets at either end of the baseboard.

The components should now be mounted on the baseboard, and the only other constructional work which has to be carried out is to make the copper screen which is interposed between the coils in the detector circuit. This consists of a piece of 20 gauge copper, 4 in. by  $6\frac{1}{2}$  in.

Half an inch is turned over at one end at right-angles, by means of which the screen is fixed to the baseboard, soldering tags being placed under one of the fixing screws so as to allow of the screen being connected to earth. It should be noted also that a soldering tag is fixed by means of a nut and bolt to the metal screen on which the

that there is plenty of room to carry out the wiring and that none of the joints that have to be made are at all inaccessible, thus making the wiring-up of the receiver a straightforward and simple matter.

Ample room is left for the wiring, and this is quite straightforward, but nevertheless one or two suggestions as to the most suitable order in which to make the connections will probably be appreciated.

Quality has not been sacrificed for the sake of quantity in the "Easy-Tune" Four. The reproduction is as good as the sensitivity.

All the L.T. negative leads should be run right along the back of the panel from the filament negative terminal of the last valve and to the earth terminal.

Next it is advisable to make the aerial and earth connections to the coil base, the earth connection to the screen of the twin condenser, also the connections to earth of one side of the fixed condenser  $C_3$ .

Then complete the filament connections for the H.F. valve and then the coil and condenser connections should be completed, thus finishing off the input circuit of the H.F. valve. Now complete the output circuit of the H.F. valve, after which the filament connections for all the valves should be completed.

### Battery Connections

After this has been done the wiring for the rest of the set is pretty straightforward, and can be taken in order of grid circuit for detector valve—anode circuit, grid circuit of 1st L.F. valve—anode circuit, and so on. It will be found desirable to put in the leads to the two output terminals at a fairly early stage, while two leads which may be left to the last are the two leads going to the switch, one from the fixed condenser  $C_7$ , and the other from the junction of the stopping resistance  $R_8$  and the grid leak  $R_9$ .

After all the wiring has been completed it should carefully be checked over to make sure that no mistakes have occurred, and after this the battery leads may be connected in position. The L.T. and H.T. negative battery leads are joined together and soldered to the two left-hand contacts of the change-over switch, looking at the set from behind the panel. The L.T. positive tag can be placed under the back terminal of the filament resistance  $R_1$ , while the two H.T. positive spade tags may be placed

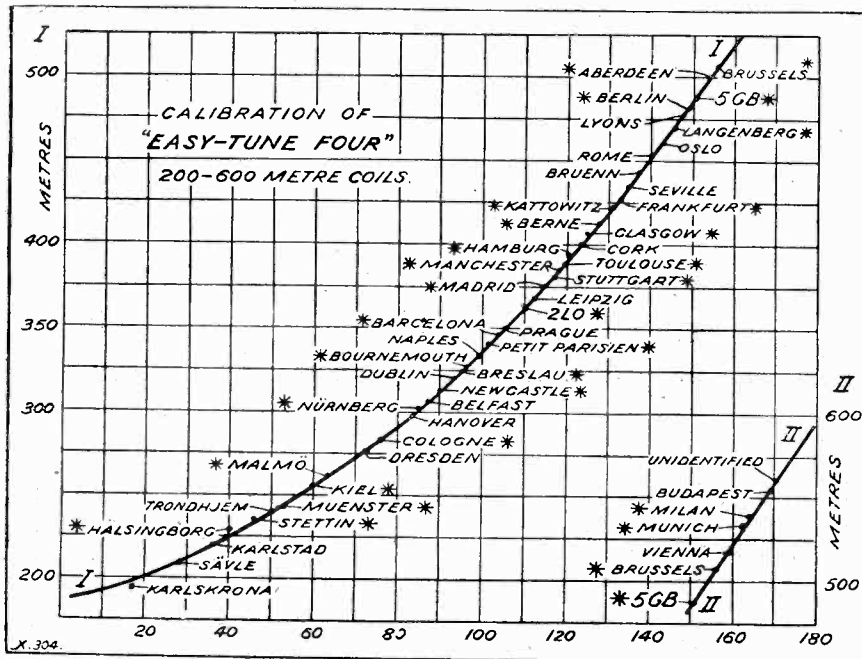

A small oblong hole has also to be drilled for the 3-pole switch, and the simplest way of doing this will be to drill a number of  $\frac{3}{16}$ -in. holes (2 B.A.) in line and then running them together with a small slotting file and filing the edges straight. The Utility switch which I have used has a small metal plate which goes on the panel through which the lever appears, and this forms a very handy template for marking out the panel for cutting out

gang condenser is mounted, so as to allow this being earthed, and it is advisable that this be done in view of the fact that both sides of the two tuning condensers  $C_1$  and  $C_4$  are at high high-frequency potential.

### Easy to Wire

The wiring diagram is drawn to scale and gives all the necessary details as to laying out the components on the baseboard, and it will be noted

respectively under the back terminal on the resistance  $R_7$  and I.P. of the L.F. transformer.

The coils should now be put in position, valves inserted and the usual tests carried out to make sure that no short-circuit of the H.T. is taking place at any point.

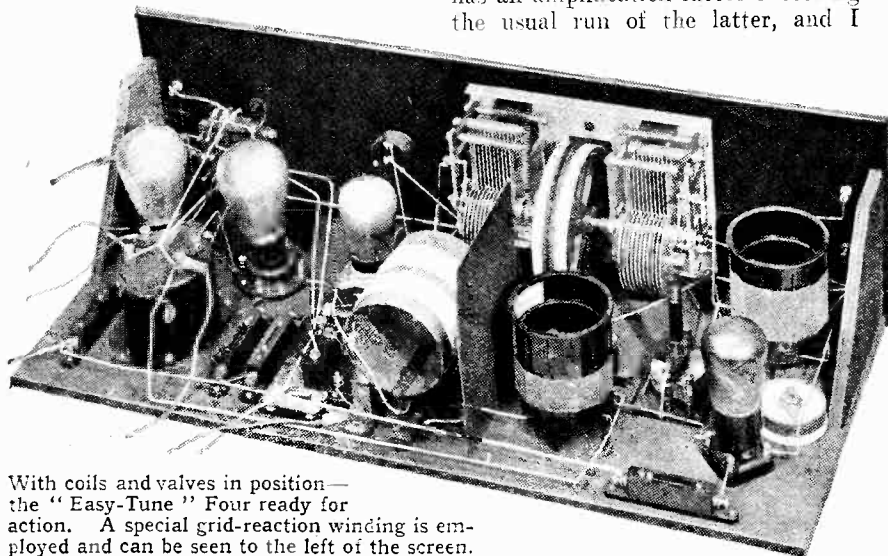

With coils and valves in position—the "Easy-Tune" Four ready for action. A special grid-reaction winding is employed and can be seen to the left of the screen.

We now come to the question of the correct valves to use in this set. For the first valve any H.F. valve having an impedance lying between 15,000 and 30,000 ohms will be suitable, e.g. P.M.5X, D.E.5B, etc., in the 6-volt class. The detector valve, however, should preferably be a special high- $\mu$  type of R.C. valve having an impedance in the neighbourhood of 70,000 ohms and an amplification factor in the neighbourhood of 35, e.g. Cosmos 55B, P.M.5B, D.E.H.610, etc.

### The L.F. Valves

The first L.F. valve should be a small power valve, if the greatest purity of reproduction is desired. If, however, a somewhat greater degree of amplification is wished for, then the use of an H.F. valve such as the P.M.5X in the 6-volt class, in particular, will be found to give a marked increase in signal strength. The last valve may be a power valve, if a great deal of volume is **not** to be handled; but where the set is to be worked on a pretty strong signal, then it is desirable to use a super-power valve in the last stage, in order to ensure that no distortion due to overloading shall occur.

Where it is not desired to use an ordinary super-power valve, with its rather low amplification factor and high anode-current consumption, and yet it is felt that an ordinary

power valve would hardly be capable of handling the volume, I can thoroughly recommend the Cosmos 6-volt Red Spot 55R valve for this position. This valve not only has a longer grid bias than an ordinary power valve—though it is not quite up to the usual super valve—but it has an amplification factor exceeding the usual run of the latter, and I

have found, under practical conditions, that it is capable of handling very nearly as much volume as a pukka super-power valve.

### Preliminary Tests

As regards what voltage valves to use, I myself have a preference for 6-volt valves, though many may prefer to use a 2-volt valve as rectifier. I would point out, however, that

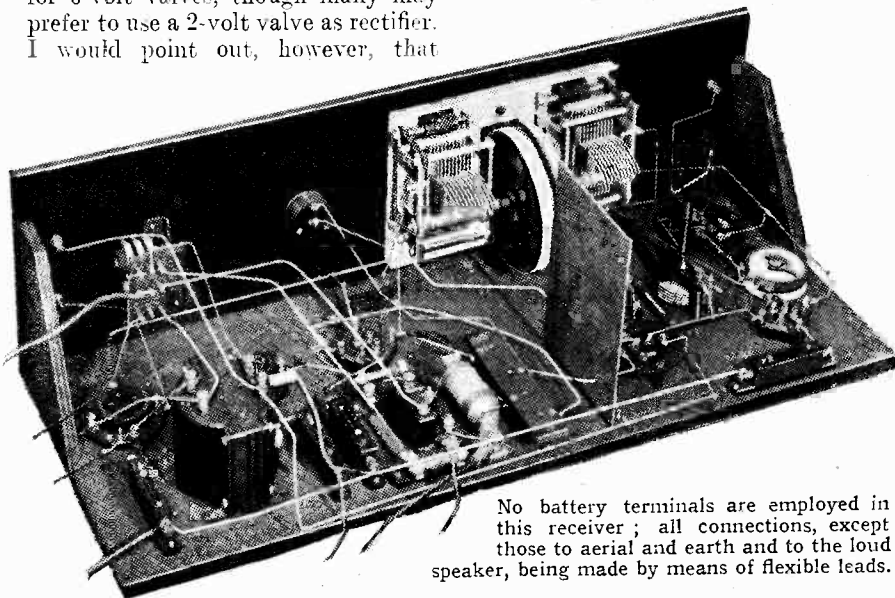

No battery terminals are employed in this receiver; all connections, except those to aerial and earth and to the loud speaker, being made by means of flexible leads.

it is most important, where a 2-volt valve is used as rectifier and higher voltage valves are used in the H.F. and L.F. stages, that the correct filament resistance be used for the valve with regard to the particular L.T. battery in use.

Having found that the set is O.K. as regards the H.T. and L.T. circuits, it should now be tested out in the ordinary way on the aerial, and for this purpose it is advisable first of all to use a somewhat low value of high-tension on the detector valve, and screw the resistance  $R_6$  down to its minimum value. This entirely cuts out reaction on the detector valve, and enables the set to be stabilised as regards the H.F. portion without complications being introduced.

### Neutralising

Where a local station is available the H.F. valve may be neutralised by turning out the filament resistance. If, however, no transmission is near enough to enable this being done, then the maximum reaction demand method should be followed.

The procedure of neutralising the set should be carried out in the neighbourhood of 50 to 60 degrees on the dial, and, if correctly stabilised, at this setting the set will be perfectly stable over the whole range of wavelengths covered by the tuning condensers; while owing to the circuit used a small amount of regeneration is introduced at the higher wavelengths where it is needed.

If with the dial set in the neighbourhood of 50 degrees the reaction control is adjusted so as that the set is just nicely stable, it will be found that fairly constant reaction effect is obtained over the whole

scale of the dials, and the set is thus easily converted into a single-control set by controlling the two tuning condensers simultaneously.

I hope to deal with other points and the construction of the coils in a future article.



*A description of the radio equipment at London's new "Air Port."  
By a Special Correspondent.*

**E**IGHT years of practical experience of wireless control at the old aerodrome at Croydon has made it possible to devise a new and greatly improved system of communication, and London may proudly boast of the finest aerodrome in the world, provided with the most up-to-date wireless equipment which the present-day technique has been able to design.

Four transmitters working on different wave-lengths, and receivers embodying the latest improvements of wireless control, have been installed for communication with aircraft in flight and with other aerodromes.

The wireless control of aeroplanes and direction finding are centred in the aerodrome control tower, an imposing structure rising some 80 ft. above the ground. In the wireless room, situated in the tower, a wireless officer is in constant touch with the aeroplanes in flight. He is in control of the receiver and the direction finder, and also operates three of the four transmitters at the transmitting station at Mitcham some 2½ miles from the aerodrome.

#### Four Transmitters

One of these three transmitters is arranged to transmit on telephony on 900 metres, the second one on telegraphy, and the third one is a spare transmitter. The fourth transmitter is controlled from a separate route traffic wireless room. It is intended to adopt in the near future a second wave-length in the neighbourhood of 1,500 metres for working telegraphy with aeroplanes, thus leaving the 900 wave free for telephony working with aircraft. As all the transmitters can work on any wave-length between 800 and 2,000 metres, a change in wave-length is simply a matter of adjustment.

Some distance from the control tower is a separate room—the route traffic wireless room—where reception and transmission takes place on 1,400 metres, mainly with other aerodromes, for the exchange of route traffic messages dealing with the departure of aircraft and other service matters. The wireless officers in the control tower and in the route traffic office work independently of each other, and matters are so arranged that no interference is possible between these two offices.

#### Special Receiver

The receiving and direction-finding gear consists of a radio-goniometer unit, used to determine the bearings of aircraft in flight, which is coupled to a Marconi type Rg.14 multi-way directional receiver. This is the latest

type of aerodrome ground receiver, arranged to receive telephony, continuous-wave, and interrupted continuous-wave signals on any wave-length between 800 and 2,000 metres. The instrument is designed for working on wave-lengths on which many services are conducted simultaneously and therefore incorporates great selectivity.

#### The Mitcham Station

The transmitting station has been built at the southern edge of Mitcham Common, 2½ miles from the aerodrome. By placing the transmitting station a few miles from the aerodrome, the four transmitters can be worked simultaneously without causing interference with the reception of signals at the aerodrome itself, and, at the same time, no obstruction is caused at the aerodrome by the masts.

Four lattice-masts each 100 ft. in height are placed at the four corners of a square, and serve to suspend four identical aerials of the inverted "L" type, each horizontal limb measuring 145 ft. The aerials are of the four-wire cage type, spaced on light metal hoops, 3 ft. in diameter.

The four down leads are connected to four lead-in insulators on the roof of the transmitting building, which is located in the centre of the transmitting site. The four lead-in insulators are placed in a row on the roof along one of the walls of the building, above the four aerial tuning inductances of the transmitters.

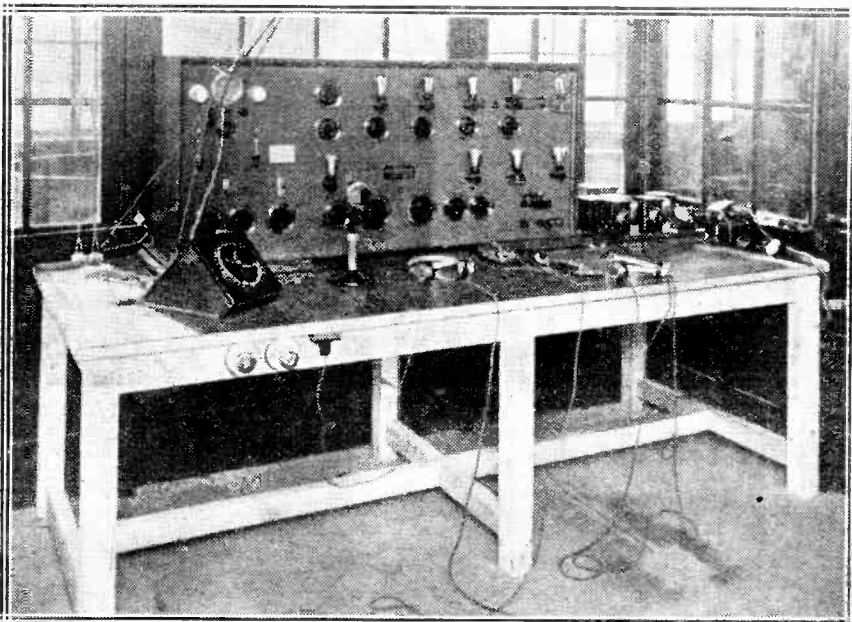

This is the wireless room in the new control tower at Croydon. From this room three of the transmitters at the transmitting station at Mitcham, 2½ miles away, can be operated by systems of remote control. On the table you will see the microphone and Morse key, and, to the left, the direction-finding unit. (Marconi Co.)



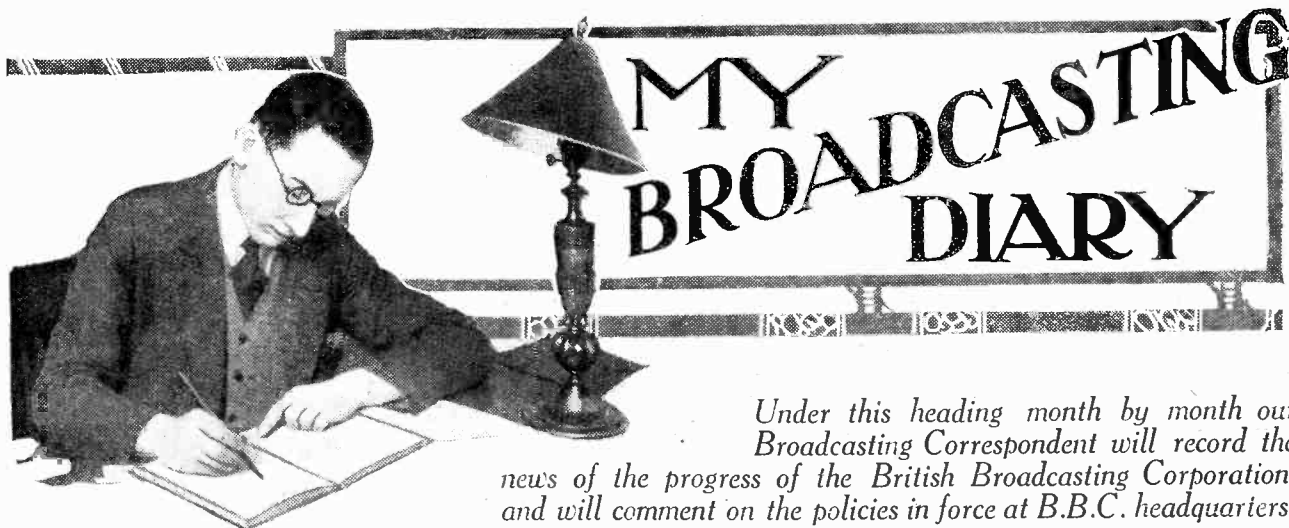

*Under this heading month by month our Broadcasting Correspondent will record the news of the progress of the British Broadcasting Corporation, and will comment on the policies in force at B.B.C. headquarters.*

### The Menace of Rigidity

**T**HE machine-like precision with which B.B.C. programmes are now arranged is not without its disadvantages. The most serious of these is obviously undue rigidity. The excuse used to be that in order to get the programmes published it was necessary to arrange them six weeks ahead of performance.

But more recently, so many syllabuses and outlines of "courses" and "series" have been undertaken that items are being forecast with detailed accuracy for six and eight months ahead. Thus the quarterly bulletin of some obscure society is apt to prevent the acceptance of a broadcast of keen topicality and importance. This tendency to "robotism" is more pronounced now than ever before, and I commend it to the serious consideration of Savoy Hill.

### Captain Eckersley's Future

I understand that the popular Chief Engineer of the B.B.C. is cumulatively unhappy about the preposterous delay of the Post Office in sanctioning the whole new Regional Scheme of distribution. Unless a more accommodating attitude is shown in official circles I should not be surprised to see Captain Eckersley leave the B.B.C. and join some concern in the trade, or start a commercial show on his own.

He is known to have received a number of most tempting offers in the past three years; but up to the present his hopes of the Regional Scheme were strong enough to resist the lure of rapid wealth. But even Captain Eckersley's patience is not unlimited, and if he receives many more buffets from officialdom, I would not be at all surprised to discover him in the trade, where he would be royally welcomed. It would be an intriguing situation. The first set marketed with Captain Eckersley's name and authority behind it might well reap a considerable fortune for all concerned.

### The Proms. Assured Again

I gather that despite difficulties of revised terms the B.B.C. has managed to reach agreement with Messrs. Chappell, with the result that the 1928 Proms. are now assured. Last year there was an eight weeks' season, this being a fortnight shorter than the traditional season of Proms. at the Queen's Hall. It is planned this year to split the difference and put on nine weeks.

I hope that the B.B.C. realises that its only mistake last year was that it did not broadcast a sufficient

number of these concerts. I presume it was "playing safe" as against possible box-office failure. But there was no real danger. The Prom. public has nothing to do with ordinary listening as such. Savoy Hill might radiate the lot, and still the hall would be crowded. Anyway, all music-lovers throughout Britain will hope for much more generous doses of this year's Proms. "on the ether."

### "New Ventures in Broadcasting"

The report of Sir Henry Hadow's committee on adult education in broadcasting contains much solace for the "uplift" school of thought. With some parts of the report most listeners would be in agreement; but there are points which give rise to justifiable apprehension. Perhaps the chief of these is involved in that blessed phrase "adequate machinery for co-operation." As in most reports of the kind, the sting is in the tail. Hence one is not surprised to discover that recommendation 14 outlines what the committee considers is "adequate machinery for co-operation."

It is suggested that there be set up a Central Council for Adult Education "composed of representatives appointed by important educational bodies, and of a

### MELBOURNE RECEIVED IN MOTOR CAR

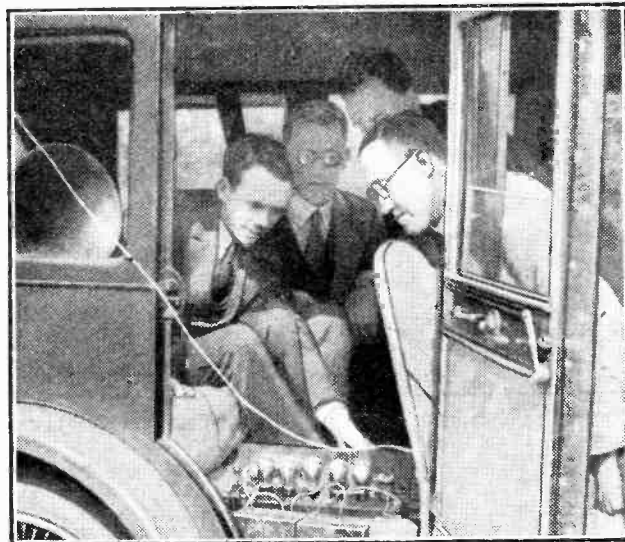

Whilst travelling along the Kentish lanes in the motor car shown, a successful attempt was recently made to pick up the 3LO Melbourne station direct.

proportion of nominated members, to which certain powers and responsibilities in connection with the planning of education and with the problems of listeners should progressively be delegated." This, in my opinion, is exceedingly dangerous doctrine.

The kind of adult education that is suitable for broadcasting should be handled by the same people that look after the entertainment. Otherwise the real function and capacity of the microphone will be speedily overlooked in a breathless rush of highbrowism and uplift. I am very surprised to see the signature of Sir John Reith appended to a report including a recommendation which, in effect, would deprive him of a considerable part of his executive power.

### The Controversy Fiasco

The almost negligible interest aroused by the alleged "controversial occasions" arranged by the B.B.C. to mark their "new freedom" proves finally the unreality of the campaign against the famous "ban." The pronouncements of party speakers on the plans and prospects of their parties have fallen extremely flat, and it is doubtful

### OUTSIDE BROADCASTS

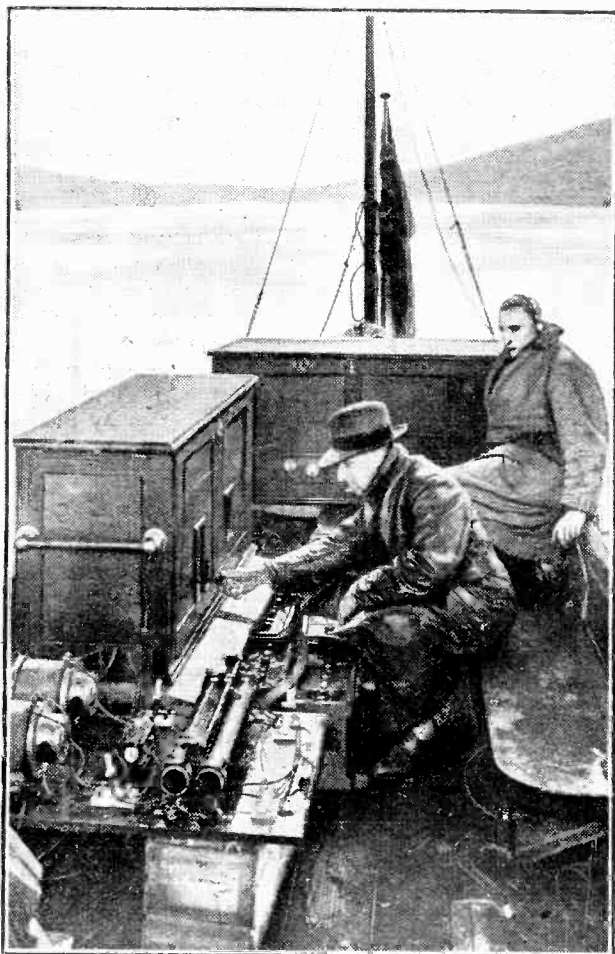

These amplifiers, which were used to broadcast the Oxford and Cambridge boat race, will be in use all the summer for relaying sporting events.

whether they have had as big an audience as do the most unpopular of the stereotyped talks.

So one can only hope that Savoy Hill will draw the correct moral, and decline to allow any more of its talent

and resources to be diverted from entertainment as such. When the General Election comes round, the party leaders will have entertainment value for listeners; and they should be put in on these grounds along with Clapham and Dwyer and other good topical turns.

### Broadcasters or Publishers?

The continued expansion of the publishing activities of the B.B.C. is slowly but surely exasperating the patience of the trade whose territory is being thus invaded. More than £100,000 appears to have been added to the B.B.C. revenue last year from profits on publications. First there was the "Radio Times," then came "World Radio," and then there followed on scores of subsidiary publications, all carrying generous advertisements, and all tapping the appropriations, big and little.

Nor is there any sign that the appetite of the B.B.C. is nearly satisfied. Canvassers working under instructions from Savoy Hill cheerfully predict the increase of revenue from publications to a quarter of a million a year. If this comes to pass, it may well create a serious situation for some publishing concerns.

The unfair thing about the competition of the B.B.C. in the publishing world is that it is built entirely on microphone publicity, which costs nothing and which is remarkably effective. In fairness to competitive publishers, the B.B.C. should not be allowed to use the microphone to sell its papers, books and pamphlets. So keen is the interest taken in the problems involved in this that there is strong probability of an attempt at Parliamentary pressure.

### John Ansell's Success

During the eighteen months in which he has been at the head of Savoy Hill's permanent orchestra, John Ansell has achieved wonderful results in that quietly efficient, unobtrusive way so characteristic of him. His qualities as a disciplinarian, combined with his orderly mind, soon manifested themselves in much better teamwork on the part of the orchestra.

Then his versatility broadened the range of effective work which could be covered. And finally his foresight in nursing fresh and likely talent has guaranteed a steady progressive improvement. The career of John Ansell with his baton at Savoy Hill is one of the pleasantest and most satisfactory chapters of the chequered history of that institution.

### Radio Drama Stagnates

What of radio drama concerning which the B.B.C. used to talk so much? "The White Chateau," given in 1925, represented the high-water mark of B.B.C. radio drama. Some of Cecil Lewis's productions since then have been moderately successful, but no one could defend the proposition that a new technique has been discovered. Noises are well done, but the average radio drama is still profoundly unconvincing.

I do not blame the broadcasters or those responsible for this part of the work. It may well be that it is useless to search for a new technique. Successes such as "The White Chateau" are dependent on the presence of some strong sentimental motive, a kind of resurgent topicality which carries them through. Without this they would not succeed, however well written, constructed and acted. I would suggest to the B.B.C. that it should undertake only a very few radio dramas, perhaps only two or three a year, but always related to some strong emotion actually present in the minds of listeners.

# AMERICA'S TELEVISION PROGRESS

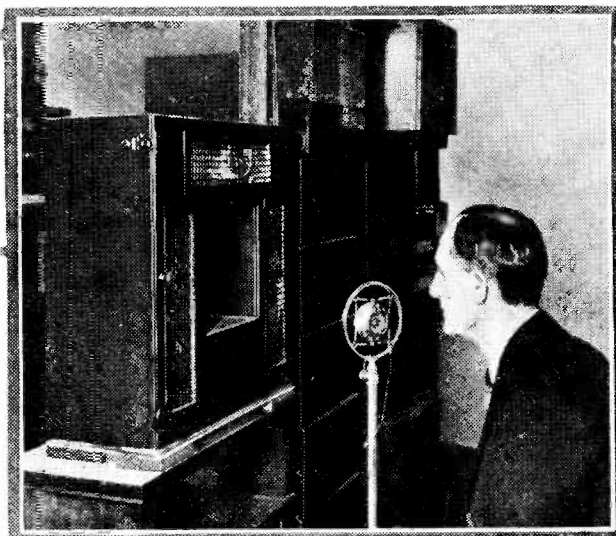

*Probably the best, if not the most spectacular, Television so far achieved was that recently demonstrated in America. Here are some interesting facts about this experiment.*

*From a Special Correspondent.*

**B**y arranging an application of long-known television principles the General Electric Company, with the Radio Corporation of America, have been able to transmit the smiles of a young woman and receive them in three New York homes.

At the transmitter was spinning before an arc-light a disc 24 in. wide, with 48 holes near the edge, arranged like the first coil of a spiral.

### "Exploring" the Object

When the disc was stationary a beam of light passed through the hole nearest the edge. A lens then directed it through a square hole in a box immediately in front, and then to a point just above and to the left of the head to be televised.

As the disc was turned slowly the beam of light travelled to the right, and as it disappeared a beam through the next disc hole—a little lower down—travelled across the top of the head.

An ordinary electric motor revolved the disc 18 times a second, and so the face was covered 18 times a second. At this speed the face seemed to be lit up by ordinary flood-lighting.

### The "Electric Eyes"

Before the "victim," however, were grouped photo-electric cells, more instantaneous in their action than our eyes. The cells thus gave out electric currents corresponding to the light reflected as the beams passed over each light or dark part of the face.

In the receiver cabinet there was a disc exactly like the one at the transmitter. Up on a shelf behind the disc was a neon lamp which

responded immediately to variations of current, representing variations of light and shade as "seen" by the photo-electric cells.

When the disc was spinning exactly in time with the one at the transmitting end—several miles away—an observer looking through an aperture near the top of the cabinet could see built up in pink and black a fairly clear moving image of the face. The image was only 1½ in. square, and magnifying lenses set in the aperture made it appear twice the size.

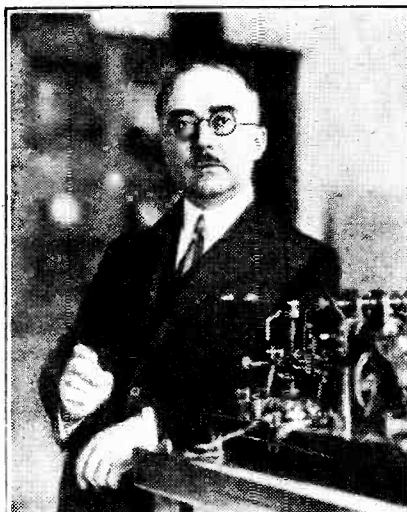

M. Edouard Belin, who recently gave a Television demonstration at Lyons.

These were the essentials in the sets used in the world's first demonstration of broadcast television to homes, but although interesting, it did not prove the *probability* of the arrival of real home television for reasons to be mentioned later.

Dr. Alexanderson has been working for months on his "television pro-

jector," a large drum with variously-set mirrors round the circumference. As this drum revolves beams of light directed on it are zigzagged over a screen to build up the received image.

This promised a new system of television reception, but when the "television to homes" demonstration was being planned it was decided that the mirror drum, while having advantages, was too clumsy. Discs with holes were therefore used.

Adoption of these discs would not solve the almost insuperable problem of a cheap and simple television set for the home, capable even of comparatively crude image reproduction. They had often been used before, and were even suggested by Plotnow as long ago as 1884.

### Methods of Synchronising

Usual ways of ensuring that the apparatus at the receiver shall be running exactly in phase with that at the transmitter are:

To use a synchronous motor and transmit a special synchronising wave, or

To synchronise with a tuning fork.

These devices mean money, expert care, amplifiers, and other elaborations, each of which takes television a step farther from the home.

An ordinary electric motor made for household use was therefore fitted in the receiver and manipulated by a hand control. But this indicates delicate and expert control, and is not satisfactory for the home.

It must be pointed out in conclusion that the experiments were carried out at great costs, both financially and in respect to manpower—it is said that 1,000 engineers participated.



How many different valves are there? That is a question I am often asked by worried constructors who are vainly attempting to solve the problem of choosing three or four valves for their sets from the multitude of D.E.'s, S.P.'s, S.S.'s, etc., that flood the market.

The answer is, "I don't know." The more I try to compile a complete list, the more am I convinced of the hopelessness of the average constructor's task. There are certainly nearer 400 than 300 different receiving valves available for ordinary use, not counting mains valves and special types.

### Increasing Chaos

It is only natural that when one manufacturer brings out a valve the others must either copy or go one better, but they must have a valve that can take the place of the one that has just been placed on the market by their rival. Consequently, with eight large valve concerns we have practically every valve in eight "different" specimens. What a difficult task for the average man when he comes to choose between A, B, C, D, E, F, G, and H—all placing an "eminently suitable" valve on the market! And for the most part they are all "eminently suitable" in that they run very close together with regard to characteristics, and one make is often just as good as another. But, even so, it does not help the man-in-the-street very much because he has to carry in his head a conglomeration of weird signs. How is he to remember that the D.E.5, P.M.6, 610 L.F., B.4 are more or less interchangeable?

*There are nearly 400 different receiving valves on the British market. Is it not time a definite nomenclature was adopted?*

By K. D. ROGERS.

What is required is a proper, lucid, and simple means of valve nomenclature that will denote the use for which the valve was designed and sufficient of its characteristics to enable the average man to decide upon the type he requires without having to delve into a pile of catalogues and makers' lists—to emerge in still more of a quandary.

The best attempt at simple classification, in my opinion, was made by Messrs. Burndepth when they instituted the "H.L." method. This has been followed by several firms, but not with the enthusiasm I would like to have seen. Thus we have the D.E.L.610—a valve of the dull-emitter L.F. variety needing 6 volts and taking .10 amp.

But why the D.E.? Most valves are of the dull-emitter type, and, it not, surely the .10 will show what class of filament they have? Burndepth's used to denote their valves as H., L., L.L., and H.L., showing that they were for H.F., L.F., super power, or general-purpose use. These letters were followed by the filament voltage and consumption as in the above case. So we had the L.L.525—a super-power taking 5 volts and .25 amp., and so on.

### A Simple Scheme

Now why not incorporate the impedance and magnification factor as well and denote the valves in some such scheme as follows:

H.F. valves could be denoted as H. for H.F., preceded by the filament voltage, and followed by the magnification factor, and then the impedance in thousands, e.g., 20/30—which incidentally gives at a glance the mutual conductance. I do not think that the filament current consumption need be stated in this case, because most valves have consumptions of .075 to .15 or .25 amp. The full details would be given on the valve box, of course.

### Typical Examples

Thus an H.F. valve having a fil. voltage of 6 and an impedance of 30,000 with magnification factor of 20 would be denoted as 6 H.20/30 while a "general-purpose" valve of 2 volts fil. voltage, with magnification of 7.5 and impedance of 15,000 would be denoted as 2 H.L.15/08—the magnification factor being taken to the nearest unit for classification purposes, and correctly stated in the fuller details given with the valve.

Screened-grid and very high mag. valves would be classified as follows: the former would be 6 S.G.110/180 and the super-power valves would be 6 S.P. 03/2.5 for valves of the 6-volt screened-grid 180,000-ohm 110-mu., and 6-volt S.P. 3-mu.-2,500-ohm classes.

The question of nomenclature is becoming really serious, for confusion upon confusion is arising owing to the large numbers of valves constantly being put upon the market.

Such a classification as I have suggested, though not by any means perfect, would, I think, do something towards clearing up the confusion which at present exists in the minds of constructors and the general listening public.

# A REMEDY FOR FADING

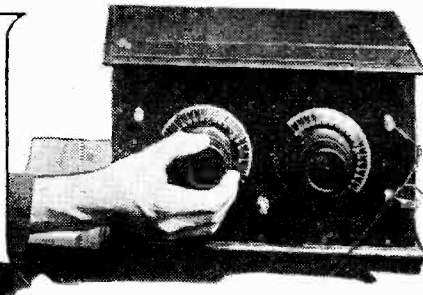

Details of an ingenious device for automatically controlling the volume of reception.

By J. C. JEVONS.

**T**HERE are various ways familiar to broadcast listeners for regulating the volume of sound coming from the loud speaker. These usually involve an adjustment by hand of a suitable knob controlling either the filament current or grid bias on one or more of the valves.

It is quite another matter, however, to devise a scheme which, without any manual control, will automatically ensure a steady output from the loud speaker, irrespective of fluctuations in the strength of the incoming signals.

### A Transmitting Problem

Such an arrangement would obviously serve a very useful purpose in preventing the irritating effect due to fading where—especially when listening to a distant station—a period of full-strength reproduction is followed every few minutes either by a complete “fade-away” or else a spell of bare audibility.

To some extent the same problem occurs in transmission, particularly in systems where the original microphone current is passed through several banks of amplifiers before being applied to modulate the carrier wave.

Here the effect of slight accidental variation in the strength of the speaker's voice is amplified up out of all proportion to the original fault, and develops into a “blast” which, quite apart from its unpleasant effect upon the ears, may cause serious damage to the transmitting gear, particularly the valves.

### “Gain Regulation”

In the ordinary way any such happening is circumvented by means of a control panel placed in charge of a special operator, who listens-in at the transmitting station and supervises the output generally, raising or lowering the overall amplification by hand control as the need arises.

It is possible, however, to make the “gain regulation,” as it is called, perfectly automatic.

In broadcast reception, fluctuations in strength due to fading are usually of the order of several minutes' duration, so that the “control” is well within the limits of practical requirements.

### Also Prevents “Blasting”

A circuit arrangement which has been used in commercial long-distance signalling for securing the same result is illustrated in the diagram. Here part of the output from the rectifying valve D is shunted back to operate a delicate relay, such as a thermal ammeter, which in turn changes the grid bias on the first H.F. valve from one definite setting to another according as the strength of signal rises or falls.

Although this does not afford such an elastic range of control as the one

As will be seen from the drawing, part of the rectified current flowing in the plate of the detector valve D is fed back through the transformer T to a thermal ammeter W. The length of the wires W, it must be understood, increases or decreases according to the strength of the rectified current flowing through them, and the resulting change in temperature.

### Alternative Grid Bias

When the current is too weak the wires W contract and straighten out, thus pulling-over the delicately pivoted armature R, so that it makes contact on the left-hand side. This cuts out the heavy bias battery B, and inserts a weaker battery B<sub>1</sub>. The result is that the H.F. amplifier valve V<sub>1</sub> is now working on a more sensitive part of the curve, and the overall amplification through the system is increased, with a corresponding gain in output from the loud speaker.

On the other hand, if the loud-speaker response is excessive, the current through the thermal wires W rises. Under the increased heating effect, the wires lengthen and allow a spring S to pull back the armature R on to the right-hand contact. This restores the heavy negative bias from the battery B, so that the loud-speaker response is immediately cut down to normal strength.

[Ed. Note.—Another scheme for providing an automatic control of volume was described in the April issue of

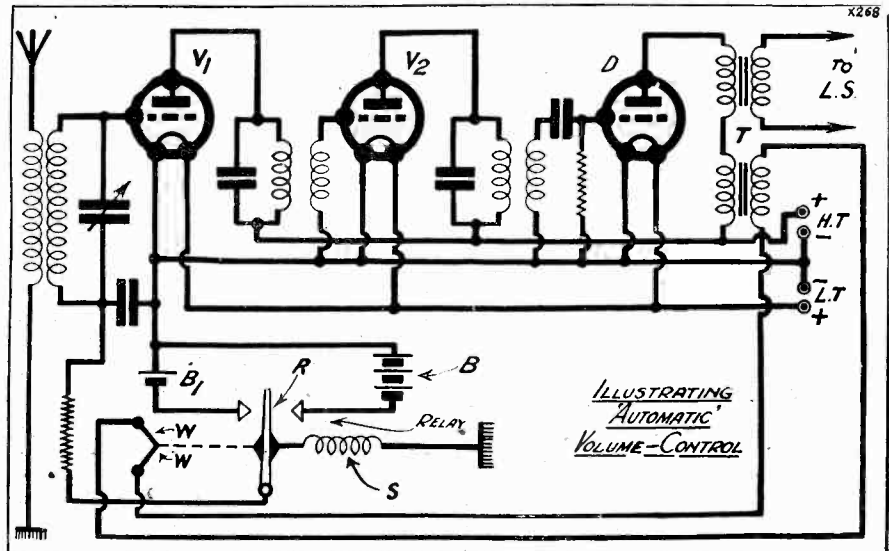

By means of a thermo-ammeter the strength of reception is automatically controlled as shown above.

previously described, it will clearly prevent the received signals from sinking to inaudibility on the one hand, or “blasting” on the other.

MODERN WIRELESS. This scheme is due to an American scientist, and is essentially a method of biasing an H.F. valve with fed-back energy.]



Further practical details of the short-wave receiver described in last month's "M.W."

By C. P. ALLINSON, A.M.I.R.E.

**I**N the course of some experiments which I have carried out with the short-wave receiver which I described last month, I have come across some interesting points concerning the handling of this set and getting the best results from it.

The chief of these problems has been the reception of very short wave-lengths in the neighbourhood of 10 metres. My original attempts

thinner wire wound in single-layer fashion and stuck up solid with shellac so as to prevent the vibration of individual turns, which would, of course, affect the reaction and tuning controls of the receiver.

On plugging this coil into position I found that although a better control of reaction was obtained than by the use of a single-turn grid coil, it was nevertheless still uncertain in its action and extremely liable to give rise to that unfortunate grid-leak or threshold howl which, bursting forth at a moment when you least expect it, leaves you deafened for some five minutes.

**That Threshold Howl**

Now in the course of my short-wave experiments I have usually found that this form of grid-leak howl is either due to incorrect aerial coupling or incorrect reaction-coil coupling. To test out whether the aerial coupling was affecting the reaction control in this manner, I pulled out the aerial coil entirely and disconnected the aerial from the set. The difficulty, however, still persisted.

It was therefore clear to me that the trouble was due to the coupling between the reaction and grid coil, and I therefore stripped out the reaction coil which I had tried and put in another coil which was made as follows: I wound twelve turns of 28 gauge D.S.C. wire in jumble fashion on a 3/4-in. former, binding the whole thing tightly together with thread.

When this reaction coil was completed it was found just to fit inside the first turn of the grid coil, and it was therefore carefully placed in position and securely fixed so as to prevent any shake; the actual end of the coil to which it was coupled being the low-tension end.

It was found that with this coil

a delightful control of oscillation was obtained over the whole range covered by the four-turn grid coil with the aerial removed. With the aerial coil placed in position, however, a bad dead spot was found, even with the coil placed at the loosest coupling setting, and a smaller aerial coil consisting of three turns only was made up and tried out. This was still found to give a slight dead spot which, however, was easily got over by slightly increasing the H.T. on the detector valve.

**Still Lower**

On measuring up the wave-length range of this coil it was found that it went up just above 2XAD and down to about 14 metres. In view of the fact, however, that considerable overlap was present—more, indeed, than was necessary with the next coil up in the range—I determined to cut the number of turns on the grid coil down still further and see how far down I could get with the set.

While testing out this coil I actually listened to a test transmission from 2XAD, who was carrying out experimental work with PCJJ and 5SW. Speech was perfectly clear, although there was a little high-speed fading, but there was very little I missed of one side of the conversation. I noted while listening to him that, in the pauses where PCJJ replied to him, I heard some faint talking in the 2XAD studio, and on listening carefully the explanation suddenly came to me. 2XAD was receiving PCJJ on the loud speaker and PCJJ's reply was being picked up by transmitting microphone and being re-broadcast. Had that loud speaker been placed a little closer to the microphone I could have sat here in London

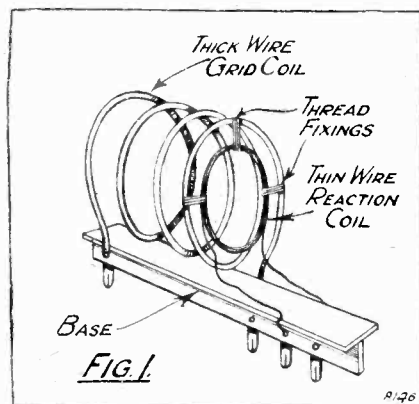

to get down to this wave-length were made with a single-turn coil having a two- or three-turn reaction coil coupled to it. I found, however, that this was very irregular in its action, and, further, was extremely liable to go off into a bad grid-leak howl if the reaction was increased so as to get the set just oscillating. The reaction was also very patchy, and I was not at all satisfied with the handling of the receiver.

**Reaching Down**

In order, therefore, to get down to the lower wave-lengths, I decided to make up a special ultra short-wave coil consisting of two or three turns of wire, being only an inch in diameter. First of all, I started by winding the coil with four turns of 10 gauge wire an inch in diameter, spaced about 1/4 in. The reaction winding consisted of seven or eight turns of

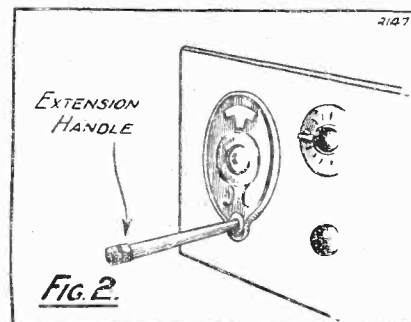

and listened to both sides of the conversation being carried on between America and Holland.

To return, however, to the point in question, I next reduced the grid coil to three turns, and experimented with different sizes of reaction winding to find which would give the smoothest

and most consistent control of reaction. I found the correct number of turns to be seven, the same construction of the reaction coil and same method of coupling it to the grid coil being employed as before.

In making up the smaller grid coil, I removed the turn from the grid end of it, which also had the effect of loosening the coupling between the grid and aerial coils. With a three-turn coil it was found that the whole wave-length range was from approximately 18 metres down to about 13.5 metres, and it seemed to be rather obvious from this that I was fast approaching the lower limits of the receiver below which reception could not be carried out owing to the shunt capacities which existed in the receiver. I determined, however, to persevere and see how far down I could get. It was obvious that the grid coil could still further be reduced, and yet retain a certain amount of overlap with the next coil up.

#### Smaller Grid Coil

I therefore took a further turn off the grid coil, and now found that in order to obtain satisfactory reaction nine turns for the reaction coil

were required. With this coil I found that the wave-length range was approximately from 17.5 metres down to about 12.5.

#### Critical Reaction

With the two-turn coil it was found necessary to use between nine and ten turns of fine wire, bunched together as a reaction coil; the actual value that I found most suitable being nine turns. The number required may, of course, vary a turn or so, according to the method of winding employed. This coil was placed inside the low-tension end of the grid coil, and was supported by means of threads so as to keep its coupling constant with the grid coil. I found that one turn too many resulted in the receiver oscillating over the whole range covered by the tuning condenser, even with the reaction condenser set at zero, unless the value of H.T. was reduced on the detector valve; and as I wished to keep the rectification efficiency high, I preferred to use as high a voltage as possible on this valve, so that I determined to reduce the size of the reaction coil. The construction of this special short-wave coil is shown

on the sketch in Fig. 1, which I think makes the construction fairly clear.

I had hoped that I might possibly be able to get down as low as 7 or 8 metres, but I am afraid that it is out of the question with this set owing to the various stray capacities lumped across the grid coil, which present a definite limit to the lowest wave-length receivable.

#### The Grid Potentiometer

Having dealt with the question of getting down on to the very short wave-lengths with this receiver, I will now turn to that of obtaining maximum efficiency from the set. The most important point to bear in mind is that if anything like satisfactory efficiency is to be obtained the control of reaction must be smooth and progressive. It is for this reason that a potentiometer has been incorporated in this receiver, so as to enable the grid potential of the detector valve to be determined at a value most suitable both for rectification and smooth reaction control. For instance, it may be found in many cases that where the slider is placed on the positive end of the winding, so that full positive is applied to the grid of the valve, although the signal will be exceedingly strong, backlash will be present in the oscillation control, and thus make it difficult to get the best results from the receiver.

On the other hand, if the slider is placed in the negative end so that zero bias is applied to the grid of the valve, reaction is so smooth as to make it imperceptible when going in and out of oscillation, but there will quite likely be a serious drop in signal strength. By suitably adjusting the potentiometer, however, it will be found possible to find a point where the signal strength is up to standard, while the smoothness of reaction leaves little to be desired.

#### Important Leak Value

Incidentally, I may mention here that slight variations in the potentiometer will be required in some cases when a different coil is used.

Another component which has an important effect on the reaction control is the grid leak. An unsuitable value of grid leak would make it extremely difficult to obtain smooth reaction control, and will also adversely affect signal strength.

It is also important that the grid leak used be a reliable one, for if of poor quality it may become noisy and entirely drown reception.

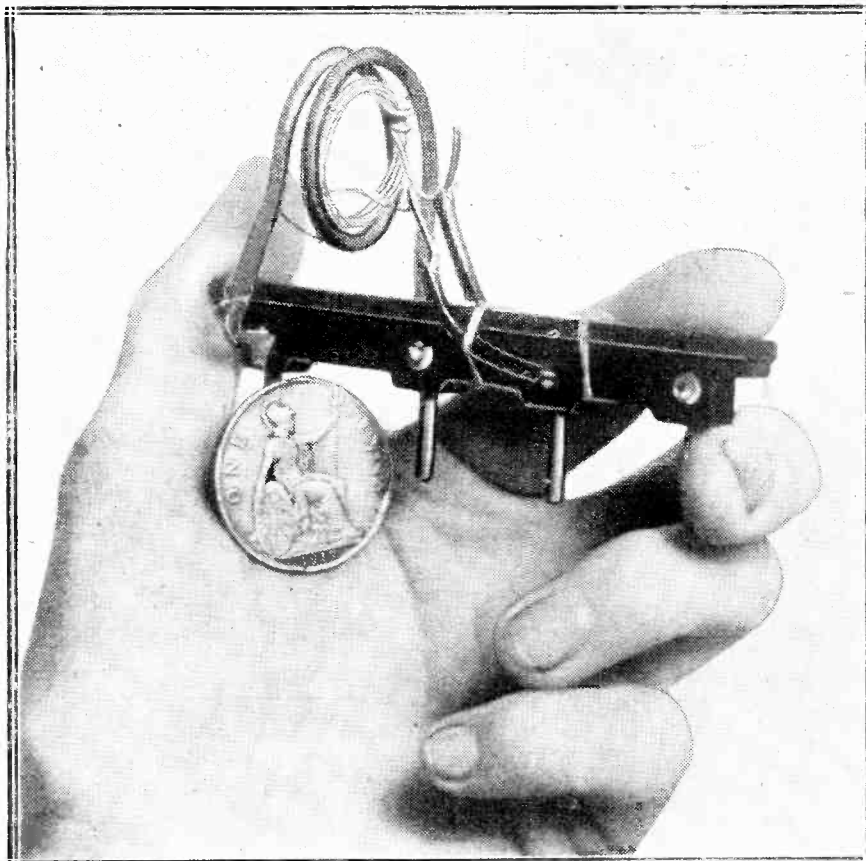

A good idea of the size of the smallest grid coil with its accompanying reaction winding can be obtained from this photograph.

The question of aerial coupling should also be investigated. Last month I mentioned the usual method for overcoming dead spots, but at the same time it is advisable to use as tight a coupling between your aerial and grid coils as possible without dead spots or difficulty in obtaining a satisfactory reaction control being experienced. Allied to the question of the aerial coil to use is also the question of an aerial.

### A Question of Aerials

Working the other night on 2XAD, I found that I obtained a most marked improvement in signal strength by transferring the set from my own aerial, which incidentally is not a very long one, to a small counterpoise which I had had erected for transmission work. The aerial is actually about 30 ft. high, and is probably about 30 ft. long, the down lead not being more than about 20 to 25 ft. at the outside, since the set is located on the first floor. The counterpoise consists of 20-ft. length of wire carried horizontally about 1 ft. from the wall, and is about 12 ft. from the ground. The lead to the counterpoise does not go to one end of it, but is tapped on at about a quarter the way along. Using this instead of the aerial lead resulted in a very marked increase in signal strength on the very short waves.

Further, in order to obtain the maximum efficiency from this set you should overhaul your earth lead carefully. My earth lead which runs to a water-pipe is not more than 6 or 8 ft. long, and owing to the fact that I have recently moved into my present residence it is only twisted round the water-pipe and no proper clip used.

### Efficient Earth Essential

In the course of my experiments I had occasion to remove the earth lead from the set, and much to my surprise I found that it made no difference at all to either the signal strength of the station I was receiving nor to the tuning. This test, as a matter of fact, was carried out on 2XAD, while I know that the earth is functioning more or less satisfactorily on the broadcast wave-length since its removal from a set working under these conditions causes a very marked drop in signal strength. It is apparent, however, that it is absolutely useless for short-wave work, and, needless to say, it is being overhauled with all possible dispatch.

The next point to consider is the question of valves to use in this set. I myself am using a high-mu R.C.

valve as the rectifier, and two valves which I found exceedingly efficient in this position are the Mullard P.M.5B and Cosmos S.P.55B, both being 6-volt valves. Care should be taken in the choice of this valve, not only from the point of view of obtaining smooth reaction and good signal strength, but also from the question of obtaining a silent background. I have found that some valves tend to give a rather noisy background while others are exceedingly microphonic. With some valves it is impossible, for instance, to tune a station in, for the simple reason that as soon as the tuning dial is touched the valve gives out a loud ringing noise which makes it impossible to hear any signal.

### The L.F. Side

On the other hand, a valve which gives a noisy background, consisting of a continuous rushing sound, again makes it difficult, if not impossible, to read a weak signal, and if a valve functions satisfactorily in a short-wave receiver in the neighbourhood of 10 to 15 metres there is nothing very much wrong with it.

The first L.F. valve is resistance-capacity coupled to the second L.F. valve, and in view of the value of the coupling resistance used in the unit which I have employed, the right valve to use here is again a high-mu R.C. valve. For the last valve a small power valve may be employed or else an H.F. valve. I myself am using at the moment an H.F. valve of the

P.M.5X, D.E.5B type, and find that this, of course, gives increased signal strength over an ordinary power valve. It was also quite satisfactory with a loud speaker which had a high-resistance high-impedance winding, though in many cases it may be desirable to use a small power valve, or a valve which certainly has a lower impedance than that which I am employing at the moment, in order to obtain better reproduction on the loud speaker.

### Avoiding Hand-Capacity

In view of the fact that my earth lead was not acting as an earth on this set, I found that I was getting a certain amount of hand-capacity effects from the front metal panel, which instead of being at earth potential, as it would be if my earth lead really went to earth, is up in the air. I therefore fitted a couple of extension handles to the two vernier controls on my slow-motion dials, and the method of attaching these is shown in Fig. 2. The extension handle consisted of a 4½-in. length of inch ebonite rod, it being tapered off at the end to about ¾ in., drilled up the centre at that end and tapped out 2 B.A. The other end was milled for about an inch, so as to afford a good grip, and the small adjusting knob on the vernier dials was removed and the extension handle screwed on in its place. Two of these handles were used, one for tuning and one for reaction, and were found greatly to facilitate the handling of the receiver.

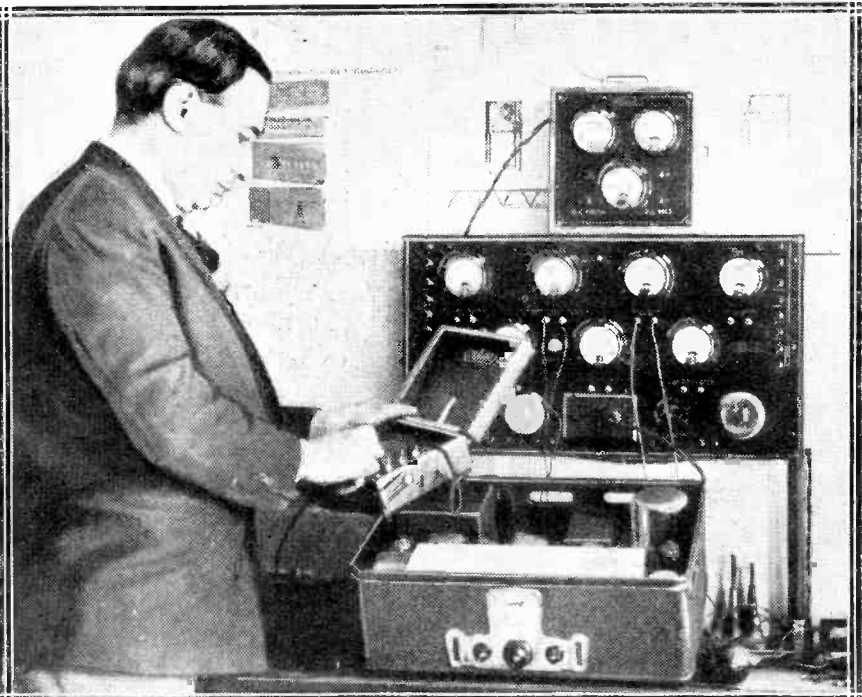

Testing a receiver by means of a special test-board which enables faults of any kind to be located



# Build this two-valve amplifier with LISSEN parts for

**YOU** can build a 2-valve amplifier—to give perfect loudspeaker results in conjunction with your present crystal or 1-valve set—at a cost of only about £1 8s. 6d. The parts required for a conventional 2-valve amplifier are as under:—

1 Lissen L.F. Transformer	- - - - -	8/6
1 Lissen R.C.C. Unit	- - - - -	4/-
1 Lissen Rheostat (7 ohms)	- - - - -	2/6
2 Lissen Valveholders at 1/- each	- - - - -	2/-
1 Lissen Fixed Condenser	- - - - -	1/-
1 Lissen Filament Switch	- - - - -	1/-
		19s. 0d.
1 Ebonite Panel, size about 8" x 6" x 1/4"	- - - - -	4/-
1 Ebonite Terminal Strip, about 5" x 2" x 1/4"	- - - - -	1/-
1 Baseboard (from your local joiner), 8" x 6" x 1/4"	- - - - -	6d.
Screws, Terminals and Wire, about	- - - - -	4/-
<b>Total cost (except valves and batteries)</b>	<b>- - - - -</b>	<b>£1 8s. 6d.</b>

# parts for 28/6

10,000 radio dealers will sell you all these parts at the prices stated. No matter what may be specified in any circuit or instructions you are building to, use Lissen parts wherever you can. Your radio dealer will also willingly tell you how to connect every circuit you are interested in if you tell him you intend to use Lissen parts and buy them from him.

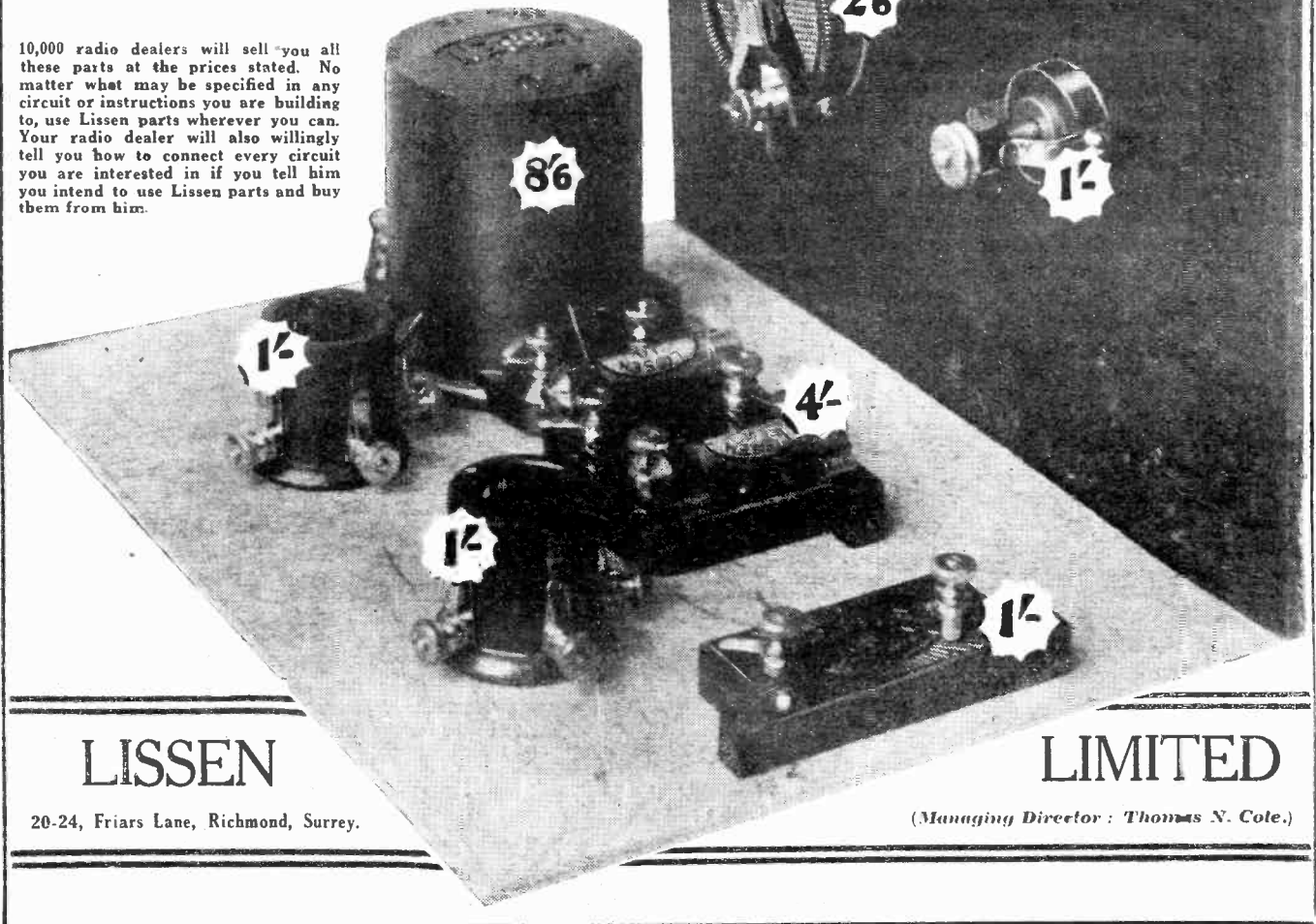

**LISSEN**

20-24, Friars Lane, Richmond, Surrey.

**LIMITED**

(Managing Director: Thomas N. Cole.)

# The "M.W." Standardized Loading Coil

By G. P. KENDALL, B.Sc.

IT was decided some considerable time ago that sets with switching for long and short waves would occupy a very important place among future designs for the home constructor, and a good deal of work has been done on the subject in the "M.W." Research Dept., as will have been gathered from a preliminary announcement elsewhere regarding a special four-valve set to be described in a future issue.

In the course of this work it was realised that loading coils of practically identical types were being used in one way or another in nearly all the circuits we were working upon, and this seemed worthy of separate investigation before proceeding further. It was soon found that certain main features were common to all the loading coils which we had used, and it seemed that by making certain special provisions in the design it would be possible to standardise a specification for a loading coil which would serve for a very large proportion of the future "all-wave" set designs.

## Helping the Constructor

Obviously it would be a great convenience to both designer and constructor if such a standard coil can be decided upon, since it would mean that the designer, for his part, need not work out a special coil for each set, while the constructor would probably find that since the same coil was being used for a large number of sets he could buy it ready wound, and so escape a rather tedious job. The matter was evidently of sufficient importance to warrant a considerable amount of investigation, and we have now found it possible to decide upon a specification for a standard loading coil of quite a simple nature, which will serve practically every need in sets of the kind we are considering.

## A Simple Coil

This coil consists of a single plain winding of a certain definite inductance, with taps at fixed positions, and it should be wound in such a way that if a reaction winding is required for some special circuit it can be wound on over the top of the

main winding by the constructor himself in a few minutes.

It is not proposed to fix any of the details of construction of the standard coil in the specification, since there is nothing critical about it, and any scheme which suits the convenience of the individual constructor or manufacturer will serve the purpose, within the following limitations: the overall diameter should not exceed 3 in., nor the length 2 in.

## What is Required

The method of winding should be of a type giving fairly low self-capacity and reasonably low high-frequency resistance, and, obviously, it should be of one of the "concentrated" types to enable a reasonably stout gauge of wire to be used and yet maintain the necessary compactness. It has *not* been found satisfactory to use a plain single-layer winding of the very fine wire often used for long-wave coils; to compress the coil within the desired limits it would be necessary to use so

The coils which we are using are constructed as follows: The former is a piece of "Becol" ribbed tube, with an outside diameter of 3 in., and a length of 1 3/4 in., with six ribs. In each of these ribs eight slots are cut, down to the full depth of the rib, about 1/16 in. wide, and with a space of 1/8 in. between the cuts. There are thus eight slots to accommodate the winding, which is of the simple section type, the turns being run into each slot quite irregularly.

## The Windings

In each slot there are 27 turns of No. 26 D.S.C. wire, giving a total of 216 turns. (The desired inductance is roughly 3,000 microhenries.) Tappings are made at the 25th, 60th, and 80th turns, and these have been found to cover all the requirements of the usual circuits.

The total inductance and position of theappings in proportion to the total number of turns, it will be seen, are the only data needed by the constructor, the practical details being left to his own discretion, subject to the requirements laid down as to self-capacity and H.F. resistance. Of course, if the constructor has any doubts as to his ability to work out a design to conform to these requirements he will be well advised to keep closely to the example which has been given.

All the necessary data is now in

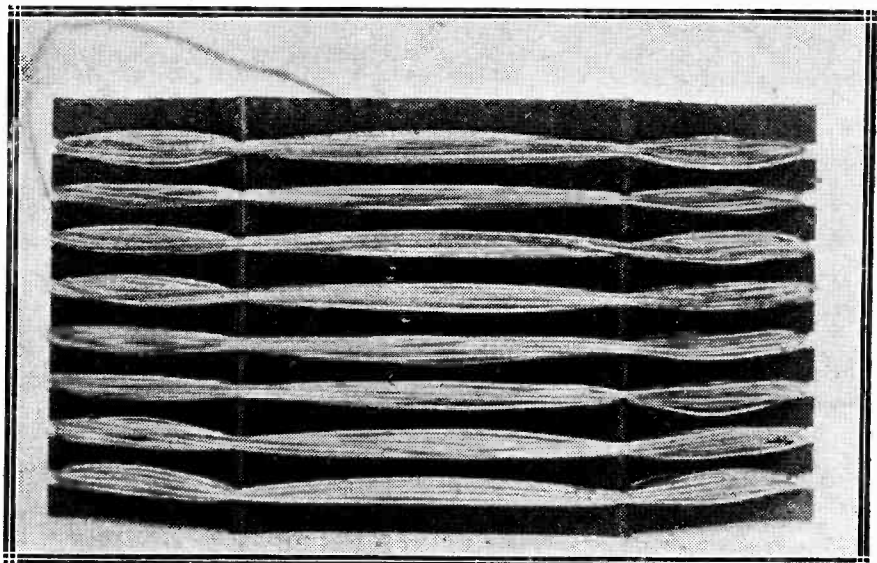

The version of the standard loading coil used for the first tests was wound on a slotted and ribbed former.

fine a gauge that the H.F. resistance would be too high. Actually, it has been found that a satisfactory coil can be produced by the use of No. 26 gauge double silk-covered wire.

the reader's possession, and he will see in future issues in what a variety of ways the coil can be used. The threeappings enable a great variety of circuit and switching schemes to be obtained.

# THE NEW METHOD - TRICKLE CHARGING!



Trickle charging means a continuous, consistent and automatic supply of current to L.T. Accumulators.

It is far and away the surest and cheapest method. Philips Trickle Charger is the unit to use and gives a charging rate varying with the size of your battery from 150 mA to 195 mA. Philips Trickle Charger is doubly economical. Not only is the running cost almost negligible, but the size of the L.T. Battery may be reduced to a minimum. One of 3 or 4 actual ampere hours capacity is fully sufficient. Post the coupon below now for full details.

**TRICKLE  
CHARGER**  
**55/-**

**PRICE, INCLUDING  
VALVE**

Completely wired, ready for use.



# PHILIPS *for Radio*

**POST THIS STRIP FOR COMPLETE DESCRIPTION**

To Philips Lamps Ltd., Radio Dept., Philips House, 145, Charing Cross Road, London, W.C.2.

Please send me at once full detailed description of your new Trickle Charger.

Name .....

Address .....

Date .....



# RADIO and the GRAMOPHONE

*A section for the Music Lover.*  
 Conducted by **KEITH D. ROGERS**

**L**AST month I discussed the fitting of the gramophone pick-up to three popular sets placed on the market by well-known valve manufacturers. Since then a number of readers have asked me to explain how to fit their pick-ups so that the tracks they trace across the record surface are correct. The aligning of pick-up and tone arm is a most essential part in the fitting, because unless both the tone arm and the pick-up are correctly placed, undue wear will occur on the record, and in many cases harshness in reproduction will result.

### Three Main Points

There are three main things to be watched for when fitting a pick-up to a gramophone. One is that the pick-up needle should make an angle of about 60° to the record's face, when looked at from the side; another is that the whole of the sweep of the pick-up and the needle should be arranged so that the needle comes in line with the grooves on the record as nearly as possible, and the third is to make sure that the needle touches the record at right-angles, when looked at from the front. A glance at the sketches on the next page will show exactly what I mean.

In a few cases it will be found that the original tone arm on the gramophone

will fit the pick-up, and everything will be perfectly in line to start with, but in some cases trouble may be met, and recently I have had a certain amount of trouble in aligning a pick-up which has just appeared on the market and which is made by a well-known German firm. What happened in this case will perhaps help readers, especially if I explain carefully the various steps I took in order to obtain correct alignment.

With the rapid development taking place in the design of L.F. amplifiers and loud speakers, and also in the production of gramophone records, it is natural that these two sections of the radio and gramophone industries should be combined for the benefit of the music-loving public.

The electrical "pick-up" has enabled this combination to take place, with the result that anyone with a reasonably efficient valve set can, for a very small outlay, enjoy all the benefits that radio and the gramophone have to offer.

In this section of MODERN WIRELESS each month will be discussed both technical and other data of interest to the set owner who is also interested in gramophones, whether from a technical or purely utilitarian point of view.

In addition to articles on the operating side of amplifier and pick-up combinations, and various hints and tips of value to the constructor and set owner, a brief survey and critique of the latest gramophone records is included, making the section of vital interest to all music-lovers.

On fitting the pick-up to the tone arm I found that it was on a slant, so that the needle did not make an angle of 90° with the line AC. It was found that the needle was working on one side of the groove more than the other, and when it reached the inside of the record undue scratching was noticed. Obviously that had to be remedied if the best results were to be obtained from the pick-up, and the longest life from the record.

### Preliminary Difficulties

On getting the pick-up arranged so that the needle made an angle of 90° with the line AC, I found that the swing of the tone arm did not allow the pick-up to work to the best advantage. What happened was that the needle, in its path across the record, traced an arc of a circle, which, although it passed through the centre-pin of the turntable, as it should do, did not allow the needle to run parallel straight down any of the grooves in the record.

This perhaps needs a little explanation. It will be obvious if you pass a pick-up gradually across your record, or a sound box for that matter, that the needle will traverse an arc. Now, in a properly aligned sound-box, or pick-up, the needle will at one point be absolutely straight in one

Round the World  
with the  
**Brown**

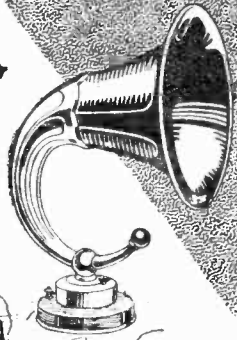

The "Brown"  
HQ Loud Speaker  
Price . . . £6

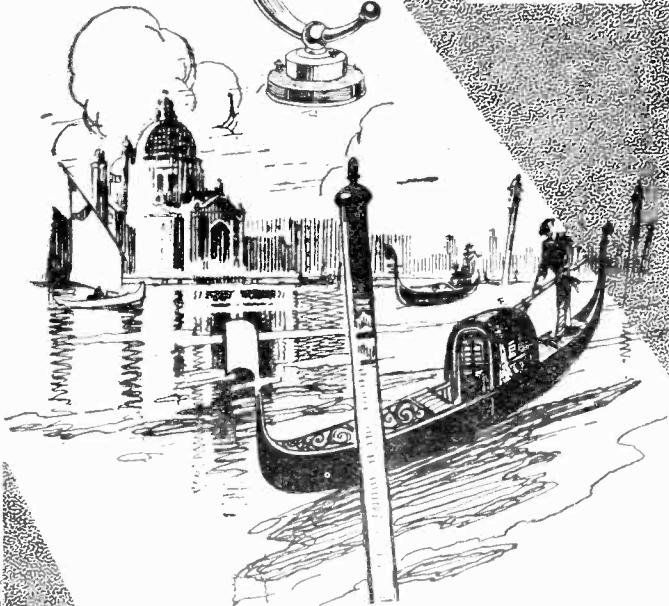

In the City of Waterways  
(VENICE)

**S**HEER from the waters of the Canal, stately palaces raise spire and turret into the waning sunlight. Smoothly the gondola glides and through the stillness comes the sound of music, ringing true and clear across the waters. It is the "Brown" Loud speaker, reproducing with its own inimitable realism.

All over the world, the perfect realism of the "Brown" Loud Speaker is enjoyed by those who enjoy good reception. All over the world the standard of Loud Speaker reproduction is set and maintained by the "Brown."

they listen to the

**Brown**

The Loud Speaker on which the sun  
never sets

Advt. S. G. Brown, Ltd., Western Ave., N. Acton, W 3.

© 2417

# KILOCYCLE TUNING

FOR GREATER SELECTIVITY

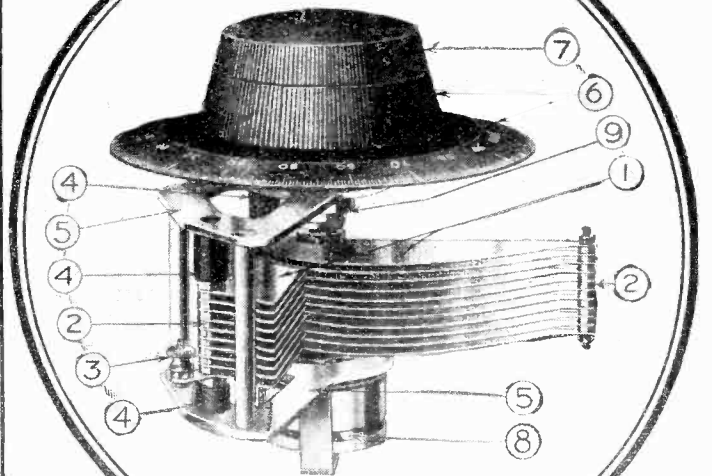

Complete  
with Knob  
& Dial &  
Vernier.

**12/-**

How delightful to be always certain of your station—to be able to tune in whatever station you desire, with no time wasted in undecided searching.

In design and workmanship, the Dubilier K.C. Condenser maintains the recognised Standard of Dubilier efficiency and, like all Dubilier products, is unsurpassed in performance. Used in conjunction with the Dubilier Toroids it will give uniform Kilocycle tuning.

WHAT YOU GET FOR YOUR MONEY.

1. VANES of stout brass sheet. 2. SPACERS, between which vanes are firmly clamped, ensuring rigidity and eliminating possible resistance through loose connections. Consistent spacing assured by the extreme accuracy to which spacers are turned.
3. TERMINALS—one giving direct connection with the frame and rotary vanes and the other with the fixed vanes.
4. INSULATORS of high quality moulding material under compression, forming an effective insulation of the stator plates, and eliminating dielectric losses.
5. END PLATES of the skeleton type, ensuring rigidity and lightness.
6. KNOB AND DIAL of finest finish and engraved 0 to 100 with half divisions. Main knob rotates moving vanes direct.
7. SMALL KNOB. This moves independently of the main knob and works a slow-motion drive.
8. SLOW-MOTION BALL DRIVE. Approx. reduction ratio of 200-1, enabling precise timing adjustments to be easily secured.
9. BALL RACE, giving a velvet-smooth movement whether the direct or slow-motion drive is used, and with entire absence of backlash in either case. One Hole Fixing— $\frac{1}{2}$ -in. clearance. A large nut is provided for mounting on bench. Maximum Capacity '0005.



Advt. of the Dubilier Condenser Co. (1925) Ltd., North Acton, W 3, © 139A

of the grooves. That is to say, it will make what we call a tangent with the curve of the groove itself.

Now, if the pick-up is arranged so that the needle does not run straight down the groove, it will bear either to one side or other of the groove. This will mean increased wear of the

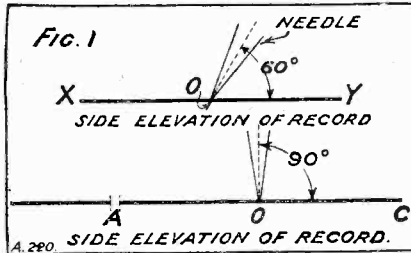

record and distortion of reproduction, and in cases, such as when used with Broadcast records where thin walls are employed, this means a very short life for the record and, incidentally, very bad reproduction.

**Use Old Record**

It is not a bad plan to use an old record in order to test the alignment of the pick-up. Failing an old record, a piece of cardboard could be cut out and placed on the turntable, and lines drawn on this, as shown in the diagram. The advantage of the record, however, is that you have the natural grooves there, and you can see exactly how the needle is running in these grooves, and can test whether it is going to run parallel in the centre of the playing surface of the record. This point is marked O on Fig. 2.

I used an old record for this test, and exactly what I did is as follows: I first of all took the record and drew a diameter right across it, right through the centre with a straight ruler, using a pointed scriber.

The record was placed on the turntable, and a rough test of the tone arm and pick-up was made. The tone arm, of course, was unscrewed and was not fixed to the base of the gramophone in any way.

**Angle of Incidence**

At the first try things were absolutely hopeless, but after a little bit of juggling (this business has to be done slowly to get absolutely satisfactory results) I was able to arrange a swing of the tone arm so that the needle from the pick-up crossed that diameter which I scratched on the record exactly in the centre of the record right where the pin from the turn-table goes through the record and at the outside edge.

I then marked the track of the needle and drew the lines WB and XY,

the point O on the tangent being the point at which the needle has to be in line with the playing groove of the record.

It was then found that I had been doing the test with the needle on the pick-up at the wrong angle to the record.

**Not Difficult**

I mention this because it may save readers from wasting time, for if you do that test with the needle at about 45 degrees on the record you will find that on correcting this and making it about 60 degrees your alignment will all go out again. So this time I very carefully checked up the angle of the needle and made it 60 degrees with the surface of the record. Then I altered the tone arm again until I got its sweep and arm from the centre of the record to the outside crossing the diameter that I had drawn at the point.

The record is, at the conclusion, so placed on the turn-table that the chord WB to the arc WOB allows the needle to run absolutely parallel with the tangent half-way across that diameter.

One must arrange the needle to run parallel with that tangent, at the same time testing it with the arc touching the diameter at the centre and at the outside. This, though not an easy matter, is not so difficult as would appear from reading this article. It takes a little time and a little patience, but once it is done it is always done, and the results are well worth the trouble taken.

**Question of Needles**

With regard to the use of any particular needle it is difficult to lay down a law; it is largely a matter of choice and as to which needle suits the pick-up best. I have found that, under general conditions, the loud needle seems to give the better results, especially if the pick-up is inclined to chatter at all. Tungstyle needles are excellent for pick-up purposes, and a number of pick-up manufacturers advise the use of these needles exclusively. It saves a lot of bother with regard to changing the needle, for they can be run for a large number of times.

With some pick-ups, and noticeably the German one I mentioned earlier in the article, the medium or even the soft needle seems to give better results. If a pick-up is fairly sensitive there is no sense in using a loud needle, provided that the pick-up does not chatter. If it *does* chatter

it will be found that a loud needle seems to be better than a soft one or a medium one.

Fibre needles do not, in my opinion, go very well with pick-ups. I have tried them under different conditions, with different amplifiers and different pick-ups, but only once did I ever find the fibre needle to go really well, and that was on an experimental pick-up used with a very loud organ record. Here the strength of the record itself was great enough to overcome the loss of power which always accompanies the use of such needles.

**Split Fibres**

One trouble with this type of needle lies in the tendency for the fibre to split when a sudden loud blare from a trumpet or loud organ stop is encountered. It then calmly proceeds to play in two grooves at once, the split point dividing. This causes the most weird result and the machine has to be stopped and the needle either changed or cut by means of the special fibre needle cutters that can be obtained from any of the gramophone stores.

To those who are really interested in pick-up work from the scientific point of view, I would recommend that they try all the different kinds of needles they can possibly get, until they find one which truly suits their pick-up and amplifier, but to those who are using pick-ups just for pleasure purposes I would recommend that they keep a box of loud and a box of medium tone needles; that they use the medium tone if possible, providing the pick-up does not chatter, and they should use the loud tone if the pick-up is inclined to chatter rather a great deal.

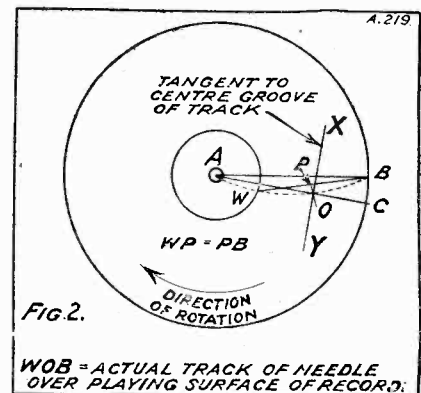

FIG. 2.

WOB = ACTUAL TRACK OF NEEDLE OVER PLAYING SURFACE OF RECORD.

Some pick-ups do not seem inclined to chatter at all, and with such pick-ups medium needles can be employed with the greatest satisfaction.

**PICK-UPS TESTED**

I HAVE recently had the pleasure of testing the latest Celestion Woodruffe pick-up. It will be remembered that this firm brought out a pick-up some twelve months ago, and that this immediately met with great success and was used by a great number of people for demonstrations and that sort of thing. It had, however, one or two little defects which have since been remedied, and now the new Woodruffe pick-up is a greatly improved piece of work.

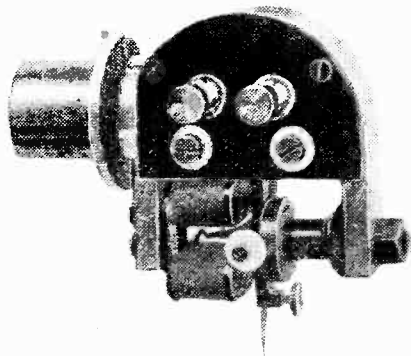

The Celestion Woodruffe pick-up.

It is a little crude in that it has the magnet windings rather exposed, and it requires a little care in handling, but otherwise I have no adverse criticism to make except, perhaps, that it is a little on the large size. This, however, is no disadvantage, because weight has been kept down in a wonderful manner and the adjustment enables a completely straight track of the armature to be obtained.

**Excellent Results**

This is essential in good pick-up design because if the armature holding the needle is not dead straight, and if it has a pull more to one side than to the other, it is bound to wear on one side of the grooves of the record more than on the other side, resulting in uneven wear and poor reproduction.

It is available at four guineas to suit any type of tone arm, and can be plugged straight across the grid and filament of the first amplifying valve. The results obtained from this pick-up are really good. The wear on the record is extremely light, and certainly not more, I should say, than that of an average sound-box.

**The Phonovox**

One of the earliest pick-ups placed upon the market was that made by The Igranic Electric Co., Ltd., and

termed the Phonovox. This is a light, neat little instrument which will give excellent results and which is available for any type of tone arm.

It is supplied complete with volume control and adaptor, and costs only £2 10s. In use it was found that a loud needle suited this pick-up best, as medium or soft needles were rather inclined to chatter to an excessive degree.

**Correct Alignment Essential**

As regards the pick-up, the aligning up of the pick-up with the record and the tone arm is a very essential business if the best results are to be obtained. Unless the pick-up is correctly aligned any tendency to chatter will be greatly accentuated, and distortion will be the result. Wrong alignment does not cause chatter with a pick-up which is not inclined to chatter at all, but if there is a definite suggestion of a little too much play in the needle arrangement of the pick-up there, incorrect alignment will emphasise this tendency and will cause poor results of any loud passages, especially where deep bass is concerned.

**"Bright" Reproduction**

I know a number of people who possess Igranic pick-ups and they all express the utmost satisfaction with them. A little more damping, I think, would be an advantage, as rather an exaggeration of some of the high notes occurs if cornet and soprano-saxophones are played.

These high notes rather tend to overbalance the lower ones, though perhaps this might not be noticeable to any but a very critical ear.

In general, this makes for a bright rendering of a record, and is preferable, in my opinion, to the over-damped, dead renderings which I have heard from some pick-ups.

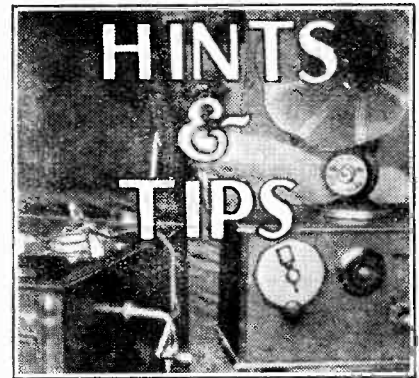

FIBRE needles will often eliminate a great deal of record surface noise and are sometimes useful where piano and organ solos are being reproduced.

For average operation medium-tone needles will be found best, especially if the pick-up is efficiently damped and does not chatter.

If bad chattering takes place when medium needles are used, loud needles or the fibre variety should be employed, though in cases of excessive chattering the pick-up should be changed.

Don't forget the grid bias on your "detector" valve, it will do a great deal towards pure reproduction.

A good volume control of the 250,000 or 500,000-ohm potentiometer type, placed across the pick-up, is almost essential for best results. Fine gradations of volume can be obtained by this means without distortion.

A cone loud speaker is usually better than the horn type for pick-up reproduction.

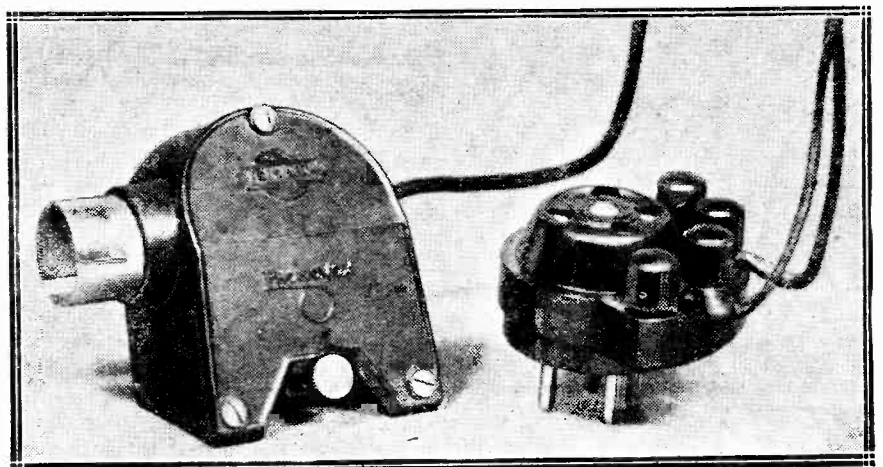

The Phonovox (Igranic) pick-up with the special plug-in adaptor.

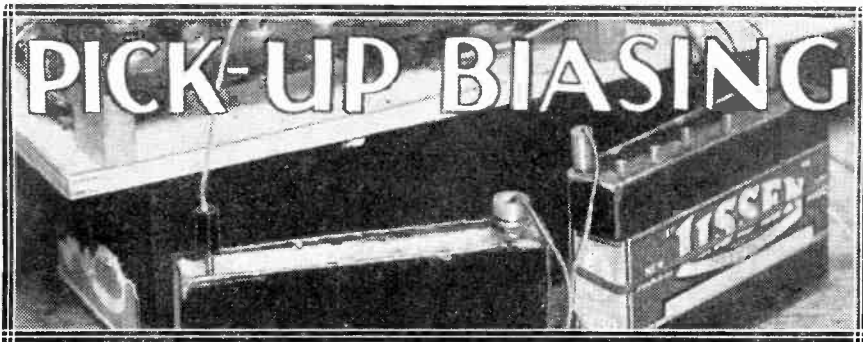

Correct grid biasing is as essential when a set is used as a gramophone amplifier as when it is employed as a radio receiver.

By G. T. KELSEY.

To improve upon the high standards of the modern gramophone, by recourse to electrical reproduction, it is necessary to pay very careful attention first to the

It is in connection with the latter and, alas, often neglected subject that I propose to devote a few paragraphs—particularly with regard to the biasing of the “detector” valve.

To obtain the maximum volume from a set used in conjunction with a gramophone pick-up, it is common practice to connect the pick-up directly across the grid and filament of what is normally the detector valve.

### The “Detector” Stage

Under modern conditions, this valve is usually of the “H.F.” variety, and in cases where a resistance stage follows, is often of the “R.C.” type, and when it is realised that the output from a reasonably sensitive pick-up is what might be termed “single valve strength,” it should be quite apparent that some provision for biasing this valve is very desirable.

Bearing in mind the strength of the output from the pick-up, the use of the “detector” valve without bias gives rise to the possibility of distortion in the first valve, which, amplified in subsequent stages, is likely to have a very detrimental effect upon the actual reproduction.

### A Convenient Method

In the case of a low-resistance pick-up, where it is necessary to use a transformer to couple it to the “detector” valve, the question of applying negative bias to this valve becomes very simple, and all that it is necessary to do is to connect a biasing battery between the end of the secondary winding remote from the grid (usually I.S.) and L.T.—as shown in Fig. 1.

A very convenient method of applying bias to the “detector” valve when using a high-resistance pick-up is shown in Fig. 2.

It should be pointed out that the amount of negative bias required on the “detector” valve, especially if it is of the “R.C.” type, is not likely to exceed from 1½ to 3 volts, depending, of course, upon the amount of H.T. in use.

### Calculating Bias

There is a rule of thumb by which it is possible to arrive at the approximately correct bias value, and this approximation is obtained by dividing twice the “mu” or amplification factor of the valve into the H.T. voltage on the plate of the valve in use.

Even with a correctly biased “detector” valve, a very sensitive pick-up may have a sufficiently large output to cause slight overloading,

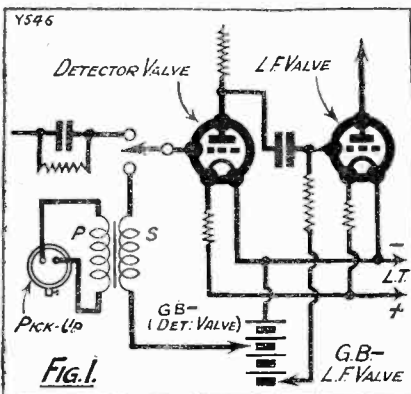

pick-up, then to the amplifier, and finally to the means of reproduction.

It is really only the second of these which concerns the home constructor from the point of view of adjustment, and, having once obtained a good amplifier, the question of obtaining satisfactory results rests almost entirely upon the choice of suitable valves, the use of plenty of

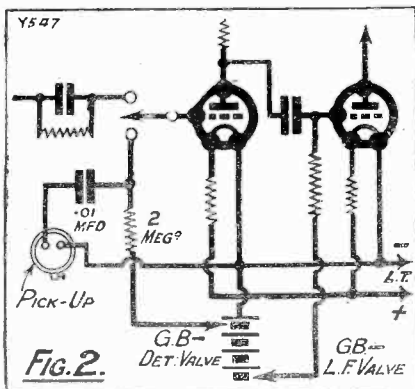

H.T. and, lastly, but by no means of least importance, the careful use of grid bias.

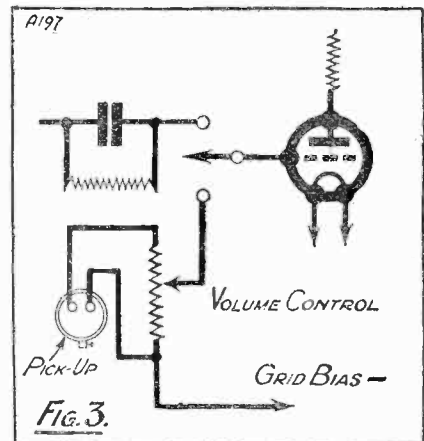

and since a volume control in any case is a very desirable feature, it is a good plan to use it between the pick-up and the first valve.

The circuit given in Fig. 3 shows how this can be done with a high-resistance pick-up, while the suitable connections for the low-resistance type are given in Fig. 4. In both of

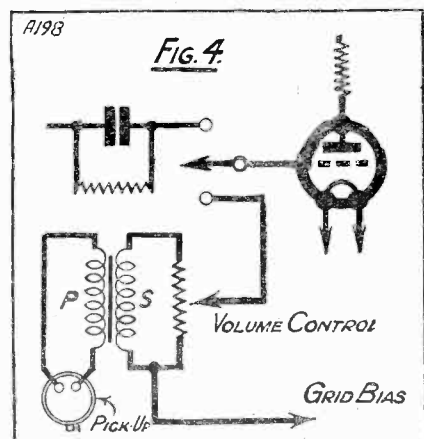

these cases a potentiometer having a resistance of 200,000 or 300,000 ohms is quite suitable.



Pat. No. 276,867.

# Modernise your

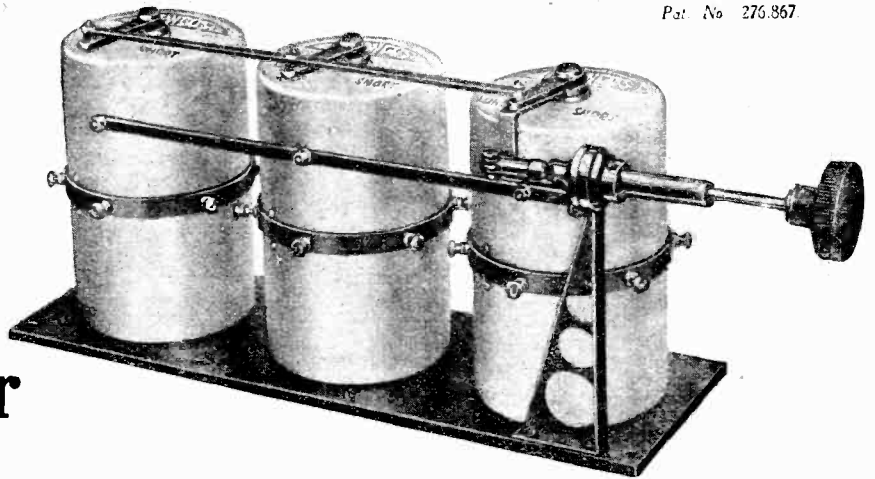

Ref. No. DSP/3  
One SP Aerial Coil  
and two Split  
Primary H.F.  
Transformers, the  
last with Reinartz  
Reaction. Per unit

£5

## 1926 "SOLODYNE"!

This LEWCOS Dual Screen Coil improves reception and makes tuning easier. You have 250-550 and 1,000-2,000 wave-length range in one unit. Panel controlled, the set fits exactly into the space occupied by the old type of three separate coils and bases. Perfectly balanced. Obtainable from stock through all wireless dealers

THE LONDON ELECTRIC WIRE CO. & SMITHS LTD.,  
Playhouse Yard, Golden Lane, London, E.C.1.

# LEWCOS DUAL SCREENED COILS

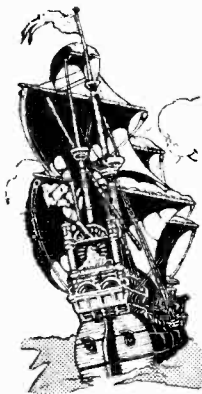

### Freighted with Fine Fiction

An Argosy story is *always* a good story. The policy of this brilliant magazine is to print only those stories which are indisputably *great*, and written by the acknowledged master writers of the past and the present day. *Read it regularly.*

# The ARGOSY

Magazine

Now On Sale.

Buy a Copy TO-DAY. 1/-

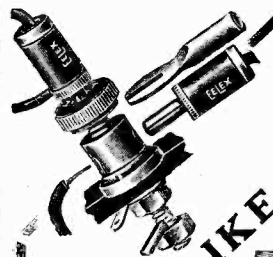

Outstanding Advantages No. 2.

VICE-LIKE GRIP



if you use EELIX Treble-Duty Terminals.

Write for List V.26 which gives details of the many other outstanding advantages of



**EELIX**  
TREBLE-DUTY  
TERMINALS

J. J. EASTICK & SONS,  
Eelx House, Bunhill Row, Chiswell Street, London, E.C.1



THE CABINETS  
FOR PORTABLES

Best design, best materials, best workmanship. Answers every requirement. Specified by leading set designers. Write for full details.

"IDEAL" MODEL

Built to accommodate anyone unit, complete with inner frame, baseboard, lock, nickel-plated fittings etc.

Oak - - 52.6

Mahogany - 58 -

CARRINGTON  
MANUFACTURING Co., Ltd.

Camco Works, Sanderstead  
Road, South Croydon.

Phone: Croydon 0623 (2 lines)

# RECENT RECORD RELEASES



## Orchestral and Band

*Brunswick.* **Mascherae** (two parts). Overture (Mascagni). The Berlin State Orchestra, conducted by the composer. (80028. 12 in. 4s. 6d.)

An exceedingly good record, well recorded. The strings come out in an exceptionally fine manner, and the whole piece is full of that life that is so characteristic of the works of Mascagni.

*Broadcast.* **Anitra's Dance** and **In the Hall of the Mountain King** (Grieg). Band of H.M. Life Guards. (221. 1s. 3d.)

Two interesting band pieces that are deservedly popular. They are well recorded and give good results with pick-ups.

*Pathé Actuelle.* **L'Arlesienne** (four parts). Bizet. The Pathé Symphony Orchestra. (15252-15253. 12 in. 4s. 6d.)

These two records of the well-known suite by Bizet are not full enough and appear to be "under-modulated," as it were. The record is a little harsh and the rendering rather restrained.

*Zonophone.* **The Rhapsody in Blue.** Gershwin. Bert Firman and his Orchestra. (A335. 12 in. 4s.)

An entirely novel rendering of this famous jazz classic which is both distinctive and extremely pleasing. Occasional passages occur where a little more could have been made of them, but on the whole the rendering is excellent. The piano part is extremely well played, and in a cleaner and more well-defined manner than is usual in this piece, which is a searching test of pianoforte technique.

## Instrumental

*Brunswick.* **Meditation** (Piano with incidental Violin) and **Some of These Days** (Piano with incidental Trumpet). Lee Sims. (3714. 10 in. 3s.)

Not a particularly good recording; inclined to be harsh at times, while the incidental music is too "incidental" and could have been brought out a bit more with advantage.

*Absent* (Metcalf) and **Love's Old Sweet Song.** Organ. Played by Archie Parkhouse at the Broadway Cinema, Stratford. (145. 10 in. 3s.)

Two well-restrained and pleasing items in which the characteristics of the pieces are well portrayed. Archie Parkhouse has commendably restrained from being too "sugary"—a fault with many cinema organists. Perhaps there is a little too much use of the tremulant, which becomes a little wearying at times.

*Zonophone.* **"Classica" Pot-pourri** (two parts). Cinema Organ. Charles W. Saxby, F.R.C.O. (A334. 12 in. 4s.)

A fine selection of classical favourites played in an excellent manner. This record is one of the best organ recordings made in recent months.

## Vocal

*Broadcast.* **Service Broadcast From St. Martin's in the Fields** (Feb. 12, 1928) (four parts). (222 and 223. 1s. 3d.)

A remarkable recording which is entirely successful. The Vocalion Co. are to be congratulated upon the way they have handled this difficult task. Two impressive and realistic records which require electrical reproduction to do them full justice.

*Zonophone.* **The Green Hills O' Somerset** (Coates) and **It Is Only A Tiny Garden** (Haydn Wood). Sydney Coltham (Tenor) with Orchestra. (5070. 10 in. 2s. 6d.)

Excellent recordings of two old favourites. They come out very well when reproduced by means of a pick-up and good amplifier.

**The Blue Danube** (Strauss) and **The Song Is Ended** (Berlin). Foster Richardson (Bass) and Orchestra. (5072. 10 in. 2s. 6d.)

Two popular items that are well sung. There is also nothing the matter with the recording from a technical point of view.

**The Company Sergeant-Major** (Sanderson) and **The Gay Cavalier** (Breville-Smith). Foster Richardson (Bass) and Orchestra. (5073. 10 in. 2s. 6d.)

This record is rather spoiled by inferior diction and the rendering that is not quite as good as it might be.

**The Black Jacks** (two parts). Humorous Dialogue. George Le Maire and Rex Van. (5077. 10 in. 2s. 6d.)

Intensely American, but excellently recorded and very well done. Would appeal to those who are fond of 100 per cent Yankee dope.

*Zonophone.* **A Little Bit of Heaven** (Gardner) and **That's Another One Gone** ("Phi-Phi"). Will Gardner (Entertainer) with Piano. (5079. 10 in. 2s. 6d.)

Two excellent recordings. The diction and style is above reproach and the items make really amusing hearing.

## Dance Records

*Brunswick.* (10 in. 3s.) **Sugar** (F.T.) and **Again** (W.). Fred Elizalde and his Music. (150.)

A record that will become very popular.

**Way Down South in Heaven** (F.T.) and **There's a Ricketty Ricketty Shack** (F.T.). Frank Black and his Orchestra. (3717.)

**Keep Sweeping Cobwebs Off the Moon** (F.T.) and **The Song is Ended** (W.). (3715.)

An excellent record, very well played.

*Broadcast.* (1s. 3d.) **Miss Annabelle Lee** (F.T.) and **There's a Ricketty Ricketty Shack** (Yale Blues). (212.) **You Don't Like It—Not Much** (F.T.) and **Marvellous** (F.T.). (213.)

Both by the Kentucky Revellers, and played with well marked rhythm.

**She Don't Wanna** (F.T.) and **The Song is Ended** (W.). (214.) (Both at the Stoll Picture Theatre, London.)

**Sugar** (Yale Blues) and **There's a Cradle in Caroline** (F.T.). (215.)

**Are You Lonesome To-night?** (W.) and **Janette** (W.). (216.) (At the Stoll Picture Theatre, London.)

**Together, We Two** (F.T.) and **Highways are Happy Ways** (F.T.). (217.) (At the Stoll Picture Theatre.)

(Continued on page 573.)



**T**HE first day of May! What a date! How it has inspired the poets, made the lovers soppier than ever, brought the blushes of pride to May Queens, warmed up the early crops of "atmospherics," and induced the unwary to venture forth beyond the shelter of bricks and mortar with a bike, a pillion, pillion-bumper (feminine), a portable receiver and gauzy underclothing. Of the effect of May Day on the imagination of those patriotic citizens who parade that day in crowds, wave flags of crimson hue and make speeches containing lots and lots of hard words, such as "proletarianism" and "boor-joys," I say nothing; controversy about mental states—their cause, effects, and treatment, is banned from these columns.

**Mutilated Morse Memories**

But what a date! Once the apple of my eye—and now I don't care a fig for it, being steeped in melancholy. Mays are not what they were in those years when wireless was a matter of praying for a signal to come through before the coherer tapped itself dumb silly; when half a dozen mutilated Morse signals on a paper tape represented the result of twelve hours' hard work, relieved only by baccy, sandwiches, and a case of bottled beer which was one's seat, bed, prayer-stool, desk and locker in a crazy hut on a wind-blown, sea-



... Where a man's throat could be slit for the price of a dozen eggs. And no questions asked.

fogged hill five miles from nowhere in particular. Verily, we were giants in those days, long before schoolchildren, plumbers and electric-bell fitters learned to speak glibly of the ether.

In May things really seem to begin. The B.B.C. becomes frolicsome and conceives botanical "talks." In England the snow nearly disappears and the first torrents of summer are heralded by the rains of the late spring. Astronomers write to the papers to tell an incredulous public that the sun is still put. Jew-boys in Strand shops announce "genuine sales" of winter clothes; umbrella merchants rub their hands together and anxiously feel their seaweed.

**Catastrophic May!**

The radio trade says "Portable," and its publicity men order large quantities of pictures of pretty girls and men with Grecian profiles and impeccable trousers, all posed round receivers (*foreground*) and in idyllic scenery (*distance*).

But it is not for this sort of tripe that you have paid a bob and turned at once to the pages containing the lines indited by your faithful transient who is for ever *en passant*. No! you expect, and with reason, the usual monthly feast of wisdom, mellowed ripe and rare. Alas, my poor brothers—no connection with meat extracts—you are foredoomed to disappointment! Instead, read the May experiences of one who prefers a warm September to a brilliant May. If you do not profit your money will be returned at the doors—in the form of coupons in a "sweep" for the benefit of indigent journalists.

I was born in May—a catastrophe which still afflicts me. In May I got my first job. In May—the same May—I lost it. The rest of that particular May I spent in trying to make my father understand why I was absolutely correct in tying a dead mouse to the gov'nor's coat collar.

Ethically correct! It was a bet. Bets are sacred. But he couldn't see it.

One merry May Day I proposed to contract the holy bond of matrimony with an unwholly holy barmaid, and when it came to a show-down my father remarked that May was his unlucky month. Heredity is a mar-

vellous thing. So is a cheque. Pa's cheque shut Miss Peroxide up like a trap. She wed a "drummer" in the pickle trade. He died on Mafeking Day—of earache.

It was in a May at the beginning of the century that I struck radio. On one of those calm, warm evenings, when Youth calls unto Beauty, when the back-gardens are full of gardening papas, and the parks full of lads and lasses feeling foolishly happy for no particular reason—on such a night some scientific johnny, devoid of innards, lacking heart, and with his blood at about three above freezing-point, was billed to lecture on the wonders of science at one of the local tabernacles.

I was at that time technically out-of-work, but keeping the books of a local printer for pocket-money—on the strength of a second-class Society of Arts certificate for book-keeping. What a scream! Three days after I left him, he wrote to ask how it was that I left a balance of £39 odd in the

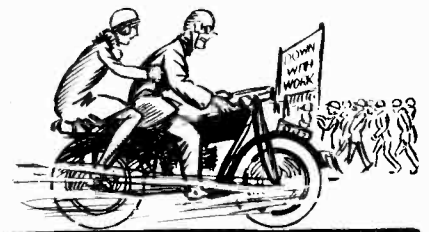

... May 1st.—With a bike, a pillion, and pillion-bumper (feminine!).

books and an actual balance of £239! Dash it! The man didn't know when he was well off.

Well, this boss—peace to his ashes!—was mighty strong on uplift and gave me a ticket for the lecture, bidding me take voluminous notes. When I arrived, minus a notebook, he packed me off to the shop for paper. A Spartan gov'nor, that! How little I foresaw that some years later paper and radio would be my stock-in-trade—with a lot of ink thrown in.

**Early Days of Radio**

That evening I saw the scientific johnny cause a bell to ring by radio. Distance—three yards. Spark transmission. Wave-length unknown. Many dear old people present thought it was a conjuring trick and breathlessly waited for the next feat; goldfish, or perhaps rabbits, and a wonderful top-hat. It was too dark for me to take the proper notes, and Henry Hugstaff had an epileptic fit in the middle of the lecture.

A coherer was passed round for inspection—shrieks from the ladies!

and debilitated lemonade was on tap in the vestry Heavens! How was I to know that in a few years I was to be running a wireless station in an island which in former years had supplied soldiers to Alexander the Great—an island where real sherry was fourpence a litre and a man's throat could be slit for the price of a dozen eggs? And no questions asked.

I realise that this month's yarn is frightfully tragic, so far. We shall be skittish anon.

Another glorious May Day dawns. I am undergoing a practical examination in wireless. My mind is a complete blank. The examiner—curse him!—looks as fit as a fiddler and plays with the apparatus like a boy with a set of ninepins. He is concocting devilries for me alone. He propounds questions which only an entirely evil mind could conceive. I answer pure nonsense.

### Making a "Fan"

He politely—and maliciously—asks me to discover the fault in a circuit. I pat the condensers and pull the wires. By a special miracle I discover that the dirty dog has shoved a wad of tissue-paper between two vital contacts. I pass with honours. I am a wireless man at last. But I am ten years older. I go to China forthwith, to show the Chinks how to do miracles. One day I will tell you of wireless in China in the old days. It's a nightmare!

Years pass. I feel at least eighty years old. Syndicates have exploded; men are again out-of-work, I amongst them. Broadcasting had blossomed and reliable "old hands" are needed to keep the unenlightened public "on the rails," for sets are refusing to work, aerials are playing the deuce,

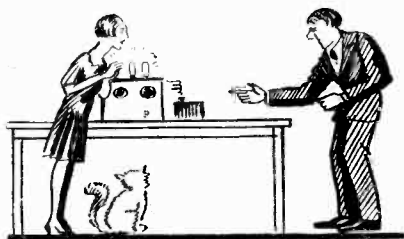

"I had the tea-time programme going within twenty minutes. . . ."

and batteries refuse to batt. I meet my friend and employer, Smawt. Note the name—*Smawt*; Isaac Smawt.

I say *friend*, because he came into action during one of my financial crises; but thus far and no farther. I would not swap D.X. lies with a man like Smawt, nor would I willingly be found on the next slab to him in a

mortuary. He is the kind of man that would weigh an electron before he bought it. He takes his hair-cuttings home from the barber's for cushion-stuffing. He would not inflate a kid's air-balloon free of charge. He takes the knocker off his front door during the period December 20th to December 31st, and he tried to sue a Countess because she sold him a Queen Alexandra rose (one penny) which had no odour.

### A Radio Service

To cut short a long story, let me say that Smawt was, to the best of my knowledge, the first Radio Service Promoter.

"You've got der knowledge," he said, "and I sully der gabbital. A fine salary for you with den per shent gomishion on der shales of der share pards." Translated into English, this meant that I was to breeze into British homes, put the radio O.K., and sell new bits and pieces for a rake-off of ten per centum. If that isn't English, I'd like to know what it is. Very good! As I had been existing for a month on the proceeds of the "popping" of my dress clothes, field-glasses, and "crush" hat, I harnessed myself to der gabitalist; chiefly because I loved the field-glasses, which I had carried with me over four-fifths of the globe.

According to Smawt's notions my conversation was to run something after this fashion.

"Great Scott, madam! What do you expect with an aerial like that? You've been swindled. For the sum of one guinea I will supply and erect an efficient antenna system. Heavens, and look at that battery! No wonder the set howls. For two guineas I will let you have a guaranteed electric battery of the first water, and will remove this useless contraption absolutely *gratis*—though I should be obliged if you would not tell everybody, as my usual charge for rubbish collecting is five shillings per pound weight.

### The Professional Spirit

"All the same, I'm afraid I can't do much to mend matters unless you let me re-instal the "earth" system, ten shillings; and even then you will be handicapped by being stuck with that set. Look at it! Absolute junk! I'm ashamed of my fellow men when I see what old iron they have sold you. Better place the whole matter in my hands, fifteen guineas, and I will remove the old

set positively free of all cost to you—but don't let it leak out, or I shall be besieged with orders and people do so impose on my good nature."

Now, mark how the professional spirit defeats the machinations of the mercenary mind. I admit that when I knocked at the first house I was as Smawtian as Smawt himself. The ticket for those field-glasses was burning a hole in my pocket, and I fully intended to get the price out of No. 4, Rural Mansions, alias "Tantallon Towers," a £1,200 rough-cast "Building Society" structure, inhabited by creatures called "Hope-Watkins."

The charmingest little bird opened the door. What a divine lisp, too! "Mithter Joneth," she said, "I



"... I proposed to Miss Hope-Watkins. The anther wath a lemon. . . ."

don't know wath the matter with the wireleth. Ith not worked for ageth and Mithter Hope Watkinth thath the grid ith leaking."

### "I Fell For It!"

I was not proof against this sort of customer. It is estimated that a mug is born every time the clock ticks, such is the bounty of providence, and it was the mugs we were angling after; but this specimen did not fight fair; she and her leaky gridth! I forgot all about Smawt, I fear. There was a radio set gone blooey; there was a defenceless woman; there was I, ready to put on the superior professional air and show her all my pretty tricks and cleverness. I fell for it. May 13th, I remember.

It was only a burnt-out primary. No new aerial, earth, or heaven required—or sold. I had the tea-time programme going within twenty minutes and then came tea for two. As she poised her hand over the sugar-bowl and, uplifting her eyebrows, queried the number of lumps I required, I noticed that she wore no wedding-ring. So the leaky-grid theorist was papa! Just so!

In the following May I proposed to Miss Hope-Watkins. The anther wath a lemon.

A dreary month, my comrades. Here's to a warm September.

# Stand the test of time

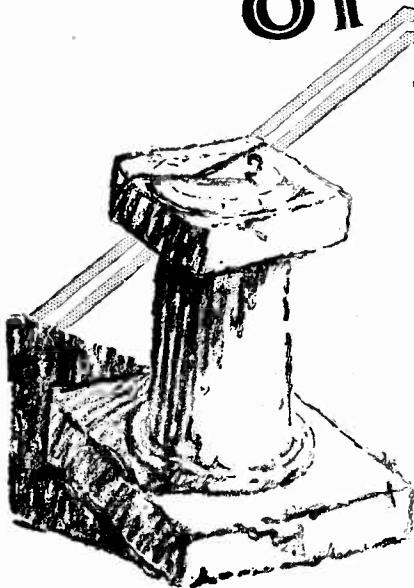

The reputation behind T.C.C. Condensers is your safeguard. For 22 years T.C.C. Condensers have been used wherever conditions called for thorough dependability and minute accuracy. It is this reputation that has made experts specify T.C.C. Condenser in countless circuits. They know it is not worth while to prejudice the success of their sets for a few pence.

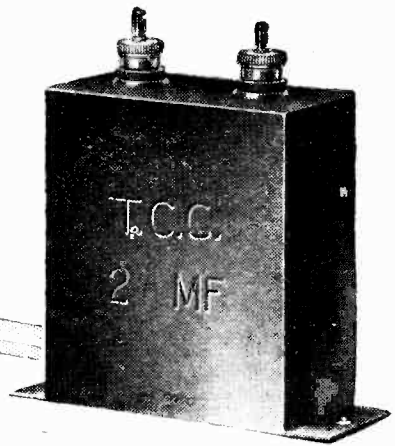

## T.C.C. CONDENSERS IN THE GREEN CASES

Specified for the COSSOR "MELODY MAKER"

Advt. Telegraph Condenser Co. Ltd., Wales-Farm Rd., N. Acton, London, W.3

CA 2433

### THE GAMBRELL

#### NEUTROVERNIA CONDENSER

This serves a threefold purpose.

1. For use as a Balancing Condenser
2. For use as a Capacity Reaction Control
3. For use as a Vernier Condenser

It is suitable for either panel or baseboard mounting. Has wide capacity range, approximately 2/38 micro-microfarads. Cannot short—has ebonite di-electric. It is a precision job throughout and is a valuable component for securing the very best results in modern circuits. Price: 5/6 each. Obtainable from all dealers.



#### GAMBRELL CENTRE-TAPPED COILS

Because of their efficiency and the greatly improved results which their design ensures, they are used and recommended by experts for circuits designed for selectivity, and from which the utmost results are to be obtained. Their use is not limited to centre-tapped circuits. Standard socket fitting. In any circuit requiring plug-in coils, "Gambrells" will ensure the finest possible results.

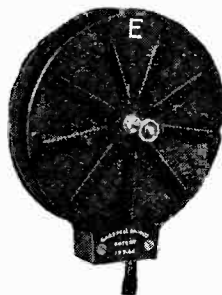

Size	A2	A	A	B1	B	C	D	E1	E	F	G
Price	4/10	4/10	5/-	5/3	5/6	5/9	6/3	6/9	7/9	8/6	10/-
Approx. No. of turns	15	25	30	40	50	75	100	150	200	300	500

Centre-Tapped 6d. extra.

Write for interesting leaflets dealing with the above and also full particulars of the range of Gambrell Mains Receivers for both A.C. and D.C. supply.

GAMBRELL BROS., LTD., 76 Victoria Street, London, S.W.1

### Building the 1928 Solodynes?

#### 5-VALVE MODEL

We claim outstanding advantages for the special "Cylidon" 3 Condenser Assembly. Greater selectivity, easier tuning, better control, finer adjustment, and no extra drum to buy. Built as one unit on aluminium chassis. PRICE £3 12 6, or complete with screens, £4 10 0. Drilled Aluminium Base, 7/6. Drilled Copper Base, 12/6.

#### 3-VALVE MODEL

This circuit specifies the "Cylidon" Twin Thumb Control Condenser. Price, complete with drums, (0005) £2 7 0

Bébé Condenser for the 1928 Solodynes. Price (0001) 7/6

IMMEDIATE DELIVERY AVAILABLE



WRITE FOR FULL PARTICULARS

SYDNEY S. BIRD & SONS, LTD., Cylidon Works, Sarnesfield Road, Enfield Town, Middlesex.

Phone: Enfield 2071-2

Grams: "Capacity Enfield."

### IT IS IT!

#### THE LATEST

4 and 6 Pinless Contact Foolproof Becol Formers. Complete, ready for winding. NO PINS—NO WRONG CONTACTS. Can be fixed in the dark.

FORMER 6/- BASE 4/6.

Inland Postage and Packing, 9d. extra.

Inside formers for above

1 3/4" x 1 1/2" x 2 1/4" 6d. each.

Packing and postage, 3d. extra.

As described and illustrated in "Modern Wireless," January, 1928, issue.

Write for Handbook on Circuits and Windings fully illustrated—Price 6d. post free

Sole Makers

THE BRITISH EBONITE CO. LTD., HANWELL, LONDON, W.7.



## RADIO NOTES AND NEWS OF THE MONTH

A feature in which our Contributor brings to your notice some of the more interesting and important Radio news items.

Conducted by "G. B."

### Russian Radio

ACCORDING to the "Daily Mail," broadcasting in Soviet Russia is being more and more employed for the purpose of fostering the Communist regime. It has been pointed out that a typical programme shows that out of a total of twenty-eight items covering a period of about sixteen hours, only two and a quarter hours are devoted to entertainment, the rest being merely propaganda. In Soviet Russia nearly every village has been provided with a receiving set and every household subscribes to a line which connects them with a main receiver.

### Blackmail by Wireless

During the recent grain crisis in Soviet Russia the official broadcasting stations were instructed to worry the

peasants to deliver grain to the Government buyers. The announcers obtained the names of peasants from spies who reported that they refused to give up their grain to the Government buyers, and if you have listened in recently you will have heard the Russian announcers at the beginning and end of each item broadcasting items like this:

"Ivan Ivanovitch, you have a stock of poltava, you have a stock of grain. Deliver it at once to the nearest collecting centre. We know how much you have and where you keep it. Unless you deliver it you know the consequences."

This is a first-class example of blackmail by wireless and shows how strong a weapon broadcasting can be in the hands of an unscrupulous Government.

### Radio Drama

A great deal of expectation is going on in the Radio Drama Department of the B.B.C., especially in connection with the evolution of its feature programmes. Complaints also have been made from time to time (states the "Daily Telegraph" Wireless Correspondent) that broadcasting is becoming stereotyped—that is, that the programmes are becoming far too identical in form—and in order to overcome this, experiments have been made to frame the evening's entertainment and so dispense with announcements. Programmes will shortly be given which will present an artistic whole based on a central idea, topical or otherwise, and a recent example may be cited in the "Town and Country" programme.

It is suggested that these programmes will, to begin with, be given not more than once a fortnight.

### Trouble With Trams

Broadcasting matters crop up quite a good deal these days in the House of Commons, and recently the Postmaster-General was asked whether he had any official information as to the success of experiments in Germany with regard to the elimination of interference with broadcast

(Continued on page 564.)

## BEYOND THE EXPECTATIONS OF THE MOST CRITICAL REALISM—



PRICE  
£9 - 10

You can hear the bowing of the strings of the double bass and the beats of the drum in their true tone-colour with a MAGNAVOX MOVING COIL LOUD SPEAKER UNIT. There are no jarring resonances, no "s" sounds missing, and the violin does not sound like a flute.

The unit is complete with input transformer, leads and switch, ready for connecting right away to your set.

No troublesome pot magnet to wind, no ticklish job in centring the delicate moving coil. All that is done for you in the MAGNAVOX UNIT—and done as a precision job should be by people who specialised in moving coil loud speakers in 1915.

Type R 4.	Field winding takes 5 amp. at 6 volts from an accumulator or trickle charger	-	£9-10-0
Type R 5 1.	For D.C. mains 105 120 mains. Consumption 5 watts	-	£10-10-0
Type R 5 2.	For D.C. mains 220 240 mains. Consumption 5 watts	-	£10-10-0
Type M7K.	Fitted with permanent field magnet	-	£3-2-6

Ask your radio dealer for a MAGNAVOX MOVING COIL LOUD SPEAKER UNIT and enjoy realistic reproduction. In case of difficulty write direct to—

# MAGNAVOX

The Originators of the Moving Coil Speaker

**THE ROTHERMEL CORPORATION LTD**  
24-26, MADDOX STREET, LONDON. W.1.  
Telephone:- Mayfair 0578, 0579.

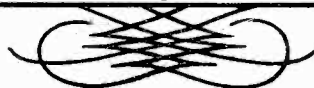



**THE UNIQUE**



**VARIABLE FRICTION BRAKE**

*What the Experts say!*

"... the moving vanes of the J.B. variables can be tightened by means of the ingenious friction devices incorporated in their movements. There is a small round-headed screw on each which takes up the pressure applied to the spindle by a small collar."

—"POPULAR WIRELESS."

Both S.L.F. and Log. Plain models are equipped with this unique Variable Friction Brake.

Prices of J.B. S.L.F. & Log. Plain Models:  
 .0005 mfd., 11/6; .00035 mfd., 10/6; .00025 mfd., 10/-; .00015 mfd. (S.L.F.), 10/-; .0001 mfd. (Log.), 10/-.

**JACKSON BROS.**  
 & POLAND ST- OXFORD ST  
 LONDON - W 1 Telephone GERRARD 7433



The claims which we make for our batteries are not extravagant, even technical experts in recently published reports say that we give a very conservative estimate of their life.

*We definitely claim that a "Ripaults" is the most economical to buy and the most efficient battery to use.*

Let your next battery be a "Ripaults" and prove our statements. No matter what set you have there is a "Ripaults" to suit it.

**RIPAULTS SELF-REGENERATIVE H.T. DRY BATTERIES**

Give 50% Longer Life

60-volt (Chocolate label) 10/6. 99-volt (Chocolate label) 16/6

Also obtainable in double, treble and quadruple capacities.

*If slightest difficulty in obtaining locally, write us.*

FREE: Illustrated folder H.T. 3 giving details of our full range of Batteries and "LIFE CHART" with "RIGHT CHOICE" table. Apply to—



1, KING'S ROAD, ST. PANCRAS, LONDON, N.W.1

**GOOD NEWS FOR SET BUILDERS**

In response to the urgent demand for first-class sets for family use, Mr. PERCY W. HARRIS, M.I.R.E., has now prepared the

**Wireless Constructor Envelopes**

The first two of this series are NOW on Sale, price 1/6 per envelope (by post 1/9).

**Envelope No. 1.—THE RADIANO THREE.** A famous loud speaker set which you can build in an hour or two—no soldering necessary and a wide range of components to choose from.

**Envelope No. 2.—THE CONCERT FOUR.** Made of standard parts, all easily obtainable, this is a highly-sensitive, long-distance set, giving powerful reproduction of wonderful quality. Covering both long and short wave-lengths, with a switch for 3 or 4 valves, it is essentially a set to enjoy, both in building and operation.

In each envelope you will find every detail of the set simply explained; photographic reproductions and diagrams are included, as well as a full-size Blue Print.

**NOW ON SALE ————— Price 1/6**

By post 1/9, from Wireless Constructor Envelopes, The Amalgamated Press, Ltd., Bear Alley, Farringdon Street, London, E.C.4.

**RADIO NOTES AND NEWS OF THE MONTH**  
 —continued from page 562

reception caused by electrical trolley-cars and tramways, etc. The Postmaster-General was also asked whether the tramway authorities were co-operating with his technical engineers in an endeavour to eliminate such trouble in this country. The Postmaster-General said he understood that no real remedy had yet been found, either in this country or in Germany, for interference in broadcasting caused by trams, etc. Experiments were going on with various devices, especially in Birmingham, Glasgow and Blackpool, but they had not yet been completed, and engineers of the B.B.C. and Post Office were co-operating with tramway authorities in an endeavour to find a remedy.

**Empire Listeners**

Another question asked in the House dealt with the establishment of a broadcasting service for receiving at moderate cost in such places as West Africa and East and Central African Colonies, where thousands

of British citizens were in remote and lonely stations and where a broadcasting service would be a great boon to them. The reply given was that the difficulty in providing such a service lay not in the transmission but the reception. The B.B.C. had been conducting daily transmissions from its short-wave station, 5 S W, ever since December 12th last, and

\*-----\*

**KEEP "IN TUNE"**  
 with all radio developments  
 and news.  
 Read  
**POPULAR WIRELESS**  
 and be up-to-date.  
*Every Thursday*      *Price 3d.*

\*-----\*

from time to time programmes had been heard in Africa and elsewhere. The B.B.C., however, had stated that prolonged experiments under varying conditions were necessary before a definite receiving set policy could be evolved. It was suggested that the Government could give help in the matter, and Colonial Governments were co-operating by forwarding reports on local reception.

**That £1,000 Television Challenge**

Our contemporary, "Popular Wireless," announces the definite and formal withdrawal of the £1,000 television challenge to Mr. Baird. Mr. Baird has been given ample time in which to make up his mind whether he or his company would accept the challenge and thus demonstrate before an impartial investigatory committee of scientists the possibilities of his system. However, as our contemporary points out, the fact that Mr. Baird has refused the challenge has, at any rate, done a great deal to clear up the misconception which existed in the public mind with regard to television.

**Gas for L.T.**

A Marconiphone receiver drawing its low-tension supply from a gas thermopile was one of the exhibits which attracted a good deal of attention at the Gas Company's stand at the recent Ideal Homes Exhibition. Tests are now being carried out by the South Metropolitan Gas Co. and these show that the low filament current required by this set can be provided by six cubic feet of gas per hour and that reception is quite equal to that obtained when accumulators are used.

(Continued on page 566.)

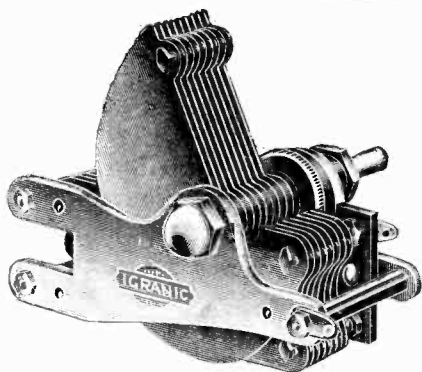

**Permanent Accuracy**

Vanes positively spaced and rigidly braced by an ingenious locking bar method give to the Igranik "Lokvane" Variable Condenser a feature possessed by no other at the price—**permanent accuracy**. Stations always come in at the same dial reading, provided the rest of the circuit remains constant. The same locking bar feature explains its remarkably reasonable price. It enables rapid assembly while still maintaining the highest possible standard of precision.

**The Igranik "Lokvane" Variable Condenser**

offers more easy, accurate tuning features than many condensers at twice the price. List No. J.539 gives full particulars.

**PRICES.**

00015 mfd. ..	8/6
0003    " ..	9/6
0005    " ..	10/6

**IGRANIK ELECTRIC COMPANY, LIMITED,**

149, Queen Victoria Street, LONDON, E.C.4.

Works: Bedford.

Branches: Manchester, Birmingham, Cardiff, Leeds, Newcastle, Bristol, Glasgow.

**EVERY REQUISITE FOR THE ELECTRIC GRAMOPHONE in Stock**

**MAGNAVOX MOVING COIL LOUD SPEAKERS**, 6-volt type, £9 10s. each; 100 volts and 240 volts, £10 10s. each; Permanent Magnet type, £3 2s. 6d. each.

**ELECTRIC PICK-UPS**.—G.E.C., £2 5s.; Magnum, £1 15s.; Lissen, 15/-; Alden, 17/6; Celestion, £4 5s.; Igranik, £1 17s. 6d.; Brown, £4; Amplion Viva-Vox, complete with volume control, 50/-; Edison Bell, £1 7s. 6d.

**VOLUME CONTROLS**.—Igranik, 7/6.

**ADAPTORS**.—Igranik, 5/-; Lissen, 1/6.

**ELECTRIC GRAMOPHONE**, complete with turntable and silent electric motor for universal use on A.C. or D.C. current, any voltage, £6 6s. each.

**MOTOR GENERATORS** of every type for A.C. or D.C. up to 600 volts; also the new generators for delivering both high and low tension. Quotations upon inquiry.

Also **NEW AMPLION A.C.9A. LOUD SPEAKER**, complete with two-valve amplifier.

**OUR INTERNATIONAL RADIO CATALOGUE**

(3rd edition) will be sent to all enthusiasts sending 6d. to cover cost of postage and packing.

**WILL DAY, LTD.**

(The Best in the West),

**19, Lisle Street, Leicester Square, LONDON, W.C.2**

Telephone (2 lines): Regent 0921 and 0922.

Telegrams: Titles, Westrand, London.



*When you balance your radio Budget do not forget to enter amongst the assets*

## **POPULAR WIRELESS**

This fine Thursday-Threepennyworth is well worth a small weekly subscription, because it offers the brightest and best radio reading every week. But there is more in it than that. Full of hints, tips, and practical how-to-make articles, "P.W." is

## **A SOUND RADIO INVESTMENT**

*Scores of readers have testified that one 3d. issue of "P.W." has saved them Pounds!*

Written by experts for the man who has not too much money to spend, is there any wonder that thousands say they cannot afford to miss

Every  
Thursday

**POPULAR WIRELESS**  
THE PAPER THAT MADE  
**WIRELESS POPULAR**

**3d.**

# A review that became A TRIBUTE

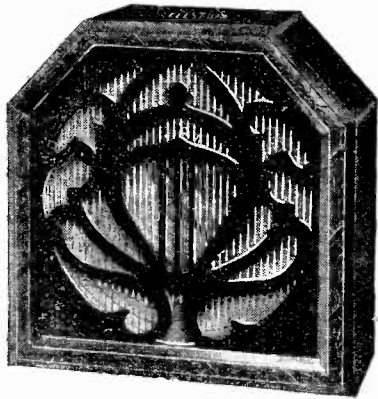

**Celestion" Model C.12**  
the subject of this  
striking testimony.

The following review of "Celestion" from "Popular Wireless" is of particular importance to listeners, coming as it does from a foremost radio journal.

**"POPULAR WIRELESS,"**  
dated 31/3/28, praises warmly:—

"We found 'Celestion' Model C.12 perfectly satisfactory on each of the several sets with which it was tested, ranging from two valves to a multi-valver of the super kind.

"It is some time since we have experienced so much pleasure during a loud-speaker test and WE HAVE NO HESITATION IN SAYING THAT WE CONSIDER THIS 'CELESTION' A LONG WAY AHEAD OF ITS CLASS. Those of our readers who have the opportunity should endeavour to hear it in operation. We are sure they will agree with us when we say it is a revelation in what sound design and construction mean to such an instrument."

"P.W." 31/3/28.

Write for illustrated folder and also for new Gramophone Pick-up leaflet.

# CELESTION

*The Very Soul of Music*

Write to Dept. H.

**THE CELESTION RADIO CO.,**  
Hampton Wick, Kingston-on-Thames.

Showrooms :

33/35, VILLIERS ST.,  
W.C.2.

French Agents :

CONSTABLE & CO.,  
PARIS.

## RADIO NOTES AND NEWS OF THE MONTH

—continued from page 564—

### 'Oirish

The "Sunday Independent," of Ireland, in a recent article on television, said: "It is quite possible that apparatus already made can transmit even over as great a distance as London to New York a blurred picture of a big face and see it open and shut its mouth, but it might be difficult to tell whether it was a human face or a psychic reproduction of a departed codfish."

This is one of the most admirable descriptions of a televised image we have seen in print for many a long day.

### Going Some

At the recent Wireless Exhibition, in Chicago, some extraordinary apparatus for accurate electrical measurements was exhibited. One amplifier which was shown, and which employed 350,000 volts, could send a current of electrons at the rate of 150,000

## MODERN WIRELESS

is

### The Leading Radio Monthly

Full of valuable information and  
unrivalled in reliability.

PLACE A REGULAR ORDER NOW

Price 1/-

miles per second. Another device was exhibited which was capable of taking measurements accurate to the one-millionth of an inch.

Messrs. Ferranti, the well-known transformer makers in this country, recently built a transformer capable of delivering one million volts. It is expected that experiments in connection with these tremendous voltages will lead to a great deal of new information with regard to the electron.

### York Minster

York Minster, like any other great historical building, has its acoustical problems. Thousands of visitors are attracted to the famous cathedral, but for some time past it has been found difficult to find adequate seating accommodation within audible range of the pulpit. A series of tests carried out by the Marconiphone Co. have now culminated in the instalment of a permanent public address system.

## AERIAL SIDELIGHTS

—continued from page 488

and pair of telephones are connected across the ends of the coil sufficient power must be developed to push and pull the diaphragms of the 'phones, thus setting up sound waves which are the exact counterpart of those in the distant studio. This pushing and pulling of the diaphragm in order to set up the sound waves represent a definite expenditure of energy, and it is this that represents the load upon the aerial. As in any other power system it is a great advantage to use a kind of gearing.

### Aerial Damping

If the load imposed on an aerial coil is a fairly heavy one, and we connect the aerial wire to one end of the coil, and the earth wire to the other end of it, the presence of the load will tend to stop the aerial currents flowing freely. True, by adopting end-of-coil connections we ensure that all the aerial energy is led into the coil, but we also inevitably harness all the "drag" of the coil to the aerial. If, however, we take the aerial lead and take it to a separate coil, or to an intermediate point between the two ends, we are in effect changing to a lower gear. Formerly all the energy in the aerial was applied to the tuned circuit, and this heavy load damped or "held down" the aerial and reduced the energy available. With looser coupling, such as that given by well-separated coils, only a portion of the aerial energy is passed into the circuit, and consequently the aerial currents are left with greater freedom to flow. The effect is analogous to changing gear. There is a certain degree of loss due to the fact that not all the available energy is applied direct to the load, but this is more than counterbalanced by the fact that the load is exercising a much smaller drag, and consequently the energy available for transfer is greater.

### Varying the Coupling

From the foregoing it will readily be appreciated that what is the ideal coupling for one set of signals, say, very weak ones, is not ideal for signals from another station which are double, or perhaps half, the strength. It is for these reasons that some form of variable aerial coupling is desirable, especially with a valve set where a wide variety of input signal strength is being dealt with, when searching for distant stations.

# Send your valve troubles to us for solution

Our experts will solve them by the Matched Valve Service giving you a Better Service with a Better Valve at a Better Price.

**6/6**

H.F. DET.  
R.C. L.F.

**9/-**

POWER



Sent by return post.

Write for full particulars.

All goods sent post free.

**ELIMINATORS.**  
D.C. 27/6 to £3.  
A.C. £4/17/6 and £5/10/0.

**"BERITON" ALL-BRITISH SPEAKER.**  
Three days' trial, 25/- C.O.D.

**BATTERIES.**  
Longest Life—Constant Voltage—Lowest Price.

6 9 60-Volt.  
1 3 9-Volt.

# Beriton

BERITON LTD. (Dept. M), 20, Bartlett's Buildings, Holborn Circus, LONDON, E.C.1.

## The WHITELINE VALVE HOLDER

Mechanically and Electrically Perfect.

**Bowyer-Lowe** **2/3**



**Cabinets of Quality for every Set.**  
Full illustrated particulars from the Actual Manufacturers. V. C. Bond & Sons, 61, Hackney Grove, Mare St., London, E.8.

**WHEN YOUR 'DRY' BATTERY DRIES UP!**

**REPLACE for the LAST time**

**WITH THE PERMANENT STANDARD H.T. SUPPLY**

**IT RECHARGES ITSELF OVERNIGHT**

Deferred Terms: No Deposit, Cash Orders, carriage paid.

2-valve sets, A.4. 90 volts 24/10  
3.5 valve sets, D.6.108 volts 38/6  
Super sets, F.6.126 volts 69/3

**GET THIS FREE BOOK** Take the first step. Send for FREE Booklet describing every detail for installing and maintaining this super efficient and money-saving battery. (Dept. F), The Wet H.T. Battery Co., 12, 13 & 14 Brownlow St. W.C.1.

## HINTS FOR THE HANDYMAN

—continued from page 520

without causing (a) capacity effects, and (b) short-circuits to occur.

The ideal instrument for the purpose can be made by inserting a length of 1/4-in. round ebonite rod into a file handle. If the rod is six or eight inches in length hand-capacity effects do not occur, and there is obviously no risk of causing a short circuit. Give each of the grid leaks, anode resistances and clip-in condensers a good steady push with its end. Should this test prove negative the wiring must be tackled.

Whatever the size of your set, it will contain a good many leads. But starting from the aerial end one can work through to the plate circuit of the last valve, testing every lead in turn, in a very few minutes with the tool under description. Matters are made much easier if a small hack-saw cut is made in its end. This fits over the leads and enables each to be given a good shake.

The loose lead that is causing the trouble is very soon detected, for as soon as it is moved with the point of the wiring tester a perfect fusilade of crackles breaks out. The source of the trouble can be located in this way with almost incredible rapidity, and the faulty connection can then be set right either with the soldering iron, or with the long insulated box spanner.

### Screw-Down Connections

Soldering has gone so much out of fashion that most constructors nowadays use screw-down connections wherever possible. For some quaint reason, which I am completely unable to understand, many components with screw-down terminals are provided also with soldering tags. To make use of these is a work of super-erogation, for at every contact one makes two connections, a soldered and a screw-down, instead of one, and there are therefore exactly twice as many possible sources of breakdown as there need be.

As the result of a good deal of experience I am quite convinced that, except possibly in a receiving set intended for ultra-short-wave work, the screw-down connection, if properly made, is every whit as satisfactory as the soldered. But do not rely upon the milled-headed nuts

(Continued on page 568.)

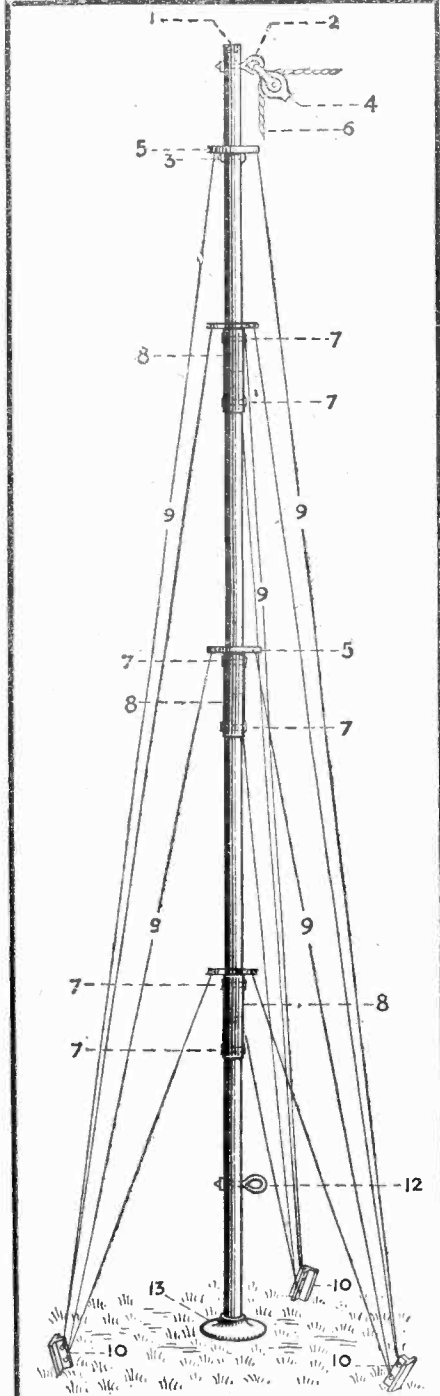

## LAKER STEEL MAST 30ft. 22/6

A wonderfully efficient aerial support designed and constructed by Engineers and manufactured from best British Tubular Steel.

A handsome mast that will be a distinct ornament to your garden. Can be erected in a few minutes and occupies only a small ground area.

Mast outfit sent complete as illustrated and carriage paid if you will add 1/6 towards cost of carriage.

**J. & J. LAKER CO., LTD., Engineers,**  
Kent House Road, Beckenham, Kent.

Contractors to H. M. Govt., British Broadcasting Corp. and to Colonial stations throughout the Empire.

Always bear in mind that an efficient aerial is the most important factor for good radio reception

Every responsible dealer stocks "Laker" outdoor wireless fittings. Ask for list, or write us direct.

## Used the world over

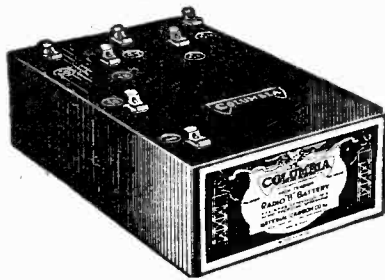

### Columbia

No. 4780, 60 volts type : 22/6.

This statement is literally true, and the reason is that Columbia High Capacity Batteries are the cheapest and most efficient in the world. They save you money! The 60 volts type weighs 13 lbs., as compared with 5 lbs. in other batteries of the same voltage. This means that you are getting more than three batteries for the cost of two. Ask your dealer for Columbia—the battery that lasts.

Price of 60 volts type : 22/6

Don't hesitate to write to us if you are unable to obtain Columbia Batteries from your dealer.

Columbia High Capacity Batteries are manufactured by the National Carbon Co., the world's largest battery manufacturers, and are sold under the full guarantee of this Company.

**J. R. MORRIS**

15, Kingsway, London, W.C.2.

Scotland: J. T. Cartwright, 3, Cadogan St., Glasgow

### THE DIX-ONEMETER



is a precision instrument of universal use, with an ingenious system of Multipliers, which enable full scale readings of any value to be made over a wide range. 1 Millivolt to 2,000 volts, 50 ohms to 50 megohms. Mirror Scale, Jewelled knife-edge, a £10 de Luxe Model. PRICE 55/- Multipliers, 6/6 each.

GET OUR NEW 72-PAGE CATALOGUE

Over a thousand bargains are listed, and hundreds illustrated. SEND 3d. IN STAMPS.

ELECTRADIX RADIOS, 218, Upper Thames Street, LONDON, E.C.4.

### The World's Finest H.F. Choke

specially recommended for all receivers with 2 or more stages of H.F. because the Climax binocular method of winding gives no field effects.

The only effective H.F. Choke for both long and short wave work.

High self inductance. Low self capacity. One hole fixing.

Ideal as anode or reaction choke in any circuit.

THE CLIMAX H.F. CHOKE.

From all dealers 8/6

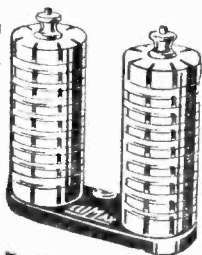

**CLIMAX**  
A YEAR AHEAD

Climax Radio Electric, Ltd. Quill Works. Putney. S.W.15.

ALL APPLICATIONS FOR ADVERTISING SPACE in "MODERN WIRELESS" must be made to the Sole Advertising Agents, JOHN H. LILE, LTD., 4 LUDGATE CIRCUS, LONDON E.C.4

### HINTS FOR THE HANDYMAN

—continued from page 567

provided in valve holders, coil holders, holders for grid leaks, anode resistances, clip-in condensers, variable condensers, high-frequency chokes, low-frequency transformers, and other components.

They are a delusion and a snare. Even the strongest fingers cannot get a milled nut really tight. If you do not believe me, screw down one or two of these as hard as you can, and then apply to it a pair of flat-nosed pliers. You will find that you can give the nut at least half a turn without exerting any undue force.

### Maintaining Tight Contact

By far the best tip is to remove every milled nut as a preliminary. The nuts so discarded may be placed in cigarette tins labelled 4 B.A. or 6 B.A., and they will come in very handily for hook-up purposes if you are experimenting with new circuits. In the real honest-to-goodness re-

### "POPULAR WIRELESS"

Keeps you in touch with the world of radio. It contains articles by all the leading authorities on wireless and is profusely illustrated.

Every Thursday :: At all Booksellers

Price 3d.

ceiving set replace every milled nut with a hexagon counterpart and tighten it down with a box spanner. You will then have no fault to find with your connections and a loose lead is an exceedingly unlikely occurrence. I have one or two sets now made over two years ago with connections of the kind recommended, and no trouble has occurred in any of them.

From time to time nuts should be "felt" with the box spanner to see whether they require a little tightening. On occasion it may be found that one will stand a fraction of a turn. One point of some importance should be mentioned. In a few components the terminal is formed by a screw driven upwards from below into a hole, and held in place simply by the lower round nut. In such cases it is always as well to apply a lock-nut before connection is made, having previously tightened up the round nut as much as possible with flat-nosed pliers.

### IMAGINATION AND THE LISTENER

—continued from page 522

vision than by sound; and when, as in the case of broadcasting, sound only may be utilised, the handicap is accentuated a thousandfold.

### "Artistic Purity"

Without suggesting that the B.B.C. should prostitute itself to the level of stimulating the imagination "by hook or by crook," there is much it can legitimately do in advising listeners as to the best way in which to enjoy the various plays broadcast from time to time.

It is legitimate to create an atmosphere for the public enjoyment of art. There are certain members of the so-called *intelligentsia* who maintain and insist that the plays of Shakespeare, for example, should be presented without scenery, and that at the most only black-drapery, etc., etc., should be used for scenery and background effects; and they maintain also that the characters interpreting the roles in any of Shakespeare's plays need not necessarily be dressed in the costumes of the period dealt with by the play.

This form of "artistic purity" may be very good theoretically, but it is not, on the whole, efficacious in practice. That has been proved more than once, and only quite recently by the production of "Macbeth" in modern clothes.

The production of "Macbeth" in modern clothes was an experiment, and Sir Barry Jackson, the originator of the experiment, was quite entitled to claim that it was an attempt to prove a theory that the beauty of Shakespeare's plays needed no assistance from period settings or from period costumes. But, unfortunately, "Macbeth" produced in modern clothes and modern settings made an appeal only to a very limited audience.

### "Merely Ridiculous"

Primarily, the contrast merely tickled one's sense of the ridiculous. It would have been more satisfactory to test Sir Barry Jackson's theory by broadcasting "Macbeth." That would have been a truer test of the poetic and intellectual appeal of the beauty of Shakespeare's language than the rather abnormal experiment of dressing the characters in the play in modern clothes.

(Continued on page 569.)

**IMAGINATION AND THE LISTENER**

—continued from page 568

This, however, is scarcely the correct analogy, for Sir Barry Jackson's experiment resulted, if not by intention at least by fault, in producing an atmosphere to the play which was inimical to its appreciation by an average audience.

But a natural atmosphere is, for the normal man, only natural when he goes to a theatre, and when he listens to broadcasting it is not to be expected that he will enjoy even a thrilling melodrama by wireless if he is sitting in a rococo drawing-room, in the full glare of electric light, with possibly the tea things surrounding him, a blazing fire in the hearth, and his wife and children scattered round him.

**Wrong Atmosphere**

Have you ever read a ghost story on a fine summer's afternoon, lying in a hammock in the garden, and have you ever read a ghost story late at night by the light of a flickering candle, with the wind moaning and wailing outside, and sometimes whistling down the chimney? If you have read, for example, "The Monkey's Paw," by Jacobs, or one of Poe's "thrillers," or even that wonderful unfinished poem of Coleridge's, "Christabel," you will know full well the emotional difference between your experience of reading such a story or such a poem in broad daylight and in reading it late at night.

**The Spell is Broken**

Reading such a story in the daytime you perceive, perhaps intelligently, the skill of the author, but in perceiving that skill the spell is broken. Pleasure in reading a book, says Lord Macaulay, may be the effect of ideas which some unmeaning expression, striking a train of associations, may have called up in one's own mind as they have furnished to the author, the beauties one admires.

So with broadcasting. It would perhaps naturally enhance the listener's perception of the artistry of a broadcast play, dealing, let us say, with a tragedy in a coal mine, if one could take the loud speaker down into the coal cellar and there, painfully reposing upon jagged lumps of coal, listen in semi-obscurety (certainly with no more illumination than that

(Continued on page 570.)

**The MULLARD PERMACORE TRANSFORMER**

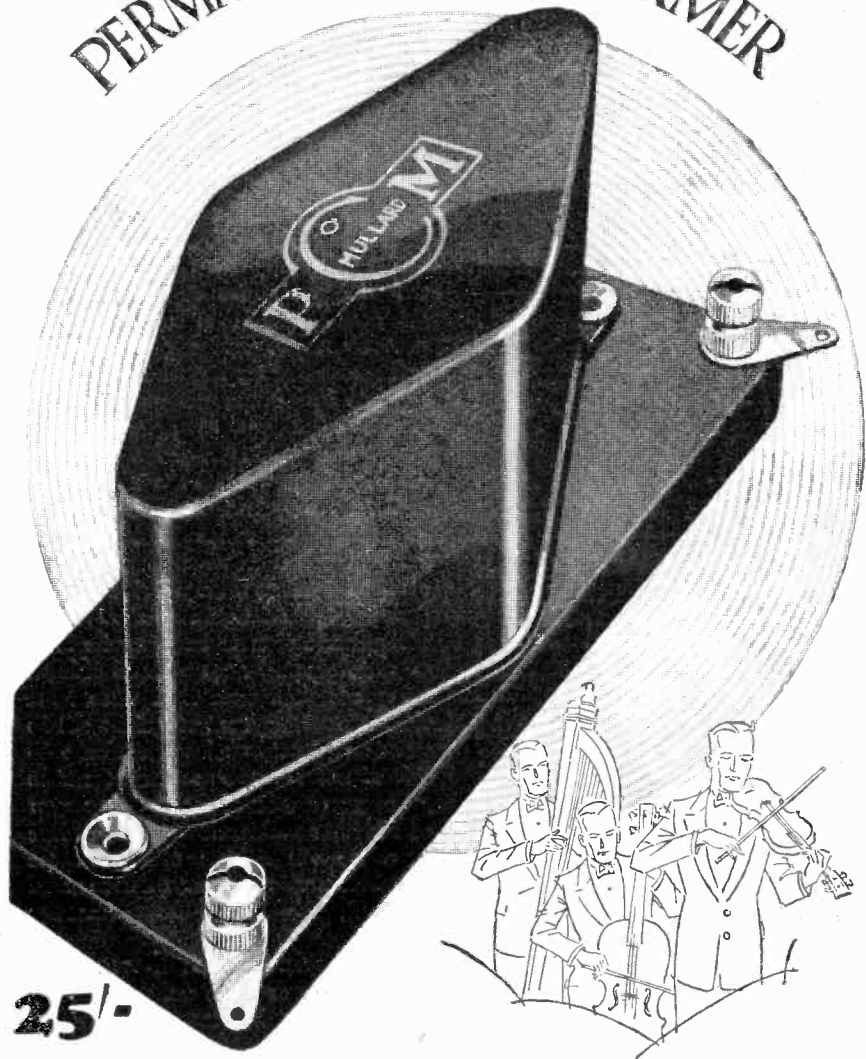

**25/-**

**No resonant peaks to give unnatural reproduction**

The new Mullard "Permacore" Transformer is based upon absolutely revolutionary principles which give these outstanding features.

Small in size; large in amplification. High flux density without saturation. All shrillness eliminated. Gives life to every note. Silver primary, nickel secondary: windings that will not deteriorate.

**NO RESONANT PEAK.**—The windings of the Mullard Transformer have been so selected that no resonant peak occurs at about 8,000—10,000 cycles as is usually the case. The primary is wound with silver, the secondary with nickel, causing the elimination of resonant peaks.

The iron in the Mullard Permacore allows the use of a high flux density in a circuit of exceedingly small dimensions. This new wonder Mullard Transformer is the finest L.F. Transformer ever produced.

OBTAINABLE FROM ALL RADIO DEALERS.

**Mullard**  
**MASTER · RADIO**

# HIGH TENSION

Aspire to heights of perfect purity of tone from A.C. Mains by building yourself the remarkable

## "ECONOMIST H.T. UNIT"

with SUPRECISION components, as recommended in Mr. L. H. Thomas's article, "Popular Wireless," April 14th.

Here is the circuit:

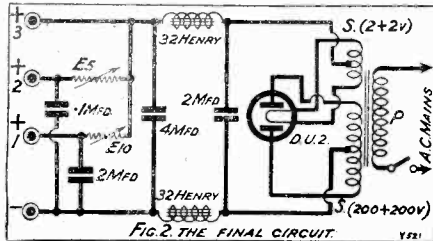

FIG. 2. THE FINAL CIRCUIT.

These the famous components:

- SUPRECISION Power Transformer No. 703 17/6
- SUPRECISION Double Power Choke No. 751 14/-
- Bradleyohm Resistance .. E5, 9/6; E10, 9/6
- Condensers, 4 mf. 6/9; 2 mf. (2), 8/-; 1 mf. 1/9
- Mullard DU2 Valve or Philips No. 506 22/6

Please mention voltage and periodicity of A.C. Mains when ordering. Particulars free on request of SUPRECISION Eliminator Components, OVER-NIGHT Battery Chargers, and high resistance SUPRECISION Measuring Instruments, from:

**F. C. HEAYBERD & CO.,**  
8/9, Talbot Court, Eastcheap, London, E.C.3.  
(One minute from Monument Underground Station.)

### WET H.T. BATTERIES

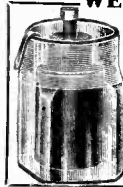

Solve all H.T. troubles.  
SELF-CHARGING, SILENT, ECONOMICAL  
JARS (waxed) 2 1/2" x 1 1/2" sq. 1/3 doz.  
Zincs New type, 11d. doz. SACS 1 2 doz.  
Sample doz. (12 volts), complete with  
bands and electrolyte, 4/3, post 9d.  
Sample unit, 6d. 16-page booklet  
free. Bargain list free.  
AMPLIFIERS. 1-Valve 19s. 2-Valve 30s.  
2-Valve All-Station Set 41  
M. TAYLOR, 57, Studley Rd.,  
Stockwell, London.

ALEXANDER BLACK, The Wireless Doctor, will call (London and Home Counties) and cure your set; sets installed, maintained, and brought up to date; moving coil speaker, gramophone pick-ups, and H.F. eliminators demonstrated by appointment—2a, Woodville Grove, N.16. Sloane 5105, or Clissold 3697.

## The HOME for your WIRELESS SET

Owing to expiration of lease and ultimate removal, we have decided to reduce our large stock of STANDARD WIRELESS CABINETS and we are making

**GREAT REDUCTIONS DURING MAY & JUNE**  
Seize this opportunity at once.

**MAKERIMPORT Co.**

Dept. 2,  
50a, Lord Street, LIVERPOOL.



From £3 15 0.  
Write to-day for descriptive pamphlet and suggestions for adapting your receiver or panel in our Standard Cabinets.  
Immediate Delivery.

**PLEASE be sure to mention "MODERN WIRELESS" when communicating with Advertisers. THANKS!**

## IMAGINATION AND THE LISTENER

—continued from page 569

afforded by a guttering candle), to the vocal appeal of the play as reproduced by the loud speaker!

### The Best "Atmosphere"

But, seriously, we suggest that the B.B.C. should always preface a play with hints as to the atmosphere in which the listener will find it most conducive to enjoy that play. Advice, we are well aware, has often been given to listen to a broadcast play in darkness. That is excellent advice, for in darkness the imagination awakens. Milton suffered from the great affliction of blindness, but would he ever have written such a magnificent masterpiece as "Paradise Lost" if blessed with sight while living in an age of depravity, licentiousness, and bankrupt artistry?

The example is an extreme one, but legitimate. The artistic appeal of broadcasting is still so much in its youth that we have not yet had time to train ourselves to a finer perception of an appreciation of its artistic possibilities, and until that training has been accomplished and more experience gained in apprehending this new form of art, we must, within legitimate bounds, adopt artificial means for stimulating our imagination when listening to broadcasting, and especially broadcast plays.

### Better Equipment

And, therefore, by attempting to create an atmosphere in our own homes when we are listening to a broadcast play or a poetic recitation, or even a fine symphony, we shall merely be adopting an expedient which, although it may offend the purist, would at least enable us more enjoyably to train ourselves to an appreciation of what, after all, is theoretically the most intelligent and the most satisfying medium of artistic entertainment.

## WHAT READERS THINK

—continued from page 524

twenty years before any vast strides were made, because it apparently required a knowledge which was altogether outside our present scope.

Only a few days ago, this view was again expressed by myself in the Press, so you will realise my astonishment to find myself "billed" with the

optimists, when I have already been rebuked for my pessimism on this very point!

A good deal of hard work has taught me that other people's views should not be too strongly supported or condemned. Radio is almost embryonic, but its rapid advance during a mere thirty years inclines me to believe that to define the impossible is no easy task.

I must apologise for the length of this letter, but I am anxious not to be thought one of those extraordinary people who considers his own fixed ideas to represent finality on any subject.

I do not find it difficult to achieve humility in scientific thought!

I am, Sir,

Your obedient servant,

A. M. Low,

A.C.G.I., M.I.A.E., F.C.S.

London, W.4.

We are glad to publish the above letter in view of the fact that in the preface to "Television for the Home," Prof. Low wrote (inter alia): "Radio Television is no longer a dream, it is an accomplished fact."

And also (inter alia): "But television is a necessity, and by the methods at present on the road to commercial success we shall, before long, possess the power to sit in London while we sign our cheques in Australia, and we shall be able to see and speak to our relatives as they fly in safety around the world."

Not impossible, we agree; but the writer of the above, in using the expression "before long" in such a vague way, might mean in a few years or in a few hundreds of years. It is an example of the unjustifiable optimism—scientifically unjustifiable—which we have continually criticised. We are therefore all the more glad to publish the above letter.

THE EDITOR.

### "Those Unnecessary 4-Volters"

SIR,—I have read Mr. Keith D. Rogers' article on 4-volt valves in "Popular Wireless" and also in MODERN WIRELESS. In the latter he asks for readers' remarks, and so am sending this letter.

Taking the various types of H.F., Det., and L.F. valves in turn, I should like to suggest:

(i) The Cossor 410 H.F. is identical with the 610 H.F.

(ii) There are plenty of good L.F. valves for 4 volts.

(iii) As for a super-power valve, the Mullard 254 has exactly the same characteristics as the 256.

In conclusion, I will use Mr. Rogers' own argument, quite an excellent one, that the additional first cost and also upkeep of 6-volt valves do not warrant their being on the market.

I hope he will agree that "away with the 6-volters" would be a better slogan for valve manufacturers, as what Mullards and Cossors can do could be done by other firms.

Yours truly,

W. E. M.

New Brighton, Cheshire.

(Continued on page 571.)

## Pay for your Radio as you use it BUT

Be certain you buy from a firm who can give you service.

Many of the firms now offering radio goods on Easy Payments regard this business as a side line only. We were one of the pioneers in the Radio Industry, operating before the boom, and we have specialised in radio ever since. Consequently, we can offer our customers expert technical service based on years of practical experience. In buying from us you are safe in the knowledge that should you have any little difficulties or require any advice, we are able and willing to help you entirely free of charge.

## 17/6 brings the MAGNAVOX MOVING COIL LOUD SPEAKER

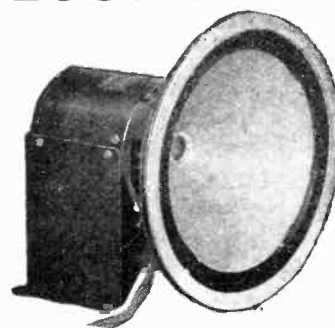

Works off 6-Volt Accumulator. Delivered on first payment of

**17/6**

Balance in 11 monthly payments of 17/6. (Also supplied for working off D.C. Mains.)

Loud Speaker as above and 6-volt: 40/80 Oldham or Exide Accumulator, uncharged.	12 monthly payments of
	<b>21/9</b>
Loud Speaker as above and Trickle Charger to operate direct off A.C. Mains.	12 monthly payments of
	<b>22/6</b>

Please state voltage of mains when ordering.

### SPECIAL OFFER OF FREE Baffle BOARD

To the customers sending the first 50 orders received for either of the above items we will present, free of charge, a plain 7-ply baffle board, cut to size and drilled, complete with all necessary screws, etc., ready for fixing. This baffle board can also be supplied in polished Oak or Mahogany finish at an extra cost of 10/6, which should be added to the first instalment.

Polished Console Cabinet, incorporating baffle board in front, and with open back, standing on four legs. Dimensions approximately 24 in. x 36 in., giving ample space for amplifier if required. In Mahogany, Dark Oak, or Golden Oak - Cash **£4 4 0**

Or by 12 monthly payments of **7/9**.

Cabinet as above, complete with Loud Speaker and Accumulator - Cash **£16 2 0**

Or 12 monthly payments of **£1 9 6**

Cabinet as above, but with Trickle Charger instead of Accumulator - Cash **£16 8 0**

Or 12 monthly payments of **£1 10 3**  
Delivered on payment of first instalment.

## THIS YEAR'S BEST SET THE 1928 SOLODYNE

We can supply all the parts of this unique receiver for 12 monthly payments of

**33/9**

Delivered on payment of first instalment  
—and we guarantee you good results.

We supply all radio needs on easy payments. Call at our showrooms select any set or component. Goods are delivered to approved customers on first payment. No big deposit. No need to wait. Write, or call, for our illustrated Art Brochure showing our wonderful range of instruments.

**PETO-SCOTT Co., Ltd.**  
77, CITY ROAD, E.C.1.

62, HIGH HOLBORN, W.C. LONDON,  
and 4, MANCHESTER ST., LIVERPOOL.

(A) 2431

## WHAT READERS THINK

—continued from page 570

### Unwanted Valves

SIR,—I see that in your article on the unnecessary 4-volters in the March of MODERN WIRELESS, Mr. Rogers invites readers' opinions. I have read the article and thoroughly agree. I wish you could persuade manufacturers to give us a little more information about their products. What I want to know is the impedance and mutual conductance. Actually, one hardly ever gets this in an advertisement. Why not have a standard method of giving these, say, voltage and current in three-figure groups, as is usual already, and a fraction added, the numerator being amplification factor, the denominator impedance in thousands.

The Mullard P.M.1 H.F. would become

P.M.210  $\frac{14}{28}$ ,

and the Marconi D.E.P.215 would become

Marconi 215  $\frac{6}{6}$ .

I have recently searched several journals with a view to renewing the valves on my 5-valver (at present S.T.). The only maker who tells one anything is the maker of valves at 3s. 6d., so I am going for those.

Yours faithfully,  
C. H. M. STURGES.

S.E.10.

(Mr. Rogers deals with the question of nomenclature in "Valve Varieties" on page 574.)

### To Many Types

SIR,—I feel I must thank you for the article on valves in the current issue of MODERN WIRELESS. Mr. Rogers supplies me with information I have been seeking for more than four years. When I built my first set I considered the question of the amount of current taken by valves, and made inquiries such as "Why use 6-volt valves instead of 2- or 4-volt valves?" "What is the advantage?" "Why use bright-emitters taking half an ampere instead of dull-emitters consuming only .06 of an ampere?" No one could answer these questions, the answers I got were: "I don't know, I have always used bright-emitters," or "I have always used a 6-volt accumulator."

(Continued on page 573.)

H.T. from the Mains

D.C.  
**34/-**  
Complete

### CLIMAX H.T. SUPPLY UNITS

Study these special features of Climax Auto-Bat H.T. Units and then the prices. Ten H.T. Tappings with one fixed and two variable voltages. Insulated sockets, insulated wander plugs, insulated terminals. Earthed metal cases. Safety-first design. Shock-proof. Fire-proof. Large guaranteed outputs. No mains noise. Same simple control as with ordinary H.T. Battery. Very attractive finish.

Climax Auto-Bat D.C. Model. 100/250 volts. Output approx. 200 volts max. on 200 250 volt mains, and 100 volts max. on 100/125 volt mains. 50 milliamperes max. PRICE **34/-**

Climax Auto-Bat A.C. Model. 200/250 volts, 40/100 cycles. 100/125 volts, 40/100 cycles. Output approx. 150 volts max. H.T. at 50 milliamperes. PRICE **£4**

Plus royalty 12/6 net, plus 2 D.U. to rectifying valves at 15/- each. Complete **£6.2.6** obtainable from all radio dealers.

# CLIMAX

A YEAR AHEAD  
CLIMAX RADIO ELECTRIC LTD.  
Quill Works, Putney, London, S.W.15

**THAT OLD BIKE!** Put pounds on its value by fitting it. Quite easy with our self-acting, ready panelled lining. Sets, Gold, Green or Red, 10d., with instructions. Gold and Red, etc., 1/- List and samples, 2d.

M. W. AXON & HARRISON, LTD., JERSEY, ENG.

## Self-Adjusting!

For best performance your valves require a variable filament control to supply the definite current they need, despite L. T. battery variations. AMPERITE is the only self-adjusting and automatic filament valve control that does this. Takes the "guess" inconvenience and unsightliness out of panel rheostats. Simplifies wiring, panel design, and tuning. Prolongs valve life. Order by name. Accept nothing else. For sale by all dealers. Price 5/-, with mounting.

Write for FREE "AMPERITE BOOK" of season's best circuits and latest construction data.

Distributed by  
ROTHERMEL RADIO CORP. OF CT BRITAIN LTD.  
24, Maddox St. London, W.1

# AMPERITE

REG. PAT. OFF.

The "SELF-ADJUSTING" Rheostat

# ARTCRAFT

RADIO BRITAIN'S CABINETS  
BEST VALUE  
New Catalogue Free

THE ARTCRAFT COMPANY  
156, CHERRY ORCHARD R. CROYDON



Fit the  
**LOTUS REMOTE CONTROL**  
to your  
**Cossor Melody Maker**

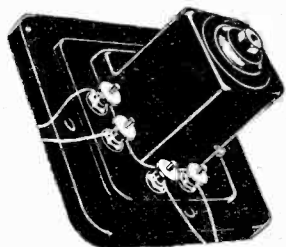

—and increase the enjoyment and comfort of good reception. Don't have a good set and restrict it to one room. Reception from your Cossor Melody Maker can take place in every room in the house—independently—simultaneously—and without interference, if you fit a Lotus Remote Control.

You can wire two rooms yourself in half an hour at a cost of a few shillings. Ask your retailer for a free blue print or send a postcard to the makers.

For your Melody Maker you need:—

- 1 Lotus L.T. & H.T. Relay.
- 2 Filament Control Wall Jacks, 2 Jack Plugs, 21 yds. 4-strand wire .. **30/-**
- Similar outfit, but for set using H.T. Eliminator, 45/-.
- This wires two rooms. Each additional room -7/6 extra.

**LOTUS**  
**REMOTE CONTROLS**

*Recommended by the Makers of the Cossor Melody Maker.*

*Made by the Makers of the famous Lotus Buoyancy Valve Holder, and Lotus Vernier Coil Holder.*

**GARNETT, WHITELEY & CO., Ltd.,**  
Broadgreen Road - **LIVERPOOL.**



**IN OUR TEST ROOM**  
*—continued from page 530*

many chokes on the market which are suitable for this latter purpose. The Igranic type "F" has the essential requirements of moderate ohmic resistance and ample inductance when passing fairly heavy currents. This Igranic component retails at 15s.

**Igranic Filament Transformer**

Igranic Electric Co., Ltd., have produced a filament transformer suitable for use with KL1 valves. Operating direct from the alternating current mains, this transformer supplies an ample supply of current at 3.5 volts for a receiver using up to four KL1 valves. It also has the special feature that, whether one, two, three or four valves are in use, the output voltage remains the same within the limits of the 5 per cent specified by the valve manufacturers.

This is a very important advantage, because it renders the use of heavy current-carrying rheostats unnecessary. The valves can be connected direct to the transformer. There are three types of this transformer available, suitable for 100-110-volt, 200-220-volt, and 230-250-volt mains. The price is 30s. It is a well-made component, and is of the completely shielded variety. We have tested it and found it O.K. It does not get unduly hot, and there is, of course, no humming from loose armatures or other such defects. Components that have to be connected directly across mains supplies must be chosen with discrimination, but this Igranic product appears to be perfectly safe and reliable.

**Portable-Set Loud Speaker**

There is a special Amplion loud speaker for portable receivers. It is known as the "Amplion Cone Assembly," and consists of a cone and a reproducing unit, fixed to a fretted grill, which can be fixed directly to the front of a cabinet. It is supplied in two sizes, one having a 9-in. cone and a junior type unit, which is known as the A.C.13, price £2 10s., and the A.C.11, which has a 12-in. cone, a senior reproducing unit, and which sells at £3 10s. It gives very good results. There is ample bass and very little colouration. The view has been expressed that one cannot expect quality of reproduction with a portable receiver. But there is no reason why one should not with a speaker of this type if the receiver is carefully designed.

**TELEVISION NOTES OF THE MONTH**  
*—continued from page 531*

are now on sale in Great Britain. They are made according to the patents of Professor Hans Thirring, head of the Physics department in the University of Vienna. Professor Thirring, who has specialised on the cells, gave me a demonstration with some of his best models in his laboratory. He uses them in the talking-film apparatus he has invented. "But for television," he told me, "selenium cells can never be suitable."

**From Australia**

I try to keep in touch with television efforts in all parts of the world. Lately, I had Australia scoured, and I came into touch with Mr. Robert T. Haines, of Sydney, who has a television system he began to develop in 1890. His ideas were mentioned in the London papers, he tells me, in 1907, when he lectured before the Royal Photographic Society on other of his inventions.

**Have You An Idea?**

More part-time television efforts I have traced in Canada, the United States, France, the Free State, Birmingham, Hull, and London. Of course, there are others, and I should be glad to hear from readers who have really worth-while ideas. Send notes and sketches, and photographs, and anything you please to me, care of MODERN WIRELESS.

As a hint, I suggest that if you wish to invent a real television apparatus—and win a fortune—ignore all the present systems, and **TRY SOMETHING DIFFERENT.** Without mechanism, if you can.

**Will They Work?**

Just as the presses are waiting to begin their clatter and rumble, a rumour has started in America that television sets will be on sale there this summer. No names are given, but it is said that the sets will be on the lines of those used by the G.E.C. in their recent broadcast to homes from Schenectady.

**Two-In-One**

An equally mysterious statement comes from an unnamed representative at the Radio Corporation of America predicting that "one year ought to see television in the home."

WILLIAM J. BRITAIN



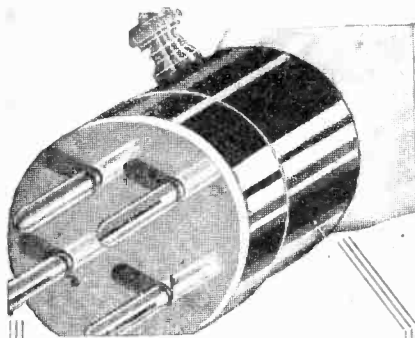

## REALLY BETTER

The wonderful A.P. tetrode (4-electrode) valves you have seen talked about and used in "Modern Wireless."

They require only half the usual H.T. yet give better selectivity and purer reproduction.

They can be used at once, on any set, without alteration.

They are so good that we send them on 3 clear days' approval against cash order.

Write to-day for history and data of the "A.P." Tetrodes, with reports by "Popular Wireless," "Amateur Wireless," etc.

### ANELOY PRODUCTS,

36, Hindmans Rd., E. Dulwich, London, S.E. 22  
Phone: New Cross 4074.

### PERFECTA COILS for

"MODERN WIRELESS" 1928 "SOLODYNE," short or long wave, 40/-; bases, 4/6 the set. "M.W." Wave-Trap, 13/-; "Radio-gram 4," set with bases, 14/-; Cossor coil, green silk wires, terminals, pavolin former, 6/9; Litz wound, 11/6.

All coils, screens, chokes, transformers to specification; quotation by return. Consult us; we can save you considerable time and money.

H. HACKER & SONS,

25, HIGH STREET, MAIDENHEAD.

### TRANSFORMS YOUR WIRELESS

"RADIOLA" THE BUREAU

Takes your Set



A STATELY HOME!

Batteries, etc.

From £5.5.0

In many sizes.

Fully Guaranteed.

"RADIOLA" De Luxe

WINS HIGHEST APPROVAL of Radio Press, leading experts and over 3,000 delighted clients. 3 ft. high. Rich solid oak or mahogany—a magnificent finish—at loud-speaker cost only. LET US HELP YOU.—Suggestions and FULL LIST of exclusive designs FREE. Send now. Obtainable only from:—

**PICKETT'S**  
CABINETS

M.W. Works, BEXLEYHEATH, Kent.

PLEASE be sure to mention "MODERN WIRELESS" when communicating with Advertisers. THANKS!

### RECENT RECORD RELEASES

—continued from page 558

*Tired Hands* (W.) and *When Day is Done* (F.T.). (226.) (At the Stoll Picture Theatre.)

All by Harry Bidgood and his Broadcasters.

Excellent records which increase one's wonder at the "Broadcast" method of recording.

*Pathé Actuelle. An' Furthermore* and *Clementine*. (11531.)

An American type of "voice and orchestra" record that is not too well done.

*Pathé Perfect*. (1s. 6d.) *Why Am I Blue?* (W.) and *Janette* (W.). Lennox Dance Orchestra. (P352.)

The *Calinda* (F.T.) and *Little Boy Blue* (F.T.). Lud Guluskin and his Orchestra. (P350.)

*Did You Mean It?* (F.T.) and *There's a Rickety Rackety Shack* (F.T.). (P345.)

Three very enjoyable records.

*Parlophone*. (3s.) *The Grind Out* (Yale) and *The Wabash Blues* (Yale). Boyd Seuter (Clarinet Solo with Guitar, Piano Acc.). (R3505.)

An excellent record by a world-famous player. Certainly the best clarinet record we have heard. The recording is above reproach.

*For My Baby* (F.T.) and *Changes* (F.T.). Sam Lanin's Famous Players. (R3498.)

Another Parlophone masterpiece, "Changes" has a charm of its own. The orchestration is remarkably well done, and is novel without being bizarre.

### WHAT READERS THINK

—continued from page 571

As there appeared to be no advantage in using more than '06, I decided on the 4-volt valve, and have used none other since. For four years I have wanted to know why manufacturers took the trouble to make any valve but '06's, and why anyone should be so foolish as to use any other.

I am of Mr. Rogers' opinion that the 4-volt valve is unnecessary, and I shall say further, the 6-volt valve is unnecessary also, the 2-volt is all that is needed, and with a little improvement, as you say, would give the same amplification as the 6-volt.

Yours faithfully,

Sheffield.

H. O. COULSON.

573.

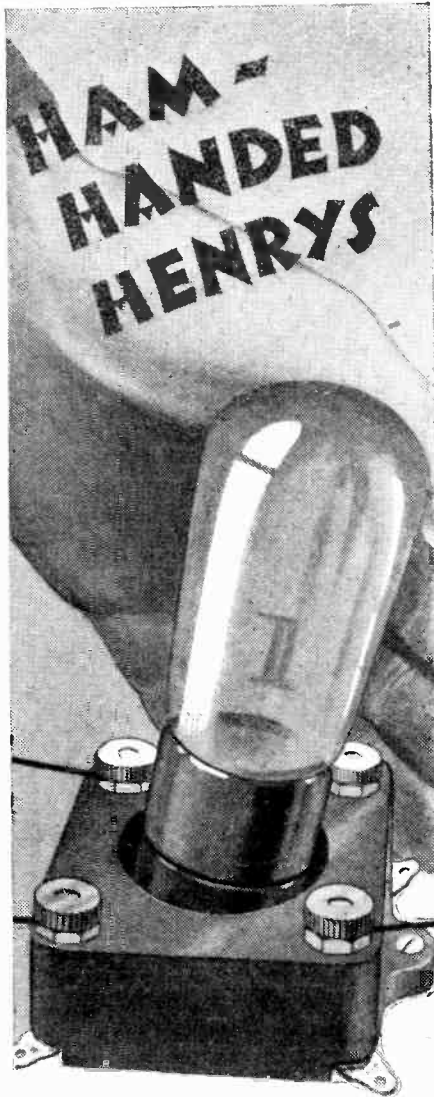

You know them. They just want to try something in your set. Ping! An awkward hand has hit your valve.

A Benjamin Valve Holder would have saved you the cost of a new valve. For this valve holder is sprung on 4 one-piece springs. Strong springs but delicate. Springs that absorb the slightest vibration or the greatest shock.

Fit Benjamin Valve Holders in every stage of your receiver. But be sure the valve holders are Benjamin, because no others will so efficiently absorb shock and disperse microphonic noises.

# BENJAMIN

## VALVE HOLDERS

2/-

THE BENJAMIN ELECTRIC LTD.,  
Brantwood Wks., Tariff Rd., TOTTENHAM, N.17



**Price reduced**

from MAY 1st.

**NEW 8/6 PRICE**

**TRANSFORMER**

The popular SHROUDED MODEL

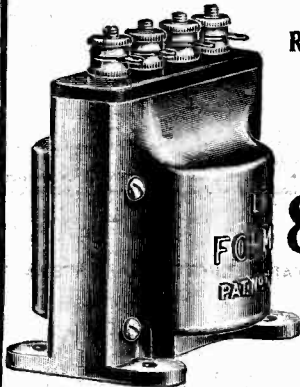

RATIOS

1 - 3  
and  
1 - 5

**8/6**

ABSOLUTELY

The

**SMALLEST  
LIGHTEST**

AND MOST

**EFFICIENT**

**CONDENSER**

"1928" LOG

SPAN FULLY OPEN

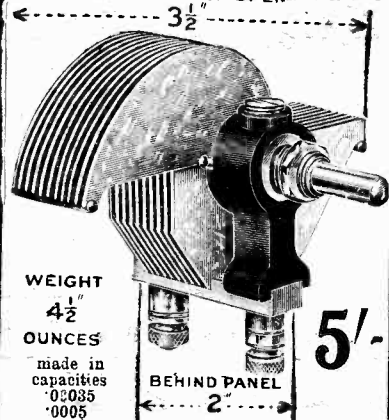

WEIGHT  
4 1/2  
OUNCES  
made in  
capacities  
0.035  
0.005

**5/-**

Write for Literature

Crown Works, 22, Cricklewood Lane, N.W.2  
Telephone: Hampstead 1787.

**"PRACTICAL TELEVISION"**

FROM such a title the average wireless enthusiast, when buying Mr. Larner's book\*, will very naturally expect to find a sound and scientific exposition of the latest advances in television technique.

More particularly he will be interested to discover in what respects the Baird Televisor can fairly lay claim to represent a distinct and outstanding advance on other known systems of television, bearing in mind the remarkable claims that have recently been made for this apparatus.

**Disappointing**

In this respect he will unfortunately find little cause for satisfaction, though there is a great deal of other matter, well worth reading, inside the covers of Mr. Larner's book.

Mr. J. L. Baird contributes a foreword which is mainly concerned with generalities and optimism.

Seven chapters out of ten are chiefly concerned with the historical growth and development of still-picture transmission; the discovery and application of the selenium cell; photo-electric phenomena and their applications to picture transmission; and the theory of the formation of optical images.

This section also contains a summary of the early work done by various continental and American investigators in the field of television proper, as distinct from mere still-life transmission.

Mention is also made, in a special chapter, of the theoretical advantages attaching to the use of the cathode ray as a means for exploring the picture at the transmitting end, and of reassembling the signal components in reception.

Coming to what should be the cream of the text-book, namely, the chapter on the Baird Televisor, it is disappointing to find that both the transmitting and receiving apparatus correspond practically in every detail with descriptions published many months ago in the technical Press.

**"Special Cell"**

Mr. Larner states that "the special type of light-sensitive cell used by Mr. Baird gives an instantaneous effect, and it is possible with such a cell to send a figure, a picture, or a series of moving pictures, like a scene made up of moving people, in rapid succession."

But what the serious-minded reader would be more interested to learn is why, if this can be done with Mr. Baird's cell, as the inference is, it cannot be done with other light-sensitive cells.

It should be added that a description is given of a new "optical lever" system of lenses, recently patented by Mr Baird, which is stated to increase the speed of traverse of the exploring beam of light. It does not seem possible, however, to do this except at the expense of a corresponding loss in intensity of the incident beam of light.

As a further development, Mr. Baird proposes to utilize two or more light-cells in place of one, each cell operating on a distinct frequency. This would apparently involve the employment of a wide band of frequencies in transmitting the corresponding image through the ether. Similarly a plurality of light-sources may be installed at the receiving end.

As regards synchronization—one of the most difficult problems in television—it is ingeniously explained that two motors are used, one a D.C. motor driving the obturator discs,

**IT PAYS**

to become a regular reader of

**Modern Wireless**

The paper with the guarantee.

Every constructional design thoroughly tested.

You cannot go wrong if you build an "M.W." set.

Every Month - - - Price 1-

Place your order now.

and the other an A.C. motor of 500 cycles which "sends out a synchronizing signal." Mr. Larner does not say that this system was used for the recent transatlantic transmission, and it would indeed be difficult to imagine that it could serve the required purpose over so large a distance.

**A Rosy Future?**

The last chapter deals with the Noctovisor and Phonovisor. In conclusion, Mr. Larner says: "At the time of writing television sets are not available to the public, but their advent cannot long be delayed. The first sets will, we may anticipate, show only the most simple of scenes, a head-and-shoulders view of the person speaking, or possibly a simple scene, such as a few figures on a stage with little details."

\* "Practical Television," by E. T. Larner, with a foreword by J. L. Baird. Published by Ernest Benn. Ltd. 10s. 6d. net.

**THE FINISHING TOUCH**

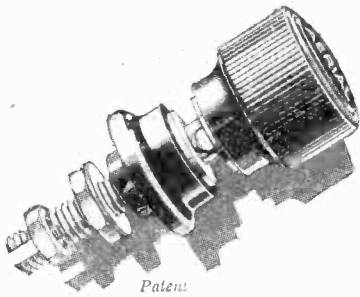

Patent

Belling-Lee Terminals are the finishing touch to any Receiver. They are a combination of Beautiful Finish and First Class Workmanship.

Belling-Lee Terminals are Bakelite insulated and made with 30 different engravings.

**PRICES.**

Type "B" illustrated, sold in an attractive carton carrying a year's guarantee. Price 9d. each.

Type "M" as type "B" but non-insulated. Price 6d. each.

Type "R" Cheap competitive insulated terminal with rotating name. Price 3d. each.

Illustrated catalogue free on request.

**BELLING-LEE TERMINALS**

BELLING & LEE, Ltd., Queensway Works, Ponders End, Middlesex.

**"PEERLESS" JUNIOR RHEOSTAT**

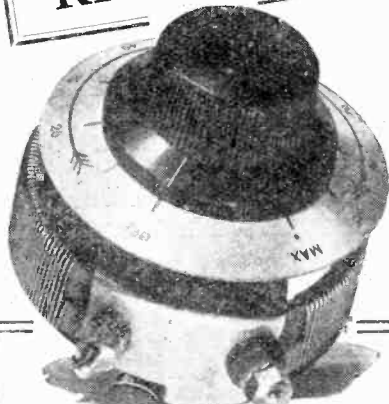

The engraved nickel dial gives a pleasing finish to a robustly constructed and well-designed component. An "off" position is provided, while a definite stop makes short-circuit impossible. Stocked in 2, 6, 10, 15, 30 and 60 ohms.

**2/3 each**

The Bedford Electrical & Radio Co. Ltd.  
22, Campbell Road, Bedford.  
London Glasgow  
21, Fartlett's Bldgs. 113, St. Vincent  
Holborn Circus, E.C.4 Street, G.2

**RADIO ABROAD**

—continued from page 532

sources of income. The present broadcast publicity, however, is badly done, and it is felt that if the method of its presentation could be considerably improved, the objections to it would be largely done away with.

**Radio Records**

For the first time, gramophone records of an American radio broadcast programme are offered to the public in the United States. The well-known Victor Company has the distinction of pioneering in this direction, and the first example is a set of three double-sided records of the ceremonies connected with the national welcome to Colonel Lindberg, the Atlantic flyer, at Washington.

On these records you have the voice of President Coolidge, the interspersed announcements of Graham McNamee, a short address by Colonel Lindberg, and his longer speech at the National Press Club. It's all there, and if you close your eyes it is not hard to imagine that the events are actually taking place. The cheers of the crowd, the applause interrupting the speakers, the blare of the bands, and the quiet, unruffled voice of Lindberg.

It is time that more of the historic events which are now being offered to the radio listener with impressive regularity were preserved in permanent form. The few records already made being a rather belated start in the right direction.

**Radio In Canada**

The Canadian Government, through its radio branch, has installed seven direction-finding stations on the Atlantic coast and one on the Pacific, as well as six radio beacons on the Atlantic coastline.

These stations are especially built to give bearings to ships which have lost their direction in fogs or during storms. They contain the latest apparatus and practical application has shown that the bearings given by them have been extremely accurate, saving many a ship from stranding on the rock-strewn coast of the Maritime Provinces.

One hundred and forty-five ships, by the latest available census taken early last spring, plying between Canadian ports, are equipped with direction-finding apparatus.

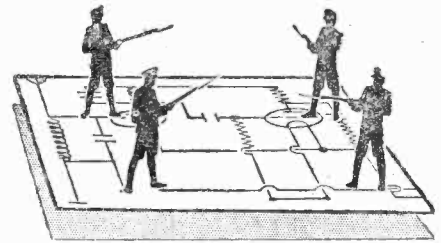

**PROTECTION at 4 vital points in the circuit**

VALVE SET OWNERS are rapidly realising the enormous importance of incorporating an accurate measuring instrument in series with the valve circuit itself. Without this protection there is no definite method of obtaining that vitally important adjustment of plate and filament current. Newly charged accumulators for instance register 25 volts above normal! Without a Sifam Radio Meter you cannot adjust this excess. Reception appears the same but the life of your valves is reduced by hundreds of hours! Haphazard control is out of date. Modern set design demands Sifam accuracy and Sifam protection! Follow the lead of over 250,000 listeners who have learned the wisdom and saving by using Sifam Radio Meters. Your dealer will gladly show you the popular priced range, or write direct for leaflet "Detecting Distortion," free from SIFAM ELECTRICAL INSTRUMENT CO. LTD. (Dept. M.W.) 10a, Page Street WESTMINSTER S.W.1.



**RADIO METERS**

**NEW MODEL.**  
Pocket Voltmeter,  
4,000 ohms. High 9/6  
Res. Heavy Nickel  
Case.

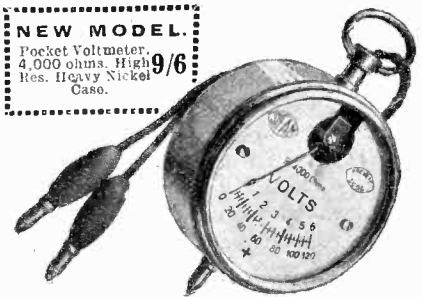

**It's safer with Sifam**

**Real ACCUMULATOR HIRE SERVICE. H.T. OR L.T.**

We lend you one of our fine wireless accumulators while we recharge yours. Or keep you continually supplied with our own fully-charged accumulators. Collection, maintenance and delivery free, anywhere within 12 miles of Charing Cross. Any voltage or capacity. Skilled service. The famous C.A.V. accumulators supplied for H.T.

Write for full particulars to-day  
**RADIO SERVICE (London) LTD.,**  
105F, Torrignano Avenue, Kentish Town, N.W.  
Telephone: North 0623-4-5.

**EVERYTHING RADIO ON EASY TERMS**

**WOOLDRIDGE RADIO CO. LTD.**  
17 & 18, LISLE ST. LEICESTER SQUARE  
LONDON, W.C.2.

## Adult Education and Broadcasting

—continued from page 502

choice of items to all or practically all listeners. Alternative programmes should become fully available with the execution of the scheme of regional stations.

6. Broadcast education can fill many gaps in the existing adult education movement; it can widen the field from which students are drawn by its power to reach and stimulate a large public; it can provide a means of education for those beyond the reach of other agencies; it can put listeners in touch with the leaders of thought and the chief experts in many subjects; and it can lead on to more formal or more intensive study. There is little danger that it will supplant other educational facilities, especially if the educational bodies take their share in developing it.

### A "Follow-up" Policy

7. Discussion-groups, formal or informal, may very greatly increase the value to be obtained from broadcast talks. It is important that every encouragement should be given to the formation of such groups, and all possible help given to them.

8. The follow-up policy inaugurated by the B.B.C. requires to be still further developed in three main directions:

- a. In the direction of increased publications, including a weekly illustrated educational journal;
- b. In the direction of increased publicity;
- c. In the direction of increased organising activity. An adequate follow-up service should include advice on technical difficulties, on reading and private study, on the formation of wireless-discussion groups, on other agencies for continued study, as well as replies to correspondence.

9. The satisfactory solution of the problems of reception is of the highest importance. Only by raising the general standard of reception, and by securing the correct use and maintenance of receiving sets, can the fullest advantage be gained from broadcasting. This calls for a development of the service of visiting and advisory engineers to give advice and instructions to those responsible for sets

for educational purposes. It is also important that advice should be available on how to secure the efficient construction of sets to the B.B.C. educational specifications.

10. The broadcast programme requires the greatest freedom of experiment in matter and presentation. Controversial subjects should not be cut out. Strict care must be taken in choosing those who are to speak on such subjects at the microphone, but if those chosen have a proper sense of their responsibility they should have as full freedom as possible to deal with their subject from the educational standpoint.

11. The technique of broadcast lecturing requires continual experiment. The possession of personality, and the ability to convey it to an invisible audience, are of paramount importance.

12. The most satisfactory method of providing a regular educational service would be to set aside the whole or the main part of one wave-length capable of covering the whole country to a special service of lectures, music, etc. Until this proves practicable, a definite proportion of time in general programmes should be allotted to general talks, and certain periods at appropriate times of day should be allotted to more formal education. Under a system of alternative wave-lengths, the latter would require at least one hour daily after 7.30 p.m., in addition to talks at other times of day.

### A Central Council

13. In order to develop the policy outlined above, it will be necessary to invite the educational forces of the country to share the responsibility for the work. This calls for the creation of a Central Council for Adult Education, composed of representatives appointed by important educational bodies, and of a proportion of nominated members, to whom certain powers and responsibilities in connection with the planning of educational programmes and with the problems of the listeners should progressively be delegated. It will be necessary also to establish Area Councils to represent local opinion and to deal with local problems. A representative from each Area Council would sit on the Central Council.

14. The cost of such developments as have been outlined can, and in our view should, be met out of that part of the revenue from licences which is at present retained by the Postmaster-General, over and above the costs of collection and administration.

**All the leading radio set-designers write for**  
**POPULAR WIRELESS**—the Paper that made **WIRELESS POPULAR**  
 Published every Thursday. Price Threepence. Worth Double.

### INDEX TO ADVERTISERS

	Page
Amperite Rheostat	571
Aneloy Products	573
Artcraft Company, The	571
Axon & Harrison	571
"Argosy Magazine"	557
Belling & Lee Ltd.	575
Benjamin Electric, Ltd.	573
Bedford Electrical and Radio Co., Ltd.	575
Bird, Sydney S. & Sons, Ltd.	561
Black, Alexander	570
Bond, V. C. & Sons	567
Bowyer-Lowe Co., Ltd.	567
British Ebonite Co., Ltd.	561
Brown, S. G., Ltd.	553
Burne-Jones & Co., Ltd.	473
Bevton, Ltd.	567

	Page
Carrington Manfg. Co.	557
Celestion Radio Co., The	566
Cossor, A. C., Ltd.	474
Climax Radio Electric, Ltd.	568, 571
Dubilier Condenser Co. (1925), Ltd.	553
Day, Will, Ltd.	564
Eastick, J. J., & Sons	557
Electradix Radios	568
Forno Company, The	574
Gambrell Bros., Ltd.	561
Garnett, Whiteley & Co., Ltd.	572
Hacker, H., & Sons	573
Hayberd, F. C., & Co.	570
Igranie Electric Co., Ltd.	564
Jackson Bros.	563
Laker, J. & J., Co., Ltd.	567
Lissen, Ltd.	549
London Elec. Wire Co. & Smiths, Ltd.	557
Makerimport Co.	570
Metro-Vick Supplies, Ltd.	Cover iii
Morris, J. R.	568

	Page
Mullard Wireless Service Co., Ltd.	Cover ii, 569
Peto-Scott Co., Ltd.	571
Philips Lamps, Ltd.	551
Pickett's Cabinet Works	573
"Popular Wireless"	565
Radio Service (London), Ltd.	575
R.I. & Varley, Ltd.	Cover iv
Rothermel Corpn., Ltd.	562
Ripaults, Ltd.	563
Sifam Electrical Inst. Co., Ltd.	575
Taylor, M.	570
Telegraph Condenser Co., Ltd.	561
Wet H.T. Battery Co.	567
Wooldridge Radio Co., Ltd.	575
Wireless Constructor Envelopes	563

All communications concerning advertising in "Modern Wireless" must be made to John H. Lile, Ltd., 4, Ludgate Circus, London, E.C.4. Telephone: City 7261.



# Your duty towards your neighbour!

## ONE H.F. STAGE

There is a large Public who are content with reception from the local Station and Daventry, whose requirements can be met by the ordinary 3 Valve re-acted Detector Set of which there are so many varieties advertised with fanciful names. To get more than this inevitably means "oscillation" with consequent howling and annoyance to your neighbours. The B.B.C. definitely state that one H.F. stage is essential at the following ranges, if loud speaker reproduction is to be anything but "indifferent":—

100-150 miles from Daventry.	5 X X.	4 Valves.	1 H.F. stage.
50-100 " " "	5 G B.	" "	1 H.F. stage.
Over 15 " " "	Main Station.	" "	1 H.F. stage.

These figures obviously allow for that factor of safety which is so necessary if consistently pleasing reception is to be obtained under all conditions.

One neutrodyne stage of H.F. will give that additional sensitivity necessary for more distant reception, with radiation reduced to a minimum.

The Met-Vick 4 Valve A.N.P. Constructor's Set is the ideal solution. With the additional H.F. stage, there is no need to force the set. Using A.N.P. coils the set is stabilised, screening is unnecessary and high voltage factor Valves can be used. Additional selectivity is provided by a Tuned loose coupled aerial circuit, brought into action when required. Delightful to operate and cheap to build, the parts with two sets of coils costing only £9.

The Met-Vick A.N.P. 4 is pre-eminently the 4 Valve Set of the Day. If unable to obtain instruction book from your dealer, write for Publication No. 7117/5 or 7117/4 (the A.C. Valve Model) free on request.

## MET-VICK

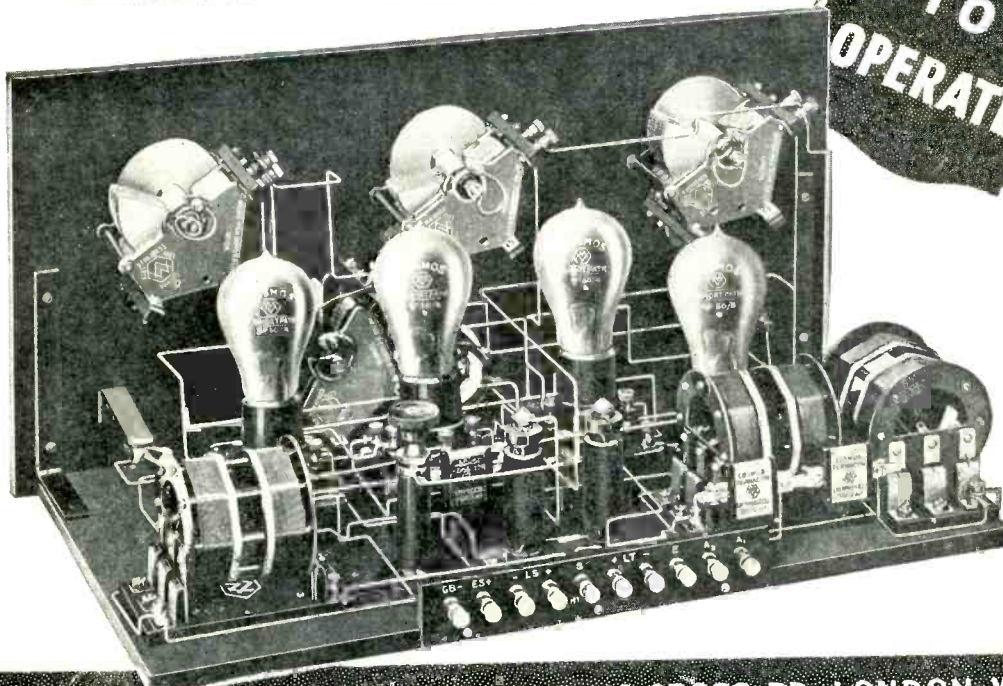

RP  
104

METRO VICK SUPPLIES LTD 155, CHARING CROSS RD. LONDON. W.C.2.

# NOTHING LIKE THIS EVER BEFORE ACHIEVED

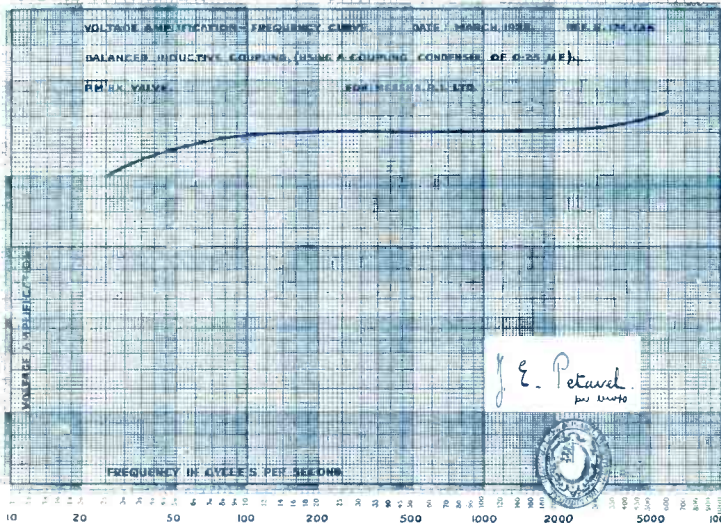

You've never seen such a wonderful transformer curve as this before! There's no other N.P.L. Transformer Curve—and remember, that's the only curve of *real* value—showing anything like as good results. Look at the lower end of the frequency scale—scarcely any drop to speak of—and you'll begin to realise why the deep bass notes come out so well when you use our Straight Line Super Transformer. The slight increase in amplification at the upper end of the scale adds to the beauty of radio reception, and shows this Transformer to be particularly suitable for Gramophone Reproduction where the high notes are so often lost.

With one exception (*vide Back Cover "Popular Wireless," April 14th*) the results shown by this curve are even better than those obtained with Resistance Capacity Coupling.

Particulars of our *Balanced Inductive Method of Coupling* will be found in our illustrated 48-page Booklet, "*Low Frequency Amplification*" (price 1/-), which contains additional N.P.L. curves, interesting circuits and diagrams, and a wealth of up-to-date information on all forms of L.F. Inter-valve Coupling.

**Straight Line Super Transformer**  
**25/-**

*Illustrated 16-page leaflet C.17—free on application—gives full particulars and interesting circuits.*



SPECIALISTS IN  
L.F. AMPLIFICATION



**Varley** LTD.

**THE MARK OF BETTER RADIO**

Kingsway House, 103, Kingsway, London, W.C.2. Telephone: Holborn 5303.