

Hobby

Electronics

Project Electronics For Everyone

90p

SOFT OPTIONS

Special Feature

Technology In Waiting:
Video Disc
Interactive
System For
Home Computers



Simple
Conductance
Meter Project

Top Projects To Build...

ZX81 Tape Controller • Mains Intercom

BI-PAK BARGAINS

PRECISION MORSE KEYS



Well designed beginners key. Fully adjustable. Dims: Base 82mm x 45mm. O/No. VP 122. **£1.85**



Double-paddle, squeeze action. Body dims: 83 x 65 x 35mm. Weight 150g. O/No. VP 123. **£20.00**



Vertical action. Robust ABS body weighted with heavy metal plate. Screw terminals. Silver contacts. Usual adjustments. Body dims: 150 x 75 x 50mm. Weight 0.5kg. O/No. VP 124. **£21.00**

ANTENNA SWITCH 2 and 3 WAY

Co-axial switch for one transceiver to two antennae or one antenna to two transceivers. Dims: 86 x 55 x 32mm (Body). O/No. VP 113. **£4.50**

As above but 3-way. O/No. VP 114. **£4.75**

HIGH PASS FILTER/SUPPRESSOR

CB/TV. High pass filter. Reduces unwanted signals picked up by antenna. Dims: 45 x 25 x 17mm. O/No. VP 115. **45p**

LOW PASS FILTER

Designed to reduce harmonics on the VHS and TV band. Cut-off frequency: 30MHz. V.S.W.R.: Less than 1.2 to 1. Insertion loss: -0.2dB @ 27MHz Impedance: 50ohms. Dims: 80 x 55 x 40mm. O/No. VP 116. **£2.75**



ANTENNA COUPLER

Transceiver/car radio antenna coupler. With co-axial cables. One co-axial terminates in antenna plug and the other in PL259 plug. Dims: 67 x 46 x 30mm. O/No. VP 117. **£2.00**



TAPE RECORDER SWITCH

Unit to control motor of tape recorder. 1.8m cord and 2.5mm plug attached. On/Off switch. Dims: 55 x 20 x 20mm. O/No. VP 127. **£1.00**

DC-DC POWER SUPPLY

DC to DC adaptor. Plugs into car cigar lighter aperture. Output 3, 4.5, 6, 7.5, 9, 12V @ 800mA. Has universal output spidier plug, also 9V battery snap and polarity reversing facility. O/No. VP 119. **£2.45**

SPEAKER PROTECTOR

Limits voltage to speaker or to the permissible max., by automatically introducing a resistor in series with speakers. When excessive voltage is reduced the unit resets itself. Electronic voltage-sensing relay circuit. Spring terminals. Cut-off level adjustable from 10W-120W. Full instructions included. Dims: 85 x 74 x 25mm. O/No. VP 118. **£9.95**

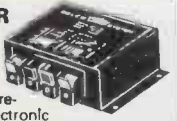

ELECT & PIEZO BUZZERS

PIEZO
Miniature round piezo-electronic buzzer. White plastic. Low consumption. Frequency: 4kHz approx. Output: 70dB (A) @ 1. typ. Power: 12Vd.c. 4mA. Dims: 22 (dia) x 11.5mm. Fixing Centres: 26.5mm. O/No. VP 107. **95p**

PIEZO
Piezo buzzer. White plastic. 90mm leads. For use on a.c. mains. Frequency: 3.5kHz approx. Output: 85dB (A) @ 1m typ. Power: 240Vac. 5mA. Dims: 32 (dia) x 14mm. Fixing centres: 38mm. O/No. VP 108. **£1.15**

ELECTRONIC
Miniature electronic buzzers. Solid state Ivory plastic. 150 leads. Frequency: 500 Hz approx. Dims: 22 x 16 x 15mm. Output: 82dB (A) @ 1m typ. Fixing centres: 26mm. 6V 25mA: VP 83. 3V 25mA: O/No. VP 82. 9V 25mA: O/No. VP 84. **80p each**

SUB-BOX

A neat swivelling disc provides close tolerance substitution resistors of 36 preferred values from 50ohms to 1Kohm. Simply fix clips into circuit and swivel until optimum result is achieved. O/No. VP 112. **£4.75**



MINIATURE VICE

Miniature plastic and metal vice with strong suction base for portability. Single action to secure or release suction. Plastic jaws with rubber pads 20mm wide, open out to 40mm. Dims: 85 x 65 x 60mm approx. **FANTASTIC VALUE** O/No. VP 95 ONLY **£1.60**

LEARN A LINGO!

PILLOW SPEAKER
Slim under pillow unit. 80ohms 2" speaker. 1.5m lead with 3.5mm mono jack plug. Black. Dims: 65 (dia) x 17mm. O/No. VP 88. **£1.25**



METRIC & BRITISH MEASURES

Steel tapes in sturdy ABS plastic case. Silk wrist strap. These yellow coated convex tapes have inch and metric graduations. Automatic push-button return. 2m long x 13mm wide. O/No. VP 89. **£1.00**
3m long x 13mm wide. O/No. VP 90. **£1.50**
5m long x 16mm wide. O/No. VP 91. **£2.00**

BATTERY TESTER

Tests all types of battery including standard, NICAD, Alkaline etc. Takes all standard sizes including 6V lantern batteries and watch/bearing cells. Also tests fuses and lamps by means of internal 9V (PP3) battery. Can also be used to recharge NICAD batteries by means of external 3-12Vd.c. power supply (not included). Full instructions provided. Dims: 185 x 103 x 30mm. O/No. VP 101. **£7.00** (approx.)

FM MONITOR

FM monitor for 2 metre band. All metal. Attached earphone. PL259/SO239 connectors. 144MHz 10W maximum. Dims: (Body) 55 x 30 x 23mm. O/No. VP 120. **£4.20**



DUMMY LOAD

50 ohms 30W. UHF co-axial plug fitting (PL259). O/No. VP 121. **£5.20**



PICK-UP COIL

Large telephone pick-up coil for high sensitivity. Suction pad to stick to telephone. 90cm lead to 3.5 jack plug. Connects direct to cassette recorder. Dims: 32 (dia) x 17mm (body) 39mm (dia) sucker. **£1.00**

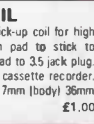

VALUE PACKS

| Pak No. | Qty | Description | Price |
|---------|-----|---|-------|
| VP1 | 300 | Assorted Resistors Mixed Types | £1.00 |
| VP2 | 300 | Carbon Resistors 1/4 Watt Pre-Formed | £1.00 |
| VP3 | 200 | 200 | £1.00 |
| VP4 | 150 | 1/2 Watt Resistors 100 ohm-1M Mixed | £1.00 |
| VP5 | 200 | Assorted Capacitors All Types | £1.00 |
| VP6 | 200 | Ceramic Caps Miniature - Mixed | £1.00 |
| VP7 | 100 | Mixed Ceramic Disc 1p1 - 56p1 | £1.00 |
| VP8 | 100 | Mixed Ceramic Disc 68p1 - 015p1 | £1.00 |
| VP9 | 100 | Assorted Polyester/Polystyrene Caps | £1.00 |
| VP10 | 50 | C200 Type Caps Metal Foil Mixed | £1.00 |
| VP11 | 100 | Electrolytics - All Sorts | £1.00 |
| VP12 | 60 | Bead Type Polystyrene Min Caps | £1.00 |
| VP13 | 50 | Silver Mica Caps Ass 5.6p1 - 150p1 | £1.00 |
| VP14 | 50 | Silver Mica Caps Ass 180p1 - 4700p1 | £1.00 |
| VP15 | 50 | High Voltage Disc. Ceramic 750v - 8Kv Mixed | £1.00 |
| VP16 | 50 | Wirewound Res. 9W (avg) Ass 1 ohm - 12K | £1.00 |
| VP17 | 50 | Metres PVC Covered Single Strand Wire Mixed Colours | £1.00 |
| VP18 | 30 | Metres PVC Covered Multi Strand Wire Mixed Colours | £1.00 |
| VP19 | 40 | Metres PVC Single/Multi Strand Hook-Up Wire Mixed | £1.00 |
| VP20 | 6 | Rocker Switches 5 Amp 240v | £1.00 |
| VP21 | 20 | Pcs. 1 - 2 & 4 mm Plugs & Sockets Matching Sues | £1.00 |

| | | | |
|------|-----|--|-------|
| VP22 | 200 | Sq. Inches Total. Copper Clad Board Mixed Sizes | £1.00 |
| VP23 | 20 | Assorted Slider Pots Mixed Values | £1.00 |
| VP24 | 10 | Slider Pots 40 mm 22K 5 x Log 5 x Lin | £1.00 |
| VP25 | 10 | Slider Pots 40 mm 47K 5 x Log 5 x Lin | £1.00 |
| VP26 | 20 | Small 1/2" Red LED'S | £1.00 |
| VP27 | 20 | Large 2" Red LED'S | £1.00 |
| VP28 | 10 | Rectangular 2" Green LED'S | £1.00 |
| VP29 | 30 | Ass. Zener Diodes 250mW - 2W Mixed Vts. Coded | £1.00 |
| VP30 | 10 | Ass. 10W Zener Diodes Mixed Vts. Coded | £1.00 |
| VP31 | 10 | 5 Amp SCR'S TO-66 50-400v Coded | £1.00 |
| VP32 | 20 | 3 Amp SCR'S TO-96 Up To 400v Uncoded | £1.00 |
| VP33 | 200 | Si Diodes Switching Like IN4148 DO 35 | £1.00 |
| VP34 | 200 | Si Diodes Gen. Purpose Like DA200/BA13/16 | £1.00 |
| VP35 | 50 | 1 Amp IN4000 Series Si Diodes Uncoded All Good | £1.00 |
| VP36 | 8 | Bridge Rects. 4 x 1 Amp 4 x 2 Amp Mixed Vts. Coded | £1.00 |
| VP37 | 8 | Black Instrument Type Knobs With Pointer 1" Std | £1.00 |
| VP42 | 10 | Black Heatsinks To Fit TO.3, TO.220 Ready Drilled | £1.00 |
| VP43 | 4 | Power-Fan Heatsinks 2 x TO.3 2 x TO.66 Size | £1.00 |

TRANSISTOR CLEARANCE

All Sorts Transistors. A mixed bag NPN-PNP Silicon & Germ. Mainly Uncoded You To Sort Pack includes Instructions For making Simple Transistor Tester. Super Value. Order No. VP60. **£1.00**

BI-PAK SOLDER DESOLDER KIT

Kit comprises: O/No. VP 80
1 High Quality 25 Watt General Purpose Lightweight Soldering Iron 240v mains incl. 3/16" (4.7mm) bit
1 Quality Desoldering Pump High Suction with automatic ejection
Knurled anti-corrosive casing and Teflon nozzle 1.5 metres of De-Soldering braid on plastic dispenser.
2 vds (1.83m) Resin Cored Solder on Card
1 Heat Shunt too tweezer Type
Total Retail Value over £12.00
OUR SPECIAL KIT PRICE £9.95

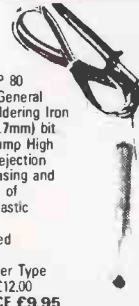

BI-PAK PCB ETCHANT AND DRILL KIT

Complete PCB Kit comprises
1 Expo Mini Drill 10,000RPM 12Vd.c. incl. 3 collets & 3 x Twist Bits
1 Sheet PCB Transfers 210mm x 150mm
1 Etch Resist Pen
1 Jb pack FERRIC CHLORIDE crystals
3 sheets copper clad board
2 sheets Fibreglass copper clad board
Full instructions for making your own PCB boards
Retail Value over £15.00
OUR BI-PAK SPECIAL KIT PRICE £9.95
ORDER NO. VP 81



TECASBOTY

THE ELECTRONIC COMPONENTS AND SEMICONDUCTOR BARGAIN OF THE YEAR!

This collection of Components and Semiconductors for the hobbyist is probably the most value-packed selection ever offered, it consists of Resistors, carbon and wirewound of various values. Capacitors: All types, sorts and sizes including electrolytics. Potentiometers - single, dual, slider and preset. Switches, Fuses, Heatsinks, Wire, P.C.B. Board, Plugs, Sockets etc., PLUS a selection of Semiconductors for everyday use in popular Hobby Projects. These include: SCR'S, Diodes, Rectifiers, Triacs & Bridges as well as a first class mix of Transistors and I.C.'s. In all, we estimate the value of this in current retail catalogues to be over £25! So, help yourself to a great surprise and order a Box TODAY for ONLY at BI-PAK. Remember, stocks are limited so hurry! You can call us on 0920 3182/3442 and order just **£6.50** with your Barclaycard or Access Card - 24hr Answerphone Service NOW. Order No. VP 85.



OUR GREAT NEW 1984 CATALOGUE

Presented with a Professional Approach and Appeal to ALL who require Quality Electronic Components, Semiconductors and other Accessories ALL at realistic prices. There are no wasted pages of useless information so often included in Catalogues published nowadays. Just solid facts i.e. price, description and individual features of what he has available. But remember, BI-PAK'S policy has always been to sell quality components at competitive prices and THAT WE STILL DO. We hold vast stocks "in stock" for fast immediate delivery, all items in our Catalogue are available ex stock. The Catalogue is designed for use with our 24 hours "ansaphone" service and the Visa/Access credit cards, which we accept over the telephone. To receive your NEW 1984 BI-PAK Catalogue, send 75p PLUS 25p p&P to:-

Use your credit card. Ring us on Ware 3182 NOW and get your order even faster. Goods normally sent 2nd Class Mail. Remember you must add VAT at 15% to your order. Total Postage add 75p per Total order.



BI-PAK

Send your orders to: HE6PW6 BI-PAK PD BOX 6 WARE, HERTS SHOP AT 3 BALDOCK ST. WARE, HERTS
TERMS CASH WITH ORDER, SAME DAY DESPATCH, ACCESS, BARCLAYCARD ALSO ACCEPTED. TEL. (0920) 3182, GIRD 388 7006
ADD 15% VAT AND 75p PER ORDER POSTAGE AND PACKING

Hobby Electronics

JUNE 1984
Vol 6 No 6

PROJECTS

- ★TWO WAY MAINS INTERCOM 13
Don't lay a trail - take the mains road.
- ★CONDUCTANCE METER 23
The ideal meter for debugging PCBs.
- ★AUDIO MILLIVOLTMETER 51
A low-cost piece of test gear for audio buffs.
- ★HE ZX81 CASSETTE TAPE CONTROLLER 59
Bring your contacts under control.

FEATURES

- ★ALL ABOUT ELECTRONICS PART 11 44
Takes a look at TV standards.

SPECIAL

- ★★SOFT OPTIONS 27
The second edition of our regular survey of practical and educational software, and the people who write it.

REGULARS

- Monitor 6
- What's On Next 18
- Points Of View 20
- Buylines 26
- HE Bookshelf 50
- HE Backnumbers 56
- Forward Bias 57
- HE PCB Service 63
- HE PCB Page 64

Editor: Ron Keeley
Deputy Editor: Helen P. Armstrong BA
Technical Editorial Assistant: Terry Johnson
Technical Illustrator: Jerry Fowler
Advertising Manager: Joanne James
Copy Control: Lynn Collis
Managing Editor: Ron Harris BSc
Chief Executive: T. J. Connell

We are not normally able to deal with technical enquiries by phone, so please don't ring. Write to us with an SAE.



Audio Millivoltmeter — page 51



Soft Options — page 27



ZX81 Cassette Tape Controller — page 59

Hobby Electronics is normally published on the second Friday of the month prior to the cover date.
Hobby Electronics, No. 1, Golden Square, London W1R 3AB, 01 437 0626, Telex No 8811869. Published by Argus Specialist Publications Ltd.
Origination by Ebony Typesetting, Trion House, 13 Dean Street, Liskeard, Cornwall PL14 4AB.
Distributed by S. M. Distribution Ltd, 16/18 Trinity Gardens, London SW9 8DX.

Printed by The Garden City Press, Letchworth, Herts SG6 1JS. Covers printed by Alabaster Passmore.
Notice: The contents of this publication including all designs, plans, drawings and programs and all copyright and other intellectual property rights therein belong to Argus Specialist Publications Ltd. All rights conferred by the Law of Copyright and other intellectual property rights by virtue of international copyright conventions are specifically reserved to Argus Specialist Publications Limited and any reproduction requires the prior written consent of the Company. All reasonable care is taken in the preparation of the magazine to ensure accuracy, but Argus Specialist Publications Ltd cannot be held responsible legally. ©Copyright 1984 Argus Specialist Publications Ltd. Member of Audit Bureau of Circulation.

Cirkit. A new name

This year Ambit will stop being Ambit. And become Cirkit.

Cirkit is more than just a change of name. It means a better service for you. Faster delivery.

A bigger range of the best and latest products with well over 10,000 different items available.

Everything for the home and industrial user.

A whole new Cirkit range of constructional kits, graded for the student, expert and enthusiast.

Modules to build for everyone.

Cirkit is a go ahead company that believes in giving service to its customers.

There's a technically skilled staff to help you.

We keep in touch with the manufacturers and we know what's going on.

As soon as new products are available, Cirkit has them.

Cirkit means a bigger catalogue. A better company to deal with.

And a wider than ever range of products that's growing all the time.

For you, Cirkit means a bigger stock and better service.

For further information send for our latest catalogue or visit one of our three outlets at: 200 North Service Road, Brentwood, Essex, CM14 4SG; 53 Burrfields Road, Portsmouth, Hampshire, PO3 5EB; Park Lane, Broxbourne, Hertfordshire, EN10 7NQ.

To: Cirkit Holdings PLC, Park Lane, Broxbourne, Hertfordshire.

I enclose 80p. Please send me your latest catalogue and 3 x £1 discount vouchers!

Name _____

Address _____

Telephone _____

Area of Special Interest _____

Cirkit

Bigger Stock. Better Service.

HE 6

Computer Products

A complete range from Connectors to Board Level product

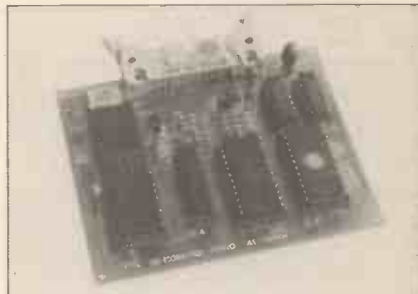

| | | |
|-----------------------------|----------|-------|
| C12 Computer Cassette | 21-00012 | 0.55 |
| BBC to Centronics Printer | 03-10019 | 7.25 |
| BBC to 25 way D Male | 03-10021 | 4.50 |
| 25 way D Socket | 10-25200 | 1.90 |
| 25 way D Plug | 10-25100 | 1.30 |
| Cover for 25 way D | 10-25322 | 0.93 |
| 20 up Eprom Eraser | 40-82100 | 31.25 |
| Z80 A Industrial Controller | 40-82000 | 49.95 |
| 6802 Industrial Controller | 40-68020 | 49.95 |
| 6502 Industrial Controller | 40-65020 | 49.95 |
| Z8 Basic/Debug Controller | 41-00904 | 50.00 |

Nicad Batteries & Chargers

Minimum life 600 (300 PP3 size) full charge/discharge cycles. Batteries must be charged from a constant current source only. All batteries are supplied only with a residual charge and should be charged before used.

| | | | | 1.9 | 10.49 |
|--------------------|-------------------|--------|----------|------|-------|
| AA | 1.2V | 500mAH | 01-12004 | 0.80 | 0.74 |
| C | 1.2V | 2.2AH | 01-12024 | 2.35 | 1.99 |
| D | 1.2V | 4.0AH | 01-12044 | 3.05 | 2.85 |
| PP3 | 8.4V | 110mAH | 01-84054 | 3.70 | 3.50 |
| CH1/22 PP3 Charger | 11mA for 16 hours | | 01-00159 | | 4.30 |

| | | | | | |
|------------------------------|--|--|----------|--|------|
| CH8/RX Multi-purpose Charger | | | 01-02204 | | 9.40 |
|------------------------------|--|--|----------|--|------|

Will recharge AA, C, D and PP3 size cells with automatic voltage selection. Will recharge following combination: 6 x D, 6 x AA, 6 x C, 2 x PP3, 2 x D + 2 x C, 2 x D + 2 x AA, 2 x D + 1 x PP3, 2 x C + 2 x AA, 2 x C + 1 x PP3, 2 x AA + 1 x PP3.

| | | | | | |
|-----------------|--|--|----------|--|------|
| Battery Adaptor | | | 01-12001 | | 0.96 |
|-----------------|--|--|----------|--|------|

Sold in pairs: one to convert AA size to C size and one to convert C to D size. Both may be used together to convert an AA to D size.

Semiconductors

Linear IC's

| | | | |
|---------|------------------------------|----------|------|
| LM301AN | DIL version | 61-03011 | 0.44 |
| LM308CN | DIL version | 61-03081 | 0.65 |
| LM311CN | Popular comparator | 61-00311 | 0.46 |
| LM324 | Low power quad op amp | 61-03240 | 0.67 |
| LM339N | Low power quad comparator | 61-03390 | 0.68 |
| LM346 | Programmable quad op amp | 61-00346 | 3.72 |
| LF347 | Quad Bi-FET op amp | 61-00347 | 1.82 |
| LM348 | Quad 741 type op amp | 61-03480 | 1.26 |
| LF351 | Bi-FET op amp | 61-03510 | 0.49 |
| LF353 | Dual version of LF351 | 61-03530 | 0.76 |
| LM380N | IW AF power amp | 61-00380 | 1.00 |
| NE555N | Multi-purpose low cost timer | 61-05550 | 0.45 |

for a better service.

| | | | |
|-----------|---|----------|------|
| NE556N | Dual version of the 555 | 61-05560 | 0.50 |
| uA741CN | DIL low cost op amp | 61-07411 | 0.22 |
| uA747CN | Dual 741 op amp | 61-07470 | 0.70 |
| uA748CN | 741 with external frequency comp | 61-04780 | 0.40 |
| HA1388 | 18W PA from 14V | 61-01388 | 2.75 |
| TDA2002 | 8W into 2 ohms power amp | 61-02002 | 1.25 |
| UJLN2283 | 1W max. 3-12V power amp | 61-02283 | 1.00 |
| MC3357 | Low power NBFM IF system and detector | 61-03357 | 2.85 |
| UJLN3859 | Low current dual conversion NBFM IF and detector | 61-03859 | 2.95 |
| LM3900 | Quad norton amp | 61-39000 | 0.60 |
| LM3909N | 8-pin DIL LED flasher | 61-39090 | 0.68 |
| KB4445 | Radio control 4 channel encoder and RF | 61-04445 | 1.29 |
| KB4446 | Radio control 4 channel receiver and decoder | 61-04446 | 2.75 |
| ICM7555 | Low power CMOS version of timer | 61-75550 | 0.98 |
| ICL8038CC | Versatile AF signal generator with sine/square/triangle OPs | 61-08038 | 4.50 |
| TK10170 | 5 channel version of KB4445 | 61-10170 | 1.87 |
| HA12002 | Protection monitor system for amps, PSUs, TXs etc | 61-12002 | 1.22 |
| HA12017 | 83dB S/N phono preamp 0.001% THD | 61-12017 | 0.80 |
| MC14412 | 300 baud MODEM controller (Eduro/US specs) | 61-14412 | 6.85 |

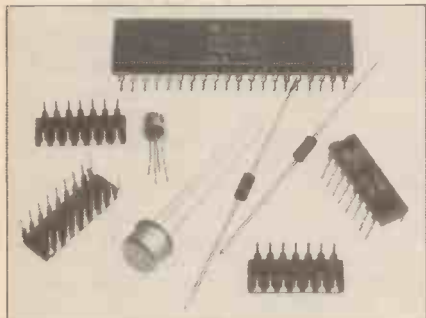

Microprocessor & Memories

| | | | |
|----------|--------------------------------|----------|-------|
| Z80A | Popular and powerful 8-bit CPU | 26-18400 | 3.40 |
| Z80AP10 | 2 port parallel input/output | 26-18420 | 2.95 |
| Z80A CTC | 4 channel counter/timer | 26-18430 | 2.90 |
| Z8671 | Z8 Micro comp. and Basic | 26-08671 | 17.50 |
| 6116-3 | 16K (2Kx8) CMOS RAM 200nS | 26-36116 | 6.68 |
| 26132-6 | 32K (4Kx8) quasi RAM 350nS | 26-06132 | 15.00 |
| 4116-2 | 16K (16Kx1) 150nS | 26-24116 | 1.59 |
| 2764 | 64K (8Kx8) 450nS | 26-02764 | 9.50 |
| 2732 | 32K (4Kx8) 450nS | 26-02732 | 5.70 |

Voltage Regulators

| | | | |
|------|-----------------|----------|------|
| 7805 | 5V 1A positive | 27-78052 | 0.40 |
| 7812 | 12V 1A positive | 27-78122 | 0.40 |
| 7815 | 15V 1A positive | 27-78152 | 0.40 |
| 7905 | 5V 1A negative | 27-79052 | 0.49 |
| 7912 | 12V 1A negative | 27-79122 | 0.49 |
| 7915 | 15V 1A negative | 27-79152 | 0.49 |

Transistors

| | | | |
|-------|---------------------|----------|------|
| BC182 | General purpose | 58-00182 | 0.10 |
| BC212 | General purpose | 58-00212 | 0.10 |
| BC237 | Plastic BC107 | 58-00237 | 0.08 |
| BC238 | Plastic BC108 | 58-00238 | 0.08 |
| BC239 | Plastic BC109 | 58-00239 | 0.08 |
| BC307 | Complement to BC237 | 58-00307 | 0.08 |
| BC308 | Complement to BC238 | 58-00308 | 0.08 |

| | | | |
|---------|---------------------------------|----------|------|
| BC309 | Complement to BC239 | 58-00309 | 0.08 |
| BC327 | Driver/power stage | 58-00327 | 0.13 |
| BC337 | Driver/power stage | 58-00337 | 0.13 |
| MPSA13 | NPN Darlington | 58-04013 | 0.30 |
| MPSA63 | PNP Complement to MPSA13 | 58-04063 | 0.30 |
| J310 | JFET for HF-VHF | 59-02310 | 0.69 |
| J176 | JFET analogue switch | 59-02176 | 0.65 |
| 3SK51 | Dual gate MOSFET-VHF amp | 60-04051 | 0.60 |
| 3SK88 | Dual gate MOSFET-Ultra lo noise | 60-04088 | 0.99 |
| TIP31A | Output stage | 58-15031 | 0.35 |
| TIP32A | Complement to TIP31A | 58-15032 | 0.35 |
| VN66AF | V MOS Power FET | 60-02066 | 0.95 |
| ZTX3866 | E-line version 2N3866 | 58-03866 | 0.45 |
| IN4001 | Rectifier diode | 12-40016 | 0.06 |
| IN4002 | Rectifier diode | 12-40026 | 0.07 |
| IN4148 | General purpose silicon | 12-41486 | 0.05 |

Silicon Controlled Rectifiers

| | | | |
|-----------|-----------|----------|------|
| BRY55-100 | 100V .8A | 52-55100 | 0.50 |
| C106DI | 400V 4.0A | 52-00106 | 0.70 |
| C122DI | 400V 8.0A | 52-00122 | 1.45 |

3mm Diameter LEDs

| | | | |
|-------|--------|----------|------|
| V178P | Red | 15-01780 | 0.15 |
| V179P | Green | 15-01790 | 0.16 |
| V180P | Yellow | 15-01800 | 0.18 |

5mm Diameter LEDs

| | | | |
|--------|--------|----------|------|
| CQY40L | Red | 15-10400 | 0.12 |
| CQY72L | Green | 15-10720 | 0.15 |
| CQY74L | Yellow | 15-10740 | 0.15 |

Infra-Red LEDs

| | | | |
|-------|----------|----------|------|
| CQY99 | Emitter | 15-10990 | 0.56 |
| BPW41 | Detector | 15-30410 | 1.51 |

Tri Colour LED

| | | | |
|------|---------------------|----------|------|
| V518 | Orange-Green-Yellow | 15-05180 | 0.60 |
|------|---------------------|----------|------|

Capacitors

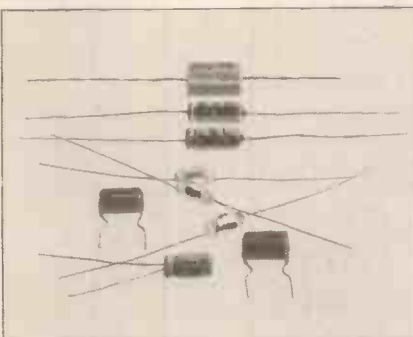

Aluminium Electrolytics Radial PCB Mounting

| | | | |
|------|------|----------|------|
| 10u | 16V | 05-10606 | 0.24 |
| 47u | 16V | 05-47606 | 0.28 |
| 47u | 25V | 05-47607 | 0.28 |
| 470u | 6.3V | 05-47705 | 0.36 |
| 470u | 16V | 05-47706 | 0.48 |

Tantalum Beads

| | | | |
|------|------|----------|------|
| 1uF | 35V | 05-10501 | 0.18 |
| 10uF | 16V | 05-10601 | 0.28 |
| 47uF | 6.3V | 05-47601 | 0.45 |
| 47uF | 16V | 05-47602 | 0.92 |

Monolithic Capacitors

| | | |
|------|----------|-----------|
| | | Pack of 3 |
| 1n | 04-10204 | 0.39 |
| 10n | 04-10304 | 0.42 |
| 100n | 04-10404 | 0.45 |

Low Voltage Disc Cermaic

| | | |
|-----|----------|-----------|
| | | Pack of 5 |
| 1n | 04-10203 | 0.20 |
| 10n | 04-10303 | 0.20 |

Polyester (C280)

| | | |
|------|----------|-----------|
| | | Pack of 3 |
| 10n | 04-10305 | 0.18 |
| 47n | 04-47305 | 0.24 |
| 100n | 04-10405 | 0.24 |
| 470n | 04-47405 | 0.51 |
| 1uF | 04-10505 | 0.66 |

R F Components

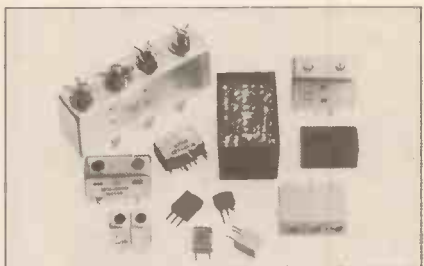

Filters

CFU/LFB CFW/LFH SERIES

Miniature 455kHz filters. I/P and O/P impedance 2K.

| | | | | |
|-----------------|----------------------------------|-------|----------|------|
| | | -6dBW | -40dBW | |
| LFB6/CFU455H | 6kHz | 18kHz | 16-45512 | 1.95 |
| LFB12/CFU455F | 12kHz | 26kHz | 16-45515 | 1.95 |
| LFH6S/CFW455HT | 6kHz | 14kHz | 16-45525 | 2.45 |
| LFG12S/CFW455FT | 12kHz | 22kHz | 16-45528 | 2.45 |
| CFM2455A | Mechanical IF Filters for 455kHz | | 19-45530 | 0.77 |

Crystal Filters 2 Pole Types

| | | | |
|---------|---------------------|----------|------|
| 10M15A | 10.7 Centre Freq. | 20-10152 | 2.10 |
| 10M08AA | 10.695 Centre Freq. | 20-11152 | 3.49 |

Inductors

We offer the complete Toko range of fixed and variable inductors. Over 500 coils from audio to V.H.F. See catalogue for details.

Soldering Irons (Antex)

| | | | |
|--------|---|----------|------|
| CS240 | Iron 240VAC 17 Watts | 54-22300 | 5.20 |
| XS-240 | Iron 25W 240V High heat capacity | 54-22500 | 5.40 |
| SK6 | Presentation pack of one XS-240 with ST4 stand | 54-22510 | 7.20 |
| MLXS | Handy 12V 15W soldering iron complete with crocodile clips and solder | 54-20004 | 5.60 |

Please add 15% VAT to all advertised prices and 60p post and packing. Minimum order value £2 please. We reserve the right to vary prices in accordance with market fluctuation.

MONITOR

Soft Swap

Acornsoft, the software division of Acorn Computers, are giving their customers an opportunity to part-exchange software on cassette for the same software on disc.

To take advantage of the offer, customers should return their cassette, without its outer box, to Acornsoft, plus a remittance for half the cost of the same program on disc (inclusive of VAT), to Disk Replacement Service, Acornsoft Ltd., c/o Vector Marketing, Denington Industrial Estate, Wellingborough, Northants NN8 2RL. To find out whether a particular program is available on forty or eighty track discs, check the most recent Acornsoft catalogue, available from Acorn dealers or from Acornsoft Ltd., 4a Market Hill, Cambridge CB2 3NJ. Whether or not you think this is good value depends on how badly you want to acquire a disc at the expense of your cassette, but it is certainly an unusual service. One which purveyors of Videodisc and Compact Disc players might in due course consider?

6809 Group

A newsletter and User Group for users of the 6809 microprocessor has been founded.

The newsletter will come out bimonthly (six times a year), and will feature a software section for 6809 assembly routines and programs, as well as programs in other languages; a 6809 assembly language course for those updating from other processors (so far, only 6502 and Z80); a hardware section for circuits relevant to the 6809 or to computers in general; a free advertisement page for members, and a letters page, as well as other incidental articles.

Subscription will be yearly, half yearly or by individual issue, at 70p per issue to begin with, with the price coming down if there is enough support. The group would like contributions of articles and items for the newsletter.

Those interested please contact Mr. W. Gibbons, 9, St. Thomas Hill, Launceston, Cornwall PL15 8BL.

Computer Fair

Europe's biggest personal and small business computer exhibition, The Computer Fair, will be once again staged at Earls Court from June 14-17, 1984. This event will feature a 'Business/Trade Only Day' on June 14, to enable trade and business people to visit the show before the crowds converge. The exhibition has also been arranged in two distinct areas — one for home computer enthusiasts, the other for business exhibitors. Attendance at the 1984 Show is expected to match that of the 1983 when nearly 50,000 people attended. Sinclair Research, who chose the 1982 Computer Fair to unveil the Spectrum Microcomputer and in 1983 exhibited new peripherals



for this system, are back this year to show their latest computer the Sinclair QL. Commodore will be displaying home and personal computers including the SX-64 portable computer. Acorn will be showing bitstik graphics (computer aided drawing) systems on the BBC Micro.

The Computer Fair will be open from 10.00am — 6.00pm on June 14 (Business/Trade Only Day), June 15 and 16, and from 10.00am - 5.00pm on June 17. For further information on all aspects of the event, contact the Exhibition Manager, The Computer Fair, Reed Exhibitions, Surrey House, 1 Throwley Way, Sutton, Surrey SM1 4QQ. Tel: 01 643 8040.

Don't Overheat

OK Industries are now stocking a temperature-controlled soldering station. Features of the station are stability within 5% over 100-500°C, power and heater indicators, a temperature indicator, proportional control and a 24V 48W low-leakage iron. The unit is earthed to protect MOS or CMOS chips, and comes in a 115V or 230V model. Various soldering tips are available.

Enquiries to OK Industries UK Ltd., Dutton Land, Eastleigh, Hants SO5 4AA. Tel: (0703) 619841.

Not An Armon A Leg

Armon Electronics have supplemented their range of push-button digital multimeters with an advanced rotary-switched model, the HC-5010.

Housed in an ABS cabinet, fitted with recessed input jacks to obviate shock hazard, and a tilt stand for bench use, the meter is supplied with a 9V battery,

test leads and a comprehensive instruction manual, and comes in polyfoam packing. A no-quibble guarantee covers the instrument against defects in workmanship and materials for twelve months.

Readings are on a 3½ digital LCD display, which has low battery and polarity indication, with automatic decimal point. A twenty-position rotary switch selects the functions and ranges. Resistance ranges extend from 20R to 20MR, with a resolution of 10mR on the 20R range, and include a diode test position and a continuity buzzer. The amp ranges are also extended — 20uA range, and accuracies of 1 to 3% AC and 0.5 to 3% DC, depending on range selected.

Voltage range is from 200mV to 750V AC or 1,000V DC. Resolution is 10uV on the 200mV ranges, with accuracies of 0.25% DC and 1% AC. All ranges and functions are protected against overload.

The price is £35.95 plus VAT. Further details can be obtained from Armon Electronics Ltd., Cottrell House, 53/63 Wembley Hill Rd., Wembley, Middlesex, HA9 8BH. Tel: 01 902 4321.



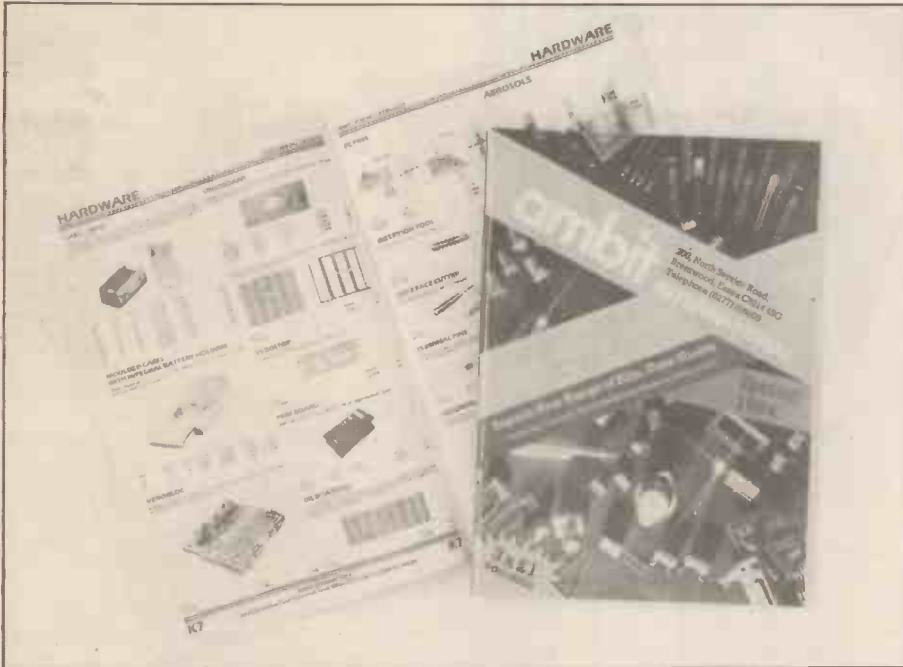

Ambit Out

Ambit International's Spring 1984 catalogue is now available from newsagents and from Ambit themselves, cover price 80p. The catalogue features components, kits, data sheets, batteries, crystals and electronics books, as well as three £1 discount vouchers. Everything can be obtained mail order, or from Ambit's three retail outlets at 200 North Service Rd., Brentwood, 53 Burrfield Rd., Portsmouth and Park Lane, Broxbourne. Catalogues can be ordered from Ambit International, 200 North Service Rd., Brentwood, Essex CM14 4SG. If you can't get them locally.

Electronics Circuit

The British Amateur Electronics Club's Spring journal contains a guide to designing and making PCBs, (copiously illustrated); "The Computer And Its Uses Part 1"; Notes From An Experimenter's Workshop; Electronics A-Z Part 5 — Atomic Structure And Semiconductors; and the usual letters, news, small ads, list of component suppliers offering discounts to members, etc. A very meaty issue, this one. Enquiries about membership to the Chairman, Mr. C. Bogod, "Dickens", 26 Forrest Rd., Penarth, S. Glamorgan. The BAEC is a very good thing for anyone learning, or teaching themselves, electronics, with lots of hints and practical information.

The Prize Is To The Swiftest

\$100,00 for the First Prize is the reward being offered by Video Games International, and their partners for this year's "Invent A Game" competition.

We wish they'd given us a bit more warning so that we could let those of our readers who aren't avid readers of the "international specialist press" (which must mean the computer press) but who nevertheless enjoy games and programming, that this competition is happening. Entries close on May 31st, which is about three weeks' time, but anyone who is thinking of entering or who has a new game gleaming in his or her eye is invited to contact Mr. Mark Eliot on (0753) 652711/2 to find out more about the competition. The address, for those of you who trust not in telephones, is Video Games International, Pinewood Studios, Iver Heath, Bucks SL0 0NH.

Take Cover

John Wise Ltd., are a small company who produce various useful articles in acrylic. Of interest to Hobby readers might be model-type dust covers and also display cases and stands, made to the customer's requirements. Enquiries to their new address, John Wise Ltd., 5 Alpha Rd., West Green, Crawley, Sussex RH11 7DH. Tel. (0293) 542889.

Page Of Aquarius

A new monthly magazine, Aquarius User, has been launched for the owners of the Aquarius micro. The magazine contains news and information about the computer and peripherals, software reviews, hints and listings, and letters pages. At present it is available at a subscription rate of £12 per year.

For information contact Aquarius User, 66 Wymering Rd., London W9.

BBC Data Base

Clares Micro Supplies announce what is probably the most powerful data base yet available for the BBC Micro. Beta-Base has the facility for 200 fields, fields of up to 254 bytes and records in excess of 2000, with Redefine and Transfer options to make a file more versatile, a powerful sort and search facility, calculations on all mathematical fields and a variety of printing options.

Beta-Base's secret lies in the fact that it has been written as a disc based data base. The total size of any file is purely limited by the size of the disc drives.

Priced at £25 (inc. VAT) Beta-Base comes with a fully comprehensive manual and a demonstration program. Beta Base is available from Clares Micro Supplies, 98 Middlewich Road, Rudheath, Northwich, Cheshire CW9 7DA. Tel: (0606) 48511, and selected retail outlets.

A Fair Copper

As an alternative to printed circuit boards, adhesive copper strip sold in rolls can be used. Copperfoil Enterprises' Copperfoil tape is a thin pure copper strip backed by an adhesive formulated to withstand high temperatures and take soldered connections. The tape is suitable for voltages up to 240VAC/DC and a current carrying capacity of 5A, but is not recommended for mains voltage. The tape can be bonded to almost any insulated surface, including paper and plastic.

The tape is available in 4, 4.75, 6 and 8mm widths, in 33 metre rolls. Enquiries to Copperfoil Enterprises, 141 Lyndhurst Drive, Hornchurch, Essex RM11 1JP. We tested a strip and found that it was a little inclined to lift, temporarily, if subjected to prolonged contact with a hot soldering iron but otherwise stayed put and took a good solder contact.



MONITOR

Back To Basics

Wilmslow Audio, the loudspeaker kits specialists, now have three new models in the Wharfedale Speakercraft range.

Designated the L50, L90B and L140, these are two-way systems of 11, 17 and 20 litres respectively. Unlike most previous small Wharfedale speakers, these are all of 8R impedance. This new Speakercraft MANUAL is available free from Wilmslow.

Volt loudspeakers have come up with an answer to the problem of adding extra bass units to compact 'speakers'. Two new units, the 8in DVC220DS and the 10in DV250 overcome the problem of matching low-sensitivity small speakers with the higher sensitivity of a bass unit in a larger enclosure, by having their sensitivities tailored to match smaller units. They are fitted with dual voice coils, so that the bass output of both channels can be fed via third order networks into a single bass unit.

The 8in speaker is suitable for wall mounting or enclosure mounting, the 10in unit for enclosure mounting only. Computer optimised tuning details can be supplied with either type for the chosen cabinet volume, and with or without grilles fitted.

Full details from Wilmslow Audio Ltd., 35/39 Church St., Wilmslow, Cheshire SK9 LAS. Please send 12x9in SAE. Tel: (0625) 529599.

Electron Add-on

FBC Systems have produced what will be one of the first, if not the only (by the time you read this) extension for the Acorn Electron so far: a switched joystick interface.

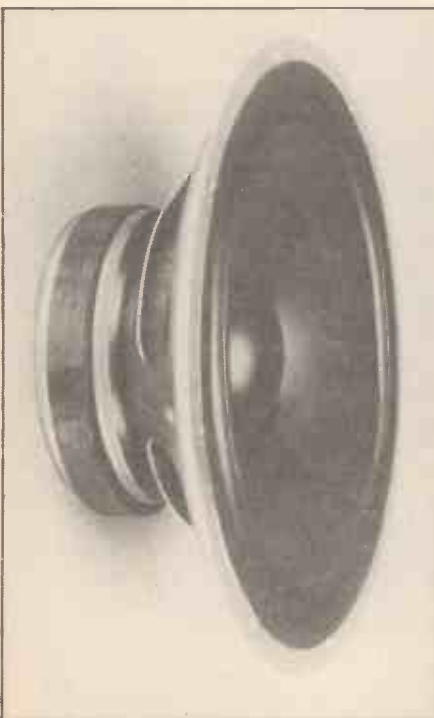

The plug-in cartridge takes all standard Atari-style joysticks, and FBC say that it is considerably quicker to read their interface than it is to read a normal keyboard input or A/D convertor. PCB have been in consultation with various Electron software houses, and intend to demonstrate their product at computer shows round the country during this year.

Enquiries to Breheny Advertising Ltd., 1 The Channel, Union St., Ashbourne, Derbyshire. Tel: (0335) 43729.

Circuit Layout By Apple

For Apple users doing electronic design, come two programs to assist in calculation and layout of electronic circuits.

Avant-Garde Creations's 'Hi-Res Electronic Design' allows the user to create fast and neat electronic schematics and save them as picture files on disc or via a printer, including labelling. A single keytouch chooses from ninety-eight different electronic components, or for choosing shape rotation. Components can be moved around the screen using an ordinary games paddle or joystick.

Korsmeyer's 'Electronic Design' gives a menu-driven array of electronic formulae for quick calculation.

Information from the distributors, Pete & Pam Computers, New Hall Hay Rd., Tawntentstall, Rossendale, Lancs BB4 6JG. Tel: (0706) 212321. The Avant-Garde program costs £19.95 plus VAT; no price is quoted for the other package.

Flat Transformer

Avel-Lindberg have issued a leaflet on what has been claimed to be the world's thinnest transformer (remember when a transformer was a lump of solid iron requiring a suitcase or at least a small rucksack to transport it?).

Their OB (on-board) PCB-mounting transformers are 10.5mm high, by 57mm by 68mm and conform to high industrial standards. Dual primary windings can be connected in parallel for 120VAC or in series for 240VAC nominal operation at either 50Hz or 60Hz. The transformers are available with a range of secondary winding ratings. Both direct soldering and screw-fixings are provided for.

Information from Avel-Lindberg Ltd., South Ockendon, Essex, RM15 5TD. Tel: (0708) 853444.

It's A Draw

Reekie Technology (who are based in East Twickenham and not, as you might think, in Edinburgh) has launched a drafting aid for BBC Model B micros, with software available on disc or cassette, and software for other micros under development.

Image Plotter allows the micro to reproduce maps, graphs, line drawings etc. to be reproduced with great exactness, from where they can be stored with the help of a printer. The plotter comes ready assembled with a handbook and calibration sheet. Made of aluminium and weighing 350g, the plotter costs £49.45 inc. VAT. Reekie do not specify whether this includes carriage, but they do say that Image Plotter is only available mail order at present.

They are also planning a low-cost X-Y plotter for use with the Image Plotter.

Orders and enquiries to Reekie Technology Company, Beaufort Rd., Off Richmond Rd., East Twickenham, Middx. TW1 2PH. Tel: 01 892 2877.



MONITOR



Going For Brokers

New pro-standard test equipment from **Electronic Brokers** includes three autorangeing multimeters and a brace of portable oscilloscopes.

The 70 Series digital multimeters by Fluke comprise the basic JF73 with 0.7% accuracy, the JF75 with 0.5%

accuracy, manual override and an audible continuity bleeper, and the JF77, with 0.3% accuracy, has a touch-hold facility which allows the user to concentrate on setting the test leads without watching the display. When a stable reading is achieved, a bleeper sounds, and the reading is held until a new test point is selected.

The two oscilloscopes are the Philips PM3254 and PM3256. Both are dual trace, with separate variable control of the main and delayed timebases, variable hold-off, X-Y display facilities, and TTL triggering. The trigger-view function can also be used as a third channel. The PM3254 has a single timebase and the PM3256 a delayed timebase.

Being designed for portability, the two scopes are strongly built around a tubular chassis, with a shoulder strap. Both can be operated from AC or DC power supplies.

For further information contact **Electronic Brokers Ltd.**, 61/65 Kings Cross Rd., London WC1X 9LN. Tel: 01 278 3461.

ZX Projects Go North

Distribution of the popular **ZX81 Hi-Res Graphics Board** (HE July '83) is now being handled by **Kelan/Hobbyboard**,

Hookstone Park, Harrogate, N. Yorks.

All the orders have been passed across from **Cambridge Computing**, and any queries about orders should be sent to **Kelan**. The modifications to the **ZX81 Programmable Joystick** to make it compatible with **Sinclair Microdrives** are being finalised at present, so any reader who is waiting for news about the modified boards should be hearing shortly.

Marshall Catalogue

A. Marshall (London) Ltd. have issued their new, 56-page 1984 catalogue. With over 8,000 items listed, the catalogue costs £1.00 post paid, £1.50 overseas, and 75p to callers at their shop at **85 West Regent St., Glasgow G2 2QD**. Tel: 041 332 4133.

In The Modem

"Modems... what are they? Of what benefit are they to a micro owner/user? What services can be accessed...?" enquires a letter from **Tandata's** PR company. **Tandata**, of course, are becoming well known for their **Tm100** smart modem, and are bringing out another model, the **Tm200**, with both full and half duplex at various rates.

Now **Tandata** have issued an information special edition of their **Tandata Newsletter** describing how modems can be connected and used with different microcomputers. They invite anyone who would like a copy of the leaflet to write to them at **Tandata Marketing Ltd.**, Albert Rd. North, Malvern, Worcs WR14 2TL.

Appliance Brochure

Superswitch, makers of small domestic appliances and specialists in products to improve home security, have produced a new range brochure. Available free, it contains details of all the company's latest products, including their dimmers and timers. Amongst the new items featured are a battery driven, passive infra-red intruder alarm, low voltage outdoor lighting, smoke alarms, and the Long-lite rechargeable torch. All these have been introduced by **Superswitch** during the last few months.

Further information from **Superswitch Electric Appliances Ltd.**, 7 Station Trading Estate, Camberley, Surrey GU17 9AH. Tel: (0276) 34556.

Go Forth And Multitask

Users who want **FORTH** for their **BBC Micros** will now find in on a 16K EPROM type 27128 from **Skywave Software**, going under the name of **Multi-FORTH 83**. This version of **FORTH** has been specially written for the **BBC**.

The EPROM can be plugged into the micro's sideways ROM area so that it has a higher priority than the **BASIC** ROM. It is multi-tasking, so that the user can have several **FORTH** programs on the go at once; compatible with the **MOS** so that the **Disc Directory** and other **DFS** commands can be used, and **MOS** commands can be used from within the **FORTH**; capable of maintaining files of more than 32K which can be stored on disc alongside non-**FORTH** files; vectored so that the more powerful features can be user-redefined; extensively documented, and with a number of other special features.

Multi-FORTH 83 costs £40 plus p&p and VAT from **Skywave Software**, 73 Curzon Rd., Boscombe, Bournemouth BH1 4PW. Tel: (0202) 302385.



MONITOR

Graphics Stylus

Computapix Ltd, has launched the PIXSTIK computer graphics stylus, which comes complete with its own "paintbox" software, and when connected to the VIC 20 or Commodore 64K home computers turns into a multi-purpose drawing instrument.

PIXSTIK offers a choice of sixteen colours to work in, and a range of predetermined shapes can be drawn, in addition to the freehand facility and commands that will among other things finish off the drawing in filled, unfilled or paintbrush style.

The ABC mode enables users to animate what they have drawn, bounce it backwards and forwards on the screen, and even run it cartoon fashion. "The real beauty of the PIXSTIK lies in the ease with which anyone can operate it, whether doodling or drawing seriously, and it even has a built-in eraser" say Computapix. PIXSTIK comes complete with an instructional manual, software and three computer games, at the price of £29.95, including VAT and p&p.

Orders and enquires to **Computapix Ltd, Gores Road, Kirkby Industrial Estate, Kirkby, Liverpool, L33 7UA.** Tel: 051 548 7111.

Time Control

An inexpensive Swiss-made 24-hour timeswitch that will plug into any 13-amp socket can be set to control burglar repelling lights and radio at up to five separate times during twenty-four hours. Maximum load is 13-amp (3100W at 240V 50Hz). It will also switch on radios or tape recorders to catch sports results or news programmes. Once set, it operates round the clock continuously until switched off or reprogrammed.

Five pairs of operating pegs are supplied, red for 'on' and blue for 'off'. They are housed in a compartment in



the clock until needed, when they are inserted against the times that switching is to take place. Operation is simple and there is an indicator which shows whether the switch is on or off and allows the current or next switching phase to be over-ridden if required. The price is £14.00 including VAT and p&p.

Enquiries to **Semiconductor Supplies Ltd., Dawson House, 128/130 Carshalton Rd., Sutton, Surrey SM1 4RS.** Tel: 01 643 1126.

Light Work

A work holder with a 'quick-release' trigger to allow PCBs to be removed and replaced in a matter of seconds is available from **Electronic & Computer Workshop Ltd.** The special attachments which fit to the PCB holding arms can be repositioned to hold such small components as switches etc. during soldering operations.

The MCP-2 Work Holder can hold boards up to 12in long, is multi-positional and can revolve around 360°. The 'quick-release' trigger arm works by

spring tension which is adjusted by means of a knurled knob. The heavy die-cast base of the Work Holder incorporates two trays for holding components and other small parts.

A simple but very effective tool is the **Telpro Automatic Wire Stripper** which, with a one squeeze operation strips the insulation from single and stranded wires without damage. Its wide jaws permit fast and accurate stripping without any nicking or scraping of the wire and a gauge is supplied to ensure consistent lengths of stripping.

Two models are available: the AWS-1 will cut five diameters of wire: 1.0, 1.6, 2.0, 2.6, and 3.2mm., while the AWS-2 will cut four diameters, 0.5, 1.2, 1.6, and 2.00mm. It is priced at £5.00 plus £1.00 p&p and VAT.

The versatile **Velleman Light Computer** is available in kit form, priced at £31.50 plus £1.00 p&p and VAT.

The kit has eight programs stored in an EPROM, each of which can be selected by a switch. The largest consists of over one hundred steps, and each program will give a particular lighting effect via seven outputs, to which groups or festoons of lamps may be connected. Various configurations are available: running lights; forward and reverse; flip-flop function and specific advertising sign functions. The circuit can be adapted for use in discos, in educational applications, and to test security systems.

Specifications include a 24-240VDC lamp supply; 2 x 12VAC logic supply and a maximum triac output of 600W. Other features include user selectable programs in EPROM, adjustable speed and buffered outputs (emitter-follower). There is no limit on the number of circuits which may be connected together in cascade and synchronised. Similarly there is no limit on the number of controllable outputs.

For further information please contact: **Electronic & Computer Workshops Ltd., 171 Broomfield Road, Chelmsford, Essex CM1 1RY.** Tel: (0245) 262149.

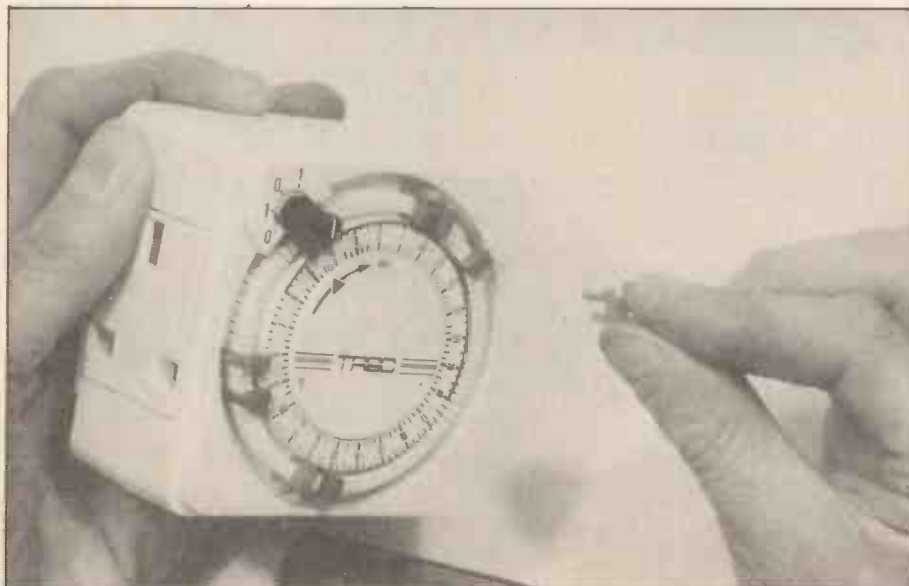



Take A Tip

New to the range of production soldering tools offered by Tele-Production Tools is a temperature controlled pencil iron designated the Thermomatic.

This new iron, which is rated at 24/50W, has a 'closed loop' electronic control system enclosed in the handle and is fully adjustable from 200° to 400°C. The Thermomatic, which may be used with any 24V power supply, has no moving parts and creates no magnetic or electrical interference whatsoever.

Safety features include burn-resistant silicon rubber lead, self-extinguishing polycarbonate handle and low operational voltage. A range of fourteen iron-clad long-life bits are available for use with the Thermomatic, which include screwdriver, chisel and conical shaped tips.

The average price of the Thermomatic is £14.00 exclusive of VAT.

For further details contact Tele-Production Tools Ltd., Stiron House, Electric Avenue, Westcliffe-on-Sea, Essex SS0 9NW. Tel: (0702) 352719.

Microelectronics Off The Shelf

The first packaged range of micro-electronic components to be sold exclusively through high street model and hobby shops have been announced by Micromate Ltd of Bedford.

Based on experience on the industrial side, the MicroMate range covers the most commonly used components, at prices from 30p to £5 per pack. The latter price is for a single chip, but many components will be packaged in stock box quantities. The range includes resistors, capacitors, optoelectronics, relays, switches, connectors and small specialist tools. All are packaged in clear plastic packs, so the contents can be clearly seen.

Where the range, which is extensive but basic, does not include some specifically needed component, shop-keepers can order it directly from MicroMate's stocklist of 2,000 components, all bought direct from the manufacturers, for ex-stock delivery. The bespoke service back-up to the off the peg trade also includes free advice from MicroMate, though, since the company intends to deal only through retail outlets, queries will have to be passed to them through the stockists, not sent direct.

At present, MicroMate offer only components but they are planning to develop the product range towards specific project kits, and ultimately may sponsor microelectronics design competitions to foster interest among modellers.



Glue Gun

A hotmelt Glue Gun from Steinel (UK) Ltd., called the Gluemate has been designed and engineered from scratch to overcome problems encountered with trigger operated glue guns.

The trigger action was specifically engineered to give more precise control over the glue feed, and has increased glue feed at the nozzle by up to 38% over existing trigger operated models. The gun incorporates a valve arrangement in the nozzle which ensures an even and continuous flow of glue, for fine assembly and filling and sealant jobs as well as for insulation, repairs, reinforcement, bonding and encapsulation.

At a RRP of £19.95 (including VAT), the Gluemate is for both hobbyist and professional craftsman.

The gun heats up rapidly, being ready for use in 3 to 4 minutes, and is supplied with a clip-on stand. The heater housing is double insulated and the choice of a self-regulating heater control system has eliminated the need for potentially unreliable mechanical thermostats. The Gluemate will operate off any mains voltage from 100 to 240 volts.

An inexpensive and versatile LED Voltage Tester, the Master Check-3, aimed at hobbyist and professional users alike, is now available. It is a two-terminal, hand-held instrument, which will measure AC and DC voltages in the range from 6V to 415V RMS, from an LED array display.

The unit is simple to use, due to its construction, comprising two probes connected by a cable, one of which contains the measurement electronics and display LEDs. This means that users keep their eyes on their hands, rather than looking at a separate meter. Surge rated voltage is 6kV and input impedance is from two to 50k Ω . PTC controlled, depending on the input voltage.

Applications for the Master Check-3 including battery testing, checking three phase motors, and the testing of domestic equipment and hobby projects. Frequency range is from 0 to 100Hz and peak current is 180mA at 380V.

For further information contact Steinel (UK) Ltd., 17, Reddick Trading Estate, Sutton Coldfield, West Midlands B75 7BU Tel: 021 378 2820.

Prize Games

Tomy, who make the Robo I robot arm (shortly to be the subject of a control/interface project incorporating the Sinclair Spectrum and other micros in *Digital and Micro Electronics*) have won the 1984 Electronic Games Arcade Award in the USA for their Tomytronic 3-D Sky Attack, which is, despite the reference to 'arcade' a hand-held game which uses parallel screens to set its space battle in three dimensions.

Don't be surprised if there is a heavy crop of 3-D games in the near future. HE

Mains Intercom

This two-way intercom system transmits through the mains wiring of the rooms where it is installed, is easy to set up and has no trailing wires between the stations.

R. A. Penfold

WHILE INTERCOMS using connecting wires between each unit are not yet extinct, over the years there has been a steady trend in favour of so called "wireless" intercoms where the signals are carried from one unit to another through the mains wiring.

Anyone who has installed an ordinary intercom, with two or three way cables trailing around the house, will appreciate the relative ease with which a "wireless" type intercom can be installed. But there are disadvantages in the use of a "wireless" system, the main one being the relatively high cost and complexity of the equipment, though for most users the ease which this type of intercom can be fitted and used more than compensates for these drawbacks.

This through-mains intercom is a simple two-station system which should provide good results when used between any two rooms of a house or other buildings. However, in common with other intercoms of this general type, it is not likely to give usable results with the two stations in separate buildings, except in the case of (say) a house and a shed or other outbuilding which share the same mains circuit.

This short range is, in fact, an essential feature since the equipment would otherwise almost certainly be illegal to use, and problems with interference from other intercoms would in many areas make the equipment unusable. Of course, for most purposes communications from one room to another, or between an outbuilding and the house, is all that is required from an intercom system.

System Operation

An ordinary intercom is basically just an amplifier plus two loudspeakers (one at each end of the system). A

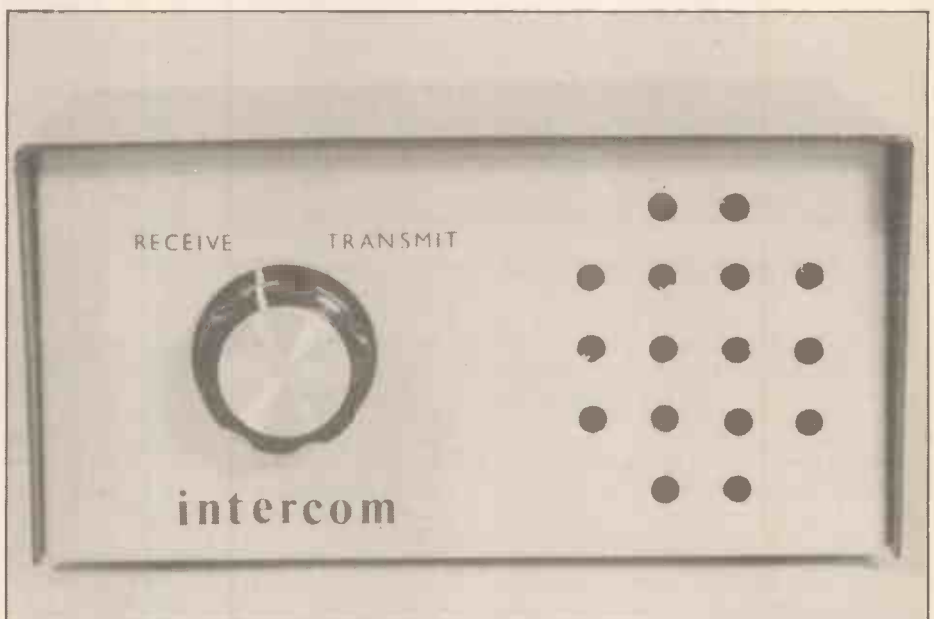

switch is used to control which loudspeaker is connected to the input of the amplifier (and operates in reverse as a sort of moving coil microphone), and which is fed from the output. This gives two way communications with the send/receive switching at one end of the system.

A simple arrangement of this type is not really suitable for a through-mains intercom. Here the signal is carried by the mains earth lead plus either the "L" or "N" lead. Most wireless intercoms, including this design, use the "N" lead to provide the second connection; it has the advantage of being at virtually the same potential as the earth lead, while with the "L" lead there is the full 240 volts AC mains voltage to contend with.

In the case of the "N" lead things are not totally straightforward since there is a low impedance from this lead to earth, and in most cases there

will also be a substantial amount of noise on this line. Simply coupling the output of an amplifier to the earth and "N" leads is not likely to give satisfactory results, and could be dangerous anyway.

The normal approach with this type of intercom is to use a low power frequency modulated carrier signal at about one or two hundred kilohertz. The use of frequency modulation helps to minimise problems with noise pick-up in the mains wiring (plus the inevitable mains "hum"), and enables a relatively loose (and safe) coupling to the mains supply to be utilized. Figure 1 shows in block diagram form the arrangement used in this intercom. Note that this is only one end of the system, and that two such units are required.

The transmitter is the more simple section of the unit, and this is comprised of a preamplifier, amplifier, and voltage controlled oscillator (VCO). The loudspeaker doubles as

Mains Intercom System

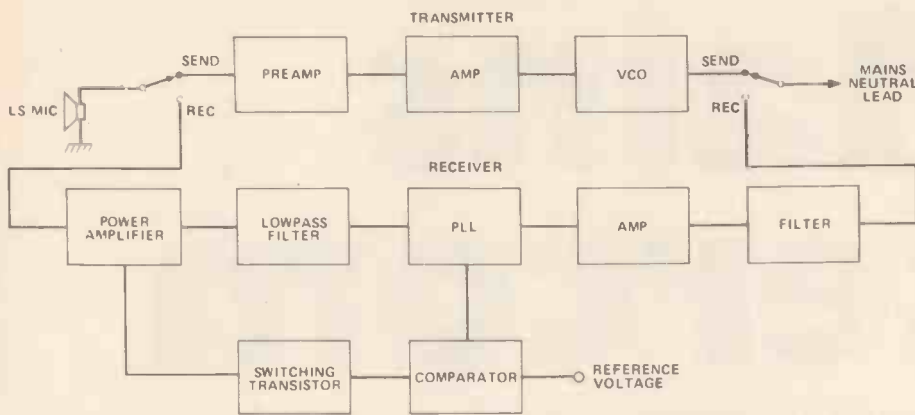

Figure 1. This block diagram shows the layout of the intercom station. Two of these units are needed.

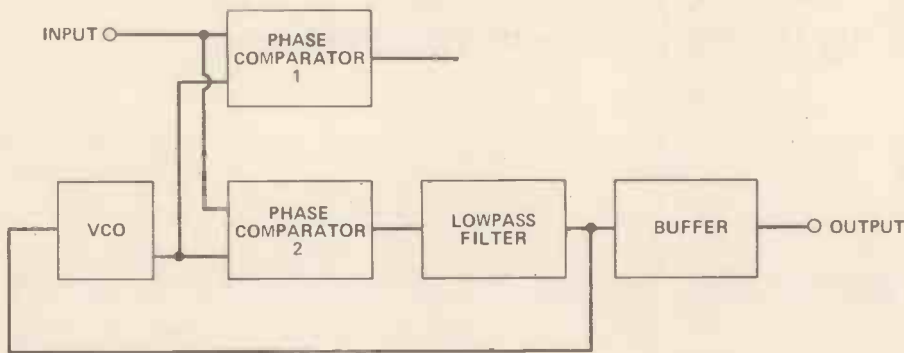

Figure 2. Block diagram of the phase locked loop which acts as the FM detector.

the microphone, as in a conventional intercom, and this provides a very low signal level of typically well under 1 millivolt RMS. Two stages of amplification are therefore needed in order to drive the VCO adequately.

The VCO itself is a simple C-R type; at the relatively low frequencies involved here an L-C oscillator is not needed.

The send/receive switch connects the loudspeaker to the transmitter or receiver circuit, as appropriate, and also connects the mains "N" lead to the appropriate section of the unit.

The receiver has an L-C bandpass

filter at the input, and this helps to reduce the noise content on the input signal. The output from the filter is at a reasonably high level (typically a few hundred millivolts), and a single stage of amplification is adequate to bring the signal to a high enough level to drive the next stage of the receiver.

This is a phase locked loop (PLL) which is used here primarily as an FM detector. This must convert the rises and falls in input frequency into corresponding variations in output voltage. The phase locked loop actually consists of a number of

stages in itself, and the block diagram of Figure 2 helps to explain the way in which this circuit functions.

If we ignore phase comparator 1 for the moment, the input signal is applied to one input of phase comparator 2. The other input of the comparator is fed from the output of a VCO. The control voltage for the latter is provided by the phase comparator by way of a lowpass filter which smooths out the rapid changes in voltage at the output of the comparator and gives a more suitable control voltage for the VCO.

The output from the phase comparator goes to a high voltage if the VCO frequency is lower than that of the input signal, or even if the VCO is slightly lagging in phase. This high control voltage raises the frequency of the VCO so that is brought in line with the input signal.

Conversely, if the VCO is at a higher frequency than the input signal, the output of the phase comparator goes to a low voltage and reduces the VCO's operating frequency.

Thus the VCO tracks the input signal, staying on the same frequency and in-phase with this signal, provided it remains within the locking range of the circuit and there are no very rapid frequency changes. In this case though, it is not the VCO signal that is of interest, but the control voltage. This rises and falls in sympathy with the input frequency, and provides the demodulated audio signal.

This signal is obtained via a buffer stage which ensures that excessive loading of the control voltage and a consequent malfunction is avoided. This arrangement may seem to be a rather complicated way of providing FM demodulation, but in practice phase locked loops provide excellent results, especially in an application such as this where the input signal is almost certain to be contaminated with a fair amount of noise.

The phase locked loop integrated circuit used in this design is the CMOS 4046BE, and an unusual feature of this device is the inclusion of two phase comparators. When phase comparator 1 is used, under no signal conditions the VCO goes to its centre frequency. With phase comparator 2 the VCO switches off in the absence of an input signal. In this application there is no discernable difference in performance provided by the two comparators.

If we return to the block diagram of Figure 1, the demodulated output of the PLL is fed to a lowpass filter. This helps to reduce background noise, and the restricted high frequency output of the unit is perfectly adequate for communications purposes. Finally, the signal is fed to a power amplifier and then to the loudspeaker.

Some additional circuitry is needed to provide a squelch action, as the circuit otherwise provides a very loud noise output in the absence of a



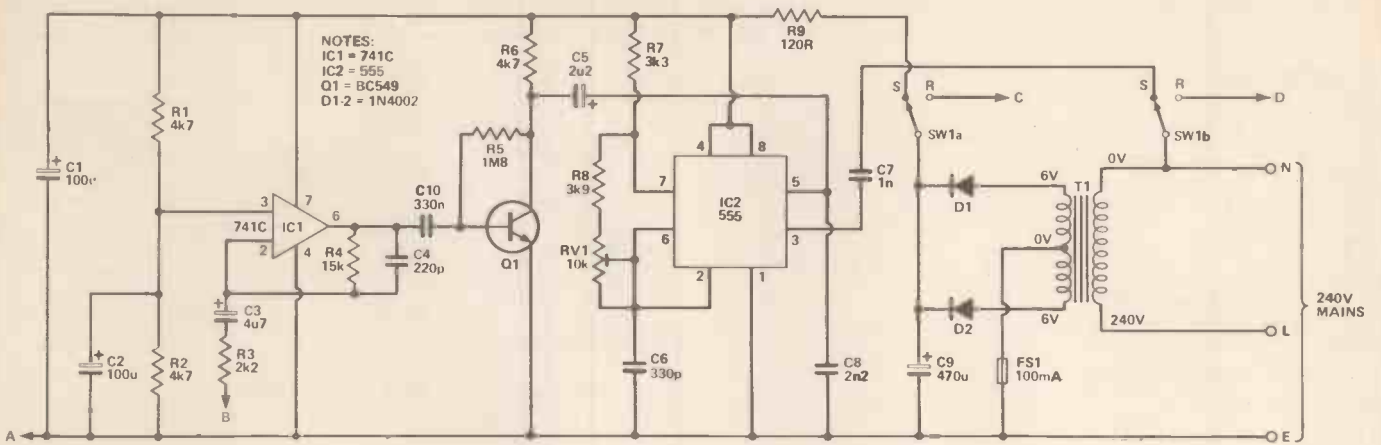

Figure 3. The circuit of the transmitter section of the intercom stations.

proper input signal.

The DC output from the PLL rises significantly in the presence of a proper input signal, and this is detected by a voltage comparator which then turns off a switching transistor. Under stand-by conditions this transistor is used to feed a DC bias to the power amplifier which prevents it from operating properly and blocks the audio (noise) output.

Transmitter Circuit

Figure 3 shows the circuit diagram for the transmitter section of the unit.

The preamplifier is a simple operational amplifier inverting mode circuit. This has only a modest amount of voltage gain (about seven times), but this can be boosted if necessary by raising the value of R4. However, in general it is best to have slightly too little gain rather than a bit too much, as this gives better intelligibility. Q1 is a common emitter amplifier and this provides most of the circuit's audio gain.

A 555 astable is used as the VCO, as it has the advantage, over most of the alternatives, of low cost and a strong output. The output is loosely coupled to the mains "N" lead by C7. RV1 enables the output frequency to be adjusted to a suitable range from the receiver circuit; the operating frequency is around 200kHz.

It is quite easy to frequency modulate a 555 astable, and the modulation signal is simply applied to pin 5 of the device. The circuit oscillates by first charging C6 to two thirds of the supply voltage, then discharging it to one third of the supply potential, then charging it again, and so on.

The modulation voltage fed to pin 5 merely modified the two thirds of V+ threshold level. Raising this level results in C6 having to charge and discharge for a longer period of time on each cycle, and reduces the output frequency. Reducing the threshold voltage reduces the charge and discharge times of C6 and gives increased output frequency.

Although this is only a rather crude way of generating an FM signal, it actually works quite well in practice

and is more than adequate for this application.

The power supply is a simple non-stabilised type which uses fullwave (push-pull) rectification; it is used to power both the transmitter and receiver circuits. R9 and C1 give additional smoothing to the transmitter supply. SW1a is used to cut off power from the transmitter when the unit is in the "receive" mode, so that the transmitter does not produce interference and reduce the quality of the received signal.

Receiver Circuit

The receiver circuit appears in Figure 4. C11 couples the signal from the "N" main lines to the primary winding of T2. This is actually a 455kHz IF transformer used in reverse to act as a step-up transformer and bandpass filter.

C12 shunts the internal tuning capacitor of T2 and reduces the resonant frequency to about 200kHz. The adjustable core of T2 is used to set the input filter for peak

Figure 4. The circuit of the receiver station. The coupling to the neutral line is via T2, which acts as a step-up transformer and bandpass filter.

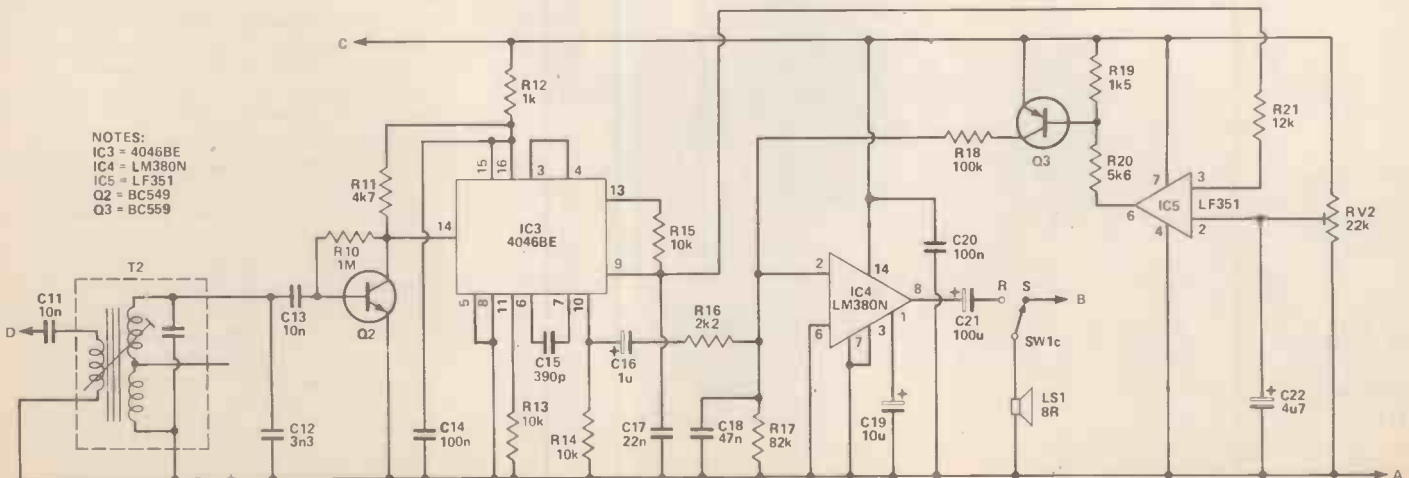

Parts List

RESISTORS

(All 1/4 watt 5%)

| | |
|--------------|------|
| R1, 2, 6, 11 | 4k7 |
| R3, 16 | 2k2 |
| R4 | 15k |
| R5 | 1M8 |
| R7 | 3k3 |
| R8 | 3k9 |
| R9 | 120R |
| R10 | 1M |
| R12 | 1k |
| R13, 14, 15 | 10K |
| R17 | 82k |
| R18 | 100k |
| R19 | 1k5 |
| R20 | 5k6 |
| R21 | 12k |

POTENTIOMETERS

| | |
|-----|------------------------------|
| RV1 | 10k 0.1 watt horiz preset |
| RV2 | 22k 0.1 watt horiz preset |

CAPACITORS

| | |
|-----------|-----------------------------|
| C1, 2, 21 | 100u, 10V radial electro |
| C3, 22 | 4u7 63V radial electro |
| C4 | 220p ceramic plate |
| C5 | 2u2 63V radial electro |

| | |
|---------|----------------------------|
| C6 | 330p ceramic plate |
| C7 | 1n carbonate |
| C8 | 2n2 carbonate |
| C9 | 470u 10V radial electro |
| C10 | 330n carbonate |
| C11, 13 | 10n polyester |
| C12 | 3n3 carbonate |
| C14, 20 | 100n ceramic |
| C15 | 390p ceramic plate |
| C16 | 1u 63V radial electro |
| C17 | 22n polyester |
| C18 | 47n carbonate |
| C19 | 10u 25V radial electro |

SEMICONDUCTORS

| | |
|-----|----------------|
| IC1 | 741C op-amp |
| IC2 | 555 timer |

| | |
|-------|------------------------------|
| IC3 | 4046BE phase locked loop |
| IC4 | LM380N audio power amp |
| IC5 | LF351 bifet op-amp |
| Q1, 2 | BC549 NPN silicon |
| Q3 | BC559 PNP silicon |
| D1, 2 | 1N4002 1A 100V rectifiers |

MISCELLANEOUS

| | |
|-----|--------------------------------------|
| T1 | 6V-0V-6V 100mA mains transformer |
| T2 | Toko YHCS11100 455kHz last IFT |
| SW1 | 3-way 4-pole rotary with end stop |
| LS1 | 8 ohm 66mm (approx.) loudspeaker |
| FS1 | 20mm 500mA quick blow |

Case, about 150 x 100 x 75mm;
printed circuit board; control knob;
20mm chassis mounting fuse-
holder; mains lead, wire, 6BA
fixings, etc.

Note that the above list is for one unit only.

BUYLINES page 26

performance.

The output from T2 is at a fairly high level, being a couple of hundred millivolts RMS or so, but phased locked loop IC3 requires standard 5 volt logic input levels. Q2 is therefore used as a common emitter amplifier which clips the input signal and provide a suitable signal for IC3.

IC3 has a built-in 5.4 volt zener diode, and in conjunction with load resistor R12 this is used to provide a stabilised supply for both Q2 and the phase locked looped circuit.

R13 and C15 are the timing

components for IC3's VCO. R15 plus C17 form the lowpass filter, and R14 is the discrete load resistor for the source follower buffer stage at the output of the device.

The audio output is coupled by C16 to the lowpass filter which is comprised of R16 and C18, after which the signal passes to the input of a power amplifier based on the ever-popular LM380. This drives the loudspeaker via DC blocking capacitor C21 and one pole of the send/receive switch (SW1). The squelch circuit uses IC5 as the voltage comparator,

and Q5 as the switching transistor.

Q3 is normally switched on so that a strong DC bias is provided to the input of the power amplifier by way of R18. This drives the output of IC4 fully positive and prevents any audio output from being produced.

When a proper input signal is present the voltage at pin 9 of IC3 increases, sending the output of IC5 high, switching off Q3, and permitting the audio amplifier to operate normally. RV2 is adjusted to give a satisfactory reference voltage at the inverting input of IC5.

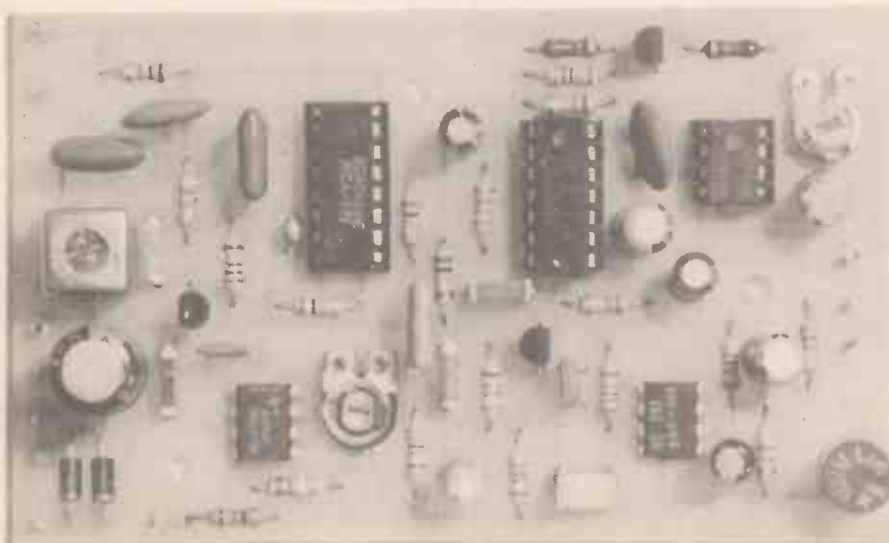

Construction

Details of the printed circuit and wiring are provided in Figure 5.

In most respects construction of the board is perfectly straightforward, but in order to get all the components to fit onto the board properly it is essential to use the miniature printed circuit mounting capacities specified in the components list.

IC3 is a CMOS device and it should be fitted in a 16 pin DIL IC socket. The other normal antistatic handling precautions should also be observed. Be careful to fit the semiconductors the right way round, especially IC2, which has the opposite orientation to the other four integrated circuits. Veropins are used at points where connections to T1, SW1, and LS1 will be made.

A metal case having approximate

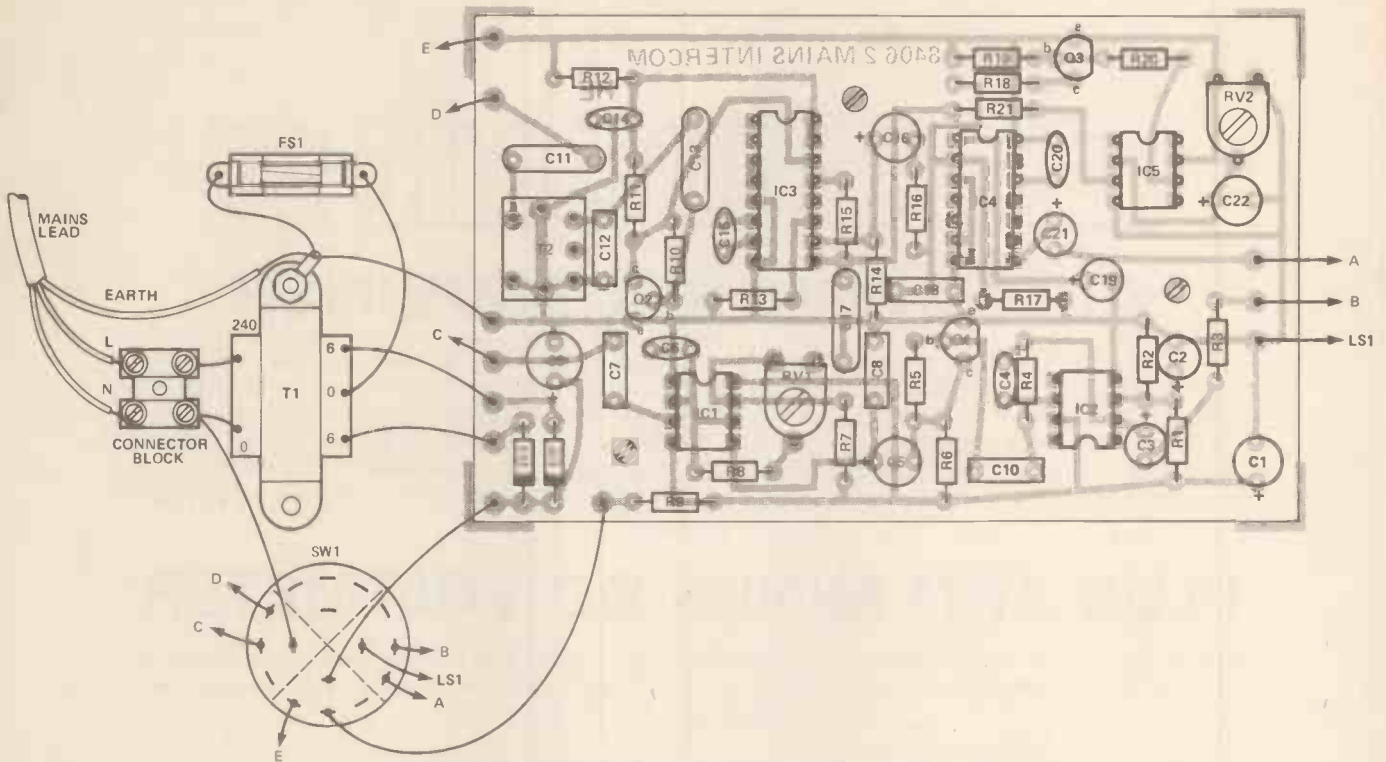

Figure 5. The component layout. Apart from the normal caution with CMOS devices and component orientation, care should be taken to use the correct miniature circuit-mounting components where specified, or the components will not fit the board.

dimensions of 150 by 100 by 75mm is just about adequate to accommodate all the components. SW1 is fitted on the left hand section of the front panel, and LS1 is mounted on the extreme right hand end of the panel.

A 4-pole 3-way rotary switch (with the end stop set for 2-way operation) is the least expensive type to use for SW1, but an alternative such as a multipole changeover toggle type can be used if preferred.

A speaker grille is then required, but this can just consist of a matrix of holes about 5mm in diameter drilled in the front panel. With most miniature loudspeakers there is no provision for screw fixing, and LS1 will need to be glued in position on the front panel.

T1 and the holder for FS1 are mounted at the left hand end of the chassis, leaving sufficient space for the component panel on the right hand section of the chassis. A soldertag on one of T1's mounting bolts provides a chassis connection point.

Note that it is essential for T1 and LS1 to be mounted as far apart as possible, since LS1 (when used as a microphone) will otherwise pick-up strong mains "hum" from T1.

The component panel is mounted using 6BA fixings, including spacers about 6mm long to keep the connections on its underside away from the metal chassis. A hole for the mains lead is drilled in the rear panel of the case, and this should be fitted with a grommet to protect the

cable.

Finally, the hard wiring is added using ordinary multistrand connecting wire. Most small mains transformers have flying leads rather than tags, and a two-way connector block is then used to connect the mains lead to the primary winding of T1. These are normally sold in twelve way blocks, but a two way section is easily cut from one of these using a sharp knife.

As the mains supply is involved be careful to avoid wiring errors, and thoroughly check the wiring before fitting the mains plug and connecting

the unit to the mains supply.

Adjustment

Start with RV1 and RV2, set with their wipers at roughly the centre of their tracks. With one unit set to transmit and the other set to receive it is likely that the system will provide communications, but if not, adjustment of RV1 at the transmitter should rectify matters.

RV1 and T2 are then adjusted to optimise results, and the setting of T2's core will probably not be critical. Carry out the final adjustment with the units in separate rooms (to avoid "howl around"), and use a helper or (say) a radio set to provide sounds for the transmitter. Of course, this procedure must then be repeated with the roles of the two units reversed.

With one unit set to receive and no proper input signal present, adjusting RV2 well in a clockwise direction should result in loud noise emanating from the loudspeaker. If RV2 is set just far enough in a clockwise direction to eliminate the noise, a good squelch action should be obtained. This adjustment should then be repeated for the second station.

In use SW1 must, of course, be left in the "receive" position on both units. For one station to call the other it is merely necessary for the caller to set his or her unit to "transmit" and speak into the microphone ("Mr Watson, come here. I want you.").

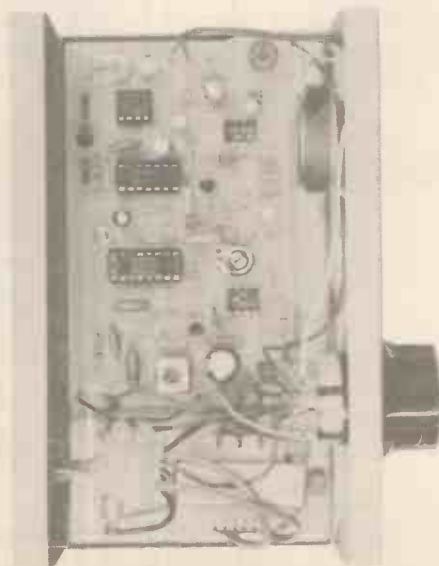

COMING SOON TO . . .

Hobby Electronics

AUDIO CONTROL AMPLIFIER

As part of our complete stereo preamplifier project (which began with the Power Supply Unit in February of this year) we present our audio control amp. The very highest of fi, this amplifier has several unusual features, including a width control, electronic switching, and a middle range tone control. It can be built into other modular amplifier designs (as can the PSU) as well as the HE system. And it's stereo. The designer rejected several high-specification commercial preamps in favour of designing and building this one, so don't miss it if you're into audio.

PLUS AND MINUS DC VOLTMETER

This is a low-cost \pm DC Voltmeter, straightforward to build and useful, which will measure plus and minus volts without altering the lead configuration. An ideal 'O' level project, with a practical application.

MAPLIGHT DIMMER

The latest in in-car accessories is a handy, automatic maplight for night-time navigation: but if you're reading for more than a few minutes, the lamp light gets mighty warm. And the driver complains about the distraction. What do you do? Dim the light — and cool it. And it's very small and easy.

ALL ABOUT ELECTRONICS

The twelfth and final episode of our long-running beginners' series looks at the future of television and radio communications techniques, among other things of interest to everyone in electronics.

SOFT OPTIONS — SOFTWARE FOR THE REAL WORLD

The second issue of Soft Options gets among the media with an interview with the Saturday Show's computer man, Chris Palmer, and other people involved in the show's live computer slot. And we look at the rise of one of educational computing's most respected small software companies.

Please reserve me copies of the July issue of

**Hobby
Electronics**

for
Name

Address

.

.



**Hobby
Electronics**

July issue on sale
at you newsagent
from 8th June.
Place your order
now!

Although these articles are being prepared for the next issue, circumstances may alter the final content.

FEEL HEALTHIER WITH ZEPHION

Bring fresh clean air into your home with the Zephion Air Ioniser.



Air free from smoke, dust and other pollutants of modern day living can bring to many the relief of breathing comfortably once again.

We are confident that you will be delighted with the Zephion Air Ioniser, but if you are not entirely satisfied a full money back guarantee is available if items are returned in good condition within 28 days.

BUILD IT YOURSELF!

TO:- Dataplus Developments
81, Cholmeley road
Reading, Berks.
RG1 3LY TEL:- 0734 67027

NAME:-
ADDRESS:-

clip the coupon ✂

ZEPHION KITS @ £24.15p
(Kits include all parts)

ZEPHION AIR TONERS
BUILT AND TESTED. @ £34.50p

Money immediately refunded if items returned in good condition.

Prices include VAT & postage; allow 14 days for delivery. DATAPLUS.HÉ

Send for my CATALOGUE ONLY 75p (plus 25p post/packing)

My all-inclusive prices quoted in the Catalogue are the lowest. All below normal trade price — some at only one tenth of manufacturers quantity trade.

Millions of components : thousands of different lines

Rechargeable Nickel Cadmium batteries (ex unused equipment)
AA(HP7) 1.25volt 500ma. Set of four £2
I.T.T. Mercury Wetted relay 20-60 VDC Coil. SPC0. 2A 79p or 10 for £7
Clear L.E.D. illuminates Red, Green or Yellow depending upon polarity/current.
Oblong 5 x 2½mm Face 25p or 100 for £23 or 1000 for £200
5mm Red Flashing L.E.D. 25p or 10 for £2.25

Watch/Calculator/Lighter etc, Mercury batteries
RW52(PX675) RW54 Made by Ray-O-VAC
RW56 (DH323,WH8) 31p each or
RW57, RW58 10 for £2.60, 100 for £21

IN4004 or IN4006 Diodes. 300 for £6.48p
TO5 or TO18 Heatsinks 7½p, 100 for £6.50, 1000 for £55
Clipover Heatsink for I/C or TO202 device 21 x 18mm
18p or 100 for £16.50 or 1000 for £155
Heatsink for TO3 or Plastic Power 19p, 100/£17.50, 1000/£165
Modern Telephone Handset and lead in white, red, blue, grey, yellow, green or black £2
Plessey SG403. 3 Watt amp. From bankrupt source, hence sold as untested, at 4 for 60p or 10 for £1.20p.

SEND PAYMENT PLUS 16p SAE OR LABEL

Prices you would not believe before inflation!

BRIAN J. REED

TRADE COMPONENTS
ESTABLISHED 27 YEARS

161 St. Johns Hill, Battersea, London SW11 1TQ
Open 11 am till 6.30pm Tues. to Sat. Telephone: 01-223 5016

TOROIDALS

The toroidal transformer is now accepted as the standard in industry, overtaking the obsolete laminated type. Industry has been quick to recognise the advantages toroidals offer in size, weight, lower radiated field and, thanks to I.L.P., PRICE.

Our large standard range is complemented by our SPECIAL DESIGN section which can offer a prototype service within 14 DAYS together with a short lead time on quantity orders which can be programmed to your requirements with no price penalty.

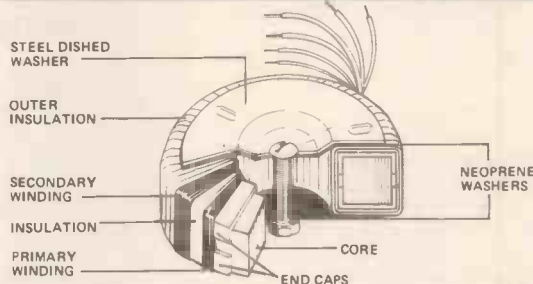

| 15 VA 62 x 34mm 0.35Kg Regulation 19% | 50 VA 80 x 35mm 0.9Kg Regulation 13% | 120 VA 90 x 40mm 1.2Kg Regulation 11% | 225 VA 110 x 45mm 2.2Kg Regulation 7% | 500 VA 140 x 60mm 4Kg Regulation 4% | | | | | | | | | | | | | | | | | | | | | | | | | | | | | | | | | | | | | | | | | | | | | | | | | | | | | | | | | | | | | | | | | | | | | | | | | | | | | | | | | | | | | | | | | | | | | | | | | | | | | | | | | | | | | | | | | | | | | | | | | | | | | | | | | | | | | | | | | | | | | | | | | | | | | | | | | | | | | | |
|--|--|---|---|---|----|-------|-------|--|-------|-----|------|--|-------|-----|------|--|-------|-------|------|--|-------|-------|------|--|-------|-------|------|--|-------|-------|------|--|-------|-------|------|--|-------|-------|------|--|---|-------|-------|--------|-------|-------|-------|-----------|-----------|------------|--------|-----|-------|----------------|----------------|---------------|-------|-----|------|-------|-----|------|-------|-------|------|-------|-------|------|-------|-------|------|-------|-------|------|-------|-------|------|-------|-------|------|-------|-----|------|-------|-----|------|-------|-----|------|--|------------|--------|-------|---------------|-------|-------|-------|-------|-------|------|-------|-------|------|-------|-------|------|-------|-------|------|-------|-------|------|-------|-------|------|-------|-------|------|-------|-------|------|-------|-----|------|-------|-----|------|-------|-----|------|---|--------|------------|-----|---------------|-------|-------|-------|-------|-------|------|-------|-------|------|-------|-------|------|-------|-------|------|-------|-------|------|-------|-----|------|-------|-----|------|-------|-----|------|
| <table border="1"> <thead> <tr> <th>SERIES</th> <th>SECONDARY</th> <th>RMS</th> <th>Current</th> </tr> <tr> <th>No</th> <th>Volts</th> <th>Volts</th> <th></th> </tr> </thead> <tbody> <tr><td>0x010</td><td>6+6</td><td>1.25</td><td></td></tr> <tr><td>0x011</td><td>9+9</td><td>0.83</td><td></td></tr> <tr><td>0x012</td><td>12+12</td><td>0.63</td><td></td></tr> <tr><td>0x013</td><td>15+15</td><td>0.50</td><td></td></tr> <tr><td>0x014</td><td>18+18</td><td>0.42</td><td></td></tr> <tr><td>0x015</td><td>22+22</td><td>0.34</td><td></td></tr> <tr><td>0x016</td><td>25+25</td><td>0.30</td><td></td></tr> <tr><td>0x017</td><td>30+30</td><td>0.25</td><td></td></tr> </tbody> </table> <p>(encased in ABS plastic)</p> | SERIES | SECONDARY | RMS | Current | No | Volts | Volts | | 0x010 | 6+6 | 1.25 | | 0x011 | 9+9 | 0.83 | | 0x012 | 12+12 | 0.63 | | 0x013 | 15+15 | 0.50 | | 0x014 | 18+18 | 0.42 | | 0x015 | 22+22 | 0.34 | | 0x016 | 25+25 | 0.30 | | 0x017 | 30+30 | 0.25 | | <table border="1"> <thead> <tr> <th>80 VA</th> <th>90 VA</th> <th>160 VA</th> </tr> <tr> <th>30 VA</th> <th>30 VA</th> <th>40 VA</th> </tr> <tr> <th>70 x 30mm</th> <th>90 x 30mm</th> <th>110 x 40mm</th> </tr> <tr> <th>0.45Kg</th> <th>1Kg</th> <th>1.8Kg</th> </tr> <tr> <th>Regulation 18%</th> <th>Regulation 12%</th> <th>Regulation 8%</th> </tr> </thead> <tbody> <tr><td>3x010</td><td>6+6</td><td>6.64</td></tr> <tr><td>3x011</td><td>9+9</td><td>4.44</td></tr> <tr><td>3x012</td><td>12+12</td><td>3.33</td></tr> <tr><td>3x013</td><td>15+15</td><td>2.66</td></tr> <tr><td>3x014</td><td>18+18</td><td>2.22</td></tr> <tr><td>3x015</td><td>22+22</td><td>1.81</td></tr> <tr><td>3x016</td><td>25+25</td><td>1.60</td></tr> <tr><td>3x017</td><td>30+30</td><td>1.33</td></tr> <tr><td>3x028</td><td>110</td><td>0.72</td></tr> <tr><td>3x029</td><td>220</td><td>0.36</td></tr> <tr><td>3x030</td><td>240</td><td>0.33</td></tr> </tbody> </table> | 80 VA | 90 VA | 160 VA | 30 VA | 30 VA | 40 VA | 70 x 30mm | 90 x 30mm | 110 x 40mm | 0.45Kg | 1Kg | 1.8Kg | Regulation 18% | Regulation 12% | Regulation 8% | 3x010 | 6+6 | 6.64 | 3x011 | 9+9 | 4.44 | 3x012 | 12+12 | 3.33 | 3x013 | 15+15 | 2.66 | 3x014 | 18+18 | 2.22 | 3x015 | 22+22 | 1.81 | 3x016 | 25+25 | 1.60 | 3x017 | 30+30 | 1.33 | 3x028 | 110 | 0.72 | 3x029 | 220 | 0.36 | 3x030 | 240 | 0.33 | <table border="1"> <thead> <tr> <th>110 x 50mm</th> <th>300 VA</th> </tr> <tr> <th>2.6Kg</th> <th>Regulation 6%</th> </tr> </thead> <tbody> <tr><td>7x013</td><td>15+15</td><td>10.00</td></tr> <tr><td>7x014</td><td>18+18</td><td>8.33</td></tr> <tr><td>7x015</td><td>22+22</td><td>6.82</td></tr> <tr><td>7x016</td><td>25+25</td><td>6.00</td></tr> <tr><td>7x017</td><td>30+30</td><td>5.00</td></tr> <tr><td>7x018</td><td>35+35</td><td>4.28</td></tr> <tr><td>7x026</td><td>40+40</td><td>3.75</td></tr> <tr><td>7x025</td><td>45+45</td><td>3.33</td></tr> <tr><td>7x033</td><td>50+50</td><td>3.00</td></tr> <tr><td>7x028</td><td>110</td><td>2.72</td></tr> <tr><td>7x029</td><td>220</td><td>1.36</td></tr> <tr><td>7x030</td><td>240</td><td>1.25</td></tr> </tbody> </table> | 110 x 50mm | 300 VA | 2.6Kg | Regulation 6% | 7x013 | 15+15 | 10.00 | 7x014 | 18+18 | 8.33 | 7x015 | 22+22 | 6.82 | 7x016 | 25+25 | 6.00 | 7x017 | 30+30 | 5.00 | 7x018 | 35+35 | 4.28 | 7x026 | 40+40 | 3.75 | 7x025 | 45+45 | 3.33 | 7x033 | 50+50 | 3.00 | 7x028 | 110 | 2.72 | 7x029 | 220 | 1.36 | 7x030 | 240 | 1.25 | <table border="1"> <thead> <tr> <th>625 VA</th> <th>140 x 75mm</th> </tr> <tr> <th>5Kg</th> <th>Regulation 4%</th> </tr> </thead> <tbody> <tr><td>9x017</td><td>30-30</td><td>10.41</td></tr> <tr><td>9x018</td><td>35-35</td><td>8.92</td></tr> <tr><td>9x026</td><td>40-40</td><td>7.81</td></tr> <tr><td>9x025</td><td>45-45</td><td>6.94</td></tr> <tr><td>9x033</td><td>50-50</td><td>6.25</td></tr> <tr><td>9x042</td><td>55-55</td><td>5.68</td></tr> <tr><td>9x028</td><td>110</td><td>5.68</td></tr> <tr><td>9x029</td><td>220</td><td>2.84</td></tr> <tr><td>9x030</td><td>240</td><td>2.60</td></tr> </tbody> </table> | 625 VA | 140 x 75mm | 5Kg | Regulation 4% | 9x017 | 30-30 | 10.41 | 9x018 | 35-35 | 8.92 | 9x026 | 40-40 | 7.81 | 9x025 | 45-45 | 6.94 | 9x033 | 50-50 | 6.25 | 9x042 | 55-55 | 5.68 | 9x028 | 110 | 5.68 | 9x029 | 220 | 2.84 | 9x030 | 240 | 2.60 |
| SERIES | SECONDARY | RMS | Current | | | | | | | | | | | | | | | | | | | | | | | | | | | | | | | | | | | | | | | | | | | | | | | | | | | | | | | | | | | | | | | | | | | | | | | | | | | | | | | | | | | | | | | | | | | | | | | | | | | | | | | | | | | | | | | | | | | | | | | | | | | | | | | | | | | | | | | | | | | | | | | | | | | | | | | | | | | | | | | |
| No | Volts | Volts | | | | | | | | | | | | | | | | | | | | | | | | | | | | | | | | | | | | | | | | | | | | | | | | | | | | | | | | | | | | | | | | | | | | | | | | | | | | | | | | | | | | | | | | | | | | | | | | | | | | | | | | | | | | | | | | | | | | | | | | | | | | | | | | | | | | | | | | | | | | | | | | | | | | | | | | | | | | | | | | |
| 0x010 | 6+6 | 1.25 | | | | | | | | | | | | | | | | | | | | | | | | | | | | | | | | | | | | | | | | | | | | | | | | | | | | | | | | | | | | | | | | | | | | | | | | | | | | | | | | | | | | | | | | | | | | | | | | | | | | | | | | | | | | | | | | | | | | | | | | | | | | | | | | | | | | | | | | | | | | | | | | | | | | | | | | | | | | | | | | |
| 0x011 | 9+9 | 0.83 | | | | | | | | | | | | | | | | | | | | | | | | | | | | | | | | | | | | | | | | | | | | | | | | | | | | | | | | | | | | | | | | | | | | | | | | | | | | | | | | | | | | | | | | | | | | | | | | | | | | | | | | | | | | | | | | | | | | | | | | | | | | | | | | | | | | | | | | | | | | | | | | | | | | | | | | | | | | | | | | |
| 0x012 | 12+12 | 0.63 | | | | | | | | | | | | | | | | | | | | | | | | | | | | | | | | | | | | | | | | | | | | | | | | | | | | | | | | | | | | | | | | | | | | | | | | | | | | | | | | | | | | | | | | | | | | | | | | | | | | | | | | | | | | | | | | | | | | | | | | | | | | | | | | | | | | | | | | | | | | | | | | | | | | | | | | | | | | | | | | |
| 0x013 | 15+15 | 0.50 | | | | | | | | | | | | | | | | | | | | | | | | | | | | | | | | | | | | | | | | | | | | | | | | | | | | | | | | | | | | | | | | | | | | | | | | | | | | | | | | | | | | | | | | | | | | | | | | | | | | | | | | | | | | | | | | | | | | | | | | | | | | | | | | | | | | | | | | | | | | | | | | | | | | | | | | | | | | | | | | |
| 0x014 | 18+18 | 0.42 | | | | | | | | | | | | | | | | | | | | | | | | | | | | | | | | | | | | | | | | | | | | | | | | | | | | | | | | | | | | | | | | | | | | | | | | | | | | | | | | | | | | | | | | | | | | | | | | | | | | | | | | | | | | | | | | | | | | | | | | | | | | | | | | | | | | | | | | | | | | | | | | | | | | | | | | | | | | | | | | |
| 0x015 | 22+22 | 0.34 | | | | | | | | | | | | | | | | | | | | | | | | | | | | | | | | | | | | | | | | | | | | | | | | | | | | | | | | | | | | | | | | | | | | | | | | | | | | | | | | | | | | | | | | | | | | | | | | | | | | | | | | | | | | | | | | | | | | | | | | | | | | | | | | | | | | | | | | | | | | | | | | | | | | | | | | | | | | | | | | |
| 0x016 | 25+25 | 0.30 | | | | | | | | | | | | | | | | | | | | | | | | | | | | | | | | | | | | | | | | | | | | | | | | | | | | | | | | | | | | | | | | | | | | | | | | | | | | | | | | | | | | | | | | | | | | | | | | | | | | | | | | | | | | | | | | | | | | | | | | | | | | | | | | | | | | | | | | | | | | | | | | | | | | | | | | | | | | | | | | |
| 0x017 | 30+30 | 0.25 | | | | | | | | | | | | | | | | | | | | | | | | | | | | | | | | | | | | | | | | | | | | | | | | | | | | | | | | | | | | | | | | | | | | | | | | | | | | | | | | | | | | | | | | | | | | | | | | | | | | | | | | | | | | | | | | | | | | | | | | | | | | | | | | | | | | | | | | | | | | | | | | | | | | | | | | | | | | | | | | |
| 80 VA | 90 VA | 160 VA | | | | | | | | | | | | | | | | | | | | | | | | | | | | | | | | | | | | | | | | | | | | | | | | | | | | | | | | | | | | | | | | | | | | | | | | | | | | | | | | | | | | | | | | | | | | | | | | | | | | | | | | | | | | | | | | | | | | | | | | | | | | | | | | | | | | | | | | | | | | | | | | | | | | | | | | | | | | | | | | |
| 30 VA | 30 VA | 40 VA | | | | | | | | | | | | | | | | | | | | | | | | | | | | | | | | | | | | | | | | | | | | | | | | | | | | | | | | | | | | | | | | | | | | | | | | | | | | | | | | | | | | | | | | | | | | | | | | | | | | | | | | | | | | | | | | | | | | | | | | | | | | | | | | | | | | | | | | | | | | | | | | | | | | | | | | | | | | | | | | |
| 70 x 30mm | 90 x 30mm | 110 x 40mm | | | | | | | | | | | | | | | | | | | | | | | | | | | | | | | | | | | | | | | | | | | | | | | | | | | | | | | | | | | | | | | | | | | | | | | | | | | | | | | | | | | | | | | | | | | | | | | | | | | | | | | | | | | | | | | | | | | | | | | | | | | | | | | | | | | | | | | | | | | | | | | | | | | | | | | | | | | | | | | | |
| 0.45Kg | 1Kg | 1.8Kg | | | | | | | | | | | | | | | | | | | | | | | | | | | | | | | | | | | | | | | | | | | | | | | | | | | | | | | | | | | | | | | | | | | | | | | | | | | | | | | | | | | | | | | | | | | | | | | | | | | | | | | | | | | | | | | | | | | | | | | | | | | | | | | | | | | | | | | | | | | | | | | | | | | | | | | | | | | | | | | | |
| Regulation 18% | Regulation 12% | Regulation 8% | | | | | | | | | | | | | | | | | | | | | | | | | | | | | | | | | | | | | | | | | | | | | | | | | | | | | | | | | | | | | | | | | | | | | | | | | | | | | | | | | | | | | | | | | | | | | | | | | | | | | | | | | | | | | | | | | | | | | | | | | | | | | | | | | | | | | | | | | | | | | | | | | | | | | | | | | | | | | | | | |
| 3x010 | 6+6 | 6.64 | | | | | | | | | | | | | | | | | | | | | | | | | | | | | | | | | | | | | | | | | | | | | | | | | | | | | | | | | | | | | | | | | | | | | | | | | | | | | | | | | | | | | | | | | | | | | | | | | | | | | | | | | | | | | | | | | | | | | | | | | | | | | | | | | | | | | | | | | | | | | | | | | | | | | | | | | | | | | | | | |
| 3x011 | 9+9 | 4.44 | | | | | | | | | | | | | | | | | | | | | | | | | | | | | | | | | | | | | | | | | | | | | | | | | | | | | | | | | | | | | | | | | | | | | | | | | | | | | | | | | | | | | | | | | | | | | | | | | | | | | | | | | | | | | | | | | | | | | | | | | | | | | | | | | | | | | | | | | | | | | | | | | | | | | | | | | | | | | | | | |
| 3x012 | 12+12 | 3.33 | | | | | | | | | | | | | | | | | | | | | | | | | | | | | | | | | | | | | | | | | | | | | | | | | | | | | | | | | | | | | | | | | | | | | | | | | | | | | | | | | | | | | | | | | | | | | | | | | | | | | | | | | | | | | | | | | | | | | | | | | | | | | | | | | | | | | | | | | | | | | | | | | | | | | | | | | | | | | | | | |
| 3x013 | 15+15 | 2.66 | | | | | | | | | | | | | | | | | | | | | | | | | | | | | | | | | | | | | | | | | | | | | | | | | | | | | | | | | | | | | | | | | | | | | | | | | | | | | | | | | | | | | | | | | | | | | | | | | | | | | | | | | | | | | | | | | | | | | | | | | | | | | | | | | | | | | | | | | | | | | | | | | | | | | | | | | | | | | | | | |
| 3x014 | 18+18 | 2.22 | | | | | | | | | | | | | | | | | | | | | | | | | | | | | | | | | | | | | | | | | | | | | | | | | | | | | | | | | | | | | | | | | | | | | | | | | | | | | | | | | | | | | | | | | | | | | | | | | | | | | | | | | | | | | | | | | | | | | | | | | | | | | | | | | | | | | | | | | | | | | | | | | | | | | | | | | | | | | | | | |
| 3x015 | 22+22 | 1.81 | | | | | | | | | | | | | | | | | | | | | | | | | | | | | | | | | | | | | | | | | | | | | | | | | | | | | | | | | | | | | | | | | | | | | | | | | | | | | | | | | | | | | | | | | | | | | | | | | | | | | | | | | | | | | | | | | | | | | | | | | | | | | | | | | | | | | | | | | | | | | | | | | | | | | | | | | | | | | | | | |
| 3x016 | 25+25 | 1.60 | | | | | | | | | | | | | | | | | | | | | | | | | | | | | | | | | | | | | | | | | | | | | | | | | | | | | | | | | | | | | | | | | | | | | | | | | | | | | | | | | | | | | | | | | | | | | | | | | | | | | | | | | | | | | | | | | | | | | | | | | | | | | | | | | | | | | | | | | | | | | | | | | | | | | | | | | | | | | | | | |
| 3x017 | 30+30 | 1.33 | | | | | | | | | | | | | | | | | | | | | | | | | | | | | | | | | | | | | | | | | | | | | | | | | | | | | | | | | | | | | | | | | | | | | | | | | | | | | | | | | | | | | | | | | | | | | | | | | | | | | | | | | | | | | | | | | | | | | | | | | | | | | | | | | | | | | | | | | | | | | | | | | | | | | | | | | | | | | | | | |
| 3x028 | 110 | 0.72 | | | | | | | | | | | | | | | | | | | | | | | | | | | | | | | | | | | | | | | | | | | | | | | | | | | | | | | | | | | | | | | | | | | | | | | | | | | | | | | | | | | | | | | | | | | | | | | | | | | | | | | | | | | | | | | | | | | | | | | | | | | | | | | | | | | | | | | | | | | | | | | | | | | | | | | | | | | | | | | | |
| 3x029 | 220 | 0.36 | | | | | | | | | | | | | | | | | | | | | | | | | | | | | | | | | | | | | | | | | | | | | | | | | | | | | | | | | | | | | | | | | | | | | | | | | | | | | | | | | | | | | | | | | | | | | | | | | | | | | | | | | | | | | | | | | | | | | | | | | | | | | | | | | | | | | | | | | | | | | | | | | | | | | | | | | | | | | | | | |
| 3x030 | 240 | 0.33 | | | | | | | | | | | | | | | | | | | | | | | | | | | | | | | | | | | | | | | | | | | | | | | | | | | | | | | | | | | | | | | | | | | | | | | | | | | | | | | | | | | | | | | | | | | | | | | | | | | | | | | | | | | | | | | | | | | | | | | | | | | | | | | | | | | | | | | | | | | | | | | | | | | | | | | | | | | | | | | | |
| 110 x 50mm | 300 VA | | | | | | | | | | | | | | | | | | | | | | | | | | | | | | | | | | | | | | | | | | | | | | | | | | | | | | | | | | | | | | | | | | | | | | | | | | | | | | | | | | | | | | | | | | | | | | | | | | | | | | | | | | | | | | | | | | | | | | | | | | | | | | | | | | | | | | | | | | | | | | | | | | | | | | | | | | | | | | | | | |
| 2.6Kg | Regulation 6% | | | | | | | | | | | | | | | | | | | | | | | | | | | | | | | | | | | | | | | | | | | | | | | | | | | | | | | | | | | | | | | | | | | | | | | | | | | | | | | | | | | | | | | | | | | | | | | | | | | | | | | | | | | | | | | | | | | | | | | | | | | | | | | | | | | | | | | | | | | | | | | | | | | | | | | | | | | | | | | | | |
| 7x013 | 15+15 | 10.00 | | | | | | | | | | | | | | | | | | | | | | | | | | | | | | | | | | | | | | | | | | | | | | | | | | | | | | | | | | | | | | | | | | | | | | | | | | | | | | | | | | | | | | | | | | | | | | | | | | | | | | | | | | | | | | | | | | | | | | | | | | | | | | | | | | | | | | | | | | | | | | | | | | | | | | | | | | | | | | | | |
| 7x014 | 18+18 | 8.33 | | | | | | | | | | | | | | | | | | | | | | | | | | | | | | | | | | | | | | | | | | | | | | | | | | | | | | | | | | | | | | | | | | | | | | | | | | | | | | | | | | | | | | | | | | | | | | | | | | | | | | | | | | | | | | | | | | | | | | | | | | | | | | | | | | | | | | | | | | | | | | | | | | | | | | | | | | | | | | | | |
| 7x015 | 22+22 | 6.82 | | | | | | | | | | | | | | | | | | | | | | | | | | | | | | | | | | | | | | | | | | | | | | | | | | | | | | | | | | | | | | | | | | | | | | | | | | | | | | | | | | | | | | | | | | | | | | | | | | | | | | | | | | | | | | | | | | | | | | | | | | | | | | | | | | | | | | | | | | | | | | | | | | | | | | | | | | | | | | | | |
| 7x016 | 25+25 | 6.00 | | | | | | | | | | | | | | | | | | | | | | | | | | | | | | | | | | | | | | | | | | | | | | | | | | | | | | | | | | | | | | | | | | | | | | | | | | | | | | | | | | | | | | | | | | | | | | | | | | | | | | | | | | | | | | | | | | | | | | | | | | | | | | | | | | | | | | | | | | | | | | | | | | | | | | | | | | | | | | | | |
| 7x017 | 30+30 | 5.00 | | | | | | | | | | | | | | | | | | | | | | | | | | | | | | | | | | | | | | | | | | | | | | | | | | | | | | | | | | | | | | | | | | | | | | | | | | | | | | | | | | | | | | | | | | | | | | | | | | | | | | | | | | | | | | | | | | | | | | | | | | | | | | | | | | | | | | | | | | | | | | | | | | | | | | | | | | | | | | | | |
| 7x018 | 35+35 | 4.28 | | | | | | | | | | | | | | | | | | | | | | | | | | | | | | | | | | | | | | | | | | | | | | | | | | | | | | | | | | | | | | | | | | | | | | | | | | | | | | | | | | | | | | | | | | | | | | | | | | | | | | | | | | | | | | | | | | | | | | | | | | | | | | | | | | | | | | | | | | | | | | | | | | | | | | | | | | | | | | | | |
| 7x026 | 40+40 | 3.75 | | | | | | | | | | | | | | | | | | | | | | | | | | | | | | | | | | | | | | | | | | | | | | | | | | | | | | | | | | | | | | | | | | | | | | | | | | | | | | | | | | | | | | | | | | | | | | | | | | | | | | | | | | | | | | | | | | | | | | | | | | | | | | | | | | | | | | | | | | | | | | | | | | | | | | | | | | | | | | | | |
| 7x025 | 45+45 | 3.33 | | | | | | | | | | | | | | | | | | | | | | | | | | | | | | | | | | | | | | | | | | | | | | | | | | | | | | | | | | | | | | | | | | | | | | | | | | | | | | | | | | | | | | | | | | | | | | | | | | | | | | | | | | | | | | | | | | | | | | | | | | | | | | | | | | | | | | | | | | | | | | | | | | | | | | | | | | | | | | | | |
| 7x033 | 50+50 | 3.00 | | | | | | | | | | | | | | | | | | | | | | | | | | | | | | | | | | | | | | | | | | | | | | | | | | | | | | | | | | | | | | | | | | | | | | | | | | | | | | | | | | | | | | | | | | | | | | | | | | | | | | | | | | | | | | | | | | | | | | | | | | | | | | | | | | | | | | | | | | | | | | | | | | | | | | | | | | | | | | | | |
| 7x028 | 110 | 2.72 | | | | | | | | | | | | | | | | | | | | | | | | | | | | | | | | | | | | | | | | | | | | | | | | | | | | | | | | | | | | | | | | | | | | | | | | | | | | | | | | | | | | | | | | | | | | | | | | | | | | | | | | | | | | | | | | | | | | | | | | | | | | | | | | | | | | | | | | | | | | | | | | | | | | | | | | | | | | | | | | |
| 7x029 | 220 | 1.36 | | | | | | | | | | | | | | | | | | | | | | | | | | | | | | | | | | | | | | | | | | | | | | | | | | | | | | | | | | | | | | | | | | | | | | | | | | | | | | | | | | | | | | | | | | | | | | | | | | | | | | | | | | | | | | | | | | | | | | | | | | | | | | | | | | | | | | | | | | | | | | | | | | | | | | | | | | | | | | | | |
| 7x030 | 240 | 1.25 | | | | | | | | | | | | | | | | | | | | | | | | | | | | | | | | | | | | | | | | | | | | | | | | | | | | | | | | | | | | | | | | | | | | | | | | | | | | | | | | | | | | | | | | | | | | | | | | | | | | | | | | | | | | | | | | | | | | | | | | | | | | | | | | | | | | | | | | | | | | | | | | | | | | | | | | | | | | | | | | |
| 625 VA | 140 x 75mm | | | | | | | | | | | | | | | | | | | | | | | | | | | | | | | | | | | | | | | | | | | | | | | | | | | | | | | | | | | | | | | | | | | | | | | | | | | | | | | | | | | | | | | | | | | | | | | | | | | | | | | | | | | | | | | | | | | | | | | | | | | | | | | | | | | | | | | | | | | | | | | | | | | | | | | | | | | | | | | | | |
| 5Kg | Regulation 4% | | | | | | | | | | | | | | | | | | | | | | | | | | | | | | | | | | | | | | | | | | | | | | | | | | | | | | | | | | | | | | | | | | | | | | | | | | | | | | | | | | | | | | | | | | | | | | | | | | | | | | | | | | | | | | | | | | | | | | | | | | | | | | | | | | | | | | | | | | | | | | | | | | | | | | | | | | | | | | | | | |
| 9x017 | 30-30 | 10.41 | | | | | | | | | | | | | | | | | | | | | | | | | | | | | | | | | | | | | | | | | | | | | | | | | | | | | | | | | | | | | | | | | | | | | | | | | | | | | | | | | | | | | | | | | | | | | | | | | | | | | | | | | | | | | | | | | | | | | | | | | | | | | | | | | | | | | | | | | | | | | | | | | | | | | | | | | | | | | | | | |
| 9x018 | 35-35 | 8.92 | | | | | | | | | | | | | | | | | | | | | | | | | | | | | | | | | | | | | | | | | | | | | | | | | | | | | | | | | | | | | | | | | | | | | | | | | | | | | | | | | | | | | | | | | | | | | | | | | | | | | | | | | | | | | | | | | | | | | | | | | | | | | | | | | | | | | | | | | | | | | | | | | | | | | | | | | | | | | | | | |
| 9x026 | 40-40 | 7.81 | | | | | | | | | | | | | | | | | | | | | | | | | | | | | | | | | | | | | | | | | | | | | | | | | | | | | | | | | | | | | | | | | | | | | | | | | | | | | | | | | | | | | | | | | | | | | | | | | | | | | | | | | | | | | | | | | | | | | | | | | | | | | | | | | | | | | | | | | | | | | | | | | | | | | | | | | | | | | | | | |
| 9x025 | 45-45 | 6.94 | | | | | | | | | | | | | | | | | | | | | | | | | | | | | | | | | | | | | | | | | | | | | | | | | | | | | | | | | | | | | | | | | | | | | | | | | | | | | | | | | | | | | | | | | | | | | | | | | | | | | | | | | | | | | | | | | | | | | | | | | | | | | | | | | | | | | | | | | | | | | | | | | | | | | | | | | | | | | | | | |
| 9x033 | 50-50 | 6.25 | | | | | | | | | | | | | | | | | | | | | | | | | | | | | | | | | | | | | | | | | | | | | | | | | | | | | | | | | | | | | | | | | | | | | | | | | | | | | | | | | | | | | | | | | | | | | | | | | | | | | | | | | | | | | | | | | | | | | | | | | | | | | | | | | | | | | | | | | | | | | | | | | | | | | | | | | | | | | | | | |
| 9x042 | 55-55 | 5.68 | | | | | | | | | | | | | | | | | | | | | | | | | | | | | | | | | | | | | | | | | | | | | | | | | | | | | | | | | | | | | | | | | | | | | | | | | | | | | | | | | | | | | | | | | | | | | | | | | | | | | | | | | | | | | | | | | | | | | | | | | | | | | | | | | | | | | | | | | | | | | | | | | | | | | | | | | | | | | | | | |
| 9x028 | 110 | 5.68 | | | | | | | | | | | | | | | | | | | | | | | | | | | | | | | | | | | | | | | | | | | | | | | | | | | | | | | | | | | | | | | | | | | | | | | | | | | | | | | | | | | | | | | | | | | | | | | | | | | | | | | | | | | | | | | | | | | | | | | | | | | | | | | | | | | | | | | | | | | | | | | | | | | | | | | | | | | | | | | | |
| 9x029 | 220 | 2.84 | | | | | | | | | | | | | | | | | | | | | | | | | | | | | | | | | | | | | | | | | | | | | | | | | | | | | | | | | | | | | | | | | | | | | | | | | | | | | | | | | | | | | | | | | | | | | | | | | | | | | | | | | | | | | | | | | | | | | | | | | | | | | | | | | | | | | | | | | | | | | | | | | | | | | | | | | | | | | | | | |
| 9x030 | 240 | 2.60 | | | | | | | | | | | | | | | | | | | | | | | | | | | | | | | | | | | | | | | | | | | | | | | | | | | | | | | | | | | | | | | | | | | | | | | | | | | | | | | | | | | | | | | | | | | | | | | | | | | | | | | | | | | | | | | | | | | | | | | | | | | | | | | | | | | | | | | | | | | | | | | | | | | | | | | | | | | | | | | | |

Why a Toroid?
 * Smaller size & weight to meet modern 'slimline' requirements.
 * Low electrically induced noise demanded by compact equipment.
 * High efficiency enabling conservative rating whilst maintaining size advantages.
 * Lower operating temperature.

Why ILP?
 * Ex-stock delivery for small quantities.
 * Gold service available. 21 days manufacture for urgent deliveries.
 * 5 year no quibble guarantee.
 * Realistic delivery for volume orders.
 * No price penalty for call off orders.

Prices Including P&P and VAT

| VA | Size | £ | VA | Size | £ |
|-----|------|-------|-----|------|-------|
| 15 | 0 | 7.43 | 160 | 5 | 12.90 |
| 30 | 1 | 8.08 | 225 | 6 | 16.30 |
| 50 | 2 | 10.10 | 200 | 7 | 18.55 |
| 80 | 3 | 10.81 | 500 | 8 | 25.73 |
| 120 | 4 | 11.73 | 625 | 9 | 31.63 |

For 110V primary insert "0" in place of "X" in type number.
 For 220V primary (Europe) insert "1" in place of "X" in type number.
 For 240V primary (UK) insert "2" in place of "X" in type number.
 IMPORTANT: Regulation - All voltages quoted are FULL LOAD.
 Please add regulation figure to secondary voltage to obtain off load voltage.

Mail Order — Please make your crossed cheques or postal orders payable to ILP Electronics Ltd.
 Trade — We will open your credit account immediately upon receipt of your first order.

Post to: ILP Electronics Ltd., Dept. 2
 Graham Bell House, Roper Close,
 Canterbury, Kent. CT2 7EP
 Tel: (0227) 54778 Telex: 965780

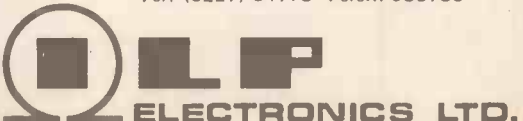

POINTS OF VIEW

Feel like sounding off?
Then write to the Editor stating your Point of View!

Component Confidence

Dear Editor,

I have just received my March issue of HE and I feel I must come to your defence against the criticisms of Mr. Watson of Hull with respect to your cost estimates for projects.

My first copy of HE was the 1983 October issue and I too was interested in the Audio Level Meter. I did a quick survey of the adverts and found your estimate was about right. In fact I was holidaying in Colchester so I had a little trip to Rapid Electronics at Boxted.

I received a very cordial welcome and was served on a while-you-wait basis by a very competent and helpful staff. My total costs were £6.99 inc. VAT. Had I ordered by post my cost would have been an additional 58p. As a saver I went for separate LEDs and clips.

I also received a free catalogue and a good recommendation for a pub lunch. Thank you, Rapid, and please, Mr. Watson, do your homework, you can save pounds.
Yours faithfully,
Southam,
Leamington Spa.

It's nice to see a vote of confidence for the components suppliers. As for Mr. Watson of Hull, don't be too hard on him — his figures were so way out that we reckon he must have had a case of bad luck. However, it does help to check prices if you are buying from a small, or non-specialist outlet.

Right Side Of The Law

Dear Sir,

Over the past few years my son and I have made a lot of the projects in your magazine. Some have been better than others but all have been interesting and all have worked, and we've got a lot of satisfaction and enjoyment from them. But there's one exception, the Big Ear (HE December '83).

We have tried this twice, with new components, but still can't get it to go; we get crackles and hums but no response through the microphone. From Points Of View we notice that mistakes do creep into some of the circuits occasionally, and we wonder whether this has happened with the Big Ear? Can you help us?
Yours faithfully,
D. Beasley,
Newbury,
Berks.

There are two immutable Laws which govern this correspondence box, and doubtless those of all technical publications:

1) Very rarely will your readers get around to telling you how good you are, unless they also have a query about an instance in which you aren't.

2) Very rarely will your readers write you an absolute stinker, but if they do, the entire year's allocation will arrive in the same week, leaving you to think of helpful replies which are neither homicidal nor suicidal.

But neither homicide nor suicide is required in this case. There were two misprints in the Big Ear. These were corrected in December '83, and the design improved to get around component tolerance problems, which were causing some of the Big Ears to work badly or not at all. Mr. Beasley has been sent a copy of the corrections.

Air Turns Blue

Dear Editor,

We are pleased to announce our new range of light-emitting diodes for 1984. As you will see from the enclosed sample, we have made a breakthrough in the manufacture of LEDs and our range now includes the blue variety, which has been a right b***** (He means "bother" — Ed.) to produce commercially.

Unlike many companies still experimenting with silicon carbide, we found quite by chance that stained carrot juice doped with particles of liquorice allsorts, give the required spectral resonance. During ionisation tests this was found to be 465nm with a deviation of ± 6 nm which is well with the "turquoise blue" limits for standard blue LEDs.

Blue LEDs must be driven from an AC source, similar to liquid crystal diodes, ie the pins must be driven in antiphase. Kits which enable the home constructor to manufacture his own LEDs are available from most local greengrocers.

Yours faithfully,
Barney Splatbanger,
Bodgitt & Spludge UK,
No Fixed Address.

Some persons obviously have a deviation of rather more than ± 6 nm, especially those who lay themselves open to being positively identified as Mr. Wakely of Wimbledon among sixty other unopened letters after a year's absence, merely by the typeface on

their hairy old typewriter. We've got news for you, mate. April Fool's Day 1984 was also Mothers' Day — so we've passed your suggestions on to your mum. The samples were delicious. Thanks very much.

Projects In The Air

Dear Sir/Madam,

At the present time a number of student projects are being considered, and I should be very grateful if you would kindly provide me with the following information as soon as possible:

i) Details of the Stereo Amplifier (November '76); Intruder Alarm (October '80); Slide-Tape Synchroniser Unit (December '82) and Audio Mixer (December '78), as well as any subsequent errors in these publications.

Yours faithfully,

S. Gough,
Student Engineer Training Centre,
Royal Aircraft Establishment,
Farnborough,
Hants.

We'll pass this request straight on to our photocopy department.

We get a number of requests from colleges and students who want to use Hobby projects for their course work. We don't often hear, though, how they got on in the end (for the Laws governing this phenomenon, see above). So how about letting us know if a Hobby project has been useful as the basis for study, and letting us have any suggestions for making project articles more informative for students. We can pass suggestions on to our authors.

Wither Weller?

Dear Sir,

I write in the hope you may assist me in locating the current address of Weller Electronics Ltd., whose old address is listed as Redkirk Way, Horsham, Sussex.

I purchased a soldering iron from a local shop and it is defective. Regrettably, the shop has closed down and I am not able to return it to them.

I hope you can oblige.

Yours faithfully,
C. N. Austwick,
Potters Bar,
Herts.

The only address we have for Weller with regard to their soldering irons is

that of Cooper Tools Ltd., Sedling Rd., Wear, Washington, Tyne & Wear NE38 9BZ. Tel. (0632) 466062, who represent Weller. I suggest you contact Cooper Tools and give them full details of your iron, how you obtained it, and what is wrong with it, and they should be able to advise you.

Antique Book

Dear Sir,
While recently reading through one of your back issues (January '79 to be exact) I noticed a book advertised on page 20 titled "Transducers In Measurement And Control".

As I recently started working for a company which deal exclusively in transducer measuring and control equipment, and as I know almost nothing about transducers, it sounds to me as if this would be a good investment.

I would just like to ask if this book is still in print and if so, how much and where I can get it from.

I've only recently got back into electronics again after a three year layoff.

Any help rendered will be gratefully received.

Yours sincerely,
Andy Turner,
Wokingham,
Berks.

Transducers In Measurement And Control was actually published as a series in ETI between May 1972 and September 1973. It was so erudite that various bodies requested that it should be published as a special publication, which it duly was, and was available in that form for a number of years.

However, in due course (another victim of the recession) demand was no longer sufficient to justify a reprint, and the book went out of print. The articles are still available. However, as the standard photocopy charge for a single article is £1.50, this would be prohibitively expensive. Also, the series may now be out of date. I suggest that, if you are still interested, you contact the Editor on ETI, at the same address as HE, tell him about your problem, and see what he can suggest.

NiCad Knowledge

Dear Sir,
I note that you intend to publish a Battery Eliminator/NiCad charger unit for personal stereos, etc. This prompts me to write and suggest that HE publishes a related feature on NiCads and their uses, care and maintenance.

I know a little about this subject, but not enough. For example, I know that for the best performances and maximum life, they should be charged at a constant current of approx. one tenth of their rated amp/hour capacity, eg AA size 500mA/hr cells

at 50mA. I do in fact have a home built charger to do this for most sizes of NiCad.

I am told that from time to time they should also be 'cycled', ie discharged at a steady rate until totally discharged, then recharged normally, this process to be repeated three times. What I would like to see in HE is a circuit to enable this to be done safely and without the need for constant attention. My charger is an adaptation of an RS design, using a 7805 voltage regulator as a constant current generator.
Yours faithfully,
M. L. Peake,
Bilston,
W. Midlands.

A useful idea backed with practical suggestions. We have been thinking about doing a feature or series on batteries for some time and will be looking into this.

The cycling process you mention is the best procedure to use. The cycling does not have to be repeated three times, and the batteries can be discharged instantly by connecting a wire across them (in which case stand back, as they can give off a great deal of current for a brief moment). However, you risk shortening the life of your NiCads if you take shortcuts, although you are unlikely to actually destroy them.

Overseas Amp

Dear Sir,
I'm a six form student and I require some help which I thought you could give me.

I'm interested in building up an amplifier for my stereo cassette player. The amplifier must be about 40W per channel. Can you send me an illustrated diagram with the parts I would need and the cost for these parts? If these cannot be done, can you please suggest an alternative by which I can find this diagram. Hoping I haven't caused you any trouble, and thanking you in advance for your co-operation.
Yours faithfully,
Malcolm Micallef,
Malta.

We've had a look through the back indexes of HE and ETI, but there is nothing which would specifically suit your purpose without a lot of alteration.

We suggest you write to Bernard Babani (publishing) Ltd., The Grampians, Shepherds Bush Rd., London W6 7NF, UK, and ask for *Audio Amplifier Construction* by R. A. Penfold, number BP122; this will give you the basics of amplifier construction from which you can work out your own specification. The book costs £2.25, and please also include enough to cover return postage to your home. It is an ordinary paper-back sized book.

Out Of Prints

Dear Sir,
Do you still have the PCB aids called Hobbyprints?

If so, do have any for the Digital Frequency Meter (HE April '80) and also for the Mini-Synth (HE November '80)? But I have the greatest need for the DFM because I'm building a stylus organ and since I have to adjust the pots for the notes, I need the DFM.

If you haven't, can you give me a design as good as your DFM, since it's the best and I haven't found any constructional details of a DFM from anywhere else.
Yours sincerely,
D. E. Jones,
Hackney,
London.

Regrettably we stopped producing Hobbyprints two or three years ago, as most people seemed to be managing without them. However, you can successfully make your own "Hobbyprint" by tracing the PCB foil from the magazine onto a piece of thin tracing paper, or transparent artist's film, with a fine-tipped black pen. This calls for a steady hand, especially where the connections for ICs are concerned, as there is no room for flexibility as there is with other components.

Use an artist's drawing pen, or a very fine felt-tipped pen with indelible ink for preference, or a good, fine fountain pen; in fact, the pen which you wrote your letter with should do the job. You can then use this mask to expose the PCB, and any small faults can be rectified when the PCB is made.

Etch Resist

Dear Sir,
Please give me information on how to mix ferric chloride to etch my own PCBs. I have tried it three times but was not able to produce a presentable board.

I have copper clad boards purchased from Radio Spares. I also have the chemicals but do not know the proportion of the mixture.

Please help; I shall be very grateful.
Yours faithfully,
E. D. Chukwudinma,
University Of Jos,
Nigeria.

The first question we asked was: what sort of boards are you using? If you are using normal copper board, then a mixture of about one pound of ferric chloride to a pint-and-a-half of water, plus a few ccs of hydrochloric acid for luck, will work, although some experimentation with the strength of the mixture might be worthwhile.

If, on the other hand, you have boards already coated with etch resist, which some RS board is, the board has to be exposed with ultra violet light and developed in a mild solution of sodium hydroxide, before etching with the ferric chloride in the normal way.

H.E. PROJECT KITS

Full Kits inc. PCBs, hardware, electronics, cases (unless stated), Less batteries. If you do have the issue of H.E. which includes the project — you will need to order the instruction reprint as an extra — 50p each. Reprints available separately 50p each + p&p 50p.

| | |
|--|-----------------------|
| SPRING REVERB UNIT, May 84 | £22.48 |
| ANALOGUE TEST SET (less speaker) April 1984 | £25.89 |
| TIME OUT April 84 | £20.79 |
| OFFBEAT METRONOME Mar 84 | £12.99 |
| LIGHTNING CHESS TIMER Mar 84 | £12.99 |
| INFRA-RED CAMERA CONTROL Feb 84 | £17.49 |
| C.B. FIELD STRENGTH METER Feb 84 | £14.15 |
| BASSMAN Dec 83 (with PCB) | £10.38 |
| CONTINUITY TESTER Dec 83 | £5.55 |
| MOISTURE GAUGE Dec 83 | £10.98 |
| ULTRASONIC INTRUDER ALARM no case Oct 83 | £14.85 |
| WHISTLE SWITCH Aug 83 less mic | £19.98 |
| STEREO SPREADER July 83 | £6.36 |
| SINCLAIR SOUND BOARD Jun 83 less case | £18.98 |
| BAT LIGHT (car battery indicator) Jun 83 less case | £5.48 |
| TTL LOGIC PROBE June 83 | £8.78 |
| AUTO TESTER May 83 | £7.35 |
| STALL THIEF May 83 (Inc relay) | £12.36 |
| STEREO VOICE OVER UNIT April 83 | £10.27 |
| OPTIONAL MIC PRE-AMP April 83 (no case) | £4.59 |
| PHASE FOUR Dec 82 | £20.58 |
| STEREO NOISE GATE Dec 82 | £16.88 |
| TAPE/SLIDE SYNCHRONIZER Dec 82 | £23.90 |
| ODOMETER Nov 82 | £16.48 |
| EZ INTERFACE BOARD Sept 82 inc edge con | £312.46 |
| AUTO WAH June 82 20.88 case £13.51 | |
| AUTO GREENHOUSE SPRINKLER June 82 less pump and power supply | £15.82 |
| ECHO REVERB UNIT May 82 Less case Economy case WB3 | £38.48 £3.75 extra |
| DIGITAL THERMOMETER May 82 including case + bezel | £18.59 £22.98 |
| AUDIO SIGNAL GENERATOR May 82 | £10.98 |
| CABLE TRACKER May 82 | £23.10 |
| DIGITAL CAPACITANCE METER Apr 82 | £4.25 |
| SIGNAL TRACER Apr 82 | £13.99 |
| BIKE ALARM Apr 82 | £7.99 |
| DIGITAL DICE Mar 82 | £11.98 |
| NOISELESS FUZZBOX Feb 82 | £18.10 |
| MASTHEAD AMPLIFIER Feb 82 | £25.37 |
| DBUM SYNTHESIZER Dec 81 Full kit | £14.12 |
| GUITAR HEADPHONE AMPLIFIER Dec 81 | £4.12 |
| IN CAR CASSETTE POWER SUPPLY | |

| | |
|---|----------------------------|
| Dec 81 | £5.25 |
| SCRATCH FILTER Nov 81. | Mono £6.48 Stereo £9.50 |
| LED VU METER Nov 81 less case | £5.48 |
| SIMPLY STYLUS ORGAN Nov 81 less case | £13.98 |
| METRONOME Nov 81 | £15.15 |
| TELEPHONE BELL REPEATER Oct 81 | 14p meter |
| Med linking wire extra | |
| COMBINATION LOCK Oct 81 less case | £19.98 |
| 'DIANA' METAL LOCATOR Sept 81 | £37.50 |
| VARIABLE BENCH POWER SUPPLY Aug 81 | £29.48 |
| ULTRASOUND BURGLAR ALARM July 81 | £21.98 |
| ELECTRONIC DOOR BUZZER July 81 | £6.48 |
| ELECTRONIC METRONOME July 81 | £5.48 |
| CONTINUITY CHECKER June 81 | £6.80 |
| ENVELOPE GENERATOR June 81 | £19.48 |
| PUBLIC ADDRESS AMPLIFIER March 81 | £21.48 |
| Extras — horn speakers £6.35 each PA MIC | £4.85 |
| FUZZ BOX March 81 | £11.98 |
| WINDSCREEN WIPER CONTROL March 81 | £8.98 |
| STEAM LOC WHISTLE March 81 | £14.38 |
| PHOTOGRAPHIC TIMER March 81 | £3.85 |
| HEATBEAT MONITOR Feb 81 | £27.50 |
| TWO-TONE TRAIN HORN Feb 81 | £6.16 less case |
| MEDIUM WAVE RADIO Feb 81 | £8.98 |
| CHUFFER Jan 81, less case | £8.25 |
| BATTERY CHARGE MONITOR Dec 82 | £6.34 |
| MEMORY BANK-MINI SYNTHESIZER Nov & Dec 80 | £36.48 |
| TRANSISTOR TESTER Nov 80 | £7.25 inc test leads |
| GUITAR PRE-AMP Nov 80 | £7.25 |
| Intruder Alarm Oct 80 case extra | £23.10 |
| TOUCH SWITCH Sept 80 | £2.99 less case & contacts |
| GUITAR PHAER Sept 80 | £17.88 |
| SOUND OPERATED FLASH TRIGGER July 80 no skt | £5.83 |
| FOG HORN June 80 | £7.30 |
| SPEED CONTROLLER FOR R/C April 80 | £19.20 (less case) |
| DIGITAL FREQUENCY METER April 80 | £43.98 |
| GUITAR TUNER Nov 79 | £14.10 |
| CAR ALARM Feb 79 | £14.20 |

I.C.s
TRANSISTORS
CAPACITORS

TOOLS
RESTORERS
HARDWARE

CASES
KITS
PCBs

MAGENTA

SOLDERING/TOOLS

| | |
|--|--------|
| ANTEX X5 SOLDERING IRON 25W | £6.29 |
| SOLDERING IRON STAND | £2.18 |
| SPARE BITS, Small, standard large each for X5+X2S | £1.04 |
| SOLDER, Handy, size | £1.38 |
| SOLDER CARTON | £2.50 |
| DESOLDER BRAID | 66p |
| HEAT SINK TWEEZERS | 35p |
| DESOLDER PUMP | £6.48 |
| HOW TO SOLDER LEAFLET | 13p |
| LOW COST CUTTERS | £1.88 |
| LOW COST LONG NOSE PLIERS | £1.88 |
| WIRE STRIPPERS & CUTTERS | £2.88 |
| PRECISION PETITE | |
| 12V PCB DRILL | £12.80 |
| DRILL STAND | £8.78 |
| VERO SPOT FACE CUTTER | £1.76 |
| PIN INSERTION TOOL | £2.52 |
| VEROPINS (pk of 100 0.1") | 65p |
| MULTIMETER TYPE 1 (1,000 ohm) | £5.85 |
| CROCODILE CLIP TEST LEAD SET, 10 leads with 20 clips | £1.15 |
| RESISTOR COLOUR CODE CALCULATOR 23p | |
| CONNECTING WIRE PACK TYPE ED. 11 colours | 40p |
| ILLUMINATED MAGNIFIERS | |
| Small 2" dia (5 x mag) | £1.32 |
| Large 3" dia (4 x mag) | £2.52 |
| CORE TRIM TOOL | 39p |
| PRESET TRIM TOOL | 60p |
| FREEZER AEROSOL | £1.59 |
| CONTACT CLEANER AEROSOL | £1.45 |
| ELECTROL CONDUCTIVE PAINT | £4.99 |
| PVC TAPE (RGB) 3 reels | 39p |
| SCREWDRIVER SET | £1.98 |
| POCKET TOOL SET | £3.98 |
| DENTISTS INSPECTION MIRROR | £2.85 |
| JEWELLERS EYEGLASS | £1.50 |
| PLASTIC TWEEZERS | 66p |
| pair of probes with leads(cc). | 77p |
| 0 MAX PUNCHES | |
| 3/8" £2.98; 1/2" £3.06; 5/8" £3.17; 3/4" £3.24. | |
| Speakers Min 8 ohm 87p; 64 ohm 89p, 80 ohm 90p | |
| Crystal earpiece | 57p |
| Magnetic earpiece | 19p |
| Stethoscope attachment | 69p |
| Mono headphones | £3.36 |
| Stereo headphones | £5.40 |
| Telephone pickup coil | 68p |
| Min buzzer 6V 75p, 12V 72p. | |
| Euro breadboard | £6.20 |
| S Dec breadboard | £3.98 |
| Bimboard breadboard | £6.98 |
| Verobloc breadboard | £5.88 |



MULTIMETER TYPE 2 (YN360TR) 20K ohm, AC + DC volts, DC current, 4 very useful resistance ranges we've used it and we like it. £14.99

FUN WITH ELECTRONICS

Enjoyable introduction to electronics. Full of very clear, full colour pictures and easy to follow text. Ideal for all beginners — children and adults. Only basic tools needed. 64 full colour pages cover all aspects — soldering — fault finding — components (identification and how they work). Also full details of how to build 6 projects — burglar alarm, radio, games, etc. Requires soldering — 4 pages clearly show you how. COMPONENTS SUPPLIED ALLOW ALL PROJECTS TO BE BUILT AND KEPT. Supplied less batteries & cases. FUN WITH ELECTRONICS, COMPONENT PACK £16.48 BOOK EXTRA £1.25. Book available separately.

MORE KITS AND COMPONENTS IN OUR LISTS
FREE PRICE LIST
Price list included with orders or send sae (9 x 4)
CONTAINS LOTS MORE KITS, PCBs & COMPONENTS

ELECTRONICS CATALOGUE

Illustrations, product descriptions, circuits all included. Up-to-date price list enclosed. All products are stock lines for fast delivery.
Send 80p in stamps or add 80p to order.
FREE to Schools/Colleges requested on official letterhead.

MAGENTA ELECTRONICS LTD
HE11, 135 Hunter St., Burton-on-Trent Staffs., DE14 2ST. Mail Order Only.
(0283) 65435 S.A.E. enquiries.
Add 50p p&p to all orders. Prices include VAT. Access & Visa phone/post

| | |
|---|--------|
| PCB etching kit | £6.48 |
| ZXB1 edge connector | £2.25 |
| Ferrite rod 5 inch | 59p |
| PPS clips 10p, PPS clips 11p. | |
| 2 Station intercomm | £10.53 |
| IC Sockets 8 pin 16p; 14 pin 17p; 16 pin 18p. | |
| Traditional Style Ball | £1.95 |
| Public Address Mic 50k | £4.95 |
| Mic Insert Crystal | 45p |
| Cassette Mic | £1.29 |
| Pillow Speaker | £1.40 |
| Horn speaker 5 1/2" 8 ohm | £1.40 |
| BOOKS: see our price list | |

24 hr Answerphone for orders.
Official school orders welcome.
OVERSEAS: Payment must be in sterling
IRISH REPUBLIC + BFPO — UK PRICES.
EUROPE: UK PRICES + 10%.
ELSEWHERE: WRITE FOR QUOTE.
Goods normally despatched by return of post.

MASTER ELECTRONICS NOW!

The PRACTICAL way!

YOUR CAREER..YOUR FUTURE..YOUR OWN BUSINESS..YOUR HOBBY
THIS IS THE AGE OF ELECTRONICS!
the world's fastest growth industry..

Our new style course will enable anyone to have a real understanding of electronics by a modern, practical and visual method. No previous knowledge is required, no maths, and an absolute minimum of theory.

You learn by the practical way in easy steps, mastering all the essentials of your hobby or to start, or further, a career in electronics or as a self-employed servicing engineer. All the training can be carried out in the comfort of your own home and at your own pace.

A tutor is available to whom you can write personally at any time, for advice or help during your work. A Certificate is given at the end of every course.

You will do the following:

- Build a modern oscilloscope
- Recognise and handle current electronic components
- Read, draw and understand circuit diagrams
- Carry out 40 experiments on basic electronic circuits used in modern equipment using the oscilloscope
- Build and use digital electronic circuits and current solid state 'chips'
- Learn how to test and service every type of electronic device used in industry and commerce today. Servicing of radio, T.V., Hi-Fi, VCR and microprocessor/computer equipment.



British National Radio & Electronics School Reading, Berks RG1 1BR

FREE!
COLOUR BROCHURE

Please send your brochure without any obligation to

I am interested in:

NAME _____
ADDRESS _____
HE/6/842 _____

- COURSE IN ELECTRONICS as described above
 RADIO AMATEUR LICENCE
 MICROPROCESSORS
 OTHER SUBJECTS please state below

Post now to:

British National Radio & Electronics School Reading, Berks RG1 1BR

BLOCK CAPS PLEASE



OR TELEPHONE US
0734 51515 OR
TELEX 22758
(24 HR SERVICE)

HE Conductance Meter

Resistance measures the difficulty of current flow. Conductance measures the ease of current flow. By a coincidence, it's easier to troubleshoot circuits with a conductance meter.

Jim Aman

DURING a period of trouble shooting on a printed circuit board, a need arose by the author for a simple meter or other indicating device which could detect the swarf, solder splashes etc, but most importantly short circuits between the tracks. At the same time the device could be used to give meaningful readings of the impedance of the circuit without causing any semiconductor junctions to become turned on.

As the resistance — more correctly the impedance between the tracks is very large, a simple ohm meter could not be used to give any sort of useful readings. Thus the Conductance Meter was designed to fulfil this need and make a troubleshooter's nightmare become a dream.

Conductance

Some people may wonder why we are measuring the conductance of a circuit rather than the more normal resistance. The main reason why this is so lies behind the definition of conductance.

Beginners are nearly always taught first that resistance opposes the passage of current. The idea of conductance is the *ease* with which a current can be made to flow rather than the *difficulty*.

Conductance is defined as: the number of amps caused to flow by one volt.

Conductance is usually measured in mhos, although Siemens is also quite often used. The symbol for conductance is G or \bar{U} — an inverted

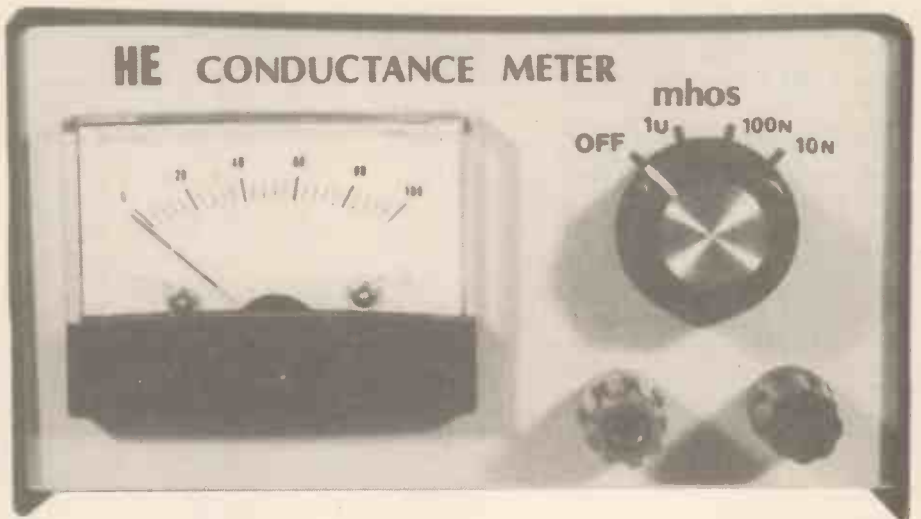

ohms sign, rather appropriate as it is the opposite of ohms!

So $I = E \times G$ is an alternative form of $I = E \div R$, where I = current, E = voltage, R = resistance and G = conductance. In other words conductance is the reciprocal of resistance.

To digress for a moment, it is worthwhile considering that it is an advantage to use conductance in calculations — particularly in parallel circuits as: $GT = G1 + G2 + \dots + Gn$.

A Conducted Tour Of The Circuit

The full circuit for the unit is shown

in Figure 1. The non-inverting input (pin 3) of IC1 is connected to a reference voltage of 100mV. As the feedback resistor network (R4-6) is connected between the output and the inverting input of the IC, this will tend to make the output zero. With a circuit connected to the probes, a current will flow through R1. This will cause a current to flow through the feedback network, and the voltage drop across the selected resistor will be directly proportional to the "current conducting" from one probe to another.

This voltage drop is fairly small and so we use IC2 as a high impedance buffer to measure the voltage. The output of IC2 then drives the meter to provide an indication of the circuit

Conductance Meter

conductance.

As regards the remaining components, RV5 allows the output of IC2 to be zeroed, while RV6 sets the full scale deflection of the unit. Capacitors C1 and C2 provide decoupling of the supply lines and D1 protects the input of IC2 from excessive input voltages.

The variable preset resistor RV1 sets the reference voltage on pin 3, and the two Zener diodes protect the input of IC1 from high voltages. The remaining presets allows for individual adjustment of each range.

Notice we are using two separate supplies for each op-amp. This is necessary because of the very high impedance involved and the fact that the loading effect of IC2 may cause large errors in the operation of IC1.

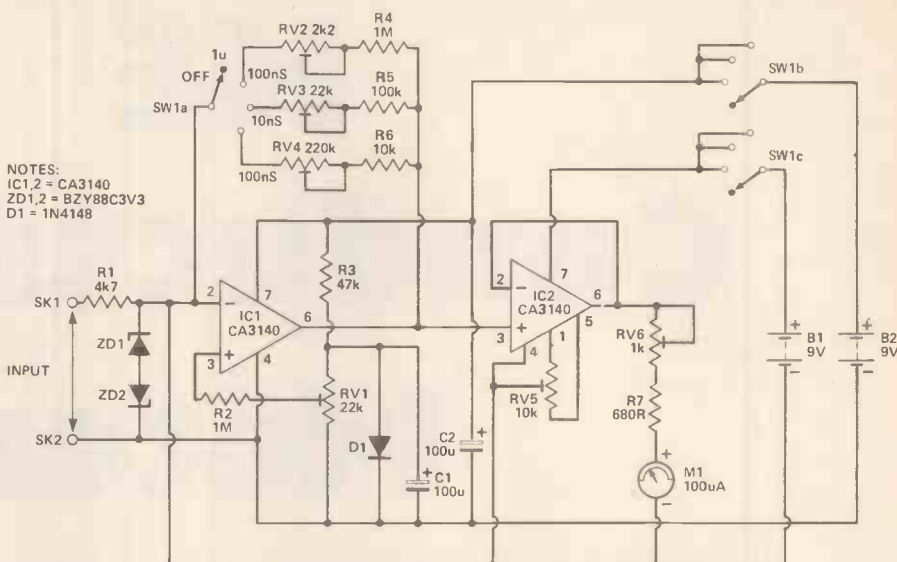

NOTES:
IC1,2 = CA3140
ZD1,2 = BZY88C3V3
D1 = 1N4148

Figure 1. The Circuit. IC2 acts as a high impedance buffer to measure small voltage drops across the appropriate resistor.

Construction

The construction of the unit is fairly straight forward but care needs to be taken. The circuit can be built on either Veroboard or a PCB — we have used Veroboard. When building the unit take care to keep the probe connections well apart from each other. Also ensure that the Veroboard tracks are clean and free from solder flux. A stiff paint brush or a small wire brush can be used here to clean the tracks. Do not attempt to spray the copper tracks with a flux spray or similar.

Figure 2 shows all the required construction. The size of case you use depends on what you have to hand — ours was 14 x 13 x 7cm approximately. Note the box must be metal. The position of the various front panel controls can be seen in the photographs. The probes can be constructed from short lengths of multi-strand test lead wire fitted at each end with a crocodile clip and a 4mm plug.

Calibration

With the probes not connected adjust RV1 to give 100mV on its wiper. Do this using a high impedance voltmeter preferably a digital type. Next adjust RV5 to give a zero reading on the unit's meter on all ranges. This is especially important on the most sensitive range (10nS), although you may find that a true zero reading cannot be obtained easily, if this is the case then leave RV5 set at the lowest point possible.

Next connect the probes and set SW1 to the 100nS range. Connect a precision 10 M resistor across the probes and adjust RV3 for full scale deflection. The switch to the 1 uS range and connect a 1M resistor across the probes. Adjust RV2 for a full scale deflection. Finally a 100M resistor is connected

Parts List

RESISTORS

(All ¼ W 5% carbon)

| | | |
|-------|-------|------|
| R1 | | 4k7 |
| R2, 4 | | 1M |
| R3 | | 47k |
| R5 | | 100k |
| R6 | | 10k |
| R7 | | 680R |

POTENTIOMETERS

| | | | |
|--------|-------|------|--------------|
| RV1, 3 | | 22k | horiz preset |
| RV2 | | 2k2 | horiz preset |
| RV4 | | 220k | horiz preset |
| RV5 | | 10k | horiz preset |
| RV6 | | 1k | horiz preset |

CAPACITORS

| | | | |
|-------|-------|------|-------------------|
| C1, 2 | | 100u | 16V axial electro |
|-------|-------|------|-------------------|

SEMICONDUCTORS

| | | | |
|--------|-------|-----------|-----------------|
| IC1, 2 | | CA3140 | op-amp |
| ZD1, 2 | | BZY88C3V3 | 3V3 400mW Zener |
| D1 | | 1N4148 | silicon diode |

MISCELLANEOUS

| | | | |
|------------------------------------|-------|--------------|----------------|
| SW1 | | 3 pole 4 way | rotary switch |
| M1 | | 100uA | analogue meter |
| SK1, 2 | | 4mm sockets | |
| Metal case, 140 x 130 x 70mm; | | | |
| Veroboard; test probes (see text); | | | |
| control knob; two PP3 batteries | | | |
| and clips; connecting wire, solder | | | |
| etc. | | | |

BUYLINES page 26

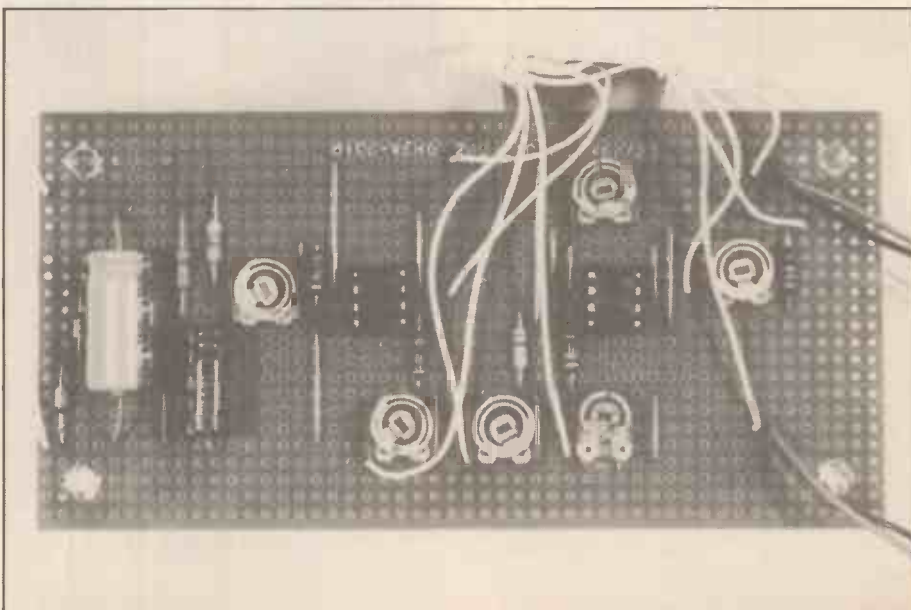

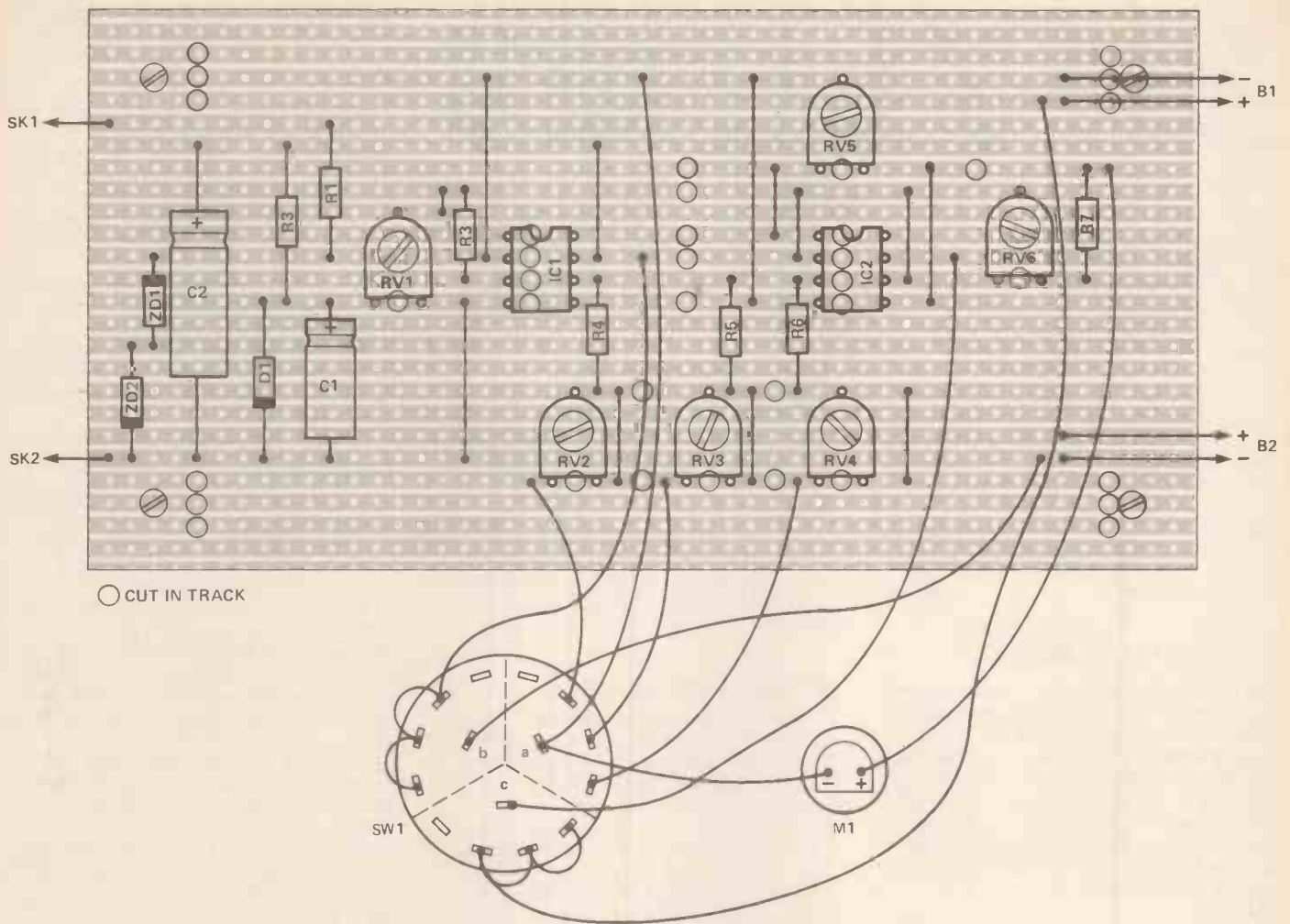
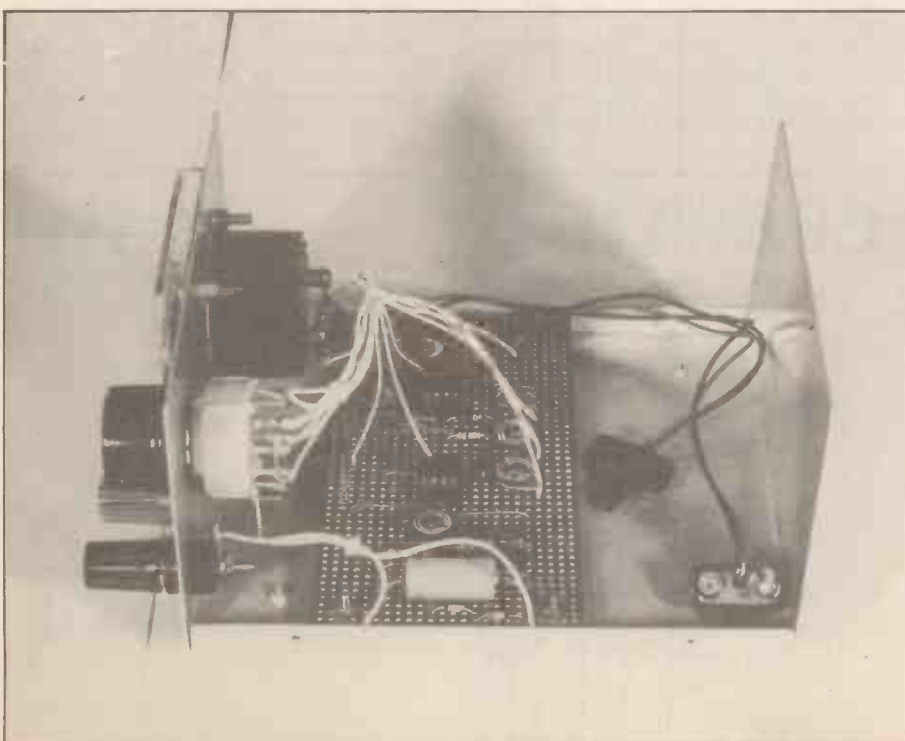

Figure 2. The Vero layout and components. Extra care needs to be taken that there are no solder bridges or short circuits.



across the probes and the 10nΩ range is adjusted using RV4. If no 100M resistor is available then ten series connected 10M resistors can be used.

In Use

The operation of the unit is quite straight forward. With the circuit under test switched off, the probes are connected across suitable points on the circuit board — across the supply lines would be a suitable starting point. The range switch is then adjusted to give a reading on the meter.

If you wish to translate the readings into resistance then remember that the lower the conductance, then the higher the resistance is. For example, a reading of 5nΩ is noted, this translates to a resistance of 50M.

Conversely note that say, a reading of 0.5uΩ indicates that the current is finding it particularly easy to flow (remember the definition of conductance), which means in simpler language that there is a short of some kind across the circuit!

BUYLINES

Oops!

How many of you noticed in last month's Buylines we gave buying information etc. on the Conductance Meter? One Million . . . Two Million . . . Now how many noticed that the article did not appear in that issue? One . . . Two . . . Three . . . Fine.

We all make mistakes but it's nice to be ahead of our schedule for once!

For the benefit of readers we reproduce the Conductance Meter text, together with the correct text which should have gone in last month. This was for the Mains Touch Switch and our apologies to those who missed these words of wisdom.

Now for this month's projects (with the correct text!)

Conductance Meter

No buying problems with this project] but do shop around for the panel meter. You can try **Watford Electronics** for starters. The one we used is normally referred to in catalogues as a 'T' type. Others such as the much cheaper 'M' types can also be used. Note the maximum size of meter one could use with the recommended case is 60 x 48 x 32mm.

Approximate cost excluding case and materials for probes is £11. There is no PCB for this project.

Mains Touch Switch

All components for this project are readily available and should present no difficulties. The AC capacitor can be found in the **Maplin** catalogue if no other supplier can be found.

Note that all the components must be miniature types, and here it is better to obtain the PCB before buying the components. The Zener diode ZD1 can be increased to a 10W device to increase the power handling of the unit, typically slow.

Because the PCB carries mains voltages it is very important that all the soldered joints are well made and smooth.

It is worth spending time on the soldering to insure that there is no danger of short circuits etc.

The estimated cost for this project is #4, and this does not include the PCBs, which can be obtained from our PCB service as usual.

ZX Tape Controller

The estimated cost for this project is £6.75, excluding the edge connector, case and printed circuit board.

As a PCB is used, it is important to use the correct relays as specified in

the text, i.e. **Maplin** YX94C and YX95D.

Other types can of course be tried, but will obviously mean changes to the board.

The PCB is available as usual from our PCB service.

Audio Millivoltmeter

Not given in the Parts List is the actual size of panel meter used in the prototype. The size is 50x45x30mm. Shop around for the meter as prices vary widely. Try **TK Electronics** for starters.

The estimated cost for this project is £10, and this excludes the cost of the case and printed circuit board, which is of course available from our PCB service.

Wireless Intercom

A fairly substantial project this! Remember that two units are required for the full intercom facility, and the Parts List gives the components required for just one unit.

The cost for just one unit is estimated at £10. This excludes the case and printed circuit board (available from the PCB service).

Despite the relatively high cost of the project (£20 for a complete system), the advantages of FM are obvious, and this project compares favourably with other "commercial" units costing slightly more.

The case size given *just* takes the PCB and other components comfortably. In view of the varying sizes of transformers some constructors may like to use a case with more substantial dimensions.

Because of the risk from mains voltage it is best to use a metal case

for each unit. Also take great care with your construction techniques.

Prices

There appears in the world, some sort of raw material crisis as regards semiconductor material. This means that semiconductors, particularly 74 and 74LS integrated circuits are in short supply. So don't complain to your supplier, he has problems of his own!

You may also have noticed in many advertisements the polite message "check prices before ordering".

A wise message, and one which you should take note if you want your components in a hurry and all at the same time.

Catalogues

Will advertisers (and those who don't) note that the HE catalogue library is looking very sparse nowadays. Your latest catalogue and/or price list (retail) would be very welcome.

We think the reason is obvious. We need the catalogues to price up our projects and to help readers look for the best possible prices. If we don't have your catalogue we cannot (and probably won't) recommend you as a source of supply.

And just to prove that some companies already think like this, we have received not a couple of weeks ago, three, yes three, catalogues from **TK Electronics** (11, Boston Road, London. W7 3SJ Tel: 01 579 9794/2842). Thank you gentlemen.

Needless to say, most of the projects this month were priced-up using their catalogues.

The catalogue consists of 28 crammed packed A5 pages, with most components ranging from common or garden resistors through switch cleaners, twist drills to kits of various shapes and sizes. One negative comment. The prices on the page do not include VAT. A slight inconvenience when hurriedly looking through comparing prices.

BEASTIES BY AH



SOFT OPTIONS

Editorial

In a recent edition of the *Financial Times*, Alan Cane wrote an article called "Junk Programs", in which it was reported that Britain's largest teaching union complained that evaluating educational software "had proved especially difficult, with no reference points from which to work".

Fortunately, the NUT spokesman had overcome this problem, and was able to tell Mr. Cane that, "Most educational software is junk. It is unreliable and rubbishy."

So it might be cynically thought, are some of the statements put out by some unions, which ought to know better.

Who has ever successfully evaluated a teacher? When did a book reviewer last dismiss the printing industry because he found it difficult to establish points of reference for his reviews?

Could it possibly be a fear of the unknown, which has provoked such extreme reaction, or do spirits of Captain Ludd disturb the slumbers of the NUT?

There is undoubtedly poor software around. Undeniably, there are overpriced packages which offer inadequate return to the purchaser. Obviously, we haven't yet worked out how to use the home-micro to the full and, yes, it's a madman's paradise at the moment. Of course, the NUT has a duty to comment on all of this.

But does its duty dictate that it should damn the whole software industry with sweeping pronouncements on "rubbish" and "junk"?

Would it not be more in keeping with teaching tradition if it were to guide, advise, comment constructively and ultimately help achieve a reasonable standard of product?

One way of doing this, it is suggested in the same article, is to set up a "central agency" to "evaluate and classify" software for schools use, with parents benefitting from such guidance.

Well, it is 1984, after all, and doubtless Big Brother would have approved.

Whatever happened to commonsense, personal judgement, individual choice? There are as many opinions on what makes a good or worthwhile program as there are types of machine to run them on, and different types of mind will extract different values from each package.

What is really needed, surely, is concerted pressure for a more realistic price structure and a satisfactory method of viewing the stuff before you buy it, and here the NUT might well have a useful role as lobbyist.

There are signs that the software market is improving its standards. Not all houses are cowboys, by a very long way, and some are very good indeed.

It is no more difficult to identify a good program when one emerges than it is to identify a good book. It just calls for a little more practice, a little more intelligence and a little less hysteria than certain bodies of opinion are presently displaying.

Contents

Hard News 2

All the news of new releases and new developments in educational computing.

Interactive Video Discs 4

The technology is developed, the applications are clear, but where is the hardware? We're still waiting.

Soft Talk 8

Program reviews this month of Good Housekeeping's Mr. T's Shape Games, two Shakespearean productions from Penguin Study Software, more from Ampalsoft, and others too.

How I Learnt To Stop Worrying .. 14 And Love The Computer

The tale of a teacher in training for computer literacy. Should he have taken up jogging?

Wednesday 11th April saw the launch of the Amstrad home computer package, the CPC 464, and if production goes according to schedule, you will be able to see this remarkable machine in shops such as Boots, Dixons, Comet and Rumbelows at the beginning of June, and you may even be able to buy one. It will set you back £229, inclusive of VAT, for the "smallest" system.

This price includes a proper typewriter-style keyboard, a built in cassette recorder (which takes standard-size cassettes) and a high-resolution monochrome monitor. The specification of the silicon bits-and-pieces is equally impressive with a screen display which can give eighty columns of text, a palette of twenty-seven colours and resolution to 640 x 200 pixels, stereo sound, and an industry standard BASIC which has a few extra and interesting commands.

If this specification at just over £200 seems impossible, reflect for a moment what Amstrad are attempting to achieve. They judge that in the audio market-place the consumer prefers a package (the Tower System) devoid of separate pieces strung together with a multiplicity of cables and connectors and that it is natural to move into the low-cost-micro arena with a similar package deal. Alan Michael Sugar, the company's chairman, says:

"The CPC 464, with its all-in-one packaging and the £229 price tag, brings the home computer within reach of almost every family in the country. Amstrad, with its aggressive marketing style, is committed to winning a large slice of this growing market."

Those of us queuing for a certain 32-bit micro might like to know that Alan Sugar intends to sell 200,000 Amstrad computers between now and Christmas, and that

SOFT OPTION

barring typhoons in the China Seas the first shipment of Korean-assembled CPC 464s should be in the High Street stores by the time you're reading this.

At the Amstrad launch, ten CPC 464s, in varying configurations, were all running well and looked to be production models, although the "insides" were never revealed... What *was* freely available for scrutiny, however, was a dozen or so pieces of cassette-based and disc-based software, including Hisoft's PASCAL, Digital Research's LOGO and the NEWSTAR wordprocessor.

The usual arcade-games were also in evidence, as were some early-learning educational programs from Bourne Educational Software Ltd. The

latter company also wrote the "Welcome" tape which is supplied with every Amstrad computer. To ensure a steady supply of software for their new machine, Amstrad have set up a software division called Amsoft. William Poel, head of Amsoft, is confident that the company will have fifty programs available for sale in June.

Amstrad say that they have designed their computer to provide both newcomers and experienced programmers with a non-idiosyncratic BASIC and an operating system (to be fully explained in a separate advanced-user's manual) which will provide a friendly environment in which existing software may be tailored and new software written. The various systems will provide a sound foundation for educational establishments that have hitherto been unable to find the cash to purchase the number of computers, monitors, etc that are required to provide the type of hands-on experience that cannot be achieved with one or two micros amongst a class of thirty.

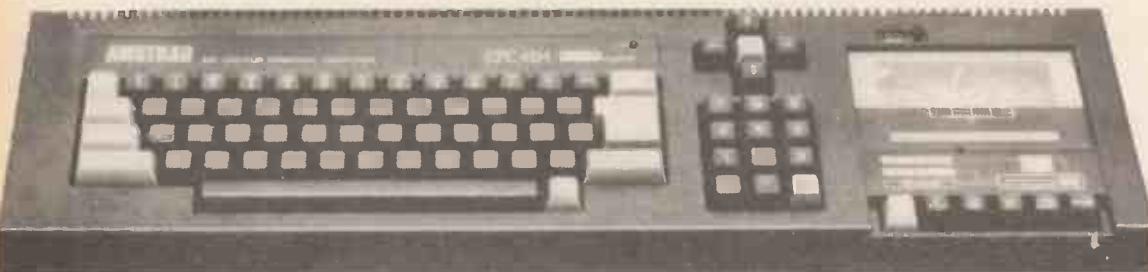

Book Trade Set Fair For Software

The 13th London Book Fair took place at the Barbican Exhibition Hall, right in the heart of London, between the 10th and the 13th of April, and it was notable for three things.

Not only was it substantially larger than the previous years, with 699 stands, representing a majority of the publishing trade, but it was also open to the public for limited periods. More significant than either of these factors, perhaps, was the deliberate inclusion of software and computer areas, which demonstrated clearly the very serious commitment

to computer assisted learning (or CAT, as we shall doubtless, increasingly, see it referred to), which book publishers have made over the last eighteen months.

Names such as Penguin, Collins, Nelson and Hutchinson are familiar to just about anyone who has ever read a book, and all now are deeply involved in the publishing, not merely of books about computers, but actual software. Their example is being emulated by many less well known, but just as respectable companies, all of whom are sure that there is a need for professionally produced, quality software which they should fulfill.

The first signs are that their instincts about the market are right. All the companies we spoke to were pleased with the interest shown by both dealers and the public in their products, and all were agreed that, whilst it was early days to be talking about profit, the prospects for educational software were healthy.

Penguin Software's academic marketing manager, Andrew Welham, said that sales of the company's new Study Software range were encouraging.

All the retailers who had taken the tapes initially had now re-ordered, which, since the

Shakespeare study aids were launched only in March, is an indication of the interest there has been.

Penguin are also pleased about the reaction they have received from the teaching community, from which they were expecting at least a degree of scepticism — founded only perhaps on the general association of software with 'computer games' rather than more enduring applications such as teaching. Instead, teachers on the whole have welcomed the six tapes currently available, as a step in the direction educational software should be taking, and Penguin are now considering ways of adapting their pro-

HARD NEWS

grammes for use in the classroom.

Shiva are moving in the other direction. After enthusiastic reaction from teachers who have used the company's eleven numeracy and logic packages in schools, Neville John, director of Shiva, has announced plans to offer the programs for general sale, suitably modified for the home market.

After the advent fifteen months ago of Collins' "Spectrum Starter Packs", which represented a first venture into the software market, the company has expanded its range to incorporate Early Learning programs.

Ken Hills, the Publishing Director of Collins, is enthusiastic about the prospects. Reaction from retailers to the new programs has been good, which is not surprising since they feature Paddington Bear, who is now obviously concealing a micro in the famous suitcase.

On a more ambitious level, Collins are also promising a BBC starter pack. This involves fifteen hours of programming for the user, at the end of which marathon, the company confidently predicts total competence in the basics of the subject. In common with an increasing number of publishing houses, Collins are emphatically looking to pastures new.

Pirates

Chalksoft Ltd. are moving into the arena with educational programs for the BBC Micro, Spectrum and VIC 20. One of their first ventures is an 'adventure educational program' (definitely an emerging trend). "Pirate" takes the player over sea and land, through battles, rocks, reefs,

mysteries and shipwrecks and all the paraphernalia of pirate tradition, in the cause of "strategy, planning and mapping"

Two programs for the Acorn Electron involve punctuation and grid co-ordinates. 'Punc-man', based graphically on Pacman-type games has Punc-man retrieving full stops and capitals eaten by Noshier and replacing them in their correct position; "Invisible Man" has a cartoon figure hidden in a grid, which has to be searched by means of choosing the right co-ordinates. These programs are aimed at 7-11-year-olds.



For older students, Chalksoft have Eiffel Tower, a French-learning program for the BBC 32K and Spectrum 48K, with Commodore 64 to follow. Other language programs, in German, Spanish, and English, including a 'Words and Pictures' program for 3-7-year-olds, are in progress.

More information from Chalksoft Ltd., 37 Willowlea Rd., Worcester WR3 7QP. Tel: (0905) 55192.

Robots On The March

The emerging trend towards a general curiosity about computer control applications is revealing itself in increased robot activity. Now that so many micro owners — includ-



ing very young micro owners — have familiarised themselves with programming, the question "What next?" arises. Writing games programs is usually the first stage in a developing computerate's self-education. The next stage looks as if it is going to be computer control of the outside world.

Robots are an effective means of learning and teaching computer control, quite apart from their entertainment value.

The ZEAKER robot is already familiar to some from its run under licence to Coln Robotics over the last year. Now the rights have reverted to the designer, David Buckley.

Mr. Buckley and colleague Robin Bradbeer have set up the new company IGR — The Droidsmiths (Inter-Galactic Robots) Ltd. with a hand-picked team to market personal robots for domestic, educational and leisure use, initially a family of Zeakers.

Following ZEAKER I comes ZEAKER II, the "draw-droid", which is being launched at the London Festival of Computing's Computer Fair in April.

ZEAKER II is a turtle robot with a mobile pen, and is designed to interface with LOGO, which is available on some microcomputers and is becoming more commonplace. LOGO for the Sinclair Spectrum has been scheduled for release at around the same time.

The ZEAKER III is scheduled for launch later in the year, and will be a buggy-type, expandable by the addition of extra modules, selling in kit form for under £100.

IRG are beginning their career by giving ZEAKER I a substantial price cut on its previous price of around £200. Further information can be had from Robin Bradbeer at IGR, Unit 208, Highbury Workshop, 22 Highbury Grove, London N5.

O LEVEL MATHS/PHYSICS

For 32K BBC Micros & Electrons
Multiple-Choice Revision Programs

- Large database of questions — random selection for each test.
- End of test score, time-report, answer-check
- Cut-off option, on time-up you're marked on the number of questions completed.

£10.95 per cassette (inc. p&p): Both for £20
S.A.E. for further details.

Heliwell
Software

157 St. Peters Rd.,
Reading RG6 1 PG

Interactive Video Disc System

Video disc systems are the latest in home entertainment, but how long before the industry extends its vision to the educational horizon? Soft Options examines the potential of a technology in waiting . . .

by Richard Sargent

The influence of television on the people of the Western World is indisputable. It fascinates the viewer with moving images in full colour, attracting and holding attention for more hours than might seem reasonable, but whether educational television has proved a significant resource in the last 20 years is a moot point.

Moreover, the market for videocassette recorders, so ably exploited by the Japanese electronics industry on the one hand, and the TV rental companies on the other, had demonstrated that even relatively expensive systems have found their way into numerous households.

However, both television and video tape suffer from a major drawback so far as educational material is concerned: they follow the sequential format inherited from cine-film, and once the viewer starts to watch "a programme" he tends to watch without pause until its end.

This is desirable, if not essential, for entertainment and recreational programmes, but it is highly undesirable for most educational purposes.

Even the best of contemporary schools and college TV broadcasting can leave dissatisfied customers, both





Philips' LaserVision is the favoured technology for interactive video systems, though the Long Play version shown here would not be suitable.

among teachers and taught. the information disseminated.

Programmes, ephemeral by definition, are designed as units of continuous narrative or argument. The viewer cannot pause, reflect or take notes while viewing without losing the thread of the argument.

The level, format, structure and language of any given transmission are influenced by the potential audience as conceived by the producer and thus the usefulness of any specific programme for any particular student is rather a matter of chance than design.

The student cannot question the system to clarify his or her understanding, and the tendency is towards passive acceptance by the viewer of

Advances in video cassette recorders have begun to redress this balance, and the latest machines provide the facility to stop, slow down, or retrace steps during a programme. Although it is possible to extend computer control to these recorders, true random access to the material on the tape is not possible, and still-frame techniques are best avoided due to excessive tape degradation.

Magnetic tape technology has serious limitations, and so it is only now, with the emerging videodisc technology, that the concept of "Interactive Video" is approaching maturity, and when it does arrive a great many old and inefficient methods of learning will be swept aside.

The Pioneer LaserDisc, with in-built facilities for remote control, has been adapted for computer interactive control.

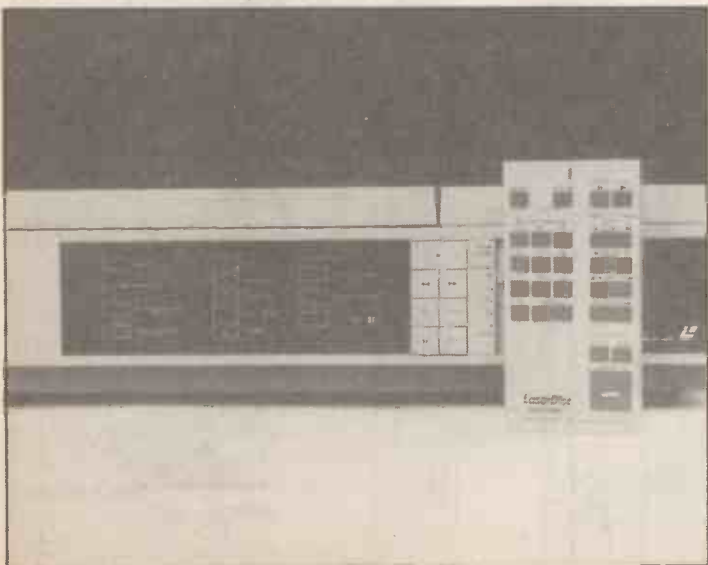

Soft Options, June 1984

Interactive Video embodies the immense potential which results from the convergence of technologies: the TV and film industry which can make available documentaries, archival material and custom-produced programmes, and the computer industry which can make the micros manipulate the video and turn it into a contemporary or historical window looking at the real world but allowing interaction with that window-world with a higher degree of control than would be possible in the real world.

The videodisc has been with us since the 1960s in experimental form, and after many

this, but the pricing structure is likely to reinforce it: at £200 the CED player is at least half the price of the LaserVision player.

It should be said here that the quality of picture obtainable from both systems is superb, and can only be fully appreciated if the video signal is fed into a monitor rather than to a domestic television receiver. The pictures, rock-steady, brilliant and sharp, can only be matched by those found within recording studios.

However, the CED disc is delicate and will, if played excessively, begin to wear and



Learning to fly a kite, a hang glider, or a 747... interactive video systems could provide a vivid insight into the mechanics of flight.

false starts there are now two main contenders for the lucrative home and educational market: the CED Video Disc System (formerly called the RCA Selectavision system) and the Philips' LaserVision system.

Both use double-sided discs, 12 inches in diameter, which sell for between £10 and £20, but there the similarity ends. The systems use totally different principles to extract the video and sound information from the disc surface. All the indications are that the CED Videodisc will be used for standard sequential viewing and will figure large in the domestic market, whereas the LaserVision will be used in the business and information dissemination fields. Not only are there technical reasons for

degrade whereas the LaserVision disc is robust and cannot be worn out in normal use, however many times it is played.

The LaserVision optical video disc (hereafter simply called the disc) was invented and developed over 10 years by Philips in their Dutch laboratories.

Each disc carries colour television information, two sound tracks and associated control data on a single spiral track which can give about one hour of continuous viewing if it is a Long Play (CLV) disc or 37 minutes if it is an Active Play (CAV) disc.

The programme track is read by a micro-fine laser beam inside the player. Because

Man of Vision

Michael Grove is a man "obsessed by the problems of education". A product of a traditional grammar school, whose restless enthusiasms were never satisfactorily catered for by the system, Mr. Grove is an Interior Designer with more than a passing interest in the micro revolution.

During the past three or four years he has conceived and designed a video disc interactive system which, if properly funded and promoted, could, he believes, help change the face of education as we know it.

The video disc interactive system he sees as an integral part of the educational revolution. "The beauty of the video disc is that it encompasses every facility that mankind has known up until now to communicate an image, all on one disc.

From the educationalists point of view, Michael Grove says the system has the ability to "tell the user what he's going to see before he sees it, what he is seeing while he is seeing it and what he has seen after he's seen it. Any tool which can give you that kind of potential is a very powerful tool".

Michael Grove took his ideas to Acorn. "I have



worked in association with them since they had 25 people — now they have nearly 500." The association has spawned a working system, exhibited by Orbis Computers at several big computing fairs during the last 18 months, but the problems of finance make it unlikely that working systems will find their way into schools in the near future.

Grove is encouraged by the attitude of Government departments, where he has found a small core of people who understand that the future is with the infants of today, and who are therefore anxious to examine the possibilities of developing the systems specifically for the primary market.

The MEP, too, has been constructive in its attitudes, but in a sense video disc interactive systems are still of the future.

As Quentin Bell, Acorn's PR company, say, "It is still very much a technology in search of an application".

Michael Grove is philosophical. Ideally, he would like to make a system which is sophisticated, yet imposes few restraints on the user and to do it at a rock bottom price. He recognises that as a designer he has the freedom to think such Utopian thoughts, but that market forces render such things impossible for commercial companies.

Nevertheless he is optimistic and believes the next five to eight years will bring his project to fruition.

One of the applications that he envisages is vocational retraining of the working population, and since the interview with him, the EEPTU (the Electrician's Union) has announced co-operation in just such a scheme.

This country is fortunate in that, despite a history of good ideas pre-empted or given away to foreign markets, it still produces people like Michael Grove, who have the imagination, initiative and energy to get new technologies off the ground.

Mary Sargent

there is no stylus and no physical contact between the disc surface the discs do not wear out, and are thought to have an impressively long life.

In the case of the Active Play disc, the programme track is segmented into 54,000 separate frames, each of which is numbered and can be randomly accessed. It is this feature that make the CAV disc quite unlike any other video disc.

There is a microprocessor already fitted in all the current videodisc players, but it is kept busy supervising the precise positioning of the read-head on the track and controlling the speed of the turntable, etc.

On the "industrial/educational" players there is a second micro onboard which gives the machine a certain amount of intelligence, since it can accept instructions from the keyboard or from information encoded on the disc itself. But perhaps more importantly, this micro allows the machine to communicate with an external computer.

Under the control of purpose-written programs, the full potential of the disc player is realised. A search can be made for any one of the 54,000 frames, Teletext data, already interleaved between the frames on some discs, can be extracted and read. The picture can be shown in sequence with sound, or static, as in a slide display. The frames can be strepped through slowly, backwards or forwards, or reviewed at fast speed.

The teletext data or data from the computer's floppy discs can be overlaid on the screen entirely or in boxes. Computer generated graphics can be included in the complete programme.

The equipment already exists, and it is not particularly expensive.

The two current LaserVision players from Philips are very much domestic models and cannot be connected to computer systems. The



Pioneer LD 1100 laser disc player, on the other hand, although designed for the consumer entertainment market, has features that make it possible to utilize it for a degree of interactive programming, and can be linked to various makes of micro.

Pioneer offer a general purpose interface, and a prototype interface specifically designed to connect to a BBC microcomputer has been demonstrated by Orbis Computer Ltd, an Acorn subsidiary.

Laser discs are expensive to produce and it is not surprising that there are, as yet, few titles suitable as the basis of a computer assisted learning program, although most of the big-name companies are waiting in the wings, presumably to see how the sales of domestic machines and entertainment-discs progresses.

Among those interested are Thorn-EMI from the film and disc industry, Longman and Macmillan from the publishing houses, and BBC Enterprises/Open University representing TV Education.

Preparing the master-copy disc from an existing high-quality film costs in the region of £2000, but the cost for an interactive package which



Interactive Programming of the First Kind - following the leader.

would including original filming and the software to handle the subject matter is variously estimated to be £30,000 to £100,000.

In view of these costs, it is perhaps a little surprising to find such Active Play disc titles such as David Attenborough's BBC *Videobook of British Garden Birds*, BBC's *Romance of the Indian Railways* and the Open University's

Help your child to read in the vanguard of educational (in its broadest sense) material.

The entertainment area is rather better catered for with some 400 Long-Play titles currently available for the domestic Philips system.

As with all new technologies, it is easy to pull impressive figures out of the hat which "prove" how wonderful the system is.

Yes, certain optical discs can carry the entire text of *Encyclopedia Britannica* with room to spare but that might not interest an eight-year-old, or for that matter, his teacher.

But what a group of teachers saw demonstrated in the Summer of '83 left them all asking "When could my school have one of these?". The system they saw was a BBC micro with a single floppy disc and its own black and white monitor linked to a Pioneer disc player with its own colour monitor.

If a picture is worth a thousand words then a video disc under computer control

must be worth ten-thousand. Single-stepping the TV frame forwards through the flight of a bird; a wave breaking on the shore-line; a complex chemical reaction — minute detail can be seen by the student, perhaps for the first time ever, and it can be explained and believed because it is real.

It is likely that the video disc will first be used in schools as a superior audio-visual aid which will communicate with the teacher and a class group in a set-up which probably won't look like any different from today's teaching sessions with a Video Cassette Recorder.

However, the interactive disc system also has its own program language, Microtext-plus in the case of Orbis system, and any Active Play disc can be turned into an individual work station which can tutor the student in a friendly and flexible manner.

It is this arrangement which is likely to find its way into a great many households before the end of the decade, and when that happens, the face of education in Britain will have to change.

Down-market video disc systems for the consumer may offer potential for computer control in the future.



Soft Talk

This month's reviews have been written by primary and secondary teachers, and by parents with children of the ages catered for by the programs on test.

Mr. T's Shape Games

(Good Housekeeping/Edbury Software)

48K Spectrum
BBC Model B
For ages 3-6
Price: £12.95

Good Housekeeping are marketing a range of educational programs designed for the home computer, and for children aged 3 to 6.

Each package aims to provide activities for a parent and child together, and is designed to encourage discussion and establish the techniques and vocabulary appropriate to the subject. It moves on to games for one and two players with adult help or on their own, as they wish.

The games use amusing graphics and an animated character called Mr. T. Sound effects and tunes provide necessary stimulation and reward all the children's efforts, which helps maintain their interest. The accompanying sound handbook suggests follow-up activities and gives useful advice, such as "This is a game for a child to play with an adult. You might use it instead of reading a story — but not at bedtime when your child is tired."

The emphasis is on making the learning process for both adult and child, an important point since the child's whole

attitude to computers and computing can be influenced by these early experiences.

Children can work at their own pace, which removes the potential frustration of continuous failure, or the boredom of too much repetition. Different levels of ability and age are catered for, and the adult can select the level of difficulty or leave the program to adjust automatically to increasing ability.

Operation of the program is uniform throughout the range, and even parents new to computing need only a quiet half hour alone with the handbook and the program to ensure a problem free introduction for their child.

Each cassette comes in a glossy book-style box, with the handbook, and costs £12.95. It is a matter for individual choice whether that sort of price for one early learning program is worthwhile, considering the books and toys which are available for this age-group.

Some of the programs have a greater potential for long term use than others. Mr. T's Shape Games has two programs on it: the first is *Figsaw*, a shape recognition game.

The game begins with a pattern made up of two or more shapes on the screen. Once the pattern is complete, a

triangle, square, or other shape appears at the top and slides down over the position. The child fits the shape into a matching part on the pattern by pressing the SPACE bar to stop it at the appropriate place, and there is a suitable margin for error to take account of failure to hit the bar at exactly the right instant.

Played with an adult, the game encourages increased perception by the asking of questions — several are suggested in the handbook.

This is suitable for teaching three or four year olds about shapes and is an enjoyable game for older children, the increasing levels of difficulty extending its useful life.

The second program is called *Shape Maker*, and in this game the player builds up a pattern or picture by choosing different shapes, changing their size, positioning them on screen and colouring them in. It requires continuous help from an adult, because the options at each

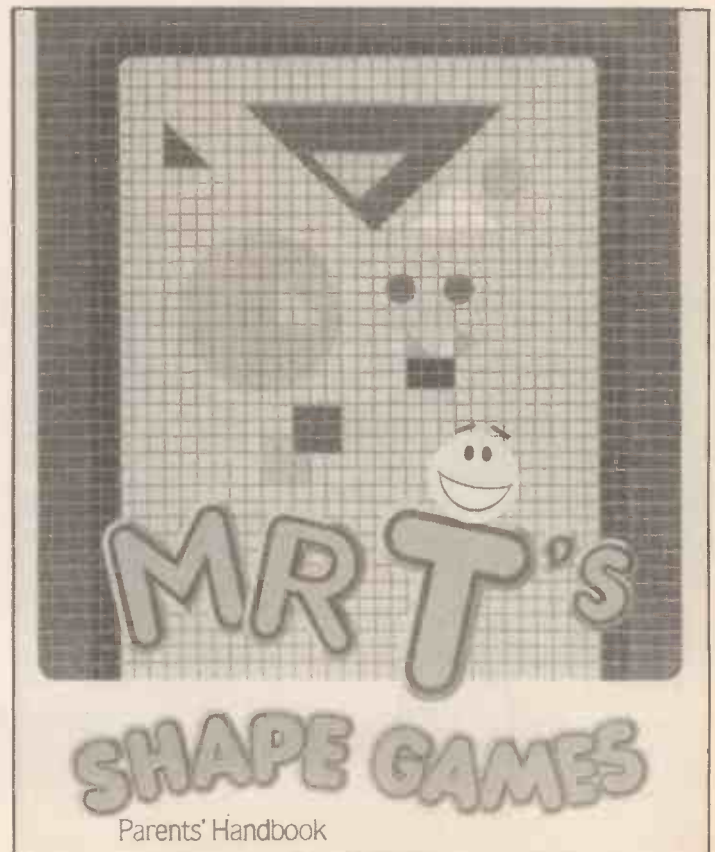

stage require extensive explanation.

The game is designed to explore the relationship between various shapes and their symmetry. It is, in fact, laying the foundations for the study of geometry. Some children might find their inability to control the program alone frustrating, but by the age of

about seven, they should be able to allow their artistic abilities full rein unaided!

Good Housekeeping programs are generally available from branches of W. H. Smith and from leading High Street retailers. Versions for 48K Spectrums will be available in May, priced at £9.95.

Cartesian

(Flite Software)

BBC Model B

Price: £27.75 (disc) or £24.90 (cassette)

Reviewed by Robert Newell

Cartesian is a package aimed at promoting an understanding of the value of mathematical functions and determining their roots. The cover notes claim: "High resolution graphics and excellent documentation mean that in a short time you should absorb most of the concepts relating to calculus and the solution of polynomials."

This is ambitious, since it implies that the program and documentation are in themselves sufficient to promote a large measure of self-instruction in a wide area, and I do not feel that the package achieves this.

The documentation consists of an 18 page booklet, of which only five pages are devoted to explaining the mathematical principles involved in the very wide field the program deals with, and a supplementary page dealing with fairly significant alterations to the operation of the program.

It is adequate, but not excellent, and successful running of the program will involve some intelligent

experimentation with the keyboard beforehand!

Having said that, I believe this program is capable of giving considerable help to a student using it to supplement conventional teaching material. It could also be constructively used as a classroom teaching aid.

Specifically, the package permits the following operations: (a) Graphical presentation of a function and its first derivative. Up to six degrees of freedom can be handled and the value of a function over a very wide range of values of x and y can be examined by means of a series of displayed manipulation commands.

(b) Calculating the roots of the equation using the Newton-Rapheson method.

(c) Calculating the definite integral of the function (areas under the curve) using Simpson's Rule.

(d) Solving complex equations. The program will find the roots of quadratic equations not having real solutions.

The program is in two parts which are chained in the usual way. The first part sets up the screen and other parameters, and then loads the main program, which is written in BASIC.

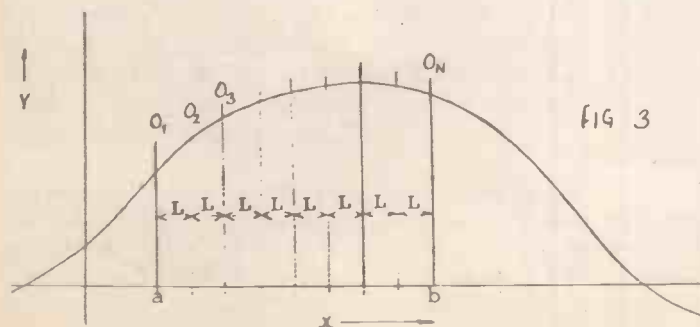

cartesian

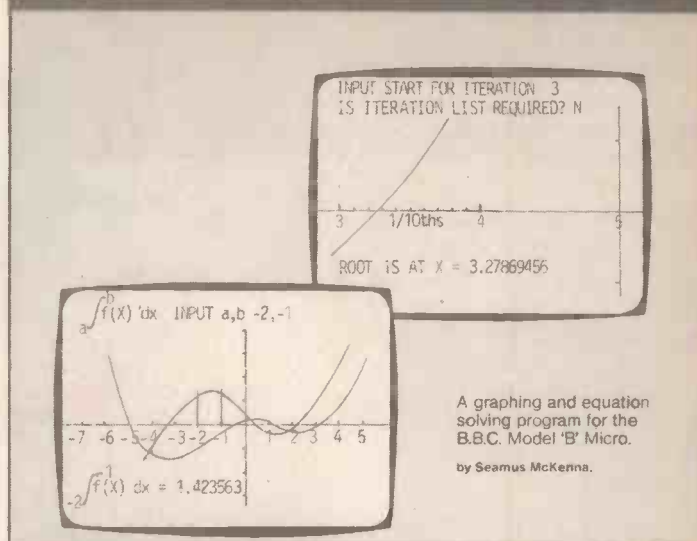

It is possible to escape and examine the code by pressing E. The BREAK key has been redefined to re-run the program, which can be restarted after exiting, provided the display mode has not been changed.

The program itself is fascinating to use.

The program itself is fascinating to use. Function plotting is fast, and it is great fun to enter different types to see what shaped curves result. Some patience is needed initially in finding the best scale and off-set for the axes for plotting a particular function, but this becomes easier with practice.

Three example functions are included in the appendix and are useful for preliminary experiments.

The differential of the curve can be plotted at any time and the screen is only cleared on command so that several functions can be plotted at once, if required. This allows comparison, and the program could be recommended on the basis of this display facility alone. It could not fail to give any student an insight into, and understanding of, the way functions behave.

The roots of the equation defined by the function may be discovered by a single key command. The Newton-Rapheson iterative method is used and the program asks for

an initial approximation, which may be found by noting the position(s) where the plotted function crosses the x -axis. Computation is fast, too.

The definite integral is evaluated using Simpson's Rule. Again, a single key command is required, and the program requests the interval wanted. The method for both routines is fully described in the handbook.

The program will also evaluate the roots of a complex equation, but only for the quadratic case. It does this by explicit calculation using the co-efficient of the expression, which must be typed in. I did not find this capability particularly useful or instructive.

Cartesian is fun to use, which should go a long way towards ensuring that it is used, and it is both powerful and flexible enough to be of real benefit to any serious student of mathematics.

Only refinement of the screen display and an updating of the handbook, together with the inclusion of a few sample sessions, are needed to turn this very good piece of software into a truly excellent package.

'Cartesian' is available from Flite Software, Findrum, Convoy, Co. Donegal, Ireland. Telephone 010 353 74 22286 or 010 353 74 22025 for details.

Henry IV Part 1
(Penguin Study Software)
48K Spectrum
Price: £5.95
O-level/CSE standard

Reviewed by **Francis Josephs**

This is an interesting program, simple to use and with a clear screen display, but although Penguin recommend it for use by CSE and O-level students, I would think it rather too difficult for the first group and not complex enough for the O-level students.

I don't think it likely that the program allows "very sophisticated studies" of the text, as is claimed, but a student can benefit from it by following a character or theme of his choice through the play, with a series of intelligent questions, statements and observations.

Standard explanations are not given, but although the absence of easy answers is an excellent feature, it might perhaps have provided encouragement and stimulation if, occasionally, a clue were given as to whether the student was on the right track.

Alternatively, a supplementary question, such as "Does this passage suggest a. or b.? If a, then how do you explain c.?" might have been helpful.

A source of confusion might be in the line references, which refer only to the Penguin New Shakespeare text. By the end

HENRY IV PART ONE



© MAHONEY + MARTIN

of a scene, there can be as much as six or seven lines difference between different editions of the play, so it would seem logical to quote the first line of the reference, to avoid misunderstanding.

At the end of the searches I was disappointed to find no overall conclusion, no series of questions for future consideration, not even a suggested critic or book to read.

A **specific option** which I found unsatisfactory was the examination of language. I thought it superficial, since it failed to examine the use of language in any depth at all, and a search of Act IV produced the fatuous statement, "You were searching a part of the play for something that was not there to any significant extent." That would have surprised Shakespeare!

I would also have liked to see

two levels of questions, to cater for the different standards of exams and to allow for the increased understanding of specific students.

This is a useful program for

Macbeth offers students the chance to review the major characters and themes in combinations of up to three at a time.

The program indicates other possible cross-references, or informs you that there is no worthwhile point to follow up.

Each reference to the play is from Penguin's successful New Shakespeare texts, and is accompanied by questions or statements that encourage the student to think carefully about the play.

The screen display is excellent, with an uncluttered and well-balanced layout that is easy to read and follow. A cursor allows you to choose topics and either follow one topic through the entire play, or through individual acts, or



© MAHONEY + MARTIN

enabling students to think about and memorise themes and characters, and is especially useful for the less well motivated pupils, who will like the format.

It is valuable because it requires close working with the text, but it is not all that it is claimed to be. There are definable faults and some missed opportunities, but even so I shall keep my review copy for future use.

Macbeth

(Penguin Study Software)
48K Spectrum
Price: £5.95
O-level/CSE standard
 Reviewed by **David Cooper**

select further topics for comparison.

In theory, then, an excellent program that combines thoroughness with imagination. It was when we turned to investigate one theme that the advantages and the disadvantages became apparent.

There are seven references to the Witches in Act 1; many of them are so short as to be obscure, and one is both confusing and misleading.

We are told that "the witches and all they stand for set the tone of the play." Even if it were true, it is vague, and the blank space left on the screen



might suggest that a more thoughtful comment would have been better.

Worse, we are told of the famous line "Fair is foul and foul is fair" that this "inability to see" leads to destruction — a comment that neither I nor my A-level students could understand. In effect, the comments here are rather too enigmatic for most pupils to use on their own.

They could, however, be the basis for excellent class discussion, if any teacher chose to use a lot of class time in this way!

The merit of this program lies its ability to place characters and themes in an interesting relationship, even if at times it dismisses as obvious and beneath discussion points that would be worth considering with CSE pupils.

In this context, it is worth mentioning two omissions that, if included, would help all students — line references to quotations used in the comments, and a list of all the references on each topic at the end.

Where do these programs fit in? Revision notes, including Penguin's own new series, are cheaper and allow the student to turn back a page (the computer program does scroll back).

On the other hand, used as a revision aid, the program will enable anyone to improve their understanding both of individual scenes and the overall pattern of the play.

I'll buy some of the others in the series, but I look forward to a second edition that chooses its words more carefully, and isn't afraid to go into some detail on each reference chosen.

Penguin Study Software is available from branches of W. H. Smith, Boots, and all good book shops.

Soft Options, June 1984

Birds In Fresh Waters

Following a stream of other distinguished publishing houses, Penguin have not merely waddled to the edge, but have plunged headlong into the perilous soft seas, with six programs designed to launch the Bard on his most innovative voyage since printing was introduced. The first series are designed for the O-level/CSE candidate.

It is a formidable undertaking, and the advertising division of Penguin Books hasn't made it any easier.

"The first truly revolutionary breakthrough in the study of literature since the invention of printing." "... such a claim requires a totally original concept — Penguin study software is exactly that." "The Ultimate Blackboard". "... gives Total Access." and more moderately, "the best piece of Educational software to be launched in 1984."

It cannot be said that the admen haven't done their stuff. On the other hand, such hyperbole might obscure the interesting facts that Penguin's software team has also done its stuff, and not at all badly.

Stripping away, as one must, the adulatory gunk, reveals the workmanlike product which, if it doesn't achieve the dizzy heights constructed for it by the dream factory boys, at least represents hope, and light on the hitherto bleak horizon of software for learning.

As was to be expected, Penguin have taken care to use the right tools. Many Educationalists feel that serious software should be designed, if not written, by people with knowledge of the subject as it is taught — in other words, in-service teachers.

So Study Software is written by two in-service teachers of English literature, with thirty years experience be-

PENGUIN STUDY SOFTWARE

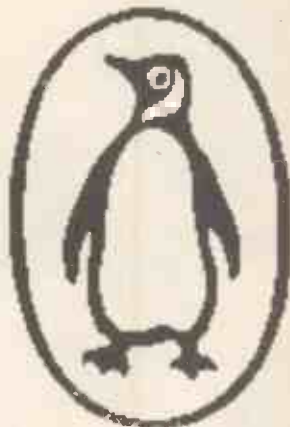

tween them, and strong views on the need for teachers to be involved in microcomputing.

Complaints about obscure instructions and poor mechanics of some programs have also been listened to, and Study Software is a thoroughly efficient and well presented range of programs. Were their rumbly about price? At £5.95 for each cassette, Penguin have placed their products within the range of the finances of the home users for whom they are intended. The reviews printed here were written by two senior English masters at two separate secondary schools. Although Study Software is intended for the student revising at home, professional opinion was obviously relevant, and the more so because Penguin admitted to "expecting some flak" from the teaching profession, on account of daring to try to "teach Shakespeare on the computer".

Of course they are not trying to do this, and their apprehensions have not been justified. Reactions seem, rather, to be interest and qualified approval, notwithstanding the earnest young gentleman who enquired of

the authors at the press launch as to whether they suffered qualms about Shakespeare's opinion of their enterprise. They were very nice to him.

They were also very nice about more serious questions. Neither the authors nor Penguin Software division are claiming to have found all the answers to the problems inherent in educational programs, and they seem genuinely concerned to benefit from constructive comment.

Since Penguin are heavily committed to software, with a promised range of twenty or so titles initially (not all Shakespeare) and John Mahoney and Stewart Martin are now both out of teaching and into full-time programming, it's in everybody's interests that they should be receptive.

This kind of professionalism and dedication of resources can only be in the best interests of the educational software market generally. Penguin have proved their value in the publishing world beyond the need for comment. The signs are that they can only be of value to the software industry, too.



Maths 'O' Level Revision Part One

**Calculus, Arithmetic,
Construction**

(Ampalsoft)

Cheshire Cat Educational
Series for Dragon 32
computers.

BBC Model B version
available from April 1984.
Price: £14.95

Reviewed by N. E. Martin.

There is nothing offered by this computer course that could not be done in a book, but given that revision is a boring fact of life, if doing it on your Dragon is more fun then that may be a good and sufficient reason for using a computer, at least while the novelty lasts.

The course comes on two cassettes and all the following topics are covered in depth: Areas and Volumes, Ratios and Percentages, Interest, Averages, Velocity and Acceleration, Equations of lines, Gradients, Differentiation, Turning Points, Integration, Areas and Volumes by Integration, Geometrical Constructs, Lines, Angles, Loci and Examination Techniques.

The topics covered on each side of a cassette are detailed on the fact card provided (although for some reason Ratios are omitted from Arithmetic 1) which also contain clear instructions on how to run the program.

Each side of the cassette is menu driven by the major headings, as are most of the sub-sections. It is therefore easy to select a particular topic for revision, and there is no requirement to complete one section before going on to the next. At the end of each screen displayed (apart from the menus themselves) you have the option of returning to the top level menu, continuing to the next page or going back to the previous page.

In general each topic is covered in four parts: a brief explanation; some worked examples; a set of questions for you to attempt; and the answers. At the end of the answer screen you can request details of the working of any or all of the questions.

This is not a teaching course and should not be used as such. Its explanations and examples serve only as a reminder of previously absorb-

ed (?) facts. However in both the examples and the questions it sets, the program attempts to show the various ways in which an examiner may approach a subject and you should end up knowing how to apply your knowledge to most questions. It would perhaps be useful to draw students' attention to this point.

The examination techniques given on the last side are all good stuff. Don't ever underestimate technique — whatever exam you are taking, it can pick up that vital mark for you! In terms of information per byte, this must be one of the best value programs around and if you are hooked on computing it may help you get your Maths O-Level too.

The Cheshire Cat series is available from Boots computer departments, Dragon Data, and selected High Street stores.

Advanced BASIC Tutorial

(Ampalsoft)

Cheshire Cat Educational Series
for Dragon 32 computers.

BBC Model B version
available from April 1984.

Price: £14.95

Reviewed by N. E. Martin.

This course assumes that the user already has some knowledge of the BASIC language, although there is a brief revision session included. It could equally well be used by anyone familiar with other high level languages who wished to extend their knowledge to include BASIC.

The course covers three major areas — graphics, music and formatted output — together

with a number of smaller but very important topics such as string-handling, subroutines, arrays etc. Details of the areas covered on each side of the two cassettes are contained in the fact card provided, which also gives simple instructions on how to load and run the programs and a recommended order of study.

Each side of the tape is a self-contained section driven by a menu of topics. Each topic is presented as a sequence of screen displays and at the end of each display the user has the option of continuing to the next screen, going back to the previous screen or returning to menu selection. This enables him to control how much or how little of each section he wishes to cover.

The first side includes a brief revision session, further PRINT facilities, array and data handling and some notes on using the cassette recorder. In general the presentation of the material was clear, but unnecessarily slow, and more use could have been made of highlighting and flashing to emphasise various points.

There was insufficient user interaction to maintain interest, particularly during explanations of PRINT USING. This was a powerful tool, which would have been enhanced by more specific explanation and lots more interaction.

The second side covering variable values, mathematical features, subroutines, functions, strings and sounds/music, proceeded at a better pace, but were two screens of ASCII conversion table really useful? Surely, these would have been printed on the fact card, if needed.

Cheshire Cat Advanced Level Basic Tutorial includes:-

- Drawing Shapes and Moving Pictures
- Music and Noises
- High and Low Resolution Graphics
- Sub-Routines and User Functions
- Manipulating String Variables
- Numbers and Mathematics
- Arrays and Data
- Typing and Testing Programs
- and a complete PRACTICAL session providing Exercises, Examples and Solutions.

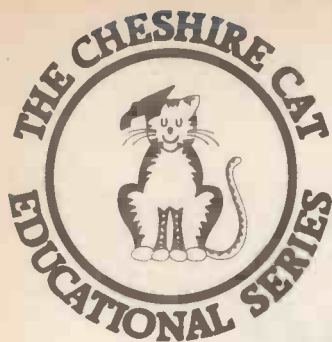

Young Learners I

(Rose Software)
16K or 48K Spectrum
Price: £5.95

Reviewed by **A. J. Verdin**
The tape contains four programs of the drill-and-practice kind, so beloved of software houses. This type of program is most easily available to the public, and they are always described as educational.

The coverage of strings and music, however, gave a good idea of the extensive facilities available, but more interactive work would have improved it.

Side three goes into graphics, with details of high and low resolution screens is well explained and the user is given the opportunity to experiment with various settings of SET and RESET in a "controlled environment".

But be warned that a colour screen is essential to gain most benefit from this section.

Side four contains exercises covering the earlier material, together with sample programs producing the requisite output. Once again, a colour screen is essential, since the colour graphic exercises could not sensibly be attempted in black and white.

In general, the course contains a lot of good material but does not take sufficient advantage of the facilities a computer offers for user interaction. In particular, a different method of presentation would allow the user to work at his own speed, and more use of question and answer sessions within the tutorial would improve the user's grasp of the facts presented.

On a technical note, BREAK was sometimes disabled for short periods, but worked in general, and on none of the Ampalsoft programs did we manage to upset or break them by a silly input.

The Cheshire Cat series is available from Boots computer departments, Dragon Data and selected High Street Stores.

Soft Options, June 1984

ABACUS is an exercise in addition, up to either 10 or 20, using two horizontal abaci with beads sliding from right to left, one at a time. These enable counting on the first line as they appear, and then on to count on the second line. After the answer has been entered, the same exercise is repeated on the vertical abacus, the computer numbering the beads as they appear.

A picture of a house and garden is built up with each answer that is correct at the first attempt. The colouring of the beads seems to be random and it is unfortunate that, if we have to go through the same process twice, the colours should not appear in the same order each time, so as to appear to be the same beads each time.

The program would have been more useful had there been an option for choosing any total up to 10 been available, since children need to be confident with the lower numbers first. The program is friendly, saying hello and asking for the user's name, although the flashing screens are both annoying and unnecessary.

The building up of the picture was appealing, but the whole process of counting beads twice takes so long that boredom inevitably sets in.

Time is perhaps the best of the four programs. The menu comprises four options: 1) on the hour only; 2) plus half hours; 3) plus quarter hours; 4) any time at all.

A clock with two hands pointing to 12 is displayed,

and the user is invited to set it to a time specified by the computer. The time is given in two ways, ie '10 to 9' or 8.50. The long hand is moved by using L and ENTER, then the short hand by using S and ENTER. If the set time is incorrect, a clock face showing the correct time is displayed.

This program can give plenty of practice at each stage of telling the time, and seemed to be fun to use.

SHOPPING claims to familiarise the user with the eight coins in current use".

But nothing can familiarise a young child with coins except handling the coins themselves; certainly the crudely labelled

like a Snakes and Ladders board. First the computer throws a dice and then the number of the square where the counter should land has to be entered. If the answer is correct, the counter moves up a ladder, but if incorrect it drops down a snake.

The program gives some practice at using a number line, but the graphics are uninspiring, and the noise irritating. Playing the real game of Snakes and Ladders is more fun.

Although 'Time' is quite a valuable teaching aid, the other programs, owing to their lack of innovation, soon become boring and are ultimately less enjoyable and

Preparation of this programme is the responsibility of the user. Send SAE for Catalogue of all our products to: Rose Software, 148 Widney Lane, Solihull, West Midlands B91 3LH

SPECTRUM 16K/48K SOFTWARE

YOUNG LEARNERS I

ABACUS
TELLING THE TIME
SNAKES
SHOPPING

ROSE SOFTWARE
SPECTRUM 16K or 48K

outlines which appear on the screen will not do so.

The user is invited to buy items, selecting the correct coins exactly, or to work out the appropriate change from a specified amount, so in effect this program is simply an electronic workbook, and the answer will need to be worked using coins. The only role of the computer is to provide instant feedback.

Snakes is a board game, with numbers from 0 to 34 arranged

instructive than the real activities they are meant to replace.

Rose Software is available either direct or from selected High Street stores. New full colour packaging, to be released shortly, is expected to result in a price increase.

Rose Software,
148 Widney Lane,
Solihull,
West Midlands,
B91 3LH
021-705 2895

How I Learnt To Stop Worrying And Love The Computer

An everyday story of a teacher's re-programming as an adept in the world of bits, bytes and bugs.

by Barry Birch

Barry Birch is head of Geography at South Kilburn High School, and has recently acquired a Diploma in Professional Studies in Education (Computing). He is considering taking the British Computer Society exams, having been granted exemption from Part 1.

I teach in an Inner London comprehensive school, where I am Head of Geography. Among my talents, I number a complete absence of any mathematical ability, a situation which has not altered since my failure to achieve O-level in this most holy of disciplines.

Three years ago I became aware of the micro-electronic revolution when the school acquired its subsidised 380Z and invested in half a dozen or so ZX81s.

Awareness, however, is far from being interest, as all teachers know, too well, and it was not until a year later that an instinct for self-preservation led me to delve deeper.

A group of colleagues already enamoured of The Chip demonstrated to the rest of us a course they had developed for all third year pupils. It involved, among other things, an introduction to programming in BASIC, using the ZX81. It suddenly dawned on



Extract from Glib Gloss — the guide to the real meaning of the jargon of everyday computer folk . . .

Word Processor: Computer salesman in pursuit of a gullible customer.

me that the pupils whom I taught and loved so well were about to gain an insight into a totally new area of knowledge and would be well placed to score some points off Sir.

It obviously behaved me to acquire, not merely some well timed enthusiasm, but some fairly fireproof knowledge, and that right speedily.

Despite, therefore, my complete indifference to the

workings of electronic gadgetry and my studious avoidance of all matters mathematical, I cultivated an intense interest in micro-computing. It's amazing what children can inspire one to do!

I began by following the same course designed for the third years, and I enjoyed it! I decided I knew how Columbus felt when discovering the New Worlds. I shall never forget the pride I felt when I

wrote my first 10 line program. It flashed my name on and off screen continuously and I'd always yearned to see my name in lights.

With help and encouragement from the Head of Computing, I quickly became adept with conversational bits and bytes and bugs, and I also learnt a lot. One of the things I learnt was that my non-existent maths *did not matter* to my growing addiction to computing, since there were plenty of aspects to this new learning where logical thinking and hard work were of far greater importance.

This is an eternal truth which doesn't receive enough publicity, in my opinion. Can it be that mathematicians are in a conspiracy to keep it all to themselves?

In recognition of my services in discovering this fact for mankind, two years ago I was seconded to a course at South Bank Polytechnic to study for a Diploma in Professional Studies in Education, (Computing), which is, I think, the only full-time course available to teachers who wish to re-train to teach Computer Studies to O-level, or whose non-computing colleagues can't stand their enthusiasm during break any longer.

At the time, the Manpower Services were paying LEAs a proportion of the wages of teachers accepted for this type of course, which made it easier for people like me to get secondment. This is, sadly, no longer the case. I don't think my secondment had anything to do with the decision . . .



Extract from Glib Gloss — the guide to the real meanings of the jargon of everyday computer folk . . .

Byte: Computers do this to hands that feed incorrect information.

There were twenty-seven teachers on my course, of several varieties, ranging from the completely ignorant to those who knew it all and wanted a bit of paper to prove it. There were Historians, Geographers, French and English teachers and a liberal supply of — guess who — mathematicians.

Undeterred, we set to with vim and vigour, causing some heartache to the hapless tutors — teaching teachers is a thankless task. They don't take kindly to it, and it is to the tutor's credit that they tried so hard to reassess the course as we went along.

And as we went along, it

became apparent that, just as I and others like me struggled with the maths-based sections, so the mathematicians floundered when it came to computer applications, computer effects on society and teaching methods and resources. Some of my best friends are mathematicians, but it was still nice to watch them suffer.

Back at school, after successfully completing the course, I find a large proportion of my timetable devoted to computing in its various aspects. I still

have a lot to learn, but the Head of Computing is still talking to me and is very helpful. I share teaching of O-level Computing studies course in the 6th form, and also inflict upon them a Computer Appreciation class, which originated as part of my course work, and I now teach the third year Technology module in programming that started it all. I'm also involved with a BASIC programming course run for local people by the school, so I don't feel that the LBA wasted

it's money.

So far as I'm concerned, teaching Computing means being under constant pressure to keep abreast of new developments, new books, new software, not to mention keeping ahead of the third years, and there's no time to relax. It also means a renewed enthusiasm for teaching as a career.

Computer assisted learning is now affecting every subject on the curriculum and it is time that certain things were acknowledged. The traditional link between maths and computing should be severed and the micro-computing revolution seen for what it is — an exciting and challenging prospect for Education, and open to teachers of any and every persuasion. As a well-known propagandist might have said, and only just didn't . . .

"Oh Brave New World, that has such people in it; Geographers and all, re-trained for CAL."

CARTESIAN can graph the simplest of functions

OR THE MOST COMPLICATED, SUCH AS $F(x) = \sin x / x$, OR THIS LITTLE BEAUTY: $F(x) = (e^x)^{\sin x}$

THE PROGRAM IS VERY WELL DESIGNED AND "USER FRIENDLY". AN 18 PAGE BOOKLET, DESCRIBING THE PACKAGE AND ALL UNDERLYING MATHEMATICAL PRINCIPLES, COMES WITH EACH COPY.

CARTESIAN IS AVAILABLE NOW FOR THE BBC B, ACORN ELECTRON, APPLE IIe AND APPLE EUROPLUS.

IT THEN GOES ON TO DO AN AWFUL LOT MORE. LIKE DRAWING THE DIFFERENTIAL CURVE AND OBTAINING THE DEFINITE INTEGRAL. LIKE EXTRACTING ROOTS WHEREVER THEY EXIST, EVEN WHEN THE FUNCTION HAS MULTIPLE ROOTS. LIKE SOLVING COMPLEX EQUATIONS. LIKE ALLOWING FOR MANY GRAPHS TO BE OVERLAID ONE ON THE OTHER. LIKE LETTING THE USER ANIMATE THE SCALES AND AXES IN ORDER TO REACH ANY PART OF THE CURVE, AND TO MAGNIFY SEGMENTS.

NATURALLY IF CARTESIAN CAN HANDLE THE FUNCTIONS ABOVE, THEN IT CAN ALSO TAKE CARE OF QUADRATICS, CUBICS, TRIG. FUNCTIONS, POLYNOMIALS, CIRCLES AND ELLIPSES.

TEACHERS CAN USE THIS PACKAGE TO DO STRAIGHT FORWARD THINGS SUCH AS TO DEMONSTRATE THE SHAPE AND BEHAVIOUR OF FUNCTIONS AND THEIR DIFFERENTIALS. THEY CAN SIMPLY SOLVE EQUATIONS. OR THEY CAN USE IT TO AID IN THE DESIGN OF TEST QUESTIONS SUCH AS THOSE INVOLVING MAXIMA AND MINIMA.

PUPILS AND STUDENTS LIKE TO EXPERIMENT WITH CARTESIAN. KNOWLEDGE GAINED IN THIS WAY HAS A LASTING QUALITY.

-5 -4 -3 -2 -1 1 2 3 4 5 6 7 8 9 10 11 12 13 14 15 16

COST: DISC FORMAT: £27.75
CASSETTE : £24.90

There is no vat on UK or NI orders.

ACCESS OR BARCLAYCARD (VISA) MAIL ORDERS AND OFFICIAL ORDERS ARE VERY WELCOME.

FLITE
software

FINDRUM, CONVOY, CO. DONEGAL,
IRELAND. TELEPHONE (074)47227

MAIL ORDER (UK): 010 353 74 22286
TELEPHONE & 010 353 74 22025

OUT NOW!

MICRO CHOICE

YOUR COMPUTER BUYER'S GUIDE

\$2.25
Summer
1984

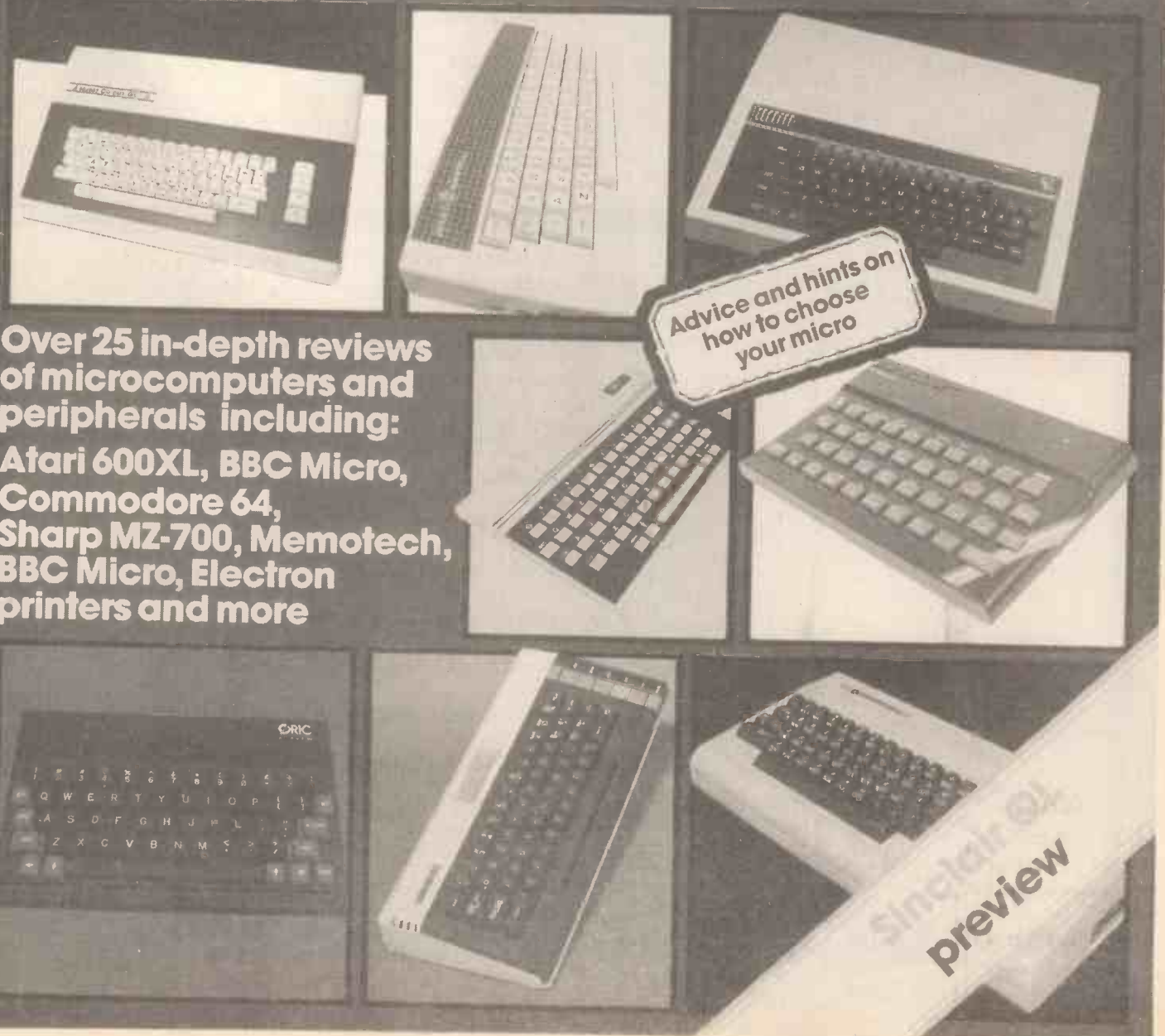

**Over 25 in-depth reviews of microcomputers and peripherals including:
Atari 600XL, BBC Micro, Commodore 64, Sharp MZ-700, Memotech, BBC Micro, Electron printers and more**

Advice and hints on how to choose your micro

Single issue preview

Marshall's

A. MARSHALL (LONDON) LTD

A. Marshall (London) Ltd.
Electronic Component Distributors
85 WEST REGENT STREET
GLASGOW G2 2AW
TELEPHONE: 041 332 4133

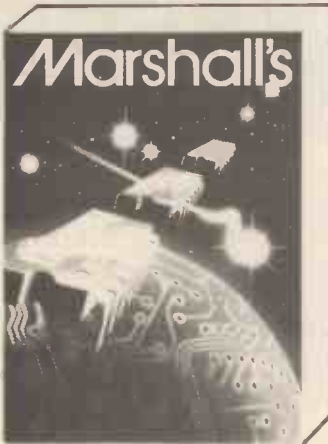

1984 CATALOGUE NOW OUT!

THE NEW MARSHALL'S 1984 CATALOGUE is now available — one of the biggest and best catalogues ever produced by MARSHALL'S.

56 pages crammed from cover to cover with components, accessories and testgear.

New products include I.D.C. Plugs & Sockets, 'D' Plugs & Sockets, DIL Headers, Ribbon Cable, Kits, Toroidal Transformers, I.C.'s, Capacitors, Test Probes, and lots more — something for everyone.

TRADE, EXPORT, RETAIL AND MAIL ORDER SUPPLIED.

75p to callers, £1.00 post paid — Europe, £1.50 rest of the world.

WHERE TO FIND US

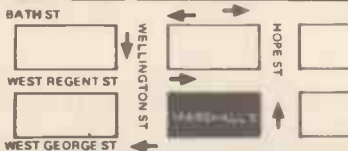

CALL IN AND SEE US

9-5.30 MON TO FRI
9-5.00 SAT
EXPRESS MAIL ORDERS
ACCESS/BARCLAYCARDS
WELCOME
SAME DAY SERVICE



MAIL ORDER

WE REGRET WE CANNOT
ANSWER MAIL ORDER/
STOCK ENQUIRIES
WITHOUT AN S.A.E.
SAME DAY SERVICE
TRADE AND EXPORT
ENQUIRIES WELCOME

TELEPHONE

MAIL ORDER
041-332-4133
SHOP AND STOCK
ENQUIRIES
041-332-4133
TELEX
261507 REF. 2194

Mini Drill PLUS Stand Only £17.99.

(Including VAT, Postage & Packing).

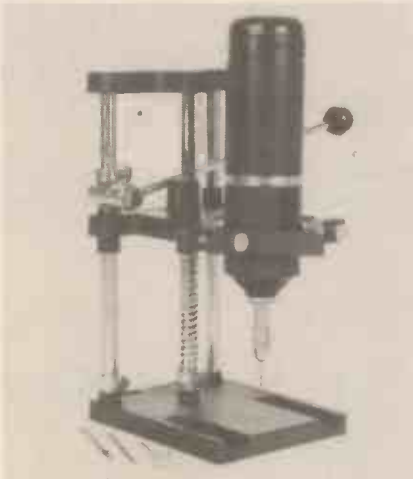

The D-3 mini drill is ideal for the hobby enthusiast. Its small, compact size, and light weight make it perfect for use in areas of restricted access. It can be run from mains (with suitable adaptor), directly from a car battery, or even from its own battery power source. It comes complete with three chucks, four bits and one grinding bit. Also supplied is a 6 foot lead. The drill is contained in its own individual plastic box.

The drill stand is made from steel and plastic, giving strength with light weight. The stand has a spring return, and upper and lower adjustable movement stops. It also has screw holes for attaching to a worktop.

An optional transformer is available for only £4.95p.
D-3 MIN DRILL 6-12 VOLTS DC. 2200 RPM. 260gm. DIAMETER 42mm.
LENGTH (WITHOUT BIT) 190mm. POWER SUPPLY 4xUM3 BATTERIES, OR AC
ADAPTOR 6-12V. MAX 15V 2A.
Send Cheque/Postal Order to:

VAN GELDER (UK) LIMITED

Unit 1, South Road, Southend Airport Southend-on-Sea, Essex SS2 6YG
Barclaycard and Access accepted. Please quote number. Credit card holders
may order by telephone. Tel: (0702) 548681.

MAKE YOUR OWN P.C.B.'s.

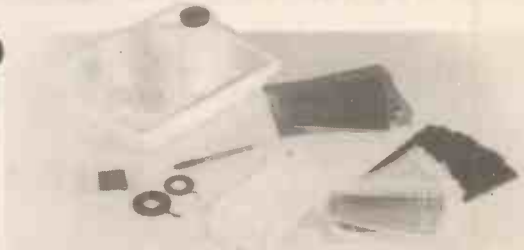

Top quality FR4 Grade Epoxy Glass Fibre Laminate 1/16" thick

| | | |
|--------|---|-------|
| HB/019 | 4 x 3 inches single sided (3) | £1.26 |
| HB/020 | 6 x 4 inches single sided (2) | £1.68 |
| HB/021 | 6 x 9 inches single sided (1) | £1.89 |
| HB/025 | 4 x 3 inches double sided (3) | £1.44 |
| HB/026 | 6 x 4 inches double sided (2) | £1.92 |
| HB/027 | 6 x 9 inches double sided (1) | £2.16 |
| | Assorted single & double sided approx 1 sq. foot | £2.25 |
| | Ferric Chloride etchant granules to make 1 litre | £1.25 |
| HB/016 | Protective Gloves (3 pairs) | £1.05 |
| HB/084 | 1 litre storage bottle | £0.50 |
| HB/014 | plastic etching tray | £2.54 |
| HB/088 | Instruction sheet for PCB making | £0.60 |
| HB/630 | "How to Design & Make Your Own PCB" Book | £1.95 |
| HB/017 | Copper cleaning block | £1.49 |
| HB/001 | Etch resist transfers (assorted pads) | £2.08 |
| HB/004 | Transfer spatula | £0.70 |
| HB/083 | Etch resist pen | £1.35 |
| HB/209 | 0.020 inch track tape | £1.05 |
| HB/211 | 0.031 inch track tape | £1.05 |
| | Full Catalogue (refundable with 1st order over £10) | £1.50 |

Prices inclusive of VAT, carriage 60p in U.K. Overseas orders please add extra carriage to published prices.

hobbyboard

a division of
KELAN ENGINEERING LTD.
27-29 Leadhall Lane,
Harrogate, N. Yorks.

ALL ABOUT ELECTRONICS

Our new **Beginner's Series** tells you all you'd like to know about electronics. From start to finish. All about components and circuits, all the theory you need to get started in the world of electronics.

Keith Brindley

PART 9 of *All About Electronics*, in the April issue of *Hobby Electronics*, introduced us to the concept of communications. We saw how a transmission medium, forming a transmission channel between source and receiver, could be used in a number of ways to transmit information of some description.

By dividing up the available resources of the transmission medium we can multiplex many information signals together (from many different sources) at one end of the channel, and demultiplex the signals apart again at the channel's other end.

The telecommunications system we looked at quite closely in the April issue was the UK telephone system, which mainly uses cable (either twisted-pair, or coaxial cable) as its transmission medium. Two main types of multiplexing signals onto the cables of the telephone system are used: frequency division multiplexing (FDM) with single sideband amplitude modulation, and time division multiplexing (TDM) with pulse code modulation.

Transmission Principles

The principles involved in the telephone system with its cable transmission medium are the same principles used in other telecommunications with other media. For example, frequency division multiplexing is the way signals are transmitted in radio systems which use air as the transmission medium. Of course, some of the concepts in radio communications are different to the concepts in telephone communications. Broadcast radio communications are based on the fact that a single radio

station transmits signals with a particular carrier frequency over the air, with no single direction. In this way thousands, possibly millions, of people are able to receive the one-way broadcasts if they have a radio receiver. The telephone system in contrast is a point-to-point communications system in which a two-way link is set up between two people. It is important to see the basic difference between the two types of telecommunications systems, because the different purposes which they serve have more or less defined the way each has evolved

and also defines how they will evolve in the future.

One of the biggest practical constraints which any system has (whether the system is a telecommunications system, a digital system, or, in fact, a non-electronic system) is cost. If a product is too expensive, that is, more than the customer is prepared to pay, it will not sell. Companies are generally in business to make profits, so a manufacturer will normally make its products with profit in mind — the products must therefore be cheap enough so that the customer is prepared

Figure 1. A television system, showing a camera and microphone which convert the scene and sound into electric signals which are transmitted as a radio broadcast. The television receiver reconverts the received electric signals back to vision and sound.

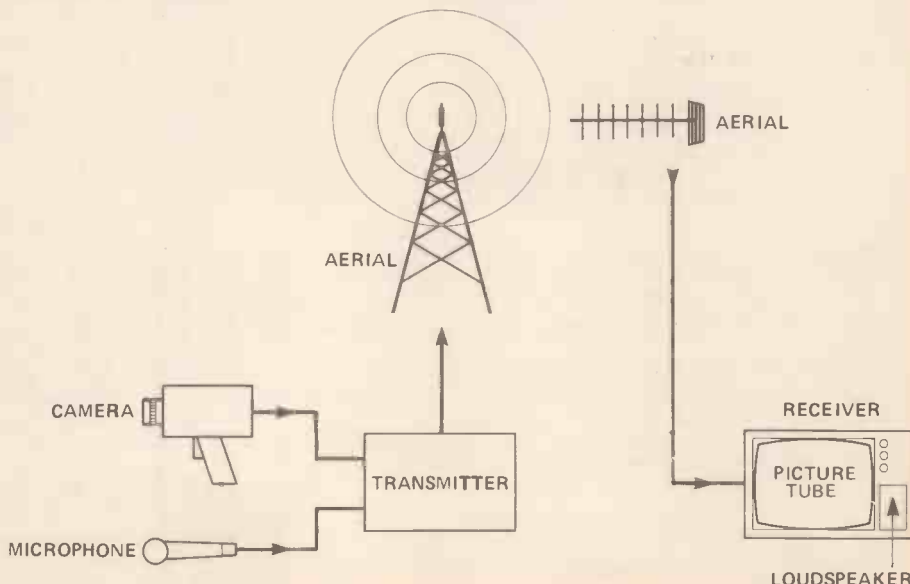

to buy, but also so that the company makes its desired profit. This month we are going to study another classic telecommunications system — television — and we will see how the cost constraints which television faces defines the quality and quantity of the service given to the paying customer.

Television is enormously popular. Nearly every home in the UK has at least one TV set, and a proportion have two or more. This signifies that the price range, within which manufacturers of TVs sell their products, must be acceptable to the majority of people.

Now, TV sets are very complex items of machinery. They are not cheap because they have design, development and production costs, so in order that manufacturers can maintain a reasonable profit margin while pricing their product low enough to allow the customer to buy. TVs are generally made to the minimum acceptable standards. This minimum standard is largely governed by the customer, because it is the customer who has to use the TV. It is the customer who has the choice in the showroom to look at a selection of TV sets and decide whether the better picture, or higher quality sound of one TV set is worth £X more than another.

Once in a while, a leap in quality is made in TV standards, which although due to the customers' desire for higher quality, is largely out of the customers' control. For instance, the change from 405-line to the present 625-line picture standard, occurring about twenty years ago was such a leap. The addition of colour transmissions and colour TV sets (about fifteen years ago) was another. Future ones look set to be satellite TV broadcasting and cable TV systems; we'll have a look at those next month. Again, however, it is the customer who in the end pays for the increased quality.

TV Standards

So, what is this minimum acceptable standard? To define it, we need to go back to basics and look at how TV sets work, and how the TV signal is broadcast and received.

Television communications generally, consist of radio transmissions in the ultra-high frequency (UHF) band, between about 470MHz and 940MHz. The total band used is divided up into 8MHz slots or "channels" in which a single TV signal may be transmitted. Radio transmissions at these frequencies are not particularly long distance, covering approximately circular areas of no more than about fifty miles' radius, so by careful positioning of TV transmitters and careful frequency allocation the same transmission frequencies may be used by more than one transmitter throughout the land, without interference problems. We'll see how these 8MHz channels contain all the information required for a TV receiver, ie the customers' TV set to form the picture and sound, as we look at the principles of TV.

The television shown in Figure 1 shows how the microphone converts

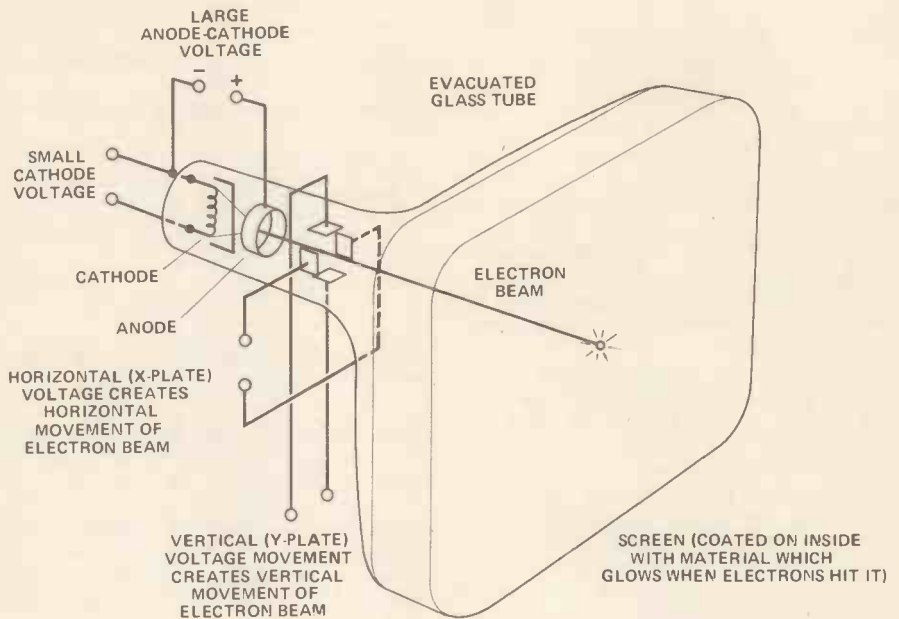

Figure 2. A cathode ray tube (CRT) which displays television pictures by controlling the brightness of an electron beam as it is scanned over the screen.

the audio information from the scene, say the couple's voices, into electrical signals to be transmitted. The microphone acts as a simple audio-electric transducer, providing an output voltage or current which changes as the audio sounds themselves change. The electrical information the microphone provides is simply an analogue representation of the original sound.

It would be nice if the camera shown in Figure 1 could in the same way provide a simple analogue representation of the visual scene to be transmitted. Unfortunately, this is just not possible, because the visual scene is a far more complex thing than the audio sound association with it. So, the scene has to be broken down by the camera, into smaller parts which can be transmitted by an electrical representation. Each part of the scene is transmitted in a series, such that the TV receiver can display the whole scene on the picture tube at the same time as the associated sound analogue electrical signal is converted by the loudspeaker back into sound.

Of course, all of this serial information which represents the visual scene has to be transmitted in a co-ordinated way, to allow the TV receiver to display it all, in the correct position, on the picture tube. This is done by scanning the total scene to be transmitted, dividing it up into a number of lines, and then transmitting the information relating to the amount of light in each line (the luminance signal). The UK television system divides the scene into 625 lines, but other systems use a different number of lines, eg the American television system has 525 lines, the French 819 lines. When each line has been scanned, and the whole scene has been transmitted, the procedure is started again, so that the transmission is a never-ending cycle of scanned lines, each 625-line cycle corresponding to

transmission of a complete scene.

At the receiver, these individual lines are each displayed separately on the screen of the picture tube to make up the whole scene again, for the viewer to look at.

Only An Illusion

Even from this simple explanation it is obvious that the whole process of transmitting and receiving TV pictures relies on the couple of basic optical illusions:

- The eye cannot focus accurately enough on the displayed picture to see that it is composed of 625 individual lines. This optical illusion is also used quite effectively to print photographs in publications (like Hobby Electronics) where the photograph is divided up before printing into literally thousands of tiny dots. The size of the dots when printed defines which areas of the photograph are dark (large dots) and which areas are light (small dots). As long as the picture is quite acceptable, because the eye cannot detect each line (or dot) individually.
- The eye cannot detect rapid changes between similar scenes. If each scene of 625 lines is displayed for just a small time on the TV picture tube, before being replaced by a new 625-line scene, the eye is unable to detect the fact that separate scenes are being displayed. This effect, known as the "persistence of vision", is also used in the cinema where rapid successions of individual film frames are projected onto the cinema screen.

Knowing these optical illusions, we are now in a position to calculate the minimum standard of picture quality

that can be used by a television communications system to give acceptable quality to the consumer.

First, let's start with the minimum number of lines required. If we remember that, in most cases, a viewer sits at an approximate distance of five times the screen size from the television, then we can use this as a convenient starting point. This 5x rule is, however, only a guideline, and factors such as room size, viewers' vision and even hearing can affect a viewers' subjective position in relation to the television.

A typical TV picture tube size (measured diagonally) is 600mm, so the 5x distance is 3m from the TV. Now at this distance a human eye with 'reasonable' vision (another subjective factor) can just detect between two dark lines separated by a distance of 0.6mm.

Now, a diagonal picture tube size of 600mm means that the tube height is 360mm (measure it yourself if you don't believe it!). So, if a 360mm high picture tube is viewed there, must be:

$$\frac{360}{0.6} = 600 \text{ lines}$$

on tube to enable an acceptable picture. With a similarity too close to be coincidental, the UK television system is based on a 625-line picture.

Flicker

The required repetition rate, or picture frequency, of the scene displayed on the television tube is just as subjective as the required line number. It depends not on the viewer but also on the brightness of the displayed picture — the brighter the picture, the more noticeable the flicker between individually displayed scenes.

Over the brightness range which modern television picture tubes are capable of, flicker is just about noticeable at a frequency of approximately sixty pictures a second. So, it would seem that sixty pictures a second is just about the minimum acceptable number we should use in our television system. But, this leaves us with one problem — the UK mains frequency is 50Hz, which causes interference with the ideal 60Hz picture frequency. The interference would manifest itself as an irritating flashing on the television picture tube at the difference frequency of 10Hz. It is caused because the power supplies generally used within television receivers are not complex circuits and do not produce stabilized (ie level) DC voltages. Instead, quite significant ripple voltages occur naturally at 50Hz on the DC voltages used within the receiving circuits. These ripples, and therefore the interference could be reduced electronically to an insignificant level if more complex, stabilising power supply circuits were used. But, such power supply circuits would be correspondingly more expensive — and this would defeat the aim of producing a television receiver which is as cheap as possible. So, the frequency difference

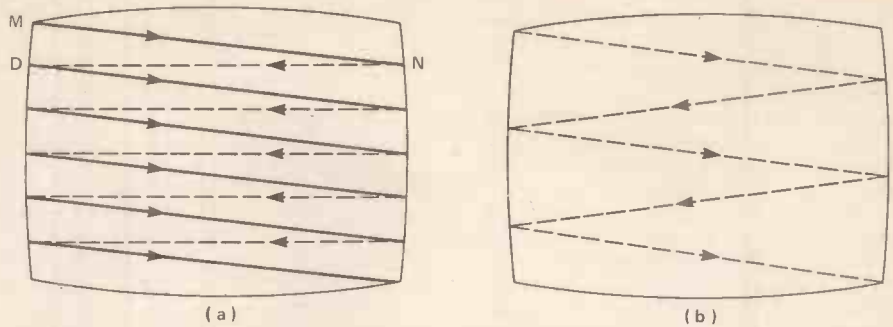

Figure 3. A possible scanning pattern, known as a raster, of the lines and field of a television system.

between mains and picture frequencies is reduced instead: and, in fact, the picture frequency in the UK and throughout Europe is equal to the mains frequency — 50Hz. The result of this lowering of standards is that the viewing brightness must be also reduced to maintain a flicker-free picture.

It is interesting to note that the acceptable quality picture brightness of North American television receivers is higher than that of European receivers because, like our system, the picture frequency has been set at mains frequency, but the North American mains frequency is 60Hz!

Cathode Ray Tube

Now that we have defined the minimum acceptable quality picture for a television system, we find that it corresponds closely to the existing UK system, we can begin to look at just exactly how this picture is transmitted, received and displayed. Picture display is straightforward and is undertaken on the screen of a cathode ray tube (CRT). A CRT of a monochromatic television receiver is shown in Figure 2. It is formed essentially by an evacuated glass tube. At the narrow end is a cathode, heated by a small voltage, which gives off electrons. The electrons, being negatively charged, are attracted to the positively biased anode. As the electrons move towards the anode, their velocity builds up so that they are travelling fast enough to go right through the anode and carry on as an electron beam which hits the CRT screen. The screen is coated with

material which gives off light as the electron beam hits it.

Varying the number of electrons allowed through the anode to the screen by, say, varying the anode biasing voltage, varies the amount of light at the screen. So the brightness of the light may be controlled, electronically, by increasing or decreasing the anode bias voltage. Biasing voltages applied to the x- and y-plates of the CRT attract or repel the electron beam to or from the plates — bending the beam in horizontal and vertical directions — so that its position as it hits the screen can be altered. By varying the plate voltages in a logical and controlled manner, the beam can be made to scan the screen, and a possible way is shown in Figure 3. Here a pattern of six lines is shown, starting at the top left hand corner. The complete line pattern is known as a raster. If we imagine the raster to be contained within x- and y-axes of a graph then the motion in the x-axis direction (ie, horizontally) is known as the line scan, and the motion in the y-axis direction (ie, vertically) is the field scan. Another way of controlling the beam is with the use of coils which, when energised with an applied voltage, can deflect the beam.

The line scan of the first line, from point M to point N, corresponds to the first line of the picture, and the brightness of line varies in accordance with the received signal of the first scanned line from the camera. The line scan from point N to point O is known as a line flyback. This occurs much more rapidly than the left-to-right scan and, in fact, the display is blanked (with say a low anode voltage) during flyback so

Figure 4. Line scan and field scan voltages at the x- and y-plates of a CRT.

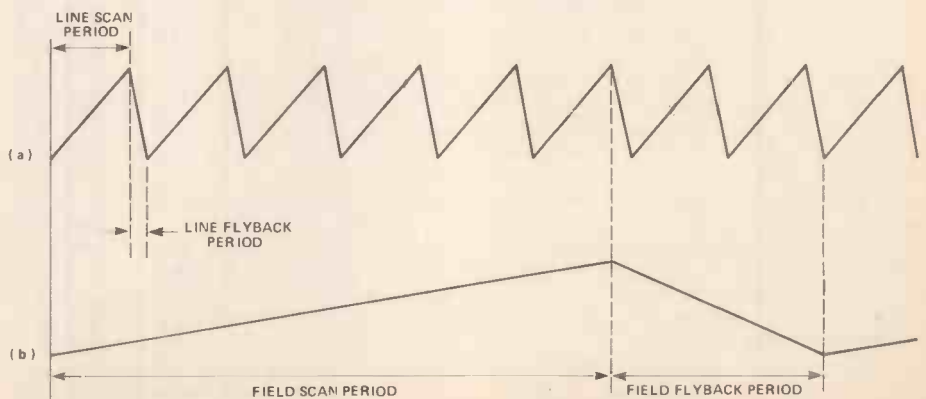

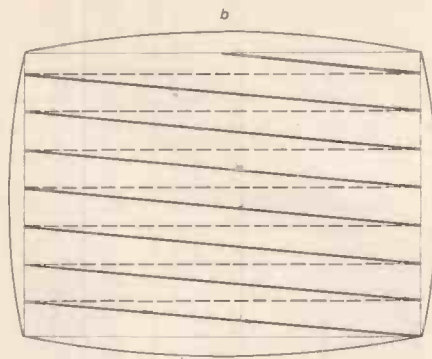
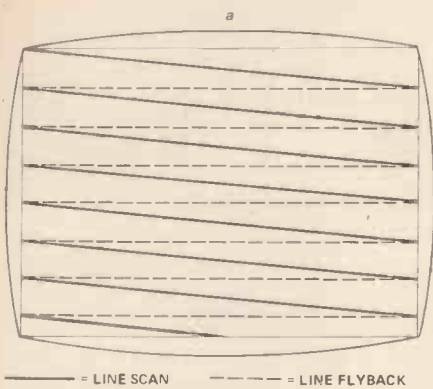

Figure 5a) the odd field of the UK 625-line television system b) the corresponding even field.

Figure 6. A single raster of lines, used in the UK 625-line television system, composed of two separate fields.

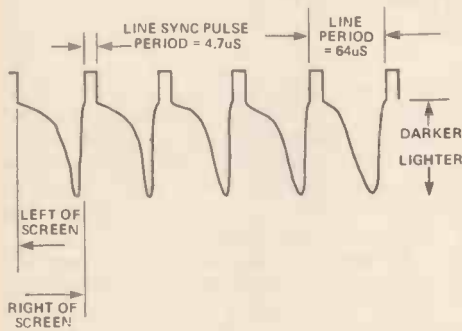

Figure 7. Video waveform showing five line periods, with line sync pulses of 4.7 us duration and varying luminance signals.

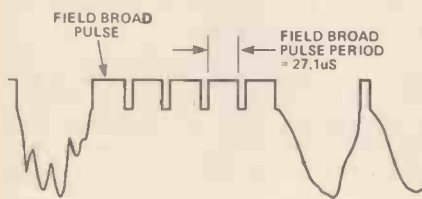

Figure 8. Video waveform showing five field broad pulses of 27.1 us duration, used to reset the field sync.

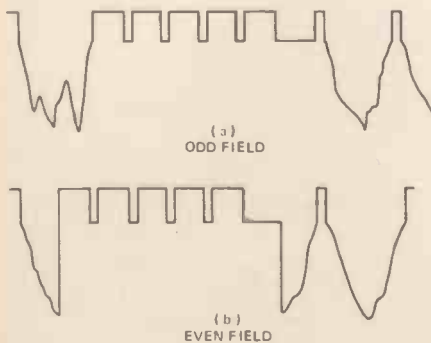

Figure 9. Showing the difference between positioning of field broad pulses in a) the odd field, and b) the even field.

that we cannot see it (this is shown by the broken lines). From then on, lines 2, 3, 4, and 5 are scanned, with flyback, until the left-to-right scan of 6 has ended, at point P. The scan now has to return to the beginning of the raster to start again. The field flyback (Figure 3b) accomplishes this, during which there are two complete line scans.

Figure 4 shows the voltages at the horizontal and vertical (x and y) deflection plates of the CRT to produce this raster and you can see the longer left-to-right line scan period than the right-to-left line flyback period (Figure 4a). Similarly, the longer field scan period can be seen, compared with the field flyback, in Figure 4b.

The complete UK television system raster is, of course, more complex than this example but nevertheless is based on the same idea. Figure 5 shows the principle of the complete raster. These are, as we know, a total of 625 lines per raster, but these are split into two separate fields of 312.5 lines each. The odd field (lines 1, 3, 5, 7 etc.) is shown in Figure 5a, while the even field (lines 2, 4, 6, 8 etc.) is shown in Figure 5b. These two fields are interlaced on the CRT screen to produce the single raster, as shown on Figure 6. In this way, the UK television system maintains a field frequency of 50Hz but the actual picture frequency (ie, two fields) is 25Hz. Because there are 625 lines per picture the line frequency is 15,625Hz (ie, 625 x 25).

Everything But The Kitchen Sync

Obviously, the transmission and reception of television picture signals requires that the TV receiver is in time with the transmitter. The first line of the displayed scene (ie, the top line on the picture tube) must be the first line of the transmitted one; likewise the one hundredth line must be the same; and so must the six hundred and twenty-fifth. If this wasn't so the picture would be at best displayed half-on, half-off the tube; at worst it would be an incomprehensible jumble of uncoordinated lines.

This timing and coordination of each line is done by transmitting special synchronising signals with the luminance signal of each line. These sync

pulses are detected by the TV receiver which 'locks on' to the transmitted signal and displays the correct scene.

Now, to display the line, in sync, so that a correct scene may be made on the CRT screen, the sync pulses have to contain the following information which the receiver decodes and uses to control the electron beam of the CRT:

- when an line starts and ends
- where a field starts and ends
- which field it is

Figure 7 shows a section of five line periods which illustrates how the luminance signal of each line varies (the lower the luminance signal voltage the brighter the electron beam's spot on the CRT screen). By observing the shape of each line's luminance signal we can see that in this example the left hand half of the screen is darker than the right hand side — at least over five lines shown. In between each line's luminance signal is a line sync pulse which is used within the receiver to set the beginning and end of each of the saw tooth line scans of Figure 4a. The dimensions of these line sync pulses are strictly maintained so that if the receiver 'sees' a sync pulse of 4.7us duration, it must be a line sync pulse.

A field sync pulse, however, has a duration of 27.1us, and is generally known as a field broad pulses might be used to synchronise field scanning is shown in Figure 8. Because the line signal is blanked during the field flyback, no luminance signal is shown over the five field broad pulses, corresponding to two and a half line periods. When the receiver detects the 2.71 sync pulses, the field scan sawtooth waveform (Figure 4b) is ended, and a new sawtooth signal is started.

The receiver can differentiate between odd and even fields, by making use of the fact that an odd field starts at the beginning of its first line, while the even field starts half way through a line. The difference in signal waveforms at the end of each field is apparent in Figure 9.

The final waveform, actually used in

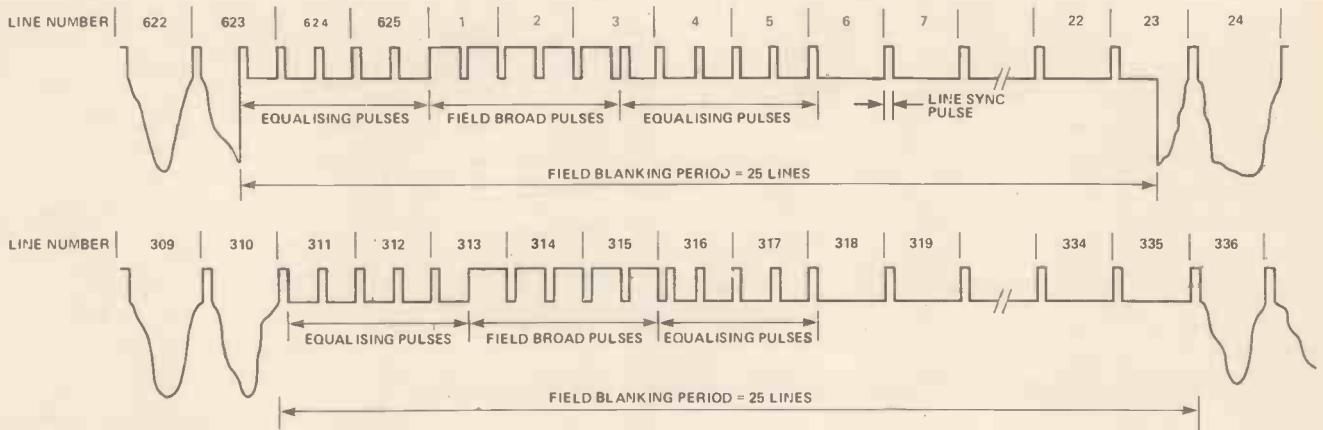

Figure 10. Video waveform of the UK 625-line television system, showing blanked lines per field.

the UK television system, is somewhat different to this however, because many more lines, apart from the two and a half periods of the field broad pulses, are blanked. The UK television system in fact allows for up to twenty-five blanked lines out of each field. So, in any one picture, only 575 lines may be active. A set of typical line and field sync pulses is shown in Figure 10 for both odd and even fields.

Sound, Lights, Action

We're in a position now to see how the complete television signal sound, luminance and sync, is transmitted over the 8MHz channels. Radio broadcasts are used, which are amplitude modulated for the vision signals (including sync pulses), and frequency modulated for the sound signals. A spectrum of the whole signal is shown in Figure 11 and it can be seen that the

vision signal takes up the majority of the 8MHz channel width (about 7.75MHz); the sound channel takes up only a few kHz, and a guard band, separating each channel, of about 0.25MHz is included.

The vision signal, although amplitude modulated, is not broadcast using any of the methods we have met previously (double sideband) but another method — vestigial sideband (VSB). Figure 12 shows a spectrum of a VSB signal in which the broken line indicates how the lower sideband of a complete double sideband signal is made up. VSB is used in television signal broadcasting because a complete double sideband transmission of the vision signal is too wasteful of channel space. A complete double sideband transmission of the required vision signal would require 12MHz of space, but single sideband transmissions, require complex receiver circuits. VSB transmissions however, are not too wasteful of channel space yet simple receiving circuits can demodulate the signal.

A block diagram of all mains parts of

a monochrome television receiver is shown in Figure 13 and possible waveforms at selected points throughout are included. The components involved in each of the blocks and the circuit used are not important, but the functions they perform are.

Finally, we can take a look at the transmission, reception and display of colour television pictures. Colour broadcasts in the UK were first transmitted in comparatively recent times — the USA have had colour television for well over twenty years. The USA colour system does, however, suffer from the problem that the displayed colours do vary with the received signal. The UK, and all European, colour television systems overcame this problem technically and so were worth the wait.

Display of colour picture relies on the fact that the CRT has, not one but three electron beams. Each beam is accurately controlled to fall onto phosphors on the CRT screen which, instead of emitting only white light, emit one of three

Figure 11. Spectrum of a monochrome broadcast television signal.

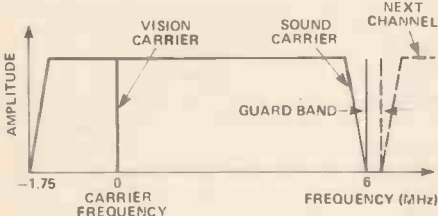

Figure 12. Spectrum of a vestigial sideband broadcast signal.

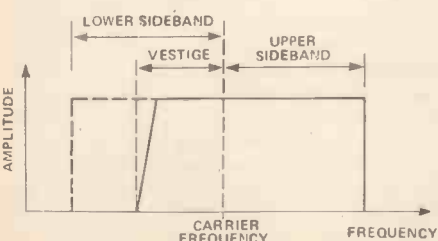
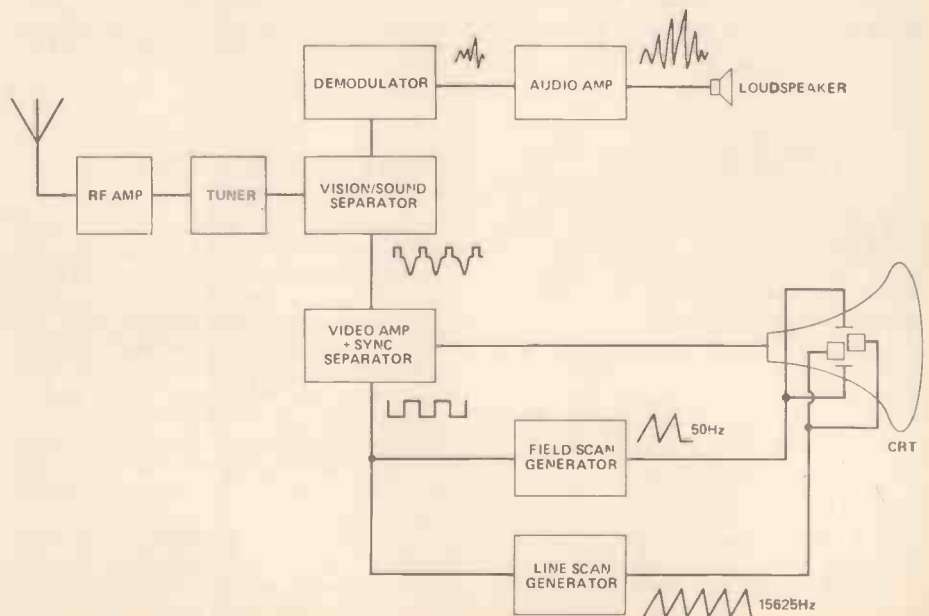

Figure 13. Block diagram of the main parts of a television receiver.



different colours. Thus one beam falls only on green parts, one falls only on blue parts and one only on red parts and the three parts will emit coloured light of a strength according to the strength of the three beams.

The phosphors are arranged in strict rotation, ie red, green, blue; red, green, blue, etc., so no one coloured part is adjacent to another part of the same colour.

Red, green and blue are primary colours when emitted from a light source. In combination they can make up any other colour. For example: an equal mixture of red and green produces yellow; an equal mix of red, green and blue produces white. So by controlling the relative strengths of the electron beams hitting the adjacent phosphors on the screen the various colours required can be displayed on the screen.

Three Parts And One Hole

This whole colour display process, of course, relies totally on the fact that the CRT can be accurately manufactured, with small enough phosphors and controllable electron beams. Generally the groups of three colours, known as triads, are only a millimetre or so across, which gives an idea of the accuracy involved.

To aid correct positioning of each beam onto its coloured part, a metal sheet is positioned inside the CRT, close to the screen. In the sheet are small holes corresponding to the each colour on the triads. As an electron beam is directed at the screen it is allowed to pass only through a single hole in the sheet. Thus only a part of the beam actually passes through to the screen, a

Figure 15. A more realistic spectrum of the signal of monochrome television system.

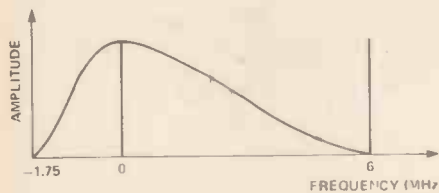

Figure 16. A possible spectrum of a colour television system broadcast signal, showing luminance, chrominance, and sound carriers.

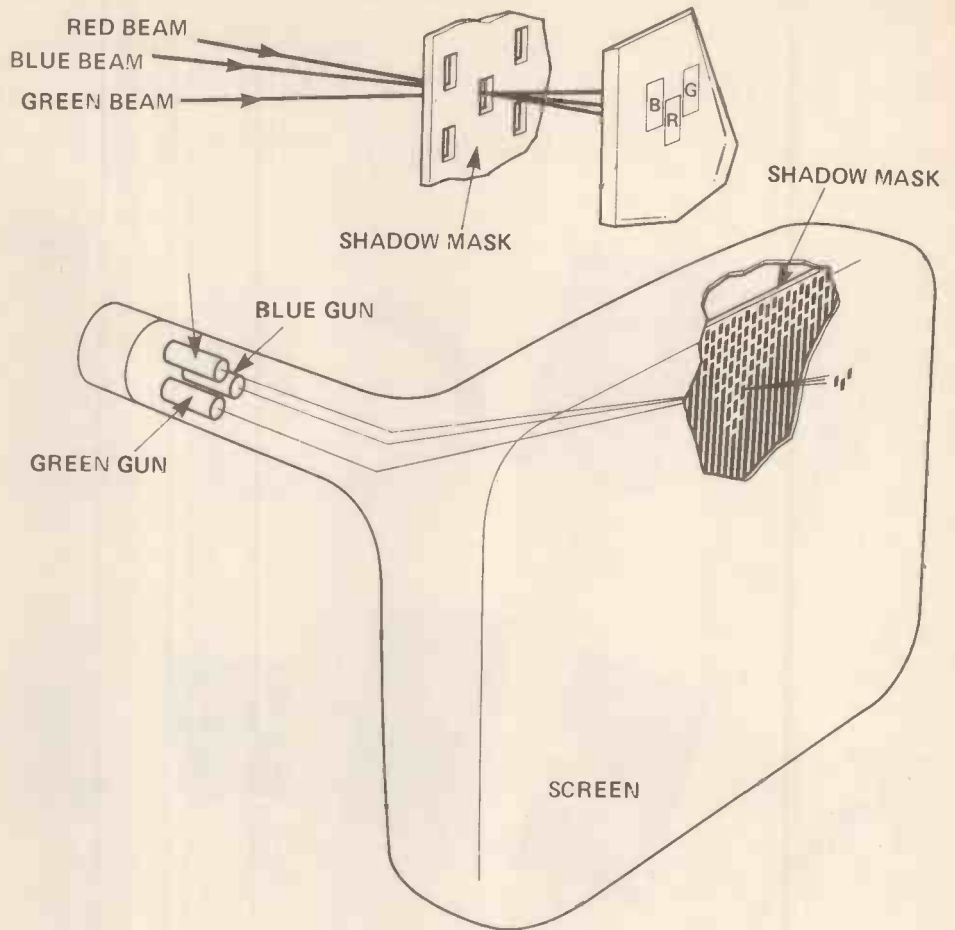
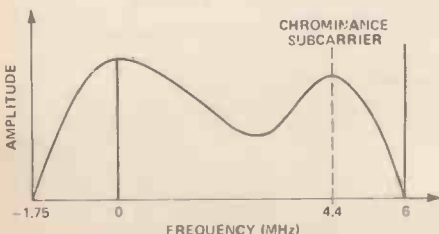

Figure 14. A colour CRT showing the three electron guns, the shadow mask and the produced triads.

“shadow” being formed over the rest of the screen. With accurate positioning of the sheet, and accurate shaping of the holes, each beam can be made to fall only on its allotted colour. The metal sheet is often known as a shadow mask — a usefully descriptive term — and an illustration of a colour CRT is shown in Figure 14. In it, the three electron beams, the shadow mask and the triads are clearly seen. The beams from each electron gun is deflected over the screen in the same way as in the monochrome CRT of Figure 2 ie, with deflecting coils.

To display colour pictures, it is obvious that the control circuitry in a colour television receiver must be correspondingly more complex than that of a monochrome receiver. Not only does a luminance signal (the same as the monochrome luminance signal) have to be generated to control the brightness of the screen (or parts of it) but also chrominance signals which control the various colours on the screen. Transmission of the chrominance signals is no real problem — in the spectrum of Figure 14 we saw that the vision signal spread from -1.75MHz to +6MHz. Although this is perfectly true, the strength of the vision signal is much lower at high frequencies than at lower

frequencies. A more realistic impression of signal powers is shown in Figure 15, and you can see the fall in strength above about 3MHz. The UK television system makes use of this fact to broadcast colour chrominance signals, by superimposing them on a second carrier wave, the chrominance sub-carrier, which is spaced at a frequency of 4.43MHz above the luminance signal carrier frequency. Figure 16 shows the possible result of such a combined luminance, chrominance and sound television broadcast signal.

Conclusion

Television systems are not new; they have been with us now, in one form or another, for decades. They have evolved slowly with consumer demands to their present state. What the next step in their evolution is, however, as yet undecided, but will probably be along one or more of three possible directions: cable distribution rather than radio broadcasts; satellite broadcasts; or digital transmissions. We'll take a brief look, among other things, at these next month, in the final part of All About Electronics.

BOOKSHELF

THE HE BOOKSHELF is pleased to offer you a range of top quality electronics paperbacks for you to read and enjoy delivered direct to your door!



IC PROJECTS FOR BEGINNERS £1.95
Especially written for the beginner offering a range of simple projects



THE ART OF PROGRAMMING THE ZX81 £1.95 Shows you how to use the features of the ZX81 in programs that fit into 1K and are still fun to use



EASY ADD-ON PROJECTS FOR SPECTRUM, ZX81 & ACE £2.25 This book describes how to build a number of electronic projects which you can use with your Spectrum, ZX81 or Jupiter Ace microcomputer



ELECTRONIC PROJECTS FOR CARS AND BOATS £1.95 Fifteen fairly simple projects complete with stripboard layouts



25 SIMPLE AMATEUR BAND AERIALS £1.95 This concise book describes how to build amateur band aerials that are simple and inexpensive to construct and perform well



HOW TO DESIGN YOUR OWN PCBs £1.95 The purpose of this book is to familiarise the reader with sophisticated methods of producing printed circuit boards (P.C.B.s)



MODEL RAILWAY PROJECTS £1.95 Build your own controllers, signals and sound effects and add realism to your model railway



A Z80 WORKSHOP MANUAL £2.75 This book is intended for people who wish to progress beyond the stage of basic programming to topics such as machine-code and assembly language programming or need hardware details of the Z-80 based computer



THE ART OF PROGRAMMING THE ZX SPECTRUM £2.80 Simply helps you get the most out of your Spectrum



CB PROJECTS £1.95 Shows you how to make a number of useful and interesting CB accessories



THE ART OF PROGRAMMING THE 16K ZX81 £2.50 Concentrates on good programming style and helps you use your 16K RAM pack and ZX printer to the full



POPULAR ELECTRONIC PROJECTS £1.95 An interesting collection of projects which will appeal to most hobbyists



AN INTRODUCTION TO VIDEO £1.95 For the person who has just or is just about to buy or rent some video equipment but is not sure what it is all about



HOW TO MAKE WALKIE-TALKIES £1.95 All you need to know to build your own walkie-talkies



HOW TO USE OP-AMPS £2.25 All you need to know about Op-Amps. A source book of circuits and design calculations



POPULAR ELECTRONIC CIRCUITS — BOOK 1 £1.95 Contains over 70 useful and interesting circuits covering a wide range of subjects



POPULAR ELECTRONIC CIRCUITS — BOOK 2 £2.25 Over 140 pages of useful and interesting circuits



PRACTICAL ELECTRONIC BUILDING BLOCKS — BOOK 1 £1.95 Most circuits are built up from building blocks of a standard type. The book shows the reader how to combine these blocks to produce projects of their own design



PRACTICAL ELECTRONIC BUILDING BLOCKS — BOOK 2 £1.95 Most circuits are built up from building blocks of a standard type. The book shows the reader how to combine these blocks to produce projects of their own design



ELEMENTS OF ELECTRONICS — BOOK 1 £2.25 The Simple Electronic Circuits and Components



ELEMENTS OF ELECTRONICS — BOOK 2 £2.25 Alternating Current Theory



ELEMENTS OF ELECTRONICS — BOOK 3 £2.25 Semiconductor Technology



ELEMENTS OF ELECTRONICS — BOOK 4 £2.95 Microprocessing Systems and Circuits



ELEMENTS OF ELECTRONICS — BOOK 5 £2.95 Communication

To receive your books you only need ✓ the I for each title you require and send this page duly completed with your remittance to the address stated.

I enclose my cheque/Postal Order/Money Order (delete as necessary)



for £..... (payable to ASP Ltd)



OR

Debit my Access/Barclaycard (delete as necessary)

.....

Name (Mr/Mrs/Miss).....

Address.....

Signature.....

SEND TO:
HE BOOKSHELF, 513 London Road,
Thornton Heath, Surrey CR4 6AR
Please use **BLOCK CAPITALS** and include post codes.

Number of books ordered.....

Total value of books £.....

Add 75p P&P

TOTAL PAYMENT £.....

Audio Millivoltmeter

A straightforward millivoltmeter specially well adapted for hobby use, as it is simple to operate, with virtually the same frequency response in each of its three ranges.

R. A. Penfold

AN audio millivoltmeter is an extremely useful piece of test equipment, especially when used in conjunction with an AF signal generator or function generator, such as the designs featured in recent issues of Hobby Electronics.

An ordinary multimeter switched to a low AC voltage range will often suffice for measurements such as frequency response testing and voltage gain measurement, but problems can sometimes arise due to the equipment under test providing an inadequate signal level to give a significant reading on the meter.

This is especially the case when making signal to noise ratio measurements where the noise signal is typically only about two millivolts or less. Also, when testing filters an adequate signal level may be obtained within the passband, but outside the passband the signal may quickly fall to an adequate level, making proper plotting of the filter's response impossible.

High Sensitivity

An audio millivoltmeter has a much higher level of sensitivity than a multimeter. Whereas the most sensitive AC voltage range of a multimeter is typically about one to five volts for full scale deflection, most millivoltmeters have a full scale sensitivity of only a few millivolts on the lowest range. In fact the more sophisticated instruments have full scale value in the microvolt range, but for amateur use a relatively simple unit such as the one featured here is perfectly adequate.

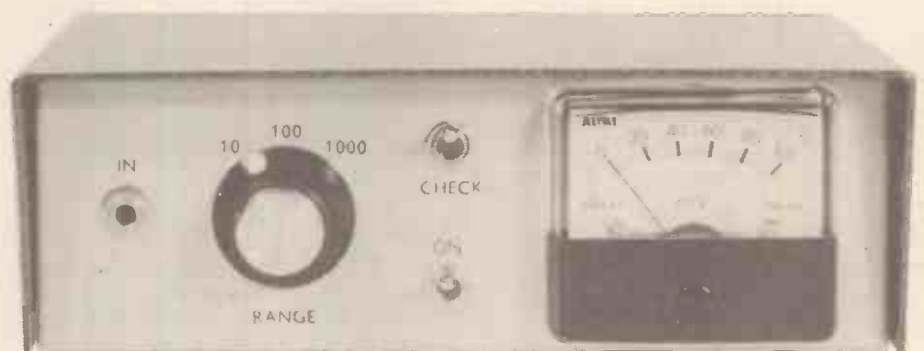

Figure 1. The block diagram of the Audio Millivoltmeter. This circuit is not quite the simplest form of millivoltmeter available: the circuit has been designed to give first-class performance while avoiding some of the problems associated with simpler circuits.

It has three ranges of 10, 100, and 100 millivolts RMS for full scale deflection, together with a high input impedance of just over one megohm and an upper -3dB point at about 200kHz. The frequency response is virtually flat from 20Hz to 100kHz, and unlike some instruments, there is no significant change in the response from one range to another. The performance figures have been chosen to be adequate for the majority of audio measurements, but by having relatively modest sensitivity and bandwidth figures the circuit is not hyper-critical and prone to instability etc.

Block Diagram

Circuits of this type can be based on a single operational amplifier, but there are disadvantages in such a simple system. One is a reduction in the frequency bandwidth of the circuit, often resulting in an adequate bandwidth when the unit is used on its most sensitive ranges. Circuits of this type are also apt to be relatively unstable and lack good repeatability.

This design uses a slightly more complicated system, but one which gives excellent performance and reliability. Figure 1 shows the block diagram of the millivolt meter.

Buffer Amplifier

The buffer amplifier at the input gives the unit its high input impedance. A high input impedance is important as the unit might otherwise significantly load the circuit under test, giving a reduction in the signal level when the meter is connected to the unit, and a misleading reading. The next stage is a three-step attenuator, and this gives the unit its three measuring ranges.

The attenuator is placed in a low impedance part of the circuit so that it does not require any frequency compensation components and setting up. A slight drawback of this system, as opposed to having the attenuator at the input of the unit, is that the input stage has to handle the full input voltage swing. This prevents medium and high voltage ranges from being included, but this is not of great importance since an ordinary multimeter can handle these adequately.

Voltage Amp

The next stage is a voltage amplifier which brings the signal up to an adequate level to drive the final stage, which is an active rectifier. With most multimeters the meter movement is driven via an ordinary (passive) rectifier circuit, but this is not

Figure 2. The basic half-wave rectifier circuit; the design uses this principle to overcome the non-linearity of the diodes.

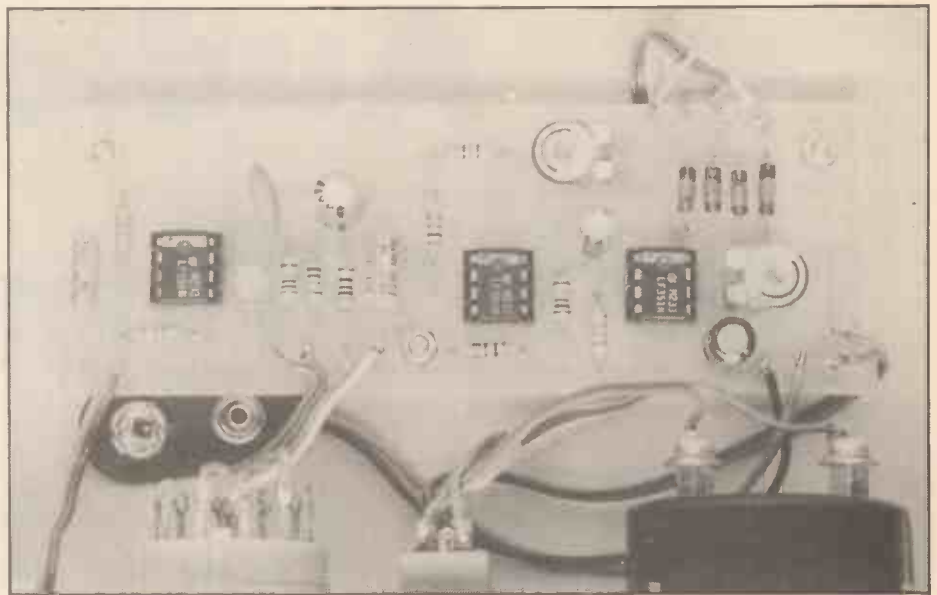
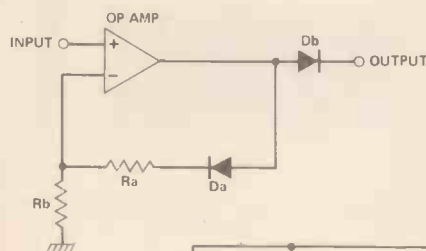

practical in this application. All practical diodes have severe non-linearity in their forward voltage/current characteristic.

Silicon diodes are the worst offenders, with an extremely high resistance until the forward bias voltage reaches about 0V5 to 0V6. The resistance then rapidly falls to a very low level. This gives non-linear scaling, but with a fairly high full scale deflection voltage sensitivity, the non-linearity is not severe (although it is still severe enough for most multimeters to use separate DC and AC voltage scales).

Active Rectifier

With a full scale deflection sensitivity of only a few millivolts, even allowing for some amplification ahead of the meter, the non-linearity would be extremely pronounced if the most suitable type of diode for this application was to be selected. There

are several ways around the problem, but the most practical is to use an active rectifier which utilizes negative feedback to overcome the nonlinearity of the diode

Figure 2 shows the basic circuit of a half wave active rectifier, and this helps to explain the way in which circuits of this general type function.

The circuit is almost a straightforward non-inverting operational amplifier type, and differs from this configuration only in that diode, Da has been included in the negative feedback path, and diode, Db is included in series with the output. With the standard circuit a negative feedback action balances the inverting (-) and non-inverting (+) input voltages.

If, for the sake of this explanation, we assume that Ra and Rb have the same value, in order to maintain the balance, the output of the amplifier must assume a value equal to double the input voltage in order to

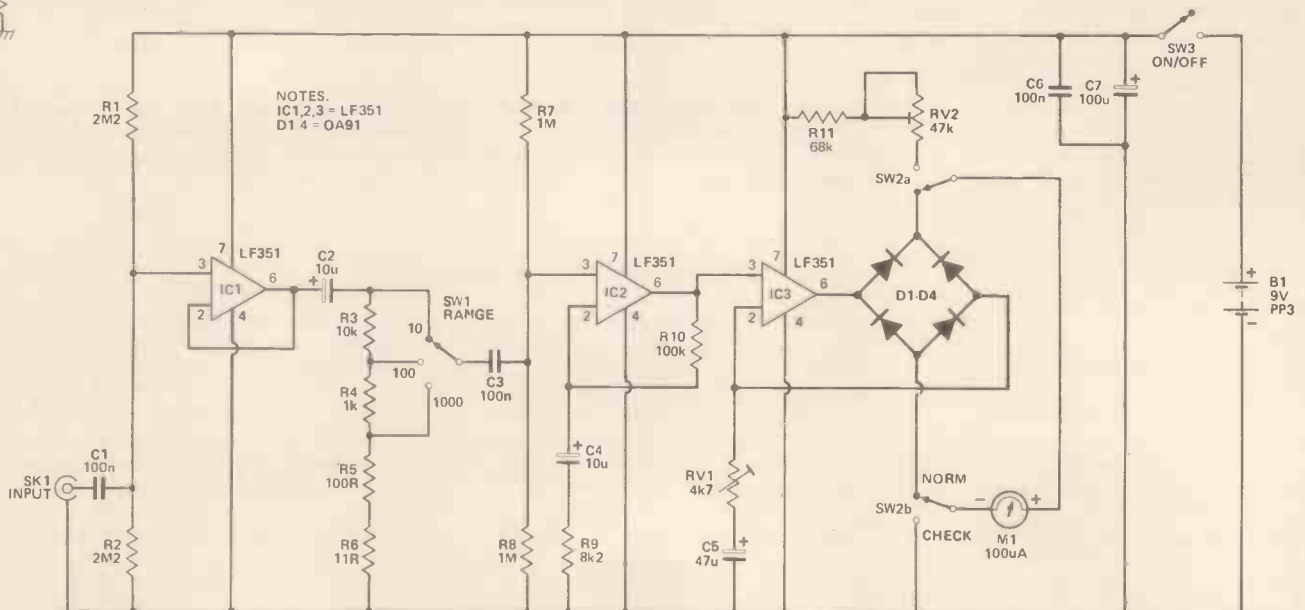

Figure 3. The circuit of the Audio Millivoltmeter.

compensate for the voltage drop produced by Ra and Rb.

Things are much the same with the two diodes included in circuit. However, in order to maintain the input voltage balance the output voltage from the operational amplifier has to go to double the input voltage plus the voltage dropped across Da. The output from the circuit as a whole is therefore equal to double the input voltage, plus the voltage drop through Da, minus the voltage drop through Db. In other words, the inclusion of Da boosts the output voltage of the operational amplifier by an amount that compensates for the voltage drop through Db, and effectively eliminates the non-linearity of Db (which provides the rectification).

As we shall see shortly, the rectifier circuit used in this circuit is actually somewhat different to the basic half wave type of Figure 2, but it uses the same operating principle.

Circuit Operation

Figure 3 shows the full circuit diagram of the millivoltmeter. The input buffer stage is a conventional operational amplifier and the non-inverting type.

Resistor R1 plus R2 bias the circuit and have values which give the circuit the required high input impedance. Although at first sight an ordinary 741C operational amplifier may seem adequate for IC1, it must be borne in mind that this stage must be able to handle signals of up to one volt RMS at frequencies of up to about 200kHz or so. The slew rate of the 741C is not adequate for signals having such rapid voltage changes, and a more modern device such as the LF351 therefore has to be used.

Capacitor C2 couples the output of IC1 to a simple three stage decade attenuator. Switch SW1 is used to select the desired output of the attenuator, and this is, of course, the range switch.



The next IC, IC2 is used as the basis of the voltage amplifier, and this is a conventional non-inverting circuit having its voltage gain set at just over 13 times by R9 and R10. Resistors R7 and R8 have been given high values so that the amplifier has a high input impedance, about 500, and does not load the attenuator significantly (which would effectively degrade its accuracy).

Rectifier Stage

The final IC, IC3 acts as the basis of the active rectifier stage, and this uses the bridge rectifier formed by D1 to D4 to provide full wave rectification for the meter. However, the rectifier is included in the negative feedback circuit of IC3 so that the output voltage of IC3 is modified by an amount that compensates for the voltage drop through the diodes.

Germanium rather than silicon diodes are used in the circuit as germanium types, at the low currents involved here, have a much lower forward voltage drop than silicon types. This does not make much difference to the low frequency performance of the circuit where the amount of negative feedback and slew rate provided by IC3 are more than

adequate to cope, but it helps to give improved performance at high frequencies where these two parameters are barely adequate. The preset RV1 is adjusted to give the circuit the correct sensitivity. The other resistor (Ra in Figure 2) in the negative feedback circuit is the resistance of the meter.

Power

The circuit has a simple battery check facility, and in the battery check mode, SW2 switches meter M1 across the supply lines via the series resistance of R11 and RV2. Preset, RV2 is adjusted to give the meter a full scale sensitivity of 10V. Power is supplied by a small PP3 size 9 volt battery, and the current consumption of the circuit is only about five milliamps.

Construction

It is advisable to use a metal case for this project so that the circuit is screened against mains "hum" and other electrical interference. A metal instrument case measuring about 150 x 100 x 50mm is ideal. This assumes that a fairly small meter is used, such

Parts List

RESISTORS

(All 1/4 watt 5% unless noted)

| | |
|-------|------------------|
| R1, 2 | 2M2 |
| R3 | 10k |
| R4 | 0.4 watt 1% 1k |
| R5 | 0.4 watt 1% 100R |
| R5 | 0.4 watt 1% 100R |
| R6 | 0.4 watt 1% 11R |
| R6 | 0.4 watt 1% 11R |
| R7, 8 | 1M |
| R9 | 8k2 |
| R10 | 100k |
| R11 | 68k |

POTENTIOMETERS

| | |
|-----|------------|
| RV1 | 4k7 |
| | 0.1W horiz |

| | |
|-----|------------|
| RV2 | 47k |
| | 0.1W horiz |

CAPACITORS

| | |
|-------|------------------|
| C1, 3 | 100n |
| | polyester |
| C2, 4 | 10u |
| | 25V radial elect |
| C5 | 47u |
| | 10V radial elect |
| C6 | 100n |
| | ceramic |
| C7 | 100u |
| | 10V radial elect |

SEMICONDUCTORS

| | |
|-------------|------------------------|
| IC1, 2, 3 | LF351 |
| | bifet op amp |
| D1, 2, 3, 4 | 0A91 |
| | germanium signal diode |

MISCELLANEOUS

| | |
|-----|---|
| M1 | 100u |
| | moving coil panel meter |
| SW1 | 3 way 4 pole |
| | rotary switch |
| SW2 | DPDT |
| | miniature toggle switch |
| SW3 | SPST |
| | miniature toggle switch |
| SK1 | 3.5mm |
| | jack socket |
| B1 | 9 volt |
| | PP3 size |
| | Metal instrument case 150 x 100 x 50mm; printed circuit board; control knob; battery connector; 6BA or M3 fixings; Veropins; test leads; wire, etc. |

BUYLINES page 26

Audio Millivoltmeter

as the 50 x 45 mm type used on the prototype. From the electrical point of view any meter having a full scale sensitivity of 100 microamps should operate properly in the circuit.

The front panel layout can be seen from the photographs, but any sensible layout is suitable. The only awkward point here is the cutout for the meter, and this is 1.5 inches (38mm) in diameter for the usual 60 x 45mm and 50 x 45mm moving coil panel meters.

Assuming that special cutting equipment is not available, probably the easiest way of making the cutout is to clearly mark the perimeter of the required hole on the front panel, and then drill a ring of closely spaced holes of about 3mm to 3.5mm in diameter just inside the marking line. Using a miniature round file the holes are then joined up and the central piece of metal is removed. Then a large half-round file is used to smooth and carefully enlarge the cutout to the correct size. The meter also requires four small diameter mounting holes for its built-in mounting screws. The positions of these on the front panel can easily be marked using the meter itself as a sort of template.

Details of the printed circuit board and wiring are provided in Figure 4.

Watch Your Soldering

The only special point to note when constructing the board is that D1 to D4 are germanium devices, and that these are more easily damaged by overheating than the more common silicon devices. Therefore, when connecting these to the board take care not to leave the soldering iron on each joint any longer than is absolutely necessary.

Fit Veropins to the board at the positions where connections to SK1 and the controls will be made, and then mount the board on the base panel of the case using 6BA or M3 fixings. These must include spacers about 6mm long to hold the connections on the underside of the board away from the metal case.

To complete the unit, the wiring is added, and this is all completed using ordinary PVC insulated connecting wire. Keep the leads from SK1 to the board reasonably short and direct, and well away from IC2 and IC3.

Adjustment

Start with RV1 and RV2 both adjusted fully anticlockwise. With SW2 set to the "check" position and the unit switched on there should be a substantial deflection of the meter. Use a multimeter set to a suitable DC voltage to measure the battery voltage, and then adjust RV2 for a corresponding reading on M1. The battery should be replaced when its voltage falls to about 7V5 to 8V.

In order to adjust RV1, first set the

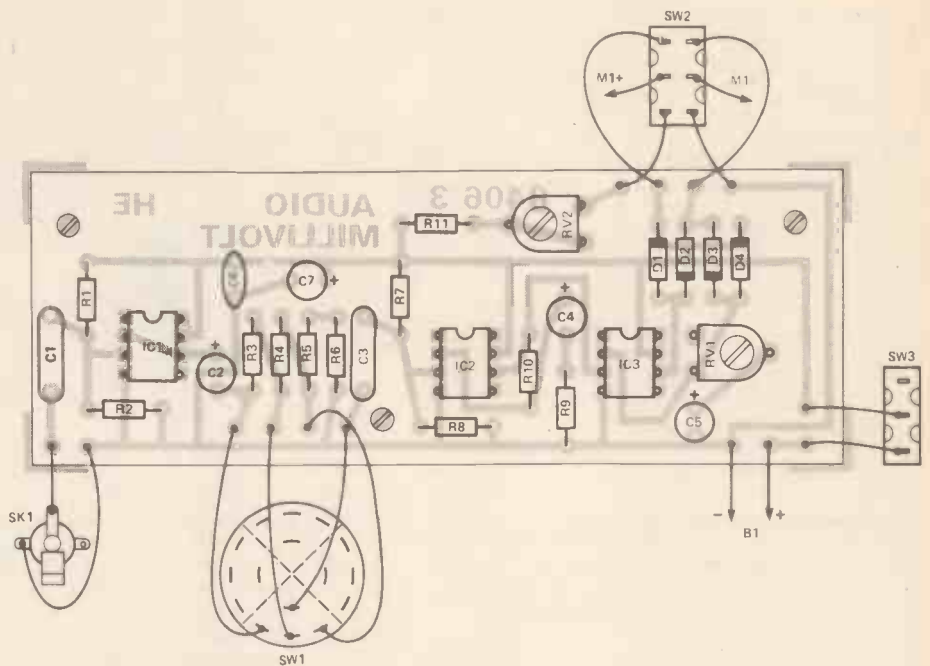
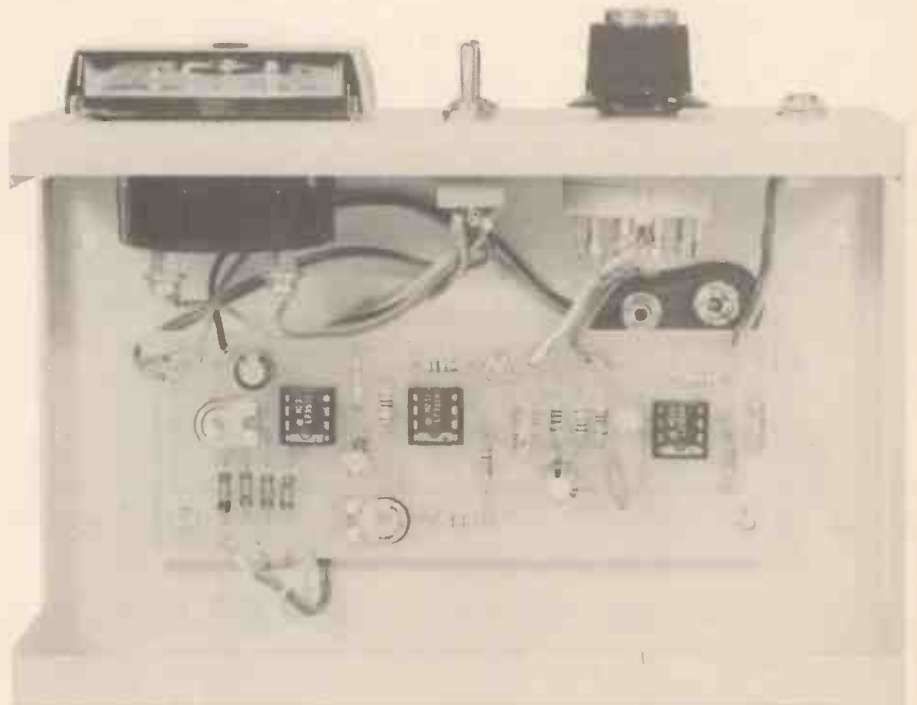

Figure 4. The component layout. Construction is straightforward on this board, but take care not to over-solder the germanium diodes, which are susceptible to heat damage.



unit to the "normal" mode. Incidentally, do not worry if there is a strong but brief deflection of the meter when the unit switch on in the "normal" mode. This is just caused by the capacitors in the circuit taking up their working charges, and nothing in the circuit will come to any harm.

With an audio sinewave input signal of known amplitude and within the measuring range of the unit connected to the input, set SW1 to a suitable range and then adjust RV1 for the correct reading. If only a limited amount of test gear is available it might be difficult to obtain a suitable reference level. The easiest solution to the problem is probably to

use an ordinary multimeter set to a low AC voltage range to monitor the output of the signal generator, and adjust the generator for an output of one volt RMS. Most multimeters provide good accuracy at AC voltages of around one volt, and this should give a one volt calibration signal of adequate accuracy.

In use, a set of leads is required, and this consists of a screened lead about one metre long with the inner conductor terminated in a test prod. A second test prod connects to the outer braiding via an ordinary insulated lead about 150mm in length. Of course, the other end of the cable is fitted with a 3.5mm jack plug to match SK1.

Affordable Accuracy · Low Cost Multimeters from Armon

SPECIFICATION MODELS

HC-6010 & HC-7030 DIGITAL

- ★ 10 amp AC/DC
- ★ Battery: Single 9V drycell. Life: 200 hrs.
- ★ Dimensions: 170 x 89 x 38mm
- ★ Weight: 400g Inc. battery
- ★ Mode Select: Push Button
- ★ AC DC Current: 200 μ A to 10A
- ★ AC Voltage: 200mV to 750V
- ★ DC Voltage: 200mV to 1000V
- ★ Resistance: 200 Ω to 20M Ω
- ★ Input impedance: 10M Ω
- ★ Display: 3 $\frac{1}{2}$ Digit 13mm LCD
- ★ O/Load Protection: All ranges



HC-6010
0.5% Accuracy
£29.95

HC-7030
0.1% Accuracy
£35.95



HC102BZ
£13.00

SPECIFICATION HM 102R ANALOGUE

- ★ DC Voltage: 0-25, 1, 2.5, 10, 25, 100, 250, 1000 volts
- ★ AC Voltage: 0-10, 25, 100, 250, 1000 volts
- ★ Decibels: -20 to +22dB
- ★ DC Current: 0-50, 500 μ A, 0-5, 50, 500mA
- ★ Ohmmeter: 0-6 Megaohms in 4 ranges
- ★ Power Supply: One 1.5 V Size 'A' battery (incl)
- ★ Size & Weight: 135 x 91 x 39mm, 280gr.

HC 102 BZ WITH BUZZER BATTERY SCALE, 10A DC RANGE

HC102R
£11.00

ARMON ELECTRONICS LTD.

Dept. E, Cottrell House, 53-63 Wembley Hill Road, Wembley, Middlesex HA9 8BH

Telephone 01-902 4321 (3. lines). Telex 923985

Please add 15% to your order for VAT. P&P free of charge. Payment by cheque with order. Offer applicable to mainland UK only.

Please allow 15 days for delivery.

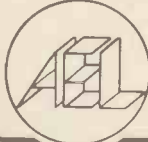

MODEL COVERS

All sizes catered for with the base of your choice and colour. Let us help you keep your pride and joy in good condition. Trade or Retail enquiries welcome.

6mm rebate base for 3mm clear perspex cover 4" high x 12" long x 6" wide = 12.00p. + pp.

TELEPHONE OR WRITE
ALL ENQUIRIES ANSWERED

John Wise Limited
5 Alpha Road, West Green
Crawley, Sussex RH11 7DH
Tel: Crawley 542889

PARNDON ELECTRONICS LTD.

Dept. 22, 44 Paddock Mead, Harlow, Essex. CM18 7RR. Tel: 0279 32700

RESISTORS: 1/4 Watt Carbon Film E24 range \pm 5% tolerance

Bandollered and colour coded. Full Range 1R0-10M.

£1.00 per hundred mixed (Min 10 per value) £8.50 per thousand mixed (Min 50 per value)

Special stock pack 60 values. 10 of each £5.50

RECTIFIERS

| | | |
|-------|-------|-------|
| | 1 Amp | 3 Amp |
| 50V | 3p | 14p |
| 100V | 4p | 14p |
| 200V | 5p | 14p |
| 400V | 6p | 19p |
| 600V | 8p | 20p |
| 1000V | 9p | 25p |

VOLTAGE REGULATORS - 1 amp/T0220

Positive voltage 5.8, 12, 15, 24V 40p

Negative voltage 5, 12, 15V 43p

CAPACITORS - Mixed special

£2.00 pack. Tant bead: 5 off OR

AL. ELEC: 30 off. Our choice of

Values/Voltages

DIL SOCKETS

8 pin - 10p. 14 pin - 11p. 16 pin - 12p. 18 pin - 19p. 20 pin - 21p
22 pin - 23p. 24 pin - 25p. 28 pin - 27p. 40 pin - 42p.

DIODES: IN4148 £1.60 per hundred

ALL PRICES INCLUDE V.A.T. & POST & PACKING - NO EXTRAS

MIN ORDER - UK £1.00 OVERSEAS £5 CASH WITH ORDER PLEASE

X-Stock Items Same Day Despatch

No Project Is Complete Without The Right Housing ...

KMT

The unique new modular enclosure.

Suitable for alarm systems, counters, interfaces amplifiers, model control units and many other projects.

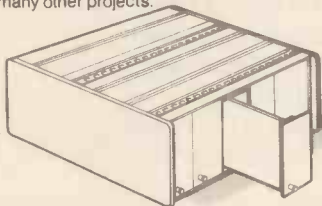

Easy to assemble - just 10 screws.

Easy on the pocket - house your projects economically and professionally.

For full size eurocards (100 x 160mm) mounted horizontally in the 35TE front panel kit.

Half size eurocards (100 x 80mm) mounted vertically included as part of all front panel kits (except 35TE), with connector included.

Hi-Style Desk Top Case

Designed to house keyboards and displays on two 1.6mm silver anodised aluminium panels. The light brown case is manufactured from high impact polystyrene and has a textured finish.

- Casing-High impact textured ABS

- Colour-Brown, front and base panels 1.6mm satin anodised aluminium

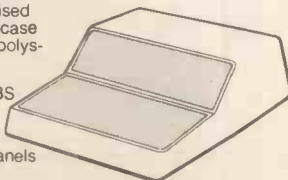

Hand Held Box



This box is moulded in two sections and has a textured finish. The battery compartment accepts a PP3 or nickel cadmium stack 25 x 45mm long. A circuit board 56 x 105mm may be mounted on three pillars in the base, location being provided by a 3mm spigot. The top moulding will accept a circuit board 71 x 107mm.

- Material-Textured ABS
- Colour-Dark brown

Plastic Boxes

Type A

Plastic boxes consisting of a top and bottom moulding with front and rear aluminium panels, positively retained in the two halves.

- Top and bottom moulding-High ABS.
- Colour-Light grey top: dark grey base.
- Front and rear panels-Satin anodised aluminium 1.6mm thick.

Type B

Constructed of high impact polystyrene, these handsome two-toned grey boxes are suitable for wall mounting and free standing instruments. The two halves of the box are held together by screws inserted from the base.

- Material-High impact polystyrene
- Colour-Top light grey: base dark grey
- Panels-Satin anodised aluminium

Send 50p for a copy of the catalogue with details of the full range available.

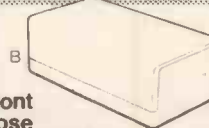
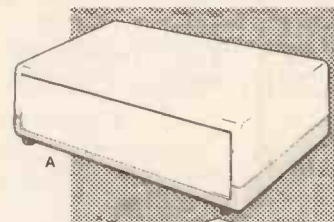

... Why don't you choose BICC-Vero Enclosures. A complete range where quality and economy are combined.

BICC-VERO ELECTRONICS LIMITED

Retail Department,
Industrial Estate,
Chandlers Ford,
Hants SO5 3ZR
Tel (04215) 62829



BACKNUMBERS

February 1983
 Incremental Timer, Pop Amp 4 & 5, Power Supply for digital applications, the Birth of Broadcasting, Random Access Memories, A Directory of Electronic Kits and Modules, Book Guide.

March 1983
 HE EPROM Programmer, Pop Amps 6 & 7, Signal Powered Loudspeaker Protector, Over-voltage Cut-Out, ROMs & EPROMs, the Arrival of Television, Car Computer Review, Radio Rules — Propagation and Aerials, Finishing Touches, Famous Names.

April 1983
 Auto Power Down, EPROM Programmer Part 2, Stereo Voice Over, Tools and Test Equipment Survey, Components and Hardware Directory, Tools For The Trade, Components For Computing — Interrupts, Radio Rules — RF Interference and Measurements, Radio Controlled Gerbil.

May 1983
 Car Security Cutout, Demister/Aerial Conversion, HE Auto Tester, BBC Micro/HEBOT Interface, Careers In Electronics Part 1, Radio Rules — the RAE, Aces High, DIY Loudspeakers Review, The Micro Age, Famous Names.

June 1983
 ZX Sound Board, Car Battery Warning Device, Pop Amps 8, CB Push-To-Talk Switcher, Traffic Light Toy, Digital Displays, Careers — Technical Writing, Electronics In The Home, Book Reviews, Famous Names.

July 1983
 Soft Fuzz, ZX81 High Resolution Graphics Board, Simple Tremolo, Stereo Image Expander, Pop Amps 9, All About Electronics Part 1, Oric 1, Review, Careers — British Telecom, Famous Names.

August 1983
 Programmable Joystick Controller, Whistle Switch, Expanding the ACE, Car Aerial Winder, Enlarger Timer, Electromagnets and Ohm's Law, Careers — TV and Radio Transmission, Famous Names.

September 1983
 Sound Pressure Level Meter, Tremoleko, Power Supply Unit, HE Gripometer, Cable & Satellite TV, Careers — TV and Radio Studio Engineering, Resistance and Capacitance.

October 1983
 Audio Level Meter, Hi-Voltage Meter, Jupiter 2, Interface Card, Ultrasonic Intruder Alarm, FX Computer review, Careers — Customer Service Engineer, Introduction to Semiconductors, Eight-page Circuit Supplement.

November 1983
 HE Parametric Equaliser, Car Interior Light Relay, Windscreen Wiper Relay, Simple Stereo Pre-Amplifier, Dual Purpose Power Supply, Short Circuits, Digital Circuits, Careers — Microcomputers.

December 1983
 General Purpose Light Meter, HE Bassman, Moisture Gauge, Simple Continuity Tester, A Zener Diode Primer, Logic Gates, I Almost Met, Junction FETs.

January 1984
 Slot Car Lap Counter, HE Quizmaster, Transatlantic Power Reducer, Mainframe pop Group, Careers — the Army, Op-Amps, 1982/1983 Indexes.

February 1984
 Infra Red Camera Control, Audio Power Switching Module, Car Timing Relay, CB Field Strength Meter, Careers — The Navy, Directory of Electronic Components and Hardware Suppliers 1984.

All issues for 1983 and 1984 are available unless specifically marked as out of print.

Backnumbers of Hobby Electronics are available for the current year and the previous year, at the current price of £1.40. For issues from prior to this, or for current issues which are now sold out, we do a photocopying service. Each article costs £1.50, and information as to its title and publication date should be given. Ordering backnumbers or photocopies could hardly be easier: just fill in the coupon, cut it out, and sent it to the appropriate address.

**HOBBY ELECTRONICS
 BACKNUMBER ORDER FORM TO:**



**Backnumbers
 Hobby Electronics
 Infonet Ltd.
 Times House
 179 The Marlowes
 Hemel Hempstead
 Herts HP1 1BB**

Please send me the following items:

NAME

ADDRESS

.....

.....

.....

Back issues at £1.40 each

I enclose £.....

Cheques and Postal Orders should be made payable to ASP Ltd.

**HOBBY ELECTRONICS
 PHOTOCOPY ORDER FORM TO:**



**Photocopies
 Hobby Electronics
 ASP Ltd.
 No. 1 Golden Square
 London W1R 3AB**

Please send me the following items:

NAME

ADDRESS

.....

.....

Photocopies of in the

..... issue at £1.50 each

I enclose £.....

Cheques and Postal Orders should be made payable to ASP Ltd.

FORWARD BIAS

Questions, answers and errata from readers and writers.

Only one, very small error to report from HE April '84: on page 17, under the heading "More About Tuned Circuits", in the final column, the sentence "A nanohenry + 10⁻⁹ henries" should read "A nanohenry = 10⁻⁹ henries". As errata come, you can't get a lot smaller than that . . .

Next, a report and query from a reader:

Re: Low Power Pilot Light
HE September '81

Dear Sir/Madam,

With regard to the above project, I have found the following errors: 1) In Figure 1 and Figure 2 (overlay) the LED 1

connection annotations are reversed (C and A).

2) In Figure 2, C1 positive should go to Veroboard D8, not C8.

3) In two of the Pilot Lights constructed did not operate properly. The LED stayed on permanently and did not flash. I found that inserting a 470R resistor in series with the +9V power line corrected this. Could you explain why?

4) Are there any more errors regarding this project?

Yours faithfully,
J. S. Runacre,
Sittingbourne,
Kent.

Thanks to Mr. Runacre. No, there are no other errata reported for this project; the errata have almost certainly been reprinted at some stage, but as we don't have an index of errata, I can't tell you when. They will be reappear in due course when FB gets to September '81.

The cause of the problem is probably the tolerances of the components in the two models you built adding up to the "wrong direction", causing R3 to malfunction. If you reduce the value of R3 in these models, you should find that the extra 470R resistor becomes unnecessary.

COLLECTED BOOBS

Continuing excerpts from the Hobby Electronics Errata Box

Temperature Controlled Soldering Iron

(HE October '80)

In Figure 2, ZD1 is shown the wrong way round. If it has been soldered in like this it will almost certainly need replacing.

Tug Of War

(HE October '80)

In Figure 1 R20 should be 2k2, not 8k2. In Figure 2, pin 4 of IC3 should be connected to R19. Part of the PCB is missing, and should be replaced with tinned copper wire.

Kitchen Timer

(HE October '80)

In the Circuit Diagram and Parts List, R17 should be 3k9 and not 82k.

Double Dice

(HE November '80)

In Figure 2, the pin numbers for ICs 2c and 4c are wrong. The correct pin-outs are:

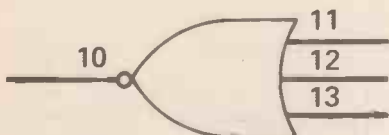

The connections on the PCB are correct.

Guitar Preamp

(HE November '80)

In Figure 1, C7 should be 22uF tantalum as shown in the Parts List.

In Figure 2, there should be a track break at J8.

In Figure 3, the screen of the lead from C10/RV3 (volume) should be connected to H14 (the earth track).

Bench Amplifier

(HE January '81)

In Figure 2, the power connections to the Veroboard should be reversed, ie + goes via SW1 to Veroboard point 23H, and goes directly to Veroboard point 24F.

The Q1 connections should be: emitter to Veroboard Point E2, collector to Veroboard point G2 and base to Veroboard point F1, ie the transistor is moved down one hole.

Sound-Into-Light Module

(HE January '81)

In Figure 5, the Veroboard track should be broken underneath C5, eg at B25. Pins 6 and 7 of IC1 should be linked together.

Heartbeat Monitor

(HE February '81)

In Figure 2, the off-board 100k resistor is incorrect. Instead, with reference to

Figure 2, the right-hand signal generator input should be connected to C6 where the 100k resistor is now connected, and a cable link should be made from this point round to the - connection of the battery on the PCB. (This is only for test purposes.)

Hi-Z Voltmeter

(HE February '81)

On Figure 2, the three connections (to pin 5) at F10, F11 and F13 should be moved up to the next track (pin 6) (E10, E11 and E13 respectively). There should be a track cut at G16.

Public Address Amplifier

(HE March '81)

In Figure 2, R3 (top connection), R2 and Q1 should be moved down one row on the Veroboard, as shown:

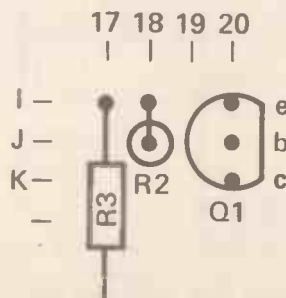

TRANSTEL DOT MATRIX PRINTER Compact
Serial Interface 230V. With info. £65 ea
TELETYPE ASR33 — DATA DYNAMIC (Printer,
Keyboard, Punch & Reader) RS232 £75
RACAL MODEM type 2200/24 £100
TRT SEMATRON 1022 Modem £20
CRED TELEPRINTER 75. Very Good Condition £25
9" MONITOR Cased Non-Standard With info. £20 ea
12" MONITOR Cased Non-Standard With info. £15 ea
AZTEC 20" Black & White MONITOR Video In. £50 ea
TV Style 20" MONITOR Black & White Video In. £30 ea
GENERAL ELECTRIC TERMINET Printer with
Keyboard Upper/Lower case £125 ea
ICL Version of above. No keyboard £95 ea
QWERTY KEYBOARD. Push to make. Uncased. £15 ea
P&P £4.
CARRIAGE ALL UNITS £7.

STEPPING MOTORS
Type 1. 200 Steps 4 Phase (5 wire) 12/24V 25 oz inch.
2 1/4" dia. £15
Type 2. 8/12 Steps 3 Phase 12/24V. 1 1/4" dia. £2 ea
5 for £5.70
Type 3. 24 Steps 4 wire 5V 3.3A 0-250rpm 0-200PPs
2 1/4" dia. £10 ea
Type 4. 200 Steps 120V (3 wire) 25 oz inch.
2 1/4" dia. £4 ea

MOTORS
SYNCHRONOUS 2 Phase 9V AC. 375rpm Cap start.
Will DC step — 8 steps per rev. £1 ea
GEARED 117/230V 50HZ 4" dia. £5 ea P&P £4
GEARED 115/230V 1 RPM 2 1/4" dia. £4 ea P&P £2
MOTOR 12V DC 3" dia. £3.50 ea. P&P £3

TRANSFORMERS
TOROIDAL 13.5-0-13.5V 8VA £1.50 ea 10 off £12
TOROIDAL 0-12V; 0-12V 10VA per winding. £4 ea
10 off £35 P&P £2
AUTO 240V Input 115V 1A £1.25 ea
Sub-Min 12-0-12V 4VA. 75p ea 10 off £8. P&P £2
Printed Circuit Mounting 120/240V. Input Sec
15V 0.4A twice £1.50 ea
Chassis Mounting 120/240V. £1.50 ea
9V0.33A twice — £1.50 ea. 20V0.15A twice — £1.50 ea.
6V0.5A twice — £1.50 ea. 12V0.96A twice — £1.50 ea.
7.5V 3.34A twice — £3 ea.
Sub-Min PULSE TRANSFORMER Centre tapped.
Suitable Thyristor Triggering — 20p ea. 10 off £1.80.
Many other transformers available — please enquire.

CAPACITORS
Electrolytic 15000mfd 25mfd 25V 20pea 10 off £1.80
Sprague Compolytic 18,000 mfd 10V Screw
terminal. £1 ea
Electrolytic 900mfd 100V Screw
terminal. 50p ea. 10 off £4

SAMPLE OF STOCK — SAE or TELEPHONE for LISTS Please check availability before ordering. Min order of Goods £4. Min P&P £1.50. VAT at 15% MUST be added to TOTAL of Goods & Packaging

STEWART OF READING
110 WYKEHAM ROAD, READING, BERKS RG5 1PL.
Tel: 0734 88041
Callers welcome 9am-5.30pm Monday to Saturday inclusive

OSCILLOSCOPES
TELEQUIPMENT D75. Dual Trace 50MHZ
Delay Sweep £400
S E LABS SM111 Dual Trace 20MHZ. £200
TEKTRONIX 585A with 82 Plug-in Dual Trace
85MHZ Dual TB Delay Sweep £200
TEKTRONIX 545B with CA Plug-in 24MHZ Dual Trace
Dual TB £160
Ex-Ministry CT436 Dual Beam 6MHZ. £60
SE LABS STROBE 5M8 £125
METROHM BATTERY MEGGER 500V. £40
ADVANCE Dual Stab DC Power Supply PPS. 0-30V;
0-1A twice. Metered. £50
AVO TRANSISTOR TESTER TT169. With leads. £20
P&P £2.
CARRIAGE ALL UNITS £7.
RANGE OF NEW SCOPES AVAILABLE —
Please enquire

Tantalum Bead 0.1 mfd 35V. 10 off £1. 100 off £7.50
De-Coupling — 0.4725V, 0.005 100V; 0.47 12V;
0.001 200V/33pF. 10 off 30p. 100 off £2

SWITCHES
ILLUMINATED ROCKER 2 pole 250V 8A.
Orange. 50p ea. 10 off £4
ROCKER 2 pole 0/0 — 12p each. 10 off £1.80
TOGGLE Centre off DPDT 20p each 10 off £1.80
SLOTTED OPTO SWITCH with data 50p each 10 off £4
Min MICROSWITCH V3-Button. 30p ea. 10 off £2.50
I.C. SOCKETS
10 pin-10p; 22 pin-15p; 14 pin-8p 100 off £6
36 pin-15p; 40 pin-25p; 16 pin-8p 100 off £6

RIBBON CABLE
10 way-50p per metre 10 metres £4
14 way-75p per metre 10 metres £6
PCB KEYBOARD PAD 19 Push Contacts 0-9; A-F plus 3
optional — £1.50 ea. 10 off £12
KEYBOARD PAD 12 Alma Reed Switches Push to make
0-9; & Blank £4 ea. 5 off £15 P&P £3
TOKIN NOISE FILTER VG215FU. 250VAC 15A
50/60 Hz With fixing bracket. £2 each
BLACK RIBBONS for Teletypes/
Teletinters 75p ea 6 off £4
I.T.T. LOUDSPEAKER 2 1/2" 50ohm
0.2W 75p ea 10 off £6.50
FERRANTI PHOTOCELL type MS15 50p ea 10 off £4
VUMETER Scaled 0-5 Size 1 1/2"x1 1/2" 50p ea. 10 off £4
I.E.C. MAINS LEAD 2 metre Heavy duty 60p ea 10 off £5
MICROPHONE/EARPIECE INSERTS 75p ea. 10 off £6
CINCH CONNECTOR STRIP 12way. Screw con-
nections 35p ea 10 off £3.
CABLE TIES White 9cm; Black 12cm. 50 for 50p

EXECUTIVE TELEPHONES — PUSH BUTTON
Many functions including 10 number memory, repeat
dialing etc. Will connect to GPO system. Brand New.
£25 each P&P £4.

FIND YOUR WAY THROUGH THE DIGITAL ELECTRONICS MAZE

First there was **SUPERKIT**

and now . . .
NEW

SUPERKIT II

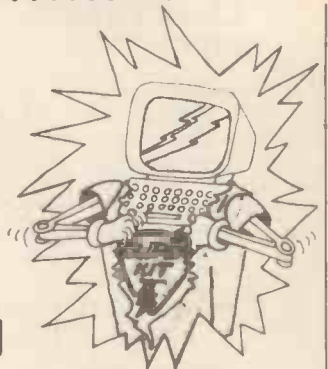

This practical self-instruction kit has been developed to extend the original beginners' SUPERKIT. SUPERKIT II includes an instruction manual and many more components, enabling you to design and use adders, subtractors, counters (ripple, up/down, synchronous, decade and Gray code), registers, pattern recognisers and 7-segment displays. You need the board and components from SUPERKIT to enable you to build the circuits in SUPERKIT II. Together the two kits provide an excellent introduction to digital electronics — what really goes on inside a computer.

SUPERKIT. (SUP) £22.00 SUPERKIT II (SUP II) £16.00
Special price £36.00 for both (SUP + II) (inc. VAT and p & p)

The SUPERKIT series is backed by our theory courses, **DIGITAL COMPUTER LOGIC** (beginners' course), which covers the design of logical circuits, and **DIGITAL COMPUTER DESIGN** (more advanced), which covers the design of digital computers. **MICROPROCESSORS AND MICROELECTRONICS** teaches you what a microprocessor is and what it can do.

DIGITAL COMPUTER LOGIC (DCL) £7.00
DIGITAL COMPUTER DESIGN (DCD) £9.50
MICROPROCESSORS AND MICROELECTRONICS (MIC) £6.50

Please send for full information on these and our other courses.
GUARANTEE If you are not completely satisfied, return the item to us within 28 days for a full refund. All prices include worldwide surface postage (ask for prepayment invoice for airmail). Allow 28 days for delivery in UK. Overseas payment by international credit card or by bank draft drawn on a London bank.

CAMBRIDGE LEARNING LTD, Unit 99, Rivermill Site, FREEPOST, St Ives, Cambs PE17 4BR, England.

Tel: 0480-67446
VAT No 313026022 Transcash No 2789159 Reg No 1328762
Please send me (initial letters used):

..... SUP @ £22.00 DCL @ £7.00
..... SUP II @ £16.00 DCD @ £9.50
..... SUP + II @ £35.00 MIC @ £6.50

I enclose a cheque/PO payable to Cambridge Learning Ltd for £

Please charge my credit card,
No Expiry date

Telephone orders from credit card holders accepted on
0480 67446 (24 hrs)

Name

Address

..... Signature

FREE CAREER BOOKLET

Train for success, for a better job, better pay

Enjoy all the advantages of an ICS Diploma Course, training you ready for a new, higher paid, more exciting career.

Learn in your own home, in your own time, at your own pace, Through ICS home study, used by over 8 million already! Look at the wide range of opportunities awaiting you. Whatever your interest or skill, there's an ICS Diploma Course there for you to use.

Send for your **FREE CAREER BOOKLET** today —no cost or obligation at all.

| | |
|--|--|
| C & G BASIC ELECTRONICS <input type="checkbox"/> | ELECTRONIC ENGINEERING <input type="checkbox"/> |
| C & G RADIO AMATEUR'S Exam <input type="checkbox"/> | COMPUTER PROGRAMMING <input type="checkbox"/> |
| RADIO & AUDIO ENGINEERING <input type="checkbox"/> | TV & AUDIO SERVICING <input type="checkbox"/> |
| RUNNING YOUR OWN BUSINESS <input type="checkbox"/> | ELECTRICAL INSTALLATIONS/CONTRACTING <input type="checkbox"/> |
| AUTO MECHANICS <input type="checkbox"/> | C & G BASIC MECHANICAL ENGINEERING <input type="checkbox"/> |

Name

Address

P.Code

ICS Dept EA164
ICS School of Electronics
160 Stewarts Road
London SW8 4UJ

01-622 9911 (all hours)

CACC



CAMBRIDGE LEARNING

Unit 99, Rivermill Site, FREEPOST,
St Ives, Cambs PE17 4BR, England



ZX81 Microphone Connector

This twin relay output port for the ZX81 gives the computer more control over a cassette recorder via the cassette interface, and avoids feedback problems in loading and saving data. It has other uses, too.

R. A. Penfold



Figure 1. The block diagram, showing the twin relays and the connections to the earphone and microphone sockets.

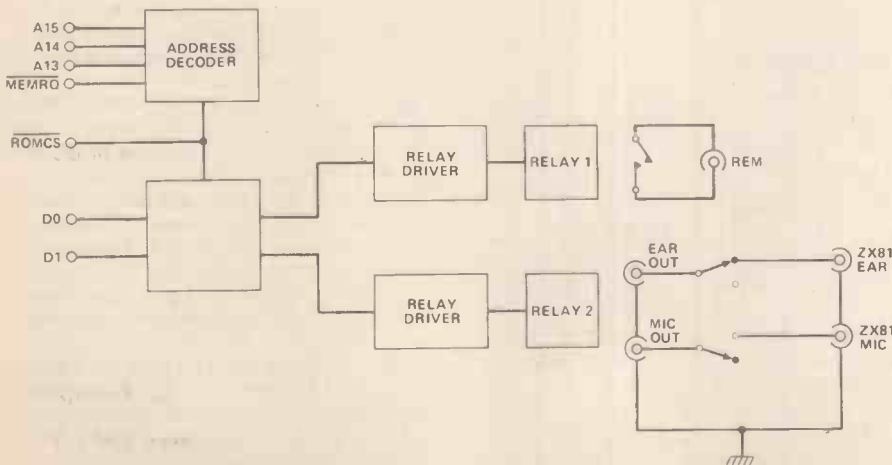

ALTHOUGH the ZX81's cassette interface has received at least its fair share of criticism, if used correctly with a cassette recorder and tape of reasonable quality it provides fairly reliable saving and loading. However, in some respects this interface is quite crude, and it does not provide any form of tape motor control.

Futhermore, with most recorders problems with feedback arise if the equipment is used with both the earphone and microphone leads connected at once. In order to overcome this it is necessary to connect only the lead actually in use. This makes the ZX81 cassette interface a little awkward to use, especially when saving programs, which is when the absence of any automatic motor control is most noticeable.

Controller Operation

This project is basically just a twin relay output port for the ZX81, and it is primarily intended as an aid to loading and saving, although it can be used in many other ZX81 applications which require a twin relay port. The block diagram of Figure 1 helps to explain the way in which the system operates.

If we consider the relay switching first, one of the relays has a single make contact which is used to activate the motor of the cassette recorder. The other relay has double pole changeover contacts, and these are arranged so that normally the earphone socket of the recorder is connected through to the "Ear" socket of the ZX81, but the microphone socket of the recorder is disconnected from the "Mic" socket of the ZX81.

In order to load a program it is just a matter of activating relay 1 so that

ZX81 Cassette Controller

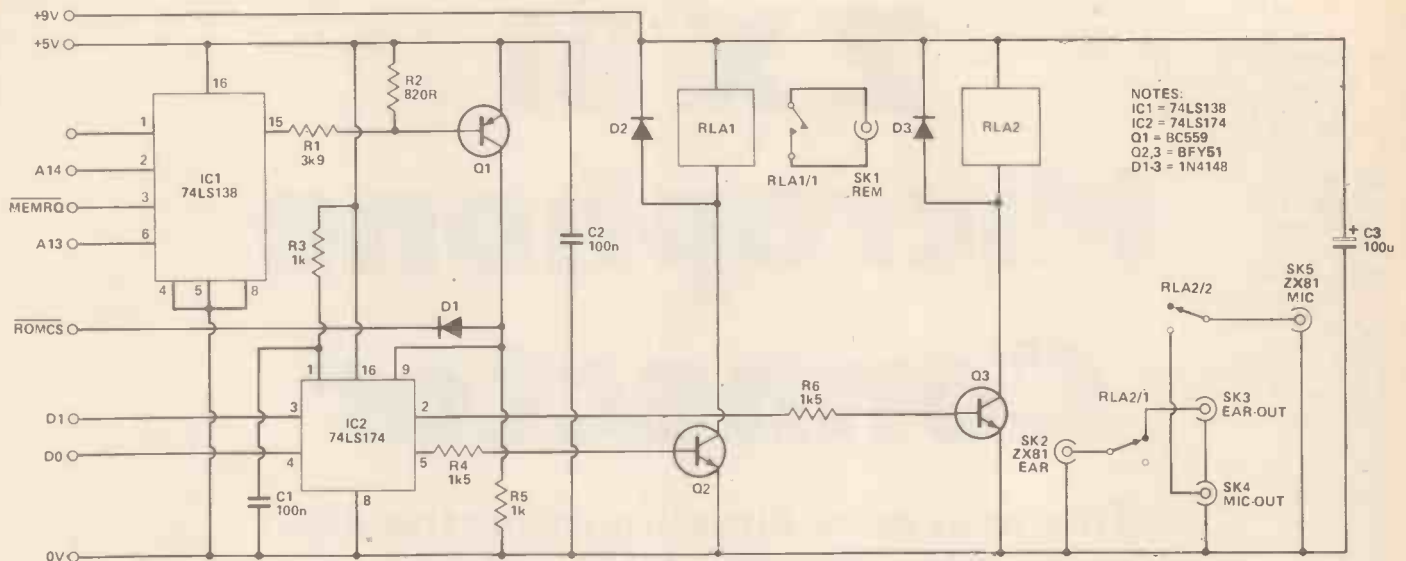

NOTES:
 IC1 = 74LS138
 IC2 = 74LS174
 Q1 = BC559
 Q2,3 = BFY51
 D1,3 = 1N4148

Figure 2. The Circuit Diagram of the ZX81 Tape Controller. Power is supplied by the computer.

Parts List

RESISTORS

(All 1/4W 5% carbon)

| | |
|-------|------|
| R1 | 3k9 |
| R2 | 820R |
| R3, 5 | 1k |
| R4, 6 | 1k5 |

CAPACITORS

| | |
|----|-------------------------|
| C1 | 100n polyester |
| C2 | 100n ceramic |
| C3 | 100u 16V radial electro |

SEMICONDUCTORS

| | |
|----------|------------------------------|
| IC1 | 74LS138 3-to-8 line decoder |
| IC2 | 74LS174 hex D-type flip/flop |
| D1, 2, 3 | 1N4148 silicon signal diode |
| Q1 | BC559 silicon PNP |
| Q2, 3 | BFY51 silicon NPN |

MISCELLANEOUS

| | |
|--------------|------------------------------------|
| SK1 | 2.5mm jack socket |
| SK2, 3, 4, 5 | 3.5mm jack socket |
| RLA1 | 12 volt 300 ohm coil SPDT contacts |
| RLA2 | 12 volt 300 ohm coil DPDT contacts |

Printed circuit board; plastic case, about 150 x 80 x 50mm; ZX81 edge connector and 10-way ribbon cable; two 16-pin DIL IC sockets; Veropins, wire, etc.

BUYLINES page 26

The relays are:- Maplin YX94C and YX95D.

the motor in the recorder is switched on, and then switching this relay off again once the program has been successfully loaded. In order to save a program both relays must be switched on, and then off again once the program has been saved. No plugging and unplugging of the microphone and earphone leads is needed as this is effectively done by relay 2.

The circuit which drives the relays is a fairly conventional ZX81 2-bit output port. An address decoder circuit decodes only lines A13 to A15, plus the MEMRQ line so that the port is placed in the ZX81's memory map rather than in its input/output map. This is done simply because ZX81 BASIC language does not include IN and OUT instructions, and input/output devices can only be operated from BASIC using PEEK and POKE in conjunction with memory mapping.

The decoded output is used to control two data latches which are fed from lines D0 and D1 of the data bus. The latched outputs drive the relays via conventional single transistor relay drivers. The address decoder is also used to disable the ZX81's ROM which would otherwise interfere with the output port.

The Circuit

Figure 2 shows the full circuit diagram of the ZX81 Tape Controller Unit. The address decoder is based on IC1, which is a 74LS138 three-to-eight line decoder. In this circuit the three address inputs are fed from lines A15, A14, and MEMRQ, while the positive enable input of the device is used to decode A13. IC1 also has two negative enable inputs, but these are not needed in this circuit and are simply connected to the negative supply rail so that they are permanently enabled.

Only output 0 at pin 15 of IC1 is utilized in this design, and this output

goes low when A14, A15, and MEMRQ are low and A13 is high. In other words, when any address in the range 8192 to 16383 is accessed.

If it is a positive pulse that is required to operate both the data latches and the ROMCS line, and Q1 is used as an inverter to convert the output of IC1 to a signal of the correct polarity.

The output of Q1 is used to directly drive the clock pulse input of the data latches, but it drives the ROMCS line via diode D1. The reason for disabling the ZX81's ROM is that only partial address decoding is used in the ZX81, and apart from its base addresses, the ROM appears at various address blocks throughout the 64K address range. Taking the ROMCS line high disables the ROM, so that an address block occupied by one of these "ROM echoes" can be used for other devices.

However, internal circuits of the ZX81 operate the ROMCS line, and must not be prevented from doing so by external circuits, or the computer will "crash". D1 is therefore included in series with the output to the ROMCS line so that Q1 can pull this line high when a suitable address is accessed, but it does not hold it low at other times.

IC2 is the data latch, a 74LS174 device. It is actually a hex D-type flip/flop, but it works well in this application, and the four unused flip/flops are just ignored. R3 and C1 are used to provide a negative reset pulse to the "master reset" terminal at switch-on. This ensures that initially both relays are in the off state.

The relay driver circuits have Q2 and Q3 as standard common emitter switches, with the usual protection diodes (D2 and D3) in their collector circuits. The main circuit is supplied with power by the stabilised 5 volt output of the ZX81. A 5 volt supply is inadequate for most relays, and the non-stabilised 9 volt (nominal) output of the ZX81 is therefore used to

supply the relays and their drivers.

The relay switching circuit is exactly the same as the arrangement outlined in Figure 1 and described earlier. An important point to note is that neither side of the motor control output (SK1) connects to the earth rail. With most cassette recorders neither of the remote control terminals connect to earth, and connecting either terminal to this rail usually prevents the remote control facility from operating (and could even damage the recovery).

The total current consumption of the circuit is under 100 milliamps, even with both relays switched on, and the ZX81 is readily able to supply a current of this modest magnitude.

Construction

The plastic case having approximate outside dimensions of 150 by 80 by 50 millimetres is adequate to comfortably accommodate all the components. The suggested front panel layouts can be seen by referring to the photographs.

It is advisable to have the two sockets which connect to the ZX81 well separated from the three which connect to the cassette recorder so that the unit is easily wired into the system without making any errors.

SK1 is a 2.5mm jack, while the other four sockets are 3.5mm jack types. These match the types fitted to the ZX81, and probably those fitted to your recorder as well, but alternative types can of course be fitted if these would be more convenient in use.

As explained previously, neither side of SK1 must be allowed to come into electrical contact with the earth rail. What this means in practice is that either a metal case must not be used, or SK1 must be an insulated type (or insulated from the metal case). In practice it is probably best to use a plastic case and avoid any insulation problems with SK1.

Details of the printed circuit board and the wiring are provided in Figure 3. In most respects there are no unusual points when constructing the board, but be very careful to connect the three diodes with the correct polarity, especially D2 and D3. Also make sure that the other semiconductors and C3 are fitted the right way round.

Provided the relays specified in the components list are used, they will plug straight into the printed circuit board without any difficulty. From the electronic point of view any relay that will operate reliably on a supply potential of about 9 volts, has a coil resistance of around 200 ohms or more, and has suitable contacts is perfectly suitable for use in this project.

The problem with alternative relays is that they are almost certain to be physically different from those used in the prototype, and will not fit onto the board properly unless the track layout is suitable modified. They could be mounted off-board, but this is not a very neat solution and could be

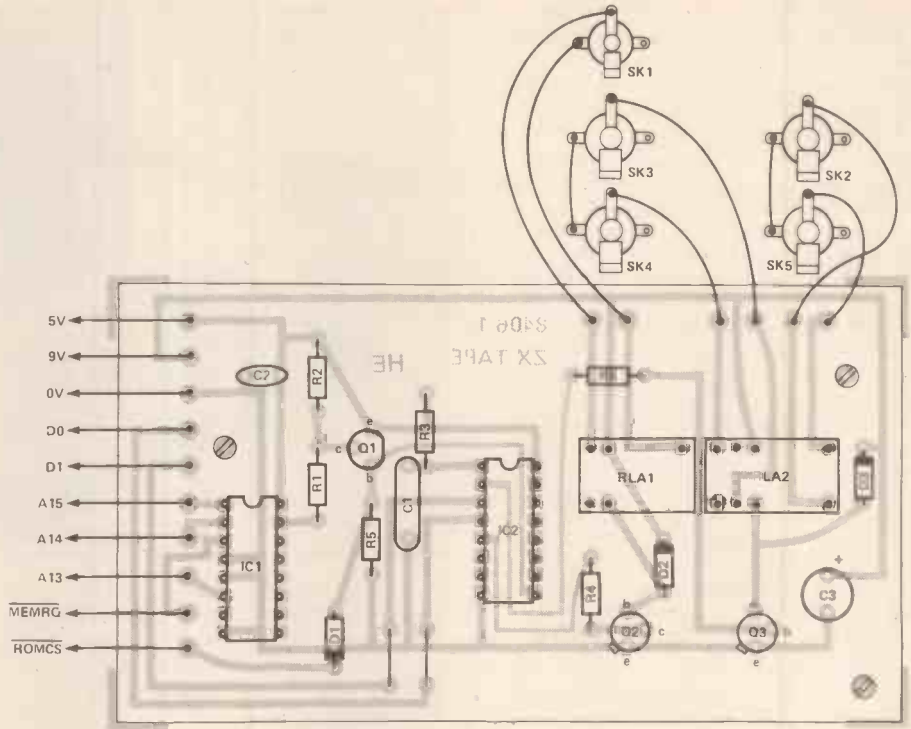

Figure 3. The component layout. Whereas relays other than those specified will work perfectly well, they may not fit into the layout given. We don't advise using different relays unless you are happy about your ability (and willingness!) to alter the tracks somewhat if necessary.

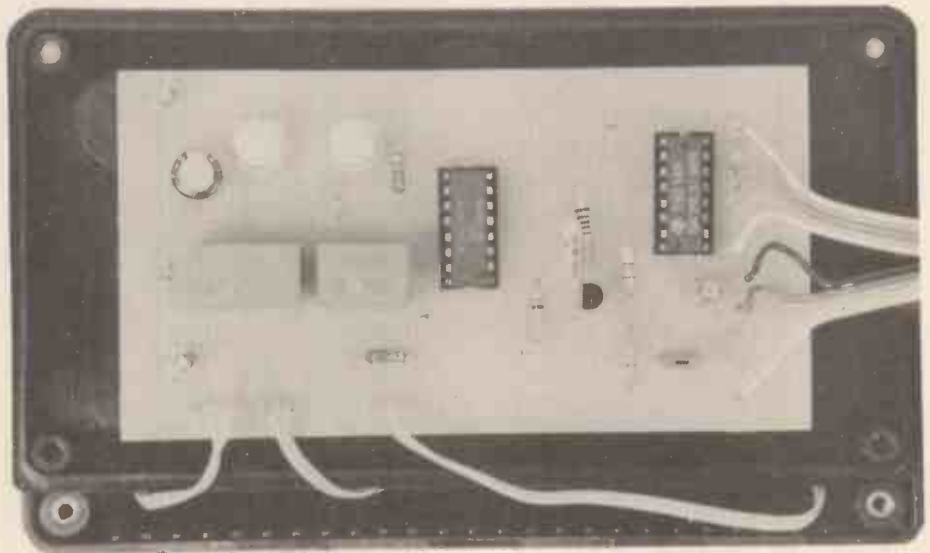
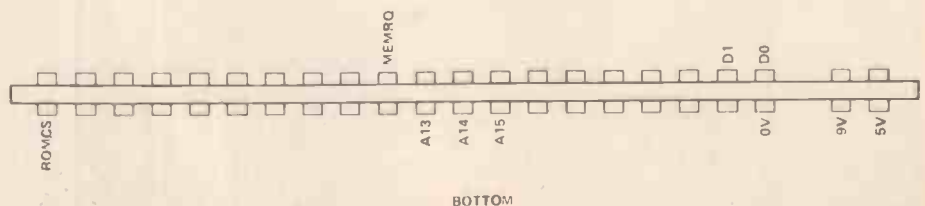

Figure 4. A close-up of the correct connections from the ten-way ribbon cable to the ZX's edge connector.



ZX81 Cassette Controller

difficult to implement satisfactorily.

For this reason it is much easier to use the specified components, especially for those who have limited experience of electronic project construction.

Fit Veropins to the board at places where connections to the ZX81's edge connector and the sockets will be made. Do not overlook the two link wires just to one side of D1. The completed board is then mounted on the rear panel of the case using M3 or 6BA fixings. The wiring to the sockets is then added using ordinary multi-strand connecting wire.

The connections to the ZX81's edge connector are made using a piece of ten-way ribbon cable about 0.5 metres long and terminated in a ZX81 style 2 by 23 way (plus polarising key) edge connector. Be careful to connect the lead to the edge connector correctly — Figure 4 shows the necessary connections. A cutout for the ribbon cable to pass through is filed in the case at any convenient point.

In Use

After giving the completed unit a couple of thorough checks, connect it to the ZX81's edge connector and switch on the computer. It should operate normally, and the relays in the controller should not switch on. Typing POKE 9000,3 into the ZX81, then hitting RETURN should result in both relays switching on. Then typing POKE 9000,0 and hitting RETURN should switch them off again.

There should be no difficulty in connecting the unit to the "Ear" and "Mic" sockets of the ZX81, and the leads supplied with the machine can be used. Similarly, the earphone and microphone sockets of the controller connect to the corresponding sockets of the recorder in the same way that the ZX81 originally connected to the recorder.

In order to connect the control output of the controller to the "Control" or "Remote" input of the recorder a lead fitted with two 2.5mm jack plugs will probably be needed.

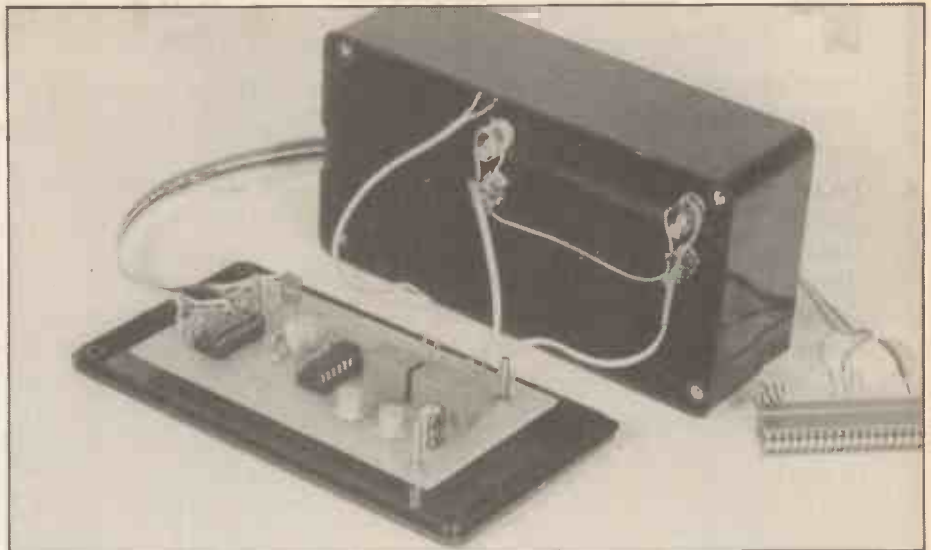

Some cassette recorders use DIN connectors, and you will then need to refer to the handbook for the recorder to determine what type of plug is needed and the correct method of connection.

As the ZX81 cannot have multiple statements, a short program must be used when saving a program (and there must be a small amount of memory left to accommodate this program). The way this is done is to place the tape control program at higher line numbers than the main program.

For instance, if the main program ends at line 3590, the control program could be placed at any lines from 3591 up to the maximum acceptable line number for the ZX81.

The three program lines are shown below (complete with sample line numbers):
3600 POKE 9000,3
3700 SAVE "Program Name"
3800 POKE 9000,0

The first line switches on the cassette motor and sets the controller to the "save" mode; the next line saves the program; and the last one switches off the motor and sets the controller back to the "load" mode.

To run the control program simply type GOTO followed by the first line number of the control program (ie

GOTO 3600) in the above example), and then hit RETURN. This is not quite as cumbersome as it might seem due to the ZX81 keyword system, and it is quite quick and easy in use.

Of course, when the main program is run the control program (which is also saved) is of no consequence as the program never reaches the three line numbers concerned. Remember to have the cassette in the recorder at the point where the program must commence, and to press both the "record" and "play" keys before starting the control program.

When loading a program it is really just a matter of typing:

```
POKE 9000,1
```

to enable the cassette motor to be switched on, then:

```
LOAD "Program Name"
```

to load the program, followed by

```
POKE 9000,0
```

to switch off the motor once the program has been loaded. A simple control program similar to the one used when saving programs could be used, but the final POKE to switch off the motor would not function, since the loaded program would replace the control one. This is not much of a drawback, as it is really when saving programs that automatic tape control is really useful, and things are much less critical during load operations..

BEASTIES

BY RH

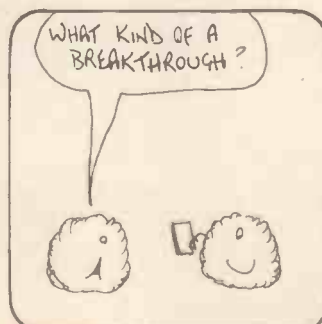
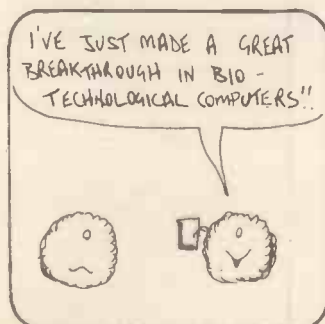
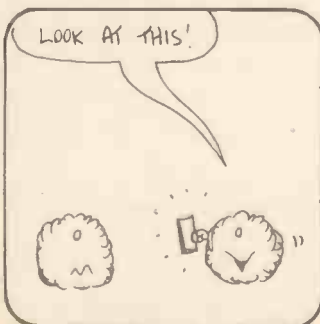

HE PCB SERVICE

Ready made
PCBs
For Readers!

PRINTED CIRCUIT BOARDS (PCBs) for HE projects have often represented an obstacle for our readers. Some of you, no doubt, make your own but our PCB Service saves you the trouble.

NOW you can buy your PCBs direct from HE. All (non-copyright) PCBs will be available automatically from the HE PCB Service. Each board is produced from the same master as that used for the published design and so each will be a true copy, finished to a high standard.

Apart from the PCBs for this month's projects, we are making available some of the popular designs from earlier issues. See below for details. *Please note that only boards for projects listed below are available: if it isn't listed we can't supply it.*

| | | | | | | | | |
|------------------------------------|-------------------------------------|--------|----------------------------------|---------------------------------|-------|---------------------------------|---|-------|
| June 82 HE/8206/1 | Power Supply Design | £2.85 | January 83 HE/8301/1 | Chip Probe | £2.09 | October 83 HE/8310/1 | Ultrasonic Alarm | £3.67 |
| HE/8206/2 | Auto-Wah | £3.54 | HE/8301/2 | Switched Mode Regulator | £2.25 | HE/8310/2 | Audio Level Meter | £3.55 |
| HE/8206/3 | Auto Greenhouse Sprinkler | £3.97 | February 83 HE/8302/1 | Incremental Timer | £8.20 | HE/8310/3 | High Voltage Meter | £3.99 |
| HE/8206/4&5 | Telephone Timer (Set of two) | £7.48 | HE/8302/2 | DigiTester PSU | £7.71 | November 83 HE/8311/1 | Wiper Delay | £3.22 |
| July 82 HE/8207/1 | Tanover | £2.45 | March 83 HE/8303/1 | Loudspeaker Protector | £2.89 | HE/8311/2 | Light Delay | £3.21 |
| HE/8207/2 | TVI Filter | £2.05 | HE/8303/2 | Overvolt Cutout | £2.59 | December 83 HE/8312/1 | Damp Meter | £3.32 |
| HE/8207/3 | Computer PSU | £8.83 | April 83 HE/8304/1 | 6502 EPROMMER | £8.26 | HE/8312/2 | Continuity Tester | £1.39 |
| HE/8207/4 | Solar Radio | £2.28 | HE/8304/2&3 | Ducker Main Board | £4.09 | HE/8312/3 | Light Meter | £3.63 |
| August 82 HE/8208/1&2 | Digital Millivoltmeter (Set of two) | £4.99 | HE/8304/3 | Preamplifier Board | £2.66 | HE/8312/4 | Bassman | £2.75 |
| HE/8208/3&4 | Audio-Analyser (Set of two) | £13.28 | HE/8304/4 | Power Down | £2.42 | January 84 HE/8401/1 | Power Reducer | £3.69 |
| September 82 HE/8209/1&2 | Signal lights Main Module | £2.25 | May 83 HE/8305/1 | BBC Interface | £5.54 | HE/8401/2 | Lap Counter | £7.00 |
| HE/8209/3 | Junction Module | £1.96 | HE/8305/3 | Stall Thief | £2.88 | HE/8401/3 | Quizmaster | £3.23 |
| HE/8209/4 | ZX Interface | £3.84 | HE/8305/4 | Auto-Test | £2.88 | February 84 HE/8402/1 | Audio PSU | £5.62 |
| October 82 HE/8210/1 | Flash Point Alarm | £2.45 | June 83 HE/8306/1 | Sinclair Sound Board | £3.22 | HE/8402/2 | Field Memory | £3.23 |
| HE/8210/2 | Negative Voltage Generator | £1.71 | HE/8306/2 | CB Rap Latch | £1.90 | HE/8402/3 | Camera Remote Transmitter | £2.67 |
| HE/8210/3 | Squelch Unit | £2.90 | HE/8306/3 | Bat Light (Car battery monitor) | £2.59 | HE/8402/4 | Receiver | £3.48 |
| November 82 HE/8211/1 | Pedometer/Odometer | £2.45 | HE/8306/4 | Traffic Light Toy | £2.94 | HE/8403/1 | Timing Strobe | £3.61 |
| December 82 HE/8212/1 | Phase Four | £3.25 | July 83 HE/8307/1 | Soft Fuzz | £3.19 | March 84 HE/8403/1 | Offbeat Metronome | £3.46 |
| HE/8212/2 | Microlog | £4.58 | August 83 HE/8308/1 | Whistle Switch | £5.06 | HE/8403/2 | Sinewave Generator | £3.31 |
| HE/8212/3&4 | Tape/Slide (Set of Two) | £6.05 | HE/8308/2 | Ace Interface | £4.05 | HE/8403/3 | Lightning Timer | £3.35 |
| HE/8212/5 | TV Amp | £6.56 | HE/8308/3 | Enlarger Timer | £3.36 | April 84 HE/8404/1 | Analogue Test Set | £4.31 |
| HE/8212/6 | Lofty | £3.00 | HE/8308/4 | Auto-Winder | £3.43 | HE/8404/2 | Time Out | £3.54 |
| HE/8212/7 | Noise Gate | £4.14 | September 83 HE/8309/1 | Tremoleko | £3.61 | May 84 HE/8405/1 | Spring Reverb | £3.70 |
| HE/8212/8 | Low Cost Alarm | £2.65 | HE/8309/2 | SPL Meter | £4.85 | HE/8405/2 | Touch Switch | £3.11 |
| | | | | | | HE/8405/3 | Touch Switch (Double sided touch plate) | £5.49 |
| | | | | | | June 84 HE/8406/1 | ZX81 Tape | £3.81 |
| | | | | | | HE/8406/2 | Mains Intercom | £3.78 |
| | | | | | | HE/8406/3 | Millivoltmeter | £3.33 |

PLACE an order for your PCBs using the form below (or a piece of plain paper if you prefer not to cut the magazine), then simply wait for your PCBs to drop through your letterbox, protected by a Jiffy bag.

HE PCB Service, Argus Specialist Publications Ltd., No. 1, Golden Square, London W1R 3AB.

I enclose a cheque/Postal Order made payable to ASP Ltd, for the amount shown below Price.

OR

I wish to pay by Barclaycard. Please charge my account number



OR

I wish to pay by Access. Please charge to my account number



SIGNATURE

NAME

(BLOCK CAPITALS)

ADDRESS

(BLOCK CAPITALS)

Add 45p p & p

0.45

Please allow 21 days for delivery

Total Enclosed

£

PCB FOIL PATTERNS

The foil pattern for the Audio Millivoltmeter project. We couldn't get the full title of the project on the board — hence the abbreviated title!

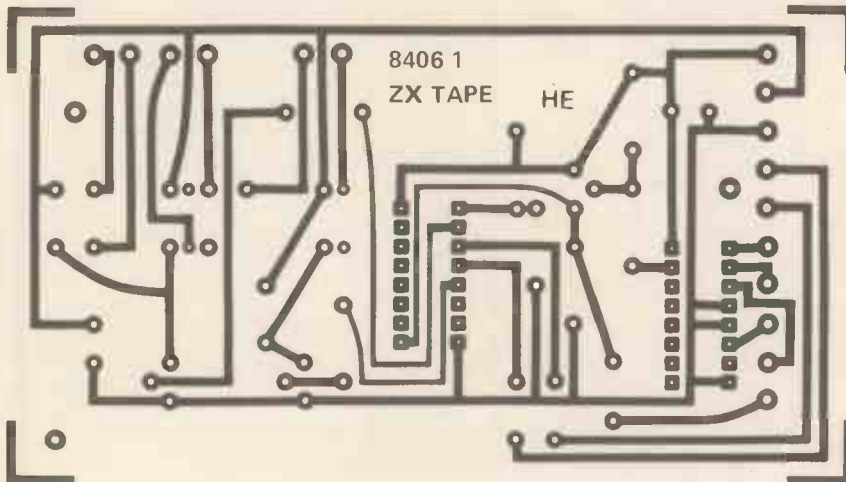
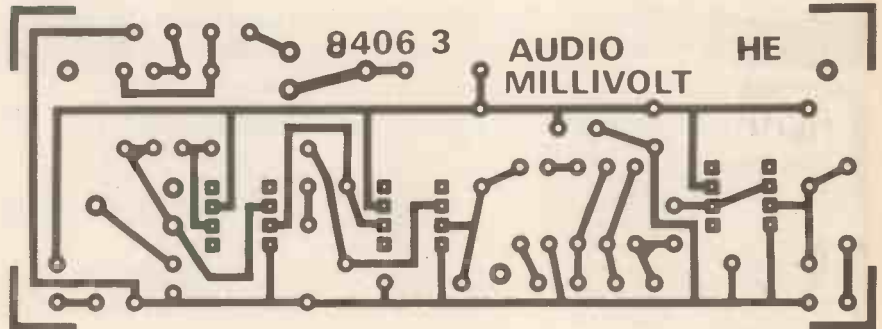

The foil pattern for the ZX tape Controller. This time we had plenty of room — but not the right size lettering!

The most complex pattern this month: The Mains intercomm foil pattern. Because it is fairly complex, it may be a little difficult to do this by home construction methods, so the ready-made board from our service would be the best idea. Board size right — lettering right!

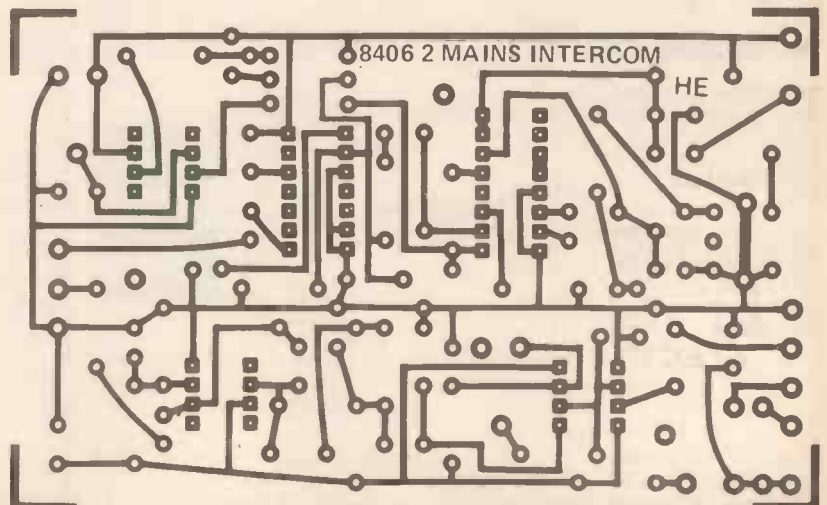

Lineage:

35p per word (minimum 15 words)
Semi-display £8.20 per single column centimetre
Ring for information on series bookings/discounts



01-437 0699

Send your requirements to:
Debbie Miller
ASP Ltd.,
1 Golden Square,
London W1R 3AB

All advertisements in this section must be prepaid.
Advertisements are accepted subject to the terms and conditions printed on the advertisement rate card (available on request)

ALARMS

TIMED ENTRY EXIT CONTROL ALARM - PANEL

MAINS-BATT.
MODEL 9000E
-ONLY-

£29.50 INC

2 ZONE - (33-89)

- FULL 2 YEAR GUARANTEE
- Adjustable entry-exit with buzzer.
- Regulated power supply (1.2 amp).
- Latching 24 hour circuit.
- Visual & audible wake test.

PLEASE SEND FOR FREE CATALOG OF ALARM EQUIPMENT FROM
SIMPSONS ELECTRONIC ALARMS
70 PRIORY ROAD LIVERPOOL L4 2JZ.
TRADE SUPPLIED

051-260-0300

SECURITY Alarm Systems

FREE COMPREHENSIVE CATALOGUE!

- LOWEST DISCOUNT PRICES
- HIGHEST QUALITY EQUIPMENT
- FREE DIY DESIGN GUIDE
- FULLY ILLUSTRATED
- MICROCHIP CIRCUITRY
- QUICK DESPATCH SERVICE
- FULL INSTRUCTIONS

SEND SAE OR PHONE

C.TEC SECURITY, Dept HE
60 Market St, Wigan WN1 1HX
Telephone (0942) 42444

Trade Enquiries Welcome

A1 INTRUDER ALARMS

Wholesale Alarm Suppliers
Latest D.I.Y. &
Wholesale Published Catalogue
Write off for your copy
86 Derby Lane, Old Swan,
Liverpool 13 (Dept HE)
Tel: 051-288 3483
or 051-220 0590

LARGE STOCK OF BURGLAR ALARM EQUIPMENT: As used in the trade. JN Security Centre, 176 Sydenham Rd., London SE26 5JZ. 01-778 1111. Showrooms open 6 days.

WHO CAN PUT A PRICE ON PEACE OF MIND!

Home security is now available at trade prices
Professional Equipment at Low, Low, Low Prices!

- No Gimmicks
- All Prices include VAT
- Complete with Full Year Guarantee
- Instructions & Two Year Colour
- Free Technical Advice
- Immediate Despatch
- Control panels

Advanced Security Products Ltd
2 Ealing Road, Aintree,
Liverpool L9 0HU, Merseyside
Tel: 051 525 3440
Do it now before it's too late!

BURGLAR ALARM equipment.
Ring Bradford (0274) 731532
for our catalogue, or call at our large showrooms opposite Odsal Stadium.

LANCASHIRE

E.E. ETESON ELECTRONICS
158 Lower Green
Poulton-le-Fylde Blackpool
Tel: (0253) 885107
Open 9:30 am-12:30, 1:30-5:30
Closed Wed. & Sun.
Electronic Component Specialists

COMPUTERS

CONTROL

Plug-ins for the DRAGON 32
RELAY OUTPUT UNIT
FITTED 2 RELAYS - £16.75
Space for 6 more
FAST A-D CONVERTER WITH
APPLICATION SOFTWARE
£29.50

Other units available. Please send A4 S.A.S.E. for the full details.

P.N.P. COMMUNICATIONS
(Dept. H.E.)
62 Lawes Avenue, Newhaven
East Sussex BN9 9SB
Tel: 0273 514465

RADIO SERVICES

VINTAGE WIRELESS COMPANY 1914-1960

Radios, amplifiers, service sheets, valves, vintage components. Books new and used.
Repairs and Restorations.
Mail Order only.
Tudor House, Casoham St.,
Mangotsfield BS17 3EN
Tel: 565472

EQUIPMENT

AERIAL AMPLIFIERS Improve weak television reception. Price £6.70. S.A.E. for leaflets. Electronic Mailorder, Ramsbottom, Lancashire BLO 9AGH.

THIS SPACE
COULD BE
WORKING FOR
YOU
Tel: 01-437 0699

BOOKS & PUBLICATIONS

PARAPHYSICS JOURNAL (Russian translations). Psychotronics, Kirlianography, heliphonic music telekinetics. Computer software. SAE 4 x 9".— Parolab, Downton Wilts.

COMPONENTS

BRITISH TELECOM plug sockets and leads, etc. Tel: C.W.A.S (0274) 731532. Or visit our showroom opposite Odsal Stadium, Bradford.

COPPER CLAD PCB Laminate cut to your size. Details. S.A.E. Waring, St. Marys Cottage, Tedburn, Exeter.

WE SUPPLY a wide range of electronic components and service parts. Also new telephone plugs and sockets, joystick interfaces and leads for most computers. Burglar alarm equipment including sensor sirens, bells, buzzers all at competitive prices. Write or phone for details. Shudehill Supply Co. Ltd., 53 Shudehill, Manchester M4 4AW. 061-834 1449.

BOOKS

Be your own boss with our new published business manuals. Both with full fault guides and business know how.
Domestic appliance reconditioning and repair for profit.
2 volumes only £12.50 post free.
A guide to professional sewing machine repairs for profit.
2 volumes only £8.50 post free.
Leaflets available.
Mr. Marchant, Dept H.E.
30 Chester Road East, Shotton,
Clwyd, N. Wales

PLANS 'N DESIGN

AMAZING electronic plans, lasers, gas, ruby, light shows, high voltage teslas, van de graph, surveillance devices, ultrasonics, pyrotechnics, new solar generator, 150 more projects, catalogue S.A.E., Plancentre, Bromyard Road Industrial Estate, Ledbury HR8

FOR SALE

KIA RETURN AN AD No.15... 100 watt guitar/mic amplifier... case + controls & sockets... FET.IC preamp & selector, MJ3001 outputs... Simply post ad 15 + £10.85... 0 KIA-8, LS29 9DZ.

KITS

PRINTED CIRCUITS. Make your own simply, cheaply and quickly! Golden Fotolac light-sensitive lacquer — now greatly improved and very much faster. Aerosol cans with full instructions, £2.25. Developer 35p. Ferric chloride 55p. Clear acetate sheet for master 14p. Copper-clad fibreglass board, approx. 1mm thick £1.75 sq. ft. Post/Packing 50p. White House Electronics, Castle Drive, Praa Sands, Penzance, Cornwall.

BITS, KITS & P/CS. For CB, Audio, Music, Lighting, Studio etc. E.g., Quality MOSFET 50/100W amp board kit £26.00 inc., Superkrunch CB noise reduction board kit £7.75 inc. Manufacturers surplus stock test gear, tools etc. Send large SAE for lists to: Airedale Components, Black Edge Farm, Black Edge Lane, Denholme Gate, West Yorkshire BD13 4ET.

HOBBY ELECTRONICS

CLASSIFIED ADVERTISEMENT — ORDER FORM

If you have something to sell now's your chance! Don't turn the page — turn to us!
Rates of charge: 30p per word per issue (minimum of 15 words).
 and post to **HOBBY ELECTRONICS, CLASSIFIED DEPT., 1 Golden Square, London W1**

| | | | | | |
|--|--|--|--|--|--|
| | | | | | |
| | | | | | |
| | | | | | |
| | | | | | |
| | | | | | |
| | | | | | |
| | | | | | |
| | | | | | |
| | | | | | |
| | | | | | |

Please place my advert in **HOBBY ELECTRONICS** for issues commencing as soon as possible.
 I am enclosing my Cheque/Postal Order/International Money Order for: (delete as necessary) £. . . . (Made payable to A.S.P. Ltd)
 Please use **BLOCK CAPITALS** and include post codes.
Classification
Name (Mr/Mrs/Miss/Ms)
(delete accordingly)
Address

Signature **Date**
Daytime Tel. No.

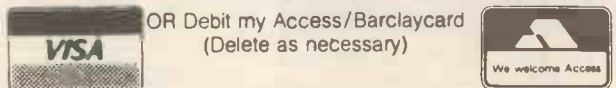

| | | | | | | | | | | | | | | |
|--|--|--|--|--|--|--|--|--|--|--|--|--|--|--|
| | | | | | | | | | | | | | | |
|--|--|--|--|--|--|--|--|--|--|--|--|--|--|--|

All classified advertisements must be paid for in advance.



KITS FROM £7 ... TO £60

Sparkrite

Buy Sparkrite Brand Leading Auto Electronics in self-assembly kit form — And save pounds!!

- Electronic Ignition systems — contact triggered and contactless
- Electronic Car Security Systems — including a new ultrasonic unit
- Car Drive Computer — with 12 functions

SEND FOR FREE LITERATURE PACK — TODAY!
 8 SOPHISTICATED KITS TO CHOOSE FROM.

To:

SPARKRITE (A Division of Stadium Ltd.), Queensway, Enfield, EN3 4SD.
 Telephone: 01-804 4343

NAME

ADDRESS

HE

H. E. June 1984 Advertisers Index

- Armon Electronics 55
- Bicc Vero 55
- Bi-pak IFC
- B.K. Electronics IBC
- B.N.O.S. IBC
- B.N.R.&E.S. 22
- Brian J. Reed 19
- Cambridge Learning 58
- CirKit 4, 5
- Dataplus Developments 19
- Enfield Electronics OBC
- Europa Electronics 12
- ICS 58
- ILP 19
- John Wise Ltd 55
- Kelan Engineering 43
- Litesold 12
- Magenta Electronics 22
- Marshalls Ltd 43
- Parndon Electronics 55
- Sparkrite 66
- Stewarts of Reading 58
- Vangelder U.K. Ltd 43
- Heliwell Software Soft Options
- Flite Software Soft Options

B.N.O.S. ELECTRONICS

“NiCAD Batteries”

We can supply, from stock, quality batteries from one or more of the following companies: Ever Ready, Saft and Hitachi, at unbelievable prices and a complete range of chargers.

ALL THESE PRODUCTS CARRY A FULL YEAR'S GUARANTEE



| Format | Capacity (AH) | Height (mm) | Diameter (mm) | Prices | | |
|---------|---------------|------------------|---------------|--------|-------|-------|
| | | | | 1-9 | 10-24 | 25-99 |
| AAA | 0.18 | 45.0 | 10.5 | 1.34 | 1.27 | 1.22 |
| 1/3AA* | 0.10 | 18.0 | 14.3 | 1.58 | 1.50 | 1.44 |
| 1/2AA* | 0.24 | 28.1 | 14.3 | 1.45 | 1.37 | 1.32 |
| AA | 0.50 | 50.2 | 14.3 | 0.90 | 0.85 | 0.82 |
| AA* | 0.50 | 50.2 | 14.3 | 0.96 | 0.91 | 0.88 |
| 1/2A* | 0.45 | 28.1 | 17.3 | 1.53 | 1.45 | 1.38 |
| RR* | 1.20 | 42.1 | 22.6 | 1.70 | 1.61 | 1.52 |
| C | 2.20 | 49.7 | 25.9 | 2.40 | 2.30 | 2.20 |
| D (sub) | 1.20 | 60.5 | 32.9 | 2.40 | 2.30 | 2.20 |
| D | 4.00 | 60.5 | 32.9 | 3.50 | 3.32 | 3.15 |
| D* | 4.00 | 60.5 | 32.9 | 3.59 | 3.41 | 3.24 |
| F* | 7.00 | 91.3 | 32.9 | 6.85 | 6.50 | 6.20 |
| SF* | 10.00 | 91.3 | 41.7 | 10.50 | 9.50 | 8.90 |
| PP3 | 0.11 | 49 × 26.5 × 17.5 | | 4.35 | 4.10 | 3.85 |

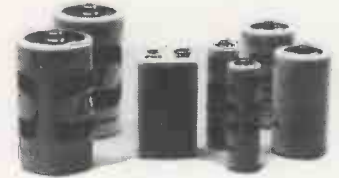

* Denotes cell fitted with solder tags

NiCAD Chargers

AC.1 SAFT MAZDA AA charger, charges 1 to 4 AA cells £5.75 PC.3 SAFT MAZDA PP3 charger, charges 1 or 2 PP3 cells £5.75 MC.4 JECKSON MULTICHARGER, charges 2 or 4 AA, C or D cells £7.00 MC.6 SAFT MAZDA MULTICHARGER, charges 1 to 4 AA, C or D cells, or 1 or 2 PP3 cells £8.75



BNOS Electronics (Dept HE) Bigods Hall, Great Dunmow, Essex CM6 3BE

Telephone (0371) 4677

All prices include VAT, Postage is free on all UK orders sent with cash over £5, for UK orders under £5, please add 60p to order total.

Trade enquiries welcomed

BSR P256 TURNTABLE

P256 turntable chassis ● S shaped tone arm ● Belt driven ● Aluminium platter ● Precision calibrated counter balance ● Anti-skate (bias) device ● Damped cueing lever ● 240 volt AC operation (Hz) ● Cut-out template supplied ● Completely manual arm. This deck has a completely manual arm and is designed primarily for disco and studio use where all the advantages of a manual arm are required.
Price £32.35 each. £2.50 P&P



PIEZO ELECTRIC TWEETERS — MOTOROLA

Join the Piezo revolution. The low dynamic mass (no voice coil) of a Piezo tweeter produces an improved transient response with a lower-distortion level than ordinary dynamic tweeters. As a crossover is not required these units can be added to existing speaker systems of up to 100 watts (more if 2 put in series). FREE EXPLANATORY LEAFLETS SUPPLIED WITH EACH TWEETER.

LARGE S.A.E.
For details of disco mixers, speakers, kits, amp - modules, burglar alarms, turntables etc.

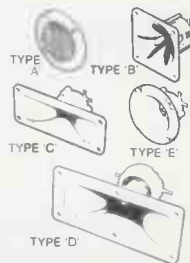

TYPE 'A' (KSN2036A) 3" round with protective wire mesh, ideal for bookshelf and medium sized Hi-fi speakers. Price £4.29 each + 30p P&P
TYPE 'B' (KSN1005A) 3 1/2" super horn. For general purpose speakers, disco and P.A. systems etc. Price £4.99 each + 30p P&P
TYPE 'C' (KSN6016A) 2" × 5" wide dispersion horn. For quality Hi-fi systems and quality discos etc. Price £5.99 each + 30p P&P.
TYPE 'D' (KSN1025A) 2" × 6" wide dispersion horn. Upper frequency response retained extending down to mid range (2KHz). Suitable for high quality Hi-fi systems and quality discos. Price £7.99 each + 30p P&P.
TYPE 'E' (KSN1038A) 3 3/4" horn tweeter with attractive silver finish trim. Suitable for Hi-fi monitor systems etc. Price £4.99 each + 30p P&P.

LOUDSPEAKERS POWER RANGE

THREE QUALITY POWER LOUD-SPEAKERS (15", 12" and 8" See Photo) Ideal for both Hi-Fi and Disco applications. All units have attractive cast aluminium (ground finish) fixing escutcheons. Specifications and Prices.
15" 100 watt R.M.S. Impedance 8 ohms. 50 oz. magnet. 2" aluminium voice coil. Res. Freq. 20 Hz. Freq. Resp. to 2.5KHz. Sens. 97dB. Price: £34.00 each + £3.00 P&P
12" 100 watt R.M.S. Impedance 8 ohms. 50 oz. magnet. 2" aluminium voice coil. Res. Freq. 25Hz. Freq. Resp. to 4 KHz. Sens. 95dB. Price: £24.50 each + £3.00 P&P
8" 50 watt R.M.S. Impedance 8 ohms. 20 oz. magnet. 1 1/2" aluminium voice coil. Res. Freq. 40Hz. Freq. Resp. to 6KHz. Sens. 92dB Black Cone. Price: £9.50 each. Also available with black protective grille. Price: £10.50 each. P&P £1.50.



12" 85 watt R.M.S. McKENZIE C1285GP (LEAD GUITAR, KEYBOARD, DISCO) 2" aluminium voice coil, aluminium centre dome. 8 ohm imp., Res. Freq. 45Hz. Freq. Resp. to 6.5KHz. Sens. 98dB. Price £24.99 + £3 carriage
12" 85 watt R.M.S. McKENZIE C1285TC (P.A., DISCO) 2" aluminium voice coil. Twin cone. 8 ohm imp., Res. Freq. 45Hz. Freq. Resp. to 14KHz. Price £24.99 + £3 carriage
15" 150 watt R.M.S. McKENZIE C15 (BASS GUITAR, P.A.) 3" aluminium voice coil. Die cast chassis. 8 ohm imp., Res. Freq. 40Hz. Freq. Resp. to 4KHz. Price £49 + £4 carriage Cabinets fixings in stock S.A.E.

OMP POWER AMPLIFIER MODULE

READY BUILT

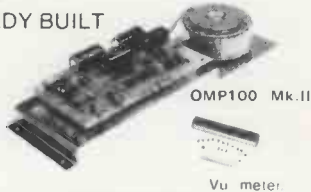

New model.
Improved specification

NEW OMP100 Mk.II POWER AMPLIFIER MODULE Power Amplifier Module complete with integral heat sink, toroidal transformer power supply and glass fibre p.c.b. assembly. Incorporates drive circuit to power a compatible LED Vu meter. New improved specification makes this amplifier ideal for P.A., Instrumental and Hi-Fi applications.
SPECIFICATION
Output Power:— 110 watts R.M.S.
Loads:— Open and short circuit proof 4/16 ohms.
Frequency Response:— 15Hz - 30KHz - 3dB
T.H.D.:— 0.01%
S.N.R. (Unweighted):— -118dB ± 3.5dB
Sensitivity for Max Output:— 500mV at 10K.
Size:— 360 × 115 × 72mm. Price:— £31.99 + £2.50 P&P. Vu Meter Price:— £8.50 + 50p P&P

MOS-FET HIGH SPEC. MODULES

MOS-FET VERSIONS AVAILABLE UP TO 300 W. R.M.S.
100 Watt 300mm × 123mm × 60mm Price: £39.99 + £2.50 P&P
200 Watt 300mm × 150mm × 100mm Price: £62.99 + £3.50 P&P
300 Watt 330mm × 147mm × 102mm Price: £79.99 + £4.50 P&P

PANTEC HOBBY KITS. Proven designs including glass fibre printed circuit board and high quality components complete with instructions.

FM MICROTRANSMITTER (BUG) 90/105MHz with very sensitive microphone. Range 100/300 metres. 57 × 46 × 14mm (9 volt) Price: £7.99 + 75p P&P.
3 WATT FM TRANSMITTER 3 WATT 85/115MHz varicap controlled, professional performance. Range up to 3 miles 35 × 84 × 12mm (12 volt) Price: £12.49p + 75p P&P.
SINGLE CHANNEL RADIO CONTROLLED TRANSMITTER / RECEIVER 27MHZ Range up to 500 metres. Double coded modulation. Receiver output operates relay with 2amp/240 volt contacts. Ideal for many applications. Receiver 90 × 70 × 22mm (9/12 volt). Price: £16.49. Transmitter 80 × 50 × 15mm (9/12 volt). Price: £10.29 P&P + 75p each. S.A.E. for complete list.



3 watt FM Transmitter

★ SAE for current lists. ★ Official orders welcome. ★ All prices include VAT. ★ Sales Counter. ★

B. K. ELECTRONICS

UNIT 5, COMET WAY, SOUTHEND-ON-SEA.
ESSEX SS2 6TR TEL 0702-527572



ENFIELD ELECTRONICS
208 Baker Street, Enfield, Middlesex. EN1 3JY Tel: 01-366 1873



TRANSISTORS table listing various transistor types like AC125, AC126, AC127, etc., with their respective part numbers and prices.

TTL table listing TTL components such as 7417, 7420, 7421, etc., and LS TTL components like 74LS00, 74LS01, 74LS02, etc.

CMOS table listing CMOS components such as CD4000, CD4001, CD4002, etc., and DIODES table listing diodes like AA119, AA215, etc.

RECHARGEABLE BATTERIES table listing battery types like HP2, HP2.1, etc., and D CONNECTORS table listing connector types like 9 way, 15 way, etc.

ZENER DIODES table listing zener diodes like BZX1C1A, BZX7V5, etc., and REGULATORS table listing regulator types like LM304H, LM309H, etc.

ALUMINIUM BOXES table listing box sizes like 311/2 x 191 x 91, etc., and VERO PLASTIC BOXES table listing box sizes like BIK 71 x 49 x 25, etc.

Prices for TTL components are changing all the time. Please phone for current prices. NEW ILLUSTRATED CATALOGUE NOW AVAILABLE. £1 include VAT plus P&P. 50p P&P ON ALL ORDERS UNDER £10. TELEPHONE ORDERS ACCEPTED WITH ACCESS & BARCLAYCARD OFFICIAL ORDERS MOST WELCOME FROM SCHOOLS ETC. WE ARE OPEN MONDAY TO SATURDAY 9-6 PM. All prices include V.A.T. Same day despatch.