

# Hobby Electronics

ISSN 0142-6192

February '80  
45p

**PASSIONMETER  
FINGER TESTING GOOD**



**Kit Review Special**  
*Two For The Price of One*

**North American Radio**

*KEZY Does It*

**Short Circuits Special**

*More Experimental Designs*

**Infra Red Remote Control**

*Lighten Your Load*

**Into Electronics Construction**

*New Starter Series*



# IT'S HAPPENED AGAIN !

## THE PART THREE CATALOGUE IS PUBLISHED & WE HAVE MOVED TO BIGGER PREMISES.

Yes, it's here at last - the all new Part Three Catalogue. Fun for all the family, and the usual update on all that is new, worthwhile and exciting in the world of Radio and Communications. A big section on frequency synthesis techniques covering broadcast tuners, to communication quality transmitter systems. More new products than ever - **RADIO CONTROL** parts, crystal filters, ceramic filters for 455kHz and the new range of TOKO CFSS low temperature coefficient types for 10.7MHz. Details on new radio ICs, including the new 41A11225, the CA3189E look-alike with 84dB signal to noise, and adjustable muting threshold. Radio control ICs - and an updated version of the RCM&E 8 channel FM receiver - now with an Ambit designed screened front end, with 27MHz ceramic bandpass filter, LCD panel clock timer modules - the neatest and best LCD panel DVVL yet (only £19.45 each + VAT), the new 5 decade resolution DFM3 for LW/MF/VHF with LCD readout. The DFM6 with fluorescent display to 10kHz resolution on VHF, 1kHz on SW. A 1kHz HF synthesiser with five ICs - the list is endless. Get your copy of the catalogue now. Post publication price is 60p (inc PP etc). The previous two sections are also required for a complete picture: Parts 1 & 2 £1 the pair, All 3 £1.50. And don't miss our spot the gibbon contest, together with a quiz to see if you can spot the differences between a neolithic cave drawing and a circuit diagram of one of our competitor's tuners. (\* Yes, we still haven't learnt how to spell.)

### Updated RCME FM radio control RX kit



- 8 Channel RC receiver (FM)
- Single IC RF/IF/Detector
- Single IC decoder
- 27MHz ceramic filter input
- FET RF stage with double tuned bandpass filter
- Dual ceramic filter IF
- Based on RCM&E FM system
- Best quality SLM servo connector block
- ONLY £16.10 inc VAT (kit) (includes new SLM case)

### DOES YOUR ONE GLOW GREEN IN THE DARK ??

Our DFM4 does, since it uses a vacuum fluorescent display for direct readout of MW/LW/FM. Basically the same as the DFM2, (LCD Version). £24.45 kit (inc VAT) Transformer with all necessary windings for DFM4 - £2.50 inc VAT.

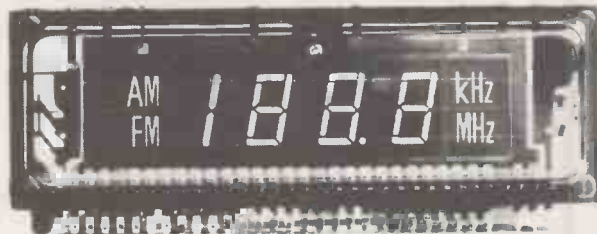

Not illustrated here - but also now available is the DFM6. This is a vacuum fluorescent display version of our immensely popular DFM3 (LCD). Resolution is 100Hz to 3.9999MHz, 1kHz to 39.999MHz, and 10kHz to 200.00MHz; all standard IF offsets (inc. 10.7MHz on shortwave) are available via diode programming.

### New series of radio modules in fully screened cans:



### UM1181 VHF band 2 VARICAP TUNERHEAD

5 tuned circuit, with image/purifier better than -80dB, buffered LO output, MOSFET RF stage, FET IF preamp, tunes with only 1% to 8v, -9dBm 3rd order Intercept. 1off price £12.00 inc VAT. (100off) OA)

911225 FM IF strip with all mod cons for the HiFi tuner: All types use 804dB S/N Hitachi IC, with muting, AFC, AGC, meter outputs for signal level and centre zero. IF preamp stage.

'A' Dual linear phase ceramic filters, with MOSFET (AGC'd) IF preamp and a 3rd narrow filter with DC filter selection. Dual tuned FM detector stage. £23.95 inc VAT (built)

'B' Dual ceramic filters, single tuned detector stage £14.95 inc VAT (All 'A' series units are set up with a spectrum analyzer for best THD)

### 91072 AM RADIO TUNER MODULES - DC TUNED and DC SWITCHED Available February '80

All include buffered LO output, mechanical IF filter (TOKO CFMO) 1-10v tuning bias, switching by a single pole to earth

A MW/LW (150 to 350kHz LW range) with ferrite rod antenna

B As 'A' but also including SW1 or SW2 (specify.)

SW1 = 1.8 to 4MHz SW2 = 5 to 10MHz

C With both SW ranges

Prices one off inc VAT

'A' £14.43 'B' £15.90 'C' £17.50 (Custom types OA)

There is a danger - when advertizing in some magazines - that because we do not find space to list everything we sell in every ad., that some readers forget about half the ranges we stock. So to summarize the general ranges:

#### TOKO

Chokes, coils for AM/FM/SW/MPX, Audio filters etc  
Filters: Ceramic for AM/FM, LC for FM, MPX etc.  
Polyvaricons

#### Micrometals

ICs for radio, clock LSI, radio control, MPX decoders etc  
Dust iron cores for toroids for resonant and EMI filters  
Toroid mounts

#### Hitachi

Radio/audio/mpx linear ICs  
100W MOSFETs, small signal FETs, MOSFETs and bipolar

And the following groups of products from a broad range of sources:

**Semiconductors** -specializing in radio devices, Plessey SL1600, EUROPE's best selection of AM/FM and communications devices. Power MOSFETs, WORLD'S LOWEST NOISE AUDIO small signal transistors, BAR graph LED drivers for linear and log.  
CD4000 series CMOS, TTL/LPSTTL, standard linears (741, 301, 3080 etc). MPUs, memories. Small signal transistors from AEG BC237/8/9 families etc. (1000 off BC239C : 5.2p ea)  
LEDs: AEG 3mm/5mm round, 2.5x5mm flat, red, green, orange, yellow. The best prices you will find for quality products.  
MOSFETs for RF signal processing, including the BF960 UHF device, and 3SK51 for VHF. Varicap diodes for 17:1 capacity ratio tuning

**FREQUENCY READOUT LSI** from OKI with a one-chip answer to most digital frequency display needs (and various modules).

**Crystal and ceramic ladder filters** from leading manufacturers, ferrite rods, various ferrite beads and a range of crystals for 'standard' frequencies and both AM and FM radio control at 27MHz. Trimmer capacitors.

**METERS** - a new range of linear movement types, plus many 'indicator' types for VU, all types of tuning indicators etc.

**SOCKETS** - a new range that are better quality than Texas low profile, yet better priced.

**Modules for AM/FM/STEREO**, complete kits for tuners, audio amplifiers from Larsholt.

**SWITCHES** - complete low cost DIY systems for push button arrays, keyboard switches.

**DOUBLE BALANCED MIXERS** - MCL SBL1, replacement for MD108 etc. And cheaper.

OUR LATEST MOVING EXPERIENCE : At last, we have moved to the address below. There is car parking for customers approaching via North Service Road (an extension of North Road Avenue, entrance opposite the Brentwood Fire Station.) Pedestrian access from the High Street (alongside 117 High Street). The new building is six times bigger than our Gresham Road offices, and we will be installing a much expanded sales counter in the fullness of time. NEW TELEPHONE NUMBER (0277) 230909, TELEX NUMBER (as before) 995194 AMBIT G. See you there !

# 200 North Service Road, Brentwood, Essex.

# Hobby Electronics

Vol. 2, No. 4

February 1980

## PROJECTS

**Passion Meter** ..... 10  
Hot stuff



**Infra-Red Remote Control** 27  
Light Switch



**Win Indicator** ..... 59  
Fast fingers

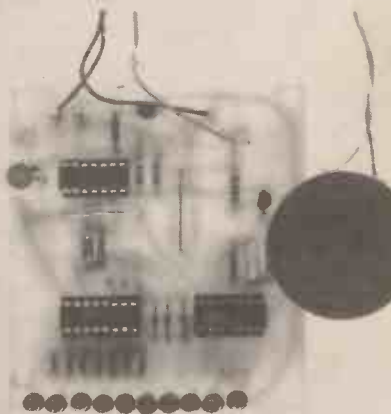

## FEATURES

**Clever Dick** ..... 14  
A pen pusher

**Short Circuit Special** .. 16  
Experimental extravaganza

**Breadboard Report** .... 23  
Were you there?

**KEZY Does it** ..... 38  
Radio revelations



**Kit Review Special** ... 45  
Build 'em both

**Power to the People** .... 51  
Drive those circuits

**Breaker One Four** ..... 63  
Government report

**Into Electronics Construction**  
..... 65  
New series

## NEWS AND INFORMATION

**Monitor** ..... 6

**Books** ..... 33, 36  
Bound to please

**HE Next Month** ..... 35  
Another winner

**Market Place** ..... 42  
Spare cash depot

**ETI Next Month** ..... 44  
Whatever next?

**Circuit Design** ..... 48  
A new special

**Hobbyprints** ..... 49  
Quick circuits

**Binders For HE** ..... 71  
Blue Bound

**Specials** ..... 72  
What's new?

**Mini Ads** ..... 73  
Sale Time

### Hobby Electronics

145 Charing Cross Road,  
London WC2H 0EE  
01-437 1002 (4 lines)

**Published** by Modmags Ltd,

**Distributed** by Argus Distribution Ltd,  
**Printed** by QB Ltd, Colchester

Hobby Electronics is normally published  
on the second Friday of the month prior  
to the cover date.

**Editor:** Halvor Moorshead

**Assistant Editor:** Rick Maybury

**Project Team:** Ray Marston, Steve Ramsa-  
hadeo, John FitzGerald, Keith Brindley

**Production:** Diego Rincon, Dee Camilleri

**Technical Artists:** Paul Edwards, Tony  
Strakas, Joanne Barseghian

**Advertising:** Chris Surgenor, Steve Rowe,  
Sandie Neville, Kate Smith

**Admin. Staff:** Margaret Hewitt, Bren Good-  
win, Tim Salmon, Tracey Campbell, Lorraine  
Radmore, Lorraine Stout, Marlin Felix, Halina  
Di-Lallo, Joan Brimm

**Copyright:** All material in this publication is  
subject to world-wide copyright protection.  
Permission to reproduce printed circuit board  
patterns commercially or marketing kits of the  
projects must be sought from the Editor. All  
reasonable care is taken in the preparation of  
the magazine to ensure accuracy but Mod-  
mags cannot be held responsible for it legally.



# Simply ahead . .

## ILP'S NEW GENERATION OF HIGH



I.L.P. modular units comprise five power amplifiers, pre-amp which is compatible with the whole range, and the necessary power supply units. The amplifiers are housed and sealed within heatsinks all of which will stand up to prolonged working under maximum operating conditions.

With I.L.P. performance standards and quality already so well established, any advances in I.L.P. design are bound to be of outstanding importance — and this is exactly what we have achieved in our new generation of modular units. I.L.P. professional design principles remain — the completely adequate heatsinks, protected sealed circuitry, rugged construction and excellent performance. These have stood the test of time far longer than normally expected from ordinary commercial modules. So we have concentrated on improvements whereby our products will meet even more stringent demands such, for example, as those revealed by vastly improved pick-ups, tuners, loudspeakers, etc., all of which can prove merciless to an indifferent amplifier system. I.L.P. modules are for laboratory and other specialised applications too.

**PRODUCTS OF THE WORLD'S FOREMOST SPECIALISTS  
IN ELECTRONIC MODULAR DESIGN**

ALSO AVAILABLE FROM A NUMBER OF SELECTED APPOINTED STOCKISTS

# and staying there

## PERFORMANCE MODULAR UNITS

### HY5 PRE-AMPLIFIER

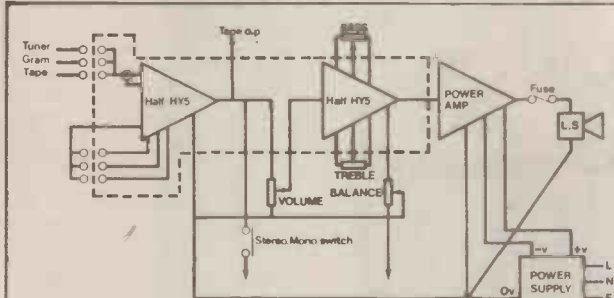
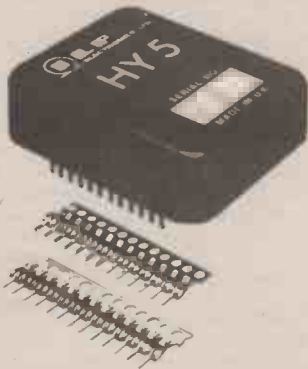

VALUES OF COMPONENTS FOR CONNECTING TO HY5  
 Volume — 10K  $\Omega$  log.  
 Bass/Treble — 100K  $\Omega$  linear. | Balance — 5K  $\Omega$  linear.

The HY5 pre-amp is compatible with all I.L.P. amplifiers and P.S.U.'s. It is contained within a single pack 50 x 40 x 15 mm. and provides multi-function equalisation for Magnetic/Ceramic/Tuner/Mic and Aux (Tape) inputs, all with high overload margins. Active tone control circuits; 500 mV out. Distortion at 1KHz—0.01%. Special strips are provided for connecting external pots and switching systems as required. Two HY5's connect easily in stereo. With easy to follow instructions.

£4.64 + 74p VAT

### THE POWER AMPLIFIERS

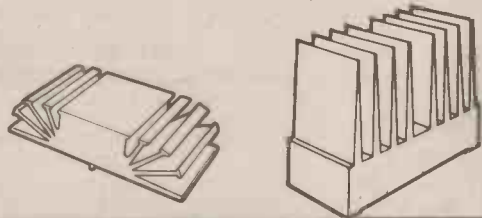
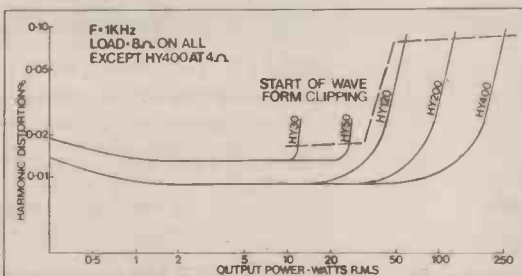

| Model | Output Power R.M.S.   | Distortion Typical at 1KHz | Minimum Signal/Noise Ratio | Power Supply Voltage | Size in mm | Weight in gms | Price + V.A.T. |
|-------|-----------------------|----------------------------|----------------------------|----------------------|------------|---------------|----------------|
| HY30  | 15 W into 8 $\Omega$  | 0.02%                      | 80dB                       | -20 -0 +20           | 105x50x25  | 155           | £6.34 + 95p    |
| HY50  | 30 W into 8 $\Omega$  | 0.02%                      | 90dB                       | -25 -0 +25           | 105x50x25  | 155           | £7.24 + £1.09  |
| HY120 | 60 W into 8 $\Omega$  | 0.01%                      | 100dB                      | -35 -0 +35           | 114x50x85  | 575           | £15.20 + £2.28 |
| HY200 | 120 W into 8 $\Omega$ | 0.01%                      | 100dB                      | -45 -0 +45           | 114x50x85  | 575           | £18.44 + £2.77 |
| HY400 | 240 W into 4 $\Omega$ | 0.01%                      | 100dB                      | -45 -0 +45           | 114x100x85 | 1.15Kg        | £27.68 + £4.15 |

Load impedance — all models 4 - 16  $\Omega$   
 Input sensitivity — all models 500 mV  
 Input impedance — all models 100K  $\Omega$   
 Frequency response — all models 10Hz - 45Hz - 3dB

### THE POWER SUPPLY UNITS

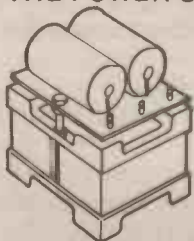

I.L.P. Power Supply Units are designed specifically for use with our power amplifiers and are in two basic forms — one with circuit panel mounted on conventionally styled transformer, the other with toroidal transformer, having half the weight and height of conventional laminated types.

|        |   |                    |
|--------|---|--------------------|
| PSU 30 | $\pm 15V$ at 100ma to drive up to five HY5 pre-amps | £4.50 + £0.68 VAT  |
| PSU 36 | for 1 or 2 HY30's                                   | £8.10 + £1.22 VAT  |
| PSU 50 | for 1 or 2 HY50's                                   | £8.10 + £1.22 VAT  |
| PSU 70 | with toroidal transformer for 1 or 2 HY120's        | £13.61 + £2.04 VAT |
| PSU 90 | with toroidal transformer for 1 HY200               | £13.61 + £2.04 VAT |
| PSU180 | with toroidal transformer for 1 HY400 or 2 x HY200  | £23.02 + £3.45 VAT |

**NO QUIBBLE  
 5 YEAR GUARANTEE  
 7-DAY DESPATCH ON  
 ALL ORDERS  
 INTEGRAL  
 HEATSINKS  
 BRITISH DESIGN AND  
 MANUFACTURE  
 FREEPOST SERVICE  
 —see below**

### ★ ALL U.K. ORDERS DESPATCHED POST PAID HOW TO ORDER, USING FREEPOST SYSTEM

Simply fill in order coupon with payment or credit card instructions. Post to address as below but do not stamp envelope — we pay postage on all letters sent to us by readers of this journal.



**L.P. ELECTRONICS LTD.**  
 FREEPOST 4 Graham Bell House, Roper Close,  
 Canterbury, Kent CT2 7EP.  
 Telephone (0227) 54778 Telex 965780

Please supply . . . . . Total purchase price £ . . . . .

I enclose Cheque  Postal Orders  International Money Order

Please debit my Account/Barclaycard Account No. . . . .

NAME . . . . .

ADDRESS . . . . .

Signature . . . . .

# Monitor



## STAR TREK

Treading boldly where no journalist without a preview ticket dares to go, we beamed ourselves down to Leicester Square to see Star Trek—The Motion Picture. The multi million dollar budget seemed to have been well spent, on effects at least. The storyline seemed a bit vague to us, only becoming clear in the last reel. Without doubt though, the special effects department have nearly equalled 2001 (still the best) and are easily as good as Star Wars.

The Enterprise has undergone a great deal of redecoration during the past ten years. The transporters still needs some sorting out, as was seen during one particularly gory bit early in the film.

All in all a good film for 'Trekkies,' well up to standard. The bald lady we have seen so much of in the press lately is a bit of a let down as was the total absence of "Beam me up Scottie." You tend to spend the whole film waiting for that immortal phrase.

Don't miss it. Now how about this Black Hole business and Star Wars 2.

## PLAYFUL ADAM

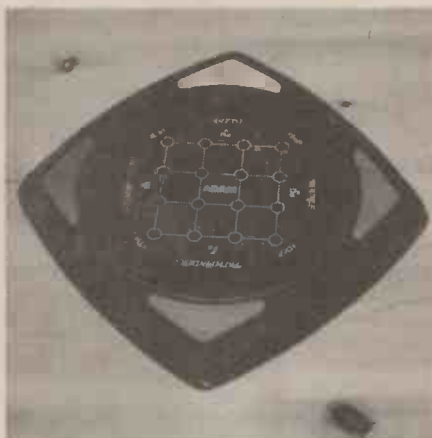

Looking suspiciously like another game also having a gentleman's name Adam will play three games and a quite admirable selection of tunes on its four brightly coloured buttons.

Firstly the games. Number one is called Ditto, it bears more than a passing resemblance to that 'other' game whereby you have to duplicate an ever-increasing sequence of lights and sounds. Failure is rewarded with a 'raspberry' like note from the machines innards. The second game is called Pathfinder, the player has to locate the escape route from the board by a system of trial and error. Each of the playing buttons shifts the LED indicator in a North, South, East, West direction until the edge of the playing area is reached. A win is greeted by a little tune but if a wrong move is made the player has to start from the beginning, remembering all the previous moves. The last game is somewhat confusing, we had the misfortune to loose the instructions so actual playing was

rather difficult. It appears that by a combination of luck and manual dexterity the players are supposed to deflect the moving row of LEDs away from their corner by pressing the appropriate coloured button.

The final attraction is called Memory tune. By pressing individual buttons and combinations of buttons the machine will play and memorise the whole musical (Do, Ray, Me etc) scale. There is provision to insert spaces so quite a creditable selection of 'stylised' tunes can be composed and played back. Each tune is accompanied by a rather pleasing light show from the LED 'playing field'. The machine comes with a tune book containing instructions for around 30 (rather dubious sounding) popular tunes.

Adam is now available from Kramer & Co for £19.95, quite a bit less than its 'look alike' rival. Kramer can be found lurking at 9 October Place, Holders Hill Road, London NW4 1EJ.



## BREADBOARD KIT

Continental Specialities Corporation have introduced a very comprehensive breadboard kit containing all the components needed to make three DC power supplies. The PB203AK kit comes complete with all of the electronic components, case and breadboard modules as well as nuts, bolts connecting wire and solder.

The finished 'Proto Board' incorporates three large breadboards plus four long busbars and one shorter one, sufficient for around 24 14 pin IC packages.

The three power supplies are all fully independent and well regulated giving +5 V, 1A and  $\pm 15$  V, 0.5A. The  $\pm 15$  V supplies can be adjusted over the range 7-18 V. The kit comes complete with a robust, earthed metal case measuring 248 x 168 x 83 mm. For more details contact CSC at; Shire Hall Industrial Estate, Saffron Walden, Essex CB11 3AQ.



## News from the Electronics World

### TOUCH TESTER

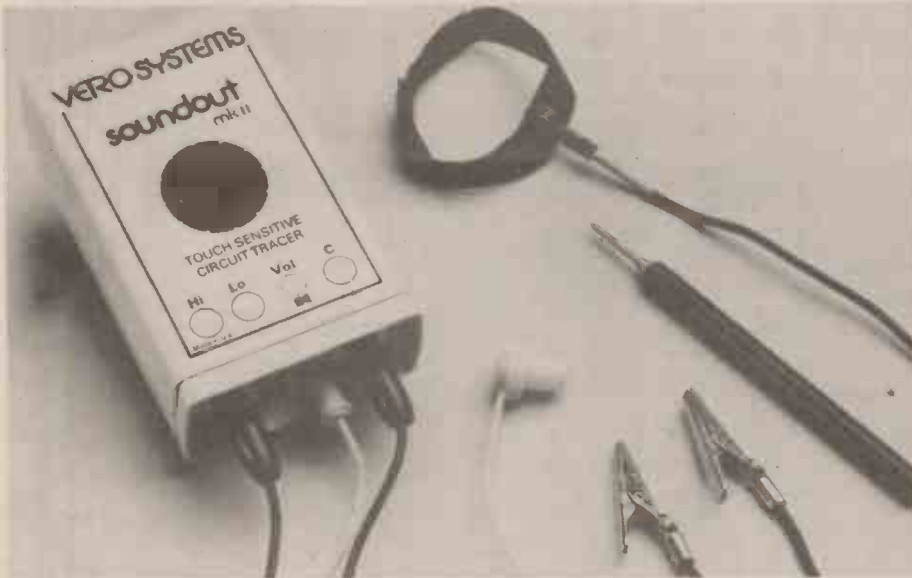

Simple continuity testers have been around for some time now. They usually indicate a short circuit visually by a light bulb or aurally by means of a buzzer. In either case, unless the circuit under test had a resistance of under 10 to 15 ohms it wouldn't work.

This new tester from Vero Systems improves upon the traditional method by using the human body as a conductor leaving both hands free of probes. The unit has dual capability with high (15M ohms) and low (2.5 k ohms) impedance inputs. The low current consumption

ensures that the readily accessible PP3 should last for at least six months. The unit's internal audible indicator gives confirmation of continuity, in noisy environments the optional earphone can be used. A wrist strap and crocodile clips or probes are all available for use with the kit. These are optional extras however.

At the risk of making some dreadful puns; if you want to get in touch with Vero they can be contacted at; 362 Spring Road, Sholing, Southampton, Hampshire SO9 5QJ.

### MICRO MOUTHPIECE

Our spies in the USA have told us that Tandy (Radio Shack) have now started to offer a couple of interesting add-ons for the TRS 80. The first is an "experimental" Voice Recognition unit, the experimental bit is rather played down but we suspect it means that it might not work very well. The second device is a voice synthesizer, the technology used here is a little

more reliable. It will allow you to communicate verbally with your TRS 80, though its more than likely that it would be a rather one-sided conversation, judging by the "experimental" bit. Doubtless this will be the shape of things to come, we await with baited breath. By the way, if you are interested, prices are in excess of 400 dollars (around £200) for each of the units.

We are tempted to buy one of these to handle all the 'phone enquiries we get every week.

### THIN SCREEN AT LAST?

The rather dark and fuzzy photograph shown here is one of the first prototypes of the much vaunted thin screen solid state TV set. This one comes from the laboratories of Toshiba and uses LEDs for display. From the vague information we have it would appear that this model is a colour set. The LCD flat screen has yet to appear but you can be sure that we will be amongst the first to publish details.

Meanwhile the Sinclair flat screen (a squashed CRT tube on it's side) should be making its appearance in the next few months, watch this space for details.

### BOOK REVIEWS

Four new books this month. If you've got any spare book tokens left over from Christmas, maybe something here will interest you. The first two both come from the pen of one Tom Duncan and are called 'Adventures with Micro-Electronics' and 'Adventures with Physics.' The first of these two looks very instructive indeed, filled with practical circuits built on a popular breadboard system. It should be of interest to almost anyone wishing to get their feet wet with ICs. Price £3.25. Number two is unashamedly for the pre to mid-teen age group and describes about 30 simple (though very interesting) experiments that can be tried out at home with the minimum of equipment. Price for this one is a very reasonable £2.95. Both of these books are hard bound and are published by John Murray Ltd.

The next two books both come from our old friend Bernard Babani Ltd. The first by Robert Penfold is called Single IC projects (BP 65 £1.50). All of the projects in the book are simple to construct and are based on a single IC. Some of the projects employ a couple of extra transistors but in most cases the IC is the only active device. The projects are laid out on strip boards making it suitable for beginners as well as our more experienced bretheren (and sitheren!/?

Last but not least we have Elements of Electronics by F. A. Wilson Book 3 (BP 64 £2.25). This book was written to compliment the other two in the series, providing an inexpensive but comprehensive introduction to modern electronics. Much of the book can be easily understood by anyone with a basic grounding in physics and mathematics. Should be suitable for students and schools where this subject is covered in any detail.

### ATARI OWNERS CLUB

Would you believe it? Yes, of course you would. If you are the proud owner of an Atari Video Computer you can become a member of the Official Atari Owners Club. In this month's bulletin there is news of the latest games cartridge to hit the screens. Its called the Indy 500. There are two basic race track games for your cathode-ray car to hurtle around, accompanied by the usual assortment of "lifelike" sound effects. You can also play a game called Crash 'n' Score, a kind of dodgems game where points are scored by crashing into your opponents cars. Variations on these games include invisible or blinking cars, ice or oil patches, making a total of 14 games on this cartridge. Price for the game, including a pair of driving controllers is around £34 including VAT. At your games shop about now.

### ERRATA

Did you notice the lack of Errata last month? We are getting better. Two silly ones this month, the labels on the Digi-Die projects (IC2 and 3) got themselves transposed. The link from pins 14 and 16, (IC2 and 3 again) to the +ve has gone missing, just wire in a link from these pins to the pad with R1 and R2 that goes to the battery +ve.



# MARPLIN

## ELECTRONIC SUPPLIES



### SOLDER

A high quality standard solder by Ersin Multicore. Ideal for miniature components 225wg. 4kg reel, about 163 metres. Order as FY70M Price £7.87



### MINIATURE TRANSFORMERS

Good quality mains transformers to BS415. 6V type: secondaries 0-6V at 500mA + 0-6V at 500mA. Order as WB06G Price £2.19  
9V type: secondaries 0-9V at 500mA + 0-9V at 500mA. Order as WB11M Price £2.58  
12V type: secondaries 0-12V at 250mA + 0-12V at 250mA. Order as WB10L Price £2.19  
15V type: secondaries 0-15V at 200mA + 0-15V at 200mA. Order as WB15R Price £2.19.



### AMP KITS

Complete kits of parts with full instructions to make hi-fi amplifiers with excellent specifications.  
8W amp kit: Order as LW36P Price £3.83  
50W amp kit: Order as LW350 Price £13.73  
150W amp kit: Order as LW32K Price £14.89

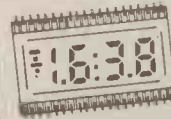

### LIQUID CRYSTAL DISPLAY

High quality 3 1/2 digit 12.7mm (1/2") high figures. Display for use centre colon for use in 12 hour clocks and decimal points, plus and minus signs and overflow indicator for use in panel meters. Order as FY89W Price £8.89

### 20,000 OHM/VOLT MULTIMETER

A 20,000 ohms per volt multimeter at an incredibly low price. DC volts 5, 25, 125, 500, 2,500; AC volts 10, 50, 250, 1,000; DC amps 0 to 0.05mA, 0 to 250mA; Resistance 0 to 50k, 0 to 5M ohms; Decibels -20 to +22dB. Complete with test leads, battery and instruction leaflet. Order as YB83E Price £13.70



### SIREN

A small, but penetrating siren operating on 12V DC (1.2A) Dia. 75mm. Order as YB25C Price £9.11



### McKENZIE POWER SPEAKERS

High quality, high power speakers. 12in. 50W 8Ω Order as X079L Price £18.79  
12in. 50W 16Ω Order as X080B Price £18.79  
12in. 80W 8Ω Order as X081C Price £26.92  
12in. 80W 16Ω Order as X082D Price £26.92  
15in. 150W 8Ω Order as X083E Price £57.80  
15in. 150W 16Ω Order as X084F Price £57.80



### PIEZO HORN TWEETER

Very simply added to any speaker system up to 100W rms. No crossover required. Distortion <1% Order as WF09K Price £5.27



### CLOCK MODULE

Module requires only transformer and two push switches to operate 4 digit, 0.7in red LED display. Alarm and radio outputs. Battery back up when mains fail. Sleep and snooze timer. Seconds display. Just add speaker for alarm tone. Full details on page 267 of our catalogue. Order as XL140 Price £8.41



### QUICK CHARGE RECHARGEABLE CELL

1.2V. Size AA(HP7). Fully recharged in 5 hours with 150mA. Capacity: 450mAh. Will last for at least 500 full charge/discharge cycles. Change to quick charge cells now! Order as LR74R Price £1.49

### MIC STAND

Quality microphone stand extends to 1.5m. Boom arm 1m long adjustable. Stand: Order as XB45Y Price £12.71  
Boom: Order as XB46A Price £11.25

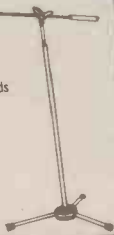

### SOLDERING IRONS & KITS

Antex CX iron. 17W miniature. Order as FY62S Price £4.85  
Antex X25 iron. 25W. Order as FR12M Price £4.85  
CX iron with stand in presentation pack. Order as FY68Y Price £6.85  
X25 iron with stand in presentation pack. Order as FY69A Price £6.85



### REVERBERATION SYSTEM

The 'concert hall' sound in your living room. Driver module: Order as XB85G Price £6.14  
Requires + and - 15V 20mA power supply ready built suitable for Driver Module. Order as YL17T Price £4.73  
Spring line with 3 sec. reverb time: Order as XL08J Price £4.93  
Spring line with 7 sec. reverb time: Order as XB84F Price £11.13



### KEYBOARDS

High quality keyboards with hard-wearing sloping fronted plastic keys. With keys mounted on nylon bushed steel levers 49-note C to C.

Order as XB15R Price £23.99  
61-note C to C. Order as XB16S Price £29.90  
With keys pivoted on a hard-wearing moulded fulcrum. 49-note C to C. Order as XB17T Price £19.93



### MULTIMETER & TRANSISTOR TESTER

Superb high sensitivity multimeter and transistor tester in one. Sensitivity 100,000 ohms per volt DC. Ranges DC volts 0.5, 2.5, 10, 50, 250, 1,000; AC volts 5, 10, 50, 250, 1,000; DC current 0.01, 0.025, 0.5, 5, 50, 500mA, 10A; AC current 10A; Resistance 5k, 50k, 5M, 50M ohms; Decibels -10dB to +62dB. Complete with test leads, three leads for transistor tester batteries and instruction leaflet. Order as YB87U Price £39.30

### POCKET MULTIMETER

Amazing value 4,000 ohms per volt DC jewelled moving coil meter. Ranges: DC volts 5, 25, 250, 500; AC volts 10, 50, 500, 1,000; DC amps 0 to 0.25mA, 0 to 250mA; Resistance 0 to 600k ohms; Decibels -10 to +22dB. Size only 3 1/4 x 2 1/4 x 1 1/4 inches. Complete with test leads, battery and instructions. Order as FL600 Price £6.75



### TURNTABLES

Autochanger complete with stereo ceramic cartridge and circuit to make a complete low-cost record player ideal for the young pop fan. Order as X000A Price £16.30  
Single play rim-drive turntable with stereo ceramic cartridge. Order as XB23A Price £24.79  
Single play belt drive turntable 'S'-shaped tone arm. Order as XB25C Price £30.63

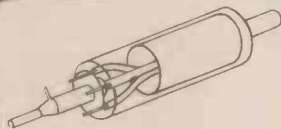

### LASER TUBE

A helium neon 0.5mW laser tube. Full details on page 262 of our catalogue. Order as XL11M Price £104.35

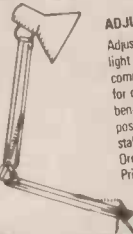

### ADJUSTABLE LAMP

Adjustable to get a bright light on miniature components. With bracket for clamping or bolting to bench or wall. Shade and position fully adjustable and stable. Finished in white. Order as XY25C Price £10.90

All prices include VAT and postage and packing, but if total under £4 please add 30p handling charge. Prices guaranteed until February 8th 1980. Export customers deduct 13% and export postage will be charged extra at cost.

Please use order code. All items in stock at time of going to press.

FOR FULL CATALOGUE DETAILS SEE BACK COVER

# MARPLIN

## ELECTRONIC SUPPLIES LIMITED

All mail to PO Box 3, Rayleigh, Essex SS6 8LR. Telephone: Southend (0702) 554155.

Shop: 284 London Road, Westcliff-on-Sea, Essex (closed on Monday). Telephone: Southend (0702) 554000.

# Passionmeter



***Passionate Paul calibrates the Passionmeter while delicious Dee watches with amazement. Build one now and check yourself out!***

MANY OF YOU have probably seen those small glass vessels, available from 'joke' and 'magic' novelty shops, sold as 'passionmeters'. They consist of a series of glass bulbs, one above the other, containing a red liquid at the lower end. At the touch of a hot palm the liquid bubbles its way toward the top — how high it bubbles depending on how hot the grasping palm happens to be!

The HE passionmeter uses an electronic technique to measure the passionate user's level of excitement — or stress — indicating this on a 'ladder of LEDs'.

Now, a person in the throes of a passion (or under some stress, all the same thing for our purposes) undergoes certain physiological changes. Amongst such obvious and observable alterations as bulging eyes, flushed visage, foaming at the mouth and steam issuing from the auditory orifices . . . are more subtle phenomena. The one we are concerned with is skin resistance.

Skin resistance has a number of characteristics which make it a suitable variable for measuring the level of personal passion. The *lower* the skin resistance of a subject, the greater level of emotional stress. And vice versa.

Skin resistance increases with age, decreases with perspiration (as from exertion) and varies according to the activity recently engaged in. A finger which has just finished the washing up will exhibit a lower skin resistance than one which has just assisted reading a newspaper.

With high skin resistance, few or none at all! of the LEDs will light. With decreasing skin resistance more of the LEDs in the ladder will light, climbing all the way to the top with a subject at the height of passion — or one who has just finished the washing up.

You will notice the lack of an on/off switch. As a CMOS IC is used in this project, the 'no-finger' (i.e. non-operating) current consumption is so low that battery drain is three-fifths of five-eighths of half of 30% of the leakage across the battery terminals — negligible in fact. Hence, no switch.

We built the project into a small plastic and aluminium Verobox, with a hole in the front panel for the insertion of a finger. This size of box is very handy as the battery just fits in behind the printed circuit board and is neatly held with a little packing.

## CONSTRUCTION

If you use ordinary copper foil PCB you will find after a while the areas of copper which are used for contacts will attract grease and oxidation which will affect the performance of the meter. The best way to stop this is to thoroughly clean and degrease the copper foil and then tin the areas which are used as skin contacts (the large black areas on the PCB track).

Use an IC holder for IC1, it makes fault location so much easier plus the fact that the chip is less likely to be damaged by insertion. Make sure that it is the right way round. It is a CMOS integrated circuit which means that it can be damaged by static from your fingers — so don't get hold of it by its legs!

Do not forget the wire link on the PCB. When soldering the components in, keep all of them as close to the board as possible with the exception of the LEDs, of course, which go on to the front panel of your case. Make sure that the LEDs are connected in circuit the right way round. Figure 1 shows how to tell the cathode from the anode. **HE**

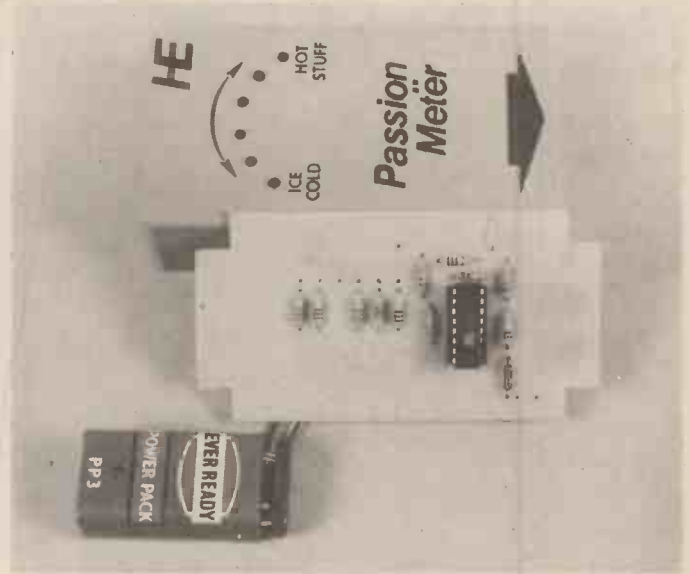
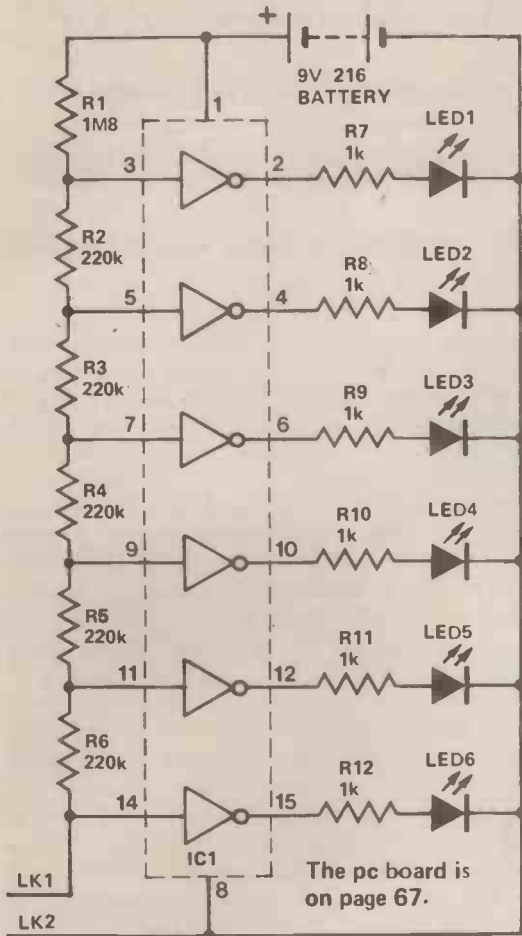
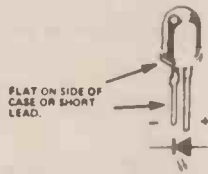

*Above. Naked Passion (meter). Use of a PCB and straightforward design make this project a cinch to build. Only the LEDs need to be wired in to complete construction as no ON-OFF switch is required. The contact pads are underneath the PCB at the right.*

Left. Fig. 1. Circuit diagram for passionmeter.

## How It Works

The operation of this circuit depends on the difference in skin resistance between different people. The lower the skin resistance, the more of the LEDs will light up.

This resistance is measured between the pads on the circuit board. As the finger of the person to be tested is pressed against the circuit board, it will cover both of these pads and the resistance between them will drop from its 'un-fingered' state in which the resistance across the pads is high) to a value less than 1M. This will cause the voltage on the resistor chain R1 to R6 to drop.

The 'gates' in the 4049 integrated circuit are inverters. This is, whatever happens on the inputs, the opposite will happen at the outputs. In this case, the inputs are being dragged to a low voltage. When the voltage on the input of any particular gate drops below about 4.5 V (half the supply voltage) the output will change from 0 V to 9 V. This will drive current through the appropriate LED.

As the resistance across the contacts decreases, more of the gates will be turned on, causing LEDs in the line to light up.

When no finger is present, none of the LEDs are lit and the current drawn by the circuit is so small that an on/off switch is unnecessary.

## Parts List

### RESISTORS (All 1/2W. 5%)

|        |      |
|--------|------|
| R1     | 1M8  |
| R2-R6  | 220k |
| R7-R12 | 1k   |

### SEMICONDUCTORS

|           |            |
|-----------|------------|
| IC1       | 4049B      |
| LED1-LED6 | TIL220R    |
|           | Red LEDs   |
|           | or similar |

### MISCELLANEOUS

B1 PP3 9V battery, Battery clip, PCB. Box to suit.

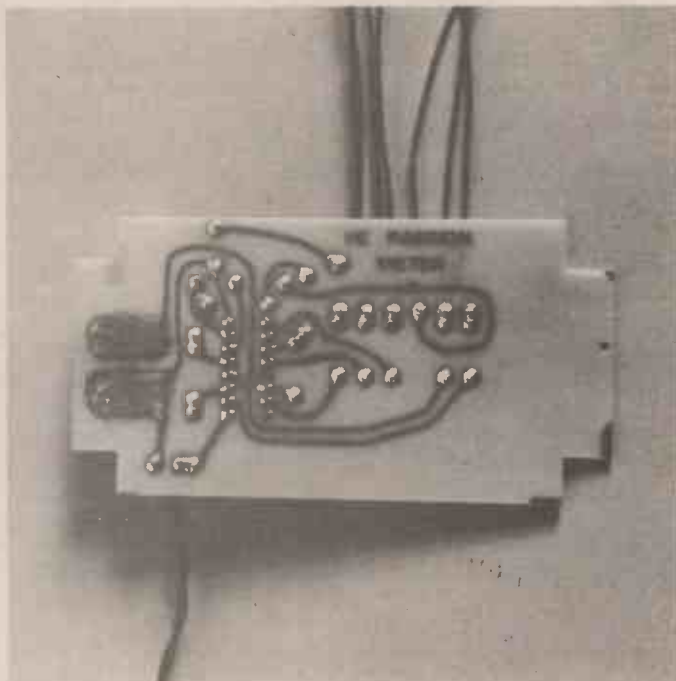

Above: Simple PCB design makes an easy-to-build project.

Left: Fig. 2. PCB for Passionmeter.

Lower left: Fig. 3. Overlay for Passionmeter.

Below: A single 9V battery powers the project which fits neatly in its case.

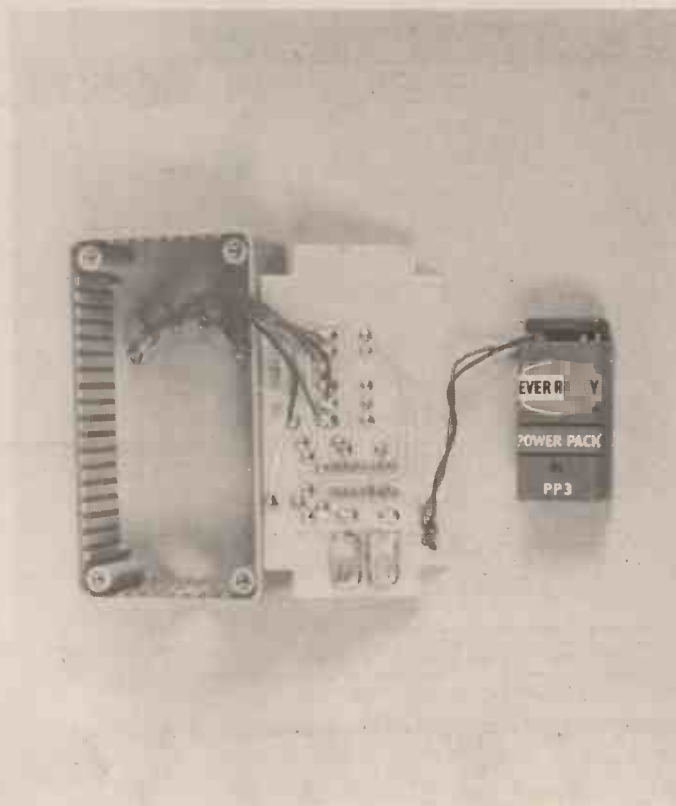
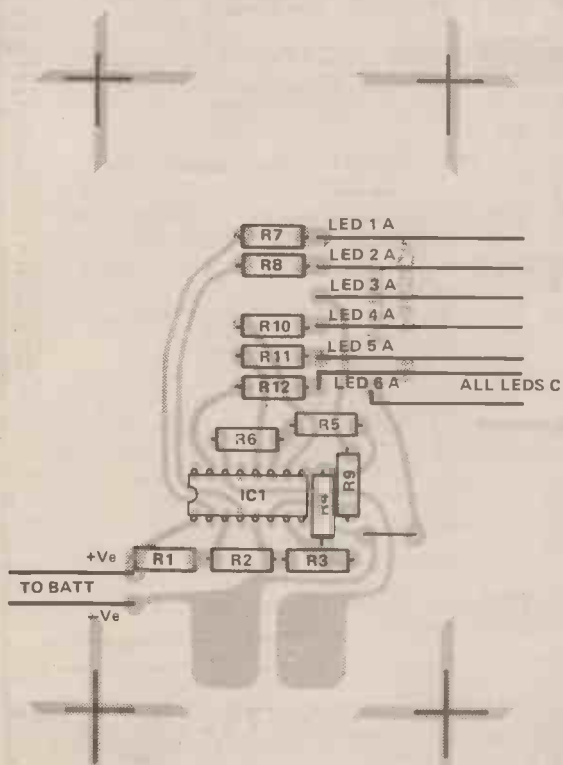
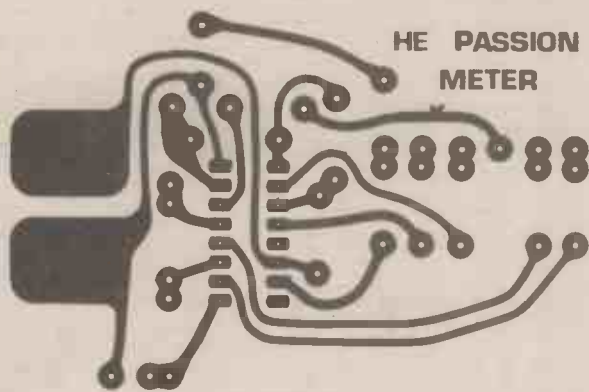

# Great 1980 Sale

**SUPER SOUND SAVING! DINDY**



**LOW NOISE CASSETTES**

|                                  |       |
|----------------------------------|-------|
| SJ30 10 C30 15 min per side      | £2.00 |
| SJ55 10 C46 23 min per side (LP) | £2.60 |
| SJ31 10 C90 45 min per side      | £3.50 |
| SJ32 10 C120 40 min per side     | £4.50 |

**ALL REDUCED!**

**CAPACITOR PAKS**

|  |                |
|--|----------------|
| 16201 18 electrolytics                 | 4.7uF-10uF     |
| 16202 18 electrolytics                 | 10uF-100uF     |
| 16203 18 electrolytics                 | 100uF-680uF    |
| <b>All 3 at SPECIAL PRICE of £1.30</b> |                |
| 16160 24 ceramic caps                  | 22pF-82pF      |
| 16161 24 ceramic caps                  | 100pF-390pF    |
| 16162 24 ceramic caps                  | 470pF-3300pF   |
| 16163 24 ceramic caps                  | 4700pF-0.047pF |
| <b>All 4 at SPECIAL PRICE of £1.70</b> |                |

**RESISTOR PAKS**

| Order No.                              | Resistor Values                  | Price |
|--|----------------------------------|-------|
| 16213                                  | 60 $\frac{1}{4}$ W 100ohm-820ohm |       |
| 16214                                  | 60 $\frac{1}{4}$ W 1K-8.2K       |       |
| 16215                                  | 60 $\frac{1}{4}$ W 10K-82K       |       |
| 16216                                  | 60 $\frac{1}{4}$ W 100K-820K     |       |
| 16217                                  | 40 $\frac{1}{2}$ W 100ohm-820ohm |       |
| 16218                                  | 40 $\frac{1}{2}$ W 1K-8.2K       |       |
| 16219                                  | 40 $\frac{1}{2}$ W 10K-82K       |       |
| 16220                                  | 40 $\frac{1}{2}$ W 100K-820K     |       |
| <b>All 4 at SPECIAL PRICE of £1.80</b> |                                  |       |

**IC SOCKET PAKS**

| IC                             | Pin       | F.E.T.s | Price |
|--------------------------------|-----------|---------|-------|
| SJ36                           | 14 8 pin  |         |       |
| SJ37                           | 12 14 pin |         |       |
| SJ38                           | 11 16 pin | 2N3819  | £0.17 |
| SJ39                           | 8 18 pin  | 2N5458  | £0.18 |
| SJ40                           | 7 20 pin  | 2N4220  | £0.28 |
| SJ41                           | 6 22 pin  | 2N4860  | £0.25 |
| SJ42                           | 5 24 pin  |         |       |
| SJ43                           | 4 28 pin  |         |       |
| SJ44                           | 3 40 pin  | 2N6027  | £0.25 |
|                                |           | BRV56   | £0.25 |
| <b>(PROGRAMMABLE UNIUNION)</b> |           |         |       |
| <b>ALL AT ONLY £1.00 each</b>  |           |         |       |

**VOLTAGE REGULATORS**

| Cast TO220       |       |          |       |
|------------------|-------|----------|-------|
| Positive         | Price | Negative |       |
| uA7805           | £0.65 | uA7905   | £0.70 |
| uA7812           | £0.65 | uA7912   | £0.70 |
| uA7815           | £0.65 | uA7915   | £0.70 |
| uA7818           | £0.65 | uA7918   | £0.70 |
| uA7824           | £0.65 | uA7924   | £0.70 |
| uA723 14 pin DIL |       |          | £0.35 |
| LM309K TO3       |       |          | £1.10 |

**OPTOELECTRONICS DISPLAYS**

| LED            | Price each             | Display Price each        | Price each |
|----------------|------------------------|---------------------------|------------|
| 1510 707 LED   | £0.70                  | Display Price each        | £1.80      |
| 1511 747 LED   | £1.85                  | Display Price each (dual) | £1.85      |
| 1512 727 LED   |                        |                           |            |
| <b>LEDs</b>    |                        |                           |            |
| SJ78 .125 LED  | Diffused RED           | £0.08                     |            |
| SJ79 .2 LED    | Diffused RED           | £0.08                     |            |
| SJ120 .125 LED | Bright RED             | £0.09                     |            |
| SJ121 .2 LED   | Bright RED             | £0.09                     |            |
| 1502 .125 LED  | Diffused GREEN         | £0.11                     |            |
| 1505 .2 LED    | Diffused GREEN         | £0.11                     |            |
| 1503 .125 LED  | Diffused YELLOW        | £0.11                     |            |
| 1506 .2 LED    | Diffused YELLOW        | £0.11                     |            |
| SJ80 .2 LED    | Bright YELLOW          | £0.14                     |            |
| SJ82 .2 LED    | Clear Illuminating RED | £0.10                     |            |
| SJ83 .125 LED  | Clear Illuminating RED | £0.10                     |            |

**2nd QUALITY LED PAKS**

| LED  | Price | Price   |
|--|-------|---|
| 1507 10 Assorted colours & size  | £0.85 |   |
| 1522 10 .125 RED   | £0.50 |   |
| 1523 10 .2 RED   | £0.50 |   |
| <b>1508/.125 .125 5 for £0.10</b>  |       |   |
| <b>1508/.2 .2 5 for £0.12</b>  |       |   |
| SJ81 2 1 Infra RED emitter - Fairchild FP100                                     |       | £1.00   |
| SJ98 5 Photo Detector MEL11 + Data   |       | £1.00   |
| ORP12 NORP12 Cad Cell  |       | £0.45   |
| SJ99 4 IIT 5870 ST Nixie Tubes   |       | £1.00   |
| SJ29 Texas NPN silicon transistors 2S503=BC108 TO-18 metal can - perfect & coded |       | 50 off £2.80 - 100 off £4.00 - 1,000 off £35.00 |

**NICKEL CADMIUM RECHARGEABLE BATTERIES**

|   |                     |
|---|---------------------|
| S128 35000 Cell size - U2   | £2.80               |
| <b>SUPER DUPER COMPONENT BOX</b>  |                     |
| Min. 3lbs in weight consisting of a fantastic assortment of Electronic Components - Pots, Resistors, Condensers, Switches, Relays, Board-Semiconductors, Wire, Hardware, etc., etc. |                     |
| * This is a large box and is sent separate to your order.   |                     |
| S140  | £2.50 including P&P |

**CALCULATOR CHIP**

|                      |       |
|----------------------|-------|
| GOM2-C500 24 pin MOS | £0.50 |
|----------------------|-------|

**IC INSERTION EXTRACTION TOOL**

|      |            |
|------|------------|
| 2015 | £0.35 each |
|------|------------|

**TRANSISTORS**

| Type        | Price    | Type      | Price    |
|-------------|----------|-----------|----------|
| AC107       | £0.20    | BC251     | £0.10    |
| AC126       | £0.14    | BC261     | £0.14    |
| AC127       | £0.18    | BC327     | £0.12    |
| AC128       | £0.15    | BC328     | £0.12    |
| AC128K      | £0.24    | BC337     | £0.12    |
| AC176       | £0.16    | BC338     | £0.12    |
| AC171K      | £0.24    | BC440     | £0.28    |
| AC187       | £0.18    | BC441     | £0.28    |
| AC187K      | £0.28    | BC460     | £0.28    |
| AC188       | £0.18    | BC461     | £0.28    |
| AC188K      | £0.28    | BC477     | £0.15    |
| AD161/162MP | £0.85/pr | BC478     | £0.15    |
| AD140       | £0.60    | BC479     | £0.15    |
| AD149       | £0.53    | BC547     | £0.08    |
| AF239       | £0.85    | BC548     | £0.08    |
| BC107       | £0.08    | BC549     | £0.08    |
| BC107A      | £0.08    | BC557     | £0.10    |
| BC107B      | £0.07    | BC558     | £0.08    |
| BC107C      | £0.08    | BC559     | £0.10    |
| BC108       | £0.08    | BCY70     | £0.13    |
| BC108A      | £0.08    | BCY71     | £0.13    |
| BC108B      | £0.07    | BCY72     | £0.13    |
| BC108C      | £0.08    | BD115     | £0.48    |
| BC109       | £0.08    | BD131     | £0.30    |
| BC109B      | £0.07    | BD132     | £0.30    |
| BC109C      | £0.09    | BD135     | £0.28    |
| BC113       | £0.10    | BD136     | £0.28    |
| BC114       | £0.12    | BD239A/MP | £0.80/pr |
| BC116       | £0.18    | BF115     | £0.20    |
| BC118       | £0.10    | BF167     | £0.20    |
| BC140       | £0.20    | BF173     | £0.20    |
| BC142       | £0.18    | BF195     | £0.09    |
| BC147       | £0.07    | BF196     | £0.09    |
| BC148       | £0.07    | BF197     | £0.10    |
| BC149       | £0.07    | BF257     | £0.22    |
| BC157       | £0.08    | BF258     | £0.22    |
| BC158       | £0.08    | BF259     | £0.22    |
| BC159       | £0.08    | BF259     | £0.22    |
| BC169C      | £0.08    | BF339     | £0.20    |
| BC170       | £0.08    | BF340     | £0.20    |
| BC171       | £0.07    | BF719     | £0.22    |
| BC172       | £0.07    | BF880     | £0.22    |
| BC173       | £0.08    | BFT84     | £0.20    |
| BC177       | £0.13    | BFT85     | £0.20    |
| BC178       | £0.13    | BFX29     | £0.20    |
| BC179       | £0.13    | BFX64     | £0.20    |
| BC182       | £0.07    | BFY50     | £0.15    |
| BC182L      | £0.07    | BFY51     | £0.15    |
| BC183       | £0.07    | BFY52     | £0.18    |
| BC183L      | £0.07    | BP19/20MP | £0.70/pr |
| BC184       | £0.07    | NJE340    | £0.60    |
| BC207       | £0.08    | NJE2955   | £0.75    |
| BC208       | £0.08    | NJE3055   | £0.60    |
| BC209       | £0.08    | MPSA05    | £0.18    |
| BC212       | £0.07    | MPSA06    | £0.18    |
| BC212L      | £0.07    | MPSA55    | £0.18    |
| BC213       | £0.07    | MPSA56    | £0.15    |
| BC214       | £0.07    | OC25      | £0.50    |
| BC214       | £0.07    | OC26      | £0.45    |
| UC214L      | £0.07    | OC28      | £0.60    |
| OC29        | £0.85    | OC29      | £0.85    |
| OC35        | £0.85    | OC35      | £0.85    |
| OC36        | £0.80    | OC36      | £0.80    |
| OC42        | £0.18    | OC42      | £0.18    |
| OC44        | £0.12    | OC44      | £0.12    |
| OC45        | £0.18    | OC45      | £0.18    |
| OC71        | £0.12    | OC71      | £0.12    |
| OC72        | £0.18    | OC72      | £0.18    |
| OC75        | £0.18    | OC75      | £0.18    |
| OC81        | £0.20    | OC81      | £0.20    |
| TIP29       | £0.30    | TIP29     | £0.30    |
| TIP29A      | £0.30    | TIP29A    | £0.30    |
| TIP29B      | £0.32    | TIP29B    | £0.32    |
| TIP29C      | £0.34    | TIP29C    | £0.34    |
| TIP30       | £0.30    | TIP30     | £0.30    |
| TIP30A      | £0.30    | TIP30A    | £0.30    |
| TIP30B      | £0.32    | TIP30B    | £0.32    |
| TIP30C      | £0.34    | TIP30C    | £0.34    |
| TIP31       | £0.30    | TIP31     | £0.30    |
| TIP31A      | £0.32    | TIP31A    | £0.32    |
| TIP31B      | £0.32    | TIP31B    | £0.32    |
| TIP31C      | £0.34    | TIP31C    | £0.34    |
| TIP32       | £0.30    | TIP32     | £0.30    |
| TIP32A      | £0.30    | TIP32A    | £0.30    |
| TIP32B      | £0.32    | TIP32B    | £0.32    |
| TIP32C      | £0.34    | TIP32C    | £0.34    |
| TIP41       | £0.34    | TIP41     | £0.34    |
| TIP41A      | £0.34    | TIP41A    | £0.34    |
| TIP41B      | £0.34    | TIP41B    | £0.34    |
| TIP41C      | £0.38    | TIP41C    | £0.38    |
| TIP42       | £0.34    | TIP42     | £0.34    |
| TIP42A      | £0.34    | TIP42A    | £0.34    |
| TIP42B      | £0.38    | TIP42B    | £0.38    |
| TIP42C      | £0.38    | TIP42C    | £0.38    |
| TIP2955     | £0.50    | TIP2955   | £0.50    |
| TIP3055     | £0.48    | TIP3055   | £0.48    |
| ZTX107      | £0.08    | ZTX107    | £0.08    |
| ZTX108      | £0.08    | ZTX108    | £0.08    |
| ZTX109      | £0.10    | ZTX109    | £0.10    |
| ZTX130      | £0.10    | ZTX130    | £0.10    |
| ZTX301      | £0.10    | ZTX301    | £0.10    |
| ZTX302      | £0.12    | ZTX302    | £0.12    |
| ZTX500      | £0.12    | ZTX500    | £0.12    |
| ZTX501      | £0.10    | ZTX501    | £0.10    |
| ZTX502      | £0.12    | ZTX502    | £0.12    |
| ZN696       | £0.10    | ZN696     | £0.10    |
| ZN706       | £0.08    | ZN706     | £0.08    |
| ZN706A      | £0.10    | ZN706A    | £0.10    |
| ZN708       | £0.10    | ZN708     | £0.10    |
| ZN1302      | £0.15    | ZN1302    | £0.15    |
| ZN1303      | £0.15    | ZN1303    | £0.15    |
| ZN1513      | £0.18    | ZN1513    | £0.18    |
| ZN1711      | £0.18    | ZN1711    | £0.18    |
| ZN1893      | £0.25    | ZN1893    | £0.25    |
| ZN2218      | £0.18    | ZN2218    | £0.18    |
| ZN2218A     | £0.18    | ZN2218A   | £0.18    |
| ZN2219      | £0.18    | ZN2219    | £0.18    |
| ZN2219A     | £0.20    | ZN2219A   | £0.20    |
| ZN2221      | £0.18    | ZN2221    | £0.18    |
| ZN2221A     | £0.20    | ZN2221A   | £0.20    |
| ZN2222      | £0.18    | ZN2222    | £0.18    |
| ZN2222A     | £0.18    | ZN2222A   | £0.18    |

**DIODES**

| Type   | Price | Type   | Price |
|--------|-------|--------|-------|
| AA119  | £0.06 | OA70   | £0.08 |
| BA100  | £0.08 | OA79   | £0.08 |
| BA148  | £0.13 | OA81   | £0.08 |
| BA173  | £0.13 | OA90   | £0.08 |
| BAX13  | £0.06 | OA91   | £0.08 |
| BAX18  | £0.06 | OA95   | £0.08 |
| BA200  | £0.08 | IN34   | £0.08 |
| OA202  | £0.07 | IN60   | £0.07 |
| BY100  | £0.18 | IN414B | £0.08 |
| BY126  | £0.12 | IN4001 | £0.04 |
| BY127  | £0.14 | IN4002 | £0.04 |
| OA47   | £0.08 | IN4003 | £0.05 |
| IN4004 | £0.06 | IN4004 | £0.06 |
| IN4005 | £0.07 | IN4005 | £0.07 |
| IN4006 | £0.08 | IN4006 | £0.08 |
| IN4007 | £0.09 | IN4007 | £0.09 |
| IN5400 | £0.10 | IN5400 | £0.10 |
| IN5401 | £0.13 | IN5401 | £0.13 |
| IN5402 | £0.18 | IN5402 | £0.18 |
| IN5404 | £0.15 | IN5404 | £0.15 |
| IN5406 | £0.18 | IN5406 | £0.18 |
| IN5407 | £0.23 | IN5407 | £0.23 |
| IN5408 | £0.18 | IN5408 | £0.18 |
| IS44   | £0.63 | IS44   | £0.63 |

**LINEAR**

| Type    | Price | Type    | Price |
|---------|-------|---------|-------|
| CA270   | £0.95 | SN7613N | £1.65 |
| CA3099  | £1.70 | SN7623N | £1.60 |
| CA3090  | £3.00 | SN76115 | £1.60 |
| LM380   | £0.80 | TAA550  | £0.30 |
| LM381   | £1.35 | TAA621A | £1.80 |
| LM3900  | £0.60 | TBA120B | £0.60 |
| MC1310P | £0.85 | TBA641A | £1.10 |
| NE555   | £0.18 | TBA800  | £0.75 |
| NE556   | £0.55 | TBA810  | £0.85 |
| TBA820  | £0.85 | TBA820  | £0.85 |
| uA703   | £0.20 | uA703   | £0.20 |
| uA709C  | £0.25 | uA709C  | £0.25 |
| uA710   | £0.25 | uA710   | £0.25 |
| uA711   | £0.25 | uA711   | £0.25 |
| 741P    | £0.16 | 741P    | £0.16 |
| TAA661  | £1.25 | TAA661  | £1.25 |
| TAA661B | £1.25 | TAA661B | £1.25 |

**THYRISTORS**

| Type                      | Price | Type | Price |
|---------------------------|-------|------|-------|
| THY1A/501 1 Amp 50v TO5   | £0.18 |      |       |
| THY1A/400 1 Amp 100v TO5  | £0.32 |      |       |
| THY3A/50 3 Amp 50v TO64   | £0.25 |      |       |
| THY3A/200 3 Amp 200v TO64 | £0.32 |      |       |
| THY3A/400 3 Amp 400v TO64 | £0.40 |      |       |
| THY5A/50 5 Amp 50v TO66   | £0.25 | </   |       |

# Clever Dick

**Clever Dick is starting a collection of pens after the little gift from Wurlitzer this month. We also hear from one of our more 'mature' readers reminiscing on the 'golden days' of electronics when the PP3 was unheard of.**



NOW THAT the battered remains of countless Christmas toys have been cleared up, electronic toys have uttered their last pitiful squeaks, we shall return to business with the equally pitiful noises coming from Mr T. Borough's Amplifier.

Dear Dick,

I have a Pioneer stereo unit. One of the channels has become distorted, the left one to be precise. Any help would be appreciated.

Before I go could you suggest any substitutes for these transistors: 2SA720, 2SB507, 2SC1318.

T. Brough,  
Stoke-on-Trent.

It must be said that this is a genuine letter and we've got scores more just like it to prove it.

Sorry, Mr Brough, even if you furnished us with model, serial number and twenty Polaroid photographs of the rogue amplifier we couldn't help you. A job like that can only be undertaken by a qualified serviceman with the device in front of him, in a well equipped workshop. Not us, armed with only a bent typewriter.

However, all is not lost, general purpose replacements (and we can't be more specific than that) for the transistors are as follows: 2SA720 = BCW37, 2SB507 = BD590, 2SC1318 = BCW36.

Please try to keep your questions a little less vague and they'll stand a better chance of being answered.

Do you remember the piece in November's Clever Dick about the Hobbytune? We mentioned how good it was but not quite a 'pocket Wurlitzer'. Surprise, surprise, Wurlitzer in the shape of Dave Lucas has written to us, sending us a genuine Wurlitzer pen. Many thanks Dave. Now, what was that about HEBOT being the Rolls Royce of Robots???

We mention quite a few books in HE, a couple in particular we strongly recommend to anyone interested in electronics. This letter from J E Wright emphasises the point.

Dear Sirs,

With reference to Ray Marston's article under 'Chit Chat' re Books — September '79.

I would like to get all of these, namely 'Foundations of Wireless and Electronics', 'Electronics It's Easy' and 'Newnes Radio & Electronics Engineers Pocket Book'.

Presumably the first and last will have to be ordered from my local W. H. Smith & Sons but your E.T.I. publication of 'Electronics It's Easy,' can it be supplied by you?

Would you kindly advise me and I will let you have the requisite cheque to cover.

I would be at fault if I did not add that I find your magazine of the greatest possible help to me as the pure amateur.

J E Wright,  
Chelmsford.

As you point out, Electronics It's Easy is available from us, now reprinted in one volume. See the Specials Ad in this issue for details. The other two are not quite so easy, because of their specialist nature you will probably have to order them. If you are able to get to London shops like Foyles in Charing Cross Road (near the HE office) you will find that they stock a vast range of technical books. Thanks for the comments, we're suitably embarrassed.

It is always good to hear from someone who has seen this hobby of ours grow from its earliest days. Mr J A Briscoe remembers the days of crystal receivers and wonders if they couldn't be brought up to date.

Dear Dick,

In a reminiscent mood the other day, I pondered on the incredible magic that hit us about sixty years ago. Radio is all such an accurate science these days, but back in 1920 all we needed was a length of wire across the roof and down the wall, connected to a few turns of wire on a cardboard former, tuned by tapings or even by a simple metal plate adjusted near the coil (a non-magnetic metal plate close to an air-cored coil reduced its inductance). Then the vital piece of "crystal", usually a small piece of galena (lead ore) clamped in a brass cup with three tiny screws, with a contact made from a springy piece of wire — the "Cat's Whisker". In series, a pair of high impedance headphones. That was all, except for the earth connection. Sometimes the output was loud enough for "Phones-on-the-table". The galena and wire contact was of course a tiny diode.

It seems to me, now that everything required is so easily obtained, it should be possible to make a receiver without batteries. If we were to be content with very low power output (Phones-on-the-table cannot have been much more than about 20 microwatts) then it should be possible to obtain that much power by rectifying a loud signal, and then using this current to amplify other signals to audible level.

Something for nothing is always an attractive idea. How about that for a future project?

J A Briscoe  
North Yorks.

That is a very interesting idea Mr Briscoe, one that we believe has been tried many times before. We remember in particular one design for a crystal receiver that actually drove a small loudspeaker, trouble was, you had to live under the transmitter to get any kind of volume.

However, taking your suggestion a stage further, how about a solar-powered radio with Ni-Cad back-up for night-time use? This was an idea for a project in HE. Perhaps your letter will inspire us to do something about it.

Lastly we have a letter from a doctor. He raises a question that for some time we have been investigating.

Dear Dick,

I and my son read your column with interest each week, and find many of the projects and designs in the magazines very intriguing. However, as a doctor, I am particularly interested in the applications to medicine.

For some time in our practice we have coveted an electrocardiogram for use with our patients, but the cost of a new one at around £1,000 has deterred us. Do you know of anyone who has produced such a machine in kit form so that we could build one ourselves?

I shall be most interested in your reply.

Dr Ronald N. C. Douglas,  
Glasgow

During our investigations we came across some rather disturbing facts. It would appear that circuits purporting to be of 'medical' use might be illegal or at least heavily frowned upon by the BMA. Because of this we can only publish circuits of little more than 'novelty' value, if we're to claim they are for medical use we would run into trouble.

Nevertheless our sister magazine ETI has published a Heart Rate Monitor in Top Projects 7. We published a GSR monitor in the June issue, again it has only a novelty value. If there is anyone out there willing to clarify this point we would be glad to hear from you. We have one or two interesting circuits that we cannot publish for running foul of the law. How about a one transistor pacemaker????

HE



I THINK THEY'RE GETTING  
JUST A LITTLE BIT CARRIED  
AWAY WITH THESE COMPUTER-  
RECOGNITION TAGS!!



KB-79

## First the EuroBreadBoard Now the EuroSolderBoard



Design on a EuroBreadBoard — Instal on a EuroSolderBoard

### First the EuroBreadBoard

Will accept 0.3" and 0.6" pitch DIL IC's, Capacitors, Resistors, LED's, Transistors and components with up to .85mm dia leads. 500 individual connections PLUS 4 integral Power Bus Strips along all edges for minimum inter-connection lengths. All rows and columns numbered or lettered for exact location indexing (ideal for educational projects). Long life, low resistance (<10m ohms) nickel silver contacts. £6.20 each or £11.70 for 2 including 1 or 2 EuroSolderBoards FREE

### Now the EuroSolderBoard

New 100mm square, 1.6mm thick printed circuit board with pre-tinned tracks identically laid out, numbered and lettered to EuroBreadBoard pattern. Four 2.5mm dia fixing holes. £2.00 for set of three ESB's or FREE with every EuroBreadBoard

### And don't forget the EuroSolderSucker

Ideal for tidying up messy solder joints or freeing multi-pin IC's, this 195mm long, all metal, high suction desoldering tool has replaceable Teflon tip and enables removal of molten solder from all sizes of pcb pads and track. Primed and released by thumb, it costs only £7.25 including VAT & PP



Snip out and post to David George Sales,  
Unit 7, Higgs Industrial Estate, 2 Herne Hill Road, London SE24 0AU

David George Sales, HE 2  
Unit 7, Higgs Ind. Est., 2 Herne Hill Rd., London SE24 0AU.  
Please send me:-

- |  |          |                       |        |
|--|----------|-----------------------|--------|
| 1 EuroBreadBoard<br>(plus 1 free EuroSolderBoard)      | @ £ 6.20 | <input type="radio"/> | Please |
| or 2 EuroBreadBoards<br>(plus 2 free EuroSolderBoards) | @ £11.70 | <input type="radio"/> | Tick   |
| or 3 EuroSolderBoards                                  | @ £ 2.00 | <input type="radio"/> |        |
| or 1 EuroSolderSucker                                  | @ £ 7.25 | <input type="radio"/> |        |

All prices are applicable from Jan. 1st 1980 and include VAT & PP but add 15% for overseas orders.

Name .....

Company .....

Address .....

Tel. No. ....

Please make cheques/P.O. payable to David George Sales and allow 10 days for cheque clearance and order processing

# Short Circuits Special

One of the most popular features of Hobby Electronics are our short circuits. They are simple-to-build circuits intended for the more experienced constructor not needing to follow step by step instructions. For this reason we have not included any PCB design etc. In the following six pages we have included some of the most interesting short circuits, ever! Why not have a go.

HE

## SIMPLE SW RADIO

This simple SW set tunes from about 5 to 17Mhz, covering the 19, 25, 31, 39 and 49 metre broadcast bands. It can be used with an external aerial and earth (which connect to SK1 and SK2 respectively), but it provides reception of a large number of stations just using a short telescopic aerial. For the sake of simplicity a TRF (tuned radio frequency) type circuit and a ready made coil are used in the set.

VC1 is the tuning control, and this component forms the tuned circuit together with the main winding of T1. Signals from a long wire aerial are coupled to the tuned circuit via a small coupling winding on T1, but if a telescopic aerial is used it is necessary to directly couple it to the tuned circuit in order to obtain a signal of reasonable strength. Signals at the frequency selected by the tuned circuit are fed into the gate of Q1 which is used as a common source RF amplifier/regenerative detector. The process of regeneration merely entails sending some of the output from Q1 drain back to the input of the circuit so that it is amplified for a second time. This is achieved by using a third winding on T1, with C1 providing DC blocking and RV1 controlling the amount of regeneration.

There are several reasons for using regeneration. The obvious advantage of this technique is that it gives increased gain and sensitivity. A less obvious one is that it increases the detection efficiency

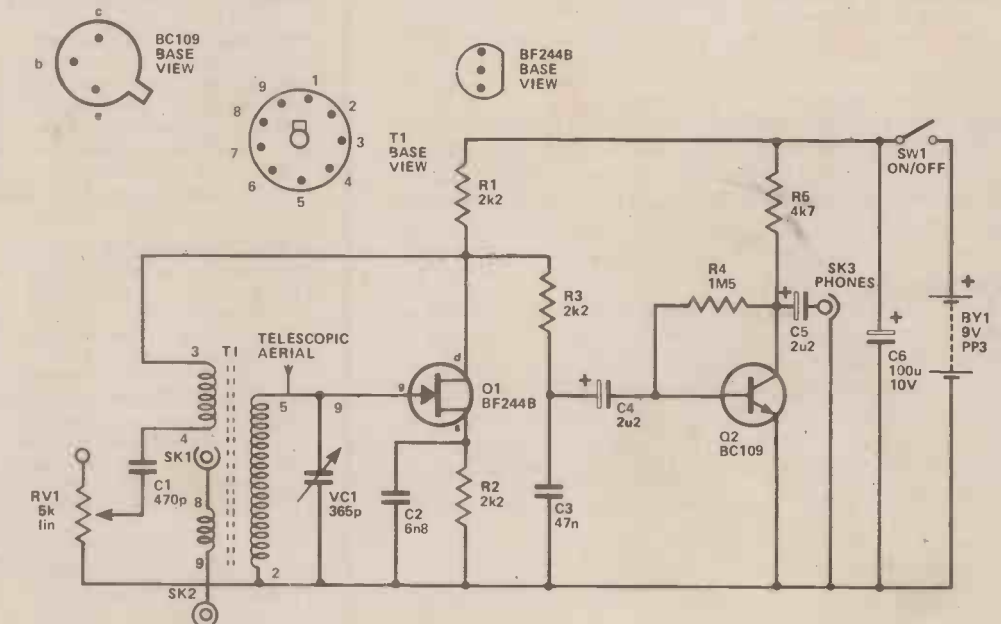

of the circuit. This type of detector relies upon the fact that the amplifier will amplify one set of half cycles more than the other set, giving a crude form of rectification. Thus, by adding an RF filter (R3 and C3) at the output of the amplifier the RF signal is removed to leave the detected AF signal in the conventional manner. Regeneration increases the inequality between the levels of amplification received by the two sets of half cycles, giving improved rectification and detection efficiency. Regeneration also produces improved selectivity, enab-

ling the set to pick out just one station at a time from the crowded SW broadcast bands.

The audio output from the detector is considerably amplified by a common emitter stage based on Q2 before being fed to a crystal earphone or a pair of high impedance headphones. S1 is the on/off switch, and the current consumption of the set is only about 2mA.

Construction should not be difficult, but all the RF wiring should be kept reasonably short and direct. T1 can either be mounted in a B9A valveholder or it can be mounted by the built-in screw-

thread and nut. In use, RV1 should be adjusted to just below the threshold of oscillation whereupon maximum sensitivity and selectivity is obtained. Adjusting RV1 beyond the threshold of oscillation will not give improved results, but will simply cause received stations to be accompanied by an audio tone, making proper reception impossible. (Note that RV1 will need to be readjusted each time the tuning control is altered by more than a few degrees in order to maintain optimum sensitivity and prevent the set breaking into oscillation.



# Short Circuits

## MORSE PRACTICE OSCILLATOR

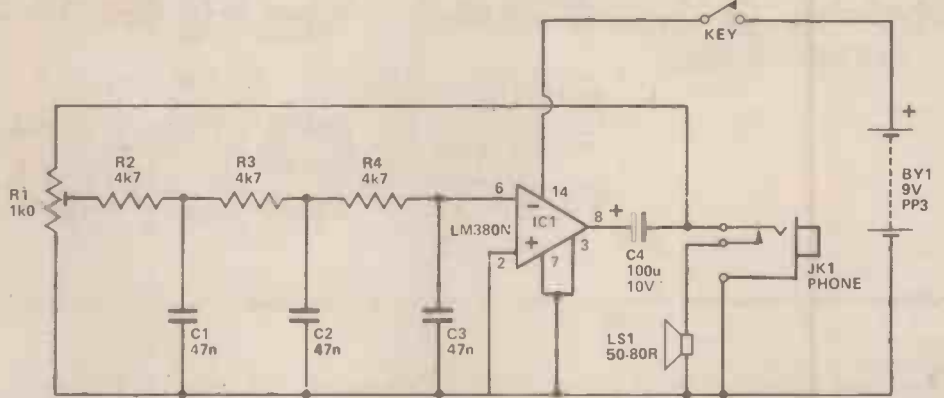

Although not essential, a Morse practice oscillator can be of considerable help when learning the Morse code, particularly if it is employed in conjunction with a cassette or tape recorder so that it can be used for both sending and receiving training. The simple unit described here has provision for an internal loudspeaker, and also has an output for a crystal earpiece, high impedance headphones, or a recorder.

The circuit is based on an audio power amplifier device (IC1) which is used in a phase shift oscillator circuit. Feedback is applied between the output and inverting (—) input of IC1 by way of a three section phase shift

network. The purpose of this network is to invert the signal so that positive feedback is applied to the amplifier, and the required oscillation is produced. The three sections are formed by R2 — C1, R3 — C2, and R4 — C3, each of these sections providing 60 degrees of phase shift at a certain frequency. Thus, at this frequency there is a total phase shift of 180 degrees through the three sections, and the inverting action is obtained. The circuit therefore oscillates at this frequency, which is approximately 1.5kHz with the

specified values.

Ideally a circuit of this type should provide a sinewave output, as a pure tone is easy to listen to for long periods, and is the waveform produced by an actual CW (Morse) transmission when it is resolved by a receiver. This type of circuit will provide a reasonably pure sinewave signal if the gain of the amplifier just slightly more than compensates for losses through the feedback circuit. This is achieved in this case by adjusting R1 to give the appropriate loss level through the feedback path. In practice this

merely backed off close to the point where oscillation ceases due to lack of feedback. Do not be tempted to back off R1 too far, as although this will give a very pure output, the circuit may become unreliable.

The output signal is fed to the loudspeaker via C4 and a break contact on the output socket. The latter automatically cuts off the speaker when a plug is inserted into the socket. The unit provides an output power of about 100 mW RMS, and has a current consumption of approximately 20 mA with the key down.

## DOORBZZER

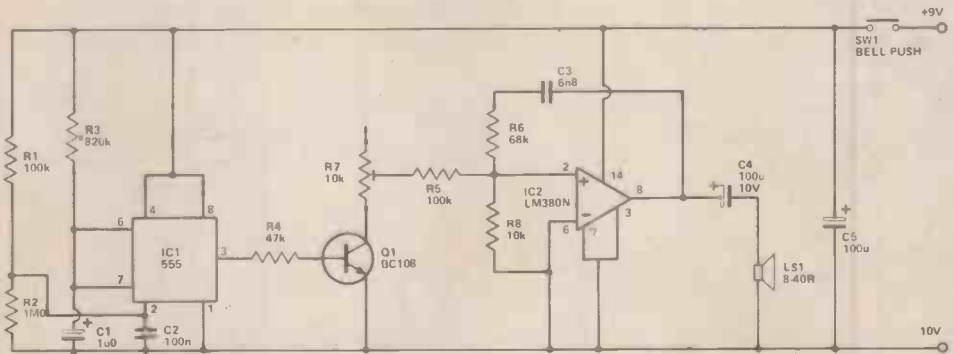

This unit is a two-tone doorbuzzer of the type that produces an initial tone for about one second, followed by a tone of lower pitch. The effect is similar to a conventional two-tone doorbell.

The audio tone is generated by IC2 which is an LM380N audio power amplifier. It is made to oscillate by applying positive feedback between its output and non-inverting input, and the frequency of oscillation is governed by the values of R6, R8, and C3. The specified values give an operating frequency of about 500Hz. The output from IC2 is fed to a loudspeaker via DC blocking capacitor C4, and an output power of nearly 1 watt RMS is obtained using an 8 ohm speaker. This falls to only about

200 mW RMS with a 40 ohm speaker, although this should still provide adequate volume for most situations.

The two-tone effect is obtained by the inclusion of IC1 and its associated components. This is a 555 IC connected in the monostable mode, and it produces a positive output pulse of just under one second in duration (set by R3 and C1) when a negative trigger pulse is applied to its pin 2. Such a pulse is produced at switch on, since C2 will initially be uncharged and will

take pin 2 of IC1 to the negative supply potential. C2 rapidly charges by way of R1 though, so that the trigger input is quickly taken positive, and does not remain negative at the end of the output pulse (this would have the effect of lengthening the output pulse). When power is removed from the circuit, R2 rapidly discharges C2 so that the monostable is triggered when the device is operated again.

Q1 is biased hard into conduction by the output pulse from IC1, and it therefore effectively

connects the series resistance of R5 and R7 in parallel with R8. This increases the operating frequency of the oscillator by an amount that is controlled by R5. At the end of the pulse from IC1, the oscillator operates at its normal, lower frequency, giving the required two-tone effect. R5 is adjusted to give two tones that give a pleasant effect.

The current consumption of the circuit varies from just over 100mA with an 8 ohm speaker down to about 40mA with a 40 ohm type.

# Short Circuits

## METRONOME

There have been a great number of electronic metronome designs published over the last few years, and the majority of these are designed to simulate the sound of a mechanical metronome (Maelzel's metronome). The usual method of achieving this consists of feeding brief pulses to a loudspeaker at the appropriate beat rate, these pulses giving the required "clicking" sounds. One drawback of this system is that a normal miniature loudspeaker can only give rather limited volume from such a signal.

One way of producing a more effective metronome that is not easily masked by the sound of the music, is to feed the speaker with a pulsed tone. The diaphragm of the speaker does not then make a single backward and forward movement, but makes several such movements in rapid succession,

giving a much more noticeable and penetrating sound. The sound produced is somewhat different to that of a conventional metronome, but is nevertheless perfectly acceptable in practice.

The circuit shown here is for a metronome of this type. The audio tone is produced using a 555 astable circuit based on IC2 and its associated components. The timing components (R4, R5, and C3) give a roughly squarewave

output at a frequency of about 1.24kHz. This signal is fed to the loudspeaker via DC blocking capacitor C4.

IC1 is used in another astable circuit which is used to briefly pulse on the tone generator at the required beat rate. The operating frequency of this oscillator can be varied from about 290 pulses per minute with RV1 at minimum resistance, down to about 48 per minute when it is set at maximum

resistance. The timing component values have been chosen to give very brief negative output pulses, and during these Q1 becomes cut off. Normally Q1 holds pin 4 of IC2 at only a fraction of a volt, and prevents the tone generator from oscillating, but this muting is removed when Q1 becomes cut off, and a brief tone burst is fed to the speaker.

The average current consumption of the circuit is about 20 mA.

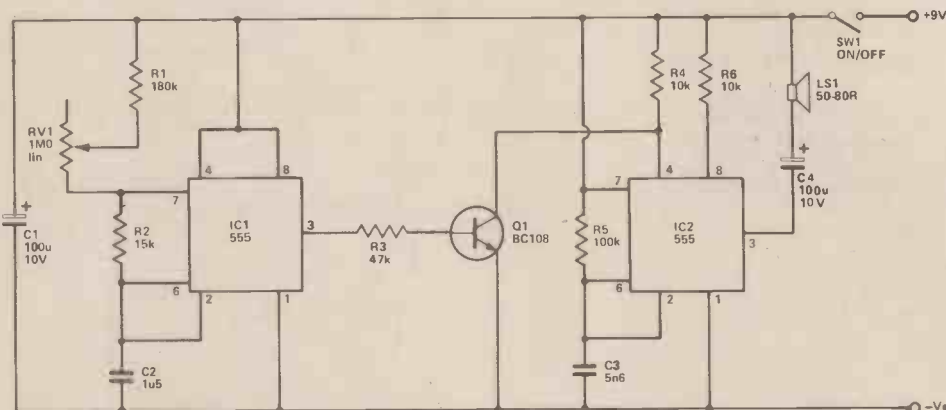

## GENERAL PURPOSE AMPLIFIER

This useful amplifier will provide an output power of up to about 8 watts RMS at low distortion (less than 0.1% THD) into an 8 ohm impedance loudspeaker when using a 28 volt supply. If used with a 4 ohm loudspeaker the output power is increased to about 12 watts RMS or so, with the distortion being roughly doubled (although obviously still quite low). The circuit will operate with lower supply voltages down to less than 9 volts, but the use of a lower supply potential inevitably leads to a reduction in the maximum output power.

The circuit utilises a TDA2030 integrated circuit which is a modern device that is superior in performance and easier to use than most previous devices. It is used in much the same way as an operational amplifier, and like an operational amplifier it has both inverting (—) and non-inverting (E) inputs. In this circuit it is used in the inverting amplifier mode. The non-inverting input is biased to half the supply potential by R2 and R3, and C2 decouples any hum or other noise that would otherwise be coupled by this potential divider from the supply lines into the non-inverting input of IC1. R4 biases the

inverting input of IC1, with a negative feedback action stabilising the output at half the supply voltage under quiescent conditions. This ensures that the circuit can provide the highest possible unclipped peak to peak output voltage swing (and output power). R4 also forms part of the negative feedback loop which sets the gain, and input impedance of the circuit, R1 forming the other half of the network. The voltage gain is approximately equal to R4 divided by R1, or about 30 times (30dB) with the specified values. This

gives the circuit an input sensitivity of about 260 mV RMS for 8 watts into 8 ohms. The value of R1 sets the input impedance of the amplifier at 22k, but volume control RV1 shunts the input to give a minimum input impedance of 11k.

Input and output DC blocking are given by C1 and C4 respectively. C3 and R5 are a Zobel network and aid the stability of the circuit. C5 provides supply decoupling and should be mounted close to IC1.

The circuit layout is not especially critical, and attempts to

induce instability into the prototype actually failed! The signal to noise ratio of the circuit is extremely good, an unweighted figure of approximately — 80dB being obtained from the prototype. IC1 must be mounted on a substantial heatsink which can be the metal case or chassis of the unit. The TDA2030 has both short circuit and thermal overload protection circuitry. The quiescent current consumption is about 40 mA rising to approximately 500 mA with an output of 8 watts into 8 ohms.

TDA2030 TOP VIEW

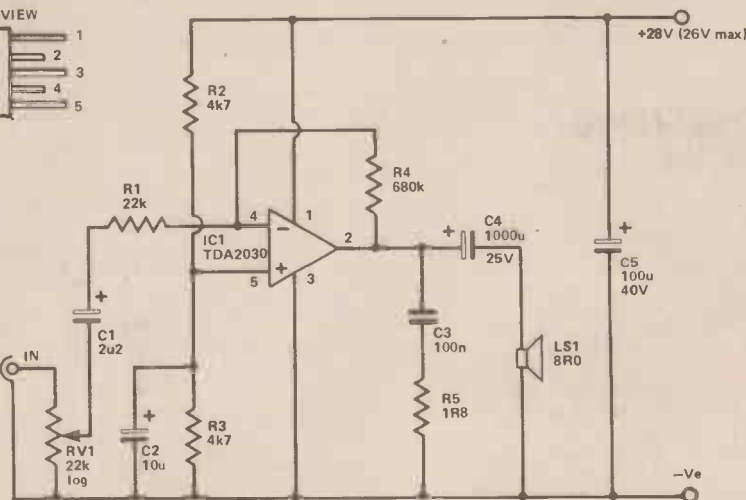

# Short Circuits

## ULTRASONIC TRANSMITTER

In conjunction with the ultrasonic receiver described here, this transmitter forms a simple ultrasonic remote control link. The system is a basic type where a pair of normally open relay contacts at the transmitter close for the duration that a push-button switch at the transmitter is depressed. In common with other ultrasonic links the range of this system is not very great, being up to about 10 metres. It is perfectly suitable for use in a number of applications though, such as remote controlled garage doors, lighting, models, etc. No licence is needed for this type of equipment incidentally.

The transmitter circuit is merely required to produce a 40 kHz signal which is fed to a special transducer that generates the ultrasonic sound waves. The transducer is a Piezoelectric device which has a peak response at the transmitter frequency of 40 kHz. These transducers are normally sold in pairs, one device for use in the transmitter and the other in the receiver. Often the two devices are identical, but some types have one transducer optimised for transmit-

ting and the other optimised for receiving. The manufacturers or retailers literature should make it clear as to which transducer to use in which circuit, where this is applicable.

The oscillator circuit used in this transmitter is based on a LM380N audio power amplifier IC. This is capable of giving a reasonably high peak to peak output vol-

tage swing at 40 kHz, and has a low output impedance so that the loading effect of the transducer does not significantly reduce the output level. The circuit is made to oscillate by applying positive feedback from the output to the non-inverting (+) input using C3. The frequency of operation is controlled by R2, and in practice this can simply be adjusted by trial and

error to a setting that gives satisfactory results with the transmitter and receiver several metres apart. C1 and C2 are supply decoupling capacitors, and C1 should be mounted physically close to IC1. On/off switching is provided by SW1 which is an ordinary push-to-make, non-locking type. The current consumption of the circuit is about 15 mA.

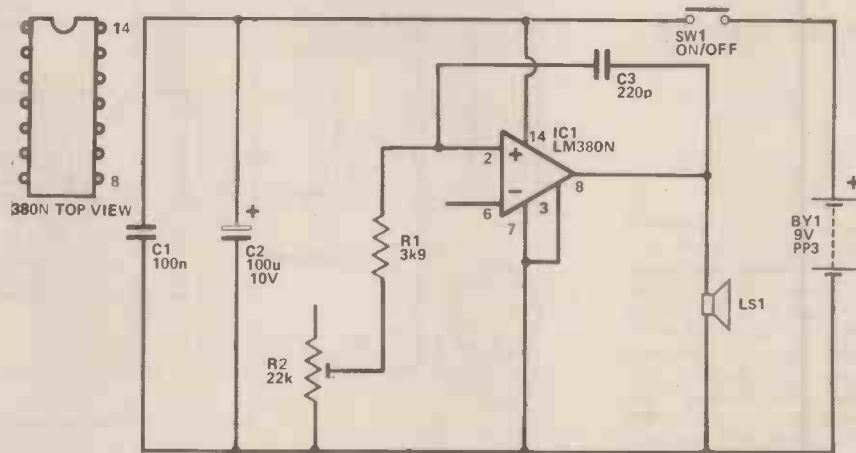

## ULTRASONIC RECEIVER

The receiving transducer only provides a low signal level, the actual output voltage being only a fraction of a millivolt when the equipment is used near the limit of its range. It is therefore necessary to considerably amplify the signal in order to bring it to a high enough level to operate a relay driver circuit. The transducer is very inefficient at ordinary audio frequencies, giving the circuit reasonably good immunity to spurious operation by audio frequency sounds. However, as is the case with most units of this type, tapping the transducer, or very loud high frequency sounds in close proximity to it can cause unwanted operation of the device.

In this circuit the required amplification is obtained using what is virtually a standard two stage, direct coupled, common emitter amplifier. Emitter bypass capacitor C1 has a lower value than would normally be employed in an amplifier of this type because the response of the circuit only needs

to extend down to 40 kHz and does not need to include audio frequencies. In fact it is better that the circuit's response should be rolled off an audio frequency in order to give improved immunity to spurious operation by ordinary sounds.

The amplified signal is fed by C2 to a audio frequency rectifier and smoothing circuit which is comprised of D1, D2 and C3. In the presence of a suitably strong output signal this gives a positive bias

of sufficient strength to bias Q3 hard on, and activate the relay coil which forms its collector load. In the absence of a signal from the transmitter, no bias is produced and the relay remains switched off. Thus the relay can be energised and de-energised by switching the transmitter on and off. D3 is the normal protective diode which suppresses the transient generated across the relay as it switches off.

The relay can be any type having a coil resistance of about

120 ohms or more, an operating voltage of about 6 to 9 volts, and contacts of the correct type and adequate rating for the proposed load. The quiescent current consumption of the unit is only about 2 mA., rising to about 40 mA. when the relay is activated.

Note that ultrasonic waves are highly directional, and except at close ranges it is necessary to aim the transmitting transducer at the receiving one in order to obtain good results.

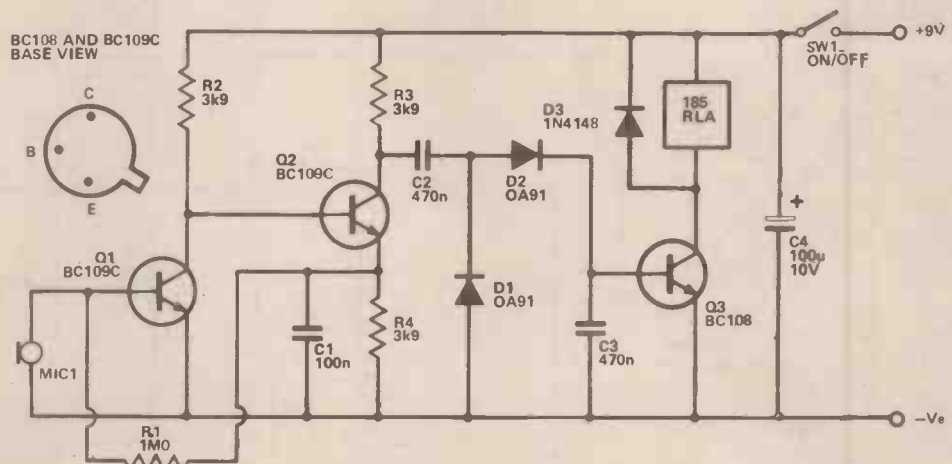

# Short Circuits

## WATER ALARM

This simple water detector circuit can be used in such applications as a rain alarm, cistern overflow alarm, or just to indicate when the water in a bath has reached the required depth.

The circuit really consists of two sections; an electronic switch and an audio alarm generator. Q1 is used as the switch, and under normal conditions it is cut off, supplying no significant current to the alarm generator circuit which forms its collector load. The sensor in Q1's base circuit merely consists of two pieces of metal insulated from one another. However, the sensor is arranged so that when the rain, bath water, or whatever touches the sensor, it bridges the two pieces of metal. Although pure water is a very poor conductor of electricity, the water in practical applications is likely to contain small amounts of impurities which will be sufficient to make the water conduct reasonably well. Thus when water is detected by the sensor, the resistance it exhibits falls to a relatively low level (typically, a few kilohms), biasing Q1 hard into conduction. Virtually

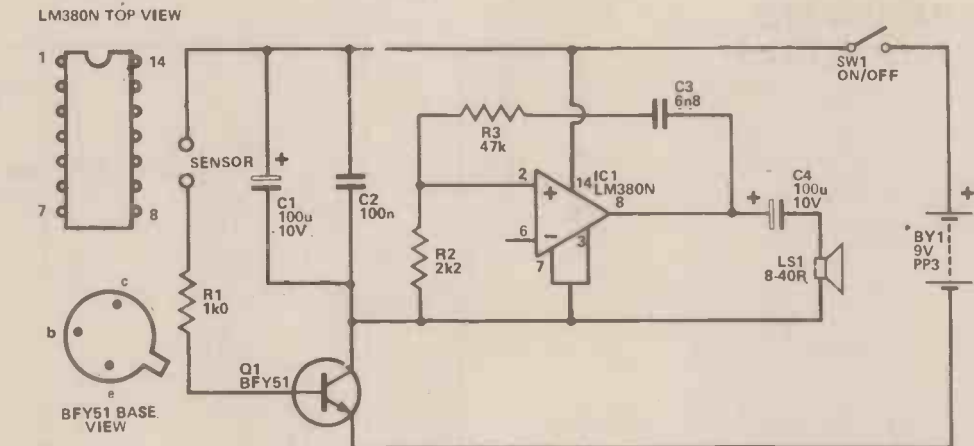

the full supply voltage is then supplied to the alarm circuit, and the alarm sounds. R1 is a current limiting resistor which prevents Q1 from passing an excessive base current if a short circuit or very low impedance should appear across the sensor.

An LM380N audio power amplifier device (IC1) is used to generate the audio alarm signal. It is made to oscillate by using C3,

R3, and R2 to give frequency selective positive feedback between the output and non-inverting (+) input of the device. The circuit oscillates at approximately 600 Hz, and provides an output of a few hundred milliwatts to a miniature loudspeaker. This gives a reasonably loud and penetrating sound.

Under quiescent conditions the circuit consumes less than one microamp, and so even with con-

tinuous use the battery will have virtually its shelf life. With the alarm sounding, the current consumption increases to about 30 to 100 mA. (depending on the speaker impedance). Note that C2 should be mounted physically close to IC1.

A little ingenuity must be used when making the sensor. In most applications a small piece of stripboard will be all that is needed.

## AUTOMATIC FADER

This unit can be used at discos, slide shows, film shows, etc. At the flick of a switch it can be used to automatically fade a signal in or out without introducing any clicks or other background sounds. Normally a unit of this type is used to control background music (providing a simple method of fading it out during a commentary and returning it again afterwards), or some similar application.

In this circuit P channel JFET transistor Q1 is used as a voltage controlled resistance. Its drain to source resistance actually forms a voltage controlled attenuator in conjunction with R1. The input signal is applied to this by way of DC blocking capacitor C2. When power is initially applied to the circuit, C4 will be uncharged and the gate to source voltage of Q1 is therefore zero. This gives Q1 a low drain to source resistance of only about 100 ohms, causing high losses through the relatively high resistance of R1. As the ratio of these two resistances is about 10,000 to 1, the output from the attenuator is only about one 10,000th of the input level (-80dB) and the signal is thus effectively cut off. As C4 begins to charge via R2, Q1 becomes increasingly reverse biased, causing its drain to source resistance to increase. As this

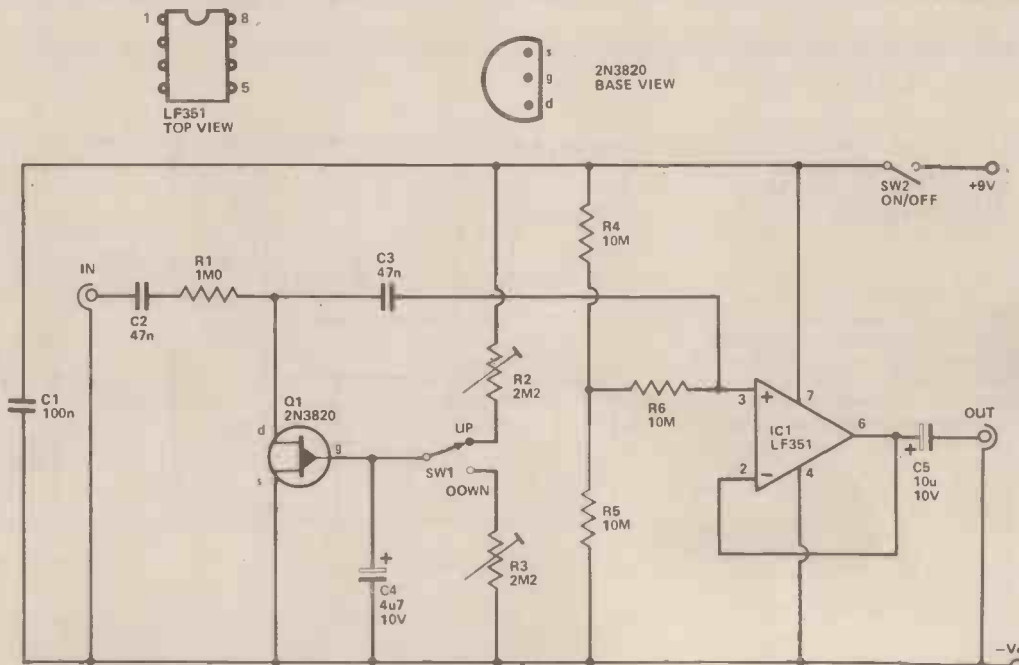

resistance increases, the losses through R1 decrease, causing the signal to "fade" in. Eventually the drain to source resistance of Q1 reaches its maximum value of about 1,000 megohms, which gives no significant losses through R1.

Switching SW1 to the "down" position gradually discharges C4 through R3, returning the bias on Q1 to its original state and fading out the

signal once again. Switching SW1 back to the "up" position returns the reverse bias to Q1, bringing the signal back up to full level once again. IC1 is simply used as a high impedance buffer stage that ensures little loading is placed on the attenuator so that it is permitted to function correctly.

The fade up and fade down times are controlled by the settings of R2

and R3 respectively, and can be adjusted from a fraction of a second to as much as about 8 seconds or so. If the full fade out level of about -80dB is not required, a 1M preset can be inserted between Q1 drain and the junction of R1-C3. The fade out level can then be adjusted from about 6dB to the full 80dB using this component. The current consumption of the unit is only about 2 mA.

# Short Circuits

## CHRISTMAS TREE LIGHTS FLASHER

The usual method of getting the lights on a Christmas tree to flash on and off is to use a bimetal-strip type flashing bulb in the series chain of bulbs. As this switches on and off it breaks the circuit to all the bulbs so that they switch on and off in unison. One drawback of this system is that most flashing bulbs provide a rather irregular flash rate, and another is that it cannot be used to operate two sets of lamps so that when one set switches off, the other switches on.

Both these problems can be overcome by using the simple circuit shown here. It is a low frequency oscillator (about 0.5 Hz) which controls the lights via a relay. Thus the lights are switched on for periods of about one second in duration at intervals of roughly one second in length. By using a changover relay contact it is possible to use two sets of lights with the relay switching the power alternately from one set of lights to the other. If this alternate mode of operation is not required, then one set of lights is simply omitted.

The unit is powered from a simple stabilised mains power

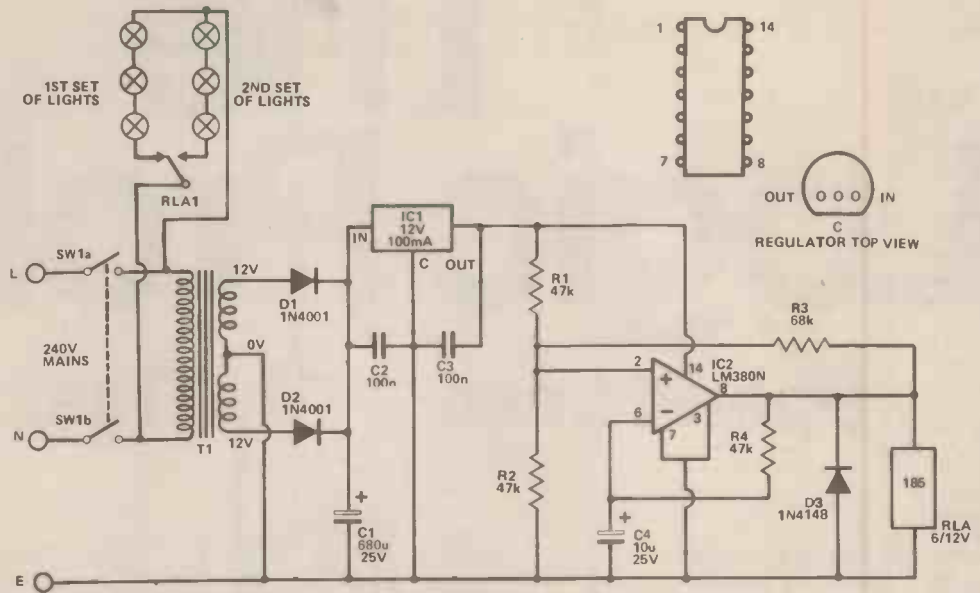

supply having on/off switch S1, stepdown and isolation transformer T1, push-pull rectifier D1 and D2, smoothing capacitor C1, and 12V monolithic regulator chip IC1. C2 and C3 aid the stability and transient response of IC1, and should be mounted physically close to this component.

A well known oscillator configuration is used here, but it is a little

unusual in that it employs an audio power amplifier IC, rather than the more normal operational amplifier device. However, the LM380N audio IC has, like an operational amplifier, both inverting (-) and non-inverting (+) inputs, and can be used in operational amplifier type circuits. In this application it has the advantage of having a power output stage that can

directly drive the relay with the family high current it requires. D3 is used to suppress the high back-EMF which is generated across the relay coil as it de-energises, and which could otherwise destroy IC2.

The switch on and switch off times of the circuit are proportional to the value of C4, and if desired they can be altered by changing the value of this component.

## SIMPLE M.W. RADIO

This simple radio gives many hours of use from a PP3 battery, and will give good volume from a crystal earphone when tuned to all but the weakest of MW transmissions. A TRF circuit is used for the sake of low cost and simplicity, but the level of performance is almost equal to that of a good superheat design.

L1 is the tuned winding of the ferrite aerial, and VC1 is the tuning capacitor. The signal picked-up and selected by the aerial is coupled via low imped-

ance coupling winding L2 to a conventional common emitter amplifier staged based on Q1. Some of the output from Q1's collector is coupled back to the ferrite aerial by R1 and C1. R1 controls the amount of feedback, or regeneration as it is normally known in this application. One purpose of the regeneration is to produce increased amplification, and thus give improved sensitivity. It also improves the ability of the set to select just one of several closely spaced transmissions, or the "selectivity" as this is termed. This is also very important since all the selectivity of the set is provided by a single

tuned circuit, and performance would be very poor in this respect without the use of regeneration.

Most of the output from Q1 is fed to a simple diode detector circuit which uses D1, D2, C4 and R4. This halfwave rectifies the RF signal and smoothes the remaining RF half cycles to leave the audio signal. This is then fed to a low noise audio stage which uses IC1 in the inverting mode. IC1 is a low noise bifet operational amplifier, and its closed loop voltage gain is set by the ratio of R5 to R8 at about 550 times. A crystal earphone is a high impedance device from the output of IC1. The current consumption of

the set is only about 2 mA.

The aerial coil must be positioned on the rod such that the full MW band can be received. This is a matter of trial and error. The coil is then glued or taped in place. R1 is adjusted for the lowest value that does not cause the circuit to oscillate at any setting of VC1 (oscillation causes a tone to accompany received station). If regeneration cannot be obtained, reverse the connections to L2. Keep the wiring to the "hot" ends of VC1 and L1 well away from the wiring to Q1 collector or controllable regeneration may result.

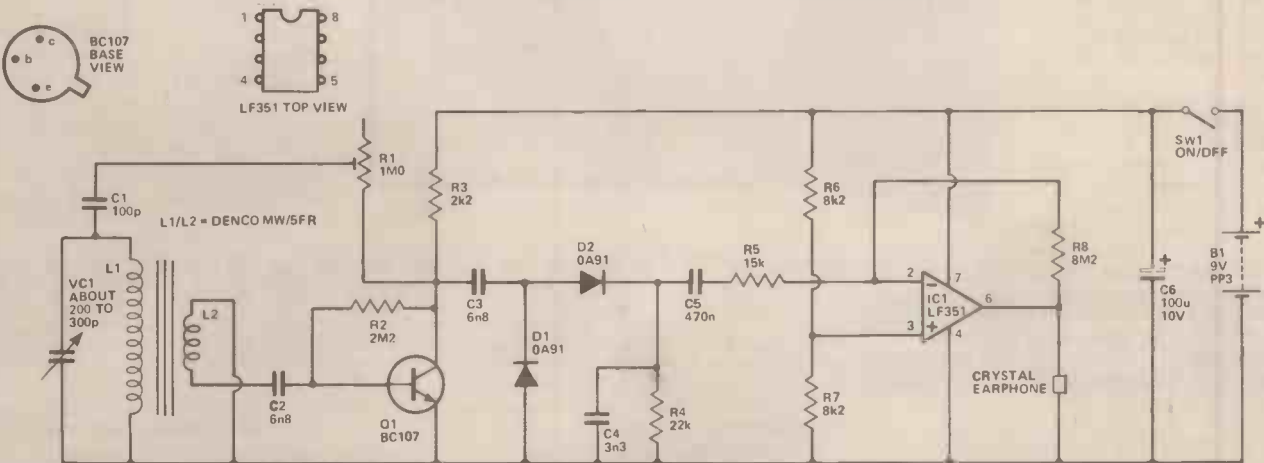

# The Logic Probes

## Spend Less

## Test More



### LP-1 Logic Probe

The LP-1 has a minimum detachable pulse width of 50 nanoseconds and maximum input frequency of 10MHz. This 100 K ohm probe is an inexpensive workhorse for any shop, lab or field service tool kit. It detects high-speed pulse trains or one-shot events and stores pulse or level transitions, replacing separate level detectors, pulse stretchers and pulse memory devices.

All for less than the price of a DVM

**£31.00\***



### LP-2 Logic Probe

The LP-2 performs the same basic functions as the LP-1, but, for slower-speed circuits and without pulse memory capability. Handling a minimum pulse width of 300 nanoseconds, this 300 K ohm probe is the economical way to test circuits up to 1.5 MHz. It detects pulse trains or single-shot events in TTL, DTL, HTL and CMOS circuits,

replacing separate pulse detectors, pulse stretchers and mode state analysers.

(Available in kit form LPK-1 £11-92)

**£18.00\***

*The logic probes shown are all suitable for TTL, DTL, HTL and CMOS circuits.*

*\*price excluding P.&P. and 15% VAT*

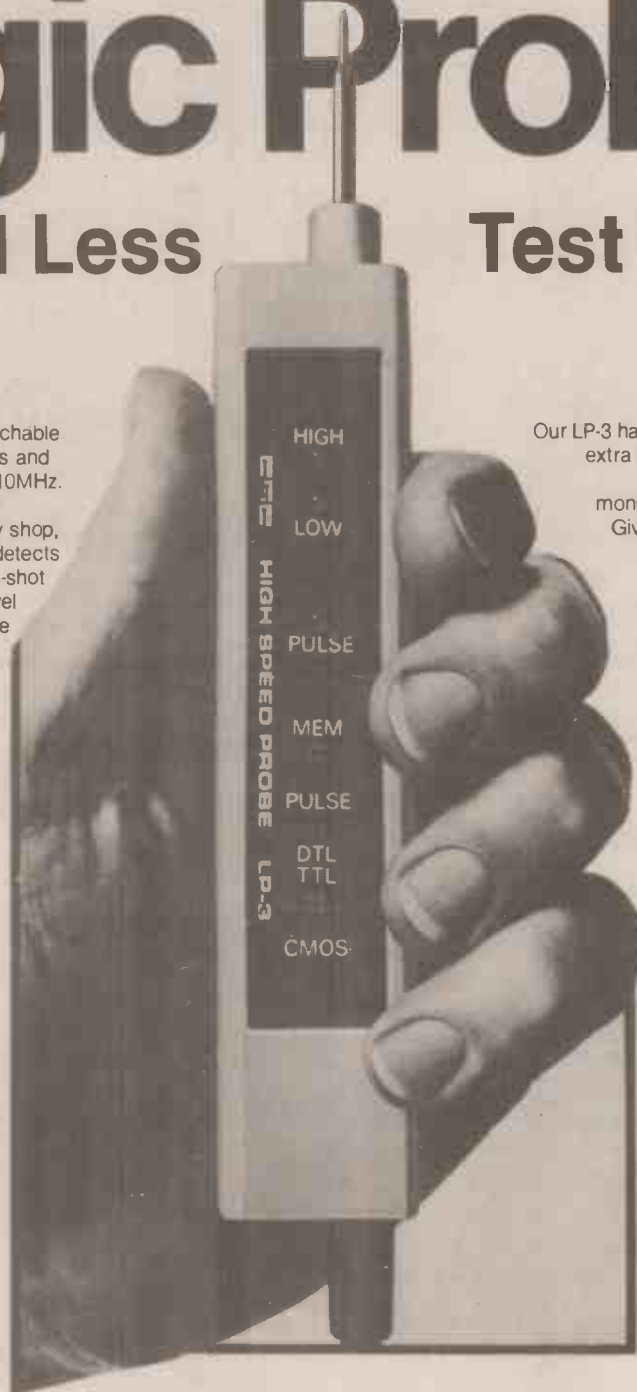

### LP-3 Logic Probe

Our LP-3 has all the features of the LP-1 plus extra high speed. It captures pulses as narrow as 10 nanoseconds, and monitors pulse trains to over 50 MHz. Giving you the essential capabilities of a high-quality memory scope at 1/1000th the cost.

LP-3 captures one shot or low-rep-events all-but-impossible to detect any other way.

All without the weight, bulk, inconvenience and power consumption of conventional methods.

**£49.00\***



### The New Pulser DP-1

The Digital Pulser: another new idea from C.S.C. The DP-1 registers the polarity of any pin, pad or component and then, when you touch the 'PULSE' button, delivers a single no-bounce pulse to swing the logic state the other way. Or if you hold the button down for more than a second, the DP-1 shoots out pulse after pulse at 1000 Hz.

The single LED blinks for each single pulse, or glows during a pulse train. If your circuit is a very fast one, you can open the clock line and take it through its function step by step, at single pulse rate or at 100 per second. Clever! And at a very reasonable price.

**£51.00\***



CONTINENTAL SPECIALTIES CORPORATION



C.S.C. (UK) Limited,  
Dept. 14J, Shire Hill Industrial Estate, Unit 1,  
Saffron Walden, Essex CB11 3AQ.  
Telephone: Saffron Walden (0799) 21682  
Telex: 817477

C.S.C. (UK) Ltd., Dept.14J, Shire Hill Industrial Estate, Unit 1, Saffron Walden Essex CB11 3AQ  
Prices include P.&P. and 15% VAT

|      |        |     |      |        |     |      |        |     |      |        |     |       |        |     |
|------|--------|-----|------|--------|-----|------|--------|-----|------|--------|-----|-------|--------|-----|
| LP-1 | £37.38 | Qty | LP-2 | £22.14 | Qty | LP-3 | £58.08 | Qty | DP-1 | £60.38 | Qty | LPK-1 | £14.86 | Qty |
|------|--------|-----|------|--------|-----|------|--------|-----|------|--------|-----|-------|--------|-----|

Name \_\_\_\_\_ Address \_\_\_\_\_

I enclose Cheque/P.O. for £ \_\_\_\_\_ or debit my Barclaycard/Access/  
American Express card no. \_\_\_\_\_ exp. date \_\_\_\_\_

**FOR IMMEDIATE ACTION** — The C.S.C. 24 hour, 5 day a week service.  
Telephone (0799) 21682 and give us your Barclaycard, Access, American Express  
number and your order will be in the post immediately.

for FREE  
catalogue  
tick box



# Breadboard Show Report



***Judging by all the press coverage, it was aptly named a HOBBY ELECTRONICS show. HEBOT was there too; the star of the show!***

AROUND THE BEGINNING OF DECEMBER, the 4th to 8th to be precise, the London Breadboard Show 'happened' at the Royal Horticultural Hall.

The Modmags stand (us, ETI, HE and CT) was probably the largest and almost certainly the most populated, both sides of the counter.

So, enough trumpet-blowing, the show is the largest amateur electronics event of the year. Most of the companies involved in this field were there and by all accounts it was a runaway success.

On these three pages we have tried to show some of the main highlights of the show, topped of course by the amazing HEBOT.

See you all next year for an even bigger show. Don't forget the Electronics Bazaar at Alexander Palace in June, we'll be there too.

***Above. There was plenty to see and lots of goodies to try! All these people are rushing to see the HEBOT demonstration.***

***Left. HOBBY ELECTRONICS shared the stand with its sister publications ETI and Computing Today. The PET computer was as popular as ever with the visitors.***



**Left: Richard Becker of Powertran demonstrates the String Ensemble.**

*The musical machine's designer Tim Orr was on hand from time to time to reset the controls. These synth's are getting so complicated you'll soon need a licence to drive one! There were plenty of other sound machines on show and it all added to the sonic sensations.*



**Above right: Geoff Chapman of REMCON demonstrates the HEBOT to an enthralled audience. There were daily performances on the hour!**

*There were three HEBOTS on display, alas there would have been many more but for the orders for chassis that had to be met. On certain days it was literally impossible to get to the stand, spectators were often three deep!*



**Right: How does it do it? HEBOT confuses the crowd as it follows a wire loop around the display stand. By the way. The photo-transistors and ICs used in HEBOT may be obtained from Technomatic. See their Ad. in ETI.**

*The demonstration table used only a single wire. The sensors were sensitive enough to be buried at least one inch below the surface. The top for this particular HEBOT was enhanced by using Prisma-Tape, giving a multi-colour effect under the spotlights.*





# Show Report



*Left: Thanks to Joy Cheshire and JVC for the loan of their equipment.*

*Whenever Joy used the camera quite a large crowd seemed to materialise from nowhere, could it be they all wanted to see themselves on TV?*

*Below: The ETI 'Pinball Wizard' was a great attraction on the stand. 'Breakout' is the name of the game.*



*Above: Halvor Moorshead (HE's editor) explaining the ETI Transcendent Synthesiser.*



*Left: The videotape equipment showing a short film of the HE offices.*



*Below: Mr Corbett, one of our most valued readers, he is always first to tell us of any errors that occur now and again.*



## DIGITAL VOLTMETER/ THERMOMETER KIT



Based on the ICL7106. This kit contains a PCB resistor, presets, capacitors, diodes, IC and 0.5" liquid crystal display. Components are also included to enable the basic DV kit to be modified to a Digital Thermometer, using a single diode as the sensor. Requires a 3mA 9V supply (PP3 battery) **£20.75**

## 24 HOUR CLOCK/ APPLIANCE TIMER KIT



Switches any appliance up to 1kW on and off at preset times once per day. Kit contains AY-5-1230 IC, 0.5" LED display, mains supply, display drivers, switches, LEDs, triac, PCBs & full instructions. **CT1000K Basic Kit £14.90**  
**CT1000KB with white box (56 x 131 x 71mm) £17.40**  
**Ready Built £22.50**

## TRIACS

400V Plastic Case (Texas)

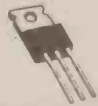

|                 |     |     |      |
|-----------------|-----|-----|------|
| 3A              | 49p | 16A | 90p  |
| 8A              | 58p | 20A | 165p |
| 12A             | 70p | 25A | 190p |
| 6A with trigger |     |     | 80p  |
| 8A isolated tab |     |     | 82p  |
| Diac            |     |     | 18p  |

## OPTO



| LEDS        |     | Square LED |                     |
|-------------|-----|------------|---------------------|
| 0.1" Red    | 9p  | Red.       | Size: 5 x 2.5 x 9mm |
| 0.2" Red    | 9p  |            | high                |
| 0.2" Green  | 12p |            | 20p                 |
| 0.2" Yellow | 12p |            |                     |

|  |       |
|--|-------|
| DL727 0.5" 2-digit CA                                  | £1.50 |
| DL304 (pin compatible with DL704)                      |       |
| 0.3" CC Red  | 7p    |
| DL847/DL850 (pin compatible with DL747/750) 0.8" CA/CC | £1.80 |

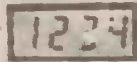

Liquid Crystal Display 0.5" 3/2 digit **£7.50**  
**SPECIAL IL74 Opto Isolator 45p**

## LIGHTING CONTROL KITS

Directly replace conventional light switches and control up to 300W of lighting. No mains rewiring. Insulated touchplates. Easy to follow instructions.  
**TD300K TOUCHDIMMER.** Single touchplate with alternate action. Brief touch switches lamp on and off, longer touch dims or brightens lamp. Neon lamp helps find the switch in the dark **£6.50**  
**TDE/K Extension kit for TD300K for 2-way switching etc. £1.50**  
**TSD300K — TOUCHSWITCH & DIMMER.** Single touchplate, small knob controls brightness **£5.50**  
**TSA300K — AUTOMATIC.** Single touchplate. Time delay variable 2 secs to 3 1/2 mins. **£4.30**  
**LD300K — LIGHTDIMMER KIT £2.90**

## BOXES



Moulded in high impact ABS. Supplied with lids and screws. Black or white.  
B2 95x71x35mm **65p**  
B3 115x95x37mm **70p**

## RESISTORS

1/4W 22 ohm-10M E12 Series  
Pack of 10 (1 value) **10p**  
10 Packs (10 values) **80p**



## INTEGRATED CIRCUITS

|   |       |
|---|-------|
| 555 Timer                                       | 21p   |
| 741 Op. Amp                                     | 18p   |
| AY-5-1224 Clock                                 | £2.60 |
| AY-5-1230/2 Clock/Timer                         | £4.20 |
| AY-3-1270 Thermometer                           | £8.20 |
| ICL7106 DVM (LCD drive)                         | £7.00 |
| LM377 Dual 2W Amp                               | £1.45 |
| LM379S Dual 6W Amp                              | £3.50 |
| LM380 2W Audio Amp                              | 80p   |
| LM382 Dual low noise pre-amp                    | £1.00 |
| LM386 250mW low voltage amp                     | 75p   |
| LM1830 Fluid Level Detector                     | £1.50 |
| LM2907 f-v Converter                            | £1.40 |
| LM3909 LED Flasher/Oscillator                   | 55p   |
| LM3911 Thermometer                              | £1.20 |
| LM3914 Dot/Bar Driver                           | £2.10 |
| MM57160 (stack) Timer                           | £5.90 |
| MM74C911 4-digit display controller             | £6.50 |
| MM74C915 7-segment-BCD converter                | 96p   |
| MM74C926 4-digit counter with 7-segment outputs | £4.50 |
| S5668 Touchdimmer                               | £2.50 |
| S9263 Touchswitch 16-way                        | £4.85 |
| TBA800 5W Audio Amp                             | 58p   |
| TBA810AS 7W Audio Amp                           | 85p   |
| TDA1024 Zero Voltage Switch                     | £1.00 |
| TDA2020 20W Audio Amp                           | £2.85 |
| ZN1034E Timer                                   | £1.80 |

All ICs supplied with data and circuits. Data sheets only 5p.

ALL COMPONENTS ARE BRAND NEW AND TO SPECIFICATION. ADD VAT AT CURRENT RATE TO ABOVE PRICES PLUS 30p P&P. MAIL ORDER — CALLERS WELCOME BY APPOINTMENT.

# TK Electronics

(H.E.), 106 STUDLEY GRANGE ROAD  
LONDON W7 2LX. TEL. 01-579 9794



# Card Frames



Our 19" Card frame will house your projects in a 'professional' manner. It is designed to take Eurocards or Modules and offers facilities for interconnection through 2-part DIN 41612 or direct edge connectors.

A full range of compatible items are available — all selected from the established range of industrial products — boards, accessories, cases etc. Just send 40p. and we'll send you our catalogue by return — it's got the lot!

VERO ELECTRONICS LTD RETAIL DEPT.  
Industrial Estate, Chandler's Ford,  
Hampshire SO5 3ZR  
Tel: (04215) 62829



# Infra Red Remote Control

***A state-of-the-art project that lets you turn any electrically powered device on and off via a remote control transmitter. The device uses an infra-red data link and has a useful range of around 30 feet.***

THIS REMOTE-CONTROL PROJECT can be used to turn any electrically powered device, such as a radio, TV, heater, etc., on and off from ranges up to 30 feet, provided that the remote device is in the line-of-sight of the operator. The project uses an infra-red remote control 'link' and, unlike most other types of remote control system, does not need an operating license, has no trailing wires to trip the unwary, is not susceptible to acoustic interference and does not generate radio or TV interference.

The control system consists of two separate units, a hand-held infra-red transmitter and a remotely-located mains powered infra-red receiver unit with a bistable relay output. The relay output terminals are used as a 'switch' that makes or breaks the power feed to the device (radio, TV, etc) that is being controlled. The transmitter unit contains only one control, a press-button

switch, which connects battery power to the circuit which causes a coded high-efficiency infra-red beam to be generated. This invisible beam is aimed at the receiver and causes its output relay to change state, thereby giving an alternate ON-OFF-ON relay switching action via the transmitter.

We've taken a lot of trouble with this project to ensure that the system has both good range and high reliability, ie, high sensitivity but excellent rejection of spurious and unwanted electrical and optical signals. This has resulted in fairly complex circuitry in both the transmitter and the receiver. Consequently, the project is not suitable for the absolute beginner, but can be tackled with reasonable confidence by the novice with a moderate amount of constructional experience. The complete system uses only two pre-set controls, and can be set up without the use of test gear.



*Just a few suggestions. Applications are limited only by imagination!*

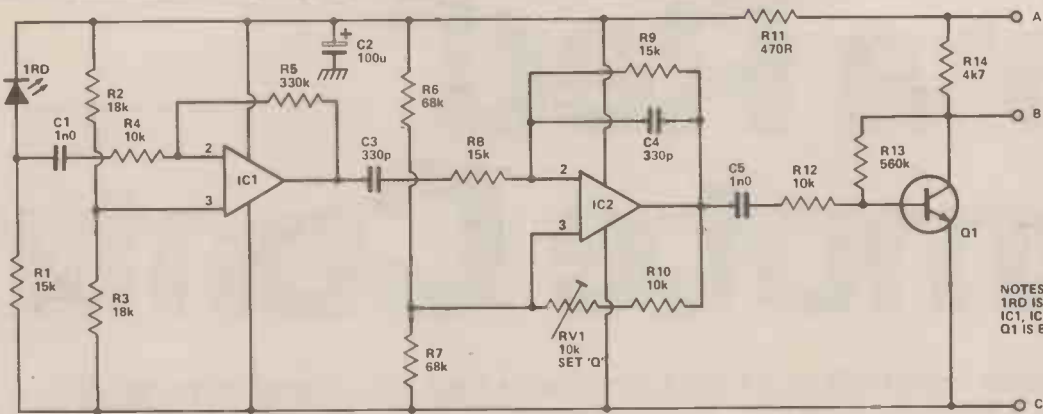

Fig. 1. Circuit diagram of the IR receiver section.

NOTES:  
1RD IS SFM 205  
IC1, IC2 ARE CA3140  
Q1 IS BC182L

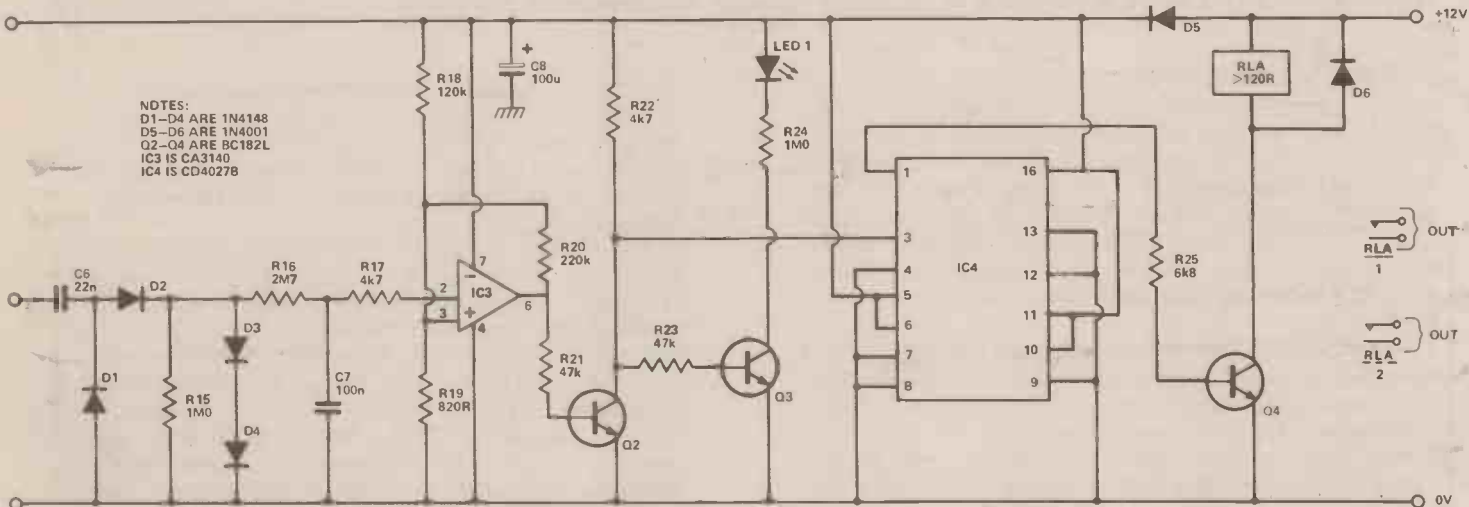

Fig. 2. Circuit diagram of the receiver decoder and relay driver.

NOTES:  
D1-D4 ARE 1N4148  
D5-D6 ARE 1N4001  
Q2-Q4 ARE BC182L  
IC3 IS CA3140  
IC4 IS CD4027B

## How it Works

### THE RECEIVER

The receiver circuit can be broken down into three distinct sections, a high-gain non-inductive selective pre-amplifier, a signal detector and a bistable relay driver. The coded infra-red signal beam is initially picked up by a detector diode 1RD and appears as a very small signal voltage across R1. The high frequency (greater than several kHz) components of this signal are passed through the IC1 x33 voltage amplifier and then fed to IC2.

IC2 is a Wien selective amplifier that is fixed-tuned (via C3-R8 and C4-R9) to approximately 25-30 kHz. The transmitter circuit is also tuned to this frequency, so IC2 enables the receiver to discriminate between wanted and unwanted signals. The 'Q' or tuning sharpness of the circuit is adjustable via RV1: R6 and R7 form part of the Q-adjustment circuitry and must have the values shown. Note that, unlike most inductivity-tuned selective amplifiers, this circuit is not susceptible to interference from radiated electrical signals. The output signals from IC2 are passed on to Q1, where they are further amplified and made available at terminal 'B' of the pre-amplifier.

The output signals from the 'B' terminal of the pre-amplifier are rectified by D1-D2 and amplitude-limited by D3-D4. The resulting DC

voltage is passed on, via integrating network R16-C7, to the input of regenerative voltage comparator IC3, which switches low when its input signal exceeds a hundred millivolts or so. Because of the integrating action of R16-C7, however, the input of IC3 goes adequately high only when the 'B' output of the pre-amplifier is continuously present for a period in excess of 200 mS or so, thereby ensuring that the circuit rejects spurious or transient signals.

As the output of IC3 switches low it turns Q2 off and causes Q2 collector to switch high. As the collector switches high it drives Q3 and LED 1 on (thus giving a visual indication of the switching action) and simultaneously feeds a single 'clock' pulse (a rising edge) to bistable IC4, which then changes state and in turn changes the state of the relay via Q4. Thus, the relay switches from the OFF to the ON state, or vice versa, each time a coded transmission signal is received, provided that the transmission signal is of adequate strength and has a duration greater than 200 mS or so.

The complete receiver circuit is powered from a 12 volt supply derived from the mains via a simple power pack. The circuit draws 100 mA or less when the relay is on. The relay contacts are used to make or break the mains connections to external devices such as radios, TVs, etc.

Fig. 3. Circuit diagram for the HE Infra Red control transmitter.

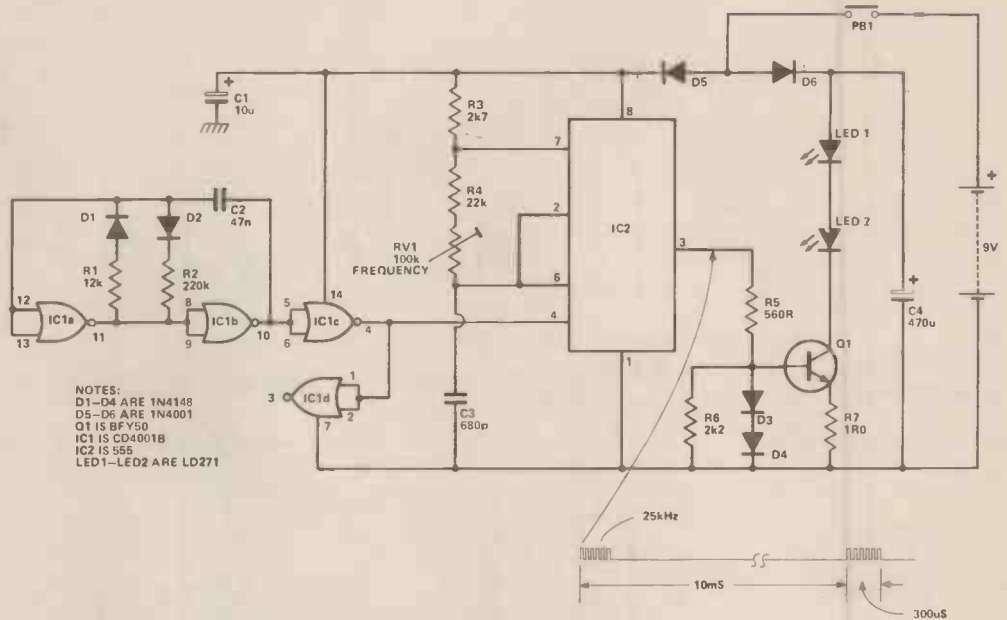

## How it Works

### THE TRANSMITTER

An invisible infra-red beam can be generated by passing a current through a suitable infra-red light emitting diode (IR LED). The strength of the beam is proportional to the magnitude of the energising current and to the number of LEDs used. To produce a beam adequate to cover our specified 30 foot range it is necessary to pass *peak* currents of about 500 mA through two series-connected LEDs, as shown in our transmitter circuit.

An important point to note here is that it is possible to produce these high *peak* currents while drawing only a low *mean* current from the supply battery. In our circuit we achieve this by rapidly pulsing the IR LED currents on and off at a 25 kHz rate for a brief 300 uS period once in every 10 mS, thereby giving a total *on* time of only 150 mS in every 10 mS period. This technique has two useful effects. First, it reduces the *mean* current consumption of the IR LEDs to  $500 \text{ mA} \times (150\mu\text{S} / 10 \text{ 000}\mu\text{S}) = 7.5\text{mA}$  while still giving the required 500 MA *peak* current. Second, it enables the infra-red beam to be frequency coded, so that the

receiver can distinguish it from other (unwanted) sources of infra-red radiation.

The transmitter circuit comprises two distinct sections, with IC1 and IC2 acting as a waveform generator and Q1 and its associated components acting as a high-current IR LED driver. When PB1 is closed, the battery supply is independently connected to the waveform generator circuit via D5-C1 and to the IR LED driver circuit via D6-C4: this form of connection prevents undesirable interaction between the two circuit sections.

In the waveform generator section, IC1a to IC1c are wired as a buffered-output non-symmetrical astable multivibrator that produces ON and OFF times of 300 uS and 10 mS respectively. IC1d is unused. The output of IC1 is used to gate IC2, which is wired as a 25 kHz (nominal) astable: the frequency of this astable is variable over a limited range via RV1. The circuit diagram shows the waveform that is produced at the output of IC2. This waveform is used to drive constant-current generator Q1 via the R5-R6-D3-D4-R7 network. The IR LEDs (LED 1 and LED 2) are wired in series with the collector of Q1 and derive their high peak currents from storage capacitor C4.

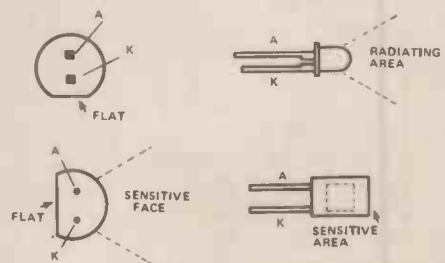
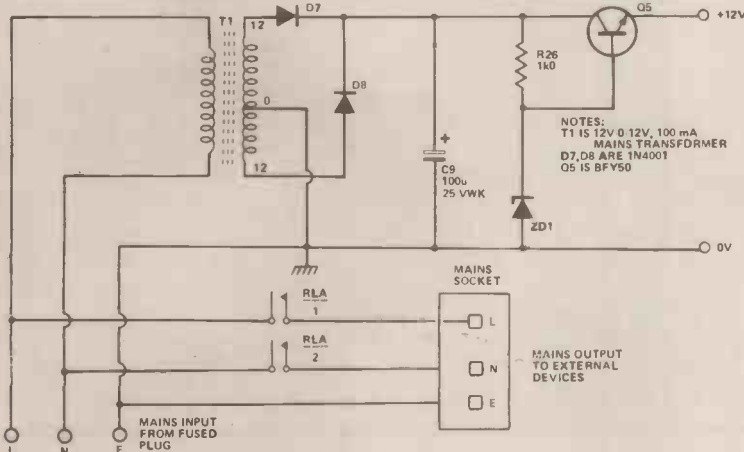

Fig. 4. Connection diagram for the PSU and relay switching circuitry.

# Parts List

## HE IR Remote Control Switch...

- RESISTORS (all 1/4W 5%)  
 R1 12k  
 R2 220k  
 R3 2k7  
 R4 22k  
 R5 560R  
 R6 2k2  
 R7 1R0

## POTENTIOMETERS

- RV1 100k sub-min preset, horizontal mounting

## CAPACITORS:

- C1 10u 35 V tantalum  
 C2 47n polycarbonate  
 C3 680p polystyrene  
 C4 470u 10 V electrolytic

## SEMICONDUCTORS:

- IC1 4001B  
 IC2 555  
 Q1 BFY50  
 D1-D4 IN4148  
 D5, D6 IN4001  
 LED 1, LED 2 LD271

## MISCELLANEOUS

- PB1, push button (momentary action)  
 PP3, Battery  
 Vero flip top case, order No 202-21317D

## Receiver Pre-amplifier

- RESISTORS (all 1/4W 5%)  
 R1, 8, 9 15k  
 R2, 3 18k  
 R4, 10, 12 10k  
 R5 330k  
 R6, 7 68k  
 R11 470R  
 R13 560k  
 R14 4k7
- POTENTIOMETERS  
 RV1 10k Sub min. horizontal preset

## CAPACITORS

- C1, 5 1n0 polystyrene  
 C2 100u 25 V PCB type electrolytic  
 C3, 4 330p Polystyrene

## SEMICONDUCTORS

- IC1, IC2 CA3140  
 Q1, 1R BC182L  
 1RD SFH205

## MISCELLANEOUS

- 1, 3 way Wafercon Plug  
 1, 3 way Wafercon Socket

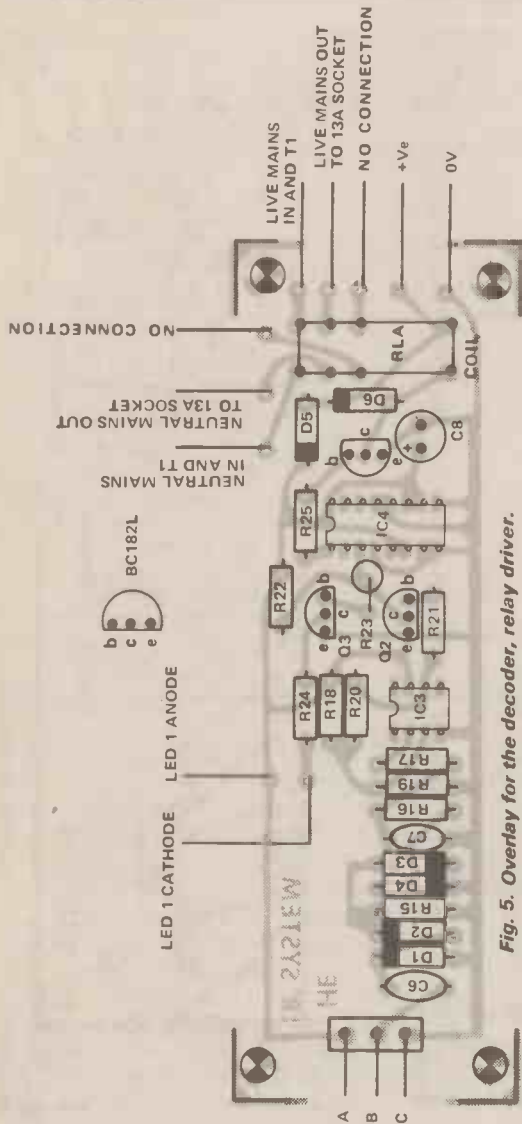

Fig. 5. Overlay for the decoder, relay driver.

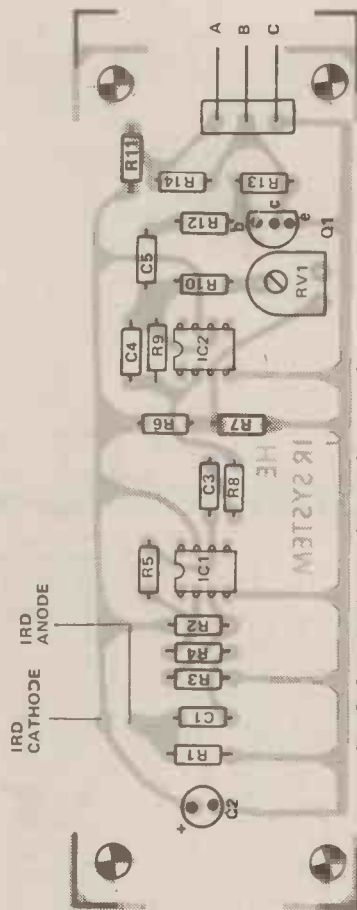

Fig. 6. Overlay for the IR receiver section.

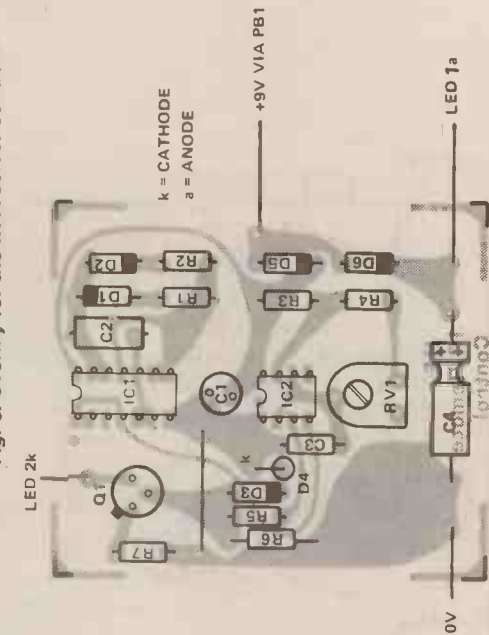

Fig. 7. Overlay diagram for the IR transmitter.

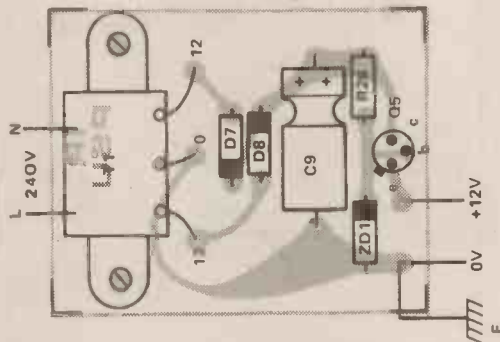

Fig. 8. PCB foil pattern for the receiver PSU.

## Detector and Bi-stable Relay Driver

### RESISTORS

R15 1MΩ  
 R16 2M7  
 R17, 22 4k7  
 R18 120k  
 R19 820R  
 R20 220k  
 R21, 23 47k  
 R24 1k0  
 R25 6k8

### CAPACITORS

C6 22n polyester Mullard C280  
 C7 100n polyester Mullard C280  
 C8 100u 25 V pCB type electrolytic

### SEMICONDUCTORS

IC3 CA3140  
 IC4 CD4027B  
 Q1, 4 BC182L  
 DI-D4 IN4148  
 D5-D6 IN4001

### MISCELLANEOUS

1, 3 way Watercon plug  
 1, 3 way Watercon socket  
 Relay 12 V coil greater than 120R DPCO PCB type  
 Case Norman type

### Power Supply

RESISTOR  
 R26 1k0

### CAPACITOR

C9 100u 25 V axial electrolytic

### SEMICONDUCTORS

Q5 BFY50  
 D7-D8 IN4001  
 ZD1 BZY88 12 V 400 mW

### MISCELLANEOUS

T1, 12-0-12 @ 100mA

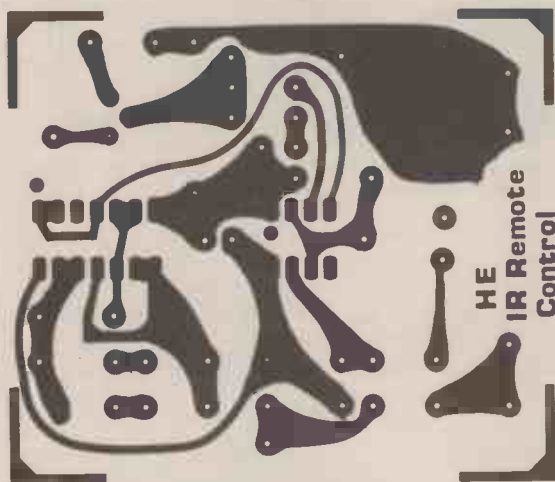

Fig. 9. PCB for the IR transmitter.

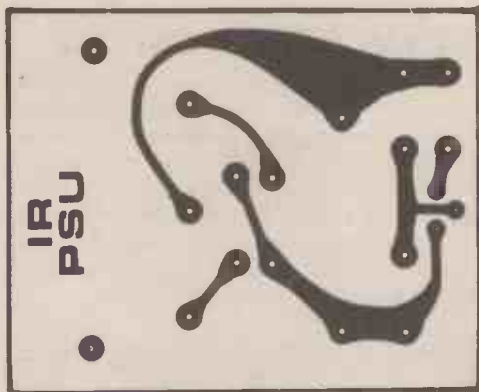

Fig. 10. Overlay for the receiver PSU.

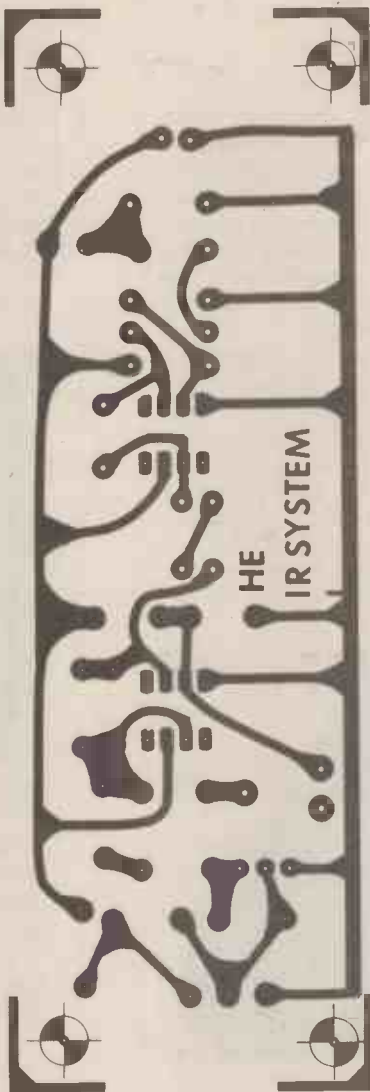

Fig. 11. PCB foil pattern for the receiver front-end.

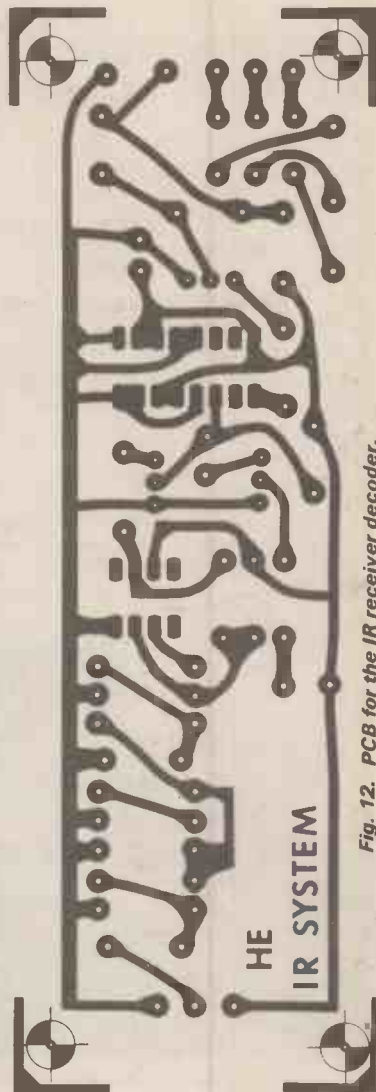

Fig. 12. PCB for the IR receiver decoder.

## Buylines

The LD271, SFH205 along with the relay (order as RL6 12V DPCO) can be obtained from Watford Electronics. The Watercon plugs and sockets are available from Maplin Electronic Supplies, all other components used in the infra red system should be readily available from major mail order companies that advertise in this issue.

## CONSTRUCTION: THE TRANSMITTER

All components except the two infra-red LEDs and PB1 and the battery are mounted on a single PCB. Take special care to observe the polarities of all semiconductor devices and the electrolytic capacitors when assembling the components on the PCB. The two ICs should be mounted in low-level holders and all components should be mounted close to the board. Use Veropins for making the four external connections to the board.

When construction of the PCB is complete, drill two  $\frac{1}{4}$  inch holes in the hinge-end of the flip-top Vero case, with each hole roughly  $\frac{3}{8}$  inch from a corner of the case. Now fit the two IR LEDs into place in the holes using standard 0.2 inch LED mounting clips and connect the cathode of LED 1 to the anode of LED 2. Fit the PCB and the battery into the case, after carefully double-checking all PCB connections, using sticky fixers. Complete the two connections to the IR LED's and the connections to the battery and the PB1 push-button switch.

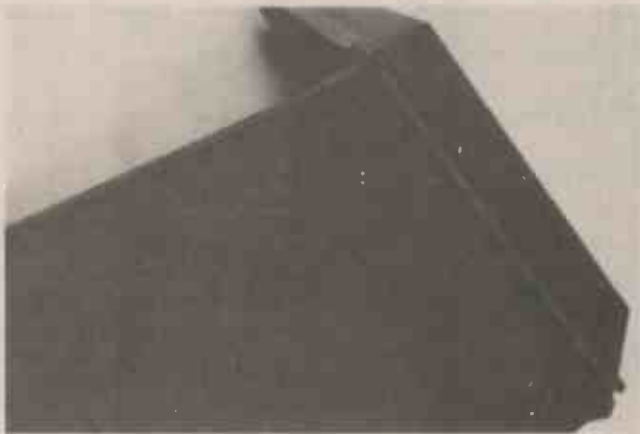

Mounting details of the transmitter LEDs.

On our prototype, PB1 is a low-profile PCB-mounting keyboard switch and is fixed to the Verocase front panel with impact adhesive after first drilling two switch-contact clearance holes in the panel. Take care when positioning this switch to ensure that it is not inadvertently activated by closure of the flip-top of the case; alternatively, cut a switch-clearance hole in the flip-top. Do not finally fix the front panel into place until the receiver circuit has been built and the complete system has been adjusted for maximum sensitivity.



The transmitter. The panel has been removed to show the electronics.

## CONSTRUCTION: THE RECEIVER

The receiver unit is built up on three separate PCBs, all fitted into an 8" x 5" x 2" case. Start construction by building the small power supply board, taking care to fit all components in the polarity shown. When construction is complete, double-check all wiring and then temporarily make a mains connection to the primary of T1 and check that approximately 12 volts DC are available at the output of the board. Switch off and remove the temporary mains connection.

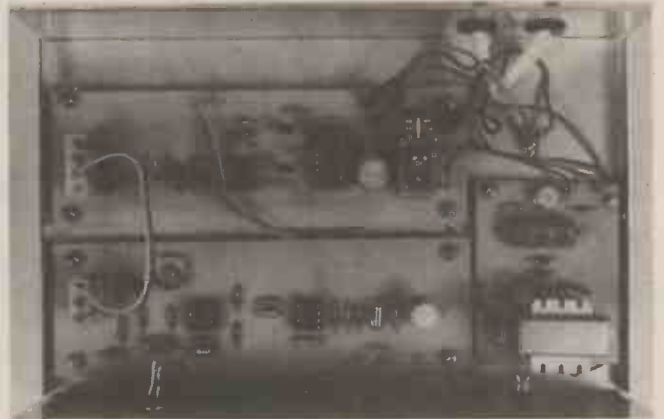

Close-up of the receiver boards. The relay current handling must be within limits for the load to be switched.

Next, wire up the DETECTOR/BISTABLE-RELAY-DRIVER board, taking great care to ensure that all components are assembled in the polarity shown. The two ICs should be mounted in suitable sockets. Relay RLA must be the type recommended in Buylines. When construction of this board is complete, carefully re-check all wiring.



The receiver in its aluminum case. A simple design like this looks unobtrusive.

At this stage you can fit the two complete boards into a suitable case. Drill two  $\frac{1}{4}$ " holes in the case front panel as shown in the photo's. One hole is intended to accept LED 1 and the other acts as a window for IRD. Drill two holes in the rear panel, of sufficient size to accept mains cable grommets. Next fix the two PCBs in place, leaving sufficient space for the preamplifier board. Now refer to the PCB overlays and the power supply circuit diagram and interwire the two boards, noting the following specific points.

- EARTHS**
- (1) The neutrals of the mains input and output cables and the 0 V lead of the power supply must be connected to chassis.



# Infra Red Remote

- (2) The LIVE mains input lead goes to the COMMON terminal of one set of relay contacts and also to one side of T1 primary. The NEUTRAL mains input lead goes to the COMMON terminal of the other set of relay contacts and to the other side of T1 primary.
- (3) The mains output connections to the external 13A socket can be taken from either the two relay connections shown in the diagram or from the two unmarked relay output terminals (the relay actually used on the board is a 2-pole changeover type).

When the circuit has been constructed as described above, complete the power supply connections between the two boards, fit LED 1 to the front panel and wire it to the board. Now plug a lamp or some other mains load into the external 13A socket, switch the mains on and check the functional performance of the unit by momentarily connecting a 47k resistor between D5 cathode and the top of R15. As the resistor is connected, LED 1 should turn on and the relay should change state, making or breaking the mains connection to the external lamp. When the resistor is disconnected, LED 1 should turn off but the relay should not change state. The external lamp can be turned on and off the alternately connecting and disconnecting this resistor.

When the above check is complete, switch off the mains and proceed with the final stage of construction, the assembly of the pre-amplifier components. When construction is complete, fit the board into the case, interconnect the pre-amplifier to the detector/B-R-D board and, finally, tape infra-red detector IRD into place behind the front-panel 'window' (with its sensitive surface facing outwards) and complete its connection to the pre-amplifier board.



Try connecting the IR control unit up to a cassette player. Some interesting reactions can be obtained by hiding the receiver and transmitter from view.

Now switch the circuit on and adjust sensitivity control RV1 so that LED 1 turns on and then turn RV1 back so that LED 1 just turns off again. Next, take a deep breath, cross your fingers, aim the IR transmitter at the receiver unit and briefly press the transmit button. If all is well, LED 1 will illuminate and the relay will change state. If this action is not obtained, either the pre-amplifier or the transmitter is defective.

When you are satisfied that the IR system is functioning correctly, you can set it for maximum sensitivity by simply adjusting frequency control RV1 in the transmitter to give the maximum possible operating range. When the transmitter and receiver pre-sets are correctly adjusted the system should have an effective range of about 30 feet. Finally, fix the transmitter front panel firmly into place.

HE

## Books from the HE Book Service

**28 Tested Transistor Projects** ..... £1.55  
Richard Torrens. The projects can be split down into simple building blocks which can be recombined for ideas of your own.

**Electronic Projects for Beginners** ..... £1.85  
F. G. Rayer. Divided into 'No Soldering Projects,' Radio and Audio Frequency, Power Supplies and Miscellaneous.

**Practical Electronic Calculations and Formulae** ..... £2.55  
F. A. Wilson. A valuable reference for the home and laboratory, containing all the most frequently used, and some of the less well known electronic formulae and calculations.

**Popular Electronic Projects** ..... £1.75  
R. A. Penfold. A collection of the most popular types of circuits and projects using modern, inexpensive and freely available components.



**Digital IC Equivalents and Pin Connections** ... £2.85  
Adrian Michaels. Covers most popular types and gives details of packaging, families, functions, country of origin and manufacturer.

**Radio Stations Guide** £1.75  
B. Babani and M. Jay. An invaluable aid to everyone with a radio receiver helping them to obtain maximum entertainment, value and enjoyment from their set.

**Linear IC Equivalents and Pin Connections** ... £3.10  
Adrian Michaels. Gives most essential data for popular devices.

**Electronic Security Devices** ..... £1.75  
R. A. Penfold. Full of constructional circuits covering the most basic security systems to the Ultrasonic and Doppler Shift systems.

**How To Build Your Own Solid State Oscilloscope** ..... £1.80  
F. G. Rayer. The book contains concise practical instructions so that even an inexperienced hobbyist can construct a fairly sophisticated instrument with the minimum of difficulty and expense.

**50 FET (Field Effect Transistor) Project** ..... £1.55  
F. G. Rayer. Contains something of interest for every class of enthusiast. Short Wave Listener, Radio Amateur, Experimenter or audio devotee.

**50 Circuits Using 7400 Series ICs** ..... £1.65  
R. N. Soar. The author has managed to compile no less than 50 interesting and useful circuits using this range of devices, covering many different aspects of electronics.

Note that all prices include postage and packing. Please make cheques etc. payable to Hobby Electronics Book Service (in Sterling only please) and send to:

**Hobby Electronics Book Service, P.O. Box 79  
Maidenhead, Berks.**

**Essential Theory for the Electronics Hobbyist** £1.55  
G. T. Rubaroe gives the hobbyist a background knowledge tailored to meet his specific needs.

**Beginners Guide to Building Electronic Projects** ..... £1.55  
R. A. Penfold. Covers component identification, tools, soldering, constructional methods and examples of simple projects are given.

**50 Projects using IC CA3130** ..... £1.25  
R. A. Penfold. Describes audio projects, RF project, Test Equipment, Household and miscellaneous circuits.

**IC 555 Project** ..... £2.05  
E. A. Parr. Circuits are given for the car, model railways, alarms and noise makers. Also covers the related devices 556, 558 and 559.

**Second Book of CMOS IC Projects** ..... £1.80  
R. A. Penfold. Following in the success of the original CMOS projects book we present the second volume covering all aspects of CMOS technology from multivibrators to triggering devices.

# All these advantages...

- Instant all-weather starting
- Smoother running
- Continual peak performance
- Longer battery & plug life
- Improved fuel consumption
- Improved acceleration/top speed
- Extended energy storage

## ..in kit form

SPARKRITE X5 is a high performance, top quality inductive discharge electronic ignition system designed for the electronics D.I.Y. world. It has been tried, tested and proven to be utterly reliable. Assembly only takes 1-2 hours and installation even less due to the patented 'clip on' easy fitting.

The superb technical design of the Sparkrite circuit eliminates problems of the contact breaker. There is no misfire due to contact breaker bounce which is eliminated electronically by a pulse suppression circuit which prevents the unit firing if the points bounce open at high R.P.M. Contact breaker burn is eliminated by reducing the current by 95% of the norm.

There is also a unique extended dwell circuit which allows the coil a longer period of time to store its energy before discharging to the plugs. The unit includes built in static timing light systems function light and security change-over switch. Will work all rev counters.

**Fits all 12v negative-earth vehicles with coil/distributor ignition up to 8 cylinders.**

### THE KIT COMPRISES EVERYTHING NEEDED

Die pressed case. Ready drilled aluminium extruded base and heat sink, coil mounting clips and accessories. All kit components are guaranteed for a period of 2 years from date of purchase. Fully illustrated assembly and installation instructions are included.



Roger Clark the world famous rally driver says "Sparkrite electronic ignition systems are the best you can buy."

# Sparkrite

HIGH PERFORMANCE ELECTRONIC IGNITION

Electronics Design Associates, Dept. HE / 2  
82 Bath Street, Walsall, WS1 3DE. Phone: (0922) 614791

Name \_\_\_\_\_

Address \_\_\_\_\_

Phone your order with Access or Barclaycard

Inc. V.A.T. and P.P.

QUANTITY REQD.

I enclose cheque/PO's for

X5KIT £16.95

ACCESS OR BARCLAY CARD No.

£

Cheque No.

Send SAE if brochure only required.

# GREENWELD

443A Millbrook Road Southampton SO1 0HX

All prices include VAT at 15% — Just add 30p post



## COMPONENT CABINET IDEAL FOR THE NEWCOMER TO ELECTRONICS

Contains hundreds of brand new resistors, capacitors, transistors, diodes and i.c.s. All useful values, carefully chosen to help the new constructor pursue his hobby without finding himself short of some vital parts!

All parts contained in clearly marked bags in a plastic storage cabinet 232 x 121 x 185mm with 9 drawers into which all parts can be neatly located.

If bought individually parts plus case would cost over £45 but we are offering this for ONLY £31.95 + £1 P&P. Simply send a cheque or PO for £32.95 for immediate despatch.

### CONTENTS

- 200 1/4 watt resistors
- 20 Wire wound resistors
- 70 Ceramic Capacitors
- 70 Mylar Capacitors
- 50 Polyester Capacitors
- 56 Electrolytic Capacitors
- 61 Transistors
- 12 I.C.s
- 20 L.E.D.s
- 55 Diodes and rectifiers

Altogether 614 components

Price includes current catalogue and Greenweld pen for reordering supplies. Plus free surprise gift.

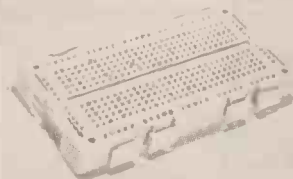

## VEROBLOC BREADBOARD

New from Verob, this versatile aid for building and testing circuits can accommodate any size IC. Blocks can be joined together. Bus strips on X & Y axis — total 360 connection points for just £3.70.

## 3W Amp Module

Ready built and tested, this handy amplifier will prove very useful around the workshop. Just requires 17V ac source (and 8R spkr) as bridge rect and smoothing cap are mounted on the PCB. The 4 transistor circuit provides enough sensitivity for most applications. Supplied complete with circuit diagram and wiring details. Only £1.75. Suitable transformer, £2.20.

## DISC CERAMIC PACK

Amazing variety of values and voltages from a few pF to 2.2uF1 3V to 3kV1 200 £1 500 £2.25 1000 £4.00.

## DIODE SCOOP!!!

We have been fortunate to obtain a large quantity of untested, mostly unmarked glass silicon diodes. Testing a sample batch revealed about 70% useable devices — signal diodes, high voltage rects and zeners may all be included. These are being offered at the incredibly low price of £1.25/1,000 — or a bag of 2,500 for £2.25. Bag of 10,000 £8. Box of 25,000 £17.50.

## AERIALS

X901 Telescopic 8 section 970mm long extended. 175mm collapsed. Swivel joint. 2BA fixing hole in base. 75p.  
X904 Ferrite rod 140mm x 9mm LW/MW/coupling coils, each independently moveable 64p.  
X905 As above, but LW/coupling coil together on moveable former 65p.

## THE NEW 1980 GREENWELD CATALOGUE

### FEATURES INCLUDE

- 60p Discount Vouchers
- Quantity prices for bulk buyers
- Bargain List Supplement
- Reply Paid Envelope
- Priority Order Form
- VAT inclusive prices

All for only 40p + 20p post

## 1000 RESISTORS £2.50!!

New stock just arrived — Carbon Film 2% & 5%, 1/4 & 1/2W, all brand new, but have pre-formed leads, ideal for PC mtng. Enormous range of popular mixed values for just £2.50/1,000; £11/5,000; £50/25,000

## INVERTER

Prepare for the Power Cuts! Ready built inverter. 290x55x37mm 24V DC In, will power 6 x 8W fluorescent tubes. Circuit supplied. Only £2.90

## SCR PANEL & REED PANELS

Z525 Contains 11 800mA 60V 2N5061 SCR's, 11 6V8 zeners, 11 1N4004 diodes + Rs, Cs etc. Only £1.00.

Z526 10 24V reed relays, 22 1N4004 10 weird ICs, Rs Cs etc. 60p.

Z527 2 x 6V reed relays, 6x2S030 or 25230 6x400V rects, + Rs. Only 50p.

## WIRE AND FLEX

Solid core — ideal for breadboards etc 50 x 2m lengths many assorted colours, total 100m for £1.30.

Flex packs — 5 x 5m lengths of multi-strand thin flex, ideal for wiring up circuits. Only 35p.

## EX-COMPUTER PANELS

Z528 Pack of boards containing 100s Rs, Cs diodes, including at least 50 transistors. Only £1.20.

Z529 TTL pack — Panels with 74 series on, together with code sheet. From simple gates to complex counters. 20 ICs £1. 100 ICs £4.

## VERO OFF CUTS

Packs of 100 sq ins of good size pieces about 4x2in. in the following types:  
K541 0.1in. copper clad £1.50  
K544 0.1in. plain £1.50  
Also pieces 2 1/2 x 1in. — 10/£1.20 100/£9. 17x3 1/4 in. x 0.1in. sheets, 10/£16.50

Large range of Standard Veroboard and boxes/cases in stock. Details in Catalogue.

**SCOOP!!!** Verobox type 2522, unused but has 3 1/2in. holes in one end and 1 1/2in. hole in the other, so instead of £3.96, we are selling these at £1.85.

## BUZZERS, MOTORS & RELAYS

Z401 Powerful 6V DC, all metal construction, 50mm dia x 20mm 70p.

Z402 Miniature type, 3-9V, only 22x15x16mm. Very neat 65p.

Z450 Miniature 6V DC motor, high quality type, 32mm dia x 25mm high, with 12mm spindle. Only £1.

Z451 12V high torque motor 30mm dia x 40mm high, with 10mm spindle. 65p.

W892 Heavy duty 12V relay, ideal for car use — single 15A make contact. Coil 25R 85p.

W890 DIL reed relay SPCO 2.4-10V 200R coil. Only £2.20.

## VU METERS

V002 Twin type. 2 metres 40x40mm and driver board, supplied with circuit and connexion data £3.50.

V003 New type, just in. Twin type moulded in one piece, 80x40mm (no driver board but suitable circuit supplied) £2.50.

## CLOCK CASE BARGAIN

Z472 Oval format, overall size 130x68x87mm deep, with built in stand. Rear panel drilled to accept 4 switches + alarm 60p.

**Next  
Month**

# Hobby Electronics

## MOBILE MICROELECTRONICS



We have managed to "persuade" one of the country's leading motoring journalists into writing a feature for us. He will be taking a look at the impact electronics has been making on the world of automotive engineering and some of the advances we can expect in the next few years.

Already we have cars (if you can afford them) like the Aston Martin Lagonda that are almost completely computer controlled, is this the shape of cars to come? We think so, find out all about it next month.

## SHORT WAVE RADIO

Have you ever wondered why there are so few designs around for really simple SW radios? We think it's because most designers are a bit afraid of RF circuitry. After all digital equipment is so easy to design, most of the hard work has already been done by the IC designer.

So, we at HE have girded the loins, put our noses to the grindstone and come up with a really first-class design for a SW radio. We won't promise it'll cover 27 MHz (after all, there's not much to listen to, is there?) on the other hand it just might. Miss next month's copy and you will never know.

## PETTING IT TOGETHER



Rick Maybury's latest report from the west coast of America comes from the Commodore factory in Silicon Valley California where the famous PET computer is assembled. The PET is probably the best known of all the minicomputer systems and Commodore have lost no time in carving out for themselves a very large slice of the market, find out why next month.

## 25 WATT MODULE

Here we have Keith Brindley putting the finishing touches to the prototype of the 25 Watt modular Amplifier for next month's HE. The final design will be built on a PCB and should set a new standard in medium power amplifiers. This project should be ideal for use in a home-built stereo system. Although we haven't published a purpose-built pre-amp it will happily work alongside the Tantrum pre-amp and virtually any other design, depending of course how far you want to go.

By using readily available components it should cost appreciably less than the commercial modules on the market.

To save you the trouble of finding a suitable PSU design we are publishing one designed for the job.

## TOUCH SWITCH

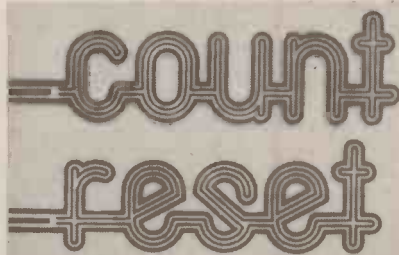

How would the world of amateur electronics exist without the ubiquitous touch switch? How have we got the nerve to publish another? Simple, they are easy to build and are a really great introduction to electronics.

Add a touch of class to your projects with next month's super design. Featuring novel circuitry and using only two inexpensive ICs with genuine capacitive operation we feel sure this one is going to be a winner. Ten channels are available and any one may be selected under fingertip control. Full constructional details next month. We know that you won't want to miss it.

## PSU MODULE

To complement the 25 watt power amplifier module we have designed a purpose-built PSU. The power supply to be described next month will happily drive two 25 watt modules (with some to spare) and will still be relatively cheap and easy to build.



**The March issue will be on sale February 8th**

The items mentioned here are those planned but circumstances may affect the actual contents

# Hobby Electronics Book Service

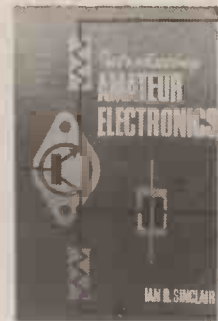

## POPULAR ELECTRONICS BOOKS

|   |       |
|---|-------|
| Sinclair, I. R., Introducing Electronic Systems .....       | £1.80 |
| Sinclair, I. R., Introducing Amateur Electronics .....      | £1.55 |
| Sinclair, I. R., Electronic Fault Diagnosis .....           | £3.45 |
| Sinclair, I. R., Repairing Pocket Transistor Radios .....   | £2.50 |
| Sinclair, I. R., Oscilloscope In Use .....                  | £3.00 |
| Sinclair, I. R., Understanding Electronic Components .....  | £4.00 |
| Sinclair, I. R., Understanding Electronic Circuits .....    | £4.00 |
| Kitchen, H. T., Handtools For Electronic Workshop .....     | £2.75 |
| Kitchen, H. T., Electronic Test Equipment .....             | £5.00 |
| Capel, V., How To Build Electronic Kits .....               | £2.20 |
| Darr, J., How to test almost everything electronic .....    | £3.50 |
| Brown, R. M., How to read electronic circuit diagrams ..... | £4.10 |

## AUDIO

|   |       |
|---|-------|
| Earl, J., Audio Technicians Bench Manual .....                | £3.50 |
| Earl, J., Pickups and Loud Speakers .....                     | £3.50 |
| Earl, J., Tuners and Amplifiers .....                         | £3.00 |
| Earl, J., Cassette Tape Recorders .....                       | £5.25 |
| Earl, J., ABC of Hi-Fi .....                                  | £4.25 |
| Capel, V., Microphones In Action .....                        | £3.00 |
| Capel, V., Improving Your Hi-Fi .....                         | £3.50 |
| Capel, V., Creative Tape Recording .....                      | £4.00 |
| Hellyer, H. W., Tape Recorders .....                          | £4.25 |
| Sinclair, I. R., Audio Amplifiers For Home Construction ..... | £2.75 |

## RADIO CONTROL

|   |       |
|---|-------|
| Aldridge, D., Transistorised Radio Control For Models ..... | £3.50 |
| Drake, J., Radio Controlled Helicopter Models .....         | £3.95 |
| Jeffries, C. R., Radio Control For Model Yachts .....       | £1.85 |
| Safford, E. L., Radio Control Manual .....                  | £2.45 |

## COOKBOOKS

|  |        |
|--|--------|
| Tracton, K., BASIC Cookbook .....  | £4.10  |
| Lancaster, D., TTL Cookbook .....  | £7.00  |
| Lancaster, D., RTL Cookbook .....  | £4.65  |
| Lancaster, D., CMOS Cookbook .....   | £8.20  |
| Jong, W., IC Op Amp Cookbook .....   | £10.00 |
| Lancaster, D., T.V. Typewriter Cookbook .....  | £7.75  |
| Lancaster, D., Cheap Video Cookbook .....  | £7.00  |
| Jong, W., IC Timer Cookbook .....  | £7.50  |
| Lancaster, D., Incredible Secret Money Machine (a how to cook book for setting up your computer or technical business) ..... | £4.95  |

## QUESTIONS AND ANSWERS

SIMPLE AND CONCISE ANSWERS TO MANY QUESTIONS WHICH PUZZLE THE BEGINNER.

|   |       |
|---|-------|
| Coker, A. J., Q & A On Electric Motors .....    | £1.90 |
| Hellyer, H., Q & A On Radios and T.V. ....      | £1.90 |
| Hibberd, R., Q & A On Integrated Circuits ..... | £1.90 |
| Jackson, K., Q & A On Electricity .....         | £1.90 |
| Brown, C., Q & A On Hi-Fi .....                 | £1.90 |
| Brown, C., Q & A On Transistors .....           | £1.90 |
| Brown, C., Q & A On Electronics .....           | £1.90 |
| Reddihough, J., Q & A On Colour T.V. ....       | £1.90 |
| Miller, H., Q & A On Electric Wiring .....      | £1.90 |

## CONSTRUCTOR GUIDES

|  |       |
|--|-------|
| Graham, P., Simple Circuit Building .....                | £2.60 |
| Colwell, M., Electronic Diagrams .....                   | £2.60 |
| Colwell, M., Electronic Components .....                 | £2.60 |
| Colwell, M., Printed Circuit Assembly .....              | £2.60 |
| Ainslie, A., Practical Electronic Project Building ..... | £2.60 |
| Colwell, M., Project Planning and Building .....         | £2.60 |

## BEGINNER'S GUIDE

|  |       |
|--|-------|
| Sinclair, I. R., Beginner's Guide To Tape Recording .....      | £3.35 |
| Sinclair, I. R., Beginner's Guide To Integrated Circuits ..... | £3.35 |
| Sinclair, I. R., Beginner's Guide To Audio .....               | £3.35 |
| King, G. J., Beginner's Guide To Radio .....                   | £3.35 |
| King, G. J., Beginner's Guide To Television .....              | £3.35 |
| King, G. J., Beginner's Guide To Colour T.V. ....              | £3.35 |
| Guilou, F., Beginner's Guide To Electric Wiring .....          | £3.35 |

## PROJECT BOOKS

|   |       |
|---|-------|
| Marston, R. M., 110 Cosmos Digital IC Projects For The Home Constructor .....   | £3.95 |
| Marston, R. M., 110 Wave Form Projects For The Home Constructor .....           | £3.95 |
| Marston, R. M., 110 Op Amp Projects For The Home Constructor ..                 | £3.95 |
| Marston, R. M., 110 Semiconductor Projects For The Home Constructor .....       | £3.95 |
| Marston, R. M., 110 Thyristor/SCR Projects For The Home Constructor .....       | £3.95 |
| Marston, R. M., 110 Electronic Alarm Projects For The Home Constructor .....    | £3.95 |
| Marston, R. M., 110 Integrated Circuits Projects For The Home Constructor ..... | £3.95 |
| Marston, R. M., 20 Solid State Projects For The Car and Garage ..               | £3.20 |
| Marston, R. M., 20 Solid State Projects For The Home .....                      | £3.20 |

Note that all prices include postage and packing. Please make cheques, etc. payable to Hobby Electronics Book Service (in sterling only please) and send to:

Hobby Electronics Book Service,  
P.O. Box 79,  
Maidenhead, Berks.

# STEVENSON

## Electronic Components

| CMOS |     |      |     |
|------|-----|------|-----|
| 4020 | 50p | 4050 | 25p |
| 4022 | 50p | 4060 | 80p |
| 4023 | 13p | 4066 | 30p |
| 4024 | 40p | 4068 | 13p |
| 4025 | 13p | 4069 | 13p |
| 4026 | 90p | 4070 | 13p |
| 4027 | 28p | 4071 | 13p |
| 4028 | 45p | 4072 | 13p |
| 4029 | 50p | 4081 | 13p |
| 4030 | 50p | 4093 | 36p |
| 4040 | 55p | 4510 | 60p |
| 4041 | 55p | 4511 | 60p |
| 4042 | 55p | 4518 | 65p |
| 4043 | 50p | 4520 | 60p |
| 4044 | 90p | 4528 | 60p |
| 4046 | 90p |      |     |
| 4049 | 25p |      |     |

FULL DETAILS IN CATALOGUE!

| TTL  |      |       |      |
|------|------|-------|------|
| 7473 | 20p  | 74141 | 55p  |
| 7474 | 22p  | 74145 | 55p  |
| 7475 | 25p  | 74148 | 90p  |
| 7476 | 20p  | 74150 | 55p  |
| 7478 | 55p  | 74151 | 40p  |
| 7486 | 20p  | 74154 | 65p  |
| 7489 | 135p | 74157 | 40p  |
| 7490 | 25p  | 74164 | 55p  |
| 7492 | 30p  | 74165 | 55p  |
| 7493 | 25p  | 74170 | 100p |
| 7494 | 45p  | 74174 | 55p  |
| 7495 | 35p  | 74177 | 50p  |
| 7496 | 45p  | 74190 | 50p  |
| 7497 | 25p  | 74191 | 50p  |
| 7498 | 35p  | 74192 | 50p  |
| 7499 | 38p  | 74193 | 50p  |
| 7500 | 35p  | 74196 | 50p  |
| 7501 | 35p  | 74197 | 50p  |
| 7502 | 45p  | 74199 | 90p  |

| OPTO     |           |        |           |
|----------|-----------|--------|-----------|
| LED's    | 0.125in.  | 0.2in  | each 100+ |
| Red      | TIL209    | TIL220 | 9p 7.5p   |
| Green    | TIL211    | TIL221 | 13p 12p   |
| Yellow   | TIL213    | TIL223 | 13p 12p   |
| Clips    | 3p        | 3p     |           |
| DISPLAYS |           |        |           |
| DL704    | 0.3 in CC |        | 130p 120p |
| DL707    | 0.3 in CA |        | 130p 120p |
| FND500   | 0.5 in CC |        | 100p 80p  |

| SKTS                                |     |       |     |
|-------------------------------------|-----|-------|-----|
| 8pin                                | 8p  | 18pin | 14p |
| 14pin                               | 10p | 20pin | 16p |
| 16pin                               | 11p | 22pin | 17p |
| 24pin                               | 14p | 28pin | 16p |
| 32pin                               | 16p | 40pin | 17p |
| 3 lead T018 or T05 socket. 10p each |     |       |     |
| Soldercon pins: 100:50p 1000:370p   |     |       |     |

| PCBS   |        |         |                         |
|--|--------|---------|-------------------------|
| VEROBOARD  |        |         |                         |
| Size in.   | 0.1in. | 0.15in. | Vero Cutter 80p.        |
| 2.5 x 1  | 14p    |         |                         |
| 2.5 x 3.75   | 45p    | 45p     |                         |
| 2.5 x 5  | 54p    | 54p     | Pin insertion tool 108p |
| 3.75 x 5   | 64p    | 64p     |                         |
| 3.75 x 17  | 205p   | 185p    |                         |
| Single sided pins per 100 40p 40p  |        |         |                         |
| Top quality fibre glass copper board. Single sided. Size 203 x 95mm. 60p each. |        |         |                         |
| "Dalo" pens. 75p each.   |        |         |                         |
| Five mixed sheets of Alfac. 145p per pack.                                     |        |         |                         |

| RESISTORS  |      |      |       |
|--|------|------|-------|
| Carbon film resistors. High stability, low noise 5%.   |      |      |       |
| E12 series. 4.7 ohms to 10M. Any mix:  |      |      |       |
| 0.25W  | 1p   | 0.9p | 1000+ |
| 0.5W   | 1.5p | 1.2p | 1p    |
| Special development packs consisting of 10 of each value from 4.7 ohms to 1 Meg-ohm (650 res) 0.5W £7.50. 0.25W £5.70. |      |      |       |
| METAL FILM RESISTORS   |      |      |       |
| Very high stability, low noise rated at ¼W 1%. Available from 51ohms to 330k in E24 series. Any mix:                   |      |      |       |
| 0.25W  | 4p   | 100+ | 1000+ |
|  |      | 3.5p | 3.2p  |

PLEASE WRITE FOR YOUR FREE COPY OF OUR 80 PAGE CATALOGUE OF COMPONENTS. OVER 2500 ITEMS LISTED.



| LINEAR  |      |         |      |
|---------|------|---------|------|
| LF356   | 80p  | NE531   | 98p  |
| LM301AN | 26p  | NE555   | 23p  |
| LM308   | 60p  | NE556   | 60p  |
| LM318N  | 75p  | NE567   | 100p |
| LM324   | 45p  | RC4136  | 100p |
| LM339   | 45p  | SN76477 | 230p |
| LM378   | 230p | TBA800  | 70p  |
| LM379S  | 410p | TBA810S | 100p |
| LM380   | 75p  | TDA1022 | 620p |
| LM3900  | 50p  | TL081   | 45p  |
| LM3909  | 65p  | TL084   | 125p |
| LM3911  | 100p | ZN414   | 80p  |
| MC1458  | 32p  | ZN425E  | 390p |
| MM57160 | 590p | ZN1034E | 200p |

| TRANSISTORS |      |         |     |
|-------------|------|---------|-----|
| AC127       | 17p  | BCY72   | 14p |
| AC128       | 16p  | BD131   | 35p |
| AC176       | 18p  | BD132   | 35p |
| AD161       | 38p  | BD139   | 35p |
| AD162       | 38p  | BD140   | 35p |
| BC107       | 8p   | BFY50   | 15p |
| BC108       | 8p   | BFY51   | 15p |
| BC108C      | 10p  | BFY52   | 15p |
| BC109       | 8p   | MJ2955  | 98p |
| BC109C      | 10p  | MPSA06  | 20p |
| BC147       | 7p   | MPSA56  | 20p |
| BC148       | 7p   | TIP29C  | 60p |
| BC177       | 14p  | TIP30C  | 70p |
| BC178       | 14p  | TIP31C  | 65p |
| BC179       | 14p  | TIP32C  | 80p |
| BC182       | 10p  | TIP2955 | 65p |
| BC182L      | 10p  | TIP3055 | 55p |
| BC184       | 10p  | ZTX107  | 14p |
| BC184L      | 10p  | ZTX108  | 14p |
| BC212       | 10p  | ZTX300  | 16p |
| BC212L      | 10p  |         |     |
| BC214       | 10p  |         |     |
| BC214L      | 10p  |         |     |
| BC477       | 19p  |         |     |
| BC478       | 19p  |         |     |
| BC548       | 10p  |         |     |
| BCY70       | 14p  |         |     |
| BCY71       | 14p  |         |     |
| ZTX500      | 16p  |         |     |
| 2N697       | 12p  |         |     |
| 2N3053      | 18p  |         |     |
| 2N3054      | 50p  |         |     |
| 2N3055      | 50p  |         |     |
| 2N3442      | 135p |         |     |
| 2N3702      | 8p   |         |     |
| 2N3703      | 8p   |         |     |
| 2N3704      | 8p   |         |     |
| 2N3705      | 9p   |         |     |
| 2N3706      | 9p   |         |     |
| 2N3707      | 9p   |         |     |
| 2N3708      | 8p   |         |     |
| 2N3819      | 15p  |         |     |
| 2N3920      | 44p  |         |     |
| 2N3904      | 8p   |         |     |
| 2N3905      | 8p   |         |     |
| 2N3906      | 8p   |         |     |
| 2N4058      | 12p  |         |     |
| 2N4057      | 32p  |         |     |
| 2N4549      | 32p  |         |     |
| 2N5777      | 50p  |         |     |

| DIODES                  |            |            |     |
|-------------------------|------------|------------|-----|
| 1N914                   | 3p         | 1N4006     | 6p  |
| 1N4001                  | 4p         | 1N5401     | 13p |
| 1N4002                  | 4p         | BZY88 ser. | 8p  |
| ITT Full spec. product. |            |            |     |
| 1N4148                  | £1.40/100. |            |     |

| CAPACITORS   |          |     |  |
|--|----------|-----|--|
| TANTALUM BEAD  |          |     |  |
| 0.1, 0.15, 0.22, 0.33, 0.47, 0.68,   | each     |     |  |
| 1 & 2.2uF @ 35V  |          | 8p  |  |
| 4.7, 6.8, 10uF @ 25V   |          | 13p |  |
| 22 @ 16V, 47 @ 6V, 100 @ 3V  |          | 16p |  |
| MYLAR FILM   |          |     |  |
| 0.001, 0.01, 0.022, 0.033, 0.047   |          | 3p  |  |
| 0.068, 0.1   |          | 4p  |  |
| POLYESTER  |          |     |  |
| Mullard C280 series  |          |     |  |
| 0.01, 0.015, 0.022, 0.033, 0.047, 0.068, 0.1,  |          | 5p  |  |
| 0.15, 0.22   |          | 7p  |  |
| 0.33, 0.47   |          | 10p |  |
| 0.68   |          | 14p |  |
| 1.0uF  |          | 17p |  |
| CERAMIC  |          |     |  |
| Plate type 50V. Available in E12 series from 22pF to 1000pF and E6 series from 1500pF to 0.047uF |          |     |  |
| RADIAL LEAD ELECTROLYTIC   |          |     |  |
| 63V 0.47 1.0 2.2 4.7 10  |          | 5p  |  |
|  | 22 33 47 | 7p  |  |
|  |          | 13p |  |
|  |          | 20p |  |
| 25V 10 22 33 47  |          | 5p  |  |
|  |          | 8p  |  |
|  |          | 10p |  |
|  |          | 15p |  |
|  |          | 23p |  |

| CONNECTORS   |            |                |             |
|--|------------|----------------|-------------|
| JACK PLUGS AND SOCKETS   |            |                |             |
| 2.5mm  | unscreened | screened       | socket      |
| 3.5mm  | 9p         | 13p            | 7p          |
| Standard   | 9p         | 14p            | 8p          |
| Stereo   | 16p        | 30p            | 15p         |
|  | 23p        | 36p            | 18p         |
| DIN PLUGS AND SOCKETS  |            |                |             |
|  | plug       | chassis socket | line socket |
| 2pin   | 7p         | 7p             | 7p          |
| 3pin   | 11p        | 9p             | 14p         |
| 5pin 180°  | 11p        | 10p            | 14p         |
| 5pin 240°  | 13p        | 10p            | 16p         |
| 1mm PLUGS AND SOCKETS  |            |                |             |
| Suitable for low voltage circuits. Red & black. Plugs: 6p each Sockets: 7p each.                 |            |                |             |
| 4mm PLUGS AND SOCKETS  |            |                |             |
| Available in blue, black, green, brown, red, white and yellow. Plugs: 11p each Sockets: 12p each |            |                |             |
| PHONO PLUGS AND SOCKETS  |            |                |             |
| Insulated plug in red or black   |            |                | 9p          |
| Screened plug  |            |                | 13p         |
| Single socket  | 7p         | Double socket  | 10p         |

## JANUARY SPECIALS

A range of special offer items valid during January. All orders placed for these items must be received during January.

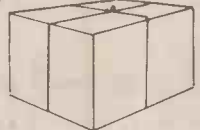

|  |       |       |
|--|-------|-------|
| Pack of 3 x LM380  | 225p  | 200p  |
| Pack of 30 x 1N4001  | 120p  | 100p  |
| Pack of 4 x FND500   | 400p  | 350p  |
| Pack of 15 x 2N3702  | 120p  | 100p  |
| Pack of 15 x BC107   | 120p  | 100p  |
| Special pack of nuts + bolts containing over 600 4BA + 6BA nuts, bolts and washers |       |       |
|  | 330p  | 250p  |
| Pack of 4 red + 4 black crocodile clips  | 64p   | 50p   |
| Mixer control knobs, per 100 (mixed) colours to suit                               |       |       |
|  | 1400p | 1300p |

## MULTIMETERS

A really smart looking multimeter with an impressive specification for such a small size. The very clean scale in white and green on a black background makes this meter very easy to read. The D.C. Impedance of this meter is 4K ohms per volt which is exceptionally good compared with the vast majority of multimeters of a similar size. £5.95 each.



| SPECIFICATION |                                |
|---------------|--------------------------------|
| DC Volts      | 5V 25V 250V 500V (4K ohms/V)   |
| AC Volts      | 10V 50V 500V 1000V (2K ohms/V) |
| DC Current    | 250uA 250mA                    |
| Resistance    | 0 - 600K (7K ohms centre)      |

## PANEL METERS

High quality 2" wide view meters. Zero adjustment. Back illumination wiring. Available in 50 uA, 100 uA, 500 uA, 1mA, 100mA, 500mA, 1A. £4.95 ea. VU meter similar style. £1.50 ea.



## SLIDE POTENTIOMETERS

Good quality 60mm travel slider with 80mm fixing centres. Available from 5k - 500K in log and linear. 55p each. Suitable black knobs 6p ea. Coloured knobs 10p ea.



We now offer one of the widest ranges of components at the most competitive prices in the U.K. See catalogue for full details. We welcome callers at our shop in College Rd, Bromley, from Mon-Sat, 9am-6pm (8pm on Weds and Fridays). Special offers always available. We also provide an express telephone order service. Orders received before 5pm are shipped same day. Contact our sales office now with your requirements. TELEPHONE: 01-464 2951/5770.

Quantity discounts on any mix TTL, CMOS, 74LS and Linear circuits: 100+ 10%, 1000+ 15%. Prices VAT inclusive. Please add 30p for carriage. All prices valid to April 1980. Official orders welcome.

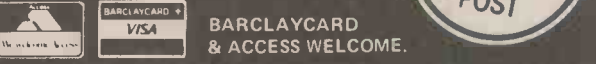

Mail orders to: STEVENSON (Dept HE)

# 76 College Road, Bromley, Kent BR1 1DE.

# KEZY Does It

*This month, Rick Maybury reports from Los Angeles American radio. He takes a long hard look at one of the cities foremost stations KEZY and some of the surprising techniques used in this kind of 'saturation' broadcasting.*

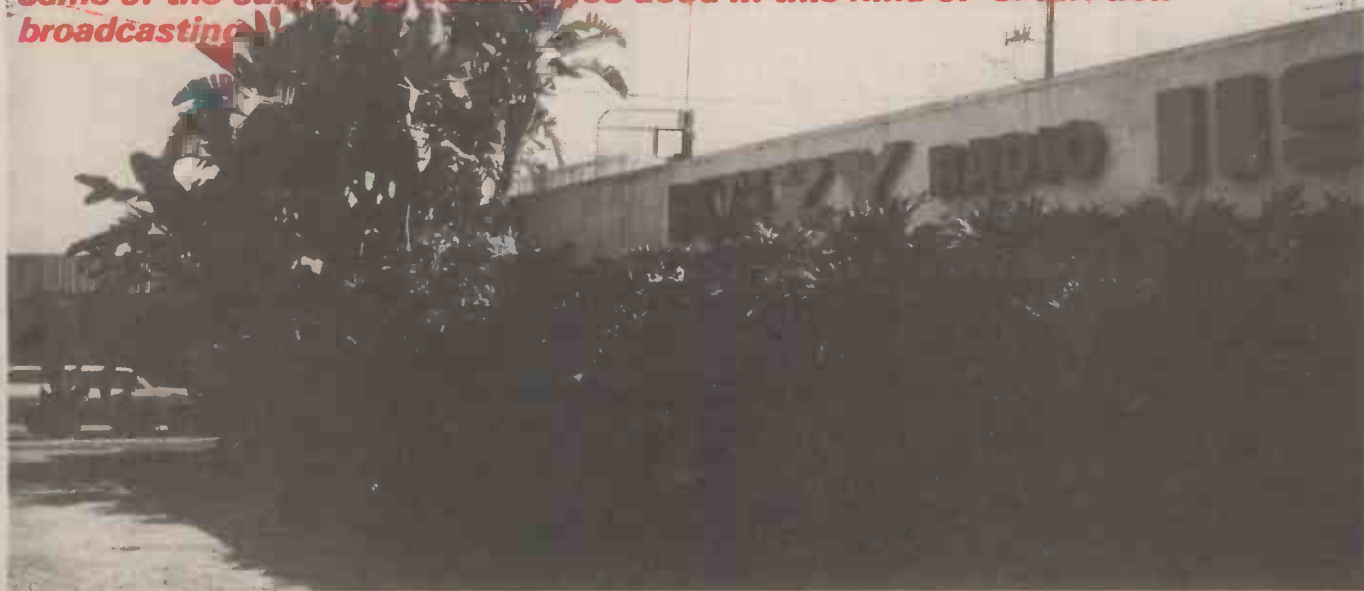

*The microwave 'up-link' antennae can be seen on the extreme left of the picture.*

IMAGINE A CITY SIXTY MILES ACROSS, a population approaching three million and eighty five radio stations. That is Los Angeles in a nutshell. The sheer size of the city is almost unimaginable by European standards. It would be equivalent to London stretching to Brighton.

The populace of Los Angeles have a bewildering choice of entertainment, apart from the 85 radio stations they have a dozen or so networked TV channels and up to 12 cable and community TV stations. We took the opportunity to visit just one of the LA radio stations called KEZY, it is fairly typical in that it has an AM and FM stereo output aimed at two distinctly different audiences.

## **RATINGS**

KEZY is currently running about twelfth in the all-important ratings league. The Americans have an almost paranoid obsession for ratings when assessing a station's popularity. The audiences are calculated by a selected group of listeners paid by the survey company to keep a 'diary' on their day's listening, not the most reliable method. Current estimates show KEZY has an audience of around 289,000.

American radio is probably unique in that it has such a diversity in audiences on AM and FM. The AM audiences are largely composed of teenagers, the music content (radio drama is almost unheard of) is mainly singles or chart material, something they refer to as 'raw' music. The FM material is mainly albums, or 'sophisticated' classical music. Not surprisingly these audiences tend towards the mid twenties to middle age group and almost certainly a large female audience, mainly housewives.



*Outside the station, KEZY is physically very small, only about 30 people work here.*

## **TAKE YOUR PICK**

The actual programme content is just about limitless. Each station will stick to one particular type of entertainment, ranging from Country and Western through hard rock to non-stop Gospel. One or two of the stations run a continuous news service or phone-in type programme. Needless to say the vast majority of the stations run a 24-hour service and that almost without exception are commercially funded.

The difficulties in running a 24-hour service are quite staggering both financially and practically so KEZY in common with most other American FM stations use a technique called automatic broadcasting.



*Inside this air conditioned room is the equipment used for the automated FM broadcasts. The tape deck on the upper left contains all of the verbal 'breaks' between records. The lower deck has all of the music. The cartridge bank in the centre holds all of the pre-recorded adverts. Below that the micro-processor unit that controls everything.*



*Some of the editing desks used to compile the FM material.*

### **IS IT LIVE . . .**

Automatic Broadcasting is almost entirely confined to the FM stations, the AM tends to be regarded as being more 'live', a particular quality of the sound that is almost impossible to duplicate. The method used is extremely simple. The DJ usually spends the day prior to transmission recording the 'breaks' in between records, voice overs etc and run-ups to non-recorded material like news reports. He or she can record a three-hour programme in about half an hour. It is then up to an engineer to put together a tape of the particular music used and superimpose on the tape command signals at inaudible frequencies to switch cartridges containing

commercials etc on and off and cue news reports.

The commercial breaks are also automated, the sequences that a particular set of commercials are to be transmitted in are fed into a micro-processor control unit. It looks after all of the tapes etc and at the appropriate moment will instruct one of a bank of cartridge players to switch in and play.

It is interesting to note that the audiences are deliberately kept unaware that the station is automated. The continual striving for the 'live' sound makes it very difficult indeed for anyone to tell the difference.

### **OWN YOU'RE OWN STATION**

KEZY is pretty average by LA standards, something like 30 people are employed by the station, most of those being on the administrative or advertising side.

The initial cost for setting up an automated FM station is remarkably small, something like £50,000 for the equipment. Provided you can secure FCC (Federal Communications Committee) approval virtually anyone can own a radio station. Indeed many community or 'cult' groups will have their own outlet, this is best illustrated by the number of 'fringe' religious groups that operate a twenty-four hour service, everyone from the Scientologists to the transcendental meditationists are catered for.

KEZY has a fully automated FM and live AM, they concentrate on rock and punk on the AM (American Punk is far removed from our own, being much tamer).

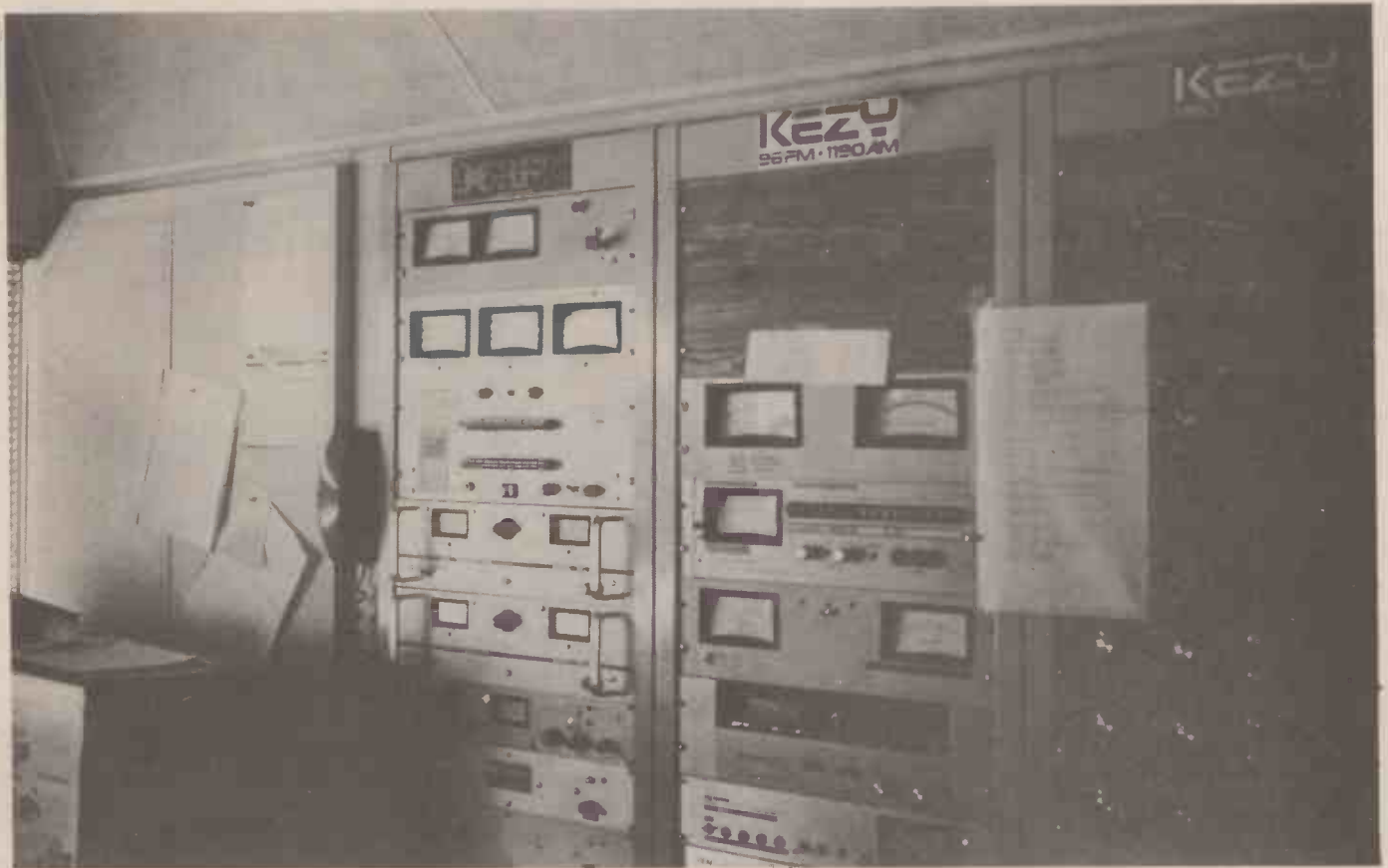

*The equipment used for the microwave up-link from studio to transmitter site.*



*One of the news readers at work editing material for the weekly programme of all the week's best material.*

The FM service is a mixture of hard rock and very well presented news aimed at a relatively intelligent audience. This often reflects in the quality and content of advertising. A lesser station is easily identified by the 'My dad says' type of ad, where for the sake of cost the advertiser uses his son to extoll the virtues of his wares.

KEZY has a fully equipped studio specifically for ad production. This particular studio has an impressive library of sound effects recordings, rarely seen outside the BBC.

Despite all of the station's expertise and potential size of the audience it is surprisingly cheap to transmit an advert. The primetime, or 'Drivetime' (rush hour when most of the audience are captive in the amazing traffic

jams that typify LA) will only set you back about sixty dollars (about £30) for one 30 second slot. Not at all bad when you consider how many people may be listening.

## WIDESPREAD WATTS

Now for the technical stuff. The power of KEZY (and most of the others) is around 5,000 watts (5kW) non directional propagation. As the actual transmitter tower is physically separated from the studio by about ten miles a microwave 'up link' is used to relay the output from the studio to the transmitter site. Because of the density of radio traffic several other stations share the same tower. The atmospheric conditions are such

*'Hollywood Jack' at work in the main AM studio, most AM output is live.*







*Inside the news studio, much of the engineering is done by the disc jockey or presenter.*

that the AM coverage is roughly doubled at night, reaching nearly the whole LA area.

Almost 90% of the programme material on both AM and FM is held on tape, playing actual records has become something of a rarity these days. The equipment is very up-to-date using the latest advances in micro-processor programming techniques to control the output. A constant printout is available for both AM and FM schedules to give the station operators an idea of what has gone out and what is about to go out. This flexibility enables them to make last-minute changes to allow for developments in the news etc. Whilst we were there the situation of the Iranian seige of the American Embassy in Terhan was causing some

headaches. Programme schedules on FM were being re-vamped to permit insertion of news up-dates. This involved telling the micro-processor control unit to expect a newscast at a particular time. This would automatically time the available material and re-schedule it to fit the extra broadcasts in. This would not necessarily be a problem except that news programmes are 'networked' by radio stations on a nationwide basis so the individual station has to be able to transmit important news of a moment's notice.

The disc-jockeys at KEYZY are typically American, from the overtly sincere to the outrageously extrovert 'Hollywood Jack' one of the station's main AM personalities.

One of the more 'serious' news readers told us of some of the dramatic moments that running a 'local' station entails. Suicides in particular are quite common, desperate people often phone the station in order to seek sympathy. At the other end of the scale, something as seemingly inconsequential as a lost dog has been given air time and in one instance they launched a widespread search to find the lost dog of one elderly, critically ill lady. The response to the call was promptly answered resulting in the lady's dog plus a few other 'strays' being found.

These 'human' touches seem to contradict the almost 'sterile' usage of automated broadcasting techniques. This, however, is semi-deliberate, to the extent that a directive from the station manager states that small scale 'fluffs' during recording should not be edited out. We are tempted to ask whether it will be used over here in Britain. Maybe it is already. Tony Blackburn a recording, HmMMMMM . . .

HE



*The ad. and voice-over studio.*

# HE MARKET

## LCD CHRONO



We feel we've got to tell you carefully about this offer. Why? Because our price is so enormously lower than anywhere else you may suspect the quality.

The display is LCD and shows the seconds as well as the hours — and minutes — press a button and you'll get the date and the day of the week.

Press another button for a couple of seconds and you have a highly accurate stopwatch and hundredths of a second displayed and giving the time up to an hour. There is a lap time facility as well — and of course a back light.

Our Chrono comes complete with a high grade adjustable metal strap and is fully guaranteed.

**£11.95**

## ALARM-CHRONO LCD



This new addition to our unbeatable selection of bargains is no ordinary LCD watch. It's a slim, multi-function, dual time chronograph alarm watch, no less.

This model will show hours, minutes, seconds, date, day of the week, stop watch, split time, alarm and alternate dual time zone — not all at once, of course. There is also a night light.

Hours, minutes, seconds and day of the week are displayed continuously, while the date will appear at the touch of a button. The day of the week is indicated by a flag. When used as a stopwatch, the maximum count is 0.1 secs. short of thirteen hours.

**£19.95**

To:  
**LCD Watch Offer**  
**HE Magazine**  
**145 Charing Cross Road**  
**London WC2H 0EE**  
 Please find enclosed my cheque / PO for £11.95 (payable to HE Magazine) for my LCD Chronograph.

Name .....

Address .....

.....

.....

To:  
**ALARM/CHRONO LCD WATCH Offer**  
**HE Magazine**  
**145 Charing Cross Road**  
**London WC2H 0EE**  
 Please find enclosed my cheque / PO for £19.95 (payable to HE Magazine) for my Alarm/Chrono LCD watch.

Name .....

Address .....

.....

.....

Please allow 28 days for delivery

# PLACE

## DIGITAL ALARM

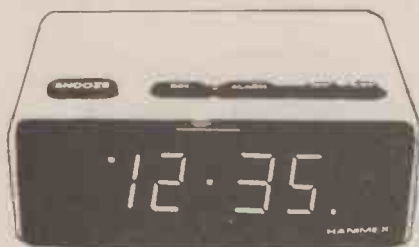

THIS IS THE THIRD digital alarm clock that we are offering (we regret the earlier versions are no longer available). We have sold thousands and thousands of these and our buying power enables us to offer a first rate branded product at a really excellent price.

The Hanimex HC-1100 is designed for mains operation only (240V/50Hz) with a 12 hour display, AM/PM and Alarm Set indicators incorporated in the large display. A switch on the top controls a Dim-Bright display function.

Setting up both the time and alarm is simplicity itself as buttons are provided for both fast and slow setting and there's no problem about knocking these accidentally as a 'locking' switch is provided under the clock. A 9-minute 'snooze' switch is located at the top.

An example of this clock can be seen and examined at our Charing Cross Road offices.

**£10.60**

## CLOCK RADIO



You probably won't believe us as we're selling the goods but we're going to tell you anyway! We have *rejected* eight clock radios for Marketplace, they were all cheap enough but the quality was so poor that we couldn't have lent our name to them. However, we are now able to offer another portable LCD Clock Radio to you which meets our standards.

The clock is a 12-hour one with AM/PM indicated and a back light. The radio is Medium Wave with very nice quality for a small speaker. The alarm can be either a beep-beep type or the radio, there's also a snooze facility.

The cylindrical construction is in keeping with the very modern styling. The tuning dial is actually incorporated into one of the end caps!

We won't even mention the RRP — but just check on comparable prices — you'll find ours a bargain.

An example of this Clock Radio can be seen and examined at our Charing Cross Road offices.

**£17.95**

To: Hanimex Alarm Offer  
HE Magazine  
145 Charing Cross Road  
London WC2H 0EE

Please find enclosed my cheque/PO for £10.60 (payable to HE Magazine) for a Hanimex Digital Alarm Clock.

Name .....

Address .....

To: CLOCK RADIO Offer  
HE Magazine  
145 Charing Cross Road  
London WC2H 0EE

Please find enclosed my cheque/PO for £17.95 (payable to HE Magazine) for my Clock Radio.

Name .....

Address .....

All offers inclusive of 15% VAT and Postage

## Car Audio

### Manual MW/LW



Full medium and long wave tuning. Complete with speaker and mountings. Suitable for positive or negative chassis. Latest model.

**£10.25 + £1.00 Post**

### Push-Button MW/LW



One LW, four MW buttons plus manual tuning. Complete with speaker and mountings. Latest model, negative chassis only.

**£15.95 + £1.00 Post**

### Stereo FM/Cassette + MW



Standard cassettes and FM in stereo plus medium wave. Tone and balance controls. Fast forward facility on tape. Adjustable shafts. Suitable for 4 or 8 ohm speakers (not supplied). This model is discounted elsewhere at £50 up.

**£40.95 + £1.00 Post**

### Stereo Speaker Set



Suitable for above stereo unit. Good quality in surface mounted casing, 5W nominal, 8W peak.

**£4.00 (pair)**

+ 70p Post

### Telescopic Car Antenna

Multi-section standard type, suitable for angled mounting with locking key.

**£1.60 + 30p Post**

## Metal Detector

### ★ Induction Balance Model



Built with sensitivity up to 10in on single coin; fitted with speaker and meter; PP3 battery; 7in dia. search head. Telescopic stem. Excellent pin-pointing, positive reaction to non-ferrous, negative reaction to iron. This model's normal price is £39.95!

**£24.50 + £1.00 Post**

All goods guaranteed one year. 10-day money-back offer. Goods ex-stock at time of going to press. Callers by appointment only please. Send s.a.e. for illustrated leaflet.

**Minikits Electronics Ltd.**  
88H Hainault Road  
Leytonstone  
London, E.11

# electronics today

international

What to look for in the March issue: on sale February 1st



## TV SOUNDS GOOD?

Tired of tinny tunes from your telly? The melodic meanderings start out from the transmitter in super-duper hi-fi, but the cost cutting sounds section of your set takes care of that, lowering the fi at the speed of light. Next month Richard Maybury explores the world of TV sound and comes up with a few ideas on improving it.

## ELECTROMYOGRAM

The ETI Muscle Meter senses the tiny electrical impulses associated with muscle activity. As Superman flexes his biceps you can hear it all happening and see the activity building up on a meter.

## THE ULTIMATE METAL LOCATOR

Calling all treasure hunters. How many times has your metal detector gone ping or buzz or hello sailor and you've shifted half a ton of Surrey only to find a non-bio-degradable ring pull tab? Well, next month we have a discriminating metal locator for you.

The magic machine rejects nails, bottle caps, aluminium foil and ring pull tabs. The design also features full ground effect exclusion over normal or high permeability soils. Search for your pot of gold with deepseeking VLF plus three TR discriminating ranges. Instant tuning recall is made possible by a push button memory circuit.

## BLACK HOLES

When a massive star reaches the end of its life, uses the last of its nuclear fuel and explodes as a supernova, one of three things can happen. The supernova explosion may destroy the core, or, if a small core remains, it may become a neutron star, or, if it is large enough, it may collapse to form a black hole.

Next month Ian Graham has a bash at explaining that most enigmatic of astronomical propositions — the black hole.

## HEATER POWER CONTROLLER

With most heater controllers, your heater is either on or off and the room temperature fluctuates several degrees either side of 'comfy'. Our design will keep your room temperature stable to within half a degree. In addition, by using zero voltage switching, RF interference is avoided.

If you're into Biofeedback you can use the ETI Muscle Meter to learn to relax more effectively. On the other hand, if you're into having fun, there's plenty of scope for doing your own thing. Watch this space (give or take a few pages) to find out how the miracle machine picks out the fractions of a microvolt of relaxed muscles from the volts of 50 Hz hum present in the body — induced from power and light wiring.



# Kit Review Special

## THE FLEET FPS-3 SERVO



### **FLEET FPS-3 SERVO. A versatile DIY servo kit for the radio control enthusiast.**

THE FLEET FPS-3 is a miniature, lightweight (1.4 oz), high-thrust (4 lb) remote control servo that is supplied complete with alternative mechanics to give either a rotary or linear-mode output. The device uses the latest Ferranti 419 servo IC plus two transistors and is a thoroughly modern, state-of-the-art, unit.

The FPS-3 can be used with any DC supply in the range 3.5 to 6.5 volts. It is designed for use with standard digital-proportional radio control systems generating positive pulses with widths in the range 0.8 to 2.2 mS and frame periods in the range 10 to 20 mS. The FPS-3 is available in ready-built form at £14.50 or as a kit (minus a 3-pin input plug) at £11.45. The kit seemed to give a worth-while saving, so we sent off for one.

### **THE KIT**

The kit comes, complete with a 4-page instruction sheet, in two plastic packages, one holding the servo mechanics and the other the electronic bits and pieces. The "electronics" pack includes a diminutive (inch x 5/8 inch) PCB, which hold the 14-pin IC and the fifteen other components that complete the circuit. It is *essential* to have access to a miniature soldering iron, with a bit no larger than 3/32 inch, in order to satisfactorily fix the components to this PCB. The instruction sheet gives adequate assembly instructions and construction should present no real problems if reasonable care is taken.

The "mechanical" part of the kit includes the motor, servo case, gear train and cover. We decided to make the "rotary output" version of the unit. We had to study the assembly diagram with great care and make a couple of dry runs before we finally got the hang of assembling the gear train. Similarly, we had minor problems fitting the motor and gear-driven pot into place. This is one of those instances, however, where once you've got the hang of things it becomes easy to assemble additional units.

Once we'd completed the electronic and mechanical constructional processes we coupled the whole lot together, connected the resulting servo unit to a suitable test set, and checked the servo's functional performance. It operated correctly first time and gave a very adequate performance, with negligible overshoot or hunting and with a good response time and bags of torque.

### **CONCLUSIONS**

The completed unit is thoroughly professional and modern, as good as "the best." Our unit took roughly two hours to assemble, because we were totally unfamiliar with the device. We reckon we could assemble a second unit in half of this time. The kit is excellent, the instruction sheet "good."

All-in-all, the kit represents excellent value for money and is highly recommended, particularly if you are buying more than one of them. The kit is available from Fleet Control Systems, 47 Fleet Road, Fleet, Hants. Tel. No. Fleet 5011. 3-pin servo plugs and sockets are available at an additional 27 pence each.



## HEATHKIT DIGITAL MULTIMETER

*One of the newest kits in the Heathkit range is a hand held multimeter and we were eager to get our hands on one for review purposes.*

AS FAR AS PRICE IS CONCERNED, the Heathkit IM-2215 Portable Digital Multimeter is quite costly, and if you have ever browsed through a Heathkit catalogue you will no doubt know that most of their kits are so. But, to be fair to Heath, the kit is of excellent quality. So overall it represents good value for money at around £80. Everything you might need to complete the meter, except the 9V battery, is provided. And, if it wasn't for their limited shelf life it would be a safe bet to assume that a battery would have been there. The kit even includes a small magnifying glass, with which the builder can identify components or check for PCB faults, etc. Heath are past masters in kit production and their expertise certainly shows in this fine example.

The kit comes complete in a cardboard box, measuring about 9 by 6 by 4 and after unpacking everything to check against the parts list, it seems unbelievable that all of the components and hardware will fit into the small blue case of the meter. However, fit it does, and relatively easily too, the main reason for this being the neat, well designed main printed circuit board. The board is double-sided, pre-drilled with plated through holes and is pre-tinned for ease of soldering. The instruction manual gives important warnings on the handling and care of this circuit board which really are commonsense, eg the washing of hands before holding, etc.

In one way or another, literally everything (including the display board) fits onto this main PCB, as can be seen in the photographs — sockets, switches, components, etc. and it forms a very compact sub-chassis which fits neatly into the hand-held case. Because of the importance of this board and some quite intricate circuitry, good soldering technique is vital. The kit builder is advised by the manual (more about this "bible" later) not to use larger than 40 watt soldering iron with a  $\frac{1}{8}$  to  $\frac{3}{16}$  tip for soldering. Even this will probably be a bit hefty (Excuse the pun), so if you have a 15 watt or a 25 watt iron you may find things somewhat easier. Anyway, remember to keep your iron tip clean by wiping it as often as possible on a damp cloth or sponge.

Included in the manual is one of the finest descriptions of "how to solder" that has ever been put onto paper. Being a practical task there is nothing like having a soldering iron in your hand to find out how it is done, but nevertheless the method described should instill even the absolute beginner with confidence before he has even picked up the circuit board. Another ten out of ten for Heath!

Following the step by step assembly instructions, carefully and fairly slowly the kit takes around six hours to complete, including initial tests and calibration and in our case the meter worked perfectly first time. It is remarkably simple to construct and there really are only



The bits and pieces which make up the Heathkit IM 2215 digital multimeter.

The sub-chassis of the multimeter, just before insertion into its case.

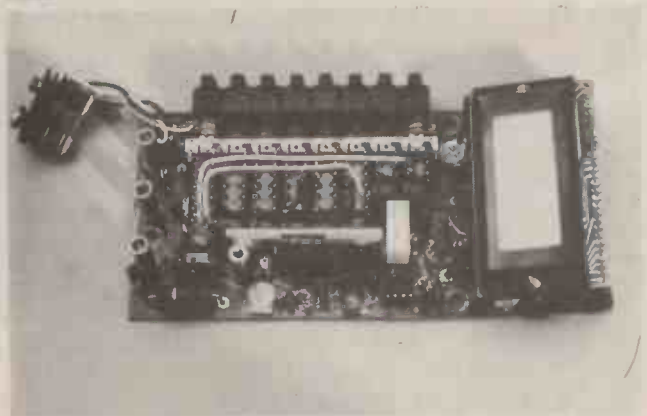

two tricky areas — the insertion of those most dreaded of things, protected CMOS ICs (there are two) and the construction of the liquid crystal display board. The handling of CMOS ICs is enough to give anyone a severe cardiac arrest and there is no immediate answer to the problem, just take your time and be careful. As far as the display is concerned, if you had three pairs of hands it would still be fiddly, but at least not too much damage can be done by heavy handling. Assembly instructions only take up about half of the manual, the remainder dealing with specifications of the meter; use of the meter; faultfinding and a circuit description. All sections of which are as detailed and accurate as the construction section.

Calibration of the meter can be undertaken by an internally supplied reference or with the use of external

equipment. Both methods are fully described. The internal reference method produces a meter whose specifications are slightly less accurate than that of a meter calibrated by external equipment — but only just (literally only a fraction of a per cent). So there really is no need to go out of your way in trying to find the necessary equipment for laboratory calibration.

The meter itself has five DC voltage ranges ( $\pm 200$  mV,  $\pm 2$  V,  $\pm 20$  V,  $\pm 200$  V and  $\pm 1000$  V); five voltage ranges (200 mV, 2 V, 20 V, 200 V, 750 V); four direct current ranges ( $\pm 2$  mA,  $\pm 20$  mA,  $\pm 200$  mA,  $\pm 2000$  mA); four alternating current ranges (2 mA, 20 mA, 200 mA, 2000 mA); and six resistance ranges (200R, 2K, 20K, 200K, 2000K, 20M).

Included is a very nice feature, whereby the battery condition, if low, is indicated on the liquid crystal display, which registers when the battery has less than 20% of its life left. You won't, however, see this very often because an alkaline PP3 type battery will give over 200 hours of operation.

Opinions vary from individual to individual as to whether digital multimeters are better than those of the analogue type. The choice is purely personal in the end of course, but it is probably true to say that unless you actually get hands-on-experience of a digital meter you will never know the advantages. As far as this particular multimeter is concerned, it is a light, portable, easily used and accurate instrument. Our kit, as we have previously stated, worked perfectly upon completion and there is no reason to assume that another would not have done (allowing that the necessary care is taken in construction). On first sight, it might appear that the kit is expensive, but we conclude that it is well worth every penny. The meter really is a pleasure to build and to use, and we congratulate Heath on a fine introduction to their kit range.

# Electronic Circuit Design

## No. 1

Selected Reprints from **electronics today**

### Introduction

Since ETI was originally launched in Britain in April 1972 we have published nearly 5000 pages of editorial matter: much of this has been devoted to electronic projects of course. In our history we have republished the best of these projects in Top Projects No 1-No 7, we have also reprinted the Tech-Tips and other circuits in Circuits Book No 1 and No 2 and our beginners series Electronics-It's-Easy is now on its third reprint. We have not however, until now, brought together the best features dealing with electronic design. Nearly

1500 pages have been devoted to this in recent years and this special is the first of a series of three which will bring together the best 250-300 of these. Although some features are from quite early issues they have only been included because we feel that age has not withered them. We hope that the contents help the reader understand at least some of the aspects of electronic circuit design.

Halvor Moorshead  
Editorial Director — ETI

**VOL.1  
OUT NOW**

**VOL.2  
OUT  
FEB 1st**

AT YOUR NEWSAGENT  
Or order from: Specials,  
Modmags Ltd, 145 Charing  
Cross Road, London, WC2H  
0EE. Send cheque/PO for  
£1.25 + 25p (P&P) (per  
volume) and please  
write your name and  
address on the back  
of your payment.

### Contents:

- CMOS ..... 54  
How to use these versatile ICs
- Audio Amplifiers ..... 59  
Tim O'Neil gives over the design principles
- ..... 70  
de to SCR: .....  
setul cr

# Electronic Circuit Design

## No.1

Selected Reprints from  
**electronics today**

**£1.25**

**NEW  
FROM  
ETI!**

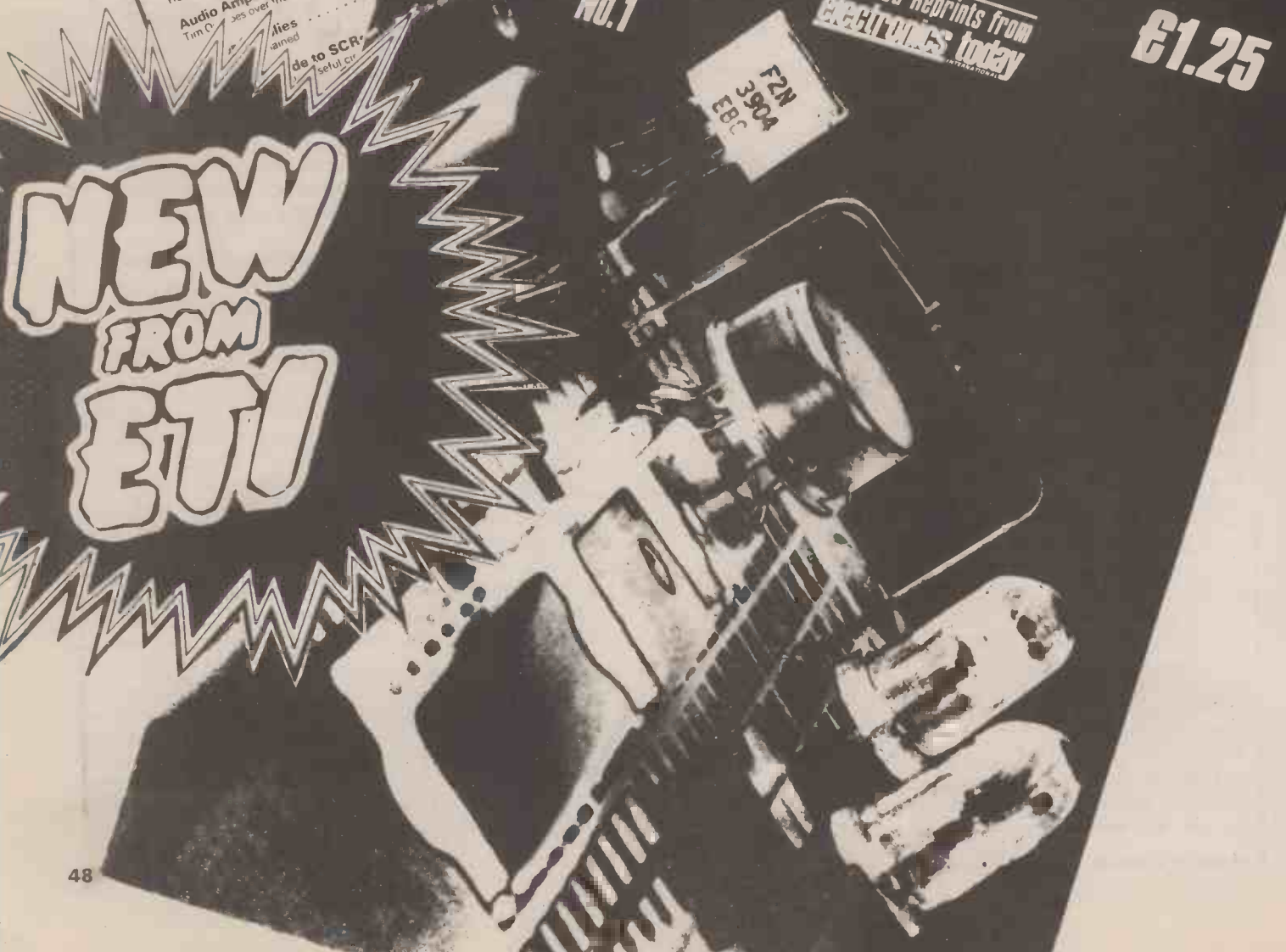



# What's new from Heathkit?

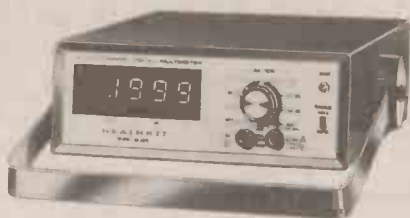

IM 2212 - Auto Ranging DMM



IO 4105 - Single Beam 5 MHz Oscilloscope



IM 5217 - Portable Multimeter

## Plus

- \* GD 1290 - VLF Metal Locator
- \* HX 1681 - CW Transmitter
- \* IR 5201 - XY Recorder
- \* CI 1525 - Car Temperature Indicator

These brand new self-assembly kits are designed to the highest specification. The step-by-step instructions make them easy to build at your leisure in your own home.

And first class quality makes them excellent value for money.

Details of the full Heathkit range are available in the Heathkit catalogue. Send for your copy now.



IM 2215 - Hand-held DMM

Soldering  
Iron offer  
**FREE**

To: Heath (Gloucester) Limited Dept. (HE2), Bristol Road, Gloucester, GL2 6EE.

Please send a copy of the Heathkit catalogue. I enclose 20p in stamps.

Name \_\_\_\_\_

Address \_\_\_\_\_

N.B. If you are already on the Heathkit mailing list you will automatically receive a copy of the latest Heathkit catalogue without having to use this coupon.

When you receive your catalogue you will get details of this free offer.



There are Heathkit Electronics Centres at 233 Tottenham Court Road, London (01-636 7349) and at Bristol Road, Gloucester (0452 29451).

# HEATHKIT

## HE Binders



Now that Hobby Electronics is in to its second volume the need for a good strong binder is greater than ever.

In line with our policy of value for money, we will outline some of the alternative uses an HE binder can be put to.

- (1) *Blocking cat-flaps to prevent stray cats from entering your kitchen.*
- (2) *Blocking off car radiators during cold weather.*
- (3) *Temporary bridges for model train layouts.*
- (4) *Emergency umbrellas.*
- (5) *A hat for HEBOT.*

Of course, you could use them for keeping those valuable copies of HE in pristine condition, but that's up to you.

To become the proud owner of these blue bound, gold embossed works of art just send us £3.20 without delay.

Send your cheque, postal order, pools win or gold fillings (to the value of £3.20) to;

**Hobby Electronics Binders,  
145 Charing Cross Road,  
London WC2H 0EE.**

# C B Beasties

LEGALISE C.B.!!  
WHY SHOULD RADIO 1  
D.S.'S HAVE ALL  
THE FUN?



Ab. 79

IT'S MY NEW  
RADIO-CONTROLLED  
ILLEGAL C.B. RADIO SEEKER-  
OUTER AND ELIMINATOR!!



Ab. 79

HOW DO YOU LIKE MY  
NEW INVENTION?



WHAT'S SO NEW ABOUT A  
CASSETTE RECORDER AND  
MICROPHONE?



... AH, ROGER, GOOD  
BUDDY. WHAT'S  
YOUR TWENTY?



THE FACT THAT IT'S  
A C.B. RADIO IN  
DISGUISE!!



HEY, HEY, GOOD BUDDY.  
WHAT'S YOUR  
TWENTY-THREE?

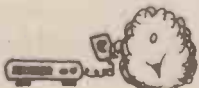

"WHAT'S YOUR TWENTY"  
PLUS FIFTEEN PERCENT  
VAT!!



Ab. 79

## HAND-HELD GAMES

|                       |        |
|-----------------------|--------|
| Elec. Mastermind      | £12.90 |
| Digits                | £14.95 |
| Zap                   | £11.95 |
| Amaze-a-Tron          | £18.95 |
| U.F.O. Master Blaster | £24.95 |
| Enterprise 4 in 1     | £24.95 |
| Space Alert           | £15.90 |
| Auto Race             | £15.90 |
| Soccer                | £21.50 |
| Atari Touch Me        | £26.95 |
| Destroyer             | £16.95 |
| Football (2 player)   | £24.95 |

Commodore Watches  
LCD Snooze Alarm  
£20.95 Our Price £14.90  
1-year guarantee

## KITS

|                              |        |
|------------------------------|--------|
| Pinball Wizard               | £28.90 |
| Play 7 games on your tv. Box | £6.50  |
| Set for P.W.                 | £3.90  |
| Mains Adaptor                | £3.90  |
| C.E.H. 202-1                 | £18.90 |
| Versatile car alarm          |        |
| CHROMA-CHIME                 |        |
| 24-tune door chimes          |        |
| Kit                          | £10.50 |
| Built                        | £15.90 |
| FIRE-SMOKE ALARM             |        |
|                              | £15.90 |

C.B. - C.B. - C.B. - C.B.  
Disguised Aerials, S.W.R.  
R.F. Pre-Amp Connectors,  
etc

## CHESS COMPUTERS

|                    |         |
|--------------------|---------|
| Star Chess TV Game | £63.35  |
| Chess Champion     | £54.95  |
| Challenger 7       | £99.00  |
| Challenger 10      | £160.00 |
| Voice Challenger   | £230.00 |
| Chessmate (8)      | £59.95  |
| Bridge Challenger  | £290.00 |
| Backgammon         | £90.00  |
| Checkers 4         | £90.00  |
| Database           | £89.95  |
| Atari V.C.S.       | £159.00 |

ZODIAC  
Astrology Computer  
£34.95

## N.I.C.

61 Broad Lane, London, N.15  
Day-Tel: 01-808 0377 Evg.: 01-889 9736

DHIO SCIENTIFIC Superboard II. Fully built 50Hz model for British TV sets, cassette interface, uses your TV as a VDU, full keyboard, 8K basic, 4K ram. We are the only people who include a free power supply and modulator kit in our price of £188 + 15% VAT post free.

SINCLAIR PRODUCTS. New 10MHz scope £145, pfm200 £51.95, case £3.40, adaptor £3.40, connector kit £11.27. Microvision TV £81, adaptor £8.88, pdm35 £29.78, adaptor £3.40, case £3.40, dm350 £71.82, dm450 £102.17, dm235 £51.95, rechargeable batts £7.99, adaptor £3.94, case £8. Enterprise prog. calculator + accessories £19.95.

COMPUTER GAMES chess champion 6 £49.95. Chess challenger 7 £84. Philips G7000 home computer £149. Videopaks £12.95. Atari videocomputer £147. Cartridges £14.95. COMPONENTS: 1N4148 0.1p, 1N4002 3.1p, 741 18p, Bc182, bc184, bc212, bc214, bc548 5.5p. Resistors 1/4W 5% E12 10R to 10M 1p, 0.8p for 50+ of one value. 16V electrolytics. 5.1, 2.5, 10, 22mf 5p, 100mf 5p, 1000mf 10p, 1 1b FeCl £1.30. Dialo pen 84p, 40 sq. ins. pcb 45p. Polystyrene capacitors E12 63V 10 to 1000p 3p, 1n2 to 10n 4p. Ceramic capacitors 50V E6 22pf to 47n 2p. Zeners 400mW E24 2v to 33v 7p. TV GAMES: AY-3-8500 + kit £7.26. Rifle kit £5.27. AY-3-8600 + kit £17.28. Stunt cycle chip + kit £18.88. AY-3-8603 chip £13.83. TRANSFORMERS: 0-0-6V, 1 1/2 £2.80, 9-0-9V 75ma 78p, 1a £2.22, 2a £3.13. 12-0-12V 100ma 82p, 1a £2.80.

IC AUDIO AMPS with pcb. JC12 6W £2.08. JC20 10W £3.14. BATTERY ELIMINATORS 3-way type 6/7 1/2 / 9v 300ma £3.14. 100ma radio type with press-studs. 5v £3.67, 9+9v £4.79. Car converter 12v input, output 4 1/2 / 6 / 7 1/2 / 9v 800ma £2.66.

BATTERY ELIMINATOR KITS 100ma radio types with press-studs 4 1/2 v £1.48, 6v £1.48, 9v £1.48, 4 1/2 + 4 1/2 v £1.92, 6 + 6 v £1.92, 9 + 9 v £1.82. Stabilised 8-way types 3 1/4 v / 6 / 7 1/2 / 9 / 12 / 15 / 18v 100ma £2.50, 1Amp £6.30. Stabilised power kits 2-18v 100ma £2.99, 1-30v 1A £6.20, 1-30v 2A £11.24. 12v car converter 6/7 1/2 / 9v 1A £1.35. T-DEC AND CSC BREADBOARDS s-dec £3.79, t-dec £4.59, u-dec £4.89, u-dec £7.16, exp4b £2.84, exp300 £8.81, exp350 £7.62, exp325 £1.84. BI-PAK AUDIO MODULES s450 £25.06, AL60 £5.06, Pa100 £17.33, Spm80 £4.74, Bm80 £8.08. Stereo 30 £21.57, AL30A £4.08, Pa12 £8.38, Pa12 £1.58, Ma60 £38.27.

## SWANLEY ELECTRONICS

Dept. HE, 32 Goldsall Rd., Swanley, Kent  
Post 30p extra. Prices include VAT unless stated. Official and overseas orders welcome. Lists 24p post free. Mail order only.



# C. B. CITY LTD.



119d PROSPECT ROAD  
FARNBOROUGH, HANTS  
0252-318141 (EVES & WEEKENDS)

C. B. CITY is dedicated to all present and future Citizen Band Enthusiasts

We stock a full range of everything you are likely to require and more. If not, we can most probably obtain it.

Duff Rig?? Then why not take advantage of our repair service — absolute confidence guaranteed.

Access, Credit Cards accepted

Just send 3 x 10p stamps for our 16-page fully illustrated comprehensive catalogue

**REMEMBER!!** Until C.B. becomes legal we **DO NOT** sell rigs

# Power to the People

*We all need electricity, but how do we get it? Ian Sinclair looks at the multitude of methods we use to generate, store and use electricity today*

WHERE DO YOU GET the power to run these circuits? Do you use expensive, but convenient, batteries or cheaper, but heavy, mains supplies? What sort of batteries do you use, or do you need stabilised mains supplies? For the answers to your power problems — read on!

Batteries are ideal for low voltage circuits which use comparatively low currents and which have to be portable. If your circuit project uses just a few transistors, or some op-amps, or CMOS digital ICs, then chances are the current drain is so low that a dry battery is the best type of power supply. One possible exception is when there is a seven-segment LED readout — these devices can easily use 20 mA per segment when illuminated, making the life of a dry battery pretty short.

## ESCAPE-PROOF CELLS

The most common type of dry battery is based on the zinc-carbon cell (Fig. 1). The voltage is generated by the chemical action of ammonium chloride (in paste form) on the zinc case, and the hydrogen bubbles which are produced from the chemical reaction are absorbed by the manganese dioxide which is packed around the carbon rod. This action (called depolarisation) is important because hydrogen in gas form does not conduct electricity, so that a layer of hydrogen gas around the carbon rod would make the cell an open circuit. In use, the carbon rod is the positive pole of the cell and the zinc case is the negative pole. Because the zinc is being eaten away by the ammonium chloride jelly during the life of the cell, there is some risk that the jelly will start to leak from an old cell, so 'leakproof' cells use an additional casing of steel around the zinc. Always use these leakproof types in electronic equipment, because ammonium chloride can make a fair old mess of a PCB and all the components on it.

If your circuit has a very low current drain (measured in microamps rather than milliamps), a mercury dry cell may make more sense, because these types can deliver current over very long periods with a steady voltage output. Mercury cells are available in the smaller sizes, such as the AAA size of rod battery and, of course, the button type of watch or calculator battery. An alternative to mercury types for very small cells is the silver oxide cell.

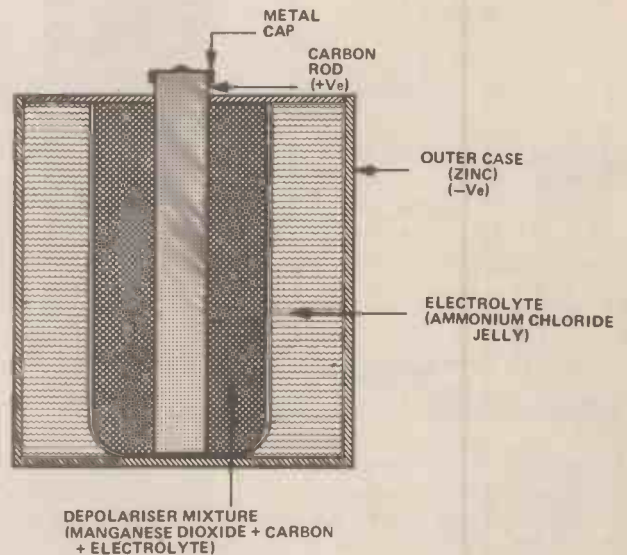

**Fig. 1. A zinc-carbon cell, still the most widely used for batteries.**

If your project needs rather a lot of current and must be operated with no mains cables, then a rechargeable cell or cells will have to be used. The most common type is nickel-cadmium — it's expensive and not always as reliable as its manufacturers claim. Nickel-cadmium cells and batteries are made in sizes which match the sizes of dry cells, but with rather lower voltage. For example, the AAA size Ni-Cad cell has only 1.25 V output compared to the 1.5 V of a zinc-carbon cell and the PP3 size has only 8.4 V compared to the 9.0 V of the zinc-carbon. As a price comparison, a Ni-Cd PP3 will cost anything from £4.50 to £10, depending on whether you get it wholesale price or retail, as compared to the 60p or so for the drycell. In addition, you need a constant current charger — a car battery charger is sudden death to Ni-Cd cells — and you have to keep the cells working. Most failures of Ni-Cad cells seem to occur when equipment is under-used. In general they thrive on hard work and last well providing that they are run right down and then immediately recharged.

## INTERNAL RESISTANCE

Oddly enough, the sealed construction of the Ni-Cad cell, which lets us operate these cells, like dry batteries, in any position, has now been copied to produce lead-acid cells, built along the same lines as the familiar car battery. This is no novelty, really, because sealed jelly-electrolyte lead-acid cells could be bought as Army surplus in 1946, but the sizes have shrunk a bit even if the prices have expanded.

All batteries, wet or dry, primary or secondary, have internal resistance, which is simply the electrical resistance of the materials inside the battery. The effect of this internal resistance is to cause the output at the terminals when current is drawn to be less than the voltage which the battery generates. We can understand why this should happen by drawing a circuit in which the internal resistance is represented as a separate resistor (Fig. 2).

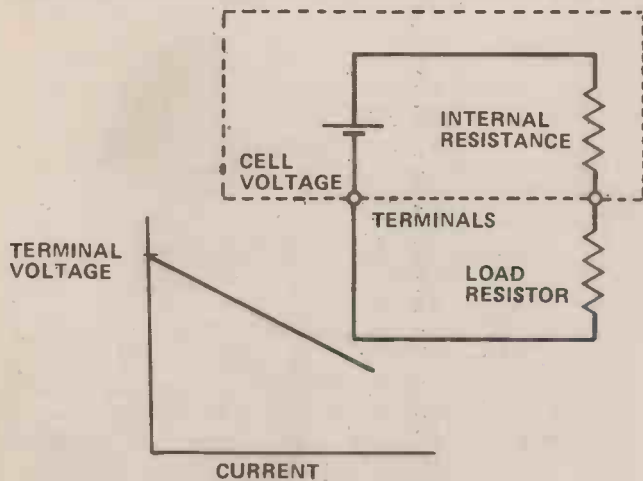

Fig. 2. Internal resistance (a) and its effect (b).

For example, if the battery has a voltage of 9 V at zero current, and the internal resistance is  $4 R$ , then a current of 0.5 A (500 mA) drain from this battery would cause a voltage drop of  $0.5 \times 4 = 2$  V across the internal resistance. Since you can't connect across the internal resistor, the voltage at the terminals is now  $9 \text{ V} - 2 \text{ V} = 7 \text{ V}$ , and this will drop still lower if more current is drained. Fig. 3 shows how to calculate the internal resistance of a battery from measurements of voltage across the terminals. Dry batteries have fairly small

E—READING OF VOLTMETER WHEN SW IS OPEN  
V—READING OF VOLTMETER WHEN SW IS CLOSED  
R1—VALUE OF LOAD RESISTOR IN OHMS

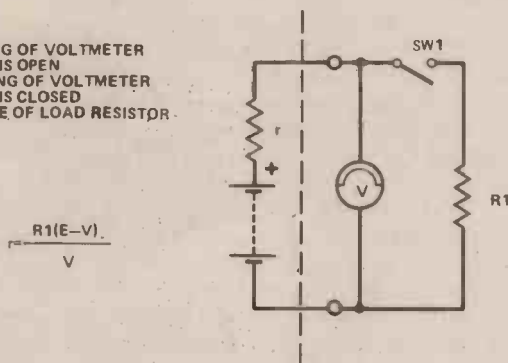

Fig. 3. Calculating the amount of internal resistance.  $R1$  should be a 5% wirewound resistor, value about  $1R5$  for each volt of battery voltage ( $9R$  for a 6V battery, for example).

internal resistance values (about  $0R5$  or less per cell) when fresh, but the internal resistance is considerably greater when the cells are nearly exhausted. Always test the voltage of a cell when a resistor is connected across it — it's a better guide. For cells of SP11 size, a suitable resistance value is around  $1R5$  per cell (so that  $6R$  would be used for a 6 V, four cell battery).

Rechargeable cells have much lower internal resistance values, due mainly to the use of liquid electrolyte. The internal resistance of nickel-cadmium cells is particularly low and that's why they need a special recharging circuit which passes a fixed amount of current for any voltage of cell. The charges used for lead acid cells give a fairly constant voltage and rely on the fact that discharged lead-acid cells have a higher internal resistance than fully charged cells, so that when the cell voltage is low, the high resistance prevents the charger passing too much current. As the cell charges, the resistance drops, but the voltage rises, so that, once again, the amount of current that can pass is limited. Ni-Cad cells have such low internal resistances at all times that a constant voltage supply would pass excessive current. The danger of exceeding the rated charging current is that the cell is sealed and the gas produced when excessive charging currents are used will build up pressure until the cell bursts, making a nasty mess of anything near it. Fig. 4 shows a simple Ni-Cad constant current charger circuit.

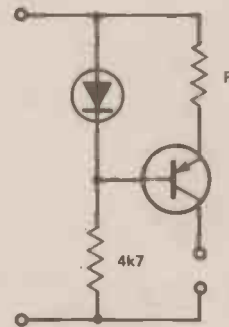

Fig. 4. A simple constant-current supply for a Ni-Cad cell. The current in milliamps is approximately equal to  $21R$ , when  $R$  is in kilohms.

## HORSES AND COURSES

However you go about it, using batteries for anything but the simplest low-current circuits is an expensive way of buying electricity, so that the more ambitious project builder will need a mains power supply unit (PSU). Such units are surprisingly inexpensive to build (less than the price of a PP3 nickel-cadmium cell, for example), but will operate your circuits until the cows come home just for the price of mains electricity — which at the moment works out at 2p per kWh. In case you don't realise how cheap that is, a unit using 10 W, the average consumption of a Hi-Fi set-up, can run for 50 hours for one penny. Even at 100 W consumption, you get five hours for a penny. By contrast, you would get about half a minute of use of a PP9 dry battery taking 10 W at a cost of around 60p. It's horses for courses here, you simply don't use batteries to deliver power of 10 W or so.

## THREE IN ONE

A simple mains PSU consists of three parts. There must be a transformer to step down the mains voltage to the lower voltage we need, a rectifier to convert AC into current flowing in one direction and a reservoir capacitor to convert pulses of current into smooth DC. A typical circuit is shown in Fig. 5 for a nominal 9 V supply.

Because the PSU uses mains voltage at its input, the usual high voltage safety precautions have to be observed. If the PSU is built into a metal box or cabinet, then *the metal work must be earthed* by soldering the earth wire of the mains cable to the metal or to a well-secured solder tag. If a plastic box is used, then the earth cable should still be secured to the frame of the mains transformer, and a lead should be taken to the output of the supply if the negative side of the supply is not to be earthed. Separating the earth and the negative leads allows us to use positive earth supplies if we like, but one side of the output must always be earth connected.

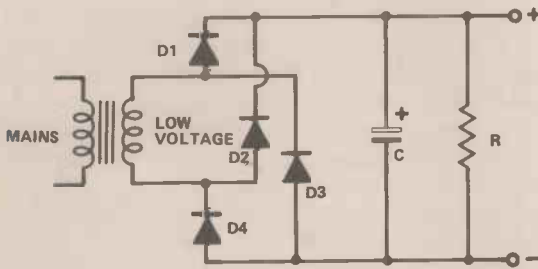

Fig. 5. A rectifier bridge power supply (mains switch and fuse not shown).

## CLAMP THAT CABLE

An additional safety requirement is that the mains cable into the PSU must be well secured, so that if someone (you, perhaps) trips over the cable, the connections will not tear out. Suitable cable clamps can be obtained which are designed for this job — do not use makeshift clamps which can damage the cable. For equipment which is so heavy that the cable would pull out of any clamp, a plug/socket connection to the case of the PSU is acceptable provided that the plug and socket are of an approved type and built to standard BS4491. Remember that if your construction doesn't measure up to modern safety standards, you are responsible for any accidents that may be caused.

The action of a PSU of the type shown in Fig. 5 is something like this. When you switch on, the AC sinewave at one end of the transformer will be in antiphase to the sinewave at the other end of the winding. One pair of diodes will conduct, leading current through the load (the circuit which is powered by the PSU) and also charging up the reservoir capacitor until the peak of the voltage wave is reached. As the wave voltage drops the diodes stop conducting and the load current is supplied by the capacitor discharging. When the sinewave voltages at the transformer reverse, the other pair of diodes will conduct whenever the wave

voltage is greater than the voltage across the capacitor. The capacitor is now topped up with charge once again, until the voltage across it equals the peak of the wave voltage. The way that the diodes are connected ensures that the current through the load is always in the same direction and the reservoir capacitor ensures that the current keeps flowing even when the diodes are not conducting.

If very little current is taken, the supply is almost perfectly smooth DC, but larger amounts of load current will cause the reservoir capacitor to discharge during the time when the diodes are not conducting. This causes an alternating voltage, or 'ripple', on top of the DC voltage and it is this ripple which is the cause of 'hum' from a power supply. The amount of ripple voltage, peak to peak, is approximately given by:

$$V = \frac{1000It}{C}$$

where  $I$  is the load current in mA,  $t$  is the time between peaks (10 ms for a bridge rectifier) and  $C$  is the capacitance of the reservoir capacitor in microfarads. For example, if we decide to use a 500  $\mu\text{F}$  reservoir capacitor on a bridge circuit supplying 100 mA (= 0.1 A), then the ripple voltage is

$$\frac{1000 \times 0.1 \times 10}{500} \text{ volts,}$$

which is 2 V. This isn't too good, but a capacitor of 5000  $\mu\text{F}$  will reduce the ripple to 0.2 V which is much better.

The simple rectifier bridge plus reservoir capacitor type of power supply works well providing we don't expect too much of it, but it does have a fairly large internal resistance. If the circuit needs a steady voltage, unaffected by changes in mains supply voltage or in the amount of current being taken by the load, then a stabilising circuit (stabiliser or regulator) is to reduce the output voltage to a level which is then held steady despite changes in mains voltage or load current and which has no detectable ripple voltage.



A collection of batteries, most of which would be found in any home.

Fig. 6 shows a simple zener diode regulator. The output from the reservoir capacitor is 12 V, but the voltage across the zener diode, providing that at least 2 mA is flowing, is only 5 V. Since the ripple voltage affects only the peak of the waveform (11.5 V to 12.5 V), no ripple appears on the output from the stabiliser and the difference between the supply voltage and the stabilised voltage appears across the resistor. The resistor value is calculated so that the zener diode will still pass current even when the load demands its maximum current. For example, if the maximum load current is 50 mA, then allowing for 2 mA through the zener diode, a total of 52 mA must drop 7 V (12 V—5 V) across R1. The value of R1 is therefore

$$\left(\text{from } R = \frac{V}{I}\right) \quad \frac{7}{52} \text{ k}$$

which is 0.135k or 135R — the nearest preferred value is 120R.

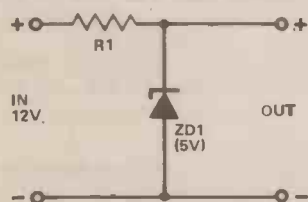

Fig. 6. A simple zener-diode voltage stabiliser.

## SERIES STABILISER

For larger load currents, a series stabiliser such as that of Fig. 7 is used. Q2 is a power transistor used to control the flow of current to the load so that the voltage across the load is constant. A sample of the voltage across the load is selected by resistors R3 and R4 and fed to the negative input of an operational amplifier IC1. The action of this IC is to amplify the difference in voltages at its two inputs, marked + and —, and the output voltage is always in antiphase to the — input voltage. The zener diode fixes the voltage at the + input of the IC. Now if the output voltage rises too high, making the voltage at the — input higher than the zener diode voltage, the voltage at the output of the IC will drop, causing Q1 to be biased back. This in turn will bias Q2 back so that the current fed to the load is reduced. Since this will reduce the voltage at the output, the rise of voltage has been corrected. Similarly, any drop in output voltage will cause the voltage at the — input of the IC to drop, making the output voltage rise, increasing the bias on Q1 and Q2 and so providing more current to the load. Once again, this corrects the fall in voltage, so that the stabilisation is automatic.

While a stabiliser circuit such as this one is most effective, several factors can cause the stabilisation to fail. One possibility is attempting to stabilise at an output voltage which is too close to the supply voltage, for example providing a 10 V stabilised supply from a 12 V unregulated supply. This causes problems because the

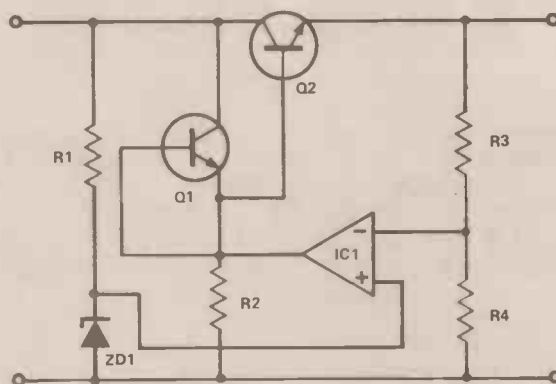

Fig. 7. A series stabiliser circuit using an operational amplifier.

12 V will drop as more current is passed, and when the unregulated voltage becomes too low there is not enough voltage across the two transistors to keep current flowing. A second problem concerns the IC which must be a type which permits the input and output voltages to rise close to the supply voltage — the popular 741 does not do this. The third problem is that if the reservoir capacitor of the unregulated circuit is too small, all the stabilisers in the world will not prevent ripple from appearing on the output voltage.

One final headache arises when a stabiliser works too well! If the output is accidentally shorted, the stabiliser will burn out its transistors trying to keep the output voltage constant. The addition of the circuit of Fig. 8

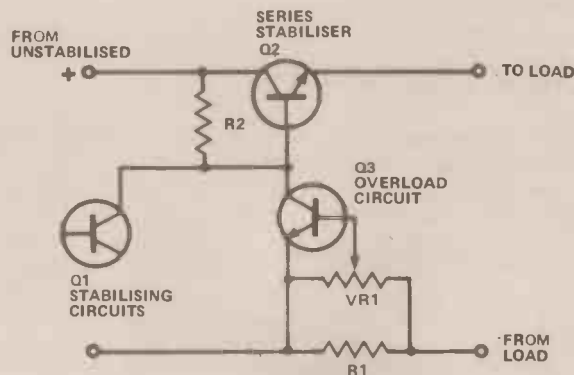

Fig. 8. An overload protection circuit. The potentiometer RV1 is used to set the current at which the protection operates. R1 is a low-value resistor, 1R0 or less.

prevents such a situation. When the current returning from the load passes through R1, a voltage ( $V = R1 \times I$  load) appears across the base and emitter of Q3. If this voltage is sufficient to switch Q3 on, the collector of Q3 will conduct and its connection to the base resistor of Q2 will cause Q2 to switch off, so switching off the stabiliser. Saved, you might say, by yet another chunk of silicon!

HE

# Hobby Chit~Chat

**In this month's 'Chit-Chat' Ray Marston looks at low-cost burglar- and security-alarm circuits**

BURGLAR ALARMS and home security systems are genuinely useful projects that are always popular amongst electronics hobbyists. The most important feature to look for in such alarms is their system reliability or immunity to false alarms. Most 'clever' alarm systems, such as those using ultrasonic, infra-red, or proximity-detection principles, tend to be rather unreliable and, generally speaking, should be avoided like the plague, particularly when they are amateur-designed circuits published in electronics hobbyist magazines other than HE and ETI (most projects published in HE are designed by the journal's team of professional engineers).

The most reliable types of burglar alarm are those that use electro-mechanical devices such as microswitches, reed-and-magnet switches, or pressure mat switches, as intrusion sensors. Fig 1 shows the simplest of all types of burglar alarm. The circuit is activated via normally-open (close-to-operate) switches such as pressure mats and consumes zero standby current. When any of the switches close the relay turns on the self-latches via contacts RLA/1 and the alarm is activated via contacts RLA/2. This circuit can be used to give a reasonable degree of security to a small house.

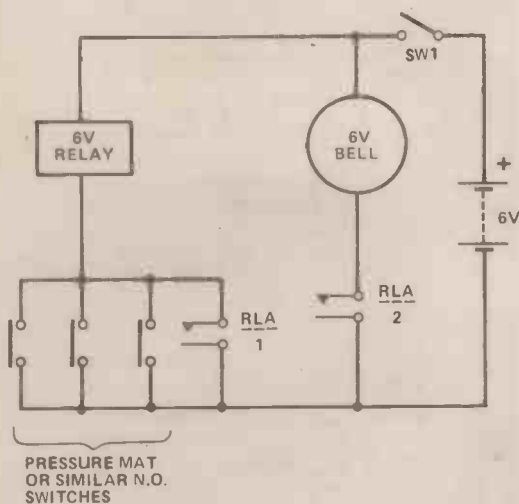

**Fig 1. This simple close-to-operate self-latching burglar alarm is adequate for many domestic applications**

## BREAK-TO-OPERATE ALARM SYSTEMS

An alternative type of alarm system is shown in Fig 2. Here, normally, closed switches are used as intrusion sensors. Normally, with all switches closed, the base and emitter terminals of Q1 are shorted together, so Q1 and the relay are off. If any of the sensor switches open, Q1 and the relay are turned on via R1 and the relay is self-latched via contacts RLA/1.

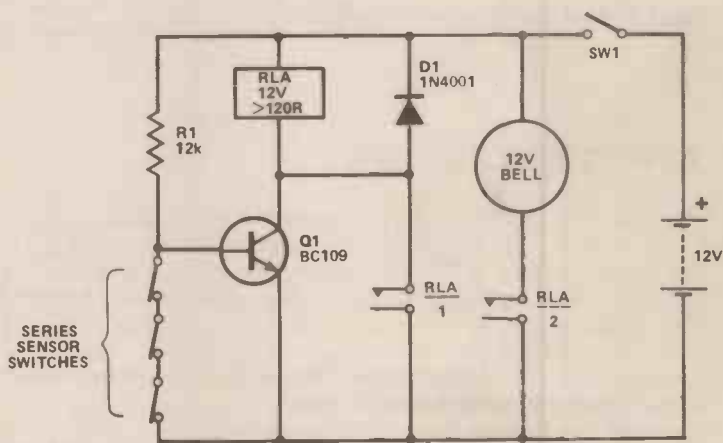

**Fig 2. This simple break-to-operate alarm consumes 1mA standby current**

This basic 'break-to-operate' type of circuit has two distinct advantages. First, the alarm automatically activates if any of the sensor-switch leads are cut or broken. Second, the series-connected switches of the circuit are far easier to install in a building than the parallel-connected switches of the Fig 1 circuit. This second point is particularly important when complex switch-wiring installations are concerned. A major disadvantage of the Fig 2 circuit is that it draws a fairly hefty 'standby' current of 1 mA via hold-off resistor R1.

Fig 3 shows an improved version of the basic Fig 2 circuit. Here, IC1 is a 4-gate CMOS IC with one of its gates used as a simple inverting buffer between R1 and Q1. The use of this gate enables the R1 value to be increased to 12M, thereby reducing the circuit's

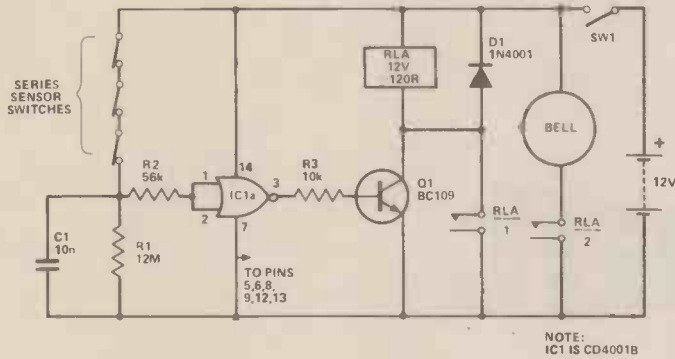

Fig 3. This CMOS-aided alarm draws only 1mA standby current

standby current to an insignificant 1 uA. Note the use of C1 and R2 in this circuit. In practical installations many metres of wire may be used to interconnect the series sensor switches and this wire tends to pick up spurious pulses and signals, particularly during thunderstorms. C1 helps reject these spurious signals and R2 protects the IC against lightning-induced spikes.

An alternative type of break-to-operate alarm circuit is shown in Fig 4. In this case the self-latching action is performed by the IC1a-IC1b bistable circuit. C2 and R4 cause the bistable output to latch low at the moment that SW1 is closed, ensuring that the relay and alarm are off. If any of the sensor switches are activated they cause a 'high' signal to be fed to pin 2 of the bistable, which then latches into a high-output state which turns on Q1 and RLA. Relay contacts RLA/1 are used to activate an external alarm generator.

Note in the Fig 4 circuit that R2 is wired in series with the series sensor switches, thereby enabling the circuit to be activated by either the series switches or by paralleled pressure-mat switches wired across R1. The circuit thus makes a versatile burglar alarm. The circuit is designed to activate an external alarm generator that is equipped with its own power supply.

Fig 5 shows how the above circuit can be modified to give auto-turn-off alarm action, so that the alarm sounds as soon as an intrusion is detected but turns off again automatically after four minutes or so. This action is obtained via IC1a and IC1b, which are wired together as a monostable or one-shot multivibrator that is triggered by the sensor switches.

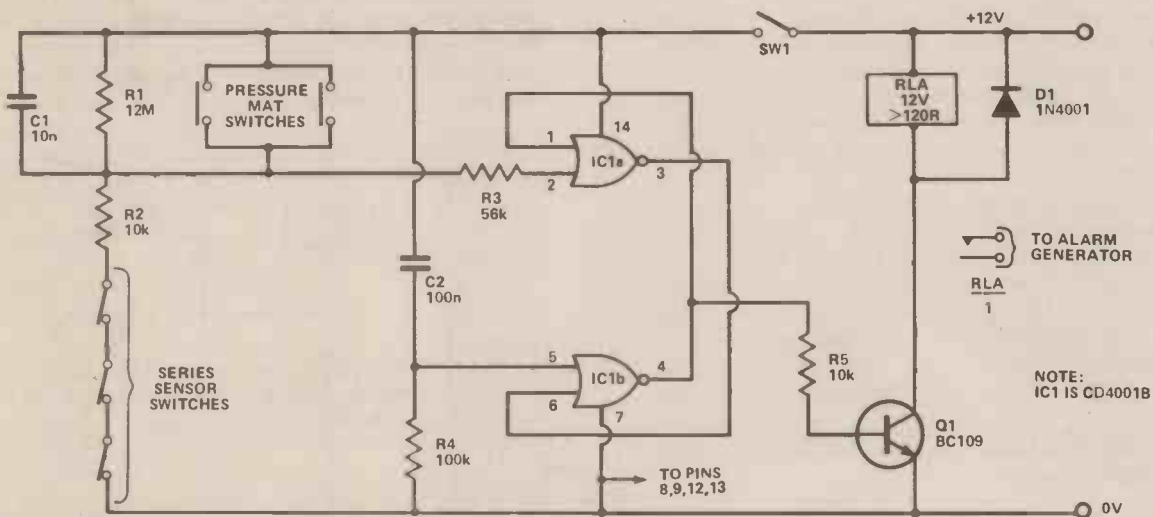

Fig 4. A simple self-latching burglar alarm

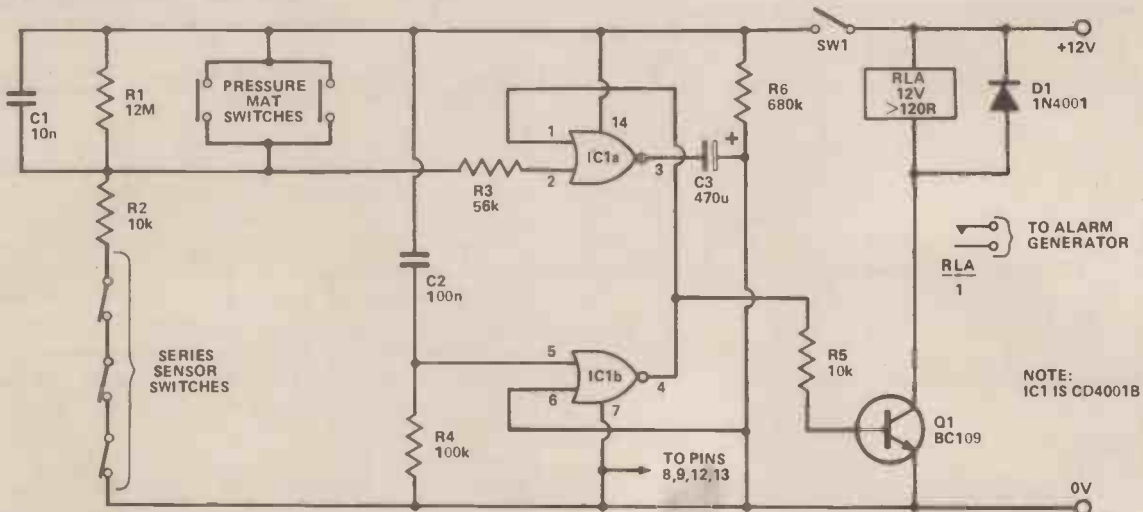
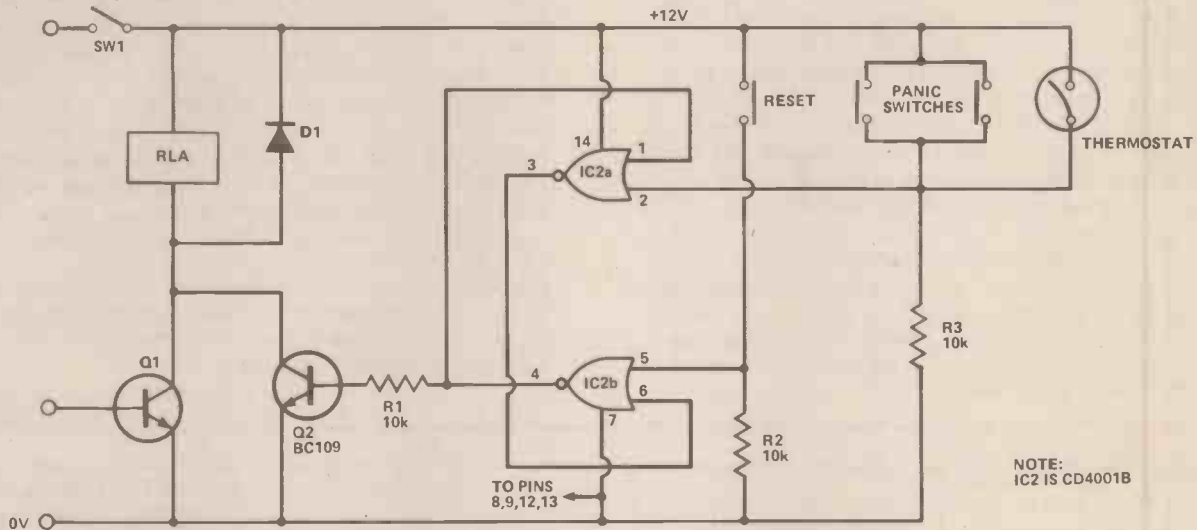

Fig 5. An auto-turn-off burglar alarm (turn off delay = 4 minutes)





**Fig 6. 'Panic' and 'Fire' alarm circuit can be added to the Fig 4 or 5 circuits**

Note in the Fig 4 and 5 circuits that Q1 and the relay are permanently connected to the power supply rails, even when SW1 is open. This fact makes it easy to add accessories such as fire detectors and 'panic' buttons, which must be permanently enabled, to the basic circuits. 'Panic' buttons are push-button switches that are placed in vulnerable intrusion areas such as halls, kitchens and bedrooms, to enable aid to be summoned via a self-latching alarm generator at any time.

Fig 6 shows a practical add-on 'Panic' and 'Fire' alarm circuit that can be used with either of the Fig 4 and 5 circuits. IC2a and IC2b are wired as a bistable latch that can be used to turn the relay on (via Q2) via any of a number of parallel-connected panic switches or fire-sensing thermostats. Note that if you decide to combine (say) the Fig 5 and 6 circuits into a single unit, it is still necessary to use two independent ICs for IC1 and IC2, since these ICs must have isolated supply connections.

## A COMPREHENSIVE HOME SECURITY SYSTEM

The burglar alarm circuits that we've looked at so far all give useful but limited performances. This month's final circuit, by contrast, gives an outstandingly good perfor-

mance and incorporates a number of sophisticated features. The circuit is that of a comprehensive home security system and is shown in Fig 7. The circuit is powered from a 12 volt supply and draws a quiescent current of only a few uA.

The operating theory of the Fig 7 circuit is fairly complex. The power supply to the CMOS circuitry is smoothed via D3 and C4, ensuring that the circuitry is not adversely influenced by power-supply transients. This factor enables the alarm system and the alarm generator (a bell or electronic siren, etc) to share the same power supply. Normally, with SW1 closed and all sensor switches inactive, LED 1 and the relay and alarm are all off. C1-R3 and C2-R5 suppress the effects of any transients or lightning-induced spikes that are on the switch wiring.

If any of the sensor switches activate, the inputs of IC1a and IC1b go high. This action causes LED 1 to turn on and (normally) causes the relay to immediately turn on via Q1 and IC1c-IC1d. As the relay turns on it self-latches via contacts RLA/1 and activates the alarm generator via contacts RLA/2. Note that the self-latching relay is permanently wired to the supply circuit and can be activated at any time via panic buttons or fire-sensing thermostats, as shown in the diagram.

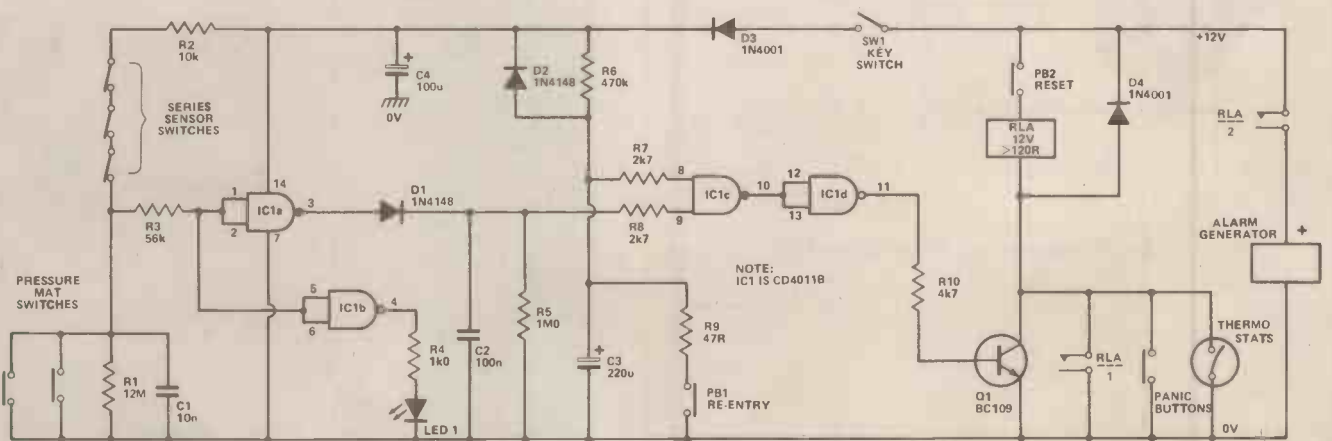

**Fig 7. A comprehensive high-performance home security system**

In the previous paragraph we've described what happens under 'normal' conditions, when SW1 has been closed for more than a couple of minutes. An exception to this occurs when SW1 is first closed or if PB1 is pressed and then released. Under either of these conditions the C3-R6-IC1c network disables the Q1 input circuitry for approximately 100 seconds. At the end of this period the circuit returns to normal operation. This facility is of great practical value, as follows.

When the system is first turned on via SW1, LED 1 should remain off, indicating that all sensors are inactive. If LED 1 does illuminate, a sensor fault is indicated and the owner is thereby warned to locate the fault before the alarm sounds. If the owner wishes, he may leave the premises via a protected door without sound-

ing the alarm during this 100 second 'hold off' period. At the end of the period the system reverts to normal operation and will activate the alarm generator instantly if an intrusion subsequently occurs. On his return the owner can re-enter the premises via a protected door without sounding the alarm by first operating the (concealed) PB1 'RE-ENTRY' switch and thereby initiating a new hold-off period. SW1 should ideally be a key switch or a concealed switch.

The Fig 7 circuit can be used with a wide variety of types of alarm generator circuit, including bells, sirens, electronic sirens, etc. These alarms can, if required, be chosen to given an auto-turn-off action. Suitable alarm-generator circuit will form the main subject of next month's 'Chit-Chat' feature.

HE

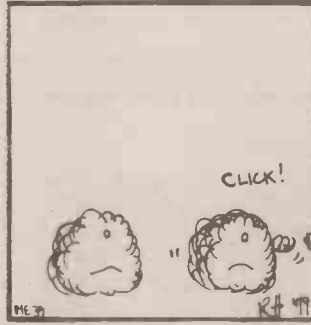
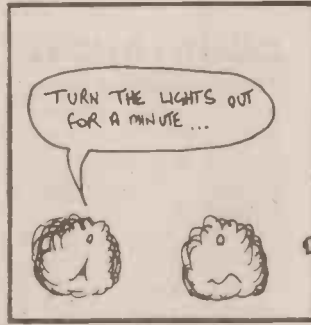
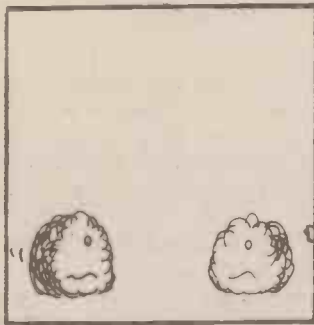

## Random Electronic

# EASY DICE

Build your own 'EASY DICE' from the 5 integrated circuits and full components supplied, including box and descriptive instructions.

Complete  
or  
Kit

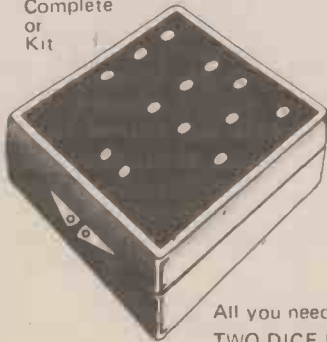

P.C.B.  
Layout

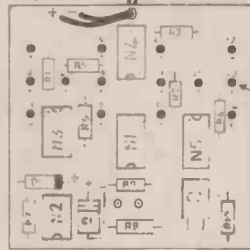

All you need is a soldering iron  
TWO DICE FACES TOUCH CONTROL..

- |   |                     |       |              |
|---|---------------------|-------|--------------|
| a | *Self Assemble Dice | £3.95 | plus 25p p&p |
| b | *Ready built Dice   | £4.75 | plus 25p p&p |

Order now from: **Menorcrest Electronics Ltd.**

1 Hatton Court, Ipswich, Suffolk. 0473 210151

Amount enclosed £ \_\_\_\_\_

Name \_\_\_\_\_

Address \_\_\_\_\_

please state amount required in appropriate box  a  b

# TEE SHIRTS

We won't guarantee HE Tee-Shirts will make your soldering any better, we won't even claim it will make your projects work first time. What we will say is that it will protect your body from harmful Ultra-Violet radiation from the sun, embarrassing Tomato Ketchup stains on your hairy chest and overweight wallets (if bought as directed in sufficient quantity).

Yes folks, for just £2 all inclusive you can be the first kid on your block to own a brand new HE Tee-Shirt. If you buy more than one your torso need never be left unprotected whilst your other one is in the wash.

Send your cheque, PO or anything negotiable to:  
**HE TEE SHIRTS, 145 Charing Cross Rd, London WC2H 0EE.**



# Win Indicator

**An inexpensive and easily-built project that is bound to be a winner with all games enthusiasts with ten or fewer arms.**

THIS PROJECT IS DESIGNED TO BE USED in those 'first-person-to-press-the-button-wins-the-game' types of activity that are so popular at parties and fund-raising functions. The device enables up to ten contestants to participate in such games and gives a virtually infallible audio-visual indication of the true winner of the game, even when all contestants *seem* to operate their push-buttons simultaneously.



*We scoured the local games shop to come up with a few examples that would benefit from such a device.*

In this project, each contestant is assigned a numbered push-button, with which an identically numbered LED (light-emitting-diode) is associated. Prior to the start of each game, the game referee presses a RESET button, which causes all LEDs to turn off and causes an electronic scanning circuit to start sequentially inspecting the state of each switch at a rate of several thousand scans per second. The 'game' switch to be subsequently operated causes the scanning action to lock at that switch position and activate a simple memory circuit, which energises an audible alarm and latches on the individual numbered LED that is associated with the winning switch; all subsequent switch operations are ignored by the unit. The alarm and the winning LED remain on until the referee again operates the RESET switch.

The HE Multi-Input 'Game Won' Indicator circuit is powered from a single 9 volt battery and is an easy and inexpensive project to build. It can be used with any

number of GAME switches up to a maximum of ten. Unwanted switches are simply omitted from the circuit.

## CONSTRUCTION

All components except the switches and speaker are mounted on a single PCB. Construction should present few problems, provided that normal care is taken to ensure that all components are fitted in the correct polarity. The following minor points should, however, be noted.

- (1) The ten indicator LEDs are mounted close to one edge of the board. The LEDs should be given individual functional checks (by connecting them across a 9 volt supply via a 470R limiting resistor) before soldering them into place.
- (2) Five under-board links are used to connect the LEDs to the output of IC1.
- (3) Connections to the 'top' terminals of the ten external GAME switches are made via three top-board Veropins and seven under-board connections. The 'bottom' terminals of all ten switches are wired together and taken to R2 via a single Veropin connection.

When construction is complete you can connect the unit to a speaker and a 9 volt battery and give it a simple functional test, as already described. The completed unit can then be fitted into a suitable case of your own choice. 

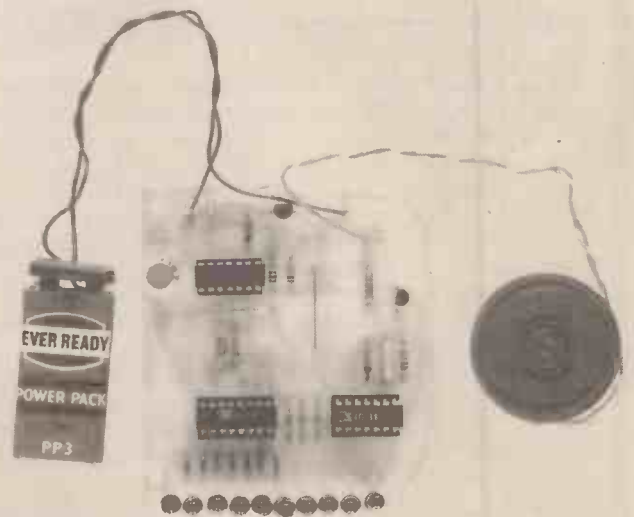

*As you can see we have left the choice of a box up to the individual constructor, similarly the LED panel may be used as a separate board for remote applications.*

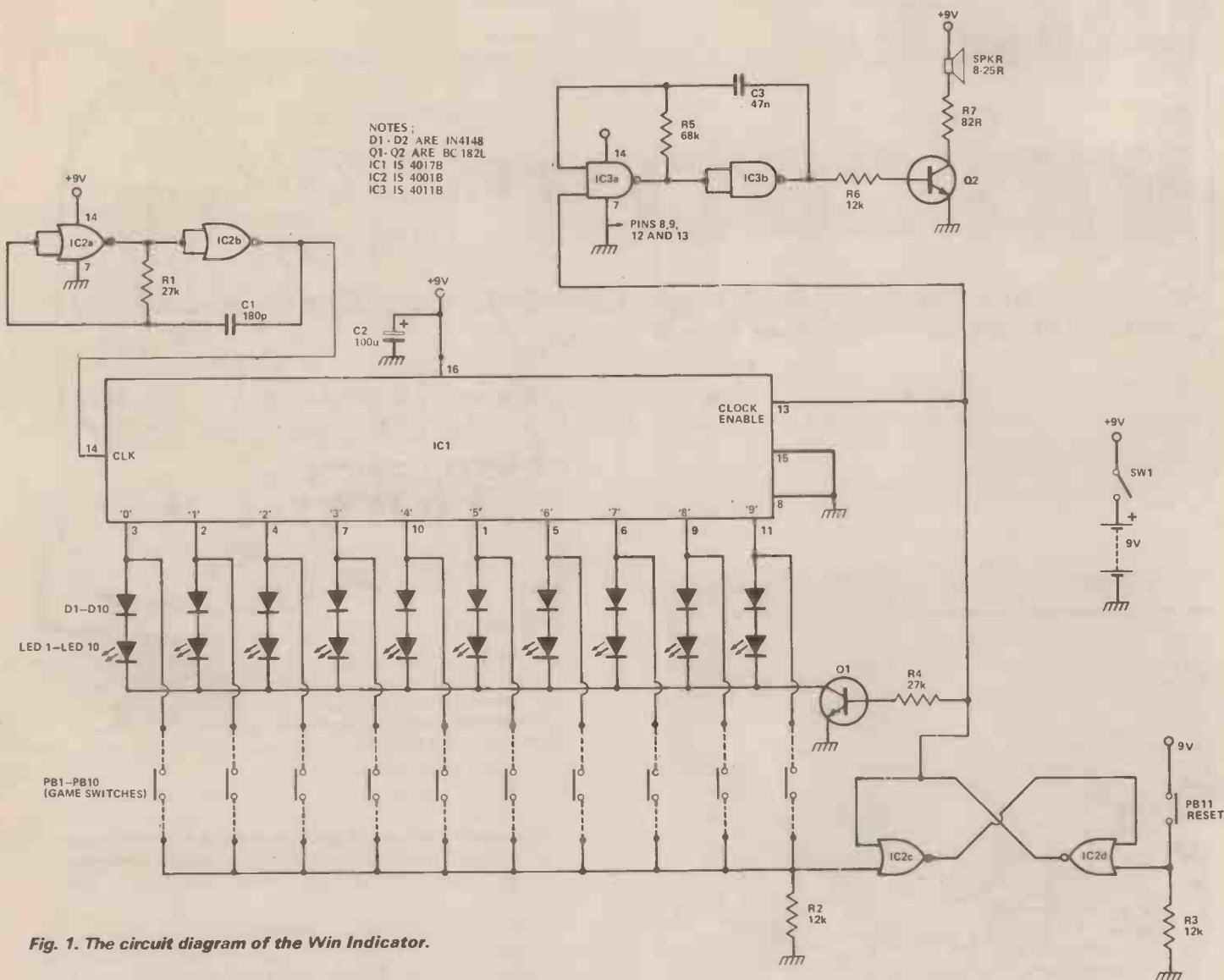

Fig. 1. The circuit diagram of the Win Indicator.

## How It Works

IC1 is a 4017 'decade-divider-with-ten-decoded-outputs'. When this IC receives clock signals its ten decoded outputs sequentially go high in synchrony with the clock signals, with only one output being high at any given moment of time. An indicator LED is wired between each of these current-limited outputs and ground via switching transistor Q1. IC2a-IC2b are wired as a fast astable 'clock' generator that is permanently operational when on/off switch SW1 is closed. IC2c-IC2d are wired as a simple bistable that can be SET by a brief positive pulse across R2 or RESET via PB11. The output of the bistable is fed to the CLOCK ENABLE terminal of IC1, to the base of Q1 via R4 and to the input of a gated sound generator that is built around IC3 and Q2.

At the start of each 'game' the IC2c-IC2d bi-stable is reset via PB11. Under this condition IC1 accepts clock signals but Q1 is turned off, so none

of the LEDs are operational. The IC3-Q2 sound generator is also turned off. In this mode of operation, sample or 'scanning' pulses are sequentially applied to one side of each of the normally-open game switches at the 'clock' rate.

If any of the PB1-PB10 GAME switches become momentarily closed during this operation the scanning pulse will pass through the switch to the SET position. Under this condition the CLOCK ENABLE terminal of IC1 goes high, causing the IC to lock at that scan position. Simultaneously, Q1 turns on, causing the LED associated with the winning switch to illuminate and give a visual indication of the game winner. The sound generator also activates at this time, giving an audible indication of the 'game won' state. The audio/visual indication then remains on until the bistable is reset via PB11 or until the circuit is turned off via SW1.

## Parts List

### RESISTORS

|          |     |
|----------|-----|
| R1, 4    | 27k |
| R2, 3, 6 | 12k |
| R5       | 68k |
| R7       | 82R |

### CAPACITORS

|    |                            |
|----|----------------------------|
| C1 | 180p polystyrene           |
| C2 | 100u 25 V PCB electrolytic |
| C3 | 47n polyester Mullard C280 |

### SEMICONDUCTORS

|                                       |        |
|---------------------------------------|--------|
| IC1                                   | 4017   |
| IC2                                   | 4001   |
| IC3                                   | 4011   |
| Q1, 2                                 | BC182L |
| D1, 2                                 | IN4148 |
| Led1-10, are standard 0.2in. Red leds |        |

### MISCELLANEOUS

|                                    |  |
|------------------------------------|--|
| PB1-11 are momentary push buttons. |  |
| LS1, 8-25R                         |  |

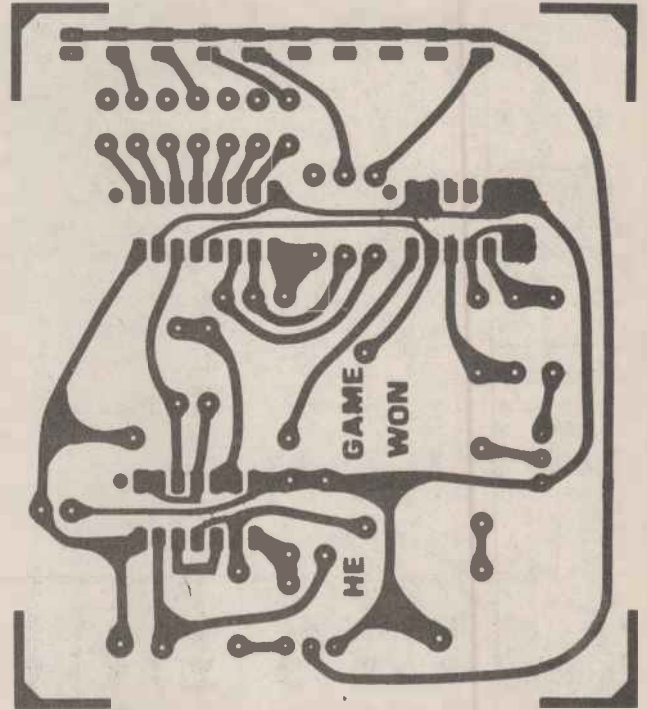

Fig. 2. Above. The PCB foil pattern for the Game Win Indicator. As was mentioned earlier the use of an all-in-one design is purely a matter for personal choice. The unit will function equally well with the LED indicator panel on a separate board.

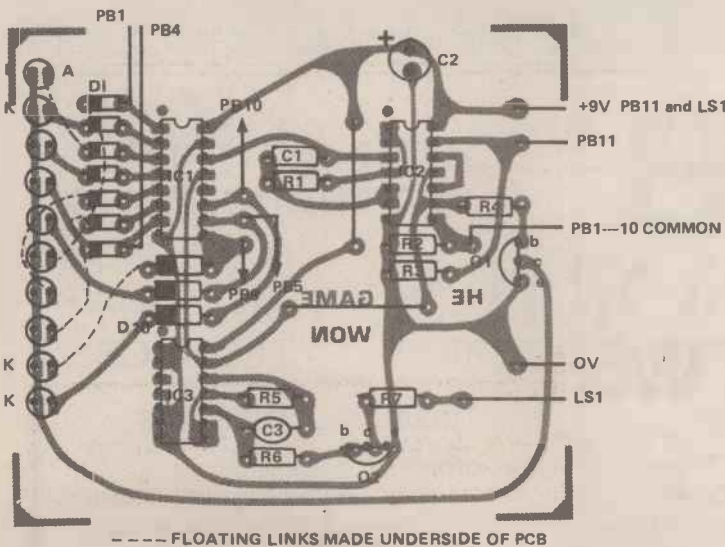
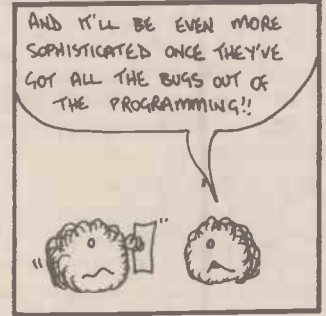
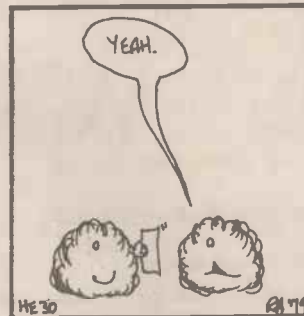
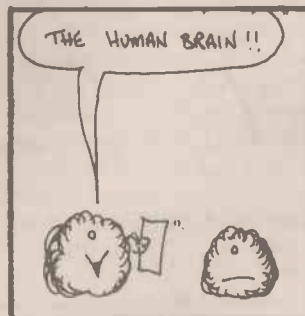
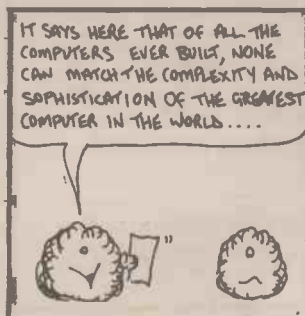

Fig. 3. Left. Overlay diagram, ensure that all polarised components, ie ICs, diodes etc are inserted the right way round. This causes more 'dead' projects than any other factor.

## Buylines

None of the components used in this project should be difficult to obtain. We have not specified push button switches as virtually any type will do, however make sure they are push-to-make and that they do not 'lock' in the ON position otherwise confusing results may be obtained or the reset will not work.



# The NEW Marshall's 79/80 catalogue is just full of components

*and that's not all . . .*

. . . our new catalogue is bigger and better than ever. Within its 60 pages are details and prices of the complete range of components and accessories available from Marshall's.

These include Audio Amps, Connectors, Boxes, Cases, Bridge Rectifiers, Cables, Capacitors, Crystals, Diacs, Diodes, Displays, Mountsinks, I.Cs, Knobs, LEDs, Multimeters, Plugs, Sockets, Pots, Publications, Relays, Resistors, Soldering Equipment, Thyristors, Transistors, Transformers, Voltage Regulators, etc., etc.

Plus details of the NEW Marshall's 'budget' Credit Card. We are the first UK component retailer to offer our customers our own credit card facility.

Plus — Twin postage paid order forms to facilitate speedy ordering.

Plus — Many new products and data.

Plus 100% of prices cut on our popular lines including I.Cs, Transistors, Resistors and many more.

If you need components you need the new Marshall's Catalogue.

Available by post 65p post paid from **Marshall's, Kinggate House, Kinggate Place, London NW5 4TA**. Also available from any branch to callers 50p.



Retail Sales: London: 40 Cricklewood Broadway, NW2 3ET. Tel: 01-462 0161/2. Also 325 Edgware Road, W2. Tel: 01-722 4242. Glasgow: 95 West Regent Street, G2 2UD. Tel: 041-332 4133. And Bristol: 105A Stokes Croft, Bristol. Tel: 0272 426801/2.

## K40

SUPEREX CB  
AUVICO CB  
TURNER CB  
HYGAIN

RETAIL  
& TRADE

# CB

## ACCESSORIES

HAM

INTERNATIONAL CB  
H.M.P. & E.A.  
ANTENNAS  
TELEX CB

## K40

SPEECH PROCESSORS  
(inc. K40, Telex)  
POWER MIKES  
MAGIC MIKE  
(without cord)  
SPEECH COMPRESSORS  
VOICE OPERATED MIKES

K40 BASE LOAD  
DV27 - all types  
DX27 - inc. 'S' type  
DK27 - with or without  
Splitter Box  
ELECTRIC AM/FM/CB  
(no loading coil)

DISGUISED ANTENNAS  
BASE ANTENNAS  
(inc. Beam, Omnidirectional,  
Balcony, Loft & Indoor)  
ANTENNA ACCESSORIES  
(inc. Splitter, Cable, PL259,  
Plugs etc.)

SWR METERS  
SWR/POWER METERS  
SWR/POWER/MODULATION  
METERS  
SWR/POWER/  
MODULATION/  
FIELD STRENGTH  
METERS

# WINTJOY

Ltd.

COMMUNICATIONS EQUIPMENT DISTRIBUTORS

103 High Street,  
Shepperton, Middlesex

Tel: Walton-on-Thames 48145

POWER SUPPLIES  
LINEAR AMPLIFIERS  
(up to 200W)

MOTORCYCLE CB  
ACCESSORIES

☆ until Rigs become legal we will be unable to supply them ☆

JRA

# Breaker One-Four

Send any news, comments, or information you may have to:  
**Breaker One Four,  
Hobby Electronics,  
145 Charing Cross Road,  
London WC2H 0EE.**

**A very busy month, we have details of the Government statement on CB and a report on the CB clubs meeting last month plus some news of the demonstration in London on December 15th.**

WE'RE NEARLY THERE, the great announcement may not have been everything we had hoped for but at least there are no technical difficulties. We feel that the whole question of CB could have been squashed for a good few years if the Home Office had said there was a problem, who can argue with the Official Secrets Act?

In response to the scores of phone calls and letters we have reproduced the press release from the Government. Take a pat on the back for all of the signatures on the petitions, they did take notice. By the way, the number shown is somewhat low as we still have quite a few that arrived after our deadline, maybe we will give them to the Home Secretary to remind him. The spelling mistake on the first line is theirs, not ours.



HOUSE OF COMMONS  
LONDON SW1A 0AA

27 November 1979

The Officers of the Parliamentary Capital Band Radio Committee met the Minister of State at the Home Office yesterday. A great deal of work has been done by the Home Office on the question of legalisation of CB Radio. The Minister was sympathetic to the principle and said that there were no insuperable technical difficulties.

The Officers agreed with the Minister that the 27 mhz frequencies (at present used by model aircraft controllers) would not be legalised.

The Minister explained that the real problem was that the administration of the scheme would require more civil servants at a time when the Government was introducing a programme to cut down the numbers of the civil service. The Officers pointed out that the administration could be self financing and would need a minimum of civil servants. The Minister took note of this view but could make no promise as to future legislation.

A petition organized by the magazine "Hobby Electronics" praying that CB Radio could be legalised and containing 16822 signatures was presented to the Minister by Mr Patrick Wall, the Chairman of the Parliamentary Committee.

*The press release from the Government on the 27th November.*

## DAMP DEMO

Yes, BOF was at the demonstration in Hyde Park on Saturday the 15th December. Yes, we did get exceedingly wet and to make it a complete nightmare the camera failed to wind on so no pix, sorry.

Having dutifully turned up at about five minutes before the appointed hour, located the miserable, soaking gathering, right in the middle of a wind-swept expanse (who's idea was that? the tea hut was only about a hundred yards away), we proceeded to take about a dozen ill-fated pictures. It was interesting to count the police, a conservative estimate put them at about 100, most of them drifting away to the comfort of their coaches parked nearby. By around 11.15 there were something like 30 bedraggled, placard carrying demonstrators, not too much seemed to be happening so the stalwart BOF reporter decided to call it a day and squelch his way home to dry off.

A little while later a phone call from a fellow reporter enquired "where were you." It turned out that after the rain had stopped CB demonstrators turned up in their hundreds, the demonstration went ahead and a good time was had by all. Anyone care to share a case of double pneumonia.

Word has it that another demonstration is planned for the middle of January. If we have recovered by then we will be there, this time two cameras and a working umbrella. A report on that next month.

Note to demonstration organisers. Please do not hold demonstrations on Saturdays near Christmas. Avoid as far as practical wet, blustery days and in future hold them a little nearer the tea hut.

## CB ON SALE

Several companies seem to have 'sprung up' in the last few months offering CB goodies. To avoid the sharks BOF has been looking at some of the more respectable dealers.

For those of you looking for something 'special' in CB hardware. Wintjoy Ltd of 103, High Street, Shepperton, Middlesex have just opened their doors. They boast an impressive stock of some 1500 different items, the K40 speech processor mike at about £40 sounds interesting. They have the dealership for several other hard-to-get items including the 'Magic Mike' a cordless radio mike that dispenses with those cumbersome trailing leads. If anyone is interested in setting up a dealership with them they would also like to hear from you.



The meeting of the CB clubs took place on the 2nd of December as planned, we must apologise for our absence, at the time we were setting up the Breadboard show at the Horticultural Hall and it was just impossible to get along.

Nevertheless our spies were there, by all accounts it was a very useful meeting. It appears that a 'Steering Committee' made up of representatives from the clubs media etc will attempt to keep the campaign going, this time in a much higher gear.



This rather interesting picture dropped onto BOFs desk the other day, The device is a mobile telephone operating at 27 MHz. It comes from Tandy (Radio Shack). We must stress that as far as we know Tandy are not selling them over here but we must admit that something looking suspiciously like it has been seen in one or two shops in London recently.

In a similar vein, a couple of companies are blatantly advertising walkie-talkies for sale in this country, they do operate on 27MHz and hence are illegal but please don't be caught, they are practically useless as CB sets having a range of about as far as you could shout. Besides that they are grossly overpriced, similar equipment is sold in the States as toys for around three or four pounds a pair.

## CB CATALOGUE

The first 'English' CB catalogue arrived the other day, it comes from City, (see ad in this issue) and is very complete. (Dare we say a bit naughty in places too). A really comprehensive section on aerials, connectors and accessories at very reasonable prices. Some examples a superb looking omni-directional base station antenna for under £30, TVI filters for £3.49, power mike for around £20 and a combined SWR, Power and Field Strength meter for £10.75 highly recommended reading.

## NEXT MONTH

Something a little special next month, we have been presented with a K40 speech processor mike. As it



The K40 speech processor mike

would be impossible for us to do an actual test we have decided to assess it scientifically. See what fun and games we had with that next month.

With a little luck we shall be giving you the results of the Tape Competition and the latest news on the demonstration in London.

One last titbit from a good friend, apparently someone is importing rigs into the country bearing the Hy-Gain label. Hy-Gain went out of business some two years ago and these rigs are not from them, don't be caught because part from anything else they are rubbish and an awful lot of them are apparently breaking down.

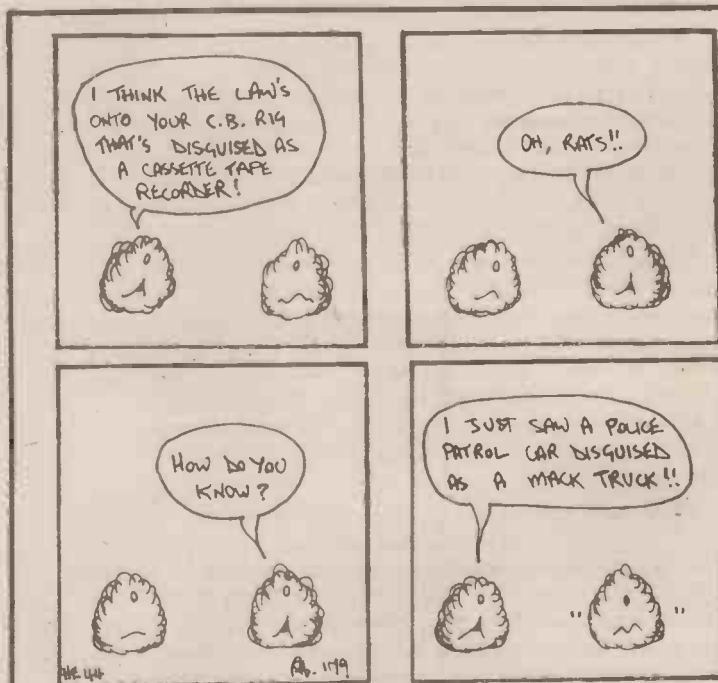



# Into Electronics Construction

*Electronic construction isn't half as mysterious as some people think. Ian Sinclair shows how-to-do-it in this short series. In part one we will be looking at some basic circuit components and build a simple, working project.*

STOP RIGHT THERE. Are you thumbing through this magazine, perhaps for the first time, wondering how you could get started? Maybe you're already well into electronics — but do you know someone who would like to get started? Spread the news, order the copies, for this is the *absolute beginners'* spot, starting here and now and running for six months.

It's always difficult for a beginner to start a new hobby. There are all the new words to learn just to begin with. After that, what to buy? How do you get it all working properly? We've guided lots of beginners through all these problems which spring up when you're getting into electronics, and the result is a scheme which we reckon is pretty watertight. Stand by for launching!

We're not going to come up with a great stream of theory, because this is a *practical* series. What we're going to start with, then, is the gadget which makes the whole series possible. It's not the cheapest item on the shopping list, but it gets you into electronics construction so easily and with so little waste of materials that it pays for itself right away. It's called a Eurobreadboard and there's a photo of it right there at Fig. 1.1

What is it and what does it do? Well, it's a chunk of plastic whose top surface is dotted with holes. You can push wires (but only single-strand wires, please) into these holes. When you do that, the wire is gripped by a metal clip which also makes an electrical connection, and that electrical connection means that electricity can flow from the wire to the clip or from the clip to the wire if there's a battery connected somewhere to move the electricity.

Now the cunning thing about all this is that the clips aren't separate, they are connected together in groups of five. Let's demonstrate this — connect two wires to the lampholder. If you've never done anything of the sort before, what you do is to cut the plastic coating (called insulation) from about half an inch of one end of a wire, and curl the bare bit of wire around the screw connection

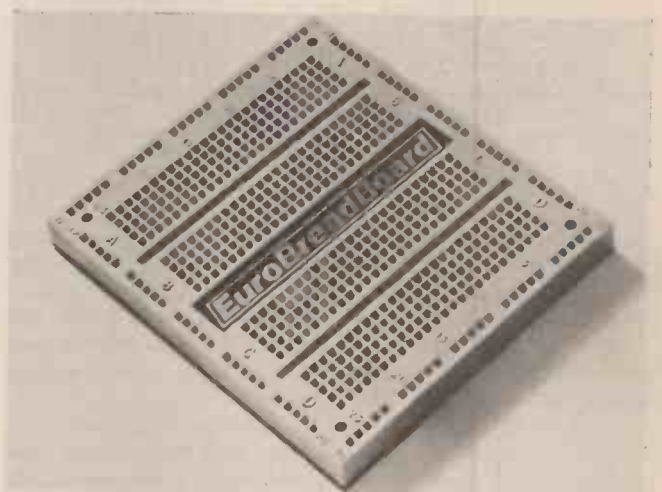

**Fig. 1.1** The Eurobreadboard. Complete circuits can be constructed on this device without soldering, and components plugged in and out as desired.

of the lampholder. Screw the connector down on the wire, then repeat with another length of wire connected to the other connection of the lampholder. Now screw in a 6 V 0.04 A bulb — that's the type which is used for the rear light of cycle dynamo outfits. This little lot — the bulb in its holder with the wires — is now a component for your circuits.

Connections to the 6 V battery are not so easy to arrange. The easiest way is to buy a connector lead, but these usually have stranded wire, made up of several fine strands so as to make the wire more flexible. If this stranded wire is pushed into a Eurobreadboard socket, assuming you can ever get it to go in, the fine strands will separate and bend and catch in the metal clips. If you know someone who can solder the strands together, that's one cure. If not, buy the connector clips by themselves, and connect a wire to each, using single

strand wire, one with black insulation and one with red. Fasten the wires to the connectors as shown in Fig. 1.3. Make sure that you've connected each wire to the right clip — the cup-shaped one is positive and the button-shaped one is negative. These connectors fit into the oppositely-shaped connectors on top of the battery. Clamp the wires tightly on to the connectors when you're sure that they are the right way round, using pliers.

Don't connect the clips to the battery until the other ends of the wire have been inserted into different parts of the Eurobreadboard. Why not? Because if the ends of the wires touch each other, the battery will use up all its energy sending electricity around the wires, and there will be nothing left for you. This sort of thing is called a short circuit; batteries don't like short circuits. OK so far? You now have two components — a lamp bulb in its holder and a battery with its connecting wires. You also have a Eurobreadboard, and we can now start.

**BATTERY HOLDER**

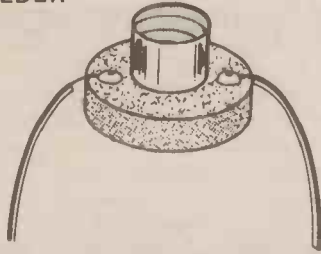

**Fig. 1.2** A battery holder for a 6 V bulb. The wires are attached to the holder by screws, and the insulation is stripped off so that the bare ends can be inserted into the Eurobreadboard.

## MAPPING

Take a look at the Eurobreadboard. There are letters and numbers printed on it. These are like a post-code or a map-reference — they let us tell you which group of holes to use, because we can't point to the right place on the board — we're not on the telly yet. The letters are used for columns; there are four columns on the board, and the numbers are used for rows of contacts. For example, if we say — 'plug into 5A, that means plug a wire into any one of the holes in row five, column A.

Now we're going to show you that the clips of one group are all connected. Plug the red battery wire into one hole on group 5A, and one wire (doesn't matter which one) of the light bulb into any other hole along line 5A. Plug the other wire from the other light bulb into one hole (any one) of group 10A. Now plug the black battery wire into another hole on line 10A. Connect the clips to the battery. What happens?

What makes the bulb light is a movement of electricity through it; we call this movement electric current. This electric current moves easily through wires like the connecting wires we've used, and through the metal clip connections inside the Eurobreadboard. The current is pushed around by the battery, it's the quantity we call voltage which does the pushing. You can plug one of the leads of the lamp into any hole along line 5A — they're all connected. In the same way, you can plug the other lead of the lamp into any hole along line 10A — these ones are all connected. What happens if you take a lead from 5A and plug it into 1A? What happens if you take the lead from 10A and plug it into 15A?

The reason that the lamp doesn't light is that line 15A isn't connected to line 10A, or any other line, and line

1A isn't connected to line 5A, or any other line. Electric current from a small battery can't flow where there isn't a connection; there has to be a continuous 'roadway' of metal. The plastic of the Eurobreadboard doesn't let electric current flow.

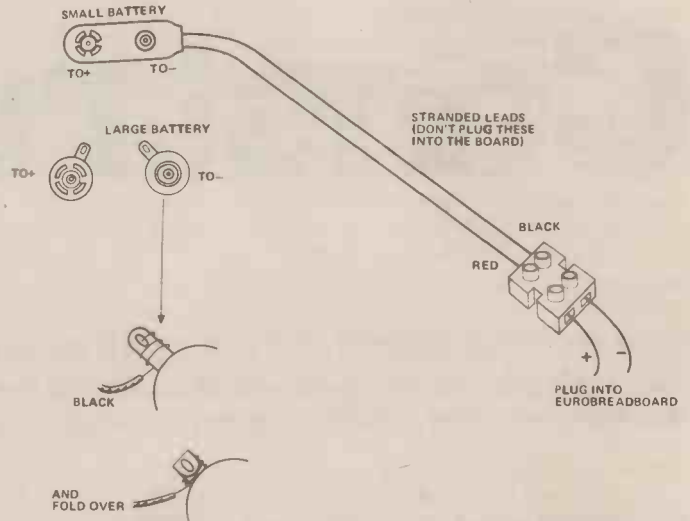

**Fig. 1.3** Connecting to batteries. The small connectors have stranded ends, and will have to be used along with a piece of terminal block (Maplin HF01B), with single-core wire attached to the block to connect to the Eurobreadboard. The large clips will have to be attached to single-core wire by wrapping and clamping as shown. See the shopping-list for details of batteries and clips.

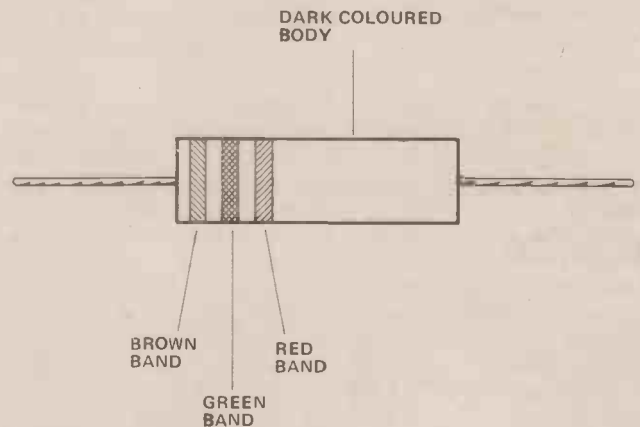

**Fig. 1.4** The 1K5 resistor.

## RESISTANCE TO CHANGE

The next step introduces two more components from your starter-pack. One is a 1K5 resistor, illustrated in Fig. 1.4. The coloured bands are a way of coding the amount of electrical resistance, because that's what this component does — it resists electric current and controls how much electric current can flow. Let's see it in action. Keep the red battery wire on 5A and the black one on 10A, just as you had them before. Now plug in the 1k5 resistor with one of its wire leads (either one) into 10A and the other into 15A. Don't try to put two wires into one hole — you don't need to when you're using a Eurobread board because all the clips along a line are connected. Connect your 6 V lamp bulb now by plugging the leads in, one into 15A and the other into 5A. There's now a complete electrical road (or circuit), just as there was before, current can flow from the battery-

# Into Electronics Construction

positive connection, through the resistor and the lamp bulb and back to the battery — trace out the path if you like. Does the bulb light?

No, it doesn't mean that the bulb has blown or that the battery's flat. It just could be that the resistor simply doesn't allow enough current to flow through the bulb to light it. How can we check that possibility?

Here's one way. There's a component called an LED in your starter-pack. The letters stand for Light-Emitting Diode, and we'll be using this component several times. What's important at the moment is that these little wonders will light up when a small electric current flows through them, so we should be able to detect smaller currents than will work a 6 V lamp bulb. As it happens, though, electric current passes through this LED in one direction only, so that if the LED is connected the wrong way round, nothing can happen. We'll meet more components like this later on, but right now we need to know which way of connecting the LED is the right way round. If you've bought your LEDs from Maplin, and they are the types specified, then there's a small flat bit on the circular rim (Fig. 1.5). The wire lead nearest this connects to the part of the LED which is called the cathode, and the LED will work correctly if this lead is the one connected to the negative of the battery. If you get the leads the wrong way round the LED will not light, and it may never light afterwards even if you correct the wiring.

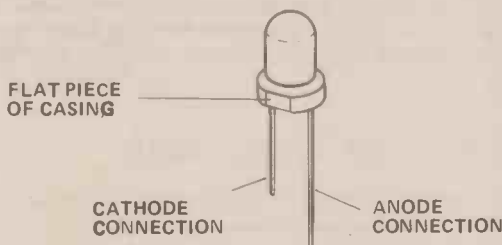

Fig. 1.5 The LED. It's important to get the leads right way round.

## MIS-LED

Now connect up. This is the last time we'll describe connections in such detail. From now on, the connections will be listed in a table (Table 1.1 shows these ones just to show how it's done). The battery positive, the red wire, is plugged into line 5A, and the battery negative — black wire — is plugged into line 10A. The 1K5 resistor is then connected between 10A and 15A. The cathode lead of the LED is plugged into 15A, and its other lead, called the anode, into 5A. Now connect the battery and take a look!

If you don't see a red glow inside the LED, check that it's connected the right way round. The glow shows that current is flowing, not enough current to make a 6 V 0.06 A lamp bulb light, but enough to make the LED glow. The 1K5 resistor we added to the original arrangement has cut down the amount of electric current which could flow.

Now for the next trick. This time we introduce a new component, one of the 100 $\mu$ F (that  $\mu$ F is pronounced 'microfarad') Look at the markings on the body of the capacitor; you should see the 100 $\mu$ F printed there. Once again, this is a component which has to connect into the circuit the right way round. One end may be coloured red or have a + sign on it, the other end may be coloured black or have a — sign on it. Once again, if it's

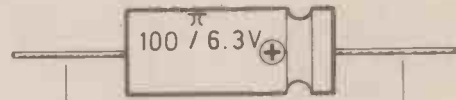

THIS END HAS TO CONNECT AT THE NEGATIVE END OF THE CIRCUIT

THIS END MUST CONNECT TOWARDS THE POSITIVE END OF THE CIRCUIT

Fig. 1.6 The 100  $\mu$ F capacitor. Like the LED, this has to be inserted correct way round.

connected in the wrong way round it probably won't work. What we're going to do is to add this component into the circuit. The connections are shown in Table 1.2; make these connections before connecting the battery to its clips. Start by taking the battery red lead out of 5A and placing it in any hole in 5B. Now connect the 100 $\mu$ F capacitor so that its red (+) end is connected into 5B and its negative (black —) end into 5A. Check your connections against the list in table and get ready for action.

Look carefully at the LED, and connect the battery to its clips. What happens? Does the LED keep glowing? Now take the positive clip off the battery again, and touch it momentarily on the negative clip. This won't harm the battery because the + end of the battery isn't connected. Repeat the operation now, watching the LED and touching the + clip to the battery +.

The brief flash of the LED shows that a capacitor lets current flow only for a short time. This is called charging current, and it happens only when there has been a change of voltage. Remember voltage? It's the thing that pushes current around the circuit. We caused a change of voltage when we connected the battery. Once the battery was connected, the voltage stopped changing and the current through the capacitor stopped. Could we have made the current flow for a longer time? We could, in fact, by using a bigger capacitor means one with a greater value of capacitance, perhaps 500 $\mu$ F instead of 100 $\mu$ F. We could also make the flash of the LED very brief by using a smaller value of capacitor, such as 1 $\mu$ F. We could even make the flash so briefly that we couldn't see it!

## SILICON DIODE

Now we can make use of the components we know so far to find out what another component does. The new component is a silicon diode, code numbered 1N4148. Connect up the diode in a circuit with a battery, a 1K5 resistor and the LED, using the connections list shown in Table 1.3. For the moment, don't pay any attention to which way round the 1N4148 diode is connected, but remember that the LED must go in the right way round. Does the LED light? Now connect the 1N4148 diode the other way round by unplugging, turning the diode round and plugging it in again. Is the LED lit now?

A diode allows current to pass only in one direction. Which direction? It's usually marked on the diode in the form of a white dot or band at the cathode end of the diode. When the marked cathode end is connected to battery negative (even if there's a resistor between it and the battery negative), and the other end is connected to battery positive, current can flow. There has to be a resistor somewhere in the circuit, otherwise too much current flows and your diode goes up in a puff of smoke. We've used the 1K5 resistor to keep the current down in

this circuit. If the diode is connected the wrong way round, with its anode to negative and its cathode to positive, then no current flows.

We don't, of course, use all of our components all the time, and in the electronic circuits which we'll build during this series, there will usually be a few components left over. Take care of your components, for we shall be using the same ones over and over again. Electronic components don't wear out in the way that mechanical parts do, so that if you are careful about the way you plug and unplug the components on the Eurobreadboard there's no reason why any of the lead wires should be damaged. As far as electrical damage goes, if the connections are correctly made, none of the circuits in this series will cause any component to overheat or cause any damage. If a component fails, it's always because of a fault in the way the circuit is wired up.

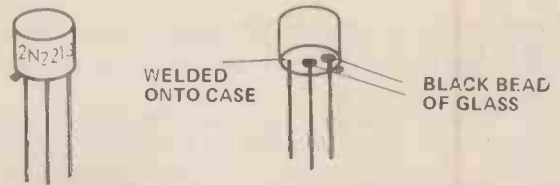

**Fig. 1.7** The diode. The cathode end is marked by a white (or black) band.

## THE TRANSISTOR

Having got that little lot off the chest, we have another component to examine and use — it's a transistor. Transistors come in all sorts of shapes and sizes, mostly small. The type we are using is not one of the very small ones, it's packed inside a small sealed metal case which is called a TO-5 can. The metal can isn't just for protection, it helps to carry heat away from the transistor. Because the transistor is connected to the metal inside the can, the metal can is part of your circuit. It will be at the same voltage, so that if you let the metal can of the transistor touch against any other part of your circuit, the wire leads of components or the metal can or another transistor, you will cause a short circuit which will probably destroy the transistor. Don't imagine that you can separate the can from what it's touching against in time to stop any damage, you can't move that fast! The only way to avoid damage is to check your circuit very carefully before you connect the battery, making sure that there isn't a short circuit anywhere. If you do find one, and sort it out, don't stop looking — there's probably another one somewhere. One way of helping to avoid short circuits is to use insulating sleeve, called Systoflex, over all the wire leads of the components. If this sleeving is cut to a length about 10mm shorter than the wire it will leave enough wire exposed to make the connection into the breadboard, and ensures that you won't have to worry about anything coming against the wire lead. If you use Systoflex on all the wire leads, all you have to worry about is having the correct connections and keeping the transistor cans apart.

Now for a closer look at these transistors. For a start, the transistor is quite unlike any of the other components we've used so far, because it has three lead-out wires. These three wires connect to different places inside the transistor, so that we must connect the right wire to the right place in the circuit. Only one way round is correct, and if the transistor is connected incorrectly, it's almost



**Fig. 1.8** The type of transistor we are going to use. There is a metal tab on the metal case which marks the position of the emitter wire lead.

certainly by-byes when the battery is connected. Transistors either work perfectly or not at all, and a transistor which has been wrongly connected at the time when the circuit was switched on will probably never work again. Nothing dramatic happens when a transistor blows, no flash or bang, but it can't be repaired — the only way is to make sure that it never goes wrong in the first place.

How do we know which lead is which? That depends on the type of transistor we're using, but we give ourselves a bit of assistance by having different names for the parts of the transistor to which the three wires connect. The names for the three connections are emitter, base and collector; you're going to keep coming across these names, so the sooner you can memorise them the better. All transistors have these three connections (some have a fourth connection, but that does not concern us at the moment), but the way in which the connections are arranged varies from one transistor type to another. Fortunately, the type of transistor we're using uses a simple way of recognising these leads, and all the transistors which are mounted in this same type of can, the TO-5, have the same system for recognising the lead-out wires.

## THE NAME OF THE GAME

Different transistor types are identified by their type numbers, American transistors use numbers starting with 2N, and the transistors we're using may be coded as 2N697 or 2N2219. European transistors use more letters and a shorter number, and we can make use of the ones coded BFY50 or BFY 51. All of these types are very similar, and are contained in the same sort of TO-5 can, and have their leadout wires arranged in the same way, so it doesn't matter which type out of these four you actually have.

To find out which leadout wire is which, hold the transistor by its can so that the wires are pointing towards you. You'll see that there is a small metal tab on the can (Fig. 1.9). It's not for opening the can, it is used to locate the leadout wires. The leadout wire next to this tab is the one we call the emitter. Now take another look at the wires, and you'll notice that two of them come through small blobs of glass which are sealed to the metal of the can. The third one, however, is welded to the metal of the can. That's the leadout wire we call the collector. The one between these two is the one called the base.

With the wires pointing towards you, then, starting at the metal tab, the leads are emitter, base, collector, in that order. Practise this as much as you need to — you should be able to identify these leads right away without having to think about it too much (the leads, I mean). Remember, though, that this way of identifying the leads is correct only for the transistors in this type of can. A few transistors types use similar cans, but with all-glass undersides; the order of the wires is the same,

# Into Electronics Construction

but there's no wire welded to the metal that you can see. The 2N1711 is of this type.

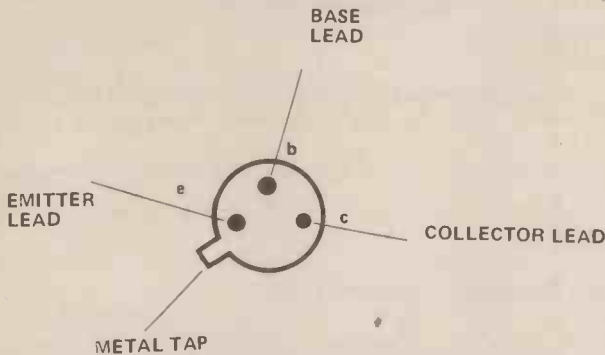

Fig. 1.9 The transistor connections, seen from the underside.

## TRANSISTOR TWOSOME

That's all you need to know for the show so far, and we can now start building a working transistor circuit. This one uses two transistors, four resistors, two capacitors and two LEDs, most of the components in your starter-pack, in fact, mounted on the Eurobreadboard. The 6 V battery is used as a power supply.

First of all, you need to make the correct connections. Start by connecting in the transistors. Remember that it's a good idea to use 1mm Systoflex sleeving over all the leads — but not, of course, so long that there isn't enough wire left bare to plug into the Eurobreadboard. The transistors plug into the holes on the board which are shown in Fig. 1.10. You can use any of the holes along a line, such as 5A, because all the holes along a line are connected, remember. One line has two transistor leads, the emitter leads of both transistors, so you must use two holes in that line. Don't try to squeeze both of the wires into one hole of the Eurobreadboard — you'll probably bend the wires.

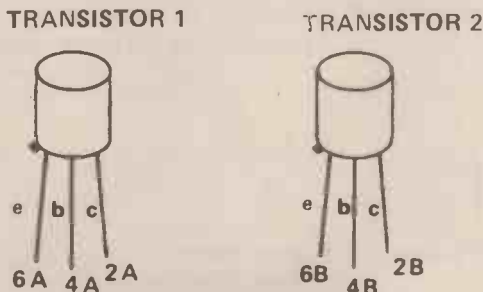

Fig. 1.10 How the two transistors are arranged in the circuit.

Check that you've got the transistors in the right places, and connect in the two LEDs (Fig. 1.11). Remember that there's a correct way round for these components, and they won't work the other way round. Worse still, connecting them the wrong way round and passing current can damage them. If you have any doubt about the LEDs, check them by using the arrangement we used earlier (Table 1.1) but not when the transistors are connected. If you can't remember the arrangement, mark the LED cathode (—) lead with a white spot. The stuff that stationers sell for painting over typing mistakes is ideal, it's called Tippex liquid. We'll probably be using it again later, so it's useful to have around. Once you're

sure of the right connections, plug the LEDs into position.

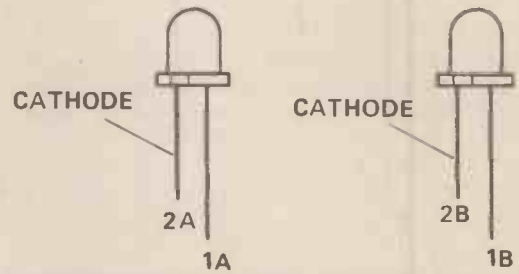

Fig. 1.11 The connections to the LEDs.

Now add the capacitors. We're using two capacitors which are marked with the values 100  $\mu$ F (or 100mF) and which are coded red (+) at one end or black (—) at the other. These also must be connected the right way round, so Fig. 1.12 shows where they go.

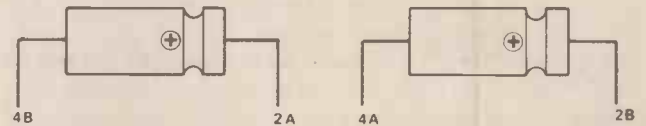

Fig. 1.12 The connections to the capacitors.

We're nearly finished. There are four resistors to go in, two whose value is 1K5 and two whose value is 22K. The 1K5 resistors have colour bands which are BROWN, GREEN, RED, and the 22K resistors have colour bands which are RED, RED, ORANGE. Ignore any silver or gold bands, they don't affect the value as far as we're concerned. The plug-in points for these resistors are shown in Fig. 1.13, and they can go in either way round.

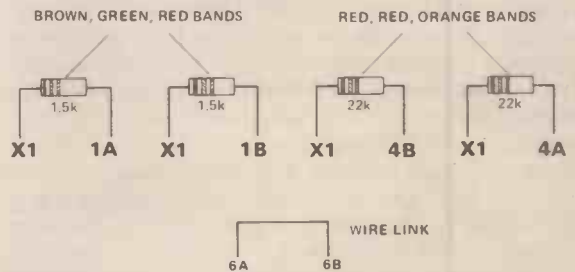

Fig. 1.13 How the resistors are connected into the circuit, along with the wire link.

That completes all the connections of components, apart from the battery. Stop now and check all of your connections, using the table in Fig. 1.4. Make sure in particular that you've identified the transistor lead-out, wires correctly and that the LEDs are the right way round. If you've got these points right there's less chance of blowing a transistor or an LED.

## TELLING TIME

Big moment now. Plug the battery leads to the board as shown in Fig. 1.14 making sure that they're the right way round, and clip the leads to the battery. Now watch the LEDs. Is it all happening? Without any mechanical

# Into Electronics Construction

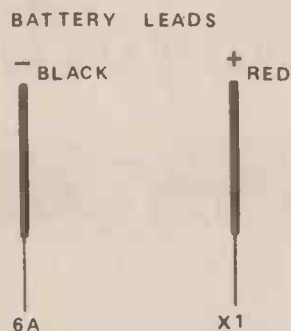

Fig. 1.14 The battery connections to the Eurobreadboard.

switches, and in complete silence, the LEDs are switching on and off. The switching is being done by the transistors, with the resistors controlling the currents which flow, and the capacitors making sure that each LED is on for just the time that is allowed for it.

You can change this on/off time. Disconnect the battery, remove the two 100  $\mu$ F capacitors and replace them with two 680  $\mu$ F capacitors. Remember that these, too, must be the right way round, and can be plugged into the same holes as were used for the 100  $\mu$ F capacitors. When the new capacitors are in place, and checked, connect the battery up again, and watch the LEDs. What effect would you say the larger capacitors have had on the rate of flashing?

More next month on what the transistor does, and on what happens in this and other circuits. **HE**

## SHOPPING LIST FOR PART 1

Eurobreadboard from David George Sales, r/o 74 Crayford High St., CRAYFORD, Kent.

Other components can be purchased from any of the component suppliers advertising in this magazine, but for convenience, the Maplin reference numbers have been given.

|   | Maplin No.     |
|---|----------------|
| Batten holder for MES bulbs             | RX86T          |
| 6 V 0.04 or 0.06 A MES bulbs            | WL77J          |
| Solid core wire, black (10m pack)       | BL85G          |
| Solid core wire, red                    | BL92A          |
| Solid core wire, white                  | BL94C          |
| 2 $\times$ 1K5 resistors                | M1K5           |
| 2 $\times$ 22K resistors                | M22K           |
| 2 $\times$ 100 $\mu$ F, 10 V capacitors | FB48C          |
| 2 $\times$ 680 $\mu$ F, 16 V capacitors | FB77J          |
| 2 $\times$ LED                          | WL27E          |
| 1 $\times$ diode 1N4148                 | QL80B          |
| 2 $\times$ BFY50 or 2N2219              | QF27E or QR11M |
| 1mm Systoflex (1m length)               | BH05F          |

Batteries: All of the projects in this series will operate from 6 V or from 9 V, but the lamp bulbs used in the first few projects have a longer life operated from 6 V. The options are as follows:

- For 6 V (a) Use PP1 battery, with clips type HF27E (Maplin)  
 (b) Use battery holder HF29G (Maplin), and clips type HF28F
- For 9 V (a) Use PP3 battery with small clips type HF28F  
 (b) Use PP9 battery with large clips HF27E

TABLE 1.1

| Track Number | Connections          |
|--------------|----------------------|
| 5A           | Battery +, LED anode |
| 10A          | Battery -, 1K5       |
| 15A          | LED cathode, 1K5     |

NOTE: there is only one resistor used here, so we need only state that one lead from it is on track 10A, and the other on 15A. When several resistors are listed, their reference numbers will have to be shown.

TABLE 1.2

| Track Number | Connections            |
|--------------|------------------------|
| 5B           | Battery +, capacitor + |
| 5A           | Capacitor -, LED anode |
| 10A          | Battery -, 1K5         |
| 15A          | LED cathode, 1K5       |

TABLE 1.3

| Track Number | Connections                   |
|--------------|-------------------------------|
| 5A           | Battery +, 1K5                |
| 10A          | 1K5, one end of diode         |
| 15A          | Battery -, other end of diode |

TABLE 1.4

| Track Number | Connections   |
|--------------|---|
| X1           | Battery +, one end of both 1K5 and both 22K resistors   |
| 1A           | LED (1) anode, other end of one 1K5                     |
| 2A           | LED (1) cathode, + end of 100 $\mu$ F (1), Q1 collector |
| 4A           | Q1 base, - end of 100 $\mu$ F (2), 22K                  |
| 6A           | Q1 emitter, battery -, link to 6B                       |
| 6B           | Q2 emitter, link from 6A                                |
| 4B           | Q2 base, - end of 100 $\mu$ F (1), 22K                  |
| 2B           | Q2 collector, + end of 100 $\mu$ F (2), LED (2) cathode |
| 1B           | 1K5, LED (2) anode                                      |



# ELECTRONI-KIT

## DENSHI KITS SPECIAL OFFER

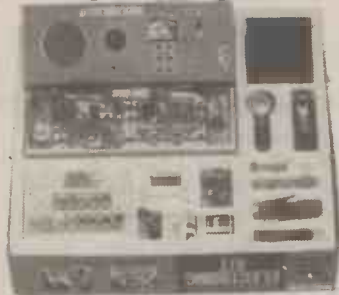

"... fun and entertainment as well as education"

(EVERYDAY ELECTRONICS mag.)

The SR-3A kit (over 100 circuits) and the SR-3A de luxe kit (over 105 circuits) are available again, at little more than their 1977 prices!

Circuits are constructed by plugging the encapsulated components into the boards provided, following the instruction manual. Technical details are also given concerning each project. The components are used over and over again and you can design your own circuits too, or use the kit as a useful testing board.

No previous experience of electronics is required but you learn as you build — and have a lot of fun, too. The kits are safe for anyone.

### SR-3A KIT

16½x10x2½" £29.95

Build over 100 projects including 3-TR reflex radio receiver, 3-TR radio receiver with RF amplifier, 2-TR reflex radio receiver, 3-TR amplifier for crystal mike, 3-TR amplifier for speaker/mike, 3-TR signal tracer, Morse Code trainer, 2-TR electronic organ, electronic metronome, electronic bird, electronic cat, electronic siren, electronic gun, 2-TR sleeping aid, high voltage generator, discontinuity warning device, water supply warning device, photoelectric alarming device, 3-TR burglar alarm, 3-TR water supply warning device, 3-TR water level warning device, 3-TR photo-electric alarming device, Morse Code trainer with sound and light, discontinuity warning device with sound and light, water level warning device with sound and light, electronic metronome with sound and light, buzzer with sound and light, wireless mike, wireless telegraph set, wireless discontinuity warning device, wireless water level warning device, wireless water supply warning device, and wireless photoelectric warning device, etc. etc.

### SR-3A de luxe KIT

(Illustrated. 16x14x3½") £39.95

Similar to SR-3A, more components including solar cell and additional Speaker unit plus sophisticated control panel.

All kits are guaranteed and supplied complete with extensive construction manuals PLUS Hamlyn's "All colour" 160-page book "Electronics" (free of charge) whilst stocks last.

Prices include batteries, educational manuals, free book, VAT, P&P (in the UK), free introduction to the British Amateur Electronics Club.

Cheque/P.O./Access/Barclaycard (or 16p for illustrated literature) to DEPT. HE.

**ELECTRONI-KIT LTD.**  
RECTORY COURT, CHALVINGTON,  
E.SUSSEX, BN27 3TD (032 183 579)

# SPECIALS FROM MODMAGS

Mark your envelopes Specials, and send them to Specials, Modmags Ltd, 145 Charing Cross Road London, WC2H 0EE.

### ETI CIRCUITS

Books 1 & 2.

Each volume contains over 150 circuits, mainly drawn from the best of our Tech-Tips. The circuits are indexed for rapid selection and an additional section is included which gives transistor specs, and plenty of other useful data. Sales of this publication have been phenomenal — hardly surprising when the circuits cost under 1p each!

£1.50 + 25p P&P each.



### electronics tomorrow

75p



### ELECTRONICS TOMORROW

Comprised entirely of new material, the edition covers such diverse topics as Star Wars and Hi-Fi! The magazine contains projects for everyone — none of which have appeared in ETI — and a look at the future of MPUs, audio, calculators and video. How can you not read it?

75p + 25p P&P.

### TOP PROJECTS

Book 1 + 2: £2.50 + 25p P&P.

Master mixer, 100W guitar amp, low power laser, printmeter, transistor tester, mixer preamp, logic probe, Ni-Cad charger, loudhailer, 'scope callibrator, electronic ignition, car theft alarm, turn indicator cancellor, brake light warning, LM3800 circuits, temperature alarm, aerial matcher, UHF-TV preamp, metal locator, four input mixer, IC power supply, rumble filter, IC tester, ignition timing light, 50W stereo amp, and many more.

Book 3: SOLD OUT! Book 4: £1.00 + 25p P&P. Book 5: £1.00 + 25p P&P. Book 6: £1.00 + 25p P&P.



### TOP PROJECTS

Book 7: £1.25 + 25p P&P.

ER II loudspeaker, CCD phaser, 3-channel tone control, bass enhancer, continuity tester, bench supply, LCD digital multimeter, digital frequency meter, wide range oscillator, ETI wet, egg timer, house alarm, porch light, torch finder, light dimmer, IB metal locator, electronic bongos, puzzle of the drunken sailor, race track, ultrasonic switch, tic-tac radio, rev counter, Transcendent 2000, spirit level.

### ELECTRONICS — IT'S EASY

This very successful beginners' series has now been reprinted in one volume. The book covers just about every aspect of electronic theory and is ideal for anyone just starting out in this fascinating hobby.

£3.60 + 25p P&P each

### Electronics — It's Easy



### INTO ELECTRONICS PLUS

The complete series of Ian Sinclair's series Into Electronics Plus a selection of some of the most popular and informative articles from HE. Everything from Home Computing to making your own PCBs. £1 + 25p P&P.



## BARGAINS FOR THE ELECTRONIC HANDYMAN BRANDED LED DIGITAL ALARM CLOCKS



(1)

(2)



(3)

Returned to Service Department within guarantee period.

- (1) With alarm repeat — S.R.S.P. of £17.00 offered at £3.95 inc. VAT.
- (2) With luxury lamp and repeat alarm as featured in most major U.K. Mail Order catalogues, S.R.S.P. £31.00—offered at £7.95 inc. V.A.T.
- (3) With integral luxury light and repeat alarm also as featured in most major U.K. Mail Order catalogues, S.R.S.P. of £32.00—offered at £7.45 inc. V.A.T.

These will be sold as received from our customers with the existing fault(s) and without guarantee.

Discounts available on large bulk purchases

**PRESCOTT CLOCK AND WATCH COMPANY LIMITED**

Prescott House, Humber Road, London NW2 6ER

**PLEASE MENTION  
HOBBY ELECTRONICS  
WHEN REPLYING TO  
ADVERTISEMENTS**

## PRINTED CIRCUITS and HARDWARE

Comprehensive range Constructors' Hardware and accessories.

Selected range of popular components  
Full range of HE printed circuit boards,  
normally ex-stock, same day despatch at  
competitive prices.

P.C. Boards to individual designs  
Resist-coated epoxy glass laminate for the  
d.i.y. man with full processing instructions (no  
unusual chemicals required).

Full range of etch resist transfers, and other  
drawing materials for p.c. boards.

Send 15p for catalogue.

**RAMAR CONSTRUCTOR  
SERVICES  
MASON'S ROAD  
STRATFORD-ON-AVON  
WARWICKS, Tel. 4879**

# CLASSIFIED INFORMATION

### Semi-Display:

- 1-3 insertions — £4.00 per single column centimetre
- 4-11 insertions — £3.50 per s.c.c.
- 12 insertions — £3.00 per s.c.c.

### Classified:

- 15 pence per word (minimum 25 words)
- Box number £1.00 extra.

### ALL ADVERTISEMENTS IN THIS SECTION MUST BE PRE-PAID

Closing date: 2nd Friday in month preceding publication.

Advertisements are accepted subject to the terms and conditions printed on the advertisement rate card (available on request).

Cheques and postal orders should be crossed and made payable to "Hobby Electronics".

**CLASSIFIED ADS, HOBBY ELECTRONICS**  
145 Charing Cross Road, London WC2H 0EE  
(Telephone: 01-437 1002)

**OSCILLOSCOPE £12?** Convertor plugs into TV aerial socket and converts it to large screen oscilloscope (Components cost approx. £12). Circuit and details £3. B. Kerr, 27 Coles Road, Milton, Cambridge CB4 4BL.

**INTRODUCTION TO MICROPROCESSORS AND COMPUTING.** 50 pages of diagrams and explanation to get you started. Price £2.30 + 45p postage.  
**EDUCATIONAL DATA AND TECHNICAL SERVICES**

59 Station Road, Cogenhoe, Northampton NN7 1LU

## AD. INDEX

|                       |         |
|-----------------------|---------|
| AMBIT INTERNATIONAL   | 2       |
| BI-PAK SEMICONDUCTORS | 13      |
| C.B. CITY             | 50      |
| C.S.C.                | 22      |
| DAVID GEORGE SALES    | 15      |
| E.D.A.                | 34      |
| ELECTRONI-KIT         | 72      |
| FUTURE ELECTRONICS    | 73      |
| GREENWELD             | 34      |
| HEATHKIT              | 49      |
| I.L.P. ELECTRONICS    | 485     |
| MAPLIN                | 9 & 76  |
| MARSHALLS             | 62      |
| MEMORCREST            | 58      |
| METAC                 | 74 & 75 |
| MINIKITS              | 43      |
| NIC MODELS            | 50      |
| S. & G. SERVICES      | 73      |
| STEVENSON             | 37      |
| SWANLEY ELECTRONICS   | 50      |
| TECHNOMATIC           | 71      |
| T.K. ELECTRONICS      | 26      |
| VERO ELECTRONICS      | 26      |
| WATFORD ELECTRONICS   | 7       |
| WINTJOY LTD           | 62      |

## P.C.B.'S FOR H.E. PROJECTS

|                        |      |
|------------------------|------|
| <b>Nov.</b>            |      |
| Hebot (Board A)        | 3.00 |
| R2D2 Radio             | .30  |
| Guitar Tuner           | .50  |
| <b>Dec.</b>            |      |
| Hebot (Board B)        | 3.00 |
| Ring Modulator         | .90  |
| Speed Controller       | 2.50 |
| Bargraph Car Voltmeter | .60  |
| <b>Jan.</b>            |      |
| Hebot Loop Drive       | 1.30 |
| Scalextric Lap Counter | 6.00 |
| Power Supply           | 1.40 |
| Digi-Die               | 1.50 |
| Crosshatch Generator   | 1.80 |

**Feb.**  
Boards available at 12p per sq. inch. (E.G.A board the size of this ad = 132p)

Prices include V.A.T. P.&P.

P.B.C.'s also produced from customers own masters, send artwork for quotation.

Mail order only.

Cash with order to:

**S & G SERVICES (HULL)**  
43 Wheeler Street  
Hull, North Humberside

**ADAMIN MINIATURE 15 SOLDERING IRON**—The professional iron used by the G.P.O. and major companies. 12W. 240V 14-bit range £3.81

**BRINDLEY HAND TOOLS**—Durable 4" snipe nose, flat nose, round nose, diagonal cutting, side cutting pliers — all with insulated handles £4.08

**DESOLDERING PUMP**—Powerful suction miniature model with replaceable PTFE nozzle £4.72

**COMPONENT DRAWERS**—Tough plastic—ideal for electronic parts. 15 drawers £5.00, 20 7.00, 28 (3 different sizes) £9.00

**VICE**—Sturdy 3 1/2" table-top mounting vice. An extra pair of hands when soldering, project building, etc £12.00

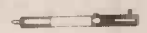

## FUTURE ELECTRONICS

UNIT B1, PARKHALL TRADING ESTATE  
MARTELL ROAD, LONDON SE21

PRICES INCLUDE VAT  
+ P&P. GOODS SENT  
BY RETURN WITH  
OUR FREE CATALOGUE.

# Quartz Melody Multi-Alarm Chrono For 1980 Try this 34 Function

for only £ 19.95

## Count-down Timer

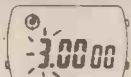

Can be used for a host of applications from boiling an egg to warning you your parking meter is expired.

The timer is presettable to 23 hours 59 mins. 00 secs. in 1 min. steps and counts down in 1 sec. steps. It operates quite independently of the other counters and the watch can be in any other mode whilst it is being used.

At the preset time the musical tone will sound for 1 minute.

## Alarm

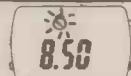

The alarm can be set at 1 minute intervals to any time within the 24 hour period.

A clear firm musical tone sounds for 1 minute at the appointed time. An automatic roll-over to the normal time is a feature after the alarm has been read. A clear indicator displays whether the alarm is set or not.

## Time Zone

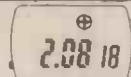

The time zone enables you to tell the time in two places at once. It can be useful on holiday or business trips. Just programme the second time zone and it will be permanently recorded for your easy reference.

## Chronograph



This watch incorporates a sophisticated and very accurate stop/start counter which has many applications in sporting events and timing for recordings etc.

**Mode 1:** Is the normal stop-watch mode. Stop-Start-Zero.

**Mode 2:** The lap timer enables first and second past the post times to be recorded. The display is frozen but the counter continues to count.

**Mode 3:** Longer timing intervals, such as journey times, can be recorded whilst the watch is reading its normal time, or the count-down is being used. The counter counts to 1 hour in 1/100 sec. steps in all its modes.

★  
GUARANTEED  
SAME DAY  
DISPATCH  
★

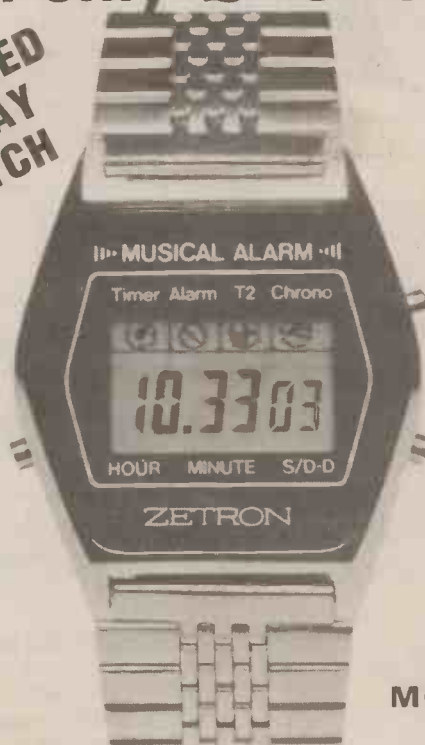

MODEL M30

### Display Format (NORMAL TIME DISPLAY)

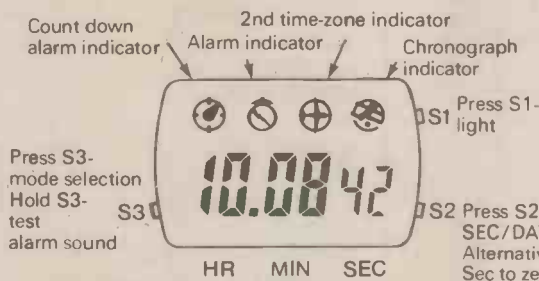

Press S3-  
mode selection  
Hold S3-  
test  
alarm sound

S1 Press S1-  
light  
S2 Press S2-  
SEC/DATE  
Alternative hold S2-  
Sec to zero

5 independent working modes

- i) Normal watch
- ii) Count down alarm
- iii) Alarm
- iv) Dual time zone
- v) 1/100 sec. chronograph

Display indicators  
(not all shown)

A very impressive new watch at a superbly low price from Metac. This super slim watch is only 7mm thick (that's thinner than most mechanical tick-tocks), but its micro-processor heart packs 34 different features.

In addition to those listed on the left the watch can display the day of the week in French or German or English (just select the one that suits you).

It has fast and slow setting rates for the counter and the alarm as well as the normal time setting.

There are 7 display indicators, 6 digits and a back light for night viewing. The 5 working modes are independent of each other, and the watch can be operated in all 5 modes at once.

FOR ORDERING INFORMATION PLEASE SEE OVER

# Metac

ELECTRONICS  
& TIME CENTRES

North & Midlands  
67 High Street, DAVENTRY  
Northamptonshire  
Telephone: 03272 76545

South of England  
327 Edgware Road  
LONDON W.2  
Telephone: (01) 723 4753

**QUARTZ LCD  
5 Function**

Hours, mins, secs, month, date, auto calendar, back light, fully adjustable bracelet to fit all wrists.

**£6.65**

Guaranteed same day despatch.  
Very slim, only 6mm thick.



M1

**SOLAR QUARTZ LCD  
5 Function**

Genuine solar panel with battery back-up. Hours, mins., secs. Day / date. Fully adjustable bracelet. Back-light. Only 7mm thick.

**£8.65**

Guaranteed same day dispatch.



M2

**QUARTZ LCD**

**11 Function SLIM CHRONO**

6 digit, 11 functions. Hours, mins., secs., day, date, day of week. 1/100th, 1/10th, secs.; 10X secs., mins. Split and lap modes. Back-light, auto calendar. Only 8mm thick. Stainless steel bracelet and back. Adjustable bracelet. Metac Price

**£10.65** Thousands sold!

Guaranteed same day dispatch



M3

**QUARTZ LCD**

**ALARM 7 Function**

Alarm. Hours, mins., secs. Month, date, day. 6 digits. 3 flags plus continuous display of day and date or seconds. Back-light. Only 9mm thick

~~£12.65~~

**£9.95**

Guaranteed same day dispatch



M4

**MULTI ALARM  
6 Digits  
10 Functions**

- \* Hours, mins., secs.
- \* Month, date, day
- \* Basic alarm
- \* Memory date alarm
- \* Timer alarm with dual time and 5 country zone
- \* Back light.
- \* 8mm thick.

**£18.65**



M5

**FRONT-BUTTON ALARM  
Chrono Dual Time**

6 digits, 5 flags. 22 functions. Constant display of hours and mins. plus optional seconds or date display. AM / PM indication. Month, date. Continuous display of day. Stop-watch to 12 hours 59.9 secs. in 1/10 second steps. Split and lap timing modes. Dual time zones. Only 8mm thick. Back-light.



Fully adjustable open bracelet. ~~£22.65~~ **£18.95** Guaranteed same day dispatch.

M6

**SOLAR QUARTZ LCD  
Chronograph with Alarm  
Dual Time Zone Facility**

6 digits, 5 flags. 22 functions. Solar panel with battery back-up. 6 basic functions stop-watch to 12 hours 59.9 secs. in 1/10 sec. steps. Split and lap timing modes. Dual time zones. Alarm. 9mm thick. Back-light. Fully adjustable bracelet.

~~£27.95~~ **£19.95**

M7



**ALARM CHRONO  
with 9 World  
Time Zones**

- \* 6 digits, 5 flags.
- \* 6 basic functions.
- \* 8 further time zones.
- \* Count-down alarm.
- \* Stop-watch to 12 hours 59.9 secs. in 1/10 sec. steps.
- \* Split and lap timing modes.
- \* Alarm.
- \* 9mm thick.
- \* Back-light
- \* Fully adjustable bracelet.

~~£29.65~~ **£24.95**

M8



**SOLAR QUARTZ LCD  
Chronograph**

Powered from solar panel with battery back-up. 6 digit, 11 functions. Hours, mins., secs., day date, day of week 1/100th, 1/10th secs. 10X secs., mins. Split and lap modes. Back light. Auto calendar. Only 8mm thick. Stainless steel bracelet and back. Adjustable bracelet. Metac Price

**£13.65**

Guaranteed same day dispatch.

M9



**LADIES DAY WATCH  
QUARTZ LCD**

Ladies Day Watch only 25 x 20mm and 6mm thick. Hours, minutes, seconds, day, date, backlight and auto calendar. Elegant metal bracelet in silver or gold fully adjustable to suit very slim wrists. State colour preference.

**£9.95**

Guaranteed same day despatch

M15



**LADIES FASHION WATCH  
QUARTZ LCD**

Lady's Fashion Watch. Elegant bracelet in bronze / gold finish or silver colour. Hours, minutes, seconds, day, date, backlight and auto calendar. Adjustable for the slimmest of wrists.

State colour preference.

**£14.95**

Guaranteed same day despatch

M17



**LADIES COCKTAIL WATCH  
QUARTZ LCD**

Lady's Cocktail Watch. Highly functional watch which also suits those special occasions. Beautifully designed with a very thin bracelet which retains strength as well as elegance. Hours, mins., secs., day, date, backlight and auto calendar. Bracelet fully adjustable to suit slim wrists. State gold or silver finish.

**£19.95**

Guaranteed same day despatch

M18



**HANIMEX  
Electronic  
LED Alarm Clock**

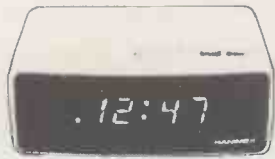

Features and Specification: Hour/minute display. Large LED display with p.m. and alarm on indicator. 24 Hours alarm with on/off control. Display flashing for power loss indication. Repeatable 9-minute snooze. Display bright/dim modes control. Size: 5.15" x 3.93" x 2.36" (131mm x 111mm x 60mm). Weight: 1.43 lbs (0.65 kg).

**£10.20** Thousands sold!  
Mains operated.

Guaranteed same day despatch.

M13

**Special Offer  
EXECUTIVE  
ALARM  
WATCH**

6 functions plus alarm. Conference signal, 5 minute snooze alarm. Conference signal sounds 4 secs. before main alarm to give advance warning and option to cancel. Snooze sounds 5 mins. after main alarm and is always preceded by the conference signal.

~~£14.95~~ **£9.95**

M60

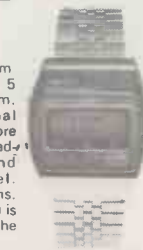

**MACY QUARTZ  
ANALOGUE**

Automatic calendar day and date, infinite bracelet. This man's watch has elegance as well as the robust appearance provided by a watch with traditional features. Accuracy is provided by a quartz crystal powered by a long life miniature battery.

**£24.95**

M21



**Metac price break-through for an  
Alarm Chronograph with  
Dual Time**

Only ~~£16.95~~  
Only **£14.50**



**OUTSTANDING FEATURES**  
\* **DUAL TIME.** Local time always visible and you can set and recall any other time zone (such as GMT). Also has a light for night viewing  
\* **CALENDAR FUNCTIONS** include the date and day in each time zone.  
\* **CHRONOGRAPH/STOPWATCH** displays up to 12 hours, 59 minutes and 59.9 seconds. On command, stopwatch display freezes to show intermediate (split/lap) time while stopwatch continues to run. Can also switch to and from timekeeping and stopwatch modes without affecting either's operation.  
\* **ALARM** can be set to any time within a 24-hour period. At the designated time, a pleasant, but effective buzzer sounds to remind or awaken you!  
Guaranteed same day despatch

M16

**HOW TO ORDER**

Payment can be made by sending cheque, postal order, Barclay, Access or American Express card numbers. Write your name, address and order details clearly, enclose 40 pence per single item for post and packing or the amount stated in the advert. All products carry 1 year written guarantee and full money-back 10 day reassurance. Battery fitting and electronic calibration service is available to customers at any Metac shop. All prices include VAT currently at 15%.

**Metac Wholesale:**

Trade enquiries — send for a complete list of prices for all the goods advertised plus many more not shown, also minimum order details.  
Telephone orders: Credit card customers can telephone orders direct to Daventry (03272) 76545 or Edgware Road 01-723 4753 24 hours a day.



Service Enquiries: 03272-77659  
CALLERS WELCOME. Shops open 9.30am-6.00pm.

**Metac**

**ELECTRONICS  
& TIME CENTRES**

North & Midlands  
67 High Street, DAVENTRY  
Northamptonshire  
Telephone: 03272 76545

South of England  
327 Edgware Road  
LONDON W.2  
Telephone: (01) 723 4753

# MAPLIN



A 63-key ASCII keyboard with 625-line TV interface, 4-page memory and microprocessor interface. Details in our catalogue.



Our catalogue even includes some popular car accessories at marvellous prices.



A 10-channel stereo graphic equaliser with a quality specification at an unbeatable price when you build it yourself. Full specification in our catalogue.



These are just some of the metal cases we stock. There are dozens of plastic ones to choose from as well. See pages 52 to 57 of our catalogue.



Our bi-monthly newsletter contains guaranteed prices, special offers and all the latest news from Maplin.

A massive new catalogue from Maplin that's even bigger and better than before. If you ever buy electronic components, this is the one catalogue you must not be without. Over 280 pages - some in full colour - it's a comprehensive guide to electronic components with hundreds of photographs and illustrations and page after page of invaluable data.



Mobile amateur radio, TV and FM aerials plus lots of accessories are described in our catalogue.



A digitally controlled stereo synthesiser the 5600S with more facilities than almost anything up to £3,000. Build it yourself for less than £750. Full specification in our catalogue.



A superb range of microphones and accessories at really low prices. Take a look in our catalogue - send the coupon now!



An attractive mains alarm clock with radio switching function and battery back up! Complete kit with case only £18.38 (incl. VAT & p & p) MA1023 module only £8.42 (incl. VAT).

**MAPLIN**  
ELECTRONIC SUPPLIES LTD

Post this coupon now for your copy of our 1979-80 catalogue price 70p.

Please send me a copy of your 280 page catalogue. I enclose 70p (plus 37p p&p). If I am not completely satisfied I may return the catalogue to you and have my money refunded. If you live outside the U.K. send £1.35 or ten International Reply Coupons. I enclose £1.07.

NAME \_\_\_\_\_

ADDRESS \_\_\_\_\_

HE/2/80



A superb technical bookshop in your home! All you need is our catalogue. Post the coupon now!



A hi-fi stereo tuner with medium and long wave, FM stereo and UHF TV sound! Full construction details in our catalogue.

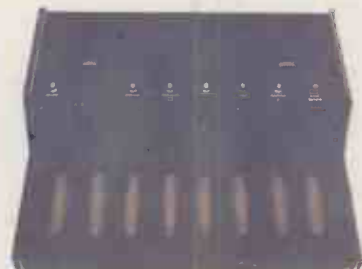

Add-on bass pedal unit for organs. Has excellent bass guitar stop for guitarists accompaniment. Specification in our catalogue.

All mail to:-  
P.O. Box 3, Rayleigh, Essex SS6 8LR.  
Telephone: Southend (0702) 554155.  
Shop: 284 London Road, Westcliff-on-Sea, Essex.  
(Closed on Monday).  
Telephone: Southend (0702) 554000.