

EVERYDAY

APRIL 1996

PRACTICAL

ELECTRONICS

FULLY S.O.R. £2.45

BAT BAND CONVERTER

Listen to the
sounds of bats

HEARING TESTER

*Assess the quality of
your hearing*

MIND MACHINE

Mk Programmer
III Construction

VALVES TODAY

The history and present day uses

CIRCUIT SURGERY

Roundup of readers'
comments & questions

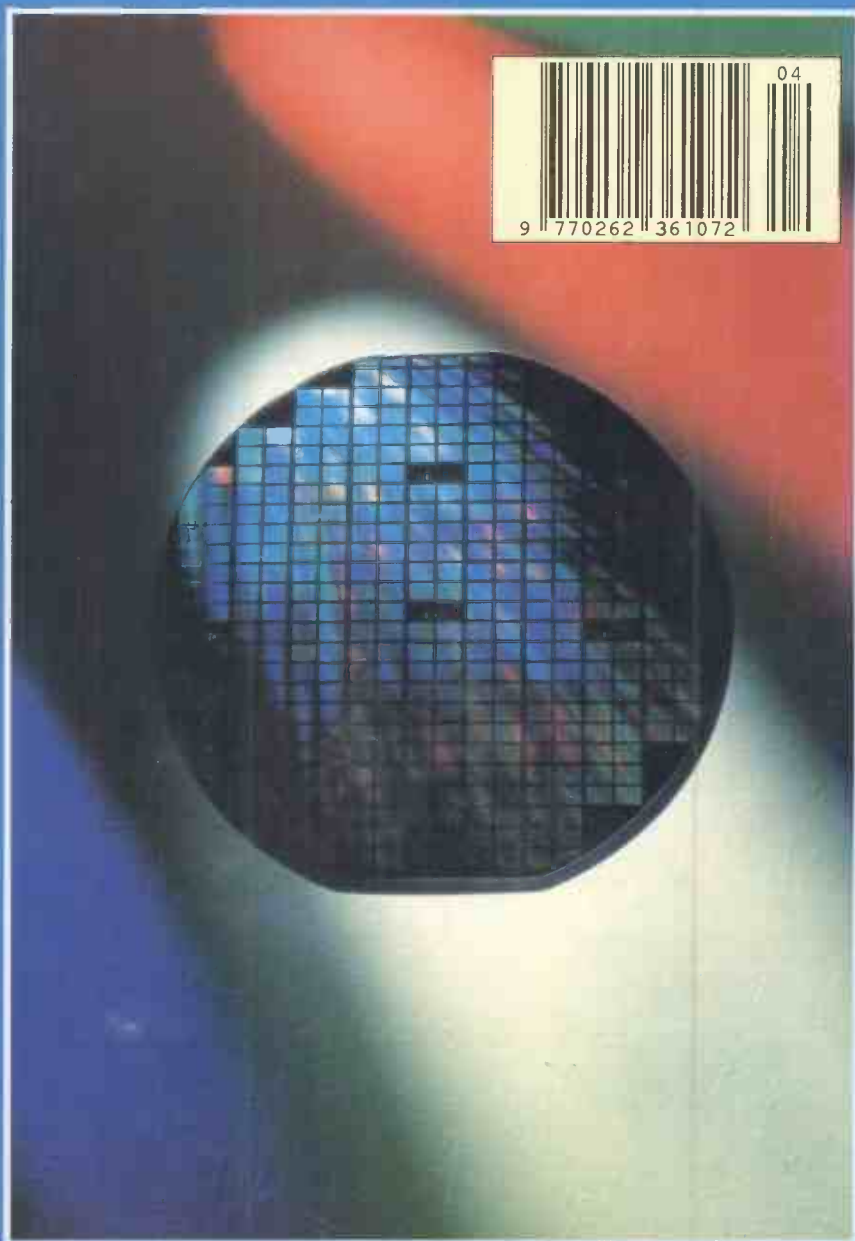

THE NO. 1 INDEPENDENT
MAGAZINE FOR
ELECTRONICS TECHNOLOGY
& COMPUTER PROJECTS

SURVEILLANCE TELESCOPE Superb Russian zoom telescope adjustable from 15x to 60x! complete with metal tripod (impossible to use without this on the higher settings) 66mm lens, leather carrying case £149 ref BAR69

RADIATION DETECTOR SYSTEM Designed to be wall mounted and connected into a PC, ideal for remote monitoring, whole building coverage etc. Complete with detector, cable and software. £19.95 ref BAR75

WIRELESS VIDEO BUG KIT Transmits video and audio signals from a miniature CCTV camera (included) to any standard television! All the components including a PP3 battery will fit into a cigarette packet with the lens requiring a hole about 3mm diameter. Supplied with telescopic aerial but a piece of wire about 4' long will still give a range of up to 100 metres. A single PP3 will probably give less than 1 hours use. £99 REF EP79. (probably not licensable!)

CCTV CAMERA MODULES 46X70X29mm, 30 grams, 12v 100mA, auto electronic shutter, 3.6mm F2 lens, CCIR, 512x492 pixels, video output is 1v p-p (25 ohm). Works directly into a scart or video input on a tv or video. IR sensitive. £79.95 ref EF137.

IR LAMP KIT Suitable for the above camera enables the camera to be used in total darkness! £5.99 ref EF138.

REMOTE CONTROL/TAN DATA TD1400 MODEM/VIEWDATA Complete system comprising 1200/75 modem, auto dialler, infra red remote keyboard, (could be adapted for PC use?) psu, UHF and RGB output, phone lead, RS232 output, composite output. Absolute bargain for parts alone! £9.95 ref BAR33.

9 WATT CHIEFTAN TANK LASERS Double beam units designed to fit in the gun barrel of a tank, each unit has two semi conductor lasers and motor drive units for alignment. 7 mile range, full circuit diagrams, new price £50,000? us? £349. Ring for info.

TWOWAY MIRROR KIT Includes special adhesive film to make two way mirror(s) up to 60"x20". (glass not included) includes full instructions. £12 ref TW1.

NEW HIGH POWER RF TRANSMITTERS

AMPLIFIERS Assembled PCB transmitters, 4 types available, 12.6vdc 90 watt 1.5-30mhz 75 ohm in/out FM/AM £75 ref RF1 12.6vdc 40 watt 50-200mhz 50 ohm in/out FM/AM £65 ref RF2 28vdc 125 watt 1.5-30mhz 75 ohm in/out FM/AM £85 ref RF3 28vdc 100 watt 50-200mhz 50 ohm in/out FM/AM £75 ref RF4 A heat sink will be required, ring for price and availability. If you intend using these as audio transmitters you will need a also need a preamp. Complex module available at £40 ref RF5.

COMPUTER/WORKSHOP/HIFI RCB UNITS Complete protection from faulty equipment for everybody! Inline unit fits in standard IEC lead (extends it by 750mm), fitted in less than 10 seconds, reset/test button, 10A rating. £9 each Ref MM5.

RADIO CONTROLLED CARS FROM £7 EACH!!!!

THOUSANDS AVAILABLE RING/FAX FOR DETAILS!

MAGNETIC CARD READERS (Swipes) £9.95 Cased with flyleads, designed to read standard credit cards! they have 3 wires coming out of the head so they may write as well? complete with control electronics PCB, just £9.95 ref BAR31

WANT TO MAKE SOME MONEY? STUCK FOR AN IDEA? We have collated 140 business manuals that give you information on setting up different businesses, you peruse these at your leisure using the text editor on your PC. Also included is the certificate enabling you to reproduce (and sell) the manuals as much as you like! £14 ref EP74

PANORAMIC CAMERA OFFER Takes double width photographs using standard 35mm film. Use in horizontal or vertical mode. Complete with strap £7.99 ref BAR1

COIN OPERATED TIMER KIT Complete with coin slot mechanism, adjustable time delay, relay output, put a coin slot on anything you like! TV's, videos, fridges, drinks cupboards, HIFI. Takes 50p's and £1 coins. DC operated. price just £7.99 ref BAR27.

ZENTH 900 X MAGNIFICATION MICROSCOPE Zoom, metal construction, built in light, shrimp farm, group viewing screen, lots of accessories. £29 ref ANAYLT.

AA NICAD PACK Pack of 4 tagged AA nicads £2.99 ref BAR34

PLASMA SCREENS 222x310mm, no data hence £4.99 ref BAR67

NIGHTSIGHTS Model TZ54 with infra red illuminator, views up to 175 metres in full darkness in infrared mode, 150m range, 45mm lens, 13 deg angle of view, focussing range 1.5m to infinity. 2 AA batteries required. 950g weight. £210 ref BAR61. 1 years warranty

MEGA AIR MOVERS 375 cubic feet per min, 240v 200 watt, 2,800 rpm, reversible, 7"x7" UK made, new. Aluminium, current list price about £180 ours? £29.95 ref BAR35.

LIQUID CRYSTAL DISPLAYS Bargain prices, 16 character 2 line, 65x14mm £1.99 ref SM1612A 16 character 2 line, 99x24mm £2.99 ref SM1623A 20 character 2 line, 83x19mm £3.99 ref SM2020A 16 character 4 line, 62x25mm £5.99 ref SMC1640A

TAL-1 110MM NEWTONIAN REFLECTOR TELESCOPE Russian. Superb astronomical 'scope, everything you need for some serious star gazing! up to 169x magnification. Send or fax for further details £249 ref TAL-1

GOT AN EXPENSIVE BIKE? You need one of our bottle alarms, they look like a standard water bottle, but open the top, insert a key to activate a motion sensor alarm built inside. Fits all standard bottle cameras, supplied with two keys. SALE PRICE £7.99 REF SA32.

GOT AN EXPENSIVE ANYTHING? You need one of our cased vibration alarms, keyswitch operated, fully cased just fit it to anything from videos to caravans, provides a years protection from 1 PP3 battery, UK made. SALE PRICE £4.99 REF SA33.

DAMAGED ANSWER PHONES These are probably beyond repair so just £4.99 each. BT response 200 machines. REF SA30.

COMMODORE GAMES CONSOLES Just a few of these left to clear at £5 ref SA31. Condition unknown.

COMPUTER DISC CLEAROUT We are left with a lot of software packs that need clearing so we are selling at disc value only 50 discs for £4, that's just 8p each! (our choice of discs) £4 ref EP66

IBM PS2 MODEL 160Z CASE AND POWER SUPPLY Complete with fan etc and 200 watt power supply. £9.95 ref EP67

DELL PC POWER SUPPLIES 145 watt, +5,-5,+12,-12, 150x150x85mm complete with switch, flyleads and IEC socket.

WOLVERHAMPTON BRANCH NOW OPEN AT WORCESTER ST W'HAMPTON TEL 01902 22039

SALE PRICE £9.99 ref EP55

1.44 DISC DRIVES Standard PC 3.5" drives but returns so they will need attention SALE PRICE £4.99 ref EP68

1.2 DISC DRIVES Standard 5.25" drives but returns so they will need attention SALE PRICE NOW ONLY £3.50 ref EP69

PP3 NICADS Unused but some storage marks. £4.99 ref EP52

DELL PC POWER SUPPLIES (Customer returns) Standard PC psu's complete with fly leads, case and fan. +12v, -12v, +5v, -5v SALE PRICE £1.99 EACH worth it for the bits alone! REF DL1. TRADE PACK OF 20 £29.95 REF DL2.

GAS HOBS AND OVENS Brand new gas appliances, perfect for small flats etc. Basic 3 burner hob SALE PRICE £24.99 ref EP72. Basic small built in oven SALE PRICE £79 ref EP73

RED EYE SECURITY PROTECTOR 1,000 watt outdoor PIR switch SALE PRICE £6.99 ref EP75

ENERGY BANK KIT 100 6"x6" 6v 100mA panels, 100 diodes, connection details etc. £69.95 ref EF112

PASTEL ACCOUNTS SOFTWARE, does everything for all sizes of businesses, includes word processor, report writer, windowing, networkable up to 10 stations, multiple cash books etc. 200 page comprehensive manual, 90 days free technical support (0345-326009 try before you buy!) Current retail price is £129, SALE PRICE £9.95 ref SA12. SAVE £120!!!

MINI MICRO FANS 12V 1.5" sq SALE PRICE £2. Ref SA13.

12V AMP LAPTOP psu's 110x55x40mm (includes standard IEC socket) and 2m lead with plug. 100-240v IP. £6.99 REF SA15.

COMPLETE PC 300 WATT UPS SYSTEM Top of the range UPS system providing protection for your computer system and valuable software against mains power fluctuations and cuts. New and boxed. UK made. Provides up to 5 mins running time in the event of complete power failure to allow you to run your system down correctly. LAST FEW TO CLEAR AT £59 SAVE £30 ref SEP149P1

SOLAR PATH LIGHTS Low energy walklights powered by the sun built in PIR so they work when you walk past. Includes solar panel & rechargeable bat. SALE PRICE £19.95 REF EP62

BIG BROTHER PSU Cased PSU, 6v 2A output, 2m o/plead, 1.5m input lead, UK made, 220v. SALE PRICE £4.99 REF EP7



Check out our
WEB SITE

<http://www.pavillon.co.uk/bull-electrical>

RACAL MODEM BONANZA! 1 Racial MPS1223 1200/75 modem, telephone lead, mains lead, manual and comms software, the cheapest way onto the net! all this for just £13 ref DEC13.

4.6mw LASER POINTER. BRAND NEW MODEL NOW IN STOCK! supplied in fully built form (looks like a nice pen) complete with handy pocket clip (which also acts as the on/off switch.) About 60 metres range! Runs on 2 AAA batteries. Produces thin red beam ideal for levels, gun sights, experiments etc. just £39.95 ref DEC49 TRADE PRICE £28 MIN 10 PIECES

BULL TENS UNIT Fully built and tested TENS (Transcutaneous Electrical Nerve Stimulation) unit, complete with electrodes and full instructions. TENS is used for the relief of pain etc in up to 70% of sufferers. Drug free pain relief, safe and easy to use, can be used in conjunction with analgesics etc. £49 Ref TEN/1

COMPUTER RS232 TERMINALS. (LIBERTY) Excellent quality modern units, (like wye 50, s) 2xRS232, 20 function keys, 50 thro to 38,400 baud, menu driven port, screen, cursor, and keyboard setup menus (18 menu's). £29 REF NOV4.

RUSSIAN MONOCULARS Amazing 20 times magnification, coated lenses, carrying case and shoulder strap £29.95 REF BAR73

PC PAL VGA to TV CONVERTER Converts a colour TV into a basic VGA screen. Complete with built in psu, lead and sware.. Ideal for laptops or a cheap upgrade. Supplied in kit form for home assembly. SALE PRICE £25 REF SA34

EMERGENCY LIGHTING UNIT Complete unit with 2 double bulb floodlights, built in charger and auto switch. Fully cased. 6v 8AH lead acid req'd. (secondhand) £4 ref MAG4P11.

SWINGFIRE GUIDED MISSILE WIRE. 4,200 metre reel of ultra thin 4 core insulated cable, 28lbs breaking strain, less than 1mm thick! Ideal alarms, intercoms, dolls house's etc. £13.99 ref EP51

ELECTRIC CAR WINDOW DE-ICERS Complete with cable, plug etc SALE PRICE JUST £4.99 REF SA28

AUTO SUNCHARGER 155x300mm solar panel with diode and 3 metre lead fitted with a cigar plug. 12v 2watt £8.99 REF SA25.

ECLATRON FLASH TUBE As used in police car flashing lights etc, full spec supplied, 60-100 flashes a min. £6.99 REF SA15B.

24v AC 96WATT Cased power supply. New. £9.99 REF SA40

MILITARY SPEC GEIGER COUNTERS Unused and straight from Her majesty's forces. SALE PRICE £44 REF SA16

*SOME OF OUR PRODUCTS MAY BE UNLICENSABLE IN THE UK

BULL ELECTRICAL

250 PORTLAND ROAD, HOVE, SUSSEX.
BN3 5QT. (ESTABLISHED 50 YEARS).

MAIL ORDER TERMS: CASH, PO OR CHEQUE
WITH ORDER PLUS £3 P&P PLUS VAT.
PLEASE ALLOW 7-10 DAYS FOR DELIVERY (PHONE ORDERS
WELCOME (ACCESS, VISA, SWITCH, AMERICAN EXPRESS))

TEL: 01273 203500
FAX: 01273 323077

E-mail bulk@pavillon.co.uk

MICRODRIVE STRIPPERS Small cased tape drives ideal for stripping. Lots of useful goodies including a smart case, and lots of components. SALE PRICE JUST £4.99 FOR FIVE REF SA26

SOLAR POWER LAB SPECIAL You get TWO 6"x6" 6v 130mA solar cells, 4 LED's, wire, buzzer, switch plus 1 relay or motor. Superb value kit SALE PRICE JUST £4.99 REF SA27

RGB/CGA/EGA/TTL COLOUR MONITORS 12" in good condition. Back analysed metal case. SALE PRICE £49 REF SA16B

PLUG IN ACORN PSU 19v AC 14w. £2.99 REF MAG3P10

POWER SUPPLY fully cased with mains and o/p leads 17v DC 900mA output. Bargain price £5.99 ref MAG6P9

ACORN ARCHMEDES PSU +5v @ 4.4A on/off sw uncased, selectable mains input. 145x100x45mm £3.99 REF MAG7P2

13.8V 1.9A PSU cased with leads. Just £9.99 REF MAG10P3

UNIVERSAL SPEED CONTROLLER KIT Designed by us for the C5 motor but ok for any 12v motor up to 30A. Complete with PCB etc. A heat sink may be required. £17.00 REF: MAG17

PHONE CABLE AND COMPUTER COMMUNICATIONS PACK Kit contains 100m of 6 core cable, 100 cable clips, 2 line drivers with RS232 interfaces and all connectors etc. Ideal low cost method of communicating between PCs over a long distance utilizing the serial ports. Complete kit £8.99. Ref comp1.

VIEWDATA SYSTEMS made by Phillips, complete with internal 1200/75 modem, keyboard, psu etc RGB and composite outputs, menu driver, autodialler etc. SALE PRICE £12.99 REF SA18

AIR RIFLES. 22 As used by the Chinese army for training purposes, so there is a lot about! £39.95 REF EF78. 500 pellets at £1.50 ref EF80.

PLUG IN POWER SUPPLY SALE FROM £1.60 Plugs in to 13A socket with output lead, three types available, 9vdc 150mA £1.50 ref SA19, 9vdc 200mA £2.00 ref SA20, 6.5vdc 500mA £2 ref SA21.

VIDEO SENDER UNIT. Transmits both audio and video signals from either a video camera, video recorder, TV or Computer etc to any standard TV set in a 100' range! (tune TV to a spare channel) 12v DC op. Price is £15 REF: MAG15 12v psu is £5 extra REF: MAG5P2

***MINIATURE RADIO TRANSCIEVERS** A pair of walkie talkies with a range up to 2km in open country. Units measure 22x52x155mm. Including cases and earpieces. 2xPP3 req'd. £30.00 pr. REF: MAG30

***FM TRANSMITTER KIT** housed in a standard working 13A adapter! the bug runs directly off the mains so lasts forever! why pay £700? or price is £15 REF: EF62 (kit) Transmits to any FM radio.

***FM BUG BUILT AND TESTED** superior design to kit. Supplied to detective agencies. 9v battery req'd. £14 REF: MAG14

TALKING COINBOX STRIPPER COMPLETE WITH COIN SLOT MECHANISMS originally made to retail at £79 each, these units are designed to convert an ordinary phone into a payphone. The units have the locks missing and sometimes broken hinges. However they can be adapted for their original use or used for something else?? SALE PRICE JUST £2.50 REF SA23

GAT AIR PISTOL PACK Complete with pistol, darts and pellets £12.95 Ref EF82B extra pellets (500) £4.50 ref EF80.

6"x12" AMORPHOUS SOLAR PANEL 12v 155x310mm 130mA. SALE PRICE £4.99 REF SA24.

FIBRE OPTIC CABLE BUMPER PACK 10 metres for £4.99 ref MAG5P13 ideal for experimenters! 30m for £12.99 ref MAG13P1

MIXED GOODIES BOX OF MIXED COMPONENTS WEIGHING 2 KILOS YOURS FOR JUST £6.99

lenses, good light gathering properties. £19.95 ref R/7.

RATTLE BACKS Interesting things these, small piece of solid perspex like material that if you try to spin it on the desk it only spins one way! in fact if you spin it the 'wrong' way it stops off its own accord and goes back the other way! £1.99 ref GI/J01.

GYROSCOPES Remember these? well we have found a company that still manufactures these popular scientific toys, perfect gift or for educational use etc. £6 ref EP70

HYPOTHERMIA SPACE BLANKET 215x150cm aluminised foil blanket, reflects more than 90% of body heat. Also suitable for the construction of two way mirrors! £3.99 each ref O/L041.

LENSTATIC RANGER COMPASS Oil filled capsule, strong metal case, large luminous points. Sight line with magnifying viewer. 50mm dia, 86gm. £10.99 ref O/K604.

RECHARGE ORDINARY BATTERIES UP TO 10 TIMES! With the Battery Wizard! Uses the latest pulse wave charge system to charge all popular brands of ordinary batteries AAA, AA, C, D, four at a time! Led system shows when batteries are charged, automatically rejects unsuitable cells, complete with mains adaptor. BS approved. Price is £21.95 ref EP31.

TALKING WATCH Yes, it actually tells you the time at the press of a button. Also features a voice alarm that wakes you up and tells you what the time is! Lithium cell included. £7.99 ref EP26.

PHOTOGRAPHIC RADAR TRAPS CAN COST YOU YOUR LICENCE! The new multiband 2000 radar detector can prevent even the most responsible of drivers from losing their licence! Adjustable audible alarm with 8 flashing leds gives instant warning of radar zones. Detects X, K, and Ka bands, 3 mile range, 'over the hill' 'around bends' and 'rear trap' facilities. micro size just 4.25"x2.5"x.75". Can pay for itself in just one day! £79.95 ref EP3.

SANYO NICAD PACKS 1200mx14mm 4.8v 270 mA H suitable for cordless phones etc. Pack of 2 just £5 ref EP78.

3" DISCS As used on older Amstrad machines, Spectrum plus3's etc £3 each ref BAR400.

STEREO MICROSCOPES BACK IN STOCK Russian, 200x complete with lenses, lights, filters etc very comprehensive microscope that would normally be around the £700 mark, our price is just £299 (full money back guarantee) full details in catalogue. Ref 95300.

WE BUY SURPLUS STOCK FOR CASH

BUYERS DIRECT LINE 0860 425692
FREE CATALOGUE

100 PAGE CATALOGUE NOW AVAILABLE, 50P STAMP OR FREE ON REQUEST WITH ORDER.

Projects

- DOLBY PRO-LOGIC DECODER** **FREE cover-mounted booklet**
Recreate that amazing "cinema sound" in your living room. Full constructional details for the *only* d.i.y. kit in the world for the Dolby Pro-Logic surround-sound system. It's the project of the Decade! 262
- BAT-BAND CONVERTER** by Bill Mooney
Have you got bats in your belfry, or anywhere else for that matter? Allows the bat's ultrasonic calls to be heard through an ordinary a.m. radio. 274
- MIND MACHINE Mk III - 2** by Andy Flind
Relaxing with our low-cost Mind Entrainment aid is made easier by adding on its easy-to-program sequence generator 288
- EVENT COUNTER** by Max Horsey
Keep count of the score, whether it's zapper guns, sheep or . . . whatever. A *Teach-In '96* project 288
- HEARING TESTER** by John Becker
Find out how good your hearing *really* is. This customised sig-gen drives stereo headphones and quantifies amplitude and frequency thresholds. 310

Series

- CIRCUIT SURGERY** by Alan Winstanley
Wheatstone bridge; CMOS 555 astable; etchant disposal; BNC; flashing l.e.d.s.; *UK Sources FAQ*; sites for sore eyes! 267
- TEACH-IN '96 - A Guide to Modular Circuit Design - 6**
by Max Horsey
Showing how simple modules can be used as the building blocks for larger designs. Switch debouncer, monostables, binary/BCD counter, l.c.d. decoder/driver and display module 282
- INTERFACE** by Robert Penfold
An RS232C serial port and a UART lets you interface to the outside world 304
- AMATEUR RADIO** by Tony Smith G4FAI
Is Morse relevant?; FASC; campaign for 7MHz; amateur search for ETI; developments in China 324

Features

- EDITORIAL** 261
- NEW TECHNOLOGY UPDATE** by Ian Poole
New methods of packaging i.c.s; high power SMDs and improved heat loss 271
- INNOVATIONS** 272
Everyday news from the world of electronics
- FOX REPORT** by Barry Fox
Windows pain; *reMorseless* frustrations 280
- BACK ISSUES** Did you miss these? 294
- VALVES TODAY** by Ian Poole
The trusty thermionic valve still has a role to play. We examine its nature, history and present day use. 296
- SHOPTALK** with David Barrington
Component buying for EPE projects 306
- OHM SWEET OHM** by Max Fidling
Never mind quality, when it comes to professionalism, colour speaks loudest! 306
- ELECTRONICS VIDEOS** 309
Our range of educational videos
- CHROMO-FLORISTICS** by Zola McMalcolm
Software controlled illumination modifies flower colourings during growth 316
- DIRECT BOOK SERVICE** 319
A wide range of technical books available by mail order
- PRINTED CIRCUIT BOARD SERVICE** 322
PCBs for EPE projects
- ADVERTISERS INDEX** 328

- Readers Services • Editorial and Advertisement Department** 261

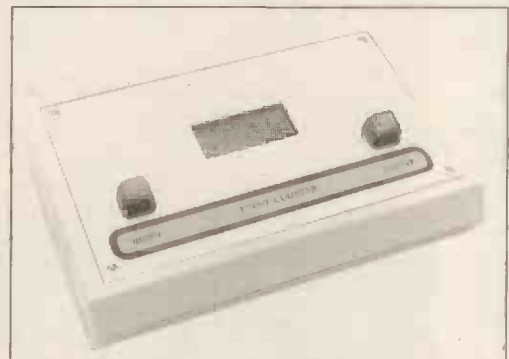

© Wimborne Publishing Ltd 1996. Copyright in all drawings, photographs and articles published in **EVERYDAY PRACTICAL ELECTRONICS** is fully protected, and reproduction or imitations in whole or in part are expressly forbidden.

Our May '96 issue will be published on Thursday, 4th April 1996. See page 251 for details.

Everyday Practical Electronics, April 1996

MIDI ANALYSER

Know at a glance what MIDI commands are being murmured by your musical instruments. Simply plugs into the MIDI cabling. Uses a PIC microcontroller and a 40-character 2-line l.c.d. screen to decode and reveal the parameters in text and bargraphs, including note value, octave number, key velocity, after-touch, channels in use, and much more. There's even a keyboard display of the notes played!



PIR DETECTOR

Is there anybody there? Know for sure with this passive infra-red detector. Using a readily concealable sensor, it can help protect virtually anything, indoors or out. It has micropower operation and can be battery powered at a remote site. Equally ideal for the garage, garden shed or front porch!

COUNTDOWN TIMER

With four 7-segment l.e.d.s as the display, this versatile design can count down from 99 minutes 59 seconds, or any lesser period set by thumbwheel switches, sounding an alarm at the end of the count. Can also be used with a relay as a remote power controller.

CATHODE RAY TUBES

The cathode ray tube (c.r.t.) is one of the most successful inventions ever made. It has been in widespread use for over fifty years, and despite the fact that other thermionic devices are rarely used these days, the production of c.r.t.s. is still increasing.

Even now with many companies spending vast amounts of money developing other forms of display, the c.r.t. still outperforms most of them. It offers a high definition, full colour capability, high light output, wide angle of view, and above all it is relatively cheap to produce.

This special feature looks at its history and present day use.

EVERYDAY

PRACTICAL

ELECTRONICS

MAY ISSUE ON SALE THURSDAY, APRIL 4



Integrated PCB & Schematic Design System for Windows™

New Version 3.5

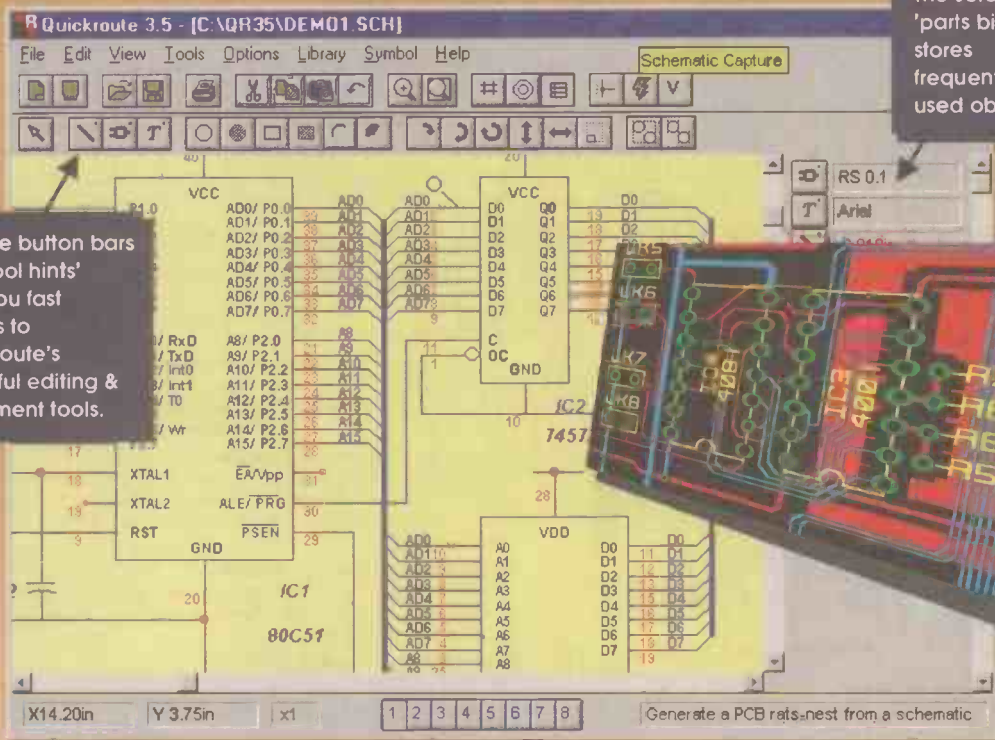

Multiple button bars with 'tool hints' give you fast access to Quickroute's powerful editing & placement tools.

The scrolling 'parts bin' stores frequently used objects.

"..of all the products included here, this is my personal favourite... Really, that's all I have to say about Quickroute - it certainly gets my vote!"

Review of QR 3.0 & other products
Computer Shopper Nov 95

EASY TO USE

Quickroute 3.5 is a powerful, affordable and easy to use integrated schematic & PCB design system for Windows. With its multiple button bars, 'tool hints' and 'parts bin', Quickroute helps you to design quickly and efficiently

POWERFUL

There are four different versions of Quickroute giving you a choice of features & price. Quickroute is available with multi-sheet schematic capture, auto-routing, 'engineering change' (modification of a PCB from a schematic), copper fill, and a range of file import/export options. See the table for a selection of features.

AFFORDABLE

Prices are Designer (£149), PRO (£249) and PRO+ (£399). The Personal edition is available for just £68, but has the manual provided on disk as on-line help. Post & Packing is £5 (UK), £8 (EC), £12 (World). VAT must be added to the total price.

Personal
Designer
PRO
PRO+

	Personal	Designer	PRO	PRO+
PCB & Schematic Design	✓	✓	✓	✓
Schematic Capture		✓	✓	✓
Auto router			✓	✓
Design Rule Checking			✓	✓
Export WMF & Tango			✓	✓
Export Gerber/NC-Drill			✓	✓
Extended Libraries			✓	✓
Tango + Gerber import				✓
Update PCB from schematic				✓
DXF & SPICE Export				✓
Copper Fill				✓

Tel/Fax 0161 449 7101



Quickroute Systems Ltd., 14 Ley Lane, Marple Bridge, Stockport, SK6 5DD, U.K.

email info@quicksys.demon.co.uk



Phone now for more information

Prices and specifications subject to change without notice. All trade marks are acknowledged & respected.

SURVEILLANCE

PROFESSIONAL QUALITY KITS

No. 1 for Kits

Whether your requirement for surveillance equipment is amateur, professional or you are just fascinated by this unique area of electronics SUMA DESIGNS has a kit to fit the bill. We have been designing electronic surveillance equipment for over 12 years and you can be sure that all our kits are very well tried, tested and proven and come complete with full instructions, circuit diagrams, assembly details and all high quality components including fibreglass PCB. Unless otherwise stated all transmitters are tuneable and can be received on an ordinary VHF FM radio.

Genuine SUMA kits available only direct from Suma Designs. Beware inferior imitations!

UTX Ultra-miniature Room Transmitter

Smallest room transmitter kit in the world! Incredible 10mm x 20mm including mic. 3-12V operation. 500m range.....£16.45

MTX Micro-miniature Room Transmitter

Best-selling micro-miniature Room Transmitter
Just 17mm x 17mm including mic. 3-12V operation. 1000m range.....£13.45

STX High-performance Room Transmitter

Hi performance transmitter with a buffered output stage for greater stability and range. Measures 22mm x 22mm including mic. 6-12V operation, 1500m range.....£15.45

VT500 High-power Room Transmitter

Powerful 250mW output providing excellent range and performance. Size 20mm x 40mm. 9-12V operation. 3000m range.....£16.45

VXT Voice Activated Transmitter

Triggers only when sounds are detected. Very low standby current. Variable sensitivity and delay with LED indicator. Size 20mm x 67mm. 9V operation. 1000m range...£19.45

HVX400 Mains Powered Room Transmitter

Connects directly to 240V AC supply for long-term monitoring. Size 30mm x 35mm. 500m range.....£19.45

SCRX Subcarrier Scrambled Room Transmitter

Scrambled output from this transmitter cannot be monitored without the SCDM decoder connected to the receiver. Size 20mm x 67mm. 9V operation. 1000m range.....£22.95

SCLX Subcarrier Telephone Transmitter

Connects to telephone line anywhere, requires no batteries. Output scrambled so requires SCDM connected to receiver. Size 32mm x 37mm. 1000m range.....£23.95

SCDM Subcarrier Decoder Unit for SCR X

Connects to receiver earphone socket and provides decoded audio output to headphones. Size 32mm x 70mm. 9-12V operation.....£22.95

ATR2 Micro Size Telephone Recording Interface

Connects between telephone line (anywhere) and cassette recorder. Switches tape automatically as phone is used. All conversations recorded. Size 16mm x 32mm. Powered from line.....£13.45

UTLX Ultra-miniature Telephone Transmitter

Smallest telephone transmitter kit available. Incredible size of 10mm x 20mm! Connects to line (anywhere) and switches on and off with phone use. All conversation transmitted. Powered from line. 500m range.....£15.95

TLX700 Micro-miniature Telephone Transmitter

Best-selling telephone transmitter. Being 20mm x 20mm it is easier to assemble than UTLX. Connects to line (anywhere) and switches on and off with phone use. All conversations transmitted. Powered from line. 1000m range.....£13.45

STLX High-performance Telephone Transmitter

High performance transmitter with buffered output stage providing excellent stability and performance. Connects to line (anywhere) and switches on and off with phone use. All conversations transmitted. Powered from line. Size 22mm x 22mm. 1500m range.....£16.45

TKX900 Signalling/Tracking Transmitter

Transmits a continuous stream of audio pulses with variable tone and rate. Ideal for signalling or tracking purposes. High power output giving range up to 3000m. Size 25mm x 63mm. 9V operation.....£22.95

CD400 Pocket Bug Detector/Locator

LED and piezo bleeper pulse slowly, rate of pulse and pitch of tone increase as you approach signal. Gain control allows pinpointing of source. Size 45mm x 54mm. 9V operation.....£30.95

CD600 Professional Bug Detector/Locator

Multicolour readout of signal strength with variable rate bleeper and variable sensitivity used to detect and locate hidden transmitters. Switch to AUDIO CONFORM mode to distinguish between localised bug transmission and normal legitimate signals such as pagers, cellular, taxis etc. Size 70mm x 100mm. 9V operation.....£50.95

QTX180 Crystal Controlled Room Transmitter

Narrow band FM transmitter for the ultimate in privacy. Operates on 180 MHz and requires the use of a scanner receiver or our QRX180 kit (see catalogue). Size 20mm x 67mm. 9V operation. 1000m range.....£40.95

QLX180 Crystal Controlled Telephone Transmitter

As per QTX180 but connects to telephone line to monitor both sides of conversations. 20mm x 67mm. 9V operation. 1000m range.....£40.95

QSX180 Line Powered Crystal Controlled Phone Transmitter

As per QLX180 but draws power requirements from line. No batteries required. Size 32mm x 37mm. Range 500m.....£35.95

QRX180 Crystal Controlled FM Receiver

For monitoring any of the 'Q' range transmitters. High sensitivity unit. All RF section supplied as a pre-built and aligned module ready to connect on board so no difficulty setting up. Output to headphones. 60mm x 75mm. 9V operation.....£60.95

A build-up service is available on all our kits if required.

UK customers please send cheques, POs or registered cash. Please add £1.50 per order for P&P. Goods despatched ASAP allowing for cheque clearance. Overseas customers send sterling bank draft and add £5.00 per order for shipment. Credit card orders welcomed on 0827 714476.

OUR LATEST CATALOGUE CONTAINING MANY MORE NEW SURVEILLANCE KITS NOW AVAILABLE. SEND TWO FIRST CLASS STAMPS OR OVERSEAS SEND TWO IRCS.

★★★ Specials ★★★

DLTX/DL RX Radio Control Switch

Remote control anything around your home or garden, outside lights, alarms, paging system etc. System consists of a small VHF transmitter with digital encoder and receiver unit with decoder and relay output, momentary or alternate, 8-way di1 switches on both boards set your own unique security code. TX size 45mm x 45mm. RX size 35mm x 90mm. Both 9V operation. Range up to 200m.

Complete System (2 kits).....£50.95
Individual Transmitter DLTX.....£19.95
Individual Receiver DLRX.....£37.95

MBX-1 Hi-Fi Micro Broadcaster

Not technically a surveillance device but a great idea! Connects to the headphone output of your Hi-Fi, tape or CD and transmits Hi-Fi quality to a nearby radio. Listen to your favourite music anywhere around the house, garden, in the bath or in the garage and you don't have to put up with the DJ's choice and boring waffle. Size 27mm x 60mm. 9V operation. 250m range.....£20.95

**SUMA
DESIGNS**

DEPT. EE
THE WORKSHOPS, 95 MAIN ROAD,
BAXTERLEY. NEAR ATHERSTONE,
WARWICKSHIRE CV9 2LE
VISITORS STRICTLY BY APPOINTMENT ONLY



Tel/Fax:
01827 714476

GREAT VALUE ON SURPLUS STOCKS!!!

POWER SUPPLY



X9040 An excellent cased PSU by Asterc, model AA16490 with built in fan, ideally suited for computer use. Mains IEC in/out connectors, fuse holder, push on-off switch and 5 connectors to motherboard, disk drives, etc. All sockets are numbered and a label gives the breakdown of current and voltage to each pin of each socket. Total power 133W, with maxima as follows: +5V 16.1A, -5V 0.3A, +12V 4A, -12V 0.3A. Overall size 175 x 157 x 95mm **£15.00**

NEW RANGE OF LOW COST EDUCATIONAL METERS

Ideal for the laboratory, these meters have screw terminals that also accept 4mm plugs. Size 120 x 80 x 33mm.



TEC0100 0-1A **£6.95**
TEC0102 0-2A **£6.95**
TEC0103 0-5A **£6.95**
TEC0104 0-6V **£6.95**
TEC0105 0-15V **£6.95**

COMPUTER MANUALS



From Amstrad, 4 original manuals:
X6423 PC2386 User Manual and MS-DOS Guide
X6424 Portable PPC5 12/640 Manual
X6425 PC 1640 User Instructions
X6426 PC 1640 Technical Reference Manual.
 All the same price - **£3.00 each, all 4 £10.00**

NI-CADS AND CHARGER



X6098 6V constant current ni-cad charger for up to 4 1.2V cells. Red LED indicates charging at 100mA and after 14 hours, the green LED illuminates and charging stops. **Great value at £3.95**



X6183 8 brand new AA cells shrink wrapped in a pack with connector. Made by Poweronic, USA. Great value - would cost £9.60 if bought separately. **Special Price £5.95**



TBP305 Brand new battery pack by Ora, measuring 90 x 58 x 19mm. Contains 5 x AA ni-cads rated 700mA. **Great value at just £3.95**

SUPER MOTOR DEAL

One of the best parcels we have seen for some time - over 150,000 low voltage DC motors in a variety of shapes and sizes. Ideal for modellers and experimenters, they are of the highest quality - but at our usual low, low prices.

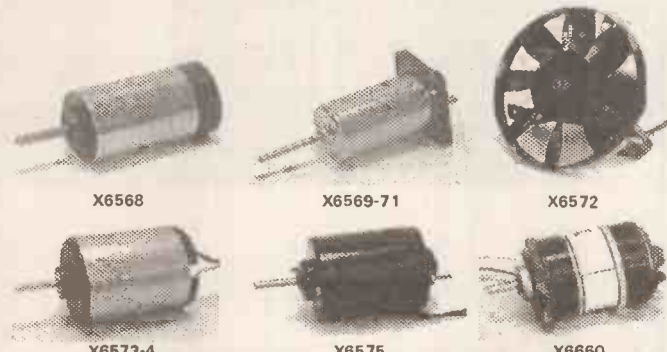

Code	Volts	RPM	Current	Body lxd	Sp'dle lxd	Weight	Qty	Price	100+
X6568	12V	13,000	180mA	55x29mm	21x4mm	113g	13,960	£1.60	0.90
X6569	10.5V	9,000	220mA	35x19mm	20x2.3mm	30g	50,720	£1.00	0.60
X6570	9V	13,000	460mA	35x19mm	20x2.3mm	30g	13,039	£1.00	0.60
X6571	6V	12,000	600mA	35x19mm	20x2.3mm	30g	49,355	£1.00	0.60
X6572	12.8V	6,000	4A	100x70mm	30x9.5mm	954g	478	£4.00	2.40
X6573	12V	4,000	600mA	69x48mm	24x4mm	287g	3,418	£4.00	2.40
X6574	12V	11,000	1600mA	69x48mm	21x4mm	287g	5,081	£4.00	2.40
X6575	7-12V	4/6,000	700-1450mA	107x69mm	30x6.3mm	900g	15,878	£5.00	3.00
X6660	12V	4,000	500mA	75x52mm	20x4mm	331g	2,000	£5.00	3.00

Notes:

All motors are reversible except X6575
X6568-71 and **X6575** are all made by Permanent Magnet Motors
X6568 has 2x2.5mm dia sockets for connexion
X6569-71 are identical in size and shape, but they can quickly be identified by the coloured plastic base, white grey and red respectively. Connexion is by M2.5 studs

X6572 is made by AC Delco, and is a vehicle fan. The plastic fan is 165mm dia. Connexion is by 2m flying lead with spade and bullet connectors
X6573-4 have flying lead connexions 250mm long
X6575 Connexion by flying leads 180mm long
X6660 is made by Micron and is completely sealed with flying leads 210mm long

VIDEO BATTERY CONDITIONER AND CHARGER

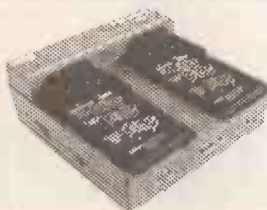

X6452 These are brand new units by Sima - the Powermax +2. Beautifully made unit that both reconditions and charges two 6V, 7.2V or 9.6V video ni-cads at the same time. Requires 12-15V 1.5A input. Discharges at 0.5A, charges at 1A. LED indicators display charge/discharge for each battery, also capacity. Excellent value! **Only £15.00**

BATTERIES

X3523 Slim line 6V 1000mAh battery pack by Ever Ready, BP55. Size 90 x 46 x 20mm. **£12.00**

SUITABLE PSU

X6445 This PSU provides 13V at 1A, so will charge at slightly less than 1A. **£5.95**



HALF PRICE 1996 DIARIES

OUR POPULAR RANGE OF DESK DIARIES PRINTED ON GOOD QUALITY PAPER

Contents:

- 1995 to 1998 Calendars
- 1996/97 Year Planner
- Staff Holiday Chart
- Public Holiday Schedule for 10 Countries
- Metric to Imperial Conversion Charts
- Dress, Trouser, Jacket and Shoe Sizes
- BR Intercity and Colour London Underground Maps
- Week and Day Number
- Mini Calendar at base of each double page
- Address and Phone Number Pages

Available in Red, Blue, Black or Green.
 (Please state 2nd/3rd choice)

A5W A5 size, week to view Was £1.95 Now **£0.99**

A5D A5 size, page a day Was £3.95 Now **£1.99**

A4W A4 size, week to view Was £3.95 Now **£1.99**

A4D A4 size, page a day Was £6.95 Now **£3.49**

GREENWELD
 ELECTRONIC COMPONENTS



Minimum credit card order £12.00. Official orders welcome from Education - minimum invoice charge £15.00. Payment accepted by cheque, PO, cash, bank tokens. Switch, Access, Visa, Connect

27D Park Road · Southampton · SO15 3UQ
 TELEPHONE: 01703 236363 · FAX: 01703 236307
 INTERNET: <http://www.herald.co.uk/clients/G/greenweld/greenweld.html>
 EMAIL via CompuServe 100014, 1463

1996 CATALOGUE NOW AVAILABLE!

Only **£2.00 UK/BFPO** - Overseas **£4.00**

196 pages of bargains - from craft accessories to power supplies, electronic components to toolkits...and much more in between!

Our stores (over 10,000 sq. ft.) have enormous stocks. We are open 8.00am - 5.30pm Monday to Saturday. Come and see us!

TOOLS



2710 Aluminium mitre block 140 x 50 x 25mm with two 45 degree and one 90 degree cutting slots. Grooved base lip on base to hold against workbench. **£5.50**



P23 Head magnifying glass. Velcro strap secures lightweight (110g) device to head. Double lens system with compensation glass enables four magnifications - 1.8, 2.3, 3.7 and 4.8 times. **£19.95**

SUPER TORX DRIVER DEAL

These screwdrivers are becoming an essential tool as more and more manufacturers resort to using tamperproof screws, but until now you had to pay an arm and a leg for a set. We've 'done a deal' with a major supplier of these and can offer them singly or in sets at a never to be repeated price!

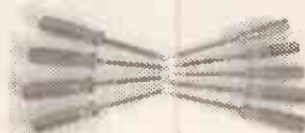

X6309 Full set of 9 - T10, T15, T20, T25, T27, T30, T40, T45 and T90 - would normally cost around **£40.00**. Our Price **£9.95**

X6310 Small set - T10, T15, T20, T25 and T27. **£6.95**

X6311 Large set - T30, T40, T45 and T50. **£4.95**

X6312 + Size. Also available individually at **£2.00** each.



Also from the same source, some other fine quality tools:

(a) Pliers

ETFN Precision flat nose pliers, 150mm long with orange cushioned handles and spring loaded opening. **£2.95**

ETNN Precision needle nose pliers, 150mm long with orange cushioned handles and spring loaded opening. **£2.95**

(b) Tweezers

STS Four piece stainless steel tweezer set - needle point, duck bill needle point, duck bill flat point and reverse action. **£2.50**



X6147 Versatile soft padded instrument case measuring 250 x 250 x 80mm, with expanding side pocket 175 x 80 x 90mm. Both have velcro fasteners. On one side are two apertures, one 15 x 15mm and the other 80 x 40mm covered by a leatherette flap. Strong carrying handle. Grey material with black edging. 100's of uses. Only **£2.95**

JUST ARRIVED!!

Details in latest list:

- 20 Pallets of Mobile Radio Accessories
- More Motors and Solenoids
- Huge Relay Parcel
- Another Job Lot of Mobile Radio Bits
- 20,000 Relays
- 800 Modems

"For just £6.00 a year, you'll be the first to receive details of new stocks every month - many items never appear in these ads, as they're snapped up by Subscribers!"

ELECTRONICS PRINCIPLES 3.0

Electronics Principles 3.0

Basics Dc Theory Ac Theory Transistors Diodes Binary No's Digital Op - Amps

Two's Complement Numbers.

RC Parallel Circuit.

Tri-State Data Latch.

Inverting Operational Amplifier

Resistor 'Rin'

Resistance

Ohms
 kOhms
 Mohms

Actual Value: 25000
Formatted Value: 25k

Cancel OK

Vin = 200mV

Vout = 2V

Rin = 10k
Rf = 100k
Gain (Av) = 10

Formulae.

Gain (Av) = $\frac{R_f}{R_{in}}$

Vout = Input * Gain (Av)

OP-Amps

Inverting
 Non-Inverting 1
 Non-Inverting 2
 Dual-Supply
 Differential

New Values

Resistor Rin: 10k
Resistor Rf: 100k
Input V: 200mV

Calculations Toggle Theory Print

Complete Package Still Only £49.95.

ELECTRONICS TOOLBOX VERSION 3.0

A Windows version of the popular Toolbox Software. Presents over a hundred commonly used formulae in a way that makes calculations easier, thus encouraging experimentation in circuit design. Just select the formula, 'pop' in your values and find the result!

Only £19.95

GCSE MATHEMATICS VERSION 2.0

A series of programs covering all the major topics required by the school syllabus. An easy to use package enabling you to study or revise in what we believe is an interesting and enjoyable way. There are over one hundred and fifty mathematics topics with interactive, full colour graphics, enabling a "learning through doing" approach to encourage experimentation. As used in many schools throughout the UK.

Only £49.95 Also available MATHEMATICS PRINCIPLES 2.0 covers all the GCSE topics but without reference to the school syllabus. Particularly useful to mature and overseas students.

EPT Educational Software, Pump House, Lockram Lane, Witham, Essex. UK. CM8 2BJ. Tel/Fax: 01376 514008.

E-Mail Address, Sales@eptsoft.demon.co.uk WWW Pages. <http://www.octacon.co.uk/ext/ept/software.htm>

Upgrades, Site Licence details or further information: Please telephone.

Add £2 per order for UK post and packing. Make cheques payable to EPT Educational Software.

Switch, Visa and Mastercard orders accepted - please give card number, expiry date.

OVERSEAS ORDERS: Add £2.50 postage for countries in the EEC. Outside EEC add £3.50 for airmail postage.

Pico Releases PC Potential

Pico's Virtual Instrumentation enable you to use your computer as a variety of useful test and measurement instruments or as an advanced data logger.

Hardware and software are supplied together as a package - no more worries about incompatibility or complex set-up procedures. Unlike traditional 'plug in' data acquisition cards, they simply plug into the PC's parallel or serial port, making them ideal for use with portable PC's.

Call for your Guide on 'Virtual Instrumentation'.

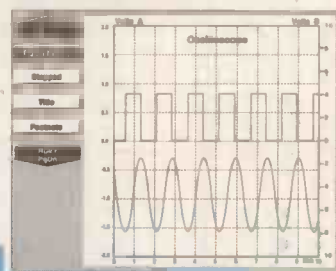

PicoScope
'Virtual instrument' software.

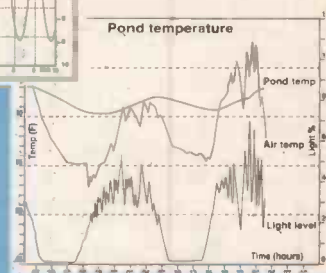

PicoLog
Advanced data logging software.

NEW from Pico TC-08 Thermocouple to PC Converter

8 channel Thermocouple Interface

- Connects to your serial port - no power supply required.
- Supplied with PicoLog datalogging software for advanced temperature processing, min/max detection and alarm.
- 8 Thermocouple inputs (B,E,J,K,N,R,S and T types)
- Resolution and accuracy dependant on thermocouple type. For type K the resolution is better than 0.1°C.

TC-08 £ 199

TC-08 + Calibration Certificate £ 224

complete with PicoLog, software drivers and connecting cable. A range of thermocouple probes is available.



SLA-16 & SLA-32 Logic Analysers

Pocket sized 16/32 channel Logic Analysers

- Connects to PC serial port.
- Up to 50MHz sampling.
- Internal and external clock modes.
- 8K Trace Buffer.

SLA-16 £ 219

SLA-32 £ 349

with software, power supply and cables



ADC-100 Virtual Instrument

Dual Channel 12 bit resolution

- Digital Storage Scope
- Spectrum Analyser
- Frequency Meter
- Chart Recorder
- Data Logger
- Voltmeter

The ADC-100 offers both a high sampling rate (100kHz) and a high resolution. It is ideal as a general purpose test instrument either in the lab or in the field. Flexible input ranges ($\pm 200\text{mV}$ to $\pm 20\text{V}$) allows the unit to connect directly to a wide variety of signals.

ADC-100 with PicoScope £199

with PicoScope & PicoLog £219

ADC-10

1 Channel 8 bit

- Lowest cost in the Pico range
- Up to 22kHz sampling
- 0-5V input range



The ADC-10 gives your computer a single channel of analog input. Simply plug into the parallel port.

ADC-10 with PicoScope £49

PicoScope & PicoLog £59

Carriage UK free, Overseas £9 Oscilloscope Probes (x1, x10) £10

PICO TECHNOLOGY

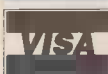

Pico Technology Ltd. Broadway House, 149-151 St Neots Rd, Hardwick, Cambridge. CB3 7QJ
Tel: (0)1954 - 211716 Fax: (0)1954 - 211880 E-mail: 100073.2365 @compuserve.com



Phone or FAX for sales, ordering information, data sheets, technical support. All prices exclusive of VAT



MAIL ORDER ONLY • CALLERS BY APPOINTMENT

EPE MICROCONTROLLER P.I. TREASURE HUNTER

The latest MAGENTA DESIGN - highly stable & sensitive - with μ C control of all timing functions and advanced pulse separation techniques.

- New circuit design 1994
- High stability drift cancelling
- Easy to build & use
- No ground effect, works in seawater



- Detects gold, silver, ferrous & non-ferrous metals

- Efficient quartz controlled microcontroller pulse generation.
- Full kit with headphones & all hardware

KIT 847.....£63.95

DIGITAL LCD THERMOSTAT

A versatile thermostat using a thermistor probe and having an l.c.d. display. MIN/MAX memories, -10 to 110 degrees Celsius, or can be set to read in Fahrenheit. Individually settable upper and lower switching temperatures allow close control, or alternatively allow a wide 'dead band' to be set which can result in substantial energy savings when used with domestic hot water systems. Ideal for greenhouse ventilation or heating control, aquaria, home brewing, etc. Mains powered, 10A SPCO relay output. Punched and printed case.

KIT 841.....£29.95

PORTABLE ULTRASONIC PEST SCARER

A powerful 23kHz ultrasound generator in a compact hand-held case. MOSFET output drives a special sealed transducer with intense pulses via a special tuned transformer. Sweeping frequency output is designed to give maximum output without any special setting up.

KIT 842.....£22.56

DIGITAL CAPACITANCE METER

A really professional looking project. Kit is supplied with a punched and printed front panel, case, p.c.b. and all components. Quartz controlled accuracy of 1%. Large clear 5 digit display and high speed operation. Ideal for beginners - as the μ F, nF and pF ranges give clear unambiguous read out of marked and unmarked capacitors from a few pF up to thousands of μ F.

KIT 493.....£39.95

ACOUSTIC PROBE

A very popular project which picks up vibrations by means of a contact probe and passes them on to a pair of headphones or an amplifier. Sounds from engines, watches, and speech travelling through walls can be amplified and heard clearly. Useful for mechanics, instrument engineers, and nosey parkers!

KIT 740.....£19.98

WINDICATOR

A novel wind speed indicator with LED read-out. Kit comes complete with sensor cups, and weatherproof sensing head. Mainspower unit £5.99 extra.

KIT 856.....£28.00

BUCCANEER I.B. METAL DETECTOR

An Induction Balance (I.B.) detector with audible output. Providing good sensitivity and easy construction. COMPLETE KIT - INCLUDES ALL HARDWARE, HANDLE, SEARCH HEAD, PCB etc.

CIRCUIT REJECTS IRON WHILST PICKING UP GOLD, SILVER, COPPER etc.
A SOLID RELIABLE DESIGN.

KIT 719.....£54.99

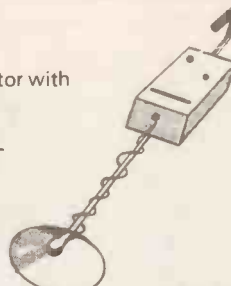

1000V & 500V INSULATION TESTER

Superb new design. Regulated output, efficient circuit. Dual-scale meter, compact case. Reads up to 200 Megohms.

Kit includes wound coil, cut-out case, meter scale, PCB & ALL components.

KIT 848.....£32.95



MOSFET MkII VARIABLE BENCH POWER SUPPLY 0-25V 2-5A.

Based on our MkI design and preserving all the features, but now with switching pre-regulator for much higher efficiency. Panel meters indicate Volts and Amps. Fully variable down to zero. Toroidal mains transformer. Kit includes punched and printed case and all parts. As featured in April 1994 EPE. An essential piece of equipment.

KIT 845.....£64.95



ULTRASONIC PEST SCARER

Keep pets/pests away from newly sown areas, fruit, vegetable and flower beds, children's play areas, patios etc. This project produces intense pulses of ultrasound which deter visiting animals.

- KIT INCLUDES ALL COMPONENTS, PCB & CASE
- EFFICIENT 100V TRANSDUCER OUTPUT
- COMPLETELY INAUDIBLE TO HUMANS

KIT 812.....£14.81



SPACEWRITER

An innovative and exciting project. Wave the wand through the air and your message appears. Programmable to hold any message up to 16 digits long. Comes pre-loaded with "MERRY XMAS". Kit includes PCB, all components & tube + instructions for message loading.

KIT 849.....£16.99



12V EPROM ERASER

A safe low cost eraser for up to 4 EPROMS at a time in less than 20 minutes. Operates from a 12V supply (400mA). Used extensively for mobile work - updating equipment in the field etc. Also in educational situations where mains supplies are not allowed. Safety interlock prevents contact with UV.

KIT 790.....£28.51

MOSFET 25V 2.5A POWER SUPPLY

High performance design has made this one of our classic kits. Two panel meters indicate Volts and Amps. Variable from 0-25 Volts and current limit control from 0-2.5A. Rugged power MOSFET output stage. Toroidal mains transformer.

KIT 769.....£56.82

INSULATION TESTER

A reliable and neat electronic tester which checks insulation resistance of wiring and appliances etc., at 500 Volts. The unit is battery powered, simple and safe to operate. Leakage resistance of up to 100 Megohms can be read easily. A very popular college project.

KIT 444.....£22.37

DIGITAL COMBINATION LOCK

Digital lock with 12 key keypad. Entering a four digit code operates a 250V 16A relay. A special anti-tamper circuit permits the relay board to be mounted remotely. Ideal car immobiliser, operates from 12V. Drilled case, brushed aluminium keypad.

KIT 840.....£19.86

E.E. TREASURE HUNTER P.I. METAL DETECTOR MKI

Magenta's highly developed & acclaimed design. Quartz crystal controlled circuit MOSFET coil drive. D.C. coupled amplification. Full kit includes PCB, handle, case & search coil.

- KIT INC. HEADPHONES
- EFFICIENT CMOS DESIGN
- POWERFUL COIL DRIVE

- DETECTS FERROUS AND NON-FERROUS METAL - GOLD, SILVER, COPPER ETC.
- 190mm SEARCH COIL
- NO 'GROUND EFFECT'

KIT 815.....£45.95



Comstep PC Computer Interface and Driver board

Drives two motors from PC parallel port. Supplied with comprehensive software. Needs 12Volt 1A supply.

With 2-200
Step Motors

Kit 846.....£67.00

Power Booster for Comstep

Adds to Comstep and allows motors up to 4 Amps to be driven. Two boosters drive two motors from a single Comstep. Uses standard Comstep software.

With MD24
Motors

Kit 850.....£39.95

EDUCATIONAL BOOK & PACK

ADVENTURES WITH ELECTRONICS

The classic book by Tom Duncan used throughout schools. Very well illustrated, ideal first book for age 10 on. No soldering. Uses an S.DEC breadboard.

Book & Components.....£28.95

Book only.....£7.99

Versatile Stepping motor Interface

A Magenta design, gives Half and Full-Wave drive. Up to 1Amp and 24Volts. CMOS inputs - Drive from logic or computer port. Needs power supply.

Kit 816.....£9.82

DC Motor/Gearboxes

Our Popular and Versatile DC motor/Gearbox sets. Ideal for Models, Robots, Buggies etc. 1-5 to 4-5V Multi ratio gearbox gives wide range of speeds.

LARGE TYPE - MGL £6.95

SMALL - MGS - £4.77



Stepping Motors

MD38...Mini 48 step...£8.65

MD35...Std 48 step...£12.98

MD200...200 step...£16.80

MD24...Large 200 step...£22.95



PIC DEVELOPMENT & TRAINING SYSTEM PIC

YOUR KEY TO ANOTHER NEW AGE OF ELECTRONICS

PICs are being used more and more because they allow complicated jobs to be done with a single chip. All the work is done by programming. One PIC replaces a board full of ICs. Saving time, space, power, and MONEY.

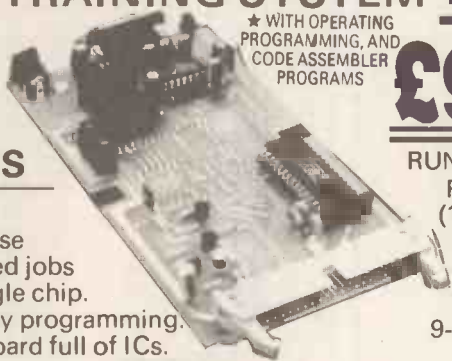

★ WITH OPERATING PROGRAMMING, AND CODE ASSEMBLER PROGRAMS

£99 INCLUDING VAT
+ £3.00 p&p

RUNS WITH ANY PC POWER SUPPLY (12V at 200mA)

£8.99

PC LEADS
9-WAY **£6.00**

25-WAY **£7.00**

HOW DO I START WITH PICs?

- STEP 1** – Buy the PIC-DATS Development & Training System
STEP 2 – Follow May & June '95 EPE Series – showing how to program for practical applications
STEP 3 – Start writing and testing your own programs

PIC PROJECT – LIGHT CONTROLLER DEVELOPMENT SYSTEM (NO SOFTWARE)

A real-world application for a PIC microchip. This project can be made to do just what you chose by writing your own software. It can be programmed to work as a 4-Channel Light Chaser or a simple controller for domestic lighting. Zero volt crossing signal is provided and there is a 4x3 matrix keypad. (Less case).

Kit 855.....**£35.95**

PIC 16C84 DISPLAY DRIVER

NEW!

USES PIC16C84 to drive a 2 UNEX16 LCD Display.

Another **NEW** PIC project from Magenta. Supplied with PCB, industry standard 2 line x 16 character display, PIC16C84, components, and software to include in your own programs. Full display data and program service code is applied. Ideal development base for meters, terminals, calculations, counters, timers etc. Just waiting for your application.

KIT Ref. 860.....**£17.99**

SIMPLE PIC16C84 PROGRAMMER

NEW!

Based on the design in February '96 EPE. Magenta have made a proper PCB for this circuit and a full kit of parts. The PCB eliminates the risk of layout errors. Additional contact points are provided to allow connection to RA and unused RB pins when testing programs. Kit includes 1 – PIC16C84 chip, lead, connector and all software.

Programmer Kit – with software disk, lead, connector and PIC16C84 chip, including PCB.

Kit 857.....**£12.99**

Power Supply Unit 12V-14V.....**£3.99**

Extra PIC16C84 Chips.....**£7.36**

KIT HIGHLIGHT

We have noticed a number of customers buying the PIC 16C84 Programmer and Kit 855. This is an ideal combination. Kit 855 allows *Mains Power* to be controlled safely using a PIC16C84. Experiment with chaser patterns and dimming using phase control. Special kit with all components and blank PIC16C84 and reprints.

Kit 855/16C84.....**£39.95**

6800 DEVELOPMENT AND TRAINING SYSTEM

Never before at this price! Our own 6800 board kit. Used all over the world in schools and universities. Double Eurocard PCB with RAM, ROM, and I/O. Full featured MONITOR and LINE BY LINE ASSEMBLER ON BOARD. Just needs power, and a serial link to your PC. Supplied with full data and applications course. Use to learn, or as a stand-alone computer board.

£55.00!

Kit Ref 601



BAT DETECTOR



An excellent circuit which reduces ultrasound frequencies between 20 and 100 kHz to the normal (human) audible range. Operating rather like a radio receiver the circuit allows the listener to tune-in to the ultrasonic frequencies of interest. Listening to Bats is fascinating, and it is possible to identify various different types using this project. Other uses have been found in industry for vibration monitoring etc.

KIT 814.....**£21.44**

Mini-Lab & Micro Lab Electronics Teach-In 7

As featured in EPE and now published as Teach-In 7. All parts are supplied by Magenta. *Teach-In 7* is £3.95 from us or EPE Full Mini Lab Kit – £119.95 – Power supply extra – £22.55 Full Micro Lab Kit – £155.95 Built Micro Lab – £189.95

MAGENTA

Tel: 01283 565435 Fax: 01283 546932

All prices include VAT. Add £3.00 p&p.



Tel (0191) 251 4363
Fax (0191) 252 2296

ELECTRONIC COMPONENTS
Station Road, Cullercoats,
Tyne & Wear
NE30 4PQ
U.K.

AD847JN	£6.50	TBA800	£0.70	BY126	£0.13	AC128	£0.40	BC338	£0.10	BDS53C	£0.47		
AD9596KN	£7.73	TBA810S	£0.64	BY127	£0.18	AC187	£0.48	BC338-25	£0.10	BDX54C	£0.50		
ADEL2020AN	£5.06	TBA820M	£0.39	BY133	£0.10	AC188	£0.48	BC348B	£0.14	BF180	£0.31		
ADM222AH	£3.55	TDA1024	£1.49	OA47	£0.28	ACY17	£3.84	BC357	£0.25	BF182	£0.31		
ADM232AAN	£3.55	TDA1170S	£1.83	OA90	£0.07	AD149	£1.67	BC393	£0.73	BF185	£0.58		
ADM485JN	£2.97	TDA2002	£1.04	OA91	£0.10	AD161	£0.92	BC414C	£0.13	BF194	£0.31		
ADM690AN	£5.13	TDA2004	£3.11	OA200	£0.10	AD162	£0.92	BC441	£0.40	BF194B	£0.19		
ADM691AN	£6.48	TDA2030	£1.18	OA202	£0.29	AD166	£0.16	BC461	£0.40	BF195	£0.19		
ADM695AN	£6.48	TDA2050V	£3.98	Zener 2.7 to 33V		BC107B	£0.17	BC463	£0.29	BF244	£0.35		
ADP044FP	£5.58	TEA5115	£5.11	400mW	£0.08	BC108	£0.14	BC478	£0.32	BF244B	£0.35		
BUF04GP	£8.56	TL061CP	£10.14		£0.14	BC108A	£0.16	BC479	£0.32	BF244C	£1.41		
CA741CE	£0.26	TL062CP	£0.60	Bridge Rectifiers				BC108C	£0.16	BC490	£0.24	BF257	£0.33
CA747CE	£0.39	TL064CN	£0.72	W005 1.5A 50V	£0.19	BC109	£0.17	BC516	£0.22	BF259	£0.33		
CA3046	£0.37	TL071CP	£0.48	W02 1.5A 200V	£0.20	BC109C	£0.18	BC517	£0.20	BF327	£0.38		
CA3059	£1.16	TL072CP	£0.50	W04 1.5A 400V	£0.22	BC114	£0.41	BC527	£0.20	BF355	£0.38		
CA3080E	£0.73	TL074CN	£0.58	W06 1.5A 600V	£0.22	BC115	£0.41	BC528	£0.20	BF423	£0.13		
CA3130E	£0.98	TL081	£0.33	W08 1.5A 800V	£0.27	BC116	£0.41	BC537	£0.20	BF451	£0.19		
CA3140E	£0.51	TL082CP	£0.54	W10 1.5A 1kV	£0.24	BC118	£0.41	BC568	£0.08	BF459	£0.33		
CA3189E	£1.22	TL084CN	£0.63	BR32 3A 200V	£0.36	BC132	£0.36	BC569	£0.08	BF469	£0.36		
CA3240E	£1.12	TL705ACP	£1.62	BR34 3A 400V	£0.40	BC134	£0.36	BC578	£0.09	BF479	£0.29		
DG211CJ	£1.55	TL707CP	£1.62	BR36 3A 600V	£0.33	BC135	£0.36	BC579	£0.09	BF484	£0.31		
DG212CJ	£1.55	TL727CP	£0.54	BR62 6A 200V	£0.70	BC140	£0.25	BC58C	£0.08	BF485	£0.32		
DG411DJ	£3.11	TMPO1FP	£5.60	BR68 6A 800V	£0.59	BC141	£0.27	BC594	£0.10	BF550	£0.20		
DG412DJ	£4.19	U2A240CN	£2.30	1004 10A 400V	£1.39	BC142	£0.31	BC595	£0.10	BFY51	£0.35		
EL2020CN	£4.99	ULN2003	£0.52	2502 25A 200V	£1.68	BC143	£0.34	BC596A	£0.08	BFY52	£0.28		
EL2030CN	£5.67	ULN2004A	£1.28	2506 25A 600V	£1.75	BC149	£0.21	BC597B	£0.08	BS107	£0.21		
ICL7106	£2.80	ULN2608	£0.40	Thyristors				BC154	£0.36	BC597C	£0.08	BS170	£0.23
ICL711DCPA	£1.06	ULN2803	£0.90	TO12AA	£0.30	BC157	£0.12	BC598	£0.08	BS176	£1.35		
ICL7621	£1.70	ULN2803	£1.06	TIC160	£0.36	BC159	£0.28	BC599	£0.08	BU126	£1.32		
ICL8038	£5.25	ZN414Z	£1.16	TIC116D	£0.66	BC160	£0.28	BC60A	£0.36	BU126C	£1.32		
ICM7555	£0.36	ZN416E	£1.99	TIC126D	£0.77	BC170	£0.16	BC60B	£0.09	BUX20A	£1.24		
ICM7556	£0.98	ZN1034E	£3.11	Triacs				BC170B	£0.16	BC637	£0.21	BU326A	£1.54
L165V	£2.63	EPROM's				Z1015DA	£0.42	BC171	£0.11	BC638	£0.21	BU500	£1.40
L272M	£1.89	2716	£4.46	TIC226D	£0.65	BC171B	£0.16	BC639	£0.21	BU508A	£1.42		
L297	£6.37	2732	£4.84	BT408-600B	£0.99	BC172	£0.13	BC640	£0.21	BU508B	£1.42		
L298	£6.99	2762	£4.20	BT408-600B	£0.96	BC172B	£0.13	BCV70	£0.22	BU526	£1.74		
LF347N	£0.86	2764-25	£4.20	2N236D	£0.25	BC177	£0.18	BCV71	£0.20	BU806	£1.06		
LF351N	£0.45	27C010	£5.74	2N246A	£0.86	BC178	£0.18	BCV72	£0.20	BUT11A	£1.30		
LF353N	£0.42	27128-20	£4.08	2N246B	£0.86	BC179A	£0.17	BD135	£0.21	BUX8A	£0.78		
LF356	£0.84	27C128-20	£4.08	2N2904A	£0.25	BC182	£0.11	BD136	£0.21	IRF540	£1.60		
LM301A	£0.25	27256-20	£4.85	2N2905A	£0.25	BC182A	£0.11	BD137	£0.23	IRF740	£1.80		
LM308N	£0.58	27C256-20	£3.68	2N2907	£0.20	BC182B	£0.12	BD138	£0.22	MJ2501	£1.60		
LM311N-8	£0.32	27C512	£3.42	2N2907A	£0.20	BC182L	£0.08	BD139	£0.26	MJ2001	£1.80		
LM318	£1.28	RAM				2N2118A	£0.28	BD140	£0.08	MJ1101S	£2.11		
LM319N-14	£0.96	4164-15	£1.78	2N2228A	£0.18	BC183	£0.08	BD150C	£0.82	MJ11016	£2.56		
LM324	£1.10	616-10	£1.53	2N246A	£0.86	BC183LB	£0.08	BD165	£0.42	MJE340	£0.48		
LM335Z	£1.22	6264-10	£3.16	2N2904A	£0.25	BC184	£0.08	BD187	£0.39	MJE350	£0.40		
LM339N	£0.20	41256-10	£2.80	2N2905A	£0.25	BC184L	£0.08	BD201	£0.40	MPSA05	£0.14		
LM348N	£0.31	62256-10	£5.35	2N2907	£0.20	BC186	£0.33	BD202	£0.40	MPSA06	£0.12		
LM358N	£0.27	511000-8	£8.54	2N2907A	£0.20	BC204C	£0.72	BD203	£0.40	MPSA13	£0.12		
LM377	£2.57	514256-8	£6.88	2N2926	£0.16	BC206B	£0.72	BD204	£0.40	MPSA42	£0.17		
LM380N-14	£1.12	A/D Converters				2N3053	£0.27	BD222	£0.58	TIP29C	£0.31		
LM381N	£2.64	Data Acquisition				2N3054	£0.85	BD225	£0.42	TIP30C	£0.31		
LM386	£0.79	AD420AN	£25.88	AD420AN	£25.88	BC207B	£0.72	BD228	£0.50	TIP32C	£0.41		
LM392N	£0.79	AD557JN	£8.75	AD557JN	£8.75	BC209A	£0.72	BD232	£0.50	TIP32E	£0.41		
LM393N	£0.79	AD754AJN	£18.48	AD754AJN	£18.48	BC212L	£0.08	BD238	£0.32	TIP33C	£0.72		
LM709T	£0.79	AD775JN	£20.88	AD775JN	£20.88	BC212LB	£0.08	BD240C	£0.37	TIP41A	£0.48		
LM733	£1.04	AD7726KN	£25.69	AD7726KN	£25.69	BC213	£0.08	BD243B	£0.50	TIP42C	£0.52		
LM748CN-8	£3.38	AD7528JN	£8.63	AD7528JN	£8.63	BC213B	£0.08	BD244A	£0.53	TIP47	£0.68		
LM579CP	£3.38	AD7545AKN	£14.04	AD7545AKN	£14.04	BC213LC	£0.08	BD244C	£1.18	TIP48	£0.62		
LM1458	£5.22	AD7581JN	£25.80	AD7581JN	£25.80	BC214	£0.08	BD245C	£1.18	TIP50	£0.53		
LM1881	£3.10	AD7828JN	£20.33	AD7828JN	£20.33	BC214L	£0.08	BD246	£1.18	TIP21	£0.21		
LM2917N8	£0.72	ICL7109CP	£7.75	ICL7109CP	£7.75	BC225	£0.15	BD246C	£1.18	TIP22	£0.48		
LM3900N	£1.70	ICL7591FP	£3.51	ICL7591FP	£3.51	BC225B	£0.09	BD283	£0.61	TIP25	£0.46		
LM3909N	£1.70	ICL7591FP	£3.51	ICL7591FP	£3.51	BC238B	£0.09	BD400	£0.79	TIP27	£0.40		
LM3911	£2.56	ZN425E	£5.94	ZN425E	£5.94	BC238C	£0.09	BD400	£0.79	TIP132	£0.46		
LM3914	£2.30	ZN426E	£5.13	ZN426E	£5.13	BC239C	£0.10	BD411	£0.41	TIP137	£0.56		
LM3915	£2.70	ZN427E	£8.78	ZN427E	£8.78	BC250A	£0.15	BD442	£0.37	TIP142	£1.08		
LM3600	£1.66	ZN428E	£5.94	ZN428E	£5.94	BC251	£0.13	BD534	£0.50	TIP147	£1.12		
LMC660CN	£2.16	ZN439E	£7.13	ZN439E	£7.13	BC252	£0.13	BD535	£0.50	TIP295S	£0.67		
LMC6032IN	£1.55	ZN448E	£7.02	ZN448E	£7.02	BC261B	£0.30	BD536	£0.65	TIP305S	£0.93		
LMC6042IN	£1.82	Voltage Regulators				2N5222	£0.57	BD581	£0.62	VNI0KM	£0.48		
LP311N	£0.74	7805	£0.44	7805	£0.44	BC267B	£0.30	BD597	£0.92	VN66AFD	£1.50		
LP324N	£0.74	7808	£0.50	7808	£0.50	BC308	£0.10	BD648	£0.52	ZTX300	£0.16		
LP339N	£0.73	7812	£0.38	7812	£0.38	BC319C	£0.13	BD650	£0.53				
MAX202CPE	£2.97	7815	£0.38	7815	£0.38	BC327	£0.10	BD707	£0.42				
MAX208CNG	£6.99	7818	£0.50	7818	£0.50	BC327-16	£0.10	BD708	£1.04				
MAX220CPE	£5.06	7815	£0.38	7815	£0.38	BC328	£0.10	BD807	£0.80				
MAX222CPE	£5.06	7905	£0.40	7905	£0.40	BC328-16	£0.10	BDX32	£1.78				
MAX232CPE	£1.26	7912	£0.38	7912	£0.38	BC337	£0.10	BDX33C	£0.49				
MAX238CNG	£6.88	7915	£0.38	7915	£0.38	BC337-25	£0.12	BDX34C	£0.50				
MAX242CPE	£5.51	7924	£0.38	7924	£0.38	Electrolytic Radial Capacitors							
MAX631ACP	£4.49	78L05	£0.26	78L05	£0.26	µF 16v	25v	63v	100v	450v			
MAX635ACP	£4.49	78L08	£0.23	78L08	£0.23	0.47	---	---	£0.05	£0.07			
MC1488	£0.39	78L12	£0.23	78L12	£0.23	---	---	£0.05	£0.06	£0.23	1.0		
MC1489	£0.39	78L15	£0.24	78L15	£0.24	---	---	£0.05	£0.06	£0.31	2.2		
MC3302	£0.56	78L24	£0.39	78L24	£0.39	---	---	£0.05	£0.06	£0.39	4.7		
MC3340P	£1.60	79L05	£0.28	79L05	£0.28	---	---	£0.05	£0.06	£0.08	10		
MC4558P	£0.36	79L08	£0.28	79L08	£0.28	---	---	£0.05	£0.06	£0.09	---		
MV500DP	£2.63	79L12	£0.28	79L12	£0.28	---	---	£0.06	£0.06	£0.11	---		
MV601DP	£2.97	79L15	£0.28	79L15	£0.28	---	---	£0.06	£0.06	£0.11	---		
NE531	£2.47	79L24	£0.22	79L24	£0.22	---	---	£0.09	£0.09	---	---		
NE555N	£0.25	AD4666AN	£3.44	AD4666AN	£3.44	---	---	£0.11	£0.11	---	---		
NE556N	£0.36	LM200CV	£1.24	LM200CV	£1.24	---	---	£0.11	£0.11	---	---		
NE565	£1.84	L296	£1.83	L296	£1.83	---	---	£0.31	£0.31	---	---		
NE566N	£0.90	L387A	£3.24	L387A	£3.24	---	---	£0.57	£0.57	---	---		
NE567N	£0.39	LM2904CT	£2.30	LM2904CT	£2.30	---	---	£0.29	£0.29	---	---		
NE571N	£2.47	LM317T	£0.58	LM317T	£0.58	---	---	£0.29	£0.29	---	---		
NE592	£0.62	LM338K	£1.84	LM338K	£1.84	---	---	£0.37	£0.37	---	---		
NE593N	£0.80	LM334Z	£1.35	LM334Z	£1.35	---	---	£1.11	£1.11	---	---		
NE594N	£0.64	LM338K	£5.52	LM338K	£5.52	Resistors							
OP07CN	£1.42	LM723	£0.29	LM723	£0.29	1/4W Carbon Film 5% E12 Series	10-10M	£0.02	Each	£0.60	per 100		

EVERYDAY PRACTICAL ELECTRONICS

VOL. 25 No. 4

APRIL '96

Editorial Offices:

EVERYDAY PRACTICAL ELECTRONICS EDITORIAL
ALLEN HOUSE, EAST BOROUGH, WIMBORNE
DORSET BH21 1PF

Phone: Wimborne (01202) 881749

Fax: (01202) 841692. DX: Wimborne 45314

Due to the cost we cannot reply to orders or queries by Fax.

See notes on Readers' Enquiries below - we regret lengthy technical enquiries cannot be answered over the telephone.

Advertisement Offices:

EVERYDAY PRACTICAL ELECTRONICS
ADVERTISEMENTS

HOLLAND WOOD HOUSE, CHURCH LANE
GREAT HOLLAND, ESSEX CO13 0JS

Phone/Fax: (01255) 850596

WORK SMARTER!

These days most businesses are being bombarded with information on how "new" communications systems can help them be more efficient, or sell more competitively, or deal more intelligently with customers, etc. We, of course, are not immune to this - although we tend to go our own way.

Our initial Internet link-up is via our contributor Alan Winstanley and *EPE* has had a presence on the Net for some time now, answering technical queries and providing information for interested parties around the world. Our name features on other pages on the WWW as well; for instance Jake Rothman's *Simple Theremin* project (Sept. 95) is noted on the Theremin site, etc. Alan has also produced his own FAQ (frequently asked questions) which lists UK suppliers of all things electronic for the designer and constructor. See *Circuit Surgery* for more details on the FAQ and on *EPE* Internet.

INSTANT ACCESS

We are also presently working on a new Fax On Demand service for past projects. We hope to make this service available to readers in about a month's time. The idea is that you will be able to instantly access any project published over the last year (this might be extended to cover earlier issues if response is good) via a fax machine and pay a premium rate for the 'phone call. It will not replace our *Back Issues Service* (see page 294) but it will allow you to get an article almost instantly.

DEVELOPMENT

Both of these services - *EPE* Internet and Fax On Demand - will be gradually developed over the coming months. While we do not see these methods of providing articles replacing the printed magazine - at least not in the next decade - they will certainly add to the availability of information and should add to the overall value of the publication. Our Internet connection has already resulted in plenty of interest, and a number of new subscription orders, from the other side of the Atlantic. It is very rewarding to see the response of American readers when they compare *EPE* with their "home grown" titles.

While we may not all like computers and computing they have become a necessity for modern communications; but, rest assured, even if you want nothing to do with PCs, MACs or whatever else comes along, *EPE* will continue to cater for your needs electronic.

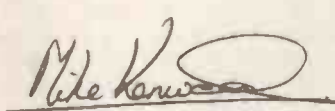

SUBSCRIPTIONS

Annual Subscriptions for delivery direct to any address in the UK: £24. Overseas: £30 (£47.50 airmail). Cheques or bank drafts (in £ sterling only) payable to *Everyday Practical Electronics* and sent to *EPE* Subscriptions Dept., Allen House, East Borough, Wimborne,

Dorset BH21 1PF. Tel: 01202 881749. Subscriptions start with the next available issue. We accept Access (MasterCard) or Visa. (For past issues see the *Back Issues* page).

BINDERS

Binders to hold one volume (12 issues) are available from the above address. These are finished in blue p.v.c., printed with the magazine logo in gold on the spine. Price £5.95 plus £3.50 post and packing (for overseas readers the postage is £6.00 to everywhere except Australia and Papua New Guinea which cost £10.50). Normally sent within seven days but please allow 28 days for delivery - more for overseas orders.

Payment in £ sterling only please. Visa and Access (MasterCard) accepted, minimum credit card order £5. Send or phone your card number and card expiry date with your name, address etc.



Editor: MIKE KENWARD

Secretary: PAM BROWN

Deputy Editor: DAVID BARRINGTON

Technical Editor: JOHN BECKER

Business Manager: DAVID J. LEAVER

Subscriptions: MARILYN GOLDBERG

Editorial: Wimborne (01202) 881749

Advertisement Manager:

PETER J. MEW, Frinton (01255) 850596

Advertisement Copy Controller:

DEREK NEW, Wimborne (01202) 882299

READERS' ENQUIRIES

We are unable to offer any advice on the use, purchase, repair or modification of commercial equipment or the incorporation or modification of designs published in the magazine. We regret that we cannot provide data or answer queries on articles or projects that are more than five years old. Letters requiring a personal reply must be accompanied by a stamped self-addressed envelope or a self-addressed envelope and international reply coupons. Due to the cost we cannot reply to queries by Fax.

All reasonable precautions are taken to ensure that the advice and data given to readers is reliable. We cannot, however, guarantee it and we cannot accept legal responsibility for it.

COMPONENT SUPPLIES

We do not supply electronic components or kits for building the projects featured, these can be supplied by advertisers.

We advise readers to check that all parts are still available before commencing any project in a back-dated issue.

We regret that we cannot provide data, or answer queries, on projects that are more than five years old.

ADVERTISEMENTS

Although the proprietors and staff of EVERYDAY PRACTICAL ELECTRONICS take reasonable precautions to protect the interests of readers by ensuring as far as practicable that advertisements are *bona fide*, the magazine and its Publishers cannot give any undertakings in respect of statements or claims made by advertisers, whether these advertisements are printed as part of the magazine, or in inserts.

The Publishers regret that under no circumstances will the magazine accept liability for non-receipt of goods ordered, or for late delivery, or for faults in manufacture. Legal remedies are available in respect of some of these circumstances, and readers who have complaints should first address them to the advertiser.

TRANSMITTERS/BUGS/TELEPHONE EQUIPMENT

We advise readers that certain items of radio transmitting and telephone equipment which may be advertised in our pages cannot be legally used in the UK. Readers should check the law before buying any transmitting or telephone equipment as a fine, confiscation of equipment and/or imprisonment can result from illegal use or ownership. The laws vary from country to country; overseas readers should check local laws.

BAT BAND CONVERTER

BILL MOONEY



Use your a.m. portable radio and this novel design to tune-in to the secret world of bats.

THIS small unit will convert the ultrasonic sounds or calls emitted by bats into a medium wave signal for reception on a portable a.m. radio. No electrical connection is required between the radio and the Bat Band Converter.

The main interest in sound above the audio range is for listening to bats but an ultrasound detector has many uses and can reveal a world of sound normally closed to human perception. The jingle of coins or the rattling of keys in your pocket produces surprising amounts of ultrasound.

Tearing paper and bursting bubbles in lemonade are trivial sources of ultrasound but there are serious commercial uses for a detector, like listening for engine wear and finding leaks in pipes. Ultrasound also has some obscure applications, for example the effectiveness of textile or paper softeners can be assessed by measuring the amount of ultrasound it produces when compressed or flexed.

BAT CHATTER

If the high frequency sound vibrations produced by bats are detected and converted to electrical signals by a transducer, the result is a band of signals from about 15kHz to about 110kHz. Most radio receivers don't cover such Very Low Frequency (v.l.f.) bands and so a converter is required.

In radio terms, a 100kHz range is relatively narrow and it can easily fit into a quiet corner of the medium wave band. In this converter the "bat band" is translated to the space around 1MHz (one megahertz), just over half way up the tuning dial. The radio receiver does most of the work, saving on costs and greatly simplifying the project.

On the author's portable radio the bat band covers about 0.5cm of tuning range, only a small adjustment is therefore required to scan the whole band. You won't wear out the mechanism or your fingers by searching over such a small range.

Bats are helpful to us in this respect because they chatter over quite a wide frequency range. In practice, for use as a simple bat detector, the radio can be set to about 50kHz and only occasional tweaking is required.

The Bat Band Detector is based on a 40kHz ultrasonic transducer of the type used for security or remote control applications. The result is a peak in sensitivity around 40kHz.

In its basic form the bat signal is envelope detected as though it was an amplitude modulated signal. A Beat Frequency Oscillator (B.F.O.) can be added to the system later – see next month. This can have an interesting effect, adding "colour" to the sound from most sources.

Some bat signals will then be heard as bursts of a high pitched chirps or clicks rather than a low frequency tone.

Surface mount (SMD) construction has been used for simplicity and compactness, and for the fun of it. The completed p.c.b. for this project is slim enough to fit inside most portable radios. This would eliminate the need for use of a separate battery. But it would mean adding an on/off switch and so on. All the SMD bits are available and important constructional points are covered as required.

BAT BAND

The limits of the bat band extend from about 12kHz to 150kHz worldwide, depending on the species. There can be some overlap with humans at the lower end. This is heard as a high pitched crackling but to most of us, bats are silent.

The constant frequency pulse of the Lesser Horseshoe is about 110kHz and the Greater Horseshoe about 85kHz, both lasting for approximately 20ms. The pulses from ordinary bats decrease in frequency from a peak at about 80kHz.

It has been found that the number of pulses per second and their duration varies and three phases can be identified as: Search, Approach and Terminal. As the bat locates, homes-in and captures its prey there is a general speeding up of pulse activity. The pulse rate increases, the frequency drops faster and pulses get shorter.

In the course of one pulse the frequency drops to half or one third of its starting value. For example from 80kHz to 40kHz or 35kHz.

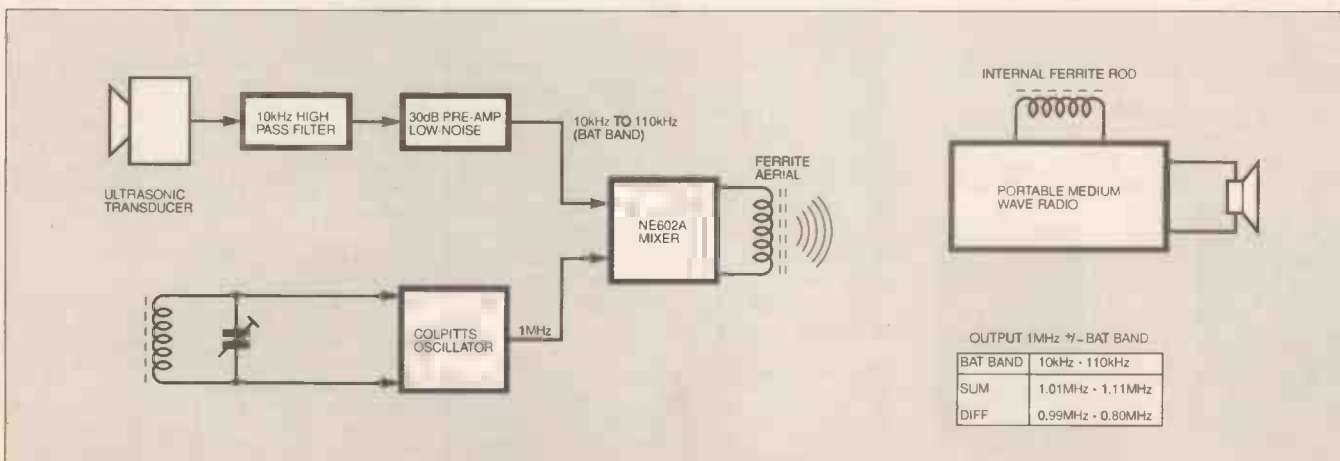

Fig. 1. Block diagram showing the functional elements of the Bat Band Converter.

Ordinary or common bats will emit somewhere in the region of 10 to 35 pulses per second in normal flight but the rate can increase rapidly to over 100 pulses per second at the "home-in" phase. Since the pulses from ordinary bats are so short, a few milliseconds, the detector/receiver will produce clicks, thuds and tones rather than whistles.

HOW IT WORKS

The functional elements of the Bat Band Converter are shown in the block diagram of Fig. 1. The audio component of the signal from the ultrasonic transducer is attenuated in the simple input filter. The remaining ultrasonic signals are then boosted slightly before reaching the mixer where they are combined with a 1MHz local oscillator.

Sum and difference mixer products are produced and coupled to the Radio Receiver by a tuned ferrite rod which acts as a transmitting aerial. Obviously a medium wave receiver with a built in ferrite rod aerial is a must.

Our bat band is therefore translated to two places on the radio dial. This is quite useful as we can choose the quietest range at any one time.

Low bat band frequencies are closest to the 1MHz oscillator which can be received as a useful marker. Tuning away from this in either direction will correspond to the higher frequency ultrasonic signals. The lower band is inverted so that when we tune lower in frequency on the radio we will be covering higher frequency bat signals.

The portable radio provides most of the gain and filtering along with the ability to tune over the bat band. The receiver also provides envelope (or product) detection, automatic gain control (a.g.c.), and finally power to drive a loudspeaker or headphones.

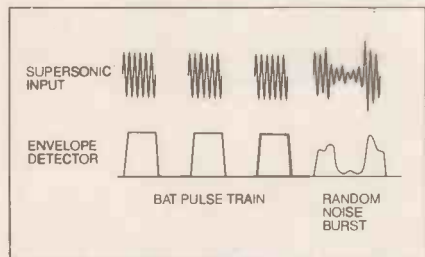

Fig. 3. Envelope detection in an a.m. radio

ENVELOPE DETECTION

The result of envelope detection is shown in Fig. 3. If a series of say 50kHz pulses lasting say 20ms is received then for each burst we get a corresponding 20ms envelope.

If 20 of these are received in a second then a 20Hz buzz will be heard from the radio. Similarly, a burst of ultrasonic noise will produce an audio envelope from the radio.

There is no correct way to decode the high frequency mechanical vibrations produced by a bat. The signals contain phase, harmonic and directional components which cannot be translated faithfully to human audio. The addition of a beat frequency oscillator to give a simple form of product detection will give a slightly different representation.

ABOUT BATS

Bats are an important group of animals representing about one quarter of all mammals. On a world wide basis there are 19 families and some 950 different species. In Britain we have two types of horseshoe bat and about a dozen types of ordinary bats.

Scientifically, bats are known as chiroptera or hand-wing because their wings are in fact an evolution of the hand with the membrane extended between the five fingers. The thumb remains easily discernible as a strong bat characteristic protruding from the front edge of the wing.

They all catch insects and avoid objects in flight by use of an echo location system. This involves emitting short ultrasonic pulses and then listening for and interpreting the echoes in the silence between the pulses.

The horseshoe bats emit their sound through a specially shaped nose and have a pig like appearance. Ordinary bats emit the pulse through the mouth and have dog like features.

The native bats of Britain and Ireland are listed in Table 1. The Pipistrelle is the smallest and the most common. The Noctule is the largest and can emerge before dark to hunt with swifts and other insect predators.

The horseshoe bats use fixed frequency pulses. All others bats have pulses which are lower and variable in frequency.

ULTRASOUND

The ultrasonic pulse is emitted from the bat as a cone in front of the animal. On reaching the target some of the mechanical energy is absorbed and some is scattered in all directions. A tiny portion returns to

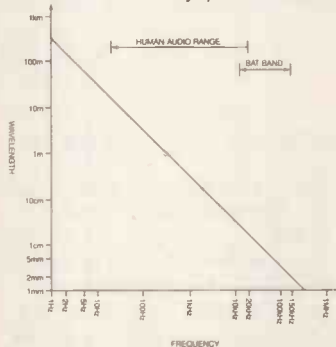

Fig. 2. Wavelength of sound in air on log scale.

the bat. Their ears are relatively large of necessity, and the inner ear mechanism is highly specialised for high frequency sensitivity and spatial resolution.

The short wavelength of ultrasound is required for bats to locate, identify and catch often very small insects. A Pipistrelle, for instance, can locate and devour a tiny 2mm long fruit fly in a fraction of a second. An evening's catch can amount to well over 500 insects.

It is evident that bats are capable of using all the information in the returned echo such as doppler, phase shifts and harmonic patterns to characterise the target. The wavelength (λ) of sounds of different frequencies (f) are given in Fig. 2.

This graph uses the commonly accepted velocity of sound in air (c) of 344 meters per second and the relationship is: $\lambda = c/f$. We can see from this that bats favour wavelengths of a few millimetres which is similar to the size of their prey.

BAT WATCH

Under the Wildlife and Countryside Act 1981 it is illegal for anyone without a licence to intentionally kill, injure or handle a bat of any species in Great Britain; to possess a bat, whether alive or dead (unless obtained legally); or to disturb a bat when roosting.

Ringling or marking bats or photographing them (except when in flight outdoors) requires a licence from the nature Conservancy Council. It is also an offence to sell or offer for sale any bat, whether alive or dead, without a licence.



Left: **Pipistrelle**
40-50kHz
Location:
Throughout
Great Britain
and Ireland

Right: **Greater/Lesser Horseshoe**
80-100kHz
Location:
S/W England,
Wales, North to
Yorkshire.



FOR FURTHER INFORMATION CONTACT:
Nature Conservancy Council, Northminster
House, Peterborough, PE1 1UA. Tel: 01733
40345 or your local bat group

Table 1. Bats found in Britain and Ireland

Bat type	Abundance	Region	Wingspan (cm)	Body (cm)
GREATER HORSESHOE	Scarce	SW England	34	6.4
LESSER HORSESHOE	Common	Wales, SW England, W. Eire.	25	4
PIPISTRELLE	Abundant & Widespread	All Eng, Scot, Wales, Eire & NI	22	3.5
NOCTULE	Common	All Eng. (except for north). All Wales.	36	7.5
LEISLERS	Rare	Central England	30	3.5
SEROTINE	Common	S & E England up to Midlands	36	6.4
COMMON LONG-EARED	Abundant & Widespread	All Eng, Wales	25	4.5
NATTERER'S	Common	Scot (except northern areas). All Eire & NI	28	4.5
BARBASTELLE	Uncommon	All Eng & Wales, SW Scot. All Eire & NI	27	4.5
MOUSE-EARED	Very rare (Extinct?)	SE & mid England, S. Wales.	40	7
BECHSTEIN'S	Very rare	Sussex, Dorset	28	4.5
WHISKERED	Common	Dorset	24	4
DAUBENTON'S	Common	All Eng, Wales, S. Scot	25	4.5
	Widespread	All Eng, Wales. Most Scot, Eire-except SW	25	4.5

Bat Band Converter

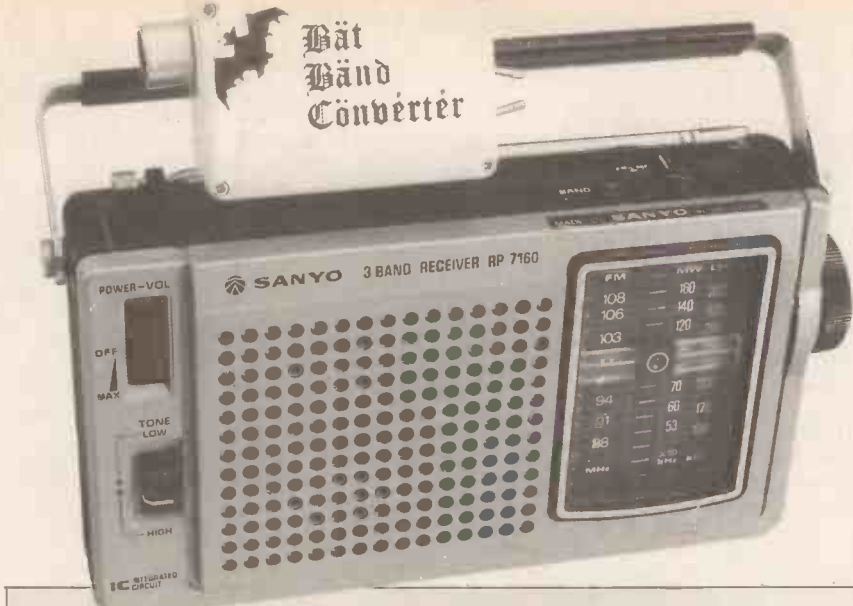

Across the outputs is a parallel tuned circuit consisting of coil L1 and variable trimming capacitor TC1.

The coil L1 is wound on a short ferrite rod which acts as a transmitting aerial and couples the mixer products to the radio receiver. The trimmer TC1 allows the output circuit to be tuned, but in practice the response is very broad and the setting is not critical.

Every effort has been made to minimise the current drain of the circuit. With a fresh alkaline battery at 9V it draws 4.6mA and the device will go on working down to 6V at 3.7mA. In fact, reasonable results were noted at 3.5V supply. The series resistor R6 limits the maximum voltage to IC1 to 8V, which is its design limit.

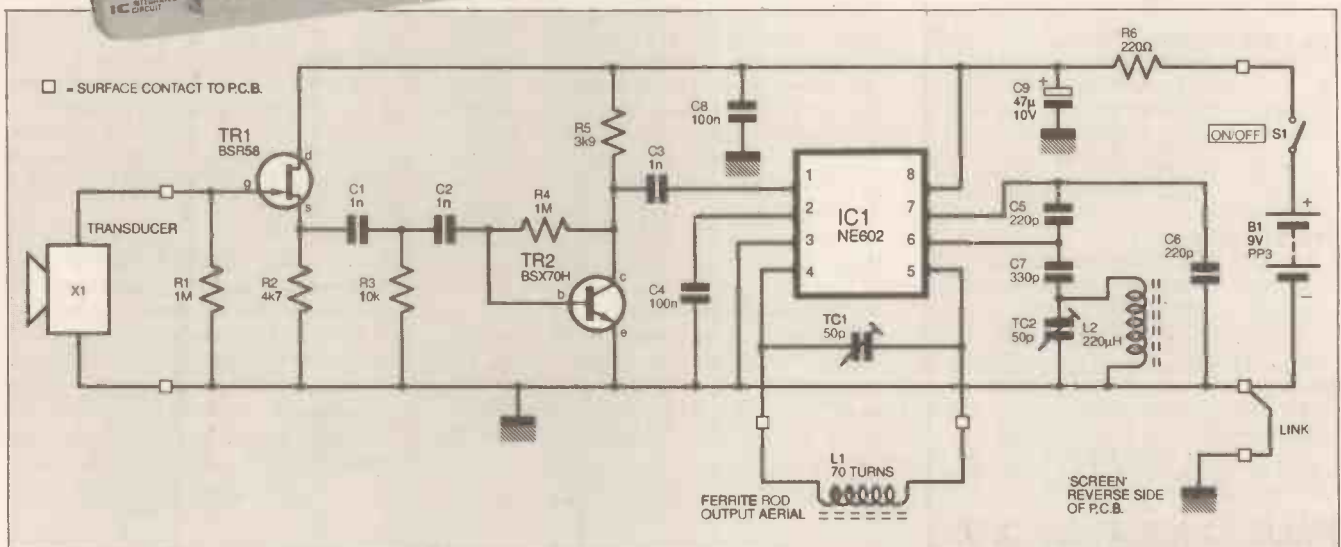

Fig. 4. Full circuit diagram for the Bat Band Converter. Note that the small squares are the p.c.b. "surface mount" pads.

A typical portable radio will have a bandwidth of 8kHz. The response will drop off slowly beyond this central flat region, extending out to 15kHz to 20kHz.

A 100kHz bat band will therefore be covered in just a few tuning steps. This is aided by the wide bandwidth occupied by bats so that at least part of the call is likely to be caught even if the radio is well off tune.

CIRCUIT DESCRIPTION

The full circuit diagram of the Bat Band Converter is shown in Fig. 4. All components, with the exception of the transducer X1, On/Off switch and ferrite rod aerial, are surface mount devices (SMDs).

The signals from the ultrasonic transducer X1 are very small, microvolts rather than millivolts. A low noise f.e.t. input stage, TR1, has minimal loading effect on transducer X1 and provides a low impedance source for the passive high pass filter.

This simple filter consists of capacitors C1, C2, and resistor R3. It attenuates signals below about 15kHz but the "roll off" is very gradual. Mid-range and lower frequency audio is strongly reduced.

The falling sensitivity of transducer X1 further limits the audio frequencies reaching the mixer IC1. Despite this level of attenuation a little audio still gets through the system but it has no effect on the ultrasonic operation.

When the receiver is tuned close to the 1MHz local oscillator a little audio feedback will be heard. This is a real help with tuning-in because it readily identifies the low frequency end of the bat band.

The transistor TR2 is a low noise amplifier and the SMD type BCX70H works well in this circuit. IC1 is a double balanced mixer and Colpitts oscillator in one package. The signal inputs at pin 1 and pin 2 are used in unbalanced mode, with pin 2 decoupled by capacitor C4.

COLPITTS OSCILLATOR

The components around pin 6 and pin 7 are the frequency determining elements for the Colpitts oscillator. This runs at 1MHz with the values given and makes use of a miniature SMD inductor (L2), eliminating the need to wind a coil.

Operation will therefore be spot-on frequency first time. The trimmer capacitor TC2 allows the frequency to be altered slightly, about 50kHz, so that at least one of the bat band ranges can be placed on a relatively quiet spot near to 1MHz on the medium wave. This oscillator is very forgiving and you can pick a quieter frequency just by altering the capacitors as required.

The NE602 mixer, IC1, is a flexible device in terms of input and output options. The output, pin 4 and pin 5, are used in a balanced configuration in this design.

CIRCUIT BOARD

The circuit is fabricated with surface mount components (SMDs). This makes printed circuit board population possible without drilling a single hole. The procedure for producing a p.c.b. ready for population is essentially the same as that for through-hole components.

The printed circuit board component layout and full size copper foil master is illustrated in Fig. 5. This board is available from the EPE PCB Service, code 984. (This includes next month's B.F.O. board.)

CONSTRUCTION

To solder the "chip" components on the p.c.b. a fine-nosed pair of tweezers will be helpful. You can go to town on equipping yourself for SM work and it all makes life easier and more productive. But for a "one off" project you can manage with a standard fine tipped soldering iron and solder as used for through-hole construction.

A magnifying glass will help if the eyesight is not so good. A test of this is whether you can read the code number on the chip resistors. Chip capacitors appear to have no markings on them.

The soldering procedure is to anchor one end of the component first. Place the chip in the position required and hold it there with the tweezers whilst soldering one end.

A little solder has to be carried on the iron to the joint for this. Normally the flux would have evaporated in the short

COMPONENTS

Resistors

- R1, R4 1M (EIA code 105)
- R2 4k7 (EIA code 472)
- R3 10k (EIA code 103)
- R5 3k9 (EIA code 392)
- R6 220Ω (EIA code 221)

All surface mount (SMD), size 1206

See
**SHOP
TALK**

Page

Capacitors

- C1, C2, C3 1n COG dielectric, 50V (3 off)
- C4, C8 100n X7R dielectric 50V (2 off)
- C5, C6 220 COG dielectric, 50V (2 off)
- C7 330p COG dielectric, 50V
- (All above SMD size 1206)
- C9 47μ SMD tantalum, 10V
- TC1, TC2 50pF sealed or open SMD trimmer (2 off)

Semiconductors

- TR1 BSR58 *n*-channel low-noise f.e.t., SMD – SOT23
- TR2 BCX70H *n*pn low-noise amp. transistor, SMD – SOT23 package
- IC1 NE602AD mixer/oscillator, SMD – SO8 package

Miscellaneous

- L1 470μH 70 turns 30a.w.g. Kynar wire on 6.5cm ferrite rod (see text)
- L2 220μH fixed, SMD type CM32 or similar

Printed circuit board available from *EPE PCB Service*, code 984a/b conv/B.F.O. (next month); plastic box, size 75mm x 50mm x 25mm; piece of screened lead; 30a.w.g. Kynar insulated wire; PP3 battery and connector; multistrand connecting wire; solder etc.

Approx cost
guidance only

£19

excluding batt.

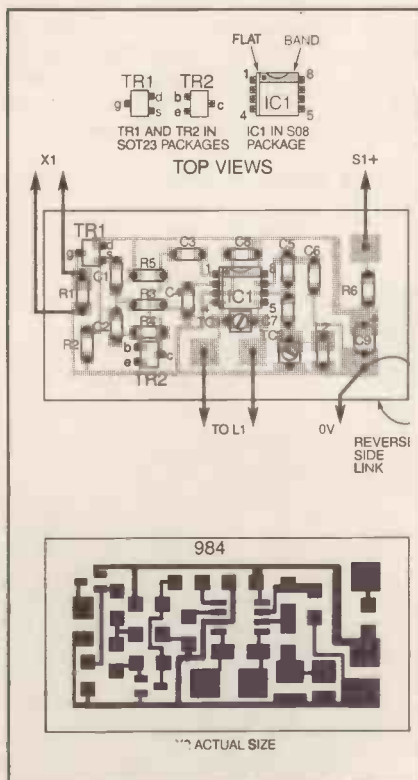

Fig. 5. Printed circuit board component layout and copper foil master pattern.

time it takes to get to the component but the flux coating on the p.c.b. replenishes it to some extent and a reasonable joint is possible. The use of a wooden toothpick to hold the chip in place for soldering is probably a better alternative to the tweezers.

Having soldered one end, the chip is anchored and the second end can be soldered at leisure.

Try not to use too much solder as this will reduce the reliability of the joint.

This method can also be used for the transistors and the i.c. Just anchor one or two pins whilst holding it down. Note the pin identifications given in Fig. 5. Pin 1 of IC1 is indicated by a line, a dot or a bevelled edge. The BSR58 f.e.t. transistor has the pinouts as indicated. If you substitute it for another type the connections may differ.

Don't forget to make a connection from the circuit-side ground to the reverse side copper plane which will act as a useful screen. Note that resistor R3 crosses a track and will need a little care in placement. It is not a bad policy to clean the p.c.b. free of flux with proprietary p.c.b. cleaner after population is completed.



FERRITE COIL

The off-board components pose no problems except perhaps for coil L1. This is made by cutting down a standard 10mm dia. ferrite rod to a length of about 6.5cm.

To do this, simply scribe the rod right around its circumference with a small file and then snap it off. Sharp edges can then carefully be filed down.

The coil consists of 70 turns of 30a.w.g. Kynar insulated wire close wound. This wire is the type used for "wirewrap" and is invaluable for SM work. It is silver plated and is easy to solder.

The project is housed in a small plastic box measuring 75mm x 50mm x 25mm approximately. The positioning of the p.c.b. and off-board components are shown in Fig. 6. All holes should be

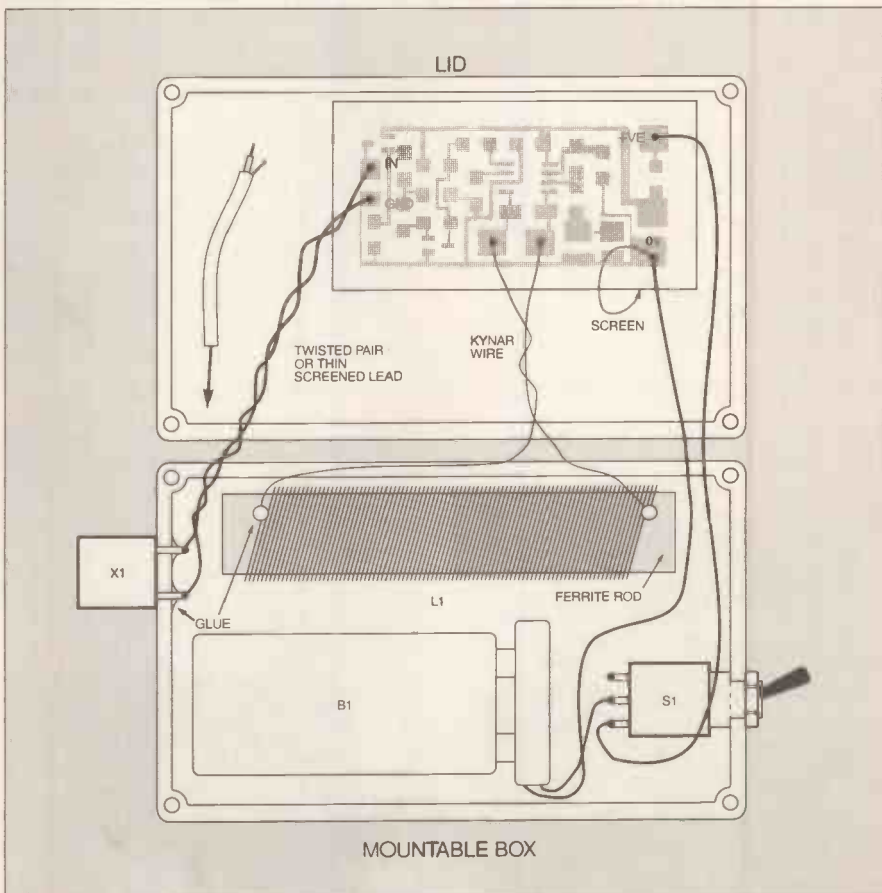

Fig. 6. Component layout and interwiring to off-board components. The photograph at the top of the page shows how, when completed, the unit will fit in the palm of the hand.



drilled and de-burred before adding any components. The p.c.b. fits nicely in the lid of the box as it has a very low profile.

Liberal use of a glue gun is advocated in this project. The windings of coil L1 are fixed with glue and the whole coil, including ferrite rod, is tucked away in the base of the box and held with glue, see photographs. A dab of glue also holds the transducer X1 in position and fixes the p.c.b. to the box lid.

A couple of Terry clips are bolted to the two holes in the specified mountable box. The unit then clips onto the Radio carrying handle. Unfortunately it doesn't slip so easily into the anorak pocket now!

OPERATION

Getting this detector working is very simple and probably no test gear will be needed. Assuming you have double checked the wiring visually, take the plunge and apply some voltage from a PP3 battery. An alkaline type will give more consistent performance.

It is a good idea to check the current with a multimeter and if it is around 4.5mA there is a good chance that all is working fine. The voltage on TR1 source (s) copper pad should be about 2.5V. The voltage on TR2 collector (c) pad should be about 6V with a fresh battery but could be around 4V as the battery runs down.

Place the Converter close to a medium wave radio receiver tuned to around 1MHz. You should get some audio feedback if you have the right carrier. Now tune up or down from this position carefully until the feedback ceases.

Skin on skin is a remarkable source

of ultrasound and ideal for checking the operation of this converter. Just rub your thumb and finger together in front of the ultrasonic transducer X1 and tune the radio for maximum signal from the speaker. Repeat the operation but tuning to the other side of the carrier.

If neither of these positions are free from strong stations then find the nearest quiet spot and adjust trimmer TC2 for maximum output from the finger test. Don't expect a totally quiet background as the medium wave is fairly packed.

There is also a low level continuous hiss at the highest sensitivity position around 40kHz. The converter has been used for many hours and the odd background station has not been a problem.

Incidentally, you can put the output on top of a station which you want to listen to. There won't be very much interference from the detector until a bat appears in the vicinity.

HEADPHONE LISTENING

A pair of headphones is probably more socially acceptable in certain circumstances. Walkman type earphones will also give a better bass response than the average portable radio loudspeaker.

This will be useful for the lower, 10 pulses per second, bat sounds. With such low frequency pulses it is the harmonic content which is prominent.

Finally, the output coil can be trimmed for optimum response using trimmer TC1. Considerable control over the operation can also be achieved by adjusting the position relative to the receiver. Very close

Table 2. Sources of Ultrasound

Expanded Polystyrene	Strong signals on squeezing
Paper	Broad band noise on tearing
Hair	Random noise on combing
Fizzy Drinks	Very strong clicks or roar
Watch Strap Buckle	Metallic sound
Coins	Very loud metallic sound
Fabrics	Random noise on stroking
Dry Grass	Noise when walked on
Crinkly Plastic Bags	Similar to audible sound
Aerosol Sprays	Very strong source of noise
Pin Dropping	Metallic sound on a hard surface

proximity will reveal mixer and front end noise from the converter. The carrier will also begin to operate the receivers' a.g.c., reducing its gain and this may help to reduce background signals.

FIELD TRIALS

For field testing it is wise to enquire from the local "batmen" as to where you are likely to find bats. Bats can be plentiful in an area but you can easily miss them. The detector will receive sounds from several meters away. On the first field test, lots of bats were heard on the detector, but no visual contact was made. This explains why bat "detectors" are so called.

The time just after sunset onwards is the best for bat activity but they are very difficult to see; a good reason for their deciding to hunt at this time. In general bats come out at dusk when it is not raining or windy. There is evidence that their appearance correlates with low atmospheric pressure.

Areas near healthy water where there are plenty of weeds and possibly bushes or trees, hence plenty of insects, are popular. Towns also support many bats, particularly in older established areas.

With the very short wavelength involved here a small parabolic reflector could be effective in extending the range of a bat detector, but it would be more directional. Anything above about 20cm (23 wavelengths at 40kHz) should be useful.

Some interesting sources of ultrasound are listed in Table 2. This will give you something to do during daylight hours!

Next Month: A simple SMD add-on B.F.O.

The completed Bat Band Converter, including next month's B.F.O. board.

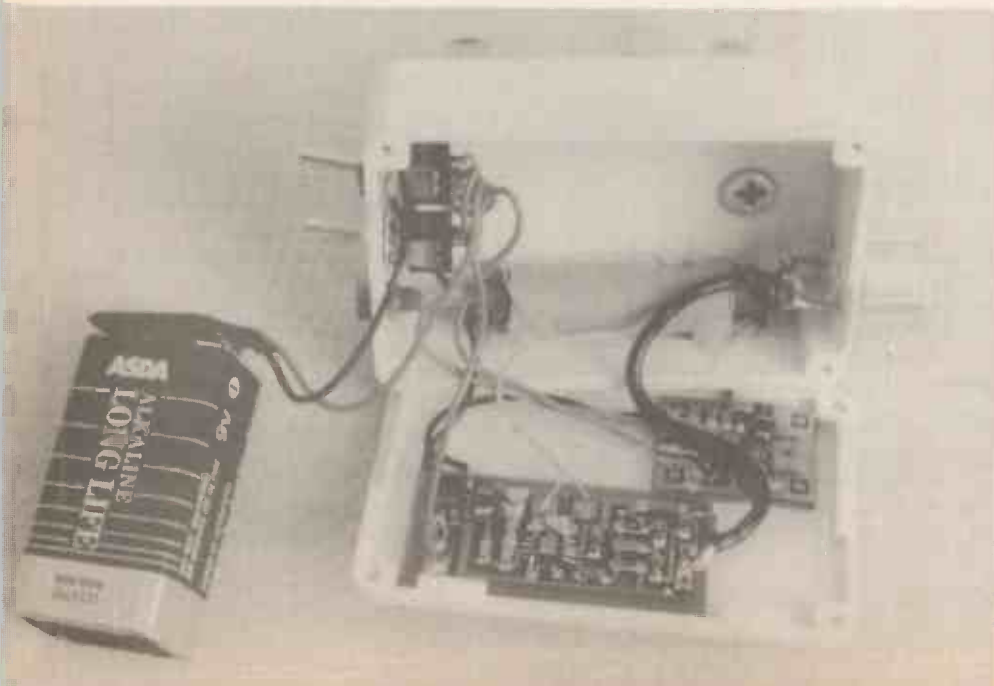

CIRCUIT SURGERY

ALAN WINSTANLEY

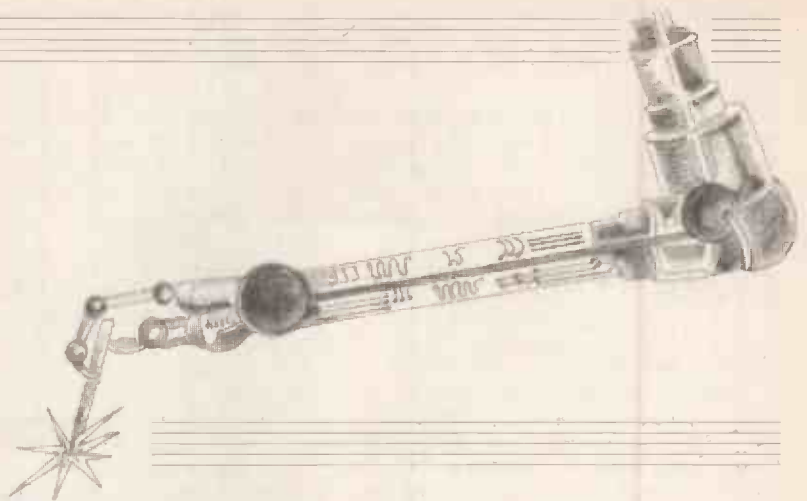

Our lucky dip into the EPE postbag (and Internet In-Tray!) of readers' questions and comments, plus news of the new UK Sources FAQ! Something for everyone, we hope.

RUMMAGING around in the Internet electronics newsgroups – an increasingly important educational resource for today's students – I spotted this question raised by a young student. It might interest other readers.

Wheatstone Bridge

I'm a High School student working on a class project, and I desperately need all the information I can get on the Wheatstone Bridge – i.e. how to make one, use one, etc.? Thanks from Mead School District 354, USA.

Imagine two resistors R1 and R2, connected to form a simple potential divider, as shown in Fig. 1. The output voltage (V_O) is determined by the ratio of the two resistors, using the formula shown.

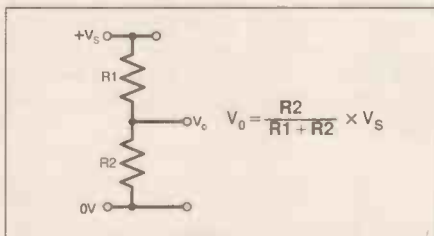

Fig. 1. A potential divider.

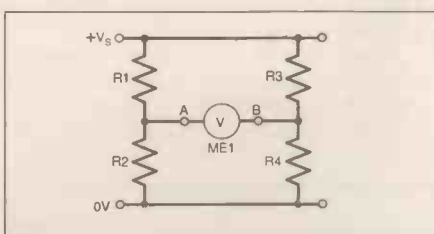

Fig. 2. Two potential dividers form a Wheatstone bridge.

Ignoring things like output current which upset calculations a little, if both resistors are of equal value, then the output is *half* the power supply voltage. By adding two potential dividers together as in Fig. 2, a Wheatstone Bridge is formed.

The output is then taken from the "middle", at points A and B between which I've drawn a voltmeter, ME1. If all four resistors were identical in value, then

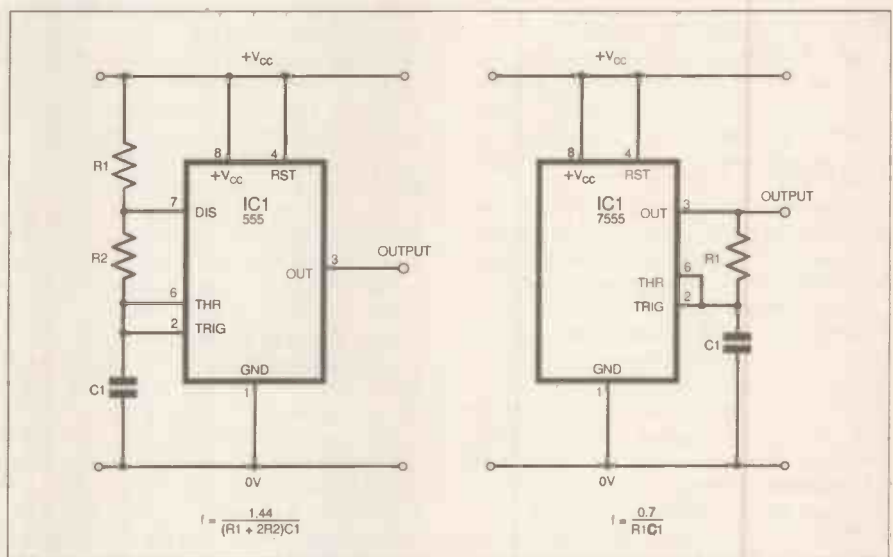

Fig. 3. (a) The classic 555 astable and (b) the CMOS version.

there would be *no* output voltage from the Wheatstone Bridge – because there would be no potential difference between A and B. Assume a 10V rail, then both A and B will be +5V. The voltmeter won't register anything.

By varying the values of any of the resistors, the potential dividers will swing higher or lower, and this will produce an imbalance in the outputs. Imagine R1 is, say, 66kΩ (kilohms) and R2 is 33kΩ – so point A will therefore be at +3.3V with respect to the 0V rail. If R3 is 33kΩ and R4 is 66kΩ, then B will be +6.6V with reference to 0V. The voltage difference between A (+3.3V) and B (+6.6V) is 3.3V, and this would show on the voltmeter.

A digital voltmeter is the best way to measure this, since unlike a moving coil meter, it will happily swing either positive or negative and the digital display's annunciators will show the polarity of the signal measured. A moving coil meter won't take so kindly to this treatment!

So what use has it? Well, the Wheatstone Bridge could be made with a variety of fixed and variable resistors, and if you include a thermally-sensitive resistor (*thermistor*), then the Wheatstone

Bridge output will swing according to the measured temperature, or you could use a photo-resistor or maybe a strain gauge.

An alternative example is a typical gas sensor which has two elements; one being the main sensor, the other is a "compensating" element to allow for ambient humidity changes, etc. Such a sensor could form one half of a Wheatstone Bridge, the output of which would connect to an amplifier circuit.

555 Astable – Fewer Parts

I guess that almost everyone knows how to use the venerable 555 timer chip, but I've recently noticed several examples of the astable version cropping up using a less familiar arrangement, where only one timing resistor and capacitor are needed.

The classic 555 astable requires two timing resistors as shown in Fig. 3a. The capacitor C1 charges up through two resistors R1 and R2, but discharges just through R2. The internal comparators of the chip switch the output high or low accordingly, depending on whether the capacitor is charging up or discharging.

A different arrangement is shown in Fig. 3b where one resistor (R1) feeds back between the output (pin 3) and the

threshold (pin 6). If the CMOS version ICM7555 is used, its high impedance inputs allow a 50 per cent duty cycle to be generated.

As *EPE* reader **Luiz Marcondes** of Brazil says in an E-mail, the bipolar NE555 version suffers a 1.4V voltage drop from the supply rail and won't allow a 50 per cent duty cycle. The timing formula is $f = 0.7/RC$. Give it a try!

Disposal of Etchant

One or two suggestions came in concerning a safe "environmentally-friendly" way of getting rid of spent p.c.b. etchant.

Probably the best suggestion so far came from a Hewlett Packard employee in the USA who advocates mixing it with cheap concrete pre-mix, of the type bought in small bags from DIY stores. Use the ferric chloride instead of water. When it's hardened, it will have pretty well locked up the copper and iron, and neutralised the acid, he says. It can then be thrown into the dustbin.

BNC – Meaning What?

Many technical expressions are in common use and it's interesting when you can unravel their origins. A recent question popped up in the newsgroup *sci.electronics.components* which caught my eye:

I am curious to know what the acronym BNC (as in BNC connector) stands for. I have been told it could be Berkeley Nuclear Connector or Bayonet Naval Connector. Are either of these correct?

Erm, no! After some debate, during which my spell-checker was rendered insensible, including offerings of Baby N Connector (mine, also wrong!), Baby Nut Connector, Bayonet Nut Coupler, Bloomin' Nice Connector (!), **Tom Clark** of Maryland, USA tells us that the name actually emerged during the mid 1940s.

The connector was co-designed by Messrs. Neill and Concellman. Hence, Bayonet Neill-Concellman or BNC for short. The "N" type is a Neill connector twist-on version for 1/2in. co-axial cable, whilst the "C" type is the Concellman bayonet-style for the same.

Also look out for TNC (Threaded Neill-Concellman). You will still see BNC and TNC connectors in widespread use today, more than fifty years later.

Flashing l.e.d. indicators

Hmmm... something that crops up continually at the moment! My thanks again to reader **Mr. J. Corfield** of Bishop's Castle, Shropshire who corresponds regarding my simple Cycle L.E.D. Flasher (*Circuit Surgery*, October '95 and February '96). Which is best, an LM3909 circuit or a flashing l.e.d.? The latter, Mr. Corfield says:

As a test, I used three "AA" size alkaline batteries together with four 10mm Super Bright l.e.d.s (Maplin UK46A) – these flashed continuously for no less than 240 hours by which time the voltage had dropped to 2.2V, and they were still visible! So the proof of the pudding is in the eating!

At the risk of encouraging more mail, another constructor reports that an LM3909 i.c. flasher circuit with one "D" cell has lasted over a year and a half, rather approaching the shelf life of the battery itself. Using two "C" cells in a

fast single-l.e.d. flasher, I've managed a good nine months, or 6,500 hours. So take your pick!

On the same subject, Mr. Corfield noted that flashing l.e.d.s blinked merrily away even at 2.2V, but how do you use them if you want a *higher* voltage – say a 12V car battery? A typical flashing l.e.d. (f.l.e.d.) has a forward voltage (V_f) rating of 9V to 12V, 13V maximum.

Many types of f.l.e.d. have an internal current control which is claimed to make them unsuitable for use with a series dropping resistor. If you *do* use a series resistor, then another potential problem is that when the flashing l.e.d. is in the "off" state, there is no voltage drop across the resistor and therefore virtually the full rail voltage appears across the l.e.d. instead! So care is needed to ensure that the device's *maximum* voltage ratings are observed.

RC Suppressors

My thanks to **Alex Patrick** and **Lionel Titchener** both of whom are interested in suppressing relay contacts against interference. Alex E-mailed a brief schematic to *Circuit Surgery*. He wants to suppress some mains relay contacts switching a UV Exposure Unit, whilst Lionel is trying to reduce interference created in a machine.

Often, relay contacts will "pit" and blacken and ultimately wear out, especially if they have to switch heavy inductive loads. If the relay has a transparent case, you can often see a green-white flash as the contacts arc over when they open.

How to help protect relay contacts using a "snubber" is shown in Fig. 4. These are available as ready-potted 100Ω/100nF 250V a.c. networks which you can apply directly across the contacts RLA1.

The capacitor C1 quenches any contact arcing and thereby prevents pitting. Suitable parts include the RS 238-463 and equivalents. I wasn't surprised that Alex suffered suppression problems with his circuit, since the contacts are switching a pair UV fluorescent lights in a p.c.b. exposure unit, and these can produce a considerable "spike" when they switch off. This can play havoc with external circuitry.

A subtle side effect is that R1C1 forms a path for the a.c. supply in series with the load, which will *not* be totally isolated from the mains. I've known neon indicator lamps to glow mysteriously even when the load has been switched off – the snubber was the culprit!

UK Sources FAQ

Many scores of readers asked for a reprint of the "Nicad" text document which was downloaded from the Internet. I

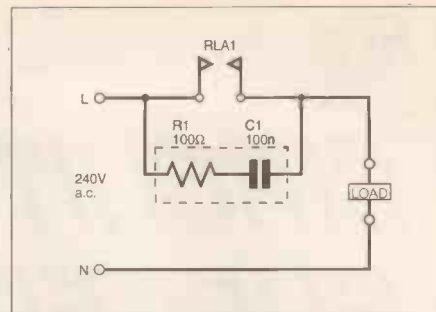

Fig. 4. An RC "snubber" will suppress interference and lengthen contact life.

owe a big "thank you" to Ed.'s secretary, Pam, who has been a blur, photocopying it to keep up with demand! Anyone subscribing to the Internet's *sci.electronics.components* newsgroup will have seen my **UK Sources FAQ** (Frequently Asked Questions) posted there, and this has been welcomed by readers overseas and particularly by those who depend on mail order sources to enjoy their hobby or science.

I've now published a *printed* copy especially for readers who don't use the Internet. The **UK Sources FAQ** has already grown into a listing of about 200 names, addresses, phone and fax numbers, plus any other useful information, about UK-based suppliers of electronic components, software specialists, industrial and hobbyist/educational distributors, publishers, component and equipment manufacturers' names and addresses – and more besides!

Hot off the *Circuit Surgery* computer, I've personally researched and cross-checked this Internet-style document which is some 20 pages long. If you'd like a printed copy, it costs £5.95 including postage – please mail a cheque or PO (in UK funds only please) made payable to: Alan Winstanley, at the Editorial Offices. Over a hundred hours' work went into the **UK Sources FAQ** – I hope you find it useful! It is also available by E-mail, free of charge.

Circuit Surgery appears bi-monthly. If you have any suggestions for inclusion in a future *Surgery*, please write to: Alan Winstanley, *Circuit Surgery*, Wimborne Publishing Ltd., Allen House, East Borough, Wimborne, Dorset, BH21 1PF, United Kingdom, or E-mail to alan@epemag.demon.co.uk.

Please note we cannot deal with queries concerning the repair or modification of commercial equipment. A personal reply cannot always be guaranteed but we will attempt to offer help wherever possible.

Sites for Sore Eyes!

Finally, a brief round up on the Internet: one of the most significant events recently on our corner of the web is the opening of the WWW site for **RS Components Ltd.** View it on <http://www.worldserver.pipex.com/rs> – and also check out <http://www.farnell.co.uk> which is another attractive and informative site, with links to many semiconductor manufacturers.

Meantime, several regular readers have asked, am I on "The Web"? Sure – mine was amongst the firsts to open when CompuServe started offering web space – feel free to drop in on my own humble World Wide Web home page which has been up since the end of last year – http://ourworld.compuServe.com/homepages/alan_winstanley is the URL. You can also E-mail me, either personally or at *EPE*, via this site.

Is your PCB design package not quite as "professional" as you thought? Substantial trade-in discounts still available.

Board Capture

Schematic Capture Design Tool

- Direct netlist link to BoardMaker2
- Forward annotation with part values
- Full undo/redo facility (50 operations)
- Single-sheet, multi-paged and hierarchical designs
- Smooth scrolling
- Intelligent wires (automatic junctions)
- Dynamic connectivity information
- Automatic on-line annotation
- Integrated on-the-fly library editor
- Context sensitive editing
- Extensive component-based power control
- Back annotation from BoardMaker2

£395

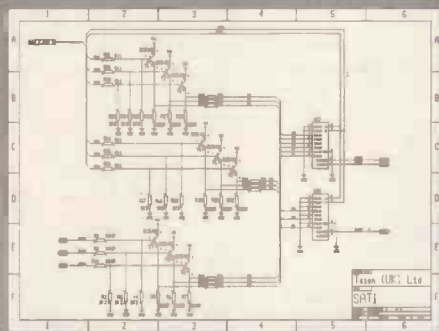

BoardMaker

BoardMaker1 - Entry level

- PCB and schematic drafting
- Easy and intuitive to use
- Surface mount and metric support
- 90, 45 and curved track corners
- Ground plane fill
- Copper highlight and clearance checking

£95

BoardMaker2 - Advanced level

- All the features of BoardMaker1
- Full netlist support- BoardCapture, OrCad, Schema, Tango, CadStar
- Full Design Rule Checking both mechanical and electrical
- Top down modification from the schematic
- Component renumber with back annotation
- Report generator- Database ASCII, BOM
- Thermal power plane support with full DRC

£395

Board Router

Gridless re-entrant autorouter

- Simultaneous multi-layer routing
- SMD and analogue support
- Full interrupt, resume, pan and zoom while routing

£200

Output drivers - Included as standard

- Printers - 9 & 24 pin Dot matrix, HPLaserjet and PostScript
- Penplotters - HP, Graphtec & Houston
- Photoplotters - All Gerber 3X00 and 4X00
- Excellon NC Drill and Annotated drill drawings (BM2)

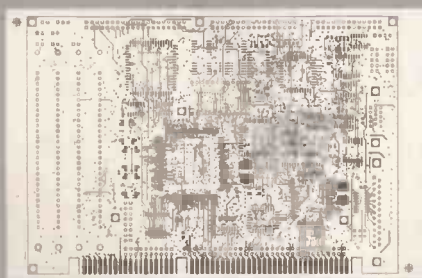

All trademarks acknowledged

For further information contact
Tsien (UK) Limited
 Aylesby House
 Wenny Road, Chatteris
 Cambridge, PE16 6UT
 Tel 01354 695959
 Fax 01354 695957
 E-mail Sales@tsien.demon.co.uk

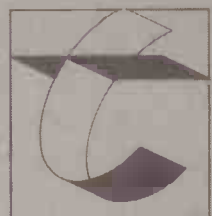

tsien

THE ELECTRONICS SERVICE MANUAL

ESM

ESM IS ABOUT ELECTRONICS AND ELECTRONIC EQUIPMENT, EXPLAINING:

- What it is • How it works • How to test it • How to take it apart
- How to find faults • How to fix it

OFFERING:

- Down to earth advice • Vital data • Facts to feast on
- Knowledge at your finger-tips

T

TOPICS COVERED:

- TV • Audio • Video • Computers • Disk drives • Techniques
- Test gear • Workshops • Addresses • Pinouts • Symbols • Safety
- Logos • Tools • Data • etc

W

WHO IT'S FOR:

- Across the board appeal!
- Ideal for: Technicians • Engineers • Students • Hobbyists

L

LITERARY MERIT:

- Authoritatively written • Clearly presented • Highly readable
- A living library in words, drawings and photographs

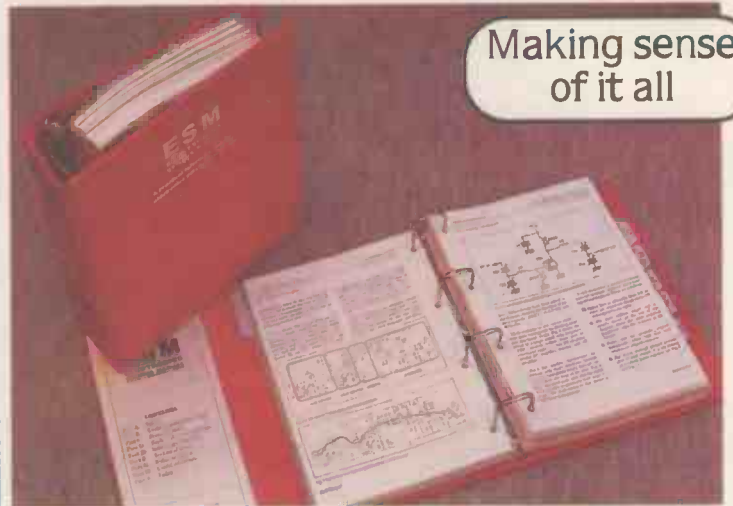

Making sense of it all

S

SUPPLEMENTS

Detailed technical servicing notes on various types of equipment are covered in the quarterly Supplements, plus additional valuable information for other sections of the Manual

F

FREE

We will send you the latest Supplement FREE with your Manual

P

PRICES

Manual only £39.95 plus P&P
Over 850 A4 pages edited by Mike Tooley. Supplied in robust ring binder. Latest Supplement included FREE. 24-hour despatch

Supplements £23.50 plus P&P

Approximately 160 pages of facts and data in each Supplement

G

GUARANTEE

Our NO-QUIBBLE MONEY-BACK GUARANTEE gives you *complete peace of mind*. If you are not entirely happy with the Manual or its Supplements, for whatever reason, simply return to us in good condition (within 30 days for the Manual, 10 days for Supplements) and we will make a FULL REFUND of your payment. (Overseas buyers do have to pay the postage charge.)

H

HOW TO OBTAIN ESM

Order now! - just fill in the order form.
Or, to find out more about ESM, ring, fax or write to:

Wimborne Publishing Ltd, Dept Y4
Allen House, East Borough, Wimborne
Dorset BH21 1PF

Tel: 01202 881749 Fax: 01202 841692

ELECTRONICS SERVICE MANUAL COVERAGE AND CONTENTS

SAFETY

Safety practices, life-saving techniques, legal requirements

UNDERPINNING KNOWLEDGE

Electronics theory, component theory & functions, circuit techniques, fault diagnosis, detailed equipment principles

PRACTICAL SKILLS

Component identification, avoiding static, soldering & component replacement techniques

TOOLS AND EQUIPMENT

Choosing tools & test gear, workshop practice, optimising test equipment

SERVICING TECHNIQUES

The Supplements include detailed guidelines on how to service specific types of electronic equipment

TECHNICAL NOTES

Detailed examination of how specific types of electronic equipment work

REFERENCE DATA

Detailed tables of specifications for semiconductors, including pinouts

USEFUL ADDRESSES

Manufacturers' & suppliers' addresses, including logos

INDEX

Itemised key subjects in the Manual and individual Supplements

PRIORITY ORDER FORM

Full name:.....
(BLOCK CAPITALS PLEASE)

Address:

Post code:.....

Telephone Number:

I enclose cheque/PO payable to WIMBORNE PUBLISHING LTD

Please charge my Access (Mastercard)/Visa card. Expiry date.....

Card No:

(Please advise cardholder's address if different from above)

Please send me each new quarterly Supplement when it is published. I understand that these are billed separately and that they can be returned within 10 days or discontinued at any time.

I understand that should I decide not to keep the Manual I can return it to you within 30 days for a FULL REFUND (overseas customers must pay the postage).

Signature:

Please send this form (or copy) to: Wimborne Publishing Ltd, Y4, Allen House, East Borough, Wimborne Dorset BH21 1PF

PLEASE URGENTLY SEND ME

Item	Cost	Postage	Total
ESM Manual	£39.95	£	£
One Supplement free with Manual	FREE	FREE	£0.00
Payment in £ Sterling only		Total	£

POSTAGE CHARGES

Postal Region	Manual	
	Surface	Air
UK	£5.50	-
Eire	-	£11
Europe (EEC)	-	£20
Europe (Non-EEC)	£20	£26
USA & Canada	£25	£32
Far East & Australia	£31	£33
Rest of World	£25	£44

NOTE: Surface mail can take over 10 weeks to some parts of the world. Each Manual weighs about 4kg when packed.

New Technology Update

Ian Poole looks at a new method of integrated circuit packaging and also takes the heat out of the latest surface mount technology.

INTEGRATED circuit packaging or encapsulation is far more involved than may appear at first sight. The packages which are widely used today range from the traditional dual-in-line or d.i.l. varieties, through to a host of surface mount varieties like the small outline SO range and quad flat-packs or q.f.p.s.

Plenty of design effort has been put into choosing the correct outlines for each of these packages. In addition to this, the materials which are used to make up the packages themselves are highly specialised, ranging from plastics to ceramics.

Fire Hazard

In view of the specialised nature of the materials used, relatively few companies make them. This factor was highlighted a couple of years ago when one of the major factories in Japan producing these plastics was destroyed by fire. Analysts in the industry quickly predicted major shortages in the plastic itself, and hence in integrated circuits.

This forced some panic buying by many i.c. users, but fortunately the disaster was averted because other manufacturers of these plastics saw they could increase their section of the market and stepped up their output to fill the gap. Accordingly, the predicted shortfall did not appear to be nearly as great as was initially expected.

Plastics are the most widely used type of material for the packages. Their properties are normally a balance which the manufacturers have to make between one parameter and another. This has led to new methods being sought to improve the processes wherever possible.

To give an example of the problems encountered by manufacturers, it is found that the make up the plastic can affect factors like moisture absorption. This is important because it affects problems including device delamination and long term reliability. Unfortunately, the same features which reduce the moisture content result in a reduced thermal stability in the material.

Sticking Together

Adhesion is another problem which occurs. It is vital that the internal components of the circuit bond well to the encapsulating material. Unfortunately, if the components bond well to the plastic, it is found that the plastic tends to stick to the moulds, making reuse and cleaning more time consuming and costly.

In order to help overcome these and other problems, a company in the Netherlands has developed an improved method of delivering the materials. Whilst this may seem to be a very small innovation, nothing could not be further from the truth.

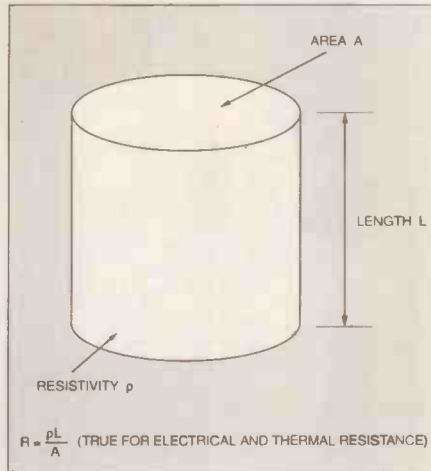

Fig. 1. Electrical and thermal resistance of a material.

Currently, materials are normally delivered as powder compressed into pellets. These can absorb water very easily, and they are also very dusty. The other danger is that small voids appear in the plastic during manufacture, trapping air and moisture.

In contrast, the new material is extruded into a large pencil form. This is then vacuum sealed before delivery so that no moisture or other impurities can be absorbed. The vacuum sealing material is also used to help free the material from the mould, reducing the problems of cleaning the moulds after use.

In this way the new process works across all stages of the manufacturing process. It also allows manufacturers greater degrees of freedom in experimenting with new materials.

High Power SMDs

The revolution in surface mount technology is continuing its rapid advance into new areas of semiconductor technology. High voltage operational amplifiers (op.amps) used to be only available in traditional through-hole packages. The high voltages and power dissipations make it more difficult to use smaller surface mount packages until recently.

For some very high power op.amps, voltages of up to 300V and peak currents of 100mA are specified. If these are to be reliable, the large amounts of heat produced must be removed quickly from the device otherwise its temperature would rise too high, possibly destroying it.

Even if the chip is not destroyed, it may run very hot. This can reduce the long term reliability because it is found that the hotter any circuit runs, the less reliable it becomes.

In order to be able to remove the heat at a sufficiently high rate, a very good heat conductor is required. The base material has to be extremely good at removing heat, because a large amount of heat is generated in a very small space. A material with a very low thermal resistance is also required otherwise the flow of heat is reduced and the temperature will rise.

Heated Exchange

When considering the heat flow aspects of a design, there are many similarities with the flow of current through an electrical circuit. Just as there is an electrical resistance, so there is also a thermal resistance. Also, like the electrical resistance, the thermal resistance is proportional to the length of the item and is inversely proportional to the area (see Fig. 1). In other words making the item as wide and as short as possible whilst using a material with the lowest possible thermal resistivity will reduce the overall resistance and increase the heat conductivity.

In the case of the integrated circuit, the problem is quite difficult. The chip itself is small, reducing the area of contact between the chip and the heat sink. This gives a possible area of high resistance.

The manufacturers of the new integrated circuit obtained a license for the use of a copper based material initially developed by NASA for the Space Shuttle. Unfortunately, this base material like many other good heat conductors also conducted electricity.

Thermal Coat

To overcome this problem a thin insulative layer was needed. This also had to be able to be a good conductor of heat, but by making it thin enough it would not need to have as high a conductivity as the copper based material.

The material which was finally chosen was a specialised thermoplastic developed in conjunction with DuPont, the chemical manufacturer. With a thin film of the thermoplastic coating the copper based heat-sink, it was found that the new materials worked very well and would enable the integrated circuit chip to be kept cool enough to operate reliably.

Other new design aspects were incorporated into the package. When compared to most standard packages the inside appears to be upside down. The chip is mounted onto the upper surface.

This enables the heat to flow by the shortest path to the top of the package where it is dissipated into the air. For greater levels of heat dissipation a further heatsink can be attached to the top.

FLIGHT AND CHIPS

BLUE Chip Technology's ADC-44d PC I/O Card has been chosen as the interface for the motion system and controls in a revolutionary new flight simulator designed to demonstrate flight mechanics theory to graduates of aerodynamics and design.

The first teaching simulator has just been delivered to City University, where it is expected that student projects will involve extending the use of the interface card to drive other parameters.

Designed by Merlin Products, the simulator is a single seat fully enclosed cockpit on a motion system with flight controls and an in-cockpit visual display. Capable of demonstrating the practical effects of changing aircraft design parameters, such as wingspan, tailspan and engine position, it also has the distinction of being the first simulator to use compressed air for movement, rather than more expensive and less environmentally friendly hydraulics.

At the heart of the simulator control is a Pentium-based PC with a number of slots already occupied with the multimedia sound system and visual cards. The new single ADC card copes with all the I/O (analogue and discrete) and leaves a



The revolutionary simulator which demonstrates flight mechanics theory.

slot free for the video splitter card which drives the on-board and off-board display.

The ADC-44d card has 16 analogue inputs, five selectable gain ranges, covering $\pm 50\text{mV}$ to $\pm 10\text{V}$ full scale, and with A-to-D conversion of 12-bit resolution at $3\mu\text{s}$.

There are also four analogue outputs with unipolar and bipolar operation.

For further information, contact Tudor Roberts, Blue Chip Technology Ltd, The Leonard Building, Chester Aerospace Park, Manor Lane, Deeside, Clwyd, CH5 3QZ. Tel: 01244 520222.

ADC PIC

MICROCHIP'S newest 8-bit microcontroller provides advanced analogue features including a low-power 8-bit analogue to digital converter (ADC), brown-out detection and pulse-width modulation.

The mid-range one-time programmable (OTP) PIC16C72 offer 5-MIPS (Million Instructions Per Second) performance, small footprint 28-lead SSOP package (surface mount), low power consumption of less than $15\mu\text{A}$ from a 3V supply, and serial communications capability.

On-chip program memory is 2048 words of Eprom and 128 bytes of data RAM. The 5-channel 8-bit ADC includes Sample and Hold, and is accurate to $\pm 1\text{LSB}$, with a sample acquisition time of only $16\mu\text{s}$ per channel. Other on-chip peripherals include a

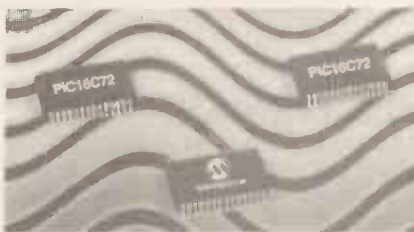

comprehensive timer sub-system, providing a real-time clock, two 8-bit and one 16-bit counter-timer modules, plus one-channel capture/compare pulse-width modulation.

For more information about the PIC16C72 and other PIC microcontrollers, contact Arizona Microchip Technology Ltd., Unit 6, The Courtyard, Meadowbank, Furlong Road, Bourne End, Bucks, SL8 5AJ. Tel: 01628 851077. Please mention *EPE* when responding.

BIOTECHNOLOGY

"The European Union should adopt a positive approach to the development of biotechnology", Science and Technology Minister Ian Taylor commented recently.

Speaking at a biotechnology conference in Brussels, Ian Taylor acknowledged the need for regulation, but stressed that this must be proportionate to the risks involved and be interpreted sufficiently flexibly to reflect scientific progress and practical experience.

He further stressed that Europe should be a producer of biotechnology, not simply a consumer. This requires encouragement for industrial R&D and technology transfer taking place in the EU through a more supportive regulatory climate.

Undoubtedly, further confirmation of the Government's commitment to technology is welcomed. Perhaps research into the allied subject of Chromo-Floristics (see elsewhere in this issue) might also receive encouragement!

MAGNETIC FIELD SENSOR

AT last! The FGM-3 magnetic field sensor newly introduced by Speake & Co Ltd is bound to create a stir amongst all designers who have been longing for a linear alternative to analogue Hall-effect devices.

Based on the flux-gate principle, the FGM-3 is a very sensitive field sensor operating in the ± 50 microtesla range. It is a simple 3-terminal device which can be powered from a single 5V supply and is ideal for interfacing to a microcontroller or computer.

The device produces a robust 5V rectangular output pulse whose frequency varies inversely with the field strength (giving a period directly proportional to the field). The typical frequency swing for the full field strength range is from about 50kHz to 120kHz.

Typically, the FGM-3's temperature coefficient is 0.003%/°C at 25°C. Since the sensitivity range covers the earth's field magnitude, multiple sensors can be arranged to provide compass or full 3-dimensional orientation systems, using the earth's field as a reference.

Other applications include conventional magnetometry, ferrous metal detectors, internal vehicle re-orientation alarm sensors, external vehicle or ship passage sensors, wreck-finders, non-contact current sensing or measurement, conveyor belt sensors or counters, and in conjunction with small permanent magnets, movement and proximity sensors, plus ferrous



impurity detectors for non-magnetic alloys.

For use with applications requiring a larger range of field strength, external feedback winding techniques can increase both the sensor's magnetic range and its linearity.

Interfacing is simple in that it requires only one bit of a digital input port per channel of measurement. The technique is to count input pulses for a fixed period to determine the frequency of the incoming signal. Field strength is then calculated from these results. Alternatively, where a faster response is required, the time between successive like-edges permits the direct determination of period.

Costing £14 each (£16.45 including VAT and post), the FGM-3 is obviously a highly versatile device. We are actively pursuing an idea for a project using it!

To obtain more information about the FGM-3, contact Speake & Co Ltd, Dept. EPE, Elvicta Estate, Crickhowell, Powys NP8 1DF. Tel: 01873 811281. Mention *EPE* when asking.

Turnpike V1.11

AN early version of this British-designed Internet software package (which contains some bought-in American know-how) for IBM PC owners was reviewed in November 1995's issue of *EPE*. I rated it highly for its extreme ease of setting up, since it contains dial-up scripts for every known UK Internet access provider. Although rather non-intuitive in parts, I also commended its graphical presentation of Usenet threads, plus the ease of setting up multiple mail addresses.

Turnpike is a single-machine Windows solution for E-mail, news, and FTP (file transfer protocol) but, very significantly, its latest incarnation (Version 1.11) now includes a fully registered version – with no more to pay – of the Netscape World Wide Web browser (V1.22) which can be launched at the press of an icon. The package therefore contains everything which the mainstream Internet user is likely to need, at least for now. Problems we experienced with occasional video driver clashes seem to have disappeared in the latest release.

Of equal significance is the decision by service provider Demon Internet Services to offer Turnpike as its officially-approved Windows package. Demon have dumped their own ill-starred WinDIS suite of disjointed Windows software (which I too abandoned, never fully configuring it successfully) in favour of promoting Turnpike at a special price of £29.37 all inclusive, to its customers. Turnpike originally retailed at £99 – before being slashed to half price at £49.95 to non-Demon accounts.

A self-help newsgroup Demon.IPSupport.Turnpike recently opened for users and indeed, Turnpike's support has been seen to put many larger software houses to shame.

Contact Turnpike Sales on 01306 747747, or check their WWW site on <http://www.turnpike.com>. Demon Sales is on 0181 371 1234, or by E-mail on internet@demon.net, and is to be found on URL <http://www.demon.net/>. Turnpike is still recommended. – Alan Winstanley.

TECHNOLOGY CURRICULUM

A major national conference to look at the relationship between the culture of designing and making in schools, and state of the art technology in manufacturing industries, is to be held on Wednesday 20th March 1996 at the Beeches Management Centre, Bournville, Birmingham.

Aimed at teachers and senior managers in schools, the conference concentrates on the theme of manufacturing in the technology curriculum. Areas to be covered include: virtual reality, European dimensions, communications technologies (the Internet, E-mail), video conferencing, in addition to computer-aided design and manufacture, mechatronics and GNVQ manufacturing.

The conference is organised by the Technology Enhancement Programme (TEP), which is funded by the Gatsby Charitable Foundation and administered by the Engineering Council. TEP aims to enhance and enrich technology education and training for all pupils and students in schools and colleges in the UK. It recognises the urgent need to educate and train teachers and student-teachers in the knowledge and understanding of the subject.

For more information, contact TEP, The Engineering Council, 10 Maltravers Street, London WC2R 3ER. Tel: 0171 240 7891.

LINCOLNSHIRE EVENT

The Lincolnshire AMS '96 Computer and Electronics Show takes place on Sunday 14th April 1996, from 10.00am to 5.00pm, at the Springfield Exhibition Centre, Springfield Gardens, Camelgate, Spalding, Lincs, PE12 6ET. Tel: 01775 724843 or 713253. Entry price is: Adult £2.50, OAP £2.30, children under 14 are free.

At the show will be a wide range of new and second user goods, accessories, electronic components, multimedia, CDs, software, upgrades, consumables, etc. There will also be a bring and buy sale.

Plenty of free parking will be available, plus a patio cafe and licensed bar.

P.C.B. MAKING

Readers who want to make their own p.c.b.s will be pleased to know that ESR Electronic Components have issued their latest catalogue. Entitled *1996 PCB Production Catalogue*, it covers all aspects of p.c.b. production for hobby, education and professional use. It is ideal for those who are involved in prototype or small volume work.

The catalogue is fully illustrated and claims to carry all that is required to take an idea, on paper or from a simple prototype on breadboard, matrixboard or stripboard, through to the final p.c.b. layout and production. The contents cover development, drafting materials, p.c.b. laminates, p.c.b. equipment, chemicals, tools, and health and safety.

Many new products are included, all competitively priced, making this catalogue a comprehensive one-stop source for p.c.b. production.

For a FREE copy, send an A4 s.a.e. (with 47p of stamps) to ESR Electronic Components, Dept EPE, Station Road, Cullercoats, Tyne and Wear, NE30 4PQ. Tel: 0191 251 4363.

MIND MACHINE Mk III PROGRAMMER

ANDY FLIND

Part Two



Relax your mind with this add-on, "user friendly" 16-slider programmer. Capture that "feel good factor" now!

IN LAST month's issue, the circuit diagram and construction of the Mind Machine Mk III "Sound and Lights" p.c.b. was described. This produces signals for stimulating relaxing electrical brain-wave patterns for its user, the frequency of these signals being controlled by a d.c. voltage applied to the board.

For test purposes the control described was manual through a variable resistor (potentiometer VR3) but the circuit is intended for use with a programmable driver, so that a really deep relaxing session can be enjoyed without the user having to think about the controls at all. This Add-on 16-Slider Programmer project can store and supply such a control sequence.

IN STORE

The problem with programming is to devise a suitable way of creating and storing the program sequences. Previous projects from the designer have used RAM storage, which was tricky to enter the

sequence into, magnetic tape which required good quality recording equipment and tapes, and a computerised system using a BASIC program which generated the signal from lines of "data".

This last was probably the best of the above methods and was used by the author until quite recently, when the Sinclair Z88 computer performing the task finally expired! It was still a fiddly task to set it up for a session though.

Attempts were made to operate the system from a Psion Series 3a, but it's difficult to obtain a suitable output from this and most potential constructors would not possess one anyway. However, the author's "dream" of a simple, self-contained programmable *Mind Machine* refused to die and, with this project, perhaps it has at last arrived.

SEQUENCE PROGRAMMER

The programmer uses a row of sixteen slider potentiometers (pots). Placed side

by side, these display the "shape" of the program graphically from their slider positions which can, of course, be instantly adjusted or changed by the user. Favourite programs could even be stored as stiff cardboard templates to be pressed against the sliders for aligning them to the required pattern.

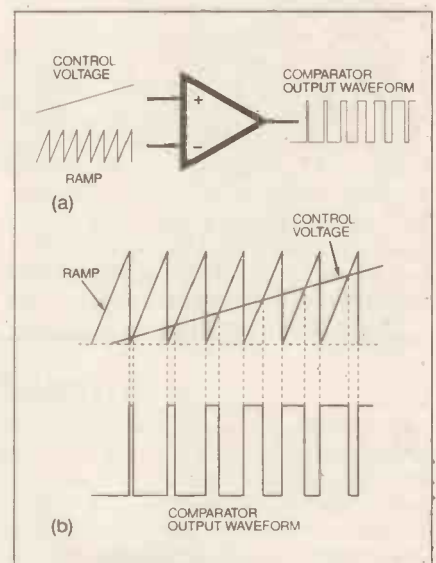

Fig. 1. (a) Use of an analogue comparator to vary duty cycle and (b) waveforms for above circuit.

WARNING NOTICE

Photic stimulation at Alpha frequencies can cause seizures in persons suffering from Epilepsy. For this reason such people MUST NOT try this project.

A user who is not a known epileptic, but when using the *Mind Machine* begins to experience an odd smell, sound or other unexplained effects, should TURN IT OFF IMMEDIATELY and seek professional medical advice.

Because of the above possibility, the *Mind Machine* should not be used while on your own.

YOU MUST TREAT THIS UNIT WITH DUE RESPECT

In the prototype the sliders are concealed internally beneath a cover plate, leaving just basic controls for Volume, L.E.D. Brilliance and session Time on the front panel, with switches for On-Off, program Reset/Run and l.e.d. Phase. The uncluttered panel is far more user-friendly than earlier versions, and with careful layout it is easy to operate the *Mind Machine* with the eyes closed.

HOW IT WORKS

The circuit selects the control voltages from the slider pots one by one through a sixteen-channel analogue multiplexer i.c.. Of course, if the program were to be implemented in just sixteen steps over half an hour or more these would be noticeable,

so a gradual transition between each voltage and the next is needed.

With such long – and variable – time intervals this cannot be achieved easily with a simple integrator circuit. So, the method used is to keep switching the multiplexer rapidly between each value and the succeeding one, gradually dwelling less on the current one and more on the next, so that with a little low-pass filtering the output makes the smooth transition required.

This needs appropriate address generation for the multiplexer, with an oscillating “bit” of gradually increasing period that is added to the main address. Surprisingly, this can be implemented with just seven CMOS logic chips and less than a dozen passive components, making this a very simple circuit to construct.

In order to explain the way in which the extra address “bit” is digitally produced, it is worth taking a look at an equivalent analogue circuit. If a series of pulses with fixed frequency but variable pulse width is needed, one way of generating them is with a comparator and a “ramp” waveform, the ramp being compared with a control voltage as shown in Fig. 1a.

The response of this circuit to a gradually increasing control input, with the output pulse width increasing with the rising voltage, is shown in Fig. 1b. The circuit used by this project has a similar but digital equivalent of this arrangement.

CIRCUIT DESCRIPTION

The complete circuit diagram for the Add-on 16-slider Programmer is shown in Fig. 2. Working from left to right, the circuit begins with IC1, an ICM7555 timer connected as an oscillator to generate the system “clock”. The oscillator frequency is controlled by rotary control VR1 over a range of about 1250Hz down to 140Hz, corresponding to an overall running time from about six minutes to an hour.

The clock is followed by a total of nineteen binary divider stages, the first seven contained in IC2 with a further twelve in IC3. Forgetting IC4, IC5 and IC6 for the moment, the last four divider outputs, taken from IC3 pins 12, 14, 15 and 1 respectively, form the four-bit binary address for the multiplexer IC7. This i.c. connects analogue signals from one of 16 inputs to a single output according to the value of the binary address supplied to pins 10, 11, 14 and 13.

DIGITAL RAMP

The four outputs of divider IC3 immediately preceding those used as the main address for IC7 can be thought of as a slow “digital ramp”, having a binary value which rises through sixteen steps from zero to maximum before each increment of the main address takes place.

A similar but faster “digital ramp” is taken from the last four outputs of IC2, and the two are compared by IC4. This is a CMOS 4063B four-bit “magnitude comparator”, which is the digital equivalent of the analogue comparator in Fig. 1.

The output of IC4, from pin 5, is positive or “high” whilst the input from IC3, the “slow ramp”, has a higher binary value than the fast one taken from IC2. Like the analogue version, the output pulses have a

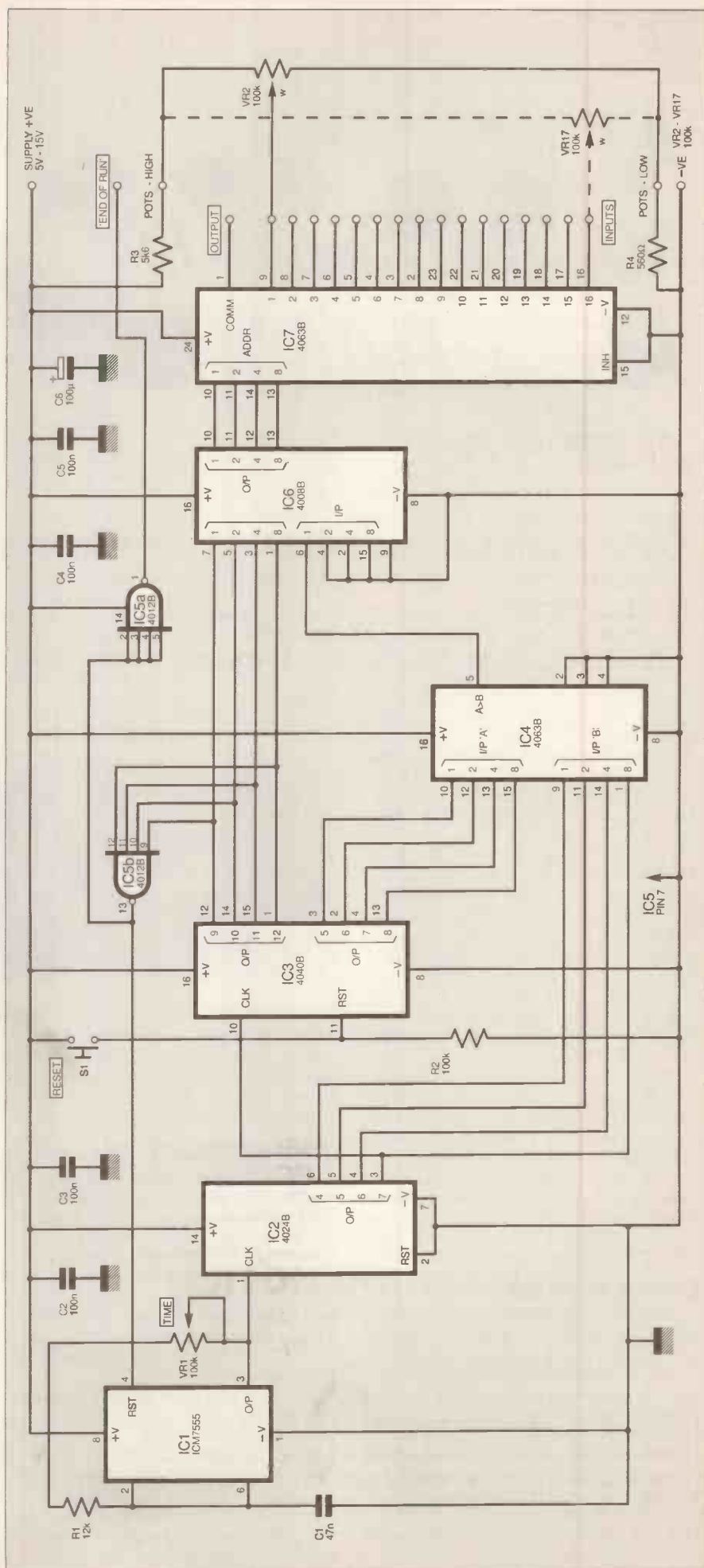

Fig. 2. Completed circuit diagram for the Add-on Mind Machine Mk III Programmer.



frequency set by the fast ramp with a period controlled by the slow one. However, the digital version uses no parts other than the i.c.s and is perfectly synchronised to the main address generation.

IN ADDITION

The single-bit output from IC4 pin 5 now has to be added to the main address so that, whilst it is high, the next input in the programmed sequence is selected. This addition is carried out by IC6, a CMOS 4008B four-bit "full adder".

The main address is connected to one input and the single "bit" from IC4 to the least significant bit of the other. The remaining three bits of this input are wired low (0V).

The result is that, when the input from IC4 is low, the output is the same as the main address but when it is high, the output becomes the main address plus one. Multiplexer IC7 correspondingly selects either the input specified by the main address or the next one up, switching between them at reasonable frequency and gradually dwelling less on the lower one and more on the higher as the value of the "slow ramp" rises.

The average d.c. value of the output from IC7 therefore starts with the input value selected by the main address and rises in sixteen steps towards the next one, so the voltage sequence programmed by the user on the sixteen slider pots is executed in 240 steps. Some low-pass filtering is needed, this is provided by resistor R2 and capacitor C1 on the *Sound and Lights* printed circuit board (last month).

END OF RUN

One half of the dual four-input NAND gate IC5 is connected to the four main address bits to detect the end of the sequence. So long as at least one bit is low, the output (pin 13) of this gate, IC5b, remains positive, holding the "reset" pin 4 of oscillator IC1 high so that it can run.

When the final address value is reached all four bits go high and the output of IC5b goes low, pulling IC1's reset low to stop the clock and halt the program. IC5a inverts the output from IC5b to provide a positive "end of run" signal.

This may be used to indicate to the user that the session is complete. If it is

connected to the "End of Run" input of last month's *Sound and Lights* p.c.b. it will extinguish the glasses i.e.d.s.

Switch S1 resets the program to the beginning of the sequence by resetting divider IC3. This reset action is not extended to IC2 as this takes a maximum of less than a second for a complete cycle of all seven outputs. If S1 remains closed, the address to IC7 stays permanently at zero which allows the unit to be operated manually from the first slider potentiometer VR2 for testing.

The slider pots used in this project are all 100k linear types. The sixteen of them

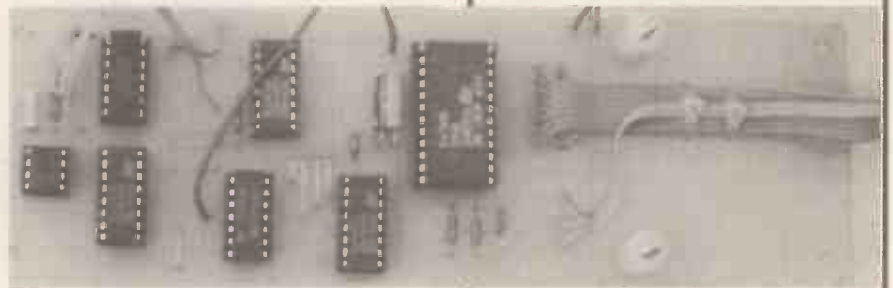

Completed Programmer p.c.b.

in parallel have a nominal value of 6.25k, which is shunted (when setting-up) to reduce the overall value to 5 kilohms (5k). Series resistors R3 and R4 give the required range of control voltage.

CONSTRUCTION

The component layout and full size underside copper foil master pattern for the Programmer printed circuit board are shown in Fig. 3. This board is available from the *EPE PCB Service*, code 983.

Construction and testing of this board is relatively straightforward. The eight top-side links should be fitted first. No complaints about these please - this circuit took shape on a piece of stripboard that had sixty-one links!

The four resistors should be fitted next, followed by d.i.l. sockets for the i.c.s, the ceramic capacitors (C2 to C5), polyester capacitor (C1) and then the radial electrolytic C6. To maintain a low profile the leads of C6 are bent, allowing it to lie horizontally on the board so a dab of glue will help to keep it secure. The i.c. sockets enable testing to be carried out in logical steps to minimise the chance of component damage should a fault be present.

Leads should be soldered to the board for all the external connections. Two 8-way ribbon cables were used to connect the prototype board to VR2-VR17 slider pot wipers; after soldering these were secured to the board with a couple of small cable ties to eliminate strain on their connections.

BOARD TESTING

Following a careful check of construction and soldering, testing can commence. Pins 13 and 14 of the socket for IC5 should be short-circuited, which can be

COMPONENTS

Resistors

R1	12k
R2	100k
R3	5k6
R4	560Ω

Plus: 1k (5 off); 27k; 330k shunt resistors - see text
All 0-6W 1% metal film

Potentiometers

VR1	100k rotary carbon, lin
VR2 to VR17	100k slider carbon, lin. (16 off)

Capacitors

C1	47n polyester layer
C2 to C5	100n resin-dipped ceramic (4 off)
C6	100μ radial elect. 16V

See

SHOP
TALK
Page

Semiconductors

IC1	ICM7555 CMOS version of 555 timer
IC2	4024B CMOS 7-stage divider
IC3	4040B CMOS 12-stage divider
IC4	4063B CMOS 4-bit magnitude comparator
IC5	4012B CMOS dual 4-input NAND gate
IC6	4008B CMOS 4-bit full adder
IC7	4067B CMOS 16-way analogue multiplexer

Miscellaneous

S1 sub-min. slide switch
Printed circuit board available from *EPE PCB Service*, code 983; plastic case with aluminium front and rear panels, size 205mm x 140mm x 75mm (see text and last month); 8-pin d.i.l. socket; 14-pin d.i.l. socket (2 off); 16-pin d.i.l. socket (3 off); 24-pin d.i.l. socket; 8-way ribbon cable; knob; connecting wire; chassis plate (see text); M2 screws: 12.5mm (1/2in.) threaded p.c.b. spacers (8 off); solder etc.

Approx cost
guidance only

£40

excl. case and batts.

done by pushing a loop of thin wire into the relevant socket hole connections. This maintains a positive voltage to IC1's "reset" input so that the oscillator will run.

The variable Time control VR1 should be connected to its leads from the p.c.b., then IC1 should be inserted, observing the usual precautions against damage by static. Power can be applied from a 9V supply. The supply current should be minimal throughout testing – the entire board draws only about half a milliamp. The slider pots add a little to this when they are connected, but the drain should never exceed two or three milliamps.

SPOT CHECK

If the oscillator output, pin 3 of IC1, is checked with a meter it should show an average d.c. voltage of about half the supply, indicating that the oscillator is running. If an oscilloscope or frequency meter is available the output frequency range can be checked. It should be around 140Hz to 1250Hz with the higher value at the counter-clockwise end of VR1's range.

Next, IC2 can be inserted. The input to this is to pin 1, whilst the four outputs used are taken from pins 3, 4, 5 and 6. The frequencies of these are in reverse order, i.e. pin 6 is the highest, pin 3 the lowest. With Time control VR1 clockwise for the lowest oscillator frequency, pin 3 should be oscillating slowly enough for the cycles to be observed with a meter, confirming operation to this point.

The 12-stage divider IC3 should now be inserted. The input to this is at pin 10. The slow operation of IC3's outputs makes checking more difficult, but if the

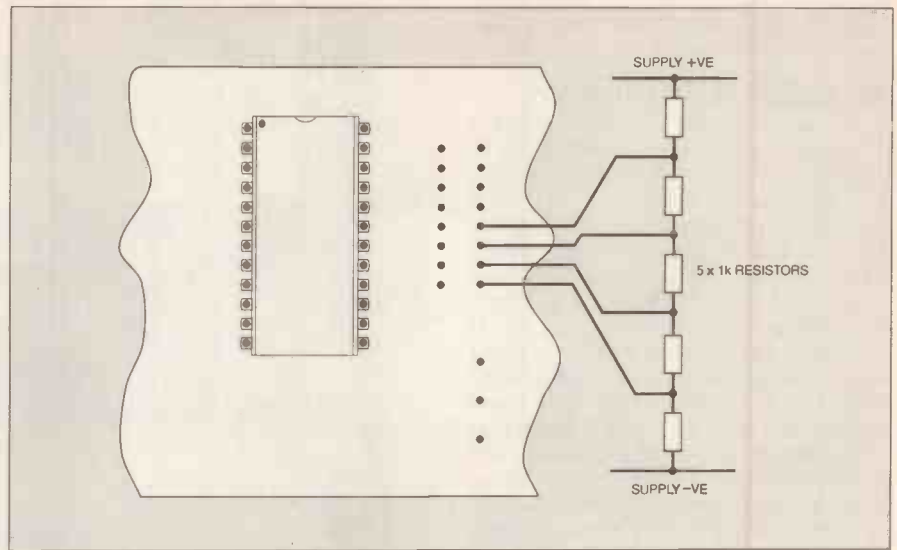

Fig. 4. Temporary input shunt resistors for testing.

oscillator is set to its highest rate with VR1 fully counter-clockwise, the output from pin 3 can be observed changing state about every 1.5 seconds.

Next, IC4 should be inserted and the average value of the output from pin 5 checked with a meter, with VR1 still set for the highest frequency. The reading should be seen rising gradually by steps until it reaches the full supply voltage and then dropping sharply back to zero before starting to rise again.

If this works, IC6 can be fitted and the output from pin 10 should be monitored. This should appear to be stepping gradually up to full supply, then gradually down again.

Following this, the shorting link should be removed from the socket of IC5 and this i.c. and IC7 inserted. Whilst the slider controls could be connected for a final test, it's probably more convenient to check the circuit with a chain of one kilohm (1k) resistors supplying voltages from the supply to the first four inputs (pins 9 to 6) of IC7 as shown in Fig. 4.

If the circuit is now powered up and the "reset" leads (for S1) are shorted together briefly, with a high oscillator frequency the meter should show the output from IC7 rising in an apparently smooth progression as the first four inputs are scanned. At slower oscillator rates the meter may be seen jumping between the

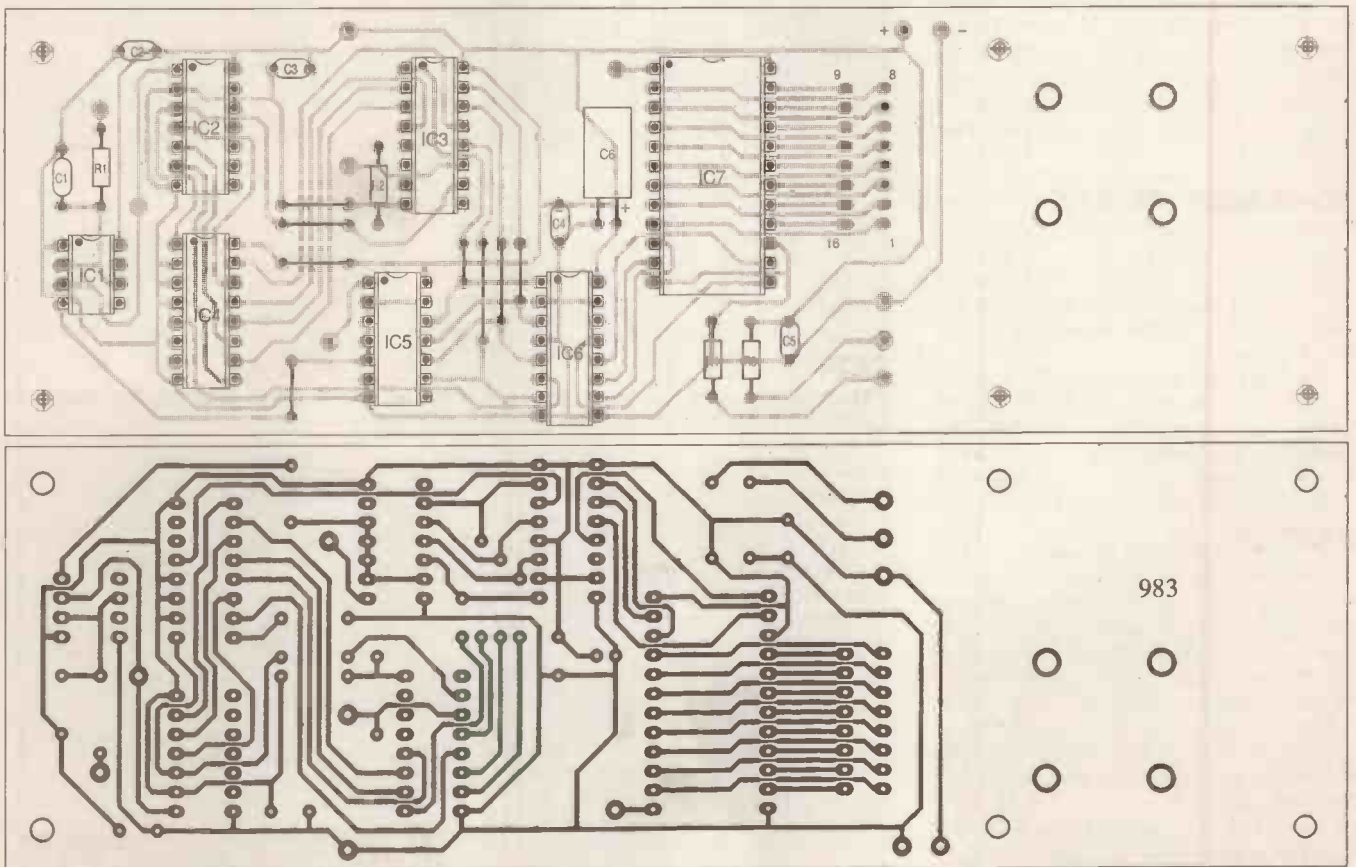

Fig. 3. Programmer printed circuit board component layout and full size underside copper foil master pattern. The inner group of four holes on the right are for the ribbon cable ties – see photograph on opposite page.

two currently selected input values. This completes board testing.

SLIDER ASSEMBLY

The prototype of this project used a "Verobox" with dimensions of 205mm × 140mm × 75mm. Although this resulted in a neat finished unit it involved quite a bit of tricky assembly work so constructors not so concerned with appearance might like to devise something a little easier. However, some construction details may be helpful to all builders.

Mounting of the slider pots is the major consideration. Those used in the prototype were described as being 9mm wide but in practice they were very slightly wider than this. The "tangs" projected from open slots, through which the resistive tracks could be clearly seen, coated with a grease to which dust and other foreign matter might adhere.

It would be difficult enough to provide a dust seal for one pot, let alone sixteen in a tightly-packed row, so it was decided to protect them by placing them inside the case, beneath a cover, and facing downwards to minimise the problem of dirt and dust falling into them. They are secured with an M2 screw at each end; these must not project too far into the body as this would restrict slider movement.

The shortest screws to hand were some 3mm too long so, to avoid the task of shortening all thirty-two, the pots were mounted on a chassis plate cut from 3mm thick material with a square hole provided for the tangs to project through. A slightly larger corresponding hole was cut in the bottom of the case and an aluminium cover plate made to fit into this.

The cover plate is held in place by magnetic strips glued to both it and the case. This gives rapid and easy access to the sliders. The tangs are not fitted with knobs as there was no room – in fact they were cut slightly shorter to provide clearance for the cover plate.

CHASSIS PLATE

The chassis plate with the slider controls is attached to mounting pillars in the case with self-tapping screws. It has a cut-out at the back so that a holder for eight AA batteries will fit, and an aluminium bracket keeps this in place.

Four half-inch threaded spacers are used to hold the Program p.c.b. above the sliders, and another four are used for mounting the Sound and Lights p.c.b. above it. The boards are drilled with matching holes for this "sandwich" like construction.

If the box described is used, considerable care is needed to locate the pots so that there is adequate room for the controls, the two p.c.b.s above them, the output sockets and the battery pack. One small error made by the author was to fit two slide switches too close to the left-hand end of the front panel. These then fouled one of the four securing pillars in the lid, necessitating some delicate "plastic surgery"!

It is, of course, perfectly in order to use a larger case for easier assembly. One suggestion is the use of a plastic storage box with a hinged lid, perhaps a plastic "briefcase", with all the controls on an internal

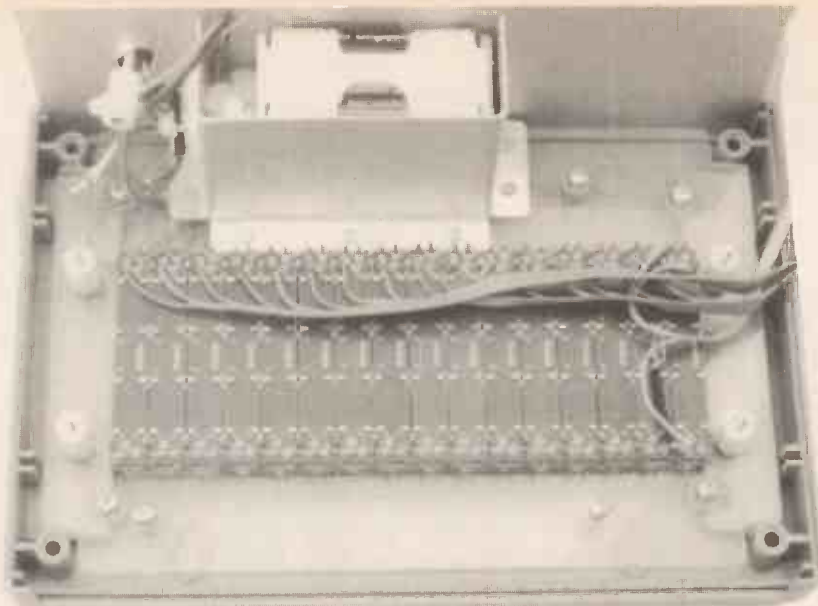

Wiring to the slider potentiometers. The pots are mounted on a piece of clear plastic "chassis plate" which is fixed to the base of the case.

panel for easy access. It would still look presentable with the lid closed. Battery access would be easier too. The prototype uses a pack of eight AA NiCads with a charging socket on the rear panel.

FINAL WIRING

The connections between this board and the one described last month are shown in Fig. 5, whilst connections to the slider pots are shown in more detail in Fig. 6.

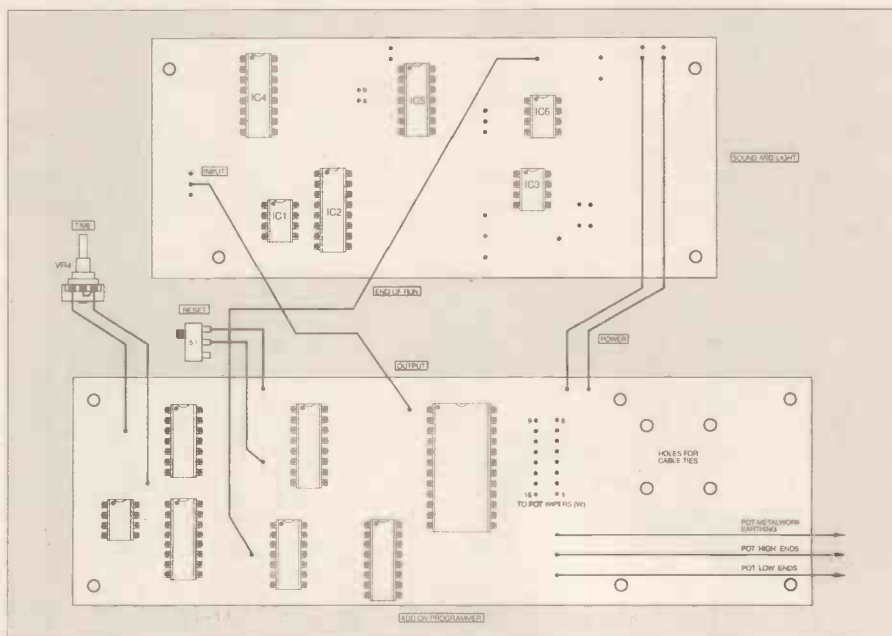
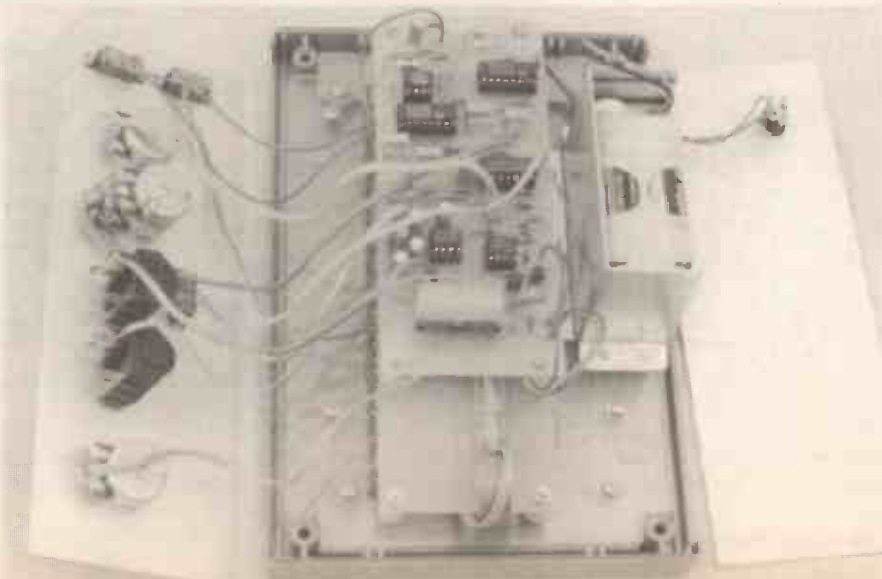

Fig. 5. Interwiring between the two Mind Machine p.c.b.s. The boards mounted "sandwich" fashion in the case can be seen below.





Base access cutout for program controls.
Metal cover plate is held in place by magnetic strips.

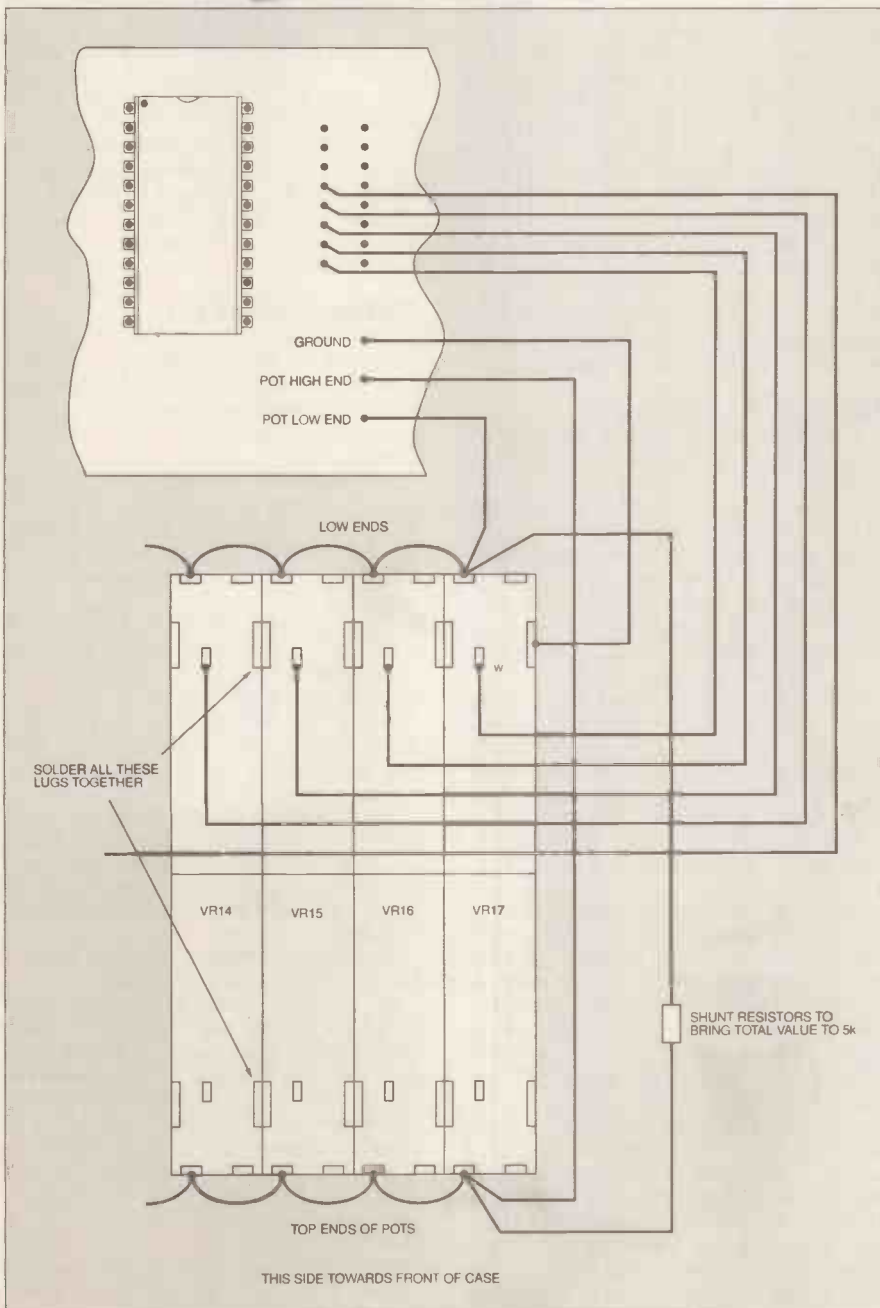

Fig. 6. Details of wiring together of the program slider pots.

The connection of the resistor(s) used to shunt the slider pots to a total of 5k is also shown in this drawing.

The nominal value of these resistors is 25k, which could be made up from 27k and 330k in parallel. However, if a DVM is available it might be preferable to check the value of the sixteen pots connected in parallel and select a precise shunt value, thus compensating for the high tolerance allowed in potentiometer resistances.

Be very sure of the slider pot connections before wiring up the ribbon cables as it is a time-consuming and fiddly task that no-one would wish to repeat! The pots will probably be dual-gang types, if so only one side of each is used. This leaves the useful option of transferring connections to the other half should any become faulty! The tags on the metal bodies of the pots are soldered together and connected to the negative supply rail for screening against external interference.

IN USE

Slide switches are recommended for all three switch functions including Reset, as the best way to use the unit is to turn it on, leaving it in "reset" whilst the glasses and headphones are set up. This allows it to settle to the first programmed frequency.

When all is ready "run" is selected and the program commences. The sockets used for the glasses and headphones are standard 1/4in. types as insulated mounting versions are readily available for use on metal panels. Headphones and glasses fitted with smaller plugs can be used with adaptors.

This Programmer can be used with the original *Mind Machine* sound and lights board, published back in December 1991. To do this, it should first be powered from the +5V regulated supply present on the earlier board.

There are various points where this might be tapped, but for anyone in doubt, resistor R49 and R50 of the older p.c.b. could be replaced with wire links and the power obtained from points "A" (positive) and "C" (negative). The output from IC7 of the new Programmer p.c.b. can then be connected to point "B" and the assembly should work without problems.

Program sequences are for the individual to experiment with. The author's favourite is to start high in *Beta*, drop rapidly down to *Alpha*, then slowly down through *Theta* and perhaps briefly into *Delta*, then back up to *Alpha*, then maybe another trip down into *Theta* before returning back up through *Alpha* to *Beta*. The overall session time used is generally around twenty to thirty minutes.

There will doubtless be some constructors who would like to try programmed operation but are reluctant to shell out for the sixteen slider pots and attempt the tricky business of connecting them. Next month, details will be given of an alternative programmer using magnetic tape.

It's not as delightfully quick and easy to use as this project, but it's cheap and simple to construct and, unlike the previous tape-controlled system, it works happily with poor-quality mono recording equipment.

Next Month: An inexpensive Tape Recorder Controller.

FOX REPORT

by Barry Fox



Windows Pain

Microsoft is now turning the screw on people like me who do not want to commit to Windows 95. We would prefer to continue using DOS and the previous version, of Windows (3.1), on the principle that "if it ain't broke don't fix it".

Loading Win 95 can create all kinds of problems. Sometimes this is because of bugs in Win 95. Other times is because there are no software drivers available for older peripherals, such as printers and CD-ROM drives, or because the manufacturers of new hardware have been slow on writing Win 95 drivers. Even major manufacturers, including Hewlett Packard, have been unable to provide Win 95 drivers for new laser printers.

The result is that systems which worked under Windows 3.1, stubbornly refuse to work under Windows 95. I know, I have tried loading 95 and run into brick walls. The manufacturers and software publishers all blame each other, or they blame Microsoft and bugs. So no-one carries the can.

Unhelpful

User self-help is well nigh impossible because the manuals that come with Win 95 are superficial, like the handbook for a new car that only tells you where to put the petrol, and is no help on a cold morning when the car refuses to start. People who have spent years getting under the bonnet of DOS and Windows 3.1 find that by replacing both systems Win 95 runs with a completely different set of rules.

Win 95 also needs more memory and hard disk space than Win 3.1, which means that old PCs may not upgrade. All in all it makes far better sense to wait a while with existing hardware, DOS and Win 3.1, until the bugs in Win 95 are ironed out and new drivers available. After wasting far too much time I got rid of Win 95 by re-formatting my hard disc and re-loading old Windows.

Soon after, Microsoft offered me the chance to try some new CD-ROMs from its "Home" software catalogue. But several of them (e.g. Music Central and World Atlas) will run only under Win 95, not under Win 3.1. The only way to use them is to load Windows 95, which for many people may mean buying a new PC.

Microsoft's glib justification of this policy is that it "rewards people who have bought Windows 95". I say, nonsense; it drives DOS/3.1 users into buying Windows 95. And as such it stinks. But it may help accelerate an investigation into the way Microsoft does business.

Re-Morse-less Debate

I am not surprised that radio amateurs get such a rotten press, and the national newspapers ignorantly bundle serious hams with CB after-burners.

Recently I needed to report on the "great Morse debate" for a radio programme and science magazine. I knew from Tony Smith's column in EPE (February 1996) that the President of the Radio Society of Great Britain, Clive Trotman, had written an open letter to over 1,000 people. They had been in touch with Trotman after the Government's Radiocommunications Agency had decided to support abolition of the Morse test without discussing the matter with the RSGB.

I tried phoning the official rule makers, the International Telecommunications Union, in Geneva. But the ITU's Morse expert never got back to me.

I phoned the RSGB and asked if I could talk with Clive Trotman? No. He was the Past President, not the present President. Well, could I talk to the present president, Peter Shephard? No. That could not be arranged either. I could only talk with the RSGB's office staff. But no-one was available.

Promised calls were not returned. Only by persistence over a period of weeks did I get a full run-down on the debate, in lay terms. By then a national newspaper would have given up and written the story anyway, complete with mistakes.

Historical Facts

For non-specialist readers, here are the simple facts of a complex but fascinating dispute:

Samuel Morse invented a digital code of long and short pulses in the late 1830s. It was first used to send messages down telegraph wires and later for radio. The beauty of the system is that it is very robust. As long as the operator can hear tone pulses above background noise and static, the message gets through.

The transmitter and receiver can be very inexpensive and the tone signal takes up far less space in the radio spectrum than speech or data. So Morse is ideal for sending messages over long distances between the six million amateurs round the world. But Morse is only useful if everyone can understand the code.

The ITU allocates amateur bands in slots of the radio spectrum, over a wide range of frequencies. National governments police the ITU's system with a common licensing scheme. The HF bands, at below 30 MHz, are best for long range communication because at these frequencies the signals reflect off the upper atmosphere and "skip" across continents. The VHF and UHF bands work only over short distances.

The ITU's scheme distinguishes between A and B licences. A "full" A licence permits use of all frequencies, including the sought-after HF band. A-licensed hams can send speech and data, or use Morse. But to get the licence they must learn to send and receive Morse Code at 12 words a minute. Learning is very

arduous but the obligation ensures that anyone who sends a Morse message on the HF bands can be sure that everyone who receives will be able to read it. B licence holders need not learn Morse but can only use the VHF and UHF bands.

Surveying Dissent

Last year the New Zealand government broke ranks and proposed an end to the Morse test. The UK government's DTI and its Radiocommunications Agency supported the move. "Morse is outdated, we support an end to the mandatory test. It may be better to have a technology exam" says a DTI spokesman.

The RSGB complains that it was not consulted. But for whatever reason the RSGB represents only a little more than half the number of people in the UK who pay the RA for a licence. But now the RSGB is in on the act and conducting an independent survey of all amateurs in the UK; 32,000 members RSGB, and the 28,000 licensed operators who are not members of the society.

Everyone will be asked to vote for or against the Morse requirement. The RSGB is also asking all the other ham societies in Europe and the Eastern bloc to carry out similar research. They can then take an international vote at the International Amateur Radio Conference to be held in Tel Aviv in October. The ITU will make its final decision at the next World Radio Conference, planned for 1999. If New Zealand's plan is adopted, Morse Code could be dead by the turn of the century.

Opinions Split

"We have no mandate from our members to give an opinion", said Peter Kirby, the RSGB's General Manager when I asked. Fair enough, so I asked amongst amateurs for a cross section of opinion.

Bill Capstick, a Morse-user for forty years, voices a concern that many hams are reluctant to express for fear of being branded elitist. "If we make it too easy, we could open the bands to CB operators".

Capstick also reminds that Morse takes up far less space on the airwaves than speech. "And it is classless. You can't tell someone's accent".

Angus McKenzie won the RSGB's Supreme Award for radio amateurs and has used Morse for 35 years. But he wants an end to the mandatory test. "It is an imposition on the disabled" says McKenzie who is blind. "It is very difficult to pass the test because you cannot write the words as you receive them. The test may discourage excellent operators".

McKenzie believes that many people will still choose to learn Morse.

"In an international emergency there may be someone stranded with a weak transmitter and an aerial in a tree, who can only get through by using Morse. But on any frequency there will always be thousands of people listening, and some of them will always know Morse".

Said Paul Rollin, a member of the First Class Operators Club for amateurs who use only Morse, "The test acts a filter which stops the nine HF bands getting too crowded. Without it there will be very little new blood with Morse skills. It will be like people driving classic cars and waving to each other".

WINTER 1995/6 CATALOGUE



The new winter '95/96 edition has 280 pages packed with over 4000 products.

- ▶ New editions to our computer section further extending our range of PC components and accessories at unbeatable prices
- ▶ Free competition with a chance of winning a Hameg 30MHz oscilloscope
- ▶ 100's of new products including; Books, Component Packs, Connectors, Switches, Test Equipment and Tools.
- ▶ New range of oscilloscopes from Hameg and extended range of mobile phone batteries and accessories
- ▶ Latest PIC Microcontroller IC's and programmer
- ▶ New 70cms mobile transceiver for the novice radio amateur enthusiast
- ▶ 280 pages, 26 sections and over 4000 products from some of the worlds finest suppliers
- ▶ Available at most newsagents or direct from Cirkuit
- ▶ **Send for your copy today!**

£1.95
+ 30p p&p

Cirkuit



Cirkuit Distribution Ltd

Park Lane · Broxbourne · Hertfordshire · EN10 7NQ
Telephone: 01992 448899 · Fax: 01992 471314

RADIO DATA MODULES MODEM TRANSCEIVERS

UK, E.E.C, Scandinavia, Eastern Europe, North & South America, Middle East, South Africa, New Zealand, Far East or Australia. Wherever you are, we have a module on the right frequency for you!

New !: TXR-XXX-DTR100



Only 55 x 23 x 15mm

20% Discount On Evaluation Pairs
UK, US, EEC or Australian Models

- * Efficient 5V operation *
- * 400 to 500MHz Versions *
- * Range up to 5Km *
- * Compact Size Ideal for Hand Helds *
- * UK, North American, Australian *
- * MPT, I-ETS & FCC Approval *
- * Up or 64 selectable channels *
- * 100+ Price Only £115.00 *

Low Voltage Transmitters Simplify Interfacing !

- * Reduce Component Count, Cost, Size & Power Drain *
- * Twice as fast as the -A version, up to 20,000 bps *
- * Drives directly from a PIC output Port !!! *
- * Available UK Approved MPT1340 418MHz *
- * Export I-ETS-300-220, 433.92MHz *



TXM-418-F Transmitter



SILRX-418-F Receiver

*** Special UK 40% Off Introductory Offer ***
*** Only £29.95 per pair Inc VAT ***

Exclusive : South African Modules on 403MHz

- * TXM-403-A, SILRX-404-A, RXM-403-A *
- * High Quality FM system > 120M Range *
- * Evaluation Kits Available *
- * No Price Surcharge *
- * Eg : 1000 + TXM's Only £5.95 Each *



RXM-403-A

VHF Modules for UK, Australia and Beyond !

- * UK, 173MHz to MPT1344 & MPT1328 Licence Exempt *
- * Miniature Low Cost 1 & 10mW Transmitters *
- * 173.500MHz Transmitters & Transceivers for Australia *
- * PCB mount or canned, Superhet Receivers *
- * Low Cost Meter Reading Transceivers on 183.8875MHz *
- * Prices from < £20.00 to £340.00 each *



RXM-173/183-4666-60

World Leading BIM Transceiver £84.95 per pair !



BIM-418-F

Approved to MPT1340 & I-ETS-300-220

World leading in price, performance and size the BIM high speed transceiver has already found a home around the World in many wire free products from computer networks, hand held terminals to EPOS. Available on 418 and 433.92MHz

- * 5V Operation, PIC Compatible Logic *
- * Exclusive RS232 Serial Version £79.95 *
- * Packet Controller Parallel i/o Board £79.95 *
- * Evaluation Kit with 2 BIM's £149.95 *
- * Volume Discounts Prices Available for OEM's



BIM-433-RPC

Check our Prices, Now with Free Postage ! *

Transmitters (1+ Price)

TXM-418-A 0.25mW ...£12.50
TXM-433-A 0.25mW ...£14.75
TXM-418-F 0.25mW ...£14.75
TXM-433-F 0.25mW ...£14.75
TXM-403-A 0.25mW ...£14.75
TXM-173-4689 1mW ...£22.50
TXM-173-4689 10mW ...£24.50
TXM-184-4689 10mW ...£29.95

Antennas (1+ price)

Helical-173MHz ...£4.90
1/4 Wave 418MHz ...£4.90
Dipole 418MHz ...£23.50
VHF Whip Antenna ...£35.00
UHF End Fed Dipole ...£35.00

Receivers (1+ price)

SILRX-418-A ...£22.50
RXM-418-A ...£29.05
SILRX-433-A ...£23.95
SILRX-403-A ...£23.95
RXM-403-A ...£29.05
SILRX-418-F ...£23.95
SILRX-433-F ...£23.95
RXM-173-60 ...£31.62
RXM-184-60 ...£31.62



*Prices unless otherwise stated exclude VAT. Carriage free on all non-account mainland UK orders. Insurance available at additional cost.

Credit Card Payments Welcome. Exports 2/4 day delivery by DHL, UPS or Air Express Available. All prices in Pounds Sterling

Radio - Tech Limited, Overbridge House, Weald Hall Lane
Thornwood Common, Epping, Essex CM16 6NB.
Sales +44 (0) 181 368 8277 Fax +44 (0) 181 361 3434
International +44 (0) 1992 57 6107 Fax +44 (0) 1992 56 1994

TEACH-IN '96

A Guide to Modular Circuit Design

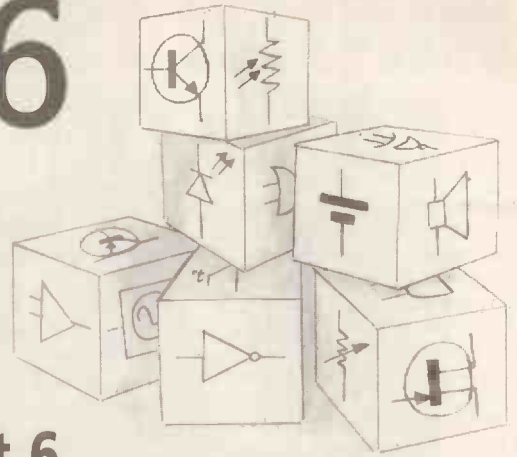

Max Horsey

Part 6

DURING this series of articles, a range of circuit modules is examined, divided into Input, Processor and Output sections. Where possible a choice of module is offered within each section.

Each of the ten Parts of the Series is accompanied by a constructional article explaining how a complete project may be devised by employing the modules described, together with a p.c.b. design. Each project will be one of many possible ideas that could be

implemented and it is hoped that readers will design for themselves a variety of circuits by combining modules provided in the whole series.

The proposed range of modules covered by the Series is detailed in Part 1, Table 1.1. Each module is chosen to link easily with adjacent modules in the same Part, but modules may also be linked with modules in other Parts of the Series.

Max Horsey is Head of Electronics at Radley College.

TEACH-IN Parts 6 and 7 are related to counters, timers and displays. The modules are particularly suitable for a "Pick and Mix" approach. For example, the Decade Counter Module here is equally suitable for use with the liquid crystal display (l.c.d.) module also in Part 6, or the light emitting diode (l.e.d.) display module in Part 7.

Throughout the series, circuits have generally been designed for use with a power supply of 12V. Note, though, that some l.c.d.s have a maximum rating of 9V. Check with the data in the component supplier's catalogue. All the modules in Parts 6 and 7 will operate on 9V if required.

DISPLAY MODULES

The more difficult and expensive l.c.d. module has been chosen for Part 6 because it uses almost no power and is particularly suited to battery driven projects. So the project accompanying Part 6 elsewhere in these pages is a portable battery driven *Event Counter* - an ideal add-on for the *Infra-Zapper* project associated with Part 5.

A 7-segment l.e.d. display is less expensive and much simpler to use, but cannot be switched on permanently if the project is driven by batteries. Details of l.e.d. display modules are given in Part 7.

The following is a summary of the modules covered in Parts 6 and 7:

Part 6:

INPUT MODULE: Switch debouncer circuits

PROCESSOR MODULES: L.C.D. interface circuit - ready-made counter module, binary coded decimal (BCD) counter, based on a CMOS 4029B i.c.

OUTPUT MODULE: L.C.D. decoder/driver

Part 7:

INPUT MODULES: Obtaining a clock pulse from an a.c. mains supply, obtaining

a clock pulse from a crystal oscillator

PROCESSOR MODULES: Diode logic gates, divide by 100 counter, BCD counter with l.e.d. 7-segment display, based on a CMOS 4026B

OUTPUT MODULE: L.E.D. 7-segment driver based on a CMOS 4511B

ANTI-BOUNCE CIRCUITS

Switch contact bounce can be a serious problem in electronic circuits, particularly counting circuits. The problem occurs because the metal contacts of switches do not close cleanly when the switch is pressed or turned on. Instead, they tend to vibrate. The same condition can occur when the switch is opened.

If a pushbutton switch is linked to a counter module, the counter will register correctly immediately the switch is pressed, but the vibration of the contacts bouncing can cause additional pulses to be generated, as illustrated in Fig. 6.1. Consequently, each press of the switch can produce several counts. A counter circuit would, in the instance of Fig. 6.1, register four counts instead of one.

Some switches are worse than others in this respect, but a small number, including the Hall-effect sensor type (which is actually an i.c. device), are bounce free.

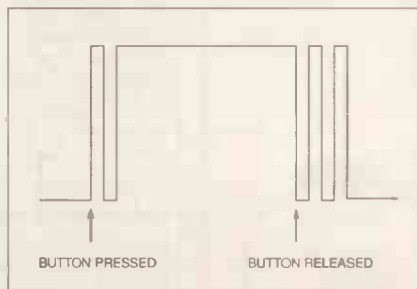

Fig. 6.1. Multiple pulses caused by switch contacts bouncing.

SOLUTIONS

Fortunately, switch contacts only bounce for a very short time compared with the time for which a pushbutton switch, for example, is generally pressed. Therefore, a timing circuit which reacts at the first moment of the contact being made, but ignores subsequent vibrations, can remove the problem.

Of course, if the time set is too long it will be impossible to press a button several times in quick succession. If the time is too short the circuit may fail to soak up all the bounces.

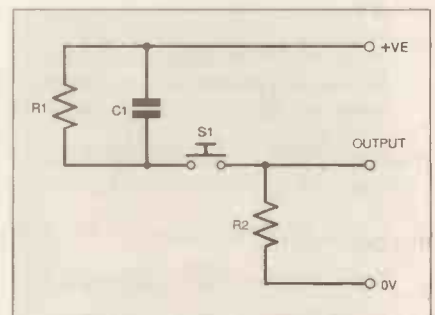

Fig. 6.2. Simple switch debounce circuit. Switch S1 is a normal open type.

A simple switch debounce circuit is shown in Fig. 6.2. When the switch (S1) is open (not pressed) the output will be at 0V due to the action of resistor R2. Resistor R1 will ensure that the potential (voltage) on each side of the capacitor, C1, is equal. The capacitor is said to be *discharged* since both sides are at the same voltage, i.e. positive in this case.

Assuming that the values of R1 and R2 are chosen with some care, and if the value of R2 is, say, ten times less than R1, the output can only be about one tenth of the supply voltage if the switch is held closed, ignoring the effect of C1 and the resistance of the circuit into which the output is being fed.

At the moment when the switch is pressed, the output will become positive, i.e. equal to the supply voltage, since both sides of C1 are at this voltage.

Of course, C1 will rapidly acquire a charge differential across it (charge up) due to the effect of R2. In other words, the voltage on its lower side (as seen in Fig. 6.2) will fall towards 0V, at a rate determined by its value and the value of R2. Therefore, subsequent bounces of the switch cannot produce further positive pulses at the output.

When the switch is released, C1 discharges again as the voltage at its lower side becomes equal to the positive supply voltage, due to the action of R1.

The values of the components are quite critical for a particular circuit and the amount of bounce to be removed. For example, if the output is connected to the Clock input of a CMOS counter, and where R1 and R2 are the only resistors involved in connection with that input, then try values of 100nF for C1, 100kΩ for R1 and 10kΩ for R2.

RESPONSE SPEED

Note that the value of R1 sets the compulsory time interval between switch presses, and R2 sets the duration of the positive pulse. The capacitor value affects both times equally. Also be aware that if the minimum voltage that can exist at the junction of R1 and R2 is too high, then the following i.c. may not respond to it as a logic 0 level (see Part 1 - Logic Gate Switch).

A further problem exists: the voltage change across the capacitor is designed to be a slow one. As explained in Part 1 (Logic Switches), slowly changing voltages on the input of a logic i.c. can, in extreme cases, cause transient pulses to be generated. Consequently, an inadequately designed debouncing circuit could produce more problems than it solves!

A little experimentation may be required for the best results from the circuit of Fig. 6.2. Mathematicians may try calculating the time intervals involved but much will depend upon the particular switch in use - and its degree of bounce.

To sum up the simple debounce circuit of Fig. 6.2:

ADVANTAGES:

- Simple
- Inexpensive

DISADVANTAGES:

Can reduce the problem but may not always solve it

Response can be affected by the following circuit

IMPROVED DEBOUNCING

The circuit shown in Fig. 6.2 will be adequate for many applications, and many counting circuits will respond well to the rather crude pulse shape obtained. However, if a single perfect pulse is required then the answer can be provided by a monostable, of the CMOS NOR type described in Part 2, Fig. 2.8 or Fig. 2.9, for example. This is the technique chosen for use in the Event Counter project.

For a monostable, the time period chosen will depend on the extent of the bounce and the maximum rate at which the switch might need to be pressed. A long monostable time period (e.g. one second) will mean that the maximum

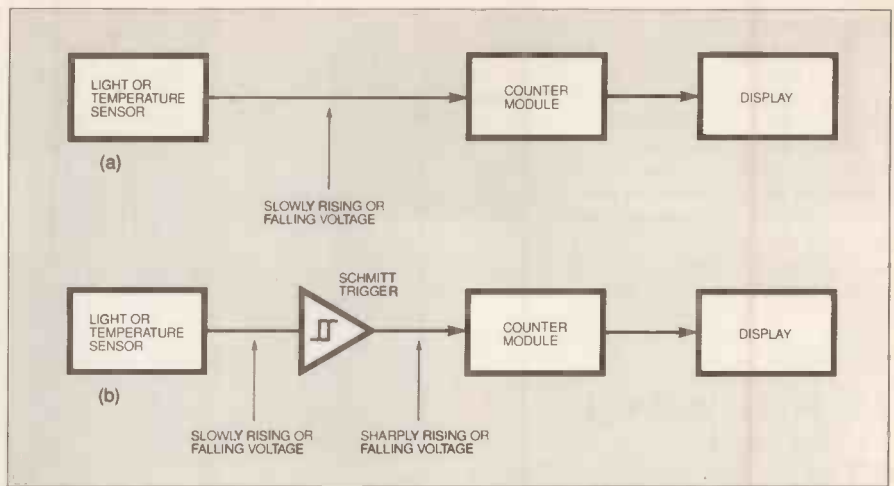

Fig. 6.3. The circuit in (a) is unlikely to respond well to slowly changing voltage levels. The inclusion of the Schmitt trigger in (b) improves the situation.

switch pressing rate is once per second. A short time period (e.g. 10ms) will allow the switch to be pressed 100 times per second.

The latter rate may sound ridiculous, but this type of problem might occur if the speed of a rotating shaft were being counted automatically, using a magnet mounted on the shaft and a reed switch at the side. In this case the monostable time period must be long enough to soak up the contact bounce but short enough to permit the maximum count frequency required.

It will be apparent that measuring the speed of a rapidly rotating shaft is not easy with a reed switch and magnet. In practice, a sensor inherently free of bounce, such as a Hall-effect sensor switch would be more suitable.

SCHMITT TRIGGERS

Counting circuits require a *change* of voltage to register a count; the *static* level of the voltage has no effect on them. The response to the change is known as *edge triggering*. In other words, the counter reacts to the vertical edge of a pulse. Some react to the *rising* edge, others to the *descending* one.

There is less likelihood of counters responding incorrectly if the pulse is well shaped, rapidly changing from one logic level to the other. Indeed, if a counter input is a.c. coupled (via a capacitor - see Part 2, Fig. 2.5) to the source being monitored, the counter may not respond at all to slowly changing levels of source voltage.

As an example of a poor signal source, take the light or temperature sensor modules discussed at some length in Part 1. These produce slowly changing output voltages as the light or temperature changes. Even if the voltage changes were sufficiently great to be considered as logic 0 or logic 1 values, they would be unlikely to satisfactorily trigger a counting circuit connected as shown in Fig. 6.3a.

In this configuration, it would be all too easy for the voltage to hover around the counter's trigger voltage threshold, resulting in numerous undesirable transient pulses being counted, instead of individual events. Consequently counting the number of times the light or temperature level rises and falls about a given value would produce grossly inaccurate results.

The inclusion of a Schmitt trigger circuit between the sensor and the counter, as shown in Fig. 6.3b, can help to solve the problem.

Schmitt triggers were discussed earlier in Part 1, Fig. 1.7 to Fig. 1.11. They can be made from CMOS logic gates, op.amps, or purchased ready-made in i.c. form.

COUNTER MODULE

Possibly the simplest and least expensive way of achieving a counter circuit is to use a ready-made counter module. Several such modules are available which contain a liquid crystal display plus a debouncing and decoding circuit.

The type discussed here is a 5-digit module which can operate at a maximum

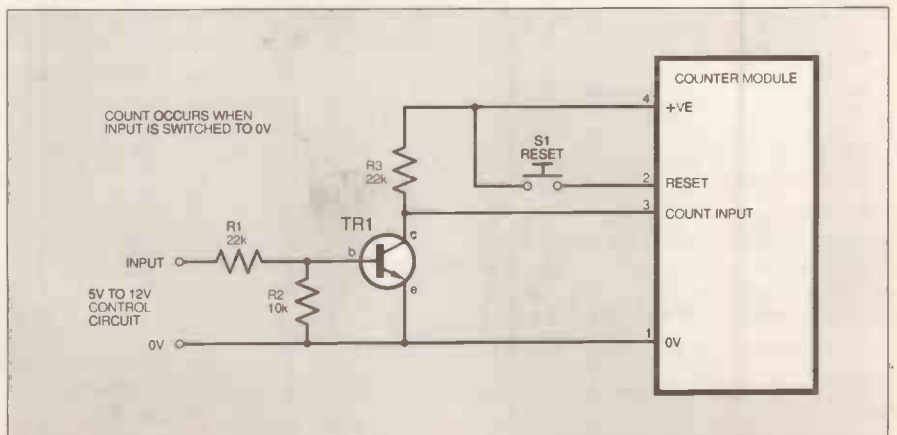

Fig. 6.4. An interface circuit for use with the counter module described in the text.

rate of seven counts per second. This rather low frequency limits its usefulness in some ways, but has the advantage that almost any pushbutton switch can be used without the problem of contact bounce being considered.

The module includes a reset input, produces square wave outputs of 512Hz and 32768Hz, and will also drive a piezo sounder directly. It runs from a 1.5V cell (which plugs directly into the module) and consumes so little current that it may be left switched on permanently.

See *Shop Talk* for details about where to buy this module.

COUNTER MODULE INTERFACE

Since the module operates from a 1.5V cell, it cannot be connected directly to any module in this *Teach-In* series. Consequently, an interface circuit is needed.

Shown in Fig. 6.4 is a transistor-based interface circuit and a basic block diagram of a counter module. The pin numbers relate to the counter module suggested in *Shop Talk*, if other modules are used, check the pin numbers with the data sheet enclosed with the module.

The circuit uses a transistor, TR1, in a similar way to the transistor processing circuit outlined in Part 1 (Fig. 1.5). The purpose of the transistor is to provide a buffer between the higher voltage signal source and the lower voltage counter module. Remember that the counter is operating on its own 1.5V supply, whereas the signal source circuit is likely to be operating on 5V, 9V or 12V.

When a 5V to 12V signal is applied to the Input, the collector of the transistor is pulled down to 0V. When the transistor is turned off, its collector voltage rises to the positive supply of the counter module i.e. 1.5V. The counter input is thus never allowed to rise to a voltage higher than its own supply.

The transistor can be any low power high gain *npn* type, such as BC108, BC184L etc. The values of the two input resistors, R1 and R2, are chosen so that the transistor will turn off even if the input voltage fails to fall all the way to zero. For example, the output from a 741 op.amp working on a single rail supply cannot fall lower than about 1V.

Note that the transistor inverts the input signal. Since the counter reacts to a positive transition (i.e. counts when the voltage rises), the counter will react when the transistor input signal switches from positive to 0V, i.e. when it falls. In some applications, this may not matter, but if it does, then a second transistor may be used to re-invert the signal as shown in Fig. 6.5.

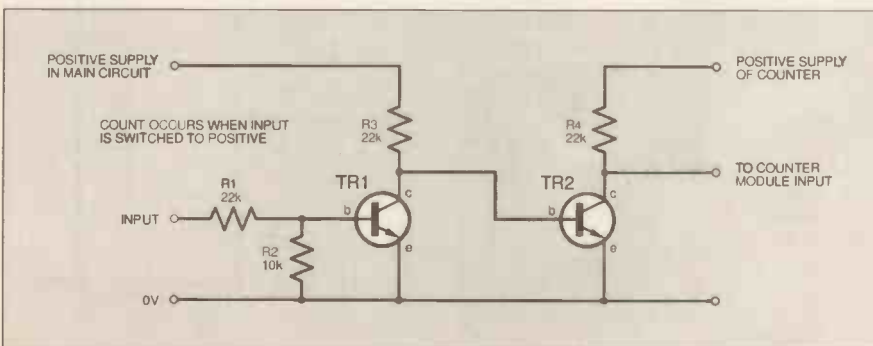

Fig. 6.5. The use of a second transistor inverts the logic of the circuit in Fig. 6.4.

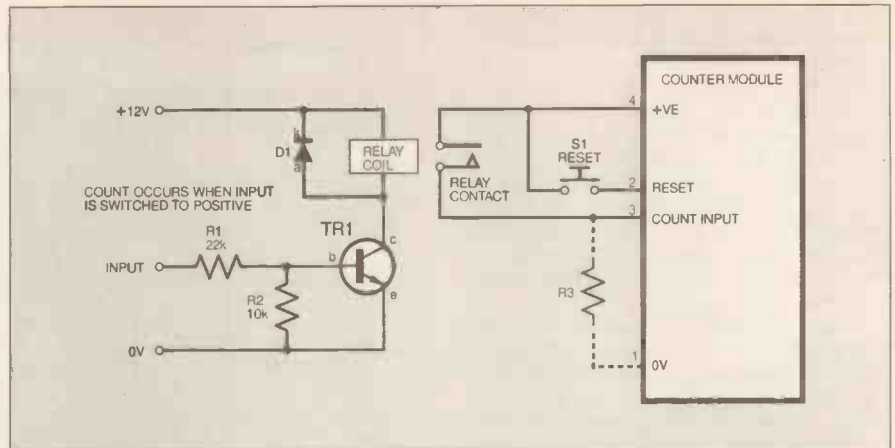

Fig. 6.6. Using a relay to completely isolate the counter module from its pulse source.

The second transistor, TR2, does not require a base resistor since only a small current can flow through the 22k Ω resistor R3 in series with the positive supply from the main circuit.

TOTAL ISOLATION

The counter module is a delicate device and any fault in the transistors in Fig. 6.4 or Fig. 6.5 could cause damage to it. If complete isolation is preferred, the relay circuit in Part 1 Fig. 1.13c could be used as shown in Fig. 6.6. There are more sophisticated isolation devices available, but they will not be discussed here.

Unlike the circuit of Fig. 6.4, the relay controlled counter counts when the input switches to positive.

The values of the resistors and the transistor type are a little more critical in the circuit of Fig. 6.6 since sufficient current must be available for the relay coil to allow correct operation. The principles outlined in Part 1 may be used

to calculate the resistor values for a particular type of transistor and relay.

If in doubt, use an *npn* Darlington transistor, such as TIP121 or TIP122, and the resistor values shown in Fig. 6.6. This combination is likely to work with any normal 12V relay.

Note, though, that some counter modules may not like having their count input left floating when the relay contacts are open. The inclusion of resistor R3 may be required for satisfactory operation. A suggested value is 10k Ω .

There is also the possibility that the relay contacts may bounce. If counter modules are used which react faster than the one suggested here, this may cause erroneous count pulses. In this case, the circuit of Fig. 6.2 may be required, the relay contacts replacing switch S1.

ADVANTAGE:

Provides total isolation for the counter module

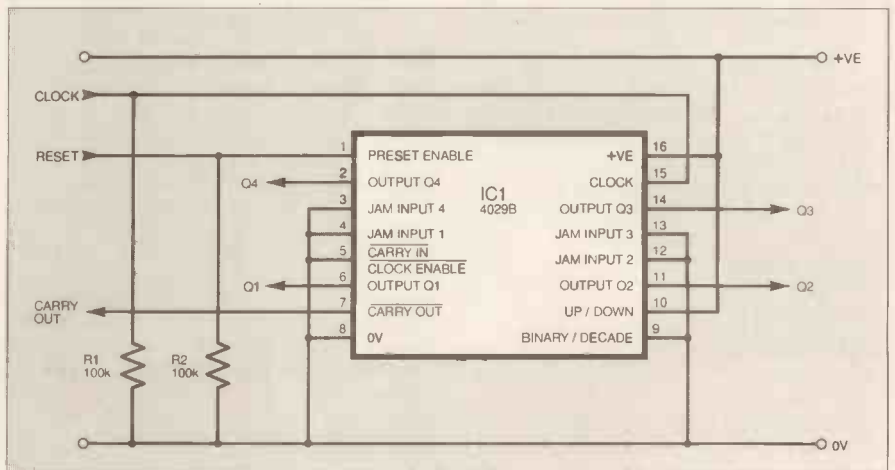

Fig. 6.7. Counter module based on a 4029B i.c.

DISADVANTAGES:

The relay adds to cost, size and power consumption

Contact bounce may cause erroneous counting in some modules

Maximum counting speed is limited by the speed at which the relay can operate

BINARY/DECADE COUNTER

In Fig. 6.7 is shown a counter module based on the CMOS 4029B i.c. It is basically a binary counter which counts pulses (responding to their rising edges),

and provides an answer in binary on its outputs Q1, Q2, Q3, Q4.

Note that Q1 outputs what is known as the "least significant bit" (i.e. the right hand binary digit of the number) and Q4 outputs the "most significant bit" (right hand binary digit). These outputs can be connected to an l.c.d. or l.e.d. display-driving output module. For a 7-segment l.e.d. display such a module could be based on the CMOS 4511B i.c. For an l.c.d., it could be based on the CMOS 4543B i.c., as will be seen in Fig. 6.9.

Note that an understanding of the binary system is not required in order to use the 4029B i.c. shown in Fig. 6.7. However, the binary system is worth a brief mention.

A binary digit (known as a bit) can be 0 (logic 0) or 1 (logic 1). Decimal 0 is equal to binary 0; decimal 1 is equal to binary 1. But decimal 2 is equal to binary 10 (pronounced *one, zero* – not *ten*). The binary system is based on powers of two. The following table may help clarify this:

Table 6.1.
Decimal to Binary Conversion

DECIMAL	BINARY			
	2 ³ =8	2 ² =4	2 ¹ =2	2 ⁰ =1
0	0	0	0	0
1	0	0	0	1
2	0	0	1	0
3	0	0	1	1
4	0	1	0	0
5	0	1	0	1
6	0	1	1	0
7	0	1	1	1
8	1	0	0	0
9	1	0	0	1
10	1	0	1	0
11	1	0	1	1
12	1	1	0	0
13	1	1	0	1
14	1	1	1	0
15	1	1	1	1

Without offering a lengthy description, notice the patterns of numbers. Note, for example, that the decimal number 6 equals binary 0110, in other words a one in the 4's column (i.e. 2 to the power of 2), plus a one in the 2's column (i.e. 2 to the power of 1). The table is based on 4-bit binary arithmetic (a 4-bit number is known as a *nibble*; an 8-bit number is a *byte*).

The maximum 4-bit binary number is 1111, which equals decimal 15. However, if a counter i.c. is to feed a decimal display, the maximum decimal number required per display is 9 (i.e. binary 1001). Counters which count up to 9, then reset to 0 and carry, are known as Binary Coded Decimal (BCD) counters. Some counter i.c.s, such as the 4029B, can be set to count to decimal 15, or decimal 9.

The 4029B can provide a full binary count from 0 to 15 (i.e. binary 1111), before automatically resetting back to 0. To achieve this, pin 9 must be connected to positive. If pin 9 is connected to 0V the i.c. is in BCD mode, and automatically resets at the tenth count. Note that the output is still in binary, it is only the point at which the i.c. resets which is affected.

In Fig. 6.7 details are shown on how the 4029B can be connected to count up in binary coded decimal, starting at 0, and providing a carry-out after 9. It may be reset to 0 at any time if a positive pulse is applied to the reset input, pin 1.

The i.c. counts up by one each time the clock input is made positive. As with the counter module already discussed, a very clean signal is required. Once again, a simple pushswitch would suffer from contact bounce, where several pulses are produced each time the switch is pressed. In such cases, a debouncing circuit would also be needed.

The 4029B 4-bit binary/decade counter is a particularly flexible device. Its full pin layout is as follows:

- Pin 1 Preset enable (or Reset), normally 0V, resets when it is made positive
- Pin 2 Output Q4
- Pin 3 Parallel load (JAM) input 4
- Pin 4 Parallel load (JAM) input 1
- Pin 5 Carry in, normally 0V, carries in when made positive
- Pin 6 Output Q1
- Pin 7 Carry out, normally positive, but switches to 0V at maximum count when counting up, or minimum count when counting down
- Pin 8 0V power supply
- Pin 9 Binary/Decimal select, must be made positive for binary, 0V for decimal
- Pin 10 Up/Down count, must be made 0V for down, positive for up
- Pin 11 Output Q2
- Pin 12 Parallel load (JAM) input 2
- Pin 13 Parallel load (JAM) input 3
- Pin 14 Output Q3
- Pin 15 Clock input, counts at rising edge of clock pulse
- Pin 16 Positive supply

PARALLEL LOAD INPUTS

Four of the pins are known as *parallel load* or *JAM* inputs. These pins are used to set up a binary number. Whenever the reset pin is made positive, the i.c. jumps to the number set by means of the parallel load inputs.

For example, there may be a need to build a timer which counts down in minutes and seconds. If the count is at, say, 4 minutes 00 seconds, the next count must be 3 minutes 59 seconds. In other words the tens column of the seconds counter has to jump from 0 to 5 (not 0 to 9 as in an ordinary counter).

The parallel load inputs would need to be set at binary 0101 (i.e. decimal 5) to cause the i.c. to jump in this way. Note that the parallel load system is only active when pin 1 is positive.

A practical example of how the parallel load system is used to set up an initial number will be seen in the *Countdown Timer* project associated with Part 7.

CASCADING

Whenever the maximum or minimum count is reached, the next clock input causes the i.c. to reset, and a carry-out pulse is produced from pin 7. This pin is normally positive, but goes low when zero is displayed. At the next clock pulse, pin 7 switches to positive again, a change which can be used as a clock pulse for the next counter.

Several counters can be cascaded like this to achieve tens, hundreds, etc. This is a fairly straightforward method of cascading the 4029B. However, there are also more subtle ways of cascading and a CMOS data book showing example circuits should be consulted for more information.

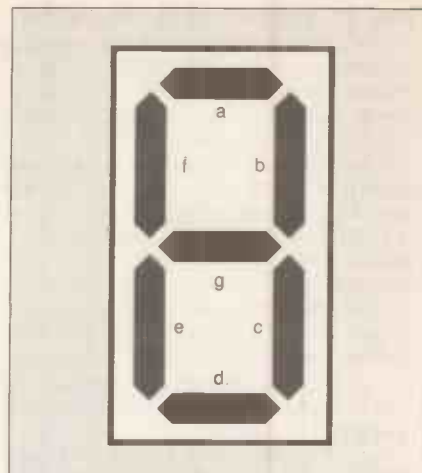

Fig. 6.8. Notation for 7-segment digit.

DISPLAY MODULES

Since the output modules in Part 6 and Part 7 are concerned with driving 7-segment l.c.d. or l.e.d. displays, consider first the nature of this type of display, as outlined in Fig. 6.8.

Conventionally, the individual segments of a 7-segment display are labelled a to g. Integrated circuits which drive these segments have their outputs similarly labelled and connected to them accordingly.

A number 0 is displayed by lighting up segments a, b, c, d, e, f. A 1 is displayed by lighting segments b and c, and so on.

Although the segment labelling system is standardised, unfortunately the order in which the pins accessing the segments are arranged is not. It is important, therefore, to establish which segments of the display are connected to which pins.

This information can be obtained from component suppliers' catalogues and, in practice, a display from one catalogue is likely to have a similar pin arrangement to a display of identical size and shape from another.

An important point to also note is that l.e.d. displays are manufactured as two specific types: *common cathode* and *common anode*. More on this in Part 7. They are not interchangeable. A circuit designed for one type cannot drive the other type without the use of an additional logic inverting chip between it and the display.

Liquid crystal displays are manufactured differently and do not have anode/cathode variations.

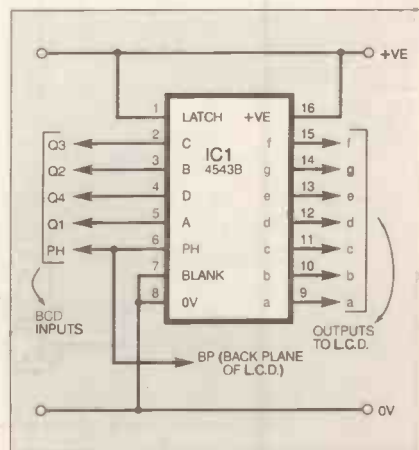

Fig. 6.9. Type 4543B l.c.d. decoder/driver i.c.

L.C.D. DECODER/DRIVER

In Fig. 6.9 is shown a module which is based on the CMOS 4543B i.c. It requires a BCD input, and provides an output suitable for driving a single 7-segment l.c.d. digit.

It is common for l.c.d.s to be supplied with more than one digit in the same display. Each digit thus requires one 4543B i.c. to drive it. (There are also special i.c.s which can drive more than one digit.)

It is necessary to look up in the catalogue or data supplied with the display to check which pins are connected to which segments of which digits! If this sounds potentially confusing... it can be!

Liquid crystal displays differ in several respects to l.e.d. displays. They are physically much more delicate – they can be easily squeezed to destruction. They are also static sensitive – use the same care as with a CMOS i.c. (*never solder them directly* – use a socket).

Several pins are devoted to driving decimal points, colons, etc. Unused pins should be connected to the backplane (BP) pin. Most important of all, l.c.d.s require a square wave applied to their backplane. The same square wave is applied to the PH pin of the i.c. used to drive the display. The frequency of the square wave should be between 30Hz and 100Hz. A d.c. voltage must *never* be supplied to l.c.d. pins.

The pin arrangement of the 4543B BCD to seven segment latch/decoder/driver i.c. is as follows:

- Pin 1 Latch disable. Must be tied positive. When held at 0V, the number displayed is "frozen"
- Pin 2 Binary input C (usually from output Q3 of driving i.c.)
- Pin 3 Binary input B (usually from output Q2 of driving i.c.)
- Pin 4 Binary input D (usually from output Q4 of driving i.c.)
- Pin 5 Binary input A (usually from output Q1 of driving i.c.)
- Pin 6 The PH input i.e. requires a square wave as described above
- Pin 7 Blanking input: Must be tied to 0V. When positive, digit is turned off
- Pin 8 0V supply
- Pin 9 Output to l.c.d. segment a
- Pin 10 Output to l.c.d. segment b
- Pin 11 Output to l.c.d. segment c
- Pin 12 Output to l.c.d. segment d
- Pin 13 Output to l.c.d. segment e
- Pin 14 Output to l.c.d. segment g
- Pin 15 Output to l.c.d. segment f
- Pin 16 Positive supply

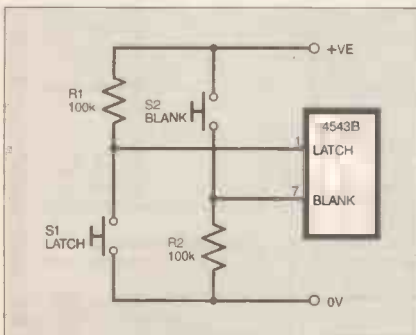

Fig. 6.10. Switched control of the blanking and latching for the 4543B.

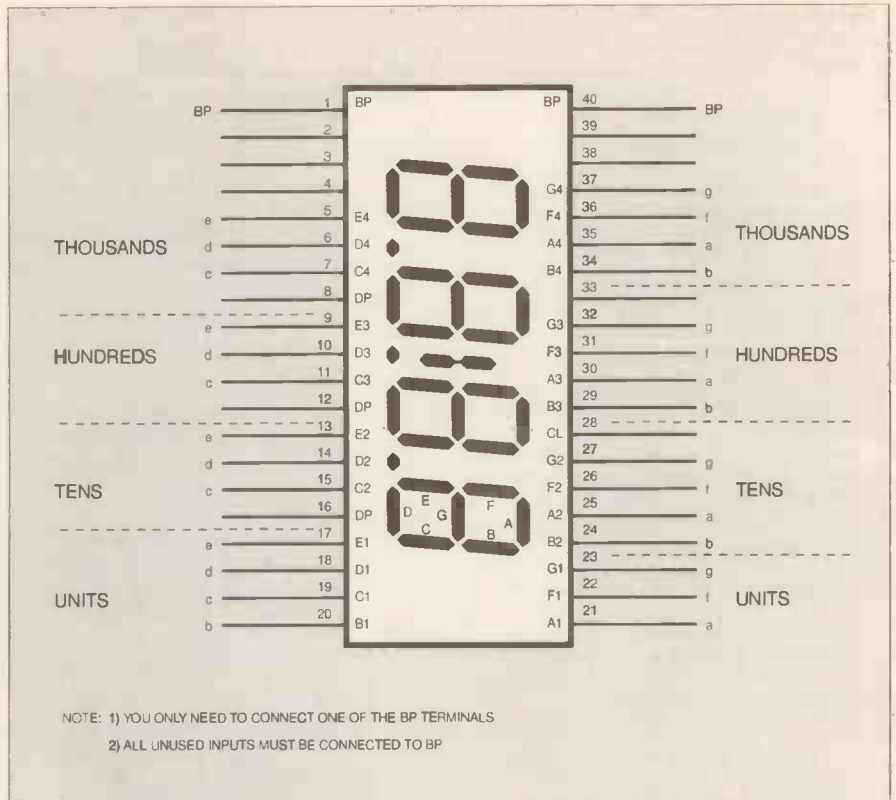

Fig. 6.11. Typical pinouts for a 4-digit l.c.d. module.

(P.C.B. designers will recognise that the sequence, which is not in strict alphabetic order, is often well suited to easier p.c.b. tracking layouts! Ed.)

Pin 1 of the i.c. can be used to make a number "latch" i.e. not change even though the inputs may be changing. Use a tie-up resistor, R1, as shown in Fig. 6.10 so that pin 1 is normally held positive, but can be taken to 0V by pressing switch S1, so latching the display.

To blank out the digit (turn off all segments), use the second arrangement shown in Fig. 6.10. Resistor R2 normally holds pin 7 at 0V. When switch S2 is pressed, the pin is taken positive, so blanking the display.

LIQUID CRYSTAL DISPLAY

As stated above, the l.c.d. must be handled with great care. It is both physically and electrically delicate. Even touching the pins may cause damage (it will certainly make the segments flicker – which may prove to be an expensive form of entertainment!).

Warning: Some l.c.d.s have a maximum rating of 9V. Check with the data available from the supplier if the use of a 12V power supply is required.

L.C.D.s can be bought in various digit quantity configurations: for example, 3-5-digit (displaying up to 1999), 4-digit (up to 9999) and 4-5-digit (up to 19999) are just some of those available. Although there is a lot of conformity between l.c.d. types, the pin arrangement *must* be checked against the data from the supplier.

In Fig. 6.11 is shown the typical pin arrangement for a 4-digit l.c.d. (displaying up to 9999). The pins not labelled may either be not used by the l.c.d. or reserved for other display options, such as plus and minus signs, for example.

Note that the "backplane" (BP) is common to all the segments in the display and must be connected to the same square

wave supply as the pin known as "PH" in the driver i.c.

A block diagram of a typical circuit arrangement required to drive an l.c.d. is shown in Fig. 6.12.

The 30Hz to 100Hz square wave can be obtained from an astable (see Part 4) or other suitable clock source, such as the crystal oscillator timing circuit based around the CMOS 4060B counter to be described in Part 7 (pin 15 of the counter outputs a frequency of 32Hz).

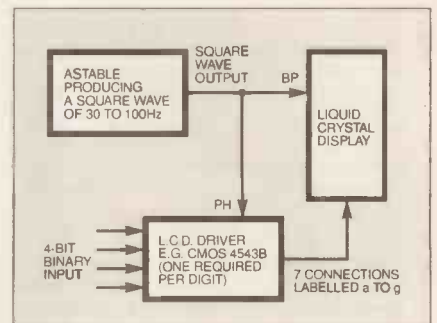

Fig. 6.12. Typical circuit arrangement for driving an l.c.d.

EXAMPLE PROJECT

The Events Counter unit is the example project (elsewhere in these pages) which shows how the modules in *Teach-In* Part 6 can be combined in a practical application.

PREVIOUS PARTS

You have just read (and enjoyed, we hope) the sixth part of this *Teach-In* series. If you have missed any of the earlier parts, we can supply the copies of *EPE* which include them – see the **Back Issues** page. There are four more parts yet to come – don't miss them!

HART AUDIO KITS – YOUR VALUE FOR MONEY ROUTE TO ULTIMATE HI-FI

HART KITS give you the opportunity to build the very best engineered hi-fi equipment there is, designed by the leaders in their field, using the best components that are available.

Every HART KIT is not just a new equipment acquisition but a valuable investment in knowledge, giving you guided hands-on experience of modern electronic techniques.

In short HART is your 'friend in the trade' giving you, as a knowledgeable constructor, access to better equipment at lower prices than the man in the street.

You can buy the reprints and construction manual for any kit to see how easy it is to build your own equipment the HART way. The FULL cost can be credited against your subsequent kit purchase.

Our list will give you full details of all our Audio Kits, components and special offers.

INTRODUCING

The Hart "Chiara"

Single-Ended Class "A" Headphone Amplifier.

Most modern high fidelity amplifiers either do not have a headphone output facility, or this may not be up to the highest standard.

The new Hart "Chiara" has been introduced as an add-on unit to remedy this situation, and will provide two ultra high quality headphone outlets. This is the first unit in our 2000 Range of modules to be introduced through the year. Housed in the neat, black finished, Hart Minibox it features the wide frequency response, low-distortion and "musicality" that one associates with designs from the renowned John Linsley Hood.

Both outputs will drive any standard high quality headphones with an impedance greater than 30 ohms and the unit is ideal for use with the Sennheiser range. A signal link-through makes it easy to incorporate into your system and two extra outputs, one at output level and one adjusted by the Volume control are available on the back panel. The high level output also makes a very useful long-line driver where remote mounted power amplifiers are used. Power requirements are very simple and can be provided by either of our new "Andante" power supplies. Use the K3565 to drive the "Chiara" on its own, K3550 if driving other modules as well.

Volume and Balance controls are provided and as befits any unit with serious aspirations to quality these are the ultra high quality Alps "Blue Velvet" components.

Very easily built, even by beginners, since all components fit directly on the single printed circuit board and there is no conventional wiring whatsoever. The kit has very detailed instructions, and even comes with a roll of Hart audiograde silver solder. It can also be supplied factory assembled and tested.

Selling for less than the total cost of all the components, if they were bought separately, this unit represents incredible value for money and makes an attractive and harmonious addition to any hi-fi system.

K2100 The total cost of a complete set of all components to build this unit is £126.37. Our special discount price for all parts bought together as a kit is.....**£109.50**

K2100SA Series Audiophile, with extra selected components.....**£112.46**

HART TC1D Triple Purpose TEST CASSETTE

Now available again and even better than before! Our famous triple purpose test cassette will help you set up your recorder for peak performance after fitting a new record/play head. This quality precision Test Cassette is digitally mastered in real time to give you an accurate standard to set the head azimuth, Dolby/VU level and tape speed, all easily done without test equipment.

TC1D Triple Purpose Test Cassette.....**£9.99**

Send or phone for your copy of our FREE List of these and many other Kits & Components. Enquiries from Overseas customers are equally welcome, but PLEASE send 2 IRCs if you want a list sent surface post, or 5 for Airmail.

Ordering is easy. Just write or telephone your requirements to sample the friendly and efficient HART service. Payment by cheque, cash or credit card. A telephoned order with your credit card number will get your order on its way to you THAT DAY.

Please add part cost of carriage and insurance as follows:—INLAND Orders up to £20 - £1.50,

Orders over £20 - £3.50. Express Courier, next working day £10.

OVERSEAS - Please see the ordering information with our lists.

NEW BOOK

"Audio Electronics"

And now, hot off the press, yet another classic from the pen of John Linsley Hood. Following the ongoing enormous success of his "Art of Linear Electronics" the latest offering is the all-new edition of "Audio Electronics", now entirely re-written by the master himself.

Underlying audio techniques and equipment is a world of electronics that determines the quality of sound. For anyone involved in designing, adapting or using digital or analogue audio equipment understanding electronics leads to far greater control over the reproduced sound.

The subjects covered include tape recording, tuners, power output stages, digital audio, test instruments and loudspeaker crossover systems. John's lifetime of experience and personal innovation in this field allow him to apply his gift of being so familiar with his subject that he can write clearly about it and make it both interesting and comprehensible to the reader.

Containing 240 pages and over 250 line illustrations this new book represents great value for money at only £18.99 plus £2.50 postage. Send or telephone for your personal copy now.

ALPS "Blue Velvet"

Precision Audio Controls



To fulfil the need for ultra high quality controls we import a special range of precision audio pots in values to cover most quality amplifier applications. All in 2-gang stereo format, with 20mm long 6mm diam. steel shafts, except for the 50K Log which is 25mm x 6mm. Overall size of the manual pot is 27W x 24H x 27Deep, motorised versions are 72.4mm Deep from the mounting face. Mounting bush for both types is 8mm diameter.

Now you can throw out those noisy ill-matched carbon pots and replace with the real hi-fi components only used selectively in the very top flight of World class amplifiers. The improvement in track accuracy and matching really is incredible giving better tonal balance between channels and rock solid image stability.

The motorised versions use a 5V DC motor coupled to the normal control shaft with a friction clutch so that the control can be operated manually or electrically. The idea of having electrically operated pots may seem odd, archaic even, but it is in fact the only way that remote control can be applied to any serious HI-FI system without loss of quality. The values chosen are the most suitable available for a low loss passive volume and balance control system, allowing armchair control of these two functions.

Our prices represent such super value for pots of this quality due to large purchases for our own kits.

MANUAL POTENTIOMETERS
2-Gang 100K Lin.....£15.67
2-Gang 10K, 50K or 100K Log.....£16.40
2-Gang 10K Special Balance, zero crosstalk and zero centre loss.....£17.48

MOTORISED POTENTIOMETERS
2-Gang 20K Log Volume Control.....£26.20
2-Gang 10K RD Special Balance, zero crosstalk and less than 10% loss in centre position.....£26.98

REEL TO REEL HEADS

999R 2/4 R/P 100mH.....£16.84
We have a few erase heads to suit which can only be supplied when 2 R/P heads are purchased £36.80

TAPE RECORDER CARE PRODUCTS

DEM1 Mains Powered Tape Head
Demagnetizer, prevents noise on playback due to residual head magnetisation.....£4.08
DEM115 Electronic, Cassette Type, demagnetizer.....£8.61

LINSLEY HOOD 'SHUNT FEEDBACK' RIAA MOVING COIL & MOVING MAGNET PICKUP PREAMPLIFIERS



The HART K1450 Magnetic pickup preamplifier kit features a totally discrete component implementation with a specially designed low input impedance front end and the superior sound of the Shunt Feedback circuitry. High quality components fitting to an advanced double-sided printed circuit board make this a product at the leading edge of technology that you will be proud to own. Nevertheless with our step by step instructions it is very easy and satisfying to assemble. The higher current consumption of this unit means that it is best powered by our new Andante Audio Power Supply, itself an advanced piece of technology in a matching case. This supplies the superbly smoothed and stabilised supply lines needed by any sensitive preamplifier and features a fully potted Hi-grade toroidal transformer along with a special limited shift earth system for hum free operation. The K1450 is suitable for all moving coil and moving magnet transducers this unit is especially recommended for, and will extract the very best from the modern generation of low output high quality moving coil transducers.

K1450 Kit, complete with all parts ready to assemble inside the fully finished 228mm x 134mm x 63mm case. Kit includes full, easy to follow, assembly instructions as well as the Hart Guide to PCB Construction, we even throw in enough Hart Audiograde Silver Solder to construct your kit!

K1450SA Series Audiophile version with selected components.....**£111.58**
.....**£133.94**

HIGH QUALITY REPLACEMENT CASSETTE HEADS



Do your tapes lack treble? A worn head could be the problem. For top performance cassette recorder heads should be replaced every 1,500 hours. Fitting one of our high quality replacement heads could restore performance to better than new! Standard inductances and mountings make fitting easy on nearly all machines (Sony are special dimensions, we do not stock) and our TC1 Test Cassette helps you set the azimuth spot on. As we are the actual importers you get prime parts at lower prices, compare our prices with other suppliers and see All our heads are suitable for use with any Dolby system and are normally available ex-stock. We also stock a wide range of special heads for home construction and industrial users.

HC80 NEW RANGE High Beta Permalloy Stereo head. Modern space saver design for easy fitting and lower cost. Suitable for chrome, metal and ferric tapes, truly a universal replacement head for everything from hi-fi decks to car players and at an incredible price too.....£11.70
HRP373 Downstream monitor comb head.....£62.59
HQ551A 4-Track R/P.....£8.75
HQ551S Sony Mount 4-Tr. R/P.....£14.90
HQR560 Rotary Base 12.5mm R/P/E.....£21.90
HQR570 Rotary Base 15mm R/P/E.....£22.59
HQR580 Rotary Base 12.5mm R/P.....£14.29

HART Classical CD's.

Top quality, Full Digital (DDD), over 100 titles from only £1.99! Ring or send for your list!

TECHNICAL BOOKSHELF

We stock a good range of books of interest to the electronics and audio enthusiast, including many reprinted classics from the valve era. Some were in last month's advertisement, but see our list for the full range.

New this month is the GEC Valve designs book at £18.95, and the VTL Book, a modern look at valve designs, £17.95.

QUALITY AUDIO KITS

24 hr. SALES LINE (01691) 652894

ALL PRICES INCLUDE UK/EC VAT





EVENT COUNTER

MAX HORSEY **PCB DESIGN BY CHRISTOPHER CAULKIN**

Keep count of events as they happen, from an Infra-Zapper gun to – well – almost anything!

DESIGNED for portable operation, this Event Counter uses a liquid crystal display (l.c.d.) which consumes a negligible amount of current. The project illustrates the way in which some of the modules described in *Teach-In* Part 6 can be connected together, and also shows one way to connect an l.c.d. to a counter circuit.

Two pushbutton switches are provided, one for incrementing the count, the other for resetting to zero. Of course, the counter may be connected to any other device instead of a switch. For example, it could be fed from the output of a light sensor module (as described in *Teach-In* Part 1) for automatic counting of objects on a conveyor belt.

The counter may also be connected to the *Infra-Zapper* featured as the constructional project for Part 5, for automatic target score indication.

BLOCK DIAGRAM

The way in which the modules are linked together is shown in the block diagram of Fig.1. There are two inputs available. One input is buffered by a monostable (from Part 2, Fig.2.8) which removes any contact bounce produced by the internal triggering switch or an external signal source. The problem of contact bounce is described in Part 6. The maximum pulse rate at this input is about 14Hz.

The second input bypasses the monostable and allows pulses at a higher rate (up to about 2MHz) to be counted.

From the monostable, or by direct input, the signal is delivered to the "units" counter integrated circuit (i.c.) type 4029B which produces a 4-bit binary-coded-decimal (BCD) output. This output is fed to an i.c. type 4543B which is designed for driving l.c.d.s., in this instance providing outputs for the seven segments of the "units" digit.

As also described in Part 6, the electrical signals required for the segments have to be alternating at a frequency of between 30Hz and 100Hz. The same frequency is fed to the "BP" (backplane) pin of the display. If the signal to a particular segment is *in-phase* with (i.e. the same as) the signal to BP, then the segment "disappears" (is

turned off). If the signal to a segment is of the *opposite* phase to BP then the segment is turned on (turns black).

This may sound complicated, but the 4543B i.c. sorts everything out, providing its "PH" pin and the "BP" pin(s) on the display are both connected to the same square wave signal. The square wave signal is obtained using an astable, as described in Part 4 (see Fig.4.2 to Fig.4.6).

CIRCUIT DIAGRAM

The full circuit diagram for the Event Counter is shown in Fig.2. Despite its complicated appearance, there are very few components other than i.c.s, and there is much repetition. For example, each digit requires a similar module comprising a 4029B i.c. linked to a 4543B i.c.

Pushbutton switch S1 allows the counter to be triggered manually. Any minor electrical noise is removed by capacitor C2, and resistor R2 ensures that the voltage at IC1 pin 8 remains at zero unless the switch is pressed or an external input is received.

NOR gates IC1c and IC1d are connected to form a monostable. The values of resistor R4 and capacitor C4 set a pulse period of about 0.07 seconds. This allows the input switch contacts to bounce for a maximum of 0.07s without causing false counts.

An external input via SK1 is also provided here, allowing slow pulses, which could contain contact-bounce signals or other fluctuations capable of adversely triggering a counter, to be processed cleanly.

If the input signal is bounce-free – for example, if the input is from a Hall-effect sensor – then the monostable period could be reduced. Alternatively, bounce-free signals could be fed directly into pin 15 of IC5 (the units counter) via socket SK2.

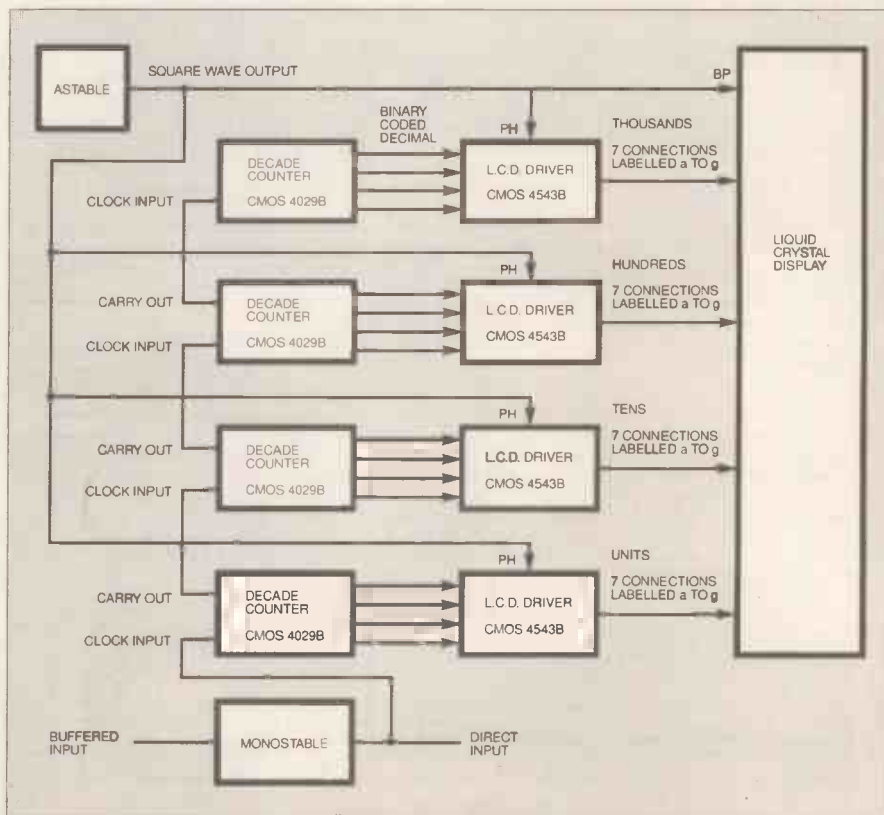

Fig. 1. Block diagram for the Event Counter.

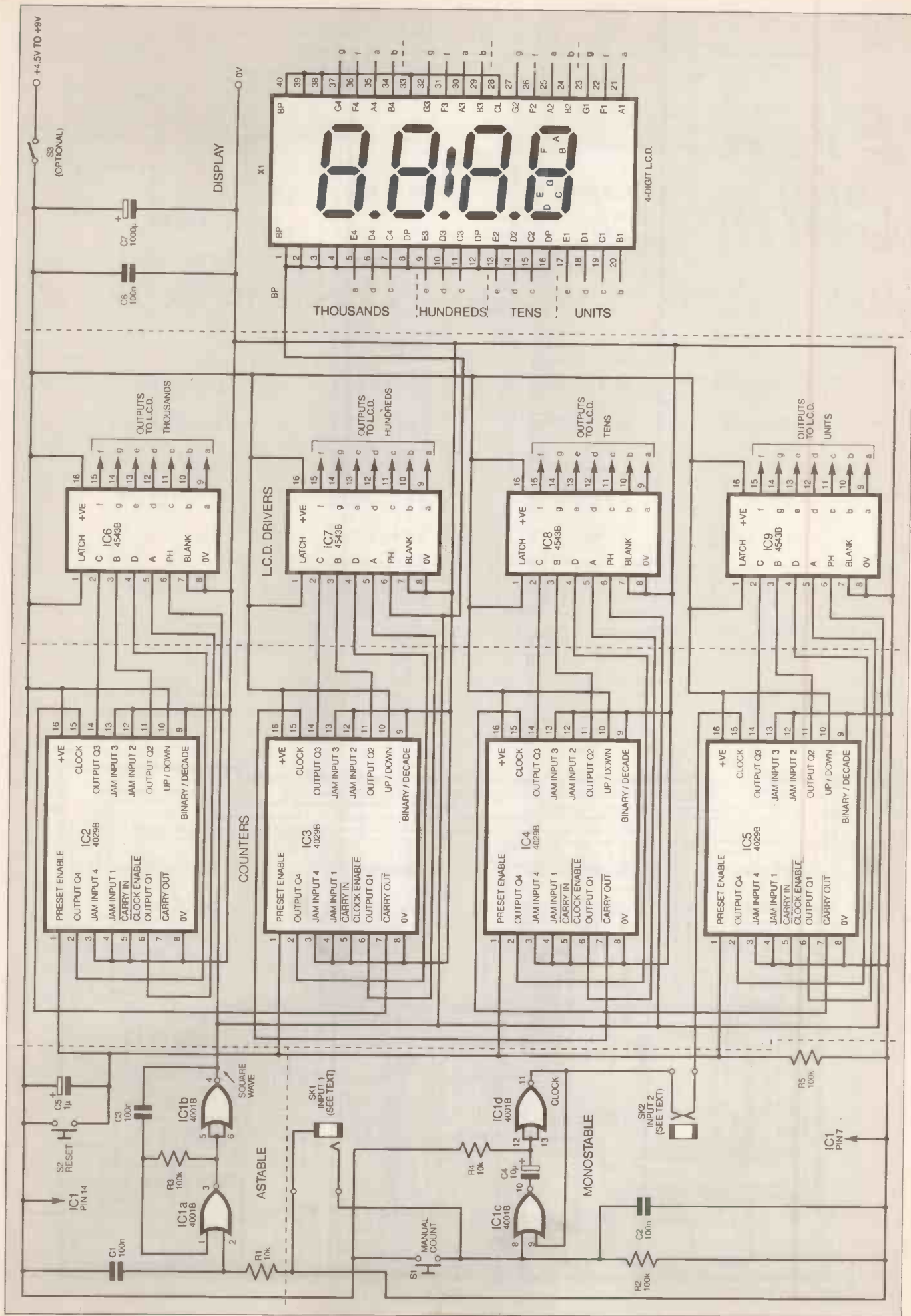

Fig. 2. Complete circuit diagram for the Event Counter.

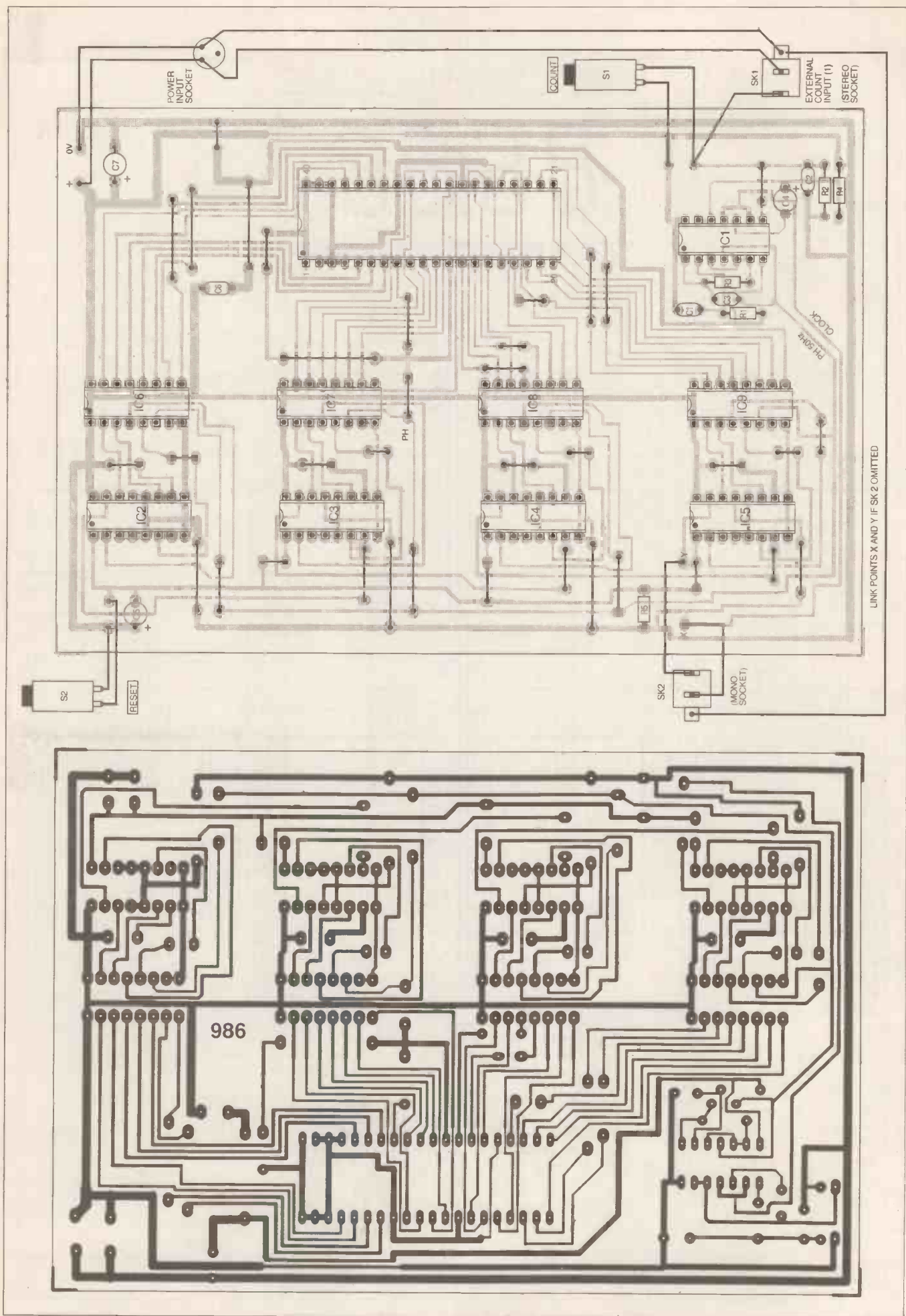
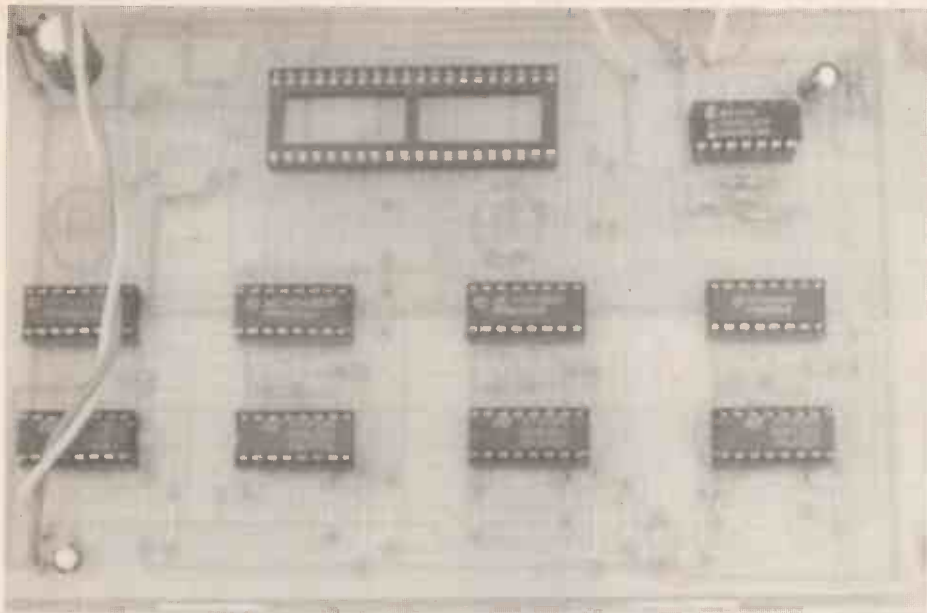

Fig. 3. Printed circuit board component layout and full-size underside copper foil track master pattern.



Inserting a plug into this socket automatically cuts out signals from the monostable.

Note that external input signals must come from circuits which have the same power supply voltage as the counter.

ASTABLE

NOR gates IC1a and IC1b are used to form an astable which generates the square wave required by l.c.d.s. The values of resistor R3 and capacitor C3 set the astable for an output frequency at IC1b pin 4 of about 50Hz.

Since the astable may fail to start oscillating at power on, capacitor C1 and resistor R1 are added to provide a positive pulse at IC1a pin 2 when power is applied. This "kick start" effect was discussed in Part 4 (Fig.4.5).

The output from IC1b pin 4 is connected to pin 6 (the "PH" pin) of all the l.c.d. drivers (IC6 to IC9) and the "BP" (back-plane) pin of the display. Two BP pins are provided on the display, but they are internally linked and so only one needs to be connected.

COUNTING

The clock signal from the monostable, or directly from socket SK2, is fed to IC5 pin 15.

All the "parallel load" (JAM) inputs of the type 4029B counters (IC2 to IC5) are tied to 0V, so that the display jumps to zero at reset. Parallel load inputs are an interesting feature of the 4029B. They are discussed in Part 6 and their purpose is illustrated in the *Countdown Timer* project associated with Part 7.

From IC5, the binary outputs, denoted as Q1, Q2, Q3 and Q4, are connected to IC9. This i.c. suitably decodes the count for driving a 7-segment display, and synchronises the output with the square wave from the astable as described earlier.

The 7-segment outputs a to g are connected to the appropriate inputs of the l.c.d. (Incorrect linking of counters and l.c.d.s can be a source of endless amusement, and frustration, with all sorts of odd "numbers" appearing. If the display purchased has the same pinouts as the one shown in Fig.2 - which it is likely to have - all should be well.)

CASCADING AND RESETTING

Note that IC5 pin 10 is tied to the positive rail. This causes the i.c. to count up. IC5 pin 9 is tied to 0V, causing the i.c. to count in BCD. In other words, it resets after a count of nine, rather than 15. Each time IC5 reaches its maximum count (nine in this case), the voltage at its pin 7 (carry-out) becomes 0V. When the i.c. goes beyond its maximum count (i.e. returns to 0), the voltage at pin 7 returns to positive.

This voltage change is used to trigger the clock input of the next counter, IC4 pin 15. There are other ways of cascading these counter i.c.s and a carry-in pin is provided for use in situations other than that required here.

The preset enable (pin 1) is used to reset each counter and is normally kept at 0V by resistor R5. When resetting of the count back to zero is required, switch S2 can be pressed, causing pin 1 of each counter to become positive. To prevent the circuit from initially displaying a random number, capacitor C5 provides a positive pulse

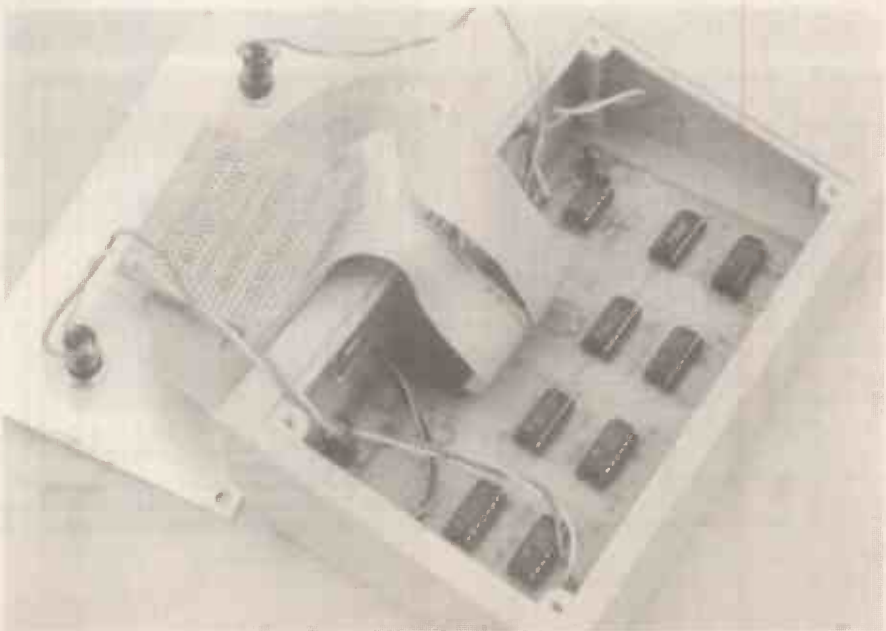

COMPONENTS

Resistors

R1, R4 10k (2 off)
R2, R3,
R5 100k (3 off)
All 0.25W 5% carbon
film, or better

See

SHOP
TALK
Page

Capacitors

C1 to C3,
C6 100n ceramic disc (4 off)
C4 10 μ radial elect. 25V
C5 1 μ radial elect. 63V
C7 1000 μ radial elect. 16V

Semiconductors

IC1 4001B quad 2-input NOR
gate
IC2 to
IC5 4029B binary/decimal
counter (4 off)
IC6 to
IC9 4543B l.c.d. decoder/driver
(4 off)

Miscellaneous

S1, S2 push-to-make switch (2 off)
S3 s.p.s.t. toggle switch
(see text)
SK1 3.5mm stereo jack socket
(see text)
SK2 3.5mm mono jack socket
(see text)
X1 4-digit l.c.d. display

Printed circuit board, available from the
EPE PCB Service, code 986; 14-pin d.i.l.
socket; 16-pin d.i.l. socket (8 off); 20-pin
s.i.l. socket (4 off); stripboard, 0.1in pitch,
26 holes x 31 strips; 20-way ribbon cable
(see text); 40-pin IDC socket and plug
(see text); power supply socket (optional
- see text); plastic case with sloped panel
(ABS console 2801) 190mm x 62mm
(max. height) x 100mm; connecting wire;
solder, etc.

Approx cost
guidance only

£38
excluding case

to all the reset pins at the moment when power is first switched on.

The rest of the circuit is merely a copy of the "Units" section, with capacitors C6 and C7 providing supply decoupling. Switch S3 is an optional master power on/off control.

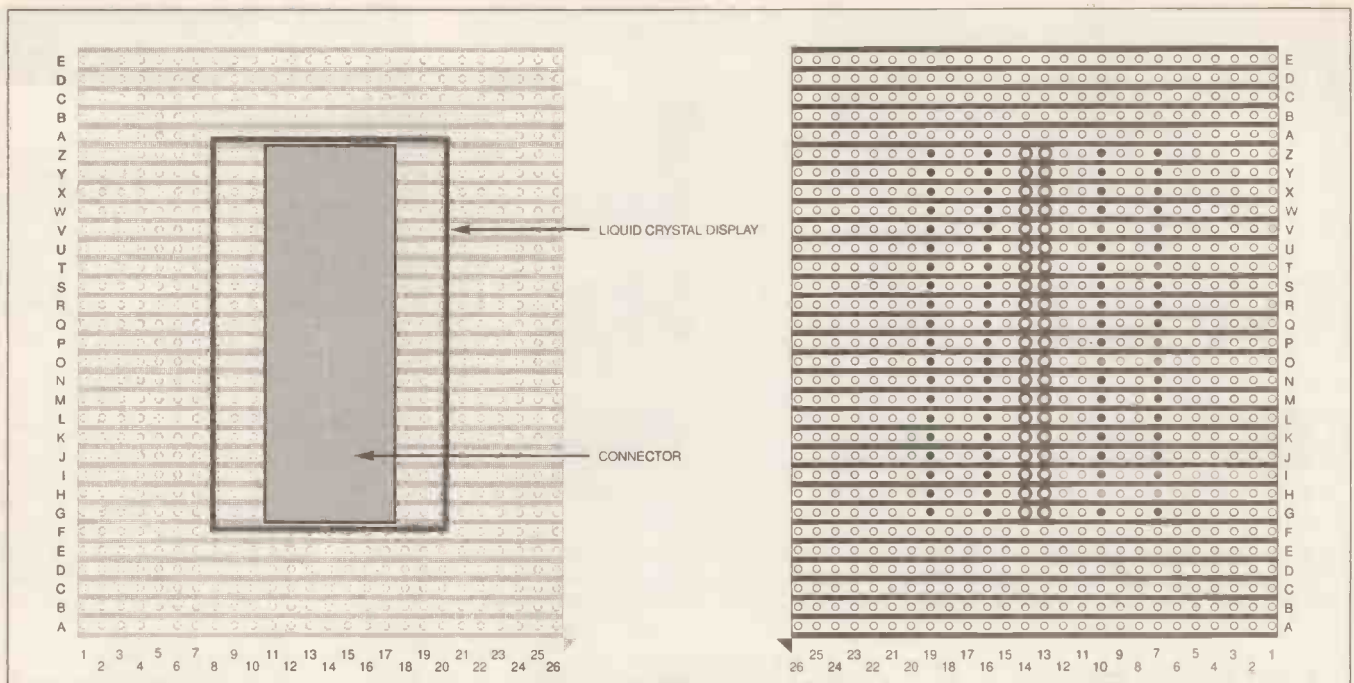

Fig. 4. Stripboard layout details for the l.c.d. module.

CONSTRUCTION

Full details of the printed circuit board (p.c.b.) for the Event Counter are shown in Fig.3. This board is available from the *EPE PCB Service*, code 986.

Begin by inserting the d.i.l. (dual-in-line) i.c. sockets, checking that their notches line up with the diagrams. Although the sockets do not *have* to be fitted the correct way round, the notch serves as an indicator to help insert each i.c. correctly. Do not fit the i.c.s yet!

Fit the wire links in the positions indicated. Wire links are easily fitted if long bare wire is used. Solder one end into place, then pull the wire through the other hole before cutting the wire to length. It should be possible to pull each wire link so that it is neat and straight.

Check that the electrolytic capacitors are fitted the correct way round, as shown on the diagram, and insert terminal pins for the external connections.

L.C.D. CONNECTIONS

With the prototype, the l.c.d. was mounted on a piece of stripboard (Veroboard), as shown in Fig.4. At the p.c.b. end, a 40-pin d.i.l. socket was soldered into the p.c.b. so that the display could be connected via ribbon cable. A ribbon cable connector (40-pin IDC connector) will plug directly into the socket.

A similar IDC connector was used at the stripboard end, but soldered directly into place. It is important to note that the connector at the stripboard end must be positioned on the non-copper side, i.e. the same side as the l.c.d., otherwise the connections will be in a mirror image. Note that two 20-way ribbon cables are necessary (rather than one 40-way), to allow the cables to be folded correctly at the stripboard end.

Take great care when soldering the pads for the l.c.d. since several tracks run between pairs of pads on the p.c.b.

Two 20-pin s.i.l. (single-in-line) sockets were soldered into the stripboard for

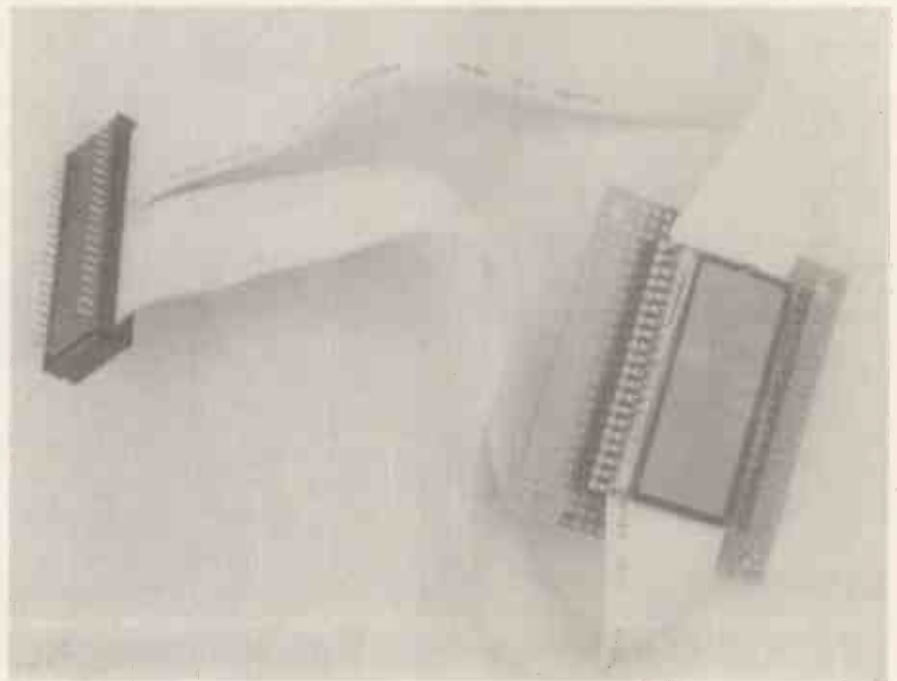

the display, then two more s.i.l. sockets were pushed into the first to provide the clearance necessary. The l.c.d. will then sit over the top of the ribbon cable connector, assuming that the ribbon cables are folded neatly.

This method was chosen since it produces a neat finish and reliable connections. It also had the considerable advantage that an updated p.c.b. could be substituted very quickly, an important requirement when developing a new project.

However, the method may seem cumbersome and separate wires could be connected between the p.c.b. and stripboard if preferred. In this case try to ensure that they are colour-coded, or confusion is sure to set in!

Note that all the unused pins of the display are connected to BP. They could be

linked to the BP pin at the stripboard end to save a number of wires, providing they are identified correctly!

CASE DETAILS

The case layout can be seen in the photographs. The most awkward part is cutting out the rectangular hole for the display. Holes will also be required in the front panel for the Count switch S1 and the Reset switch S2. If a power on/off switch is required, it may be mounted at the side of the case, together with an optional external power connection. Sockets SK1 and SK2 can also be mounted on the side of the case. (Note that SK2 was not included on the prototype counter.)

The lower section of the suggested sloping front case may be detached from the base, making the positioning of the p.c.b. much simpler. The p.c.b. can be

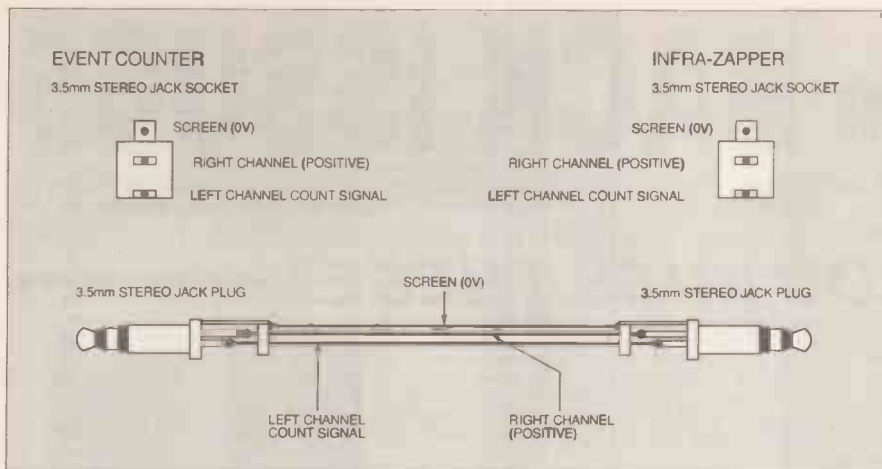

Fig. 5. Details of connections between the Event Counter and Infra-Zapper unit.

secured with self-adhesive p.c.b. mounts. The l.c.d. stripboard is mounted to the metal front panel by means of long self-adhesive p.c.b. supports.

INFRA-ZAPPER LINKING

If the counter is to be linked with the *Infra-Zapper*, then a stereo jack socket may be used for the count input at SK1, to also deliver power from the *Infra-Zapper* to the counter. In Fig.5 are shown details of how a 3.5mm stereo jack socket may be used to deliver the count signal, a 0V link and a positive link. Correctly used, the link allows the counter to power the Zapper, or the Zapper to power the counter.

Beware: If a *mono* plug is inserted accidentally a short circuit will occur. The "power link" should not be used if both projects have their own power supply.

TESTING

Connect a power supply of between 6V and 9V, switch on and check the display. If all is well, four zeros should appear. Press the Count switch S1. The count should advance by one at each press. Try the Reset switch S2.

Next check that the counter "carries" correctly as it moves past nine. Checking that the "carry" works beyond 999 is tedious to say the least! Either trust to luck or, if possible, use a signal generator. (Another astable could be built for the purpose, using one of the circuits in Part 4.)

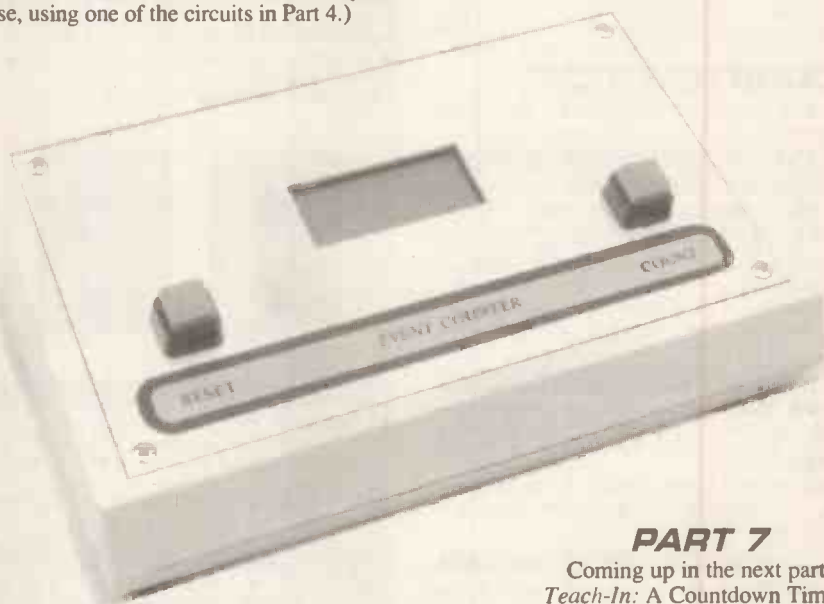

PART 7

Coming up in the next part of *Teach-In: A Countdown Timer.*

NEXT MONTH WE CALL THE TUNE WITH A MIDI ANALYSER – TAKE YOUR PIC – SEE PAGE 251 ORDER YOUR COPY NOW!

PIC EEZE

This is the easiest way to start using PIC microcontrollers. PIC EEZE is a modular system that allows a cheap entry level which builds into a powerful and versatile development platform.

PIC EEZE-1 – Supports 16C61/64/71/74/84 and serial EEPROMS and LPAK. £44.95

PIC EEZE-2 – As above plus supports 16C54/55/56/57/58. £52.95

PIC EEZE-3 – All above plus In Circuit Emulation. £72.95

LPAK – An introduction to PIC programming. This board plugs into the PIC EEZE system and has on board 7-segment displays, LED's and buttons which can be controlled via software to show simple PIC programming for beginners. £28.00

DPAK – Demonstration board for 18/28 pin PIC's. Stand alone c/w ready built oscillator, regulation, 7-segment displays, LED's and buttons. £28.00

The system can be upgraded when ready. PIC EEZE-1 to PIC-EEZE-2 upgrade £9.95, PIC EEZE-1/2 to PIC EEZE-3 upgrade £29.95. PIC EEZE is also software upgradeable for future versions of PIC devices, the software will be made available FREE. We also supply PIC's and serial EEPROMS at affordable prices with discounts to our users. The system is being developed further and future FREE software will allow PIC EEZE-2/3 to give PC I/O port and Analogue data logger.

All PIC EEZE systems come complete with assembler, simulator and programming/editing software. A suitable PSU and parallel lead are required, we supply a lead at £4.00 and a PSU (3/4, 5/6/7, 5/9/12V @300Ma) at £4.95. We will also give any support we can to our users with their PIC projects etc.

Next day response. Please add £2.00 P&P and make cheques/P.O.'s payable to Lennard Research, and send to 29 Lavender Gardens, Jesmond, Newcastle upon Tyne NE2 3DD. or Telephone (0191) 281 8050 for further details and our range of products/prices.

HIGH QUALITY LOW COST C.C.T.V. CAMERA

VERY LOW LIGHT LEVEL.
AUTO ELECTRONIC SHUTTER.
COMPOSITE VIDEO OUT VIA BNC PLUG.

SMALL DISCRETE SIZE.
CAN BE USED WITH PC DIGITISER.



This super quality CCD camera can be connected into your existing TV or video using the AV channel and can be used for discrete surveillance or observing your property externally using a suitable weatherproof housing. Can accommodate lighting levels ranging from daylight to street lighting using its built in electronic shutter. Excellent when using with an infra red source. Built in wide angle fixed focus lens the camera has a resolution of 380 TVL. Can be housed inside an empty floodlight case, (extra).

Special offer price of only: **£79.95 Plus VAT (P&P £3.50)**

For full range of CCTV products send SAE to:
Direct CCTV Ltd., Dept. PE27., Unit 6, Carrick Court, Forrest Grove
Business Park, Middlesbrough, TS2 1QE.

BACK ISSUES

We can supply back issues of *EPE* by post, many issues from the past five years are available. An index for each year is also available – see order form. Alternatively, indexes are published in the December issue for that year. Where we are unable to provide a back issue a photostat of any *one article* (or *one part* of a series) can be purchased for the same price.

DID YOU MISS THESE?

OCT. '94

PROJECTS • Digilogue Clock • Visual/Audio Guitar Tuner • Hobby Power Supply • Audio Auxplexer • Experimental Seismograph, Part 2.
FEATURES • Electronics from the Ground Up, Part 1 with FREE PC Software • Calculation Corner, Part 10.

NOV. '94 Photostats Only (see below)

PROJECTS • 1000V/500V Insulation Tester • Video Modules, Part 1 (Simple Fader, Improved Fader, Video Enhancer) • Active Guitar Tone Control • Power Controller • TV Off-er.
FEATURES • Electronics from the Ground Up, Part 2 • Consumer Electronics Show.

DEC. '94

PROJECTS • Spacewriter Wand • *EPE* Fruit Machine • Universal Digital Code Lock • Video Modules, Part 2 (Horizontal Wiper, Vertical Wiper, Audio Mixer) • Rodent Repeller.
FEATURES • Electronics from the Ground Up, Part 3 • Embedded Controllers • Index for Volume 23.

JAN. '95 Photostats Only (see below)

PROJECTS • Magnetic Field Detector • Moving Display Metronome • Model Railway Track Cleaner • Beating the Christmas Lights • *EPE* Fruit Machine, Part 2 • Video Modules, Part 3 (Dynamic Noise Limiter, System Mains Power Supply).
FEATURES • Electronics from the Ground Up, Part 4 • Electromagnetic Compatibility • Checking Transistors.

FEB. '95

PROJECTS • 12V 35W PA Amplifier • Foot-Operated Drill Controller • The Ultimate Screen Saver • MIDI Pedal Board • Model Railway Signals.
FEATURES • Electronics from the Ground Up, Part 5 • Transformerless Power Supplies • Quickroute 3.0 Review.

MARCH '95

PROJECTS • Multi-Purpose Thermostat • Name of the Game-1 Counterspell • Sound Activated Switch • Audio Amplifier • Light Beam Communicator.
FEATURES • Electronics from the Ground Up, Part 6 • Understanding PIC Micro-controllers • Visio Graphics Software Review. **FREE** Multi-Project PCB with this issue.



APRIL '95

PROJECTS • National Lottery Predictor • Auto-Battery Charger • Light-Activated Switch • Switch On/Off Timer • Continuity Tester • Name of the Game-2 Counterspin.
FEATURES • Electronics from the Ground Up, Part 7 • Circuit Surgery • The Hard Cell (Mobile Telephones).

MAY '95 Photostats Only (see below)

PROJECTS • PIC-DATS-1 (PIC Development and Training System) • R.F. Signal Generator - 1 • MIDI Pedal • Club Vote Totaliser • Name of the Game-3, On Your Marks and Games Timer.
FEATURES • Electronics from the Ground Up, Part 8 • Las Vegas Show Report.

JUNE '95 Photostats Only (see below)

PROJECTS • PIC-DATS-2 (PIC controlled 4-Channel Light Chaser) • *EPE* HiFi Valve Amplifier - 1 • R.F. Signal Generator - 2 • AA to PP3 Converter • Name of the Game - 4, Star-Struck!, Six-Shot Light Zapper, Wander Wands.
FEATURES • Electronics from the Ground Up, Part 9 • Smart Cards.

JULY '95

PROJECTS • Windicator • Curtain Winder • Ramp Generator - 1 • High Voltage Capacitor Reformer • *EPE* HiFi Valve Amplifier - 2
FEATURES • Bridge Rectification Enhanced • Ingenuity Unlimited.

AUG '95

PROJECTS • Solar Seeker • Personal Practice Amplifier • Infra-Red Remote Control Unit • Versatile Microcontrolled 3-Digit Timer • Ramp Generator - 2.
FEATURES • Static • Circuit Surgery.

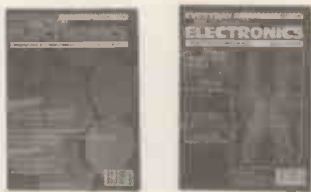

SEPT '95 Photostats Only (see below)

PROJECTS • Simple Theremin • Low Range Ohmmeter Adaptor • Comprehensive Security System • Vandata • Hum-Free Battery Eliminator.
FEATURES • Cave Radio • Ingenuity Unlimited.

OCT '95

PROJECTS • Ginormous VU Meter • Sound Switch • Audio Sinewave Generator • Treble Booster • Infra-Red Controller/Alarm • Capacitor Check • Experimenter's Bargraph Test Board.
FEATURES • Circuit Surgery • Security Tagging • Using Bargraph Displays. **FREE** • Multi-Project PCB with this issue.

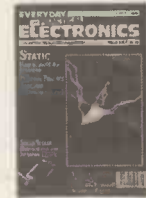

NOV 95

PROJECTS • Digital Delay Line • Video Enhancer • 50Hz Field Meter • Temperature Warning Alarm • Current Tracer • Distortion Effects Unit.
FEATURES • Teach-In '96 Part 1 • Developments in Radio Broadcasting Technology • Turnpike for Windows Review • Ingenuity Unlimited.

DEC 95

PROJECTS • Light Operated Switch • Stereo "Cordless" Headphones • *EPE* Met Office - 1 • Modular Alarm System • Audio Meter and Amplifier.
FEATURES • Teach-In '96 Part 2 • Circuit Surgery • Index for Volume 24.

JAN 96

PROJECTS • Printer Sharer • Mains Signalling Unit • Automatic Camera Panning System • Audio Signal Generator • *EPE* Met Office - 2.
FEATURES • Teach-In '96 Part 3 • Ingenuity Unlimited • European Consumer Electronics Show • Techniques - Actually Doing It • Maths Plus Review • Decibels and dBm Scale.

FEB '96

PROJECTS • Simple PIC16C84 Programmer • Mains Signalling Unit - 2 • PIC Electric Meter - 1 • Vari-Speed Dice • Analogue Frequency Meter.
FEATURES • Teach-In '96 Part 4 • Circuit Surgery • Making Your Own P.C.B.s • Techniques - Actually Doing It.

MARCH '96

PROJECTS • Mind Machine Mk III Part 1 • High Current Stabilized Power Supply • Multi-Purpose Mini Amplifier • Infra-Zapper • PIC-Electric Meter - 2.
FEATURES • Teach-In '96 Part 5 • Ingenuity Unlimited • Flight PAL Trainer Review. **FREE** • Headphones (UK copies only).

BACK ISSUES ONLY £2.50 each inc. UK p&p.

Overseas prices £3.10 each surface mail, £4.10 each airmail.

We can also supply issues from earlier years: 1990 (except March), 1991 (except May, June, Aug., Sept. and Nov.), 1992 (except April and Dec.), 1993 (except Jan., Feb. and March), 1994 (except April, June and Nov.), 1995 (except Jan., May, June and Sept.). Please note we are not able to supply copies (or 'stats of articles) of *Practical Electronics* prior to the merger of the two magazines in November 1992.

Where we do not have an issue a photostat of any *one article* or *one part* of a series can be provided at the same price.

ORDER FORM - BACK ISSUES - PHOTOSTATS - INDEXES

Send back issues dated

Send photostats of (article title and issue date)

Send copies of last five years indexes (£2.50 for five inc. p&p - Overseas £3.10 surface, £4.10 airmail)

Name

Address

I enclose cheque/P.O./bank draft to the value of £.....

Please charge my Visa/Mastercard £.....

Card No. Card Expiry Date

Note: Minimum order for credit cards £5. Please supply name and address of cardholder if different from that shown above

SEND TO: Everyday Practical Electronics, Allen House, East Borough, Wimborne, Dorset BH21 1PF.

Tel: 01202 881749. Fax: 01202 841692. (Due to the high cost we cannot reply to queries or orders by Fax.)

Payments must be in £ sterling - cheque or bank draft drawn on a UK bank.

Normally supplied within seven days of receipt of order.

Send a copy of this form, or order by letter if you do not wish to cut your issue.

M4/96

CADPAK for Windows

CADPAK is especially suited to educational, hobby and small scale schematic and PCB design. CADPAK includes both schematic drawing and 32-bit PCB drafting tools but as an entry level product, there is no netlist link between them.

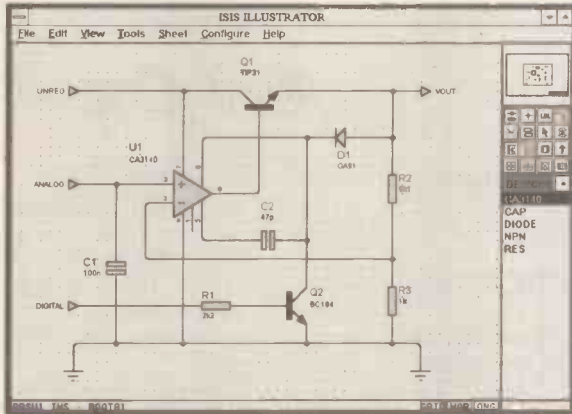

The schematic drawing module of CADPAK, ISIS Illustrator, enables you to create circuit diagrams like the ones in the magazines.

- Runs under Windows 3.1 making full use of Windows features such as on-line help.
- Full control of appearance including line widths, fill styles, fonts, colours.
- Automatic wire routing & dot placement.
- Fully automatic annotator.
- Complete with device and comprehensive package libraries for both through hole and SMT parts.
- Advanced route editing allows deletion or modification of any section of track.
- Gerber, Excellon and DXF outputs as well as output via Windows drivers. Also includes Gerber viewer.
- Exports diagrams to other applications via the clipboard.
- CADPAK is also available for DOS.

CADPAK FOR WINDOWS £ 149
CADPAK FOR DOS £ 79

PROPAK for Windows

PROPAK has all of the features in CADPAK plus netlist based integration, automatic power plane generation and a powerful auto-router. PROPAK includes enough schematic capture and PCB design functionality for all but the most demanding applications.

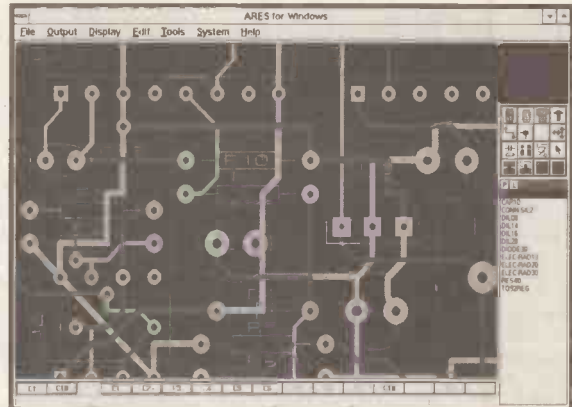

PROPAK's schematic drawing editor ISIS ILLUSTRATOR+ includes even more features than ISIS ILLUSTRATOR. PROPAK's 32-bit PCB design tool, ARES for Windows, is our most powerful and easy to use yet.

- Multi-sheet and hierarchical designs.
- Netlist link between modules guarantees consistency between schematic and PCB.
- Netlists are also compatible with SPICE-AGE and most other electronics CAD packages.
- Generates a full bill of materials.
- ASCII data import facility.
- Electrical rules and connectivity checkers.
- Ratsnest display with automatic update during placement and routing.
- Multi-strategy autorouter gives high completion rates.
- Power plane generator creates ground planes with ease.
- PROPAK is also available for DOS.

PROPAK FOR WINDOWS £ 495
PROPAK FOR DOS £ 395

Call or fax us today for a demo pack. Please state whether you would like a DOS or Windows pack.

Prices exclude postage (£5 for UK) and VAT. ISIS ILLUSTRATOR and ARES for Windows are also available separately. All manufacturers trademarks acknowledged.

labcenter

E l e c t r o n i c s

53-55 Main St. Grassington, N. Yorks. BD23 5AA

Tel: 01756 753440 Fax: 01756 752857

THERMIONIC VALVES



IAN POOLE

Part One

Valves may be ancient in origin, but they are still much used, especially in display applications.

THE TRUSTY thermionic valve still finds uses in a wide variety of applications. Whilst it may not seem like the latest in technology when compared to the latest microprocessor containing hundreds of thousands of transistors, valves still have their place in today's technology.

It is only necessary to watch TV to use one form of thermionic device. The cathode ray tube (covered next month) still remains the most widely used form of display for televisions because of its low cost and high performance. Valve technology is also used in other areas, particularly where high powers are involved. Broadcast stations, for example, use valves for the high power sections of their transmitters.

Apart from these commercial uses many audio enthusiasts still prefer valve amplifiers. It is said that the sound they produce is more natural than that produced by semiconductors. In fact, there is a growing interest in valve technology, and a number of new products, both kits and ready-made, are now available for the enthusiast.

EDISON'S DISCOVERY

The foundations for the discovery of the valve were laid many years before any ideas were patented. One of the crucial steps was taken by Thomas Edison, the famous American inventor.

Around 1880 he was investigating methods of increasing the life of light bulbs. At the time this was one of the major problems impeding the growth of electric lighting. One of the effects which was occurring was a blackening on the inside of the bulb after a number of hours of operation.

Reasoning that the effect was caused by particles emanating from the filament, Edison placed a second electrode into the bulb and placed a charge on it to repel the particles. In doing this, Edison noticed that current could flow between the filament and the second electrode, but only in one direction.

Surprisingly, Edison did not manage to find a use for this discovery, but he did name it the Edison Effect. It was the

Englishman, Professor Ambrose Fleming, who discovered a use for the new device.

FLEMING

Fleming had been acting as a consultant to Marconi, and had in fact designed the transmitter which had sent the first wireless messages across the Atlantic in 1901. In undertaking this work, Fleming realised that the weakest link in wireless equipment of the time was the means of detecting the signals.

At the time, very insensitive instruments called "coherers" were used. Fleming had been pondering the problem for a number of years, and he described that he had "a sudden very happy thought" as he was walking down Gower Street in central London one morning.

He instructed his laboratory assistant to set up an Edison Effect bulb and see if it would detect wireless waves. It did, and Fleming patented his idea in 1904, naming it an oscillation valve because of the one-way or valve-type effect it had on wireless oscillations.

LEE de FOREST

Across the Atlantic, another inventor named Lee de Forest took Fleming's valve a stage further, adding a third electrode into the glass bulb. It may seem surprising now, but de Forest only used this valve as a detector, not realising it could be used to amplify signals.

It took until around 1911 before this fact was discovered. After which, people soon saw the possibilities and were quick to exploit the idea. Lee de Forest himself built a telephone repeater and, although its performance was very limited, the telephone company A.T.&T. saw its possibilities.

IMPROVEMENTS

The performance of these first valves was poor. Initially, people thought that some gas molecules were required in the envelope for them to operate correctly. However, in 1915 an American named Irvin Langmuir discovered that fully evacuated envelopes would improve their performance. Accordingly, new "hard" valves with much better performance were introduced.

Despite the improvements, difficulties still remained with the use of early valves. The main problem was in trying to ensure that they remained stable and did not burst into oscillation. Several attempts

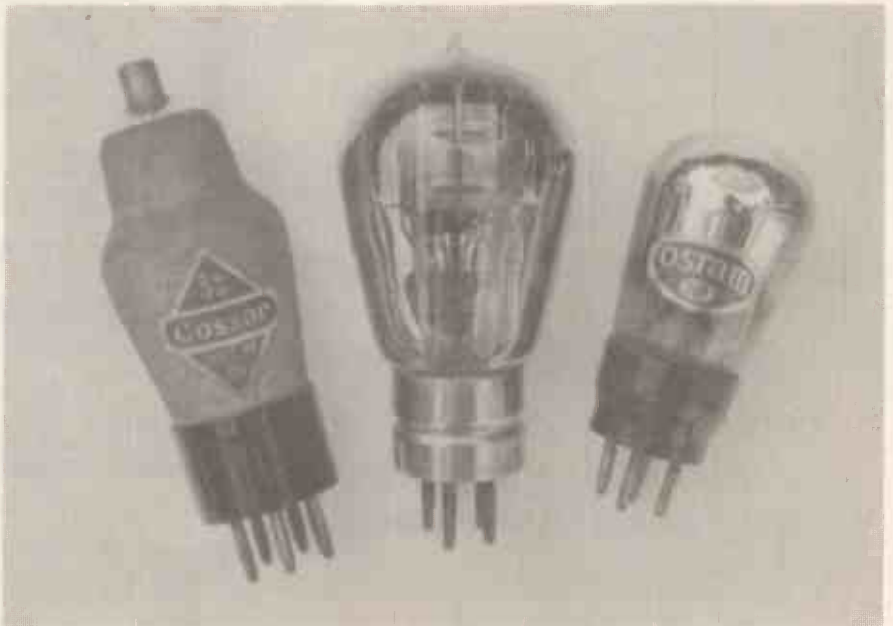

Early receiving valves.

were made to try to reduce the anode-grid capacitance. One engineer named H.J. Round succeeded in making a significant improvement in this area, but it was not the final solution.

This came in 1926 when a valve with a fourth electrode, the screen grid, was introduced. Placed between the normal control grid and the anode, it reduced the capacitance to almost zero.

Even this design was improved when in 1929 another electrode was added. Called the suppressor grid, this improved a discontinuity in the characteristic of the valve caused by electrons hitting the anode and bouncing off.

INDIRECT HEATING

Another major improvement was associated with the operation of the heaters. Initially, the heater was electrically connected to the cathode. However, it was discovered that this did not need to be the case and indirectly heated cathodes were introduced.

This enabled valve circuits to be powered from just two supplies, a low voltage one for the heaters and a high voltage one for the anode circuit. Previously, separate batteries were needed for each valve to set up the correct circuit conditions, which made them very expensive to run.

RISE AND FALL

With the major problems of valves overcome, their use rose rapidly in the 1930s. A large proportion of households had their own radios and the production of valves rose to millions every year. The Second World War also gave a major impetus to their production.

In the 1950s, new smaller valves were introduced. However, thermionic valve technology soon had to contend with semiconductors. The first transistor was invented in the late 1940s, but it was not until about twenty years later that the real impact was seen. Valves were surpassed by the much more reliable and efficient transistors.

Remarkably quickly, the age of the valve passed. Thermionic technology was

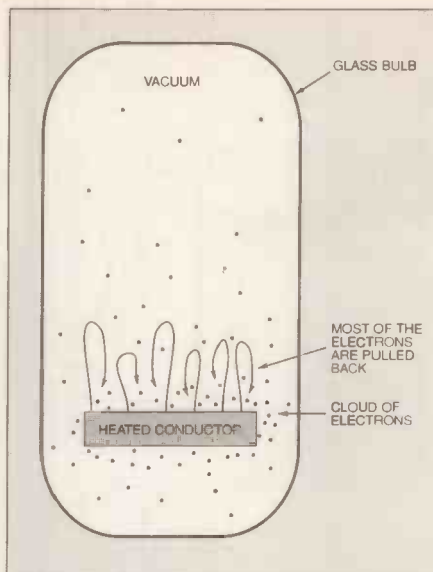

Fig. 1. Thermionic emission from a heated conductor.

relegated to a few specialised areas, although cathode ray tube production still rose. With the development of many new types of display, though, it is likely that even in this application they will soon be overtaken.

BASIC OPERATION

The operation of all valves is based around a phenomenon called "thermionic emission". An electric current consists of the movement of electrons within a conductor. Therefore, for a current to flow, there must be free electrons available within the structure of the material.

Under most conditions, these electrons will remain within the conductor. If the conductor is heated, then the energy of the electrons increases and some actually obtain sufficient energy to overcome the forces holding them, and they escape.

Once the electrons escape, the conductor becomes positively charged. However, because electrons are negatively charged and dissimilar charges attract one another, there is now a force trying to pull the electron

back. In fact, when thermionic emission takes place like this, there will be a cloud of electrons around the surface emitting them, as shown in Fig. 1. This happens when the filament of a light bulb heats up to radiate light.

In many respects, the thermionic emission of electrons is very similar to the evaporation from the surface of a liquid. Molecules normally remain in the liquid, but when they gain a sufficient amount of energy, they overcome the restraining forces within the liquid and they leave.

HIGH TEMPERATURES

For thermionic emission to take place, temperatures in excess of 900°C must be reached. At these temperatures, many metals which are normally used for carrying current, such as copper, oxidize rapidly and are not suitable. This means that the number of materials which can be used is severely limited.

The materials which are commonly used are tungsten, thoriated tungsten and certain oxide-coated substances. As shown in Fig. 2, oxide-coated emitters operate best at lower temperatures, whilst tungsten does not appear to be nearly as good. However, tungsten is very rugged and is used when very high operating voltages are needed.

Oxide-coated emitters are the most commonly used. They usually consist of a nickel base which is coated with a mixture of barium and strontium carbonates. During the manufacturing process, the carbonates are converted to their oxide forms and the resultant gases removed.

The efficiency of oxide-coated emitters is very high, but they must be treated more carefully than some other materials. They are, for example, more easily poisoned by the effects of unwanted gasses or excessive ion bombardment which can happen under some conditions.

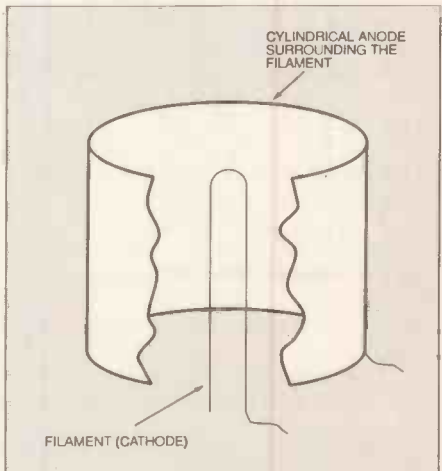

Fig. 3. A diode valve.

BASIC VALVE

The simplest form of thermionic valve is known as a diode. It consists of two electrodes (hence the name di-ode), the cathode and the anode, as shown in Fig. 3, contained within an evacuated glass bulb.

During operation, the cathode is heated by an electrical current flowing through it, and electrons leave its surface. The anode is given a positive potential and this attracts the electrons towards it. As the electrons travel towards the anode, they should encounter as few gas molecules as possible. If electrons do encounter gas molecules, they may collide with them, which will impede their progress and reduce the efficiency of the valve.

As the anode is unheated and positively charged, no electrons leave it. Consequently, electron flow only takes place from the cathode to the anode. In other words, the thermionic diode acts as a one-way mechanism for the flow of electricity. As such, it can be used in a variety of applications, from power rectification to radio detection or demodulation.

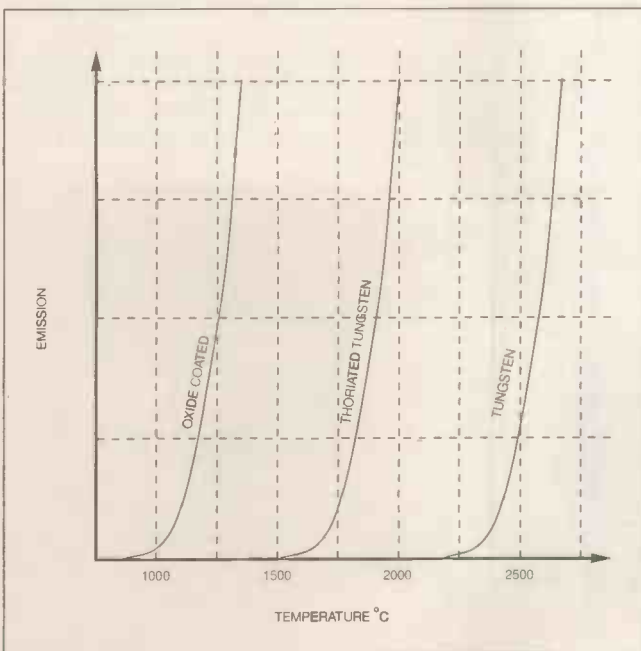

Fig. 2. Electron emission from different materials.

DIODE CHARACTERISTICS

When electrons leave the cathode, they form a cloud which tends to prevent any further electrons leaving. When a positive potential is applied to the anode, this starts to overcome the space charge and electrons flow towards it. As the potential on the anode is increased, the flow of electrons increases as well. Any excess electrons which are not pulled towards the anode are repelled back to the cathode by the space charge.

As the anode voltage increases, a point is eventually reached when the space charge is totally neutralised and the electron flow is limited by the number which can be emitted by the cathode. At this point, the only method of increasing the electron flow is to increase the capacity

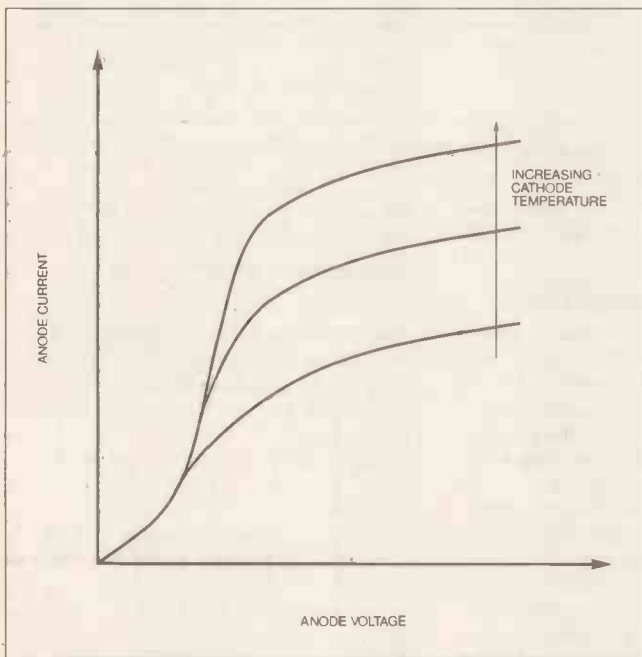

Fig. 4. Anode current with varying anode voltage.

of the cathode. This can be achieved by increasing its temperature, as illustrated by the curves shown in Fig. 4.

INDIRECT HEATING

In the first valves that were made, the cathode and heater were one and the same. This considerably restricted the design of the circuits and usually meant that large batteries had to be used to supply the heaters.

To overcome this problem, indirectly-heated cathodes were introduced. To achieve this, the indirectly-heated cathode normally consists of a hollow tube, often closed at the top end, as shown in Fig. 5.

Inside the tube is a filament which indirectly heats the cathode by radiation. Whilst the heater and cathode are reasonably close so that the maximum amount of heat is transferred, the two are electrically insulated from one another.

This means that they can operate at different voltages and a number of heaters can be run off the same supply without interfering with the operating conditions of the cathode. This is particularly important in circuits where the cathode must be run at a potential above ground, as will be seen later.

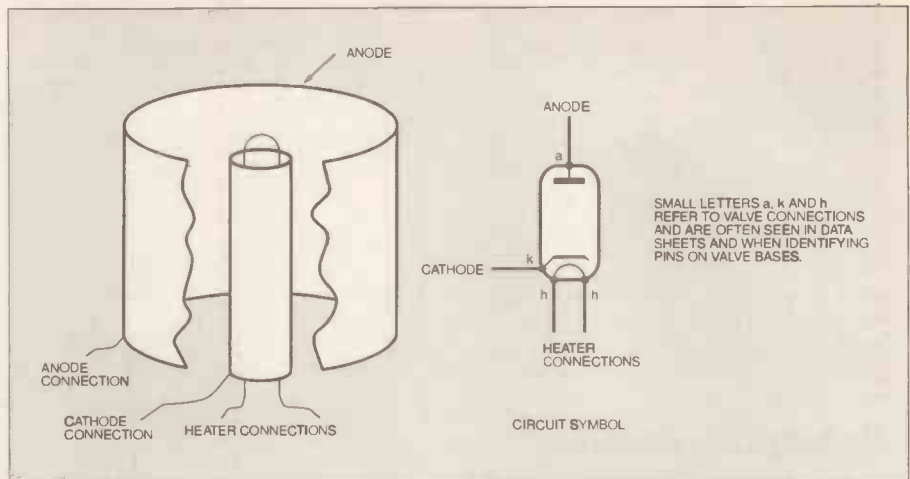

Fig. 5. An indirectly-heated cathode.

A second advantage of an indirectly heated cathode is that an alternating current can be used to power the heater circuit without any hum entering the cathode and anode circuits. This cannot be achieved satisfactorily with a directly heated system.

TRIODE VALVE

On its own, the thermionic diode valve has many uses. However, it was the invention of the triode which made valves an indispensable part of wireless technology and brought

the dawn of the new age of electronics.

Basically, a triode is a diode valve to which a third electrode has been added. This electrode is called a grid and is placed between the anode and the cathode. It is used in such a way that it controls the number of electrons which can flow between the other two electrodes. In view of this, it is often called the "control grid".

Whilst the grid must insert a potential between the cathode and anode, it must not act as a complete screen, and electrons must be able to pass through it. The grid can be made of a thin wire gauze or mesh, but more often it consists of a wire helix made from molybdenum or nickel and supported on two or more wires. The shape of the grid will vary from one type of valve to the next, but will surround the cathode as shown in Fig. 6.

By placing a potential onto the grid, the space charge around the cathode can be changed in the same way as varying the anode voltage. Under most operating conditions, a negative voltage is applied to the grid and in this way it does not attract any electrons. The more negative it is made, though, the more the electrons will be repelled and confined to the area around the cathode. Hence the current flow will be reduced. However, if the negative potential on the grid falls to zero, more current will flow in the anode circuit.

In the same way that the characteristics of the diode valve could be plotted out, it is possible to do the same for the triode. In this case there is another variable, namely the grid voltage. The graph in Fig. 7 shows the current taken by the anode of the valve as the grid voltage is varied.

From this it can be seen that as the grid voltage is reduced, so the anode current is increased. In fact, if a small alternating voltage is superimposed on the steady grid voltage or bias, it can be seen that this will produce relatively larger changes in anode current.

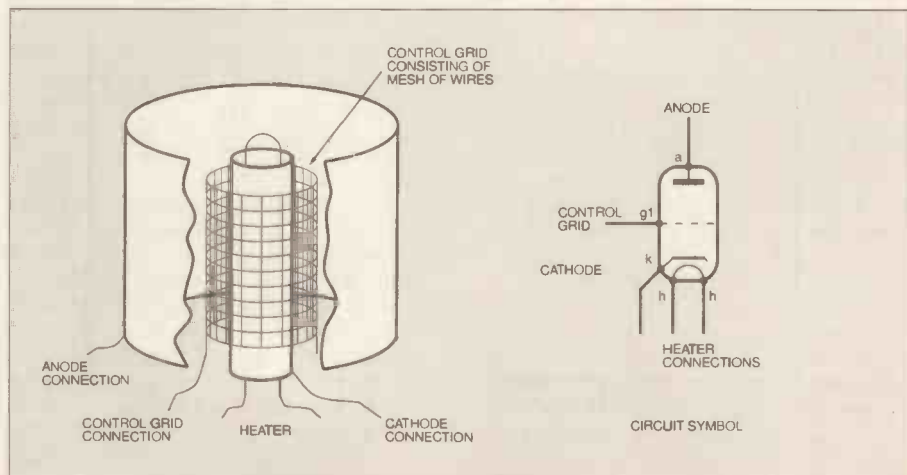

Fig. 6. Construction of a triode valve.

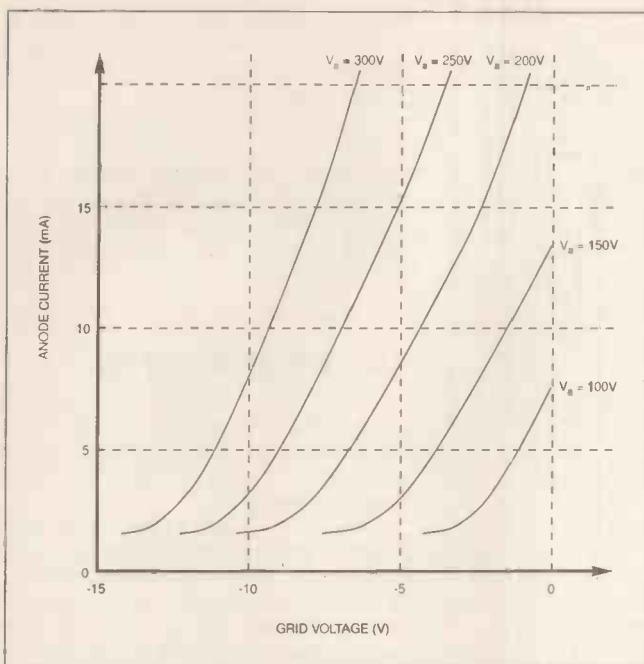

Fig. 7. Anode current vs. grid voltage for a triode valve.

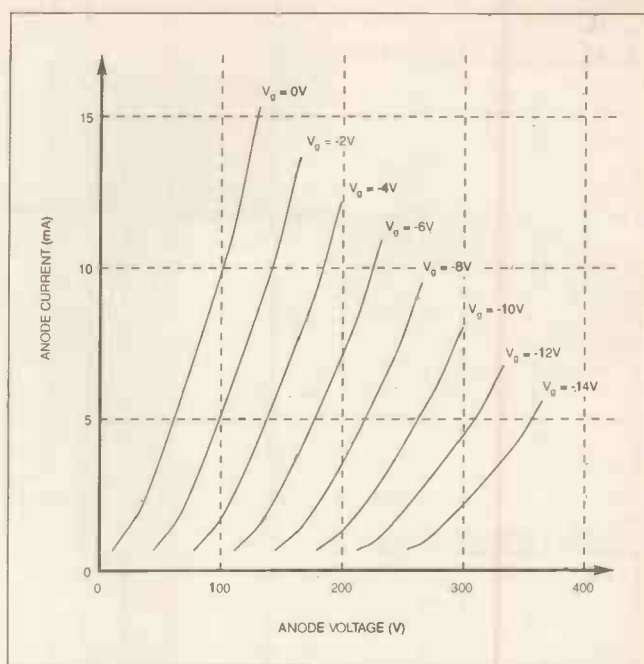

Fig. 8. Anode current vs. anode voltage for a triode valve.

Curves can also be plotted for the anode current against anode voltage for differing values of grid bias, as shown in Fig. 8. Again, from these it can be seen that the greater the negative bias on the grid, the less current flows in the anode circuit.

Normally, the grid has a fixed negative bias applied so that it remains negative, and any a.c. signal is superimposed on this. If the grid does become positive for any reason, then it will not repel the electrons, but instead it will attract them and a current will flow in the grid circuit. This is usually not desirable and accordingly circuits are designed to ensure that it does not happen.

TETRODE VALVE

By introducing further grids into the valve construction, it is found that the performance can be enhanced in a number of ways. One of the early problems encountered with valves was their inherent instability. The capacitance between the anode and grid would lead to signals being fed back from the output to the input. This made the circuit burst into oscillation very easily. In view of its action of screening the grid and anode from one another, it is called the "screen grid".

To enable this grid to perform its functions as a screen, its mesh is made much finer than that of the control grid. However, it cannot be made too fine otherwise the flow of the electrons is limited. Nevertheless, it is possible to reduce the anode grid capacitance by a factor of 500 or more. Typically, the anode grid capacitance will be only a very small fraction of a picofarad; too small to cause a problem in most circuits.

Unlike the control grid, the screen grid is maintained at a positive voltage, but below that of the anode. Most of the electrons travelling towards the anode pass straight through the screen grid, although some are caught. These manifest themselves as screen current, which must be kept to a minimum otherwise the screen grid can suffer damage from overheating.

Normally, the screen grid is run from a

lower voltage supply than the anode, or it is connected to the high tension supply through a high value resistor. It is also normal to decouple it to ground via a capacitor. This ensures that it does not carry any signal and can perform its function as a screen satisfactorily.

With the screen grid correctly biased, it is found that a tetrode gives an increase in amplification over a triode. To find out the reason for this it is necessary to look at the characteristics of the triode. In Fig. 7 it can be seen that the anode current is very dependent on the anode voltage.

This effect means that when a change in grid voltage causes the anode current to rise, any resistance in the anode circuit will cause the voltage to fall, and in turn reduce the anode current. With the introduction of the screen grid, the anode voltage has very little effect on the anode current, as shown in Fig. 9.

Whilst the tetrode gives a distinct advantage over the triode, the introduction of the second grid leads to a new problem. When large signals are present, it is very easy for the anode potential to fall below that of the screen grid. When this happens, electrons can bounce off the anode and flow towards the screen grid in an effect known as secondary emission.

As a result, there can be a significant rise in screen grid current and a fall in the anode current, which can cause significant levels of signal distortion. This can be seen as

the kink in the characteristic curve of the tetrode shown in Fig. 9.

BEAM TETRODE

One way of overcoming the kink in the characteristic graph is to modify the existing electrodes in the valve, to produce what is called a beam tetrode. The control and screen grids are modified to have the same pitch, enabling the electrons to pass through more easily. In addition to this, a pair of plates are added, as shown in Fig. 10.

They are normally connected to the cathode or earth and beam the electrons towards the anode. As they are at a low potential, they tend to repel any electrons leaving the anode, almost totally eliminating the secondary emission.

The first beam tetrodes were intended mainly for audio purposes, but as their production improved, radio frequency versions became commonplace.

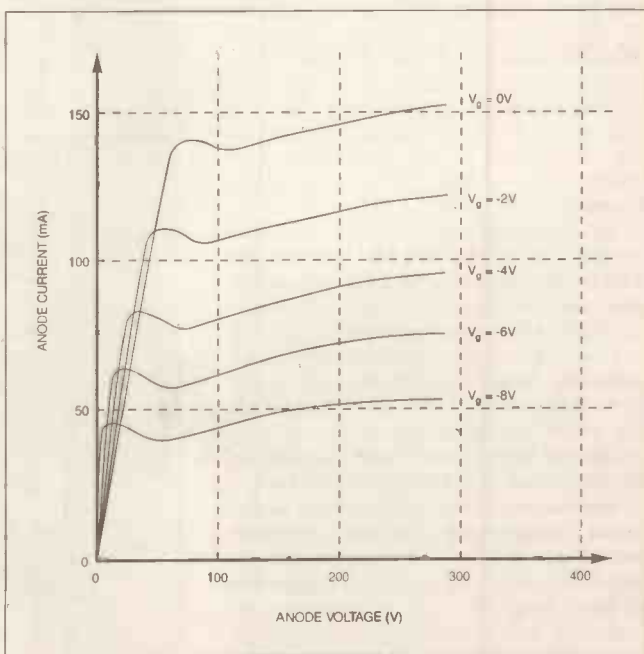

Fig. 9. Anode current vs. anode voltage for a tetrode valve.

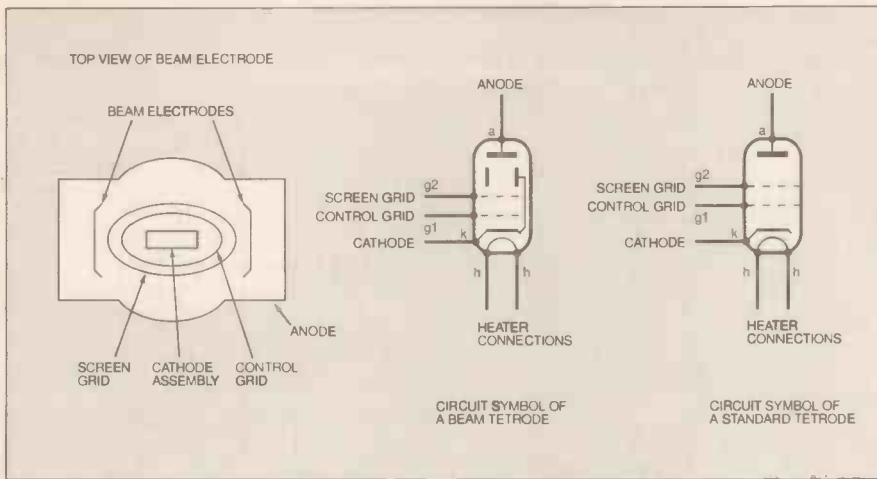

Fig. 10. Construction of a beam tetrode.

PENTODE VALVE

Another way in which secondary emission can be suppressed is by the introduction of a third grid. Called the "suppressor grid", it is introduced between the anode and the screen grid. The potential of this grid is kept low, often at ground, or that of the cathode.

In the hey-day of valves, pentodes were possibly the most widely used form of valve, providing high levels of gain, linearity and freedom from instability. Beam tetrodes tended to be used for high power applications and triodes for other specialised uses.

CHARACTERISTICS

There are a number of characteristics for a valve which are used to specify its operation. Some are fairly obvious; the heater voltage, for example.

Although there are a number of standards for heater voltages, the most common is 6.3V. Having a common standard allows all the valves in a set to be run in parallel from the same supply.

One of the main exceptions to this is that a 5V standard is often adopted for rectifiers in power supplies. As a result, many mains transformers for use with valves have two separate heater windings: one for the rectifier valve, and the other for all the other valves. Naturally, there are many other standards, but many of them are not so common now.

The maximum anode voltage is also quoted. Often valves in a normal domestic set would have a high voltage or high tension (h.t.) supply of around 250V. However, high power valves would normally run off higher voltages. The 6L6, which was a very popular high output valve commonly used in guitar amplifiers, has a maximum anode voltage of 360V.

Other values are also important, including the screen grid voltage and current. If these are exceeded, then the screen grid may dissipate excessive heat and reduce the life of the valve.

Another value which is often quoted is called the anode slope resistance which is designated as r_a . This is applicable to any valve, including a diode, and it is effectively the value of resistance which the valve represents to an alternating current flowing through it.

Taking the static characteristic for the valve shown in Fig. 11, a small change in anode voltage will cause a correspond-

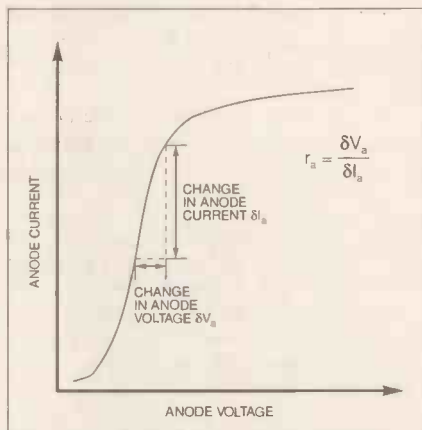

Fig. 11. Anode slope resistance.

ing change in current. Dividing the voltage change by the current change gives the anode slope resistance. In fact, it is the reciprocal of the slope of this curve.

The mutual conductance (g_m) is also very important. This is the ratio of the change in anode current to the change in grid voltage for a constant anode voltage. It is expressed in milliamps per volt, or

sometimes as micromhos. These values are both the same, where 1mA/V is equal to 1000 micromhos. It is used for defining various circuit parameters.

Finally, there is the amplification factor μ (mu). This is used by designers to give an indication of the order of amplification which the valve might be able to give. It is obtained from the other valve characteristics by multiplying the anode resistance by the mutual conductance:

$$\mu = g_m \times r_a$$

VALVE CIRCUITS

Just as there is a whole variety of transistor circuits, the same is true for valves. Also, these circuits can be made up from basic building blocks, and using them in ingenious ways.

The most basic valve circuit is the diode rectifier. This is used in a variety of circumstances. Possibly the most common is as a rectifier in a power supply circuit. The basic valve can only provide half-wave rectification, as shown in Fig. 12. In order to remove the hum, large capacitors are needed.

In view of this, a much more efficient full-wave rectifier circuit can be used. Whilst it is quite possible to use two single diodes, a much more convenient method is to use a double diode valve i.e. a valve with two diodes in it, as shown in Fig. 13. Here both halves of the waveform are rectified to give an output which is far easier to smooth and remove the hum.

Diode rectifier circuits are fairly simple. Circuits for the triode, which has more electrodes, are a little more complicated. It has already been mentioned that the grid must be held at a negative potential when compared to the cathode. If it is not, then large currents will flow which may cause damage to the valve or other components in the circuit. This biasing is achieved as shown in Fig. 14.

The grid is held at earth potential by connecting it to ground via a high value

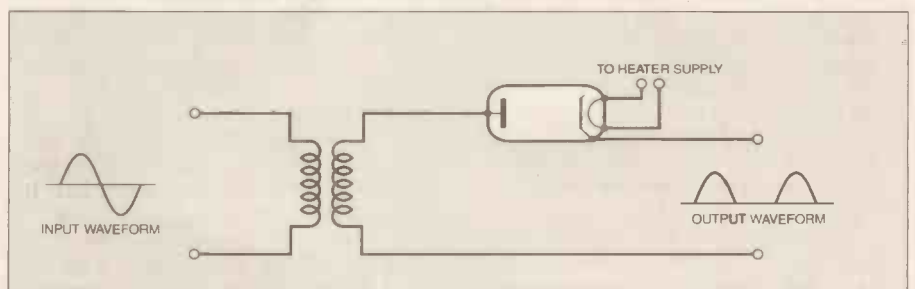

Fig. 12. Diode valve as a half-wave rectifier.

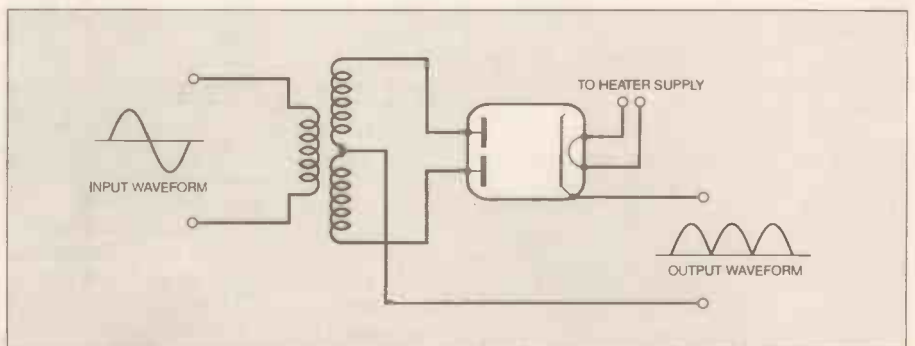

Fig. 13. Double-diode valve used in a full-wave rectifier circuit.

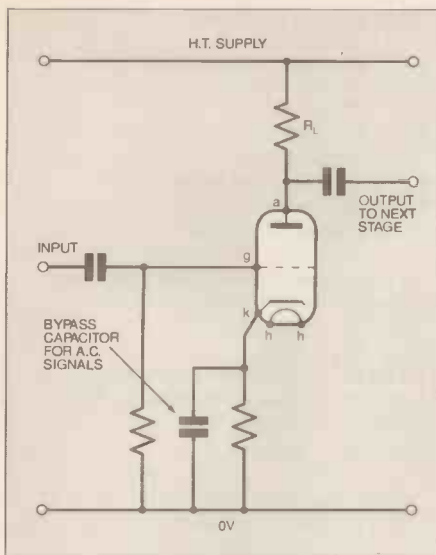

Fig. 14. Basic triode circuit.

resistor. A resistance, often 100kΩ and sometimes more, can be used because of the high input impedance of the valve. The cathode is connected to ground via a lower value resistance. The current flowing through this part of the circuit will cause a voltage to be developed across the resistor. Accordingly, the cathode will rise to a voltage above earth, and this means that the cathode will have a higher potential than the grid, or in other words, the grid will be negatively biased.

The bias is held as the steady state condition for the valve. Any alternating waveforms to be amplified are then superimposed on the bias voltage. However, as the grid, and the anode for that matter, are set at voltages above ground, coupling capacitors are needed to connect the different stages together.

When the grid is fed with an alternating signal, the varying grid voltage causes the anode current to vary accordingly, as shown in Fig. 15. Since this varying current is developed across all resistances in the anode circuit, it results in a correspondingly varying anode voltage.

As shown in the circuit of the triode amplifier (Fig. 14), there is a resistor in the anode circuit. The total resistance is equal to the anode resistance r_a plus the external load impedance, which includes R_L .

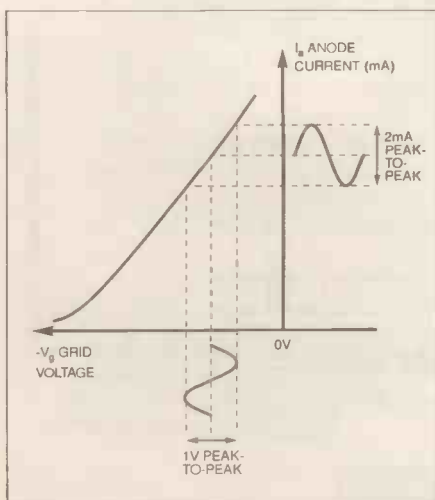

Fig. 15. The varying voltage on the grid causes a varying anode current.

These resistances act as a potential divider and, consequently, the theoretical maximum amplification value of μ can never be totally reached. The voltage amplification of the stage is thus given by the formula:

$$A_v = \mu \times R / (r_a + R)$$

In this formula, the value of R is the total of all the load resistances. In other words, if the stage drives a low impedance load, this forms a parallel load and must be included. Often the impedance of the following stage will be much higher than the resistance in the anode path and it can be ignored. However, in many instances it has to be included as part of the calculation.

TETRODE AND PENTODE CIRCUITS

Obviously, there are a number of differences between an ordinary triode amplifier circuit and that for a tetrode or pentode. Even so the basic calculations remain the same.

A few additions need to be made to the circuit, though. In the case of the tetrode, the additional screen grid needs to be held at a potential below that of the anode. Usually, this is accomplished by connecting this grid to the high tension or anode supply voltage via a resistor, as shown in Fig. 16.

The fact that the screen grid will draw some current means that the resistor will drop some voltage. By knowing the current drawn, it is possible to calculate the value of resistor required to give a certain voltage drop. Often a value of 100kΩ or more is typical.

In addition to the resistor from the supply, a decoupling capacitor connected to ground needs to be incorporated. This is required to ensure that any signals appearing on the screen grid are removed and that the grid remains at a constant potential. If the capacitor was not included, then the screening function would not operate satisfactorily and the circuit would be more likely to oscillate. The value of the capacitor must be high enough to remove the lowest frequencies likely to be encountered.

In certain power amplifier applications, particularly radio frequency amplifiers of a few hundred watts or more, the screen grid may be run from its own regulated supply to ensure that its voltage does not rise above its limits under any conditions. If this happens the valve may be damaged.

The circuit for the pentode requires little in the way of addition to that used for the tetrode, as seen in Fig. 17. The suppressor grid is normally held at ground potential and is usually connected directly to ground or to the cathode without the use of any additional components.

VALVE BASES

Over the years, a number of standard valve bases have been adopted. These enable standard sockets to be used, simplifying the construction of circuits.

In the early days of valves, a number of bases with five pins were used. However, as the years progressed, an eight pin "Octal" base with an orientation "key" in the centre was introduced. It became a widely used standard for many years and as a result it was often known as the

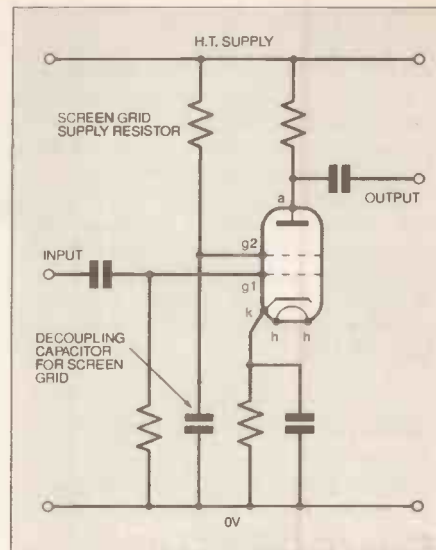

Fig. 16. A circuit for a tetrode amplifier.

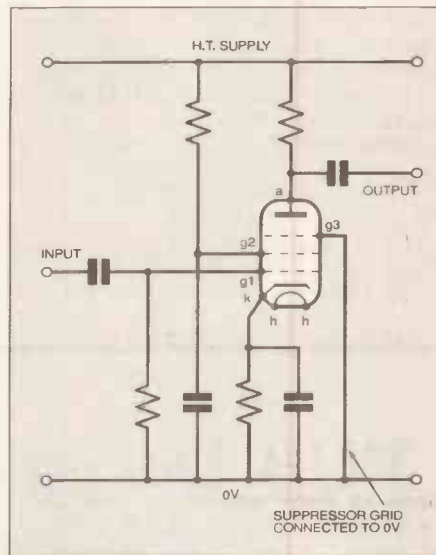

Fig. 17. A circuit for a pentode amplifier.

International Octal base. Famous valves like the 6L6, 6V6, and many others used it.

Another similar base was used for the metal-canned EF50, a valve which was widely used in radar equipment in the Second World War. Having nine thinner pins the base was designated the B9G.

With the push towards smaller valves in the late fifties and early sixties, two more modern bases became commonplace. Designated the B7G and B9A, the number denoting the quantity of pins, these were much smaller than their predecessors. Not only was the base itself much smaller, but valves using these bases had the pins passing straight through the glass envelope without the need for any additional support on the outside. This considerably reduced manufacturing costs as there were fewer stages in the manufacturing process.

NUMBERING SYSTEMS

Like other active components, valves are type-numbered, and over the years a variety of different systems have been used. Often the numbers were allocated by the manufacturers themselves. This resulted in a host of different valve types, many of which were virtually identical. To overcome this problem, new cross-company numbering systems were devised.

There are two main systems, of which one is mainly used for valves manufactured within Europe, and the other for the USA. Both systems are used alongside one another, and often direct equivalents are available. Sometimes the valves were marked with both type numbers.

The European system is given in Table 1. The first letter denotes the heater supply required. Subsequent letters show the functions contained within the envelope. In many cases, more than one function is contained and this is shown by using more than one letter.

Table 2. American Valve Numbering System.

First Figure (indicates heater voltage)	
0	Cold-cathode
1	0B to 1.6V
5	4.6V to 5.6V
6	5.6V to 6.6V
7	6.3V Loctal
12	12.6V
35	around 35V

Second and other characters are serial numbers.

Suffixed Letters:

G	Large glass envelope
GT	Small glass envelope
M	Metallised
X	Low-loss base
W	Military-type base

Table 1. European Valve Numbering System

First letter (indicates heater supply):		Subsequent figures (indicating base):	
A	4V a.c.	20 to 29	B8G (Loctal)
C	200mA a.c. and d.c.	30 to 39	Octal
D	Battery supply 1.2V to 1.4V	40 to 49	B8A
E	6.3V a.c. and d.c.	50 to 59	Miscellaneous constructions
G	5V a.c.	60 to 79	Subminiature types
K	2V battery supply	80 to 89	B9A
P	300mA	90 to 99	B7G
U	100mA a.c. and d.c.		

If the number is in excess of 100, the first figure should be disregarded.

The decade numbers indicate the type of valve base used, i.e. all valves with numbers between 80 and 89 have a B9A base. Then any further digits give the serial number of the valve type itself. Once more than ten valves of a given type were registered, a figure "1" was placed in front of the number, e.g. EF189. In fact, this valve requires a 6.3V heater, it contains a pentode and has a B9A base.

The American system shown in Table 2 does not give as much information about the valve. The first number indicates the

heater voltage, and the suffixes give the type of envelope used. The intervening characters identify the valve type itself. For example, a 6V6GT has heaters operating on a voltage between 5.6V and 6.6V, and has a small glass envelope.

NEXT MONTH

In Part 2, a good look is taken at cathode ray tubes. They have been in widespread use for over 50 years and although the hey-day of other thermionic devices has passed, the production of c.r.t.s is still increasing.

PCB Designer



Runs on any PC running Windows 3.1, Windows 95 or Windows NT with a minimum 2MB RAM
Will work with any Windows supported printer and monitor

For Windows 3.1, '95 or NT

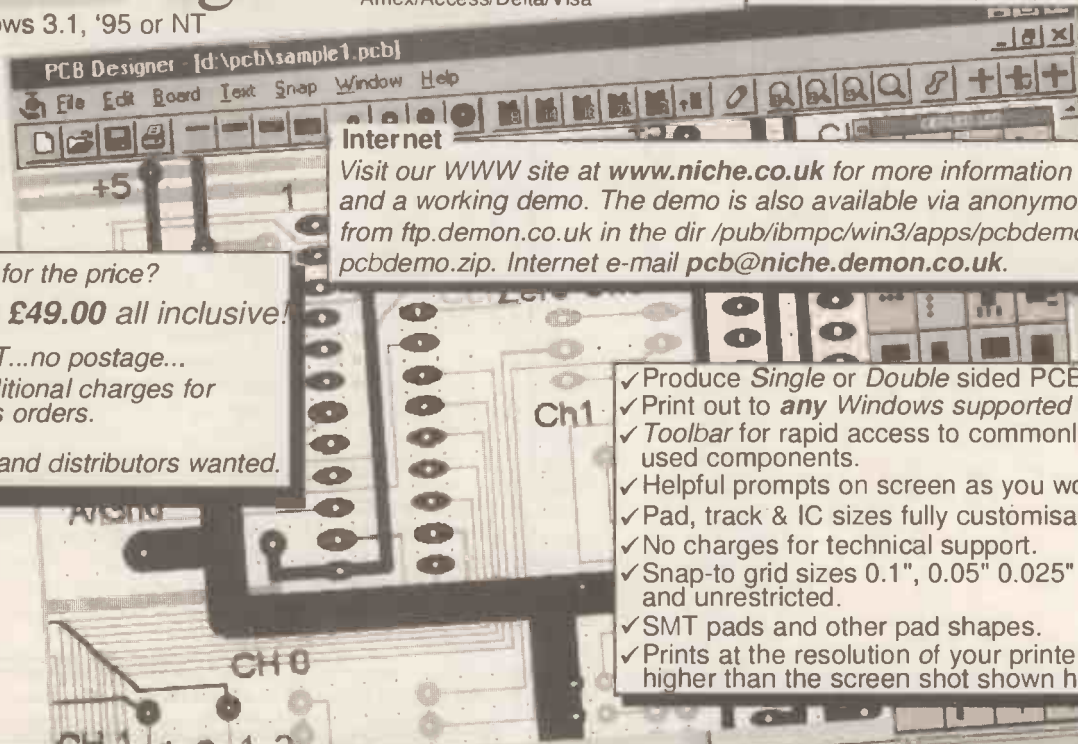

Looking for the price?
It's just £49.00 all inclusive!
...no VAT...no postage...
...no additional charges for overseas orders.
Dealers and distributors wanted.

Internet
Visit our WWW site at www.niche.co.uk for more information and a working demo. The demo is also available via anonymous FTP from [ftp.demon.co.uk](ftp://ftp.demon.co.uk/pub/ibmpc/win3/apps/pcbdemo/) in the dir /pub/ibmpc/win3/apps/pcbdemo/ as [pcbdemo.zip](ftp://ftp.demon.co.uk/pub/ibmpc/win3/apps/pcbdemo/pcbdemo.zip). Internet e-mail pcb@niche.demon.co.uk.

- ✓ Produce *Single* or *Double* sided PCBs.
- ✓ Print out to *any* Windows supported printer.
- ✓ *Toolbar* for rapid access to commonly used components.
- ✓ Helpful prompts on screen as you work.
- ✓ Pad, track & IC sizes fully customisable.
- ✓ No charges for technical support.
- ✓ Snap-to grid sizes 0.1", 0.05" 0.025" and unrestricted.
- ✓ SMT pads and other pad shapes.
- ✓ Prints at the resolution of your printer, much higher than the screen shot shown here.

Niche Software (UK)

22 Tavistock Drive, Belmont, Hereford, HR2 7XN.

Phone (01432) 355 414

Available in South Africa from JANCA Enterprises, PO Box 32131, 9317 Fichardtpark at R299,00

OMNI ELECTRONICS

174 Dalkeith Road, Edinburgh EH16 5DX ★ 0131 667 2611

The supplier to use if you're looking for:-

★ A WIDE RANGE OF COMPONENTS AIMED AT THE HOBBYIST ★ COMPETITIVE VAT INCLUSIVE PRICES ★



★ MAIL ORDER - generally by RETURN OF POST ★

★ FRIENDLY SERVICE ★

1995/6 CATALOGUE NOW IN STOCK!
COST: £2.00. Includes vouchers to offset against future purchases.

OPEN: Monday-Thursday 9.15 - 6.00.

Friday 9.15-5.00

Saturday 9.30-5.00



VARIABLE VOLTAGE TRANSFORMERS

INPUT 220V/240V AC 50/60
OUTPUT 0V-260V

	Price	P&P
0.5KVA 2.5 amp max	£31.90	£6.00
	(£44.53 inc VAT)	
1KVA 5 amp max	£41.15	£7.00
	(£56.58 inc VAT)	
2KVA 10 amp max	£59.40	£8.50
	(£79.78 inc VAT)	
3KVA 15 amp max	£78.65	£8.50
	(£102.40 inc VAT)	
5KVA 25 amp max	£139.15	
	(Plus Carriage)	

Buy direct from the Importers. Keenest prices in the country.
COMPREHENSIVE RANGE OF TRANSFORMERS-LT-ISOLATION & AUTO 110V-240V Auto transfer either cased with American socket and mains lead or open frame type. Available for immediate delivery.

WIDE RANGE OF XENON FLASHTUBES

Write/Phone your enquiries

ULTRA VIOLET BLACK LIGHT FLUORESCENT TUBES

4ft 40 watt £14.00 (callers only)	(£16.45 inc VAT)
2ft 20 watt £9.00 (callers only)	(£10.58 inc VAT)
12in 8 watt £4.80 + 75p p&p	(£5.52 inc VAT)
6in 6 watt £3.96 + 50p p&p	(£4.24 inc VAT)
6in 4 watt £3.96 + 50p p&p	(£4.24 inc VAT)

230V AC BALLAST KIT

For either 6in, 9in or 12in tubes £6.05 + £1.40 p&p

(£8.75 inc VAT)

The above Tubes are suitable for Forged Bark Note detection, security marking etc.
Other Wavelengths of U.V. TUBE available please tele phone your enquiries.

400 WATT UV LAMP

Only £38.00 + £4.00 p&p (£49.35 inc VAT)

160 WATT SELF-BALLASTED BLACK LIGHT MERCURY BULB

Available with E.S. fitting

Price Inc VAT & p&p £25.55



12V D.C. BILGE PUMPS

500 GPH 15ft head 3 amp £19.98

1750 GPH 15ft head 9 amp £34.55

Also now available:

24V D.C. 1750 GPH 15ft head

5 amp £35.55

All designed to be used submerged.

PRICES INCLUDE P&P & VAT

SUPER HY-LIGHT STROBE KIT

Designed for Disco, Theatrical use etc.

Approx 16 joules. Adjustable speed £50.00 + £3.00 p&p

(£62.28 inc VAT)

Case and reflector £24.00 + £3.00 p&p (£31.73 inc VAT)

SAE for further details including Hy-Light and Industrial Strobe Kits.

SERVICE TRADING CO

57 BRIDGMAN ROAD, CHISWICK, LONDON W4 5BB

TEL: 0181-995 1560 FAX: 0181-995 0549

ACCOUNT CUSTOMERS MIN. ORDER £10

Showroom open Monday/Friday

5 KVA ISOLATION TRANSFORMER

As New Ex-Equipment, fully shrouded, Line Noise Suppression, Ultra Isolation Transformer with terminal covers and knock-out cable entries. Primary 120V/240V, Secondary 120V/240V, 50/60Hz, 0.005pF Capacitance, Size, L 37cm x W 19cm x H 18cm, Weight 42 kilos. Price £120 + VAT. Ex-warehouse. Carriage on request.

24V DC SIEMENS CONTACTOR

Type 3TH8022-0B 2 x NO and 2 x NC 230V AC 10A. Contacts. Screw or Din Rail fixing. Size H 120 x W 45 x D 75mm. Brand New Price £7.63 incl. P&P and VAT.

240V AC WESTOOL SOLENOIDS

TT2 Mod. 1 Rat. 1 Max. stroke 3/8in. Base mounting 3/8in. stroke 5lbs pull approx. TT6 Mod. 1 Rat. 1 Max. stroke 1 in. Base mounting 3/8in. stroke 15lbs pull approx. SERIES 400 Mod. 1 Rat. 2 Max. stroke 3/8in. Front mounting 3/8in. stroke 15lbs pull approx. Price incl p&p & VAT. TTS £5.88, TT6 £8.81, SERIES 400 £7.64.

AXIAL COOLING FAN

230V AC 120mm square x 38mm 3 blade 10 watt Low Noise fan. Price £7.29 incl. P&P and VAT.

Other voltages and sizes available from stock. Please telephone your enquiries.

INSTRUMENT CASE

Brand new. Manufactured by Imhol. L 31 x H 18 x 19cm Deep. Removable front and rear panel for easy assembly of your components. Grey textured finish, complete with case feet. Price £16.45 incl. P&P and VAT. 2 off £28.20 inclusive.

SEWING MACHINE MOTOR

Brand new 220V/240V AC/DC SEW-TRIC 2 lead Brush Motor. Size L 100mm x H 70mm x W 55mm. Spindle 1/4 in. dia. x 1 in. long. Price £14.10 inc p&p & VAT.

GEARED MOTORS

71 RPM 20lb/inch torque reversible 115V AC input including capacitor and transformer for 240V AC operation. Price inc VAT and p&p £27.73.

SOLID STATE EHT UNIT

Input 230V/240V AC, Output approx 15KV. Producing 10mm spark. Built-in 10 sec timer. Easily modified for 20 sec, 30 sec to continuous. Designed for boiler ignition. Dozens of uses in the field of physics and electronics, e.g. supplying neon or argon tubes etc. Price less case £8.50 + £2.40 p&p (£12.81 inc VAT) NMS.

EPROM ERASURE KIT

Build your own EPROM ERASURE for a fraction of the price of a made-up unit. Kit of parts less case includes 12in 8 watt 2537 Angst Tube Ballast unit, pair of bl-pin leads, neon indicator, on/off switch, safety microswitch and circuit £15.00 + £2.00 p&p (£19.98 inc VAT)

WASHING MACHINE WATER PUMP

Brand new 240V AC fan cooled. Can be used for a variety of purposes. Inlet 1/2in. outlet 1in. dia. Price includes p&p & VAT. £11.20 each or 2 for £20.50 inclusive.

JCG ELECTRONIC PROJECTS

PO BOX HP79 WOODHOUSE STREET HEADINGLEY LEEDS LS6 3XN

KITS

RADIO KITS/TRANSMITTERS/REMOTE CONTROLS

- MICRO FM (a). 1km range transmitter, 80-100MHz preset. Received on any FM Radio. 2 x 3cm. £6.95
- MICRO FM (b). 1km range, 2 x 3.5cm. £7.95
- ULTRA MINI FM. 200mtrs range. 80-100MHz, runs off watch battery (inc.), only 1 x 2cm. £9.95
- FM TRACKER. Transmits a constant tone for direction finding, tracking etc. 80-110MHz. £6.50
- FM RECEIVER (a). Small high quality FM receiver. Covers standard FM broadcast bands. Will drive headphones (not inc.). £10.90
- FM RECEIVER (b). As (a) but with 3 watt audio power amplifier and tuning LED. £13.50
- CRYSTAL RADIO. Great introduction to radio electronics. Includes tuner, ferrite aerial and earphone. £8.50
- AM RADIO. Single chip radio for use with headphones, (not inc.) or an external amplifier. £9.90
- I.R. REMOTE CONTROL. Single channel for lights, garage doors etc. Transmitter - £8.95 Receiver (with mains relay) - £11.60
- 27MHz RADIO CONTROL. Single channel, XTAL controlled Transmitter - £9.50 Receiver (with mains relay) - £15.45

MICRO TRANSMITTERS GUIDE

★ Only £3.95

★ Easy to follow guide to building short range F.M. transmitters and surveillance devices. Packed with useful information and circuits.



(Some of the circuits included cannot be used legally in the UK)

PREAMPS/AUDIO

- AU10 GENERAL PURPOSE PREAMP for audio applications where low noise isn't a priority - guitar amps etc. 9V-15V, variable gain and high output. £4.20
- AU11 LOW NOISE PREAMP for more critical input stages. Ideal for mixers etc. 9V-15V, variable gain. £4.50
- AU12 ULTRA LOW NOISE PREAMP. Professional standard. Uses an NE5534 i.c. 9V-15V, variable gain. £5.99
- AU13 SMALL SIGNAL. Single Fet preamp for boosting low output piezo pickups or acoustic transducers. £3.90
- AU14 SMALL SIG + EQ. An AU13 with a simple three-band passive EQ circuit. Designed for piezo pu's. £6.90
- AU15 SINGLE TRANSISTOR. Low noise preamp for electric guitars etc. Preset gain. BC148. £3.90
- AU16 ACTIVE TONE CONTROL. 12dB cut and boost. bass and treble with preamp. Includes pots. £9.95
- AU17 7-BAND EQ board for graphic/tone control applications. Pots included. £14.95
- AU18 NOISE REDUCTION SYSTEM. High quality dynamic noise gate with variable effect and level. £15.95
- AU19 ANALOGUE DELAY. "Bucket brigade" delay line. Variable clock frequency for producing double track and echo effects etc. Delay times from 2-5 to 51ms. £18.50

SEND S.A.E. FOR A LIST OF OUR FULL RANGE OF RADIO AND AUDIO KITS. ALL KITS COME COMPLETE WITH PRE-DRILLED P.C.B.'S, HIGH SPEC COMPONENTS AND FULL INSTRUCTIONS - MAIL ORDER ONLY - MAKE CHEQUES PO'S PAYABLE TO J.C.G. PLEASE ADD 50p POSTAGE AND PACKING.

Get into PIC Programming with Forest Electronic Developments!

PIC Basic Controller Modules - from £27.00

The PIC BASIC controllers offers a well featured BASIC language running in real time directly on a PIC Microcontroller. The 16C57 version offers 16 lines of programmable I/O, a serial interface and a 4MHz clock. Our new 16C74 version features 8k EEPROM with up to 2000 lines of BASIC, 8 x A/D inputs and PWM D/A outputs, 27 lines of programmable I/O, 3 timers and interrupt support in BASIC, and an interrupt driven serial RS232 interface.

16C57 module kit 2k EEPROM £27.00 Prebuilt £33.00

16C57 module kit 8k EEPROM £30.00 Prebuilt £36.00

16C74 module kit 4MHz £35.00 Prebuilt £42.00

16C74 module kit 20MHz £40.00 Prebuilt £46.00

Full instructions, latest development software and documentation on 3.5" disk are included.

PIC Programmer - kit £35.00, pre-built £45.00

Programs 16C54/55/56/57/58, 16C64, 16C71/74, 16C84. Operates over serial link to a PC. Includes all components, PCB and programmed PIC, plus Windows and DOS software and Windows based development system latest versions of Microchip's assembler and Simulator on 3.5" disk. ZIF sockets not included (these are not essential and may be added later)

Add £7.50 for a serial cable to link either project to the PC.

Add £3.00 for Postage, Packing and Handling, all orders which are held in stock will be sent by return, first class post. Send a cheque/PO payable to:

Forest Electronic Developments

(R.J.Abbott G.M.Warner)

10 Holmhurst Avenue, Christchurch, Dorset, BH23 5PQ.

Sales queries, 01425-275962, Technical queries, 01425-274068

Visit our web site at

<http://www.ibmpcug.co.uk/~gmwarner/fed.htm>

INTERFACE

Robert Penfold



ASLOW but steady flow of letters are received from readers who wish to interface all manner of things to the RS232C serial ports of their PCs, but have no idea about how this type of interfacing is approached.

One the face of it, a serial port is ideal for the basis of many do-it-yourself add-ons. It provides an 8-bit input port, an 8-bit output port, plus some handshake lines. As an RS232C port is a standard form of interface, it is not even PC specific, and with suitable software a serial port project should be usable with practically any computer.

Serial Killers

In reality, using serial ports is something less than straightforward, and they are not really suitable for all applications. As practically anyone who has used a serial port will testify, it often takes a fair amount of experimentation to get the port to communicate with the outside world at all!

Once any basic interfacing difficulties have been overcome, it requires a UART (Universal Asynchronous Receiver/Transmitter) to convert the serial data from the computer into bytes of parallel data, and to make the conversion in the opposite direction.

Some simple signal processing circuitry is also required, because RS232C signals are at nominal voltage levels of plus and minus 12V, not at the normal five volt logic levels required by the UART. None of the circuitry is particularly involved, but a UART is not particularly cheap at about £7 for the industry standard 6402 UART.

Before embarking on a project that interfaces to a computer via a "serial link" it is as well to consider one or two inherent drawbacks of serial interfacing. One is simply that it only provides a basic eight inputs and eight outputs.

It is possible to use some additional circuitry to effectively increase the number of inputs and outputs, but this can considerably increase the complexity of a project. A parallel printer port or proper PIO card is likely to be a better method of interfacing in most cases.

The relatively slow speed of a serial port is something that has to be borne in mind with any application that requires a rapid transfer of data. The highest standard baud rate for an RS232C serial port is 19200 baud, but it has to be remembered that 19200 is the maximum number of bits per second, and not the maximum number of bytes.

Including start and stop bits there are at least ten bits per serial byte, giving a maximum transmission rate of 1.92 kilobytes per second. This is high enough for many practical applications, but is clearly inadequate for something like audio digitising via a fast analogue-to-digital converter.

Right Connections

Connection details for a standard 25-pin PC serial port (a), and the cut down

9-pin version used on many modern PCs (b) are shown in Fig. 1. In fact it seems to be normal for modern PCs to have one serial port of each type.

A female D-type connector having the appropriate number of pins is needed in order to make the connections to each port. Most PCs have two serial ports, which have the operating system names "COM1" and "COM2".

For basic two-way serial interfacing it is only necessary to use three terminals on each port. These are the GND (ground) terminal, the TXD (transmitted data), and RXD (received data) terminals. The ground terminals of the two ports

than the computer can digest properly. Handshaking is still not essential, since it would presumably be possible to slow down the operating speed of the peripheral to a rate that the computer could handle.

Whether or not handshaking is used, and whatever type of link is used, there is no point in having a peripheral that generates data at such a high rate that the computer cannot process it.

Free Flowing

Where possible it is definitely advisable to avoid using handshaking, and to have a system that never generates data at a

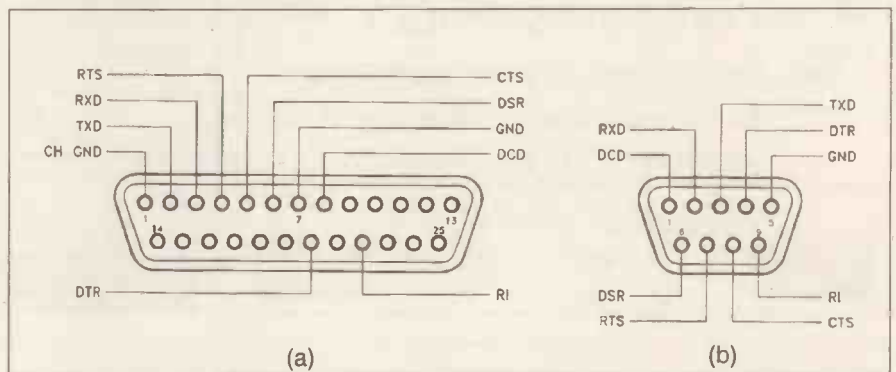

Fig. 1. Connection details for 25-pin (a) and 9-pin (b) PC serial port.

are simply wired together, but the TXD and RXD pins are cross coupled.

The problem with this simple arrangement is that it does not provide any handshaking to control the flow of data in either direction. This does not matter in many cases, where the rate at which data is generated will always be too slow to produce any overflows. In some cases though, this may well be a possibility.

When the computer is sending data it is usually quite easy to use a delay loop or some "dummy" instructions to prevent data from being fed to the serial port at a higher rate than it can handle. Also, the operating system uses a small amount of memory to act as a buffer, and this can accommodate occasional bursts of data, provided only small amounts are involved.

If a slow programming language is used, such as an interpreted BASIC, it may well be that the computer will not be able to write data at a high enough rate to produce data overflows. Using a high baud rate obviously minimises the risk of data being lost.

The slowest part of the system might be the circuit at the other end of the serial link. This is unlikely, since most electronic circuits operate at speeds that make RS232C links look rather pedestrian. Once again, this is something that can be handled via delays in the software rather than handshaking.

With data flowing from the peripheral device to the computer there is a real risk of data being sent at a higher rate

higher rate than any other part of the system can handle. Unfortunately, the fact that no handshaking is used does not mean that the handshake lines of the PC can simply be ignored. With a simple three wire serial link it is unlikely that the computer will be persuaded to transmit any data unless some of the handshake inputs are connected to handshake outputs.

The basic idea is that a handshake output is set "high" when a port is ready to receive data, or "low" when a hold-off is required. Handshake inputs that are left unconnected often "float" to the low state, effectively indicating that a hold-off is required on the serial output.

Consequently, you can send masses of data to the port, but none of it will be transmitted. Where this problem occurs, and provided the port's handshake outputs are not in use, simply interconnecting some of the handshake inputs and outputs normally provides a solution.

Clear Line

The two handshake inputs are CTS (Clear To Send) and DSR (Data Set Ready). Having two sets of handshake lines complicates matters, and there is no obvious reason for this doubling up. Some computer serial ports do not include both, but they are both present and correct on a PC serial port.

In use, the CTS line often seems to be used to control the flow of data on a byte-by-byte basis, with DSR being used to indicate that the receiving device is

off-line. However, these can be used the other way round. If one of these handshake lines is not implemented, it is usually the CTS input.

Where both lines are implemented it is normally necessary for both of them to be taken high in order to permit data to freely flow from the port. Provided the RTS (Request To Send) and DTR (Data Terminal Ready) outputs are not otherwise in use, connecting them to the DSR and CTS inputs (respectively) should give the desired result.

Ring Indicator (RI) and Data Carrier Detect (DCD) are specifically for use with modems. They are both inputs, and they are used by the modem to indicate that it has detected a ringing signal, and that it has detected a carrier signal.

They are not normally required in general serial interfacing, although the DCD line is sometimes used as a sort of off-line/on-line indicator. For interfacing to do-it-yourself projects they are not normally required.

6402 UART

There are many serial interface chips available, but most of these are intended for specific microprocessor families. For projects that are based on conventional logic chips it is necessary to use a UART. These have the ability to operate with microprocessors, but are primarily designed for operation in conventional logic circuits.

The word format, and other settings are programmed via a number of inputs, and not via a data bus. Pinout details for the 6402 UART, which has a standard 40-pin d.i.l. encapsulation, are shown in Fig. 2.

If we take the receiver section of the 6402 first, RBR0 to RBR7 (pins 12 to 5) are the receiver buffer register outputs.

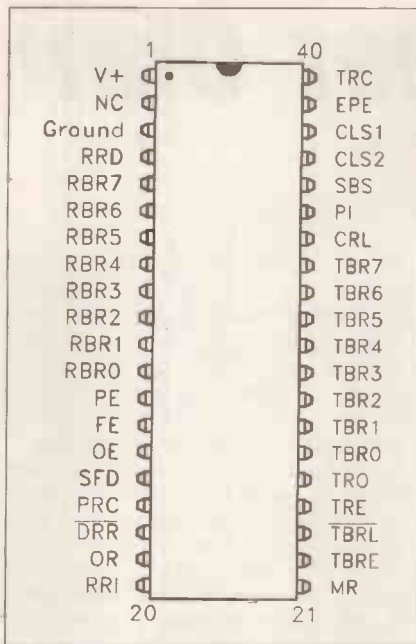

Fig. 2. Pinouts of the 6402 UART.

In other words, it is on these eight outputs that decoded bytes of data appear.

In some data sheets these are called RBR1 to RBR8, but I am using the conventional 0 to 7 numbering for data inputs and outputs. Pin 4 must be taken low in order to activate these outputs.

The serial data is fed to pin 20, the receiver register input (RRI). The RS232C signal must first be converted to standard 5V logic levels, and it must also be inverted.

The reception baud rate is controlled by the clock signal fed to pin 17, and is one sixteenth of the clock frequency. In

other words, the clock frequency must be 16 times the required baud rate, or 307.2kHz for a baud rate of 19200 baud for example.

For standard baud rates some odd clock frequencies are required, but these can be obtained via a crystal oscillator and a multi-stage binary divider. Crystals having suitable frequencies for baud rate control are readily available at quite low cost.

Parity of Words

The transmitter and receiver sections must have the same word format, and this is set by the logic levels on pins 35 to 39. Pin 35 is set "low" to enable parity checking, or "high" to disable it.

With parity checking enabled, taking pin 39 low selects odd parity, and setting it high selects even parity. Pin 36 is taken low for one stop bit, or high for two stop bits. With parity checking switched off, the logic level on pin 39 is unimportant. The number of data bits is set using pins 37 and 38, and varies from five bits with a binary value of 00 to eight bits with a binary value of 11.

For general interfacing purposes the best word format is eight data bits, one stop bit, and no parity. This enables full eight bit bytes of data to be handled, with only two additional bits being added per serial byte (the stop bit plus the mandatory start bit).

This word format is selected by setting pin 36 low, and pins 35, 37, 38, and 39 high. Pin 34 must be strobed or taken permanently high in order to load the data on these pins into the word format register.

Next Month: we will consider the transmitter section of the 6402, together with some practical circuits to provide serial interfacing to a PC.

SHOP

TALK

with David Barrington

Dolby Pro-Logic Decoder (Booklet)

The Dolby chip used in the *Dolby Pro-Logic Decoder* (Free booklet) project is subject to strict licensing agreements and is not available separately. This project is only available in kit form.

Two versions are available; the "Short Form" kit and a "Full" kit.

The Short Form kit is complete except for case and power transformer and is ideal for incorporating into a customer set-up with pre-amp and power amp module. The Full Kit is claimed to give the best value option by producing a complete stand-alone decoder which can be used with any audio system.

The kits are only available from Magenta Electronics (Tel.01283 565435), 135 Hunter Street, Burton on Trent, Staffs, DE14 2ST, for the sum of: £99 Short Form, code 858; and £124.99 Full Kit, code 869. A carriage charge of £3 must be added to each order.

Bat Band Converter

As the *Bat Band Converter* is built using "surface mount devices (SMDs)" extreme care and patience is required when soldering-up the small p.c.b. Also, some of the SMDs are not that readily available.

This applies particularly to the BSR58 low-noise f.e.t. and the mixer/oscillator i.c. type NE602AD. We understand from the designer, that *Gothic Crellon* (Tel.01743

788878) of Wokingham are willing to supply these on a "one-off" basis, cash with order. Call them first for details.

The 220µH inductor came from Electromail (Tel. 01536 204555), code 234-966 and the small mountable box from Maplin, code FK73Q. The ferrite rod, Kynar wire (used for wirewrapping) and ultrasonic transducer should be available from most of our component advertisers, such as Greenweld, Cirkit, Cricklewood, Omni, ESR and Maplin.

The small surface mount printed circuit board is available from the *EPE PCB Service*, code 984. This includes the small add-on B.F.O. Unit board.

Event Counter (Teach-In '96)

No problems should be encountered when buying components for the *Event Counter*, this month's *Teach-In* project, but a couple of items require further comment.

The sloping-front case used in the model is fairly expensive, around £11, and came from Maplin's ABS Console range, code YN29G. This was selected to take the p.c.b., but readers may wish to choose their own style of case. The printed circuit board is available from the *EPE PCB Service*, code 986.

Most of our component advertisers carry stocks of multi-pin connectors and should be able to offer a suitable type to link-up the display. The ribbon cable connector in the

model came from Rapid Electronics, (Tel. 01206 751166) code 80-0215.

Teach-In '96

The 5-digit liquid crystal display module mentioned in the "Counting Circuit" section of this month's *Teach-In* series came from Maplin, code FS13P (listed under Counters, as against LCD's in their catalogue index). Most component advertisers should also be able to offer a suitable display module.

Mind Machine Mk III - Programmer

We do not expect any purchasing problems to be encountered by readers tackling the *Mind Machine Programmer*. All components should be "off-the-shelf" parts.

Some readers have asked for the source of the case, called-up last month. This is a Verobox type 202-21035F, obtained from Maplin, code LL06G.

The Programmer p.c.b. is available from the *EPE PCB Service*, code 983. Once again, all readers must heed the "warning panel" in the article about possible side effects when using the unit.

We cannot foresee any component buying problems that are likely to confront readers undertaking the *Hearing Tester* project. Finally, the only problem with the *Chromofloristics Horticulture* project is that it *must* be propagated on 1 April! otherwise you will get weird results.

TAKE NOTE

Printer Sharer

Page 18, Fig. 6. The socket for IC5 should be 14 pins, locating notch to the right as shown. A *link wire* then connects between the two "unused" pins (routing socket SK2 pin 11 to resistor R9).

Ohm Sweet Ohm

Max Fidling

Hey! Big Spender

Although I'm not the world's greatest spender on electronics, the trouble with opening a credit card is that it's easy to splash out without a second thought on anything which might take one's fancy. Impulse buying, I think they call it.

As the Boss will tell you, I'm also a devil for keeping things just in case I ever need them. Experience tells me that as soon as I sling out my prized selection of old washing machine pumps and motors, for example, I just know that the washer will expire in a puff of smoke, and the pump will stagger out, waving a white flag! Hence, I carry more spare pumps than Hotpoint.

Anyway, back to credit cards. I'd taken my "flexible fiend" along with me to have a look at new multimeters, with a view to perhaps buying one. My trusty moving coil effort had never been the same since I tested a 230V mains socket when the meter was "accidentally" set to a low resistance range: the meter needle had acquired an awkward bend in it, which co-incidentally aligned exactly with the meter's end-stop...

Going Digital

I had decided the time was ripe to "go digital" since all the professionals have a digital multimeter. Not wishing to be seen lagging behind, I wanted to be up there alongside them!

I already had my colour-coded screw-driver set, all carefully co-ordinated to match my plastic toolbox, plus a set of pliers and wire-cutters which sported natty cushioned handles. Except that my precision wire cutters had recently failed to cut some steel 22 gauge wire (I was fixing the garden fence at the time), and a circular indentation on the blades' edges bore testimony to where the fence had gained the upper hand over Taiwan's finest drop-forged steel.

Undeterred, a-hunting multimeters I did go and a short car journey later, in my

favourite electronics shop, my eyes fell upon a vast array of test equipment, displayed impressively behind the counter. I had become a regular visitor at the shop, though I noticed that the staff always seemed to either look very busy, or disappear and make a cup of tea whenever I arrived, though why, I wasn't too sure.

Glancing longingly at a row of digital delights, I spotted one particular meter which stood out from the masses of black boxes - mainly because it was, er, banana yellow. This was bound to impress my friends, I thought, because professionals all have yellow multimeters, so here was my chance to increase my esteem.

The fearful-looking assistant handed me the goodies, which had a pair of test leads clattering down on the counter. I stabbed the buttons on the meter repeatedly, determined to give the impression of a highly-qualified, discerning buyer (a professional, in fact) all set to test the meter to destruction.

Talking Box

This meter, I saw, had one particular feature which I hadn't seen elsewhere: it spoke. A small loudspeaker grille gave the game away.

Just the ticket for when I'm rummaging inside a project, I mused! Pressing the "Voice" button, a tinny robot-like voice intoned "ON! Zero Volts. Zero Volts! ZERO VOLTS!"

"Yes, yes," I thought, "I get the idea, now shut up!" as I prodded the rubbery button again. "OFF!!" it declared, as I gagged it.

The meter was going at half-price, apparently shop soiled, and with my ever-keen eye for a bargain, the deal was struck. One deft swipe of my plastic card later I was soon wending my way home carrying the booty.

Piddles, my trusty moggie, sidekick and general smart Alec, greeted me at the workshop door as I stepped inside, brandishing my new vocal multimeter still in



its display carton, with the tip of a test probe now poking through the cardboard.

Yellow Peril

The moggie jumped up onto the bench and peered at the yellow peril. I hooked up my bench power supply and connected it to the multimeter's sockets, and switched it on.

My finger nudged the "Voice" button once more. "ON!!" said the meter. "Zero Volts. Zero Volts! ZERO VOLTS!!" it articulated monotonously. Piddles peered more closely at the meter, with ears pricked up inquisitively.

Turning the power supply's voltage control up and down (as you do), I could see the power supply's meter swinging towards the end-stop. "Twelve Point Three Volts!! Twelve Point Two Volts!! Twelve Point Three Volts!!" boomed the meter, relentlessly. I stabbed the Voice button once more.

At this point I started to question whether this was such a good idea. Maybe this explained why the Geest-coloured gizmo was going cheap! "OFF!!" burbled the meter, in apparent agreement. Still, it's yellow, and that's what counts!

3lb mixed component pack.....	£4.95
Jumbo component pack.....	£10
250 off mixed capacitors.....	£4.95
250 off i.c. sockets.....	£3.95
1000 off mixed ceramic caps.....	£7.50*
20 off mixed crystals/filters.....	£4.95
25 off mixed relays.....	£3.50
100 off phono plugs.....	£2.95*
10 off mixed displays.....	£3.75*
50 off d.i.l. switches.....	£3.75*
30 off mixed heatsinks.....	£3.75*
30 off mixed switches.....	£3.75*
Brand new 360k 5¼" floppy drive.....	£4.50
5¼" to 3½" floppy drive converter leads.....	£1.50*
50ft BNC to BNC lead.....	£1.75
2 phono plug to 2 phono plug lead.....	£1.50*
21-Pin SCART plug to SCART plug lead (all connected).....	£3.50*
As above but plug to socket.....	£3.50*
SCART plug to 4 phone plug lead.....	£2.95
10 off crocodile clip leads.....	£3.50*

Universal Test Lead Kit.....	£3.75*
VALVES	
QQV0310, £10*, QQV0320A, £10*;	
QQV0640A, £20*; ECC82, £3*;	
ECH81, £2*; PCL805, £3*;	
ORP 11, £3; ORP 40, £3; CV 4004,	
4005, 4006, 4007, 4014, 4020,	
4024, 4043, 4055, 4064, 5042,	
5080, ALL £5 each*	
QUANTITY DISCOUNTS AVAILABLE PLEASE RING.	
We also buy all forms of electronic components, p.s.u.'s, disk drives etc. Lists to below address.	
ALL PRICES INCLUDE V.A.T. PLEASE ADD £2.00 p&p EXCEPT ITEMS MARKED* WHICH ARE 50P. SAE FOR BULK BUYING LIST PAYMENT WITH ORDER TO:	
Dept EE, COMPELEC,	
14 Constable Road,	
St. Ives, Huntingdon,	
Cambs PE17 6EQ	
Tel/Fax: 01480 300819	

N. R. BARDWELL LTD (EPE)	
200 Signal diodes 1N4148.....	£1.00
75 Rectifier Diodes 1N4001.....	£1.00
50 Rectifier Diodes 1N4007.....	£1.00
10 W02 Bridge Rectifiers.....	£1.00
5 NE555 Timer I.C.s.....	£1.00
50 Ass'd. Zener Diodes.....	£1.00
30 BC212L Transistors.....	£1.00
30 BC213L Transistors.....	£1.00
30 BC214C Transistors.....	£1.00
30 BC237 Transistors.....	£1.00
20 BC327 Transistors.....	£1.00
30 BC328 Transistors.....	£1.00
30 BC337 Transistors.....	£1.00
30 BC478 Transistors.....	£1.00
30 BC546 Transistors.....	£1.00
30 BC547 Transistors.....	£1.00
30 BC548 Transistors.....	£1.00
30 BC549 Transistors.....	£1.00
25 BC557 Transistors.....	£1.00
30 BC558 Transistors.....	£1.00
30 BC559 Transistors.....	£1.00
25 BC640 Transistors.....	£1.00
30 MPSA42 Transistors.....	£1.00
30 MPSA92 Transistors.....	£1.00
20 2N3702 Transistors.....	£1.00
20 2N3904 Transistors.....	£1.00
5 78L12 12V 100mA Pos Regulators.....	£1.00
10 79M08 8V 500mA Neg Regulators.....	£1.00
25 5mm red l.e.d.s.....	£1.00
25 3mm red l.e.d.s.....	£1.00
25 Ass'd. high brightness l.e.d.s.....	£1.00
50 Axial l.e.d.s (Diode package).....	£1.00
12 Ass'd. 7-segment displays.....	£1.00
2 ORP 12 light dependant resistors.....	£1.00
30 Ass'd. IF transformers.....	£1.00
48 Ass'd. coil formers.....	£1.00
100 Ass'd. RF chokes (inductors).....	£1.00
30 Ass'd. connectors edge,d.i.l., sil etc.....	£1.00
30 Ass'd. d.i.l. sockets up to 40-pin.....	£1.00
200 Ass'd. disc ceramic capacitors.....	£1.00
80 Ass'd. capacitors 1nF to 1µF.....	£1.00
80 Ass'd electrolytic capacitors.....	£1.00
10 4P3W MBB min. rotary switches.....	£1.00
20 Mini. SPIC slide switches.....	£1.00
20 1" glass reed switches.....	£1.00
200 4N7 mini axial capacitors.....	£1.00
24 24-pin d.i.l. wire wrap i.c. s.kts.....	£1.00
1 12V motorised volume control 50k.....	£1.00
50 Grommets 6-3mm ld, 9-5mm od.....	£1.00
100 c/1 ¼W 5% resistors any one value, E24, range 1R to 10M.....	£0.45
Prices include V.A.T. postage £1.25. Stamp for Lists	
288 Abbeydale Road, Sheffield S7 1FL	
Phone (0114) 2552886 Fax (0114) 2500689	

BTEC
Certified



TUTOR
Supported

NATIONAL
COLLEGE OF
TECHNOLOGY

The National College of Technology offer a range of packaged learning short courses for study at home or in an industrial training environment which carry modular BTEC awards leading to a higher BTEC certificate. Study can commence at any time and at any level enabling you to create a study routine to fit around existing commitments. Courses on offer include:

Analogue Electronics
Digital Electronics
Fibre/Optoelectronics
Mechanics & Mechanisms
Programmable Logic Controllers
Electronic Testing & Fault Diagnosis

Tutor support and BTEC certification are available as options with no travelling or college attendance required. These very popular courses which are ideal for vocational training contain workbooks, audio cassette lectures, PCB's, instruments, tools, components and leads as necessary to support the theoretical and practical training. Whether you are a newcomer to electronics or have some experience and simply need an update or certification, there is probably a distance learning course ready for you. Write or telephone for details to:

National College of Technology
NCT Ltd., PO Box 11
Wendover, Bucks
Tel: (01296) 624270



M.G.C. Electronics
PHONE/FAX: 01476 79974

- FM MICRO BUG TRANSMITTER 88-108MHZ 500 METRE RANGE KIT **£3.99 BUILT £7.00**
- FM BUG AS ABOVE 1000 METRE RANGE KIT **£4.99 BUILT £8.00**
- FM ULTRA SMALL BUG 1.5MM X 20MM X 1.5MM 88-108MHZ 100 METRE RANGE BUILT/BOXED **£15.00**
- FM TELEPHONE TAP BUG POWERED FROM THE LINE AND TRANSMITS BOTH SIDES OF THE CONVERSATION 88-108MHZ 500METRE RANGE KIT **£10.00. BUILT/ BOXED £14.00**
- FM 1.3A 3 WAY ADAPTER BUG BUILT/TESTED **£25.00**
- FM BUG HOUSED IN A PRIMARY PHONE SOCKET 88-108MHZ 500 METRE RANGE KIT **£15.00 BUILT £23.00**
- TRACKING TRANSMITTER AND RECEIVER 418MHZ 2KM RANGE FOR TRACKING OF VEHICLES, PEOPLE, ANIMALS ETC **£90.00**
- BUG CONSTRUCTORS MANUAL- A BOOK CONTAINING DOZENS OF VHF, CRYSTAL CONTROLLED BUGS, TELEPHONE TAPS, INFINITY TRANSMITTERS ETC **£6.00**
- 4 WATT FM BROADCAST QUALITY TRANSMITTERS 88-108MHZ KIT **£40.00 BUILT/TESTED/AUGNED £60.00**
- 15 WATT FM BROADCAST QUALITY TRANSMITTERS 88-108 TUNED TO YOUR SPECIFICATION, BOXED/BUILT/AUGNED
- 30 WATT FM BROADCAST QUALITY TRANSMITTER AS ABOVE BOXED/BUILT/AUGNED **£165.00**
- INFRARED CAMERA SIZE 40mm x 40mm x 40mm (SEE IN THE DARK CAPABILITY) PLUGS DIRECTLY INTO VCR ETC ONLY **£150.00**
- LASER DIODES 1mW 670NM RED **£75.00**
- LASER DIODES 5mW 670NM RED **£95.00**
- LASER DIODES 3mW 633NM RED OVER 10 TIMES VISIBLY BRIGHTER THAN THE 670NM LASERS. EQUIVALENT TO THE HE-NE LASERS,
- 250 WATT 12V DC TO MAINS AC INVERTER IDEAL FOR RUNNING A TV, FRIDGE, STEREO, LIGHTS ETC WHEN ON THE MOVE IN YOUR CAR OR WHEN CAMPING/CARAVANNING FROM THE CAR BATTERY. **£140**
- AA SOLAR POWERED BATTERY CHARGER **£9.99**
- WATCH AS YOU BUILD RADIO RECEIVER KIT WHICH INCLUDES STEP BY STEP CONSTRUCTION GUIDE ON A VHS TAPE AND ALL COMPONENTS TO BUILD THE RADIO. **£25.00**
- PC/IBM COMPATIBLE RELAY CARD USED TO CONTROL ROBOTICS, PROCESS CONTROL, HOME AUTOMATION, LAMPS ETC. PROGRAMS ON 3.5 OR 5.25 INCH DISKS PLEASE STATE WHEN ORDERING. **£45.00**
- ALL KITS SUPPLIED WITH HIGH QUALITY PCB AND COMPONENTS. PRICES INCLUDE V.A.T. WITH ORDERS LESS THAN £10.00 PLEASE ADD £1.00 P&P, ORDERS OVER £10 PLEASE ADD £2.50 P&P. SEND S.A.E. FOR FULL CATALOGUE CONTAINING FUSES, RF TRANSISTORS, CAPS, RESISTORS, DISPLAYS, TRIACS, AMPS, LASERS, FIBRE OPTIC LINKS, KITS ETC AND MUCH MORE! CHEQUES/POSTAL ORDERS PAYABLE TO:
M.G.C. ELECTRONICS, SUITE 501, INTERNATIONAL HOUSE, 223 REGENT STREET, LONDON W1R 8GD. PHONE/FAX: 01476 79974

"Your low cost route to embedded 8051"



MICRO-PRO 51

"Hardware/software upgradeable programmer for the 8051 family"

- Accepts up to 40 pin DIL directly via Aries ZIF socket
- Surface mount and PLCC package adaptors available as optional extras
- Atmel 8951/8952 & 1051/2051 ICE cables available as optional extras
- Field programmable hardware to allow future upgradeability
- Fast PC parallel port based design.

ONLY £125

Programming support for the following devices:
Generic 8751/8752 microcontrollers from Intel & Philips
Atmel 8951/8952 FLASH replacements for the 8751/8752
Atmel 1051/2051 20-pin FLASH 8051 microcontroller derivatives
Serial EEPROMS families: 24Cxx, 93Cxx, 59Cxx, 25Cxx



KEIL C51 PK LITE

"The complete Ansi-C development environment for the 8051"

- Optimising Ansi-C compiler
- dscope-51-8051 software simulator & source level debugger
- uVision-Integrated Windows based C51 project management system
- Support for most 8051 derivatives eg. Atmel, Intel, Siemens etc.
- Numerous microcontroller language extensions for the fastest, tightest code

ONLY £110

(Restricted to 2K total program code, SMALL model only)



Embedded C51 Starter Systems for the 8051 family

"Everything you require to develop an embedded 8051-based project in C"

- MICRO-PRO 51 device programmer
- KEIL C51 PK LITE
- Sample Atmel FLASH microcontrollers
- Full suite of C51 demonstration software

Atmel 8051 FLASH Microcontroller Range

	8951	8952	1051	2051
FLASH code ROM	4K	8K	1K	2K
RAM	128	256	64	128
I/O	32	32	15	15
Timer/Counter (16 bit)	2	3	1	2
Serial Port	YES	YES	NO	YES
Interrupt Sources	5	8	3	5
Pins (DIL/PLCC)	40/44	40/44	20	20
Special features		Timer 2	Comparator	Comparator

895X-ST (ONLY £215)

Comes complete with samples of Atmel 8951 and 8952 40 pin microcontrollers

X051-ST (ONLY £199)

Comes complete with samples of Atmel 1051 and 2051 20 pin microcontrollers

Equinox Technologies, 229 Greenmount Lane Bolton BL1 5JB, Lancashire, ENGL AND
Tel: (01204) 492010 Fax: (01204) 494883 Int. dialling code (UK +44 1204)
E-mail: sales@equintec.demon.co.uk Web Page: www.demon.co.uk/equintec
All prices exclusive of VAT and carriage.



LEARN ALL ABOUT ELECTRONICS

The essential reference work

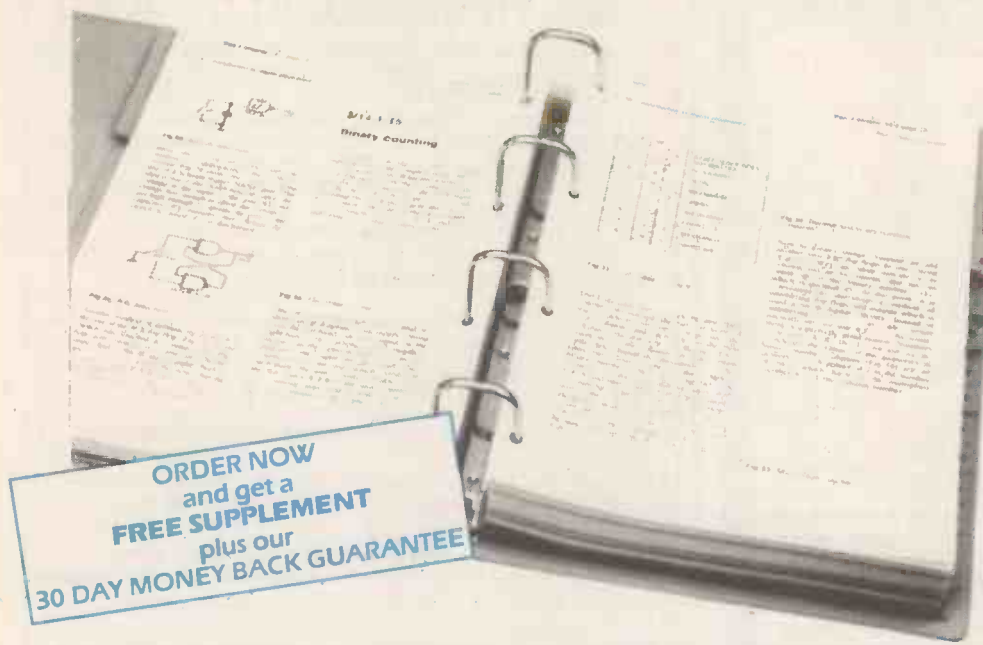

- Easy-to-use format
- Clear and simple layout
- Comprehensive subject range
- Regular Supplements
- Sturdy ring-binder
- Projects to build
- Components checklists
- Extensive data tables
- Detailed supply information
- Ready-to-transfer PCBs
- Detailed assembly instructions
- Professionally written

The revised edition of **The Modern Electronics Base Manual** contains practical, easy-to-follow information on the following subjects:

BASIC PRINCIPLES: Symbols, components and their characteristics, active and passive component circuits, power supplies, acoustics and electroacoustics, the workshop, principles of metrology, measuring instruments, digital electronics, analogue electronics, physics for electronics.

CIRCUITS TO BUILD: From basic principles to circuit-building. The Modern Electronics Manual and its Supplements describe how to assemble radios, loudspeakers, amplifiers, car projects, computer interfaces, measuring instruments, workshop equipment, security systems, etc.

ESSENTIAL DATA: Extensive tables on diodes, transistors, thyristors and triacs, digital and linear i.c.s., microprocessors.

The Manual also has an extensive **Glossary**, and covers **Safety, Specialist Vocabulary with Abbreviations and Suppliers**. The most comprehensive reference work ever produced at a price you can afford, the revised edition of **THE MODERN ELECTRONICS MANUAL** provides you with all the essential information you need.

OVER 1,000 A4 loose leaf pages in a sturdy ring binder all for just **£39.95 plus £6.00** post and packing. Regular Supplements continuously extend the Manual with new material, each Supplement contains approximately 160 pages of information. These are sent about five times a year and cost **£23.50 plus £2.50** p&p. You can of course return any Supplement (within 10 days) or cancel the Supplements at any time.

GUARANTEE

Our 30 day money back guarantee gives you **complete peace of mind**. If you are not entirely happy with the Manual, for whatever reason, simply return it to us in good condition within 30 days and we will make a **full refund of your payment** - no small print and no questions asked.
(Overseas buyers do have to pay the postage charge)

Wimborne Publishing Ltd., Dept. Y4
Allen House, East Borough,
Wimborne,
Dorset BH21 1PF
Tel: 01202 881749 Fax: 01202 841692

PLEASE send me **THE MODERN ELECTRONICS MANUAL** plus a **FREE SUPPLEMENT**.

I enclose payment of **£45.95**. I shall also receive the appropriate supplements several times a year. These are billed separately and can be discontinued at any time. Should I decide not to keep the Manual I will return it to you within 30 days for a full refund.

FULL NAME
(PLEASE PRINT)

ADDRESS.....

..... POSTCODE

SIGNATURE.....

I enclose cheque/PO payable to Wimborne Publishing Ltd.

Please charge my Visa/Mastercard/Access

Card No. Card Ex. Date

ORDER FORM

Simply complete and return the order form with your payment to the following address:
**Wimborne Publishing Ltd, Dept. Y4
Allen House, East Borough, Wimborne,
Dorset BH21 1PF**

OVERSEAS ORDERS: All overseas orders must be prepaid and are supplied under a money-back guarantee of satisfaction. If you are not entirely happy with the Manual return it within a month for a refund of the purchase price (you do have to pay the overseas postage). **SEND £39.95 PLUS THE POSTAGE SHOWN BELOW:**

EIRE	AIR MAIL ONLY £11
EUROPE (E.E.C. Countries)	AIR MAIL ONLY £20
EUROPE (non E.E.C.)	SURFACE MAIL £20, AIR MAIL £26
U.S.A & CANADA	SURFACE MAIL £25, AIR MAIL £32
FAR EAST & AUSTRALIA	SURFACE MAIL £31, AIR MAIL £33
REST OF WORLD	SURFACE MAIL £25, AIR MAIL £44

Note surface mail can take over 10 weeks to some parts of the world. Each manual weighs about 4kg including the free supplement when packed.

All payments must be made in £s Sterling payable to Wimborne Publishing Ltd. We accept Mastercard (Access) and Visa credit cards.

VIDEOS ON ELECTRONICS

A range of videos designed to provide instruction on electronics theory. Each video gives a sound introduction and grounding in a specialised area of the subject. The tapes make learning both easier and more enjoyable than pure textbook or magazine study. They have proved particularly useful in schools, colleges, training departments and electronics clubs as well as to general hobbyists and those following distance learning courses etc.

VT201 to VT206 is a basic electronics course and is designed to be used as a complete series, if required.

VT201 54 minutes. Part One; D.C. Circuits. This video is an absolute must for the beginner. Series circuits, parallel circuits, Ohms law, how to use the digital multimeter and much more. **Order Code VT201**

VT202 62 minutes. Part Two; A.C. Circuits. This is your next step in understanding the basics of electronics. You will learn about how coils, transformers, capacitors, etc are used in common circuits. **Order Code VT202**

VT203 57 minutes. Part Three; Semiconductors. Gives you an exciting look into the world of semiconductors. With basic semiconductor theory. Plus 15 different semiconductor devices explained. **Order Code VT203**

VT204 56 minutes. Part Four; Power Supplies. Guides you step-by-step through different sections of a power supply. **Order Code VT204**

VT205 57 minutes. Part Five; Amplifiers. Shows you how amplifiers work as you have never seen them before. Class A, class B, class C, op.amps. etc. **Order Code VT205**

VT206 54 minutes. Part Six; Oscillators. Oscillators are found in both linear and digital circuits. Gives a good basic background in oscillator circuits. **Order Code VT206**

By the time you have completed VT206 you have completed the basic electronics course and should have a good understanding of the operation of basic circuit elements.

VCR MAINTENANCE

VT102 84 minutes: Introduction to VCR Repair. Warning, not for the beginner. Through the use of block diagrams this video will take you through the various circuits found in the NTSC VHS system. You will follow the signal from the input to the audio/video heads then from the heads back to the output. **Order Code VT102**

VT103 35 minutes: A step-by-step easy to follow procedure for professionally cleaning the tape path and replacing many of the belts in most VHS VCR's. The viewer will also become familiar with the various parts found in the tape path. **Order Code VT103**

Each video uses a mixture of animated current flow in circuits plus text, plus cartoon instruction etc., and a very full commentary to get the points across. The tapes are imported by us and originate from VCR Educational Products Co, an American supplier. (All videos are to the UK PAL standard on VHS tapes)

Now for the digital series of six videos. This series is designed to provide a good grounding in digital and computer technology.

VT301 54 minutes. Digital One; Gates begins with the basics as you learn about seven of the most common gates which are used in almost every digital circuit, plus Binary notation. **Order Code VT301**

VT302 55 minutes. Digital Two; Flip Flops will further enhance your knowledge of digital basics. You will learn about Octal and Hexadecimal notation groups, flip-flops, counters, etc. **Order Code VT302**

VT303 54 minutes. Digital Three; Registers and Displays is your next step in obtaining a solid understanding of the basic circuits found in today's digital designs. Gets into multiplexers, registers, display devices, etc. **Order Code VT303**

VT304 59 minutes. Digital Four; DAC and ADC shows you how the computer is able to communicate with the real world. You will learn about digital-to-analogue and analogue-to-digital converter circuits. **Order Code VT304**

VT305 56 minutes. Digital Five; Memory Devices introduces you to the technology used in many of today's memory devices. You will learn all about ROM devices and then proceed into PROM, EPROM, EEPROM, SRAM, DRAM, and MBM devices. **Order Code VT305**

VT306 56 minutes. Digital Six; The CPU gives you a thorough understanding in the basics of the central processing unit and the input/output circuits used to make the system work. **Order Code VT306**

By now you should have a good understanding of computer technology and what makes computers work. This series is also invaluable to the computer technician to understand the basics and thus aid troubleshooting.

VT401 61 minutes. A.M. Radio Theory. The most complete video ever produced on a.m. radio. Begins with the basics of a.m. transmission and proceeds to the five major stages of a.m. reception. Learn how the signal is detected, converted and reproduced. Also covers the Motorola C-QUAM a.m. stereo system. **Order Code VT401**

VT402 58 minutes. F.M. Radio Part 1. F.M. basics including the functional blocks of a receiver. Plus r.f. amplifier, mixer oscillator, i.f. amplifier, limiter and f.m. decoder stages of a typical f.m. receiver. **Order Code VT402**

VT403 58 minutes. F.M. Radio Part 2. A continuation of f.m. technology from Part 1. Begins with the detector stage output, proceeds to the 19kHz amplifier, frequency doubler, stereo demultiplexer and audio amplifier stages. Also covers RDS digital data encoding and decoding. **Order Code VT403**

VT501 58 minutes. Fibre Optics. From the fundamentals of fibre optic technology through cable manufacture to connectors, transmitters and receivers. **Order Code VT501**

ORDERING: Add £1.50 p&p per order for UK orders. **OVERSEAS ORDERS:** Add £3 postage for countries in the EEC. Overseas orders outside the EEC countries add £3 per tape airmail postage (or £6 per order surface mail postage).

All payments in £ sterling only (send cheque or money order drawn on a UK bank).

Visa and Mastercard orders accepted - please give card number, card expiry date and cardholder's address if different from the delivery address.

Orders are normally sent within seven days but please allow a maximum of 28 days - longer for overseas orders.

Send your order to: Direct Book Service, 33 Gravel Hill, Merley, Wimborne, Dorset BH21 1RW (Mail Order Only)

Direct Book Service is a division of

Wimborne Publishing Ltd.,

Tel: 01202 881749. Fax: 01202 841692

£29.95
each inc. VAT

UCANDO
VCR EDUCATIONAL PRODUCTS COMPANY
PRESENTS

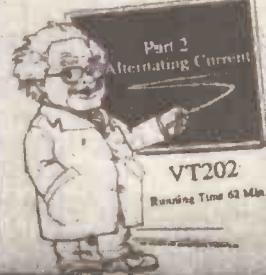

UCA
VCR EDUCATIONAL

PHOTOTRANSISTOR

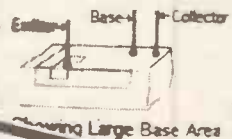

ORDER EIGHT OR MORE TOGETHER - GET ONE FREE (or order 16 together and get TWO FREE)

★★★★ **NEW** ★★★★★

VT502 LASER TECHNOLOGY

The latest release from UCANDO is a 57 minute video on Laser Technology. The video is divided into five sections each looking at a different type of laser. Following a basic introduction covering some of the common uses of laser devices, the video proceeds to cover the operation of the Ruby Rod laser, HeNe laser, CO₂ gas laser and semiconductor laser devices. It also covers the basics of CD and bar code scanning.

PHOTOTRANSISTOR



HEARING TESTER

JOHN BECKER



Find out how well your hearing responds to frequency and volume, and gain a useful item of workshop audio test gear.

ARGUABLY, next to sight, hearing is our second most valuable sense. Consequently, even if no doubt about its effectiveness exists, it can still be reassuring to have its quality assessed in terms of frequency and amplitude threshold response.

The Hearing Tester described here offers a means of doing a non-medical check of how well your ears behave. It has been designed as a simple to use unit from which quantitative frequency and amplitude measurements can be taken using an existing digital voltmeter (DVM). Results can be recorded and used as a reference for future tests.

Tests can be made using any stereo headphones, including those which were cover-mounted (UK copies only) on last month's *EPE*. Loudspeakers, from four ohms upwards can also be driven by the unit. Each channel can deliver 500mA.

Additionally, the unit can be used as a workshop Audio Signal Generator. It generates three waveforms, square, triangle, and an approximation to a sine wave. It is for use on a 9V d.c. power supply or battery. The frequency range is about 128Hz to over 19kHz and output amplitude is variable from nil to about 3V peak-to-peak.

Although the unit produces good results, it should not be considered as a precision

workshop instrument. Nor should it be regarded as a definitive medical tool.

FREQUENCY GENERATOR

The block diagram for the Hearing Tester is shown in Fig. 1. At the left of the illustration, the first block is the Frequency Generator module. Perhaps, more specifically, it should be termed a Function Generator since it produces three

waveforms. The circuit diagram for this block is shown in Fig. 2.

The first point to note is the reference voltage circuit around op.amp IC1c. Resistors R1 and R2 halve the nominal 9V power supply voltage and capacitor C1 smooths it. IC1c buffers and outputs it from pin 8, where C2 provides additional smoothing. This 4.5V reference voltage is made use of by all main circuit blocks except for the frequency-to-voltage converter in Fig. 5.

The oscillator circuit itself is formed around IC1a and IC1b. It is a conventional dual op.amp configuration in which the frequency is principally set by capacitor C6 and the total feedback resistance provided by resistor R9 and potentiometers VR1 and VR2.

Coarse frequency setting is done by VR2, and VR1 sets it more precisely.

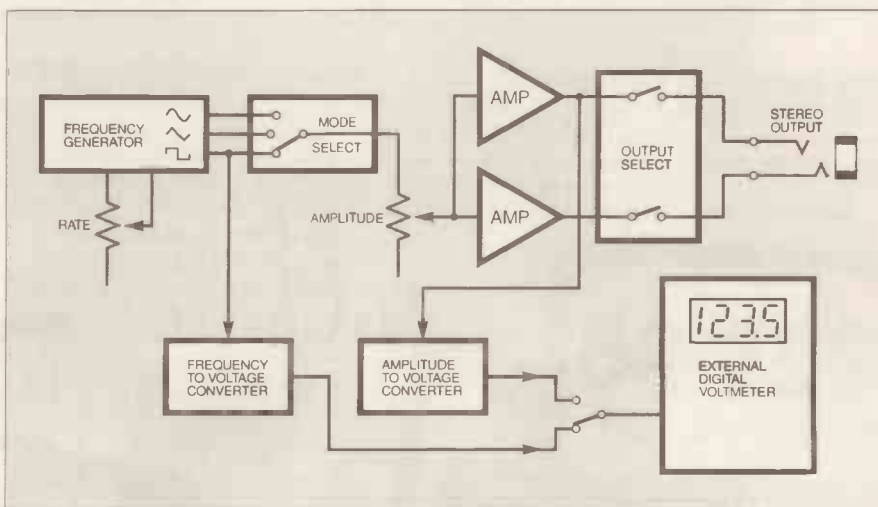

Fig. 1. System block diagram for the Hearing Tester.

Note, though, that the effect of using VR1 will only be of significance when VR2 is set for a low resistance, i.e. for higher frequency use.

SQUARES AND TRIANGLES

A triangle wave is output from IC1a pin 1, and a square wave is output from IC1b pin 14. If an external frequency counter is to be used, the square wave output is available to it via the optional socket SK4.

Square wave amplitude is the maximum voltage swing that can be achieved at IC1b's output, about 7V peak-to-peak (pk-pk) for a 9V power supply.

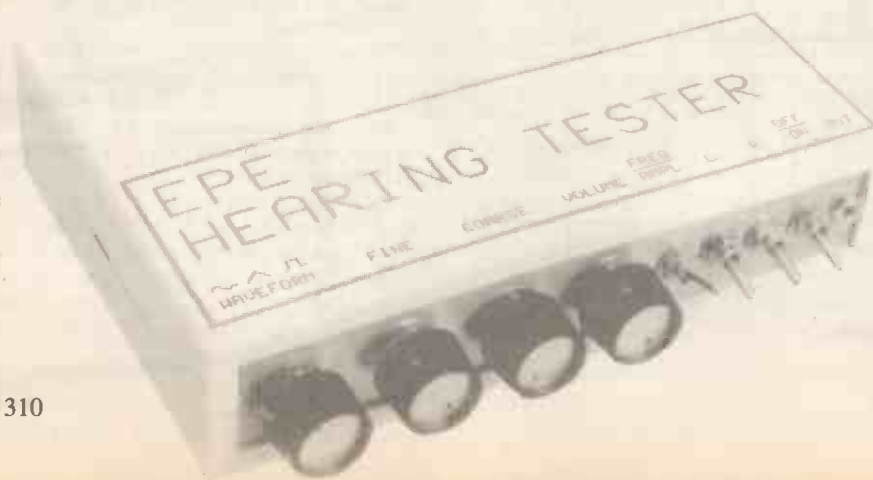

On the other hand, the triangle wave amplitude is determined by the hysteresis factor set by resistors R7 and R10. With the resistance values shown, the triangle has a pk-pk swing of about 3V. The swing can be reduced by increasing the value of R10, or reducing the value of R7. It is not advisable to try for a larger swing since this may prevent the circuit from oscillating.

THIRD WAVEFORM

Loosely described above as a sine wave, the third waveform is in reality a flattening of the triangle wave rather than a true sine. This is the only waveform which is to be used for hearing tests since the other two, especially the square wave, could contain harmonic frequencies which might cause a false hearing response.

The triangle wave is fed through capacitor C5 and resistor R11 to the back-to-back diodes D1 and D2. The other ends of the diodes are held at the mid-range voltage level from IC1c pin 8.

Due to their forward voltage drop, the diodes attenuate the signal to approximately 1V pk-pk. The signal is then fed via R3 to op.amp IC1d. Here it is amplified by about three times, according to the ratio of R3 to R5, producing an output swing at IC1d pin 7 of roughly 3V pk-pk.

SIGNAL OUTPUT

All three waveforms are routed to switch S2, which selects the one to be fed via C4 to the Volume control VR3. The square wave is fed via an additional resistor, R12. This limits its maximum swing available from VR3 to just over 3V

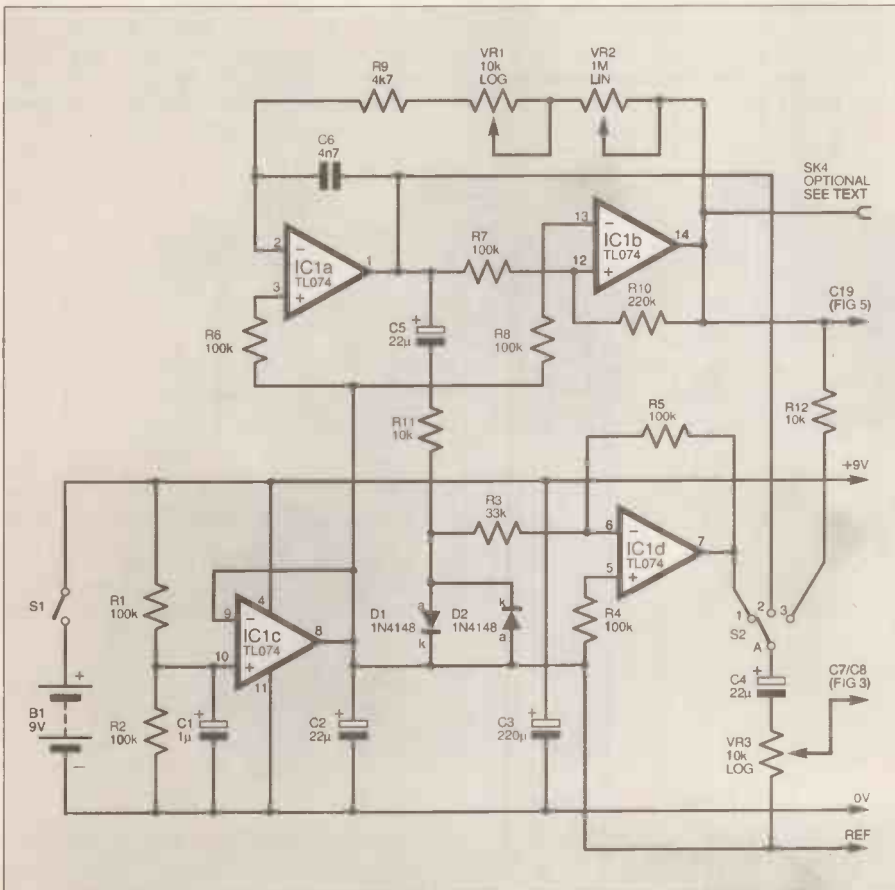

Fig. 2. Circuit diagram for the oscillator/frequency generator stage of the Hearing Tester.

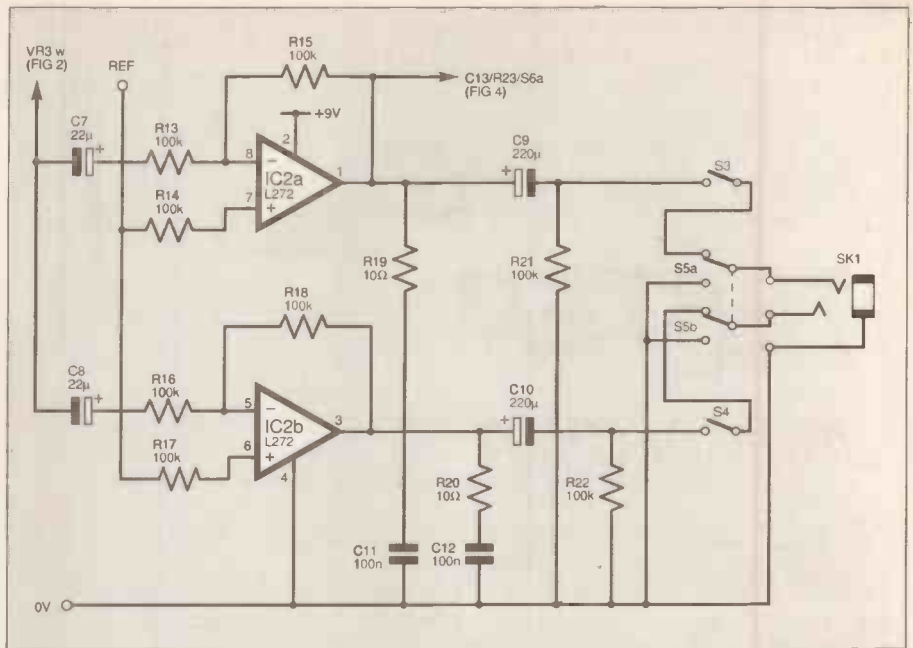

Fig. 3. Circuit diagram of the stereo power amplifier stage.

pk-pk. Effectively, all waveforms thus have roughly the same practical maximum amplitude.

From VR3, the signal is fed jointly to the stereo power amplifier, whose circuit diagram is shown in Fig. 3.

Both amplifier channels are identically formed around the dual power op.amp IC2a and IC2b. The signal is capacitively coupled inwards by C7 and C8. As set by resistors R13/R15 and R16/R18, the signals are merely buffered, i.e. given neither gain nor attenuation.

The op.amp outputs are then coupled via C9 and C10 to the switched network formed by S3, S4 and S5. From there, the selected signal(s) can be fed to stereo headphones or loudspeakers.

Inclusion of the two Zobel networks, consisting of R19/C11 and R20/C12, prevents high frequency instability from occurring.

Four switched output options are available: left on, right on, both on, both off. Switches S3 and S4 select channel signal routing to S5. Resistors R21 and R22 reduce the possibility of signal clicks being heard when S3 and S4 are switched on. They are not totally effective in this, and very tiny clicks can still be heard when listening attentively.

Switch S5 is double-poled and serves as a master output on/off switch. In its off position, the headphones or speakers are held grounded on all terminals, ensuring that no signal breakthrough can be heard.

The L272 op.amp specified can supply 500mA from each channel. It does not need a heatsink. Using the EPE cover-mounted headphones from last month's issue (UK only), a random sample of which was found to have a resistance of 52 ohms, the maximum output power from the circuit in Fig. 3 is about 58mW pk-pk per channel.

AMPLITUDE DETECTOR

The circuit which detects the r.m.s. amplitude of the signal output from the amplifier is shown in Fig. 4.

Basically, it is a precision rectifier circuit, but, unlike some rectifiers, it does not produce a smooth d.c. output. Rather, it retains the original input a.c. waveform whilst superimposing on it a d.c. level relative to its amplitude.

The d.c. difference between the input and output waveforms is then monitored by a "floating" meter. The common meter input (COM) is connected to the original signal, which provides a reference level, and the processed signal is fed to the other meter input (+VE).

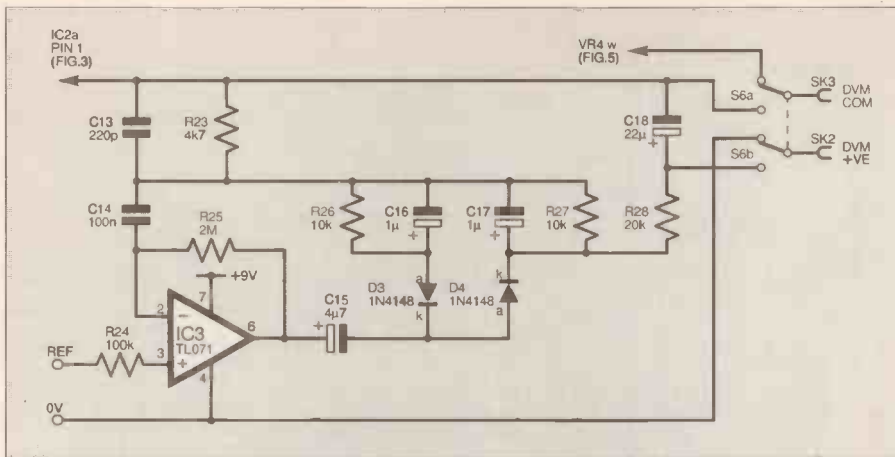

Fig. 4. Circuit diagram for the r.m.s. amplitude detector/rectifier stage.

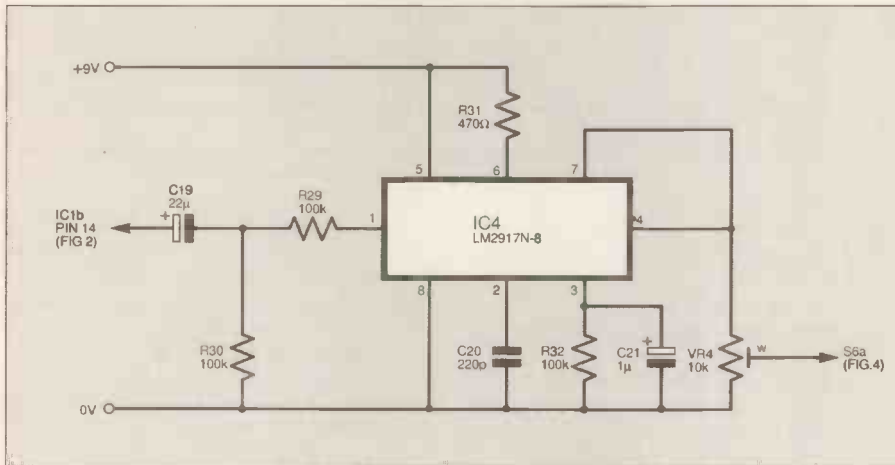

Fig. 5. Circuit diagram for frequency-to-voltage converter section.

Both parts of S6 are shown in the amplitude monitoring position. Their other position is used for connecting the meter to the frequency-to-voltage converter in Fig. 5. For that circuit, the output to the meter is referenced to the 0V line.

Although a TL071 op.amp is specified for IC3, chosen for its extended frequency range, in practice a 741 has also been found satisfactory for the unit's role as a hearing tester. The 741 has a lower frequency range than the TL071, but its output is linear enough up to at least 16kHz, beyond which frequency most human ears cannot hear.

The circuit is *not* suitable for use with a normal analogue meter due to the latter's low input impedance which will adversely affect the reading.

FREQUENCY MONITORING

A commonly encountered tachometer circuit is used to convert the signal frequency to an equivalent d.c. voltage. Its diagram is shown in Fig. 5.

Via capacitor C19 and resistor R29, the square wave signal from IC1b pin 14 in Fig. 2 is input to IC4 pin 1. Capacitor C20 differentiates the input pulses, shortening their length by an amount relative to the capacitance value - smaller capacitance, shorter pulses. These pulses are fed to capacitor C21, which charges up by an amount relative to the their duration. Between pulses, C21 is discharged at a rate determined by resistor R32.

After a bit of further internal processing, the level of the voltage on C21 is output from IC4 pin 4 to the load potentiometer VR4. The latter is used to set the actual voltage sent to the meter via switch S6, enabling trimming of the meter reading to match the frequency. An alternative trimming method would have been to make R32 a variable resistor.

Using the meter on a suitable d.c. range, the resulting reading is the r.m.s. value of the difference between the two signals. Observing both waveforms on a dual-trace oscilloscope will show the effect.

In the circuit of Fig. 4, the input signal is taken from IC2a pin 1 (Fig. 3). This

signal is also routed to the meter common connection via switch S6a. The signal is processed by the network around IC3, with diodes D3 and D4 performing full-wave rectification. The resulting signal at the junction of R28 and C18 is output to the meter's positive connection via S6b.

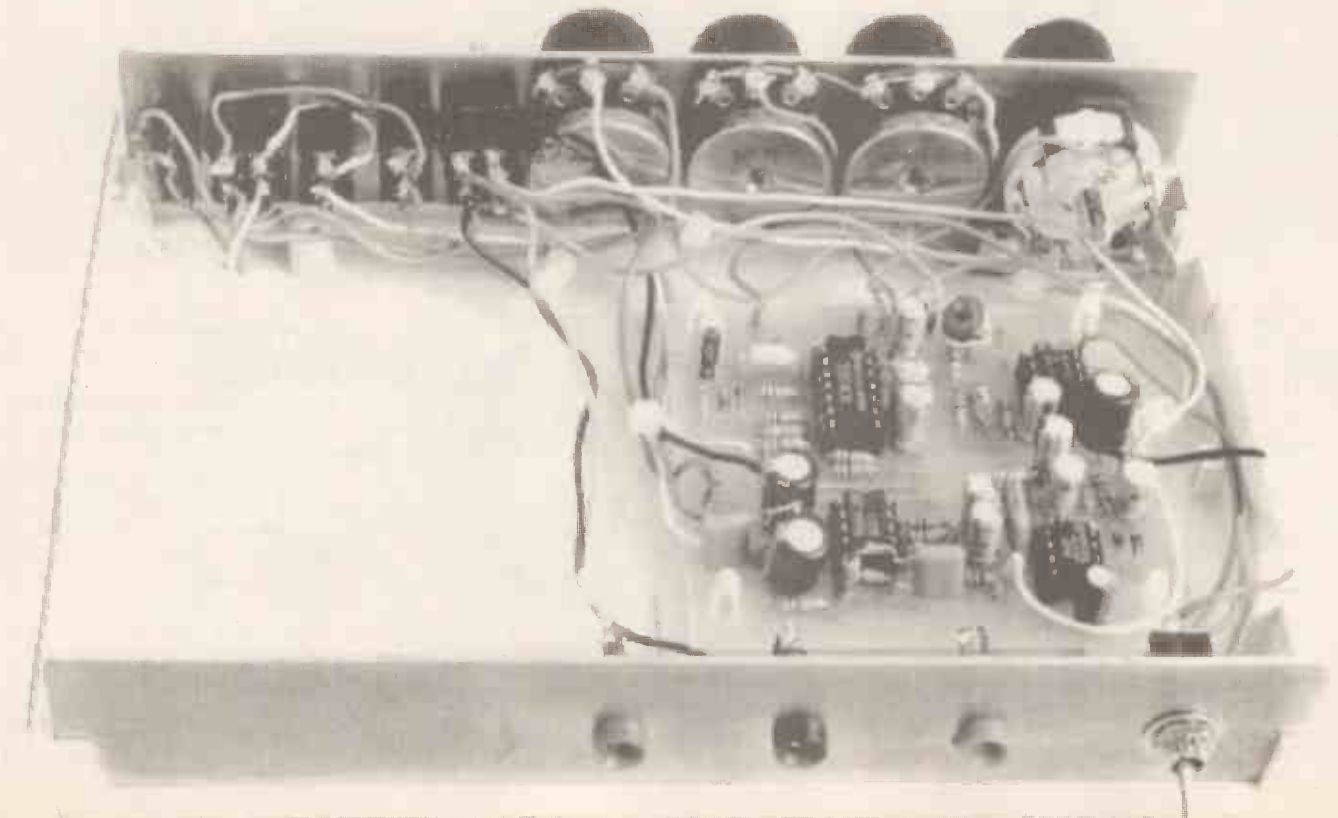

HEARING TESTER

BOARD CONSTRUCTION

COMPONENTS

Resistors

R1, R2, R4 to R8, R13 to R18, R21, R22, R24, R29, R30, R32	100k (19 off)
R3	33k
R9, R23	4k7 (2 off)
R10	220k
R11, R12, R26, R27	10k (4 off)
R19, R20	10Ω (2 off)
R25	2M
R28	20k
R31	470Ω

All 0.25W 5% carbon film or better

Capacitors

C1, C16, C17, C21	1μ radial elect. 16V (4 off)
C2, C4, C5, C7, C8, C18, C19	22μ radial elect. 16V (7 off)
C3, C9, C10	220μ radial elect. 16V (3 off)
C6	4n7 polystyrene
C11, C12, C14	100n polyester (3 off)
C13, C20	220p polystyrene (2 off)
C15	4μ7 radial elect. 16V

Potentiometers

VR1, VR3	10k rotary carbon, log. (2 off)
VR2	1M rotary carbon, lin.
VR4	10k min. round carbon, preset

Semiconductors

D1 to D4	1N4148 signal diode (4 off)
IC1	TL074 quad f.e.t. op.amp
IC2	L272 dual power op.amp
IC3	TL071 f.e.t. op.amp
IC4	LM2917N-8 tachometer

Miscellaneous

S1, S3, S4	s.p.d.t. min. toggle switch (3 off)
S2	single-pole 3-way rotary switch (or 4p 3w)
S5, S6	d.p.d.t. min. toggle switch (2 off)
SK1	3.5mm stereo jack socket
SK2, SK3	socket to suit DVM (2 off)
SK4	socket to suit external frequency counter (optional - see text)

Printed circuit board, available from the *EPE PCB Service*, code 985; 8-pin d.i.l. socket (3 off); 14-pin d.i.l. socket; knob (4 off); plastic case, size 180mm x 120mm x 40mm, with separate front and rear panels; stereo headphones (see text); self-adhesive p.c.b. support (4 off); 9V battery and clip or holder; cable ties; 1mm terminal pins; connecting wire; solder, etc.

See
**SHOP
TALK**
Page

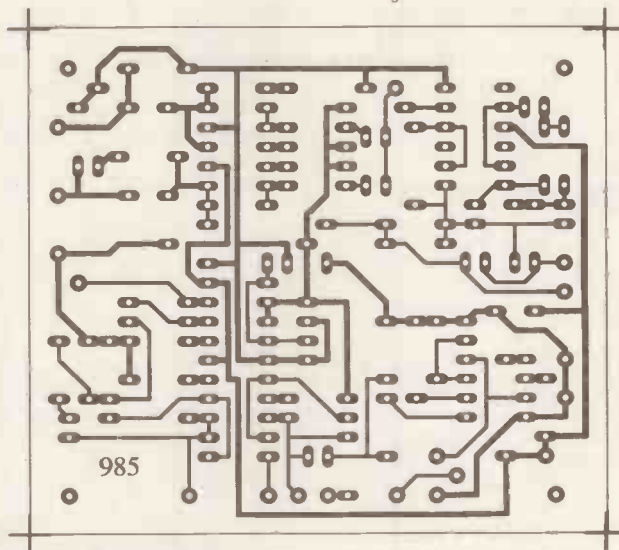
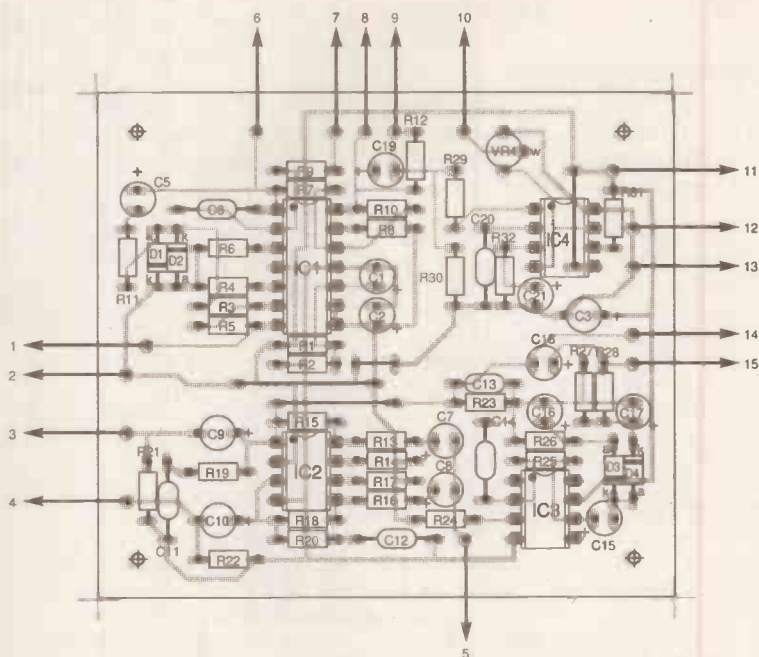
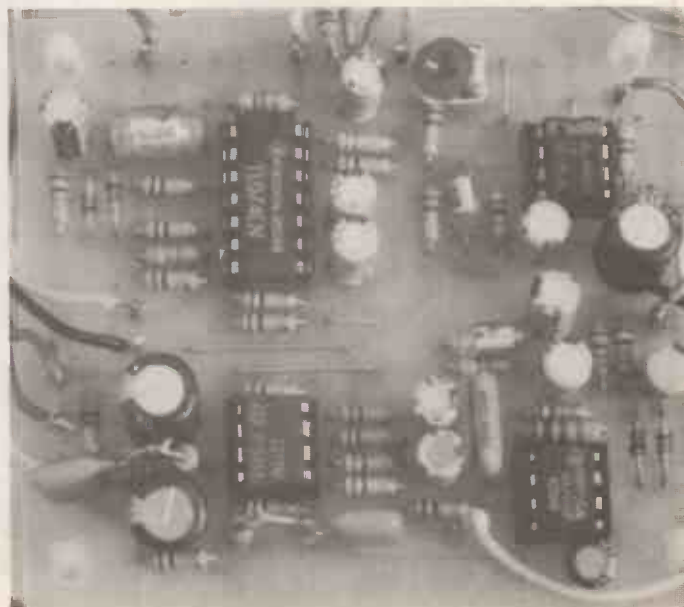

Fig. 6. Printed circuit board topside component layout and underside full size copper foil master pattern for the Hearing Tester. The completed prototype p.c.b. is shown below.



Approx cost
guidance only

£29
excluding case

Resistor R31 feeds the power supply to an internal Zener diode reference voltage generator.

CONSTRUCTION

The Hearing Tester is built on a single printed circuit board (p.c.b.), full details of which are shown in Fig. 6. The board is available from the *EPE PCB Service* code 985.

Start off p.c.b. assembly by inserting the four on-board wire links, one of which goes under IC4. Other components may be inserted and soldered in any order you feel content with, probably in order of size, taking note of polarities where marked. Finally, insert 1mm terminal pins for the wires to the off-board components.

The unit is housed in a plastic case of the type which has separate aluminium front and rear panels. Drill them out according to the measured positions shown in Fig. 7.

If the unit is not to be used with an external frequency counter, socket SK4 can be omitted.

Wire up the p.c.b. to the panel mounted components, as also shown in Fig. 7. Note that capacitor C4 is mounted on switch S2, using the latter's pin 6 as an anchor point for the negative connection.

Be neat with the interconnecting wires, using cable ties to keep them tidy. The use of screened cable is not required.

CHECKING OUT

Using a close-up magnifying glass, check all the soldered joints and make sure there are no solder shorts between i.c. pins. Double-check component positioning and polarity.

Plug in the headphones and connect up the power, either from a 9V battery, or a 9V power supply. Set rotary switch S2 to the third position, for square wave, and turn down volume control VR3 to minimum (to protect your ears at switch on!). Switch on all toggle switches.

Check that approximately 4.5V is available at IC1 pin 8. Play around with the settings of all three panel pots, varying the signal amplitude and frequency. Turn switch S3 through all three positions, checking that a different quality of sound is available at each position, bright for square wave, less bright for triangle, and mellow for sine.

Confirm that switches S3, S4 and S5 behave as expected.

METER CHECKING

Set a DVM to a d.c. voltage range of about 2V maximum and connect its leads appropriately into SK2 and SK3. Switch S6 to the Amplitude setting. Turning up VR3 from minimum to maximum, the meter reading should change from about 0V to 1.4V. This shows the r.m.s. value of the signal being output to socket SK1. There may be a very slight voltage difference between the low and high frequencies for the same setting of VR3.

Switch S6 to the Frequency setting, leaving the meter still connected. If a frequency counter is available, connect it to SK4. Turn VR1 and VR2 to maximum, for the highest frequency. Note the frequency counter reading, say 19410Hz. Observe the meter and adjust preset VR4 until it shows an equivalent reading, i.e. 1.941V.

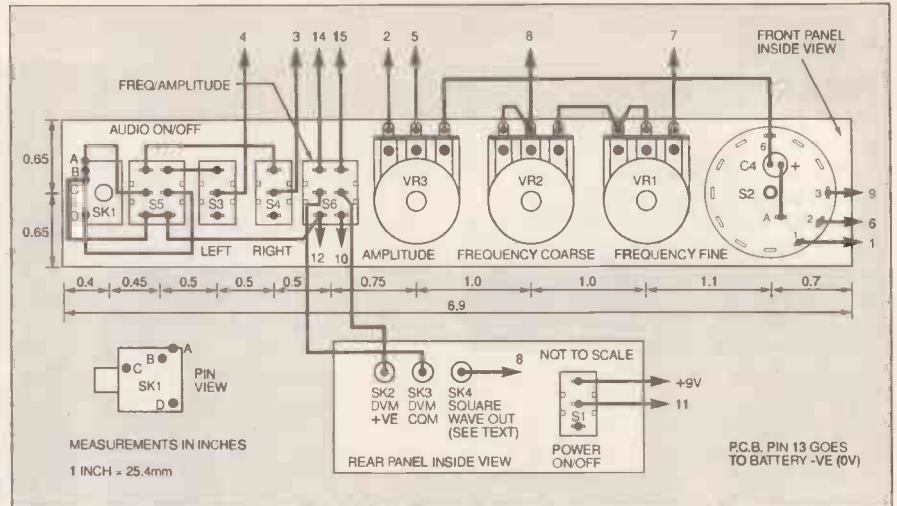

Fig. 7. Drilling and wiring details for the Hearing Tester front and rear panels.

Set VR1 and VR2 for minimum frequency and compare the frequency counter and meter readings. To within a few Hertz/mV, they should be similar, although probably not identical. On the prototype, 128Hz produced a meter reading of 16.5mV (which, strictly speaking, should represent 165Hz). Since the hearing tests are mainly concerned with the ability to hear mid to high frequency signals, the bottom end of the frequency scale is less important.

If an external frequency counter is not available, it should be assumed that the maximum rotation of VR4 produces a voltage output which, for all practical purposes, adequately represents the frequency.

IN USE

To actually check out hearing ability, each ear should be tested separately, ascertaining at what amplitude a given frequency is just heard.

Originally, it had been expected that this would best be carried out switching

the master output switch, S5, on and off. Tests showed, though, that fractionally varying the volume level up and down established a better hearing threshold result. Indeed, S5 could be omitted if preferred.

Hearing tests *must* be carried out in a silent room. Although it may be tempting to have a computer turned on in order to key-in the various readings taken, mechanical noise from the computer will prevent hearing thresholds from being reliably monitored. (Does no-one make a PC that's silent? They all seem to generate disk drive rotation noise.)

For reasons unknown, it was found that using an external frequency counter plugged in while doing hearing tests caused harmonic interference, at upper frequency levels. This could be heard on the headphones, only at a very low level though, but one which was sufficient to disrupt the tests for minimum audible signal amplitude. Consequently, *only* the DVM should be used during these tests – unplug an external counter.

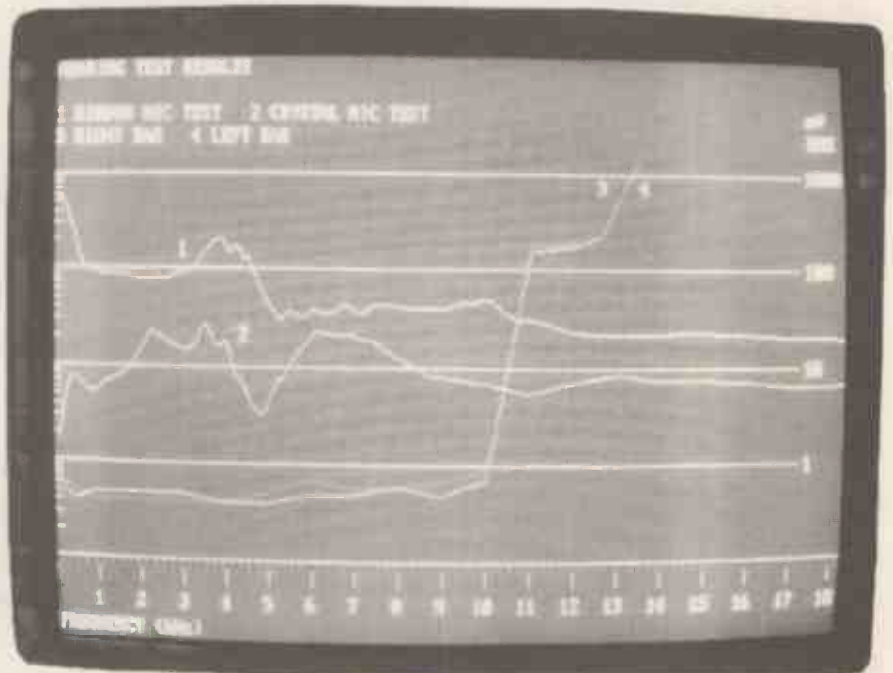

Screen graph plots showing: (1) plot of r.m.s. readings and (2) headphone characteristic test plot using a cheap crystal microphone. Graphs (3) and (4) show the designer's test results.

Have a large sheet of paper handy on which to jot down meter readings.

HEAR, HEAR

Put on the headphones, making sure that they fit comfortably in the best position. Switch off one channel and set both frequency and output volume to maximum. Set switch S2 to Sine wave. It is highly unlikely that anything will be heard.

Slowly, using Fine control VR1, reduce the frequency until it is just audible. Fractionally turn VR1 back and forth until the exact point at which the tone is heard is found. With S6 set to Frequency, note the meter reading.

Gradually reduce the volume until the tone is no longer heard. Minutely adjust the volume up and down until the threshold point is firmly established. Switch S6 to Amplitude and note the meter reading.

Patience is now required for the rest of the tests! The author opted to check the amplitude thresholds in the same above fashion at approximately 100Hz intervals – time consuming! At each frequency, it and its amplitude were noted down.

Having done this for one ear, do it for the other. Turn the headphones round so that the same earpiece is being used (in case of imbalance between the earpieces).

Do the same tests again, from high to low frequency, noting the meter readings. If patience still exists, both sets of tests can be done again using the other earpiece, remembering to switch over channels with S3 and S4.

GRAPHICS

From the noted figures, graphs can be drawn showing clearly how each ear has responded. The author entered the figures into a text file via a word processor. A QuickBasic routine was then written which automatically screen-plotted graphs from the file data. The results are shown in the screen photo. Amplitude values are plotted logarithmically, frequency values are plotted linearly.

Graphs three and four show the ear test results. Before commenting on them, though, an explanation of the other two graphs:

Since the Hearing Tester was intended to be used with last month's (UK copies only) *EPE* cover-mounted headphones, it seemed prudent to check their linearity in case some form of frequency/amplitude compensation needed to be added to the circuit. (It had been confirmed previously that the Hearing Tester's overall response would be predominantly linear.)

RESPONSE TESTS

A pair of headphones was plugged into the unit and placed alongside a very good quality ribbon microphone. The mic was then plugged into the preamp of a Revox (very high quality) tape recorder, whose characteristics can be set for a flat response across a frequency range which spans well to either side of the Hearing Tester's.

Setting the preamp for an arbitrary gain factor, an oscilloscope and DVM were connected to the Revox's headphone output. At 100Hz intervals from 128Hz to 10kHz, the Hearing Tester frequency was altered and the scope and meter readings noted. Readings were then taken at 1kHz intervals. The scope readings were taken as pk-pk

voltages, whereas the meter readings were taken as r.m.s. voltages.

Graph line one in the photo shows a plot of the r.m.s. readings. On the assumption the mic and the Revox responses are linear across the frequency range monitored, the graph shows some interesting facts.

The first is that, despite their small size, the headphones show an *increase* in output level at the low end of the frequency scale. A *decrease* had been expected.

Secondly, following an initial reduction which roughly levels off from 700Hz to 3kHz, the output peaks in amplitude at around 3.8kHz. It then falls again until 5kHz, after which it remains fairly consistent until 10kHz, falling a bit to 12kHz. Now it stays remarkably flat right beyond 19kHz (the screen display is notated to 18kHz).

The same test was done for three other sets of the headphones. Although their responses are not shown on the graph, the results were very similar for each of them, a difference of only a couple of hundred Hertz being noticed for where the middle peak occurred. This was true for both left and right earpieces when tested separately.

It is assumed that the middle peaking has been intentionally designed into the headphones to suit the characteristics of music played through typical audio units.

Also of interest was the fact that across the frequency range, the scope waveform remained quite-well shaped.

Graph two was created purely for curiosity's sake, to test and plot the headphone characteristics by using a cheap crystal microphone. The amplitude results were markedly different.

Furthermore, the waveform shape generated by the mic in response to a sine wave audio signal from the headphones was horrendous! Full of distortions, peaks and troughs, not to mention harmonics. Obviously a cheap mic is totally unsuitable for testing headphone response.

HEARING GRAPHS

Returning to the hearing graphs, the amplitude balance between the two ears is shown to be pretty even across the entire frequency range. Minor differences are probably due more to experimental error than actual dissimilarities.

What is interesting, though, is that the amplitude threshold is at a very low level for frequencies from 128Hz to about 10kHz, typically between 0.4mV r.m.s. and 0.8mV r.m.s. (the Volume control was close to its minimum setting). The amplitude required then increases dramatically from 10kHz to 11kHz, at which the level is about 105mV r.m.s.

At the top end of the scale, an imbalance between the maximum frequency heard by each ear becomes apparent. The right ear is

capable of hearing up to a maximum frequency of 12.6kHz, whereas the left ear can hear up to 13.6kHz. The amplitude at this point is about 1V r.m.s.

DEFECTIVE HEARING

There could be many reasons for which other people's hearing tests might result in graphs that are significantly different from each other. Age is one factor; the ability to hear high frequencies and low amplitudes decreases as the body gets older. A "normal" youthful ear can probably hear frequencies between about 16Hz and 16kHz at reasonably low amplitude levels.

A point not to be overlooked is that measured responses may also differ between individuals whose ears are equally perfect. The fact is that some people are able to concentrate harder than others when *listening* for a sound.

Acoustic musicians, sound engineers, film technicians and other audio professionals are more likely to be able to pick out tones at lower levels than those who are untrained. They can *focus* on them. Beware, though, that short bursts of low level tones can be *imagined* when concentrating hard!

However, an easily corrected situation might exist which prevents satisfactory hearing, both of amplitude and frequency. A natural body process is to produce wax in the ears. Despite normal hygiene, this can build up, causing a partial blockage which impedes sound trying to reach the eardrum. The effect can be like having cotton wool in the ears.

This situation can be cured by having the ears syringed, a simple matter which can be carried out by a doctor or surgery nurse. Warm water is gently flushed into the external ear passages, either with a broad-bore syringe, or via a tube attached to a tiny pulsed pump. It's actually quite a pleasant experience, and it can dramatically improve hearing. *Do NOT try doing it for yourself – serious ear damage could be caused.*

It may also be found that hearing ability is reduced during a cold, and for two or three weeks after it. Internal ear passages can become blocked as a result of a cold, dampening the response of the various ear mechanics. Hearing tests made during and after a cold could show interesting response changes.

A more serious hearing disorder might be found in those who are regularly subjected to high levels of sound. Prolonged periods of exposure can result in deafness. Amplified musicians and disco-goers beware!

Finally, whilst it is stressed that the Hearing Tester should not be regarded as a medical tool, if it gives you *any* doubt about the effectiveness of your hearing, *seek professional medical advice.* □



Wiring to front panel controls and output socket.

CHROMO-FLORISTICS

ZOLA McMALCOLM



Photo: A make-shift rigid wire frame makes an ideal support for the I.e.d.s, readily allowing them to be angled into position.

Using only a few PC-controlled I.e.d.s, plant colourings can be modified to order.

WITH Spring sprung, and Winter now nearly an ice-age behind, gardener's thoughts are well turned to the newly softened soil and the greenness thrusting its inquisitive feelers into the milder air. Life, never truly dormant even in the depths of snow and ice, is bursting forth once more, every bud hastening upwards and outwards in the race to bloom and catch the attention of winged insects, unwitting pollen-covered transient messengers, bearing the cyphers whose key is the catalyst that sparks the creation of this year's seeds, from which will germinate another generation in another year, an unending cycle, new each similar season, but ancient in the unrelenting urge for the species and its genes to survive.

Few of us can resist the temptation to play our part in shaping the survival path of domestic plant species, caring and attending them within our own small plot of earth, keenly helping Garden Centre sales bloom as greatly as the myriad varieties of flowers and trees and shrubs we eagerly select and transport home, saloons and hatchbacks, estates and vans laden to the roof, a modern Woods of Birnham or Dunsinane on the move again to conquer barrenness around the flowerbed-moted castles we call Home.

BIO-BOTANICS

Yet, as you probably know well, it is not just those tending their gardens who are intent on helping Nature perpetuate the different species and sub-species of plants loved for their colours, shapes and perfumes, or flavours on the plate! Behind the horticultural scenes are botanists, chemists and other agricultural specialists who are dedicated to selecting, cross-pollinating, micro-propagating and generally manipulating hybrid plant varieties which, perhaps conceitedly, we regard as superior to those that evolution has for itself created.

As chief experimental botanist for an Electro-Horticultural Research Laboratory, my job for many years has involved research into plant genetic engineering, some aspects of it relating to the enhancement of plant varieties whose blooms are grown to satisfy the public's

pleasure from visual displays. It may surprise some of you, but it is an activity which, in some respects, can heavily involve electronic technology, varying from the simplest of soil moisture sensing irrigation systems, to those which probe deeply into the very nature of the plant's DNA genetic code of life.

Indeed, only a few years back, our main laboratory in Kent pioneered the genetic enhancement of the variety now known affectionately as *Digitalis Electronicus*, the common version of which is better known as the Foxglove (*Digitalis Vulgaris*). This pioneering work resulted in a plant variety whose leaf-cell chemistry was modified to increase the rate at which it could change hue in response to focussed laser beams, an attribute which is destined to become an essential part of electro-biological data storage for the fourth generation of intelligent computers being developed for the 21st Century.

CHROMATIC IRRADIATION

An off-shoot of our experimental work has resulted in the discovery of a side-effect which at present still has a degree of novelty about it, but which is beginning to create an interest amongst

other horticultural researchers, particularly those in the floral belt around Spalding in Lincolnshire, St Floristiane in Jersey, and Bloemingen in Holland. In experiments with plants other than *Digitalis*, certain earlier blooming types were found to exhibit chromatic changes in response to irradiation by particular wavelengths of light.

It will not have gone unnoticed that in temperate climates, such as those in Britain, wild flowers at the end of Winter are likely to be white, such as the snowdrop, those in the early Spring are predominantly yellow, like the daffodil, then as the next few months progress, the dominant colours progress through blues and purples (bluebells and violets), pinks and reds (apple blossoms and poppies), greens (spurges) and whites again (bindweeds).

Whilst it is obvious that there are many exceptions and that not all flowers follow a colour progression pattern with respect to the time of year, and although it is clear that some colours are in response to soil conditions - acid soils can induce redness, alkaline soils can promote blue hues - there is sufficient correlation between petal colour and the changing light wavelength conditions which prevail as Spring progresses on to become

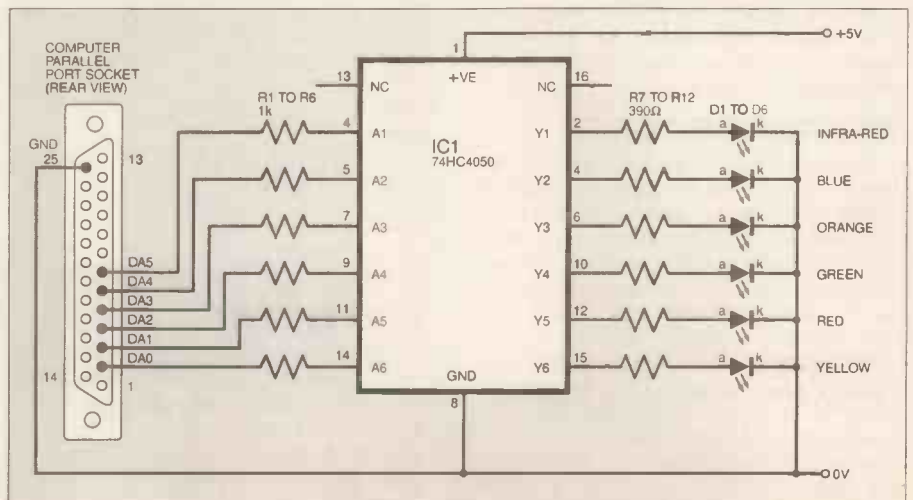

Fig. 1. Simple PC interface circuit for controlling I.e.d.s.

Summer, to support the idea that exposing plants to artificial light of specific colours might engender a synchronic pigmentation response from some of them.

Traditional gardeners may feel reluctant to accept the possibility that light other than white might influence colour changes in plants which are traditionally believed to have their colour determined by genetic factors, arguing instead that light only encourages the plant to grow towards it in order to benefit from its radiant energy. Sceptics should recall, though, that chlorophyll, which is the active chemical substance responsible for a plant's ability to photosynthesise, is green and that it ceases to be produced in the redder shades of Autumnal light; remember the truth in the song line, "When the green leaves of Summer turn to the reds, browns and golds of Autumn, to lie in the gutter, dead"?

SUSCEPTIBILITY

It has been experimentally borne out in laboratory tests, in which quite simple electronic systems were used to control the wavelength of light projected onto young seedlings, that it is possible to change the expected colour of flowers, and that some plants are more susceptible to change than others, notably the primula family in general, and the *Primula Harlequina Apriliosii* (April Harlequin) in particular.

Possibly proving an exception to the above hypothesis, primulas are frequently variegated in their colourings, not uncommonly having different colours produced by the same plant, but despite this (or perchance even because of it - their chroma genes being less rigid in their dominant attributes), they are very responsive to illuminated influence of their flower colours.

Perhaps not surprising, therefore, is the discovery that, during periods when normal illumination is suppressed, i.e. natural night-time hours, very low levels of coloured light can be influential on primulas and that even the humble l.e.d. can be used in the early stages of their growth, changing their colour towards that of the illuminating l.e.d. By positioning different coloured l.e.d.s around a flower bud, as the bud opens it can be found that individual petals have been re-coloured accordingly.

However, an additional factor also plays an important part in the process. It requires the duration of the exposure to be controlled by varying the mark-space ratios of the illumination on/off periods, and this ratio must itself be changed during growth. Obviously it is easy for a computer to generate the necessary waveform ratios for controlling a group of differently coloured l.e.d.s in close proximity to a plant. In our other laboratory at WPL Bio-Research Ltd in Dorset, we have set up over 1500 banks of multiplexed l.e.d. driver circuits which are controlled from the computer's expansion socket and powered from a high current d.c. power supply.

SIMPLE DEMONSTRATION

As proved in our early trials, though, it is possible to demonstrate the effectiveness of the basic technique using a simpler system. All that is required is a PC-compatible computer capable of running one of

Listing 1. Software example.

```

10 REM PLANT CHROMINANCE CONTROL PROGRAM - ZOLA McMALCOLM
15 REM THIS PROGRAM WILL RUN ON QBASIC OR GWBASIC
20 DATA U!F!D!S!F!F!O!J!T!O!P!X!T!I!P!X!J!O!H!U!I!F!D!P!E!F!T!B!O!E!U!I!F!J!S!B!T!D!J!J!F!R!V!J!W!B!M!F!O
30 DATA U!T!X!J!J!D!I!B!S!F!C!F!J!O!H!P!V!U!Q!V!U!P!U!I!F!Q!B!S!B!M!F!M!Q!S!J!O!U!F!S!Q!P!S!U!J!G!J!Z!P
40 DATA V!J!B!W!F!U!I!F!D!J!S!D!V!J!U!P!G!J!H!P!O!F!D!P!O!O!F!D!U!F!E!U!P!M!F!E!T!U!I!F!Z!X!J!M!M!
50 DATA C!F!G!W!B!T!J!O!H!B!D!D!P!E!J!O!H!M!Z!J!U!X!J!M!M!C!F!T!F!F!O!U!P!C!F!B!X!P!S!L!J!O!H!D!J!S!D
60 DATA V!J!U!J!P!U!I!F!S!X!J!T!F!E!F!B!S!F!Q!F!S!F!B!E!F!S!P!M!B!I!T!U!S!F!B!U!F!E!Z!P!V!U!P!B!
70 DATA C!J!U!P!G!B!O!F!M!B!C!P!S!B!U!F!K!P!L!F!U!P!D!P!N!F!N!P!S!B!U!F!B!Q!S!J!M!G!J!S!T!U!T!I!F!F!Y!Q!F
80 DATA D!U!T!U!I!B!U!Z!P!V!J!X!J!M!M!T!F!F!U!I!F!G!V!O!O!Z!T!J!E!F!B!O!E!T!F!O!E!T!U!I!F!B!Q!Q!S!P!Q!S!J!B!U
90 DATA F!H!S!F!F!U!J!O!H!J!H!P!U!D!I!B!J!I!P!X!T!V!Q!F!S!D!I!S!P!N!B!G!M!P!S!B!M!J!U!J!D!Q!S!J!N!P!B!Q!S!J!M!P!D!J!P!V!T"
100 CLS:SCREEN 9:COLOR 15,1:FOR A=1 TO 8:READ A$(A):NEXT S=15:OUT &H378,0
110 DELAY=1:REM THIS IS TEST RUN VALUE. FOR PLANT CONTROL SET DELAY=11371
140 PRINT"PRESS ANY KEY TO TERMINATE EXPERIMENT"
150 LOCATE 5,1:J=5:K=1:G=0:FOR A=1 TO 9:A$(A)=A$(A):FOR C=1 TO LEN(A$)
160 FOR X=1 TO DELAY:NEXT
170 IF INKEY$<>" " THEN COLOR 15,1:LOCATE 18,1:OUT &H378,0:STOP
180 B$=MID$(A$,C,1):J$=B$+CHR$(ASC(DATE$+TIME$)):K$=B$+" "
190 H=ASC(J$)*(2^VAL(J$))-1:IF H=92 THEN J=J+1:K=1:GOTO 250
200 D=H:FOR T=7 TO 0 STEP-1:Z=2^T:W=D/Z
210 IF W>=1 THEN D=D-Z:K$=K$+"1 ":GOTO 230
220 K$=K$+"0 "
230 NEXT:LOCATE 3,20:PRINT H;" ";K$;" ";CHR$(H)
240 LOCATE J,K:PRINT CHR$(H);:K=K+1:OUT &H378,H
250 NEXT:NEXT:PRINT S=(S+1) AND 15:IF S=0 THEN S=2
260 COLOR S,1:GOTO 150

```

the Basic programming dialects through which it can access the parallel printer port that has an electronic buffer connected to it, allowing a few l.e.d.s to be turned on and off with sufficient current flowing through them to make their brilliance meaningful (the computer port has insufficient power available to satisfactorily turn on l.e.d.s directly), as shown in the drawing of Fig. 1.

The circuit consists of a buffering integrated circuit type 74HC4050 (IC1) connected to the computer's parallel printer port, with the i.c.'s six outputs coupled to variously coloured l.e.d.s, D1 to D6, via current-limiting resistors R7 to R12. The six inputs of IC1 control the l.e.d.s according to codes supplied by the computer, and they are buffered by resistors R1 to R6 in order to avoid loading conflict when the computer is turned on but IC1 is not.

Naturally, the l.e.d.s must have their colours arranged as shown to correspond to the controlling mark-space ratio pulses output according to the computer program. The infra-red l.e.d.'s purpose is to create a very dark red petal colour. This simple circuit can easily be put together on a small piece of stripboard, connecting the l.e.d.s to it via wires which are long enough for them to be positioned around plants, as shown in the heading photograph. It must only be powered from a 5V or 6V power supply (a 6V battery is suitable).

SOFTWARE

An example of a Basic program written to suit normal primulas (the hybrid laboratory variety is not publicly available) is shown in Listing 1. All you need to do is plug the buffer circuit board into the computer parallel port socket (via wires connected to suitable plug of course - 25-way D-type male connector), place the l.e.d.s

close to the selected flower buds and run the program. The screen will start to display the codes being output to the l.e.d.s in a readily understandable format.

Colour influencing by the l.e.d.s is most beneficial at night when the plants are in a quasi-dormant state; daylight should still be allowed to reach the plants to let normal growth take place. The program should be kept running for as long as you feel it is beneficial, at the longest it will not be needed beyond the day when the flowers have opened fully. It is a program and circuit which can obviously be easily changed to control l.e.d.s for situations other than flower colour modification, in which case, of course, other data codes can be substituted for those shown, and the program simplified.

GARDENERS' CHOICE

Naturally, it cannot be guaranteed that all primulas will respond with a colour change that is readily discernible to the eye (although a spectrometer would probably confirm the hue factor), since primula qualities may differ between garden centres; choose those from a good garden centre which are in very early bud, making a note of their expected colours and keeping them adequately watered, then the chances are that you will be delighted with the results you've achieved.

Although it is likely that all PC-compatible computers will be able to satisfactorily run the Basic program, you are strongly advised to type in the program and run it before spending any money on components, just in case the computer comes up with unexpected display results, which should tell you whether or not it is worth building the experiment. There is no reason, though, why you shouldn't buy the primulas now, they are colourful in any event and should bring you a lot of pleasure. □

£1 BARGAIN PACKS

- List 5

If you would like to receive the other four £1 lists and a lot of other lists, request these when you order or send SAE.

TEST PRODS FOR MULTIMETERS with 4mm sockets. Good length very flexible lead, Ref: D86.
8 OHM PM SPEAKERS, size 8" x 4", pack of two. These may be lightly rusty and that is why they are so cheap but are electrically OK, Ref: D102.
PAXOLIN PANELS, size 6" x 6", approximately 1/16" thick, pack of two, Ref: D103.
13A SOCKET, virtually unbreakable, ideal for trailing lead, Ref: D95.
PIEZO BUZZER with electronic sounder circuit, 3V to 9V D.C. operated, Ref: D76.
DITTO but without internal electronics, pack of two, Ref: D75.
LUMINOUS ROCKER SWITCH, approximately 30mm sq, pack of two, Ref: D64.
ROTARY SWITCH, 9-pole 6-way, small size and 1/4" spindle, pack of two, Ref: D54.
FERRITE RODS, 7" with coils for Long and Medium waves, pack of two, Ref: D52.
DITTO but without the coils, pack of three, Ref: D52.
SLIDE SWITCHES, SPDT, pack of 20, Ref: D50.
MAINS DP ROTARY SWITCH with 1/4" control spindle, pack of five, Ref: D49.
ELECTROLYTIC CAP, 800µF at 6-4V, pack of 20, Ref: D48.
ELECTROLYTIC CAP, 1000µF + 1000µF 12V, pack of 10, Ref: D47.
MINI RELAY with 5V coil, size only 26mm x 19mm x 1mm, has two sets of changeover contacts, Ref: D42.
MAINS SUPPRESSOR CAPS 0.1µF 250V A.C., pack of 10, Ref: 1050.
TELESCOPIC AERIAL, chrome plated, extendable and folds over for improved F.M. reception, Ref: 1051.
MES LAMP HOLDERS, slide on to 1/4" tag, pack of 10, Ref: 1054.
PAXOLIN TUBING, 1/4" internal diameter, pack of two, 12" lengths, Ref: 1056.
ULTRA THIN DRILLS, 0.4mm, pack of 10, Ref: 1042.
20A TOGGLE SWITCHES, centre off, part spring controlled, will stay on when pushed up but will spring back when pushed down, pack of two, Ref: 1043.
HALL EFFECT DEVICES, mounted on small heatsink, pack of two, Ref: 1022.
12V POLARISED RELAY, two changeover contacts, Ref: 1032.
PAXOLIN PANEL, 12" x 12" 1/16" thick, Ref: 1033.
MINI POTTED TRANSFORMER, only 1.5VA 15V-0V-15V or 30V, Ref: 964.
ELECTROLYTIC CAP, 32µF at 350V and 50µF section at 25V, in aluminium can for upright mounting, pack of two, Ref: 995.
PRE-SET POTS, one megohm, pack of five, Ref: 998.
WHITE PROJECT BOX with rocker switch in top left-hand side, size 78mm x 115mm x 35mm, unprinted, Ref: 1006.
6V SOLENOID, good strong pull but quite small, pack of two, Ref: 1012.
FIGURE-8 MAINS FLEX, also makes good speaker lead, 15m, Ref: 1014.
HIGH CURRENT RELAY, 24V A.C. or 12V D.C., three changeover contacts, Ref: 1016.
LOUDSPEAKER, 8 Ohm 5W, 3-7" round, Ref: 962.
NEON PILOT LIGHTS, oblong for front panel mounting, with internal resistor for normal mains operation, pack of four, Ref: 970.
3.5MM JACK PLUGS, pack of 10, Ref: 975.
WANDER PLUGS, pack of 10, Ref: 986.
PSU, mains operated, two outputs, one 9.5V at 550mA and the other 15V at 150mA, Ref: 988.
ANOTHER PSU, mains operated, output 15V A.C. at 320mA, Ref: 989.
PHOTOCELLS, silicon chip type, pack of four, Ref: 939.
LOUDSPEAKER, 5" 4 Ohm 5W rating, Ref: 946.
230V ROD ELEMENTS, 500W terminal-ended, 10" long, pack of two, Ref: 943.
LOUDSPEAKER, 7" x 5" 4 Ohm 5W, Ref: 949.
LOUDSPEAKER, 4" circular 6 Ohm 3W, pack of 2, Ref: 951.
FERRITE POT CORES, 30mm x 15mm x 25mm, matching pair, Ref: 901.
PAXOLIN PANEL, 8 1/2" x 3 1/2" with electrolytics 250µF and 100µF, Ref: 905.
CAR SOCKET PLUG with P.C.B. compartment, Ref: 917.
FOUR-CORE FLEX suitable for telephone extensions, 10m, Ref: 918.
VERO OFF-CUTS, approximately 30 square inches of useful sizes, Ref: 927.
PROJECT CASE, 95mm x 66mm x 23mm with removable lid, held by four screws, pack of two, Ref: 876.
SOLENOIDS, 12V to 24V, will push or pull, pack of two, Ref: 877.
2M MAINS LEAD, 3-core with instrument plug moulded on, Ref: 879.
TELESCOPIC AERIAL, chrome plated, extendable, pack of two, Ref: 884.
MICROPHONE, dynamic with normal body for hand holding, Ref: 885.
CROCODILE CLIPS, superior quality flex, can be attached without soldering, five each red and black, Ref: 886.
BATTERY CONNECTOR FOR PP3, superior quality, pack of four, Ref: 887.
LIGHTWEIGHT STEREO HEADPHONES, Ref: 898.
PRESETS, 470 Ohm and 220 kilohm, mounted on single panel, pack of 10, Ref: 849.
THERMOSTAT for ovens with 1/4" spindle to take control knob, Ref: 857.
12V-0V-12V 10W MAINS TRANSFORMER, Ref: 811.
18V-0V-18V 10W MAINS TRANSFORMER, Ref: 813.
AIR-SPACED TRIMMER CAPS, 2pF to 20pF, pack of two, Ref: 818.
AMPLIFIER, 9V or 12V operated Mullard 1153, Ref: 823.
2 CIRCUIT MICROSWITCHES, icon, pack of 4, Ref: 825.
LARGE SIZE MICROSWITCHES (20mm x 6mm x 10mm) changeover contacts, pack of two, Ref: 826.
MAINS VOLTAGE PUSH SWITCH with white dolly, through panel mounting by hexagonal nut, Ref: 829.
POINTER KNOB for spindle which is just under 1/4", like most thermostats, pack of four, Ref: 833.



MAINTENANCE FREE BATTERIES

The YUASA batteries are sealed lead-acid types and they can be used in any position and are virtually maintenance free. We have two popular ones in stock at bargain prices, the 12V 15AH will cost you only £10, Order Ref. 10P140. This battery would also stand in as a car battery in an emergency.

The other one we have is much smaller, it is a 12V 2.3AH, regular price £14, yours for £5, Order Ref. 5P258. These batteries are in tip top condition, virtually unused and fully guaranteed.

DRY BATTERIES All high wattage, heavy duty type. Four popular types in stock:-
1 1/2V HP7, sometimes known as the penlight battery, four for 60p, Order Ref: GT10.

1 1/2V HP2, sometimes known as the big torch battery, two for 60p, Order Ref: GT11.

1 1/2V HP11, also a popular torch battery, two for 50p, Order Ref: GT12.

9V, ever popular PP3, 2 for £1, Order Ref: GT13.
35mm PANORAMIC CAMERA. Has super wide lens, ideal for holiday viewing, is focus free and has an extra bright and clear view finder. Brand new and guaranteed, individually boxed, £6.50, Order Ref: 6.5P2.

0V-20V D.C. PANEL METER. This is a nice size, 65mm sq. It is ideal if you are making a voltage variable instrument or battery charger. Price £3, Order Ref: 3P188.

FLASHING BEACON. Ideal for putting on a van, a tractor or any vehicle that should always be seen. Uses a XENON tube and has an amber coloured dome. Separate fixing base is included so unit can be put away if desirable. Price £7.50, Order Ref: 7.5P13.

BIG BUYER

Please note if you order 10 of an item you may deduct 10%. If you order 25, then deduct 25% but add VAT. If you need 100 or more, you can usually deduct 40% but please ring to confirm.

12V 2A TRANSFORMER, £2, Order Ref: 2P337.
12V-0V-12V TRANSFORMER, 35VA, £2.50, Order Ref: 2.5P13.

HIGH RESOLUTION MONITOR. 9" by Philips, in metal frame for easy mounting. Brand new, offered at less than the price of the tube alone, £15, Order Ref: 15P1.

15W 8" 8 OHM SPEAKER AND 3" TWEETER. Amstrad, made for their high quality music centre, £4 per pair, Order Ref: 4P57.

INSULATION TESTER WITH MULTIMETER. Internally generates voltages which enables you to read insulation directly in Megohms. The multimeter has four ranges: A.C./D.C. volts; 3 ranges milliamps; 3 ranges resistance and 5 amp range. Ex-British Telecom, tested and guaranteed OK, yours for only £7.50 with leads, carrying case £2 extra, Order Ref: 7.5P4.

We have some of the above testers not working on all ranges, should be repairable, we supply diagram, £3, Order Ref: 3P176.

LCD 3 1/2 DIGIT PANEL METER. This is a multi-range voltmeter/ammeter using the A-D converter chip 7106 to provide five ranges each of volts and amps. Supplied with full data sheet. Special snip price of £12, Order Ref: 12P19.

MINI BLOW HEATER. 1kW, ideal for under desk or airing cupboard, etc. Needs only a simple mounting frame, £5, Order Ref: 5P23.

MEDICINE CUPBOARD ALARM. Or it could be used to warn when any cupboard door is opened. The light shining on the unit makes the bell ring. Completely built and neatly cased, requires only a battery, £3, Order Ref: 3P155.

DON'T LET IT OVERFLOW! Be it bath, sink, cellar, sump or any other thing that could flood. This device will tell you when the water has risen to the pre-set level. Adjustable over quite a useful range. Neatly cased for wall mounting, ready to work when battery fitted, £3, Order Ref: 3P156.

£1.50 BARGAIN PACKS

NI-CAD BATTERY 3-6V with P.C.B. mounting prongs, Order Ref: 1.5P2.
6-DIGIT COUNTER 12V, Order Ref: 1.5P3.
PAIR OF ULTRASONIC MODULES, one sender, one receiver, Order Ref: 1.5P4.
100-CORE CABLE, any length, Order Ref: 1.5P6 per metre.
KEY SWITCH, two-position, complete with two Yale type keys, Order Ref: 1.5P12.
CASSETTE MOTOR, 9V brushless, Order Ref: 1.5P14.
80 OHM COAX TV CABLE, extra thin, 10m, Order Ref: 1.5P17.
WATERPROOF SPEAKER, 3 1/2" round, 8 Ohm 11W, Order Ref: 1.5P27.
6V 1A ENCASED POWER SUPPLY with input and output leads, Order Ref: 1.5P22.
FLOUORESCENT CHOKE for 60W or 80W tube, Order Ref: 1.5P23.
3" TWEETER 8 Ohms 15W, Order Ref: 1.5P28.
13A SWITCH SOCKET, white, Order Ref: 1.5P29.
RELAY, flash-proof, 12V coil, SPDO, Order Ref: 1.5P31.
ENCASED PSU, twin outputs, 15V 850mA and 9V 550mA, both A.C. output, Order Ref: 1.5P32.
12V MOTOR, mini but quite powerful, 32mm diameter, 25mm long, Order Ref: 1.5P33.

£2 BARGAIN PACKS

20W TWEETER 4" x 4" 8 Ohm by Goodmans, Order Ref: 2P403.
MOVING COIL CHARGE METER, 0-3A, Order Ref: 2P366.
LIGHT-OPERATED SWITCH, kit of parts, Order Ref: 2P369.
W-SHAPED 30W FLOUORESCENT TUBE by Philips. Ideal name plate illuminator, Order Ref: 2P372.
DIMMER SWITCH, standard size plate, colours - red, yellow, green, blue, Order Ref: 2P380.
TOROIDAL TRANSFORMER TV 5A, Order Ref: 2P390.
TELEPHONE EXTENSION LEAD, flat plug one end, socket the other, 12m, Order Ref: 2P338.
INTERNAL TELEPHONE EXTENSION, 4-core cable, 25m, Order Ref: 2P339.
FIGURE-8 FLEX, mains voltage, 50m, Order Ref: 2P345.
INFRA-RED RECEIVER, has fitted TV receiver, Order Ref: 2P304.
LCD CLOCK MODULE with details on other uses, Order Ref: 2P307.
AM/FM RADIO RECEIVER with speaker and dial but not cased, Order Ref: 2P308.
12V 200mA PSU on 13A base, Order Ref: 2P313.
2A MAINS FILTER AND PEAK SUPPRESSOR, Order Ref: 2P315.
45A DP 250V SWITCH on 6" x 3" gold plate, Order Ref: 2P316.
D.C. VOLT REDUCER, 12V-6V, fits into car lighter socket, Order Ref: 2P318.
SOLAR CELL 3V, five of these in series would make you a 12V battery charger, £2 each, Order Ref: 2P374.
PERMANENT MAGNET SOLENOID, opposite action, core is released when voltage is applied, Order Ref: 2P327.
HEATER PAD, not waterproof, Order Ref: 2P329.
DISK DRIVE, complete less stepper motor, has all the electronics to control stepper motor, Order Ref: 2P280.
15V 320mA A.C. POWER SUPPLY, in case with 13A base, ideal for bell or chime controller, Order Ref: 2P281.
POWERFUL MAINS MOTOR with 4" spindle, Order Ref: 2P262.
20M 80 OHM TV COAX, Order Ref: 2P270.
LOCTITE METAL ADHESIVE, tube and some accessories, Order Ref: 2P215.
6-DIGIT COUNTER, mains operated, Order Ref: 2P235.
2-GANG 0-0005 TUNING CAPACITOR, standard size, made by Jacksons, Order Ref: 2P240.
13A ADAPTORS, takes two 13A plugs, pack of 5 - £2, Order Ref: 2P187.
3-CORE 5A PVC FLEX, 15m, Order Ref: 2P189.
MAINS TRANSFORMER, 15V 1A, Order Ref: 2P198.
FLIP-OVER CLOCK, mains operated, only requires a simple case, Order Ref: 2P205.
THERMOSTAT with calibrated knob, oven temperatures, Order Ref: 2P158.
7-SEGMENT NEON DISPLAYS, pack of 8, Order Ref: 2P126.
MODERN TELEPHONE HANDSET, ideal office extension, Order Ref: 2P94.
13A SWITCH SOCKET on satin chrome plate, Order Ref: 2P95.
500 STAPLES, hardened pin, suit burglar alarm or telephone wire, Order Ref: 2P99.
PAD SWITCH for under carpets, Order Ref: 2P119.
6 1/2" FAN AND MAINS MOTOR, Order Ref: 2P64.
24V STEREO POWER SUPPLY, Mullard, Order Ref: 2P80.
UP TO 90 MIN 25A SWITCH, clockwork, Order Ref: 2P90.
UNI-SELECTOR, 25-way, 3-pole, Order Ref: 2P53.
POWERFUL MAINS MOTOR, 1 1/2" stack, double spindle, Order Ref: 2P55.
POWER SUPPLY FOR MODELS, 6V to 12V variable and reversible, Order Ref: 2P3.
MAINS TO 115V AUTO TRANSFORMER 100W, ex-GPO, Order Ref: 2P6.
MAINS TIME AND SET SWITCH 25A, up to nine hours delay, Order Ref: 2P9.
MOTORISED SIX MICROSWITCHES but motor 50V A.C., Order Ref: 2P19.
TWIN EXTENSION LEAD, ideal lead lamp, Black & Decker tools, etc, 20m, Order Ref: 2P20.
MAINS COUNTER, resettable, 3 digit, Order Ref: 2P26.

Prices include VAT and carriage cost if order over £25 otherwise add £3. Send cash, uncrossed postal orders, cheque or quote credit card number.

J & N FACTORS

Pilgrim Works (Dept. E.E.)
Stairbridge Lane, Bolney,
Sussex RH17 5PA

Telephone: 01444 881965
(Also fax but phone first)

Direct Book Service

The books listed have been selected by *Everyday Practical Electronics* editorial staff as being of special interest to everyone involved in electronics and computing. They are supplied by mail order direct to your door. Full ordering details are given on the last book page. For another selection of books see next month's issue.

Everyday Practical Electronics Books

ELECTRONIC PROJECTS - BOOK 1

Published by *Everyday Practical Electronics* in association with Magenta Electronics.

Contains twenty of the best projects from previous issues of EE each backed with a kit of components. The projects are: Seashell Sea Synthesiser, EE Treasure Hunter, Mini Strobe, Digital Capacitance Meter, Three Channel Sound to Light, BBC 16K Sideways Ram, Simple Short Wave Radio, Insulation Tester, Stepper Motor Interface, Eprom Eraser, 200MHz Digital Frequency Meter, Infra Red Alarm, EE Equaliser Ioniser, Bat Detector, Acoustic Probe, Mains Tester and Fuse Finder, Light Rider - (Lapel Badge, Disco Lights, Chaser Light), Musical Doorbell, Function Generator, Tilt Alarm, 10W Audio Amplifier, EE Buccaneer Induction Balance Metal Detector, BBC Midi Interface, Variable Bench Power Supply, Pet Scarer, Audio Signal Generator.

128 pages (A4 size) **Order code EP1** £2.45

ELECTRONICS TEACH-IN 88/89 - INTRODUCING MICROPROCESSORS

Mike Tooley BA (published by *Everyday Practical Electronics*)

A complete course that can lead successful readers to the award of a City and Guilds Certificate in Introductory Microprocessors (726/303). The book contains everything you need to know including full details on registering for assessment, etc. Starting with basic terminology, integrated circuits, logic families and numbering systems the text builds in stages, with revision and assessments built in, up to programming, languages, flow charts, etc. The course is ideal for the newcomer to the subject.

80 pages (A4 size) **Order code 11-88/89** £2.45

ELECTRONICS TEACH-IN No. 6 DESIGN YOUR OWN CIRCUITS

(Published by *Everyday Practical Electronics*) Mike Tooley BA

This book is designed for the beginner and experienced reader alike, and aims to dispel some of the mystique associated with the design of electronic circuits. It shows how even the relative newcomer to electronics can, with the right approach, design and realise quite complex circuits.

Fourteen individual p.c.b. modules are described which, with various detailed modifications, should allow anyone to design and construct a very wide range of different projects. Nine "hands-on" complete DIY projects have also been included so readers can follow the thinking behind design, assembly, construction, testing and evaluation, together with suggested "mods" to meet individual needs. The practical projects have each been designed to stand on their own as complete items of equipment. P.C.B.s for all the modules and projects are available by mail order.

The subjects covered in each chapter of the book are: Introduction and Power Supplies; Small Signal Amplifiers; Power Amplifiers; Oscillators; Logic Circuits; Timers; Radio; Power Control; Optoelectronics.

The nine complete constructional projects are: Versatile Bench Power Supply; Simple Intercom; Bench Amplifier/Signal Tracer; Waveform Generator; Electronic Die; Pulse Generator, Radio Receiver; Disco Lights Controller; Optical Communications Link.

136 pages (A4 size) **Order code 11/89** £3.45

TEACH-IN No. 7 plus FREE Software ANALOGUE AND DIGITAL ELECTRONIC COURSE

(Published by *Everyday Practical Electronics*) Alan Winstanley and Keith Dye

B. Eng(Tech)AMIEE

The highly acclaimed *Teach-In* series, which included the construction and use of the *Mini Lab* and *Micro Lab* test and development units, has been put together in book form. Additionally EPT Educational Software have developed a GCSE Electronics software program to complement the course and a FREE DISC covering the first two parts of the course is included with the book.

An interesting and thorough tutorial series aimed specifically at the novice or complete beginner in electronics. The series is designed to support those undertaking either GCSE Electronics or GCE Advanced Levels, and starts with fundamental principles.

If you are taking electronics or technology at school or college, this book is for you. If you just want to learn the basics of electronics then this is for you. If you are teaching electronics or technology you must make sure you see it. *Teach-In No. 7* will be invaluable if you are considering a career in electronics or even if you are already training in one. The *Mini Lab* and software enable the construction and testing of both demonstration and development circuits. These learning aids bring electronics to life in an enjoyable and interesting way; you will both see and hear the electron in action! The *Micro Lab* microprocessor add-on system will appeal to higher level students and those developing microprocessor projects.

152 pages (A4 size) **Order code 11/7** £3.95



Computers and Computing

HOW TO CHOOSE A SMALL BUSINESS COMPUTER SYSTEM

D. Weale

This book is for anyone intending to buy an IBM compatible computer system, whether it is their first system or a replacement. There are sections on hardware, application and systems programs and how to actually make your choice as well as sections on the law, ergonomics and a glossary of common terms.

The text contains many useful tips and some warnings (which could save much effort and expense).
114 pages **Order code BP323** £4.95

MAKING MS-DOS WORK FOR YOU (covers version 6.2)

N. Kantaris & P. R. M. Oliver

This book was written with the busy person in mind and, as such, it has an underlying structure based on "what you need to know first, appears first". Nonetheless, the book has also been designed to be circular, which means that you don't have to start at the beginning and go to the end.

The book explains: How to write customised batch files which allow you to display what you want on your screen, and in the form and order you want it, instead of being forced to use the DOS prompt on a blank screen. How to design and set up a fast interactive and professional looking menu system, so that you or anyone else can run utility applications or commercial software packages easily. How the ANSYS display and keyboard commands can be used to position the cursor on any part of the screen, change the intensity of the displayed characters or change their colour. How the Edit screen editor or the Edlin line editor can be used to enter ESCAPE (ANSI.SYS) commands into simple ASCII files to allow control of both your screen display and your printer. How to control the operation of the two main types of printers in use today, Epson compatible dot matrix and HP compatible laser printers. How to use several routines, such as moving and finding files, protecting files from accidental erasure,

a simplified backup process, a screen saver, and a disc cataloguing system.

The Debug program and how it can be used to create, see and change the contents of any file, including those of programs written in assembler code. This includes how to find your way around the names and tasks of the CPU registers and the meaning of some simple assembler mnemonics.

182 pages **Order code BP319** £4.95

MULTIMEDIA ON THE PC

Ian R. Sinclair

In this book, you'll find out what a CD ROM is, how it works, and why it is such a perfect add-on for a PC, allowing you to buy programmes, text, graphics and sound on a CD. It also describes the installation of a CD ROM drive and a sound card, pointing out the common problems that arise, and then shows how to use them to create a complete multimedia presentation that contains text, photos, a soundtrack with your own voice recorded as a commentary, even animation and edited video footage.

184 pages **Order code P-112** £11.95

A CONCISE INTRODUCTION TO MS-DOS

N. Kantaris

(Revised Edition Covers Version 6.2)

This guide is written with the non-expert, busy person in mind and, as such, it has an underlying structure based on "what you need to know first, appears first". Nevertheless, the guide is also designed to be circular, which means that you don't have to start at the beginning and go to the end. The more experienced user can start from any section.

176 pages **Order code BP232** £3.95

UNDERSTANDING PC SPECIFICATIONS

R. A. Penfold (Revised Edition)

If you require a microcomputer for business applications, or a high quality home computer, an IBM PC or compatible is often the obvious choice. They are competitively priced, and are backed up by an enormous range of applications programs, hardware add-ons, etc. The main difficulty for the uninitiated is deciding on the specification that will best suit his or her needs. PCs range from simple systems of limited capabilities up to complex systems that can happily run applications that would have been considered beyond the abilities of a microcomputer not so long ago. It would be very easy to choose a PC system that is inadequate to run your applications efficiently, or one which goes beyond your needs and consequently represents poor value for money.

This book explains PC specifications in detail, and the subjects covered include the following: Differences between types of PC (XT, AT, 80386, etc); Maths co-processors; Input devices (keyboards, mice, and digitisers); Memory, including both expanded (EMS) and extended RAM; RAM disks and disk caches; Floppy disk drive formats and compatibility; Hard disk drives (including interleave factors and access times); Display adaptors, including all standard PC types (CGA, Hercules, Super VGA, etc); Contains everything you need to know if you can't tell your EMS from your EGAI.

128 pages **Order code 1P252** £4.95

AN INTRODUCTION TO 6800 ASSEMBLY LANGUAGE

R. A. & J. W. Penfold

Obtain a vast increase in running speed by writing programs for 6800 based micros such as the Commodore, Amiga, Atari ST range or Apple Macintosh range etc, in assembly language. It is not as difficult as one might think and this book covers the fundamentals.

112 pages **Order code 8P1E4** £2.95

Testing and Test Gear

HOW TO USE OSCILLOSCOPES AND OTHER TEST EQUIPMENT

R. A. Penfold

This book explains the basic function of an oscilloscope, gives a detailed explanation of all the standard controls, and provides advice on buying. A separate chapter deals with using an oscilloscope for fault finding on linear and logic circuits, plenty of example waveforms help to illustrate the control functions and the effects of various fault conditions. The function and use of various other pieces of test equipment are also covered, including signal generators, logic probes, logic pulser, and crystal calibrators.

104 pages

Temporarily out of print

Theory and Reference

UNDERSTANDING DIGITAL TECHNOLOGY

F. A. Wilson C.G.I.A., C.Eng., F.I.E.E., F.I. Mgt.

This book examines what digital technology has to offer and then considers its arithmetic and how it can be arranged for making decisions in so many processes. It then looks at the part digital has to play in the ever expanding Information Technology, especially in modern transmission systems and television. It avoids getting deeply involved in mathematics.

Various chapters cover: Digital Arithmetic, Electronic Logic, Conversions between Analogue and Digital Structures, Transmission Systems. Several Appendices explain some of the concepts more fully and a glossary of terms is included. Altogether a useful foray into the digital world both for newcomers and also for those who need some revision or updating.

183 pages

Order code BP376 £4.95

A REFERENCE GUIDE TO PRACTICAL ELECTRONICS TERMS

F. A. Wilson C.G.I.A., C.Eng., F.I.E.E., F.I. Mgt.

Electronic devices surround us on all sides and their numbers are increasing without mercy. Ours is the problem therefore in keeping up with this relentless expansion. Unfortunately we cannot know it all and most of us do not wish to afford the cost of large reference books which explain many concepts in fair detail. Here is an answer, an inexpensive reference guide which explains briefly (but we hope, well) many of the underlying electronics features of practical devices, most of which, to a certain extent, control our lives.

This book is in effect more than just a dictionary of practical electronics terms, it goes a stage further in also getting down to fundamentals. Accordingly the number of terms may be limited but the explanations of the many which are included are designed to leave the reader more competent and satisfied – and this is without the use of complicated mathematics which often on first reading can be confusing.

For those who also wish to get right down to the root of the matter, there is a second volume entitled *A Reference*

PRACTICAL MIDI HANDBOOK

R. A. Penfold

The Musical Instrument Digital Interface (MIDI) is surrounded by a great deal of misunderstanding, and many of the user manuals that accompany MIDI equipment are quite incomprehensible to the reader.

The Practical MIDI Handbook is aimed primarily at musicians, enthusiasts and technicians who want to exploit the vast capabilities of MIDI, but who have no previous knowledge of electronics or computing. The majority of the book is devoted to an explanation of what MIDI can do and how to exploit it to the full, with practical advice on connecting up a MIDI system and getting it to work, as well as deciphering the technical information in those manuals.

128 pages

Order code PL101 £6.95

AN INTRODUCTION TO LOUDSPEAKERS AND ENCLOSURE DESIGN

V. Capel

This book explores the various features, good points and snags of speaker designs. It examines the whys and wherefores so that the reader can understand the principles involved and so make an informed choice of design, or even design loudspeaker enclosures for him or herself. Crossover units are also explained, the various types, how they work, the distortions they produce and how to avoid them. Finally there is a step-by-step description of the construction of the *Kapellmeister* loudspeaker enclosure.

148 pages

Temporarily out of print

ACOUSTIC FEEDBACK – HOW TO AVOID IT

V. Capel

Feedback is the bane of all public address systems. While feedback cannot be completely eliminated, many things can be done to reduce it to a level at which it is no longer a problem.

Much of the trouble is often the hall itself, not the equipment, but there is a simple and practical way of greatly improving acoustics. Some microphones are prone to feedback while others are not. Certain loudspeaker systems are much better than others, and the way the units are positioned can produce or reduce feedback. All these matters are fully explored as well as electronic aids such as equalizers, frequency-shifters and notch filters.

The special requirements of live group concerts are considered, and also the related problem of instability that is sometimes encountered with large set-ups. We even take a look at some unsuccessful attempts to cure feedback so as to save readers wasted time and effort duplicating them.

Also included is the circuit and layout of an inexpensive but highly successful twin-notch filter, and how to operate it.

92 pages

Order code BP310 £3.95



Guide to Basic Electronics Terms (BP286), each of the books referring to its companion as necessary.

A reference guide for practically everybody concerned with electronics.

432 pages

Order code BP287 £5.95

ELECTRONIC MODULES AND SYSTEMS FOR BEGINNERS

Owen Bishop

This book describes over 60 modular electronic circuits, how they work, how to build them, and how to use them. The modules may be wired together to make hundreds of different electronic systems, both analogue and digital. To show the reader how to begin building systems from modules, a selection of over 25 electronic systems are described in detail, covering such widely differing applications as timing, home security, measurement, audio (including a simple radio receiver), games and remote control.

200 pages

Order code BP266 £3.95

PREAMPLIFIER AND FILTER CIRCUITS

R. A. Penfold

This book provides circuits and background information for a range of preamplifiers, plus tone controls, filters, mixers, etc. The use of modern low noise operational amplifiers and a specialist high performance audio preamplifier i.c. results in circuits that have excellent performance, but which are still quite simple. All the circuits featured can be built at quite low cost (just a few pounds in most cases).

The preamplifier circuits featured include: Microphone preamplifiers (low impedance, high impedance, and crystal). Magnetic cartridge pick-up preamplifiers with R.I.A.A. equalisation. Crystal/ceramic pick-up preamplifier. Guitar pick-up preamplifier. Tape head preamplifier (for use with compact cassette systems).

Other circuits include: Audio limiter to prevent overloading of power amplifiers. Passive tone controls. Active tone controls. PA filters (highpass and lowpass). Scratch and rumble filters. Loudness filter. Audio mixers. Volume and balance controls.

92 pages

Order code BP409 £3.95

Project Building

ELECTRONIC PROJECTS FOR EXPERIMENTERS

R. A. Penfold

Many electronic hobbyists who have been pursuing their hobby for a number of years seem to suffer from the dreaded "seen it all before" syndrome. This book is fairly broad and squarely aimed at sufferers of this complaint, plus any other electronics enthusiasts who yearn to try something a bit different. No doubt many of the projects featured here have practical applications, but they are all worth a try for their interest value alone.

The subjects covered include:- Magnetic field detector, Scrambler/descrambler, Bat detector, Bat style echo location, Noise cancelling, LED stroboscope, Infra-red "torch", Electronic breeze detector, Class D power amplifier, Strain gauge amplifier, Super hearing aid.

138 pages

Order code BP371 £4.95

PRACTICAL FIBRE-OPTIC PROJECTS

R. A. Penfold

While fibre-optic cables may have potential advantages over ordinary electric cables, for the electronics enthusiast it is probably their novelty value that makes them worthy of exploration. Fibre-optic cables provide an innovative interesting alternative to electric cables, but in most cases they also represent a practical approach to the problem. This book provides a number of tried and tested circuits for projects that utilize fibre-optic cables.

The projects include:- Simple audio links, F.M. audio link, P.W.M. audio links, Simple d.c. links, P.W.M. d.c. link, P.W.M. motor speed control, RS232C data links, MIDI link, Loop alarms, R.P.M. meter.

All the components used in these designs are readily available, none of them require the constructor to take out a second mortgage.

132 pages

Order code BP374 £4.95

45 SIMPLE ELECTRONIC TERMINAL BLOCK PROJECTS

R. Babington

Contains 45 easy-to-build electronic projects that can be constructed, by an absolute beginner, on terminal blocks using only a screwdriver and other simple hand tools. No soldering is needed.

Most of the projects can be simply screwed together, by following the layout diagrams, in a matter of minutes and

readily unscrewed if desired to make new circuits. A theoretical circuit diagram is also included with each project to help broaden the constructor's experience and knowledge.

The projects included in this book cover a wide range of interests under the chapter headings: Connections and Components, Sound and Music, Entertainment, Security Devices, Communication, Test and Measuring.

163 pages

Order code BP378 £4.95

HOW TO DESIGN AND MAKE YOUR OWN P.C.B.S

R. A. Penfold

Deals with the simple methods of copying printed circuit board designs from magazines and books and covers all aspects of simple p.c.b. construction including photographic methods and designing your own p.c.b.s.

80 pages

Order code BP121 £2.50

A BEGINNER'S GUIDE TO MODERN ELECTRONIC COMPONENTS

R. A. Penfold

The purpose of this book is to provide practical information to help the reader sort out the bewildering array of components currently on offer. An advanced knowledge of the theory of electronics is not needed, and this book is not intended to be a course in electronic theory. The main aim is to explain the differences between components of the same basic type (e.g. carbon, carbon film, metal film, and wire-wound resistors) so that the right component for a given application can be selected. A wide range of components are included, with the emphasis firmly on those components that are used a great deal in projects for the home constructor.

166 pages

Order code BP285 £3.95

ELECTRONICS SIMPLIFIED – CRYSTAL SET CONSTRUCTION

F. A. Wilson, C.G.I.A., C.Eng., F.I.E.E., F.I.E.R.E., F.B.I.M.

Especially written for those who wish to participate in the intricacies of electronics more through practical construction than by theoretical study. It is designed for all ages upwards from the day one can read intelligently and handle simple tools.

80 pages

Temporarily out of print

COMPUTERS AND MUSIC – AN INTRODUCTION

R. A. Penfold

Computers are playing an increasingly important part in the world of music, and the days when computerised music was strictly for the fanatical few are long gone.

If you are more used to the black and white keys of a synth keyboard than the QWERTY keyboard of a computer, you may be understandably confused by the jargon and terminology bandied about by computer buffs. But fear not, setting up and using a computer-based music making system is not as difficult as you might think.

This book will help you learn the basics of computing, running applications programs, wiring up a MIDI system and using the system to good effect, in fact just about everything you need to know about hardware and the programs, with no previous knowledge of computing needed or assumed. This book will help you to choose the right components for a system to suit your personal needs, and equip you to exploit that system fully.

174 pages

Order code C107 £8.95

ELECTRONIC PROJECTS FOR GUITAR

R. A. Penfold

This book contains a collection of guitar effects and some general purpose effects units, many of which are suitable for beginners to project building. An introductory chapter gives guidance on construction.

Each project has an introduction, an explanation of how it works, a circuit diagram, complete instructions on strip-board layout and assembly, as well as notes on setting up and using the units. Contents include: Guitar tuner; Guitar preamplifier; Guitar headphone amplifier; Soft distortion unit; Compressor; Envelope waa waa; Phaser; Dual tracking effects unit; Noise gate/expander; Treble booster; Dynamic treble booster; Envelope modifier; Tremolo unit; DI box.

110 pages

Temporarily out of print

HIGH POWER AUDIO AMPLIFIER CONSTRUCTION

R. A. Penfold

Practical constructional details of how to build a number of audio power amplifiers ranging from about 50 to 300/400 watts r.m.s. Includes MOSFET and bipolar transistor designs.

96 pages

Order code BP277 £3.95

Circuits and Design

PRACTICAL ELECTRONIC FILTERS

Owen Bishop

This book deals with the subject in a non-mathematical way. It reviews the main types of filter, explaining in simple terms how each type works and how it is used.

The book also presents a dozen filter-based projects with applications in and around the home or in the constructor's workshop. These include a number of audio projects such as a rhythm sequencer and a multi-voiced electronic organ.

Concluding the book is a practical step-by-step guide to designing simple filters for a wide range of purposes, with circuit diagrams and worked examples.

88 pages **Order code BP298** £4.95

ELECTRONIC ALARM CIRCUITS MANUAL

R. M. Marston

One hundred and forty useful alarm circuits, of a variety of types, are shown in this volume. The operating principle of each one is explained in concise but comprehensive terms, and brief construction notes are given where necessary.

Aimed at the practical design engineer, technician and experimenter, as well as the electronics student and amateur.

124 pages **Order code NE11** £13.95

DIGITAL GATES AND FLIP-FLOPS

Ian R. Sinclair

This book, intended for enthusiasts, students and technicians, seeks to establish a firm foundation in digital electronics by treating the topics of gates and flip-flops thoroughly and from the beginning.

Topics such as Boolean algebra and Karnaugh mapping are explained, demonstrated and used extensively, and more attention is paid to the subject of synchronous counters than to the simple but less important ripple counters.

No background other than a basic knowledge of electronics is assumed, and the more theoretical topics are explained from the beginning, as also are many working practices. The book concludes with an explanation of microprocessor techniques as applied to digital logic.

200 pages **Order code NE106** £8.95

ELECTRONIC CIRCUITS FOR THE COMPUTER CONTROL OF ROBOTS

Robert Penfold

Robots and robotics offer one of the most interesting areas for the electronics hobbyist to experiment in. Today the mechanical side of robots is not too difficult, as there are

robotics kit and a wide range of mechanical components available. The microcontroller is not too much of a problem either, since the software need not be terribly complex and many inexpensive home computers are well suited to the task.

The main stumbling block for most would-be robot builders is the electronics to interface the computer to the motors, and the sensors which provide feedback from the robot to the computer. The purpose of this book is to explain and provide some relatively simple electronic circuits which bridge this gap.

92 pages **Order code BP179** £2.95

ELECTRONIC POWER SUPPLY HANDBOOK

Ian R. Sinclair

This book covers the often neglected topic of electronic power supplies. All types of supplies that are used for electronics purposes are covered in detail, starting with cells and batteries and extending by way of rectified supplies and linear stabilisers to modern switch-mode systems, i.e. switch-mode regulators, DC-DC converters and inverters.

The devices, their operating principles and typical circuits are all dealt with in detail. The action of rectifiers and the reservoir capacitor is emphasised, and the subject of stabilisation is covered. The book includes some useful formulae for assessing the likely hum level of a conventional rectifier reservoir supply.

136 pages **Order code PC108** £7.95

50 SIMPLE LED CIRCUITS

R. N. Soar

Contains 50 interesting and useful circuits and applications, covering many different branches of electronics, using one of the most inexpensive and freely available components - the light-emitting diode (LED). Also includes circuits for the 707 common anode display.

64 pages **Order code BP42** £1.95

BOOK 2 50 more i.e.d. circuits.

50 pages

Order code BP87 £1.95

CIRCUIT SOURCE BOOK 1

A. Penfold

Written to help you create and experiment with your own electronic designs by combining and using the various standard "building block" circuits provided. Where applicable, advice on how to alter the circuit parameters is given.

The circuits covered in this book are mainly concerned with analogue signal processing and include: Audio

amplifiers (op.amp and bipolar transistors); audio power amplifiers; d.c. amplifiers; highpass, lowpass, bandpass and notch filters; tone controls; voltage controlled amplifiers and filters; triggers and voltage comparators; gates and electronic switching; bargraphs; mixers; phase shifters, current mirrors, hold circuits, etc.

Over 150 circuits are provided, which it is hoped will be useful to all those involved in circuit design and application, be they professionals, students or hobbyists.

182 pages **Order code BP321** £4.95

CIRCUIT SOURCE BOOK 2

R. A. Penfold

This book will help you to create and experiment with your own electronic designs by combining and using the various standard "building blocks" circuits provided. Where applicable, advice on how to alter the circuit parameters is provided.

The circuits covered are mainly concerned with signal generation, power supplies, and digital electronics.

The topics covered in this book include: 555 oscillators; sinewave oscillators; function generators; CMOS oscillators; voltage controlled oscillators; radio frequency oscillators; 555 monostables; CMOS monostables; TTL monostables; precision long timers; power supply and regulator circuits; negative supply generators and voltage boosters; digital dividers; decoders, etc.; counters and display drivers; D/A and A/D converters; opto-isolators, flip/flops, noise generators, tone decoders, etc.

Over 170 circuits are provided, which it is hoped will be useful to all those involved in circuit design and application, be they professionals, students or hobbyists.

192 pages **Order code BP422** £4.95

HOW TO USE OP. AMPS

E. A. Parr

This book has been written as a designer's guide covering many operational amplifiers, serving both as a source book of circuits and a reference book for design calculations. The approach has been made as non-mathematical as possible.

160 pages **Order code BP88** £2.95

A BEGINNER'S GUIDE TO TTL DIGITAL ICs

R. A. Penfold

This book first covers the basics of simple logic circuits in general, and then progresses to specific TTL logic integrated circuits. The devices covered include gates, oscillators, timers, flip/flops, dividers, and decoder circuits. Some practical circuits are used to illustrate the use of TTL devices in the "real world".

142 pages **Order code BP332** £4.95

Radio, TV, Satellite

PROJECTS FOR RADIO AMATEURS AND S.W.L.S.

R. A. Penfold

This book describes a number of electronic circuits, most of which are quite simple, which can be used to enhance the performance of most short wave radio systems.

The circuits covered include:- An aerial tuning unit; A simple active aerial; An add-on b.f.o. for portable sets; A wavetrapp to combat signals on spurious responses; An audio notch filter; A parametric equaliser; C.W. and S.S.B. audio filters; Simple noise limiters; A speech processor; A volume expander.

Other useful circuits include a crystal oscillator, and RTTY/C.W. tone decoder, and a RTTY serial to parallel converter. A full range of interesting and useful circuits for short wave enthusiasts.

92 pages **Order code BP304** £3.95

AN INTRODUCTION TO AMATEUR RADIO

I. D. Poole

Amateur radio is a unique and fascinating hobby which has attracted thousands of people since it began at the turn of the century.

This book gives the newcomer a comprehensive and easy to understand guide through the subject so that the reader can gain the most from the hobby. It then remains an essential reference volume to be used time and again. Topics covered include the basic aspects of the hobby, such as operating procedures, jargon and setting up a station. Technical topics covered include propagation, receivers, transmitters and aerials etc.

150 pages **Order code BP257** £3.50

AERIAL PROJECTS

R. A. Penfold

The subject of aerials is vast but in this book the author has considered practical aerial designs, including active, loop and ferrite aerials which give good performances and are relatively simple and inexpensive to build. The complex theory and mathematics of aerial design have been avoided.

Also included are constructional details of a number of aerial accessories including a pre-selector, attenuator, filters and a tuning unit.

96 pages **Temporarily out of print**

SIMPLE SHORT WAVE RECEIVER CONSTRUCTION

R. A. Penfold

Short wave radio is a fascinating hobby, but one that seems to be regarded by many as an expensive pastime these days. In fact it is possible to pursue this hobby for a minimal monetary outlay if you are prepared to undertake a bit of d.i.y., and the receivers described in this book can all be built at low cost. All the sets are easy to construct, full wiring diagrams etc. are provided, and they are suitable for complete beginners. The receivers only require simple aerials, and do not need any complex alignment or other difficult setting up procedures.

The topics covered in this book include: The broadcast bands and their characteristics; The amateur bands and their

characteristics; The propagation of radio signals; Simple aerials; Making an earth connection; Short wave crystal set; Simple t.r.f. receivers; Single sideband reception; Direct conversion receiver.

Contains everything you need to know in order to get started in this absorbing hobby.

88 pages **Order code BP377** £3.95

AN INTRODUCTION TO AMATEUR COMMUNICATIONS SATELLITES

A. Pickford

Communications and broadcast satellites are normally inaccessible to individuals unless they are actively involved in their technicalities by working for organisations such as British Telecom, the various space agencies or military bodies. Even those who possess a satellite television receiver system do not participate in the technical aspects of these highly technological systems.

There are a large number of amateur communications satellites in orbit around the world, traversing the globe continuously and they can be tracked and their signals received with relatively inexpensive equipment. This equipment can be connected to a home computer such as the BBC Micro or IBM compatible PCs, for the decoding of received signals.

This book describes several currently available systems, their connection to an appropriate computer and how they can be operated with suitable software.

102 pages **Order code BP240** £3.95

A GUIDE TO THE WORLD'S RADIO STATIONS (1995/96)

P. Shore

Provides the casual listener, amateur radio DXer and the professional radio monitor with an essential reference work designed to guide him or her around the ever more complex radio bands. This new edition has been completely revised and rewritten and incorporates much more information which is divided into the following sections:

Listening to Short Wave Radio; Choosing a Short Wave Radio Receiver; How to Use the IRSG; Abbreviations; County Codes; Worldwide Short Wave Radio Stations; European, Middle Eastern and African Long Wave Radio Stations; European, Near and Middle Eastern and African Medium Wave Radio Stations; Canadian Medium Wave Radio Stations; USA Medium Wave Radio Stations; Broadcasts in English; Programmes for DXers and Short Wave Listeners; UK FM Radio Stations; Time Differences From GMT; Wavelength/Frequency Conversion.

256 pages **Order code BP355** £5.95

DIRECT BOOK SERVICE ORDERING DETAILS

Please state the title and order code clearly, print your name and address and add the required postage to the total order.

Add £1.50 to your total order for postage and packing (overseas readers add £3 for countries in the EEC, or add £6 for all countries outside the EEC, surface mail postage) and send a PO, cheque, International money order (£ sterling only) made payable to Direct Book Service or credit card details (including card expiry date), Visa or Mastercard (Access) - minimum credit card order is £5 - quoting your name and address, the order code and quantities required to DIRECT BOOK SERVICE, 33 GRAVEL HILL, MERLEY, WIMBORNE, DORSET BH21 1RW (mail order only).

Although books are normally sent within seven days of receipt of your order, please allow a maximum of 28 days for delivery. Overseas readers allow extra time for surface mail post.

Please check price and availability (see latest issue of Everyday Practical Electronics) before ordering from old lists.

For a further selection of books see next month's issue.

DIRECT BOOK SERVICE IS A DIVISION OF WIMBORNE PUBLISHING LTD.

QUASAR Electronics

QUASAR ELECTRONICS

SECURITY

ULTRASONIC MOVEMENT DETECTOR
Xtal controlled oscillator, detector circuits & edge mounted transducers on one PCB just 75x40mm. Detection range 4-7m. Adjustable sensitivity LED indicator. Outputs to drive external relay/circuits. 9V DC operation. 3049-KT. £14.95



CCD CAMERA

Latest high quality low-light, IR-sensitive camera module from KOCOM # CA-H34C for Video Intercom CCTV, Surveillance etc. Six IR LED's on board allow camera to 'see' in the dark. Half the size of a cigarette pack!

FEATURES
* Compact & light camera PCB module 54x38mm
* Low power consumption
* Low illumination requirements (0.1Lux)
* High quality, high resolution image
* Maintenance free
* Built-in electronically controlled auto-iris
* Internal synchronisation

ASSEMBLED UNIT: 3047-AS £89.95

REPORTS & PLANS

N.B. MINIMUM ORDER CHARGE FOR PLANS AND REPORTS IS £5.00 PLUS NORMAL P.&P.

TELEPHONE BUG DETECTION Why spend a fortune on expensive bug detection equipment when you can Do-it-Yourself for next to nothing! All you need to know is in this easy to understand report. R001 £2.00

SUPER-EAR LISTENING DEVICE Complete plans to build your own parabolic dish microphone. Listen to distant voices and sounds through open windows and even walls! Made from readily available parts. R002 £3.50

TELEPHONE BUG PLANS Build your own micro-beetle telephone bug. Suitable for any phone. Transmits over 250 metres - more with good receiver. Made from easy to obtain, cheap components. R006 £3.00

RADIO & TV JOKER PLANS We show you how to build three different circuits for disrupting TV picture and sound plus FM radio! May upset your neighbours & the authorities! DISCRETION REQUIRED. R017 £3.50

INFINITY TRANSMITTER PLANS Complete plans for building the famous Infinity Transmitter. Once installed on the target phone, device acts like a room bug. Just call the target phone & activate the unit to hear all room sounds. Great for home/office security! R019 £3.00

THE ETHER BOX CALL INTERCEPTOR PLANS Grabs telephone calls out of thin air! No need to wire-in a phone bug. Simply place this device near the phone lines to hear the conversations taking place! R025 £3.00

Full details of our complete range of Reports & Plans can be found in our Main catalogue.

GENERAL KITS

3 DIGIT LED COUNTER 2 board basic event counter. Main board has 3 digit counter circuit. 2nd board has Count & Reset switches & debounce circuit. Cascaded with other boards to provide more digits. Box & battery holder provided. 9V battery. 78x50x25mm. 3001-KT. £14.95

LED SEQUENCE FLASHER 5 red LED's flash in sequence. Ideal for model railways. On/off switch. COB PCB 15x8mm (spare provided). 3V powered. 3052-KT. £3.95

OP-AMP FUNCTION GENERATOR Quad Op-Amp connected as oscillator & wave shapers to generate audio range wave-forms. Oscillator generates Square Wave from 6Hz to 6KHz. Other amps produce Triangle & pseudo Sine outputs. Solder pad outputs. 9V powered. 47x40x22mm. 3023-KT. £4.95

LOGIC PROBE Original, modern design tests both CMOS & TTL circuits as well as detecting test states. Gives visual & audio indication of logic states found. Powered from circuit under test. It's operation is fully explained. 3024-KT. £7.95

ROULETTE LED A great introduction to gambling... er electronics! Watch the 'ball' spin round the roulette wheel, slow down & drop into slot. Uses 10 LED's, CMOS decade counter & Op-Amp to teach Voltage Controlled Oscillator (VCO) principles. 9V powered. Educational & fun! 3006-KT. £10.95

PELTIER JUNCTION HEAT PUMP Boil or freeze water instantly! Use for regulated cooling of temperature sensitive components and much more. 3066-KT. £21.95

9V XENON TUBE FLASHER This powerful high voltage xenon flasher runs off a simple 9V battery. A transformer is used to step up the 9V supply voltage to the high voltage required to flash the 25mm long tube. Flash rate adjustable between 0.25 to 2 second intervals. 3022-KT. £11.95

LM383 AMPLIFIER MODULE Proven, popular building block for use in any audio project where general amplification required. Power output dependent on supply voltage & load resistance. Typical ratings: Over 10W for 16V supply, & 2W speaker, 1W for 9V supply & 8W speaker. 3047-KT. £9.95

plus AUDIO • EDUCATIONAL • LASER • SECURITY • TEST GEAR • BOOKS & more

All kits are high quality projects supplied with all components, fibre glass PCB's & comprehensive instructions. FREE CATALOGUE with order or send 2 x 1st Class stamps (refundable) for details of over 100 kits & publications. Mail order only. Please ADD £2.00 P. & P. per order & make cheques/PO's payable to Quasar Electronics. All prices include VAT at 17.5%. Goods normally despatch within 5 working days but please allow 28 days for delivery.

Unit 14 Sunningdale BISHOP'S STORTFORD Herts CM23 2PA
E-mail: 101364.3510@compuserve.com

COMBINATION LOCK Versatile electronic lock comprising main circuit & separate 9 key touch-pad for remote opening of lock. 120VAC/10A relay supplied. 9-12V. 3029-KT. £9.95

LIGHT ALARM Protect your valuables with this practical, clever little circuit. Alarm sounds if even the smallest amount of light falls on the circuit. Place in cash box etc. 3008-KT. £4.95

THE SCREAMER! Frighten the life out of any unsuspecting/unwanted guest! Piercing alarm siren gives out a massive 110db of ear piercing noise. Box supplied has two 35mm piezo elements already built into their own resonant cavity. PCB also fits inside box to give a neat, compact unit. Can be used as part of an alarm circuit or just for the fun of it! 6-9V operation. 3016-KT. £9.95

SURVEILLANCE

High performance surveillance kits. Room transmitters supplied with sensitive electret microphones & battery holders/clips. All transmitters can be received on an ordinary VHF FM radio.

MTX - Miniature 3V Transmitter
Easy to build & guaranteed to transmit 500 metres (over 1000m possible with higher voltage & better aerial). 3-9V operation. Only 45x18mm. 3007-KT. £5.50

MRTX - Miniature 9V Room Transmitter
Our best selling 'bug'. Super sensitive, high power - 1000m range (Up to 2 miles with 18V supply & better aerial). 9V operation. 45x19mm. 3018-KT. £5.50

HPTX - High Power Room Transmitter
High performance, 2 stage transmitter gives greater stability & high quality reception: 1000m range with 9V battery, 6-12V operation. On/off switch. Size 70x15mm. 3032-KT. £7.50

VTX - Voice Activated Transmitter
Activates only when sounds are detected. Low standby current conserves battery power. Adjustable sensitivity & turn-off delay. 6V operation. Size 63x38mm. Powerful 2 stage transmitter. 1000m range. 3028-KT. £9.50

TRI - Telephone Recording Interface
Connect between phone line & cassette recorder. Automatic-ally switches on tape when phone is used. Records all conversations. Powered from line. 48x32mm. 3033-KT. £6.50

TRVS - Tape Recorder Vox Switch
Very sensitive, voice activated switch - automatically turns on cassette recorder when sounds are detected. Adjustable sensitivity & turn-off delay. 115x19mm inc. mic. 3013-KT. £7.50

MTTX - Miniature Telephone Transmitter
Attaches anywhere to phone line. Transmits only when phone is used! Uses phone line as aerial & power source. 500m range. 45x15mm. 3016-KT. £5.50

Two Station Intercom/Hard Wired Bug
Simple two wire intercom/hard wired bug. Each unit has its own speaker, microphone & amplifier (LM386). Can be modified to a hard wired 'bug' by using 4 strand ribbon cable to send power from the receiving unit to the remote bug unit. 9V operation. 3021-KT. £12.95

Telephone Amplifier Kit
Pick-up coil & sensitive amplifier let you hear conversations without even holding the phone! Can be used for surveillance purposes. 3055-KT. £9.95

LED DICE The classic electronic project that never loses its popularity. Combines a great game with an easy introduction to electronics & simple circuit analysis. 7 LED's simulate a real dice face. The dice rolls, slows down, stops on a number at random. Uses a 555 timer & counter IC. Box included. 9V operation. 3003-KT. £8.95

STAIRWAY TO HEAVEN GAME This game of skill tests your hand-eye co-ordination. If you press the switch each time the green part of the bi-polar LED lights you climb higher up the stairway... but miss & you start again! Introduces you to several basic electronic circuits. Box provided. 9V operation. 78x50x19mm Rolfe Harris NOT included. 3005-KT. £8.95

DC MOTOR SPEED CONTROLLER Control the speed of any common DC motor rated up to 100W (5A). Operates on 5-15V. Uses NE555 IC to pulse-width modulate a TIP122 high current, switching power transistor. In this way torque of the motor is not lowered. Box mounted. 3067-KT. £19.95

SWITCHING POWER SUPPLY Replace expensive 9V batteries with cost-efficient 1.5V cells IC based circuit acts as a step-up switching power supply. Selectable 1.5 or 3V DC outputs. Gives a fixed output of 9V @ 18mA from a 1.5V 'AA' cell. Solder pads for input/output. 1 cell & 2 cell 'AA' holders & jumper switches supplied. 40x15x12mm. 3035-KT. £4.95

SINGLE CHIP AM RADIO Complete mini sized AM radio on a PCB. Tuned Radio Frequency front-end, AM Radio IC & 2 stages of audio amplification. All components supplied inc. prewound coil & speaker. 32x102mm. 3063-KT. £9.95

TRAIN SOUNDS 4 selectable sounds - Whistle Blowing, Level Crossing Bell, Chugging & 'Clickety-Clack'. 2.5-6V. Supplied with all components inc. speaker. 16x23mm COB PCB, switches & 2 x 'AA' battery holders. SG1. £4.95

PCB SERVICE

Printed circuit boards for certain EPE constructional projects are available from the PCB Service, see list. These are fabricated in glass fibre, and are fully drilled and roller tinned. All prices include VAT and postage and packing. Add £1 per board for airmail outside of Europe. Remittances should be sent to The PCB Service, *Everyday Practical Electronics*, Allen House, East Borough, Wimborne, Dorset BH21 1PF. Cheques should be crossed and made payable to *Everyday Practical Electronics* (Payment in £ sterling only).

NOTE: While 95% of our boards are held in stock and are dispatched within seven days of receipt of order, please allow a maximum of 28 days for delivery - overseas readers allow extra if ordered by surface mail.

Back numbers or photostats of articles are available if required - see the *Back Issues* page for details.

Please check price and availability in the latest issue. Boards can only be supplied on a payment with order basis.

Many p.c.b.s which are no longer available from us can be made by Etch-Tech Boards PO Box 1566, Salisbury, Wilts SP1 3XX.

Special KNOCK DOWN SALE of PCBs.

We have a few p.c.b.s left from past projects these are being offered at the knock down price of £1.00 each - no matter what size they are (some of these boards are worth over £8.00 each) while stocks last. This price includes VAT and UK post - overseas orders please add 50p postage (or £1 per board for airmail postage).

£1.00 EACH
inc. VAT and p&p

Doorbell Delay 616; Mldi Pedal 639, Midi Merge 640; Audio Lead Tester 641; Power Supply 25V 700mA 656; Hand Tally, main board 699 and display board 700; Automatic Light Control - PSU board 747; Modular Disco Lights - Masterlink 752 - Dimmer Interface 765 - VU Sound Module 767; Knockerbox 775; Auto Nightlight 779; Sonic Continuity Tester, 789; Tie Pulser, 794; Cricket Game, 798; Quick Prom, 799; Emergency Lighting Unit, 816; Car Electric Window Enhancer, 821; Simplify Atari STFM Interface, 822; Personal Stereo Amp. Add-On, 823; Electronic Fire, 820; Mind Machine MkII - Magic Lights, 827; Superhet Radio Control Receiver, 828; Linear Clock - Timing Board 830, Display Board, 831; Universal Alarm Module, 9070; Electronic Snooker Scoreboard, 832; Mind Machine MkII - Computer Interface, 833; Electronic Gong, 835.

Any of the above for just £1 each Inc. VAT and p&p.

Back numbers or photostats of articles are available see the *Back Issues* page for details.

PROJECT TITLE	Order Code	Cost
Bike Odometer (pair of boards)	AUG 93 836/7	£7.00
Amstrad PCW A to D Converter (double-sided)	838	£9.85
Experimental Electronic Pipe Descaler	839	£5.50
Sound Activated Camera Trigger	SEP 93 840	£5.34
L.E.D. Sandglass	OCT 93	
Main and Display boards	841/2	£7.30
Kettle Alert	843	£5.19
Linear Power Supply (double-sided)	844	£9.77
Multi-Purpose Audio System		
Six Channel Stereo Mixer	845	£11.98
Multi-Purpose Audio System	NOV 93	
Microphone Pre-Amp module	846	£4.88
RIAA Pre-Amp module	847	£5.11
20 Metre Receiver	848	£6.63
Multi-Purpose Audio System	DEC 93	
Tone Control and 1W Stereo Amplifier	849	£6.09
Tone Control	850	£5.12
1W Stereo Amplifier	851	£4.88
Three-Way Christmas Tree Lights Flasher	853	£5.65
Auto Alarm	854	£5.49
250W/600W Battery to Mains Inverter	855	£13.92
Multi-Purpose Audio System	JAN 94	
10W + 10W Stereo Power Amplifier		
Amplifier	852a	£5.65
Power Supply	852b	£5.49
Pond Heater Thermostat	856	£5.77
Timer/NiCad Capacity Checker	857	£6.30
Multi-Purpose Audio System	FEB 94	
Balanced Microphone Preamplifier	858	£5.30
Balanced Microphone Power Supply	859	£5.14
Whistle Controlled Light Switch	860	£5.19
Battery to Mains Inverter - U.P.S. charger board	862	£7.38
Three Phase Generator	MAR 94	
Visual Doorbell	863	£5.80
CCD TV Camera - Control Board (double-sided, plated-through-hole)	865	£15.00
Telephone Ring Detector	APR 94	
CCD TV Camera		
Combined Video, Test & Ext Plug Boards	866a/e	£11.00
Frame Grab Control (double-sided p.t.h.)	867	£15.00
EPE SoundDAC PC Sound Board	868	£4.77
MOSFET Variable Bench Power Supply	869	£5.80

PROJECT TITLE	Order Code	Cost
L.E.D. Matrix Message Display Unit MAY '94		
Display Board	870	£18.00
CPU Board	871	£7.20
Stereo Noise Gate	873	£6.14
Simple TENS Unit	875	£5.84
Capacitance/Inductance Meter	876	£6.44
Advanced TENS Unit JUN '94	877	£6.56
Digital Water Meter - Scaler	878	£11.19
Counter/Display	879	pair
L.E.D. Matrix Message Display Unit		
Keypad	872	£5.19
PC Interface	880	£5.82
Microprocessor Smartswitch	881	£5.61
Microcontroller P.I. Treasure Hunter	882	£6.60
Print Timer JULY '94	874	£5.82
Watering Wizard	883	£6.60
Simple NiCad Charger	884	£4.98
Voxbox	885	£6.90
Stereo HiFi Controller - 1 Power Supply	886	£5.66
Stereo HiFi Controller - 2 AUG '94		
Main Board	887	£7.39
Expansion/Display Boards (pair)	888	£9.80
Dancing Fountains - 1 Pre.amp	889	£5.28
Pump Controller	890	£5.41
Filter	891	£5.23
6802 Microprocessor Development Board	894	£9.15
Dancing Fountains - 2 SEPT '94		
PC-Compatible Interface (double-sided)	892	£10.90
Automatic Greenhouse Watering System	895	£5.33
Seismograph - 1 Sensor/Filter	896	£6.23
Clock/Mixer	897	£5.87
3-Channel Lamp Controller	899	£8.17
Seismograph - 2 OCT '94		
PC-Compatible Interface (double-sided)	898	£10.72
Visual/Audio Guitar Tuner	900	£7.55
Digilogue Clock	901	£12.50
Hobby Power Supply	902	£5.00
Audio Auxilplexer - Control Board	903	£7.72
Receiver	904	£6.24
Power Controller NOV '94	905	£4.99
1000V/500V Insulation Tester	906	£5.78
Active Guitar Tone Control	907	£4.50
TV Off-er (pair)	908/909	£7.25
Video Modules - 1		
Simple Fader	910	£5.12
Improved Fader	911	£6.37
Video Enhancer	912	£5.15
Rodent Repeller DEC '94	913	£6.26
EPE Fruit Machine	914	£8.14
Video Modules - 2		
Horizontal Wiper	916	£6.23
Vertical Wiper	917	£6.35
4-Channel Audio Mixer	918	£6.20
Spacewriter Wand	921	£4.00
Universal Digital Code Lock	922	£6.25
Video Modules - 3 JAN '95		
Dynamic Noise Limiter	919	£5.92
System Mains Power Supply	920	£4.98
Magnetic Field Detector	923	£5.77
Model Railway Track Cleaner	924	£5.11
Moving Display Metronome	925	£6.24
The Ultimate Screen Saver FEB '95	927	£5.66
Foot-Operated Drill Controller	928	£5.73
Model Railway Signals	929	£5.96
12V 35W PA Amplifier	930	£12.25
Multi-Purpose Thermostat MAR '95	931	£6.30
Multi-Project PCB	932	£3.00
Sound-Activated Switch		
Audio Amplifier		
Light Beam Communicator (2 boards required)		
Multi-Project PCB APR '95	932	£3.00
Light-Activated Switch		
Switch On/Off Timer		
Continuity Tester		
Auto Battery Charger	934	£5.36
National Lottery Predictor	935	£5.34
R.F. Signal Generator - R.F./Mod. MAY '95	936	£6.48
Coil & Power Supply (pair)	937a/b	£6.10
MIDI Pedal	938	£7.78
Club Vote Totaliser	939	£6.05
PIC-DATS Development System (double-sided p.t.h.)	940	£9.90
EPE HiFi Valve Amplifier - JUNE '95		
Phase splitter	941	£6.71
PIC-DATS 4-channel Light Chaser	942	£7.90
HV Capacitor Reformer JULY '95	943	£5.60
Ramp Generator		
Logic Board (double-sided p.t.h.) & Analogue board (pair)	944/5	£32.00
Automatic Curtain Winder	946	£6.75
Windicator	947	£4.10

PROJECT TITLE	Order Code	Cost
Microcontrolled 3-Digit Timer AUG '95	933	£6.61
IR Remote Control - Transmitter	948	£5.76
- Receiver	949	£6.14
Personal Practice Amplifier	950	£6.09
Low-Range Ohmmeter Adaptor SEPT '95	926	£5.55
Simple Theremin	952	£6.68
Vandata		
Boot Control Unit	953	£10.52
Display Unit	954	£6.61
Sound Switch OCT '95	915	£6.55
Multiple Project PCB	932	£3.00
Audio Sinewave Generator		
Treble Booster		
Infra-Red Controller/Alarm (2 boards required)		
Capacitor Check	955	£5.76
Ginormous VU Meter	956	£9.31
Multiple Project PCB NOV '95	932	£3.00
Video Enhancer		
Current Tracer		
Distortion Effects Unit		
Digital Delay Line	958	£8.04
50Hz Field Meter	959	£8.32
Temperature Warning Alarm (Teach-In '96)	960	£6.15
Stereo "Cordless" Headphones DEC '95		
Transmitter	961	£8.04
Receiver	962	£7.66
EPE Met Office - Sensor/Rainfall/Vane	963/965	£11.33
Spiral transparency free with above p.c.b.		
Light-Operated Switch	966	£6.37
Modular Alarm System (Teach-In '96)	967a/b	£7.12
Audio Meter and Amplifier	968	£5.99
EPE Met Office - JAN '96		
Computer Interface (double-sided)	964	£7.69
Audio Signal Generator	969	£6.58
Mains Signalling Unit, Transmitter and Receiver	970/971 (pr)	£9.09
Automatic Camera Panning (Teach-In '96)	972	£6.63
Printer Sharer	973	£9.93
Analogue Frequency Meter Feb '96	957	£6.70
Vari-Speed Dice (Teach-In '96)	974	£5.69
Mains Signalling Unit - 2		
12V Capacitive PSU	975	£6.07
Multi-Purpose Mini Amplifier MAR '96	976	£6.12
PIC-Electric - Sensor/PSU - Control/Display	977/978 (pr)	£9.90
High Current Stabilised Power Supply	979	£6.62
Mind Machine Mk III - Sound and Lights	980	£7.39
Infra-Zapper Transmitter/Receiver (Teach-In '96)	981/982 (pr)	£8.01
Mind Machine Mk III - Programmer APRIL '96	983	£7.36
Bat Band Converter/B.F.O.	984a/b	£5.80
Hearing Tester	985	£6.87
Event Counter (Teach-In '96)	986	£8.39

EPE PRINTED CIRCUIT BOARD SERVICE

Order Code Project Quantity Price

Name.....

Address.....

I enclose payment of £.....(cheque/PO in £ sterling only) to:



Everyday
Practical Electronics



Access (MasterCard) or Visa No.
Minimum order for credit cards £5

Signature..... Card Exp. Date.....

Please supply name and address of cardholder if different from the address shown

REPORTING

AMATEUR RADIO

Tony Smith G4FAI

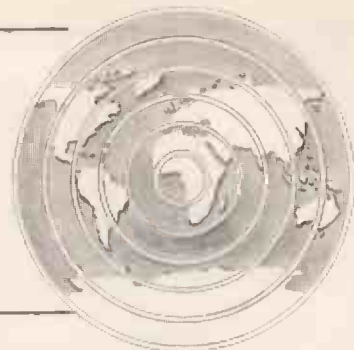

IS MORSE RELEVANT?

The Radiocommunications Agency (RA) has asked the Radio Society of Great Britain "as the national representative for radio amateurs in the UK" to consider formally the proposal to delete Radio Regulation 2735, which was referred from last year's World Radio Conference (*WRC-95*) to *WRC-99*, and to give their views on it.

In a letter published in *RadCom*, journal of the RSGB, Roger Louth, the RA's Director of Mobile Services, says:

"Fundamentally, we need to give thought as to whether there should be two classes of licence and, if there should, whether the Morse Test is a relevant means of differentiation . . .

"It is now timely to reconsider this issue and to decide whether the Morse requirement is one which radio amateurs see relevant to the next millennium."

RSGB SURVEY

Accordingly, the RSGB is to conduct a survey of all radio amateurs, listeners and other interested parties, to obtain their views on the qualifications and licensing structure necessary for the UK Amateur Service.

The RA itself has previously indicated its view that the Morse test is no longer relevant. If the test is abolished and it is not replaced with some other qualification, the result could be a single licence permitting operation on all amateur bands without a second examination of any kind.

If the test were to be replaced with something else, there is debate over what could take its place. Some argue there should be a test of computer keyboard skills to reflect the interests of many of those who have campaigned to see an end to the Morse test.

Others suggest there should be several alternative tests, retaining Morse as one of them. That way newcomers could choose their own path to the h.f. licence, depending on their particular interests and aptitudes. Whatever the final outcome, the "no-code" debate will go on for a few more years yet!

FASC

Meanwhile, the International Amateur Radio Union's special committee, mentioned briefly in this column in the February issue, has begun work.

This committee, known as the Future of the Amateur Service ad-hoc Committee (FASC), is to examine the international regulations governing the Amateur Service and Amateur-Satellite Service (other than frequency allocations) and will suggest what changes, if any, are desirable to properly reflect the objects, needs, obligations, and privileges of these services for the next century.

Amongst other things, it is to look at the nature and content of transmissions of amateur stations; the provision of emergency communications; means to facilitate the international recognition of amateur licenses; and the technical and operational qualifications for radio amateurs.

This committee will be active for the next three years and its proposals, after discussion and agreement by IARU member societies and Regions, will develop into an IARU position for consideration at *WRC-99*.

CAMPAIGN

Also of concern to radio amateurs is a further matter referred by *WRC-95* to *WRC-99*, i.e.: "Examination by the adequacy of the frequency allocations for HF broadcasting from about 4MHz to 10MHz taking into account . . . the needs of other services."

In the UK and Europe the amateur 40m band covers 7MHz to 7.1MHz, and in some other parts of the world, including North America, it is from 7MHz to 7.3MHz.

The IARU has been seeking a worldwide allocation of at least 300kHz in the vicinity of 7MHz, so not only must the present allocations be protected from the pressure of broadcasters who wish to expand their own allocations, but the IARU's own campaign for expansion of the 40m band needs to be developed for consideration at *WRC-99*.

This work is being undertaken by an IARU 7MHz Strategy Committee which in the near future will be asking national societies, like the RSGB, to seek the support of their administrations (in the UK, the RA) for the proposed expansion of the 40m amateur band.

SEARCH FOR ETI

The SETI League Inc., a non-profit, educational and scientific corporation, is looking for radio amateurs and other microwave experimenters to help in the Search for Extra-Terrestrial Intelligence.

It plans to deploy and coordinate amateur radio telescopes around the world in an intensive search for microwave signals of possible intelligent extra-terrestrial origin. When fully operational, *Project Argus* will provide the first ever continuous monitoring of the entire sky in all directions in real time.

Amateurs with suitable scanning equipment, including a digital signal processor, spectrum analysis software and a home computer, will be asked to monitor the range 1.4GHz to 1.7GHz in 10Hz steps. For various reasons, this frequency range is considered by SETI scientists to represent a natural, universal communications band.

The League will assign participating amateurs specific search declinations to

ensure full sky coverage, and will act as a clearing house for information and results.

EARTH DAY

A typical amateur radio telescope, says the SETI League, can be built at a cost similar to that of a typical *OSCAR* satellite station, ranging from a few hundred to a few thousand dollars, depending upon the expertise of the builder. Such radio telescopes, they claim, are capable of detecting microwave radiation from technologically advanced civilizations several hundred light years away.

The theory is that while one dedicated amateur radio telescope would take nearly six thousand years to complete one full sweep of the chosen frequencies in all directions from the earth's surface, 5,520 experimenters could do the same survey in one year.

The necessary hardware, software, protocols and procedures are being distributed to League members, and the search phase of *Project Argus* begins on "Earth Day", April 21, 1996.

For further information, contact *The SETI League, Dept EPE, 433 Liberty St., PO Box 555, Little Ferry, NJ 07643, USA* (or E-mail info@setileague.org).

DEVELOPMENTS IN CHINA

Amateur radio continues to develop in China. Individuals can now obtain amateur licences, where previously only club operation was allowed. The first examinations have been held and the first home station licences issued.

There are four licence grades, with different power limitations: 500 watts and 100 watts on all authorised bands; 10 watts on limited bands, and a fourth grade requiring no examination allows operation on 29.5MHz f.m. only, with home-built equipment. The no-exam licenses are only valid for 12 months, after which operators *must* upgrade to one of the other licenses.

Last October, the Chinese Radio Sports Association (CRSA) hosted the first Beijing International DX Convention, with delegates attending from many countries, together with about 80 Chinese amateurs.

Two special event stations operated over the weekend of the convention, one from the convention hotel, and one from the Great Wall of China. Each overseas visiting amateur was issued with a Visitor's Licence to operate on the two metre band in Beijing, using the callsign "B/(home call)".

This was the first time foreign visitors have been permitted such operation. (*Information from Amateur Radio, journal of the Wireless Institute of Australia*).

PORTABLE X RAY MACHINE PLANS Easy to construct plans on a simple and cheap way to build a home X-ray machine! Effective device, X-ray sealed assemblies, can be used for experimental purposes. Not a toy or for minors! £65/et. Ref FXP1.

TELEKINETIC ENHANCER PLANS Mystify and amaze your friends by creating motion with no known apparent means or cause. Uses no electrical or mechanical connections, no special gimmicks yet produces positive motion and effect. Excellent for science projects, magic shows, party demonstrations or serious research & development of this strange and amazing psychic phenomenon. £45/et Ref F/TK1.

ELECTRONIC HYPNOSIS PLANS & DATA This data shows several ways to put subjects under your control. Included is a full volume reference text and several construction plans that when assembled can produce highly effective stimuli. This material must be used cautiously. It is for use as entertainment at parties etc only, by those experienced in its use. £15/et. Ref F/EH2.

GRAVITY GENERATOR PLANS This unique plan demonstrates a simple electrical phenomena that produces an anti-gravity effect. You can actually build a small mock spaceship out of simple materials and without any visible means - cause it to levitate. £10/et Ref F/GRA1.

WORLDS SMALLEST TESLA COIL/LIGHTENING DISPLAY GLOBE PLANS Produces up to 750,000 volts of discharge, experiment with extraordinary HV effects, 'Plasma in a Jar', St Elmo's fire, Corona, excellent science project or conversation piece. £5/et Ref F/BTC1A/G5.

COPPER VAPOUR LASER PLANS Produces 100mw of visible green light. High coherence and spectral quality similar to Argon laser but easier and less costly to build yet far more efficient. This particular design was developed at the Atomic Energy Commission of NEGEV in Israel. £10/et Ref F/CV1.

VOICE SCRAMBLER PLANS Miniature solid state system turns speech sound into indecipherable noise that cannot be understood without a second matching unit. Use on telephone to prevent third party listening and bugging. £6/et Ref F/V59.

PULSED TV JOKER PLANS Little hand held device utilises pulse techniques that will completely disrupt TV picture and sound works on FM too! DISCRETION ADVISED. £8/et Ref F/TJ5.

BODYHEAT TELESCOPE PLANS Highly directional long range device uses recent technology to detect the presence of living bodies, warm and hot spots, heat leaks etc. Intended for security, law enforcement, research and development, etc. Excellent security device or very interesting science project. £8/et Ref F/BHT1.

BURNING, CUTTING CO2 LASER PLANS Projects an invisible beam of heat capable of burning and melting materials over a considerable distance. This laser is one of the most efficient, converting 10% input power into useful output. Not only is this device a workhorse in welding, cutting and heat processing materials but it is also a likely candidate as an effective directed energy beam weapon against missiles, aircraft, ground-to-ground, etc. Particle beams may very well utilize a laser of this type to blast a channel in the atmosphere for a high energy stream of neutrons or other particles. The device is easily applicable to burning and etching wood, cutting, plastics, textiles etc. £12/et Ref F/LC7.

MYSTERY ANTI GRAVITY DEVICE PLANS Uses simple concept. Objects float in air and move to the touch. Defies gravity, amazing gift, conversation piece, magic trick or science project. £6/et Ref F/ANT1K.

ULTRASONIC BLASTER PLANS Laboratory source of sonic shock waves. Blow holes in metal, produce 'cold' steam, atomize liquids. Many cleaning uses for PC boards, jewellery, coins, small parts etc. £6/et Ref F/ULB1.

ULTRA HIGH GAIN AMP/STETHOSCOPIC MIKE/SOUND AND VIBRATION DETECTOR PLANS Ultrasensitive device enables one to hear a whole new world of sounds. Listen through walls, windows, floors etc. Many applications shown, from law enforcement, nature listening, medical heartbeat, to mechanical devices. £6/et Ref F/HGA7.

ANTI DOG FORCE FIELD PLANS Highly effective circuit produces time variable pulses of acoustical energy that dogs cannot tolerate. £6/et Ref F/D0G2.

LASER BOUNCE LISTENER SYSTEM PLANS Allows you to hear sounds from a premises without gaining access. £12/et Ref F/LLIST1.

CRAWLING INSECT ROASTER PLANS Harmless high frequency energy pulses destroy pests as they crawl into the energy field! £4/et Ref F/RCR1.

LASER LIGHT SHOW PLANS Do it yourself plans show three methods. £6 Ref F/LLS1.

PHASOR BLAST WAVE PISTOL SERIES PLANS Handheld, has large transducer and battery capacity with external controls. £6/et Ref F/PSP4.

INFINITY TRANSMITTER PLANS Telephone line grabber/room monitor. The ultimate in home/office security and safety! simple to use! Call your home or office phone, push a secret tone on your telephone to access either: A) On premises sound and voices or B) Existing conversation with break-in capability for emergency messages. £7 Ref F/TELEGRAB.

BUG DETECTOR PLANS Is that someone getting the goods on you? Easy to construct device locates any hidden source of radio energy! Sniffs out and finds bugs and other sources of bothersome interference. Detects low, high and UHF frequencies. £5/et Ref F/BD1.

ELECTROMAGNETIC GUN PLANS Projects a metal object a considerable distance - requires adult supervision. £5 Ref F/EML2.

ELECTRIC MAN PLANS, SHOCK PEOPLE WITH THE TOUCH OF YOUR HAND! £5/et Ref F/EMA1.

PARABOLIC DISH MICROPHONE PLANS Listen to distant sounds and voices, open windows, sound sources in 'hard to get' or hostile premises. Uses satellite technology to gather distant sounds and focus them to our ultra sensitive electronics. Plans also show an optional wireless link system. £8/et Ref F/PM5.

2 FOR 1 MULTIFUNCTIONAL HIGH FREQUENCY AND HIGH DC VOLTAGE, SOLID STATE TESLA COIL AND VARIABLE 100,000 VDC OUTPUT GENERATOR PLANS Operates on 9-12vdc, many possible experiments. £10 Ref F/HVM7/TCL4.

WOLVERHAMPTON BRANCH NOW OPEN AT WORCESTER ST W'HAMPTON TEL 01902 22039

INFINITY TRANSMITTERS The ultimate 'bug' fits to any phone or line, undetectable, listen to the conversations in the room from anywhere in the world! 24 hours a day 7 days a week! Just call the number and press a button on the mini controller (supplied) and you can hear everything! Ring or Fax for latest price!

SWITCHED MODE PSU'S 244 watt, +5 32A, +12 6A, -5 0.2A, -12 0.2A. There is also an optional 3.3v 25A rail available. 120/240v V/P. Cased, 175x90x145mm. IEC inlet suitable for PC use (6/drive connectors 1 mboard). £10 Ref PSU1.

VIDEO PROCESSOR UNITS 7/6v 10AH BATT/12V 8A TX Not too sure what the function of these units is but they certainly make good strippers! Measures 390x320x120mm, on the front are controls for scan speed, scandelay, scan mode, loads of connections on the rear. Inside 2 x 6v 10AH sealed lead acid batts, pcb's and a BA7 12v toroidal transformer (mains in). Condition not known, may have one or two broken knobs due to poor storage. £17.50 Ref VP2.

RETRON NIGHT SIGHT Recognition of a standing man at 300m in 1/4 moonlight, hematically sealed, runs on 2 AA batteries, 80mm F1.5 lens, 20mw infrared laser included. £325 Ref RETRON.

MINI FM TRANSMITTER KIT Very high gain preamp, supplied complete with FET electret microphone. Designed to cover 88-108 Mhz but easily changed to cover 63-130 Mhz. Works with a common 9v (PP3) battery. 0.2W RF. £7 Ref 1001.

3-30V POWER SUPPLY KIT Variable, stabilized power supply for lab use. Short circuit protected. Suitable for professional or amateur use 24v 3A transformer is needed to complete the kit. £14 Ref 1007.

1 WATT FM TRANSMITTER KIT Supplied with piezo electric mic. 8-30vdc. At 25-30v you will get nearly 2 watts! £12 Ref 1009.

FM/AM SCANNER KIT Well not quite, you have to turn the knob yourself but you will hear things on this radio that you would not hear on an ordinary radio (even TV). Covers 50-160mhz on both AM and FM. Built in 5 watt amplifier, inc speaker. £15 Ref 1013.

3 CHANNEL SOUND TO LIGHT KIT Wireless system, mains operated, separate sensitivity adjustment for each channel, 1,200 w power handling, microphone included. £14 Ref 1014.

4 WATT FM TRANSMITTER KIT Small but powerful FM transmitter, 3 RF stages, microphone and audio preamp included. £20 Ref 1028.

STROBE LIGHT KIT Adjustable from 1-60 Hz (a lot faster than conventional strobes). Mains operated. £16 Ref 1037.

LIQUID LEVEL DETECTOR KIT Useful for tanks, ponds, baths, rain alarm, leak detector etc. Will switch 2A mains. £5 Ref 1081.

COMBINATION LOCK KIT 9 key, programmable, complete with keypad, will switch 2A mains. 9v dc operation. £10 Ref 1114.

PHONE BUG DETECTOR KIT This device will warn you if somebody is eavesdropping on your line. £6 Ref 1130.

ROBOT VOICE KIT Interesting circuit that distorts your voice adjustable, answer the phone with a different voice! 12vdc £9 Ref 1131.

TELEPHONE BUG KIT Small bug powered by the phone line, starts transmitting as soon as the phone is picked up! £8 Ref 1135.

3 CHANNEL LIGHT CHASER KIT 800 watts per channel, speed and direction controled supplied with 12 LEDs (you can fit fluorescents instead to make kit mains, not supplied) 9-12vdc £17 Ref 1026.

12V FLOURESCENT LAMP DRIVER KIT Light up 4 foot tubes from your car battery! 9v 2A transformer also required. £8 Ref 1069.

VOXSWITCH KIT Sound activated switch ideal for making bugging tape recorders etc, adjustable sensitivity. £8 Ref 1073.

6"X12" AMORPHOUS SOLAR PANEL 12v 155x310mm 130mA. Bargain price just £5.99 ea REF MAG6P12.

FIBRE OPTIC CABLE BUMPER PACK 10 metres for £4.99 Ref MAG6P13 ideal for experimenters! 30 m for £12.99 Ref MAG13P1

ROCK LIGHTS Unusual things these, two pieces of rock that glow when rubbed together believed to cause rain! £3 a pair REF E29.

3' by 1' AMORPHOUS SOLAR PANELS 14.5v, 700mA 10 watts, aluminium frame, screw terminals, £44.95 Ref MAG45.

ELECTRONIC ACCUPUNCTURE KIT Builds into an electronic version instead of needles! good to experiment with. £7 Ref 7P30.

SHOCKING COIL KIT Build this little battery operated device into all sorts of things, also gets worms out of the ground! £7 Ref 7P36.

FLYING PARROTS Easily assembled kit that builds a parrot that actually flaps its wings and flies! 50 m range £6 Ref EF2.

HIGH POWER CATAPULTS Hinged arm brace for stability, tempered steel yoke, super strength latex power bands. Departure speed of ammunition is in excess of 200 miles per hour! Range of over 200 metres! £7.99 Ref R/9.

PHILLIPS PRO COLOUR MONITORS, SCART INPUT OUR PRICE JUST £80 REF BAR328.

BALLON MANUFACTURING KIT British made, small blob blows into a large, longlasting balloon, hours of fun! £3.99 Ref GI/E99R

CLEARANCE SECTION, MINIMUM ORDER £15, NO TECHNICAL DETAILS AVAILABLE, NO RETURNS, TRADE WELCOME.

2000 RESISTORS ON A REEL (SAME VALUE) 99P REF BAR340
AT LEAST 200 CAPACITORS (SAME VALUE) 99P REF BAR342
INFRA RED REMOTE CONTROLS JUST 99P REF BAR333
CIRCUIT BREAKERS, OUR CHOICE TO CLEAR 99P REF BAR335
MICROWAVE CONTROL PANELS TO CLEAR £2 REF BAR 329
2 TUBES OF CHIPS (2 TYPES OUR CHOICE) 90P REF BAR305
LOTTERY PREDICTOR MACHINE! JUST £1.50 REF BAR313
HELLA/ROVER ELECTRIC H/LAMP LEVELLER £2 REF BAR311
SINCLAIR CS 16" TYRES TO CLEAR AT JUST 75P REF BAR310
LARGE MAINS MOTORS (NEW) TO CLEAR AT 75P REF BAR318
MODEMS ETC FOR STRIPPING £2.50 EACH REF BAR324
110V LARGE MOTORS (NEW) TO CLEAR AT 50P REF BAR332
MODULATOR UNITS UNKNOWN SPEC JUST 50P REF BAR323
GX4000 GAMES COSOLES JUST £4 REF BAR320
SMART CASH MEMORY STORAGE DEVICE, LOADS OF BITS INSIDE, PCB, MOTOR, CASE ETC. BUMPER PACK OF 5 COMPLETE UNITS TO CLEAR AT £2.50 (FOR 5) REF BAR 330.
2 CORE MAINS CABLE 2M LENGTHS PACK OF 4 £1 REF BAR337
PC USER/BASIC MANUALS, LOADS OF INFO. £1 REF BAR304
PCB STRIPPERS TO CLEAR AT 2 FOR 99P REF BAR341
3 M 3 CORE MAINS CABLE AND 13A PLUG. 60P REF BAR325

***SOME OF OUR PRODUCTS MAY BE UNLICENSEABLE IN THE UK**

BULL ELECTRICAL
250 PORTLAND ROAD, HOVE, SUSSEX.
BN3 5QT. (ESTABLISHED 50 YEARS).

MAIL ORDER TERMS: CASH, PO OR CHEQUE
WITH ORDER PLUS £3 P&P PLUS VAT.
PLEASE ALLOW 7-10 DAYS FOR DELIVERY (OUR ORDERS WELCOME (ACCESS VISA, SWITCH, AMERICAN EXPRESS))

TEL: 01273 203500
FAX 01273 323077
E-mail bull@pavilion.co.uk

Check out our WEB SITE
<http://www.pavillon.co.uk/bull-electrical>

PREAMP MIXER KIT 3 input mono mixer, sep bass and treble controls plus individual level controls. 18vdc, input sens 100mA. £15 Ref 1052.

METAL DETECTOR KIT Range 15-20cm, complete with case, 9vdc. £8 Ref 1022.

SOUND EFFECTS GENERATOR KIT Produces sounds ranging from bird chips to sirens. Complete with speaker, add sound effects to your projects for just £9 Ref 1045.

16 WATT FM TRANSMITTER (BUILT) 4 stage high power, preamp required 12-18vdc, can use ground plane, yagi or open dipole. £69 Ref 1021.

HUMIDITY METER KIT Builds into a precision LCD humidity meter, 9ic design, pcb, lcd display and all components included. £29

PC TIMER KIT Four channel output controlled by your PC, will switch high current mains with relays (supplied). Software supplied so you can program the channels to do what you want whenever you want. Minimum system configuration is 286, VGA, 4.1, 640k, serial port, hard drive with min 100k free. £24.99

DIVING RODS Expensive technology cannot challenge the fool

proof art of water diving, passed down from generation to generation. Seeing is believing. Use in the home, garden, countryside or desert, it's divinely simple! £4.99 a pair Ref E3.

HUGE BUBBLE MAKING KIT You'll be amazed at the size of the bubbles you can achieve with this bubble making kit. Once you have got the knack it is possible to make bubbles up to 40 feet long. £11.99 Ref E/9.

FM CORDLESS MICROPHONE This unit is an FM broadcasting station in miniature. 3 transistor transmitter with electret condenser mic + fet amp design result in maximum sensitivity and broad frequency response. 90-105mhz, 50-1500hz, 500 foot range in open country! PP3 battery required. £15.00 Ref 15P42A.

MAGNETIC MARBLES They have been around for a number of years but still give rise to curiosity and amazement. A pack of 12 is just £3.99 Ref GI/R20

STETHOSCOPES A fully functioning stethoscope for all those intricate projects. Enables you to listen to motors, pipes, heartbeats, walls, insects etc. £6 Ref MAR6P6.

NICKEL PLATING KIT Professional electroplating kit that will transform rusting parts into showpieces in 3 hours! Will plate onto steel, iron, bronze, gunmetal, copper, welded, silver soldered or brazed joints. Kit includes enough to plate 1,000 sq inches. You will also need a 12v supply, a container and 2 12v light bulbs. £39.99 Ref NIK39.

Miniature adjustable timers, 4 pole o/o output 3A 240v, HY1230S, 12VDC adjustable from 0-30 secs. £4.99
HY1260M, 12VDC adjustable from 0-60 mins. £4.99
HY2405S, 240v adjustable from 0-5 secs. £4.99
HY24065M, 240v adjustable from 0-60 mins. £6.99

DRINKING BIRD Remember these? Hook onto wine glass (supplied) and they drink, standup, drnk, standup ETC! £4 each Ref F1

SOLAR POWER LAB SPECIAL You get TWO 6"x6" 6v 130mA solar cells, 4 LEDs, wire, buzzer, switch plus 1 relay or motor. Superb value kit just £5.99 REF: MAG6P8

BUGGING TAPE RECORDER Small voice activated recorder, uses micro cassette complete with headphones. £28.99 Ref MAR29P1.

PLUG IN ACORN PSU 19v AC 14w. £2.99 REF MAG3P10

POWER SUPPLY fully cased with mains and o/p leads 17v DC 900mA output. Bargain price £5.99 Ref MAG6P9

9v DC POWER SUPPLY Standard plug in type 150ma 9v DC with lead and DC power plug. price for two is £2.99 Ref AUG3P4.

COMPOSITE VIDEO KIT Converts composite video into separate H sync, V sync, and video. 12v DC. £8.00 REF: MAG8P2.

GYROSCOPE About 3" high and an excellent educational toy for all ages! Price with instruction booklet £6 Ref EF15.

FUTURE PC POWER SUPPLIES These are 295x135x60mm, 4 drive connectors 1 mother board connector. 150watt, 12v fan, iec inlet and on/off switch. £12 Ref EF6.

VENUS FLY TRAP KIT Grow your own carnivorous plant with this simple kit £3 Ref EF34.

6"X12" AMORPHOUS SOLAR PANEL 12v 155x310mm 130mA. Bargain price just £5.99 ea REF MAG6P12.

FIBRE OPTIC CABLE BUMPER PACK 10 metres for £4.99 Ref MAG6P13 ideal for experimenters! 30 m for £12.99 Ref MAG13P1

ROCK LIGHTS Unusual things these, two pieces of rock that glow when rubbed together believed to cause rain! £3 a pair REF E29.

3' by 1' AMORPHOUS SOLAR PANELS 14.5v, 700mA 10 watts, aluminium frame, screw terminals, £44.95 Ref MAG45.

ELECTRONIC ACCUPUNCTURE KIT Builds into an electronic version instead of needles! good to experiment with. £7 Ref 7P30.

SHOCKING COIL KIT Build this little battery operated device into all sorts of things, also gets worms out of the ground! £7 Ref 7P36.

FLYING PARROTS Easily assembled kit that builds a parrot that actually flaps its wings and flies! 50 m range £6 Ref EF2.

HIGH POWER CATAPULTS Hinged arm brace for stability, tempered steel yoke, super strength latex power bands. Departure speed of ammunition is in excess of 200 miles per hour! Range of over 200 metres! £7.99 Ref R/9.

PHILLIPS PRO COLOUR MONITORS, SCART INPUT OUR PRICE JUST £80 REF BAR328.

BALLON MANUFACTURING KIT British made, small blob blows into a large, longlasting balloon, hours of fun! £3.99 Ref GI/E99R

CLEARANCE SECTION, MINIMUM ORDER £15, NO TECHNICAL DETAILS AVAILABLE, NO RETURNS, TRADE WELCOME.

2000 RESISTORS ON A REEL (SAME VALUE) 99P REF BAR340
AT LEAST 200 CAPACITORS (SAME VALUE) 99P REF BAR342
INFRA RED REMOTE CONTROLS JUST 99P REF BAR333
CIRCUIT BREAKERS, OUR CHOICE TO CLEAR 99P REF BAR335
MICROWAVE CONTROL PANELS TO CLEAR £2 REF BAR 329
2 TUBES OF CHIPS (2 TYPES OUR CHOICE) 90P REF BAR305
LOTTERY PREDICTOR MACHINE! JUST £1.50 REF BAR313
HELLA/ROVER ELECTRIC H/LAMP LEVELLER £2 REF BAR311
SINCLAIR CS 16" TYRES TO CLEAR AT JUST 75P REF BAR310
LARGE MAINS MOTORS (NEW) TO CLEAR AT 75P REF BAR318
MODEMS ETC FOR STRIPPING £2.50 EACH REF BAR324
110V LARGE MOTORS (NEW) TO CLEAR AT 50P REF BAR332
MODULATOR UNITS UNKNOWN SPEC JUST 50P REF BAR323
GX4000 GAMES COSOLES JUST £4 REF BAR320
SMART CASH MEMORY STORAGE DEVICE, LOADS OF BITS INSIDE, PCB, MOTOR, CASE ETC. BUMPER PACK OF 5 COMPLETE UNITS TO CLEAR AT £2.50 (FOR 5) REF BAR 330.
2 CORE MAINS CABLE 2M LENGTHS PACK OF 4 £1 REF BAR337
PC USER/BASIC MANUALS, LOADS OF INFO. £1 REF BAR304
PCB STRIPPERS TO CLEAR AT 2 FOR 99P REF BAR341
3 M 3 CORE MAINS CABLE AND 13A PLUG. 60P REF BAR325

WE BUY SURPLUS STOCK FOR CASH
BUYERS DIRECT LINE 0860 425692

FREE CATALOGUE
100 PAGE CATALOGUE NOW AVAILABLE, 45P STAMP OR FREE ON REQUEST WITH ORDER.

ELECTRONICS

Everyday Practical Electronics reaches nearly twice as many UK readers as any other independent monthly hobby electronics magazine, our audited sales figures prove it. We have been the leading independent monthly magazine in this market for the last eleven years.

If you want your advertisements to be seen by the largest readership at the most economical price our classified and semi-display pages offer the best value. The prepaid rate for semi-display space is £8 (+VAT) per single column centimetre (minimum 2.5cm). The prepaid rate for classified adverts is 30p (+VAT) per word (minimum 12 words).



All cheques, postal orders, etc., to be made payable to Everyday Practical Electronics. **VAT must be added.** Advertisements, together with remittance, should be sent to Everyday Practical Electronics Advertisements, Holland Wood House, Church Lane, Great Holland, Essex CO13 0JS. Phone/Fax (01255) 850596.

For rates and information on display and classified advertising please contact our Advertisement Manager, Peter Mew as above.

RCS VARIABLE VOLTAGE D.C. BENCH POWER SUPPLY
Up to 38 volts d.c. at 6 amps continuous, 10 amps peak, fully variable from 1 to 38 volts. Twin Voltage and Current meters for easy read-out. 240 volt a.c. input. Fully smoothed, size 1 1/2" x 11 x 4 1/2" inches.

 **£96 inc. VAT carriage £6**

RADIO COMPONENT SPECIALISTS
337 WHITEHORSE ROAD, CROYDON SURREY, CR0 2HS. Tel: 0181-684 1665

 
Lots of transformers, high volt caps, valves, speakers, in stock. Phone or send your wants list for quote.

Printed Circuit Board design and manufacture. Photography from Gerber data enlargement or reduction of taped artwork.

Call:
SEVERNSIDE PHOTO-TOOLS
(01746) 763203

288

CAMBRIDGE Z88 A4 NOTEBOOK COMPUTER AVAILABLE AGAIN £99.
ONLY 1" THICK, 4xAA BATTs. 20 HOURS WORK. LCD SCREEN, 72 Crs, 6 LINES, 82K RAM, EXTRA RAMS & EPROMS, 9 pin D SERIAL PORT, ROM HAS BBC BASIC, W/PROCESSOR, SPREADSHEET, DATA BASE, IMP/EXPORT TO PC etc, V52 TERMINAL.

W.N. RICHARDSON & CO.
PHONE/FAX 01494 871319
6 RAVENSMead, CHALFONT ST PETER, BUCKS, SL9 0NB.
POST £5. ACCESS, VISA, ETC.

THE PARALLEL INTERFACE POWER CARD by HANDDI Ltd for complete **COMPUTER CONTROL.**
This could be your most useful and cheapest computer/PC "add-on" at only £19.95... Post FREE!
Drives robotics, motor speeds, stepper motors, lamps, relays etc. using its 8 x 20V/2A outputs.
Many sold already for successful Model Railway Layout control... FULL INSTRUCTIONS supplied!
Send cheque for £19.95 OR S.A.E. for details to:- HANDDI Ltd. P.O. 503, Milton Keynes, MK5 6JD.

BTEC ELECTRONICS TECHNICIAN FULL-TIME TRAINING
THOSE ELIGIBLE CAN APPLY FOR E.T. GRANT SUPPORT AN EQUAL OPPORTUNITIES PROGRAMME
O.N.C., O.N.D. and H.N.C.
Next course commences **Monday 22nd April 1996**
FULL PROSPECTUS FROM

LONDON ELECTRONICS COLLEGE
(Dept EPE) 20 PENYWERN ROAD EARLS COURT, LONDON SW5 9SU
TEL: 0171-373 8721

FIRST ON THE WEB
with over 300 kits: lasers, night vision, µC teaching, PIC programmers, CCD cameras, UHF remote control, FM bugs, amplifiers, Peltier modules. See our web page at:
<http://www.hk.super.net/~diykit>
Use your old PC as a dedicated controller. Plug in our relay board into the parallel port. Eight relays on board. Comes complete with two software packages (DOS & W3.1) and all components. Kit 74. £19.25 airmail post inc. Just send your cheque to:

DIY ELECTRONICS
PO Box 88458, Sham Shui Po, Hong Kong

THE BRITISH AMATEUR ELECTRONICS CLUB
exists to help electronics enthusiasts by personal contact and through a quarterly Newsletter.
For membership details, write to the Secretary:
Mr. J. F. Davies, 70 Ash Road, Cuddington, Northwich, Cheshire CW8 2PB.
Space donated by Everyday Practical Electronics

Miscellaneous

PROTOTYPE PRINTED CIRCUIT BOARDS one offs and quantities, for details send s.a.e. to B. M. Ansbro, 38 Poynings Drive, Hove, Sussex BN3 8GR, or phone Brighton 883871.

G.C.S.E. ELECTRONICS KITS, at pocket money prices. S.A.E. for FREE catalogue. SIR-KIT Electronics, 70 Oxford Road, Clacton, CO15 3TE.

PLDs AND EPROMS copied or programmed. We supply logic devices/convert discrete logic to PLDs. Also PCBs designed. Send for details to PO Box 1561 Bath (01225 444467).

VALVE ENTHUSIASTS: Capacitors and other parts in stock. For free advice/lists please ring, Geoff Davies (Radio), Tel: 01788 574774.

PRINTED CIRCUIT BOARDS - QUICK SERVICE. Prototype and Production. Artwork raised from magazines or draft designs at low cost. PCB's also designed from schematics. Production assembly also undertaken. For details send to P. Agar, 36 Woodcot Avenue, Belfast, BT5 5JA or phone 01232 473533 (7 days).

AMAZE YOUR FRIENDS with your own "PLASMA DISPLAY LAMP". Fascinating science project! Complete kit only £24.95. (+£1.50 p&p) or plans only £5.95 (+50p p&p). Cheques or postal orders to: P.P.S., 33B Rowlands Road, Worthing, W. Sussex, BN11 3JJ.

HIGH VOLTAGE DC-DC CONVERTERS, PCB Mounting, 12/24 volt input. Fully encapsulated, ideal for GEIGER, PHOTOMULTIPLIER and ION MOTOR experiments. 2kV Unit £19.00 each or 10kV Unit £49.00 each. Quantity discounts available direct from manufacturer. S.A.E. for further information to:- P.P.S., 33B Rowlands Road, Worthing, W. Sussex, BN11 3JJ. 01903 214100.

25MHz DUAL BEAM OSCILLOSCOPE, Philips PM3212, £150 o.n.o. (01284) 769187.

NBZ80-S Z80 COMPUTER TRAINING SYSTEM, Breadboarding area, Hex keypad, display, manuals, tutorial. learn about Z80 CPU, programming, interrupts, logic chips etc. £80 o.n.o. (01284) 769187.

FOR SALE: MICROCHIP PICSTART 16B1 development system with manuals and box complete, only 6 months old, cost £160 sell for half price. Phone evenings 01202 518665.

OSILLOSCOPE, Tetrax 541A, all valve model, 30 MHz, good condition, £65. Advance Signal Generator, £30. (01952) 460618.

100 WATT AMPLIFIER MODULES, £8.95; 3 Heatsinks ±50V D.C. ex-equip; 12-40V slider P.S.U.'s, £5.00. K.I.A., 1 Regent Road, Ilkely.

MAGAZINES 25p EACH, PE, ETI, Wireless World, mostly 1977 to 1983. 01932 873005.

PIY! IC PROGRAMMER plus EPROM UV Eraser and supporting data. Complete package £350. Tel: (01743) 410243.

EVERYDAY PRACTICAL ELECTRONICS

SUBSCRIPTION ORDER FORM

Annual subscription rates (1996):
UK £24.00.
Overseas £30.00 surface mail, £47.50 airmail.

To:
Everyday Practical Electronics,
Allen House, East Borough,
Wimborne,
Dorset BH21 1PF

Tel: 01202 881749
Fax: 01202 841692

Name

Address

I enclose payment of £.....

(cheque/PO in £ sterling only, payable to Everyday Practical Electronics). Alternatively send Access or Visa number and card expiry date.

Signature

Please supply name and address of cardholder if different from the subscription address shown above. Subscriptions can only start with the next available issue. For back numbers see the Back Issues page.

M4/96

TRAIN TODAY FOR A BETTER FUTURE

Now you can get the skills and qualifications you need for career success with an ICS Home Study Course. Learn in the comfort of your own home at the pace and times that suit you. ICS is the world's largest, most experienced home study school. Over the past 100 years ICS have helped nearly 10 million people to improve their job prospects. Find out how we can help YOU. Post or phone today for FREE INFORMATION on the course of your choice.

Electrical Contracting
Electrical Engineering
C & G Basic Electronics
C & G Basic Mechanics
TV, Video & Hi-Fi Servicing
Refrigeration & Air Conditioning
PC Repair
Electronic Engineering

Call 0141 306 1195

Please send me my Free Information on your Electronics Courses.

Mr/Mrs/Ms/Miss
(BLOCK CAPITALS PLEASE)

Date of Birth / /

Address

Postcode

Occupation

Tel. No.

ICS International Correspondence Schools, Dept. ZEEED, FREEPOST 882, 8 Elliot Place, Clydeway Centre, Glasgow, G3 8BR. Tel. 0141 306 1195 (9am-7pm) or Tel/Fax: Ireland 01 285 2533. Further offers, which may be of interest, may be sent to you by ICS or other carefully selected companies.

SERVICE MANUALS & Technical Books

Available for most equipment, any make, age or model.
Return the coupon for your FREE catalogue

MAURITRON TECHNICAL SERVICES (BPE)

8 Cherry Tree Road, Chinnor, Oxon, OX9 4QY.

Tel: 01844-351694. Fax: 01844 352554.

Please forward your latest catalogue for which I enclose 2 x 1st Class Stamps or £4.11 inc VAT for the Service Manuals Index on PC Disc plus catalogue.

NAME

ADDRESS

POSTCODE

Photocopy this coupon if you do not wish to cut the magazine

VISA



Cooke International

SUPPLIER OF QUALITY USED TEST INSTRUMENTS

ANALYSERS, BRIDGES, CALIBRATORS, VOLTMETERS, GENERATORS, OSCILLOSCOPES, POWER METERS, ETC. ALWAYS AVAILABLE

ORIGINAL SERVICE MANUALS FOR SALE
COPY SERVICE ALSO AVAILABLE

EXPORT, TRADE AND U.K. ENQUIRIES WELCOME

SEND FOR LISTS OF EQUIPMENT & MANUALS

ALL PRICES EXCLUDE VAT AND CARRIAGE

DISCOUNT FOR BULK ORDERS SHIPPING ARRANGED

OPEN MONDAY TO FRIDAY 9AM-5PM

Unit Four, Fordingbridge Site, Main Road, Barnham, Bognor Regis,
West Sussex, PO22 0EB

Tel (+ 44) 01243 545111/2 Fax (+ 44) 01243 542457

EQUIPMENT & ACCESSORIES PURCHASED

INFOTECH & STREE

76 Church St, Larkhall, Lanarks, ML9 1HE

Phone (01698) 883334/888343 or Fax (01698) 884825

Remember: Not only do we have every sheet ever produced, but we also have

The World's Largest Collection of SERVICE MANUALS & CIRCUITS

We are now successfully running a Library Service which allows you to borrow any manual you want for as long as you want, and when you need another manual, just return the one you have, plus a £4.95 exchange fee and tell us what you want next.

*Borrow any Service Manual for £4.95
regardless of its size or normal cost*

The cost of this service is a yearly subscription fee of only £59.95.
Join now & get a free 'Data Ref Guide'.

SHERWOOD ELECTRONICS

Special Packs £1 each - choose 1 x £1 pack FREE
with every 10 purchased

SP1	15 x 5mm Red Leds	SP116	3 x 10mm Green Leds
SP2	15 x 5mm Green Leds	SP118	2 x Cmos 4047
SP3	12 x 5mm Yellow Leds	SP119	4 x Cmos 4072
SP4	10 x 5mm Amber Leds	SP125	10 x 1000/16V radial elect caps
SP6	15 x 3mm Red Leds	SP130	100 x Mixed 0.5W C.F. resistors
SP7	12 x 3mm Green Leds	SP133	20 x 1N4004 diodes
SP8	10 x 3mm Yellow Leds	SP134	15 x 1N4007 diodes
SP10	100 x 1N4148 diodes	SP135	6 x Min. slide switches
SP11	30 x 1N4001 diodes	SP136	3 x BFY50 transistors
SP12	30 x 1N4002 diodes	SP137	4 x W005 1.5A bridge rectifiers
SP18	20 x BC182 transistors	SP142	2 x Cmos 4017
SP19	20 x BC183 transistors	SP144	3 x TIP31A transistors
SP20	20 x BC184 transistors	SP145	6 x ZTX300 transistors
SP21	20 x BC212 transistors	SP146	10 x 2N3704 transistors
SP22	20 x BC214 transistors	SP151	4 x 8mm Red Leds
SP23	20 x BC549 transistors	SP152	4 x 8mm Green Leds
SP24	5 x Cmos 4001	SP153	4 x 8mm Yellow Leds
SP25	4 x 555 timers	SP154	15 x BC548 transistors
SP26	4 x 741 Op.amps	SP156	3 x Stripboard, 14 strips/ 27 holes
SP27	5 x Cmos 4002	SP160	10 x 2N3904 transistors
SP28	5 x Cmos 4011	SP161	10 x 2N3906 transistors
SP29	4 x Cmos 4013	SP165	2 x LF351 Op.amps
SP31	4 x Cmos 4071	SP167	6 x BC107 transistors
SP32	4 x Cmos 4077	SP170	2 x LM339 quad volt comp.
SP36	25 x 10/25V radial elect caps	SP174	20 x 22/25V radial elect caps
SP37	15 x 100/35V radial elect caps	SP175	20 x 1/63V radial elect caps
SP41	20 x Mixed transistors	SP182	20 x 4.7/50V radial elect caps
SP42	200 x Mixed 0.25W C.F. resistors	SP187	15 x BC239 transistors
SP43	2 x LM1458	SP191	3 x Cmos 4023
SP47	5 x Min. pushbutton switches	SP193	20 x BC213 transistors
SP102	20 x 8-pin DIL sockets	SP194	10 x OA90 diodes
SP103	15 x 14-pin DIL sockets	SP195	3 x 10mm Yellow Leds
SP104	15 x 16-pin DIL sockets		
SP105	5 x 74LS00		
SP106	5 x 74LS02		
SP109	15 x BC557 transistors		
SP112	5 x Cmos 4093		
SP115	3 x 10mm Red Leds		

Catalogue £1 inc. P&P or FREE
with first order.
P&P £1.25 per order. NO VAT.

Orders to:
Sherwood Electronics,
7 Williamson St., Mansfield,
Notts. NG19 6TD.

RESISTOR PACKS - 0.25W C.Film		
RP3	5 each value - total 365	£2.60
RP7	10 each value - total 730	£3.95
RP10	1000 popular values	£5.30

PIC 16C84 PROGRAMMER

LEARN THE SECRETS OF PROGRAMMING THIS VERSATILE RE-WRITABLE MICRO CONTROLLER.

PROGRAM - READ - VERIFY
EDIT PROGRAM & DATA
SAVE PROGRAM & DATA

SAVE YOURSELF HOURS OF WIRING LOGIC CHIPS
JUST PROGRAM A PIC 16C84 INSTEAD.

VERY EASY TO LEARN
IDEAL FOR ALL TYPES OF APPLICATIONS

REGUL PENIEMEN 28C PIC OP BETTER 167 DC AC700

SIMPLY CONNECTS TO YOUR COMPUTER PRINTER PORT VIA PRINTER LEAD. COMPLETE WITH SOFTWARE ON 3.5" DISK & EASY TO FOLLOW INSTRUCTIONS & PROGRAMMING DATA.

ONLY
£49
INCLUSIVE !!!
NEW

BARGAIN COMPONENT PACKS

7805 REG Pk OF 4 £1	WHILE	RED 3mm LED Pk OF 15 £1
7812 REG Pk OF 4 £1	STOCKS	GRN 3mm LED Pk OF 15 £1
TIP31A Pk OF 5 £1		YEL 3mm LED Pk OF 15 £1
TIP31A Pk OF 5 £1	LAST !!	ZTX 300 TRAN Pk OF 15 £1
2K*8 STATIC RAM Pk 4 £1		Z80 CPU 4MHZ Pk OF 2 £1
100uF 25v Min Rad Pk OF 15 £1		74HCT04 PK OF 10 £1
680uF 35V Min Rad Pk OF 10 £1		74HCT138 Pk OF 5 £1
22PF CERAMIC CAP PK OF 20 £1		74HCT245 Pk OF 4 £1
4.00 MHz Xtal PACK OF 4 £1		74HCT374 Pk OF 5 £1
32.768 Hz Xtal PACK OF 5 £1		PIC16C84 PK OF 3 £15

TELE-SALES 01530-413141

SKYMASTERS, DEPT EPE, 10 THE GREEN, ASHBY DE LA ZOUCH, LEICS LE65 1JU
TRADE / EXPORT WELCOME - FAX No 01530-412151
ALL PRICES INC VAT - PLEASE ADD £1 P/P FOR COMPONENT PACKS - SEE FOR CATALOG.

Mixed metal/carbon film resistors 1/4W E12 series 10 ohms to 1 Megohm	2p
Carbon Film resistors 1/4W 5% E24 series 0.51-R to 10MΩ	1p
100 off per value - 75p. even hundreds per value totalling 1000	£6.00p
Metal Film resistors 1/4W 10R to 1 MO 5% E12 series - 1/2p. 1% E24 series	2p
Mixed metal/carbon film resistors 1/2W E24 series 1R0 to 10MΩ	1 1/2p
1 watt mixed metal/carbon film 5% E12 series 4R7 to 10 Megohms	5p
Linear Carbon pre-sets 100mW and 1/4W 100R to 2M2 E6 series	7p
Miniature polyester capacitors 250V working for vertical mounting	
0.15, 0.22, 0.33, 0.47, 0.68 - 4p. 0.47 - 5p. 0.12, 0.15, 0.22 - 6p. 0.33 - 8p. 1.0 - 12p	
Mylar (polyester) capacitors 400V working E12 series vertical mounting	
1000p to 8200p - 3p. 0.1 to 0.68 - 4p. 0.1 - 5p. 0.12, 0.15, 0.22 - 6p. 0.47/50V - 8p	
Submini ceramic plate capacitors 100V wkg vertical mountings. E12 series	
2% 1.8pf to 47pf - 3p. 2% 56pf to 330pf - 4p. 10% 390p-4700p	4p
Disc/plate ceramics 50V E12 series 1P0 to 1000P, E6 Series 1500P to 47000P	2p
Polystyrene capacitors 63V working E12 series long axial wires	
10pf to 820pf - 5p. 1000pf to 10,000pf - 6p. 12,000pf	7p
741 Op Amp - 20p. 555 Timer - 20p. LM3900	80p
CMOS 4001 - 20p. 4011 - 22p. 4017 - 40p. 4069UB unbuffered	20p
DIL holders, 8-pin 9p; 14-, 16-, 18-pin 12p; 24-pin 18p; 28-pin 20p; 40-pin 25p.	
ALUMINIUM ELECTROLYTICS (Mfds/Volts)	
1/50, 2/250, 4/750, 10/25, 10/50	5p
22/16, 22/25, 22/50, 33/16, 47/16, 47/25, 47/50	6p
100/16, 100/25 7p; 100/50	12p
220/16 8p; 220/25, 220/50 10p; 470/16, 470/25	11p
1000/25 25p; 1000/35, 2200/25 35p; 4700/25	70p
Subminiature, tantalum bead electrolytics (Mfds/Volts)	
0.1, 0.22, 0.47, 1.0, 2.2, 3.3 @35V - 4.7/16, 6.8/10, 10/6, 10p; 6.8/35, 12p.	
4.7/25, 6.8/16, 10/6, 11p; 15/16, 22/6, 33/10, 15p; 10/25, 16p; 10/35, 22/16, 20p.	
47/10, 20p; 47/16, 25p; 47/20, 30p; 47/35, 32p; 100/3, 18p; 100/6, 22/0.6, 20p.	
VOLTAGE REGULATORS	
1A + or - 5V, 8V, 12V, 15V, 18V & 24V - 55p. 100mA, 5.8, 12, 15, V +	30p
DIODES (piv/amperes)	
75/25mA 1N4148 2p. 800/1A 1N4006 4 1/2p. 400/3A 1N5404 1p. 115/15mA OA91	8p
100/1A 1N4002 3 1/2p. 1000/1A 1N4007 5p. 60/1.5A S1M1 5p. 100/1A bridge	25p
400/1A 1N4004 4p. 1250/1A BY 127 10p. 30/150mA OA47 gold bonded	18p
Zener diodes E24 series 3V3 to 33V 400mW - 6p. 1 watt	10p
Battery snaps for PP3 - 7p for PP9	12p
L.E.D.'s 3mm. & 5mm. Red, Green, Yellow - 10p. Grommets 3mm - 2p. 5mm	2p
Red flashing L.E.D.'s require 9-12V supply only, 5mm	50p
Nails indicating LEDs with 220k resistor	10p
20mm fuses 100mA to 5A. C.I. blow 6p. ASurge 10p. Holders, chassis, mounting	10p
High speed pc drill 0.1, 1.3, 1.5, 2.0mm - 40p. Machines 12V dc	£15.00
HELPING HANDS 6 ball joints and 2 croc clips to hold awkward jobs	£4.50
AA/HP7 Nicad rechargeable cells 90p each. Universal charger unit	£6.50
AA/HP7 zinc/carbon batteries in packs of 4	£1.10 per pack
Glass reed switches with single pole make contacts - 8p. Magnets	20p
0.1" Stripboard 2 1/2" x 1" 9 rows 25 holes - 25p. 3 1/2" x 2 1/2" 24 rows 37 holes	70p
Jack plugs 2.5 & 3.5m - 14p. Sockets Panel Mtg. 2.5 & 3.5m.	10p
Ear pieces 2.5 & 3.5m, dynamic - 20p; 3.5m crystal.	£1.50
Multi cored solder, 22G - 8p yard, 18G - 14p yard.	
TRANSISTORS	
BC107/8/9 - 12p. BC547/8/9 - 8p. BC557/8/9 - 8p. BC182, 182L, BC183, 183L, BC184, 184L, BC212, 212L - 10p.	
BC327, 337, 337L - 12p. BC727, 737 - 12p. BD135/6/7/8/9 - 25p. BCY70 - 18p. BFY50/51/52 - 20p.	
BFX88 - 15p. 2N3055 - 55p. TIP31, 32 - 30p. TIP41, 42 - 40p. BU208A - £1.50, BF195, 197 - 12p.	
lonisers with seven year guarantee, 240V AC, 1st price £16.95 or more	£12.50
Do not add VAT. Postage 30p (free over £5). Stamp for list.	

THE CR SUPPLY CO

127 Chesterfield Rd., Sheffield S8 0RN Tel: 0114 2557771 Return posting

Millions of quality components at lowest ever prices!

Plus Tools, Watches, Fancy Goods, Toys. Mail order UK only.

All inclusive prices - NO VAT to add on.

Send 43p stamped self addressed label or envelope for catalogue/clearance list.

At least 2,100 offers to amaze you.

Brian J Reed

6 Queensmead Avenue, East Ewell Epsom, Surrey KT17 3EQ
Tel: 0181-393 9055

ADVERTISERS INDEX

N. R. BARDWELL	306
B.K. ELECTRONICS	Cover (iii)
BRIAN J. REED	328
BULL ELECTRICAL	Cover (ii)/325
CHATWIN GUITARS (JCG)	303
CIRKIT DISTRIBUTION	281
COMPELEC	306
COOKE INTERNATIONAL	327
CRICKLEWOOD ELECTRONICS	254
CR SUPPLY COMPANY	328
DIRECT CCTV	293
DISPLAY ELECTRONICS	250
ELECTRONICS SERVICE MANUAL	270
EPT EDUCATIONAL SOFTWARE	256
EQUINOX TECHNOLOGIES	307
ESR ELECTRONIC COMPONENTS	260
FOREST ELECTRONIC DEVELOPMENTS	303
GREENWELD ELECTRONICS	255
HART ELECTRONIC KITS	287
ICS	327
INFOTECH & STREE	327
J&N FACTORS	318
JPG ELECTRONICS	328
LABCENTER	295
LENNARD RESEARCH	293
MAGENTA ELECTRONICS	258/259
MAPLIN ELECTRONICS	Cover (iv)
MAURITRON	327
MGC ELECTRONICS	307
MODERN ELECTRONICS MANUAL	308
NATIONAL COLLEGE OF TECHNOLOGY	307
NICHE SOFTWARE	302
OMNI ELECTRONICS	303
PICO TECHNOLOGY	257
QUASAR ELECTRONICS	322
QUICKROUTE SYSTEMS	252
RADIO-TECH	281
SEETRAX CAE	254
SERVICE TRADING CO.	303
SHERWOOD ELECTRONICS	327
SKYMASTERS (ACG)	327
STEWART OF READING	254
SUMA DESIGNS	253
TSIEN	269

ADVERTISEMENT MANAGER: PETER J. MEW

ADVERTISEMENT OFFICES:
EVERYDAY PRACTICAL ELECTRONICS,
ADVERTISEMENTS,
HOLLAND WOOD HOUSE, CHURCH LANE,
GREAT HOLLAND, ESSEX CO13 0JS.
Phone/Fax: (01255) 850596

For Editorial address and phone numbers see page 261.

NEW MINI CAMERA and SPECIAL OFFERS

NEW - Mini Waterproof TV Camera, 40 x 40 x 15mm, requires 10V to 15V at 125mA with composite video output to feed into a Video or a TV with a SCART plug) It has a high resolution of 450 TV lines vertical and 360 TV lines horizontal, electronic auto iris for nearly dark (1 LUX) to bright sunlight operation and a pinhole lens with a 92 degree field of view, it focuses down to a few CM. It is fitted with a 3-wire lead (12V in and video out). £93.57 + VAT = £109.95 or 10+ £89.32 + VAT = £104.95.

High quality Stepping Motor Kits (all including stepping motors) 'Comstep' independent control of two stepping motors by PC (via the Parallel Port) with two motors and software. Kit £57.00; Built £99.00
Software support and 4-digital inputs kit. £27.00
Power Interface: 4A kit £36.00, 8A kit, £46.00
Stepper kit 4 (manual control) includes 200 step stepping motor and control circuit. £23.00
Hand Held Transistor Analyser. It tells you which lead is the base, the collector and emitter and if it is NPN or PNP or faulty. £33.45. Spare 6V battery £1.20.
LEDs 3mm or 5mm Red or Green 7p each. Yellow 11p each. Cable Ties 1p each. £9.95 per 1000, £49.50 per 10,000.

RECHARGEABLE BATTERIES

AA (HP7) 500mAh	£0.99
AA 700mAh	£1.75
C 2AH with solder tags	£3.60
D 4AH with solder tags	£4.95
12AA with solder tags	£1.55
AAA (HP16) 180mAh	£1.75
AA 550mAh with solder tags	£1.55
C (HP11) 1.2AH	£2.20
D (HP2) 1.2AH	£2.60
PP3 8.4V 110mAh	£4.95
Sub C with solder tags	£2.50
13 AA with tags (Philips CTV)	£1.95

Standard Charger, charges 4 AA cells in 5 hours or 4 Cs or Ds in 12 to 14 hours, plus 1xPP3 (1, 2, 3 or 4 cells may be charged at a time). £5.95
High Power Charger, as above but charges the Cs and Ds in 3 hours; AAs, Cs and Ds must be charged in two's. £10.95
Nickel Metal Hydride AA cells, high capacity with no memory. If charged at 100mA and discharged at 250mA or less 1100mAh capacity (lower capacity for high discharge rates). £3.75

SPECIAL OFFERS - PLEASE CHECK FOR AVAILABILITY

Stick of 4, 42mm x 16mm NiCad batteries, 171 mrm x 16mm dia., with red and black leads. 48V	£3.95
Five button cell, 6V 280mAh battery with wires (Varia 5 x 250K).	£2.45
Shaded-pole motor, 240V a.c. 5mm x 20mm shaft, 80mm x 60mm x 55mm, excluding the shaft.	£4.95
115V a.c. 80V d.c. motor, 6mm x 22mm shaft, 50mm dia. x 60mm long body (excluding the shaft) it has a replaceable thermal fuse and brushes.	£4.94 each, £3.95 100+
7-Segment, common anode, 1.e.d. display, 12mm. 45p	
LM337K, TO3 case, Variable regulator. £1.95, 100 + £1.44	
GAAs F.E.T. low leakage current S873	£1.25 each, £9.95 10+, £7.95 100+
BS250 p-channel MOSFET	45p
BC559 transistor	£3.95 per 100
BC547A transistor	20 for £1.00
74LS05 Hex inverter	£10.00 per 100
Used 8748 Microcontroller	£3.50
SL92 JHF Limiting amplifier, LC 16 surface mounting package with data sheet.	£1.95
AM27S02	£1.25 each; 90p 100+
CD4007UB	10p 100+, 6p 1000+

Sinclair Light Gun, terminated with a jack plug and PP3 clip, gives a signal when pointed at 50Hz flickering light, with output waveform chart. £3.95

DC-DC Converter, Reliability model V12P5, 12V in, 5V 200mA out, 300V input-to-output isolation, with data sheet. £4.95 each or pack of 10 £39.50

Howler Counter used 7 digit 240V a.c. 50Hz. £1.45
QWERTY keyboard, 58-key, good quality switches, new. £6.00

Alrpx AB2903-C large stepping motor 14V 7.5° step, 27 ohm, 68mm dia. body, 6.3mm shaft. £8.95 or £200 for a box of 30

Polyester capacitors, box type, 25mm lead pitch
0.9uF 250V d.c. 18p each, 14p 100+, 9p 1000+
1uF 250V d.c. 20p each, 15p 100+, 10p 1000+
1uF 50V bipolar electrolytic axial leads, 15p each, 7.5p 1000+

0.22uF 250V polyester axial leads, 15p each, 10p 1000+
Polypropylene 1uF 400V d.c. (Mira MKP10) 27.5mm pitch, 32mm x 29mm x 17mm case, 75p each, 60p 100+

Philips 123 series solid aluminium axial leads.
33uF 10V and 2.2uF 40V 40p each, 25p 100+

Philips 108 series, long life.
22uF 63V axial. 30p each, 15p 1000+

Multi-layer AVX ceramic capacitors, all 5mm each, 100V
100pF, 150cF, 220pF, 10,000pF (10n) 10p each.
5p 100+, 3.5p 1000+

500pF compression trimmer capacitor. 60p
40uF 370V a.c. motor start capacitor (dielectric type containing no p.c.b.s.) £5.95 or £49.50 for 10

Solid carbon resistors, very low inductance, ideal for r.f. circuits. 27 ohm 2W, 68 ohm 1W 25p each, 15p each 100+

We have a range of 0.25W, 0.5W, 1W and 2W solid carbon resistors - please send SAE for list

P.C. 400W PSU (Intel part 201035-001) with standard motherboard and five disk drive connectors, fan and mains input/output connectors on back and switch on the side (top for lower case) dims, 212mm x 149mm x 149mm excluding switch, £26.00 each, £138.00 for 6

MX180 Digital Multimeter 17 ranges, 1000V d.c. 750V a.c. 2Megohm 200mA transistor Hfe 9V and 1.5V battery test. £9.95

AMD 27256-3 EPROMs £2.00 each. £1.25 100+
Immac deluxe anti-glare static control panel, window size 228mm x 161mm, overall size 264mm x 200mm, held to the monitor with hook and loop tape pads. £7.95 each

DIP switch 3PCO 12-pin (ERG SDC 3-023) 60p each, 40p 100+

Disk Drive Boxes for a 5.25 disk drive, with room for a power supply, light-grey plastic 87mm x 268mm x 247mm £7.95 or £49.50 for 10

Handheld Ultrasonic Remote Control. £3.95
CV2486 Gas Relay 30mm x 10mm dia. with 3-wire terminals, will also work as a neon light. 20p each, or £7.50 per 100

All products advertised are new and unused unless otherwise stated.

Wide range of CMOS TTL, 74HC74F Linear, Transistors kits, rechargeable batteries, capacitors, tools etc. always in stock. Please add £1.95 towards P&P. VAT included in all prices

JPG ELECTRONICS

276-278 Chatsworth Road
Chesterfield S40 2BH

Access/Visa Orders:
Tel: (01246) 211202 Fax: (01246) 550959

Callers welcome 9.30am to 5.30pm
Monday to Saturday

OMP MOS-FET POWER AMPLIFIERS HIGH POWER, TWO CHANNEL 19 INCH RACK

THOUSANDS PURCHASED BY PROFESSIONAL USERS



THE RENOWNED MXF SERIES OF POWER AMPLIFIERS
FOUR MODELS:- MXF200 (100W + 100W) MXF400 (200W + 200W)
MXF600 (300W + 300W) MXF900 (450W + 450W)
ALL POWER RATINGS R.M.S. INTO 4 OHMS, BOTH CHANNELS DRIVEN

FEATURES: ★Independent power supplies with two toroidal transformers ★ Twin L.E.D. Vu meters ★ Level controls ★ Illuminated on/off switch ★ XLR connectors ★ Standard 775mV inputs ★ Open and short circuit proof ★ Latest Mos-Fets for stress free power delivery into virtually any load ★ High slew rate ★ Very low distortion ★ Aluminium cases ★ MXF600 & MXF900 fan cooled with D.C. loudspeaker and thermal protection.

USED THE WORLD OVER IN CLUBS, PUBS, CINEMAS, DISCOS ETC.

SIZES:- MXF200 W19"xH3 1/2" (2U)xD11"
 MXF400 W19"xH5 1/4" (3U)xD12"
 MXF600 W19"xH5 1/4" (3U)xD13"
 MXF900 W19"xH5 1/4" (3U)xD14 1/2"

PRICES:- MXF200 £175.00 MXF400 £233.85
 MXF600 £329.00 MXF900 £449.15
 SPECIALIST CARRIER DEL. £12.50 EACH

OMP X03 STEREO 3-WAY ACTIVE CROSS-OVER



Advanced 3-Way Stereo Active Cross-over, housed in a 19" x 1U case. Each channel has three level controls: bass, mid & top. The removable front fascia allows access to the programmable DIL switches to adjust the cross-over frequency: Bass-Mid 250/500/800Hz, Mid-Top 1.8/3/5KHz, all at 24dB per octave. Bass invert switches in each bass channel. Nominal 775mV input/output. Fully compatible with OMP rack amplifier and modules.

Price £117.44 + £5.00 P&P

STEREO DISCO MIXER SDJ3400S ★ ECHO & SOUND EFFECTS ★

STEREO DISCO MIXER with 2 x 7 band & R graphic equalisers with bar graph LED Vu meters. **MANY OUTSTANDING FEATURES:-** Including Echo with repeat & speed control, DJ Mic with talk-over switch, 6 Channels with individual faders plus cross fade, Cue Headphone Monitor, 8 sound Effects. Useful combination of the following inputs:- 3 turntables (mag), 3 decks, 5 Line for CD, Tape, Video etc.

Price £144.99 + £5.00 P&P



SIZE: 482 x 240 x 120mm

PIEZO ELECTRIC TWEETERS - MOTOROLA

Join the Piezo revolution! The low dynamic mass (no voice coil) of a Piezo tweeter produces an improved transient response with a lower distortion level than ordinary dynamic tweeters. As a crossover is not required these units can be added to existing speaker systems of up to 100 watts (more if two are put in series. **FREE EXPLANATORY LEAFLETS ARE SUPPLIED WITH EACH TWEETER.**

TYPE 'A' (KSN1036A) 3" round with protective wire mesh. Ideal for bookshelf and medium sized Hi-Fi speakers. Price £4.90 + 50p P&P.
TYPE 'B' (KSN1005A) 3 1/2" super horn for general purpose speakers, disco and P.A. systems etc. Price £5.99 + 50p P&P.
TYPE 'C' (KSN1016A) 2" x 5" wide dispersion horn for quality Hi-Fi systems and quality discos etc. Price £6.99 + 50p P&P.
TYPE 'D' (KSN1025A) 2" x 6" wide dispersion horn. Upper frequency response retained extending down to mid-range (2KHz). Suitable for high quality Hi-Fi systems and quality discos. Price £9.99 + 50p P&P.
TYPE 'E' (KSN1038A) 3 1/2" horn tweeter with attractive silver finish trim. Suitable for Hi-Fi monitor systems etc. Price £5.99 + 50p P&P.
LEVEL CONTROL Combines, on a recessed mounting plate, level control and cabinet input jack socket. 85x85mm. Price £4.10 + 50p P&P.

FLIGHT CASED LOUDSPEAKERS

A new range of quality loudspeakers, designed to take advantage of the latest speaker technology and enclosure designs. Both models utilize studio quality 2" cast aluminium loudspeakers with factory fitted grilles, wide dispersion constant directivity horns, extruded aluminium corner protection and steel ball corners, complemented with heavy duty black covering. The enclosures are fitted as standard with top hats for optional loudspeaker stands.

POWER RATINGS QUOTED IN WATTS RMS FOR EACH CABINET
FREQUENCY RESPONSE FULL RANGE 45Hz - 20KHz

ibf FC 12-100WATTS (100dB) PRICE £159.00 PER PAIR
ibf FC 12-200WATTS (100dB) PRICE £175.00 PER PAIR

SPECIALIST CARRIER DEL. £12.50 PER PAIR

OPTIONAL STANDS PRICE PER PAIR £49.00
 Delivery £6.00 per pair



IN-CAR STEREO BOOSTER AMPS

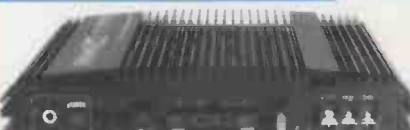

PRICES: 150W £49.99 250W £99.99
 400W £109.95 P&P £2.00 EACH

THREE SUPERB HIGH POWER CAR STEREO BOOSTER AMPLIFIERS
 150 WATTS (75 + 75) Stereo, 150W Bridged Mono
 250 WATTS (125 + 125) Stereo, 250W Bridged Mono
 400 WATTS (200 + 200) Stereo, 400W Bridged Mono
ALL POWERS INTO 4 OHMS

Features:
 ★ Stereo, bridgable mono ★ Choice of high & low level inputs ★ L & R level controls ★ Remote on-off ★ Speaker & thermal protection.

OMP MOS-FET POWER AMPLIFIER MODULES

SUPPLIED READY BUILT AND TESTED.

These modules now enjoy a world-wide reputation for quality, reliability and performance at a realistic price. Four models are available to suit the needs of the professional and hobby market i.e. Industry, Leisure, Instrumental and Hi-Fi etc. When comparing prices, NOTE that all models include toroidal power supply, integral heat sink, glass fibre P.C.B. and drive circuits to power a compatible Vu meter. All models are open and short circuit proof.

THOUSANDS OF MODULES PURCHASED BY PROFESSIONAL USERS



OMP/MF 100 Mos-Fet Output power 110 watts R.M.S. into 4 ohms, frequency response 1Hz - 100KHz -3dB, Damping Factor > 300, Slew Rate 45V/uS, T.H.D. typical 0.002%, Input Sensitivity 500mV, S.N.R. -110 dB. Size 300 x 123 x 60mm.
PRICE £40.85 + £3.50 P&P



OMP/MF 200 Mos-Fet Output power 200 watts R.M.S. into 4 ohms, frequency response 1Hz - 100KHz -3dB, Damping Factor > 300, Slew Rate 50V/uS, T.H.D. typical 0.001%, Input Sensitivity 500mV, S.N.R. -110 dB. Size 300 x 155 x 100mm.
PRICE £64.35 + £4.00 P&P



OMP/MF 300 Mos-Fet Output power 300 watts R.M.S. into 4 ohms, frequency response 1Hz - 100KHz -3dB, Damping Factor > 300, Slew Rate 60V/uS, T.H.D. typical 0.001%, Input Sensitivity 500mV, S.N.R. -110 dB. Size 330 x 175 x 100mm.
PRICE £81.75 + £5.00 P&P



OMP/MF 450 Mos-Fet Output power 450 watts R.M.S. into 4 ohms, frequency response 1Hz - 100KHz -3dB, Damping Factor > 300, Slew Rate 75V/uS, T.H.D. typical 0.001%, Input Sensitivity 500mV, S.N.R. -110 dB, Fan Cooled, D.C. Loudspeaker Protection, 2 Second Anti-Thump Delay. Size 385 x 210 x 105mm.
PRICE £132.85 + £5.00 P&P



OMP/MF 1000 Mos-Fet Output power 1000 watts R.M.S. Into 2 ohms, 725 watts R.M.S. into 4 ohms, frequency response 1Hz - 100KHz -3dB, Damping Factor > 300, Slew Rate 75V/uS, T.H.D. typical 0.002%, Input Sensitivity 500mV, S.N.R. -110 dB, Fan Cooled, D.C. Loudspeaker Protection, 2 Second Anti-Thump Delay. Size 422 x 300 x 125mm.
PRICE £259.00 + £12.00 P&P

NOTE: MOS-FET MODULES ARE AVAILABLE IN TWO VERSIONS: STANDARD - INPUT SENS 500mV, BAND WIDTH 100KHz. PEC (PROFESSIONAL EQUIPMENT COMPATIBLE) - INPUT SENS 775mV, BAND WIDTH 50KHz. ORDER STANDARD OR PEC.

LOUDSPEAKERS

LARGE SELECTION OF SPECIALIST LOUDSPEAKERS AVAILABLE, INCLUDING CABINET FITTINGS, SPEAKER GRILLES, CROSS-OVERS AND HIGH POWER, HIGH FREQUENCY BULLETS AND HORNS, LARGE (A4) S.A.E. (60p STAMPED) FOR COMPLETE LIST.



McKenzie and Fane Loudspeakers are also available.

EMINENCE:- INSTRUMENTS, P.A., DISCO, ETC

ALL EMINENCE UNITS 8 OHMS IMPEDANCE
 8" 100 WATT R.M.S. ME8-100 GEN. PURPOSE, LEAD GUITAR, EXCELLENT MID, DISCO. RES. FREQ. 72Hz, FREQ. RESP. TO 4KHz, SENS 97dB. PRICE £32.71 + £2.00 P&P
 10" 100 WATT R.M.S. ME10-100 GUITAR, VOCAL, KEYBOARD, DISCO, EXCELLENT MID. RES. FREQ. 71Hz, FREQ. RESP. TO 7KHz, SENS 97dB. PRICE £33.74 + £2.50 P&P
 10" 200 WATT R.M.S. ME10-200 GUITAR, KEY'D, DISCO, VOCAL, EXCELLENT HIGH POWER MID. RES. FREQ. 65Hz, FREQ. RESP. TO 3.5KHz, SENS 99dB. PRICE £43.47 + £2.50 P&P
 12" 100 WATT R.M.S. ME12-100LE GEN. PURPOSE, LEAD GUITAR, DISCO, STAGE MONITOR. RES. FREQ. 49Hz, FREQ. RESP. TO 6KHz, SENS 100dB. PRICE £35.64 + £3.50 P&P
 12" 100 WATT R.M.S. ME12-100LT (TWIN CONE) WIDE RESPONSE, P.A., VOCAL, STAGE MONITOR. RES. FREQ. 42Hz, FREQ. RESP. TO 10KHz, SENS 98dB. PRICE £36.67 + £3.50 P&P
 12" 200 WATT R.M.S. ME12-200 GEN. PURPOSE, GUITAR, DISCO, VOCAL, EXCELLENT MID. RES. FREQ. 58Hz, FREQ. RESP. TO 6KHz, SENS 98dB. PRICE £46.71 + £3.50 P&P
 12" 300 WATT R.M.S. ME12-300G HIGH POWER BASS, LEAD GUITAR, KEYBOARD, DISCO ETC. RES. FREQ. 47Hz, FREQ. RESP. TO 5KHz, SENS 103dB. PRICE £70.19 + £3.50 P&P
 15" 200 WATT R.M.S. ME15-200 GEN. PURPOSE BASS, INCLUDING BASS GUITAR. RES. FREQ. 46Hz, FREQ. RESP. TO 5KHz, SENS 99dB. PRICE £50.72 + £4.00 P&P
 15" 300 WATT R.M.S. ME15-300 HIGH POWER BASS, INCLUDING BASS GUITAR. RES. FREQ. 39Hz, FREQ. RESP. TO 3KHz, SENS 103dB. PRICE £73.34 + £4.00 P&P

EARBENDERS:- HI-FI, STUDIO, IN-CAR, ETC

ALL EARBENDER UNITS 8 OHMS (Except EB8-50 & EB10-50 which are dual impedance tapped @ 4 & 8 ohm)
BASS, SINGLE CONE, HIGH COMPLIANCE, ROLLED SURROUND
 8" 50watt EB8-50 DUAL IMPEDANCE, TAPPED 4/8 OHM BASS, HI-FI, IN-CAR. RES. FREQ. 40Hz, FREQ. RESP. TO 7KHz SENS 97dB. PRICE £8.90 + £2.00 P&P
 10" 50watt EB10-50 DUAL IMPEDANCE, TAPPED 4/8 OHM BASS, HI-FI, IN-CAR. RES. FREQ. 40Hz, FREQ. RESP. TO 5KHz, SENS. 99dB. PRICE £13.65 + £2.50 P&P
 10" 100watt EB10-100 BASS, HI-FI, STUDIO. RES. FREQ. 35Hz, FREQ. RESP. TO 3KHz, SENS 96dB. PRICE £30.39 + £3.50 P&P
 12" 100watt EB12-100 BASS, STUDIO, HI-FI, EXCELLENT DISCO. RES. FREQ. 26Hz, FREQ. RESP. TO 3 KHz, SENS 93dB. PRICE £42.12 + £3.50 P&P
FULL RANGE TWIN CONE, HIGH COMPLIANCE, ROLLED SURROUND
 5 1/2" 60WATT EB5-60TC (TWIN CONE) HI-FI, MULTI-ARRAY DISCO ETC. RES. FREQ. 63Hz, FREQ. RESP. TO 20KHz, SENS 92dB. PRICE £9.99 + £1.50 P&P
 6 1/2" 60WATT EB6-60TC (TWIN CONE) HI-FI, MULTI-ARRAY DISCO ETC. RES. FREQ. 38Hz, FREQ. RESP. TO 20KHz, SENS 94dB. PRICE £10.99 + 1.50 P&P
 8" 60WATT EB8-60TC (TWIN CONE) HI-FI, MULTI-ARRAY DISCO ETC. RES. FREQ. 40Hz, FREQ. RESP. TO 18KHz, SENS 89dB. PRICE £12.99 + £1.50 P&P
 10" 60WATT EB10-60TC (TWIN CONE) HI-FI, MULTI-ARRAY DISCO ETC. RES. FREQ. 35Hz, FREQ. RESP. TO 12KHz, SENS 98dB. PRICE £16.49 + £2.00 P&P

TRANSMITTER HOBBY KITS

PROVEN TRANSMITTER DESIGNS INCLUDING GLASS FIBRE PRINTED CIRCUIT BOARD AND HIGH QUALITY COMPONENTS COMPLETE WITH CIRCUIT AND INSTRUCTIONS

3W TRANSMITTER 80-108MHz. VARICAP CONTROLLED PROFESSIONAL PERFORMANCE, RANGE UP TO 3 MILES, SIZE 38 x 123mm, SUPPLY 12V @ 0.5AMP. PRICE £14.85 + £1.00 P&P

FM MICRO TRANSMITTER 100-108MHz, VARICAP TUNED, COMPLETE WITH VERY SENS FET MIC, RANGE 100-300m, SIZE 56 x 46mm, SUPPLY 9V BATTERY. PRICE £8.80 + £1.00 P&P



PHOTO: 3W FM TRANSMITTER

B.K. ELECTRONICS

UNITS 1 & 5 COMET WAY, SOUTHEND-ON-SEA, ESSEX, SS26TR.
 Tel.: 01702-527572 Fax.: 01702-420243

POSTAL CHARGES PER ORDER £1.00 MINIMUM. OFFICIAL ORDERS FROM SCHOOLS, COLLEGES, GOVT. BODIES, V.L.C. ETC. PRICES INCLUSIVE OF V.A.T. SALES COUNTER. VIS & ACCESS ACCEPTED BY POST, PHONE OR FAX.

With over 14,000 products the new Maplin Catalogue is now bigger than ever



THE EIFFEL TOWER

Built in 1889 by Alexandre Gustave Eiffel, the Eiffel Tower is 984 feet high and gives an unrivalled view of the whole of Paris.



THE NEW MAPLIN CATALOGUE

Built for 1996 by Maplin, the new catalogue is almost 1,200 pages long and gives an unrivalled view of the whole world of electronics.

Now Only £2.95

8-Way 100A Switched Consumer Unit £30.99

VAST RANGE OF ELECTRICAL FITTINGS AND CABLES

RANGE OF SATELLITE RECEIVERS AND ACCESSORIES FROM 64p TO £660

Satwalker Satellite Dish Rotator £179.99



Sport 500 Helicopter Kit £129.99

RADIO CONTROL MODELS, CONTROL GEAR AND SPARES FROM 99p TO £400

OVER 400 PAGES OF ELECTRONIC COMPONENTS FROM PRESETS TO PIC CHIPS



JUST LOOK AT THESE SUPERB EXAMPLES!

Advantage Wired Burglar Alarm Kit £99.95

HOME, CAR AND PERSONAL SECURITY FROM £7 TO £200

OVER 300 KITS FOR YOU TO BUILD FROM £5 TO £599

Electronic Sirens Sound Generator

Magellan GPS2000 Personal Navigator £234.99

RANGE OF NAVIGATION AIDS FROM £13 TO £560

OVER 100 PAGES OF COMPUTER AND NETWORK PRODUCTS

Safertap Non-Disruptive LAN Access Port £23.99

MAPLIN
ELECTRONICS AND BEYOND

Get your copy now from WHSMITH, John Menzies and Maplin stores nationwide
Or order direct NOW on 01702 554161

Catalogue Mail order Price £3.45 (inc p&p). Prices refer to the 1996 Maplin Catalogue and are inclusive of VAT.
All items are subject to availability. E&OE. Maplin Electronics, P.O. Box 3, Rayleigh, Essex, England SS6 8LR.