

SMPTE 304 HDTV CONNECTION SYSTEM 3K.93C.Y SERIES



New design, less components

The FS contact used in the 3K.93C.Y series is a re-design of the original F2 contact developed in 1992. The new FS has a reduced number of components and fits into a new designed connector.

This new product line has less components and makes no compromise on quality and the new version is still fully SMPTE 304 interface compatible. The insulator is now made in two parts with sideways insertion of the FS optical contact meaning a dedicated contact extraction tool is no longer required.

Advantages:

- New design allows easy fibre length adjustment
- No half-shells are required
- Increased internal space for the fibres and electrical conductors
- Epoxy curing time for the optical contacts halved to 20 minutes.

Precision modular connectors to suit your application

Since its creation in Switzerland in 1946 the LEMO Group has been recognized as a global leader of circular Push-Pull connectors and connector solutions. Today LEMO and its affiliated companies, REDEL and COELVER, are active in more than 80 countries with the help of over 40 subsidiaries and distributors.

Over 75000 connectors

The modular design of the LEMO range provides over 75000 connectors from miniature \varnothing 3 mm to \varnothing 50 mm, capable of handling cable diameters up to 30 mm and for up to 114 contacts. This vast portfolio enables you to select the ideal connector configuration to suit almost any specific requirement in most markets, including medical devices, test and measurement instruments, machinery, audio video broadcast, telecommunications and military.

LEMO's Push-Pull Self-Latching Connection System

This self-latching system is renowned worldwide for its easy and quick mating and unmating features. It provides absolute security against vibration, shock or pull on the cable, and facilitates operation in a very limited space.

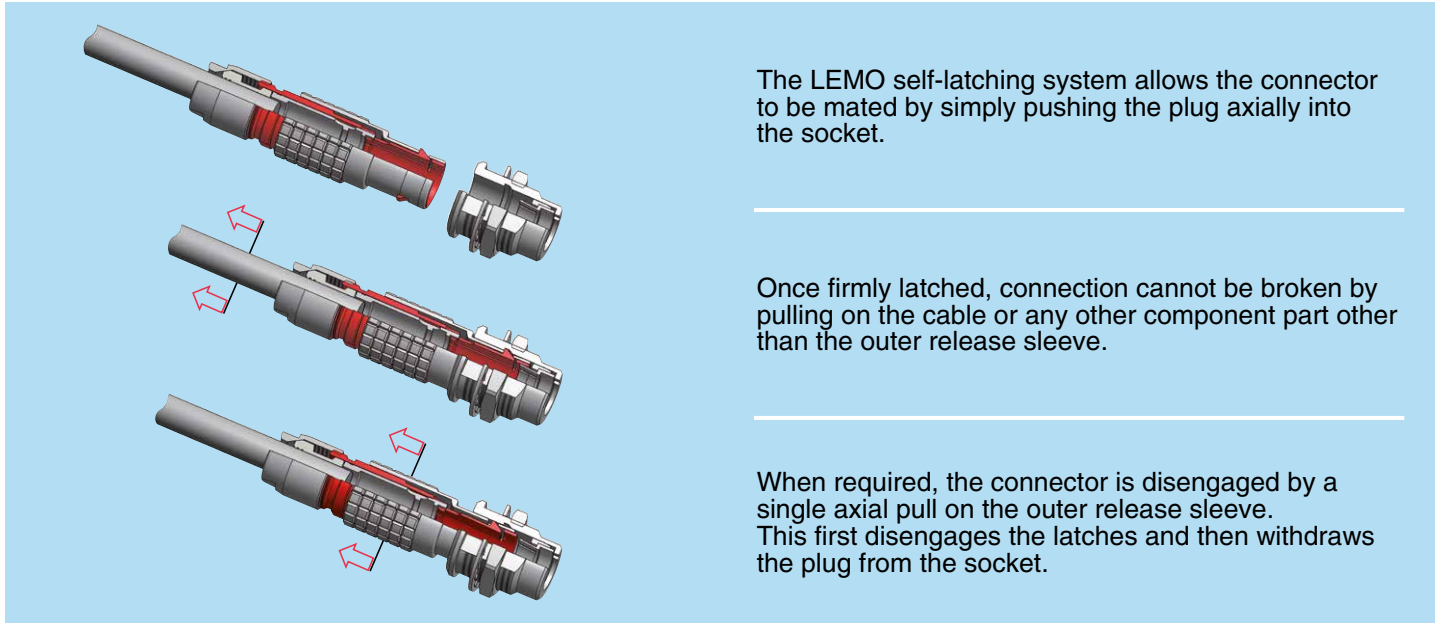

The LEMO self-latching system allows the connector to be mated by simply pushing the plug axially into the socket.



Once firmly latched, connection cannot be broken by pulling on the cable or any other component part other than the outer release sleeve.

When required, the connector is disengaged by a single axial pull on the outer release sleeve. This first disengages the latches and then withdraws the plug from the socket.

UL Recognition

LEMO connectors are recognized by the Underwriters Laboratories (UL). The approval of the complete system (LEMO connector, cable and your equipment) will be easier because LEMO connectors are recognized.

CE marking

CE marking  means that the appliance or equipment bearing it complies with the protection requirements of one or several European safety directives. CE marking  applies to complete products or equipment, **but not to electromechanical components, such as connectors.**

RoHS

LEMO connector specifications conforms the requirements of the RoHS directive (2011/65/EU) of the European Parliament and the latest amendments. This directive specifies the restrictions of the use of hazardous substances in electrical and electronic equipment marketed in Europe.

Product safety notice & disclaimers

Please read and follow all instructions specified on the last page or on our [website](#) carefully and consult all relevant national and international safety regulations for your application. Improper handling, cable assembly, or wrong use of connectors can result in hazardous situations.

LEMO products and services are provided "as is." LEMO makes no warranties or representations with regard to LEMO product & services or use of them, express, implied or statutory, including for accuracy, completeness, or security.

In no event shall LEMO be liable for any direct, indirect, punitive, incidental, special consequential damages, to property or life, whatsoever arising out of or connected with the use or misuse of LEMO's products.

3K.93C.Y Series

The LEMO 3K.93C.Y connectors with keys (W), ideal for blind mating, were developed to meet the critical requirements of the new generation of digital HDTV cameras.

The main features of this series are as follows:

- Security of the LEMO Push-Pull self-latching system
- Fitted with the new LEMO **FS** fibre optic contacts.
- Conforms to the Japanese ARIB technical report BTA S-1005B, to the SMPTE 304 standard and to the European EBU Technical Recommendation R100-1999.
- Qualified for use in UL approved equipment such as those specified in UL 1977 (UL file E119802).
- Cabled connectors have obtained the EC Attestation of conformity No: N8 00 03 39058 001 from the German TÜV Product Service.

The 3K.93C.Y series consists of eight models which will accept cables specific to this application.

Models (page 6)

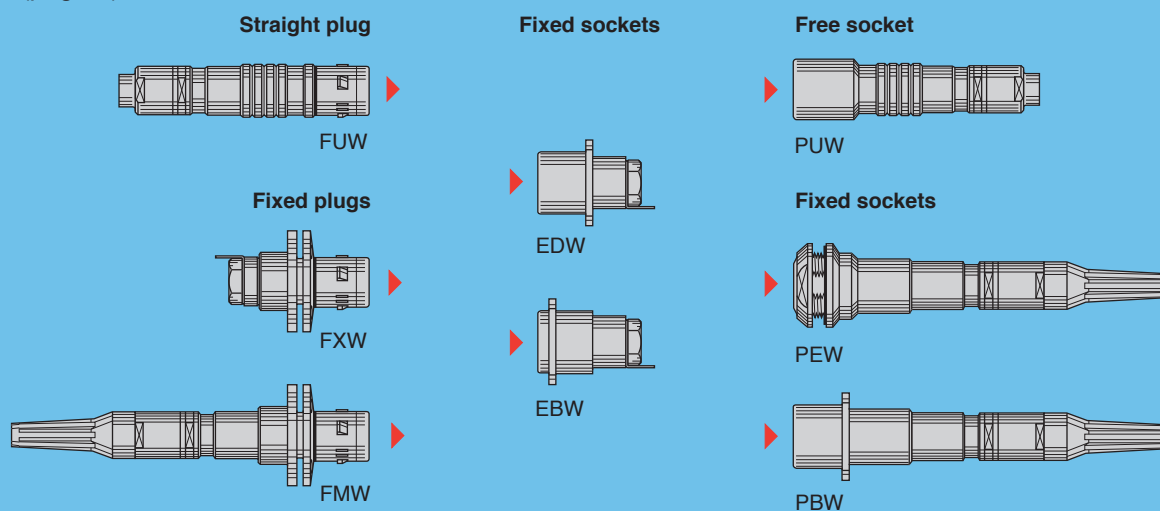

Outside Broadcast Van Configuration

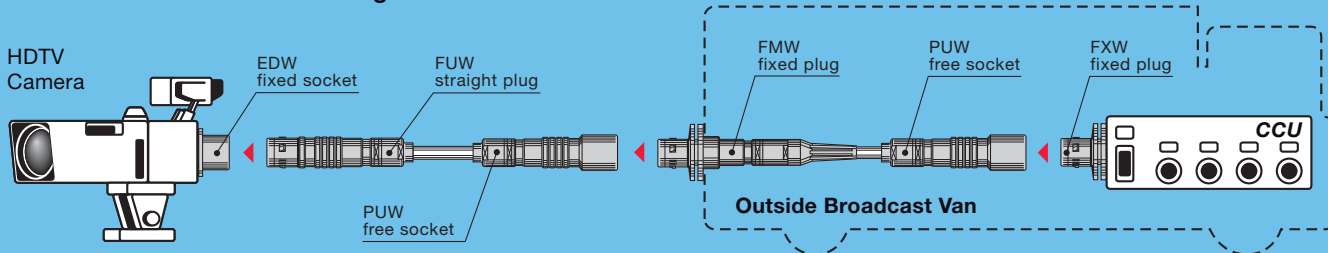

Studio Configuration

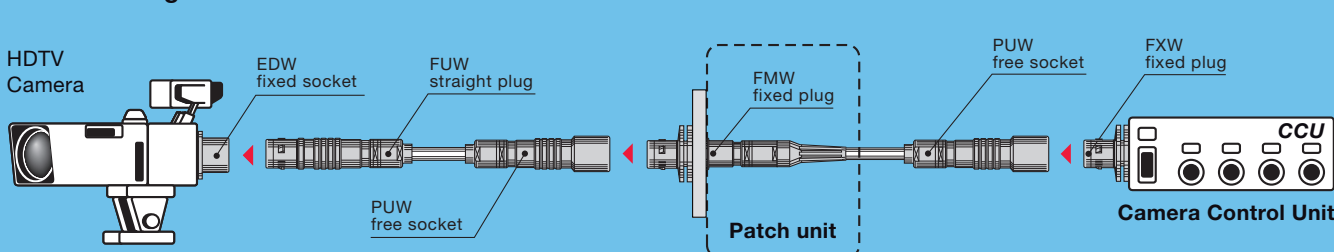

Part section showing internal components

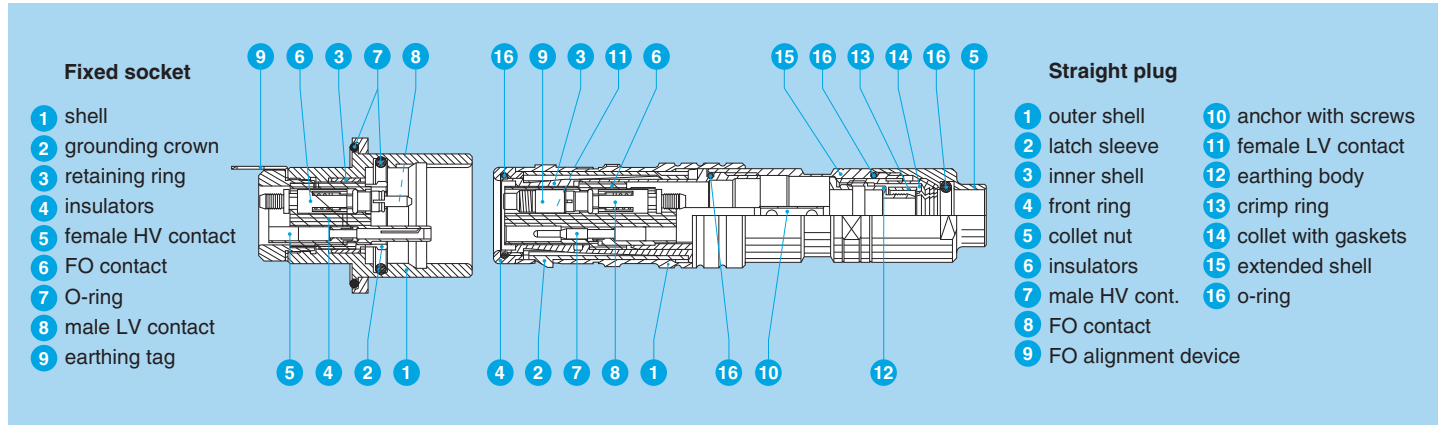

Technical characteristics

Materials and treatments

Component	Material (Standard)	Surface treatment (µm)								
		chrome			nickel		gold			
		Cu	Ni	Cr	Cu	Ni	Cu	Ni	Au	
Outer shell, collet nut and oversized collet	Brass (UNS C 38500)	0.5	3	0.3						
	Stainless steel (AISI 303)	without treatment								
Grounding crown	Special brass				0.5	3				
Latch sleeve	Stainless steel (AISI 416)	without treatment								
Locking washer	Bronze (UNS C 52100)				0.5	3				
Hexagonal nut or round nut	Brass (UNS C 38500)				0.5	3				
Male crimp contact	Brass (UNS C 34500)						0.5	3	1.0	
Female crimp contact	Bronze (UNS C 54400)						0.5	3	1.5	
Clips	Cu-Be (FS-QQ-C-530)	without treatment								
Insulator	PEEK									
Crimping tube	Copper (UNS C 18700)				0.5	3				
Other metallic components	Brass (UNS C 38500)				0.5	3				
	Stainless steel (AISI 304L)	without treatment								
O-ring and gaskets	Silicone MQ/MVQ, FPM/FKM (Viton®)									

Electrical

Characteristics	Value	Standard
Insulation resistance	> 10 ¹² Ω	IEC 60512-2 test 3a
Shell electrical continuity	< 1.6 mΩ	IEC 60512-2 test 2f
Contact resistance (signal)	< 4.8 mΩ	IEC 60512-2 test 2a
Contact resistance (power)	< 3.6 mΩ	IEC 60512-2 test 2a
Radiated emission	freq. 30-220 MHz	< 30 dBµV/m
	freq. 220-1000 MHz	< 37 dBµV/m

Optical

Characteristics	Value	Standard	Method
Average insertion loss fibre 9/125 µm	0.10 dB	IEC 61300-03-04	Insertion Method B
Return loss fibre 9/125 µm (UPC)	≥ 45 dB	IEC 61300-03-06	Branching Device Met.

Mechanical and environmental

Characteristics	Value	Standard
Mating durability (Stainless steel+St. steel)	20000 cycles	IEC 61300-02-02
Damp heat steady state	up to 95% at 60°C	IEC 61300-02-19
High temperature	+80°C	IEC 61300-02-18
Low temperature	-40°C	IEC 61300-02-17
Temperature cycling	-55°C + 90°C	
Cable retention	1000 N	IEC 61300-02-04
Impact (Method A)	2 m onto concrete floor	IEC 61300-02-12
Shock (3 cycles in 2 directions)	100 g, 10-50 ms; 20 g 6-9 ms	IEC 61300-02-09
Water resistance (Depth of 1.8 for 48 h)	IP 68 ¹⁾	IEC 60529
Salt spray corrosion test ²⁾	> 1000 h	IEC 60512-6 test 11f

Vibration

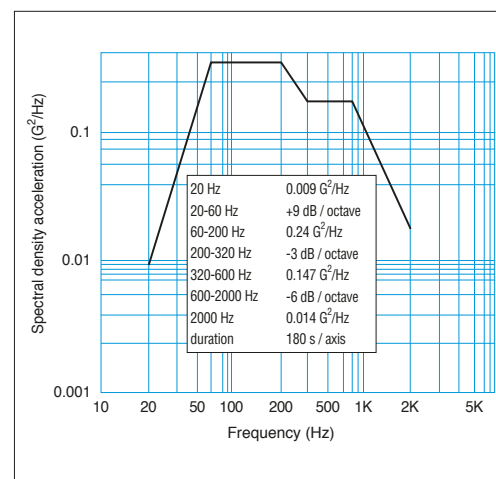

Note: ¹⁾ except FX● and FM● models.
²⁾ for chrome plated product (« C » material code).

Part number example

Straight plug and free socket

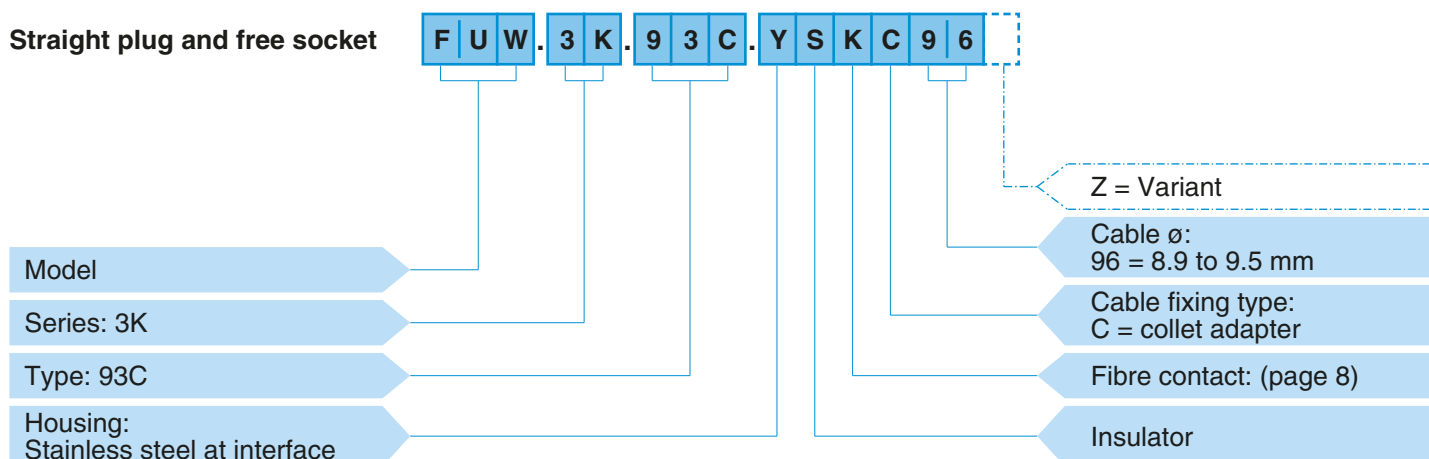

FUW.3K.93C.YSKC96 = Straight plug with keys (W), 3K series, hybrid type to accept 2 FS type fibre optic contacts, 2 power and 2 signal electrical contacts, stainless steel housing, PEEK insulator, female crimp signal contacts, cable fixing type C for 9.2 mm diameter cable.

Fixed socket

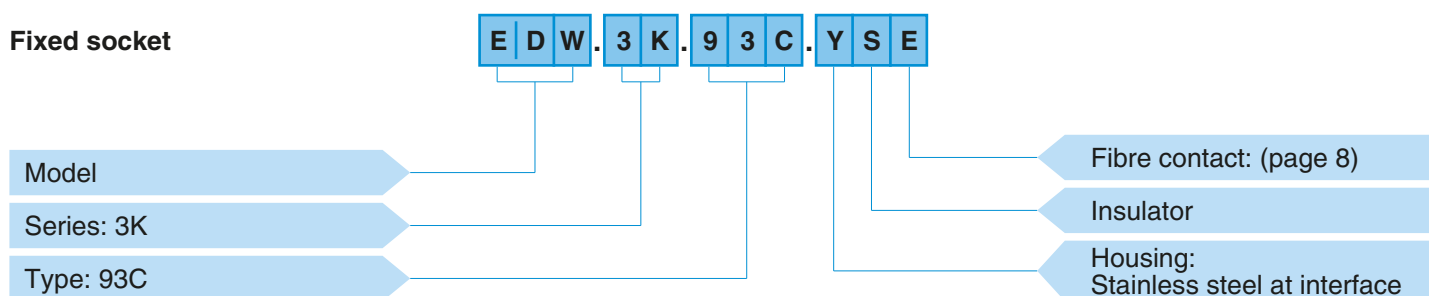

EDW.3K.93C.YSE = Fixed socket with rear square flange, keys (W), 3K series, hybrid type to accept 2 FS type fibre optic contacts, 2 power and 2 signal electrical contacts, stainless steel housing, PEEK insulator, male crimp signal contacts.



Models

FUW.3K.93C.YSKC96 Straight plug, cable collet adapter and long shell for fitting a bend relief with cap

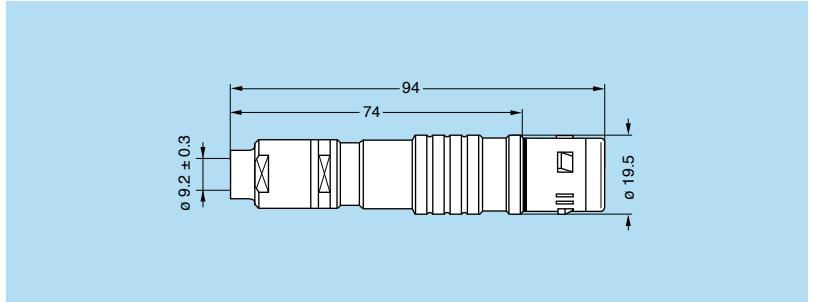

Note: The bend relief must be ordered separately (see page 9).

FXW.3K.93C.YSE Fixed plug, round flange (4 holes mounting), without collet

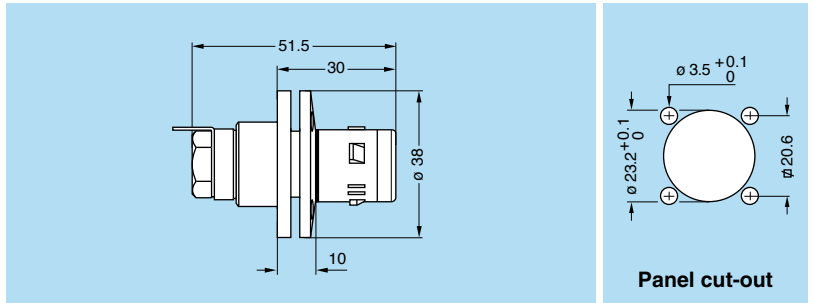

Note: Only available for IP 50 in mated condition.

FMW.3K.93C.YSKC96Z Fixed plug, round flange (4 holes mounting), cable adapter, for bend relief

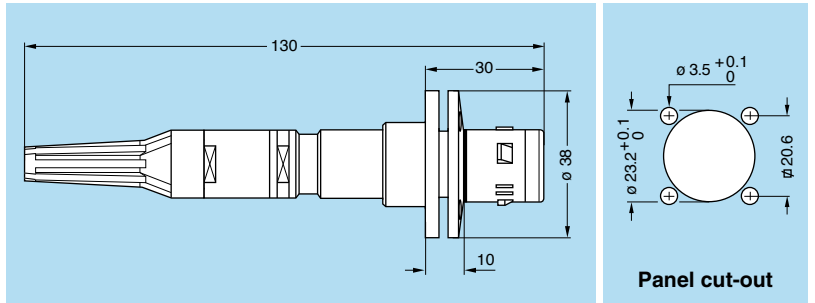

Note: Only available for IP 50 in mated condition.
The bend relief must be ordered separately (see page 9).

EDW.3K.93C.YSE Fixed socket with rear square flange, (4 holes mounting), and earthing tag

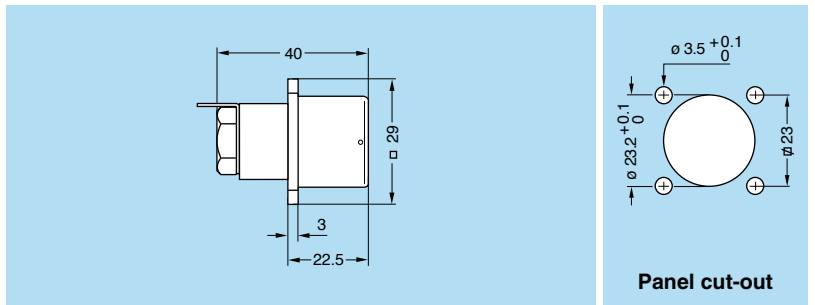

EBW.3K.93C.YSE Fixed socket with front square flange, (4 holes mounting)

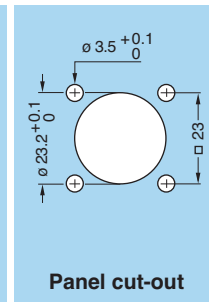
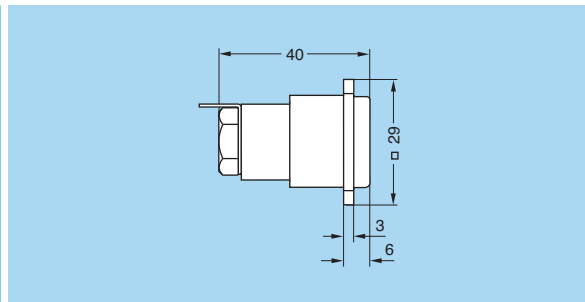

PUW.3K.93C.YSKC96 Free socket, cable collet adapter and long shell for fitting a bend relief with cap

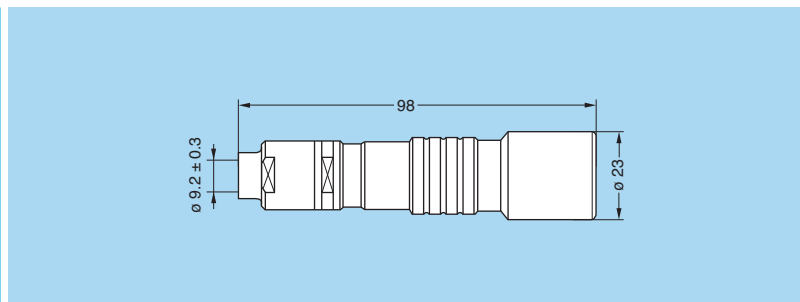

Note: The bend relief must be ordered separately (see page 9).

PEW.3K.93C.YSKC96Z Fixed socket, nut fixing, cable adapter, for bend relief (back panel mounting)

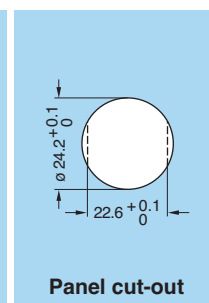
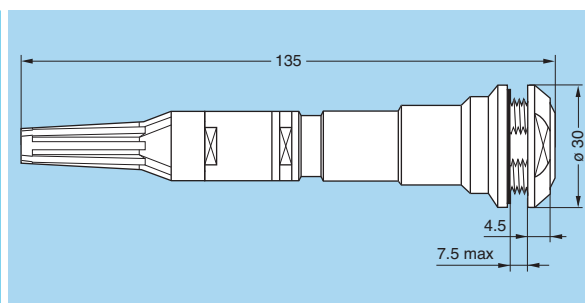

Note: The bend relief must be ordered separately (see page 9).

PBW.3K.93C.YSKC96Z Fixed socket with rear square flange, (4 holes mounting), cable adapter, for bend relief

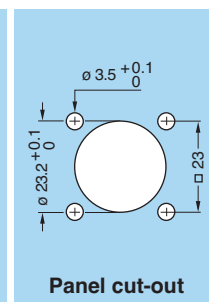
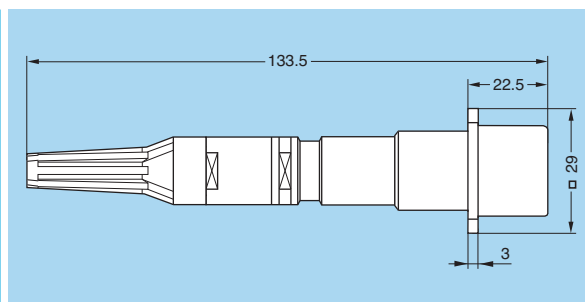

Note: The bend relief must be ordered separately (see page 9).

Insert configurations

Number of fibre optic contacts	Plug insulator	Socket insulator	Reference	Fibre optic contact			Electrical crimp contact								
				Contact type for plug	Fibre core/cladding (μm)	Ferrule bore inside ϕ (μm)	Number of contacts	Contact function	Contact type for plug	Contact ϕ (mm)	AWG range	Creepage distance and air clearance (mm)	Working voltage (V rms)	Test voltage (V rms)	Rated current (A)
2			93C	fem.	9/125	125	2	signal	LV male	0.9	20-24		≤ 42	1000	3
							2	power	HV male	1.3	14-18	> 6.5	≤ 600	2250	10

Fibre optic contact

FFS.FS Male FS Fibre Optic Contact

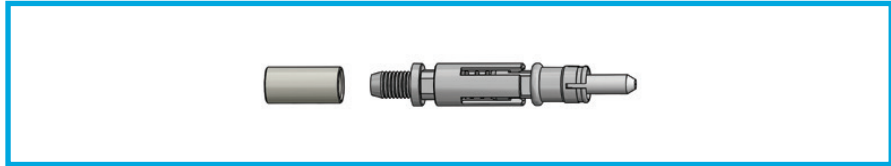

Ref.	Contact	Ferrule hole	Model	Gender	Note
E	FFS.FS.BA2.YCE30	125 μm	EDW / EBW	Male	●
K	FFS.FS.BA2.YCT10	125 μm	PUW / PEW / PBW	Male	●
X	FFS.FS.BX2.YCE30	125.5 μm	EDW / EBW	Male	●
V	FFS.FS.BX2.YCT10	125.5 μm	PUW / PEW / PBW	Male	●

● First choice - highest performance

PSS.FS Female FS Fibre Optic Contact

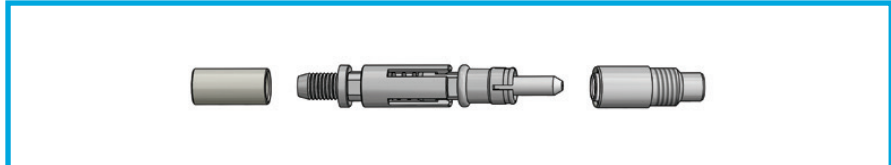

Ref.	Contact	Ferrule hole	Model	Gender	Note
E	PSS.FS.BA2.YCE30	125 μm	FXW	Female	●
K	PSS.FS.BA2.YCT10	125 μm	FUW / FMW	Female	●
X	PSS.FS.BX2.YCE30	125.5 μm	FXW	Female	○
V	PSS.FS.BX2.YCT10	125.5 μm	FUW / FMW	Female	○

● First choice - highest performance
○ Alternative - tight-fitting fibre



Accessories

GMA Bend relief

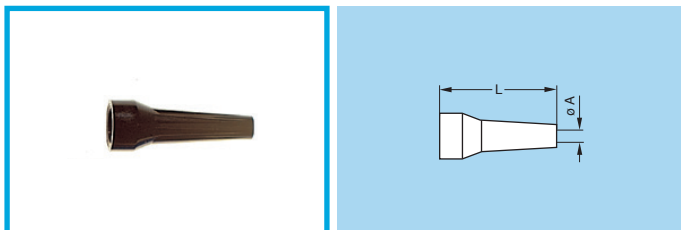

Part number	Dim. (mm)	
	A	L
GMA.3B.090.DN	9	42

Note: Other diameters and colours available upon request.

GMF Bend relief with cap for FUW plug



Part number
GMF.3K.085.EANZ

● Material: black ALCRYN®

GMP Bend relief with cap for PUW free socket

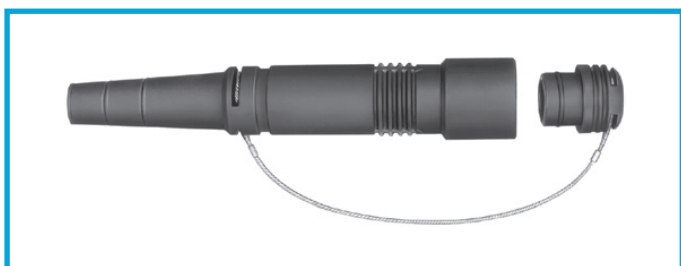

Part number
GMP.3K.085.EANZ

● Material: black ALCRYN®

GMF Coloured ring for bend relief with cap

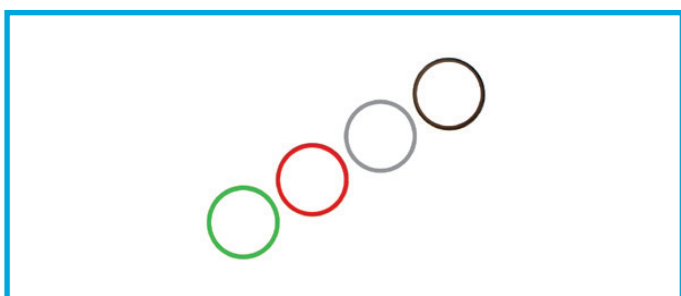

Part number	Colour
GMF.3K.265.RG	grey
GMF.3K.265.RN	black
GMF.3K.265.RR	red
GMF.3K.265.RV	green

● Material: Silicone

GM● Gaiters

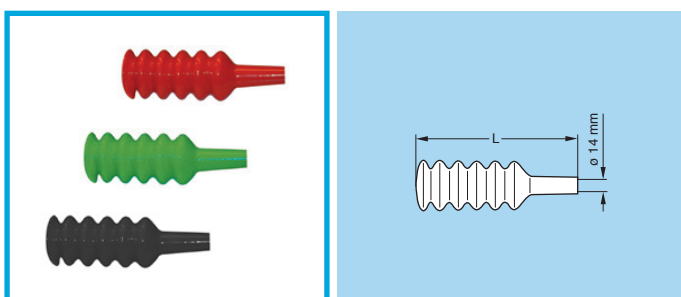

Part number	Colour	Dimension L (mm)	For connector model
GMP.3K.140.165PER	red	165	PUW
GMP.3K.140.165PEN	black	165	PUW
GMF.3K.140.156PEV	green	156	FUW
GMF.3K.140.156PEN	black	156	FUW

● Material: PVC

B●● Blanking caps

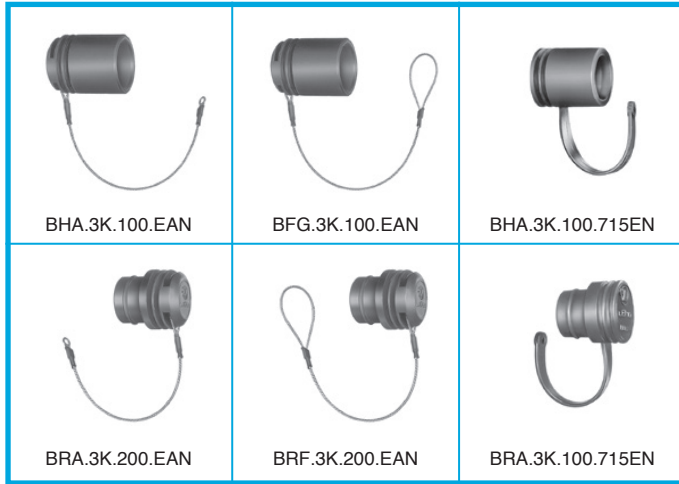

Part number	For connector model
BHA.3K.100.EAN	FMW, FXW
BRA.3K.200.EAN	EDW, PEW
BFG.3K.100.EAN	FUW
BRF.3K.200.EAN	PUW
BHA.3K.100.715EN	FMW, FXW
BRA.3K.100.715EN	EBW, EDW, PBW, PEW

● Material: black ALCRYN®

BRR Spring loaded dust cap for EDW and EBW

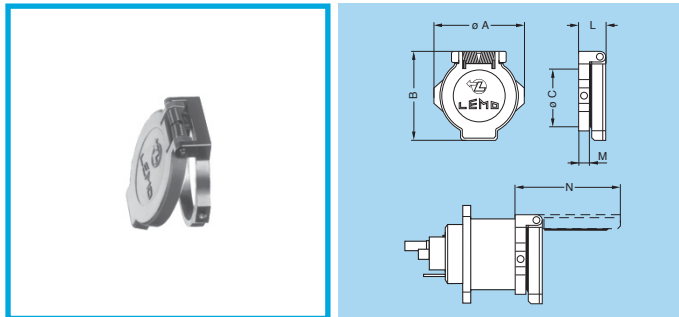

Part number	Dimensions (mm)					
	A	B	C	L	M	N
BRR.3K.200.PZSG	29	29	23	8.1	3	33.2

Note: On request, this cap is available in black. If so replace the last letter «G» of the part number by «N».

● Material: Polyoxymethylene (POM) grey (or black)

▶ Tooling

WST Fibre shield for oven curing (only 3K.93C.Y)

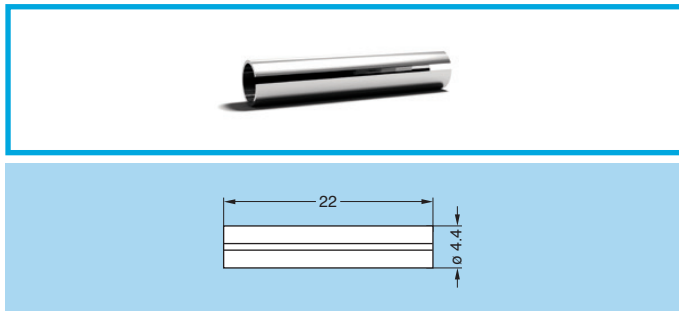

Part number
WST.TU.194.LN

● Material: Nickel plated brass

DCS.F2.035.PN Alignment device tool



Simple tool with two threaded end for installation/extraction of the F2/FS contact alignment device. For use with WST.KI.125.34 kit above.

WST.KI.125.34 Cleaning kit F2/FS contact



Fibre optic cleaning kit of 2 cotton buds, 1 dry and 1 being soaked in IPA (Isopropyl Alcohol) used for cleaning the fibre optic contacts.

DCS.F2.N02.PA Fibre Optic one-click cleaner



Insert the one-click cleaner into the insulator and push until an audible "click" is heard. The cleaner uses a mechanical push action to advance an optical grade cleaning tape. More than 500 cleaning per cleaner. Product includes special LEMO F2/FS ferrule adaptor.

WST.FB.C11.10US2 Video inspection viewer



A portable fibre optic viewer for F2/FS contact consisting of handset probe, LCD display, ferrule tips for LEMO contacts & software & United States - AC power supply all in a rugged case. European power supply version (WST.FB.C11.10EU2). An optional USB capture device is also available (part number: WST.FB.C11.00USB2).

DCS.3K.175.72LN Cable puller



The LEMO cable puller, is a pull through tool that allows passing the cable through narrow sections and protects the optical fibre during installation.

WST.TE.HDTV HD cable tester



This cable tester provides a quick and easy means of checking the functionality of HD hybrid fibre cables and cable systems. A laser source checks the fibres giving an indication of the attenuation through the whole cable or cable system, and electrical tests check for continuity of both the power and control conductors.

Note: Available on request.

Repair kit for plug FUW.3K.93C.YSKC96, free socket PUW.3K.93C.YSKC96, fixed plug FXW.3K.93C.YSE and socket EDW.3K.93C.YSE



Repair kit part number for FUW plug

FUW.3K.93C.ZSMY96

Repair kit part number for FXW plug

FXW.3K.93C.ZSM



Repair kit part number for PUW socket

PUW.3K.93C.ZSCY96

Repair kit part number for EDW socket

EDW.3K.93C.ZSC

Cable assembly

Part Number Example

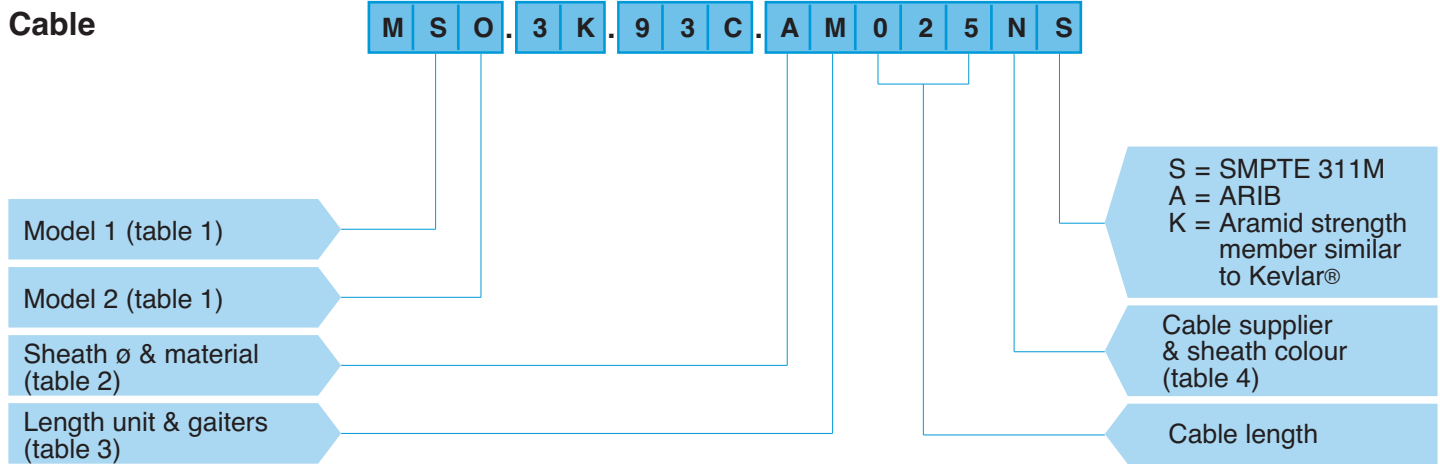

MSO.3K.93C.AM025NS = 1 FUW plug and 1 PUW socket (key W), 3K.93C.Y series, on a SMPTE 311M screened cable, 25 m length, sheath ø 9.2 mm, black RAL 9005 jacket colour, with GMF/GMP bend relief with cap.

Table 1
Model

Model 1 & 2	Code
FUW	S
FXW	N
PUW	O
EDW	Y
FMW	A
PEW	C
PBW	J

Table 2
Sheath ø & material

Sheath ø (mm)	Code	
	PVC ¹⁾	PUR
9.2	A	R
4.2	B	S
6.8	C	T
12.0	D	U
16.0	E	V

Table 3
Length unit & gaiters

	No Gaiter	Gaiters		
		Red gaiter free socket Green gaiter plug	2 black gaiters	2 yellow gaiters
cm	C	E		
dm	D	F		
m	M	G	N	J
km	K	L		
inch	I			
feet	T			

Table 4
Cable supplier & sheath colour

Code	Cable supplier & sheath colour
N	Northwire Black
G	Northwire Grey
A	Northwire Blue
F	Furukawa Black
B	Belden Black

Note: 1) PVC not recommended for temperatures below -20°C.

MSO Outside broadcast cable assembly

Cable assembly with one straight plug (FUW) and one straight socket (receptacle) (PUW), both complete with GMF/GMP bend relief with cap.

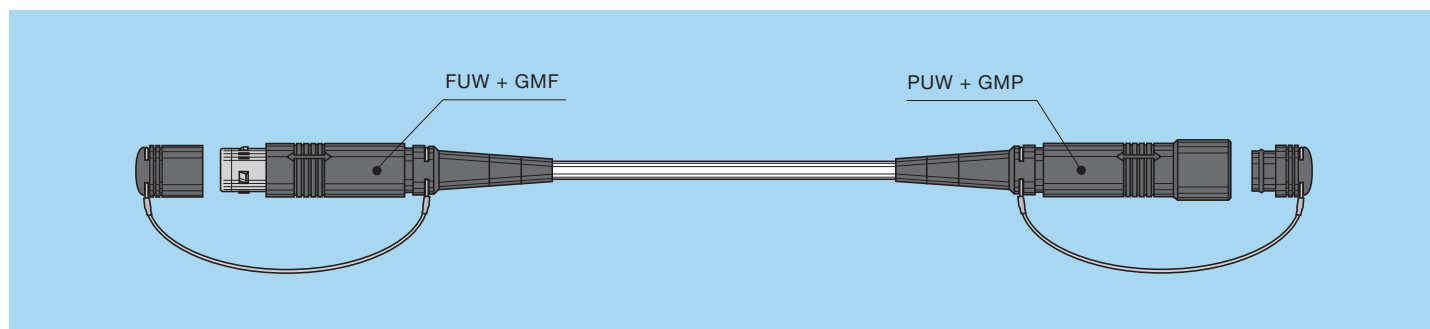

MSO Outside broadcast cable assembly

Cable assembly with one straight plug (FUW) and one straight socket (receptacle) (PUW), both complete with GMF/GMP bend relief with cap and gaiters.

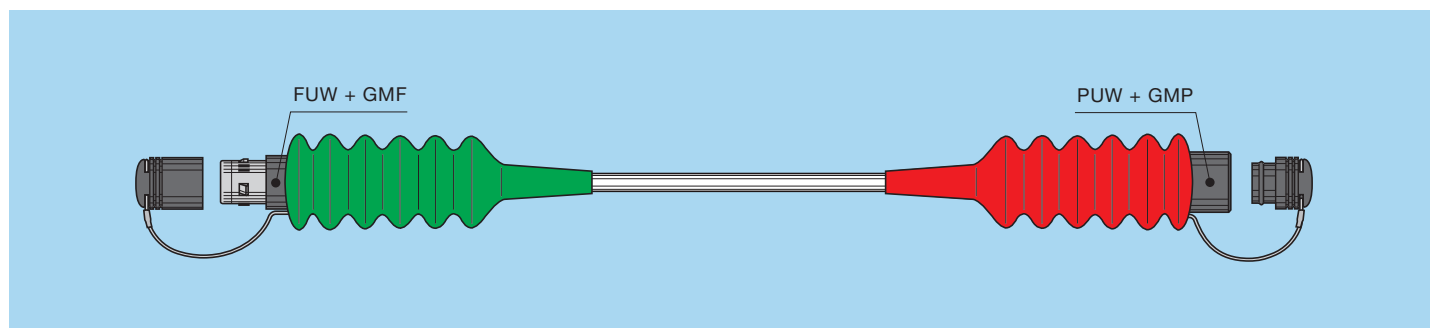

MAO Internal OB van cable assembly

Cable assembly with one fixed plug (FMW) and one straight socket (receptacle) (PUW), both complete with BHA/BRF caps.

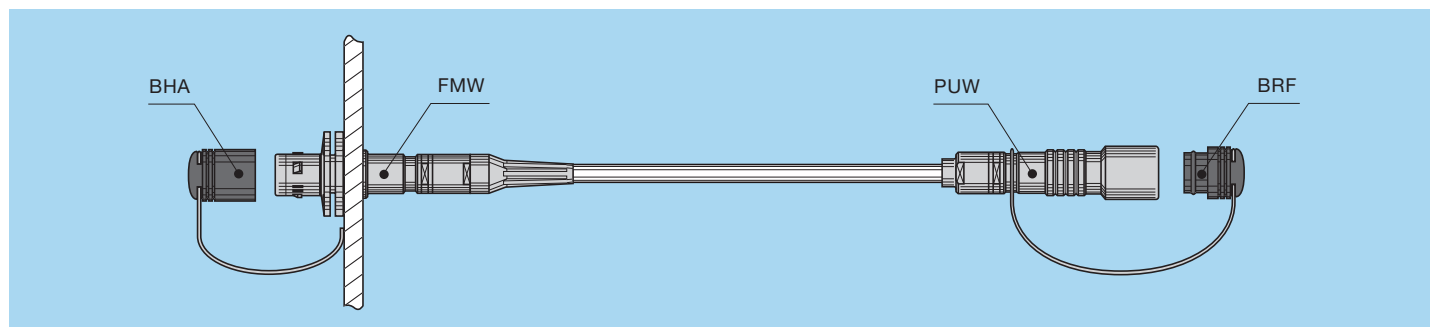

MNY Studio/Infrastructure cable assembly

Cable assembly with one fixed plug (FXW) and one straight socket (receptacle) (EDW), complete with BHA cap.

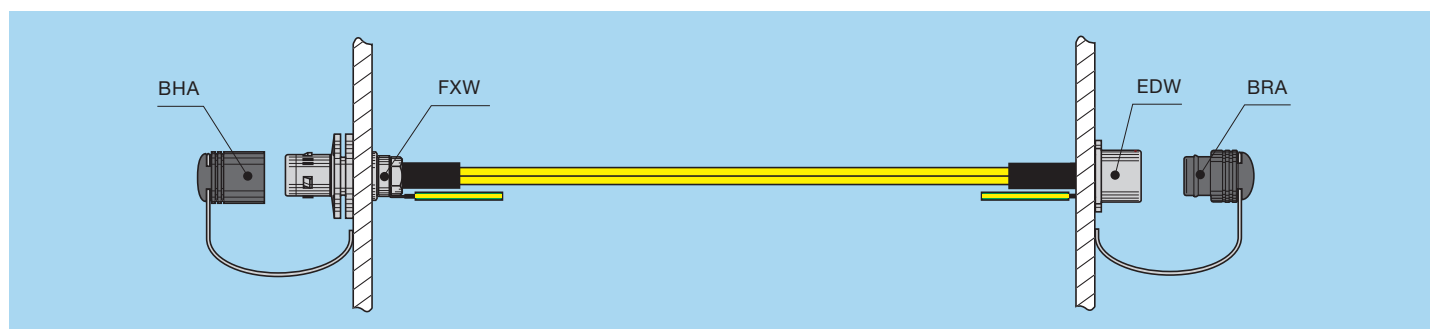

Part Number Example

Duplex pigtails

M N T 3 K 9 3 C Y Z Z C 0 5 0

Model
N = FXW
Y = EDW

T = Pigtail (LC)
S = Pigtail (ST)
C = Pigtail (SC)

Cable length (cm)

MNT.3K.93C.YZZC050 = 1 FXW plug (key W), 3K.93C.Y series and two pigtails (LC) on the other side, 50 cm length.

MNT ECU side duplex pigtails

Assembly cable with one fixed plug (FXW) and two pigtails (LC) complete with BHA cap.

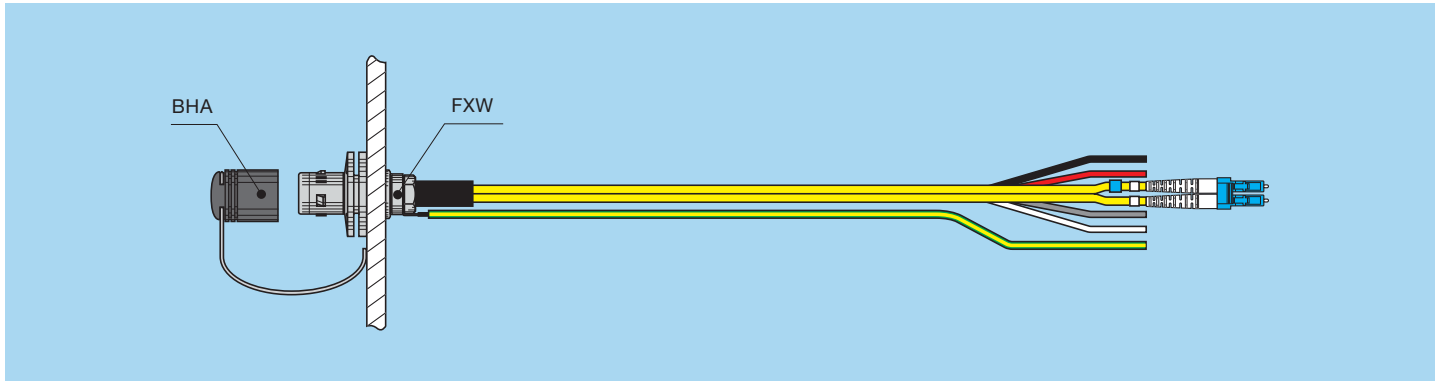

MYT Camera side duplex pigtails

Assembly cable with one fixed socket (EDW) and two pigtails (LC) complete with BRA cap.

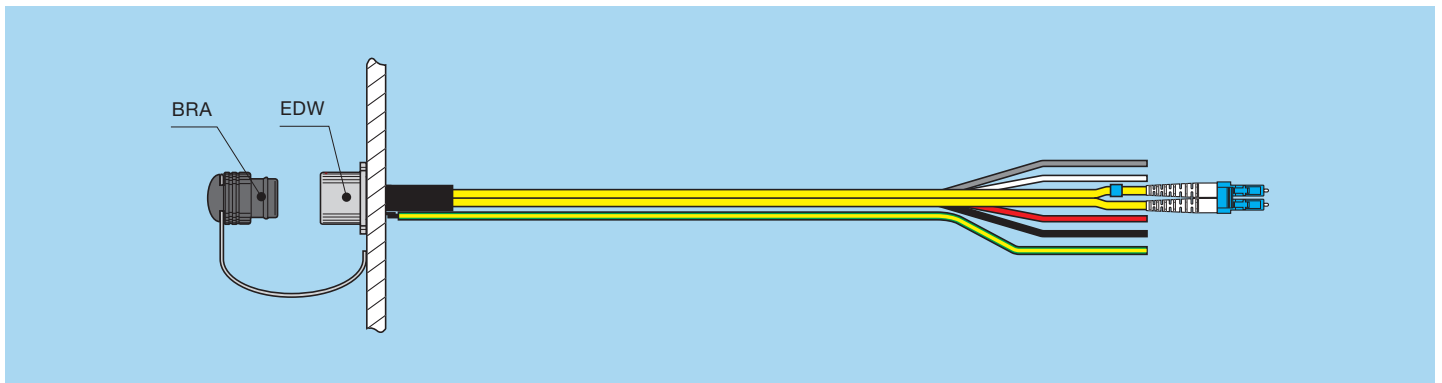

SMPTE 311 standard cable assemblies

Outside Broadcast FUW-PUW

Part number	Description
MSO.3K.93C.AM025NS	25 metre length
MSO.3K.93C.AM050NS	50 metre length
MSO.3K.93C.AM100NS	100 metre length
MSO.3K.93C.AM200NS	200 metre length
MSO.3K.93C.AM300NS	300 metre length
MSO.3K.93C.AM400NS	400 metre length
MSO.3K.93C.AM500NS	500 metre length

Internal OB van

Part number	Description
MNO.3K.93C.AM003NS	3 metre length
MNO.3K.93C.AM005NS	5 metre length
MNO.3K.93C.AM010NS	10 metre length
MNO.3K.93C.AM015NS	15 metre length
MNO.3K.93C.AM020NS	20 metre length

Studio/Infrastructure

Part number	Description
MNY.3K.93C.AM020NS	20 metre length
MNY.3K.93C.AM050NS	50 metre length

ARIB standard cable assemblies

Outside Broadcast FUW-PUW

Part number	Description
MSO.3K.93C.AM025NA	25 metre length
MSO.3K.93C.AM050NA	50 metre length
MSO.3K.93C.AM100NA	100 metre length
MSO.3K.93C.AM200NA	200 metre length
MSO.3K.93C.AM300NA	300 metre length
MSO.3K.93C.AM400NA	400 metre length
MSO.3K.93C.AM500NA	500 metre length

Internal OB van

Part number	Description
MNO.3K.93C.AM003NA	3 metre length
MNO.3K.93C.AM005NA	5 metre length
MNO.3K.93C.AM010NA	10 metre length
MNO.3K.93C.AM015NA	15 metre length
MNO.3K.93C.AM020NA	20 metre length

Studio/Infrastructure

Part number	Description
MNY.3K.93C.AM020NA	20 metre length
MNY.3K.93C.AM050NA	50 metre length

Other cable assemblies, patch cords and pigtails available on request.

Notes

Notes

Product safety notice

PLEASE READ AND FOLLOW ALL INSTRUCTIONS CAREFULLY AND CONSULT ALL RELEVANT NATIONAL AND INTERNATIONAL SAFETY REGULATIONS FOR YOUR APPLICATION. IMPROPER HANDLING, CABLE ASSEMBLY, OR WRONG USE OF CONNECTORS CAN RESULT IN HAZARDOUS SITUATIONS.

1. SHOCK AND FIRE HAZARD

Incorrect wiring, the use of damaged components, presence of foreign objects (such as metal debris), and / or residue (such as cleaning fluids), can result in short circuits, overheating, and / or risk of electric shock.

Mated components should never be disconnected while live as this may result in an exposed electric arc and local overheating, resulting in possible damage to components.

2. HANDLING

Connectors and their components should be visually inspected for damage prior to installation and assembly. Suspect components should be rejected or returned to the factory for verification.

Connector assembly and installation should only be carried out by properly trained personnel. Proper tools must be used during installation and / or assembly in order to obtain safe and reliable performance.

3. USE

Connectors with exposed contacts should never be live (or on the current supply side of a circuit). Under general conditions voltages above 30 VAC and 42 VDC are considered hazardous and proper measures should be taken to eliminate all risk of transmission of such voltages to any exposed metal part of the connector.

4. TEST AND OPERATING VOLTAGES

The maximum admissible operating voltage depends upon the national or international standards in force for the application in question. Air and creepage distances impact the operating voltage; reference values are indicated in the catalog however these may be influenced by PC board design and / or wiring harnesses.

The test voltage indicated in the catalog is 75% of the mean breakdown voltage; the test is applied at 500 V/s and the test duration is 1 minute.

5. CE MARKING

CE marking  means that the appliance or equipment bearing it complies with the protection requirements of one or several European safety directives.

CE marking  applies to complete products or equipment, **but not to electromechanical components, such as connectors.**

6. PRODUCT IMPROVEMENTS

The LEMO Group reserves the right to modify and improve to our products or specifications without providing prior notification.

7. **WARNING (Prop 65 State of California)**

Proposition 65 requires businesses to provide warnings to Californians about significant exposures to chemicals that cause cancer, birth defects or other reproductive harm. LEMO products are exempt from proposition 65 warnings because they are manufactured, marketed, and sold solely for commercial and industrial use. For further information, please visit <https://www.lemo.com/quality/LEMO-Prop-65-compliance-declaration.pdf>.

Disclaimers

LEMO works constantly to improve the quality of its products; the information and illustrations figuring in this document may therefore vary and are not binding. In any case, LEMO makes no specific warranty of merchantability, fitness for a particular purpose, third party components as such or included in assembly, non-infringement, title, accuracy, completeness, or security. The user is fully responsible for his products and applications using LEMO component.

In no event shall LEMO, its affiliates, officers, agents or employees be liable for any incidental, indirect, special or consequential damages in connection with the products or services provided by LEMO, including (without limitation) loss of profits or revenues, interruption of business, loss of use of the products or any associated equipment, materials, components or products, damages to associated equipment or in combination with other components, materials.

Reproduction of significant portions of LEMO information in LEMO data books or data sheets is permissible only if reproduction is without alteration and is accompanied by all associated warranties, conditions, limitations, and notices. LEMO is not responsible or liable for such altered documentation. Information of third parties may be subject to additional restrictions.

LEMO HEADQUARTERS

SWITZERLAND

LEMO SA

Chemin des Champs-Courbes 28 - P.O. Box 194 - CH-1024 Ecublens
Tel. +41 21 695 16 00 - e-mail: info@lemo.com

LEMO SUBSIDIARIES

AUSTRIA

LEMO Elektronik GesmbH

Lemböckgasse 49/E6-3

1230 Wien

Tel: +43 1 914 23 20 0

Fax: +43 1 914 23 20 11

salesAT@lemo.com

BRAZIL

LEMO Latin America Ltda

Av. Dr. Adhemar de Barros,

566 - Sala 1407, Vila Adyana

CEP: 12245-011

São José dos Campos - SP - Brazil

Tel: +55 11 94242 4293

info-la@lemo.com

CANADA

LEMO Canada Inc

44 East Beaver Creek Road, unit 20

Richmond Hill, Ontario L4B 1G8

Tel: +1 905 889 56 78

Fax: +1 905 889 49 70

info-canada@lemo.com

CHINA / HONG KONG

LEMO Electronics (Shanghai) Co., Ltd

First Floor, Block E,

18 Jindian Road, Pudong

Shanghai, China, 201206

Tel: +86 21 5899 7721

Fax: +86 21 5899 7727

cn.sales@lemo.com

DENMARK

LEMO Denmark A/S

Mandal Allé 16A

5500 Middelfart

Tel: +45 45 20 44 00

Fax: +45 45 20 44 01

info-dk@lemo.com

FRANCE

LEMO France Sàrl

24/28 Avenue Graham Bell

Bâtiment Balthus 4

Bussy Saint Georges

77607 Marne la Vallée Cedex 3

Tel: +33 1 60 94 60 94

Fax: +33 1 60 94 60 90

info-fr@lemo.com

GERMANY

LEMO Elektronik GmbH

Hanns-Schwindt-Str. 6

81829 München

Tel: +49 89 42 77 03

Fax: +49 89 420 21 92

info@lemo.de

HUNGARY

REDEL Elektronika Kft

Nagysándor József u. 6-12

1201 Budapest

Tel: +36 1 421 47 10

Fax: +36 1 421 47 57

info-hu@lemo.com

ITALY

LEMO Italia srl

Viale Lunigiana 25

20125 Milano

Tel: +39 02 66 71 10 46

Fax: +39 02 37 90 80 46

sales.it@lemo.com

JAPAN

LEMO Japan Ltd

2-7-22, Mita,

Minato-ku, Tokyo, 108-0073

Tel: +81 3 54 46 55 10

Fax: +81 3 54 46 55 11

info-jp@lemo.com

NETHERLANDS / BELGIUM

LEMO Connectors Nederland B.V.

Jacques Meuwissenweg 6

2031 AD Haarlem

Tel. +31 23 206 07 01

info-nl@lemo.com

NORWAY / ICELAND

LEMO Norway A/S

Soerumsandvegen 69,

1920 Soerumsand

Tel: +47 22 91 70 40

Fax: +47 22 91 70 41

info-no@lemo.com

SINGAPORE

LEMO Asia Pte Ltd

4 Leng Kee Road,

#06-09 SiS Building

Singapore 159088

Tel: +65 6476 0672

Fax: +65 6474 0672

sg.sales@lemo.com

SPAIN / PORTUGAL

IBERLEMO SAU

Brasil, 45, 08402 Granollers

Barcelona

Tel: +34 93 860 44 20

Fax: +34 93 879 10 77

info-es@lemo.com

SWEDEN / FINLAND

LEMO Nordic AB

Gunnabogatan 30

163 53 Spånga

Tel: +46 8 635 60 60

Fax: +46 8 635 60 61

info-se@lemo.com

SWITZERLAND

LEMO Verkauf AG

Grundstrasse 22 B,

6343 Rotkreuz

Tel: +41 41 790 49 40

ch.sales@lemo.com

TAIWAN

TAOYUAN TAIWAN

Tel: +886 967 132 824

speng@lemo.com

UNITED ARAB EMIRATES

LEMO Middle East Connectors LLC

Concorde Tower 11th Floor,

Office 1102, Dubai Media City,

P.O. Box 449849

Dubai, United Arab Emirates

Tel: +971 4 568 1904

info-me@lemo.com

UNITED KINGDOM

LEMO UK Ltd

12-20 North Street, Worthing,

West Sussex, BN11 1DU

Tel: +44 1903 23 45 43

lemouk@lemo.com

USA

LEMO USA Inc

P.O. Box 2408

Rohnert Park, CA 94927-2408

Tel: +1 707 578 88 11

+1 800 444 53 66

Fax: +1 707 578 08 69

info-US@lemo.com

LEMO DISTRIBUTORS

ARGENTINA, AUSTRALIA, BRAZIL, CHILE, COLOMBIA, CZECH REPUBLIC,
GREECE, INDIA, ISRAEL, NEW ZEALAND, PERU, POLAND, SOUTH AFRICA,
SOUTH KOREA, TURKEY, UKRAINE

www.lemo.com