

Technical Information

Introduction of YS1000 Series

YS1000™ Series

TI 01B08A01-01E

vigilantplant®



Notice

- The contents of this manual are subject to change without notice as a result of continuing improvements to the instrument's performance and functions.
- Every effort has been made to ensure accuracy in the preparation of this manual. Should any errors or omissions come to your attention, however, please inform YOKOGAWA Electric's sales office or sales representative.
- Under no circumstances may the contents of this manual, in part or in whole, be transcribed or copied without our permission.

Trademarks

- Our product names or brand names mentioned in this manual are the trademarks or registered trademarks of YOKOGAWA Electric Corporation (hereinafter referred to as YOKOGAWA).
- Microsoft, MS-DOS, Windows, Windows XP, and Windows NT are either registered trademarks or trademarks of Microsoft Corporation in the United States and/or other countries.
- Adobe, Acrobat, and Postscript are either registered trademarks or trademarks of Adobe Systems Incorporated.
- Ethernet is a registered trademark of XEROX Corporation.
- We do not use the TM or ® mark to indicate these trademarks or registered trademarks in this user's manual.
- All other product names mentioned in this user's manual are trademarks or registered trademarks of their respective companies.

Introduction of YS1000 Series

TI 01B08A01-01E

CONTENTS

YS1000 Series	1
Features	1
Series Products	4
YS1000 Series Products.....	4
YS1000 Series Software Product	4
YS1000 Series Products: Controllers	5
YS1000 Series Products: Other Instruments.....	6
YS1500 and YS1700	7
Getting Started	7
Basic Operations	8
Color LCD Screen: Operation Display Examples	9
Shorter Casing and Lighter Weight	12
Fail-safe	13
Specifications of YS1500 and YS1700	17
YS1500	18
Control Functions	18
Block Diagram of Single-loop Mode	20
Block Diagram of Cascade Mode	22
Block Diagram of Selector Mode	24
Self-tuning Function (STC)	26
Adjustable Setpoint Filter (SVF)	27
YS1700	28
Control Functions	28
Basic Control Module (BSC)	29
Cascade Control Module (CSC)	30
Selector Control Module (SSC)	31
Command and Calculation Module List	32
YS1000 Series	35
YSS1000 Setting Software	35
Window Configuration of YSS1000	36
YSS1000 Function Overview	37

Model and Suffix Codes	39
YS1000 Series Model and Suffix Codes	39
Housings for Replacement of Earlier Series.....	41
Difference in Form Depending on Suffix Code.....	42
Note on Using the YS100-compatible Case	43
Functional Restriction Depending on Suffix Code	44
Terminal	46
YS1500 and YS1700 Basic Type:Terminal Arrangements in Single-loop/Cascade/ Selector Modes	46
YS1700 Basic Type:Terminal Arrangements in Programmable Mode	48
YS1700 Basic Type with Expandable I/O:Terminal Arrangements of Expanded I/O	50
YS1310 Indicator with Alarm	51
YS1350 Manual Setter for SV Setting	52
YS1360 Manual Setter for MV Setting	53
Communication	54
Supervisory Communication.....	54
Peer-to-Peer Communication	55
Open Network Connectivity.....	56
Application Note	57
Temperature and Pressure Compensation for Ideal Gas	57
Boiler Drum Level Control	58
Boiler Feedwater Treatment.....	59
Compressor Anti-surge Control.....	60
Comparisons	61
Q & A	63
Dimensions	65
Dimensions of YS1000 Basic Type	65
Dimensions of YS1000 Basic Type with Expandable I/O.....	66
Dimensions of Expandable I/O Block and Expandable I/O Cable	67
Dimensions of Compatible Type for YS100	68
Dimensions of Compatible Type for YS80 Internal Unit	69
Dimensions of Compatible Type for YS80	70
Dimensions of Compatible Type for 100 Line.....	71
Revision Information	i

YS1000 Series

Features

■ Color LCD

- Easy to read thanks to a full-dot color LCD. To accommodate a variety of environmental conditions, a semi-reflective LCD ensures excellent visibility even when lit by outside light.
- In addition to a meter display which is ideal for replacing traditional controllers with pointers, an event display is newly added.
- The backlight can be switched on and off by a remote contact.

■ Improved Specifications

- Specifications improved from YS100 Series.
 - Input/output accuracy:
 - Voltage input accuracy: $\pm 0.2\% \rightarrow \pm 0.1\%$
 - Voltage output accuracy: $\pm 0.3\% \rightarrow \pm 0.1\%$
 - Current output accuracy: $\pm 1.0\% \rightarrow \pm 0.2\%$
 - Internal data format of input/output signals: 1/100 \rightarrow 1/10,000
 - Resolution of internal calculations including PID calculation: 1/4,096 \rightarrow 1/65,536
- Greater flexibility in multi-function controller models (YS1700 and YS1500) that offer selectable control functions with no need of programming, such as single-loop control, cascade control, and auto-selector control:
 - Choice of sampling PI control
 - Various status inputs and outputs can be assigned to desired DI/DO points.
 - PV, SV, and MV can be selected for the transmission output.
- More powerful control and calculation functions
 - IEEE754-format four-byte floating-point calculations enable actual values to be used in calculations.
 - Over 100 types of calculation modules are featured, including exponential and logarithmic functions, temperature compensation, and pressure compensation.
- Enhanced alarm monitoring functions
 - High-high and low-low alarms are available with controller models (YS1700 and YS1500) that were previously available only with the indicator-with-alarm model.

■ Expandable Input/Output

Choosing the basic type with I/O expandability enables future I/O expansion up to eight analog inputs, four analog outputs, and fourteen digital inputs and outputs.

■ Smaller Size for Flexible Installation

The size has been dramatically reduced for more flexible installation; mounting on a door is now possible.

- Depth: 250 mm (basic type)
- Weight: 1.6 kg (basic type)

■ Various Cases and Housings for Replacing Earlier Controllers

YS1000 Series controllers come in various cases and housings and so can replace earlier models without having to change the panel cutouts and depths.

■ Enhanced User Programming Capability (with optional YSS1000 setting software)

- Besides the well-established text programming, the new user-friendly function block programming allows the user to choose the desired method.
- Program capacity is increased to 1000 steps, two and a half times the previous model (YS170).
- The number of constant registers for the user program (Kn) is increased to 100.
- For programmed-setpoint control of the Model YS1700, two patterns can now be set.
- The PF key has an LED (Green) indicator that can be turned on and off by the user program.

■ Fail-safe

- Dual CPU
During normal operation, the main CPU performs the control functions and the display CPU performs the display functions. If either CPU fails, the other CPU in the normal state will provisionally take over the functions performed by the failed CPU, to enable display and manual operations.
- Hard manual
The hard manual circuit incorporated independently from the digital circuits enables the controller output to be adjusted manually in an emergency.

■ Security and Tools for Maintenance and Servicing

- Password protection
Engineering parameters and the user program can be password-protected. When a password is set, the parameter or program contents cannot be viewed by others.
- Tools for calibrations (under development)
 - Calibration can be performed simply by following the guidance for calibrations displayed by the optional setting software for the YS1000 Series (Model YSS1000).
 - The calibration records can be saved to the YS1000 controllers themselves, and then loaded and printed as necessary later on.

■ Nonvolatile Memory for Memory Backup

No battery or capacitor is used for memory backup, facilitating maintenance.

■ AC/DC power supply resists power supply variation

The YS1000 Series controllers can be driven by either an AC (100 V) or DC (24 V) power supply, and with the DC supply connections, polarity does not matter. (Must be specified upon ordering if using a 220 V DC power supply.)

■ Dust- and splash-proof IP54 Faceplate

Tougher environmental resistance

■ CE Mark (for basic type and compatible type for YS100)

■ FM Non-incendive Explosion Protection (optional for basic types only)

■ Communication (optional)

Ethernet (Modbus/TCP; for basic types only)

RS-485 (PC-link, Modbus, Peer-to-Peer communication, and YS protocol; unavailable for YS80 internal unit-compatible type)

DCS-LCS communication

■ Compatibility with YS100 Series

Setting and control operations can be done with the same feel.

Series Products

YS1000 Series Products

- **YS1500 Indicating Controller**

Backward compatible with YS150

Incorporates fundamental control functions required for PID control, and the necessary functions are to be selected in accordance with the user's purpose. The available functions include those functions for input signal processing, such as square root extraction and linear segment conversion, and feed-forward calculation. Cascade and selector control is also possible.

- **YS1700 Programmable Indicating Controller**

Backward compatible with YS170

A programmable controller in which control and computational functions are coded in concise language by the user. Each YS1700 can run two PID control calculations simultaneously and output the respective 4–20 mA output signals. The YS1700 can also be used as a multi-function controller without programming, in the same way as for the Model 1500 introduced below.

- **YS1310 Indicator with Alarm**

Backward compatible with YS131

Indicating alarm monitor for two inputs for simultaneous monitoring of both loops.

High-high, high, low, and low-low alarms can be detected for each of the two inputs, and logical ANDs or ORs of arbitrary alarms can be set. From among these, a total of six alarms can be assigned to alarm output contacts.

- **YS1350 Manual Setter for SV Setting**

Backward compatible with YS135

A manual loader used to output a setpoint signal to a controller. Its operation mode is switched over between cascade and manual by operation mode keys (C and M) or a status input, and a status identification output is provided as standard.

- **YS1360 Manual Setter for MV Setting**

Backward compatible with YS136

A manual loader used to output a control signal to an actuator of a final control device. Its operation mode is switched over between cascade and manual by operation mode keys (C and M) or a status input, and a status identification output is provided as standard.

YS1000 Series Software Product

- **YSS1000 Setting Software for YS1000 Series**

YSS1000 is a software product used to create and set YS1000 series parameters and user programs from a PC. It also enables tuning and user program monitoring to be made through communication with the YS1000.

YS1000 Series Products: Controllers

- **YS1500 Indicating Controller**

Incorporates fundamental control functions required for PID control, and the necessary functions are to be selected in accordance with the user's purpose. The available functions include those functions for input signal processing, such as square root extraction and linear segment conversion, and feed-forward calculation. Cascade and selector control is also possible.

- **YS1700 Programmable Indicating Controller**

A programmable controller in which control and computational functions are coded in concise language by the user. Each YS1700 can run two PID control calculations simultaneously and output the respective 4–20 mA output signals. The YS1700 can also be used as a multi-function controller without programming, in the same way as for the Model 1500 introduced below.

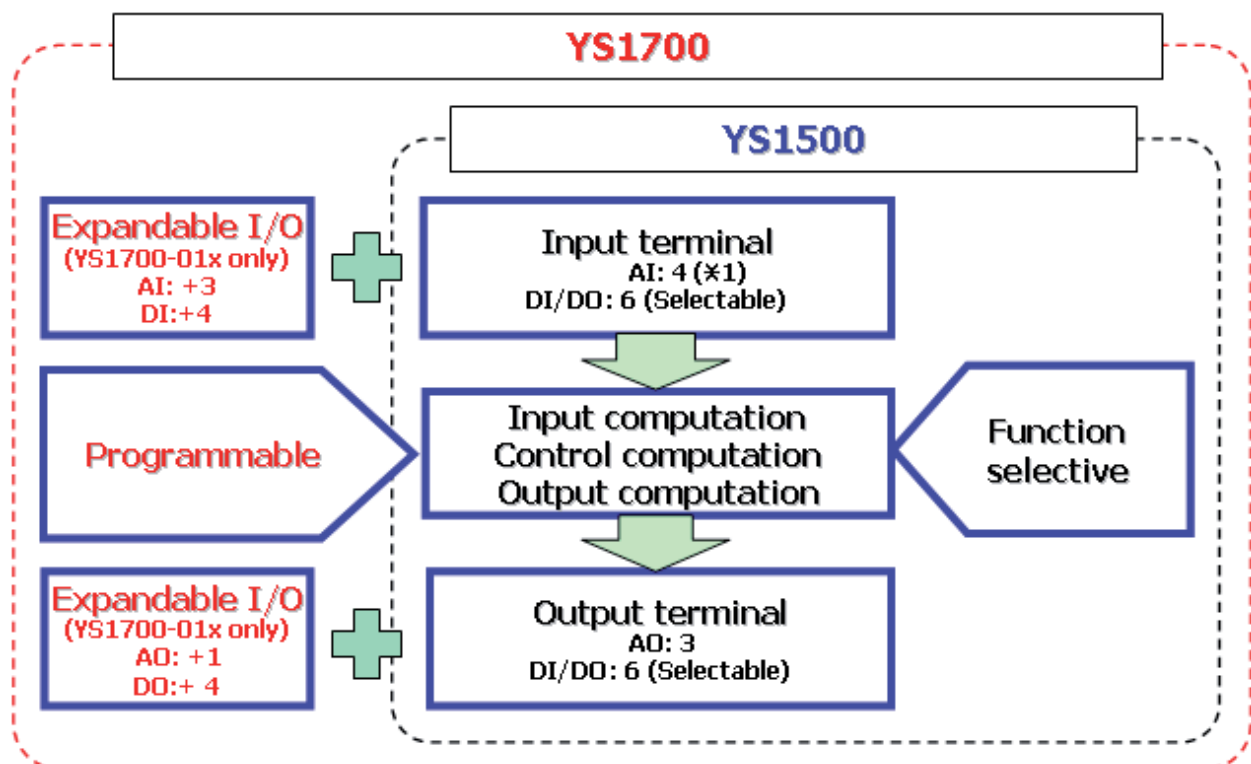

*1 AI: 5 for the program mode of the YS1700.

YS1000 Series Products: Other Instruments

- **YS1310 Indicator with Alarm**

Indicating alarm monitor for two inputs for simultaneous monitoring of both loops.

High-high, high, low, and low-low alarms can be detected for each of the two inputs, and logical ANDs or ORs of arbitrary alarms can be set. From among these, a total of six alarms can be assigned to alarm output contacts.

- **YS1350 Manual Setter for SV Setting**

A manual loader used to output a setpoint signal to a controller. Its operation mode is switched over between cascade and manual by operation mode keys (C and M) or a status input, and a status identification output is provided as standard.

- **YS1360 Manual Setter for MV Setting**

A manual loader used to output a control signal to an actuator of a final control device. Its operation mode is switched over between cascade and manual by operation mode keys (C and M) or a status input, and a status identification output is provided as standard.

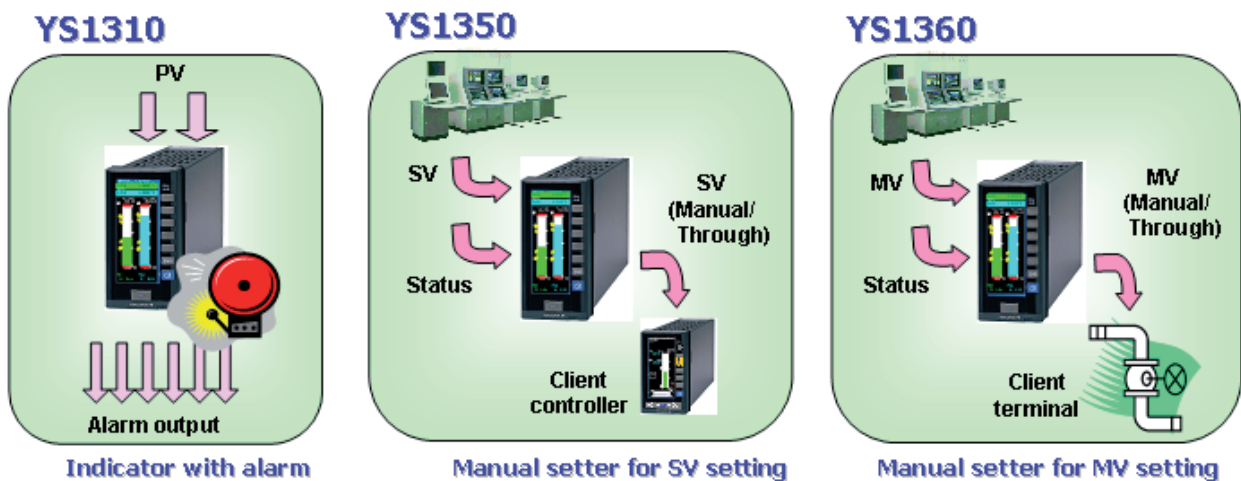

YS1500 and YS1700

Getting Started

When using a YS1000 Series controller for the first time, follow the procedure below.

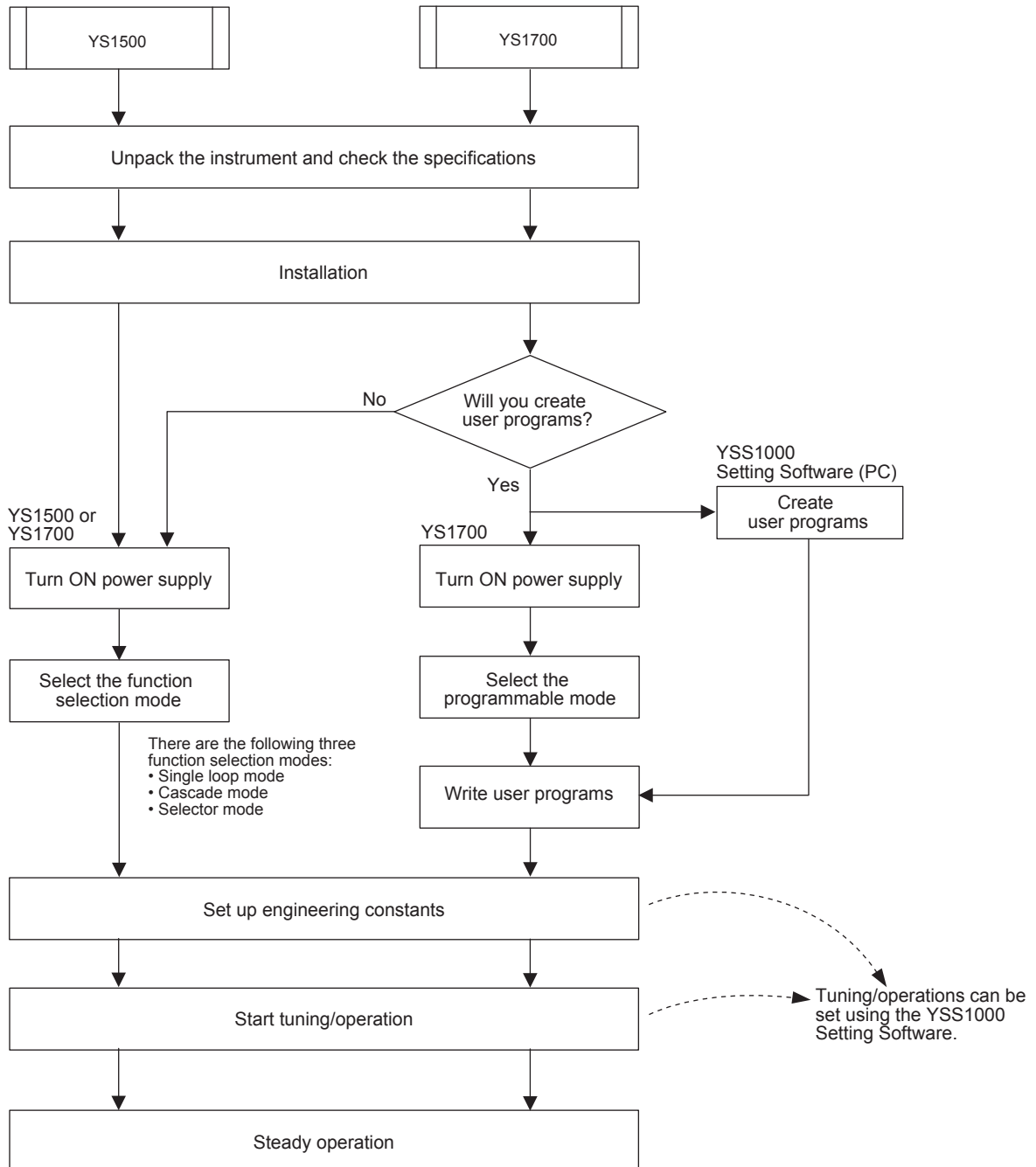

Basic Operations

■ Display Access Sequence and Operation Keys

YS1000 Series displays are composed of three groups:

1. Operation display group

Consists of LOOP displays used to change the operation mode, SV setting, and MV setting during control operation; TREND displays that show the PV, SV, and MV trend graphs; ALARM displays that show alarm details; the DUAL display that shows the statuses of two loops simultaneously (allowing user operation for one loop at a time, however); and METER displays that show the PV, SV, and MV values with the respective pointers on meter scales.

2. Tuning display group

Consists of displays used to view and change control parameters such as P, I, and D, and monitor input and output signal levels.

3. Engineering display group

Consists of displays used to set controller configurations, and view and change various registers and table settings, set input specifications, and set the password.

■ Switching Display

Follow the procedure below to switch the display.

1. Turn on the power. An operation display appears.
2. Keep pressing the **◀◀SHIFT▶▶** key and press the Page (**Ⓜ**) key. Each time you press the Page key, the display changes.
The display changes sequentially from an operation display, Tuning Menu, to Engineering Menu, then back to an operation display.

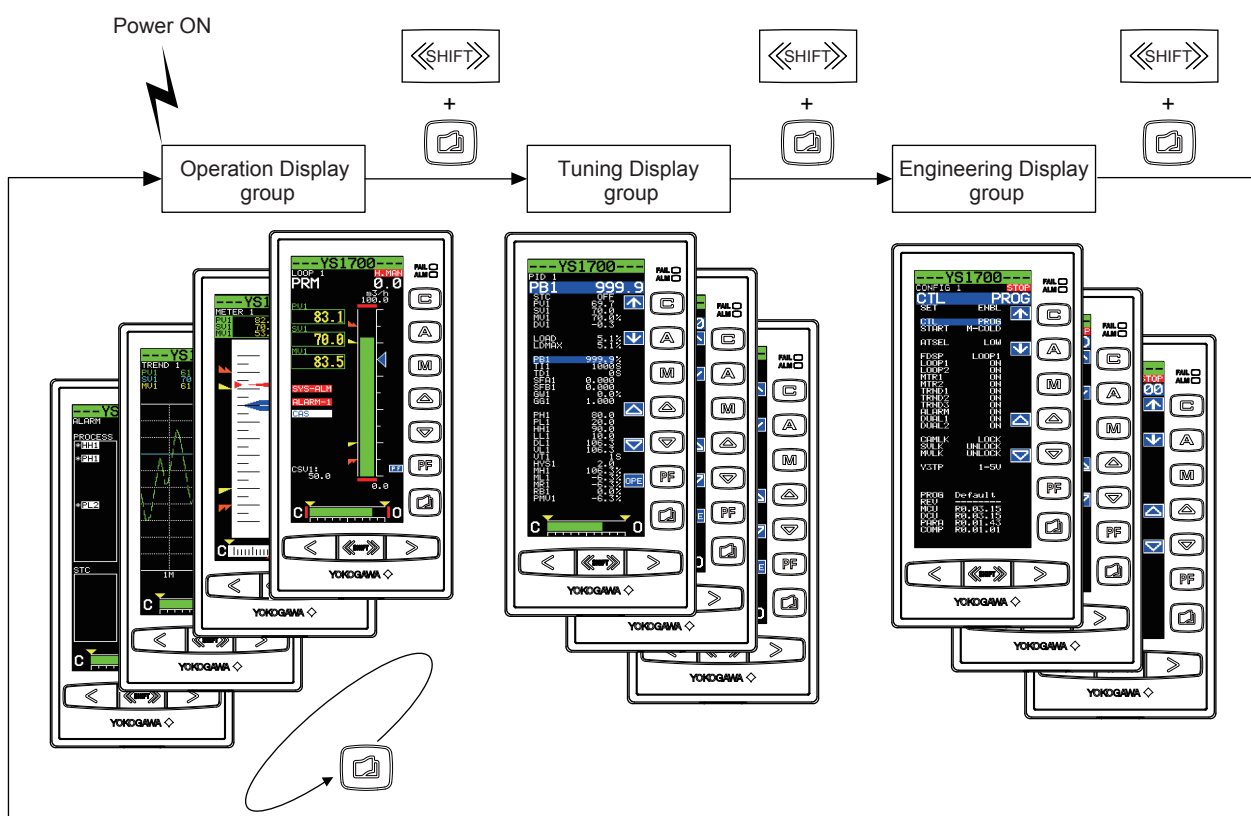

Color LCD Screen: Operation Display Examples

■ LOOP Display

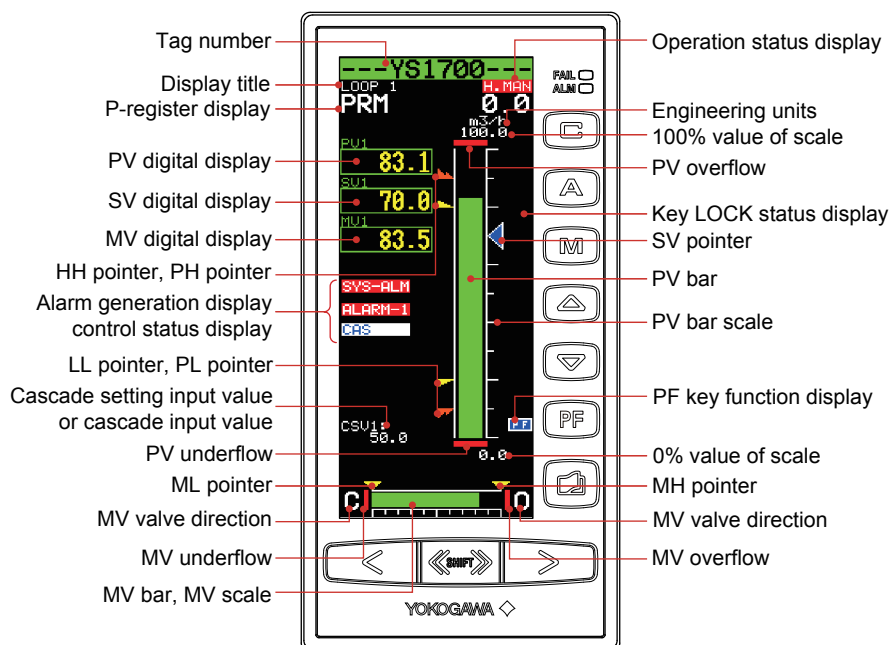

■ METER Display

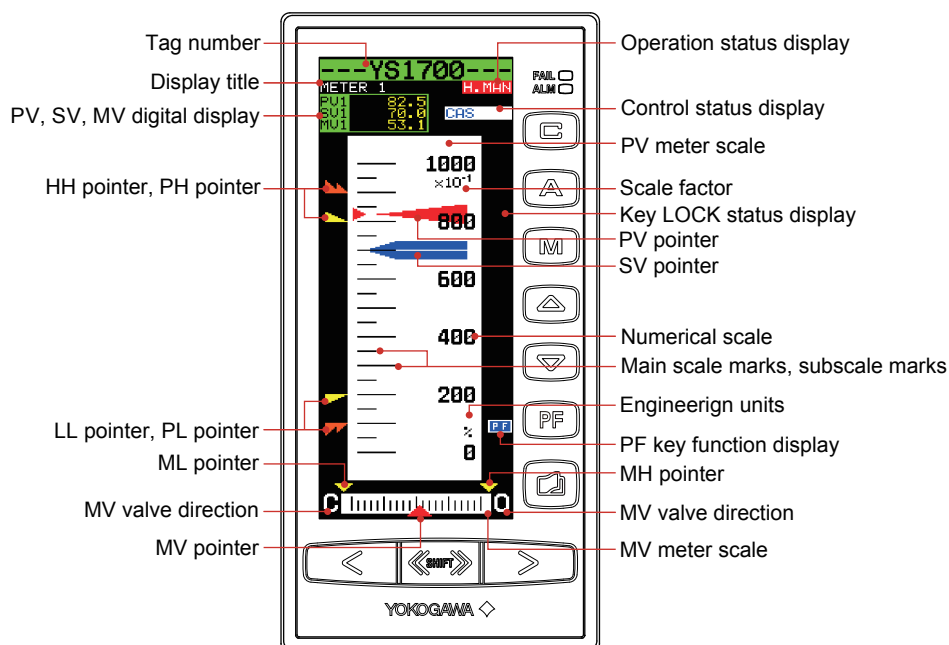

TREND Display

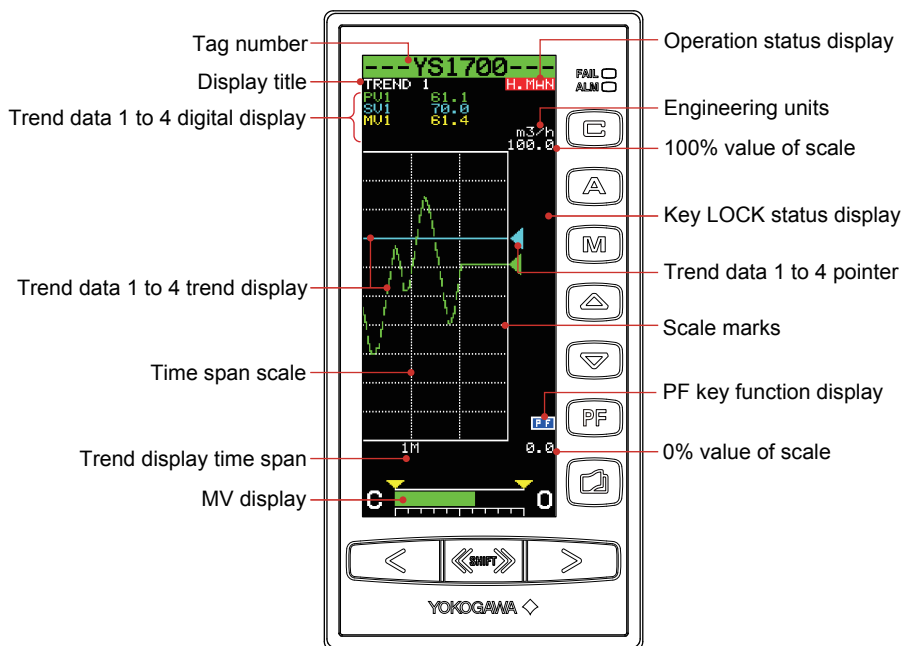

ALARM Display

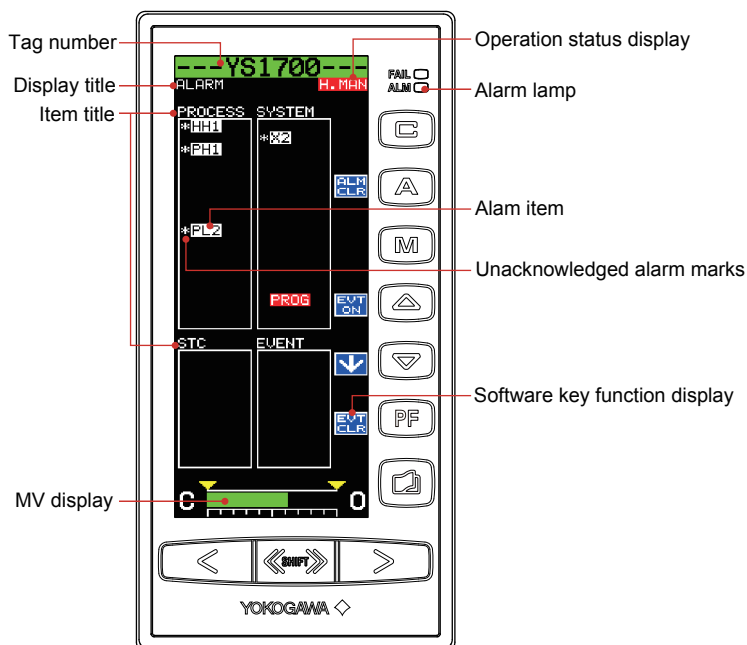

DUAL Display

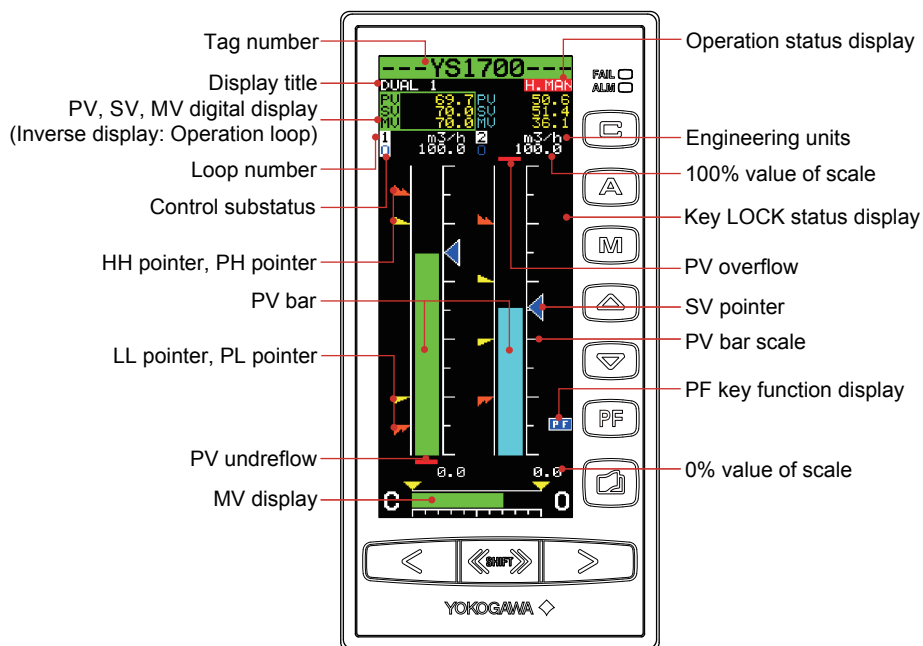

EVENT Display

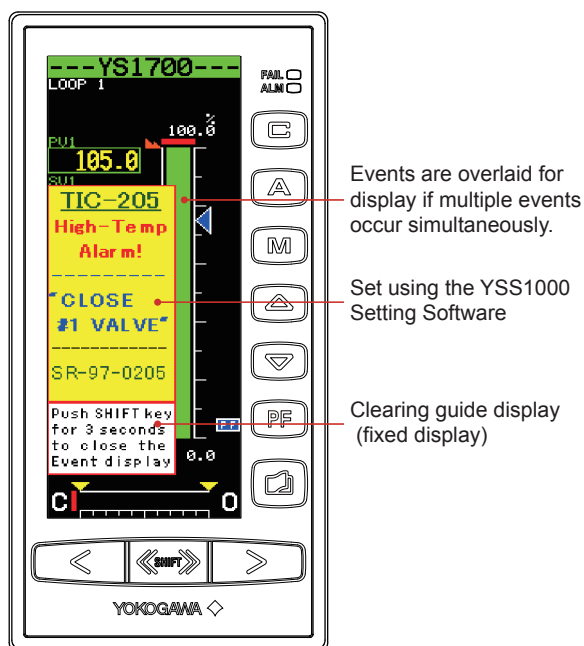

Shorter Casing and Lighter Weight

The reduced size and weight make it easier to design compact instrument panels and replace existing controllers.

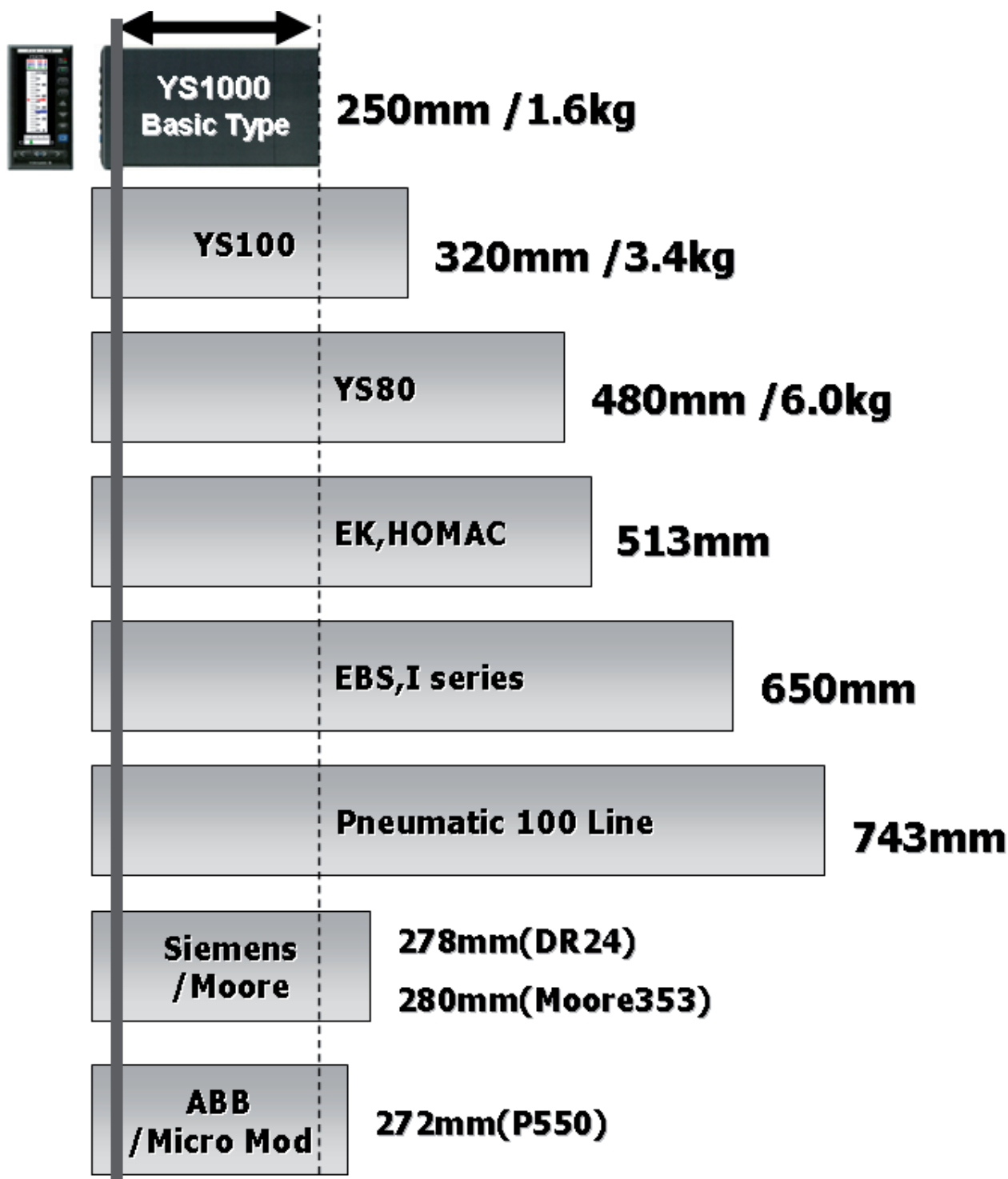

TIP

In addition to the YS1000 standard case and housing, various cases and housings compatible with those for earlier series are available for easy replacement.

Fail-safe

■ Redundant Output Backup

Dual-CPU configuration + hard manual

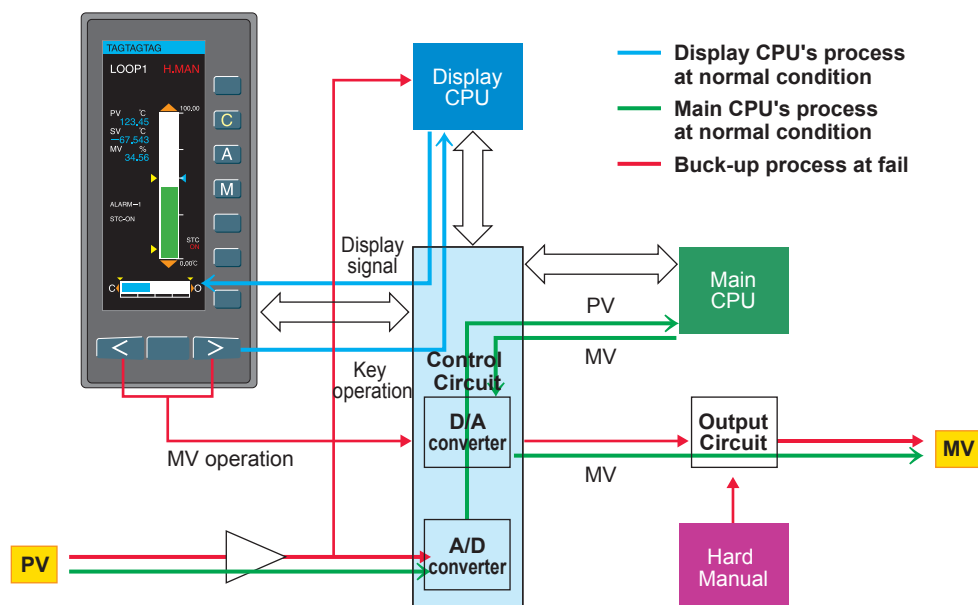

With dual-CPU construction (main CPU and display CPU), manual control capability and display continues even if an abnormality occurs on one of the CPUs. If controller self-diagnostics detects a control circuit failure, the controller can suspend analog/digital output, switch to manual mode and allow manual control by operator.

Functions \ Failure area	Main CPU fail	Display CPU fail	All CPU and Control Circuit
Control with "Hard manual"	✓	✓	✓
Manual operation with front keys	✓	✓	N/A
Display for PV and SV	✓	✓	N/A
Control algorithm	stop	stop	stop

Dual CPU

Upon Failure of Main CPU

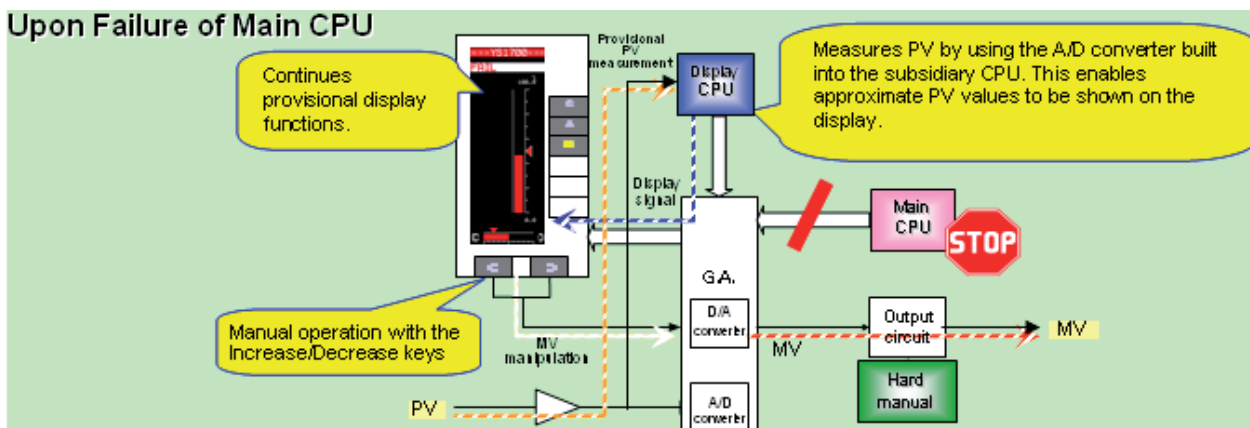

Failure of Display CPU

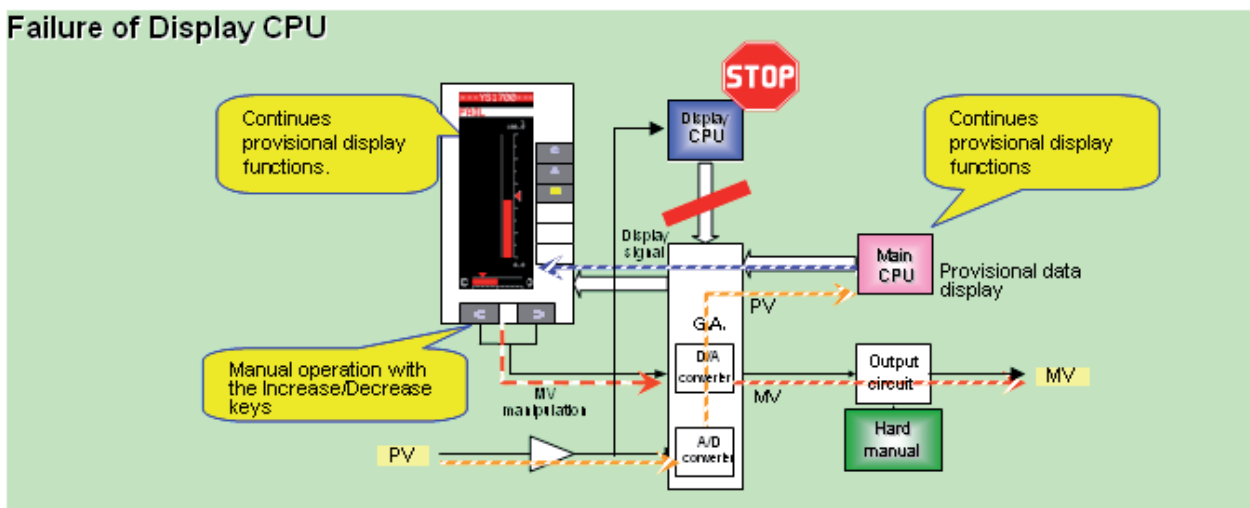

Failure of Control Circuit

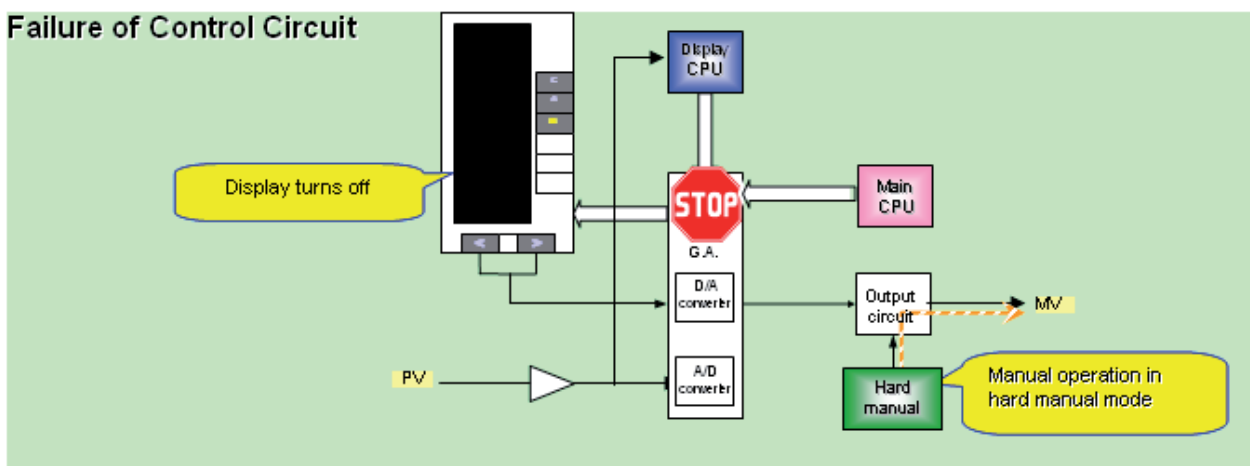

■ Hard Manual

● YS1500, YS1700, and YS1360:

- Device to enable the user to manipulate MV in an emergency
- MV manipulation capability even if both CPUs and the gate array fail simultaneously

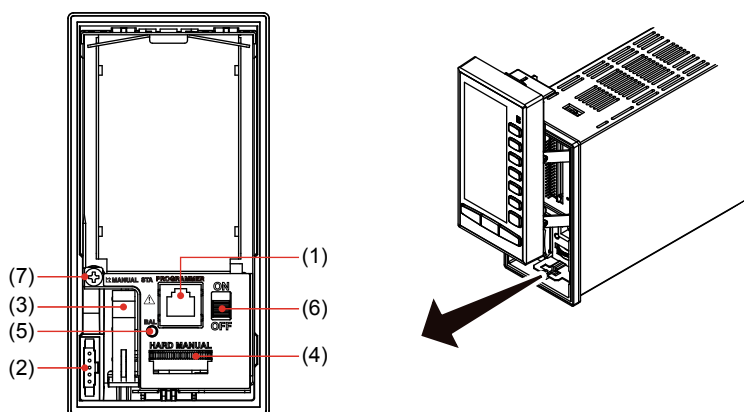

1. Computer link connector (PROGRAMMER):
Communication cable connector used when downloading, uploading, and viewing the parameter and user program set using the YSS1000 Setting Software for YS1000 Series
2. Connector for YS110 standby manual station (MANUAL STA)
3. Internal-unit release lever
4. Hard manual operation wheel (HARD MANUAL):
Used to set the output level.
5. MV balance lamp (BAL [green]):
Lights up when the control output agrees with the hard manual output level.
6. Hard manual selector switch (ON/OFF):
Used to switch over the output (MV) to the level set by the hard manual operation wheel.
7. Internal-unit fixing screw

■ Standby Manual Station

With the Model YS110 standby manual station, an internal unit can be replaced while maintaining the control output level.

YS1500, YS1700, YS1360

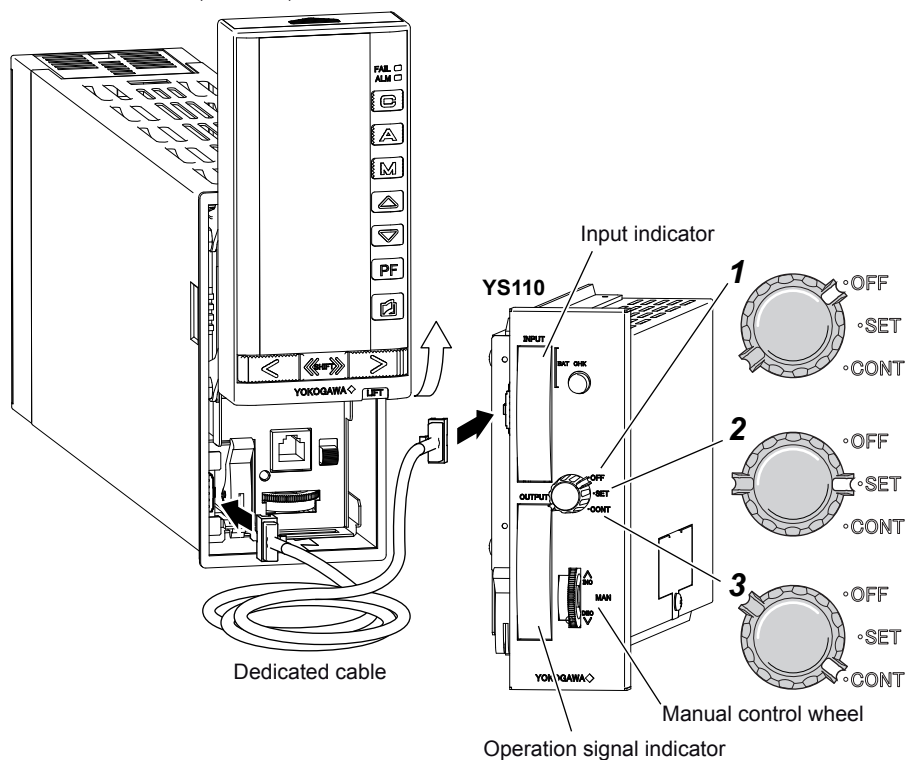

	Output Mode	Input Indicator	Operation Signal Indicator	Output Signal to Operation Terminal
1	OFF	—	Indicates manipulated output of controller or auto / manual station	Operation signal from controller or auto / manual station
2	SET	Indicates input value	Indicates manipulated output set by YS110	Operation signal from controller or auto / manual station
3	CONT	Indicates input value	Indicates manipulated output set by YS110	Operation signal from YS110

Specifications of YS1500 and YS1700

Item	YS1500 Basic Type	YS1700 Basic Type	YS1700 Basic Type (with Expandable I/O)
Front panel display	Backlight, full-dot, semi-reflective color LCD (bar graph, digital, and meter displays)		
Tuning	Via front panel display		
Analog inputs	1–5 V: 4 points	1–5 V: 5 points	1–5 V: 8 points
Analog outputs	1–5 V: 2 points (*) 4–20 mA: 1 point		1–5 V: 3 points 4–20 mA: 1 point
Contact inputs/outputs	6 points (to be chosen for use as a DI or DO individually)		14 points (6 points out of 14 are to be chosen for use as a DI or DO individually)
Fail contact output	1 point		
Control functions	<ul style="list-style-type: none"> • Single-loop control • Cascade control • Auto-selector control 	<ul style="list-style-type: none"> • Single-loop control • Cascade control • Auto-selector control • Programmable mode 	
Self-tuning function (STC)	Available		
Adjustable setpoint filter (SVF)	Available		
Calculations	<ul style="list-style-type: none"> • Measured value input calculations • Setpoint input calculations • External input calculations 	Over 100 type of calculation module	
Program capacity	—	Text programming: Up to 1000 steps Function block programming: Up to 400 modules	
Control period	100 ms	50, 100, or 200 ms	
Communication	Ethernet (Modbus/TCP) RS-485 (Modbus/RTU, PC-Link, Peer-to-Peer communication) DCS-LCS communication (with μ XL or CENTUM)		
Power supply	100 V system model: 24 to 120 V DC, polarity free; or 100 to 120 V AC, 50/60 Hz (\pm 3 Hz) 220 V system model: 135 to 190 V DC, polarity free; or 220 to 240 V AC, 50/60 Hz (\pm 3 Hz)		
Dimensions	Faceplate: 72 x 144 mm Depth: 250 mm (main body of basic type) Weight: 2.6 kg (main body of basic type)		

* YS1700: One point can be changed to 4-20 mA by a parameter setting.

YS1500

Control Functions

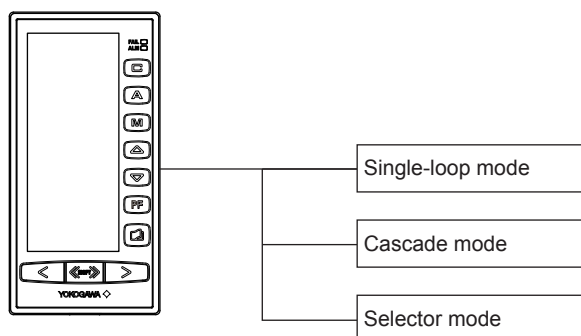

	Control Mode				
	Single-Loop	Cascade		Autoselector	
		Loop 1	Loop 2	Loop 1	Loop 2
Standard PID control	✓	✓	✓	✓	✓
Proportional (PD) control	✓	–	–	–	–
Sample-and-hold PI control	✓	✓	✓	–	–
Adjustable setpoint filter (SVF)	✓	✓	✓	✓	✓
Self-tuning function (STC)	✓	✓ ^{*1}		✓ ^{*2}	
Feedforward control	✓	✓	–	–	–
Output tracking	✓	–	–	–	–
Preset output	✓	✓		✓	
Output limiter	✓	✓		✓	
PH, PL, HH, LL, DV and VL alarm	✓	✓	✓	✓	✓

*1: Functions on primary loop when closed loop, secondary loop when open loop.

*2: Functions on unselected loop.

Blank Page

Block Diagram of Single-loop Mode

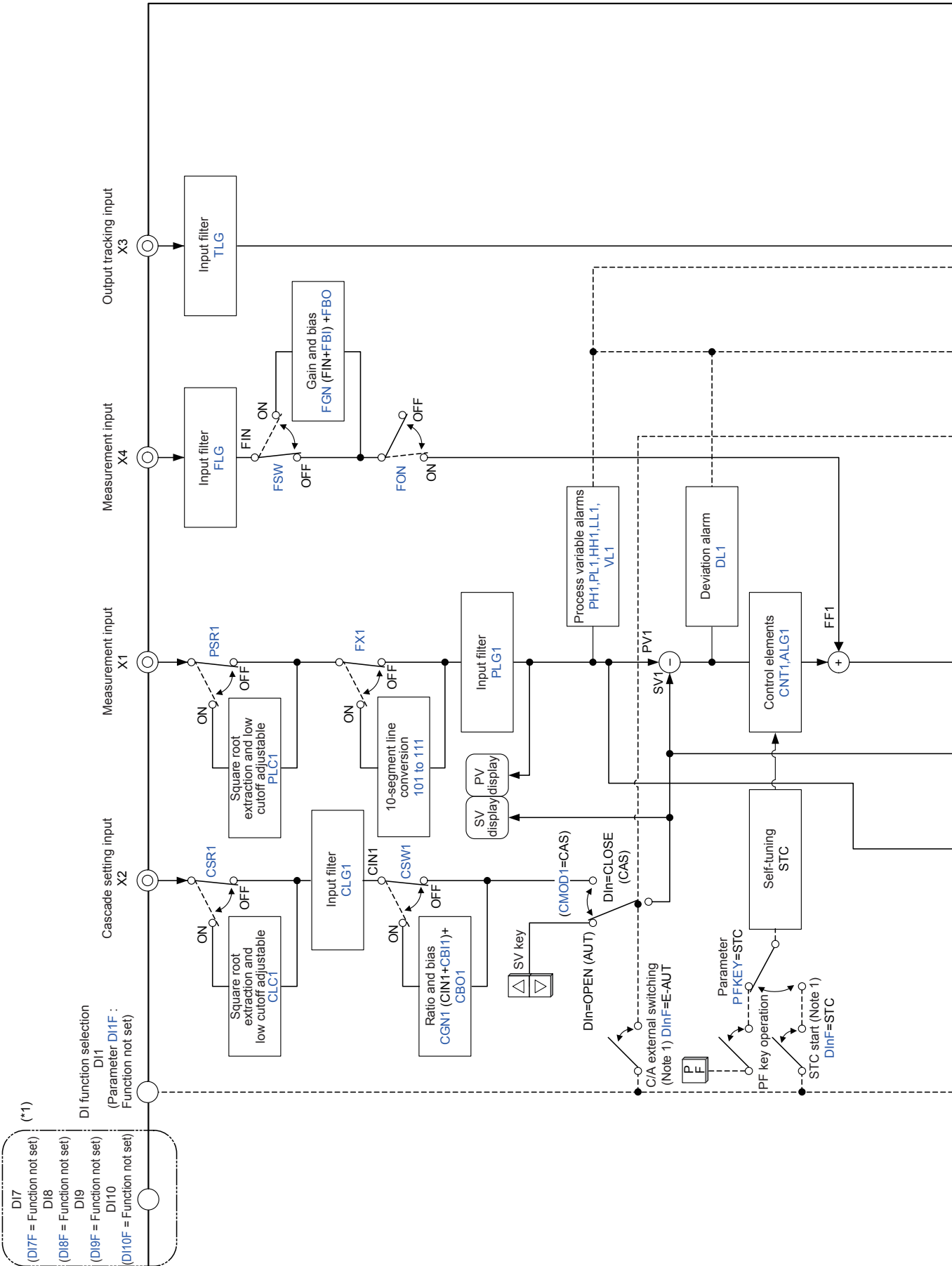

- (*)
- D17 = Function not set
 - D18 = Function not set
 - D19 = Function not set
 - (D19F = Function not set)
 - D110 = Function not set
 - (D110F = Function not set)
- DI function selection
- D11 (Parameter D11F : Function not set)

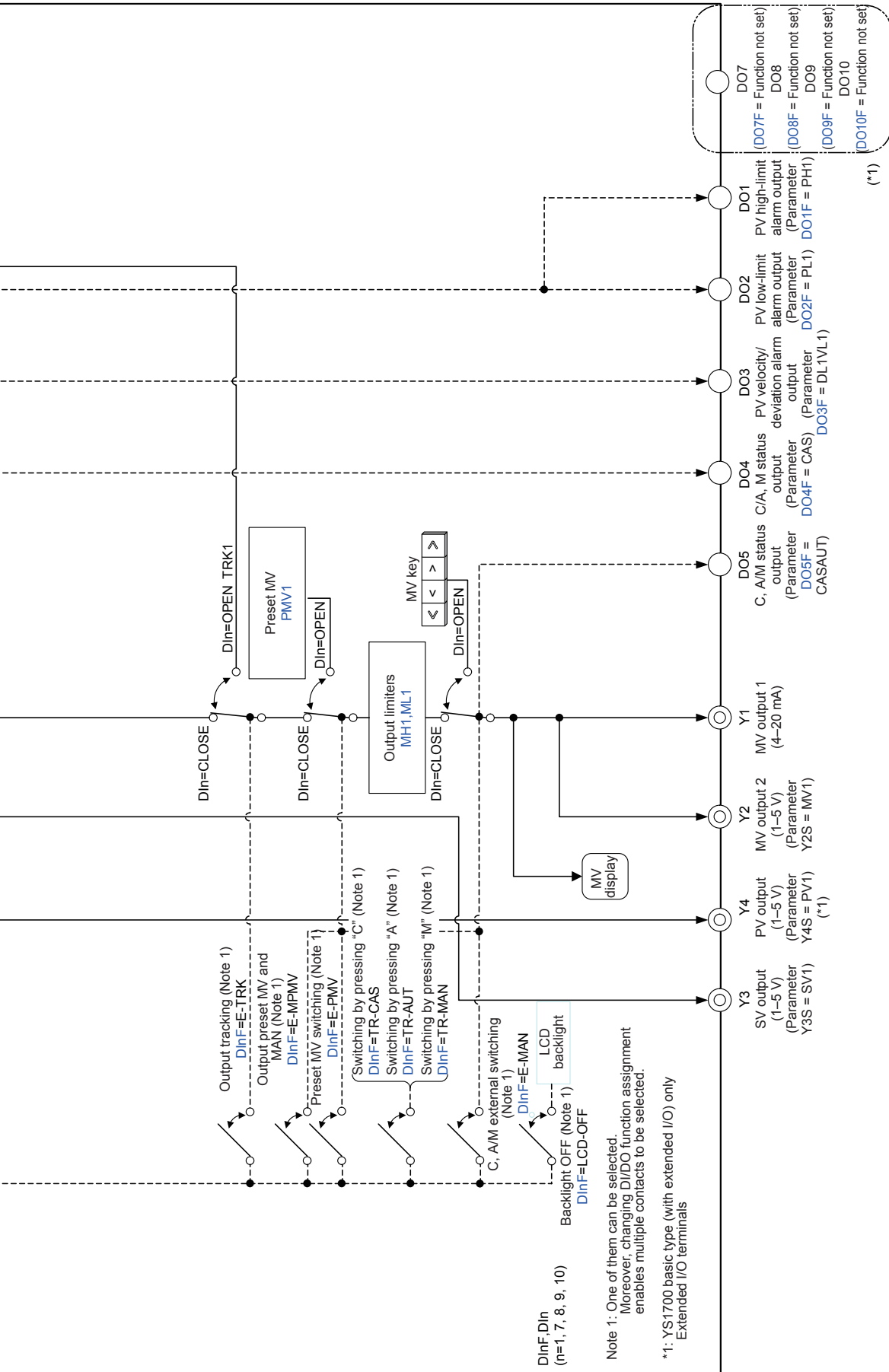

Block Diagram of Cascade Mode

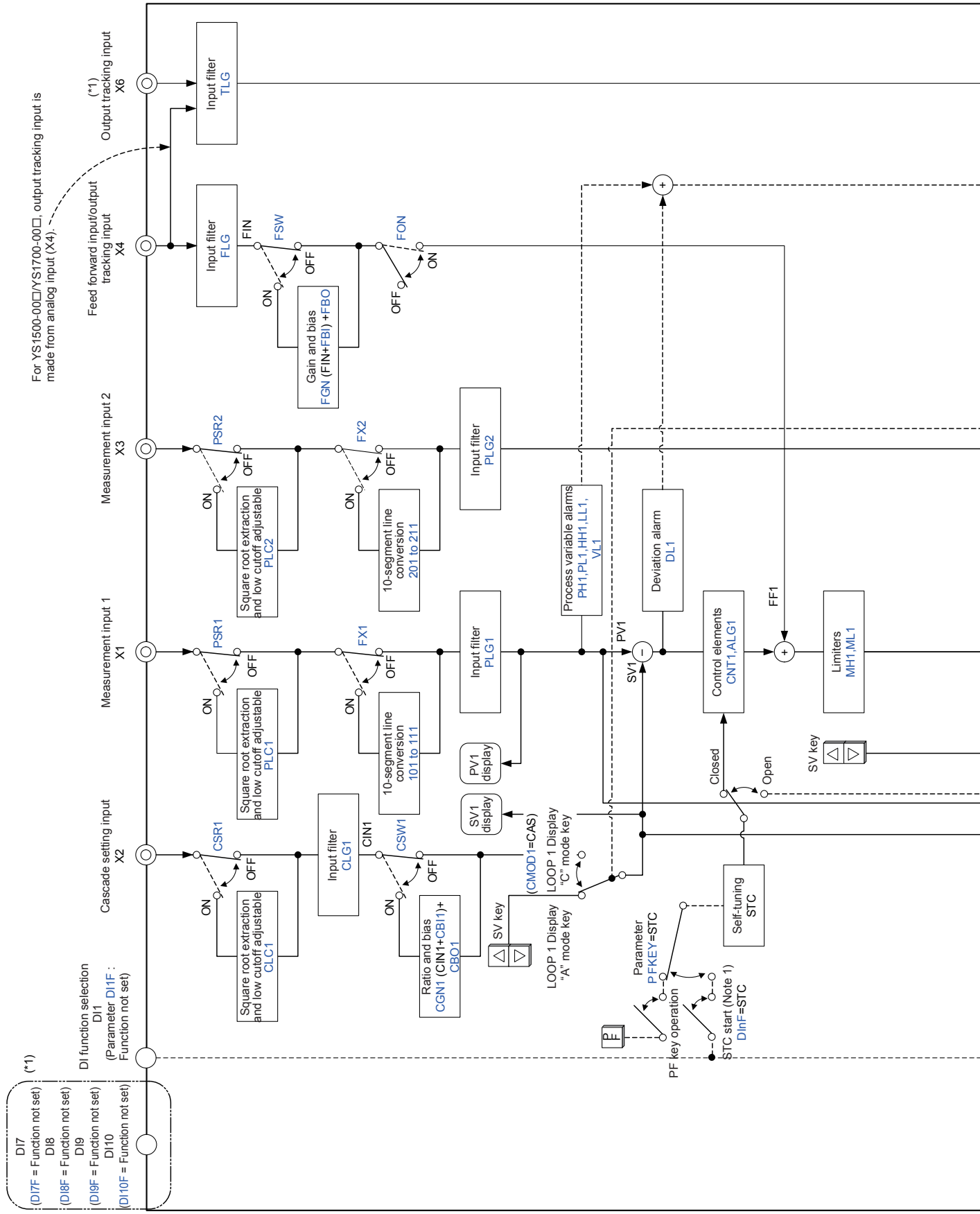

For YS1500-00□/YS1700-00□, output tracking input is made from analog input (X4).

(*)1 Output tracking input X6

Measurement input 2 X3

Measurement input 1 X1

Cascade setting input X2

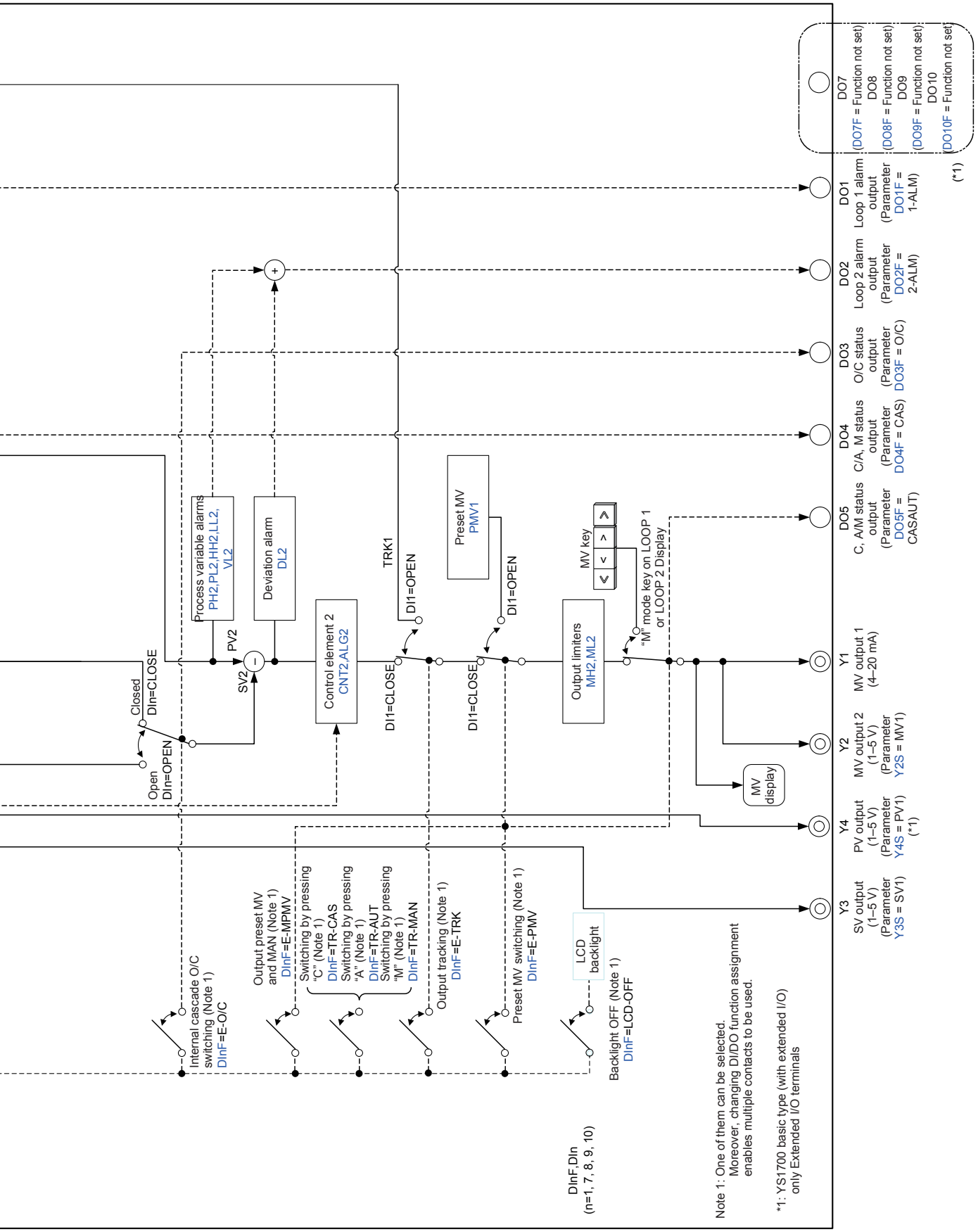

Block Diagram of Selector Mode

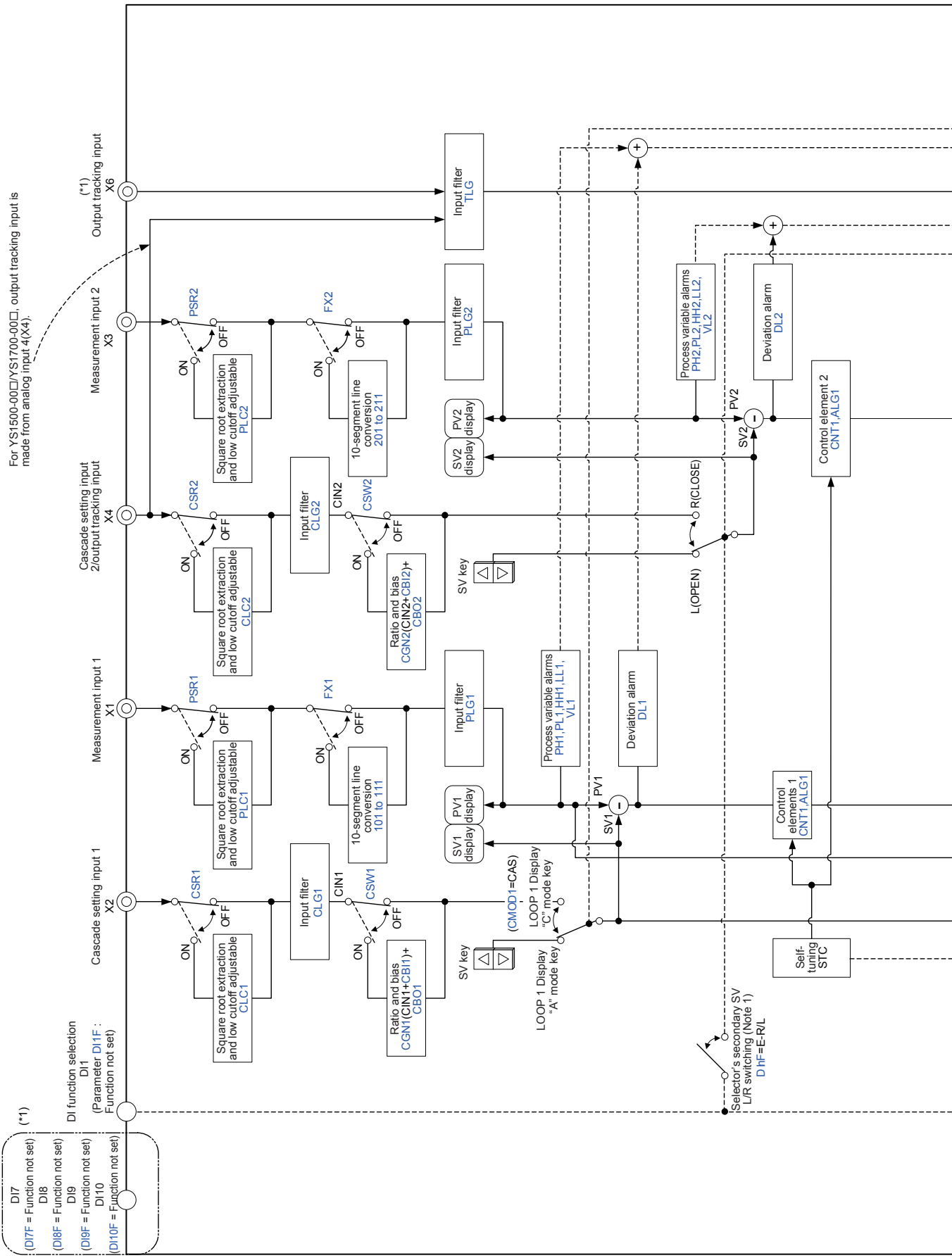

For YS1500-00□/YS1700-00□, output tracking input is made from analog input 4(X4).

- (*) D17 = Function not set
- (D17F = Function not set)
- D18 = Function not set
- (D18F = Function not set)
- D19 = Function not set
- (D19F = Function not set)
- D110 = Function not set
- (D110F = Function not set)

DI function selection
(Parameter DI1F :
Function not set)

Selector's secondary SV
L/R switching (Note 1)
DI1F=E-RL

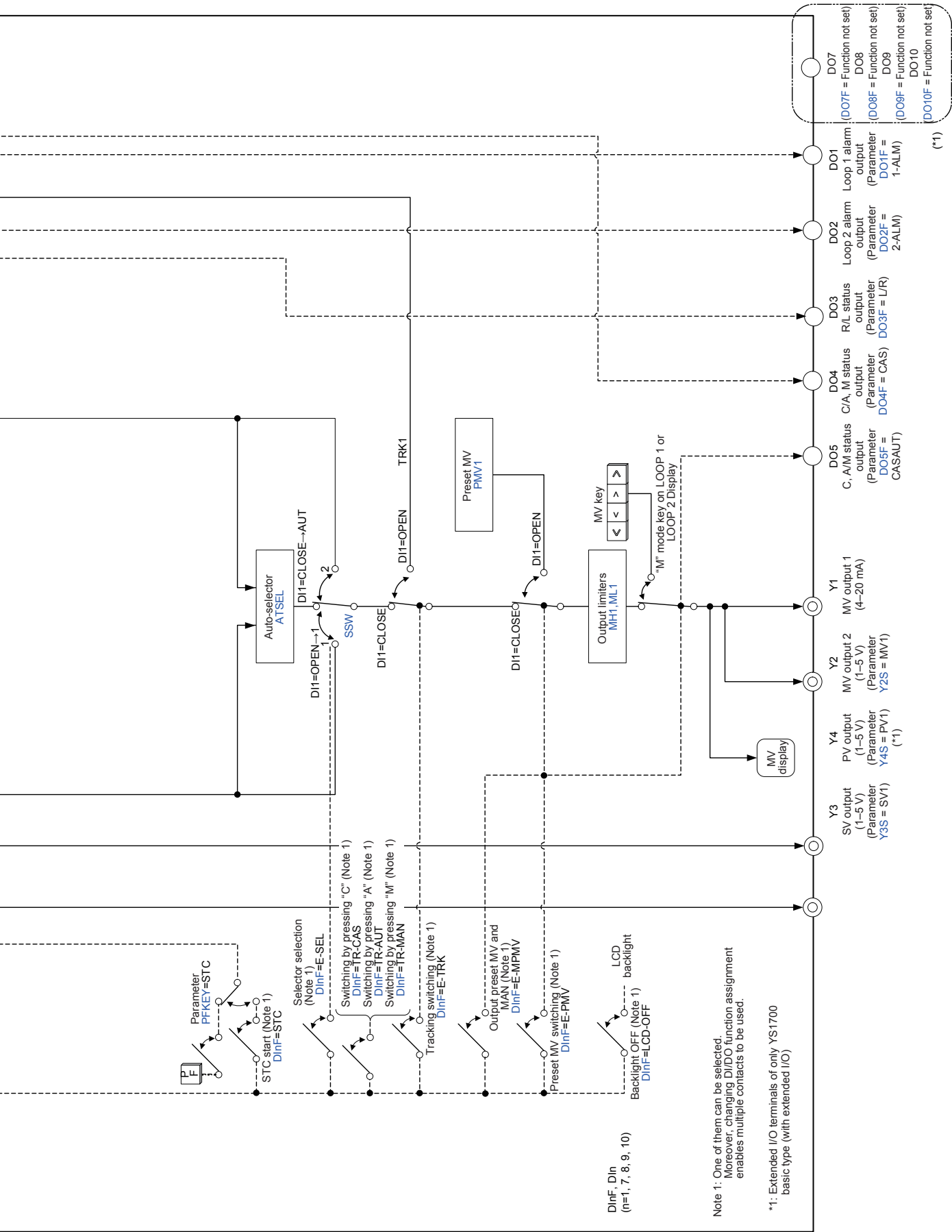

Self-tuning Function (STC)

■ Objectives

- To improve the ability to adjust for changes in process characteristics, and up sets
- To simplify, automate, and make consistent the tuning procedures

■ Features

- The PID parameters are determined based on the process characteristics that are estimated from responses to changes in SV and changes in MV.
- Long-term waveform monitoring is not needed because optimal PID parameters are calculated from the response waveform at a time.
- Process characteristic estimates can be displayed, enabling fluctuations in characteristics to be monitored.
- No cyclic identification signals are applied, preventing disturbances from affecting the process.
- Tuning can be performed on demand by the operator whenever necessary.
- Optimization to suppress disturbances as well as follow up the setpoint can be performed simultaneously.
- Users do not need to understand control theory.
- Self-tuning can be switched on and off.
- PID setting range limits can be set to avoid risks to process operation.

Adjustable Setpoint Filter (SVF)

Objectives of SVF

To optimize the ability to follow up the setpoint while maintaining the controller tuned optimally to adapt to changes in the measured value caused by disturbances.

Block Diagram

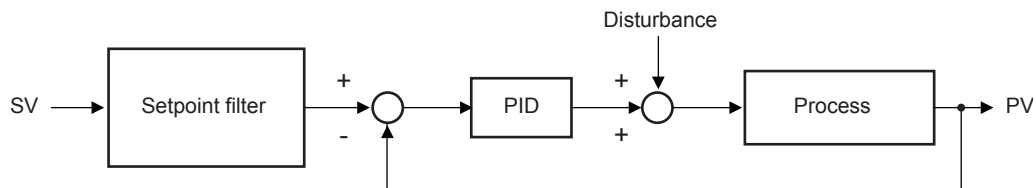

Example of Improved Ability to Follow Up Setpoint

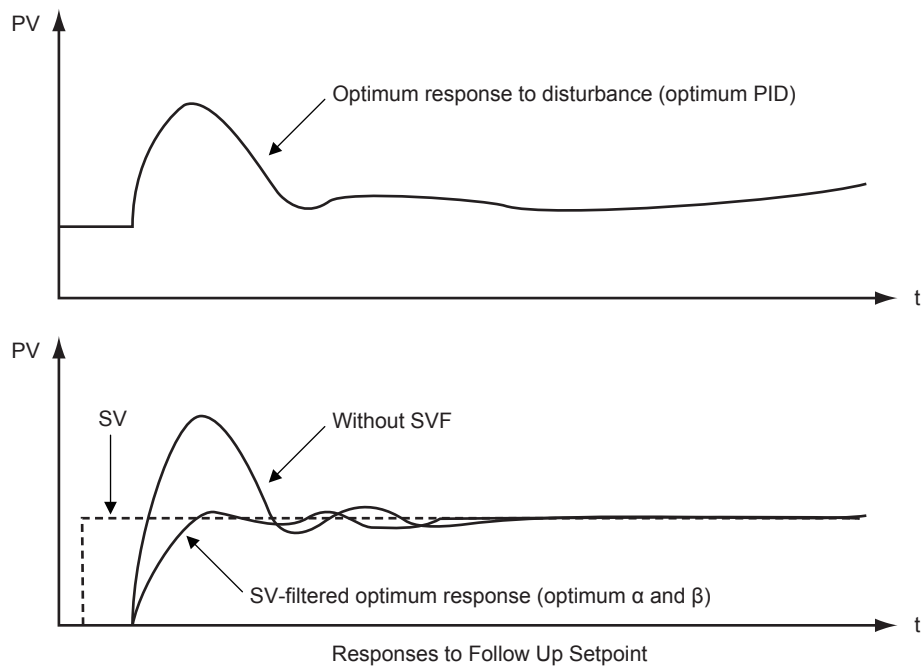

YS1700

Control Functions

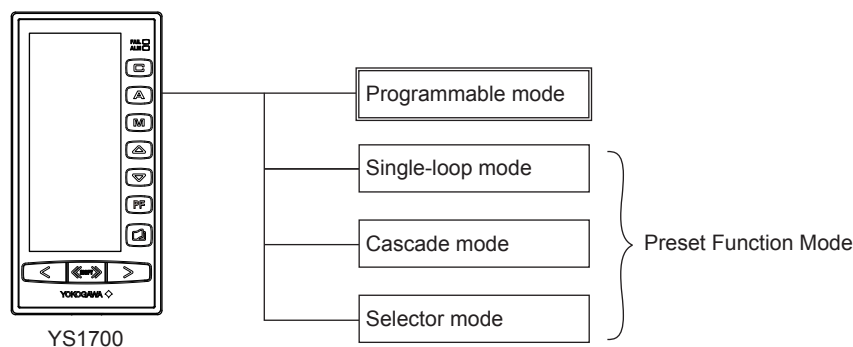

	Programmable Mode						Preset Function Mode				
	BSC 1	BSC 2	CSC		SSC		Single- Loop	Cascade		Autoselector	
			CNT1	CNT2	CNT1	CNT2		CNT1	CNT2	CNT1	CNT2
Standard PID control	✓	✓	✓	✓	✓	✓	✓	✓	✓	✓	✓
Proportional (PD) control	✓	✓	–	–	–	–	✓	–	–	–	–
Sample-and-hold PI control	✓	✓	✓	✓	✓	✓	✓	✓	✓	–	–
Batch PID control	✓	✓	–	–	–	–	–	–	–	–	–
Feedforward control	✓	✓	✓	✓	✓	✓	✓	✓	–	–	–
Output tracking	✓	✓		✓		✓	✓	–	–	–	–
Preset output	✓	✓		✓		✓	✓	✓			✓
Output limiter	✓	✓	✓	✓		✓	✓	✓	✓		✓
Adjustable setpoint filter (SVF)	✓	✓	✓	✓	✓	✓	✓	✓	✓	✓	✓
Self-tuning function (STC)		✓ ³		✓ ¹		✓ ²	✓		✓ ¹		✓ ²
PH, PL, HH, LL, DV and VL alarm	✓	✓	✓	✓	✓	✓	✓	✓	✓	✓	✓

*1: Functions on primary loop when closed loop, secondary loop when open loop.

*2: Functions on unselected loop.

*3: Either BSC1 or BSC2.

- Computation and control functions are built into the controller as a computational function library.
- One type of BSC, CSC or SSC is used for one controller at a time. However, both BSC1 and BSC2 can be used at the same time.
- Operation is the same as the YS150 in the preset function mode.
- Control period in the programmable mode is to be selected from 50 ms, 100 ms and 200 ms.
- Independent control of two loops is possible in the programmable mode.

Basic Control Module (BSC)

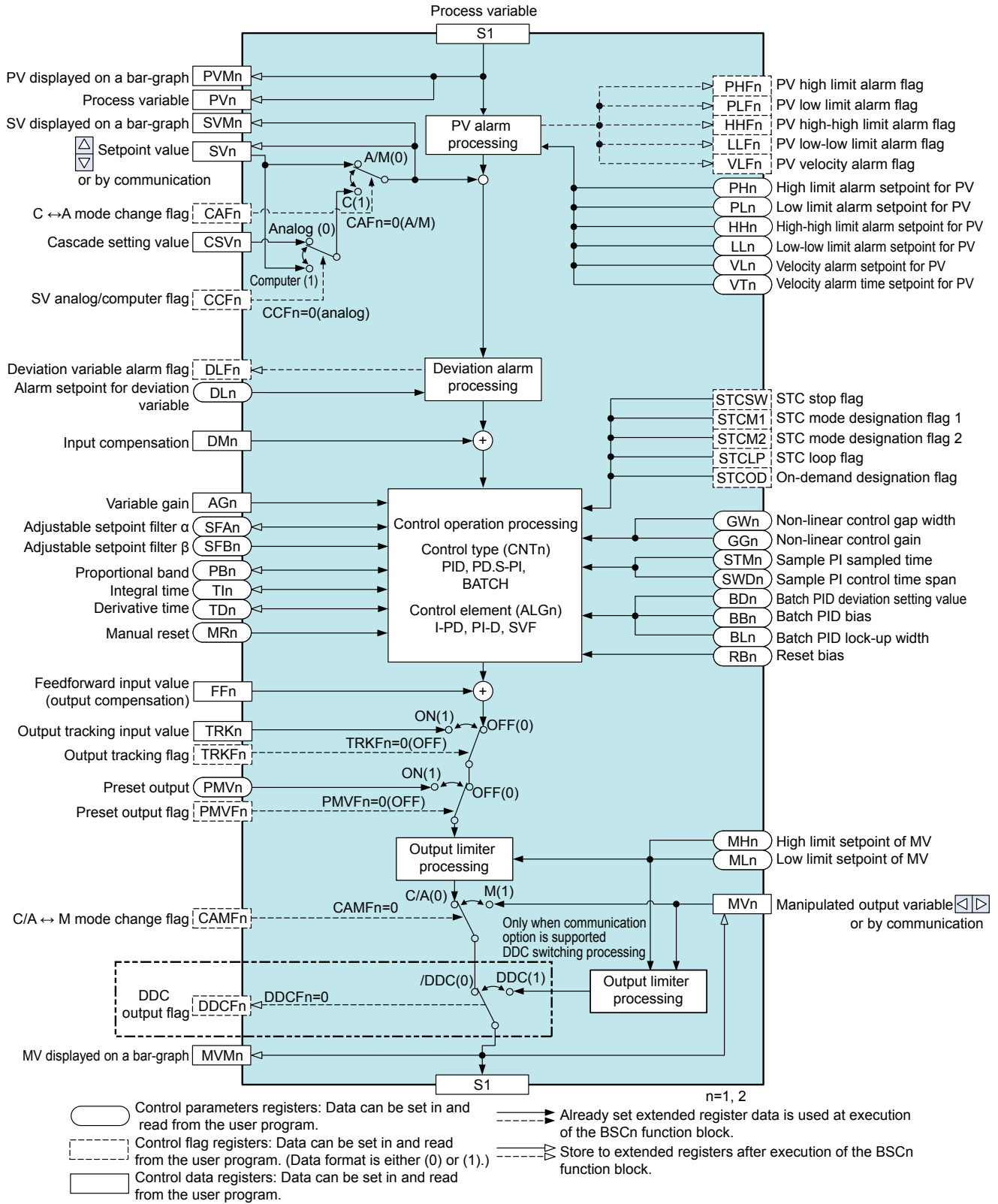

Cascade Control Module (CSC)

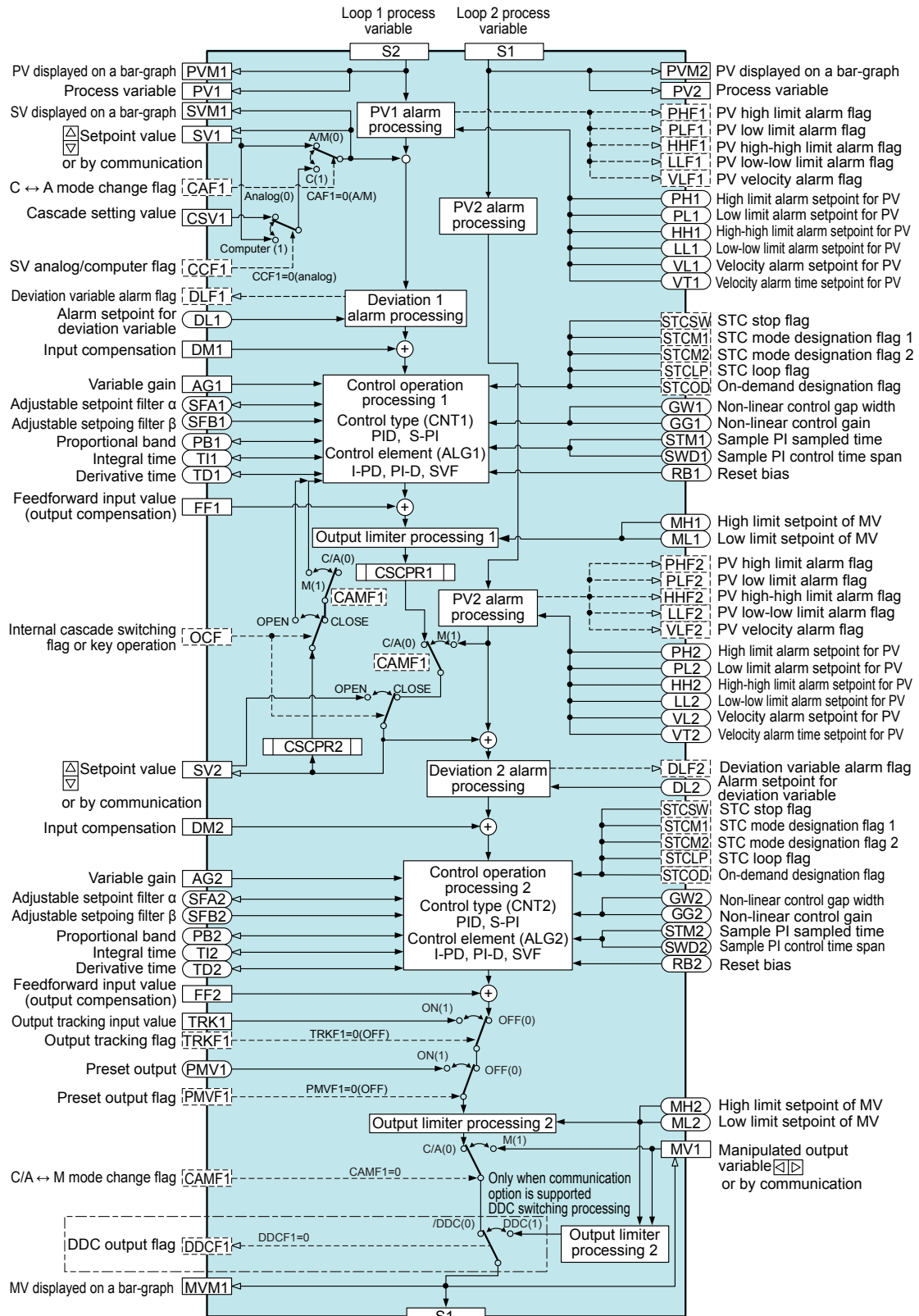

- Control parameters registers: Data can be set in and read from the user program.
- Control flag registers: Data can be set in and read from the user program. (Data format is either (0) or (1).)
- Control data registers: Data can be set in and read from the user program.
- Already set extended register data is used at execution of the CSC function block.
- Store to extended registers after execution of the CSC function block.

Selector Control Module (SSC)

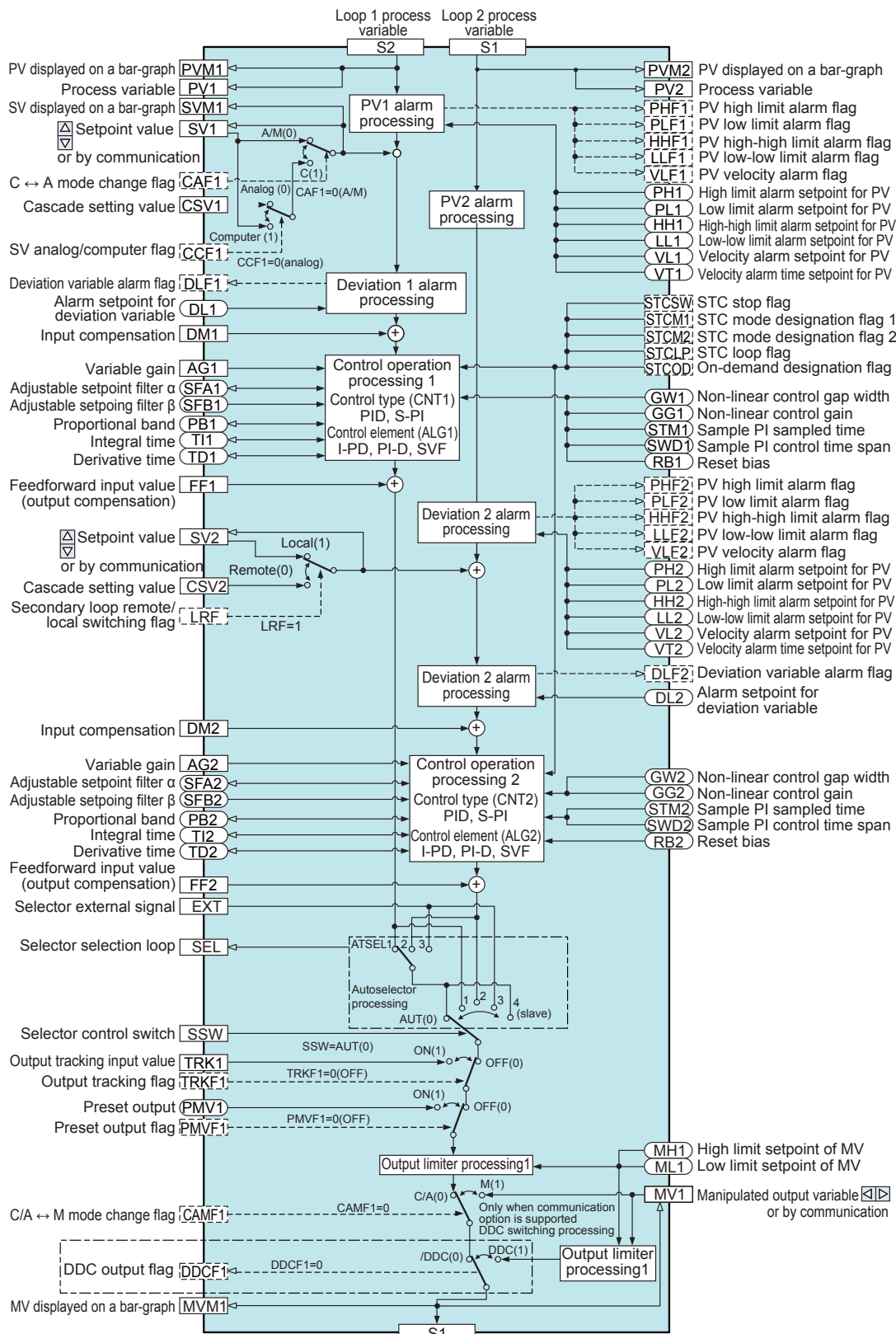

 Control parameters registers: Data can be set in and read from the user program. Already set extended register data is used at execution of the SSC function block.
 Control flag registers: Data can be set in and read from the user program. (Data format is either (0) or (1).) Store to extended registers after execution of the SSC function block.
 Control data registers: Data can be set in and read from the user program.

Command and Calculation Module List

Category	Command	Max. Serial No.	New*	Text Programming	Function Block Programming			
				Code	Symbol	Number of Inputs	Number of Parameters	Remarks
	Load			LD (reg)	Not available in function block programming. These functions are equal to "wirings" when developing programs.			
	Store			ST (reg)				
	Store to register with Enable switch		✓	STE (reg)				
	End			END				
Basic Calculations	Addition			+	+	2	0	ADDITION
	Subtraction			-	-	2	0	SUBTRACTION
	Multiplication			*	*	2	0	MULTIPLICATION
	Division			/	/	2	0	DIVISION
	Ratio		✓	RATIO	RATIO	1	3	
	Square root extraction			SQT	SQT	1	0	
	Square root extraction with variable low cutoff			SQTE	SQTE	1	1	
	Absolute value			ABS	ABS	1	0	
	High selector			HSL	HSL	2	0	
	Low selector			LSL	LSL	2	0	
	High limiter			HLM	HLM	1	1	
	Low limiter			LLM	LLM	1	1	
	Scaling		✓	SCAL	SCAL	1	2	
	Normalization		✓	NORM	NORM	1	2	
	Natural logarithm		✓	LN	LN	1	0	
	Common logarithm		✓	LOG	LOG	1	0	
	Exponential		✓	EXP	EXP	1	0	
	Power		✓	PWR	PWR	1	1	
	Temperature compensation (°C)		✓	TCMP1	TCMP1	2	1	
	Temperature compensation (°F)		✓	TCMP2	TCMP2			
	Temperature compensation (K)		✓	TCMP3	TCMP3	2	1	
	Pressure compensation (MPa)		✓	PCMP1	PCMP1	2	1	
	Pressure compensation (kgf/cm ²)		✓	PCMP2	PCMP2			
	Pressure compensation (psi)		✓	PCMP3	PCMP3			
	Conversion from DI to BCD		✓	DIBCD	DIBCD	0	2	
	Conversion from BCD to DO		✓	DOBCD	DOBCD	1	2	Special module output
	Conversion from DI to binary		✓	DIBIN	DIBIN	0	2	
	Conversion from binary to DO		✓	DOBIN	DOBIN	1	2	Special module output
	Maximum of 2 values		✓	MAX2	MAX2	2	0	
	Maximum of 3 values		✓	MAX3	MAX3	3	0	
	Maximum of 4 values		✓	MAX4	MAX4	4	0	
	Minimum of 2 values		✓	MIN2	MIN2	2	0	
	Minimum of 3 values		✓	MIN3	MIN3	3	0	
Minimum of 4 values		✓	MIN4	MIN4	4	0		
Average of 2 values		✓	AVE2	AVE2	2	0		
Average of 3 values		✓	AVE3	AVE3	3	0		
Average of 4 values		✓	AVE4	AVE4	4	0		
Increment		✓	INC	INC	1	0		
Decrement		✓	DEC	DEC	1	0		

* New: Functions that were not available in the YS170 and are newly provided with the YS1700.

Category	Command	Max. Serial No.	New*	Text Program-	Function Block Programming			
				ming	Symbol	Number of Inputs	Number of Parameters	Remarks
				Code				
Logical Operations	10-segment linearizer function	2		FXn	FXn	1	0	
	Inverse conversion of 10-segment linearizer function	2	✓	IFXn	IFXn	1	0	
	Arbitrary segment linearizer function	2		GXn	GXn	1	0	
	Inverse conversion of arbitrary segment linearizer function	2	✓	IGXn	IGXn	1	0	
	First order lag (second)	8		LAGm	LAGm	1	1	
	First order lag (minute)		✓	LAGMm	LAGMm	1	1	
	Derivative (second)	2		LEDm	LEDm	1	1	
	Derivative (minute)		✓	LEDMm	LEDMm	1	1	
	Dead time (second)	3		DEDm	DEDm	1	1	
	Dead time (minute)		✓	DEDMm	DEDMm	1	1	
	Velocity computation (second)	3		VELm	VELm	1	1	
	Velocity computation (minute)		✓	VELMm	VELMm	1	1	
	Velocity limiter	6		VLMm	VLMm	1	2	
	Moving average computation (second)	3		MAVm	MAVm	1	1	
	Moving average computation (minute)		✓	MAVMm	MAVMm	1	1	
	0 to 1 change detection	8		CCDm	CCDm	1	0	
	0 to 1 change detection	8	✓	UEDGm	UEDGm	1	0	
	1 to 0 change detection	8	✓	DEDGm	DEDGm	1	0	
	Change detection	8	✓	EDGEm	EDGEm	1	0	
	Timer (second)	8	*1	TIMm	TIMm	1	0	
	Timer (minute)		✓	TIMMm	TIMMm	1	0	
	Time out (second)	8	✓	TUPm	TUPm	1	1	
	Time out (minute)		✓	TUPMm	TUPMm	1	1	
	Program setter (second)	2		PGMm	PGMm_A PGMm_B	1 0	2 0	PGMm_A and PGMm_B are always used as a pair.
	Program setter (minute)		✓	PGMMm	PGMMm_A PGMMm_B	1 0	2 0	PGMMm_A and PGMMm_B are always used as a pair.
	Pulse input counter	8	*1	PICm	PICm	1	1	
	Totalizer pulse output	2		CPOm	CPOm	1	1	Special module output
	High limit alarm	8	*1	HALm	HALm	1	2	
	Low limit alarm	8	*1	LALm	LALm	1	2	
	Square root extraction (Low cutoff point or less: Linear)	8	✓	SQAm	SQAm	1	1	
	Square root extraction (Low cutoff point or less: Zero)	8	✓	SQBm	SQBm	1	1	
	RS flip-flop	8	✓	RSFFm	RSFFm	2	0	
Hold timer (second)	8	✓	HTIMm	HTIMm	1	1		
Hold timer (minute)		✓	HTIMMm	HTIMMm	1	1		
Previous input variable	8	✓	DELAYm	DELAYm	1	0		
Hold	8	✓	HOLDm	HOLDm	1	1		

* New: Functions that were not available in the YS170 and are newly provided with the YS1700.

*1: The number of times of use was up to four in the YS170, and is increased to eight in the YS1700.

Category	Command	Max. Serial No.	New*	Text Programming	Function Block Programming			Remarks
				Code	Symbol	Number of Inputs	Number of Parameters	
Logical Operations	AND			AND	AND	2	0	
	OR			OR	OR	2	0	
	NOT			NOT	NOT	1	0	
	Exclusive OR			EOR	EOR	2	0	
	Multi-input AND		✓	MAND	MAND	4	0	
	Multi-input OR		✓	MOR	MOR	4	0	
	Multi-input exclusive OR		✓	MEOR	MEOR	4	0	
Conditional Judgment	Comparison			CMP	CMP	2	0	
	Signal switching			SW	SW	2	1	
	Greater than or equal		✓	GE	GE	2	0	
	Greater than		✓	GT	GT	2	0	
	Less than or equal		✓	LE	LE	2	0	
	Less than		✓	LT	LT	2	0	
	In range		✓	INRNG	INRNG	3	0	
	Out of range		✓	OUTRNG	OUTRNG	3	0	
	Jump			GO @<label name>	Not available	–	–	
	Conditional jump			GIF @<label name>	Not available	–	–	
	Jump to the sub-program			GOSUB@<subprogram name>	SUB@n (*1)	4	0	
	Conditional jump to the sub-program			GIFSUB@<subprogram name>	IFSUB@n (*1)	4	1	
	Condition comparison jump to the sub-program		✓	Not available	GTSUB@n (*1)	4	2	
	Jump to the sub-program (for nesting)			Not available	SSUB@n (*2)	4	0	
	Conditional jump to the sub-program (for nesting)			Not available	IFSSUB@n (*2)	4	1	
	Condition comparison jump to the sub-program (for nesting)		✓	Not available	GSSUB@n (*2)	4	2	
Sub-program startup			SUB@<subprogram name>	Not available	–	–		
Sub-program termination			RTN	Not available	–	–		
Register Move	S register change			CHG	Not available	–	–	
	S register rotation			ROT	Not available	–	–	
Control Functions	Basic control			BSC1, BSC2	BSC1, BSC2	1	0	
	Cascade control			CSC	CSC	2	0	
	Selector control			SSC	SSC	2	0	
Others	Storage register terminal	–	–	–	Register name	1	0	
	Storage register terminal with enable switch	–	–	–	Register name	1	1	

* New: Functions that were not available in the YS170 and are newly provided with the YS1700.

*1: n = 1 to 201; *2: n = 201 to 256

YS1000 Series

YSS1000 Setting Software

PC utility software for parameter setting and user program development

- Parameter settings for the following models:

YS1700, YS1500, YS1310,
YS1350, and YS1360

- User program development for the following model:

YS1700

Three ways of connection:

- USB, RS-485, or Ethernet

Two type of programming language:

- User-friendly Function Block Programming
- Well-established Text Programming

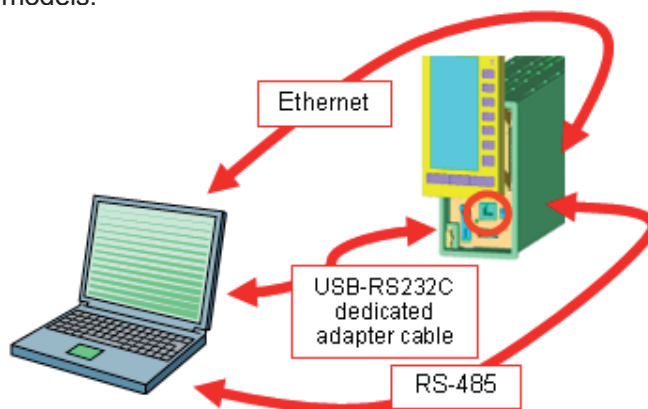

Function Block Programming

New

- Simple programming (simply connecting modules to each other)
- Easy debugging (online monitor)

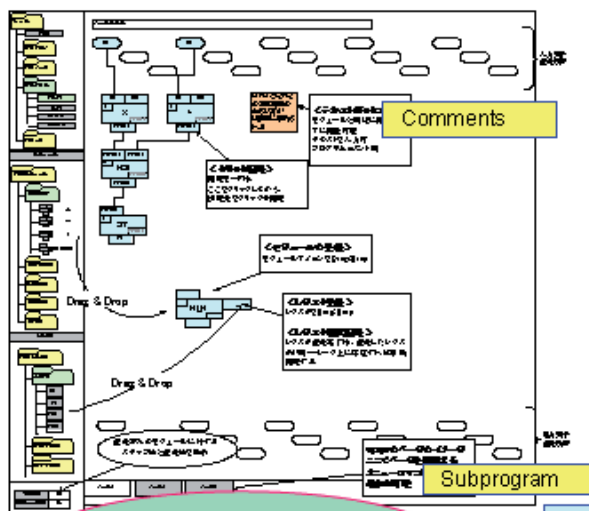

In-controller program capacity:
400 modules

Text Programming

Compatible

- Upward compatibility for running YS170 user programs
- Conversion tool available for importing from ROMs for SLPCs (Data conversion functions is under development)

STEP	PROGRAM	COMMENT
1	LD DI 1	:
2	NOT	:
3	GIF 8	:
4	LD K 16	:
5	ST FL11	:
6	LD P 1	:
7	ST T 1	:
8	LD DO 4	:
9	NOT	:
10	GIF 24	:

2.5 times larger in-controller
program capacity:
400 steps → 1000 steps

- Calculations of values in engineering units: Floating-point format
- New calculation modules: Exponential, logarithmic, temperature compensation, pressure compensation, and more
- Parts of program can be saved in subprogram units for reuse

Window Configuration of YSS1000

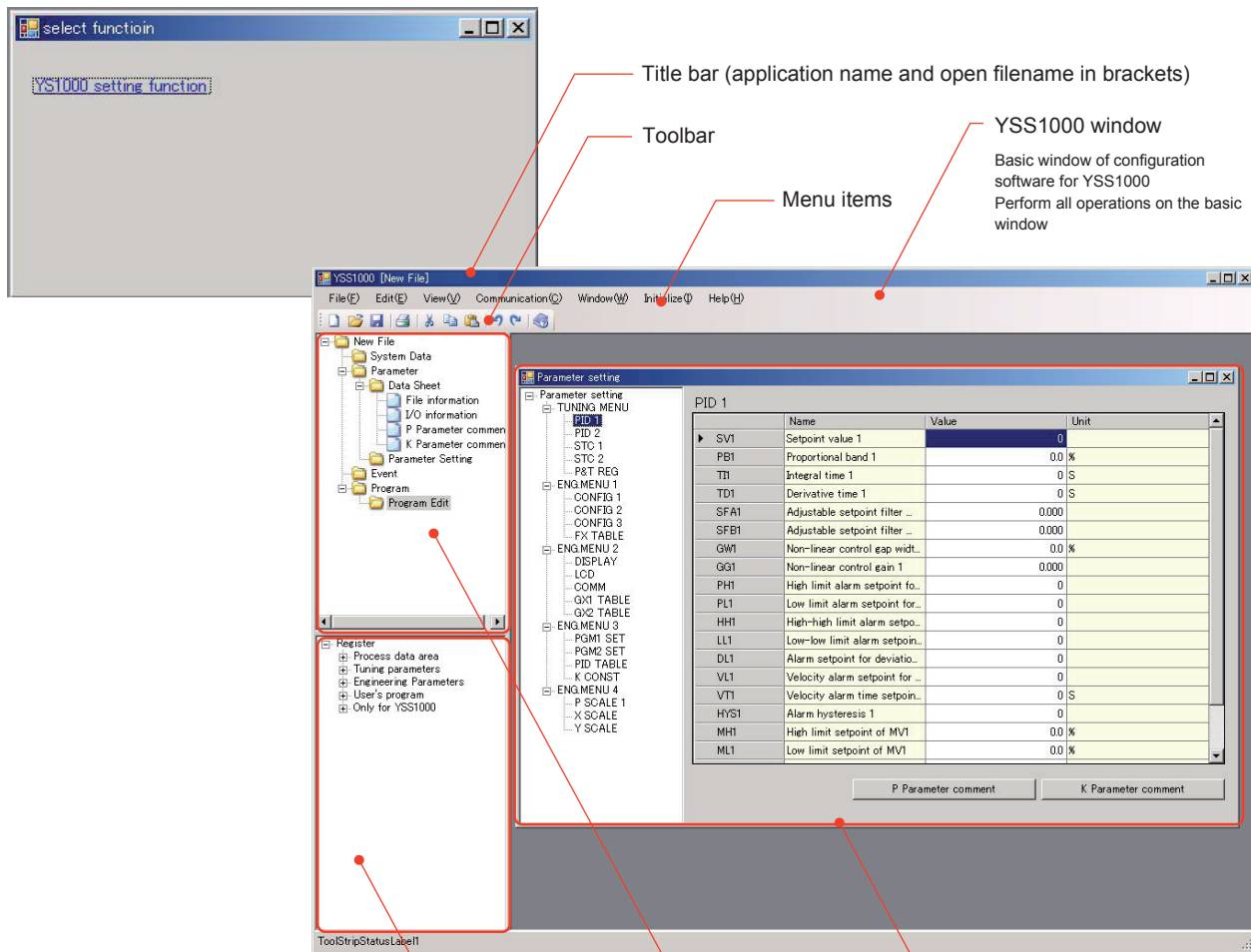

Title bar (application name and open filename in brackets)

Toolbar

Menu items

YSS1000 window
Basic window of configuration software for YSS1000
Perform all operations on the basic window

	Name	Value	Unit
▶	SV1	Setpoint value 1	0
	PB1	Proportional band 1	0.0 %
	TI1	Integral time 1	0 S
	TD1	Derivative time 1	0 S
	SFA1	Adjustable setpoint filter ...	0.000
	SFB1	Adjustable setpoint filter ...	0.000
	GW1	Non-linear control gap widt...	0.0 %
	GG1	Non-linear control gain 1	0.000
	PH1	High limit alarm setpoint fo...	0
	PL1	Low limit alarm setpoint for...	0
	HH1	High-high limit alarm setpo...	0
	LL1	Low-low limit alarm setpoint...	0
	DL1	Alarm setpoint for deviatio...	0
	VL1	Velocity alarm setpoint for ...	0
	VT1	Velocity alarm time setpoint...	0 S
	HYS1	Alarm hysteresis 1	0
	MH1	High limit setpoint of MV1	0.0 %
	ML1	Low limit setpoint of MV1	0.0 %

Various setting windows:

- Window for parameter setting
- Window for event setting
- Window for data sheet creation
- Window for program development

Folder structure view

Register view.

When a document window for register setting opens, registers are shown in the lower-left pane.

YSS1000 Function Overview

■ Settings That Can Be Made Using YSS1000

YSS1000 is computer software for setting and developing the parameters and user programs for YS1000 Series controllers, on a computer. Linking YSS1000 to a YS1000 Series controller or setter enables tuning and subprogram monitoring to be done online.

Settings in YSS1000		Description	YS1700 in Program Mode		YS1700 and YS1500 in Function Selection Mode	YS1310 YS1350 YS1360
			Function Block Programming	Text Programming		
Parameter setting	Data sheet	File information, I/O comments, and parameter comments can be set.	✓	✓	✓	✓
	Parameter data	The PID parameters, tables, scales, constants, and other parameter values can be set.	✓	✓	✓	✓
Event display settings		Messages to be displayed in a dialog box that will appear when a predefined event occurs, can be set.	✓	✓	✓	✓
User program development	Function block programming	User programs can be developed by simply connecting modules to each other.	✓			
	Text programming	User programs are coded as conventional text descriptions in Reversed Polish Notation. Text programs of up to 1000 steps can be coded.		✓		
Communication	Download Upload Compare	Parameter settings and developed programs can be uploaded to, and downloaded from, YS1000 Series controllers. (Downloads to the YS1000, however, can only be performed when the operation mode is STOP.)	✓	✓	✓	✓
	Tuning	The PID parameters can be finely tuned while monitoring the PV, SV, and MV trend graphs, and the operation mode can be changed.	✓	✓	✓	✓
	Register monitor	Registers used in the user program can be monitored.	✓	✓		
	Function block monitor	Function block diagrams configured by control modules in user programs can be monitored.	✓	✓		
	Module monitor	Input and output values of modules can be monitored.	✓			
	Simulated event display	The set event messages can be made to appear for testing on the YS1000 controller.	✓	✓	✓	✓
File	Save Open Compare	Parameter settings and user programs set in YSS1000 or, downloaded from YS1000 Series controllers, can be saved to a computer disk.	✓	✓	✓	✓
Print		Parameter settings and user programs can be printed.	✓	✓	✓	✓

■ Inspection support utilities (under development)

■ Data conversion functions (under development)

● YS100 data conversion:

Used to import data from YS100 Series instruments to the YS1000 Series. Parameter settings and user programs can be read out from YS100 Series instruments and converted into data in the format for the YS1000 Series. User files created using the Model YSS10 or YSS20 programming package can also be converted into data for the YS1000 Series. The converted data can be edited, saved to a file, printed, and uploaded to YS1000 Series controllers as data for the YS1000 Series.

● SLPC data conversion:

Used to import data from SLPC programmable indicating controllers to YS1700 controllers. Parameter settings and user programs can be read out from user ROMs for SLPCs and converted into data in the format for YS1700s. The converted data can be edited, saved to a file, printed, and uploaded to YS1000 Series controllers as data for the YS1000 Series.

To read data in user ROMs for SLPCs, an optional ROM reader is required.

Model and Suffix Codes

YS1000 Series Model and Suffix Codes

Model	Suffix Code	Option Code	Description
YS1700			Programmable indicating controller
YS1500			Indicating controller
YS1310			Indicator with alarm
YS1350			Manual setter for SV setting
YS1360			Manual setter for MV setting
	-0		Always 0
Type	0		Basic type
	1		Basic type with expandable I/O (*1)
	2		Compatible type for YS100 (with YS100 case)
	3		Compatible type for YS80 internal unit, compatible type for EBS, I, EK and HOMAC (*2) (Note1)
	4		Compatible type for YS80 (compatible size for YS80 with YS100 terminals) (Note1)
	5		Compatible type for pneumatic 100 Line (with YS100 terminals) (*3) (Note1)
Power supply	0		100 V AC and 24 V DC dual power driven
	1		220 V AC
Direct input (*4)		/A01	mV input
		/A02	Thermocouple input
		/A03	RTD input
		/A04	Potentiometer input
		/A05	Isolator
		/A06	Two-wire transmitter input (isolated)
		/A07	Two-wire transmitter input (non-isolated)
		/A08	Frequency input
		/DF	Direct input with Fahrenheit temperature range function (*10)
Communication		/A31	RS-485 communication (PC-link, Modbus, YS protocol, peer-to-peer) (*5)
		/A32	DCS-LCS communication (*6)
		/A34	Ethernet communication (Modbus/TCP) (*7)
Explosion-proof		/FM	FM nonincendive approved (FM Class I, div 2) (*8) (Note2)
Hard manual device		/NHM	Without hard manual device (always provided with standard models) (*9) (Note2)

*1: Applicable to YS1700 only. This option comes with an I/O expansion terminal block (Model YS010) and a 3-meter I/O expansion cable (Model YS011).

*2: Fits into and can be connected to a YS80 housing (Model SHUP). (Model SHUP-410 EK- and HOMAC-compatible housing and Model SHUP-100 EBS and I Series-compatible housing need to be ordered separately.)

*3: A Line-compatible housing (Model 100) needs to be ordered separately.

*4: The direct sensor input option can only be specified with suffix code -02x, -04x, or -05x. Only one input type can be specified.

*5: Cannot be specified with suffix code -03x. Options A31 and A32 cannot be specified at the same time. Please specify the communication options /A31 (RS-485 communication) to directly communicate with the CENTUM CS3000.

*6: Not applicable to Model YS1310. Options A31 and A32 cannot be specified at the same time. Please specify the communication options /A32 (DCS-LCS communication) to communicate with the CENTUM CS1000/CS3000 through the SCIU.

*7: Option A32 can only be specified with suffix code -00x or -01x.

*8: Can only be specified with suffix code -00x or -01x.

*9: Option NHM can only be specified for Models YS1700, YS1500, and YS1360. Unless specified, a hard manual device is featured.

*10: This option can be combined only with option code /A02 or /A03. If option code /DF is specified, Fahrenheit temperature range can be available for direct input range in addition to Centigrade temperature range. In case of specifying Fahrenheit temperature range for direct input, option code /DF is required. When the direct input temperature range may be changed to Fahrenheit temperature range after shipment, also specify option code /DF.

Special specifications: CE Mark- or FM nonincendive-compliance is not available for products with any option that is handled as a “special specification.”

Note: The shaded types in the above tables are still under development (the order entry is not yet available.)

Note1: The suffix codes Type 3, 4, and 5 are currently under development. The release is scheduled for August 2007, and the first delivery will be in September 2007.

Note2: An application has been made for the FM non-incendive approval. The certification and sales release is scheduled for June 2007, and the first delivery will be in July 2007.

Model	Suffix Code	Description
YSS1000		Setting Software for YS1000 Series
	-0	Always 0
	0	Always 0 (with CD media and proprietary cable)

■ Accessories (sold separately)

Product name	Model	Remarks
SHUP standard housing	SHUP-000	Available for YS1xx0-03x (Replace for YS80 Series)
SHUP long housing	SHUP-100	Available for YS1xx0-03x (Replace for I Series or EBS Series)
SHUP EK/HOMAC housing	SHUP-420	Available for YS1xx0-03x (Replace for EK/HOMAC Series)
100 Line pneumatic instrument replace housing	YS006	Available for YS1xx0-05x (Replace for 100 Line pneumatic instrument)
120 Ω terminating resistor (*)	YS020	For RS-485 communication
250 Ω shunt resistor	YS021	For a built-in 24 V transmitter power supply

- *: The YS1000's main unit has a built-in terminating resistor, which can be selected for use by setting the relevant parameter. If a terminating resistor is used in another device at the termination of the same communication system, an external terminating resistor needs to be provided to match the terminating resistance of the YS1000's built-in terminating resistor.

Housings for Replacement of Earlier Series

Compatible with the existing cases and housings of earlier series

YS1000 Series Standard Case

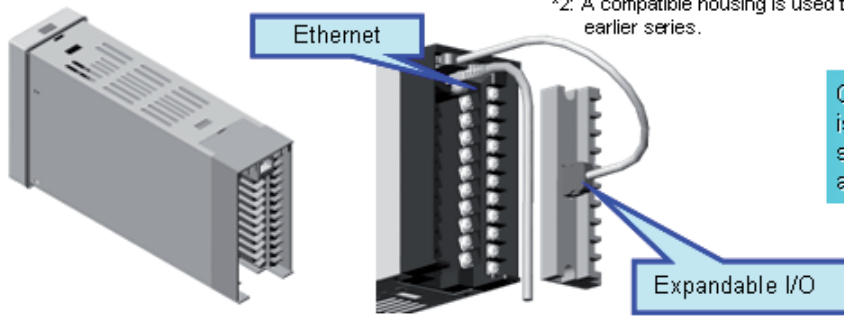

*1: A compatible case is used to replace the existing case of an earlier series.
 *2: A compatible housing is used to replace the entire, existing housing of an earlier series.

Compatibility with the YS100 Series is also considered in the terminal size (M4), terminal arrangement, and number of terminals

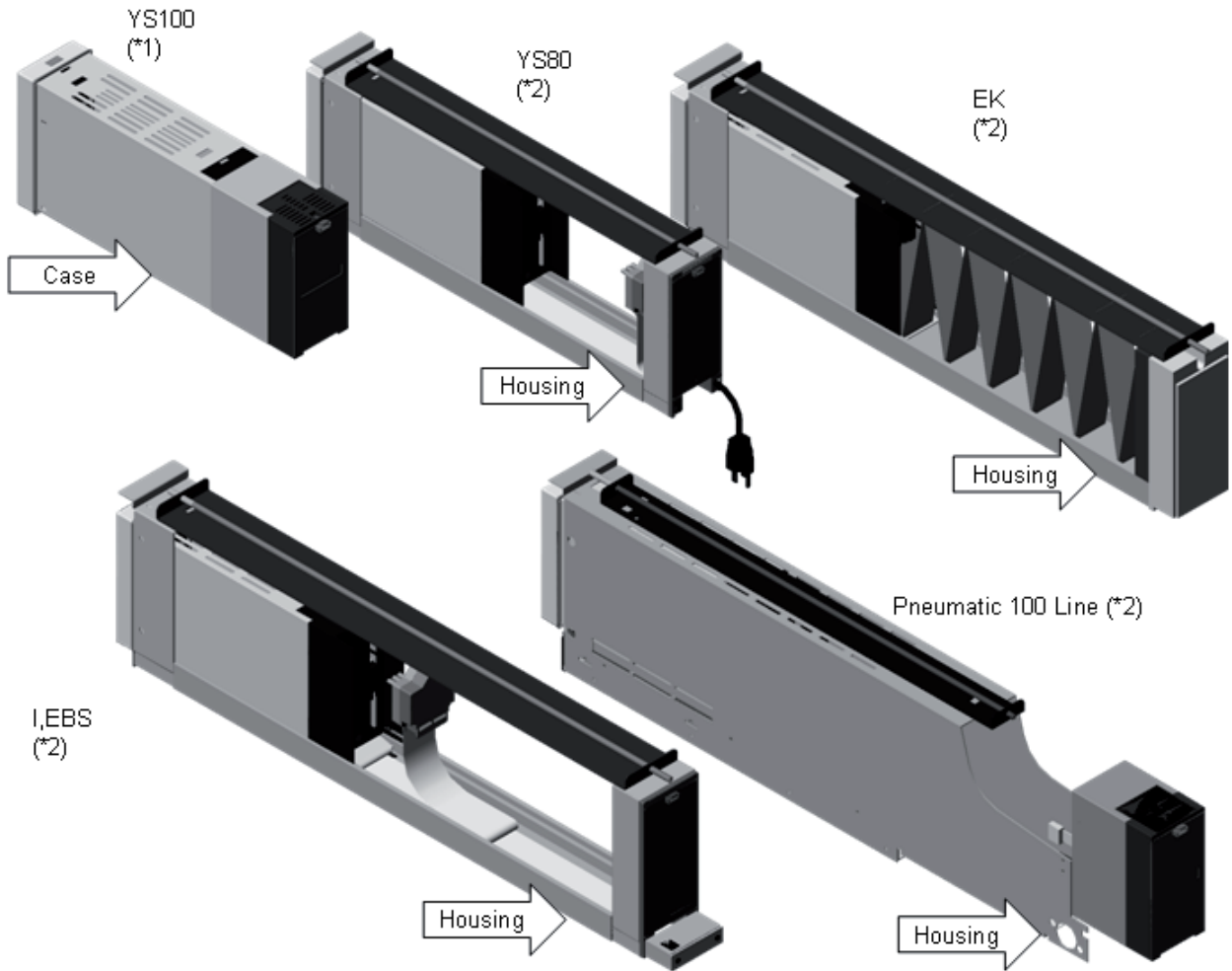

Difference in Form Depending on Suffix Code

YS1xx0-00x Basic Type

YS1000 standard case
Expandable I/O cannot be connected later.

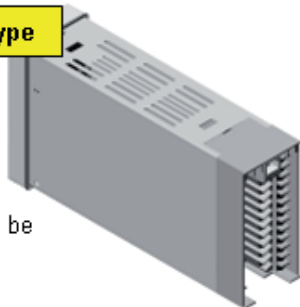

YS1xx0-01x Basic Type with Expandable I/O

Model with expandable I/O attached to a YS1000 standard case.



YS1xx0-02x Compatible Type for YS100

YS100-compatible case
An Ethernet port or expandable I/O is not available.

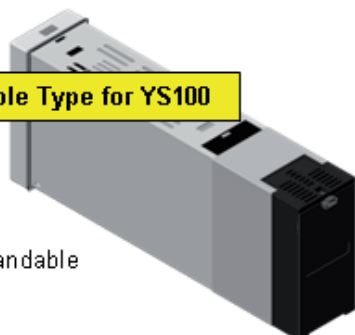

YS1xx0-03x Compatible Type for YS80 Internal Unit

Supplied in a case compatible with YS80 Series' internal units and used to fit into the housing.

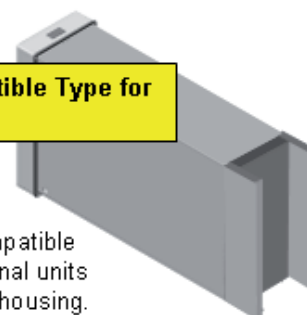

Fitting to the following housings (sold separately):

- SHUP-000 YS80 Series replacement housing
- SHUP-100 special housing for I/EBS Series replacement
- SHUP-430 special housing EK/HOMAC replacement

YS1xx0-04x Compatible Type for YS80

YS100-compatible case
An Ethernet port or expandable I/O is not available

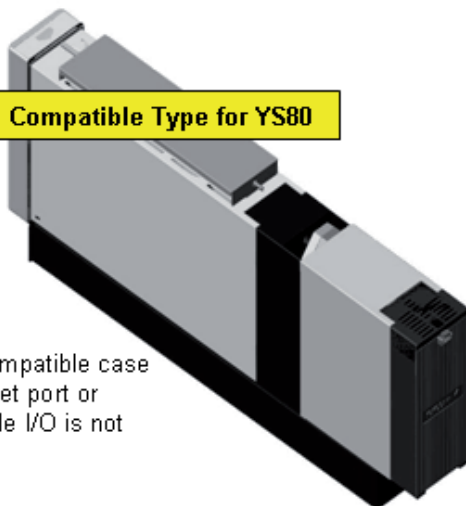

YS1xx0-05x Compatible Type for 100 Line

Supplied in a case compatible with YS100 Series' internal units and used to fit into a housing of the YS80 Series

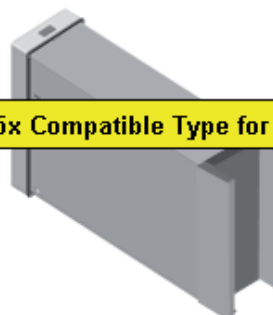

Fitting to the following housings (sold separately):

- YS006 special housing for 100 Line pneumatic controllers

Note on Using the YS100-compatible Case

■ When Using YS100-compatible Case:

- A signal converter can be built in (for direct connection to a sensor).
- The YS110 standby manual station can be plugged in.

Configuration When Choosing YS1000 Standard Case

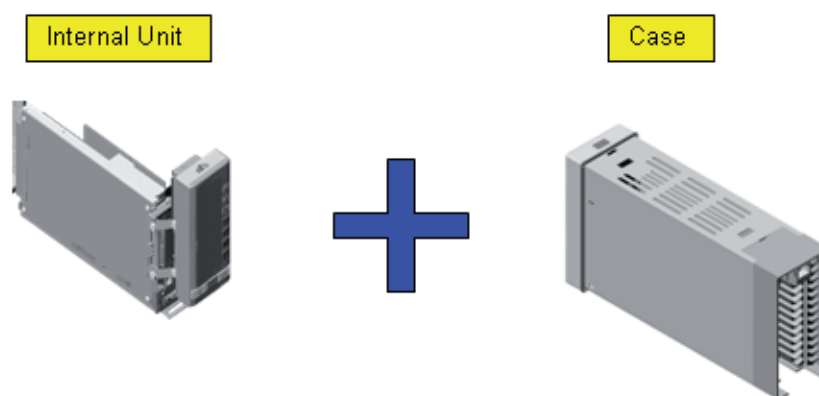

Configuration When Choosing YS100-compatible Case

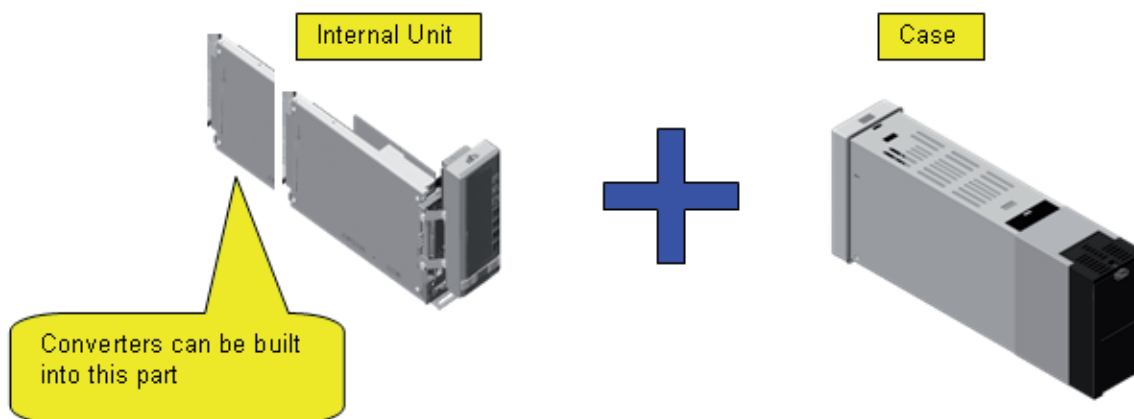

Functional Restriction Depending on Suffix Code

Suffix Code	Terminal Arrangement (Note 1)	Expandable I/O	Built-in Converters	Use with Replacement Housing	Ethernet	RS-485 (Note 4)	DCS-LCS Communication (Note 4)
(Note 5) -00x	YS1000				✓	✓	✓
-01x	YS1000 with expandable I/O	✓			✓	✓	✓
-02x	YS100-compatible		✓			✓	✓
-03x	Connector (needs housing)			✓ (Note 2)			✓
-04x	YS100-compatible		✓			✓	✓
-05x	Connector (needs housing)		✓	✓ (Note 3)		✓	✓

Note 1: Models YS1xx0-03x and -05x are supplied in a case compatible with internal units, so they need housing for signal wiring.

Note 2: Use one of the following housing according to your purpose:

Instrument to Be Replaced	Housing to Be Used
YS80 Series	SHUP-000
I Series or EBS Series	SHUP-100
EK or HOMAC Series	SHUP-420

Note 3: Use the housing below where necessary:

Instrument to Be Replaced	Housing to Be Used
100 Line pneumatic instrument	YS006

Note 4: RS-485 and DCS-LCS communication cannot be used together.

Note 5: Applicable to YS1700-01x only.

Blank Page

Terminal Arrangements in Single-loop/Cascade/Selector Modes

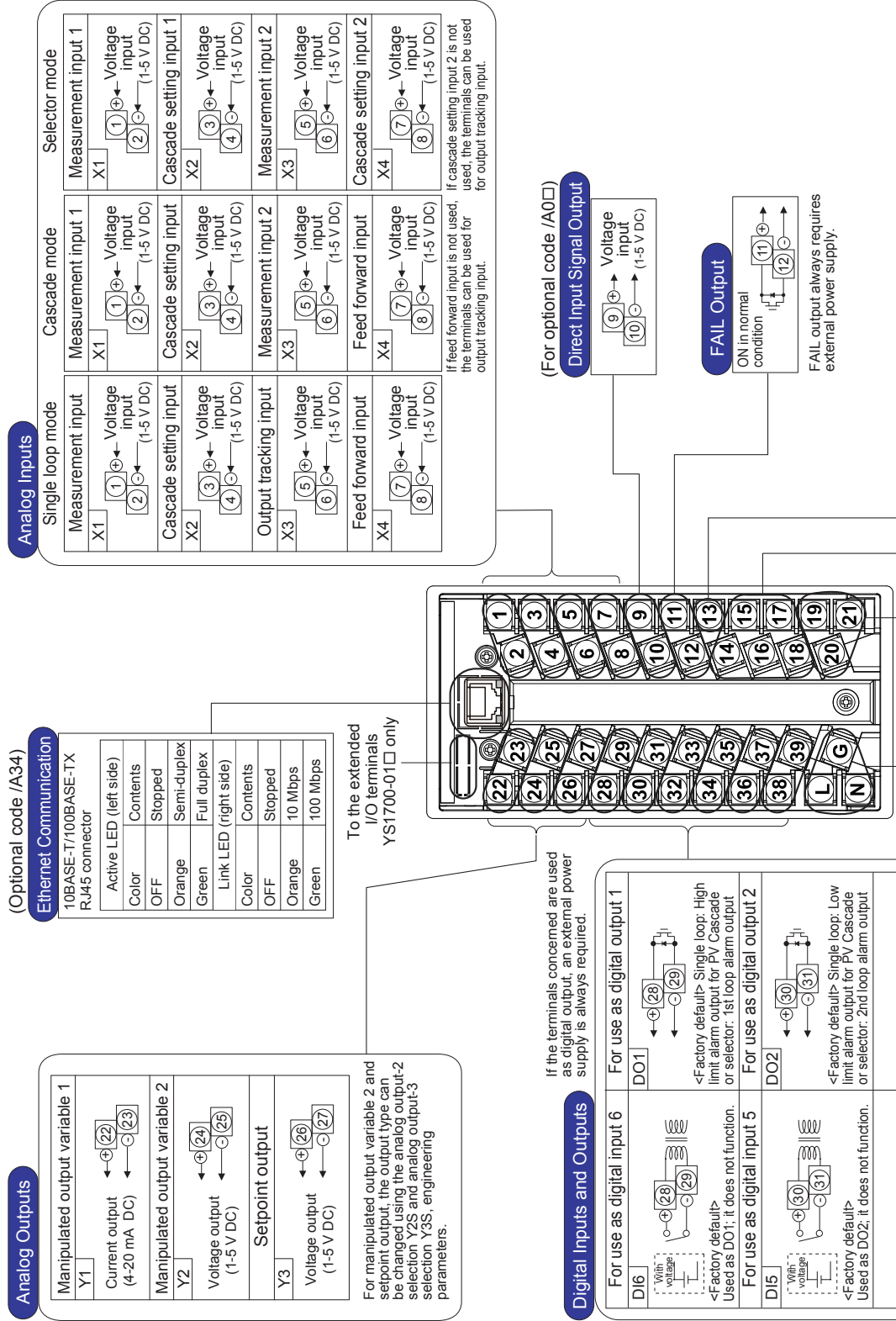

Connection of Transmitter Supply Power

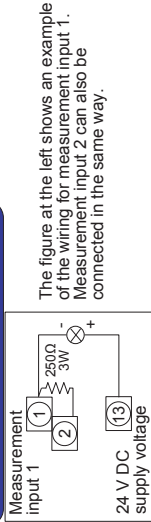

The figure at the left shows an example of the wiring for measurement input 1. Measurement input 2 can also be connected in the same way.

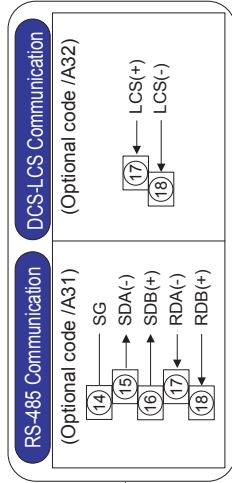

For use as digital input 4		For use as digital output 3	
D14		DO3	
<Factory default> Used as DO3; it does not function.		<Factory default> Single loop: Velocity alarm or deviation alarm output Cascade: OIC status output Selector: L/R status output	
For use as digital input 3		For use as digital output 4	
D13		DO4	
<Factory default> Used as DO4; it does not function.		<Factory default> C/A and M status output	
For use as digital input 2		For use as digital output 5	
D12		DO5	
<Factory default> Used as DO5; it does not function.		<Factory default> C/A and M status output	
For use as digital input 1		For use as digital output 6	
D11		DO6	
<Factory default> No function		<Factory default> Used as DO1; it does not function.	

Digital input hardware specifications:
 When voltage is present: For no voltage 30 V DC
 ON: -0.5 to 1 V DC ON: resistance of 200 Ω or less 200 mA or less (resistive load)
 OFF: +4.5 to 30 V DC OFF: resistance of 100 kΩ or more
 Input contact rating: 5 V DC, 20 mA or more

Digital inputs and digital outputs can be selected and used using the DI/DO designation: DI01 to DI06 and DO1 to DO6. Engineering parameters. A function can be set using DI1F to DI6F and DO1F to DO6F engineering parameters.

Power Supply

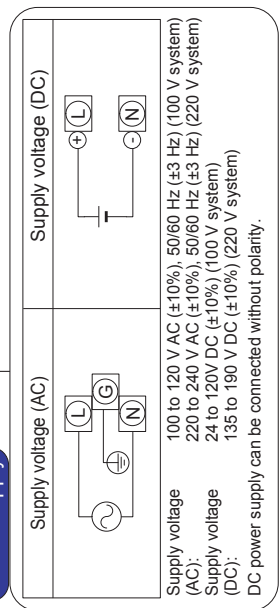

Supply voltage (AC): 100 to 120 V AC (±10%), 50/60 Hz (±3 Hz) (100 V system)
 220 to 240 V AC (±10%), 50/60 Hz (±3 Hz) (220 V system)
 Supply voltage (DC): 24 to 120 V DC (±10%) (100 V system)
 135 to 190 V DC (±10%) (220 V system)

DC power supply can be connected without polarity.

Direct Input Terminals (optional specifications)

mV input (optional code /A01)	Thermocouple input (optional code /A02)	RTD input (optional code /A03)
Potentiometer input (optional code /A04)	Two-wire transmitter input (optional code /A06, /A07)	Two-wire transmitter input (optional code /A06, /A07)
Match the wiring resistances of terminals 19 and 20 with each other.	Match the wiring resistances of terminals 19 and 21 with each other.	Match the wiring resistances of terminals 19 and 21 with each other.
Two-wire type (voltage, contact)	Two-wire type, three-wired	Two-wire type, three-wired

YS1700 Basic Type: Terminal Arrangements in Programmable Mode

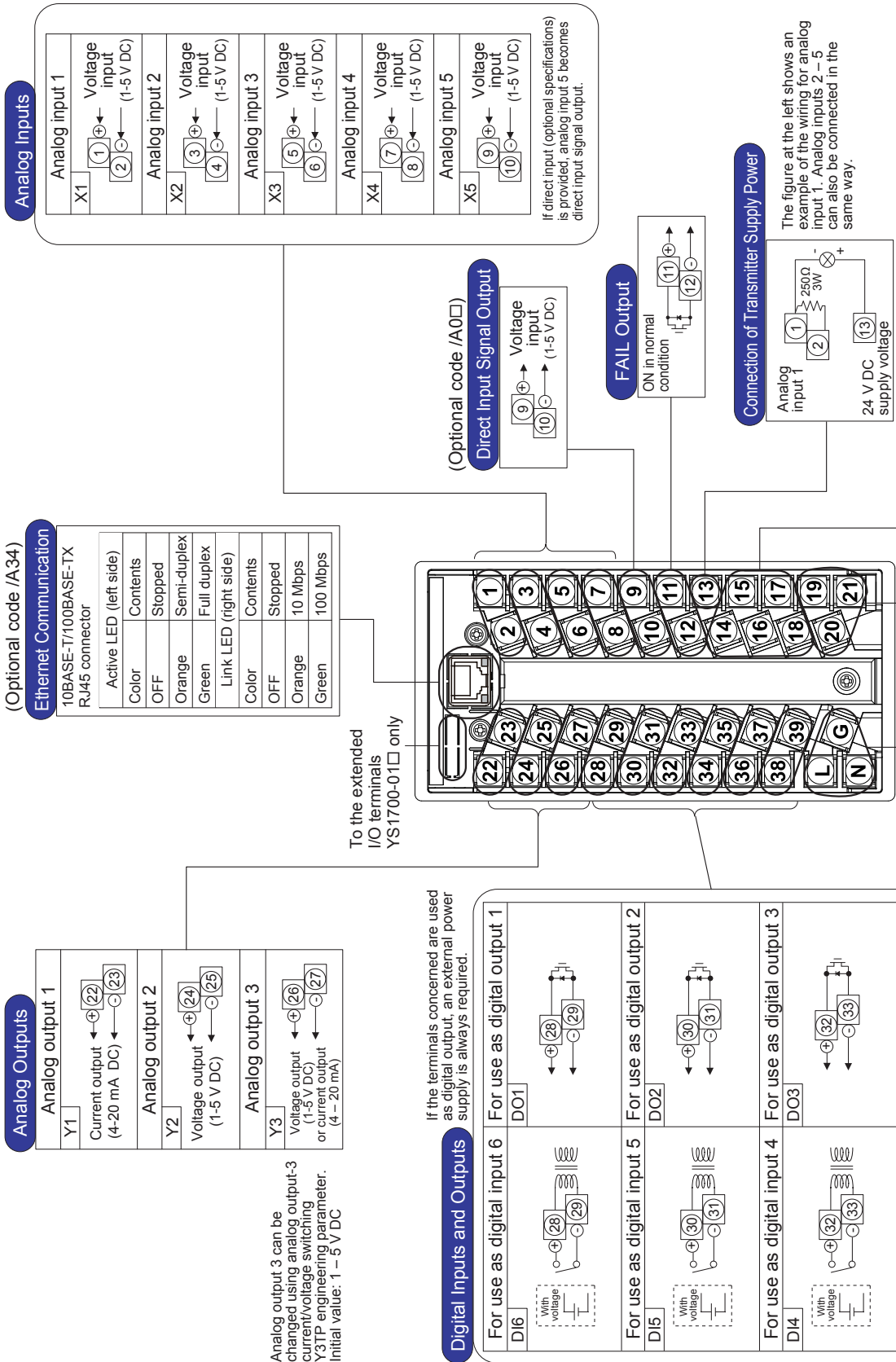

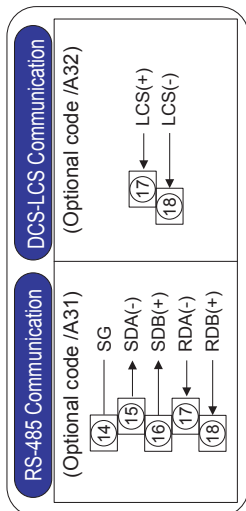

Direct Input Terminals (optional specifications)

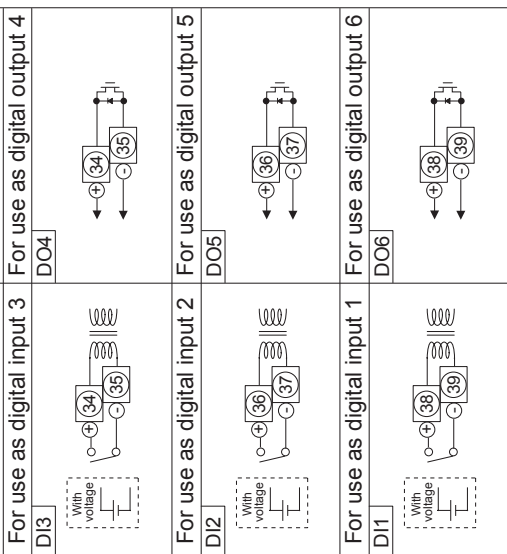
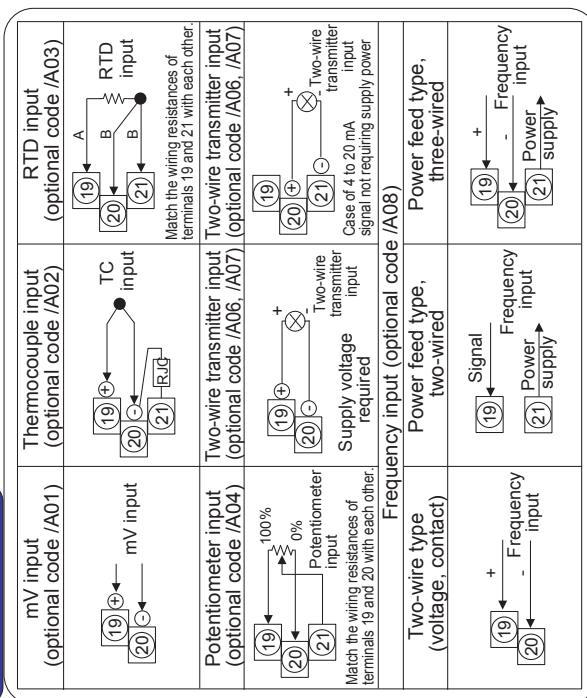

Digital input hardware specifications:
 When voltage is present: For no voltage Rating: 30 V DC
 ON: -0.5 to 1 V DC OFF: resistance of 200 Ω or less 200 mA or less (resistive load)
 OFF: +4.5 to 30 V DC OFF: resistance of 100 kΩ or more
 Input contact rating: 5 V DC, 20 mA or more
 The digital input and output functions can be set using the YSS1000 Setting Software (sold separately).

Power Supply

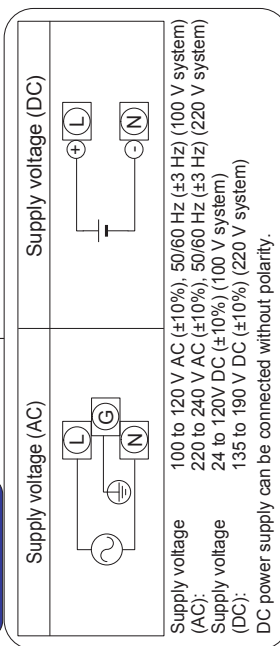

YS1700 Basic Type with Expandable I/O: Terminal Arrangements of Expanded I/O

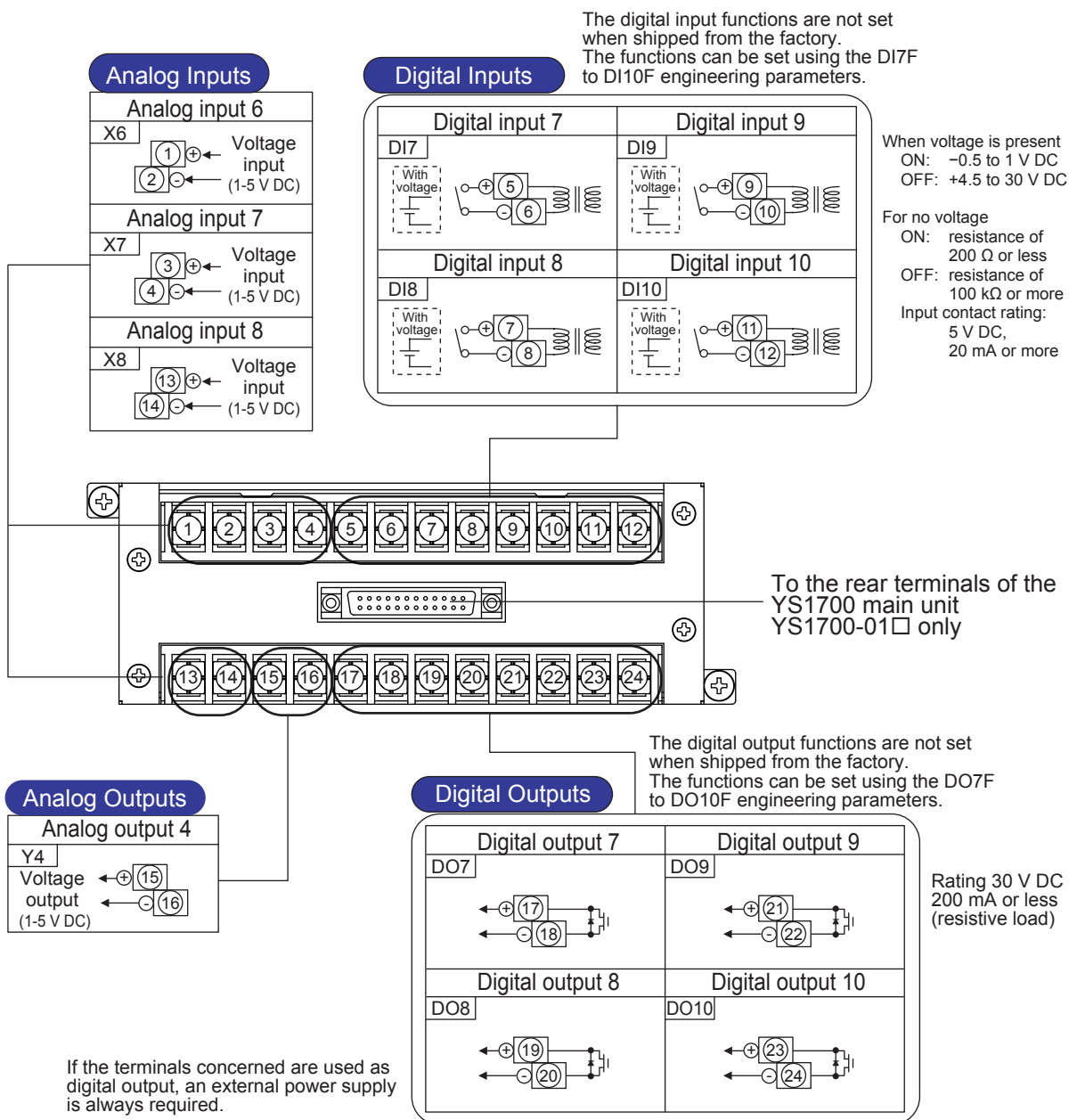

YS1310 Indicator with Alarm

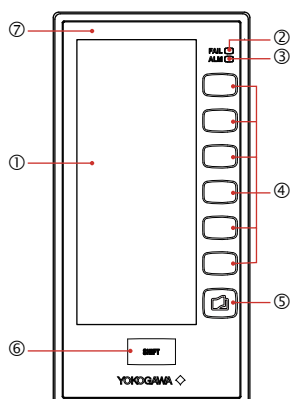

(1)	LCD display unit (color LCD): 120 x 320 dots *1
(2)	FAIL lamp (LED: red)
(3)	ALM lamp (LED: yellow)
(4)	Software key
(5)	Page key
(6)	SHIFT key
(7)	Tag label (recommended placement position)

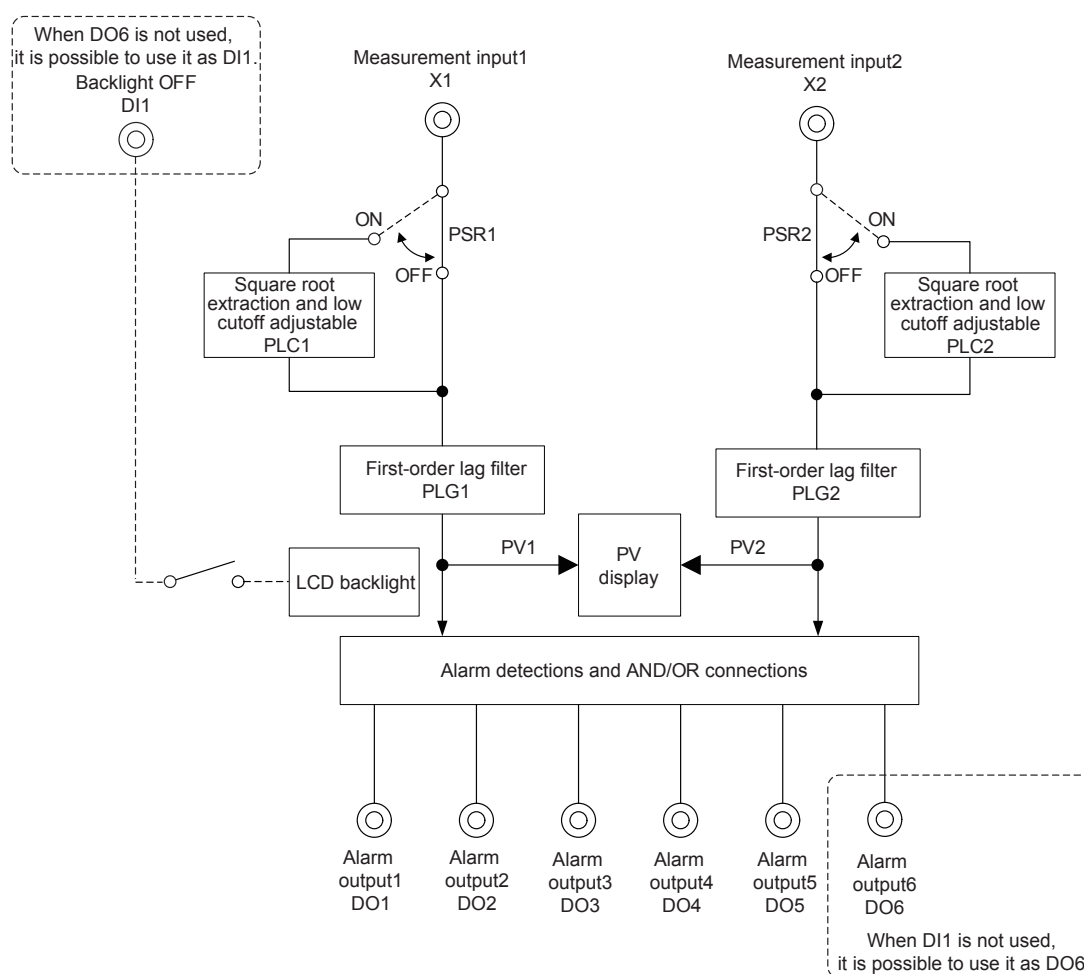

■ Features:

- Indicating alarm monitor for two inputs for simultaneous monitoring of both loops.
- Trend graph display for measured values.
- High-high, high, low, and low-low alarms can be detected for each of the two inputs.
- Logical ANDs or ORs of arbitrary alarms can be set. From among these, a total of six alarms can be assigned to alarm output contacts.

YS1350 Manual Setter for SV Setting

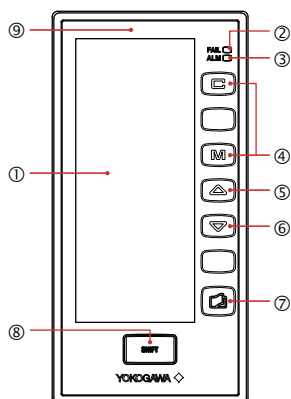

(1)	LCD display unit (color LCD): 120 x 320 dots *1
(2)	FAIL lamp (LED: red)
(3)	ALM lamp (LED: yellow)
(4)	C mode key (LED: green), M mode key (LED: yellow)
(5)	SV increase key
(6)	SV decrease key
(7)	Page key
(8)	SHIFT key
(9)	Tag label (recommended placement position)

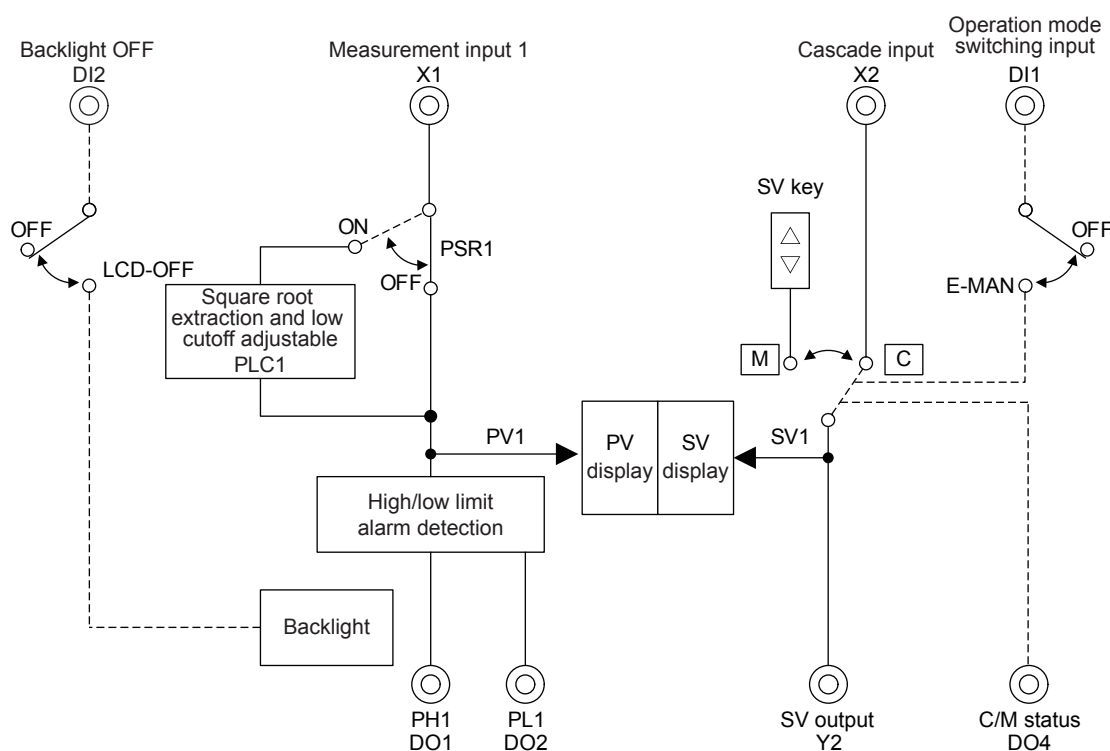

■ Features:

- A manual loader used to output a remote setpoint signal to a controller.
- Trend graph display for measured values.
- High- and low-limit alarms can be displayed, and contact outputs are available.

YS1360 Manual Setter for MV Setting

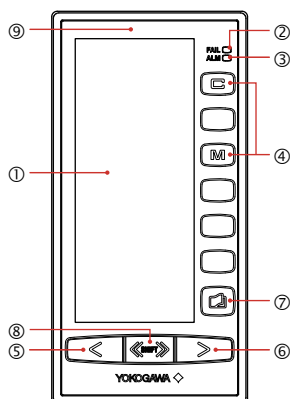

(1)	LCD display unit (color LCD): 120 x 320 dots *1
(2)	FAIL lamp (LED: red)
(3)	ALM lamp (LED: yellow)
(4)	C mode key (LED: green), M mode key (LED: yellow)
(5)	MV increase key
(6)	MV decrease key
(7)	Page key
(8)	Fast-change key/SHIFT key
(9)	Tag label (recommended placement position)

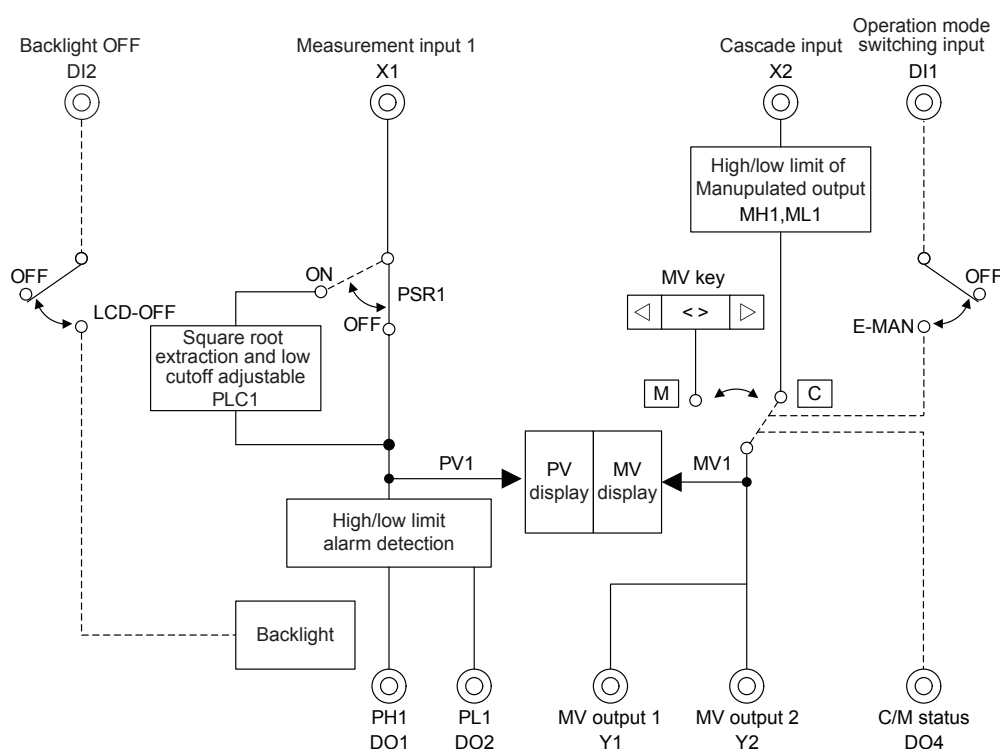

■ Features:

- A manual loader used to output a control signal to an actuator of a final control device.
- Trend graph display for measured values.
- High- and low-limit alarms can be displayed, and contact outputs are available.

Communication

Supervisory Communication

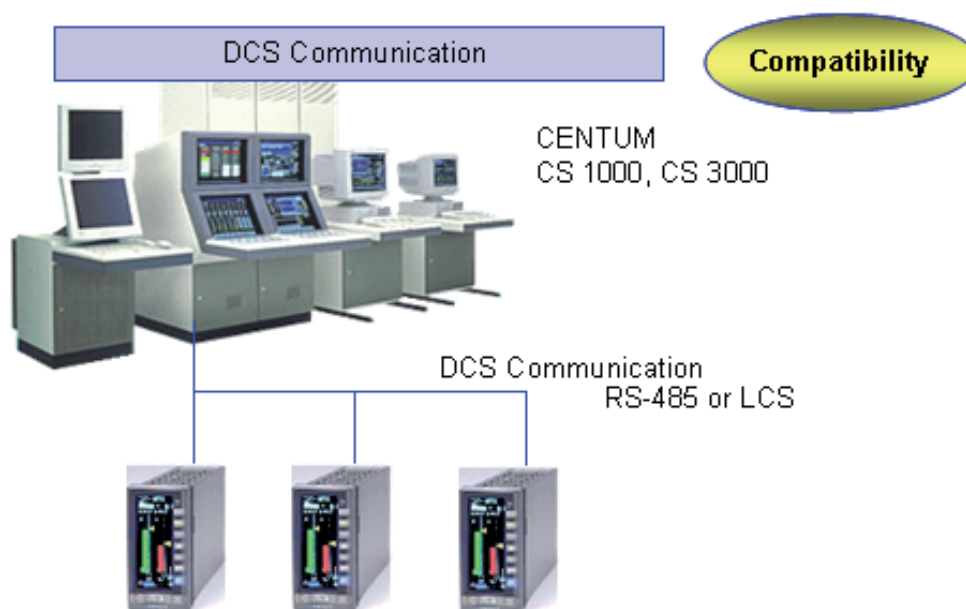

- Ideal means to back up a DCS where reliability is critical, such as in chemical plants.

- Centralized monitoring and operations via operation windows such as tuning windows and control group windows on human interface stations (HISs), are enabled.
- Communication functions can be configured using a standard builder program for the DCS.
- The DCS function blocks to correspond to individual YS1700s and YS1500s are defined as SLPCs. Each YS1350 is defined as an SMST-111, and each YS1360 as an SMST-121.
- The YS1310 cannot communicate with a DCS.
- Up to 120 YS1000 controllers and manual setters in total can be connected to each EFCS in CENTUM-XL, and up to 24 YS1000 controllers and manual setters in total can be connected to each MFCU in μ XL.
- Please specify the communication options /A31 (RS-485 communication) to directly communicate with the CENTUM CS3000.
- Please specify the communication options /A32 (DCS-LCS communication) to communicate with the CENTUM CS1000/CS3000 through the SCIU.

Peer-to-Peer Communication

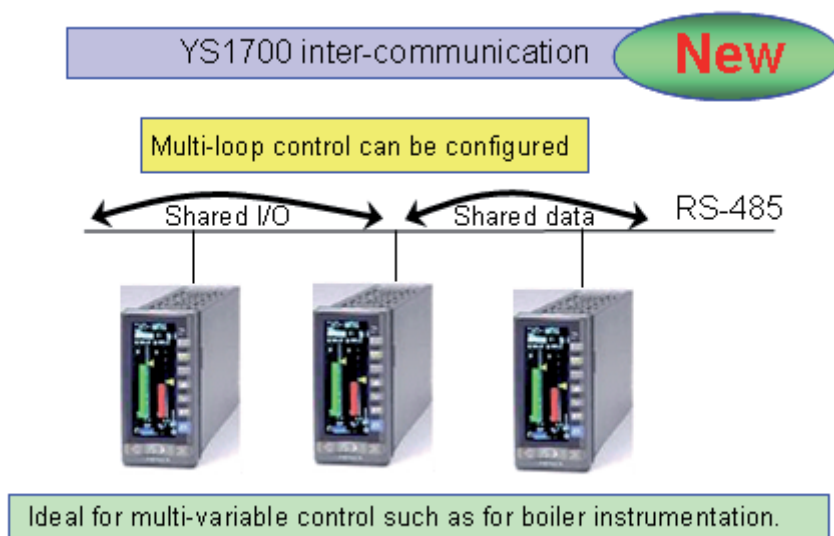

Cannot be linked to YS100 Series interlink (YS-net).

A maximum of 16 YS1000 controllers and setters can be connected per RS485 link. For 4 instruments from among these, each can transmit 4 analog data and 16 status data.

Any instrument on a RS485 inter-communication link can read all data on the same link (16 analog data and 64 status data).

- Maximum number of instruments: 32
- Maximum communication speed: 38.4K bps
- Maximum number of instruments that can transmit data: 4
- Transmitted data: 4 analog and 16 status data per sender (YS1700 instrument)
- Receiver instruments: 32
- Communication period: 200 ms on average (asynchronous to control calculation periods)

Open Network Connectivity

Open network connectivity

New

Ideal for Small-scale Instrumentation

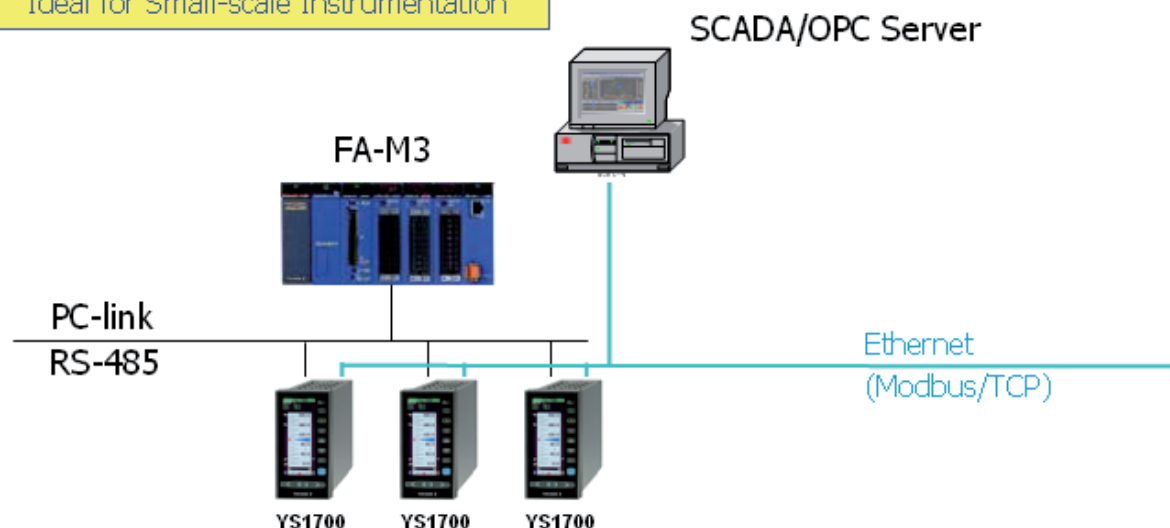

Connectible to PC-link
→ Easy connection to FA-M3 via a UT-link module

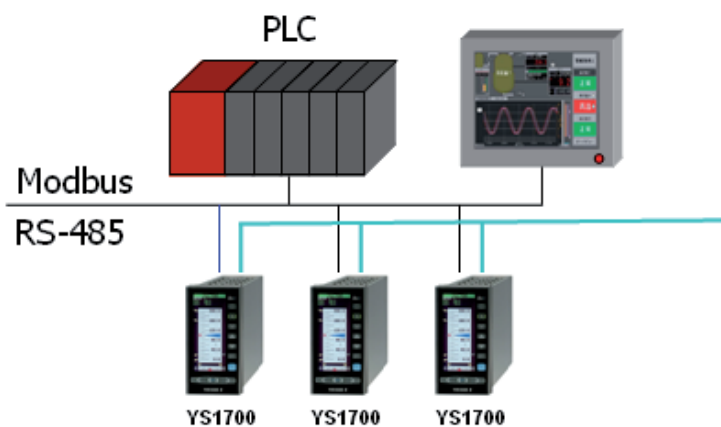

Connectible to Modbus and Ethernet (Modbus/TCP)
→ Easy connection to PLCs, SCADA, OPC Server

Application Note

Temperature and Pressure Compensation for Ideal Gas

Floating-point format calculations have enabled physical quantities (in engineering units) to be used in calculations.

- **When using calculation modules in the earlier YS Series:**

Scaling needs to be performed by the user to normalize physical quantities into the standard internal data form (0 to 100%) so that those quantities can be processed.



- **When using a temperature and pressure compensation module in a YS1700:**

- Thanks to floating-point format calculations, no scaling is needed.
- Online monitor enables the interim calculation results between calculation modules to be checked.
 - Note: Online monitor can only be used for user programs coded in function block programming, and thus cannot be used for those coded in text programming.

■ Calculations in YS1700

1. Assign scaling of temperature and pressure input values.
2. Configure a calculation block for temperature and pressure compensation of flow rates of ideal gas.
3. Assign BSC to perform a PID calculation.

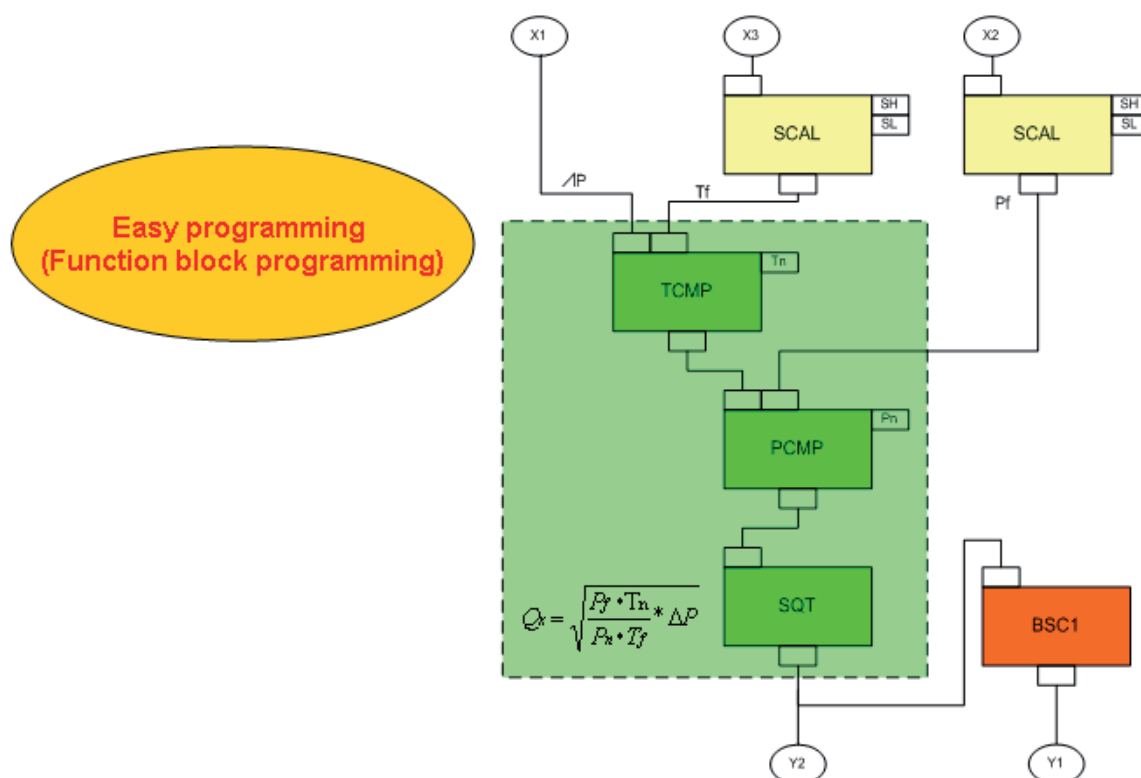

Boiler Drum Level Control

■ Problem in Boiler Drum Level Control with YS170 and SLPC:

- In the YS170 and SLPC, single-element control needs to be configured within the user program.
- The YS1700, however, offers the primary direct mode so that the user program can switch on and off single-element control by changing a parameter.

■ Three-element Control:

- Disturbances in drum level are caused by fluctuations in main steam flow.
- Figure 1 shows a typical drum level controller, which measures the drum level (1), main steam flow (2), and feedwater flow (3) and manipulates the feedwater control valve to regulate the drum level. This is three-element control.
- This three-element controller is a so-called cascade controller in which a drum level control unit is cascaded into a feedwater flow control unit.

■ Single-element Control:

- During startup of a boiler, both the feedwater and main steam flow rates remain below the measurable ranges, and this makes the three-element control with a level controller and flow controller unstable.
- In such cases, it is effective to use single-element control in which the feedwater controller is bypassed and the drum level controller directly controls the feedwater control valve.

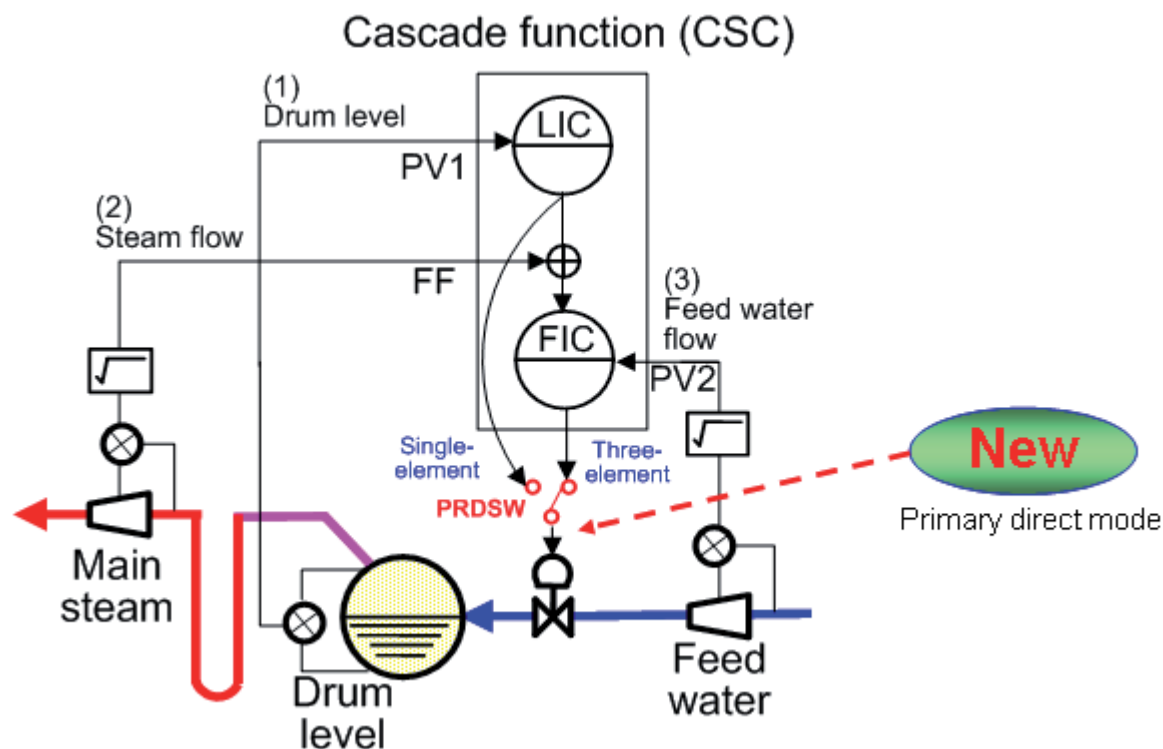

Boiler Feedwater Treatment

■ Chemical Injection (or Chemical Dosing)

- For safe and efficient operation, the quality of feedwater, steam, and condensate in boiler plants must be controlled and maintained in the most favorable conditions.
 - Example: For reclamation drain from makeup water desalination systems and condensate desalination systems, and equipment washing wastewater in thermal power stations, as well as acidic or alkaline wastewater from desalinated water production plants, a treatment appropriate for the properties of the respective wastewater quality must be employed in addition to neutralization.
- A flocculant is injected for makeup water treatment, and anti-corrosion agents such as a deoxidant and pH adjuster are also injected.
- In areas where water supply is limited, industrial wastewater and domestic wastewater need to be treated and reused.

■ Water Quality Control Requires Water Quality to Be Measured with Various Sensors and Many Analog Inputs to Be Connected.

Objects of Measurement:

- Dissolved oxygen concentration
- Dissolved oxygen saturation
- Untreated water flow rate
- Untreated water temperature
- Chemical injection rate
- pH
- Untreated water turbidity
- Electrical conductivity of untreated water

■ New: Eight Analog Inputs

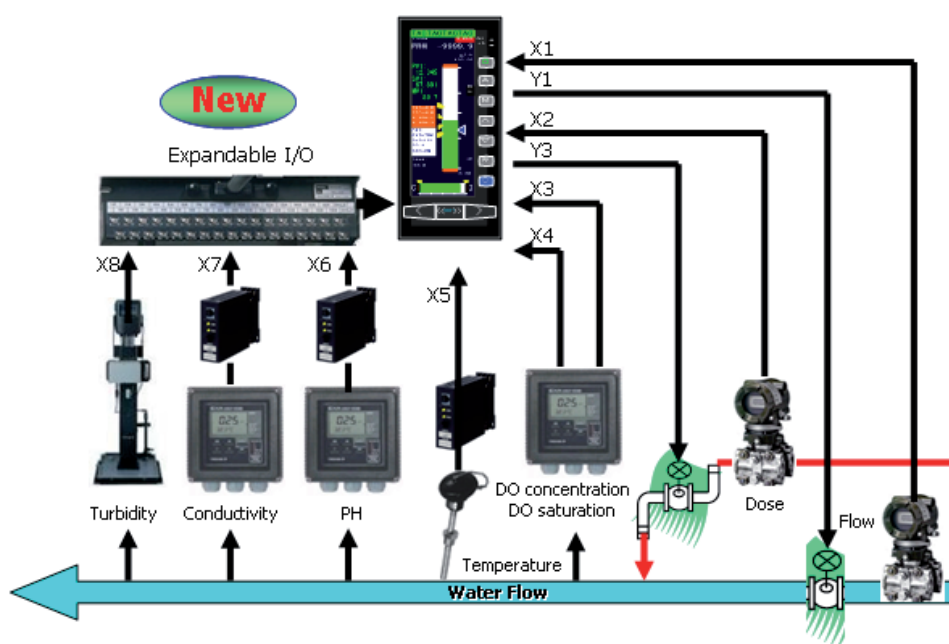

Compressor Anti-surge Control

■ Compressor Control

- Compressor start and stop
The inlet valve and blow-off valve are controlled efficiently.
- During steady-state operation
The inlet valve is controlled to regulate the blow-off flow rate of the compressed air. (Flow control)

■ Compressor Anti-surge Control

- Selector control (YS's proprietary algorithm)
The controlled object can be automatically switched over between two different factors, namely, flow rate and pressure.
- Fast 50 ms control period (programmable mode)
Enables follow-up of sudden process changes, and ensures smooth switching.
- User programming
Control including a start-up sequence can be tailored for various compressors.

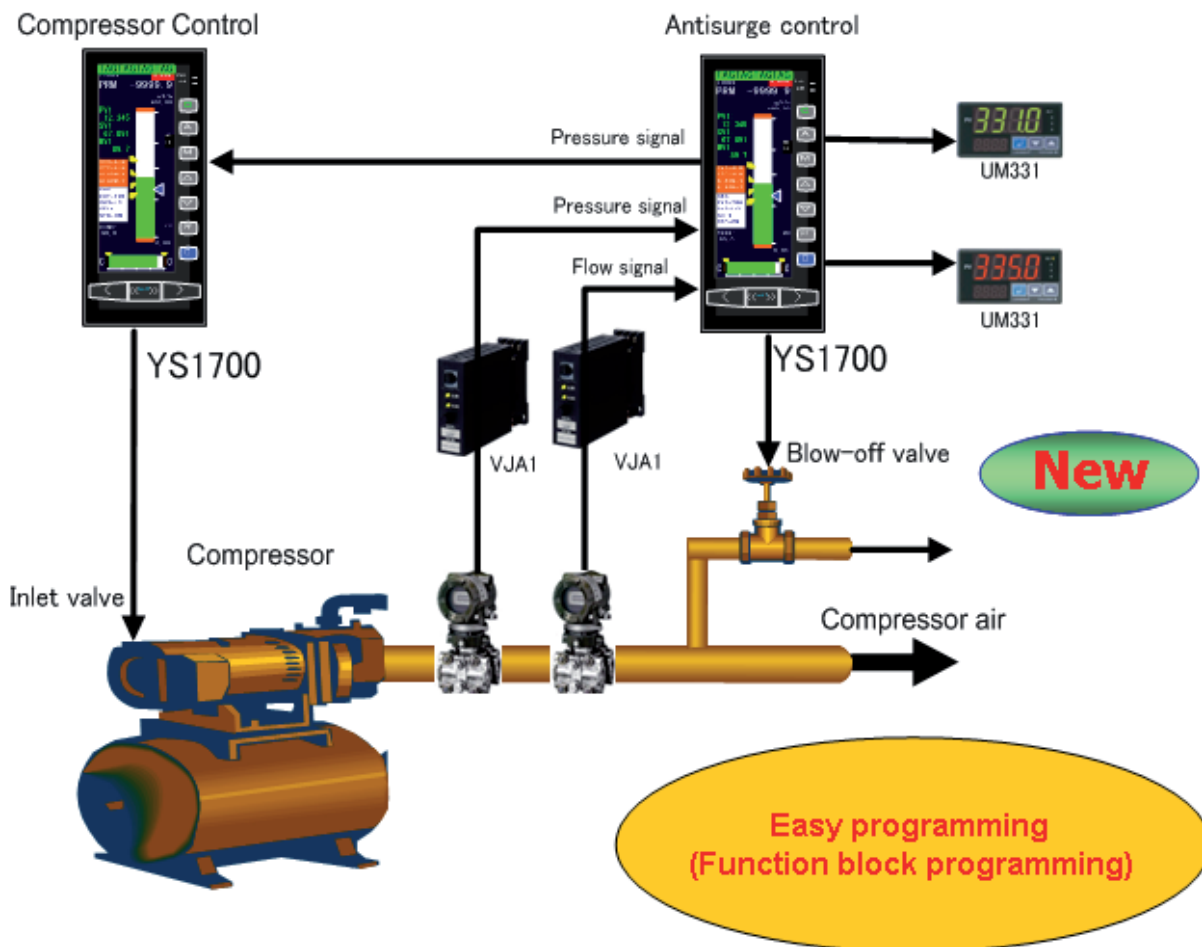

Comparisons



Item		YS1700	YS170	SLPC*E
Front display		Color full-dot LCD	Full-dot LCD	Meter
	Analog display	Available (bar and meter displays)	Available (bar display)	Available (meter display)
	Digital display	Available	Available	Not available
	Trend display	Available	Available	Not available
	Alarm display	LCD and LED	LCD and LED	LED
Dimensions		72 x 144 x 250 mm (DIN) (or YS100 or YS80 housing)	72 x 144 x 320 mm (DIN) or 87 x 182 x 480 mm (YS80 housing)	87 x 182 x 480 mm
Weight		1.6 Kg (Basic type)	2.6 Kg	5.4 Kg
User operations		Via front panel	Via front panel	SV and MV: Via front panel Parameters: Via side panel
Inputs	Analog	5 + 3	5	5
	Digital	6 (total of DIs + DOs) + 4 DOs	6 (total of DIs + DOs)	6 (total of DIs + DOs)
	Sensor direct	1 (optional: mV, TC, RTD, potentiometer, isolator, two-wire transmitter, or pulse; not available for the basic type)	1 (optional: mV, TC, RTD, potentiometer, isolator, two-wire transmitter, or pulse)	Not available
Outputs	Current	1 or 2	1 or 2	1
	Voltage	1 + 1 or 2 + 1	1 or 2	2
	Contacts	6 (total of DIs + DOs) + 4 DOs	6 (total of DIs + DOs)	6 (total of DIs + DOs)
	Fail contact	1	1	1
Transmitter power supply		2 (standard), or 1 isolated (optional) + 1 non-isolated (standard); 24 V DC, 60 mA with over-current protector	2 (standard), or 1 isolated (optional) + 1 non-isolated (standard); 24 V DC, 60 mA	Not available
Control loop	Single loop	Available	Available	Available
	Cascade	Available	Available	Available
	Selector	Available	Available	Available
	Dual loop	Available	Available	Not available
PID calculation		PID, P, sample PI, and batch PID	PID, P, sample PI, and batch PID	PID, sample PI, and batch PID
Control period		50, 100, or 200 ms	50, 100, or 200 ms	100 or 200 ms
STC		Available	Available	Available
Programming tool		PC (USB connection)	PC	SPRG programmer
Programming method		Text programming or function block programming	Text programming	Text programming
Programming capacity		Text programming: 1000 steps (main + sub) Function block programming: 400 modules	400 steps (main and sub-programs)	Main: 99 steps Sub: 99 steps
Hard manual device		Available	Available	Not available
DCS communication		Direct connection (CS 3000) or via SCIU (CS 1000/CS 3000)	Direct connection (CS 3000) or via SCIU (CS 1000/CS 3000)	Via SCIU (CS 1000/CS 3000)
RS-485		Modbus, PC-Link, or YS100	YS100	Via SCIU
Ethernet		Modbus/TCP	Not available	Not available



Item	YS1700-010/A31/A34	US1000-11/A10	UT750-51	UT551-0D
Front-face display unit	Full-dot color LCD	PV/SV/MV LED bar display,	LED + full-dot mono-chrome LCD	LED
Analog display	Available (bar and meter displays)	Available	Available	Not available
Digital display	Available	Available	Available	Available
Trend display	Available	Not available	Available	Not available
Alarm display	Available (LCD + LED)	Available (LED)	Available (LED)	Available (LED)
External dimensions	72 × 144 × 250 mm (DIN) or (YS100 or YS80 housing)	72x144x180mm(DIN)	96×96×100	96×96×100
Weight	1.6 kg (basic type)	0.8kg	1kg	1kg
Operation panel	Front panel	Front panel	Front panel	Front panel
Output operation key	Special key	Special key	Shared by parameter setting	Shared by parameter setting
Input	Analog	8	3	2
Digital	6 (total of DIs + DOs) + 4 DIs	7 DIs	7 DIs + 16 DIs (two optional units added)	7 DIs
Direct input	1: Optional (mV, TC, RTD, potentiometer, isolator, 2-wire transmitter, or pulse) (Not available for the basic type)	(Two out of analog inputs are universal inputs.)	(Two out of analog inputs are universal inputs.)	(One out of analog inputs is universal input.)
Output	Current	1 or 2	2	3
Voltage	3 or 2	1	0	0
Contact	6 (total of DIs + DOs) + 4 DOs	7 DOs	7 DOs + 16 DOs (two optional units added)	7 DOs
Fail contact		(Shared by DOs)	(Shared by DOs)	(Shared by DOs)
Transmitter Power Supply	24 V DC, 60 mA (Two transmitters can be connected.) With overcurrent protector	24 V DC, 30 mA 2 points With overcurrent protector	15 V DC (shared by transmitter output) 2 points With overcurrent protector	15 V DC (shared by transmitter output) 1 points With overcurrent protector
CONTROL LOOP	Single loop	Available	Available	Available
Cascade	Available	Available	Available	Available
Selector	Available	Not available	Not available	Not available
Dual loop	Available	Available	Available	Not available
PID Operation	PID,P,SAMPLE PI,BATCH PID	PID	PID	PID
Control Period	50,100,200msec	50,100, 200,500ms	50,100,200,500ms	100, 200,500ms
STC	Available	AT,SUPER	AT,SUPER,SUPER2	AT,SUPER,SUPER2
Programming Tools	PC	PC	PC	-
Programming Method	Text programming or function block programming	Function block programming	Function block programming	×
Programming Capacity	Text programming: 1000 steps (main + sub) Function block programming: 400 modules	60 modules	100 modules	-
Hard Manual	Available	Not available	Not available	Not available
DCS Communication	Direct communication (CS3000) or via SCIU (CS3000/CS1000)	Not available	Not available	Not available
RS-485 Communication	Available (Modbus, PC-link, YS1000)	Available (Modbus, PC-link)	Available (Modbus, PC-link, Ladder)	Available (Modbus, PC-link, Ladder)
Ethernet Communication	Available (Modbus,TCP)	Not available	Not available	Available (Modbus/TCP)
Screw Terminals	M4	M3.5	M3.5	M3.5
Safety Standards	IEC (CE marking certified)	IEC (CE marking certified), CSA	IEC (CE marking certified), UL	IEC (CE marking certified), UL
Dust- and drip-proof	IP54	IP65	IP55	IP55
Explosionproof	FM	FM,CSA	-	-

Q & A

No.	Category	Questions	Answers or Steps
1	LCD	Can the LCD brightness be adjusted?	Yes.
2	LCD	Does the LCD have a screen saver function?	Yes, it has. ECO (eco) mode is equivalent to it.
3	LCD	How does the LCD display appear in bright rooms such as areas near windows?	The LCD is of semi-reflective type; it offers excellent visibility even in bright rooms with sunlight streaming in early in the morning or at dusk. (Caution: Do not use YS1000 in locations where the LCD is in direct sunlight. Otherwise, the LCD life may be shortened.)
4	LCD	Is the LCD replaced on a display unit basis? Can the LCD be replaced while control continues?	The LCD is replaced on a display unit basis, by well-training service person. The power supply must be turned off.
5	LCD	Can the LCD backlight be replaced?	Because the backlight now has a long life, the same as that of the LCD, replacement of the backlight alone is not required, so replacement of the backlight only is not available.
6	Meter display	Is reverse swing (low scale limit > high scale limit) possible on the PV scale of a METER Display, etc.?	Yes.
7	Meter display	What are the differences in scales of an LCD-based METER Display in comparison with YS80?	An LCD-based METER Display displays the main and intermediate scale marks, but does not show subscale marks. An accurate value can be checked on a digital display.
8	Meter display	Are functions similar to those of LCD-based METER Display available on competitors' models?	The display form is specific to Yokogawa Electric.
9	Meter display	Is reverse swing (100% at the left of the display and 0% at the right) possible for analog output (needle) on a METER Display, etc.?	Not possible as standard. It may be handled by special order. Please contact to your nearest YOKOGAWA sales office.
10	Meter display	Is PV's log scale display possible?	No.
11	Meter display	Can the color of the pointer on a METER Display be changed (specified)?	It can be changed to green, blue, or pink.
12	Expandable I/O	Are there limitations on the models that can be combined with expandable I/O?	Only YS1700-01x can be combined with expandable I/O. Models other than YS1700 or various compatible models cannot be combined with expandable I/O.
13	Expandable I/O	Can the length of the expandable I/O cable be specified?	It is possible by special order. Its length can be selected from among 1 m, 5 m, and 10 m. Please contact to your nearest YOKOGAWA sales office.
14	Communication	Are Ethernet and RS-485 communications optional specifications? Can they be used in combination?	Ethernet and RS-485 communications are optional specifications. They can also be used in combination. (Ethernet is available only in the basic type.)
15	Communication	Can parameters and user programs be uploaded (read out to PC) during operations?	Yes.
16	Compatible housing	For replacement of the earlier models such as EK series (also I, EBS, etc), can their housings be used as is?	The existing housings cannot be used. A compatible housing (model: SHUP) for each series should be used and the instruments need to be replaced on a housing basis.
17	Compatible housing	For incorporation into the earlier model's compatible housing, is only the internal unit inserted and used?	The earlier model's compatible types are delivered fitted into the compatible housing (SHUP). They should be inserted into a compatible housing (SHUP) and used on a case basis.
18	Reliability	Can aluminum electrolytic capacitors be parts having defined life spans?	Parts with a life of 10 years or more are excluded from parts having defined life spans. Aluminum electrolytic capacitors have a life of more than 10 years due to use of parts with a longer life and design taking life into account, so they are not included in the parts with defined life spans.

No.	Category	Questions	Answers or Steps
19	Reliability	Is mutual complementary by dual CPU configuration specific to Yokogawa Electric?	This function is unique in YOKOGAWA product. Dual CPU configuration plus Hard Manual offers high reliability.
20	Reliability	Is an alarm issued in the event of a CPU failure?	FAIL contact is output.
21	CE marking	What about the models (types) compatible with CE marking?	The basic type, basic type (with expandable I/O), and YS100 compatible type are compatible with CE marking.
22	Setting Software	Can the YSS1000 dedicated cable be purchased on its own?	We do not sell dedicated cable alone; it is available when purchased with software as a set. However, if the cable breaks, etc., a dedicated cable can be purchased as a special order. Please contact to your nearest YOKOGAWA sales office.
23	Setting Software	Is a function for connecting with the dedicated cable on the YS1000 main unit side an optional specification?	The YS1000 main unit has the function of connecting with the dedicated cable as standard. For USB connection using YSS1000, YSS1000 comes with a dedicated cable. YS1000 requires no optional specifications.
24	Setting Software	YSS1000 is stated to be compatible with USB connection. Does the YS1000 main unit have USB terminals?	The YS1000 main unit has no USB terminal. Use the dedicated cable to connect to a PC's USB port.
25	Setting Software: user program	Can programs written in text format be automatically converted to function block programs?	Automatic conversion is not available.
26	Setting Software: user program	Can sequences or logics be written using user programs on YS1700?	Yes.
27	Setting Software: user program	Can user programs written in text format up to now be rewritten in function block programs?	Yes. However, the notation system is different.
28	Setting Software: user program	Are computations (functions and commands) available in text programming and in function block programming the same?	Control computation, arithmetic operation, and logical operation are available in both text and function block programming types. (Caution: For commands that do not need to be used due to differences in the description method, there are cases where only one of the programming types is available. This applies to commands such as branch commands, CHG (S-register replacement), and ROT (S-register rotation))
29	Setting Software: debugging	Can debugging be done offline?	YS1000 cannot handle offline debugging. Perform debugging on-line.
30	Setting Software: user program conversion tool	When will the SLPC user program conversion tool be released?	It is scheduled to be released in 2007.
31	Setting Software: user program conversion tool	When SLPC's program ROM is ported to YS1700, does the ROM need to be disconnected from SLPC?	The program ROM must be disconnected from SLPC.
32	Others: special order	Can HumiSeal coating be provided?	It can be handled by special order. Please contact to your nearest YOKOGAWA sales office.
33	Others: replacement	Integrators (STLD or YFCT) perform temperature-pressure compensation. Is this temperature-pressure compensation functionally replaceable to YS1000?	Temperature-pressure compensation is possible if the input is analog signal. If the input is pulses, it can be handled by analog conversion using a pulse-analog converter. If pulses are counted using YS1000's DI input, the minimum input pulse width needs to be 70 msec or more. (In this case, the pulse frequency is 7 Hz maximum.)

Dimensions

Dimensions of YS1000 Basic Type

Suffix Codes -00x

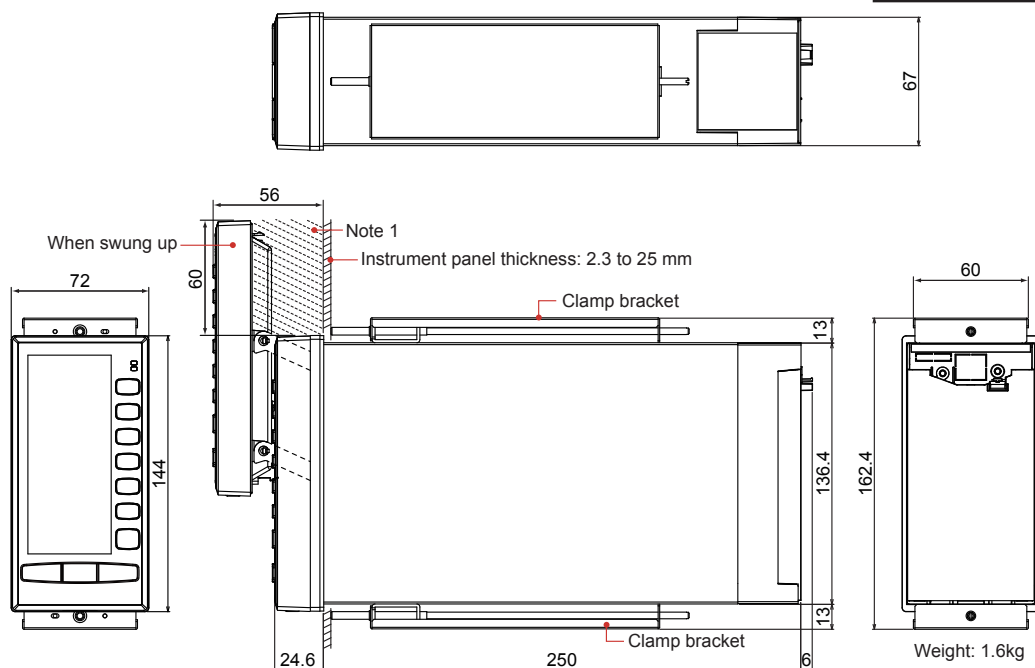

Pane Cutout Dimensions

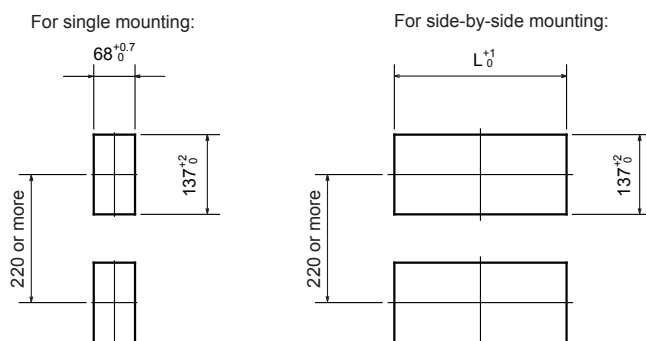

Panel Cutout Width for Side-by-side Mounting

Number of instruments to be mounted	L(mm)
2	140
3	212
4	284
5	356
6	428
7	500
8	572
9	644
10	716
11	788
12	860
13	932
14	1004

Trigonometry

Unit: mm

General tolerance = $\pm(\text{value of tolerance class IT18 based on JIS B 0401-1998}) / 2$

Note 1: If a nameplate, etc. is installed within 60 mm above the instrument, the height of the nameplate, etc. must be 30 mm or less from the panel surface.

Note 2: To ensure good air ventilation, allow space of 100 mm or more at the top and bottom of the panel.

0920E.ai

TIP

Precautions When Using This Type:

- Option code A0x (direct sensor input) is not available.
- Option codes A31 (RS-485) and A32 (DCS-LCS communication) cannot be specified at the same time.

Dimensions of YS1000 Basic Type with Expandable I/O

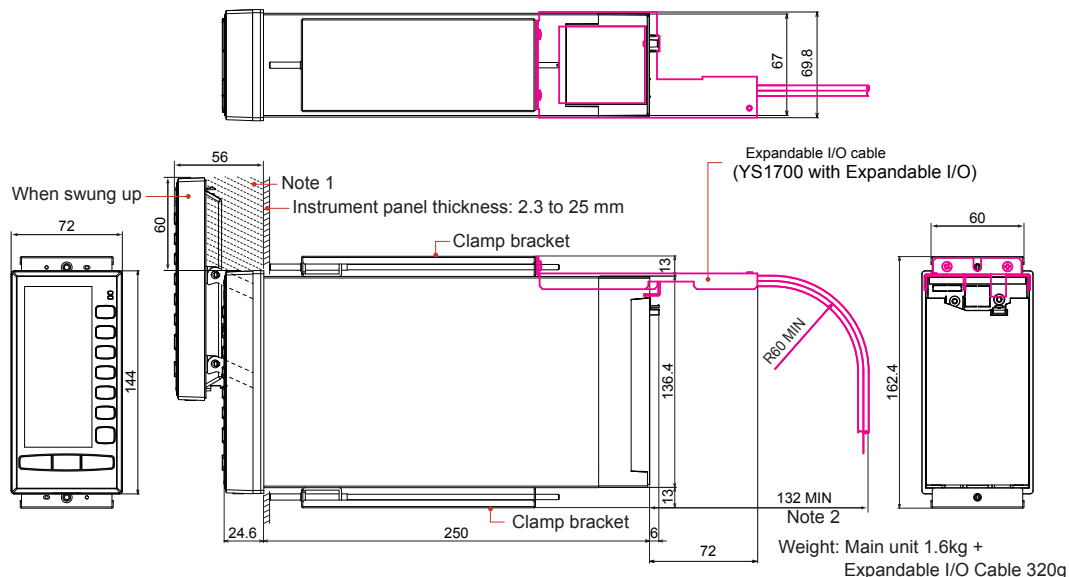
Suffix Codes -01x

Note 1: If a nameplate, etc. is installed within 60 mm above the instrument, the height of the nameplate, etc. must be 30 mm or less from the panel surface.

Note 2: When installing the expandable I/O cable, secure the wiring space of at least 60 mm for a minimum curvature radius of the cable in addition to the mounting bracket space of 72 mm from the terminal cover face of the main unit.

Pane Cutout Dimensions

For single mounting:

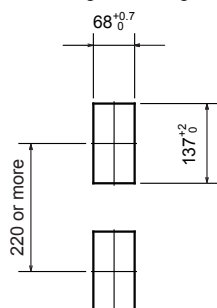

For side-by-side mounting:

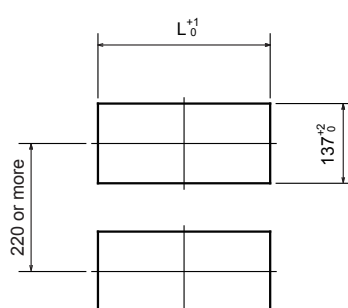

Panel Cutout Width for Side-by-side Mounting

Number of instruments to be mounted	L(mm)
2	140
3	212
4	284
5	356
6	428
7	500
8	572
9	644
10	716
11	788
12	860
13	932
14	1004

Trigonometry

Unit: mm

General tolerance = $\pm(\text{value of tolerance class IT18 based on JIS B 0401-1998}) / 2$

Note 1: If a nameplate, etc. is installed within 60 mm above the instrument, the height of the nameplate, etc. must be 30 mm or less from the panel surface.

Note 2: To ensure good air ventilation, allow space of 100 mm or more at the top and bottom of the panel.

0920_2E.ai

TIP

Precautions When Using This Type:

- Option code A0x (direct sensor input) is not available.
- Option codes A31 (RS-485) and A32 (DCS-LCS communication) cannot be specified at the same time.

Dimensions of Expandable I/O Block and Expandable I/O Cable

Suffix Code -01x

Expandable I/O Terminal Block (YS010)

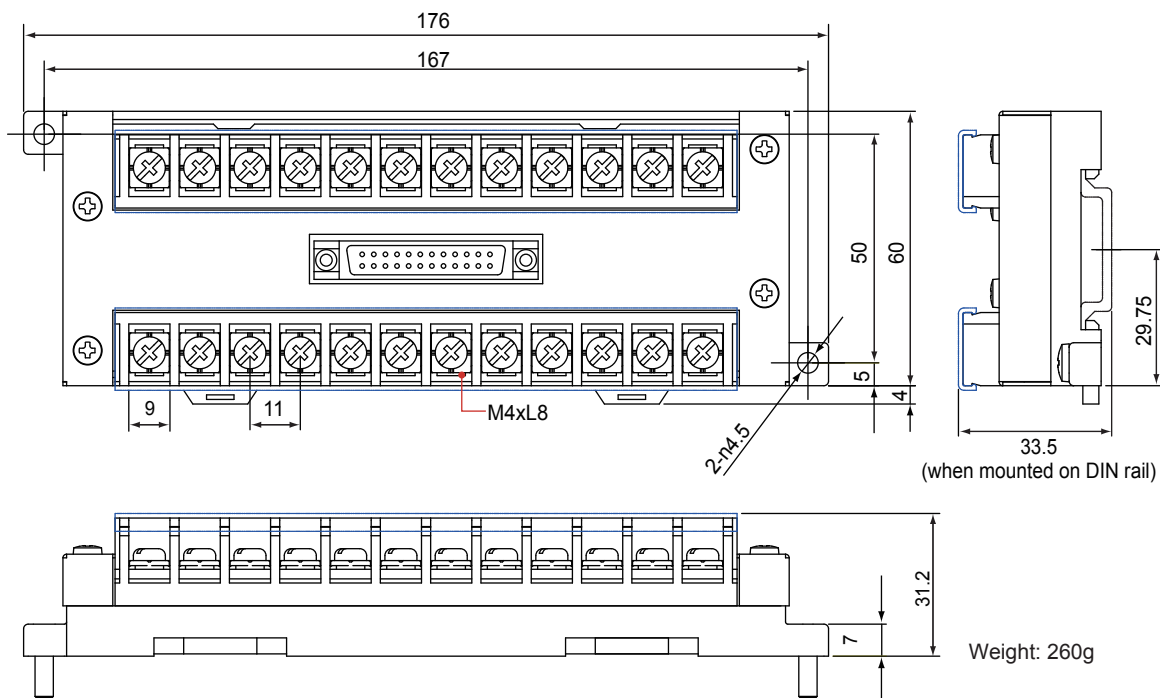

Expandable I/O Cable (YS011)

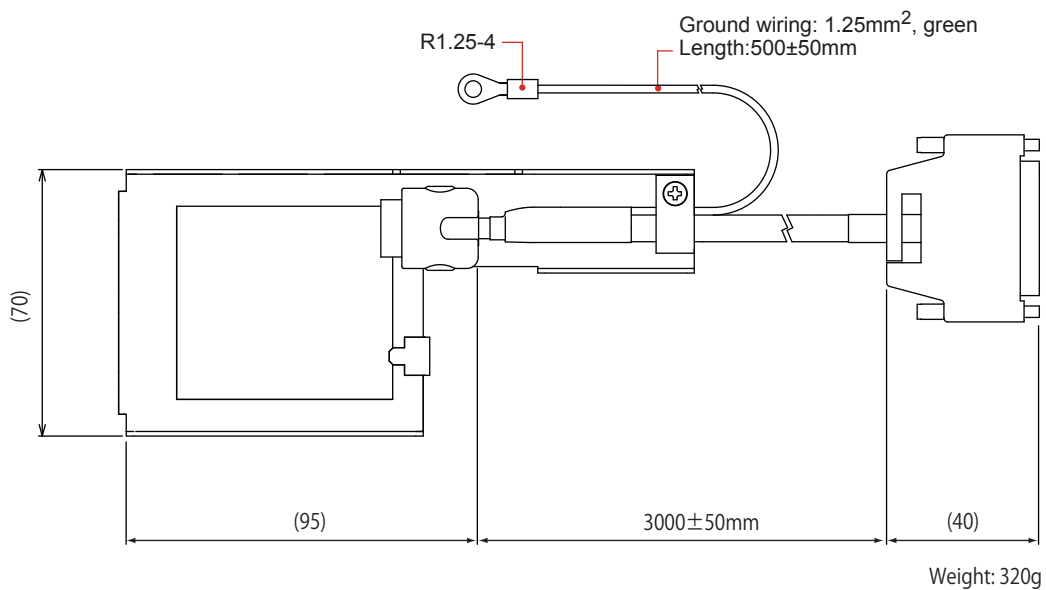

Dimensions of Compatible Type for YS100

Suffix Codes -02x

Unit: mm

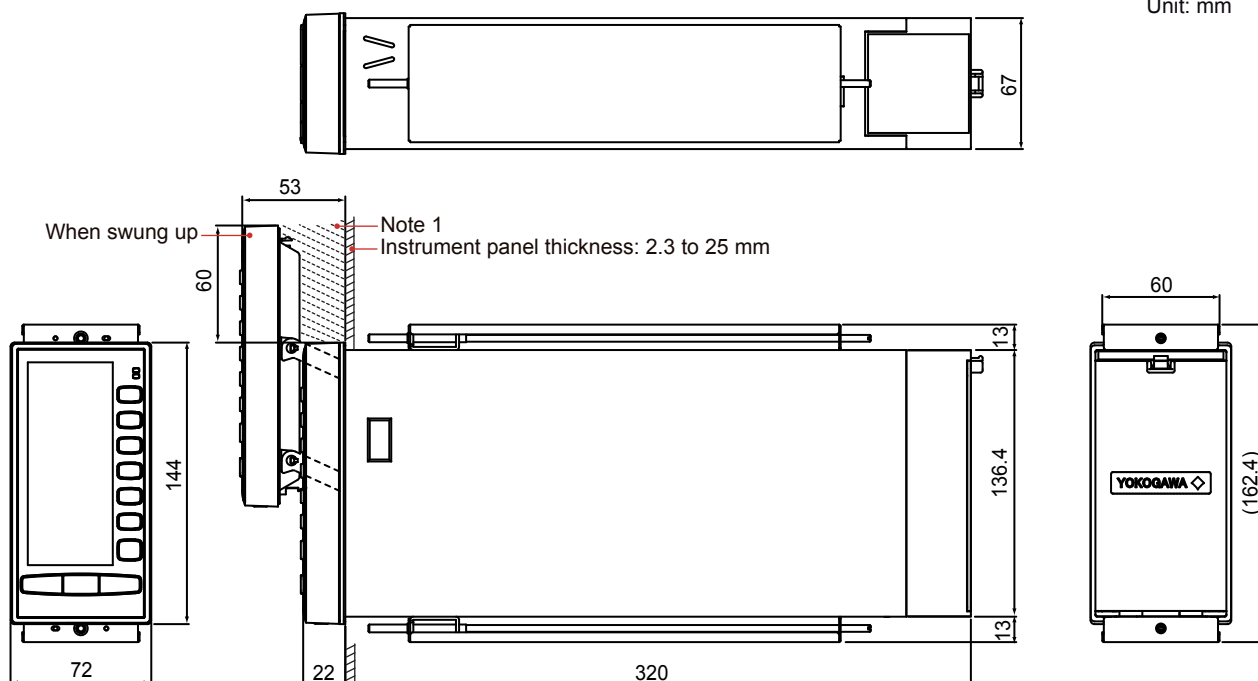

Note 1: If a nameplate, etc. is installed within 60 mm above the instrument, the height of the nameplate, etc. must be 30 mm or less from the panel surface.

Note 2: To ensure good air ventilation, allow space of 100 mm or more at the top and bottom of the panel.

Note 3: General tolerance = $\pm(\text{value of tolerance class IT18 based on JIS B 0401-1998}) / 2$

TIP

Precautions When Using This Type:

- Option code A0x (direct sensor input) is available
- Option code A34 (Ethernet) is not available.
- Option codes A31 (RS-485) and A32 (DCS-LCS communication) cannot be specified at the same time.
- Option code FM (FM nonincendive) is not available.
- CE Mark-compliance is underway.
- Not dust- or splash-proof

Dimensions of Compatible Type for YS80 Internal Unit

Suffix Codes -03x

TIP

Use this type with the SHUP housing for YS80 Series

Unit: mm

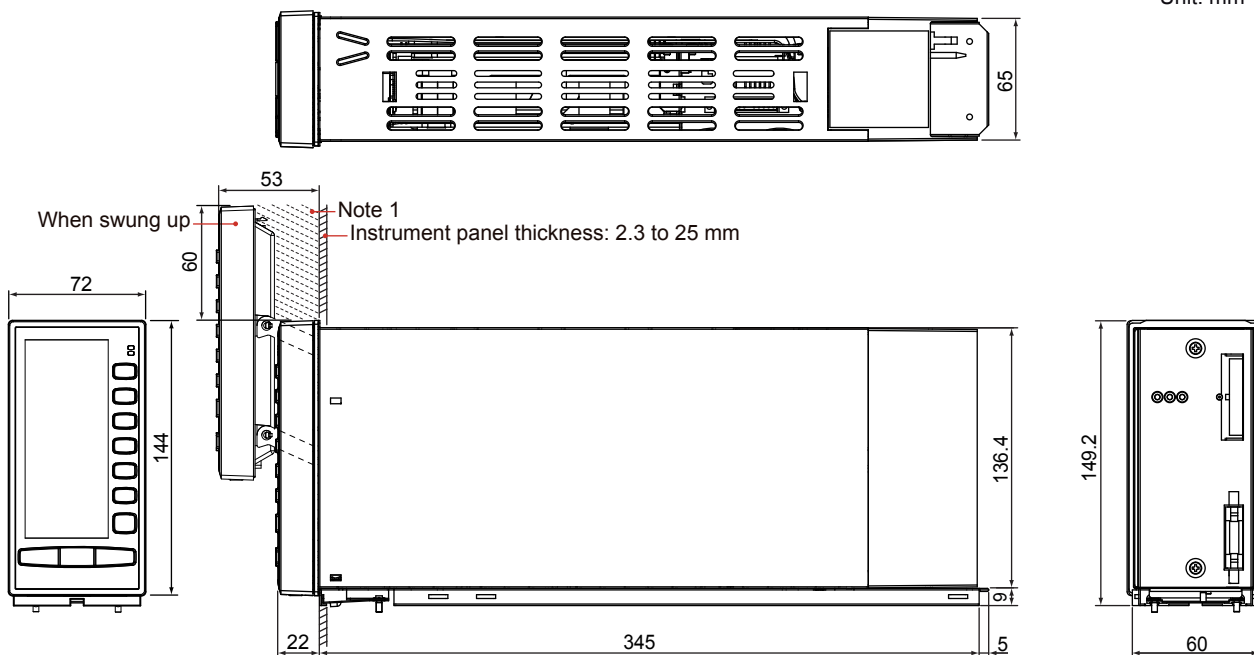

Note 1: If a nameplate, etc. is installed within 60 mm above the instrument, the height of the nameplate, etc. must be 30 mm or less from the panel surface.

Note 2: To ensure good air ventilation, allow space of 100 mm or more at the top and bottom of the panel.

Note 3: General tolerance = $\pm(\text{value of tolerance class IT18 based on JIS B 0401-1998}) / 2$

TIP

Precautions When Using This Type:

- Needs a separately sold housing for installation and wiring.
- Option code A34 (Ethernet) is not available.
- Option code A31 (RS-485) is not available
- Option code FM (FM nonincendive) is not available.
- Not compliant with CE Mark
- Not dust- or splash-proof

Instrument to Be Replaced	Housing to Be Used
YS80 Series	SHUP-000
I Series or EBS Series	SHUP-100
EK or HOMAC Series	SHUP-420

} YS80 special housings can be used to replace I, EBS, EK, and HOMAC Series.

Dimensions of Compatible Type for YS80

Suffix Codes -04x

TIP

Requires the same panel cutout dimensions and has the same depth as those of the YS80 Series.

The terminal arrangements are almost the same as those of the YS80 Series.

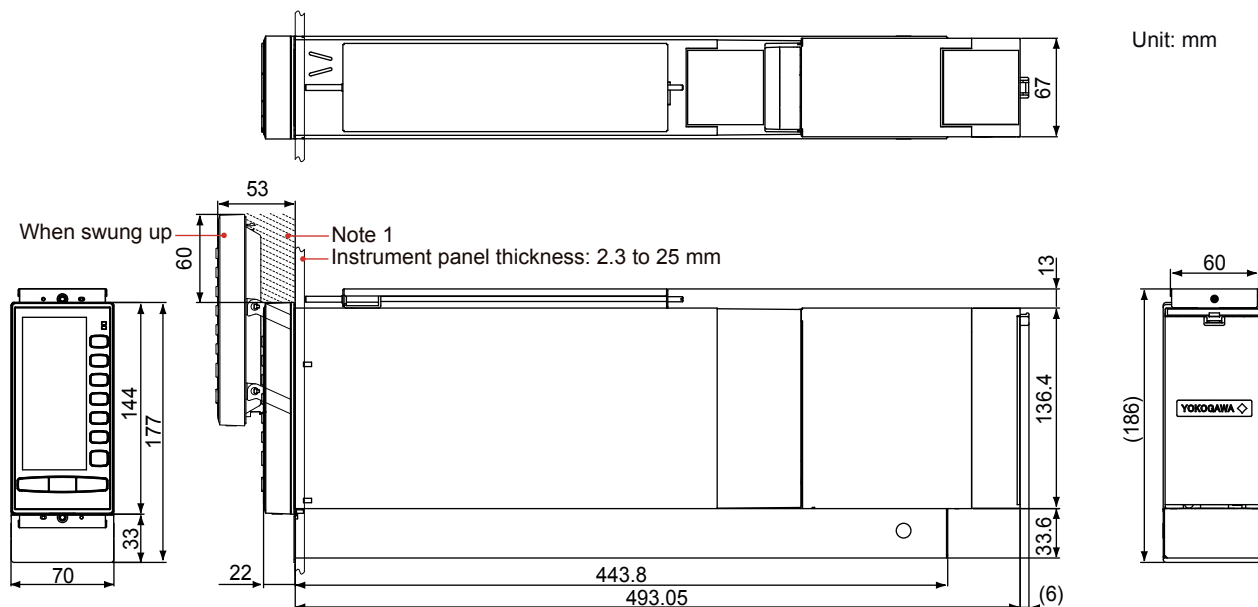

Note 1: If a nameplate, etc. is installed within 60 mm above the instrument, the height of the nameplate, etc. must be 30 mm or less from the panel surface.

Note 2: To ensure good air ventilation, allow space of 100 mm or more at the top and bottom of the panel.

Note 3: General tolerance = \pm (value of tolerance class IT18 based on JIS B 0401-1998) / 2

TIP

Precautions When Using This Type:

- Option code A0x (direct sensor input) is available.
- Option code A34 (Ethernet) is not available.
- Option codes A31 (RS-485) and A32 (DCS-LCS communication) cannot be specified at the same time.
- Option code FM (FM nonincendive) is not available.
- Not compliant with CE Mark
- Not dust- or splash-proof
- Not installed in housing (but supplied in a YS80-compliant case).

Dimensions of Compatible Type for 100 Line

Suffix Codes -05x

Unit: mm

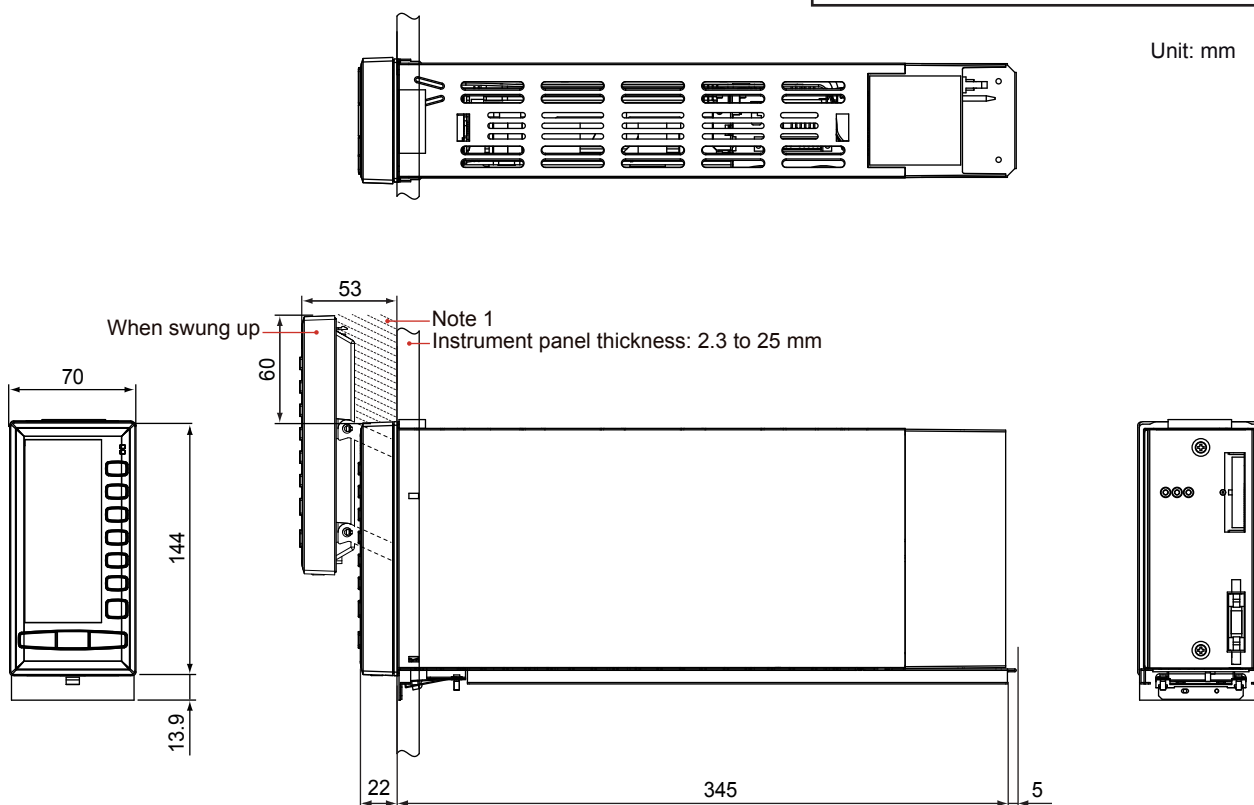

Note 1: If a nameplate, etc. is installed within 60 mm above the instrument, the height of the nameplate, etc. must be 30 mm or less from the panel surface.

Note 2: To ensure good air ventilation, allow space of 100 mm or more at the top and bottom of the panel.

Note 3: General tolerance = $\pm(\text{value of tolerance class IT18 based on JIS B 0401-1998}) / 2$

Instrument to Be Replaced	Housing to Be Used
100 Line pneumatic instrument	YS006

TIP

Precautions When Using This Type:

- Needs a separately sold housing (Model YS006) for installation and wiring.
- Option code A0x (direct sensor input) is available.
- Option code A34 (Ethernet) is not available.
- Option codes A31 (RS-485) and A32 (DCS-LCS communication) cannot be specified at the same time.
- Option code FM (FM nonincendive) is not available.
- Not compliant with CE Mark
- Not dust- or splash-proof

Blank Page

Revision Information

Title : Introduction of YS1000 Series

Manual number : TI 01B08A01-01E

Feb. 2007/1st Edition

Newly published

Mar. 2007/2nd Edition

-
- Written by Yokogawa Electric Corporation
 - Published by Yokogawa Electric Corporation
2-9-32 Nakacho, Musashino-shi, Tokyo 180-8750, JAPAN
-

Blank Page