

---

**Operation  
Guide**



**MX100  
Data Acquisition Unit**

---

**vigilantplant®**

# User Registration

Thank you for purchasing YOKOGAWA products.

We invite you to register your products in order to receive the most up to date product information. To register, visit the following URL, or click the “Product Registration” button in the opening screen of the Manual CD-ROM.

***<http://www.yokogawa.com/ns/reg/>***

# Contents

---

<b>Checking the Contents of the Package</b> .....	<b>5</b>
<b>Function Introduction</b> .....	<b>9</b>
Overview of the MX100 .....	9
Flow of Operation during Installation .....	10
Function of the Modules .....	11
Functions of the MX100 Standard Software .....	14
<b>Signal Wiring of the MX100</b> .....	<b>15</b>
Attachment Position and Channel Numbers of the Input/Output Module .....	15
Terminal Arrangement Markings on the Terminal Cover .....	15
Wiring the Universal Input Module and DCV/TC/DI Input Module .....	16
Wiring the Four-Wire RTD Resistance Input Modules .....	16
Wiring the Strain Input Modules.....	17
Wiring the Digital Input Modules (-D05, -D24) .....	21
Wiring the Analog Output Modules .....	22
Wiring the PWM Output Modules .....	22
Wiring the Digital Output Module .....	23
<b>Connection to the Network</b> .....	<b>24</b>
Connecting the Ethernet Cable to the Main Module .....	24
Checking the Communication Status.....	24
Connection to the PC.....	24
<b>Setup Procedures of the MX100 Standard Software</b> .....	<b>25</b>
Installing the MX100 Standard Software .....	25
Installation Result .....	25
<b>Operations of the MX100 Standard Software</b> .....	<b>26</b>
Connecting to or Disconnecting from the MX100 .....	26
Setting the Acquisition Conditions of the Measured Data .....	30
Setting Measurement Conditions.....	32
Monitoring the Measured Data and Setting the Display .....	35
Pausing the Updating of the Monitor Display and Reading Measured Values Using Cursors.....	40
Recording the Measured Data.....	41
Setting Alarms.....	42
Digital Output.....	44
Setting the Computation .....	46
Saving/Loading and Printing of Setup Data (Project) .....	46
Displaying Recorded Measured Data, Reading Values Using Cursors, and Statistical Computation over an Area.....	48
Printing the Displayed Data .....	53
Converting the Format of the Recorded Measured Data .....	53

---

Thank you for purchasing the MX100 Data Acquisition Unit.

This manual concisely describes the handling procedures of the MX100 Data Acquisition Unit (hereinafter the "MX100") and basic operations on the MX100 Standard Software. To ensure correct use, please read this manual thoroughly before beginning operation. The five manuals below relating to the MX100 are provided in addition to this one. Read them along with this manual. Note that the MX100 Data Acquisition Unit User's Manual (IM MX100-01E), this manual (IM MX100-02E), and the MX100 Standard Software User's Manual (IM MX180-01E) are all available on the MX100 Manual CD-ROM.

Manual Title	Manual No.	Description
MX100 Data Acquisition Unit User's Manual	IM MX100-01E	Describes the functions, installation, wiring procedures, handling precautions, and other information about the MX100.
Precautions on the Use of the MX100/MW100 Data Acquisition Unit	IM MX100-71E	Summarizes the usage precautions of the MX100/MW100.
MX100/MW100 Data Acquisition Unit Installation and Connection Guide	IM MX100-72E	Describes concisely the installation and wiring procedures of the MX100/MW100.
Control of pollution caused by MX100/MW100 products	IM MX100-91C	Describes control of pollution caused by the product.
MX100 Standard Software User's Manual	IM MX180-01E	Describes the functions and operations of the MX100 Standard Software that comes standard with the MX100 main module.

## Notes

- When configuring an MX100 system, the versions of the instruments used in the system indicated by the hardware style number and software release number must meet the following conditions.
  - The main module style number must be greater than or equal to the style numbers of any input/output modules.
  - The PC software release number must be greater than or equal to the style number of the main module.

Certain functions may become disabled on instruments or software that do not meet these conditions, or the system may not be able to be built.

- This manual describes the MX100 style number "S3," and release number R3.03 of the MX100 Standard Software. Check the style number on the name plate (see page 5 for the location of the name plate).
- Every effort has been made in the preparation of this manual to ensure the accuracy of its contents. However, should you have any questions or find any errors, please contact YOKOGAWA dealer.
- This operation guide does not cover the handling and operating procedures of Windows.
- Copying or reproducing all or any part of the contents of this manual without YOKOGAWA's permission is strictly prohibited.
- The TCP/IP software of this product and the document concerning the TCP/IP software have been developed/created by YOKOGAWA based on the BSD Networking Software, Release 1 that has been licensed from California University.

## Trademarks

- DAQMASTER is a registered trademark of Yokogawa Electric Corporation.
- Microsoft and Windows are registered trademarks or trademarks of Microsoft Corporation in the United States and/or other countries.
- Adobe and Acrobat are registered trademarks or trademarks of Adobe Systems Incorporated.
- Company and product names that appear in this manual are registered trademarks or trademarks of their respective holders.
- The company and product names used in this manual are not accompanied by the registered trademark or trademark symbols (® and ™).

## Revisions

1st Edition: May, 2003    2nd Edition: November, 2004    3rd Edition: June, 2006  
4th Edition: February, 2008    5th Edition: March, 2012

# Checking the Contents of the Package

Unpack the box and check the contents before operating the instrument. If some of the contents are not correct, or if any items are missing or damaged, contact the dealer from whom you purchased them.

## Checking the Model and Suffix Code

Check the model and suffix code on the name plate indicated in the figure below.

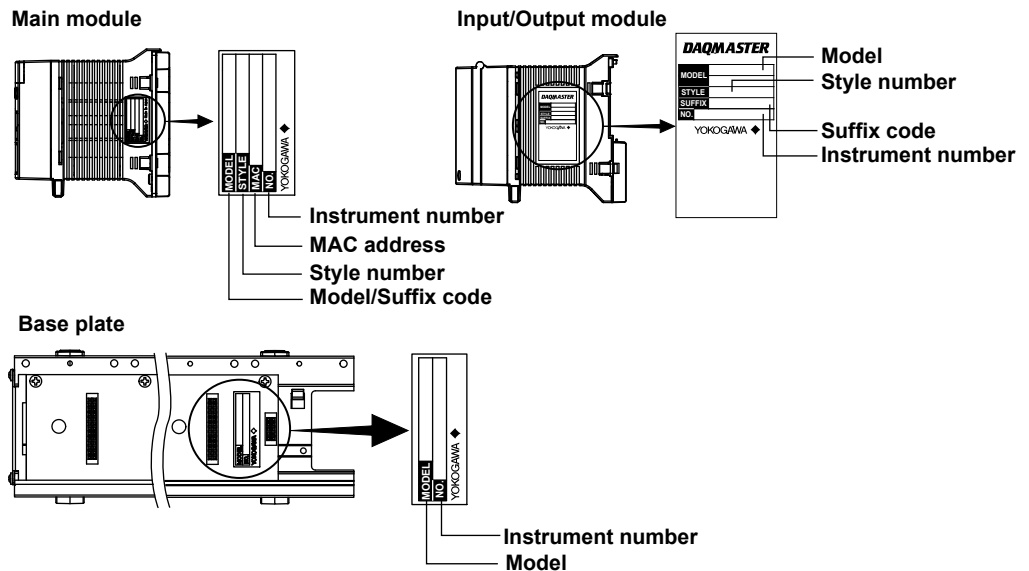

### Note

When contacting the dealer from which you purchased the instrument, please give them the NO. (instrument number) on the name plate.

## Main Module

Model	Suffix Code	Description
MX100		MX100 main module (comes with MX100 Standard Software)
Language	-E	English
Supply voltage	-1	100 VAC-240 VAC
Power supply and power cord	D	3-pin inlet, UL/CSA Standard power cord [Maximum rated voltage: 125 V; Maximum rated current: 7 A]
	F	3-pin inlet, VDE Standard power cord [Maximum rated voltage: 250 V; Maximum rated current: 10 A]
	R	3-pin inlet, AS Standard power cord [Maximum rated voltage: 240 V; Maximum rated current: 10 A]
	Q	3-pin inlet, BS Standard power cord [Maximum rated voltage: 250 V; Maximum rated current: 10 A]
	H	3-pin inlet, GB Standard power cord (complies with CCC) [Maximum rated voltage: 250 V; Maximum rated current: 10 A]
	W	Screw terminal (does not come with a power cord)
Options	/DS	Dual Save function
	/SL1*	10-CH Quick Start Package
	/SL2*	20-CH Quick Start Package
	/SL3*	30-CH Quick Start Package

\* These can not be selected together. Shipped with the MX110-UNV-M10 and MX150 installed.

## Universal Input Module, DCV/TC/DI Input Module, and Four-Wire RTD Resistance Input Module

Model	Suffix Code	Description
MX110		
Input type	-UNV	For DCV/TC/DI/3-wire RTD input
	-VTD	For DCV/TC/DI input
	-V4R	For DCV/DI/4-wire RTD/4-wire resistance input
Number of channels and measurement interval	-H04 <sup>*1</sup>	4-CH, high-speed measurement (minimum measurement interval: 10 ms)
	-M06 <sup>*1</sup>	6-CH, medium-speed measurement (minimum measurement interval: 100 ms)
	-M10 <sup>*1</sup>	10-CH, medium-speed measurement (minimum measurement interval: 100 ms)
	-L30 <sup>*1</sup>	30-CH, medium-speed measurement (minimum measurement interval: 500 ms)
Options	/NC <sup>*2</sup>	Without the plate with the clamp terminals
	/H3 <sup>*3</sup>	M3 screw terminals

\*1 -H04 or -M10 must be selected if -UNV is selected. -M06 must be selected if -V4R is selected. -VTD must be selected if -L30 is selected.

\*2 /NC can only be selected if -M10 is selected.

\*3 /H3 can only be selected if -L30 is selected.

## Strain Input Module

Model	Suffix Code	Description
MX112		
Input type	-B12	Internal bridge resistance: 120 Ω
	-B35	Internal bridge resistance: 350 Ω
	-NDI	NDIS connector for connections to an external bridge head
Number of channels and measurement interval	-M04	4-CH, medium-speed measurement (minimum measurement interval: 100 ms)

## Digital Input Module

Model	Suffix Code	Description
MX115		
Input type	-D05	Non-voltage contact, 5-V logic, open collector input
	-D24	24 V logic
Number of channels and measurement interval	-H10	10-CH, high-speed measurement (minimum measurement interval: 10 ms)
Options	/NC	Without the plate with the clamp terminals

## Analog Output Module

Model	Suffix Code	Description
MX120		
Output type	-VAO	Voltage/current output
	-PWM	Pulse width modulation output
Number of channels and output update interval	-M08	8-CH, minimum output update interval: 100 ms

## Digital Output Module

Model	Suffix Code	Description
MX125		
Output type	-MKC	A contact output
Number of channels and output update interval	-M10	10-CH, minimum output update interval: 100 ms

## Base Plate

Model	Suffix Code	Description
MX150		
Base type	-1 to -6*	Includes two brackets for DIN rail mount The value of the suffix code corresponds to the maximum number of input/output modules that can be installed. MX150-6 is for one main module, and six input/output modules.

\* One unit of the MX110-VTD-L30 requires three input/output modules' worth of space when installing.

## Standard Accessories

The following standard accessories are supplied with the main module. Check that all contents are present and that they are undamaged.

**Power Cord (one of the following power cords is supplied according to the instrument's suffix codes)\*1**

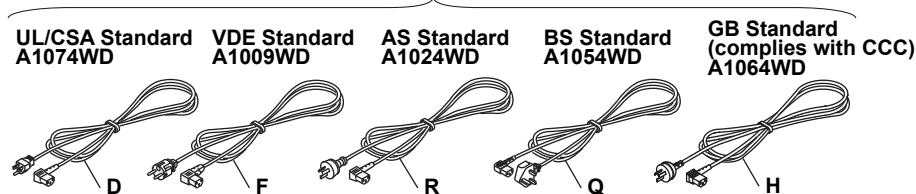

\*1 Not included when screw terminals are specified for the power section (Suffix code: W).

**MX100 Standard Software**  
Model: MX180



**MX100 Manual CD-ROM\*2**  
Part number: B8722XH



- \*2 • MX100 Data Acquisition Unit User's Manual (IM MX100-01E)
- MX100 Data Acquisition Unit Operation Guide (This manual) (IM MX100-02E)
- Contains the MX100 Standard Software User's Manual (IM MX180-01E).

**Paper Manuals**

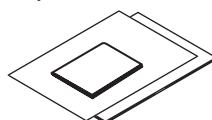

- MX100 Data Acquisition Unit Operation Guide (This manual) (IM MX100-02E)
- Precautions on the Use of the MX100/MW100 (IM MX100-71E)
- MX100/MW100 Data Acquisition Unit Installation and Connection Guide (IM MX100-72E)
- Control of pollution caused by MX100/MW100 products (IM MX100-91C)

## Optional Accessories (Sold Separately)

### Terminals

No.	Name	Model	Min. Q'ty	Note
1	10-CH screw terminal block (with RJC)	772061	1	Dedicated to the MX110-UNV-M10/MX115-D05-H10/MX115-D24-H10
2	Connection cable between the input module and screw terminal block	772062-050	1	Cable length: 50 cm <sup>*1</sup>
3	Connection cable between the input module and screw terminal block	772062-100	1	Cable length: 100 cm <sup>*1</sup>
4	Plate with clamp terminals (with RJC)	772063	1	Dedicated to the MX110-UNV-M10/MX115-D05-H10/MX115-D24-H10
5	Clamp terminal	772064	1	Dedicated to the MX110-UNV-H04
6	Clamp terminal	772065	1	Dedicated to the MX120-VAO-M08/MX120-PWM-M08/MX125-MKC-M10
7	Connector cover	772066	1	For empty slots with no module installed
8	Plate with clamp terminals	772067	1	Dedicated to the MX110-V4R-M06
9	Plate with clamp terminals (Built in bridge: 120 Ω)	772068	1	Dedicated to the MX112-B12-M04 <sup>*2</sup>
10	Plate with clamp terminals (Built in bridge: 350 Ω)	772069	1	Dedicated to the MX112-B35-M04 <sup>*2</sup>
11	Plate with screw terminals (M3 screw, with RJC)	772080	1	Dedicated to the MX110-UNV-M10, MX115-D05-H10, and MX115-D24-H10
12	Plate with clamp terminals for current (Built in shunt resistor 10 Ω)	772081	1	Dedicated to the MX110-UNV-M10
13	Plate with clamp terminals for current (Built in shunt resistor 100 Ω)	772082	1	Dedicated to the MX110-UNV-M10
14	Plate with clamp terminals for current (Built in shunt resistor 250 Ω)	772083	1	Dedicated to the MX110-UNV-M10

\*1 772062 is only applicable between the MX110-UNV-M10 and the screw terminal block (772061), the MX115-D05-H10 and the screw terminal block (772061), and the MX115-D24-H10 and the screw terminal block (772061).

\*2 772068 is only applicable to MX112-B35-M04. 772069 is only applicable to MX112-B12-M04.

## Checking the Contents of the Package

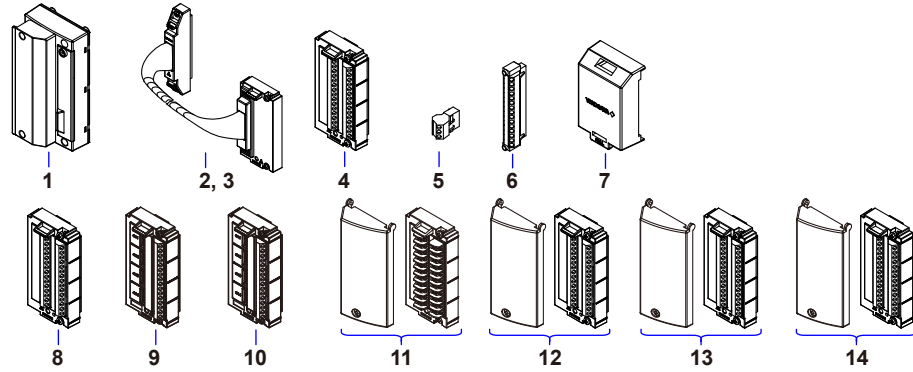

### Shunt Resistors

No.	Name	Model	Min. Q'ty	Note
15	Shunt resistor (for the clamp terminal)	438920	1	Resistance: 250 Ω ±0.1%
16	Shunt resistor (for the clamp terminal)	438921	1	Resistance: 100 Ω ±0.1%
17	Shunt resistor (for the clamp terminal)	438922	1	Resistance: 10 Ω ±0.1%
18	Shunt resistor	415920	1	Resistance: 250 Ω ±0.1%
19	Shunt resistor	415921	1	Resistance: 100 Ω ±0.1%
20	Shunt resistor	415922	1	Resistance: 10 Ω ±0.1%

### Memory cards

No.	Name	Model	Min. Q'ty	Note
21	Adapter for compact flash card	772090	1	Adapter for inserting into PC card slot
22	Compact Flash card*	772093	1	512 MB
23	Compact Flash card*	772094	1	1 GB
24	Compact Flash card*	772095	1	2 GB

\* Operating temperature range: -40 to 85°C

### Application Software (Sold Separately)

No.	Name	Model	Note
1	MXLOGGER	WX103	Data acquisition software for the MX100.
2	GateMX/MW	WX1	MX100/MW100 Gate software for connecting to DAQLOGGER data acquisition software.

### API (Sold Separately)

No.	Name	Model	Note
1	API for the MX100/DARWIN	MX190	Provides an API and extended API for the MX100 and DARWIN.

### MX100 Style Upgrade Kit\* (Sold separately)

No.	Name	Model	Note
1	MX100 Style Upgrade Kit	772050-01	Updates the old style of the MX100 main module to the latest style.
2	MX100 Style Upgrade Kit (with the /DS option)	772050-03	Updates the old style of the MX100 main module with the Dual Save function (/DS option) to the latest style.

\* Cannot be used with the special specification MX100 main module.



# Function Introduction

For further details on each function, see the *MX100 Data Acquisition Unit User's Manual* (IM MX100-01E) and the *MX100 Standard Software User's Manual* (IM MX180-01E) provided on the accompanying CD-ROM.

## Overview of the MX100

The MX100 consists of the main module equipped with an Ethernet port, input/output modules that perform input or output of signals, and the base plate that attaches and connects all of these. The main module and the PC is connected locally via the Ethernet interface in a one-to-one relationship. By installing the MX100 Standard Software into the PC, you can use the PC to configure the acquisition conditions of the measured data of the MX100 and monitor or retrieve the measured data. The MX100 Standard Software allows a single PC to connect to a single MX100 unit (up to 60 channels in terms of the number of input channels). MXLOGGER, a software program sold separately, allows one to 20 PCs to connect to a single MX100 unit (up to 1200 channels in terms of the number of input channels).

### One-to-one connection

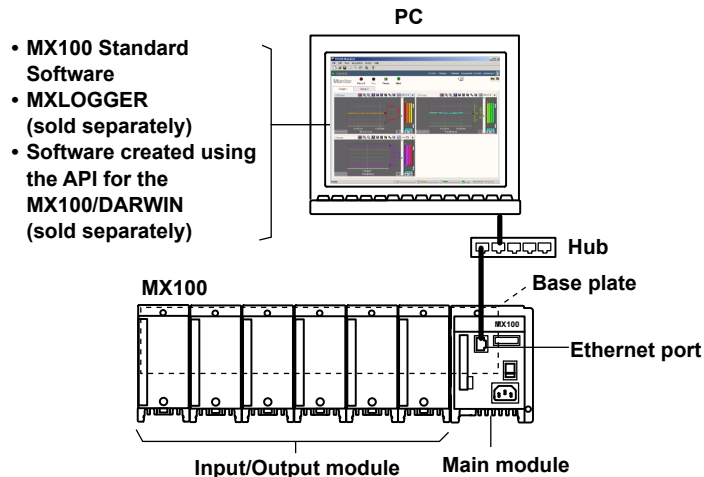

### One-to-N connection

- MXLOGGER (sold separately)
- Software created using the API for the MX100/DARWIN (sold separately)

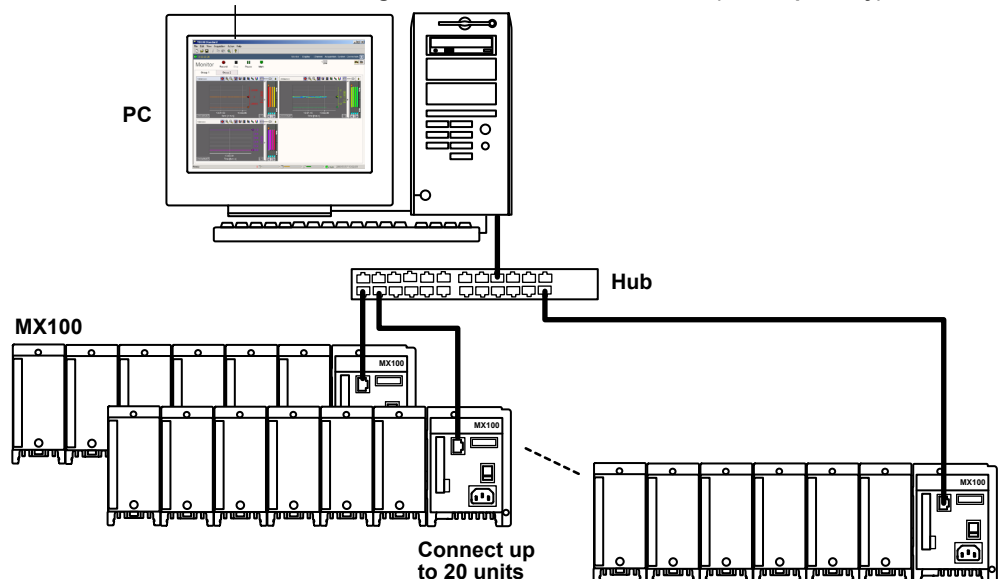

## Flow of Operation during Installation

The figure below shows the general flow of operation when the MX100 is installed initially.

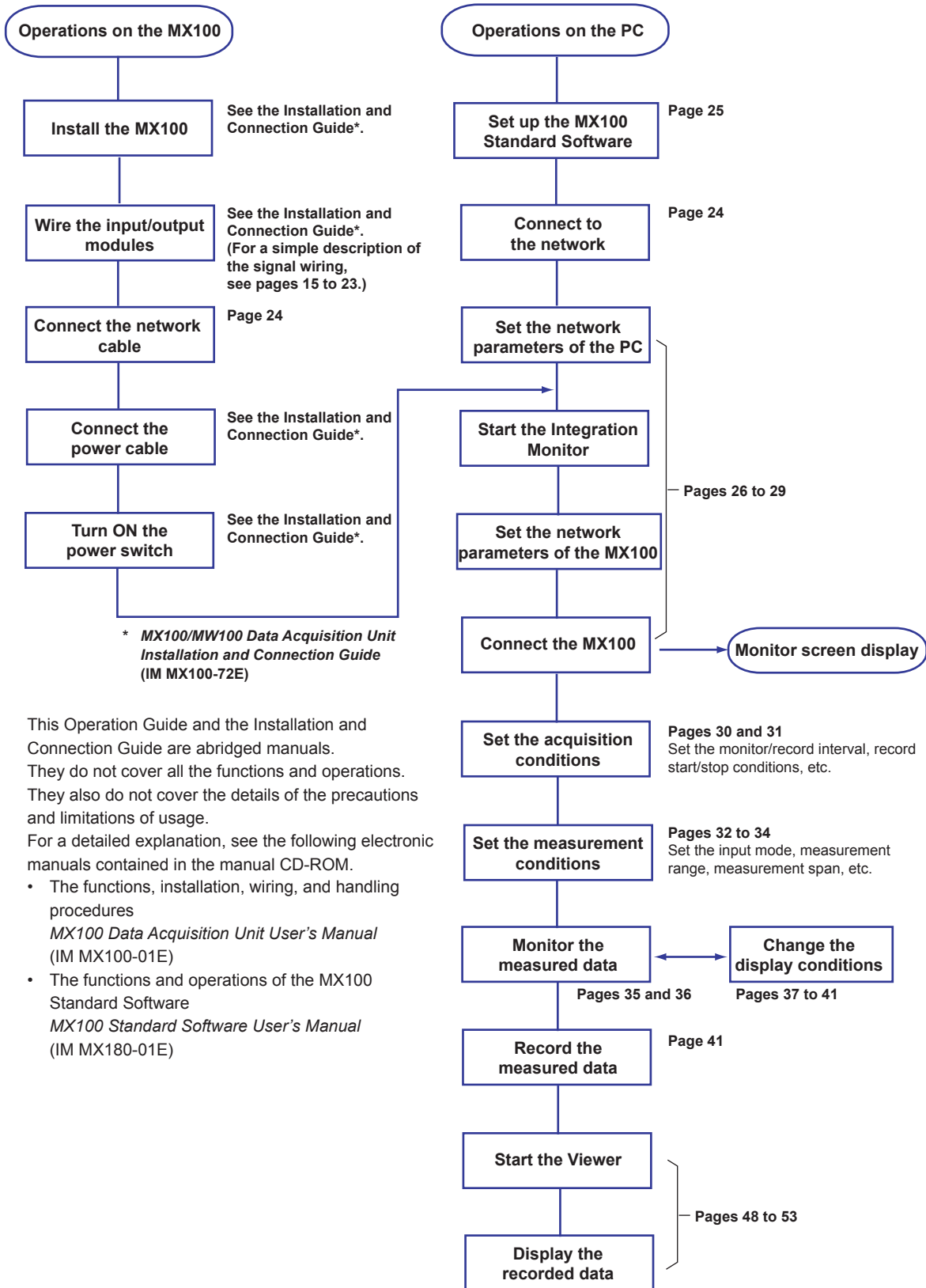

This Operation Guide and the Installation and Connection Guide are abridged manuals. They do not cover all the functions and operations. They also do not cover the details of the precautions and limitations of usage.

For a detailed explanation, see the following electronic manuals contained in the manual CD-ROM.

- The functions, installation, wiring, and handling procedures  
*MX100 Data Acquisition Unit User's Manual (IM MX100-01E)*
- The functions and operations of the MX100 Standard Software  
*MX100 Standard Software User's Manual (IM MX180-01E)*

## Function of the Modules

### Main Module

The main module is equipped with a power supply connector, a power switch, an Ethernet port, a CF card slot, a 7-segment LED, dipswitches and other parts. It contains functions such as the power supply to and the control of each input/output module, communications with a PC, data storage to the CF card when communication is disconnected.

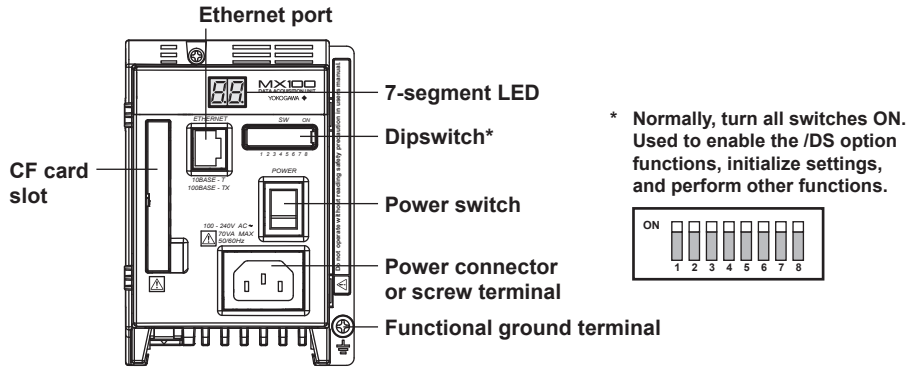

### Input/Output Modules

The following twelve types of modules are available.

- 4-CH, High-Speed Universal Input Module (MX110-UNV-H04)

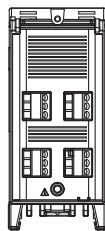

- Minimum measurement interval: 10 ms
- Maximum number of inputs: 4 inputs
- Input types: DC voltage, TC, 3-wire RTD, and DI (LEVEL, non-voltage contact)

- 10-CH, Medium-Speed Universal Input Module (MX110-UNV-M10)

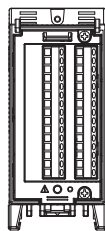

- Minimum measurement interval: 100 ms
- Maximum number of inputs: 10 inputs
- Input types: DC voltage, TC, 3-wire RTD, and DI (LEVEL, non-voltage contact)

- 30-CH, Medium-Speed DCV/TC/DI Input Module (MX110-VTD-L30)

- Minimum measurement interval: 500 ms
- Maximum number of inputs: 30 inputs
- Input types: DC voltage, TC, and DI (LEVEL, non-voltage contact)

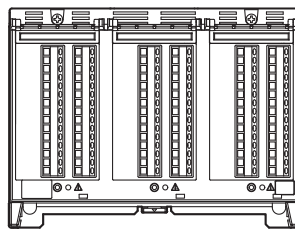

For MX110-VTD-L30

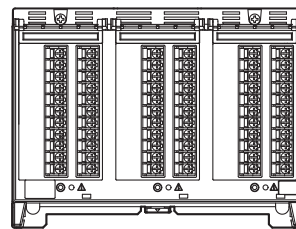

For MX110-VTD-L30/H3

- 6-CH, Medium-Speed 4-Wire RTD Resistance Input Module (MX110-V4R-M06)

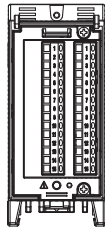

- Minimum measurement interval: 100 ms
- Maximum number of inputs: 6 inputs
- Input types: DC voltage, 4-wire RTD, 4-wire resistance, and DI (LEVEL, non-voltage contact)

- 4-CH, Medium-Speed Strain Input Module (MX112-B12-M04, MX112-B35-M04)

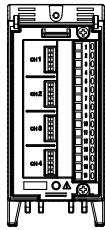

- Minimum measurement interval: 100 ms
- Maximum number of inputs: 4 inputs
- Input system: floating balanced input (isolation between channels)

- 4-CH, Medium-Speed Strain Input Module (MX112-NDI-M04)

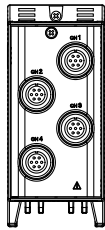

- Minimum measurement interval: 100 ms
- Maximum number of inputs: 4 inputs
- Input system: floating balanced input (non-isolation between channels)

- 10-CH, High-Speed Digital Input Module (MX115-D05-H10)

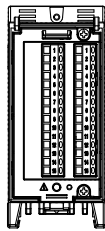

- Minimum measurement interval: 10 ms
- Maximum number of inputs: 10 inputs
- Input types: DI (non-voltage contact, open collector, 5-V logic)

- 10-CH, High-Speed Digital Input Module (MX115-D24-H10)

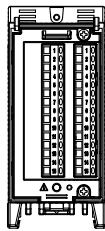

- Minimum measurement interval: 10 ms
- Maximum number of inputs: 10 inputs
- Input types: DI (24-V logic)

The 10-CH, Pulse Input Module (MX114-PSL-M10) cannot be used with the MX100. For details see “Input/Output Modules” in section 1.1 of the *MX100 Data Acquisition Unit User’s Manual* (IM MX100-01E).

- 8-CH, Medium-Speed Analog Output Module (MX120-VAO-M08)

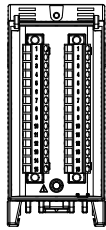

- **Output update interval: 100 ms (shortest)**
- **Maximum number of outputs: 8 outputs**
- **Output type: DC voltage, DC current**

- 8-CH, Medium-Speed PWM Output Module (MX120-PWM-M08)

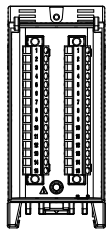

- **Output update interval: 100 ms (shortest)**
- **Maximum number of outputs: 8 outputs**
- **Output type: PWM**

- 10-CH, Medium-Speed Digital Output Module (MX125-MKC-M10)

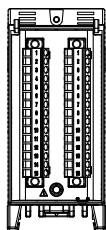

- **Output update interval: 100 ms (shortest)**
- **Maximum number of outputs: 10 outputs**
- **Output type: A contact (SPST)**

## Functions of the MX100 Standard Software

The MX100 Standard Software consists of the three software programs below.

### Integration Monitor

Enables you to connect or disconnect communications, configure acquisition conditions and display conditions of the measured channels, set up computations, monitor measured and computed data, save measured and computed data, and carry out other operations.

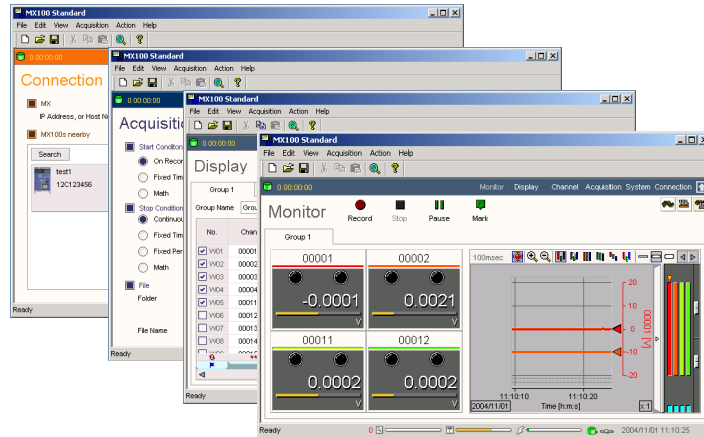

### Viewer

Enables you to display measured and computed data that has been saved, read values and perform statistical computation over an area using cursors, and convert the measured and computed data into various file formats such as Excel.

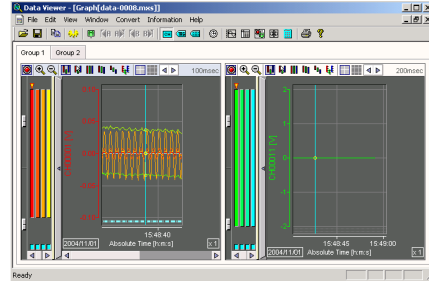

### Calibrator

This program is used to calibrate the input modules and output modules of the MX100. This operation guide does not cover the operating procedures of the software. See the *MX100 Standard Software User's Manual (IM MX180-01E)*.

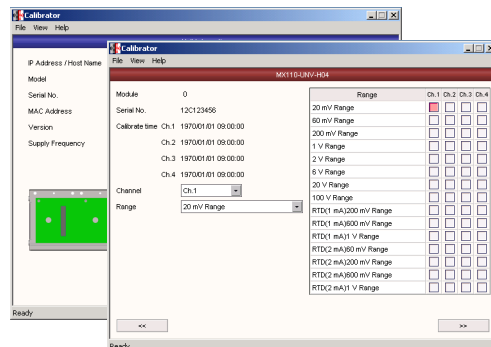

# Signal Wiring of the MX100

For a description of the installation procedure, module attachment procedure, signal wiring details, and wiring of the power supply, see the *MX100/MW100 Data Acquisition Installation and Connection Guide* (IM MX100-72E) or the *MX100 Data Acquisition Unit User's Manual* (IM MX100-01E). For the safety precautions, see the Precautions on the Use of the *MX100/MW100 Data Acquisition Unit* (IM MX100-71E) or the *MX100 Data Acquisition Unit User's Manual* (IM MX100-01E).

## Attachment Position and Channel Numbers of the Input/Output Module

The figure below shows how the MX100 Standard Software identifies the channel numbers.

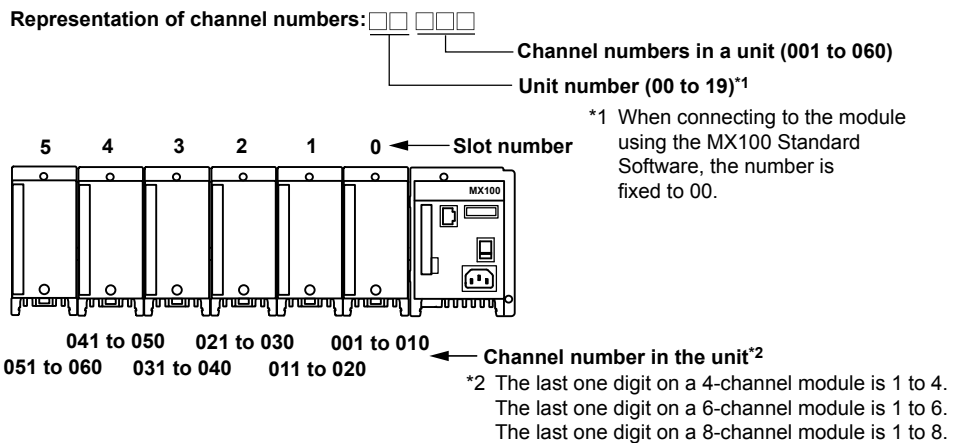

## Terminal Arrangement Markings on the Terminal Cover

On the rear side of the terminal cover of each input/output module are characters that indicate the functions of the terminals and terminal symbols. Connect the wires according to the markings. The figure below is an example only.

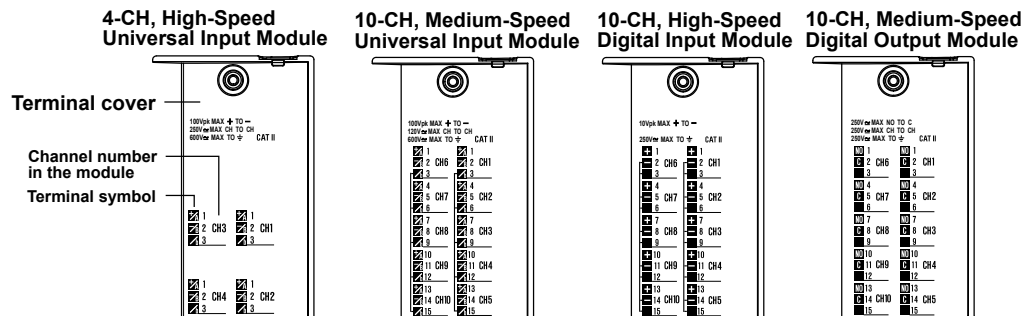

## Wiring the Universal Input Module and DCV/TC/DI Input Module

• Thermocouple input

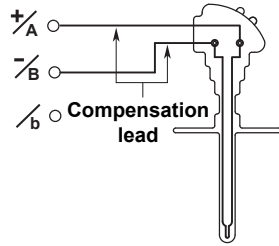

• RTD input

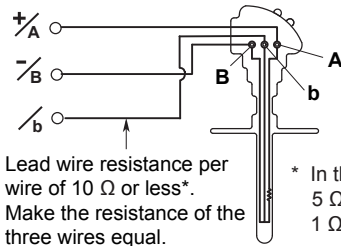

Lead wire resistance per wire of 10 Ω or less\*.  
Make the resistance of the three wires equal.

\* In the case of Pt100 Ω. 5 Ω max for Pt50 Ω. 1 Ω max. for Cu10 Ω.

• DC voltage input/DI input (contact)

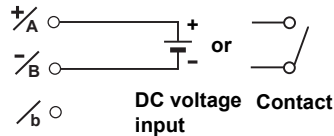

• DC current input

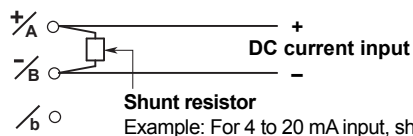

**Shunt resistor**  
Example: For 4 to 20 mA input, shunt resistance values should be 250 Ω ±0.1%.

A plate with clamp terminals for current with built-in shunt resistance can be attached to the 10-CH, Medium-Speed Universal Input Module.

Terminal type: Clamp, or screw (in the case of M3: -L30/H3)  
Applicable wire size: For -H04: 0.2 to 2.5mm<sup>2</sup> (AWG24 to 12)  
For -M10 and -L30 (clamp): 0.14 to 1.5mm<sup>2</sup> (AWG26 to 16)

**Note**

- On the 10-CH, Medium-Speed Universal Input module, RTD input terminals A and B are isolated on each channel. Terminal b is shorted internally across all channels.
- Measurement using RTDs cannot be performed with the 30-CH, Medium-Speed DCV/TC/DI Input Module.
- When the screw terminal plate (model 772080) is connected to the 10-CH, Medium-Speed Universal Input Module, the terminal arrangement differs from that of clamped terminals, so wire according to the markings on the terminal cover.

## Wiring the Four-Wire RTD Resistance Input Modules

• DC voltage input/DI (contact) input

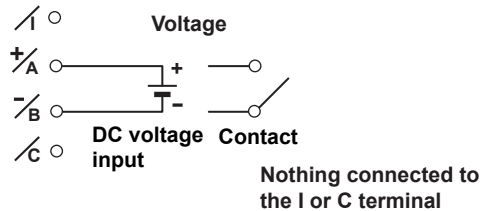

• RTD input, resistance input

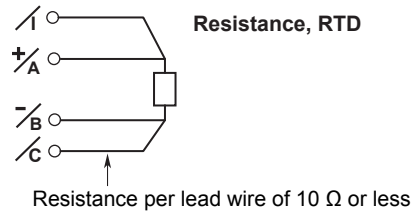

• DC current input

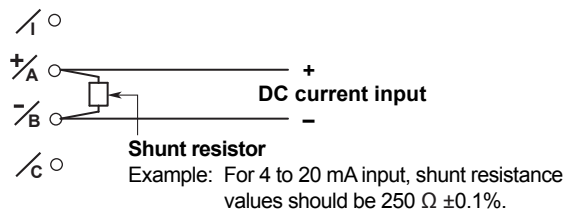

**Shunt resistor**  
Example: For 4 to 20 mA input, shunt resistance values should be 250 Ω ±0.1%.

Terminal type: Clamp  
Applicable wire size: 0.14 to 1.5mm<sup>2</sup> (AWG26 to 16)



## Wiring the Strain Input Modules

### • One-Gauge Method

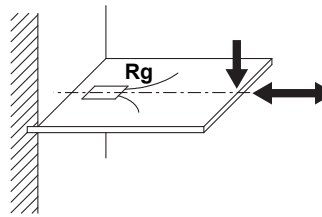
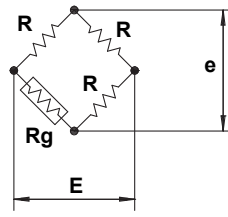

R: fixed resistance  
 r: resistance value of lead wire  
 Rg: resistance value of strain gauge  
 e: output voltage from bridge  
 E: voltage applied to bridge

### -B12, -B35

Setting switch

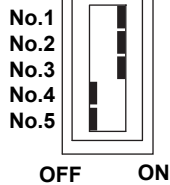

No.1	No.2	No.3	No.4	No.5
ON	ON	ON	OFF	OFF

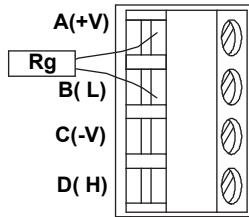

### -NDI

Bridge head (701955 or 701956)

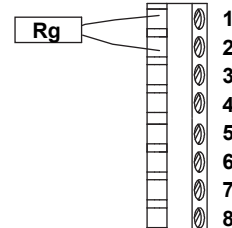

Setting switch



SW 1 2 3 4 5

SW1	SW2	SW3	SW4	SW5
ON	ON	ON	ON	OFF

### • One-Gauge Three-Wire Method

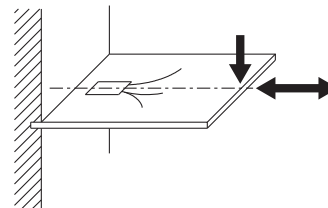
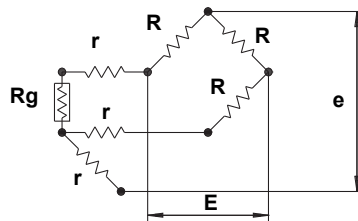

R: fixed resistance  
 r: resistance value of lead wire  
 Rg: resistance value of strain gauge  
 e: output voltage from bridge  
 E: voltage applied to bridge

### -B12, -B35

Setting switch

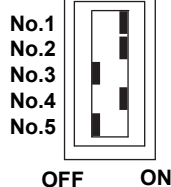

No.1	No.2	No.3	No.4	No.5
ON	ON	OFF	ON	OFF

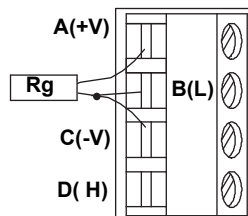

### -NDI

Bridge head (701955 or 701956)

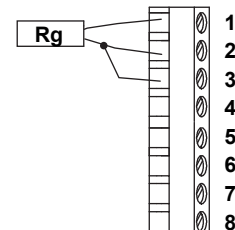

Setting switch



SW 1 2 3 4 5

SW1	SW2	SW3	SW4	SW5
OFF	ON	ON	ON	OFF

• Adjacent Two-Gauge Method

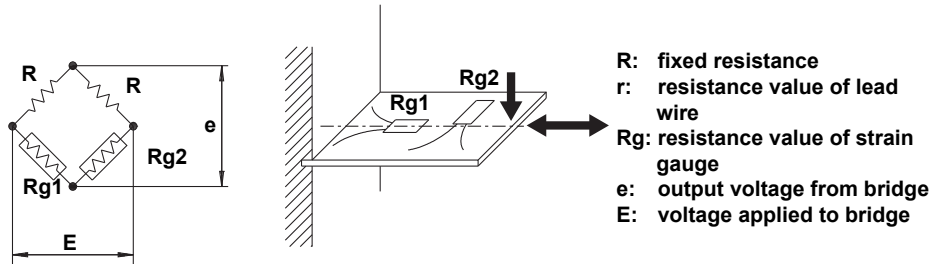

-B12, -B35

Setting switch

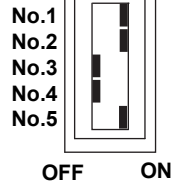

No.1	No.2	No.3	No.4	No.5
ON	ON	OFF	OFF	ON

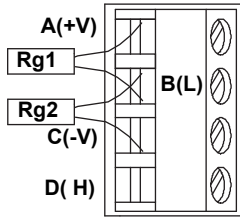

-NDI

Bridge head (701955 or 701956)



Setting switch



SW1	SW2	SW3	SW4	SW5
OFF	ON	ON	ON	OFF

• Opposing Two-Gauge Method

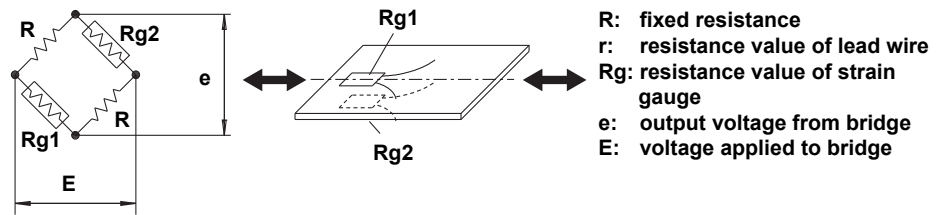

-B12, -B35

Setting switch

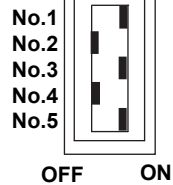

No.1	No.2	No.3	No.4	No.5
ON	OFF	ON	OFF	ON

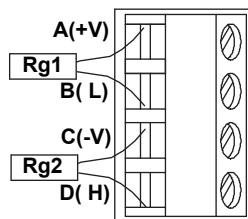

-NDI

Bridge head (701955 or 701956)

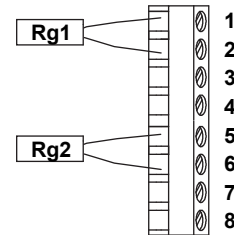

Setting switch



SW1	SW2	SW3	SW4	SW5
ON	OFF	ON	ON	OFF

• Oposing Two-Gauge Three-Wire Method

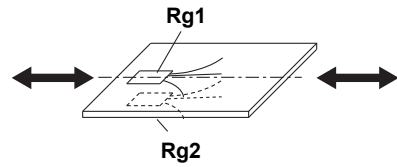
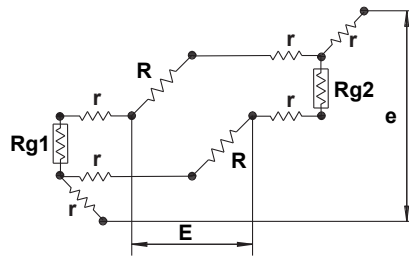

R: fixed resistance  
 r: resistance value of lead wire  
 Rg: resistance value of strain gauge  
 e: output voltage from bridge  
 E: voltage applied to bridge

-B12, -B35

Cannot be connected. Use -NDI.

-NDI

Bridge head  
 (701955 or 701956)

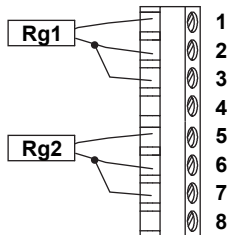

Setting switch

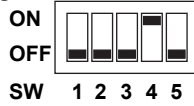

SW1	SW2	SW3	SW4	SW5
OFF	OFF	OFF	ON	OFF

• Four-Gauge Method

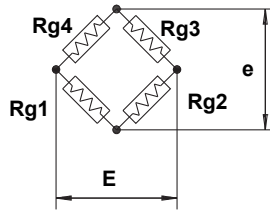

R: fixed resistance  
 r: resistance value of lead wire  
 Rg: resistance value of strain gauge  
 e: output voltage from bridge  
 E: voltage applied to bridge

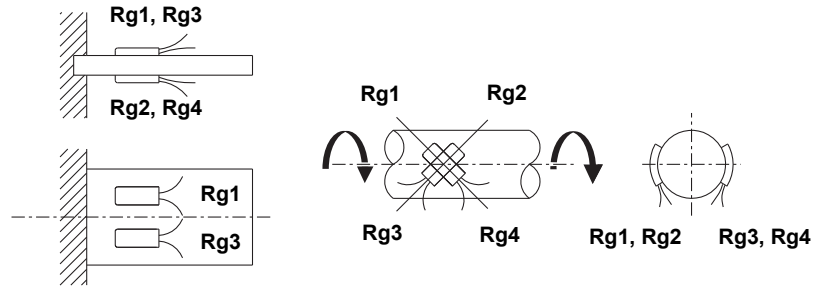

-B12, -B35

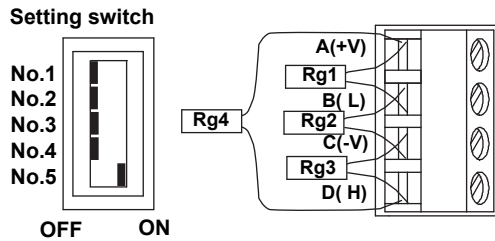

No.1	No.2	No.3	No.4	No.5
OFF	OFF	OFF	OFF	ON

-NDI

Bridge head  
 (701955 or 701956)

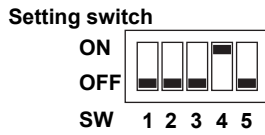
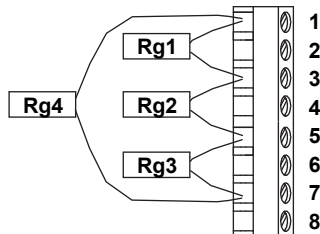

SW1	SW2	SW3	SW4	SW5
OFF	OFF	OFF	ON	OFF

## Wiring the Digital Input Modules (-D05, -D24)

### Note

- On the digital input modules, the negative terminals and empty terminals of all channels are shorted internally.
- When the screw terminal plate (model 772080) is connected to the digital input module, the terminal arrangement differs from that of clamp terminals, therefore wire according to the markings on the terminal cover.

### Wiring with the -D05 Option

#### • Contact input

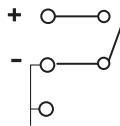

#### • Transistor input

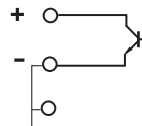

#### • 5V logic input

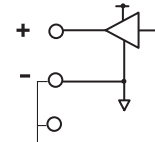

### Main Input Specifications (-D05)

Input type:	DI (non-voltage contact, open collector, and 5 V logic)
Input format:	Pull-up at approximately 5 V/approximately 5 k $\Omega$ , common electric potential between channels
Min. detection pulse width:	Twice the sampling interval or more
Input threshold level:	Non-voltage contact, open collector: ON at 100 $\Omega$ or less and OFF at 100 k $\Omega$ or greater 5-V logic: OFF at 1 V or less and ON at 3 V or greater
Contact/transistor rating:	Contact with a rating of 15 VDC or greater and 30 mA or greater Vce and Ic are transistors with ratings of 15 VDC or more, and 30 mA or more, respectively.
Terminal type:	Clamp
Applicable wire size:	0.14 to 1.5 mm <sup>2</sup> (AWG26 to 16)

### Wiring with the -D24 Option

#### • 24 V logic input

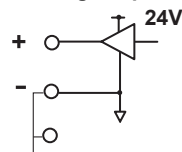

### Main Input Specifications (-D24)

Input type:	DI (24 V logic)
Input format:	Common potential between ch
Min. detection pulse width:	Twice the sampling interval or more
Input threshold level:	24 V logic: OFF at 6 V or less and ON at 16 V or greater
Terminal type:	Clamp
Applicable wire size:	0.14 to 1.5 mm <sup>2</sup> (AWG26 to 16)

### Wiring the Analog Output Modules

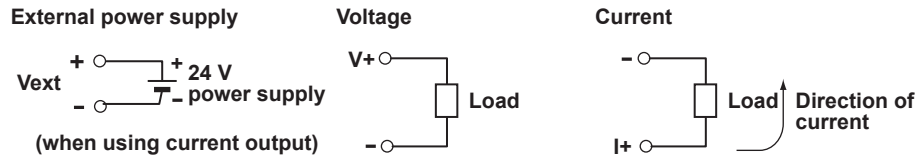

**CAUTION**

Two power supply terminals are connected internally. Therefore, do not connect a separate external power supply to them as fire can result.

#### Main Output Specifications

- Terminal type: Clamp, attached and removed in units of 4 channels
- Load impedance: Voltage 5 kΩ or more  
Current 600 Ω or less
- Applicable wire size: 0.08 to 2.5 mm<sup>2</sup> (AWG28 to 12)

### Wiring the PWM Output Modules

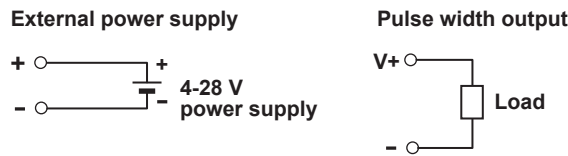

**CAUTION**

Two power supply terminals are connected internally. Therefore, do not connect a separate external power supply to them as fire can result.

#### Main Output Specifications

- Output capacity: 1A/ch max, however, 4 A or less total for all modules<sup>\*1, \*2</sup>
- Terminal type: Clamp, attached and removed in units of 4 channels
- Applicable wire size: 0.08 to 2.5 mm<sup>2</sup> (AWG28 to 12)

<sup>\*1</sup> A 1A current limit circuit is built in to the output circuit. Once the current limit circuit is ON, the circuit continues to operate unless the external power supply is turned OFF.

<sup>\*2</sup> This module has a built-in fuse. The built-in fuse protects against fires or abnormal emissions of heat due to load shortages or other abnormalities.

## Wiring the Digital Output Module

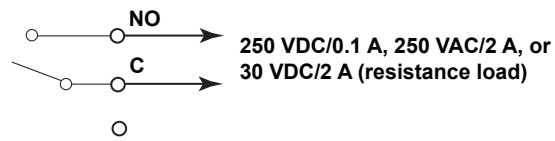

### Main Output Specifications

Contact mode: A contact (SPST)  
Contact capacity: 250 VDC/0.1 A, 250 VAC/2 A, or 30 VDC/2 A (resistance load)  
Terminal type: Clamp, attached and removed in units of 5 channels  
Applicable wire size: 0.08 to 2.5 mm<sup>2</sup> (AWG28 to 12)

### **Note**

Do not connect anything to the empty terminals of the digital output module.

# Connection to the Network

## Connecting the Ethernet Cable to the Main Module

Connect the Ethernet cable to the Ethernet port (10BASE-T/100BASE-TX) of the main module. Use a UTP cable (category 5 or better) or an STP cable for the Ethernet cable.

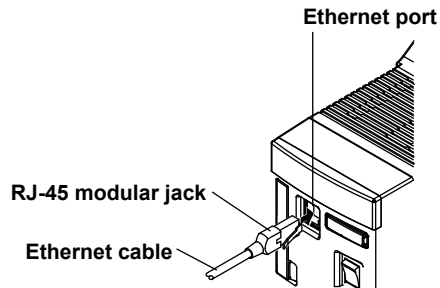

## Checking the Communication Status

You can check the status on the two LEDs at the upper-right and lower-right of the Ethernet port.

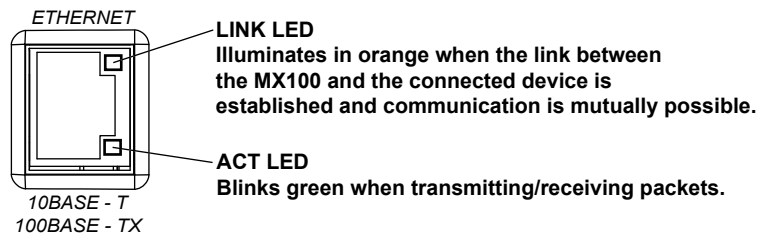

## Connection to the PC

Make the connection via a hub. As shown in the figure below, connect the MX100 to the PC locally using a one-to-one relationship.

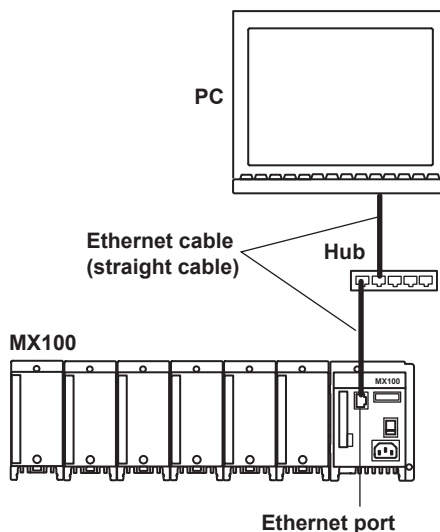

### System requirements for the MX100 Standard Software

#### OS

Windows 2000 Professional SP4,  
Windows XP SP2 (excluding x64 Edition),  
Windows Vista Home Premium (excluding the 64-bit Edition),  
or Windows Vista Business (excluding the 64-bit Edition).

#### PC

For Windows 2000 and Windows XP:  
PC with an Intel Pentium II, 400 MHz or higher CPU  
(Pentium III, 1 GHz or higher recommended), and at least 256 MB  
of memory (512 MB or more recommended)

#### For Windows Vista:

PC with an Intel Pentium 4, 3.0 GHz or higher CPU and at least  
1 GB of memory (2 GB or more recommended)

#### Hard disk

Free space: 50 MB or more (1 GB or more recommended)  
RPM: 7200 rpm or more

#### Display

1024 × 768 dot resolution or higher  
(1280 × 1024 dots or higher recommended), 65536 colors or more  
With Windows Vista, a video card recommended for the OS

### Note

- The NIC on the PC should support 100BASE-TX (recommended) or 10BASE-T.
- When connected to an external network, the communications within the network other than those related to the MX100 may hinder the measurement operations on the MX100.



# Setup Procedures of the MX100 Standard Software

For details on the setup procedure, see the *MX100 Standard Software User's Manual* (IM MX180-01E). For the MX100 Standard Software system requirements, see "Connection to the PC" in "Connection to the Network."

## Installing the MX100 Standard Software

Insert the MX100 Standard Software Setup CD-ROM in to the CD-ROM drive. The language selection screen appears. Select the language and the setup program automatically starts. If the installer does not automatically start, double-click SETUP.EXE in the DISK1 folder in the English folder on the CD-ROM.

After the setup program starts, follow the instructions that appear on the screen.

In the middle of the installation, a dialog box shown below opens prompting you to enter the serial number. The serial number is written on the label that is attached to the front of the case for the MX100 Standard Software Setup CD-ROM.

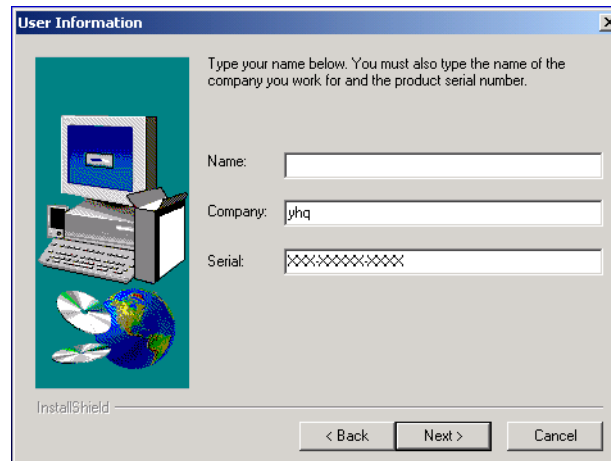

## Installation Result

When the software program is installed properly, the folder MX100 Standard is created in the specified directory (C:\ by default). MX100 Standard is registered in the program list and MX100 Standard (referred to as the Integration Monitor in this operation guide), MX100 Viewer, and MX100 Calibration are registered under it.

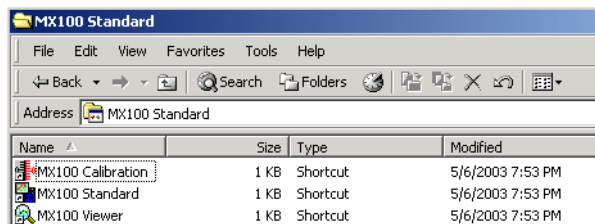

# Operations of the MX100 Standard Software

## Connecting to or Disconnecting from the MX100

Before carrying out the following procedure, check that the power switch on the MX100 is ON and that the PC is connected to the MX100 locally in a one-to-one relationship as shown under “Connection to the PC” in “Connection to the Network.”

### When Connecting for the First Time

1. Enter the IP address and subnet mask of the PC as shown in the figure below. Set the IP address of the PC to a fixed address (192.168.1.100, for example), not dynamically. Set the subnet mask to 255.255.255.0. Leave the default gateway blank or set it to 0.0.0.0.

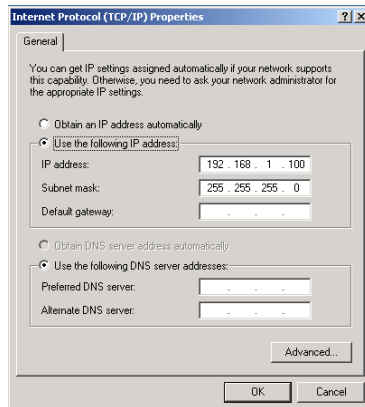

The dialog box in the left figure appears on Windows 2000. To open this dialog box, choose **Properties** from the **My Network Places** short-cut menu. Then, choose **Local Area Connection > Properties** under the **General** tab > **Internet Protocol (TCP/IP) > Properties**. On Windows XP, open **Control Panel**, choose **Network and Internet Connections > Network Connections > Local Area Connection Properties > Internet Protocol (TCP/IP)** under the **General** tab > **Properties**.

2. Click **Programs > MX100 Standard > MX100 Standard**. The Integration Monitor starts.

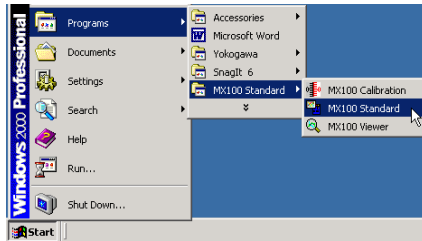

3. Click **Search**.

If an MX100 is found, icons appear in the frame containing the Search button for MX100s in the same network segment.



### Note

- If an icon for an MX100 does not appear, see “When Connection Cannot Be Made or When Connecting to Another MX100.”
- If multiple MX100s are connected in the same network segment, all of those MX100s are detected and their icons are displayed.

- Click the icon indicating the MX100.  
The network information about the MX100 appears.

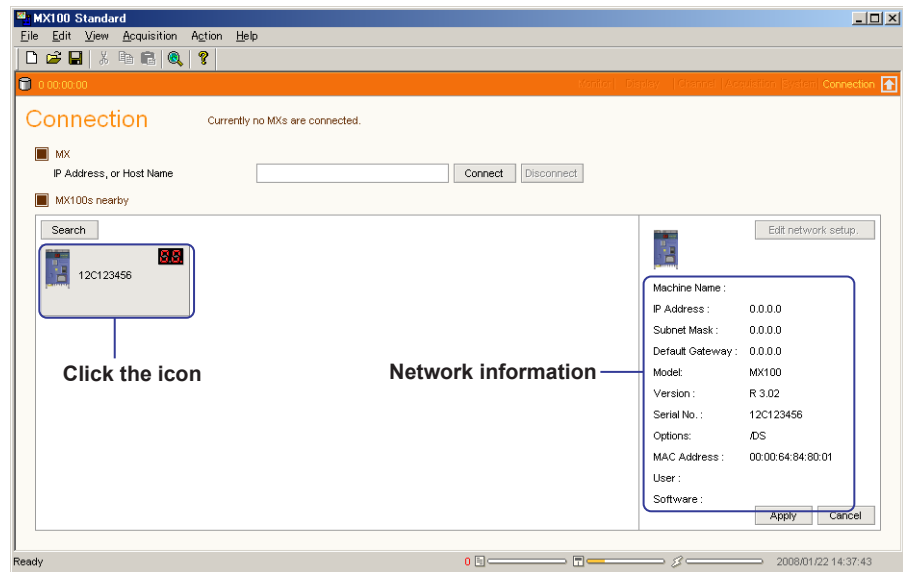

- Click **Edit Network setup** and enter the machine name and IP address.  
When you click **Edit Network setup**, the **Machine Name**, **IP Address**, **Subnet Mask**, and **Default Gateway** items turn in to text boxes.  
You can enter the machine name using up to 64 alphanumeric characters, but the entry is optional.  
The default value of the IP address, subnet mask, and default gateway is 0.0.0.0. A connection to the network cannot be made if the default IP address and subnet mask values are used.  
For example, the IP address could be changed to 192.168.1.XX (where XX is 1 to 99 or 101 to 254), and the subnet mask could be changed to 255.255.255.0. The default gateway is set to 0.0.0.0 (default value).
- Click **Apply**.

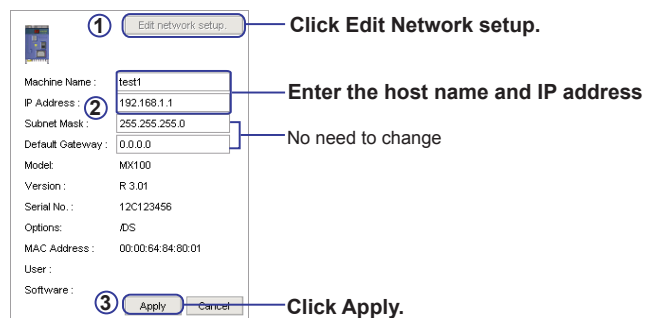

The network information disappears, and the machine name is displayed in the icon indicating the MX100.

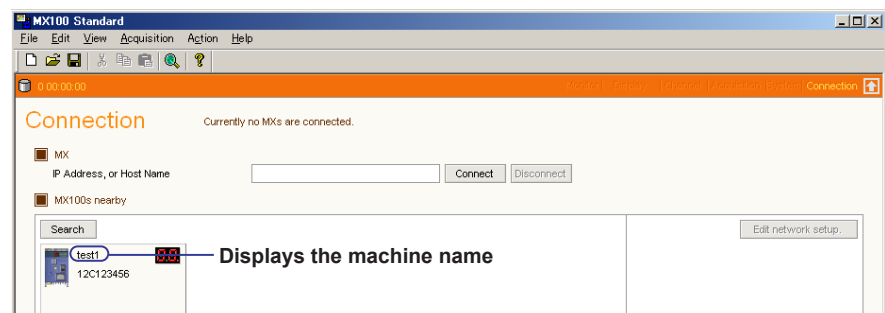

## Operations of the MX100 Standard Software

- Click the icon indicating the MX100 again.  
The network information about the connected MX100 appears again.
- Click **Connect**.

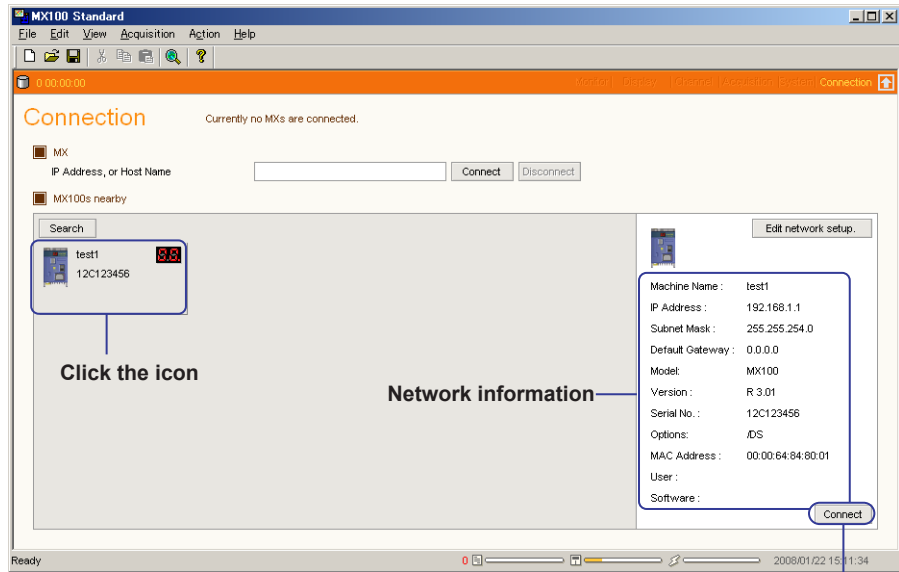

Click **Connect**.

When connected, the Monitor screen opens as shown in the figure below.

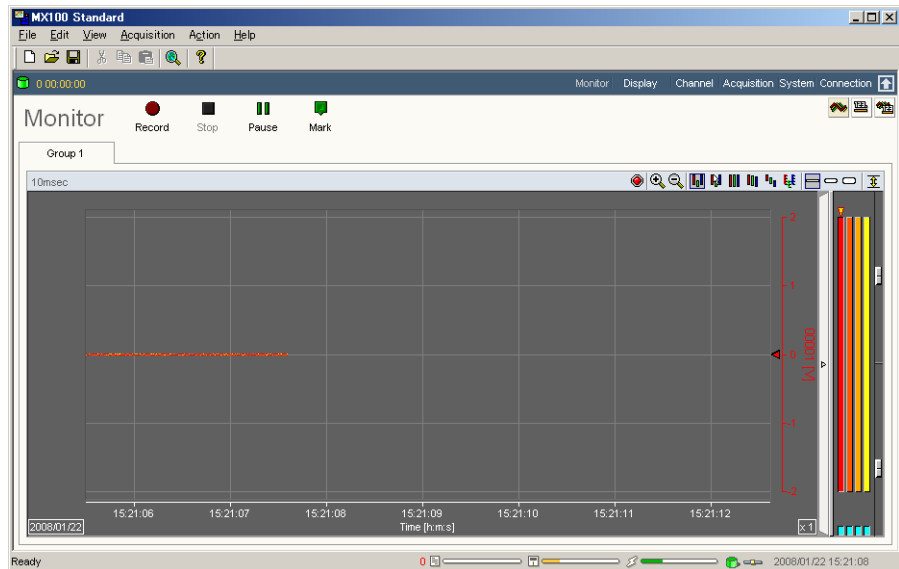

### Disconnecting

- Click **Connection** on the Monitor bar.

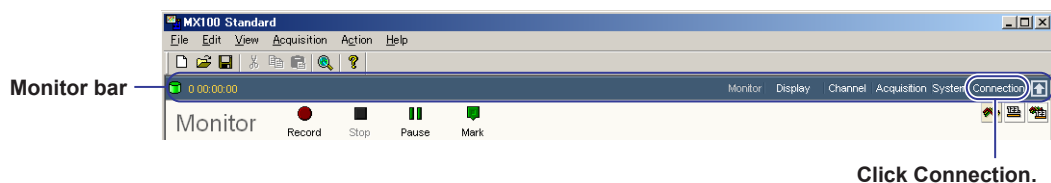

2. Click **Disconnect**.

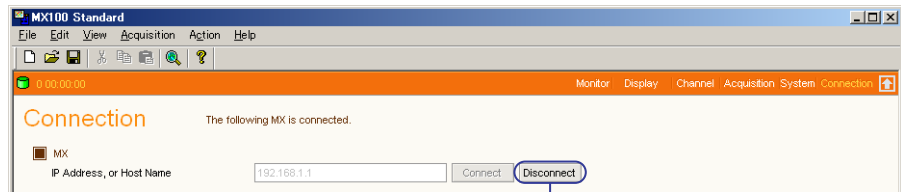

Click **Disconnect**.

**Reconnecting to the Same MX100**

- If the Connection screen is opened, click **Connect**.

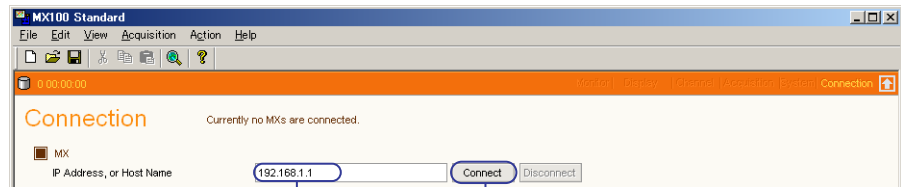

Click **Connect**.

IP address of the MX100 connected previously

- If the Integration Monitor is closed, start the Integration Monitor.  
The connection is made automatically when you start the Integration Monitor.

**When Connection Cannot Be Made or When Connecting to Another MX100**

If the MX100 that you are connecting to is already connected by another user or the connection cannot be made such as due to an incorrect designation of the IP address and you try to make a connection, the dialog box shown below remains on the screen.



If this happens, click **Cancel** in the dialog box, and click **Search** on the Connection screen. If the MX100 is in the same network segment as the PC, an icon indicating the MX100 appears in the frame containing the **Search** button. If the icon appears, click the icon to check the network information (see page 27). The user connected to the MX100 is indicated by User; the software program connected to the MX100 is indicated by Software.

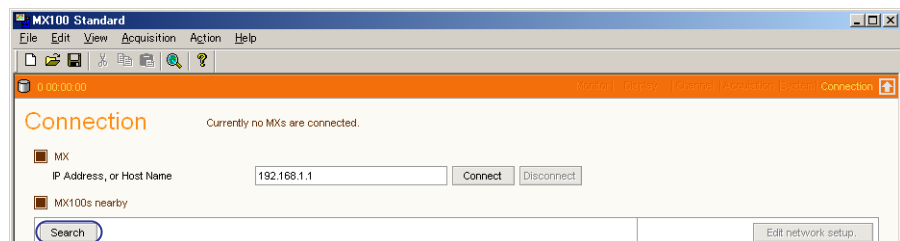

Click **Search**.

**Note**

If the module configuration changes before connecting an MX100 that has been connected previously, a message, “Some detected modules do not match the current software configuration. Rebuild based on the current MX hardware setup?” appears. For procedures in this situation, see “Reconfiguring the System” in section 2.2 of the *MX100 Standard Software User’s Manual* (IM MX180-01E).

## Setting the Acquisition Conditions of the Measured Data

Click **Acquisition** on the Monitor bar. Set the conditions on the Acquisition setup screen.

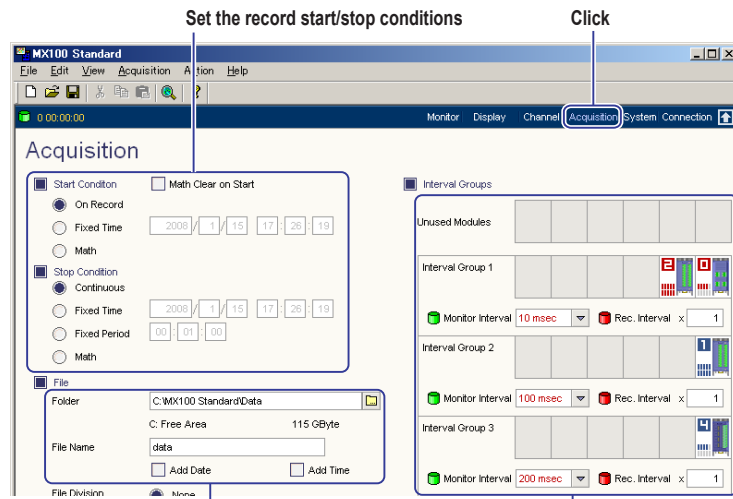

Set the save destination and name of the record file      Set the monitor interval and record interval

### Setting the Monitor Interval and Record Interval

Sets the data measurement interval. The data monitor update interval and the alarm detection interval follow this setting. However, if the specified monitor interval is short, the data monitor update interval may be slower depending on the PC environment. If the monitor interval is set greater than or equal to 2 minutes, the Integration Monitor acquires data from the MX100 at the specified interval, but the measurement interval and alarm detection interval on the MX100 are to 1 minute. The input modules can be divided into three interval groups, and different monitor intervals can be specified for each. As shown below, you can assign an input module to any of the three groups by dragging the input module on to a group.

The record interval is the interval for saving the measured data to the hard disk or other storage medium. Different record intervals can also be specified for each group. Set the record interval by entering an integer multiple (up to 128) of the monitor interval for the group.

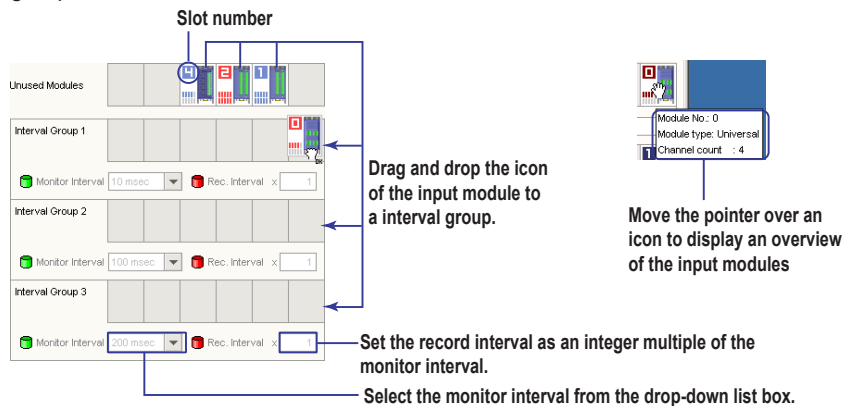

\* For math group settings, see the *MX100 Standard Software User's Manual (IM MX180-01E)*.

### Note

The shortest interval that you can specify for the monitor interval is the longest measurement interval of the shortest measurement intervals of all the input modules assigned to the same interval group. For example, if an input module with the shortest measurement interval of 10 ms and an input module with 100 ms are assigned, 100 ms is the shortest interval that can be specified for the group.

- Monitor interval setup example  
As shown in the figure below, the waveform display area is shown for each monitor interval.

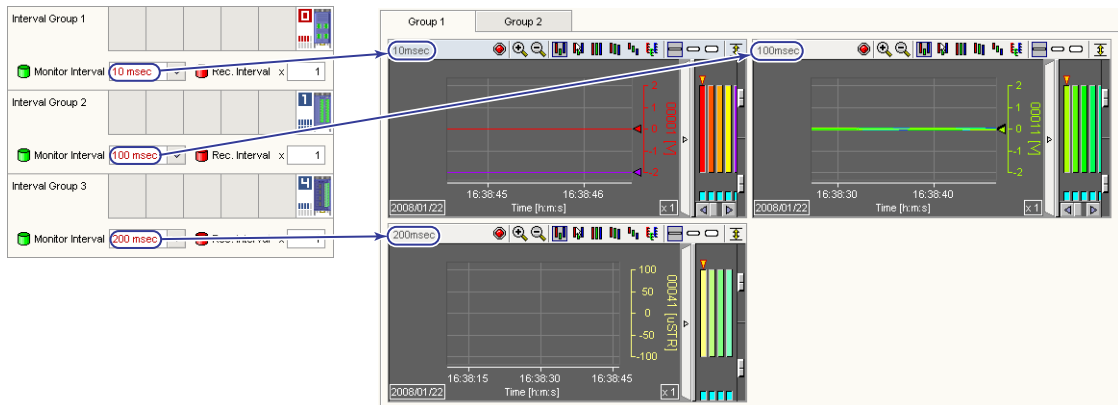

### Setting the Record Start/Stop Condition

Set the start condition for saving the measured data (computed data also if computation channels are set to be recorded) to the hard disk (record start condition) and the stop condition. For a description of the record start/stop operation, see *page 41*.

**Immediately starts recording when the Record button on the Monitor screen is clicked or Record is chosen from the Acquisition menu.**

**Starts recording at the specified date/time (year/month/day hours:minutes:seconds).**

**Immediately stops recording when the Stop button on the Monitor screen is clicked or Stop is chosen from the Acquisition menu.**

**Stops recording at the specified date/time (year/month/day hours:minutes:seconds).**

**Stops recording after the specified time (hours:minutes:seconds) elapses after the recording is started.**

\* For a description of the record start/stop condition Math, see the *MX100 Standard Software User's Manual (IM MX180-01E)*.

### Setting the Save Destination and Name of the Record File

Select the hard disk drive of your PC for the save destination. Do not specify a storage medium other than the hard disk or a network drive, as it may cause problems in terms of performance. By default, the save destination is the Data folder in the MX100 Standard folder where the MX100 Standard Software is installed.

The default file name is data. The extension is .mxd. You can also add record start date and time to the file name as follows.

- When both the date and time are added: data-0314-1316 (recording started at 13 hours 16 minutes on March 14)
- When only the date is added: data-20030314 (recording started at March 14, 2003)
- When only the time is added: data-1316 (started recording at 13 hours 16 minutes)

**When selecting the save destination folder**

**Default setting is data. (The .mxd extension is automatically added.)**

**When adding the record start time to the file name**

**When adding the record start date to the file name**

\* For a description of the File division and Comment items, see the *MX100 Standard Software User's Manual (IM MX180-01E)*.

## Setting Measurement Conditions

Click **Channel** on the Monitor bar to display the Channel setup screen. Click the **Meas. Channel** tab.

Set the items other than input mode and measurement range as necessary. For a description of setting alarms on measurement channels, see *page 42*. For a description of setting DO channels, see *page 44*. For a description of setting up computation channels, see *page 46*. For details about other channel settings, see the *MX100 Standard Software User's Manual (IM MX180-01E)*.

**Measurement channel tab**

**Click**

- Select to record, or clear to not record
- Channel number
- Select to monitor, or clear to not monitor
- Select the input mode
- Select the measurement range
- Minimum/Maximum value of span
- Check here to perform scaling\*
- Decimal point position of the scale
- Maximum/Minimum values of the scale\*
- Check here to measure the differential input (difference with respect to the measured value of the reference channel)\*
- Select the reference channel for differential input\*

\* Cannot be used when Mode is set to RRJC

- Icon of the attached module
- Click the icon to select the channels settings of the module.
- Point to the icon to display information about the module
- Select the reference channel for the remote RJC (valid only when the input mode is set to RRJC (TC))
- Unit (up to six characters, only when the Use check box of Scale is selected)
- Enter the tag number (up to 15 characters)
- Enter the tag comment (up to 30 characters)
- Set the time constant of the first-order lag filter (when the input mode is set to something other than DI)
- Set the burnout (valid only when the input mode is set to TC)
- Set the RJC (valid only when the input mode is set to TC)
- For instructions on these buttons, see the explanation under "Changing the Display Conditions" on page 37.



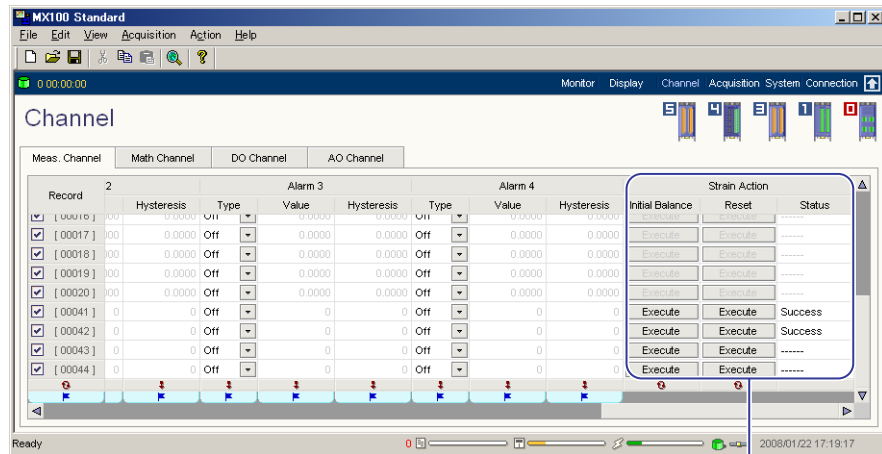

Set the initial balance for strain input channels (only when the input mode is set to STR)

### Channel Numbers

See “Attachment Position and Channel Numbers of the Input/Output Module” on page 15.

### Input Mode and Measurement Range

Select the input mode and range according to the input signal. The input types and measuring ranges vary depending on the module used.

- VOLT (DC voltage)
  - Select the measurement range from 20 mV, 60 mV, 200 mV, 2 V, 6 V, 20 V, or 100 V.
- TC (thermocouple)
  - Select the thermocouple type (referred to as Range in the setup) from Type-R, Type-S, Type-B, Type-K, Type-E, Type-J, Type-T, Type-N, Type-W, Type-L, Type-U, or KpvsAu7Fe.
- RTD1 (resistance temperature detector, measurement current: 1 mA)
  - Select the RTD type (referred to as Range in the setup) from Pt100, JPt100, HQ Pt100 (high-resolution Pt100), HQ JPt100 (high-resolution JPt100), Ni100: SAMA (Ni100 1mA SAMA), Ni100: DIN (Ni100 DIN), Ni120, Pt50, Cu10:GE, Cu10:L&N, Cu10 :WEED, Cu10:BAILEY, or J263B.
- RTD2 (resistance temperature detector, measurement current: 2 mA)
  - Select the RTD type (referred to as Range in the setup) from Pt100, JPt100, HQ Pt100 (high-resolution Pt100), HQ JPt100 (high-resolution JPt100), Pt50, Cu10:GE, Cu10:L&N, Cu10:WEED, Cu10:BAILEY, or J263B.
- RTDEX (resistance temperature detector, measured current: 0.25 mA)
  - Select the RTD type (referred to as Range in the setup) from Pt500 (default setting) or Pt1000.
- OHM (resistance)
  - Select a measurement range of 20 ohm (measured current: 1 mA), 200 ohm (measured current: 1 mA), or 2 kohm (measured current: 0.25 mA).
- DI (digital input)
  - Select LEVEL (voltage input) or CONTACT (non-voltage contact input) for the measurement range to match the input.
- STR (strain)
  - Select a measurement range of 2000  $\mu$ STR, 20000  $\mu$ STR (default value), or 200000  $\mu$ STR.
- RRJC (TC) only when measuring temperature using TCs
  - Select a channel when referring to the temperature of a relay terminal (the temperature input of the relay terminal is specified at RRJC Ref. Ch.).

### **Setting the Measurement Span**

Set the minimum and maximum values of the range that is actually measured within the measurable range.

### **Setting the Scale**

Set this item when linearly scaling the measured values. Set the scale by entering the maximum and minimum values corresponding to the maximum and minimum values of the measurement span and selecting the decimal point position of the scaled value. You can also assign a unit (up to 6 characters) to the scaled value.

### **Setting the Reference Channel for Differential Input**

Set this item when making the difference between the measured value of the channel and the measured value of the reference channel the measured value. Set the reference channel to a measurement channel with the same measurement range and whose Monitor check box is selected.

### **Setting the Remote RJC Reference Channel (Valid Only When the Input Mode Is Set to RRJC (TC))**

Set the reference channel for the remote RJC. The thermocouple type of the reference channel must be the same.

### **Setting the Time Constant of the First-Order Lag Filter (Valid Only When the Input Mode Is Set to Something Other Than DI)**

A first-order lag filter is available. Set the time constant (time until 63.2% of the output value is reached) for the case when the measurement interval is set to 1 s.

### **Setting the Burnout (Valid Only When the Input Mode Is Set to TC)**

Select the burnout detection behavior from the following.

- Up: Fix the measured value to +Over (over the upper limit of the measurement range) when a burnout is detected.
- Down: Fix the measured value to -Over (over the lower limit of the measurement range) when a burnout is detected.
- Off: Burnouts are not detected.

### **Setting the RJC (Valid Only When the Input Mode Is Set to TC)**

Select whether to use the internal reference junction compensation function of the input module or an external reference junction compensation function. When using the external reference junction compensation function, set an appropriate reference junction compensation voltage in the range of -20000  $\mu$ V to 20000  $\mu$ V.

### **Initial Balancing of Strain Input Channels (Initial Unbalance Value Adjustment)**

When configuring a bridge circuit with a strain gauge, the bridge circuit will not necessarily be balanced even if the strain of the circuit under test is zero due to the slight deviation in resistance of the strain gauge, and the measured value may not be zero (the value in such cases is called the initial unbalanced value).

Therefore, when taking measurements you must first balance the bridge and, if the strain is zero, obtain a measured value of zero. This is called initial balancing. (setting the initial unbalanced value to zero).

## Monitoring the Measured Data and Setting the Display

Click **Monitor** on the Monitor bar. You can monitor the measured data on the Monitor screen that opens.

### Monitoring the Data Using Trend Waveforms

Click

- Switch to waveform, numeric, or waveform and numeric display
- Add a mark (cannot be used when paused)
- Switch the display group
- Zoom in or out of the time axis
- Switch the display zone
- Switch the waveform width
- Turn ON/OFF the waveform display limit (clip)
- Change the grid density
- Switch the Y-axis
- Change the background darkness
- Turn ON/OFF the waveform
- Channel number and measurement unit
- Y-axis

### Monitoring the Data Using Numeric Values

Click

- Switch to waveform, numeric, or waveform and numeric display
- Channel number
- Channel display color
- Alarm indication
- Numeric display
- Level indication with respect to the scale width
- Unit

When the measured value exceeds the measurement range

When a measured or computed value is invalid

### Monitoring the Data Using Trend Waveforms and Numeric Values

The screenshot shows the 'Monitor' window in MX100 Standard. It features a menu bar (File, Edit, View, Acquisition, Action, Help) and a toolbar with icons for Manual Save, Stop, Pause, and Mark. The main area is divided into two groups: Group 1 and Group 2. Group 1 contains a 3x3 grid of numeric displays for channels 00001 through 00009, showing values like 0.0000, -0.0090, and 0.0530. Group 2 contains a waveform display for channels 00001 and 00002, showing a flat line at 0.0000. A table at the top right lists channel values for Value A, Value B, and Value B - Y. Callouts point to: 1) A toolbar icon to 'Switch to waveform, numeric, or waveform and numeric display'. 2) A button to 'Switch the display group'. 3) A red box around the waveform display area with the text 'Change the display area. When paused, you can drag to change the display area of the digital and waveform displays.' Labels at the bottom identify the 'Numeric display screen' and 'Waveform display screen'.

### Updating the Display Using the Display Menu and the Information Displayed on the Status Bar

The screenshot shows the 'Display' menu and the status bar. The menu items are: Channel, Tag No., Tag Comment, Erase Cursor, Toolbar, Status Bar, Current Time, Communication Status, Disk Space, and File. Callouts explain: 'Switch between channel number, tag number, and tag comment' (Channel); 'Turn ON/OFF the toolbar' (Toolbar); 'Turn ON/OFF the status bar' (Status Bar); 'Turn ON/OFF the displayed information on the status bar' (Communication Status, Disk Space, File). The status bar shows: 'File creation' (number of files), 'Disk space' (remaining space bar), 'Communication status' (Connected/Disconnected), 'Current time' (2003/05/14 09:17:50), 'Data rate' (rate bar), 'Monitor/Record status' (Monitoring/Recording), 'Data dropout' (warning icon), and 'Write status' (Writing/Write error).

### Changing the Display Conditions

Click **Display** on the Monitor bar. You can change the display conditions on the Display setup screen that opens. The automatic channel assignment function is convenient for assigning all the channels that were specified to be monitored in “Setting the Measurement Conditions” on page 32 to the display groups.

The screenshot shows the 'Display' configuration window in the MX100 Standard software. The window title is 'MX100 Standard' and it has a menu bar with 'File', 'Edit', 'View', 'Acquisition', 'Action', and 'Help'. Below the menu bar is a toolbar with icons for 'Monitor', 'Display', 'Channel', 'Acquisition', 'System', and 'Connection'. The main area is titled 'Display' and contains a 'Reset the scale MINMAX' button and an 'Execute' button. A status bar at the top indicates 'Assign: 20 channels per group.' and another 'Execute' button. Below this is a 'Group Name' field set to 'Group 1' and a 'Group' selector with tabs for Group 1 through Group 7. The main table lists channels with columns for No., Channel, Y-Axis, Format, Scale (Min, Max), Zone (Min, Max), Trip 1, Trip 2, and Color. At the bottom, there are several control buttons: 'Turn ON/OFF collectively', 'Assign channels automatically', 'When making the settings the same as the first item', 'Reset to default', 'To copy', and 'To not copy'.

**Click**

- Restore the default maximum and minimum values of the entire scale
- Number of channels assigned automatically
- Execute automatic channel assignment
- Switch the display group
- Group name
- Display ON/OFF
- Channel select button
- Turn scale ON/OFF when displaying multi-axis zone
- Select the Y-axis type (linear/logarithmic)
- Select the display format of the Y-axis (normal/exponent)
- Maximum/Minimum value of the scale
- Display zone position
- Turn ON/OFF the trip point display
- Trip point
- Channel display color

Turn ON/OFF collectively

Assign channels automatically

When making the settings the same as the first item

Reset to default

To copy

To not copy

### Display Groups and Group Names

The Monitor screen displays waveforms or numeric values by dividing the channels into groups. The measured/computed values can be divided into up to 10 groups. Up to 32 channels can be registered to a single group.

The channels that can be registered are those whose Monitor check boxes are selected on the Channel setup screen. When you click a channel selection button on the Display setup screen, the channel numbers of the channels that can be registered are displayed (see the figure below). You can also select the channel by tag number or tag comment by switching the tab.

You can enter a group name using up to 30 characters. By default, group names Group 1 to Group 10 are assigned.

The 'Selection' dialog box shows a table with columns for 'Channel', 'Tag No.', and 'Tag Comment'. The table contains the following data:

Channel	Tag No.	Tag Comment
None		
00001	00002	00003
00011	00012	00013
00015	00016	00017
00019	00020	

### Selecting the Display Zone of the Trend Waveform

You can select from the following. Taking the bottom and top edges of the waveform display area to be 0% and 100%, respectively, set the waveform display position by specifying the minimum value (0 to 99%) and the maximum value (1 to 100%).

- **User zone**

Displays each waveform at the position specified by Zone on the Display setup screen. A single Y-axis scale of the active waveform can be displayed.

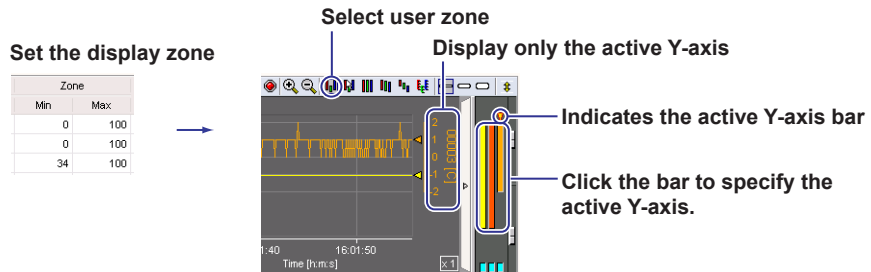

- **Edit zone**

Like the user zone, each waveform is displayed at the position specified by Zone on the Display setup screen. However, you can change the zone on the Monitor screen. A single Y-axis scale of the active waveform can be displayed.

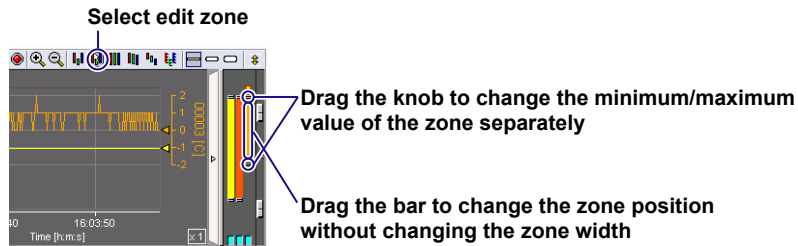

- **Full zone**

Displays all the waveforms over the full zone of the waveform display area regardless of the Zone settings on the Display setup screen. A single Y-axis scale of the active waveform can be displayed.

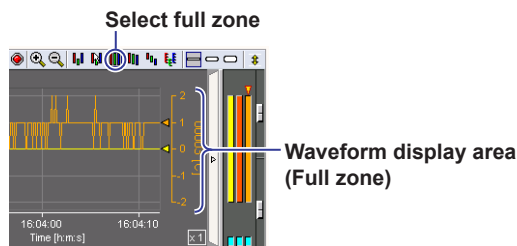

- **Slide zone**

Displays the waveforms by slightly offsetting the display position of each waveform vertically regardless of the Zone settings on the Display setup screen. A single Y-axis scale of the active waveform can be displayed.

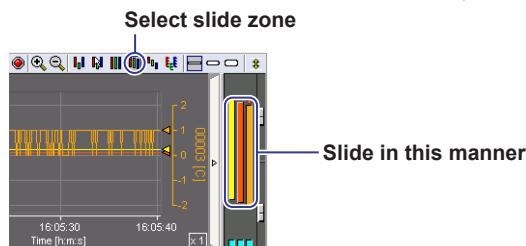

- **Auto zone**

Displays the trend waveforms by dividing the waveform display area evenly according to the number of displayed waveforms regardless of the Zone settings on the Display setup screen.

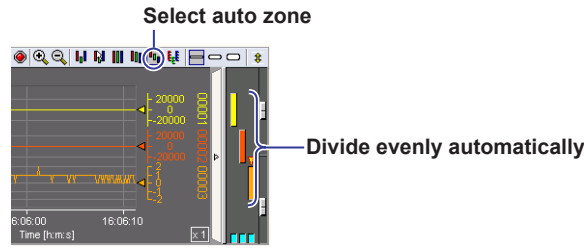

- **Multi-axes zone**

All the Y-axis scales of the displayed waveforms are aligned horizontally. To hide a Y-axis scale, clear the Y-Axis check box on the Display setup screen. The display zone is set to the position specified by Zone on the Display setup screen.

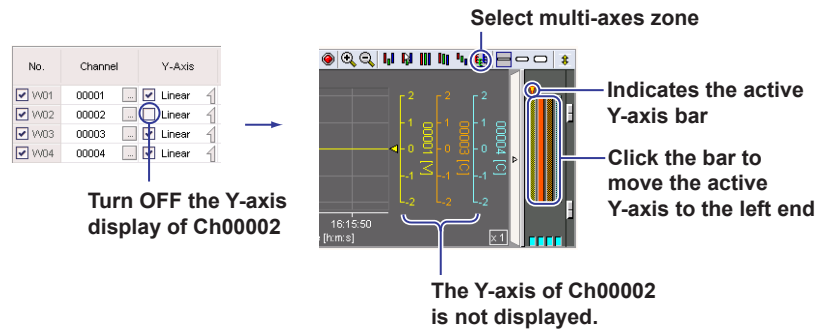

### Trip Point

You can display a trip line to indicate a particular value of interest (trip point) in the waveform display area. Two trip points (trip 1 is red, trip 2 is blue) can be set on each waveform. The trip line of the waveform corresponding to the left-most Y-axis is shown in the waveform display area.

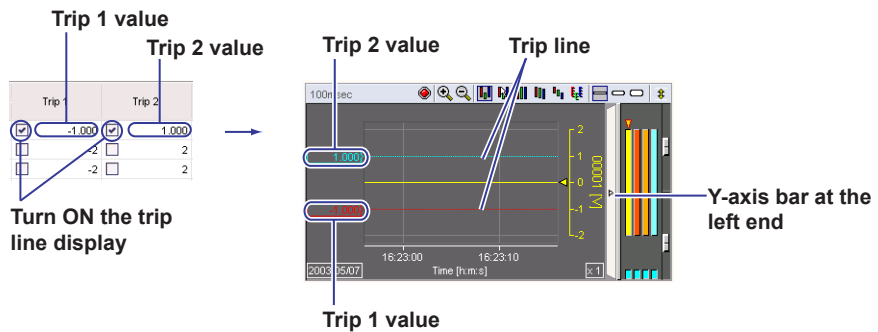

### Clipping of Trend Waveforms

By default (clip OFF), the waveform is not displayed when the measured/computed value exceeds the minimum/maximum value of the scale (see the lower left figure). When clip is turned ON, values that are smaller than the minimum value of the scale are displayed as the minimum value and the values that are larger than the maximum value of the scale are displayed as the maximum value.

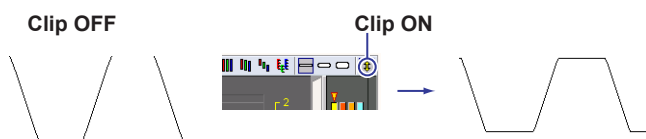

### Displaying Marks

You can display marks in the trend waveform area (see the figure below). You can enter a text to be attached to the mark ("Mark" by default) using up to 15 characters. Click the **Mark** button or choose **Mark Configuration** from the **Action** menu. You can enter the text in the dialog box that opens.

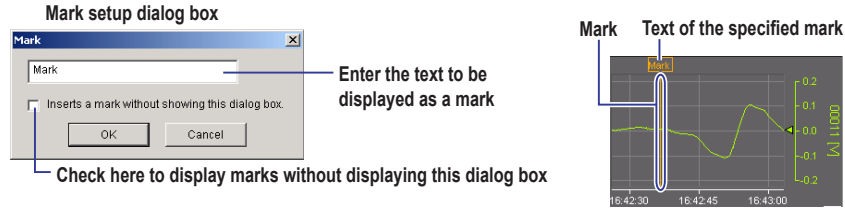

### Pausing the Updating of the Monitor Display and Reading Measured Values Using Cursors

#### Pausing and Resuming the Updating of the Monitor Display

Click the **Pause** button on the Monitor screen or choose **Pause** from the **Acquisition** menu to stop the updating of the monitor display. When paused, the word "Pause" under the button toggles between red and black. To resume the updating, click the **Pause** button on the Monitor screen or choose **Pause release** from the **Acquisition** menu.

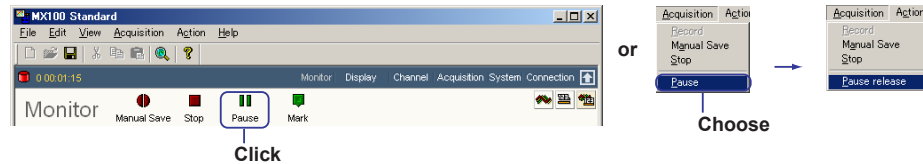

**Note**

Recording continues even when the updating of the monitor display is stopped.

#### Reading Measured Values Using Cursors

You can read measured values (computed values) using cursors when the updating of the monitor display is paused. Click the position where you wish to read the value in the waveform display area. If you wish to read another point simultaneously, drag the cursor. Cursor A appears at the position where you first clicked; Cursor B appears at the position where you released the mouse button. The measurement point is indicated by a yellow circle at the cross point of the cursor and waveform.

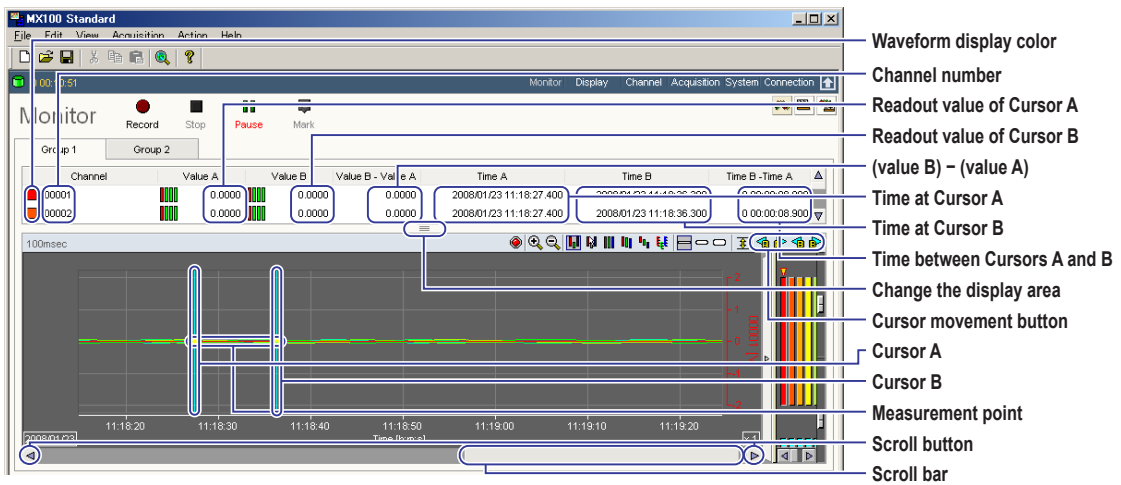



To clear the cursors, choose **Hide Cursor** from the **View** menu.

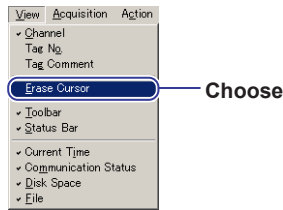

## Recording the Measured Data

For details on setting of the record start condition and setting the save destination and file name of the record file, see *page 30*.

### Record Start Operation

Click the **Record** button on the Monitor screen, or choose **Record** from the **Acquisition** menu.

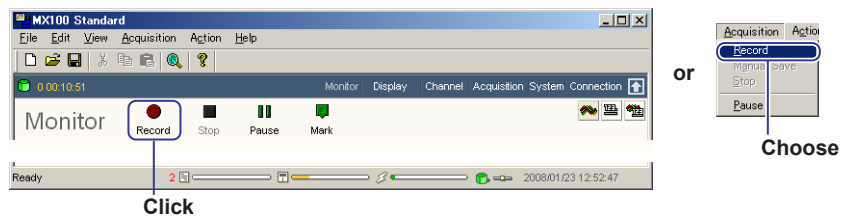

When recording starts, the display changes as shown in the figure below. To divide the file during recording, click the **Manual Save** button or choose **Manual Save** from the **Acquisition** menu.

### Changes to red when recording starts

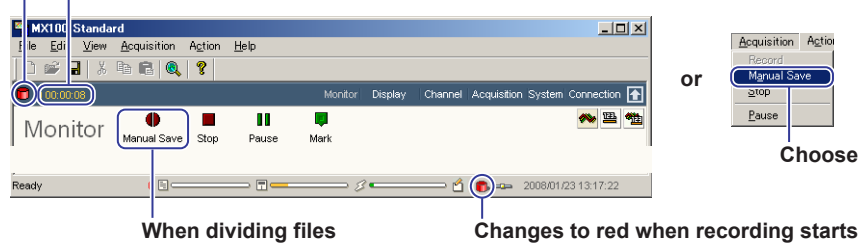

If Start Condition described is not set to On Record, recording does not start until the specified condition is met. While the Start Condition is not met, the word "Waiting" appears under the Record button (see figure below).

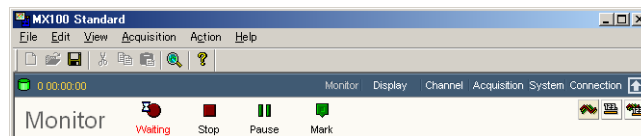

### Record Stop Operation

To stop recording when Stop Condition described is set to Manual or before the Stop Condition is met, click the **Stop** button or choose **Stop** from the **Acquisition** menu. When the message "Stop Record?" appears, click **OK**.

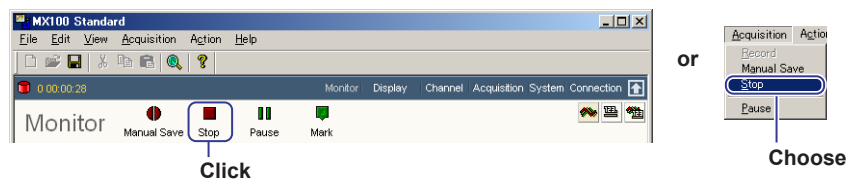

## Setting Alarms

Click **Channel** on the Monitor bar to display the Channel setup screen. Enter settings in the **Meas. Channel** or **Math Channel** tab.

For measurement channels

Click

Alarm 1 type  
Alarm value of alarm 1  
Hysterisis of alarm 1  
Alarm 2 type  
Alarm value of alarm 2  
Hysterisis of alarm 2  
Alarm 3 type  
Alarm value of alarm 3  
Hysterisis of alarm 3

Scroll to the right to display alarms 1 to 4

### Displaying Alarms on the Trend Waveform Display

The interval while an alarm is occurring is indicated by a bar at the bottom section of the waveform display area (see the figure below).

Show/Hide alarm  
Switch the active channel  
Alarm display area

Period of alarm occurrence

### Alarm Indication on the Numerical Display

Four alarm signals are displayed above the measured value (see the figure below). The changes in the color of these alarm signals indicate the alarm status.

Red: Alarm occurrence  
Green: Alarm OFF  
Black: Alarm not set

Alarm 1 status  
Alarm 2 status  
Alarm 3 status  
Alarm 4 status

00001 00002 00003 00004

1.4396 1.2899 1.1422 0.9946

**Alarm Type**

The following six alarm types are available.

When not using differential input on measurement channels, select OFF, High, or Low.

When using differential input, select OFF, dHigh, or dLow. On computation channels, select OFF, High, Low, rHigh, or rLow.

- **Upper limit alarm (High)**  
Generates an alarm when the measured or computed value is greater than or equal to the alarm value.
- **Lower limit alarm (Low)**  
Generates an alarm when the measured or computed value is less than or equal to the alarm value.
- **Differential upper limit alarm (dHigh)**  
Generates an alarm when differential input values (difference between the measured value of a channel and that of the reference channel) are greater than or equal to the alarm value.
- **Differential lower limit alarm (dLow)**  
Generates an alarm when differential input values (difference between the measured value of a channel and that of the reference channel) are less than or equal to the alarm value.

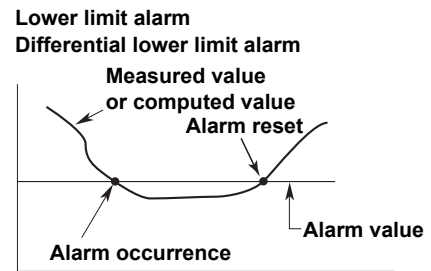
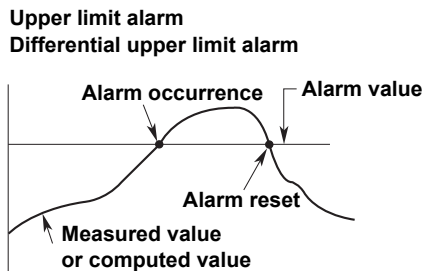

- **Upper limit on rate-of-change alarm (rHigh) ← setting only on computation channels**  
Generates an alarm if the amount of change in the computed value in the rising direction exceeds the alarm value within the rate-of-change detection interval.
- **Lower limit on rate-of-change alarm (rLow) ← setting only on computation channels**  
Generates an alarm if the amount of change in the computed value in the falling direction exceeds the alarm value within the rate-of-change detection interval.

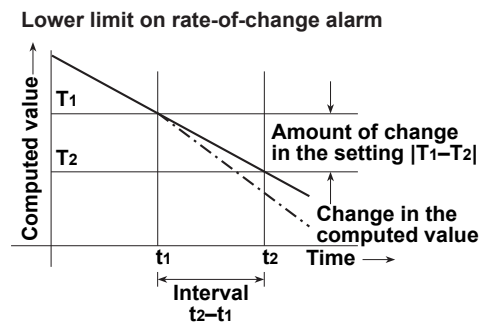
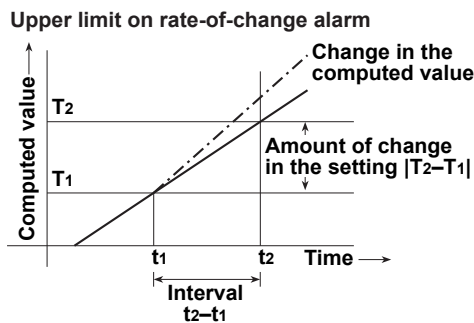

The rate-of-change detection interval is the measurement interval × measurement count. Select that measurement count (1 to 15) in the Rate-of-change alarm interval setting in the Meas. Channel settings.

**Note**

Do not close the connection between the MX100 and PC software. Computation channel alarms will not occur because the computation function does not work when using only the MX100.

### Alarm Hysteresis

You can set a width (hysteresis) to the values used to activate and release alarms. Alarm hysteresis prevents frequent activation and release of alarms when the measured/computed value is unstable around the alarm value.

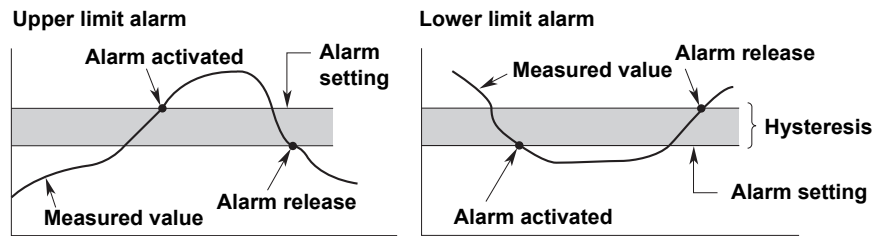

### Digital Output

Click **Channel** on the Monitor bar to display the Channel setup screen. Set the output of the digital output module in the **DO Channel** tab.

### Selecting the Action for the Digital Output

The digital output can be enabled for the following causes.

- **Alarm output**  
Outputs a signal when an alarm occurs according to the alarm settings.
- **Manual DO**  
When the manual DO button on the Monitor screen is clicked, all the DO channels assigned to the button number output relay contact signals collectively.

- **FAIL output**  
Outputs a relay contact signal when a error occurs in the main module CPU.
- **Error output**  
Outputs a relay contact signal when any of the following events occur.
  - A data output request timeout (60 s) occurs while recording data.
  - A module error occurs.

### Energized/De-energized Operation of Output Relays

You can select whether the output relay is energized or de-energized when an output event (such as an alarm) occurs. If de-energized is selected, the output relay behaves in the same fashion as when an output event occurs if the power is shut down. The default setting is Energized. The FAIL output is fixed to De-energized.

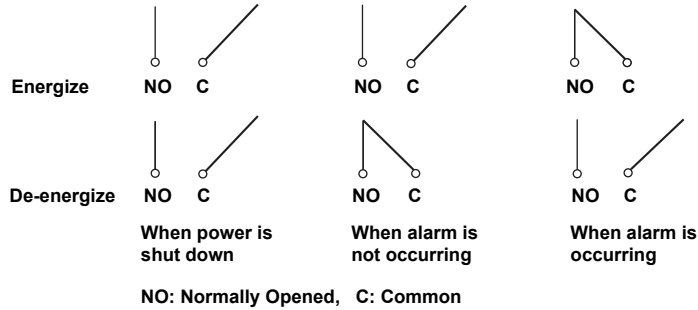

### Hold/Non-Hold of Output Relays

Select the behavior of the output relay when an output event is released (recovers to a normal condition). The default setting is Non-hold

- Turn OFF the output relay with the release of the output event (non-hold).
- Hold the output relay at ON until the **Relay ACK** button (see below) is clicked.

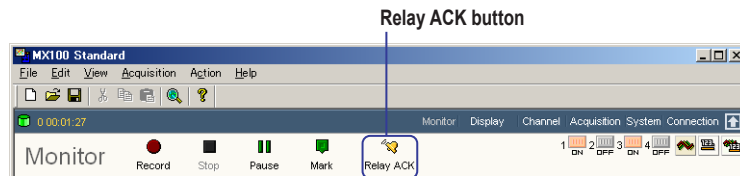

#### • When set to non-hold

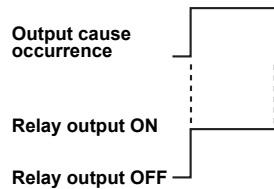

#### • When set to hold

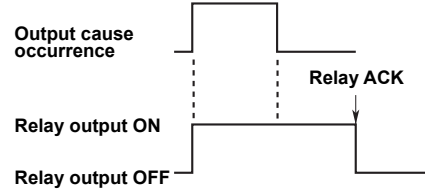

### Note

If connection with the PC is dropped, the state at the point at which the DO output was dropped is retained. However, DO output to which measurement channel alarm detection is assigned functions normally even if the connection with the PC is dropped.

## Setting the Computation

You can enter computing equations using operators, constants, and functions. The computed results be displayed and recorded (saved). Computation allows you to determine the average/maximum/minimum of a specified channel on a specified date/ time or output events (start/stop record, reset time, etc.) under specified conditions. For details on computations including available operators, constants, and functions, see the *MX100 Standard Software User's Manual* (IM MX180-01E).

Set computations using **Math Channel** on the **Channel** setup screen in the figure below. Set the monitor interval and record interval for computed data on the **Acquisition** setup screen.

**Math channel tab**

**Click**

**Channel**

Meas. Channel | **Math Channel** | DO Channel | AO Channel

Record	Monitor	Expression	Dec. Point	Min	Max	Unit	Tag No.	Tag Comment
<input checked="" type="checkbox"/>	<input checked="" type="checkbox"/>	ch(1)+ch(2)	4	-100.0000	100.0000		Tag99001	TagComment 99001
<input checked="" type="checkbox"/>	<input checked="" type="checkbox"/>	ch(3)+ch(99001)	4	-100.0000	100.0000		Tag99002	TagComment 99002
<input checked="" type="checkbox"/>	<input checked="" type="checkbox"/>	ch(4)*K01	4	0.0000	250.0000		Tag99003	TagComment 99003
<input checked="" type="checkbox"/>	<input checked="" type="checkbox"/>		4	-100.0000	100.0000		Tag99004	TagComment 99004
<input checked="" type="checkbox"/>	<input checked="" type="checkbox"/>		4	-100.0000	100.0000		Tag99005	TagComment 99005

Label	Value
K01	120.0000
	0.0000
	0.0000
	0.0000
	0.0000

Timer	Action	Interval[sec]	On-period[sec]	Off-period[sec]
Timer1	Edge	3600	0	0
Timer2	Level	3600	0	0
Timer3	Off	3600	0	0

Calculate +Over/-Over as the MAX/MIN value of a range. Interval of rate-of-change alarm 1

**Annotations:**

- Enter the constant value
- Enter the label for identifying the constant
- Select to record, or clear to not record (saving of computed data)
- Computation channel numbers
- Select to monitor, or clear to not monitor
- Enter the equation
- Enter the unit for computed values (up to 6 characters)
- Enter the tag number (up to 15 characters)
- Enter the tag comment (up to 30 characters)

**Settings when using the timer in the computation**

- Check here to calculate +Over and -Over as maximum and minimum values of the measurement range
- Enabled when rHigh or rLow is selected for the type

## Saving/Loading and Printing of Setup Data (Project)

### Saving Setup Data (Project)

From the File menu, choose **Save** or **Save As** to save the setup data. The default save destination is the folder depends on the system that is running. The extension is .mxx. The default file name is NewProject.mxx.

**or**

File name: **NewProject.mxx**

Save as type: MX100 Standard Project File (\*.mxx)

### Loading Setup Data (Project)

From the File menu, choose **Open**.

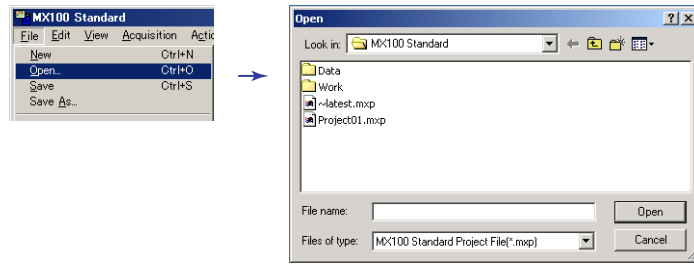

### Printing Setup Data

From the **File** menu, choose **Print**. Settings such as the network information of the MX100, information about the attached modules, acquisition conditions, and measurement conditions are printed in tables.

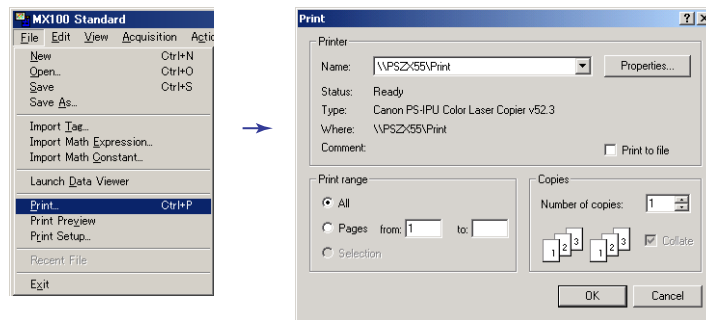

### Print image

Print image

**Unit**

Model: MX100  
Version: H 3.01  
Serial No: \*2C268285  
Wave Mode: Cycles/Mode

Temperature Unit: C  
A/D Integration Time: AUTO  
Unit No: 01

**Network Information**

MAC Address: 08 00 04 00 00 00  
IP Address: 192.168.1.100  
Default Gateway: 192.168.1.1  
Subnet Mask: 255.255.255.0  
Net No: 34376

**Acquisition**

Stop Condition: On Record  With Clear on Stop  
Stop Condition: Continuous

**File**

Folder: C:\ProgramData\Temp\100Data  
File Name: Blank  Add Date  Add Time  
File Extension: None  
Comment:

**Module Arrangement**

No.	Type	Group	Interval	Record Interval
1	AP1104-250-F04	Group 1	100 msec	100 msec
2	AP1104-250-F03	Group 1	100 msec	100 msec
3	AP115-024-F10			
4	AP120-040-F08			
5	AP112-025-F04			
6	AP125-040-F08			

Module Interval: \*100 msec      Module Interval: \*100 msec

**Channel**

Chan No.	P/UC	P/UC	Chan	Unit	Tag No.	Tag Comment	Filter	Bandwidth	Scale		Data
									Min	Max	
10000-1			VOLT	2V	-2.0000	2.0000					
10000-2			VOLT	2V	-2.0000	2.0000					
10000-3			VOLT	2V	-2.0000	2.0000					
10000-4			VOLT	2V	-2.0000	2.0000					
10000-5			VOLT	2V	-2.0000	2.0000					
10000-6			VOLT	2V	-2.0000	2.0000					
10000-7			VOLT	2V	-2.0000	2.0000					
10000-8			VOLT	2V	-2.0000	2.0000					
10000-9			VOLT	2V	-2.0000	2.0000					
10000-10			VOLT	2V	-2.0000	2.0000					
10000-11			VOLT	2V	-2.0000	2.0000					
10000-12			VOLT	2V	-2.0000	2.0000					
10000-13			VOLT	2V	-2.0000	2.0000					
10000-14			VOLT	2V	-2.0000	2.0000					
10000-15			VOLT	2V	-2.0000	2.0000					
10000-16			VOLT	2V	-2.0000	2.0000					
10000-17			VOLT	2V	-2.0000	2.0000					
10000-18			VOLT	2V	-2.0000	2.0000					
10000-19			VOLT	2V	-2.0000	2.0000					
10000-20			VOLT	2V	-2.0000	2.0000					

Chan No. P/UC P/UC Chan Unit Tag No. Tag Comment Filter Bandwidth RUC

## Displaying Recorded Measured Data, Reading Values Using Cursors, and Statistical Computation over an Area

You can display measured or computed data that has been recorded.

1. Choose **Programs > MX100 Standard > MX100 Viewer** to start the Viewer. You can also choose **Launch Historical Viewer** from the **File** menu or click the  button on the Integration Monitor.

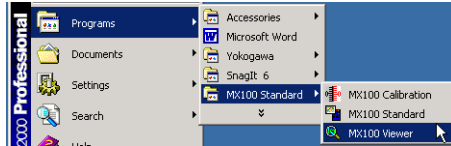

2. From the **File** menu, choose **Open**.

You can also click the  button on the toolbar.

The Open dialog box opens.

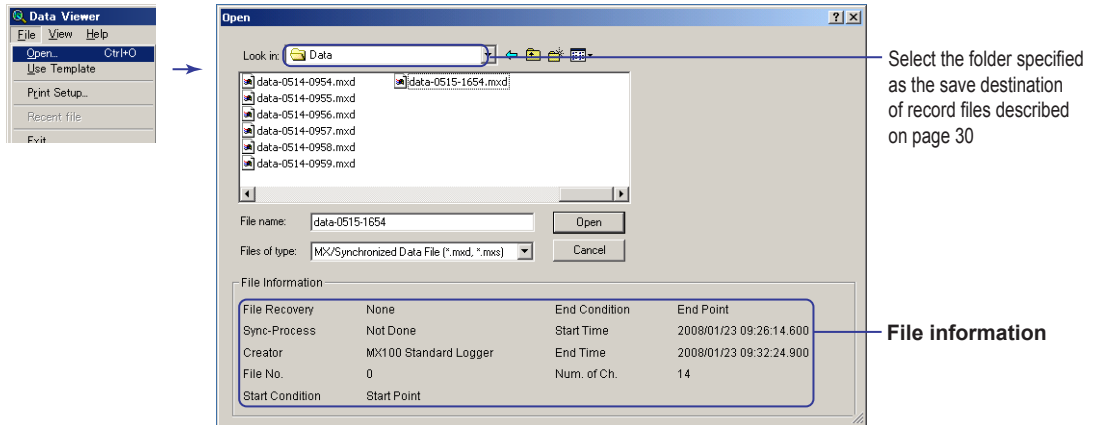

Select the folder specified as the save destination of record files described on page 30

File information

3. Select the file you wish to load and click **Open**.

The waveform display window opens.

When a file recorded using the Integration Monitor is opened, a dialog box for confirming whether to carry out synchronization (see the note below) opens. Click **Yes** or **No**.

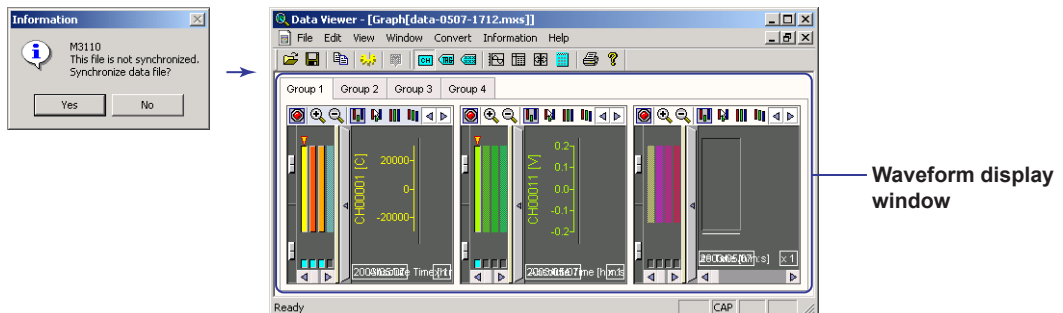

Waveform display window

### Note

The data recorded using the Integration Monitor has time stamps attached by the MX100 (see section 1.2, “Main Module Functions” in the *MX100 Data Acquisition Unit User’s Manual* (IM MX100-01E)). When synchronization is carried out, the time is corrected to the time on the PC, and the data is saved using the corrected time. The name of the created file remains the same but with a different extension .mxs. The file with .mxd extension before synchronization is not deleted.



### Changing the Display on the Waveform Display Window

You can change the display using operations similar to the waveform display area of the Monitor screen of the Integration Monitor.

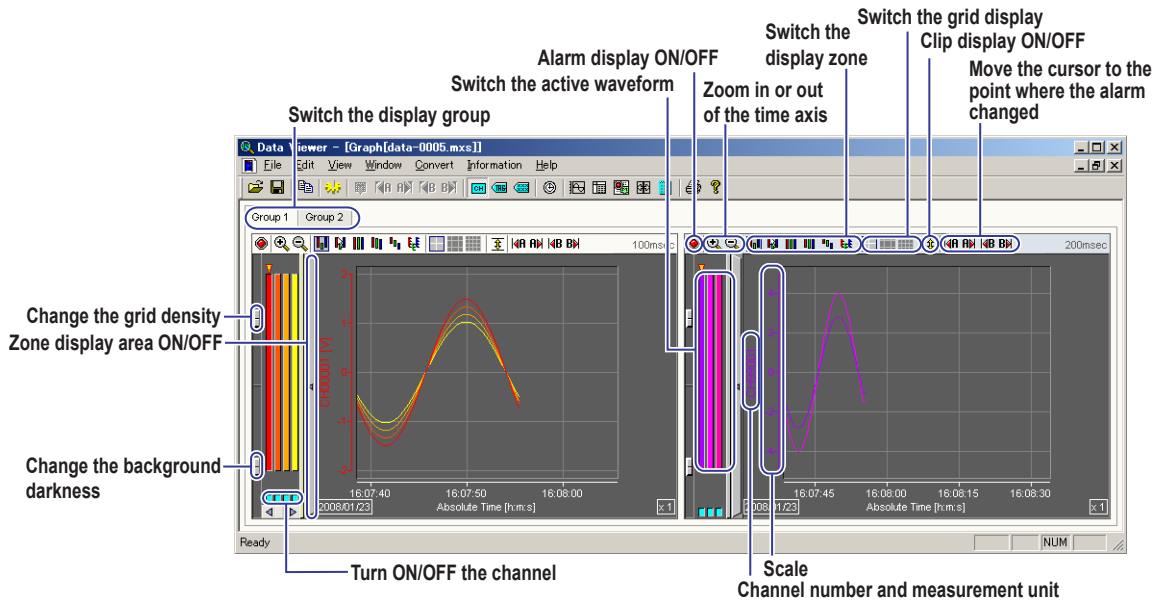

### Changing the Display Using the Toolbar

See the explanation in the figure below.

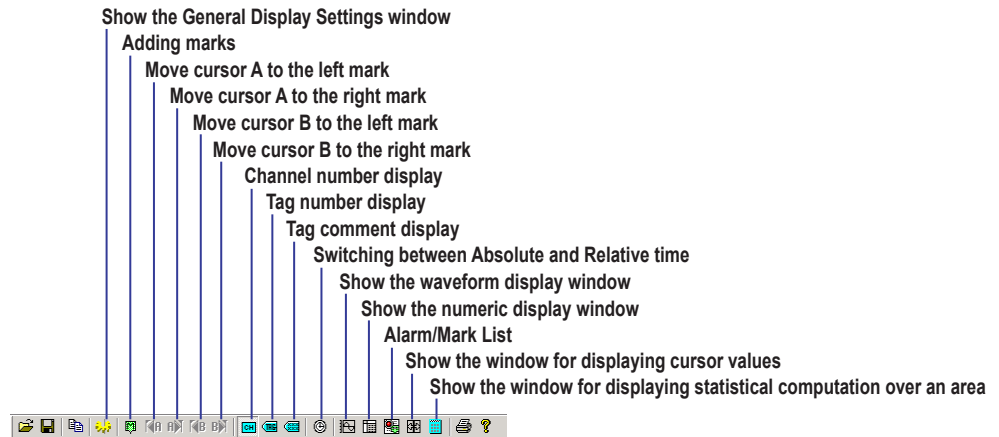

### Changing the Display Using the Menu

Choose appropriate commands from the **Edit**, **View**, and **Window** menus to change the display.

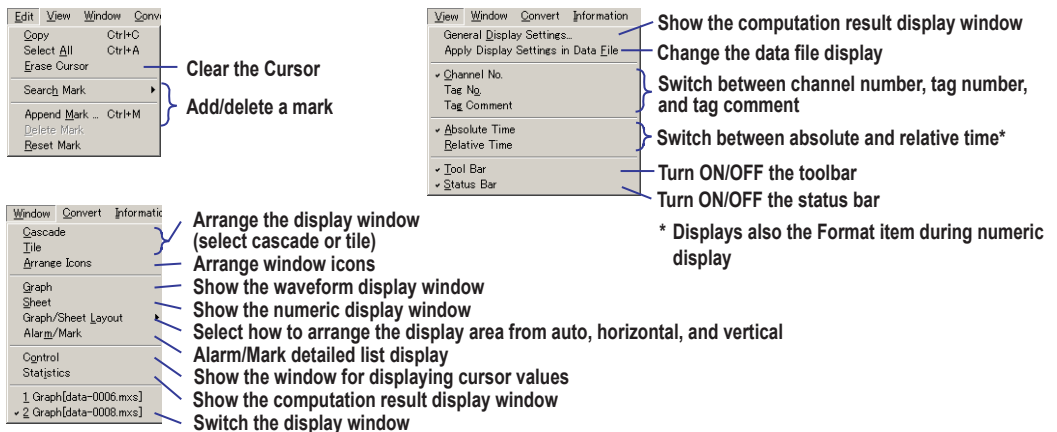

### Changing the Display Using the Display Setup Window

See the explanation in the figure below. Change the display settings and click **OK**. Set the display for each display group. The settings are similar to the Display screen on the Integration Monitor.

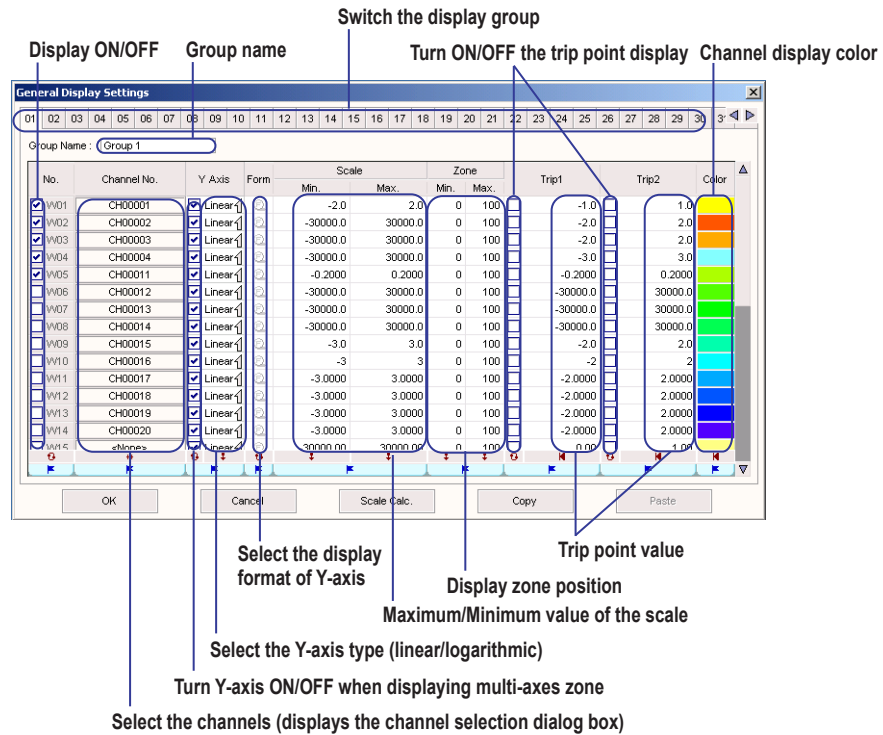

### Numeric Display

You can also show the numeric display window (see the figure below). With the waveform display window open, click the  button on the toolbar or choose **Sheet** from the **Window** menu. When groups with different monitor intervals are present, the screen is divided accordingly.

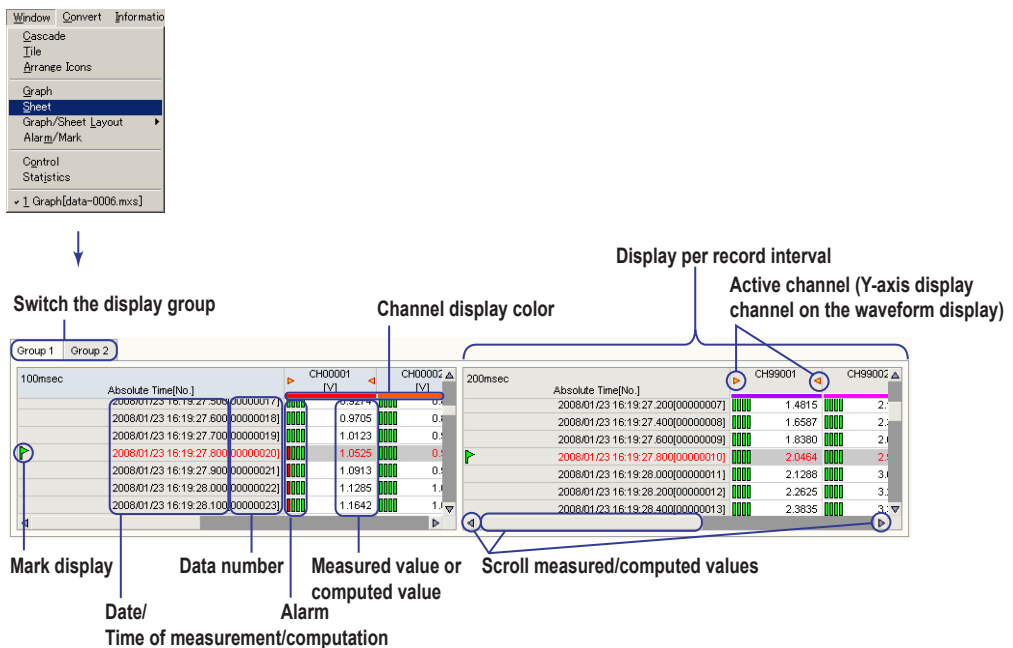

### Reading Values Using Cursors

Click the tab of the group on which you wish to read values using cursors on the waveform display window. Click the position where the measured (computed) data is to be read in the waveform display area on the waveform display window. If you wish to read another point simultaneously, drag the cursor. Cursor A appears at the position where you first clicked; Cursor B appears at the position where you released the mouse button. The measurement point is indicated by a yellow circle at the cross point of the waveform and cursor. You can move the waveform that is displayed in the waveform display area using the scroll buttons or scroll bar.

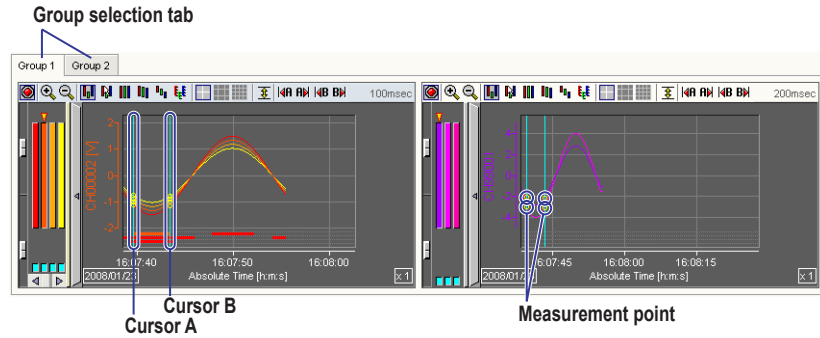

You can show a window displaying the cursor measurement values (see the figure below). From the **Window** menu, choose **Control**.

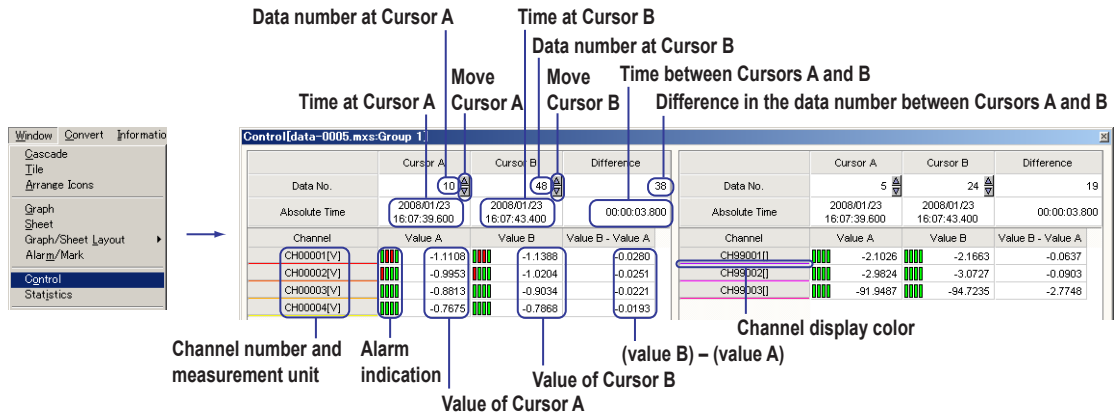

### Statistical Computation over an Area of Measured Data

Show the cursors in the same fashion as when reading the values using cursors. Cursor A is the start position of computation area; Cursor B is the end position of the computation area.

From the **Window** menu, choose **Statistics** to open the Statistics window shown in the figure below.

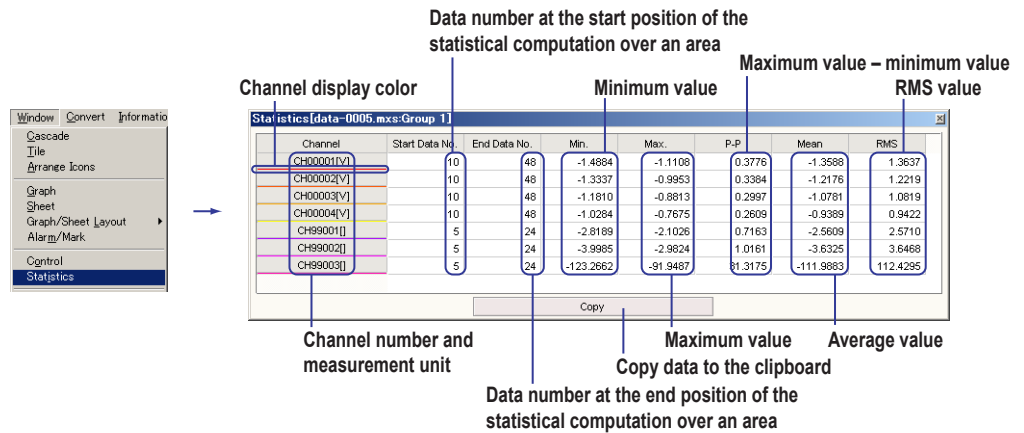

### Alarm/Mark List Display

Displays a detailed list of alarms and marks.  
 From the Window menu, choose Alarm/Mark List.  
 You can also click the  button on the toolbar.

- Alarm List

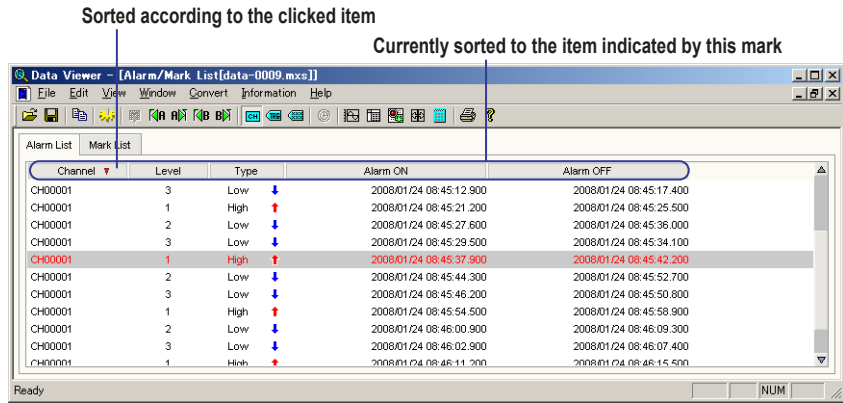

- Mark List

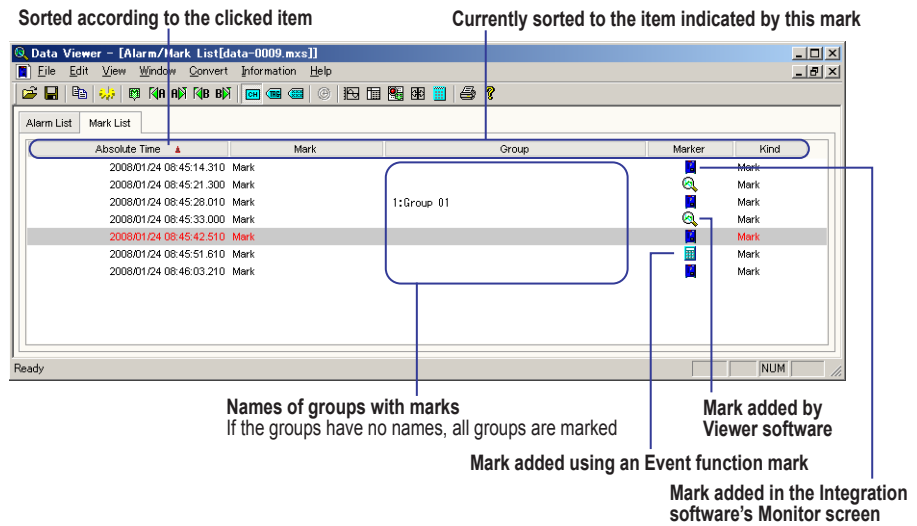

## Printing the Displayed Data

To print waveforms, open the waveform display window; to print numeric values, open the numeric display window. If multiple windows are open, click the window that you wish to print. To print values read by the cursors or statistical computation over an area, open those windows also.

After selecting the object to be printed, choose **Print Setting** from the **File** menu. In the Print Setting dialog box, set **Range**, **Color**, and **Print Groups**, and then click **OK**. Then, choose **Print** from the **File** menu to execute the printing. When printing numeric values, you only need to set the range.

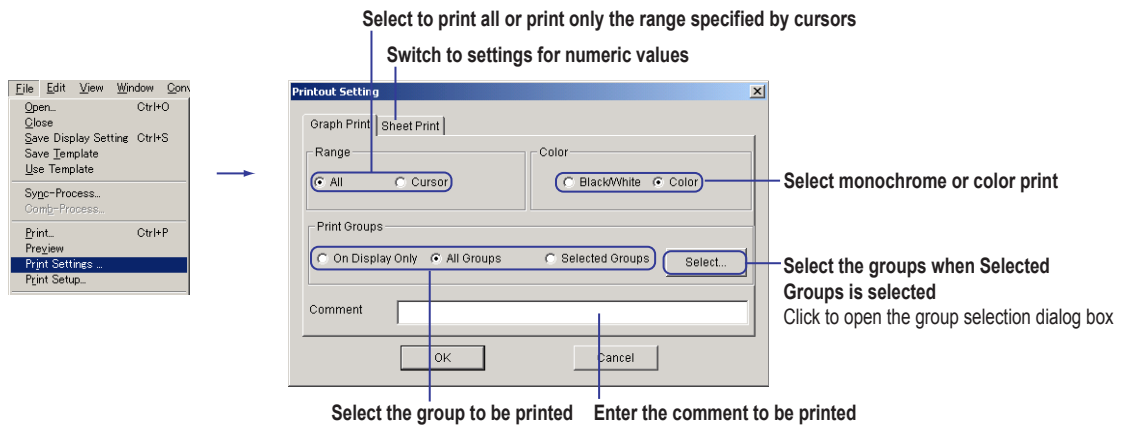

## Converting the Format of the Recorded Measured Data

Conversion can be made into the following formats.

ASCII	Text data with each data point separated by a comma. The extension is .txt.
Excel	Data that can be opened using Microsoft's spreadsheet application Excel version 8.0 (Excel 97) or later. The extension is .xls.
Lotus	Data that can be opened using IBM's Lotus 1-2-3 spreadsheet application version 2.0 or later. The extension is .wj2.

From the **Convert** menu, choose **To ASCII**, **To Excel**, or **To Lotus**. Then, convert the data using the dialog box that opens (see the figure below). There is a limitation in the number of data points that can be handled in the Excel conversion or Lotus conversion. Before executing the conversion, set the channels/groups to be converted, the conversion range, and the step so that the number of data points is appropriate.

