

INSTALLATION DRAWING

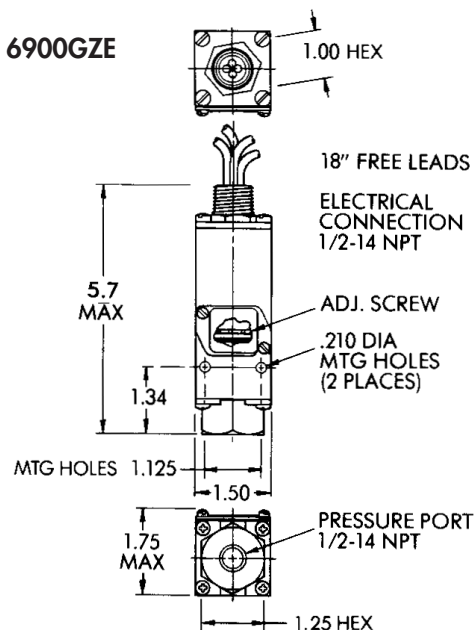

6900GZE
SHIPPING WT.
APPROX. 19 OZ.
(539 GRAMS)

Press. 1 to 2500 psi

**SERIES:
6900GZE**

Standard Features:

- U.L./CSA
- Explosion Proof:**
Div. 1, 2
- NEMA: 4, 7, 9, 13

AMBIENT TEMP. RANGE

-30° to 160° F
-34° to 71° C

OPERATING AND ORDERING DATA:

PRESSURE SWITCHES MODEL 6900GZE		1/2" STAINLESS STEEL PRESSURE PORT AND DIAPHRAGM		Wetted Parts	316 SST Viton	
Max Sys. Press. psi	Proof (Test) Press. psi	Adjustable Set-Point Range		Approx. Dead- band psi	Model No.	
		On Incr. Press. psi	On Decr. Press. psi		MODEL SPDT-Std.	MODEL DPDT "M"
500	750	3-20	1-18	2	6900GZE12	6900GZEM12
500	750	9-75	3-69	6	6900GZE14	6900GZEM14
1500	2000	18-150	6-138	12	6900GZE16	6900GZEM16
1500	2000	45-375	15-345	30	6900GZE18	6900GZEM18
2000	3000	300-1000	225-925	75	6900GZE20	6900GZEM20
3000	4500	700-2500	520-2320	180	6900GZE22	6900GZEM22

Options Code:

- "F" Ethylene Propylene O-ring
- "7008" Gold Contacts
- "7042" SST Body
- "7043" SST Body & Gold Contacts
- "7044" Monel Port & Diaphragm
- "7045" Hastelloy Port & Diaphragm
- "7052" Exp. Proof w/3' Leads
- "7054" Exp. Proof w/6' Leads
- "7065" Exp. Teflon Wire & SST Diaphragm

ELECTRICAL CHARACTERISTICS:
RATING OF SWITCH ELEMENT

VOLTS	AMPERES	
	SPDT Res.	DPDT "M" Res.
125 AC - 50/60 Hz	11	11
250 AC - 50/60 Hz	11	11
30 DC	5	5
125 DC	.5	.5

SCHEMATIC AND WIRING CODE:

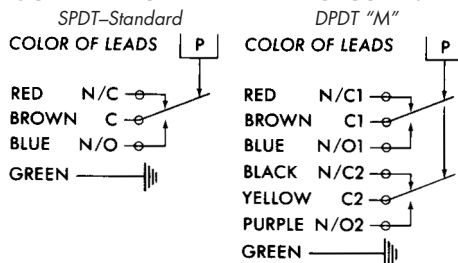

ENCLOSURE/CERTIFICATIONS:

Div. 1 explosion-proof and hermetically sealed electrical assembly Part No. 46-1058 (46-1061 for "M" model option), listed by both Underwriter's Laboratories, Inc. (File No. E32961) and CSA Testing Laboratories (File No. 22921) for hazardous locations, Class 1, Groups A, B, C, and D; Class 2 Groups E, F, and G.

HOW TO ORDER: Specify model number, add desired "options" listing letter codes first followed by numbers:
Custom Control Sensors, Inc. • 21111 Plummer Street, Chatsworth, CA 91311 • Tel: (818)341-4610 • Fax: (818)709-0426
e-mail: switchnet@ccsdualsnap.com • http://www.ccsdualsnap.com