



SVB SERIES II

Gas-Fired Hot Water
Induced Draft Boilers

Models

SVB-2

SVB-3

SVB-4

SVB-5

SVB-6

SVB-7

INSTALLATION, OPERATION & MAINTENANCE MANUAL



C.S.A. Certified
For Natural Gas Or Propane



H
Tested For 50 psi.
ASME
Working Pressure



ECR international
EST. 1928
A Family of Heating & Cooling Brands.

Manufactured by:
ECR International, Inc.
2201 Dwyer Avenue, Utica NY 13501
web site: www.ecrinternational.com

P/N 240011589, Rev. A [08/03/2016]

TABLE OF CONTENTS

Safety Messages	3
Dimensions.....	4
Boiler Ratings & Capacities	5
Installation Procedure	6
Ventilation & Combustion Air.....	7
Installation System Piping	8
Vent Installation	11
Horizontal Venting Instructions	14
Optional Horizontal Venting Instruction.....	19
Gas supply Piping	20
Electrical Wiring	22
Sequence of Operation	23
Wiring Diagrams.....	24
Starting Your Boiler.....	25
Checking and Adjusting	27
Maintaining Your Boiler.....	29
Service Hints	30
Equipment & Optional Accessories	31
Appendix A - Control Module	33
A.1 Installation Environment Considerations.....	33
A.2 Electrical Connections Connect Module Connectors	33
A.3 Adjusting Settings.....	33
A.4 Display	33
A.5 Operation	34
A.6 Boiler High Limit Temperature Controller	37
A.7 Troubleshooting	37
A.8 Troubleshooting Error Codes	37
A.9 Intermittent Pilot	38

SAFETY MESSAGES

IMPORTANT: Read the following instructions **COMPLETELY** before installing!!

Safety Symbols & Warnings

The following defined symbols are used throughout this manual to notify the reader of potential hazards of varying risk levels.

DANGER

Indicates a hazardous situation which, if not avoided, **WILL** result in death or serious injury

WARNING

Indicates a hazardous situation which, if not avoided, could result in death or serious injury.

CAUTION

Indicates a hazardous situation which, if not avoided, could result in minor or moderate injury.

NOTICE

Used to address practices not related to personal injury.

**KEEP THIS MANUAL NEAR BOILER
RETAIN FOR FUTURE REFERENCE**

WARNING

Fire, explosion, asphyxiation and electrical shock hazard. Improper installation could result in death or serious injury. Read this manual and understand all requirements before beginning installation.

WARNING

Keep boiler area clear and free from combustible materials, gasoline and other flammable vapors and liquids.
DO NOT obstruct air openings to the boiler room. Modification, substitution or elimination of factory equipped, supplied or specified components may result in personal injury or loss of life.
TO THE OWNER - Installation and service of this boiler must be performed by a qualified installer.
TO THE INSTALLER - Leave all instructions with boiler for future reference.
When this product is installed in the Commonwealth of Massachusetts the installation must be performed by a Licensed Plumber or Licensed Gas Fitter.

CAUTION

Laceration, burn hazard. Metal edges and parts may have sharp edges and/or may be hot. Use appropriate personal protection equipment to include safety glasses and gloves when installing or servicing this boiler. Failure to follow these instructions could result in minor or moderate injury.

DIMENSIONS

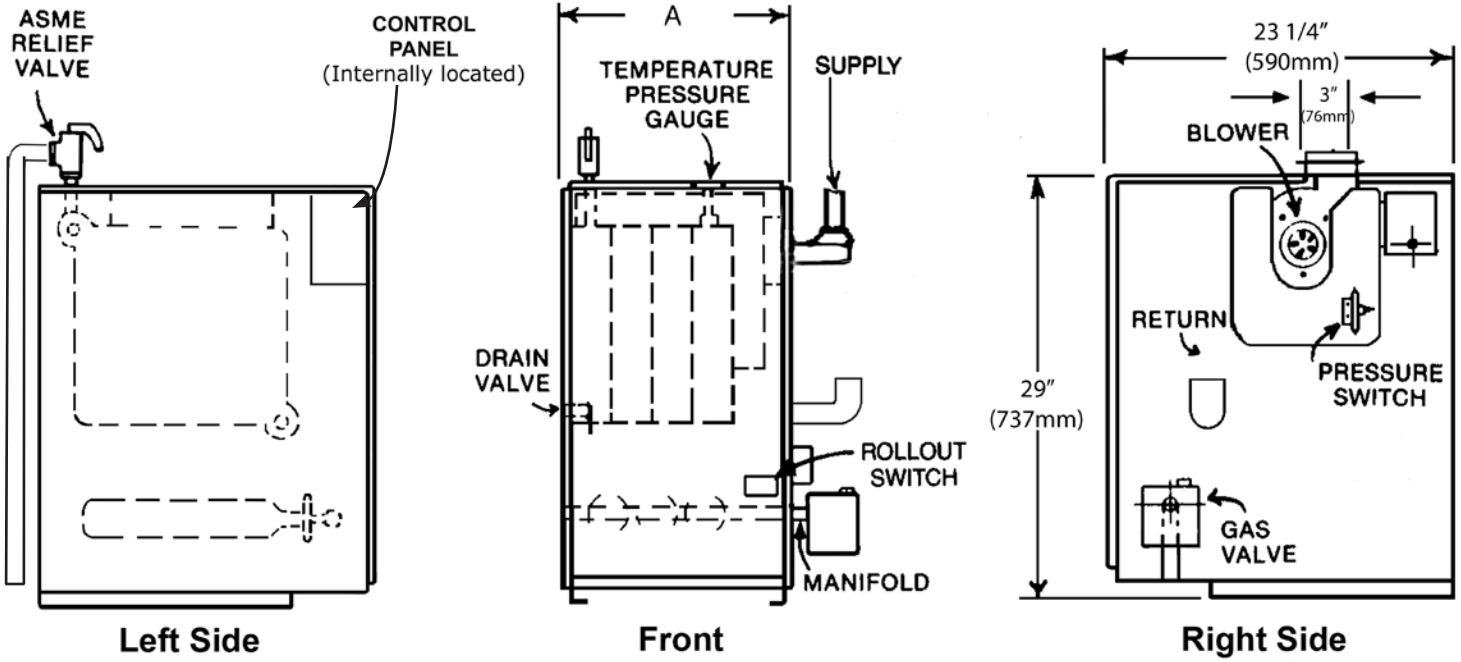

Model	Width (A)
SVB-2	11
SVB-3	14-1/4
SVB-4	17-1/2
SVB-5	20-3/4
SVB-6	24
SVB-7	27-1/4

BOILER RATINGS & CAPACITIES



Table 1 - RATINGS NATURAL AND PROPANE GASES

Model	Input *Mbh	Heating Capacity *Mbh	**Net AHRI Rating Water *Mbh	AFUE	Vent Diameter (Inches)	
					To Chimney (Category I)	Horizontal Vent (Category III)
SVB-2	42.5	36	31	84.4	4	3
SVB-3	75.0	63	55	83.4	4	3
SVB-4	112.5	94	82	83.0	4	3
SVB-5	150.0	125	109	82.7	4	3
SVB-6	187.5	155	135	82.3	4	4
SVB-7	225.0	186	162	82.0	4	4

* MBH = 1,000 Btuh = British Thermal Unit Per Hour. Boilers are equipped for altitudes up to 2,000 feet only. U.S.A. Only - For altitudes above 2,000 feet, ratings should be reduced at the rate of 4% for each 1,000 feet above sea level. Canada Only - Boilers may be used at high altitude (2,000-4500 feet/640-1350m) by using a certified field conversion kit, resulting in a 10% de-rate. Contact Provincial authority having jurisdiction for installations above 4500 ft (1350m) above sea level. + Heating Capacity based on D.O.E. (Department of Energy) test procedure.

**Net AHRI Water Ratings indicate amount of remaining heat input that can be used to heat the radiation or terminal units. Net AHRI Ratings shown are based on an allowance of 1.15 Selection of boiler size should be based upon "Net AHRI Rating" being equal to or greater than calculated heat loss of building.

Manufacturer should be consulted before selecting a boiler for installations having unusual piping and pickup requirements.

New York City MEA Number 484-84-E Vol. IV.

This boiler cannot be used with all types of chimneys. Read these instructions carefully before installing.

These Gas-Fired Hot Water Boilers are low pressure, sectional cast iron boilers Design Certified by C.S.A. (Canadian Standards Association) for use with Natural and Propane Gases. Constructed and hydrostatically tested for maximum working pressure of 50 psi in accordance with A.S.M.E. Boiler and Pressure Vessel Code Section IV Standards for cast iron heating boilers.

Boilers must stand on noncombustible floor. If installed on combustible floor, please refer to Repair Parts manual for appropriate Combustible Floor Base part number.

Boilers For Use At High Altitude

Boiler is factory equipped for use at altitudes of 0-2,000 feet above sea level. For use at altitudes above 2,000 feet above sea level, input ratings are reduced by change in main burner orifice size.

U.S.A. Only - For altitudes above 2,000 feet above sea level, input ratings should be reduced at rate of 4% for each 1,000 feet above sea level. Consult National Fuel Gas Code (NFPA54/ANSI Z223.1), or manufacturer for correct orifice sizing information. High altitude orifices are available from boiler manufacturer.

Canada Only - For altitudes in range of 2,000-4,500 feet (610 - 1350m) above sea level, boilers may be field equipped for use at high altitude by using a certified field conversion kit. The change in main burner orifice size results in the boiler's input rating being reduced by 10%. The conversion shall be carried out by a manufacturer's authorized representative, in accordance with the requirements of the manufacturer, provincial or territorial authorities having jurisdiction and in accordance with the requirements of CSA-B149 Natural Gas and Propane Installation Code. The certified field conversion kit includes a conversion data plate, which must be attached to the boiler adjacent to the rating plate, indicating that the boiler has been converted for high altitude use. The conversion data plate must be filled in with the correct conversion information.

For altitudes over 4500 feet (1350m), contact Provincial authority having jurisdiction.

INSTALLATION PROCEDURE

⚠ WARNING

Improper installation, adjustment, alteration, service or maintenance could result in death or serious injury.

1. The installation must conform to the requirements of the authority having jurisdiction or, in the absence of such requirements, to the National Fuel Gas Code, ANSI Z223.1/NFPA 54, and/or Natural Gas and Propane Installation Code, CAN/CSA B149.1
2. Where required by authority having jurisdiction, installation must conform to the Standard for Controls and Safety Devices for Automatically fired Boilers, ANSI/ASME CSD-1.
3. This boiler series is classified as a Category I. Vent installation shall be in accordance with "Venting of Equipment," of the National Fuel Gas Code, ANSI Z223.1/NFPA 54, or "Venting Systems and Air Supply for Appliances," of the Natural Gas and Propane Installation Code, CAN/CSA B149.1, or applicable provisions of the local building codes.
4. Boiler has met safe lighting and other performance criteria with gas manifold and control assembly on boiler per latest revision of ANSI Z21.13/CGA 4.9.
5. Install such that gas ignition system components are protected from water (dripping, spraying, rain, etc.) during appliance operation and service, (circulator replacement, condensate trap, control replacement, etc.).
6. Locate boiler on level, solid base as near chimney as possible and centrally located with respect to heat distribution system as practical.
7. Verify you have the right size boiler before starting installation. See rating and capacity table.
8. When installed in utility room, door should be wide enough to allow largest boiler part to enter, or to permit replacement of another appliance such as water heater.
9. Boiler installed in building under construction, take care to insure clean combustion air supply during construction process. Airborne particulates such as from drywall dust and from fiberglass insulation can clog burner ports and cause incomplete combustion and sooting.

⚠ WARNING

Fire hazard. Do not install boiler on combustible flooring or carpeting. Failure to follow these instructions could result in death or serious injury.

NOTICE

Follow local regulations with respect to installation of CO detectors.

10. **FOR INSTALLATION ON NON-COMBUSTIBLE FLOORS ONLY** - For installation on combustible flooring special base must be used. (See Replacement Parts Section.) **Do Not Install Boiler on carpeting.**
11. Verify boiler is supplied with correct type of gas, fresh air for combustion, and suitable electrical supply.

Figure 1 - Minimum Clearances To Combustible Construction

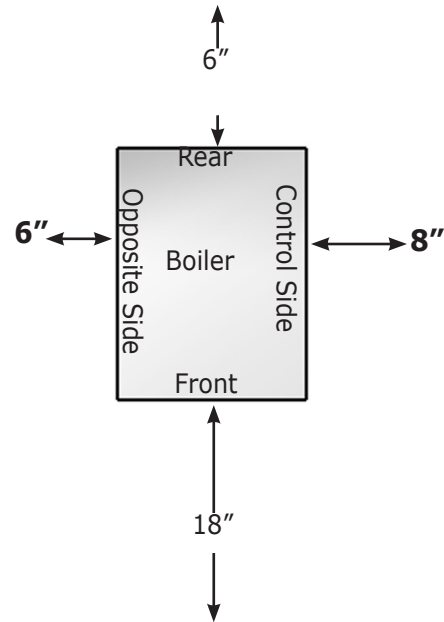

Table 2 - BOILER MINIMUM CLEARANCE TO COMBUSTIBLES

Unit	Minimum Clearances
Top	6" (152mm)
Rear	6" (152mm)
Control Side	8" (203mm)
Opposite Side	6" (152mm)
Front (Alcove)	18" (457mm)
Flue/Vent Connector	6" (152mm)
Near Boiler Piping	1" (24mm)

Set unit on concrete or other noncombustible material base or floor. **DO NOT INSTALL ON CARPETING.**

VENTILATION & COMBUSTION AIR

Provide combustion air and ventilation air in accordance with the section "Air for Combustion and Ventilation," of the National Fuel Gas Code, ANSI Z223.1/NFPA 54, or Sections 8.2, 8.3 or 8.4 of Natural Gas and Propane Installation Code, CAN/CSA B149.1, or applicable provisions of local building codes.

Provide make-up air where exhaust fans, clothes dryers, and kitchen ventilation equipment interfere with proper operation.

National Fuel Gas Code recognizes several methods of obtaining adequate ventilation and combustion air. Requirements of the authority having jurisdiction may override these methods.

- » Engineered Installations. Must be approved by authority having jurisdictions.
- » Mechanical Air Supply. Provide minimum of 0.35 cfm per Mbh for all appliances located within space. Additional requirements where exhaust fans installed. Interlock each appliance to mechanical air supply system to prevent main burner operation when mechanical air supply system not operating.
- » All Indoor Air. Calculate minimum volume for all appliances in space. Use a different method if minimum volume not available.
 - o Standard Method. Cannot be used if known air infiltration rate is less than 0.40 air changes per hour. See Table 3 for space with boiler only. Use equation for multiple appliances.

$$\text{Volume} \geq 50 \text{ ft}^3 \times \text{Total Input [Mbh]}$$
 - o Known Air Infiltration Rate. See Table 3 for space with boiler only. Use equation for multiple appliances. Do not use an air infiltration rate (ACH) greater than 0.60.

$$\text{Volume} \geq 15 \text{ ft}^3/\text{ACH} \times \text{Total Input [Mbh]}$$
 - o Refer to National Fuel Gas Code for opening requirements between connection indoor spaces.

- » All Outdoor Air. Provide permanent opening(s) communicating directly or by ducts with outdoors.
 - o Two Permanent Opening Method. Provide opening commencing within 12 inches of top and second opening commencing within 12 inches of bottom enclosure.
 - Direct communication with outdoors or communicating through vertical ducts. Provide minimum free area of 1 in² per 4 Mbh of total input rating of all appliances in enclosure.
 - Communicating through horizontal ducts. Provide minimum free area of 1 in² per 2 Mbh of total input rating of all appliances in enclosure.
 - o One Permanent Opening Method. Provide opening commencing within 12 inches of top of enclosure. Provide minimum clearance of 1 inch on sides and back and 6 inches on front of boiler (does not supersede clearance to combustible materials).
 - o Combination Indoor and Outdoor Air. Refer to National Fuel Gas Code for additional requirements for louvers, grilles, screens and air ducts.
- » Combination Indoor and Outdoor Air. Refer to National Fuel Gas Code for application information.

National Gas and Propane Installation Code Requires providing air supply in accordance with:

- » Section 8.2 and 8.3 when combination of appliances has a total input of up to and including 400 Mbh (120 kW).
 - o Does not have draft control device.
- » Section 8.4 when combination of appliances has total input exceeding 400 Mbh (120 kW).
- » Refer to Natural Gas and Propane Installation Code for specific air supply requirements for enclosure or structure where boiler is installed, including air supply openings and ducts.

Table 3 - Air Infiltration Rate

Input Mbh	Standard Method	Known Air Infiltration Rate Method (Air Changes Per Hour)					
		0.1	0.2	0.3	0.4	0.5	0.6
42.5	2125	6375	3188	2125	1594	1275	1063
75	3750	11250	5625	3750	2813	2250	1875
112.5	5625	16875	8438	5625	4219	3375	2813
150	7500	22500	11250	7500	5625	4500	3750
187.5	9375	28125	14063	9375	7031	5625	4688
225	11250	33750	16875	11250	8438	6750	5625

⚠ WARNING

Burn and scald hazard. Safety relief valve could discharge steam or hot water during operation. Install discharge piping per these instructions.

1. Refer to local codes and appropriate ASME Boiler and Pressure Vessel Code for additional installation requirements. Install safety relief valve using pipe fittings provided with boiler. See Figure 2
2. Install safety relief valve with spindle in vertical position.
3. Do not install shutoff valve between boiler and safety relief valve.
4. Install discharge piping from safety relief valve. See Figure 2.
 - » Use $\frac{3}{4}$ " or larger pipe.
 - » Use pipe suitable for temperatures of 375°F (191°C) or greater.
 - » Individual boiler discharge piping shall be independent of other discharge piping.
 - » Size and arrange discharge piping to avoid reducing safety relief valve relieving capacity below minimum relief valve capacity stated on rating plate.
 - » Run pipe as short and straight as possible to location protecting user from scalding and properly drain piping.
 - » Install union, if used, close to safety relief valve outlet.
 - » Install elbow(s), if used, close to safety relief valve outlet and downstream of union (if used).
 - » Terminate pipe with plain end (not threaded).

Figure 2 - Safety Relief Valve Discharge Piping

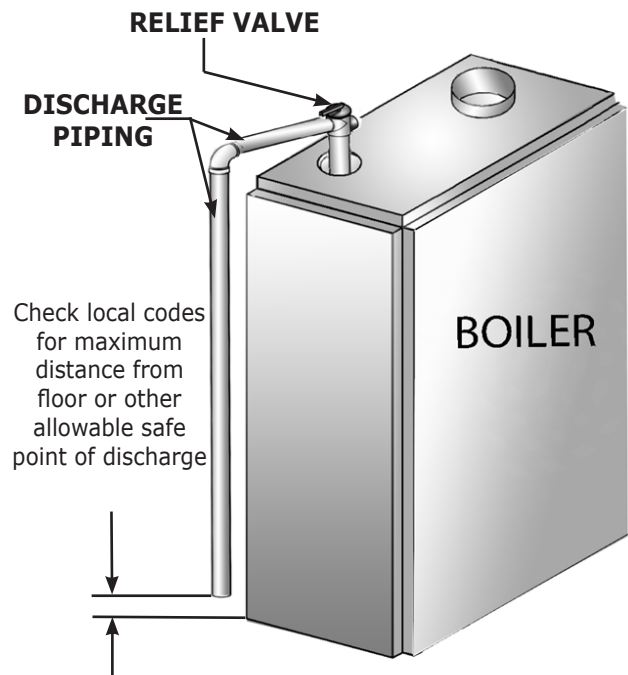

Figure 3 - Forced Hot Water Typical Piping

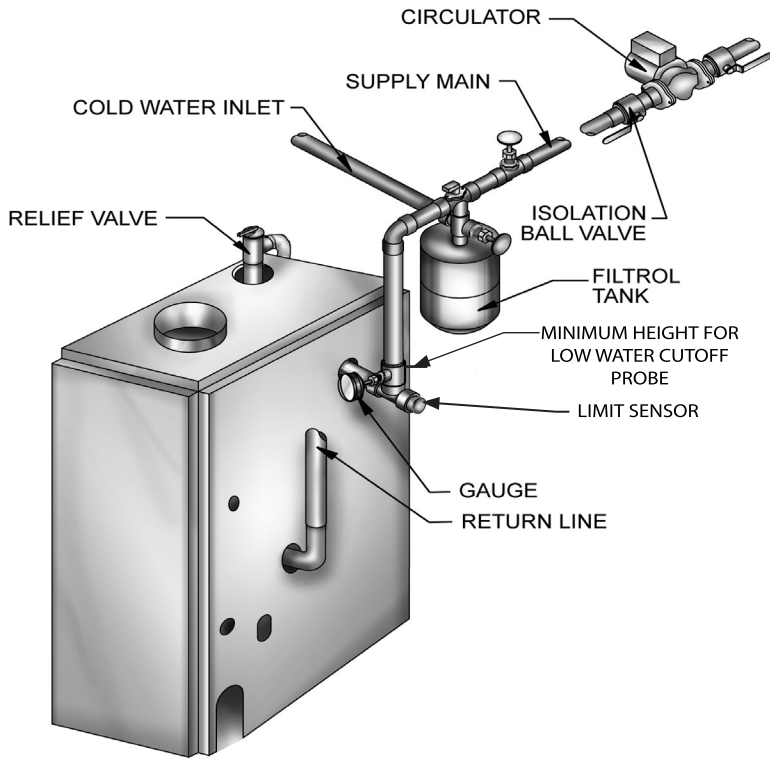
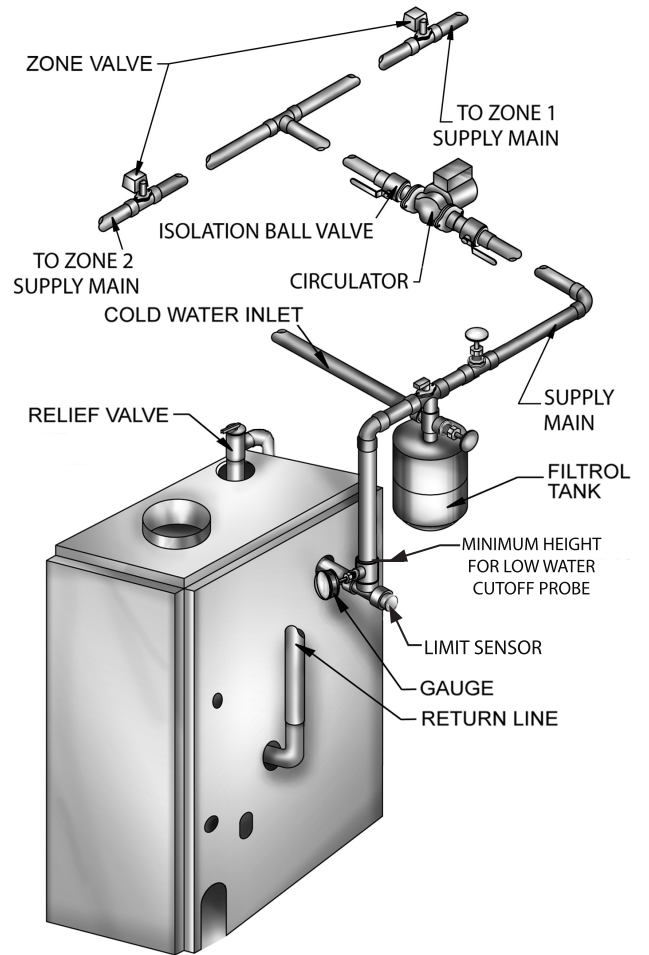

Figure 4 - Forced Hot Water Typical Piping With Zone Control Valve



INSTALLATION SYSTEM PIPING

- » Install radiation units (panels, radiators or cabinets) and supply and return mains first then make connections at boiler.
- » Verify clean water supply is available when connecting cold water supply to water valve. Install sand strainer at pump when water supply is from well or pump.
- » Provide low water cutoff device when boiler is installed above radiation level or as required by the Authority having jurisdiction, either provide as part of boiler or at time of boiler installation. Periodic inspection is necessary, as is flushing of float type devices, per manufacturers specific instructions. Refer to Figures 3 & 4 for minimum height for installation of LWCO. Use kit # 550002998 and follow instructions included with kit. When using LWCO other than kit listed follow specific LWCO manufacturer instructions.
- » Boiler used in connection with refrigeration systems shall be installed so chilled medium is piped in parallel with heating boiler with appropriate valves to prevent chilled medium from entering heating boiler. See Figure 5.
- » Boiler connected to heating coils located in air handling units exposed to refrigerated air circulation, piping system shall be equipped with flow control valves or other automatic means to prevent gravity circulation of boiler water during cooling cycle.

Low Design Water Temperature Systems (Below 140°F) And Large Water Content Systems

Condensation is corrosive and can eventually cause severe damage to boiler and venting system.

- » Minimum design return water temperature to prevent condensation in boiler and venting is 120°F. Minimum high limit setting is 140°F.
- » Boiler used in heating systems where design water temperatures below 140°F are desired (e.g. radiant floor heating), a 3-way or 4-way mixing valve or suitable alternative is required to prevent low temperature return water from entering boiler. When using mixing valve, follow manufacturer's installation instructions.
- » Boiler connected to system having large water content (such as former gravity system), suggest use of bypass piping. See Figure 6.

Figure 5 - Piping Arrangements For Boiler When Used In Connection With Refrigeration System

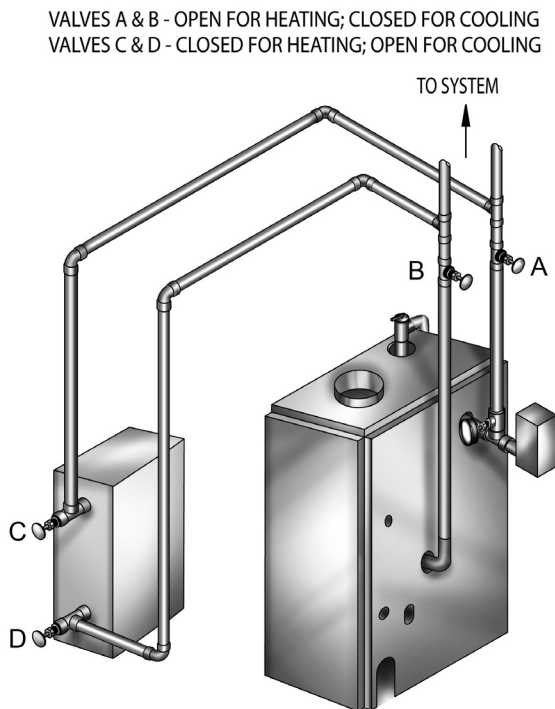
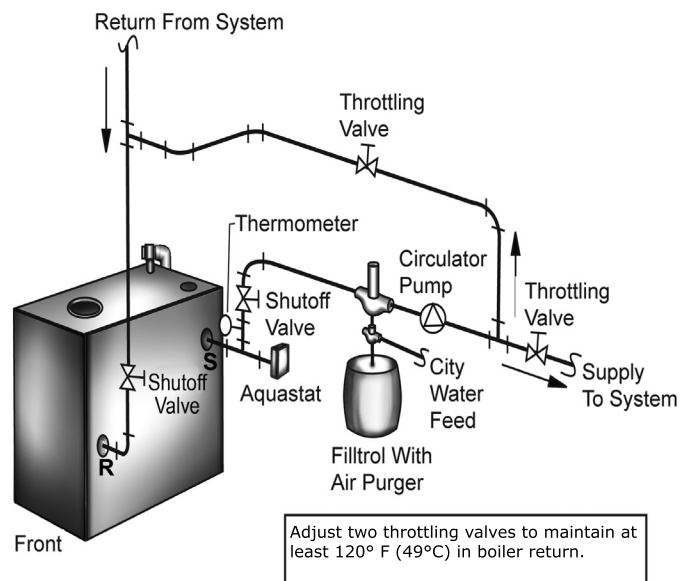

Figure 6 - Bypass Piping



Check Your Chimney

Chimney must be clean, right size, properly constructed and in GOOD CONDITION.

1. Installation must conform to requirements of the authority having jurisdiction or, in absence of such requirements, to the National Fuel Gas Code, ANSI Z223.1/NFPA 54 or of the Natural Gas and Propane Installation Code, CAN/CSA B149.1, or applicable provisions of the local building codes..
2. Boiler's induced draft blower has 3" outlet. 3" X 4" increaser fitting is included in parts bag. Locate increaser fitting on outlet of induced draft blower, and secure gas-tight with bead of furnished silicone sealant. Increaser fitting is required on this boiler for Category I venting, and 4" is minimum permissible vent diameter. This does not imply vent connector is intended to be 4" diameter pipe. Vent connector shall be sized according to appropriate venting tables in the National Fuel Gas Code and may be required to be larger than 4" diameter.

NOTICE

Boiler installation for chimney venting is not complete unless increaser fitting is located and secured.

3. These are high efficiency boilers with low stack or exhaust temperature.
4. Venting into masonry chimney without liner, line chimney from top to bottom with either:
 - A. Listed Type B vent pipe
 - B. Listed flexible vent liner
 - C. Poured ceramic liner.
5. Outside chimneys should not be used unless they are (choose one of the following):
 - A. Enclosed in a chase
 - B. Lined with Type B vent pipe
 - C. Use listed flexible vent liner
 - D. Use certified chimney lining system
6. Vent connector from boiler to chimney should run as directly as possible with as few elbows as possible.
7. Where possible, it is recommended to common vent water heater and boiler. Consult appropriate Vent Sizing Tables in National Fuel Gas Code for specific requirements of multiple appliance venting.
8. Boiler is only appliance connected to vent, Type B vent pipe is recommended for vent connector.
9. Slope pipe up from boiler to chimney not less than 1/4" per foot (21mm/m).
10. End of vent pipe must be flush with inside face of chimney flue. Use sealed-in thimble for chimney connection.

11. Fasten sections of vent pipe with sheet metal screws to make piping rigid. Use stovepipe wires to support pipe from above.
12. Do not connect to fireplace flue.
13. Do not install damper on this boiler.

Minimum Vent Pipe Clearance

- » Use Type B vent pipe through crawl space. Where vent pipe passes through combustible wall or partition, use ventilated metal thimble. Thimble should be 4 inches larger in diameter than vent pipe.
- » Boiler installed with single wall vent, must have 6" clearance between its surface and any combustible material. New Type B gas vent or flexible liner must be installed in accordance with instructions furnished with vent. Maintain clearances as specified for vent pipe.
- » Verify vent pipe is fire-stopped where it goes through floor or ceiling. It should have approved vent cap with clearances from roof. If clearances are less than shown in have vent checked by local authorities. See Figure 7, Page 11.
- » Vent connectors serving appliances vented by natural draft shall not be connected into any portion of mechanical draft systems operating under positive pressure.

Figure 7 - Type B Gas Vent

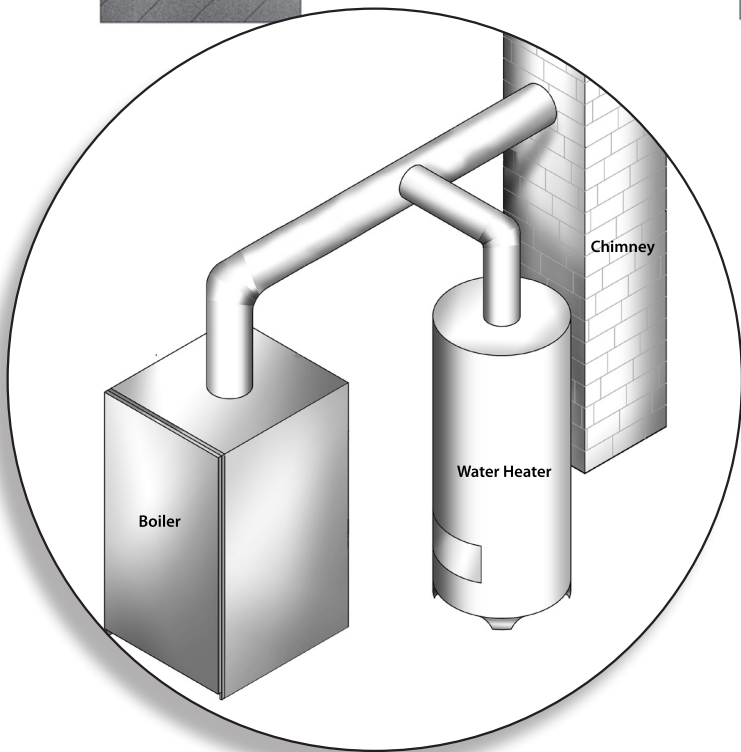
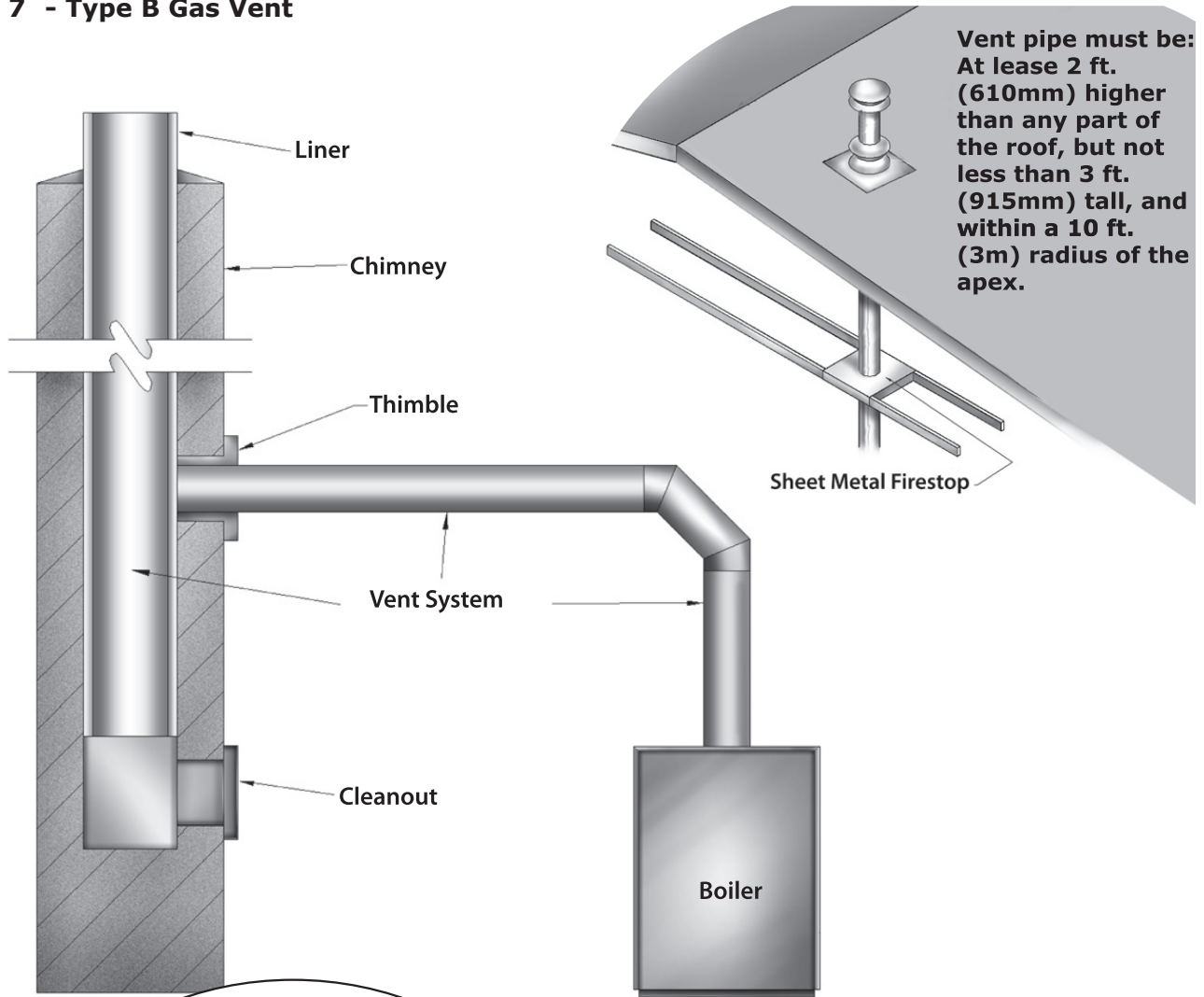

CHECK YOUR CHIMNEY

For boilers for connection to gas vents or chimneys, vent installations shall be in accordance with "Venting of Equipment", of the National Fuel Gas Code, ANSI Z223.1/NFPA 54, or of the Natural Gas and Propane Installation Code, CAN/CSA B149.1, or applicable provisions of the local building codes.

Removing Existing Boiler From Common Venting System

When an existing boiler is removed from a common venting system, the common venting system is likely to be too large for proper venting of the appliances remaining connected to it.

At the time of removal of an existing boiler, the following steps shall be followed with each appliance remaining connected to the common venting system placed in operation, while the other appliance remaining connected to the common venting system are not in operation.

1. Seal any unused openings in the common venting system.
2. Visually inspect the venting system for proper size and horizontal pitch and determine there is no blockage or restriction, leakage, corrosion and other deficiencies which could cause an unsafe condition.
3. Insofar as is practical, close all building doors and windows and all doors between the space in which the appliances remaining connected to the common venting system are located and other spaces of the building. Turn on clothes dryers and any appliance not connected to the common venting system. Turn on any exhaust fans, such as range hoods and bathroom exhausts, so they will operate at maximum speed. Do not operate a summer exhaust fan. Close fireplace dampers.
4. Place in operation the appliance being inspected. Follow the lighting instructions. Adjust thermostat so appliance will operate continuously.
5. Test for spillage at the draft hood relief opening after 5 minutes of main burner operation. Use flame of a match or candle, or smoke from a cigarette, cigar, or pipe.
6. After it has been determined that each appliance remaining connected to the common venting system properly vents when tested as outlined above, return doors, windows, exhaust fans, fireplace dampers and any other gas-burning appliance to their previous conditions of use.
7. Any improper operation of the common venting system should be corrected so the installation conforms with the National Fuel Gas Code, ANSI Z223.1/NFPA 54, and/or the Natural Gas and Propane Installation Code, CAN/CSA B149.1. When re-sizing any portion of the common venting system, the common venting system should be re-sized to approach the minimum size determined using the appropriate tables in Chapter 13 of the National Fuel Gas Code, ANSI Z223.1/NFPA 54, and/or the Natural Gas and Propane Installation Code, CAN/CSA B149.1.
8. It is recommended that existing gas vents be checked to be sure they meet local codes.

INDUCED DRAFT HIGH EFFICIENCY BOILERS

Horizontal (Category III) venting systems must be installed in accordance with these instructions.

Maximum Horizontal Vent Length For Stainless Steel Vent Pipe - 30' Plus One 90° Elbow Plus Vent Terminal.

Minimum Horizontal Vent Length - 2' Plus One 90° Elbow Vent Termination.

Additional elbows are equivalent to 6 feet of straight pipe for 4" diameter 90° elbow or 3 feet of straight pipe for 3" diameter 90° elbow. 2, 3, 4, 5, Section Boilers use 3" vent pipe; for 6, 7 Section Boilers use 4" vent pipe.

CHOICE OF VENT PIPE MATERIAL

- » U. L. Listed Z-Flex Z-Vent Stainless Steel Vent Pipe.
- » U. L. Listed Heat-Fab Saf-T-Vent Stainless Steel Vent Pipe.
- » U. L. Listed Flex-L Star-34 Stainless Steel Vent Pipe.
- » U. L. Listed ProTech Systems FasNSeal Stainless Steel Vent Pipe.

Figure 8 - Induced Draft High Efficiency Boilers

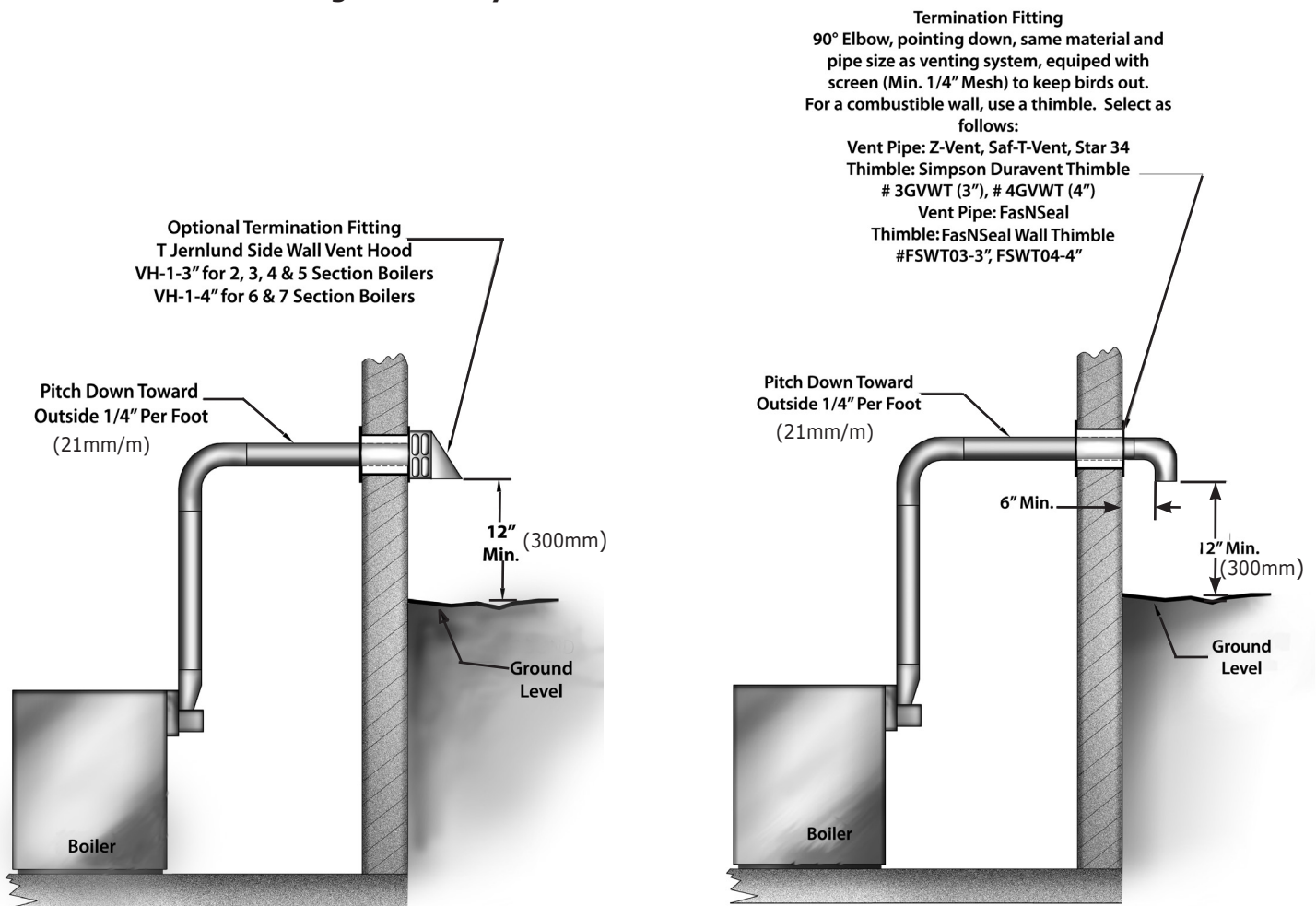

HORIZONTAL VENTING INSTRUCTIONS

1. These boilers may be vented horizontally as shown in Figure 8, Page 13. The vent pipe is pitched **down** from the boiler to the vent termination. Do not connect other appliances to this vent.
2. Vent Pipe Material:
 - A. UL Listed Z-Flex Z-Vent stainless steel vent pipe from boiler to vent termination,
-or-
 - B. UL Listed Heat-FabSaf-T-Vent stainless steel vent pipe from boiler to vent termination,
-or-
 - C. UL Listed Flex-L StaR-34 stainless steel vent pipe from boiler to vent termination,
-or-
 - D. UL Listed ProTech FasNSeal stainless steel vent pipe from boiler to vent termination.
3. Clearance to Combustible Materials: For stainless steel vent pipe maintain 6" minimum air space clearance to combustible materials.
4. Vent Pipe Size:
 - A. 2, 3, 4 and 5 section boilers use 3" vent pipe connected directly to the outlet of the induced draft blower.
 - B. 6 and 7 section boilers use 4" vent pipe, starting with a 3" to 4" stainless steel vent pipe transition that is connected directly to the outlet of the induced draft blower. Do not use 3" vent pipe on 6 or 7 section boilers.
5. Vent Pipe Length:
 - A. For stainless steel vent pipe, the maximum horizontal vent length is 30 feet plus one 90° elbow plus termination fitting.
 - B. Minimum horizontal vent length for all vent materials is 2 feet plus one 90° elbow plus termination fitting.
 - C. For additional elbows reduce the maximum vent length as shown:
 - » 3" - 90° elbow - reduce vent length 3 feet per each 3" elbow
 - » 4" - 90° elbow - reduce vent length 6 feet per each 4" elbow
6. Vent Termination Fitting: For all vent pipe materials, you may use either:
 - A. A 90° elbow pointing down, fitted with a minimum 1/4" mesh screen to keep out rodents and birds. The elbow shall be of the same material and size as vent pipe. The elbow exit should be at least 6" away from exterior wall as shown in Figure 7, Page 11.
-or-
 - B. Tjernlund VH-1 Series side wall vent hood. For 2, 3, 4, 5 section boilers use VH-1-3", For 6, 7 section boilers use VH-1-4".
7. Vent Pipe Termination Location (Figure 8, Page 13):
 - A. When venting through combustible walls, combustible clearances must be considered. The VH-1 Side wall vent hood provides both the outside vent termination and a double wall pipe for passing through a combustible wall up to 8" thick (VH-1-4") or 9" thick (VH-1-3"). The hole in the wall must be 6 1/4" square for 3" vent pipe and 7 1/2" square for 4" vent pipe, in order to insert the VH-1 side wall vent hood. The VH-1 may also be used in noncombustible walls.
 - B. If the 90° elbow is the termination fitting of choice, then the single wall pipe will be passing through the side wall. For combustible walls, a UL listed thimble shall be used where the single wall pipe passes through the wall. For combustible walls using Z-Vent, Saf-T-Vent, or StaR-34 vent pipe, use the following:
 - » 3" vent pipe - use Simpson's Duravent 3" thimble
 - » 4" vent pipe - use Simpson's Duravent 4" thimble. Maximum wall thickness with this thimble is 7 inches.

Example: 6 section boiler has 3 elbows plus the termination fitting. This means 2 additional 4" elbows will be used, at 6 feet per elbow. This is equivalent to 12 feet of pipe (2 x 6 =12), therefore maximum vent length is now 18 feet (30 -12 =18).

For combustible walls using ProTech FasNSeal where the single wall vent pipe must pass through the side wall, a UL Listed FasNSeal wall thimble shall be used. The thimble is adjustable for different wall thickness, with a maximum wall thickness of 7 inches. Seal the thimble along the outside edge of the plate with caulk or silicone and fasten to the wall with screws or nails.

- C. For single wall pipe through non-combustible walls, the hole through the wall need only be large enough to maintain pitch of vent pipe, and provide proper sealing. Thimble is not required for single wall pipe passing through noncombustible walls.

Figure 9 - Horizontal Venting Clearances

Note: If there is a potential for excessive winds, special consideration should be given to locate the vent termination away from the windward side of the building.

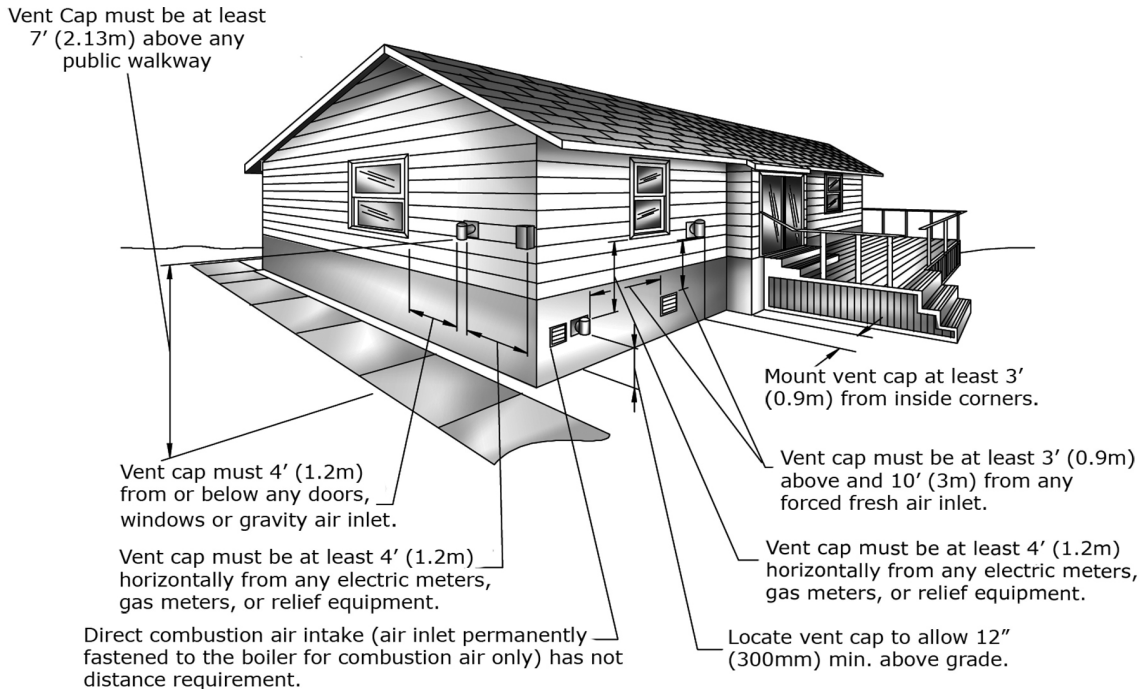

D. Vent Termination

- o Venting system shall terminate at least 3 feet (0.9m) above any forced air inlet located within 10 feet (3m).
- o Venting system shall terminate at least 4 feet (1.2m) below, 4 feet (1.2m) horizontally from, or 1 foot (300 mm) above any door, window, or gravity air inlet into any building.
- o Bottom of vent shall be located at least 12 inches (300mm) above grade.
- o Termination of vent shall be not less than 7 feet (2.13m) above adjacent public walkway.
- o Vent terminal shall not be installed closer than 3 feet (0.9m) from inside corner of L shaped structure.
- o Termination of vent should be kept at least 3 feet (0.9m) away from vegetation.
- o **United States** - Terminate vent system at least 4 feet (1.22m) horizontally from, and in no case above or below, unless a 4 feet (1.22m) horizontal distance is maintained, from electric meters, gas meters, regulators and relief equipment. See Figure 9.
- o **Canada** - Terminate vent system at least 6 feet (1.83m) horizontally from, and in no case above or below, unless 6 feet (1.83m) horizontal distance is maintained, from gas and electric meters, regulators and relief equipment.
- o Venting system shall terminate at least 4 feet below any eave, soffit, or roof overhang.
- o Venting system shall not terminate underneath any deck, patio, or similar structure.
- o Place vent on wall away from prevailing winter wind. Locate or guard vent to prevent accidental contact with people or pets.
- o Terminate vent above normal snow-line. Avoid locations where snow may drift and block vent. Ice or snow may cause boiler to shut down if vent becomes obstructed.
- o Under certain conditions, flue gas will condense, forming moisture. Take steps to prevent building materials at vent terminal from being damaged by exhaust of flue gas.

HORIZONTAL VENTING INSTRUCTIONS

8. Joining and Sealing the Vent Pipe:

The vent pipe needs to be both watertight and gas tight. Seal all joints and seams as follows:

A. For Z-Flex Z-Vent stainless steel vent pipe use a high temperature silicone sealant rated for 550°F. The outside of the male end and inside of the female end of the pipe must be cleaned with brake cleaner before applying silicone bead. For 3" vent pipe runs begin with the male end of the vent pipe over the boiler's induced draft blower outlet. For 4" vent pipe runs begin with a 6" length of 3" Z-Vent over the boiler's induced draft blower outlet, to which an even bead of high temperature silicone sealant should be applied. Then connect the 3" Z-Vent to a Z-Vent 3" to 4" reducer. Then continue the 4" Z-Vent pipe run by connecting the 4" male end of the Z-Vent to the reducer. (A locking band may be used around this joint for additional support.) Then following the sealing instructions, push the 4" male end of the Z-Vent over the 4" increaser fitting. When using the Tjernlund VH-1 vent hood, the female end (flared end) of the vent pipe will be connected to the termination hood. The male end of the vent hood must be crimped before pushing the Z-Vent over the vent hood's connecting pipe. Before the pipes are joined, apply a ¼" bead of silicone one inch from the end of the male end. Then push the pipes together as far as they will go making sure any seams are aligned and oriented upward. Now apply another bead of silicone around this joint and smooth out. Then use a Z-Flex locking band around the center of the joint.

1. Apply the high temperature silicone approximately one inch from the end, around the male end of the pipe in an even ¼" bead.
2. Pipes can now be pushed together as far as they will go. The seams on pipe should be aligned and oriented upward in all horizontal appliances. Apply another bead of silicone around this joint and smooth out.
3. Slide locking band over center of joint and tighten gear clamps. Make sure locking band is centered on joint.
4. Check all joints and seams for gas tightness.
5. Horizontal venting shall have slope not less than ¼" every 12 inches (21mm/m) downward away from the boiler to prevent collection of condensate throughout the assembly.
6. Allow sealant to cure for 24 hours before operating appliance.

B. For Heat-Fab Saf-T-Vent stainless steel vent pipe use a high temperature silicone sealant rated for 550°F The outside of the male end and inside of the female end of the pipe must be cleaned before applying the silicone bead. For 3" vent pipe runs, the male end of the vent pipe which goes over the outlet of the boiler's induced draft blower must be crimped. The vent pipe should be crimped as minimal as possible to provide a tight fit over the outlet. After crimping is completed follow the instructions for applying silicone sealant. For 4" vent pipe runs, begin with a Saf-T-Vent 3" to 4" increaser fitting over the boiler's induced draft blower outlet, to which an even bead of high temperature silicone sealant should be applied. Then continue the 4" Saf-T-Vent pipe run by connecting the 4" male end of the Saf-T-Vent to the increaser. (A locking band may be used around this joint for additional support.) The vent flow must be in the direction indicated on the vent pipe. When using the Tjernlund VH-1 vent hood, the female end (flared end) of the vent pipe will be connected to the termination hood. Apply high temperature silicone in an even ¼" bead approximately ¼" to ⅜" from the end of the vent hood's connecting vent pipe. Also, run a similar size bead of silicone sealant down the seam weld of the vent pipe. Then push the female end over the vent hood's connecting vent pipe.

1. Apply the high temperature silicone around the male end of the pipe (without the tabs) in an even ¼" bead. Silicone bead should be approximately ¼" to ⅜" from the end of the male end. Also, run a similar size bead of silicone sealant down the seam weld at the end of each joint.
2. Pipes can now be pushed together as far as they will go. The seams on the vent pipe should be aligned and oriented upward in all horizontal appliances. With a moistened finger or flat tool, spread any sealant that squeezes out around the circumference of the joint.
3. Attach the sections together with the locking rings and tabs (except at the blower outlet where no locking ring exists.) Inspect the joint to ensure that flue gases will not leak. If necessary apply additional sealant around the joint.
4. Horizontal venting shall have a slope not less than ¼" every 12 inches (21mm/m) downward away from the boiler to prevent collection of condensate throughout the assembly.
5. Allow the sealant to cure for 24 hours before operating the appliance.

HORIZONTAL VENTING INSTRUCTIONS

- C. For Flex-L StaR-34 stainless steel vent pipe use a high temperature silicone sealant rated for 550°F. Before applying silicone, the outside of the male end and inside of the female end of the pipe must be cleaned using a cleaner, such as methyl ethyl ketone (MEK) or naphtha. For 3" vent pipe runs, begin with the male end of the vent pipe over the boiler's induced draft blower outlet. For 4" vent pipe runs begin with a StaR-34 3" to 4" increaser fitting over the boiler's induced draft blower outlet. For both 3" and 4" vent pipe runs, apply a bead of silicone sealant around the blower outlet and around the inside of the male end of vent pipe going over the blower's outlet. When using the Tjernlund VH-1 vent hood, the female end (flared end) of the vent pipe will be connected to the termination hood. Apply high temperature silicone in an even ¼" bead approximately ¼" from the end of the vent hood's connecting vent pipe. Also, run a similar size bead of silicone sealant down the seam weld of the vent pipe. Then push the female end over the vent hood's connecting vent pipe. Now fill in the channel inlet with silicone sealant. Do not try to insert the joiner band, instead fasten the vent pipe to the vent hood's pipe with a steel gear clamp.
1. Apply the high temperature silicone around the male end of the pipe in an even ¼" bead. Silicone bead should be approximately ¼" from the end of the male end. Also, run a similar size bead of silicone sealant down the seam weld at the end of each joint.
 2. The seams on the vent pipe should be aligned and oriented upward in all horizontal vent pipe runs.
 3. Insert the male end of one into the female end of the other. Push the pipe together so the female end rests up against the stop bead of the male end.
 4. Insert a StaR-Joiner Band into the inlet of the beaded channel. Feed the Joiner Band in so it makes its way around the pipe, back to the channel inlet and it overlaps itself by about ½".
 5. Cut the excess Joiner Band so it lays flat in the beaded channel. Fill the inlet of the beaded channel with high temperature silicone. Smooth out the silicone over the channel inlet and the silicone between the female end and the stop bead of the male end.
 6. Horizontal venting shall have a slope not less than ¼" every 12 inches (21mm/m) downward away from the boiler to prevent collection of condensate throughout the assembly.
 7. Allow the sealant to cure for 24 hours before operating the appliance.
- D. For ProTech Systems FasNSeal stainless steel vent pipe no cleaning fluid is required. For 3" vent pipe runs on 2, 3, 4 and 5 section boilers, begin by locating the FasNSeal Ametek Adapter over the boiler's induced draft blower. Continue the vent pipe run with 3" FasNSeal vent pipe. For 6 and 7 section boilers, begin by locating the FasNSeal Ametek Adapter over the boiler's induced draft blower. Then connect a FasNSeal 3" to 4" increaser to the 3" adapter outlet. Continue the vent pipe run with 4" FasNSeal vent pipe. Other than the Ametek Adapter and increaser fitting, DO NOT use 3" vent pipe on 6 or 7 section boilers. FasNSeal vent pipe is joined and sealed by the use of an internal sealing gasket and a locking band on the female end of each vent pipe. All components should be examined for possible shipping damage prior to installation. Align all vent pipe seams and orient upward in all horizontal applications. Adjustable vent lengths are available for 4" diameter vent piping. For 3" diameter vent piping, square cut male end at the desired length. For 2, 3, 4 and 5 section boilers using the VH-1-3" vent hood, connect the FasNSeal Vent to the VH-1-3" vent hood using FasNSeal Adapter #FSC-DUN-3. This adapter has no internal sealing gasket. To attach the adapter to the vent hood, crimp the 3" vent hood pipe, apply a ¼" bead of high temperature silicone sealant around the outside of the vent hood's crimped connecting pipe and a similar bead of high temperature silicone around the inside of the FasNSeal adapter. After pressing the two pipes together and tightening locking band, finish creating a complete seal by filling FasNSeal adapter's notched hole with high temperature silicone. For 6 and 7 section boilers using the VH-1-4" vent hood, an adapter is not required. The 4" FasNSeal vent pipe connects directly to the VH-1-4" vent hood, and is joined and sealed by internal gasket and locking band.
- To join and seal the FasNSeal vent pipe:
1. Insert male end into female section.
 2. Push the units together as far as possible.
 3. Firmly tighten locking band with a nut driver.
 4. DO NOT penetrate the FasNSeal vent pipe with fasteners.
 5. Horizontal venting shall have a slope of not less than ¼" every 12 inches (21mm/m) downward away from the boiler to prevent the collection of condensate throughout the assembly.

HORIZONTAL VENTING INSTRUCTIONS

9. Support Spacing:

Do not restrict thermal expansion movement of the vent. The vent pipe must expand and contract freely with temperature change. Each run of vent piping shall be supported as follows:

- A. Z-Flex stainless steel vent piping requires a loose fitting metal strap or similar support at each joint at a maximum of 4 feet between supports.
- B. Heat-Fab stainless steel vent piping requires a support for every 6 feet of horizontal piping run. The support must be secured using at least #10 fasteners to a solid material (solid masonry or wood framing or blocking.) Do not fasten to drywall sheathing using hollow wall anchors. Each support will be 1½ inch lower than the previous support when spaced 6 feet apart.
- C. Flex-L stainless steel vent piping requires a loose fitting metal strap or similar support at each joint at a maximum of 4 feet between supports.
- D. ProTech stainless steel vent piping requires one loose fitting FasNSeal support strap for every 6' of horizontal vent.

10. If the horizontal vent must go through a crawl space or other unheated space, the cool temperatures will likely cause the flue gases to continuously condense inside the vent pipe. Do not insulate the vent pipe. It must be visible for monthly inspection. Insure that the vent pipe is properly pitched away from the boiler, with no low spots, so that condensate in the vent will drain away from the boiler. An insulated enclosure or chase, with access for inspection and servicing of the vent, may be required to prevent freezing of liquid condensate. Consult the vent pipe manufacturer's instructions for specific guidelines.

11. At the beginning of each heating season and monthly during the heating season, check all vent pipes and the vent terminal to make sure there are no obstructions. Periodically clean the screen in the vent terminal.

OPTIONAL HORIZONTAL VENTING INSTRUCTION

Horizontal venting with power venter is an alternate method of sidewall venting. This boiler is CSA listed for sidewall venting with standard single wall galvanized or Type B vent pipe when using the following power venter kits, which were specifically sized for these boilers:

Table 4 - Field Controls	
Number Of Boiler Sections	Field Controls Power Venter
2, 3, 4, 5	*SWG-4G
6, 7	**SWG-5

Some possible reasons for using a power venter for sidewall venting:

- 1. May be preferred by local codes.
 - 2. Need for vent piping run beyond 30' (9.1m) (but not more than 50' (15.2m)).
 - 3. Boiler installation site experiences gusting or high winds. Power venter helps prevent boiler from short cycling due to gusting or high winds by providing vent exhaust pressures greater than boiler's induced draft blower alone.
 - 4. Installers or homeowners may prefer negative pressure vent system.
 - 5. May be more cost effective than stainless steel venting, particularly at longer vent length.
- *Field Controls SWG-4G Power Vent Kit includes:
- » SWG-4HD Power Venter
 - » MG-1 4" Barometric Draft Controller
 - » CK-43F Control Kit.
- **Field Controls SWG-5 Power Vent Kit:
- » Purchased as individual component with purchase of CK-43F Control Kit.

Verify power venter installation is allowed by local codes. Follow power venter manufacturer installation instructions issued with power venter kits.

- » Power venter may be equipped with its own fan. Boiler fan shall remain in place and unaltered when using a power venter.
- » When sidewall venting, flue gases must be vented to a point in relation to prevailing wind, allowing them to freely disperse without being blown back at the building causing discoloration, or into building through doors or windows causing odors.
- » Flue gases may under certain conditions condense, forming moisture. Prevent building materials at vent terminal from being damaged by exhausted flue gas.
- » When installing single wall galvanized vent pipe for power venting follow power venter manufacturer installation instructions for layout and location of barometric draft control and termination connections.
- » When joining and sealing single wall galvanized or Type B vent piping use RTV silicone sealant with minimum temperature rating of 400°F.
- » 3" vent pipe runs, begin with female end of vent pipe over the boiler's induced draft blower outlet.
- » 4" vent pipe runs begin with galvanized 3" to 4" increaser fitting (supplied- parts bag) over induced draft blower outlet. Follow by placing female end of 4" vent pipe over increaser fitting.
- » When joining pieces of single wall galvanized vent pipe, use substantial bead of silicone at the joint to insure leak proof connection.

CAUTION

WHAT TO DO IF YOU SMELL GAS

- » Do not try to light any appliance.
- » Do not touch any electrical switch; do not use any phone in your building.
- » Immediately call your gas supplier from a neighbor's phone. Follow gas supplier's instructions.
- » If you cannot reach your gas supplier, call the fire department.

Connecting Gas Piping

Gas line enters boiler from right side. Flexible gas connectors must never breach any boiler openings.

- » Use piping materials and joining methods acceptable to authority having jurisdiction. In absence of such requirements:
 - » USA - National Fuel gas Code, ANSI Z223.1/NFPA 54
 - » Canada - Natural Gas and Propane Installation Code, CAN/CSA B149.1
- » All pipe compound must be resistant to liquefied petroleum gas.
- » Install ground joint union in gas supply line between shut-off valve and boiler controls.
- » Install sediment trap upstream of gas controls.
- » Use two pipe wrenches when making connection to gas valve to keep it from turning.
- » Install manual shut-off valve in vertical pipe about 5 feet (1.5m) above floor. See Figure 10.
- » Tighten all joints securely.
- » Propane gas connections should only be made by licensed propane installer.
- » Two-stage regulation should be used by propane installer.
- » Propane gas piping should be check by propane installer.

Figure 10 - Gas Piping At Boiler

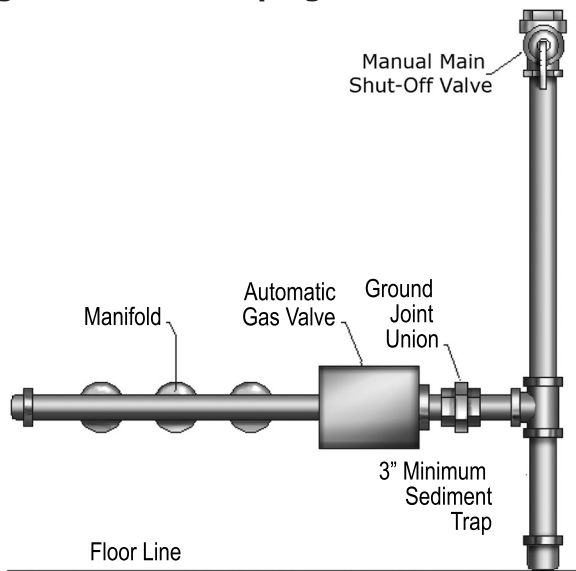

Check Gas Supply

Gas pipe must be correct size for length of run and for total BTU per hour input of all gas utilization equipment connected to it. See Table 6 & 7, Page 20 for proper size. Be sure your gas line complies with local codes and gas company requirements.

DANGER

Fire Hazard. Do not use matches, candles, open flames, or other methods providing ignition source. Failure to comply will result in death or serious injury.

Table 5 - Gas Pressures

PRESSURE	GAS	
	NATURAL	PROPANE
MIN. SUPPLY	5" w.c.	11" w.c.
MAX. SUPPLY	13.5" w.c.	13.5" w.c.
MANIFOLD	3.5" w.c.	10" w.c.

Verify minimum pressure while boiler is operating.
Verify maximum pressure when boiler is not operating

Check Gas Piping

Pressure test boiler and gas connection before placing boiler in operation.

- » Pressure test over 1/2 psig (3.5 kPa). Disconnect boiler and its individual gas shutoff valve from gas supply system.
- » Pressure test at 1/2 psig (3.5 kPa) or less. Isolate boiler from gas supply system by closing manual gas shutoff valve. See Figures 5-6 Page 9.
- » Locate leakage using gas detector, noncorrosive detection fluid, or other leak detection method acceptable to authority having jurisdiction.
- » Correct leaks immediately and retest.

GAS SUPPLY PIPING

Table 6 - NATURAL GAS

Length of Pipe - Ft.	Pipe Capacity - BTU Per Hour Input Includes Fittings			
	½"	¾"	1"	1¼"
20	92,000	190,000	350,000	625,000
40	63,000	130,000	245,000	445,000
60	50,000	105,000	195,000	365,000

Table 7 - PROPANE GAS

Length of Pipe - Ft.	Pipe Capacity - BTU Per Hour Input Includes Fittings			
	Copper Tubing*		Iron Pipe	
	⅝"	¾"	½"	¾"
20	131,000	216,000	189,000	393,000
40	90,000	145,000	129,000	267,000
60	72,000	121,000	103,000	217,000

***Outside diameter:**

Measure length of pipe or tubing from gas meter or propane second stage regulator.

⚠ WARNING

Electrical shock hazard. Turn OFF electrical power supply at service panel before making electrical connections. Failure to do so could result in death or serious injury.

Electrical Wiring

See wiring diagram Figure 12 page 23 for details. Refer to Ladder Diagram from document envelope received with boiler.

Electrically bond boiler to ground in accordance with requirements of authority having jurisdiction. Refer to:

- » USA- National Electrical Code, ANSI/NFPA 70.
- » Canada - Canadian Electrical Code, Part I, CSA C22.1: Safety Standard for Electrical Installations.

If any of the original wire as supplied with this appliance must be replaced, it must be replaced with type 105°C thermoplastic wire or its equivalent

Circulator harness is factory wired to control module. Connect harness to circulator in field. See Figure 11.

Electric Power Supply

Run a separate 115 volt circuit from separate over current protective device 15 ampere circuit in electrical service entrance panel.

LWCO kit 550002998 wiring includes wiring instructions and diagrams.

Connect 115 volt power supply to terminals L1 (HOT) and L2 inside J box.

Run 14 gauge or heavier copper wire from boiler to grounded connection in service panel or properly driven and electrically grounded ground rod.

Thermostat Installation

1. Thermostat should be installed on an inside wall about four feet above the floor.
2. NEVER install a thermostat on an outside wall.
3. Do not install a thermostat where it will be affected by drafts, hot or cold pipes, sunlight, lighting fixtures, televisions, a fireplace, or a chimney.
4. Check thermostat operation by raising and lowering thermostat setting as required to start and stop the burners.
5. Instructions for the final adjustment of the thermostat are packaged with the thermostat (adjusting heating anticipator, calibration, etc.)
6. Set heat anticipator at .2 amps. 24 volt thermostat connects to yellow low voltage wires labled T.

Figure 11 - Control Module Panel

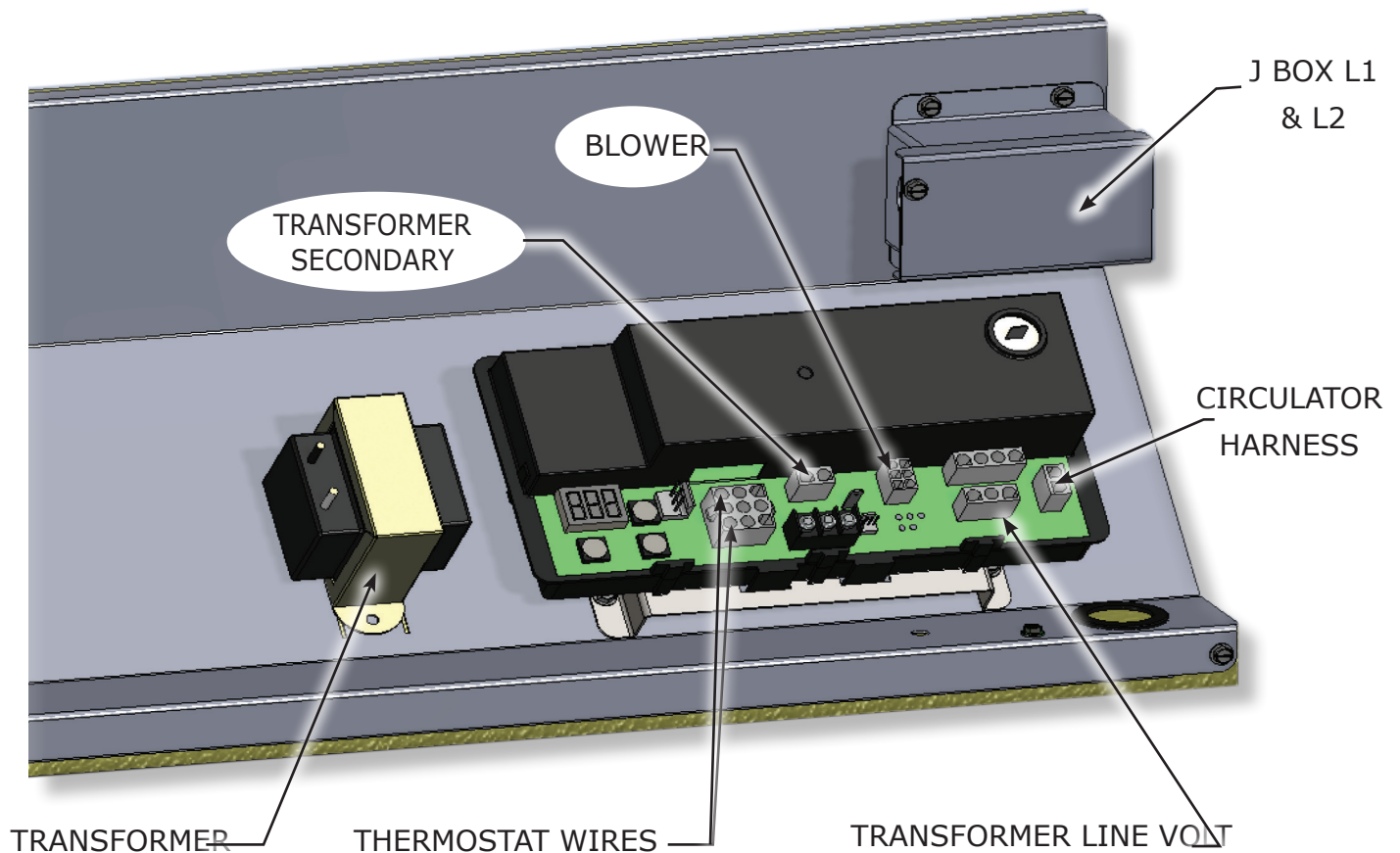

Sequence of Operation -Figure 12, Page 23.

1. Thermostat calls for heat, control relay contacts.
2. Circulator pump is powered through terminals C1 and C2. Control holds off burner and attempts to satisfy thermostat with residual boiler heat.
3. Induced draft blower and transformer primary are powered.
4. When blower gets up to speed and blower suction pressure reaches pressure switch set point, pressure switch contacts close sending 24 volts to pilot control from transformer secondary.
5. Pilot gas valve opens and spark initiates to light pilot burner.
6. When pilot flame is proven, spark drops out.
7. Main gas valve opens and pilot burner ignites main burners.
8. If boiler water temperature reaches high limit set point, high limit contacts open, cutting power to blower and pilot control. Burners extinguish and blower stops. Circulator pump continues to run as long as the thermostat continues to call for heat. When boiler water temperature drops past the high limit set point and through the differential, high limit contacts close, repeating steps 3-7.
9. If venting system becomes blocked, blower suction pressure will drop below pressure switch set point, opening pressure switch contacts and cutting power to pilot control. Burners will extinguish, but blower will remain powered as long as thermostat continues to call for heat. If venting system clears, steps 4-7 will repeat.
10. Thermostat is satisfied, ending call for heat. Relay coil is de-energized, opening contacts. Burners extinguish. Blower and circulator pump stop.

Figure 12 - Control Module

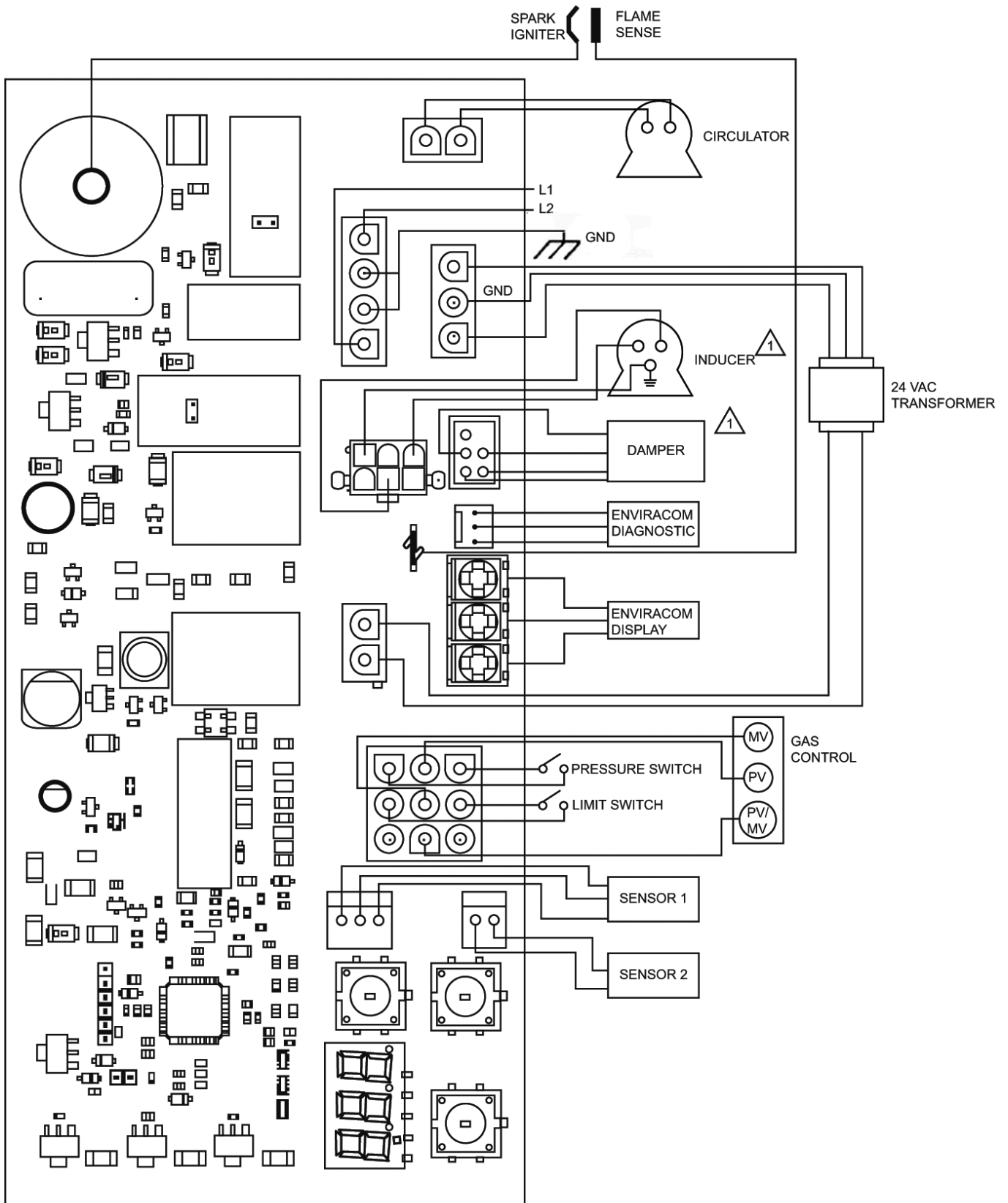

 OPTIONAL DEPENDING ON CONFIGURATION
 Damper is not an option.

NOTICE

Do not add water into hot empty boiler.

Filling System With Water

- » Close air vents on all radiation units. Open valves to these units.
- » Verify boiler and expansion tank drain valves are closed. Air bleed screw on tank drain fitting should be closed.
- » Open valve in line from boiler to expansion tank.
- » Open water inlet to your boiler and leave open.
- » Start with lowest radiation unit. Open air vent on this unit. When all air has escaped and water starts to flow from vent, close it.
- » Go to next radiation unit, and repeat this process.
- » Repeat until you have covered every radiation unit in system. End at highest unit in system.
- » If units have automatic vents, manual venting is unnecessary but it will speed up proper filling of system.
- » If system is closed expansion tank system, you may have automatic fill valve. Leave it open to refill system automatically as needed.
- » Check temperature-pressure gauge. Note position of hand indicating pressure. This should be between 10 and 15 psi. Any lowering of this movable hand below 10 psi indicates loss of water due to leakage. Automatic fill valve should compensate for this. Instructions are packaged with valve.

⚠ WARNING

If you do not follow these instructions exactly, a fire or explosion may result causing property damage, personal injury or loss of life.

- » This appliance is equipped with an ignition device which automatically lights burner. **Do NOT try to light this burner by hand.**
- » Before operating smell all around appliance area for gas. Be sure to smell next to floor because some gas is heavier than air and will settle to the floor.
- » **Use only your hand to turn the gas shutoff valve.** Never use tools. If valve will not turn by hand, do not try to repair it, call a qualified service technician. Force or attempted repair may result in fire or explosion.
- » **Do not use this appliance if any part has been under water.** Immediately call a qualified service technician to inspect appliance and to replace any part of control system and any gas control which has been under water.

LIGHTING PROCEDURE FOR BOILER WITH INTERMITTENT PILOT SYSTEM

For Your Safety, Read Before Operating!!

- A. This appliance is equipped with an ignition device which automatically lights the pilot. Do not try to light appliance by hand.

⚠ CAUTION

WHAT TO DO IF YOU SMELL GAS



- » Do not try to light any appliance.
- » Do not touch any electrical switches; do not use any phone in your building.
- » Immediately call your gas supplier from a neighbor's phone. Follow the gas supplier's instructions.
- » If you cannot reach your gas supplier, call the fire department.

Operating Instructions.

1. **STOP! Read Safety Information on previous page.**
2. Set the thermostat to lowest setting.
3. Turn off all electric power to the appliance.
4. This appliance is equipped with an ignition device which automatically lights the burner. Do not attempt to light pilot by hand.
5. Remove burner access panel.

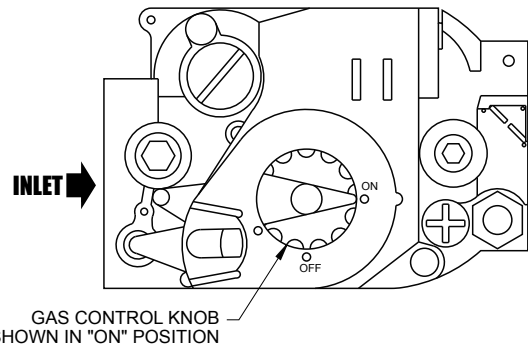
Figure 13 - Gas Control Knob



6. Depress gas control knob slightly and turn clockwise  to "OFF" position.
7. Wait five (5) minutes to clear out any gas. If you then smell gas STOP! Follow WHAT TO DO IF YOU SMELL GAS. If you don't smell gas, go to next step.
8. Turn gas control knob counterclockwise  to "ON."
9. Turn on all electric power to the appliance.
10. Set thermostat to desired setting.
11. After visually inspecting the flame, replace lower front panel.
12. If appliance will not operate after several tries, turn gas control knob to "OFF" and call your service technician or gas supplier.

To Turn Off Gas To The Appliance

1. Set the thermostat to lowest setting.
2. Turn off all electric power to the appliance if servicing is to be performed.
3. Depress gas control knob slightly and turn clockwise  to "OFF" position. Do not force.

Gas Valve Safety Shutdown Test

⚠️ WARNING

Electrical shock hazard. Follow instructions to turn off electric power. Failure to do so could result in death or serious injury.

Ignition system safety shutoff device must be tested after placing boiler in operation. With main burners firing, disconnect ignition cable from intermittent pilot control box. Gas valve should shut off main burners. **TURN OFF ELECTRIC POWER** to boiler before reconnecting ignition cable, to prevent electric shock.

Adjust Pilot Burner

1. Remove screw cover over pilot adjusting screw.
2. Insert small screwdriver and adjust flame as needed. See Figure 14 & 15. Turn screw counterclockwise  to increase flame, clockwise to decrease.

Main Burner(S)

Main burners do not require primary air adjustment and are not equipped with primary air shutters.

Main burner flames form sharp blue inner cones in softer blue outer mantel, with no yellow. Puffs of air from blowing on flame or stamping on floor will cause flames to turn orange momentarily. *This is not unusual.* Remain still when observing main burner flames. See Figure 16, Page 27. If flame appearance is not correct, check main burner orifices, burner throat and flame ports for dust and lint obstruction. It may be necessary to remove rollout shield to observe main burner flames. Replace rollout shield after observation.

Adjust Limit Controls

Instructions for each control are included with the controls.

Recommended Boiler Water Temperatures

Settings can be changed after you have had some idea how the system works. **Example:** *If your system does not give enough heat in very cold weather, you can raise limit setting to 190°F.*

Figure 14 - Automatic Gas Valve

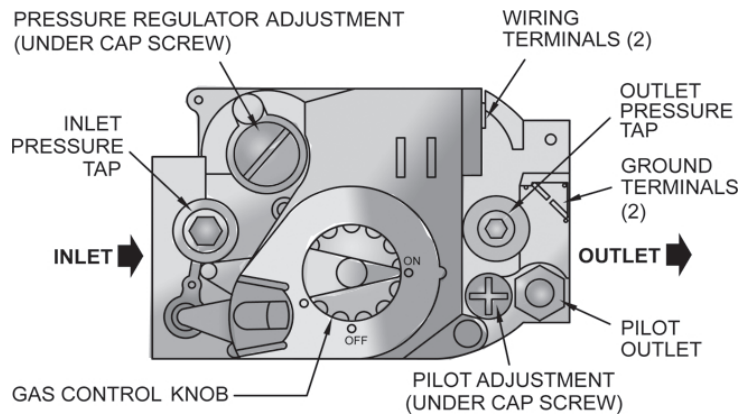

Figure 15 - Pilot Flame Adjustment

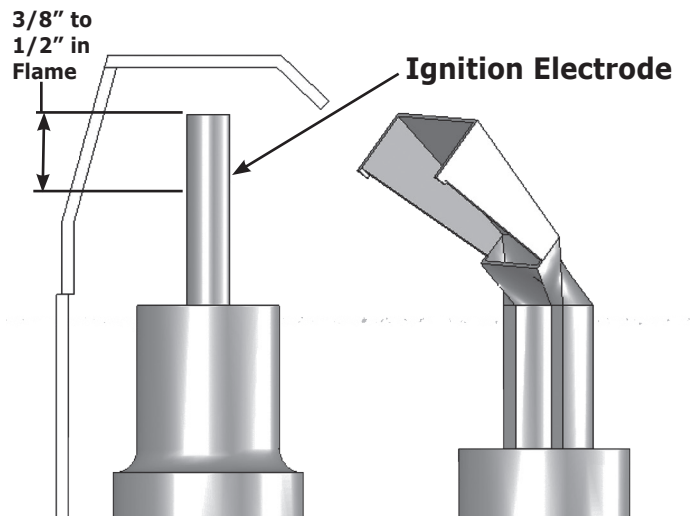
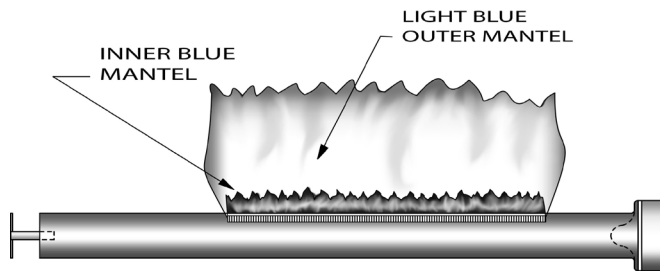

Figure 16 - Main Burner Flame

Main burner flame should form sharp blue inner mantel with no yellow.

Adjust Thermostat Heat Anticipator

Instruction for final adjustment of thermostat are packaged with thermostat.

1. Set Heat anticipator at .2.
2. Check thermostat operation. When set above temperature indicated on thermometer, boiler burners should ignite. Verify thermostat turns off boiler when room temperature reaches selected setting and starts boiler operating when room temperature falls few degrees. After setting limit control to desired setting, check to see if it shuts off gas supply to burners.
3. Turn your thermostat up to call for heat and let your boiler run until temperature of water reaches limit setting. Gas valve shuts off and circulator keeps running until thermostat is satisfied, or water cools enough to restart burners through limit control.
4. To check operation of contacts in pressure switch, disconnect rubber tubing (located between blower and pressure switch) from pressure switch, while boiler is operating. Burners extinguish and blower keeps running. When tubing is reconnected to pressure switch, ignition sequence begins, resulting in ignition of main burners.
5. Set thermostat for desired temperature.

Safe lighting and other performance criteria were met with gas manifold and control assembly provided on boiler when boiler underwent tests specified in ANSI Z21.13.

Burners

Beginning of heating season visually check pilot end main burner flames. See Figures 13, and 15.

Safety Relief Valve

Test safety relief valve for proper operation. Refer to valve manufacturer's instructions packaged with relief valve.

Expansion Tank (Non-diaphragm)

Tank may become waterlogged, or may receive excess of air. Frequent automatic opening of safety relief valve indicates water logging. High boiler temperature accompanied by unusually low radiation unit temperature (and "knocking") indicates excess air in tank.

To correct:

1. Close valve between boiler and tank. Drain tank until empty.
2. Check all tank plugs and fittings. Tighten as necessary.
3. Open valve between boiler and tank. Water will rise to normal height in tank if you have automatic fill valve (otherwise, manually refill system).

Boiler Flue Passages

Recommend following checked annually by qualified service agent.

- » flue passages
- » burner adjustment
- » operation of controls

Before start of each season (or whenever system has been shut down for some time) recheck whole system for leaks and recheck boiler and vent pipe for leaks. Replace or patch any boiler seals that are faulty. Before start of each season (or whenever system has been shut down for some time) recheck the whole system for leaks . . . and recheck the boiler and vent pipe for leaks. Replace or patch any boiler seals that are faulty.

Vent Pipe

Venting and piping should be checked at least monthly. If vent piping shows any sign of leaking, replace immediately.

Water System

If system is to remain out of service during freezing weather, always **drain it** completely (water left in to freeze will crack pipes and/or boiler).

Cleaning Your Boiler And Burners

Flue passages between sections should be examined yearly and cleaned if necessary.

To clean:

- » Remove burners, pilot, and vent pipe.
- » Remove top and front jacket panels.
- » Remove two screws attaching intermediate front panel to left and right side jacket panels.
- » Remove control panel as a unit.
- » Remove draft diverter and intermediate front panel.
- » Carefully remove cerafelt gasket strips.
- » Clean passageways between sections with flexible handle wire brush. Remove dirt from bottom of boiler and from between sections by vacuuming.
- » Verify all flame ports in burners are open and clear. Shake out or blow out all loose dirt in burners.
- » Reseal seams between adjacent sections as necessary with 400° F RTV silicone sealant.
- » Reassemble all parts.
- » Verify tightness of pilot connections and condition of burner flames after reassembly. See Figures 13 and 14.
- » Verify vent pipe connections to chimney are secure and no obstructions are present.

Blower

Blower motor features permanently lubricated ball bearing construction. Lubrication is not required.

Circulator Pump Isolation Valves

Operate isolation valves in circulator pump flanges manually once or twice per year to prevent valves from becoming stuck in open position

Rotate valves from open position to closed position and back to open position.

Low Water Cut-off(s)

Inspect field sourced low water cut-offs annually or as recommended by low water cut-off manufacturer. Flush float type low water cut-off(s) per manufacturer's instructions.

Housekeeping

- » Keep boiler area clear and free from combustible materials, gasoline and other flammable vapors and liquids.
- » Keep boiler area clear of debris and other materials obstructing flow of combustion and ventilation air.

SERVICE HINTS

You may avoid inconvenience and service calls by checking these points before you call for service:

⚠ CAUTION
WHAT TO DO IF YOU SMELL GAS
<ul style="list-style-type: none"> » Do not try to light any appliance. » Do not touch any electrical switch; do not use any phone in your building. » Immediately call your gas supplier from a neighbor's phone. Follow the gas supplier's instructions. » If you cannot reach your gas supplier, call the fire department.

IF YOUR SYSTEM IS NOT HEATING OR NOT GIVING ENOUGH HEAT . . .

POSSIBLE CAUSE	WHAT TO DO
Thermostat is not set correctly	Reset thermostat
Burner is not operating properly	Check flame. If it is yellow, the burner is not getting enough air. Or, if flame is blue and noisy and seems to lift off the burner, the burner is getting too much air. Contact your service agency.
No electric power to boiler	Check over-current protection. Check to be sure electric power supply circuit is "ON".
Controls out of adjustment	Reset according to instructions.
Radiators not heating	Open radiator vents to excess air. Check flow control valve (if used). It may be in closed position.
Circulating pump not running	Check over-current protection. Check relay operation.
Poor electrical contact	Check all control terminals and wire joints.
Chimney flue is blocked	Pressure switch will not close and pilot spark will not operate to start pilot. Have your service technician check and correct, if necessary.
Rollout switch blown	Have your service technician check heat exchanger for blockage. Replace rollout switch with exact replacement.

IF BURNER IS NOISY . . .

POSSIBLE CAUSE	WHAT TO DO
Gas input amount is incorrect	Contact your service technician.

RELIEF VALVE LEAKING . . .

POSSIBLE CAUSE	WHAT TO DO
Dirt on seat	Open valve manually. Allow water to run and clear valve seat.
Water logged expansion tank	Drain tank, see manufacturer instructions.

HAVE YOUR SERVICE AGENCY CHECK ANY PROBLEM YOU ARE UNABLE TO CORRECT.

⚠ WARNING

Burn and scald hazard. Safety relief valve could discharge steam or hot water during operation. Install discharge piping per these instructions.

SAFETY RELIEF VALVE

Safety relief valve is required on your boiler. Water expands as it is heated. If there is no place for water to expand into, water pressure will build up inside boiler and system. Should this happen, safety relief valve will automatically open at predetermined pressure. This will relieve the strain on boiler and system. Run pipe from relief valve outlet (pipe must be same size as outlet and open end must not be threaded) to open drain, tub or sink, or other suitable drainage point not subject to freezing. Failure to do so may cause water damage or injury should safety relief valve release.

EXPANSION TANK

Expanding water flows into expansion tank. Tank should be correct size. Tank is filled with air. As water expands it compresses air in the tank to form air pressure cushion. This "spring-like" cushion serves to maintain correct operating water pressure regardless of water temperature. This assures "full measure" of water, even in highest radiation unit of system. It also prevents blowing off of safety relief valve. Air in tank in beginning (with system filled with cold water) is sufficient for proper operation. Tank also serves as trap for excess air in system. Air would cause gurgling in pipes and in efficient circulation in radiators if left in system.

It is possible for tank to become "waterlogged" (filled with water). It can also become overfilled with air. This can happen after filling system with new water. Fittings provided on tank and in line to tank are for bleeding off excess water or air.

When installing this tank, it is important:

1. Tank be higher than boiler top.
2. Pipe to tank continuously rises up to tank (so air can "bubble" up to it).

DIAPHRAGM TYPE EXPANSION TANK

Diaphragm type expansion tank takes place of conventional expansion tank. Carefully read instructions packed with your tank assembly.

Tank comes with 10-12 pounds per square inch air charge. This is the same as pressure produced in system by automatic fill valve. When system is first filled, tank will contain little or no water.

As water is heated its pressure increases. It expands into tank, compressing air in tank. Compressed air cushion permits water in system to expand as temperature changes. Diaphragm type tank can be mounted on air purger fitting or at any convenient place in supply or return line.

AIR ELIMINATING FITTING (AIR PURGER)

Air purger is used to remove excess air from system. It is installed in supply line. It will eliminate air from water before it reaches radiators and bleed off this air.

MAIN AIR VENT FOR DOWN FLOW SYSTEMS OR DIAPHRAGM TYPE EXPANSION TANK

Before system is filled with water, there is air in pipes and radiation units. Some of it will be trapped as system is filled. It is possible to eliminate most of this air through air vent on radiation units. Main air vent will speed and simplify this. Install on highest point in supply main when all radiation is below top of boiler.

AUTOMATIC FILL VALVE

For a safe, efficient operation, hot water system must be **completely filled** with water. Adding new water, when needed can be done manually (by use of hand valve in water supply line). Requires regular attention to system's needs. Automatic fill valve accomplishes this without attention. Install in supply line on hot water boilers only. Valve operates through water pressure differentials. It does not require electrical connection.

DRAIN VALVE

Manual valve provides means of draining all water from boiler and system. It is often installed in 3/4" tapping at bottom of end boiler section. Or it can be installed in tee where return line enters boiler.

WATER TEMPERATURE CONTROL

Water temperature limit control in relay is adjustable and may be set as necessary. It may be set as low as 140°F, or as high as 220°F. This depends on type and amount of radiation involved and weather conditions.

CIRCULATING PUMP

Every forced hot-water system requires circulating pump. Separate pump or zone valve is required for each zone, if you have a two or more zone system. Pump must have capacity to provide circulation required by your system. Pump is connected into main just ahead of boiler. It is also wired to electrical system.

BLOWER (Draft Inducer)

Blower provides means for pulling air through boiler and exhausting flue gasses into vent system. Blower shuts off when burners are not firing. This keeps heat in house rather than having it go up chimney.

PRESSURE SWITCH

Air pressure switch works on negative pressure. When blower comes on air pressure switch operates intermittent pilot and gas valve. Air pressure switch is factory set and will only work when blower operates properly. It will not allow boiler to come on if blower does not generate enough pressure or if venting system is blocked.

Factory Pressure Switch Set point:

-0.4" wc. for 2-5 section boilers.

-0.5" w.c. for 6-7 section boilers.

ROLLOUT SWITCH

(FLAME ROLLOUT SAFETY SHUTOFF)

Rollout switch is temperature-sensitive fuse link device. Located on boiler base just outside fire box. In event of heat exchanger flueway blockage causing flame to roll out of fire box, fuse does not change in appearance when blown.

If rollout switch blows, it must be replaced with exact replacement. Check heat exchanger flueways for blockage when restoring system to operating condition. DO NOT operate system without rollout switch.

A.1 Installation Environment Considerations

⚠ WARNING

If you do not follow these instructions exactly, a fire or explosion may result causing property damage, personal injury or loss of life.

- » **Do not use this appliance if any part has been under water.** Immediately call a qualified service technician to inspect appliance and to replace any part of control system and any gas control which has been under water.
- » Do not allow water to drip on controls. Prevent condensation by allowing air circulation around module and gas control.
- » Do not use corrosive chemicals around or on module or gas control.

- » Install plastic cover. Limits contamination from accumulation of dust or grease.
- » Controls can be damaged by excessively high temperatures. Verify adequate air circulation around louvers is maintained when installing boiler.

A.2 Electrical Connections

Connect Module Connectors Figure 11, Page 21

- » L1& L2 leads inside J box using wire nuts. Secure J box cover.
- » Circulator harness to circulator. Harness comes plugged into module with Molex[®] plug.
- » Thermostat connection to yellow wires marked TT using wire nuts.
- » Ensure remaining Molex[®] plug connectors have not worked loose during transit.
- » Check sensing bulb is fully inserted in well and is not loose.

A.3 Adjusting Settings

To discourage unauthorized changing of settings, procedure to enter adjustment mode is required.

To enter adjustment mode, press UP, DOWN, and I buttons (see Figure 1) simultaneously for three seconds. Press and release I button until parameter requiring adjustment is displayed:

- o "SP_" Setpoint (180 °F default setting; adjustable between 130 and 220 °F)
- o "Df_" Setpoint Differential (15 °F default setting; adjustable between 10 and 30 °F)
- o "°F_" Degrees Fahrenheit

Press UP or DOWN button until parameter has reached desired value. After 60 seconds without any button inputs, control automatically returns to READ mode.

A.4 Display

In RUN mode, status items and parameters are viewable.

Example, to display setpoint, control flashes "sp" (setpoint) followed by temperature (i.e., 135), followed by °F or °C.

To read settings, press and release I key to find parameter of interest.

Example, press and release I until setpoint (sp) is displayed, followed by three-digit number, i.e., 190, followed by °F or °C. Press I button again will display (S1T) Sensor 1 Temperature followed by three-digit number and corresponding degree designator.

See Display Readout.

Figure 17 - Display Readout

Text	Description	Shows
sta	Current State	StA
s1t	Sensor 1 Temperature	S1t
sp	Setpoint	SP
dff	Setpoint Differential	dFF
hr	Heat Request Status	hr
err	Error Code	Err
fla	Flame Current	FLA
°F	Degrees Fahrenheit	°F
°C	Degrees Celsius	°C
uA	Micro Amps	uA

A.5 Operation

Module continuously monitors boiler water temperature and fires or shuts off burner based on this temperature data.

1. When "Call for Heat" occurs, control enables circulator and monitors boiler water temperature to determine whether thermostat can be satisfied without firing burners.
2. Control determines burner operation is required, module proceeds to start burner (see state codes list) and heats water in boiler until setpoint temperature is achieved or thermostat is satisfied. .
3. Burner is de-activated, ignition module completes heating cycle, returns to idle and waits for temperature to drop again.
4. Circulator is turned on throughout "Call for Heat."

APPENDIX A - CONTROL MODULE

Table 8 - Operation Error Codes

Error Code	Error Description	Error display clearing (once error condition has disappeared)					
		Clears itself when root problem resolved	Cycle Power OFF	Push any key	Up/down key when status is displayed	Explanation	Things to look for
2	Pressure switch failed to open (stuck closed)	x	x			Control relies on pressure switch to verify inducer motor is running and vent is clear. Switch should open at end of heat cycle, but this did not occur	1. Check pressure switch 2. Check tubes going to pressure switch, verify no obstruction. 3. Check wiring to pressure switch 4. Remove wire connections to pressure switch. If code persists, replace control."
4	Flame current lower than threshold	x	x			Control requires strong enough signal to verify flame is present. Signal is too low.	1. Check pilot flame sense is clean 2. Check for proper ground 3. Check wiring 4. Check for correct pilot orifice 5. Check there are no gas leaks in pilot tubing.
6	Flame sensed out of normal sequence		x		x	Control circuit is sensing flame rectification when there should be none.	1. Check gas valve 2. Check all electrical connections are tight
18	Electronic failure			x		Control believes it is defective	1. Try reset by cycling power or push any key. 2. Check wiring to pilot and main valve. 3. Otherwise, control will require replacement
23	Flame sensed during Pre-purge		x		x	Pilot is being sensed too soon in ignition sequence	1. Check gas valve 2. Check all electrical connections are tight
24	Flame sensed during Post-purge		x		x	Pilot is being sensed too late in shutdown sequence	1. Check gas valve 2. Check all electrical connections are tight
29	Pressure switch failed to close (switch stuck open)	x	x			Control relies on pressure switch to verify inducer motor is running and vent is clear. Switch must close at start of heat cycle, but this did not occur	1. Check pressure switch 2. Check venting, verify no obstructions 3. Check tubes going to pressure switch, verify no obstruction. 4. Check wiring to pressure switch 5. Jumper wire connections to pressure switch. If code persists, replace control. Be sure to remove jumper.
32	Temperature sensor failure	x	x			Temperature sensor is not providing expected reading	1. Check sensor is plugged into control board 2. Check sensor wiring is not damaged 3. Scroll display reading to ""bt"", and hold sensor bulb securely in your hand. It should read temperature close to body temperature. If not, replace sensor.
57	Flame rod shorted to burner ground	x	x			Control did not detect voltage difference between flame sense wire and ground	1. Check flame sense wire on pilot assembly is not frayed or otherwise damaged. If so, replace pilot assembly. <i>Note! These are high temperature wires. Do not attempt field repair.</i> 2. Check there is not moisture collecting on control board
58	AC line frequency error	x	x			AC frequency is incorrect or noisy	1. Some electric or electronic devices may generate electromagnetic interference. Verify none is present. 2. Check thermostat connection
59	Line voltage error	x	x			Line voltage (or, possibly thermostat) is either too high or too low	Source problem is likely in electrical external to boiler. Control will clear itself and resume normal operation once the situation is resolved. Check BOTH line power and thermostat wiring.
60	Thermostat input higher than threshold	x	x			Certain types of thermostat may not be compatible with control circuitry	Verify boiler works properly by jumping yellow thermostat wires. If so, replace thermostat (or possible thermostat wires)
61	Line voltage unstable	x	x			Unstable line voltage - possibly too many heavy loads switching on and off	1. Check if current draw on this branch circuit from house breaker box might have very heavy loads switching on or off 2. Check power coming into house. Source problem is likely in electrical external to boiler. Control will clear itself and resume normal operation once situation is resolved.
62	Soft Lockout-Max retries exceeded		x	x		Control sensed consecutive instances of no flame signal while trying to light pilot.	1. Check control ground connection 2. Check pilot ignition wire for good condition and connection 3. Clean pilot tip 4. Check pilot tube; assure no gas leaks 5. Check correct pilot orifice is being used 6. Check gas line pressure
63	Soft Lockout-Max recycles exceeded		x	x		Control sensed consecutive instances of loss of pilot flame signal AFTER main burners are lit.	1. Check gas valve 2. Check all electrical connections are tight 3. Check pilot rod is clean 4. Check gas line pressure 5. Check for adequate draft 6. Check for adequate combustion air.
64	Soft Lockout-Internal Failure		x	x		Control is sensing something wrong with electrical circuitry	1. Check all wiring is correct. Refer to wiring diagram 2. Check there is good ground to pilot bracket.
65	Hard Lockout-Temperature above limit		x	x		Control sensed water temperature which is too high for safe boiler operation.	1. Check water is circulating properly through boiler. 2. Check there is not air in system 3. <i>If pressure relief valve opened, there is definitely a problem with water circulation!</i> 4. If any of the above 3 are true, the root problem is in hot water circulation. 5. Scroll display reading to ""bt"", and hold sensor bulb securely in your hand. It should read temperature close to body temperature. If not, replace sensor.

Note: In event of multiple errors, the highest error number is displayed first.

Note: Error codes 18 and 65 - Hard Lockout will not expire. Requires operator reset. No volatile memory (error will not be remembered if power is off).

Error codes 6, 23, 62, 63 and 64 - Soft Lockout of 1 hour duration if not reset. Control will then resume normal operation. If source error is still present a second soft lockout is possible.

All other codes - No lockout. Control will resume normal operation immediately when source error is resolved.

APPENDIX A - CONTROL MODULE

Table 9 - Induced Draft Models State Codes

1. State code sequence through a normal heat cycle.			
Order	State code	Definition	Explanation
a	1	Idle	There is no call for heat; and/or:
b	1	Circulator	Thermostat has called for heat. Control activated system circulator pump and is waiting to see if there is enough heat stored in the boiler to satisfy the t'stat without firing the burners. This may last as long as 2 minutes, but will typically be much less.
c	17	Diagnostics	Pilot valve diagnostics/current leakage detection. Typically a few seconds.
d	2	Wait for pressure switch to open	Inducer motor should be off while boiler is off to conserve energy. Control is verifying motor is acutally offr (switch must be open).
e	3	Wait for pressure switch to close	Control starts inducer (vent motor). A pressure switch must close to verify motor is operating and vent to outside is not obstructed. If this does not occur after one minute, control will go into ERR29. Should the switch eventually close, control will resume normal operation.
f	4	Pre purge	Control is clearing gases out of the heat exchanger. Also, internal electronic diagnostic check is performed.
g	6	Spark	Spark for ignition. There should be audible sparking (buzzing) noise. This will last until control detects pilot flame, but no more than 30 seconds. (If no flame is detected after trial period, sparking will stop, and 5 minute delay will occur before control tries again. STA10 will be displayed during this period).
h	7	Flame stabilization	Pilot flame must be strong enough (1 uA) for control to release main burners. This will last up to 10 seconds. (If flame is still not strong enough after 10 seconds, control will shut off the pilot, wait 5 minutes, then try again. STA10 will be displayed during this 5 minute period).
i	8	Running	Main burners are providing heat. This will continue as long as thermostat requires. During this period, control will monitor pilot signal, boiler temperature, damper, and limit switches to assure safe operation.
j	9	Post-purge	Inducer motor is purging gases after heat cycle.
k	1	Post operation.	Circulator pumps will continue for short time to deliver stored heat to house before it has a chance to escape during coming off period.
2. Other possible state codes			
j	10	Retry Recycle Delay	5 minute delay after pilot signal is lost. EITHER: 1. Control failed to detect pilot flame after spark period. Check pilot for contamination; check ignition wire; check electrical ground; check pilot flame. 2. Control lost pilot flame signal AFTER main burners were lit. Check for adequate draft and combustion air. Check gas line for adequate pressure.
k	11	Wait for pressure switch to open - failed closed	Inducer is still off, but pressure switch has not opened at beginning of heat cycle. Alarm is sent, but no lockout occurs.
l	12	Wait for pressure switch to close - failed open	Inducer is on but pressure switch has not closed yet at beginning of heat cycle. Alarm message is sent but no lockout occurs.
m	13	Soft lock out	Soft lockout duration is one hour, may override with manual reset. Appropriate error code will flash alternately.
n	14	Hard lock out	Requires manual reset. Unacceptable high water temperature (err 65) and onboard electronics failure (err 18) are the only hard lockouts on this model.
o	15	Wait for limit to close	One of the safety limits - rollout, or Low water cutoff (if one is field installed on 24V safety circuit) has been activated. Control will resume normal operation once limit is reset. Underlying cause why limit switch opened MUST be investigated.
p	16	Flame out of sequence	Flame signal sensed before trial for ignition. Appropriate alarm is sent. OR Flame signal sensed out of sequence during post purge OR Flame signal present when not expected. Appropriate alarm is sent.
q	17	Diagnostics	Onboard self check performed at various points during operation sequence.

A.6 Boiler High Limit Temperature Controller

- » When water temperature reaches setpoint, controller ends heating cycle.
- » When water temperature drops below setpoint minus differential, controller restarts heat cycle to re-heat boiler water.
- » If water temperature exceeds maximum allowed temperature (220°F or 104°C), controller enters manual reset lockout state.
- » For models having reset capability, press any onboard button or cycle power to reset.

Figure 18 - Basic Control Algorithm Example

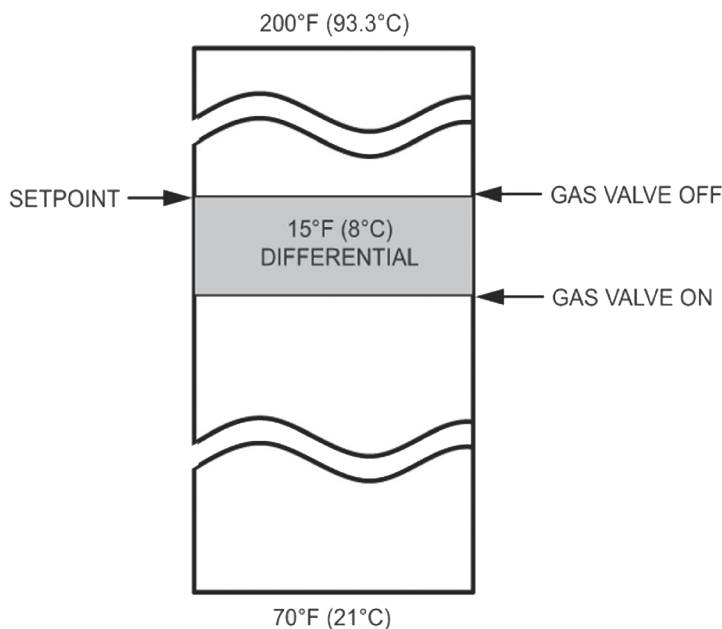

A.7 Troubleshooting

- » Following service procedures are provided as general guide.
- » On lockout and retry models, meter readings between gas control and ignition module must be taken within trial for ignition period. Once ignition module shuts off, lockout models must be reset through key buttons and display. On retry models, wait for retry or reset at thermostat.
- » Check for correct installation and wiring before replacing any component.
- » Control module cannot be repaired. If it malfunctions, it must be replaced.
- » Use only qualified service agent to service ignition systems.

1. Perform checkout as first step in troubleshooting.
2. Check troubleshooting guide to pinpoint cause of problem. See Table 8, page 35.
3. If troubleshooting indicates ignition problem, see Ignition System Checks to isolate and correct the problem.
4. Perform checkout procedure following troubleshooting guide again to verify system is operating normally.

A.8 Troubleshooting Error Codes

Integrated boiler control uses advanced diagnostic capability to assist in troubleshooting error conditions. Table 8 shows codes that could arise on integrated display during fault.

Suggestions are provided in Table 8 for servicing these potential errors.

A.9 Intermittent Pilot

Ignition System Checks

STEP 1: Check ignition cable.

- » Verify ignition cable does not run in contact with metal surfaces.
- » Verify only factory supplied Ignition cable (or approved replacement) is used.
- » Verify connections to ignition module and igniter or igniter-sensor are clean and tight.
- » Verify ignition cable provides good electrical continuity.

STEP 2:

Verify ignition system grounding. Nuisance shutdowns are often caused poor or erratic grounding.

Common ground is required for module and pilot burner/igniter sensor.

- Check for good metal-to-metal contact between pilot burner bracket and the main burner.
- Check ground lead from GND (BURNER) terminal on module to pilot burner. Verify connections are clean and tight. If wire is damaged or deteriorated, replace with No. 14-18 gauge, moisture-resistant, thermoplastic insulated wire with 105°C [221°F] minimum rating.
- Check ceramic flame rod insulator for cracks or evidence of exposure to extreme heat, which can permit leakage to ground. Replace pilot burner/igniter sensor and provide shield if necessary.
- If flame rod or bracket is bent out of position, restore to correct position.

STEP 3: Check spark ignition circuit.

Disconnect ignition cable at SPARK terminal on module.

WARNING

Electrical shock hazard. Ignition circuit generates over 10,000 volts. Turn OFF electrical power supply at service panel before making electrical connections. Failure to do so could result in death or serious injury.





Energize module and listen for audible sparking noise. When operating normally, there should be buzzing noise turns on and off twice per second for duration of 1–7 seconds, depending on model.

STEP 4: Verify pilot and main burner light-off.

- » Initiate call for heat. Turn thermostat above room temperature. Ignition sequence may be delayed by thermal purge until boiler water temperature is below 140°F (60°C)
- » Watch pilot burner during ignition sequence.
 - Verify ignition spark continues after pilot is lit.
 - Verify pilot lights and spark stops, verify main burner does not light.
- » If so, ensure adequate flame current as follows.
 - Turn off boiler at circuit breaker or fuse box.
 - Clean flame rod with emery cloth.
 - Verify electrical connections are clean and tight. Replace damaged wire..
 - Check for cracked ceramic insulator, which can cause short to ground, and replace igniter-sensor if necessary.
 - At gas valve, disconnect main valve wire from MV terminal.
 - Turn on power and set thermostat to call for heat. Pilot should light, main burner will remain off because main valve actuator is disconnected.
 - Check pilot flame. Verify it is blue, steady and envelops 3/8 to 1/2 in. [10 to 13 mm] of flame rod. Figure 19 for possible flame problems and causes.
 - If necessary, adjust pilot flame by turning pilot adjustment screw on gas control clockwise to decrease or counterclockwise to increase pilot flame. Following adjustment, always replace pilot adjustment cover screw and tighten firmly to assure proper gas control operation. Figure 14, Page 26.
 - Set temperature below room set-point to end call for heat.

- » Recheck ignition sequence as follows.
 - Reconnect main valve wire.
 - Adjust thermostat above room temperature.
 - Verify ignition sequence at burner.
 - If spark does not stop after pilot lights, replace module.
 - If main burner does not light or if main burner lights and system locks out, check module, ground wire and gas control as described in troubleshooting table. See Table 9, Page 35.

Figure 19 - Pilot Flame

APPEARANCE	CAUSE
<p>SMALL BLUE FLAME</p> 	<p>CHECK FOR LACK OF GAS FROM:</p> <ul style="list-style-type: none"> • CLOGGED ORIFICE FILTER • CLOGGED PILOT FILTER • LOW GAS SUPPLY PRESSURE • PILOT ADJUSTMENT AT MINIMUM
<p>LAZY YELLOW FLAME</p> 	<p>CHECK FOR LACK OF AIR FROM:</p> <ul style="list-style-type: none"> • DIRTY ORIFICE • DIRTY LINT SCREEN, IF USED • DIRTY PRIMARY AIR OPENING, IF THERE IS ONE • PILOT ADJUSTMENT AT MINIMUM
<p>WAVING BLUE FLAME</p> 	<p>CHECK FOR:</p> <ul style="list-style-type: none"> • EXCESSIVE DRAFT AT PILOT LOCATION • RECIRCULATING PRODUCTS OF COMBUSTION
<p>NOISY LIFTING BLOWING FLAME</p> 	<p>CHECK FOR:</p> <ul style="list-style-type: none"> • HIGH GAS PRESSURE
<p>HARD SHARP FLAME</p> 	<p>THIS FLAME IS CHARACTERISTIC OF MANUFACTURED GAS</p> <p>CHECK FOR:</p> <ul style="list-style-type: none"> • HIGH GAS PRESSURE • ORIFICE TOO SMALL

Correct Pilot Flame: 3/8 to 1/2 inch in flame. See Figure 15, Page 27.

IMPORTANT

In accordance with Section 325 (f) (3) of the Energy Policy and Conservation Act, this boiler is equipped with a feature that saves energy by reducing the boiler water temperature as the heating load decreases. This feature is equipped with an override which is provided primarily to permit the use of an external energy management system that serves the same function.

THIS OVERRIDE MUST NOT BE USED UNLESS AT LEAST ONE OF THE FOLLOWING CONDITIONS IS TRUE:

- » An external energy management system is installed that reduces the boiler water temperature as the heating load decreases.
- » This boiler is not used for any space heating
- » This boiler is part of a modular or multiple boiler system having a total input of 300,000 BTU/hr or greater.
- » This boiler is equipped with a tankless coil.



UTICA BOILERS
2201 Dwyer Avenue
Utica NY 13501

web site: www.ecrinternational.com