



# ADB2

## WHITE PAPER



VERSION 1.0  
NOVEMBER 2022

# White Paper ADB2

## Table of Contents

<b>1. Introduction.....4</b>	<b>3. Scenarios for the setup of distribution systems .....9</b>	<b>5. Requirements for HbbTV terminals .....22</b>	<b>Annex .....28</b>
1.1. Market potential of ADB2+TA..... 4	3.1. Watermark insertion ..... 10	5.1. General requirements ..... 22	ADB2 test result..... 28
	3.1.1. Types and related data elements of watermarking .....10	5.1.1. Broadband formats.....22	Abbreviations ..... 30
<b>2. Service scenarios for ADB2 usage.....7</b>	3.1.2. DVB recommendations related to video watermarking .....12	5.2. Requirements related to elements of the ADB2 specification ..... 23	References ..... 31
2.1. Service scenarios based on standard HbbTV..... 7	<b>3.2. AIT generation ..... 13</b>	5.2.1. App discovery via audio watermark in HDMI.....23	Imprint..... 32
2.2. Service scenarios based on HbbTV TA extensions..... 8		5.2.2. App discovery via video watermark in HDMI.....23	
2.2.1. Replacing non-adjacent spots in an ad break with pre-fetched substitution ads .....8	<b>4. Scenarios for the setup of end user devices ..... 14</b>	5.2.3. Monitoring audio watermark while playing broadband .....24	
2.2.2. Replacing multiple adjacent spots (or whole ad breaks) with streamed substitution ads .....8	4.1. Bilateral connection HDMI device - TV..... 15	5.2.4. Monitoring video watermark while playing broadband .....24	
2.2.3. Replacing broadcast by regional video lasting several minutes .....8	4.2. Additional soundbar connected to TV ..... 16	5.2.5. HDMI scaling.....25	
	4.3. Soundbar inserted between HDMI device and TV ..... 17	5.2.6. TA-HDMI profile 2.....25	
	4.4. Dual HbbTV terminal ..... 18	5.2.7. CEC support.....25	
	4.5. Dynamic Ad Insertion (DAI) over operator platform ..... 19	<b>5.3. Optional elements of the ADB2 specification not required..... 26</b>	
	4.6. Additional hints for HDMI device handling from ADB2 specification ..... 20	5.3.1. App discovery via DVB-SI .....26	
		5.3.2. Watermarks via DVB signal .....26	
		5.3.3. Decoding extended vp1 msg .....26	
		5.3.4. Broadband overlay .....27	
		5.3.5. App hiding at watermark loss .....27	

The purpose of this document is to describe requirements for HbbTV devices for a market introduction of ADB2+TA in Germany. The technical profile described here will be the basis of several new services which are planned by German broadcasters starting 2023 in addition to existing HbbTV services. The following requirements are very closely aligned with the HbbTV ADB2+TA (ETSI TS 103 464 V1.3.1 (2022-01)) standard. HbbTV ADB2+TA defines how to enable HbbTV Services and targeted advertising where linear broadcast TV terminates in a STB and is then passed to an HbbTV TV over an HDMI connection. It includes the watermark-based signalling from "ADB Specification Phase 2 TS 103 464 V1.2.1 (2020-05)".

The White Paper refers to typical usage scenarios and points to several specification elements of specific criticality. Furthermore, it addresses some implementation topics which are not fully specified in the standard. Finally, the aspect of ADB2 testing is covered.

# 1. Introduction

## 1.1. Market potential of ADB2+TA

ADB2+TA target markets are TV households, where a non-HbbTV/DAS capable STB is used. Especially markets with a high and increasing IPTV and cable penetration (with legacy STBs) will benefit from watermarking when trying to achieve a short time to market.

Further market potential can be found in households with other HDMI devices, e.g. OTT streaming sticks.

ADB2+TA is of high relevance for the German market, due to stable numbers of cable households and managed IPTV households (with legacy non-HbbTV/DAS-capable STBs) and increasing numbers of connected TV households as shown in Figure 1:

**Figure 1: Distribution of transmission paths in Germany (2022)\*:**

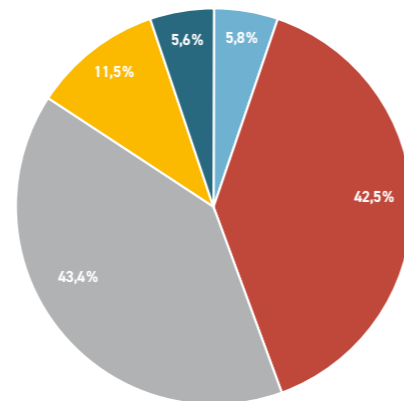

**Number of TV households: 38,773 million**  
**Distribution of transmission paths in Germany**

	2022	(2021)
Terrestrial	5.8%	(6.7%)
Satellite	42.5%	(43.5%)
Cable	43.4%	(43.7%)
IPTV (managed)	11.5%	(10.1%)
Connected TV only	5.6%	(4.7%)

\* Digitalisierungsbericht Video 2022, Hrsg. die medienanstalten  
[www.die-medienanstalten.de/publikationen/video-trends-2022](http://www.die-medienanstalten.de/publikationen/video-trends-2022)

Some typical criteria for operator-specific STBs (OSTBs) in vertical, managed IPTV markets are:

- OSTBs in most cases do not support HbbTV
- Replacement of legacy devices by new STB models will not happen in the short / mid-term, as OSTBs have minimum life cycles that have been defined before they were shipped
- The roll-out of new OSTB models may require a premium upsell or contract extensions from a customer's point of view, which will also slow down the transition process
- Many TV sets will be replaced before new STB models will be distributed

With regards to horizontal market STBs:

- Only some STBs support HbbTV, some manufacturers may implement HbbTV TA in the future
- However, a large number of TV households remain equipped with horizontal market STBs (e.g. legacy STBs or STBs designed for the low-end market) that will not support HbbTV (TA)

The number of households that German broadcasters are currently unable to reach with their HbbTV services, as HbbTV is not supported by the TV reception device (e.g. where a Set-Top-Box is used), ranges between 25% and 30%. These shares can be put on a level with the estimated market potential calculation for watermarking in Germany.

As a result, the German market shows a significant market share of approx. 9–12 million households which could be reached with general HbbTV and TA functions using ADB2+TA only.

Further estimations of the ADB2 market potential in various countries – typically with high and increasing IPTV and Cable penetration – can be found in the following diagram published by

Verance which corresponds also to early DVB studies. This underlines the relevance of this standard and allows manufacturers to deploy their implementations in many markets.

**Percent of households needing watermark (HDMI)**

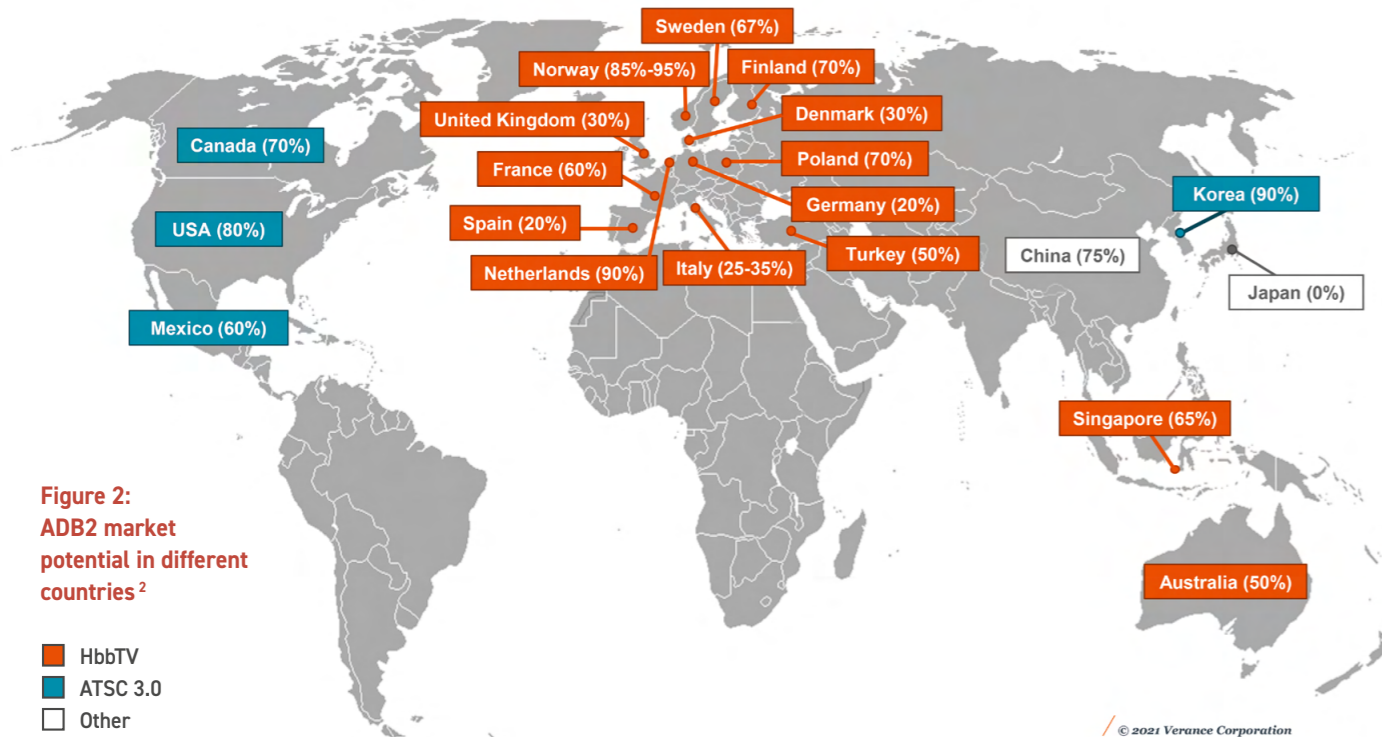

**Figure 2:**  
 ADB2 market potential in different countries<sup>2</sup>

<sup>2</sup> Verance, Presentation "Targeted Advertising using Watermarking" at 9th HbbTV Symposium, November 2021

## 2. Service scenarios for ADB2 usage

### 2.1. Service scenarios based on standard HbbTV

The standard HbbTV applications used today in the German market by both public and commercial broadcasters are expected to work in the ADB2 context.

**Related functions are specifically:**

- Autostart plus life cycle management of all apps listed in the XML-AIT
- All GUI rendering options
- Rendering the application GUI on top of the "broadcast" video (which is the HDMI input in the ADB2 context)
- Handling of all key events
- Scaling and positioning of the "broadcast" video
- Stopping the "broadcast" video and playing IP videos of all formats defined by the HbbTV core spec via AV control object and HTML5 media element
- Stream events (trigger via audio watermark or transmission of payload via video watermark)

**It is known that some functions technically cannot be implemented or are not part of the ADB2 specification. Among these are:**

- Channel change or component selection for the "broadcast" video by the HbbTV app
- Any form of media sync
- DSM-CC data carousels or DSM-CC stream events

## 2.2. Service scenarios based on HbbTV TA extensions

The following service scenarios based on the TA extensions of ADB2 are expected to be supported:

### 2.2.1. Replacing non-adjacent spots in an ad break with pre-fetched substitution ads

- An ad break contains one or multiple placement opportunities (POs), so that one broadcast ad or multiple, non-adjacent broadcast ads, provided by a STB via HDMI, can be replaced with targeted substitution ad(s)
- DAS is timed precisely by referring to a watermark timeline
- For each DAS process, the substitution content is pre-fetched completely in advance
- Switching from and to HDMI-Input is implemented using the Fast Media Switch API

### 2.2.2. Replacing multiple adjacent spots (or whole ad breaks) with streamed substitution ads

- POs are provided by multiple adjacent broadcast ads or even whole ad breaks, provided by a STB via HDMI
- DAS is timed precisely by referring to a watermark timeline
- Substitution content is not fully pre-fetched in advance but rather streamed “live” – i.e. a personalized combination of simulcasted broadcast ads and substitution ads is provided as DVB-DASH stream
- Switching from and to HDMI Input is implemented using the Fast Media Switch API

Note: It is assumed that multiple spots can be prebuffered as long as the buffer is not full.

### 2.2.3. Replacing broadcast by regional video lasting several minutes

- A news show contains one element in the linear broadcast that can optionally be replaced by a regional content item of several minutes length
- The first 10–20 seconds of the regional content video are prebuffered on the terminal
- Switching from and to HDMI-Input is implemented using the Fast Media Switch API based on a video watermark timeline

## 3. Scenarios for the setup of distribution systems

ADB2 watermarking provides an optional alternative method for the delivery of HbbTV and DVB-TA signalling from broadcasters to receivers. In a typical distribution system arrangement using watermarking, a watermark embedder is connected to an automation system and receives SCTE 104 messages to signal ad placement op-

portunities via a SDI interface. The methods of inserting video and audio watermarks have initially been specified in ATSC. Video and audio watermarks can pass through network/platform operator systems seamlessly and are transmitted to a ADB2 compliant receiver via HDMI.

Figure 3: Distribution system setup with ADB2 watermarking

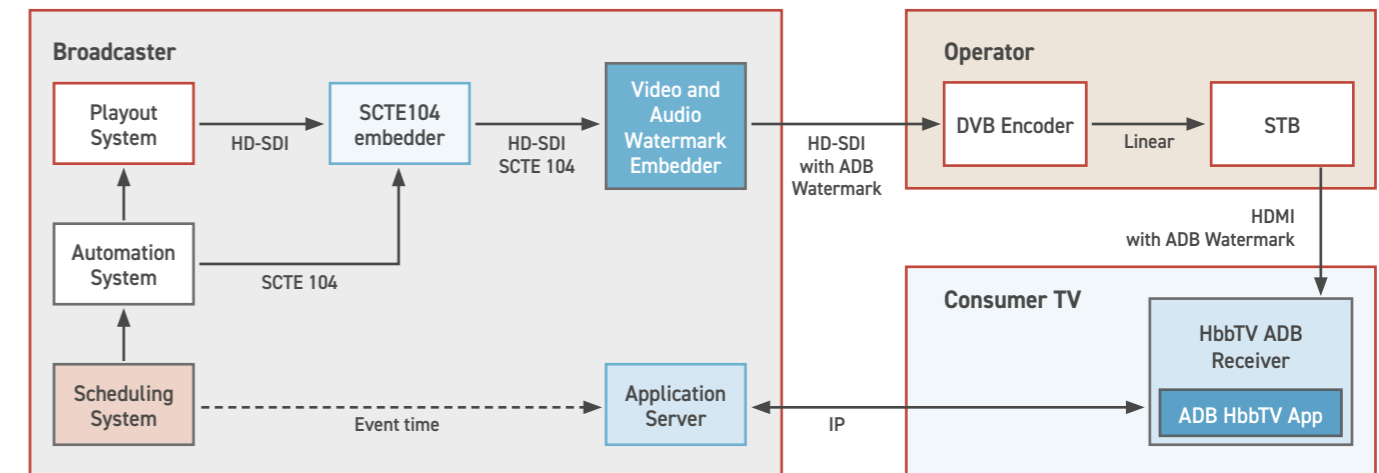

### 3.1. Watermark insertion

#### 3.1.1. Types and related data elements of watermarking

The ADB2 specification foresees the usage of two types of watermarking, audio and video watermarking. Both variants have been specified by ATSC and taken over by HbbTV as a part of ADB2. Their respective properties are:

##### Audio watermarking

- Specified as “VP1” in ATSC3 A/334:2016, “Audio Watermark Emission”, approved 19 September 2016<sup>3</sup>
- Low bitrate of 33 bit/s
- Has to be inserted into all audio channels
- Mandatory for starting HbbTV apps

##### Video watermarking

- Specified as ATSC3 A/335:2016, “Video Watermark Emission, with Amendments No. 1 and No. 2”, approved 2<sup>nd</sup> of February 2021<sup>4</sup>
- 240 bit/TVline at recommended encoding parameters (see 3.1.2) resulting at 12 kbit/s for 50 Hz videos
- Not mandatory for starting HbbTV apps
- Helps to increase operational stability (STB is muted or shows EPG overlays)
- Allows to transport equivalent to DSM-CC stream events

<sup>3,4</sup> <https://www.atsc.org/atsc-documents/type/3-0-standards>

The table on page 11 provides an overview over the data elements carried via watermarking:

Id	Watermark message		Video wm*	Audio wm*	Description
04	vp1_msg	server_field	✓	✓	Contains the server code which is static and identifies the service (and optionally service components). The codes are registered via RadioDNS Ltd. The terminal uses this code to make a DNS request for the XML-AIT domain.
		interval_field			25 bit counter which is incremented for every VP1 message (i.e. every 1.5 seconds). Provides the watermark timeline in combination with the Time Anchor delivered by the AIT.
		query_flag			1 bit flag toggling to trigger AIT updates and allowing the app to retrieve real time data from a web server which can be fed into HbbTV applications.
05	dynamic_event_msg		✓		Equivalent to DSM-CC stream events; allows to transmit 256 bytes of data to the HbbTV application via video watermarks.
07	extended_vp1_msg		✓		Time offset of the video carrying the current VP1 message relative to the first frame in its VP1 Message Group, in units of 1/30 of a second. Required to produce the timeline in a quick way (e.g. when using trick play). Else not required for frame accuracy.

\* watermarking

If there is a requirement to detect the selection of audio components at the HDMI device (e.g. standard audio vs. audio description) on the application level then different server codes have to be used for different audio tracks. If not, all audio tracks and the video track can use the same server code.

### 3.1.2. DVB recommendations related to video watermarking

The DVB project has examined watermarking as one of the technical concepts to implement DAS.

The document “Dynamic substitution of content in linear broadcast Part 1: Carriage and signalling of placement opportunity information in DVB Transport Streams” (Draft-TS-103-752-1v121 / chapter 8.4.2.)<sup>5</sup> presents some rules related to video watermarking which are relevant for ADB2 usage and therefore quoted here:

*“To minimize the likelihood of viewers observing the video watermark, broadcasters are advised to take perceptual quality into account when selecting and configuring A/335 video watermark embedding equipment and to use the watermark such that the visual impact is reduced as much as possible. To achieve this, the following Usage Rules shall be followed:*

<sup>5</sup> [https://dvb.org/wp-content/uploads/2020/12/A178-1r1\\_Dynamic-substitution-of-content-in-linear-broadcast\\_Part1\\_Signaling\\_Draft-TS-103-752-1v121\\_Feb-2021.pdf](https://dvb.org/wp-content/uploads/2020/12/A178-1r1_Dynamic-substitution-of-content-in-linear-broadcast_Part1_Signaling_Draft-TS-103-752-1v121_Feb-2021.pdf)

- *Broadcasters shall not employ the 2X Data Rate Video Watermark.*
- *When the 1X Data Rate Video Watermark is employed, luma values for the Encoded Data value of “1” shall be set to either: (a) the lowest permitted luma value; or (b) a level that is materially invisible to the viewer when displayed together with the video content.*
- *ATSC A/335 video watermarking applied in accordance with all requirements of the present clause 8.4.2 may be included during and within the landing zones immediately adjacent to advertising and other content that constitutes a PPO.*
- *ATSC A/335 video watermarking that is materially invisible to the viewer when displayed together with the video content may be included in any broadcast content.*

*NOTE: “Materially invisible” means not degrading the quality of the content to typical viewers under normal viewing conditions.”*

### 3.2. AIT generation

As in the standard broadcast context, also for ADB2 HbbTV applications are launched via AITs, i.e., all required app parameters including the app URL are contained in such an AIT. For ADB2 the AITs are provided as XML files on web servers. They are retrieved by the HbbTV terminal via the following steps:

- After a channel change to a new service the terminal reads the watermarking on the new service and extracts the server code from the watermarks
- The terminal performs a DNS request on hbbtvdns.org with the server code as a parameter and receives back the domain of the related broadcaster (which has registered his server code at hbbtvdns.org before)
- The terminal performs a https request on that broadcaster domain on the XML AIT
- After parsing the received XML AIT, the terminal launches the HbbTV application

The XML AIT contains all data elements which are included in the conventional broadcast AIT as well.

For ADB2, HbbTV has defined some more additional data elements which are needed in this context. These are listed in ADB 7.1.2 in tables 11 and 12.

The additional data elements are mainly required to equip the vb object with the usual metadata needed by the HbbTV app. Almost all of them can be kept static. It is assumed that scheduled AIT updates are not required for the German market.

The handling of different audio components depends on the requirement to detect the selection of audio components at the HDMI device (e.g. standard audio vs. audio description) on the application level. The AIT extensions for ADB2 allow to associate component detection with a differentiation of server codes across multiple audio tracks.

# 4. Scenarios for the setup of end user devices

This section describes typical scenarios for the setup of devices in the home environment as they are relevant for ADB2 usage.

Many audio configurations are possible between STB and TV. To analyse all realistic user interactions – some of which might result in a bad user experience – each scenario is accompanied by a list of issues/challenges they face and possible approaches to overcome them.

The “HDMI Device” can be any device receiving a linear TV signal like a conventional Set-Top-Box connected to a broadcast network or an OTT-streaming box or HDMI stick connected to the Internet.

The TV set is supporting HbbTV including ADB2+TA and is connected to the Internet. This TV set is the device for which the requirements of this document apply.

According to Deutsche TV-Plattform/GfK SE study<sup>6</sup> (7th of December 2021), 94% of consumers value a good sound reproduction of their TV. The findings and related market shares are:

- Three quarters (77%) of consumers do not use external sound equipment (scenario covered in section 4.1.)

Almost a quarter (23%) is not satisfied with the audio quality and therefore uses external home-cinema equipment. From this quarter of consumers:

- 58% use soundbars (~15% of all consumers) (scenario covered in section 4.2.)
- 31% use AV-Receivers (~8% of all consumers) (scenario covered in section 4.3.)

<sup>6</sup> [https://tv-plattform.de/wp-content/uploads/2021/12/DTVP\\_TV\\_Ton\\_2021-12-02.pdf](https://tv-plattform.de/wp-content/uploads/2021/12/DTVP_TV_Ton_2021-12-02.pdf)

## 4.1. Bilateral connection HDMI device – TV

The most common scenario for setting up the devices at the end user is a direct connection of the HDMI device to the TV’s HDMI-input – an estimated 77% of these households do not use any external sound equipment.

Figure 4

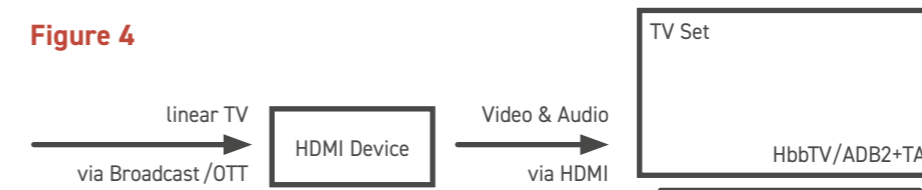

Issue description	Solution approach
The user has to change the RCUs when changing usage from STB to TV. This may be at least nasty or even confusing when the assignment of the functions is not clear.	The user should get a hint when first using ADB2 (it needs to be determined if manufacturer or broadcaster will trigger the information, e.g. via HbbTV app) explaining how to use “red button” apps. CEC can help to avoid changing RCUs if this feature is activated on the HDMI device and CEC versions are compatible (for CEC, keys which currently have to focus within HbbTV apps shall not be sent via CEC).
When the user mutes the HDMI device and the HDMI device performs the mute by itself, the audio watermark disappears and unless video watermarks are applied, the TV would terminate HbbTV apps even if they just play long videos.	Use video watermarks.
When loudness adjustments on the TV and the STB differ, then IP videos will be too loud or too quiet.	Should not happen in most cases as loudness control is performed on the TV only via CEC.



### 4.2. Additional soundbar connected to TV

In this scenario an additional soundbar or AV-Receiver is connected to the TV via HDMI-ARC output or an optical link. There is no relevant difference between both audio connection variants in this context. Estimated 15% of households use HDMI devices (soundbars act as extended TV-speakers).

Figure 5

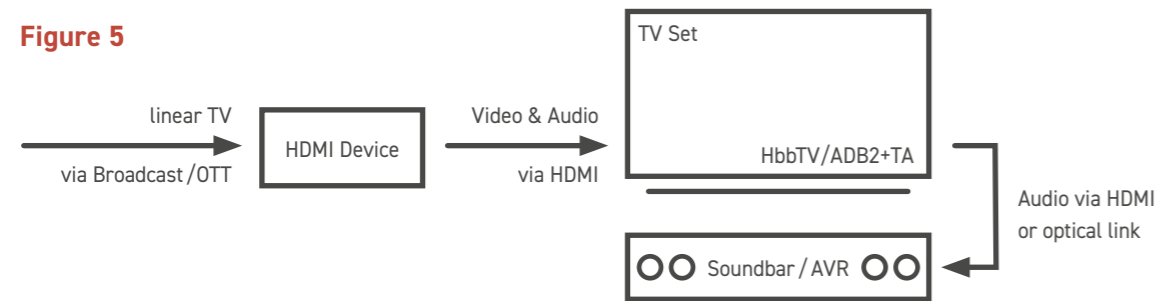

Issue description	Solution approach
Handling of RCU of soundbar?	Should not be an issue, volume control via CEC by STB/TV.
The user has to change the RCUs when changing usage from STB to TV.	Same issue as 4.1.
Muting HDMI device like 4.1.	Same issue as 4.1.
Loudness adjustment?	Same issue as 4.1.

### 4.3. Soundbar inserted between HDMI device and TV

In this case, the HDMI device is connected directly to the soundbar which delivers the video (and potentially also the audio) to the TV set via the TV's HDMI-input. An estimated maximum of 8% of households use AV-Receivers, but only 4% of consumers connect the AVR in the middle, as a source-selector to the TV. The remaining 4% connect their soundbars to the TV output (covered in section 4.2).

However, this use case comes with some limitations (see below). As this scenario does not seem to be relevant for the German market due to its limited market share, it is not a target for applying ADB2+TA use cases. It is regarded only with the focus of avoiding malfunctions on ADB2 enabled TV sets.

Figure 6

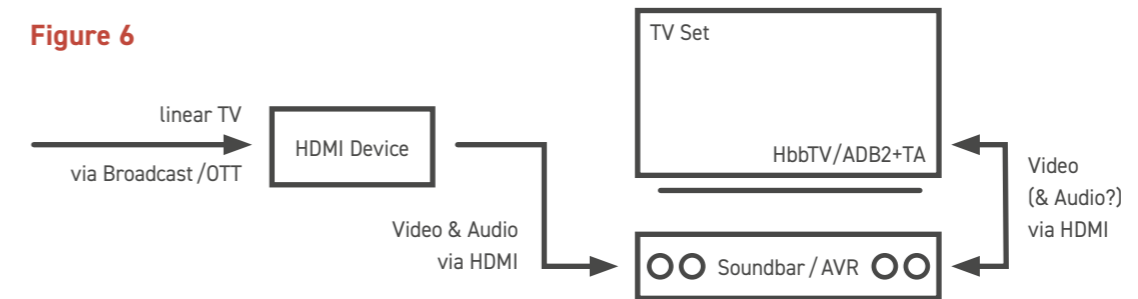

Issue description	Solution approach
Sound system used to play STB audio, TV always muted.	No solution possible, but irrelevant due to limited market share. Malfunction on the TV set can be avoided using audio output capabilities of the terminal (see section 10.2.2 of the ADB2 spec).
Audio watermark may not reach the TV set.	No solution possible, but irrelevant due to limited market share. No malfunction will happen on the TV set as HbbTV app will not start at all.
Video watermark may be terminated by video-processing of AV-Receiver, due to cropping, scaling or overlays.	No solution possible, but irrelevant due to limited market share. Missing video watermark can be detected by the HbbTV app to avoid malfunction.

#### 4.4. Dual HbbTV terminal

This scenario describes a setup where the HDMI device and the TV set both support HbbTV and both are connected to the Internet and therefore we would have HbbTV applications running on the TV screen. One option could be to ingest a watermark into the video on the HDMI device to signal a running HbbTV app to the TV set. If the TV set receives such a watermark it has to disable its own application.

Figure 7

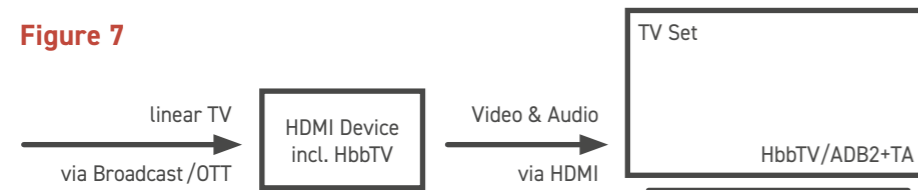

Issue description	Solution approach
Two HbbTV applications may show their GUIs on the TV screen when HbbTV enabled STBs are used.	<ol style="list-style-type: none"> <li>1) Ingest a video watermark in the upstream app on the HDMI device and inhibit the app on the downstream app on the TV set.</li> <li>2) Show a banner on the TV by the HbbTV app and offer the viewer to deactivate the HbbTV app of the current broadcast channel. Such a banner may be required anyhow to get consent from the viewer.</li> </ol>
DAS runs on both devices.	<p>Actually, the "red button" app hides after 10 seconds and the video watermark on the HDMI device could be just covered by the HbbTV app thus the stream event would be inhibited for the ADB2 enabled TV set. In this case, the DAS would not be started. Also DAS on the HDMI devices could be blacklisted because for now Set-Top-Boxes which support HbbTV TA are not known.</p> <p>Remark: It is still unclear how the Switch-In could be prevented from being shown on the TV set when the autostart application starts.</p>

#### 4.5. Dynamic Ad Insertion (DAI) over operator platform

Vertical (operator) platform providers could already have implemented server-side dynamic ad insertion (DAI) and thus already have exchanged the spots in linear TV. In this scenario it would be preferable to suppress the ad replacement on the TV device using ADB2. Otherwise, ad-impressions would be counted which have not been presented to the TV viewer.

Figure 8

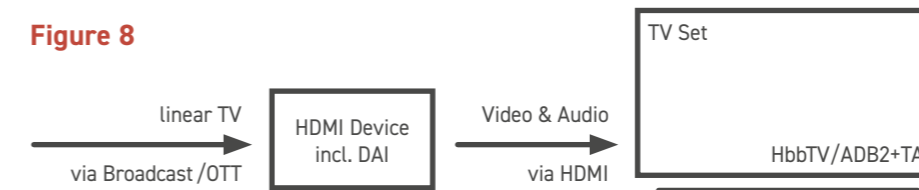

Issue description	Solution approach
DAI already took place on the STB	<ol style="list-style-type: none"> <li>1) The Broadcaster provides a separate signal feed without watermarking for the platform provider.</li> <li>2) The AWM could be filtered out in the backend of the operator by a device or a plugin on the video encoder.</li> <li>3) Replace the ad break opener in linear IPTV stream using DAI together with the spots. The video/audio watermark would then be overlaid and the ADB2 device will terminate the ad substitution app.</li> <li>4) Opener and ad videos are equipped with watermarks using a different server code and thus triggering a component change event for the HbbTV app on the ADB2 TV.</li> </ol>

### 4.6. Additional hints for HDMI device handling from ADB2 specification

In its informative Annex D, the ADB2 specification provides very valuable hints for adapting the behaviour of HbbTV applications in general and specifically also for applications performing DAS.

They are targeting two areas:

#### Annex D.1: Audio configuration of TV and HDMI device

As described in sections 4.1 - 4.3 above, there is a number of device configurations and these are related to different possibility of audio setups. In section 10.2.2 ADB2 has defined an interface ("XML capabilities") that allows HbbTV applications to query the audio configuration of the TV. Annex D.1 of ADB2 describes and gives an example how an application performing DAS can determine whether the present environment allows such function.

(one example of a possible decision process is shown in figure D.1 on the following page).

#### Annex D.2: Actions performed on the HDMI device

A number of actions can be performed at the HDMI device which may interfere with HbbTV applications running on the ADB2 TV. These can be a channel change, trick play, EPG and other overlays or muting the audio. Annex D.2 describes how they can be detected prior to and during the ad substitution using various events and how the application can react on them.

Figure 9: Example audio configuration decision process (ETSI TS 103 464 V1.3.1, Annex D.1)

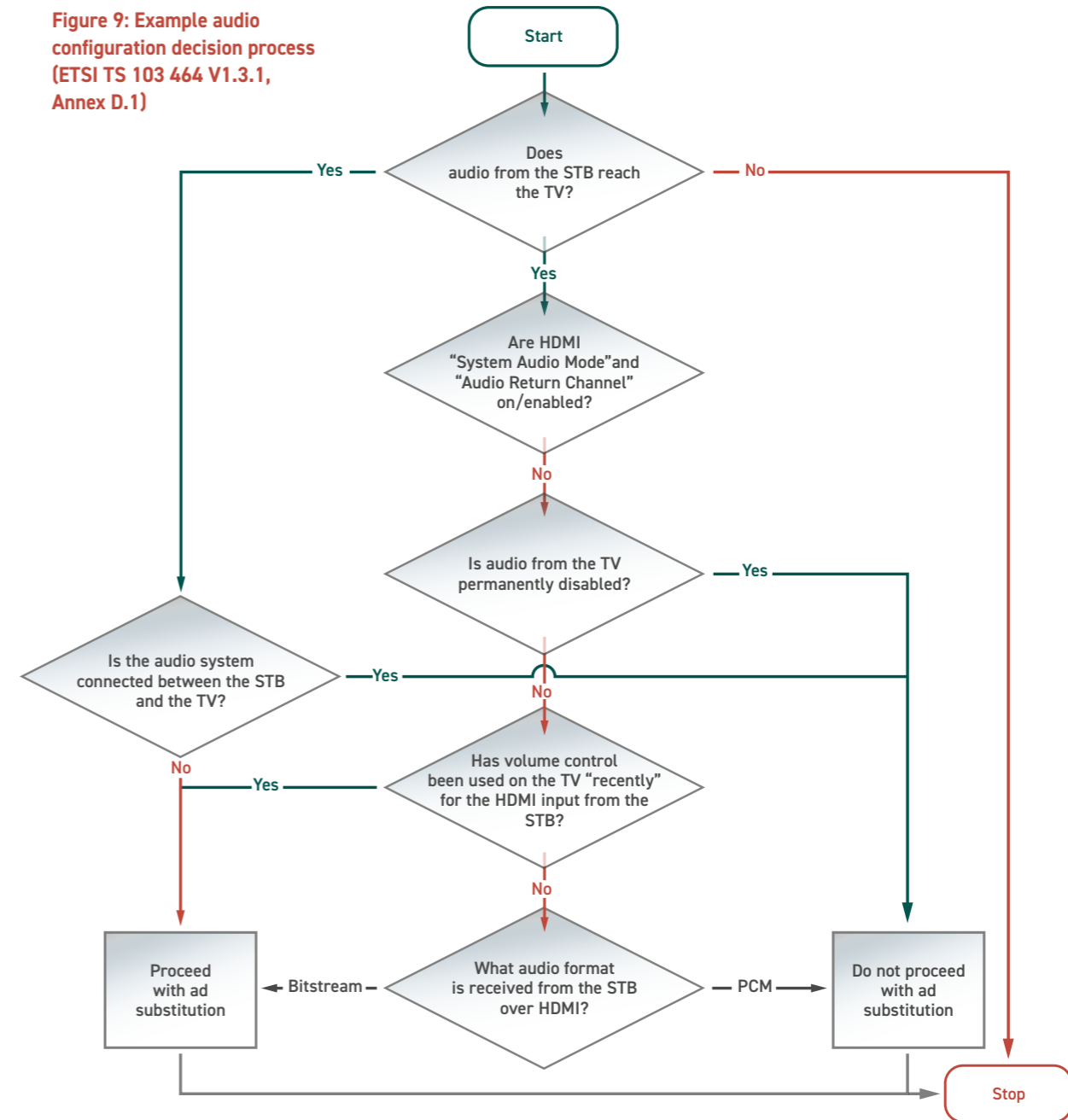

# 5. Requirements for HbbTV terminals

The following requirements refer to the typical usage scenarios described in section 4 and point to several specification elements of specific criticality. Furthermore, it addresses some implementation topics which are not fully specified in the standard.

## 5.1. General requirements

### 5.1.1. Broadband formats

For switching between displaying video received via HDMI and video received via broadband and vice-versa, all the following broadband formats (corresponding to ETSI TS 103 736-1 V1.1.1 (2020-06)) shall be supported:

- Media file for non-adaptive HTTP streaming, e.g. mp4 video
- DASH streams
- Multi-period DASH streams
- MSE

using the following video and audio codecs:

- AVC SD/HD video + HE-AAC audio
- HEVC HD SDR video + HE-AAC audio
- HEVC HD SDR video + E-AC-3 audio

## 5.2. Requirements related to elements of the ADB2 specification

The following requirements refer to optional elements in the HbbTV ADB2+TA Specification TS 103 464 V1.3.1.

### 5.2.1. App discovery via audio watermark in HDMI

#### Description:

- Terminal supports application discovery (plus timeline plus stream events) via audio watermarking
- Status in ADB2+TA Spec, 6.3.3: mandatory, if terminal supports watermark monitoring at all

#### Explanation:

Mandatory in our context anyhow.

### 5.2.2. App discovery via video watermark in HDMI

#### Description:

- Terminal supports application discovery (including timeline and dynamic events)
- Status in ADB2+TA Spec, 6.3.3: optional

#### Explanation:

The most critical use case for the video watermark is enabling the TV to detect the user pressing the “EPG” button on the STB. In addition, for many STBs, pressing the “mute” key will not mute the box itself but forward the “mute” key to the TV. But for the remaining STBs where “mute” is executed on the STB itself, video watermark is the only way to avoid terminating the HbbTV app on “mute”.

### 5.2.3. Monitoring audio watermark while playing broadband

---

**Description:**

- Terminal is able to monitor audio watermarking via HDMI while playing broadband AV content
- Status in ADB2+TA Spec, 6.3.3: optional in ADB2 generally, but mandatory if the TA option is supported

**Explanation:**

Required for the same reasons as for video watermarking in general. Relevant to detect all sorts of overlays/apps like STB-menus and -apps on the STB like YouTube & Netflix. Without this option, the user activities are only detected at the end of a replaced ad, which might be 20–30 seconds or even longer if an entire ad break is being replaced.

### 5.2.4. Monitoring video watermark while playing broadband

---

**Description:**

- Terminal is able to monitor video watermarking via HDMI while playing broadband AV content
- Status in ADB2+TA Spec, 6.3.3: optional

**Explanation:**

Required for similar reasons as “monitoring AWM WhilePlaying Broadband”. Only way to detect overlays on STB while HbbTV terminal plays IP video. Without this option, an EPG overlay is only detected at the end of a replaced ad.

### 5.2.5. HDMI scaling

---

**Description:**

- Terminal is able to scale the HDMI signal
- Status in ADB2+TA Spec, 10.2.2: optional

**Explanation:**

Feature used in many standard HbbTV applications today in the German market.

### 5.2.6. TA-HDMI profile 2

---

**Description:**

- Three different profiles are defined for the switching performance; profile 2 is the one required for the German market
- Status in ADB2+TA Spec, 10.2.3: if TA is supported, three different performance profiles can be specified

**Explanation:**

ADB2 profile 2 is equivalent to HbbTV TA profile 2 and is expected to be the typical requirement of broadcasters in this context.

### 5.2.7. CEC support

---

**Description:**

- Terminal does support forwarding key events via CEC to the HDMI device
- Keys which currently have to focus within HbbTV apps shall not be sent via CEC
- Status in ADB2+TA Spec, 10.2.2/A.2.2: optional

**Explanation:**

This feature helps to simplify the user journey by allowing to operate HDMI device and HbbTV apps using only the remote control of the TV.

### 5.3. Optional elements of the ADB2 specification not required

---

For the avoidance of doubt, these sections list the remaining optional elements of the ADB2 specification which are not required for the German market.

#### 5.3.1. App discovery via DVB-SI

---

**Description:**

- Terminal supports application discovery via DVB-SI (regular broadcast case when AIT is missing in broadcast)
- Status in ADB2+TA Spec, 5.3.1/10.2.2: optional

**Explanation:**

Broadcast AITs are assumed to be present in all DVB signals.

#### 5.3.2. Watermarks via DVB signal

---

**Description:**

- Terminal supports WM monitoring for DVB signals as input
- Status in ADB2+TA Spec, 6.3.3: optional

**Explanation:**

Broadcast AITs are assumed to be present in all DVB signals.

#### 5.3.3. Decoding extended vp1 msg

---

**Description:**

- Terminal supports using the extended vp1 message for rapid syncing after seeking using video watermarks
- Status in ADB2+TA Spec, 6.3.3: optional (not mentioned as mandatory)

**Explanation:**

Mainly relevant for PVR/seeking which is not part of our use cases.

#### 5.3.4. Broadband overlay

---

**Description:**

- Broadband AV content can overlay HDMI video which is still visible. The equivalent in standard HbbTV would be IP video overlays broadcast video which is still visible (which is not supported on devices today)
- Status in ADB2+TA Spec, 10.2.2: optional

**Explanation:**

Feature not available on any HbbTV terminal today, so not needed in the ADB2 context.

#### 5.3.5. App hiding at watermark loss

---

**Description:**

- On watermark loss, an HbbTV app can be hidden or terminated
- Status in ADB2+TA Spec, 6.4.3: hiding optional (“terminals should hide the application”)

**Explanation:**

Usage of both audio and video watermarks will provide sufficient stability to allow terminating the app when both watermarks are lost.

# ADB2 test result

On the 7th of April 2022, a first on-air ADB2 watermark transmission test was performed with the aim of verifying that both audio and video watermarks can be retransmitted and decoded with sufficient robustness across all relevant platforms present in the German market.

The test was conducted via the ARD TV channel "One HD" originated at ARD-POC. The audio and video watermarking was inserted offline into the MXF source file by Verance. Verance embedded the video with the A/335 video watermark carrying the extended VP1 payload using version 1.0.1 of the aspect video watermark embedder, and the PCM main audio track with the A/334 audio watermark carrying the VP1 Payload using version 0.40.177 of the aspect audio watermark embedder. In both cases, default embedding parameters have been used.

The TV signal was recorded by members of the TF ADB2 at different locations via the HDMI output of various STBs and HDMI sticks using the Elgato HD 60S+ HDMI-to-USB interface and the Elgato 4K capture utility software for Windows.

57 HDMI recordings of approximately 5' duration each were made via all relevant distribution and redistribution channels, both broadcast and OTT, and using a variety of receiving equipment.

Due to a fault in the stream setup (in some platforms a Dolby audio track was used for retransmission which had not been watermarked), the coverage of the test was lower than intended. Therefore, following the same procedure and watermark encoding, a second test was conducted on the 6th, 7th and 11th of July 2022.

The output of the second test was another set of 27 HDMI recordings.

All recordings of both tests have subsequently been analysed offline by Verance and detailed test reports have been provided by Verance.

Except for a pitch fault in one HDMI stick, all audio watermarks could be decoded without delay or error. For video watermarks, in some cases the decoding performance was degraded a bit, but decoding was possible in all cases where the setup was correct.

Note:

In some cases, audio or video watermarks could not be decoded at all or only with errors. The cause for this could be identified as a result of the test procedure (mentioned issue with Dolby soundtrack, dropouts of the HDMI capture card, wrong version of TV service, significantly too low audio level on HDMI output).

## High-level overview of test results:

	AUDIO WATERMARKING		VIDEO WATERMARKING	
	1st test [57 recordings]	2nd test [27 recordings]	1st test [57 recordings]	2nd test [27 recordings]
Detection without delays and errors in the 5' recordings	31	18	53	26
No detection possible due to a -3% slowing down of the stream in the HDMI device	4	4	0	0
Detection possible, but 1-2 watermark losses within 5'	0	0	4	0
No detection or errors due to setup or recording issues	22	5	0	1

## Overall rating of the test:

Taking into account that

- a number of tests failed or could not be done at all due to reasons beyond ADB2 watermarking concept (audio without watermarking used for retransmission, flaws in HDMI recordings)
- the -3% signal slowdown in devices can be regarded as a failure on the devices which will be fixed
- that the conversion 1080 → 720 → 1080 involved in the video path introduces some degradation on top of the re-encoding

both audio and video watermarking proved to be of sufficient robustness to allow stable ADB2 operation.

## Abbreviations

---

<b>ADB</b>	Application Discovery over Broadband
<b>Ad break</b>	Advertisement break
<b>AIT</b>	Application Information Table
<b>CEC</b>	Consumer Electronics Control
<b>DAS</b>	Dynamic Ad Substitution
<b>DAI</b>	Dynamic Ad Insertion
<b>DASH</b>	(MPEG DASH) Dynamic Adaptive Streaming over HTTP
<b>DVB-SI</b>	Digital Video Broadcasting – Service Information
<b>HbbTV</b>	Hybrid broadcast broadband TV
<b>HTTP</b>	Hypertext Transfer Protocol
<b>HbbTV-TA</b>	Hybrid broadcast broadband TV for Targeted Advertising
<b>OSTB</b>	Operator-specific STBs
<b>PO</b>	Placement Opportunity
<b>PVR</b>	Personal Video Recorder
<b>RCU</b>	Remote Control Unit
<b>STB</b>	Set-Top-Box

For further abbreviations and explanations of advertising technology please refer to the Glossary Addressable TV of Deutsche TV-Plattform:

[https://tv-plattform.de/wp-content/uploads/2022/10/DTVP\\_Glossary\\_Addressable\\_TV\\_V1.pdf](https://tv-plattform.de/wp-content/uploads/2022/10/DTVP_Glossary_Addressable_TV_V1.pdf)

## References

---

### Hybrid Broadcast Broadband TV; Application Discovery over Broadband ETSI TS 103 464 V1.3.1 (2022-01)

TS 103 464 – V1.3.1 – Hybrid Broadcast Broadband TV; Application Discovery over Broadband (etsi.org)  
[https://www.etsi.org/deliver/etsi\\_ts/103400\\_103499/103464/01.03.01\\_60/ts\\_103464v010301p.pdf](https://www.etsi.org/deliver/etsi_ts/103400_103499/103464/01.03.01_60/ts_103464v010301p.pdf)

### DVB: Dynamic substitution of content in linear broadcast

#### Part 1: Carriage and signalling of placement opportunity information in DVB Transport Streams

A178-1r1\_Dynamic-substitution-of-content-in-linear-broadcast\_Part1\_Signalling\_Draft-TS-103-752-1v121\_Feb-2021 (dvb.org)

[https://dvb.org/wp-content/uploads/2020/12/A178-1r1\\_Dynamic-substitution-of-content-in-linear-broadcast\\_Part1\\_Signalling\\_Draft-TS-103-752-1v121\\_Feb-2021.pdf](https://dvb.org/wp-content/uploads/2020/12/A178-1r1_Dynamic-substitution-of-content-in-linear-broadcast_Part1_Signalling_Draft-TS-103-752-1v121_Feb-2021.pdf)

### DVB: Dynamic substitution of content in linear broadcast;

#### Part 2: Interfacing to an advert decisioning service and optimal preparation of media

ETSI TR 103 752-2 V1.1.1 (2020-12)

TR 103 752-2 – V1.1.1 – Digital Video Broadcasting (DVB); Dynamic substitution of content in linear broadcast; Part 2: Interfacing to an advert decisioning service and optimal preparation of media (etsi.org)

[https://www.etsi.org/deliver/etsi\\_tr/103700\\_103799/10375202/01.01.01\\_60/tr\\_10375202v010101p.pdf](https://www.etsi.org/deliver/etsi_tr/103700_103799/10375202/01.01.01_60/tr_10375202v010101p.pdf)

### ATSC Standard: Content Recovery in Redistribution Scenarios

A/336, “Content Recovery in Redistribution Scenarios” (netdna-ssl.com)

<https://muygs2x2vhb2pjk6g160f1s8-wpengine.netdna-ssl.com/wp-content/uploads/2020/06/A336-2019-Content-Recovery-in-Redistribution-Scenarios-with-Amend-1.pdf>



## Imprint

---

### **Publisher:**

Deutsche TV-Plattform e.V.  
www.tv-plattform.de  
Register of Associations Amtsgericht Frankfurt am Main  
No. 73VR9797

### **Editors:**

ADB2 Task Force of the Smart Media Working Group  
of Deutsche TV-Plattform

### **Head of the Smart Media Working Group:**

Nicole Agudo Berbel  
Head of the ADB2 Task Force:  
Frank Heineberg, RTL Deutschland/CBC;  
Klaus Merkel, RBB

### **Contact:**

Deutsche TV-Plattform  
Lyoner Str. 9, c/o ZVEI  
60528 Frankfurt am Main  
mail@tv-plattform.de  
phone: +49 69 6302-311

### **About Deutsche TV-Plattform:**

Deutsche TV-Plattform is an association of more than 50 members, including commercial and public service broadcasters, streaming services, appliance manufacturers, Internet companies, infrastructure operators, service and technology providers, research institutes and universities, state and federal authorities, and other companies, associations, and institutions concerned with digital media. Since its launch in 1990, it has been the goal of this non-profit organization to establish digital technologies based on open standards.

### **Authors:**

Louay Bassbouss, Fraunhofer FOKUS  
Rainer Biehn, Bayerische Medien Technik  
Volker Blume, TP Vision  
Michael Eckhart, Panasonic  
Martin Fähnrich, Panasonic  
Ulrich Freyer, TU Ilmenau  
Ulrike Haltrich, Sony  
Frank Heineberg, RTL Deutschland/CBC  
Stefan Knopp, Seven.One Entertainment Group  
Torben Konopka, Hisense  
Klaus Merkel, RBB  
Siegbert Meßmer, Seven.One Entertainment Group  
Kai Mysliwicz, Seven.One Entertainment Group  
Malte Niemeyer, RTL Deutschland/CBC  
Arnd Paulsen, Dolby  
Sina Ruhland, Seven.One Entertainment Group  
Jan Stadler, RTL Deutschland/CBC  
Jan Wessels, Media Broadcast

### **Disclaimer:**

The information in this White Paper was thoroughly researched and assembled to the best of our knowledge, based on the unbiased approach of Deutsche TV Plattform's Smart Media Working Group / ADB2 Task Force. Any information herein reflects the status quo at the editorial deadline. However, the members of the working group and Deutsche TV-Plattform cannot guarantee its quality and/or that the compiled information is current, correct, and complete. Therefore, Deutsche TV-Plattform, as the publisher of this brochure, cannot accept any liability for material or immaterial loss or damage arising from the use of this publication or its content or as a result of inaccurate or incomplete information contained therein.