



Andy Beshear
GOVERNOR

TRANSPORTATION CABINET

200 Mero Street
Frankfort, Kentucky 40601

Jim Gray
SECRETARY

October 24, 2023

CALL NO. 101
CONTRACT ID NO. 231340
ADDENDUM # 2

Subject: Fayette County, NHPP 1602(003)
Letting October 26, 2023

- (1) Revised - Proposal Bid Items - Pages 233-239 of 239
- (2) Revised Plan Sheets - R1, T25, T35, T39, T45, T47, T49, T52
- (3) Added - Plan Sheets - S21-S30
- (4) Removed Plan Sheets - T42 and T44

Proposal revisions are available at <http://transportation.ky.gov/Construction-Procurement/>.

If you have any questions, please contact us at 502-564-3500.

Sincerely,

Rachel Mills,

A handwritten signature in black ink that reads "Rachel Mills".

Rachel Mills, P.E.
Director
Division of Construction Procurement

RM:mr
Enclosures

PROPOSAL BID ITEMS

231340

Page 1 of 7

Report Date 10/24/23

Section: 0001 - PAVING

LINE	BID CODE	ALT	DESCRIPTION	QUANTITY	UNIT	UNIT PRIC	FP	AMOUNT
0010	00001		DGA BASE	23,838.00	TON		\$	
0020	00018		DRAINAGE BLANKET-TYPE II-ASPH	13,559.00	TON		\$	
0030	00020		TRAFFIC BOUND BASE	36.00	TON		\$	
0040	00100		ASPHALT SEAL AGGREGATE	30.30	TON		\$	
0050	00103		ASPHALT SEAL COAT	3.80	TON		\$	
0060	00194		LEVELING & WEDGING PG76-22	1,636.00	TON		\$	
0070	00217		CL4 ASPH BASE 1.00D PG64-22	15,272.00	TON		\$	
0080	00219		CL4 ASPH BASE 1.00D PG76-22	13,397.00	TON		\$	
0090	00342		CL4 ASPH SURF 0.38A PG76-22	7,771.00	TON		\$	
0100	00358		ASPHALT CURING SEAL	37.70	TON		\$	
0110	02071		JPC PAVEMENT-11 IN	2,062.00	SQYD		\$	
0120	02101		CEM CONC ENT PAVEMENT-8 IN	40.40	SQYD		\$	
0130	02676		MOBILIZATION FOR MILL & TEXT	1.00	LS		\$	
0140	02677		ASPHALT PAVE MILLING & TEXTURING	3,183.00	TON		\$	
0150	02702		SAND FOR BLOTTER	94.40	TON		\$	
0160	20071EC		JOINT ADHESIVE	49,500.00	LF		\$	
0170	21289ED		LONGITUDINAL EDGE KEY	34,406.00	LF		\$	
0180	24891EC		PAVE MOUNT INFRARED TEMP EQUIPMENT	1,985,598.00	SF		\$	
0190	24970EC		ASPHALT MATERIAL FOR TACK NON-TRACKING	94.00	TON		\$	

Section: 0002 - ROADWAY

LINE	BID CODE	ALT	DESCRIPTION	QUANTITY	UNIT	UNIT PRIC	FP	AMOUNT
0200	00078		CRUSHED AGGREGATE SIZE NO 2	8,430.00	TON		\$	
0210	01000		PERFORATED PIPE-4 IN	11,545.00	LF		\$	
0220	01010		NON-PERFORATED PIPE-4 IN	396.00	LF		\$	
0230	01015		INSPECT & CERTIFY EDGE DRAIN SYSTEM	1.00	LS		\$	
0240	01792		ADJUST MANHOLE	1.00	EACH		\$	
0250	01825		ISLAND CURB AND GUTTER	28,232.00	LF		\$	
0260	01845		ISLAND INTEGRAL CURB	756.00	LF		\$	
0270	01875		STANDARD HEADER CURB	29.00	LF		\$	
0280	01891		ISLAND HEADER CURB TYPE 2	471.70	LF		\$	
0290	01982		DELINEATOR FOR GUARDRAIL MONO DIRECTIONAL WHITE	37.00	EACH		\$	
0300	02003		RELOCATE TEMP CONC BARRIER	325.00	LF		\$	
0310	02014		BARRICADE-TYPE III	20.00	EACH		\$	
0320	02015		CEMENT CONCRETE ISLAND	1,105.00	SQYD		\$	
0330	02091		REMOVE PAVEMENT	10.00	SQYD		\$	
0340	02157		PAVED DITCH TYPE 1	70.00	SQYD		\$	
0350	02159		TEMP DITCH	4,249.00	LF		\$	
0360	02160		CLEAN TEMP DITCH	2,124.00	LF		\$	
0370	02200		ROADWAY EXCAVATION	43,101.00	CUYD		\$	
0380	02203		STRUCTURE EXCAV-UNCLASSIFIED	448.00	CUYD		\$	
0390	02223		GRANULAR EMBANKMENT	42.00	CUYD		\$	
0400	02242		WATER	750.00	MGAL		\$	

PROPOSAL BID ITEMS

231340

Page 2 of 7

Report Date 10/24/23

LINE	BID CODE	ALT	DESCRIPTION	QUANTITY	UNIT	UNIT PRIC	FP	AMOUNT
0410	02351		GUARDRAIL-STEEL W BEAM-S FACE	2,237.50	LF		\$	
0420	02360		GUARDRAIL TERMINAL SECTION NO 1	1.00	EACH		\$	
0430	02367		GUARDRAIL END TREATMENT TYPE 1	6.00	EACH		\$	
0440	02369		GUARDRAIL END TREATMENT TYPE 2A	6.00	EACH		\$	
0450	02381		REMOVE GUARDRAIL	1,418.00	LF		\$	
0460	02429		RIGHT-OF-WAY MONUMENT TYPE 1	28.00	EACH		\$	
0470	02432		WITNESS POST	2.00	EACH		\$	
0480	02469		CLEAN SINKHOLE	1.00	EACH		\$	
0490	02483		CHANNEL LINING CLASS II	1,390.00	TON		\$	
0500	02484		CHANNEL LINING CLASS III	81.00	TON		\$	
0510	02545		CLEARING AND GRUBBING - 35.9 ACRES	1.00	LS		\$	
0520	02555		CONCRETE-CLASS B	347.00	CUYD		\$	
0530	02562		TEMPORARY SIGNS	576.00	SQFT		\$	
0540	02585		EDGE KEY	118.00	LF		\$	
0550	02603		FABRIC-GEOTEXTILE CLASS 2	28,351.00	SQYD		\$	
0560	02612		HANDRAIL-TYPE A-2	155.00	LF		\$	
0570	02650		MAINTAIN & CONTROL TRAFFIC	1.00	LS		\$	
0580	02651		DIVERSIONS (BY-PASS DETOURS)	1.00	LS		\$	
0590	02671		PORTABLE CHANGEABLE MESSAGE SIGN	8.00	EACH		\$	
0600	02690		SAFELOADING	48.00	CUYD		\$	
0610	02701		TEMP SILT FENCE	4,249.00	LF		\$	
0620	02703		SILT TRAP TYPE A	38.00	EACH		\$	
0630	02704		SILT TRAP TYPE B	38.00	EACH		\$	
0640	02705		SILT TRAP TYPE C	38.00	EACH		\$	
0650	02706		CLEAN SILT TRAP TYPE A	38.00	EACH		\$	
0660	02707		CLEAN SILT TRAP TYPE B	38.00	EACH		\$	
0670	02708		CLEAN SILT TRAP TYPE C	38.00	EACH		\$	
0680	02720		SIDEWALK-4 IN CONCRETE	2,172.00	SQYD		\$	
0690	02721		REMOVE CONCRETE SIDEWALK	11.00	SQYD		\$	
0700	02726		STAKING	1.00	LS		\$	
0710	02775		ARROW PANEL	4.00	EACH		\$	
0720	02898		RELOCATE CRASH CUSHION	2.00	EACH		\$	
0730	03171		CONCRETE BARRIER WALL TYPE 9T	325.00	LF		\$	
0740	04793		CONDUIT-1 1/4 IN	90.00	LF		\$	
0750	04795		CONDUIT-2 IN	60.00	LF		\$	
0760	04811		ELECTRICAL JUNCTION BOX TYPE B	4.00	EACH		\$	
0770	04820		TRENCHING AND BACKFILLING	130.00	LF		\$	
0780	04829		PIEZOELECTRIC SENSOR	6.00	EACH		\$	
0790	04830		LOOP WIRE	4,100.00	LF		\$	
0800	04895		LOOP SAW SLOT AND FILL	680.00	LF		\$	
0810	04953		TEMP RELOCATION OF SIGNAL HEAD	15.00	EACH		\$	
0820	05950		EROSION CONTROL BLANKET	7,149.00	SQYD		\$	
0830	05952		TEMP MULCH	366,775.00	SQYD		\$	
0840	05953		TEMP SEEDING AND PROTECTION	91,694.00	SQYD		\$	
0850	05963		INITIAL FERTILIZER	7.00	TON		\$	
0860	05964		MAINTENANCE FERTILIZER	7.00	TON		\$	
0870	05985		SEEDING AND PROTECTION	100,635.00	SQYD		\$	
0880	05990		SODDING	21,300.00	SQYD		\$	
0890	05992		AGRICULTURAL LIMESTONE	30.00	TON		\$	

PROPOSAL BID ITEMS

231340

Page 3 of 7

Report Date 10/24/23

LINE	BID CODE	ALT	DESCRIPTION	QUANTITY	UNIT	UNIT PRIC	FP	AMOUNT
0900	05997		TOPSOIL FURNISHED AND PLACED	1,200.00	CUYD		\$	
0910	06401		FLEXIBLE DELINEATOR POST-M/W	20.00	EACH		\$	
0920	06404		FLEXIBLE DELINEATOR POST-M/Y	7.00	EACH		\$	
0930	06511		PAVE STRIPING-TEMP PAINT-6 IN	40,000.00	LF		\$	
0940	06512		PAVE STRIPING-TEMP PAINT-8 IN	757.00	LF		\$	
0950	06514		PAVE STRIPING-PERM PAINT-4 IN	930.00	LF		\$	
0960	06542		PAVE STRIPING-THERMO-6 IN W	858.00	LF		\$	
0970	06543		PAVE STRIPING-THERMO-6 IN Y	355.00	LF		\$	
0980	06546		PAVE STRIPING-THERMO-12 IN W	1,042.00	LF		\$	
0990	06547		PAVE STRIPING-THERMO-12 IN Y	106.00	LF		\$	
1000	06565		PAVE MARKING-THERMO X-WALK-6 IN	2,098.00	LF		\$	
1010	06566		PAVE MARKING-THERMO X-WALK-12 IN	5,581.00	LF		\$	
1020	06567		PAVE MARKING-THERMO STOP BAR-12IN	29.00	LF		\$	
1030	06568		PAVE MARKING-THERMO STOP BAR-24IN	1,042.00	LF		\$	
1040	06574		PAVE MARKING-THERMO CURV ARROW	103.00	EACH		\$	
1050	06575		PAVE MARKING-THERMO COMB ARROW	3.00	EACH		\$	
1060	06576		PAVE MARKING-THERMO ONLY	5.00	EACH		\$	
1070	06585		PAVEMENT MARKER TY IVA-MW TEMP	121.00	EACH		\$	
1080	06588		PAVEMENT MARKER TY IVA-BY TEMP	419.00	EACH		\$	
1090	06610		INLAID PAVEMENT MARKER-MW	931.00	EACH		\$	
1100	06612		INLAID PAVEMENT MARKER-BY	18.00	EACH		\$	
1110	06613		INLAID PAVEMENT MARKER-B W/R	50.00	EACH		\$	
1120	06614		INLAID PAVEMENT MARKER-B Y/R	10.00	EACH		\$	
1130	08901		CRASH CUSHION TY VI CLASS BT TL2	2.00	EACH		\$	
1140	08904		CRASH CUSHION TY VI CLASS C	6.00	EACH		\$	
1150	10020NS		FUEL ADJUSTMENT	96,457.00	DOLL	\$1.00	\$	\$96,457.00
1160	10030NS		ASPHALT ADJUSTMENT	148,862.00	DOLL	\$1.00	\$	\$148,862.00
1170	20063EN9T		DRY-LAID ROCK FENCE	2,133.00	LF		\$	
1180	20099ES842		PAVE MARK TEMP PAINT STOP BAR	405.00	LF		\$	
1190	20166ES810		TEMPORARY PIPE	180.00	LF		\$	
1200	20191ED		OBJECT MARKER TY 3	6.00	EACH		\$	
1210	20359NN		GALVANIZED STEEL CABINET	4.00	EACH		\$	
1220	20360ES818		WOOD POST	8.00	EACH		\$	
1230	20550ND		SAWCUT PAVEMENT	28,575.00	LF		\$	
1240	20782NS714		PAVE MARKING THERMO-BIKE	1.00	EACH		\$	
1250	21417ES717		PAVE MARK THERMO CONE CAP-SOLID YELLOW	346.00	SQFT		\$	
1260	22664EN		WATER BLASTING EXISTING STRIPE	5,300.00	LF		\$	
1270	23158ES505		DETECTABLE WARNINGS	493.00	SQFT		\$	
1280	23270ES717		PAVE MARK TY 1 TAPE-CURV ARROW	27.00	EACH		\$	
1290	23721NN		LANDSCAPING	1.00	LS		\$	
1300	24386EC		PAVE MARKING THERMO-BIKE LANE ARROW	1.00	EACH		\$	
1310	24640ED		OBJECT MARKER TYPE 1	6.00	EACH		\$	
1320	24679ED		PAVE MARK THERMO CHEVRON	180.00	SQFT		\$	
1330	24683ED		PAVE MARKING-THERMO DOTTED LANE EXTEN	324.00	LF		\$	
1340	24701ED		CORED HOLE IN DRAINAGE PIPE	2.00	EACH		\$	
1350	24814EC		PIPELINE INSPECTION	6,624.00	LF		\$	
1360	24845EC		UTILITY COORDINATION	1.00	LS		\$	

PROPOSAL BID ITEMS

231340

Page 4 of 7

Report Date 10/24/23

LINE	BID CODE	ALT	DESCRIPTION	QUANTITY	UNIT	UNIT PRIC	FP	AMOUNT
1370	24995EC		PAVE STRIPING-SPRAY THERMO-6 IN W	32,487.00	LF		\$	
1380	24996EC		PAVE STRIPING-SPRAY THERMO-6 IN Y	16,778.00	LF		\$	

Section: 0003 - DRAINAGE

LINE	BID CODE	ALT	DESCRIPTION	QUANTITY	UNIT	UNIT PRIC	FP	AMOUNT
1390	00440		ENTRANCE PIPE-15 IN	65.00	LF		\$	
1400	00466		CULVERT PIPE-30 IN	152.00	LF		\$	
1410	00520		STORM SEWER PIPE-12 IN	25.00	LF		\$	
1420	00521		STORM SEWER PIPE-15 IN	2,653.00	LF		\$	
1430	00522		STORM SEWER PIPE-18 IN	7,561.00	LF		\$	
1440	00524		STORM SEWER PIPE-24 IN	2,375.00	LF		\$	
1450	00526		STORM SEWER PIPE-30 IN	107.00	LF		\$	
1460	00528		STORM SEWER PIPE-36 IN	394.00	LF		\$	
1470	01210		PIPE CULVERT HEADWALL-30 IN	1.00	EACH		\$	
1480	01456		CURB BOX INLET TYPE A	102.00	EACH		\$	
1490	01493		DROP BOX INLET TYPE 2	2.00	EACH		\$	
1500	01496		DROP BOX INLET TYPE 3	4.00	EACH		\$	
1510	01568		DROP BOX INLET TYPE 13S	2.00	EACH		\$	
1520	01577		DROP BOX INLET TYPE 14	7.00	EACH		\$	
1530	01650		JUNCTION BOX	8.00	EACH		\$	
1540	01756		MANHOLE TYPE A	5.00	EACH		\$	
1550	01767		MANHOLE TYPE C	2.00	EACH		\$	
1560	02607		FABRIC-GEOTEXTILE CLASS 2 FOR PIPE	21,869.00	SQYD	\$2.00	\$	\$43,738.00
1570	03385		PVC PIPE-6 IN	32.00	LF		\$	
1580	23126EN		BORE AND JACK PIPE-18 IN	155.00	LF		\$	
1590	23952EC		DRAINAGE JUNCTION BOX TY B	1.00	EACH		\$	

Section: 0004 - BRIDGE-RCBC-STA 118+41.00

LINE	BID CODE	ALT	DESCRIPTION	QUANTITY	UNIT	UNIT PRIC	FP	AMOUNT
1600	02203		STRUCTURE EXCAV-UNCLASSIFIED	220.00	CUYD		\$	
1610	02403		REMOVE CONCRETE MASONRY	40.00	CUYD		\$	
1620	08100		CONCRETE-CLASS A	170.00	CUYD		\$	
1630	08150		STEEL REINFORCEMENT	27,705.00	LB		\$	

Section: 0005 - BRIDGE-RCBC-STA.164+87.90

LINE	BID CODE	ALT	DESCRIPTION	QUANTITY	UNIT	UNIT PRIC	FP	AMOUNT
1640	02203		STRUCTURE EXCAV-UNCLASSIFIED	261.00	CUYD		\$	
1650	02403		REMOVE CONCRETE MASONRY	13.00	CUYD		\$	
1660	08100		CONCRETE-CLASS A	90.00	CUYD		\$	
1670	08150		STEEL REINFORCEMENT	8,977.00	LB		\$	

Section: 0006 - BRIDGE-RCBC-STA 136+30-PEDESTRIAN UNDERPASS

PROPOSAL BID ITEMS

231340

Page 5 of 7

Report Date 10/24/23

SECTION: 0006 - BRIDGE ROADS - 150' TO 500' PAVED SURFACE

LINE	BID CODE	ALT	DESCRIPTION	QUANTITY	UNIT	UNIT PRIC	FP	AMOUNT
1680	02612		HANDRAIL-TYPE A-2	95.00	LF		\$	
1690	02998		MASONRY COATING	525.00	SQYD		\$	
1700	08003		FOUNDATION PREPARATION	1.00	LS		\$	
1710	08100		CONCRETE-CLASS A	260.00	CUYD		\$	
1720	08150		STEEL REINFORCEMENT	40,067.00	LB		\$	

Section: 0007 - SEWER

LINE	BID CODE	ALT	DESCRIPTION	QUANTITY	UNIT	UNIT PRIC	FP	AMOUNT
1730	02556		CONCRETE CAP	1.75	CUYD		\$	
1740	15000		S BYPASS PUMPING	1.00	EACH		\$	
1750	15092		S MANHOLE	2.00	EACH		\$	
1760	15099		S MANHOLE TAP EXISTING	2.00	EACH		\$	
1770	15112		S PIPE PVC 08 INCH	130.00	LF		\$	

Section: 0008 - SIGNING

LINE	BID CODE	ALT	DESCRIPTION	QUANTITY	UNIT	UNIT PRIC	FP	AMOUNT
1780	06405		SBM ALUMINUM PANEL SIGNS	2,864.00	SQFT		\$	
1790	06406		SBM ALUM SHEET SIGNS .080 IN	170.00	SQFT		\$	
1800	06407		SBM ALUM SHEET SIGNS .125 IN	240.50	SQFT		\$	
1810	06410		STEEL POST TYPE 1	556.50	LF		\$	
1820	06412		STEEL POST MILE MARKERS	2.00	EACH		\$	
1830	06422		OSS ALUMINUM 60 FT TRUSS	1.00	EACH		\$	
1840	06436		OSS ALUMINUM 75 FT TRUSS	2.00	EACH		\$	
1850	06441		GMSS GALV STEEL TYPE C	4,935.00	LB		\$	
1860	06449		REM OVERHEAD SIGN SUPPORT STR	1.00	EACH		\$	
1870	06450		REM OVERHEAD STRUC CONC BASE	2.00	EACH		\$	
1880	06451		REMOVE SIGN SUPPORT BEAM	12.00	EACH		\$	
1890	06490		CLASS A CONCRETE FOR SIGNS	10.50	CUYD		\$	
1900	06491		STEEL REINFORCEMENT FOR SIGNS	550.00	LB		\$	
1910	21134ND		REMOVE-STORE AND REINSTALL SIGN -LEXINGTON GUIDE SIGNS	3.00	EACH		\$	
1920	21373ND		REMOVE SIGN	49.00	EACH		\$	
1930	21596ND		GMSS TYPE D	27.00	EACH		\$	
1940	24631EC		BARCODE SIGN INVENTORY	51.00	EACH		\$	

Section: 0009 - SIGNALIZATION

LINE	BID CODE	ALT	DESCRIPTION	QUANTITY	UNIT	UNIT PRIC	FP	AMOUNT
1950	04780		FUSED CONNECTOR KIT	21.00	EACH		\$	
1960	04820		TRENCHING AND BACKFILLING	715.00	LF		\$	
1970	04845		CABLE-NO. 14/7C	18,970.00	LF		\$	
1980	04886		MESSENGER-15400 LB	3,350.00	LF		\$	
1990	04932		INSTALL STEEL STRAIN POLE	24.00	EACH		\$	

PROPOSAL BID ITEMS

231340

Page 6 of 7

Report Date 10/24/23

LINE	BID CODE	ALT	DESCRIPTION	QUANTITY	UNIT	UNIT PRIC	FP	AMOUNT
2000	04953		TEMP RELOCATION OF SIGNAL HEAD	148.00	EACH		\$	
2010	06406		SBM ALUM SHEET SIGNS .080 IN	15.00	SQFT		\$	
2020	06472		INSTALL SPAN MOUNTED SIGN	2.00	EACH		\$	
2030	20093NS835		INSTALL PEDESTRIAN HEAD-LED	34.00	EACH		\$	
2040	20188NS835		INSTALL LED SIGNAL-3 SECTION	65.00	EACH		\$	
2050	20266ES835		INSTALL LED SIGNAL- 4 SECTION	9.00	EACH		\$	
2060	20390NS835		INSTALL COORDINATING UNIT	6.00	EACH		\$	
2070	20631ND		INSTALL POLE MOUNTED SIGN	14.00	EACH		\$	
2080	21743NN		INSTALL PEDESTRIAN DETECTOR	34.00	EACH		\$	
2090	23157EN		TRAFFIC SIGNAL POLE BASE	124.00	CUYD		\$	
2100	23222EC		INSTALL SIGNAL PEDESTAL	9.00	EACH		\$	
2110	23235EC		INSTALL PEDESTAL POST	17.00	EACH		\$	
2120	23750EC		INSTALL ILLUMINATED STREET SIGN	4.00	EACH		\$	
2130	23865EC		INSTALL CCTV CAMERA (REVISED 10-24-23)	2.00	EACH		\$	
2140	24900EC		PVC CONDUIT-1 1/4 IN-SCHEDULE 80	655.00	LF		\$	
2150	24901EC		PVC CONDUIT-2 IN-SCHEDULE 80	120.00	LF		\$	
2160	24902EC		PVC CONDUIT-3 IN-SCHEDULE 80	160.00	LF		\$	
2170	24908EC		INSTALL SIGNAL CONTROLLER-TY ATC	6.00	EACH		\$	
2180	24955ED		REMOVE SIGNAL EQUIPMENT	6.00	EACH		\$	
2190	26119EC		INSTALL RADAR PRESENCE DETECTOR TYPE A	22.00	EACH		\$	

Section: 0010 - LIGHTING

LINE	BID CODE	ALT	DESCRIPTION	QUANTITY	UNIT	UNIT PRIC	FP	AMOUNT
2200	04740		POLE BASE	84.00	EACH		\$	
2210	04760		POLE W/SECONDARY CONTROL EQUIP (REVISED 10-24-23)	1.00	EACH		\$	
2230	04795		CONDUIT-2 IN	1,390.00	LF		\$	
2240	04820		TRENCHING AND BACKFILLING	14,965.00	LF		\$	
2242	04833		WIRE-NO. 8 (ADDED 10-24-23)	1,500.00	LF		\$	
2244	04940		REMOVE LIGHTING (ADDED 10-24-23)	1.00	LS		\$	
2250	20391NS835		ELECTRICAL JUNCTION BOX TYPE A	24.00	EACH		\$	
2252	21563NN		SPLICE BOX (ELECTRICAL, 8"x6"x4") (ADDED 10-24-23)	6.00	EACH		\$	
2254	24750EC		LED TUNNEL LUMINAIRE (ADDED 10-24-23)	6.00	EACH		\$	
2260	24900EC		PVC CONDUIT-1 1/4 IN-SCHEDULE 80	11,055.00	LF		\$	

Section: 0011 - INTELLIGENT TRANSPORTATION SYSTEMS

LINE	BID CODE	ALT	DESCRIPTION	QUANTITY	UNIT	UNIT PRIC	FP	AMOUNT
2270	04810		ELECTRICAL JUNCTION BOX	15.00	EACH		\$	
2280	04820		TRENCHING AND BACKFILLING	7,330.00	LF		\$	
2290	21077ED		FIBER OPTIC CABLE	7,660.00	LF		\$	

PROPOSAL BID ITEMS

231340

Page 7 of 7

Report Date 10/24/23

LINE	BID CODE	ALT	DESCRIPTION	QUANTITY	UNIT	UNIT PRIC	FP	AMOUNT
2300	24121EC		HDPE CONDUIT-2 IN-SCHEDULE 80	7,330.00	LF		\$	
2310	24922EC		FIBER OPTIC SPLICE ENCLOSURE	2.00	EACH		\$	

Section: 0012 - DEMOBILIZATION &/OR MOBILIZATION

LINE	BID CODE	ALT	DESCRIPTION	QUANTITY	UNIT	UNIT PRIC	FP	AMOUNT
2320	02568		MOBILIZATION	1.00	LS		\$	
2330	02569		DEMOBILIZATION	1.00	LS		\$	

SHEET NO.	DESCRIPTION
R2-R2U	LAYOUT SHEETS
R3-R5	TOTAL QUANTITIES
R5-R51	PLAN AND PROFILE SHEETS
R52-R56	RIGHT OF WAY SUMMARY SHEETS
R57-R61	COORDINATE CONTROL SHEETS
R62-R69	UTILITY SHEETS
R70-R72	EROSION CONTROL SHEETS
R81-R102	SOIL PROFILE SHEETS
R103-R110	PIPE DRAINAGE SHEETS
R111-R149	STRUCTURE PLANS
S1-S7	A. 164+88 8X5 RCBC EXT
S8-S14	STA. 136+30 14X9 PEDESTRIAN RCBC
S15-S20	OVERHEAD SIGN SUPPORT STRUCTURES
S21-S30	TRAFFIC PLANS (SIGNING)
T1-T23	UNUSED
T24	TRAFFIC PLANS (SIGNALS)
T25-T38	TRAFFIC PLANS (LIGHTING)
T39-T51	UNUSED
T42	UNUSED
T43	UNUSED
T44	UNUSED
T45-T59	TRAFFIC PLANS (ITS)
U1-U3	UTILITY RELOCATION PLANS
X1-X112	CROSS SECTION SHEETS

SHEETS NOT INCLUDED IN TOTAL SHEETS
R20-R2U, R130, R210, R50, R51, R53
R80-R80e, R810, R900

STANDARD DRAWINGS	
RBE-100-11	RDH-110-02
RBI-001-12	RDX-030-07
RBI-002-07	RDX-310-04
RBI-004-06	RDI-001-10
REM-115-10	RDI-002-05
RBM-120-02	RDI-020-10
RBR-001-13	RDI-021-01
RBR-005-11	RDI-025-06
RBR-010-06	RDI-026-01
RBR-015-06	RDI-040-01
RBR-018	RDI-041-01
RBR-020-07	RDM-001-07
RBR-025-06	RDM-010-06
RBR-055-01	RDM-011-05
RDB-002-12	RDM-012-03
RDB-003-08	RDM-013-04
RDB-013-07	RDM-055
RDB-014-06	RDM-100-03
RDB-015-04	RDM-105-03
RDB-016-03	RDP-001-06
RDB-017-03	RDP-005-05
RDB-018-04	RDX-001-06
RDB-019-04	RDX-002-04
RDB-020-05	RDX-005-03
RDB-270-09	RDX-160-06
RDB-271-05	RDX-210-03
RDB-272-07	RDX-220-05
RDB-273-06	RDX-225-01
RDB-400-05	RFG-005-06
RDB-410-06	RFW-001-06
RDB-420-05	RGS-001-07
RDD-001-06	RGS-002-06
RDD-040-05	RGS-001-06
	RGX-005-06

TOTAL STANDARD DRAWINGS: 102

DESIGN CRITERIA

CLASS OF HIGHWAY	URBAN ARTERIAL
TYPE OF TERRAIN	ROLLING
DESIGN SPEED	55
REQUIRED NPSD	495
REQUIRED PSD	N/A
LEVEL OF SERVICE	
ADT PRESENT (2006)	44000
ADT FUTURE (2030)	70500
DHV (2030)	7100
D %	
T %	33

GEOGRAPHIC COORDINATES

LATITUDE 38 DEGREES 51 MINUTES 09 SECONDS NORTH
 LONGITUDE 84 DEGREES 29 MINUTES 25 SECONDS WEST

DESIGNED

% RESTRICTED SD _____
 LEVEL OF SERVICE _____
 MAX. DISTANCE W/O PASSING _____

Commonwealth of Kentucky DEPARTMENT OF HIGHWAYS

PLANS OF PROPOSED PROJECT FAYETTE NEWTOWN PIKE (KY 922) NHPP 1602 (003)

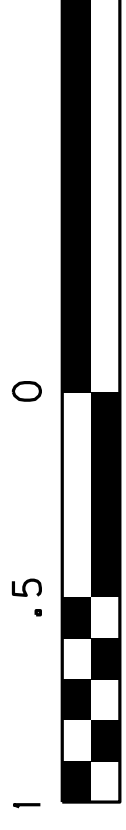
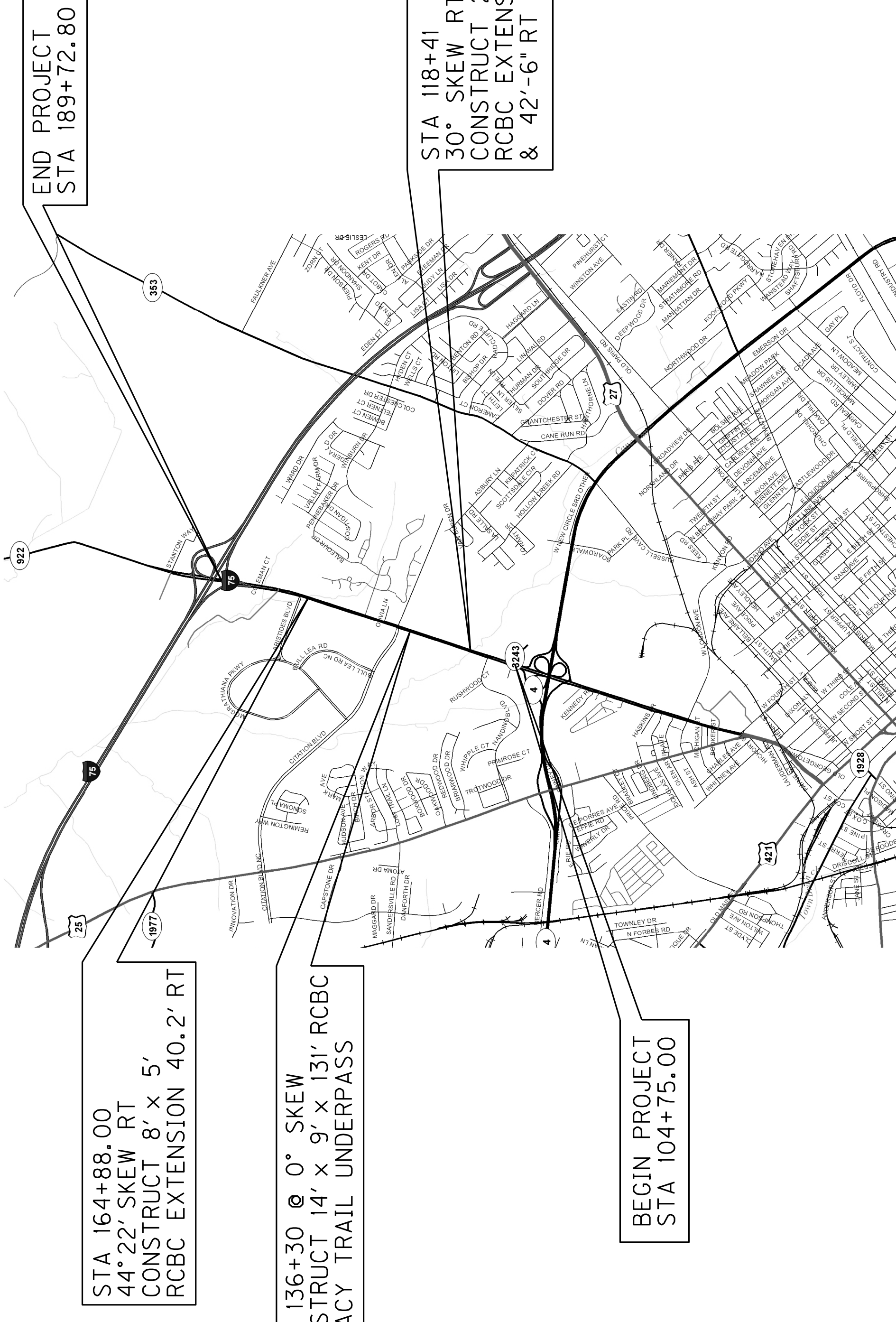

LAYOUT MAP

ITEM NO.	7-252.00
PROJECT NUMBER:	FD52 034 0922 001-004
NHPP NUMBER:	NHPP 1602(003)
LETTING DATE:	
RECOMMENDED BY:	JOSHUA SAMPLES
PROJECT MANAGER:	
DATE:	SEPTEMBER 12, 2023
KY. REGISTRATION NO.:	23691

Commonwealth of Kentucky
DEPARTMENT OF HIGHWAYS
COUNTY OF
FAYETTE

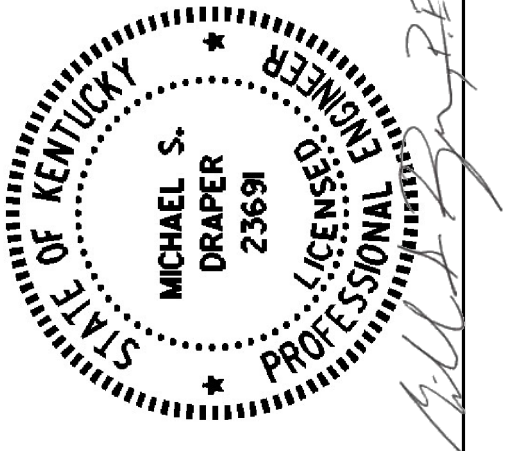

PLAN APPROVED BY: _____ STATE HIGHWAY ENGINEER DATE: _____

THESE PLANS ARE FOR GRADE,
DRAIN AND SURFACING.

THIS PROJECT IS A PARTIALLY
CONTROLLED ACCESS HIGHWAY.
ACCESS SHALL BE PROVIDED ONLY
WHERE SPECIFICALLY INDICATED
ON PLANS.

THIS PROJECT IS ON THE NH SYSTEM

STA 118+41
30° SKEW RT
CONSTRUCT 20' x 8'
RCBC EXTENSION 47'-6" LT
& 42'-6" RT

STA 164+88.00
44° 22' SKEW RT
CONSTRUCT 8' x 5'
RCBC EXTENSION 40.2' RT

STA 136+30 @ 0° SKEW
CONSTRUCT 14' x 9' x 131' RCBC
LEGACY TRAIL UNDERPASS

BEGIN PROJECT
STA 104+75.00

END PROJECT
STA 189+72.80

COUNTY OF	ITEM NO.	SHEET NO.
FAYETTE	7-252.00	RI

Commonwealth of Kentucky DEPARTMENT OF HIGHWAYS

PLANS OF PROPOSED PROJECT FAYETTE NEWTOWN PIKE (KY 922) NHPP 1602 (003)

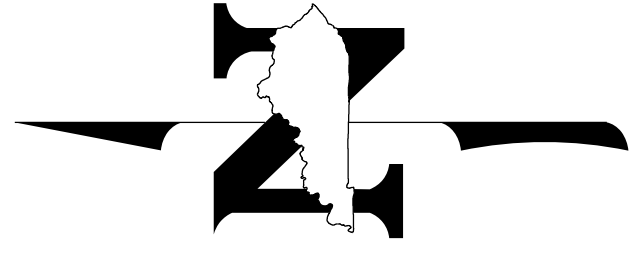

THESE PLANS ARE FOR GRADE,
DRAIN AND SURFACING.

THIS PROJECT IS A PARTIALLY
CONTROLLED ACCESS HIGHWAY.
ACCESS SHALL BE PROVIDED ONLY
WHERE SPECIFICALLY INDICATED
ON PLANS.

THIS PROJECT IS ON THE NH SYSTEM

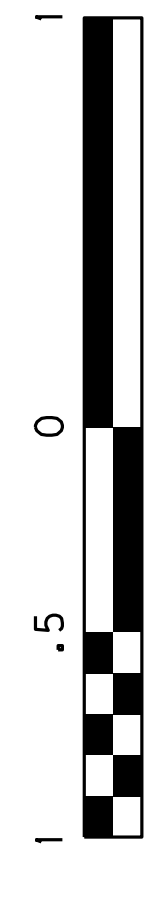
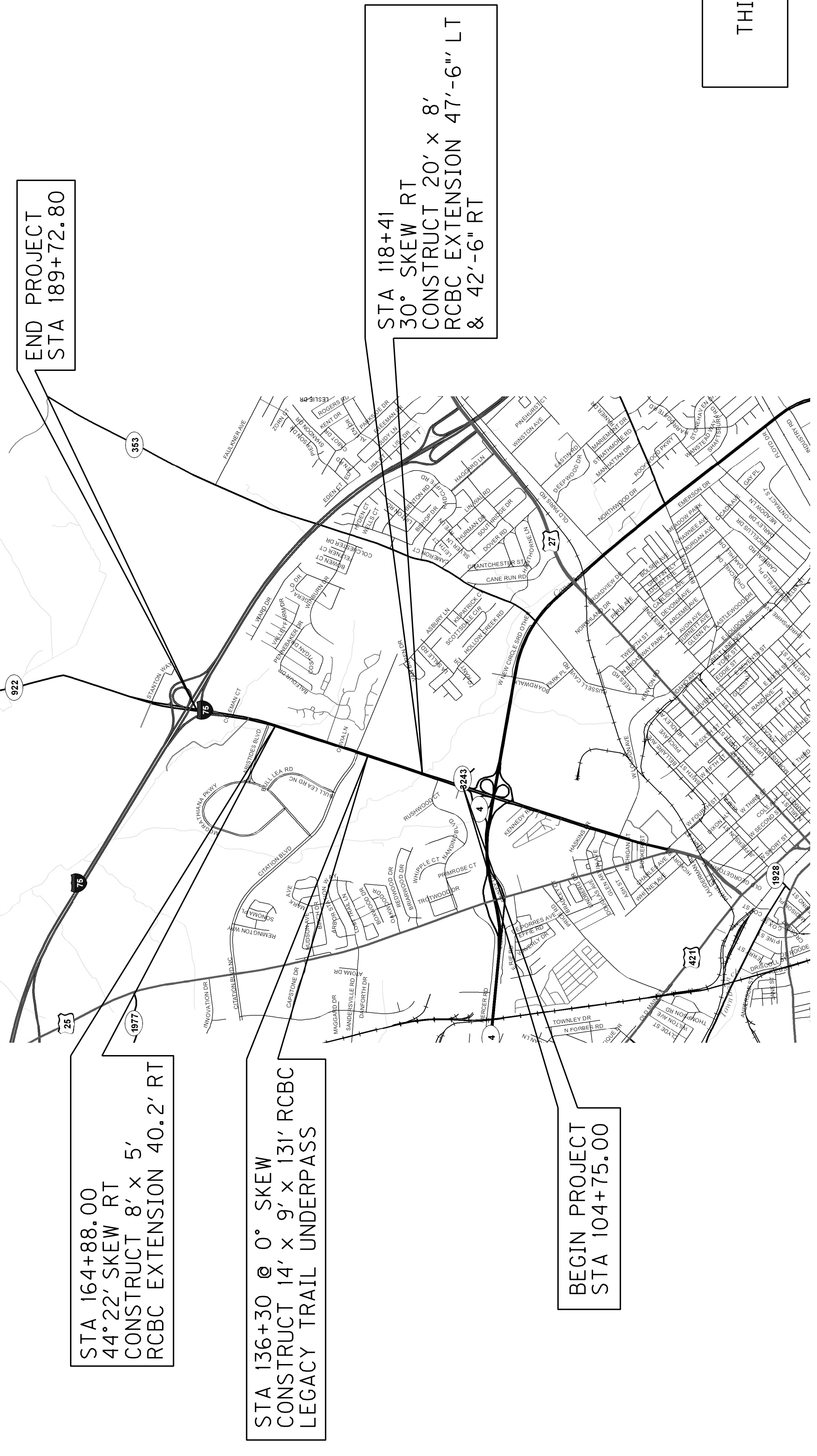

LAYOUT MAP

SHEET NO.	DESCRIPTION
R2-R2U	LAYOUT SHEETS
R3-R5U	PROFILES-SUMMARY OF QUANTITIES
R6-R7U	PLAN AND PROFILE SHEETS
R8-R10U	RIGHT OF WAY SUMMARY SHEETS
R11-R13U	COORDINATE CONTROL SHEETS
R14-R16U	TRAILING SHEETS
R17-R19U	EROSION CONTROL SHEETS
R20-R22U	SOIL PROFILE SHEETS
R23-R25U	PIPE DRAINAGE SHEETS
S1-S7	STRUCTURE PLANS
S8-S14	STA. 164+88.00 RCBC EXT
S15-S21	STA. 164+88.00 RCBC EXT
S22-S30	OVERHEAD SIGN SUPPORT STRUCTURES
T1-T23	TRAFFIC PLANS (SIGNING)
T24-T38	TRAFFIC PLANS (SIGNALS)
T39-T43	TRAFFIC PLANS (LIGHTING)
T44-T45	UNUSED
T46-T47	UNUSED
T48-T49	TRAFFIC PLANS (ITS)
U1-U3	UTILITY RELOCATION PLANS
X1-X12	CROSS SECTION SHEETS

SHEETS NOT INCLUDED IN TOTAL SHEETS
R26-R29, R30, R210, R50, R51, R53
R800-R806, R810, R900

STANDARD DRAWINGS	
RBE-100-11	RDH-110-02
RBJ-001-12	RGX-030-07
RBK-002-07	RGX-040-03
RBL-004-06	RGX-200-01
REM-115-10	RPM-100-11
RBM-120-02	RPM-110-07
RBR-001-13	RPM-120-07
RBR-005-11	RPM-150-08
RBR-010-06	RPM-152-08
RBR-015-06	RPM-170-09
RBR-018	RPN-115-05
RBR-020-07	RPS-010-11
RBR-025-06	RPS-020-14
RBR-055-01	RPS-032-06
RDB-002-12	RPS-033-07
RDB-003-08	RPS-034-07
RDB-013-07	RPM-010-04
RDB-014-06	RPM-010-05
RDB-015-04	RPM-015-04
RDB-016-03	RPM-020-06
RDB-017-03	TPM-170-01
RDB-018-04	TPM-171-01
RDB-019-04	TPM-203
RDB-020-05	TPM-205
RDB-270-09	TPM-206
RDB-271-05	TTC-115-04
RDB-272-07	TTC-120-04
RDB-273-06	TTC-125-03
RDB-400-05	TTC-155-02
RDB-410-06	TFW-001-06
RDB-420-05	TTD-120-03
RDD-001-06	TTD-125-03
RDD-040-05	TTS-110-02
	TTS-115-02

TOTAL STANDARD DRAWINGS: 102

DESIGN CRITERIA	
CLASS OF HIGHWAY	URBAN ARTERIAL
TYPE OF TERRAIN	ROLLING
DESIGN SPEED	55
REQUIRED NPSD	495
REQUIRED PSD	N/A
LEVEL OF SERVICE	
ADT PRESENT (2006)	44000
ADT FUTURE (2030)	70500
DHV (2030)	7100
D %	
T %	33

GEOGRAPHIC COORDINATES	
LATITUDE	38 DEGREES 51 MINUTES 09 SECONDS NORTH
LONGITUDE	84 DEGREES 29 MINUTES 25 SECONDS WEST

DESIGNED	
% RESTRICTED SD	
LEVEL OF SERVICE	
MAX. DISTANCE W/O PASSING	

ITEM NO.	LENGTH	MILES	FOR EQUALITIES	NOT INCLUDED	RAILROAD CROSSINGS	NO.	BRIDGES	NO.	DATE
7-252.00	8497.8	1.609							10-05-2023
ADDED									
DEDUCTED									

**Commonwealth of Kentucky
DEPARTMENT OF HIGHWAYS
COUNTY OF
FAYETTE**

ITEM NO. 7-252.00
PROJECT NUMBER: FD52 034 0922 001-004
NHPP 1602(003)
LETTING DATE: _____

RECOMMENDED BY: JOSHUA SAMPLES
PROJECT MANAGER
DATE: SEPTEMBER 12, 2023

BY: Michael Draper
DATE: September 12, 2023
KY. REGISTRATION NO.: 23691

STATE OF KENTUCKY
MICHAEL S. DRAPER
23691
LICENSED PROFESSIONAL ENGINEER

PLANNED AND SUBMITTED BY
DIZ
1800 HARBOR COURT
LEXINGTON, KENTUCKY 40505

PLANNED AND SUBMITTED BY
DIZ
1800 HARBOR COURT
LEXINGTON, KENTUCKY 40505

PLANNED AND SUBMITTED BY
DIZ
1800 HARBOR COURT
LEXINGTON, KENTUCKY 40505

50-70 FT OVERHEAD SIGN SUPPORT TRUSS GENERAL NOTES

Specifications:

All references to the standard specifications are to the 2019 Edition of the Kentucky Transportation Cabinet Standard Specifications for Road and Bridge Construction. All references to the AASHTO Specifications are to the AASHTO LRFD Specifications for Structural Supports for Highway Signs, Luminaires, and Traffic Signals with Interims through 2022.

Design:

Designed in accordance with AASHTO LRFD Specifications for Structural Supports for Highway Signs, Luminaires, and Traffic Signals with Interims through 2022 using the following parameters:

- 1700 year MRI, with 120 MPH Design Wind Speed
- Finite Fatigue
- 10 Year MRI, 76 MPH Service Wind Speed
- Fatigue Design Loads: Natural Wind Gust, Truck-Induced Wind Gust

Superelevation of Roadway:

The contractor shall allow for differences in elevations across the full shoulder width as shown in the Roadway Plans in maintaining the required 18 foot minimum vertical clearance to the bottom, of the lowest part of the sign or support. Sign shall be centered over the lane or lanes to which it applies, or as specified in the Signing Plans.

Material Design Specifications:

For Class "A" Concrete
 $f'_c = 3,500$ psi
 For Steel Reinforcement
 $f_y = 60,000$ psi
 For Structural Steel
 $f_y = 50,000$ psi
 $f_y = 42,000$ psi
 For Steel Columns and Chords
 $f_y = 35,000$ psi

Material Specifications:

AASHTO Specifications or ASTM, Current edition, as designated below shall govern the materials furnished:

Steel Shapes galvanized in accordance with ASTM A123:

Structural Steel: ASTM A992 Grade 50, ASTM A572 Grade 50
 Steel Diagonals: ASTM A53 Grade B, ASTM A500 Grade B, or C, ASTM A1085 Grade A
 Steel Columns and Chords: ASTM A500 Grade B or C, ASTM A1085 Grade A

Steel Hardware galvanized in accordance with ASTM A153:

High Strength Bolts ASTM F3125 Grade A325
 U-bolts ASTM A307 Grade A
 Anchor Bolts ASTM F1554 Grade 55
 Heavy Hex Nuts ASTM A194 2H
 Flat Washers ASTM F436

Concrete:

Class "A" Concrete shall be used throughout, and shall be paid for at the unit bid price for Class "A" Concrete for Signs.

Beveled Edges:

All exposed concrete edges are to be beveled $\frac{3}{4}$ " unless otherwise shown.

Reinforcement:

Dimensions shown from the face of concrete to bars are to center of bar unless otherwise shown. Spacing of bars is from center to center of bars. Clear distance to face of concrete is 2 inches unless otherwise noted. Reinforcing bars in the plans shall be epoxy coated in accordance with section 811.10 of the Standard Specifications.

Any reinforcing bars designated by the suffix (s) in a Bill of Reinforcement shall be considered a stirrup bar for purposes of bend diameters.

Payment for reinforcement shall be paid for at the unit bid price for Steel Reinforcement for Signs.

Shop Drawings:

The contractor shall submit detailed shop drawings to the Division of Construction for review prior to fabrication in accordance with the specifications. The roadway cross section developed by the contractor is to accompany the shop drawings. The shop drawings and roadway cross section will also be forwarded to the engineer to review.

Bolted Connections:

All bolted connections shall include lock washers. After bolted connections are complete, threads shall be scored to prevent nut loosening. Care shall be taken not to damage the nut and threads engaged by the nut. Damaged nuts shall be replaced at the contractors expense.

Fabrication:

The sign support shall be fabricated in accordance with the AASHTO Specifications. Any damaged galvanization shall be repaired in accordance with ASTM A780. Perform all welding according to requirements specified in ANSI/AASHTO/AWS D1.1 Structural Welding Code Current edition with interims.

Mill Test Reports:

Submit Mill Test Reports in accordance with section 607.03.13 of the Standard Specifications

Vent/Drain Holes for Galvanization

Vent/drain holes shall be drilled in the column or chord member at each end of all closed diagonal members prior to welding. The holes shall be spaced as equally as possible across the chord/column surface where the diagonal member opening projects. Vent/drain holes shall be shown in the shop drawings for approval. Total area of vent/drain holes at each end shall be equal to or less than the following:

- 30% of the diagonal inside cross sectional opening for members with inside diameters greater than or equal to 3 inches.
- 45% of the diagonal inside cross sectional opening for members with inside diameters less than 3 inches.

Footings:

All footings shall be poured against undisturbed earth. The maximum allowable service bearing pressure is 3 kips per square foot.

Design Limits:

This standard drawing is applicable to all overhead sign supports that meet the following criteria:

Maximum Total Sign Area:	800 SF
Minimum Vertical Clearance of Sign Above Roadway:	18 FT
Maximum Height of Sign Above Roadway:	44 FT
Maximum Sign Panel Height:	24 FT
Maximum Exit Panel Height:	4.5 FT
Span Range:	50 FT - 70 FT
Min. Sign Edge Distance to Column CL:	12 FT / 18 FT
Max./Min. Column Height (HL/HR):	27 FT / 18 FT
Min. Pedestal Height (FL/FR):	14 FT
Min. Pedestal Offset behind Guardrail:	6 FT
Min. Pedestal Projection above soil:	2.5 FT
Min. Fill above Base of Footing:	3 FT

Design Chart:

A registered professional engineer licensed to practice in the Commonwealth of Kentucky shall fill out the Design Chart based on the design cross section at the location where the truss is to be erected, the actual signs to be used, and the instructions herein. The Engineer's name shall appear in the "Checked By:" Box of the title block of this sheet. The Engineer is responsible for verifying the information based on the contractor's submitted cross sections and reviewing the fabricators shop drawings in detail.

Roadway Cross Section:

The contractor shall take field measurements at each sign location and develop a cross section showing the following:

- Pedestal and median heights
- Pedestal offset distance behind guardrail
- Column Heights
- Minimum Vertical Clearance to each sign

Any work associated with developing and furnishing the Roadway Cross Section shall be incidental to OSS Sign Truss.

Payment:

All engineering, materials, labor, equipment, and any other incidentals necessary to furnish and install the sign truss as detailed in these standards and the shop drawings shall be paid for at the unit bid price for OSS Sign Truss.

Fabricator Certification:

The fabricator shall be AISC Certified for SBR (Certified Bridge Fabricator - Simple).

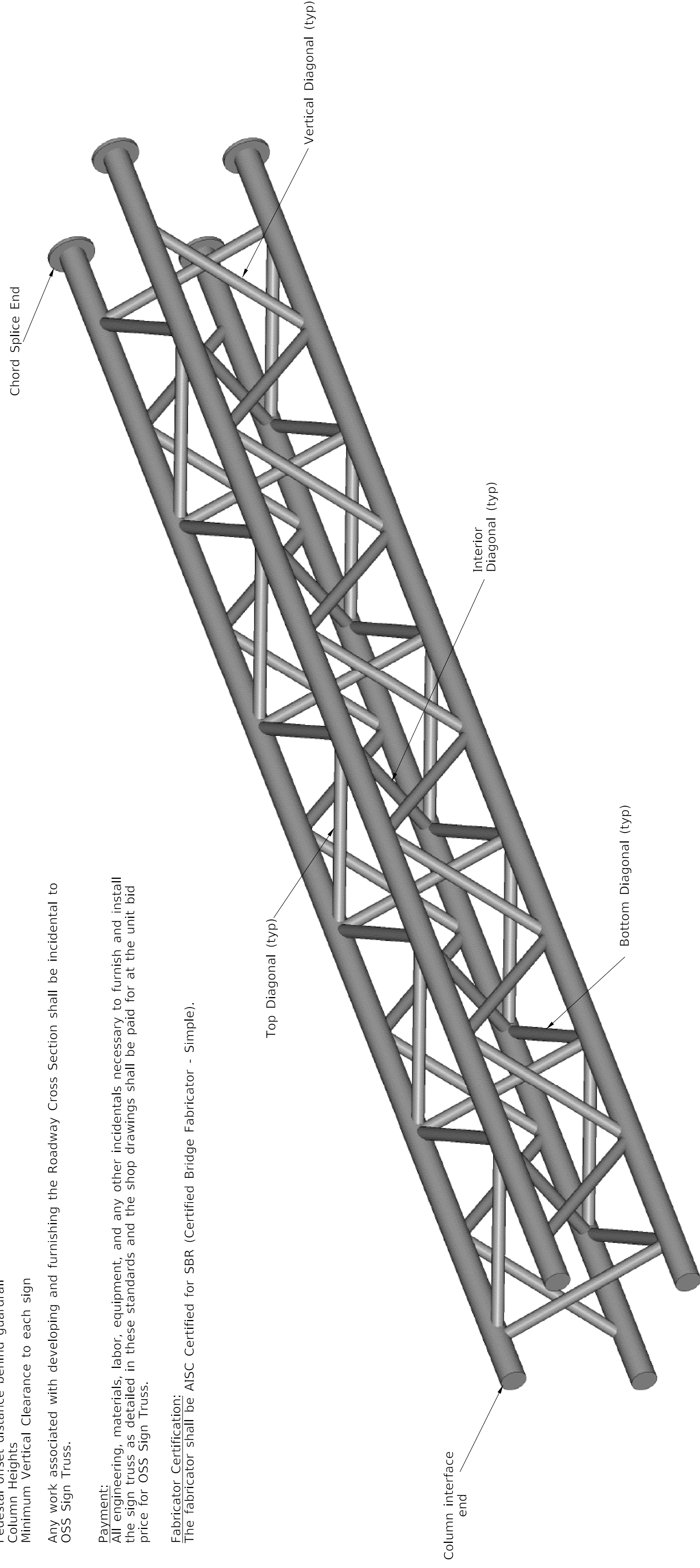

ISOMETRIC VIEW OF TYPICAL TRUSS MODULE

(FOR INFORMATION ONLY)

 COMMONWEALTH OF KENTUCKY DEPARTMENT OF HIGHWAYS	REVISION	DATE	PREPARED BY	CHECKED BY	ROUTE KY 922	ITEM NO. 7-252.00	COUNTY OF FAYETTE
	DATE PLOTTED: \$\$\$DATE\$\$\$\$	USER: \$\$\$USER\$\$\$\$	FILE NAME: \$\$\$designs\$filespecifications\$\$\$	DESIGNED BY:	DETAILED BY:	CROSSING STA 112+50	SHEET NO. S21

GENERAL NOTES

CROSSING
STA 112+50

50-70 FT OVERHEAD SIGN SUPPORT TRUSS GENERAL NOTES

ADDED SHEET

Specifications:

All references to the standard specifications are to the 2019 Edition of the Kentucky Transportation Cabinet Standard Specifications for Road and Bridge Construction. All references to the AASHTO Specifications are to the AASHTO LRFD Specifications for Structural Supports for Highway Signs, Luminaires, and Traffic Signals with Interims through 2022.

Design:

- Designed in accordance with AASHTO LRFD Specifications for Structural Supports for Highway Signs, Luminaires, and Traffic Signals with Interims through 2022 using the following parameters:
- 1700 year MR, with 120 MPH Design Wind Speed
- Finite Fatigue
- 10 Year MR, 76 MPH Service Wind Speed
- Fatigue Design Loads: Natural Wind Gust, Truck-Induced Wind Gust

Superelevation of Roadway:

The contractor shall allow for differences in elevations across the full shoulder width as shown in the Roadway Plans in maintaining the required 18 foot minimum vertical clearance to the bottom, of the lowest part of the sign or support. Sign shall be centered over the lane or lanes to which it applies, or as specified in the Signing Plans.

Material Design Specifications:

- For Class "A" Concrete $f'_c = 3,500$ psi
- For Steel Reinforcement $f_y = 60,000$ psi
- For Structural Steel $f_y = 50,000$ psi
- For Steel Columns and Chords $f_y = 42,000$ psi
- For Steel Diagonals $f_y = 35,000$ psi

Material Specifications:

AASHTO Specifications or ASTM, Current edition, as designated below shall govern the materials furnished:

Steel Shapes galvanized in accordance with ASTM A123:

- Structural Steel: ASTM A992 Grade 50, ASTM A572 Grade 50
- Steel Diagonals: ASTM A53 Grade B, ASTM A500 Grade B, or C, ASTM A1085 Grade A
- Steel Columns and Chords: ASTM A500 Grade B or C, ASTM A1085 Grade A

Steel Hardware galvanized in accordance with ASTM A153:

- High Strength Bolts ASTM F3125 Grade A325
- U-bolts ASTM A307 Grade A
- Anchor Bolts ASTM F1554 Grade 55
- Heavy Hex Nuts ASTM A194 2H
- Flat Washers ASTM F436

Concrete:

Class "A" Concrete shall be used throughout, and shall be paid for at the unit bid price for Class "A" Concrete for Signs.

Beveled Edges:

All exposed concrete edges are to be beveled $\frac{3}{4}$ " unless otherwise shown.

Reinforcement:

Dimensions shown from the face of concrete to bars are to center of bar unless otherwise shown. Spacing of bars is from center to center of bars. Clear distance to face of concrete is 2 inches unless otherwise noted. Reinforcing bars in the plans shall be epoxy coated in accordance with section 811.10 of the Standard Specifications.

Any reinforcing bars designated by the suffix (s) in a Bill of Reinforcement shall be considered a stirrup bar for purposes of bend diameters.

Payment for reinforcement shall be paid for at the unit bid price for Steel Reinforcement for Signs.

Shop Drawings:

The contractor shall submit detailed shop drawings to the Division of Construction for review prior to fabrication in accordance with the specifications. The roadway cross section developed by the contractor is to accompany the shop drawings. The shop drawings and roadway cross section will also be forwarded to the engineer to review.

Bolted Connections:
All bolted connections shall include lock washers. After bolted connections are complete, threads shall be scored to prevent nut loosening. Care shall be taken not to damage the nut and threads engaged by the nut. Damaged nuts shall be replaced at the contractors expense.

Fabrication:

The sign support shall be fabricated in accordance with the AASHTO Specifications. Any damaged galvanization shall be repaired in accordance with ASTM A780. Perform all welding according to requirements specified in ANSI/AASHTO/AWS D1.1 Structural Welding Code Current edition with interims.

Mill Test Reports:

Submit Mill Test Reports in accordance with section 607.03.13 of the Standard Specifications

Vent/Drain Holes for Galvanization

Vent/drain holes shall be drilled in the column or chord member at each end of all closed diagonal members prior to welding. The holes shall be spaced as possible across the chord/column surface where the diagonal member opening projects. Vent/drain holes shall be shown in the shop drawings for approval. Total area of vent/drain holes at each end shall be equal to or less than the following:

- 30% of the diagonal inside cross sectional opening for members with inside diameters greater than or equal to 3 inches.
- 45% of the diagonal inside cross sectional opening for members with inside diameters less than 3 inches.

Footings:

All footings shall be poured against undisturbed earth. The maximum allowable service bearing pressure is 3 kips per square foot.

Design Limits:

This standard drawing is applicable to all overhead sign supports that meet the following criteria:

- Maximum Total Sign Area: 800 SF
- Minimum Vertical Clearance of Sign Above Roadway: 18 FT
- Maximum Height of Sign Above Roadway: 44 FT
- Maximum Sign Panel Height: 24 FT
- Maximum Exit Panel Height: 4.5 FT
- Span Range: 50 FT - 70 FT
- Min. Sign Edge Distance to Column CL: 12 FT / 18 FT
- Max./Min. Column Height (HL/HR): 27 FT / 14 FT
- Min. Pedestal Height (FL/FR): 14 FT
- Min. Pedestal Offset behind Guardrail: 6 FT
- Min. Pedestal Projection above soil: 2.5 FT
- Min. Fill above Base of Footing: 3 FT

Design Chart:

A registered professional engineer licensed to practice in the Commonwealth of Kentucky shall fill out the Design Chart based on the design cross section at the location where the truss is to be erected, the actual signs to be used, and the instructions herein. The Engineer's name shall appear in the "Checked By:" Box of the title block of this sheet. The Engineer is responsible for verifying the information based on the contractor's submitted cross sections and reviewing the fabricators shop drawings in detail.

Roadway Cross Section:

The contractor shall take field measurements at each sign location and develop a cross section showing the following:

- Pedestal and median heights
- Pedestal offset distance behind guardrail
- Column Heights
- Minimum Vertical Clearance to each sign

Any work associated with developing and furnishing the Roadway Cross Section shall be incidental to OSS Sign Truss.

Payment:

All engineering, materials, labor, equipment, and any other incidentals necessary to furnish and install the sign truss as detailed in these standards and the shop drawings shall be paid for at the unit bid price for OSS Sign Truss.

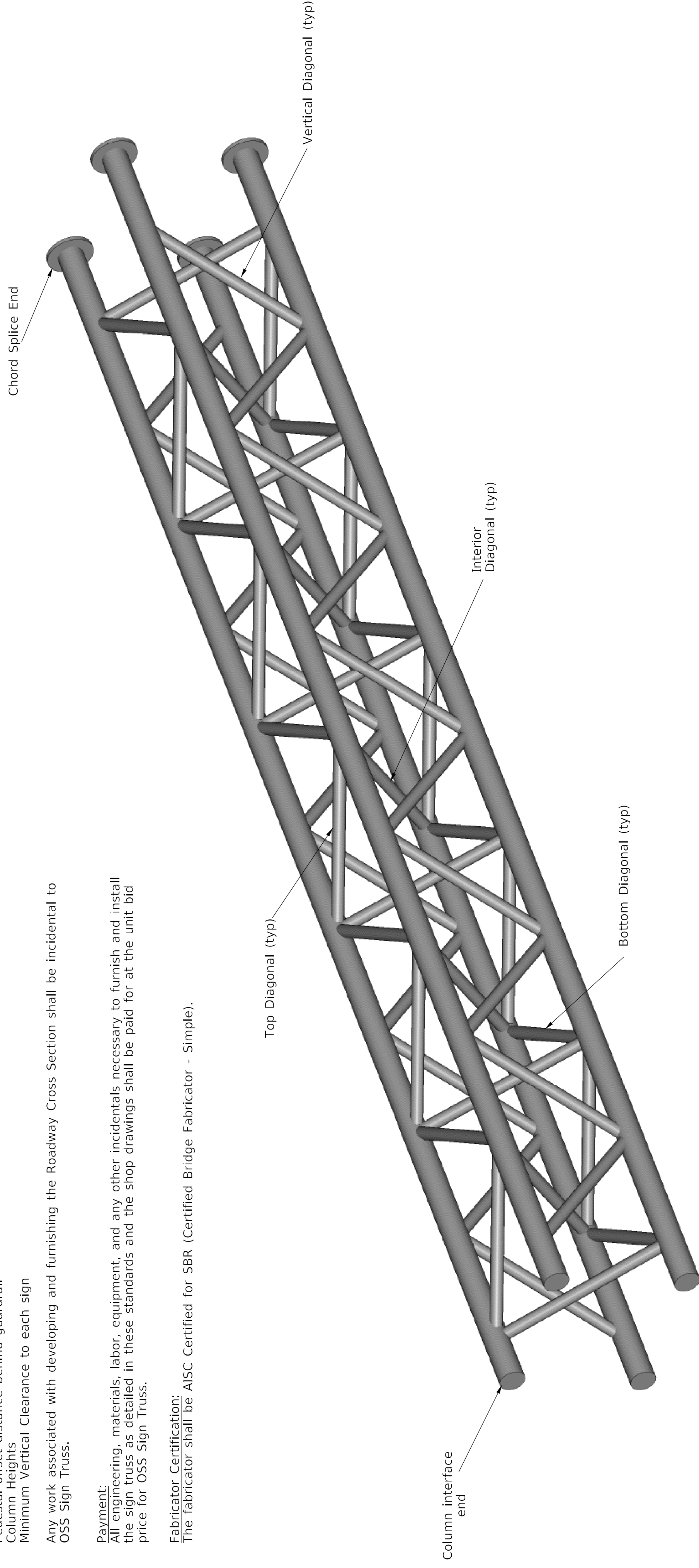

Fabricator Certification:

The fabricator shall be AISC Certified for SBR (Certified Bridge Fabricator - Simple).



ISOMETRIC VIEW OF TYPICAL TRUSS MODULE

(FOR INFORMATION ONLY)

 COMMONWEALTH OF KENTUCKY DEPARTMENT OF HIGHWAYS	 TRANSPORTATION CABINET	REVISION 	DATE 	PREPARED BY 	CHECKED BY
		GENERAL NOTES CROSSING STA 112+50		ROUTE KY 922	ITEM NO. 7-252.00 SHEET NO. S21
				COUNTY OF FAYETTE	

Sign No.	STATION	SPAN		SUPPORT HEIGHT		FOOTING HEIGHT	
		L	HL	HR	FL	FR	
P-70*	112+50	60'-0"	19'-3"	18'-7"	10'-7"	10'-0"	
Total Area**	SIGN A		SIGN B		Area		
468.0 SF	I.D. (A)	18'	12'	18'	14'	262.0 SF	
	Horiz.			Horiz.	Vert.		
	I.D. (B)						

*See Sheet T17 for Sign Details
See Sheet S29 for cross-section of truss

** Total Area includes the sum of all of the signs on the structure and shall not exceed 800 square feet.

① Maximum space between sign brackets = 4'-0"
Maximum sign overhang past chord at sign brackets = 2'-0"

L	Y
50	3/16"
55	1/4"
60	5/16"
65	7/16"
70	1/2"

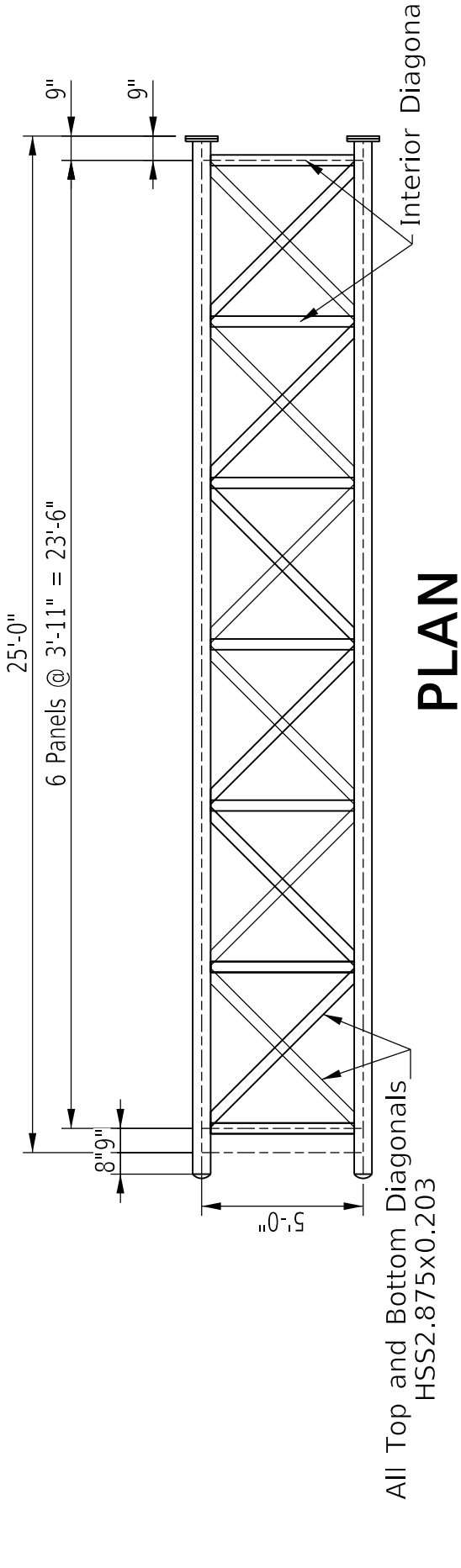
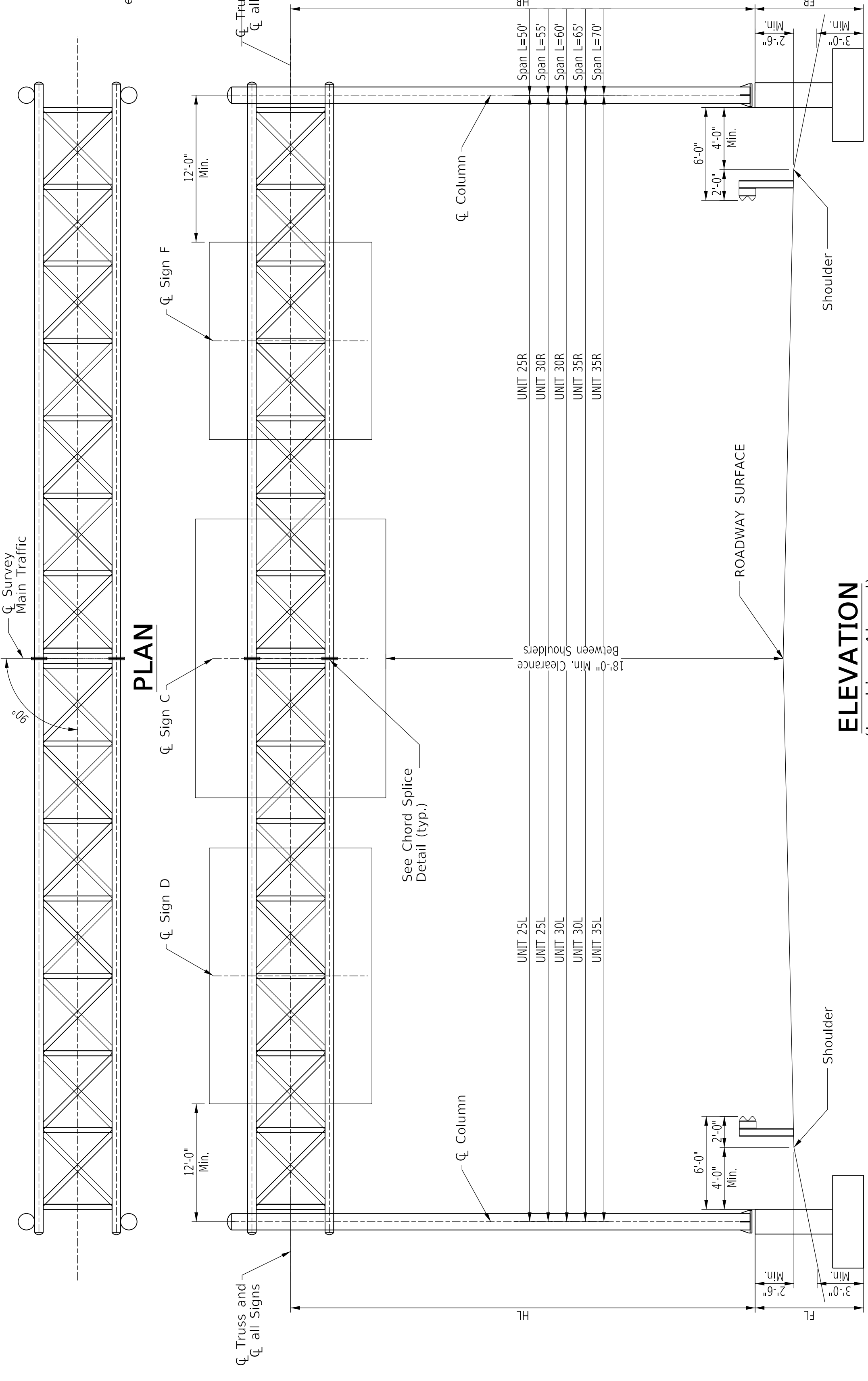
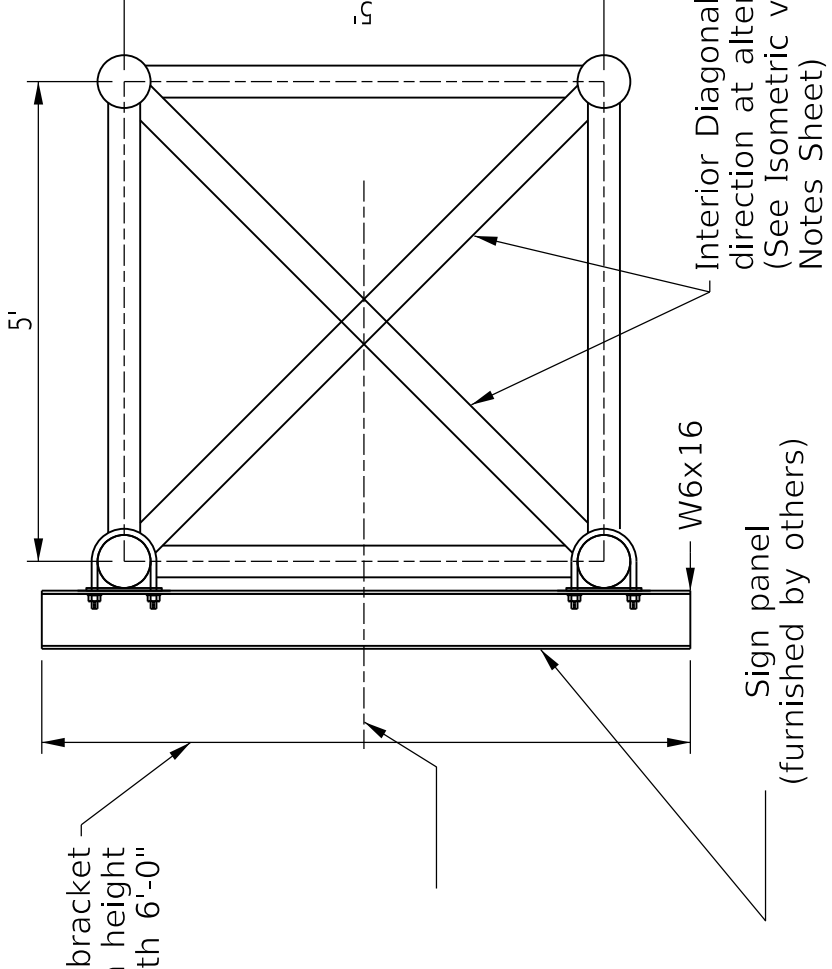
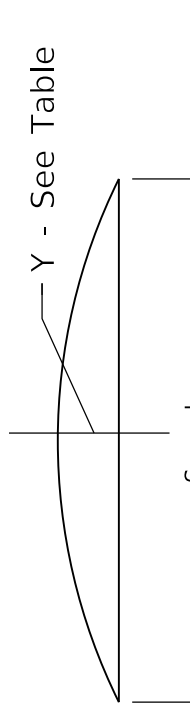

ELEVATION (UNIT 25L/R)

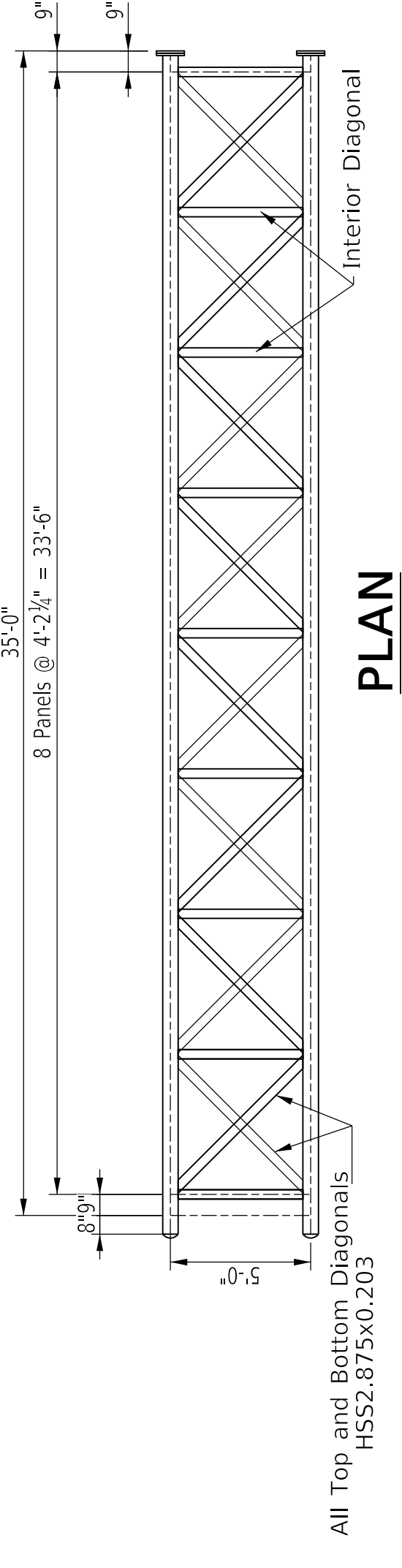

ELEVATION (UNIT 35L/R)

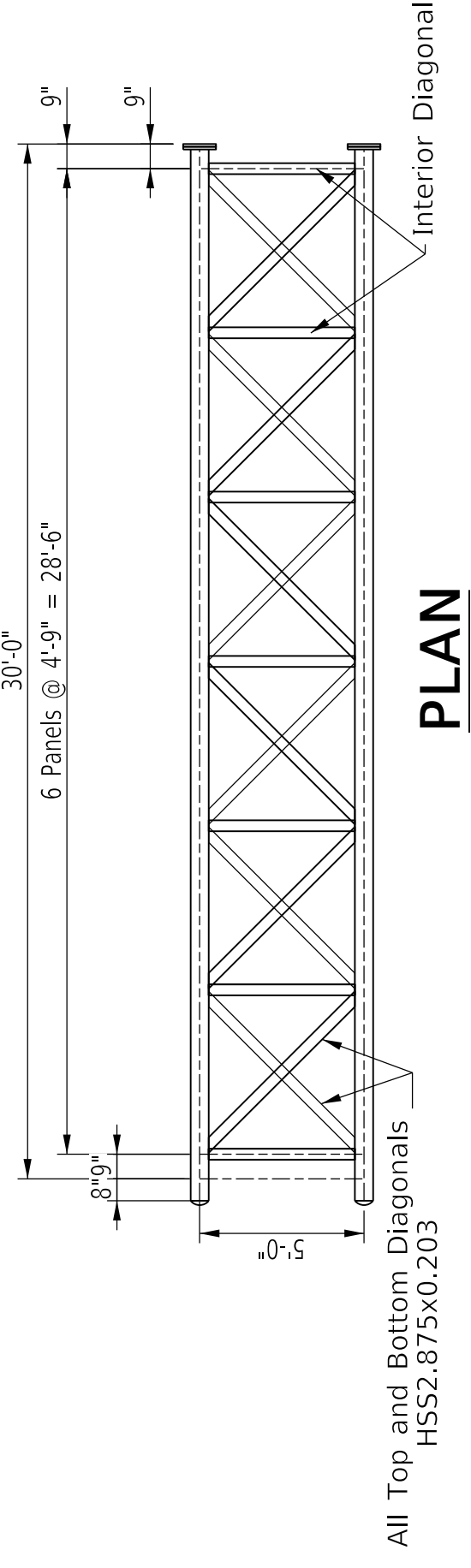

ELEVATION (UNIT 30L/R)

ELEVATION (Looking Ahead)

Sign No.	STATION	SPAN		SUPPORT HEIGHT		FOOTING HEIGHT	
		L	HL	HR	FL	FR	
P-70*	112+50	60'-0"	19'-3"	18'-7"	10'-7"	10'-0"	
Total Area**	SIGN A		SIGN B		Area	Vert.	Area
	I.D. (A)	Horiz. (A)	I.D. (B)	Horiz. (B)			
468.0 SF	18'	12'	216.0 SF	14'	14'	252.0 SF	

*See Sheet T17 for Sign Details
See Sheet S29 for cross-section of truss

** Total Area includes the sum of all of the signs on the structure and shall not exceed 800 square feet.

① Maximum space between sign brackets = 4'-0"
Maximum sign overhang past chord at sign brackets = 2'-0"

L	Y
50	3/16"
55	1/4"
60	5/16"
65	7/16"
70	1/2"

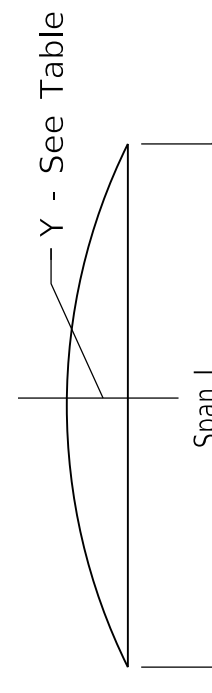

CAMBER DIAGRAM

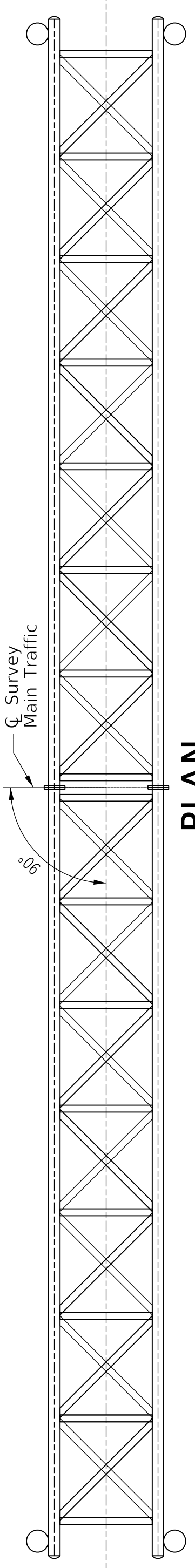
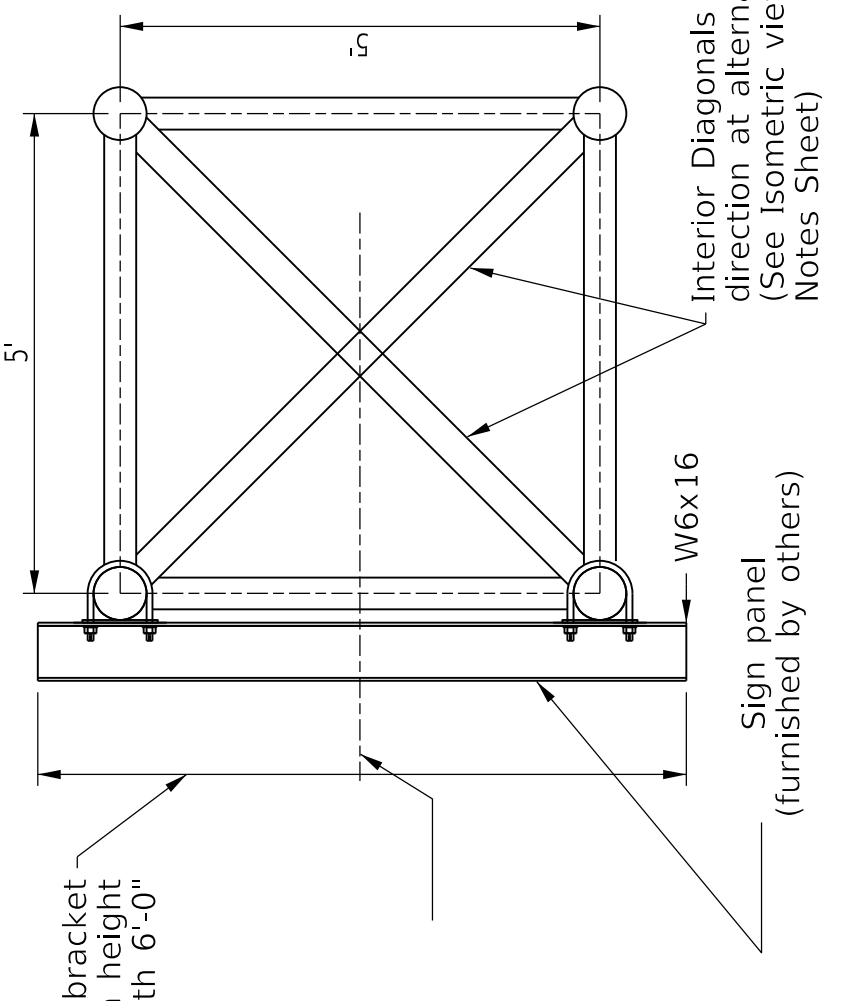

PLAN

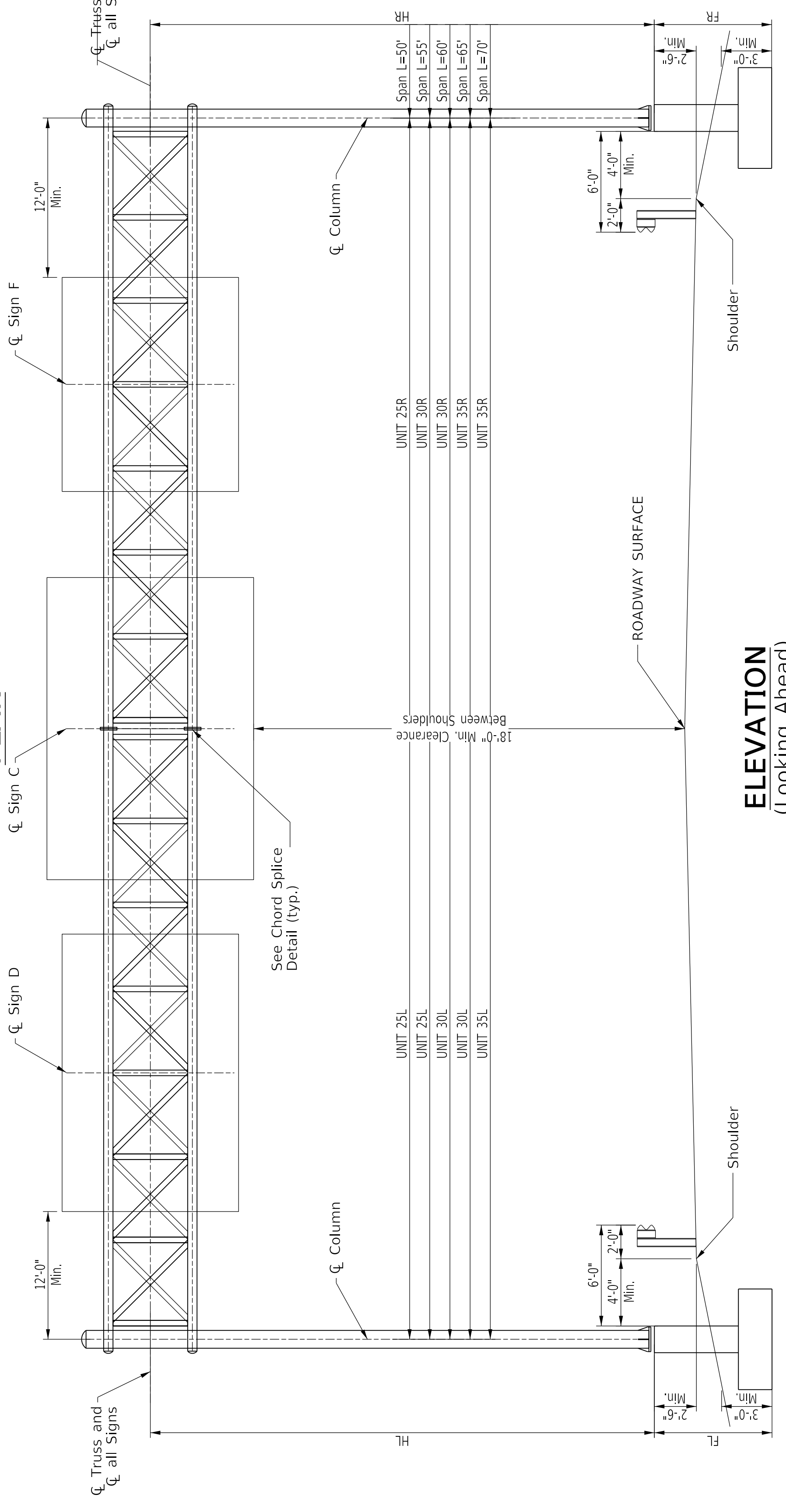

ELEVATION (Looking Ahead)

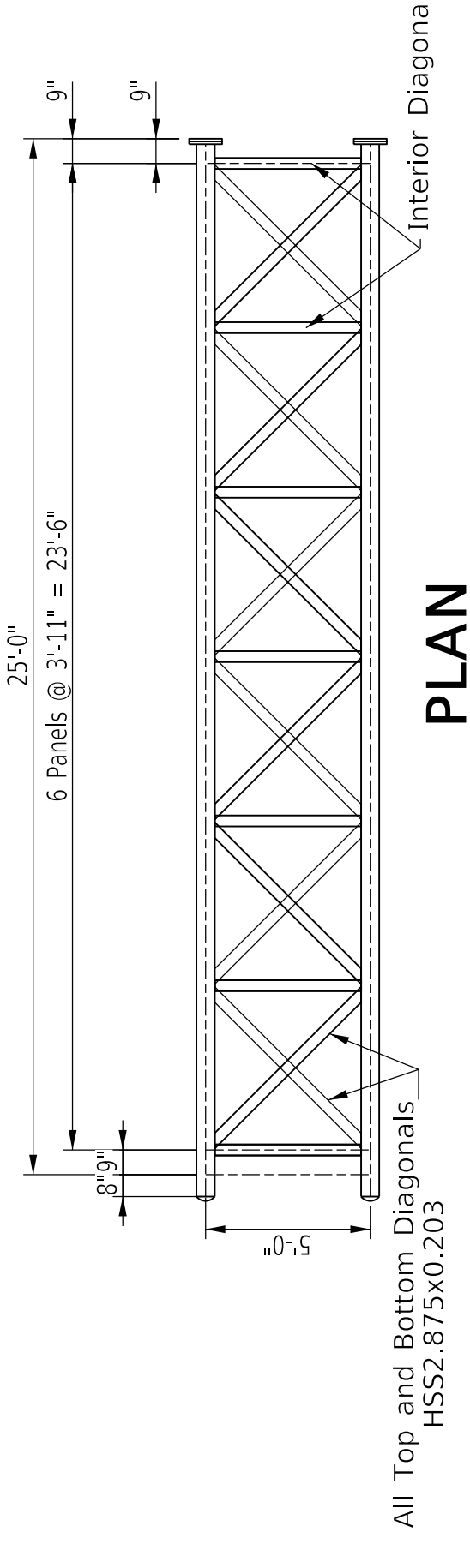

PLAN

ELEVATION (UNIT 25L/R)

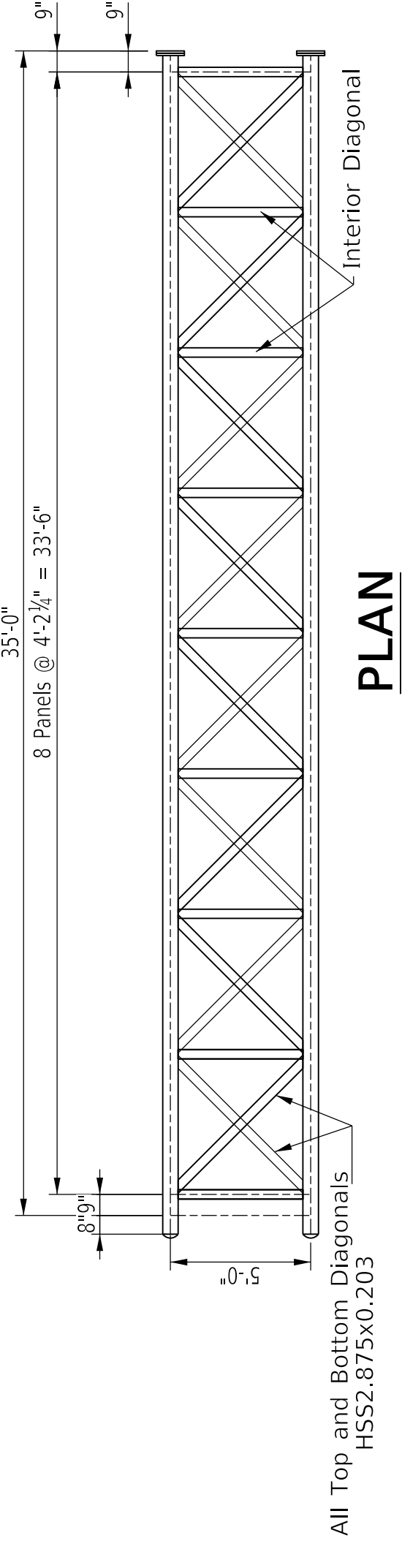

PLAN

ELEVATION (UNIT 35L/R)

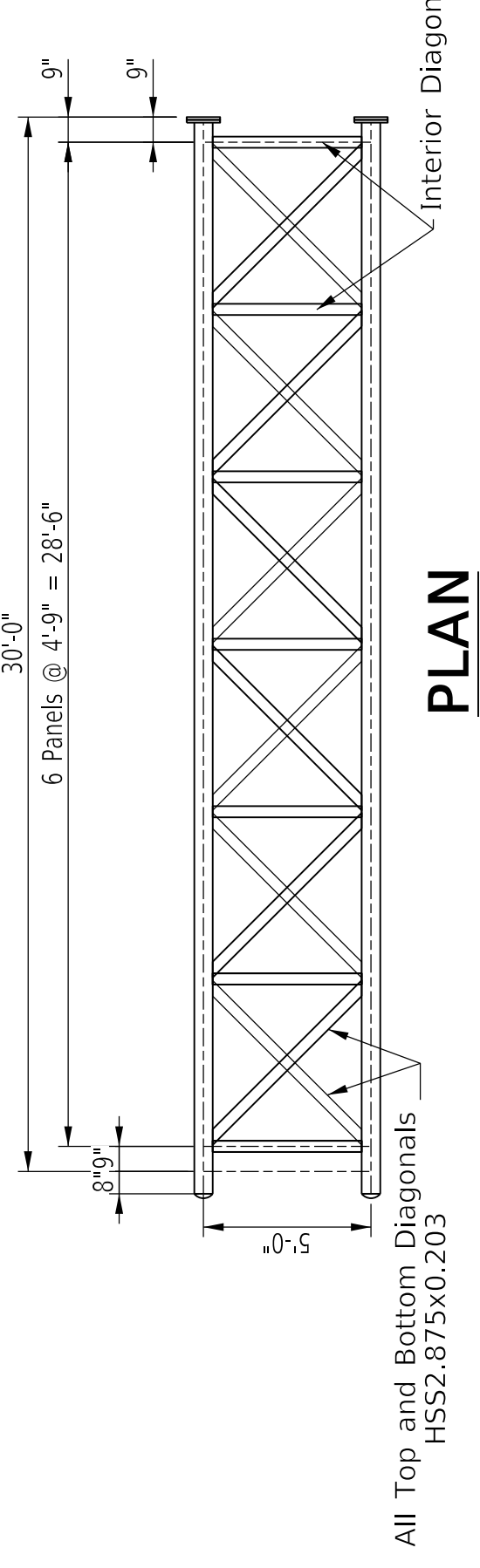

PLAN

ELEVATION (UNIT 30L/R)

ADDED SHEET

BILL OF REINFORCEMENT FOR FOOTING

MARK	TYPE	NO.	SIZE	LENGTH		LOCATION
				FT.	IN.	
A1	5	40	#7	FL/FR+0'-9"	6	Footing & Wall
A2	Str	44	#5	8	6	Footing
A3	Str	12	#7	21	6	Footing
A4(S)	14	Var.	#4	27	0	Wall
A5(S)	15	3	#5	22	4	Anchorage
A6	Str	9	#5	21	6	Footing

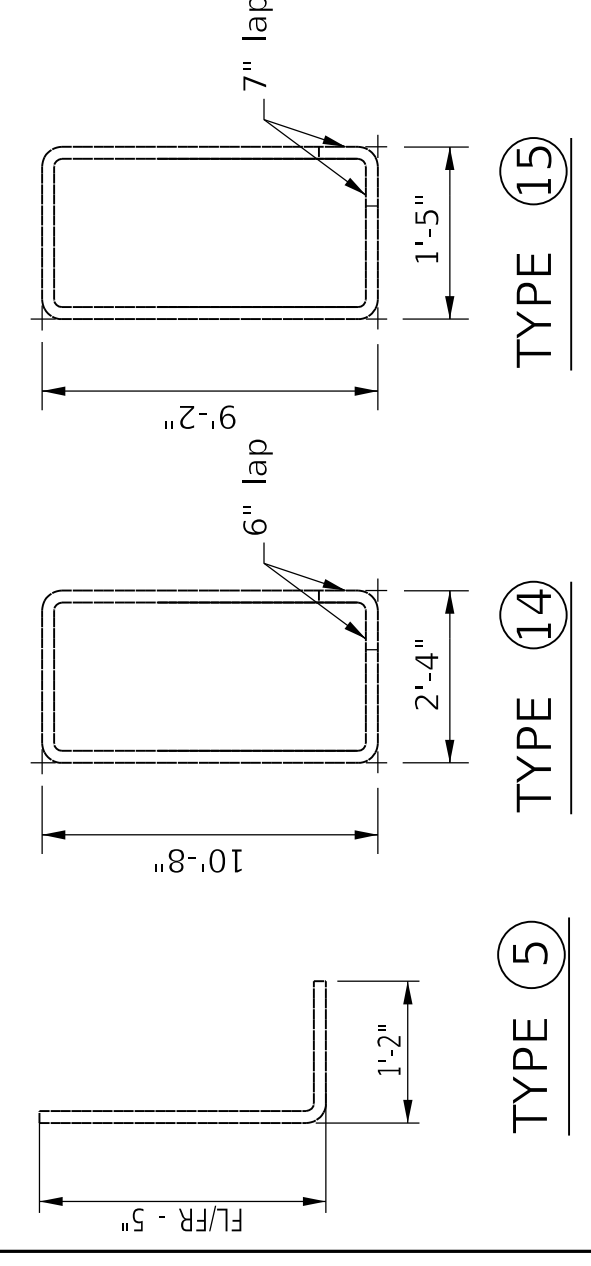

* ESTIMATE OF QUANTITIES FOR FOOTING

Conc. Class "A"(cyd)	Reinforcement(lbs)
FL/FR=6'-0"	17.5
1' of additional Pedestal height	1.1
	183.1
	100

* Approx. estimate is for information only. Tabulated FL and FR shall be verified by the Engineer in the field.

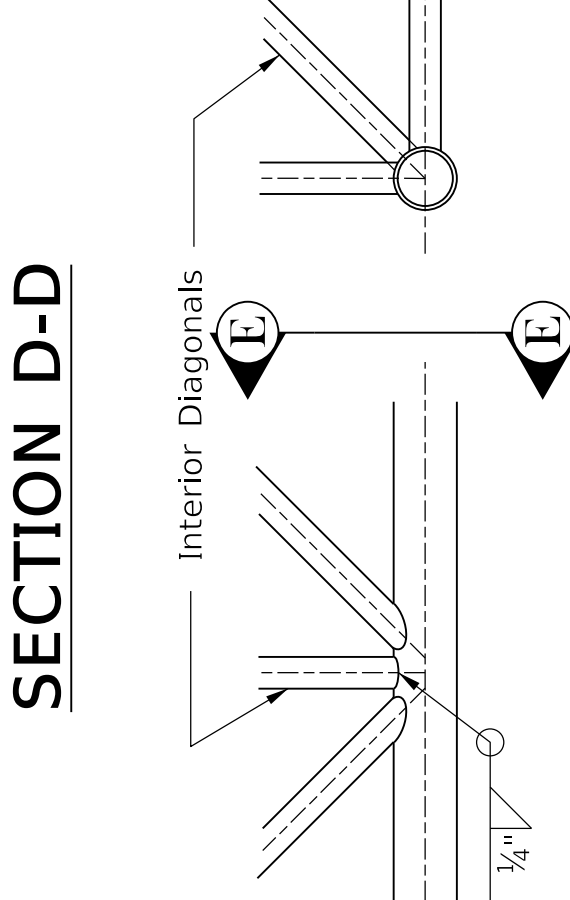
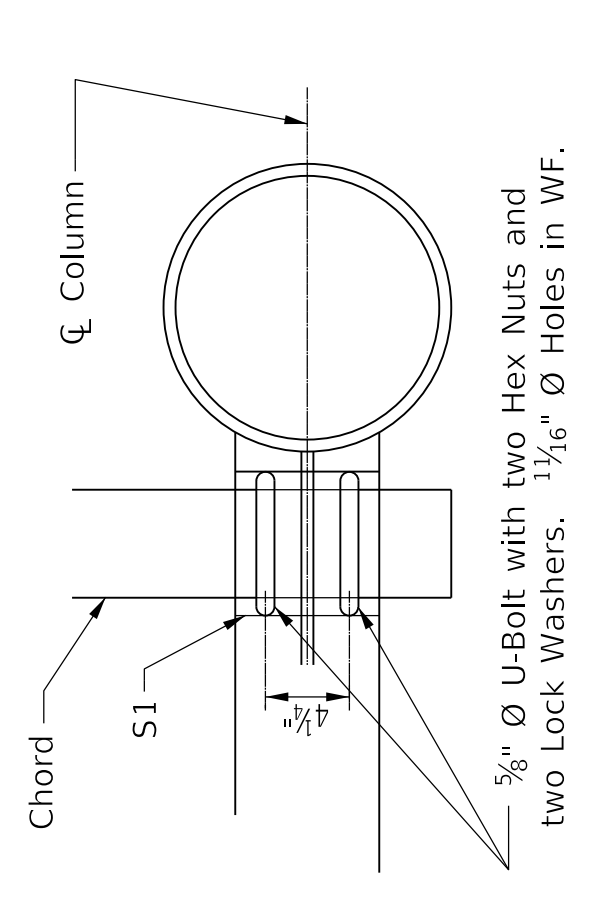

TYPICAL PANEL POINT DETAIL
See Vent/Drain Hole Note

* Approx. estimate is for information only. Tabulated FL and FR shall be verified by the Engineer in the field.

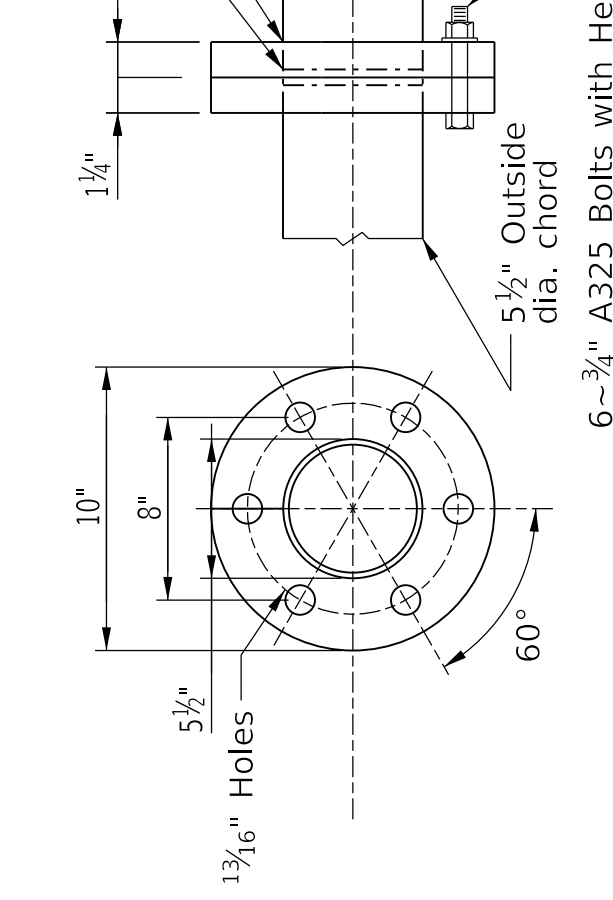

CHORD SPLICE

Note: Only 1 bolt shown for clarity.

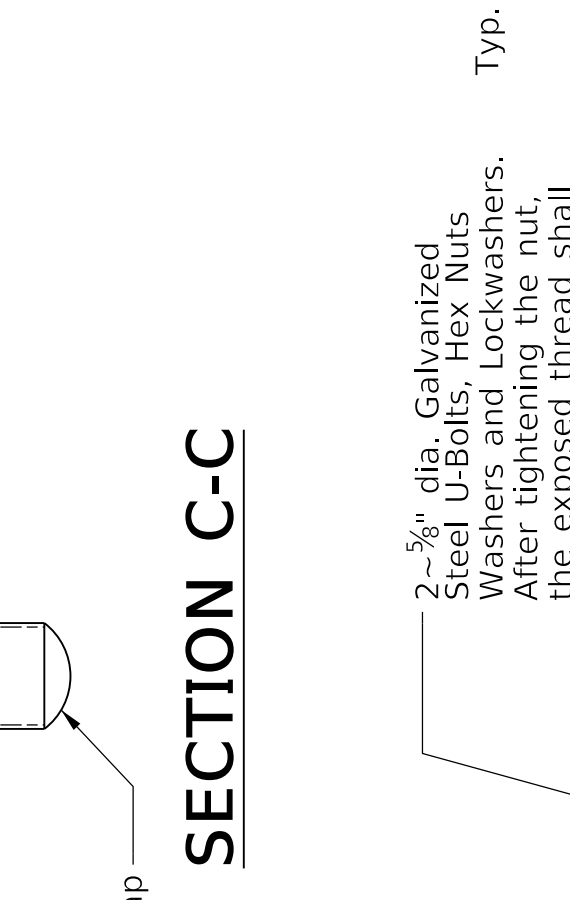
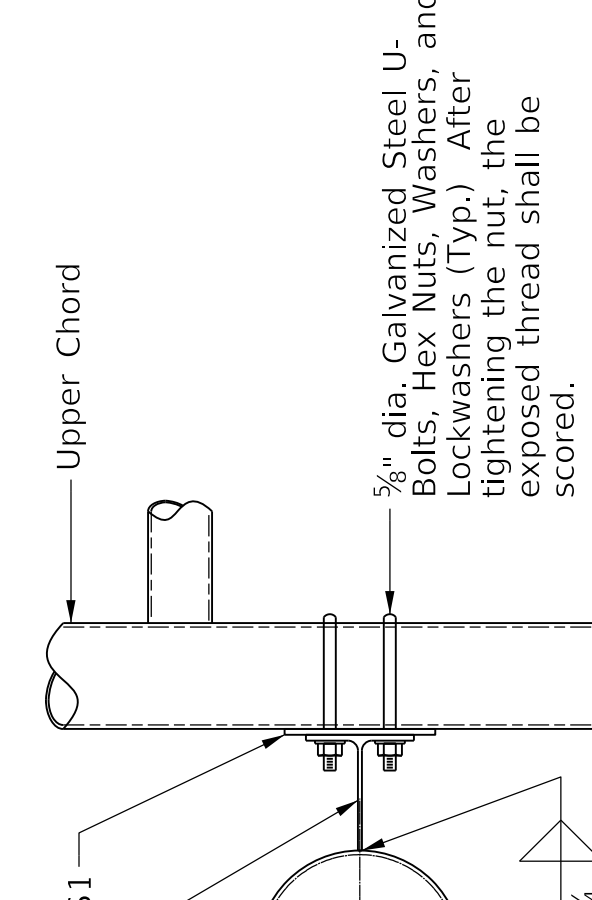

TYPICAL PANEL POINT DETAIL
See Vent/Drain Hole Note

* Approx. estimate is for information only. Tabulated FL and FR shall be verified by the Engineer in the field.

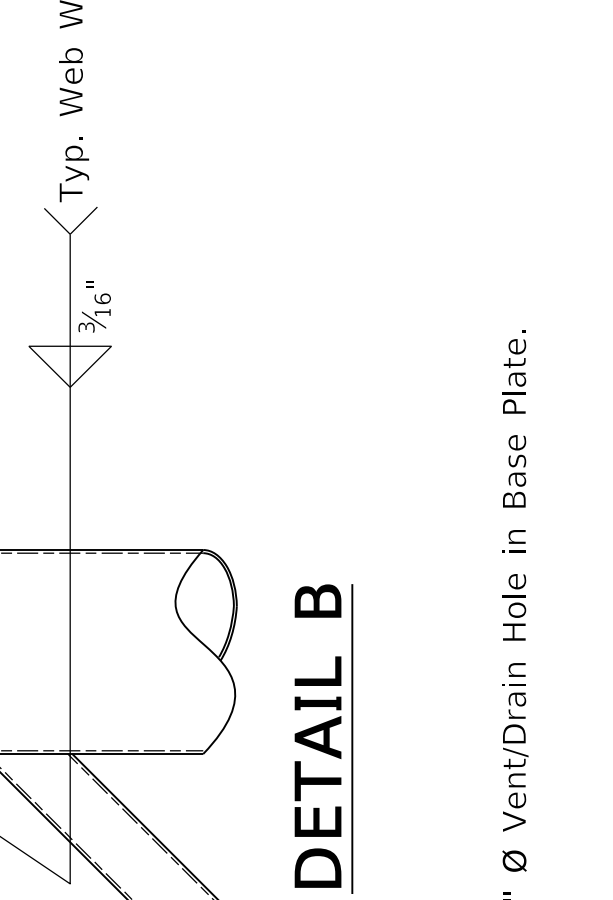

CHORD SPLICE

Note: Only 1 bolt shown for clarity.

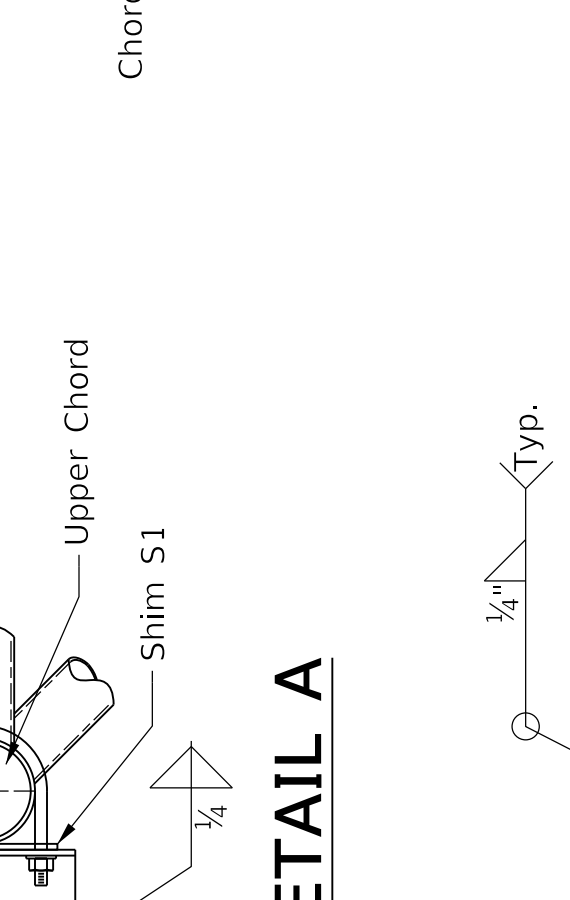
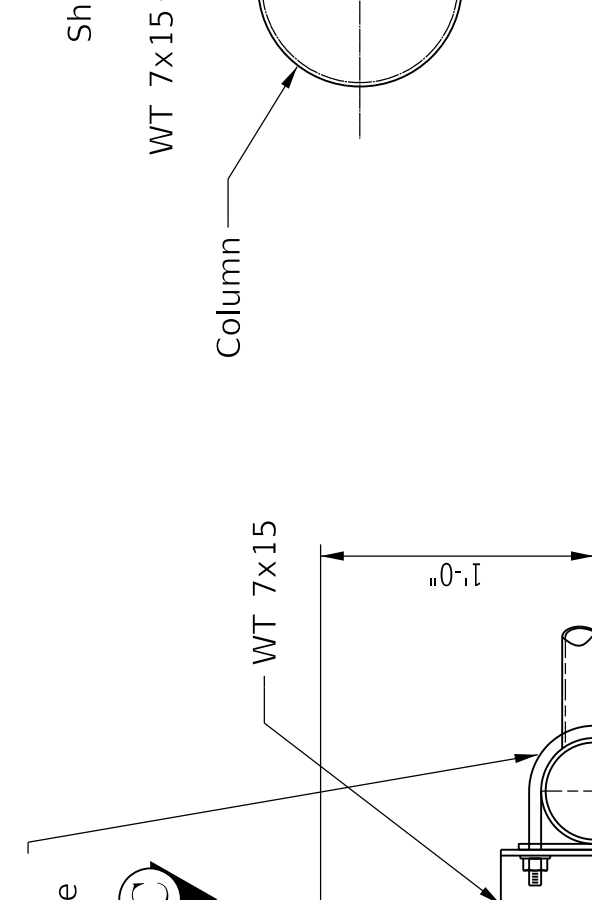

DETAIL A

See Vent/Drain Hole Note for more information

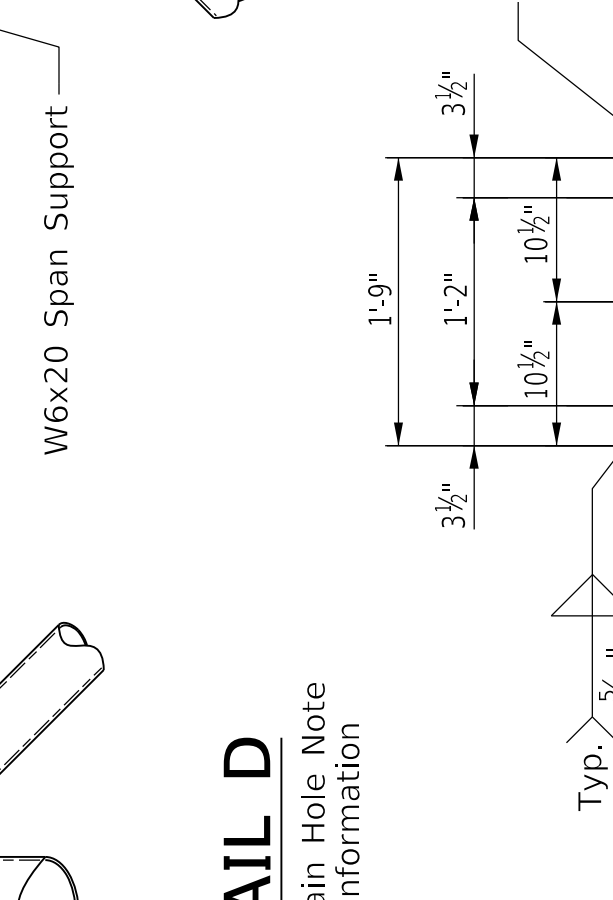

DETAIL B

See Vent/Drain Hole Note for more information

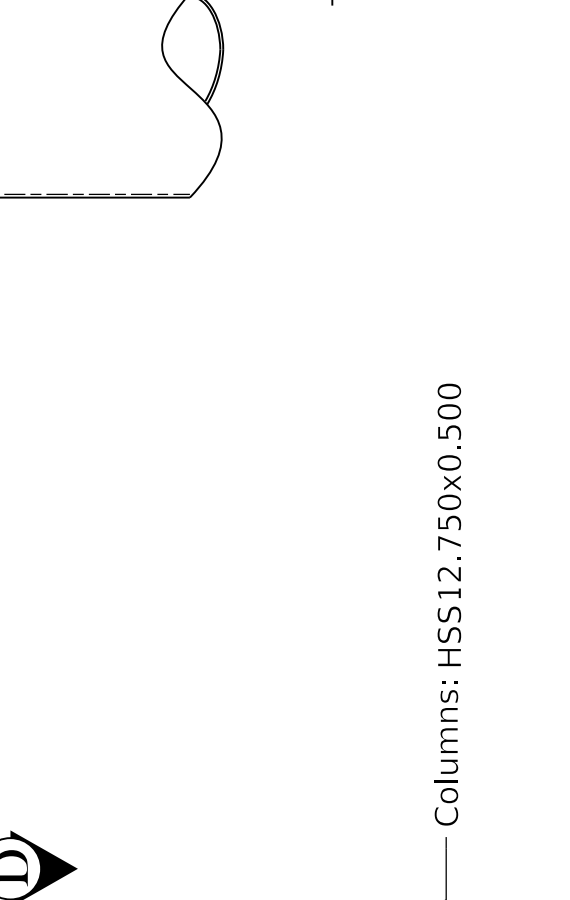
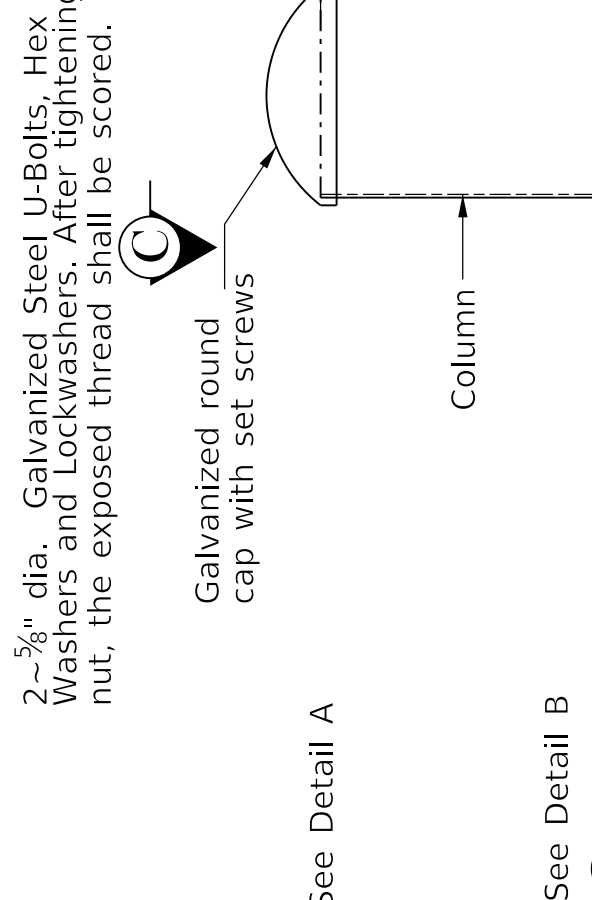

DETAIL C

See Vent/Drain Hole Note for more information

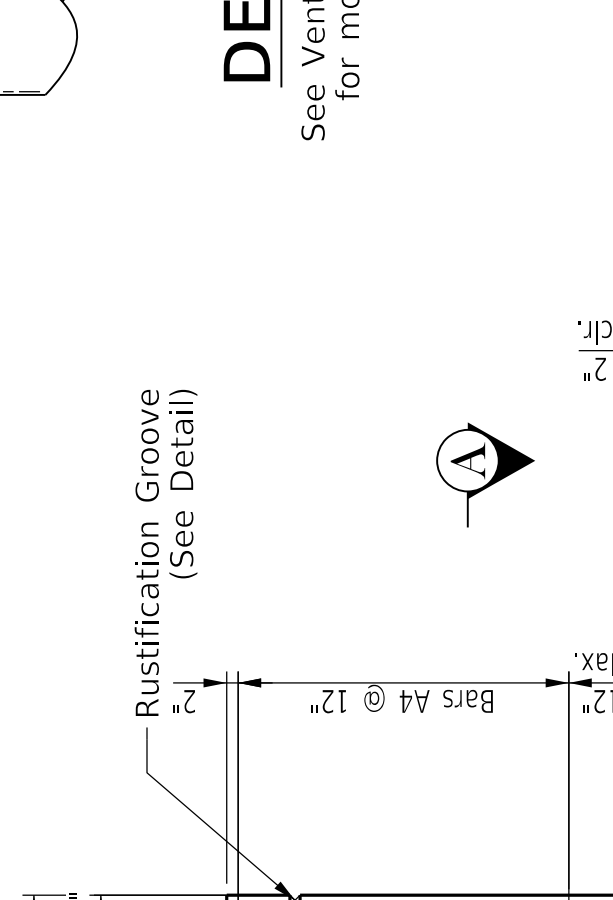

DETAIL D

See Vent/Drain Hole Note for more information

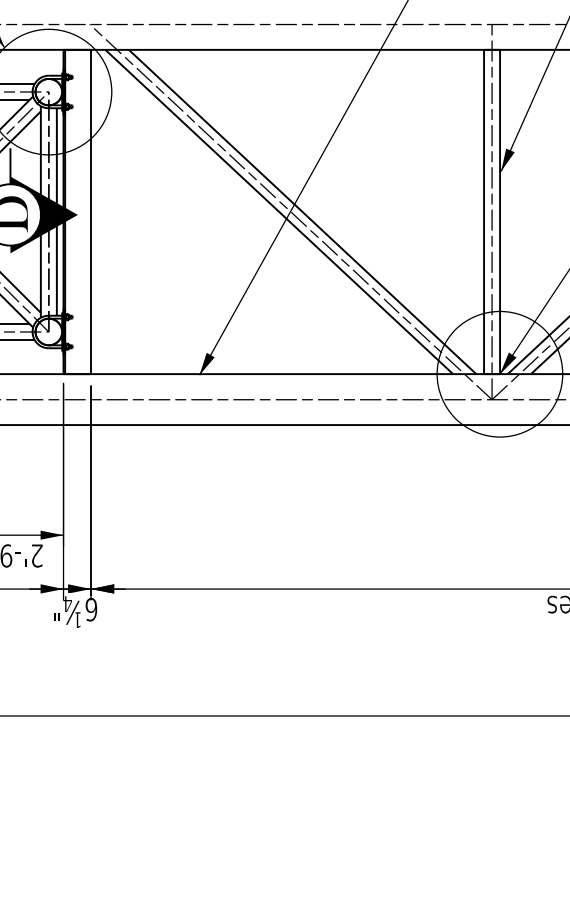
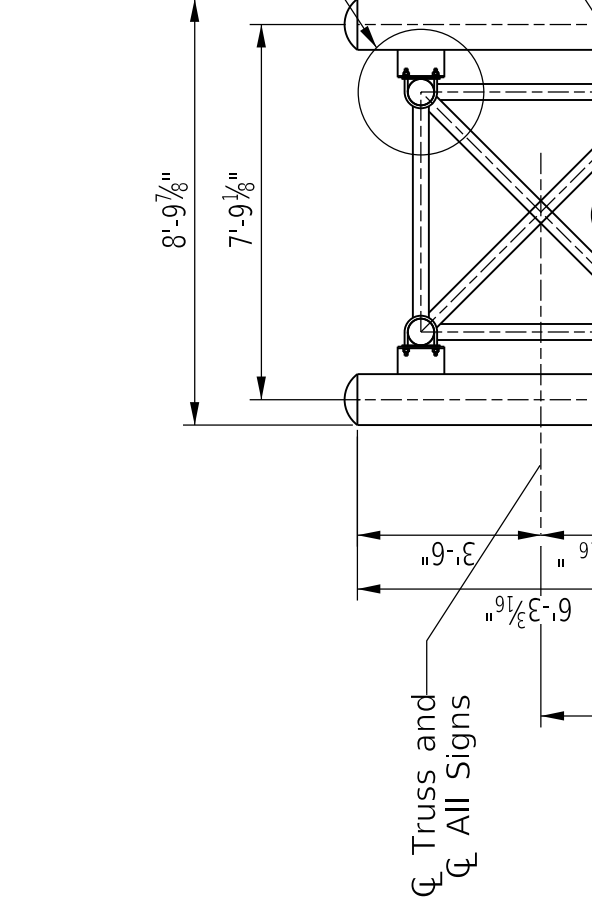

DETAIL E

See Vent/Drain Hole Note for more information

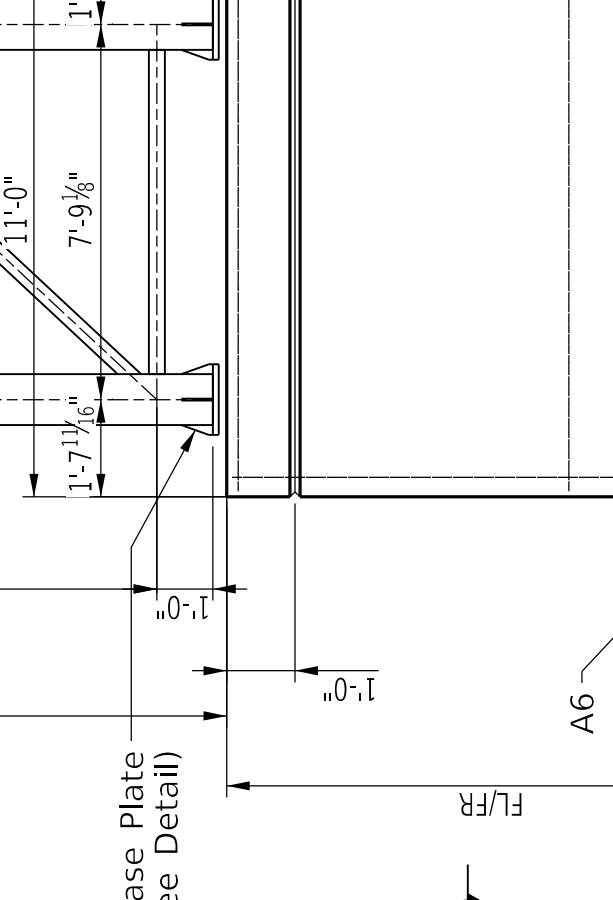

DETAIL F

See Vent/Drain Hole Note for more information

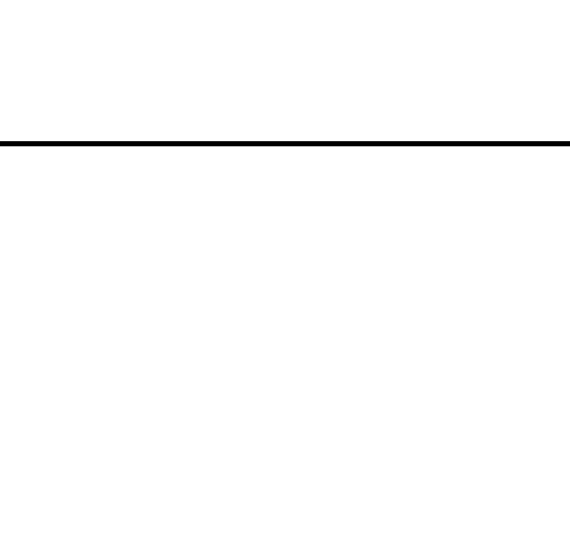
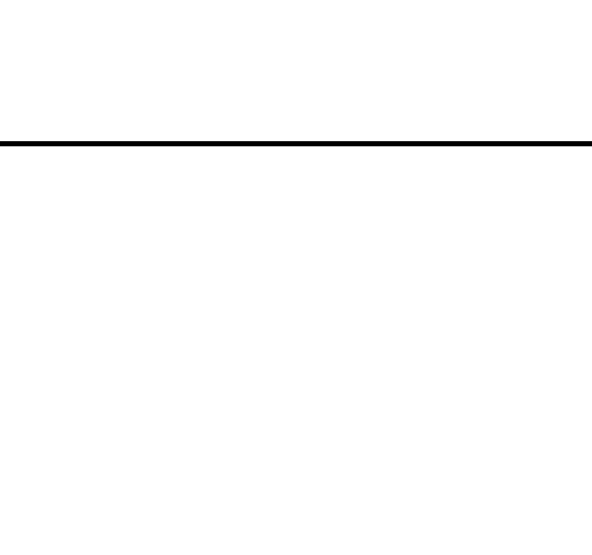

DETAIL G

See Vent/Drain Hole Note for more information

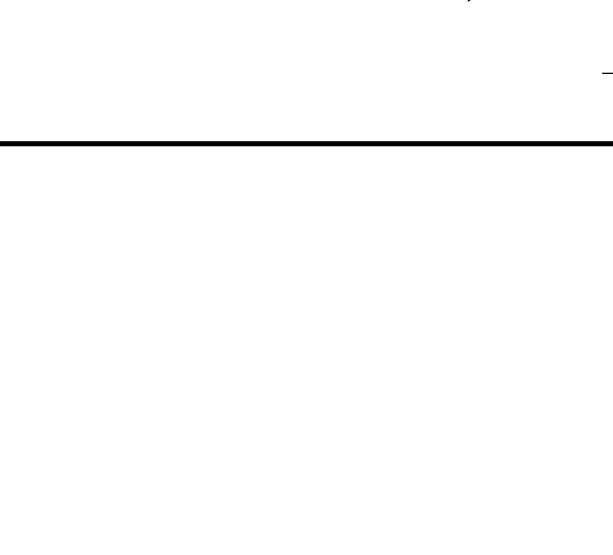

DETAIL H

See Vent/Drain Hole Note for more information

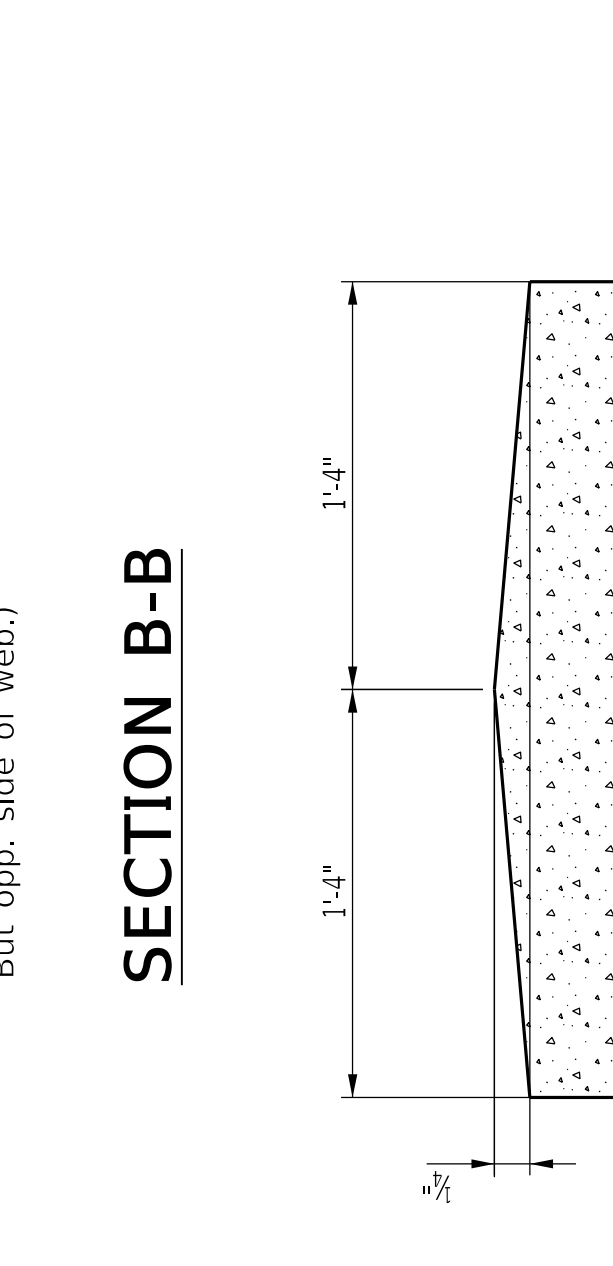

SECTION A-A

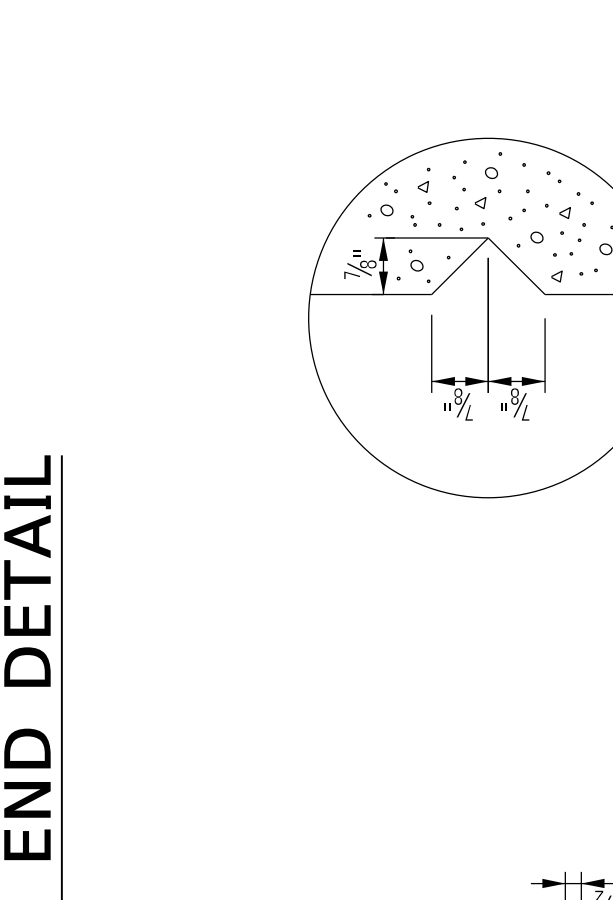

TOP OF PEDESTAL SLOPE DETAIL

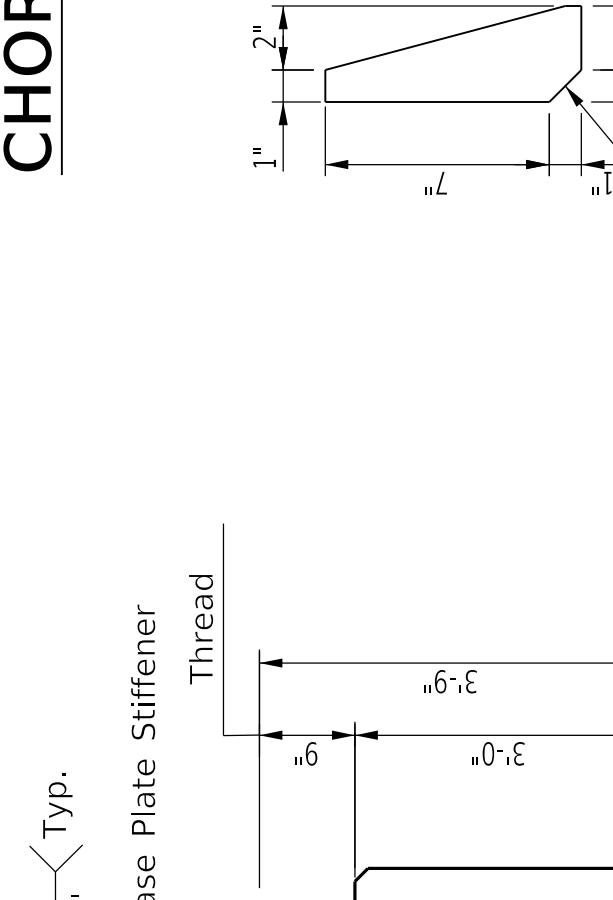

SECTION C-C

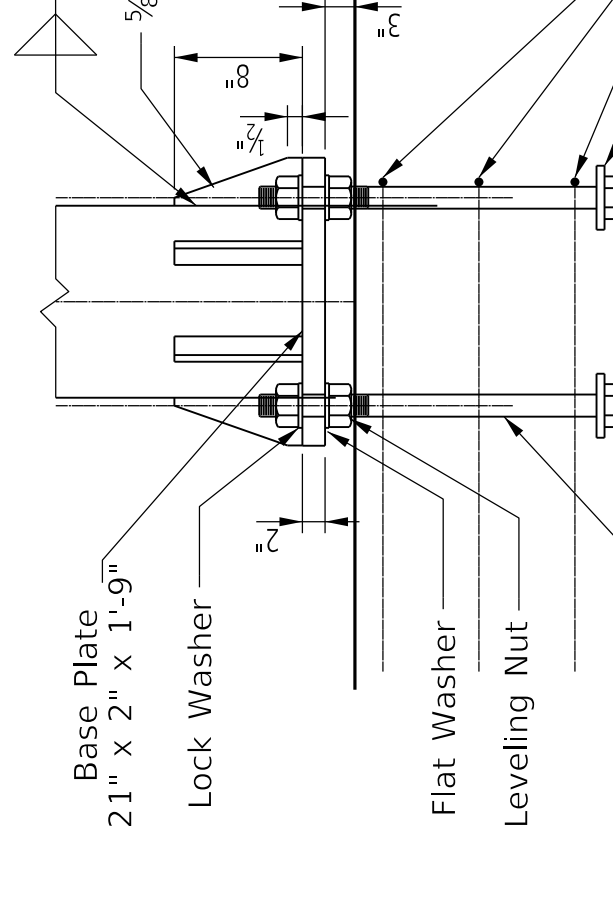

SECTION D-D

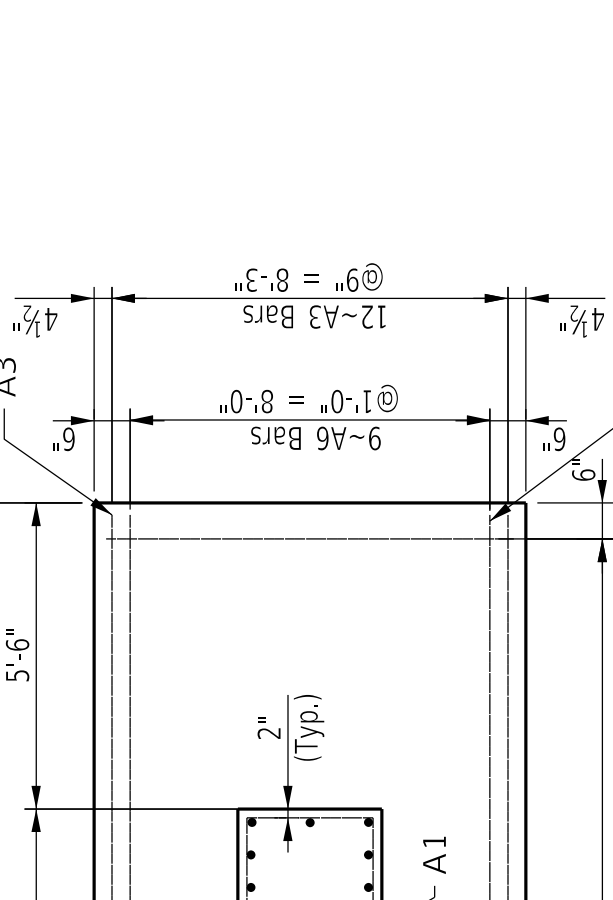

SECTION E-E

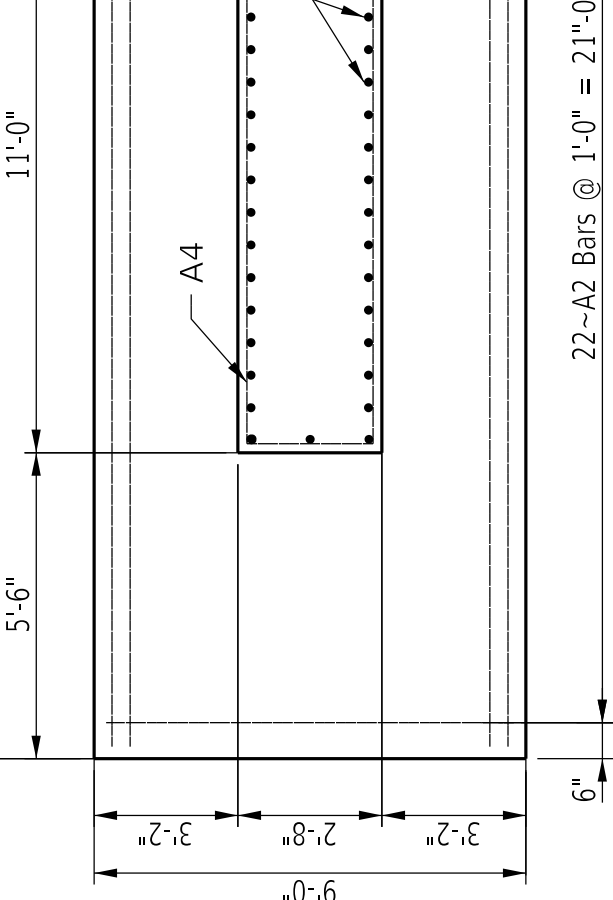

SECTION F-F

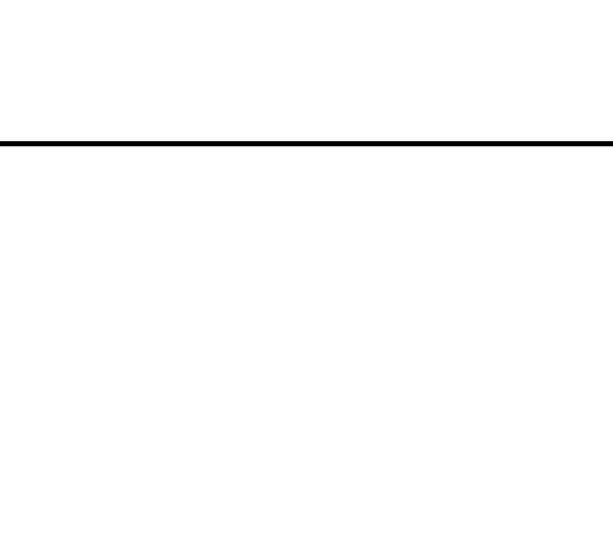

SECTION G-G

COMMONWEALTH OF KENTUCKY
DEPARTMENT OF HIGHWAYS

ROUTE
KY 922

CHECKED BY
TRUSS DETAILS 50-70

DATE
7-25-00

DESIGNED BY
S23

REVISION

DATE PLOTTED: \$\$\$DATE\$\$\$
USER: \$\$\$USER\$\$\$
FILE NAME: \$\$\$designfiles\$\$\$specifications\$\$\$

BILL OF REINFORCEMENT FOR FOOTING

MARK	TYPE	NO.	SIZE	LENGTH		LOCATION
				FT.	IN.	
A1	5	40	#7	FL/FR+0'-9"	6	Footing & Wall
A2	Str	44	#5	8	6	Footing
A3	Str	12	#7	21	6	Footing
A4(S)	14	Var.	#4	27	0	Wall
A5(S)	15	3	#5	22	4	Anchorage
A6	Str	9	#5	21	6	Footing

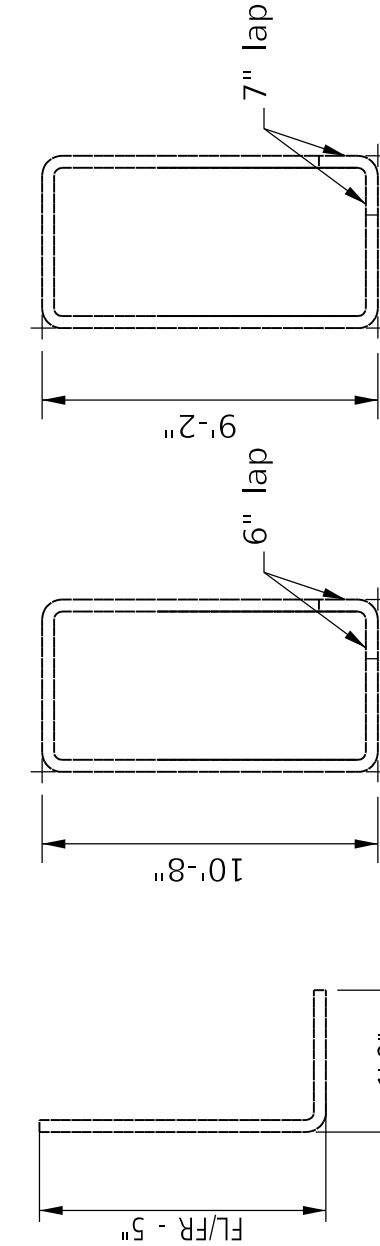

*** ESTIMATE OF QUANTITIES FOR FOOTING**

FL/FR=6'-0"	Conc. Class "A"(cyd)	Reinforcement(lbs)
1' of additional Pedestal height	17.5	1831
	1.1	100

* Approx. estimate is for information only. Tabulated FL and FR shall be verified by the Engineer in the field.

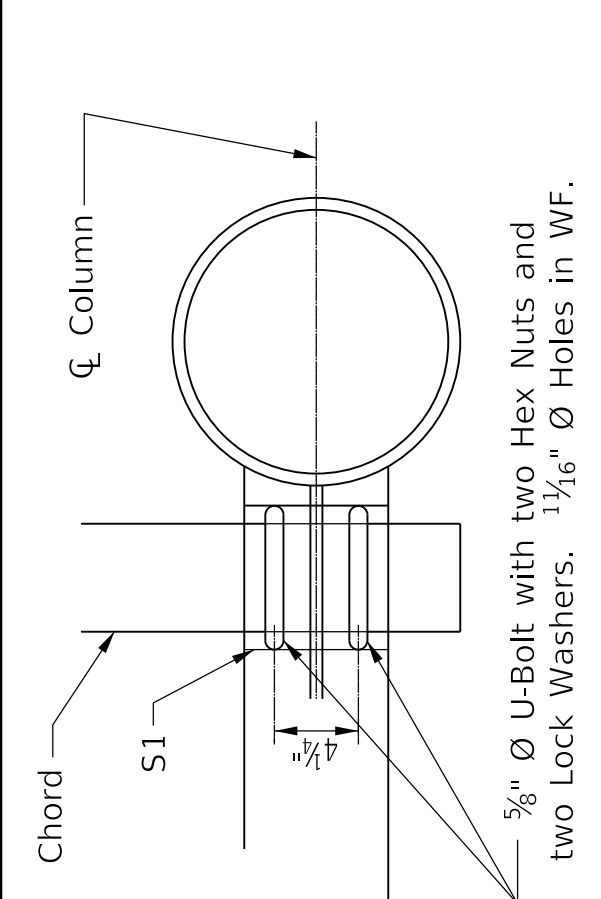

SECTION D-D

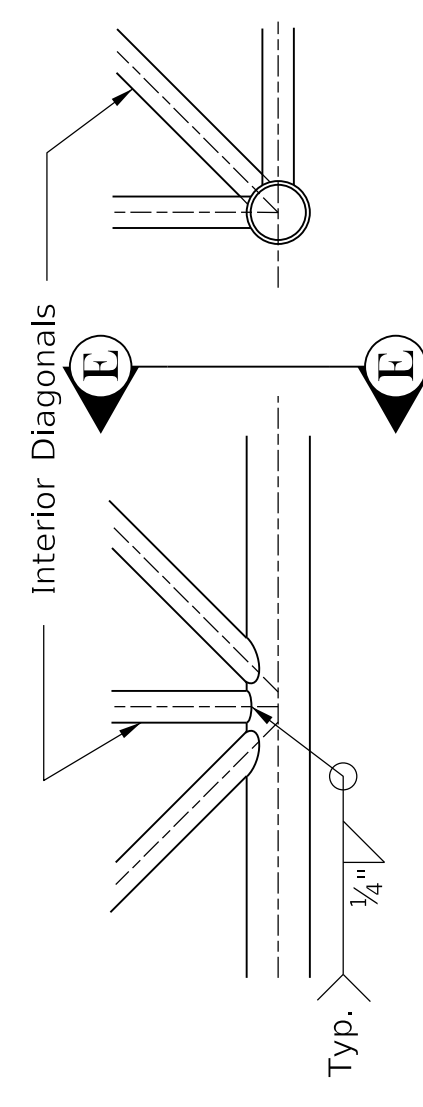

SECTION E-E

TYPICAL PANEL POINT DETAIL

See Vent/Drain Hole Note

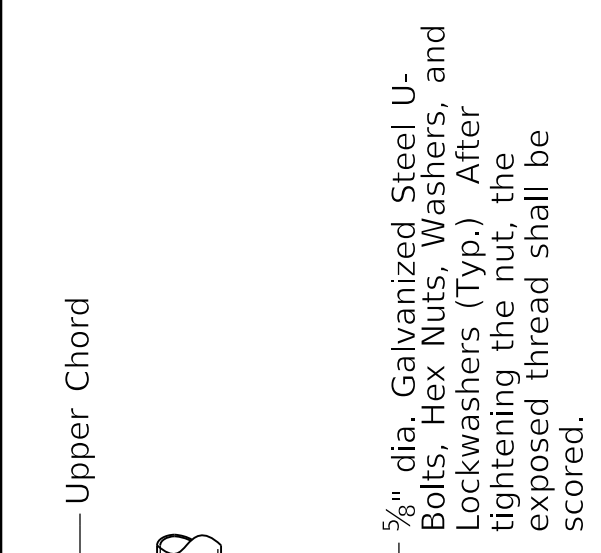

SECTION C-C

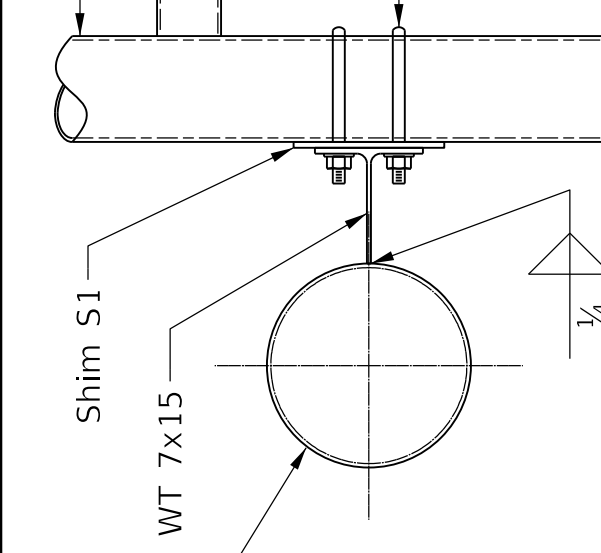

DETAIL A

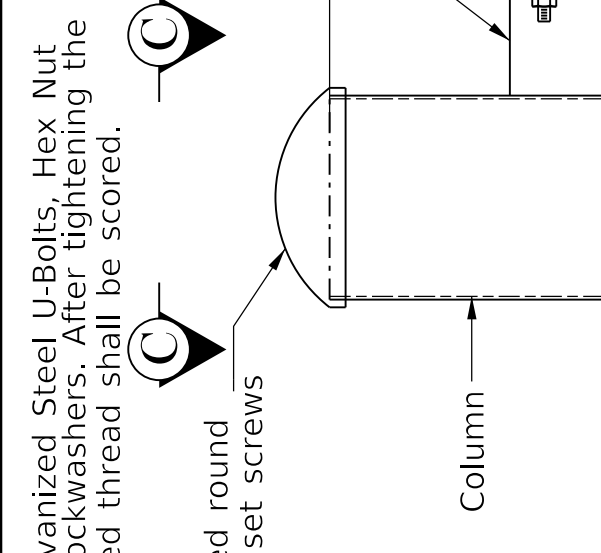

DETAIL B

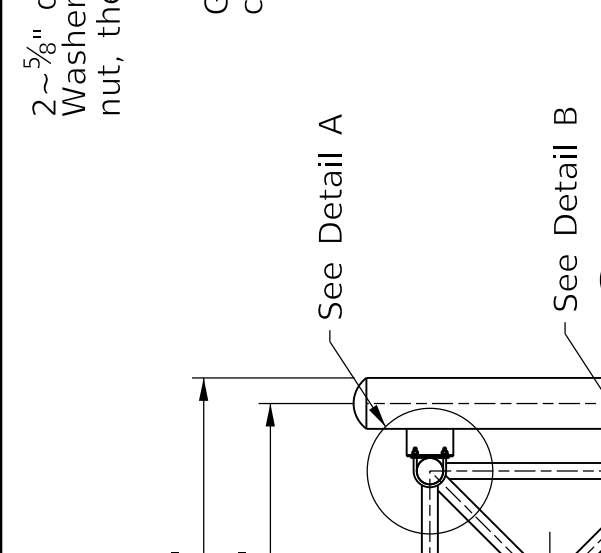

DETAIL C

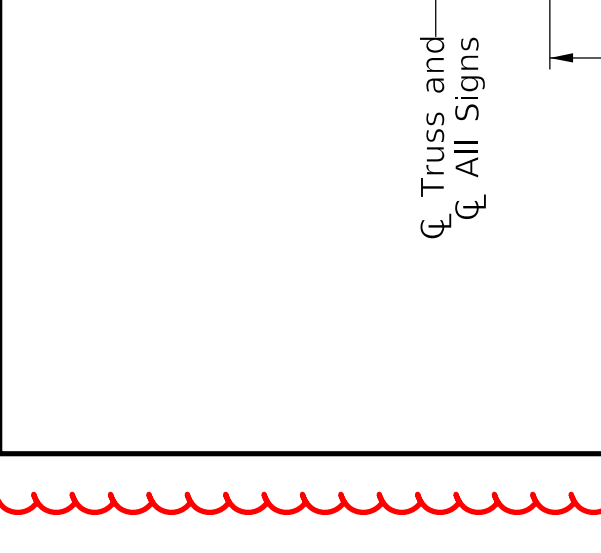

DETAIL D

2-3/8" dia. Galvanized Steel U-Bolts, Hex Nuts, Washers, and Lock Washers (Typ.) After tightening the nut, the exposed thread shall be scored.

2-3/8" dia. Galvanized Steel U-Bolts, Hex Nuts, Washers, and Lock Washers. After tightening the nut, the exposed thread shall be scored.

2-3/8" dia. Galvanized Steel U-Bolts, Hex Nut Washers and Lock Washers. After tightening the nut, the exposed thread shall be scored.

2-3/8" dia. Galvanized Steel U-Bolts, Hex Nut Washers and Lock Washers. After tightening the nut, the exposed thread shall be scored.

2-3/8" dia. Galvanized Steel U-Bolts, Hex Nut Washers and Lock Washers. After tightening the nut, the exposed thread shall be scored.

1/4" Dia. Galvanized Steel U-Bolts, Hex Nuts, Washers, and Lock Washers (Typ.) After tightening the nut, the exposed thread shall be scored.

1/4" Dia. Galvanized Steel U-Bolts, Hex Nuts, Washers, and Lock Washers. After tightening the nut, the exposed thread shall be scored.

1/4" Dia. Galvanized Steel U-Bolts, Hex Nut Washers and Lock Washers. After tightening the nut, the exposed thread shall be scored.

1/4" Dia. Galvanized Steel U-Bolts, Hex Nut Washers and Lock Washers. After tightening the nut, the exposed thread shall be scored.

1/4" Dia. Galvanized Steel U-Bolts, Hex Nut Washers and Lock Washers. After tightening the nut, the exposed thread shall be scored.

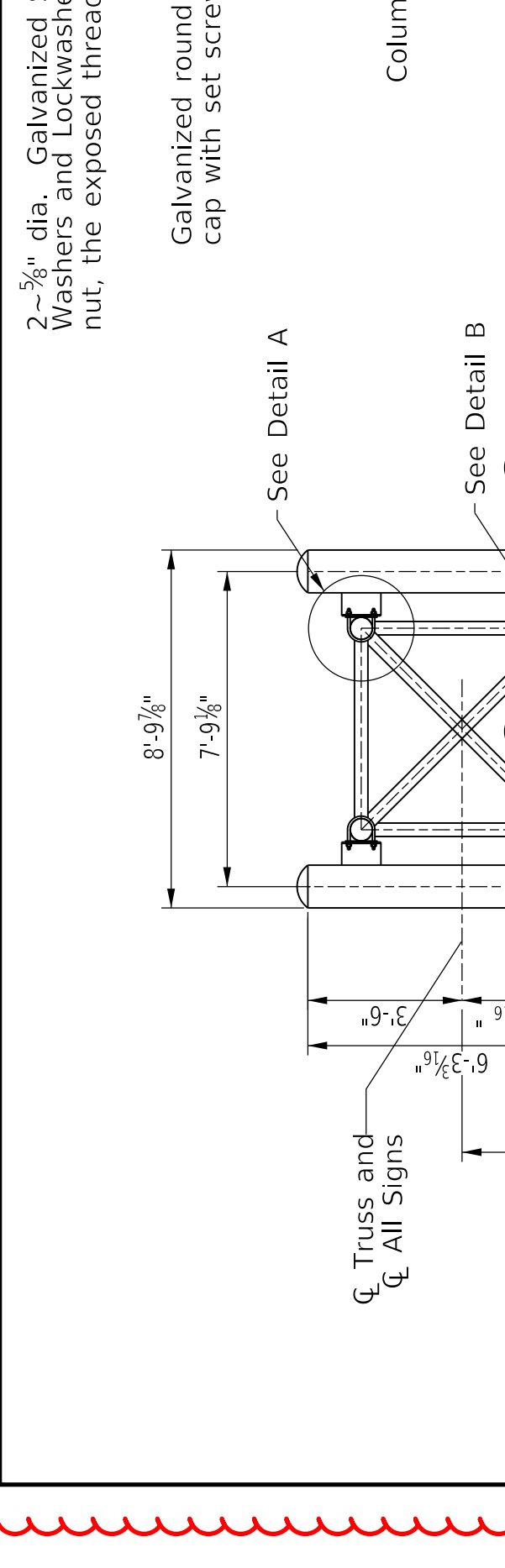

SIDE ELEVATION



SECTION A-A

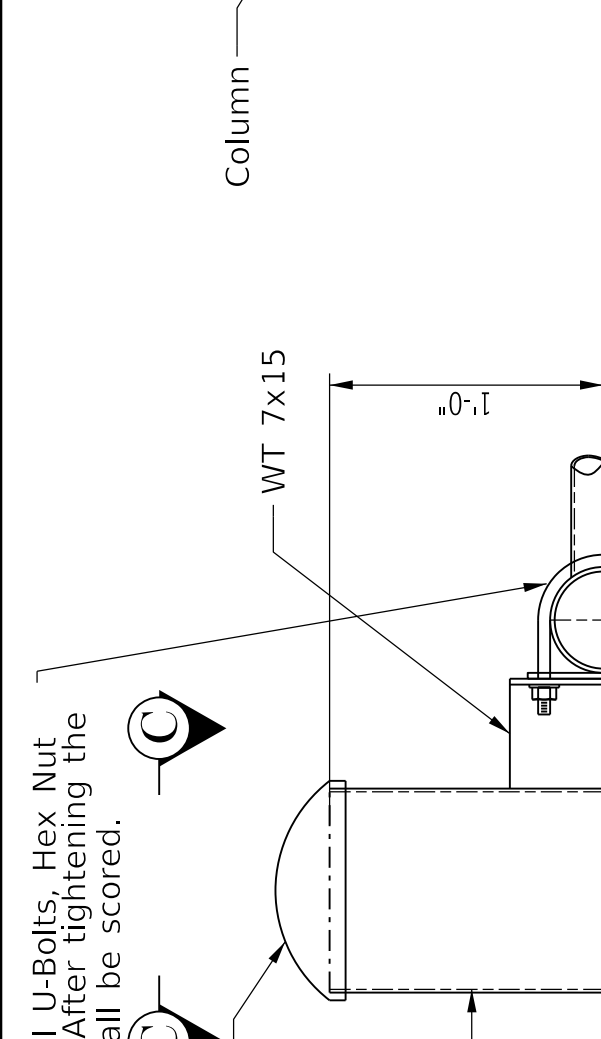

CHORD END DETAIL

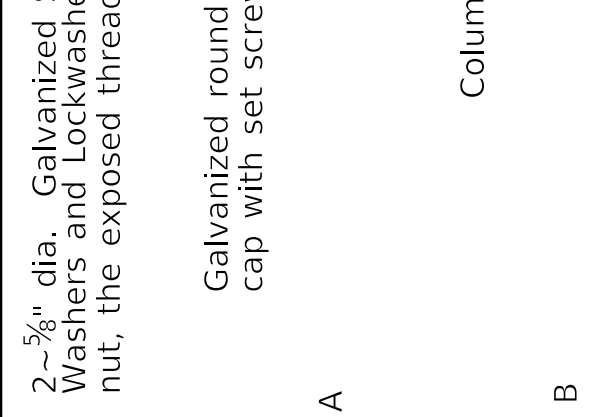

CHORD SPlice

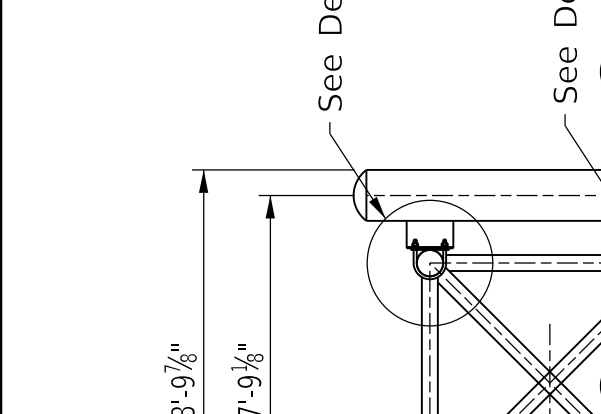

TYPICAL PANEL POINT DETAIL

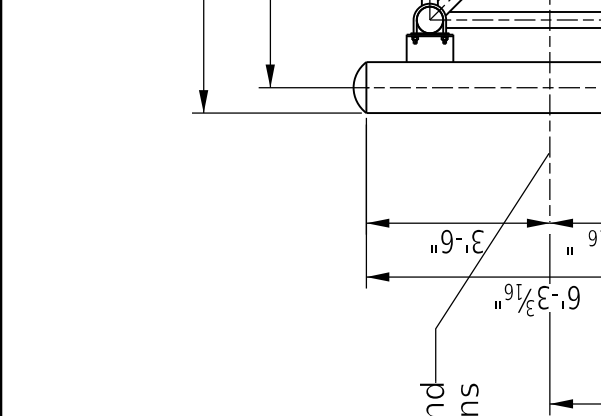

BASE PLATE DETAIL

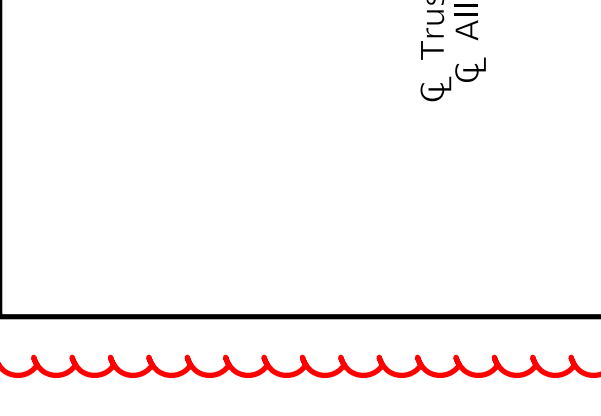

BASE PLATE STIFFENER DETAIL

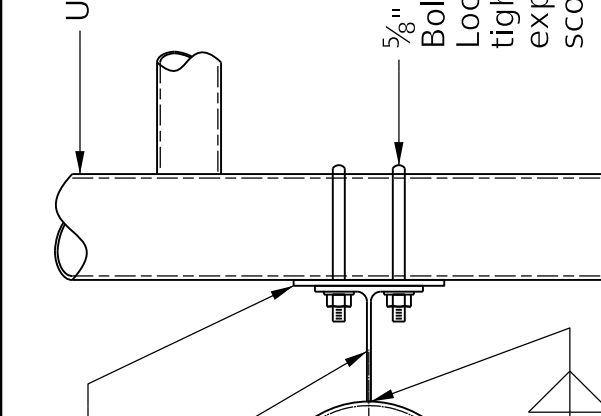

RUSTIFICATION GROOVE

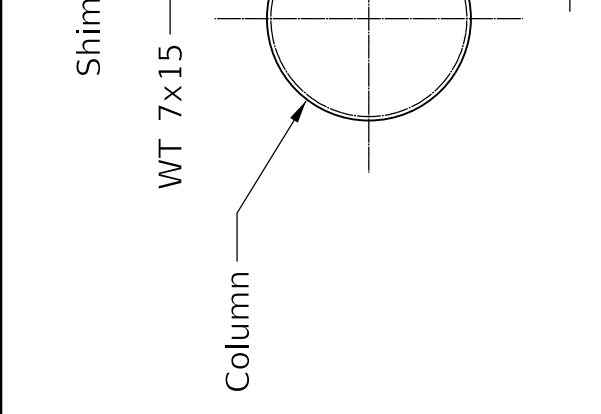

TOP OF PEDESTAL SLOPE DETAIL

ADDED SHEET

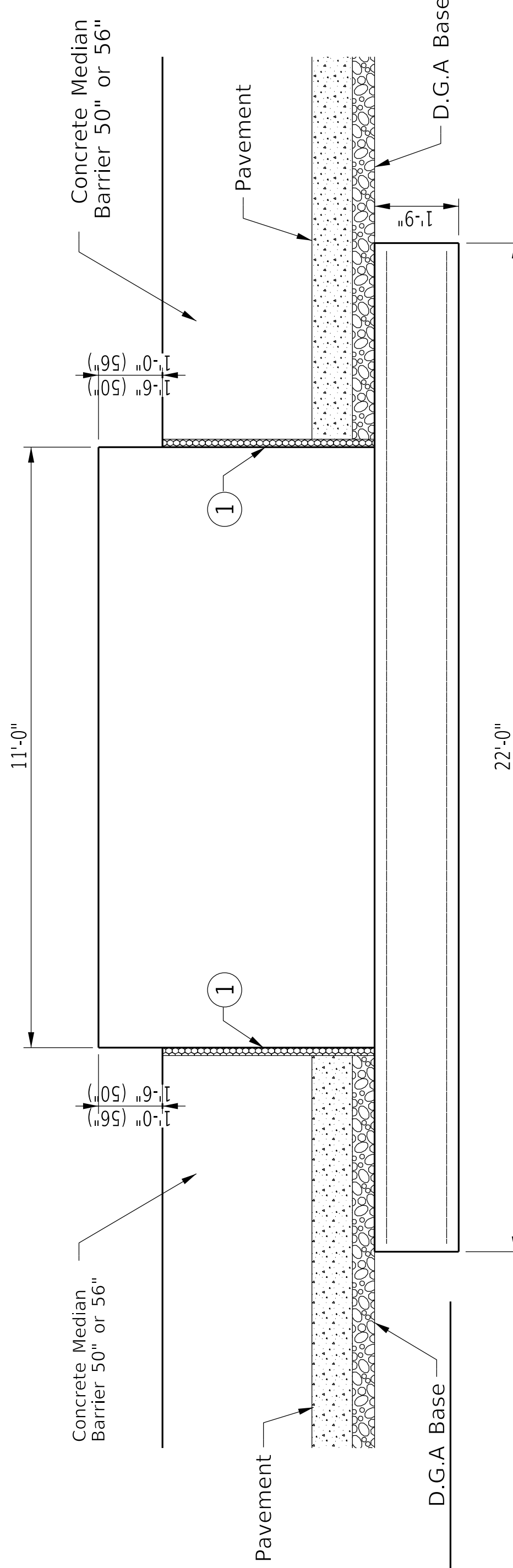

SIDE ELEVATION MEDIAN

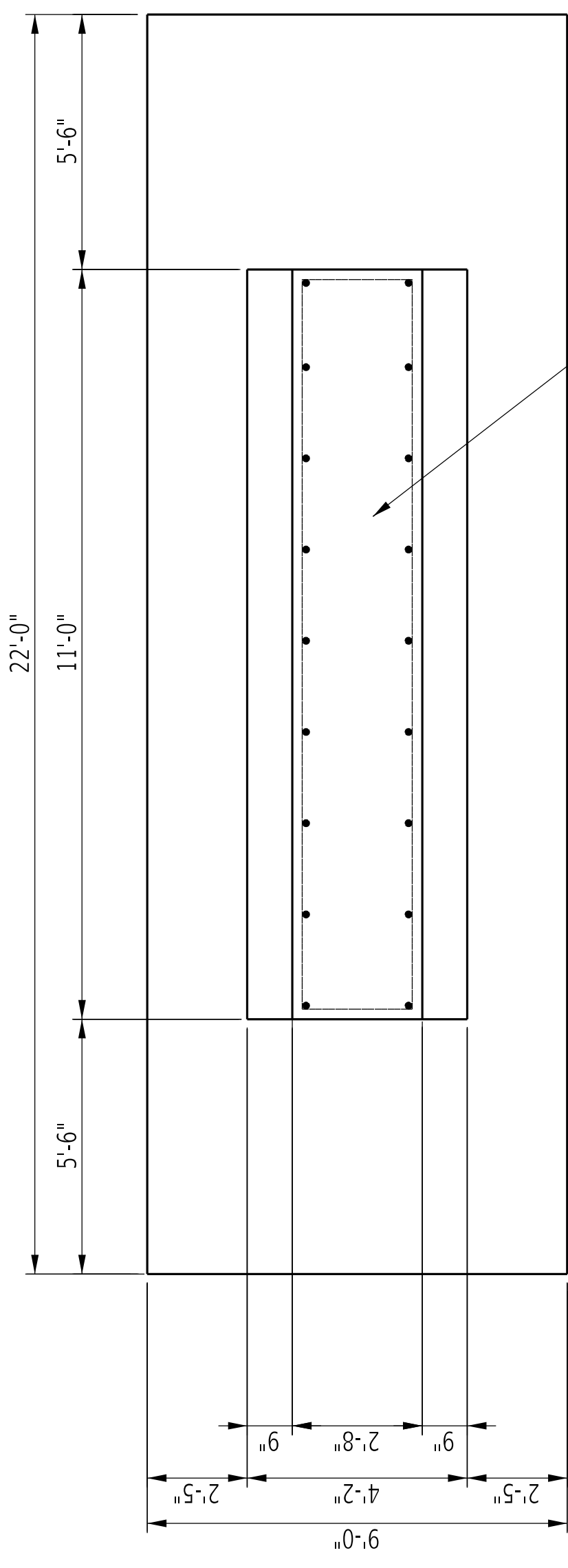

PLAN VIEW MEDIAN

SEE TRUSS DETAILS SHEET FOR REINFORCEMENT

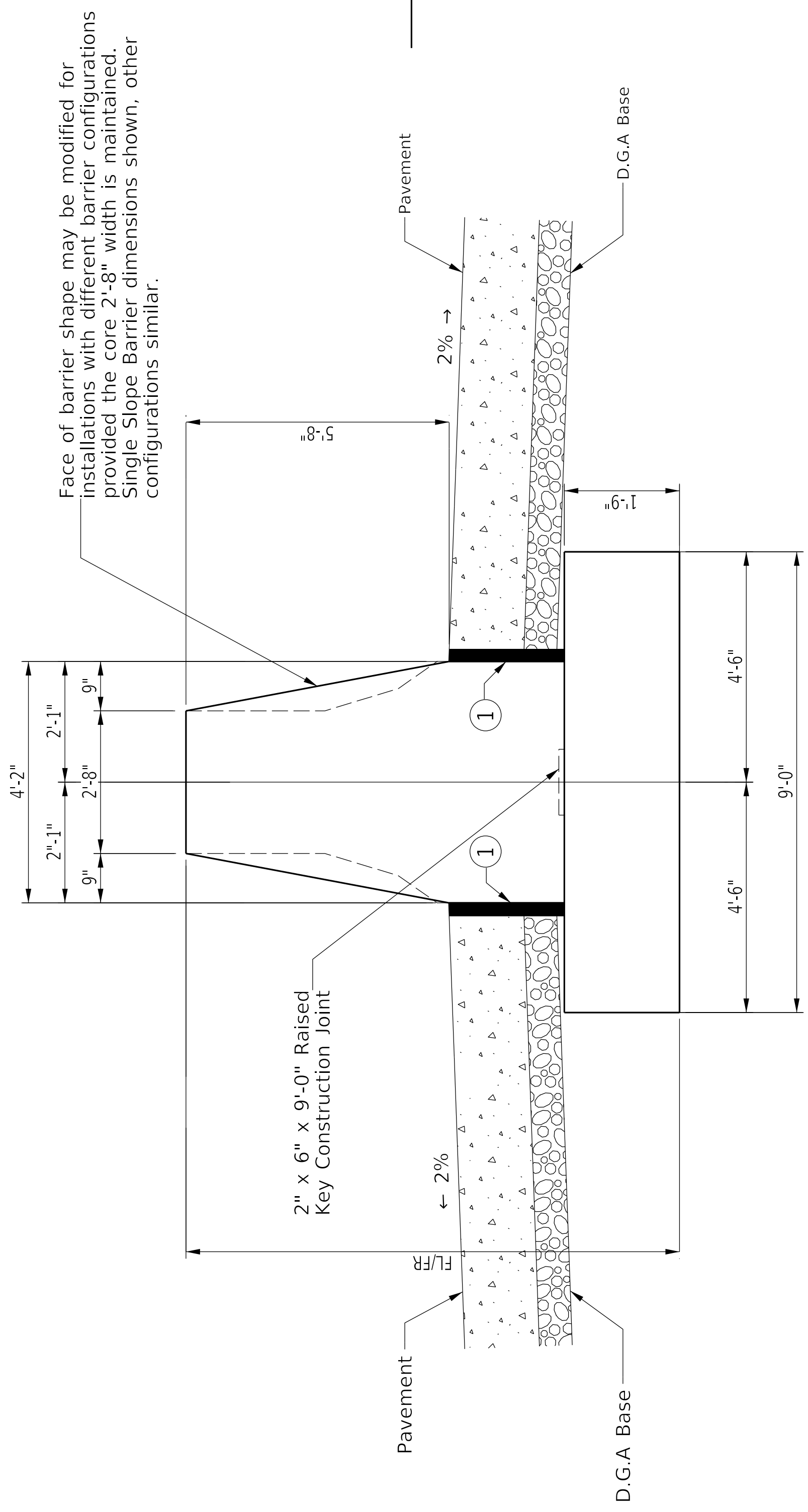

END VIEW MEDIAN
(At Sign Truss)

NOTE:
FOR DETAILS SEE TRUSS LAYOUT
AND TRUSS DETAILS SHEET

Note:
① 1/2" PRE-MOLDED EXPANSION MATERIAL

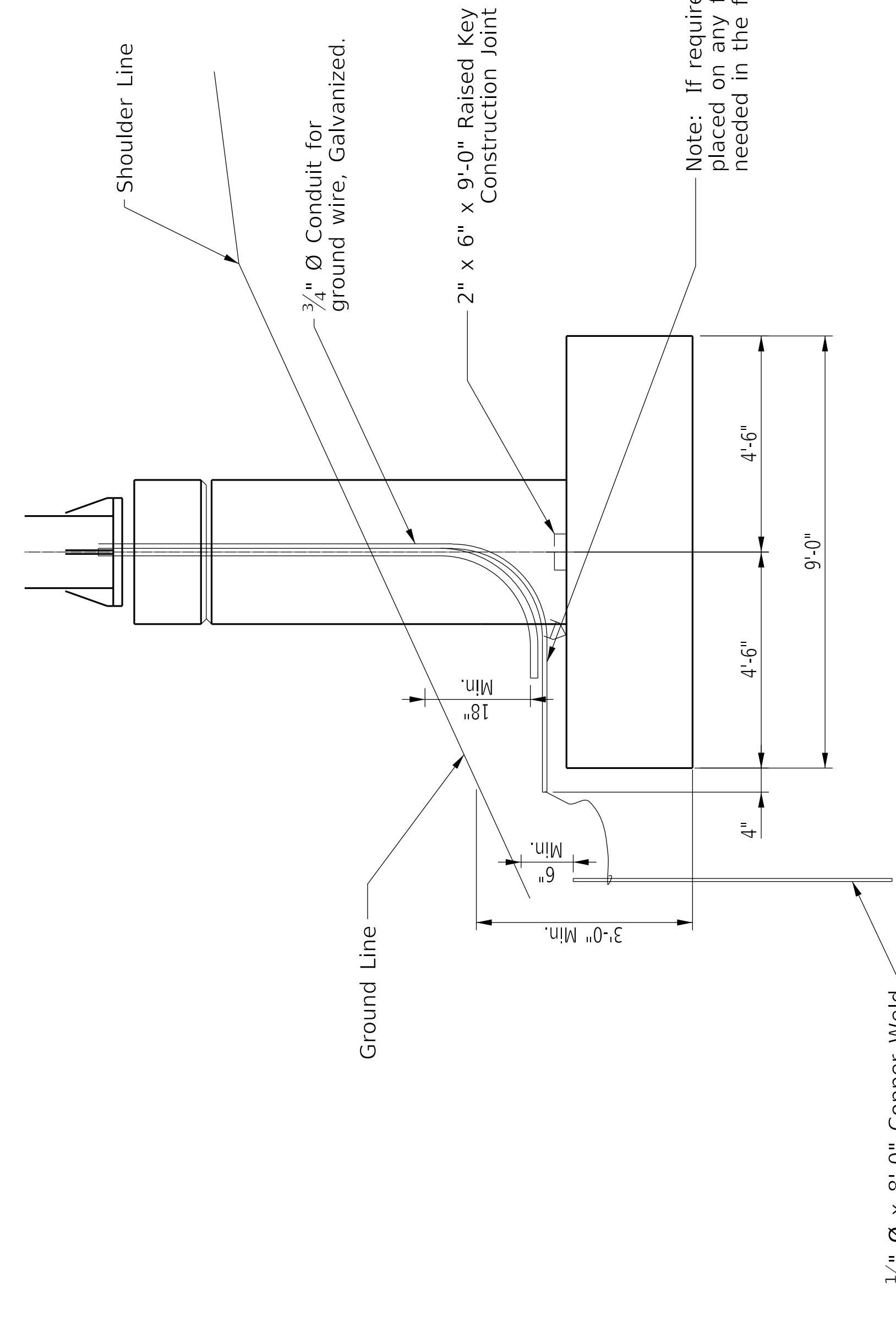

END VIEW PEDESTAL

See Truss Details Sheet for Plan View

* Approx. estimate is for information only. Tabulated FL/FR shall be verified by the Engineer in the field.

PLAN VIEW MEDIAN BARRIER TAPER

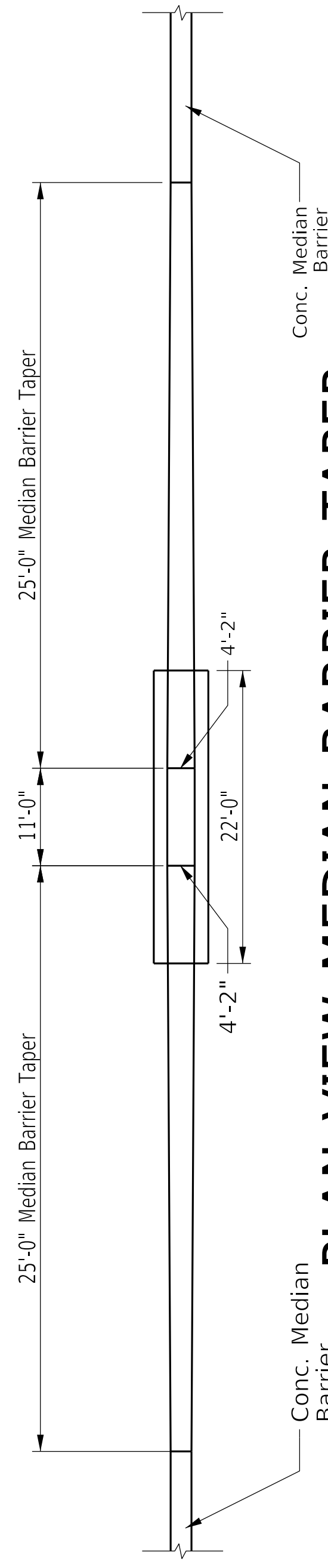

* ESTIMATE OF QUANTITIES FOR MEDIAN FOOTING

FL/FR=8'-0"	Conc. Class "A" Steel Reinforcement	2031 lbs
1' of additional Pedestal height	Conc. Class "A"	21.7 cu.yds.
	1' of additional Pedestal height	1.7 cu.yds.
		100 lbs

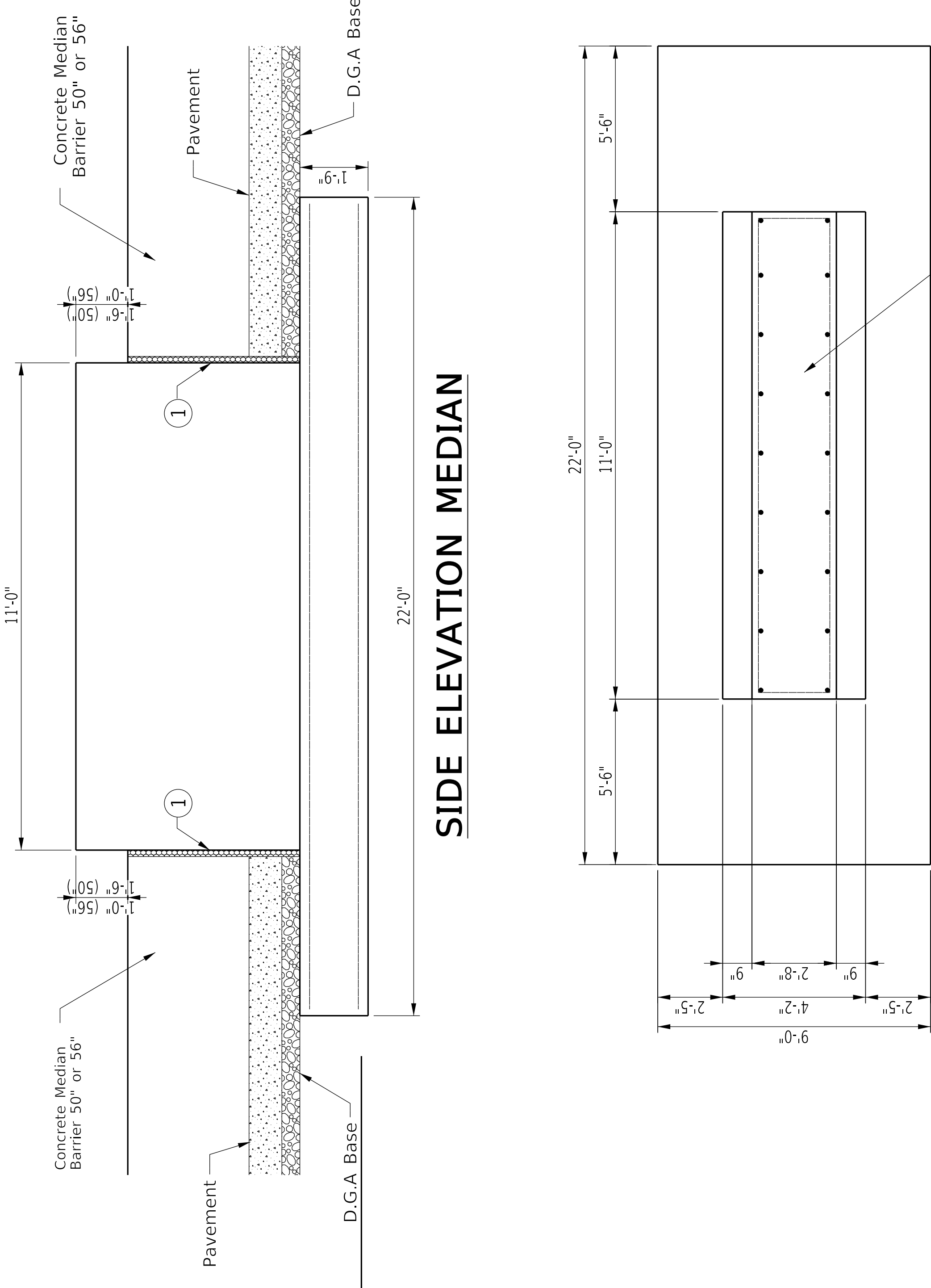

PLAN VIEW MEDIAN

SEE TRUSS DETAILS SHEET FOR REINFORCEMENT

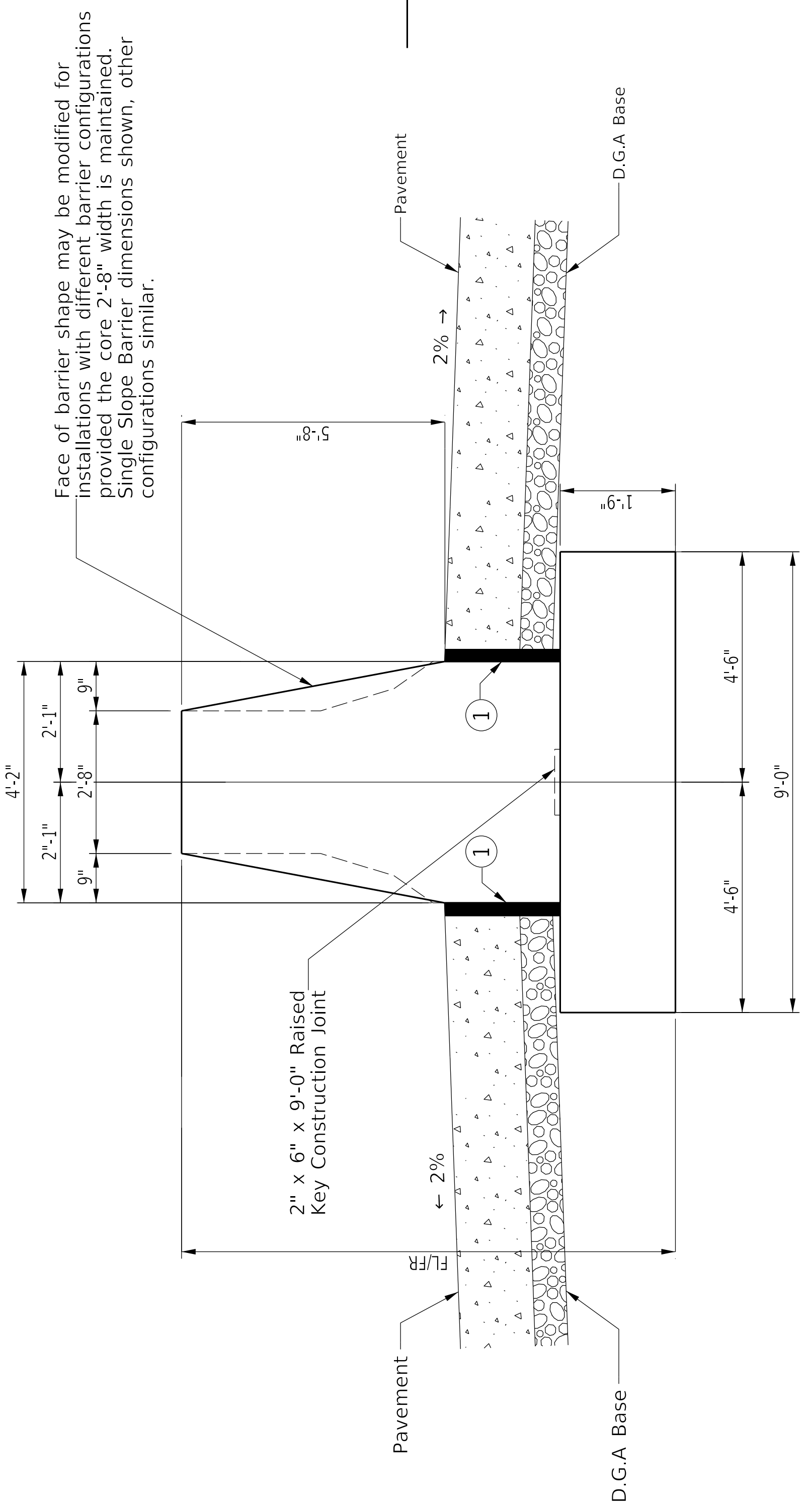

END VIEW MEDIAN (At Sign Truss)

NOTE: FOR DETAILS SEE TRUSS LAYOUT AND TRUSS DETAILS SHEET

Note: ① 1/2" PRE-MOLDED EXPANSION MATERIAL

ADDED SHEET

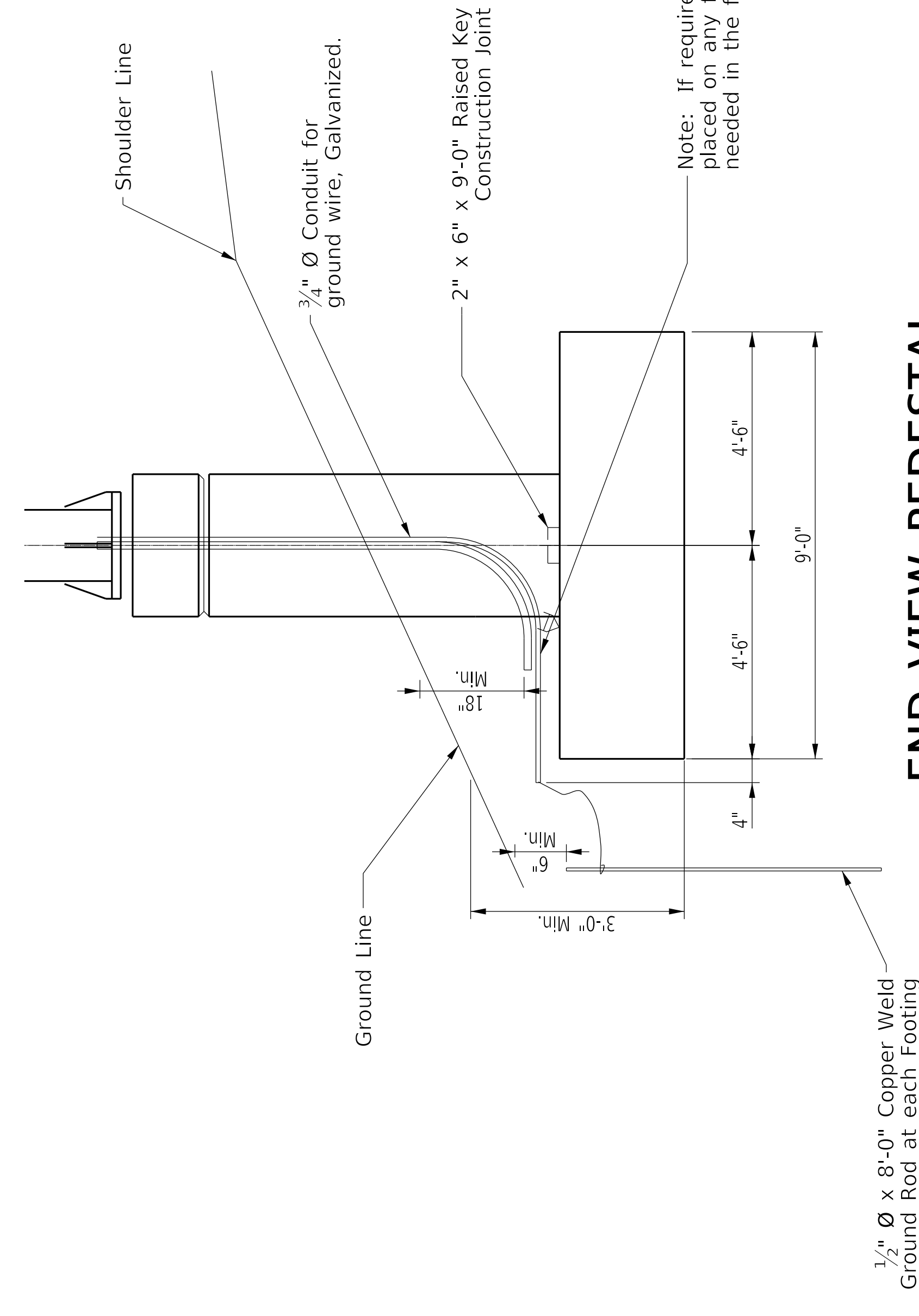

PLAN VIEW MEDIAN BARRIER TAPER

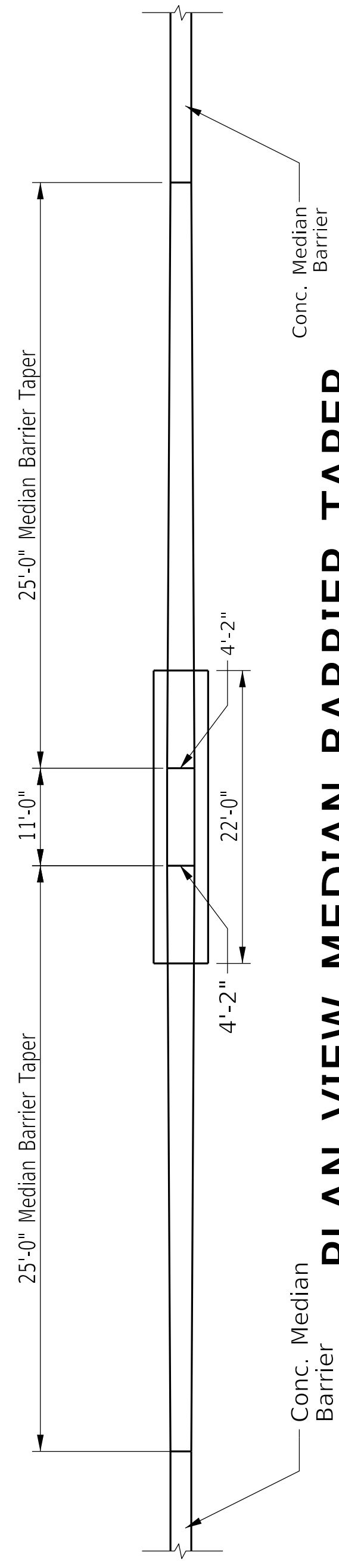

* Approx. estimate is for information only. Tabulated FL/FR shall be verified by the Engineer in the field.

*** ESTIMATE OF QUANTITIES FOR MEDIAN FOOTING**

FL/FR=8'-0"	Conc. Class "A" Steel Reinforcement	2031 lbs
1' of additional Pedestal height	Conc. Class "A"	21.7 cu.yds.
	1' of additional Pedestal height	1.7 cu.yds.
		100 lbs

75-105 FT OVERHEAD SIGN SUPPORT TRUSS GENERAL NOTES

Specifications:

All references to the standard specifications are to the 2019 Edition of the Kentucky Transportation Cabinet Standard Specifications for Road and Bridge Construction. All references to the AASHTO Specifications are to the AASHTO LRFD Specifications for Structural Supports for Highway Signs, Luminaires, and Traffic Signals with Interims through 2022.

Design:
Designed in accordance with AASHTO LRFD Specifications for Structural Supports for Highway Signs, Luminaires, and Traffic Signals with Interims through 2022 using the following parameters:

- 1700 year MRIL with 120 MPH Design Wind Speed
- Finite Fatigue
- 10-Year MRIL 76 MPH Service Wind Speed
- Fatigue Design Loads: Natural Wind Gust; Truck-Induced Wind Gust

Superelevation of Roadway:

The contractor shall allow for differences in elevations across the full shoulder width as shown in the Roadway Plans in maintaining the required 18 foot minimum vertical clearance to the bottom, of the lowest part of the sign or support. Sign shall be centered over the lane or lanes to which it applies, or as specified in the Signing Plans.

Material Design Specifications:

For Class "A" Concrete
 $f_c = 3,500$ psi
 For Steel Reinforcement
 $f_y = 60,000$ psi
 For Structural Steel
 $f_y = 50,000$ psi
 $f_y = 42,000$ psi
 For Steel Columns and Chords
 $f_y = 35,000$ psi

Material Specifications:

AASHTO Specifications or ASTM, Current edition, as designated below shall govern the materials furnished:

Steel Shapes galvanized in accordance with ASTM A123:

Structural Steel: ASTM A992 Grade 50, ASTM A572 Grade 50
 Steel Diagonals: ASTM A53 Grade B, ASTM A500 Grade B or C, ASTM A1085 Grade A
 Steel Columns and Chords: ASTM A500 Grade B or C, ASTM A1085 Grade A

Steel Hardware galvanized in accordance with ASTM A153:

High Strength Bolts ASTM F3125 Grade A325
 U-bolts ASTM A307 Grade A
 Anchor Bolts ASTM F1554 Grade 55
 Heavy Hex Nuts ASTM A194 2H
 Flat Washers ASTM F436

Concrete:

Class "A" Concrete shall be used throughout, and shall be paid for at the unit bid price for Class "A" Concrete for Signs.

Beveled Edges:

All exposed concrete edges are to be beveled $\frac{3}{4}$ " unless otherwise shown.

Reinforcement:

Dimensions shown from the face of concrete to bars are to center of bar unless otherwise shown. Spacing of bars is from center to center of bars. Clear distance to face of concrete is 2 inches unless otherwise noted. Reinforcing bars in the plans shall be epoxy coated in accordance with section 811.10 of the Standard Specifications.

Any reinforcing bars designated by the suffix (s) in a Bill of Reinforcement shall be considered a stirrup bar for purposes of bend diameters.

Payment for reinforcement shall be paid for at the unit bid price for Steel Reinforcement for Signs.

Shop Drawings:

The contractor shall submit detailed shop drawings to the Division of Construction for review prior to fabrication in accordance with the specifications. The roadway cross section developed by the contractor is to accompany the shop drawings. The shop drawings and roadway cross section will also be forwarded to the engineer to review.

Bolted Connections:

All bolted connections shall include lock washers. After bolted connections are complete, threads shall be scored to prevent nut loosening. Care shall be taken not to damage the nut and threads engaged by the nut. Damaged nuts shall be replaced at the contractors expense.

Fabrication:

The sign support shall be fabricated in accordance with the AASHTO Specifications. Any damaged galvanization shall be repaired in accordance with ASTM A780. Perform all welding according to requirements specified in ANSI/AASHTO/AWS D1.1 Structural Welding Code Current edition with interims.

Mill Test Reports:

Submit Mill Test Reports in accordance with section 607.03.13 of the Standard Specifications

Vent/Drain Holes for Galvanization

Vent/drain holes shall be drilled in the column or chord member at each end of all closed diagonal members prior to welding. The holes shall be spaced as equally as possible across the chord/column surface where the diagonal member opening projects. Vent/drain holes shall be shown in the shop drawings for approval. Total area of vent/drain holes at each end shall be equal to or less than the following:

30% of the diagonal inside cross sectional opening for members with inside diameters greater than or equal to 3 inches.
 45% of the diagonal inside cross sectional opening for members with inside diameters less than 3 inches.

Footings:
All footings shall be poured against undisturbed earth. The maximum allowable service bearing pressure is 3 kips per square foot.

Design Limits:
This standard drawing is applicable to all overhead sign supports that meet the following criteria:

Maximum Total Sign Area: 1000 SF
 Minimum Vertical Clearance of Sign Above Roadway: 18 FT
 Maximum Height of Sign Above Roadway: 44 FT
 Maximum Sign Panel Height: 24 FT
 Maximum Exit Panel Height: 4.5 FT
 Span Range: 75 FT - 105 FT
 Min. Sign Edge Distance to Column CL: 12 FT
 Max./Min. Column Height (HL/HR): 27 FT / 18 FT
 Max. Pedestal Height (FL/FR): 14 FT
 Min. Pedestal Offset behind Guardrail: 6 FT
 Min. Pedestal Projection above soil: 2.5 FT
 Min. Fill above Base of Footing: 3 FT

Provided that all other design limits are adhered to, this standard may be used for span lengths less than those shown by using 2 of the truss modules.

Design Chart:

A registered professional engineer licensed to practice in the Commonwealth of Kentucky shall fill out the Design Chart based on the design cross section at the location where the truss is to be erected, the actual signs to be used, and the instructions herein. The Engineer's name shall appear in the "Checked By:" Box of the title block of this sheet. The Engineer is responsible for verifying the information based on the contractor's submitted cross sections and reviewing the fabricators shop drawings in detail.

Roadway Cross Section:

The contractor shall take field measurements at each sign location and develop a cross section showing the following:

Pedestal and median heights
 Pedestal offset distance behind guardrail
 Column Heights
 Minimum Vertical Clearance to each sign

All work associated with developing and furnishing the Roadway Cross Section shall be incidental to OSS Sign Truss.

Payment:

All engineering, materials, labor, equipment, and any other incidentals necessary to furnish and install the sign truss as detailed in these standards and the shop drawings shall be paid for at the unit bid price for OSS Sign Truss.

Fabricator Certification:

The fabricator shall be AISC Certified for SBR (Certified Bridge Fabricator - Simple).

Sign No.	STATION	SPAN		SUPPORT HEIGHT		FOOTING HEIGHT	
		L	75'-0"	HL	HR	FL	FR
P-36*	174+00			22'-9"	20'-4"	10'-0"	10'-9"
Total Area**	SIGN A		SIGN B		SIGN B		Area
	I.D.	Vert.	I.D.	Horiz.	Vert.	Area	
816 SF	17'	10'	170 SF	(B)	34'	20'	646 SF

* See sheet T16 & T18 for Sign Detail
 See sheet S30 for Cross-Section of Truss

** Total Area includes the sum of all of the signs on the structure and shall not exceed 1000 square feet.

Sign No.	STATION	SPAN		SUPPORT HEIGHT		FOOTING HEIGHT	
		L	75'-0"	HL	HR	FL	FR
P-79*	105+00			18'-9"	18'-9"	10'-7"	9'-1"
Total Area**	SIGN A		SIGN B		SIGN B		Area
	I.D.	Horiz.	Vert.	I.D.	Horiz.	Vert.	
469 SF	18'	12'	216 SF	(B)	18'	14'	252 SF

* See sheet T17 for Sign Detail
 See sheet S29 for Cross-Section of Truss

** Total Area includes the sum of all of the signs on the structure and shall not exceed 1000 square feet.

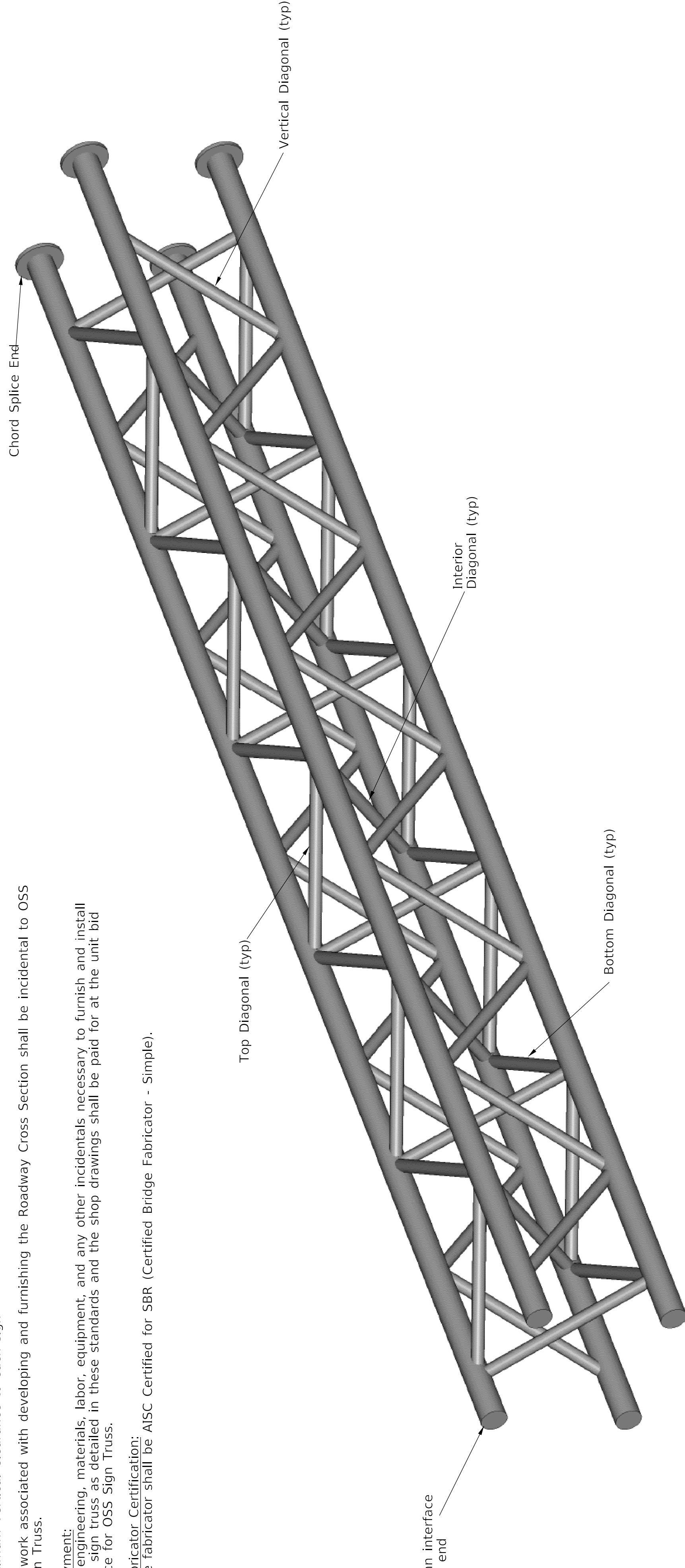

ISOMETRIC VIEW OF TYPICAL TRUSS MODULE

(FOR INFORMATION ONLY)

 COMMONWEALTH OF KENTUCKY DEPARTMENT OF HIGHWAYS	REVISION	DATE	PREPARED BY	DATE:	CHECKED BY:	ROUTE	ITEM NO.	COUNTY OF
						KY 922	7-252.00	FAYETTE
				DESIGNED BY:			SHEET NO.	
				DETAILED BY:			S25	
						CROSSING		
						STA 105+00 & STA 174+00		

GENERAL NOTES

75-105 FT OVERHEAD SIGN SUPPORT TRUSS GENERAL NOTES

Specifications:

All references to the standard specifications are to the 2019 Edition of the Kentucky Transportation Cabinet Standard Specifications for Road and Bridge Construction. All references to the AASHTO Specifications are to the AASHTO LRFD Specifications for Structural Supports for Highway Signs, Luminaires, and Traffic Signals with Interims through 2022.

Design: Designed in accordance with AASHTO LRFD Specifications for Structural Supports for Highway Signs, Luminaires, and Traffic Signals with Interims through 2022 using the following parameters:

- 1700 year MR, with 120 MPH Design Wind Speed
- Finite Fatigue
- 10-Year MR, 76 MPH Service Wind Speed
- Fatigue Design Loads: Natural Wind Gust; Truck-Induced Wind Gust

Superelevation of Roadway:

The contractor shall allow for differences in elevations across the full shoulder width as shown in the Roadway Plans in maintaining the required 18 foot minimum vertical clearance to the bottom, of the lowest part of the sign or support. Sign shall be centered over the lane or lanes to which it applies, or as specified in the Signing Plans.

Material Design Specifications:

For Class "A" Concrete
 For Steel Reinforcement
 For Structural Steel
 For Steel Columns and Chords
 For Steel Diagonals

$f'_c = 3,500$ psi
 $f_y = 60,000$ psi
 $f_y = 50,000$ psi
 $f_y = 42,000$ psi
 $f_y = 35,000$ psi

Material Specifications:

AASHTO Specifications or ASTM, Current edition, as designated below shall govern the materials furnished:

Steel Shapes galvanized in accordance with ASTM A123:

Structural Steel: ASTM A992 Grade 50, ASTM A572 Grade 50
 Steel Diagonals: ASTM A53 Grade B, ASTM A500 Grade B or C, ASTM A1085 Grade A
 Steel Columns and Chords: ASTM A500 Grade B or C, ASTM A1085 Grade A

Steel Hardware galvanized in accordance with ASTM A153:

High Strength Bolts ASTM F3125 Grade A325
 U-bolts ASTM A307 Grade A
 Anchor Bolts ASTM F1554 Grade 55
 Heavy Hex Nuts ASTM A194 2H
 Flat Washers ASTM F436

Concrete:

Class "A" Concrete shall be used throughout, and shall be paid for at the unit bid price for Class "A" Concrete for Signs.

Beveled Edges:

All exposed concrete edges are to be beveled $\frac{3}{4}$ " unless otherwise shown.

Reinforcement:

Dimensions shown from the face of concrete to bars are to center of bar unless otherwise shown. Spacing of bars is from center to center of bars. Clear distance to face of concrete is 2 inches unless otherwise noted. Reinforcing bars in the plans shall be epoxy coated in accordance with section 811.10 of the Standard Specifications.

Any reinforcing bars designated by the suffix (s) in a Bill of Reinforcement shall be considered a stirrup bar for purposes of bend diameters.

Payment for reinforcement shall be paid for at the unit bid price for Steel Reinforcement for Signs.

Shop Drawings:

The contractor shall submit detailed shop drawings to the Division of Construction for review prior to fabrication in accordance with the specifications. The roadway cross section developed by the contractor is to accompany the shop drawings. The shop drawings and roadway cross section will also be forwarded to the engineer to review.

Bolted Connections:
 All bolted connections shall include lock washers. After bolted connections are complete, threads shall be scored to prevent nut loosening. Care shall be taken not to damage the nut and threads engaged by the nut. Damaged nuts shall be replaced at the contractors expense.

Fabrication:

The sign support shall be fabricated in accordance with the AASHTO Specifications. Any damage galvanization shall be repaired in accordance with ASTM A780. Perform all welding according to requirements specified in ANSI/AASHTO/AWS D1.1 Structural Welding Code Current edition with Interims.

Mill Test Reports:

Submit Mill Test Reports in accordance with section 607.03.13 of the Standard Specifications

Vent/Drain Holes for Galvanization

Vent/drain holes shall be drilled in the column or chord member at each end of all closed diagonal members prior to welding. The holes shall be spaced as possible across the chord/column surface where the diagonal member opening projects. Vent/drain holes shall be shown in the shop drawings for approval. Total area of vent/drain holes at each end shall be equal to or less than the following:

30% of the diagonal inside cross sectional opening for members with inside diameters greater than or equal to 3 inches.
 45% of the diagonal inside cross sectional opening for members with inside diameters less than 3 inches.

Footings:

All footings shall be poured against undisturbed earth. The maximum allowable service bearing pressure is 3 kips per square foot.

Design Limits:

This standard drawing is applicable to all overhead sign supports that meet the following criteria:

Maximum Total Sign Area: 1000 SF
 Minimum Vertical Clearance of Sign Above Roadway: 18 FT
 Maximum Height of Sign Above Roadway: 44 FT
 Maximum Sign Panel Height: 24 FT
 Maximum Exit Panel Height: 4.5 FT
 Span Range: 75 FT - 105 FT
 Min. Sign Edge Distance to Column CL: 12 FT
 Max./Min. Column Height (HL/HR): 27 FT / 18 FT
 Max. Pedestal Height (FL/FR): 14 FT
 Min. Pedestal Offset behind Guardrail: 6 FT
 Min. Pedestal Projection above soil: 2.5 FT
 Min. Fill above Base of Footing: 3 FT

Provided that all other design limits are adhered to, this standard may be used for span lengths less than those shown by using 2 of the truss modules.

Design Chart:

A registered professional engineer licensed to practice in the Commonwealth of Kentucky shall fill out the Design Chart based on the design cross section at the location where the truss is to be erected, the actual signs to be used, and the instructions herein. The Engineer's name shall appear in the "Checked By:" Box of the title block of this sheet. The Engineer is responsible for verifying the information based on the contractor's submitted cross sections and reviewing the fabricators shop drawings in detail.

Roadway Cross Section:

The contractor shall take field measurements at each sign location and develop a cross section showing the following:

Pedestal and median heights
 Pedestal offset distance behind guardrail
 Column Heights
 Minimum Vertical Clearance to each sign

All work associated with developing and furnishing the Roadway Cross Section shall be incidental to OSS Sign Trusses.

Payment:

All engineering, materials, labor, equipment, and any other incidentals necessary to furnish and install the sign truss as detailed in these standards and the shop drawings shall be paid for at the unit bid price for OSS Sign Trusses.

Fabricator Certification:

The fabricator shall be AISC Certified for SBR (Certified Bridge Fabricator - Simple).

Sign No.	STATION	SPAN		SUPPORT HEIGHT			FOOTING HEIGHT	
		L		HL	HR	FL	FR	
P-36*	174+00	75'-0"		22'-9"			10'-0"	
Total Area**	SIGN A		SIGN B					
	I.D.	Horiz.	Vert.	I.D.	Horiz.	Vert.	Area	
816 SF	(A)	17'	10'	170 SF	(B)	34'	20'	646 SF

* See sheet T16 & T18 for Sign Detail
 See sheet S30 for Cross-Section of Truss

** Total Area includes the sum of all of the signs on the structure and shall not exceed 1000 square feet.

Sign No.	STATION	SPAN		SUPPORT HEIGHT			FOOTING HEIGHT	
		L		HL	HR	FL	FR	
P-79*	105+00	75'-0"		18'-9"			10'-7"	
Total Area**	SIGN A		SIGN B					
	I.D.	Horiz.	Vert.	I.D.	Horiz.	Vert.	Area	
469 SF	(A)	18'	12'	216 SF	(B)	18'	14'	252 SF

* See sheet T17 for Sign Detail
 See sheet S29 for Cross-Section of Truss

** Total Area includes the sum of all of the signs on the structure and shall not exceed 1000 square feet.

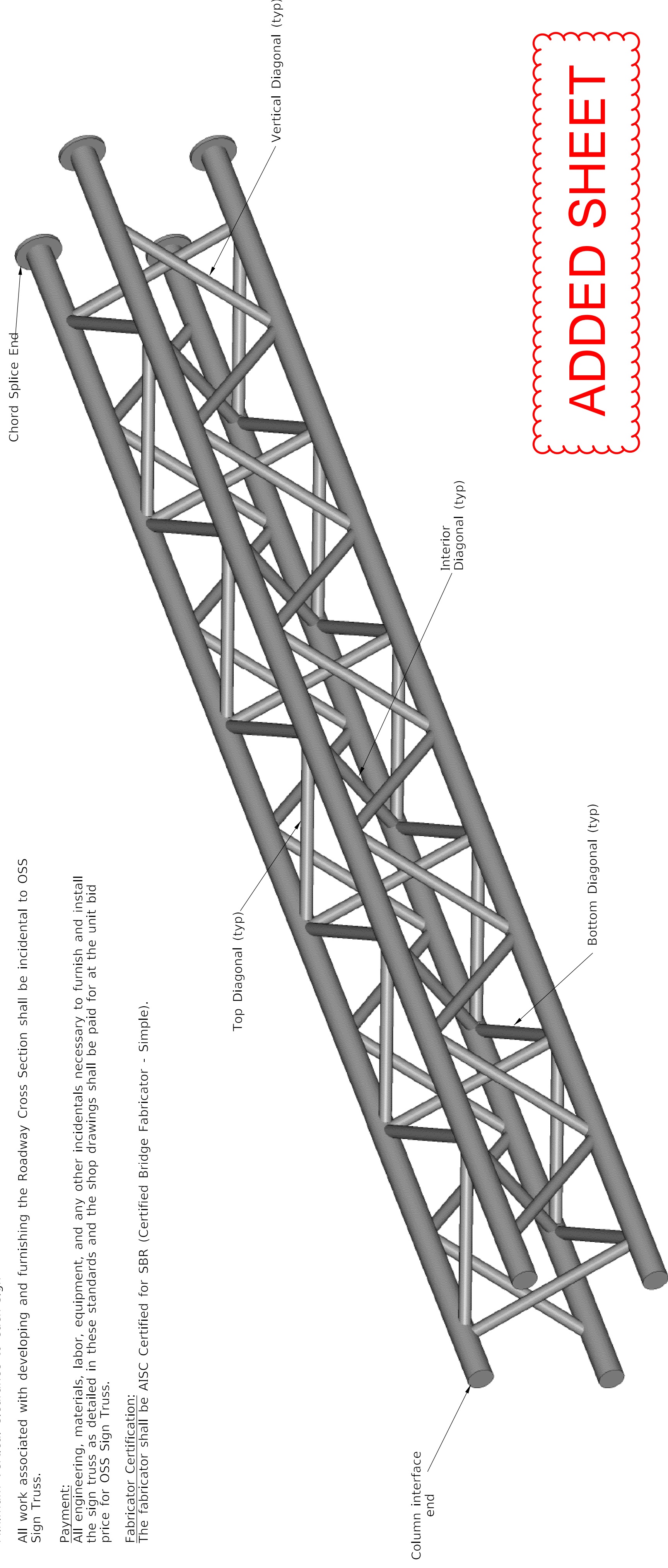

ADDED SHEET

ISOMETRIC VIEW OF TYPICAL TRUSS MODULE

(FOR INFORMATION ONLY)

 COMMONWEALTH OF KENTUCKY DEPARTMENT OF HIGHWAYS	REVISION <table border="1" style="width: 100%; height: 40px;"> <tr><td> </td></tr> </table>		DATE <table border="1" style="width: 100%; height: 40px;"> <tr><td> </td></tr> </table>		PREPARED BY _____	CHECKED BY _____	COUNTY OF FAYETTE
			ROUTE KY 922	ITEM NO. 7-252.00	SHEET NO. S25		
			CROSSING STA 105+00 & STA 174+00				
USER: \$\$\$SUSER\$\$\$ DATE PLOTTED: \$\$\$DATE\$\$\$ FILE NAME: \$\$\$FILESPECIFICATIONS\$\$\$							

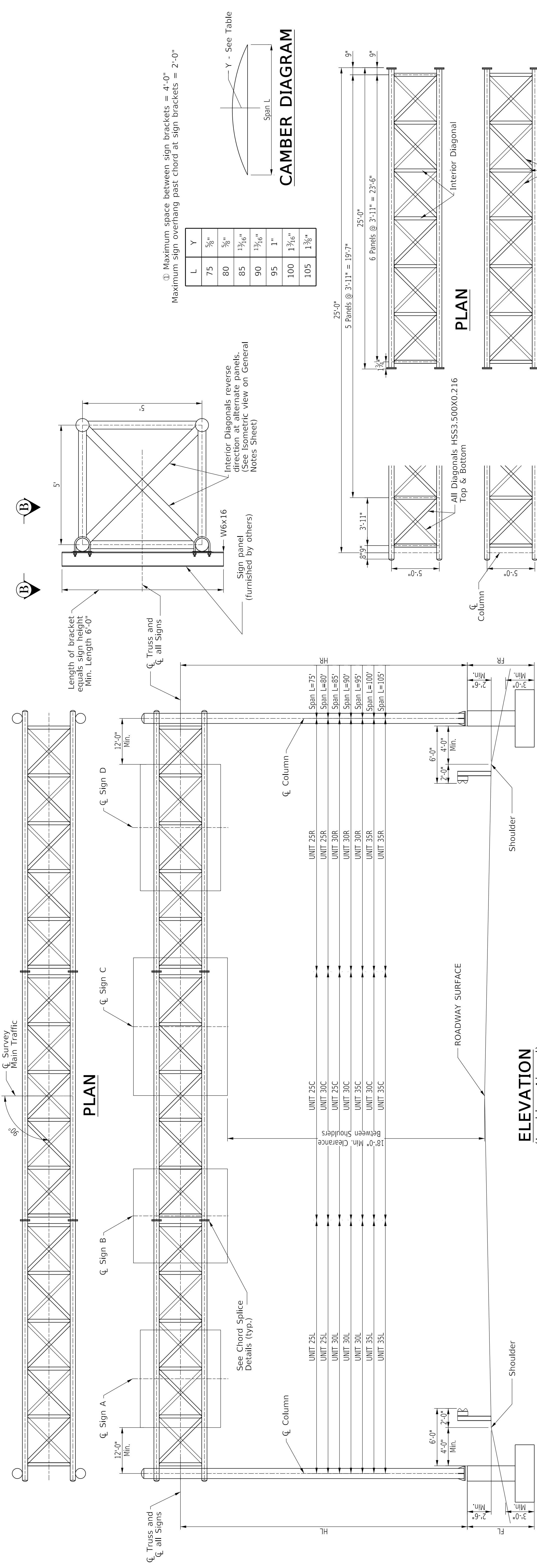

① Maximum space between sign brackets = 4'-0"
Maximum sign overhang past chord at sign brackets = 2'-0"

L	Y
75	3/8"
80	3/8"
85	13/16"
90	13/16"
95	1"
100	1 3/16"
105	1 3/8"

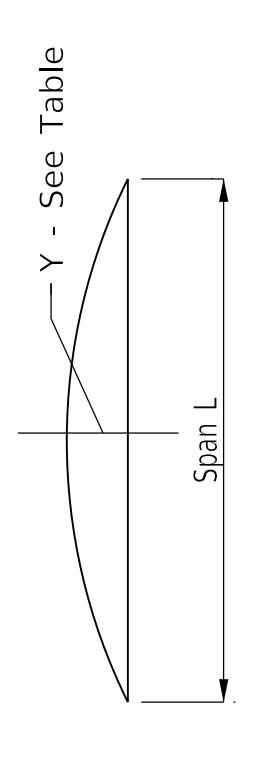

CAMBER DIAGRAM

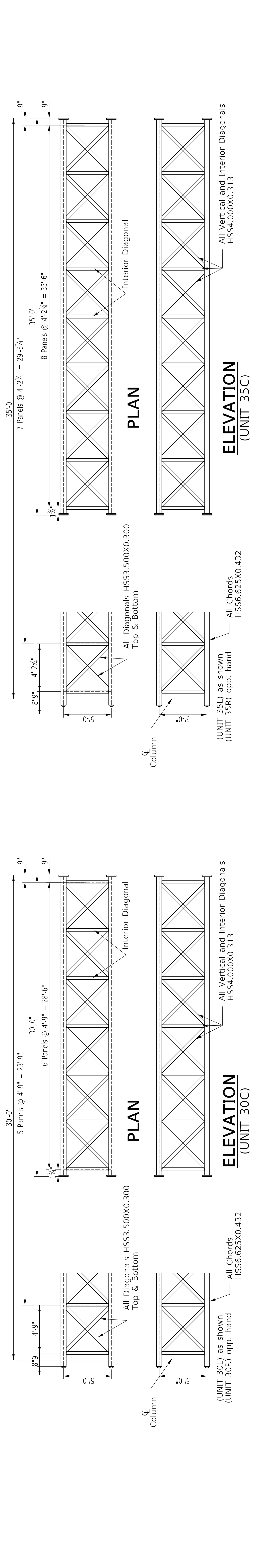

ADDED SHEET

① Maximum space between sign brackets = 4'-0"
Maximum sign overhang past chord at sign brackets = 2'-0"

L	Y
75	3/8"
80	3/8"
85	13/16"
90	13/16"
95	1"
100	1 3/16"
105	1 3/8"

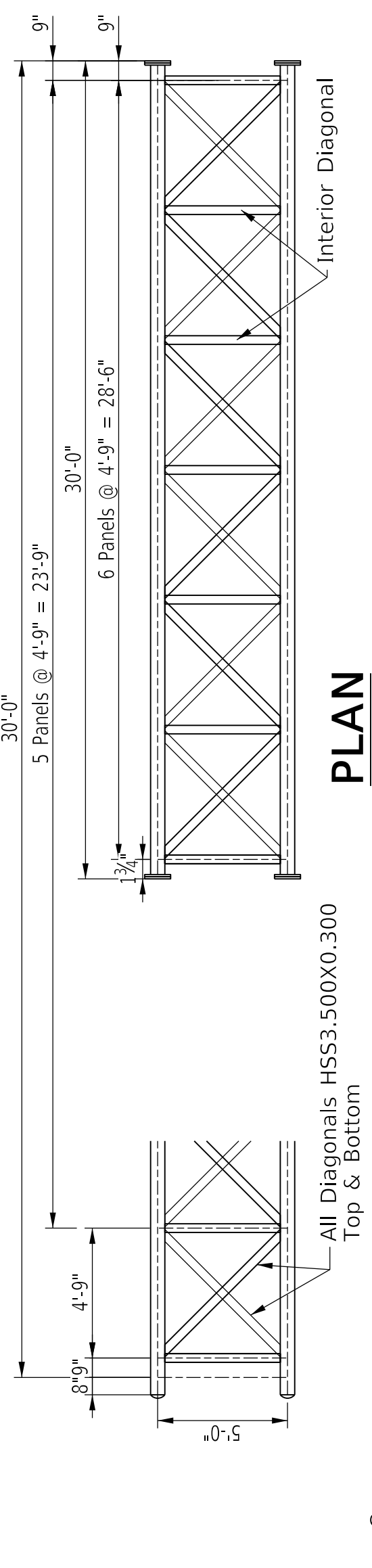
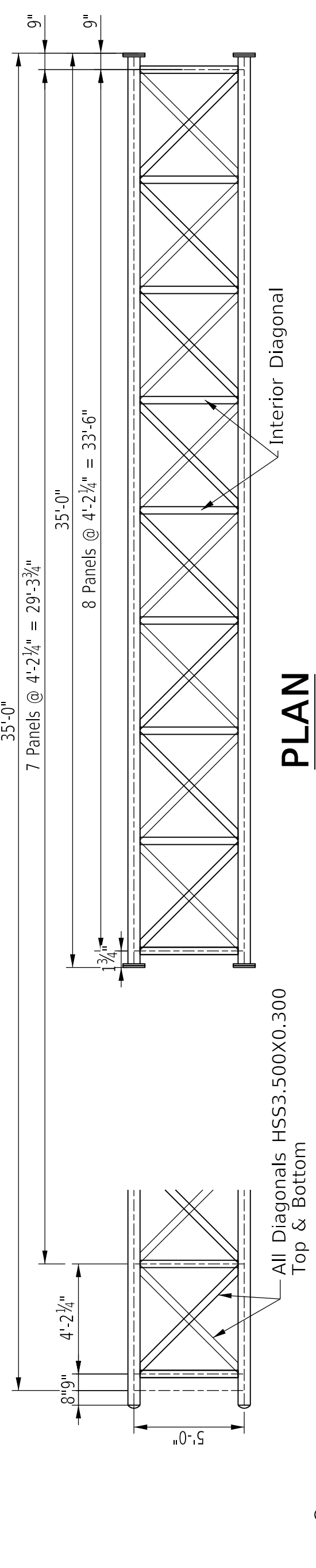
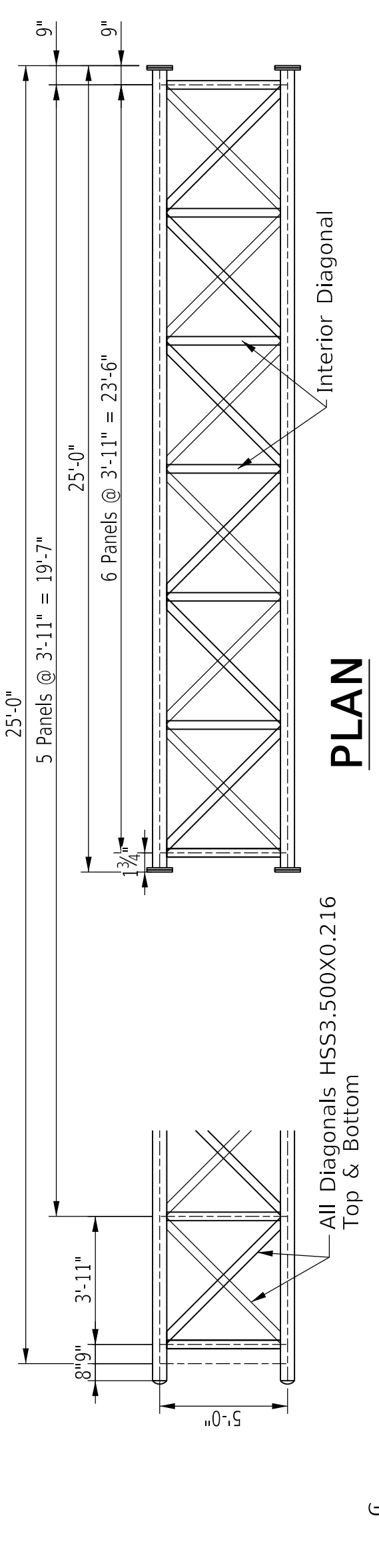
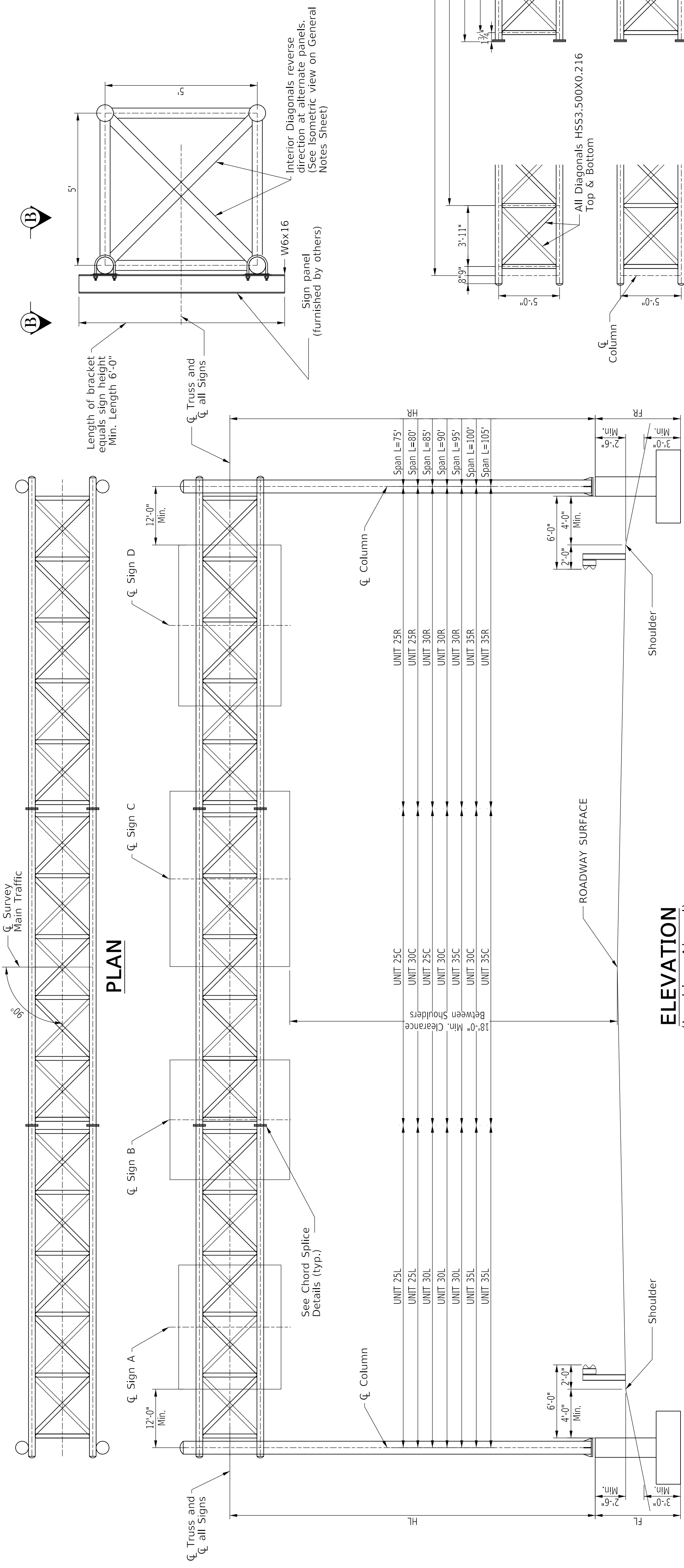
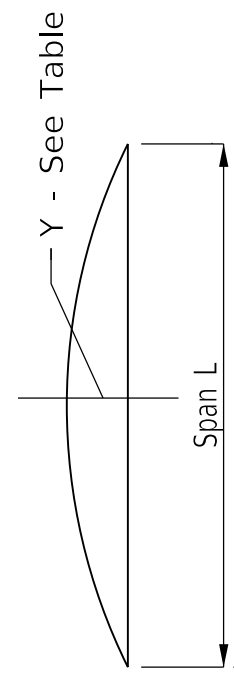

BILL OF REINFORCEMENT FOR FOOTING

MARK	TYPE	NO.	SIZE	LENGTH		LOCATION
				FT.	IN.	
A1	5	40	#8	FL/FR+0'-11"	6	Footing & Wall
A2	Str	54	#5		6	Footing
A3	Str	14	#8		6	Footing
A4(S)	14	Var.	#4		27	0
A5(S)	15	3	#5		22	4
A6	Str	10	#5		26	6

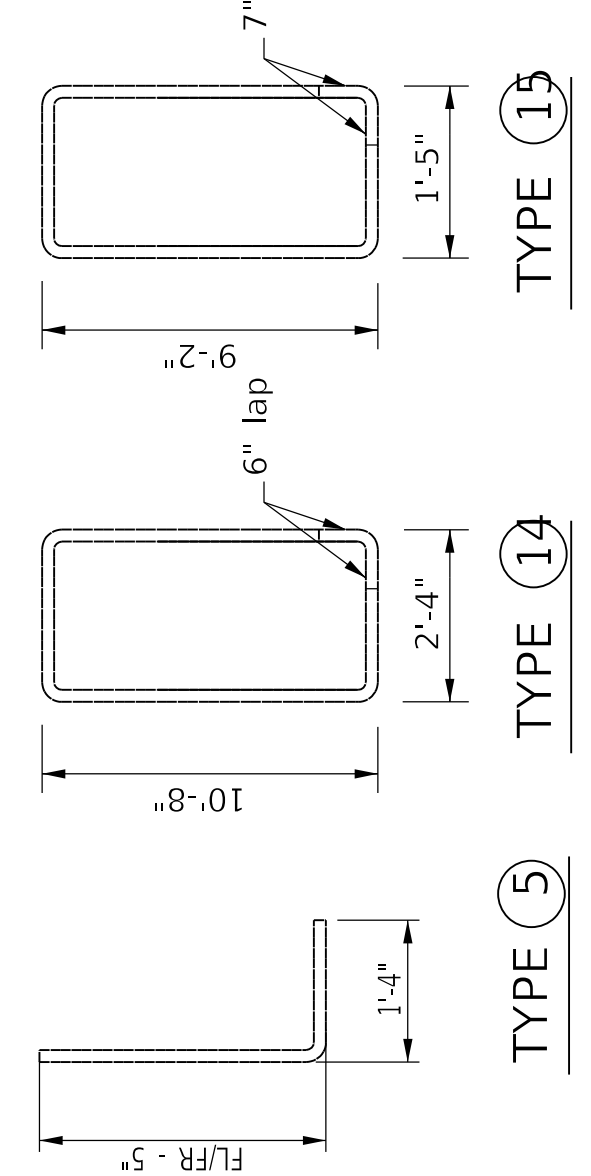

*** ESTIMATE OF QUANTITIES FOR FOOTING**

FL/FR=6'-0"	Conc. Class "A"(cyd)	Reinforcement(lbs)
1' of additional Pedestal height	22.1	2701
	1.1	125

* Approx. estimate is for information only. Tabulated FL and FR shall be verified by the Engineer in the field.

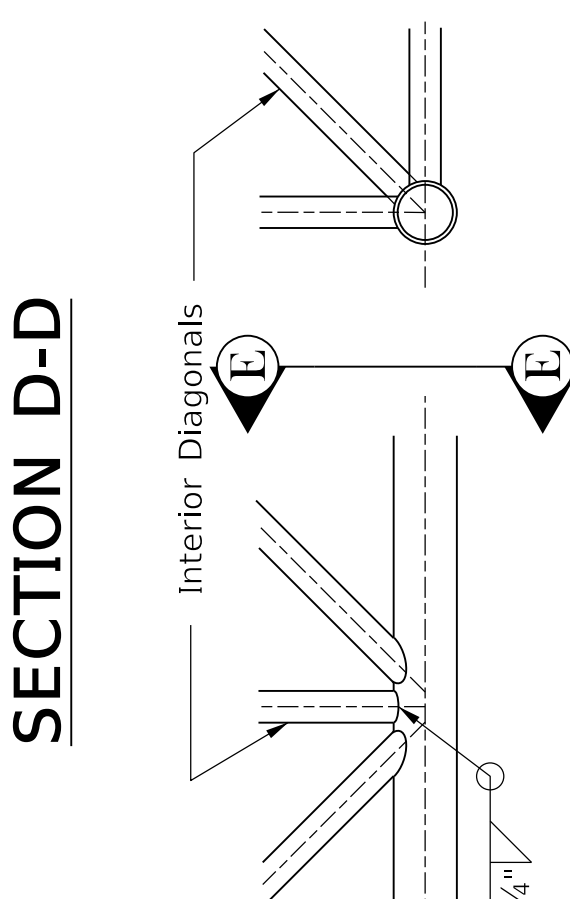
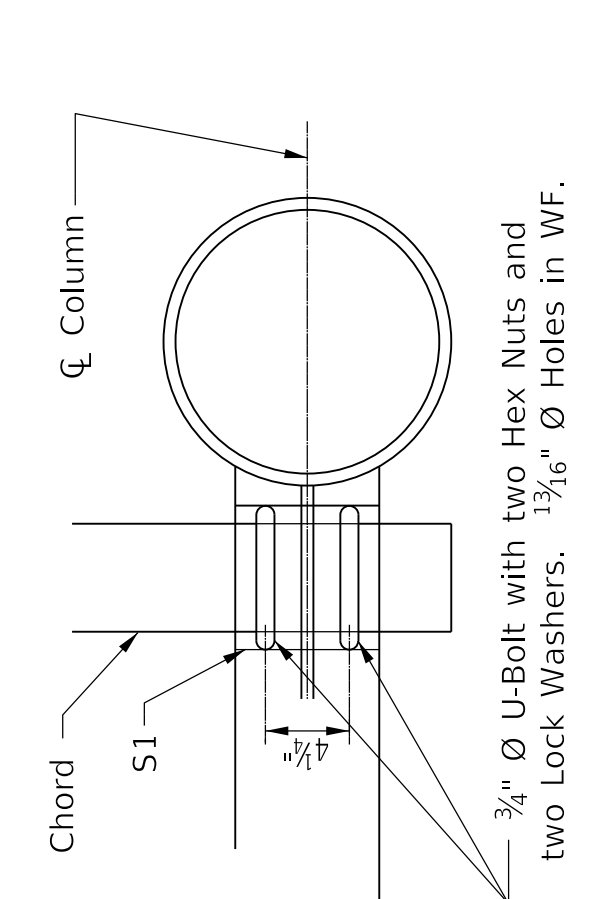

TYPICAL PANEL POINT DETAIL
See Vent/Drain Hole Note

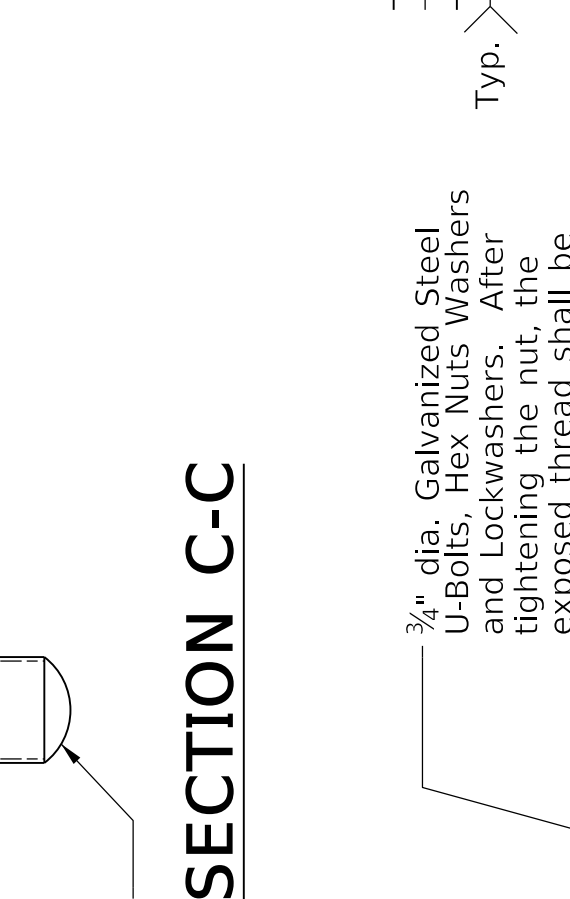
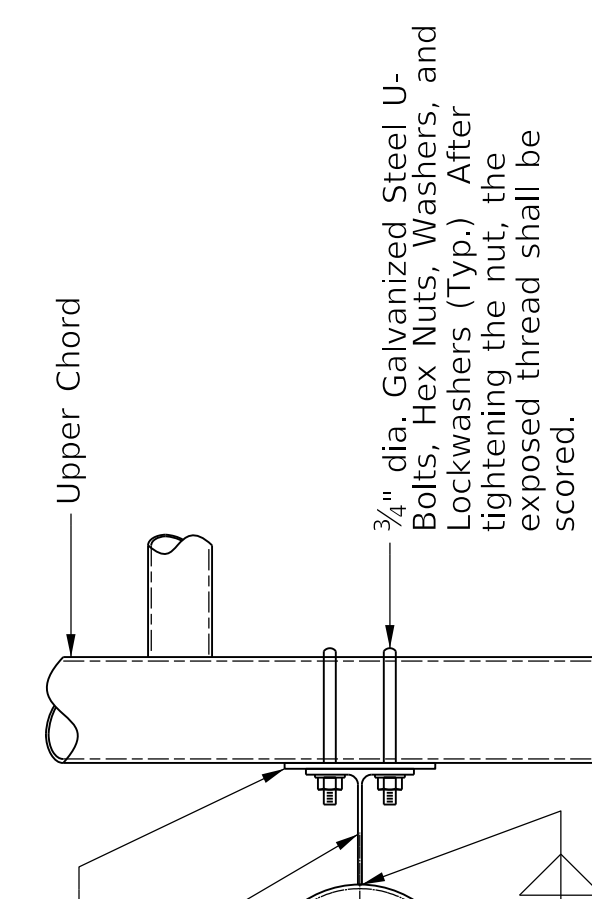

CHORD SPLICE

6-7/8" A325 Bolts with Hex Nuts and Lock Washers
Note: Only 1 bolt shown for clarity.

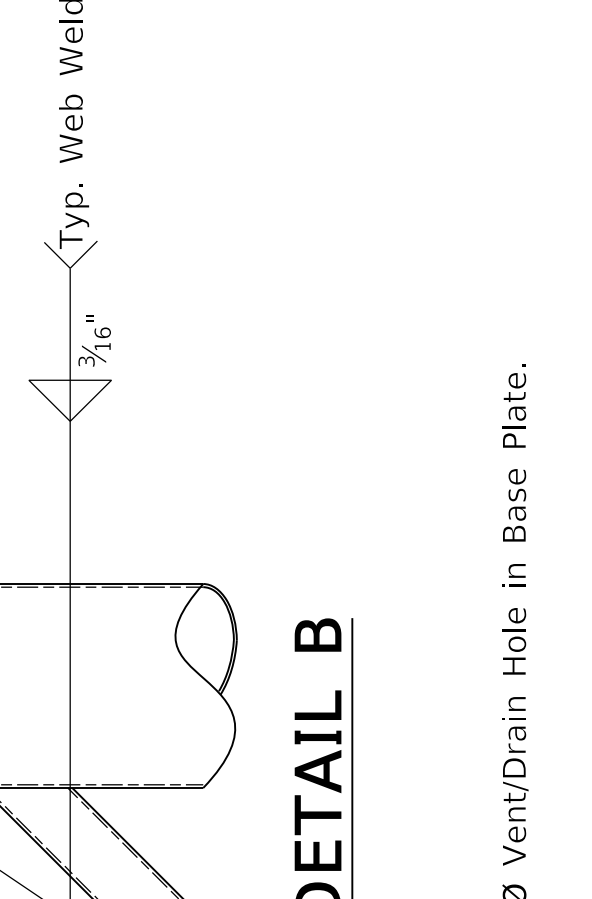

BASE PLATE DETAIL

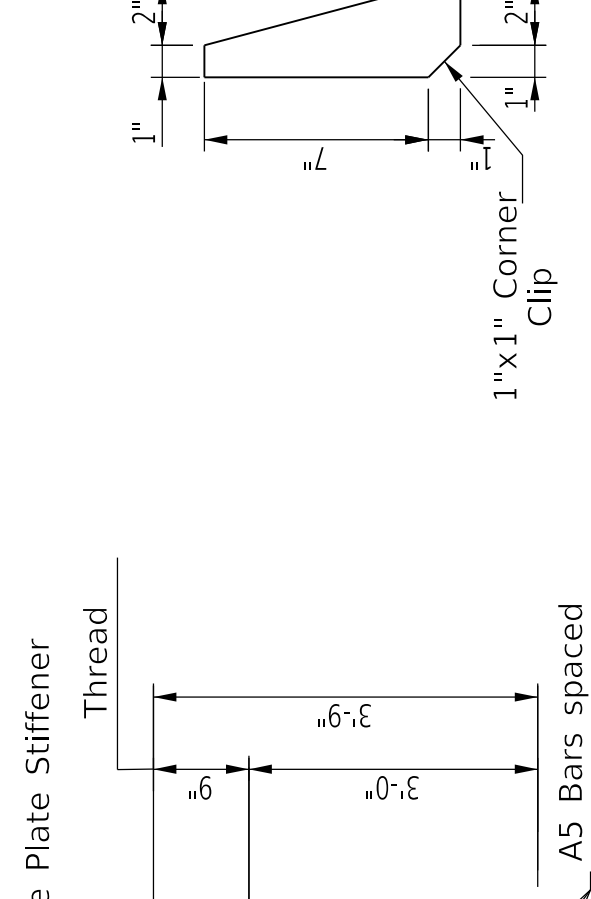

TOP OF PEDESTAL SLOPE DETAIL

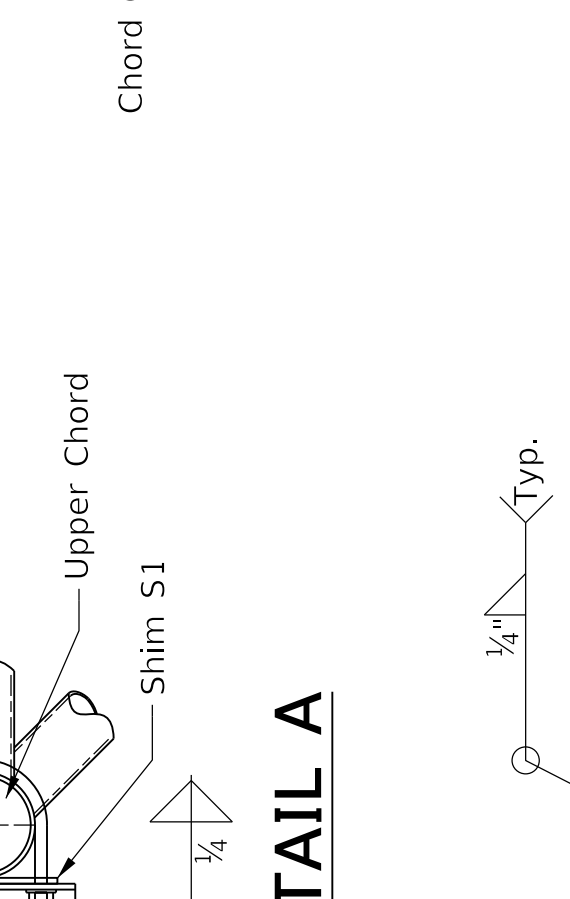
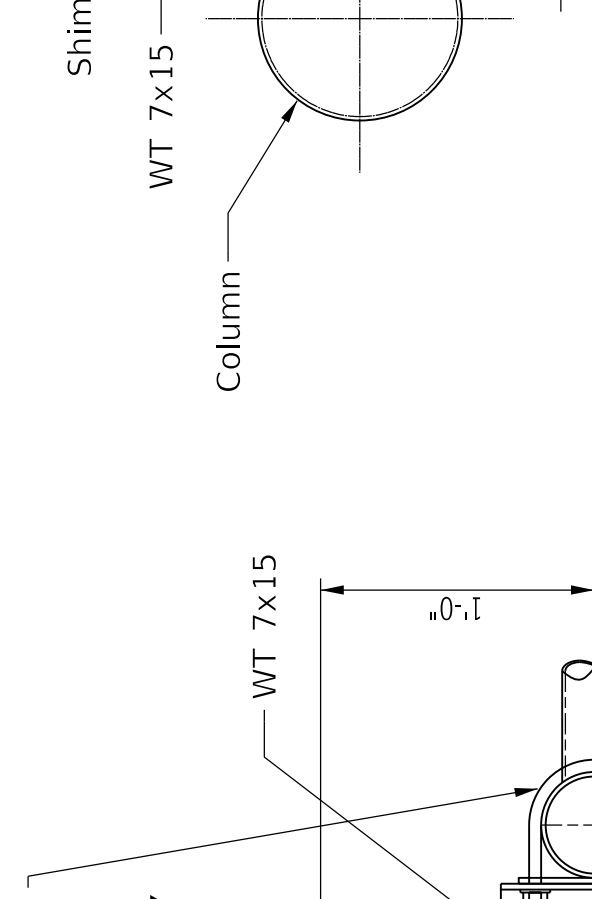

DETAIL D
See Vent/Drain Hole Note for more information

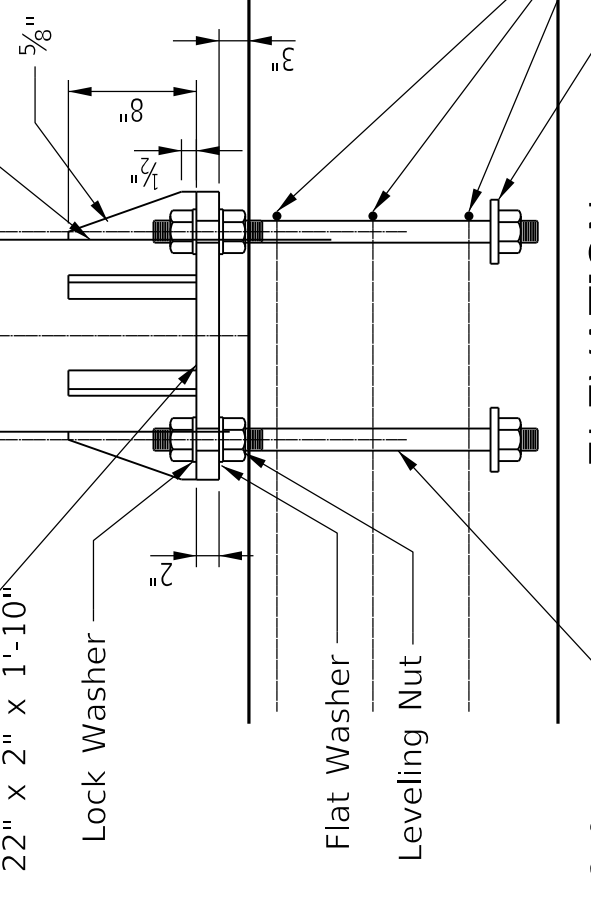
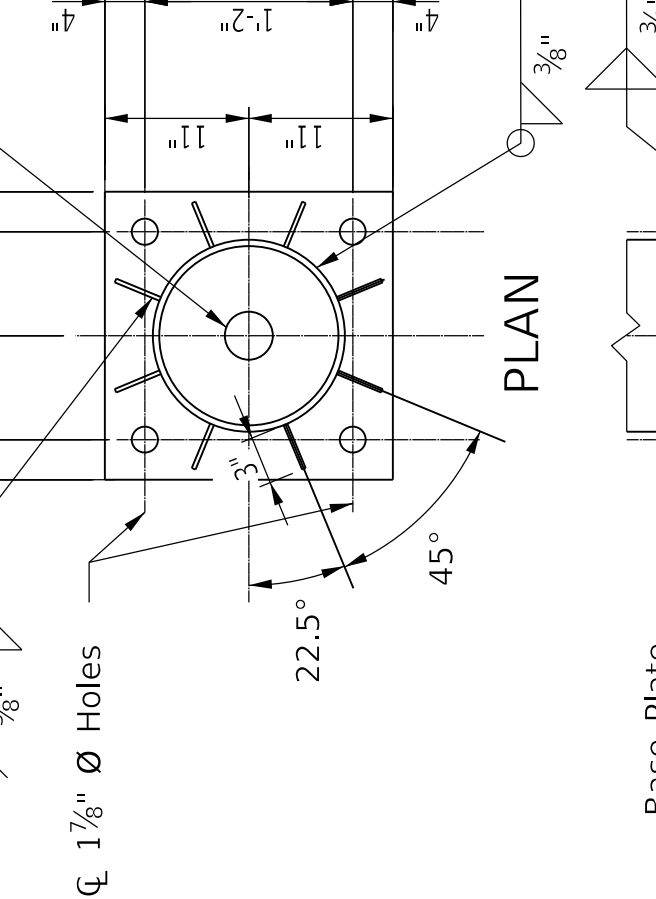
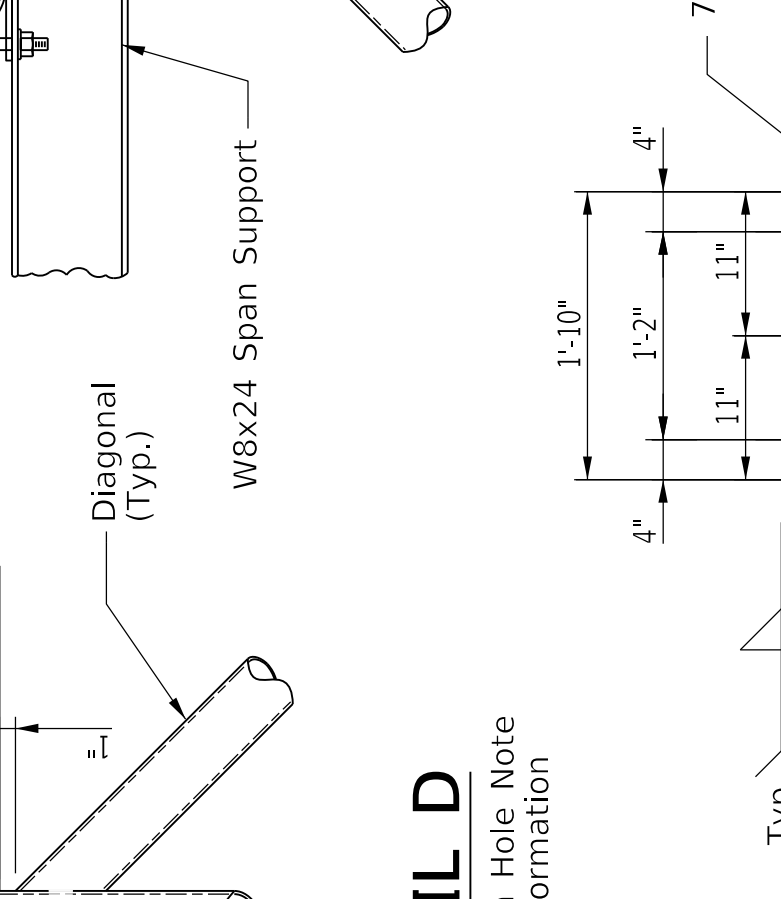

BASE PLATE DETAIL

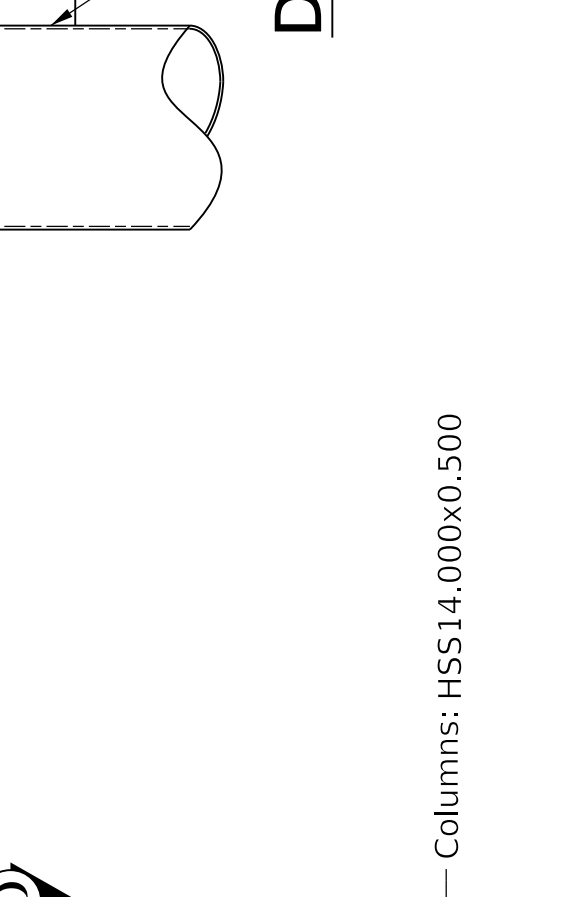
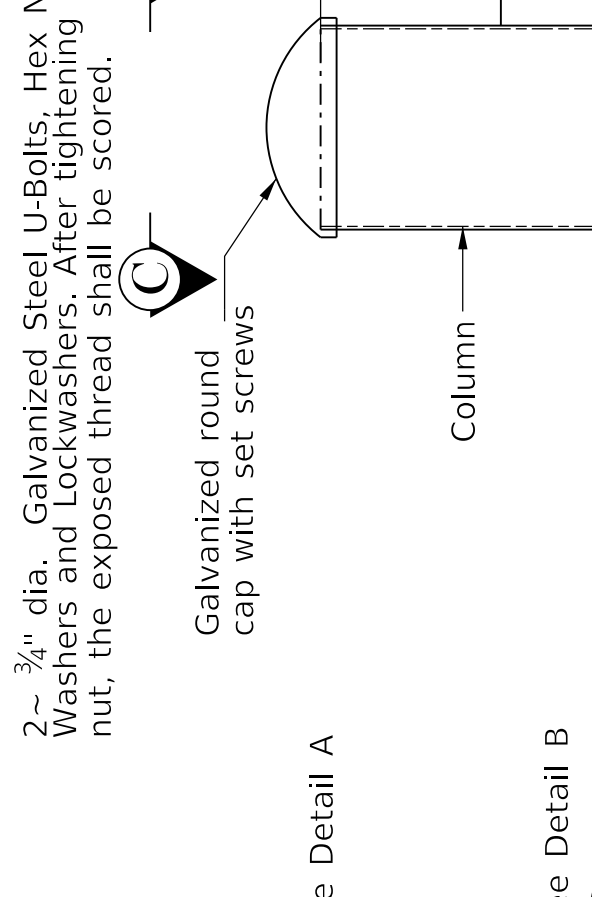

DETAIL D
See Vent/Drain Hole Note for more information

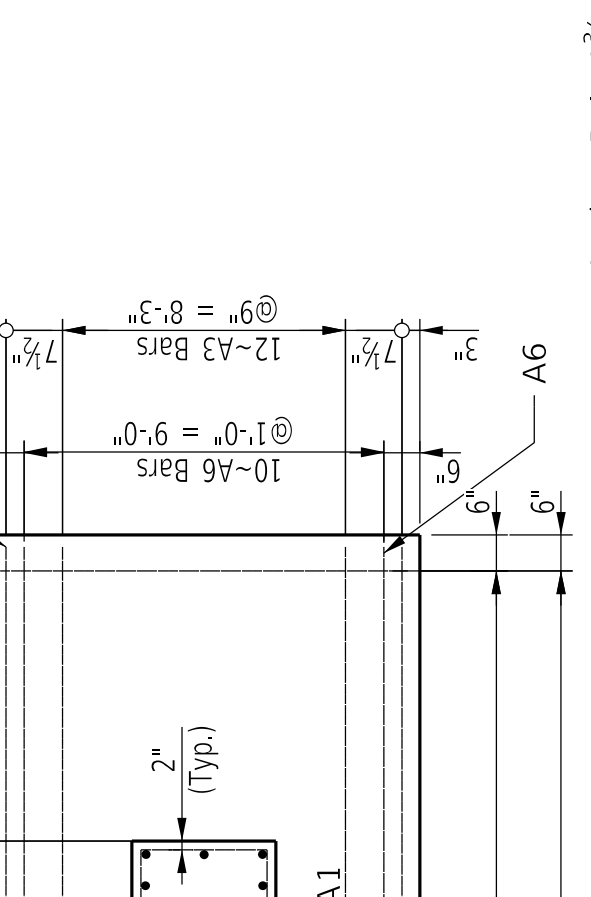
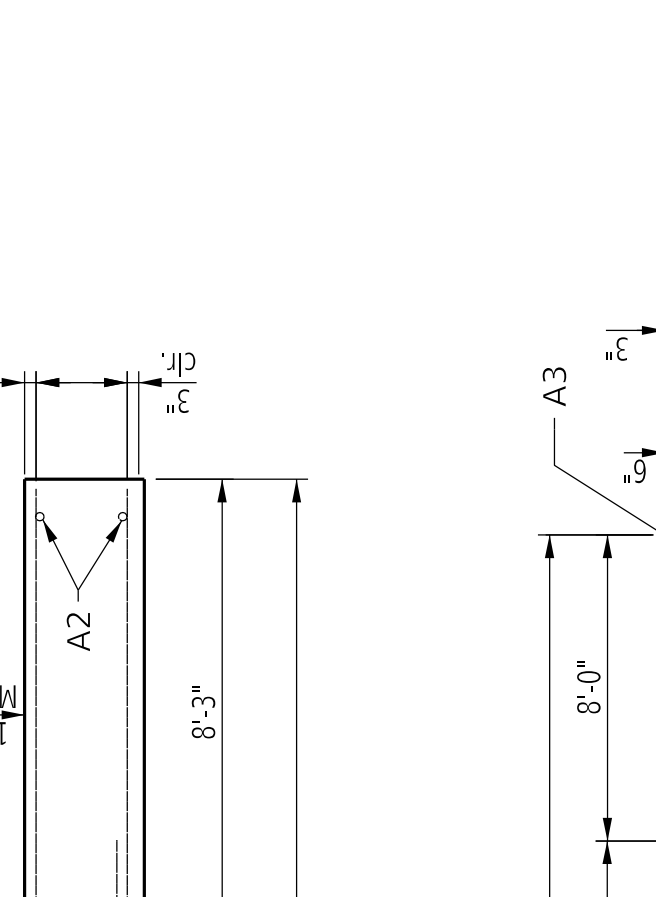
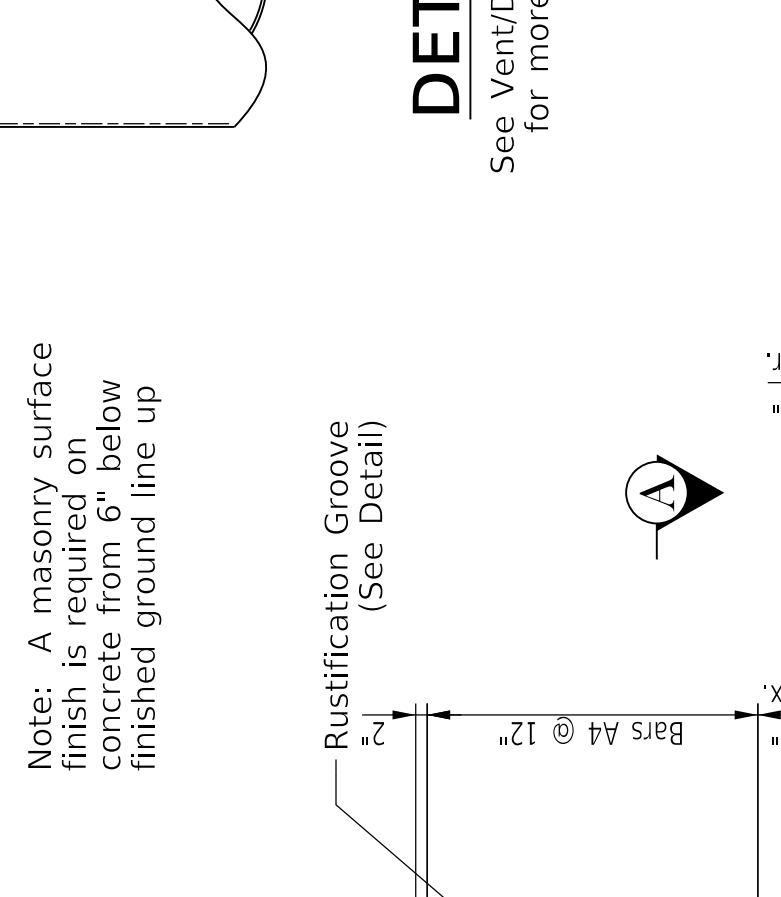

BASE PLATE DETAIL

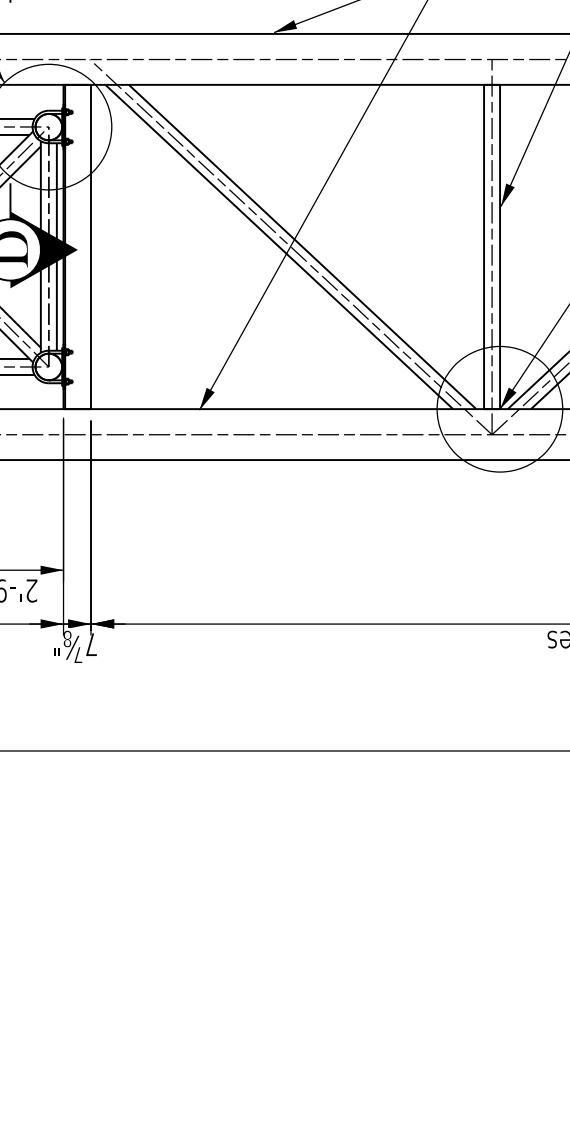
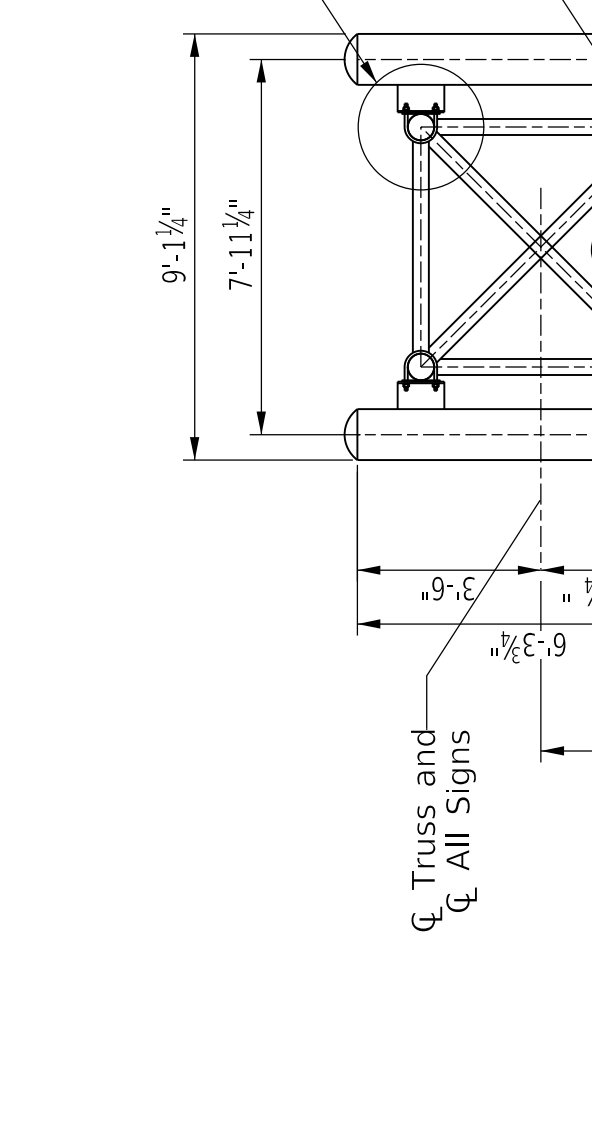

SECTION A-A

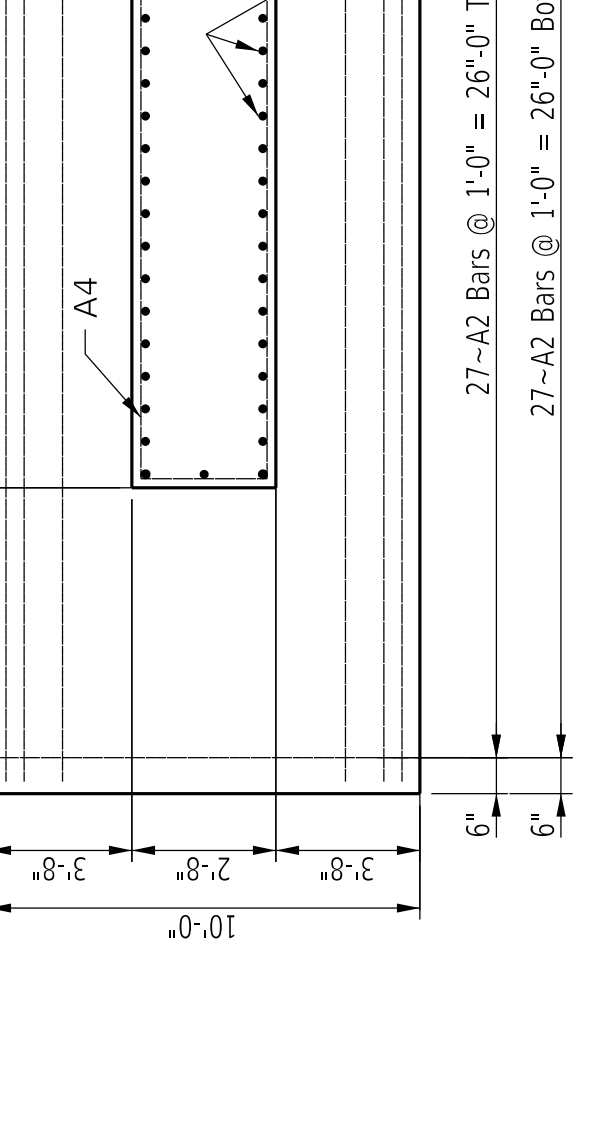
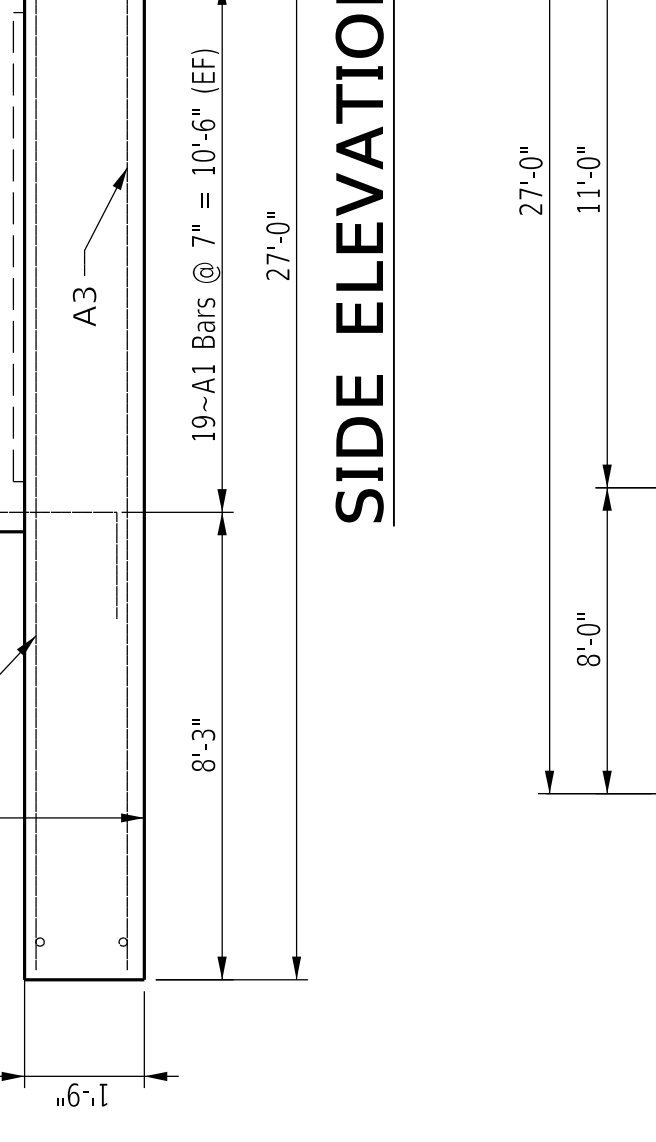
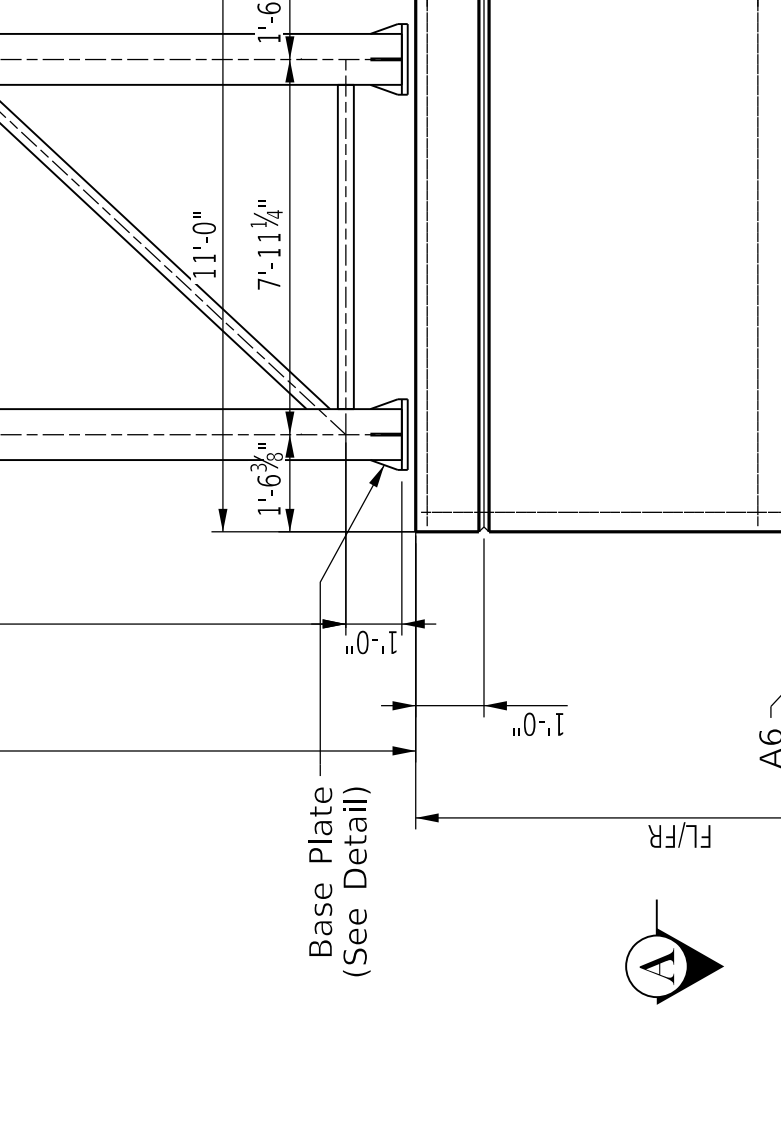

SECTION A-A



SECTION E-E



SECTION E-E



SECTION E-E



SECTION E-E

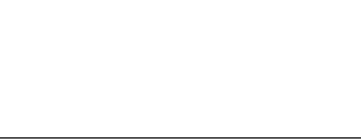

SECTION E-E

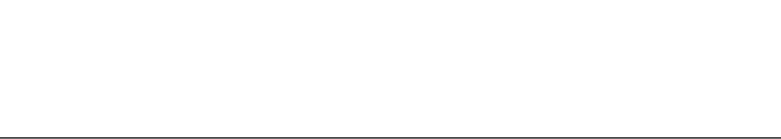

SECTION E-E



SECTION E-E



SECTION E-E



SECTION E-E



SECTION E-E



SECTION E-E

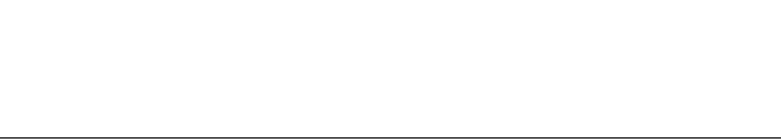

SECTION E-E



SECTION E-E

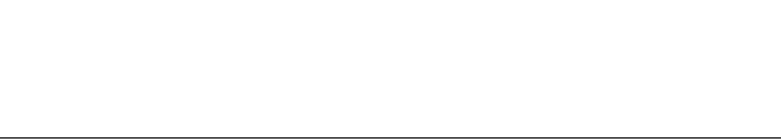

SECTION E-E



SECTION E-E



SECTION E-E



SECTION E-E



SECTION E-E



SECTION E-E



SECTION E-E

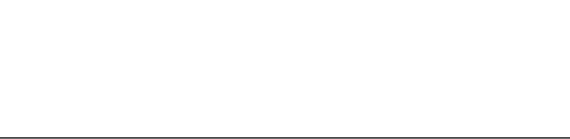

SECTION E-E



SECTION E-E



SECTION E-E



SECTION E-E



SECTION E-E



SECTION E-E



SECTION E-E



SECTION E-E

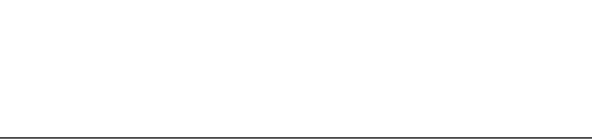

SECTION E-E



SECTION E-E



SECTION E-E

BILL OF REINFORCEMENT FOR FOOTING

MARK	TYPE	NO.	SIZE	LENGTH		LOCATION
				FT.	IN.	
A1	5	40	#8	FL/FR+0'-11"	6	Footing & Wall
A2	Str	54	#5	9	6	Footing
A3	Str	14	#8	26	6	Footing
A4(S)	14	Var.	#4	27	0	Wall
A5(S)	15	3	#5	22	4	Anchorage
A6	Str	10	#5	26	6	Footing

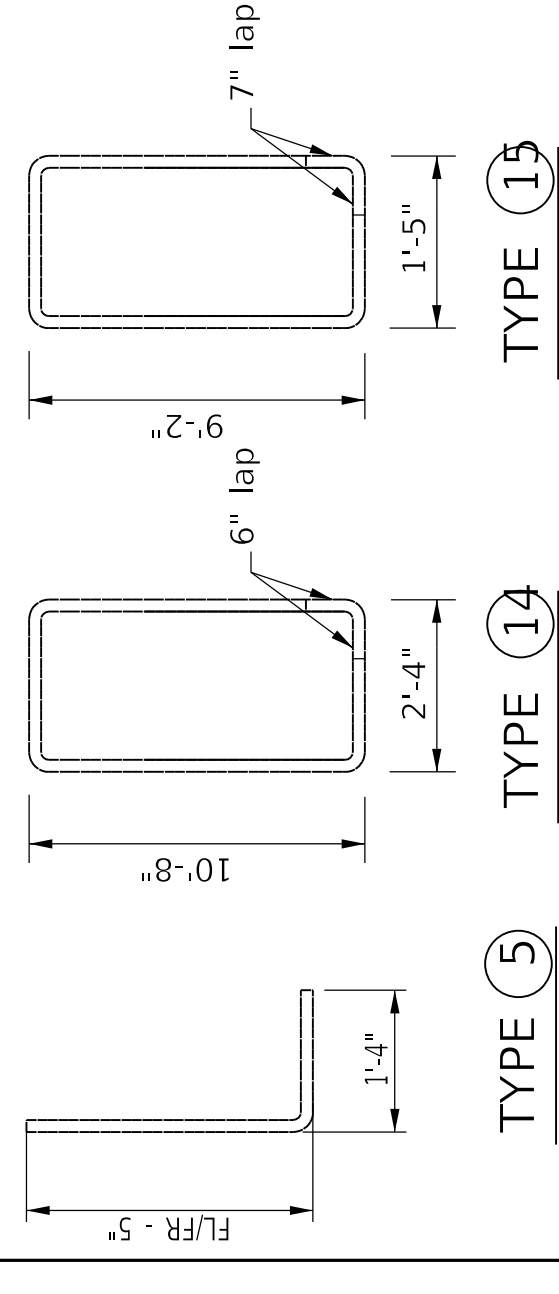

*** ESTIMATE OF QUANTITIES FOR FOOTING**

Conc. Class "A"(cyd)	Reinforcement(lbs)
22.1	2701
1.1	125

1' of additional Pedestal height

* Approx. estimate is for information only. Tabulated FL and FR shall be verified by the Engineer in the field.

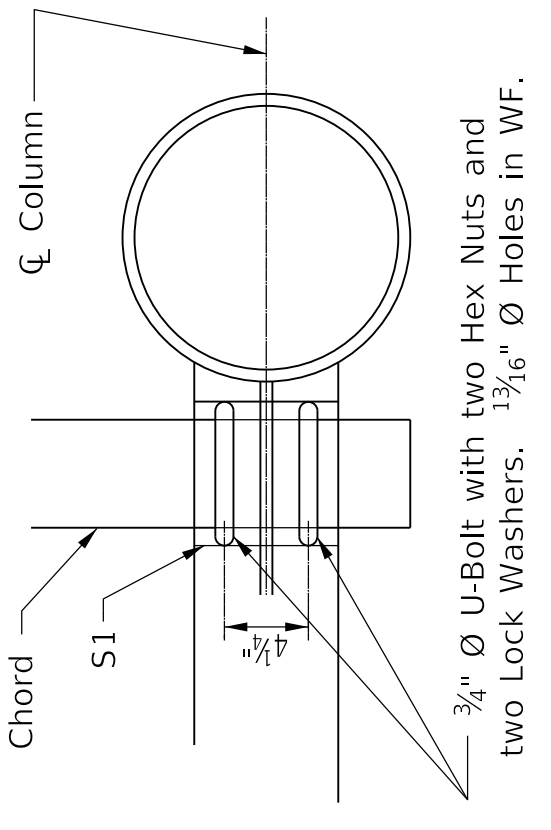

SECTION D-D

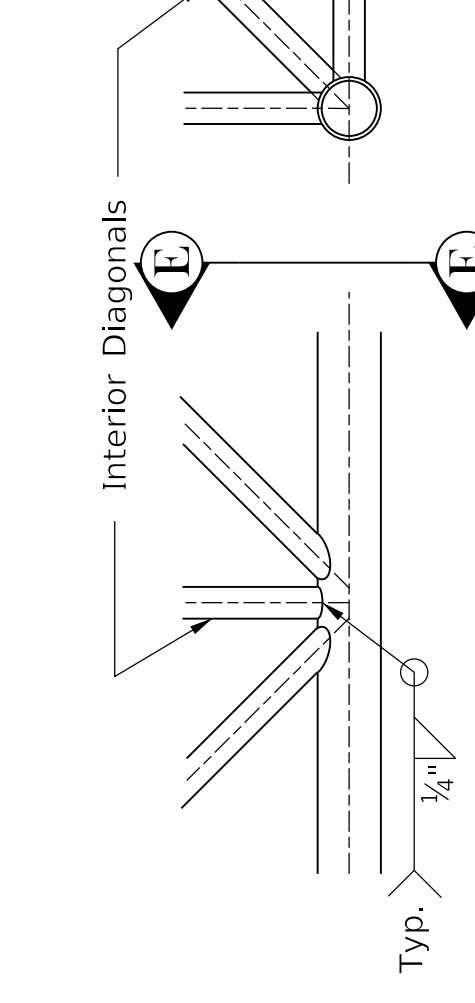

SECTION E-E

TYPICAL PANEL POINT DETAIL

See Vent/Drain Hole Note

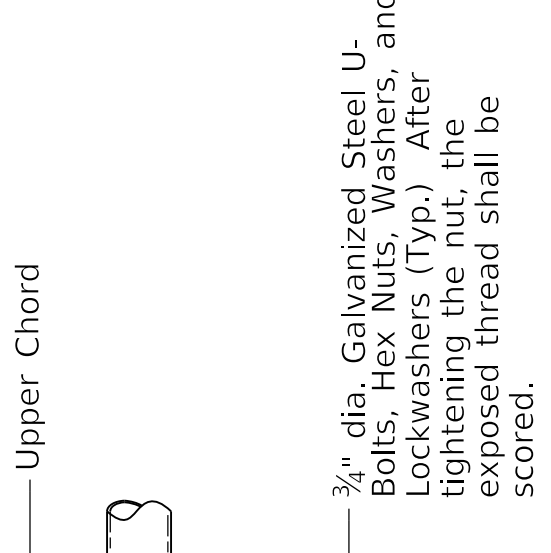

SECTION C-C

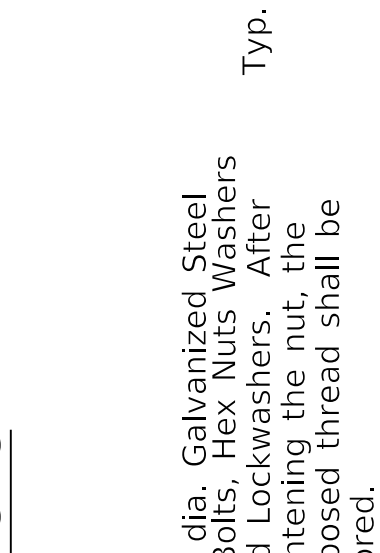

SECTION E-E

TYPICAL PANEL POINT DETAIL

See Vent/Drain Hole Note

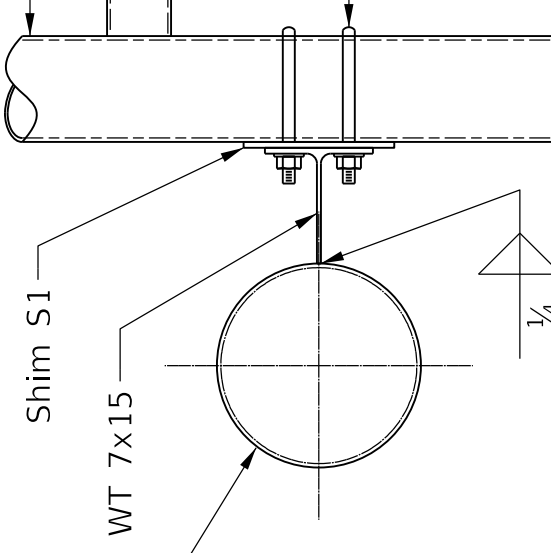

DETAIL A

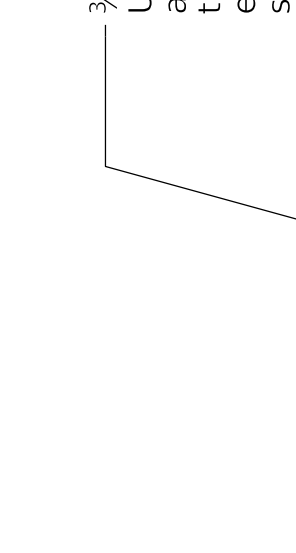

DETAIL B

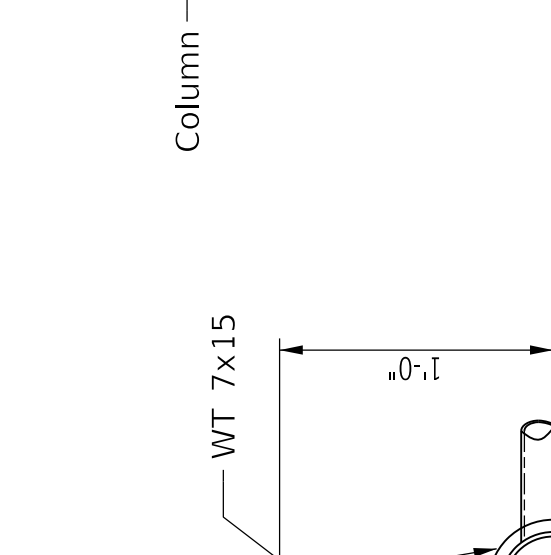

DETAIL C

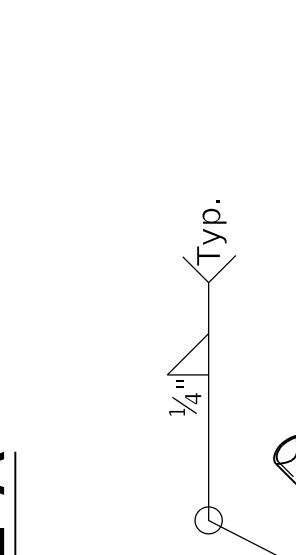

DETAIL D

See Vent/Drain Hole Note for more information

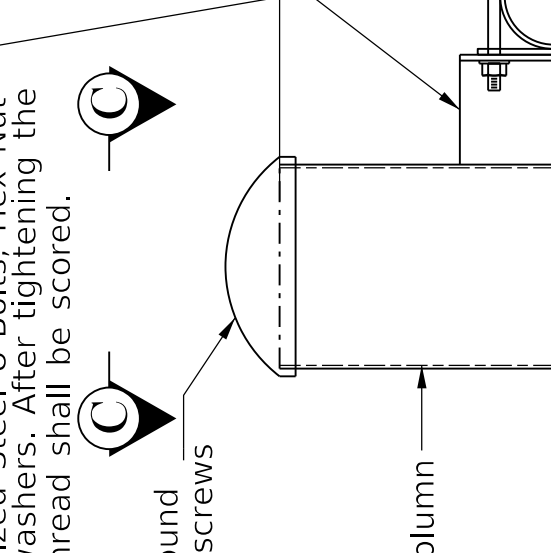

SECTION C-C

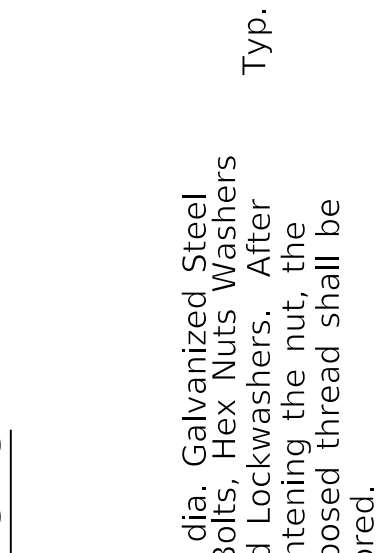

SECTION E-E

TYPICAL PANEL POINT DETAIL

See Vent/Drain Hole Note

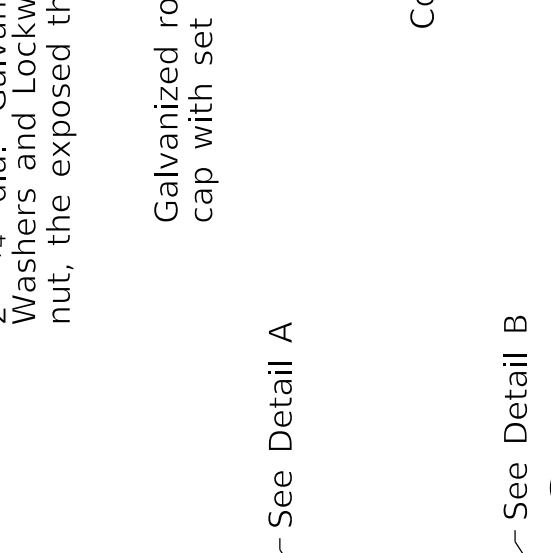

DETAIL A

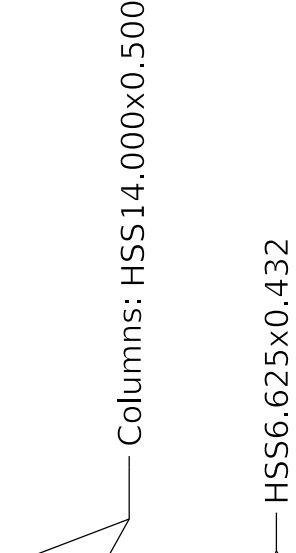

DETAIL B

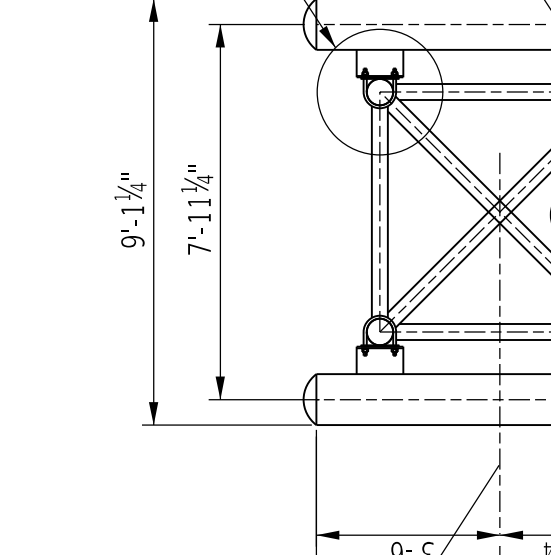

DETAIL C

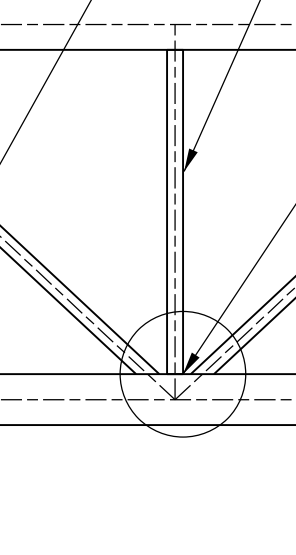

DETAIL D

See Vent/Drain Hole Note for more information

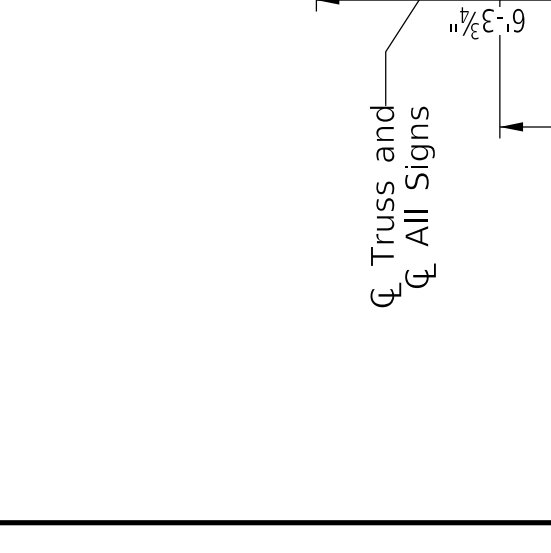

SECTION C-C

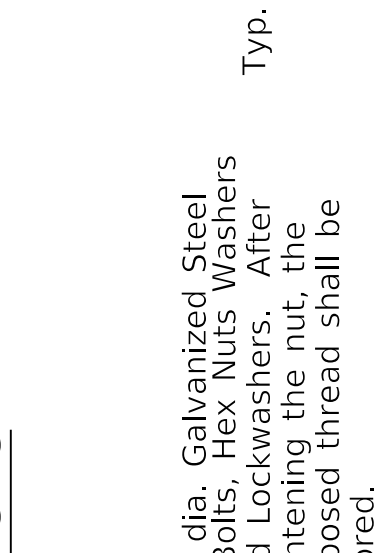

SECTION E-E

TYPICAL PANEL POINT DETAIL

See Vent/Drain Hole Note

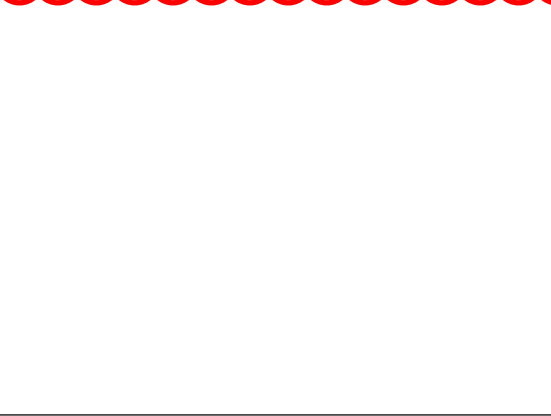

DETAIL A



DETAIL B

DETAIL C

DETAIL D

See Vent/Drain Hole Note for more information

SECTION C-C

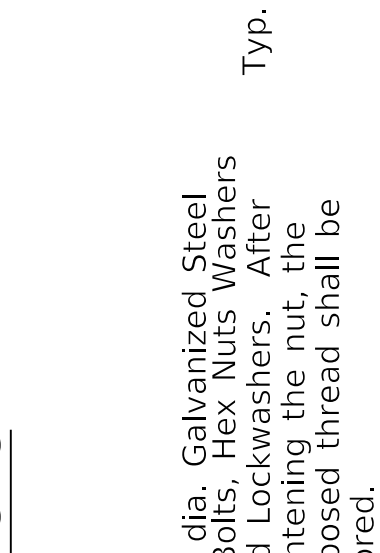

SECTION E-E

TYPICAL PANEL POINT DETAIL

See Vent/Drain Hole Note

DETAIL A

DETAIL B

DETAIL C

DETAIL D

See Vent/Drain Hole Note for more information

SECTION C-C

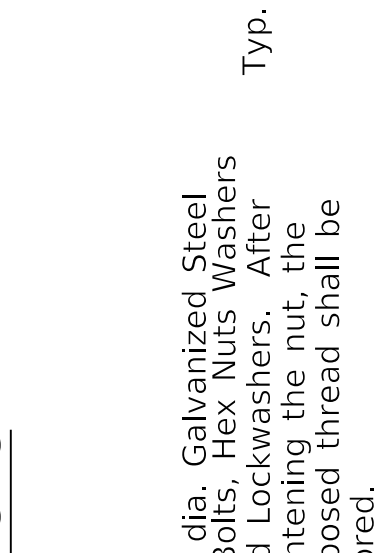

SECTION E-E

TYPICAL PANEL POINT DETAIL

See Vent/Drain Hole Note

DETAIL A

DETAIL B

DETAIL C

DETAIL D

See Vent/Drain Hole Note for more information

SECTION C-C

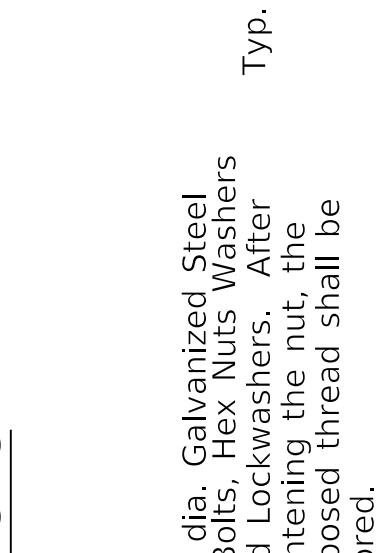

SECTION E-E

TYPICAL PANEL POINT DETAIL

See Vent/Drain Hole Note

DETAIL A

DETAIL B

DETAIL C

DETAIL D

See Vent/Drain Hole Note for more information

SECTION C-C

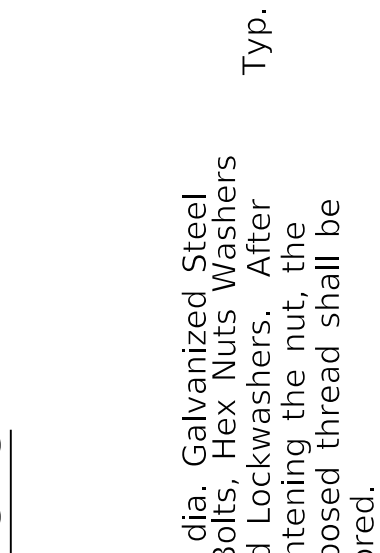

SECTION E-E

TYPICAL PANEL POINT DETAIL

See Vent/Drain Hole Note

DETAIL A

DETAIL B

DETAIL C

DETAIL D

See Vent/Drain Hole Note for more information

SECTION C-C

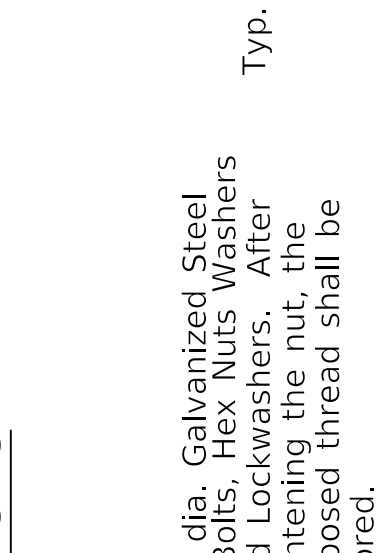

SECTION E-E

TYPICAL PANEL POINT DETAIL

See Vent/Drain Hole Note

DETAIL A

DETAIL B

DETAIL C

DETAIL D

See Vent/Drain Hole Note for more information

SECTION C-C

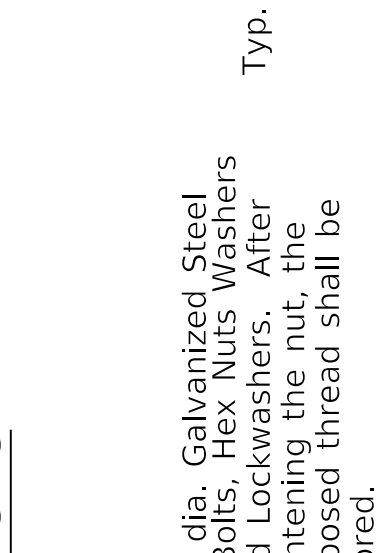

SECTION E-E

TYPICAL PANEL POINT DETAIL

See Vent/Drain Hole Note

DETAIL A

DETAIL B

DETAIL C

DETAIL D

See Vent/Drain Hole Note for more information

SECTION C-C

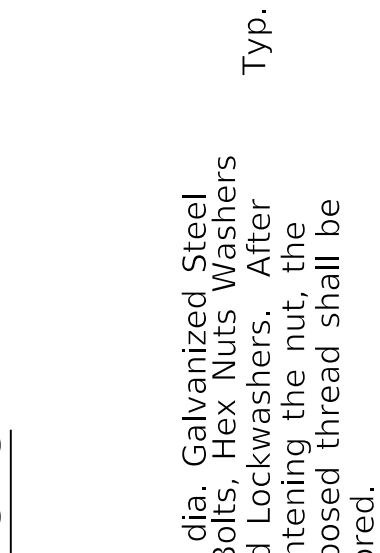

SECTION E-E

TYPICAL PANEL POINT DETAIL

See Vent/Drain Hole Note

DETAIL A

DETAIL B

DETAIL C

DETAIL D

See Vent/Drain Hole Note for more information

SECTION C-C

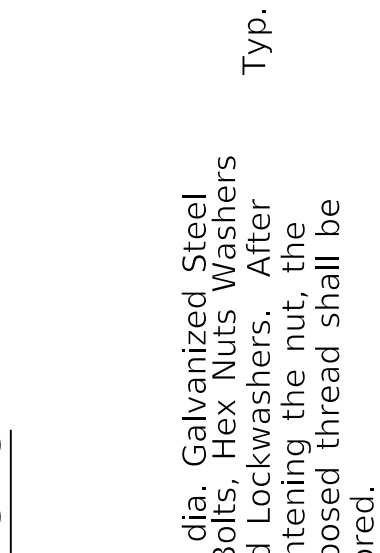

SECTION E-E

TYPICAL PANEL POINT DETAIL

See Vent/Drain Hole Note

DETAIL A

DETAIL B

DETAIL C

DETAIL D

See Vent/Drain Hole Note for more information

SECTION C-C

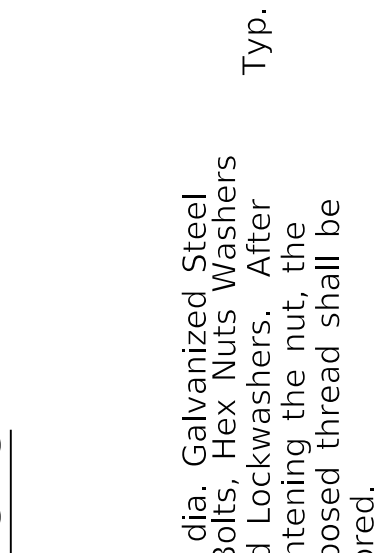

SECTION E-E

TYPICAL PANEL POINT DETAIL

See Vent/Drain Hole Note

DETAIL A

DETAIL B

DETAIL C

DETAIL D

See Vent/Drain Hole Note for

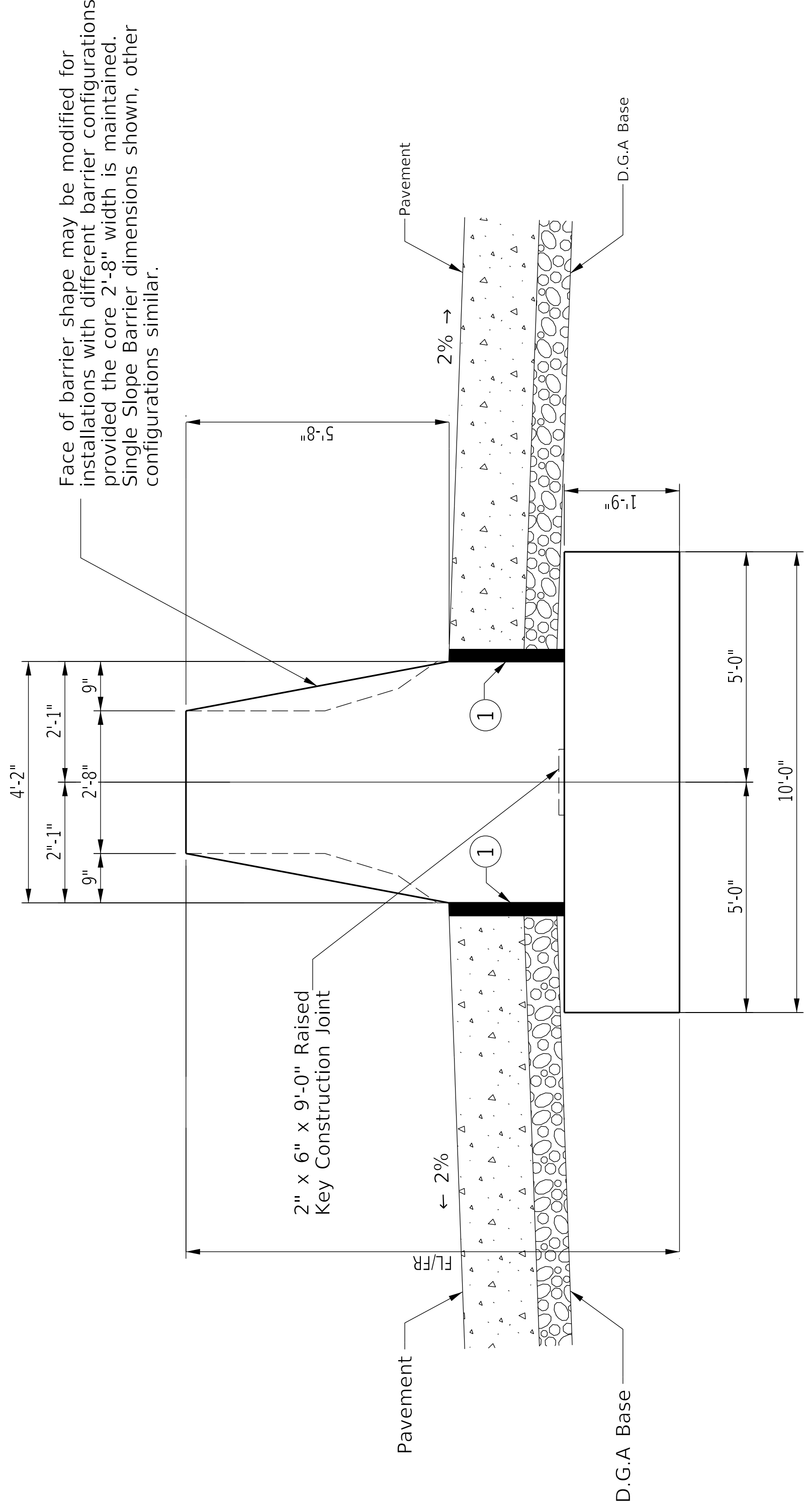

END VIEW MEDIAN
(At Sign Truss)

Note:
① 1/2" PRE-MOLDED EXPANSION MATERIAL

NOTE:
FOR DETAILS SEE TRUSS LAYOUT
AND TRUSS DETAILS SHEET

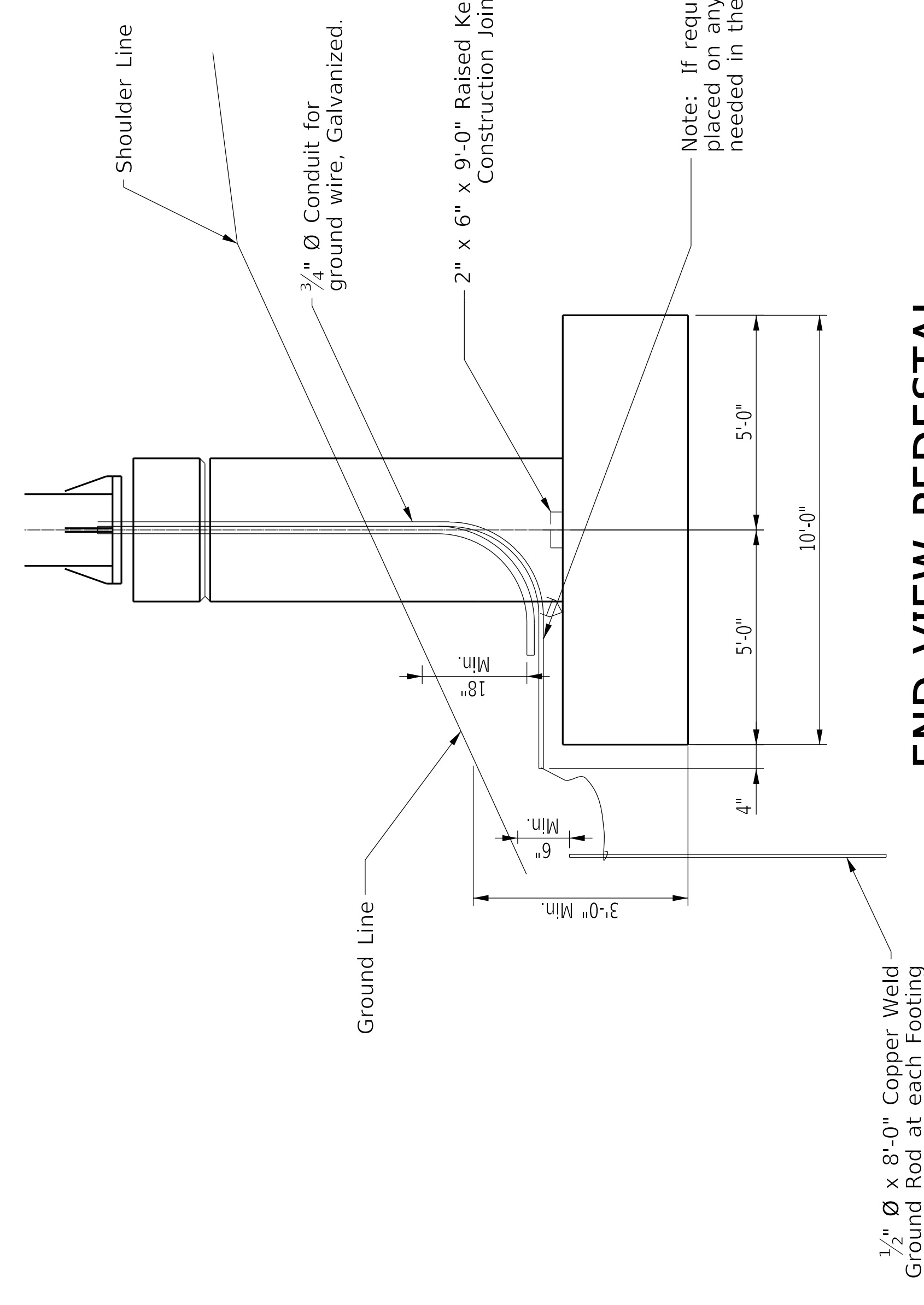

END VIEW PEDESTAL

See Truss Details Sheet for Plan View

1/2" Ø x 8'-0" Copper Weld
Ground Rod at each Footing

Note: If required, conduit may be placed on any face of pedestal as needed in the field.

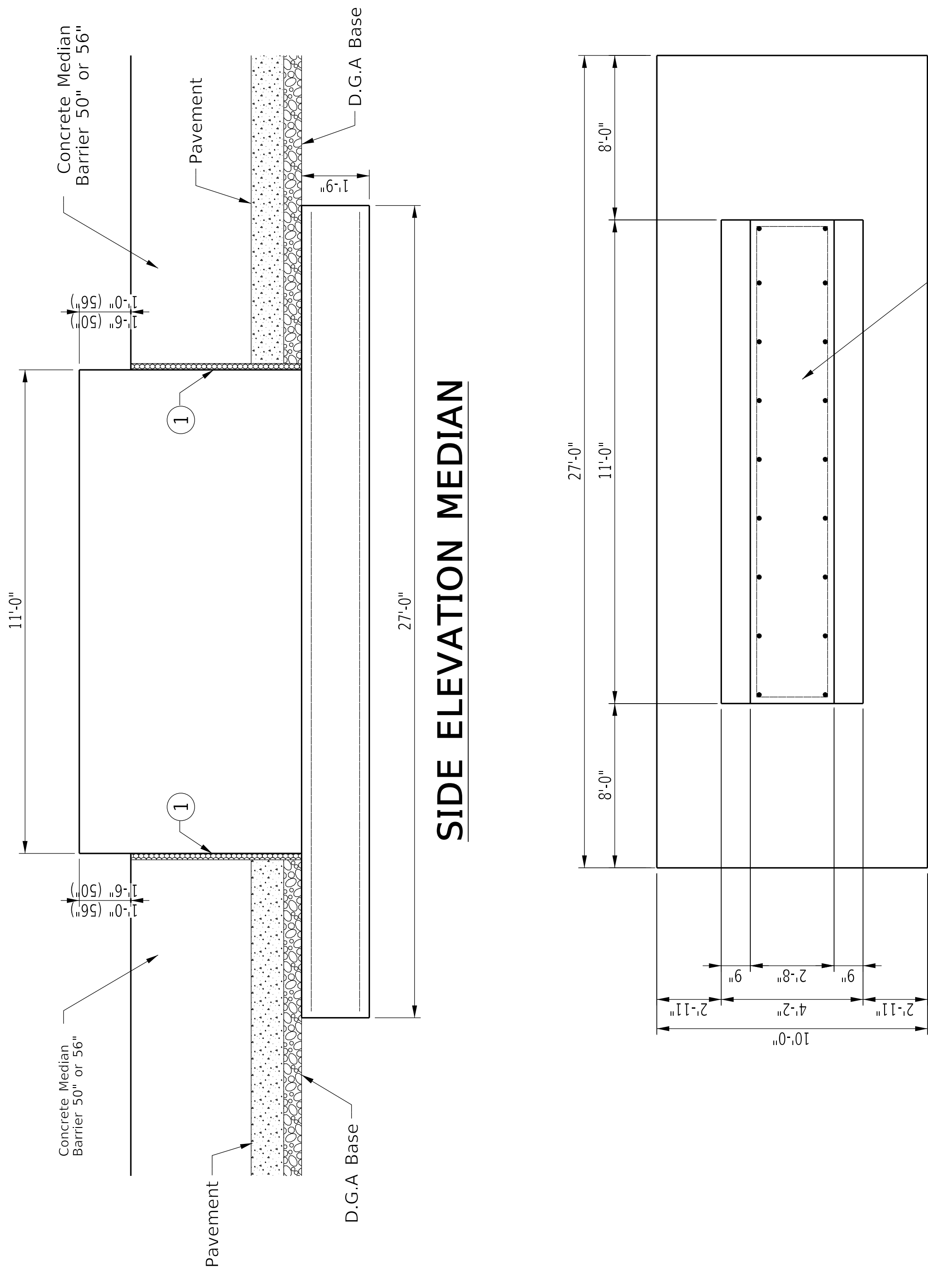

SIDE ELEVATION MEDIAN

PLAN VIEW MEDIAN

SEE TRUSS DETAILS SHEET FOR REINFORCEMENT

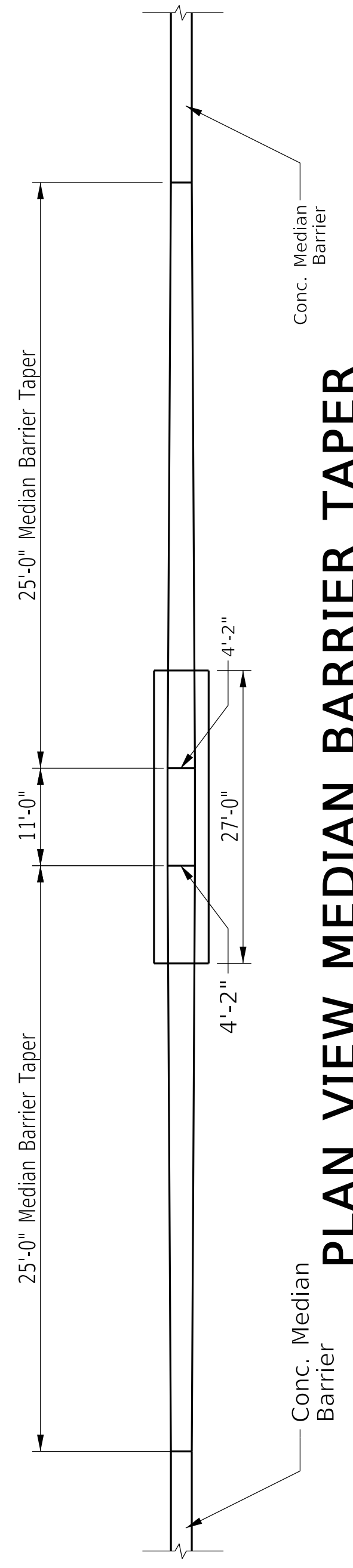

PLAN VIEW MEDIAN BARRIER TAPER

* Approx. estimate is for information only. Tabulated FL/FR shall be verified by the Engineer in the field.

* ESTIMATE OF QUANTITIES FOR MEDIAN FOOTING	
Conc. Class "A" Steel Reinforcement	2951 Lbs.
FL/FR=8'-0"	
1' of additional Pedestal height	1.7 cu.yds.
	125 Lbs.

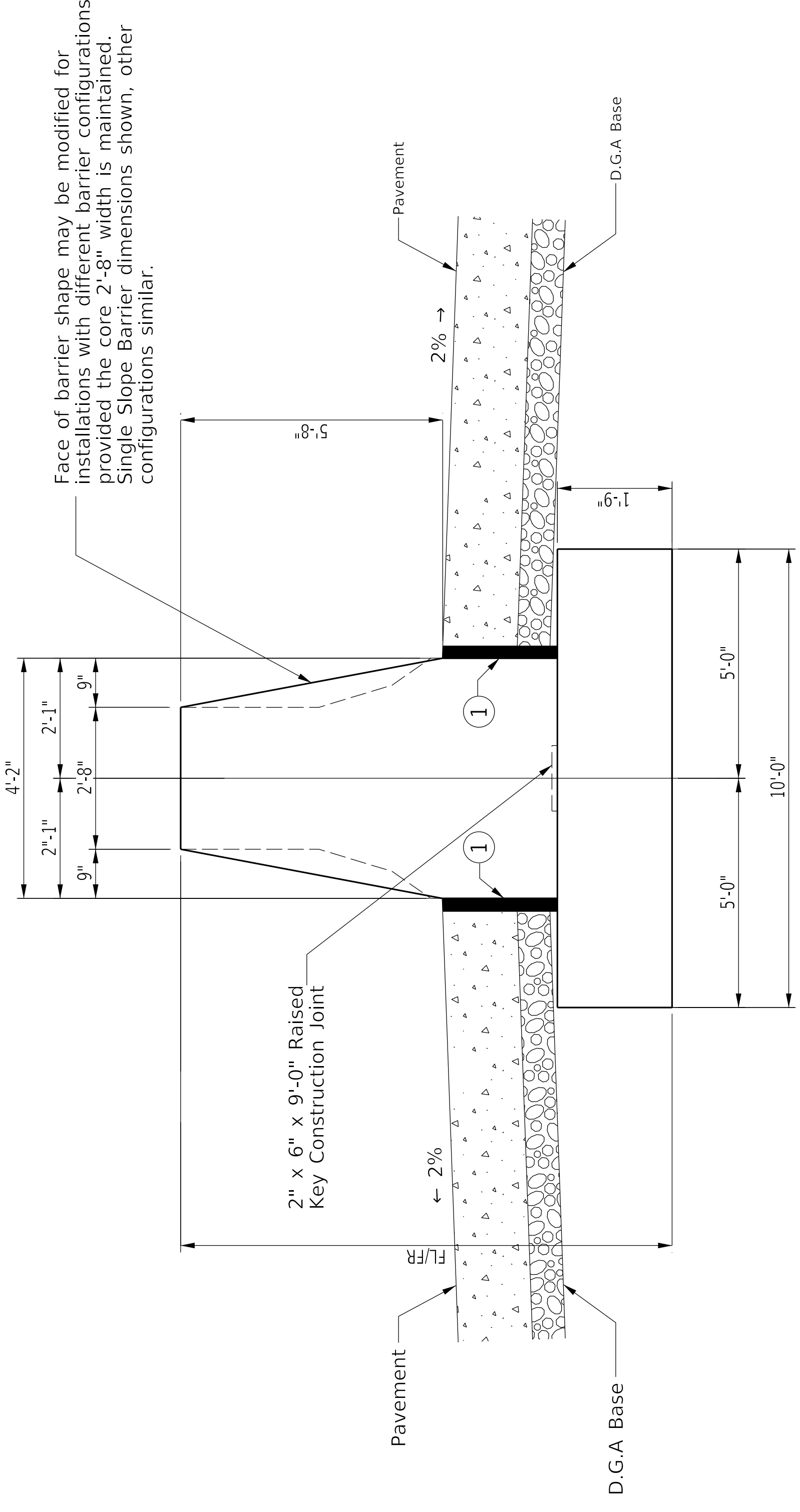

END VIEW MEDIAN (At Sign Truss)

Note:
① 1/2" PRE-MOLDED EXPANSION MATERIAL

NOTE:
FOR DETAILS SEE TRUSS LAYOUT
AND TRUSS DETAILS SHEET

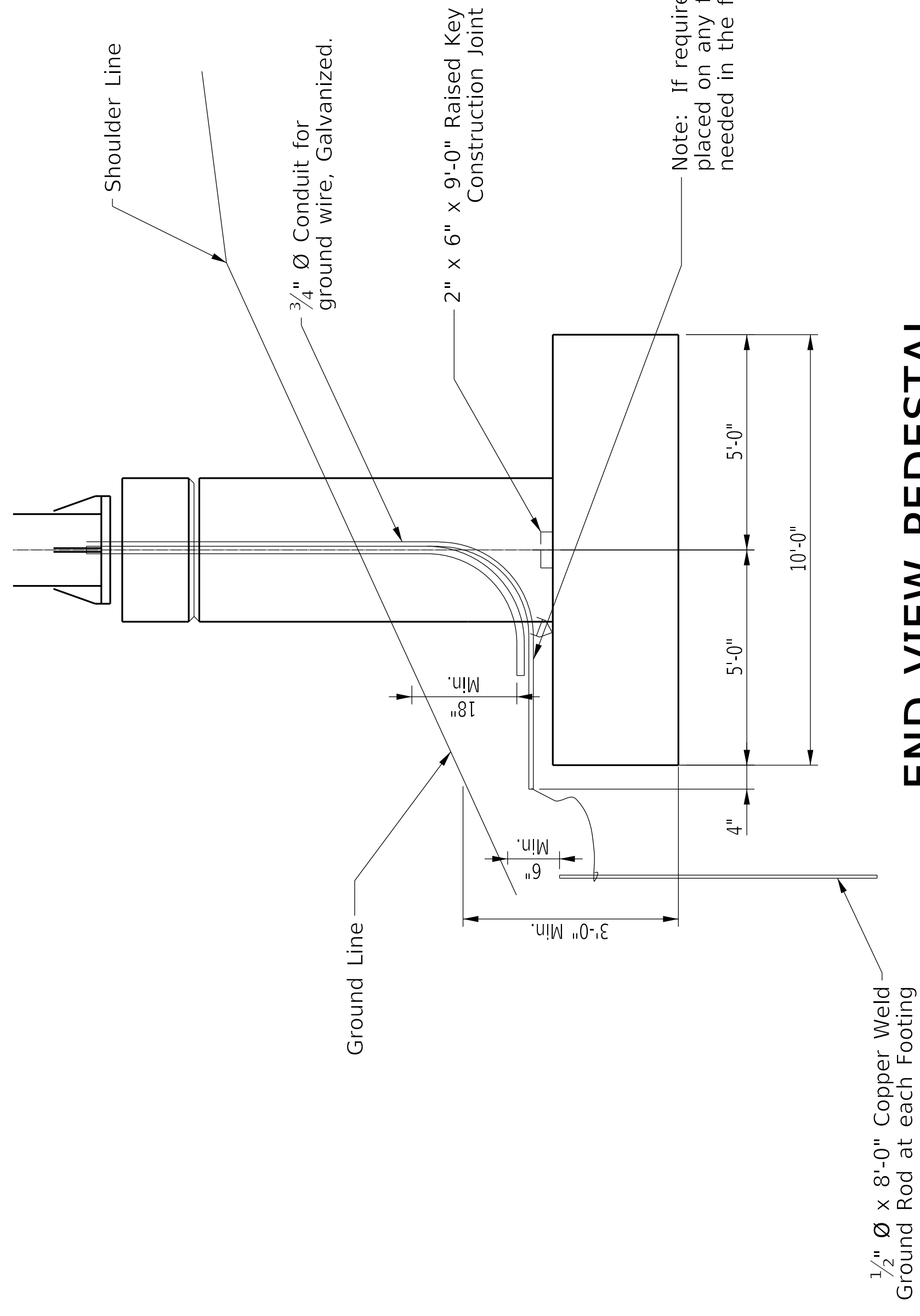

END VIEW PEDESTAL See Truss Details Sheet for Plan View

1/2" Ø x 8'-0" Copper Weld
Ground Rod at each Footing

Face of barrier shape may be modified for installations with different barrier configurations provided the core 2'-8" width is maintained. Single Slope Barrier dimensions shown, other configurations similar.

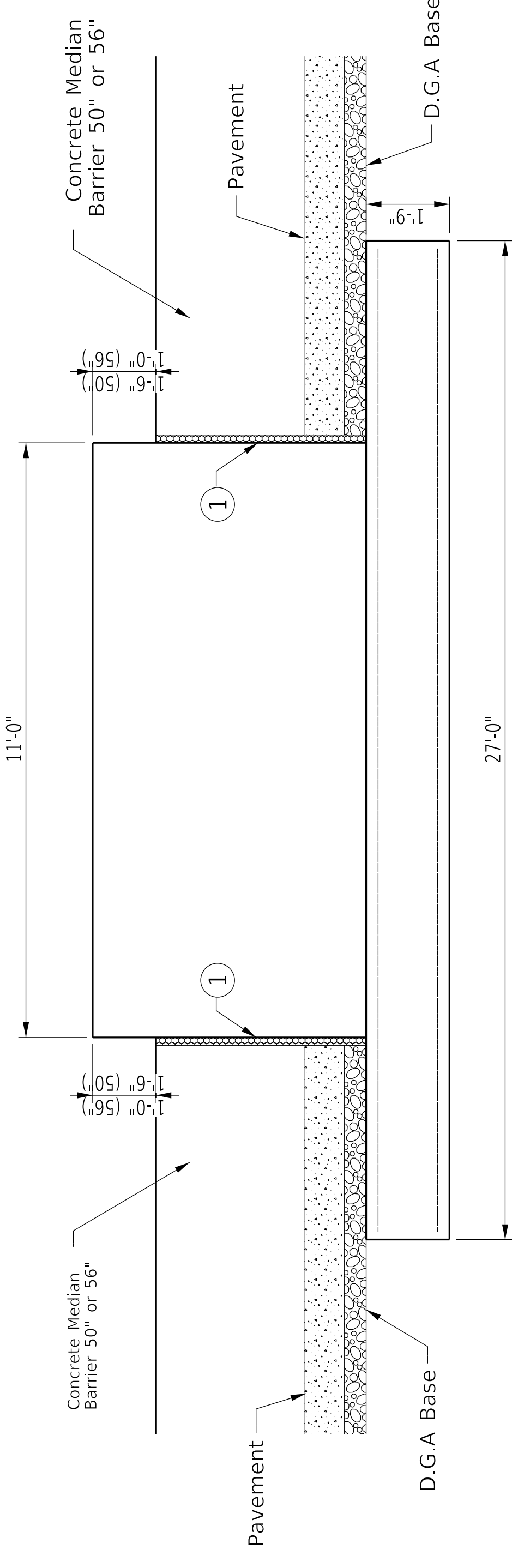

SIDE ELEVATION MEDIAN

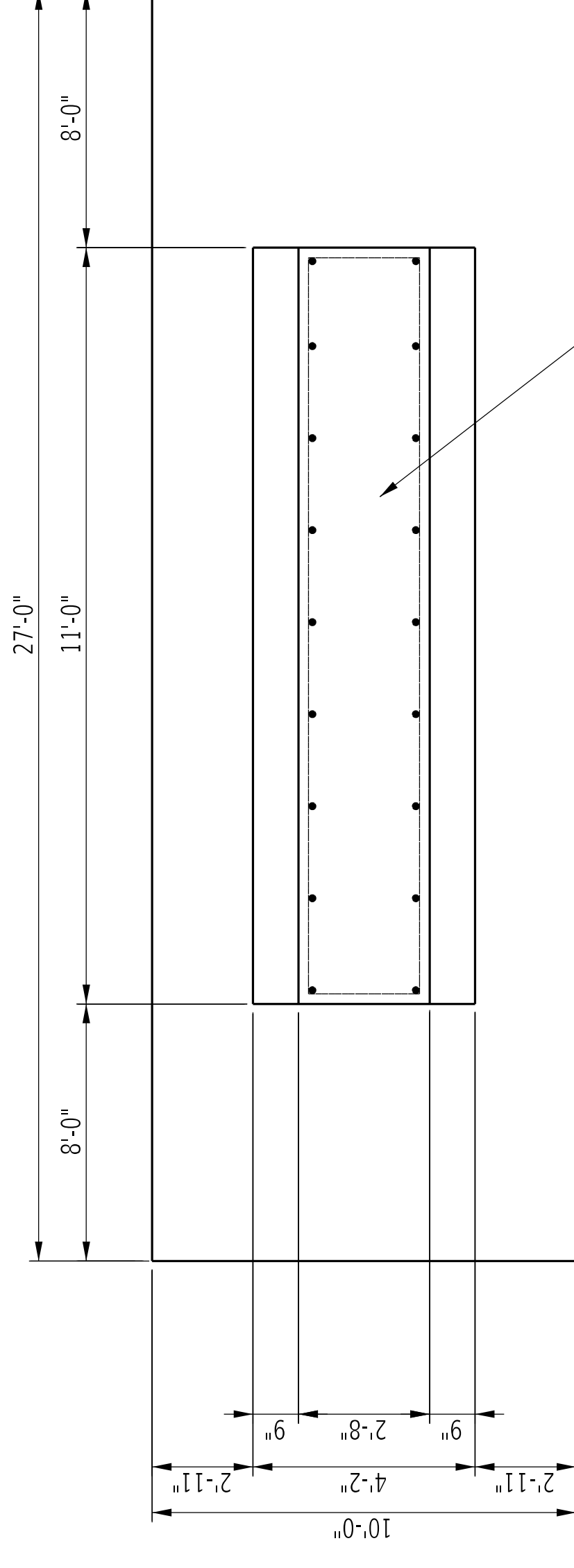

PLAN VIEW MEDIAN

SEE TRUSS DETAILS SHEET
FOR REINFORCEMENT

ADDED SHEET

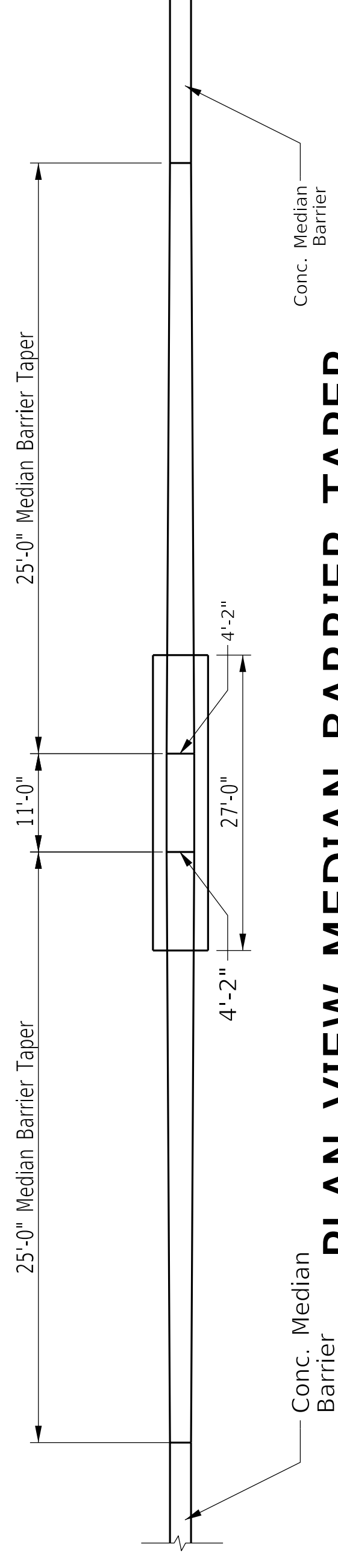

PLAN VIEW MEDIAN BARRIER TAPER

* Approx. estimate is for information only. Tabulated FL/FR shall be verified by the Engineer in the field.

* ESTIMATE OF QUANTITIES FOR MEDIAN FOOTING	
Conc. Class "A" Steel Reinforcement	2951 Lbs.
FL/FR=8'-0"	
1' of additional Pedestal height	1.7 cu.yds.
	125 Lbs.



COMMONWEALTH OF KENTUCKY
DEPARTMENT OF HIGHWAYS

REVISION	DATE

PREPARED BY

DATE:
DESIGNED BY:
DETAILED BY:

FOUNDATION LAYOUT
CROSSING
STA 105+00 & STA 174+00

ROUTE
KY 922

COUNTY OF
FAYETTE

COUNTY OF	ITEM NO.	SHEET NO.
FAYETTE	7-252.00	S29

Sections shown For Information Only, per OSS General Notes; contractor shall take field measurements for submission of shop drawings.

Sign No.	STATION	SUPPORT HEIGHT			FOOTING HEIGHT		
		L	HL	HR	FL	FR	FR
P-70*	105+00	60'-0"	18'-3"	18'-7"	10'-7"	10'-0"	10'-0"
Total Area**	SIGN A	SIGN B	SIGN A		SIGN B		Area
			Horiz.	Vert.	Horiz.	Vert.	
468 SF	18'	12'	18'	14'	18'	14'	252 SF

* See sheet T17 for Sign Detail
 See sheets S21-S24 for 50-70FT Truss Detail Sheets
 ** Total Area includes the sum of all of the signs on the structure and shall not exceed 800 square feet.

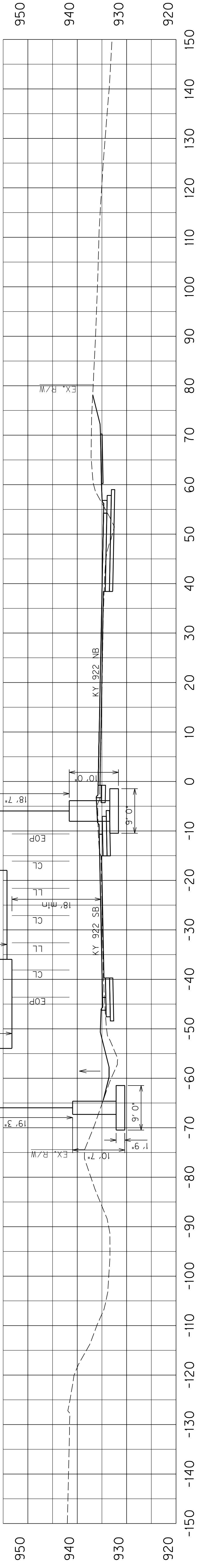

112+50
SIGN #P-70

Sign No.	STATION	SUPPORT HEIGHT			FOOTING HEIGHT		
		L	HL	HR	FL	FR	FR
P-79*	105+00	75'-0"	18'-9"	18'-9"	10'-9"	9'-1"	9'-1"
Total Area**	SIGN A	SIGN B	SIGN A		SIGN B		Area
			Horiz.	Vert.	Horiz.	Vert.	
468 SF	18'	12'	18'	14'	18'	14'	252 SF

* See sheet T17 for Sign Detail
 See sheets S25-S28 for 75-105FT Truss Detail Sheets
 ** Total Area includes the sum of all of the signs on the structure and shall not exceed 1000 square feet.

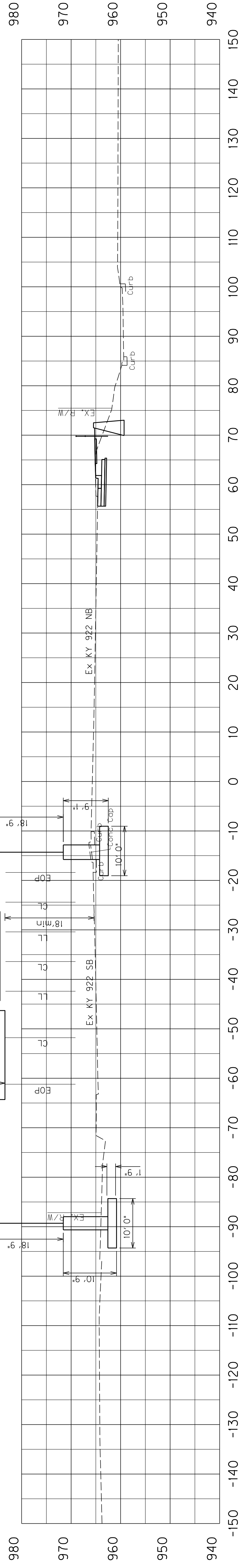

105+00
SIGN #P-79

SCALE: 1" = 10' HORIZONTAL
 1" = 10' VERTICAL

NEWTOWN PIKE KY 922
 CROSS-SECTIONS OF TRUSSES
 SIGNS #P-79, #P-70

COUNTY OF	ITEM NO.	SHEET NO.
FAYETTE	7-252.00	S29

Sections shown For Information Only, per OSS General Notes; contractor shall take field measurements for submission of shop drawings.

Sign No.	STATION	SPAN		SUPPORT HEIGHT		FOOTING HEIGHT		
		L	HR	HL	HR	FL	FR	
P-70*	105+00	60'-0"	18'-3"	18'-7"	10'-7"	10'-0"	10'-0"	
Total Area**	468 SF	SIGN A		SIGN B				
		Horiz.	Vert.	Area	I.D.	Horiz.	Vert.	Area
		18'	12'	216 SF	(B)	18'	14'	252 SF

* See sheet T17 for Sign Detail
 See sheets S21-S24 for 50-70FT Truss Detail Sheets
 ** Total Area includes the sum of all of the signs on the structure and shall not exceed 800 square feet.

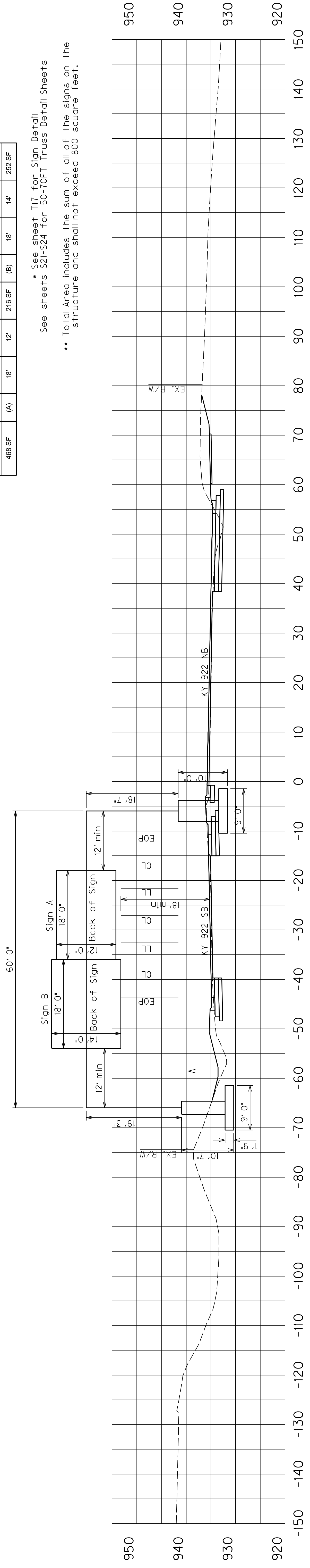

112+50
SIGN #P-70

ADDED SHEET

Sign No.	STATION	SPAN		SUPPORT HEIGHT		FOOTING HEIGHT		
		L	HR	HL	HR	FL	FR	
P-79*	105+00	75'-0"	18'-9"	18'-9"	10'-9"	9'-1"	9'-1"	
Total Area**	468 SF	SIGN A		SIGN B				
		Horiz.	Vert.	Area	I.D.	Horiz.	Vert.	Area
		18'	12'	216 SF	(B)	18'	14'	252 SF

* See sheet T17 for Sign Detail
 See sheets S25-S28 for 75-105FT Truss Detail Sheets
 ** Total Area includes the sum of all of the signs on the structure and shall not exceed 1000 square feet.

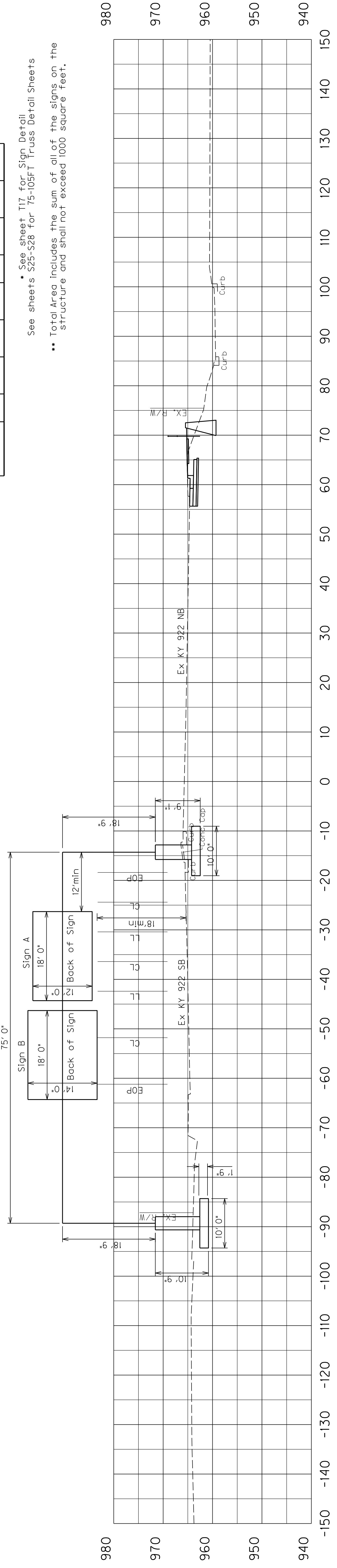

105+00
SIGN #P-79

SCALE: 1" = 10' HORIZONTAL
 1" = 10' VERTICAL

NEWTOWN PIKE KY 922
 CROSS-SECTIONS OF TRUSSES
 SIGNS #P-79, #P-70

COUNTY OF	ITEM NO.	SHEET NO.
FAYETTE	7-252.00	S30

Sections shown For Information Only, per OSS General Notes:
contractor shall take field measurements for submission of shop drawings.

Sign No.	STATION	SPAN		SUPPORT HEIGHT		FOOTING HEIGHT	
		L	HR	HL	HR	FL	FR
P-36*	174+00	75'-0"	22'-9"	22'-9"	20'-4"	10'-0"	10'-6"
Total Area**	SIGN A		SIGN B		Area		Area
	I.D.	Vert.	I.D.	Vert.	(A)	(B)	
816 SF	17'	10'	34'	20'	170 SF	646 SF	646 SF

- * See sheet T16 & T18 for Sign Detail
- See sheets S25-S28 for 75-105FT Truss Detail Sheets
- ** Total Area includes the sum of all of the signs on the structure and shall not exceed 1000 square feet.

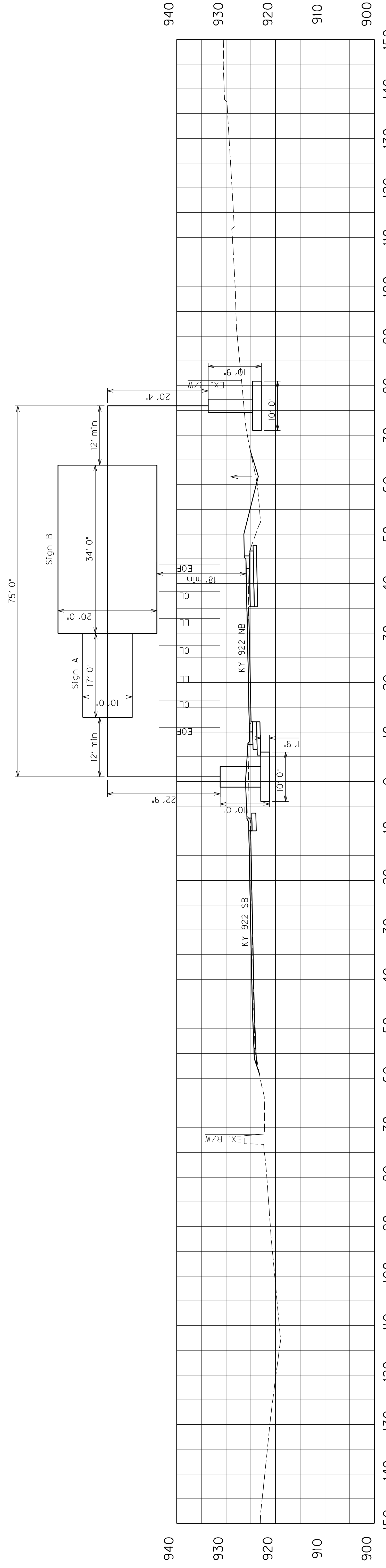

174+00
SIGN #P-36

SCALE: 1" = 10' HORIZONTAL
1" = 10' VERTICAL

NEWTOWN PIKE KY 922
CROSS-SECTION OF TRUSSES
SIGN #P-36

COUNTY OF	ITEM NO.	SHEET NO.
FAYETTE	7-252.00	S30

Sections shown For Information Only, per OSS General Notes:
contractor shall take field measurements for submission of shop drawings.

Sign No.	STATION	SPAN		SUPPORT HEIGHT		FOOTING HEIGHT	
		L	HR	HL	HR	FL	FR
P-36*	174+00	75'-0"	22'-9"	22'-9"	20'-4"	10'-0"	10'-6"
Total Area**	SIGN A		SIGN B		Area		Area
	I.D.	Vert.	I.D.	Vert.	(A)	(B)	
816 SF	17'	10'	34'	20'	170 SF	646 SF	

- * See sheet T16 & T18 for Sign Detail
- See sheets S25-S28 for 75-105FT Truss Detail Sheets
- ** Total Area includes the sum of all of the signs on the structure and shall not exceed 1000 square feet.

ADDED SHEET

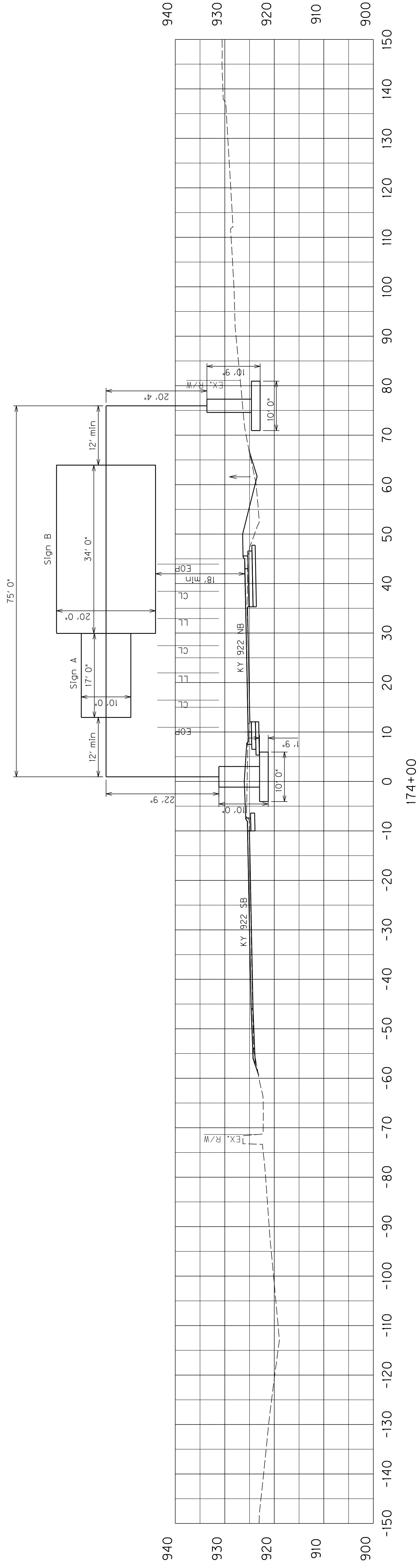

174+00
SIGN #P-36

SCALE: 1" = 10' HORIZONTAL
1" = 10' VERTICAL

NEWTOWN PIKE KY 922
CROSS-SECTION OF TRUSSES
SIGN #P-36

TRAFFIC SIGNAL ESTIMATE OF QUANTITIES

ITEM CODE	ITEM	UNIT	NEW TOWNSHIP	NANDINO	CITATION	SUGAR MAPLE	ARISTIDES	COLEMAN	TOTAL
4780	FUSED CONNECTOR KIT	EACH	0	8	4	0	9	0	21
4820	TRENCHING AND BACKFILLING	LIN FT	105	170	190	35	205	10	715
4845	CABLE - NO. 14/7C	LIN FT	410	4010	4740	1230	3950	930	18970
4886	MESSENGER - 15400 LB	LIN FT	550	590	640	460	590	520	3350
4932	INSTALL STEEL STRAIN POLE	EACH	4	4	4	4	4	4	24
4953	TEMPORARY RELOCATION OF SIGNAL HEAD	EACH	28	24	30	18	30	18	148
6406	SBM ALUMINUM SHEET SIGNS 0.080 IN	SQ FT	0	0	15	0	0	0	15
6472	INSTALL SPAN MOUNTED SIGN	EACH	0	0	2	0	0	0	2
20093NS835	INSTALL PEDESTRIAN HEAD LED	EACH	8	8	8	2	8	0	34
20188NS835	INSTALL SIGNAL - 3 SECTION LED	EACH	12	10	15	8	12	8	65
20266ES835	INSTALL SIGNAL - 4 SECTION LED	EACH	2	2	0	1	3	1	9
20390NS835	INSTALL COORDINATING UNIT	EACH	1	1	1	1	1	1	6
2063IND	INSTALL POLE MOUNTED SIGN	EACH	4	3	0	2	3	2	14
21743NN	INSTALL PEDESTRIAN DETECTOR	EACH	8	8	8	2	8	0	34
23157EN	TRAFFIC SIGNAL POLE BASE	CU YD	21	22	25	15	23	18	124
23222EC	INSTALL SIGNAL PEDESTAL	EACH	0	3	2	0	4	0	9
23235EC	INSTALL PEDESTAL POST	EACH	6	2	5	2	2	0	17
23750EC	INSTALL ILLUMINATED STREET SIGN	EACH	0	0	4	0	0	0	4
23865EC	INSTALL CCTV CAMERA	EACH	0	0	1	0	1	0	2
24900EC	PVC CONDUIT-1/4 INCH-SCH 80	LIN FT	95	160	175	30	195	0	655
24901EC	PVC CONDUIT-2 INCH-SCH 80	LIN FT	0	0	0	40	40	40	120
24902EC	PVC CONDUIT-3 INCH-SCH 80	LIN FT	60	0	40	0	0	0	160
24908EC	INSTALL SIGNAL CONTROLLER - TY ATC	EACH	1	1	1	1	1	1	6
24955ED	REMOVE SIGNAL EQUIPMENT	EACH	1	1	1	1	1	1	6
26119EC	INSTALL RADAR PRESENCE DETECTOR TYPE A	EACH	4	4	4	3	4	3	22

THE STANDARD SPECIFICATIONS FOR ROAD AND BRIDGE CONSTRUCTION, CURRENT EDITION, AND OTHER SPECIAL NOTES AND SPECIFICATIONS WILL APPLY ON THIS PROJECT. SEE SECTION 706, 723, AND 112 FOR MEASUREMENT AND OTHER DETAILS. SEE SECTION 602 FOR SPIRAL REINFORCEMENT SPLICING.

THE CONTRACTOR SHALL BE RESPONSIBLE FOR PICKING UP MATERIALS FOR INSTALL ITEMS AT KYTC'S DIVISION OF EQUIPMENT WAREHOUSE (1239 WILKINSON BOULEVARD, FRANKFORT, KY 40622). THE FOLLOWING PROCEDURES SHALL BE FOLLOWED FOR MATERIAL RELEASE. FAILURE TO FOLLOW THESE PROCEDURES MAY RESULT IN LONG DELAYS OR REFUSAL TO DISTRIBUTE MATERIALS UPON ARRIVAL.

- CONTRACTOR SHALL SECURE THE SIGNATURES OF KYTC'S PROJECT ENGINEER AND THE ELECTRICAL CONTRACTOR'S FOREMAN ON THE PROJECT MATERIALS RELEASE FORM. IF THE RELEASE FORM IS NOT IN THE PROPOSAL, CONTACT KIM STAMPER OR KERRY DECKER WITH THE DIVISION OF TRAFFIC OPERATIONS BY PHONE (502-782-8994/502-782-5536) OR EMAIL (KIM.STAMPER@KY.GOV/KERRY.DECKER@KY.GOV).
- CONTRACTOR SHALL CONTACT THE WAREHOUSE TO PREARRANGE PICK UP OF MATERIALS. CONTRACTOR SHALL EMAIL THE PROJECT MATERIALS RELEASE FORM WITH REQUIRED SIGNATURES TO THE WAREHOUSE AT KIM.STAMPER@KY.GOV AND SHALL NOTIFY THE WAREHOUSE BY PHONE (502-782-8994/502-330-8153) OR EMAIL KIM.STAMPER@KY.GOV AT LEAST TWO (2) WORKING DAYS PRIOR TO ARRIVAL.
- CONTRACTOR SHALL ALSO CONTACT THE SYSTEM OPERATIONS BRANCH OF THE DIVISION OF TRAFFIC OPERATIONS BY PHONE (502-782-5543/502-782-5547) OR EMAIL (JOE.THOMPSON@KY.GOV/LARRY.IRISH@KY.GOV) AT LEAST TWO (2) WORKING DAYS PRIOR TO ARRIVAL TO FACILITATE PROGRAMMING OF ROUTERS.
- CONTRACTOR SHALL ARRIVE AT THE KYTC'S DIVISION OF EQUIPMENT WAREHOUSE (1239 WILKINSON BOULEVARD, FRANKFORT, KY 40622) AT THE PREARRANGED DATE/TIME FOR MATERIAL PICK UP. TO FACILITATE THIS PROCESS, ENSURE CONTRACTOR'S DELIVERY DRIVER HAS A COPY OF THE PROJECT MATERIALS RELEASE FORM WITH THE REQUIRED SIGNATURES.

CONSTRUCTION AND MEASUREMENT NOTES THAT ARE CONTRARY TO SECTION 723

SUBSECTION: 03.02 POLES AND BASES INSTALLATION. B)
 REVISION: REPLACE ENTIRE TABLE WITH THE FOLLOWING:

MAXIMUM SERVICE FORCES	DRILLED SHAFT DATA				VERTICAL BARS TOTAL	TIES OR SPIRAL BAR SIZE	SPACING OR PITCH (IN.)
	DIAMETER (IN.)	< 2:1 GROUND SLOPE	2:1 GROUND SLOPE*	ROCK			
0-9.9	3.6	6	6	6.5	8	#4	2
10-19.9	3.6	8	6	9	8	#4	2
20-29.9	3.6	8	6	10.5	8	#4	2
30-39.9	3.6	10.5	6	10.5	8	#4	2
40-49.9	3.6	10	6	12.5	8	#4	2
50-59.9	3.6	11	6	13.5	8	#4	2
60-69.9	3.6	12.5	6	17.5	8	#4	2
70-79.9	3.6	14.5	6	19.5	8	#4	2
80-89.9	3.6	17	6	21	8	#4	2
90-99.9	3.6	18.5	6.5	25	8	#4	2
100-149.9	4.2	21	7.5	25.5	8	#4	2
150-199.9	4.2	21.5	7.5	25.5	8	#4	2
200-249.9	4.8	22.5	7.5	25.5	8	#4	2
250-299.9	4.8	22.5	7.5	25.5	8	#4	2
300-399.9	4.8	22.5	7.5	25.5	8	#4	2
400-499.9	4.8	22.5	7.5	25.5	8	#4	2
500-600	4.8	22.5	7.5	25.5	8	#4	2

SUBSECTION: 03.12 WIRING INSTALLATION.
 REVISION: SEE TRAFFIC OPERATIONS WEBSITE FOR WORD DOCUMENT TO REPLACE ALL CHARTS FOR WIRING TO SHOW CHANGES FOR EQUIPMENT GROUNDING.

SUBSECTION: 04.22 REMOVE SIGNAL EQUIPMENT. (CONSTRUCTION ONLY)
 REVISION: REPLACE THE PARAGRAPH WITH THE FOLLOWING:
 THE DEPARTMENT WILL MEASURE THE QUANTITY BY EACH. THE DEPARTMENT WILL NOT MEASURE BACKFILLING AND THE DISPOSAL OR TRANSPORTATION OF EQUIPMENT AND MATERIALS ASSOCIATED WITH ANY STRUCTURAL OR ELECTRICAL COMPONENT OF THE SIGNAL SYSTEM INCLUDING, BUT NOT LIMITED TO POLE BASES, POLES, JUNCTION BOXES, CABINETS, AND WOOD POLES FOR PAYMENT AND WILL CONSIDER THEM INCIDENTAL TO THIS ITEM OF WORK.

MEASUREMENT NOTES THAT ARE IN ADDITION TO SECTION 723

INSTALL SIGNAL CONTROLLER TYPE ATC. THE DEPARTMENT WILL MEASURE THE QUANTITY AS EACH INDIVIDUAL UNIT INSTALLED. THE DEPARTMENT WILL NOT MEASURE THE CONCRETE BASE, MOUNTING THE CABINET, CONNECTING THE SIGNAL AND DETECTORS, EXCAVATION, BACKFILLING, RESTORATION, ANY NECESSARY POLE MOUNTING HARDWARE, ELECTRIC SERVICE, ELECTRICAL INSPECTION FEES, AND REQUIRED BUILDING FEES INVOLVING UTILITY SECONDARY/PRIMARY SERVICE FOR PAYMENT AND WILL CONSIDER THEM INCIDENTAL TO THIS ITEM OF WORK. THE DEPARTMENT WILL ALSO NOT MEASURE CONNECTING THE INDUCTION LOOP AMPLIFIERS, PEDESTRIAN ISOLATORS, LOAD SWITCHES, MODEL 400 MODEM CARD FOR PAYMENT AND WILL CONSIDER THEM INCIDENTAL TO THIS ITEM OF WORK. THE DEPARTMENT WILL ALSO NOT MEASURE FURNISHING AND INSTALLING ELECTRICAL SERVICE CONDUCTORS, CONDUITS, ANCHORS, METER BASE, FUSED CUTOUT, FUSES, GROUND RODS, GROUND LUGS, AND GROUND WIRES FOR PAYMENT AND WILL CONSIDER THEM INCIDENTAL TO THIS ITEM OF WORK.

INSTALL RADAR PRESENCE DETECTOR TYPE A SHALL CONSIST OF INSTALLATION OF A POLE MOUNTED RADAR PRESENCE SENSOR, SENSOR MOUNTING BRACKET, SENSOR CABLES, INTERFACE BOXES, LEAD-IN CABLE, CONNECTORS (FURNISHED BY CONTRACTOR), AND CONTROLLER INTERFACE ASSEMBLY. RADAR PRESENCE DETECTOR TYPE A BID ITEM SHALL INCLUDE ALL LABOR REQUIRED TO PROVIDE A FUNCTIONAL DETECTION SYSTEM. RADAR PRESENCE DETECTOR TYPE A SHALL BE INSTALLED AND WIRED IN ACCORDANCE WITH THE MANUFACTURER'S INSTRUCTIONS. AFTER THE DETECTOR IS INSTALLED AND BEFORE THE DETECTOR IS POWERED ON, THE CONTRACTOR SHALL COORDINATE WITH DISTRICT TRAFFIC DIVISION'S REPRESENTATIVES TO SCHEDULE A TIME TO PERFORM THE DETECTOR SETUP. THE CONTRACTOR SHALL DOUBLE CHECK TO VERIFY THAT ALL WIRING IS CORRECTLY INSTALLED AND CONNECTED BEFORE SCHEDULING THE SETUP WORK. REPRESENTATIVES FROM KYTC AND/OR THE MANUFACTURER OR SALES REPRESENTATIVE WILL ASSIST WITH SETUP AND CALIBRATION. THE CONTRACTOR SHALL PROVIDE A BUCKET TRUCK AND OPERATORS AT THIS TIME FOR FINAL AIMING OF THE SENSORS. THE CONTRACTOR SHALL PROVIDE INDIVIDUALS CAPABLE OF OPERATING THE SETUP SOFTWARE AND LEARNING THE SETUP PROCESS SO THAT FUTURE INSTALLATIONS MAY BE COMPLETED WITHOUT ASSISTANCE FROM OTHERS.

INSTALL RADAR ADVANCE DETECTOR TYPE B SHALL CONSIST OF INSTALLATION OF A POLE MOUNTED RADAR PRESENCE SENSOR, SENSOR MOUNTING BRACKET, SENSOR CABLES, INTERFACE BOXES, LEAD-IN CABLE, CONNECTORS (FURNISHED BY CONTRACTOR), AND CONTROLLER INTERFACE ASSEMBLY. RADAR ADVANCE DETECTOR TYPE B BID ITEM SHALL INCLUDE ALL LABOR REQUIRED TO PROVIDE A FUNCTIONAL DETECTION SYSTEM. RADAR ADVANCE DETECTOR TYPE B SHALL BE INSTALLED AND WIRED IN ACCORDANCE WITH THE MANUFACTURER'S INSTRUCTIONS. AFTER THE DETECTOR IS INSTALLED AND BEFORE THE DETECTOR IS POWERED ON, THE CONTRACTOR SHALL COORDINATE WITH DISTRICT TRAFFIC DIVISION'S REPRESENTATIVES TO SCHEDULE A TIME TO PERFORM THE DETECTOR SETUP. THE CONTRACTOR SHALL DOUBLE CHECK TO VERIFY THAT ALL WIRING IS CORRECTLY INSTALLED AND CONNECTED BEFORE SCHEDULING THE SETUP WORK. REPRESENTATIVES FROM KYTC AND/OR THE MANUFACTURER OR SALES REPRESENTATIVE.

THE CONTRACTOR SHALL MAKE AN INSPECTION OF THE PROJECT SITE PRIOR TO SUBMITTING A BID AND SHALL BE THOROUGHLY FAMILIARIZED WITH EXISTING CONDITIONS. SUBMISSIONS OF A BID WILL BE CONSIDERED AN AFFIRMATION OF THIS INSPECTION HAVING BEEN COMPLETED.

DESIGNED BY: CRG
 DATE SUBMITTED: 9/11/2023

Commonwealth of Kentucky
DEPARTMENT OF HIGHWAYS
 COUNTY OF
FAYETTE

PROJECT NUMBER: 7-252.00
 F004 034 0922 001-003 D

TRAFFIC SIGNAL
 ESTIMATE OF QUANTITIES
 MEASUREMENT, CONST, AND MISC NOTES

TRAFFIC SIGNAL ESTIMATE OF QUANTITIES

ITEM CODE	ITEM	UNIT	NEW TOWNSHIP	NANDINO	CITATION	SUGAR MAPLE	ARISTIDES	COLEMAN	TOTAL
4780	FUSED CONNECTOR KIT	EACH	0	8	4	0	9	0	21
4820	TRENCHING AND BACKFILLING	LIN FT	105	170	190	35	205	10	715
4845	CABLE - NO. 14/7C	LIN FT	410	4010	4740	1230	3950	930	18970
4886	MESSENGER - 15400 LB	LIN FT	550	590	640	460	590	520	3350
4932	INSTALL STEEL STRAIN POLE	EACH	4	4	4	4	4	4	24
4953	TEMPORARY RELOCATION OF SIGNAL HEAD	EACH	28	24	30	18	30	18	148
6406	SBM ALUMINUM SHEET SIGNS 0.080 IN	SQ FT	0	0	15	0	0	0	15
6472	INSTALL SPAN MOUNTED SIGN	EACH	0	0	2	0	0	0	2
20093NS835	INSTALL PEDESTRIAN HEAD LED	EACH	8	8	8	2	8	0	34
20188NS835	INSTALL SIGNAL - 3 SECTION LED	EACH	12	10	15	8	12	8	65
20266ES835	INSTALL SIGNAL - 4 SECTION LED	EACH	2	2	0	1	3	1	9
20390NS835	INSTALL COORDINATING UNIT	EACH	1	1	1	1	1	1	6
2063IND	INSTALL POLE MOUNTED SIGN	EACH	4	3	0	2	3	2	14
21743NN	INSTALL PEDESTRIAN DETECTOR	EACH	8	8	8	2	8	0	34
23157EN	TRAFFIC SIGNAL POLE BASE	CU YD	21	22	25	15	23	18	124
23222EC	INSTALL SIGNAL PEDESTAL	EACH	0	3	2	0	4	0	9
23235EC	INSTALL PEDESTAL POST	EACH	6	2	5	2	2	0	17
23750EC	INSTALL ILLUMINATED STREET SIGN	EACH	0	0	4	0	0	0	4
23865EC	INSTALL CCTV CAMERA	EACH	0	0	1	0	1	0	2
24900EC	PVC CONDUIT-1/4 INCH-SCH 80	LIN FT	95	160	175	30	195	0	655
24901EC	PVC CONDUIT-2 INCH-SCH 80	LIN FT	0	0	0	40	40	40	120
24902EC	PVC CONDUIT-3 INCH-SCH 80	LIN FT	60	0	40	0	0	0	160
24908EC	INSTALL SIGNAL CONTROLLER - TY ATC	EACH	1	1	1	1	1	1	6
24955ED	REMOVE SIGNAL EQUIPMENT	EACH	1	1	1	1	1	1	6
26119EC	INSTALL RADAR PRESENCE DETECTOR TYPE A	EACH	4	4	4	3	4	3	22

THE STANDARD SPECIFICATIONS FOR ROAD AND BRIDGE CONSTRUCTION, CURRENT EDITION, AND OTHER SPECIAL NOTES AND SPECIFICATIONS WILL APPLY ON THIS PROJECT. SEE SECTION 706, 723, AND 112 FOR MEASUREMENT AND OTHER DETAILS. SEE SECTION 602 FOR SPIRAL REINFORCEMENT SPLICING.

THE CONTRACTOR SHALL BE RESPONSIBLE FOR PICKING UP MATERIALS FOR INSTALL ITEMS AT KYTC'S DIVISION OF EQUIPMENT WAREHOUSE (1239 WILKINSON BOULEVARD, FRANKFORT, KY 40622). THE FOLLOWING PROCEDURES SHALL BE FOLLOWED FOR MATERIAL RELEASE. FAILURE TO FOLLOW THESE PROCEDURES MAY RESULT IN LONG DELAYS OR REFUSAL TO DISTRIBUTE MATERIALS UPON ARRIVAL.

- CONTRACTOR SHALL SECURE THE SIGNATURES OF KYTC'S PROJECT ENGINEER AND THE ELECTRICAL CONTRACTOR'S FOREMAN ON THE PROJECT MATERIALS RELEASE FORM. IF THE RELEASE FORM IS NOT IN THE PROPOSAL, CONTACT KIM STAMPER OR KERRY DECKER WITH THE DIVISION OF TRAFFIC OPERATIONS BY PHONE (502-782-8994/502-782-5536) OR EMAIL (KIM.STAMPER@KY.GOV/KERRY.DECKER@KY.GOV).
- CONTRACTOR SHALL CONTACT THE WAREHOUSE TO PREARRANGE PICK UP OF MATERIALS. CONTRACTOR SHALL EMAIL THE PROJECT MATERIALS RELEASE FORM WITH REQUIRED SIGNATURES TO THE WAREHOUSE AT KIM.STAMPER@KY.GOV AND SHALL NOTIFY THE WAREHOUSE BY PHONE (502-782-8994/502-330-8153) OR EMAIL KIM.STAMPER@KY.GOV AT LEAST TWO (2) WORKING DAYS PRIOR TO ARRIVAL.
- CONTRACTOR SHALL ALSO CONTACT THE SYSTEM OPERATIONS BRANCH OF THE DIVISION OF TRAFFIC OPERATIONS BY PHONE (502-782-5543/502-782-5547) OR EMAIL (JOE.THOMPSON@KY.GOV/LARRY.IRISH@KY.GOV) AT LEAST TWO (2) WORKING DAYS PRIOR TO ARRIVAL TO FACILITATE PROGRAMMING OF ROUTERS.
- CONTRACTOR SHALL ARRIVE AT THE KYTC'S DIVISION OF EQUIPMENT WAREHOUSE (1239 WILKINSON BOULEVARD, FRANKFORT, KY 40622) AT THE PREARRANGED DATE/TIME FOR MATERIAL PICK UP. TO FACILITATE THIS PROCESS, ENSURE CONTRACTOR'S DELIVERY DRIVER HAS A COPY OF THE PROJECT MATERIALS RELEASE FORM WITH THE REQUIRED SIGNATURES.

CONSTRUCTION AND MEASUREMENT NOTES THAT ARE CONTRARY TO SECTION 723

SUBSECTION: 03.02 POLES AND BASES INSTALLATION. B)
 REVISION: REPLACE ENTIRE TABLE WITH THE FOLLOWING:

MAXIMUM SERVICE FORCES	DRILLED SHAFT DATA				VERTICAL BARS TOTAL	TIES OR SPIRAL BAR SIZE	SPACING OR PITCH (IN.)
	DIAMETER (IN.)	< 2:1 GROUND SLOPE	2:1 GROUND SLOPE*	ROCK			
0-9.9	36	6	6	6.5	8	#4	22
10-19.9	36	8	6	9	8	#4	22
20-29.9	36	9	6	10.5	8	#4	22
30-39.9	36	10.5	6	10.5	8	#4	22
40-49.9	36	11	6	12.5	8	#4	22
50-59.9	36	12	6	13.5	8	#4	22
60-69.9	36	12.5	6	15.5	8	#4	22
70-79.9	36	14.5	6	17.5	8	#4	22
80-89.9	36	17	6	19.5	8	#4	22
90-99.9	36	18.5	6	21	8	#4	22
100-149.9	42	21.5	7.5	25	8	#4	22
150-199.9	42	22.5	7.5	25.5	8	#4	22
200-249.9	48	22.5	7.5	25.5	8	#4	22
250-299.9	48	22.5	7.5	25.5	8	#4	22
300-399.9	48	22.5	7.5	25.5	8	#4	22
400-499.9	48	22.5	7.5	25.5	8	#4	22
500-600	48	22.5	7.5	25.5	8	#4	22

SUBSECTION: 03.12 WIRING INSTALLATION.
 REVISION: SEE TRAFFIC OPERATIONS WEBSITE FOR WORD DOCUMENT TO REPLACE ALL CHARTS FOR WIRING TO SHOW CHANGES FOR EQUIPMENT GROUNDING.

SUBSECTION: 04.22 REMOVE SIGNAL EQUIPMENT. (CONSTRUCTION ONLY)
 REVISION: REPLACE THE PARAGRAPH WITH THE FOLLOWING:
 THE DEPARTMENT WILL MEASURE THE QUANTITY BY EACH. THE DEPARTMENT WILL NOT MEASURE BACKFILLING AND THE DISPOSAL OR TRANSPORTATION OF EQUIPMENT AND MATERIALS ASSOCIATED WITH ANY STRUCTURAL OR ELECTRICAL COMPONENT OF THE SIGNAL SYSTEM INCLUDING, BUT NOT LIMITED TO POLE BASES, POLES, JUNCTION BOXES, CABINETS, AND WOOD POLES FOR PAYMENT AND WILL CONSIDER THEM INCIDENTAL TO THIS ITEM OF WORK.

MEASUREMENT NOTES THAT ARE IN ADDITION TO SECTION 723

INSTALL SIGNAL CONTROLLER TYPE ATC. THE DEPARTMENT WILL MEASURE THE QUANTITY AS EACH INDIVIDUAL UNIT INSTALLED. THE DEPARTMENT WILL NOT MEASURE THE CONCRETE BASE, MOUNTING THE CABINET, CONNECTING THE SIGNAL AND DETECTORS, EXCAVATION, BACKFILLING, RESTORATION, ANY NECESSARY POLE MOUNTING HARDWARE, ELECTRIC SERVICE, ELECTRICAL INSPECTION FEES, AND REQUIRED BUILDING FEES INVOLVING UTILITY SECONDARY/PRIMARY SERVICE FOR PAYMENT AND WILL CONSIDER THEM INCIDENTAL TO THIS ITEM OF WORK. THE DEPARTMENT WILL ALSO NOT MEASURE CONNECTING THE INDUCTION LOOP AMPLIFIERS, PEDESTRIAN ISOLATORS, LOAD SWITCHES, MODEL 400 MODEM CARD FOR PAYMENT AND WILL CONSIDER THEM INCIDENTAL TO THIS ITEM OF WORK. THE DEPARTMENT WILL ALSO NOT MEASURE FURNISHING AND INSTALLING ELECTRICAL SERVICE CONDUCTORS, CONDUITS, ANCHORS, METER BASE, FUSED CUTOUT, FUSES, GROUND RODS, GROUND LUGS, AND GROUND WIRES FOR PAYMENT AND WILL CONSIDER THEM INCIDENTAL TO THIS ITEM OF WORK.

INSTALL RADAR PRESENCE DETECTOR TYPE A SHALL CONSIST OF INSTALLATION OF A POLE MOUNTED RADAR PRESENCE SENSOR, SENSOR MOUNTING BRACKET, SENSOR CABLES, INTERFACE BOXES, LEAD-IN CABLE, CONNECTORS (FURNISHED BY CONTRACTOR), AND CONTROLLER INTERFACE ASSEMBLY. RADAR PRESENCE DETECTOR TYPE A BID ITEM SHALL INCLUDE ALL LABOR REQUIRED TO PROVIDE A FUNCTIONAL DETECTION SYSTEM. RADAR PRESENCE DETECTOR TYPE A SHALL BE INSTALLED AND WIRED IN ACCORDANCE WITH THE MANUFACTURER'S INSTRUCTIONS. AFTER THE DETECTOR IS INSTALLED AND BEFORE THE DETECTOR IS POWERED ON, THE CONTRACTOR SHALL COORDINATE WITH DISTRICT TRAFFIC DIVISION'S REPRESENTATIVES TO SCHEDULE A TIME TO PERFORM THE DETECTOR SETUP. THE CONTRACTOR SHALL DOUBLE CHECK TO VERIFY THAT ALL WIRING IS CORRECTLY INSTALLED AND CONNECTED BEFORE SCHEDULING THE SETUP WORK. REPRESENTATIVES FROM KYTC AND/OR THE MANUFACTURER OR SALES REPRESENTATIVE WILL ASSIST WITH SETUP AND CALIBRATION. THE CONTRACTOR SHALL PROVIDE A BUCKET TRUCK AND OPERATORS AT THIS TIME FOR FINAL AIMING OF THE SENSORS. THE CONTRACTOR SHALL PROVIDE INDIVIDUALS CAPABLE OF OPERATING THE SETUP SOFTWARE AND LEARNING THE SETUP PROCESS SO THAT FUTURE INSTALLATIONS MAY BE COMPLETED WITHOUT ASSISTANCE FROM OTHERS.

INSTALL RADAR ADVANCE DETECTOR TYPE B SHALL CONSIST OF INSTALLATION OF A POLE MOUNTED RADAR PRESENCE SENSOR, SENSOR MOUNTING BRACKET, SENSOR CABLES, INTERFACE BOXES, LEAD-IN CABLE, CONNECTORS (FURNISHED BY CONTRACTOR), AND CONTROLLER INTERFACE ASSEMBLY. RADAR ADVANCE DETECTOR TYPE B BID ITEM SHALL INCLUDE ALL LABOR REQUIRED TO PROVIDE A FUNCTIONAL DETECTION SYSTEM. RADAR ADVANCE DETECTOR TYPE B SHALL BE INSTALLED AND WIRED IN ACCORDANCE WITH THE MANUFACTURER'S INSTRUCTIONS. AFTER THE DETECTOR IS INSTALLED AND BEFORE THE DETECTOR IS POWERED ON, THE CONTRACTOR SHALL COORDINATE WITH DISTRICT TRAFFIC DIVISION'S REPRESENTATIVES TO SCHEDULE A TIME TO PERFORM THE DETECTOR SETUP. THE CONTRACTOR SHALL DOUBLE CHECK TO VERIFY THAT ALL WIRING IS CORRECTLY INSTALLED AND CONNECTED BEFORE SCHEDULING THE SETUP WORK. REPRESENTATIVES FROM KYTC AND/OR THE MANUFACTURER OR SALES REPRESENTATIVE.

THE CONTRACTOR SHALL MAKE AN INSPECTION OF THE PROJECT SITE PRIOR TO SUBMITTING A BID AND SHALL BE THOROUGHLY FAMILIARIZED WITH EXISTING CONDITIONS. SUBMISSIONS OF A BID WILL BE CONSIDERED AN AFFIRMATION OF THIS INSPECTION HAVING BEEN COMPLETED.

DESIGNED BY: CRG
 DATE SUBMITTED: 9/11/2023

Commonwealth of Kentucky
DEPARTMENT OF HIGHWAYS
 COUNTY OF
FAYETTE

PROJECT NUMBER: 7-252.00
 F004 034 0922 001-003 D

TRAFFIC SIGNAL
 ESTIMATE OF QUANTITIES
 MEASUREMENT, CONST, AND MISC NOTES

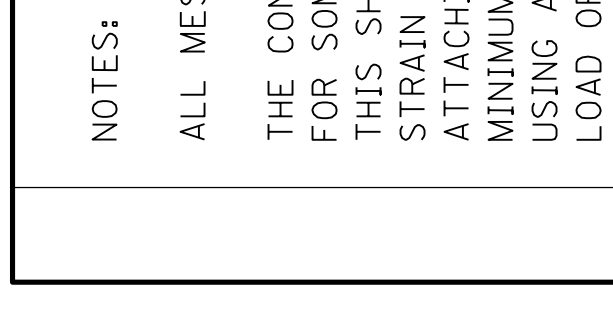
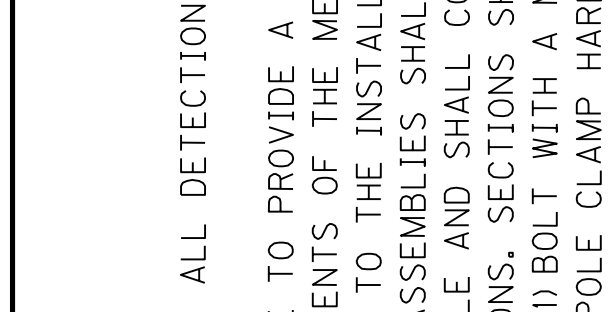
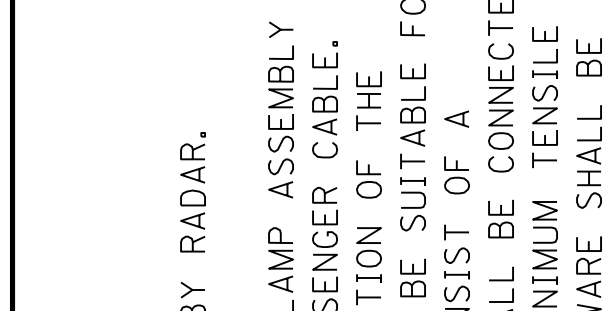
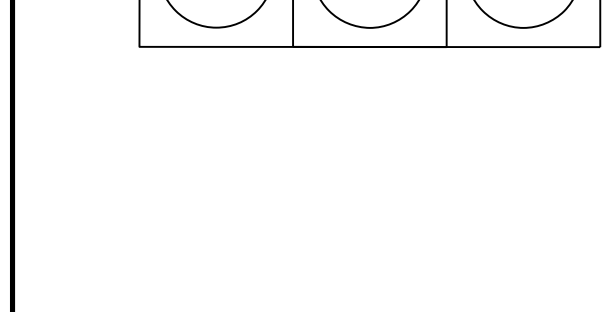
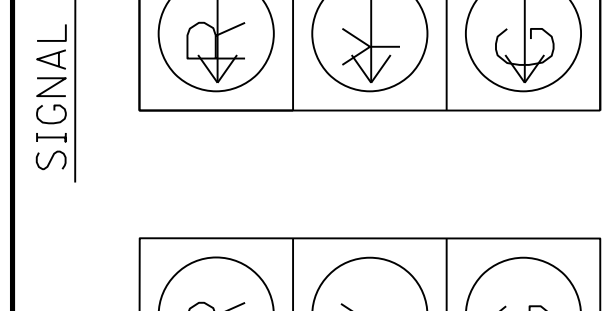
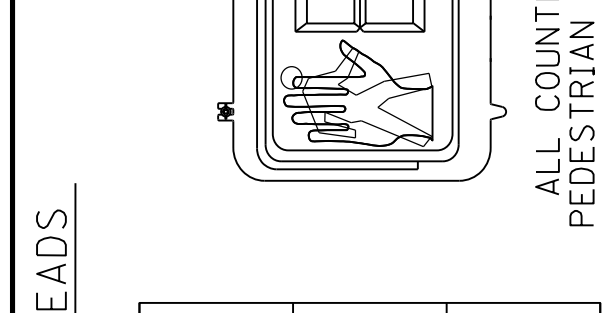
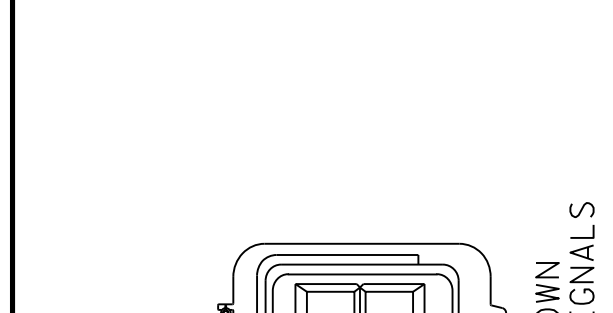
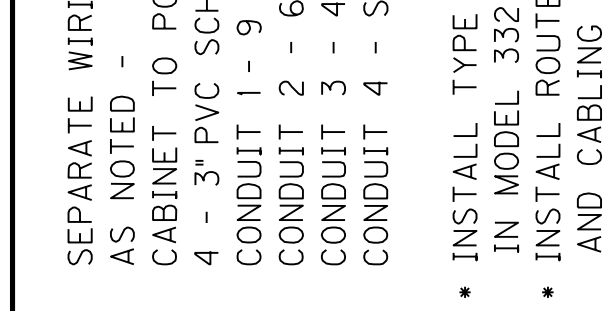
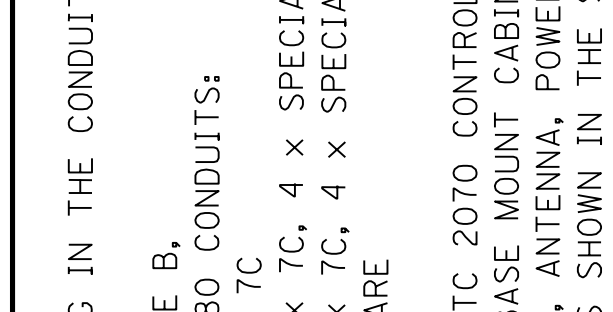
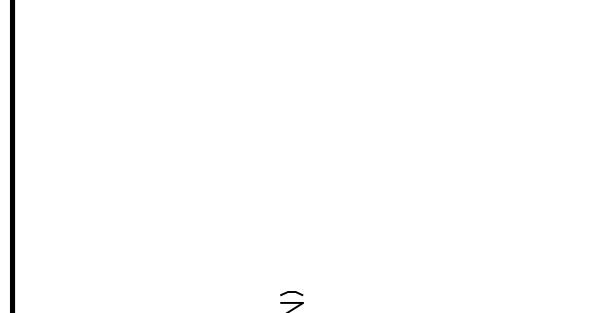
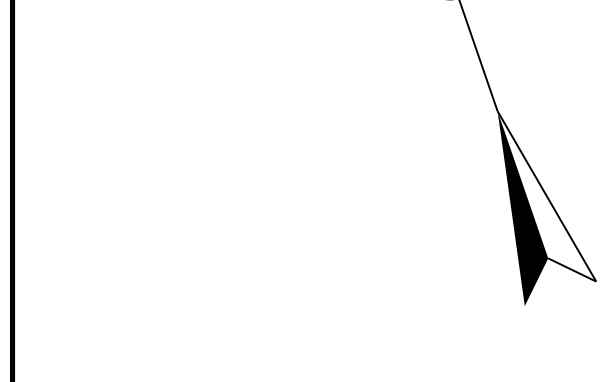

NOTES:
ALL MESSENGER IS 15.4 M. ALL DETECTION BY RADAR.
THE CONTRACTOR MAY HAVE TO PROVIDE A CLAMP ASSEMBLY FOR SOME OF THE ATTACHMENTS OF THE MESSENGER CABLE. THIS SHALL BE INCIDENTAL TO THE INSTALLATION OF THE STRAIN POLE. THE CLAMP ASSEMBLIES SHALL BE SUITABLE FOR ATTACHING MESSENGER CABLE AND SHALL CONSIST OF A MINIMUM OF TWO (2) SECTIONS. SECTIONS SHALL BE CONNECTED USING A MINIMUM OF ONE (1) BOLT WITH A MINIMUM TENSILE LOAD OF 17,050 LBS. ALL POLE CLAMP HARDWARE SHALL BE HOT-DIPPED GALVANIZED. THE CONTRACTOR SHALL SUBMIT A SHOP DRAWING OF THE PROPOSED ASSEMBLY TO THE DIVISION OF TRAFFIC OPERATIONS.
CONTRACTOR SHALL EXERCISE EXTREME CAUTION AROUND ALL UTILITIES TO INCLUDE THE GAS AND WATER LINES AND OVERHEAD UTILITIES. HAND DIG WHEN WITHIN FOUR FEET. NOTE THAT ALL UTILITIES MAY NOT BE SHOWN.
CONTRACTOR SHALL VERIFY ALL ATTACHMENT HEIGHTS IN THE FIELD SO THAT ALL SIGNAL HEADS ARE BETWEEN 17' AND 19' FROM FINISHED GRADE TO BOTTOM OF SIGNAL HEAD. ADJUST ATTACHMENT HEIGHTS AND SAG APPROPRIATELY TO AVOID OVERHEAD UTILITIES.
ALL BASES SHALL BE FLUSH WITH THE SIDEWALK, IF INSTALLED IN THE SIDEWALK.

STEEL STRAIN POLES

POLE	HEIGHT	SPAN	ATT. HT.	CALC. SERV. MOMENT	SAG
A	36	A-B	31.0	285.29	5%
B	36	A-D	33.0		
		B-A	31.0	286.98	5%
		B-C	32.0		
C	38	C-B	31.5	325.68	5%
		C-D	31.0		
D	38	D-A	31.5	327.71	5%
		D-C	32.0		

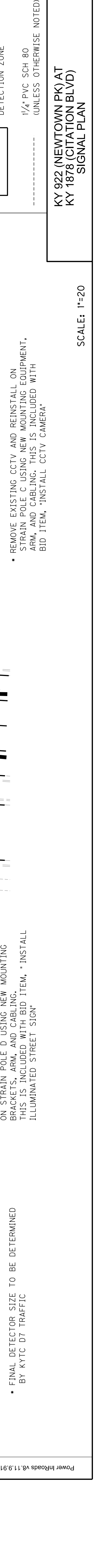
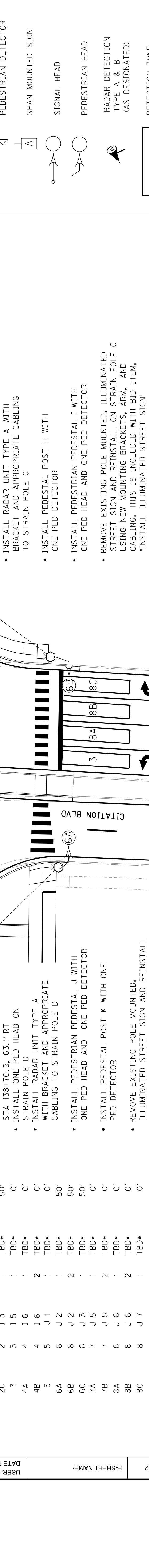
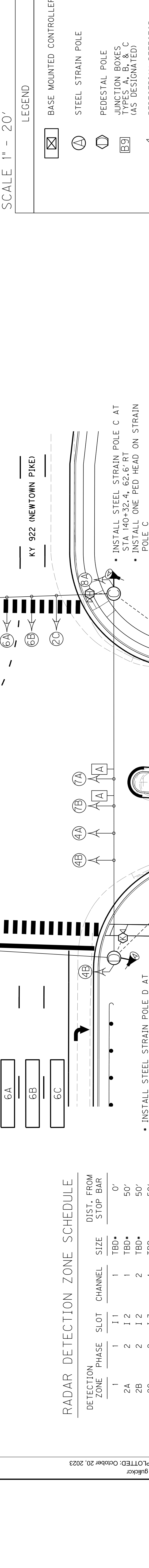
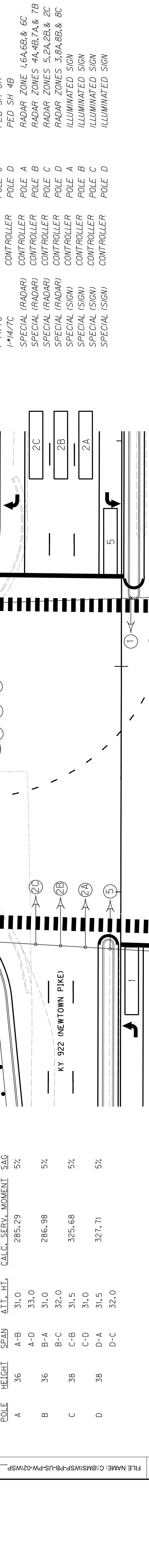
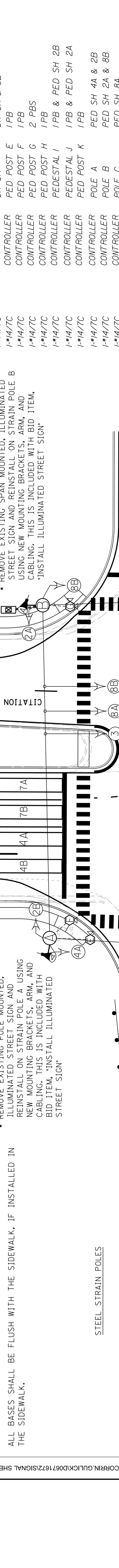

WIRING SCHEDULE

ORIGIN	ENDING	CABLE
CONTROLLER	SH 1	I-#14/7C
CONTROLLER	SH 2A	I-#14/7C
CONTROLLER	SH 3	I-#14/7C
CONTROLLER	SH 4A & 4B	I-#14/7C
CONTROLLER	SH 5	I-#14/7C
CONTROLLER	SH 6C	I-#14/7C
CONTROLLER	SH 7A & 7B	I-#14/7C
CONTROLLER	SH 8A	I-#14/7C
CONTROLLER	PED POST E	I-#14/7C
CONTROLLER	PED POST F	I-#14/7C
CONTROLLER	PED POST G	I-#14/7C
CONTROLLER	PED POST H	I-#14/7C
CONTROLLER	PEDESTAL I	I-#14/7C
CONTROLLER	IPB & PED SH 2B	I-#14/7C
CONTROLLER	IPB	I-#14/7C
CONTROLLER	POLE A	I-#14/7C
CONTROLLER	POLE B	I-#14/7C
CONTROLLER	POLE C	I-#14/7C
CONTROLLER	POLE D	I-#14/7C
CONTROLLER	RADAR ZONE 1,6A,6B, & 6C	SPECIAL (RADAR)
CONTROLLER	RADAR ZONES 4A,4B,7A & 7B	SPECIAL (RADAR)
CONTROLLER	RADAR ZONES 5,2A,2B, & 2C	SPECIAL (RADAR)
CONTROLLER	RADAR ZONES 3,8A,8B, & 8C	SPECIAL (RADAR)
CONTROLLER	ILLUMINATED SIGN	SPECIAL (SIGN)
CONTROLLER	ILLUMINATED SIGN	SPECIAL (SIGN)
CONTROLLER	ILLUMINATED SIGN	SPECIAL (SIGN)

SEPARATE WIRING IN THE CONDUIT AS NOTED.
CABINET TO POLE B.
4 - 3" PVC SCH 80 CONDUITS:
CONDUIT 1 - 9 x 7C
CONDUIT 2 - 6 x 7C, 4 x SPECIAL (ILLUMINATED SIGN)
CONDUIT 3 - 4 x 7C, 4 x SPECIAL (RADAR)
CONDUIT 4 - SPARE
• INSTALL TYPE ATC 2070 CONTROLLER IN MODEL 332 BASE MOUNT CABINET
• INSTALL ROUTER, ANTENNA, POWER SUPPLY AND CABLING AS SHOWN IN THE STANDARD STANDARD DETAIL SHEET: CONTROLLER CABINET AND ANTENNA / ROUTER DETAIL
• INSTALL STEEL STRAIN POLE B AT STA 140+26.9, 87.7' LT
• INSTALL TWO PED HEADS ON STRAIN POLE B
• INSTALL RADAR UNIT TYPE A WITH BRACKET AND APPROPRIATE CABLING TO STRAIN POLE B
• INSTALL PEDESTAL POST G WITH TWO PED DETECTORS
• INSTALL 4-3" SCH 80 PVC CONDUITS FROM STRAIN POLE B TO CONTROLLER
• REMOVE EXISTING SPAN MOUNTED, ILLUMINATED STREET SIGN AND REINSTALL ON STRAIN POLE B USING NEW MOUNTING BRACKETS, ARM, AND CABLING. THIS IS INCLUDED WITH BID ITEM. *INSTALL ILLUMINATED STREET SIGN*

• INSTALL STEEL STRAIN POLE A AT STA 138+79.3, 84.3' LT
• INSTALL TWO PED HEADS ON STRAIN POLE A
• INSTALL RADAR UNIT TYPE A WITH BRACKET AND APPROPRIATE CABLING TO STRAIN POLE A
• INSTALL PEDESTAL POST E WITH ONE PED DETECTOR
• INSTALL PEDESTAL POST F WITH ONE PED DETECTOR
• REMOVE EXISTING POLE MOUNTED, ILLUMINATED STREET SIGN AND REINSTALL ON STRAIN POLE A USING NEW MOUNTING BRACKETS, ARM, AND CABLING. THIS IS INCLUDED WITH BID ITEM. *INSTALL ILLUMINATED STREET SIGN*

• REMOVE EXISTING POLE MOUNTED, ILLUMINATED STREET SIGN AND REINSTALL ON STRAIN POLE D USING NEW MOUNTING BRACKETS, ARM, AND CABLING. THIS IS INCLUDED WITH BID ITEM. *INSTALL ILLUMINATED STREET SIGN*

• INSTALL STEEL STRAIN POLE C AT STA 140+32.4, 62.6' RT
• INSTALL ONE PED HEAD ON STRAIN POLE C
• INSTALL RADAR UNIT TYPE A WITH BRACKET AND APPROPRIATE CABLING TO STRAIN POLE C
• INSTALL PEDESTAL POST H WITH ONE PED DETECTOR
• INSTALL PEDESTAL PEDESTAL I WITH ONE PED HEAD AND ONE PED DETECTOR
• REMOVE EXISTING POLE MOUNTED, ILLUMINATED STREET SIGN AND REINSTALL ON STRAIN POLE C USING NEW MOUNTING BRACKETS, ARM, AND CABLING. THIS IS INCLUDED WITH BID ITEM. *INSTALL ILLUMINATED STREET SIGN*

• REMOVE EXISTING CCTV AND REINSTALL ON STRAIN POLE C USING NEW MOUNTING EQUIPMENT, ARM, AND CABLING. THIS IS INCLUDED WITH BID ITEM. *INSTALL CCTV CAMERA*

RADAR DETECTION ZONE SCHEDULE

DETECTION ZONE	PHASE	SLOT	CHANNEL	SIZE	DIST. FROM STOP BAR
1	1	1 1	1	TBD*	0'
2A	2	1 2	1	TBD*	50'
2B	2	1 2	2	TBD*	50'
2C	2	1 3	1	TBD*	50'
3	3	1 5	1	TBD*	0'
4A	4	1 6	1	TBD*	0'
4B	4	1 6	2	TBD*	0'
5	5	1 1	1	TBD*	0'
6A	6	1 2	1	TBD*	50'
6B	6	1 2	2	TBD*	50'
6C	6	1 3	1	TBD*	50'
7A	7	1 5	1	TBD*	0'
7B	7	1 5	2	TBD*	0'
8A	8	1 6	1	TBD*	0'
8B	8	1 6	2	TBD*	0'
8C	8	1 7	1	TBD*	0'

* FINAL DETECTOR SIZE TO BE DETERMINED BY KYTC D7 TRAFFIC

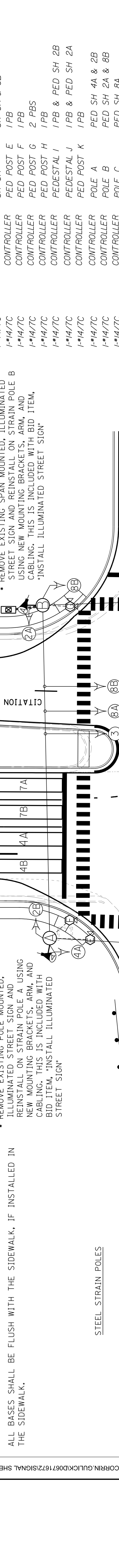

SCALE 1" = 20'

FILE NAME: C:\BMSWSP-P\US-FW-02\WSP_CORRIN\GULCK\0671672\SIGNAL SHEET 3.DGN
USER: gulcker
DATE PLOTTED: October 20, 2023
E-SHEET NAME:
Power InRoads v8: 11.9.12

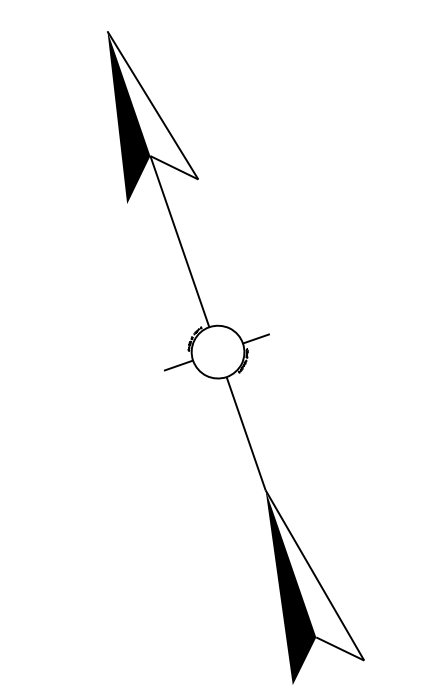

SPAN MOUNTED SIGNS

R3-5
SIGN A
30' x 36'

SIGNAL HEADS

HEAD #
2A, 2B, 2C,
4A, 4B
6A, 6B, 6C
8A, 8B

HEAD #
1, 5,
3, 7A, 7B

ALL INDICATIONS L.E.D.
ALL HEADS WILL HAVE
REFLECTIVE BACKPLATES.

SEPARATE WIRING IN THE CONDUIT
AS NOTED,
CABINET TO POLE B,
4 - 3" PVC SCH 80 CONDUITS:
CONDUIT 1 - 9 x 7C
CONDUIT 2 - 6 x 7C, 4 x SPECIAL (ILLUMINATED SIGN)
CONDUIT 3 - 4 x 7C, 4 x SPECIAL (RADAR)
CONDUIT 4 - SPARE

INSTALL TYPE ATC 2070 CONTROLLER
IN MODEL 332 BASE MOUNT CABINET
INSTALL ROUTER, ANTENNA, POWER SUPPLY
AND CABLING AS SHOWN IN THE STANDARD
STANDARD DETAIL SHEET: CONTROLLER CABINET
AND ANTENNA / ROUTER DETAIL

INSTALL STEEL STRAIN POLE B AT
STA 140+26.9, 87.7' LT
INSTALL TWO PED HEADS ON STRAIN POLE B
INSTALL RADAR UNIT TYPE A WITH BRACKET
AND APPROPRIATE CABLING TO STRAIN POLE B

INSTALL PEDESTAL POST G WITH
TWO PED DETECTORS

INSTALL 4-3" SCH 80 PVC CONDUITS
FROM STRAIN POLE B TO CONTROLLER

REMOVE EXISTING SPAN MOUNTED, ILLUMINATED
STREET SIGN AND REINSTALL ON STRAIN POLE B
USING NEW MOUNTING BRACKETS, ARM, AND
CABLING. THIS IS INCLUDED WITH BID ITEM.
INSTALL ILLUMINATED STREET SIGN

INSTALL STEEL STRAIN POLE C AT
STA 140+32.4, 62.6' RT
INSTALL ONE PED HEAD ON STRAIN
POLE C
INSTALL RADAR UNIT TYPE A WITH
BRACKET AND APPROPRIATE CABLING
TO STRAIN POLE C

INSTALL PEDESTAL POST H WITH
ONE PED DETECTOR

INSTALL PEDESTRIAN PEDESTAL I WITH
ONE PED HEAD AND ONE PED DETECTOR

REMOVE EXISTING POLE MOUNTED, ILLUMINATED
STREET SIGN AND REINSTALL ON STRAIN POLE C
USING NEW MOUNTING BRACKETS, ARM, AND
CABLING. THIS IS INCLUDED WITH BID ITEM,
INSTALL ILLUMINATED STREET SIGN

REMOVE EXISTING CCTV AND REINSTALL ON
STRAIN POLE C USING NEW MOUNTING
EQUIPMENT,
ARM, AND CABLING. THIS IS INCLUDED WITH
BID ITEM, *INSTALL CCTV CAMERA*

NOTES:

ALL MESSENGER IS 15.4 M. ALL DETECTION BY RADAR.

THE CONTRACTOR MAY HAVE TO PROVIDE A CLAMP ASSEMBLY
FOR SOME OF THE ATTACHMENTS OF THE MESSENGER CABLE.
THIS SHALL BE INCIDENTAL TO THE INSTALLATION OF THE
STRAIN POLE. THE CLAMP ASSEMBLIES SHALL BE SUITABLE FOR
ATTACHING MESSENGER CABLE AND SHALL CONSIST OF A
MINIMUM OF TWO (2) SECTIONS. SECTIONS SHALL BE CONNECTED
USING A MINIMUM OF ONE (1) BOLT WITH A MINIMUM TENSILE
LOAD OF 17,050 LBS. ALL POLE CLAMP HARDWARE SHALL BE
HOT-DIPPED GALVANIZED. THE CONTRACTOR SHALL SUBMIT A
SHOP DRAWING OF THE PROPOSED ASSEMBLY TO THE DIVISION
OF TRAFFIC OPERATIONS.

CONTRACTOR SHALL EXERCISE EXTREME CAUTION AROUND ALL
UTILITIES TO INCLUDE THE GAS AND WATER LINES AND OVERHEAD
UTILITIES. HAND DIG WHEN WITHIN FOUR FEET. NOTE THAT ALL
UTILITIES MAY NOT BE SHOWN.

CONTRACTOR SHALL VERIFY ALL ATTACHMENT HEIGHTS IN THE
FIELD SO THAT ALL SIGNAL HEADS ARE BETWEEN 17' AND 19' FROM
FINISHED GRADE TO BOTTOM OF SIGNAL HEAD. ADJUST
ATTACHMENT HEIGHTS AND SAG APPROPRIATELY TO AVOID
OVERHEAD UTILITIES.

ALL BASES SHALL BE FLUSH WITH THE SIDEWALK, IF INSTALLED IN
THE SIDEWALK.

STEEL STRAIN POLES

POLE	HEIGHT	SPAN	ATT. HT.	CALC. SERV. MOMENT	SAG
A	36	A-B	31.0	285.29	5%
		A-D	33.0		
B	36	B-A	31.0	286.98	5%
		B-C	32.0		
C	38	C-B	31.5	325.68	5%
		C-D	31.0		
D	38	D-A	31.5	327.71	5%
		D-C	32.0		

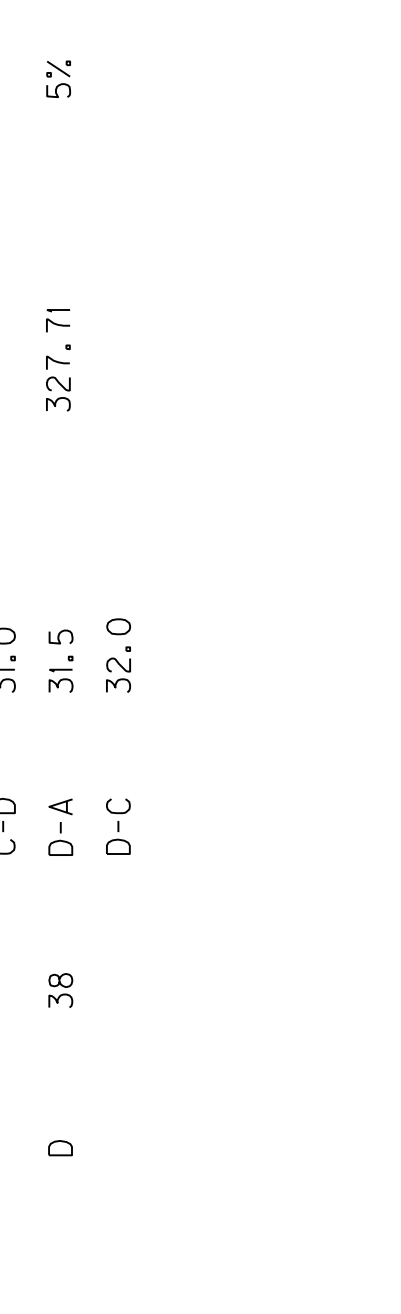

INSTALL STEEL STRAIN POLE D AT
STA 138+70.9, 63.1' RT
INSTALL ONE PED HEAD ON
STRAIN POLE D
INSTALL RADAR UNIT TYPE A
WITH BRACKET AND APPROPRIATE
CABLING TO STRAIN POLE D

INSTALL PEDESTRIAN PEDESTAL J WITH
ONE PED HEAD AND ONE PED DETECTOR

INSTALL PEDESTAL POST K WITH ONE
PED DETECTOR

REMOVE EXISTING POLE MOUNTED,
ILLUMINATED STREET SIGN AND REINSTALL
ON STRAIN POLE D USING NEW MOUNTING
BRACKETS, ARM, AND CABLING.
THIS IS INCLUDED WITH BID ITEM, *INSTALL
ILLUMINATED STREET SIGN*

WIRING SCHEDULE

ORIGIN	ENDING	CONNECTING
CONTROLLER	SH 1	SH 1
CONTROLLER	SH 2A	SH 2A, 2B, & 2C
CONTROLLER	SH 3	SH 3
CONTROLLER	SH 4B	SH 4A & 4B
CONTROLLER	SH 5	SH 5
CONTROLLER	SH 6C	SH 6A, 6B, & 6C
CONTROLLER	SH 7B	SH 7A & 7B
CONTROLLER	SH 8A	SH 8A & 8B
CONTROLLER	PED POST E	IPB
CONTROLLER	PED POST F	IPB
CONTROLLER	PED POST G	2 PBS
CONTROLLER	PED POST H	IPB
CONTROLLER	PEDESTAL I	IPB & PED SH 2B
CONTROLLER	PEDESTAL J	IPB & PED SH 2A
CONTROLLER	PED POST K	IPB
CONTROLLER	POLE A	PED SH 4A & 2B
CONTROLLER	POLE B	PED SH 2A & 8B
CONTROLLER	POLE C	PED SH 8A
CONTROLLER	POLE D	PED SH 4B
CONTROLLER	POLE A	RADAR ZONE 1, 6A, 6B, & 6C
CONTROLLER	POLE B	RADAR ZONES 4A, 4B, 7A & 7B
CONTROLLER	POLE C	RADAR ZONES 5, 2A, 2B, & 2C
CONTROLLER	POLE D	RADAR ZONES 3, 8A, 8B, & 8C
CONTROLLER	POLE A	ILLUMINATED SIGN
CONTROLLER	POLE B	ILLUMINATED SIGN
CONTROLLER	POLE C	ILLUMINATED SIGN
CONTROLLER	POLE D	ILLUMINATED SIGN

SCALE 1" = 20'

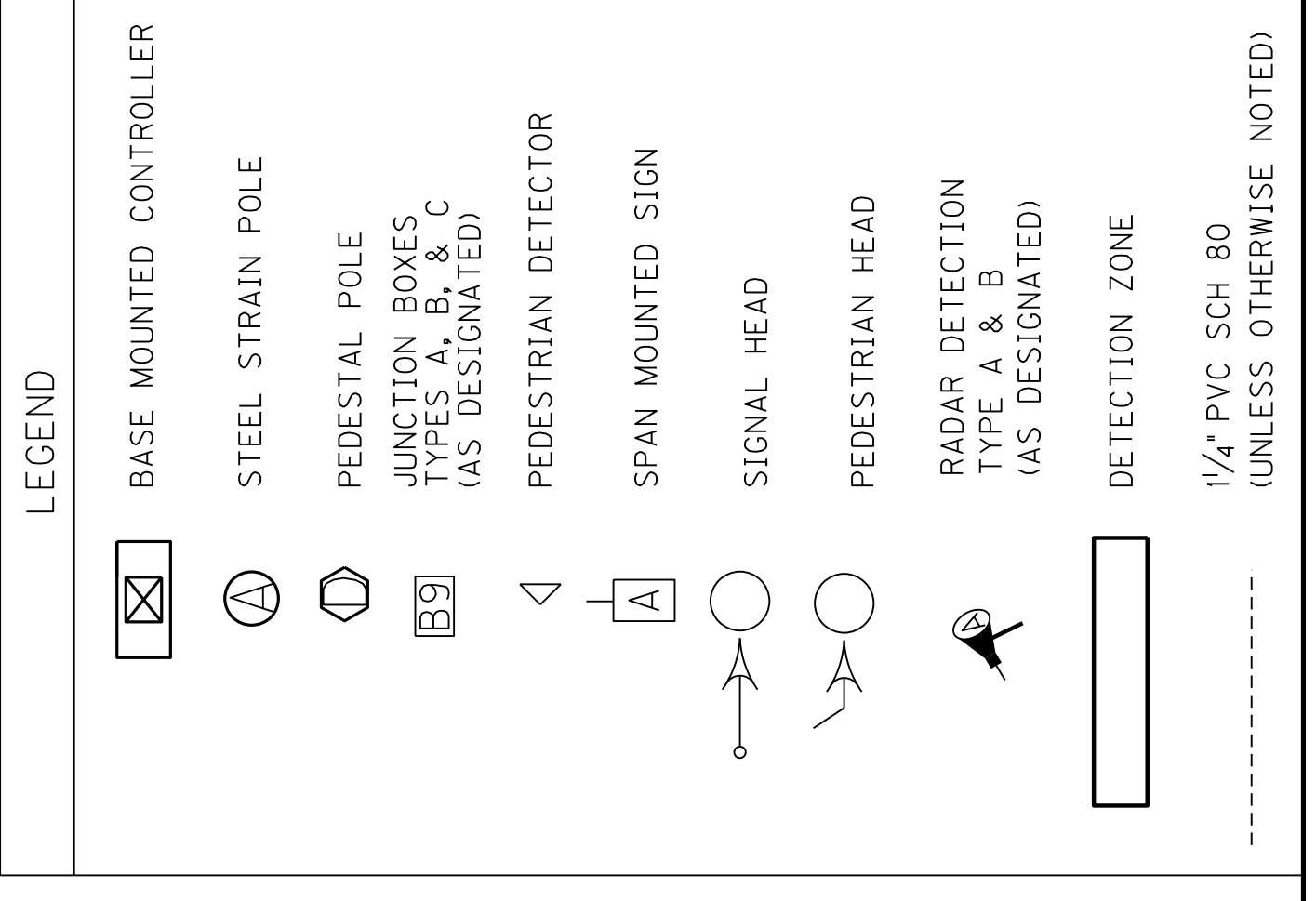

KY 922 (NEWTOWN PK) AT
KY 1878 (CITATION BLVD)
SIGNAL PLAN

SCALE: 1"=20

ROADWAY LIGHTING ESTIMATE OF QUANTITIES

TOTAL	UNITS	CODE	ITEM DESCRIPTION
84	EACH	4740	POLE BASE
1	EACH	4760	POLE W/SECONDARY CONTROL EQUIP
1390	LIN FT	4795	CONDUIT 2 INCH
14965	LIN FT	4820	TRENCHING AND BACKFILLING
1500	LIN FT	4833	WIRE - NO. 8
1	LS	4940	REMOVE LIGHTING
24	EACH	2039INS835	ELECTRICAL JUNCTION BOX TYPE A
6	EACH	21563NN	SPLICE BOX (ELECTRICAL, 8" x 6" x 4")
6	EACH	24750EC	LED TUNNEL LUMINAIRE
11055	LIN FT	24900EC	PVC CONDUIT - 1/4 INCH SCH 80

GENERAL LIGHTING NOTES:

- FOR PROPOSED CONVENTIONAL LIGHTING - KENTUCKY UTILITIES (KU) WILL INSTALL ALL LIGHT POLES, LUMINAIRES, AND CABLE. (THESE ITEMS ARE NOTED AS FUTURE ON THE PLAN SET.)
- THE CONTRACTOR INSTALLING LIGHTING FOUNDATIONS SHALL CONFIRM THE ANCHOR BOLT PATTERN AND SIZE WITH KENTUCKY UTILITIES.
- THE SPACING OF THE LIGHT POLE BASES OF THE CONVENTIONAL POLES ARE BASED ON THE FOLLOWING:
 TYPE C LUMINAIRES - CURRENT LIGHTING SOLUTIONS, ERLH LED SERIES, 14000 LUMENS,
 TYPE D LUMINAIRES - CURRENT LIGHTING SOLUTIONS, ERL2 SERIES, 23000 LUMENS,
 TYPE II DISTRIBUTION, 40K COLOR TEMPERATURE
- THE COMPLETE LIGHTING SYSTEM FOR THE PEDESTRIAN TUNNEL LIGHTING WILL BE INSTALLED AS PART OF THIS PROJECT. THIS INCLUDES THE CONTROLLER, WALLPACKS, WIRE, AND OTHER ITEMS FOR A FULLY FUNCTIONING LIGHTING SYSTEM.
- THE SPACING OF THE WALLPACKS IN THE PEDESTRIAN TUNNEL ARE BASED ON THE FOLLOWING:
 HOLOPHANE TWP LED WALLPACK SERIES, 10 LEDS, TYPE III DISTRIBUTION
 OR
 CURRENT LIGHTING SOLUTIONS EVOLVE EWLS LED WALLPACK SERIES, OPTIC CODE 25, TYPE III DISTRIBUTION

THE STANDARD SPECIFICATIONS FOR ROAD AND BRIDGE CONSTRUCTION, CURRENT EDITION, AND OTHER SPECIAL NOTES AND SPECIFICATIONS WILL APPLY ON THIS PROJECT. SEE SECTION 716 FOR MEASUREMENT AND OTHER DETAILS. SEE SECTION 602 FOR SPIRAL REINFORCEMENT SPLICING

THE CONTRACTOR SHALL MAKE AN INSPECTION OF THE PROJECT SITE PRIOR TO SUBMITTING A BID AND SHALL BE THOROUGHLY FAMILIARIZED WITH EXISTING CONDITIONS. SUBMISSIONS OF A BID WILL BE CONSIDERED AN AFFIRMATION OF THIS INSPECTION HAVING BEEN COMPLETED.

THE FOLLOWING ONLY APPLIES TO WIRE - #8, WHICH IS FOR PEDESTRIAN TUNNEL LIGHTING

ADD SENTENCE TO SECTION 834.06: ALL WIRE SHALL HAVE WORDING ADDED TO THE OUTER JACKET THAT STATES : "PROPERTY OF KENTUCKY TRANSPORTATION CABINET 502 564 0501".

ADD SENTENCE TO SECTION 834.10: ALL WIRE SHALL HAVE WORDING ADDED TO THE OUTER JACKET THAT STATES: "PROPERTY OF KENTUCKY TRANSPORTATION CABINET 502 564 0501".

CONSTRUCTION AND MEASUREMENT NOTES THAT ARE CONTRARY TO SECTION 716 & 834

SUBSECTION: 716.03.03 TRENCHING.
 REMOVE SENTENCE UNDER B: NO PAYMENT FOR ADDITIONAL JUNCTION BOXES FOR GREATER DEPTHS WILL BE ALLOWED.

SUBSECTION: 716.03.04 CONDUIT INSTALLATION
 ADD TO SECOND SENTENCE WITH THE FOLLOWING: BASES WITH BREAKWAY DEVICES INSTALLED.

SUBSECTION: 716.03.04 (K) BORE AND JACK.

REVISION: REPLACE TITLE WITH THE FOLLOWING: BORE AND JACK/OPEN CUT ROADWAY
 ADD SENTENCES AFTER LAST SENTENCE: WITH PERMISSION OF THE ENGINEER, ROADWAY MAY BE OPEN CUT IF CONDUIT IS UNDER PAVEMENT. THE CONDUIT IN OPEN CUT CAN BE EITHER 2" RIGID STEEL OR SCHEDULE 80 PVC UNDER ALL PAVEMENTS AREAS. IF IT IS THE LOOP TRANSITION FROM THE SAW SLOT, IT SHALL BE RIGID STEEL.

SECTION: 834.33 WARNING TAPE.

REVISION: REPLACE FIRST SENTENCE WITH THE FOLLOWING:
 PROVIDE DETECTABLE TYPE TAPE THAT IS 6 INCHES WIDE AND 7.0 MILS (NOMINAL) THICK.

MEASUREMENT NOTE THAT ARE IN ADDITION TO SECTION 716:

WIRE OR CABLE SHALL INCLUDE INSTALLING SPECIFIED WIRE OR CABLE WITHIN CONDUIT AS INDICATED ON THE PLAN SHEETS. INCIDENTAL TO THIS ITEM SHALL BE THE FINISHING AND INSTALLING OF SPLICE BOOTS OR ANY OTHER HARDWARE REQUIRED FOR INSTALLING CABLE. THE CONTRACTOR SHALL INSTALL ALL CABLE OR WIRE RUNS SPLICE-FREE FROM THE CONTROLLER TO EACH POLE. THE CABLE OR WIRE IS FEEDING. EXCEPTIONS TO THIS MUST BE APPROVED BY THE ENGINEER OR AS SPECIFIED ON THE PLANS. THE CONTRACTOR WILL RECEIVE WIRE IN 1000 FOOT ROLLS FROM OUR WAREHOUSE. THE CONTRACTOR SHALL RETURN ALL EXCESS WIRE TO THE TRAFFIC BARN IN DISTRICT 12. IF THE WIRE SUPPLIED DOES NOT EQUAL ENOUGH SUITABLE TO INSTALL ALL RUNS SPLICE FREE, THE CONTRACTOR CAN ASK FOR MORE WIRE TO BE SUPPLIED BY THE DIVISION OF TRAFFIC OPERATIONS. THIS REQUEST SHALL GO THROUGH THE RESIDENT ENGINEER TO CENTRAL OFFICE DIVISION OF TRAFFIC OPERATIONS. EACH RUN OF WIRE FROM POLE TO POLE (UP EACH POLE) SHALL BE THE FOLLOWING COLOR CODED: 2-BLACK (HOT) AND GREEN (GROUND). THIS NOTE ONLY APPLIES TO BID CODES 23675EC AND 24474ED.

COUNTY OF	ITEM NO.	SHEET NO.
FAYETTE	07-0252	139

DESIGNED BY: CRG
 DATE SUBMITTED: 9/11/2023

Commonwealth of Kentucky
DEPARTMENT OF HIGHWAYS

COUNTY OF

FAYETTE

PROJECT: 07-0252
 NUMBERS: FD04 034 0922 001-003 D

ROADWAY LIGHTING ESTIMATES
 OF QUANTITIES

ROADWAY LIGHTING ESTIMATE OF QUANTITIES

TOTAL	UNITS	CODE	ITEM DESCRIPTION
84	EACH	4740	POLE BASE
1	EACH	4760	POLE W/SECONDARY CONTROL EQUIP
1390	LIN FT	4795	CONDUIT 2 INCH
14965	LIN FT	4820	TRENCHING AND BACKFILLING
1500	LIN FT	4833	WIRE - NO. 8
1	LS	4940	REMOVE LIGHTING
24	EACH	2039INS835	ELECTRICAL JUNCTION BOX TYPE A
6	EACH	21563NN	SPLICE BOX (ELECTRICAL, 8" x 6" x 4")
6	EACH	24750EC	LED TUNNEL LUMINAIRE
11055	LIN FT	24900EC	PVC CONDUIT - 1 1/4 INCH SCH 80

GENERAL LIGHTING NOTES:

- FOR PROPOSED CONVENTIONAL LIGHTING - KENTUCKY UTILITIES (KU) WILL INSTALL ALL LIGHT POLES, LUMINAIRES, AND CABLE. (THESE ITEMS ARE NOTED AS FUTURE ON THE PLAN SET.)
- THE CONTRACTOR INSTALLING LIGHTING FOUNDATIONS SHALL CONFIRM THE ANCHOR BOLT PATTERN AND SIZE WITH KENTUCKY UTILITIES.
- THE SPACING OF THE LIGHT POLE BASES OF THE CONVENTIONAL POLES ARE BASED ON THE FOLLOWING:
 TYPE C LUMINAIRES - CURRENT LIGHTING SOLUTIONS, ERLH LED SERIES, 14000 LUMENS,
 TYPE D LUMINAIRES - CURRENT LIGHTING SOLUTIONS, ERL2 SERIES, 23000 LUMENS,
 TYPE II DISTRIBUTION, 40K COLOR TEMPERATURE
- THE COMPLETE LIGHTING SYSTEM FOR THE PEDESTRIAN TUNNEL LIGHTING WILL BE INSTALLED AS PART OF THIS PROJECT. THIS INCLUDES THE CONTROLLER, WALLPACKS, WIRE, AND OTHER ITEMS FOR A FULLY FUNCTIONING LIGHTING SYSTEM.
- THE SPACING OF THE WALLPACKS IN THE PEDESTRIAN TUNNEL ARE BASED ON THE FOLLOWING:
 HOLOPHANE TWP LED WALLPACK SERIES, 10 LEDS, TYPE III DISTRIBUTION
 OR
 CURRENT LIGHTING SOLUTIONS EVOLVE EWLS LED WALLPACK SERIES, OPTIC CODE 25, TYPE III DISTRIBUTION

THE STANDARD SPECIFICATIONS FOR ROAD AND BRIDGE CONSTRUCTION, CURRENT EDITION, AND OTHER SPECIAL NOTES AND SPECIFICATIONS WILL APPLY ON THIS PROJECT. SEE SECTION 716 FOR MEASUREMENT AND OTHER DETAILS. SEE SECTION 602 FOR SPIRAL REINFORCEMENT SPLICING

THE CONTRACTOR SHALL MAKE AN INSPECTION OF THE PROJECT SITE PRIOR TO SUBMITTING A BID AND SHALL BE THOROUGHLY FAMILIARIZED WITH EXISTING CONDITIONS. SUBMISSIONS OF A BID WILL BE CONSIDERED AN AFFIRMATION OF THIS INSPECTION HAVING BEEN COMPLETED.

THE FOLLOWING ONLY APPLIES TO WIRE - #8, WHICH IS FOR PEDESTRIAN TUNNEL LIGHTING
 ADD SENTENCE TO SECTION 834.06: ALL WIRE SHALL HAVE WORDING ADDED TO THE OUTER JACKET THAT STATES : "PROPERTY OF KENTUCKY TRANSPORTATION CABINET 502 564 0501".
 ADD SENTENCE TO SECTION 834.10: ALL WIRE SHALL HAVE WORDING ADDED TO THE OUTER JACKET THAT STATES: " PROPERTY OF KENTUCKY TRANSPORTATION CABINET 502 564 0501".

CONSTRUCTION AND MEASUREMENT NOTES THAT ARE CONTRARY TO SECTION 716 & 834

SUBSECTION: 716.03.03 TRENCHING.
 REMOVE SENTENCE UNDER B): NO PAYMENT FOR ADDITIONAL JUNCTION BOXES FOR GREATER DEPTHS WILL BE ALLOWED.
 SUBSECTION: 716.03.04 CONDUIT INSTALLATION
 ADD TO SECOND SENTENCE WITH THE FOLLOWING: BASES WITH BREAKWAY DEVICES INSTALLED.
 SUBSECTION: 716.03.04 (K) BORE AND JACK.
 REVISION: REPLACE TITLE WITH THE FOLLOWING: BORE AND JACK/OPEN CUT ROADWAY
 ADD SENTENCES AFTER LAST SENTENCE: WITH PERMISSION OF THE ENGINEER, ROADWAY MAY BE OPEN CUT IF CONDUIT IS UNDER PAVEMENT. THE CONDUIT IN OPEN CUT CAN BE EITHER 2" RIDID STEEL OR SCHEDULE 80 PVC UNDER ALL PAVEMENTS AREAS. IF IT IS THE LOOP TRANSITION FROM THE SAW SLOT, IT SHALL BE RIGID STEEL.

SECTION: 834.33 WARNING TAPE.

REVISION: REPLACE FIRST SENTENCE WITH THE FOLLOWING:
 PROVIDE DETECTABLE TYPE TAPE THAT IS 6 INCHES WIDE AND 7.0 MILS (NOMINAL) THICK.

MEASUREMENT NOTE THAT ARE IN ADDITION TO SECTION 716:

WIRE OR CABLE SHALL INCLUDE INSTALLING SPECIFIED WIRE OR CABLE WITHIN CONDUIT AS INDICATED ON THE PLAN SHEETS. INCIDENTAL TO THIS ITEM SHALL BE THE FURNISHING AND INSTALLING OF SPLICE BOOTS OR ANY OTHER HARDWARE REQUIRED FOR INSTALLING CABLE. THE CONTRACTOR SHALL INSTALL ALL CABLE OR WIRE RUNS SPLICE-FREE FROM THE CONTROLLER TO EACH POLE THE CABLE OR WIRE IS FEEDING. EXCEPTIONS TO THIS MUST BE APPROVED BY THE ENGINEER OR AS SPECIFIED ON THE PLANS. THE CONTRACTOR WILL RECEIVE WIRE IN 1000 FOOT ROLLS FROM OUR WAREHOUSE. THE CONTRACTOR SHALL RETURN ALL EXCESS WIRE TO THE TRAFFIC BARN IN DISTRICT 12. IF THE WIRE SUPPLIED DOES NOT EQUAL ENOUGH SUITABLE TO INSTALL ALL RUNS SPLICE FREE, THE CONTRACTOR CAN ASK FOR MORE WIRE TO BE SUPPLIED BY THE DIVISION OF TRAFFIC OPERATIONS. THIS REQUEST SHALL GO THROUGH THE RESIDENT ENGINEER TO CENTRAL OFFICE DIVISION OF TRAFFIC OPERATIONS. EACH RUN OF WIRE FROM POLE TO POLE (UP EACH POLE) SHALL BE THE FOLLOWING COLOR CODED: 2-BLACK (HOT) AND GREEN (GROUND). THIS NOTE ONLY APPLIES TO BID CODES 23675EC AND 24474ED.

COUNTY OF	ITEM NO.	SHEET NO.
FAYETTE	07-0252	139

DESIGNED BY: CRG
 DATE SUBMITTED: 9/11/2023

Commonwealth of Kentucky
DEPARTMENT OF HIGHWAYS
 COUNTY OF
FAYETTE

PROJECT 07-0252
 NUMBERS: FD04 034 0922 001-003 D

ROADWAY LIGHTING ESTIMATES
 OF QUANTITIES

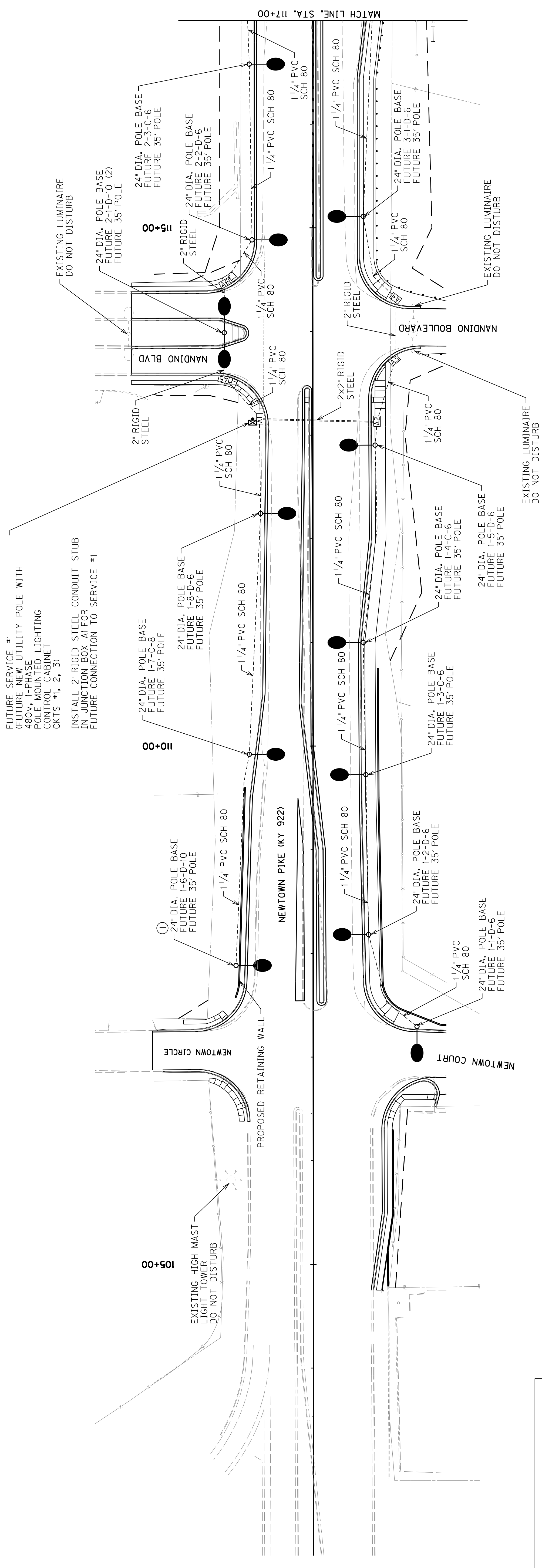
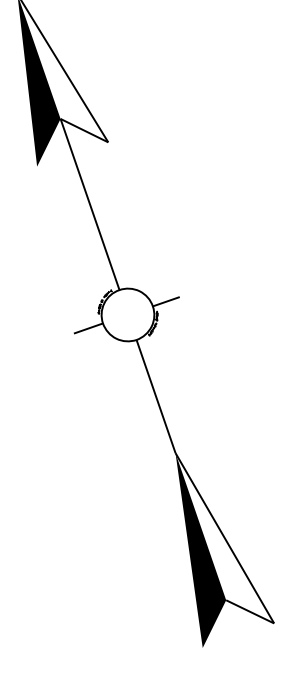

FUTURE SERVICE #1
 (FUTURE NEW UTILITY POLE WITH
 480V, 1-PHASE
 POLE MOUNTED LIGHTING
 CONTROL CABINET
 CKTS #1, 2, 3)
 INSTALL 2\"/>

LEGEND

- BASE MOUNTED CABINET
- POLE MOUNTED CABINET
- JUNCTION BOXES - TYPES A & C (AS DESIGNATED)
- 1 1/2\"/>

GENERAL NOTES

THE CONTRACTOR SHALL NOTE THE PROXIMITY OF THE STORM SEWER, THE LIGHT POLE BASES, AND THE SIDEWALKS AND ENSURE THE CONSTRUCTION SEQUENCING OF ALL ITEMS CAN BE COMPLETED WITHOUT DAMAGE TO ANY PREVIOUS CONSTRUCTION.

ALL BASES SHALL BE FLUSH WITH THE SIDEWALK, IF INSTALLED IN THE SIDEWALK.

① COMPACT BACKFILL ADEQUATELY AROUND THE LIGHT POLE BASE, AS DIRECTED BY THE PROJECT ENGINEER.



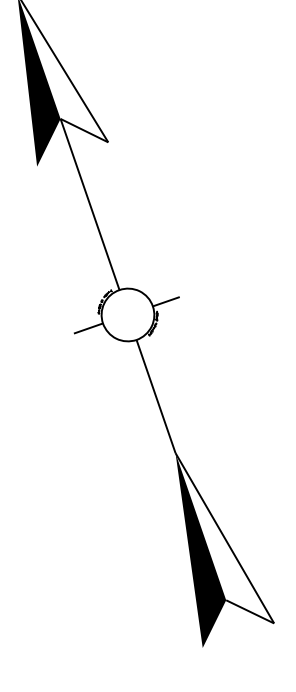



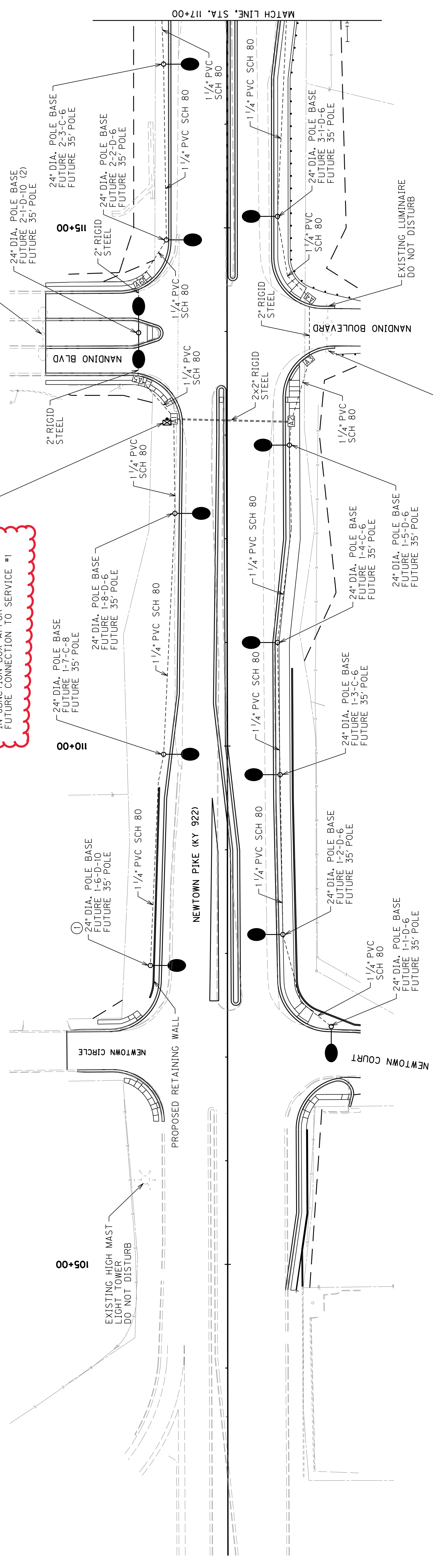



FUTURE LUMINAIRES	STATIONS/ COORDINATES	ALIGNMENT
I-1-D-6	Sta 106+29.4, 100.1' RT	KY 922
I-2-D-6	Sta 108+18.2, 53.5' RT	KY 922
I-3-C-6	Sta 109+72.4, 50.9' RT	KY 922
I-4-C-6	Sta 110+99.9, 48.5' RT	KY 922
I-5-D-6	Sta 112+90.3, 60.1' RT	KY 922
I-6-D-10	Sta 107+88.3, 74.4' LT	KY 922
I-7-C-8	Sta 109+92.2, 61.4' LT	KY 922
I-8-D-6	Sta 112+24.5, 50.5' LT	KY 922
2-1-D-10(2)	Sta 113+98.9, 85.3' LT	KY 922
2-2-D-6	Sta 114+88.4, 58.5' LT	KY 922
2-3-C-6	Sta 116+57.9, 61.1' LT	KY 922
3-1-D-6	Sta 115+11.0, 48.8' RT	KY 922



FUTURE SERVICE #1
 (FUTURE NEW UTILITY POLE WITH
 480V, 1-PHASE
 POLE MOUNTED LIGHTING
 CONTROL CABINET
 CKTS #1, 2, 3)
 INSTALL 2" RIGID STEEL CONDUIT STUB
 IN JUNCTION BOX A1 FOR
 FUTURE CONNECTION TO SERVICE #1

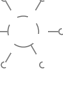

LEGEND

-  BASE MOUNTED CABINET
-  POLE MOUNTED CABINET
-  JUNCTION BOXES - TYPES A & C (AS DESIGNATED)
-  1 1/2" RIGID STEEL CONDUIT (UNLESS OTHERWISE NOTED)
-  LUMINAIRE POLE BASE (FUTURE LUMINAIRE BY OTHERS)
-  EXISTING LUMINAIRE
-  LUMINAIRE POLE BASE (FUTURE DOUBLE ARM LUMINAIRE BY OTHERS)
-  EXISTING DOUBLE ARM LUMINAIRE
-  EXISTING HIGH MAST LIGHT TOWER
-  NEW 35 FT. WOOD SERVICE POLE
-  FUTURE WALLPACK BY OTHERS

GENERAL NOTES

- THE CONTRACTOR SHALL NOTE THE PROXIMITY OF THE STORM SEWER, THE LIGHT POLE BASES, AND THE SIDEWALKS AND ENSURE THE CONSTRUCTION SEQUENCING OF ALL ITEMS CAN BE COMPLETED WITHOUT DAMAGE TO ANY PREVIOUS CONSTRUCTION.
- ALL BASES SHALL BE FLUSH WITH THE SIDEWALK, IF INSTALLED IN THE SIDEWALK.
- ① COMPACT BACKFILL ADEQUATELY AROUND THE LIGHT POLE BASE, AS DIRECTED BY THE PROJECT ENGINEER.

FUTURE LUMINAIRES	STATIONS/COORDINATES	ALIGNMENT
I-1-D-6	Sta 106+29.4, 100.1' RT	KY 922
I-2-D-6	Sta 108+18.2, 53.5' RT	KY 922
I-3-C-6	Sta 109+72.4, 50.9' RT	KY 922
I-4-C-6	Sta 110+99.9, 48.5' RT	KY 922
I-5-D-6	Sta 112+90.3, 60.1' RT	KY 922
I-6-D-10	Sta 107+88.3, 74.4' LT	KY 922
I-7-C-8	Sta 109+92.2, 61.4' LT	KY 922
I-8-D-6	Sta 112+24.5, 50.5' LT	KY 922
2-1-D-10(2)	Sta 113+98.9, 85.3' LT	KY 922
2-2-D-6	Sta 114+88.4, 58.5' LT	KY 922
2-3-C-6	Sta 116+57.9, 61.1' LT	KY 922
3-1-D-6	Sta 115+11.0, 48.8' RT	KY 922

SCALE: 1"=50'

KY 922 (NEWTOWN PK)
 LIGHTING PLAN
 STA. 104+75 TO STA. 117+00

GENERAL NOTES

THE CONTRACTOR SHALL NOTE THE PROXIMITY OF THE STORM SEWER, THE LIGHT POLE BASES, AND THE SIDEWALKS AND ENSURE THE CONSTRUCTION SEQUENCING OF ALL ITEMS CAN BE COMPLETED WITHOUT DAMAGE TO ANY PREVIOUS CONSTRUCTION. ALL BASES SHALL BE FLUSH WITH THE SIDEWALK, IF INSTALLED IN THE SIDEWALK.

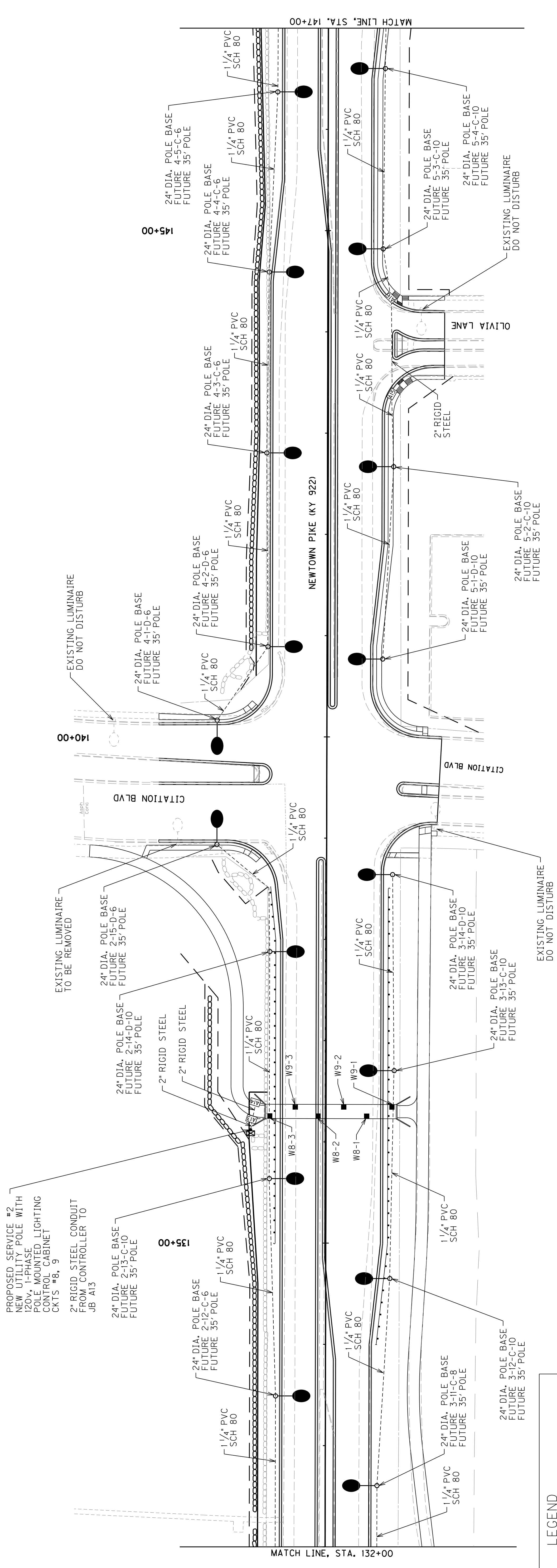
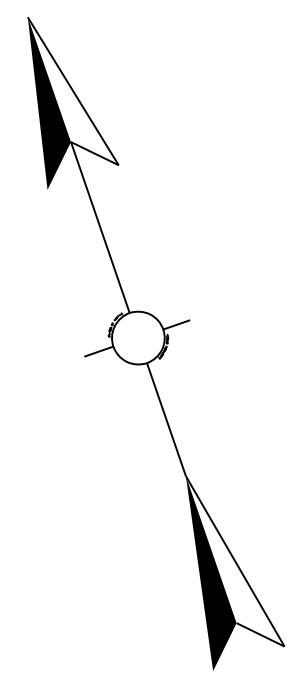

LEGEND

- BASE MOUNTED CABINET
- POLE MOUNTED CABINET
- JUNCTION BOXES - TYPES A & C (AS DESIGNATED)
- 1 1/2" RIGID STEEL CONDUIT (UNLESS OTHERWISE NOTED)
- LUMINAIRE POLE BASE (FUTURE LUMINAIRE BY OTHERS)
- EXISTING LUMINAIRE
- LUMINAIRE POLE BASE (FUTURE DOUBLE ARM LUMINAIRE BY OTHERS)
- EXISTING DOUBLE ARM LUMINAIRE
- EXISTING HIGH MAST LIGHT TOWER
- NEW 35 FT. WOOD SERVICE POLE
- FUTURE WALLPACK BY OTHERS

FUTURE LUMINAIRE	STATIONS/COORDINATES	ALIGNMENT
4-1-D-6	Sta 140+16.3, 108.4' LT	KY 922
4-2-D-6	Sta 140+89.0, 58.5' LT	KY 922
4-3-C-6	Sta 142+80.3, 59.9' LT	KY 922
4-4-C-6	Sta 144+59.0, 57.9' LT	KY 922
4-5-C-6	Sta 146+36.9, 49.8' LT	KY 922
5-1-D-10	Sta 140+77.0, 55.0' RT	KY 922
5-2-C-10	Sta 142+67.0, 65.5' RT	KY 922
5-3-C-10	Sta 144+82.1, 54.6' RT	KY 922
5-4-C-10	Sta 146+60.3, 56.3' RT	KY 922

FUTURE LUMINAIRE	STATIONS/COORDINATES	ALIGNMENT
2-12-C-6	Sta 133+49.0, 49.3' LT	KY 922
2-13-C-10	Sta 135+63.6, 56.0' LT	KY 922
2-14-D-10	Sta 137+87.8, 56.0' LT	KY 922
2-15-D-6	Sta 138+93.4, 108.4' LT	KY 922
3-11-C-8	Sta 132+60.6, 51.1' RT	KY 922
3-12-C-10	Sta 134+65.2, 63.3' RT	KY 922
3-13-C-10	Sta 136+70.5, 67.0' RT	KY 922
3-14-D-10	Sta 138+64.1, 65.2' RT	KY 922

FUTURE LUMINAIRE	STATIONS/COORDINATES	ALIGNMENT
W8-1	STRUCTURE MOUNT	LEGACY TRAIL TUNNEL
W8-2	STRUCTURE MOUNT	LEGACY TRAIL TUNNEL
W8-3	STRUCTURE MOUNT	LEGACY TRAIL TUNNEL
W9-1	STRUCTURE MOUNT	LEGACY TRAIL TUNNEL
W9-2	STRUCTURE MOUNT	LEGACY TRAIL TUNNEL
W9-3	STRUCTURE MOUNT	LEGACY TRAIL TUNNEL

KY 922 (NEWTOWN PK)
LIGHTING PLAN
STA. 134+00 TO STA. 147+00

SCALE: 1"=50'

GENERAL NOTES

THE CONTRACTOR SHALL NOTE THE PROXIMITY OF THE STORM SEWER, THE LIGHT POLE BASES, AND THE SIDEWALKS AND ENSURE THE CONSTRUCTION SEQUENCING OF ALL ITEMS CAN BE COMPLETED WITHOUT DAMAGE TO ANY PREVIOUS CONSTRUCTION. ALL BASES SHALL BE FLUSH WITH THE SIDEWALK, IF INSTALLED IN THE SIDEWALK.

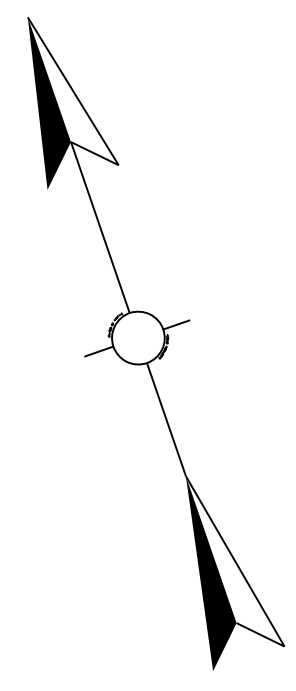

PROPOSED SERVICE #2 NEW UTILITY POLE WITH 120V, 1-PHASE POLE MOUNTED LIGHTING CONTROL CABINET CKTS #8, 9
2" RIGID STEEL CONDUIT FROM CONTROLLER TO JOB A13

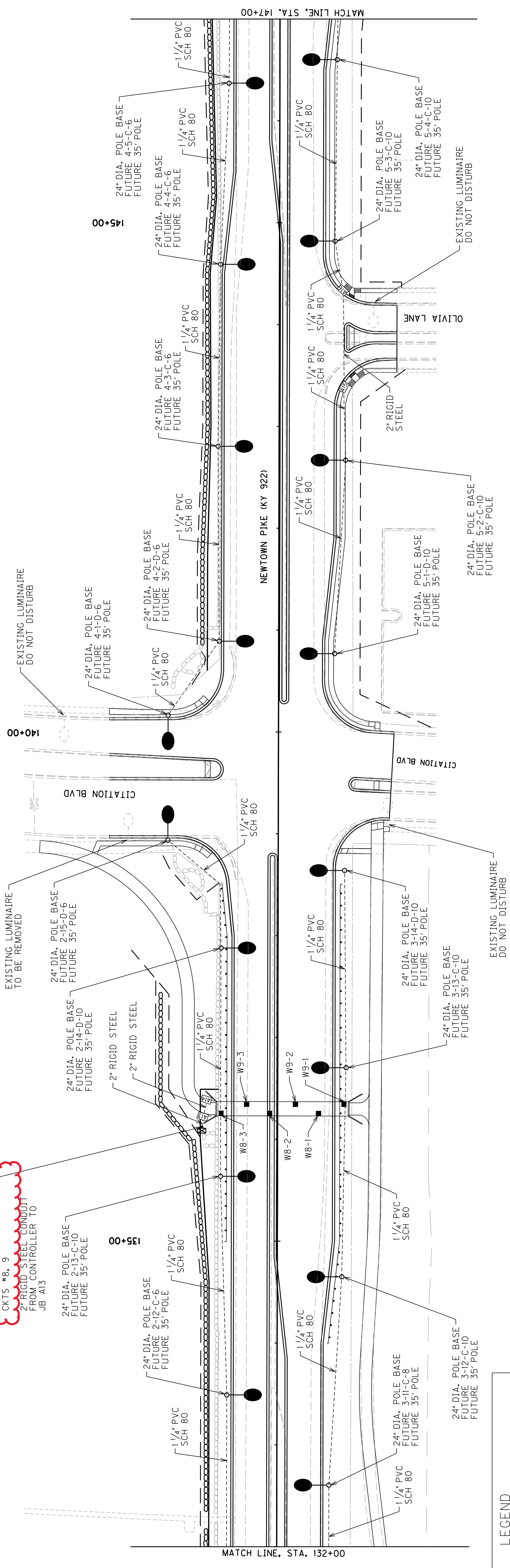

FUTURE LUMINAIRES	STATIONS/COORDINATES	ALIGNMENT
4-1-D-6	Sta 140+16.3, 108.4' LT	KY 922
4-2-D-6	Sta 140+89.0, 58.5' LT	KY 922
4-3-C-6	Sta 142+80.3, 59.9' LT	KY 922
4-4-C-6	Sta 144+59.0, 57.9' LT	KY 922
4-5-C-6	Sta 146+36.9, 49.8' LT	KY 922
5-1-D-10	Sta 140+77.0, 55.0' RT	KY 922
5-2-C-10	Sta 142+67.0, 65.5' RT	KY 922
5-3-C-10	Sta 144+82.1, 54.6' RT	KY 922
5-4-C-10	Sta 146+60.3, 56.3' RT	KY 922

FUTURE LUMINAIRES	STATIONS/COORDINATES	ALIGNMENT
2-12-C-6	Sta 133+49.0, 49.3' LT	KY 922
2-13-C-10	Sta 135+63.6, 56.0' LT	KY 922
2-14-D-10	Sta 137+87.8, 56.0' LT	KY 922
2-15-D-6	Sta 138+93.4, 108.4' LT	KY 922
3-11-C-8	Sta 132+60.6, 51.1' RT	KY 922
3-12-C-10	Sta 134+65.2, 63.3' RT	KY 922
3-13-C-10	Sta 136+70.5, 67.0' RT	KY 922
3-14-D-10	Sta 138+64.1, 65.2' RT	KY 922

FUTURE LUMINAIRES	STATIONS/COORDINATES	ALIGNMENT
W8-1	STRUCTURE MOUNT	LEGACY TRAIL TUNNEL
W8-2	STRUCTURE MOUNT	LEGACY TRAIL TUNNEL
W8-3	STRUCTURE MOUNT	LEGACY TRAIL TUNNEL
W9-1	STRUCTURE MOUNT	LEGACY TRAIL TUNNEL
W9-2	STRUCTURE MOUNT	LEGACY TRAIL TUNNEL
W9-3	STRUCTURE MOUNT	LEGACY TRAIL TUNNEL

LEGEND

	BASE MOUNTED CABINET
	POLE MOUNTED CABINET
	JUNCTION BOXES - TYPES A & C (AS DESIGNATED)
	1 1/2" RIGID STEEL CONDUIT (UNLESS OTHERWISE NOTED)
	LUMINAIRE POLE BASE (FUTURE LUMINAIRE BY OTHERS)
	EXISTING LUMINAIRE
	LUMINAIRE POLE BASE (FUTURE DOUBLE ARM LUMINAIRE BY OTHERS)
	EXISTING DOUBLE ARM LUMINAIRE
	EXISTING HIGH MAST LIGHT TOWER
	NEW 35 FT. WOOD SERVICE POLE
	FUTURE WALLPACK BY OTHERS

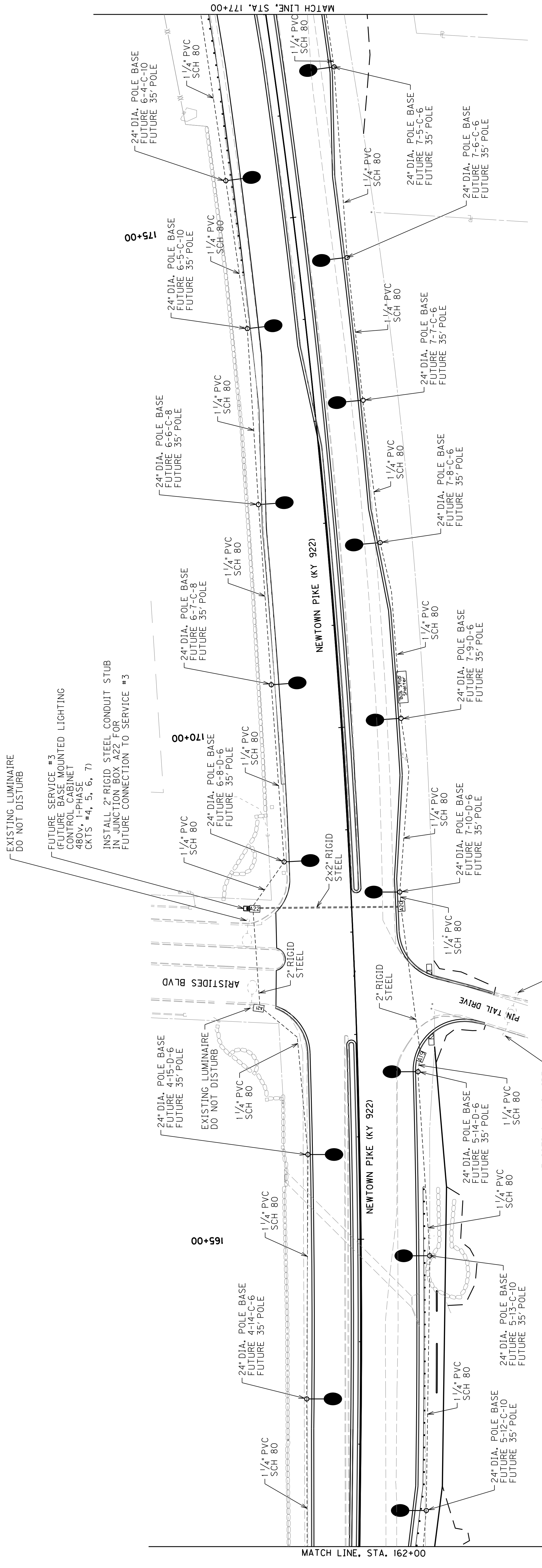
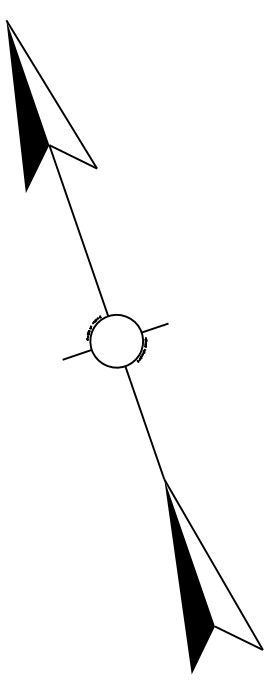

EXISTING LUMINAIRE DO NOT DISTURB

FUTURE SERVICE #3 (FUTURE BASE MOUNTED LIGHTING CONTROL CABINET 480V, 1-PHASE CKTS #4, 5, 6, 7)

INSTALL 2" RIGID STEEL CONDUIT STUB IN JUNCTION BOX A22 FOR FUTURE CONNECTION TO SERVICE #3

LEGEND

- BASE MOUNTED CABINET
- POLE MOUNTED CABINET
- JUNCTION BOXES - TYPES A & C (AS DESIGNATED)
- 1 1/2" RIGID STEEL CONDUIT (UNLESS OTHERWISE NOTED)
- LUMINAIRE POLE BASE (FUTURE LUMINAIRE BY OTHERS)
- EXISTING LUMINAIRE
- LUMINAIRE POLE BASE (FUTURE DOUBLE ARM LUMINAIRE BY OTHERS)
- EXISTING DOUBLE ARM LUMINAIRE
- EXISTING HIGH MAST LIGHT TOWER
- NEW 35 FT. WOOD SERVICE POLE
- FUTURE WALLPACK BY OTHERS

FUTURE LUMINAIRE	STATIONS/COORDINATES	ALIGNMENT
4-14-C-6	Sta 163+43.8, 53.1' LT	KY 922
4-15-D-6	Sta 165+83.8, 50.5' LT	KY 922
5-12-C-10	Sta 162+36.0, 64.4' RT	KY 922
5-13-C-10	Sta 164+83.4, 67.1' RT	KY 922
5-14-D-6	Sta 166+61.9, 58.5' RT	KY 922
6-4-C-10	Sta 175+44, 60.7' LT	KY 922
6-5-C-10	Sta 173+97.2, 57' LT	KY 922
6-6-C-8	Sta 172+24, 63.5' LT	KY 922
6-7-C-8	Sta 170+46.4, 65.4' LT	KY 922
6-8-D-6	Sta 168+24, 63.5' LT	KY 922

FUTURE LUMINAIRE	STATIONS/COORDINATES	ALIGNMENT
7-5-C-6	Sta 176+40.1, 58.6' RT	KY 922
7-6-C-6	Sta 174+55.1, 47.6' RT	KY 922
7-7-C-6	Sta 173+15.6, 47.6' RT	KY 922
7-8-C-6	Sta 171+76.6, 51.3' RT	KY 922
7-9-D-6	Sta 168+4.9, 58.6' RT	KY 922
7-10-D-6	Sta 168+36.8, 47.6' RT	KY 922

GENERAL NOTES





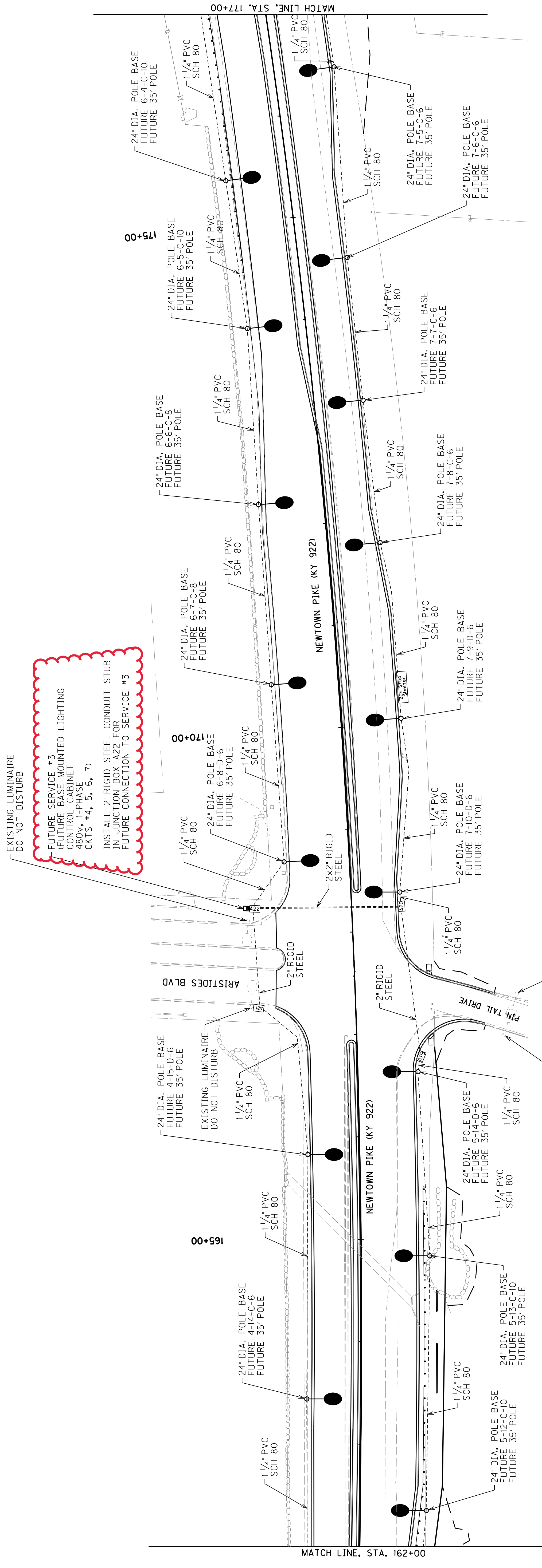
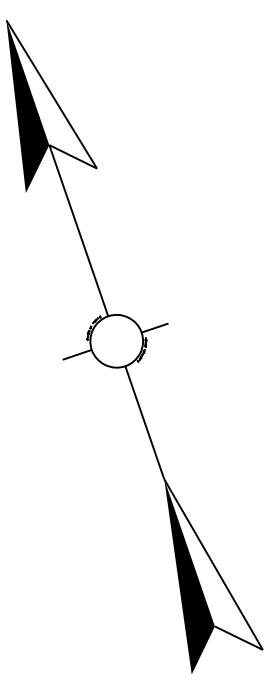



THE CONTRACTOR SHALL NOTE THE PROXIMITY OF THE STORM SEWER, THE LIGHT POLE BASES, AND THE SIDEWALKS AND ENSURE THE CONSTRUCTION SEQUENCING OF ALL ITEMS CAN BE COMPLETED WITHOUT DAMAGE TO ANY PREVIOUS CONSTRUCTION.

ALL BASES SHALL BE FLUSH WITH THE SIDEWALK, IF INSTALLED IN THE SIDEWALK.

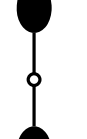

EXISTING LUMINAIRE DO NOT DISTURB
 FUTURE SERVICE #3 (FUTURE BASE MOUNTED LIGHTING CONTROL CABINET 480V, 1-PHASE CKTS #4, 5, 6, 7)
 INSTALL 2\" RIGID STEEL CONDUIT STUB IN JUNCTION BOX A22 FOR FUTURE CONNECTION TO SERVICE #3

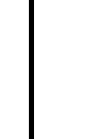
LEGEND

-  BASE MOUNTED CABINET
-  POLE MOUNTED CABINET
-  JUNCTION BOXES - TYPES A & C (AS DESIGNATED)
-  1/2\" RIGID STEEL CONDUIT (UNLESS OTHERWISE NOTED)
-  LUMINAIRE POLE BASE (FUTURE LUMINAIRE BY OTHERS)
-  EXISTING LUMINAIRE
-  LUMINAIRE POLE BASE (FUTURE DOUBLE ARM LUMINAIRE BY OTHERS)
-  EXISTING DOUBLE ARM LUMINAIRE
-  EXISTING HIGH MAST LIGHT TOWER
-  NEW 35 FT. WOOD SERVICE POLE
-  FUTURE WALLPACK BY OTHERS

FUTURE LUMINAIRE	STATIONS/COORDINATES	ALIGNMENT
4-14-C-6	S+o 163+43.8, 53.1' LT	KY 922
4-15-D-6	S+o 165+83.8, 50.5' LT	KY 922
5-12-C-10	S+o 162+36.0, 64.4' RT	KY 922
5-13-C-10	S+o 164+83.4, 67.1' RT	KY 922
5-14-D-6	S+o 166+61.9, 58.5' RT	KY 922
6-4-C-10	S+o 175+44, 60.7' LT	KY 922
6-5-C-10	S+o 173+97.2, 57' LT	KY 922
6-6-C-8	S+o 172+24, 63.5' LT	KY 922
6-7-C-8	S+o 170+46.4, 65.4' LT	KY 922
6-8-D-6	S+o 168+24, 63.5' LT	KY 922

GENERAL NOTES
 THE CONTRACTOR SHALL NOTE THE PROXIMITY OF THE STORM SEWER, THE LIGHT POLE BASES, AND THE SIDEWALKS AND ENSURE THE CONSTRUCTION SEQUENCING OF ALL ITEMS CAN BE COMPLETED WITHOUT DAMAGE TO ANY PREVIOUS CONSTRUCTION.
 ALL BASES SHALL BE FLUSH WITH THE SIDEWALK, IF INSTALLED IN THE SIDEWALK.

FUTURE LUMINAIRE	STATIONS/COORDINATES	ALIGNMENT
7-5-C-6	S+o 176+40.1, 58.6' RT	KY 922
7-6-C-6	S+o 174+55.1, 47.6' RT	KY 922
7-7-C-6	S+o 173+15.6, 47.6' RT	KY 922
7-8-C-6	S+o 171+76.6, 51.3' RT	KY 922
7-9-D-6	S+o 168+4.9, 58.6' RT	KY 922
7-10-D-6	S+o 168+36.8, 47.6' RT	KY 922

COUNTY OF	ITEM NO.	SHEET NO.
FAYETTE	07-0252	152

ITS ESTIMATE OF QUANTITIES

TOTAL	UNITS	CODE	ITEM DESCRIPTION
15	EACH	4810	ELECTRICAL JUNCTION BOX
7330	LIN FT	4820	TRENCHING AND BACKFILLING
7660	LIN FT	21077ED	FIBER OPTIC CABLE
7330	LIN FT	2412IEC	HDPE CONDUIT - 2" SCH 80
2	EACH	24922EC	FIBER OPTIC SPLICE ENCLOSURE

THE STANDARD SPECIFICATIONS FOR ROAD AND BRIDGE CONSTRUCTION, CURRENT EDITION, AND OTHER SPECIAL NOTES AND SPECIFICATIONS WILL APPLY ON THIS PROJECT. SEE SECTION 716 FOR MEASUREMENT AND OTHER DETAILS. SEE SECTION 602 FOR SPIRAL REINFORCEMENT SPLICING

THE CONTRACTOR SHALL MAKE AN INSPECTION OF THE PROJECT SITE PRIOR TO SUBMITTING A BID AND SHALL BE THOROUGHLY FAMILIARIZED WITH EXISTING CONDITIONS. SUBMISSIONS OF A BID WILL BE CONSIDERED AN AFFIRMATION OF THIS INSPECTION HAVING BEEN COMPLETED.

NOTES FOR FIBER:

- * ALL CONDUIT SHALL BE INSTALLED AND SHALL INCLUDE A 1/2" PULL ROPE WITH DETECTABLE TRACER WIRE. THIS SHALL BE INCIDENTAL TO THE CONDUIT BID ITEM AND NO PAYMENT SHALL BE MADE FOR CONDUIT INSTALLED WITHOUT REQUIRED PULL ROPE.
- * NO 90 DEGREE STUBS WILL BE ACCEPTED
- * JUNCTION BOX LIDS SHALL BE MARKED WITH "LFUGG FIBER."
- * ALL FIBER-OPTIC CABLE SHALL BE 72-STRAND SINGLE MODE FIBER. FIBER OPTIC SHALL BE CORNING MFR PART # 072ZU4-1F42D20. THIS PRODUCT MATCHES THE EXISTING FIBER-OPTIC NETWORK AND NO EXCEPTIONS WILL BE MADE.
- * DURING INSTALLATION, THE CONTRACTOR SHALL DOCUMENT FIBER OPTIC CABLE FOOTAGE LOCATED ON THE JACKET OF THE CABLE, INSIDE THE JUNCTION BOXES TO VERIFY SLACK FOOTAGES ARE CORRECT.
- * THE CONTRACTOR SHALL ENSURE THAT CABLE FOOTAGE REMAINS LEGIBLE. NO PAYMENT WILL BE MADE FOR FIBER-OPTIC CABLING WITH FOOTAGE MADE ILLEGIBLE DURING THE INSTALLATION PROCESS, AND KYTC AND LFUGG RESERVE THE RIGHT TO REJECT THE INSTALLATION. SHOULD THE INSTALLATION BE REJECTED, THE CONTRACTOR SHALL BE RESPONSIBLE FOR REMOVING AND REPLACING THE DEFICIENT CABLING.
- * THE CONTRACTOR SHALL UTILIZE SLACK LOOPS INSIDE JUNCTION BOXES WHERE NOTED ON THE CONSTRUCTION PLANS. IF THE CONTRACTOR BELIEVES AN ADDITIONAL SLACK LOOP IS NECESSARY, THE CONTRACTOR SHALL GET APPROVAL FROM THE PROJECT ENGINEER PRIOR TO INSTALLATION.
- * ALL SPLICES SHALL CONFORM CORNING CERTIFIABLE STANDARDS. MASTER SPLICES SHALL CONSIST OF SPLICING THE EXISTING SEVENTY -TWO (72) STRAND FIBER OPTIC CABLE WITH THE PROPOSED SEVENTY -TWO (72) STRAND FIBER OPTIC CABLE.
- * THE CONTRACTOR SHALL CONDUCT AN OPTICAL TEST ON PROPOSED FIBER-OPTIC CABLE PRIOR TO COMPLETING SPLICES. A POST SPLICE TEST SHALL ALSO BE COMPLETED BY THE CONTRACTOR WITH A MAXIMUM OF 0.10 DB LOSS ALLOWED. SHOULD THIS LIMIT BE EXCEEDED, A NEW SPLICE SHALL BE COMPLETED UNTIL THE 0.10 DB OR BETTER CAN BE ACHIEVED. AN ADDITIONAL TEST WILL BE COMPLETED BY LFUGG PERSONNEL PRIOR TO FINAL PROJECT ACCEPTANCE.
- * THE CONTRACTOR SHALL CONTACT LFUGG AT LEAST THREE (3) DAYS PRIOR TO COMPLETION OF AN OPTICAL TEST.
- * FIBER CABLE INSTALLATION AND SPLICES SHALL ONLY BE COMPLETED BY PERSONS WITH THE APPROPRIATE CERTIFICATIONS. THESE CERTIFICATIONS MUST INCLUDE, BUT ARE NOT LIMITED TO:
 - THE FIBER OPTIC ASSOCIATION (FOA)
 - CORNING
 - BICSI FIBER OPTICS
- * THE CONTRACTOR SHALL SUPPLY KYTC WITH VERIFICATION THAT LFUGG REQUIRED TESTING WAS COMPLETED AND THE RESULTS OF THE TESTS.

CONSTRUCTION AND MEASUREMENT NOTES THAT ARE CONTRARY TO SECTION 716 & 834

- SUBSECTION: 716.03.03 TRENCHING.
REMOVE: REMOVE SENTENCE UNDER B): NO PAYMENT FOR ADDITIONAL JUNCTION BOXES FOR GREATER DEPTHS WILL BE ALLOWED.
- SUBSECTION: 716.03.04 CONDUIT INSTALLATION
REVISION: ADD TO SECOND SENTENCE WITH THE FOLLOWING: BASES WITH BREAKWAY DEVICES INSTALLED.
- SECTION: 834.33 WARNING TAPE.
- REVISION: REPLACE FIRST SENTENCE WITH THE FOLLOWING:
PROVIDE DETECTABLE TYPE TAPE THAT IS 6 INCHES WIDE AND 7.0 MILS (NOMINAL) THICK.

DESIGNED BY: CRG	
DATE SUBMITTED: 9/11/2023	
Commonwealth of Kentucky DEPARTMENT OF HIGHWAYS	
COUNTY OF FAYETTE	
07-252 PROJECT NUMBERS: FD04 034 0922 001-003 D	

ITS ESTIMATES
OF
QUANTITIES

COUNTY OF	ITEM NO.	SHEET NO.
FAYETTE	07-0252	152

ITS ESTIMATE OF QUANTITIES

TOTAL	UNITS	CODE	ITEM DESCRIPTION
15	EACH	4810	ELECTRICAL JUNCTION BOX
7330	LIN FT	4820	TRENCHING AND BACKFILLING
7660	LIN FT	21077ED	FIBER OPTIC CABLE
7330	LIN FT	2412IEC	HDPE CONDUIT - 2" SCH 80
2	EACH	24922EC	FIBER OPTIC SPLICE ENCLOSURE

THE STANDARD SPECIFICATIONS FOR ROAD AND BRIDGE CONSTRUCTION, CURRENT EDITION, AND OTHER SPECIAL NOTES AND SPECIFICATIONS WILL APPLY ON THIS PROJECT. SEE SECTION 716 FOR MEASUREMENT AND OTHER DETAILS. SEE SECTION 602 FOR SPIRAL REINFORCEMENT SPlicing

THE CONTRACTOR SHALL MAKE AN INSPECTION OF THE PROJECT SITE PRIOR TO SUBMITTING A BID AND SHALL BE THOROUGHLY FAMILIARIZED WITH EXISTING CONDITIONS. SUBMISSIONS OF A BID WILL BE CONSIDERED AN AFFIRMATION OF THIS INSPECTION HAVING BEEN COMPLETED.

NOTES FOR FIBER:

- * ALL CONDUIT SHALL BE INSTALLED AND SHALL INCLUDE A 1/2" PULL ROPE WITH DETECTABLE TRACER WIRE. THIS SHALL BE INCIDENTAL TO THE CONDUIT BID ITEM AND NO PAYMENT SHALL BE MADE FOR CONDUIT INSTALLED WITHOUT REQUIRED PULL ROPE.
- * NO 90 DEGREE STUBS WILL BE ACCEPTED
- * JUNCTION BOX LIDS SHALL BE MARKED WITH "LFUGG FIBER."
- * ALL FIBER-OPTIC CABLE SHALL BE 72-STRAND SINGLE MODE FIBER. FIBER OPTIC SHALL BE CORNING MFR PART # 072ZU4-1F42D20. THIS PRODUCT MATCHES THE EXISTING FIBER-OPTIC NETWORK AND NO EXCEPTIONS WILL BE MADE.
- * DURING INSTALLATION, THE CONTRACTOR SHALL DOCUMENT FIBER OPTIC CABLE FOOTAGE LOCATED ON THE JACKET OF THE CABLE, INSIDE THE JUNCTION BOXES TO VERIFY SLACK FOOTAGES ARE CORRECT.
- * THE CONTRACTOR SHALL ENSURE THAT CABLE FOOTAGE REMAINS LEGIBLE. NO PAYMENT WILL BE MADE FOR FIBER-OPTIC CABLING WITH FOOTAGE MADE ILLEGIBLE DURING THE INSTALLATION PROCESS, AND KYTC AND LFUGG RESERVE THE RIGHT TO REJECT THE INSTALLATION. SHOULD THE INSTALLATION BE REJECTED, THE CONTRACTOR SHALL BE RESPONSIBLE FOR REMOVING AND REPLACING THE DEFICIENT CABLING.
- * THE CONTRACTOR SHALL UTILIZE SLACK LOOPS INSIDE JUNCTION BOXES WHERE NOTED ON THE CONSTRUCTION PLANS. IF THE CONTRACTOR BELIEVES AN ADDITIONAL SLACK LOOP IS NECESSARY, THE CONTRACTOR SHALL GET APPROVAL FROM THE PROJECT ENGINEER PRIOR TO INSTALLATION.
- * ALL SPLICES SHALL CONFORM CORNING CERTIFIABLE STANDARDS. MASTER SPLICES SHALL CONSIST OF SPLICING THE EXISTING SEVENTY -TWO (72) STRAND FIBER OPTIC CABLE WITH THE PROPOSED SEVENTY -TWO (72) STRAND FIBER OPTIC CABLE.
- * THE CONTRACTOR SHALL CONDUCT AN OPTICAL TEST ON PROPOSED FIBER-OPTIC CABLE PRIOR TO COMPLETING SPLICES. A POST SPLICE TEST SHALL ALSO BE COMPLETED BY THE CONTRACTOR WITH A MAXIMUM OF 0.10 DB LOSS ALLOWED. SHOULD THIS LIMIT BE EXCEEDED, A NEW SPLICE SHALL BE COMPLETED UNTIL THE 0.10 DB OR BETTER CAN BE ACHIEVED. AN ADDITIONAL TEST WILL BE COMPLETED BY LFUGG PERSONNEL PRIOR TO FINAL PROJECT ACCEPTANCE.
- * THE CONTRACTOR SHALL CONTACT LFUGG AT LEAST THREE (3) DAYS PRIOR TO COMPLETION OF AN OPTICAL TEST.
- * FIBER CABLE INSTALLATION AND SPLICES SHALL ONLY BE COMPLETED BY PERSONS WITH THE APPROPRIATE CERTIFICATIONS. THESE CERTIFICATIONS MUST INCLUDE, BUT ARE NOT LIMITED TO:
 - THE FIBER OPTIC ASSOCIATION (FOA)
 - CORNING
 - BICSI FIBER OPTICS
- * THE CONTRACTOR SHALL SUPPLY KYTC WITH VERIFICATION THAT LFUGG REQUIRED TESTING WAS COMPLETED AND THE RESULTS OF THE TESTS.

CONSTRUCTION AND MEASUREMENT NOTES THAT ARE CONTRARY TO SECTION 716 & 834

- SUBSECTION: 716.03.03 TRENCHING.
REMOVE: REMOVE SENTENCE UNDER B): NO PAYMENT FOR ADDITIONAL JUNCTION BOXES FOR GREATER DEPTHS WILL BE ALLOWED.
- SUBSECTION: 716.03.04 CONDUIT INSTALLATION
REVISION: ADD TO SECOND SENTENCE WITH THE FOLLOWING: BASES WITH BREAKWAY DEVICES INSTALLED.
- SECTION: 834.33 WARNING TAPE.
- REVISION: REPLACE FIRST SENTENCE WITH THE FOLLOWING:
PROVIDE DETECTABLE TYPE TAPE THAT IS 6 INCHES WIDE AND 7.0 MILS (NOMINAL) THICK.

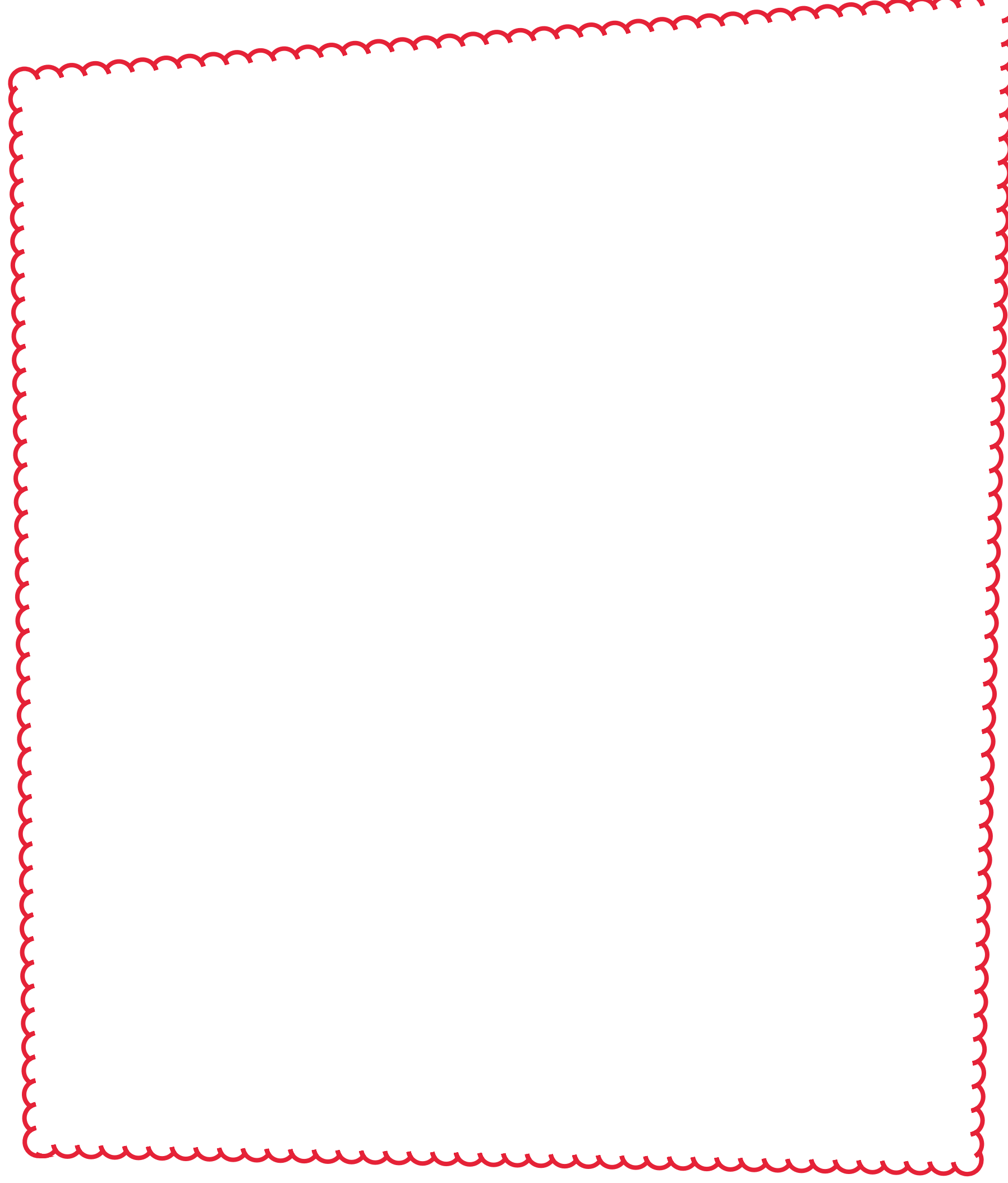

DESIGNED BY: CRG	
DATE SUBMITTED: 9/11/2023	
Commonwealth of Kentucky DEPARTMENT OF HIGHWAYS	
COUNTY OF FAYETTE	
PROJECT: 07-252	
NUMBERS: FD04 034 0922 001-003 D	
ITS ESTIMATES OF QUANTITIES	