



Providing Reliable, Manageable Power for VoIP Network Wiring Closets: A Practical Guide to IDF/MDF Infrastructure Migration and Implementation

Executive Summary

Once relegated to early adopters and casual home users, VoIP (voice over Internet protocol) has matured. It is rapidly becoming the standard for voice communications in business, education, government and healthcare. The question is not so much *if* your organization will migrate to VoIP, but *when*. Cost is the primary driver, since the data network performs double duty by carrying voice traffic as well. VoIP also offers capabilities that far exceed traditional phone systems, with unified communication platforms promising to integrate messaging, mobility, collaboration, relationship management, zoned security, intelligent call routing, disaster recovery, video, teleconferencing, status updates and other advanced features.

The transition to VoIP presents a number of challenges, including assessing the ability of your network to handle not only additional traffic, but a different type of traffic that requires real-time performance. You also need to install new equipment in the main distribution frame (MDF) and the intermediate distribution frames (IDFs) dispersed throughout your organization's network/telecom wiring closets. Typical closet designs can't handle the increased wattage and heat output of the PoE switches used to power IP phones. This is especially true where power capacity, battery backup runtime and system availability are concerned. This document discusses the basics of VoIP migration and implementation, then focuses on practical considerations for provisioning power and cooling for VoIP network/telecom wiring closets.

Table of Contents

VoIP Basics.....	3
Reasons to Switch to VoIP	4
Preparing the Data Network for VoIP	6
Core VoIP Equipment and Locations.....	6
Session Initiation Protocol (SIP).....	9
SIP Trunking	9
Benefits of SIP Trunking	10
SIP Trunking Connection Types	11
Upgrading IDF and MDF Infrastructure for VoIP.....	12
Power Capacity and Connections	13
Availability: Battery Backup Runtime	21
Availability: UPS Topology	23
Availability: Redundant Power	29
Cooling in Network/Telecom Closets.....	31
Cabling	35
Local and Remote Management	36
Maintenance and Service	38
Application Examples	40
Conclusion	44

Note: If you are primarily interested in provisioning IT infrastructure for VoIP network/telecom closets, proceed to **Upgrading IDF and MDF Infrastructure for VoIP** on page 12.

VoIP Basics

Voice traffic has traditionally been carried by dedicated circuit-switched networks. Inside an organization, call traffic is handled by a PBX system. Outside the organization, the PBX connects incoming and outgoing calls with the public switched telephone network (PSTN) over leased lines capable of handling a set number of simultaneous calls.

VoIP (voice over Internet protocol, also known as IP telephony, unified communications, cloud telephony or Internet telephony) migrates voice traffic from the circuit-switched voice network to your organization's packet-switched data network. VoIP uses an IP-PBX to route calls, or you can upgrade your current PBX to handle VoIP traffic. Depending on your implementation, you can use VoIP inside your firewall while continuing to connect incoming and outgoing calls to the PSTN, or you can extend your VoIP network (and its advanced features) beyond your firewall.

In essence, VoIP is bringing the Internet revolution full-circle. Not too long ago, Internet data was widely conveyed to end users over modems connected to the analog voice network. In ever-increasing numbers, voice is now being carried over the digital data network.

Figure 1: Traditional (Circuit-Switched) Phone Network

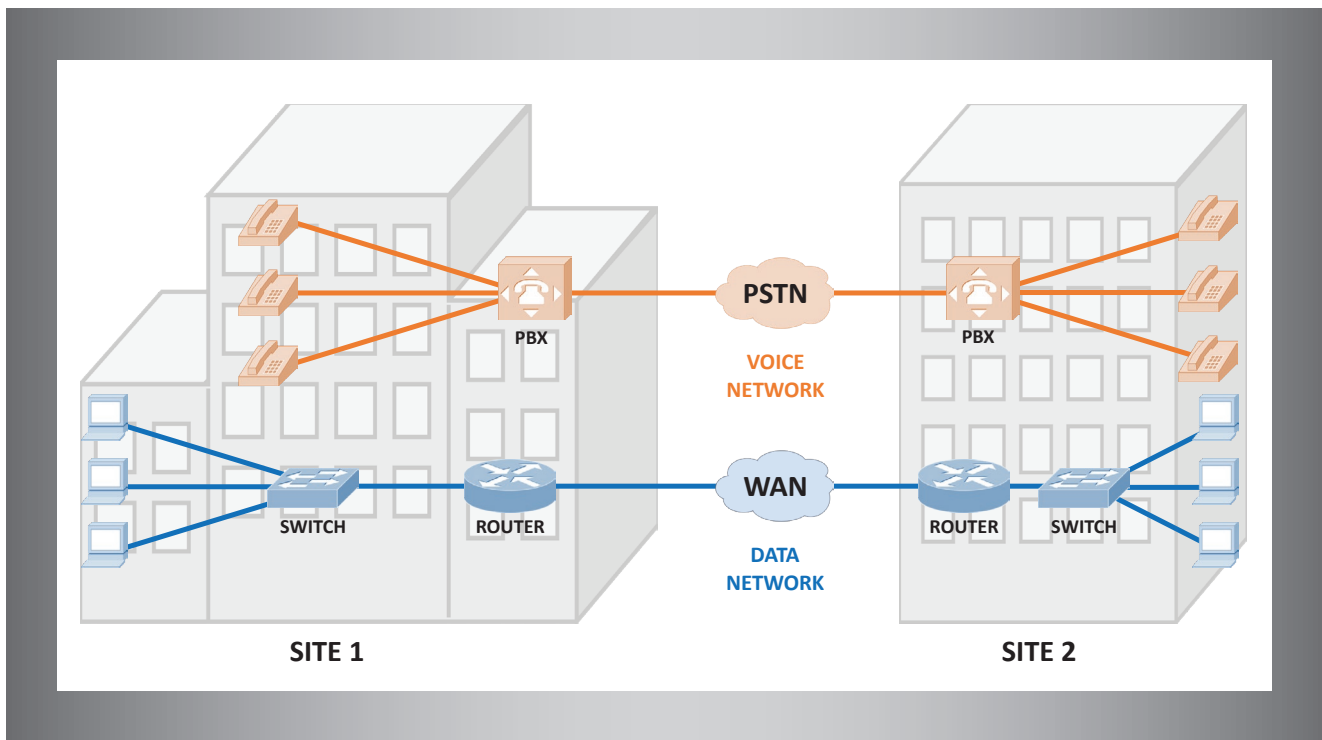

The traditional model for telephone service uses a voice network that is separate from the data network.

Figure 2: VoIP (Packet-Switched) Phone Network

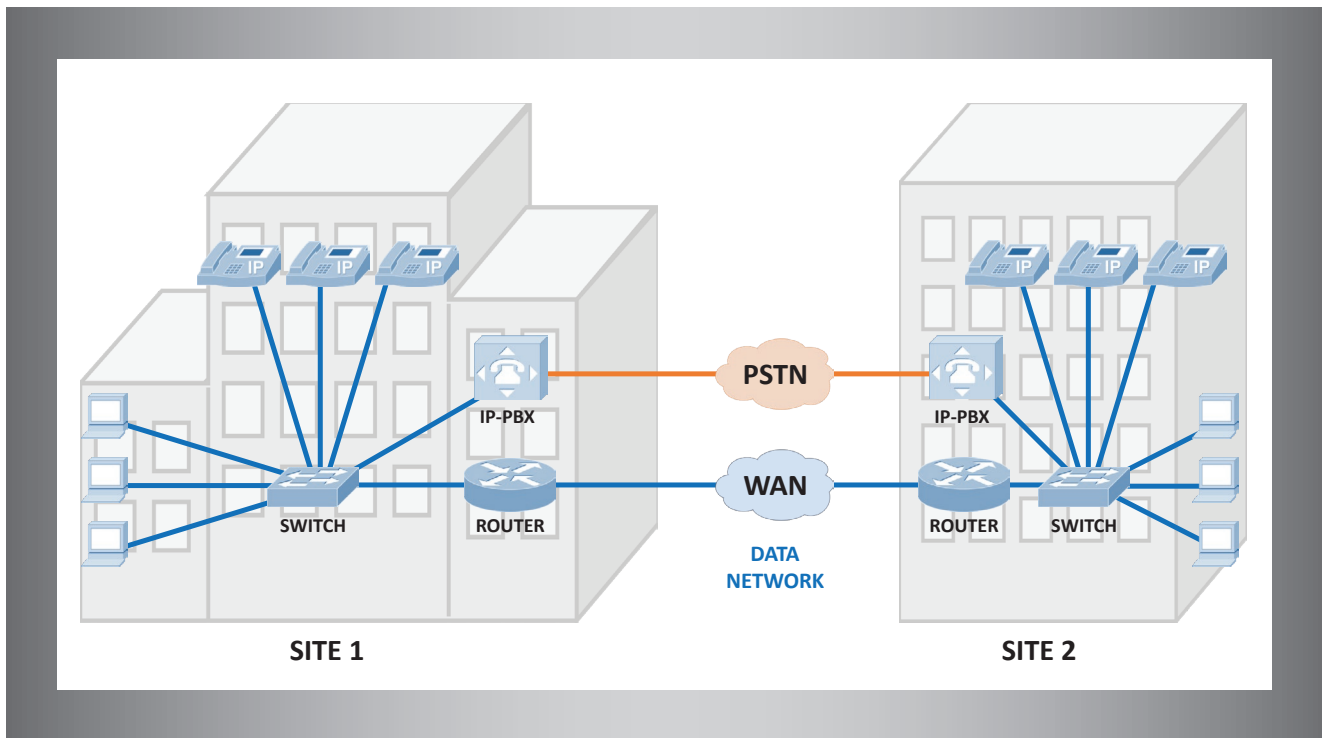

*The VoIP model for telephone service has a converged voice and data network.
The converged network may still have on-site ties to the PSTN, depending on the implementation.*

Reasons to Switch to VoIP

Circuit-switched phone networks have worked very well for more than a century, so the choice to switch to VoIP does not come lightly. The primary motivator is cost, as VoIP can reduce ongoing costs significantly. (Reducing monthly phone bills 40 to 60% is typical.) An aging, undersized or unreliable PBX that has become increasingly difficult to repair and keep up to date can also prompt an upgrade decision. Other triggers include relocation, staff increases, new offices and corporate reorganization. Or an organization may be seeking improved call routing, mobility, business continuity, disaster recovery, interactive voice response, regulatory compliance, call recording or database integration. Since the expected cost savings of VoIP can make it an essentially self-funding project, it's easy to see why VoIP is so popular.

Once your organization has decided to switch to VoIP, you may be faced with the decision of whether to implement a solution in-house or go with a hosted/cloud solution. A hosted/cloud solution relocates the IP-PBX to the cloud, where it is hosted by a service provider. A hosted/cloud solution generally has lower startup costs, but may have higher ongoing costs. It may be attractive to a smaller organization with limited IT staff or a larger organization seeking to control IT costs. If you decide to pursue a hosted/cloud solution, confirm that it meets the call quality, security and feature requirements of your organization. A hosted/cloud solution is otherwise similar to an in-house solution that employs SIP trunking. (See **SIP Trunking** on page 9 for more information.)

Figure 3: Hosted/Cloud VoIP Phone Network

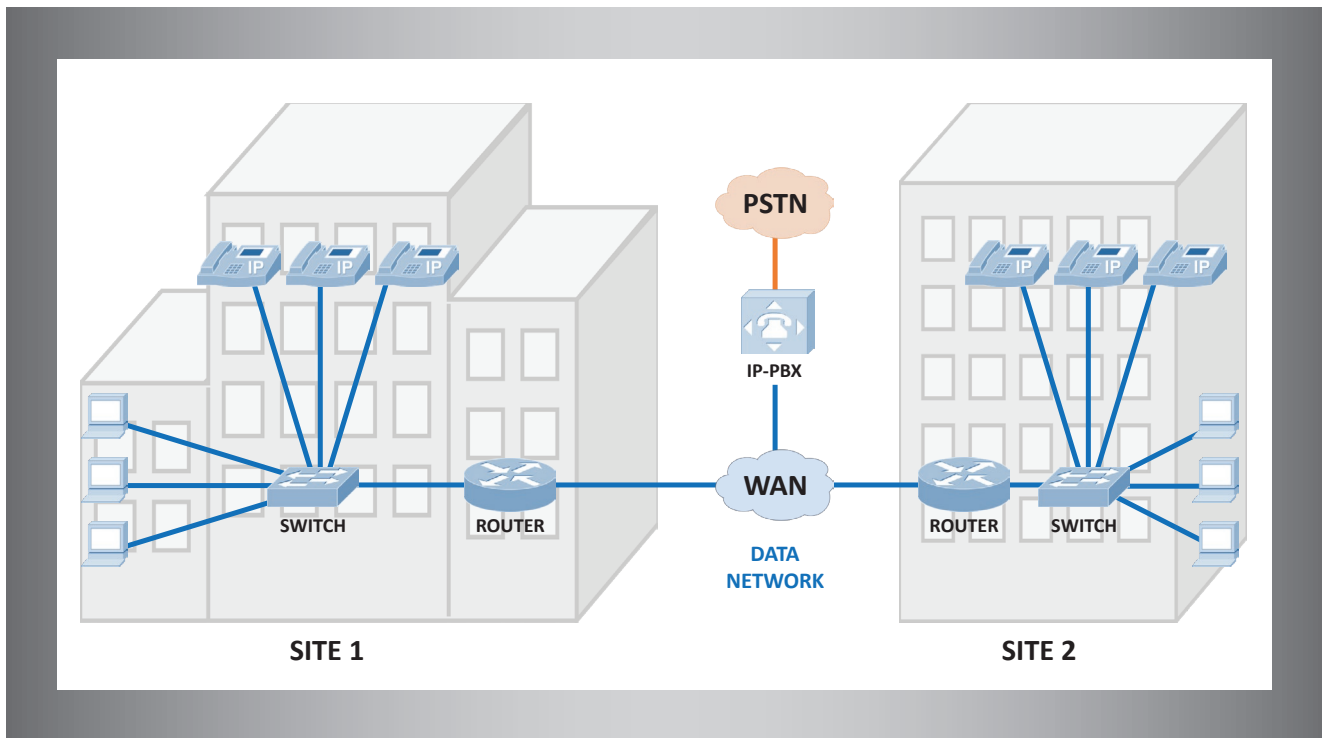

A hosted/cloud VoIP solution relocates the IP-PBX to the cloud, where it is hosted by a service provider.

Some benefits of switching to VoIP include:

- Managing one combined network instead of two separate networks.
- Reducing local and long-distance call charges.
- Adding and modifying extensions more easily through software instead of hardware.
- Providing disaster recovery through immediate failover to alternate sites.
- Staying more connected to customers and colleagues at the office or on the road.
- Adding advanced features like video and integrated messaging.

Most organizations will not have a "pure" VoIP solution. You may still need to support traditional phone lines for redundancy, disaster recovery, 911 service and security systems, so VoIP is not necessarily a way to get rid of that responsibility entirely. Legacy devices like fax machines, alarms and payment card processing terminals may also require analog lines.

Preparing the Data Network for VoIP

The main thing to remember when preparing your data network is that VoIP traffic has to be delivered to end users in real time. When an e-mail or a web page travels across your network, you want the data to arrive quickly, but it isn't a disaster if there's a slight delay. Even if the data is streaming video, buffering can cover most network hiccups and prevent the end user from noticing a problem. With real-time voice traffic, even small errors and delays can translate to poor call quality, and buffering (if any) is extremely limited because the data is not pre-recorded.

Data traffic can work well with best-effort delivery, but to maintain acceptable call quality you usually need to prioritize voice traffic by implementing quality of service (QoS) in your network hardware. QoS creates a priority lane for your real-time traffic to improve performance. An alternative to QoS is over-provisioning best-effort (non-QoS) network capacity to ensure that congestion will not slow traffic at the expected traffic peak. At the LAN level, bandwidth is inexpensive enough to make over-provisioning a viable alternative, but at the WAN level the high cost of bandwidth usually dictates the need for a smarter solution in the form of QoS. If you can't implement QoS with your current network hardware, you will need to upgrade your infrastructure, including routers and switches. You may also need to fine-tune other aspects of your network to reduce or eliminate performance issues that can affect call quality, including dropped packets, bit errors, latency, jitter, low throughput and out-of-order delivery. The codecs used to encode and compress sounds for transmission over the network also play a large role in call quality.

If you decide to use a hosted/cloud solution or SIP trunking to extend your VoIP network beyond your firewall, you will need a reliable, high-speed Internet connection with sufficient bandwidth for all your data and communications. If you require higher call quality and reliability, you may need a dedicated line for VoIP traffic. (See **SIP Trunking Connection Types** on page 11 for more information.)

Core VoIP Equipment and Locations

Your site's core VoIP equipment will be concentrated in three main locations: the network drops, the intermediate distribution frames (IDFs, usually installed inside network/telecom wiring closets) and the main distribution frame (MDF). (There's a wide range of terminology used by different organizations, and the same term can mean different things to different organizations. We're using the terminology that we encounter most frequently in the field.)

Network drops are network connection endpoints where VoIP client devices – usually IP phones – are plugged into network jacks. Employee desktops, meeting rooms, classrooms and computer labs are common locations for drops to be installed. Network drops may support your organization's non-VoIP devices as well, or you may decide to segregate VoIP and non-VoIP drops. The IP phones can be powered by AC adapters that plug into wall outlets, but it is more common for them to be powered over the network lines through network switches that support a standard called Power over Ethernet (PoE).

The copper Ethernet cables for the network drops originate in IDFs distributed throughout the building. An IDF is an open frame rack or rack cabinet where the PoE switches that power and connect VoIP devices are mounted. It may also contain non-PoE switches used to connect other device types, as well as patch panels, cable managers and other equipment.

If you don't have PoE switches and don't want to upgrade, you can add in-line power to your Ethernet lines using devices called midspans. A midspan is a bit like a patch panel that adds the required power to the Ethernet lines – unpowered lines go in, and powered lines come out. Most organizations use PoE switches (also known as endspans), however.

The IDFs are usually installed inside network/telecom wiring closets. The number of IDFs will depend on the size and layout of the site, as well as the number of network drops required. Each section or floor of a building will have an IDF that services the drops for that part of the building, within the recommended range of the network cabling. Each IDF is also connected to the MDF, typically with fiber-optic cabling.

The MDF is the entry point for the building's network/telecom cabling, which is connected to a service provider or to another building. The MDF may service nearby drops and perform some of the same functions as an IDF, using the same equipment. But its primary function is to connect the IDFs (and their network drops) to the service provider and manage the traffic going back and forth. The main connections to the WAN come in through the MDF, as well as telecommunications lines. Depending on your environment, the MDF may contain PoE and non-PoE switches, an edge router, an IP-PBX, a firewall, a session border controller, an IP-PSTN gateway or equipment that combines several of these functions. The equipment will be mounted in one or more open frame racks or rack enclosure cabinets.

Figure 4: MDF, IDFs and Network Drops

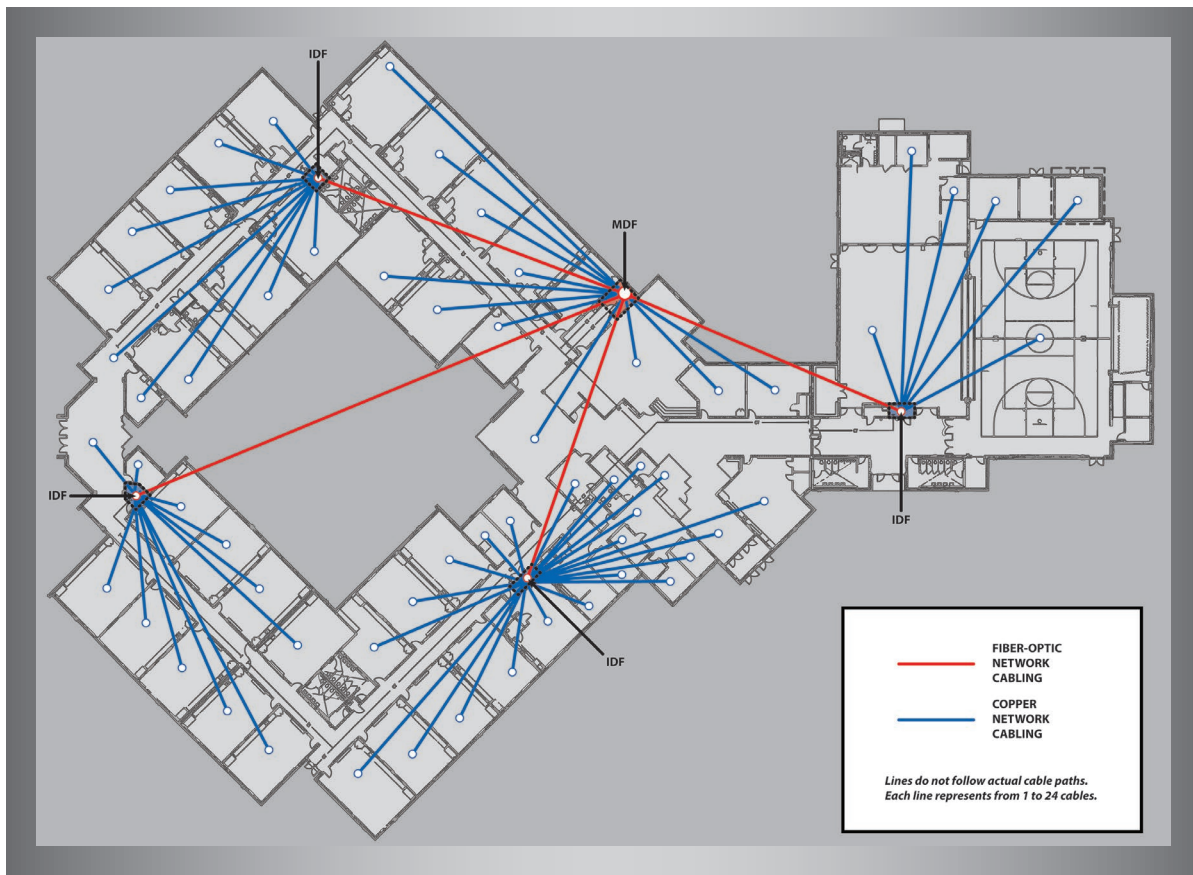

The MDF connects to each IDF with high-speed fiber-optic cabling. The MDF and IDFs provide local network drops through copper network cabling.

In order to implement VoIP, your in-house PBX will need to be able to handle IP-based call data. If you are using a PBX that isn't IP-capable, you will need to upgrade or provide adapters that enable IP connectivity for the PBX. If you are using a hosted VoIP solution, the PBX will be located/maintained at your service provider and will appear as a configurable virtual device to you. Hosted PBX features will vary by provider, so you will need to make sure the provider supports all the features required by your organization.

The addition of PoE switches to the IDFs and MDF is a special area of concern because of the increased power requirements and heat output of PoE switches. In some cases, the MDF will already have enough power and cooling capacity to handle the additional load, but this is much less likely in the network/telecom closets where the IDFs are located. It's important to evaluate the power and cooling infrastructure of each location to ensure reliable operation with the new equipment. (See **Upgrading IDF and MDF Infrastructure for VoIP** on page 12 for more information.)

Figure 5: PoE Network Switches

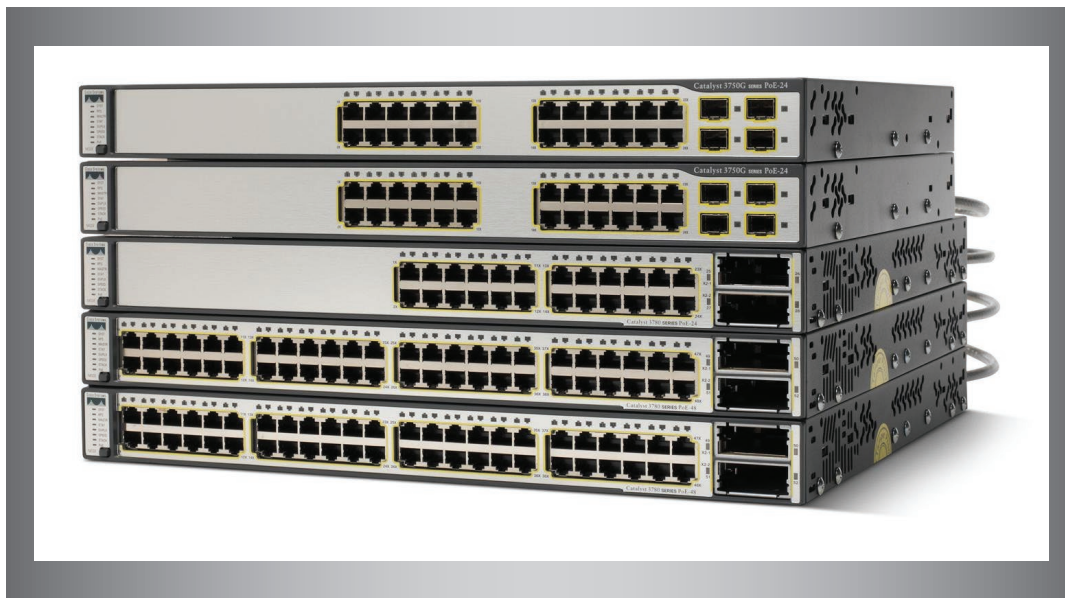

The PoE network switches used for VoIP typically require at least four times the wattage of non-PoE network switches and generate considerably more heat inside the network/telecom closet.

The IDF/MDF structure works well because it compensates for the distance limitations of data lines and leverages the inherent resilience of distributed network assets. Because of the distributed nature of the IDFs, if one of them experiences an outage, only the drops serviced by that IDF will be affected. If the MDF experiences an outage, it can take down the communications for the site. As a single location, however, it can receive additional protection that may not be affordable in every IDF location.

Session Initiation Protocol (SIP)

Session initiation protocol (SIP) is one of several protocols that were in competition to be the standard for facilitating communications between devices that use the VoIP network. At this point, the relative merit of SIP versus other protocols is academic—it's enough to know that SIP won. SIP establishes and regulates sessions (data exchanges) and RTP (real-time protocol) manages the actual data payload.

Whenever you evaluate hardware or software for your VoIP system, make sure it is SIP-compliant. Even if you do not transition to a pure SIP dataflow at this time, SIP-compliance ensures flexibility and future compatibility.

SIP Trunking

SIP trunking is a newer and rapidly growing way to connect your internal phone system to the outside world. Traditionally, your internal voice network has been connected to the PSTN through a primary rate interface (PRI), or possibly a smaller basic rate interface (BRI), which is a physical line that your organization leases from a telecom provider. Even if you have a VoIP phone system inside your facility, you may still use a PRI to connect your internal systems to the PSTN (through a VoIP/PSTN gateway) for outside calls.

With a PRI, your VoIP network extends to your firewall and stops there, handing calls to your telecommunications carrier for connection to the PSTN. With SIP trunking, your VoIP network can extend past your firewall, across the Internet, to other sites, call centers, partners and customers. A SIP trunk is an Internet connection from your IP-PBX to an Internet Telephony Service Provider (ITSP) over your existing data bandwidth or dedicated bandwidth, depending on your application requirements. (It's also possible to use a traditional PBX with a SIP trunk by adding a gateway device between them.) SIP trunks are virtual connections that can travel over a line that is used only for SIP trunking, over a dedicated line that carries SIP trunking with other IP traffic, or over the Internet on a virtual private network (VPN).

Figure 6: VoIP Network with SIP Trunking

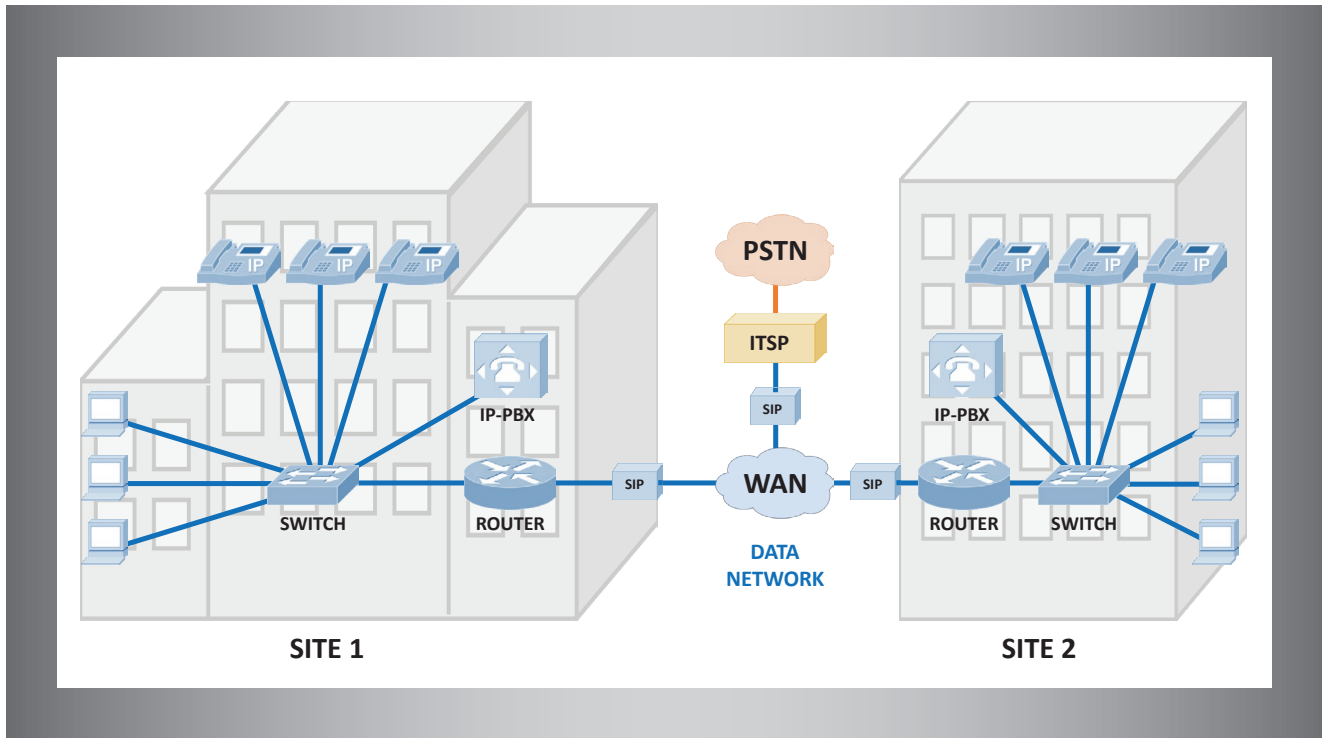

SIP trunking provides virtual trunk connections to an Internet Telephony Service Provider (ITSP) over your data bandwidth.

A hosted/cloud solution offers some of the same benefits as SIP trunking. If you use a hosted/cloud solution, you do not need a separate SIP trunk or an on-site IP-PBX.

Benefits of SIP Trunking

SIP trunking may not be ideal for every organization and every application, especially if you are able to negotiate a favorable PRI cost with your carrier. Both methods have advantages and disadvantages, but the cost and flexibility of SIP trunking is very attractive to most organizations. Without SIP trunking, you may be missing many of the advantages of deploying VoIP.

The most obvious attraction of SIP trunking is cost reduction. As an example, PRI lines in North America are typically sold as T1 lines that include 23 voice channels and a signaling channel. (The European analogue is the E1 line, which has 30 voice channels and two signaling channels.) A similar line configured for data can carry twice as many calls using SIP trunking and a high-quality codec. Depending on the requirements of the application, it's possible to carry even more calls under higher compression. Since you can't usually buy a partial T1, you have to buy PRI voice lines in multiples of 23. Scaling up or down is also cumbersome and time-consuming because PRI lines must be physically installed at your site. SIP trunk lines are virtual lines that can use your data bandwidth, so it is easy to add or remove lines at will.

SIP trunking benefits include:

- Reduction or elimination of costly PRI lines. (Keep in mind that you may want or need to retain some PRI lines to provide an out-of-band channel for failsafe communications.)
- Purchasing bandwidth in smaller increments at lower prices.
- Reduction or elimination of long-distance fees, including international calls.
- Provisioning lines with greater speed and flexibility.
- Easier set-up of disaster-recovery, failover and survivability systems.
- Quicker provisioning of new offices and employees.
- Easier scaling to accommodate temporary workforce requirements such as seasonal call centers.
- Eliminating the IP-PSTN gateway and its associated costs and complexity.

SIP Trunking Connection Types

Voice service over a PRI offers guaranteed quality of service and usually has excellent reliability. SIP trunking may not offer the same level of call quality and reliability if you simply use your existing Internet bandwidth – it will be “best effort,” without any quality of service guarantee. If your organization requires higher reliability and service quality, it may be necessary to use private or semi-private data bandwidth for your VoIP traffic. You may also wish to have a service-level agreement (SLA) with your provider that guarantees a specific level of network performance. This will increase your costs, but they are still likely to be less than PRI service.

SIP trunking connection types include:

- **Public** (Internet)
This is the least expensive solution, but it also requires a virtual private network (VPN) and offers the least security, reliability and call capacity.
- **Semi-private** (Dedicated line shared with your data traffic)
This type of connection often uses Multiprotocol Label Switching (MPLS). It is more secure and more reliable than a public connection and does not require a VPN. It is also more expensive, however, and high traffic can interfere with calls unless VoIP traffic receives priority.
- **Private** (Dedicated line devoted to your VoIP traffic)
This is the most expensive solution, but it also offers the highest security, reliability, quality and call capacity. It may use MPLS and does not require a VPN.

Figure 7: VoIP Beyond the Firewall – Typical Costs vs. Call Quality

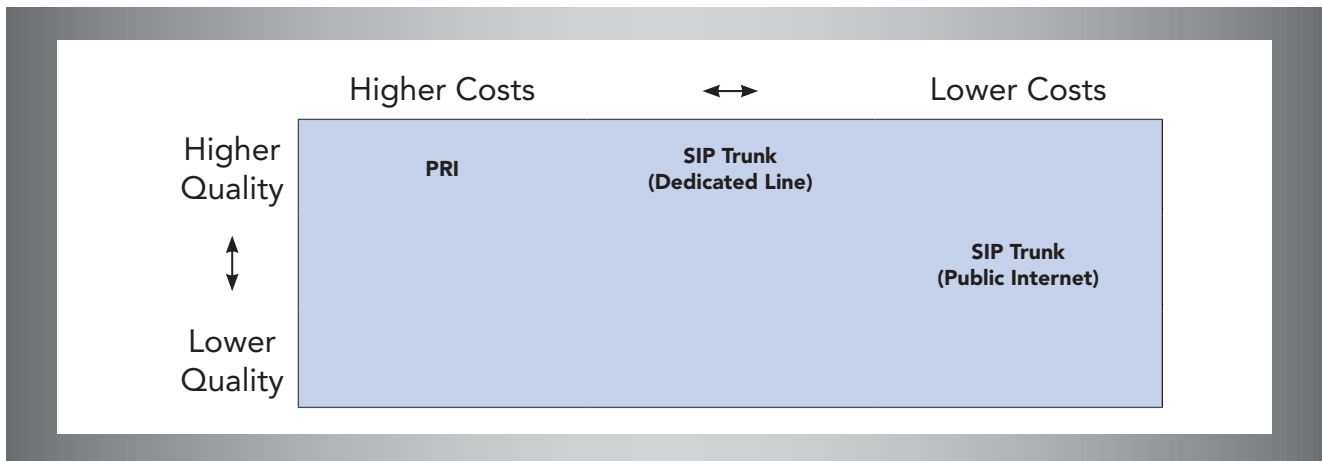

SIP trunking provides a range of cost and quality options with relatively high price/performance.

Upgrading IDF and MDF Infrastructure for VoIP

The transition to VoIP requires you to install PoE switches in the MDF and in the IDFs distributed throughout your organization’s network/telecom wiring closets. Typical network/telecom closet designs can’t handle the increased wattage and heat output of the PoE switches used to power IP phones. Your MDF may have enough reserve capacity to accommodate the PoE switches, but your IDFs are likely to be overwhelmed unless you upgrade your network/telecom closet power and cooling infrastructure.

Figure 8: The Effect of PoE Switches on Network/Telecom Closets

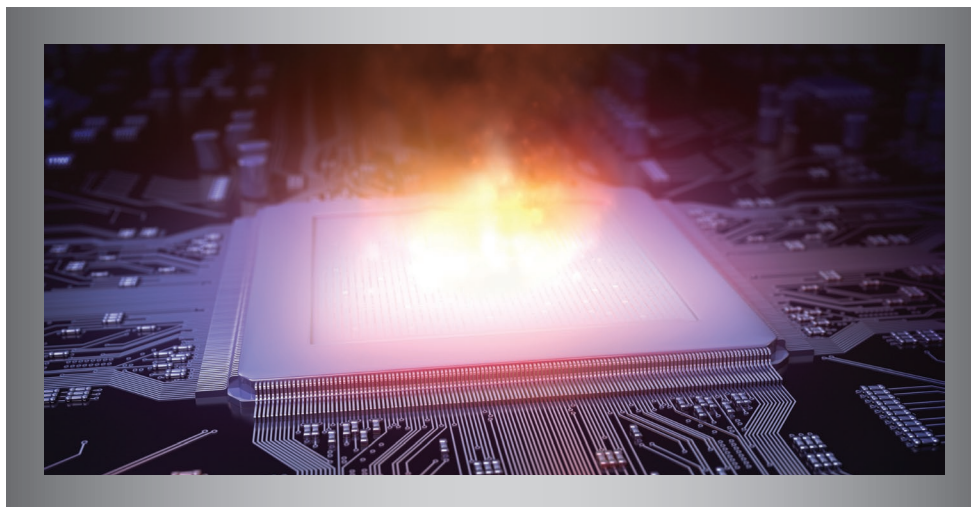

PoE switches have increased wattage and cooling requirements that can overwhelm your network/telecom closet infrastructure.

IDF/MDF infrastructure provisioning issues include:

- Providing wall outlets with sufficient power capacity and the correct voltage(s) for all the equipment that will be installed in the room.
- Providing enough UPS-supported outlets with the correct voltage(s), sufficient power capacity and sufficient battery backup runtime for the availability needs of the application.
- Selecting the best UPS topology to support the system availability needs of the application.
- Evaluating additional UPS features or add-ons that support continuous system availability by allowing hot-swappable UPS system replacement.
- Optimizing cooling and providing supplemental cooling where required.
- Providing local and remote management.
- Providing high-quality cabling for high-speed network links and reliable power connections.
- Planning maintenance and service to ensure ongoing reliability and rapid repair when required.

Additional PoE Device Types

Although we are primarily discussing IP phones when considering PoE switch requirements, there is actually a wide variety of PoE devices. Many are already commonplace, and others are likely to become so in the future. Examples include wireless access points, security cameras, RFID readers, access control systems and security systems. If you expect these types of devices to be part of your network, you should consider them when you provision bandwidth, port availability, load capacity, runtime and other resources.

Power Capacity and Connections

Reflecting on lessons learned during its own transition to VoIP, Cisco provides several best-practice recommendations in their white paper *The Transition to IP Telephony at Cisco Systems*. One of the most important recommendations is installing a UPS system to guarantee 911 service and dial tone availability:

“Plan your power: When an IP network carries voice, reliability is essential. In case of an emergency, people need to summon assistance by dialing 911. When using in-line power to switches and routers, make sure they are connected to an uninterruptible power supply (UPS system) to guarantee dial tone if the power should go out.”

And UPS systems aren't just for battery backup during power outages. They also provide essential power conditioning and power protection around the clock. This prevents your equipment from being damaged or malfunctioning when it encounters power problems like abnormal voltages, surges and line noise.

Figure 9: UPS System



A UPS system provides battery backup power to keep equipment operational during outages. It also provides 24x7 power conditioning to prevent equipment damage and malfunctions.

Most IDF network/telecom closets use 120 V power. The MDF may use 120 V, 208 V or a combination of the two. The 120/208 V combination can be provided through a 208 V UPS system that's bundled with a step-down transformer. In 120 V closets, the UPS system may have enough built-in outlets to plug in all the equipment. If additional outlets are required, you can plug a power distribution unit (PDU) into the UPS system. Some PDUs also provide additional capabilities, such as load/current metering, remote management and individually switched outlets. All these features make it easier to avoid overloads and to fix problems without making a site visit.

In order to find the right size of UPS for your closet, you need to determine your IT equipment load in watts, including room for future growth. It's difficult to determine the wattage requirement of your equipment exactly, and fluctuating requirements make this task even harder. We recommend that you do not load the UPS system past 80% of its maximum load capacity in order to leave a margin for error and headroom for fluctuating power demands during operation. If you wish to have additional capacity available for future expansion, you'll need to oversize the UPS accordingly.

You can often find information about your equipment's wattage requirements from the manufacturer's documentation or the equipment nameplate. (If the power requirements are listed in amps, multiply by the input voltage to find the wattage.) The power requirements for PoE switches are in large part determined by the number of PoE devices connected and the power requirements of each PoE device. PoE switches typically provide a maximum of 15.4 W of in-line power per port (or 30 W in the newest standard), but many IP phones require less than half of the maximum. In addition, the number of switch ports actually providing PoE power is almost always less than the total number of ports. You should be able to support your PoE switches with smaller, less-expensive UPS systems if you can determine the actual load requirement based on the number of VoIP ports in use instead of using the maximum possible value. For assistance, contact our application specialists at solutions@tripplite.com or **888.447.6227**.

An important step often overlooked when provisioning power is making sure the room itself has enough wall outlets of the correct types, including the voltage(s) and amperage(s), required to support your planned equipment configuration. If the room does not already have the required outlets, an electrician will need to install them. If this is not feasible or affordable (which may be the case if you have hundreds of IDF locations spanning multiple sites), you may need to revise your plan.

As long as you know the capacity and voltage of the available supply circuits, along with the capacity, voltage and connection requirements of the equipment you plan to install, you can make an informed decision. The capacity specifications of common single-phase North American circuits are listed in **Table 1** and recommended UPS systems for those circuits are listed in **Table 2**. For more information about UPS systems, including complete specifications and runtime data, access Tripp Lite's online UPS finder for VoIP network/telecom closets at www.tripplite.com/voipfinder or contact our application specialists at solutions@tripplite.com or **888.447.6227**.

Figure 10: UPS Finder for VoIP Network/Telecom Closets

	Number of VoIP Phones	Wattage of Each VoIP Phone	Number of Ports on the Switch	Wattage of Other Connected Equipment	Total Load Each Switch (calculated)
Switch 1	36	8W	48	60 Watts	468 Watts
Switch 2	30	8W	48	0 Watts	360 Watts
Switch 3	26	8W	48	30 Watts	358 Watts
Switch 4	44	8W	48	0 Watts	472 Watts

Total Power Consumption of PoE Switches (calculated)	1658 Watts
Wattage of Other Equipment Connected to UPS	120 Watts
Allowance for Future Growth (% of Total Load)	20
Total Closet Power Consumption (calculated)	2133.6 Watts



UPS Runtime Requirements Minimum: 30 mins Maximum: 90 mins

Tripp Lite's specialized UPS finder for VoIP network/telecom closets recommends UPS systems based on your wattage and runtime requirements.

Go to www.tripplite.com/voipfinder to access the finder.

It may not be possible to provide every type of circuit in every network/telecom closet. Some circuit types will be more difficult or expensive to provide than others, depending on your location and utility service. For example, you are unlikely to find an L6-30R outlet in a network closet because of the expense of installing it. As an IT manager, you should work with your facilities manager to determine whether sufficient capacity already exists or must be added. If capacity must be added, you will be able to find which supply circuits you can add at a reasonable cost considering both your current needs and your plans for future expansion.

Table 1: Common North American IDF/MDF Wall Outlets (Single-Phase)

Wall Outlet Type	Load Capacity*	Nominal Voltage	Max Amps*	Recommended UPS Systems (See Table 2)
 NEMA 5-15R	1.44 kW	120 V	12 A	Group 1
 NEMA 5-20R	1.92 kW	120 V	16 A	Groups 1 and 2
 NEMA L5-30R	2.88 kW	120 V	24 A	Group 3
 NEMA L6-20R	3.33 kW	208 V	16 A	Group 4
 NEMA L6-30R	5.0 kW	208 V	24 A	Group 5
Hardwire (3-Wire)	3.6 kW +	120 or 208 V	30 A +	Group 6

* Derated according to 80% plug/outlet rule per National Electrical Code (NEC). Does not apply to hardwire.

Table 2: Recommended Single-Phase UPS Systems for North American VoIP Applications

Group 1 UPS	Load Capacity	On-Line Operation	Nominal Output Voltage	½ Load Runtime	Total Rack Size	Auto Bypass?	Bypass PDU with Transfer Switch	Network Mgmt. Card (SNMPWEBCARD)	Outlets
SU750RTL2U	600 W	Yes	120 V	11+ min.	2U	Yes	Add PDUB15	Optional	6 x 5-15R
SU750XL	600 W	Yes	120 V	11+ min.	Tower	Yes	Add PDUB15	Optional	6 x 5-15R
SMART750RML2U	600 W	No	120 V	20.7+ min.	2U	No	Add PDUB15	Optional	6 x 5-15R
SU750RTLCD2U	675 W	Yes	120 V	13.9+ min.	2U	Yes	Add PDUB15	Optional	6 x 5-15R
SU1000RTL2UA	800 W	Yes	120 V	14+ min.	2U	Yes	Add PDUB15	Optional	6 x 5-15R
SU1000XLA	800 W	Yes	120 V	14+ min.	Tower	Yes	Add PDUB15	Optional	6 x 5-15R
SU1000RTLCD2U	900 W	Yes	120 V	14+ min.	2U	Yes	Add PDUB15	Optional	6 x 5-15R
SU1000XLCD	900 W	Yes	120 V	12.8+ min.	Tower	Yes	Add PDUB15	Optional	6 x 5-15R
SMART1000RML2U	900 W	No	120 V	18+ min.	2U	No	Add PDUB15	Optional	8 x 5-15R
SU1500RTL2UA	1.2 kW	Yes	120 V	14+ min.	2U	Yes	Add PDUB15	Optional	6 x 5-15R
SU1500RTL2UN	1.2 kW	Yes	120 V	14+ min.	2U	Yes	Add PDUB15	Included	6 x 5-15R
SU1500XL	1.2 kW	Yes	120 V	14+ min.	Tower	Yes	Add PDUB15	Optional	6 x 5-15R
SU1500RTLCD2U	1.35 kW	Yes	120 V	14+ min.	2U	Yes	Add PDUB15	Optional	6 x 5-15R
SU1500XLCD	1.35 kW	Yes	120 V	14+ min.	Tower	Yes	Add PDUB15	Optional	6 x 5-15R
SMART1500RML2UA	1.35 kW	No	120 V	14+ min.	2U	No	Add PDUB15	Optional	8 x 5-15R
SMART1500RMLN	1.35 kW	No	120 V	14+ min.	2U	No	Add PDUB15	Included	8 x 5-15R
SMART1500CRMXL	1.44 kW	No	120 V	14+ min.	2U	No	Add PDUB15	Optional	8 x 5-15R

Group 2 UPS	Load Capacity	On-Line Operation	Nominal Output Voltage	½ Load Runtime	Total Rack Size	Auto Bypass?	Bypass PDU with Transfer Switch	Network Mgmt. Card (SNMPWEBCARD)	Outlets
SU2200RTL2UA	1.6 kW	Yes	120 V	14+ min.	2U	Yes	Add PDUB20	Optional	6 x 5-20R, L5-20R
SU2200RTL2UN	1.6 kW	Yes	120 V	14+ min.	2U	Yes	Add PDUB20	Included	6 x 5-20R, L5-20R
SU2200XLA	1.6 kW	Yes	120 V	14+ min.	Tower	Yes	Add PDUB20	Optional	6 x 5-20R, L5-20R
SU2200RTLCD2U	1.8 kW	Yes	120 V	12+ min.	2U	Yes	Add PDUB20	Optional	6 x 5-20R, L5-20R
SU2200XLCD	1.8 kW	Yes	120 V	13+ min.	Tower	Yes	Add PDUB20	Optional	6 x 5-20R, L5-20R
SMART2200CRMXL	1.9 kW	No	120 V	28+ min.	4U	No	Add PDUB20	Optional	4 x 5-15R, 4 x 5-20R
SMART2200RML2U	1.92 kW	No	120 V	12+ min.	2U	No	Add PDUB20	Optional	4 x 5-15R, 4 x 5-20R
SMART2200RML2UP	1.92 kW	No	120 V	12+ min.	2U	No	Add PDUB20	Optional	4 x 5-15R, 4 x 5-20R
SMART2200RMLN	1.92 kW	No	120 V	12+ min.	2U	No	Add PDUB20	Included	4 x 5-15R, 4 x 5-20R
SMART2600RM2U	1.92 kW	No	120 V	12.9+ min.	2U	No	Add PDUB20	Optional	4 x 5-15R, 4 x 5-20R, L5-20R

All UPS models listed have expandable runtime, pure sine wave output, hot-swappable batteries, USB and/or serial communication ports and an LED and/or LCD control panel. Go to www.tripplite.com to view all available models with complete specifications.

Table 2: Recommended Single-Phase UPS Systems for North American VoIP Applications (continued)

Group 3 UPS	Load Capacity	On-Line Operation	Nominal Output Voltage	½ Load Runtime	Total Rack Size	Auto Bypass?	Bypass PDU with Transfer Switch	Network Mgmt. Card (SNMPWEBCARD)	Outlets
SMART3000RM2U	2.25 kW	No	120 V	10+ min.	2U	No	Add PDUB30	Optional	8 x 5-20R, L5-30R
SMART3000RM2UN	2.25 kW	No	120 V	10+ min.	2U	No	Add PDUB30	Included	8 x 5-20R, L5-30R
SU3000RTXL3U	2.4 kW	Yes	120 V	14+ min.	3U	Yes	Add PDUB30	Optional	4 x 5-15R, 4 x 5-20R, L5-30R
SU3000RTXL3UN	2.4 kW	Yes	120 V	14+ min.	3U	Yes	Add PDUB30	Included	4 x 5-15R, 4 x 5-20R, L5-30R
SU3000RTXR3U	2.4 kW	Yes	120 V	30+ min.	3U	Yes	Add PDUB30	Optional	4 x 5-15R, 4 x 5-20R, L5-30R
SU3000XL	2.4 kW	Yes	120 V	14+ min.	Tower	Yes	Add PDUB30	Optional	4 x 5-15R, 4 x 5-20R, L5-30R
SU3000RTXL2U	2.5 kW	Yes	120 V	15+ min.	2U	Yes	Add PDUB30	Optional	6 x 5-20R, L5-30R
SU3000RTXLCD3U	2.7 kW	Yes	120 V	11+ min.	3U	Yes	Add PDUB30	Optional	4 x 5-15R, 4 x 5-20R, L5-30R
SU3000XLCD	2.7 kW	Yes	120 V	13.2+ min.	Tower	Yes	Add PDUB30	Optional	8 x 5-20R, L5-30R
SMART3000RMOD2U	2.88 kW	No	120 V	11+ min.	2U	No	Integrated	Optional	6 x 5-15R, L5-30R
SMART3000RMXL2U	2.88 kW	No	120 V	10+ min.	2U	No	Add PDUB30	Optional	8 x 5-20R, L5-30R
SMART3000RMXLN	2.88 kW	No	120 V	10+ min.	2U	No	Add PDUB30	Included	8 x 5-20R, L5-30R
SMART3000CRMXL	2.88 kW	No	120 V	19+ min.	4U	No	Add PDUB30	Optional	8 x 5-20R, L5-30R

All UPS models listed have expandable runtime, pure sine wave output, hot-swappable batteries, USB and/or serial communication ports and an LED and/or LCD control panel. Go to www.tripplite.com to view all available models with complete specifications.

Table 2: Recommended Single-Phase UPS Systems for North American VoIP Applications (continued)

Group 4 UPS	Load Capacity	On-Line Operation	Nominal Output Voltage	½ Load Runtime	Total Rack Size	Auto Bypass?	Bypass PDU with Transfer Switch	Network Mgmt. Card (SNMPWEBCARD)	Outlets
SU3000RTXL3UHV	2.4 kW	Yes	208/240 V	14+ min.	3U	Yes	No	Optional	6 x 6-20R, 2 x L6-20R

Group 5 UPS	Load Capacity	On-Line Operation	Nominal Output Voltage	½ Load Runtime	Total Rack Size	Auto Bypass?	Bypass PDU with Transfer Switch	Network Mgmt. Card (SNMPWEBCARD)	Outlets
SU5000RT3U	3.5 kW	Yes	208 V + 120 V	20+ min.	7U	Yes	No	Optional	12 x 5-20R, 2 x L6-20R, 2 x L6-30R
SU5000RT3UHV	3.5 kW	Yes	208/240 V	20+ min.	5U	Yes	No	Optional	2 x L6-20R, 2 x L6-30R
SMART5000XFMRL	3.75 kW	No	208 V + 120 V	20+ min.	3U	No	No	Optional	8 x 5-20R, 2 x L6-20R, L6-30R
SMART5000RT3U	4 kW	No	208 V + 120 V	38+ min.	6U	No	No	Optional	10 x 5-15R, 2 x 5-20R, L6-30R, L14-30R
SU5000RT4UHV	4.5 kW	Yes	208/240 V	11+ min.	4U	Yes	No	Optional	2 x L6-20R, 2 x L6-30R
SU5000RT4UTF	4.5 kW	Yes	208 V + 120 V	11+ min.	6U	Yes	No	Optional	12 x 5-20R, 2 x L6-20R, 2 x L6-30R
SU6000RT4UHV	5.4 kW	Yes	208/240 V	8.5+ min.	4U	Yes	Integrated	Optional	2 x L6-20R, 2 x L6-30R
SU6000RT4UTF	5.4 kW	Yes	208/240 V + 120 V	8.5+ min.	6U	Yes	Integrated	Optional	4 x 5-15R, 8 x 5-20R, 2 x L6-20R, 2 x L6-30R

All UPS models listed have expandable runtime, pure sine wave output, hot-swappable batteries, USB and/or serial communication ports and an LED and/or LCD control panel. Go to www.tripplite.com to view all available models with complete specifications.

Table 2: Recommended Single-Phase UPS Systems for North American VoIP Applications (continued)

Group 6 UPS	Load Capacity	On-Line Operation	Nominal Output Voltage	½ Load Runtime	Total Rack Size	Auto Bypass?	Bypass PDU with Transfer Switch	Network Mgmt. Card (SNMPWEBCARD)	Outlets
SU3000RTXR3UHW	2.4 kW	Yes	120 V	30+ min.	3U	Yes	No	Optional	Hardwire
SU6000RT3U	4.2 kW	Yes	208/240 V + 120 V	20+ min.	9U	Yes	Integrated	Optional	Hardwire
SU6000RT3UHV	4.2 kW	Yes	208/240 V	20+ min.	6U	Yes	No	Optional	Hardwire
SU6000RT3UHVXL	4.2 kW	Yes	208/240 V	30+ min.	6U	Yes	No	Optional	Hardwire
SU6000RT4UHVG	5.4 kW	Yes	208/240 V	8.5+ min.	4U	Yes	Integrated	Optional	4 (C19)
SU6000RT4UHVHW	5.4 kW	Yes	208/240 V	8.5+ min.	4U	Yes	Integrated	Optional	Hardwire
SU6000RT4UTFHW	5.4 kW	Yes	208/240 V + 120 V	8.5+ min.	6U	Yes	Integrated	Optional	4 x 5-15R, 8 x 5-20R, L6-30R, Hardwire
SU8000RT3U	7.2 kW	Yes	208/240 V	13.5+ min.	6U	Yes	Integrated	Optional	4 (L6-20R), 2 (L6-30R)
SU8000RT3U1TF	7.2kW	Yes	208 V + 120 V	13.5+ min.	8U	Yes	Integrated	Optional	12 (5-15/20R), 4 (L6-20R), 2 (L6-30R)
SU8000RT3UG	7.2kW	Yes	208/240 V	13.5+ min.	6U	Yes	Integrated	Optional	6 (C19)
SU8000RT3UHW	7.2kW	Yes	208/240 V	13.5+ min.	6U	Yes	Integrated	Optional	Hardwire
SU10KRT3U	9 kW	Yes	208/240 V + 120 V	12.5+ min.	9U	Yes	Integrated	Optional	Hardwire
SU10KRT3UHV	9 kW	Yes	208/240 V	12.5+ min.	6U	Yes	Integrated	Optional	Hardwire
SU10000RT3U	9 kW	Yes	208/240 V	12.5+ min.	6U	Yes	Integrated	Optional	4 (L6-20R), 2 (L6-30R)
SU10000RT3U2TF	9 kW	Yes	208 V + 120 V	12.5+ min.	10U	Yes	Integrated	Optional	24 (5-15/20R), 4 (L6-20R), 2 (L6-30R)
SU12KRT4UHW	10.8 kW	Yes	208/240 V	8.5+ min.	8U	Yes	Integrated	Optional	Hardwire
SU16KRT	14.4 kW	Yes	208/240 V	13.5+ min.	12U	Yes	Integrated	Optional	2 (L6-30R), 8 (C19)
SU16KRT-1TF	14.4kW	Yes	208/240 V + 120 V	13.5+ min.	14U	Yes	Integrated	Optional	4 (5-15R), 8 (5-15/20R), 2 (L6-30R), 8 (C19)
SU16KRT8	14.4kW	Yes	208/240 V	13.5+ min.	12U	Yes	Integrated	Optional	8 (L6-20R), 2 (L6-30R)
SU16KRTG	14.4kW	Yes	208/240 V	13.5+ min.	12U	Yes	Integrated	Optional	8 (C19)
SU16KRTHW	14.4kW	Yes	208/240 V	13.5+ min.	12U	Yes	Integrated	Optional	Hardwire
SU20KRT	18 kW	Yes	208/240 V	12.5+ min.	12U	Yes	Integrated	Optional	2 (L6-30R), 8 (C19)
SU20KRT-1TF	18 kW	Yes	208/240 V	12.5+ min.	14U	Yes	Integrated	Optional	4 (5-15R), 8 (5-15/20R), 2 (L6-30R), 8 (C19)
SU20KRT8	18 kW	Yes	208/240 V + 120 V	12.5+ min.	12U	Yes	Integrated	Optional	8 (L6-20R), 2 (L6-30R)
SU20KRTG	18 kW	Yes	208/240 V	12.5+ min.	12U	Yes	Integrated	Optional	8 (C19)
SU20KRTHW	18 kW	Yes	208/240 V	12.5+ min.	12U	Yes	Integrated	Optional	Hardwire

All UPS models listed have expandable runtime, pure sine wave output, hot-swappable batteries, USB and/or serial communication ports and an LED and/or LCD control panel. Go to www.tripplite.com to view all available models with complete specifications.

Availability: Battery Backup Runtime

When migrating to VoIP, it is important to recognize a key difference between the public switched telephone network (PSTN) and the private data network called upon to take its place. The PSTN is connected to a massive battery array that allows it to provide emergency 911 service and dial tone availability for hours during an extended power outage. Although most private data networks incorporate some form of backup power, runtime is typically provisioned to prevent network service interruptions during brief power problems and outages that last seconds or minutes, not extended outages that last hours. This is especially true in network/telecom wiring closets, which typically receive less attention to power protection and battery backup than server rooms and data centers. In order to approach the high level of emergency 911 service and dial tone availability established by the PSTN, you need to address this difference when provisioning battery backup runtime for your network/telecom closets.

UPS system runtime during an outage, and therefore VoIP system availability, depends on the number and size of UPS system batteries. The UPS manufacturer should provide model-specific data for the estimated runtime at a variety of load levels. With an 80% load, included UPS batteries typically provide five to ten minutes of runtime. VoIP applications may require several hours of runtime, so we recommend that you choose a UPS system that can accommodate external battery packs to increase runtime to match current and future requirements. You should also select UPS systems that provide the ability to hot-swap internal or external battery packs at the end of their useful life without requiring a service interruption.

Figure 11: Expandable Runtime



A UPS system that includes an external battery connector allows you to increase runtime by connecting one or more external battery packs.

In some cases, runtime requirements will be dictated by application needs or program mandates. For example, the availability of emergency communications may require a runtime of several hours, and governmental programs may dictate that level of support. In some cases, a generator may provide extended runtime, but generators are not always available, feasible or cost-effective, especially when some devices require significantly longer runtimes than most of the other devices in the facility. Generators typically provide little or no protection from power problems, and can actually be a source of them, so UPS systems provide an important power-conditioning role even when generators are running. It is also helpful to know the historical power conditions of the site. If a site has experienced frequent outages lasting hours at a time, it will have different runtime requirements than an otherwise similar site that has experienced significantly fewer and shorter outages over the same period.

If UPS systems are only required to bridge the gap between the outage and generator startup/stability rather than being required to outlast the entire outage, UPS runtime requirements may be reduced. It is advisable, however, to include a runtime margin to allow for generator malfunctions. If the UPS runtime is only five minutes and there's a generator malfunction, the supported equipment load is likely to be dropped. If the UPS runtime is 30 minutes and there's a generator malfunction, there's a much better chance of troubleshooting and correcting the malfunction before the load is dropped. Even if the malfunction cannot be corrected, it leaves more time to execute a graceful and orderly shutdown that will preserve data and ensure system integrity.

Go to www.tripplite.com for interactive UPS battery backup runtime charts. You can see how different battery pack configurations affect runtime at any wattage level and easily compare different configurations to determine which one best fits your application. In addition, Tripp Lite's online UPS finder for VoIP network closets at www.tripplite.com/voipfinder allows you to specify wattage and runtime requirements to list UPS and battery pack options that match your requirements.

Figure 12: Interactive UPS Runtime Chart

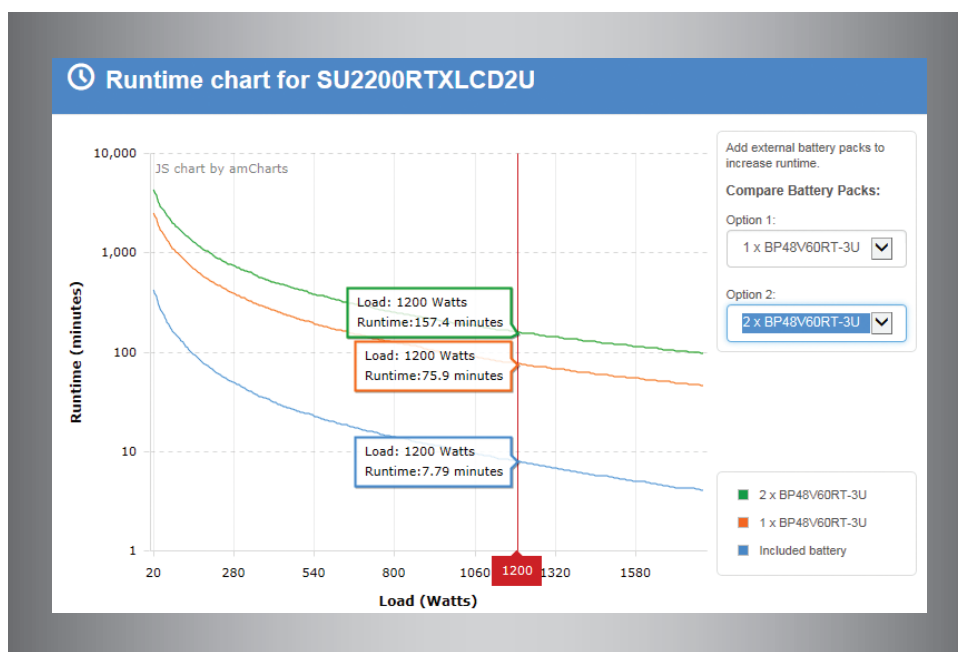

Tripp Lite's interactive UPS runtime charts allow you to see how different battery pack configurations affect runtime at any wattage level.

Availability: UPS Topology

The topology of the UPS is based on the UPS system's internal power electronics and method of conditioning power. The topology is the main factor in the UPS system's level of protection from power problems and compatibility with the power requirements of sensitive VoIP network hardware. The three most common UPS topologies are standby, line-interactive and on-line. Standby UPS systems do not provide enough protection for core VoIP hardware, but they can be used to support IP phones that use AC adapters instead of receiving in-line power via PoE (an increasingly rare occurrence). For your core VoIP equipment, however, the choice is between line-interactive and on-line UPS systems.

Generally speaking, line-interactive UPS systems have lower acquisition costs and on-line UPS systems provide significantly more protection. The question comes down to whether the extra protection is worth the extra cost. For some types of equipment, line-interactive UPS systems are suitable, but for core VoIP hardware, we strongly recommend using on-line UPS systems. They often don't cost much more, and you're less likely to experience power incompatibility problems that cause malfunctions and costly downtime. If budgetary considerations or like-for-like replacement mandates require you to use a line-interactive UPS system, make sure it provides pure sine wave output from battery to improve compatibility with sensitive equipment.

Figure 13: On-Line and Line-Interactive UPS Systems



On-line (above) and line-interactive (below) UPS systems both provide battery backup. On-line UPS systems provide stronger power protection, increased system availability and superior compatibility with sensitive VoIP equipment.

Advantages of on-line UPS systems for VoIP applications:

- Automatic internal bypass keeps connected equipment powered in the case of an overload or UPS fault.
- Zero transfer time to battery ensures that sensitive loads are not dropped when switching to UPS power during an outage.
- Wider input voltage range and tighter voltage regulation.
- Pure sine wave output for better compatibility with VoIP network equipment.
(Select line-interactive UPS systems also provide pure sine wave output.)
- Protection against frequency variations, harmonic distortions and other hard-to-diagnose power problems.
- Better protection against transient surges and EMI/RFI line noise.

One of the most important availability features of an on-line UPS systems is the automatic internal bypass. With power present, a fault in an on-line UPS system will result in the load automatically being powered by an AC bypass path inside the UPS. As long as utility power remains present, the UPS will continue to power the connected VoIP system without interruption and will continue to condition the power against basic problems. If the same thing happens with a line-interactive UPS system, the connected equipment will lose power and crash.

Figure 14: On-Line UPS Control Panel Displaying Bypass Mode

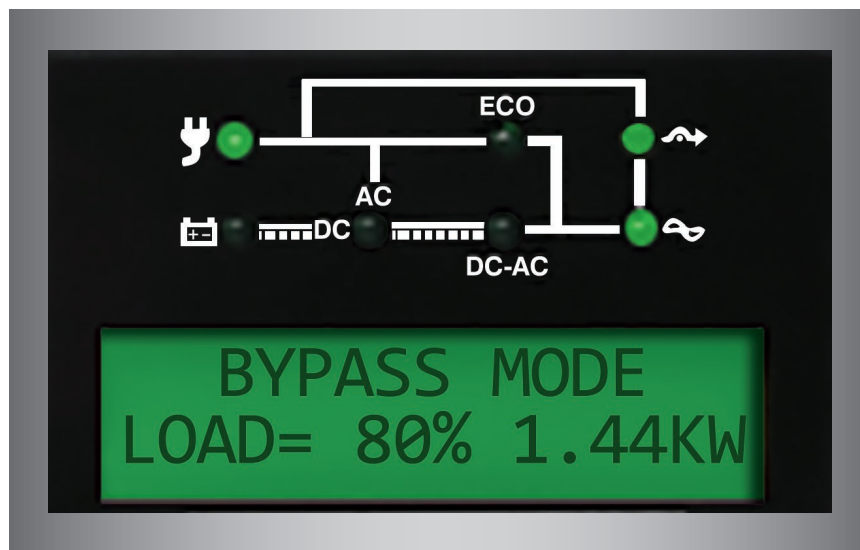

An on-line UPS system's automatic internal bypass ensures that connected VoIP equipment remains powered even if the UPS system experiences an overload or requires repair.

In either case, a service interruption will be required to replace the UPS system, unless the UPS has a bypass PDU with a manual transfer switch. The bypass PDU may be an integrated and detachable component of the UPS system (as with select SmartOnline models) or a completely separate PDU (known as a hot-swap PDU) that is connected externally. AC input and output power connections are built into the bypass PDU, where they can be physically and electrically separated from the UPS power module without disconnecting supported equipment or interrupting AC output.

Figure 15: Bypass PDU with Manual Transfer Switch

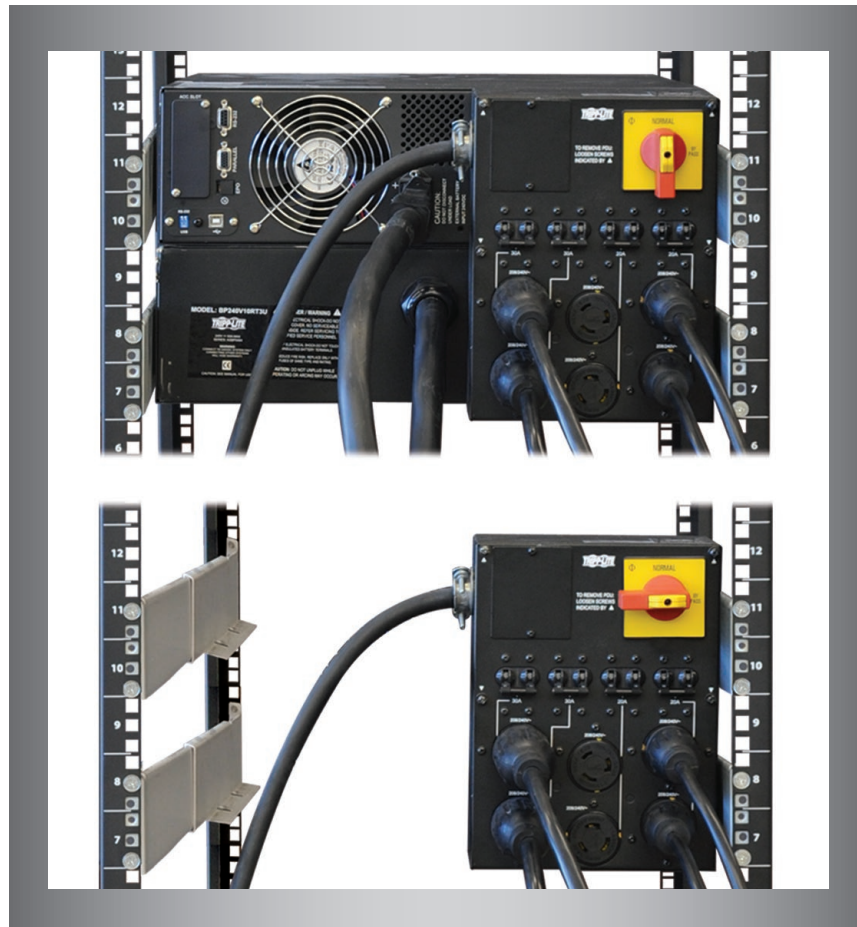

UPS systems with a bypass PDU and manual transfer switch allow the UPS to be removed for maintenance or repair without interrupting power to connected equipment. The bypass PDU may be a detachable component of the UPS system or a separate unit.

An on-line UPS system can deliver perfect AC output power to your VoIP equipment even if it encounters a very wide range of input voltages and other power problems. It does this without relying on its battery reserves, leaving it well prepared to respond to a power outage. If input voltage levels are above or below a line-interactive UPS system's automatic correction capability, the line-interactive UPS will switch to battery to maintain acceptable output voltage. In areas with chronic and extreme brownouts, this frequent switching to battery can reduce reserve power as well as shorten battery service life, which puts critical VoIP systems at greater risk during an outage.

Figure 16: Voltage Regulation – On-Line vs. Line-Interactive

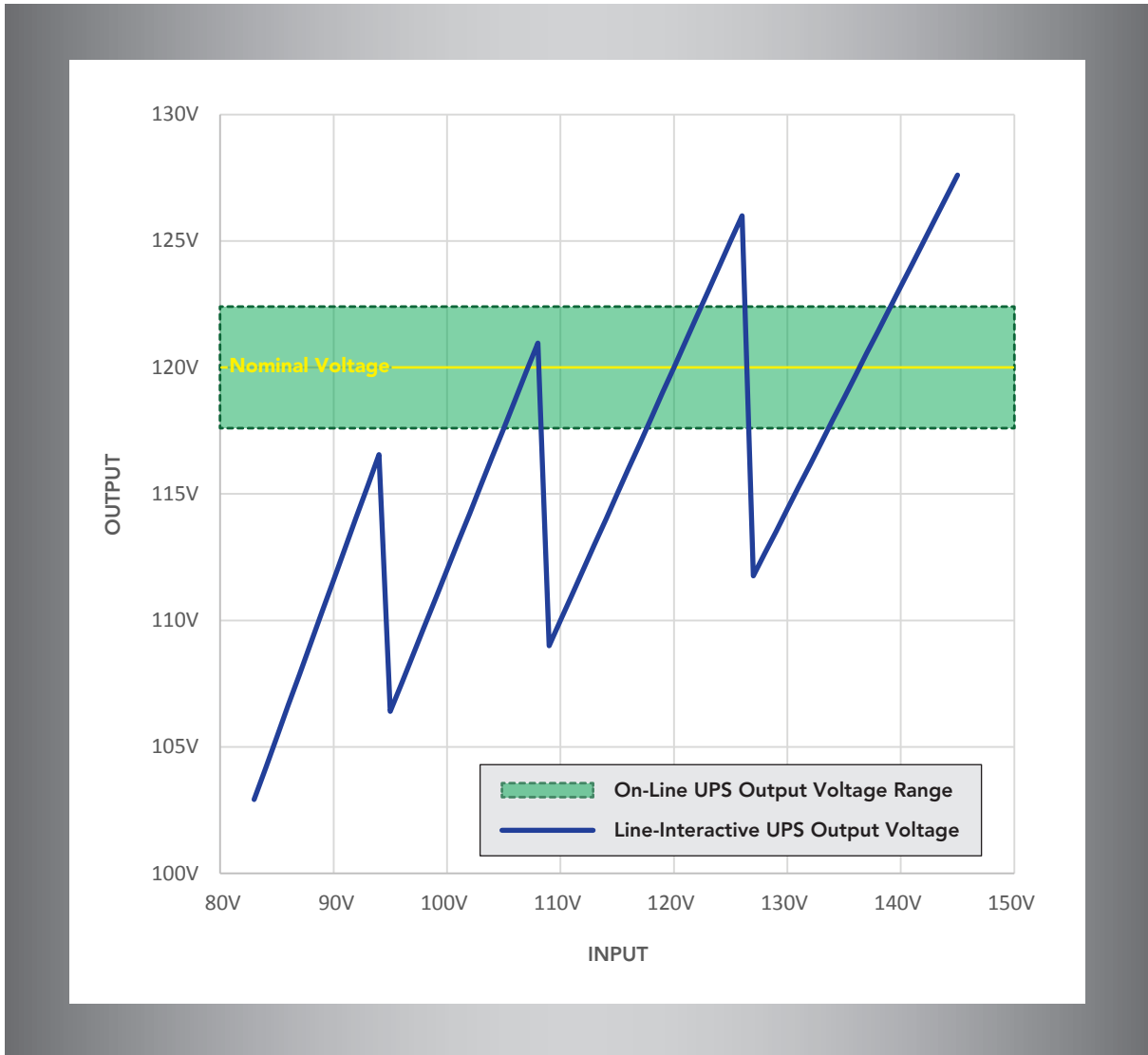

On-line UPS systems regulate output voltages within a much tighter range than line-interactive UPS systems across a wide range of input voltages.

Because of its continuous AC-to-DC-to-AC double-conversion process, an on-line UPS system has zero transfer time between power failure detection and power delivery to your VoIP equipment during an outage. While the transfer time of a line-interactive UPS system (several milliseconds) is extremely fast, this short delay may cause network packet losses or even system shutdown in some instances.

Figure 17: Transfer Time – On-Line vs. Line-Interactive

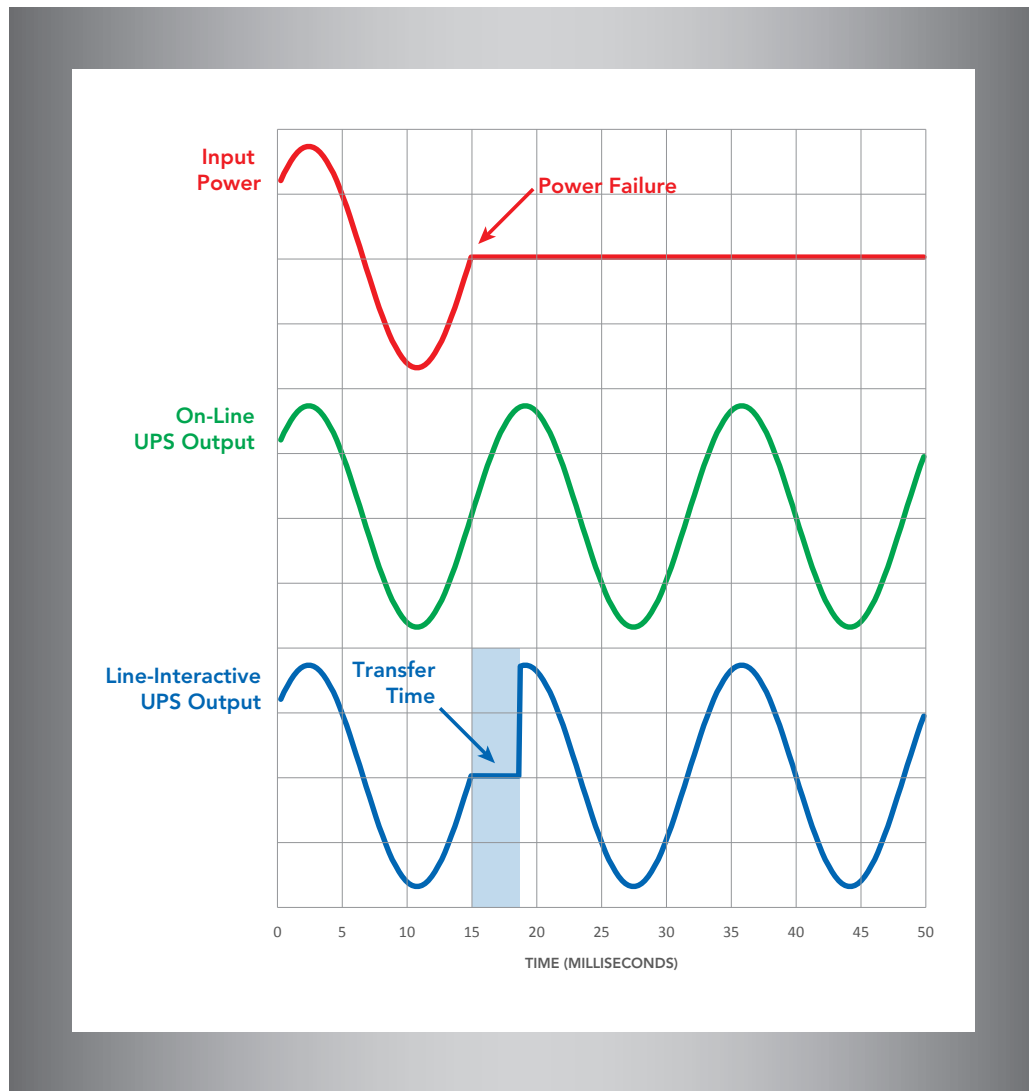

On-line UPS systems have zero transfer time to battery backup power during power outages, which may help prevent VoIP system malfunctions and shutdowns.

When evaluating the best type of UPS systems to use for your VoIP equipment, you should understand that a dropped load will produce more downtime than you might expect. Your equipment may be off for only an instant, but when power returns it takes time for servers to reboot, for IP phones to register with servers and for the system to return to normal operation. And that's if everything goes smoothly. In many cases, an unmanaged power-off or power-on sequence will cause errors that require troubleshooting and resolution before the VoIP system and your organization's vital communications are fully operational. So it is very important to avoid even a few seconds of downtime because it can easily turn into 30 minutes or more of rebooting, reinitializing, testing and troubleshooting. It's worth repeating: we strongly recommend on-line UPS systems to ensure trouble-free compatibility with all types of VoIP equipment under all conditions.

Table 3: Feature Comparison of UPS Systems for VoIP Applications

	UPS Family		
	GOOD	BETTER	BEST
Available Features	SmartPro	SmartOnline	SmartOnline Hot-Swappable
Topology	Line-Interactive	On-Line	On-Line
Surge Protection	Yes	Yes	Yes
EMI-RFI Noise Protection	Yes	Yes	Yes
Input Voltage Tolerance	Wide	Wider	Wider
Output Voltage Regulation	Yes (± 10-15% Typical)	Yes (± 2-3% Typical)	Yes (± 2-3% Typical)
Pure Sine Wave Output	Select Models	Yes	Yes
Battery Backup	Yes	Yes	Yes
Expandable Runtime	Select Models	Yes	Yes
Hot-Swappable Batteries	Yes	Yes	Yes
Auto Bypass	No	Yes	Yes
Bypass PDU	No*	No*	Yes
Built-in N+1 Redundancy	No	No	Select Models
Rack and/or Tower Form Factors	Yes	Yes	Yes
Transfer Time to Battery	2-4 ms	0 ms	0 ms

* You can add this feature to compatible models by connecting an external hot-swap PDU.

Availability: Redundant Power

Many switches, routers and servers can be equipped with redundant power supplies. If one power supply fails, a second power supply instantly steps in to power the device. We recommend redundant power supply configurations to ensure continuous VoIP system availability, but we recognize they may not fit in every budget. If it isn't possible to protect every IDF network/telecom closet location with redundant power, it may still be possible to protect the MDF, or at least key VoIP equipment in the MDF, with redundant power.

If you need to protect a "single-cord" device that does not have an option for redundant power supplies, you can provide a measure of redundancy to the single-cord device through a PDU with a built-in automatic transfer switch (ATS). A single-cord device connected to an ATS PDU is not quite as reliable as a device with redundant power supplies because the single power supply represents a vulnerable single point of failure. But it comes reasonably close and represents the best solution for approximating power path redundancy for single-cord devices.

Figure 18: Redundant Power Supplies



Most network hardware can be configured with redundant power supplies to provide increased system availability.

A single-cord device with a single PDU and supply circuit backed up by a UPS system might experience a few hours of downtime per year. All other things being equal, a single-cord device with an ATS PDU connected to separate supply circuits with UPS support might experience a few minutes of downtime per year. A dual-cord device with redundant power supplies connected to separate supply circuits with UPS support should experience almost no downtime. Whether it makes more sense for your organization to invest in higher AC power path availability largely depends on your cost of VoIP communications downtime. For some organizations, a few hours of downtime in a year might be acceptable, but for others it might be prohibitively expensive, disruptive or even dangerous. When deciding whether to use redundant power, consider whether the loss of the equipment will cause downtime, how widespread the downtime will be, and calculate your organization's cost of downtime compared to the cost of providing redundancy. (Note: Actual system availability depends on many factors other than power that are not considered here. Availability is likely to fall short of the numbers cited in the example unless the entire system has been designed to eliminate single points of failure and other weaknesses.)

Table 4: VoIP System Status During Selected Power Failure Scenarios

Scenario	Power Supply (PS) Configuration						
	1 PS	1 PS w/UPS	1 PS w/ATS+UPS	2 PS	2 PS w/1 on UPS	2 PS w/2 on UPS	2 PS w/2 UPS
	1 Circuits	1 Circuits	2 Circuits	2 Circuits	2 Circuits	1 Circuit	2 Circuits
Conditioned AC?	No	Yes	Yes	No	Partial	Yes	Yes
Power Supply Fault	Crash	Crash	Crash	OK	OK	OK	OK
AC Outage (1 Circuit)	Crash	OK	OK	OK	OK	OK	OK
AC Outage (2 Circuits)	Crash	OK	OK	Crash	OK	OK	OK
Battery Fault	N/A	OK/At Risk (Repair)	OK/At Risk (Repair)	N/A	OK/At Risk (Repair)	OK/At Risk (Repair)	OK (Repair)
Line-Interactive UPS Fault	N/A	Crash	N/A	N/A	OK/At Risk (Repair)	Crash	OK (Repair)
On-Line UPS Fault	N/A	Plan Downtime (Repair)	OK/At Risk (Repair)	N/A	OK/At Risk (Repair)	Plan Downtime (Repair)	OK (Repair)
Hot-Swappable On-Line UPS Fault	N/A	OK/At Risk	OK/At Risk (Repair)	N/A	OK/At Risk (Repair)	OK/At Risk (Repair)	OK (Repair)
UPS/Battery Fault + AC Outage (1 Circuit)	N/A	Crash	OK/At Risk (Repair)	N/A	OK/At Risk (Repair)	Crash	OK (Repair)
UPS/Battery Fault + AC Outage (2 Circuits)	N/A	Crash	Crash	N/A	Crash	Crash	OK (Repair)

Notes: Connecting a single power supply to an ATS PDU provides a single-cord device with the failure scenarios of a device with dual power supplies, except in the case of a power supply fault, which will cause a crash. Availability will be improved in all dual power supply scenarios by using dual AC supply circuits connected to separate utility sources. Connecting an on-line UPS to a hot-swap PDU with a manual transfer switch provides outcomes similar to a hot-swappable on-line UPS. "OK" status during AC outages is dependent on battery backup runtime, which must be able to last through the outage or until generators (if available) start up and stabilize. If an ATS PDU is used with a UPS, it should be an on-line UPS.

Remote/Unattended Installations

Most of the same issues that apply to VoIP network/telecom wiring closets also apply to remote/unattended installations in locations that do not have IT staff (or any staff) on-site. Contact Tripp Lite for more information about our complete suite of infrastructure solutions for remote/unattended installations, including racks, power, cooling, cabling and remote power, cooling and device management tools.

Figure 19: Intake Air Temperature Guidelines for IT Equipment

<p>>100° F (>37.8° C)</p> <ul style="list-style-type: none"> • High risk of damage and downtime • May invalidate equipment warranty
<p>90° to 100° F (32.2° to 37.8° C)</p> <ul style="list-style-type: none"> • Risk of damage and downtime • Short bursts (seconds to minutes) may be acceptable, depending on availability goals
<p>80.6° to 90° F (27° C to 32.2° C)</p> <ul style="list-style-type: none"> • Within the “allowable” range • Okay for brief periods (hours to days) • Longer periods may compromise equipment life
<p>77.1° to 80.6° F (25.1° C to 27° C)</p> <ul style="list-style-type: none"> • IT equipment operates reliably • Equipment fans use more electricity, negating other efficiency gains
<p>77° F (25° C)</p> <ul style="list-style-type: none"> • Ideal temperature for IT equipment • Both highly reliable and highly efficient
<p>64.4° to 76.9° F (18° C to 24.9° C)</p> <ul style="list-style-type: none"> • IT equipment operates reliably • As temperature drops, efficiency drops • Costs increase without added benefits
<p><64.4° F (<18° C)</p> <ul style="list-style-type: none"> • Same as above, but even more inefficient • May require costly make-up humidification

Based on ASHRAE guidelines and Tripp Lite’s experience with thousands of IT installations, intake air temperatures of 77° F (25° C) provide the best balance between cooling efficiency and equipment performance.

Cooling in Network/Telecom Closets

PoE switches use a lot more power than conventional network switches, and that means they also produce a lot more heat. Typical IDF network/telecom closets are cramped and have limited or no ventilation. They were not designed to handle the heat generated by PoE switches. You need to evaluate the heat load, environment and existing cooling solutions to determine whether additional cooling capacity will be required. The MDF may be in a larger room that’s better able to handle additional heat, but the same principles apply.

The good news is that your network/telecom closets don’t need to be kept freezing cold. In fact, manufacturers generally recommend IT equipment intake air temperatures at, or slightly above, room temperature for maximum reliability, availability and performance. “Allowable” temperatures can drift as high as 90° F (32.2° C) for limited periods of time without affecting short-term operating reliability. Most IT equipment is designed to survive even higher temperatures, though it may not run reliably. However, running at these elevated temperatures will shorten the equipment’s lifespan. (Long-term temperature increases are especially problematic for UPS batteries. For example, the estimated service life of a typical UPS battery decreases by 50% when the ambient temperature increases from 77° to 90° F.) Based on recommendations from ASHRAE (the American Society of Heating, Refrigerating and Air-Conditioning Engineers) and our own experience with thousands of IT installations, we recommend equipment air intake temperatures of 77° F (25° C) for the best cooling efficiency without compromising equipment reliability.

It is also important to avoid large, rapid temperature changes, which can be even more damaging to electronic components than high temperatures. This is because rapid heating and cooling causes the soldering of electronic components to expand and contract, stressing and potentially damaging the connections.

There are a number of rack-level best practices that you can employ to increase cooling efficiency and effectiveness, but many of them require floor-standing rack enclosures. In network/telecom closets with open frame racks and wall-mount cabinets, you need to consider cooling primarily at the room level, although there are some things you can do to make sure your rack layout isn't making heat-related problems worse.

Determine where heat-related problems exist by measuring intake air temperatures. Recirculation of hot air can raise equipment intake air temperatures far above the ambient room temperature. It doesn't matter if the room temperature is 77° F if the intake temperature is 97° F. You should also know the temperature of the room, but intake temperatures are the primary data you should use to make decisions about cooling. You can use environmental sensors to monitor temperature conditions remotely. UPS and PDU accessories, as well as stand-alone sensors, can report temperature values over the network and record time-stamped logs. They can also provide real-time warnings when temperature exceeds defined thresholds.

Natural heat dissipation through walls, ceilings and doors lowers room temperatures. However, if the room size is too small, the racks are densely populated, or surrounding areas aren't cool enough, dissipation may be unable to keep pace with the heat generated by PoE switches and other high-wattage equipment. If the network/telecom closet has a brick exterior wall with direct sun exposure, heat transfer through dissipation is also likely to be insufficient because masonry traps heat, similar to an oven. If the room has interior surrounding walls heated by the HVAC system in the winter, temperatures can also rise. And overheating can occur year-round if hot air has nowhere to go.

Separating your cold air supply from the hot air produced by your equipment is one of the keys to cooling efficiency. Even in a chilly room, a PoE switch can feed itself hot air until it overheats and shuts down. Make sure your rack and equipment layout doesn't feed the hot exhaust air from one device directly into the air intake of another. And if you have some devices that run especially hot, spread them out to avoid concentrating the heat. Limited space will restrict your ability to spread heat loads, but do the best you can with the space you have available.

Figure 20: Overheating from Exhaust Air Recirculation

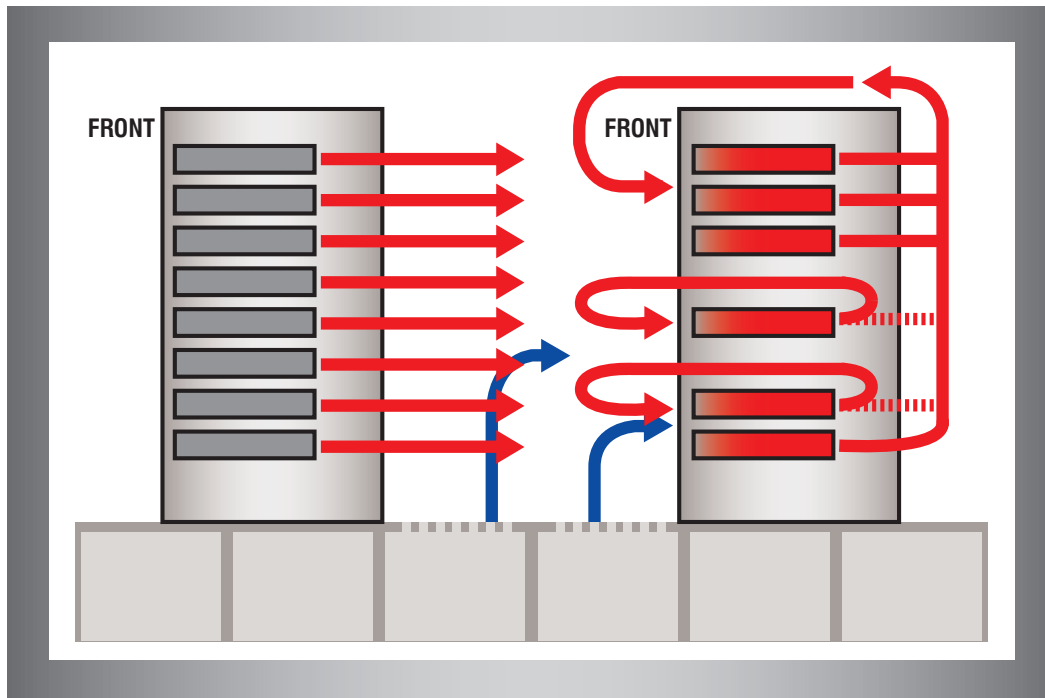

Recirculation of equipment exhaust increases intake air temperatures.

Recirculation is harder to prevent inside network closets, so supplemental cooling may be required.

Make sure you understand the proper role of HVAC systems. HVAC systems are designed for the comfort of people in the building. They have many limitations that restrict their use in IT equipment cooling applications. The thermostat for the HVAC system is probably not located in the network/telecom closet. While the temperature near the thermostat may be constant, it may still fluctuate widely in the closet. Although the HVAC system is typically unsuitable as a primary cooling solution, the HVAC return air stream may provide a convenient place to channel hot air that you need to remove from the room. The HVAC system can also provide a source of cool air outside the closet, but it's important to recognize the cycles and limitations of the HVAC system and plan accordingly.

Remove unnecessary heat sources from your network/telecom closets. Anything that adds heat to the room will make cooling more difficult and less efficient. Check for baseboard heaters, registers, vents and anything else that radiates heat or introduces warm air to the room. Incandescent light bulbs can produce as much heat as your hardware, so replace them with cooler, energy-saving CFL or LED bulbs. Also decommission unused equipment. When servers are replaced, they often remain plugged in, drawing power and generating heat. And older equipment is often less efficient, making the problem even worse.

Make sure that tangled cables aren't blocking airflow. Outside the rack, use overhead cable managers (ladders and/or troughs). Inside the rack, use horizontal and vertical cable managers to organize patch cables and power cords. A sound cable management strategy also reduces troubleshooting time, repair time and installer errors.

Passive heat removal solutions help you remove heat without introducing additional energy costs. You can use a simple, straightforward version of passive heat removal to cool a closed room. Add two vents next to a climate-controlled area: one high on a wall and the other on the wall or door near the floor. Since hot air rises, it will flow out through the upper vent and be replaced with cooler air from the lower vent. (The vents will require a source of sufficiently cool, clean air to draw from.) You can assist airflow by adding a fan to the upper vent.

If heat-related problems remain after you implement other cooling best practices, a close-coupled, self-contained air conditioning unit can be a smart and economical choice. Portable air conditioning units are ideal for cooling network/telecom closets. These compact, plug-and-play units can be rolled into place at any time with minimal disruption. They do not require any user intervention and support remote monitoring and control through the addition of an optional network management module.

Figure 21: Portable Air Conditioning Unit



A portable air conditioning unit can provide plug-and-play supplemental cooling inside a confined space.

Questions to consider for cooling your network/telecom closets:

- How many cubic feet is your closet?
- What is the maximum total wattage of the equipment in the room?
- What is the ambient temperature of the closet?
- What are the temperatures measured at key equipment intakes?
- Does the closet receive any cooling or heating from the HVAC system? Does this change during the year?
- Is the HVAC output controlled by a thermostat outside the closet?
- Does the closet have a passive vent (no fan)?
- Does the closet have an active vent (with fan)?
- Does the closet receive additional heat from a nearby room?
- Does the closet have masonry or timber/drywall construction?
- Does any wall of the closet receive direct sunlight?
- Are there any heat sources inside the closet, such as incandescent lights, space heaters, non-IT equipment or unused IT equipment that's still plugged in?

For assistance determining whether you need to install supplemental cooling based on the size of your network/telecom closet, the wattage of your VoIP equipment and other factors, contact our application specialists at solutions@tripplite.com or **888.447.6227**.

Cabling

Use high-quality copper and fiber network cabling that's fully tested and supports the latest standards. That will reduce the amount of time you spend tracking down VoIP network issues and replacing faulty cables. Use patch panels and cable managers to help you organize your cabling. In cramped spaces, use space-saving solutions that maximize functionality in minimal space, such as half-U patch panels. If your circuit-switched phone system ran over Cat1 or Cat3 wiring, you should also upgrade your copper to Cat5e or Cat6 unless enough Cat5e/6 network drops are already available. If the power cords that came with your equipment are too long, too short or do not have the right plugs for the UPS or PDU, replace them with cords of the correct length and type.

A sound cable management strategy will reduce human error, which is one of the leading causes of VoIP network downtime. Vertical and horizontal cable managers can help you organize large quantities of patch cables. Overhead cable managers, including cable troughs and ladders, route cable bundles between racks and across rooms. Keeping cables secure and organized with cable managers helps prevent misidentification, tripping hazards, inadvertent cable disconnections, blocked airflow and heat buildup. Using patch panels as part of a structured cabling system saves space, lowers maintenance costs and reduces installer errors.

Figure 22: Cable Management



Cable management is an important part of every VoIP network/telecom closet design.

Separating power and data cable bundles with cable troughs and ladders also reduces electromagnetic interference that can introduce data errors, reduce performance and degrade VoIP call quality. Keeping cable bundles separate also prevents more delicate cables from being damaged by heavier cables.

Local and Remote Management

We recommend that each UPS system have a network card (SNMPWEBCARD) to enable remote management. The network card allows you to monitor and control the UPS system via SNMP, Web, SSH or telnet. It also allows the UPS system to report conditions and issue alerts over the network. You will receive e-mails, text messages or SNMP notifications according to rules and thresholds that you define, either through an embedded interface or a separate management application such as Tripp Lite's PowerAlert® software. You can also communicate with UPS systems through communication ports connected to host computers. While most users choose network cards installed inside UPS systems for communication, the most essential requirement is to deploy and use some method of communication. Simple remote management steps taken at installation can eliminate significant problems later. Select PDUs and cooling systems also support remote management through integrated or add-on network accessories.

Figure 23: Remote Management Card

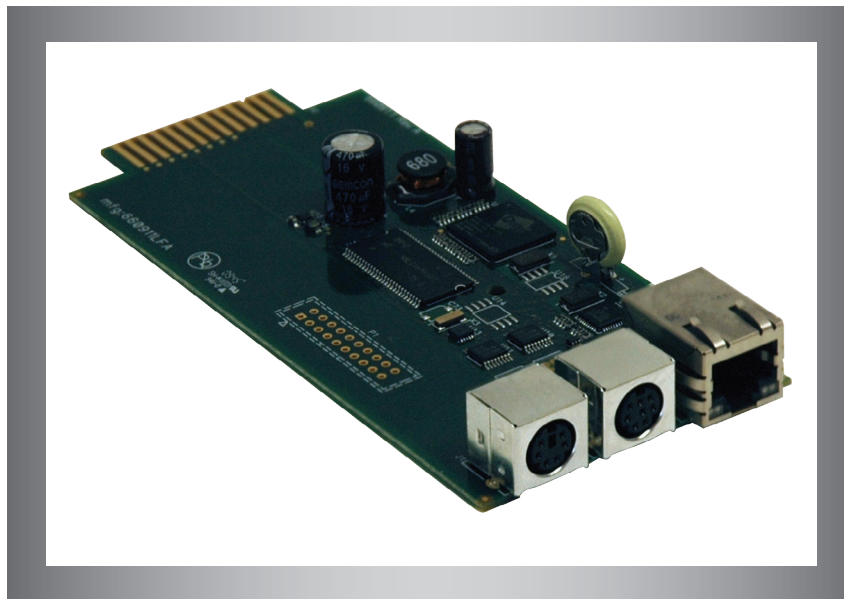

Adding a remote management card to your UPS system enables remote monitoring, alerts and control over the network, without requiring a connection to a host computer.

The UPS network card and PowerAlert software also allow you to write detailed configurations and firmware updates over the network to multiple UPS systems. If you need to set up 100 identical UPS systems in VoIP network/telecom closets at multiple sites, you can configure one unit exactly the way you want it, copy the configuration file and push it over the network to the other 99 units, wherever they may be. Right away, the network cards will save you 99 trips and the time required to set up 99 other UPS systems with detailed configurations, one at a time. They also eliminate the risk of errors and inconsistencies during setup, which is a real danger when an overworked human being has to perform a tedious multistep process dozens of times.

Most UPS systems will allow you to set alerts based on load levels, voltage levels, temperature/humidity, battery capacity, battery failure and UPS operating mode (such as normal, bypass, economy mode, on battery). Commands available for UPS systems include reboot, shut down, run inverter/battery test, switch outlet banks on/off and activate/deactivate energy-saving economy mode.

The ability to switch outlet banks on and off over the network is another big time saver, as it allows you to reset malfunctioning switches and routers immediately to correct network problems without making site visits. Many UPS systems include switchable outlet banks, and all switched PDUs allow you to switch each outlet off or on individually over the network.

If you prefer, you can manage a UPS system through a computer connected to the UPS with a USB or serial cable. You can use PowerAlert software to manage the UPS from the connected computer. The PowerAlert software on the connected computer also acts as an SNMP proxy, allowing the UPS to be managed over the network.

Figure 24: PowerAlert Management Software

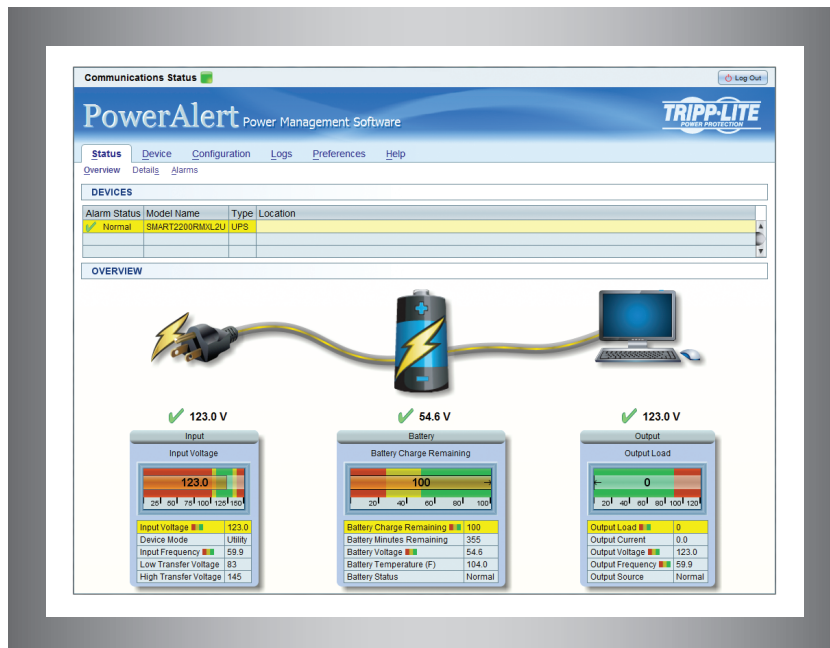

Tripp Lite's PowerAlert software can manage a single UPS connected directly to a host computer or hundreds of devices over the network.

You should also consider how to manage the other devices in your network/telecom closets, such as servers, routers and switches. IP console servers help you manage diverse platforms and widely dispersed IT assets with fewer personnel and less equipment. They provide secure remote access to both serial- and network-connected devices through a single console from any location using a network, dial-up or 3G/4G cellular connection and your preferred management tools. Out-of-band access with automatic failover provides a fail-safe alternative channel for managing critical VoIP systems if the local network or Internet connection goes down. Real-time alerts, service processor access and integrated management tools help you correct problems before they impair productivity.

Figure 25: IP Console Servers



IP console servers provide comprehensive in-band and out-of-band device management for serial- and network-connected devices.

Maintenance and Service

The most convenient service is the kind you can perform yourself, according to your own schedule and requirements. Service contracts are not only costly, they may not provide timely assistance in the case of an emergency. We recommend that you put systems in place that you can service and maintain yourself using on-hand spares or quick-ship replacements.

It's imperative that you test UPS batteries at least once per month, a process that will be much easier if you have a remote management solution in place. Without periodic battery tests, you will be rolling the dice whenever there's a power outage. Better yet, anticipate battery failures based on reported data and proactively replace UPS batteries according to your own schedule. Make sure that UPS batteries are hot-swappable so you can easily replace them without VoIP network downtime.

Where possible, install UPS systems that have an automatic internal bypass and also use integrated or external bypass PDUs to facilitate UPS replacement and allow repairs without requiring downtime. When a traditional on-line UPS system goes into bypass mode because of an internal power electronics fault, you first need to schedule a downtime window for the UPS system and connected equipment. (This is still preferable to having the system go down immediately, which will happen with a line-interactive UPS.) The repair should happen after business hours to reduce the impact on worker productivity. If you need to wait for a service technician, it adds another delay and schedule that you must accommodate. When the repair is finally ready to commence, you have to shut down and disconnect your equipment, then disconnect and remove the old UPS system from the rack. Then you need to install the new UPS in the rack and start it up. You have to reconnect your equipment, start it up and test the system to make sure everything is working properly. If hundreds of VoIP phones need to re-connect, it may take an hour of downtime before the VoIP network is fully operational.

Figure 26: Manual Transfer Switch

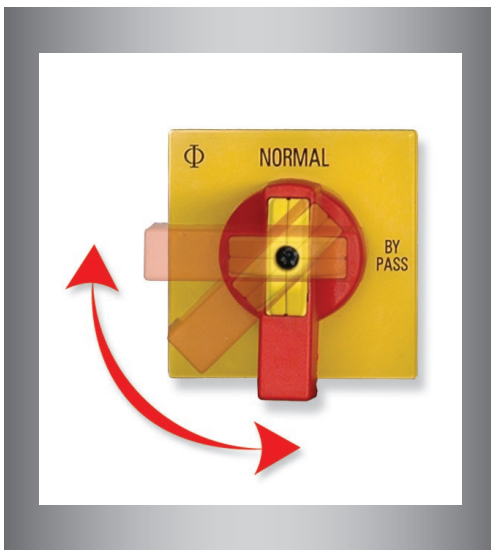

Turning the manual transfer switch on a bypass PDU allows you to remove the UPS system without interrupting power to connected equipment. The bypass PDU can be a detachable component of the UPS or an entirely separate unit.

If the UPS system has an integrated or separate bypass PDU that allows you to hot-swap the UPS system, you simply turn the manual transfer switch, detach the PDU, replace the UPS or UPS power module, reconnect the PDU and turn the manual transfer switch again. This process is not only much quicker, it allows you to do everything according to your own schedule and convenience, especially if you keep spare parts on hand. Your critical VoIP equipment does not experience even a second of downtime during the entire process.

Extended warranties may be a good idea for some equipment, but you should always evaluate the cost of the warranty versus the cost of an upgraded unit that includes a new warranty, the latest features and fresh components. Some device types suffer less wear and tear over time than others, requiring replacement less often, so take that into consideration as well.

Application Examples

Please note that the wattage listed for each PoE switch is not the maximum possible value. Most PoE switches do not support PoE devices on every port, and most PoE devices do not consume the maximum PoE wattage, so you can find more accurate power requirements by considering the number of connected PoE devices and their actual wattage. For assistance with determining wattage requirements and building your own custom solution, contact Tripp Lite's application specialists at solutions@tripplite.com or **888.447.6227**.

Application Example 1: Small IDF Network/Telecom Closet

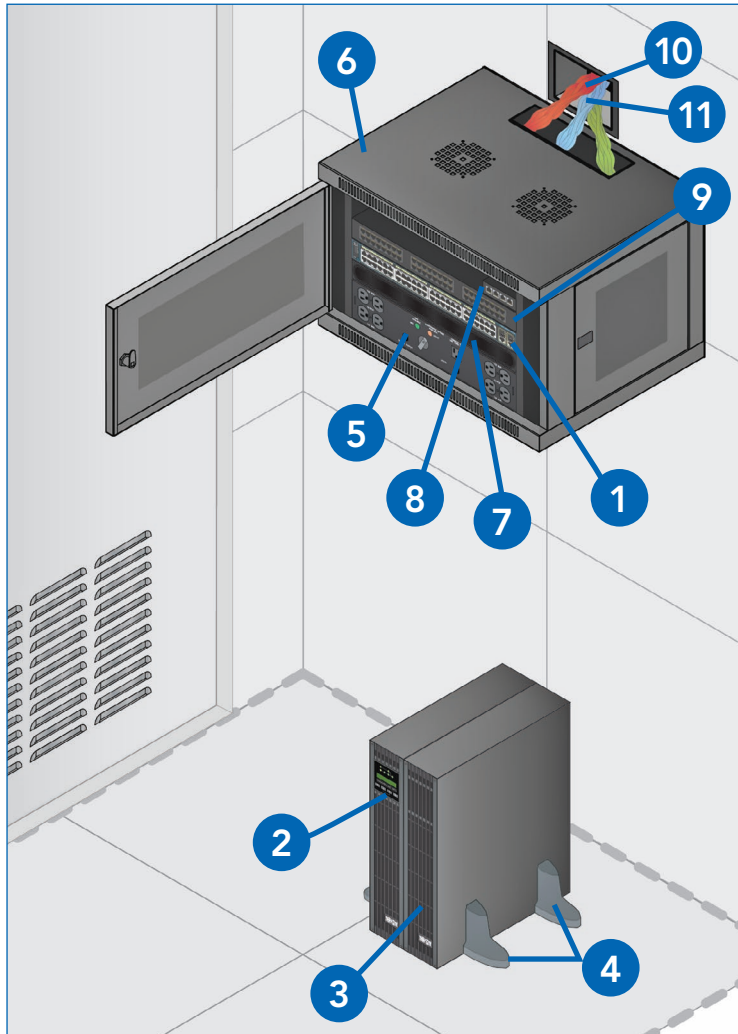

This configuration requires a NEMA 5-20R wall outlet for the UPS/PDU and a NEMA 5-15R wall outlet for the portable air conditioning unit.

Room size: 4 x 4 ft.

Total VoIP equipment load: 400 W (120 V).

VoIP equipment supported:

- 1 48-port PoE switch (400 W).

UPS systems and batteries:

- 2 SU750RTXLCD2U on-line UPS with SNMPWEBCARD remote management card.
- 3 BP24V28-2U external battery pack.
- 4 2-9USTAND tower stands.

The UPS system and external battery pack will support the connected equipment load for approximately 78 minutes during an outage.

PDUs:

- 5 PDUB15 hot-swap PDU.

Racks and cable managers:

- 6 SRW6U wall-mount rack cabinet.
- 7 SR1UBRUSH horizontal pass-through brush panel.

KVM/console solutions:

- 8 B095-004-1E 4-port compact IP console server.

Cables and patch panels:

- 9 N252-048-1U 48-port Cat6 patch panel.
- 10 N201-series Cat6 cables for copper network connections, including network drops.
- 11 N820-series fiber for switch-to-switch and MDF-to-IDF network connections.

Application Example 2: Medium/Large IDF Network/Telecom Closet

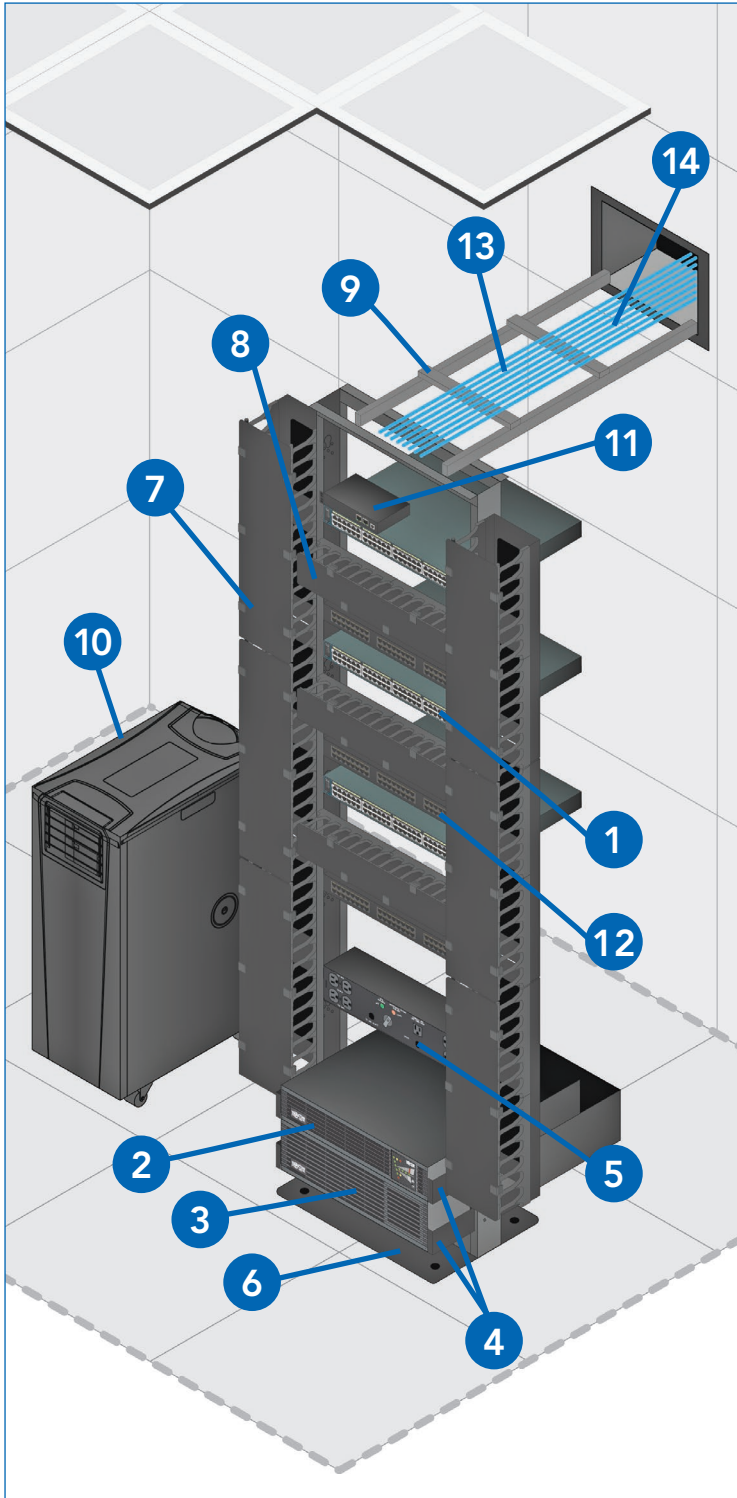

This configuration requires a NEMA 5-20R wall outlet for the UPS/PDU and a NEMA 5-15R wall outlet for the portable air conditioning unit.

Room size: 6 x 8 ft.

Total VoIP equipment load: 1,200 W (120 V).

VoIP equipment supported:

- 1 3 x 48-port PoE switches (400 W each).

UPS systems and batteries:

- 2 SU2200RTXL2UA on-line UPS with SNMPWEBCARD remote management card.
- 3 BP48V60RT-3U external battery pack.
- 4 2POSTRMKITWM and 2POSTRMKITHD 2-post rack mounting kits.

The UPS and connected external battery pack will support the equipment load for approximately 76 minutes during an outage.

PDU:

- 5 PDUB15 hot-swap PDU.

Racks and cable managers:

- 6 SR2POST 45U 2-post rack.
- 7 SRCABLEVRT6 high-density vertical cable managers.
- 8 SRCABLEDUCT2UHD high-density horizontal cable managers.
- 9 SRCABLELADDER cable ladder.

Cooling solutions:

- 10 SRCOOL12K 12,000 BTU portable air conditioning unit with SRCOOLNET remote management module (includes ENVIROSENSE temperature/humidity sensor).

KVM/console solutions:

- 11 B094-008-2E-M-F 8-port IP console server.

Cables and patch panels:

- 12 N252-048-1U 48-port Cat6 patch panel.
- 13 N201-series Cat6 cables for copper network connections, including network drops.
- 14 N820-series fiber for switch-to-switch and MDF-to-IDF network connections.

Application Example 3: MDF Network/Telecom Closet

Room size: 8 x 10 ft.

Total VoIP equipment load: 3,600 W (208 V).

VoIP equipment supported:

- 1 Modular switch chassis with 192 PoE ports (1,800 W).
- 2 4 x 2U rack servers (400 W each).
- 3 Integrated services router (200 W).

All equipment is configured with dual redundant power supplies.

UPS systems and batteries:

- 4 2 x **SU6000RT4UHV** hot-swappable on-line UPS systems with **SNMPWEBCARD** remote management cards.
- 5 4 x **BP48V60RT-3U** external battery packs.

The UPS systems and external battery packs are configured for redundancy. They will support the connected VoIP equipment load for approximately 100+ minutes during an outage – 50+ minutes for each UPS.

PDU:

- 6 2 x **PDUMV30HV** metered vertical PDUs – one connected to each UPS.

Racks and cable managers:

- 7 **SR42UB** 42U rack enclosure.
- 8 **SR2POST** 45U 2-post rack.
- 9 **SRCABLEDUCT2UHD** high-density horizontal cable managers.
- 10 **SRCABLELADDER** cable ladder.
- 11 **SR1UPANEL10** 1U blanking panels.

Cooling solutions:

- 12 **SRCOOL12K** 12,000 BTU portable air conditioning unit with SRCOOLNET remote management module (includes **ENVIROSENSE** temperature/humidity sensor).

KVM/console solutions:

- 13 **B096-016** 16-port IP console server.
- 14 **B040-008-19** 8-port KVM switch with built-in foldaway 19-inch LCD console.

Cables and patch panels:

- 15 **N252-048-1U** 48-port Cat6 patch panels.
- 16 **N201**-series Cat6 cables for copper network connections, including network drops.
- 17 **N820**-series fiber for switch-to-switch and MDF-to-IDF network connections.
- 18 **P005**-series and **P036**-series power cords for connecting server, switch and router power supplies to PDUs.

Application Example 3: MDF Network/Telecom Closet

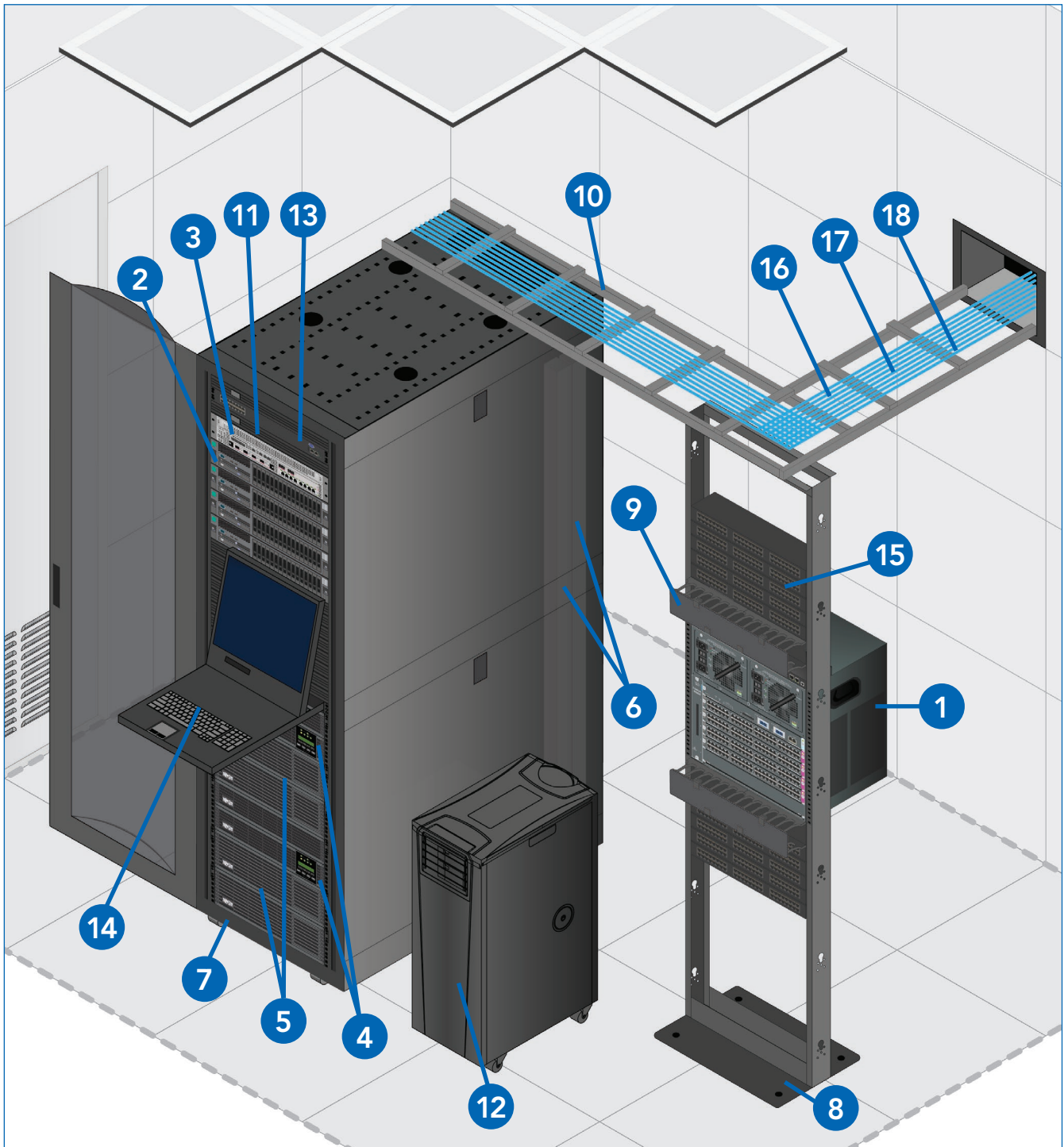

This configuration requires two NEMA L6-30R wall outlets for the redundant UPS systems and a NEMA 5-15R wall outlet for the portable air conditioning unit.

Conclusion

Typical network/telecom closet designs can't handle the increased wattage and heat output of the PoE switches used with IP phones. This is especially true where power capacity, battery backup runtime and cooling are concerned. By paying attention to the power, backup and cooling needs of your network closets, you will ensure that your VoIP system operates with greater reliability. For additional assistance with VoIP network closet provisioning, access our online tools at www.tripplite.com, e-mail solutions@tripplite.com or call our application specialists at 888.447.6227.

About Tripp Lite

Customers in the IT, telecom, industrial, commercial, corporate, healthcare, government and education sectors choose Tripp Lite for complete solutions to power, protect, connect and manage servers, network hardware and other equipment in data centers and related facilities. Tripp Lite makes more than 3,000 products, including UPS systems, battery packs, PDUs, rack enclosures, cooling solutions, surge protectors, KVM switches, cables, power strips and inverters. For more information about Tripp Lite's full line of data center solutions, visit www.tripplite.com.



Manufacturing
Excellence.



© 2015 Tripp Lite. All trademarks are the sole property of their respective owners. Tripp Lite has a policy of continuous improvement. Specifications are subject to change without notice.