

Table of Contents

Chapter 1 Product Overview	1-1
Chapter 2 Product Characteristics	2-1
Chapter 3 Architecture	3-1
3.1 Physical Description.....	3-1
3.1.2 System Specifications.....	3-3
3.2 MPUs	3-4
3.2.2 Introduction to JC165A (RPE-X1).....	3-4
3.2.3 Technical specifications	3-9
3.2.4 Introduction to JC566A (RSE-X1).....	3-9
3.2.5 Technical specifications for JC566A (RSE-X1)	3-13
3.3 FIPs	3-14
3.3.1 Introduction to FIPs	3-14
3.4 Interface Modules.....	3-18
3.4.1 10 GE	3-18
3.4.2 FE and GE	3-19
3.4.3 CPOS (Channelized to E1/T1/DS0)	3-21
3.4.4 CPOS (Channelized to E3/T3).....	3-23
3.4.5 POS (Unchannelized).....	3-24
3.4.6 OC-48/STM-16 POS	3-26
3.4.7 OC-3/STM-1 ATM.....	3-27
3.4.8 OC-48/STM-16 RPR	3-28
3.4.9 Compatible MIMs.....	3-29
3.4.10 Adaptation between FIPs and modules	3-30
3.5 High-density Ethernet Interface Cards.....	3-30
3.5.1 Introduction	3-30
3.5.2 Technical Specifications.....	3-31
3.6 Compatibility Among MPUs, FIPs, and Interface Cards.....	3-32
Chapter 4 Features	4-32
4.1 Features.....	4-32
Chapter 5 Typical Applications	5-1
5.1 Enterprise Network Application as Core Routers	5-2
5.2 Large Industry Network Application	5-3
5.3 MPLS VPN Network Application	5-5
5.4 Financial Network MSTP Distribution Application.....	5-6
Chapter 6 Ordering Information	6-1
6.1 Host	6-1

6.2 Modules 6-1

Chapter 1 Product Overview

The HP A6600 routers are new-generation multi-core routers developed to provide higher performance, flexible services, greater access capacity, and better reliability.

The HP A6604/A6608/A6616 routers (hereinafter referred to as the A6604/A6608/A6616) are high-performance service multi-core routers developed by HP for enterprise networks and carrier-edge access. The A6604/A6608/A6616 adopt two main processing units (MPUs), redundant power modules, and a distributed modular architecture, providing large switching capacity to ensure communication between line-cards at wire speed. Currently the A6604/A6608/A6616 provides two types line-cards, FIP (Flexible interface platform) including JC166B (FIP-110) and JC167B (FIP-210), SAP (Service Aggregation Platform) including JC567A (SAP-48GBE) and JC568A (SAP-24GBP). Line-card provides high-performance hardware encryption. The A6604/A6608/A6616 adopts industry-leading hardware architectures and run on HP proprietary Comware V5 platform. Abundant optional modules are available so that the A6604/A6608/A6616 can have a higher processing capability and can support more flexible configuration to fully meet the requirements of enterprise networks.

The A6604/A6608 can be used as high-performance distribution and access devices for Internet service providers (ISP) and large-scale networks, core and distribution devices for medium-scale networks, and core devices for small and medium-scale enterprise networks; while the A6616 can be used as the core devices for ISP and large-scale networks, small and medium-scale MANs, and small and medium-scale provincial networks. In addition, the A6604/A6608/A6616 can work together with other HP network devices to provide full network solutions for ISP and users in electric power, finance, tax, public security, railway and education, as well as for medium and large-sized enterprises. The full compliance with the active national and international standards ensures the interoperability with products of other manufacturers at different layers.

The A6604/A6608/A6616 support high-speed interface modules (HIMs) and provide a bus processing capability of up to 10Gbps, which can meet the high-speed performance requirements of users. In addition, the A6604/A6608/A6616 is compatible with some multi-functional interface modules (MIMs) of the HP A-MSR routers to guarantee the smooth upgrade from narrowband access to broadband access, protecting your investment.

Chapter 2 Product Characteristics

Developed by HP, the A6604/A6608/A6616 is a series of new-generation multi-core routers providing high performance services and high density accessing capacity for enterprise networks. The A6604/A6608/A6616 support distribution access to WANs at a rate of DS0 (64 Kbps) to OC48/STM-16 (2.5Gbps) as well as access to Ethernets at a rate of 10/100/1000 Mbps and 10Gbps. Equipped with diversified line-cards, the A6604/A6608/A6616 allow for high-performance forwarding and provide high-density distribution access, thus providing a scalable, smooth-upgrading, and highly cost-effective distribution access solution.



Industry's First Multi-Core High-End Router

As the first high-end router that employs the multi-core multi-thread processor, the A6600 features in high-performance, easy programmability, and flexible adaptation to L4-L7 services. The multi-core multi-thread CPU endows the A6600 with high-performance and high flexibility. Moreover, due to the CPU's easy programmability and operation, the A6600 is able to quickly respond and adapt to new services, thus meeting the requirements of managing application-layer services on routers. In the system architecture design phase, the A6600 attaches importance to hardware speedup for link layer and security services so that the multi-core CPU can use its precious resources for processing core L4-L7 services.

Powerful Routing Capacity

The A6604/A6608/A6616 support IPv4/IPv6 static routing and dynamic routing protocols, such as RIP/RIPng, OSPF/OSPFv3, IS-IS/IS-ISv6, and BGP/BGP4+.

With standard configuration, the A6604/A6608/A6616 has a large routing table capacity and a large forwarding table capacity. In addition, the A6604/A6608/A6616 supports diversified policy-based functions and route policies, allowing for flexible control and scheduling of network traffic, thus meeting different routing requirements of enterprise networks and carrier networks.

Dynamic Virtual Private Network

DVPN (Dynamic Virtual Private Network) collects, maintains, and distributes dynamic public addresses through the VPN Address Management (VAM) protocol, making VPN establishment available among enterprise's headquarters and branches that use dynamic addresses to access the public network. Compared to traditional VPN technologies, DVPN technology has more flexible and richer features, such as NAT traversal of DVPN packets, AAA identity authentication, IPSec protection of data packets, multiple VPN domains etc.

Powerful MPLS

The A6604/A6608/A6616 supports MPLS, including L2 VPN, L3 VPN services, and MPLS TE. In addition, the A6604/A6608/A6616 can work together with other HP network devices to form a powerful MPLS network, providing a high-performance, secure and hierarchical MPLS VPN solution.

Industry-Leading Encryption

The A6604/A6608/A6616 have built-in hardware encryption engines for FIPs and SAPs to provide a data encryption processing capacity greater than 3Gbps for JC167B/JC567A/JC568A (FIP-210/SAP-48GBE/SAP-24GBP), ensuring data security in WANs and intranets.

PPP Multi-link Bundling

The A6604/A6608/A6616 provides two high-speed CPOS interfaces (JC161A and JC162A) to allow for hardware MP. When the A6604/A6608/A6616 serves as a distribution node of a WAN, you can implement PPP multi-link bundling on the downlink E1 or T1 through CPOS interfaces. You can also implement reassembly and fragmentation of MP packets without affecting traffic forwarding. Each JC167B (FIP-210) can implement 10 groups of 12E1 MP bundling and 14 groups of 12T1s MP bundling at wire-speed, thus providing sufficient bandwidth for narrowband distribution networks.

Abundant Interface Types

The A6604/A6608/A6616 provides 100/1000Mbps and 10Gbps Ethernet interfaces and POS OC-48/OC-12/OC-3, CPOS OC-3 (channelized to E3/T3 or E1/T1), ATM OC-3, E3/T3, E1/T1, and serial interfaces. By providing diversified interface types, the A6604/A6608/A6616 can serve as both the distribution access of WANs and the access of LANs. This allows a flat network and simplifies the network, thus protecting your investment.

Diversified Features

The A6604/A6608/A6616 provides high-performance selective QoS solutions which are the technical basis of network services. In addition, the A6604/A6608/A6616 provides advanced queue scheduling, congestion avoidance, congestion management, traffic policing, traffic shaping, and priority

mark/remark, ensuring the bandwidth, delay, jitter, and packet loss rate of different services, thus providing distinguished services by user and service level.

The A6604/A6608/A6616 supports service features such as high-performance NAT, L2TP, GRE, and security features such as Firewall, ASPF, and URPF. They provide the distributed NetStream traffic statistics function to collect statistics for different streams, allowing you to learn the network traffic and perform network planning, security supervision, and traffic accounting. The A6604/A6608/A6616 distributed design makes the product configuration line-cards, the more, higher performance, and customers do not need to buy additional dedicated service card.

IPv6

The Internet is operating based on IPv4. With rapid development of the Internet however, the number of IPv4-defined IP addresses are running out, which hampers the further development of IP technology and networks. As the basis of next-generation networks, IPv6 has the following advantages over IPv4:

- Flexible packet format
- Greater number of IP addresses
- Effective hierarchical addressing and routing system
- Stateful and stateless address configuration
- Built-in security
- QoS
- Powerful protocol mechanism for neighbor discovery (ND)
- Scalability
- Mobility available (3GPP has decided to use IPv6 to build the next-generation IPv6 core networks)

The A6604/A6608/A6616 support the following IPv6 features:

- IPv6 address
- Link-local unicast address
- Site-local unicast address
- Global unicast address
- Multicast address
- IPv6 Neighbor Discovery (ND)
- ND host
- ND router
- IPv6 Path MTU
- IPv6 ACL
- IPv6 routing protocol
- Transition from IPv4 to IPv6
- Message translation
- IPv6-IPv4 tunnel
- NAT-PT
- IPv6 multicast
- 6PE
- 6VPE

High-Density Narrowband Distribution Access

The A6604/A6608/A6616 can provide large-capacity, high-density narrowband distribution access. For example, the A6616 can provide up to 32 channelized 155 M POS interfaces that can also be channelized to E3/T3 and E1/T1/DS0 interfaces, the processing capacity of up to 16 K physical interfaces, and wire-speed distribution for more than 1512 E1s.

Large-Capacity Broadband User Access

The A6604/A6608/A6616 supports the PPPoE server. Each line-card allows for the access of 8 K PPPoE broadband users.

Excellent Scalability

The A6604/A6608/A6616 allows for excellent scalability, providing several types of line-card, JC166B/JC167B/JC567A/JC568A (FIP-210/FIP-110/SAP-48GBE/SAP-24GBP). For example, the A6616 supports up to 16 HIMs or 32 MIMs to meet the increasing service requirements of users. And A6616 can support 8 line-cards of JC567A (SAP-48GBE), up to 384 GE interfaces.

As for file system, the A6604/A6608/A6616 provides abundant storage media, supporting external CF card, host USB, and device USB interfaces. In addition to meeting your increasing storage requirements, the A6604/A6608/A6616 provides flexible storage methods to allow for file management through different interfaces.

Perfect Security Mechanism

The A6604/A6608/A6616 supports hierarchical user management and password protection, packet filter, unicast reverse path forwarding (URPF), and control panel rate limiting, authenticating logon users and assigning access rights by user level. User authentication methods include local authentication, RADIUS authentication, TACACS, Portal and SSH (v1.5 and v2.0) authentication to ensure security of devices in networks. In particular, distributed line-card of the A6604/A6608/A6616 has built-in firewall, which provides abundant security features, such as ASPF, attack detection and protection, packet filtering etc. In addition, configure the line-cards, the more, the higher the firewall performance. Built-in firewall function can be applied on different WAN interfaces, such as Ethernet, POS, ATM etc.

Carrier-Class Reliability

The A6604/A6608/A6616 provides high reliability.

For hardware, the A6604/A6608/A6616 adopts two MPUs, redundant power modules, and a distributed modular architecture. With two MPUs equipped, the system allows you to perform an active-standby switchover, without interrupting the ongoing data forwarding or service processing on the line-cards, thus ensuring reliability. All the line-cards and modules on the A6604/A6608/A6616 are hot-swappable,

without interrupting one another. The A6604/A6608 adopts “1+1” power module redundancy and the A6616 provides four power modules that support multiple redundancy modes.

For software, the A6604/A6608/A6616 supports abundant reliability features, ensuring continuity of services when network devices are running. Such reliability features include:

- VRRP
- MPLS TE FRR
- IGP fast routing convergence
- BFD
- Hot patching for software
- OSPF/IS-IS/BGP/MPLS LDP/MPLS RSVP-TE GR (Graceful Restart)
- OSPF/IS-IS IP FRR
- IS-IS NSR
- LDP NSR

Environmental Protection Throughout the Product Lifecycle

The A6600 routers adhere to HP green design requirements and implement green design throughout the product Lifecycle.

- The routers are designed to reduce the burden to the environment throughout the lifecycle, including design, purchase, manufacture, logistics, sale, use, and recycle.
- During design, we reduce use of poisonous and hazardous substances and raw materials, increase product energy efficiency, prolong the product life span, and reduce generation of wastes, thus making continuous contribution to environmental protection.

All the A6600 routers use green components, and multiple technologies are used to ensure recycling.

- According to the standards such as RoHS, HP has established its own environmental protection standards and supply system. The A6600 routers take advantage of the system to ensure all the devices comply with those standards.
- According to WEEE directive requirements, the A6600 routers use multiple technologies to ensure recycling, including: choose suitable, recyclable materials, minimize using materials, avoid poisonous and hazardous raw materials, use single material instead of different mixed materials, mark each material type and its life span for later classification and recycling.

Energy-saving Technology in a Full Scale

The A6600 routers use compact design to reduce resource consumption, providing benefits by:

- Providing powerful functions while reducing space occupation. A single rack can accommodate multiple A6600 devices (For example, a standard 2.2 m 19-inch rack can accommodate two A6616 routers).
- Using methods such as texturing instead of electroplating, printing or bronzing to reduce energy cost.
- Adopting energy-saving design to effectively reduce energy consumption and device operating costs, and high-efficiency primary power to ensure a power transform efficiency of more than 85% during normal operation.

- Adopting the patent design of line card intelligent power-on. This design ensures the line cards to get power separately to effectively avoid peak current and reduce power consumption. The A6616 also uses intelligent power control technology to intelligently power on or off the line cards according to the affordable power of the supply and the power of online line cards, and to power off those line cards that do not need to work.
- Adopting an intelligent heat dissipation solution. The device frame adopts advanced dissipation design and fans adopt multiple-level, automatic speed control technology. The fans operating at low speeds consume only 25% of the designed power.
- Using the chips of industry-leading manufacturers, which feature advanced craft, high integration, and low power consumption. Based on the low power consumption feature of chips, intelligent management software was developed to greatly reduce whole power consumption and improve system performance.

Chapter 3 Architecture

3.1 Physical Description

- Front view

Figure 3-1 Front view of the A6616



Figure 3-2 Front view of the A6608



Figure 3-3 Front view of the A6604



• Side View

Figure 3-4 Side view of the A6616



Figure 3-5 Side view of the A6608



Figure 3-6 Side view of the A6604



- The A6604/A6608/A6616 adopts an integrated chassis, consisting of four components, namely, MPU, FIP, SAP, fan, and power supply.
- The width of the A6604/A6608/A6616 is suitable for a standard 19-inch rack and the height of the router is 5UL/7UL/20UL.
- Slot 1 of the A6604/A6608 can accommodate two MPUs of JC165A (RPE-X1), supporting “1+1” redundancy; slot 4 and slot 5 of the A6616 can accommodate two MPUs of JC165A (RPE-X1), supporting “1+1” redundancy.

- Slot 1 of the A6604/A6608 can accommodate one MPU of JC566A (RSE-X1); slot 5 and slot 4 of the A6616 can accommodate one MPU of JC566A (RSE-X1). To support “1+1” redundancy, slot 2 of A6604/A6608 or slot 6 of A6616 will be occupied.
- Slot 2 and slot 3 of the A6604 are for FIPs and SAPs; slot 2 through slot 5 of the A6608 are for FIPs and SAPs; slot 0 through slot 3 and slot 6 through slot 9 of the A6616 are for FIPs and SAPs. Each slot can accommodate one hot-swappable FIP or SAP. Intermixing of FIPs and SAPs are allowed.
- At the bottom of the A6604/A6608 chassis is the power slot for two power modules, supporting “1+1” redundancy, and online insertion and removal; and at the bottom of the A6616 chassis is the power slot for four power modules, supporting multiple redundancy modes and online insertion and removal. You can select AC power modules for AC input or DC power modules for DC input. However, never install an AC power module and a DC power module in the same chassis.
- On the right of the A6604/A6608 chassis is a vertical fan tray and the fans draw air in through the inlet vents on the left and out through the exhaust vents on the right. At the top of the A6616 chassis is a horizontal fan tray and the fans draw air out from the bottom up. The fan tray is hot-swappable and its speed is auto-adjustable.



Note

- Online insertion and removal mean turning off the power switch before removing the power module. Before inserting the power module to the router, make sure that the power module is switched off from the power supply.
- Hot-swapping means using the **remove slot num** command to stop a module from operating before removing it from the router. You can insert a module to the router without powering off your router.

3.1.2 System Specifications

Table 3-1 System specifications of the A6604/A6608/A6616

Item	Specification
Dimensions without feet and rack-mounting ears (H x W x D)	A6604: 220 x 436 x 480 mm (8.66 x 17.17 x 18.90 in.) A6608: 308 x 436 x 476 mm (12.13 x 17.17 x 18.74 in.) A6616: 880 x 436 x 480 mm (34.65 x 17.17 x 18.90 in.)
Weight	A6604: <ul style="list-style-type: none"> • 23 kg (50.71 lb) (net weight) • 38 kg (83.77 lb) (full configuration) A6608: <ul style="list-style-type: none"> • 27 kg (59.52 lb) (net weight) • 50 kg (110.23 lb) (full configuration) A6616: <ul style="list-style-type: none"> • 53 kg (116.84 lb) (net weight) • 100 kg (220.5 lb) (full configuration)
Rated voltage range	100 VAC to 240 VAC; 50 Hz or 60 Hz
Rated voltage range	-40 VDC to -60 VDC
Max. power consumption	A6604: 410 W

	A6608: 780 W A6616: 1730W
Number of MPU slots	2 (1+1 redundancy)
Number of line-card slots	A6604: 2 (regardless of type) A6608: 4 (regardless of type) A6616: 8 (regardless of type)
Interface type	10 GE 10/100/1000BASE-T RJ-45 10/100BASE-T RJ-45 1000BASE-SFP E3/CE3 T3/CT3E1/CE1 T1/CT1 SAE (synchronous) OC3-CPOS (channelized to E1/T1/DS0) OC3-CPOS (channelized to E3/T3) OC3-POS OC12-POS OC48-POS OC3-ATM
Operating temperature	0°C to 45°C (32°F to 113°F)
Operating humidity	10% to 95%, noncondensing
Altitude	-60 m to 4 km (-196.85 ft. to +13123.36 ft.)

3.2 MPUs

The A6604/A6608/A6616 supports two MPUs to implement 1+1 redundancy. As the control center of the A6604/A6608/A6616, the MPU deals with the management and route calculation of the router, and controls FIPs and SAPs. The MPUs of the A6604/A6608/A6616 include JC165A (PRE-X1, Route Processing Engine-X1) and JC566A (RSE-X1, Route Switch Engine-X1). They are described as follows:

Table 3-2 Adaption between MPU, FIP, SAP

ITEM	JC165A (RPE-X1)	JC566A(RSE-X1)
JC166B(FIP-110)	√	√
JC167B(FIP-210)	√	√
JC567A(SAP-48GBE)	×	√
JC568A(SAP-24GBP)	×	√

3.2.2 Introduction to JC165A (RPE-X1)

The JC165A (RPE-X1) features compact design, abundant management interfaces, and powerful route calculation capacity. In addition, it provides a CF card interface and USB interfaces for good scalability.

• **Main functions of JC165A (RPE-X1)**

- Route calculation, forwarding table maintenance;
- Configuring and monitoring FIPs, upgrading and resetting FIPs or interface modules; and
- Providing precise clock and real time clock (RTC) for the system.

Figure 3-7 Front view of the JC165A (RPE-X1)

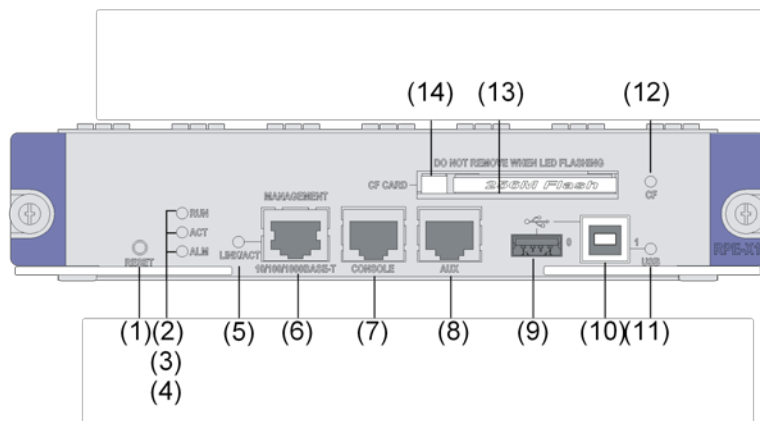

(1) RESET button (RESET)	(2) Run LED
(3) Active/Standby LED (ACT)	(4) Alarm LED (ALM)
(5) LINK/ACT LED for the Ethernet management port	(6) Management Ethernet port (MANAGEMENT)
(7) Console port (CONSOLE)	(8) AUX port (AUX)
(9) Host-mode USB port 0 (0)	(10) Device-mode USB port 1 (1)
(11) USB 1 LED	(12) CF card LED
(13) CF card	(14) CF card button

• **RESET button**

To reset the current JC165A (RPE-X1), you can press the RESET button.

- If you press the RESET button when only one JC165A (RPE-X1) is equipped, the whole system will be reset.
- If you want to perform an active-standby switchover when two JC165A (RPE-X1)s are equipped, press the RESET button on the active JC165A (RPE-X1). The system will automatically switch the services to the standby JC165A (RPE-X1), without interrupting the ongoing services.



Note

- If you perform no save operation before resetting the router, the current system configuration will not be saved after the router is reset.
- Never press the RESET button when the router is booting (when the SYS LED is flashing fast). Otherwise, the file system of the router may be damaged.

• **RUN LEDs**

There are three system LEDs, RUN, ACT, and ALM to indicate the status of the system and the current JC165A (RPE-X1). The following table describes the status LEDs:

Table 3-3 Description of the LEDs

LED	Status	Meaning
RUN (green)	Off	No power is input or the JC165A (RPE-X1) is faulty.
	Slow flashing (1 Hz)	The JC165A (RPE-X1) is operating normally.
	Fast flashing (8 Hz)	The application software is being loaded (do not power off or unplug any card in this state).
ACT (green)	Off	The JC165A (RPE-X1) is in the standby state.
	On	The JC165A (RPE-X1) is in the active state.
ALM (red)	Off	The system is operating normally and there is no alarm.
	On	A fault has occurred to the system. In this state, you need to check the system logs immediately.
	Slow flashing (8 Hz)	A critical fault has occurred to the system. In this state, you need to handle the fault immediately.

• **Management Ethernet interface LED**

The A6604/A6608/A6616 provides a 10/100/1000 Mbps autosensing RJ-45 management Ethernet interface through which you can perform software upgrading and device management, without using any service interface. Note that the management Ethernet interfaces are for out-of-band management only, not for service processing.

Table 3-4 Technical specifications for management Ethernet interfaces

Item	Specification
Connector type	RJ-45
Number of interfaces	1
Interface speed and duplex mode	<ul style="list-style-type: none"> • 10 Mbps, full/half duplex • 100 Mbps, full/half duplex • 1000 Mbps, full duplex
Interface cable and maximum transmission distance	Category-5 twisted pair with a maximum transmission distance of 100 m (328.08 ft.)
Function	Used for router software upgrading and network management

Table 3-5 Description of the management Ethernet interface LED

LED	Status	Meaning
LINK/ACT (green/yellow)	Solid yellow	A 10/100 Mbps link is present.
	Solid green	A 1000 Mbps link is present.
	Flashing yellow	Data is being received or transmitted at a rate of 10/100 Mbps.
	Flashing green	Data is being received or transmitted at a rate of 1000 Mbps.

• **Console port**

The Console port uses an RJ-45 connector through which you can connect to a background terminal PC for system debugging, configuration, maintenance, management, and software loading.

Table 3-6 Technical specifications for the console port

Item	Specification
Connector type	RJ-45
Interface type	Asynchronous EIA/TIA-232
Baud rate	<ul style="list-style-type: none"> • 9600 bps to 115200 bps • 9600 bps (default)
Transmission distance	≤ 15 m (49.21 ft.)
Function	Used to connect the serial interface of a configuration PC

• **AUX port**

The AUX port uses an RJ-45 connector through which (serving as the backup interface of the Console port) you can connect to a background terminal or a Modem for remote system debugging, configuration, maintenance, and management. You can also connect the AUX port to a background terminal PC.

Table 3-7 Technical specifications for the AUX port

Item	Specification
Connector type	RJ-45
Interface type	Asynchronous EIA/TIA-232
Baud rate	<ul style="list-style-type: none"> • 9600 bps to 115200 bps • 9600 bps (default)
Services	Used to connect the serial port of a remote PC through a pair of modems to establish a dial-up connection with the PC

• **USB**

Universal Serial Bus (USB) supports multiple-device connection at a transmission rate faster than parallel ports and serial ports. USB is hot-swappable, plug and play. USB is of two versions: USB 1.1 and USB 2.0.

Currently, the JC165A (RPE-X1) supports USB 1.1. The USB interfaces provide key storage, providing large external flash storage spaces for applications and configuration files.

You can connect the USB interfaces to an external flash disk (USB disk), which allows you to backup and recovers your files with ease.

2) **USB0: Host**

Interface USB0 provided by the JC165A (RPE-X1) is a USB 1.1-compliant A interface, through which you can connect the host to other external USB devices. You can also connect an external USB disk through interface USB0 to expand your storage capacity for file exchange, file storage, and log recording.

3) **USB1: Device**

Interface USB1 provided by the JC165A (RPE-X1) is a USB 1.1-compliant B interface, through which you can connect a device or PC host to operate on the CF card of the device.

The following table describes USB interface 1 LED:

Table 3-8 Description of USB interface 1 LED

LED	Status	Meaning
USB1 (green)	Off	No host is connected to the USB interface.
	Solid green	A host is connected to the USB interface. You can remove the USB cable in this state.
	Flashing green	Data is being received or transmitted. Do not remove the USB cable in this state.



Note

- To ensure compatibility and reliability, you are recommended to use USB disks provided by HP only.
- To avoid damages to the file system, do not remove the USB disk while the LED on the USB disk is flashing.

• **CF card slot and CF LED**

A compact flash (CF) card is used for storing logs, host files, and configuration files.

The JC165A (RPE-X1) is equipped with a built-in 256 MB CF card, which is identified with **cfa0**. In addition, the JC165A (RPE-X1) provides an external CF card slot to expand the local storage space. By adopting an external CF card design, the A6604/A6608/A6616 allows you to upgrade and replace your CF card with ease.

To meet abundant service requirements, HP provides different sizes of CF cards to protect your investment and allow for service scalability.

The following table describes the CF card LED:

Table 3-9 Description of CF card LED

LED	Status	Meaning
CF (green)	Off	No CF card is in position or the CF card cannot be identified.
	Solid green	A CF card is in position and the host has detected the CF card. You can remove the card in this state.
	Flashing green	The system is accessing the CF card. Do not remove the card in this state.



Note

- The A6600 routers only support the CF cards provided by HP and may not be compatible with those provided by other manufacturers.
- The CF card is hot-swappable. When the router is performing a file read or write operation on the CF card (the CF card LED is flashing), do not eject the CF card. Otherwise, the file system on the CF card will be damaged.

3.2.3 Technical specifications

Table 3-10 Technical specifications for JC165A (RPE-X1)

Item	Specification
Processor	Single-core CPU, 1 GHz
Flash	4 MB
Memory type and size	DDR2 PC2-3200 1 GB (default), 2 GB (maximum)
Console port	1 (9600 bps to 115200 bps, 9600 bps by default)
AUX port	1 (9600 bps to 115200 bps, 9600 bps by default)
Management interface	1 (10Base-T/100Base-TX/1000Base-T)
USB interfaces	2: USB 0: operating in the host mode; USB 1: operating in the device mode
CF card	256 MB by default for the built-in CF card; maximum 1 GB for an optional external CF card
RESET button	1
LED	RUN, ACT, ALM, LINK/ACT (management Ethernet interface), USB (device), CF
Max. power consumption	37 W

3.2.4 Introduction to JC566A (RSE-X1)

A single JC566A (RSE-X1) occupies the MPU slot. Therefore, a service card slot is needed to accommodate one more JC566A (RSE-X1). The JC566A (RSE-X1) provides various management interfaces and powerful route calculation capacity. It provides a CF card interface and USB interfaces for good scalability.

• Main functions of JC566A (RSE-X1)

- Route calculation, and forwarding table maintenance;
- Configuring and monitoring FIPs, upgrading and resetting FIPs or interface modules; and
- Providing precise clock and real time clock (RTC) for the system.

Figure 3-8 Front view of the JC566A (RSE-X1)

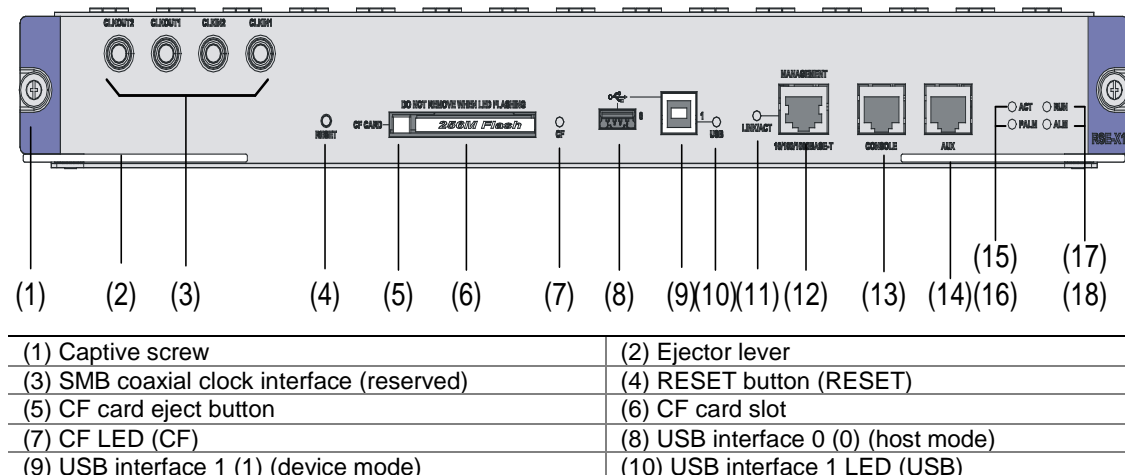

(11) Link state/data reception & transmission LED (LINK/ACT)	
(12) Management Ethernet interface (MANAGEMENT) (10/100/1000BASE-T)	
(13) Console port (CONSOLE)	(14) AUX port (AUX)
(15) Active LED of the JC566A (RSE-X1) (ACT)	(16) Power management alarm LED (PALM)
(17) Run LED (RUN)	(18) Alarm LED (ALM)

• **RESET button**

The RESET button is used to reset the JC566A (RSE-X1).

- If you press the RESET button when only one JC566A (RSE-X1) is equipped, the whole system will be reset.
- When two JC566As (RSE-X1) are equipped, you can press the RESET button on the active MPU to perform an active-standby switchover. The system will automatically switch the services to the standby JC566A (RSE-X1), without interrupting the ongoing services. Pressing the RESET button on the standby JC566A (RSE-X1) only resets the standby JC566A (RSE-X1) without affecting the operation of the system.

 **Note**

- When you use this button to reset the router, the current system configuration will not be saved.
- Never press the RESET button repeatedly when the router is booting (the SYS LED is flashing fast). Otherwise, the system may be damaged.

• **RUN LEDs**

There are four LEDs: RUN, ACT, ALM, and PALM, to indicate the status of the system and the JC566A (RSE-X1). The following table describes the LEDs: description of the LEDs

LED	Status	Meaning	
LEDs of the system operation state	RUN (green)	Off	No power is input or the JC566A (RSE-X1) is faulty.
		Slow flashing (1 Hz)	The JC566A (RSE-X1) is operating normally.
		Fast flashing (8 Hz)	The application software is loaded (do not power off or unplug any card in this state).
	ACT (green)	Off	The JC566A (RSE-X1) is in the standby state.
		On	The JC566A (RSE-X1) is in the active state.
	ALM (red)	Off	The system is operating normally and there is no alarm.
		On	A fault has occurred to the system. In this state, you need to check the system logs immediately.
		Fast flashing (8 Hz)	A critical fault has occurred to the system. In this state, you need to handle the fault immediately.
	PALM (red)	Off	The system power supply is normal.
On		The system power is insufficient.	

• **Management Ethernet interface and LED**

The A6604/A6608/A6616 provide a 10/100/1000 Mbps autosensing RJ-45 management Ethernet interface through which you can perform software upgrading and device management, without using any service interface. Note that the management Ethernet interface is for out-of-band management only, not for service processing.

Table 3-12 Technical specifications for management Ethernet interfaces

Item	Specification
Connector	RJ-45
Number of interfaces	1
Speed	<ul style="list-style-type: none"> • 10 Mbps, half/full duplex • 100 Mbps, half/full duplex • 1000 Mbps, full duplex
Interface cable and maximum transmission distance	Category-5 twisted pair with a maximum transmission distance of 100 m (328.08 ft.)
Function	For router software upgrading and network management

The following table describes the management Ethernet interface LED.

Table 3-13 Description of the management Ethernet interface LED

LED	Status	Meaning
LINK/ACT (green/yellow)	Solid yellow	A 10/100 Mbps link is present.
	Solid green	A 1000 Mbps link is present.
	Flashing yellow	Data is being received or transmitted at a rate of 10/100 Mbps.
	Flashing green	Data is being received or transmitted at a rate of 1000 Mbps.

• **Console port**

The console port uses an RJ-45 connector through which you can connect to a background terminal PC for system debugging, configuration, maintenance, management, and software loading.

Table 3-14 Technical specifications for the console port

Item	Specification
Connector type	RJ-45
Interface type	Asynchronous EIA/TIA-232
Baud rate	9600 bps to 115200 bps (9600 bps by default)
Transmission distance	≤ 15 m (49.2 ft.)
Function	Used to connect the serial interface of a local configuration PC

• **AUX port**

The AUX port uses an RJ-45 connector. As the backup interface of the Console port, the AUX port is used to connect a configuration terminal either locally or remotely through a Modem for system debugging, configuration, maintenance, and management.

Table 3-15 Technical specifications for the AUX port

Item	Specification
Connector type	RJ-45
Interface type	Asynchronous EIA/TIA-232
Baud rate	9600 bps to 115200 bps (9600 bps by default)
Function	Used to connect the serial port of a remote configuration PC through a pair of modems

• **USB**

Universal Serial Bus (USB) supports multiple-device connection at a transmission rate faster than parallel ports and serial ports. USB supports hot-swapping, and plug and play. USB is of two versions: USB 1.1 and USB 2.0.

Currently, the RSE-X1 supports USB 1.1. The USB interfaces are connected to storage devices that provide large space for storing applications, configuration files.

You can connect a USB interface on JC566A (RSE-X1) to an external flash disk (USB disk), which allows you to backup and recovers your files.

1) USB 0: Host

Interface USB 0 is a USB 1.1-compliant A interface, through which you can connect the JC566A (RSE-X1) (as the host end) to an external USB device, or an external USB disk to expand your storage capacity.

2) USB 1: Device

Interface USB 1 is a USB 1.1-compliant B interface, through which you can connect the JC566A (RSE-X1) (as the device end) to a PC (as the host end) on which you can perform operations to the CF card of the device.

The following table describes USB interface 1 LED:

Table 3-16 Description of USB interface 1 LED

LED	Status	Meaning
USB 1 (green)	Off	No host is connected to the USB interface.
	Solid green	A host is connected to the USB interface. You can remove the USB cable in this state.
	Flashing green	Data is being transmitted or received. Do not remove the USB cable in this state.

 **Note**

- To ensure compatibility and reliability, you are recommended to use USB disks provided by HP for HP A6600 routers.
- When the LED of a USB disk is flashing, do not remove the USB disk to avoid damage to the files on the USB disk.

• **CF card slot and CF LED**

A compact flash (CF) card is an advanced mobile storage product, which features high speed, large capacity, small size, little weight, and low power consumption.

The JC566A (RSE-X1) is equipped with a built-in 256 MB CF card, which is used to store application files. In addition, the JC566A (RSE-X1) provides an external CF card slot, which can be connected to an external CF card of HP to store logs, host files, and configuration files.

You can easily update and replace the external CF card without opening the device chassis.

The diversified features and services supported by the routers result in a large scale of router applications. To meet the ongoing expansion of software scale, HP provides different sizes of CF cards to protect your investment and provide service scalability.

The following table describes the CF card LED:

Table 3-17 Description of the CF card LED

LED	Status	Meaning
CF (green)	Off	No CF card is in position or the CF card cannot be identified.
	Solid green	A CF card is in position and has passed detection.
	Flashing green	The system is accessing the CF card. Do not remove the card in this state.

 **Note**

- To ensure compatibility and reliability, you are recommended to use CF cards provided by HP.
- The CF card can be removed when its LED is solid green. Do not remove it when the LED is flashing. Otherwise, the files on the CF card will be damaged.

3.2.5 Technical specifications for JC566A (RSE-X1)

Item	Specifications
Processor type	MIPS 1 GHz
Cores of processor	2
Flash	4 MB
Memory type and size	DDR2 SDRAM Default: 2GB Maximum: 4GB

Item	Specifications
NVRAM	128 KB
Console port	1 (9600 bps to 115200 bps, 9600 bps by default).
AUX port	1 (9600 bps to 115200 bps, 9600 bps by default).
Management Ethernet port	1 (10Base-T/100Base-TX/1000Base-T)
CF card	The built-in CF card has 256 MB by default. A 256 MB, 512 MB, or 1 GB external CF card can be used. (A CF card with less than 256 MB is not supported.)
USB interface	2: USB 0: A interface, operating in the host mode; USB 1: B interface, operating in the device mode
RESET button	1
Dimensions (H x W x D)	2.5 x 364.7 x 400.0 mm (0.10 x 14.36 x 15.75 in.)
Power consumption	75 W
Hot swapping	Supported

3.3 FIPs

The A6604/A6608/A6616 provides 2/4/8 line-card slots respectively, each supporting one FIP. As the service processing modules of the router and under the control of the MPU, FIPs deal with forwarding, encryption/decryption, and analyzing/filtering of data packets.

3.3.1 Introduction to FIPs

The A6604/A6608/A6616 supports two types of FIPs:

JC167B (FIP-210) provides high-speed service processing capability, and supports A6600 HIMs and HP A-MSR MIMs. It allows an HIM and an MIM to be installed at the same time. JC167B (FIP-210) provides better service processing performance and larger service capacity.

JC166B (FIP-110) supports MIMs only. It protects your existing investment.

Similar in physical architectures, the two types of FIPs each provide two GigabitEthernet (GE) combo interfaces. However, JC167B (FIP-210) supports two HIMs or two MIMs while JC166B (FIP-110) support four MIMs simultaneously.

- **FIP LED**

An FIP provides a RUN LED, as described in the following table:

Table 3-18 Description of FIP LED

LED	Status	Meaning
RUN (green)	Off	No power is input or the MPU is faulty.
	Slow flashing (1 Hz)	The system is operating normally.
	Fast flashing (8 Hz)	The application software is being loaded.

• Slots

The JC167B (FIP-210) provides two interface module slots and supports A6600 HIMs and HP A-MSR MIMs.

The interface module slots on JC167B (FIP-210) are numbered 1 and 2 from right to left, as shown in [Figure 3-9](#).

Figure 3-9 Interface module slots on JC167B (FIP-210)

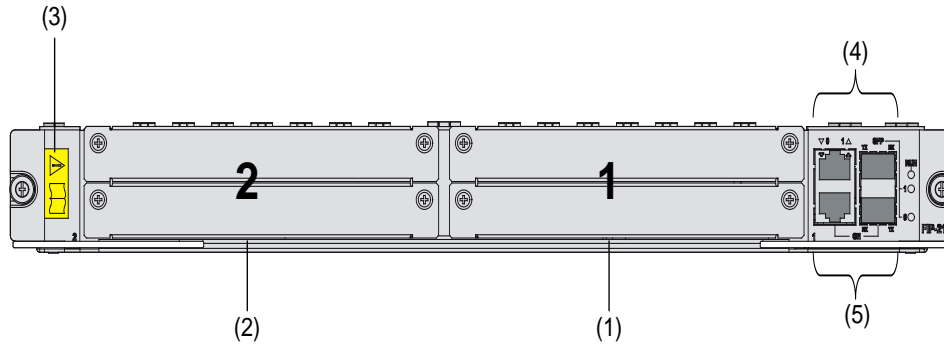

(1) Slot 1	(2) Slot 2
(3) OPEN BOOK mark	(4) Combo interface 1
(5) Combo interface 0	

The JC166B (FIP-110) provides four interface module slots and supports MIMs only. The interface module slots on JC166B (FIP-110) are numbered 1 to 4, as shown in [Figure 3-10](#).

Figure 3-10 Interface module slots on JC166B (FIP-110)

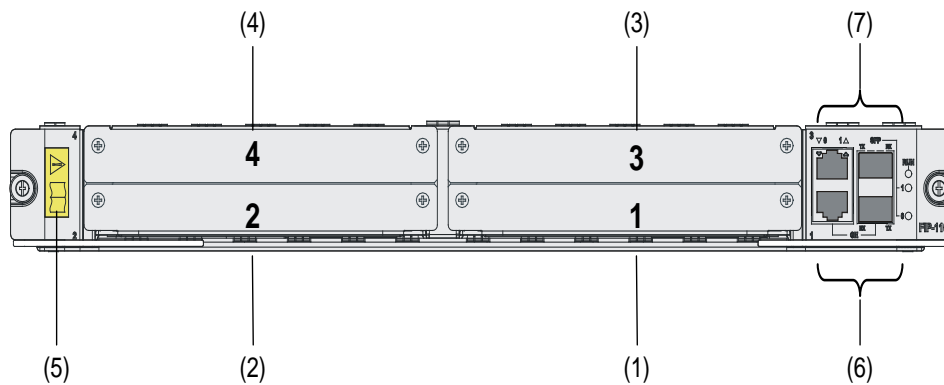

(1) Slot 1	(2) Slot 2
(3) Slot 3	(4) Slot 4
(5) OPEN BOOK mark	(6) Combo interface 0
(7) Combo interface 1	

 Note

For the JC167B (FIP-210), you can insert MIMs to the two slots at the bottom of the chassis only.

Table 3-19 Technical specifications of FIPs

Item	JC167B (FIP-210)	JC166B (FIP-110)
Processor	Multi-core MIPS CPU 1 GHz	Multi-core MIPS CPU 1 GHz
Memory size	2G (maximum 4GB)	2G (maximum 4GB)
Flash size	4 MB	4 MB
GE combo interfaces	2	2
HIM	2	Not supported
MIM	2	4
LED	RUN (FIP), SFP (SFP 0, SFP 1)	RUN (FIP), SFP (SFP 0, SFP 1)
Maximum power consumption	125 W	75 W

The two types of FIPs each have two fixed GE combo interfaces. Each combo interface consists of an Ethernet electrical interface and an Ethernet optical interface, and supports MDI/MDIX autosensing. The Ethernet electrical interfaces support rates of 10/100/1000 Mbps and half duplex/full duplex autosensing. The Ethernet electrical interface LEDs are above the RJ-45 ports. The LEDs in triangle and inverted triangle indicates the status of the lower and upper Ethernet electrical interfaces respectively. Each Ethernet optical interface supports a rate of 1000 Mbps in full-duplex mode and has an LED to indicate the status.

The following table describes the rear panel LEDs of the fixed GE interfaces:

Table 3-20 Description of fixed GE combo port LEDs

LED	Status	Description
GE0 to GE3 (yellow/green)	Off	No link is present.
	Solid green	A 1000 Mbps link is present.
	Flashing green	Data is being received or transmitted at a rate of 1000 Mbps.
	Solid yellow	A 10/100 Mbps link is present.
	Flashing yellow	Data is being received or transmitted at a rate of 10/100 Mbps.
SFP0 to SFP3 (yellow/green)	Off	No link is present.
	Solid green	A link is present.
	Flashing green	SFP data is being received or transmitted.
	Solid yellow	The system fails to detect the SFP port.

Table 3-21 Technical specifications for Ethernet electrical interfaces

Item	Specification
Connector type	RJ-45
Interface type	Autosensing

Item	Specification	
Frame format	Ethernet_II Ethernet_SNAP	
Rate and negotiation mode	10 Mbps autosensing	Half/full-duplex auto-negotiation
	100 Mbps autosensing	Half/full-duplex auto-negotiation
	1000 Mbps autosensing	Full-duplex autosensing

Table 3-22 Technical specifications for Ethernet optical interfaces

Item	Specification					
Connector type	SFP/LC					
Interface type	802.3, 802.3u, and 802.3ab					
Optical transmit power	Type	Short-haul multimode optical module (850 nm)	Medium-haul single-mode optical module (1310 nm)	Long-haul optical module (1310 nm)	Long-haul optical module (1550 nm)	Ultra-long haul optical module
	Min	-9.5 dBm	-9 dBm	-2 dBm	-4 dBm	-4 dBm
	Max	0 dBm	-3 dBm	5 dBm	1 dBm	2 dBm
Receiving sensitivity		-17 dBm	-20 dBm	-23 dBm	-21 dBm	-22 dBm
Central wavelength		850 nm	1310 nm	1310 nm	1550 nm	1550 nm
Fiber type		62.5/125 μm multimode fiber	9/125 μm single-mode fiber	9/125 μm single-mode fiber	9/125 μm single-mode fiber	9/125 μm single-mode fiber
Maximum transmission distance		0.55 km (1804.46 ft.) over category 5 twisted pairs	10 km (6.21 mi.)	40 km (24.86 mi.)	40 km (24.86 mi.)	70 km (43.49 mi.)
Duplex		1000 Mbps in full-duplex mode				

 **Note**

- For a GE combo interface, the default operating interface is the Ethernet electrical interface. You can switch between the Ethernet optical interface and the Ethernet electrical interface by using the combo enable command in interface view.
- A rate of 1000 Mbps is not available in half duplex mode.

3.4 Interface Modules

3.4.1 10 GE

I. JC168A (RT-HIM-1EXP)

Figure 3-11 JC168A (RT-HIM-1EXP)

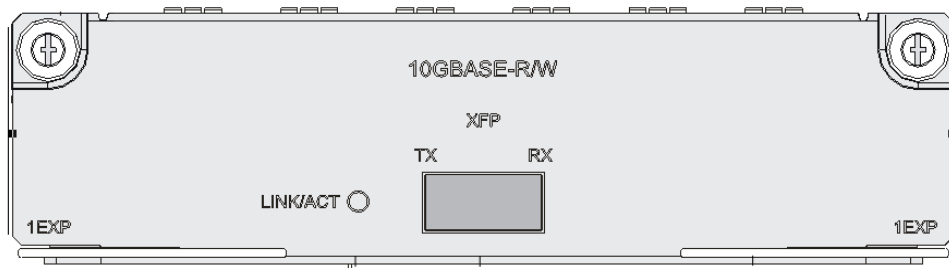

II. Introduction

JC168A (RT-HIM-1EXP) is a 1-port 10 GE optical transceiver. A JC168A (RT-HIM-1EXP) module provides one 10 Gigabit Small Form-Factor Pluggable (XFP) interface and supports switchover between LAN/WAN PHY modes. An LED is provided on the front panel and indicates the operation state.

Table 3-23 Description of the LED on the front panel of JC168A (RT-HIM-1EXP)

Status	Meaning
Off	No link is present.
Solid green	A link is present, but no data is being received or transmitted.
Flashing green	The XFP interface is receiving or sending data.

III. Interface specifications

Table 3-24 Interface specifications of JC168A (RT-HIM-1EXP)

Item	Specification
Protocol	802.3ae
Connector type	XFP/LC
Number of interfaces	1
Supported frame format	10GBASE-R/W
Interface speed	LAN PHY mode: 10.3125Gbps
	WAN PHY mode: 9.95328Gbps

3.4.2 FE and GE

I. JC164A (RT-HIM-8GBE)

Figure 3-12 JC164A (RT-HIM-8GBE)

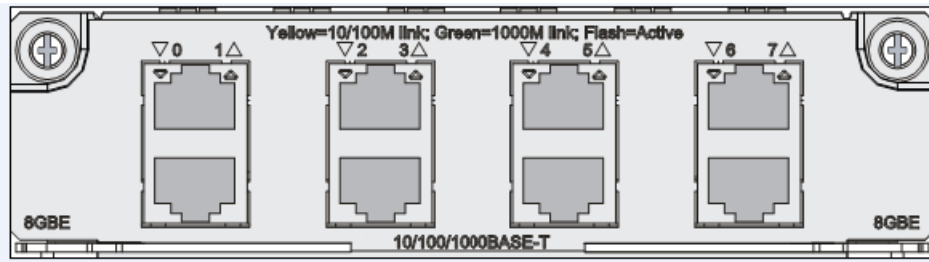

JC164A (RT-HIM-8GBE) is a high-speed Layer 3 Gigabit Ethernet interface module developed by HP for the A6600 routers. A JC164A (RT-HIM-8GBE) module provides eight RJ-45 electrical interfaces that support half/full-duplex auto-negotiation at the rate of 10/100/1000 Mbps and the Layer 3 routing function. Each interface is provided with a dual-color LED indicating the running status of the interface. JC164A (RT-HIM-8GBE) is connected to the processor through a 10-Gbps high-speed bus and can provide all the high-performance Layer 3 Ethernet interface functions.

Table 3-25 Description of the LEDs on the front panel of JC164A (RT-HIM-8GBE)

LED	Meaning
Off	No link is present or the cable is faulty.
Solid green	A 1000 Mbps link is present.
Flashing green	Data is being received or transmitted at a rate of 1000 Mbps.
Solid yellow	A 10/100 Mbps link is present.
Flashing yellow	Data is being received or transmitted at a rate of 10/100 Mbps.

II. JC163A (RT-HIM-4GBE)

Figure 3-13 JC163A (RT-HIM-4GBE)

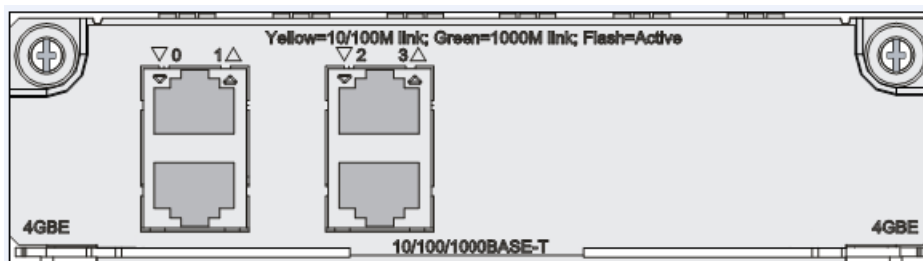

JC163A (RT-HIM-4GBE) is similar to JC164A (RT-HIM-8GBE) in function, except that it provides four RJ-45 electrical interfaces.

III. JC171A (RT-HIM-4GBP)

Figure 3-14 JC171A (RT-HIM-4GBP)

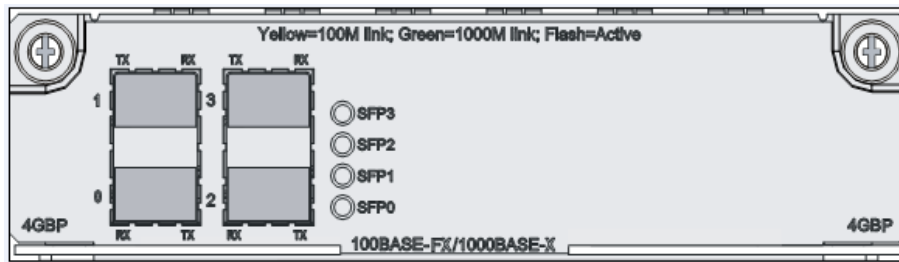

JC171A (RT-HIM-4GBP) is similar to JC163A (RT-HIM-4GBE) in function, except that it provides four SFP optical interfaces by accommodating 100/1000 Mbps SFP optical interface modules and 10/100/1000 Mbps autosensing SFP-T electrical interface modules.

IV. JC174A (RT-HIM-8GBP)

Figure 3-15 JC174A (RT-HIM-8GBP)

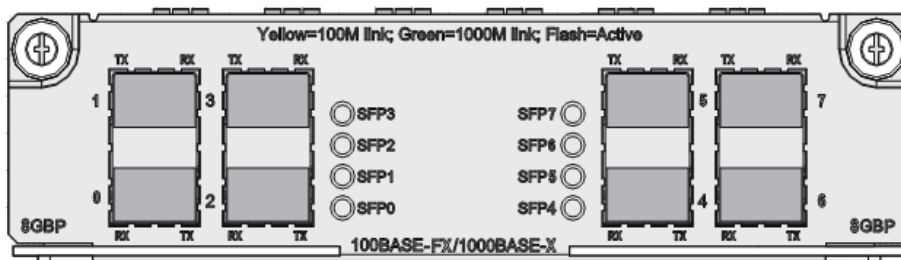

JC174A (RT-HIM-8GBP) is similar to JC164A (RT-HIM-8GBE) in function, except that it provides eight SFP optical interfaces by accommodating 100/1000 Mbps SFP optical interface modules and 10/100/1000 Mbps autosensing SFP-T electrical interface modules.

V. Specifications

Table 3-26 GigabitEthernet interface specifications

Item	Specification
Protocol	802.3, 802.3u, and 802.3ab
Interface type	Electrical interface: RJ-45 Optical interface: SFP
Cable	MDI/MDI-X autosensing
Interface speed	10 Mbps, 100 Mbps, 1000 Mbps
Transmission distance	100 m (328.08 ft.) over category 5 twisted pairs
Duplex mode	Half/full-duplex (10/100 Mbps) auto-negotiation

I. JC575A (RT-HIM-8FE)

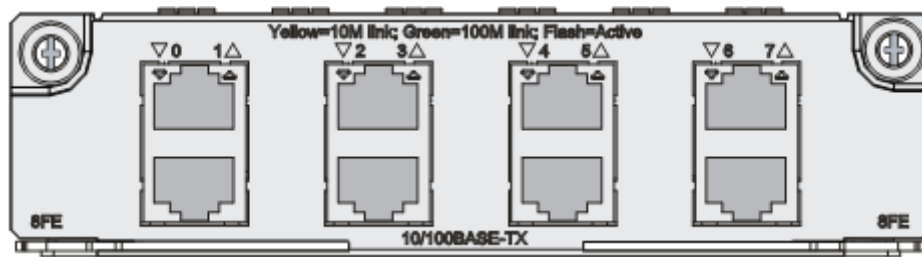

Figure 3-16 JC575A (RT-HIM-8FE)

JC575A (RT-HIM-8FE) is a Layer 3 100M Ethernet interface module developed by HP for the A6600 routers. A JC575A (RT-HIM-8FE) module provides eight RJ-45 electrical interfaces that support half/full-duplex auto-negotiation at the rate of 10/100Mbps and the Layer 3 routing function. Each interface is provided with a dual-color LED indicating the running status of the interface.

II. Specifications

Table 3-27 100M Ethernet interface specifications

Item	Specification
Protocol	802.3, 802.3u
Interface type	Electrical interface: RJ-45
Cable	MDI/MDI-X autosensing
Interface speed	10 Mbps 100 Mbps
Transmission distance	100 m (328 ft.) over category 5 twisted pairs
Duplex mode	Half/full-duplex (10/100 Mbps) auto-negotiation

3.4.3 CPOS (Channelized to E1/T1/DS0)

I. JC162A (RT-HIM-CL2P)

Figure 3-17 JC162A (RT-HIM-CL2P)

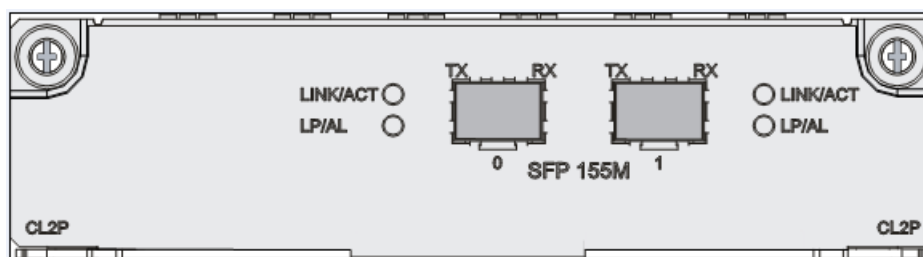

JC162A (RT-HIM-CL2P) is a high-speed OC-3/STM-1(155 Mbps) channelized packet over SONET/SDH (CPOS) interface module developed for A6600 routers by HP. A JC162A (RT-HIM-CL2P) provides two small form-factor pluggable (SFP) interfaces and each interface is provided with two LEDs, which indicate the running status and fault status, respectively.

JC162A (RT-HIM-CL2P) is connected to the processor through a 10-Gbps high-speed bus. Each CPOS interface can be channelized into 63 E1s or 84 T1s, and it can be channelized into 512 DS0s. JC162A (RT-HIM-CL2P) can receive multiplexed E1/T1 circuits on a pair of fibers through a channelized interface, largely saving the link resource, the occupied area, and the cost of local networks and devices for telecommunication service providers and large enterprises. JC162A (RT-HIM-CL2P) supports IP and MPLS traffic and the Multi-link Point-to-Point Protocol (MP), and it supports a maximum of 126 channelized E1s or 168 channelized T1s, up to 12 E1s or T1s in each MP bundle. Adopting hardware-based MP bundling, JC162A (RT-HIM-CL2P) solves the problem of low efficiency of MP bundling, and therefore improves the per-device access density.

Table 3-28 Description of the LEDs on the front panel of JC162A (RT-HIM-CL2P)

LED	Status	Meaning
LINK/ACT (green)	Off	No link is present.
	On	A link is present.
	Flashing (8 Hz)	The SFP interface is receiving or sending data.
LP/AL (yellow)	Off	No loopback or alarm.
	On	The interface is in the loopback state.
	Flashing (8 Hz)	There is at least one alarm. Alarms are defined differently for different ports. For example, a reported alarm for a T1 port can be AIS, LFA or RAI.

II. JC161A (RT-HIM-CL1P)

Figure 3-18 JC161A (RT-HIM-CL1P)

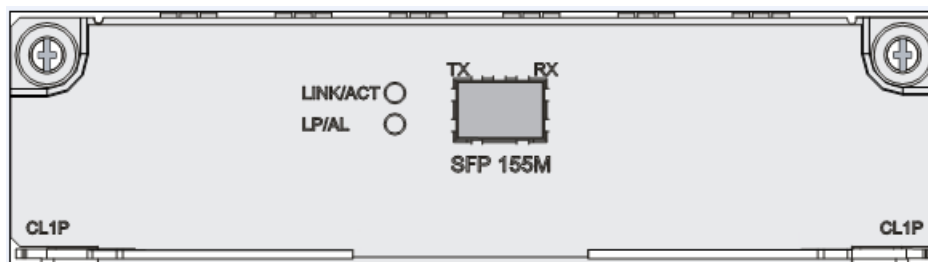

JC161A (RT-HIM-CL1P) is similar to JC162A (RT-HIM-CL2P) in function. JC161A (RT-HIM-CL1P) provides one SFP interface only.

III. SDH/SONET physical layer features and standards supported

- SONE/SDH frame optional
- Internal clock/line clock optional
- Switchover between E1 and T1
- Near-end (diagnosis) loopback and network (line) loopback
- Performance and error statistics monitoring
- Receiving/transmitting alarms, performance and error statistics monitoring:
 - a. LOS, LOF, OOF, LAIS, PAIS, LOP, LRDI, PRDI, SF, SD, LREI (line FEBE), PREI (channel FEBE), STIM, PTIM, and PLSM
 - b. B1, B2, B3, M1, and G1 error statistics

 **Note**

- JC162A (RT-HIM-CL2P)/JC161A (RT-HIM-CL1P) does not support cascading, non-channelized SDH or SONET.
- JC162A (RT-HIM-CL2P)/JC161A (RT-HIM-CL1P) does not support channelizing OC-3/STM-1 into DS3s or E3s.

3.4.4 CPOS (Channelized to E3/T3)

I. JC169A (RT-HIM-CLS2P)

Figure 3-19 JC169A (RT-HIM-CLS2P)

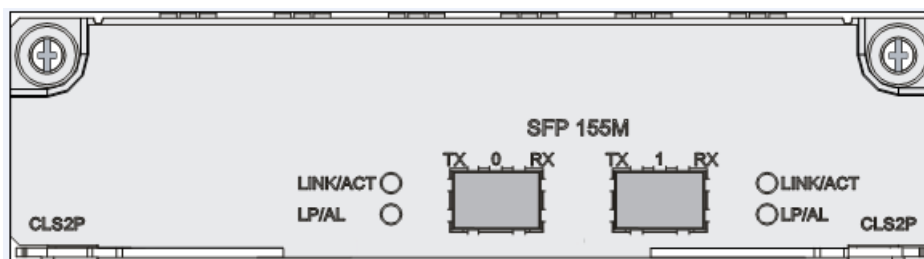

JC169A (RT-HIM-CLS2P) is a high-speed OC-3/STM-1 (155 Mbps) channelized POS E3/T3 interface module developed for A6600 routers by HP. A JC169A (RT-HIM-CLS2P) provides two SFP interfaces and each interface is provided with two LEDs, which indicate running status and fault status respectively.

The JC169A (RT-HIM-CLS2P) has the following features:

- It is connected to the processor through a 10-Gbps high-speed bus. Each OC-3/STM-1 POS interface can be channelized into three E3 or three T3 channels. Each E3/T3 channel supports the subrate processing capability, providing users with a variety of bandwidth options.
- A channelized interface can be used to connect multiplexed E3/T3 circuits over a pair of fibers, largely saving resources and investment costs, and reducing the occupied area for telecommunication service providers and large enterprises.
- It supports IP and MPLS traffic forwarding and the Multi-link Point-to-Point Protocol (MP).

Table 3-29 Description of the LEDs on the front panel of JC169A (RT-HIM-CLS2P)

LED	Status	Meaning
LINK/ACT (green)	Off	No link is present.
	On	A 155.52 Mbps link is present.
	Flashing	The SFP interface is receiving or sending data at a rate of 155.52 Mbps.
LP/AL (yellow)	Off	No loopback or alarm exists.
	On	The interface is in the loopback state.
	Flashing	There is at least one alarm.

II. JC170A (RT-HIM-CLS1P)

Figure 3-20 JC170A (RT-HIM-CLS1P)

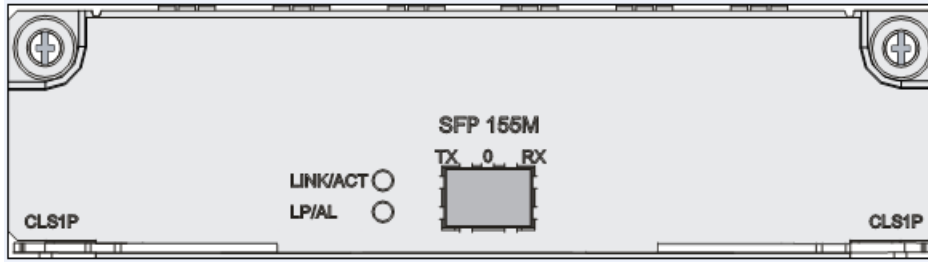

JC170A (RT-HIM-CLS1P) is similar to JC169A (RT-HIM-CLS2P) in function, except that it provides one SFP interface.

III. SDH/SONET physical layer features and standards supported

- SONET/SDH frame optional
- Internal clock/line clock optional
- Switchover between E3 and T3
- Near-end (diagnosis) loopback and network (line) loopback
- Performance and error statistics monitoring
- Receiving/transmitting alarms, performance and error statistics monitoring
 - a. LOS, LOF, OOF, LAIS, PAIS, LOP, LRDI, PRDI, SF, SD, LREI (line FEBE), PREI (channel FEBE), STIM, PTIM, and PLSM
 - b. B1, B2, B3, M1, and G1 error statistics

 **Note**

- JC169A (RT-HIM-CLS2P)/JC170A (RT-HIM-CLS1P) does not support cascading, non-channelized SDH or SONET.
- JC169A (RT-HIM-CLS2P)/JC170A (RT-HIM-CLS1P) does not support channelizing OC-3/STM-1 into T1s or E1s.

3.4.5 POS (Unchannelized)

Figure 3-21 JC172A (RT-HIM-MSP4P)

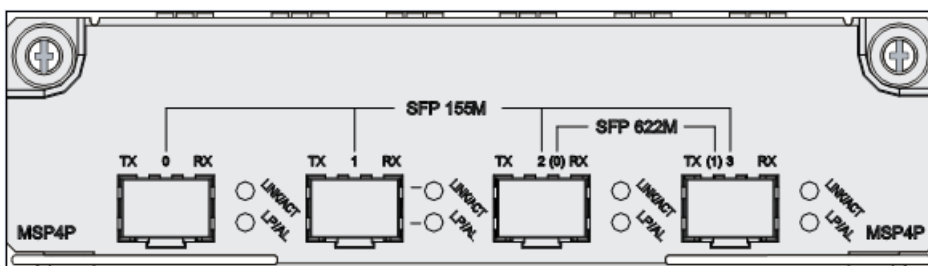

II. Introduction

JC172A (RT-HIM-MSP4P) is a high-speed OC-3/STM-1 and OC-12/STM-4 non-channelized POS module developed for A6600 routers by HP. A JC172A (RT-HIM-MSP4P) module provides four OC-3/STM-1 or two OC-12/STM-4 unchannelized POS interfaces. It supports PPP, Frame Relay, and HDLC at the data link layer and IP at the network layer. It provides POS interfaces for direct transmission of data packets over SONET/SDH.

A JC172A (RT-HIM-MSP4P) module has the following features:

- The module can be configured through the command line to work in OC-3/STM-1 POS or OC-12/STM-4 POS mode.
- The module supports the following types of hot-swappable SFP optical transceivers: multi-mode short haul (1310 nm) optical transceivers, single-mode medium haul (1310 nm) optical transceivers, single-mode long haul (1310 nm) optical transceivers, and single-mode ultra-long haul (1550 nm) optical transceivers.

Table 3-30 Description of the LEDs of JC172A (RT-HIM-MSP4P)

LED	Status	Meaning
LINK/ACT (green)	Off	No link is present.
	On	A 155.52 Mbps/622.08 Mbps link is present.
	Flashing	The SFP interface is sending or receiving data at a rate of 155.52 Mbps/622.08 Mbps.
LP/AL (yellow)	Off	No loopback or alarm exists.
	On	The interface is in the loopback state.
	Flashing	There is at least one alarm.

III. JC173A (RT-HIM-MSP2P)

Figure 3-22 JC173A (RT-HIM-MSP2P)

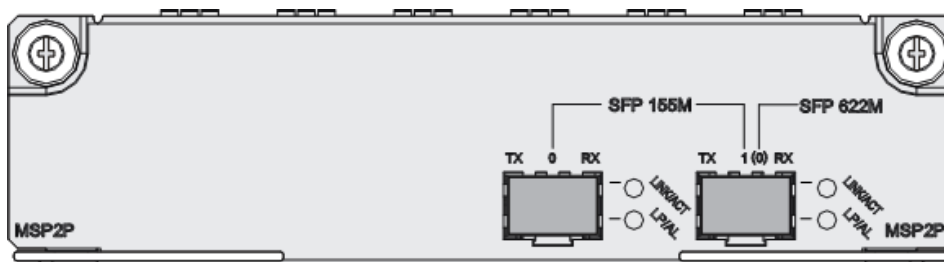

JC173A (RT-HIM-MSP2P) is similar to JC172A (RT-HIM-MSP4P) in function, except that it provides two SFP interface.

IV. SDH/SONET physical layer features and standards supported

- SONET/SDH frame optional
- Internal clock/line clock optional
- Switchover between 155M and 622M operating rates
- Near-end (diagnosis) loopback and network (line) loopback
- Performance and error statistics monitoring
- Receiving/transmitting alarms, performance and error statistics monitoring

- a. LOS, LOF, OOF, LAIS, PAIS, LOP, LRDI, PRDI, SF, SD, LREI (line FEBE), PREI (channel FEBE), STIM, PTIM, and PLSM
- b. B1, B2, B3, M1, and G1 error statistics

3.4.6 OC-48/STM-16 POS

Figure 3-23 JC494A (RT-HIM-PS1P)



II. Introduction

JC494A (RT-HIM-PS1P) is a high-speed OC-48/STM-16 (2.5Gbps) non-channelized POS module developed by HP. JC494A (RT-HIM-PS1P) supports PPP, Frame Relay, and HDLC at the data link layer and IP at the network layer. It provides POS interfaces for direct transmission of data packets over SONET/SDH.

A JC494A (RT-HIM-PS1P) module has the following features:

- The module runs in OC-48/STM-16 POS mode.
- The module supports the following SFP optical transceivers: multi-mode short haul (1310 nm) optical transceivers, single-mode medium haul (1310 nm) optical transceivers, single-mode long haul (1310 nm) optical transceivers, and single-mode ultra-long haul (1550 nm) optical transceivers.

Table 3-31 Description of the LEDs of JC494A (RT-HIM-PS1P)

LED	Status	Meaning
LINK/ACT (green)	Off	No link is present.
	On	A 2488.32 Mbps link is present.
	Flashing	The SFP interface is sending or receiving data at a rate of 2488.32 Mbps.
LP/AL (yellow)	Off	No loopback or alarm exists.
	On	The interface is in the loopback state.
	Flashing	There is at least one alarm.

III. SDH/SONET physical layer features and standards supported

- SONET/SDH frame optional
- Internal clock/line clock optional
- Near-end (diagnosis) loopback and network (line) loopback
- Performance and error statistics monitoring
- Receiving/transmitting alarms, performance and error statistics monitoring

- a. LOS, LOF, OOF, LAIS, PAIS, LOP, LRDI, PRDI, SF, SD, LREI (line FEBE), PREI (channel FEBE), STIM, PTIM, and PLSM
- b. B1, B2, B3, M1, and G1 error statistics

3.4.7 OC-3/STM-1 ATM

I. JC495A (RT-HIM-AL2P)

Figure 3-24 JC495A (RT-HIM-AL2P)

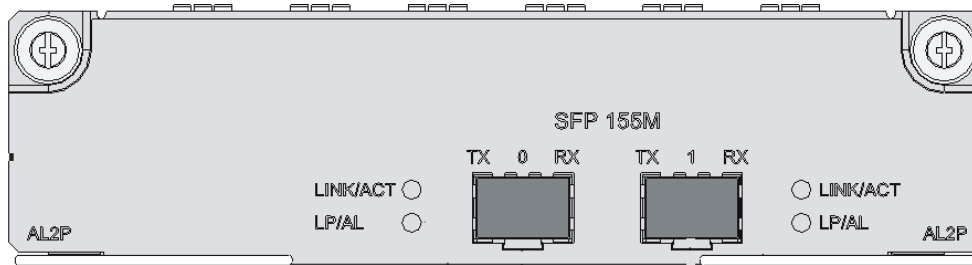

A JC495A (RT-HIM-AL2P) module is an OC-3/STM-1 (155 Mbps) Asynchronous Transfer Mode (ATM) interface module developed by HP. It provides two SFP interfaces and each interface is provided with two LEDs, which indicate interface running status and fault detecting status respectively.

The JC495A (RT-HIM-AL2P) has the following features:

- Support two frame formats, namely, SDH STM-1 and SONET OC-3C.
- Allow data scrambling transmission.
- Support line clock mode and internal clock mode.
- Provide self loopback testing measures such as internal cell loopback, external SONET/SDH loopback, and remote loopback.
- Support hot-swap.

Table 3-32 Description of the LEDs

LED	Status	Meaning
LINK/ACT (green)	Off	No link is present.
	On	A 155.52 Mbps link is present.
	Flashing	The SFP interface is receiving or sending data at 155.52 Mbps.
LP/AL (yellow)	Off	No loopback or alarm exists.
	On	The interface is in the loopback state.
	Flashing	There is at least one alarm.

II. JC175A (RT-HIM-AL1P)

Figure 3-25 JC175A (RT-HIM-AL1P)

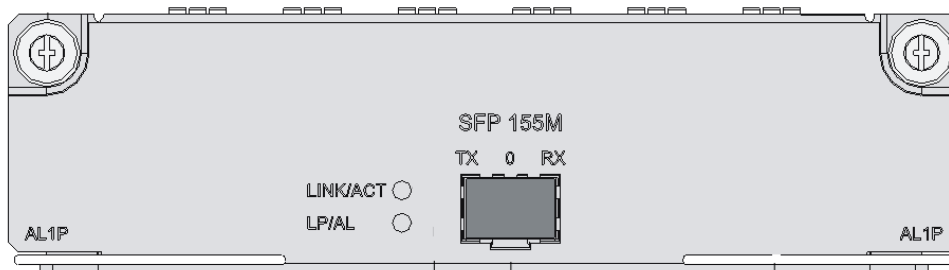

JC175A (RT-HIM-AL1P) is similar to JC495A (RT-HIM-AL2P) in function, except that it provides one SFP interface.

3.4.8 OC-48/STM-16 RPR

Figure 3-26 JC576A (RT-HIM-RS2P)

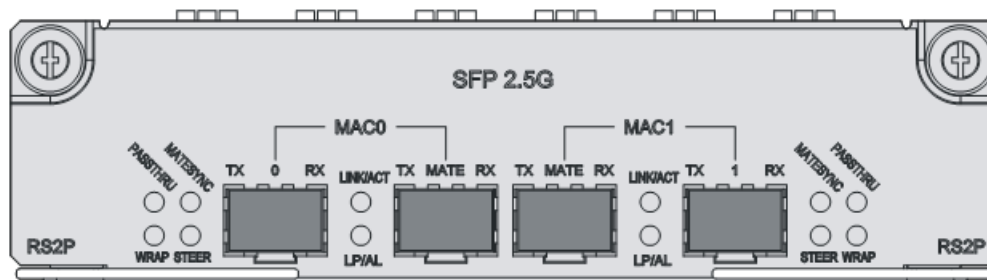

II. Introduction

The JC576A (RT-HIM-RS2P) is a 2.5 Gbps OC-48/STM-16 Resilient Packet Ring (RPR) module developed by HP. It provides two SFP RPR interfaces and two SFP Mate interfaces. Each RPR interface is provided with six status LEDs, which show the running status and fault detecting status of RPR and optical interface physical layer.

The JC576A (RT-HIM-RS2P) supports:

- Two frame formats SDH STM-16 and SONET OC-48 at the physical layer.
- Both line clock mode and internal clock mode.
- Loopback tests such as data loopback test, external SONET/SDH loopback test, and external line loopback test.
- Hot swapping.

Table 3-33 Description of the JC576A (RT-HIM-RS2P) LEDs

LED		Status	Meaning
RPR	PASSTHRU (green)	Off	The node is not in PASSTHRU.
		On	The node is in PASSTHRU.
	MATESYNC (green)	Off	The mate interface is not synchronized.
		On	The mate port is synchronized.
	WRAP	Off	No WRAP exists.

LED		Status	Meaning
	(yellow)	On	WRAP occurs on this node.
		Flashing (0.5 Hz)	WRAP occurs on another node.
	STEER (yellow)	Off	No STEER exists.
		On	STEER occurs on this node.
		Flashing (0.5 Hz)	STEER occurs on another node.
External optical interface SDH/SONET at physical layer	LINK/ACT (green)	Off	No carrier signal is being received.
		On	Carrier signals are being received.
		Flashing (4 Hz)	The interface module is receiving or sending data.
	LP/AL (yellow)	Off	No loopback or alarm exists.
		On	The interface is in the loopback state.
		Flashing (0.5 Hz)	There is at least one alarm.

III. Features supported

- SONET/SDH frame formats
- Internal clock and line clock modes
- Near-end (diagnosis) loopback and network (line) loopback
- Performance and error statistics monitoring
- Receiving/transmitting of alarms, and monitoring of performance and error statistics
 - a. LOS, LOF, OOF, LAIS, PAIS, LOP, LRDI, PRDI, SF, SD, LREI (line FEBE), PREI (channel FEBE), STIM, PTIM, and PLSM
 - b. B1, B2, B3, M1, and G1 error statistics

3.4.9 Compatible MIMs

The following table describes the MIMs supported by the A6604/A6608/A6616.

For details, refer to *HP A6604/A6608/A6616 Router Installation Manual*.

Table 3-34 MIMs supported by the A6604/A6608/A6616

Module name	Description
JD552A ①	HP A-MSR 8-port Enhanced Sync/Async Serial MIM Module
JD541A ①	HP A-MSR 4-port Enhanced Sync/Async Serial MIM Module
JD540A ①	HP A-MSR 2-port Enhanced Sync/Async Serial MIM Module
JD630A	HP A-MSR 1-port E3/CE3/FE3 MIM Module
JD628A	HP A-MSR 1-port T3/CT3/FT3 MIM Module
JD563A ②	HP A-MSR 8-port E1/CE1/PRI (75ohm) MIM Module
JF255A ②	HP A-MSR 8-port E1/Fractional E1 (75ohm) MIM Module
JC160A③	HP A-MSR 8-port T1/CT1/PRI MIM Module

Module name	Description
JC159A ^③	HP A-MSR 8-port T1/Fractional T1 MIM Module

 **Note**

- ①JD552A/JD541A/JD540A does not support asynchronous serial interface modules.
- ②JD563A/JF255A does not support PRI. The two modules do not support E1 (120 ohm) interfaces. To do so, you need a 75-120 ohm adaptor.
- ③JC160A/JC159A does not support PRI.

3.4.10 Adaptation between FIPs and modules

Table 3-35 Adaptation between FIPs and modules

FIP Module Name	JC167B (FIP-210)	JC166B (FIP-110)
HIM	√	×
MIM	√	√

3.5 High-density Ethernet Interface Cards

3.5.1 Introduction

Currently, the A6604/A6608/A6616 support two types of high-density Ethernet interface line-cards: JC567A (SAP-48GBE) and JC568A (SAP-24GBP). A high-density Ethernet interface card occupies a line card slot and is managed and controlled by the MPU.

The JC567A provides 48 100/100/1000 Mbps RJ-45 autosensing Ethernet electrical interfaces. All of them are Layer-3 interfaces, supporting IP routing, forwarding, MPLS, security, QoS, multicast, and IPv6. They can also operate as Layer-2 interfaces to provide Ethernet switching features.

The JC568A provides 24 100/1000 Mbps Ethernet optical interfaces (SFP), and provides similar functions with the JC567A.

I. Front view

Figure 3-27 Front view of the JC567A

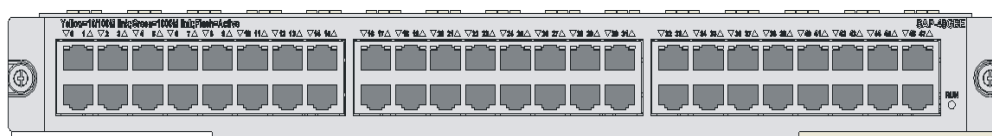
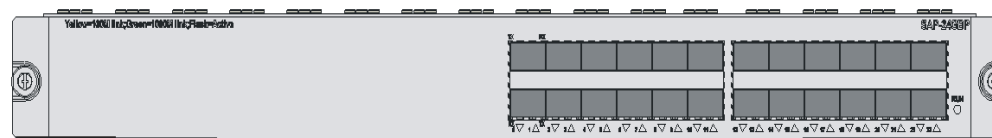

Figure 3-28 Front view of the JC568A



II. LEDs

The JC567A (SAP-48GBE) provides one system LED (RUN) and 48 yellow/green Ethernet interface LEDs, as shown in [Table 3-33](#).

The JC568A (SAP-24GBP) provides one system LED (RUN) and 24 yellow/green Ethernet interface LEDs, as shown in [Table 3-34](#).

Table 3-36 Description of LEDs on JC567A

LED	Status	Meaning
RUN (green)	Off	No power is input or the card is faulty.
	Slow flashing (1 Hz)	The card is operating normally.
	Fast flashing (8 Hz)	The application software is being loaded (do not power off or unplug the card in this state) or the card has not started up.
GE 0 to GE 47 (yellow/green)	Off	No link is present.
	Solid green	A 1000 Mbps link is present.
	Flashing green	Data is being received or transmitted at a rate of 1000 Mbps.
	Solid yellow	A 10/100 Mbps link is present.
	Flashing yellow	Data is being received or transmitted at a rate of 10/100 Mbps.

Table 3-37 Description of LEDs on JC568A

LED	Status	Meaning
RUN (green)	Off	No power is input or the card is faulty.
	Slow flashing (1 Hz)	The card is operating normally.
	Fast flashing (8 Hz)	The application software is being loaded (do not power off or unplug any card in this state) or the card has not started up.
SFP 0 to SFP 23 (yellow/green)	Off	No optical fiber link is present.
	Solid green	A 1000 Mbps optical fiber link is present.
	Flashing green	Data is being received or transmitted at a rate of 1000 Mbps on the optical fiber link.
	Solid yellow	A 100 Mbps optical fiber link is present.
	Flashing yellow	Data is being received or transmitted at a rate of 100 Mbps on the optical fiber link.

3.5.2 Technical Specifications

The following table describes the technical specification of the JC567A (SAP-48GBE) and JC568A (SAP-24GBP).

Table 3-38 Technical specifications of the JC567A and JC568A

Item	JC567A (SAP-48GBE)	JC568A (SAP-24GBP)
Dimensions (H x W x D)	45 x 399 x 412 mm (1.77 x 15.71 x 16.22 in.)	
Memory type and size	DDR2 SDRAM 2 GB (default)	
Interface type	Electrical RJ-45 interface	Optical SFP interface
Number of interfaces	48	24
Interface speed	10/100/1000 Mbps autosensing	100/1000 Mbps autosensing
SFP module types supported	N/A	100 Mbps SFP module 1000 Mbps SFP module SFP-T Electrical interface module (10/100/1000 Mbps autosensing supported)

3.6 Compatibility Among MPUs, FIPs, and Interface Cards

Table 3-39 Compatibility among MPUs, FIPs, and interface cards

	JC167B (FIP-210)	JC166B (FIP-110)
JC165A (RPE-X1)	Compatible	Compatible
JC566A (RSE-X1)	Compatible	Compatible
HIM interface card	Compatible	Incompatible
MIM interface card	Compatible	Compatible

Chapter 4 Features

4.1 Features

Table 4-1 Features of the A6604/A6608/A6616

Feature	Description
Layer 2 protocol	ARP: Dynamic/static ARP, proxy ARP, gratuitous ARP Ethernet, sub-interface VLAN PPPoE server PPP, software MP, hardware MP FR, MFR, FRF12 fragment, FR switching HDLC ATM: IPoA, PPPoA server, IPoEoA, PPPoEoA server QinQ terminating VLAN/Voice VLAN/Super VLAN/VLAN Mapping Port isolation

Feature	Description
	DLDP/LLDP Layer 2 tunnel (BPDU tunnel) GARP/GVRP STP/RSTP/MSTP IEEE802.3ad LACP Layer 2 aggregation Broadcast storm suppression Port mirroring Flexible QinQ
IP unicast routing	Static routing RIP(Routing Information Protocol) v1/v2, RIPng OSPF (Open Shortest Path First) v2/v3 BGP (Border Gateway Protocol), BGP4+ IS-IS (Intermediate System-to-Intermediate System intra-domain routing information exchange protocol), ISISv6 ECMP Route recursion Route policy Policy routing UCMP BGP support GTSM ISIS MTR
IP multicast routing	Internet Group Management Protocol (IGMP) v1/v2/v3 IGMP Snooping Protocol Independent Multicast (PIM) DM/SM Multicast Source Discovery Protocol (MSDP) MBGP Multicast static routing Multicast host tracking
Network protocol	DHCP Server DHCP Relay DHCP Client DNS Client IPv6 NTP Server NTP Client Telnet Server Telnet Client TFTP Client FTP Server FTP Client UDP Helper NQA
QoS (Quality of Service)	Traffic classification: based on port, IP address, IP priority, DSCP priority, TCP/UDP port number, and protocol type Traffic policing: CAR rate limiting, granularity configurable GTS Priority Mark/Remark Queue scheduling mechanism: FIFO, PQ, CQ, WFQ, CBWFQ Congestion avoidance algorithm: Tail-Drop, WRED LR FR QoS

Feature	Description
	Nested QoS MPLS QoS IPv6 QoS QPPB (QoS policy propagation on BGP)
Security	ACL ACL acceleration Time-based access control Packet filter firewall Stateful firewall ASPF TCP attack prevention on local host Control plane rate limiting Virtual fragment reassembly URPF Web filtering Hierarchical user management and password protection AAA RADIUS TACACS Portal 802.1x PKI Certification SSH v1.5/2.0 RSA BGP/BGP4+ support GTSM IPsec, IPsec multi-instance, IKE MAC Address Authentication Password Control Attack detection and prevention
Service	NAT, NAT multi-instance, VPN-NAT, NAT session log Connection limit GRE tunnel (point to multi-point) L2TP tunnel NetStream (support v5/v8/v9 packet frames; support IPv4, IPv6 and MPLS packets) Sflow DVPN (Dynamic VPN)
MPLS (Multiprotocol Label Switching)	L3VPN: Inter-domain MPLS VPN (OptionA/B/C), nested MPLS VPN, Hierarchy PE (HoPE), CE dual homing, MCE, multi-role host, GRE tunnel L2VPN: VPLS, Martini, Kompella, CCC, and SVC VPLS/H-VPLS MPLS TE, RSVP TE Multicast VPN
Ipv6	Basic functions: IPv6 ND, IPv6 PMTU, dual-stack forwarding, IPv6 ACL, DHCPv6 Server/Proxy IPv6 tunnel: manually configured IPv6 tunnel, configured IPv6 over IPv4 tunnel, automatic IPv6 over IPv4 tunnel, 6to4 tunnel, ISATAP tunnel, 6PE, GRE tunnel 6VPE (IPv6 MPLS L3VPN) NAT-PT Static routing Dynamic routing protocols: RIPng, OSPFv3, IS-ISv6, BGP4+

Feature	Description
	IPv6 multicast:MLDv1/v2,PIM6-DM,PIM6-SM,PIM6-SSM
Reliability	VRRP/VRRPv3 VRRP-Enhanced (VRRPE) MPLS TE FRR IP FRR: static routing/policy routing/RIP/IS-IS/OSPF IGP fast routing convergence BFD: Static Route/RIP/OSPF/ISIS/BGP/VRRP/TE FRR/IPv6 GR: OSFP/BGP/IS-IS/ LDP/RSVP RRPP (Rapid Ring Protection Protocol) Smart Link Ethernet OAM Software Hotfix ISIS NSR LDP NSR
Management and maintenance	Configuration through the CLI Configuration through the console port Telnet for configuration and remote maintenance through Ethernet port Dialing up for configuration and remote maintenance via Modem through AUX port SNMP (v1, v2c, v3) RMON (group 1, 2, 3 and 9 MIB) System logs Hierarchical alarms Ping and Tracert NQA: Network Quality Analysis, supporting collaboration with VRRP, policy-based routing, and static routing Fan detection, maintenance, and alarm Power supply detection, maintenance, and alarm CF card detection, maintenance, and alarm Temperature detection, alarm
File system	FAT format CF card USB storage device Dual image
Loading/upgrading	Loading/upgrading through the Xmodem protocol Loading/upgrading through File Transfer Protocol (FTP), and Trivial File Transfer Protocol (TFTP)

Chapter 5 Typical Applications

As a new-generation service aggregation router, the A6604/A6608/A6616 enhances both the forwarding performance and service capacity compared to traditional routers. The A6604/A6608/A6616 provides several types of line-cards to meet your interface and processing performance requirements in different networking environments. In addition, the A6604/A6608/A6616 provides two MPUs and redundant power modules to ensure high reliability. You can purchase the redundant MPU and power module as required.

A6604/A6608/A6616 provides high-density Layer 3 GE interfaces and 155 Mbps channelized POS interfaces. Each JC167B (FIP-210) can support a distribution access of more than 189 E1s (2 MB) interfaces at wire-speed. As a result, the A6604/A6608/A6616 can work as the narrowband distribution device of enterprise networks or the carrier-edge narrow access device.

Supporting service features such as high-performance NAT (abundant ALG features), GRE, and large number of users, the A6604/A6608/A6616 can also work as the egress gateway devices of enterprise networks or the broadband user access devices of carriers.

The A6604/A6608/A6616 supports MPLS, L2 VPN, and L3 VPN. With high-performance IPsec encryption, the A6604/A6608/A6616 are typically suitable to serve as the PE devices of MPLS networks or the edge-access devices of carrier's MPLS VPNs.

Featuring high density, large capacity, high performance and power service, the A6604/A6608/A6616 can meet diversified network requirements. They save your investment (multiple services supported, traditional MIMs compatible), ease your management (abundant network management approaches and extensible storage media available), and simplify your maintenance (abundant logs and remote maintenance available).

5.1 Enterprise Network Application as Core Routers

Figure 5-1 Networking application with the A6604/A6608/A6616 acting as the core routers

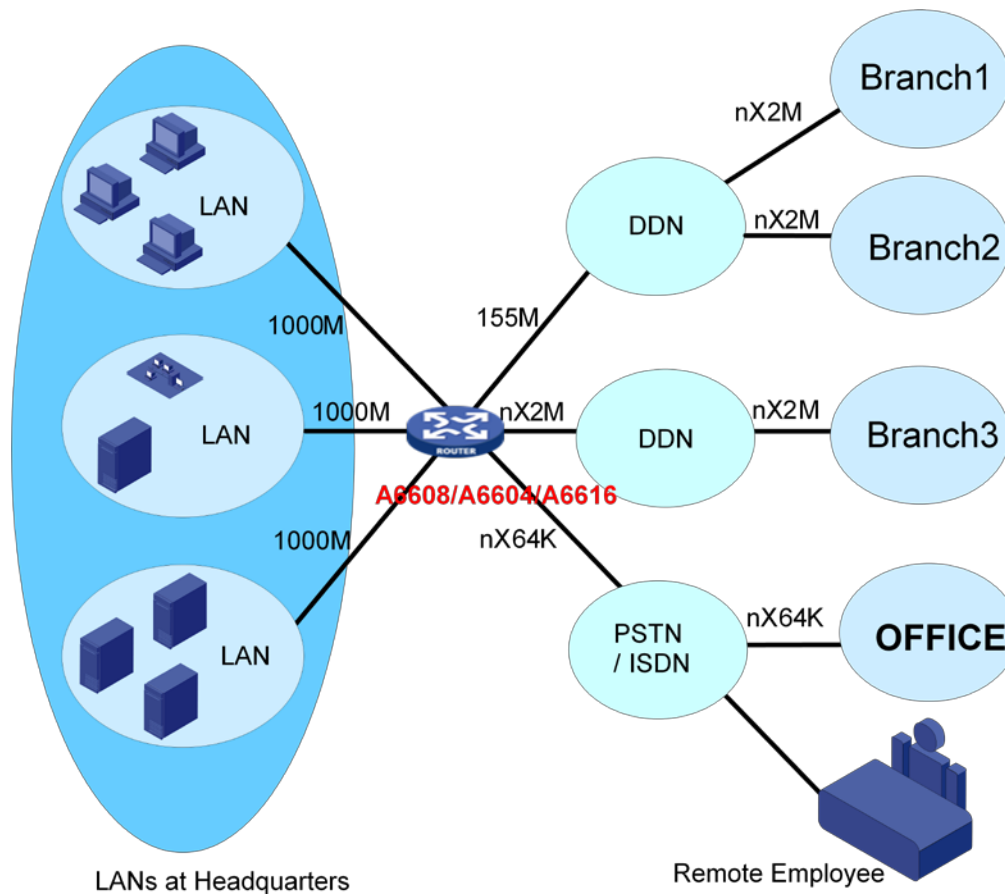

This figure shows a typical application where the A6604/A6608/A6616 server as the core devices of enterprise networks. Internally, the A6604/A6608/A6616 are connected to the LAN and servers of the enterprise through its high-density GE interfaces. Externally, the A6604/A6608/A6616 are connected to the branches at different layers through their WAN interfaces (from DS0 to 2.5 Gbps). In addition, the A6604/A6608/A6616 provide multiple secure access methods, L2TP, GRE, and IPSec to ensure security of the accesses to the branches. In the network:

- The A6604/A6608/A6616 connect to the LAN and server farm through their high-density GE interfaces, ensuring a high-speed interconnection with the intranet. In addition, the A6604/A6608/A6616 connect to the branches at different layers through their WAN interfaces at a rate ranging from DS0 (64 kbps) to 2.5 Gbps POS.
- The A6604/A6608/A6616 can access branches not using leased lines through L2TP, GRE, and IPSec to ensure higher security.
- While maintaining secure access to branches, the A6604/A6608/A6616 can run dynamic or static routing protocols on the links with access routers of the branches, so as to ensure interworking of services between those branches.

5.2 Large Industry Network Application

Figure 5-2 Large industry network application

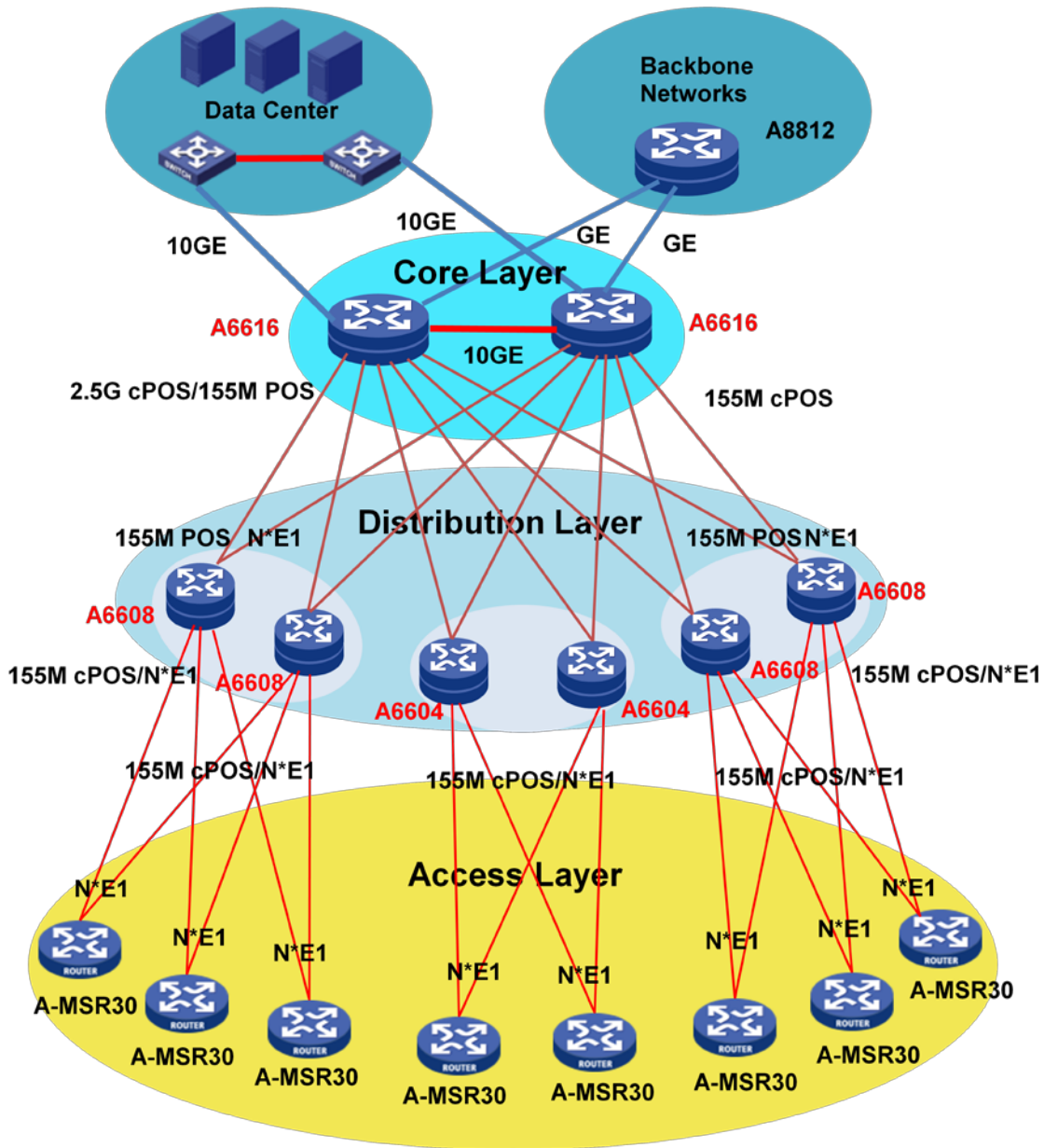

The networks of large industries such as finance industry networks, provincial-level electric power dispatching/communication networks, and taxation networks, are divided into core layer, distribution layer and access layer. The core-layer routers usually use 155 M POS or 2.5 G CPOS links to connect distribution layer routers in municipal cities. Because the A6616 has high packet processing capacity and high-density 155 M POS/2.5 G CPOS access capability, it is an ideal core-layer router. The distribution layer routers usually use 155 M CPOS for distribution. The A6604/A6608 have powerful CPOS distribution capability and thus are suitable distribution layer routers. A large-scale distribution site can choose the A6608 while small-scale ones can choose the A6604. Meanwhile, the A6600 routers can also provide carrier-level reliability in hardware or software to ensure network stability and reliability. In the network:

- The A6616 of the core-layer connects to the A6604/A6608 of the distribution layer through 155 Mbps POS interface and $N \times E1$ links. In addition, the A6604/A6608 connect to the two routers (master and slave) at the core layer through its uplinks to ensure reliable connections.
- Since the CPOS interface of the A6604/A6608/A6616 can be channelized to E1, T1 or DS0 interfaces of different rates, the A6604/A6608/A6616 can also access routers at the access layer through the uplink interfaces of the same rates (E1, T1 or DS0). In addition, the A6604/A6608/A6616 can access bandwidth-hungry routers through $n \times E1$ s (MP bundling).
- You can deploy software features as required: static routing, RIP, OSPF between access routers and the A6604/A6608/A6616; OSPF or BGP between the core router and the A6604/A6608/A6616. You can also deploy MPLS VPN in your network as required, since the A6604/A6608/A6616 support the complete MPLS feature set and can work as a PE or P device.
- A rendezvous router must be reliable in both hardware and software. The A6604/A6608/A6616 provide two MPUs, redundant power modules, and fan redundancy. The A6604/A6608/A6616 also provide reliable software features, such as VRRP, BFD, protocol-level GR, and IGP fast convergence, which can be selected in your network as required.
- The A6604/A6608/A6616 deploy QoS in Differentiated Services Model (Diffserv) mode. That is, access routers differentiate services they bear and have their services tagged with DSCP priorities by which the rendezvous router performs traffic classification and provides bandwidths for packets of different priorities. When MPLS VPN is used in the network, mapping between IP packet DSCP and MPLS packet EXP is performed on the PE router, and bandwidths are allocated for MPLS forwarding by different EXP values.

5.3 MPLS VPN Network Application

Figure 5-3 A typical application of MPLS VPN with A6604/A6608/A6616 deployed

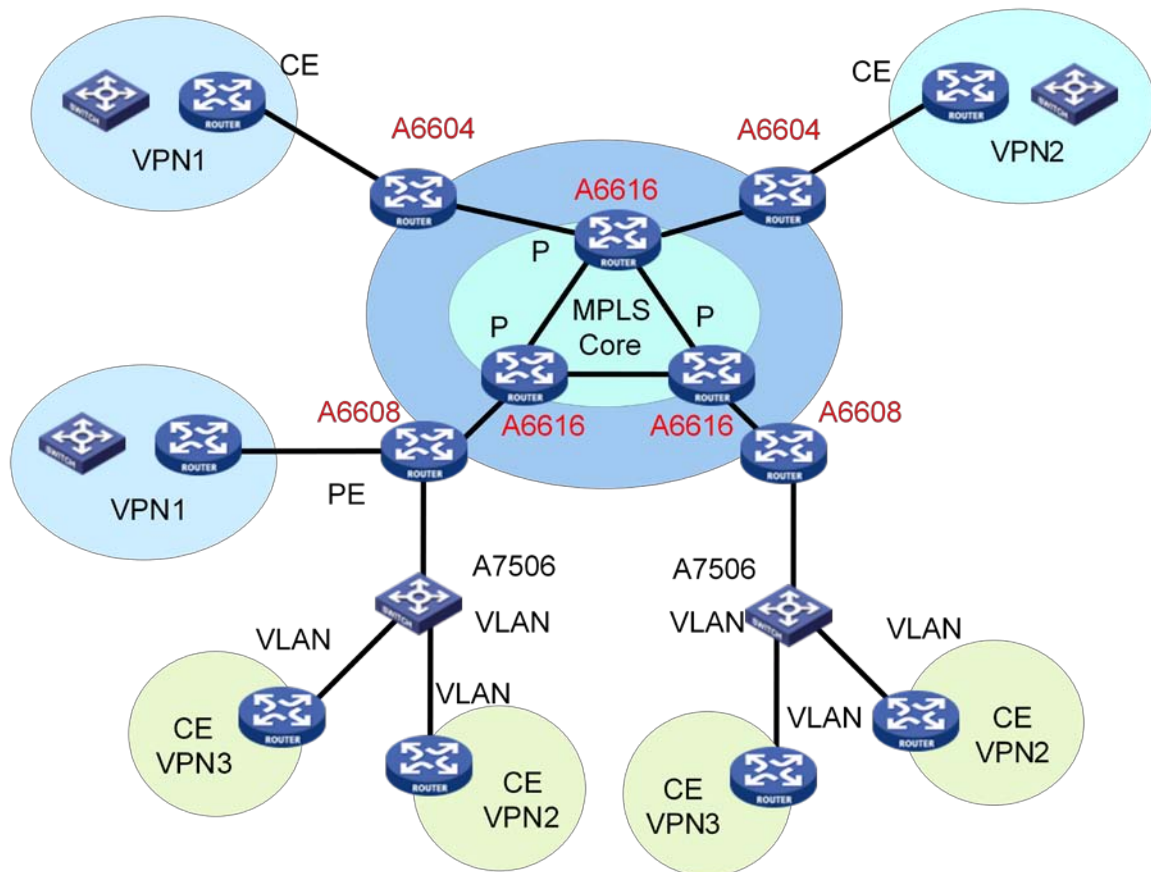

This figure shows a typical application where the A6604/A6608/A6616s form an MPLS VPN. The A6604/A6608/A6616 provide excellent MPLS functions, such as L2 VPN, L3 VPN, and MPLS TE to meet network requirements for PE devices in MPLS networks of enterprises or carriers. In the network:

- Serving as the PE devices, the A6604/A6608 connect to the access devices of VPNs. The A6616 serves as the PE device of the MPLS core networks.
- The A6604/A6608/A6616 can run MPLS L3 VPN or four types of L2 VPNs (Martini, Kompella, CCC, and SVC) to allow for flexible networks.
- L3VPN: Inter-domain MPLS VPN (Option1/2/3), nested MPLS VPN, hierarchy PE (HoPE), CE dual homing, MCE, and multi-role host can be deployed.
- To ensure reliability of PE devices, in addition to two MPUs and redundant power modules redundancy, the A6604/A6608/A6616 also support BFD, GR, and IGP fast convergence to ensure reliability of MPLS services.

5.4 Financial Network MSTP Distribution Application

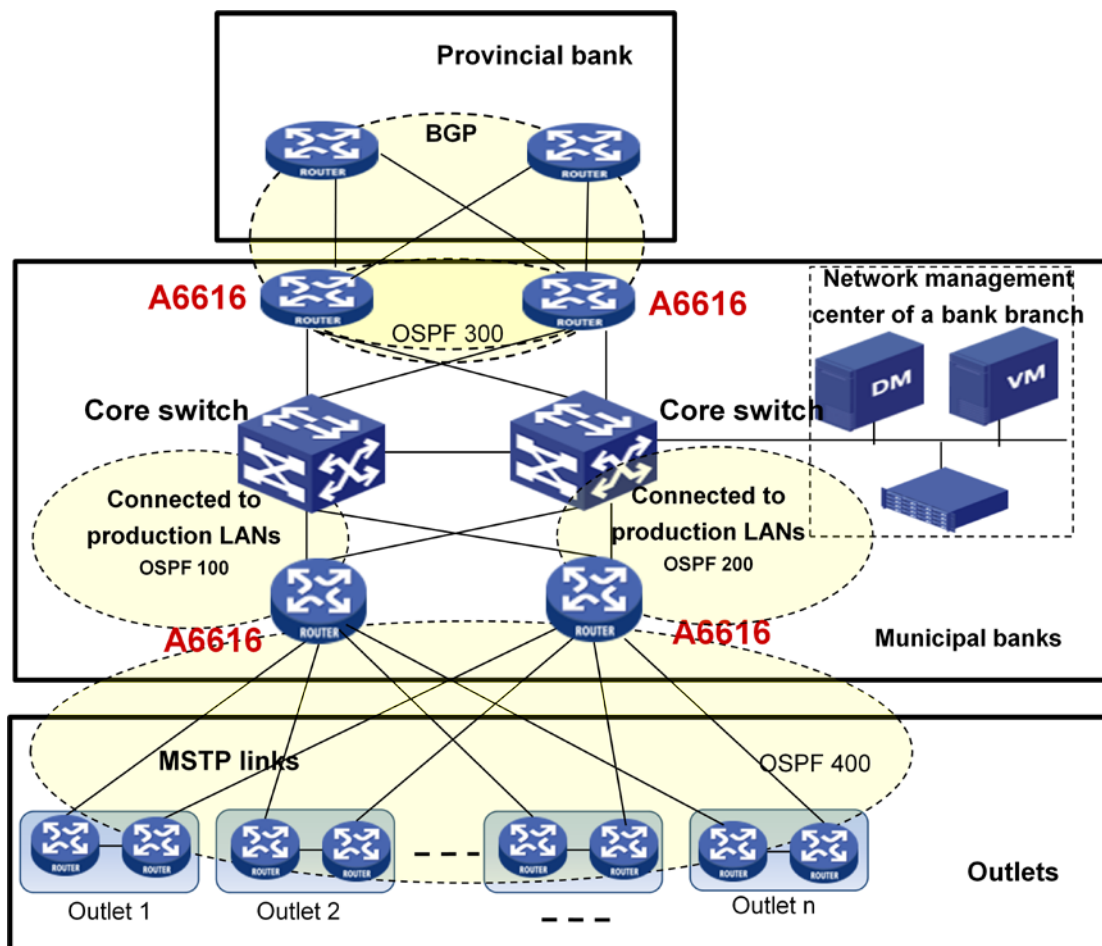

More enterprises are prone to run MSTP on their WAN links.. The figure above shows the network of a bank where distribution layer routers in a municipal city use MSTP links to connect bank outlets. The A6600 can provide high-density Ethernet interfaces. Take the A6616 for example. A single service slot can provide 48 GE interfaces and the whole router can provide up to 384 GE interfaces. All the interfaces are standard Layer 3 WAN interfaces and support IP/MPLS forwarding, security, and QoS. Therefore, the A6600 are very suitable for providing MSTP links at the distribution layer.

In this network,

- Two A6616 routers are connected to the outlets through point-to-point links. This connection method enhances reliability and facilitates network operation and maintenance.
- OSPF runs between the two A6616 routers and the outlet routers, and is used to differentiate traffic flows. The production service uses the left-side A6616 as the main link while the office service uses the right-side A6616 as the main link. The two A6616 routers back up each other.
- To detect MSTP link failures, BFD runs between the two A6616 routers and outlet routers. Once detecting a failure, BFD will immediately inform the failure to OSPF so that OSPF can quickly complete routing convergence and service switchover.

Chapter 6 Ordering Information

6.1 Host

Consider the following when purchasing the host:

I. Networking requirement

- Location of the router in the network;
- Uplink/downlink traffic to be processed by the router;
- Reliability.

II. Power supply

- DC power supply or AC power supply
- Necessity of two power modules, or more than two power modules for A6616

III. MPU

- Necessity of two MPUs
- CF card or USB devices

IV. FIP

- FIP capacity
- Type and number of interfaces
- Encryption performance

V. SAP

- SAP capacity
- Type and number of interfaces
- Encryption performance

6.2 Modules

Table 6-1 Description of A6604/A6608/A6616 interface modules

Module name	Description
Main Processing Unit (MPU)	
JC497A	HP A6600 RPE-X1 Carrier Card
JC165A	HP A6600 RPE-X1 Main Processing Unit
JC566A	HP A6600 RSE-X1 Main Processing Unit
Flexible Interface Platform (FIP)	
JC166B	HP A6600 FIP-110 Flexible Interface Platform Module
JC167B	HP A6600 FIP-210 Flexible Interface Platform Module
High-speed Interface Module (HIM)	
JC168A	HP A6600 1-port 10-GbE XFP HIM Module
JC164A	HP A6600 8-port Gig-T HIM Module
JC174A	HP A6600 8-port GbE SFP HIM Module
JC163A	HP A6600 4-port Gig-T HIM Module

Module name	Description
JC171A	HP A6600 4-port GbE SFP HIM Module
JC575A	HP A6600 8-port 10/100Base-T HIM Module
JC169A	HP A6600 2-port OC-3/STM-1 (E3/T3) CPOS SFP HIM Module
JC170A	HP A6600 1-port OC-3/STM-1 (E3/T3) CPOS SFP HIM Module
JC161A	HP A6600 1-port OC-3/STM-1 (E1/T1) CPOS SFP HIM Module
JC162A	HP A6600 2-port OC-3/STM-1 (E1/T1) CPOS SFP HIM Module
JC172A	HP A6600 4-port OC-3c/STM-1c or 2-port OC-12c/STM-4c POS SFP HIM Module
JC173A	HP A6600 2-port OC-3c/STM-1c or 1-port OC-12c/STM-4c POS SFP HIM Module
JC494A	HP A6600 1-port OC-48c/STM-16c POS/CPOS SFP HIM Module
JC495A	HP A6600 2-port OC-3c/STM-1c ATM SFP HIM Module
JC175A	HP A6600 1-port OC-3c/STM-1c ATM SFP HIM Module
JC576A	HP A6600 2-port OC-48c/STM-16c RPR SFP HIM Module
Multifunctional Interface Module (MIM)	
JD552A ①	HP A-MSR 8-port Enhanced Sync/Async Serial MIM Module
JD541A ①	HP A-MSR 4-port Enhanced Sync/Async Serial MIM Module
JD540A ①	HP A-MSR 2-port Enhanced Sync/Async Serial MIM Module
JD563A ②	HP A-MSR 8-port E1/CE1/PRI (75ohm) MIM Module
JF255A ②	HP A-MSR 8-port E1/Fractional E1 (75ohm) MIM Module
JD630A	HP A-MSR 1-port E3/CE3/FE3 MIM Module
JD628A	HP A-MSR 1-port T3/CT3/FT3 MIM Module
JC160A③	HP A-MSR 8-port T1/CT1/PRI MIM Module
JC159A③	HP A-MSR 8-port T1/Fractional T1 MIM Module
High-density Ethernet Interface Card	
JC567A	HP A6600 48-port Gig-T Service Aggregation Platform Module
JC568A	HP A6600 24-port GbE SFP Service Aggregation Platform Module
Power supply module (PWR)	
JC492A	HP A6600 650W AC Power Supply
JC493A	HP A6600 650W DC Power Supply
Accessories	
JC569A	HP A6604 Spare Fan Assembly
JC570A	HP A6608 Spare Fan Assembly
JC571A	HP A66016 Spare Fan Assembly
JC572A	HP A6604 Dustproof Frame
JC573A	HP A6608 Dustproof Frame
JC574A	HP A6616 Dustproof Frame



Note

- ①JD552A/JD541A/JD540A does not support asynchronous serial interface modules.
 - ②JD563A/JF255A does not support PRI. The two modules do not support E1 (120 ohm) interfaces. To do so, you need a 75-120 ohm adaptor.
 - ③JC160A/JC159A does not support PRI.
-