

**HRV1 & HRV2 SERIES
HEAT RECOVERY VENTILATORS**
95 thru 1200 cfm (45 thru 566 L/s) Capacity**HRV**Bulletin #210085
November 1997
Supersedes May 1995

Heat recovery ventilators provide fresh, clean outdoor air with an energy saving temperature recovery of up to 94%. Centrifugal blowers bring in fresh outdoor air while at the same time exhausting an equal amount of stale indoor air. Intake and exhaust air passes through a patented thermally conductive aluminum or enthalpic core heat exchanger bank where heat is transferred from exhaust air to incoming air. A duct system distributes the fresh air and collects the stale air.

FEATURES

Approvals — All units conform to C.S.A. and U.L. standards and most are HVI certified. All units conform to CAN/ULC-S110-M1986 for non-combustible material and CAN/ULC-S102-M88 for flame spread rating and smoke developed classification. Units are completely wired and include filters, heat exchanger banks and control panel.

Warranty —

Residential Models — Aluminium heat exchanger cores have a limited lifetime warranty, all other heat exchanger cores have a five year limited warranty. All other components have a limited warranty for five years.

Commercial Models — Aluminium heat exchanger cores have a limited warranty for fifteen years. All other components have a limited warranty for two years.

Refer to Limited Warranty Certificate included with the equipment for more details.

Cabinet — Constructed of 20 gauge pre-painted steel. Interior is lined with foil faced insulation to eliminate noise, condensation and air loss. Cabinet is designed for structural strength, long life and good looks. Efficient motors and fan housings are rubber mounted to reduce vibration and noise. Access panels are hinged and have quick release latches for easy access to filter(s) and heat exchanger(s) for servicing. Safety interlock switch automatically shuts off power to unit when access panel is removed. Threaded inserts with screws are furnished on residential models for hanging units with furnished PVC reinforced polyester rubber straps. Commercial units require support brackets and threaded rods (not included). Condensate drain pans have drain connection.

Patented Heat Exchanger Bank (Non-ERV Models) — Aluminium plates have excellent heat transfer characteristics, are nonflammable, corrosion resistant, durable and cost effective. Opposed dimples pressed into each plate ensure proper separation within each bank. Modular design ensures ease of service. Aluminum plates are mounted in a frame and easily removable for cleaning. Two bank systems feature high efficiency performance of counter flow air design.

Heat Exchanger Bank (ERV Models Only) — Enthalpic core has excellent latent and sensible heat transfer properties. The design of each plate ensures proper separation within each bank. Modular design ensures ease of service. Plates are mounted in a frame and easily removable for vacuum cleaning.

Blower — Centrifugal type direct drive PSC motors with rubber insulated mounts are furnished on all models.

Filters — All units have air filters in both the exhaust air and intake air streams. Foam filters are easily removed for cleaning and servicing. Design and location of the filters allows maximum filtration with minimum air resistance.

☼ The maple leaf symbol in this bulletin denotes Canadian only usage where applicable

NOTE — Due to Lennox' ongoing commitment to quality, Specifications, Ratings and Dimensions subject to change without notice and without incurring liability.

Plug-in Electrical Connection (-95, -150, -195, -200 & -300 Models Only) — Convenient 3 prong 120VAC plug provided for easy electrical connection.

"POOL" Models — HRV1-700SDPPPOOL and HRV1-1200SDPPPOOL models are specifically designed for indoor swimming pool room applications. Humidity level of pool room is dehumidistat controlled by the intake of dry fresh outside air and exhausting of humid stale air. When dehumidistat is satisfied, pool room air is recirculated and outside air is prevented from entering.

"TOP" Models — 45° top mounted ports allow easy installation in reduced spaces. Efficient single bank design. Defrost cycle utilizes recirculation with an internal damper.

"ERV" Models — Recommended for applications where the temperature does not drop below 25°F (4°C). Helps lower load on air conditioning system by removing humidity drawn in from the outside air. ERV models do not have defrost or condensate pans and drains.

Built-In Dehumidistat — Dehumidistat eliminates damaging high humidity conditions and is furnished and factory installed in 150SDP, -195DDP, -200SDP and -300DDP models. When indoor humidity exceeds the desired setting, the unit automatically switches to high speed blower operation to increase the exhaust of moist air and the supply of fresh air.

Base Module Digital Electronic Control Panel (HRV2 Models Only) — Control is furnished on all models. Controls unit operation with easy to use one-touch microprocessor operation. Fan control pad changes blower speeds. Single LED indicates "Power" (Green) and "Defrost" (Red) operation. Control also allows interfacing with optional digital electronic timer, remote deluxe programmable control, remote dehumidistat and air quality sensor.

Damper Defrost — Damper style defrost on "DDP" & "SDP" suffix models represents the leading edge in heat recovery ventilator technology. During defrost the damper opens permitting inside air to defrost the bank. Defrost LED on control panel indicates when automatic damper defrost occurs.

Recirculation Defrost (SRP Models) — Defrost cycle utilizes recirculation with an internal damper.

Fan Defrost — Available on "SFP" and "DFP" suffix models. Automatic temperature controlled timed cycle. Defrost cycle occurs when outdoor temperature drops below 27°F (-3°C). During defrost cycle supply air fan is de-energized and interior (stale) air is continuously exhausted.

©1997 Lennox Industries Inc.

OPTIONAL ACCESSORIES (Must Be Ordered Extra) See Optional Accessories Flowchart

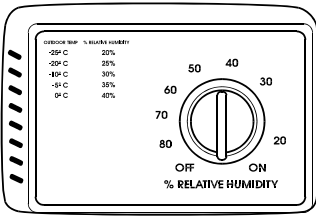

Remote Wall Mount Dehumidistat (Optional) — Remote dehumidistat control can be added using connections furnished on unit. Scaled in relative humidity from 20% to 80%; low voltage. Available in white decorator color.

Air Quality Sensor (Optional for HRV2 models only) — Remote digital air quality sensor samples indoor air quality and activates high speed blower as needed to provide increased ventilation to remove odors and airborne contaminants. Detects carbon monoxide and formaldehyde gases. White decorator color. Complete with 35 ft. (11 m) length of 3 wire control cable. Not a carbon monoxide alarm.

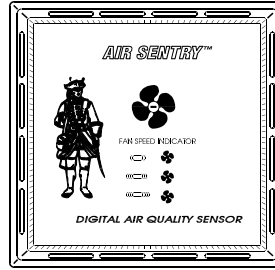

Dehumidistat Ventilation Control (Optional for HRV1-RNC and HRV2 Models) — Remote mounted control turns HRV system on and off. Scaled in relative humidity from 20% to 80%; low voltage. Dehumidistat increases ventilation when required. White decorator color. Complete with 60 ft. (18 m) length of 3 wire control cable.

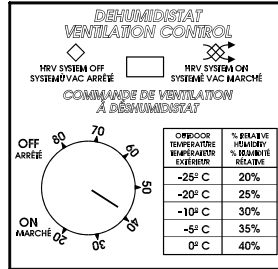

30 Minute Crank Timer (Optional) — Timer is available to control high speed blower operation for up to 30 minutes (adjustable).

60 Minute Crank Timer (Optional) — Timer is available to control high speed blower operation for up to 60 minutes (adjustable).

Insulated or Non-Insulated Flexible Ducts (Optional) — Non-insulated ducts are available for connection to optional circular grilles. Constructed of aluminum foil/polyester laminate and metalized polyester film around a steel wire helix. Fully insulated fiberglass ducts have an "R" value of 5.8 and are available for connection to optional outside weatherhoods. Available for inside use in standard 3 in. (76mm) to 10 in. (254mm) diameters and 25 foot (7.6m) lengths. Must be ordered extra. See Lennox Price Book for ordering information.

Programmable Ventilation Control (P.V.C.) (Optional for HRV2 models only) — Electronic digital control allows operation of several control functions. Features 24 hour programming with battery back-up, dehumidistat control, air quality sensor, fan and speed control, digital display for

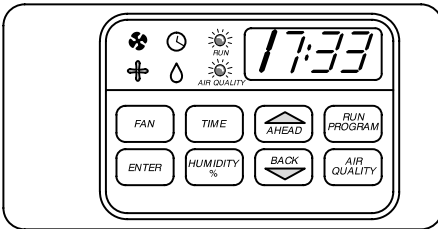

time, blower speed and humidity. LED's show operating status at a glance. White decorator color. Complete with 35 ft. (11 m) length of 4 wire control cable.

Weatherhoods (Optional for -95, -150, -195, -200, -300 Models Only) — Two required, one for intake air and one for stale air. Fully adjustable for different wall thickness. Complete with mesh bird screen, 12 inch (305 mm) galvanized duct and (2) insulating duct collars. Available in white finish.

Duct Heaters (Optional for HRV2-95 thru -300 only) — Duct heaters are available to temper incoming fresh air when required. Heaters have built-in SRC control. Available in 1 kW and 2 kW sizes in 6 inch (152 mm) and 7 inch (178 mm) diameters sizes.

Circular Techgrilles (Optional) — White molded plastic grilles are available for room distribution. Grilles are adjustable for system balancing. Available in 4 in., 5 in., 6 in. and 8 in. (102mm, 127mm, 152mm and 200mm) diameters.

Hinged Kitchen Exhaust Grille (Optional) — Louvered panel is hinged for easy access to washable aluminum filter.

Digital Electronic Timer (Optional for HRV2 models only) — Remotely located timer allows 20, 40 or 60 minute operation. One-touch button activates high speed. 3 indicator LED's show timer status. Lockout feature eliminates tampering. Mounting wallplate available in white or ivory decorator colors. Complete with 60 ft. (18 m) length of 3 wire control cable.

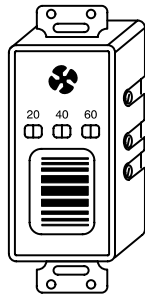

MODEL NUMBER IDENTIFICATION

HRV1-200SDP

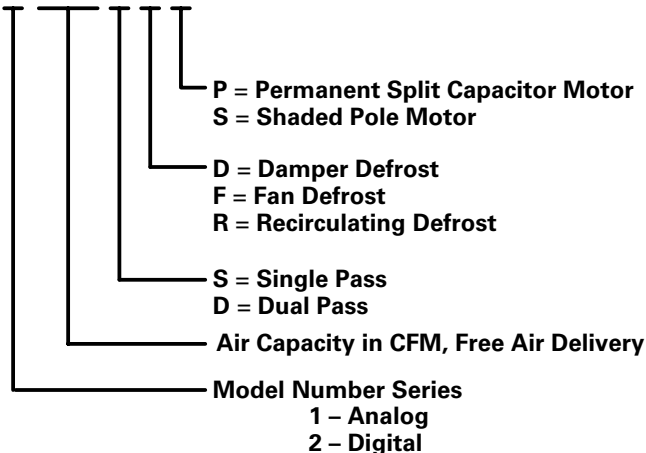

SPECIFICATIONS – RESIDENTIAL MODELS

Model No.		HRV2-95SRP	HRV2-150SDP	HRV1-150SDP-RNC2	HRV2-200SNP-ERV
Air Flow vs. Static Pressure (At High Speed)	in. wg (Pa)	cfm (L/s)	cfm (L/s)	cfm (L/s)	cfm (L/s)
	0.1 (25)	90 (42)	150 (71)	150 (71)	195 (92)
	0.2 (50)	80 (38)	135 (64)	135 (64)	185 (87)
	0.3 (75)	65 (31)	110 (52)	110 (52)	175 (83)
	0.4 (100)	35 (17)	45 (21)	45 (21)	160 (76)
0.5 (125)	-----	-----	-----	145 (68)	
Number of Speeds Available		5		2	5
Maximum temperature recovery		80%	70%		-----
Sensible effectiveness @ 64 cfm (30L/s)		80%	70%		80% @ 117 cfm (55 L/s)
Sensible efficiency @ 32°F (0°C) and 64 cfm (30L/s)		75%	61%		70% @ 117 cfm (55 L/s)
Sensible efficiency @ -13°F (-25°C) and 64 cfm (30L/s)		75%	61%		-----
Number of heat exchanger banks		1			
Defrost type		Recirculating	Damper		-----
Electrical characteristics		120 volts – 60 hertz – 1 phase			
Fan Motor – No. & Output – hp (W)		(1) 1/10 (75)			
Fan Watts – high speed (total)		136	114		80
Fan Watts – defrost mode (fan on)		80	61		-----
Amp rating (total)		1.7		1.4	
Duct Connection (Number) & diameter – in. (mm)	Inside	(2) 6 (152) oval to round		(2) 6 (152)	
	Outside	(2) 5 (127)		(2) 6 (152)	
	Defrost	-----		(1) 6 (152)	-----
Condensate drain connection (o.d.) – in. (mm)		1/2 (13)			
Shipping weight – lbs. (kg)		56 (25)	63 (29)		65 (29)
Optional Accessories (Must Be Ordered Extra)					
① Flexible Connectors – No. required & diameter – in. (mm)		(2) 6 (152)		(2) 6 (152)	
Duct Heater – Duct connection diameter – in. (mm)		-----		1 kW (95E02) 6 (152) or 2 kW (20N16) 6 (152)	
② Outside Weatherhoods – Duct connection diameter – in. (mm)		5 (127) (92E66)		6 (152) (92E53)	

① See Lennox Price Book for ordering information. Also see Price Book for additional accessories.

② 2 Required, one for fresh air, one for stale air.

Model No.		HRV2-200SDP-RNC	HRV2-200SDP	HRV2-200SDP-TOP	HRV2-195DDP	HRV2-300DDP
Air Flow vs. Static Pressure (At High Speed)	in. wg (Pa)	cfm (L/s)	cfm (L/s)	cfm (L/s)	cfm (L/s)	cfm (L/s)
	0.1 (25)	215 (102)	215 (101)	195 (92)	205 (97)	265 (125)
	0.2 (50)	205 (97)	205 (97)	190 (90)	190 (90)	260 (123)
	0.3 (75)	195 (92)	195 (92)	180 (85)	180 (85)	250 (118)
	0.4 (100)	185 (87)	185 (87)	165 (80)	165 (78)	235 (111)
0.5 (125)	170 (80)	170 (80)	150 (70)	155 (73)	220 (104)	
Number of Speeds Available		2		5		
Maximum temperature recovery		70%		80%	88%	90%
Sensible effectiveness @ 117cfm (55L/s)		67%		72%	88%	90%
Sensible efficiency @ 32°F (0°C) and 117cfm (55L/s)		60%		64%	80%	79%
Sensible efficiency @ -13°F (-25°C) and 117cfm (55L/s)		60%		70% @ 65cfm (30 L/s)	77%	75%
Number of heat exchanger banks		1			2	
Defrost type		Damper		Recirculating	Damper	
Electrical characteristics		120 volts – 60 hertz – 1 phase				
Fan Motor No. & Output – hp (W)		(1) 1/10 (75)				
Fan Watts --- high speed (total)		114	164		173	333
Fan Watts --- defrost mode (fan on)		100	100	85	100	156
Amp rating (total)		1.4			1.5	2.9
Duct Connection (Number) & diameter – in. (mm)	Inside	(2) 6 (152)			(2) 7 (178)	
	Outside	(2) 6 (152)				
	Defrost	(1) 6 (152)		-----		(1) 6 (152)
Condensate drain connection (o.d.) – in. (mm)		1/2 (13)				
Shipping weight – lbs. (kg)		72 (33)		89 (40)	108 (49)	
Optional Accessories (Must Be Ordered Extra)						
① Flexible Connectors – No. required & diameter – in. (mm)		(2) 6 (152)			(2) 7 (178)	
Duct Heater – Duct connection diameter – in. (mm)		1 kW (95E02) 6 (152) 2 kW (20N16) 6 (152)			1 kW (97E73) 7 (178) 2 kW (97E74) 7 (178)	
② Outside Weatherhoods – Duct connection dia. – in. (mm)		6 (152) (92E53)				

*2 Required, one for fresh air, one for stale air.

● See Lennox Price Book for ordering information. Also see Price Book for additional accessories.

SPECIFICATIONS – COMMERCIAL MODELS

Model No.		HRV2-500DDP		HRV1-700SDP		HRV1-700SFP		☐ HRV1-700SDP POOL		HRV1-850DFP			
Air Flow vs. Static Pressure	Speed	Low	High	Low	High	Low	High	Low	High	Low	High		
	in. wg (Pa)	cfm (L/s)	cfm (L/s)	cfm (L/s)	cfm (L/s)	cfm (L/s)	cfm (L/s)	cfm (L/s)	cfm (L/s)	cfm (L/s)	cfm (L/s)		
	0.1 (25)	280 (132)	525 (247)	445 (209)	660 (311)	445 (209)	660 (311)	445 (209)	660 (311)	700 (330)	950 (448)		
	0.2 (50)	270 (127)	500 (236)	425 (200)	640 (302)	425 (200)	640 (302)	425 (200)	640 (302)	675 (319)	915 (432)		
	0.3 (75)	247 (146)	450 (212)	410 (193)	620 (293)	410 (193)	620 (293)	410 (193)	620 (293)	625 (295)	890 (420)		
	0.4 (100)	235 (110)	425 (200)	408 (193)	610 (288)	408 (193)	610 (288)	410 (193)	610 (288)	575 (271)	825 (389)		
0.5 (125)	225 (106)	400 (188)	405 (191)	600 (283)	405 (191)	600 (283)	405 (191)	600 (283)	500 (236)	775 (366)			
Number of Speeds Available		5				3							
Number of heat exchanger banks		2		1						2			
Defrost type		Damper				Fan		Damper		Fan			
Maximum temperature recovery		90%				65%				80%			
Electrical characteristics		120 volts – 60 hertz – 1 phase											
Fan Motor No. & Output – hp (W)		(2) 1/10 (75)											
Fan Watts – high speed (total)		610				648				848			
Amp rating (total)		6.3				5.5				7.9			
Duct Connection size – in. (mm)	Inside – 2 ea.	8 x 14 (203 x 356)								8 x 20 (203 x 508)			
	Outside – 2 ea.	8 x 14 (203 x 356)											
	Defrost – 1 ea.	8 x 14 (203 x 356)				-----		8 x 14 (203 x 356)		-----			
Condensate drain conn.(o.d.) – in. (mm)		1/2 (13)											
Shipping weight – lbs. (kg)		203 (92)				167 (76)				167 (76)		280 (127)	
▼ Optional Accessories (Must Be Ordered Extra) ▼													
☒ Flexible Connectors No. required & size – in. (mm)	Inside – 2 ea.	8 x 14 (203 x 356)								8 x 20 (203 x 508)			
	Outside – 2 ea.	8 x 14 (203 x 356)											
	Defrost – 1 ea.	8 x 14 (203 x 356)				-----		8 x 14 (203 x 356)		-----			
Duct Heater		Use Lennox ED8 Duct Heater (see bulletin indexed in Electric Heat Tab section)											

☐ Remote Wall Dehumidistat Control (white), horizontal mounting (24v only) furnished as standard.

☒ See Lennox Price Book for ordering information. Also see Price Book for additional accessories.

Model No.		HRV1-850DDP		HRV1-1200SFP		HRV1-1200SDP		☐ HRV1-1200SDP POOL			
Air Flow vs. Static Pressure	Speed	Low	High	Low	High	Low	High	Low	High		
	in. wg (Pa)	cfm (L/s)	cfm (L/s)	cfm (L/s)	cfm (L/s)	cfm (L/s)	cfm (L/s)	cfm (L/s)	cfm (L/s)		
	0.1 (25)	700 (330)	950 (448)	880 (415)	1180 (557)	880 (415)	1180 (557)	880 (415)	1180 (557)		
	0.2 (50)	675 (319)	915 (432)	830 (391)	1130 (533)	830 (391)	1130 (533)	830 (391)	1130 (533)		
	0.3 (75)	625 (295)	890 (420)	790 (373)	1100 (562)	790 (373)	1100 (562)	790 (373)	1100 (562)		
	0.4 (100)	575 (271)	825 (389)	700 (330)	1050 (496)	700 (330)	1050 (496)	700 (330)	1050 (496)		
0.5 (125)	500 (236)	775 (366)	625 (295)	990 (467)	625 (295)	990 (467)	625 (295)	990 (467)			
Number of Speeds Available		3									
Number of heat exchanger banks		2		1							
Defrost type		Damper		Fan		Damper					
Maximum temperature recovery		80%				65%					
Electrical characteristics		120 volts – 60 hertz – 1 phase									
Fan Motor No. & Output – hp (W)		(2) 1/4 (187)									
Fan Watts – high speed (total)		848				972					
Amp rating (total)		7.9				8.1					
Duct Connection size – in. (mm)	Inside – 2 each	8 x 20 (203 x 508)									
	Outside – 2 each	8 x 26 (203 x 660)				8 x 20 (203 x 508)					
	Defrost – 1 each	8 x 20 (203 x 508)		-----		8 x 20 (203 x 508)					
Condensate drain connection (o.d.) – in. (mm)		1/2 (13)									
Shipping weight – lbs. (kg)		280 (127)				215 (98)					
▼ Optional Accessories (Must Be Ordered Extra) ▼											
☒ Flexible Connectors Number required and size – in. (mm)	Inside – 2 each	8 x 20 (203 x 508)									
	Outside – 2 each	8 x 26 (203 x 660)				8 x 20 (203 x 508)					
	Defrost – 1 each	8 x 20 (203 x 508)		-----		8 x 20 (203 x 508)					
Duct Heater		Use Lennox ED8 Duct Heater (see bulletin indexed in Electric Heat Tab section)									

☐ Remote Wall Dehumidistat Control (white), horizontal mounting (24v only) furnished as standard.

☒ See Lennox Price Book for ordering information. Also see Price Book for additional accessories.

TYPICAL RESIDENTIAL DUCT LAYOUT

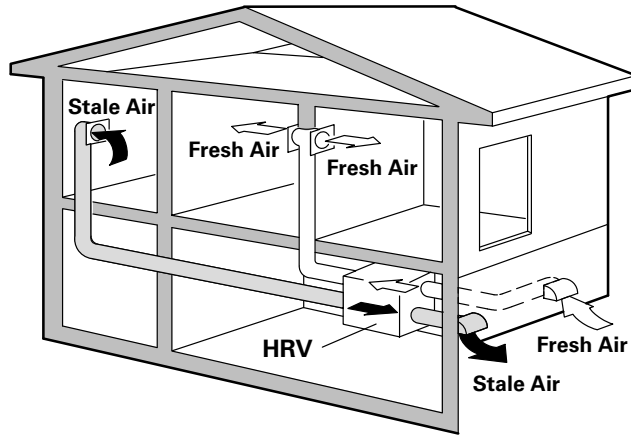

INTEGRATED RESIDENTIAL SYSTEM APPLICATIONS

DIRECT CONNECTION OF HRV FRESH AIR SUPPLY TO FURNACE RETURN AIR

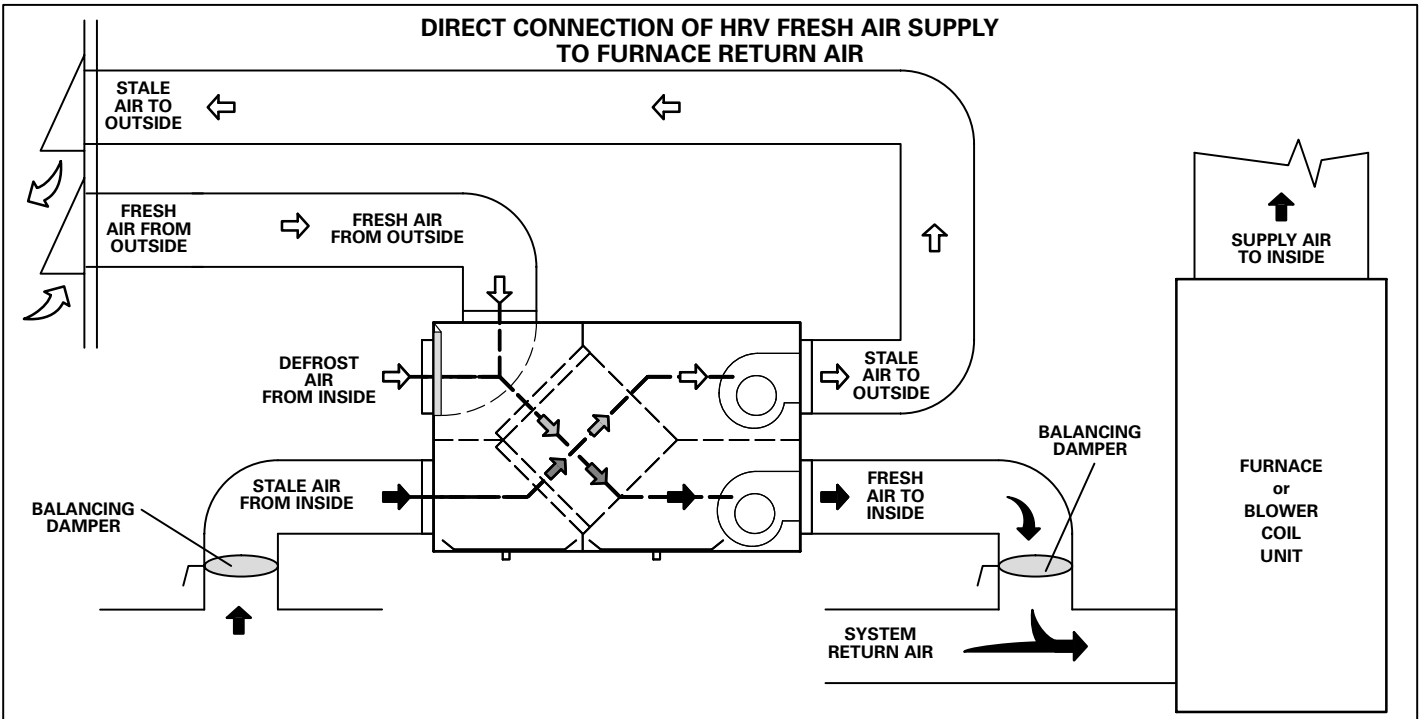

DIRECT CONNECTION OF HRV FRESH AIR SUPPLY AND STALE AIR EXHAUST TO FURNACE RETURN AIR

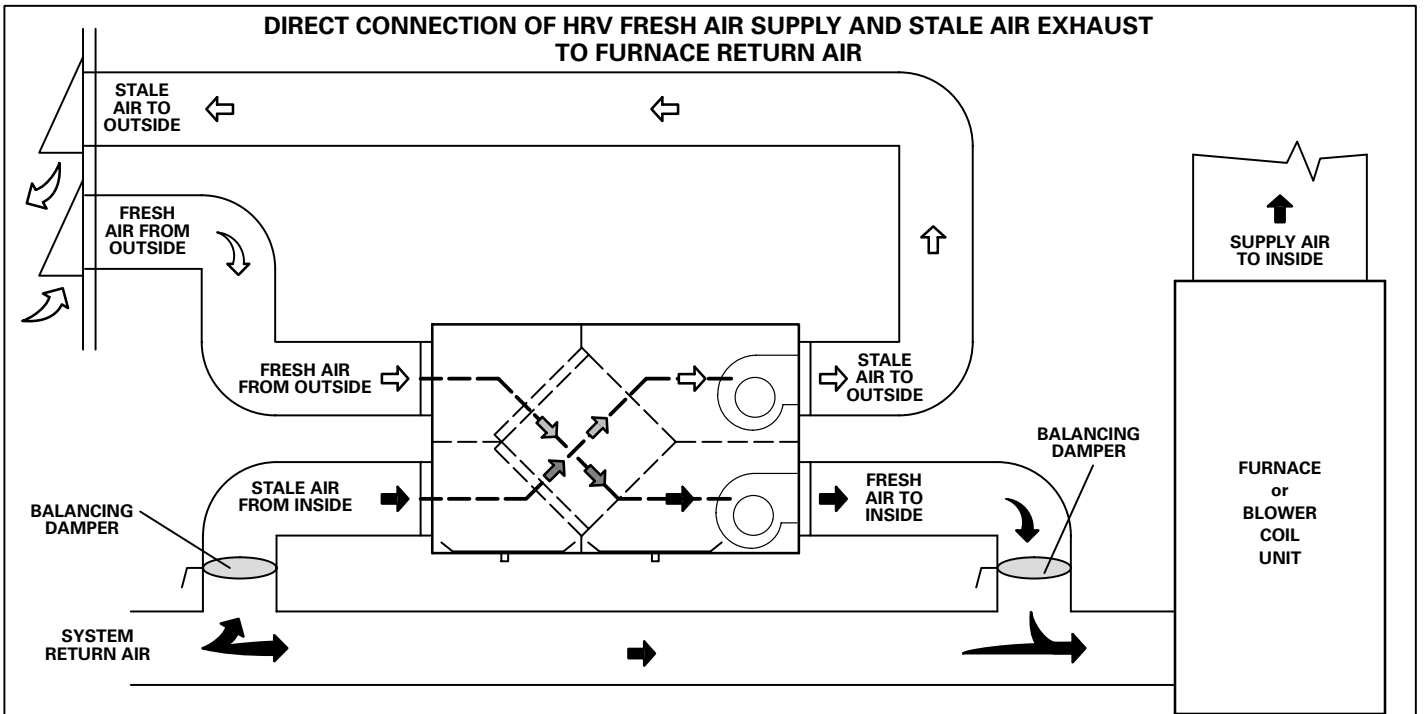

INTEGRATED COMMERCIAL SYSTEM APPLICATIONS

**HRV UNIT WITH PACKAGED ROOFTOP UNIT
(Separate Supply and Return Air Plenum)**

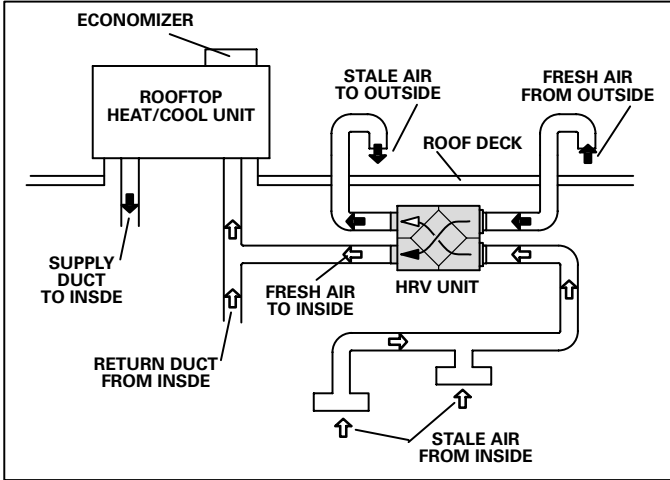

**HRV UNIT WITH PACKAGED ROOFTOP UNIT
(Ceiling Return Air Plenum)**

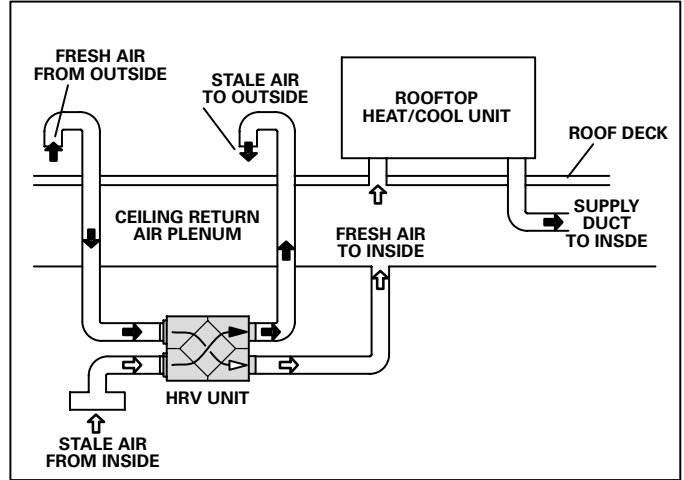

HRV1-700SDPPOOL & HRV1-1200SDPPOOL

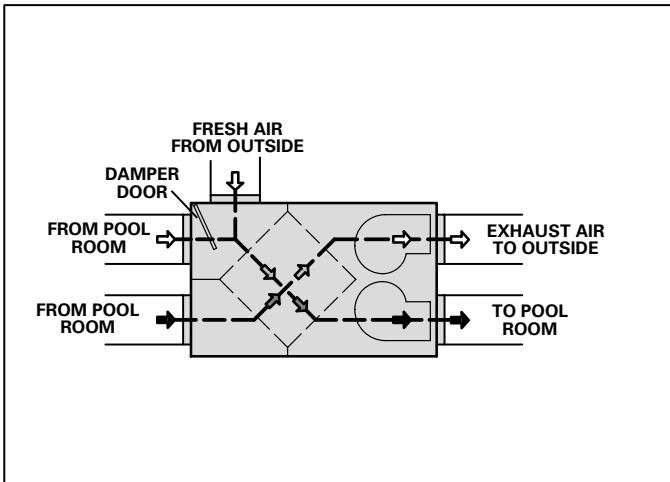

**HRV UNIT WITH PACKAGED ROOFTOP UNIT
(Separate Supply and Return Air With Economizer)**

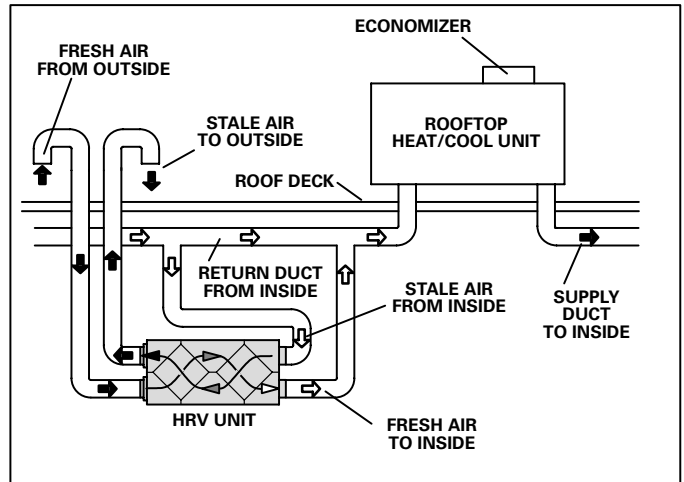

TYPICAL APPLICATIONS

OFFICE

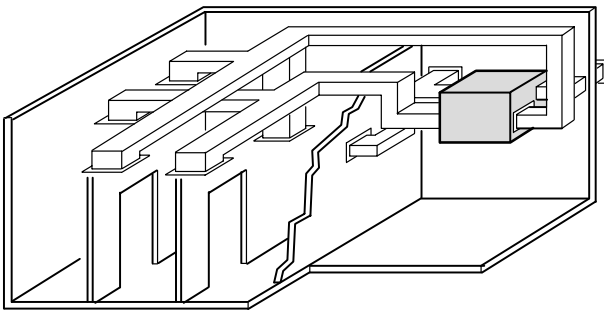

SWIMMING POOL

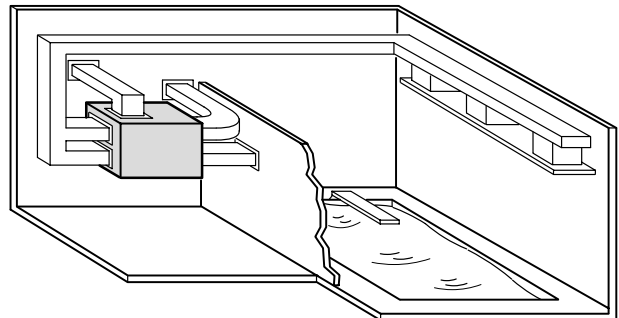

RESTAURANT

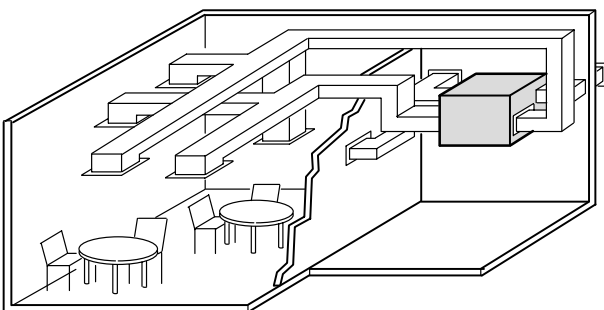

KENNEL

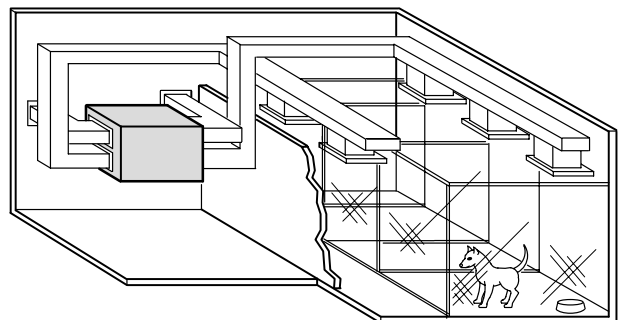

COMMERCIAL UNITS – PERFORMANCE DATA

HRV2-500DDP

BLOWER PERFORMANCE (Each Air Stream)

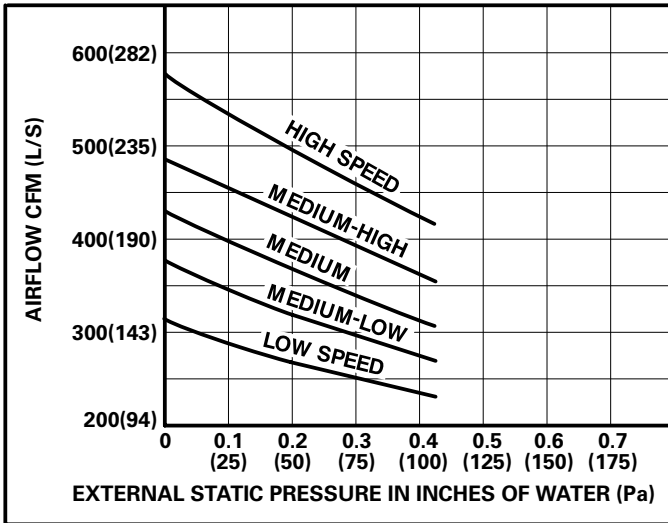

TEMPERATURE EFFECTIVENESS

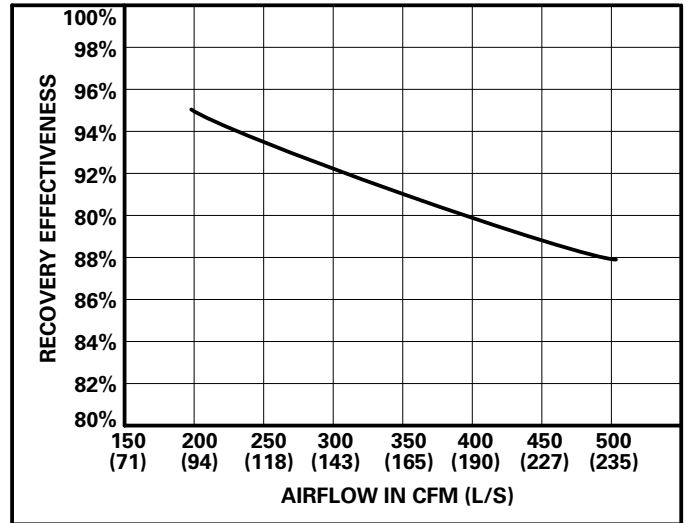

NOTE – 40% Exhaust Relative Humidity.

HRV1-700SFP, HRV1-700SDP & HRV1-700SDPPOOL

BLOWER PERFORMANCE (Each Air Stream)

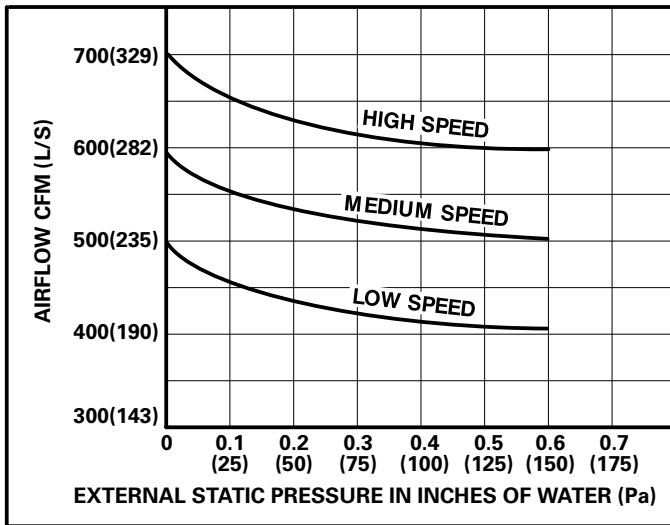

TEMPERATURE EFFECTIVENESS

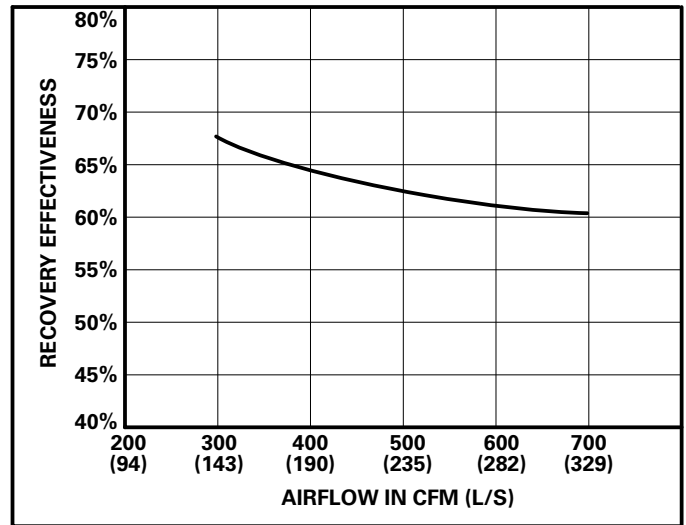

NOTE – 40% Exhaust Relative Humidity.

HRV1-850DDP & HRV1-850DFP

BLOWER PERFORMANCE (Each Air Stream)

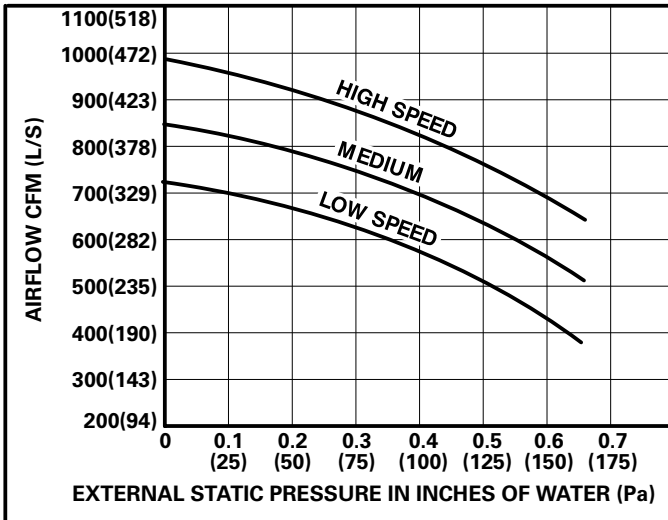

TEMPERATURE EFFECTIVENESS

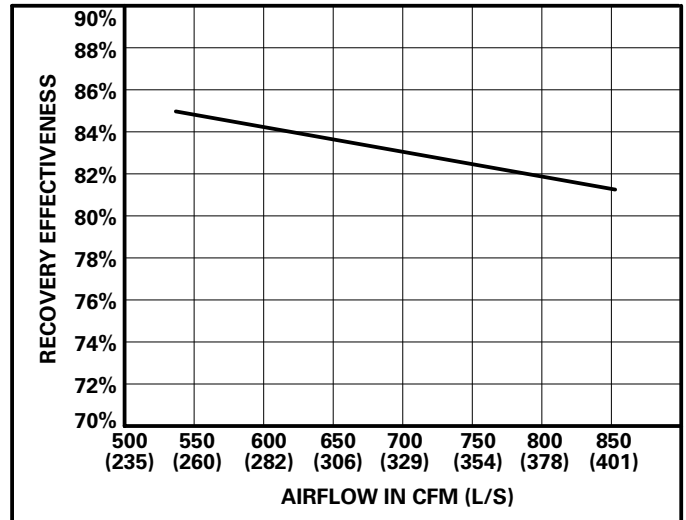

NOTE – 40% Exhaust Relative Humidity.

COMMERCIAL UNITS – PERFORMANCE DATA

HRV1-1200SFP, HRV1-1200SDP & HRV1-1200SDPPOOL

BLOWER PERFORMANCE (Each Air Stream)

TEMPERATURE EFFECTIVENESS

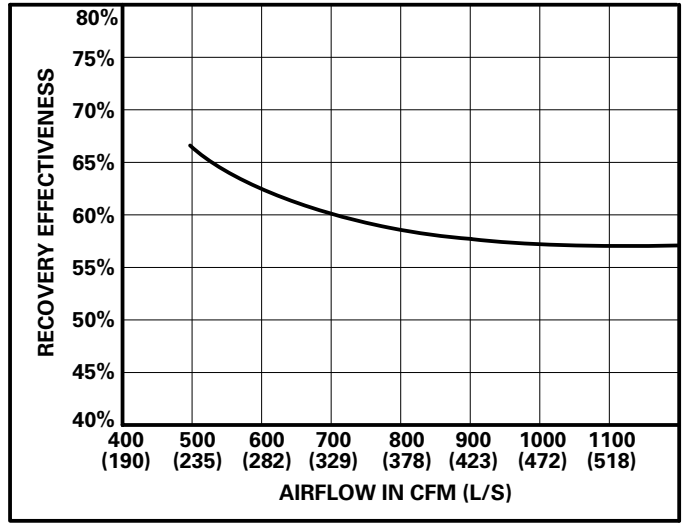
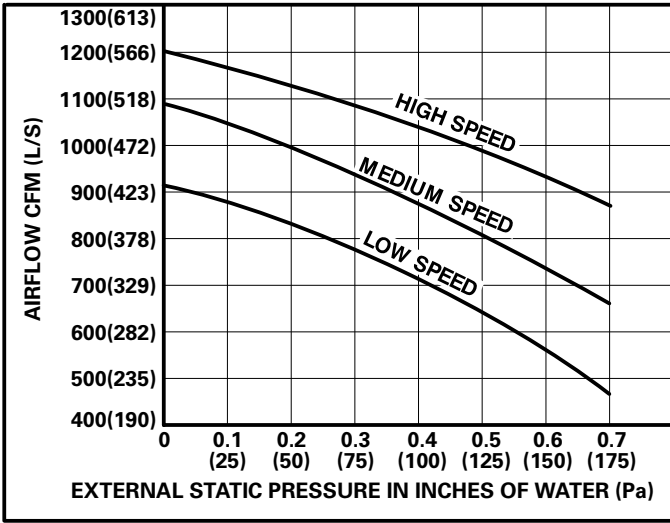

NOTE – 40% Exhaust Relative Humidity.

OPTIONAL ACCESSORIES FLOWCHART

Residential HRV2 Models

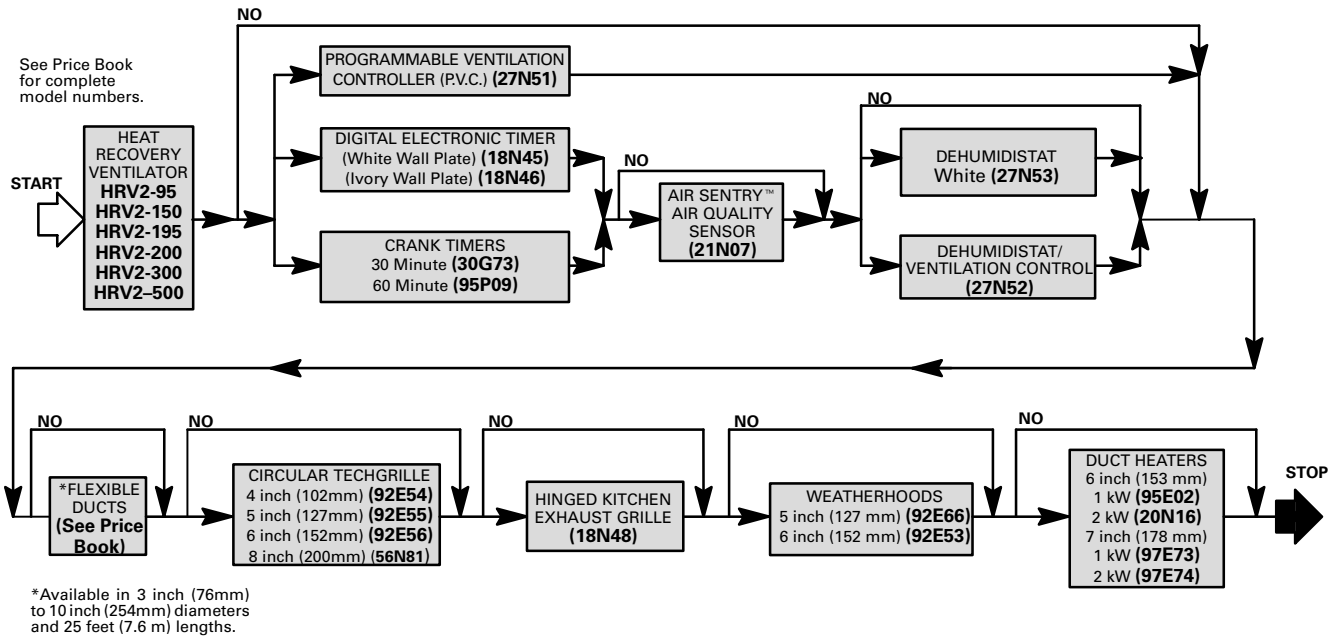

*Available in 3 inch (76mm) to 10 inch (254mm) diameters and 25 feet (7.6 m) lengths.

NOTE – Refer to Specifications tables for duct dimensions of units.

Commercial HRV1 Models

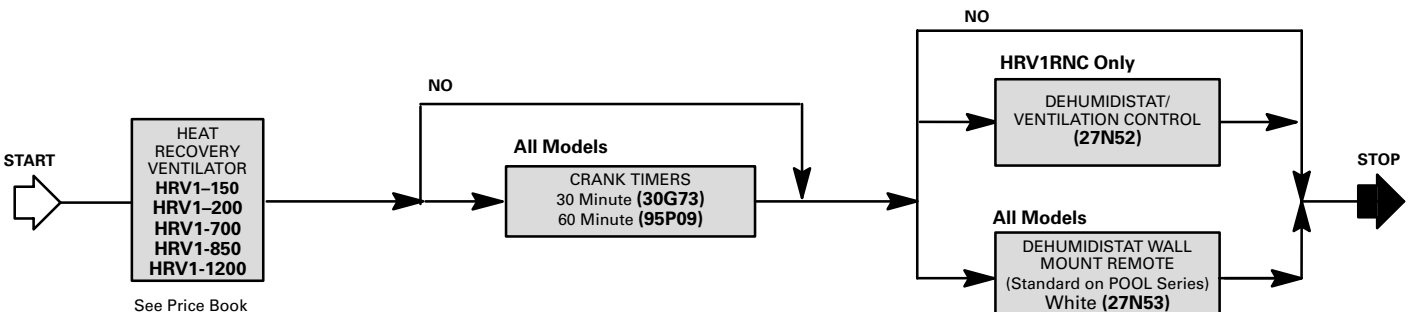

See Price Book for complete model numbers.

HRV2-95SRP MODEL

NOTE – See Specifications table for duct connection sizes.

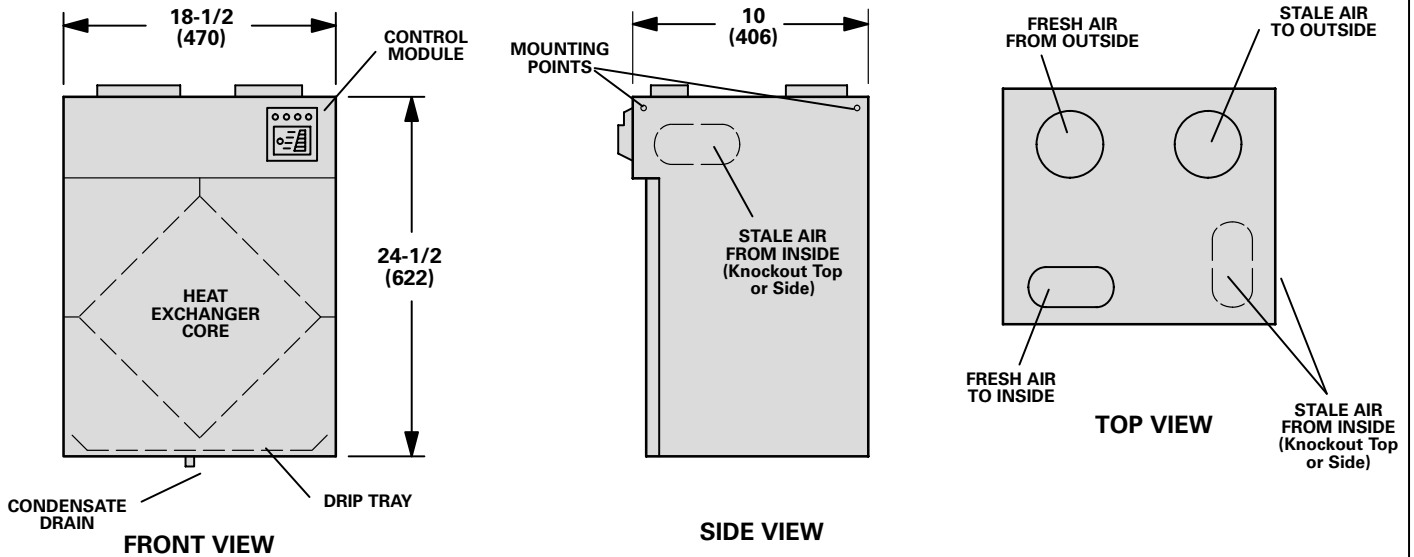

NOTE – Front clearance of 18 inches (457 mm) is recommended for servicing unit.

HRV2-150SDP & HRV2-200SDP MODELS

NOTE – See Specifications table for duct connection sizes.

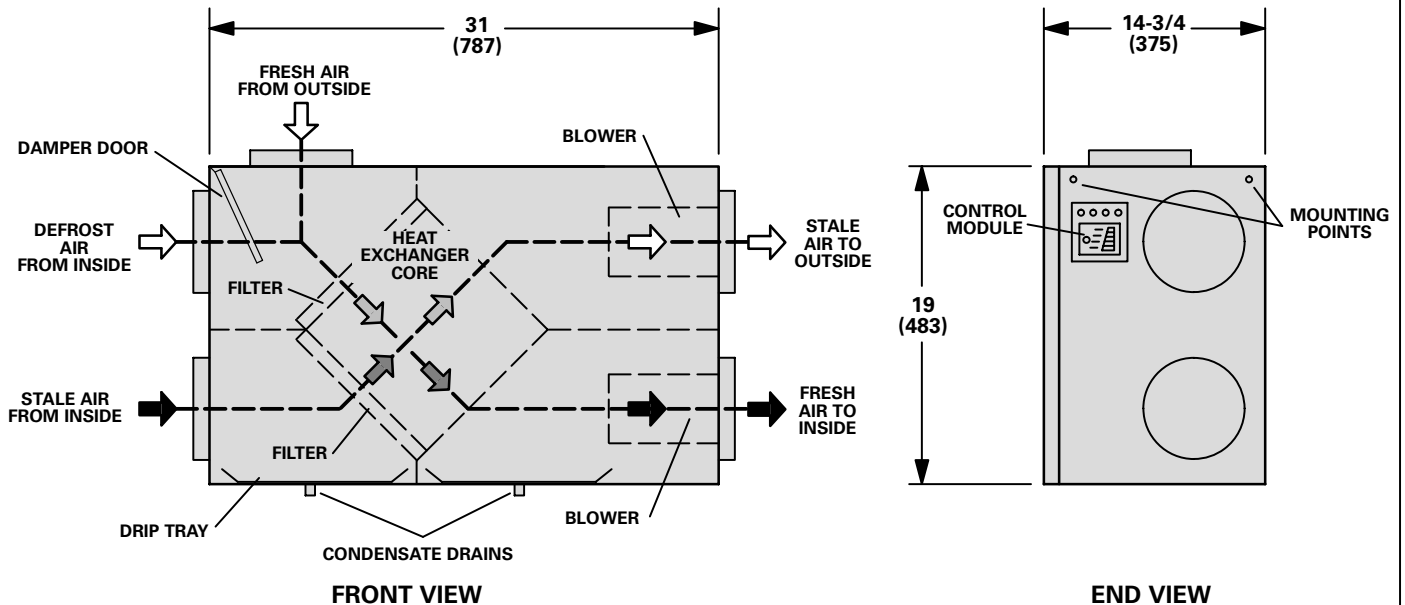

NOTE – Front clearance of 25 inches (635 mm) is recommended for servicing unit.

HRV2-200SNP-ERV MODELS

NOTE – See Specifications table for duct connection sizes.

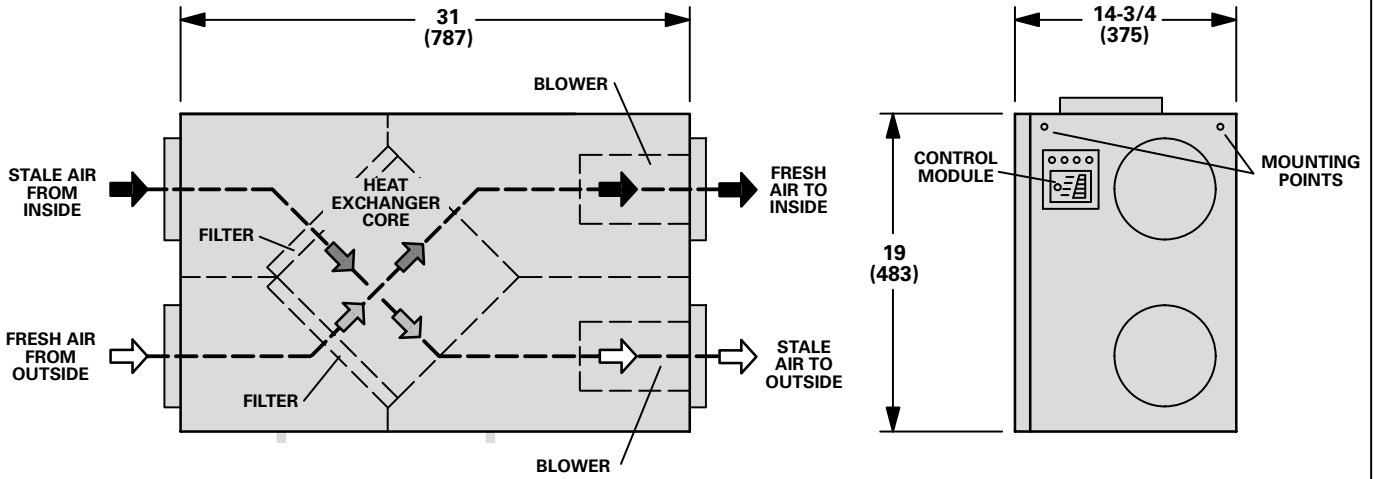

FRONT VIEW

END VIEW

NOTE – Front clearance of 25 inches (635 mm) is recommended for servicing unit.

HRV2-200SDP-TOP MODEL

NOTE – See Specifications table for duct connection sizes.

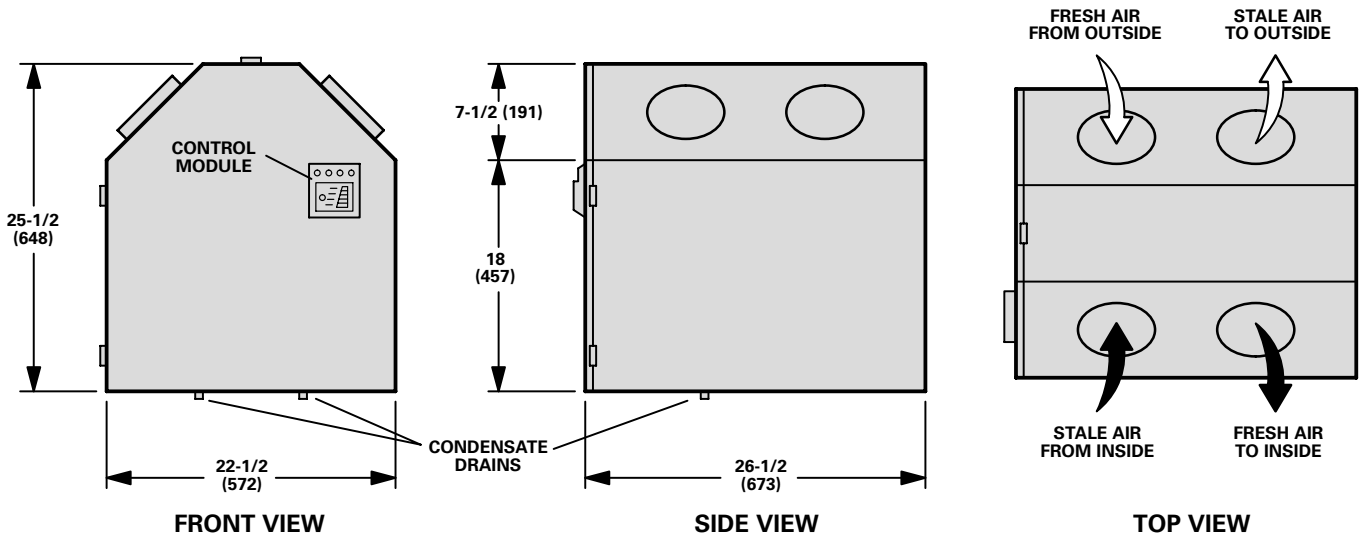

FRONT VIEW

SIDE VIEW

TOP VIEW

NOTE – Front clearance of 25 inches (635 mm) is recommended for servicing unit.

HRV2-195DDP & HRV2-300DDP MODELS

NOTE – See Specifications table for duct connection sizes.

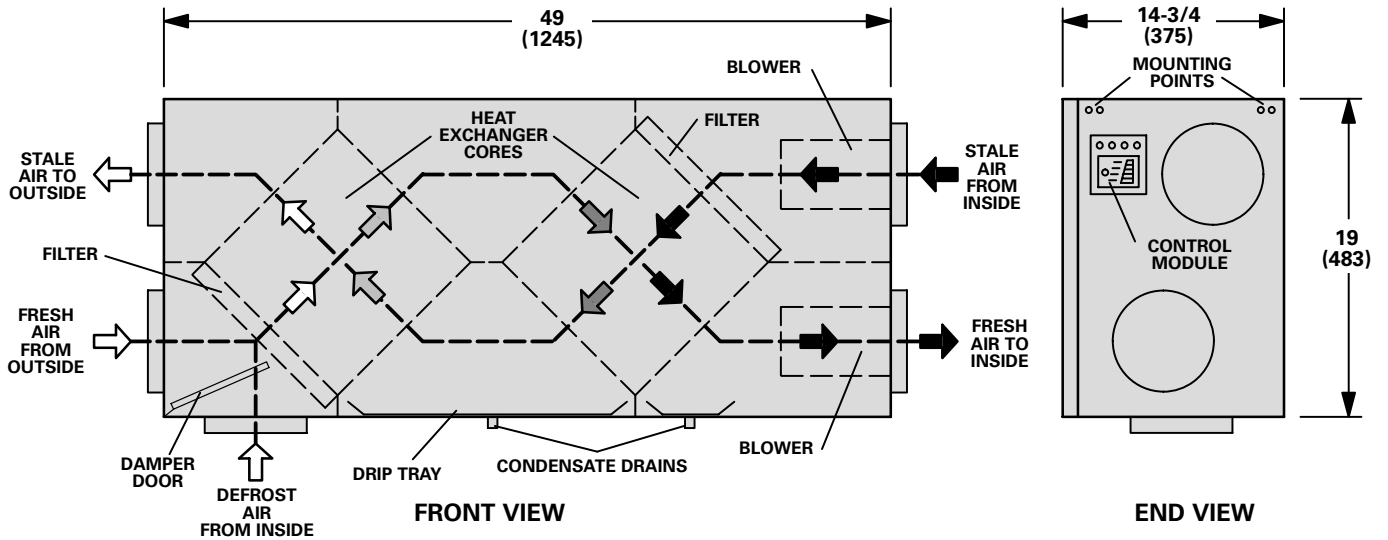

NOTE – Front clearance of 25 inches (635 mm) is recommended for servicing unit.

HRV2-500DDP, HRV1-850DFP & HRV1-850DDP MODELS

NOTE – See Specifications table for duct connection sizes.

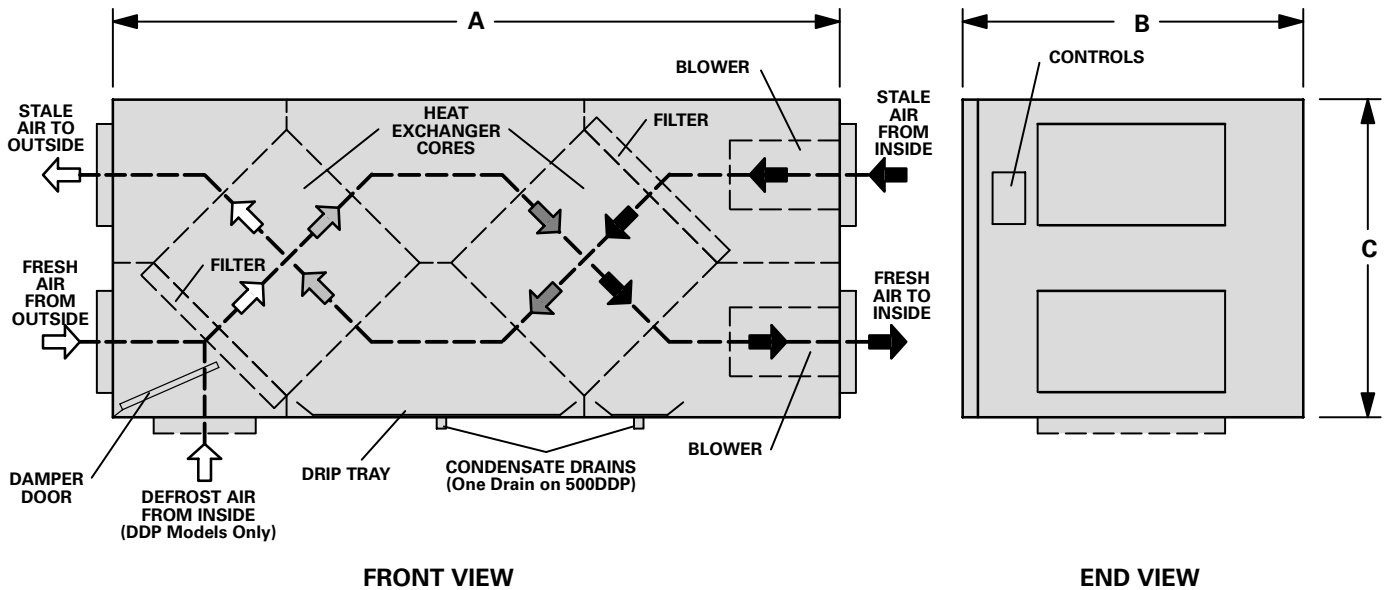

NOTE – Front clearance of 36 inches (914 mm) is recommended for servicing unit.

Model No.	A		B		C	
	in.	mm	in.	mm	in.	mm
HRV2-500DDP	49	1245	28-1/4	718	18-3/4	476
HRV1-850DFP	46-5/8	1184	41-1/2	1054	24-5/8	625
HRV1-850DDP	46-5/8	1184	41-1/2	1054	24-5/8	625

**HRV1-700SFP, HRV1-700SDP, HRV1-700SDPPPOOL,
HRV1-1200SFP, HRV1-1200SDP & HRV1-1200SDPPPOOL MODELS**

NOTE – See Specifications table for duct connection sizes.

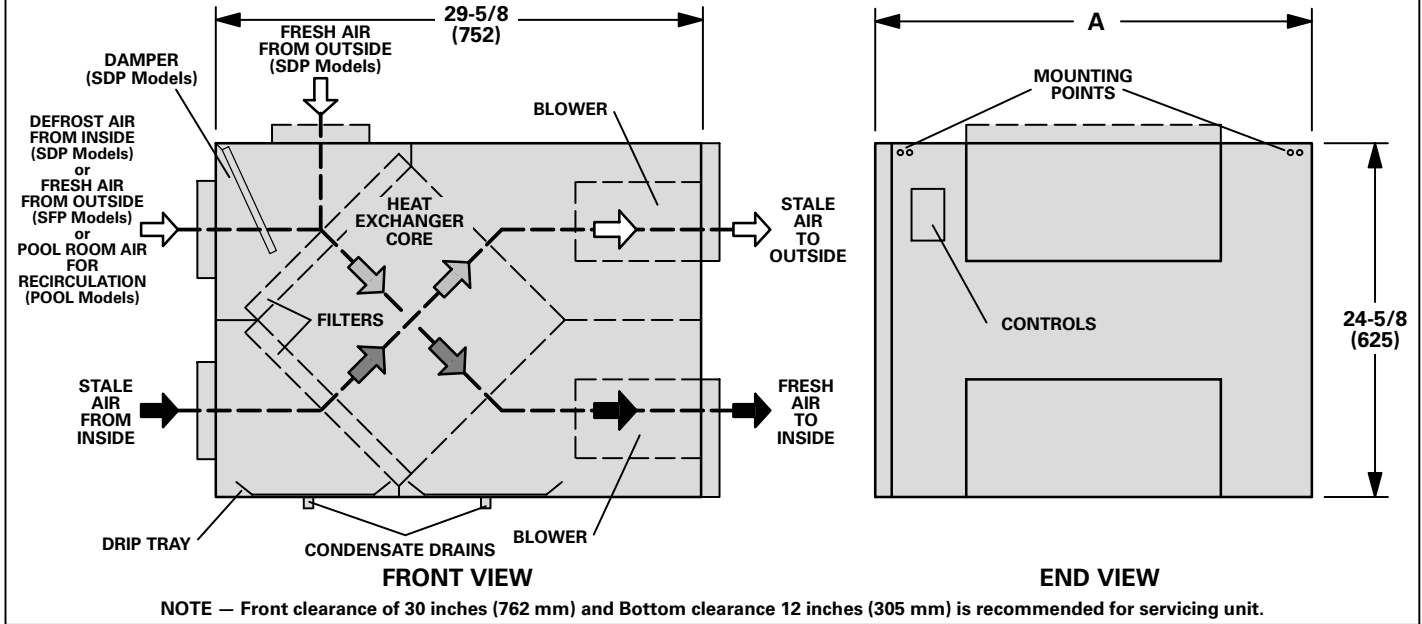

Model No.	A	
	in.	mm
700SFP, 700SDP, 700SDPPPOOL, 900SFP, 900SDP	28-3/4	727
1200SFP, 1200SDP, 1200SDPPPOOL	41-1/2	1054