

CHAIN AND BELT DRIVES

Table of Contents

FLEX-E-GEAR® CABLE DRIVE CHAIN SYSTEM	A 1 - A 14
FLEX-E-GEAR® TECHNICAL DATA	Aii
GEAR DRIVE CHAINS	
.0982 CIRCULAR PITCH - 32 PITCH	A 1
.1000 CIRCULAR PITCH - 1/10 PITCH	A 7
.1309 CIRCULAR PITCH - 24 PITCH	A 10
SPROCKET GEARS	
.0982 CIRCULAR PITCH - 32 PITCH	A 2 - A 6
.1000 CIRCULAR PITCH - 1/10 PITCH	A 8 - A 9
.1309 CIRCULAR PITCH - 24 PITCH	A 11 - A 13
FIELD SPLICE KITS	
FOR BELT SERIES 31GCF - 32GCF - 24GCF	A 14
FOR BELT SERIES 31GBF - 32GBF - 33GBF - 24GBF	A 40
FOR BELT SERIES 3CCF - 3DCF - 3CBF - 3TDF	A 69
FOR BELT SERIES 14CCF - 25CCF - 35CCF - 7CCF	A 91
FOR BELT SERIES 8TB - 20TB - 37TB - 50TB	A 146
FOR BELT SERIES 2V - 3V - 4V - 5V	A 215
FOR O-RING BELTS AND V BELTS	A 235
FLEX-E-BELT® DRIVE SYSTEMS	A 15 - A 40
FLEX-E-BELT - TECHNICAL DATA	A 15
GEAR DRIVE BELTS	
.0982 CIRCULAR PITCH - 32 PITCH	A 16-A17
.1000 CIRCULAR PITCH - 1/10 PITCH	A 30
.1309 CIRCULAR PITCH - 24 PITCH	A 37
PULLEYS (E-Z ENTRY)	
.0982 CIRCULAR PITCH - 32 PITCH	A 18-A19
.1000 CIRCULAR PITCH - 1/10 PITCH	A 31-A36
.1309 CIRCULAR PITCH - 24 PITCH	A 38-A39
DRIVE BELT GEARS	
.0982 CIRCULAR PITCH PINION SHAFT - 32 PITCH	A 20
.0982 CIRCULAR PITCH CLUSTER HUB - 32 PITCH	A 21 - A 22
.0982 CIRCULAR PITCH PIN HUB - 32 PITCH	A 23 - A 26
.0982 CIRCULAR PITCH HUBLESS - 32 PITCH	A 27 - A 28
.0982 CIRCULAR PITCH CLAMP STYLE HUB - 32 PITCH	A 29
MIN-E-PITCH® DRIVE SYSTEMS	A 41
MIN-E-PITCH - TECHNICAL DATA	A 70
CABLE CHAINS	
.1570 CIRCULAR PITCH MIN-E-PITCH - 1/20 PITCH	A 42
CHAIN SPROCKETS	
.1570 CIRCULAR PITCH - 1/20 PITCH - PIN HUB	A 43 - A 47
.1570 CIRCULAR PITCH - 1/20 PITCH - HUBLESS	A 48 - A 49
.1570 CIRCULAR PITCH - 1/20 PITCH - CLAMP HUB	A 50
DUAL CHAINS	
.1570 CIRCULAR PITCH MIN-E-PITCH - 1/20 PITCH	A 51
BELTS	
.1570 CIRCULAR PITCH MIN-E-PITCH - 1/20 PITCH	A 92
DOUBLE SPROCKETS	
.1570 CIRCULAR PITCH PIN HUB - 1/20 PITCH	A 53 - A 56
.1570 CIRCULAR PITCH HUBLESS - 1/20 PITCH	A 57 - A 58
3-D BELT	
.1570 CIRCULAR PITCH MIN-E-PITCH - 1/20 PITCH	A 59
3-D PULLEYS	
.1570 CIRCULAR PITCH PIN HUB - 1/20 PITCH	A 60 - A 63
.1570 CIRCULAR PITCH HUBLESS - 1/20 PITCH	A 64 - A 65
.1570 CIRCULAR PITCH IDLER - 1/20 PITCH	A 66 - A 68
SUPPORT & GUIDE RAILS	A 70
FLEX-E-PITCH® DRIVE SYSTEMS	A 71 - A 90
FLEX-E-PITCH - TECHNICAL DATA	A 71
CABLE CHAIN	
FLEX-E-PITCH - .1475 CIRCULAR PITCH	A 72
FLEX-E-PITCH - .250 CIRCULAR PITCH	A 80
FLEX-E-PITCH - .375 CIRCULAR PITCH	A 84
FLEX-E-PITCH - .500 CIRCULAR PITCH	A 87 - A 88
CHAIN SPROCKETS	
PIN HUB - .1475 CIRCULAR PITCH	A 73 - A 77
PIN HUB - .250 CIRCULAR PITCH	A 81, A 83
PIN HUB - .375 CIRCULAR PITCH	A 86
PIN HUB - .500 CIRCULAR PITCH	A 90
HUBLESS - .1475 CIRCULAR PITCH	A 78 - A 79
HUBLESS - .250 CIRCULAR PITCH	A 82
HUBLESS - .375 CIRCULAR PITCH	A 85
HUBLESS - .500 CIRCULAR PITCH	A 89
AIRCRAFT CABLE	A 92
BERG FIBER CABLE	A 93
CABLE THIMBLES	A 94
CABLE CRIMP BUSHINGS	A 94
CABLE CRIMP TOOL	A 94
ROW-L-ER® CHAIN DRIVE SYSTEMS	A 95 - 129
TECHNICAL DATA	A 95
LINK CHAIN	
ROW-L-ER - .1475 CIRCULAR PITCH	A 96
ROW-L-ER - .250 CIRCULAR PITCH	A 104, A 121
ROW-L-ER - .375 CIRCULAR PITCH	A 114, A 124
ROW-L-ER - .500 CIRCULAR PITCH	A 118, A 127
SPROCKETS	
PIN HUB - .1475 CIRCULAR PITCH	A 97 - A 102
PIN HUB - .250 CIRCULAR PITCH	A 106 - A 107, A 111 - A 113, A 122 - A 123
PIN HUB - .375 CIRCULAR PITCH	A 116 - A 117, A 125
PIN HUB - .500 CIRCULAR PITCH	A 120, A 128
HUBLESS - .1475 CIRCULAR PITCH	A 103 - A 104
HUBLESS - .250 CIRCULAR PITCH	A 108 - A 110
HUBLESS - .375 CIRCULAR PITCH	A 115
HUBLESS - .500 CIRCULAR PITCH	A 119
LINK PLATE LUGS	
BENT LUGS	A 126, A 129
STRAIGHT LUGS	A 126, A 129
FLEX-E-GRIP® TIMING BELT SYSTEMS	A 130 - A 146
FLEX-E-GRIP - TECHNICAL DATA	A 130 - A 131
TIMING BELTS	
.0816 (XXL) CIRCULAR PITCH	A 132, A167-A168
.200 (XL) CIRCULAR PITCH	A 136
.375 (L) CIRCULAR PITCH	A 140
.500 (H) CIRCULAR PITCH	A 144
TIMING PULLEYS	
.0816 (XXL) CIRCULAR PITCH - PIN HUB	A 133 - A 135, A163-A166
.200 (XL) CIRCULAR PITCH - PIN HUB	A 137 - A 139
.375 (L) CIRCULAR PITCH - PIN HUB	A 141 - A 144
.500 (H) CIRCULAR PITCH - PIN HUB	A 145
MAX-M-DRIVE® CABLE DRIVE CHAIN SYSTEMS ...	A 147 - A 196
TECHNICAL DATA	A 147
TIMING BELTS	
.080 (MXL) CIRCULAR PITCH - 1/8" WIDTH	A148 - A 151
.200 (XL) CIRCULAR PITCH - 1/4" WIDTH	A 169 - A 170
.375 (L) CIRCULAR PITCH - 1/2" & 3/4" WIDTH	A 183
.079/2mm (GT) CIRCULAR PITCH	A 188 - A 189
.118/3mm (GT) CIRCULAR PITCH - .354/9mm WIDTH	A 190 - A 191
TIMING PULLEYS	
.080 (MXL) CIRCULAR PITCH PIN HUB	A 152 - A 162
.200 (XL) CIRCULAR PITCH PIN HUB	A 163 - A 169
.375 (L) CIRCULAR PITCH PIN HUB	A 171 - A 182
.079/2mm (GT) CIRCULAR PITCH PIN HUB	A 184 - A 185
.118/3mm (GT) CIRCULAR PITCH PIN HUB	A 192 - A 193, A 195
TIMING PULLEY BAR STOCK	A 186 - A 187

FLEX-E-GEAR® TECHNICAL DATA

OPERATING NOTES:

Due to the unique design of molded polyurethane over a Stainless Steel cable, the gear drive chains offer a strong, flexible, quiet, lube-free drive system that can obtain zero backlash.

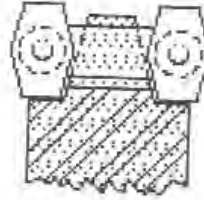

PITCH	CIRCULAR PITCH	MATERIALS	BERG'S ® NAME	PULLEY
32	.0982	Polyurethane (Blue) 1/64" (0.8mm) Dia. Stainless Steel Cable	Flex-E-Gear®	Operates with 32B, GG33 and GGF33 series.

32GCF SERIES

- Cable diameter .018 " Stainless Steel
- Ultimate tensile 30 lbs., 4 lb./pin
- Recommended Maximum Operating Speed 376 feet/min.
- Recommended Operating Load 6 - 7 lbs. *
- Minimum recommended sprocket diameter 1/2" P.D.
- Weight .13 oz/ft

PITCH	CIRCULAR PITCH	MATERIALS	BERG'S ® NAME	PULLEY
1/10	.1000	Polyurethane (Green) 1/64" Dia. Stainless Steel Cable	Flex-E-Gear®	Operates with 31A and 31B series.

31GCF SERIES

- Cable diameter .018 " Stainless Steel
- Ultimate tensile 30 lbs., 4 lb./pin
- Recommended Maximum Operating Speed 376 feet/min.
- Recommended Operating Load 6 - 7 lbs.*
- Minimum recommended sprocket diameter 3/4" P.D.
- Weight .13 oz/ft

PITCH	CIRCULAR PITCH	MATERIALS	BERG'S ® NAME	PULLEY
24	.1309	Polyurethane (Red) 1/32" Dia. Stainless Steel Cable	Flex-E-Gear®	Operates with 24B and 24A series.

24GCF SERIES

- Cable diameter 1/32 " Stainless Steel
- Ultimate tensile 100 lbs., 10 lb./pin
- Recommended Maximum Operating Speed 376 feet/min.
- Recommended Operating Load 20 - 25 lbs.*
- Minimum recommended sprocket diameter 1/2" P.D.
- Weight .14 oz/ft

* Reduce operating load by 50% for field splices.

GEAR DRIVE CHAINS

PITCH	CIRCULAR PITCH	MATERIALS	BERG'S ® NAME	SPROCKET
32	.0982	Polyurethane (Blue) .018 Dia. Stainless Steel Cable*	Flex-E-Gear®	Operates with 32B, GG33 and GGF33 series.

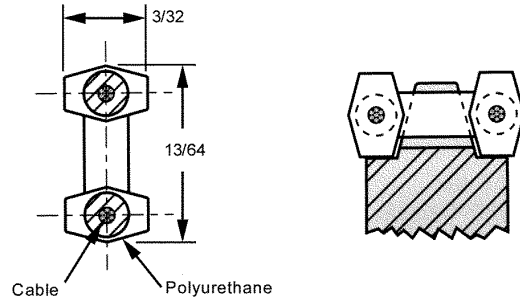
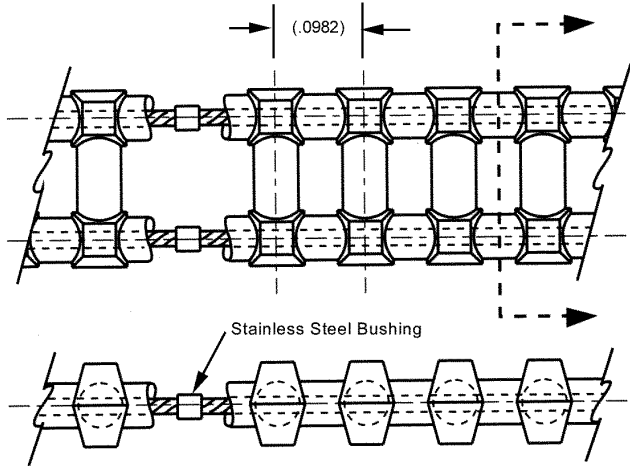

- For Field Splice Kit order 32GCF-7.
- * Available with Aramid Core. See page VII for alternative belt construction or reverse bending applications.
- **Reduce operating load rating by 50% for field splices.

STOCK NO.	NO. OF PITCHES	LENGTH (Ref.)
32GCF-49-E	49	4.811
32GCF-52-E	52	5.105
32GCF-53-E	53	5.203
32GCF-64-E	64	6.283
32GCF-67-E	67	6.577
32GCF-75-E	75	7.363
32GCF-80-E	80	7.854
32GCF-95-E	95	9.327
32GCF-112-E	112	10.996
32GCF-126-E	126	12.370
32GCF-128-E	128	12.566
32GCF-144-E	144	14.137
32GCF-158-E	158	15.512
32GCF-176-E	176	17.279
32GCF-189-E	189	18.555
32GCF-208-E	208	20.420
32GCF-220-E	220	21.598
32GCF-240-E	240	23.562
32GCF-252-E	252	24.740
32GCF-272-E	272	26.704
32GCF-283-E	283	27.783
32GCF-304-E	304	29.845
32GCF-315-E	315	30.925
32GCF-336-E	336	32.987
32GCF-346-E	346	33.968
32GCF-377-E	377	37.012
32GCF-400-E	400	39.270
32GCF-408-E	408	40.055
32GCF-432-E	432	42.412
32GCF-440-E	440	43.197
32GCF-464-E	464	45.553
32GCF-471-E	471	46.240
32GCF-480-E	480	47.124
32GCF-512-E	512	50.265
32GCF-544-E	544	53.407
32GCF-592-E	592	58.119
32GCF-608-E	608	59.690

- Infinite Lengths
- Silent Drive
- Weight .13 oz./ft
- Positive Drive
- Zero Backlash
- No Lubrication
- 90A Durometer
- Ultimate Tensile Strength 30 lbs. (4lbs./Pin) when belt is used in open loop configuration (without splice, no crimp bushing)
- Temperature Range +180°F to -15°F
- Recommended Operating Load 8 lbs.
- Recommended Max. Operating Speed 376 feet/min.

Other numbers of pitches available on request.

BULK LENGTH - NOT SPLICED	
STOCK NO.	LENGTH
32GCF-5FT	5 FT
32GCF-10FT	10 FT
32GCF-25FT	25 FT
32GCF-50FT	50 FT
32GCF-100FT	100 FT

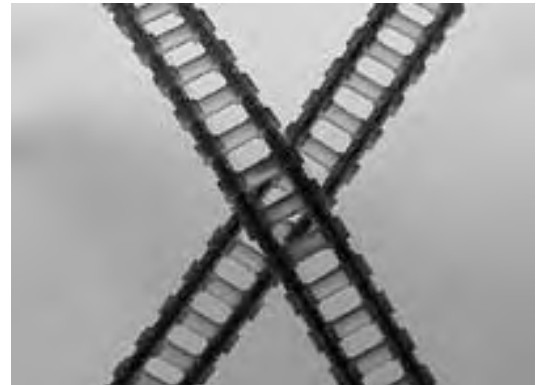

SPROCKET GEARS

PITCH	CIR. PITCH	BORE	STYLE	MATERIAL	BERG'S® NAME	CHAIN
32	.0982	1/4"	PIN HUB	Delrin®	Flex-E-Gear® Chain Drive	Operates with 32GCF Series

† Teeth runout on hub.
Other numbers of teeth available on request.

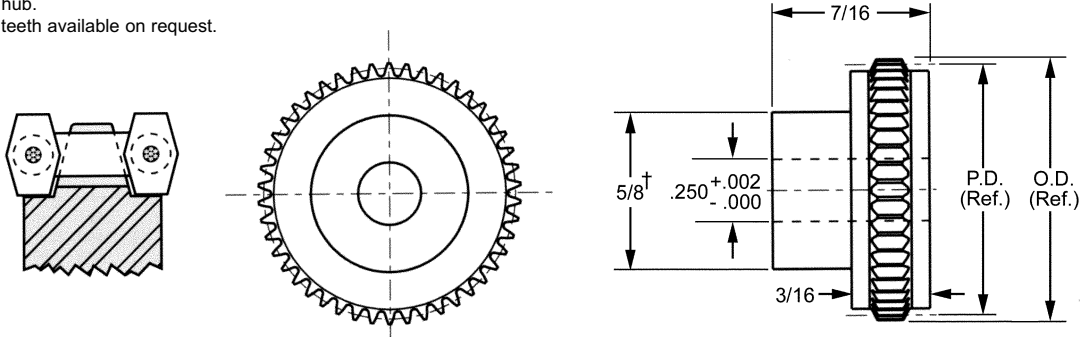

STOCK NO.	NO. OF TEETH	PITCH DIA.	OUTSIDE DIA.
32B4M-18	18†	.5625	.625
32B4M-20	20†	.6250	.688
32B4M-22	22	.6875	.750
32B4M-24	24	.7500	.813
32B4M-26	26	.8125	.875
32B4M-28	28	.8750	.938
32B4M-30	30	.9375	1.000
32B4M-32	32	1.0000	1.063
32B4M-36	36	1.1250	1.188
32B4M-40	40	1.2500	1.313
32B4M-48	48	1.5000	1.563
32B4M-56	56	1.7500	1.813
32B4M-64	64	2.0000	2.063
32B4M-72	72	2.2500	2.313
32B4M-80	80	2.5000	2.563



SPROCKET GEARS

PITCH	CIR. PITCH	BORE	STYLE	MATERIALS	BERG'S ® NAME	CHAIN
32	.0982	1/8"	PIN HUB	303 Stainless Steel 2024-T4 Aluminum Anodized	Flex-E-Gear® Chain Drive	Operates with 32GCF Series

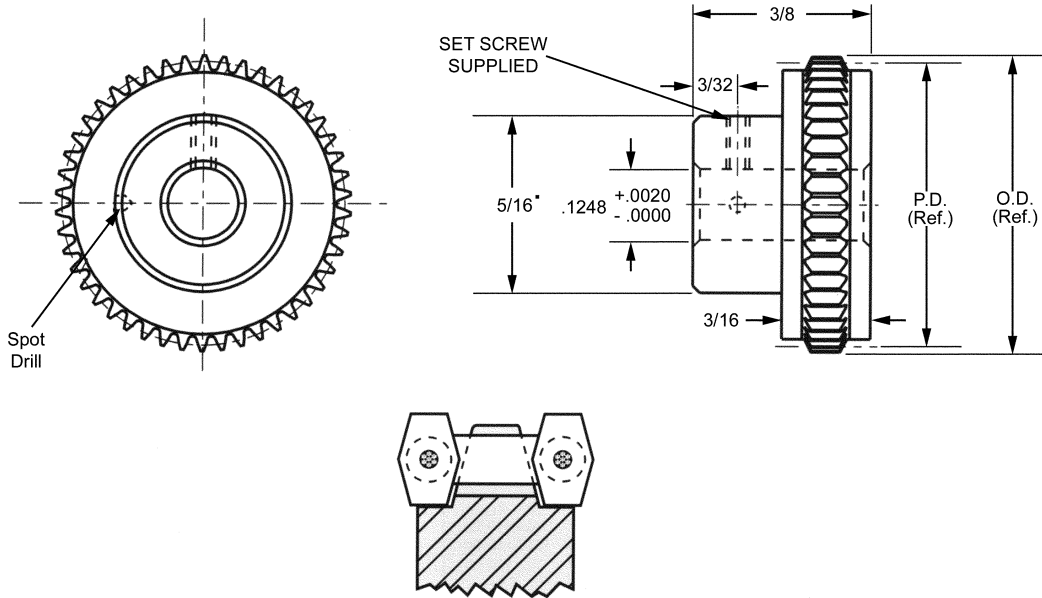

303 STAINLESS STEEL	2024-T4 ALUMINUM ANODIZED			
STOCK NO.	STOCK NO.	NO. OF TEETH	PITCH DIA.	OUTSIDE DIA.
GG33S14-13	GG33A14-13	13**	.4063	.469
GG33S14-14	GG33A14-14	14**	.4375	.500
GG33S14-15	GG33A14-15	15**	.4688	.531
GG33S14-16	GG33A14-16	16**	.5000	.563
GG33S14-18	GG33A14-18	18	.5625	.625
GG33S14-20	GG33A14-20	20	.6250	.688
GG33S14-22	GG33A14-22	22	.6875	.750
GG33S14-24	GG33A14-24	24	.7500	.813
GG33S14-26	GG33A14-26	26	.8125	.875
GG33S14-28	GG33A14-28	28	.8750	.938
GG33S14-30	GG33A14-30	30	.9375	1.000
GG33S14-32	GG33A14-32	32	1.0000	1.063
GG33S14-36	GG33A14-36	36	1.1250	1.188
GG33S14-40	GG33A14-40	40	1.2500	1.313
GG33S14-48	GG33A14-48	48	1.5000	1.563
GG33S14-56	GG33A14-56	56*	1.7500	1.813
GG33S14-64	GG33A14-64	64*	2.0000	2.063
GG33S14-72	GG33A14-72	72*	2.2500	2.313
GG33S14-80	GG33A14-80	80*	2.5000	2.563
GG33S14-88	GG33A14-88	88*	2.7500	2.813
GG33S14-96	GG33A14-96	96*	3.0000	3.063
GG33S14-112	GG33A14-112	112*	3.5000	3.563
GG33S14-128	GG33A14-128	128*	4.0000	4.063



* Alternative in 2 piece construction with 303 Stainless Steel Hub. Outline and overall dimensions change slightly.
 **Sprockets .500 P.D. and smaller for idler use only.
 • For 13-14 teeth, hub diameter equals .31.

Other numbers of teeth available on request.

Teeth could be anodized.

SPROCKET GEARS

PITCH	CIR. PITCH	BORE	STYLE	MATERIALS	BERG'S® NAME	CHAIN
32	.0982	3/16"	PIN HUB	303 Stainless Steel 2024-T4 Aluminum Anodized	Flex-E-Gear® Chain Drive	Operates with 32GCF Series

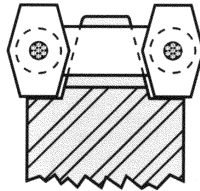
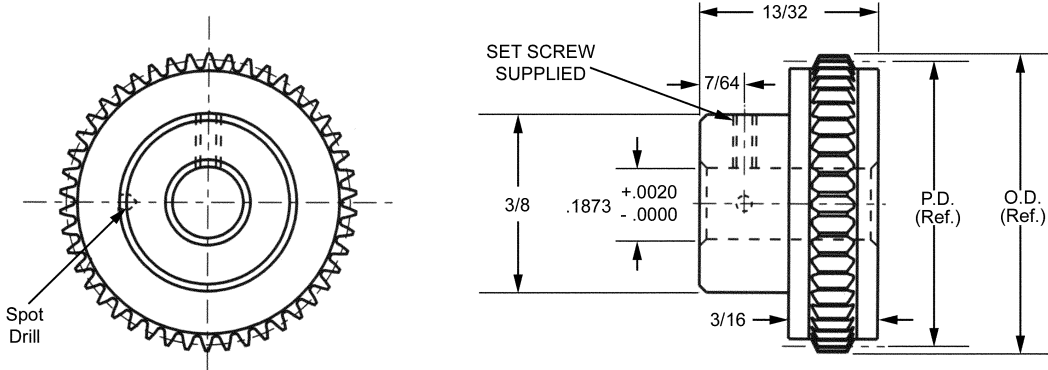

303 STAINLESS STEEL	2024-T4 ALUMINUM ANODIZED			
STOCK NO.	STOCK NO.	NO. OF TEETH	PITCH DIA.	OUTSIDE DIA.
GG33S21-15	GG33A21-15	15**	.4688	.531
GG33S21-16	GG33A21-16	16**	.5000	.563
GG33S21-18	GG33A21-18	18	.5625	.625
GG33S21-20	GG33A21-20	20	.6250	.688
GG33S21-22	GG33A21-22	22	.6875	.750
GG33S21-24	GG33A21-24	24	.7500	.813
GG33S21-26	GG33A21-26	26	.8125	.875
GG33S21-28	GG33A21-28	28	.8750	.938
GG33S21-30	GG33A21-30	30	.9375	1.000
GG33S21-32	GG33A21-32	32	1.0000	1.063
GG33S21-36	GG33A21-36	36	1.1250	1.188
GG33S21-40	GG33A21-40	40	1.2500	1.313
GG33S21-48	GG33A21-48	48	1.5000	1.563
GG33S21-56	GG33A21-56	56	1.7500	1.813
GG33S21-64	GG33A21-64	64	2.0000	2.063
GG33S21-72	GG33A21-72	72	2.2500	2.313
GG33S21-80	GG33A21-80	80	2.5000	2.563
GG33S21-88	GG33A21-88	88	2.7500	2.813
GG33S21-96	GG33A21-96	96	3.0000	3.063
GG33S21-112	GG33A21-112	112	3.5000	3.563
GG33S21-128	GG33A21-128	128	4.0000	4.063



**Sprockets .500 P.D. and smaller for idler use only.
Other numbers of teeth available on request.

Teeth could be anodized.

SPROCKET GEARS

PITCH	CIR. PITCH	BORE	STYLE	MATERIALS	BERG'S® NAME	CHAIN
32	.0982	1/4"	PIN HUB	303 Stainless Steel 2024-T4 Aluminum Anodized	Flex-E-Gear® Chain Drive	Operates with 32GCF Series

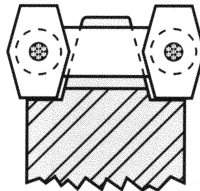
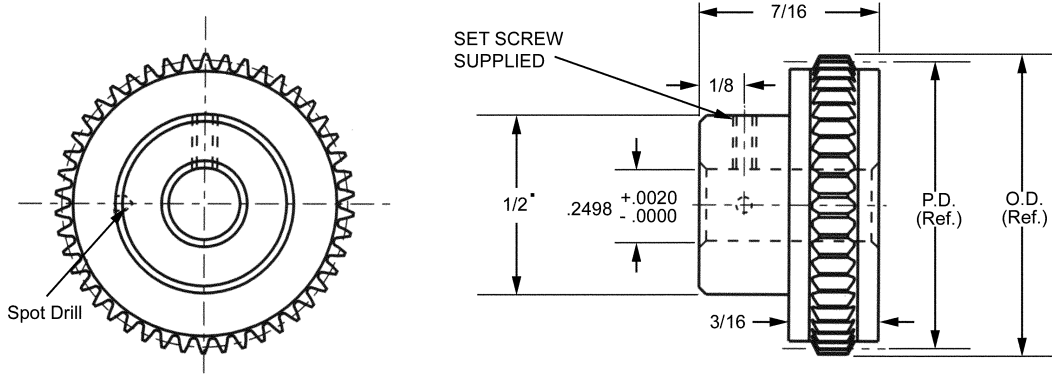

STOCK NO.	STOCK NO.	NO. OF TEETH	PITCH DIA.	OUTSIDE DIA.
GG33S28-18	GG33A28-18	18*	.5625	.625
GG33S28-20	GG33A28-20	20	.6250	.688
GG33S28-22	GG33A28-22	22	.6875	.750
GG33S28-24	GG33A28-24	24	.7500	.813
GG33S28-26	GG33A28-26	26	.8125	.875
GG33S28-28	GG33A28-28	28	.8750	.938
GG33S28-30	GG33A28-30	30	.9375	1.000
GG33S28-32	GG33A28-32	32	1.0000	1.063
GG33S28-36	GG33A28-36	36	1.1250	1.188
GG33S28-40	GG33A28-40	40	1.2500	1.313
GG33S28-48	GG33A28-48	48	1.5000	1.563
GG33S28-56	GG33A28-56	56	1.7500	1.813
GG33S28-64	GG33A28-64	64	2.0000	2.063
GG33S28-72	GG33A28-72	72	2.2500	2.313
GG33S28-80	GG33A28-80	80	2.5000	2.563
GG33S28-88	GG33A28-88	88	2.7500	2.813
GG33S28-96	GG33A28-96	96	3.0000	3.063
GG33S28-112	GG33A28-112	112	3.5000	3.563
GG33S28-128	GG33A28-128	128	4.0000	4.063



* For 18 teeth, hub diameter equals .47.
Other numbers of teeth available on request.

Teeth could be anodized.

SPROCKET GEARS

PITCH	CIR. PITCH	BORE	STYLE	MATERIALS	BERG'S® NAME	CHAIN
32	.0982	3/8"	HUBLESS	303 Stainless Steel 2024-T4 Aluminum Anodized	Flex-E-Gear® Chain Drive	Operates with 32GCF Series

Other numbers of teeth available on request.
Pin or Clamp Hubs assembled on request.

Teeth could be anodized.

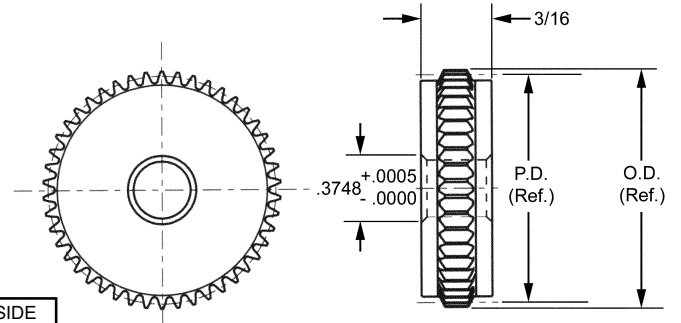
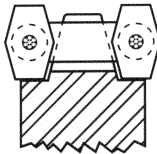

303 STAINLESS STEEL	2024-T4 ALUMINUM ANODIZED	STOCK NO.	STOCK NO.	NO. OF TEETH	PITCH DIA.	OUTSIDE DIA.
GGF33S5-32	GGF33A5-32			32	1.0000	1.063
GGF33S5-36	GGF33A5-36			36	1.1250	1.188
GGF33S5-40	GGF33A5-40			40	1.2500	1.313
GGF33S5-48	GGF33A5-48			48	1.5000	1.563
GGF33S5-50	GGF33A5-50			50	1.5625	1.625
GGF33S5-56	GGF33A5-56			56	1.7500	1.813
GGF33S5-64	GGF33A5-64			64	2.0000	2.063
GGF33S5-72	GGF33A5-72			72	2.2500	2.313
GGF33S5-80	GGF33A5-80			80	2.5000	2.563
GGF33S5-88	GGF33A5-88			88	2.7500	2.813
GGF33S5-90	GGF33A5-90			90	2.8125	2.875
GGF33S5-96	GGF33A5-96			96	3.0000	3.063
GGF33S5-100	GGF33A5-100			100	3.1250	3.188
GGF33S5-112	GGF33A5-112			112	3.5000	3.563
GGF33S5-120	GGF33A5-120			120	3.7500	3.813
GGF33S5-128	GGF33A5-128			128	4.0000	4.063



PITCH	CIR. PITCH	BORE	STYLE	MATERIALS	BERG'S® NAME	CHAIN
32	.0982	11/16"	HUBLESS	303 Stainless Steel 2024-T4 Aluminum- Anodized	Flex-E-Gear® Chain Drive	Operates with 32GCF Series

Other numbers of teeth available on request.
Pin or Clamp Hubs assembled on request.

Teeth could be anodized.

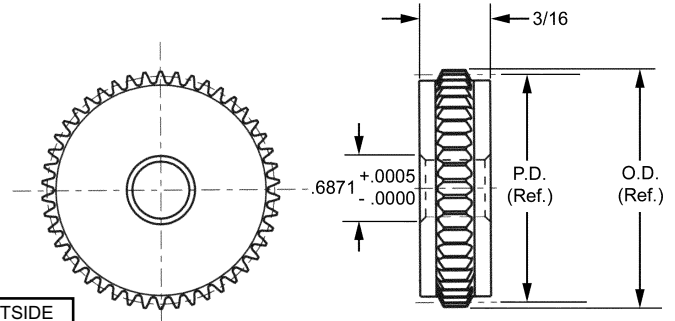
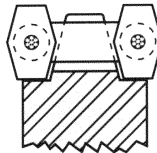

303 STAINLESS STEEL	2024-T4 ALUMINUM ANODIZED	STOCK NO.	STOCK NO.	NO. OF TEETH	PITCH DIA.	OUTSIDE DIA.
GGF33S19-32	GGF33A19-32			32	1.0000	1.063
GGF33S19-36	GGF33A19-36			36	1.1250	1.188
GGF33S19-40	GGF33A19-40			40	1.2500	1.313
GGF33S19-48	GGF33A19-48			48	1.5000	1.563
GGF33S19-50	GGF33A19-50			50	1.5625	1.625
GGF33S19-56	GGF33A19-56			56	1.7500	1.813
GGF33S19-64	GGF33A19-64			64	2.0000	2.063
GGF33S19-72	GGF33A19-72			72	2.2500	2.313
GGF33S19-80	GGF33A19-80			80	2.5000	2.563
GGF33S19-88	GGF33A19-88			88	2.7500	2.813
GGF33S19-90	GGF33A19-90			90	2.8125	2.875
GGF33S19-96	GGF33A19-96			96	3.0000	3.063
GGF33S19-100	GGF33A19-100			100	3.1250	3.188
GGF33S19-112	GGF33A19-112			112	3.5000	3.563
GGF33S19-120	GGF33A19-120			120	3.7500	3.813
GGF33S19-128	GGF33A19-128			128	4.0000	4.063



GEAR DRIVE CHAINS

PITCH	CIRCULAR PITCH	MATERIALS	BERG'S ® NAME	SPROCKET
1/10	.1000	Polyurethane (Green) .018 Dia. Stainless Steel Cable*	Flex-E-Gear®	Operates with 31A and 31B series.

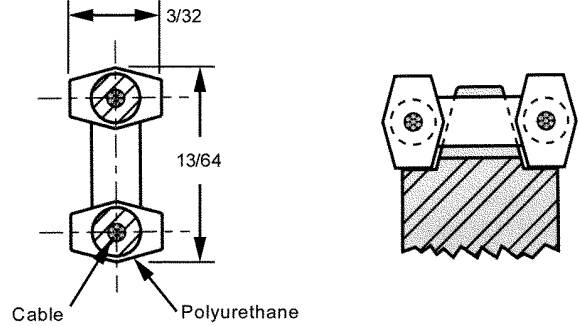
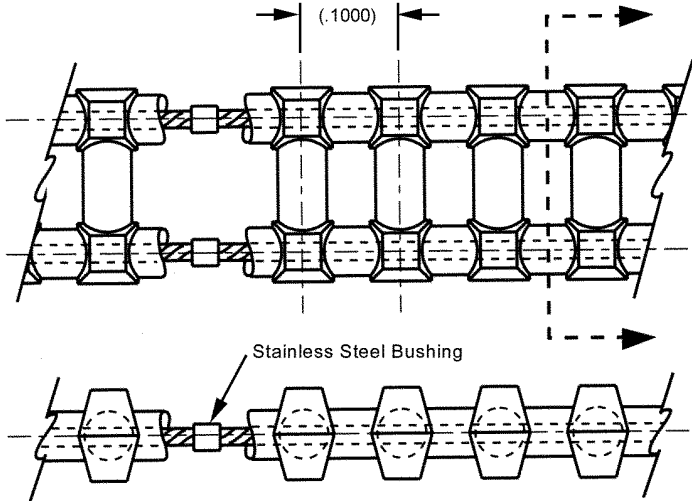

- For Field Splice Kit order 32GCF-7.
- * Available with Aramid Core. See page VII for alternative belt construction or reverse bending applications.
- **Reduce operating load rating by 50% for field splices.

STOCK NO.	NO. OF PITCHES	LENGTH (Ref.)
31GCF-45-E	45	4.50
31GCF-50-E	50	5.00
31GCF-55-E	55	5.50
31GCF-60-E	60	6.00
31GCF-65-E	65	6.50
31GCF-70-E	70	7.00
31GCF-75-E	75	7.50
31GCF-80-E	80	8.00
31GCF-85-E	85	8.50
31GCF-90-E	90	9.00
31GCF-95-E	95	9.50
31GCF-100-E	100	10.00
31GCF-105-E	105	10.50
31GCF-110-E	110	11.00
31GCF-115-E	115	11.50
31GCF-120-E	120	12.00
31GCF-125-E	125	12.50
31GCF-130-E	130	13.00
31GCF-135-E	135	13.50
31GCF-140-E	140	14.00
31GCF-150-E	150	15.00
31GCF-160-E	160	16.00
31GCF-170-E	170	17.00
31GCF-180-E	180	18.00
31GCF-190-E	190	19.00
31GCF-200-E	200	20.00
31GCF-210-E	210	21.00
31GCF-220-E	220	22.00
31GCF-230-E	230	23.00
31GCF-240-E	240	24.00
31GCF-250-E	250	25.00
31GCF-300-E	300	30.00
31GCF-360-E	360	36.00
31GCF-420-E	420	42.00
31GCF-480-E	480	48.00
31GCF-540-E	540	54.00
31GCF-600-E	600	60.00

BULK LENGTH - NOT SPLICED	
STOCK NO.	LENGTH
31GCF-5FT	5 FT
31GCF-10FT	10 FT
31GCF-25FT	25 FT
31GCF-50FT	50 FT
31GCF-100FT	100 FT

- Infinite Lengths
- Silent Drive
- Weight .13 oz./ft.
- Positive Drive
- Zero Backlash
- No Lubrication
- 90A Durometer
- Ultimate Tensile Strength 30 lbs. (4lbs./Pin)
When belt is used in open loop configuration (without splice, no crimp bushing)
- Temperature Range +180°F to -15°F
- Recommended Operating Load 8 lbs.
- Recommended Max. Operating Speed 376 feet/min.

Other numbers of pitches available on request.

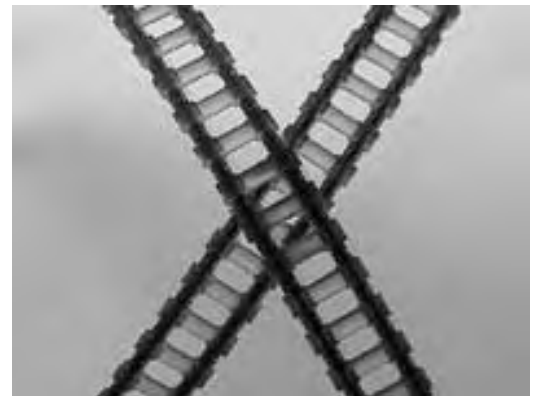

SPROCKET GEARS

PITCH	CIR. PITCH	BORE	STYLE	MATERIAL	BERG'S® NAME	CHAIN
1/10	.1000	3/8"	HUBLESS	2024-T4 Aluminum Anodized	Flex-E-Gear® Chain Drive	Operates with 31GCF Series

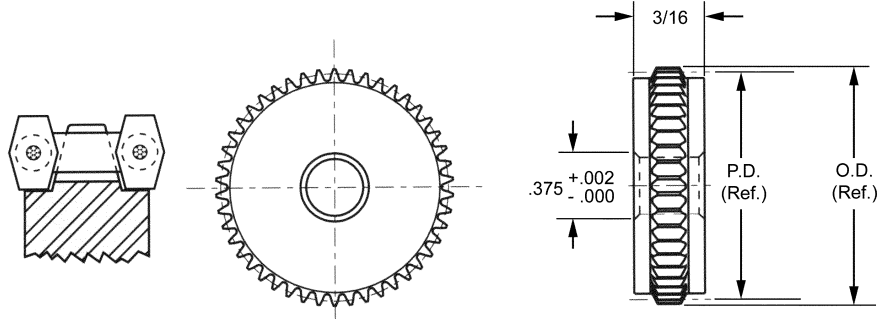

Other numbers of teeth available on request.
Pin or clamp hub available upon request.

Teeth could be anodized.

STOCK NO.	NO. OF TEETH	PITCH DIA.	OUTSIDE DIA.
31A6-22	22	.7003	.764
31A6-24	24	.7639	.828
31A6-26	26	.8276	.891
31A6-28	28	.8913	.955
31A6-30	30	.9549	1.019
31A6-32	32	1.0186	1.083
31A6-36	36	1.1459	1.210
31A6-40	40	1.2732	1.337
31A6-48	48	1.5279	1.592
31A6-56	56	1.7825	1.846
31A6-64	64	2.0372	2.101
31A6-72	72	2.2918	2.356
31A6-96	96	3.0558	3.119
31A6-112	112	3.5651	3.629

SPROCKET GEARS

PITCH	CIR. PITCH	BORE	STYLE	MATERIAL	BERG'S® NAME	CHAIN
1/10	.1000	1/8"	PIN HUB	2024-T4 Aluminum Anodized	Flex-E-Gear® Chain Drive	Operates with 31GCF Series

STOCK NO.	NO. OF TEETH	PITCH DIA.	OUTSIDE DIA.
31B2-14	14*	.4456	.509
31B2-16	16*	.5093	.573
31B2-20	20*	.6366	.700
31B2-22	22*	.7003	.764
31B2-24	24	.7639	.828
31B2-26	26	.8276	.891
31B2-28	28	.8913	.955
31B2-30	30	.9549	1.019
31B2-32	32	1.0186	1.083
31B2-36	36	1.1459	1.210
31B2-40	40	1.2732	1.337
31B2-48	48	1.5279	1.592
31B2-56	56	1.7825	1.846
31B2-64	64	2.0372	2.101
31B2-72	72	2.2918	2.356
31B2-96	96	3.0558	3.119
31B2-112	112	3.5651	3.629

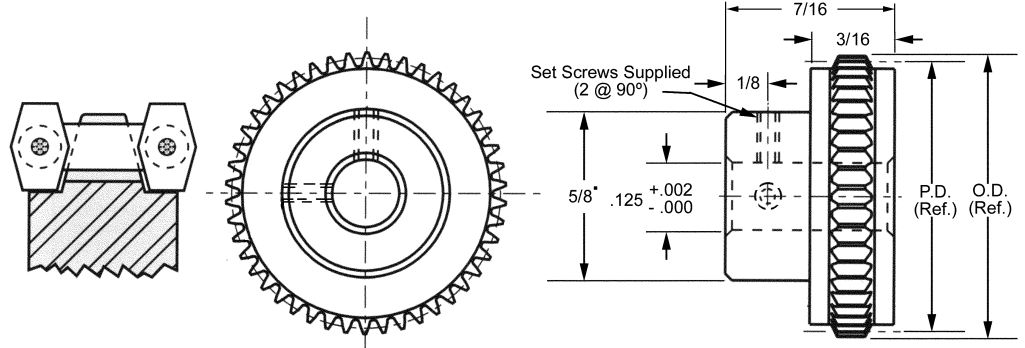

* Sprocket .500 P.D. and smaller are recommended for idler use only. • For 14-22 teeth, hub diameter equals .35. Other numbers of teeth available on request. Teeth could be anodized.

PITCH	CIR. PITCH	BORE	STYLE	MATERIAL	BERG'S® NAME	CHAIN
1/10	.1000	3/16"	PIN HUB	2024-T4 Aluminum Anodized	Flex-E-Gear® Chain Drive	Operates with 31GCF Series

STOCK NO.	NO. OF TEETH	PITCH DIA.	OUTSIDE DIA.
31B3-20	20*	.6366	.700
31B3-22	22*	.7003	.764
31B3-24	24	.7639	.828
31B3-26	26	.8276	.891
31B3-28	28	.8913	.955
31B3-30	30	.9549	1.019
31B3-32	32	1.0186	1.083
31B3-36	36	1.1459	1.210
31B3-40	40	1.2732	1.337
31B3-48	48	1.5279	1.592
31B3-56	56	1.7825	1.846
31B3-64	64	2.0372	2.101
31B3-72	72	2.2918	2.356
31B3-96	96	3.0558	3.119
31B3-112	112	3.5651	3.629

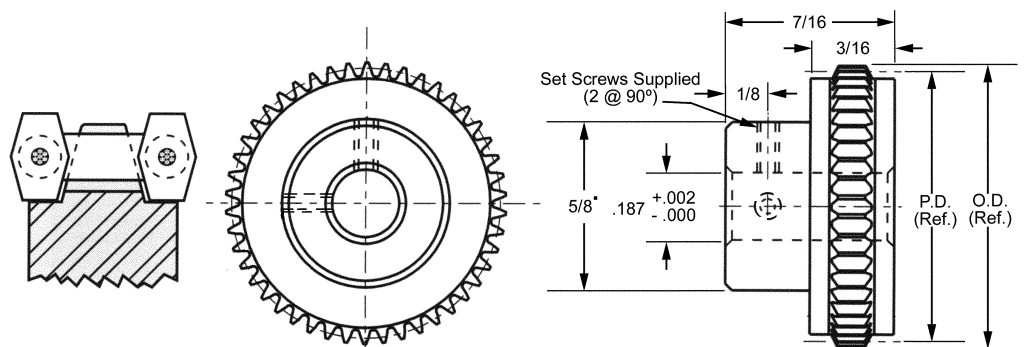

• For 20-22 teeth, hub diameter equals .55. Other numbers of teeth available on request. Teeth could be anodized.

PITCH	CIR. PITCH	BORE	STYLE	MATERIAL	BERG'S® NAME	CHAIN
1/10	.1000	1/4"	PIN HUB	2024-T4 Aluminum Anodized	Flex-E-Gear® Chain Drive	Operates with 31GCF Series

STOCK NO.	NO. OF TEETH	PITCH DIA.	OUTSIDE DIA.
31B4-20	20*	.6366	.700
31B4-22	22*	.7003	.764
31B4-24	24	.7639	.8278
31B4-26	26	.8276	.891
31B4-28	28	.8913	.955
31B4-30	30	.9549	1.0189
31B4-32	32	1.0186	1.083
31B4-36	36	1.1459	1.210
31B4-40	40	1.2732	1.337
31B4-48	48	1.5279	1.592
31B4-56	56	1.7825	1.846
31B4-64	64	2.0372	2.101
31B4-72	72	2.2918	2.356
31B4-96	96	3.0558	3.119
31B4-112	112	3.5651	3.629

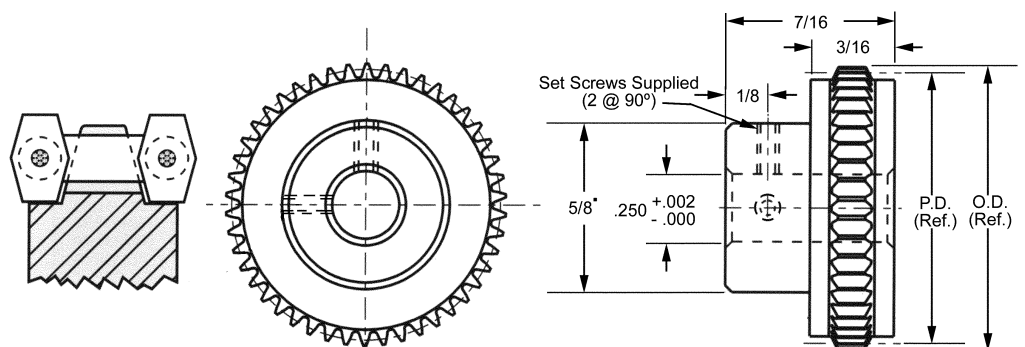

• For 20-22 teeth, hub diameter equals .55. Other numbers of teeth available on request. Teeth could be anodized.

GEAR DRIVE CHAINS

PITCH	CIRCULAR PITCH	MATERIALS	BERG'S ® NAME	SPROCKET
24	.1309	Polyurethane (Red) 1/32" Dia. Stainless Steel Cable*	Flex-E-Gear®	Operates with 24A and 24B series.

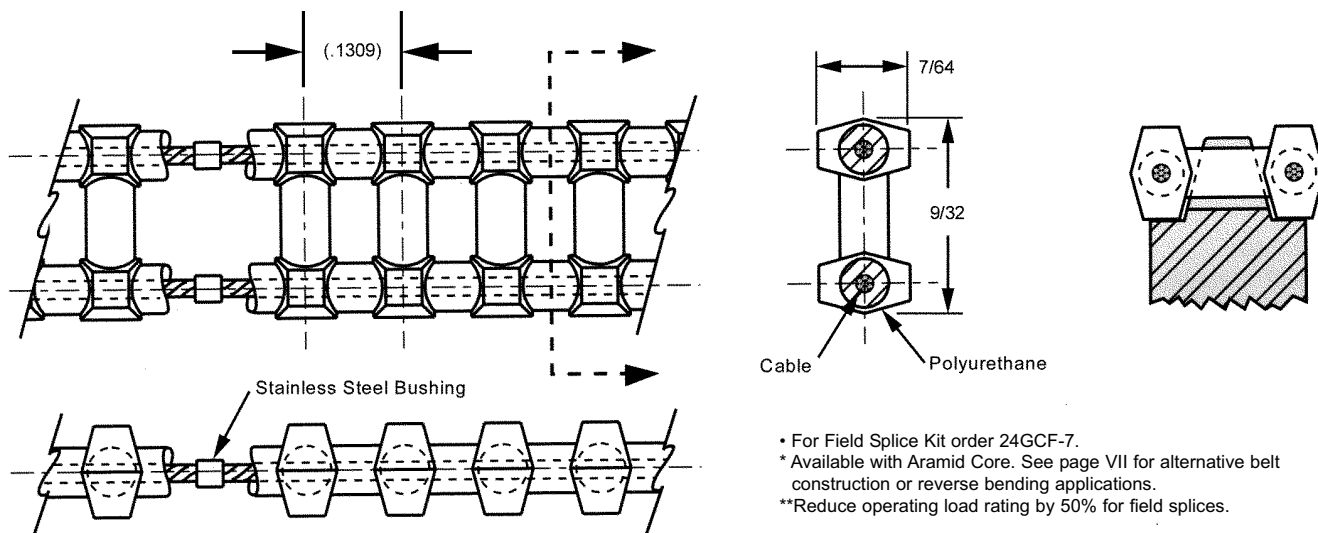

STOCK NO.	NO. OF PITCHES	LENGTH (Ref.)
24GCF-50-E	50	6.545
24GCF-52-E	52	6.807
24GCF-54-E	54	7.069
24GCF-56-E	56	7.330
24GCF-58-E	58	7.592
24GCF-60-E	60	7.854
24GCF-62-E	62	8.116
24GCF-64-E	64	8.378
24GCF-66-E	66	8.639
24GCF-68-E	68	8.901
24GCF-70-E	70	9.163
24GCF-75-E	75	9.817
24GCF-80-E	80	10.472
24GCF-85-E	85	11.126
24GCF-90-E	90	11.781
24GCF-95-E	95	12.435
24GCF-100-E	100	13.090
24GCF-105-E	105	13.744
24GCF-110-E	110	14.399
24GCF-115-E	115	15.053
24GCF-120-E	120	15.708
24GCF-130-E	130	17.017
24GCF-140-E	140	18.326
24GCF-150-E	150	19.635
24GCF-160-E	160	20.944
24GCF-170-E	170	22.253
24GCF-180-E	180	23.562
24GCF-190-E	190	24.871
24GCF-200-E	200	26.180
24GCF-220-E	220	28.798
24GCF-240-E	240	31.416
24GCF-260-E	260	34.034
24GCF-280-E	280	36.652
24GCF-300-E	300	39.270
24GCF-320-E	320	41.888
24GCF-380-E	380	49.742
24GCF-420-E	420	54.978

- Infinite Lengths
- Weight .14 oz./ft
- Positive Drive
- Zero Backlash
- No Lubrication
- Silent Drive
- Extra Strong
- 90A Durometer
- Ultimate Tensile Strength 100 lbs. (10lbs./Pin) when belt is used in open loop configuration (without splice, no crimp bushing).
- Temperature Range +180°F to -15°F
- Recommended Operating Load 25 lbs.
- Recommended Max. Operating Speed 376 ft./min.

Other numbers of pitches available on request.

BULK LENGTH - NOT SPLICED	
STOCK NO.	LENGTH
24GCF-5FT	5 FT
24GCF-10FT	10 FT
24GCF-25FT	25 FT
24GCF-50FT	50 FT
24GCF-100FT	100 FT



SPROCKET GEARS

PITCH	CIR. PITCH	BORE	STYLE	MATERIAL	BERG'S® NAME	CHAIN
24	.1309	1/4"	PIN HUB	Delrin®	Flex-E-Gear® Chain Drive	Operates with 24GCF Series

STOCK NO.	NO. OF TEETH	PITCH DIA.	OUTSIDE DIA.
24B4M-15	15†	.6243	.708
24B4M-16	16†	.6659	.749
24B4M-18	18	.7492	.832
24B4M-20	20	.8324	.916
24B4M-21	21	.8740	.957
24B4M-24	24	.9989	1.082
24B4M-30	30	1.2486	1.332
24B4M-36	36	1.4983	1.582
24B4M-42	42	1.7480	1.831
24B4M-48	48	1.9978	2.081
24B4M-60	60	2.4972	2.581

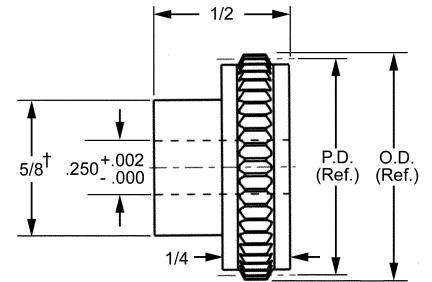
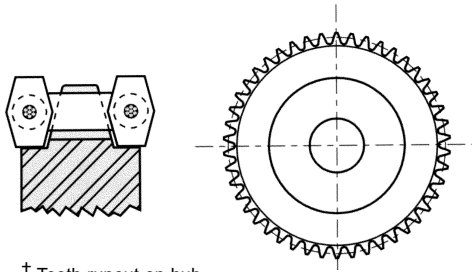

† Teeth runout on hub.
Other numbers of teeth available on request.



SPROCKET GEARS

PITCH	CIR. PITCH	BORE	STYLE	MATERIAL	BERG'S® NAME	CHAIN
24	.1309	3/8"	HUBLESS	2024-T4 Aluminum Anodized	Flex-E-Gear® Chain Drive	Operates with 24GCF Series

* Sprockets .750 P.D. and smaller for idler use only.
Other numbers of teeth available on request.

Teeth could be anodized.

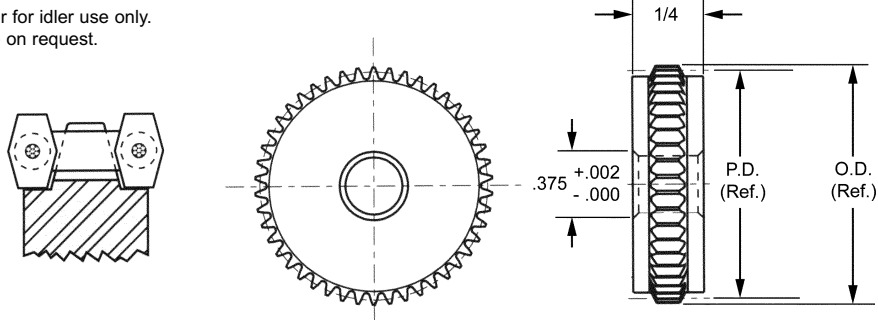

STOCK NO.	NO. OF TEETH	PITCH DIA.	OUTSIDE DIA.
24A6-15	15*	.6243	.708
24A6-16	16*	.6659	.749
24A6-18	18*	.7492	.832
24A6-20	20	.8324	.916
24A6-21	21	.8740	.957
24A6-24	24	.9989	1.082
24A6-30	30	1.2486	1.332
24A6-36	36	1.4983	1.582
24A6-42	42	1.7480	1.831
24A6-48	48	1.9978	2.081
24A6-60	60	2.4972	2.581
24A6-72	72	2.9966	3.080
24A6-96	96	3.9955	4.079
24A6-120	120	4.9944	5.078
24A6-144	144	5.9933	6.077



Teeth could be anodized.

SPROCKET GEARS

PITCH	CIR. PITCH	BORE	STYLE	MATERIAL	BERG'S® NAME	CHAIN
24	.1309	1/4"	PIN HUB	2024-T4 Aluminum Red Anodized	Flex-E-Gear® Chain Drive	Operates with 24GCF Series

STOCK NO.	NO. OF TEETH	PITCH DIA.	OUTSIDE DIA.
24B4-14	14*	.5827	.666
24B4-15	15*	.6243	.708
24B4-16	16*	.6659	.749
24B4-18	18*	.7492	.832
24B4-20	20*	.8324	.916
24B4-21	21	.8740	.957
24B4-24	24	.9989	1.082
24B4-30	30	1.2486	1.332
24B4-36	36	1.4983	1.582
24B4-42	42	1.7480	1.831
24B4-48	48	1.9978	2.081
24B4-60	60	2.4972	2.581
24B4-72	72	2.9966	3.080
24B4-96	96	3.9955	4.079
24B4-120	120	4.9944	5.078
24B4-144	144	5.9933	6.077

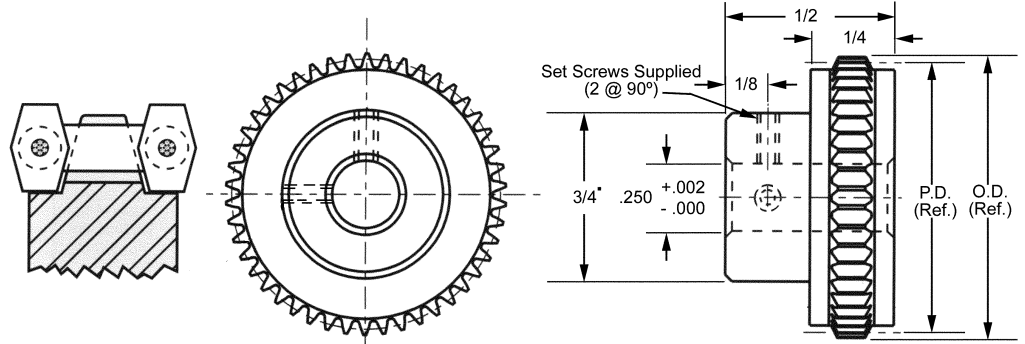

• For 14-20 teeth, hub diameter equals .47. * Sprockets .750 P.D. and smaller for idler use only. Other numbers of teeth available on request.
Teeth could be anodized.

PITCH	CIR. PITCH	BORE	STYLE	MATERIAL	BERG'S® NAME	CHAIN
24	.1309	3/8"	PIN HUB	2024-T4 Aluminum Red Anodized	Flex-E-Gear® Chain Drive	Operates with 24GCF Series

STOCK NO.	NO. OF TEETH	PITCH DIA.	OUTSIDE DIA.
24B6-18	18*	.7492	.832
24B6-20	20*	.8324	.916
24B6-21	21	.8740	.957
24B6-24	24	.9989	1.082
24B6-30	30	1.2486	1.332
24B6-36	36	1.4983	1.582
24B6-42	42	1.7480	1.831
24B6-48	48	1.9978	2.081
24B6-60	60	2.4972	2.581
24B6-72	72	2.9966	3.080
24B6-96	96	3.9955	4.079
24B6-120	120	4.9944	5.078
24B6-144	144	5.9933	6.077

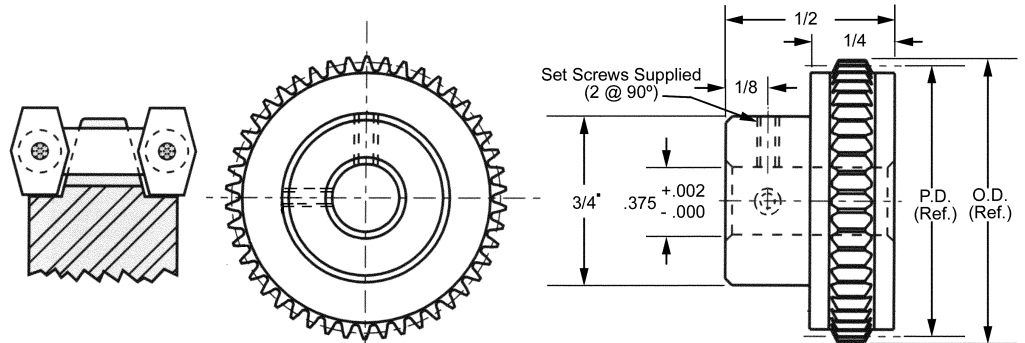

• For 18-20 teeth, hub diameter equals .64. * Sprockets .750 P.D. and smaller for idler use only. Other numbers of teeth available on request.
Teeth could be anodized.

PITCH	CIR. PITCH	BORE	STYLE	MATERIAL	BERG'S® NAME	CHAIN
24	.1309	1/2"	PIN HUB	2024-T4 Aluminum Red Anodized	Flex-E-Gear® Chain Drive	Operates with 24GCF Series

STOCK NO.	NO. OF TEETH	PITCH DIA.	OUTSIDE DIA.
24B8-20	20*	.8324	.916
24B8-21	21	.8740	.957
24B8-24	24	.9989	1.082
24B8-30	30	1.2486	1.332
24B8-36	36	1.4983	1.582
24B8-42	42	1.7480	1.831
24B8-48	48	1.9978	2.081
24B8-60	60	2.4972	2.581
24B8-72	72	2.9966	3.080
24B8-96	96	3.9955	4.079
24B8-120	120	4.9944	5.078
24B8-144	144	5.9933	6.077

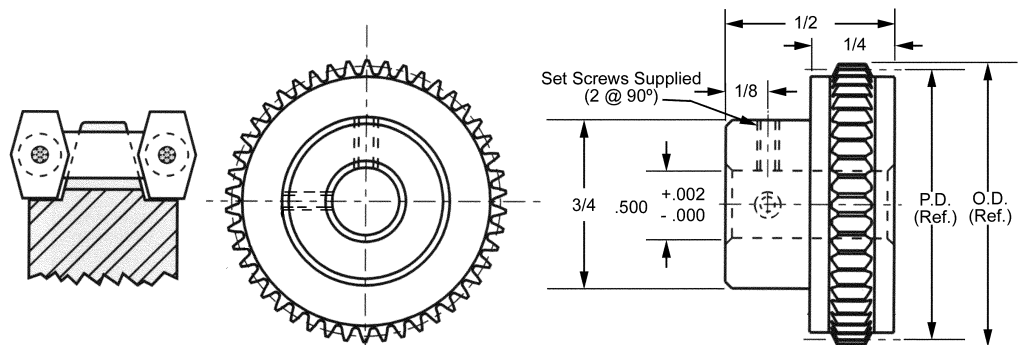

• For 20 teeth, hub diameter equals .72. * Sprockets .750 P.D. and smaller for idler use only. Other numbers of teeth available on request.
Teeth could be anodized.

FIELD SPLICE KITS

Splicing Procedures

1. Cut "BERG" *FLEX-E-GEAR*[®] sharp and square as shown, using cutter, to desired number of pitches, plus one pitch.



2. Cut plastic jacket (one pitch each side) lightly with a sharp razor blade as shown (all around). Caution: do not nick wire. Strip or twist off jacket carefully.

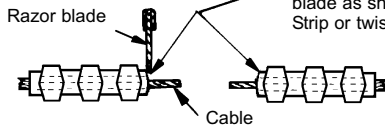

3. Slide stripped cable into oval splice bushing carefully. **Caution:** Do not fray cable. Feed cable into chamfered end of bushing last.



5. Position crimp tool over splice bushing and squeeze tightly for maximum splice strength.

4. Center bushing and be certain chain is straight before crimping.

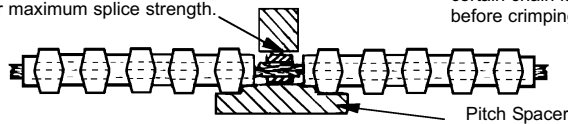

CHAIN SERIES	STOCK NO.	FIELD SPLICE KIT AND ACCESSORIES
31 & 32GCF 24GCF 16GCF	32GCF-7 24GCF-7 16GCF-7	Complete Kit Consists of: Crimp tool, Pitch Spacer, Cable Cutter, Bushings, Razor Blades & Instructions
	TL-4 TL-3	Crimp Tool For 31GCF & 32GCF Crimp Tool for 24GCF
	BU-018-S BU-032-S	Extra Splice Bushings for: 31GCF & 32GCF (1/64" Cable) 24GCF (1/32" Cable)
	TL-1	Cable Cutter for up to 3/64" Cable

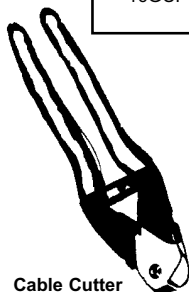

Cable Cutter



Crimp Tool

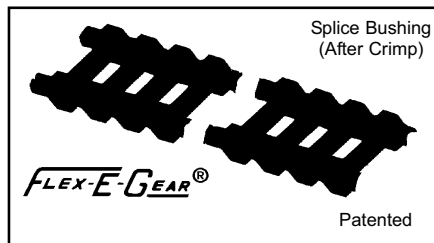

Field Splices offer only
50% of Catalog Rated Loads

W. M. BERG, INC. will factory splice to order any length chain at a nominal charge.

FLEX-E-BELT® TECHNICAL DATA

OPERATING NOTES:

Due to the single steel cable/polyurethane construction, this series offers a flexible, quiet, lube-free drive that can obtain zero backlash and up to 7° of sprocket misalignment.

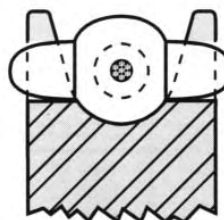

PITCH	CIRCULAR PITCH	MATERIALS	BERG'S ® NAME	PULLEY
32	.0982	Polyurethane (Blue) 1/32" (0.8mm) Dia. Stainless Steel Cable	Flex-E-Belt®	Operates with 32C, 32D, GPS, GP32, GF32 and GC32 series.

32GBF SERIES

- Weight .11 oz./ft.
 - Ultimate tensile 50 lbs., 9 lb./pin (222N, 40N/PIN) - when belt is used in open loop configuration (without splice, no crimp bushing).
 - Recommended Maximum Operating Speed 376 feet/min. (1800 rpm)
 - Recommended Operating Load 12 lbs.
 - Minimum recommended pulley diameter 1/2" P.D.
- **Reduce operating load rating by 50% for field splices.

PITCH	CIRCULAR PITCH	MATERIALS	BERG'S ® NAME	PULLEY
32	.0982	Polyurethane (Light Brown) .018" Dia. Stainless Steel Cable	Flex-E-Belt®	Operates with 32C, 32D, GPS, GP32, GF32 and GC32 series.

33GBF SERIES

- Weight 11 oz./ft.
 - Ultimate tensile 20 lbs., 7 lb./pin - when belt is used in open loop configuration (without splice, no crimp bushing).
 - Recommended Maximum Operating Speed 376 feet/min. (1800 rpm)
 - Recommended Operating Load 5 lbs.
 - Minimum recommended pulley diameter 1/2" P.D.
- **Reduce operating load rating by 50% for field splices.

PITCH	CIRCULAR PITCH	MATERIALS	BERG'S ® NAME	PULLEY
1/10	.1000	Polyurethane (Red) 1/32" Dia. Stainless Steel Cable	Flex-E-Belt®	Operates with GP31 and GF31 series.

31GBF SERIES

- Weight 11 oz./ft.
 - Ultimate tensile 50 lbs., 9 lb./pin - when belt is used in open loop configuration (without splice, no crimp bushing).
 - Recommended Maximum Operating Speed 376 feet/min. (1800 rpm)
 - Recommended Operating Load 12 lbs.
 - Minimum recommended pulley diameter 3/4" P.D.
- **Reduce operating load rating by 50% for field splices.

PITCH	CIRCULAR PITCH	MATERIALS	BERG'S ® NAME	PULLEY
24	.1309	Polyurethane (Red) 1/32" (0.8mm) Dia. Stainless Steel Cable	Flex-E-Belt®	Operates with 24C and 24D series.

24GBF SERIES

- Weight 13 oz./ft.
 - Ultimate tensile 50 lbs., 9 lb./pin - when belt is used in open loop configuration (without splice, no crimp bushing)
 - Recommended Maximum Operating Speed 376 feet/min. (1800 rpm)
 - Recommended Operating Load 12 lbs.
 - Minimum recommended pulley diameter 3/4" P.D.
- **Reduce operating load rating by 50% for field splices.

GEAR DRIVE BELTS

PITCH	CIRCULAR PITCH	MATERIALS	BERG'S ® NAME	PULLEY
32	.0982	Polyurethane (Blue) 1/32" Dia. Stainless Steel Cable*	Flex-E-Belt®	Operates with 32C, 32D, GPS, GP32, GF32 and GC32 series.

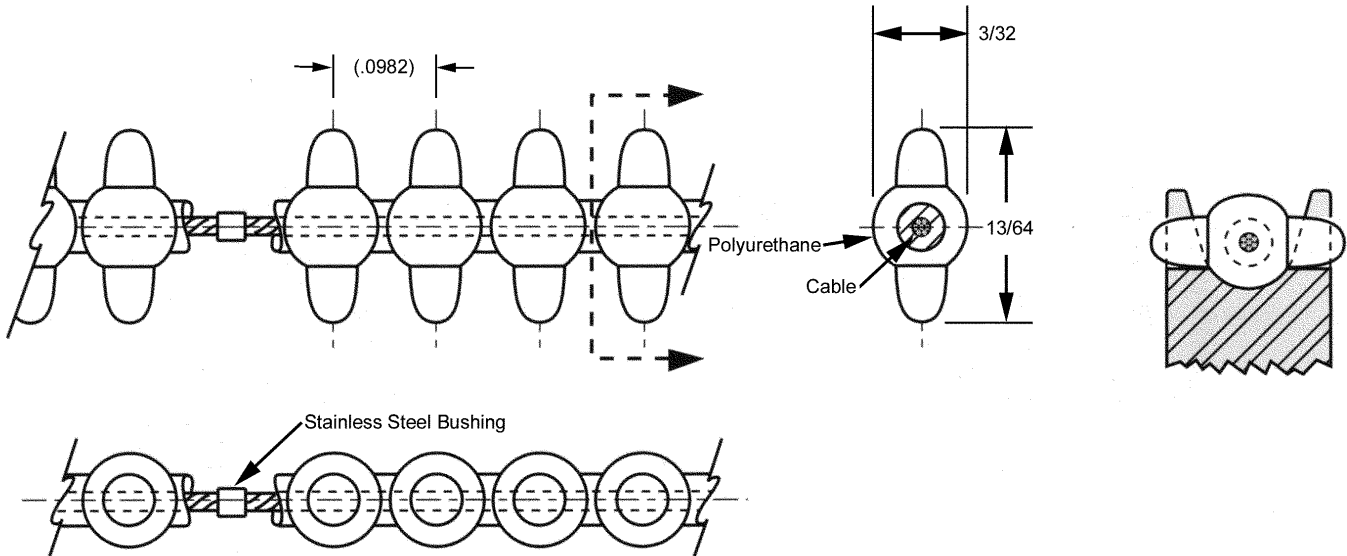

STOCK NO.	NO. OF PITCHES	LENGTH (Ref.)
32GBF-49-E	49	4.811
32GBF-52-E	52	5.105
32GBF-53-E	53	5.203
32GBF-64-E	64	6.283
32GBF-67-E	67	6.577
32GBF-75-E	75	7.363
32GBF-80-E	80	7.854
32GBF-95-E	95	9.327
32GBF-112-E	112	10.996
32GBF-126-E	126	12.370
32GBF-128-E	128	12.566
32GBF-144-E	144	14.137
32GBF-158-E	158	15.512
32GBF-176-E	176	17.279
32GBF-189-E	189	18.555
32GBF-208-E	208	20.420
32GBF-220-E	220	21.598
32GBF-240-E	240	23.562
32GBF-252-E	252	24.740
32GBF-272-E	272	26.704
32GBF-283-E	283	27.783
32GBF-304-E	304	29.845
32GBF-315-E	315	30.925
32GBF-336-E	336	32.987
32GBF-346-E	346	33.968
32GBF-377-E	377	37.012
32GBF-400-E	400	39.270
32GBF-408-E	408	40.055
32GBF-432-E	432	42.412
32GBF-440-E	440	43.197
32GBF-464-E	464	45.553
32GBF-471-E	471	46.240
32GBF-480-E	480	47.124
32GBF-496-E	496	48.694
32GBF-512-E	512	50.265
32GBF-544-E	544	53.407
32GBF-560-E	560	54.978
32GBF-576-E	576	56.549
32GBF-640-E	640	62.832

* For Field Splice Kit order 32GBF-7.

* Available with Aramid Core. See page VII for alternative belt construction or reverse bending applications.

** Reduce operating load rating by 50% for field splices.

Other numbers of pitches available on request.

- Accommodates twists and turns
- Odd Angles
- Infinite Lengths
- Silent Drive
- Weight .11 oz./ft.
- Positive Drive
- Zero Backlash
- No Lubrication
- 90A Durometer
- Ultimate Tensile Strength 50 lbs. - 9 lbs./Pin when belt is used in open loop configuration (without splice, no crimp bushing).
- Temperature Range +180°F to -15°F
- Recommended Operating Load 12 lbs.
- Recommended Max. Operating Speed 376 feet/min.

BULK FOOTAGE - NOT SPLICED	
STOCK NO.	LENGTH
32GBF-5FT	5FT
32GBF-10FT	10FT
32GBF-25FT	25FT
32GBF-50FT	50FT
32GBF-100FT	100FT



GEAR DRIVE BELTS

PITCH	CIRCULAR PITCH	MATERIALS	BERG'S ® NAME	PULLEY
32	.0982	Polyurethane (Light Brown) .018" Dia. Stainless Steel Cable*	Flex-E-Belt®	Operates with 32C, 32D, GPS, GP32, GF32 and GC32 series.

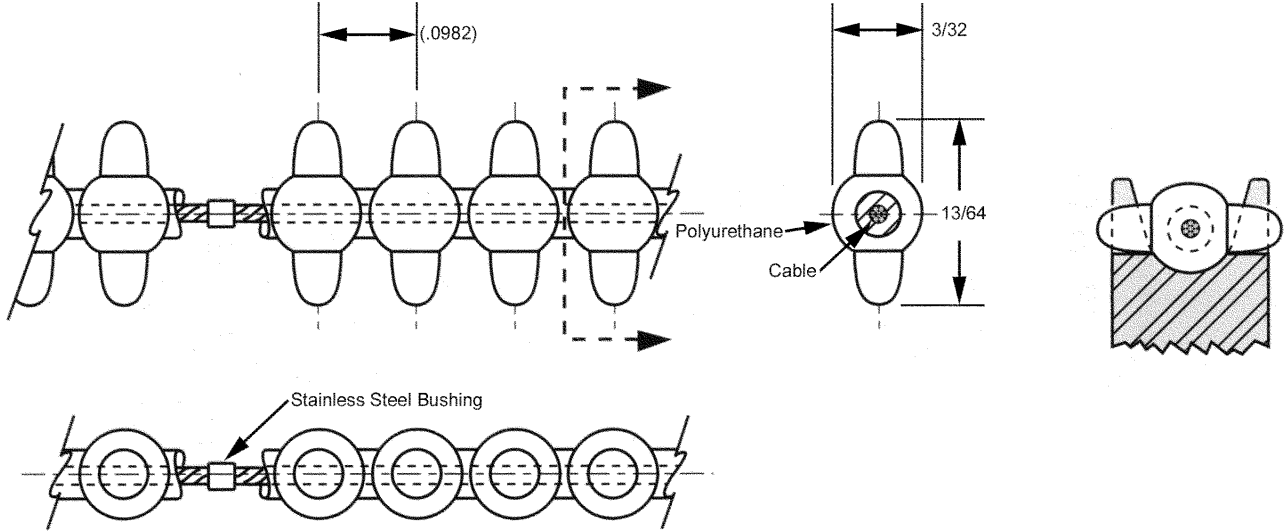

STOCK NO.	NO. OF PITCHES	LENGTH (Ref.)
33GBF-49-E	49	4.811
33GBF-52-E	52	5.105
33GBF-53-E	53	5.203
33GBF-64-E	64	6.283
33GBF-67-E	67	6.577
33GBF-75-E	75	7.363
33GBF-80-E	80	7.854
33GBF-95-E	95	9.327
33GBF-112-E	112	10.996
33GBF-126-E	126	12.370
33GBF-128-E	128	12.566
33GBF-144-E	144	14.137
33GBF-158-E	158	15.512
33GBF-176-E	176	17.279
33GBF-189-E	189	18.555
33GBF-208-E	208	20.420
33GBF-220-E	220	21.598
33GBF-240-E	240	23.562
33GBF-252-E	252	24.740
33GBF-272-E	272	26.704
33GBF-283-E	283	27.783
33GBF-304-E	304	29.845
33GBF-315-E	315	30.925
33GBF-336-E	336	32.987
33GBF-377-E	377	37.012
33GBF-400-E	400	39.270
33GBF-408-E	408	40.055
33GBF-432-E	432	42.412
33GBF-440-E	440	43.197
33GBF-464-E	464	45.553
33GBF-471-E	471	46.240
33GBF-480-E	480	47.124
33GBF-496-E	496	48.694
33GBF-512-E	512	50.265
33GBF-544-E	544	53.407
33GBF-560-E	560	54.978
33GBF-576-E	576	56.548
33GBF-640-E	640	62.832

- For Field Splice Kit order 32GBF-7.
 - * Available with Aramid Core. See page VII for alternative belt construction or reverse bending applications.
 - ** Reduce operating load rating by 50% for field splice.
- Other numbers of pitches available on request.

- Accommodates twists and turns
- Odd Angles
- Infinite Lengths
- Silent Drive
- Weight .11 oz./ft.
- Positive Drive
- Zero Backlash
- No Lubrication
- 90A Durometer
- Ultimate Tensile Strength 20 lbs. - 7 lbs./Pin
when belt is used in open loop configuration (without splice no crimp bushing).
- Temperature Range +180°F to -15°F
- Recommended Operating Load 5 lbs.
- Recommended Max. Operating Speed 376 feet/min.

BULK FOOTAGE - NOT SPLICED	
STOCK NO.	LENGTH
33GBF-5FT	5FT
33GBF-10FT	10FT
33GBF-25FT	25FT
33GBF-50FT	50FT
33GBF-100FT	100FT



E-Z ENTRY BELT PULLEYS

PITCH	CIR. PITCH	BORE	STYLE	MATERIAL	BERG'S® NAME	BELT
32	.0982	3/8"	HUBLESS	2024-T4 Aluminum Anodized	Flex-E-Belt®	Operates with 32GBF or 33GBF Series

STOCK NO.	NO. OF TEETH	PITCH DIA.	OUTSIDE DIA.
32C6-20	20 *	.6250	.688
32C6-22	22 *	.6875	.750
32C6-24	24 *	.7500	.813
32C6-26	26	.8125	.875
32C6-28	28	.8750	.938
32C6-30	30	.9375	1.000
32C6-32	32	1.0000	1.063
32C6-36	36	1.1250	1.188
32C6-40	40	1.2500	1.313
32C6-48	48	1.5000	1.563
32C6-56	56	1.7500	1.813
32C6-64	64	2.0000	2.063
32C6-72	72	2.2500	2.313
32C6-80	80	2.5000	2.563
32C6-88	88	2.7500	2.813
32C6-96	96	3.0000	3.063
32C6-112	112	3.5000	3.563
32C6-128	128	4.0000	4.063

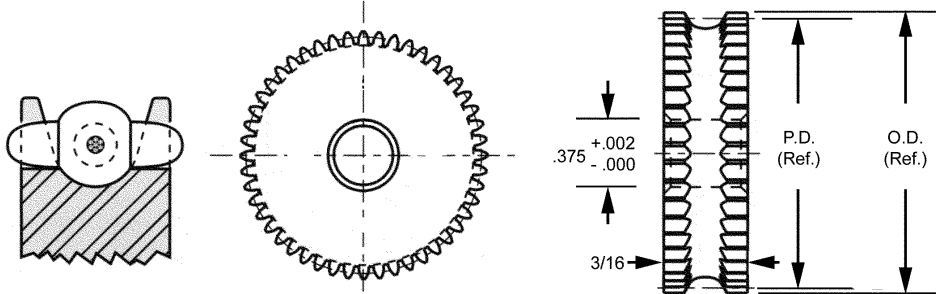

• May be used with 33GBF Belt as a drive gear.
When used with 32GBF belt, use as an idler only.
Other numbers of teeth available on request.
Teeth could be anodized.



PITCH	CIR. PITCH	BORE	STYLE	MATERIAL	BERG'S® NAME	BELT
32	.0982	1/8"	PIN HUB	2024-T4 Aluminum Anodized	Flex-E-Belt®	Operates with 32GBF or 33GBF Series

STOCK NO.	NO. OF TEETH	PITCH DIA.	OUTSIDE DIA.
32D2-16	16 *	.5000	.563
32D2-18	18 *	.5625	.625
32D2-20	20 *	.6250	.688
32D2-22	22 *	.6875	.750
32D2-24	24 *	.7500	.813
32D2-26	26	.8125	.875
32D2-28	28	.8750	.938
32D2-30	30	.9375	1.000
32D2-32	32	1.0000	1.062
32D2-36	36	1.1250	1.187
32D2-40	40	1.2500	1.313
32D2-48	48	1.5000	1.563
32D2-56	56	1.7500	1.813
32D2-64	64	2.0000	2.063
32D2-72	72	2.2500	2.313
32D2-80	80	2.5000	2.563
32D2-88	88	2.7500	2.813
32D2-96	96	3.0000	3.063
32D2-112	112	3.5000	3.563
32D2-128	128	4.0000	4.063

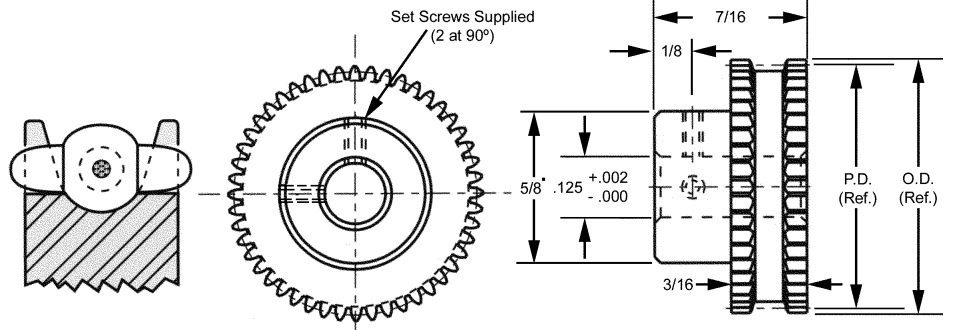

• For 16-22 teeth, hub diameter equals .41.
* May be used with 33GBF Belt as a drive gear.
When used with 32GBF belt, use as an idler only.
Other numbers of teeth available on request.
Teeth could be anodized.



E-Z ENTRY BELT PULLEYS

PITCH	CIR. PITCH	BORE	STYLE	MATERIAL	BERG'S ® NAME	BELT
32	.0982	3/16"	PIN HUB	2024-T4 Aluminum Anodized	Flex-E-Belt®	Operates with 32GBF or 33GBF Series

STOCK NO.	NO. OF TEETH	PITCH DIA.	OUTSIDE DIA.
32D3-16	16 *	.5000	.563
32D3-18	18 *	.5625	.625
32D3-20	20 *	.6250	.688
32D3-22	22 *	.6875	.750
32D3-24	24 *	.7500	.813
32D3-26	26	.8125	.875
32D3-28	28	.8750	.938
32D3-30	30	.9375	1.000
32D3-32	32	1.0000	1.063
32D3-36	36	1.1250	1.188
32D3-40	40	1.2500	1.313
32D3-48	48	1.5000	1.563
32D3-56	56	1.7500	1.813
32D3-64	64	2.0000	2.063
32D3-72	72	2.2500	2.313
32D3-80	80	2.5000	2.563
32D3-88	88	2.7500	2.813
32D3-96	96	3.0000	3.063
32D3-112	112	3.5000	3.563
32D3-128	128	4.0000	4.063

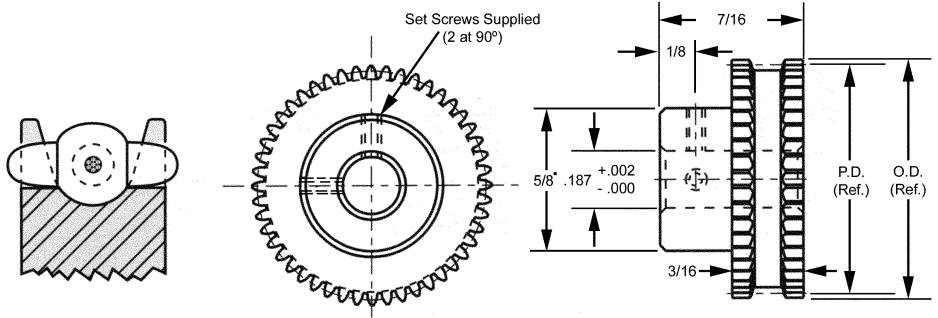

• For 16-22 teeth, hub diameter equals .41.
 * May be used with 33GBF Belt as a drive gear.
 When used with 32GBF belt, use as an idler only.
 Other numbers of teeth available on request.
 Teeth could be anodized.

PITCH	CIR. PITCH	BORE	STYLE	MATERIAL	BERG'S ® NAME	BELT
32	.0982	1/4"	PIN HUB	2024-T4 Aluminum Anodized	Flex-E-Belt®	Operates with 32GBF or 33GBF Series

STOCK NO.	NO. OF TEETH	PITCH DIA.	OUTSIDE DIA.
32D4-16	16 *	.5000	.563
32D4-18	18 *	.5625	.625
32D4-20	20 *	.6250	.688
32D4-22	22 *	.6875	.750
32D4-24	24 *	.7500	.813
32D4-26	26	.8125	.875
32D4-28	28	.8750	.9378
32D4-30	30	.9375	1.000
32D4-32	32	1.0000	1.063
32D4-36	36	1.1250	1.1878
32D4-40	40	1.2500	1.313
32D4-48	48	1.5000	1.563
32D4-56	56	1.7500	1.813
32D4-64	64	2.0000	2.063
32D4-72	72	2.2500	2.313
32D4-80	80	2.5000	2.563
32D4-88	88	2.7500	2.813
32D4-96	96	3.0000	3.063
32D4-112	112	3.5000	3.563
32D4-128	128	4.0000	4.063

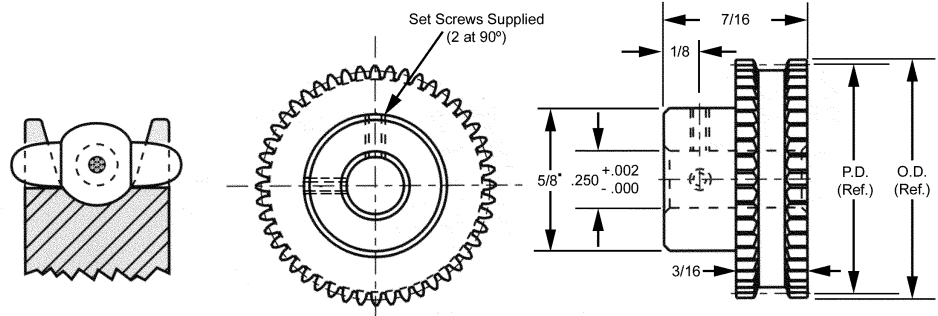

• For 16-22 teeth, hub diameter equals .41.
 * May be used with 33GBF Belt as a drive gear.
 When used with 32GBF belt, use as an idler only.
 Other numbers of teeth available on request.
 Teeth could be anodized.

DRIVE BELT GEARS

PITCH	CIR. PITCH	SHAFT DIA.	STYLE	MATERIAL	BERG'S® NAME	BELT
32	.0982	.2497	PINION SHAFT	303 Stainless Steel	Flex-E-Belt®	Operates with 32GBF or 33GBF Series

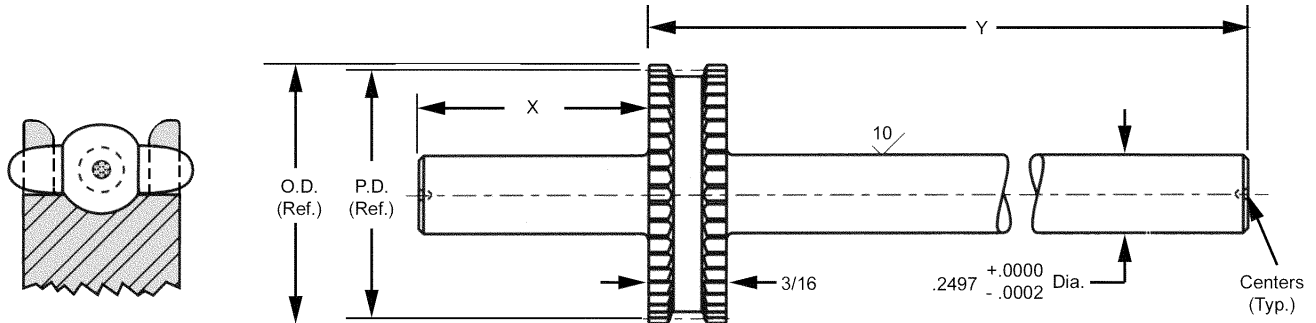

STOCK NO.	NO. OF TEETH	X	Y	PITCH DIA.	OUTSIDE DIA.
GPS-1	14 •	—	3.187	.4375	.500
GPS-2	15 •	—	3.187	.4687	.531
GPS-3	16 *	—	3.187	.5000	.562
GPS-4	14 •	1.500	1.687	.4375	.500
GPS-5	15 •	1.500	1.687	.4687	.531
GPS-6	16 *	1.500	1.687	.5000	.562

• For idler use only.

* May be used with 33GBF belt as a drive gear. When used with 32GBF belt, use as an idler only.

Other numbers of teeth available on request.



DRIVE BELT GEARS

PITCH	CIR. PITCH	BORE	STYLE	MATERIAL	BERG'S ® NAME	BELT
32	.0982	1/8"	CLUSTER HUB	303 Stainless Steel	Flex-E-Belt®	Operates with 32GBF or 33GBF Series

STOCK NO.	NO. OF TEETH	PITCH DIA.	OUTSIDE DIA.
GPS-7	14 *	.4375	.500
GPS-8	15 *	.4688	.531
GPS-9	16 •	.5000	.563

Drive Belt Cluster Hubs

- * For idler use only.
- May be used with 33GBF belt as a drive gear.
- When used with 32GBF belt, use as an idler only.
- **Bore and shoulder concentric within .0005.
- Other numbers of teeth available on request.

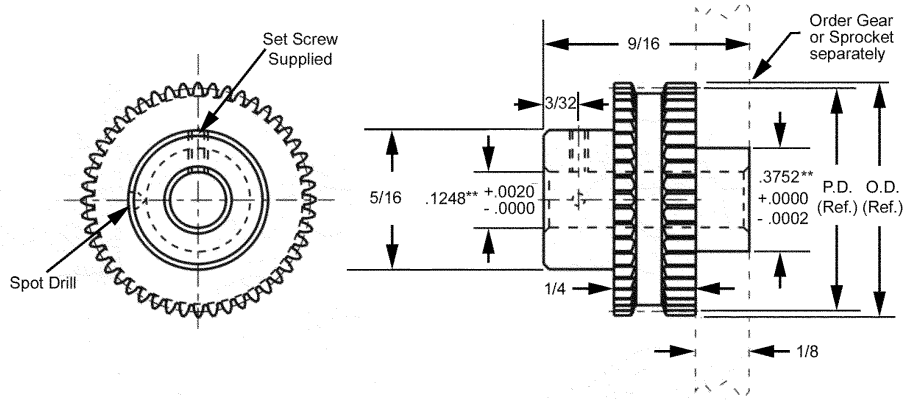

PITCH	CIR. PITCH	BORE	STYLE	MATERIAL	BERG'S ® NAME	BELT
32	.0982	3/16"	CLUSTER HUB	303 Stainless Steel	Flex-E-Belt®	Operates with 32GBF or 33GBF Series

STOCK NO.	NO. OF TEETH	PITCH DIA.	OUTSIDE DIA.
GPS-10	14 *	.4375	.500
GPS-11	15 *	.4688	.531
GPS-12	16 •	.5000	.563

Drive Belt Cluster Hubs

- * For idler use only.
- May be used with 33GBF belt as a drive gear.
- When used with 32GBF belt, use as an idler only.
- **Bore and shoulder concentric within .0005.
- Other numbers of teeth available on request.

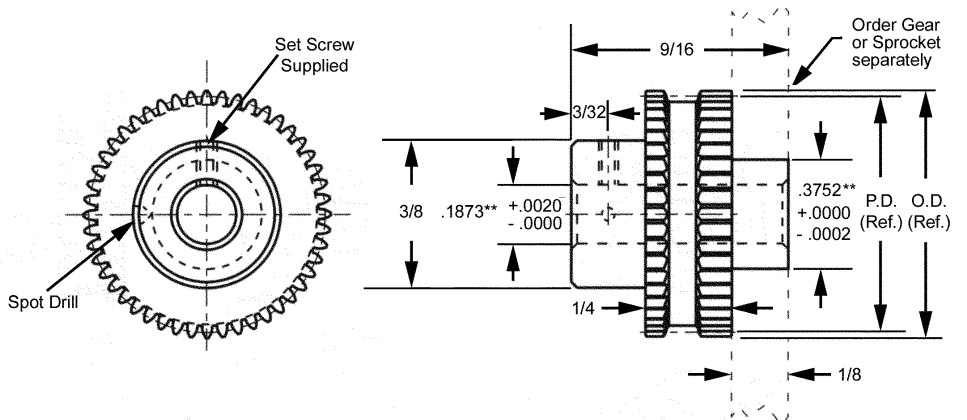

DRIVE BELT GEARS

PITCH	CIR. PITCH	BORE	STYLE	MATERIAL	BERG'S ® NAME	BELT
32	.0982	1/4"	CLUSTER HUB	303 Stainless Steel	Flex-E-Belt®	Operates with 32GBF or 33GBF Series

STOCK NO.	NO. OF TEETH	PITCH DIA.	OUTSIDE DIA.
GPS-23	14 *	.4375	.500
GPS-24	15 *	.4688	.531
GPS-25	16 •	.5000	.563

Drive Belt Cluster Hubs

- * For idler use only.
- May be used with 33GBF belt as a drive gear.
- When used with 32GBF belt, use as an idler only.
- **Bore and shoulder concentric within .0005.
- Other numbers of teeth available on request.

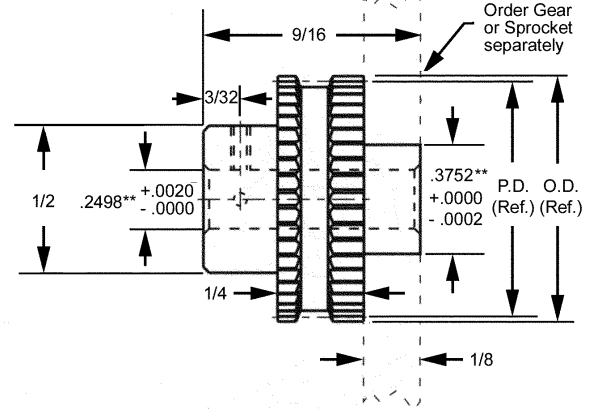
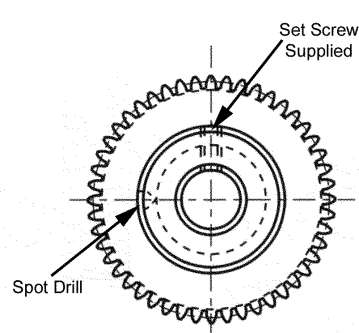

DRIVE BELT GEARS

PITCH	CIR. PITCH	BORE	STYLE	MATERIAL	BERG'S® NAME	BELT
32	.0982	1/8"	PIN HUB	303 Stainless Steel or 2024-T4 Aluminum Anodized	Flex-E-Belt®	Operates with 32GBF or 33GBF Series

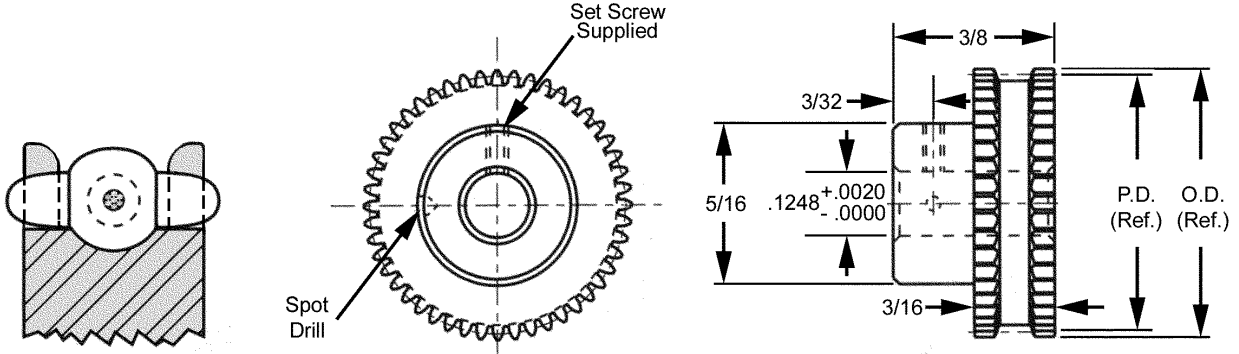

STOCK NO.	STOCK NO.	NO. OF TEETH	PITCH DIA.	OUTSIDE DIA.
GP32S14-14	GP32A14-14	14**	.4375	.500
GP32S14-15	GP32A14-15	15**	.4688	.531
GP32S14-16	GP32A14-16	16•	.5000	.563
GP32S14-18	GP32A14-18	18•	.5625	.625
GP32S14-20	GP32A14-20	20•	.6250	.688
GP32S14-22	GP32A14-22	22•	.6875	.750
GP32S14-24	GP32A14-24	24•	.7500	.813
GP32S14-26	GP32A14-26	26	.8125	.875
GP32S14-28	GP32A14-28	28	.8750	.938
GP32S14-30	GP32A14-30	30	.9375	1.000
GP32S14-32	GP32A14-32	32	1.0000	1.063
GP32S14-36	GP32A14-36	36	1.1250	1.188
GP32S14-40	GP32A14-40	40	1.2500	1.313
GP32S14-48	GP32A14-48	48	1.5000	1.563
GP32S14-56	GP32A14-56	56 *	1.7500	1.813
GP32S14-64	GP32A14-64	64 *	2.0000	2.063
GP32S14-72	GP32A14-72	72 *	2.2500	2.313
GP32S14-80	GP32A14-80	80 *	2.5000	2.563
GP32S14-88	GP32A14-88	88 *	2.7500	2.813
GP32S14-96	GP32A14-96	96 *	3.0000	3.063
GP32S14-112	GP32A14-112	112 *	3.5000	3.563
GP32S14-128	GP32A14-128	128 *	4.0000	4.063



* May be 2 piece construction with Stainless Steel Hub, outline and overall dimensions change slightly.
 ** For idler use only.
 • May be used with 33GBF belt as a drive gear. When used with 32GBF, use as an idler only.
 Other numbers of teeth available on request.
 Teeth could be anodized.

DRIVE BELT GEARS

PITCH	CIR. PITCH	BORE	STYLE	MATERIAL	BERG'S® NAME	BELT
32	.0982	3/16"	PIN HUB	303 Stainless Steel or 2024-T4 Aluminum Anodized	Flex-E-Belt®	Operates with 32GBF or 33GBF Series

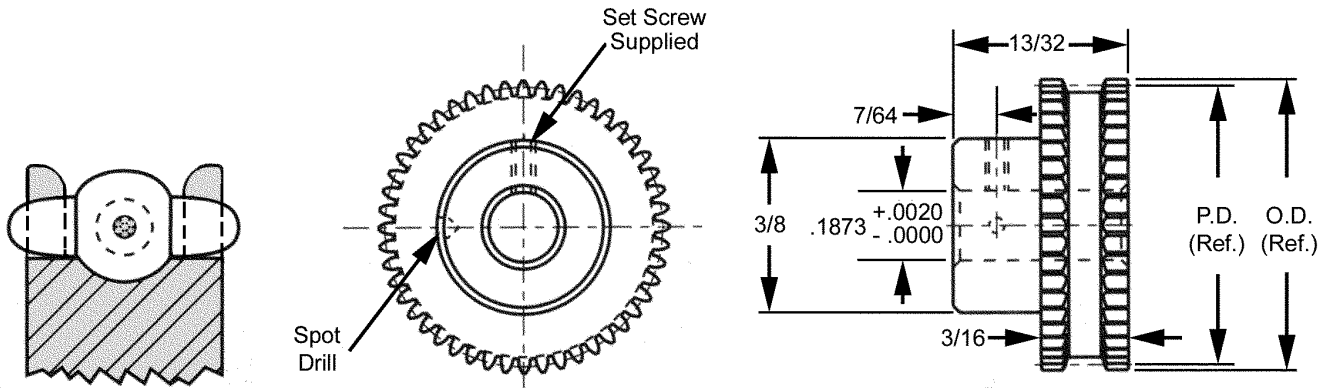

303 Stainless Steel	2024-T4 Aluminum Anodized			
STOCK NO.	STOCK NO.	NO. OF TEETH	PITCH DIA.	OUTSIDE DIA.
GP32S21-15	GP32A21-15	15*	.4688	.531
GP32S21-16	GP32A21-16	16•	.5000	.563
GP32S21-18	GP32A21-18	18•	.5625	.625
GP32S21-20	GP32A21-20	20•	.6250	.688
GP32S21-22	GP32A21-22	22•	.6875	.750
GP32S21-24	GP32A21-24	24•	.7500	.813
GP32S21-26	GP32A21-26	26	.8125	.875
GP32S21-28	GP32A21-28	28	.8750	.938
GP32S21-30	GP32A21-30	30	.9375	1.000
GP32S21-32	GP32A21-32	32	1.0000	1.063
GP32S21-36	GP32A21-36	36	1.1250	1.188
GP32S21-40	GP32A21-40	40	1.2500	1.313
GP32S21-48	GP32A21-48	48	1.5000	1.563
GP32S21-56	GP32A21-56	56	1.7500	1.813
GP32S21-64	GP32A21-64	64	2.0000	2.063
GP32S21-72	GP32A21-72	72	2.2500	2.313
GP32S21-80	GP32A21-80	80	2.5000	2.563
GP32S21-88	GP32A21-88	88	2.7500	2.813
GP32S21-96	GP32A21-96	96	3.0000	3.063
GP32S21-112	GP32A21-112	112	3.5000	3.563
GP32S21-128	GP32A21-128	128	4.0000	4.063



* For idler use only.
 • May be used with 33 GBF belt as a drive gear. When used with 32GBF belt, use as an idler only.
 Other numbers of teeth available on request.
 Teeth could be anodized.

DRIVE BELT GEARS

PITCH	CIR. PITCH	BORE	STYLE	MATERIAL	BERG'S® NAME	BELT
32	.0982	1/4"	PIN HUB	303 Stainless Steel or 2024-T4 Aluminum Anodized	Flex-E-Belt®	Operates with 32GBF or 33GBF Series

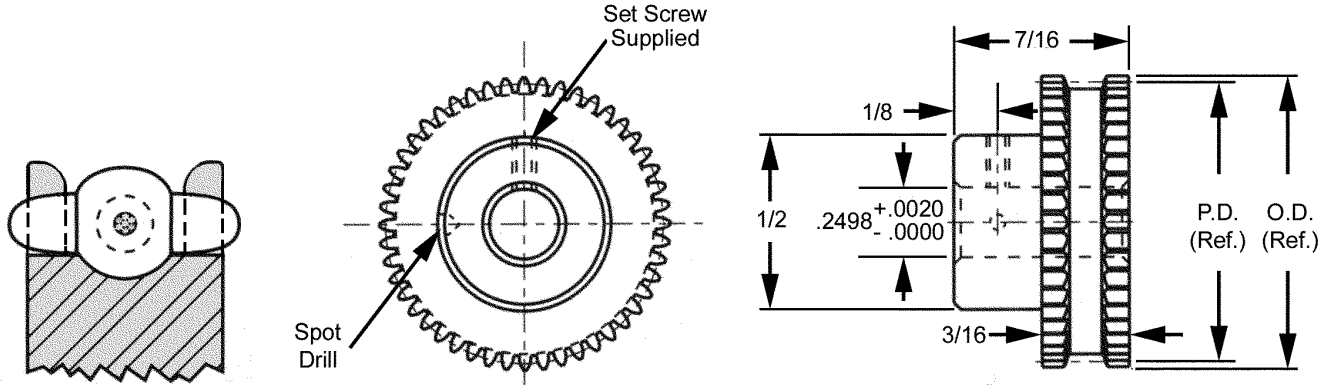

303 Stainless Steel	2024-T4 Aluminum Anodized			
STOCK NO.	STOCK NO.	NO. OF TEETH	PITCH DIA.	OUTSIDE DIA.
GP32S28-20	GP32A28-20	20•	.6250	.688
GP32S28-22	GP32A28-22	22•	.6875	.750
GP32S28-24	GP32A28-24	24•	.7500	.813
GP32S28-26	GP32A28-26	26	.8125	.875
GP32S28-28	GP32A28-28	28	.8750	.938
GP32S28-30	GP32A28-30	30	.9375	1.000
GP32S28-32	GP32A28-32	32	1.0000	1.063
GP32S28-36	GP32A28-36	36	1.1250	1.188
GP32S28-40	GP32A28-40	40	1.2500	1.313
GP32S28-48	GP32A28-48	48	1.5000	1.563
GP32S28-56	GP32A28-56	56	1.7500	1.813
GP32S28-64	GP32A28-64	64	2.0000	2.063
GP32S28-72	GP32A28-72	72	2.2500	2.313
GP32S28-80	GP32A28-80	80	2.5000	2.563
GP32S28-88	GP32A28-88	88	2.7500	2.813
GP32S28-96	GP32A28-96	96	3.0000	3.063
GP32S28-112	GP32A28-112	112	3.5000	3.563
GP32S28-128	GP32A28-128	128	4.0000	4.063



• May be used with 33GBF belt as a drive gear. When used with 32GBF belt, use as an idler only.
Other numbers of teeth available on request.
Teeth could be anodized.

DRIVE BELT GEARS

PITCH	CIR. PITCH	BORE	STYLE	MATERIAL	BERG'S® NAME	BELT
32	.0982	5/16"	PIN HUB	303 Stainless Steel or 2024-T4 Aluminum Anodized	Flex-E-Belt®	Operates with 32GBF or 33GBF Series

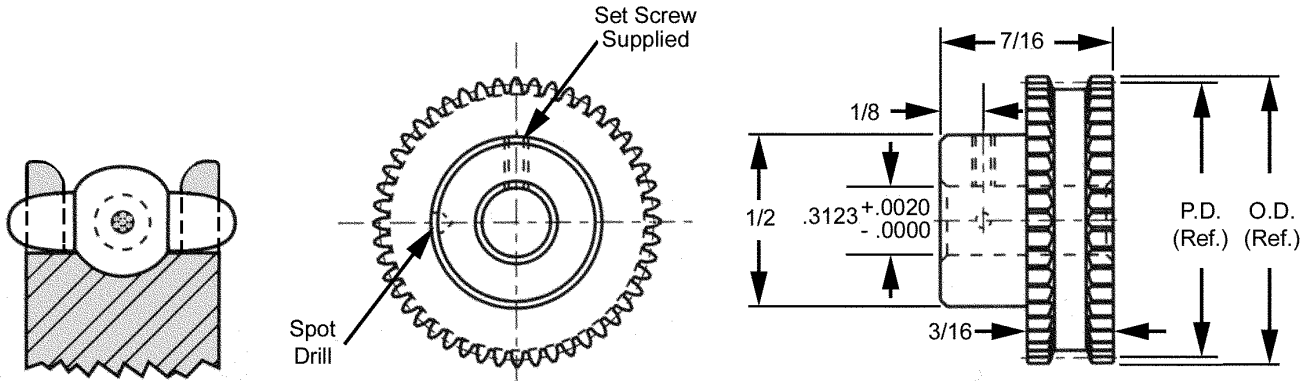

303 Stainless Steel	2024-T4 Aluminum Anodized			
STOCK NO.	STOCK NO.	NO. OF TEETH	PITCH DIA.	OUTSIDE DIA.
GP32S32-20	GP32A32-20	20*	.6250	.688
GP32S32-22	GP32A32-22	22*	.6875	.750
GP32S32-24	GP32A32-24	24*	.7500	.813
GP32S32-26	GP32A32-26	26	.8125	.875
GP32S32-28	GP32A32-28	28	.8750	.938
GP32S32-30	GP32A32-30	30	.9375	1.000
GP32S32-32	GP32A32-32	32	1.0000	1.063
GP32S32-36	GP32A32-36	36	1.1250	1.188
GP32S32-40	GP32A32-40	40	1.2500	1.313
GP32S32-48	GP32A32-48	48	1.5000	1.563
GP32S32-56	GP32A32-56	56	1.7500	1.813
GP32S32-64	GP32A32-64	64	2.0000	2.063
GP32S32-72	GP32A32-72	72	2.2500	2.313
GP32S32-80	GP32A32-80	80	2.5000	2.563
GP32S32-88	GP32A32-88	88	2.7500	2.813
GP32S32-96	GP32A32-96	96	3.0000	3.063
GP32S32-112	GP32A32-112	112	3.5000	3.563
GP32S32-128	GP32A32-128	128	4.0000	4.063



• May be used with 33GBF belt as a drive gear. When used with 32GBF belt, use as an idler only.
Other numbers of teeth available on request.
Teeth could be anodized.

DRIVE BELT GEARS

PITCH	CIR. PITCH	BORE	STYLE	MATERIAL	BERG'S® NAME	BELT
32	.0982	3/8"	HUBLESS	303 Stainless Steel or 2024-T4 Aluminum Anodized	Flex-E-Belt®	Operates with 32GBF or 33GBF Series

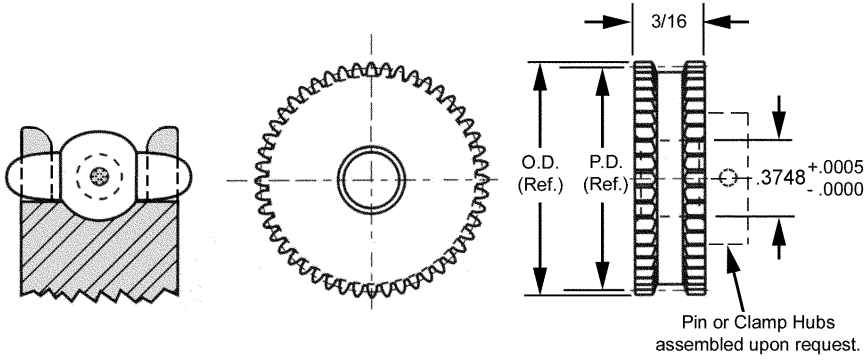

		303 Stainless Steel	2024-T4 Aluminum Anodized		
STOCK NO.	STOCK NO.	NO. OF TEETH	PITCH DIA.	OUTSIDE DIA.	
GF32S5-24	GF32A5-24	24•	.7500	.813	
GF32S5-25	GF32A5-25	25	.7813	.844	
GF32S5-26	GF32A5-26	26	.8125	.875	
GF32S5-27	GF32A5-27	27	.8438	.906	
GF32S5-28	GF32A5-28	28	.8750	.938	
GF32S5-29	GF32A5-29	29	.9063	.969	
GF32S5-30	GF32A5-30	30	.9375	1.000	
GF32S5-32	GF32A5-32	32	1.0000	1.063	
GF32S5-36	GF32A5-36	36	1.1250	1.188	
GF32S5-40	GF32A5-40	40	1.2500	1.313	
GF32S5-48	GF32A5-48	48	1.5000	1.563	
GF32S5-50	GF32A5-50	50	1.5625	1.625	
GF32S5-56	GF32A5-56	56	1.7500	1.813	
GF32S5-64	GF32A5-64	64	2.0000	2.063	
GF32S5-72	GF32A5-72	72	2.2500	2.313	
GF32S5-80	GF32A5-80	80	2.5000	2.563	
GF32S5-88	GF32A5-88	88	2.7500	2.813	
GF32S5-90	GF32A5-90	90	2.8125	2.875	
GF32S5-96	GF32A5-96	96	3.0000	3.063	
GF32S5-100	GF32A5-100	100	3.1250	3.188	
GF32S5-112	GF32A5-112	112	3.5000	3.563	
GF32S5-120	GF32A5-120	120	3.7500	3.813	
GF32S5-128	GF32A5-128	128	4.0000	4.063	

For hubs, see section I.



• May be used with 33GBF belt as a drive gear. When used with 32GBF belt, use as an idler only.
Other numbers of teeth available on request.
Teeth could be anodized.

DRIVE BELT GEARS

PITCH	CIR. PITCH	BORE	STYLE	MATERIAL	BERG'S® NAME	NOTE
32	.0982	11/16"	HUBLESS	303 Stainless Steel or 2024-T4 Aluminum Anodized	Flex-E-Belt®	Operates with 32GBF or 33GBF Series Belt

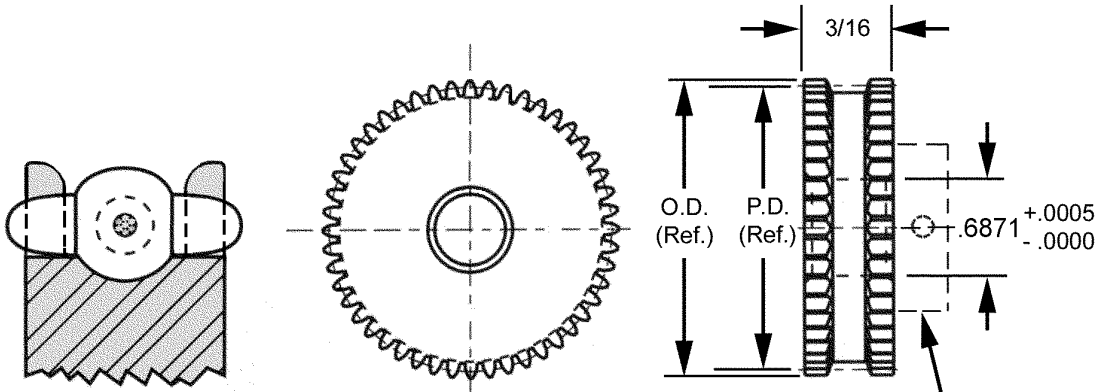

Pin or Clamp Hubs
assembled upon request.

For hubs, see section I.

303 Stainless Steel	2024-T4 Aluminum Anodized			
STOCK NO.	STOCK NO.	NO. OF TEETH	PITCH DIA.	OUTSIDE DIA.
GF32S19-24	GF32A19-24	24*	.7500	.813
GF32S19-25	GF32A19-25	25	.7813	.844
GF32S19-26	GF32A19-26	26	.8125	.875
GF32S19-27	GF32A19-27	27	.8438	.906
GF32S19-28	GF32A19-28	28	.8750	.938
GF32S19-29	GF32A19-29	29	.9063	.969
GF32S19-30	GF32A19-30	30	.9375	1.000
GF32S19-32	GF32A19-32	32	1.0000	1.063
GF32S19-36	GF32A19-36	36	1.1250	1.188
GF32S19-40	GF32A19-40	40	1.2500	1.313
GF32S19-48	GF32A19-48	48	1.5000	1.563
GF32S19-50	GF32A19-50	50	1.5625	1.625
GF32S19-56	GF32A19-56	56	1.7500	1.813
GF32S19-64	GF32A19-64	64	2.0000	2.063
GF32S19-72	GF32A19-72	72	2.2500	2.313
GF32S19-80	GF32A19-80	80	2.5000	2.563
GF32S19-88	GF32A19-88	88	2.7500	2.813
GF32S19-90	GF32A19-90	90	2.8125	2.875
GF32S19-96	GF32A19-96	96	3.0000	3.063
GF32S19-100	GF32A19-100	100	3.1250	3.188
GF32S19-112	GF32A19-112	112	3.5000	3.563
GF32S19-120	GF32A19-120	120	3.7500	3.813
GF32S19-128	GF32A19-128	128	4.0000	4.063

* May be used with 33GBF belt as a drive gear. When used with 32GBF belt, use as an idler only.

Other numbers of teeth available on request.

Teeth could be anodized.



DRIVE BELT GEARS

PITCH	CIR. PITCH	BORE	STYLE	MATERIAL	BERG'S® NAME	NOTE
32	.0982	1/4"	CLAMP HUB	303 Stainless Steel or 2024-T4 Aluminum Anodized	Flex-E-Belt®	Operates with 32GBF or 33GBF Series Belt

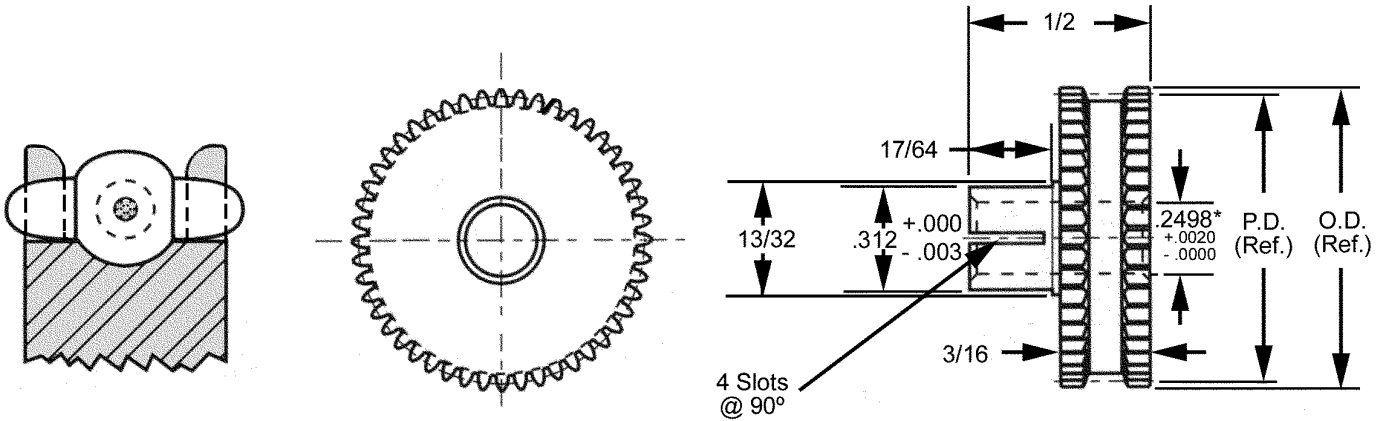

For clamps, see section I.

303 STAINLESS STEEL	2024-T4 ALUMINUM ANODIZED			
STOCK NO.	STOCK NO.	NO. OF TEETH	PITCH DIA.	OUTSIDE DIA.
GC32S28-14	GC32A28-14	14**	.4375	.500
GC32S28-15	GC32A28-15	15**	.4688	.531
GC32S28-16	GC32A28-16	16•	.5000	.563
GC32S28-18	GC32A28-18	18•	.5625	.625
GC32S28-20	GC32A28-20	20•	.6250	.688
GC32S28-22	GC32A28-22	22•	.6875	.750
GC32S28-24	GC32A28-24	24•	.7500	.813
GC32S28-26	GC32A28-26	26	.8125	.875
GC32S28-28	GC32A28-28	28	.8750	.938
GC32S28-30	GC32A28-30	30	.9375	1.000
GC32S28-32	GC32A28-32	32	1.0000	1.063
GC32S28-36	GC32A28-36	36	1.1250	1.188
GC32S28-40	GC32A28-40	40	1.2500	1.313
GC32S28-48	GC32A28-48	48	1.5000	1.563
GC32S28-56	GC32A28-56	56	1.7500	1.813
GC32S28-64	GC32A28-64	64	2.0000	2.063
GC32S28-72	GC32A28-72	72	2.2500	2.313
GC32S28-80	GC32A28-80	80	2.5000	2.563
GC32S28-88	GC32A28-88	88	2.7500	2.813
GC32S28-96	GC32A28-96	96	3.0000	3.063
GC32S28-112	GC32A28-112	112	3.5000	3.563
GC32S28-128	GC32A28-128	128	4.0000	4.063

*NOTE: 3/16" and 1/8" bores available on request.
 **For idler use only.
 • May be used with 33GBF belt as a drive gear. When used with 32GBF belt, use as an idler only.
 Other numbers of teeth available upon request.
 Teeth could be anodized.

GEAR DRIVE BELTS

PITCH	CIRCULAR PITCH	MATERIALS	BERG'S ® NAME	PULLEY
1/10	.1000	Polyurethane (Red) 1/32" Dia. Stainless Steel Cable*	Flex-E-Belt®	Operates with GP31 and GF31 series.

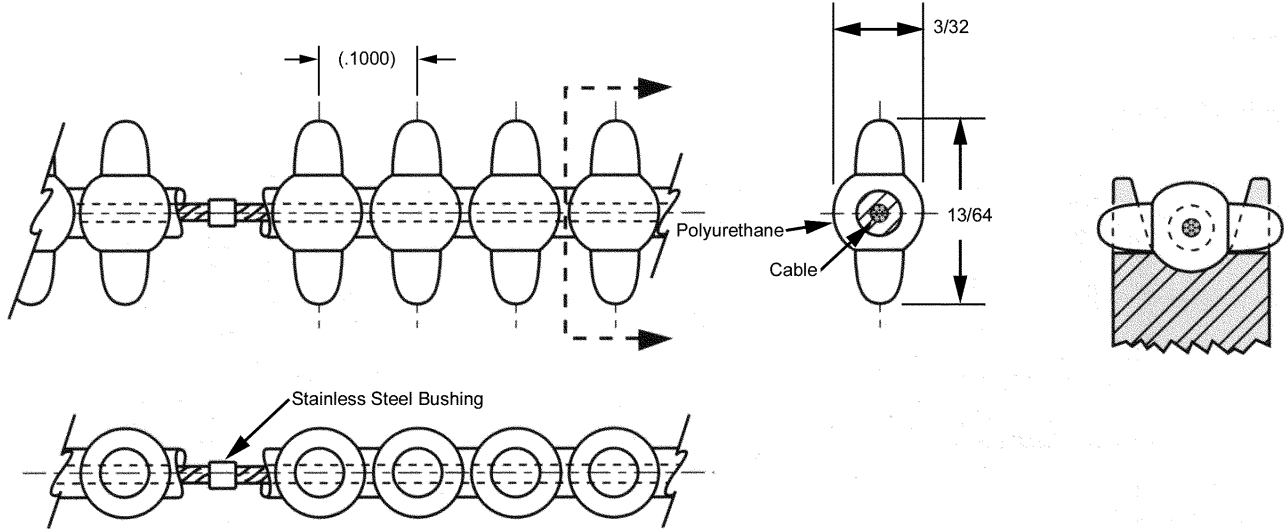

STOCK NO.	NO. OF PITCHES	LENGTH (Ref.)
31GBF-50-E	50	5.000
31GBF-52-E	52	5.200
31GBF-54-E	54	5.400
31GBF-56-E	56	5.600
31GBF-58-E	58	5.800
31GBF-60-E	60	6.000
31GBF-65-E	65	6.500
31GBF-70-E	70	7.000
31GBF-75-E	75	7.500
31GBF-80-E	80	8.000
31GBF-85-E	85	8.500
31GBF-90-E	90	9.000
31GBF-100-E	100	10.000
31GBF-110-E	110	11.000
31GBF-120-E	120	12.000
31GBF-130-E	130	13.000
31GBF-140-E	140	14.000
31GBF-150-E	150	15.000
31GBF-160-E	160	16.000
31GBF-170-E	170	17.000
31GBF-180-E	180	18.000
31GBF-190-E	190	19.000
31GBF-200-E	200	20.000
31GBF-210-E	210	21.000
31GBF-220-E	220	22.000
31GBF-230-E	230	23.000
31GBF-240-E	240	24.000
31GBF-250-E	250	25.000
31GBF-260-E	260	26.000
31GBF-270-E	270	27.000
31GBF-280-E	280	28.000
31GBF-300-E	300	30.000
31GBF-350-E	350	35.000
31GBF-400-E	400	40.000
31GBF-480-E	480	48.000
31GBF-500-E	500	50.000
31GBF-800-E	800	80.000

- For Field Splice Kit order 32GBF-7.
- * Available with Aramid Core. See page VII for alternative belt construction or reverse bending applications.
- **Reduce operating load rating by 50% for field splices.

- Odd Angles
- Infinite Lengths
- Accommodates twists and turns
- Positive Drive
- Zero Backlash
- No Lubrication
- Weight .11 oz./ft.
- 90A Durometer
- Ultimate Tensile Strength 50 lbs. - 8 lbs./Pin
When belt is used in open loop configuration (without splice, no crimp bushing).
- Temperature Range +180°F to -15°F
- Recommended Operating Load 12 lbs.
- Recommended Max. Operating Speed 376 feet/min.

BULK FOOTAGE - NOT SPLICED	
STOCK NO.	LENGTH
31GBF-5FT	5FT
31GBF-10FT	10FT
31GBF-25FT	25FT
31GBF-50FT	50FT
31GBF-100FT	100FT



E-Z-ENTRY BELT PULLEYS

PITCH	CIR. PITCH	BORE	STYLE	MATERIAL	BERG'S® NAME	BELT
1/10	.1000	1/8"	PIN HUB	303 Stainless Steel or 2024-T4 Aluminum Anodized	Flex-E-Belt®	Operates with 31GBF Series

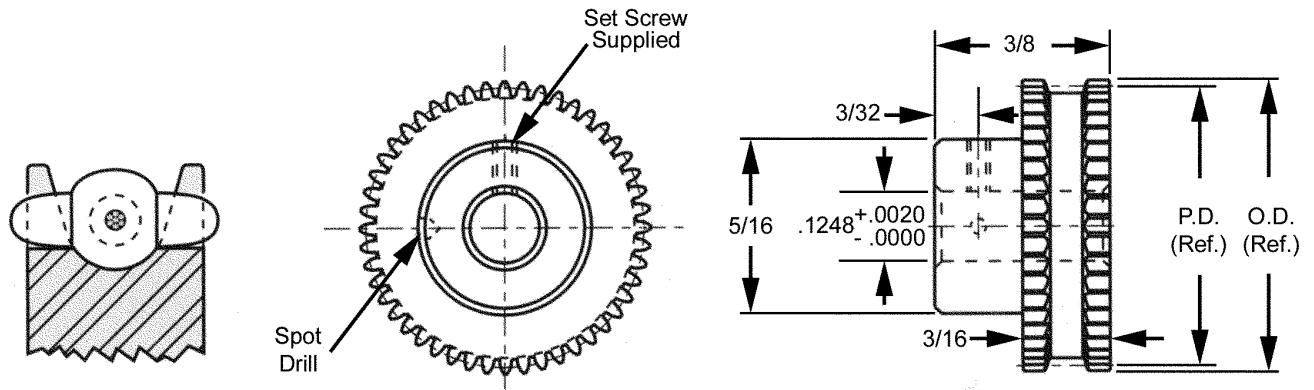

303 STAINLESS STEEL	2024-T4 ALUMINUM ANODIZED			
STOCK NO.	STOCK NO.	NO. OF TEETH	PITCH DIA.	OUTSIDE DIA.
GP31S14-14	GP31A14-14	14**	.4456	.510
GP31S14-15	GP31A14-15	15**	.4775	.541
GP31S14-16	GP31A14-16	16**	.5093	.573
GP31S14-18	GP31A14-18	18**	.5729	.637
GP31S14-20	GP31A14-20	20**	.6366	.701
GP31S14-22	GP31A14-22	22**	.7003	.764
GP31S14-24	GP31A14-24	24	.7639	.828
GP31S14-26	GP31A14-26	26	.8276	.892
GP31S14-28	GP31A14-28	28	.8912	.955
GP31S14-30	GP31A14-30	30	.9549	1.019
GP31S14-32	GP31A14-32	32	1.0186	1.083
GP31S14-36	GP31A14-36	36	1.1459	1.210
GP31S14-40	GP31A14-40	40	1.2732	1.337
GP31S14-48	GP31A14-48	48	1.5278	1.592
GP31S14-56	GP31A14-56	56*	1.7825	1.846
GP31S14-64	GP31A14-64	64*	2.0371	2.101
GP31S14-72	GP31A14-72	72*	2.2918	2.356
GP31S14-80	GP31A14-80	80*	2.5464	2.610
GP31S14-88	GP31A14-88	88*	2.8010	2.865
GP31S14-96	GP31A14-96	96*	3.0557	3.120
GP31S14-112	GP31A14-112	112*	3.5650	3.629
GP31S14-128	GP31A14-128	128*	4.0742	4.138



* May be 2 piece construction with 303 Stainless Steel Hub, outline and overall dimensions change slightly.
 ** Pulleys with .750 P.D. and smaller are for idler use only.
 Other numbers of teeth available on request.
 Teeth could be anodized.

E-Z-ENTRY BELT PULLEYS

PITCH	CIR. PITCH	BORE	STYLE	MATERIAL	BERG'S ® NAME	BELT
1/10	.1000	3/16"	PIN HUB	303 Stainless Steel or 2024-T4 Aluminum Anodized	Flex-E-Belt®	Operates with 31GBF Series

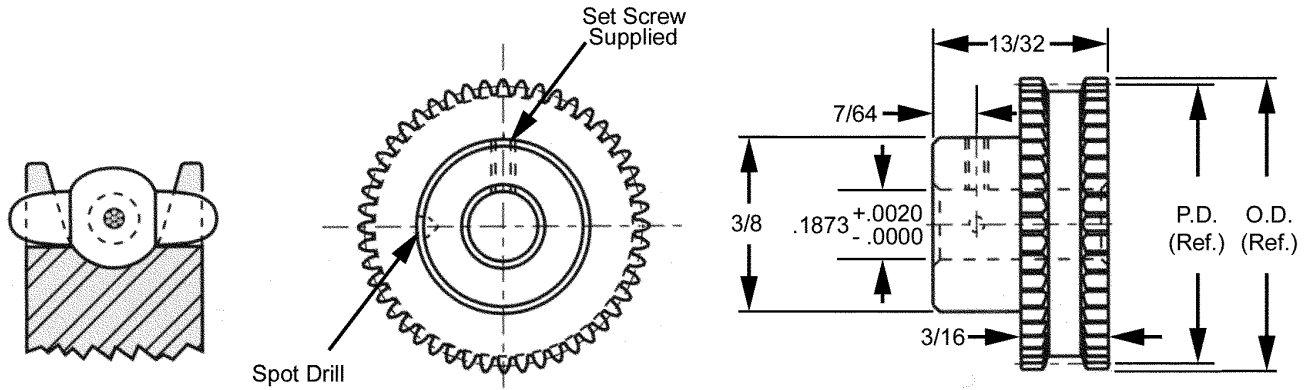

303 STAINLESS STEEL	2024-T4 ALUMINUM ANODIZED			
STOCK NO.	STOCK NO.	NO. OF TEETH	PITCH DIA.	OUTSIDE DIA.
GP31S21-15	GP31A21-15	15**	.4775	.541
GP31S21-16	GP31A21-16	16**	.5093	.573
GP31S21-18	GP31A21-18	18**	.5729	.637
GP31S21-20	GP31A21-20	20**	.6366	.701
GP31S21-22	GP31A21-22	22**	.7003	.764
GP31S21-24	GP31A21-24	24	.7639	.828
GP31S21-26	GP31A21-26	26	.8276	.892
GP31S21-28	GP31A21-28	28	.8912	.955
GP31S21-30	GP31A21-30	30	.9549	1.019
GP31S21-32	GP31A21-32	32	1.0186	1.083
GP31S21-36	GP31A21-36	36	1.1459	1.210
GP31S21-40	GP31A21-40	40	1.2732	1.337
GP31S21-48	GP31A21-48	48	1.5278	1.592
GP31S21-56	GP31A21-56	56	1.7825	1.846
GP31S21-64	GP31A21-64	64	2.0371	2.101
GP31S21-72	GP31A21-72	72	2.2918	2.356
GP31S21-80	GP31A21-80	80	2.5464	2.610
GP31S21-88	GP31A21-88	88	2.8010	2.865
GP31S21-96	GP31A21-96	96	3.0557	3.120
GP31S21-112	GP31A21-112	112	3.5650	3.629
GP31S21-128	GP31A21-128	128	4.0742	4.138



** Pulleys with .750 P.D. and smaller are for idler use only.
Other numbers of pitches are available on request.
Teeth could be anodized.

E-Z-ENTRY BELT PULLEYS

PITCH	CIR. PITCH	BORE	STYLE	MATERIAL	BERG'S ® NAME	BELT
1/10	.1000	1/4"	PIN HUB	303 Stainless Steel or 2024-T4 Aluminum Anodized	Flex-E-Belt®	Operates with 31GBF Series

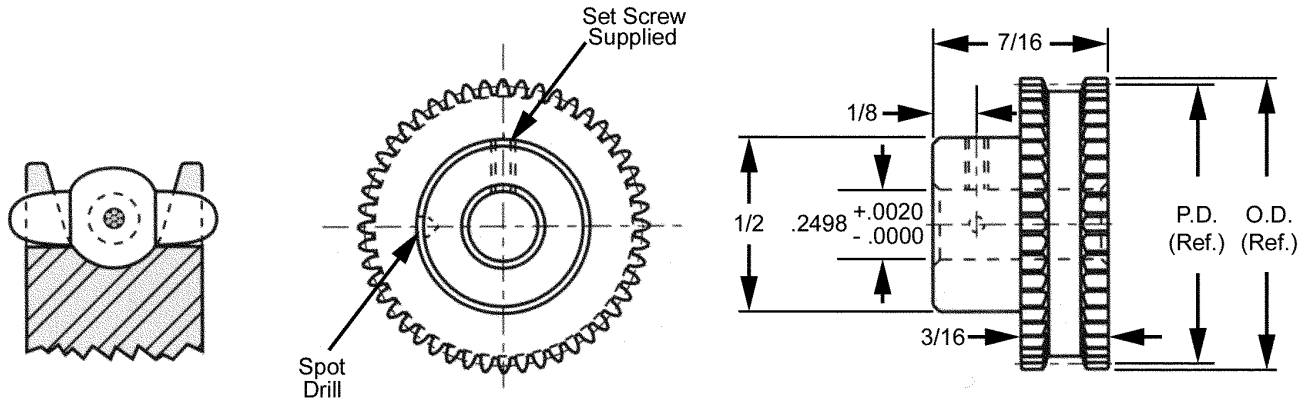

303 STAINLESS STEEL	2024-T4 ALUMINUM ANODIZED			
STOCK NO.	STOCK NO.	NO. OF TEETH	PITCH DIA.	OUTSIDE DIA.
GP31S28-20	GP31A28-20	20**	.6366	.701
GP31S28-22	GP31A28-22	22**	.7003	.764
GP31S28-24	GP31A28-24	24	.7639	.828
GP31S28-26	GP31A28-26	26	.8276	.892
GP31S28-28	GP31A28-28	28	.8912	.955
GP31S28-30	GP31A28-30	30	.9549	1.019
GP31S28-32	GP31A28-32	32	1.0186	1.083
GP31S28-36	GP31A28-36	36	1.1459	1.210
GP31S28-40	GP31A28-40	40	1.2732	1.337
GP31S28-48	GP31A28-48	48	1.5278	1.592
GP31S28-56	GP31A28-56	56	1.7825	1.846
GP31S28-64	GP31A28-64	64	2.0371	2.101
GP31S28-72	GP31A28-72	72	2.2918	2.356
GP31S28-80	GP31A28-80	80	2.5464	2.610
GP31S28-88	GP31A28-88	88	2.8010	2.865
GP31S28-96	GP31A28-96	96	3.0557	3.120
GP31S28-112	GP31A28-112	112	3.5650	3.629
GP31S28-128	GP31A28-128	128	4.0742	4.138



** Pulleys with .750 P.D. and smaller for idler use only.
Other numbers of teeth are available on request.

Teeth could be anodized.

E-Z-ENTRY BELT PULLEYS

PITCH	CIR. PITCH	BORE	STYLE	MATERIAL	BERG'S ® NAME	BELT
1/10	.1000	5/16"	PIN HUB	303 Stainless Steel or 2024-T4 Aluminum Anodized	Flex-E-Belt®	Operates with 31GBF Series

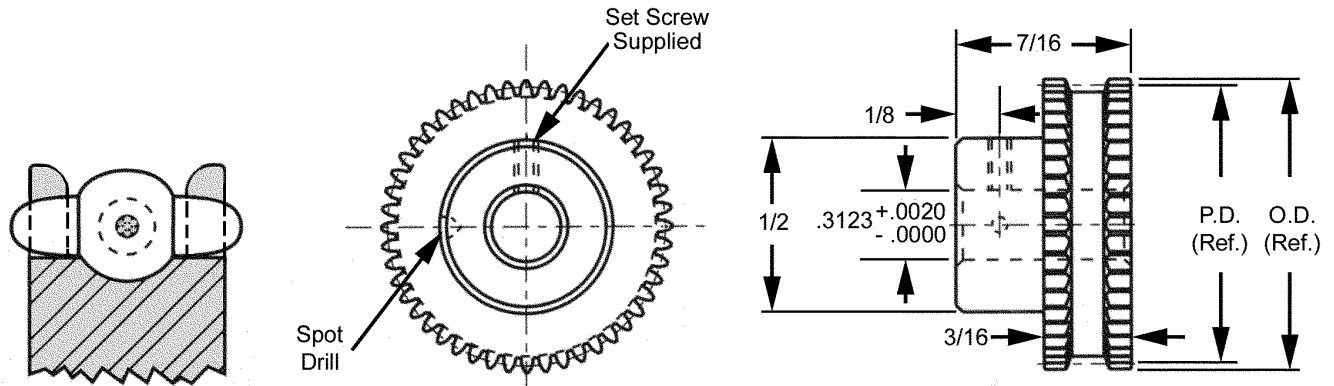

303 STAINLESS STEEL	2024-T4 ALUMINUM ANODIZED			
STOCK NO.	STOCK NO.	NO. OF TEETH	PITCH DIA.	OUTSIDE DIA.
GP31S32-20	GP31A32-20	20**	.6366	.701
GP31S32-22	GP31A32-22	22**	.7003	.764
GP31S32-24	GP31A32-24	24	.7639	.828
GP31S32-26	GP31A32-26	26	.8276	.892
GP31S32-28	GP31A32-28	28	.8912	.955
GP31S32-30	GP31A32-30	30	.9549	1.019
GP31S32-32	GP31A32-32	32	1.0186	1.083
GP31S32-36	GP31A32-36	36	1.1459	1.210
GP31S32-40	GP31A32-40	40	1.2732	1.337
GP31S32-48	GP31A32-48	48	1.5278	1.592
GP31S32-56	GP31A32-56	56	1.7825	1.846
GP31S32-64	GP31A32-64	64	2.0371	2.101
GP31S32-72	GP31A32-72	72	2.2918	2.356
GP31S32-80	GP31A32-80	80	2.5464	2.610
GP31S32-88	GP31A32-88	88	2.8010	2.865
GP31S32-96	GP31A32-96	96	3.0557	3.120
GP31S32-112	GP31A32-112	112	3.5650	3.629
GP31S32-128	GP31A32-128	128	4.0742	4.138



** Pulleys with .750 P.D. and smaller for idler use only.
Other numbers of teeth are available on request.

Teeth could be anodized.

E-Z-ENTRY BELT PULLEYS

PITCH	CIR. PITCH	BORE	STYLE	MATERIAL	BERG'S® NAME	BELT
1/10	.1000	3/8"	HUBLESS	303 Stainless Steel or 2024-T4 Aluminum Anodized	Flex-E-Belt®	Operates with 31GBF Series

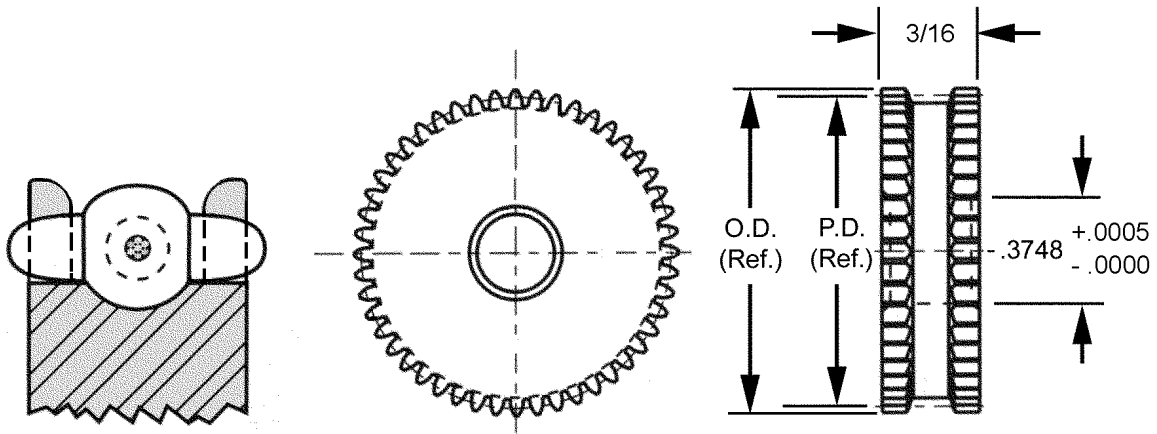

303 Stainless Steel	2024-T4 Aluminum Anodized	NO. OF TEETH	PITCH DIA.	OUTSIDE DIA.
GF31S5-24	GF31A5-24	24	.7639	.828
GF31S5-25	GF31A5-25	25	.7958	.860
GF31S5-26	GF31A5-26	26	.8276	.892
GF31S5-27	GF31A5-27	27	.8594	.923
GF31S5-28	GF31A5-28	28	.8912	.955
GF31S5-29	GF31A5-29	29	.9231	.987
GF31S5-30	GF31A5-30	30	.9549	1.019
GF31S5-32	GF31A5-32	32	1.0185	1.083
GF31S5-36	GF31A5-36	36	1.1459	1.210
GF31S5-40	GF31A5-40	40	1.2732	1.337
GF31S5-48	GF31A5-48	48	1.5278	1.592
GF31S5-50	GF31A5-50	50	1.5915	1.656
GF31S5-56	GF31A5-56	56	1.7825	1.846
GF31S5-64	GF31A5-64	64	2.0371	2.101
GF31S5-72	GF31A5-72	72	2.2918	2.355
GF31S5-80	GF31A5-80	80	2.5464	2.610
GF31S5-88	GF31A5-88	88	2.8010	2.865
GF31S5-90	GF31A5-90	90	2.8647	2.929
GF31S5-96	GF31A5-96	96	3.0557	3.120
GF31S5-100	GF31A5-100	100	3.1830	3.247
GF31S5-112	GF31A5-112	112	3.5650	3.629
GF31S5-120	GF31A5-120	120	3.8196	3.884
GF31S5-128	GF31A5-128	128	4.0743	4.138



Other numbers of teeth available on request.
Pin or Clamp hubs assembled on request.
Teeth could be anodized.

E-Z-ENTRY BELT PULLEYS

PITCH	CIR. PITCH	BORE	STYLE	MATERIAL	BERG'S® NAME	BELT
1/10	.1000	11/16"	HUBLESS	303 Stainless Steel or 2024-T4 Aluminum Anodized	Flex-E-Belt®	Operates with 31GBF Series

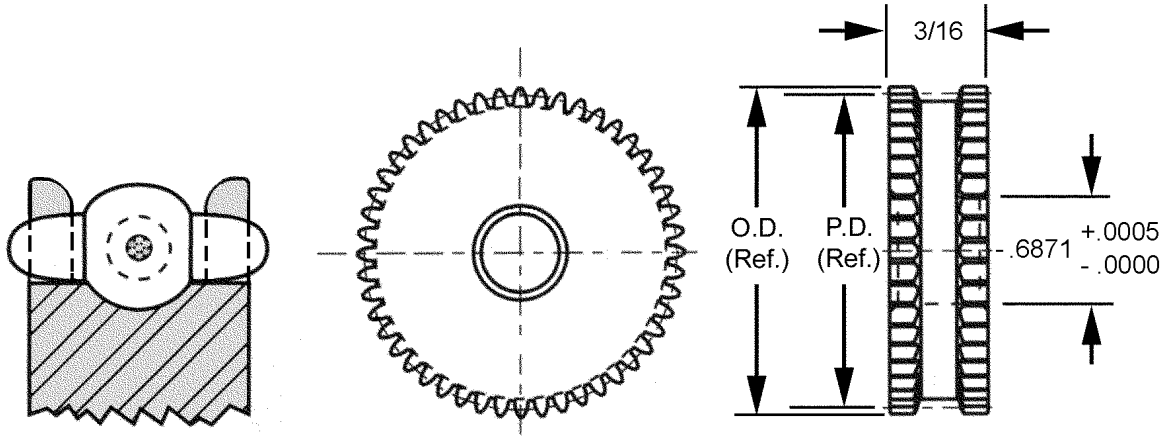

303 Stainless Steel	2024-T4 Aluminum Anodized			
STOCK NO.	STOCK NO.	NO. OF TEETH	PITCH DIA.	OUTSIDE DIA.
GF31S19-24	GF31A19-24	24	.7639	.828
GF31S19-25	GF31A19-25	25	.7958	.860
GF31S19-26	GF31A19-26	26	.8276	.892
GF31S19-27	GF31A19-27	27	.8594	.923
GF31S19-28	GF31A19-28	28	.8912	.955
GF31S19-29	GF31A19-29	29	.9231	.987
GF31S19-30	GF31A19-30	30	.9549	1.019
GF31S19-32	GF31A19-32	32	1.0185	1.083
GF31S19-36	GF31A19-36	36	1.1459	1.210
GF31S19-40	GF31A19-40	40	1.2732	1.337
GF31S19-48	GF31A19-48	48	1.5278	1.592
GF31S19-50	GF31A19-50	50	1.5915	1.656
GF31S19-56	GF31A19-56	56	1.7825	1.846
GF31S19-64	GF31A19-64	64	2.0371	2.101
GF31S19-72	GF31A19-72	72	2.2918	2.356
GF31S19-80	GF31A19-80	80	2.5464	2.610
GF31S19-88	GF31A19-88	88	2.8010	2.865
GF31S19-90	GF31A19-90	90	2.8647	2.929
GF31S19-96	GF31A19-96	96	3.0557	3.120
GF31S19-100	GF31A19-100	100	3.1830	3.247
GF31S19-112	GF31A19-112	112	3.5650	3.629
GF31S19-120	GF31A19-120	120	3.8196	3.884
GF31S19-128	GF31A19-128	128	4.0743	4.138



Other numbers of teeth available on request.
Pin or Clamp hubs assembled on request.
Teeth could be anodized.

GEAR DRIVE BELTS

PITCH	CIRCULAR PITCH	MATERIALS	BERG'S ® NAME	PULLEY
24	.1309	Polyurethane (Red) 1/32" Dia. Stainless Steel Cable	Flex-E-Belt®	Operates with 24C and 24D series.

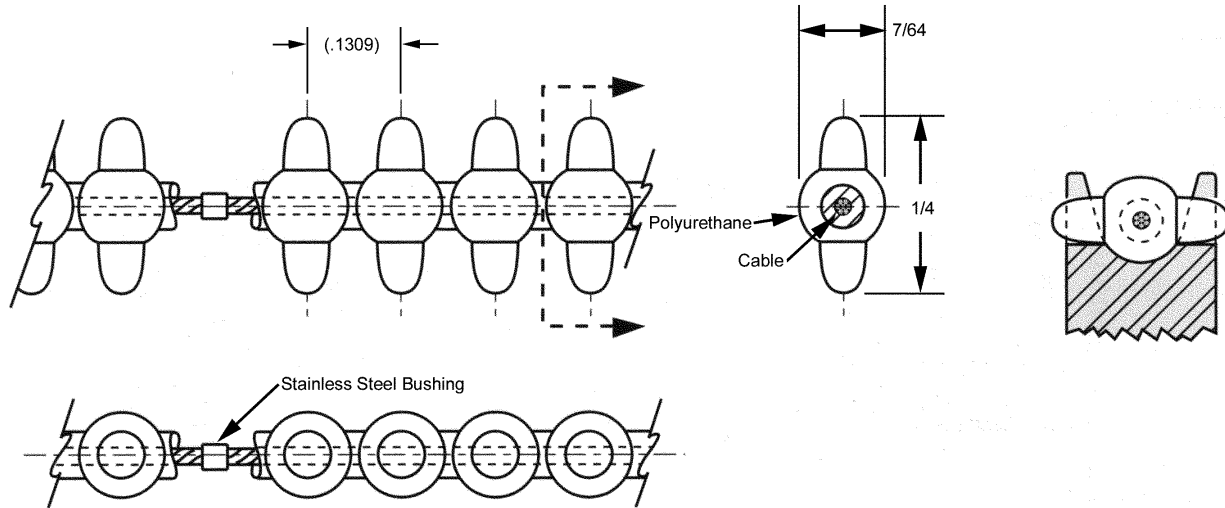

STOCK NO.	NO. OF PITCHES	LENGTH (Ref.)
24GBF-50-E	50	6.545
24GBF-52-E	52	6.807
24GBF-54-E	54	7.069
24GBF-56-E	56	7.330
24GBF-58-E	58	7.592
24GBF-60-E	60	7.854
24GBF-62-E	62	8.116
24GBF-64-E	64	8.378
24GBF-66-E	66	8.639
24GBF-68-E	68	8.901
24GBF-70-E	70	9.163
24GBF-75-E	75	9.817
24GBF-80-E	80	10.472
24GBF-85-E	85	11.126
24GBF-90-E	90	11.781
24GBF-95-E	95	12.435
24GBF-100-E	100	13.090
24GBF-105-E	105	13.744
24GBF-110-E	110	14.399
24GBF-115-E	115	15.053
24GBF-120-E	120	15.708
24GBF-130-E	130	17.017
24GBF-140-E	140	18.326
24GBF-150-E	150	19.635
24GBF-160-E	160	20.944
24GBF-170-E	170	22.253
24GBF-180-E	180	23.562
24GBF-190-E	190	24.870
24GBF-200-E	200	26.180
24GBF-220-E	220	28.798
24GBF-240-E	240	31.416
24GBF-260-E	260	34.034
24GBF-280-E	280	36.652
24GBF-300-E	300	39.270
24GBF-320-E	320	41.888
24GBF-360-E	360	47.124
24GBF-420-E	420	54.978

For Field Splice Kit order 24GBF-7.
 * Available with Aramid Core. See page VII for alternative belt construction or reverse bending applications.
 ** Reduce operating load rating by 50% for field splices.

- Positive Drive
- Accommodates twists and turns
- Odd Angles
- No Lubrication
- Infinite Lengths
- Zero Backlash
- Weight .13 oz./ft.
- 90A Durometer
- Ultimate Tensile Strength 50 lbs. - 9 lbs./Pin
- When belt is used in open loop configuration (without splice, no crimp bushing)
- Recommended Operating Load 12 lbs.
- Recommended Max. Operating Speed 376 feet/min.
- Temperature Range +180°F to -15°F

Other numbers of pitches available on request.

BULK FOOTAGE - NOT SPLICED	
STOCK NO.	LENGTH
24GBF-5FT	5FT
24GBF-10FT	10FT
24GBF-25FT	25FT
24GBF-50FT	50FT
24GBF-100FT	100FT



E-Z-ENTRY BELT PULLEYS

PITCH	CIR. PITCH	BORE	STYLE	MATERIAL	BERG'S® NAME	BELT
24	.1309	3/8"	HUBLESS	2024-T4 Aluminum Red Anodized	Flex-E-Belt®	Operates with 24GBF Series

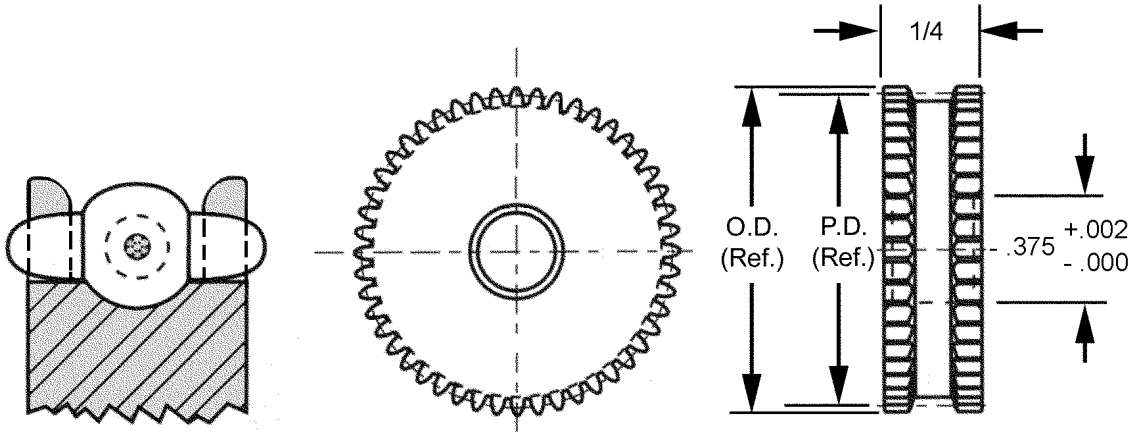

STOCK NO.	NO. OF TEETH	PITCH DIA.	OUTSIDE DIA.
24C6-15	15**	.6250	.708
24C6-16	16**	.6667	.750
24C6-18	18**	.7500	.833
24C6-20	20	.8333	.917
24C6-21	21	.8750	.958
24C6-24	24	1.0000	1.083
24C6-30	30	1.2500	1.333
24C6-36	36	1.5000	1.583
24C6-42	42	1.7500	1.833
24C6-48	48	2.0000	2.083
24C6-60	60	2.5000	2.583
24C6-72	72	3.0000	3.083
24C6-96	96	4.0000	4.083
24C6-120	120	5.0000	5.083
24C6-144	144	6.0000	6.083



** Pulleys with .750 P.D. and smaller for idler use only.

Teeth could be anodized.

E-Z-ENTRY BELT PULLEYS

PITCH	CIR. PITCH	BORE	STYLE	MATERIAL	BERG'S® NAME	BELT
24	.1309	1/4"	PIN HUB	2024-T4 Aluminum Anodized	Flex-E-Belt®	Operates with 24GBF Series

STOCK NO.	NO. OF TEETH	PITCH DIA.	OUTSIDE DIA.
24D4-14	14*	.5833	.667
24D4-15	15*	.6250	.708
24D4-16	16*	.6667	.750
24D4-18	18*	.7500	.833
24D4-20	20•	.8333	.917
24D4-21	21	.8750	.958
24D4-24	24	1.0000	1.083
24D4-30	30	1.2500	1.333
24D4-36	36	1.5000	1.583
24D4-42	42	1.7500	1.833
24D4-48	48	2.0000	2.083
24D4-60	60	2.5000	2.583
24D4-72	72	3.0000	3.083
24D4-96	96	4.0000	4.083
24D4-120	120	5.0000	5.083
24D4-144	144	6.0000	6.083

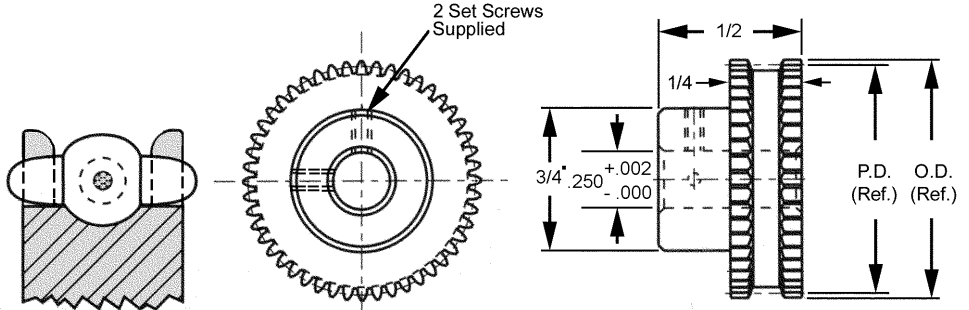

• For 14-20 teeth, hub diameter equals .47.
 * Pulleys with .750 P.D. and smaller for idler use only.

Teeth could be anodized.

PITCH	CIR. PITCH	BORE	STYLE	MATERIAL	BERG'S® NAME	BELT
24	.1309	3/8"	PIN HUB	2024-T4 Aluminum Anodized	Flex-E-Belt®	Operates with 24GBF Series

STOCK NO.	NO. OF TEETH	PITCH DIA.	OUTSIDE DIA.
24D6-18	18*	.7500	.833
24D6-20	20•	.8333	.917
24D6-21	21	.8750	.958
24D6-24	24	1.0000	1.083
24D6-30	30	1.2500	1.333
24D6-36	36	1.5000	1.583
24D6-42	42	1.7500	1.833
24D6-48	48	2.0000	2.083
24D6-60	60	2.5000	2.583
24D6-72	72	3.0000	3.083
24D6-96	96	4.0000	4.083
24D6-120	120	5.0000	5.083
24D6-144	144	6.0000	6.083

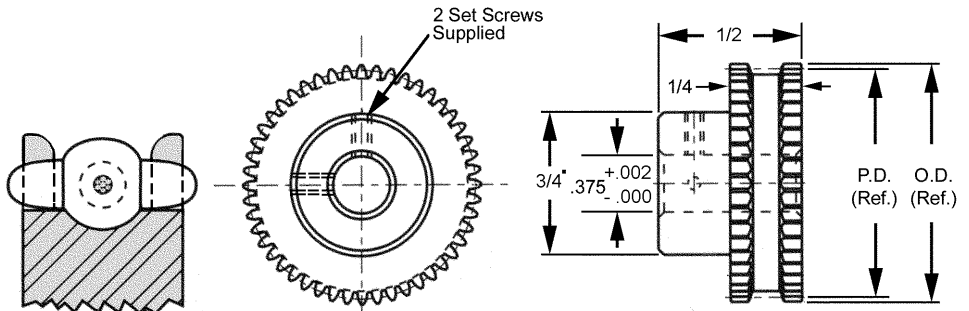

• For 18-20 teeth, hub diameter equals .64.
 * Pulleys with .750 P.D. and smaller for idler use only.

Teeth could be anodized.

PITCH	CIR. PITCH	BORE	STYLE	MATERIAL	BERG'S® NAME	BELT
24	.1309	1/2"	PIN HUB	2024-T4 Aluminum Anodized	Flex-E-Belt®	Operates with 24GBF Series

STOCK NO.	NO. OF TEETH	PITCH DIA.	OUTSIDE DIA.
24D8-20	20•	.8333	.917
24D8-21	21	.8750	.958
24D8-24	24	1.0000	1.083
24D8-30	30	1.2500	1.333
24D8-36	36	1.5000	1.583
24D8-42	42	1.7500	1.833
24D8-48	48	2.0000	2.083
24D8-60	60	2.5000	2.583
24D8-72	72	3.0000	3.083
24D8-96	96	4.0000	4.083
24D8-120	120	5.0000	5.083
24D8-144	144	6.0000	6.083

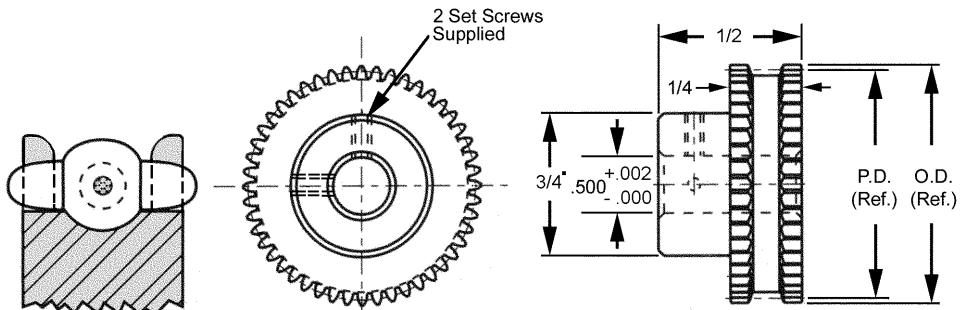

• For 20 teeth, hub diameter equals .72.
 * Pulleys with .750 P.D. and smaller for idler use only. Teeth could be anodized.

FIELD SPLICE KITS

1. Cut Berg Flex-E-Belt sharp and square as shown using cutter, to desired number of pitches, plus one pitch.



2. Cut plastic jacket (one pitch each side) lightly with a sharp razor blade as shown (all around). Strip or twist off jacket carefully.

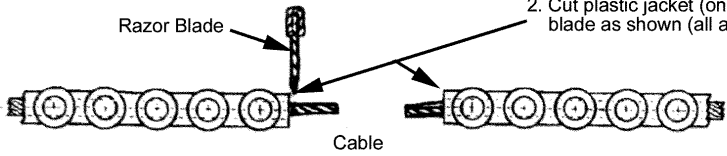

3. Slide stripped cable into oval splice bushing carefully. **Caution:** Do not fray cable. Feed cable into chamfered end of bushing last.

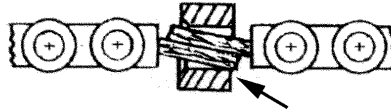

4. Center bushing and be certain belt is straight before crimping.

5. Assemble crimp tool over splice bushing and squeeze lightly for maximum bond to cable.

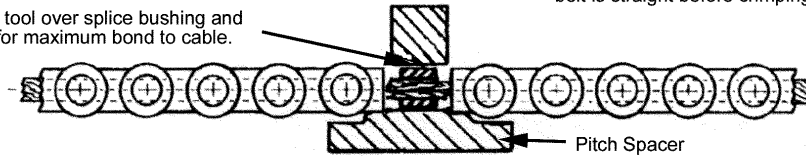

STOCK NO.	FIELD SPLICE KIT AND ACCESSORIES	BELT SERIES
33GBF-7 32GBF-7 24GBF-7	Complete Kit consists of: Crimp Tool, Pitch Spacer, Cable Cutter, Bushing, Razor Blades & Instructions	33GBF 31 & 32GBF 24GBF
TL-4 TL-3	Crimp Tool For 33GBF Crimp Tool for 24GBF, 31 GBF, 32GBF	
BU-018-S BU-032-S	Extra Splice Bushings for: 33GBF (1/64" Cable) 24GBF, 31GBF, 32GBF (1/32" Cable)	
TL-1	Cable Cutter for up to 3/64" Cable	

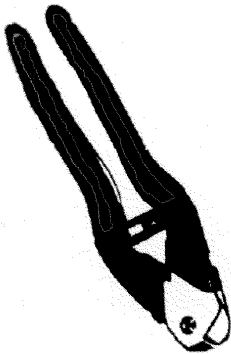

Cable Cutter



Crimp Tool

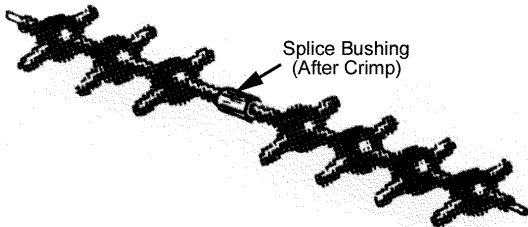

Field Splices offer only 50% of catalog rated loads.

W.M. Berg will factory splice to order any length at a nominal charge.

MIN-E-PITCH® TECHNICAL DATA

Stainless Steel or Kevlar® with Polyurethane cover.
Zero Backlash Silent Drive No Lubrication
Positive Drive Infinite Length Non-magnetic

PITCH	CIRCULAR PITCH	MATERIALS	BERG'S ® NAME	SPROCKET
1/20	.1570	Polyurethane (Red) 1/32" Dia. Stainless Steel Cable	Min-E-Pitch® Chain Drive	Operates with 3CC, 3MP, 3MF and 3MC series.

3CCF Series

- Ultimate tensile 100 lbs., 20 lb./pin when belt is used in open loop configuration (without splice, no crimp bushing).
 - Recommended Maximum Operating Speed 376 Feet/Min. (1800 rpm)
 - Recommended Operating Load 25 lbs.
 - Minimum Recommended Pulley Diameter .750" P.D.
 - Parallel Shaft Drives
- ** Reduce Operating Load Rating by 50% for field splices.

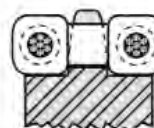

PITCH	CIRCULAR PITCH	MATERIALS	BERG'S ® NAME	SPROCKET
1/20	.1570	Polyurethane (Yellow) 1/32" Dia. Stainless Steel Cable	Min-E-Pitch® Chain Drive	Operates with 3MDP and 3MDF series.

3CBF Series

- Ultimate tensile 50 lbs., 9 lb./pin when belt is used in open loop configuration (without splice, no crimp bushing).
 - Recommended Maximum Operating Speed 376 Feet/Min. (1800 rpm)
 - Recommended Operating Load 12 lbs.
 - Minimum Recommended Pulley Diameter .750" P.D.
 - Odd Angle Shaft Drive
 - Twists & Turns
 - Non-parallel Shafts
- ** Reduce Operating Load Rating by 50% for field splices.



PITCH	CIRCULAR PITCH	MATERIALS	BERG'S ® NAME	SPROCKET
1/20	.1570	Polyurethane (Green) 1/32" Dia. Stainless Steel Cable	Min-E-Pitch® Chain Drive	Operates with 3TDP, 3TF, and 3MTB series.

3TDF Series

- Ultimate tensile 50 lbs., 9 lb./pin when belt is used in open loop configuration (without splice, no crimp bushing).
 - Recommended Maximum Operating Speed 376 Feet/Min. (1800 rpm)
 - Recommended Operating Load 12 lbs.
 - Minimum Recommended Pulley Diameter .750" P.D.
 - Three Dimensional Drives
 - Odd Angles and 90°
 - X, Y & Z Axis Drive
- ** Reduce Operating Load Rating by 50% for field splices.

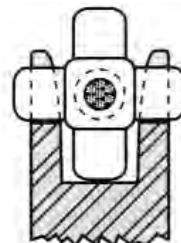

PITCH	CIRCULAR PITCH	MATERIALS	BERG'S ® NAME	SPROCKET
1/20	.1570	Polyurethane (Brown) 1/32" Dia. Stainless Steel Cable	Min-E-Pitch® Chain Drive	Operates with 3MDP and 3MDF series.

3DCF Series

- Ultimate tensile 120 lbs., 30 lb./pin when belt is used in open loop configuration (without splice, no crimp bushing).
 - Recommended Maximum Operating Speed 376 Feet/Min. (1800 rpm)
 - Recommended Operating Load 30 lbs.
 - Minimum Recommended Pulley Diameter .750" P.D.
 - Parallel Shaft Drives
 - 3 Cable Strand Strength
- ** Reduce Operating Load Rating by 50% for field splices.

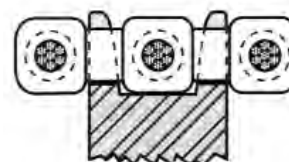

CABLE CHAINS

PITCH	CIRCULAR PITCH	MATERIALS	BERG'S ® NAME	SPROCKET
1/20	.1570	Polyurethane (Red) 1/32" Dia. Stainless Steel Cable*	Min-E-Pitch®	Operates with 3CC, 3MP, 3MF and 3MC series.

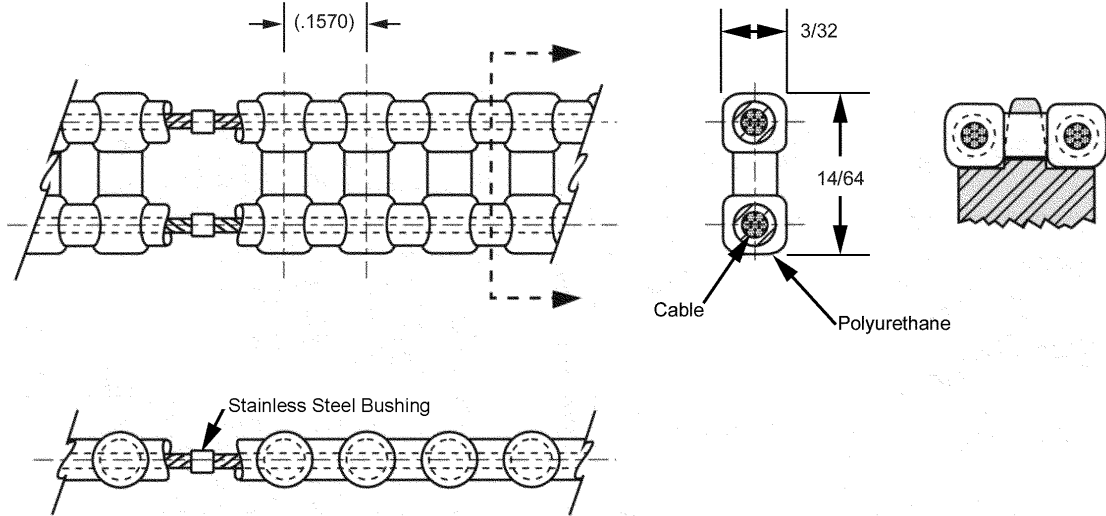

STOCK NO.	NO. OF PITCHES	LENGTH (Ref.)
3CCF-30-E	30	4.712
3CCF-35-E	35	5.498
3CCF-40-E	40	6.283
3CCF-45-E	45	7.069
3CCF-50-E	50	7.854
3CCF-55-E	55	8.639
3CCF-60-E	60	9.425
3CCF-70-E	70	10.996
3CCF-80-E	80	12.566
3CCF-90-E	90	14.137
3CCF-100-E	100	15.708
3CCF-110-E	110	17.279
3CCF-120-E	120	18.850
3CCF-130-E	130	20.420
3CCF-140-E	140	21.991
3CCF-150-E	150	23.562
3CCF-160-E	160	25.133
3CCF-170-E	170	26.704
3CCF-180-E	180	28.274
3CCF-190-E	190	29.845
3CCF-200-E	200	31.416
3CCF-210-E	210	32.987
3CCF-220-E	220	34.558
3CCF-230-E	230	36.128
3CCF-240-E	240	37.699
3CCF-250-E	250	39.270
3CCF-260-E	260	40.840
3CCF-270-E	270	42.412
3CCF-280-E	280	43.982
3CCF-290-E	290	45.553
3CCF-300-E	300	47.124
3CCF-310-E	310	48.695
3CCF-320-E	320	50.265
3CCF-330-E	330	51.836
3CCF-340-E	340	53.407
3CCF-350-E	350	54.978
3CCF-370-E	370	58.119
3CCF-400-E	400	62.832
3CCF-440-E	440	69.115

- For Field Splice Kit order 3CCR-7.
- * Available with Aramid Core. See page VII for alternative belt construction or reverse bending applications.
- **Reduce Operating Load Rating by 50% for field splices.

- Infinite Lengths
- Silent Drive
- Weight .13 oz./ft.
- Non-Magnetic
- Positive Drive
- Zero Backlash
- No Lubrication
- 90A Durometer
- Ultimate Tensile Strength 100 lbs., 20 lbs./Pin when belt is used in open loop configuration (without splice, no crimp bushings).
- Temperature Range +180°F to -15°F
- Recommended Operating Load 25 lbs.
- Recommended Max. Operating Speed 376 Feet/Min.
- Other numbers of pitches available on request.

BULK FOOTAGE - NOT SPLICED	
STOCK NO.	LENGTH
3CCF-5FT	5FT
3CCF-10FT	10FT
3CCF-25FT	25FT
3CCF-50FT	50FT
3CCF-100FT	100FT



CHAIN SPROCKETS

PITCH	CIR. PITCH	BORE	STYLE	MATERIAL	BERG'S® NAME	CHAIN
1/20	.1570	1/4"	PIN HUB	Delrin®	Min-E-Pitch® Chain Drive	Operates with 3CCF Series

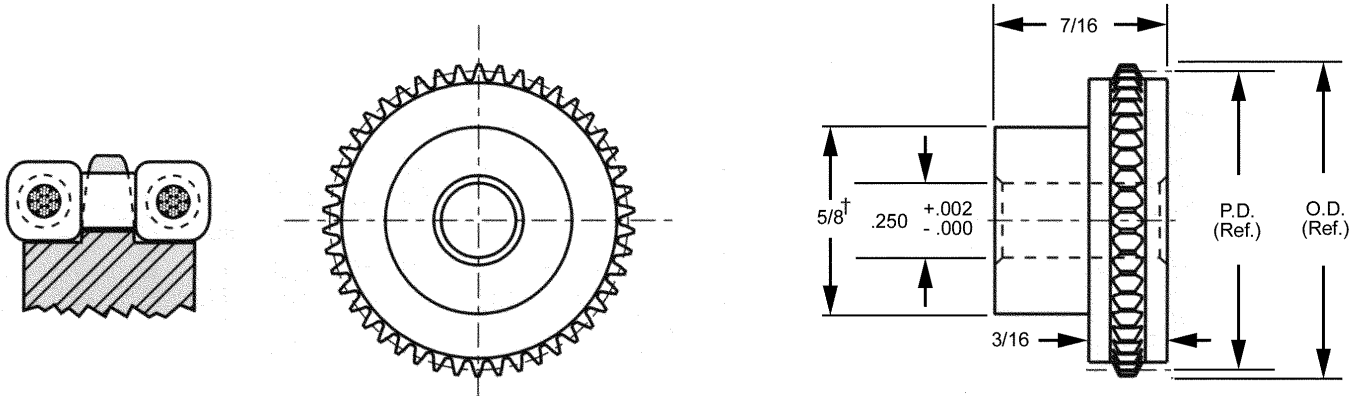

STOCK NO.	NO. OF TEETH	PITCH DIA.	OUTSIDE DIA.
3CC4M-13	13*	.6492	.711
3CC4M-14	14*	.6991	.761
3CC4M-15	15	.7490	.811
3CC4M-16	16	.7990	.861
3CC4M-18	18	.8988	.961
3CC4M-20	20	.9987	1.061
3CC4M-22	22	1.0986	1.161
3CC4M-24	24	1.1985	1.260
3CC4M-26	26	1.2983	1.360
3CC4M-28	28	1.3982	1.460
3CC4M-30	30	1.4981	1.560
3CC4M-32	32	1.5980	1.660
3CC4M-35	35	1.7478	1.810
3CC4M-36	36	1.7977	1.860
3CC4M-40	40	1.9974	2.059
3CC4M-45	45	2.2471	2.309
3CC4M-50	50	2.4968	2.559
3CC4M-55	55	2.7465	2.808



† Teeth runout on hub.
 * Sprockets .750 P.D. and smaller are recommended for idler use only.
 Other numbers of teeth available on request.

CHAIN SPROCKETS

PITCH	CIR. PITCH	BORE	STYLE	MATERIALS	BERG'S® NAME	CHAIN
1/20	.1570	1/8"	PIN HUB	303 Stainless Steel or 2024-T4 Anodized Aluminum	Min-E-Pitch® Chain Drive	Operates with 3CCF Series

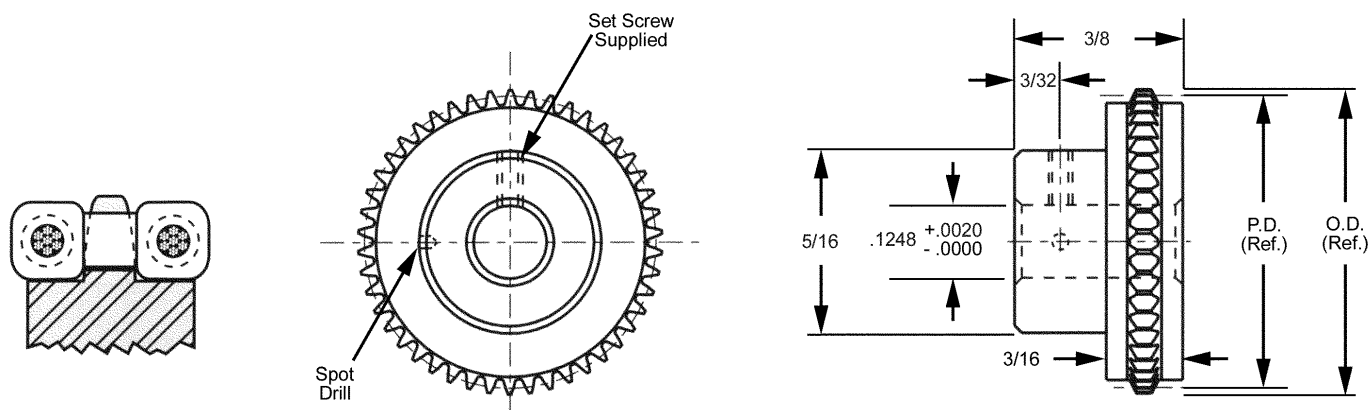

303 STAINLESS STEEL	2024-T4 ALUMINUM ANODIZED			
STOCK NO.	STOCK NO.	NO. OF TEETH	PITCH DIA.	OUTSIDE DIA.
3MP14S-10	3MP14A-10	10*	.4994	.561
3MP14S-11	3MP14A-11	11*	.5493	.611
3MP14S-12	3MP14A-12	12*	.5992	.661
3MP14S-13	3MP14A-13	13*	.6492	.711
3MP14S-14	3MP14A-14	14*	.6991	.761
3MP14S-15	3MP14A-15	15*	.7490	.811
3MP14S-16	3MP14A-16	16	.7990	.861
3MP14S-17	3MP14A-17	17	.8489	.911
3MP14S-18	3MP14A-18	18	.8988	.960
3MP14S-19	3MP14A-19	19	.9488	1.011
3MP14S-20	3MP14A-20	20	.9987	1.061
3MP14S-22	3MP14A-22	22	1.0986	1.161
3MP14S-24	3MP14A-24	24	1.1985	1.260
3MP14S-25	3MP14A-25	25	1.2484	1.310
3MP14S-26	3MP14A-26	26	1.2983	1.360
3MP14S-28	3MP14A-28	28	1.3982	1.460
3MP14S-30	3MP14A-30	30	1.4981	1.560
3MP14S-32	3MP14A-32	32	1.5980	1.660
3MP14S-35	3MP14A-35	35**	1.7478	1.810
3MP14S-36	3MP14A-36	36**	1.7977	1.860
3MP14S-40	3MP14A-40	40**	1.9974	2.059
3MP14S-45	3MP14A-45	45**	2.2471	2.309
3MP14S-50	3MP14A-50	50**	2.4968	2.559
3MP14S-55	3MP14A-55	55**	2.7465	2.808
3MP14S-60	3MP14A-60	60**	2.9962	3.058
3MP14S-65	3MP14A-65	65**	3.2458	3.308
3MP14S-70	3MP14A-70	70**	3.4955	3.558
3MP14S-75	3MP14A-75	75**	3.7452	3.807
3MP14S-80	3MP14A-80	80**	3.9949	4.057



** May be 2 piece construction with 303 stainless steel hub.
 Outline and overall dimensions change slightly.
 * Sprockets with .750 P.D. and smaller are recommended for idler use only.
 Teeth could be anodized.

CHAIN SPROCKETS

PITCH	CIR. PITCH	BORE	STYLE	MATERIALS	BERG'S® NAME	CHAIN
1/20	.1570	3/16"	PIN HUB	303 Stainless Steel or 2024-T4 Anodized Aluminum	Min-E-Pitch® Chain Drive	Operates with 3CCF Series

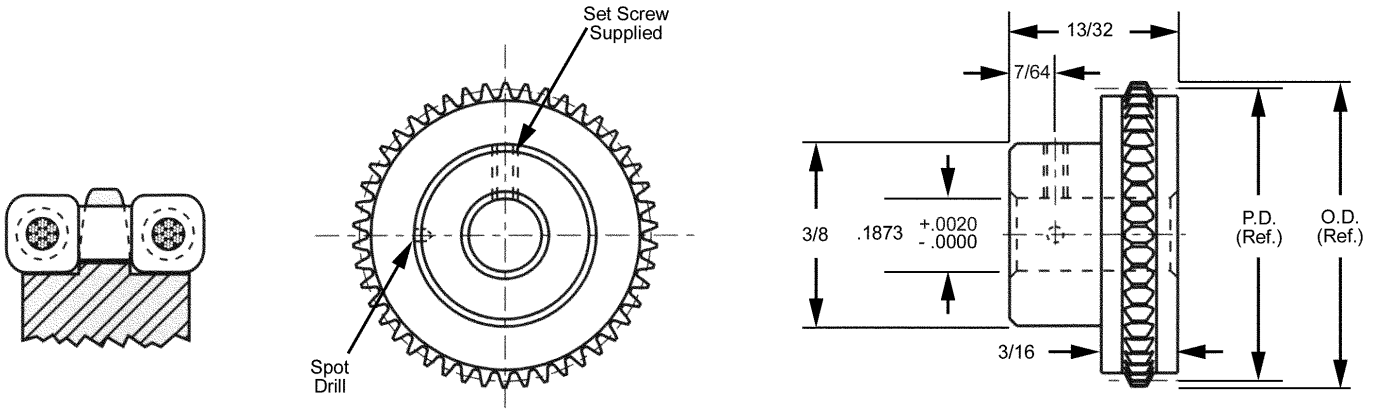

303 STAINLESS STEEL	2024-T4 ALUMINUM ANODIZED			
STOCK NO.	STOCK NO.	NO. OF TEETH	PITCH DIA.	OUTSIDE DIA.
3MP21S-10	3MP21A-10	10*	.4994	.561
3MP21S-11	3MP21A-11	11*	.5493	.611
3MP21S-12	3MP21A-12	12*	.5992	.661
3MP21S-13	3MP21A-13	13*	.6492	.711
3MP21S-14	3MP21A-14	14*	.6991	.761
3MP21S-15	3MP21A-15	15*	.7490	.811
3MP21S-16	3MP21A-16	16	.7990	.861
3MP21S-17	3MP21A-17	17	.8489	.911
3MP21S-18	3MP21A-18	18	.8988	.961
3MP21S-19	3MP21A-19	19	.9488	1.011
3MP21S-20	3MP21A-20	20	.9987	1.061
3MP21S-22	3MP21A-22	22	1.0986	1.161
3MP21S-24	3MP21A-24	24	1.1985	1.260
3MP21S-25	3MP21A-25	25	1.2484	1.310
3MP21S-26	3MP21A-26	26	1.2983	1.360
3MP21S-28	3MP21A-28	28	1.3982	1.460
3MP21S-30	3MP21A-30	30	1.4981	1.560
3MP21S-32	3MP21A-32	32	1.5980	1.660
3MP21S-35	3MP21A-35	35	1.7478	1.810
3MP21S-36	3MP21A-36	36	1.7977	1.860
3MP21S-40	3MP21A-40	40	1.9974	2.060
3MP21S-45	3MP21A-45	45	2.2471	2.309
3MP21S-50	3MP21A-50	50	2.4968	2.559
3MP21S-55	3MP21A-55	55	2.7465	2.808
3MP21S-60	3MP21A-60	60	2.9962	3.058
3MP21S-65	3MP21A-65	65	3.2458	3.308
3MP21S-70	3MP21A-70	70	3.4955	3.558
3MP21S-75	3MP21A-75	75	3.7452	3.807
3MP21S-80	3MP21A-80	80	3.9949	4.057



* Sprockets with .750 P.D. and smaller are recommended for idler use only. Other numbers of teeth are available on request.

Teeth could be anodized.

CHAIN SPROCKETS

PITCH	CIR. PITCH	BORE	STYLE	MATERIALS	BERG'S® NAME	CHAIN
1/20	.1570	1/4"	PIN HUB	303 Stainless Steel or 2024-T4 Anodized Aluminum	Min-E-Pitch® Chain Drive	Operates with 3CCF Series

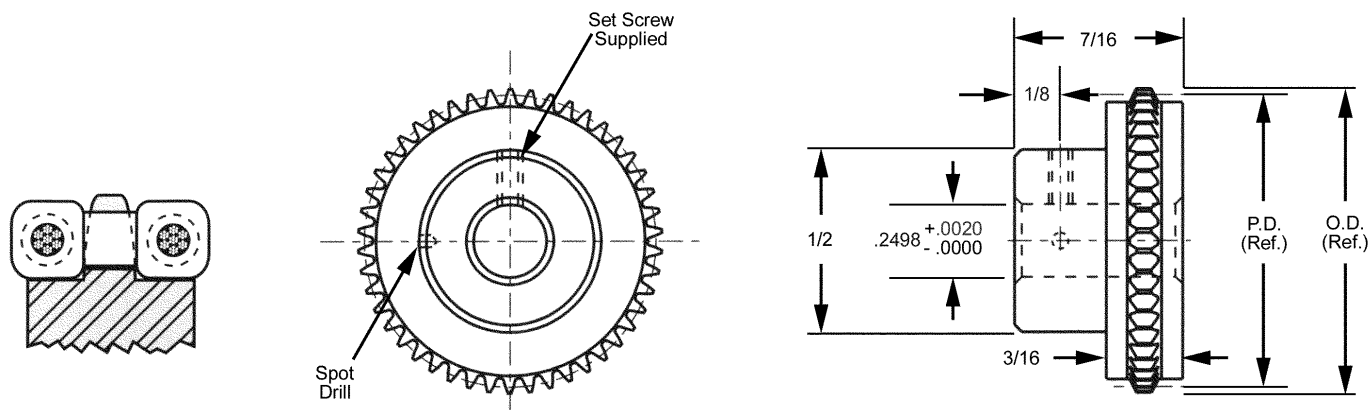

303 STAINLESS STEEL	2024-T4 ALUMINUM ANODIZED			
STOCK NO.	STOCK NO.	NO. OF TEETH	PITCH DIA.	OUTSIDE DIA.
3MP28S-12	3MP28A-12	12*	.5992	.661
3MP28S-13	3MP28A-13	13*	.6492	.711
3MP28S-14	3MP28A-14	14*	.6991	.761
3MP28S-15	3MP28A-15	15*	.7490	.811
3MP28S-16	3MP28A-16	16	.7990	.861
3MP28S-17	3MP28A-17	17	.8489	.911
3MP28S-18	3MP28A-18	18	.8988	.961
3MP28S-19	3MP28A-19	19	.9488	1.011
3MP28S-20	3MP28A-20	20	.9987	1.061
3MP28S-22	3MP28A-22	22	1.0986	1.161
3MP28S-24	3MP28A-24	24	1.1985	1.260
3MP28S-25	3MP28A-25	25	1.2484	1.310
3MP28S-26	3MP28A-26	26	1.2983	1.360
3MP28S-28	3MP28A-28	28	1.3982	1.460
3MP28S-30	3MP28A-30	30	1.4981	1.560
3MP28S-32	3MP28A-32	32	1.5980	1.660
3MP28S-35	3MP28A-35	35	1.7478	1.810
3MP28S-36	3MP28A-36	36	1.7977	1.860
3MP28S-40	3MP28A-40	40	1.9974	2.059
3MP28S-45	3MP28A-45	45	2.2471	2.309
3MP28S-50	3MP28A-50	50	2.4968	2.559
3MP28S-55	3MP28A-55	55	2.7465	2.808
3MP28S-60	3MP28A-60	60	2.9962	3.058
3MP28S-65	3MP28A-65	65	3.2458	3.308
3MP28S-70	3MP28A-70	70	3.4955	3.558
3MP28S-75	3MP28A-75	75	3.7452	3.807
3MP28S-80	3MP28A-80	80	3.9949	4.057



* Sprockets with .750 P.D. and smaller are recommended for idler use only.
Other numbers of teeth are available on request.

Teeth could be anodized.

CHAIN SPROCKETS

PITCH	CIR. PITCH	BORE	STYLE	MATERIALS	BERG'S® NAME	CHAIN
1/20	.1570	5/16"	PIN HUB	303 Stainless Steel or 2024-T4 Anodized Aluminum	Min-E-Pitch® Chain Drive	Operates with 3CCF Series

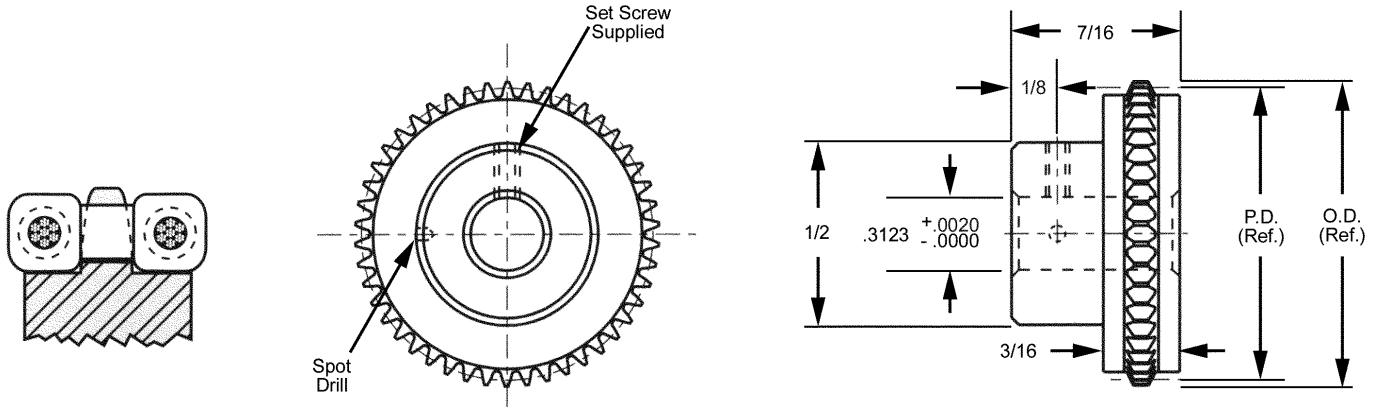

303 STAINLESS STEEL	2024T4 ALUMINUM ANODIZED			
STOCK NO.	STOCK NO.	NO. OF TEETH	PITCH DIA.	OUTSIDE DIA.
3MP32S-12	3MP32A-12	12*	.5992	.661
3MP32S-13	3MP32A-13	13*	.6492	.711
3MP32S-14	3MP32A-14	14*	.6991	.761
3MP32S-15	3MP32A-15	15*	.7490	.810
3MP32S-16	3MP32A-16	16	.7990	.861
3MP32S-17	3MP32A-17	17	.8489	.910
3MP32S-18	3MP32A-18	18	.8988	.960
3MP32S-19	3MP32A-19	19	.9488	1.010
3MP32S-20	3MP32A-20	20	.9987	1.060
3MP32S-22	3MP32A-22	22	1.0986	1.160
3MP32S-24	3MP32A-24	24	1.1985	1.260
3MP32S-25	3MP32A-25	26	1.2484	1.310
3MP32S-26	3MP32A-26	26	1.2983	1.360
3MP32S-28	3MP32A-28	28	1.3982	1.460
3MP32S-30	3MP32A-30	30	1.4981	1.560
3MP32S-32	3MP32A-32	32	1.5980	1.660
3MP32S-35	3MP32A-35	35	1.7478	1.809
3MP32S-36	3MP32A-36	36	1.7977	1.859
3MP32S-40	3MP32A-40	40	1.9974	2.059
3MP32S-45	3MP32A-45	45	2.2471	2.309
3MP32S-50	3MP32A-50	50	2.4968	2.558
3MP32S-55	3MP32A-55	55	2.7465	2.808
3MP32S-60	3MP32A-60	60	2.9962	3.058
3MP32S-65	3MP32A-65	65	3.2458	3.307
3MP32S-70	3MP32A-70	70	3.4955	3.557
3MP32S-75	3MP32A-75	75	3.7452	3.807
3MP32S-80	3MP32A-80	80	3.9949	4.056



* Sprockets with .750 P.D. and smaller are recommended for idler use only. Other numbers of teeth are available on request.

Teeth could be anodized.

CHAIN SPROCKETS

PITCH	CIR. PITCH	BORE	STYLE	MATERIALS	BERG'S® NAME	CHAIN
1/20	.1570	3/8"	HUBLESS	303 Stainless Steel or 2024-T4 Anodized Aluminum	Min-E-Pitch® Chain Drive	Operates with 3CCF Series

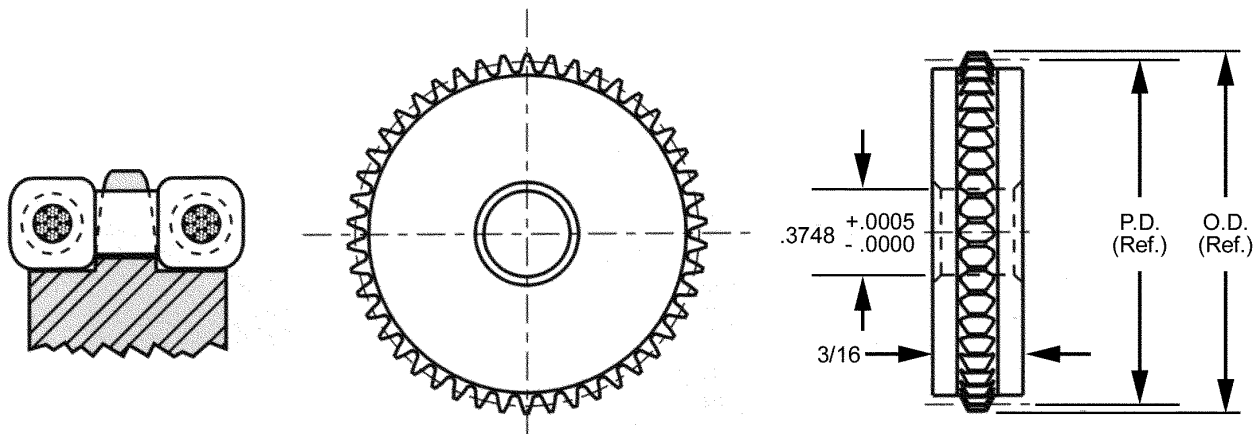

303 STAINLESS STEEL	2024-T4 ALUMINUM ANODIZED			
STOCK NO.	STOCK NO.	NO. OF TEETH	PITCH DIA.	OUTSIDE DIA.
3MF5S-14	3MF5A-14	14*	.6991	.761
3MF5S-15	3MF5A-15	15*	.7490	.811
3MF5S-16	3MF5A-16	16	.7990	.861
3MF5S-17	3MF5A-17	17	.8489	.911
3MF5S-18	3MF5A-18	18	.8988	.961
3MF5S-19	3MF5A-19	19	.9488	1.011
3MF5S-20	3MF5A-20	20	.9987	1.061
3MF5S-22	3MF5A-22	22	1.0986	1.161
3MF5S-24	3MF5A-24	24	1.1985	1.260
3MF5S-25	3MF5A-25	25	1.2484	1.310
3MF5S-26	3MF5A-26	26	1.2983	1.360
3MF5S-28	3MF5A-28	28	1.3982	1.460
3MF5S-30	3MF5A-30	30	1.4981	1.560
3MF5S-32	3MF5A-32	32	1.5980	1.660
3MF5S-35	3MF5A-35	35	1.7478	1.809
3MF5S-36	3MF5A-36	36	1.7977	1.859
3MF5S-40	3MF5A-40	40	1.9974	2.059
3MF5S-45	3MF5A-45	45	2.2471	2.309
3MF5S-50	3MF5A-50	50	2.4968	2.559
3MF5S-55	3MF5A-55	55	2.7465	2.808
3MF5S-60	3MF5A-60	60	2.9962	3.058
3MF5S-65	3MF5A-65	65	3.2458	3.308
3MF5S-70	3MF5A-70	70	3.4955	3.558
3MF5S-75	3MF5A-75	75	3.7452	3.807
3MF5S-80	3MF5A-80	80	3.9949	4.057



* Sprockets with .750 P.D. and smaller are recommended for idler use only.
Other numbers of teeth are available on request.

Teeth could be anodized.

CHAIN SPROCKETS

PITCH	CIR. PITCH	BORE	STYLE	MATERIALS	BERG'S® NAME	CHAIN
1/20	.1570	11/16"	HUBLESS	303 Stainless Steel or 2024-T4 Anodized Aluminum	Min-E-Pitch® Chain Drive	Operates with 3CCF Series

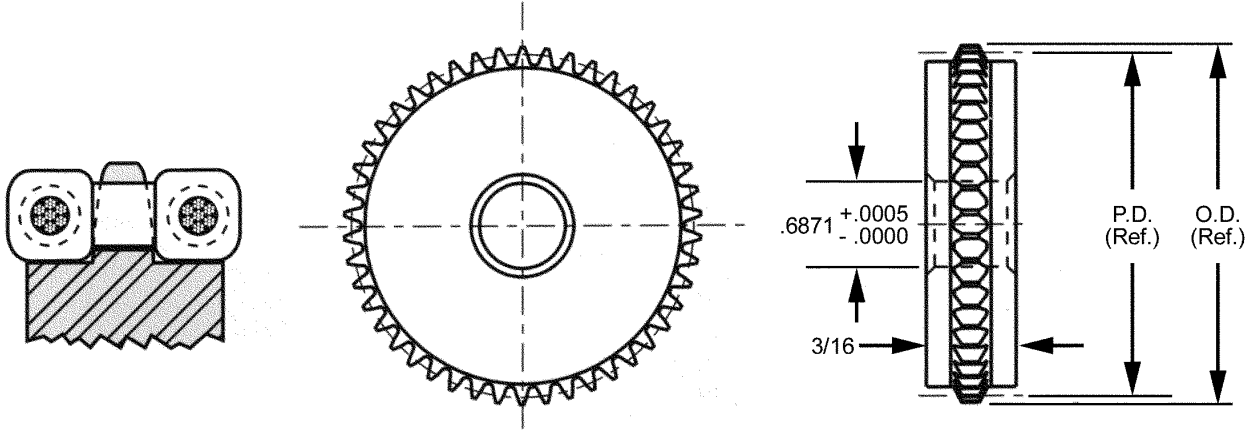

303 STAINLESS STEEL	2024T4 ALUMINUM ANODIZED			
STOCK NO.	STOCK NO.	NO. OF TEETH	PITCH DIA.	OUTSIDE DIA.
3MF19S-14	3MF19A-14	14*	.6991	.761
3MF19S-15	3MF19A-15	15*	.7490	.811
3MF19S-16	3MF19A-16	16	.7990	.861
3MF19S-17	3MF19A-17	17	.8489	.911
3MF19S-18	3MF19A-18	18	.8988	.961
3MF19S-19	3MF19A-19	19	.9488	1.011
3MF19S-20	3MF19A-20	20	.9987	1.061
3MF19S-22	3MF19A-22	22	1.0986	1.161
3MF19S-24	3MF19A-24	24	1.1985	1.260
3MF19S-25	3MF19A-25	25	1.2484	1.310
3MF19S-26	3MF19A-26	26	1.2983	1.360
3MF19S-28	3MF19A-28	28	1.3982	1.460
3MF19S-30	3MF19A-30	30	1.4981	1.560
3MF19S-32	3MF19A-32	32	1.5980	1.660
3MF19S-35	3MF19A-35	35	1.7478	1.809
3MF19S-36	3MF19A-36	36	1.7977	1.859
3MF19S-40	3MF19A-40	40	1.9974	2.059
3MF19S-45	3MF19A-45	45	2.2471	2.309
3MF19S-50	3MF19A-50	50	2.4968	2.559
3MF19S-55	3MF19A-55	55	2.7465	2.808
3MF19S-60	3MF19A-60	60	2.9962	3.058
3MF19S-65	3MF19A-65	65	3.2458	3.308
3MF19S-70	3MF19A-70	70	3.4955	3.558
3MF19S-75	3MF19A-75	75	3.7452	3.807
3MF19S-80	3MF19A-80	80	3.9949	4.057



* Sprockets with .750 P.D. and smaller are recommended for idler use only. Other numbers of teeth are available on request.

Teeth could be anodized.

CHAIN SPROCKETS

PITCH	CIR. PITCH	BORE	STYLE	MATERIALS	BERG'S® NAME	CHAIN
1/20	.1570	1/4"	CLAMP HUB	303 Stainless Steel or 2024-T4 Anodized Aluminum	Min-E-Pitch® Chain Drive	Operates with 3CCF Series

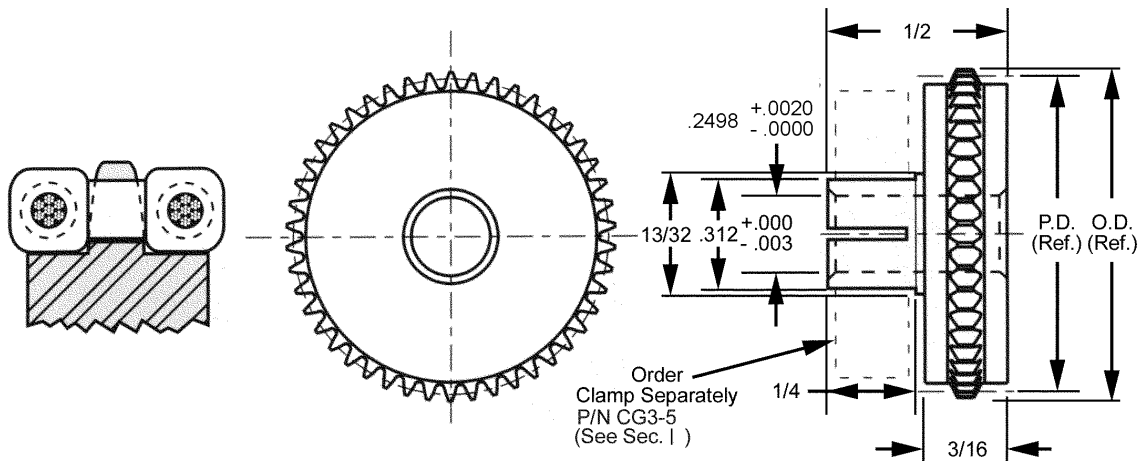

303 STAINLESS STEEL	2024-T4 ALUMINUM ANODIZED			
STOCK NO.	STOCK NO.	NO. OF TEETH	PITCH DIA.	OUTSIDE DIA.
3MC20S-12	3MC20A-12	12*	.5992	.661
3MC20S-13	3MC20A-13	13*	.6492	.711
3MC20S-14	3MC20A-14	14*	.6991	.761
3MC20S-15	3MC20A-15	15*	.7490	.811
3MC20S-16	3MC20A-16	16	.7990	.861
3MC20S-17	3MC20A-17	17	.8489	.911
3MC20S-18	3MC20A-18	18	.8988	.961
3MC20S-19	3MC20A-19	19	.9488	1.011
3MC20S-20	3MC20A-20	20	.9987	1.061
3MC20S-22	3MC20A-22	22	1.0986	1.161
3MC20S-24	3MC20A-24	24	1.1985	1.260
3MC20S-25	3MC20A-25	25	1.2484	1.310
3MC20S-26	3MC20A-26	26	1.2983	1.360
3MC20S-28	3MC20A-28	28	1.3982	1.460
3MC20S-30	3MC20A-30	30	1.4981	1.560
3MC20S-32	3MC20A-32	32	1.5980	1.660
3MC20S-35	3MC20A-35	35	1.7478	1.810
3MC20S-36	3MC20A-36	36	1.7977	1.860
3MC20S-40	3MC20A-40	40	1.9974	2.059
3MC20S-45	3MC20A-45	45	2.2471	2.309
3MC20S-50	3MC20A-50	50	2.4968	2.559
3MC20S-55	3MC20A-55	55	2.7465	2.808
3MC20S-60	3MC20A-60	60	2.9962	3.058
3MC20S-65	3MC20A-65	65	3.2458	3.308
3MC20S-70	3MC20A-70	70	3.4955	3.558
3MC20S-75	3MC20A-75	75	3.7452	3.807
3MC20S-80	3MC20A-80	80	3.9949	4.057



* Sprockets with .750 P.D. and smaller are recommended for idler use only.
Other numbers of teeth are available on request.

Teeth could be anodized.

DUAL CHAINS

PITCH	CIRCULAR PITCH	MATERIALS	BERG'S ® NAME	SPROCKET
1/20	.1570	Polyurethane (Brown) 1/32" Dia. Stainless Steel Cable*	Min-E-Pitch®	Operates with 3MDP and 3MDF series.

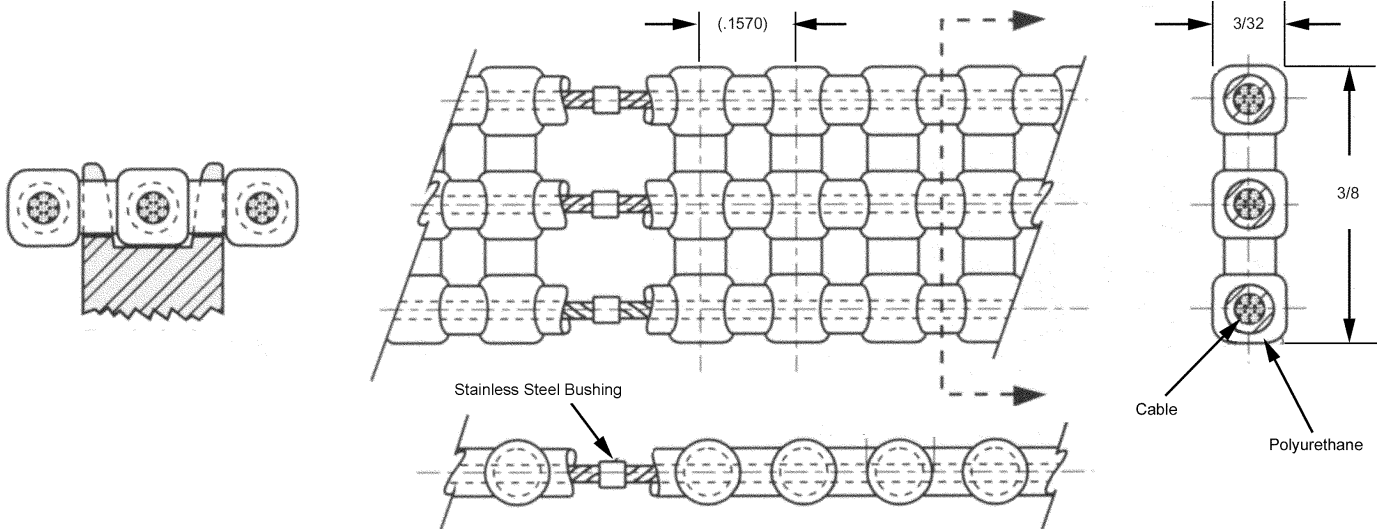

STOCK NO.	NO. OF PITCHES	LENGTH (Ref.)
3DCF-30-E	30	4.712
3DCF-35-E	35	5.498
3DCF-40-E	40	6.283
3DCF-45-E	45	7.069
3DCF-50-E	50	7.854
3DCF-55-E	55	8.639
3DCF-60-E	60	9.425
3DCF-70-E	70	10.996
3DCF-80-E	80	12.566
3DCF-90-E	90	14.137
3DCF-100-E	100	15.708
3DCF-110-E	110	17.279
3DCF-120-E	120	18.850
3DCF-130-E	130	20.420
3DCF-140-E	140	21.991
3DCF-150-E	150	23.562
3DCF-160-E	160	25.133
3DCF-170-E	170	26.704
3DCF-180-E	180	28.274
3DCF-190-E	190	29.845
3DCF-200-E	200	31.416
3DCF-210-E	210	32.987
3DCF-220-E	220	34.558
3DCF-230-E	230	36.128
3DCF-240-E	240	37.699
3DCF-250-E	250	39.270
3DCF-260-E	260	40.840
3DCF-270-E	270	42.412
3DCF-280-E	280	43.982
3DCF-290-E	290	45.553
3DCF-300-E	300	47.124
3DCF-310-E	310	48.695
3DCF-320-E	320	50.265
3DCF-330-E	330	51.836
3DCF-340-E	340	53.407
3DCF-350-E	350	54.978
3DCF-370-E	370	58.119
3DCF-400-E	400	62.832
3DCF-440-E	440	69.115

* This series is not available with alternate core configuration.
 ** Reduce Operating Load Rating by 50% for field splices.

- For Field Splice Kit order 3CCR-7.
- Zero Backlash
- Weight .21 oz./ft.
- Silent Drive
- No Lubrication
- Infinite Lengths
- 90A Durometer
- Positive Drive
- Non-Magnetic
- Ultimate Tensile Strength 120 lbs. - 30 lbs./Pin
- When belt is used in open loop configuration (without splice, no crimp bushing)
- Temperature Range +180°F to -15°F
- Recommended Operating Load 30 lbs.
- Recommended Max. Operating Speed 376 Feet/Min.

BULK FOOTAGE - NOT SPLICED	
STOCK NO.	LENGTH
3DCF-5FT	5FT
3DCF-10FT	10FT
3DCF-25FT	25FT
3DCF-50FT	50FT
3DCF-100FT	100FT



BELTS

PITCH	CIRCULAR PITCH	MATERIALS	BERG'S ® NAME	SPROCKET
1/20	.1570	Polyurethane (Yellow) 1/32" Dia. Stainless Steel Cable*	Min-E-Pitch®	Operates with 3MDP and 3MDF series.

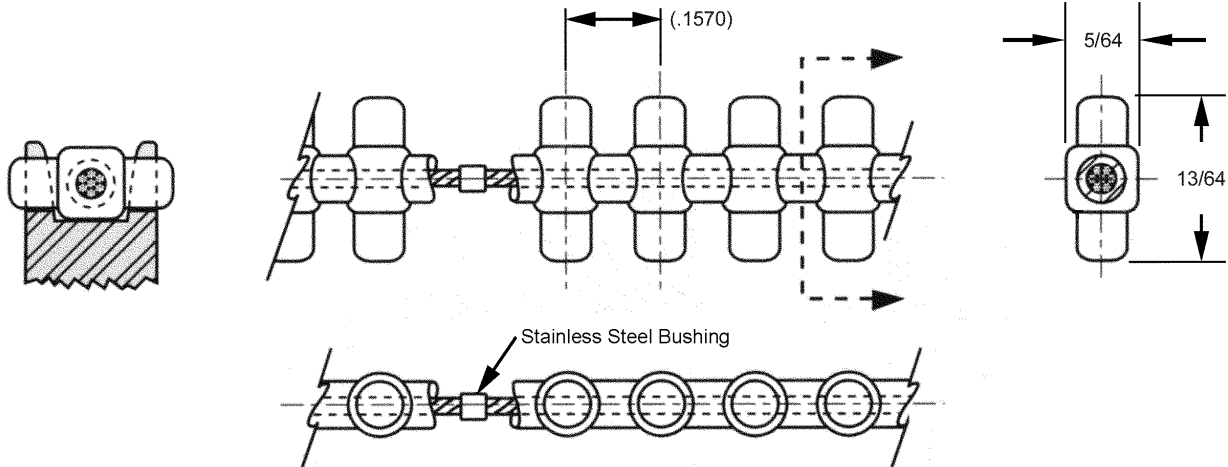

STOCK NO.	NO. OF PITCHES	LENGTH (Ref.)
3CBF-30-E	30	4.712
3CBF-35-E	35	5.498
3CBF-40-E	40	6.283
3CBF-45-E	45	7.069
3CBF-50-E	50	7.854
3CBF-55-E	55	8.639
3CBF-60-E	60	9.425
3CBF-70-E	70	10.996
3CBF-80-E	80	12.566
3CBF-90-E	90	14.137
3CBF-100-E	100	15.708
3CBF-110-E	110	17.279
3CBF-120-E	120	18.850
3CBF-130-E	130	20.420
3CBF-140-E	140	21.991
3CBF-150-E	150	23.562
3CBF-160-E	160	25.133
3CBF-170-E	170	26.704
3CBF-180-E	180	28.274
3CBF-190-E	190	29.845
3CBF-200-E	200	31.416
3CBF-210-E	210	32.987
3CBF-220-E	220	34.558
3CBF-230-E	230	36.128
3CBF-240-E	240	37.699
3CBF-250-E	250	39.270
3CBF-260-E	260	40.840
3CBF-270-E	270	42.412
3CBF-280-E	280	43.982
3CBF-290-E	290	45.553
3CBF-300-E	300	47.124
3CBF-310-E	310	48.695
3CBF-320-E	320	50.265
3CBF-330-E	330	51.836
3CBF-340-E	340	53.407
3CBF-350-E	350	54.978
3CBF-370-E	370	58.119
3CBF-400-E	400	62.832
3CBF-440-E	440	69.115

* This series is not available with alternate core configuration.
** Reduce Operating Load Rating by 50% for field splices.

- For Field Splice Kit order 3CCR-7.
- Zero Backlash
- Odd Angles
- Silent Drive
- Infinite Lengths
- 90A Durometer
- No Lubrication
- Weight .12 oz./ft.
- Positive Drive
- Ultimate Tensile Strength 50 lbs. - 9 lbs./Pin
- When belt is used in open loop configuration (without splice, no crimp bushing)
- Temperature Range +180°F to -15°F
- Recommended Operating Load 12 lbs.
- Recommended Max. Operating Speed 376 Feet/Min.

BULK FOOTAGE - NOT SPLICED	
STOCK NO.	LENGTH
3CBF-5FT	5FT
3CBF-10FT	10FT
3CBF-25FT	25FT
3CBF-50FT	50FT
3CBF-100FT	100FT



DOUBLE SPROCKETS

PITCH	CIR. PITCH	BORE	STYLE	MATERIALS	BERG'S® NAME	BELT/CHAIN
1/20	.1570	1/8"	PIN HUB	303 Stainless Steel or 2024-T4 Anodized Aluminum	Min-E-Pitch®	Operates with 3CBF & 3DCF Series

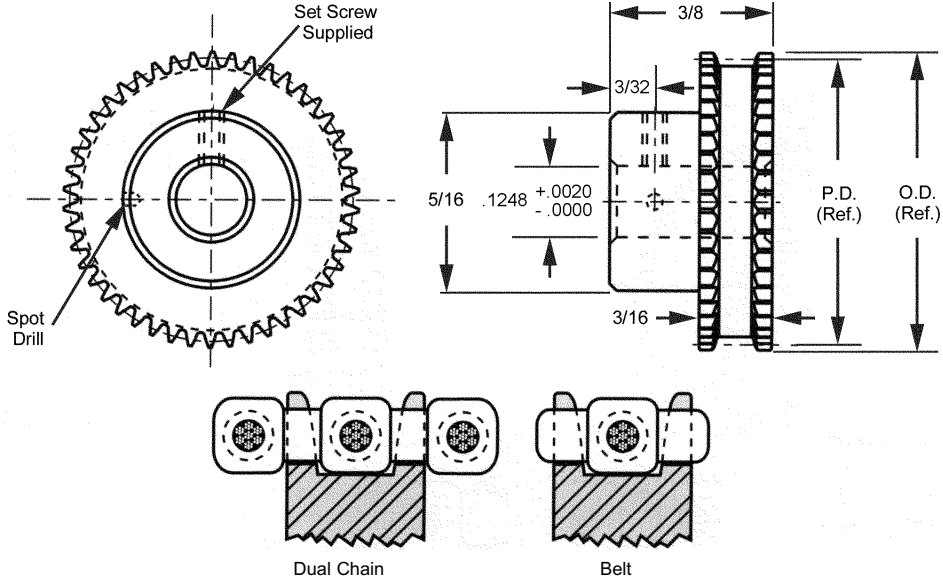

303 STAINLESS STEEL	2024-T4 ALUMINUM ANODIZED	NO. OF TEETH	PITCH DIA.	OUTSIDE DIA.
STOCK NO.	STOCK NO.			
3MDP14S-10	3MDP14A-10	10*	.4994	.561
3MDP14S-11	3MDP14A-11	11*	.5493	.611
3MDP14S-12	3MDP14A-12	12*	.5992	.661
3MDP14S-13	3MDP14A-13	13*	.6492	.711
3MDP14S-14	3MDP14A-14	14*	.6991	.761
3MDP14S-15	3MDP14A-15	15*	.7490	.811
3MDP14S-16	3MDP14A-16	16	.7990	.861
3MDP14S-17	3MDP14A-17	17	.8489	.910
3MDP14S-18	3MDP14A-18	18	.8988	.960
3MDP14S-19	3MDP14A-19	19	.9488	1.011
3MDP14S-20	3MDP14A-20	20	.9987	1.061
3MDP14S-22	3MDP14A-22	22	1.0986	1.161
3MDP14S-24	3MDP14A-24	24	1.1985	1.260
3MDP14S-25	3MDP14A-25	25	1.2484	1.310
3MDP14S-26	3MDP14A-26	26	1.2983	1.360
3MDP14S-28	3MDP14A-28	28	1.3982	1.460
3MDP14S-30	3MDP14A-30	30	1.4981	1.560
3MDP14S-32	3MDP14A-32	32	1.5980	1.660
3MDP14S-35	3MDP14A-35	35*	1.7478	1.810
3MDP14S-36	3MDP14A-36	36*	1.7977	1.860
3MDP14S-40	3MDP14A-40	40*	1.9974	2.059
3MDP14S-45	3MDP14A-45	45*	2.2471	2.309
3MDP14S-50	3MDP14A-50	50*	2.4968	2.559
3MDP14S-55	3MDP14A-55	55*	2.7465	2.808
3MDP14S-60	3MDP14A-60	60*	2.9962	3.058
3MDP14S-65	3MDP14A-65	65*	3.2458	3.308
3MDP14S-70	3MDP14A-70	70*	3.4955	3.558
3MDP14S-75	3MDP14A-75	75*	3.7452	3.807
3MDP14S-80	3MDP14A-80	80*	3.9949	4.057



* Sprockets with .750 P.D. and smaller are recommended for idler use only. Other numbers of teeth are available on request. Teeth could be anodized.

DOUBLE SPROCKETS

PITCH	CIR. PITCH	BORE	STYLE	MATERIALS	BERG'S® NAME	BELT/CHAIN
1/20	.1570	3/16"	PIN HUB	303 Stainless Steel or 2024-T4 Anodized Aluminum	Min-E-Pitch®	Operates with 3CBF & 3DCF Series

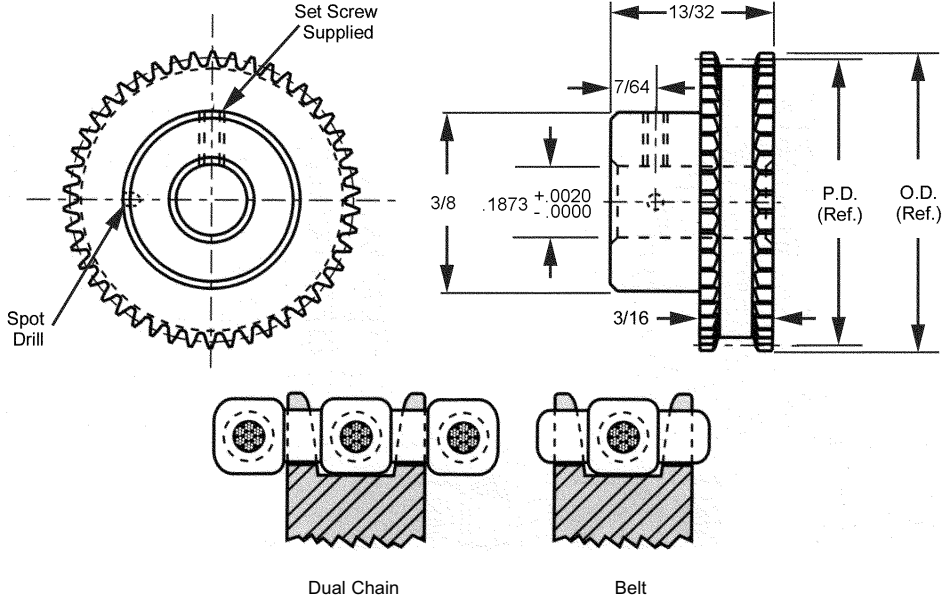

303 STAINLESS STEEL	2024-T4 ALUMINUM ANODIZED			
STOCK NO.	STOCK NO.	NO. OF TEETH	PITCH DIA.	OUTSIDE DIA.
3MDP21S-10	3MDP21A-10	10*	.4994	.561
3MDP21S-11	3MDP21A-11	11*	.5493	.611
3MDP21S-12	3MDP21A-12	12*	.5992	.661
3MDP21S-13	3MDP21A-13	13*	.6492	.711
3MDP21S-14	3MDP21A-14	14*	.6991	.761
3MDP21S-15	3MDP21A-15	15*	.7490	.811
3MDP21S-16	3MDP21A-16	16	.7990	.861
3MDP21S-17	3MDP21A-17	17	.8489	.911
3MDP21S-18	3MDP21A-18	18	.8988	.961
3MDP21S-19	3MDP21A-19	19	.9488	1.011
3MDP21S-20	3MDP21A-20	20	.9987	1.061
3MDP21S-22	3MDP21A-22	22	1.0986	1.161
3MDP21S-24	3MDP21A-24	24	1.1985	1.260
3MDP21S-26	3MDP21A-26	26	1.2983	1.360
3MDP21S-28	3MDP21A-28	28	1.3982	1.460
3MDP21S-30	3MDP21A-30	30	1.4981	1.560
3MDP21S-32	3MDP21A-32	32	1.5980	1.660
3MDP21S-35	3MDP21A-35	35	1.7478	1.810
3MDP21S-36	3MDP21A-36	36	1.7977	1.860
3MDP21S-40	3MDP21A-40	40	1.9974	2.059
3MDP21S-45	3MDP21A-45	45	2.2471	2.309
3MDP21S-50	3MDP21A-50	50	2.4968	2.559
3MDP21S-55	3MDP21A-55	55	2.7465	2.808
3MDP21S-60	3MDP21A-60	60	2.9962	3.058
3MDP21S-65	3MDP21A-65	65	3.2458	3.308
3MDP21S-70	3MDP21A-70	70	3.4955	3.558
3MDP21S-75	3MDP21A-75	75	3.7452	3.807
3MDP21S-80	3MDP21A-80	80	3.9949	4.057



* Sprockets with .750 P.D. and smaller are recommended for idler use only.
Other numbers of teeth are available on request.
Teeth could be anodized.

DOUBLE SPROCKETS

PITCH	CIR. PITCH	BORE	STYLE	MATERIALS	BERG'S® NAME	BELT/CHAIN
1/20	.1570	1/4"	PIN HUB	303 Stainless Steel or 2024-T4 Anodized Aluminum	Min-E-Pitch®	Operates with 3CBF & 3DCF Series

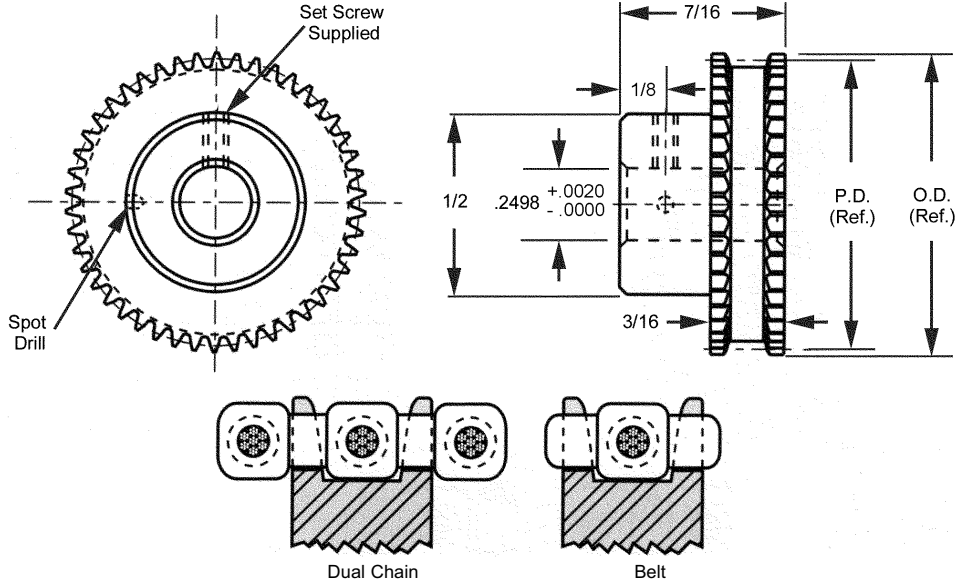

303 STAINLESS STEEL	2024-T4 ALUMINUM ANODIZED	NO. OF TEETH	PITCH DIA.	OUTSIDE DIA.
3MDP28S-12	3MDP28A-12	12*	.5992	.661
3MDP28S-13	3MDP28A-13	13*	.6492	.711
3MDP28S-14	3MDP28A-14	14*	.6991	.761
3MDP28S-15	3MDP28A-15	15*	.7490	.811
3MDP28S-16	3MDP28A-16	16	.7990	.861
3MDP28S-17	3MDP28A-17	17	.8489	.911
3MDP28S-18	3MDP28A-18	18	.8988	.961
3MDP28S-19	3MDP28A-19	19	.9488	1.011
3MDP28S-20	3MDP28A-20	20	.9987	1.061
3MDP28S-22	3MDP28A-22	22	1.0986	1.161
3MDP28S-24	3MDP28A-24	24	1.1985	1.260
3MDP28S-25	3MDP28A-25	25	1.2484	1.310
3MDP28S-26	3MDP28A-26	26	1.2983	1.360
3MDP28S-28	3MDP28A-28	28	1.3982	1.460
3MDP28S-30	3MDP28A-30	30	1.4981	1.560
3MDP28S-32	3MDP28A-32	32	1.5980	1.660
3MDP28S-35	3MDP28A-35	35	1.7478	1.810
3MDP28S-36	3MDP28A-36	36	1.7977	1.860
3MDP28S-40	3MDP28A-40	40	1.9974	2.059
3MDP28S-45	3MDP28A-45	45	2.2471	2.309
3MDP28S-50	3MDP28A-50	50	2.4968	2.559
3MDP28S-55	3MDP28A-55	55	2.7465	2.808
3MDP28S-60	3MDP28A-60	60	2.9962	3.058
3MDP28S-65	3MDP28A-65	65	3.2458	3.308
3MDP28S-70	3MDP28A-70	70	3.4955	3.558
3MDP28S-75	3MDP28A-75	75	3.7452	3.807
3MDP28S-80	3MDP28A-80	80	3.9949	4.057



* Sprockets with .750 P.D. and smaller are recommended for idler use only. Other numbers of teeth are available on request. Teeth could be anodized.

DOUBLE SPROCKETS

PITCH	CIR. PITCH	BORE	STYLE	MATERIALS	BERG'S® NAME	BELT/CHAIN
1/20	.1570	5/16"	PIN HUB	303 Stainless Steel or 2024-T4 Anodized Aluminum	Min-E-Pitch®	Operates with 3CBF & 3DCF Series

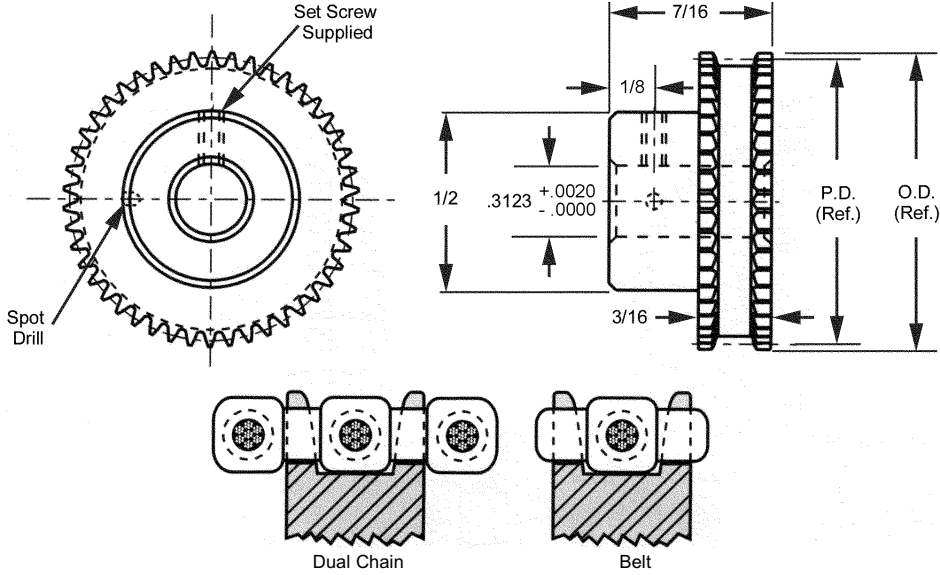

303 STAINLESS STEEL	2024-T4 ALUMINUM ANODIZED			
STOCK NO.	STOCK NO.	NO. OF TEETH	PITCH DIA.	OUTSIDE DIA.
3MDP32S-12	3MDP32A-12	12*	.5992	.661
3MDP32S-13	3MDP32A-13	13*	.6492	.711
3MDP32S-14	3MDP32A-14	14*	.6991	.761
3MDP32S-15	3MDP32A-15	15*	.7490	.810
3MDP32S-16	3MDP32A-16	16	.7990	.861
3MDP32S-17	3MDP32A-17	17	.8489	.911
3MDP32S-18	3MDP32A-18	18	.8988	.961
3MDP32S-19	3MDP32A-19	19	.9488	1.011
3MDP32S-20	3MDP32A-20	20	.9987	1.061
3MDP32S-22	3MDP32A-22	22	1.0986	1.161
3MDP32S-24	3MDP32A-24	24	1.1985	1.260
3MDP32S-25	3MDP32A-25	25	1.2484	1.310
3MDP32S-26	3MDP32A-26	26	1.2983	1.360
3MDP32S-28	3MDP32A-28	28	1.3982	1.460
3MDP32S-30	3MDP32A-30	30	1.4981	1.560
3MDP32S-32	3MDP32A-32	32	1.5980	1.660
3MDP32S-35	3MDP32A-35	35	1.7478	1.810
3MDP32S-36	3MDP32A-36	36	1.7977	1.860
3MDP32S-40	3MDP32A-40	40	1.9974	2.059
3MDP32S-45	3MDP32A-45	45	2.2471	2.309
3MDP32S-50	3MDP32A-50	50	2.4968	2.559
3MDP32S-55	3MDP32A-55	55	2.7465	2.808
3MDP32S-60	3MDP32A-60	60	2.9962	3.058
3MDP32S-65	3MDP32A-65	65	3.2458	3.308
3MDP32S-70	3MDP32A-70	70	3.4955	3.558
3MDP32S-75	3MDP32A-75	75	3.7452	3.807
3MDP32S-80	3MDP32A-80	80	3.9949	4.057



* Sprockets with .750 P.D. and smaller are recommended for idler use only.
Other numbers of teeth are available on request.
Teeth could be anodized.

DOUBLE SPROCKETS

PITCH	CIR. PITCH	BORE	STYLE	MATERIALS	BERG'S® NAME	BELT/CHAIN
1/20	.1570	3/8"	HUBLESS	303 Stainless Steel or 2024-T4 Anodized Aluminum	Min-E-Pitch®	Operates with 3CBF & 3DCF Series

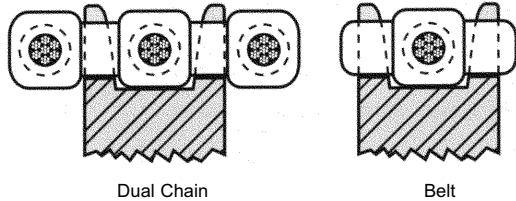
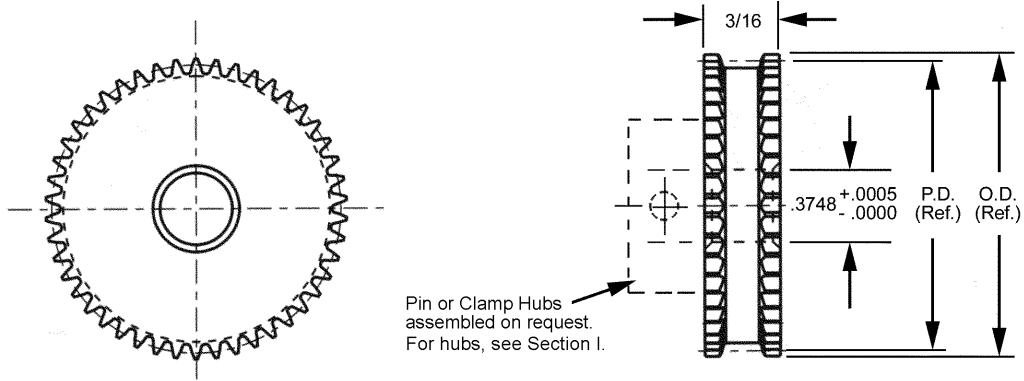

303 STAINLESS STEEL	2024T4 ALUMINUM ANODIZED			
STOCK NO.	STOCK NO.	NO. OF TEETH	PITCH DIA.	OUTSIDE DIA.
3MDF5S-14	3MDF5A-14	14*	.6991	.761
3MDF5S-15	3MDF5A-15	15*	.7490	.811
3MDF5S-16	3MDF5A-16	16	.7990	.861
3MDF5S-17	3MDF5A-17	17	.8489	.911
3MDF5S-18	3MDF5A-18	18	.8988	.961
3MDF5S-19	3MDF5A-19	19	.9488	1.011
3MDF5S-20	3MDF5A-20	20	.9987	1.061
3MDF5S-22	3MDF5A-22	22	1.0986	1.161
3MDF5S-24	3MDF5A-24	24	1.1985	1.260
3MDF5S-26	3MDF5A-26	26	1.2983	1.360
3MDF5S-28	3MDF5A-28	28	1.3982	1.460
3MDF5S-30	3MDF5A-30	30	1.4981	1.560
3MDF5S-32	3MDF5A-32	32	1.5980	1.660
3MDF5S-35	3MDF5A-35	35	1.7478	1.810
3MDF5S-36	3MDF5A-36	36	1.7977	1.860
3MDF5S-40	3MDF5A-40	40	1.9974	2.059
3MDF5S-45	3MDF5A-45	45	2.2471	2.309
3MDF5S-50	3MDF5A-50	50	2.4968	2.559
3MDF5S-55	3MDF5A-55	55	2.7465	2.808
3MDF5S-60	3MDF5A-60	60	2.9962	3.058
3MDF5S-65	3MDF5A-65	65	3.2458	3.308
3MDF5S-70	3MDF5A-70	70	3.4955	3.558
3MDF5S-75	3MDF5A-75	75	3.7452	3.807
3MDF5S-80	3MDF5A-80	80	3.9949	4.057



* Sprockets with .750 P.D. and smaller are recommended for idler use only. Other numbers of teeth are available on request.

Teeth could be anodized.

DOUBLE SPROCKETS

PITCH	CIR. PITCH	BORE	STYLE	MATERIALS	BERG'S ® NAME	BELT/CHAIN
1/20	.1570	11/16"	HUBLESS	303 Stainless Steel or 2024-T4 Anodized Aluminum	Min-E-Pitch®	Operates with 3CBF & 3DCF Series

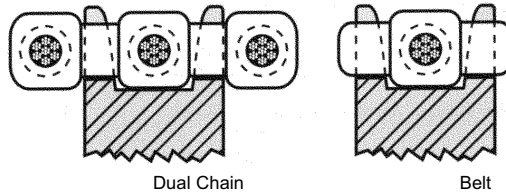
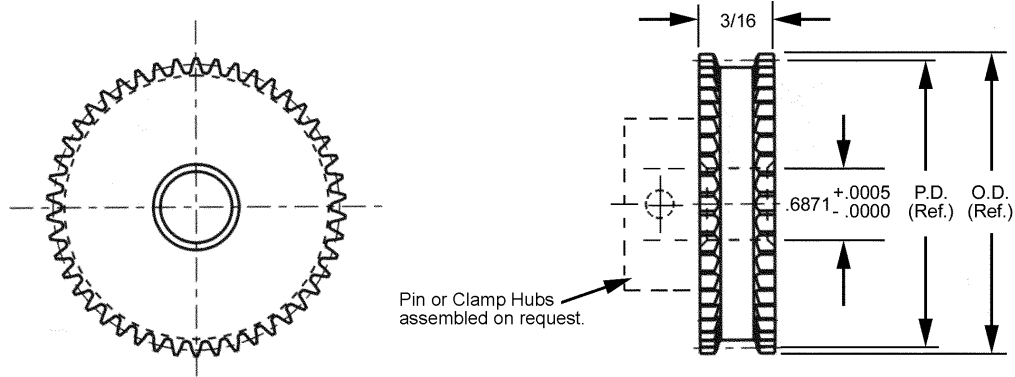

303 STAINLESS STEEL		2024-T4 ALUMINUM ANODIZED		
STOCK NO.	STOCK NO.	NO. OF TEETH	PITCH DIA.	OUTSIDE DIA.
3MDF19S-18	3MDF19A-18	18	.8988	.961
3MDF19S-19	3MDF19A-19	19	.9488	1.011
3MDF19S-20	3MDF19A-20	20	.9987	1.061
3MDF19S-22	3MDF19A-22	22	1.0986	1.161
3MDF19S-24	3MDF19A-24	24	1.1985	1.260
3MDF19S-26	3MDF19A-26	26	1.2983	1.360
3MDF19S-28	3MDF19A-28	28	1.3982	1.460
3MDF19S-30	3MDF19A-30	30	1.4981	1.560
3MDF19S-32	3MDF19A-32	32	1.5980	1.660
3MDF19S-35	3MDF19A-35	35	1.7478	1.810
3MDF19S-36	3MDF19A-36	36	1.7977	1.860
3MDF19S-40	3MDF19A-40	40	1.9974	2.059
3MDF19S-45	3MDF19A-45	45	2.2471	2.309
3MDF19S-50	3MDF19A-50	50	2.4968	2.559
3MDF19S-55	3MDF19A-55	55	2.7465	2.808
3MDF19S-60	3MDF19A-60	60	2.9962	3.058
3MDF19S-65	3MDF19A-65	65	3.2458	3.308
3MDF19S-70	3MDF19A-70	70	3.4955	3.558
3MDF19S-75	3MDF19A-75	75	3.7452	3.807
3MDF19S-80	3MDF19A-80	80	3.9949	4.057



Other numbers of teeth are available on request.

Teeth could be anodized.

3-D BELT

PITCH	CIRCULAR PITCH	MATERIALS	BERG'S ® NAME	PULLEY
1/20	.1570	Polyurethane (Green) 1/32" Dia. Stainless Steel Cable*	Min-E-Pitch®	Operates with 3TDP, 3TF, and 3MTB series.

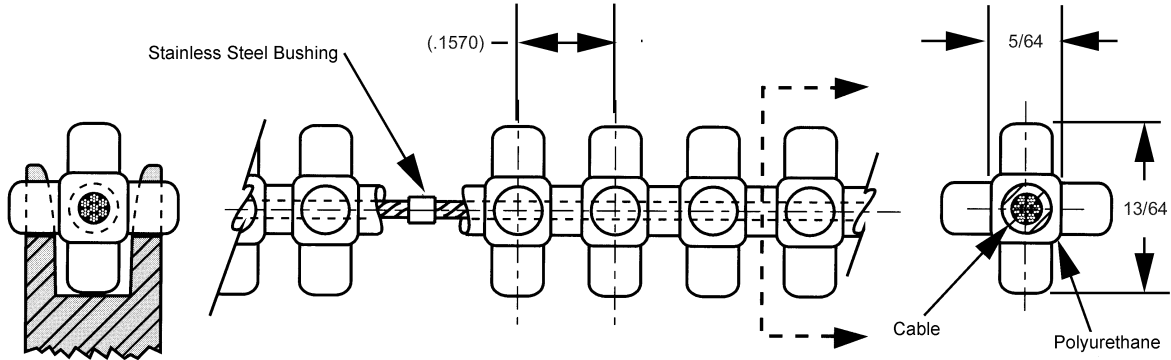

STOCK NO.	NO. OF PITCHES	LENGTH (Ref.)
3TDF-30-E	30	4.712
3TDF-35-E	36	5.655
3TDF-40-E	40	6.283
3TDF-45-E	46	7.226
3TDF-50-E	50	7.854
3TDF-55-E	56	8.796
3TDF-60-E	60	9.425
3TDF-70-E	70	10.996
3TDF-80-E	80	12.566
3TDF-90-E	90	14.137
3TDF-100-E	100	15.708
3TDF-110-E	110	17.279
3TDF-120-E	120	18.850
3TDF-130-E	130	20.420
3TDF-140-E	140	21.991
3TDF-150-E	150	23.562
3TDF-160-E	160	25.133
3TDF-170-E	170	26.704
3TDF-180-E	180	28.274
3TDF-190-E	190	29.845
3TDF-200-E	200	31.416
3TDF-210-E	210	32.987
3TDF-220-E	220	34.558
3TDF-230-E	230	36.128
3TDF-240-E	240	37.699
3TDF-250-E	250	39.270
3TDF-260-E	260	40.840
3TDF-270-E	270	42.412
3TDF-280-E	280	43.982
3TDF-290-E	290	45.553
3TDF-300-E	300	47.124
3TDF-310-E	310	48.695
3TDF-320-E	320	50.265
3TDF-330-E	330	51.836
3TDF-340-E	340	53.407
3TDF-350-E	350	54.978
3TDF-370-E	360	56.549
3TDF-400-E	400	62.832
3TDF-440-E	440	69.115

- For Field Splice Kit order 3CCR-7
- * Available with Aramid Core. See page VII for alternate belt construction and reverse bending applications.
- ** Reduce Operating Load Rating by 50% for field splices.

- Three Dimensional Drive
- Zero Backlash
- Silent Drive
- Infinite Lengths
- 90A Durometer
- No Lubrication
- Weight .12 oz./ft.
- Positive Drive
- Ultimate Tensile Strength 50 lbs. - 9 lbs./Pin
When belt is used in open loop configuration (without splice, no crimp bushing).
- Temperature Range +180°F to -15°F
- Recommended Operating Load 12 lbs.
- Recommended Max. Operating Speed 376Feet/Min.

BULK FOOTAGE - NOT SPLICED	
STOCK NO.	LENGTH
3TDF-5FT	5FT
3TDF-10FT	10FT
3TDF-25FT	25FT
3TDF-50FT	50FT
3TDF-100FT	100FT



3-D PULLEYS

PITCH	CIR. PITCH	BORE	STYLE	MATERIALS	BERG'S® NAME	BELT
1/20	.1570	1/8"	PIN HUB	303 Stainless Steel or 2024-T4 Anodized Aluminum	Min-E-Pitch® Three D Drive	Operates with 3TDF Series

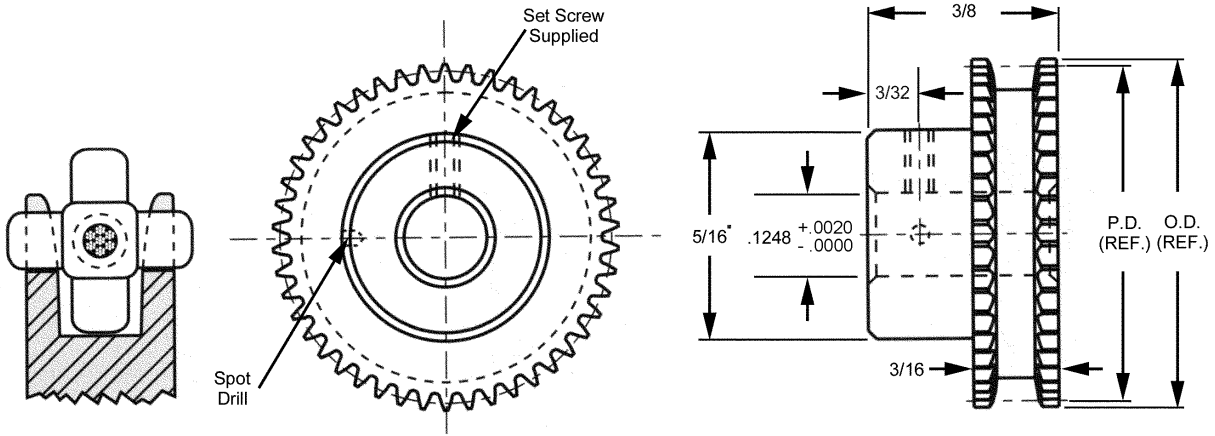

303 STAINLESS STEEL	2024-T4 ALUMINUM ANODIZED			
STOCK NO.	STOCK NO.	NO. OF TEETH	PITCH DIA.	OUTSIDE DIA.
3TDP14S-10	3TDP14A-10	10*	.4994	.561
3TDP14S-11	3TDP14A-11	11*	.5493	.611
3TDP14S-12	3TDP14A-12	12*	.5992	.661
3TDP14S-13	3TDP14A-13	13*	.6492	.711
3TDP14S-14	3TDP14A-14	14*	.6991	.761
3TDP14S-15	3TDP14A-15	15*	.7490	.811
3TDP14S-16	3TDP14A-16	16	.7990	.861
3TDP14S-17	3TDP14A-17	17	.8489	.911
3TDP14S-18	3TDP14A-18	18	.8988	.961
3TDP14S-19	3TDP14A-19	19	.9488	1.011
3TDP14S-20	3TDP14A-20	20	.9987	1.061
3TDP14S-22	3TDP14A-22	22	1.0986	1.161
3TDP14S-24	3TDP14A-24	24	1.1985	1.260
3TDP14S-25	3TDP14A-25	25	1.2484	1.310
3TDP14S-26	3TDP14A-26	26	1.2983	1.360
3TDP14S-28	3TDP14A-28	28	1.3982	1.460
3TDP14S-30	3TDP14A-30	30	1.4981	1.560
3TDP14S-32	3TDP14A-32	32	1.5980	1.660
3TDP14S-35	3TDP14A-35	35**	1.7478	1.810
3TDP14S-36	3TDP14A-36	36**	1.7977	1.860
3TDP14S-40	3TDP14A-40	40**	1.9974	2.059
3TDP14S-45	3TDP14A-45	45**	2.2471	2.309
3TDP14S-50	3TDP14A-50	50**	2.4968	2.559
3TDP14S-55	3TDP14A-55	55**	2.7465	2.808
3TDP14S-60	3TDP14A-60	60**	2.9962	3.058
3TDP14S-65	3TDP14A-65	65**	3.2458	3.308
3TDP14S-70	3TDP14A-70	70**	3.4955	3.558
3TDP14S-75	3TDP14A-75	75**	3.7452	3.807
3TDP14S-80	3TDP14A-80	80**	3.9949	4.057



** May be 2 piece construction 303 Stainless Steel hub.
 Outline and overall length change slightly.
 * For 10 teeth, hub diameter equals .29.
 * Pulleys with .750 P.D. and smaller are recommended for idler use only.
 Other numbers of teeth are available on request.

Teeth could be anodized.

3-D PULLEYS

PITCH	CIR. PITCH	BORE	STYLE	MATERIALS	BERG'S® NAME	BELT
1/20	.1570	3/16"	PIN HUB	303 Stainless Steel or 2024-T4 Anodized Aluminum	Min-E-Pitch® Three D Drive	Operates with 3TDF Series

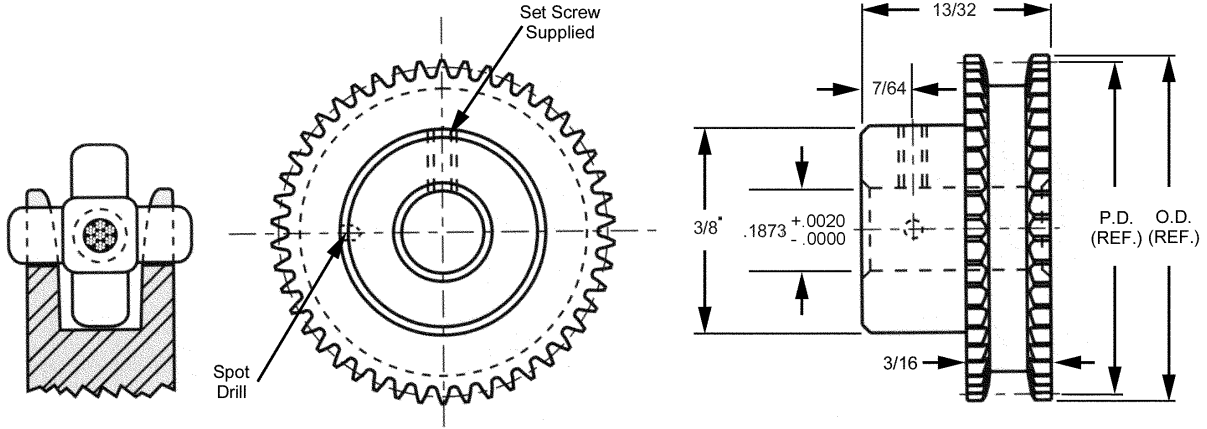

303 STAINLESS STEEL	2024-T4 ALUMINUM ANODIZED			
STOCK NO.	STOCK NO.	NO. OF TEETH	PITCH DIA.	OUTSIDE DIA.
3TDP21S-11	3TDP21A-11	11*	.5493	.611
3TDP21S-12	3TDP21A-12	12*	.5992	.661
3TDP21S-13	3TDP21A-13	13*	.6492	.711
3TDP21S-14	3TDP21A-14	14*	.6991	.761
3TDP21S-15	3TDP21A-15	15*	.7490	.811
3TDP21S-16	3TDP21A-16	16	.7990	.861
3TDP21S-17	3TDP21A-17	17	.8489	.911
3TDP21S-18	3TDP21A-18	18	.8988	.961
3TDP21S-19	3TDP21A-19	19	.9488	1.011
3TDP21S-20	3TDP21A-20	20	.9987	1.061
3TDP21S-22	3TDP21A-22	22	1.0986	1.161
3TDP21S-24	3TDP21A-24	24	1.1985	1.260
3TDP21S-25	3TDP21A-25	25	1.2484	1.310
3TDP21S-26	3TDP21A-26	26	1.2983	1.360
3TDP21S-28	3TDP21A-28	28	1.3982	1.460
3TDP21S-30	3TDP21A-30	30	1.4981	1.560
3TDP21S-32	3TDP21A-32	32	1.5980	1.660
3TDP21S-35	3TDP21A-35	35	1.7478	1.810
3TDP21S-36	3TDP21A-36	36	1.7977	1.860
3TDP21S-40	3TDP21A-40	40	1.9974	2.059
3TDP21S-45	3TDP21A-45	45	2.2471	2.309
3TDP21S-50	3TDP21A-50	50	2.4968	2.559
3TDP21S-55	3TDP21A-55	55	2.7465	2.808
3TDP21S-60	3TDP21A-60	60	2.9962	3.058
3TDP21S-65	3TDP21A-65	65	3.2458	3.308
3TDP21S-70	3TDP21A-70	70	3.4955	3.558
3TDP21S-75	3TDP21A-75	75	3.7452	3.807
3TDP21S-80	3TDP21A-80	80	3.9949	4.057



* Pulleys with .750 P.D. and smaller are recommended for idler use only.
 • For 11 teeth, hub diameter equals .34.
 Other numbers of teeth are available on request.
 Teeth could be anodized.

3-D PULLEYS

PITCH	CIR. PITCH	BORE	STYLE	MATERIALS	BERG'S® NAME	BELT
1/20	.1570	1/4"	PIN HUB	303 Stainless Steel or 2024-T4 Anodized Aluminum	Min-E-Pitch® Three D Drive	Operates with 3TDF Series

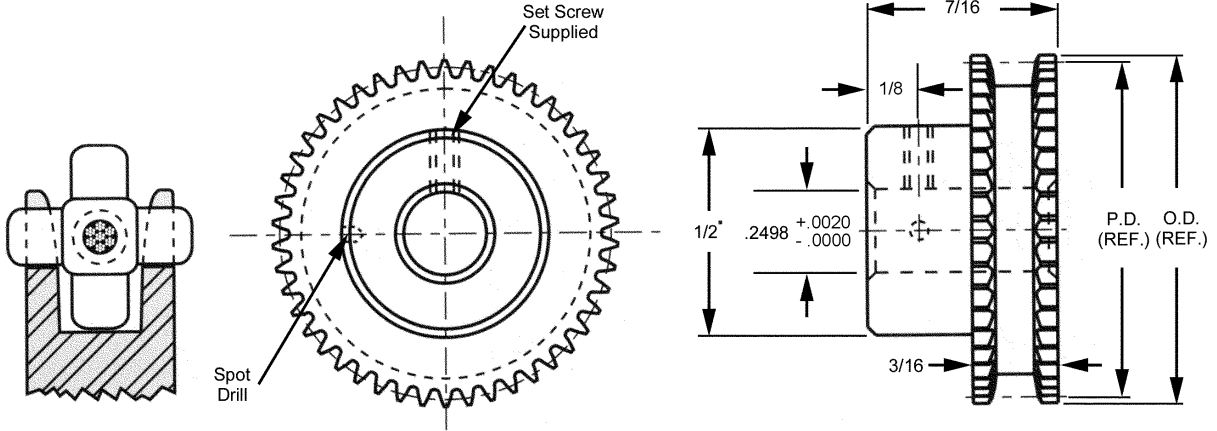

303 STAINLESS STEEL	2024-T4 ALUMINUM ANODIZED			
STOCK NO.	STOCK NO.	NO. OF TEETH	PITCH DIA.	OUTSIDE DIA.
3TDP28S-13	3TDP28A-13	13*	.6492	.711
3TDP28S-14	3TDP28A-14	14*	.6991	.761
3TDP28S-15	3TDP28A-15	15*	.7490	.810
3TDP28S-16	3TDP28A-16	16	.7990	.861
3TDP28S-17	3TDP28A-17	17	.8489	.911
3TDP28S-18	3TDP28A-18	18	.8988	.961
3TDP28S-19	3TDP28A-19	19	.9488	1.011
3TDP28S-20	3TDP28A-20	20	.9987	1.061
3TDP28S-22	3TDP28A-22	22	1.0986	1.161
3TDP28S-24	3TDP28A-24	24	1.1985	1.260
3TDP28S-25	3TDP28A-25	25	1.2484	1.310
3TDP28S-26	3TDP28A-26	26	1.2983	1.360
3TDP28S-28	3TDP28A-28	28	1.3982	1.460
3TDP28S-30	3TDP28A-30	30	1.4981	1.560
3TDP28S-32	3TDP28A-32	32	1.5980	1.660
3TDP28S-35	3TDP28A-35	35	1.7478	1.810
3TDP28S-36	3TDP28A-36	36	1.7977	1.860
3TDP28S-40	3TDP28A-40	40	1.9974	2.059
3TDP28S-45	3TDP28A-45	45	2.2471	2.309
3TDP28S-50	3TDP28A-50	50	2.4968	2.558
3TDP28S-55	3TDP28A-55	55	2.7465	2.808
3TDP28S-60	3TDP28A-60	60	2.9962	3.058
3TDP28S-65	3TDP28A-65	65	3.2458	3.308
3TDP28S-70	3TDP28A-70	70	3.4955	3.558
3TDP28S-75	3TDP28A-75	75	3.7452	3.807
3TDP28S-80	3TDP28A-80	80	3.9949	4.057



* Pulleys with .750 P.D. and smaller are recommended for idler use only.
 • For 13-14 teeth, hub diameter equals .44.
 Other numbers of teeth are available on request.

Teeth could be anodized.

3-D PULLEYS

PITCH	CIR. PITCH	BORE	STYLE	MATERIALS	BERG'S® NAME	BELT
1/20	.1570	5/16"	PIN HUB	303 Stainless Steel or 2024-T4 Anodized Aluminum	Min-E-Pitch® Three D Drive	Operates with 3TDF Series

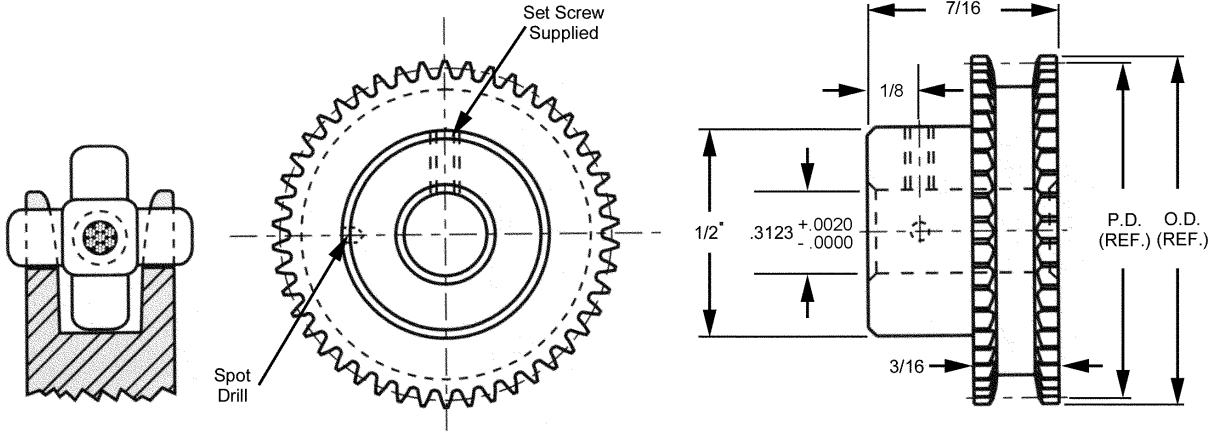

303 STAINLESS STEEL	2024-T4 ALUMINUM ANODIZED			
STOCK NO.	STOCK NO.	NO. OF TEETH	PITCH DIA.	OUTSIDE DIA.
3TDP32S-15	3TDP32A-15	15*	.7490	.811
3TDP32S-16	3TDP32A-16	16	.7990	.861
3TDP32S-17	3TDP32A-17	17	.8489	.911
3TDP32S-18	3TDP32A-18	18	.8988	.961
3TDP32S-19	3TDP32A-19	19	.9488	1.011
3TDP32S-20	3TDP32A-20	20	.9987	1.061
3TDP32S-22	3TDP32A-22	22	1.0986	1.161
3TDP32S-24	3TDP32A-24	24	1.1985	1.260
3TDP32S-25	3TDP32A-25	25	1.2484	1.310
3TDP32S-26	3TDP32A-26	26	1.2983	1.360
3TDP32S-28	3TDP32A-28	28	1.3982	1.460
3TDP32S-30	3TDP32A-30	30	1.4981	1.560
3TDP32S-32	3TDP32A-32	32	1.5980	1.660
3TDP32S-35	3TDP32A-35	35	1.7478	1.810
3TDP32S-36	3TDP32A-36	36	1.7977	1.860
3TDP32S-40	3TDP32A-40	40	1.9974	2.059
3TDP32S-45	3TDP32A-45	45	2.2471	2.309
3TDP32S-50	3TDP32A-50	50	2.4968	2.559
3TDP32S-55	3TDP32A-55	55	2.7465	2.808
3TDP32S-60	3TDP32A-60	60	2.9962	3.058
3TDP32S-65	3TDP32A-65	65	3.2458	3.308
3TDP32S-70	3TDP32A-70	70	3.4955	3.558
3TDP32S-75	3TDP32A-75	75	3.7452	3.807
3TDP32S-80	3TDP32A-80	80	3.9949	4.057



* Pulleys with .750 P.D. and smaller are recommended for idler use only. Other numbers of teeth are available on request.

Teeth could be anodized.

3-D PULLEYS

PITCH	CIR. PITCH	BORE	STYLE	MATERIALS	BERG'S® NAME	BELT
1/20	.1570	3/8"	HUBLESS	303 Stainless Steel or 2024-T4 Anodized Aluminum	Min-E-Pitch® Three D Drive	Operates with 3TDF Series

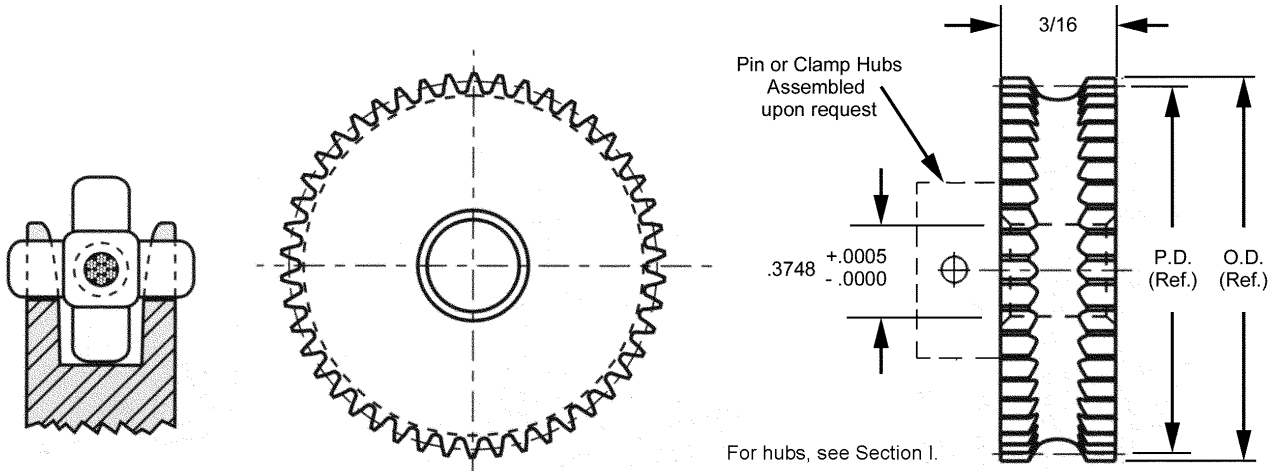

303 STAINLESS STEEL	2024-T4 ALUMINUM ANODIZED			
STOCK NO.	STOCK NO.	NO. OF TEETH	PITCH DIA.	OUTSIDE DIA.
3TF5S-14	3TF5A-14	14*	.6991	.761
3TF5S-15	3TF5A-15	15*	.7490	.811
3TF5S-16	3TF5A-16	16	.7990	.861
3TF5S-17	3TF5A-17	17	.8489	.911
3TF5S-18	3TF5A-18	18	.8988	.961
3TF5S-19	3TF5A-19	19	.9488	1.011
3TF5S-20	3TF5A-20	20	.9987	1.061
3TF5S-22	3TF5A-22	22	1.0986	1.161
3TF5S-24	3TF5A-24	24	1.1985	1.260
3TF5S-25	3TF5A-25	25	1.2484	1.310
3TF5S-26	3TF5A-26	26	1.2983	1.360
3TF5S-28	3TF5A-28	28	1.3982	1.460
3TF5S-30	3TF5A-30	30	1.4981	1.560
3TF5S-32	3TF5A-32	32	1.5980	1.660
3TF5S-35	3TF5A-35	35	1.7478	1.810
3TF5S-36	3TF5A-36	36	1.7977	1.860
3TF5S-40	3TF5A-40	40	1.9974	2.059
3TF5S-45	3TF5A-45	45	2.2471	2.309
3TF5S-50	3TF5A-50	50	2.4968	2.559
3TF5S-55	3TF5A-55	55	2.7465	2.808
3TF5S-60	3TF5A-60	60	2.9962	3.058
3TF5S-65	3TF5A-65	65	3.2458	3.308
3TF5S-70	3TF5A-70	70	3.4955	3.558
3TF5S-75	3TF5A-75	75	3.7452	3.807
3TF5S-80	3TF5A-80	80	3.9949	4.057



* Pulleys with .750 P.D. and smaller are recommended for idler use only.
Other numbers of teeth are available on request.

Teeth could be anodized.

3-D PULLEYS

PITCH	CIR. PITCH	BORE	STYLE	MATERIALS	BERG'S ® NAME	BELT
1/20	.1570	11/16"	HUBLESS	303 Stainless Steel or 2024-T4 Anodized Aluminum	Min-E-Pitch® Three D Drive	Operates with 3TDF Series

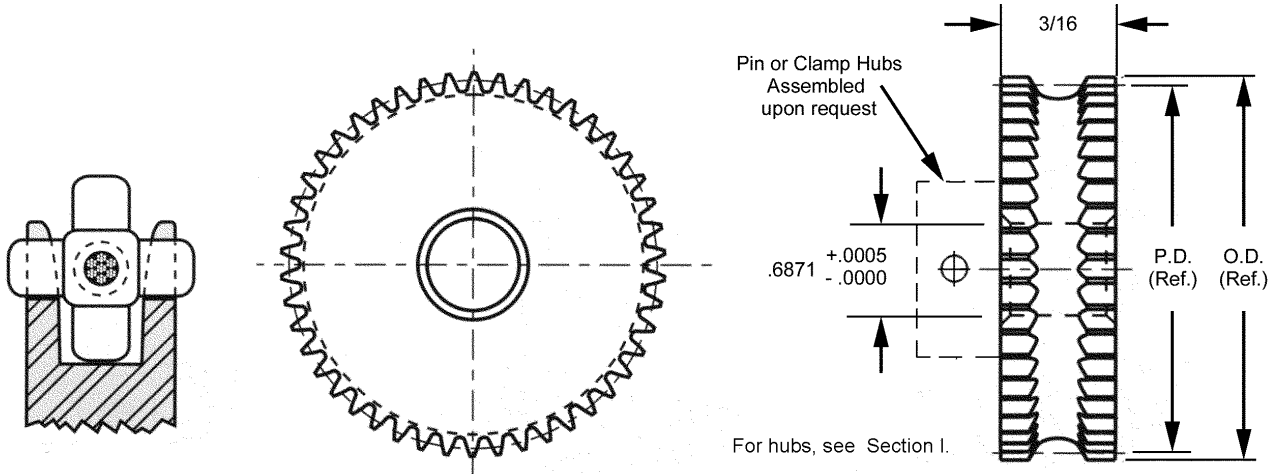

303 STAINLESS STEEL	2024-T4 ALUMINUM ANODIZED	NO. OF TEETH	PITCH DIA.	OUTSIDE DIA.
STOCK NO.	STOCK NO.			
3TF19S-14	3TF19A-14	14*	.6991	.761
3TF19S-15	3TF19A-15	15*	.7490	.811
3TF19S-16	3TF19A-16	16	.7990	.861
3TF19S-17	3TF19A-17	17	.8489	.911
3TF19S-18	3TF19A-18	18	.8988	.961
3TF19S-19	3TF19A-19	19	.9488	1.011
3TF19S-20	3TF19A-20	20	.9987	1.061
3TF19S-22	3TF19A-22	22	1.0986	1.161
3TF19S-24	3TF19A-24	24	1.1985	1.260
3TF19S-25	3TF19A-25	25	1.2484	1.310
3TF19S-26	3TF19A-26	26	1.2983	1.360
3TF19S-28	3TF19A-28	28	1.3982	1.460
3TF19S-30	3TF19A-30	30	1.4981	1.560
3TF19S-32	3TF19A-32	32	1.5980	1.660
3TF19S-35	3TF19A-35	35	1.7478	1.810
3TF19S-36	3TF19A-36	36	1.7977	1.860
3TF19S-40	3TF19A-40	40	1.9974	2.059
3TF19S-45	3TF19A-45	45	2.2471	2.309
3TF19S-50	3TF19A-50	50	2.4968	2.559
3TF19S-55	3TF19A-55	55	2.7465	2.808
3TF19S-60	3TF19A-60	60	2.9962	3.058
3TF19S-65	3TF19A-65	65	3.2458	3.308
3TF19S-70	3TF19A-70	70	3.4955	3.558
3TF19S-75	3TF19A-75	75	3.7452	3.807
3TF19S-80	3TF19A-80	80	3.9949	4.057



* Pulleys with .750 P.D. and smaller are recommended for idler use only.
Other numbers of teeth are available on request.

Teeth could be anodized.

3-D PULLEYS

PITCH	CIR. PITCH	BORE	STYLE	MATERIALS	BERG'S® NAME	BELT
1/20	.1570	1/8"	IDLER	303 Stainless Steel w/Teflon® Bushings	Min-E-Pitch® Three D Drive	Operates with 3TDF Series

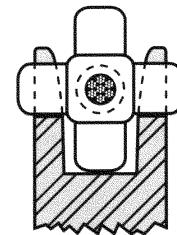
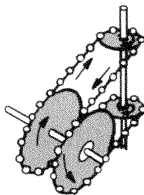
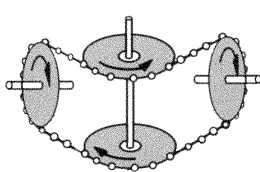
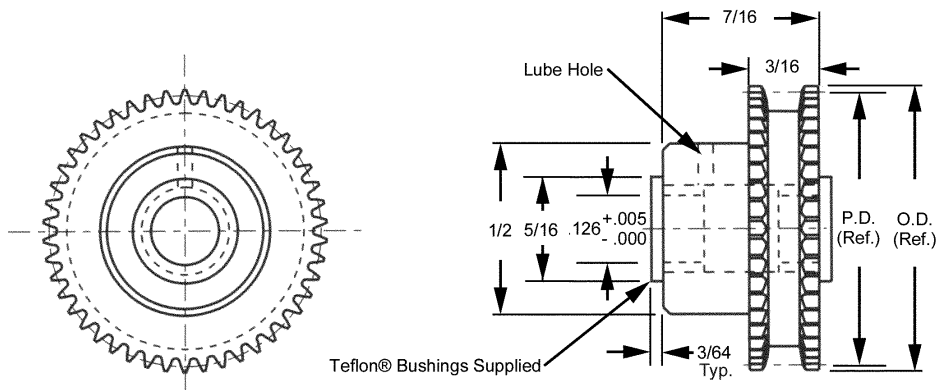

STOCK NO.	NO. OF TEETH	PITCH DIA.	OUTSIDE DIA.
3MTB28S-25	25	1.2484	1.310
3MTB28S-26	26	1.2983	1.360
3MTB28S-28	28	1.3982	1.460
3MTB28S-30	30	1.4981	1.560
3MTB28S-32	32	1.5980	1.660
3MTB28S-34	34	1.6978	1.760
3MTB28S-35	35	1.7478	1.810
3MTB28S-36	36	1.7977	1.860
3MTB28S-38	38	1.8976	1.960
3MTB28S-40	40	1.9974	2.059
3MTB28S-44	44	2.1972	2.259
3MTB28S-45	45	2.2471	2.309
3MTB28S-50	50	2.4968	2.559
3MTB28S-55	55	2.7465	2.808
3MTB28S-60	60	2.9962	3.058
3MTB28S-65	65	3.2458	3.308
3MTB28S-70	70	3.4955	3.558
3MTB28S-75	75	3.7452	3.807
3MTB28S-80	80	3.9949	4.057



Other numbers of teeth are available on request.

3-D PULLEYS

PITCH	CIR. PITCH	BORE	STYLE	MATERIALS	BERG'S® NAME	BELT
1/20	.1570	3/16"	IDLER	303 Stainless Steel w/Teflon® Bushings	Min-E-Pitch®	Operates with 3TDF Series

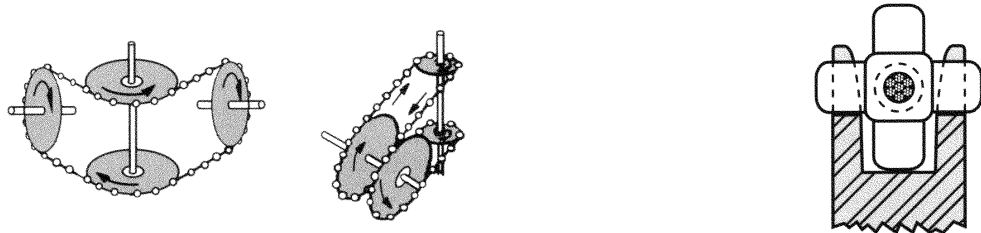
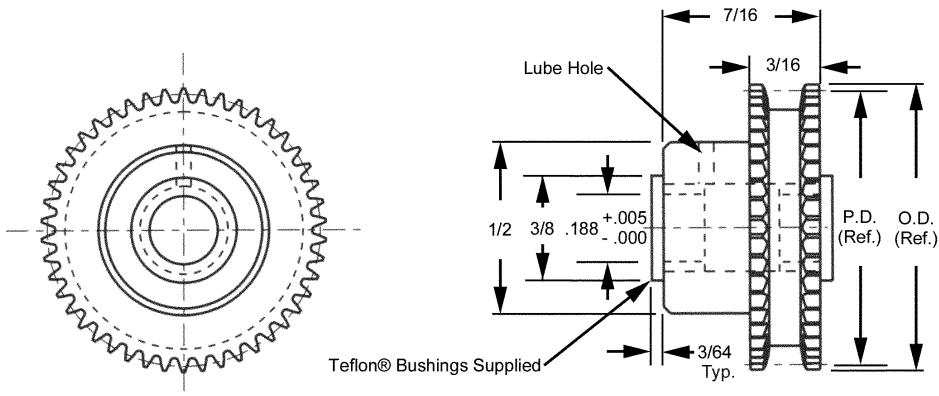

STOCK NO.	NO. OF TEETH	PITCH DIA.	OUTSIDE DIA.
3MTB32S-25	25	1.2484	1.310
3MTB32S-26	26	1.2983	1.360
3MTB32S-28	28	1.3982	1.460
3MTB32S-30	30	1.4981	1.560
3MTB32S-32	32	1.5980	1.660
3MTB32S-34	34	1.6978	1.760
3MTB32S-35	35	1.7478	1.810
3MTB32S-36	36	1.7977	1.860
3MTB32S-38	38	1.8976	1.960
3MTB32S-40	40	1.9974	2.059
3MTB32S-44	44	2.1972	2.259
3MTB32S-45	45	2.2471	2.309
3MTB32S-50	50	2.4968	2.559
3MTB32S-55	55	2.7465	2.808
3MTB32S-60	60	2.9962	3.058
3MTB32S-65	65	3.2458	3.308
3MTB32S-70	70	3.4955	3.558
3MTB32S-75	75	3.7452	3.807
3MTB32S-80	80	3.9949	4.057



Other numbers of teeth are available on request.

3-D PULLEYS

PITCH	CIR. PITCH	BORE	STYLE	MATERIALS	BERG'S® NAME	BELT
1/20	.1570	1/4"	IDLER	303 Stainless Steel w/Teflon® Bushings	Min-E-Pitch®	Operates with 3TDF Series

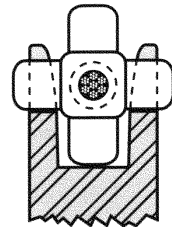
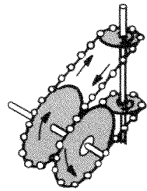
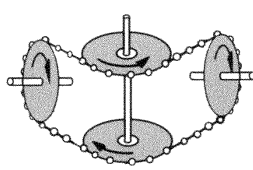
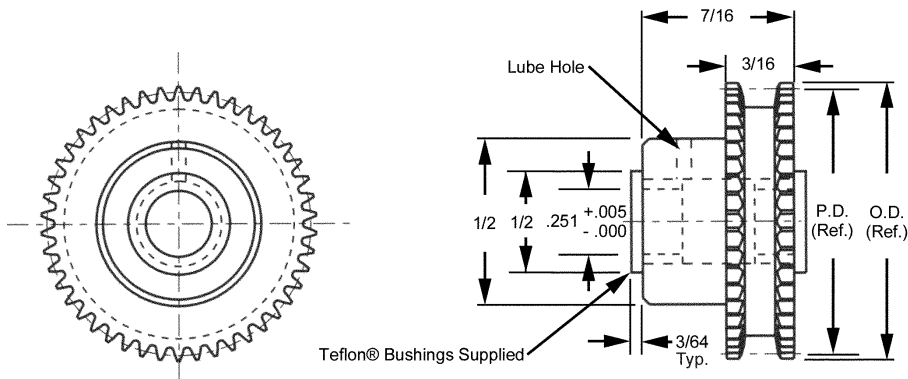

STOCK NO.	NO. OF TEETH	PITCH DIA.	OUTSIDE DIA.
3MTB42S-25	25	1.2484	1.310
3MTB42S-26	26	1.2983	1.360
3MTB42S-28	28	1.3982	1.460
3MTB42S-30	30	1.4981	1.560
3MTB42S-32	32	1.5980	1.660
3MTB42S-34	34	1.6978	1.760
3MTB42S-35	35	1.7478	1.810
3MTB42S-36	36	1.7977	1.860
3MTB42S-38	38	1.8976	1.960
3MTB42S-40	40	1.9974	2.059
3MTB42S-44	44	2.1972	2.259
3MTB42S-45	45	2.2471	2.309
3MTB42S-50	50	2.4968	2.559
3MTB42S-55	55	2.7465	2.808
3MTB42S-60	60	2.9962	3.058
3MTB42S-65	65	3.2458	3.308
3MTB42S-70	70	3.4955	3.558
3MTB42S-75	75	3.7452	3.807
3MTB42S-80	80	3.9949	4.057



Other numbers of teeth are available on request.

FIELD SPLICE KIT

Splicing Procedure

1. Cut "Berg" Min-E-Pitch sharp and square as shown, using cutter TL-1 to desired number of pitches, plus one pitch.

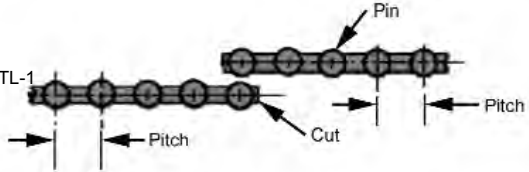

2. Cut plastic jacket (one pitch each side) lightly with sharp razor blade as shown all around. Strip or twist off jacket carefully. Caution: do not cut or fray the cable.



3. Slide stripped cable into oval splice bushing carefully. Caution: do not fray cable. Feed cable into chamfered end of bushing last.

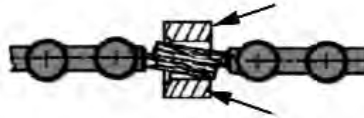

4. Center bushing and be certain chain or belt is straight before crimping.

5. Position crimp tool over bushing and squeeze tightly for maximum splice strength.

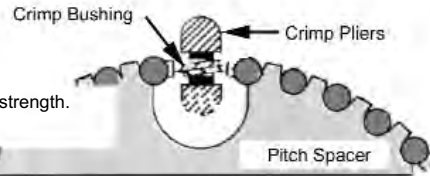

FIELD SPLICES OFFER ONLY 50% OF CATALOG RATED LOADS.

CHAIN SERIES	STOCK NO.	FIELD SPLICE KIT AND ACCESSORIES
3CCF 3DCF 3CBF 3TDF	3CCR-7	COMPLETE KIT CONSISTS OF: CRIMP TOOL, PITCH SPACER, SAMPLE CHAINS & BELTS, CABLE CUTTER, BUSHINGS, RAZOR BLADES & INSTRUCTIONS
	BU-032-S	EXTRA SPLICE BUSHING
	TL-3	CRIMP TOOL
	TL-1	CABLE CUTTER FOR UP TO 3/64" CABLE



W.M. Berg will factory splice to order any length chain at a nominal charge.

Field splices offer only 50% of catalog rated loads.

SUPPORT & GUIDE RAILS

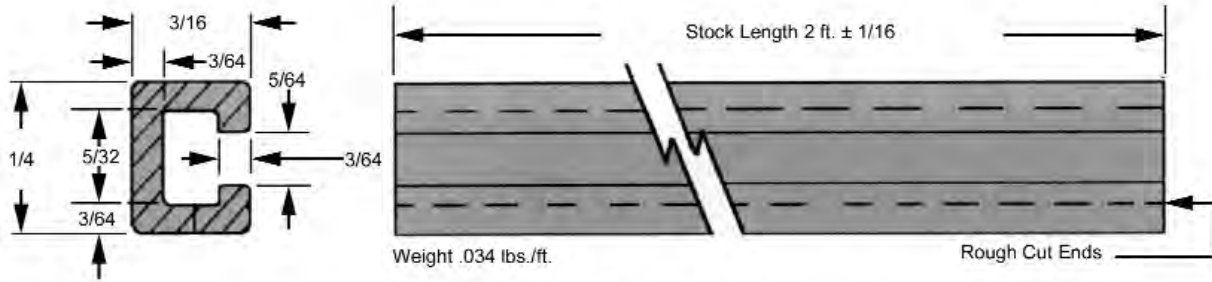

After cutting guide to suit your application, always file and funnel ends for easy entrance.

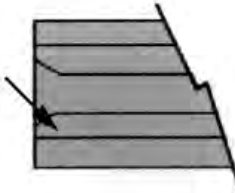

APPLICATIONS:

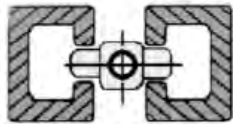

Cable Belt Guides

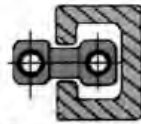

Cable Chain Guides

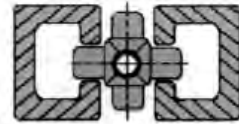

Three-D Guides

STOCK NO.
3CRR

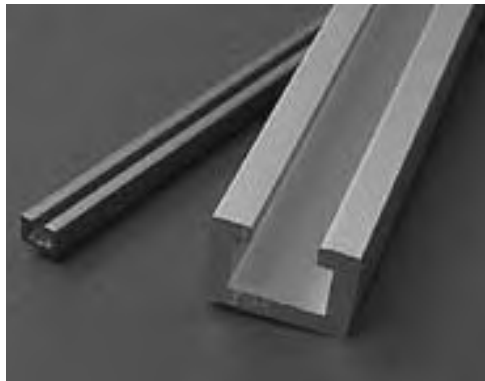

Flex-E-Pitch® TECHNICAL DATA

Operating Notes:

This chain offers zero backlash and extremely smooth operation. Always use as large a sprocket as possible for maximum cable life. *No Lubrication Required.*

CIRCULAR PITCH	PIN DIAMETER	MATERIALS	BERG'S ® NAME	SPROCKET
.1475	.090	Polyurethane (Blue) 1/32" Stainless Steel Cable	Flex-E-Pitch®	Operates with 14LC, and 14LP series.

14CCF Series

- Ultimate tensile 100 lbs., 12 lb./pin - when belt is used in open loop configuration (without splice, no crimp bushing).
- Minimum Recommended Sprocket Diameter .750 P.D.
- Recommended Maximum Operating Speed 376 Feet/Min.
- Recommended Operating Load 25 lbs.

** Reduce Operating Load Rating by 50% for field splices.

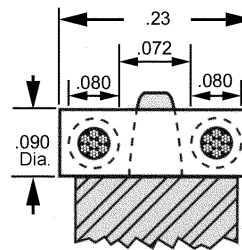

CIRCULAR PITCH	PIN DIAMETER	MATERIALS	BERG'S ® NAME	SPROCKET
.250	.130	Polyurethane (Yellow) 1/32" Stainless Steel Cable	Flex-E-Pitch®	Operates with 25LC, 25CF, and 25CP series.

25CCF Series

- Ultimate tensile 100 lbs., 22 lb./pin - when belt is used in open loop configuration (without splice, no crimp bushing).
- Minimum Recommended Sprocket Diameter .750 P.D.
- Recommended Maximum Operating Speed 376 Feet/Min.
- Recommended Operating Load 25 lbs.

** Reduce Operating Load Rating by 50% for field splices.

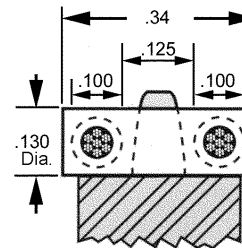

CIRCULAR PITCH	PIN DIAMETER	MATERIALS	BERG'S ® NAME	SPROCKET
.375	.200	Polyurethane (Brown) 3/64" Stainless Steel Cable	Flex-E-Pitch®	Operates with 35CF series.

35CCF Series

- Ultimate tensile 200 lbs., 50 lb./pin - when belt is used in open loop configuration (without splice, no crimp bushing).
- Minimum Recommended Sprocket Diameter 1.375" P.D.
- Recommended Maximum Operating Speed 376 Feet/Min.
- Recommended Operating Load 55 lbs.

** Reduce Operating Load Rating by 50% for field splices.

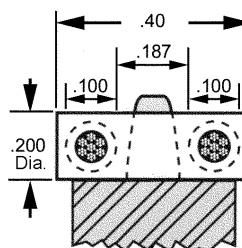

CIRCULAR PITCH	PIN DIAMETER	MATERIALS	BERG'S ® NAME	SPROCKET
.500	.306	Polyurethane (Red) 1/16" Stainless Steel Cable	Flex-E-Pitch®	Operates with 7CF series.

7CCF Series

- Ultimate tensile 300 lbs., 70 lb./pin - when belt is used in open loop configuration (without splice, no crimp bushing).
- Minimum Recommended Sprocket Diameter 1.760" P.D.
- Recommended Maximum Operating Speed 376 Feet/Min.
- Recommended Operating Load 75 lbs.

** Reduce Operating Load Rating by 50% for field splices.

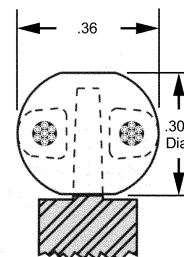

CABLE CHAIN

CIRCULAR PITCH	PIN DIAMETER	MATERIALS	BERG'S ® NAME	SPROCKET
.1475	.090	Polyurethane (Blue) 1/32" Stainless Steel Cable*	Flex-E-Pitch®	Operates with 14LC, and 14LP series.

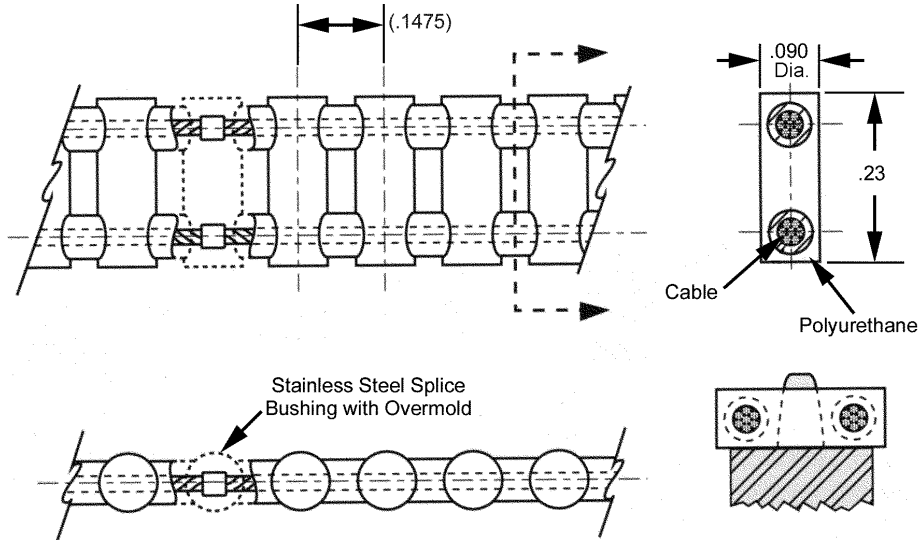

STOCK NO.	NO. OF PITCHES	LENGTH (Ref.)
14CCF-40-E	40	5.900
14CCF-50-E	50	7.375
14CCF-60-E	60	8.850
14CCF-70-E	70	10.325
14CCF-80-E	80	11.800
14CCF-90-E	90	13.275
14CCF-100-E	100	14.750
14CCF-110-E	110	16.225
14CCF-120-E	120	17.700
14CCF-130-E	130	19.175
14CCF-140-E	140	20.650
14CCF-150-E	150	22.125
14CCF-160-E	160	23.600
14CCF-170-E	170	25.075
14CCF-180-E	180	26.550
14CCF-190-E	190	28.025
14CCF-200-E	200	29.500
14CCF-210-E	210	30.975
14CCF-220-E	220	32.450
14CCF-230-E	230	33.925
14CCF-240-E	240	35.400
14CCF-250-E	250	36.875
14CCF-260-E	260	38.350
14CCF-270-E	270	39.825
14CCF-280-E	280	41.300
14CCF-290-E	290	42.775
14CCF-300-E	300	44.250
14CCF-310-E	310	45.725
14CCF-320-E	320	47.200
14CCF-330-E	330	48.675
14CCF-340-E	340	50.150
14CCF-370-E	370	54.575
14CCF-390-E	390	57.525

• For Field Splice Kit order 14CCF-7.

*Available with Aramid Core construction. See page VII for alternate belt construction and reverse belt bending applications.

** Reduce Operating Load Rating by 50% for field splices.

Designed to replace standard metal roller chain systems:

- No multiple link joints to bind.
- Lubrication is never required.
- Easily modified to any length.
- Large selection of mating sprockets.
- Infinite Lengths
- Silent Drive
- Rust Proof
- 90A Durometer
- Non-Magnetic
- Positive Drive
- Zero Backlash
- Weight .15 oz./ft.
- Ultimate Tensile Strength 100 lbs. - 12 lbs./Pin when belt is used in an open configuration (without splice, no crimp bushing)
- Temperature Range +180°F to -15°F
- Recommended Operating Load 25 lbs.
- Recommended Max. Operating Speed 376 Feet/ Min.

BULK FOOTAGE-NOT SPLICED	
STOCK NO.	LENGTH
14CCF-5FT	5 FT
14CCF-10FT	10 FT
14CCF-25FT	25 FT
14CCF-50FT	50 FT
14CCF-100FT	100 FT



CHAIN SPROCKETS

CIR. PITCH	BORE	STYLE	MATERIALS	BERG'S ® NAME	CHAIN
.1475	1/4"	PIN HUB	Delrin®	Flex-E-Pitch®	Operates with 14CCF Series

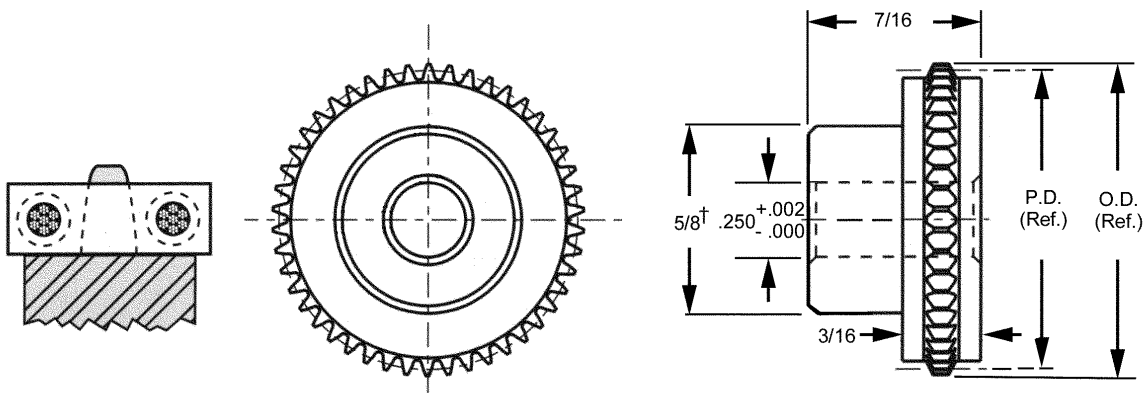

STOCK NO.	NO. OF TEETH	PITCH DIA.	OUTSIDE DIA.
14LC4M-14	14 [†] *	.6613	.741
14LC4M-15	15 [†] *	.7086	.789
14LC4M-16	16	.7558	.836
14LC4M-18	18	.8503	.930
14LC4M-20	20	.9448	1.025
14LC4M-22	22	1.0392	1.119
14LC4M-24	24	1.1337	1.214
14LC4M-26	26	1.2282	1.308
14LC4M-30	30	1.4171	1.497
14LC4M-32	32	1.5116	1.592
14LC4M-36	36	1.7006	1.781
14LC4M-40	40	1.8895	1.970
14LC4M-42	42	1.9840	2.064
14LC4M-44	44	2.0785	2.158
14LC4M-45	45	2.1257	2.206
14LC4M-50	50	2.3619	2.442
14LC4M-55	55	2.5981	2.678
14LC4M-60	60	2.8343	2.914



† Teeth runout on hub.

* Sprockets with .750 P.D. and smaller are recommended for idler use only.

Other numbers of teeth available on request.

CHAIN SPROCKETS

CIR. PITCH	BORE	STYLE	MATERIALS	BERG'S ® NAME	CHAIN
.1475	3/16"	PIN HUB	303 Stainless Steel 2024-T4 Aluminum Anodized	Flex-E-Pitch®	Operates with 14CCF Series

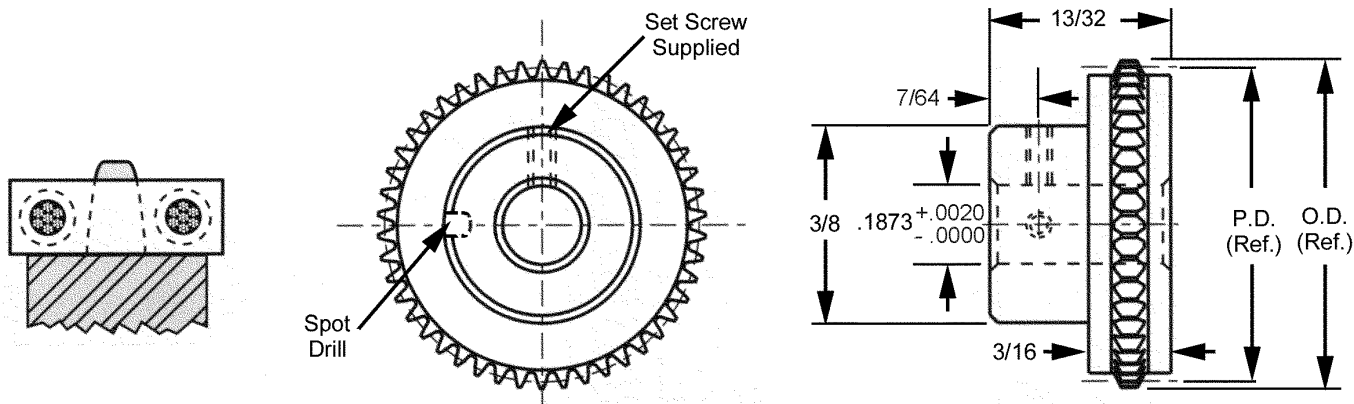

303 STAINLESS STEEL	2024-T4 ALUMINUM ANODIZED			
STOCK NO.	STOCK NO.	NO. OF TEETH	PITCH DIA.	OUTSIDE DIA.
14LC21S-10	14LC21A-10	10*	.4724	.552
14LC21S-11	14LC21A-11	11*	.5196	.600
14LC21S-12	14LC21A-12	12*	.5669	.647
14LC21S-13	14LC21A-13	13*	.6141	.694
14LC21S-14	14LC21A-14	14*	.6613	.741
14LC21S-15	14LC21A-15	15*	.7086	.789
14LC21S-16	14LC21A-16	16	.7558	.836
14LC21S-17	14LC21A-17	17	.8030	.883
14LC21S-18	14LC21A-18	18	.8503	.930
14LC21S-19	14LC21A-19	19	.8975	.978
14LC21S-20	14LC21A-20	20	.9448	1.025
14LC21S-21	14LC21A-21	21	.9920	1.072
14LC21S-22	14LC21A-22	22	1.0392	1.119
14LC21S-23	14LC21A-23	23	1.0865	1.166
14LC21S-24	14LC21A-24	24	1.1337	1.214
14LC21S-25	14LC21A-25	25	1.1809	1.261
14LC21S-26	14LC21A-26	26	1.2282	1.308
14LC21S-27	14LC21A-27	27	1.2754	1.355
14LC21S-28	14LC21A-28	28	1.3227	1.403
14LC21S-29	14LC21A-29	29	1.3699	1.450
14LC21S-30	14LC21A-30	30	1.4171	1.497
14LC21S-31	14LC21A-31	31	1.4644	1.544
14LC21S-32	14LC21A-32	32	1.5116	1.592
14LC21S-33	14LC21A-33	33	1.5588	1.639
14LC21S-34	14LC21A-34	34	1.6061	1.686
14LC21S-35	14LC21A-35	35	1.6533	1.733
14LC21S-36	14LC21A-36	36	1.7006	1.781
14LC21S-38	14LC21A-38	38	1.7950	1.875



* Sprockets with .750 P.D. and smaller are recommended for idler use only.

Other numbers of teeth available on request.

Teeth could be anodized.

CHAIN SPROCKETS

CIR. PITCH	BORE	STYLE	MATERIALS	BERG'S ® NAME	CHAIN
.1475	1/8"	PIN HUB	303 Stainless Steel Or 2024-T4 Aluminum Anodized	Flex-E-Pitch®	Operates with 14CCF Series

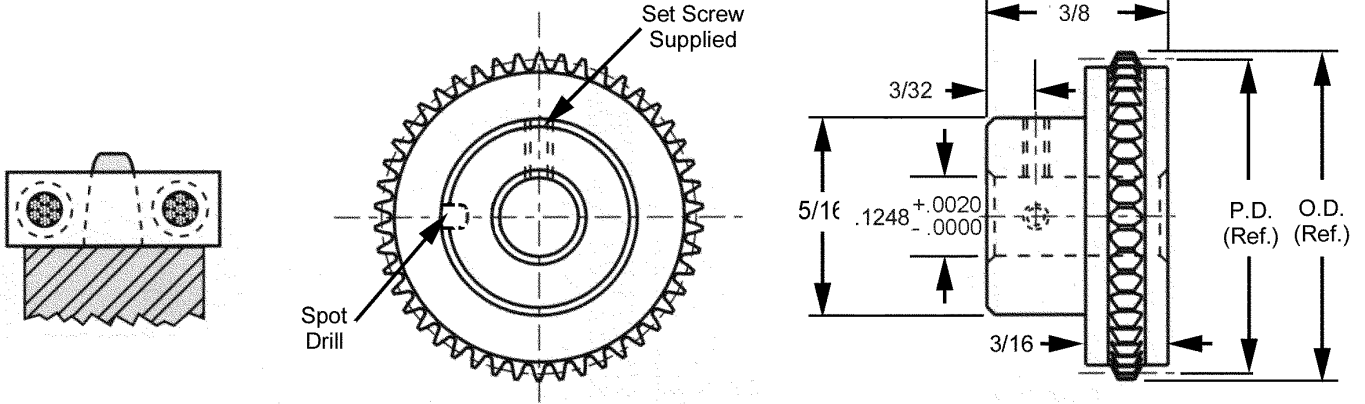

303 STAINLESS STEEL	2024-T4 ALUMINUM ANODIZED			
STOCK NO.	STOCK NO.	NO. OF TEETH	PITCH DIA.	OUTSIDE DIA.
14LC14S-10	14LC14A-10	10*	.4724	.552
14LC14S-11	14LC14A-11	11*	.5196	.600
14LC14S-12	14LC14A-12	12*	.5669	.647
14LC14S-13	14LC14A-13	13*	.6141	.694
14LC14S-14	14LC14A-14	14*	.6613	.741
14LC14S-15	14LC14A-15	15*	.7086	.789
14LC14S-16	14LC14A-16	16	.7558	.836
14LC14S-17	14LC14A-17	17	.8030	.883
14LC14S-18	14LC14A-18	18	.8503	.930
14LC14S-19	14LC14A-19	19	.8975	.978
14LC14S-20	14LC14A-20	20	.9448	1.025
14LC14S-21	14LC14A-21	21	.9920	1.072
14LC14S-22	14LC14A-22	22	1.0392	1.119
14LC14S-23	14LC14A-23	23	1.0865	1.166
14LC14S-24	14LC14A-24	24	1.1337	1.214
14LC14S-25	14LC14A-25	25	1.1809	1.261
14LC14S-26	14LC14A-26	26	1.2282	1.308
14LC14S-27	14LC14A-27	27	1.2754	1.355
14LC14S-28	14LC14A-28	28	1.3227	1.403
14LC14S-29	14LC14A-29	29	1.3699	1.450
14LC14S-30	14LC14A-30	30	1.4171	1.497
14LC14S-31	14LC14A-31	31	1.4644	1.544
14LC14S-32	14LC14A-32	32	1.5116	1.592
14LC14S-33	14LC14A-33	33	1.5588	1.639
14LC14S-34	14LC14A-34	34	1.6061	1.686
14LC14S-35	14LC14A-35	35	1.6533	1.733
14LC14S-36	14LC14A-36	36	1.7006	1.781
14LC14S-38	14LC14A-38	38	1.7950	1.875



* Sprockets with .750 P.D. and smaller are recommended for idler use only.

Other numbers of teeth available on request.

Teeth could be anodized.

CHAIN SPROCKETS

CIR. PITCH	BORE	STYLE	MATERIALS	BERG'S ® NAME	CHAIN
.1475	5/16"	PIN HUB	303 Stainless Steel 2024-T4 Aluminum Anodized	Flex-E-Pitch®	Operates with 14CCF Series

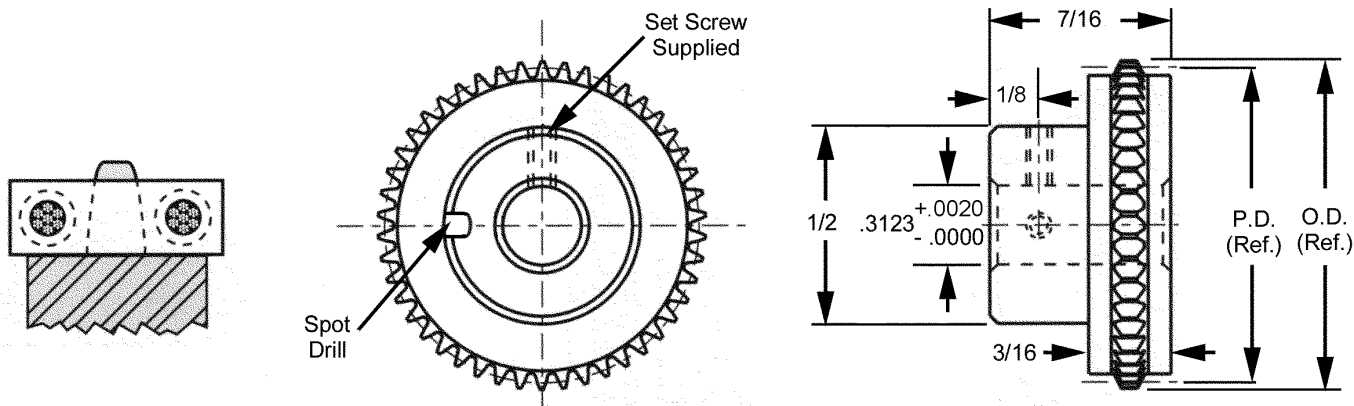

303 STAINLESS STEEL	2024-T4 ALUMINUM ANODIZED			
STOCK NO.	STOCK NO.	NO. OF TEETH	PITCH DIA.	OUTSIDE DIA.
14LC32S-13	14LC32A-13	13*	.6141	.694
14LC32S-14	14LC32A-14	14*	.6613	.741
14LC32S-15	14LC32A-15	15*	.7086	.789
14LC32S-16	14LC32A-16	16	.7558	.836
14LC32S-17	14LC32A-17	17	.8030	.883
14LC32S-18	14LC32A-18	18	.8503	.930
14LC32S-19	14LC32A-19	19	.8975	.978
14LC32S-20	14LC32A-20	20	.9448	1.025
14LC32S-21	14LC32A-21	21	.9920	1.072
14LC32S-22	14LC32A-22	22	1.0392	1.119
14LC32S-23	14LC32A-23	23	1.0865	1.166
14LC32S-24	14LC32A-24	24	1.1337	1.214
14LC32S-25	14LC32A-25	25	1.1809	1.261
14LC32S-26	14LC32A-26	26	1.2282	1.308
14LC32S-27	14LC32A-27	27	1.2754	1.355
14LC32S-28	14LC32A-28	28	1.3227	1.403
14LC32S-29	14LC32A-29	29	1.3699	1.450
14LC32S-30	14LC32A-30	30	1.4171	1.497
14LC32S-31	14LC32A-31	31	1.4644	1.544
14LC32S-32	14LC32A-32	32	1.5116	1.592
14LC32S-33	14LC32A-33	33	1.5588	1.639
14LC32S-34	14LC32A-34	34	1.6061	1.686
14LC32S-35	14LC32A-35	35	1.6533	1.733
14LC32S-36	14LC32A-36	36	1.7006	1.781
14LC32S-38	14LC32A-38	38	1.7950	1.875
14LC32S-40	14LC32A-40	40	1.8895	1.970
14LC32S-42	14LC32A-42	42	1.9840	2.064
14LC32S-44	14LC32A-44	44	2.0785	2.158



* Sprockets with .750 P.D. and smaller are recommended for idler use only.

Other numbers of teeth available on request.

Teeth could be anodized.

CHAIN SPROCKETS

CIR. PITCH	BORE	STYLE	MATERIALS	BERG'S ® NAME	CHAIN
.1475	1/4	PIN HUB	303 Stainless Steel 2024-T4 Aluminum Anodized	Flex-E-Pitch®	Operates with 14CCF Series

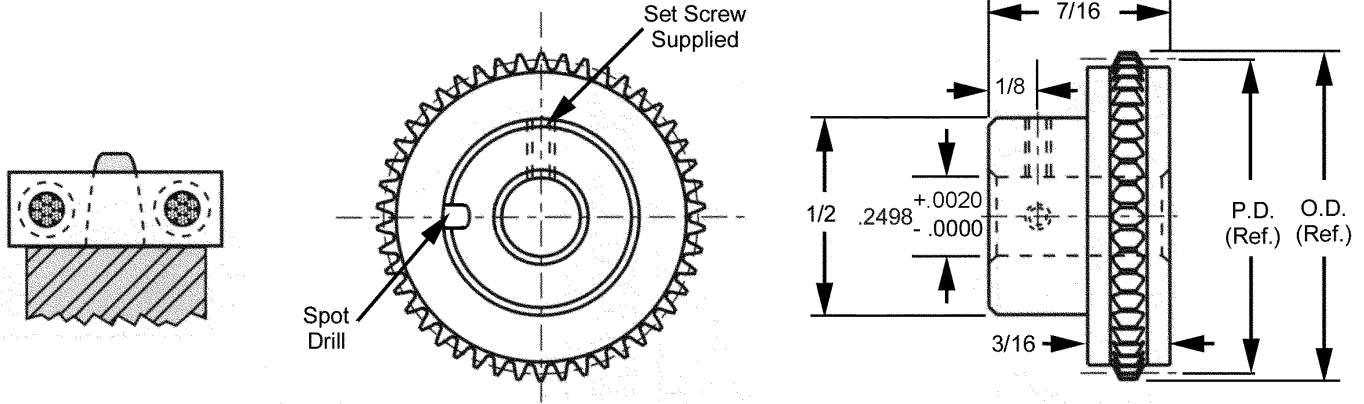

303 STAINLESS STEEL	2024-T4 ALUMINUM ANODIZED			
STOCK NO.	STOCK NO.	NO. OF TEETH	PITCH DIA.	OUTSIDE DIA.
14LC28S-13	14LC28A-13	13*	.6141	.694
14LC28S-14	14LC28A-14	14*	.6613	.741
14LC28S-15	14LC28A-15	15*	.7086	.789
14LC28S-16	14LC28A-16	16	.7558	.836
14LC28S-17	14LC28A-17	17	.8030	.883
14LC28S-18	14LC28A-18	18	.8503	.930
14LC28S-19	14LC28A-19	19	.8975	.978
14LC28S-20	14LC28A-20	20	.9448	1.025
14LC28S-21	14LC28A-21	21	.9920	1.072
14LC28S-22	14LC28A-22	22	1.0392	1.119
14LC28S-23	14LC28A-23	23	1.0865	1.166
14LC28S-24	14LC28A-24	24	1.1337	1.214
14LC28S-25	14LC28A-25	25	1.1809	1.261
14LC28S-26	14LC28A-26	26	1.2282	1.308
14LC28S-27	14LC28A-27	27	1.2754	1.355
14LC28S-28	14LC28A-28	28	1.3227	1.403
14LC28S-29	14LC28A-29	29	1.3699	1.450
14LC28S-30	14LC28A-30	30	1.4171	1.497
14LC28S-31	14LC28A-31	31	1.4644	1.544
14LC28S-32	14LC28A-32	32	1.5116	1.592
14LC28S-33	14LC28A-33	33	1.5588	1.639
14LC28S-34	14LC28A-34	34	1.6061	1.686
14LC28S-35	14LC28A-35	35	1.6533	1.733
14LC28S-36	14LC28A-36	36	1.7006	1.781
14LC28S-38	14LC28A-38	38	1.7950	1.875
14LC28S-40	14LC28A-40	40	1.8895	1.970
14LC28S-42	14LC28A-42	42	1.9840	2.064
14LC28S-44	14LC28A-44	44	2.0785	2.158



* Sprockets with .750 P.D. and smaller are recommended for idler use only.

Other numbers of teeth available on request.

Teeth could be anodized.

CHAIN SPROCKETS

CIR. PITCH	BORE	STYLE	MATERIALS	BERG'S ® NAME	CHAIN
.1475	3/8"	HUBLESS	303 Stainless Steel 2024-T4 Aluminum Anodized	Flex-E-Pitch®	Operates with 14CCF Series

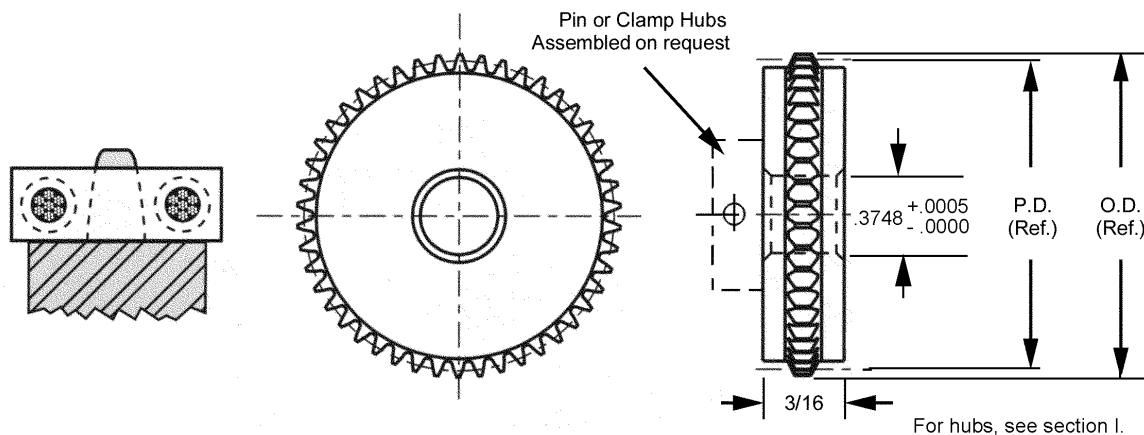

303 STAINLESS STEEL	2024T4 ALUMINUM ANODIZED			
STOCK NO.	STOCK NO.	NO. OF TEETH	PITCH DIA.	OUTSIDE DIA.
14LP5S-13	14LP5A-13	13*	.6141	.694
14LP5S-14	14LP5A-14	14*	.6613	.741
14LP5S-15	14LP5A-15	15*	.7086	.789
14LP5S-16	14LP5A-16	16	.7558	.836
14LP5S-17	14LP5A-17	17	.8030	.883
14LP5S-18	14LP5A-18	18	.8503	.930
14LP5S-19	14LP5A-19	19	.8975	.978
14LP5S-20	14LP5A-20	20	.9448	1.025
14LP5S-21	14LP5A-21	21	.9920	1.072
14LP5S-22	14LP5A-22	22	1.0392	1.119
14LP5S-23	14LP5A-23	23	1.0865	1.166
14LP5S-24	14LP5A-24	24	1.1337	1.214
14LP5S-25	14LP5A-25	25	1.1809	1.261
14LP5S-26	14LP5A-26	26	1.2282	1.308
14LP5S-27	14LP5A-27	27	1.2754	1.355
14LP5S-28	14LP5A-28	28	1.3227	1.403
14LP5S-29	14LP5A-29	29	1.3699	1.450
14LP5S-30	14LP5A-30	30	1.4171	1.497
14LP5S-31	14LP5A-31	31	1.4644	1.544
14LP5S-32	14LP5A-32	32	1.5116	1.592
14LP5S-33	14LP5A-33	33	1.5588	1.639
14LP5S-34	14LP5A-34	34	1.6061	1.686
14LP5S-35	14LP5A-35	35	1.6533	1.733
14LP5S-36	14LP5A-36	36	1.7006	1.781
14LP5S-38	14LP5A-38	38	1.7950	1.875
14LP5S-40	14LP5A-40	40	1.8895	1.970
14LP5S-42	14LP5A-42	42	1.9840	2.064
14LP5S-44	14LP5A-44	44	2.0785	2.158



* Sprockets with .750 P.D. and smaller are recommended for idler use only.

Other numbers of teeth available on request.

Teeth could be anodized.

CHAIN SPROCKETS

CIR. PITCH	BORE	STYLE	MATERIALS	BERG'S ® NAME	CHAIN
.1475	11/16"	HUBLESS	303 Stainless Steel 2024-T4 Aluminum Anodized	Flex-E-Pitch®	Operates with 14CCF Series

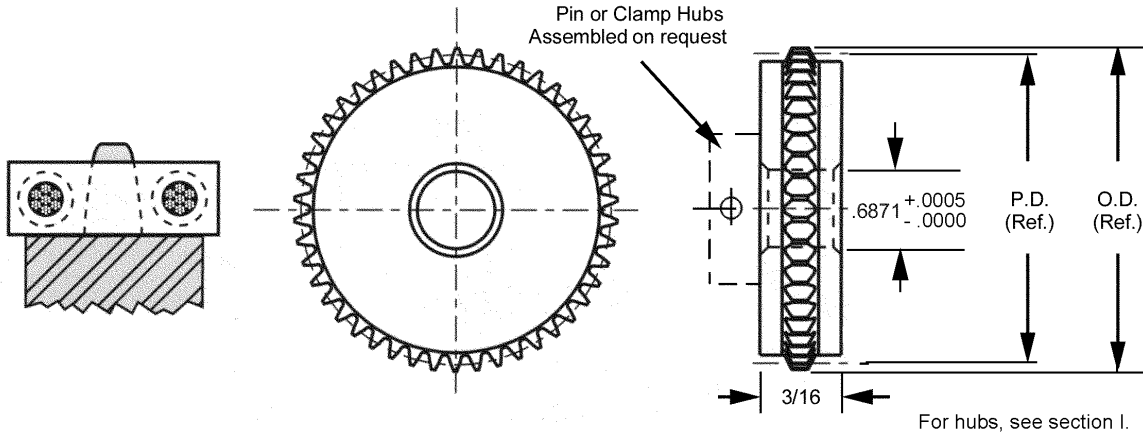

303 STAINLESS STEEL	2024T4 ALUMINUM ANODIZED			
STOCK NO.	STOCK NO.	NO. OF TEETH	PITCH DIA.	OUTSIDE DIA.
14LP19S-13	14LP19A-13	13*	.6141	.694
14LP19S-14	14LP19A-14	14*	.6613	.741
14LP19S-15	14LP19A-15	15*	.7086	.789
14LP19S-16	14LP19A-16	16	.7558	.836
14LP19S-17	14LP19A-17	17	.8030	.883
14LP19S-18	14LP19A-18	18	.8503	.930
14LP19S-19	14LP19A-19	19	.8975	.978
14LP19S-20	14LP19A-20	20	.9448	1.025
14LP19S-21	14LP19A-21	21	.9920	1.072
14LP19S-22	14LP19A-22	22	1.0392	1.119
14LP19S-23	14LP19A-23	23	1.0865	1.166
14LP19S-24	14LP19A-24	24	1.1337	1.214
14LP19S-25	14LP19A-25	25	1.1809	1.261
14LP19S-26	14LP19A-26	26	1.2282	1.308
14LP19S-27	14LP19A-27	27	1.2754	1.355
14LP19S-28	14LP19A-28	28	1.3227	1.403
14LP19S-29	14LP19A-29	29	1.3699	1.450
14LP19S-30	14LP19A-30	30	1.4171	1.497
14LP19S-31	14LP19A-31	31	1.4644	1.544
14LP19S-32	14LP19A-32	32	1.5116	1.592
14LP19S-33	14LP19A-33	33	1.5588	1.639
14LP19S-34	14LP19A-34	34	1.6061	1.686
14LP19S-35	14LP19A-35	35	1.6533	1.733
14LP19S-36	14LP19A-36	36	1.7006	1.781
14LP19S-38	14LP19A-38	38	1.7950	1.875
14LP19S-40	14LP19A-40	40	1.8895	1.970
14LP19S-42	14LP19A-42	42	1.9840	2.064
14LP19S-44	14LP19A-44	44	2.0785	2.158



* Sprockets with .750 P.D. and smaller are recommended for idler use only.

Other numbers of teeth available on request.

Teeth could be anodized.

CHAIN CABLE

CIRCULAR PITCH	PIN DIAMETER	MATERIALS	BERG'S ® NAME	SPROCKET
.250	.130	Polyurethane (Yellow) 1/32" Dia. Stainless Steel Cable*	Flex-E-Pitch®	Operates with 25LC, 25CF, and 25CP series.

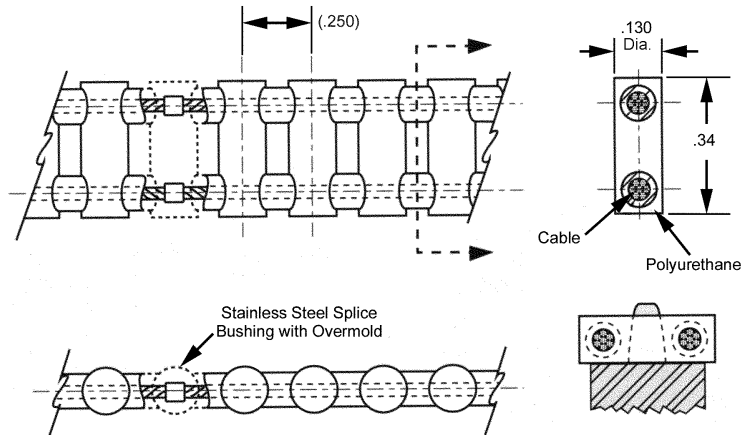

STOCK NO.	NO. OF PITCHES	LENGTH (Ref.)
25CCF-40-E	40	10.000
25CCF-50-E	50	12.500
25CCF-60-E	60	15.000
25CCF-70-E	70	17.500
25CCF-80-E	80	20.000
25CCF-90-E	90	22.500
25CCF-100-E	100	25.000
25CCF-110-E	110	27.500
25CCF-120-E	120	30.000
25CCF-130-E	130	32.500
25CCF-140-E	140	35.000
25CCF-150-E	150	37.500
25CCF-160-E	160	40.000
25CCF-170-E	170	42.500
25CCF-180-E	180	45.000
25CCF-190-E	190	47.500
25CCF-200-E	200	50.000
25CCF-210-E	210	52.500
25CCF-220-E	220	55.000
25CCF-230-E	230	57.500
25CCF-240-E	240	60.000
25CCF-250-E	250	62.500
25CCF-260-E	260	65.000
25CCF-270-E	270	67.500
25CCF-280-E	280	70.000
25CCF-290-E	290	72.500
25CCF-300-E	300	75.000
25CCF-310-E	310	77.500
25CCF-320-E	320	80.000
25CCF-330-E	330	82.500
25CCF-370-E	370	92.500
25CCF-380-E	380	95.000
25CCF-390-E	390	97.500

- For Field Splice Kit order 25CCF-7.
 - *Available with Aramid Core construction.
 - ** Reduce Operating Load Rating by 50% for Field Splices.
- See page VII for alternate belt construction and reverse belt bending applications.

Designed to replace standard metal roller chain systems:

- No multiple link joints to bind.
- Lubrication is never required.
- Easily modified to any length.
- Large selection of mating sprockets.
- Infinite Lengths
 - Silent Drive
 - Rust Proof
 - 90A Durometer
 - Non-Magnetic
 - Positive Drive
 - Zero Backlash
 - Weight .30 oz./ft.
- Ultimate Tensile Strength 100 lbs. (22 lbs./Pin)
When belt is used in open loop configuration (without splice, no crimp bushing)
 - Temperature Range +180°F to -15°F
- Recommended Operating Load 25 lbs.
- Recommended Max. Operating Speed 376 Feet/Min.

BULK FOOTAGE-NOT SPLICED	
STOCK NO.	LENGTH
25CCF-5FT	5 FT
25CCF-10FT	10 FT
25CCF-25FT	25 FT
25CCF-50FT	50 FT
25CCF-100FT	100 FT



CHAIN SPROCKETS

CIR. PITCH	BORE	STYLE	MATERIALS	BERG'S ® NAME	CHAIN
.250	1/4"	PIN HUB	Delrin®	Flex-E-Pitch®	Operates with 25CCF Series

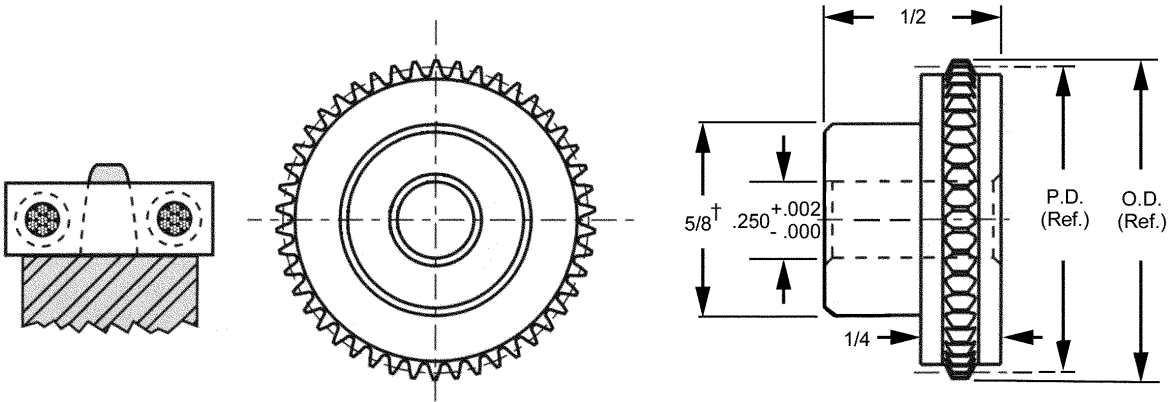

STOCK NO.	NO. OF TEETH	PITCH DIA.	OUTSIDE DIA.
25LC4M-9	9*	.7162	.836
25LC4M-10	10	.7958	.916
25LC4M-12	12	.9549	1.075
25LC4M-13	13	1.0345	1.155
25LC4M-14	14	1.1141	1.234
25LC4M-15	15	1.1937	1.314
25LC4M-16	16	1.2732	1.393
25LC4M-18	18	1.4324	1.552
25LC4M-20	20	1.5916	1.712
25LC4M-24	24	1.9099	2.030
25LC4M-25	25	1.9894	2.109
25LC4M-28	28	2.2282	2.348
25LC4M-30	30	2.3873	2.507
25LC4M-36	36	2.8648	2.985



† Teeth runout on hub.
 * Sprockets with .750 P.D. and smaller are recommended for idler use only.

Other numbers of teeth available on request.

CHAIN SPROCKETS

CIR. PITCH	BORE	STYLE	MATERIALS	BERG'S ® NAME	CHAIN
.250	3/8"	HUBLESS	2024-T4 Aluminum Anodized	Flex-E-Pitch®	Operates with 25CCF Series

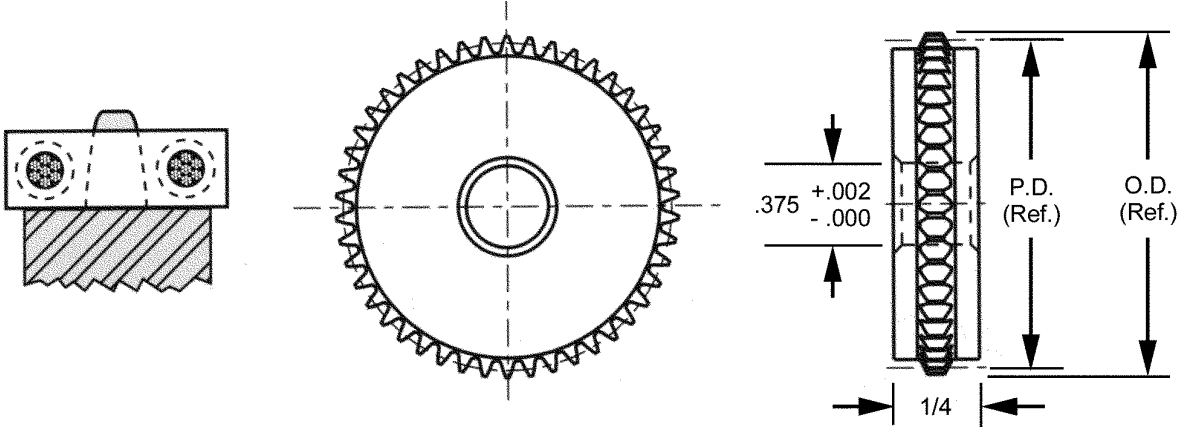

STOCK NO.	NO. OF TEETH	PITCH DIA.	OUTSIDE DIA.
25CF77A-9	9*	.7162	.836
25CF77A-10	10	.7958	.916
25CF77A-12	12	.9549	1.075
25CF77A-13	13	1.0345	1.155
25CF77A-14	14	1.1141	1.234
25CF77A-15	15	1.1937	1.314
25CF77A-16	16	1.2732	1.393
25CF77A-18	18	1.4324	1.552
25CF77A-20	20	1.5916	1.712
25CF77A-24	24	1.9099	2.030
25CF77A-25	25	1.9894	2.109
25CF77A-28	28	2.2282	2.348
25CF77A-30	30	2.3873	2.507
25CF77A-36	36	2.8648	2.985
25CF77A-40	40	3.1831	3.303
25CF77A-48	48	3.8197	3.940
25CF77A-60	60	4.7747	4.895
25CF77A-72	72	5.7296	5.850

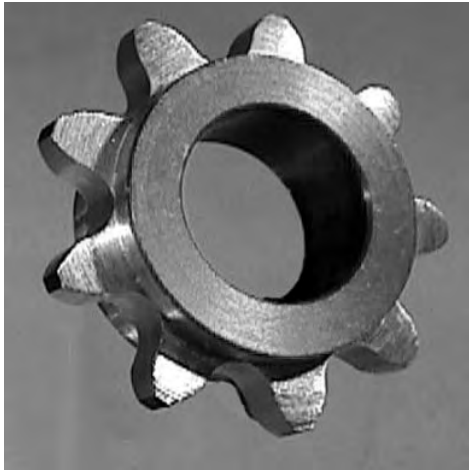

* Sprockets with .750 P.D. and smaller are recommended for idler use only.

Other numbers of teeth available on request.

Teeth could be anodized.

CHAIN SPROCKETS

CIR. PITCH	BORE	STYLE	MATERIALS	BERG'S ® NAME	CHAIN
.250	1/4"	PIN HUB	2024-T4 Aluminum Anodized	Flex-E-Pitch®	Operates with 25CCF Series

STOCK NO.	NO. OF TEETH	PITCH DIA.	OUTSIDE DIA.
25CP66A-9	9*	.7162	.836
25CP66A-10	10	.7958	.916
25CP66A-12	12	.9549	1.075
25CP66A-13	13	1.0345	1.155
25CP66A-14	14	1.1141	1.234
25CP66A-15	15	1.1937	1.314
25CP66A-16	16	1.2732	1.393
25CP66A-18	18	1.4324	1.552
25CP66A-20	20	1.5916	1.712
25CP66A-24	24	1.9099	2.030
25CP66A-25	25	1.9894	2.109
25CP66A-28	28	2.2282	2.348
25CP66A-30	30	2.3873	2.507
25CP66A-36	36	2.8648	2.985
25CP66A-40	40	3.1831	3.303
25CP66A-48	48	3.8197	3.940
25CP66A-60	60	4.7747	4.895
25CP66A-72	72	5.7296	5.850

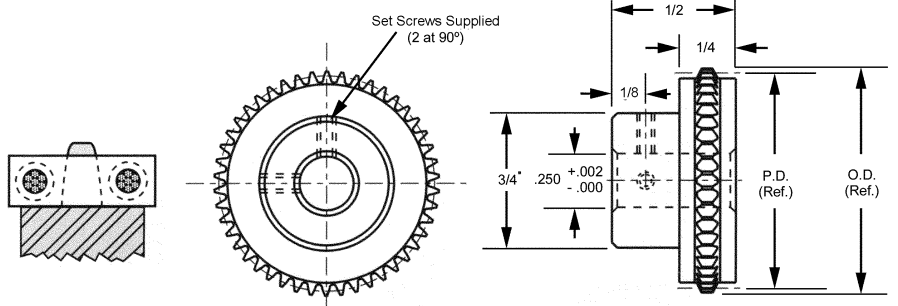

• For 9 teeth, hub diameter equals .59.
 * Sprockets with .750 P.D. and smaller are recommended for idler use only.
 Other numbers of teeth available on request.
 Teeth could be anodized.

CIR. PITCH	BORE	STYLE	MATERIALS	BERG'S ® NAME	CHAIN
.250	3/8"	PIN HUB	2024-T4 Aluminum Anodized	Flex-E-Pitch®	Operates with 25CCF Series

STOCK NO.	NO. OF TEETH	PITCH DIA.	OUTSIDE DIA.
25CP67A-9	9*	.7162	.836
25CP67A-10	10*	.7958	.916
25CP67A-12	12	.9549	1.075
25CP67A-13	13	1.0345	1.155
25CP67A-14	14	1.1141	1.234
25CP67A-15	15	1.1937	1.314
25CP67A-16	16	1.2732	1.393
25CP67A-18	18	1.4324	1.552
25CP67A-20	20	1.5916	1.712
25CP67A-24	24	1.9099	2.030
25CP67A-25	25	1.9894	2.109
25CP67A-28	28	2.2282	2.348
25CP67A-30	30	2.3873	2.507
25CP67A-36	36	2.8648	2.985
25CP67A-40	40	3.1831	3.303
25CP67A-48	48	3.8197	3.940
25CP67A-60	60	4.7747	4.895
25CP67A-72	72	5.7296	5.850

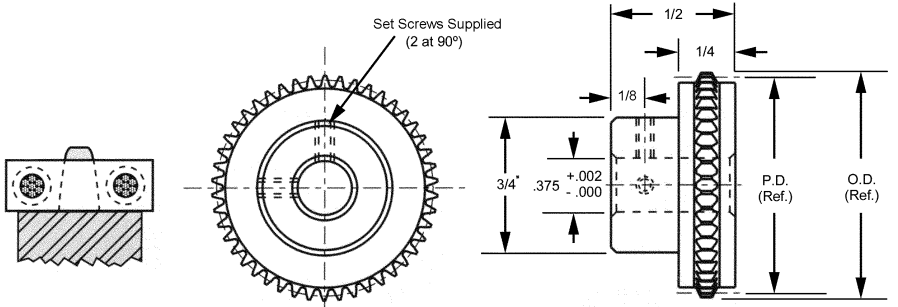

• For 9-10 teeth, hub diameter equals .59.
 * Sprockets with .750 P.D. and smaller are recommended for idler use only.
 Other numbers of teeth available on request.
 Teeth could be anodized.

CIR. PITCH	BORE	STYLE	MATERIALS	BERG'S ® NAME	CHAIN
.250	1/2"	PIN HUB	2024-T4 Aluminum Anodized	Flex-E-Pitch®	Operates with 25CCF Series

STOCK NO.	NO. OF TEETH	PITCH DIA.	OUTSIDE DIA.
25CP68A-12	12	.9549	1.075
25CP68A-13	13	1.0345	1.155
25CP68A-14	14	1.1141	1.234
25CP68A-15	15	1.1937	1.314
25CP68A-16	16	1.2732	1.393
25CP68A-18	18	1.4324	1.552
25CP68A-20	20	1.5916	1.712
25CP68A-24	24	1.9099	2.030
25CP68A-25	25	1.9894	2.109
25CP68A-28	28	2.2281	2.348
25CP68A-30	30	2.3873	2.507
25CP68A-36	36	2.8648	2.985
25CP68A-40	40	3.1831	3.303
25CP68A-48	48	3.8197	3.940
25CP68A-60	60	4.7747	4.895
25CP68A-72	72	5.7296	5.850

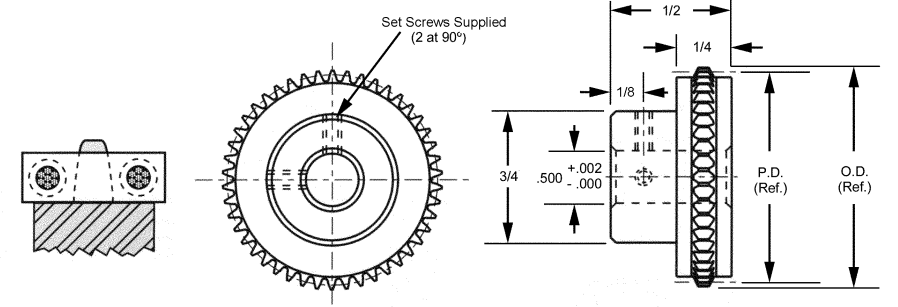

Other numbers of teeth available on request.
 Teeth could be anodized.

CHAIN CABLE

CIRCULAR PITCH	PIN DIAMETER	MATERIALS	BERG'S ® NAME	SPROCKET
.375	.200	Polyurethane (Brown) 3/64" Dia. Stainless Steel Cable*	Flex-E-Pitch®	Operates with 35CF, and 35CP series.

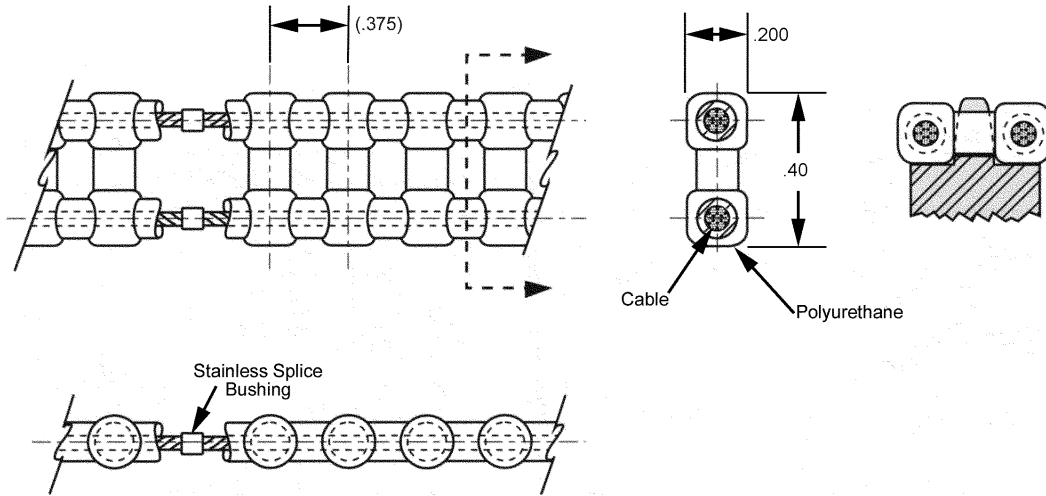

STOCK NO.	NO. OF PITCHES	LENGTH (Ref.)
35CCF-40-E	40	15.000
35CCF-50-E	50	18.750
35CCF-60-E	60	22.500
35CCF-70-E	70	26.250
35CCF-80-E	80	30.000
35CCF-90-E	90	33.750
35CCF-100-E	100	37.500
35CCF-110-E	110	41.250
35CCF-120-E	120	45.000
35CCF-130-E	130	48.750
35CCF-140-E	140	52.500
35CCF-150-E	150	56.250
35CCF-160-E	160	60.000
35CCF-170-E	170	63.750
35CCF-180-E	180	67.500
35CCF-190-E	190	71.250
35CCF-200-E	200	75.000
35CCF-210-E	210	78.750
35CCF-220-E	220	82.500
35CCF-230-E	230	86.250
35CCF-240-E	240	90.000
35CCF-250-E	250	93.750
35CCF-260-E	260	97.500
35CCF-270-E	270	101.250
35CCF-280-E	280	105.000
35CCF-290-E	290	108.750
35CCF-300-E	300	112.500
35CCF-310-E	310	116.250
35CCF-320-E	320	120.000
35CCF-330-E	330	123.750
35CCF-360-E	360	135.000
35CCF-370-E	370	138.750
35CCF-390-E	390	146.250

- For Field Splice Kit order 35CCF-7.
- *Available with Aramid Core construction.
- ** Reduce Operating Load Rating by 50% for Field Splices.
- See page VII for alternate belt construction and reverse belt bending applications.
- Designed to replace standard metal roller chain systems:
 - No multiple link joints to bind.
- Lubrication is never required.
- Easily modified to any length.
- Large selection of mating sprockets.
- Infinite Lengths
 - Silent Drive
 - Rust Proof
 - 90A Durometer
 - Non-Magnetic
 - Positive Drive
 - Zero Backlash
 - Weight .50 oz./ft.
 - Ultimate Tensile Strength 200 lbs. (50 lbs./Pin)
- When belt is used in open loop configuration (without splice, no crimp bushing)
- Temperature Range +180°F to -15°F
- Recommended Operating Load 55 lbs.
- Recommended Max. Operating Speed 376 Feet/Min.

BULK FOOTAGE-NOT SPLICED	
STOCK NO.	LENGTH
35CCF-5FT	5 FT
35CCF-10FT	10 FT
35CCF-25FT	25 FT
35CCF-50FT	50 FT
35CCF-100FT	100 FT



CHAIN SPROCKETS

CIR. PITCH	BORE	STYLE	MATERIALS	BERG'S ® NAME	CHAIN
.375	3/8"	HUBLESS	2024-T4 Aluminum Anodized	Flex-E-Pitch®	Operates with 35CCF Series

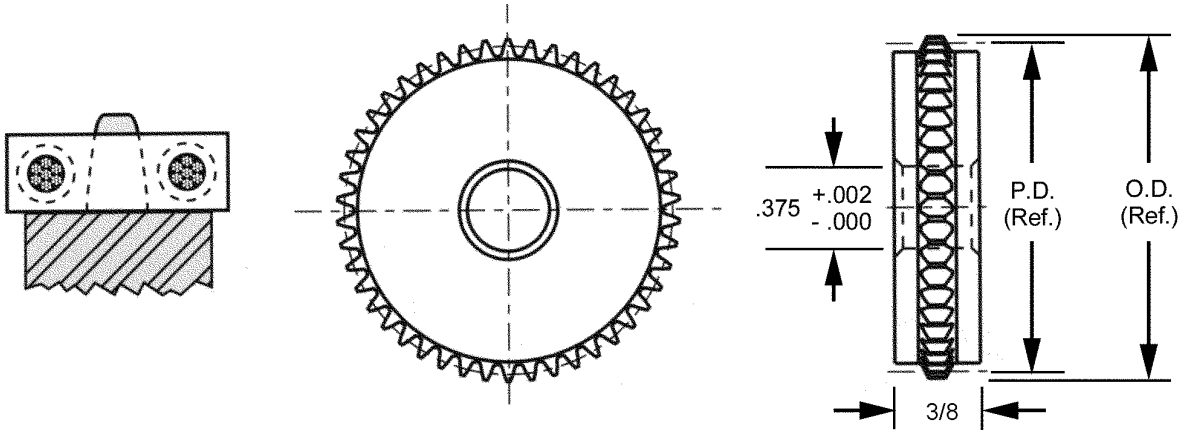

STOCK NO.	NO. OF TEETH	PITCH DIA.	OUTSIDE DIA.
35CF74A-8	8*	.9525	1.152
35CF74A-9	9*	1.0715	1.271
35CF74A-10	10	1.1906	1.390
35CF74A-11	11	1.3097	1.509
35CF74A-12	12	1.4287	1.628
35CF74A-14	14	1.6668	1.866
35CF74A-15	15	1.7859	1.985
35CF74A-16	16	1.9050	2.104
35CF74A-18	18	2.1431	2.343
35CF74A-20	20	2.3812	2.581
35CF74A-24	24	2.8574	3.057
35CF74A-25	25	2.9765	3.175
35CF74A-30	30	3.5718	3.771
35CF74A-32	32	3.8099	4.009
35CF74A-36	36	4.2862	4.486
35CF74A-40	40	4.7624	4.962
35CF74A-48	48	5.7149	5.914



* Sprockets with 1.375 P.D. and smaller are recommended for idler use only.

Other numbers of teeth available on request.
Teeth could be anodized.

CHAIN SPROCKETS

CIR. PITCH	BORE	STYLE	MATERIALS	BERG'S ® NAME	CHAIN
.375	1/4"	PIN HUB	2024-T4 Aluminum Anodized	Flex-E-Pitch®	Operates with 35CCF Series

STOCK NO.	NO. OF TEETH	PITCH DIA.	OUTSIDE DIA.
35CP57A-8	8*	.9525	1.152
35CP57A-9	9*	1.0715	1.271
35CP57A-10	10	1.1906	1.390
35CP57A-11	11	1.3097	1.509
35CP57A-12	12	1.4287	1.628
35CP57A-14	14	1.6668	1.866
35CP57A-15	15	1.7859	1.985
35CP57A-16	16	1.9050	2.104
35CP57A-18	18	2.1431	2.343
35CP57A-20	20	2.3812	2.581
35CP57A-24	24	2.8574	3.057
35CP57A-25	25	2.9765	3.175
35CP57A-30	30	3.5718	3.771
35CP57A-32	32	3.8099	4.009
35CP57A-36	36	4.2862	4.486
35CP57A-40	40	4.7624	4.962
35CP57A-48	48	5.7149	5.914

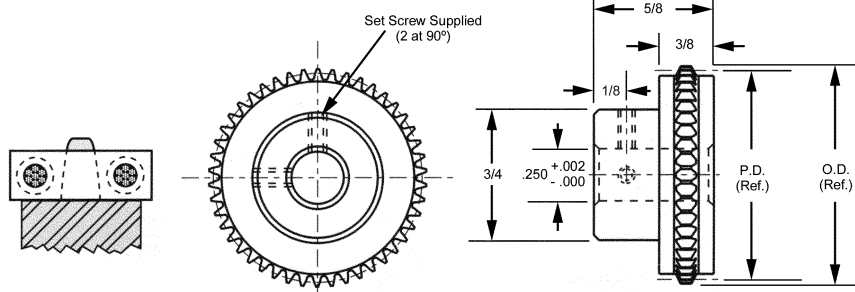

* Sprockets with 1.375 P.D. and smaller are recommended for idler use only.
Other numbers of teeth available on request.
Teeth could be anodized.

CIR. PITCH	BORE	STYLE	MATERIALS	BERG'S ® NAME	CHAIN
.375	3/8"	PIN HUB	2024-T4 Aluminum Anodized	Flex-E-Pitch®	Operates with 35CCF Series

STOCK NO.	NO. OF TEETH	PITCH DIA.	OUTSIDE DIA.
35CP58A-8	8*	.9525	1.152
35CP58A-9	9*	1.0715	1.271
35CP58A-10	10	1.1906	1.390
35CP58A-11	11	1.3097	1.509
35CP58A-12	12	1.4287	1.628
35CP58A-14	14	1.6668	1.866
35CP58A-15	15	1.7859	1.985
35CP58A-16	16	1.9050	2.104
35CP58A-18	18	2.1431	2.343
35CP58A-20	20	2.3812	2.581
35CP58A-24	24	2.8574	3.057
35CP58A-25	25	2.9765	3.175
35CP58A-30	30	3.5718	3.771
35CP58A-32	32	3.8099	4.009
35CP58A-36	36	4.2862	4.486
35CP58A-40	40	4.7624	4.962
35CP58A-48	48	5.7149	5.914

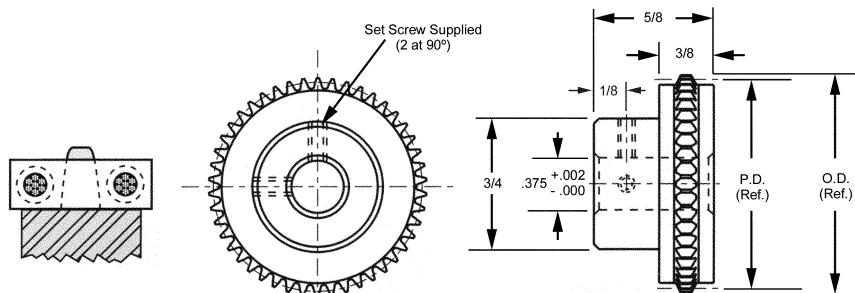

* Sprockets with 1.375 P.D. and smaller are recommended for idler use only.
Other numbers of teeth available on request.
Teeth could be anodized.

CIR. PITCH	BORE	STYLE	MATERIALS	BERG'S ® NAME	CHAIN
.375	1/2"	PIN HUB	2024-T4 Aluminum Anodized	Flex-E-Pitch®	Operates with 35CCF Series

STOCK NO.	NO. OF TEETH	PITCH DIA.	OUTSIDE DIA.
35CP59A-8	8*	.9525	1.152
35CP59A-9	9*	1.0715	1.271
35CP59A-10	10	1.1906	1.390
35CP59A-11	11	1.3097	1.509
35CP59A-12	12	1.4287	1.628
35CP59A-14	14	1.6668	1.866
35CP59A-15	15	1.7859	1.985
35CP59A-16	16	1.9050	2.104
35CP59A-18	18	2.1431	2.343
35CP59A-20	20	2.3812	2.581
35CP59A-24	24	2.8574	3.057
35CP59A-25	25	2.9765	3.175
35CP59A-30	30	3.5718	3.771
35CP59A-32	32	3.8099	4.009
35CP59A-36	36	4.2862	4.486
35CP59A-40	40	4.7624	4.962
35CP59A-48	48	5.7149	5.914

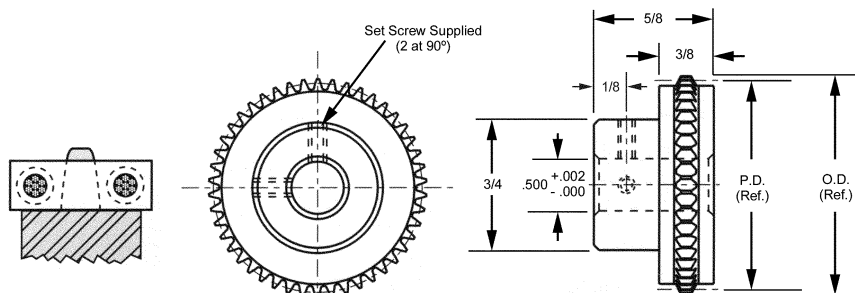

* Sprockets with 1.375 P.D. and smaller are recommended for idler use only.
Other numbers of teeth available on request.
Teeth could be anodized.

CHAIN CABLE

CIRCULAR PITCH	PIN DIAMETER	MATERIALS	BERG'S ® NAME	SPROCKET
.500	.306	Polyurethane (Red) 1/16" Dia. Stainless Steel Cable*	Flex-E-Pitch®	Operates with 7CF, and 7CP series.

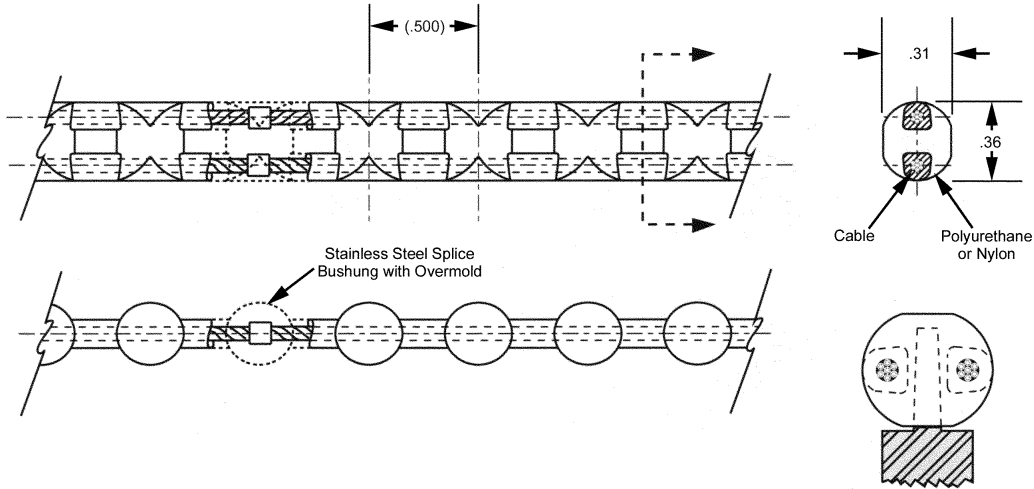

STOCK NO.	NO. OF PITCHES	LENGTH (Ref.)
7CCF-20-U	20	10.000
7CCF-22-U	22	11.000
7CCF-24-U	24	12.000
7CCF-26-U	26	13.000
7CCF-28-U	28	14.000
7CCF-30-U	30	15.000
7CCF-32-U	32	16.000
7CCF-34-U	34	17.000
7CCF-36-U	36	18.000
7CCF-38-U	38	19.000
7CCF-40-U	40	20.000
7CCF-42-U	42	21.000
7CCF-44-U	44	22.000
7CCF-46-U	46	23.000
7CCF-48-U	48	24.000
7CCF-50-U	50	25.000
7CCF-52-U	52	26.000
7CCF-54-U	54	27.000
7CCF-56-U	56	28.000
7CCF-60-U	60	30.000
7CCF-64-U	64	32.000
7CCF-68-U	68	34.000
7CCF-72-U	72	36.000
7CCF-76-U	76	38.000
7CCF-80-U	80	40.000
7CCF-84-U	84	42.000
7CCF-88-U	88	44.000
7CCF-92-U	92	46.000
7CCF-96-U	96	48.000
7CCF-100-U	100	50.000
7CCF-104-U	104	52.000
7CCF-108-U	108	54.000
7CCF-112-U	112	56.000
7CCF-116-U	116	58.000
7CCF-130-U	130	65.000
7CCF-140-U	140	70.000
7CCF-200-U	200	100.000

• Aramid & Anti-Static alternate construction available.
See page VII for information about Aramid Core and/or Anti-Static Materials, and reverse belt bending applications.

- For Field Splice Kit order 7CCF-7.
- Infinite Lengths
- Rust Proof
- Non Magnetic
- Zero Backlash
- No Lubrication Required
- Positive Drive
- Weight 1.20 oz./ft.
- 90A Durometer
- Ultimate Tensile Strength 300 lbs. (70 lbs./PIN)
When belt is used in an open loop configuration (without splice, no crimp bushing)
- Temperature Range +180°F to -15°F
- Recommended Operating Load 75 lbs.
- Recommended Operating Speed 376 Feet/MIN.

Other lengths available on request.

BULK FOOTAGE-NOT SPLICED	
STOCK NO.	LENGTH
7CCF-U-5FT	5 FT
7CCF-U-10FT	10 FT
7CCF-U-25FT	25 FT
7CCF-U-50FT	50 FT
7CCF-U-100FT	100 FT



CHAIN CABLE

CIRCULAR PITCH	PIN DIAMETER	MATERIALS	BERG'S ® NAME	SPROCKET
.500	.306	Nylon (Green) 1/16" Dia. Stainless Steel Cable*	Flex-E-Pitch®	Operates with 7CF, and 7CP series.

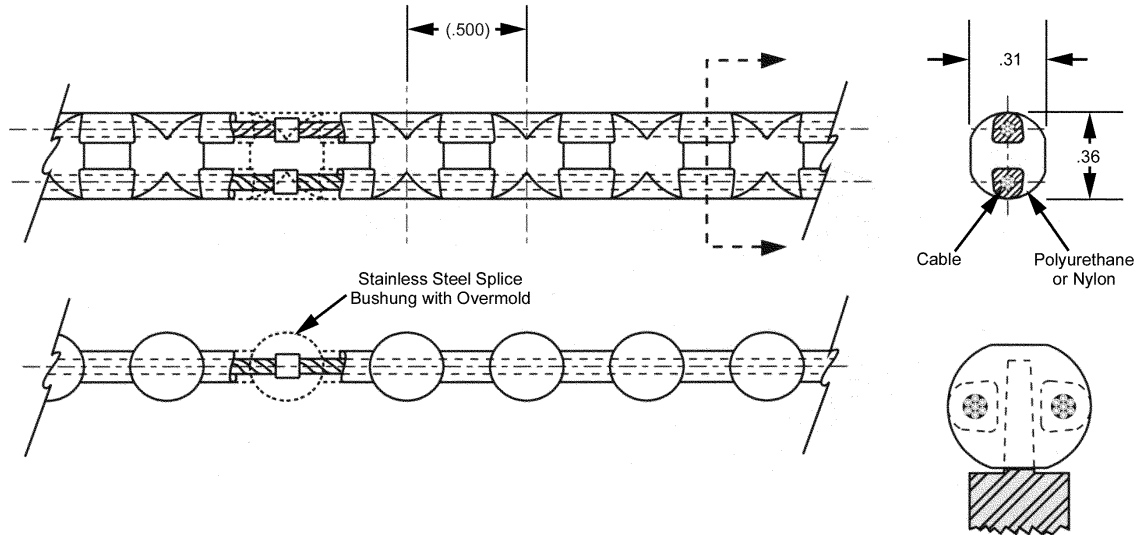

STOCK NO.	NO. OF PITCHES	LENGTH (Ref.)
7CCF-20-N	20	10.000
7CCF-22-N	22	11.000
7CCF-24-N	24	12.000
7CCF-26-N	26	13.000
7CCF-28-N	28	14.000
7CCF-30-N	30	15.000
7CCF-32-N	32	16.000
7CCF-34-N	34	17.000
7CCF-36-N	36	18.000
7CCF-38-N	38	19.000
7CCF-40-N	40	20.000
7CCF-42-N	42	21.000
7CCF-44-N	44	22.000
7CCF-46-N	46	23.000
7CCF-48-N	48	24.000
7CCF-50-N	50	25.000
7CCF-52-N	52	26.000
7CCF-54-N	54	27.000
7CCF-56-N	56	28.000
7CCF-60-N	60	30.000
7CCF-64-N	64	32.000
7CCF-68-N	68	34.000
7CCF-72-N	72	36.000
7CCF-76-N	76	38.000
7CCF-80-N	80	40.000
7CCF-84-N	84	42.000
7CCF-88-N	88	44.000
7CCF-92-N	92	46.000
7CCF-96-N	96	48.000
7CCF-100-N	100	50.000
7CCF-104-N	104	52.000
7CCF-108-N	108	54.000
7CCF-112-N	112	56.000
7CCF-116-N	116	58.000
7CCF-130-N	130	65.000
7CCF-140-N	140	70.000
7CCF-200-N	200	100.000

• Aramid & Anti-Static alternate construction available.
Aramid Core and/or Anti-Static Materials, and reverse belt bending applications available.

- For Field Splice Kit order 7CCF-7.
- Infinite Lengths
- Rust Proof
- Non Magnetic
- Zero Backlash
- No Lubrication Required
- Positive Drive
- Weight 1.20 oz./ft.
- 90A Durometer
- Ultimate Tensile Strength 300 lbs. (70 lbs./PIN)
When belt is used in an open loop configuration (without splice, no crimp bushing)
- Temperature Range +250°F to -40°F
- Recommended Operating Load 75 lbs.
- Recommended Operating Speed 376 Feet/MIN.

Other lengths available on request.

BULK FOOTAGE-NOT SPLICED	
STOCK NO.	LENGTH
7CCF-N-5FT	5 FT
7CCF-N-10FT	10 FT
7CCF-N-25FT	25 FT
7CCF-N-50FT	50 FT
7CCF-N-100FT	100 FT



CHAIN SPROCKETS

CIR. PITCH	BORE	STYLE	MATERIALS	BERG'S® NAME	CHAIN
.500	3/8"	HUBLESS	2024-T4 Aluminum Anodized	Flex-E-Pitch®	Operates with 7CCF Series

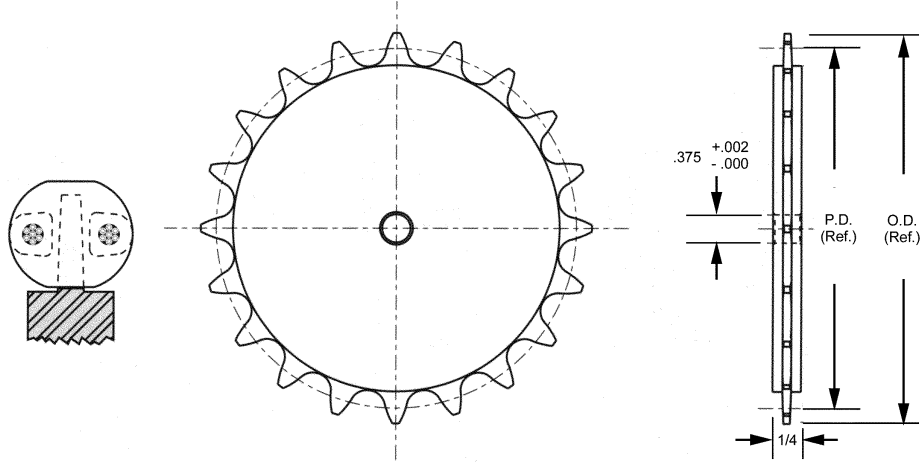

STOCK NO.	NO. OF TEETH	PITCH DIA.	OUTSIDE DIA.
7CF77A-8	8*	1.2800	1.529
7CF77A-9	9*	1.4400	1.689
7CF77A-10	10*	1.6000	1.850
7CF77A-11	11*	1.7600	2.009
7CF77A-12	12	1.9200	2.169
7CF77A-13	13	2.0800	2.330
7CF77A-14	14	2.2400	2.490
7CF77A-15	15	2.4000	2.650
7CF77A-16	16	2.5600	2.809
7CF77A-18	18	2.8800	3.129
7CF77A-20	20	3.2000	3.450
7CF77A-22	22	3.5000	3.769
7CF77A-24	24	3.8400	4.089
7CF77A-25	25	4.0000	4.250
7CF77A-28	28	4.4800	4.730
7CF77A-30	30	4.8000	5.050
7CF77A-32	32	5.1200	5.369
7CF77A-34	34	5.4400	5.689
7CF77A-36	36	5.7600	6.009
7CF77A-38	38	6.0800	6.330

* Sprockets with 1.760 P.D. and smaller are recommended for idler use only.

Other numbers of teeth available on request.

Teeth could be anodized.

CHAIN SPROCKETS

CIR. PITCH	BORE	STYLE	MATERIALS	BERG'S® NAME	CHAIN
.500	1/4"	PIN HUB	2024-T4 Aluminum Anodized	Flex-E-Pitch®	Operates with 7CCF Series

STOCK NO.	NO. OF TEETH	PITCH DIA.	OUTSIDE DIA.
7CP66A-8	8*	1.2800	1.529
7CP66A-9	9*	1.4400	1.689
7CP66A-10	10*	1.6000	1.850
7CP66A-11	11*	1.7600	2.009
7CP66A-12	12	1.9200	2.169
7CP66A-13	13	2.0800	2.330
7CP66A-14	14	2.2400	2.490
7CP66A-15	15	2.4000	2.650
7CP66A-16	16	2.5600	2.809
7CP66A-18	18	2.8800	3.129
7CP66A-20	20	3.2000	3.450
7CP66A-22	22	3.5000	3.769
7CP66A-24	24	3.8400	4.089
7CP66A-25	25	4.0000	4.250
7CP66A-28	28	4.4800	4.730
7CP66A-30	30	4.8000	5.050
7CP66A-32	32	5.1200	5.369
7CP66A-34	34	5.4400	5.689
7CP66A-36	36	5.7600	6.009
7CP66A-38	38	6.0800	6.330

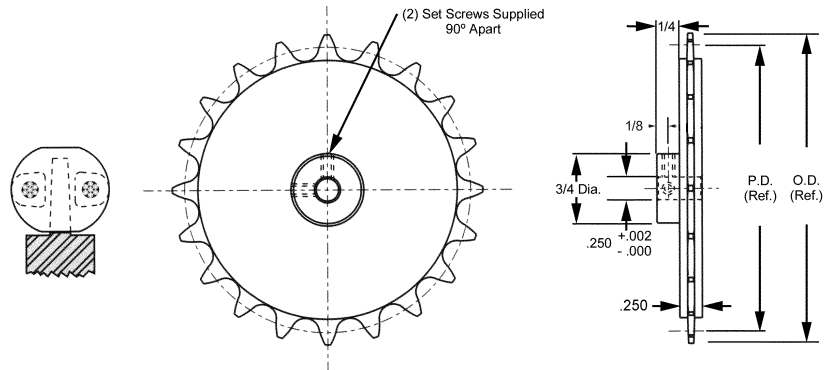

Teeth could be anodized.

* Sprockets with 1.760 P.D. and smaller are recommended for idler use only. Other numbers of teeth available on request.

CIR. PITCH	BORE	STYLE	MATERIALS	BERG'S® NAME	CHAIN
.500	3/8"	PIN HUB	2024-T4 Aluminum Anodized	Flex-E-Pitch®	Operates with 7CCF Series

STOCK NO.	NO. OF TEETH	PITCH DIA.	OUTSIDE DIA.
7CP67A-8	8*	1.2800	1.529
7CP67A-9	9*	1.4400	1.689
7CP67A-10	10*	1.6000	1.850
7CP67A-11	11*	1.7600	2.009
7CP67A-12	12	1.9200	2.169
7CP67A-13	13	2.0800	2.330
7CP67A-14	14	2.2400	2.490
7CP67A-15	15	2.4000	2.650
7CP67A-16	16	2.5600	2.809
7CP67A-18	18	2.8800	3.129
7CP67A-20	20	3.2000	3.450
7CP67A-22	22	3.5000	3.769
7CP67A-24	24	3.8400	4.089
7CP67A-25	25	4.0000	4.250
7CP67A-28	28	4.4800	4.730
7CP67A-30	30	4.8000	5.050
7CP67A-32	32	5.1200	5.369
7CP67A-34	34	5.4400	5.689
7CP67A-36	36	5.7600	6.009
7CP67A-38	38	6.0800	6.330

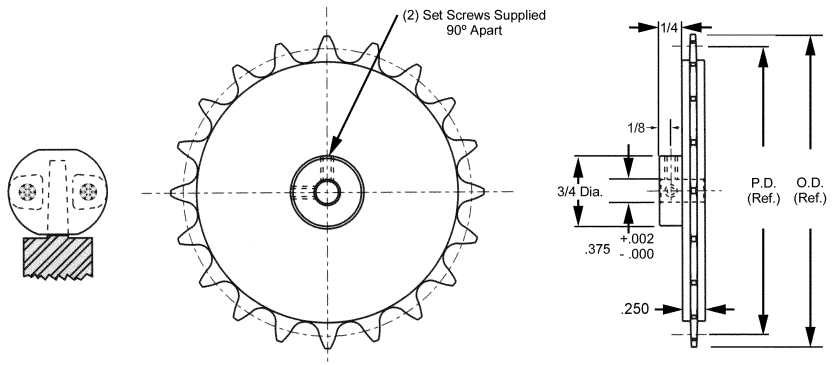

Teeth could be anodized.

* Sprockets with 1.760 P.D. and smaller are recommended for idler use only. Other numbers of teeth available on request.

CIR. PITCH	BORE	STYLE	MATERIALS	BERG'S® NAME	CHAIN
.500	1/2"	PIN HUB	2024-T4 Aluminum Anodized	Flex-E-Pitch®	Operates with 7CCF Series

STOCK NO.	NO. OF TEETH	PITCH DIA.	OUTSIDE DIA.
7CP68A-8	8*	1.2800	1.529
7CP68A-9	9*	1.4400	1.689
7CP68A-10	10*	1.6000	1.850
7CP68A-11	11*	1.7600	2.009
7CP68A-12	12	1.9200	2.169
7CP68A-13	13	2.0800	2.330
7CP68A-14	14	2.2400	2.490
7CP68A-15	15	2.4000	2.650
7CP68A-16	16	2.5600	2.809
7CP68A-18	18	2.8800	3.129
7CP68A-20	20	3.2000	3.450
7CP68A-22	22	3.5000	3.769
7CP68A-24	24	3.8400	4.089
7CP68A-25	25	4.0000	4.250
7CP68A-28	28	4.4800	4.730
7CP68A-30	30	4.8000	5.050
7CP68A-32	32	5.1200	5.369
7CP68A-34	34	5.4400	5.689
7CP68A-36	36	5.7600	6.009
7CP68A-38	38	6.0800	6.330

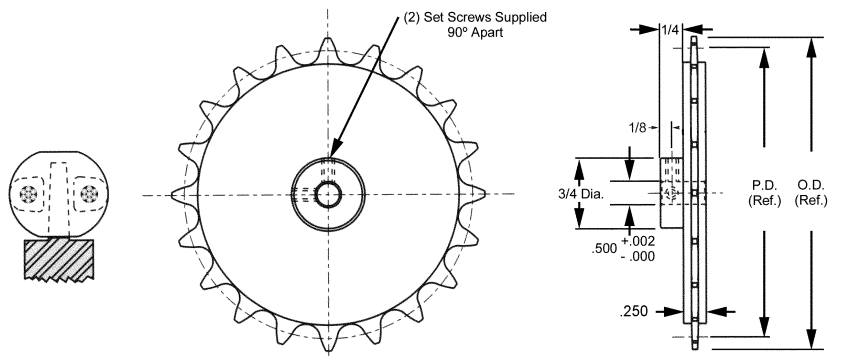

Teeth could be anodized.

* Sprockets with 1.760 P.D. and smaller are recommended for idler use only. Other numbers of teeth available on request.

FIELD SPLICE KITS

Splicing Procedures:

1. Cut "BERG" *FLEX-E-PITCH*® sharp and square as shown, using cutter, to desired number of pitches, plus one pitch.

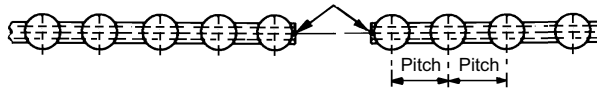

2. Cut plastic jacket (one pitch each side) lightly, with a sharp razor blade, as shown (all around). Caution: do not nick cable. Strip or twist off jacket carefully.

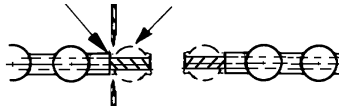

3. Slide stripped cable into oval splice bushing carefully. **Caution:** Do not fray cable. Feed cable into chamfered end of bushing last.

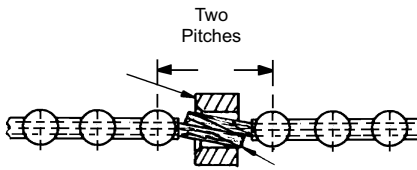

4. Center bushing and be certain chain is straight before crimping.

5. Position crimp tool over splice bushing and squeeze tightly for maximum splice strength.

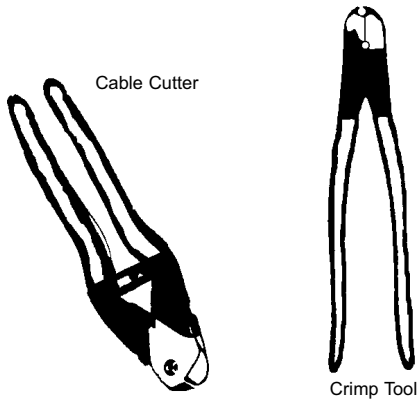
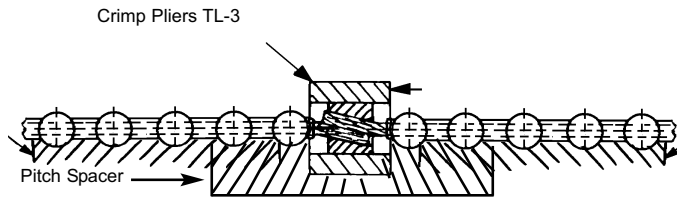

CHAIN SERIES	STOCK NO.	FIELD SPLICE KIT AND ACCESSORIES
14CCF 25CCF 35CCF 7CCF	14CCF-7 25CCF-7 35CCF-7 7CCF-7	Complete Kit Consists of: Crimp tool, Pitch Spacer, Sample Chain Cable cutter, Bushings, Razor Blades & Instructions
	TL-3 TL-7	Crimp Tool For 14CCF,25CCF,35CCF Crimp Tool 7CCF
	BU-032-S BU-046-S BU-062-S	Extra Splice Bushings for: 14CCF & 25CCF (1/32" Cable) 35CCF (3/64" Cable) 7CCF (1/16" Cable)
	TL-1 TL-2	Cable Cutter for up to 3/64" Cable Cable Cutter for 7CCF (1/16" Cable)
	TL-9	7CCF Pitch Space Fixture

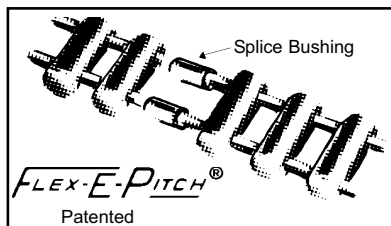

**Field Splices Offer Only
50% of Catalog Rated Loads**

AIRCRAFT CABLE

STYLE	MATERIALS	NOTE
PLAIN, UNJACKETED CABLE	302 STAINLESS STEEL	COMPLIES WITH MILITARY SPECIFICATION

Typical 7x19 Construction

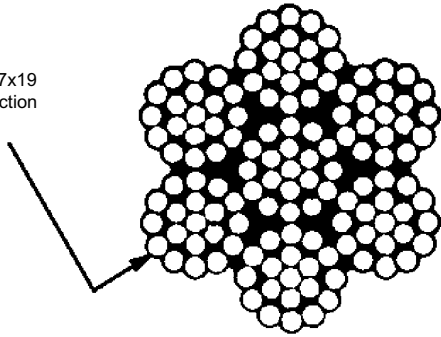

STOCK NO.	CABLE CONST.	CABLE DIA.	CABLE LENGTH (FT.)	TENSILE STRENGTH (MIN. LBS.)
AB018-25FT	7X7	1/64	25	40
AB018-50FT	7X7	1/64	50	40
AB018-100FT	7X7	1/64	100	40
AB032-25FT	7X7	1/32	25	120
AB032-50FT	7X7	1/32	50	120
AB032-100FT	7X7	1/32	100	120
AB033-25FT	7X19	1/32	25	120
AB033-50FT	7X19	1/32	50	120
AB033-100FT	7X19	1/32	100	120
AB046-25FT	7X7	3/64	25	270
AB046-50FT	7X7	3/64	50	270
AB046-100FT	7X7	3/64	100	270
AB062-25FT	7X19	1/16	25	480
AB062-50FT	7X19	1/16	50	480
AB062-100FT	7X19	1/16	100	480
AB078-25FT	7X19	5/64	50	560
AB078-50FT	7X19	5/64	50	560
AB078-100FT	7X19	5/64	100	560
AB092-25FT	7X19	3/32	25	960
AB092-50FT	7X19	3/32	50	960
AB092-100FT	7X19	3/32	100	960
AB125-25FT	7X19	1/8	25	1760
AB125-50FT	7X19	1/8	50	1760
AB125-100FT	7X19	1/8	100	1760
AB156-25FT	7X19	5/32	25	2400
AB156-50FT	7X19	5/32	50	2400
AB156-100FT	7X19	5/32	100	2400

Stainless Steel Aircraft Cable is available in additional diameters and lengths.

STYLE	MATERIALS	NOTE
NYLON JACKET CABLE	302 STAINLESS STEEL	COMPLIES WITH MILITARY SPECIFICATION

Typical 7x19 Construction

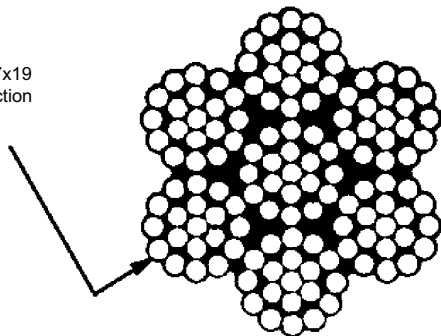

STOCK NO.	CABLE CONST.	JACKET DIA.	CABLE DIA.	CABLE LENGTH (LT.)	TENSILE STRENGTH (MIN. LBS.)
AB046N-25FT	7X7	1/16	3/64	25	270
AB046N-50FT	7X7	1/16	3/64	50	270
AB046N-100FT	7X7	1/16	3/64	100	270
AB062N-25FT	7X7	1/8	1/16	25	480
AB062N-50FT	7X7	1/8	1/16	50	480
AB062N-100FT	7X7	1/8	1/16	100	480
AB092N-25FT	7X7	3/16	3/32	25	960
AB092N-50FT	7X7	3/16	3/32	50	960
AB092N-100FT	7X7	3/16	3/32	100	960
AB125N-25FT	7X19	3/16	1/8	25	1760
AB125N-50FT	7X19	3/16	1/8	50	1760
AB125N-100FT	7X19	3/16	1/8	100	1760

Stainless Steel Aircraft Cable is available in additional diameters and lengths.

BERG FIBER CABLE

STYLE	MATERIALS	NOTE
1/64" TO 3/16" DIAMETER	ARAMID FILAMENT STRANDED	AVAILABLE IN ADDITIONAL DIAMETERS AND LENGTHS

BERG-FIBER CABLE is a continuous stranded Fiber Filament using a new Aramid Fiber. The combined multiple strands, which operate as one single working member, can now flex around much smaller pulley diameters than conventional steel cable, thus offering longer life spans as compared to steel cable. The impregnating of the flexible strands with a proprietary flexible coating serves to provide excellent resistance to self abrasion by providing a barrier between adjacent fine fiber filaments. This coating keeps all the fine filament strands together so that when the cable is cut it does not open and unwind.

BERG-FIBER CABLE has strength to weight ratio approximately (4) times higher than steel in air, and (25) times higher in water in the same given diameter, it has a high modulus of elasticity and low elongation making this cable an ideal tensile member in electro-mechanical cables and cable assemblies in addition, electrical properties and environmental resistance are excellent.

STOCK NO.	CABLE DIA.	CABLE LENGTH (FT.)	TENSILE STRENGTH (MIN. LBS.)	MINIMUM PULLEY DIA.
AA018-25FT	1/64	25	20	5/16
AA018-50FT	1/64	50	20	5/16
AA018-100FT	1/64	100	20	5/16
AA034-25FT	1/32	25	50	7/16
AA034-50FT	1/32	50	50	7/16
AA034-100FT	1/32	100	50	7/16
AA048-25FT	3/64	25	75	3/4
AA048-50FT	3/64	50	75	3/4
AA048-100FT	3/64	100	75	3/4
AA070-25FT	1/16	25	150	1-1/2
AA070-50FT	1/16	50	150	1-1/2
AA070-100FT	1/16	100	150	1-1/2
AA080-25FT	5/64	25	250	1-3/4
AA080-50FT	5/64	50	250	1-3/4
AA080-100FT	5/64	100	250	1-3/4
AA093-25FT	3/32	25	450	2"
AA093-50FT	3/32	50	450	2"
AA093-100FT	3/32	100	450	2"



Stainless Steel Aircraft Cable and Berg Fiber Cable are available in additional diameters and lengths.

CABLE THIMBLES

STYLE	MATERIALS
1/64" TO 3/16" CABLE DIAMETER	STAINLESS STEEL

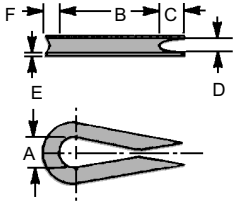

STOCK NO.	CABLE DIAMETERS	A	B	C	D	E	F
TH-032-S	.015-.046	.188	1/4	1/8	1/8	.015	3/64
TH-062-S	.046-.078	.350	43/64	3/16	3/32	.032	5/64
TH-092-S	.092-.125	.350	45/64	7/32	9/64	.032	5/64
TH-156-S	.156	.400	51/64	7/32	11/64	.032	7/64
TH-187-S	.187	.500	1"	5/16	13/64	.032	11/64



Some thimbles may have open end and/or uneven ends.

CABLE CRIMP BUSHINGS

STYLE	MATERIALS
1/64" TO 3/16" CABLE DIAMETER	AVAILABLE IN COPPER, BRASS AND STAINLESS STEEL

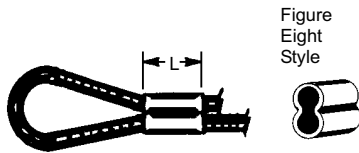

Brass and Copper

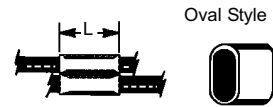

Oval Style

Stainless Steel

COPPER (C) & BRASS (B) CRIMP BUSHINGS		
BUSHING STOCK NO.	L*	Use With Bushing Crimp Tool**
BU-018-B	1/4	TL-10
BU-032-C	9/32	TL-10
BU-046-C	7/16	TL-10
BU-062-C	1/4	TL-10
BU-093-C	1/2	TL-11
BU-125-C	3/4	TL-11
BU-156-C	7/8	TL-11
BU-187-C	1-1/4	TL-11

STAINLESS STEEL CRIMP BUSHINGS		
BUSHING STOCK NO.	L*	Use With Bushing Crimp Tool**
BU-018-S	1/32	TL-4
BU-032-S	3/64	TL-3
BU-046-S	1/8	TL-3
BU-062-S	3/16	TL-7

CABLE DIA.
1/64
1/32
3/64
1/16
3/32
1/8
5/32
3/16



Copper Bushings are zinc plated.
BU-093-C can be used for 5/64 Cable
* Dimensions apply after crimping.

CABLE CRIMP TOOL

Note
See above for information on Cable Crimp Bushings mentioned below.



CRIMP TOOL STOCK NO.	Use With Bushing Stock Number(s)
TL-10	BU-018-B, BU-032-C, BU-046-C and BU 062-C
TL-11	BU-093-C, BU-125-C, BU-156-C and BU-187-C
TL-4	BU-018-S
TL-3	BU-032-S and Bu-046-S
TL-7	BU-062-S

ROW-L-ER® CHAIN TECHNICAL DATA

Operating Notes:

ROW-L-ER Chain offers no slippage due to the positive drive between chain and tooth. This series will also have negligible stretch, long life, and the ability to operate in many different hostile environments such as high temperature, high moisture, high dust or dirty areas, and corrosive atmospheres.

CIRCULAR PITCH	ROLLER DIAMETER	MATERIAL	SPROCKET
.1475	.090	Stainless Steel, Non-Magnetic, Prestretched Single Strand	Operates with 14EM and 14SP series.

.1475 Pitch Series

- Ultimate tensile 180 lbs. - Max. operating load 20lbs.
- .035lbs/ft - Must be lubricated

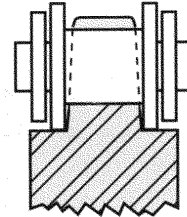

CIRCULAR PITCH	ROLLER DIAMETER	MATERIAL	SPROCKET
.250	.130	Stainless Steel or Mild Steel Single Strand, Delrin and Nylatron	Operates with 25EM and 25SP series.

.250 Pitch Series American Standard No. 25

- Ultimate tensile 700 lbs., for Stainless Steel - Max. operating load 77lbs.
875 lbs., for Mild Steel - Max. operating load 97lbs.
63lbs., for Delrin - Max. operating load 21lbs.
65lbs., for Nylatron - Max. operating load 22lbs.

- .09lbs/ft - Must be lubricated (Applies to steel chain only)

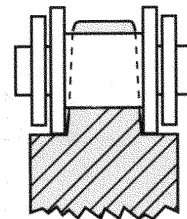

CIRCULAR PITCH	ROLLER DIAMETER	MATERIAL	SPROCKET
.375	.200	Stainless Steel or Mild Steel Single Strand, Delrin and Nylatron	Operates with 35EM and 35SP series.

.375 Pitch Series American Standard No. 35

- Ultimate tensile 1400 lbs., for Stainless Steel - Max. operating load 155lbs.
2100 lbs., for Mild Steel - Max. operating load 233lbs.
136lbs., for Delrin - Max. operating load 45lbs.
136lbs., for Nylatron - Max. operating load 45lbs.

- .22lbs/ft - Must be lubricated (Applies to steel chain only)

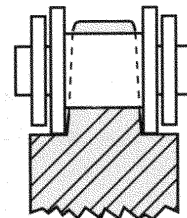

CIRCULAR PITCH	ROLLER DIAMETER	MATERIAL	SPROCKET
.500	.306 - Steel .313 - Plastic	Stainless Steel or Mild Steel Single Strand, Delrin and Nylatron	Operates with 41EM and 41SP series for steel. Operates with 40EM series for plastic.

.500 Pitch Series American Standard No. 41 - Steel, No. 40 - Plastic

- Ultimate tensile 1700 lbs., for Stainless Steel - Max. operating load 188lbs.
2400 lbs., for Mild Steel - Max. operating load 266lbs.
175lbs., for Delrin - Max. operating load 58lbs.
173lbs., for Nylatron - Max. operating load 57lbs.

- .32lbs/ft - Must be lubricated (Applies to steel chain only)

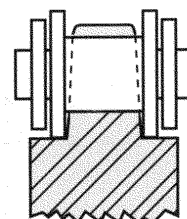

LINK CHAIN

CIRCULAR PITCH	ROLLER DIAMETER	BERG NAME	MATERIAL	SPROCKET
.1475	.090	ROW-L-ER®	Stainless Steel, Non-Magnetic, Prestretched Single Strand	Operates with 14EM and 14SP series.

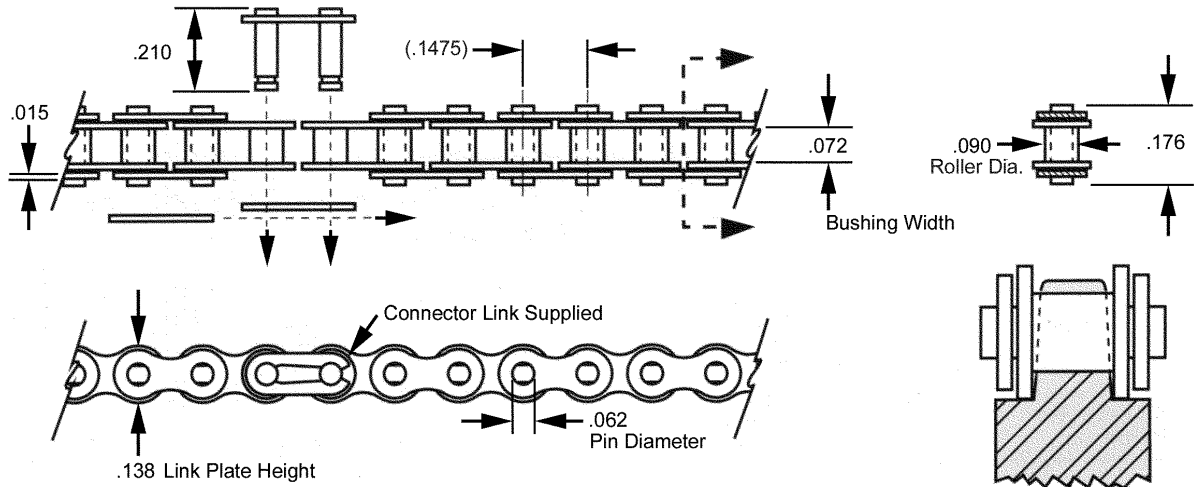

STOCK NO.	NO. OF PITCHES	LENGTH INCHES
RC14SS-40	40	5.900
RC14SS-50	50	7.375
RC14SS-60	60	8.850
RC14SS-70	70	10.325
RC14SS-80	80	11.800
RC14SS-90	90	13.275
RC14SS-100	100	14.750
RC14SS-110	110	16.225
RC14SS-120	120	17.700
RC14SS-130	130	19.175
RC14SS-140	140	20.650
RC14SS-150	150	22.125
RC14SS-160	160	23.600
RC14SS-170	170	25.075
RC14SS-180	180	26.550
RC14SS-190	190	28.025
RC14SS-200	200	29.500
RC14SS-210	210	30.975
RC14SS-220	220	32.450
RC14SS-230	230	33.925
RC14SS-240	240	35.400
RC14SS-250	250	36.875
RC14SS-260	260	38.350
RC14SS-270	270	39.825
RC14SS-280	280	41.300
RC14SS-290	290	42.775
RC14SS-300	300	44.250
RC14SS-310	310	45.725
RC14SS-320	320	47.200
RC14SS-330	330	48.675
RC14SS-340	340	50.150
RC14SS-350	350	51.625
RC14SS-360	360	53.100
RC14SS-370	370	54.575
RC14SS-380	380	56.050
RC14SS-390	390	57.524

* Maximum recommended operating load is for a slip fit connecting link, which is standard. A press fit connecting link is a special available on request.

Special lengths available on request (only even numbers of links).

Maximum recommended Operating Load = 20 lbs.*

Ultimate Tensile Strength = 180 lbs.

.035lbs/foot - Must be lubricated.

Use Connector Link Berg P/N RC14SS-CL.



STOCK NO.	LENGTH
RC14SS-5FT	5FT
RC14SS-10FT	10FT
RC14SS-25FT	25FT
RC14SS-50FT	50FT
RC14SS-100FT	100FT

SPROCKETS

CIR. PITCH	BORE	STYLE	MATERIALS	BERG'S ® NAME	CHAIN
.1475	1/4"	PIN HUB	Delrin®	ROW-L-ER®	Operates with RC14SS Series

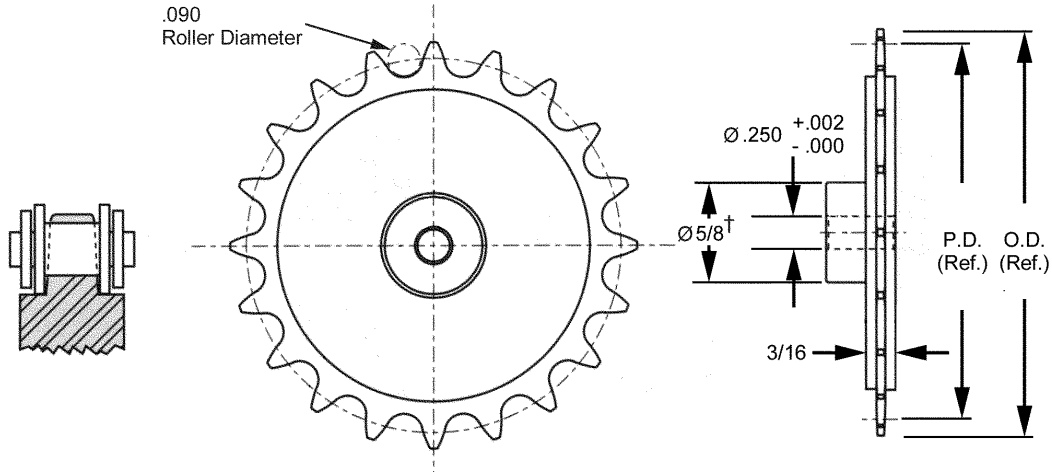

STOCK NO.	NO. OF TEETH	P.D.	O.D.
14EM4M-15	15†	.7094	.761
14EM4M-16	16†	.7561	.808
14EM4M-18	18†	.8494	.901
14EM4M-20	20	.9429	.994
14EM4M-22	22	1.0364	1.088
14EM4M-24	24	1.1300	1.182
14EM4M-26	26	1.2237	1.275
14EM4M-30	30	1.4111	1.463
14EM4M-32	32	1.5048	1.556
14EM4M-36	36	1.6924	1.744
14EM4M-40	40	1.8800	1.932
14EM4M-42	42	1.9738	2.025
14EM4M-44	44	2.0676	2.119
14EM4M-45	45	2.1145	2.166
14EM4M-50	50	2.3491	2.401
14EM4M-55	55	2.5837	2.635
14EM4M-60	60	2.8183	2.870



† Teeth runout on hub.
 Other Bore sizes and other numbers of teeth are available on request.

SPROCKETS

CIR. PITCH	BORE	STYLE	MATERIALS	BERG'S ® NAME	CHAIN
.1475	1/8"	PIN HUB	303 Stainless Steel Or 2024-T4 Aluminum Anodized	ROW-L-ER®	Operates with RC14SS Series

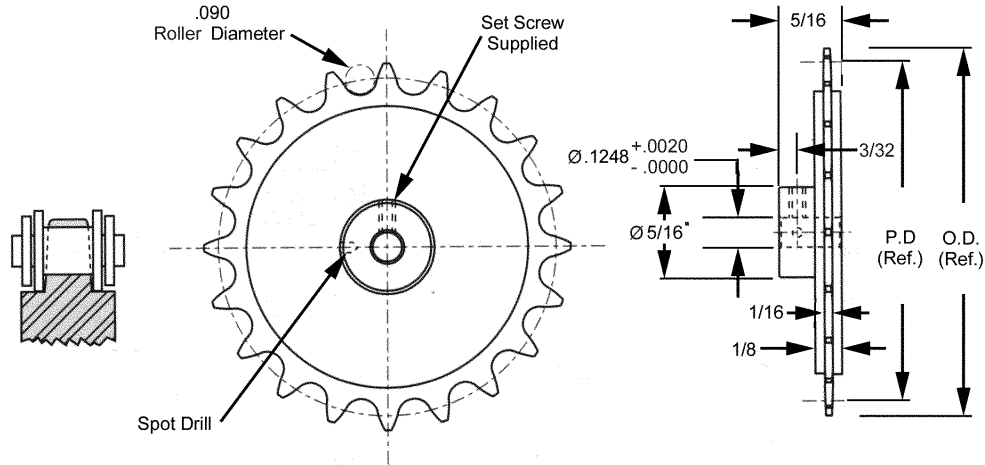

303 STAINLESS STEEL	2024T4 ALUMINUM ANODIZED			
STOCK NO.	STOCK NO.	NO. OF TEETH	PITCH DIA.	OUTSIDE DIA.
14EM10S-9	14EM10A-9	9*	.431	.483
14EM10S-10	14EM10A-10	10*	.477	.529
14EM10S-11	14EM10A-11	11	.524	.575
14EM10S-12	14EM10A-12	12	.570	.621
14EM10S-13	14EM10A-13	13	.616	.668
14EM10S-14	14EM10A-14	14	.663	.714
14EM10S-15	14EM10A-15	15	.709	.761
14EM10S-16	14EM10A-16	16	.756	.808
14EM10S-17	14EM10A-17	17	.803	.854
14EM10S-18	14EM10A-18	18	.849	.901
14EM10S-19	14EM10A-19	19	.896	.948
14EM10S-20	14EM10A-20	20	.943	.994
14EM10S-21	14EM10A-21	21	.990	1.041
14EM10S-22	14EM10A-22	22	1.036	1.088
14EM10S-23	14EM10A-23	23	1.083	1.135
14EM10S-24	14EM10A-24	24	1.130	1.182
14EM10S-25	14EM10A-25	25	1.177	1.228
14EM10S-26	14EM10A-26	26	1.224	1.275
14EM10S-27	14EM10A-27	27	1.271	1.322
14EM10S-28	14EM10A-28	28	1.317	1.369
14EM10S-29	14EM10A-29	29	1.364	1.416
14EM10S-30	14EM10A-30	30	1.411	1.463
14EM10S-31	14EM10A-31	31	1.458	1.510
14EM10S-32	14EM10A-32	32	1.505	1.556
14EM10S-33	14EM10A-33	33	1.552	1.603
14EM10S-34	14EM10A-34	34	1.599	1.650
14EM10S-35	14EM10A-35	35	1.646	1.697
14EM10S-36	14EM10A-36	36	1.692	1.744



• For 9-10 teeth, hub diameter equals .23.
Other Bore sizes and other numbers of teeth are available on request.

Teeth could be anodized.

SPROCKETS

CIR. PITCH	BORE	STYLE	MATERIALS	BERG'S ® NAME	CHAIN
.1475	3/16"	PIN HUB	303 Stainless Steel Or 2024-T4 Aluminum Anodized	ROW-L-ER®	Operates with RC14SS Series

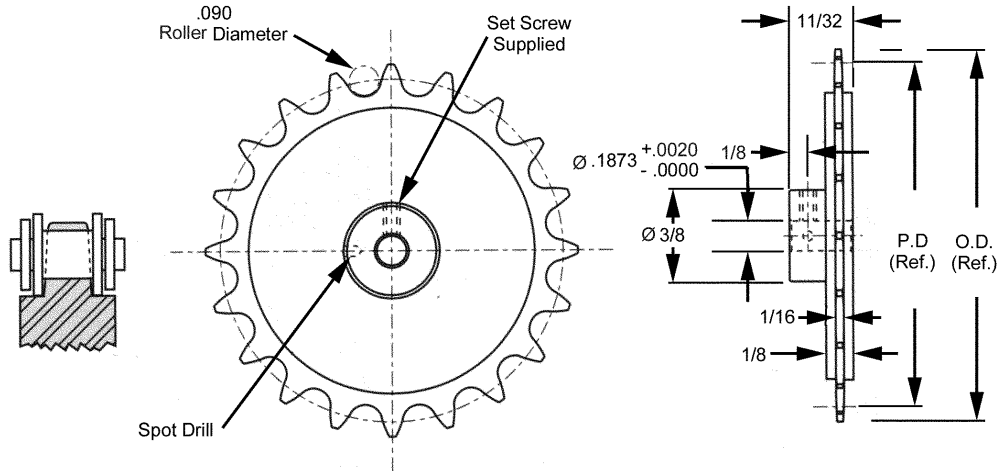

303 STAINLESS STEEL	2024T4 ALUMINUM ANODIZED			
STOCK NO.	STOCK NO.	NO. OF TEETH	PITCH DIA.	OUTSIDE DIA.
14EM19S-12	14EM19A-12	12	.570	.621
14EM19S-13	14EM19A-13	13	.616	.668
14EM19S-14	14EM19A-14	14	.663	.714
14EM19S-15	14EM19A-15	15	.709	.761
14EM19S-16	14EM19A-16	16	.756	.808
14EM19S-17	14EM19A-17	17	.803	.854
14EM19S-18	14EM19A-18	18	.849	.901
14EM19S-19	14EM19A-19	19	.896	.948
14EM19S-20	14EM19A-20	20	.943	.994
14EM19S-21	14EM19A-21	21	.990	1.041
14EM19S-22	14EM19A-22	22	1.036	1.088
14EM19S-23	14EM19A-23	23	1.083	1.135
14EM19S-24	14EM19A-24	24	1.130	1.182
14EM19S-25	14EM19A-25	25	1.177	1.228
14EM19S-26	14EM19A-26	26	1.224	1.275
14EM19S-27	14EM19A-27	27	1.271	1.322
14EM19S-28	14EM19A-28	28	1.317	1.369
14EM19S-29	14EM19A-29	29	1.364	1.416
14EM19S-30	14EM19A-30	30	1.411	1.463
14EM19S-31	14EM19A-31	31	1.458	1.510
14EM19S-32	14EM19A-32	32	1.505	1.556
14EM19S-33	14EM19A-33	33	1.552	1.603
14EM19S-34	14EM19A-34	34	1.599	1.650
14EM19S-35	14EM19A-35	35	1.646	1.697
14EM19S-36	14EM19A-36	36	1.692	1.744
14EM19S-38	14EM19A-38	38	1.786	1.838



Other Bore sizes and other numbers of teeth are available on request.

Teeth could be anodized.

SPROCKETS

CIR. PITCH	BORE	STYLE	MATERIALS	BERG'S® NAME	CHAIN
.1475	1/4"	PIN HUB	303 Stainless Steel Or 2024-T4 Aluminum Anodized	ROW-L-ER®	Operates with RC14SS Series

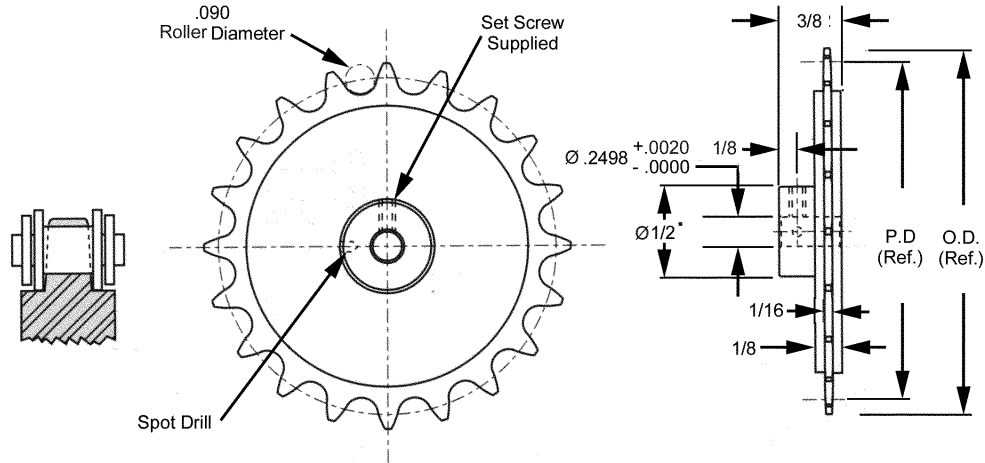

303 STAINLESS STEEL	2024T4 ALUMINUM ANODIZED			
STOCK NO.	STOCK NO.	NO. OF TEETH	PITCH DIA.	OUTSIDE DIA.
14EM26S-14	14EM26A-14	14*	.663	.714
14EM26S-15	14EM26A-15	15	.709	.761
14EM26S-16	14EM26A-16	16	.756	.808
14EM26S-17	14EM26A-17	17	.803	.854
14EM26S-18	14EM26A-18	18	.849	.901
14EM26S-19	14EM26A-19	19	.896	.948
14EM26S-20	14EM26A-20	20	.943	.994
14EM26S-21	14EM26A-21	21	.990	1.041
14EM26S-22	14EM26A-22	22	1.036	1.088
14EM26S-23	14EM26A-23	23	1.083	1.135
14EM26S-24	14EM26A-24	24	1.130	1.182
14EM26S-25	14EM26A-25	25	1.177	1.228
14EM26S-26	14EM26A-26	26	1.224	1.275
14EM26S-27	14EM26A-27	27	1.271	1.322
14EM26S-28	14EM26A-28	28	1.317	1.369
14EM26S-29	14EM26A-29	29	1.364	1.416
14EM26S-30	14EM26A-30	30	1.411	1.463
14EM26S-31	14EM26A-31	31	1.458	1.510
14EM26S-32	14EM26A-32	32	1.505	1.556
14EM26S-33	14EM26A-33	33	1.552	1.603
14EM26S-34	14EM26A-34	34	1.599	1.650
14EM26S-35	14EM26A-35	35	1.646	1.697
14EM26S-36	14EM26A-36	36	1.692	1.744
14EM26S-38	14EM26A-38	38	1.786	1.838
14EM26S-40	14EM26A-40	40	1.880	1.932
14EM26S-42	14EM26A-42	42	1.974	2.025
14EM26S-44	14EM26A-44	44	2.068	2.119



• For 14 teeth, hub diameter equals .47.
Other Bore sizes and other numbers of teeth are available on request.

Teeth could be anodized.

SPROCKETS

CIR. PITCH	BORE	STYLE	MATERIALS	BERG'S ® NAME	CHAIN
.1475	5/16"	PIN HUB	303 Stainless Steel Or 2024-T4 Aluminum Anodized	ROW-L-ER®	Operates with RC14SS Series

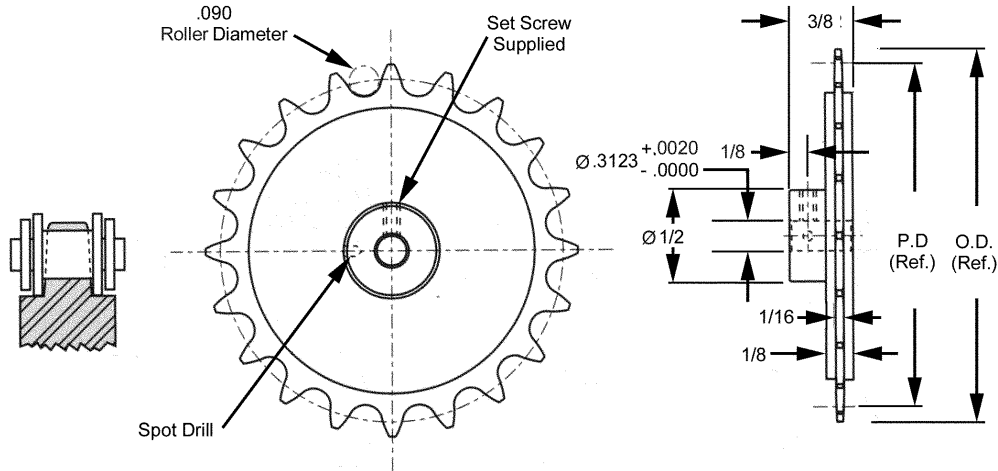

303 STAINLESS STEEL	2024T4 ALUMINUM ANODIZED			
STOCK NO.	STOCK NO.	NO. OF TEETH	PITCH DIA.	OUTSIDE DIA.
14EM31S-15	14EM31A-15	15	.709	.761
14EM31S-16	14EM31A-16	16	.756	.808
14EM31S-17	14EM31A-17	17	.803	.854
14EM31S-18	14EM31A-18	18	.849	.901
14EM31S-19	14EM31A-19	19	.896	.948
14EM31S-20	14EM31A-20	20	.943	.994
14EM31S-21	14EM31A-21	21	.990	1.041
14EM31S-22	14EM31A-22	22	1.036	1.088
14EM31S-23	14EM31A-23	23	1.083	1.135
14EM31S-24	14EM31A-24	24	1.130	1.182
14EM31S-25	14EM31A-25	25	1.177	1.228
14EM31S-26	14EM31A-26	26	1.224	1.275
14EM31S-27	14EM31A-27	27	1.271	1.322
14EM31S-28	14EM31A-28	28	1.317	1.369
14EM31S-29	14EM31A-29	29	1.364	1.416
14EM31S-30	14EM31A-30	30	1.411	1.463
14EM31S-31	14EM31A-31	31	1.458	1.510
14EM31S-32	14EM31A-32	32	1.505	1.556
14EM31S-33	14EM31A-33	33	1.552	1.603
14EM31S-34	14EM31A-34	34	1.599	1.650
14EM31S-35	14EM31A-35	35	1.646	1.679
14EM31S-36	14EM31A-36	36	1.692	1.744
14EM31S-38	14EM31A-38	38	1.786	1.838
14EM31S-40	14EM31A-40	40	1.880	1.932
14EM31S-42	14EM31A-42	42	1.974	2.025
14EM31S-44	14EM31A-44	44	2.068	2.119



Other Bore sizes and other numbers of teeth are available on request.
Teeth could be anodized.

SPROCKETS

CIR. PITCH	BORE	STYLE	MATERIALS	BERG'S ® NAME	CHAIN
.1475	3/32"	PIN HUB	303 Stainless Steel	ROW-L-ER®	Operates with RC14SS Series

STOCK NO.	B BORE	H (Inch)	OVERALL LENGTH	SET SCREW	NO. OF TEETH	PITCH DIA.	OUTSIDE DIA.
14EM95S-7	.094	15/64	11/32	NONE	7*	.340	.391

* Hub is grooved 3/32" wide next to hub to provide clearance for chain link.
 • Sprockets smaller than 10 teeth are recommended for idler use only.
 Note: Undercut: 7 Teeth D = .142

CIR. PITCH	BORE	STYLE	MATERIALS	BERG'S ® NAME	CHAIN
.1475	1/8"	PIN HUB	303 Stainless Steel	ROW-L-ER®	Operates with RC14SS Series

STOCK NO.	B BORE	H (Inch)	OVERALL LENGTH	SET SCREW	NO. OF TEETH	PITCH DIA.	OUTSIDE DIA.
14EM95S-8	.125	9/32	11/32	#2-56	8*	.385	.437
14EM95S-9		21/64			9*	.431	.483
14EM95S-10		3/8			10*	.477	.529
14EM95S-11		3/8			11*	.524	.575
14EM95S-12		25/64			12	.570	.621
14EM95S-13		25/64			13	.616	.668
14EM95S-14		25/64			14	.663	.714

* Hub is grooved 3/32" wide next to hub to provide clearance for chain link.
 • Sprockets smaller than 10 teeth are recommended for idler use only.
 Note: Undercut: 8 Teeth D = .187
 9 Teeth D = .233
 10 Teeth D = .279
 11 Teeth D = .326

CIR. PITCH	BORE	STYLE	MATERIALS	BERG'S ® NAME	CHAIN
.1475	3/16"	PIN HUB	303 Stainless Steel	ROW-L-ER®	Operates with RC14SS Series

STOCK NO.	B BORE	H (Inch)	OVERALL LENGTH	SET SCREW	NO. OF TEETH	PITCH DIA.	OUTSIDE DIA.
14EM95S-15	.188	17/32	11/32	#4-40	15	.709	.761
14EM95S-16		9/16			16	.756	.808
14EM95S-18		21/32			18	.849	.901
14EM95S-20		3/4			20	.943	.994

CIR. PITCH	BORE	STYLE	MATERIALS	BERG'S ® NAME	CHAIN
.1475	1/4"	PIN HUB	303 Stainless Steel	ROW-L-ER®	Operates with RC14SS Series

STOCK NO.	B BORE	H (Inch)	OVERALL LENGTH	SET SCREW	NO. OF TEETH	PITCH DIA.	OUTSIDE DIA.
14EM95S-22	.250	3/4	13/32	#6-32	22	1.036	1.088
14EM95S-24					24	1.130	1.182
14EM95S-28					28	1.317	1.369
14EM95S-30					30	1.411	1.463
14EM95S-34					34	1.599	1.650
14EM95S-36					36	1.692	1.744
14EM95S-40					40	1.880	1.932
14EM95S-48					48	2.255	2.307

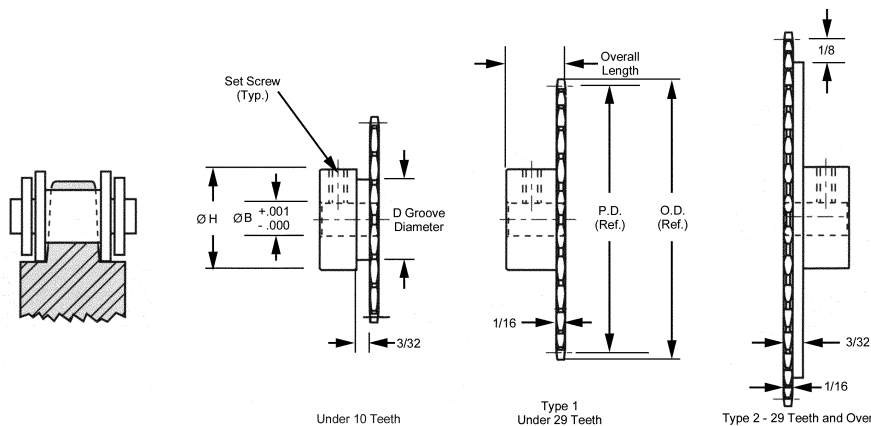

SPROCKETS

A

CIR. PITCH	BORE	STYLE	MATERIALS	BERG'S ® NAME	CHAIN
.1475	3/8"	HUBLESS	303 Stainless Steel Or 2024-T4 Aluminum Anodized	ROW-L-ER®	Operates with RC14SS Series

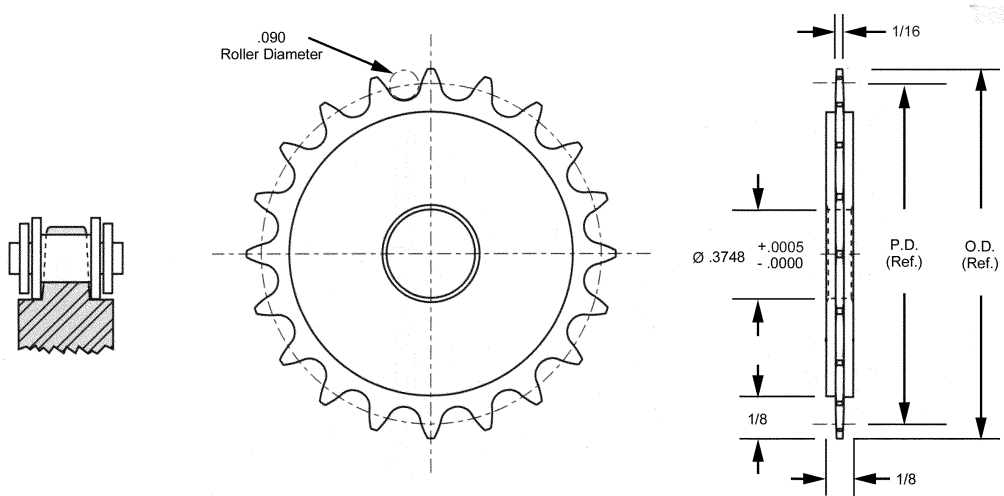

303 STAINLESS STEEL	2024T-4 ALUMINUM ANODIZED			
STOCK NO.	STOCK NO.	NO. OF TEETH	PITCH DIA.	OUTSIDE DIA.
14SP3S-14	14SP3A-14	14	.6629	.715
14SP3S-15	14SP3A-15	15	.7094	.761
14SP3S-16	14SP3A-16	16	.7561	.808
14SP3S-18	14SP3A-18	18	.8494	.901
14SP3S-20	14SP3A-20	20	.9429	.995
14SP3S-24	14SP3A-24	24	1.1300	1.182
14SP3S-25	14SP3A-25	25	1.1769	1.228
14SP3S-27	14SP3A-27	27	1.2705	1.322
14SP3S-28	14SP3A-28	28	1.3174	1.369
14SP3S-29	14SP3A-29	29	1.3642	1.416
14SP3S-30	14SP3A-30	30	1.4111	1.463
14SP3S-31	14SP3A-31	31	1.4580	1.510
14SP3S-32	14SP3A-32	32	1.5048	1.557
14SP3S-33	14SP3A-33	33	1.5517	1.604
14SP3S-34	14SP3A-34	34	1.5986	1.650
14SP3S-35	14SP3A-35	35	1.6455	1.697
14SP3S-36	14SP3A-36	36	1.6924	1.744
14SP3S-38	14SP3A-38	38	1.7862	1.838
14SP3S-40	14SP3A-40	40	1.8800	1.932
14SP3S-42	14SP3A-42	42	1.9738	2.026
14SP3S-44	14SP3A-44	44	2.0676	2.120
14SP3S-45	14SP3A-45	45	2.1145	2.166
14SP3S-48	14SP3A-48	48	2.2552	2.307
14SP3S-50	14SP3A-50	50	2.3491	2.401
14SP3S-52	14SP3A-52	52	2.4429	2.495
14SP3S-54	14SP3A-54	54	2.5368	2.589
14SP3S-55	14SP3A-55	55	2.5837	2.636
14SP3S-56	14SP3A-56	56	2.6306	2.683
14SP3S-60	14SP3A-60	60	2.8183	2.870
14SP3S-65	14SP3A-65	65	3.0530	3.105
14SP3S-70	14SP3A-70	70	3.2877	3.340
14SP3S-72	14SP3A-72	72	3.3815	3.434
14SP3S-75	14SP3A-75	75	3.5223	3.574
14SP3S-80	14SP3A-80	80	3.7570	3.809
14SP3S-85	14SP3A-85	85	3.9917	4.044



Available in Nylon or Phenolic upon request.
Other numbers of teeth available on request.
Teeth could be anodized.

SPROCKETS

CIR. PITCH	BORE	STYLE	MATERIALS	BERG'S ® NAME	CHAIN
.1475	11/16"	HUBLESS	303 Stainless Steel Or 2024T-4 Aluminum Anodized	ROW-L-ER®	Operates with RC14SS Series

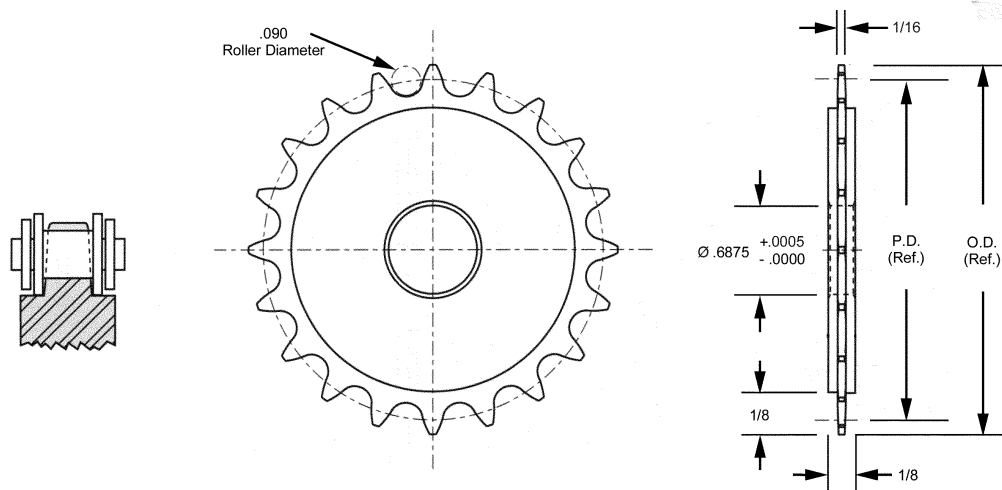

303 STAINLESS STEEL	2024T-4 ALUMINUM ANODIZED			
STOCK NO.	STOCK NO.	NO. OF TEETH	PITCH DIA.	OUTSIDE DIA.
14SP17S-14	14SP17A-14	14	.6629	.715
14SP17S-15	14SP17A-15	15	.7094	.761
14SP17S-16	14SP17A-16	16	.7561	.808
14SP17S-18	14SP17A-18	18	.8494	.901
14SP17S-20	14SP17A-20	20	.9429	.995
14SP17S-24	14SP17A-24	24	1.1300	1.182
14SP17S-25	14SP17A-25	25	1.1769	1.228
14SP17S-27	14SP17A-27	27	1.2705	1.322
14SP17S-28	14SP17A-28	28	1.3174	1.369
14SP17S-29	14SP17A-29	29	1.3642	1.416
14SP17S-30	14SP17A-30	30	1.4111	1.463
14SP17S-31	14SP17A-31	31	1.4580	1.510
14SP17S-32	14SP17A-32	32	1.5048	1.557
14SP17S-33	14SP17A-33	33	1.5517	1.604
14SP17S-34	14SP17A-34	34	1.5986	1.650
14SP17S-35	14SP17A-35	35	1.6455	1.697
14SP17S-36	14SP17A-36	36	1.6924	1.744
14SP17S-38	14SP17A-38	38	1.7862	1.838
14SP17S-40	14SP17A-40	40	1.8800	1.932
14SP17S-42	14SP17A-42	42	1.9738	2.026
14SP17S-44	14SP17A-44	44	2.0676	2.120
14SP17S-45	14SP17A-45	45	2.1145	2.166
14SP17S-48	14SP17A-48	48	2.2552	2.307
14SP17S-50	14SP17A-50	50	2.3491	2.401
14SP17S-52	14SP17A-52	52	2.4429	2.495
14SP17S-54	14SP17A-54	54	2.5368	2.589
14SP17S-55	14SP17A-55	55	2.5837	2.636
14SP17S-56	14SP17A-56	56	2.6306	2.683
14SP17S-60	14SP17A-60	60	2.8183	2.870
14SP17S-65	14SP17A-65	65	3.0530	3.105
14SP17S-70	14SP17A-70	70	3.2877	3.340
14SP17S-72	14SP17A-72	72	3.3815	3.434
14SP17S-75	14SP17A-75	75	3.5223	3.574
14SP17S-80	14SP17A-80	80	3.7570	3.809
14SP17S-85	14SP17A-85	85	3.9917	4.044



Available in Nylon or Phenolic upon request.
Other numbers of teeth available on request.
Teeth could be anodized.

NO. 25 LINK CHAIN

CIRCULAR PITCH	ROLLER DIAMETER	BERG NAME	MATERIAL	SPROCKET
.250	.130	ROW-L-ER®	Stainless Steel or Mild Steel, Non-Magnetic, Prestretched Single Strand	Operates with 25EM and 25SP series.

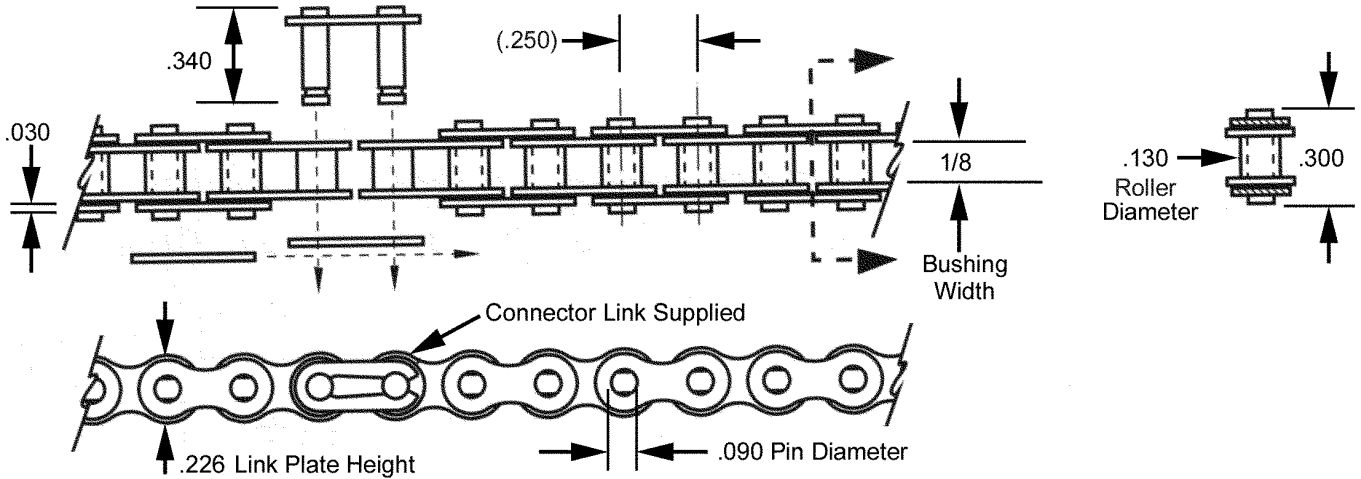

STAINLESS STEEL STOCK NO.	MILD STEEL STOCK NO.	NO. OF PITCHES	LENGTH (Inch)
RC25SS-40	RC25-40	40	10.000
RC25SS-50	RC25-50	50	12.500
RC25SS-60	RC25-60	60	15.000
RC25SS-70	RC25-70	70	17.500
RC25SS-80	RC25-80	80	20.000
RC25SS-90	RC25-90	90	22.500
RC25SS-100	RC25-100	100	25.000
RC25SS-120	RC25-120	120	30.000
RC25SS-130	RC25-130	130	32.500
RC25SS-140	RC25-140	140	35.000
RC25SS-150	RC25-150	150	37.500
RC25SS-160	RC25-160	160	40.000
RC25SS-170	RC25-170	170	42.500
RC25SS-180	RC25-180	180	45.000
RC25SS-190	RC25-190	190	47.500
RC25SS-200	RC25-200	200	50.000
RC25SS-210	RC25-210	210	52.500
RC25SS-220	RC25-220	220	55.000
RC25SS-230	RC25-230	230	57.500
RC25SS-240	RC25-240	240	60.000
RC25SS-250	RC25-250	250	62.500
RC25SS-260	RC25-260	260	65.000
RC25SS-270	RC25-270	270	67.500
RC25SS-280	RC25-280	280	70.000



STAINLESS STEEL STOCK NO.	MILD STEEL STOCK NO.	LENGTH
RC25SS-5FT	RC25-5FT	5 FT
RC25SS-10FT	RC25-10FT	10 FT
RC25SS-25FT	RC25-25FT	25 FT
RC25SS-50FT	RC25-50FT	50 FT
RC25SS-100FT	RC25-100FT	100 FT

American Standard No. 25

* Maximum recommended operating load is for a slip fit connecting link, which is standard. A press fit connecting link is a special available on request.

Special lengths available on request (only even numbers of links).

Operating load = 77 lbs. for Stainless Steel, 97lbs. for Mild Steel.

Ultimate tensile 700 lbs. for Stainless Steel, 875 lbs. for Mild Steel

.09lbs/foot - Must be lubricated.

Use Connector Link Berg P/N RC25SS-CL for Stainless Steel chain, and P/N RC25-CL for Mild Steel.

NO. 25 SPROCKETS

CIR. PITCH	BORE	STYLE	MATERIALS	BERG'S ® NAME	CHAIN
.250	1/4"	PIN HUB	Cast Polyurethane Graphite Impregnated 70D Durometer, Green	ROW-L-ER®	Operates with RC25 and RC25SS series

STOCK NO.	NO. OF TEETH	P.D.	O.D.
25EM66U-12	12†	.9659	1.083
25EM66U-13	13	1.0446	1.164
25EM66U-14	14	1.1235	1.245
25EM66U-15	15	1.2024	1.326
25EM66U-18	18	1.4397	1.567
25EM66U-20	20	1.5981	1.728
25EM66U-24	24	1.9153	2.048
25EM66U-26	26	2.0741	2.208
25EM66U-30	30	2.3917	2.528
25EM66U-36	36	2.8684	3.007

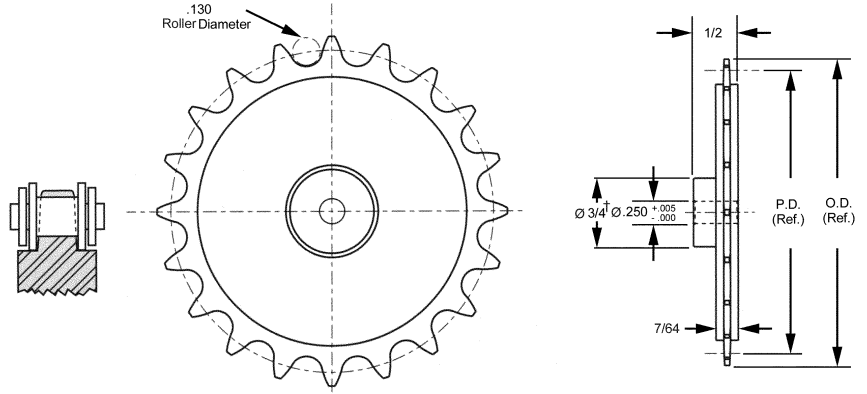

† Teeth runout on hub.
Other Bore sizes and other numbers of teeth are available on request.

CIR. PITCH	BORE	STYLE	MATERIALS	BERG'S ® NAME	CHAIN
.250	3/8"	PIN HUB	Cast Polyurethane Graphite Impregnated 70D Durometer, Green	ROW-L-ER®	Operates with RC25 and RC25SS series

STOCK NO.	NO. OF TEETH	P.D.	O.D.
25EM67U-12	12†	.9659	1.083
25EM67U-13	13	1.0446	1.164
25EM67U-14	14	1.1235	1.245
25EM67U-15	15	1.2024	1.326
25EM67U-18	18	1.4397	1.567
25EM67U-20	20	1.5981	1.728
25EM67U-24	24	1.9153	2.048
25EM67U-26	26	2.0741	2.208
25EM67U-30	30	2.3917	2.528
25EM67U-36	36	2.8684	3.007

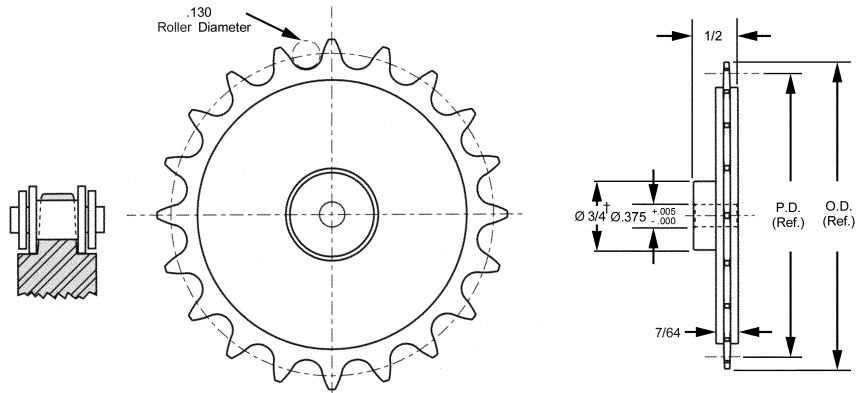

† Teeth runout on hub.
Other Bore sizes and other numbers of teeth are available on request.

CIR. PITCH	BORE	STYLE	MATERIALS	BERG'S ® NAME	CHAIN
.250	1/2"	PIN HUB	Cast Polyurethane Graphite Impregnated 70D Durometer, Green	ROW-L-ER®	Operates with RC25 and RC25SS series

STOCK NO.	NO. OF TEETH	P.D.	O.D.
25EM68U-12	12†	.9659	1.083
25EM68U-13	13	1.0446	1.164
25EM68U-14	14	1.1235	1.245
25EM68U-15	15	1.2024	1.326
25EM68U-18	18	1.4397	1.567
25EM68U-20	20	1.5981	1.728
25EM68U-24	24	1.9153	2.048
25EM68U-26	26	2.0741	2.208
25EM68U-30	30	2.3917	2.528
25EM68U-36	36	2.8684	3.007

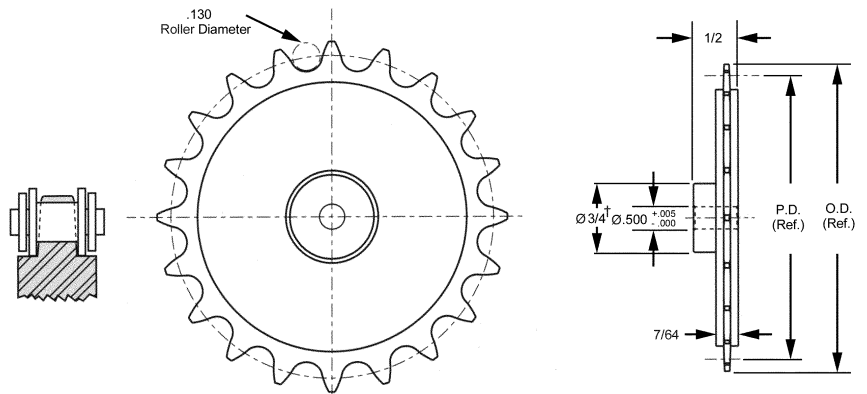

† Teeth runout on hub.
Other Bore sizes and other numbers of teeth are available on request.

NO. 25 SPROCKETS

CIR. PITCH	BORE	STYLE	MATERIALS	BERG'S ® NAME	CHAIN
.250	1/4"	PIN HUB	303 Stainless Steel Or 2024T-4 Aluminum Anodized	ROW-L-ER®	Operates with RC25 and RC25SS series

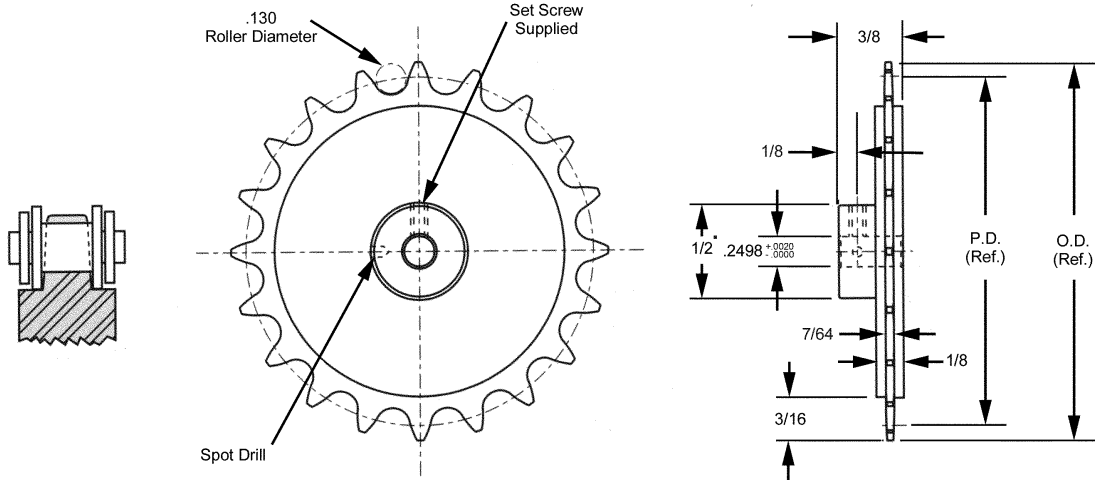

303 STAINLESS STEEL	2024T-4 ALUMINUM ANODIZED			
STOCK NO.	STOCK NO.	NO. OF TEETH	PITCH DIA.	OUTSIDE DIA.
25EM26S-9	25EM26A-9	9*	.7310	.836
25EM26S-10	25EM26A-10	10	.8090	.919
25EM26S-11	25EM26A-11	11	.8874	1.001
25EM26S-12	25EM26A-12	12	.9659	1.083
25EM26S-13	25EM26A-13	13	1.0446	1.164
25EM26S-14	25EM26A-14	14	1.1235	1.245
25EM26S-15	25EM26A-15	15	1.2024	1.326
25EM26S-16	25EM26A-16	16	1.2815	1.406
25EM26S-18	25EM26A-18	18	1.4397	1.567
25EM26S-20	25EM26A-20	20	1.5981	1.728
25EM26S-21	25EM26A-21	21	1.6774	1.808
25EM26S-22	25EM26A-22	22	1.7567	1.888
25EM26S-24	25EM26A-24	24	1.9153	2.048
25EM26S-25	25EM26A-25	25	1.9947	2.128
25EM26S-26	25EM26A-26	26	2.0741	2.208
25EM26S-28	25EM26A-28	28	2.2329	2.368
25EM26S-30	25EM26A-30	30	2.3917	2.528
25EM26S-32	25EM26A-32	32	2.5506	2.688
25EM26S-36	25EM26A-36	36	2.8684	3.007
25EM26S-40	25EM26A-40	40	3.1864	3.326
25EM26S-45	25EM26A-45	45	3.5839	3.725
25EM26S-48	25EM26A-48	48	3.8224	3.964
25EM26S-50	25EM26A-50	50	3.9815	4.123
25EM26S-54	25EM26A-54	54	4.2996	4.442



• For 9 teeth, hub diameter equals .46.
Other numbers of teeth available on request.
Teeth could be anodized.

NO. 25 SPROCKETS

CIR. PITCH	BORE	STYLE	MATERIALS	BERG'S ® NAME	CHAIN
.250	3/8"	HUBLESS	303 Stainless Steel	ROW-L-ER®	Operates with RC25 and RC25SS series

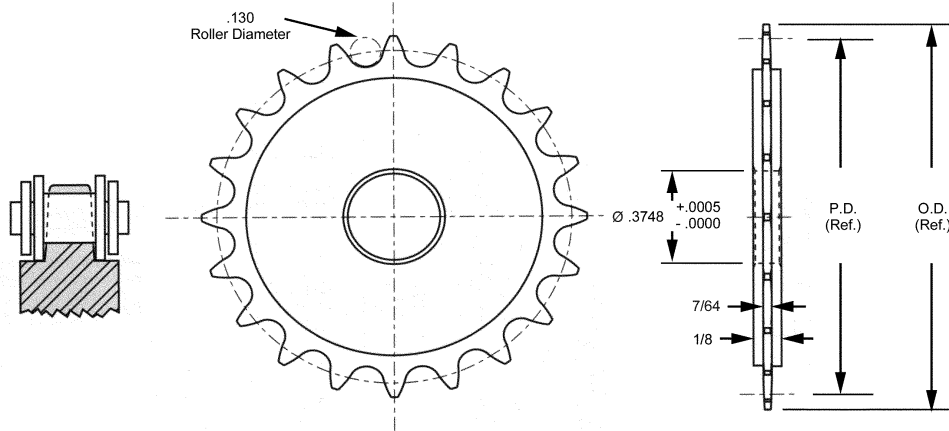

STOCK NO.	NO. OF TEETH	P.D.	O.D.
25SP3S-10	10	.8090	.919
25SP3S-11	11	.8874	1.001
25SP3S-12	12	.9659	1.083
25SP3S-13	13	1.0446	1.164
25SP3S-14	14	1.1235	1.245
25SP3S-15	15	1.2024	1.326
25SP3S-16	16	1.2815	1.406
25SP3S-17	17	1.3605	1.487
25SP3S-18	18	1.4397	1.567
25SP3S-19	19	1.5189	1.648
25SP3S-20	20	1.5981	1.728
25SP3S-21	21	1.6774	1.808
25SP3S-22	22	1.7567	1.888
25SP3S-24	24	1.9153	2.048
25SP3S-25	25	1.9947	2.128
25SP3S-26	26	2.0741	2.208
25SP3S-30	30	2.3917	2.528
25SP3S-32	32	2.5506	2.688
25SP3S-36	36	2.8684	3.007
25SP3S-40	40	3.1864	3.326
25SP3S-45	45	3.5839	3.725
25SP3S-48	48	3.8224	3.964
25SP3S-50	50	3.9815	4.123
25SP3S-54	54	4.2996	4.442
25SP3S-60	60	4.7768	4.920
25SP3S-70	70	5.5723	5.716
25SP3S-72	72	5.7314	5.875



Other Bore sizes and other numbers of teeth are available on request.

NO. 25 SPROCKETS

CIR. PITCH	BORE	STYLE	MATERIALS	BERG'S® NAME	CHAIN
.250	11/16"	HUBLESS	303 Stainless Steel	ROW-L-ER®	Operates with RC25 and RC25SS series

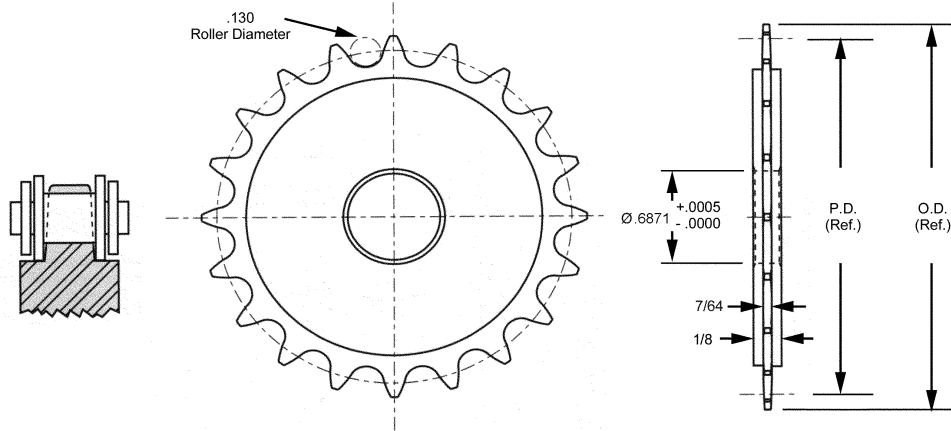

STOCK NO.	NO. OF TEETH	P.D.	O.D.
25SP17S-15	15	1.2024	1.326
25SP17S-16	16	1.2815	1.406
25SP17S-17	17	1.3605	1.487
25SP17S-18	18	1.4397	1.567
25SP17S-19	19	1.5189	1.648
25SP17S-20	20	1.5981	1.728
25SP17S-21	21	1.6774	1.808
25SP17S-22	22	1.7567	1.888
25SP17S-24	24	1.9153	2.048
25SP17S-25	25	1.9947	2.128
25SP17S-26	26	2.0741	2.208
25SP17S-30	30	2.3917	2.528
25SP17S-32	32	2.5506	2.688
25SP17S-36	36	2.8684	3.007
25SP17S-40	40	3.1864	3.326
25SP17S-45	45	3.5839	3.725
25SP17S-48	48	3.8224	3.964
25SP17S-50	50	3.9815	4.123
25SP17S-54	54	4.2996	4.442
25SP17S-60	60	4.7768	4.920
25SP17S-70	70	5.5723	5.716
25SP17S-72	72	5.7314	5.875



Other Bore sizes and other numbers of teeth are available on request.

NO. 25 SPROCKETS

CIR. PITCH	BORE	STYLE	MATERIALS	BERG'S ® NAME	CHAIN
.250	1/4"	HUBLESS	Mild Steel Parts are rust -protected	ROW-L-ER®	Operates with RC25 and RC25SS series



STOCK NO.	BORE	NO. OF TEETH	PITCH DIA.	OUTSIDE DIA.
25SP-A-18	.250	18	1.4397	1.567
25SP-A-20	.250	20	1.5980	1.728

Other numbers of teeth, keyways, modified bores and set screws available on request.

CIR. PITCH	BORE	STYLE	MATERIALS	BERG'S ® NAME	CHAIN
.250	3/8"	HUBLESS	Mild Steel Parts are rust -protected	ROW-L-ER®	Operates with RC25 and RC25SS series



STOCK NO.	BORE	NO. OF TEETH	PITCH DIA.	OUTSIDE DIA.
25SP-A-22	.375	22	1.7567	1.888
25SP-A-24	.375	24	1.9153	2.048
25SP-A-25	.375	25	1.9947	2.128
25SP-A-26	.375	26	2.0741	2.208
25SP-A-28	.375	28	2.2329	2.368
25SP-A-30	.375	30	2.3917	2.528
25SP-A-32	.375	32	2.5506	2.688
25SP-A-35	.375	35	2.7890	2.927
25SP-A-36	.375	36	2.8684	3.007

Other numbers of teeth, keyways, modified bores and set screws available on request.

CIR. PITCH	BORE	STYLE	MATERIALS	BERG'S ® NAME	CHAIN
.250	1/2"	HUBLESS	Mild Steel Parts are rust -protected	ROW-L-ER®	Operates with RC25 and RC25SS series



STOCK NO.	BORE	NO. OF TEETH	PITCH DIA.	OUTSIDE DIA.
25SP-A-40	.500	40	3.1864	3.326
25SP-A-45	.500	45	3.5839	3.725
25SP-A-48	.500	48	3.8224	3.964
25SP-A-54	.500	54	4.2996	4.442
25SP-A-60	.500	60	4.7768	4.920
25SP-A-72	.500	72	5.7314	5.875

Other numbers of teeth, keyways, modified bores and set screws available on request.

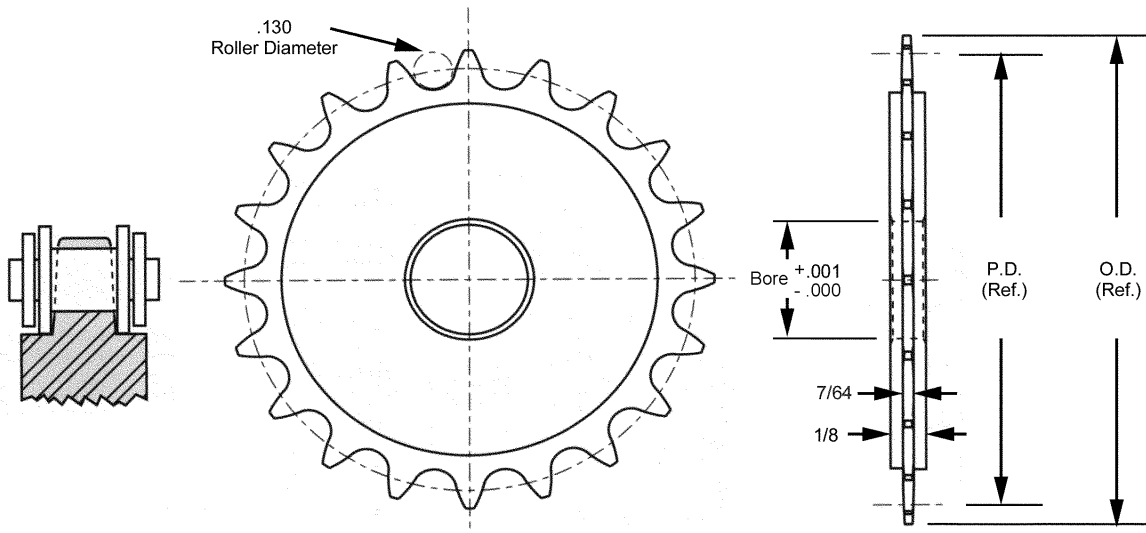

NO.25 SPROCKETS

CIR. PITCH	BORE	STYLE	MATERIALS	BERG'S ® NAME	CHAIN
.250	1/4"	PIN HUB	Mild Steel Parts are rust -protected	ROW-L-ER®	Operates with RC25 and RC25SS series

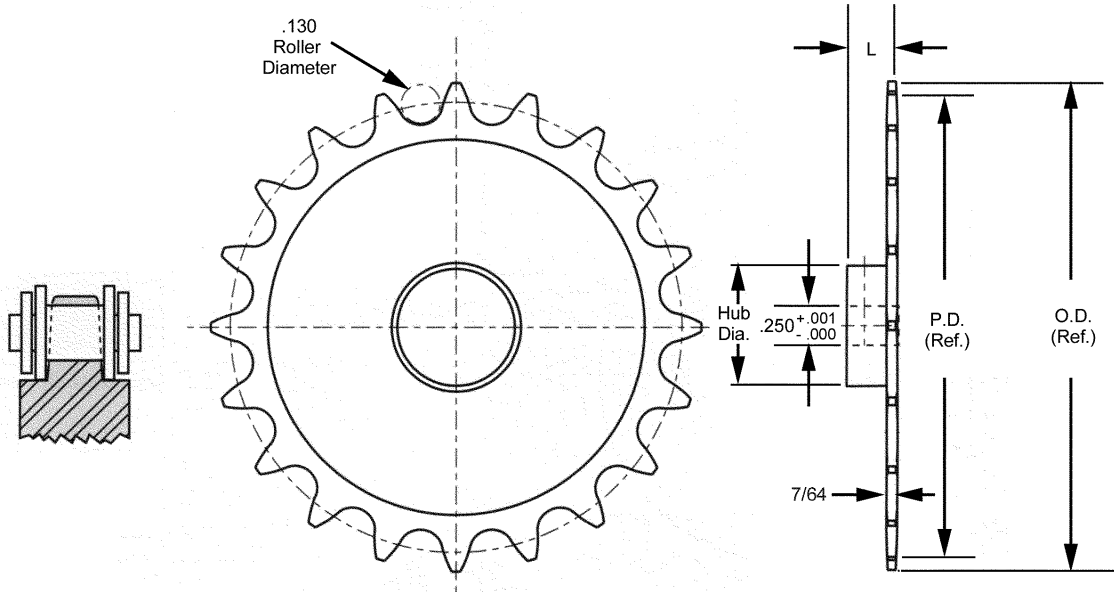

STOCK NO.	BORE	HUB DIA.	L	NO. OF TEETH	PITCH DIA.	OUTSIDE DIA.
25EM-B-9	.250	.43	.50	9	.7310	.836
25EM-B-10	.250	.50	.50	10	.8090	.919
25EM-B-11	.250	.57	.50	11	.8874	1.001
25EM-B-12	.250	.62	.50	12	.9659	1.083
25EM-B-13	.250	.72	.50	13	1.0446	1.164
25EM-B-14	.250	.81	.50	14	1.1235	1.245
25EM-B-15	.250	.89	.50	15	1.2024	1.326
25EM-B-16	.250	.96	.50	16	1.2815	1.406
25EM-B-18	.250	1.12	.50	18	1.4397	1.567
25EM-B-20	.250	1.28	.62	20	1.5980	1.728
25EM-B-21	.250	1.37	.62	21	1.6774	1.808
25EM-B-22	.250	1.43	.62	22	1.7567	1.888



Other numbers of teeth, keyways, modified bores and set screws available on request.

NO. 25 SPROCKETS

CIR. PITCH	BORE	STYLE	MATERIALS	BERG'S ® NAME	CHAIN
.250	3/8"	PIN HUB	Mild Steel Parts are rust -protected	ROW-L-ER®	Operates with RC25 and RC25SS series

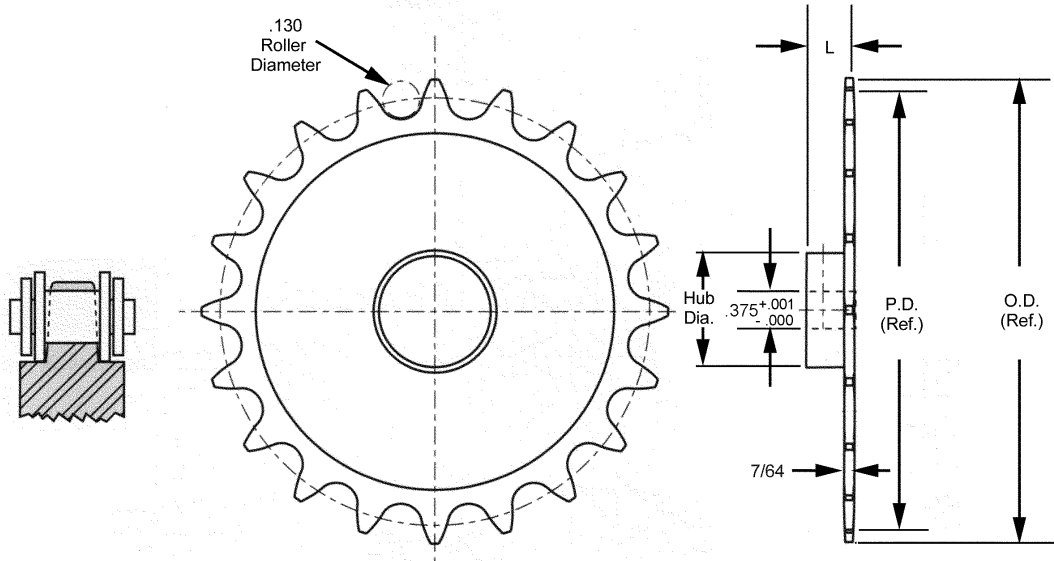

STOCK NO.	BORE	HUB DIA.	L	NO. OF TEETH	PITCH DIA.	OUTSIDE DIA.
25EM-B-24	.375	1.50	.62	24	1.9153	2.048
25EM-B-25	.375	1.50	.62	25	1.9947	2.128
25EM-B-26	.375	1.50	.62	26	2.0741	2.208
25EM-B-28	.375	1.50	.62	28	2.2329	2.368
25EM-B-30	.375	1.50	.62	30	2.3917	2.528
25EM-B-32	.375	1.50	.62	32	2.5506	2.688
25EM-B-36	.375	1.50	.75	36	2.8684	3.007

Other numbers of teeth, keyways, modified bores and set screws available on request.



NO. 25 SPROCKETS

CIR. PITCH	BORE	STYLE	MATERIALS	BERG'S ® NAME	CHAIN
.250	1/2"	PIN HUB	Mild Steel Parts are rust -protected	ROW-L-ER®	Operates with RC25 and RC25SS series

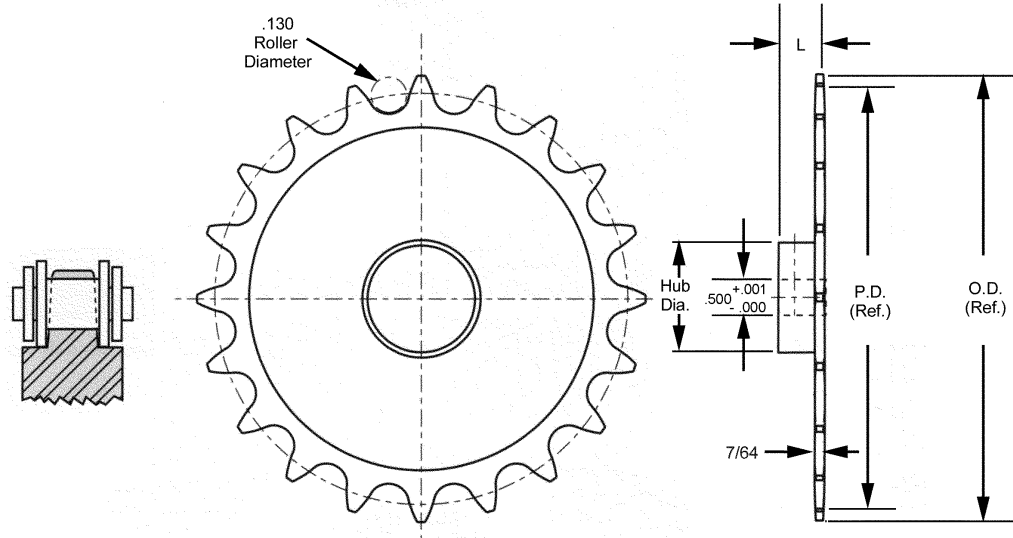

STOCK NO.	BORE	HUB DIA.	L	NO. OF TEETH	PITCH DIA.	OUTSIDE DIA.
25EM-B-40	.500	2.00	.75	40	3.1864	3.326
25EM-B-45	.500	2.00	.75	45	3.5839	3.725
25EM-B-48	.500	2.00	.75	48	3.8224	3.964
25EM-B-54	.500	2.00	.75	54	4.2996	4.442
25EM-B-60	.500	2.00	.75	60	4.7768	4.920
25EM-B-70	.500	2.00	.75	70	5.5723	5.716
25EM-B-72	.500	2.00	.75	72	5.7314	5.875

Other numbers of teeth, keyways, modified bores and set screws available on request.



NO. 35 LINK CHAIN

CIRCULAR PITCH	ROLLER DIAMETER	BERG NAME	MATERIAL	SPROCKET
.375	.200	ROW-L-ER®	Stainless Steel, Non-Magnetic, Prestretched Single Strand	Operates with 35EM and 35SP series.

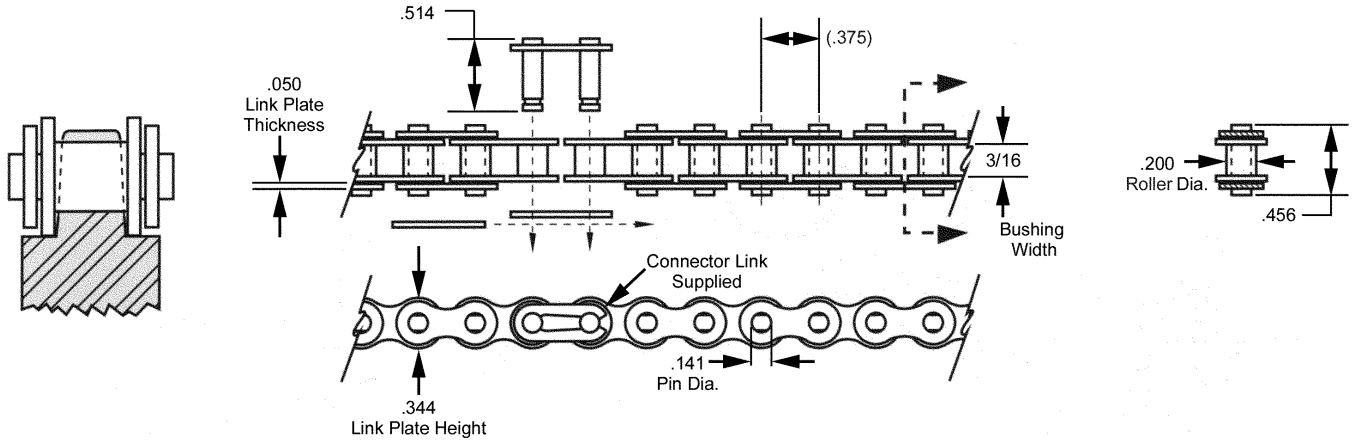

STAINLESS STEEL	MILD STEEL		
STOCK NO.	STOCK NO.	NO. OF PITCHES	LENGTH (Inch)
RC35SS-40	RC35-40	40	15.00
RC35SS-50	RC35-50	50	18.75
RC35SS-60	RC35-60	60	22.50
RC35SS-70	RC35-70	70	26.25
RC35SS-80	RC35-80	80	30.00
RC35SS-90	RC35-90	90	33.75
RC35SS-100	RC35-100	100	37.50
RC35SS-120	RC35-120	120	45.00
RC35SS-130	RC35-130	130	48.75
RC35SS-140	RC35-140	140	52.50
RC35SS-150	RC35-150	150	56.25
RC35SS-160	RC35-160	160	60.00
RC35SS-170	RC35-170	170	63.75
RC35SS-180	RC35-180	180	67.50
RC35SS-190	RC35-190	190	71.25
RC35SS-200	RC35-200	200	75.00
RC35SS-210	RC35-210	210	78.75
RC35SS-220	RC35-220	220	82.50
RC35SS-230	RC35-230	230	86.25



STAINLESS STEEL STOCK NO.	MILD STEEL STOCK NO.	LENGTH
RC35SS-5FT	RC35-5FT	5 FT
RC35SS-10FT	RC35-10FT	10 FT
RC35SS-25FT	RC35-25FT	25 FT
RC35SS-50FT	RC35-50FT	50 FT
RC35SS-100FT	RC35-100FT	100 FT

American Standard No. 35

* Maximum recommended operating load is for a slip fit connecting link, which is standard. A press fit connecting link is a special available on request.

Special lengths available on request (only even numbers of links). For odd numbers of pitches contact our sales department.

Operating load = 155 lbs. for Stainless Steel, 233lbs. for Mild Steel.
Ultimate tensile 1400 lbs. for Stainless Steel, 2100 lbs. for Mild Steel

For odd numbers of pitches contact our sales department.
for special quotation is option is available.

.22lbs/foot - Must be lubricated.

Use Connector Link Berg P/N RC35SS-CL for Stainless Steel chain, and P/N RC35-CL for Mild Steel.

NO. 35 SPROCKETS

CIR. PITCH	BORE	STYLE	MATERIALS	BERG'S ® NAME	CHAIN
.375	1/2"	HUBLESS	Mild Steel Parts are rust -protected	ROW-L-ER®	Operates with RC35 and RC35SS series



STOCK NO.	BORE	NO. OF TEETH	PITCH DIA.	OUTSIDE DIA.
35SP-A-15	.500	15	1.804	1.989
35SP-A-16	.500	16	1.922	2.110
35SP-A-17	.500	17	2.041	2.231
35SP-A-18	.500	18	2.160	2.351
35SP-A-20	.500	20	2.397	2.592
35SP-A-21	.500	21	2.516	2.712
35SP-A-22	.500	22	2.635	2.833
35SP-A-24	.500	24	2.873	3.073
35SP-A-25	.500	25	2.992	3.193
35SP-A-26A	.500	26	3.111	3.313
35SP-A-28A	.500	28	3.349	3.553
35SP-A-30A	.500	30	3.588	3.792

Other numbers of teeth, keyways, modified bores and set screws available on request.

CIR. PITCH	BORE	STYLE	MATERIALS	BERG'S ® NAME	CHAIN
.375	5/8"	HUBLESS	Mild Steel Parts are rust -protected	ROW-L-ER®	Operates with RC35 and RC35SS series



STOCK NO.	BORE.	NO. OF TEETH	PITCH DIA.	OUTSIDE DIA.
35SP-A-32A	.625	32	3.826	4.032
35SP-A-35A	.625	35	4.183	4.391
35SP-A-36A	.625	36	4.303	4.511

Other numbers of teeth, keyways, modified bores and set screws available on request.

CIR. PITCH	BORE	STYLE	MATERIALS	BERG'S ® NAME	CHAIN
.375	19/32"	HUBLESS	Mild Steel Parts are rust -protected	ROW-L-ER®	Operates with RC35 and RC35SS series



STOCK NO.	BORE	NO. OF TEETH	PITCH DIA.	OUTSIDE DIA.
35SP-A-40A	.593	40	4.780	4.989
35SP-A-45A	.593	45	5.376	5.587
35SP-A-48A	.593	48	5.734	5.946

Other numbers of teeth, keyways, modified bores and set screws available on request.

CIR. PITCH	BORE	STYLE	MATERIALS	BERG'S ® NAME	CHAIN
.375	23/32"	HUBLESS	Mild Steel Parts are rust -protected	ROW-L-ER®	Operates with RC35 and RC35SS series



STOCK NO.	BORE	NO. OF TEETH	PITCH DIA.	OUTSIDE DIA.
35SP-A-60A	.718	60	7.165	7.380
35SP-A-70A	.718	70	8.358	8.575
35SP-A-72A	.718	72	8.597	8.813

Other numbers of teeth, keyways, modified bores and set screws available on request.

NO.35 SPROCKETS

CIR. PITCH	BORE	STYLE	MATERIALS	BERG'S ® NAME	CHAIN
.375	3/8"	PIN HUB	Mild Steel Parts are rust -protected	ROW-L-ER®	Operates with RC35 and RC35SS series

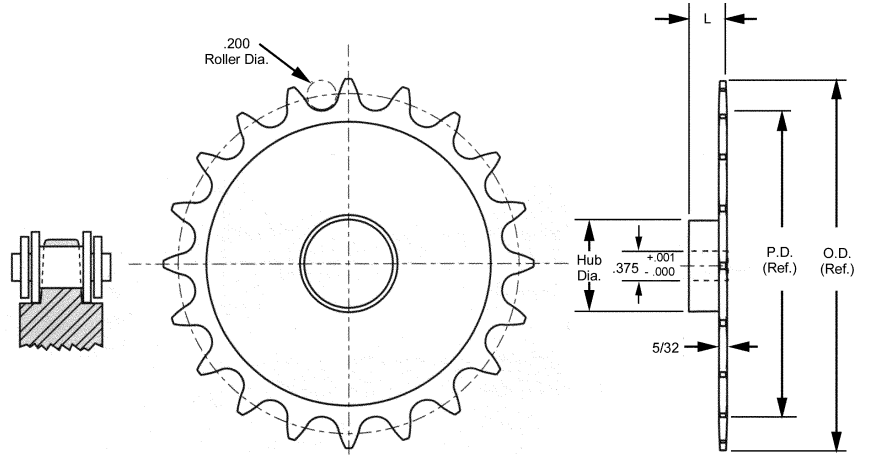

Other numbers of teeth, keyways, modified bores and set screws available on request.

STOCK NO.	BORE	HUB DIA.	L	NO. OF TEETH	PITCH DIA.	OUTSIDE DIA.
35EM-B-8	.375	.75	.75	8	.980	1.130
35EM-B-9	.375	.84	.75	9	1.096	1.255
35EM-B-10	.375	.97	.75	10	1.214	1.379
35EM-B-11	.375	1.06	.75	11	1.331	1.502

CIR. PITCH	BORE	STYLE	MATERIALS	BERG'S ® NAME	CHAIN
.375	1/2"	PIN HUB	Mild Steel Parts are rust -protected	ROW-L-ER®	Operates with RC35 and RC35SS series

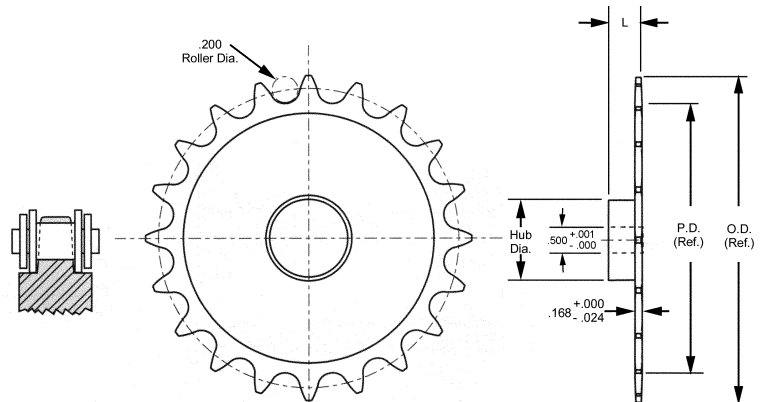

Other numbers of teeth, keyways, modified bores and set screws available on request.

STOCK NO.	BORE	HUB DIA.	L	NO. OF TEETH	PITCH DIA.	OUTSIDE DIA.
35EM-B-12	.500	1.21	.75	12	1.449	1.624
35EM-B-13	.500	1.25	.75	13	1.567	1.746
35EM-B-14	.500	1.25	.75	14	1.685	1.867
35EM-B-15	.500	1.34	.75	15	1.804	1.989
35EM-B-16	.500	1.47	.75	16	1.922	2.110
35EM-B-17	.500	1.59	.75	17	2.041	2.231
35EM-B-18	.500	1.72	.75	18	2.160	2.351
35EM-B-20	.500	1.93	.75	20	2.397	2.592
35EM-B-21	.500	2.00	.87	21	2.516	2.712
35EM-B-22	.500	2.00	.87	22	2.635	2.833
35EM-B-24	.500	2.00	.87	24	2.873	3.073
35EM-B-25	.500	2.00	.87	25	2.992	3.193
35EM-B-26	.500	2.00	.87	26	3.111	3.313
35EM-B-28	.500	2.00	.87	28	3.349	3.553
35EM-B-30	.500	2.00	.87	30	3.588	3.792
35EM-B-32	.500	2.25	.87	32	3.826	4.032

NO.35 SPROCKETS

CIR. PITCH	BORE	STYLE	MATERIALS	BERG'S ® NAME	CHAIN
.375	5/8"	PIN HUB	Mild Steel Parts are rust -protected	ROW-L-ER®	Operates with RC35 and RC35SS series

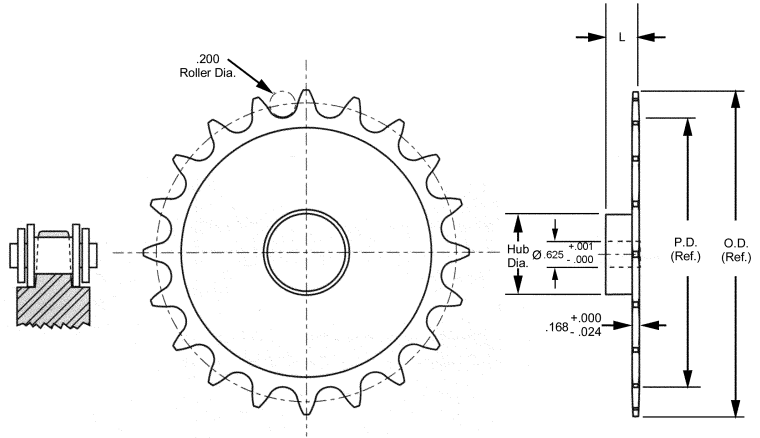

Other numbers of teeth, keyways, modified bores and set screws available on request.

STOCK NO.	BORE	HUB DIA.	L	NO. OF TEETH	PITCH DIA.	OUTSIDE DIA.
35EM-B-35	.625	2.25	.87	35	4.183	4.391
35EM-B-36A	.625	2.25	.87	36	4.303	4.511
35EM-B-40A	.625	2.25	1.00	40	4.780	4.989
35EM-B-45	.625	2.25	1.00	45	5.376	5.587
35EM-B-48	.625	2.25	1.00	48	5.734	5.946

CIR. PITCH	BORE	STYLE	MATERIALS	BERG'S ® NAME	CHAIN
.375	3/4"	PIN HUB	Mild Steel Parts are rust -protected	ROW-L-ER®	Operates with RC35 and RC35SS series

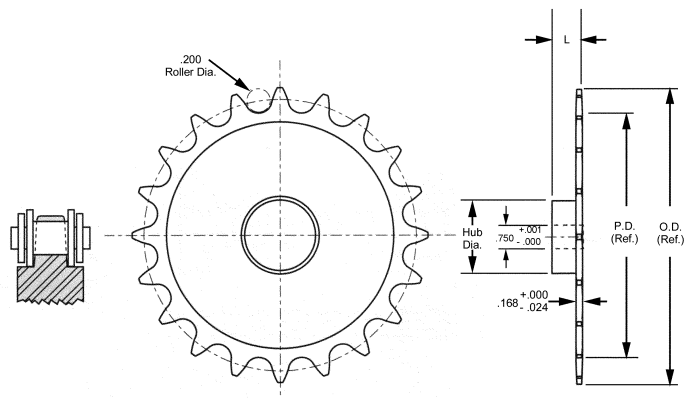

Other numbers of teeth, keyways, modified bores and set screws available on request.

STOCK NO.	BORE	HUB DIA.	L	NO. OF TEETH	PITCH DIA.	OUTSIDE DIA.
35EM-B-60A	.750	2.25	1.00	60	7.165	7.380
35EM-B-72A	.750	2.25	1.00	72	8.597	8.813

NO. 41 LINK CHAIN

CIRCULAR PITCH	ROLLER DIAMETER	BERG NAME	MATERIAL	SPROCKET
.500	.306	ROW-L-ER®	Stainless Steel, Non-Magnetic, Prestretched Single Strand	Operates with 41EM and 41SP series.

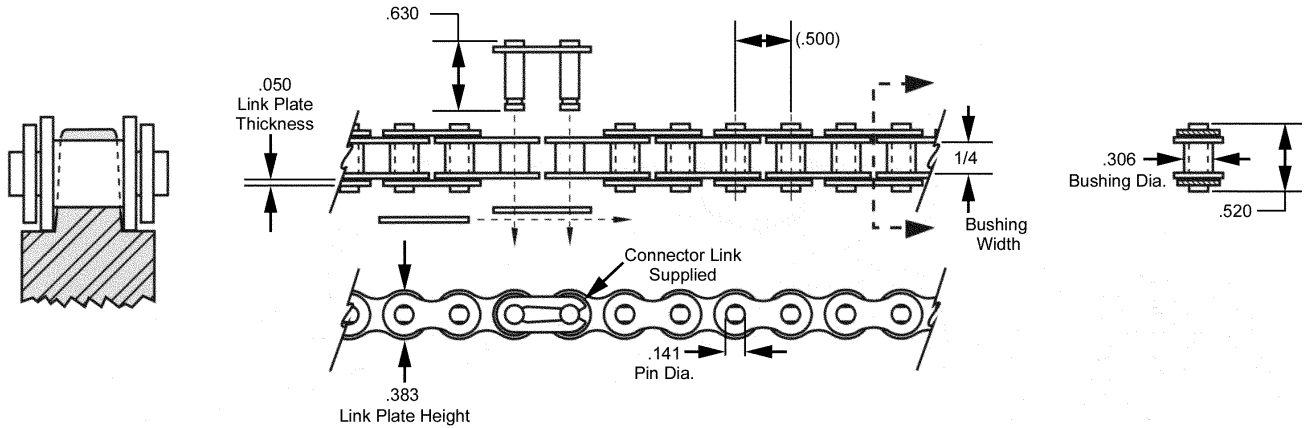

STAINLESS STEEL	MILD STEEL		
STOCK NO.	STOCK NO.	NO. OF PITCHES	LENGTH (Inch)
RC41SS-40	RC41-40	40	20.00
RC41SS-50	RC41-50	50	25.00
RC41SS-60	RC41-60	60	30.00
RC41SS-70	RC41-70	70	35.00
RC41SS-80	RC41-80	80	40.00
RC41SS-90	RC41-90	90	45.00
RC41SS-100	RC41-100	100	50.00
RC41SS-120	RC41-120	120	60.00
RC41SS-130	RC41-130	130	65.00
RC41SS-140	RC41-140	140	70.00
RC41SS-150	RC41-150	150	75.00
RC41SS-160	RC41-160	160	80.00
RC41SS-170	RC41-170	170	85.00
RC41SS-180	RC41-180	180	90.00
RC41SS-190	RC41-190	190	95.00
RC41SS-200	RC41-200	200	100.00



American Standard No. 41

* Maximum recommended operating load is for a slip fit connecting link, which is standard. A press fit connecting link is a special available on request.

Operating load = 188 lbs. for Stainless Steel, 266lbs. for Mild Steel.
Ultimate tensile 1700 lbs. for Stainless Steel, 2400 lbs. for Mild Steel

Special lengths available on request (only even numbers of links). For odd numbers of pitches contact our sales department.

.32lbs/foot - Must be lubricated.

Use Connector Link Berg P/N RC41SS-CL for Stainless Steel chain, and P/N RC41-CL for Mild Steel.

STAINLESS STEEL STOCK NO.	MILD STEEL STOCK NO.	LENGTH
RC41SS-5FT	RC41-5FT	5 FT
RC41SS-10FT	RC41-10FT	10 FT
RC41SS-25FT	RC41-25FT	25 FT
RC41SS-50FT	RC41-50FT	50 FT
RC41SS-100FT	RC41-100FT	100 FT

NO. 41 SPROCKETS

CIR. PITCH	BORE	STYLE	MATERIALS	BERG'S ® NAME	CHAIN
.500	5/8"	HUBLESS	Mild Steel Parts are rust -protected	ROW-L-ER®	Operates with RC41 and RC41SS series



STOCK NO.	BORE	NO. OF TEETH	PITCH DIA.	OUTSIDE DIA.
41SP-A-15A	.625	15	2.4049	2.652
41SP-A-16A	.625	16	2.5629	2.813
41SP-A-18A	.625	18	2.8794	3.135
41SP-A-20A	.625	20	3.1962	3.456
41SP-A-22A	.625	22	3.5133	3.777
41SP-A-24A	.625	24	3.8306	4.097
41SP-A-25A	.625	25	3.9894	4.257
41SP-A-30A	.625	30	4.7834	5.057

Other numbers of teeth, keyways, modified bores and set screws available on request.

CIR. PITCH	BORE	STYLE	MATERIALS	BERG'S ® NAME	CHAIN
.500	19/32"	HUBLESS	Mild Steel Parts are rust -protected	ROW-L-ER®	Operates with RC41 and RC41SS series



STOCK NO.	BORE	NO. OF TEETH	PITCH DIA.	OUTSIDE DIA.
41SP-A-32A	.593	32	5.1011	5.376
41SP-A-35A	.593	35	5.5779	5.855
41SP-A-36A	.593	36	5.7369	6.015

Other numbers of teeth, keyways, modified bores and set screws available on request.

CIR. PITCH	BORE	STYLE	MATERIALS	BERG'S ® NAME	CHAIN
.500	23/32"	HUBLESS	Mild Steel Parts are rust -protected	ROW-L-ER®	Operates with RC41 and RC41SS series



STOCK NO.	BORE	NO. OF TEETH	PITCH DIA.	OUTSIDE DIA.
41SP-A-40A	.718	40	6.3727	6.653
41SP-A-45A	.718	45	7.1678	7.450
41SP-A-48A	.718	48	7.6449	7.928
41SP-A-54A	.718	54	8.5992	8.884
41SP-A-60A	.718	60	9.5537	9.840
41SP-A-72A	.718	72	11.4628	11.751

Other numbers of teeth, keyways, modified bores and set screws available on request.

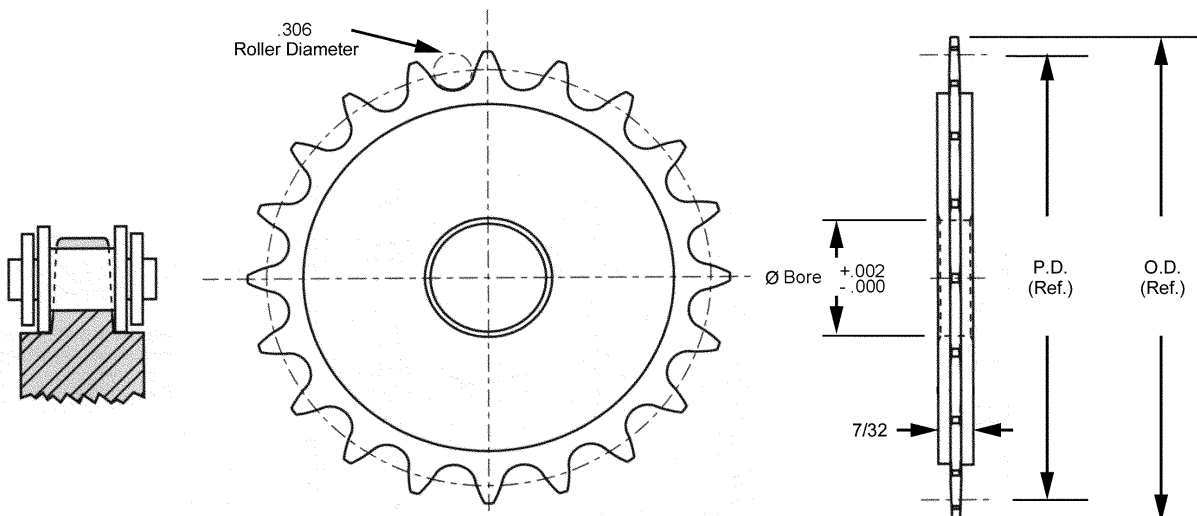

NO. 41 SPROCKETS

CIR. PITCH	BORE	STYLE	MATERIALS	BERG'S ® NAME	CHAIN
.500	1/2"	PIN HUB	Mild Steel Parts are Rust Protected	ROW-L-ER®	Operates with RC41 and RC41SS series

STOCK NO.	BORE	HUB DIA.	L	NO. OF TEETH	PITCH DIA.	OUTSIDE DIA.
41EM-B-8	.500	.98	.87	8	1.3066	1.507
41EM-B-9	.500	1.12	.87	9	1.4619	1.673
41EM-B-10	.500	1.25	.87	10	1.6180	1.838
41EM-B-11	.500	1.43	.87	11	1.7747	2.002
41EM-B-12	.500	1.56	.87	12	1.9319	2.166
41EM-B-13	.500	1.56	.87	13	2.0893	2.328
41EM-B-14	.500	1.75	.87	14	2.2470	2.490
41EM-B-15	.500	1.91	.87	15	2.4049	2.652

Other numbers of teeth, keyways, modified bores and set screws available on request.

CIR. PITCH	BORE	STYLE	MATERIALS	BERG'S ® NAME	CHAIN
.500	5/8"	PIN HUB	Mild Steel Parts are rust -protected	ROW-L-ER®	Operates with RC41 and RC41SS series

STOCK NO.	BORE	HUB DIA.	L	NO. OF TEETH	PITCH DIA.	OUTSIDE DIA.
41EM-B-16	.625	2.06	.87	16	2.5629	2.813
41EM-B-17	.625	2.23	1.00	17	2.7211	2.974
41EM-B-18	.625	2.37	1.00	18	2.8794	3.135
41EM-B-20	.625	2.75	1.00	20	3.1962	3.456
41EM-B-22	.625	3.00	1.00	22	3.5133	3.777
41EM-B-24	.625	3.25	1.00	24	3.8306	4.097
41EM-B-25	.625	3.25	1.00	25	3.9894	4.257
41EM-B-28	.625	3.25	1.00	28	4.4657	4.737
41EM-B-30	.625	3.25	1.00	30	4.7834	5.057
41EM-B-32	.625	3.25	1.00	32	5.1011	5.376
41EM-B-35A	.625	3.25	1.00	35	5.5779	5.855
41EM-B-36	.625	3.25	1.00	36	5.7369	6.015

Other numbers of teeth, keyways, modified bores and set screws available on request.

CIR. PITCH	BORE	STYLE	MATERIALS	BERG'S ® NAME	CHAIN
.500	3/4"	PIN HUB	Mild Steel Parts are rust -protected	ROW-L-ER®	Operates with RC41 and RC41SS series

STOCK NO.	BORE	HUB DIA.	L	NO. OF TEETH	PITCH DIA.	OUTSIDE DIA.
41EM-B-40	.750	3.25	1.06	40	6.3727	6.653
41EM-B-45	.750	3.50	1.06	45	7.1678	7.450
41EM-B-48	.750	3.50	1.06	48	7.6449	7.928
41EM-B-54	.750	3.50	1.06	54	8.5992	8.884
41EM-B-60A	.750	3.50	1.06	60	9.5537	9.840
41EM-B-72	.750	4.00	1.18	72	11.4628	11.751

Other numbers of teeth, keyways, modified bores and set screws available on request.

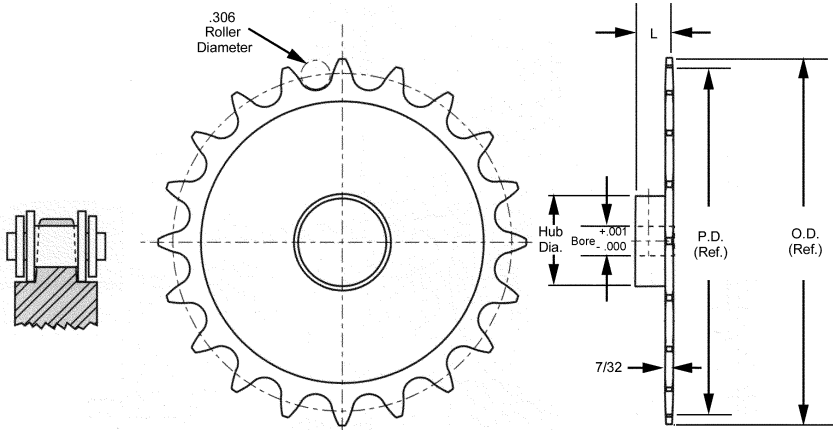

NO. 25 LINK CHAIN

CIRCULAR PITCH	ROLLER DIAMETER	BERG NAME	MATERIAL	SPROCKET
.250	.130	ROW-L-ER®	Delrin and Nylatron	Operates with 25EM and 25SP series.

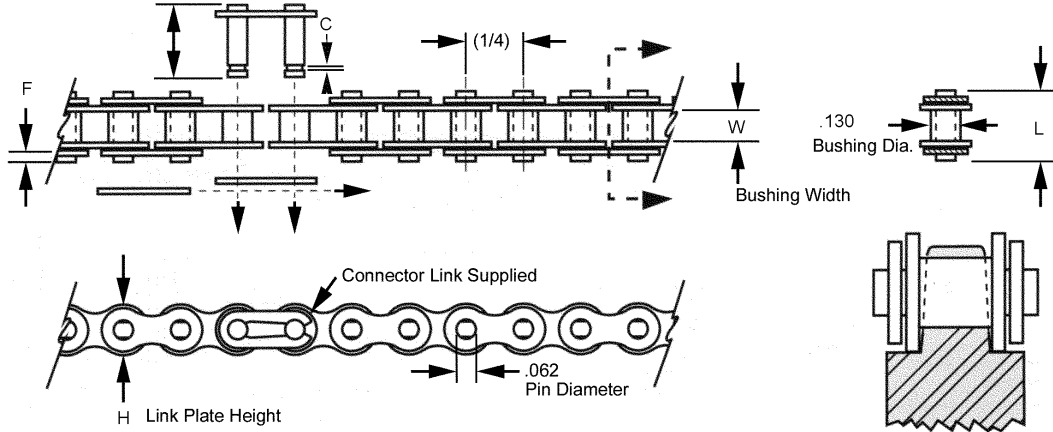

DELRIN® STOCK NO.	NYLATRON® STOCK NO.	NO. OF PITCHES	LENGTH (Inch)	PITCH	W	C	F	L	H
RC25D-40	RC25N-40	40	10.00	1/4	1/8	.105	.040	.359	.25
RC25D-50	RC25N-50	50	12.50						
RC25D-60	RC25N-60	60	15.00						
RC25D-70	RC25N-70	70	17.50						
RC25D-80	RC25N-80	80	20.00						
RC25D-90	RC25N-90	90	22.50						
RC25D-100	R025N-100	100	25.00						
RC25D-120	RC25N-120	120	30.00						
RC25D-130	RC25N-130	130	32.50						
RC25D-140	RC25N-140	140	35.00						
RC25D-150	RC25N-150	150	37.50						
RC25D-160	RC25N-160	160	40.00						
RC25D-170	RC25N-170	170	42.50						
RC25D-180	RC25N-180	180	45.00						
RC25D-190	RC25N-190	190	47.50						
RC25D-200	RC25N-200	200	50.00						
RC25D-210	RC25N-210	210	52.50						
RC25D-220	RC25N-220	220	55.00						
RC25D-230	RC25N-230	230	57.50						
RC25D-240	RC25N-240	240	60.00						
RC25D-250	RC25N-250	250	62.50						
RC25D-260	RC25N-260	260	65.00						
RC25D-270	RC25N-270	270	67.50						
RC25D-280	RC25N-280	280	70.00						

Chain Material Data:

Chain Tensile Strength @ Break (lbs.)	Delrin = 63	Nylatron GS = 65
Max. Operating Load (lbs.)	Delrin = 21	Nylatron GS = 22
Tensile (PSI)	Delrin = 9,700	Nylatron GS = 13,700
Compressive (PSI)	Delrin = 15,600	Nylatron GS = 12,500
Flexural (PSI)	Delrin = 13,600	Nylatron GS = 17,000
Water Absorption %	Delrin = 0.25	Nylatron GS = 0.8
Chain Elongation % (ultimate)	Delrin = 9	Nylatron GS = 34
@ 75% Ultimate	Delrin = 5	Nylatron GS = 14

Other materials available upon request. Other lengths available upon request.
 For material data on Polypropylene (RC25PP) and/or Kynar (RC25K) contact our technical support department.

NO. 25 SPROCKETS

CIR. PITCH	BORE	STYLE	MATERIALS	BERG'S ® NAME	CHAIN
.250	1/4"	PIN HUB	Delrin®	ROW-L-ER®	Operates with RC25D and RC25N series

STOCK NO.	NO. OF TEETH	OUTSIDE DIA. (Inch)	PITCH DIA. (Inch)	MINOR DIA. (Inch)	HUB DIA. (Inch)
25EM4E-10	10	.9191	.809	.679	17/32
25EM4E-12	12	1.083	.996	.836	39/64
25EM4E-15	15	1.326	1.203	1.073	39/64
25EM4E-16	16	1.407	1.282	1.152	39/64
25EM4E-17	17	1.487	1.361	1.231	39/64
25EM4E-18	18	1.568	1.440	1.310	39/64
25EM4E-19	19	1.648	1.519	1.389	39/64
25EM4E-20	20	1.729	1.598	1.468	39/64
25EM4E-21	21	1.809	1.677	1.547	43/64

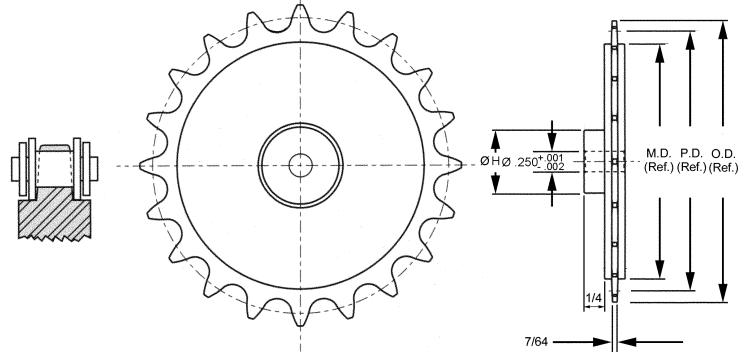

CIR. PITCH	BORE	STYLE	MATERIALS	BERG'S ® NAME	CHAIN
.250	5/16"	PIN HUB	Delrin®	ROW-L-ER®	Operates with RC25D and RC25N series

STOCK NO.	NO. OF TEETH	OUTSIDE DIA. (Inch)	PITCH DIA. (Inch)	MINOR DIA. (Inch)	HUB DIA. (Inch)
25EM5E-24	24	2.049	1.915	1.785	39/64
25EM5E-25	25	2.129	1.995	1.865	43/64
25EM5E-30	30	2.529	2.392	2.262	43/64

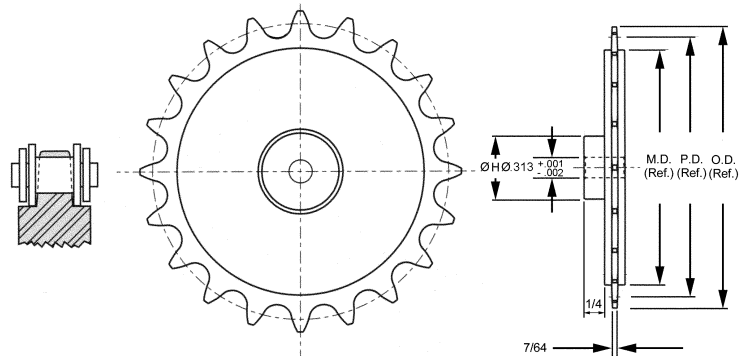

CIR. PITCH	BORE	STYLE	MATERIALS	BERG'S ® NAME	CHAIN
.250	3/8"	PIN HUB	Delrin®	ROW-L-ER®	Operates with RC25D and RC25N series

STOCK NO.	NO. OF TEETH	OUTSIDE DIA. (Inch)	PITCH DIA. (Inch)	MINOR DIA. (Inch)	HUB DIA. (Inch)
25EM6E-32	32	2.688	2.551	2.421	43/64
25EM6E-36	36	3.008	2.869	2.739	43/64
25EM6E-40	40	3.327	3.187	3.057	43/64

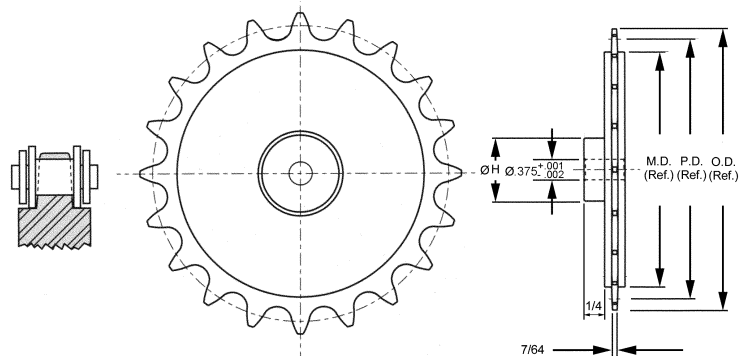

NO. 25 SPROCKETS

CIR. PITCH	BORE	STYLE	MATERIALS	BERG'S ® NAME	CHAIN
.250	1/4"	PIN HUB	NYLATRON®	ROW-L-ER®	Operates with RC25D and RC25N series

NYLATRON® STOCK NO.	NO. OF TEETH	OUTSIDE .DIA (Inch)	PITCH DIA. (Inch)	MINOR DIA. (Inch)	BORE .002/ -.000 (Inch)	HUB DIA. (Inch)	HUB PROJECTION (Inch)
25EM4GS-10	10	.919	.81	.679	.250	9/16	3/8
25EM4GS-11	11	1.002	.89	.757	.250	9/16	3/8

CIR. PITCH	BORE	STYLE	MATERIALS	BERG'S ® NAME	CHAIN
.250	5/16"	PIN HUB	NYLATRON®	ROW-L-ER®	Operates with RC25D and RC25N series

NYLATRON® STOCK NO.	NO. OF TEETH	OUTSIDE .DIA (Inch)	PITCH DIA. (Inch)	MINOR DIA. (Inch)	BORE .002/ -.000 (Inch)	HUB DIA. (Inch)	HUB PROJECTION (Inch)
25EM5GS-12	12	1.083	.97	.836	.313	11/16	3/8
25EM5GS-13	13	1.167	1.05	.915	.313	3/4	3/8
25EM5GS-14	14	1.246	1.13	.993	.313	3/4	3/8
25EM5GS-15	15	1.326	1.20	1.073	.313	3/4	3/8
25EM5GS-16	16	1.407	1.28	1.152	.313	13/16	3/8
25EM5GS-17	17	1.487	1.36	1.231	.313	29/32	3/8

CIR. PITCH	BORE	STYLE	MATERIALS	BERG'S ® NAME	CHAIN
.250	3/8"	PIN HUB	NYLATRON®	ROW-L-ER®	Operates with RC25D and RC25N series

NYLATRON® STOCK NO.	NO. OF TEETH	OUTSIDE .DIA (Inch)	PITCH DIA. (Inch)	MINOR DIA. (Inch)	BORE .002/ -.000 (Inch)	HUB DIA. (Inch)	HUB PROJECTION (Inch)
25EM6GS-18	18	1.568	1.44	1.310	.375	1	3/8
25EM6GS-19	19	1.648	1.52	1.389	.375	1-1/16	3/8
25EM6GS-20	20	1.729	1.60	1.468	.375	1-5/32	3/8
25EM6GS-21	21	1.809	1.68	1.547	.375	1-5/32	3/8
25EM6GS-22	22	1.889	1.76	1.627	.375	1-5/32	3/8
25EM6GS-24	24	2.049	1.91	1.785	.375	1-7/32	3/8
25EM6GS-26	26	2.209	2.07	1.944	.375	1-7/32	3/8
25EM6GS-27	27	2.369	2.23	2.103	.375	1-7/32	3/8
25EM6GS-30	30	2.529	2.39	2.262	.375	1-9/32	3/8

CIR. PITCH	BORE	STYLE	MATERIALS	BERG'S ® NAME	CHAIN
.250	1/2"	PIN HUB	NYLATRON®	ROW-L-ER®	Operates with RC25D and RC25N series

NYLATRON® STOCK NO.	NO. OF TEETH	OUTSIDE .DIA (Inch)	PITCH DIA. (Inch)	MINOR DIA. (Inch)	BORE .002/ -.000 (Inch)	HUB DIA. (Inch)	HUB PROJECTION (Inch)
25EM8GS-36	36	3.008	2.87	2.739	.500	1-3/8	1/2
25EM8GS-40	40	3.327	3.19	3.057	.500	1-3/8	1/2
25EM8GS-48	48	3.964	3.82	3.693	.500	1-3/8	1/2
25EM8GS-54	54	4.442	4.30	4.200	.500	1-3/8	1/2
25EM8GS-60	60	4.921	4.78	4.647	.500	1-3/8	1/2

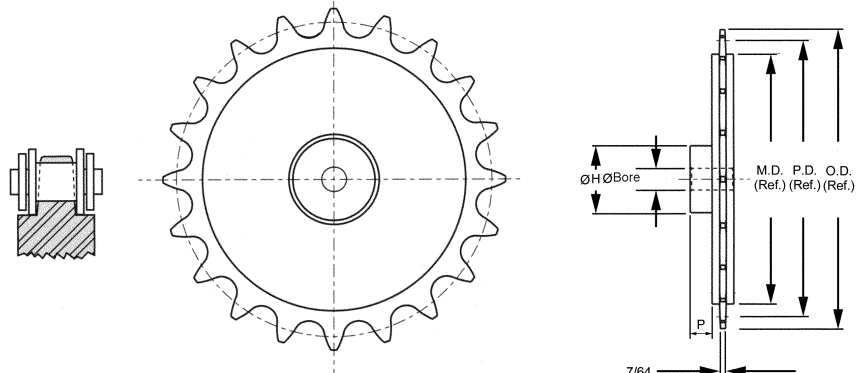

NO. 35 LINK CHAIN

CIRCULAR PITCH	ROLLER DIAMETER	BERG NAME	MATERIAL	SPROCKET
.375	.200	ROW-L-ER®	Delrin and Nylatron	Operates with 35EM and 35SP series.

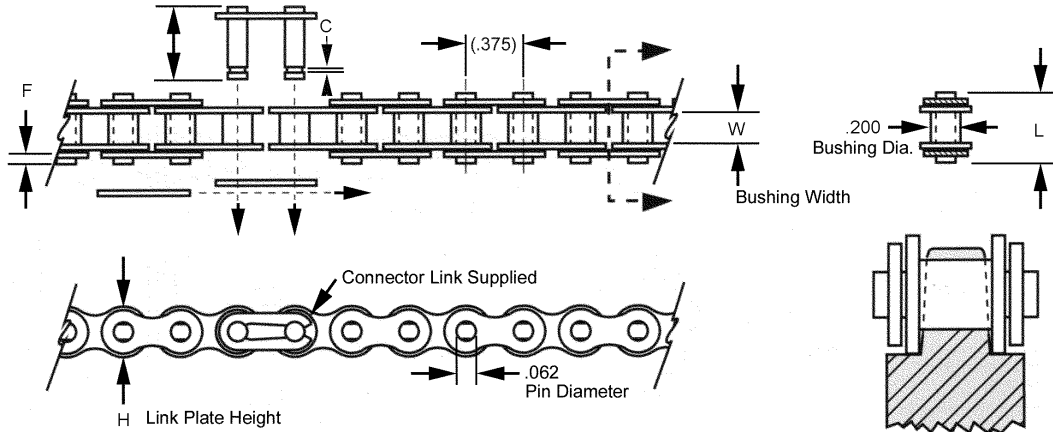

DELRIN® STOCK NO.	NYLATRON® STOCK NO.	NO. OF PITCHES	LENGTH (Inch)	PITCH	W	C	F	L	H
RC35D-40	RC35N-40	40	15.00	3/8	3/16	.141	.075	.545	.35
RC35D-50	RC35N-50	50	18.75						
RC35D-60	RC35N-60	60	22.50						
RC35D-70	RC35N-70	70	26.25						
RC35D-80	RC35N-80	80	30.00						
RC35D-90	RC35N-90	90	33.75						
RC35D-100	RC35N-100	100	37.50						
RC35D-120	RC35N-120	120	45.00						
RC35D-130	RC35N-130	130	48.75						
RC35D-140	RC35N-140	140	52.50						
RC35D-150	RC35N-150	150	56.25						
RC35D-160	RC35N-160	160	60.00						
RC35D-170	RC35N-170	170	63.75						
RC35D-180	RC35N-180	180	67.50						
RC35D-190	RC35N-190	190	71.25						
RC35D-200	RC35N-200	200	75.00						
RC35D-210	RC35N-210	210	78.75						
RC35D-220	RC35N-220	220	82.50						
RC35D-230	RC35N-230	230	86.25						

Chain Material Data:

Chain Tensile Strength @ Break (lbs.)	Delrin = 136	Nylatron GS = 136
Max. Operating Load (lbs.)	Delrin = 45	Nylatron GS = 45
Tensile (PSI)	Delrin = 9,700	Nylatron GS = 13,700
Compressive (PSI)	Delrin = 15,600	Nylatron GS = 12,500
Flexural (PSI)	Delrin = 13,600	Nylatron GS = 17,000
Water Absorption %	Delrin = 0.25	Nylatron GS = 0.8
Chain Elongation % (ultimate)	Delrin = 6	Nylatron GS = 11
@ 75% Ultimate	Delrin = 5	Nylatron GS = 9

Other materials available upon request. Other lengths available upon request.

NO. 35 SPROCKETS

CIR. PITCH	BORE	STYLE	MATERIALS	BERG'S ® NAME	CHAIN
.375	3/8"	PIN HUB	Glass filled Nylatron® GS-51	ROW-L-ER®	Operates with RC35D and RC35N series

STOCK NO.	NO. OF TEETH	OUTSIDE DIA.	PITCH DIA.	HUB DIA. (Inch)	MINOR DIA. (Inch)	L (Inch)	MAX. BORE (Inch)	STOCK BORES (Inch)
35EM6GS-9	9	1.256	1.096	5/8	.896	3/4	.375	3/8
35EM6GS-10	10	1.380	1.214	13/16	1.014	3/4	.438	3/8
35EM6GS-11	11	1.502	1.331	7/8	1.131	3/4	.500	3/8

CIR. PITCH	BORE	STYLE	MATERIALS	BERG'S ® NAME	CHAIN
.375	1/2"	PIN HUB	Glass filled Nylatron® GS-51	ROW-L-ER®	Operates with RC35D and RC35N series

STOCK NO.	NO. OF TEETH	OUTSIDE DIA.	PITCH DIA.	HUB DIA. (Inch)	MINOR DIA. (Inch)	L (Inch)	MAX. BORE (Inch)	STOCK BORES (Inch)
35EM8GS-12	12	1.625	1.449	1	1.249	3/4	.563	.500
35EM8GS-14	14	1.868	1.685	1-1/16	1.485	3/4	.750	.500
35EM8GS-15	15	1.990	1.804	1-3/8	1.604	3/4	.813	.500
35EM8GS-16	16	2.111	1.922	1-1/2	1.722	3/4	.938	.500
35EM8GS-18	18	2.352	2.159	1-1/4	1.959	3/4	1.063	.500
35EM8GS-20	20	2.593	2.397	1-1/2	2.197	7/8	1.188	.500
35EM8GS-24	24	3.074	2.873	2	2.673	7/8	1.188	.500
35EM8GS-26	26	3.314	3.111	2-1/16	2.911	7/8	1.438	.500
35EM8GS-30	30	3.793	3.588	2-1/4	3.388	7/8	1.438	.500
35EM8GS-35	35	4.392	4.138	2-1/4	3.983	7/8	1.438	.500

CIR. PITCH	BORE	STYLE	MATERIALS	BERG'S ® NAME	CHAIN
.375	5/8"	PIN HUB	Glass filled Nylatron® GS-51	ROW-L-ER®	Operates with RC35D and RC35N series

STOCK NO.	NO. OF TEETH	OUTSIDE DIA.	PITCH DIA.	HUB DIA. (Inch)	MINOR DIA. (Inch)	L (Inch)	MAX. BORE (Inch)	STOCK BORES (Inch)
35EM10GS-36	36	4.511	4.300	2-1/4	4.103	7/8	1.438	.625
35EM10GS-40	40	4.990	4.780	2-1/2	4.580	7/8	1.750	.625
35EM10GS-45	45	5.588	5.376	2-3/4	5.176	1	1.750	.625

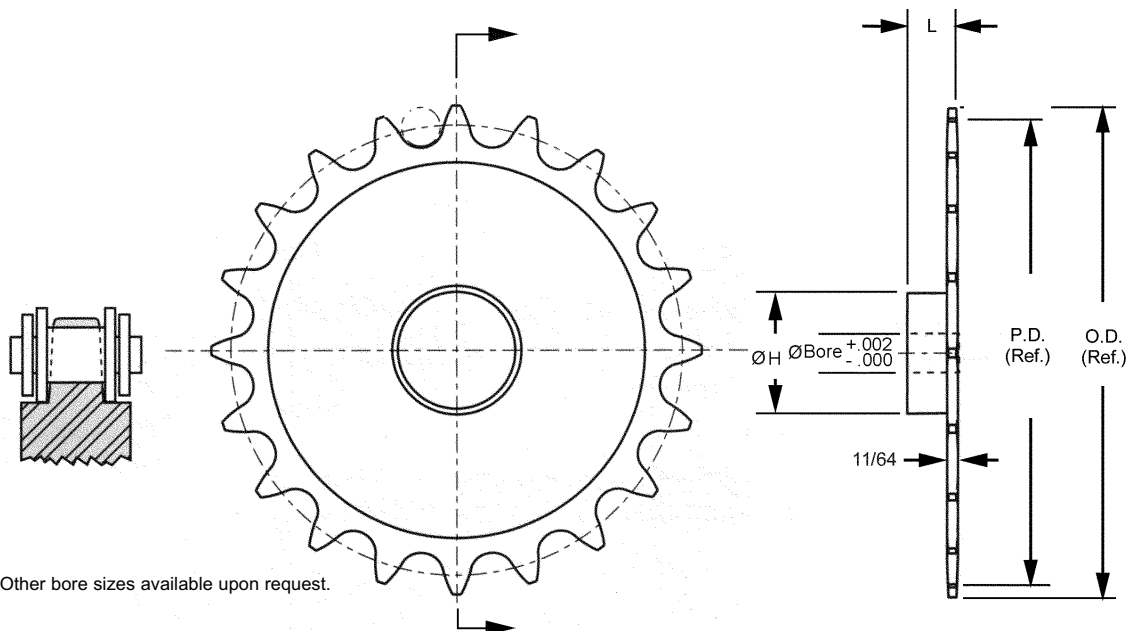

NO. 35 LINK PLATE LUGS

STOCK NUMBER	DESCRIPTION
35NBBL	BENT LUG - NYLATRON®

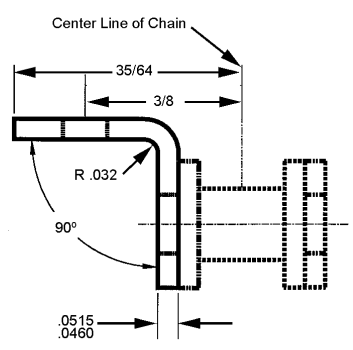
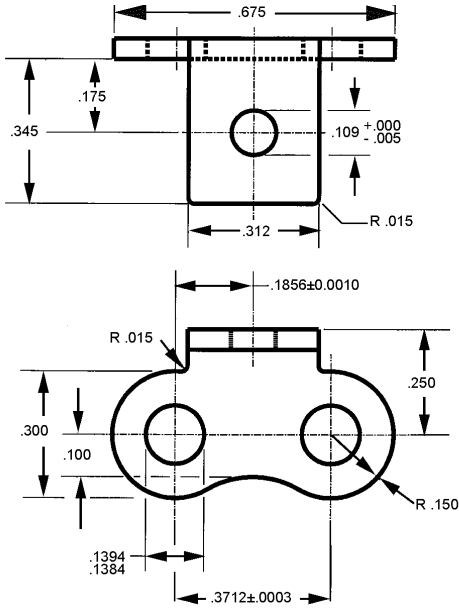

STOCK NUMBER	DESCRIPTION
35NBSL	STRAIGHT LUG - NYLATRON®

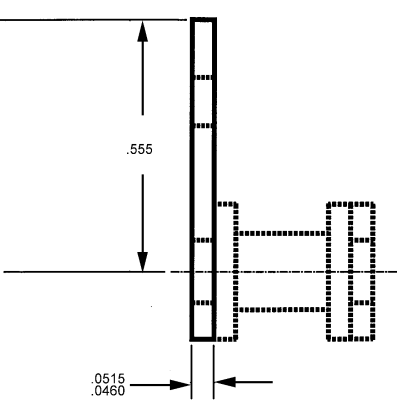
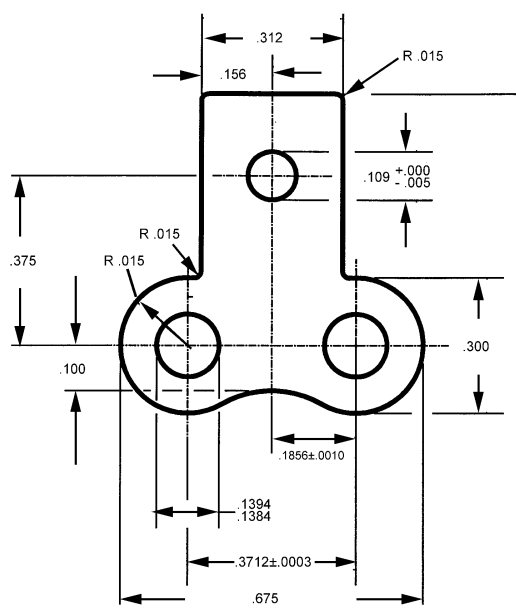

NO. 40 LINK CHAIN

CIRCULAR PITCH	ROLLER DIAMETER	BERG NAME	MATERIAL	SPROCKET
.500	.313	ROW-L-ER®	Delrin and Nylatron	Operates with 40EM series.

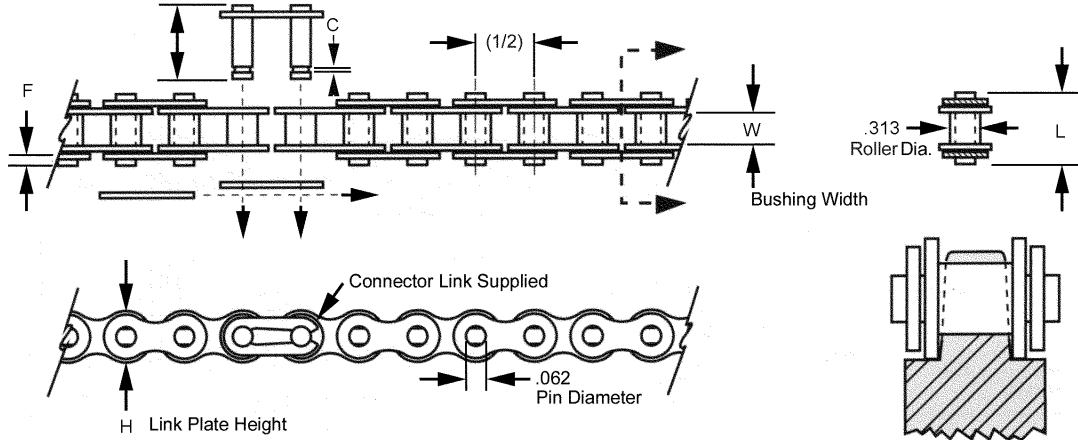

DELRIN® STOCK NO.	NYLATRON® STOCK NO.	NO. OF PITCHES	LENGTH (Inch)	PITCH	W	C	F	L	H
RC40D-40	RC40N-40	40	20.00	1/2	5/16	.156	.088	.725	.46
RC40D-50	RC40N-50	50	25.00						
RC40D-60	RC40N-60	60	30.00						
RC40D-70	RC40N-70	70	35.00						
RC40D-80	RC40N-80	80	40.00						
RC40D-90	RC40N-90	90	45.00						
RC40D-100	RC40N-100	100	50.00						
RC40D-120	RC40N-120	120	60.00						
RC40D-130	RC40N-130	130	65.00						
RC40D-140	RC40N-140	140	70.00						
RC40D-150	RC40N-150	150	75.00						
RC40D-160	RC40N-160	160	80.00						
RC40D-170	RC40N-170	170	85.00						
RC40D-180	RC40N-180	180	90.00						
RC40D-190	RC40N-190	190	95.00						
RC40D-200	RC40N-200	200	100.00						

Chain Material Data:

Chain Tensile Strength @ Break (lbs.)	Delrin = 175	Nylatron GS = 173
Max. Operating Load (lbs.)	Delrin = 58	Nylatron GS = 57
Tensile (PSI)	Delrin = 9,700	Nylatron GS = 13,700
Compressive (PSI)	Delrin = 15,600	Nylatron GS = 12,500
Flexural (PSI)	Delrin = 13,600	Nylatron GS = 17,000
Water Absorption %	Delrin = 0.250.8	Nylatron GS = 0.8
Chain Elongation % (ultimate)	Delrin = 4	Nylatron GS = 9
@ 75% Ultimate	Delrin = 3	Nylatron GS = 7

Other materials available upon request. Other lengths available upon request.

NO. 40 SPROCKETS

CIR. PITCH	BORE	STYLE	MATERIALS	BERG'S ® NAME	CHAIN
.500	1/2"	PIN HUB	Glass filled Nylatron® GS-51	ROW-L-ER®	Operates with RC40D and RC40N series

STOCK NO.	NO. OF TEETH	OUTSIDE DIA.	PITCH DIA.	HUB DIA. (Inch)	MINOR DIA. (Inch)	L (Inch)	MAX. BORE (Inch)	STOCK BORES (Inch)
40EM8GS-9	9	1.674	1.462	7/8	1.150	7/8	.500	.500
40EM8GS-10	10	1.839	1.618	1-1/8	1.306	7/8	.281	.500
40EM8GS-12	12	2.166	1.932	1-3/8	1.620	7/8	.844	.500
40EM8GS-15	15	2.652	2.405	1-7/8	2.093	7/8	1.188	.500

CIR. PITCH	BORE	STYLE	MATERIALS	BERG'S ® NAME	CHAIN
.500	5/8"	PIN HUB	Glass filled Nylatron® GS-51	ROW-L-ER®	Operates with RC40D and RC40N series

STOCK NO.	NO. OF TEETH	OUTSIDE DIA.	PITCH DIA.	HUB 'H'	MINOR DIA. (Inch)	MAX. L (Inch)	STOCK BORE (Inch)	BORES (Inch)
40EM10GS-16	16	2.814	2.563	1-7/8	2.251	7/8	1.250	.625
40EM10GS-24	24	4.098	3.831	2-1/2	3.519	1	1.375	.625

CIR. PITCH	BORE	STYLE	MATERIALS	BERG'S ® NAME	CHAIN
.500	3/4"	PIN HUB	Glass filled Nylatron® GS-51	ROW-L-ER®	Operates with RC40D and RC40N series

STOCK NO.	NO. OF TEETH	OUTSIDE DIA.	PITCH DIA.	HUB DIA. 'H'	MINOR DIA. (Inch)	L (Inch)	MAX. BORE (Inch)	STOCK BORES (Inch)
40EM12GS-32	32	5.377	5.101	2	4.789	1	1.375	.750



Other bore sizes available upon request.

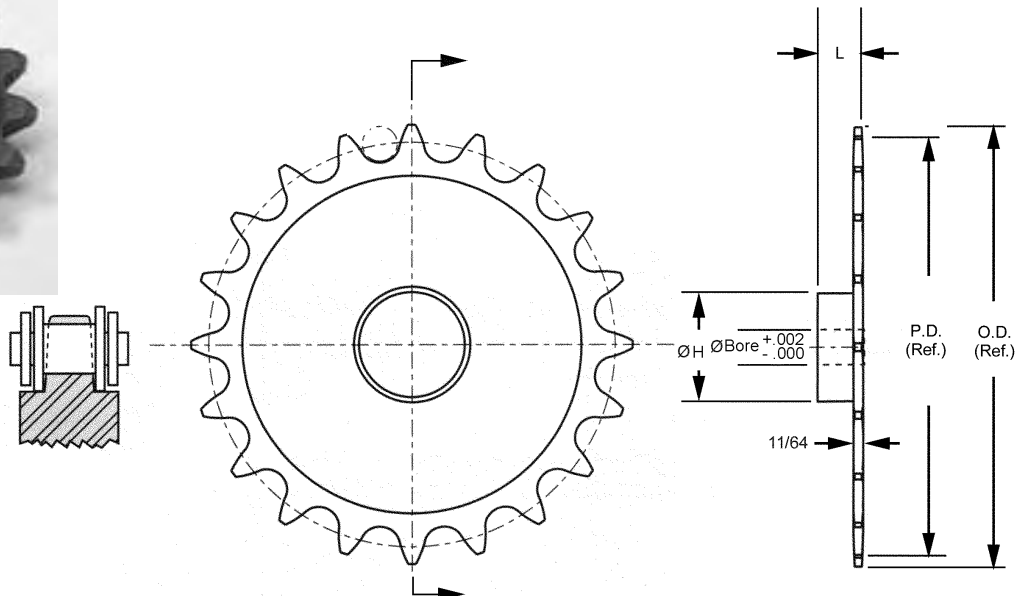

NO. 40 LINK PLATE LUGS

A

STOCK NUMBER	DESCRIPTION
40NBBL	BENT LUG - NYLATRON®

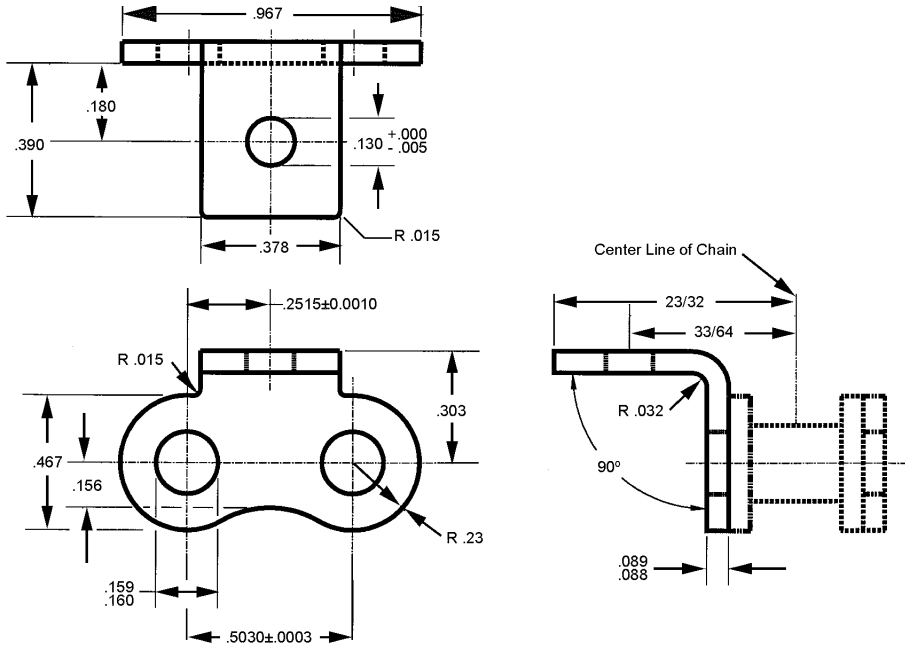

STOCK NUMBER	DESCRIPTION
40NBSL	STRAIGHT LUG - NYLATRON®

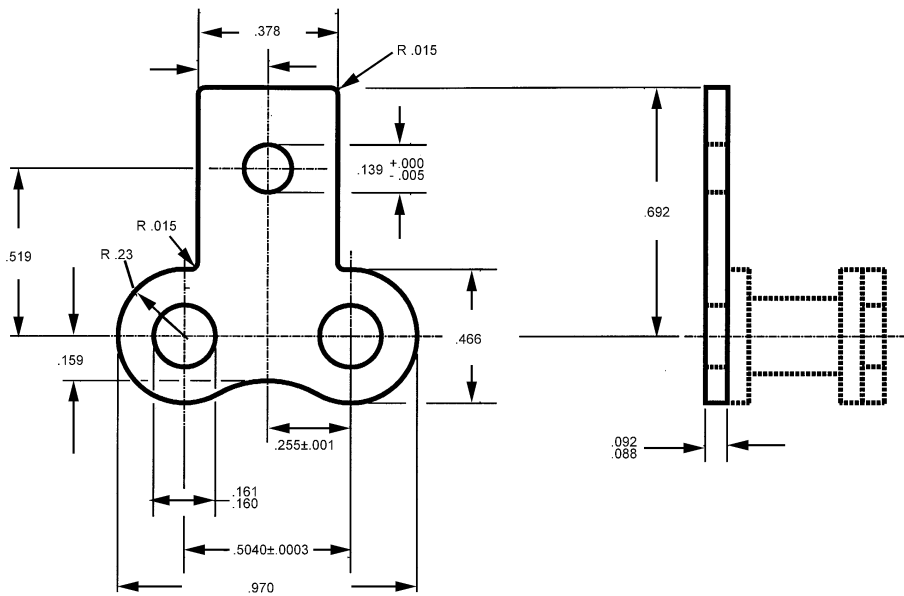

FLEX-E-GRIP TIMING BELTS TECHNICAL DATA

Features

- No Side Flanges Necessary
- Infinite Lengths
- Higher Load Capacities and Narrower Widths
- Positive Drives (Non-slip Engagement)
- No Lubrication
- Minimum Backlash
- High Mechanical Efficiency
- Extra Light Weight
- Silent Operation (No Side Flange Noise)
- Economical
- Wide Speed Range
- Broader Ratio Selection

Installation Notes

- (A) All Shafts Must Be Parallel
 (B) Use Adjustable Centers Wherever Possible
 (C) If Adjustable Centers are not Possible Use Idler Pulley Inside The Belt
 (D) Never Force Belt Over Pulleys
 (E) Avoid Reverse Bending (See Page X)

4 Compact Width Sizes

40 D. Pitch (XXL) Miniature 1/8" Wide

Equal to or stronger than conventional Timing Belts up to 5/8" wide

1/5" Pitch (XL) Extra Light 1/4" Wide

Equal to or stronger than conventional Timing Belts up to 1" wide

3/8" Pitch (L) Light 1/2" Wide

Equal to or stronger than conventional Timing Belts up to 2" wide

1/2" Pitch (H) Heavy 3/4" Wide

Equal to or stronger than conventional Timing Belts up to 2" wide

Construction

Belts - Molded in Polyurethane to meet Acid, Chemical and Environmental Conditions.

Cable - Steel Preformed Aircraft Standard Cable of both 7x7 and 7x19 Construction.

Pulleys - Aluminum 2024 (bar) MIL QQ-Q-225/6 Cond. T4 Anodized

Operating Parameters

Minimum Pulley Diameters

SIZE	MAX. SPEED R.P.M.	MIN. NO. OF GROOVES	PITCH DIAMETER
40 D.P. 8TB- SERIES	1750 1750 1160	24 20 18	.623 .520 .468
1/5" PITCH 20TB- SERIES	1750 1750 1160	14 12 11	.871 .743 .700
3/8" PITCH 37TB- SERIES	1750 1750 1160	16 14 12	1.910 1.671 1.432
1/2" PITCH 50TB- SERIES	1750 1750 1160	20 18 16	3.183 2.865 2.564

400% Stronger Than Conventional Timing Belts
 Will Not Slip, Slide, Jump, Creep or Walk Off Timing Pulley

FLEX-E-GRIP TIMING BELTS TECHNICAL DATA

Technical Data and Comparison With Standard Timing Belts

Berg 8 TB Series 20 lb. Ultimate tensile

40 Pitch - Miniature (X,XL) .0816 C.P. 1/8" Timing Belts - equal to standard 5/8" wide XXL belts
Flex-E-Grip XXL Timing Belts 1/8" wide 20 lbs. Ultimate tensile strength.

Conventional Belt	Tensile Strength
1/8" WIDE	4 lbs.
3/16" WIDE	6lbs.
1/4" WIDE	8 lbs.
5/8" WIDE	20 lbs.

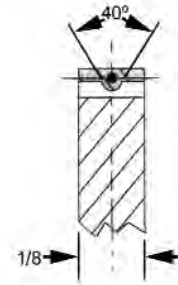

Berg 20TB Series 50 lb. Ultimate tensile

1/5 Pitch - Extra Light (XL) .200 C.P. 1/4" Timing Belts - equal to standard 1" wide XL belts
Flex-E-Grip XL Timing Belts 1/4" wide 50 lbs. Ultimate tensile strength

Conventional Belt	Tensile Strength
1/4" WIDE	10 lbs.
5/16" WIDE	12 lbs.
3/8" WIDE	15 lbs.
1/2" WIDE	21 lbs.
9/16" WIDE	23 lbs.
1" WIDE	41 lbs.

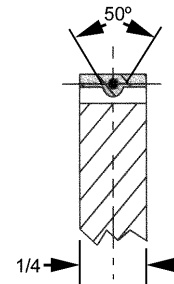

Berg 37TB Series 125 lb. Ultimate tensile

3/8" Pitch - Light (L) .375 C.P. 1/2" Timing Belts - equal to standard 2" wide L belts.
Flex-E-Grip L Timing Belts 1/2" wide 125 lbs. Ultimate tensile strength

Conventional Belt	Tensile Strength
3/8" WIDE	16 lbs.
1/2" WIDE	24 lbs.
5/8" WIDE	31 lbs.
3/4" WIDE	39 lbs.
1" WIDE	55 lbs.
2-1/2" WIDE	150 lbs.

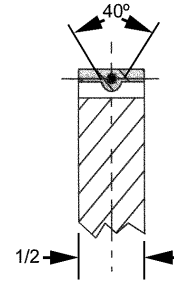

Berg 50TB Series 300 lb. Ultimate tensile

1/2" Pitch - Heavy (H) .500 C.P. 3/4" Timing Belts - equal to standard 2" wide H belts
Flex-E-Grip H Timing Belts 3/4" wide 300 lbs. Ultimate tensile strength

Conventional Belt	Tensile Strength
1/2" WIDE	59 lbs.
5/8" WIDE	80 lbs.
3/4" WIDE	99 lbs.
1" WIDE	140 lbs.
2" WIDE	300 lbs.

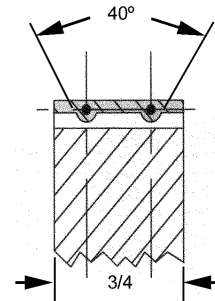

TIMING BELTS

CIRCULAR PITCH	BELT WIDTH	MATERIALS	BERG'S ® NAME	PULLEY
.0816 (XXL)	1/8"	Polyurethane (Black) 90A Duro .018 Stainless Steel Cable*	Flex-E-Grip®	Operates with 8TP series.

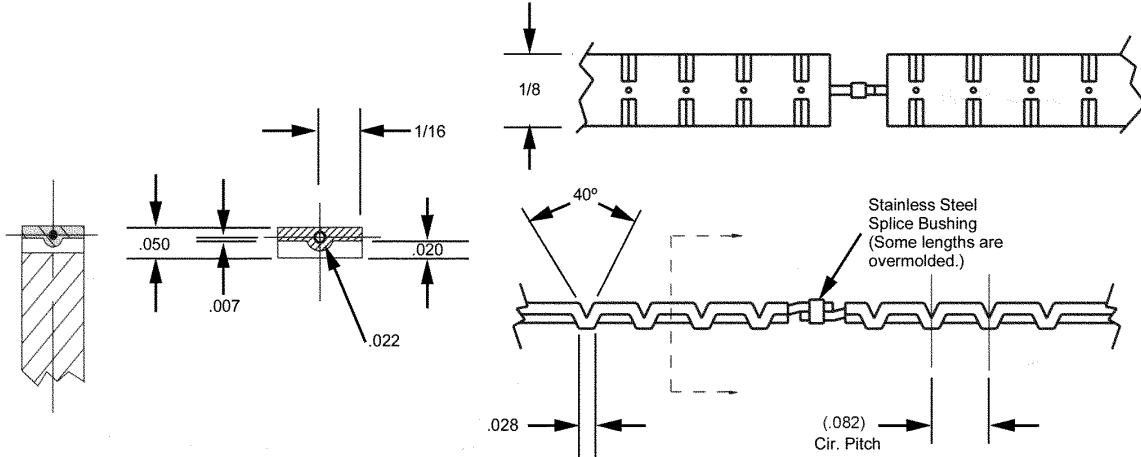

STOCK NO.	NO. OF PITCHES	LENGTH (Ref.)
8TB-24*	24	1.958
8TB-44	44	3.590
8TB-45	45	3.672
8TB-48	48	3.916
8TB-51	51	4.161
8TB-52	52	4.243
8TB-53	53	4.324
8TB-60	60	4.896
8TB-64	64	5.222
8TB-66	66	5.385
8TB-67	67	5.467
8TB-72	72	5.875
8TB-77	77	6.283
8TB-88	88	7.180
8TB-96	96	7.833
8TB-98	98	7.996
8TB-102	102	8.323
8TB-109	109	8.894
8TB-110	110	8.976
8TB-114	114	9.302
8TB-120	120	9.792
8TB-123	123	10.036
8TB-126	126	10.281
8TB-132	132	10.771
8TB-139	139	11.342
8TB-140	140	11.424
8TB-150	150	12.240
8TB-162	162	13.219
8TB-175	175	14.280
8TB-184	184	15.014
8TB-193	193	15.748
8TB-214	214	17.462
8TB-228	228	18.604
8TB-245	245	19.992
8TB-249	249	20.318
8TB-251	251	20.481
8TB-264	264	21.542

- No Flanges Required
- Infinite Lengths
- Silent Drive
- No-Walk Feature
- No Lubrication
- Weight .05 oz./ft.
- Compact Design
- Positive Drive
- Light Weigh
- Extra Strong
- Ultimate Tensile Strength 20 lbs
- Temperature Range +180°F to -15°F
- Recommended Operating Load 4-5 lbs.
- Recommended Max. Operating Speed 376 ft./min
- For Field Splice Kit order 8TB-7.

* Splices are factory overmolded



BULK FOOTAGE - NOT SPLICED	
STOCK NO.	LENGTH
8TB-5FT	5 FT
8TB-10FT	10 FT
8TB-25FT	25 FT
8TB-50FT	50 FT
8TB-100FT	100 FT

TIMING PULLEYS

CIR. PITCH	BORE	STYLE	MATERIAL	BERG'S ® NAME	BELT
.0816 (XXL)	1/8"	PIN HUB	2024-T4 Aluminum Anodized	Flex-E-Grip®	Operates with Flex-E-Grip Belt 8TB Series

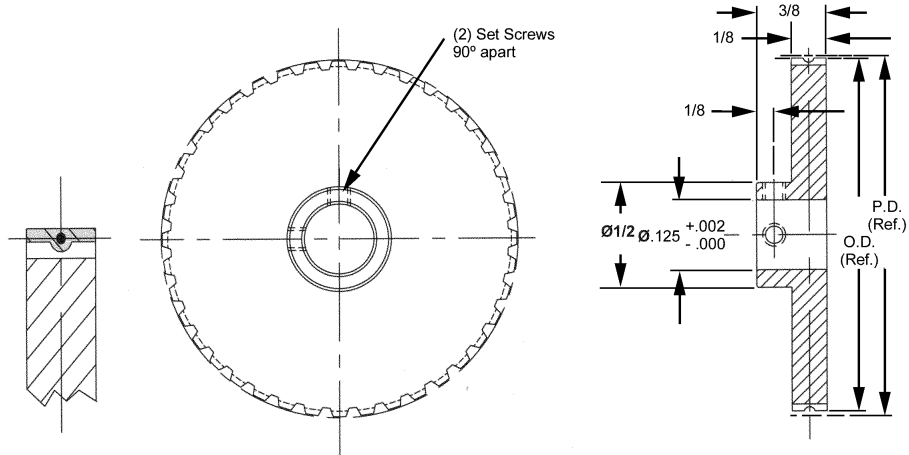

STOCK NO.	NO. OF TEETH	PITCH DIA.	OUTSIDE DIA.
8TP2-14	14*	.3636	.349
8TP2-15	15*	.3896	.375
8TP2-18	18*	.4675	.453
8TP2-20	20*	.5195	.505
8TP2-24	24	.6234	.609
8TP2-25	25	.6494	.635
8TP2-28	28	.7273	.713
8TP2-30	30	.7792	.765
8TP2-32	32	.8312	.817
8TP2-34	34	.8831	.869
8TP2-36	36	.9351	.921
8TP2-38	38	.9870	.972
8TP2-40	40	1.0390	1.024
8TP2-42	42	1.0909	1.076
8TP2-44	44	1.1429	1.128
8TP2-48	48	1.2468	1.232
8TP2-50	50	1.2987	1.284
8TP2-54	54	1.4026	1.388
8TP2-60	60	1.5584	1.544
8TP2-72	72	1.8701	1.856
8TP2-75	75	1.9481	1.934
8TP2-80	80	2.0779	2.063
8TP2-84	84	2.1818	2.167
8TP2-88	88	2.2857	2.271
8TP2-90	90	2.3377	2.323
8TP2-96	96	2.4935	2.479
8TP2-98	98	2.5455	2.531
8TP2-100	100	2.5974	2.583
8TP2-120	120	3.1169	3.102



* For 14-20 teeth, hub diameter equals .32.
 * Pulleys .468 P.D. and smaller for idler use only.
 Teeth could be anodized.

TIMING PULLEYS

CIR. PITCH	BORE	STYLE	MATERIAL	BERG'S ® NAME	BELT
.0816 (XXL)	3/16"	PIN HUB	2024-T4 Aluminum Anodized	Flex-E-Grip®	Operates with Flex-E-Grip Belt 8TB Series

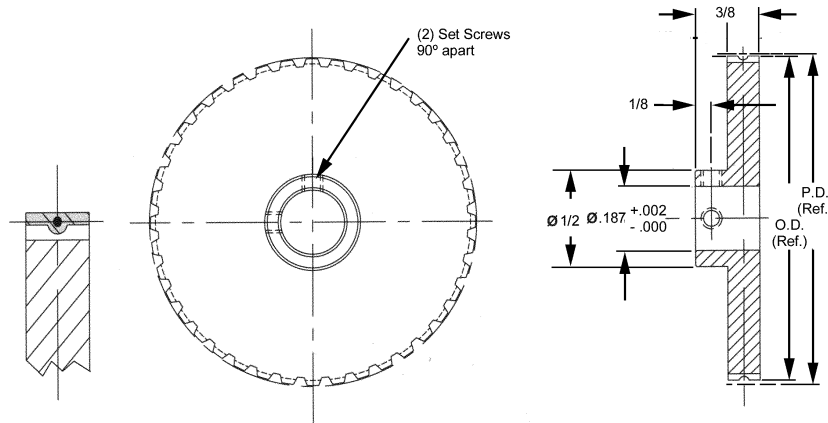

STOCK NO.	NO. OF TEETH	PITCH DIA.	OUTSIDE DIA.
8TP3-18	18*	.4675	.453
8TP3-20	20*	.5195	.505
8TP3-24	24	.6234	.609
8TP3-25	25	.6494	.635
8TP3-28	28	.7273	.713
8TP3-30	30	.7792	.765
8TP3-32	32	.8312	.817
8TP3-34	34	.8831	.869
8TP3-36	36	.9351	.921
8TP3-38	38	.9870	.972
8TP3-40	40	1.0390	1.024
8TP3-42	42	1.0909	1.076
8TP3-44	44	1.1429	1.128
8TP3-48	48	1.2468	1.232
8TP3-50	50	1.2987	1.284
8TP3-54	54	1.4026	1.388
8TP3-60	60	1.5584	1.544
8TP3-72	72	1.8701	1.856
8TP3-75	75	1.9481	1.934
8TP3-80	80	2.0779	2.063
8TP3-84	84	2.1818	2.167
8TP3-88	88	2.2857	2.271
8TP3-90	90	2.3377	2.323
8TP3-96	96	2.4935	2.479
8TP3-98	98	2.5455	2.531
8TP3-100	100	2.5974	2.583
8TP3-120	120	3.1169	3.102



* For 18-20 teeth, hub diameter equals .42
 * Pulleys .468 P.D. and smaller for idler use only.
 Teeth could be anodized.

TIMING PULLEYS

CIR. PITCH	BORE	STYLE	MATERIAL	BERG'S ® NAME	BELT
.0816 (XXL)	1/4"	PIN HUB	2024-T4 Aluminum Anodized	Flex-E-Grip®	Operates with Flex-E-Grip Belt 8TB Series

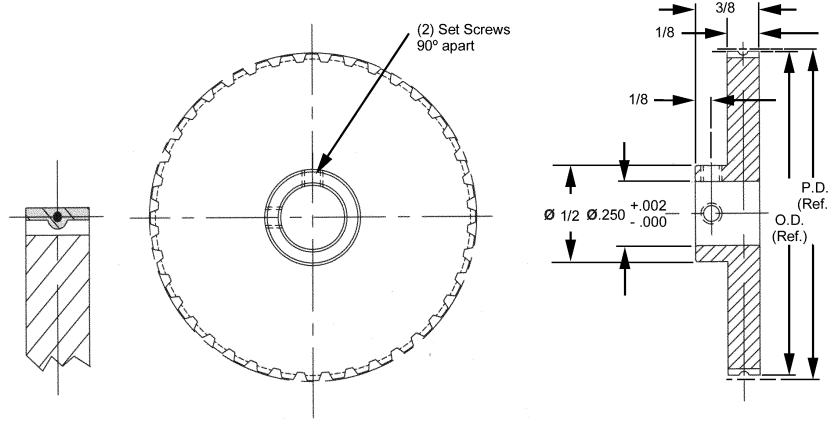

STOCK NO.	NO. OF TEETH	PITCH DIA.	OUTSIDE DIA.
8TP4-18	18*	.4675	.453
8TP4-20	20	.5195	.505
8TP4-24	24	.6234	.609
8TP4-25	25	.6494	.635
8TP4-28	28	.7273	.713
8TP4-30	30	.7792	.765
8TP4-32	32	.8312	.817
8TP4-34	34	.8831	.869
8TP4-36	36	.9351	.921
8TP4-38	38	.9870	.972
8TP4-40	40	1.0390	1.024
8TP4-42	42	1.0909	1.076
8TP4-44	44	1.1429	1.128
8TP4-48	48	1.2468	1.232
8TP4-50	50	1.2987	1.284
8TP4-54	54	1.4026	1.388
8TP4-60	60	1.5584	1.544
8TP4-72	72	1.8701	1.856
8TP4-75	75	1.9481	1.934
8TP4-80	80	2.0779	2.063
8TP4-84	84	2.1818	2.167
8TP4-88	88	2.2857	2.271
8TP4-90	90	2.3377	2.323
8TP4-96	96	2.4935	2.479
8TP4-98	98	2.5455	2.531
8TP4-100	100	2.5974	2.583
8TP4-120	120	3.1169	3.102



* For 18 teeth, hub diameter equals .42
 * Pulleys .468 P.D. and smaller for idler use only.

Teeth could be anodized.

TIMING BELTS

CIRCULAR PITCH	BELT WIDTH	MATERIALS	BERG'S ® NAME	PULLEY
.200 (XL)	1/4"	Polyurethane (Red) 90A Duro 1/32" Stainless Steel Cable*	Flex-E-Grip®	Operates with 20TP Series

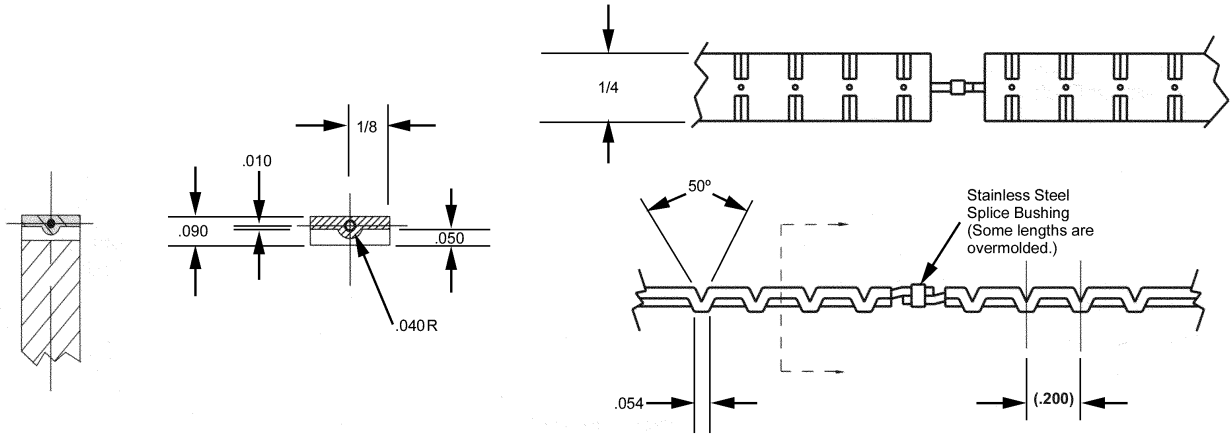

STOCK NO.	NO. OF PITCHES	LENGTH (Ref.)
20TB-10	10*	2.00
20TB-15	15*	3.00
20TB-20	20*	4.00
20TB-25	25	5.00
20TB-30	30	6.00
20TB-35	35	7.00
20TB-40	40	8.00
20TB-45	45	9.00
20TB-50	50	10.00
20TB-55	55	11.00
20TB-60	60	12.00
20TB-65	65	13.00
20TB-70	70	14.00
20TB-80	80	16.00
20TB-85	85	17.00
20TB-90	90	18.00
20TB-95	95	19.00
20TB-100	100	20.00
20TB-105	105	21.00
20TB-110	110	22.00
20TB-110	115	23.00
20TB-120	120	24.00
20TB-125	125	25.00
20TB-130	130	26.00
20TB-135	135	27.00
20TB-140	140	28.00
20TB-145	145	29.00
20TB-150	150	30.00
20TB-155	155	31.00
20TB-160	160	32.00
20TB-175	175	35.00
20TB-180	180	36.00
20TB-185	185	37.00
20TB-190	190	38.00
20TB-200	200	40.00
20TB-210	210	42.00

*Aramid Core. Alternate construction available.

- No Flanges Required
- Infinite Lengths
- Silent Drive
- No-Walk Feature
- No Lubrication
- Weight .10 oz./ft.
- Compact Design
- Positive Drive
- Light Weight
- Extra Strong
- Ultimate Tensile Strength 50 lbs.
- Temperature Range +180°F to -15°F
- Recommended Operating Load 10-12 lbs.
- Recommended Max. Operating Speed 376 ft./min.
- For Field Splice Kit Order 20TB-70

* Splices are factory overmolded

BULK FOOTAGE - NOT SPLICED	
STOCK NO.	LENGTH
20TB-5FT	5 FT
20TB-10FT	10 FT
20TB-25FT	25 FT
20TB-50FT	50 FT
20TB-100FT	100 FT

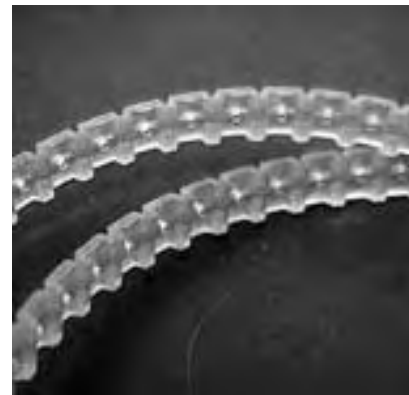

TIMING PULLEYS

CIR. PITCH	BORE	STYLE	MATERIAL	BERG'S ® NAME	BELT
.200 (XL)	1/4"	PIN HUB	2024-T4 Aluminum Anodized	Flex-E-Grip®	Operates with Flex-E-Grip Belt 20TB Series

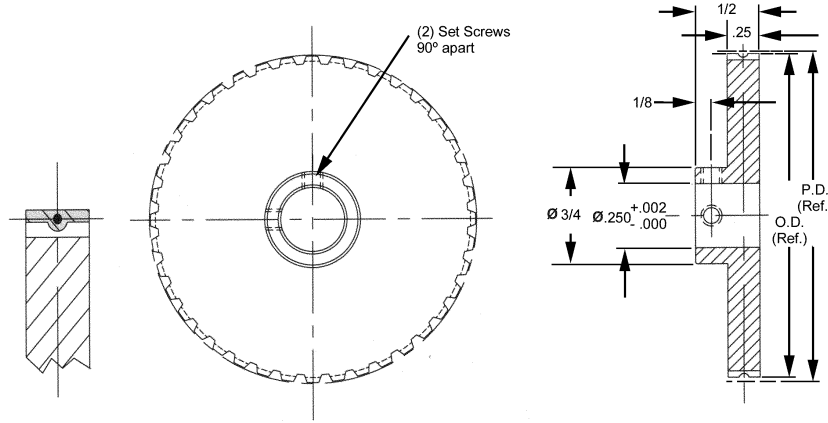

STOCK NO.	NO. OF TEETH	PITCH DIA.	OUTSIDE DIA.
20TP4-10	10*	.6366	.616
20TP4-11	11*	.7003	.680
20TP4-12	12*	.7639	.743
20TP4-14	14	.8913	.871
20TP4-15	15	.9549	.934
20TP4-16	16	1.0186	.998
20TP4-17	17	1.0823	1.062
20TP4-18	18	1.1459	1.125
20TP4-19	19	1.2096	1.189
20TP4-20	20	1.2732	1.253
20TP4-21	21	1.3369	1.316
20TP4-22	22	1.4006	1.380
20TP4-23	23	1.4642	1.444
20TP4-24	24	1.5279	1.507
20TP4-25	25	1.5916	1.571
20TP4-27	27	1.7189	1.698
20TP4-28	28	1.7825	1.762
20TP4-29	29	1.8462	1.826
20TP4-30	30	1.9099	1.889
20TP4-32	32	2.0372	2.017
20TP4-36	36	2.2918	2.271
20TP4-40	40	2.5465	2.526
20TP4-42	42	2.6738	2.653
20TP4-44	44	2.8011	2.781
20TP4-45	45	2.8648	2.844
20TP4-48	48	3.0558	3.035
20TP4-50	50	3.1831	3.163
20TP4-60	60	3.8197	3.799
20TP4-72	72	4.5837	4.563



• For 10-12 teeth, hub diameter equals .56
 * Pulleys .750 P.D. and smaller for idler use only.
 Other numbers of teeth available upon request.
 Teeth could be anodized.

TIMING PULLEYS

CIR. PITCH	BORE	STYLE	MATERIAL	BERG'S ® NAME	BELT
.200 (XL)	3/8"	PIN HUB	2024-T4 Aluminum Anodized	Flex-E-Grip®	Operates with Flex-E-Grip Belt 20TB Series

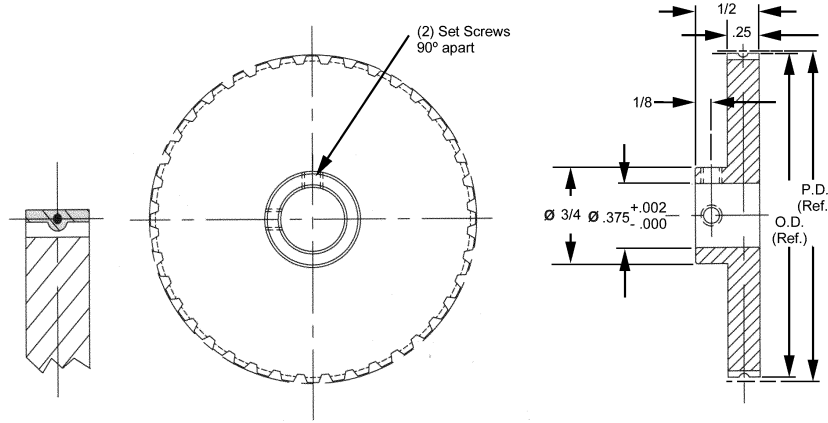

STOCK NO.	NO. OF TEETH	PITCH DIA.	OUTSIDE DIA.
20TP6-11	11*	.7003	.680
20TP6-12	12*	.7639	.743
20TP6-14	14	.8913	.871
20TP6-15	15	.9549	.934
20TP6-16	16	1.0186	.998
20TP6-17	17	1.0823	1.062
20TP6-18	18	1.1459	1.125
20TP6-19	19	1.2096	1.189
20TP6-20	20	1.2732	1.253
20TP6-21	21	1.3369	1.316
20TP6-22	22	1.4006	1.380
20TP6-23	23	1.4642	1.444
20TP6-24	24	1.5279	1.507
20TP6-25	25	1.5916	1.571
20TP6-27	27	1.7189	1.698
20TP6-28	28	1.7825	1.762
20TP6-29	29	1.8462	1.826
20TP6-30	30	1.9099	1.889
20TP6-32	32	2.0372	2.017
20TP6-36	36	2.2918	2.271
20TP6-40	40	2.5465	2.526
20TP6-42	42	2.6738	2.653
20TP6-44	44	2.8011	2.781
20TP6-45	45	2.8648	2.844
20TP6-48	48	3.0558	3.035
20TP6-50	50	3.1831	3.163
20TP6-60	60	3.8197	3.799
20TP6-72	72	4.5837	4.563



• For 11-12 teeth, hub diameter equals .62.
 * Pulleys .750 P.D. and smaller for idler use only.
 Other numbers of teeth available upon request.
 Teeth could be anodized.

TIMING PULLEYS

CIR. PITCH	BORE	STYLE	MATERIAL	BERG'S ® NAME	BELT
.200 (XL)	1/2"	PIN HUB	2024-T4 Aluminum Anodized	Flex-E-Grip®	Operates with Flex-E-Grip Belt 20TB Series

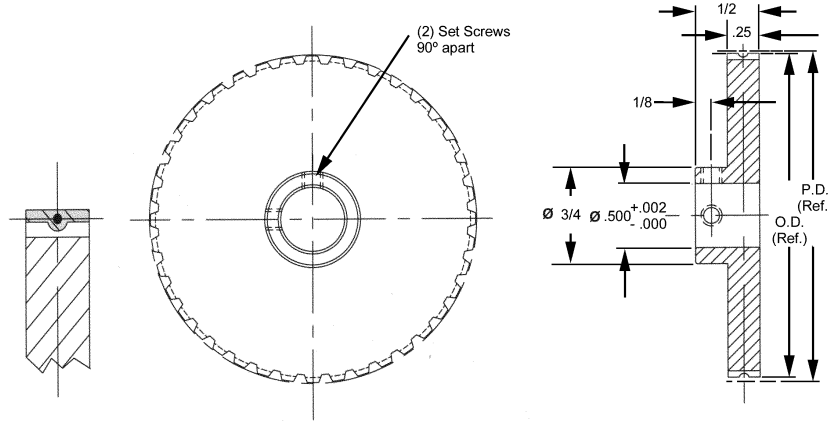

STOCK NO.	NO. OF TEETH	PITCH DIA.	OUTSIDE DIA.
20TP8-14	14	.8913	.871
20TP8-15	15	.9549	.934
20TP8-16	16	1.0186	.998
20TP8-17	17	1.0823	1.062
20TP8-18	18	1.1459	1.125
20TP8-19	19	1.2096	1.189
20TP8-20	20	1.2732	1.253
20TP8-21	21	1.3369	1.316
20TP8-22	22	1.4006	1.380
20TP8-23	23	1.4642	1.444
20TP8-24	24	1.5279	1.507
20TP8-25	25	1.5916	1.571
20TP8-27	27	1.7189	1.698
20TP8-28	28	1.7825	1.762
20TP8-29	29	1.8462	1.826
20TP8-30	30	1.9099	1.889
20TP8-32	32	2.0372	2.017
20TP8-36	36	2.2918	2.271
20TP8-40	40	2.5465	2.526
20TP8-42	42	2.6738	2.653
20TP8-44	44	2.8011	2.781
20TP8-45	45	2.8648	2.844
20TP8-48	48	3.0558	3.035
20TP8-50	50	3.1831	3.163
20TP8-60	60	3.8197	3.799
20TP8-72	72	4.5837	4.563



* Pulleys .750 P.D. and smaller for idler use only.
Other numbers of teeth available upon request.

Teeth could be anodized.

TIMING BELTS

CIRCULAR PITCH	BELT WIDTH	MATERIALS	BERG'S ® NAME	PULLEY
.375 (L)	1/2"	Polyurethane (Blue) 90A Duro 3/64" Stainless Steel Cable*	Flex-E-Grip®	Operates with 37TP Series

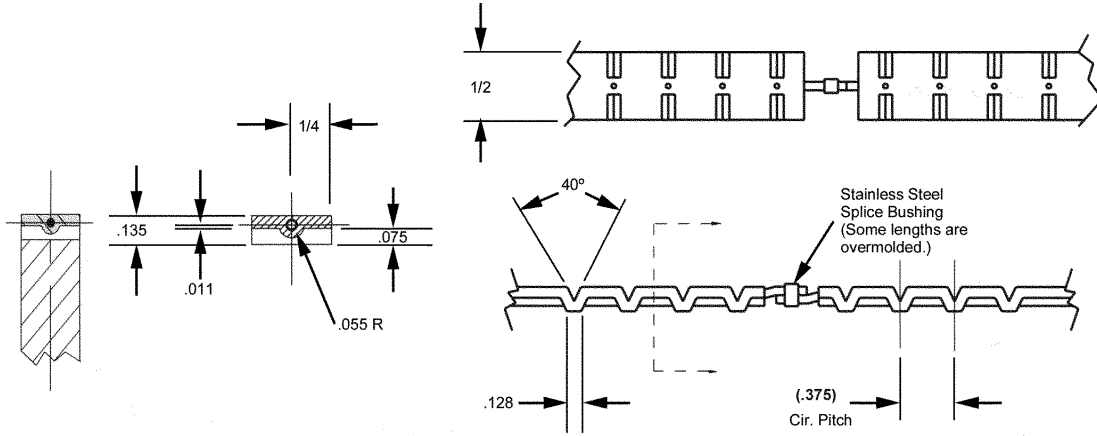

STOCK NO.	NO. OF PITCHES	LENGTH (Ref.)
37TB-20	20	7.500
37TB-22	22	8.250
37TB-24	24	9.000
37TB-26	26	9.750
37TB-28	28	10.500
37TB-30	30	11.250
37TB-33	33	12.375
37TB-36	36	13.500
37TB-40	40	15.000
37TB-45	45	16.875
37TB-50	50	18.750
37TB-56	56	21.000
37TB-60	60	22.500
37TB-64	64	24.000
37TB-68	68	25.500
37TB-72	72	27.000
37TB-80	80	30.000
37TB-86	86	32.250
37TB-92	92	34.500
37TB-98	98	36.750
37TB-100	100	37.500
37TB-104	104	39.000
37TB-108	108	40.500
37TB-112	112	42.000
37TB-116	116	43.500
37TB-120	120	45.000
37TB-124	124	46.500
37TB-128	128	48.000
37TB-132	132	49.500
37TB-136	136	51.000
37TB-140	140	52.500
37TB-144	144	54.000
37TB-148	148	55.500
37TB-152	152	57.000
37TB-156	156	58.500
37TB-160	160	60.000
37TB-176	176	66.000

Aramid Core. Alternate construction available.

- No Flanges Required
- Infinite Lengths
- Silent Drive
- No-Walk Feature
- No Lubrication
- Weight .41 oz./ft.
- Compact Design
- Positive Drive
- Light Weight
- Extra Strong
- Ultimate Tensile Strength 50 lbs.
- Temperature Range +180°F to -15°F
- Recommended Operating Load 30 lbs.
- Recommended Max. Operating Speed 376 ft./min.
- For Field Splice Kit Order 37TB-7

* Splices are factory overmolded

BULK FOOTAGE - NOT SPLICED	
STOCK NO.	LENGTH
37TB-5FT	5 FT
37TB-10FT	10 FT
37TB-25FT	25 FT
37TB-50FT	50 FT
37TB-100FT	100 FT

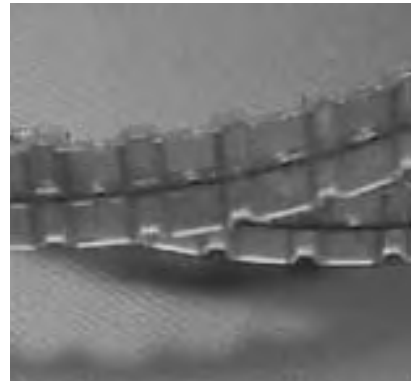

TIMING PULLEYS

CIR. PITCH	BORE	STYLE	MATERIAL	BERG'S ® NAME	BELT
.375 (L)	1/4"	PIN HUB	2024-T4 Aluminum Anodized	Flex-E-Grip®	Operates with Flex-E-Grip Belt 37TB Series

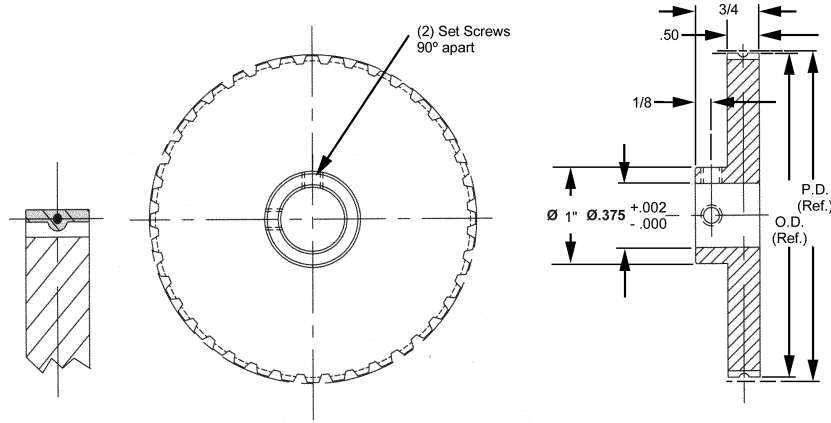

STOCK NO.	NO. OF TEETH	PITCH DIA.	OUTSIDE DIA.
37TP4-10	10*	1.1937	1.164
37TP4-11	11*	1.3130	1.284
37TP4-12	12	1.4324	1.403
37TP4-13	13	1.5518	1.522
37TP4-14	14	1.6711	1.642
37TP4-15	15	1.7905	1.761
37TP4-16	16	1.9099	1.880
37TP4-17	17	2.0292	2.000
37TP4-18	18	2.1486	2.119
37TP4-19	19	2.2680	2.239
37TP4-20	20	2.3873	2.358
37TP4-21	21	2.5067	2.477
37TP4-22	22	2.6261	2.597
37TP4-24	24	2.8648	2.835
37TP4-26	26	3.1035	3.074
37TP4-28	28	3.3422	3.313
37TP4-30	30	3.5810	3.552
37TP4-32	32	3.8197	3.790
37TP4-36	36	4.2972	4.268

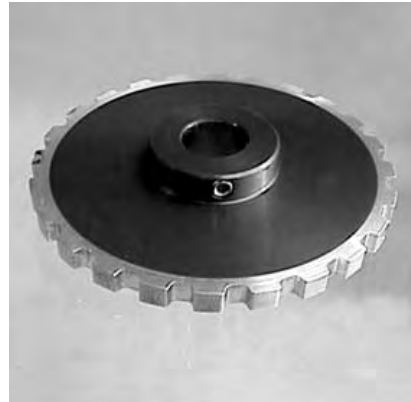

* Pulleys 1.375 P.D. and smaller for idler use only.
Other numbers of teeth available upon request.
Teeth could be anodized.

TIMING PULLEYS

CIR. PITCH	BORE	STYLE	MATERIAL	BERG'S ® NAME	BELT
.375 (L)	3/8"	PIN HUB	2024-T4 Aluminum Anodized	Flex-E-Grip®	Operates with Flex-E-Grip Belt 37TB Series

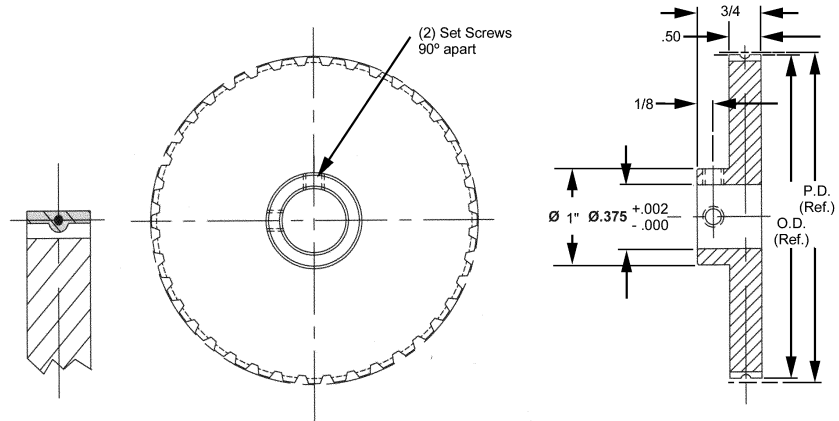

STOCK NO.	NO. OF TEETH	PITCH DIA.	OUTSIDE DIA.
37TP6-10	10*	1.1937	1.164
37TP6-11	11*	1.3130	1.284
37TP6-12	12	1.4324	1.403
37TP6-13	13	1.5518	1.522
37TP6-14	14	1.6711	1.642
37TP6-15	15	1.7905	1.761
37TP6-16	16	1.9099	1.880
37TP6-17	17	2.0292	2.000
37TP6-18	18	2.1486	2.119
37TP6-19	19	2.2680	2.239
37TP6-20	20	2.3873	2.358
37TP6-21	21	2.5067	2.477
37TP6-22	22	2.6261	2.597
37TP6-24	24	2.8648	2.835
37TP6-26	26	3.1035	3.074
37TP6-28	28	3.3422	3.313
37TP6-30	30	3.5810	3.552
37TP6-32	32	3.8197	3.790
37TP6-36	36	4.2972	4.268



* Pulleys 1.375 P.D. and smaller for idler use only.
Other numbers of teeth available upon request.
Teeth could be anodized.

TIMING PULLEYS

CIR. PITCH	BORE	STYLE	MATERIAL	BERG'S ® NAME	BELT
.375 (L)	1/2"	PIN HUB	2024-T4 Aluminum Anodized	Flex-E-Grip®	Operates with Flex-E-Grip Belt 37TB Series

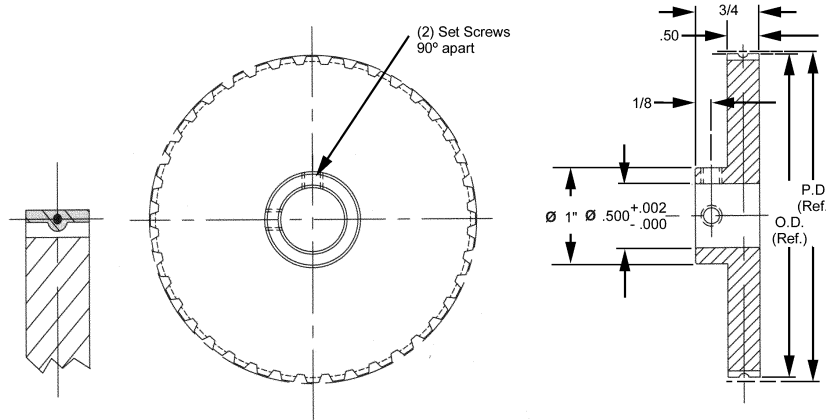

STOCK NO.	NO. OF TEETH	PITCH DIA.	OUTSIDE DIA.
37TP8-10	10*	1.1937	1.164
37TP8-11	11*	1.3130	1.284
37TP8-12	12	1.4324	1.403
37TP8-13	13	1.5518	1.522
37TP8-14	14	1.6711	1.642
37TP8-15	15	1.7905	1.761
37TP8-16	16	1.9099	1.880
37TP8-17	17	2.0292	2.000
37TP8-18	18	2.1486	2.119
37TP8-19	19	2.2680	2.239
37TP8-20	20	2.3873	2.358
37TP8-21	21	2.5067	2.477
37TP8-22	22	2.6261	2.597
37TP8-24	24	2.8648	2.835
37TP8-26	26	3.1035	3.074
37TP8-28	28	3.3422	3.313
37TP8-30	30	3.5810	3.552
37TP8-32	32	3.8197	3.790
37TP8-36	36	4.2972	4.268

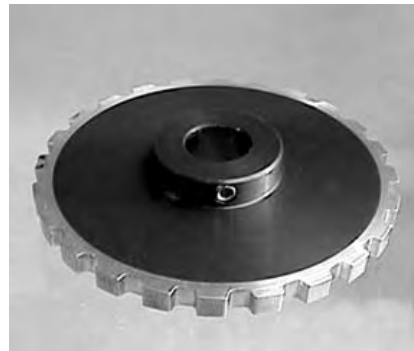

* Pulleys 1.375 P.D. and smaller for idler use only.
Other numbers of teeth available upon request.

Teeth could be anodized.

TIMING BELTS

CIRCULAR PITCH	BELT WIDTH	MATERIALS	BERG'S ® NAME	PULLEY
.500 (H)	3/4"	Polyurethane (Green) 90A Duro 1/16" Stainless Steel Cable*	Flex-E-Grip®	Operates with 50TP Series

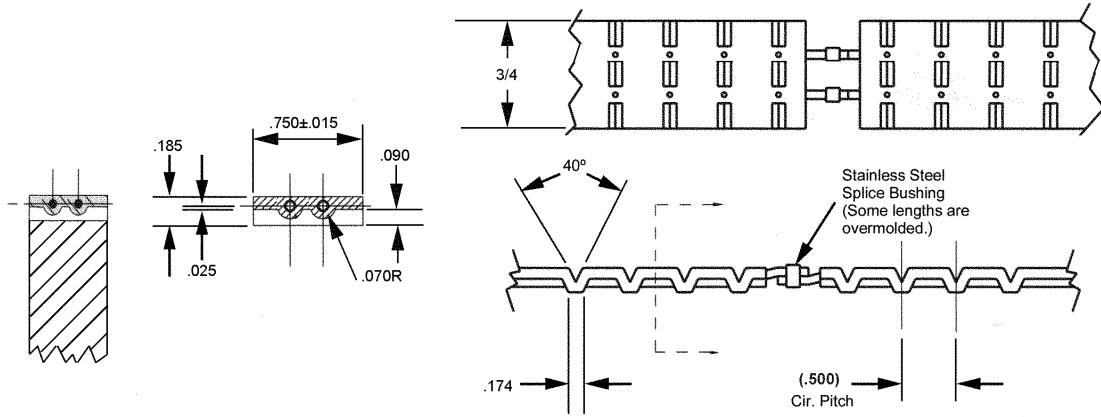

STOCK NO.	NO. OF PITCHES	LENGTH (Ref.)
50TB-32	32	16.00
50TB-36	36	18.00
50TB-40	40	20.00
50TB-44	44	22.00
50TB-48	48	24.00
50TB-50	50	25.00
50TB-54	54	27.00
50TB-56	56	28.00
50TB-60	60	30.00
50TB-64	64	32.00
50TB-66	66	33.00
50TB-70	70	35.00
50TB-72	72	36.00
50TB-75	75	37.50
50TB-78	78	39.00
50TB-80	80	40.00
50TB-84	84	42.00
50TB-88	88	44.00
50TB-90	90	45.00
50TB-96	96	48.00
50TB-102	102	51.00
50TB-108	108	54.00
50TB-114	114	57.000
50TB-120	120	60.000
50TB-126	126	63.000
50TB-132	132	66.000
50TB-140	140	70.000
50TB-150	150	75.000
50TB-160	160	80.000
50TB-170	170	85.000
50TB-180	180	90.000
50TB-190	190	95.000
50TB-200	200	100.000
50TB-225	225	112.500
50TB-250	250	125.000
50TB-275	275	137.500
50TB-400	400	200.000

Aramid Core. Alternate construction available.

- No Flanges Required
- Infinite Lengths
- Silent Drive
- No-Walk Feature
- No Lubrication
- Weight .91 oz./ft.
- Compact Design
- Positive Drive
- Light Weight
- Extra Strong
- 90A Durometer
- Ultimate Tensile Strength 300 lbs.
- Temperature Range +180°F to -15°F
- Recommended Operating Load 75 lbs.
- Recommended Max. Operating Speed 376 ft./min.
- For Field Splice Kit Order 50TB-7

Special lengths available upon request.

* Splices are factory overmolded

BULK FOOTAGE - NOT SPLICED	
STOCK NO.	LENGTH
50TB-5FT	5 FT
50TB-10FT	10 FT
50TB-25FT	25 FT
50TB-50FT	50 FT
50TB-100FT	100 FT

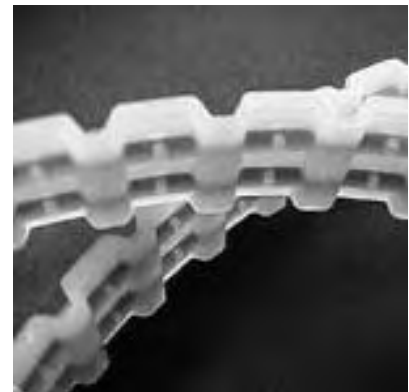

TIMING PULLEYS

CIR. PITCH	BORE	STYLE	MATERIAL	BERG'S ® NAME	BELT
.500 (H)	3/8"	PIN HUB	2024-T4 Aluminum Anodized	Flex-E-Grip®	Operates with Flex-E-Grip Belt 50TB Series

STOCK NO.	NO. OF TEETH	PITCH DIA.	OUTSIDE DIA.
50TP6-10	10	1.5916	1.539
50TP6-11	11	1.7507	1.698
50TP6-12	12	1.9099	1.857
50TP6-13	13	2.0690	2.016
50TP6-14	14	2.2282	2.176
50TP6-15	15	2.3873	2.335
50TP6-16	16	2.5465	2.494
50TP6-17	17	2.7056	2.653
50TP6-18	18	2.8648	2.812
50TP6-19	19	3.0239	2.971
50TP6-20	20	3.1831	3.131
50TP6-21	21	3.3422	3.290
50TP6-22	22	3.5014	3.449
50TP6-24	24	3.8197	3.767
50TP6-26	26	4.1380	4.086
50TP6-28	28	4.4563	4.404
50TP6-30	30	4.7747	4.722
50TP6-32	32	5.0930	5.041

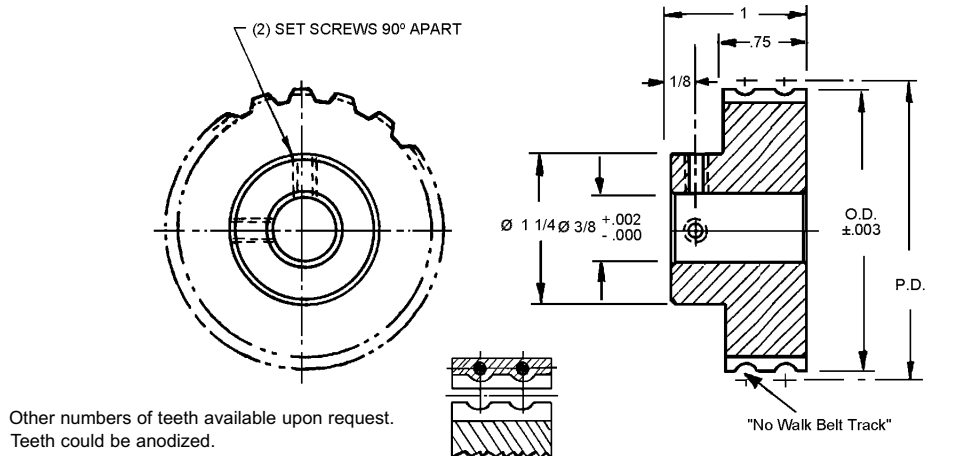

CIR. PITCH	BORE	STYLE	MATERIAL	BERG'S ® NAME	BELT
.500 (H)	1/2"	PIN HUB	2024-T4 Aluminum Anodized	Flex-E-Grip®	Operates with Flex-E-Grip Belt 50TB Series

STOCK NO.	NO. OF TEETH	PITCH DIA.	OUTSIDE DIA.
50TP8-10	10	1.5916	1.539
50TP8-11	11	1.7507	1.698
50TP8-12	12	1.9099	1.857
50TP8-13	13	2.0690	2.016
50TP8-14	14	2.2282	2.176
50TP8-15	15	2.3873	2.335
50TP8-16	16	2.5465	2.494
50TP8-17	17	2.7056	2.653
50TP8-18	18	2.8648	2.812
50TP8-19	19	3.0239	2.971
50TP8-20	20	3.1831	3.131
50TP8-21	21	3.3422	3.290
50TP8-22	22	3.5014	3.449
50TP8-24	24	3.8197	3.767
50TP8-26	26	4.1380	4.086
50TP8-28	28	4.4563	4.404
50TP8-30	30	4.7747	4.722
50TP8-32	32	5.0930	5.041

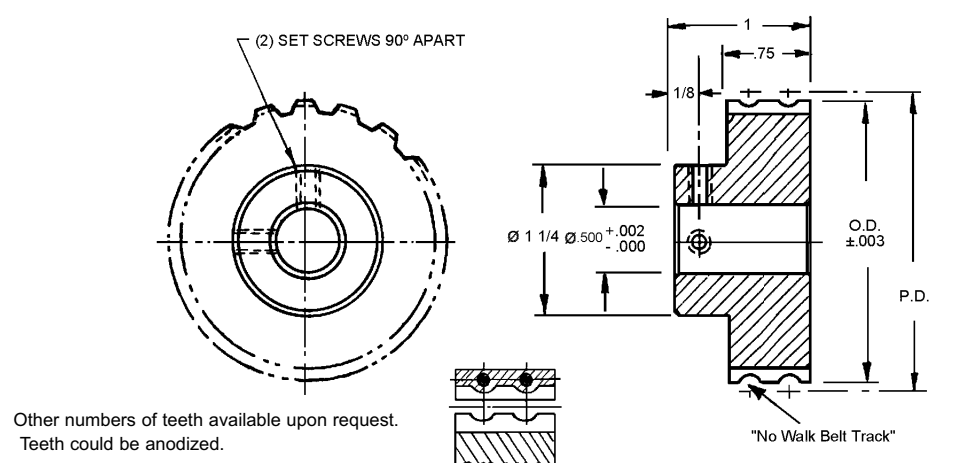

CIR. PITCH	BORE	STYLE	MATERIAL	BERG'S ® NAME	BELT
.500 (H)	5/8"	PIN HUB	2024-T4 Aluminum Anodized	Flex-E-Grip®	Operates with Flex-E-Grip Belt 50TB Series

STOCK NO.	NO. OF TEETH	PITCH DIA.	OUTSIDE DIA.
50TP10-10	10	1.5916	1.539
50TP10-11	11	1.7507	1.698
50TP10-12	12	1.9099	1.857
50TP10-13	13	2.0690	2.016
50TP10-14	14	2.2282	2.176
50TP10-15	15	2.3873	2.335
50TP10-16	16	2.5465	2.494
50TP10-17	17	2.7056	2.653
50TP10-18	18	2.8648	2.812
50TP10-19	19	3.0239	2.971
50TP10-20	20	3.1831	3.131
50TP10-21	21	3.3422	3.290
50TP10-22	22	3.5014	3.449
50TP10-24	24	3.8197	3.767
50TP10-26	26	4.1380	4.086
50TP10-28	28	4.4563	4.404
50TP10-30	30	4.7747	4.722
50TP10-32	32	5.0930	5.041

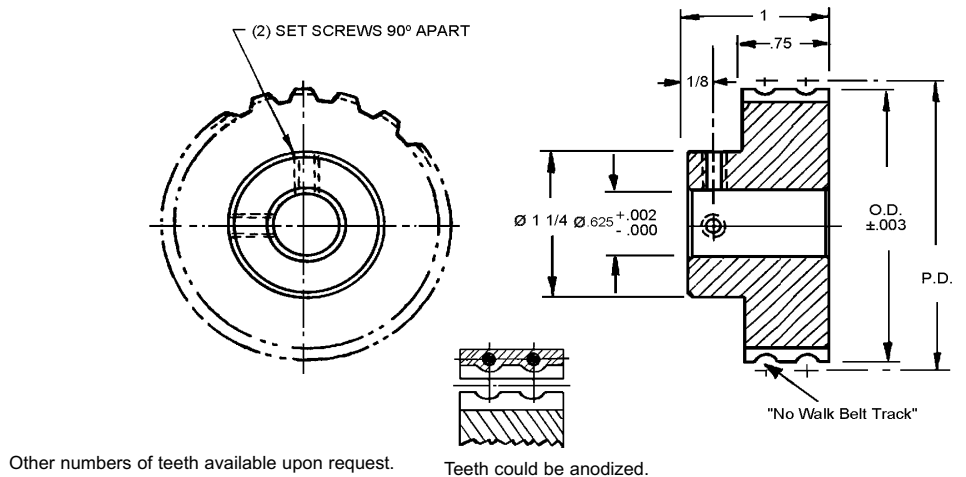

FIELD SPLICE KITS

Splicing Procedures

1. Cut Berg "Flex-E-Grip" sharp and square as shown, using cutter, to desired number of pitches, plus one pitch.



2. Cut plastic jacket (one pitch each side) lightly with sharp razor blade as shown all around. Caution: Do not cut or nick cable. Strip or twist off jacket carefully.

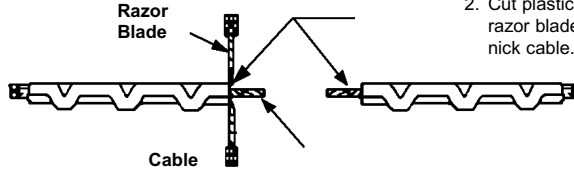

3. Slide stripped cable into oval splice bushing carefully. Caution: Do not fray cable. Feed cable into chamfered end of bushing last.

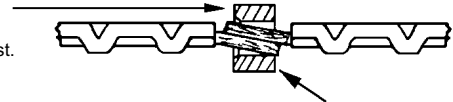

4. Center bushing and be certain belt is straight before crimping.

5. Position crimp tool over splice bushing and squeeze tightly for maximum splice strength.

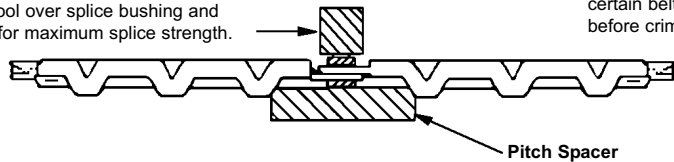

Crimp Tool



Cable Cutter

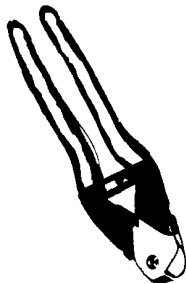

BELT SERIES	STOCK NUMBER	FIELD SPLICE KIT AND ACCESSORIES
8TB 20TB 37TB 50TB	8TB-7 20TB-7 37TB-7 50TB-7	Complete Kit Consists of: Crimp Tool, Pitch Spacer, Sample Belt Cable Cutter, Bushings, Razor Blades & Instructions
	TL-4 TL-3 TL-7	Crimp Tool for 8TB Crimp Tool for 20TB and 37TB Crimp Tool for 50TB
	BU-018-S BU-032-S BU-046-S BU-062-S	Extra Splice Bushings for: 8TB (1/64" Cable) 20TB (1/32" Cable) 37TB (3/64" Cable) 50TB (1/16" Cable)
	TL-1 TL-2	Cable Cutter for up to 3/64" Cable Cable Cutter for up to 5/64" Cable

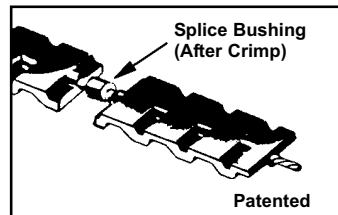

Field Splices offer only 50% of Catalog Rated Loads

W. M. Berg, Inc. will factory splice to order, any length belt at a nominal charge.

Operating Notes

Timing Belts also known as Synchronous Belts are basically flat belts with evenly spaced or pitched teeth. These teeth when matched with the grooves in the pulleys provide a positive no-slip engagement. These belts will not stretch and require no lubrication.

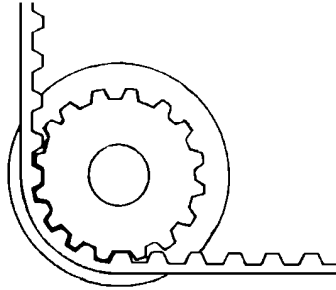

TB7 Series

- Trapezoidal Profile
- .080 Pitch
- Maximum Speed 20,000 RPM
- Maximum Pulley Diameter .25" (10 Teeth)

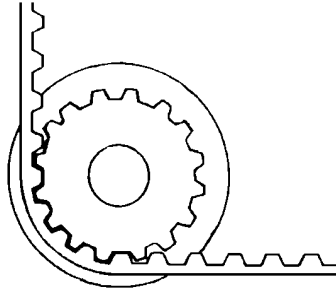

TB20 Series

- Trapezoidal Profile
- 1/5 Pitch (.200 Circular Pitch)
- Maximum Speed 10,000 RPM

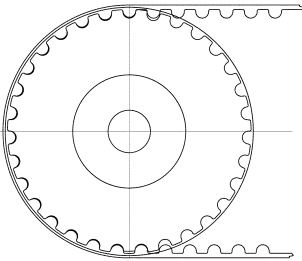

TB2 Series

- GT2 Profile
- 2mm Pitch GT2
- Maximum operating tension 25 lbs (111N) /In. of belt width
- Maximum operating speed 10,000 rpm
- Minimum pulley diameter .281 (12 teeth)

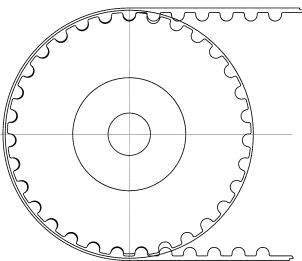

TB3 Series

- GT2 Profile
- 3mm Pitch GT2
- Maximum operating tension 114 lbs (507N) /In. of belt width
- Maximum operating speed 20,000 rpm
- Minimum pulley diameter .572 (16 teeth)

TIMING BELTS

CIRCULAR PITCH	BELT WIDTH	MATERIALS	BERG'S ® NAME	PULLEY
.080 (MXL)	1/8"	Neoprene (Black) Fiberglass reinforced	Max-M-Drive®	Operates with TP7 Series

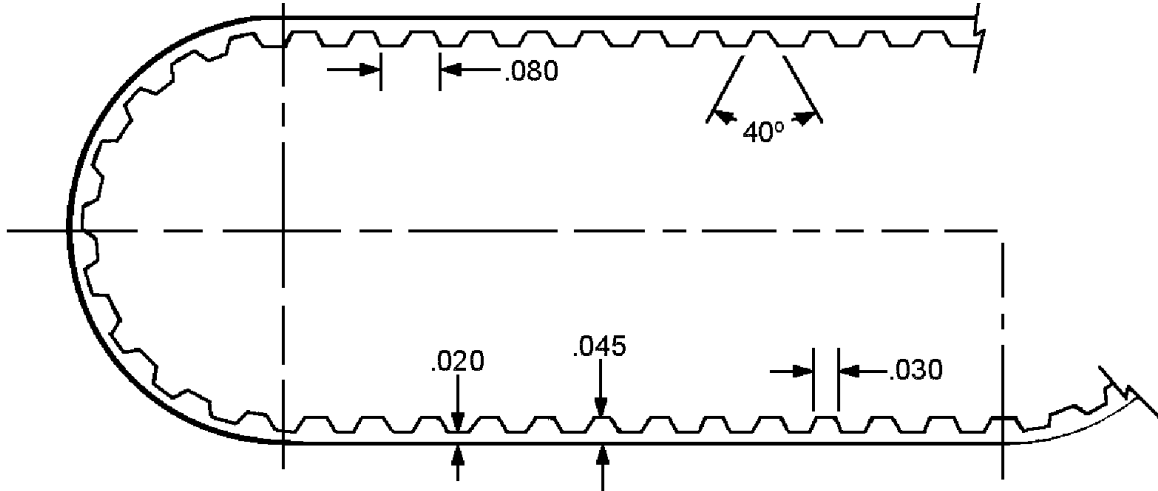

STOCK NO.	NO. OF GROOVES	LENGTH (Ref.)
TB7EF2-40	40	3.20
TB7EF2-42	42	3.36
TB7EF2-45	45	3.60
TB7EF2-50	50	4.00
TB7EF2-54	54	4.32
TB7EF2-55	55	4.40
TB7EF2-57	57	4.56
TB7EF2-60	60	4.80
TB7EF2-64	64	5.12
TB7EF2-67	67	5.36
TB7EF2-70	70	5.60
TB7EF2-73	73	5.84
TB7EF2-80	80	6.40
TB7EF2-90	90	7.20
TB7EF2-100	100	8.00
TB7EF2-105	105	8.40
TB7EF2-110	110	8.80
TB7EF2-120	120	9.60
TB7EF2-130	130	10.40
TB7EF2-150	150	12.00
TB7EF2-160	160	12.80
TB7EF2-170	170	13.60
TB7EF2-175	175	14.00
TB7EF2-190	190	15.20
TB7EF2-200	200	16.00
TB7EF2-225	225	18.00
TB7EF2-250	250	20.00
TB7EF2-300	300	24.00
TB7EF2-400	400	32.00

- High Ratios
- Allows use of small diameter pulleys
- High Speeds
- High Power Transmission
- Long Life
- Wear Resistant Nylon Facing
- Low Profile
- Quiet Operation
- Maximum speed up to 20,000 RPM
- Minimum pulley diameter .25 (10 grooves)
- Temperature Range +185°F to -30°F



TIMING BELTS

CIRCULAR PITCH	BELT WIDTH	MATERIALS	BERG'S ® NAME	PULLEY
.080 (MXL)	1/4"	Neoprene (Black) Fiberglass reinforced	Max-M-Drive®	Operates with TP7 Series

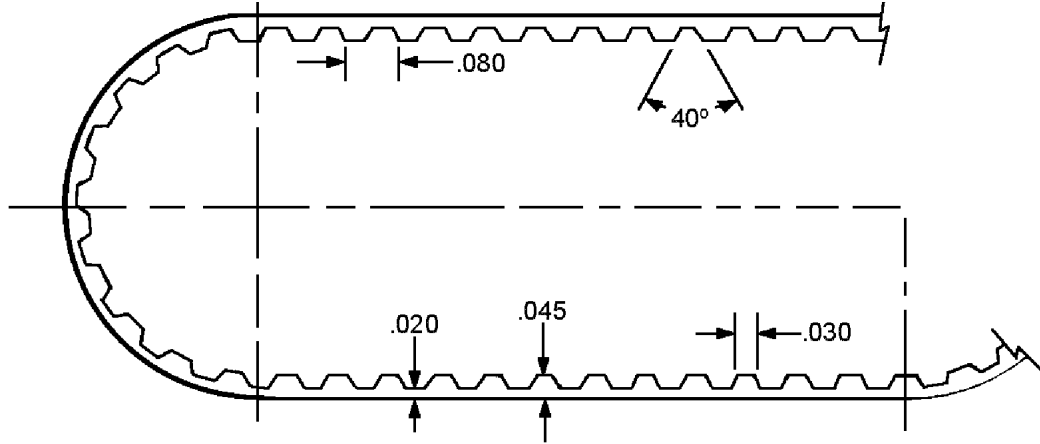

STOCK NO.	NO. OF GROOVES	LENGTH (Ref.)
TB7EF4-40	40	3.20
TB7EF4-42	42	3.36
TB7EF4-45	45	3.60
TB7EF4-50	50	4.00
TB7EF4-54	54	4.32
TB7EF4-55	55	4.40
TB7EF4-57	57	4.56
TB7EF4-60	60	4.80
TB7EF4-64	64	5.12
TB7EF4-67	67	5.36
TB7EF4-70	70	5.60
TB7EF4-73	73	5.84
TB7EF4-80	80	6.40
TB7EF4-90	90	7.20
TB7EF4-100	100	8.00
TB7EF4-105	105	8.40
TB7EF4-110	110	8.80
TB7EF4-120	120	9.60
TB7EF4-130	130	10.40
TB7EF4-150	150	12.00
TB7EF4-160	160	12.80
TB7EF4-170	170	13.60
TB7EF4-175	175	14.00
TB7EF4-190	190	15.20
TB7EF4-200	200	16.00
TB7EF4-225	225	18.00
TB7EF4-250	250	20.00
TB7EF4-300	300	24.00
TB7EF4-400	400	32.00

- High Ratios
- Allows use of small diameter pulleys
- High Speeds
- High Power Transmission
- Long Life
- Wear Resistant Nylon Facing
- Low Profile
- Quiet Operation
- Maximum speed up to 20,000 RPM
- Minimum pulley diameter .25 (10 grooves)
- Temperature Range +185°F to -30°F



TIMING BELTS

CIRCULAR PITCH	BELT WIDTH	MATERIALS	BERG'S ® NAME	PULLEY
.080 (MXL)	1/8"	Urethane Hardness Shore "A" 80-85 Polyester Cord Construction Urethane (Black or Orange)	Max-M-Drive®	Operates with TP7 Series

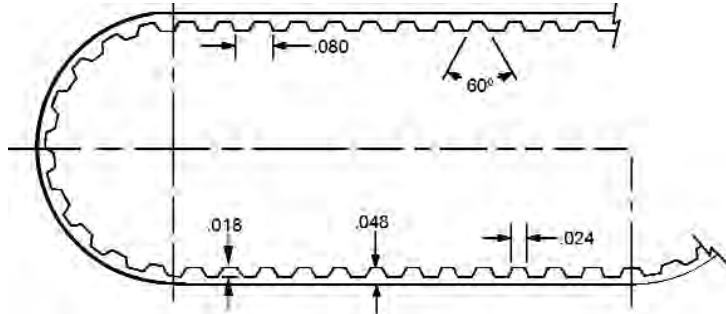

STOCK NO.	LENGTH (Ref.)	STOCK NO.	LENGTH (Ref.)
TB7UP2-30	2.400	TB7UP2-160	12.800
TB7UP2-35	2.280	TB7UP2-165	13.200
TB7UP2-40	3.200	TB7UP2-170	13.600
TB7UP2-45	3.600	TB7UP2-175	14.000
TB7UP2-48	3.840	TB7UP2-180	14.400
TB7UP2-50	4.000	TB7UP2-184	14.720
TB7UP2-55	4.400	TB7UP2-185	14.800
TB7UP2-60	4.800	TB7UP2-190	15.200
TB7UP2-65	5.200	TB7UP2-195	15.600
TB7UP2-70	5.600	TB7UP2-200	16.000
TB7UP2-71	5.680	TB7UP2-205	16.400
TB7UP2-75	6.000	TB7UP2-210	16.800
TB7UP2-78	6.240	TB7UP2-212	16.960
TB7UP2-80	6.400	TB7UP2-215	17.200
TB7UP2-81	6.480	TB7UP2-220	17.600
TB7UP2-85	6.800	TB7UP2-225	18.000
TB7UP2-87	6.960	TB7UP2-230	18.400
TB7UP2-88	7.040	TB7UP2-235	18.800
TB7UP2-90	7.200	TB7UP2-240	19.200
TB7UP2-95	7.600	TB7UP2-245	19.600
TB7UP2-97	7.760	TB7UP2-249	19.920
TB7UP2-100	8.000	TB7UP2-250	20.000
TB7UP2-102	8.160	TB7UP2-255	20.400
TB7UP2-103	8.240	TB7UP2-260	20.800
TB7UP2-105	8.400	TB7UP2-265	21.200
TB7UP2-106	8.480	TB7UP2-270	21.600
TB7UP2-110	8.800	TB7UP2-275	22.000
TB7UP2-112	8.960	TB7UP2-280	22.400
TB7UP2-114	9.120	TB7UP2-285	22.800
TB7UP2-115	9.200	TB7UP2-290	23.200
TB7UP2-118	9.440	TB7UP2-295	23.600
TB7UP2-120	9.600	TB7UP2-300	24.000
TB7UP2-122	9.760	TB7UP2-310	24.800
TB7UP2-123	9.840	TB7UP2-315	25.200
TB7UP2-125	10.000	TB7UP2-320	25.600
TB7UP2-126	10.080	TB7UP2-330	26.400
TB7UP2-130	10.400	TB7UP2-340	27.200
TB7UP2-132	10.560	TB7UP2-350	28.000
TB7UP2-135	10.800	TB7UP2-360	28.800
TB7UP2-140	11.200	TB7UP2-370	29.600
TB7UP2-144	11.520	TB7UP2-380	30.400
TB7UP2-145	11.600	TB7UP2-390	31.200
TB7UP2-150	12.000	TB7UP2-400	32.000
TB7UP2-155	12.400		

Tooth Shear Strength:
Approx. 15% Break Strength.

Break Strength:
32 lbs. Per 1/16 belt width in endless form.

Temperature Range:
Continuous 0°F to 80°F
Intermittent 250°F

TIMING BELTS

A

CIRCULAR PITCH	BELT WIDTH	MATERIALS	BERG'S ® NAME	PULLEY
.080 (MXL)	1/4"	Urethane Hardness Shore "A" 80-85 Polyester Cord Construction Urethane (Black or Orange)	Max-M-Drive®	Operates with TP7 Series

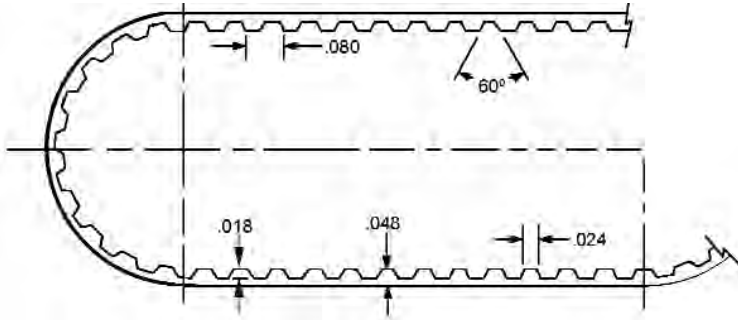

STOCK NO.	LENGTH (Ref.)	STOCK NO.	LENGTH (Ref.)
TB7UP4-30	2.400	TB7UP4-160	12.800
TB7UP4-35	2.280	TB7UP4-165	13.200
TB7UP4-40	3.200	TB7UP4-170	13.600
TB7UP4-45	3.600	TB7UP4-175	14.000
TB7UP4-48	3.840	TB7UP4-180	14.400
TB7UP4-50	4.000	TB7UP4-184	14.720
TB7UP4-55	4.400	TB7UP4-185	14.800
TB7UP4-60	4.800	TB7UP4-190	15.200
TB7UP4-65	5.200	TB7UP4-195	15.600
TB7UP4-70	5.600	TB7UP4-200	16.000
TB7UP4-71	5.680	TB7UP4-205	16.400
TB7UP4-75	6.000	TB7UP4-210	16.800
TB7UP4-78	6.240	TB7UP4-212	16.960
TB7UP4-80	6.400	TB7UP4-215	17.200
TB7UP4-81	6.480	TB7UP4-220	17.600
TB7UP4-85	6.800	TB7UP4-225	18.000
TB7UP4-87	6.960	TB7UP4-230	18.400
TB7UP4-88	7.040	TB7UP4-235	18.800
TB7UP4-90	7.200	TB7UP4-240	19.200
TB7UP4-95	7.600	TB7UP4-245	19.600
TB7UP4-97	7.760	TB7UP4-249	19.920
TB7UP4-100	8.000	TB7UP4-250	20.000
TB7UP4-102	8.160	TB7UP4-255	20.400
TB7UP4-103	8.240	TB7UP4-260	20.800
TB7UP4-105	8.400	TB7UP4-265	21.200
TB7UP4-106	8.480	TB7UP4-270	21.600
TB7UP4-110	8.800	TB7UP4-275	22.000
TB7UP4-112	8.960	TB7UP4-280	22.400
TB7UP4-114	9.120	TB7UP4-285	22.800
TB7UP4-115	9.200	TB7UP4-290	23.200
TB7UP4-118	9.440	TB7UP4-295	23.600
TB7UP4-120	9.600	TB7UP4-300	24.000
TB7UP4-122	9.760	TB7UP4-310	24.800
TB7UP4-123	9.840	TB7UP4-315	25.200
TB7UP4-125	10.000	TB7UP4-320	25.600
TB7UP4-126	10.080	TB7UP4-330	26.400
TB7UP4-130	10.400	TB7UP4-340	27.200
TB7UP4-132	10.560	TB7UP4-350	28.000
TB7UP4-135	10.800	TB7UP4-360	28.800
TB7UP4-140	11.200	TB7UP4-370	29.600
TB7UP4-144	11.520	TB7UP4-380	30.400
TB7UP4-145	11.600	TB7UP4-390	31.200
TB7UP4-150	12.000	TB7UP4-400	32.000
TB7UP4-155	12.400	-	-

Tooth Shear Strength:
Approx. 15% Break Strength.

Break Strength:
32 lbs. Per 1/16 belt width in endless form.

Temperature Range:
Continuous 0°F to 80°F
Intermittent 250°F

TIMING PULLEYS

CIRCULAR PITCH	STYLE	BELT WIDTH	BORE	MATERIALS	BERG'S ® NAME	BELT
.080 (MXL)	Single Flange Pin Hub	1/8" to 1/4"	1/8"	10% Glass Filled Polycarbonate (Black) Hub = Aluminum	Max-M-Drive®	Operates with Max-M-Drive® TB7 series

STOCK NO.	BORE + .001 - .000	NO. OF GROOVES	PITCH DIA.	OUTSIDE DIA.	FLANGE DIA. ± .03	HUB DIA.	SET SCREW
TP7E2U4-10	.125	10	.255	.235	.42	.44	#4-40
TP7E2U4-12		12	.306	.286	.47		
TP7E2U4-14		14	.357	.337	.53		

CIRCULAR PITCH	STYLE	BELT WIDTH	BORE	MATERIALS	BERG'S ® NAME	BELT
.080 (MXL)	Single Flange Pin Hub	1/8" to 1/4"	3/16"	10% Glass Filled Polycarbonate (Black) Hub = Aluminum	Max-M-Drive®	Operates with Max-M-Drive® TB7 series

STOCK NO.	BORE + .001 - .000	NO. OF GROOVES	PITCH DIA.	OUTSIDE DIA.	FLANGE DIA. ± .03	HUB DIA.	SET SCREW
TP7E3U4-15	.187	15	.362	.362	.55	.44	#6-32
TP7P3U4-20	.187	20	.509	.489	.68	.50	#6-32
TP7P3U4-21		21	.535	.515	.70		
TP7P3U4-22		22	.560	.540	.73		
TP7P3U4-24		24	.611	.591	.78		

CIRCULAR PITCH	STYLE	BELT WIDTH	BORE	MATERIALS	BERG'S ® NAME	BELT
.080 (MXL)	Single Flange Pin Hub	1/8" to 1/4"	1/4"	10% Glass Filled Polycarbonate (Black) Hub = Aluminum	Max-M-Drive®	Operates with Max-M-Drive® TB7 series.

STOCK NO.	BORE + .001 - .000	NO. OF GROOVES	PITCH DIA.	OUTSIDE DIA.	FLANGE DIA. ± .03	HUB DIA.	SET SCREW
TP7E4U4-16	.250	16	.407	.387	.58	.44	#8-32
TP7E4U4-18	.250	18	.458	.438	.58	.50	#8-32
TP7P4U4-26	.250	26	.662	.642	.83	.69	#8-32
TP7P4U4-28		28	.713	.693	.88		
TP7P4U4-30		30	.764	.744	.93		
TP7P4U4-32		32	.815	.795	.98		
TP7P4U4-34		34	.866	.846	1.04		
TP7P4U4-36		36	.917	.897	1.09		
TP7P4U4-38		38	.968	.948	1.14		
TP7P4U4-40		40	1.019	.999	1.19		
TP7P4U4-42		42	1.070	1.050	1.24		
TP7P4U4-44		44	1.120	1.100	1.29		
TP7P4U4-46		46	1.171	1.151	1.34		
TP7P4U4-48		48	1.222	1.202	1.39		
TP7P4U4-50		50	1.273	1.253	1.44		
TP7P4U4-51		51	1.299	1.279	1.48		
TP7P4U4-60	60	1.528	1.508	1.70			

CIRCULAR PITCH	STYLE	BELT WIDTH	BORE	MATERIALS	BERG'S ® NAME	BELT
.080 (MXL)	Single Flange Pin Hub	1/8" & 1/4"	5/16"	10% Glass Filled Polycarbonate (Black) Hub = Aluminum	Max-M-Drive®	Operates with Max-M-Drive® TB7 series

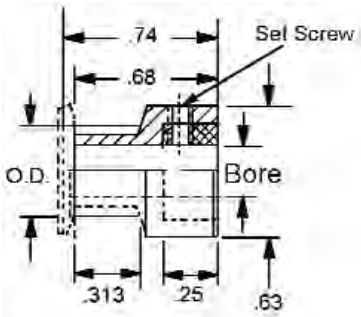

STOCK NO.	BORE + .001 - .000	NO. OF GROOVES	PITCH DIA.	OUTSIDE DIA.	FLANGE DIA. ± .03	HUB DIA.	SET SCREW
TP7P5U4-70	.313	70	1.783	1.763	1.95	.69	#10-32
TP7P5U4-72		72	1.833	1.813	2.00		
TP7P5U4-80		80	2.037	2.017	2.21		
TP7P5U4-90		90	2.292	2.272	2.46		
TP7P5U4-100		100	2.546	2.526	2.71		
TP7P5U4-110		110	2.801	2.781	2.97		
TP7P5U4-120		120	3.056	3.036	3.22		

10 - 18 Grooves - O.D. Tolerance +.003/- .001
 25 - 70 Grooves - O.D. Tolerance +.004/- .001
 71 - 120 Grooves - O.D. Tolerance +.005/- .001

TIMING PULLEYS

CIRCULAR PITCH	STYLE	BELT WIDTH	BORE	MATERIALS	BERG'S ® NAME	BELT
.080 (MXL)	Double Flange Pin Hub	1/8" to 1/4"	1/8"	10% Glass Filled Polycarbonate (Black) Hub = Aluminum	Max-M-Drive®	Operates with Max-M-Drive® TB7 series.

STOCK NO.	BORE + .001 - .000	NO. OF GROOVES	PITCH DIA.	OUTSIDE DIA.	FLANGE DIA.	HUB DIA.	SET SCREW ± .03
TP7E2W4-10	.125	10	.255	.235	.42	.44	#4-40
TP7E2W4-12		12	.306	.286	.47		
TP7E2W4-14		14	.357	.337	.53		

CIRCULAR PITCH	STYLE	BELT WIDTH	BORE	MATERIALS	BERG'S ® NAME	BELT
.080 (MXL)	Double Flange Pin Hub	1/8" to 1/4"	3/16"	10% Glass Filled Polycarbonate (Black) Hub = Aluminum	Max-M-Drive®	Operates with Max-M-Drive® TB7 series

STOCK NO.	BORE + .001 - .000	NO. OF GROOVES	PITCH DIA.	OUTSIDE DIA.	FLANGE DIA.	HUB DIA.	SET SCREW ± .03
TP7E3W4-15	.187	15	.382	.362	.55	.44	#6-32
TP7P3W4-20	.187	20	.509	.489	.68	.50	#6-32
TP7P3W4-21		21	.535	.515	.70		
TP7P3W4-22		22	.560	.540	.73		
TP7P3W4-24		24	.611	.591	.78		

CIRCULAR PITCH	STYLE	BELT WIDTH	BORE	MATERIALS	BERG'S ® NAME	BELT
.080 (MXL)	Double Flange Pin Hub	1/8" to 1/4"	1/4"	10% Glass Filled Polycarbonate (Black) Hub = Aluminum	Max-M-Drive®	Operates with Max-M-Drive® TB7 series

STOCK NO.	BORE + .001 - .000	NO. OF GROOVES	PITCH DIA.	OUTSIDE DIA.	FLANGE DIA.	HUB DIA.	SET SCREW ± .03
TP7E4W4-16	.250	16	.407	.387	.58	.44	#8-32
TP7E4W4-18	.250	18	.458	.438	.58	.50	#8-32
TP7P4W4-26	.250	26	.662	.642	.83	.69	#8-32
TP7P4W4-28		28	.713	.693	.88		
TP7P4W4-30		30	.764	.744	.93		
TP7P4W4-32		32	.815	.795	.98		
TP7P4W4-34		34	.866	.846	1.04		
TP7P4W4-36		36	.917	.897	1.09		
TP7P4W4-38		38	.968	.948	1.14		
TP7P4W4-40		40	1.019	.999	1.19		
TP7P4W4-42		42	1.070	1.050	1.24		
TP7P4W4-44		44	1.120	1.100	1.29		
TP7P4W4-46		46	1.171	1.151	1.34		
TP7P4W4-48		48	1.222	1.202	1.39		
TP7P4W4-50		50	1.273	1.253	1.44		
TP7P4W4-51		51	1.299	1.279	1.48		
TP7P4W4-60		60	1.528	1.508	1.70		

CIRCULAR PITCH	STYLE	BELT WIDTH	BORE	MATERIALS	BERG'S ® NAME	BELT
.080 (MXL)	Double Flange Pin Hub	1/8" TO 1/4"	5/16"	10% Glass Filled Polycarbonate (Black) Hub = Aluminum	Max-M-Drive®	Operates with Max-M-Drive® TB7 series

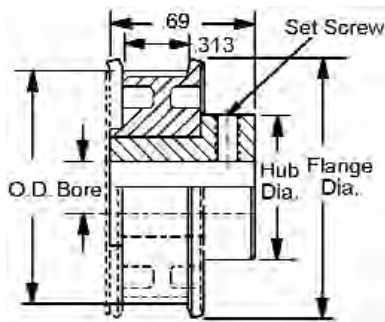

STOCK NO.	BORE + .001 - .000	NO. OF GROOVES	PITCH DIA.	OUTSIDE DIA.	FLANGE DIA.	HUB DIA.	SET SCREW ± .03
TP7P5W4-70	.313	70	1.783	1.763	1.95	.69	#10-32
TP7P5W4-72		72	1.833	1.813	2.00		
TP7P5W4-80		80	2.037	2.017	2.21		
TP7P5W4-90		90	2.292	2.272	2.46		
TP7P5W4-100		100	2.546	2.526	2.71		
TP7P5W4-110		110	2.801	2.781	2.97		
TP7P5W4-120		120	3.056	3.036	3.22		

10 - 18 Grooves - O.D. Tolerance +.003/- .001
 25 - 70 Grooves - O.D. Tolerance +.004/- .001
 71 - 120 Grooves - O.D. Tolerance +.005/- .001

TIMING PULLEYS

CIRCULAR PITCH	STYLE	BELT WIDTH	BORE	MATERIALS	BERG'S ® NAME	BELT
.080 (MXL)	Single Flange Pin Hub	1/8" to 1/4"	3/32"	Polycarbonate Lexan® with Fiberglass Reinforcement 94 V-O UL Rated	Max-M-Drive®	Operates with Max-M-Drive® TB7 series.

STOCK NO.	NO. OF GROOVES	OUTSIDE DIA.	PITCH DIA.	FLANGE DIA.	BORE +.001 -.000	HUB DIA.
TP7LDU4-10	10	.235	.255	.42	.094	7/16
TP7LDU4-11	11	.260	.280	.45		
TP7LDU4-12	12	.286	.306	.47		

CIRCULAR PITCH	STYLE	BELT WIDTH	BORE	MATERIALS	BERG'S ® NAME	BELT
.080 (MXL)	Single Flange Pin Hub	1/8" to 1/4"	1/8"	Polycarbonate Lexan® with Fiberglass Reinforcement 94 V-O UL Rated	Max-M-Drive®	Operates with Max-M-Drive® TB7 series.

STOCK NO.	NO. OF GROOVES	OUTSIDE DIA.	PITCH DIA.	FLANGE DIA.	BORE +.001 -.000	HUB DIA.
TP7L2U4-14	14	.337	.357	.53	.125	7/16
TP7L2U4-15	15	.362	.382	.55		
TP7L2U4-16	16	.387	.407	.58		

CIRCULAR PITCH	STYLE	BELT WIDTH	BORE	MATERIALS	BERG'S ® NAME	BELT
.080 (MXL)	Single Flange Pin Hub	1/8" to 1/4"	3/16"	Polycarbonate Lexan® with Fiberglass Reinforcement 94 V-O UL Rated	Max-M-Drive®	Operates with Max-M-Drive® TB7 series.

STOCK NO.	NO. OF GROOVES	OUTSIDE DIA.	PITCH DIA.	FLANGE DIA.	BORE +.001 -.000	HUB DIA.
TP7L3U4-18	18	.438	.458	.63	.187	1/2
TP7L3U4-20	20	.489	.590	.68		
TP7L3U4-21	21	.515	.535	.70		
TP7L3U4-22	22	.540	.560	.73		
TP7L3U4-23	23	.565	.585	.75		
TP7L3U4-24	24	.591	.611	.78		

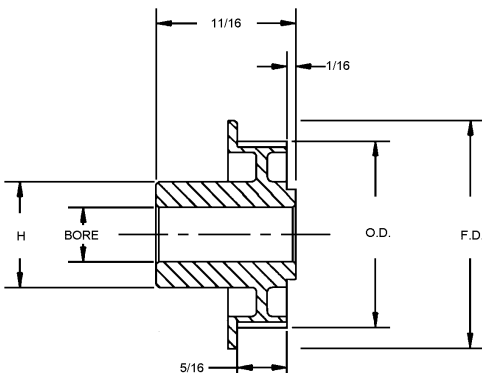

All flanges 1/16" thick.

One or two set screws are optional.

Lexan® Material Specs:

Tensile Strength (PSI) 16,000
Compressive Strength (PSI) 16,000
Flexural Strength (PSI) 19,000
Impact (ft.-lbs./in. notch) 2.0
Water Absorption (24 hrs.) Equilibrium 73% 0.29%

Examples of specials:

- Bores: D shaped, key slots, square or spline.
- Face widths other than standard.
- Hubless or hub diameters other than standard.
- Aluminum, brass or stainless steel inserts thru bore with pulley overmolded.
- Non-standard bores including metric bores are available upon request.

TIMING PULLEYS

CIRCULAR PITCH	STYLE	BELT WIDTH	BORE	MATERIALS	BERG'S ® NAME	BELT
.080 (MXL)	Single Flange Pin Hub	1/8" to 1/4"	1/4"	Polycarbonate Lexan® with Fiberglass Reinforcement 94 V-O UL Rated	Max-M-Drive®	Operates with Max-M-Drive® TB7 series.

STOCK NO.	NO. OF GROOVES	OUTSIDE DIA.	PITCH DIA.	FLANGE DIA.	BORE +.001 -.000	HUB DIA.
TP7L4U4-26	26	.642	.662	.83	.250	11/16
TP7L4U4-28	28	.693	.713	.88		
TP7L4U4-30	30	.744	.764	.93		
TP7L4U4-32	32	.795	.815	.98		
TP7L4U4-36	36	.897	.917	1.09		
TP7L4U4-40	40	.999	1.019	1.19		
TP7L4U4-42	42	1.050	1.070	1.24		
TP7L4U4-44	44	1.100	1.120	1.29		
TP7L4U4-48	48	1.202	1.222	1.39		
TP7L4U4-50	50	1.253	1.273	1.44		
TP7L4U4-60	60	1.508	1.528	1.70		

CIRCULAR PITCH	STYLE	BELT WIDTH	BORE	MATERIALS	BERG'S ® NAME	BELT
.080 (MXL)	Single Flange Pin Hub	1/8" to 1/4"	5/16"	Polycarbonate Lexan® with Fiberglass Reinforcement 94 V-O UL Rated	Max-M-Drive®	Operates with Max-M-Drive® TB7 series.

STOCK NO.	NO. OF GROOVES	OUTSIDE DIA.	PITCH DIA.	FLANGE DIA.	BORE +.001 -.000	HUB DIA.
TP7L5U4-65	65	1.635	1.655	1.82	.313	11/16
TP7L5U4-72	72	1.813	1.833	2.00		
TP7L5U4-80	80	2.017	2.037	2.21		
TP7L5U4-90	90	2.272	2.292	2.46		
TP7L5U4-100	100	2.526	2.546	2.71		
TP7L5U4-110	110	2.781	2.801	2.97		
TP7L5U4-120	120	3.036	3.056	3.22		
TP7L5U4-130	130	3.290	3.310	3.48		

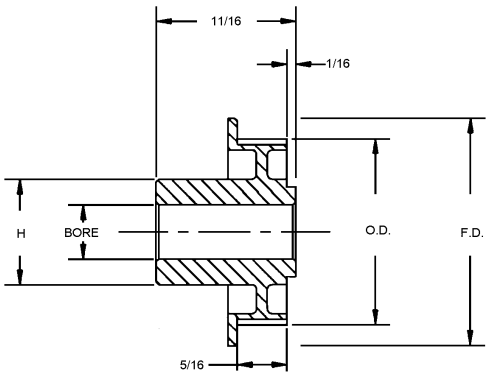

All flanges 1/16" thick.
One or two set screws are optional.

Lexan® Material Specs:
Tensile Strength (PSI) 16,000
Compressive Strength (PSI) 16,000
Flexural Strength (PSI) 19,000
Impact (ft.-lbs./in. notch) 2.0
Water Absorption (24 hrs.) Equilibrium 73% 0.29%

Examples of specials:
a. Bores: D shaped, key slots, square or spline.
b. Face widths other than standard.
c. Hubless or hub diameters other than standard.
d. Aluminum, brass or stainless steel inserts thru bore with pulley overmolded.
e. Non-standard bores including metric bores are available upon request.

TIMING PULLEYS

CIRCULAR PITCH	STYLE	BELT WIDTH	BORE	MATERIALS	BERG'S ® NAME	BELT
.080 (MXL)	Double Flange Pin Hub	1/8" to 1/4"	3/32"	Polycarbonate Lexan® with Fiberglass Reinforcement 94 V-O UL Rated	Max-M-Drive®	Operates with Max-M-Drive® TB7 series.

STOCK NO.	NO. OF GROOVES	OUTSIDE DIA.	PITCH DIA.	FLANGE DIA.	BORE +.001 -.000	HUB DIA.
TP7LDW4-10	10	.235	.255	.42		
TP7LDW4-11	11	.260	.280	.45	.094	7/16
TP7LDW4-12	12	.286	.306	.47		

CIRCULAR PITCH	STYLE	BELT WIDTH	BORE	MATERIALS	BERG'S ® NAME	BELT
.080 (MXL)	Double Flange Pin Hub	1/8" to 1/4"	1/8"	Polycarbonate Lexan® with Fiberglass Reinforcement 94 V-O UL Rated	Max-M-Drive®	Operates with Max-M-Drive® TB7 series.

STOCK NO.	NO. OF GROOVES	OUTSIDE DIA.	PITCH DIA.	FLANGE DIA.	BORE +.001 -.000	HUB DIA.
TP7L2W4-14	14	.337	.357	.53		
TP7L2W4-15	15	.362	.382	.55	.125	7/16
TP7L2W4-16	16	.387	.407	.58		

CIRCULAR PITCH	STYLE	BELT WIDTH	BORE	MATERIALS	BERG'S ® NAME	BELT
.080 (MXL)	Double Flange Pin Hub	1/8" to 1/4"	3/16"	Polycarbonate Lexan® with Fiberglass Reinforcement 94 V-O UL Rated	Max-M-Drive®	Operates with Max-M-Drive® TB7 series.

STOCK NO.	NO. OF GROOVES	OUTSIDE DIA.	PITCH DIA.	FLANGE DIA.	BORE +.001 -.000	HUB DIA.
TP7L3W4-18	18	.438	.458	.63		
TP7L3W4-20	20	.489	.590	.68		
TP7L3W4-21	21	.515	.535	.70	.188	1/2
TP7L3W4-22	22	.540	.560	.73		
TP7L3W4-24	24	.591	.611	.78		

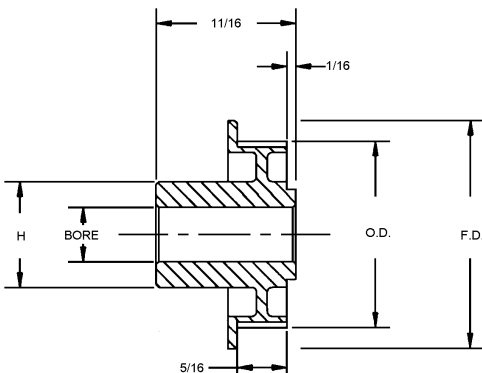

All flanges 1/16" thick.

One or two set screws are optional.

Lexan® Material Specs:

Tensile Strength (PSI) 16,000
 Compressive Strength (PSI) 16,000
 Flexural Strength (PSI) 19,000
 Impact (ft.-lbs./in. notch) 2.0
 Water Absorption (24 hrs.) Equilibrium 73% 0.29%

Examples of specials:

- Bores: D shaped, key slots, square or spline.
- Face widths other than standard.
- Hubless or hub diameters other than standard.
- Aluminum, brass or stainless steel inserts thru bore with pulley overmolded.
- Non-standard bores including metric bores are available upon request.

TIMING PULLEYS

CIRCULAR PITCH	STYLE	BELT WIDTH	BORE	MATERIALS	BERG'S ® NAME	BELT
.080 (MXL)	Double Flange Pin Hub	1/8" to 1/4"	1/4"	Polycarbonate Lexan® with Fiberglass Reinforcement 94 V-O UL Rated	Max-M-Drive®	Operates with Max-M-Drive® TB7 series.

STOCK NO.	NO. OF GROOVES	OUTSIDE DIA.	PITCH DIA.	FLANGE DIA	BORE +.001 -.000	HUB DIA.
TP7L4W4-26	26	.642	.662	.83	.250	11/16
TP7L4W4-28	28	.693	.713	.88		
TP7L4W4-30	30	.744	.764	.93		
TP7L4W4-32	32	.795	.815	.98		
TP7L4W4-36	36	.897	.917	1.09		
TP7L4W4-40	40	.999	1.019	1.19		
TP7L4W4-42	42	1.050	1.070	1.24		
TP7L4W4-44	44	1.100	1.120	1.29		
TP7L4W4-48	48	1.202	1.222	1.39		
TP7L4W4-50	50	1.253	1.273	1.44		
TP7L4W4-60	60	1.508	1.528	1.70		

CIRCULAR PITCH	STYLE	BELT WIDTH	BORE	MATERIALS	BERG'S ® NAME	BELT
.080 (MXL)	Double Flange Pin Hub	1/8" to 1/4"	5/16"	Polycarbonate Lexan® with Fiberglass Reinforcement 94 V-O UL Rated	Max-M-Drive®	Operates with Max-M-Drive® TB7 series.

STOCK NO.	NO. OF GROOVES	OUTSIDE DIA.	PITCH DIA.	FLANGE DIA	BORE +.001 -.000	HUB DIA..
TP7L5W4-65	65	1.635	1.655	1.82	.313	11/16
TP7L5W4-72	72	1.813	1.833	2.00		
TP7L5W4-80	80	2.017	2.037	2.21		
TP7L5W4-90	90	2.272	2.292	2.46		
TP7L5W4-100	100	2.526	2.546	2.71		
TP7L5W4-110	110	2.781	2.801	2.97		
TP7L5W4-120	120	3.036	3.056	3.22		
TP7L5W4-130	130	3.290	3.310	3.48		

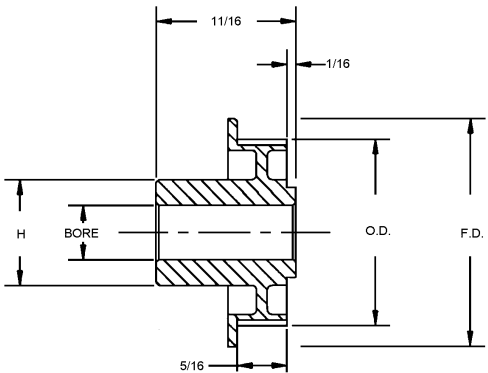

All flanges 1/16" thick."

One or two set screws are optional.

Lexan® Material Specs:

Tensile Strength (PSI) 16,000
 Compressive Strength (PSI) 16,000
 Flexural Strength (PSI) 19,000
 Impact (ft.-lbs./in. notch) 2.0
 Water Absorption (24 hrs.) Equilibrium 73% 0.29%

Examples of specials:

- a. Bores: D shaped, key slots, square or spline.
- b. Face widths other than standard.
- c. Hubless or hub diameters other than standard.
- d. Aluminum, brass or stainless steel inserts thru bore with pulley overmolded.
- e. Non-standard bores including metric bores are available upon request.

TIMING PULLEYS

CIRCULAR PITCH	STYLE	BELT WIDTH	BORE	MATERIALS	BERG'S ® NAME	BELT
.080 (MXL)	Double Flange Pin Hub	1/8"	1/8"	Aluminum Alloy Anodized	Max-M-Drive®	Operates with Max-M-Drive® TB7 series.

STOCK NO.	NO. OF GROOVES	PITCH DIA.	OUTSIDE DIA.	F.D. ±.016	A ±.016	H ±.010	B +.001/-0.000
TP7A2W2-10	10	.255	.235	.425			
TP7A2W2-11	11	.280	.260	.450	.436	.425	.125
TP7A2W2-12	12	.306	.286	.480		.450	
TP7A2W2-14	14	.357	.337	.530		.480	

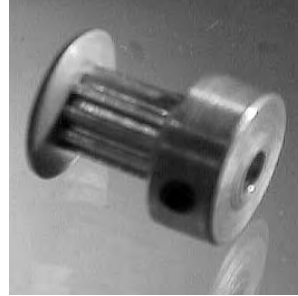
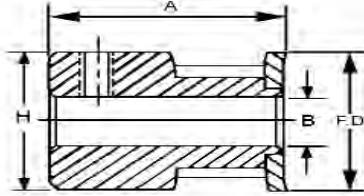

Other numbers of grooves, bores or hub styles available on request.

CIRCULAR PITCH	STYLE	BELT WIDTH	BORE	MATERIALS	BERG'S ® NAME	BELT
.080 (MXL)	Double Flange Pin Hub	1/8"	3/16"	Aluminum Alloy Anodized	Max-M-Drive®	Operates with Max-M-Drive® TB7 series.

STOCK NO.	NO. OF GROOVES	PITCH DIA.	OUTSIDE DIA.	F.D. ±.016	A ±.016	H ±.010	B +.001/-0.000
TP7A3W2-15	15	.382	.362	.555			
TP7A3W2-16	16	.407	.387	.580	.436	.555	.188

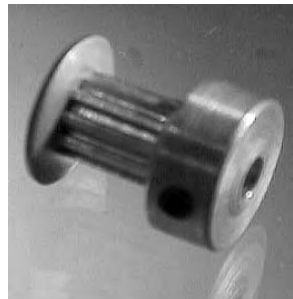
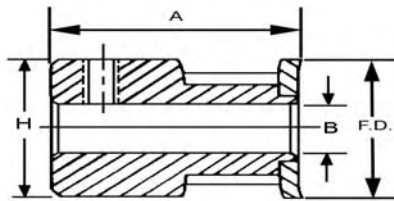

Other numbers of grooves, bores or hub styles available on request.

TIMING PULLEYS

CIRCULAR PITCH	STYLE	BELT WIDTH	BORE	MATERIALS	BERG'S® NAME	BELT
.080 (MXL)	Double Flange Pin Hub	1/8"	3/16"	Aluminum Alloy Anodized	Max-M-Drive®	Operates with Max-M-Drive® TB7 series.

STOCK NO.	NO. OF GROOVES	PITCH DIA.	OUTSIDE DIA.	F.D. ±.016	A ±.016	H ±.010	B +.001/-0.000
TP7A3W2-18	18	.458	.438	.635	.484	.312	.188
TP7A3W2-20	20	.509	.489	.685		.364	
TP7A3W2-21	21	.535	.515	.710		.390	
TP7A3W2-22	22	.560	.540	.740		.390	

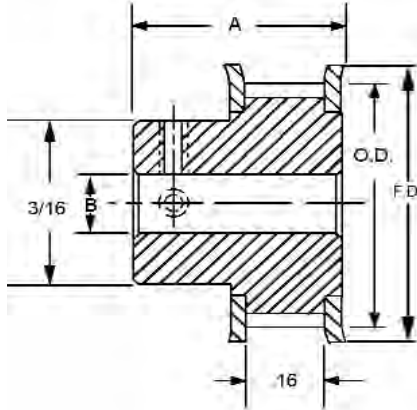

Other numbers of grooves, bores or hub styles available on request.

CIRCULAR PITCH	STYLE	BELT WIDTH	BORE	MATERIALS	BERG'S® NAME	BELT
.080 (MXL)	Double Flange Pin Hub	1/8"	1/4"	Aluminum Alloy Anodized	Max-M-Drive®	Operates with Max-M-Drive® TB7 series.

STOCK NO.	NO. OF GROOVES	PITCH DIA.	OUTSIDE DIA.	F.D. ±.016	A ±.016	H ±.010	B +.001/-0.000
TP7A4W2-24	24	.611	.591	.790	.515	.442	.250
TP7A4W2-28	28	.713	.693	.895		.494	
TP7A4W2-30	30	.764	.744	.945		.546	
TP7A4W2-32	32	.815	.795	1.000		.598	
TP7A4W2-36	36	.917	.897	1.105		.676	
TP7A4W2-40	40	1.019	.999	1.210	.754		
TP7A4W2-42	42	1.070	1.050	1.260	.531	.806	
TP7A4W2-44	44	1.120	1.100	1.315		.858	
TP7A4W2-48	48	1.122	1.202	1.420		.936	
TP7A4W2-48	48	1.122	1.202	1.420		.936	
TP7A4W2-60	60	1.528	1.508	1.730		1.222	

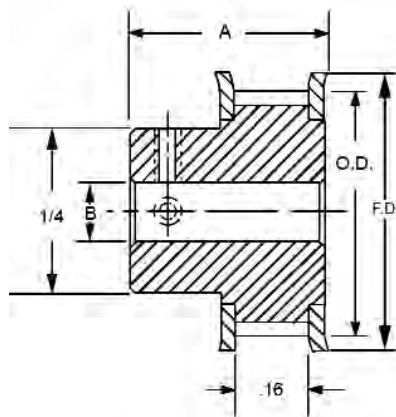

Other numbers of grooves, bores or hub styles available on request.

TIMING PULLEYS

CIRCULAR PITCH	STYLE	BELT WIDTH	BORE	MATERIALS	BERG'S ® NAME	BELT
.080 (MXL)	Double Flange Pin Hub	1/4"	1/8"	Aluminum Alloy Anodized	Max-M-Drive®	Operates with Max-M-Drive® TB7 series.

STOCK NO.	NO. OF GROOVES	PITCH DIA.	OUTSIDE DIA.	F.D. ±.016	A ±.016	H ±.010	B +.001/- .000
TP7A2W4-10	10	.255	.235	.425		.425	
TP7A2W4-11	11	.280	.260	.450	.565	.450	.125
TP7A2W4-12	12	.306	.286	.480		.480	
TP7A2W4-14	14	.357	.337	.530		.530	

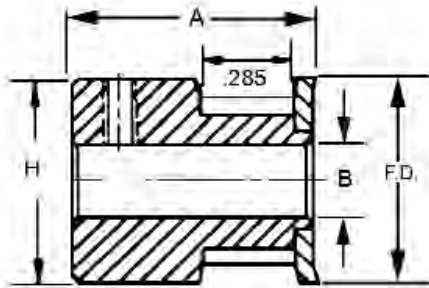

Other numbers of grooves, bores or hub styles available on request.

CIRCULAR PITCH	STYLE	BELT WIDTH	BORE	MATERIALS	BERG'S ® NAME	BELT
.080 (MXL)	Double Flange Pin Hub	1/4"	3/16"	Aluminum Alloy Anodized	Max-M-Drive®	Operates with Max-M-Drive® TB7 series.

STOCK NO.	NO. OF GROOVES	PITCH DIA.	OUTSIDE DIA.	F.D. ±.016	A ±.016	H ±.010	B +.001/- .000
TP7A3W4-15	15	.382	.362	.555	.565	.555	.188
TP7A3W4-16	16	.407	.387	.580		.580	

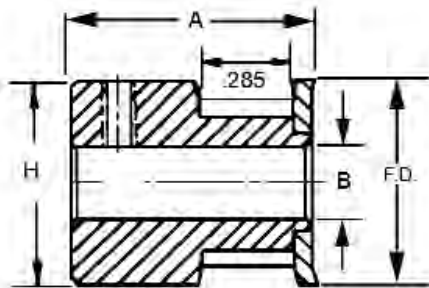

Other numbers of grooves, bores or hub styles available on request.

TIMING PULLEYS

CIRCULAR PITCH	STYLE	BELT WIDTH	BORE	MATERIALS	BERG'S ® NAME	BELT
.080 (MXL)	Double Flange Pin Hub	1/4"	3/16"	Aluminum Alloy Anodized	Max-M-Drive®	Operates with Max-M-Drive® TB7 series.

STOCK NO.	NO. OF GROOVES	PITCH DIA.	OUTSIDE DIA.	F.D. ±.016	A ±.016	H ±.010	B +.001/-.000
TP7A3W4-18	18	.458	.438	.635		.312	
TP7A3W4-20	20	.509	.489	.685	.625	.364	.188
TP7A3W4-21	21	.535	.515	.710		.390	
TP7A3W4-22	22	.560	.540	.740		.390	

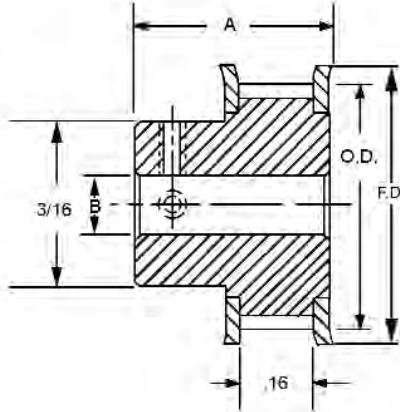

Other numbers of grooves, bores or hub styles available on request.

CIRCULAR PITCH	STYLE	BELT WIDTH	BORE	MATERIALS	BERG'S ® NAME	BELT
.080 (MXL)	Double Flange Pin Hub	1/4"	1/4"	Aluminum Alloy Anodized	Max-M-Drive®	Operates with Max-M-Drive® TB7 series.

STOCK NO.	NO. OF GROOVES	PITCH DIA.	OUTSIDE DIA.	F.D. ±.016	A ±.016	H ±.010	B +.001/-.000
TP7A4W4-24	24	.611	.591	.790		.442	
TP7A4W4-28	28	.713	.693	.895		.494	
TP7A4W4-30	30	.764	.744	.945	.687	.546	
TP7A4W4-32	32	.815	.795	1.000		.598	
TP7A4W4-36	36	.917	.897	1.105		.676	.250
TP7A4W4-40	40	1.019	.999	1.210		.754	
TP7A4W4-42	42	1.070	1.050	1.260		.806	
TP7A4W4-44	44	1.120	1.100	1.315	.718	.858	
TP7A4W4-48	48	1.222	1.202	1.420		.936	
TP7A4W4-50	50	1.273	1.253	1.470		.968	

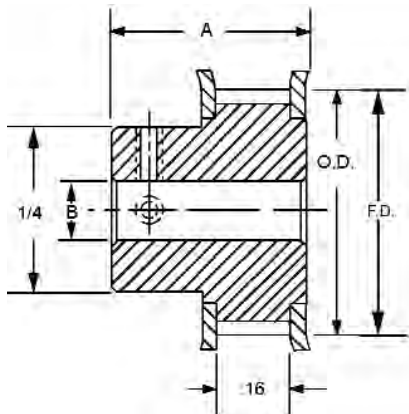

Other numbers of grooves, bores or hub styles available on request.

TIMING PULLEYS

CIRCULAR PITCH	STYLE	BELT WIDTH	BORE	MATERIALS	BERG'S ® NAME	BELT
.080 (MXL)	No Flange Pin Hub	1/4"	1/4"	Aluminum Alloy Anodized	Max-M-Drive®	Operates with Max-M-Drive® TB7 series.

STOCK NO.	NO. OF GROOVES	PITCH DIA.	OUTSIDE DIA.	A ±.016	H ±.010	B +.001/-000
TP7A4H4-60	60	1.528	1.508	.750	1.148	.250
TP7A4H4-72	72	1.833	1.813		1.195	

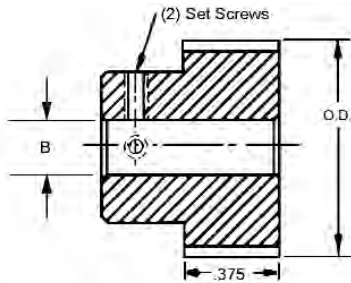

Other numbers of grooves, bores or hub styles available on request.

CIRCULAR PITCH	STYLE	BELT WIDTH	BORE	MATERIALS	BERG'S ® NAME	BELT
.080 (MXL)	No Flange Pin Hub	1/4"	5/16"	Aluminum Alloy Anodized	Max-M-Drive®	Operates with Max-M-Drive® TB7 series.

STOCK NO.	NO. OF GROOVES	PITCH DIA.	OUTSIDE DIA.	A ±.016	H ±.010	B +.001/-000
TP7A5H4-80	80	2.037	2.017	.750	1.500	.313
TP7A5H4-90	90	2.292	2.272			
TP7A5H4-100	100	2.546	2.526			

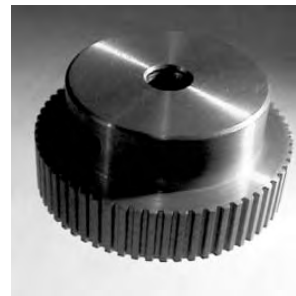
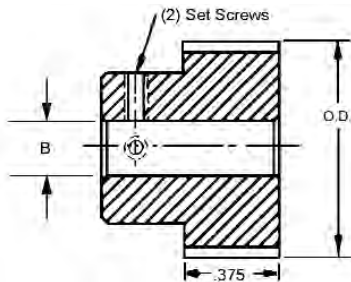

Other numbers of grooves, bores or hub styles available on request.

CIRCULAR PITCH	STYLE	BELT WIDTH	BORE	MATERIALS	BERG'S ® NAME	BELT
.080 (MXL)	No Flange Pin Hub	1/4"	3/8"	Aluminum Alloy Anodized	Max-M-Drive®	Operates with Max-M-Drive® TB7 series.

STOCK NO.	NO. OF GROOVES	PITCH DIA.	OUTSIDE DIA.	A ±.016	H ±.010	B +.001/-000
TP7A6H4-120	120	3.056	3.036	.750	1.500	.375

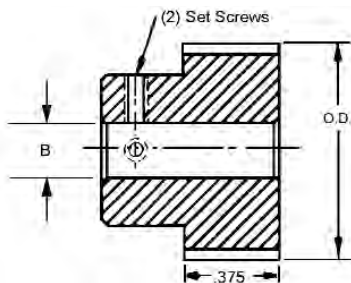

Other numbers of grooves, bores or hub styles available on request.

TIMING PULLEYS

CIRCULAR PITCH	STYLE	BELT WIDTH	BORE	MATERIALS	BERG'S ® NAME	BELT
.0816 (XXL)	Single Flange Pin Hub	1/4"	3/32"	Acetal	Max-M-Drive®	Operates with Max-M-Drive® TB40 series.

STOCK NO.	NO. OF GROOVES	O.D.	P.D.	F.D.	B +.001/-.002	H
TP8EDU4-10	10	.246	.260	.43		
TP8EDU4-11	11	.272	.286	.46	.094	7/16
TP8EDU4-12	12	.298	.312	.49		

No set screws. One or two set screws are optional at an additional charge.

Other numbers of grooves, bores or hub styles available on request.

CIRCULAR PITCH	STYLE	BELT WIDTH	BORE	MATERIALS	BERG'S ® NAME	BELT
.0816 (XXL)	Single Flange Pin Hub	1/4"	1/8"	Acetal	Max-M-Drive®	Operates with Max-M-Drive® TB40 series.

STOCK NO.	NO. OF GROOVES	O.D.	P.D.	F.D.	B +.001/-.002	H
TP8E2U4-14	14	.350	.364	.54		
TP8E2U4-15	15	.376	.390	.57	.125	7/16

No set screws. One or two set screws are optional at an additional charge.

Other numbers of grooves, bores or hub styles available on request.

CIRCULAR PITCH	STYLE	BELT WIDTH	BORE	MATERIALS	BERG'S ® NAME	BELT
.0816 (XXL)	Single Flange Pin Hub	1/4"	3/16"	Acetal	Max-M-Drive®	Operates with Max-M-Drive® TB40 series.

STOCK NO.	NO. OF GROOVES	O.D.	P.D.	F.D.	B +.001/-.002	H
TP8E3U4-18	18	.454	.468	.65		
TP8E3U4-19	19	.480	.494	.68		
TP8E3U4-20	20	.506	.520	.70	.188	1/2
TP8E3U4-21	21	.531	.546	.74		
TP8E3U4-24	24	.610	.624	.80		

No set screws. One or two set screws are optional at an additional charge.

Other numbers of grooves, bores or hub styles available on request.

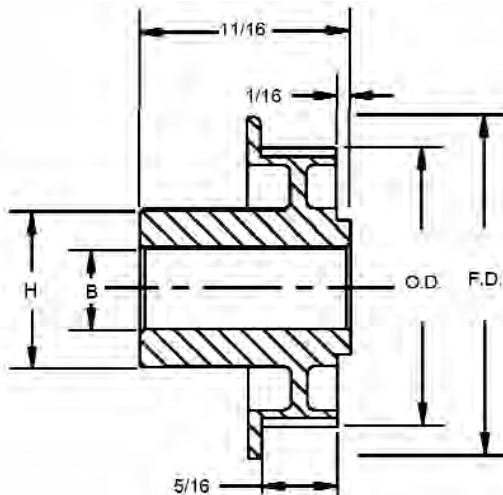

TIMING PULLEYS

CIRCULAR PITCH	STYLE	BELT WIDTH	BORE	MATERIALS	BERG'S® NAME	BELT
.0816 (XXL)	Single Flange Pin Hub	1/4"	1/4"	Acetal	Max-M-Drive®	Operates with Max-M-Drive® TB40 series.

STOCK NO.	NO. OF GROOVES	O.D.	P.D.	F.D.	B +.001/-.002	H
TP8E4U4-25	25	.636	.650	.84	.250	1/2
TP8E4U4-28	28	.714	.728	.91		
TP8E4U4-30	30	.766	.780	.96		
TP8E4U4-32	32	.818	.832	1.01		
TP8E4U4-34	34	.870	.884	1.06	.250	11/16
TP8E4U4-36	36	.922	.936	1.11		
TP8E4U4-38	38	.974	.988	1.16		
TP8E4U4-40	40	1.026	1.040	1.22		
TP8E4U4-42	42	1.078	1.092	1.27		
TP8E4U4-44	44	1.130	1.144	1.32		
TP8E4U4-46	46	1.182	1.196	1.37		
TP8E4U4-48	48	1.234	1.248	1.43		
TP8E4U4-50	50	1.286	1.300	1.48		
TP8E4U4-51	51	1.312	1.326	1.50		
TP8E4U4-54	54	1.390	1.404	1.58		
TP8E4U4-60	60	1.546	1.560	1.73		
TP8E4U4-70	70	1.806	1.820	2.00		

No set screws. One or two set screws are optional at an additional charge.

Other numbers of grooves, bores or hub styles available on request.

CIRCULAR PITCH	STYLE	BELT WIDTH	BORE	MATERIALS	BERG'S® NAME	BELT
.0816 (XXL)	Single Flange Pin Hub	1/4"	5/16"	Acetal	Max-M-Drive®	Operates with Max-M-Drive® TB40 series.

STOCK NO.	NO. OF GROOVES	O.D.	P.D.	F.D.	B +.001/-.002	H
TP8E5U4-72	72	1.858	1.872	2.04	.313	11/16
TP8E5U4-75	75	1.936	1.950	2.13		
TP8E5U4-80	80	1.066	2.080	2.26		
TP8E5U4-84	84	2.170	2.184	2.36		
TP8E5U4-90	90	2.326	2.340	2.52		
TP8E5U4-96	96	2.482	2.496	2.67		
TP8E5U4-97	97	2.508	2.522	2.71		
TP8E5U4-98	98	2.534	2.548	2.72		
TP8E5U4-99	99	2.560	2.574	2.77		
TP8E5U4-100	100	2.586	2.600	2.78		
TP8E5U4-102	102	2.638	2.652	2.83		
TP8E5U4-110	110	2.846	2.846	3.04		
TP8E5U4-120	120	3.106	3.106	3.37		

No set screws. One or two set screws are optional at an additional charge.

Other numbers of grooves, bores or hub styles available on request.

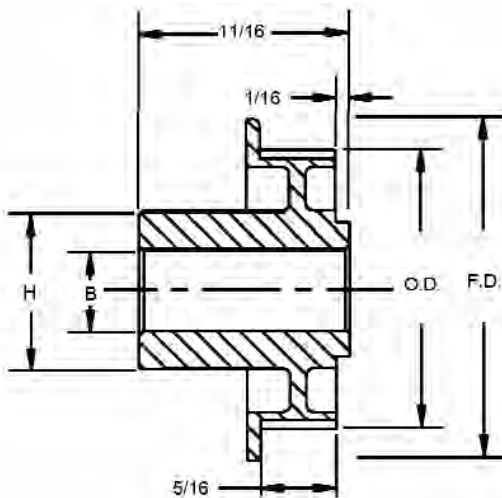

TIMING PULLEYS

CIRCULAR PITCH	STYLE	BELT WIDTH	BORE	MATERIALS	BERG'S ® NAME	BELT
.0816 (XXL)	Double Flange Pin Hub	1/4"	3/32"	Acetal	Max-M-Drive®	Operates with Max-M-Drive® TB40 series.

STOCK NO.	NO. OF GROOVES	O.D.	P.D.	F.D.	B +.001/-.002	H
TP8EDW4-10	10	.246	.260	.43		
TP8EDW4-11	11	.272	.286	.46	.094	7/16
TP8EDW4-12	12	.298	.312	.49		

No set screws. One or two set screws are optional at an additional charge.

Other numbers of grooves, bores or hub styles available on request.

CIRCULAR PITCH	STYLE	BELT WIDTH	BORE	MATERIALS	BERG'S ® NAME	BELT
.0816 (XXL)	Double Flange Pin Hub	1/4"	1/8"	Acetal	Max-M-Drive®	Operates with Max-M-Drive® TB40 series.

STOCK NO.	NO. OF GROOVES	O.D.	P.D.	F.D.	B +.001/-.002	H
TP8E2W4-14	14	.350	.364	.54		
TP8E2W4-15	15	.376	.390	.57	.125	7/16

No set screws. One or two set screws are optional at an additional charge.

Other numbers of grooves, bores or hub styles available on request.

CIRCULAR PITCH	STYLE	BELT WIDTH	BORE	MATERIALS	BERG'S ® NAME	BELT
.0816 (XXL)	Double Flange Pin Hub	1/4"	3/16"	Acetal	Max-M-Drive®	Operates with Max-M-Drive® TB40 series.

STOCK NO.	NO. OF GROOVES	O.D.	P.D.	F.D.	B +.001/-.002	H
TP8E3W4-18	18	.454	.468	.65		
TP8E3W4-19	19	.480	.494	.68		
TP8E3W4-20	20	.506	.520	.70	.188	1/2
TP8E3W4-21	21	.531	.546	.74		
TP8E3W4-24	24	.610	.624	.80		

No set screws. One or two set screws are optional at an additional charge.

Other numbers of grooves, bores or hub styles available on request.

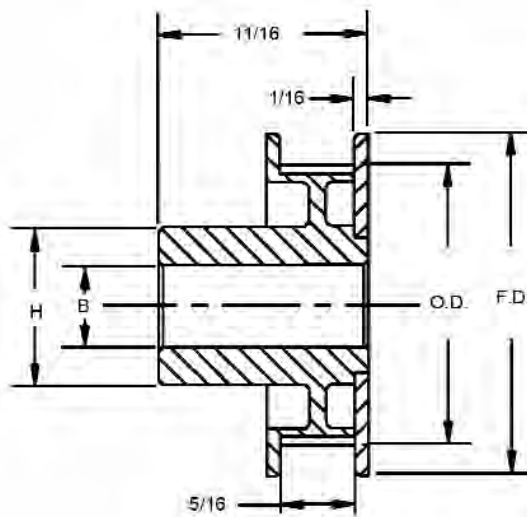

TIMING PULLEYS

CIRCULAR PITCH	STYLE	BELT WIDTH	BORE	MATERIALS	BERG'S® NAME	BELT
.0816 (XXL)	Double Flange Pin Hub	1/4"	1/4"	Acetal	Max-M-Drive®	Operates with Max-M-Drive® TB40 series.

STOCK NO.	NO. OF GROOVES	O.D.	P.D.	F.D.	B +.001/-0.002	H
TP8E4W4-25	25	.636	.650	.84		1/2
TP8E4W4-28	28	.714	.728	.91		
TP8E4W4-30	30	.766	.780	.96		
TP8E4W4-32	32	.818	.832	1.01		
TP8E4W4-34	34	.870	.884	1.06		
TP8E4W4-36	36	.922	.936	1.11		
TP8E4W4-38	38	.974	.988	1.16		
TP8E4W4-40	40	1.026	1.040	1.22		
TP8E4W4-42	42	1.078	1.092	1.27		
TP8E4W4-44	44	1.130	1.144	1.32		
TP8E4W4-46	46	1.182	1.196	1.37	.250	11/16
TP8E4W4-48	48	1.234	1.248	1.43		
TP8E4W4-50	50	1.286	1.300	1.48		
TP8E4W4-51	51	1.312	1.326	1.50		
TP8E4W4-54	54	1.390	1.404	1.58		
TP8E4W4-60	60	1.546	1.560	1.73		
TP8E4W4-70	70	1.806	1.820	2.00		

No set screws. One or two set screws are optional at an additional charge.

Other numbers of grooves, bores or hub styles available on request.

CIRCULAR PITCH	STYLE	BELT WIDTH	BORE	MATERIALS	BERG'S® NAME	BELT
.0816 (XXL)	Double Flange Pin Hub	1/4"	5/16"	Acetal	Max-M-Drive®	Operates with Max-M-Drive® TB40 series.

STOCK NO.	NO. OF GROOVES	O.D.	P.D.	F.D.	B +.001/-0.002	H
TP8E5W4-72	72	1.858	1.872	2.04		11/16
TP8E5W4-75	75	1.936	1.950	2.13		
TP8E5W4-80	80	1.066	2.080	2.26		
TP8E5W4-84	84	2.170	2.184	2.36		
TP8E5W4-90	90	2.326	2.340	2.52		
TP8E5W4-96	96	2.482	2.496	2.67		
TP8E5W4-97	97	2.508	2.522	2.71		
TP8E5W4-98	98	2.534	2.548	2.72		
TP8E5W4-99	99	2.560	2.574	2.77		
TP8E5W4-100	100	2.586	2.600	2.78		
TP8E5W4-102	102	2.638	2.652	2.83		
TP8E5W4-110	110	2.846	2.846	3.04		
TP8E5W4-120	120	3.106	3.106	3.37		

No set screws. One or two set screws are optional at an additional charge.

Other numbers of grooves, bores or hub styles available on request.

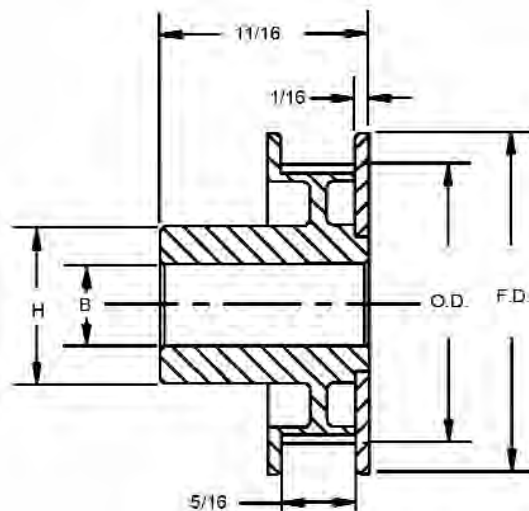

TIMING BELTS

CIRCULAR PITCH	BELT WIDTH	MATERIALS	BERG'S ® NAME	PULLEY
.0816 (XXL)	1/8"	Polyurethane Elastomer with a Polyester Cord Construction Urethane (Black or Orange)	Max-M-Drive®	Operates with TP8 Series

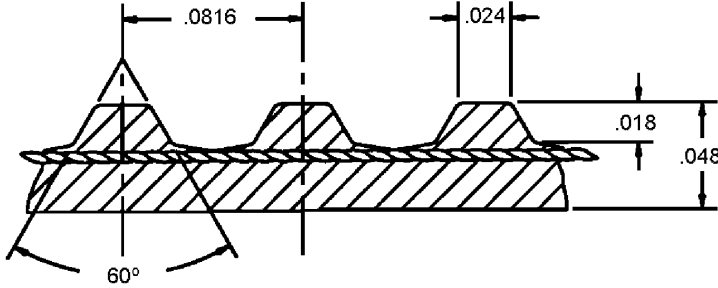

STOCK NO.	LENGTH (Ref.)	STOCK NO.	LENGTH (Ref.)	STOCK NO.	LENGTH (Ref.)
TB40UP2-24	1.958	TB40UP2-116	9.466	TB40UP2-214	17.462
TB40UP2-30	2.448	TB40UP2-118	9.629	TB40UP2-215	17.544
TB40UP2-33	2.693	TB40UP2-119	9.710	TB40UP2-220	17.952
TB40UP2-35	2.856	TB40UP2-120	9.792	TB40UP2-225	18.360
TB40UP2-40	3.264	TB40UP2-122	9.955	TB40UP2-230	18.768
TB40UP2-44	3.590	TB40UP2-123	10.037	TB40UP2-235	19.176
TB40UP2-45	3.672	TB40UP2-125	10.200	TB40UP2-240	19.584
TB40UP2-48	3.917	TB40UP2-130	10.608	TB40UP2-245	19.992
TB40UP2-50	4.080	TB40UP2-131	10.690	TB40UP2-250	20.400
TB40UP2-51	4.162	TB40UP2-132	10.771	TB40UP2-252	20.563
TB40UP2-52	4.243	TB40UP2-135	11.016	TB40UP2-255	20.808
TB40UP2-53	4.325	TB40UP2-139	11.342	TB40UP2-257	20.971
TB40UP2-55	4.488	TB40UP2-140	11.424	TB40UP2-258	21.053
TB40UP2-56	4.570	TB40UP2-143	11.669	TB40UP2-260	21.216
TB40UP2-57	4.651	TB40UP2-144	11.750	TB40UP2-264	21.542
TB40UP2-58	4.733	TB40UP2-145	11.832	TB40UP2-265	21.624
TB40UP2-60	4.896	TB40UP2-149	12.158	TB40UP2-270	22.032
TB40UP2-61	4.976	TB40UP2-150	12.240	TB40UP2-275	22.440
TB40UP2-64	5.222	TB40UP2-151	12.322	TB40UP2-280	22.848
TB40UP2-65	5.304	TB40UP2-152	12.403	TB40UP2-281	22.929
TB40UP2-69	5.630	TB40UP2-153	12.485	TB40UP2-285	23.256
TB40UP2-70	5.712	TB40UP2-154	12.666	TB40UP2-290	23.664
TB40UP2-72	5.875	TB40UP2-155	12.689	TB40UP2-295	24.072
TB40UP2-73	5.957	TB40UP2-159	12.974	TB40UP2-300	24.480
TB40UP2-75	6.120	TB40UP2-160	13.056	TB40UP2-310	25.296
TB40UP2-76	6.202	TB40UP2-162	13.219	TB40UP2-320	26.112
TB40UP2-80	6.528	TB40UP2-163	13.301	TB40UP2-324	26.438
TB40UP2-81	6.610	TB40UP2-165	13.464	TB40UP2-330	26.928
TB40UP2-85	6.936	TB40UP2-170	13.872	TB40UP2-340	27.744
TB40UP2-89	7.262	TB40UP2-175	14.280	TB40UP2-350	28.560
TB40UP2-90	7.344	TB40UP2-178	14.524	TB40UP2-360	29.376
TB40UP2-94	7.670	TB40UP2-180	14.688	TB40UP2-369	30.110
TB40UP2-95	7.752	TB40UP2-185	15.096	TB40UP2-370	30.192
TB40UP2-96	7.834	TB40UP2-190	15.504	TB40UP2-380	31.008
TB40UP2-97	7.915	TB40UP2-192	15.667	TB40UP2-390	31.824
TB40UP2-98	7.997	TB40UP2-193	15.749	TB40UP2-392	31.987
TB40UP2-100	8.160	TB40UP2-195	15.912	TB40UP2-400	32.640
TB40UP2-102	8.323	TB40UP2-200	16.320	TB40UP2-423	34.517
TB40UP2-105	8.566	TB40UP2-205	16.769	TB40UP2-436	35.578
TB40UP2-110	8.976	TB40UP2-208	16.973	TB40UP2-472	38.515
TB40UP2-115	9.384	TB40UP2-210	17.136		

Breaking Strength:
50 lbs. in endless form.

Temperature Range:
-40°F to +150°F

TIMING BELTS

CIRCULAR PITCH	BELT WIDTH	MATERIALS	BERG'S ® NAME	PULLEY
.0816 (XXL)	1/4"	Polyurethane Elastomer with a Polyester Cord Construction Urethane (Black or Orange)	Max-M-Drive®	Operates with TP8 Series

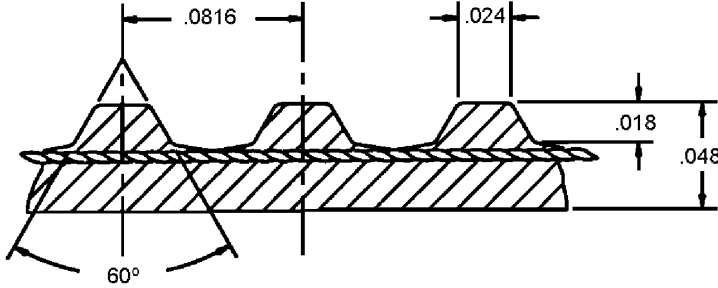

STOCK NO.	LENGTH (Ref.)	STOCK NO.	LENGTH (Ref.)	STOCK NO.	LENGTH (Ref.)
TB40UP4-24	1.958	TB40UP4-116	9.466	TB40UP4-214	17.462
TB40UP4-30	2.448	TB40UP4-118	9.629	TB40UP4-215	17.544
TB40UP4-33	2.693	TB40UP4-119	9.710	TB40UP4-220	17.952
TB40UP4-35	2.856	TB40UP4-120	9.792	TB40UP4-225	18.360
TB40UP4-40	3.264	TB40UP4-122	9.955	TB40UP4-230	18.768
TB40UP4-44	3.590	TB40UP4-123	10.037	TB40UP4-235	19.176
TB40UP4-45	3.672	TB40UP4-125	10.200	TB40UP4-240	19.584
TB40UP4-48	3.917	TB40UP4-130	10.608	TB40UP4-245	19.992
TB40UP4-50	4.080	TB40UP4-131	10.690	TB40UP4-250	20.400
TB40UP4-51	4.162	TB40UP4-132	10.771	TB40UP4-252	20.563
TB40UP4-52	4.243	TB40UP4-135	11.016	TB40UP4-255	20.808
TB40UP4-53	4.325	TB40UP4-139	11.342	TB40UP4-257	20.971
TB40UP4-55	4.488	TB40UP4-140	11.424	TB40UP4-258	21.053
TB40UP4-56	4.570	TB40UP4-143	11.669	TB40UP4-260	21.216
TB40UP4-57	4.651	TB40UP4-144	11.750	TB40UP4-264	21.542
TB40UP4-58	4.733	TB40UP4-145	11.832	TB40UP4-265	21.624
TB40UP4-60	4.896	TB40UP4-149	12.158	TB40UP4-270	22.032
TB40UP4-61	4.976	TB40UP4-150	12.240	TB40UP4-275	22.440
TB40UP4-64	5.222	TB40UP4-151	12.322	TB40UP4-280	22.848
TB40UP4-65	5.304	TB40UP4-152	12.403	TB40UP4-281	22.929
TB40UP4-69	5.630	TB40UP4-153	12.485	TB40UP4-285	23.256
TB40UP4-70	5.712	TB40UP4-154	12.666	TB40UP4-290	23.664
TB40UP4-72	5.875	TB40UP4-155	12.689	TB40UP4-295	24.072
TB40UP4-73	5.957	TB40UP4-159	12.974	TB40UP4-300	24.480
TB40UP4-75	6.120	TB40UP4-160	13.056	TB40UP4-310	25.296
TB40UP4-76	6.202	TB40UP4-162	13.219	TB40UP4-320	26.112
TB40UP4-80	6.528	TB40UP4-163	13.301	TB40UP4-324	26.438
TB40UP4-81	6.610	TB40UP4-165	13.464	TB40UP4-330	26.928
TB40UP4-85	6.936	TB40UP4-170	13.872	TB40UP4-340	27.744
TB40UP4-89	7.262	TB40UP4-175	14.280	TB40UP4-350	28.560
TB40UP4-90	7.344	TB40UP4-178	14.524	TB40UP4-360	29.376
TB40UP4-94	7.670	TB40UP4-180	14.688	TB40UP4-369	30.110
TB40UP4-95	7.752	TB40UP4-185	15.096	TB40UP4-370	30.192
TB40UP4-96	7.834	TB40UP4-190	15.504	TB40UP4-380	31.008
TB40UP4-97	7.915	TB40UP4-192	15.667	TB40UP4-390	31.824
TB40UP4-98	7.997	TB40UP4-193	15.749	TB40UP4-392	31.987
TB40UP4-100	8.160	TB40UP4-195	15.912	TB40UP4-400	32.640
TB40UP4-102	8.323	TB40UP4-200	16.320	TB40UP4-423	34.517
TB40UP4-105	8.566	TB40UP4-205	16.769	TB40UP4-436	35.578
TB40UP4-110	8.976	TB40UP4-208	16.973	TB40UP4-472	38.515
TB40UP4-115	9.384	TB40UP4-210	17.136		

Breaking Strength:
100 lbs. in endless form.

Temperature Range:
-40°F to +150°F

TIMING BELTS

CIRCULAR PITCH	BELT WIDTH	MATERIALS	BERG'S ® NAME	PULLEY
.200 (XL)	1/4"	Neoprene (Black) Fiberglass Reinforced or Urethane (Black or Orange)	Max-M-Drive®	Operates with TP20 Series

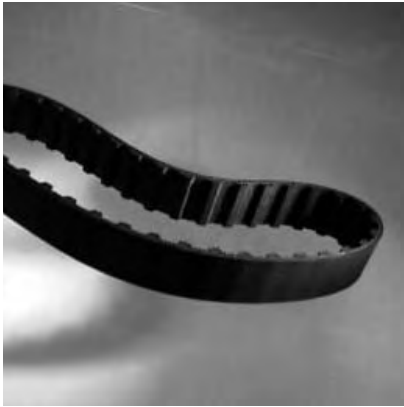
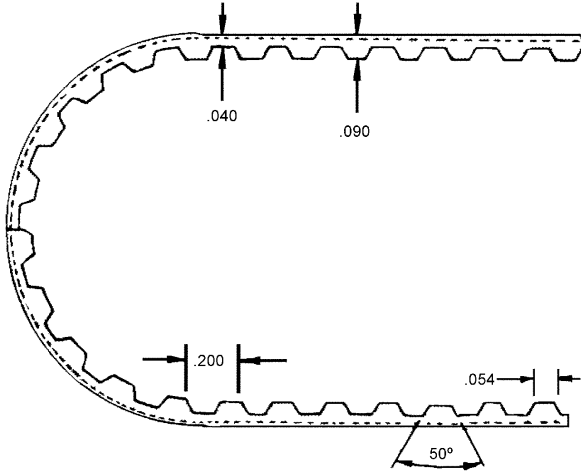

NEOPRENE STOCK NO.	URETHANE STOCK NO.	NO. OF GROOVES	LENGTH (Ref.)
TB20EF4-25	TB20UP4-25	25	5.00
TB20EF4-30	TB20UP4-30	30	6.00
TB20EF4-35	TB20UP4-35	35	7.00
TB20EF4-40	TB20UP4-40	40	8.00
TB20EF4-45	TB20UP4-45	45	9.00
-	TB20UP4-47	47	9.40
-	TB20UP4-48	48	9.60
TB20EF4-50	TB20UP4-50	50	10.00
TB20EF4-55	TB20UP4-55	55	11.00
TB20EF4-60	TB20UP4-60	60	12.00
TB20EF4-65	TB20UP4-65	65	13.00
TB20EF4-70	TB20UP4-70	70	14.00
TB20EF4-75	TB20UP4-75	75	15.00
TB20EF4-80	TB20UP4-80	80	16.00
-	TB20UP4-83	83	16.60
TB20EF4-85	TB20UP4-85	85	17.00
TB20EF4-90	TB20UP4-90	90	18.00
TB20EF4-95	TB20UP4-95	95	19.00
TB20EF4-100	TB20UP4-100	100	20.00
-	TB20UP4-105	105	21.00
TB20EF4-110	TB20UP4-110	110	22.00
TB20EF4-115	TB20UP4-115	115	23.00
TB20EF4-120	TB20UP4-120	120	24.00
TB20EF4-125	TB20UP4-125	125	25.00
TB20EF4-130	TB20UP4-130	130	26.00
TB20EF4-135	TB20UP4-135	135	27.00
TB20EF4-140	TB20UP4-140	140	28.00
TB20EF4-145	TB20UP4-145	145	29.00
TB20EF4-150	TB20UP4-150	150	30.00
TB20EF4-155	-	155	31.00
TB20EF4-165	TB20UP4-165	165	33.00
-	TB20UP4-172	172	34.40
-	TB20UP4-175	175	35.00
-	TB20UP4-180	180	36.00
-	TB20UP4-230	230	46.00

- Large Ratios
- Allows use of small diameter pulleys
- High Speeds
- High Power Transmission
- Quiet Operation
- Wear resistant nylon facing
- Maximum Speed 10,000 RPM
- Minimum Pulley Diameter .64 (10 teeth)
- Temperature Range +185°F to -30°F

TIMING BELTS

CIRCULAR PITCH	BELT WIDTH	MATERIALS	BERG'S ® NAME	PULLEY
.200 (XL)	3/8"	Neoprene (Black) Fiberglass Reinforced or Urethane (Black or Orange)	Max-M-Drive®	Operates with TP20 Series

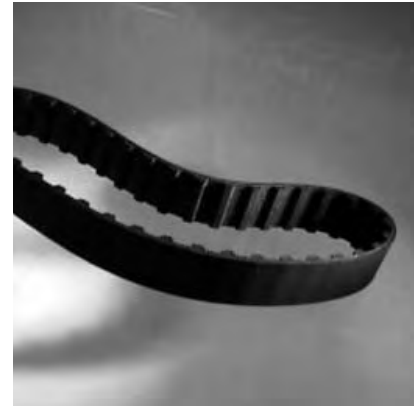
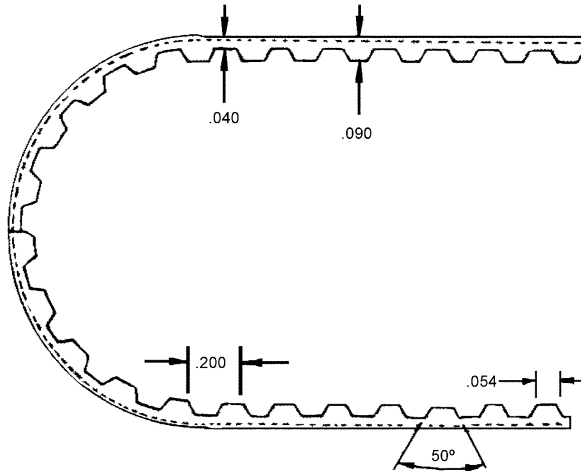

NEOPRENE STOCK NO.	URETHANE STOCK NO.	NO. OF GROOVES	LENGTH (Ref.)
TB20EF6-25	TB20UP6-25	25	5.00
TB20EF6-30	TB20UP6-30	30	6.00
TB20EF6-35	TB20UP6-35	35	7.00
TB20EF6-40	TB20UP6-40	40	8.00
TB20EF6-45	TB20UP6-45	45	9.00
TB20EF6-47	TB20UP6-47	47	9.40
TB20EF6-48	TB20UP6-48	48	9.60
TB20EF6-50	TB20UP6-50	50	10.00
TB20EF6-55	TB20UP6-55	55	11.00
TB20EF6-60	TB20UP6-60	60	12.00
TB20EF6-65	TB20UP6-65	65	13.00
TB20EF6-70	TB20UP6-70	70	14.00
TB20EF6-75	TB20UP6-75	75	15.00
TB20EF6-80	TB20UP6-80	80	16.00
TB20EF6-83	TB20UP6-83	83	16.60
TB20EF6-85	TB20UP6-85	85	17.00
TB20EF6-90	TB20UP6-90	90	18.00
TB20EF6-95	TB20UP6-95	95	19.00
TB20EF6-100	TB20UP6-100	100	20.00
TB20EF6-105	TB20UP6-105	105	21.00
TB20EF6-110	TB20UP6-110	110	22.00
TB20EF6-115	TB20UP6-115	115	23.00
TB20EF6-120	TB20UP6-120	120	24.00
TB20EF6-125	TB20UP6-125	125	25.00
TB20EF6-130	TB20UP6-130	130	26.00
TB20EF6-135	TB20UP6-135	135	27.00
TB20EF6-140	TB20UP6-140	140	28.00
TB20EF6-145	TB20UP6-145	145	29.00
TB20EF6-150	TB20UP6-150	150	30.00
TB20EF6-165	TB20UP6-165	165	33.00
TB20EF6-172	TB20UP6-172	172	34.40
TB20EF6-175	TB20UP6-175	175	35.00
TB20EF6-180	TB20UP6-180	180	36.00
TB20EF6-230	TB20UP6-230	230	46.00

- Large Ratios
- Allows use of small diameter pulleys
- High Speeds
- High Power Transmission
- Quiet Operation
- Wear resistant nylon facing
- Maximum Speed 10,000 RPM
- Minimum Pulley Diameter .64 (10 teeth)
- Temperature Range +185°F to -30°F

TIMING PULLEYS

CIRCULAR PITCH	STYLE	BELT WIDTH	BORE	MATERIALS	BERG'S® NAME	BELT
.200 (XL)	Single Flange Pin Hub	1/4"	3/16"	10% Glass filled Polycarbonate (Black) Hub = Aluminum	Max-M-Drive®	Operates with Max-M-Drive® TB20 series.

O.D. Tolerance: 10 - 28 Grooves: +.003/-0.01

Other numbers of grooves, bores or hub styles available on request.

STOCK NO.	NO. OF GROOVES	P.D.	O.D.	HUB DIA.	F.D.	B +.001 -.000	SET SCREW
TP20P3U6-10	10	.637	.617		.87	.1875	#6-32
TP20P3U6-11	11	.700	.680	.69	.93		
TP20P3U6-12	12	.764	.744		.99		
TP20P3U6-13	13	.828	.808	.75	1.06		

CIRCULAR PITCH	STYLE	BELT WIDTH	BORE	MATERIALS	BERG'S® NAME	BELT
.200 (XL)	Single Flange Pin Hub	1/4"	1/4"	10% Glass filled Polycarbonate (Black) Hub = Aluminum	Max-M-Drive®	Operates with Max-M-Drive® TB20 series.

O.D. Tolerance:

10 - 28 Grooves: +.003/-0.01

29 - 58 Grooves: +.004/-0.01

Other numbers of grooves, bores or hub styles available on request.

STOCK NO.	NO. OF GROOVES	P.D.	O.D.	HUB DIA.	F.D.	B +.001 -.000	SET SCREW
TP20P4U6-14	14	.891	.871	.75	1.12	.2500	#8-32
TP20P4U6-15	15	.955	.935		1.19		
TP20P4U6-16	16	1.019	.999		1.24		
TP20P4U6-17	17	1.082	1.062		1.31		
TP20P4U6-18	18	1.146	1.126		1.39		
TP20P4U6-19	19	1.210	1.190	1.44			
TP20P4U6-20	20	1.273	1.253	.88	1.51		
TP20P4U6-21	21	1.337	1.317		1.57		
TP20P4U6-22	22	1.401	1.381		1.63		
TP20P4U6-23	23	1.464	1.444		1.69		
TP20P4U6-24	24	1.528	1.508		1.76		
TP20P4U6-25	25	1.592	1.572	1.82			
TP20P4U6-26	26	1.655	1.635	1.89			
TP20P4U6-27	27	1.719	1.699	1.95			
TP20P4U6-28	28	1.783	1.763	2.02			
TP20P4U6-29	29	1.846	1.826	2.08			

CIRCULAR PITCH	STYLE	BELT WIDTH	BORE	MATERIALS	BERG'S® NAME	BELT
.200 (XL)	Single Flange Pin Hub	1/4"	5/16"	10% Glass filled Polycarbonate (Black) Hub = Aluminum	Max-M-Drive®	Operates with Max-M-Drive® TB20 series.

O.D. Tolerance:

29 - 58 Grooves: +.004/-0.01

60 - 72 Grooves: +.005/-0.01

Other numbers of grooves, bores or hub styles available on request.

STOCK NO.	NO. OF GROOVES	P.D.	O.D.	HUB DIA.	F.D.	B +.001 -.000	SET SCREW
TP20P5U6-30	30	1.910	1.890	.88	2.14	.3125	#10-32
TP20P5U6-31	31	1.974	1.954		2.20		
TP20P5U6-32	32	2.037	2.017		2.27		
TP20P5U6-34	34	2.165	2.145		2.40		
TP20P5U6-35	35	2.228	2.208		2.46		
TP20P5U6-36	36	2.292	2.272		2.53		
TP20P5U6-37	37	2.355	2.335		2.59		
TP20P5U6-39	39	2.482	2.462		2.71		
TP20P5U6-40	40	2.546	2.526		2.78		
TP20P5U6-42	42	2.674	2.654		2.92		
TP20P5U6-44	44	2.801	2.781	3.04			
TP20P5U6-48	48	3.056	3.036	3.29			

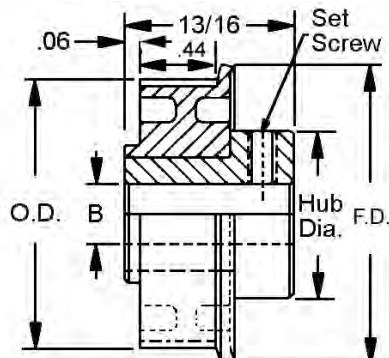

TIMING PULLEYS

CIRCULAR PITCH	STYLE	BELT WIDTH	BORE	MATERIALS	BERG'S ® NAME	BELT
.200 (XL)	Double Flange Pin Hub	1/4"	3/16"	10% Glass filled Polycarbonate (Black) Hub = Aluminum	Max-M-Drive®	Operates with Max-M-Drive® TB20 series.

O.D. Tolerance: 10 - 28 Grooves: +.003/- .001

Other numbers of grooves, bores or hub styles available on request.

STOCK NO.	NO. OF GROOVES	P.D.	O.D.	HUB DIA.	F.D.	B +.0010 -.0000	SET SCREW	LD
TP20P3W6-10	10	.637	.617		.87	.1875	#6-32	13/16
TP20P3W6-11	11	.700	.680	.69	.93			
TP20P3W6-12	12	.764	.744		.99			
TP20P3W6-13	13	.828	.808	.75	1.06			

CIRCULAR PITCH	STYLE	BELT WIDTH	BORE	MATERIALS	BERG'S ® NAME	BELT
.200 (XL)	Double Flange Pin Hub	1/4"	1/4"	10% Glass filled Polycarbonate (Black) Hub = Aluminum	Max-M-Drive®	Operates with Max-M-Drive® TB20 series.

O.D. Tolerance:
10 - 28 Grooves: +.003/- .001
29 - 58 Grooves: +.004/- .001

Other numbers of grooves, bores or hub styles available on request.

STOCK NO.	NO. OF GROOVES	P.D.	O.D.	HUB DIA.	F.D.	B +.0010 -.0000	SET SCREW	LD
TP20P4W6-14	14	.891	.871	.75	1.12	.2500	#8-32	13/16
TP20P4W6-15	15	.955	.935		1.19			
TP20P4W6-16	16	1.019	.999		1.24			
TP20P4W6-17	17	1.082	1.062		1.31			
TP20P4W6-18	18	1.146	1.126		1.39			
TP20P4W6-19	19	1.210	1.190		1.44			
TP20P4W6-20	20	1.273	1.253	1.51				
TP20P4W6-21	21	1.337	1.317	1.57				
TP20P4W6-22	22	1.401	1.381	1.63				
TP20P4W6-23	23	1.464	1.444	1.69				
TP20P4W6-24	24	1.528	1.508	1.76				
TP20P4W6-25	25	1.592	1.572	1.82				
TP20P4W6-26	26	1.655	1.635	1.89				
TP20P4W6-27	27	1.719	1.699	1.95				
TP20P4W6-28	28	1.783	1.763	2.02				
TP20P4W6-29	29	1.846	1.826	2.08				

CIRCULAR PITCH	STYLE	BELT WIDTH	BORE	MATERIALS	BERG'S ® NAME	BELT
.200 (XL)	Double Flange Pin Hub	1/4"	5/16"	10% Glass filled Polycarbonate (Black) Hub = Aluminum	Max-M-Drive®	Operates with Max-M-Drive® TB20 series.

O.D. Tolerance:
29 - 58 Grooves: +.004/- .001
60 - 72 Grooves: +.005/- .001

Other numbers of grooves, bores or hub styles available on request.

STOCK NO.	NO. OF GROOVES	P.D.	O.D.	HUB DIA.	F.D.	B +.0010 -.0000	SET SCREW	LD
TP20P5W6-30	30	1.910	1.890	.88	2.14	.3125	#10-32	7/8
TP20P5W6-31	31	1.974	1.954		2.20			
TP20P5W6-32	32	2.037	2.017		2.27			
TP20P5W6-34	34	2.165	2.145		2.40			
TP20P5W6-35	35	2.228	2.208		2.46			
TP20P5W6-36	36	2.292	2.272		2.53			
TP20P5W6-37	37	2.355	2.335		2.59			
TP20P5W6-39	39	2.482	2.462		2.71			
TP20P5W6-40	40	2.546	2.526		2.78			
TP20P5W6-42	42	2.674	2.654		2.92			
TP20P5W6-44	44	2.801	2.781		3.04			
TP20P5W6-48	48	3.056	3.036		3.29			

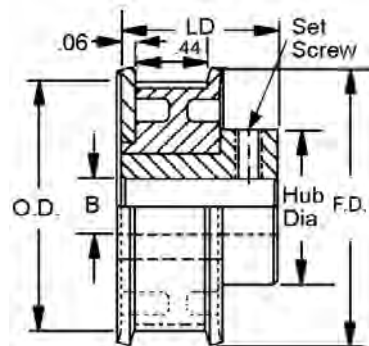

TIMING PULLEYS

CIRCULAR PITCH	STYLE	BELT WIDTH	BORE	MATERIALS	BERG'S® NAME	BELT
.200 (XL)	Single Flange Pin Hub	1/2"	3/16"	Acetal	Max-M-Drive®	Operates with Max-M-Drive® TB20 series.

Other numbers of grooves, bores or hub styles available on request.

STOCK NO.	NO. OF GROOVES	O.D.	P.D.	F.D.	B +.001 -.000	H	L	W
TP20E3U6-10	10	.617	.637	.87	.188	1/2	1	1/2
TP20E3U6-11	11	.680	.700	.93				
TP20E3U6-12	12	.744	.764	.99				

CIRCULAR PITCH	STYLE	BELT WIDTH	BORE	MATERIALS	BERG'S® NAME	BELT
.200 (XL)	Single Flange Pin Hub	1/2"	1/4"	Acetal	Max-M-Drive®	Operates with Max-M-Drive® TB20 series.

Other numbers of grooves, bores or hub styles available on request.

STOCK NO.	NO. OF GROOVES	O.D.	P.D.	F.D.	B +.001 -.000	H	L	W
TP20E4U6-14	14	.871	.891	1.12	.250	5/8	1	1/2
TP20E4U6-15	15	.935	.955	1.19				
TP20E4U6-16	16	.999	1.019	1.25				
TP20E4U6-17	18	1.126	1.146	1.38				
TP20E4U6-18	20	1.253	1.273	1.51				
TP20E4U6-20	21	1.317	1.337	1.57				
TP20E4U6-21	22	1.381	1.401	1.63				
TP20E4U6-22	24	1.508	1.528	1.76				
TP20E4U6-24	28	1.763	1.783	2.02				

CIRCULAR PITCH	STYLE	BELT WIDTH	BORE	MATERIALS	BERG'S® NAME	BELT
.200 (XL)	Single Flange Pin Hub	1/2"	5/16"	Acetal	Max-M-Drive®	Operates with Max-M-Drive® TB20 series.

Other numbers of grooves, bores or hub styles available on request.

STOCK NO.	NO. OF GROOVES	O.D.	P.D.	F.D.	B +.001 -.000	H	L	W
TP20E5U6-30	30	1.890	1.910	2.14	.313	11/16	1	1/2
TP20E5U6-32	32	2.017	2.037	2.27				
TP20E5U6-36	36	2.272	2.292	2.53				
TP20E5U6-40	40	2.526	2.546	2.78				
TP20E5U6-42	42	2.654	2.674	2.91				
TP20E5U6-44	44	2.781	2.801	3.04				
TP20E5U6-48	48	3.036	3.056	3.29				

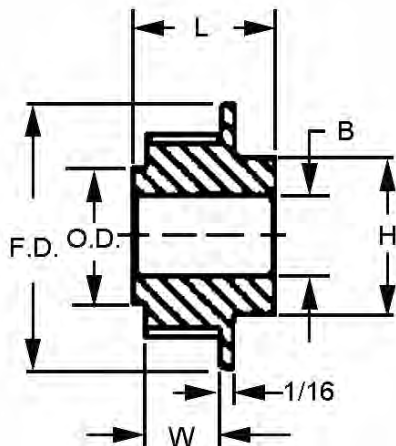

TIMING PULLEYS

CIRCULAR PITCH	STYLE	BELT WIDTH	BORE	MATERIALS	BERG'S ® NAME	BELT
.200 (XL)	Double Flange Pin Hub	1/2"	3/16"	Acetal	Max-M-Drive®	Operates with Max-M-Drive® TB20 series.

Other numbers of grooves, bores or hub styles available on request.

STOCK NO.	NO. OF GROOVES	O.D.	P.D.	F.D.	B +.001 -.000	H	L	W
TP20E3W6-10	10	.617	.637	.87	.188	1/2	1	1/2
TP20E3W6-11	11	.680	.700	.93				
TP20E3W6-12	12	.744	.764	.99				

CIRCULAR PITCH	STYLE	BELT WIDTH	BORE	MATERIALS	BERG'S ® NAME	BELT
.200 (XL)	Double Flange Pin Hub	1/2"	1/4"	Acetal	Max-M-Drive®	Operates with Max-M-Drive® TB20 series.

Other numbers of grooves, bores or hub styles available on request.

STOCK NO.	NO. OF GROOVES	O.D.	P.D.	F.D.	B +.001 -.000	H	L	W
TP20E4W6-14	14	.871	.891	1.12	.250	1/2	1	1/2
TP20E4W6-15	15	.935	.955	1.19				
TP20E4W6-16	16	.999	1.019	1.25				
TP20E4W6-17	18	1.126	1.146	1.38				
TP20E4W6-18	20	1.253	1.273	1.51		5/8		
TP20E4W6-20	21	1.317	1.337	1.57				
TP20E4W6-21	22	1.381	1.401	1.63				
TP20E4W6-22	24	1.508	1.528	1.76				
TP20E4W6-24	28	1.763	1.783	2.02				

CIRCULAR PITCH	STYLE	BELT WIDTH	BORE	MATERIALS	BERG'S ® NAME	BELT
.200 (XL)	Double Flange Pin Hub	1/2"	5/16"	Acetal	Max-M-Drive®	Operates with Max-M-Drive® TB20 series.

Other numbers of grooves, bores or hub styles available on request.

STOCK NO.	NO. OF GROOVES	O.D.	P.D.	F.D.	B +.001 -.000	H	L	W
TP20E5W6-30	30	1.890	1.910	2.14	.313	11/16	1	1/2
TP20E5W6-32	32	2.017	2.037	2.27				
TP20E5W6-36	36	2.272	2.292	2.53				
TP20E5W6-40	40	2.526	2.546	2.78				
TP20E5W6-42	42	2.654	2.674	2.91				
TP20E5W6-44	44	2.781	2.801	3.04				
TP20E5W6-44	44	2.781	2.801	3.04				
TP20E5W6-48	48	3.036	3.056	3.29				

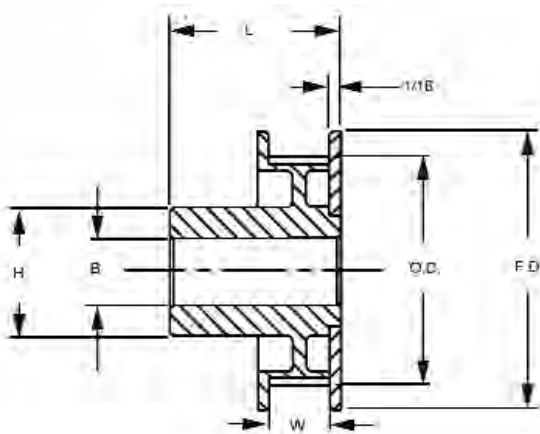

TIMING PULLEYS

CIRCULAR PITCH	STYLE	BELT WIDTH	BORE	MATERIALS	BERG'S ® NAME	BELT
.200 (XL)	Single Flange Pin Hub	7/16"	3/16"	Lexan®	Max-M-Drive®	Operates with Max-M-Drive® TB20 series.

Other numbers of grooves, bores or hub styles available on request.

STOCK NO.	NO. OF GROOVES	O.D.	P.D.	F.D.	B +.001 -.000	W	L	H
TP20L3U6-10	10	.617	.637	.87	.188	7/16	3/16	11/16
TP20L3U6-11	11	.680	.700	.93				
TP20L3U6-12	12	.744	.764	.99				
TP20L3U6-13	13	.808	.828	1.06				

CIRCULAR PITCH	STYLE	BELT WIDTH	BORE	MATERIALS	BERG'S ® NAME	BELT
.200 (XL)	Single Flange Pin Hub	7/16"	1/4"	Acetal	Max-M-Drive®	Operates with Max-M-Drive® TB20 series.

Other numbers of grooves, bores or hub styles available on request.

STOCK NO.	NO. OF GROOVES	O.D.	P.D.	F.D.	B +.001 -.000	W	L	H
TP20E4U6-14	14	.871	.891	1.12	.250	7/16	13/16	3/4
TP20E4U6-15	15	.935	.955	1.19				
TP20E4U6-16	16	.999	1.019	1.24				
TP20E4U6-17	17	1.062	1.082	1.31				
TP20E4U6-18	18	1.126	1.146	1.38				
TP20E4U6-19	19	1.190	1.210	1.44				
TP20E4U6-20	20	1.253	1.273	1.51				
TP20E4U6-21	21	1.317	1.337	1.57			7/8	
TP20E4U6-22	22	1.381	1.401	1.63				
TP20E4U6-23	23	1.444	1.464	2.69				
TP20E4U6-24	24	1.508	1.528	1.76				
TP20E4U6-25	25	1.572	1.592	1.82				
TP20E4U6-26	26	1.635	1.655	1.89				
TP20E4U6-27	27	1.699	1.719	1.95				
TP20E4U6-28	28	1.763	1.783	2.02				
TP20E4U6-29	29	1.827	1.846	2.08				

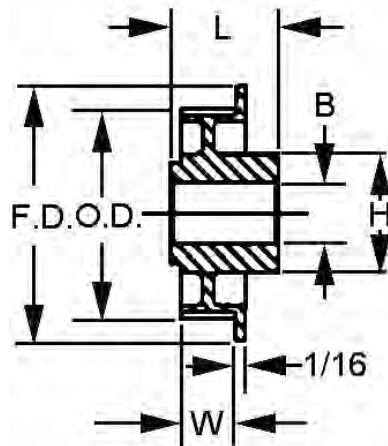

TIMING PULLEYS

CIRCULAR PITCH	STYLE	BELT WIDTH	BORE	MATERIALS	BERG'S ® NAME	BELT
.200 (XL)	Single Flange Pin Hub	7/16	5/16"	Acetal	Max-M-Drive®	Operates with Max-M-Drive® TB20 series.

Other numbers of grooves, bores or hub styles available on request.

STOCK NO.	NO. OF GROOVES	O.D.	P.D.	F.D.	B +.001 -.000	W	L	H
TP20E5U6-30	30	1.890	1.910	2.14	.313	11/16	13/16	7/8
TP20E5U6-31	31	1.954	1.973	2.20				
TP20E5U6-32	32	2.017	2.037	2.27				
TP20E5U6-34	34	2.145	2.165	2.40				
TP20E5U6-35	35	2.209	2.228	2.46				
TP20E5U6-36	36	2.272	2.292	2.53				
TP20E5U6-37	37	2.336	2.355	2.59				
TP20E5U6-39	39	2.462	2.482	2.71				
TP20E5U6-40	40	2.526	2.546	2.78				
TP20E5U6-42	42	2.654	2.374	2.92				
TP20E5U6-44	44	2.781	2.801	3.04				
TP20E5U6-48	48	3.036	3.056	3.29				

CIRCULAR PITCH	STYLE	BELT WIDTH	BORE	MATERIALS	BERG'S ® NAME	BELT
.200 (XL)	Single Flange Pin Hub	7/16"-1/2"	3/8"	Lexan®	Max-M-Drive®	Operates with Max-M-Drive® TB20 series.

Other numbers of grooves, bores or hub styles available on request.

STOCK NO.	NO. OF GROOVES	O.D.	P.D.	F.D.	B +.001 -.000	W	L	H
TP20L6U6-54	54	3.418	3.438	None	.375	1/2	7/8	1"
TP20L6U6-58	58	3.672	3.692	3.92		7/16	3/16	
TP20L6U6-60	60	3.800	3.820	None		1/2	7/8	
TP20L6U6-72	72	4.564	4.584	None		1/2	7/8	
TP20L6U6-78	78	4.946	4.966	5.19		1/2	31/32	

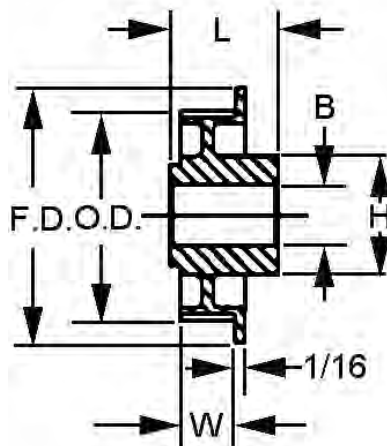

TIMING PULLEYS

CIRCULAR PITCH	STYLE	BELT WIDTH	BORE	MATERIALS	BERG'S ® NAME	BELT
.200 (XL)	Double Flange Pin Hub	7/16"	3/16"	Lexan®	Max-M-Drive®	Operates with Max-M-Drive® TB20 series.

Other numbers of grooves, bores or hub styles available on request.

STOCK NO.	NO. OF GROOVES	O.D.	P.D.	F.D.	B +.001 -.000	W	L	H
TP20L3W6-10	10	.617	.637	.87	.188	7/16	3/16	11/16
TP20L3W6-11	11	.680	.700	.93				
TP20L3W6-12	12	.744	.764	.99				
TP20L3W6-13	13	.808	.828	1.06				

CIRCULAR PITCH	STYLE	BELT WIDTH	BORE	MATERIALS	BERG'S ® NAME	BELT
.200 (XL)	Double Flange Pin Hub	7/16"	1/4"	Acetal	Max-M-Drive®	Operates with Max-M-Drive® TB20 series.

Other numbers of grooves, bores or hub styles available on request.

STOCK NO.	NO. OF GROOVES	O.D.	P.D.	F.D.	B +.001 -.000	W	L	H
TP20E4W6-14	14	.871	.891	1.12	.250	7/16	13/16	3/4
TP20E4W6-15	15	.935	.955	1.19				
TP20E4W6-16	16	.999	1.019	1.24				
TP20E4W6-17	17	1.062	1.082	1.31				
TP20E4W6-18	18	1.126	1.146	1.38				
TP20E4W6-19	19	1.190	1.210	1.44				
TP20E4W6-20	20	1.253	1.273	1.51			7/8	
TP20E4W6-21	21	1.317	1.337	1.57				
TP20E4W6-22	22	1.381	1.401	1.63				
TP20E4W6-23	23	1.444	1.464	2.69				
TP20E4W6-24	24	1.508	1.528	1.76				
TP20E4W6-25	25	1.572	1.592	1.82				
TP20E4W6-26	26	1.635	1.655	1.89				
TP20E4W6-27	27	1.699	1.719	1.95				
TP20E4W6-28	28	1.763	1.783	2.02				
TP20E4W6-29	29	1.827	1.846	2.08				

CIRCULAR PITCH	STYLE	BELT WIDTH	BORE	MATERIALS	BERG'S ® NAME	BELT
.200 (XL)	Double Flange Pin Hub	7/16	5/16"	Acetal	Max-M-Drive®	Operates with Max-M-Drive® TB20 series.

Other numbers of grooves, bores or hub styles available on request.

STOCK NO.	NO. OF GROOVES	O.D.	P.D.	F.D.	B +.001 -.000	W	L	H
TP20E5W6-30	30	1.890	1.910	2.14	.313	11/16	13/16	7/8
TP20E5W6-31	31	1.954	1.973	2.20				
TP20E5W6-32	32	2.017	2.037	2.27				
TP20E5W6-34	34	2.145	2.165	2.40				
TP20E5W6-35	35	2.209	2.228	2.46				
TP20E5W6-36	36	2.272	2.292	2.53				
TP20E5W6-37	37	2.336	2.355	2.59				
TP20E5W6-39	39	2.462	2.482	2.71				
TP20E5W6-40	40	2.526	2.546	2.78				
TP20E5W6-42	42	2.654	2.374	2.92				
TP20E5W6-44	44	2.781	2.801	3.04				
TP20E5W6-48	48	3.036	3.056	3.29				

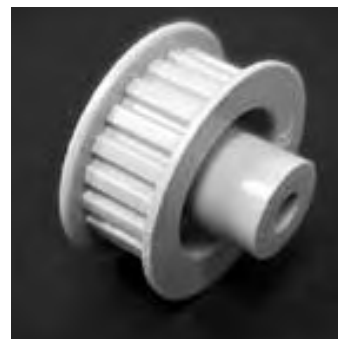
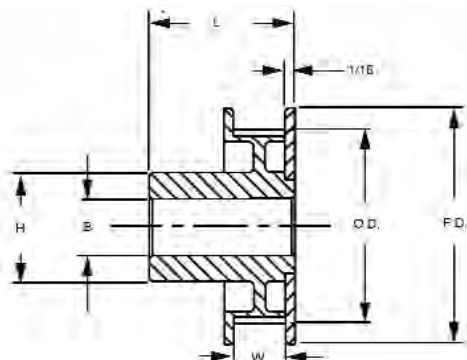

TIMING PULLEYS

CIRCULAR PITCH	STYLE	BELT WIDTH	BORE	MATERIALS	BERG'S® NAME	BELT
.200 (XL)	Double Flange Pin Hub	1/4"	3/16"	Aluminum Clear Anodized	Max-M-Drive®	Operates with Max-M-Drive® TB20 series.

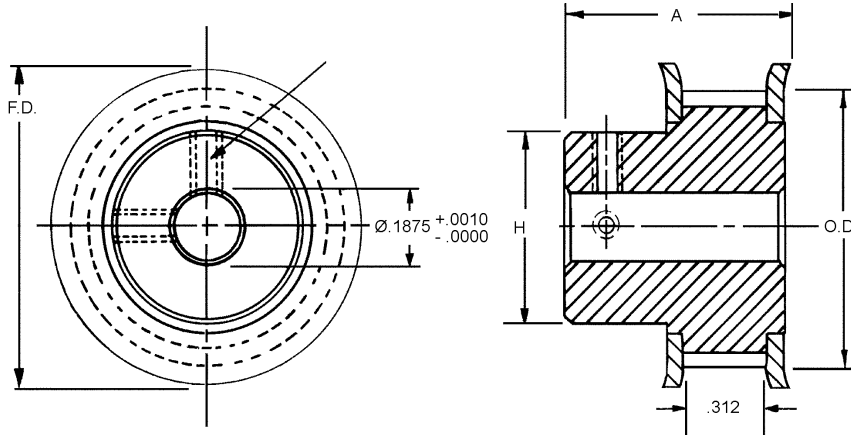

* These pulleys may contain one or two set screws.
Other numbers of grooves, bores or hub styles available on request.

STOCK NO.	NO. OF GROOVES	P.D.	O.D.	F.D.	A	H
TP20A3W4-10	10*	.637	.617	.88		3/8
TP20A3W4-11	11*	.700	.680	.94	11/16	7/16
TP20A3W4-12	12	.764	.744	1.00		1/2

CIRCULAR PITCH	STYLE	BELT WIDTH	BORE	MATERIALS	BERG'S® NAME	BELT
.200 (XL)	Double Flange Pin Hub	1/4"	1/4"	Aluminum Clear Anodized	Max-M-Drive®	Operates with Max-M-Drive® TB20 series.

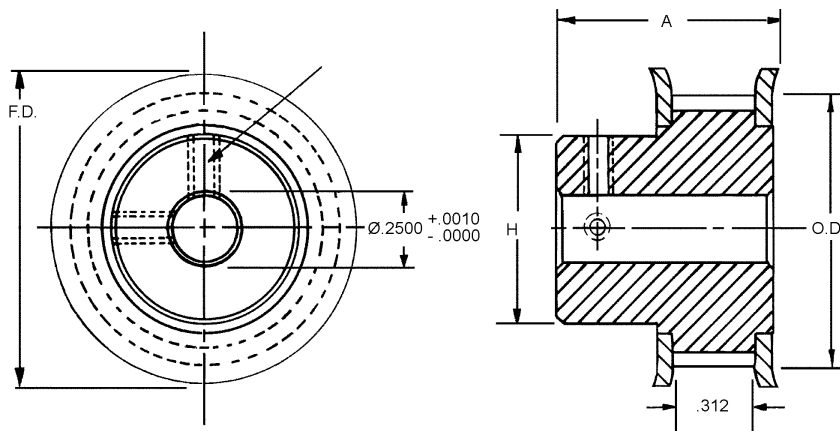

* These pulleys may contain one or two set screws.
Other numbers of grooves, bores or hub styles available on request.

STOCK NO.	NO. OF GROOVES	P.D.	O.D.	F.D.	A	H
TP20A4W4-11	11*	.700	.680	.94		7/16
TP20A4W4-12	12	.764	.744	1.00		1/2
TP20A4W4-13	13	.828	.808	1.06		9/16
TP20A4W4-14	14	.891	.871	1.09	11/16	9/16
TP20A4W4-15	15	.955	.935	1.19		5/8
TP20A4W4-16	16	1.019	.999	1.25		11/16
TP20A4W4-18	18	1.146	1.126	1.38		13/16
TP20A4W4-20	20	1.273	1.253	1.50		15/16
TP20A4W4-21	21	1.337	1.317	1.56	3/4	1
TP20A4W4-22	22	1.401	1.381	1.63		1
TP20A4W4-24	24	1.528	1.508	1.75		1-1/16
TP20A4W4-26	26	1.655	1.635	1.88		1-3/16
TP20A4W4-28	28	1.783	1.763	2.00		1-3/16
TP20A4W4-30	30	1.910	1.890	2.13	25/32	1-5/16

TIMING PULLEYS

CIRCULAR PITCH	STYLE	BELT WIDTH	BORE	MATERIALS	BERG'S ® NAME	BELT
.200 (XL)	Double Flange Pin Hub	1/4"	5/16"	Aluminum Clear Anodized	Max-M-Drive®	Operates with Max-M-Drive® TB20 series.

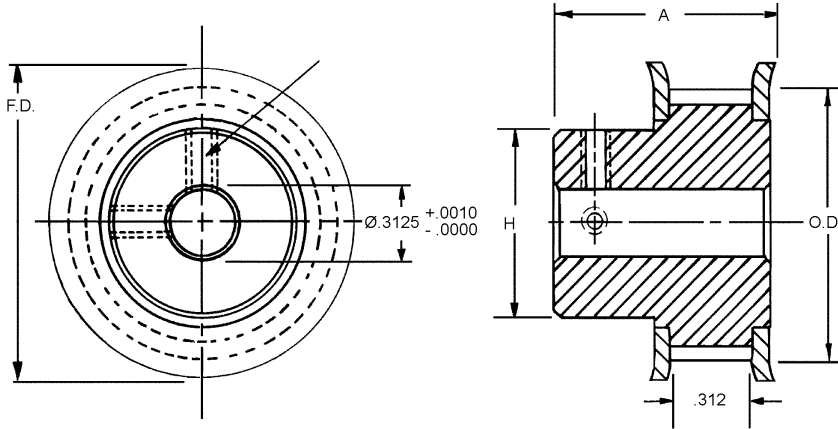

STOCK NO.	NO. OF GROOVES	P.D.	O.D.	F.D.	A	H
TP20A5W4-14	14	.891	.871	1.09		9/16
TP20A5W4-15	15	.955	.935	1.19		5/8
TP20A5W4-16	16	1.019	.999	1.25	11/16	11/16
TP20A5W4-18	18	1.146	1.126	1.38		13/16
TP20A5W4-20	20	1.273	1.253	1.50		15/16
TP20A5W4-21	21	1.337	1.317	1.56	3/4	1
TP20A5W4-24	24	1.528	1.508	1.75		1 1/16

CIRCULAR PITCH	STYLE	BELT WIDTH	BORE	MATERIALS	BERG'S ® NAME	BELT
.200 (XL)	Double Flange Pin Hub	1/4"	3/8"	Aluminum Clear Anodized	Max-M-Drive®	Operates with Max-M-Drive® TB20 series.

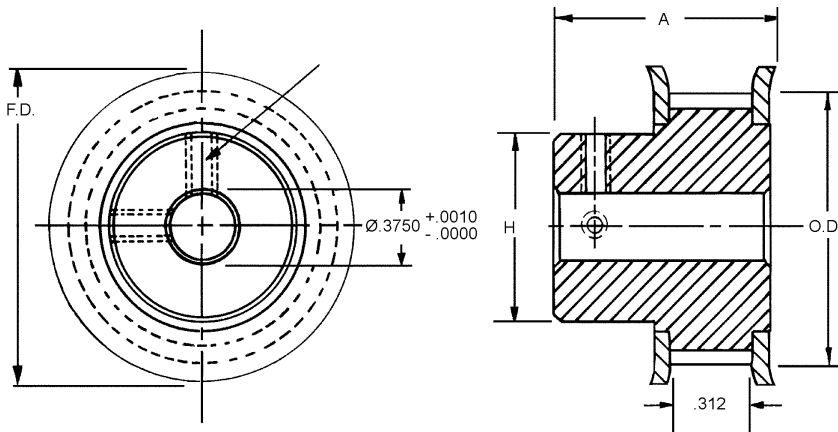

STOCK NO.	NO. OF GROOVES	P.D.	O.D.	F.D.	A	H
TP20A6W4-22	22	1.401	1.381	1.63	3/4	1
TP20A6W4-24	24	1.528	1.508	1.75		1 1/16
TP20A6W4-26	26	1.655	1.635	1.88		1 3/16
TP20A6W4-28	28	1.783	1.763	2.00	25/32	1 3/16
TP20A6W4-30	30	1.910	1.890	2.13		1 5/16

TIMING PULLEYS

CIRCULAR PITCH	STYLE	BELT WIDTH	BORE	MATERIALS	BERG'S ® NAME	BELT
.200 (XL)	Double Flange Pin Hub	3/8"	3/16"	Aluminum Clear Anodized	Max-M-Drive®	Operates with Max-M-Drive® TB20 series.

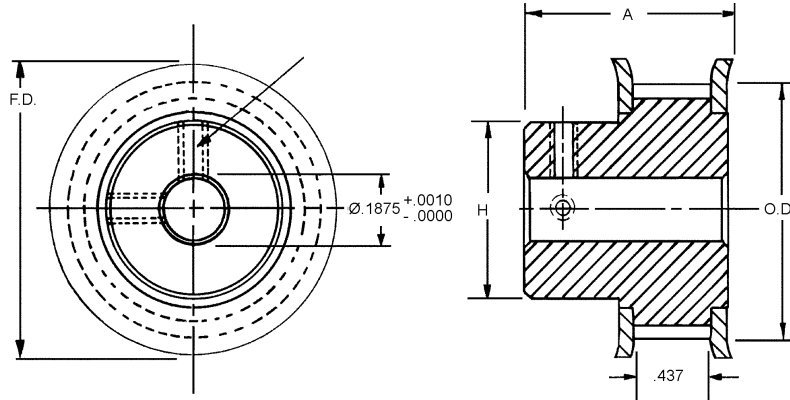

* These pulleys may contain one or two set screws.
Other numbers of grooves, bores or hub styles available on request.

STOCK NO.	NO. OF GROOVES	P.D.	O.D.	F.D.	A	H
TP20A3W6-10	10*	.637	.617	.88	13/16	7/16
TP20A3W6-11	11*	.700	.680	.94		1/2
TP20A3W6-12	12	.764	.744	1.00		1/2

CIRCULAR PITCH	STYLE	BELT WIDTH	BORE	MATERIALS	BERG'S ® NAME	BELT
.200 (XL)	Double Flange Pin Hub	3/8"	1/4"	Aluminum Clear Anodized	Max-M-Drive®	Operates with Max-M-Drive® TB20 series.

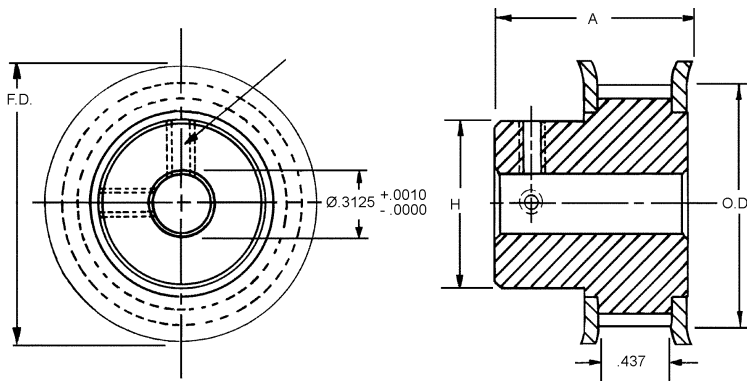

* These pulleys may contain one or two set screws.
Other numbers of grooves, bores or hub styles available on request.

STOCK NO.	NO. OF GROOVES	P.D.	O.D.	F.D.	A	H	
TP20A4W6-10*	10	.637	.617	.88	13/16	7/16	
TP20A4W6-11*	11	.700	.680	.91		1/2	
TP20A4W6-12	12	.764	.744	1.00		1/2	
TP20A4W6-13	13	.828	.808	1.06		9/16	
TP20A4W6-14	14	.891	.871	1.09		9/16	
TP20A4W6-15	15	.955	.935	1.19		5/8	
TP20A4W6-16	16	1.019	.999	1.25		11/16	
TP20A4W6-17	17	1.082	1.062	1.31		3/4	
TP20A4W6-18	18	1.146	1.126	1.38	13/16		
TP20A4W6-19	19	1.210	1.190	1.44	7/8	13/16	
TP20A4W6-20	20	1.273	1.253	1.50		15/16	
TP20A4W6-21	21	1.337	1.317	1.56		1	
TP20A4W6-22	22	1.401	1.381	1.63		1	
TP20A4W6-23	23	1.464	1.444	1.69		1 1/16	
TP20A4W6-24	24	1.528	1.508	1.75		29/32	1 1/16
TP20A4W6-25	25	1.592	1.572	1.81			1 3/32
TP20A4W6-26	26	1.655	1.635	1.88	1 3/16		
TP20A4W6-28	28	1.783	1.763	2.00	1 3/16		
TP20A4W6-30	30	1.910	1.890	2.13	1 5/16		

TIMING PULLEYS

CIRCULAR PITCH	STYLE	BELT WIDTH	BORE	MATERIALS	BERG'S ® NAME	BELT
.200 (XL)	Double Flange Pin Hub	3/8"	5/16"	Aluminum Clear Anodized	Max-M-Drive®	Operates with Max-M-Drive® TB20 series.

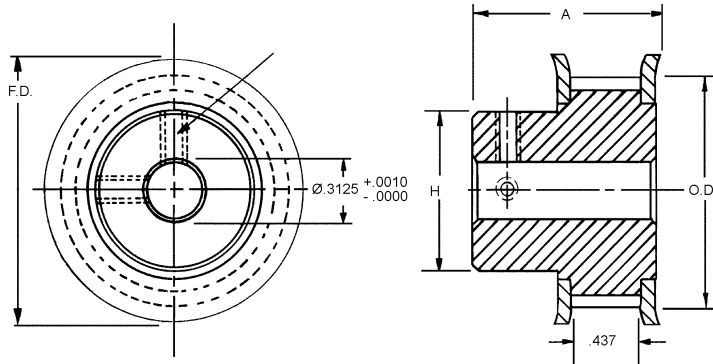

STOCK NO.	NO. OF GROOVES	P.D.	O.D.	F.D.	A	H
TP20A5W6-12	12	.764	.744	1.00		1/2
TP20A5W6-14	14	.891	.871	1.09		9/16
TP20A5W6-15	15	.955	.935	1.19	13/16	5/8
TP20A5W6-16	16	1.019	.999	1.25		11/16
TP20A5W6-18	18	1.146	1.126	1.38		13/16
TP20A5W6-20	20	1.273	1.253	1.50		15/16
TP20A5W6-21	21	1.337	1.317	1.56	7/8	1
TP20A5W6-22	22	1.401	1.381	1.63		1
TP20A5W6-24	24	1.528	1.508	1.75		1 1/16
TP20A5W6-25	25	1.592	1.572	1.81		1 3/32
TP20A5W6-26	26	1.655	1.635	1.88	29/32	1 3/16
TP20A5W6-28	28	1.783	1.763	2.00		1 3/16
TP20A5W6-30	30	1.910	1.890	2.13		1 5/16
TP20A5W6-32	32	2.037	2.017	2.25		1 7/16

CIRCULAR PITCH	STYLE	BELT WIDTH	BORE	MATERIALS	BERG'S ® NAME	BELT
.200 (XL)	Double Flange Pin Hub	3/8"	3/8"	Aluminum Clear Anodized	Max-M-Drive®	Operates with Max-M-Drive® TB20 series.

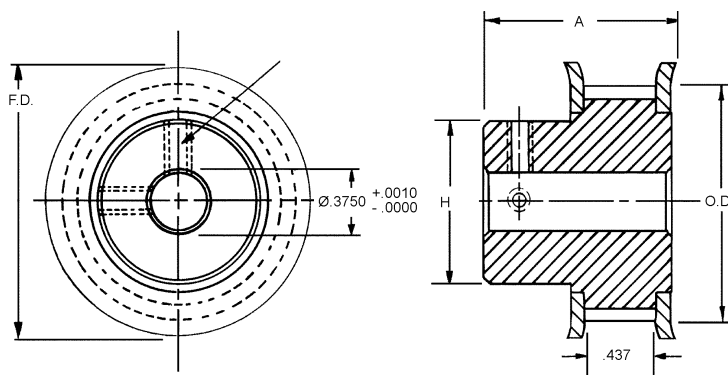

STOCK NO.	NO. OF GROOVES	P.D.	O.D.	F.D.	A	H
TP20A6W6-16	16	1.019	.999	1.25	13/16	11/16
TP20A6W6-18	18	1.146	1.126	1.38		13/16
TP20A6W6-20	20	1.273	1.253	1.50		15/16
TP20A6W6-21	21	1.337	1.317	1.56	7/8	1
TP20A6W6-22	22	1.401	1.381	1.63		1
TP20A6W6-24	24	1.528	1.508	1.75		1 1/16
TP20A6W6-25	25	1.592	1.572	1.81		1 3/32
TP20A6W6-26	26	1.655	1.635	1.88	29/32	1 3/16
TP20A6W6-28	28	1.783	1.763	2.00		1 3/16
TP20A6W6-30	30	1.910	1.890	2.13		1 5/16
TP20A6W6-32	32	2.037	2.017	2.25		1 7/16

TIMING PULLEYS

CIRCULAR PITCH	STYLE	BELT WIDTH	BORE	MATERIALS	BERG'S ® NAME	BELT
.200 (XL)	Double Flange Pin Hub	3/8"	1/2"	Aluminum Clear Anodized	Max-M-Drive®	Operates with Max-M-Drive® TB20 series.

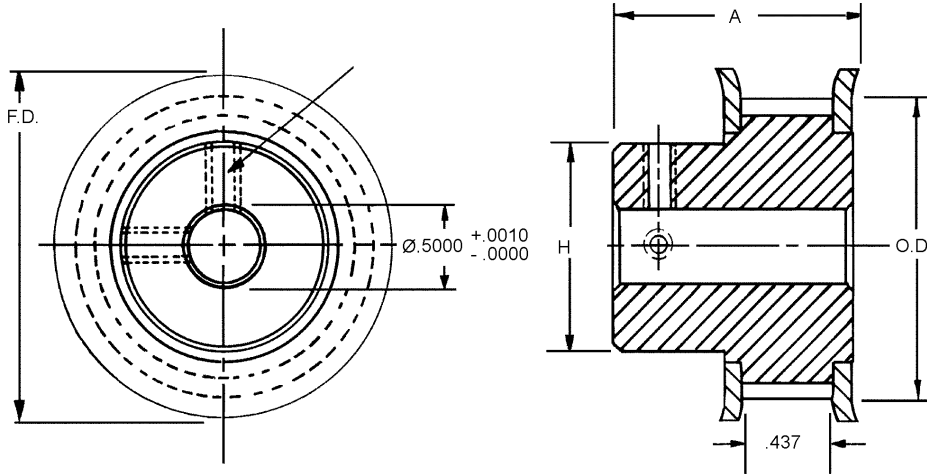

STOCK NO.	NO. OF GROOVES	P.D.	O.D.	F.D.	A	H
TP20A8W6-18	18	1.146	1.126	1.38	13/16	13/16
TP20A8W6-20	20	1.273	1.253	1.50	7/8	15/16
TP20A8W6-24	24	1.528	1.508	1.75	29/32	1 1/16
TP20A8W6-30	30	1.910	1.890	2.13		1 5/16

TIMING BELTS

CIRCULAR PITCH	BELT WIDTH	MATERIALS	BERG'S ® NAME	PULLEY
.375 (L)	1/2"	Nylon covered fiber reinforced neoprene	Max-M-Drive®	Operates with TP37 Series

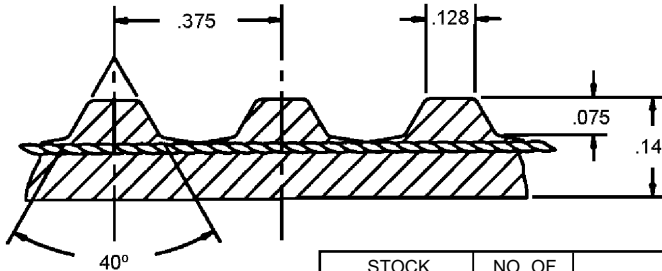

STOCK NO.	NO. OF GROOVES	LENGTH
TB37EF8-33	33	12.375
TB37EF8-40	40	15.000
TB37EF8-50	50	18.750
TB37EF8-56	56	21.000
TB37EF8-60	60	22.500
TB37EF8-64	64	24.000
TB37EF8-68	68	25.500
TB37EF8-72	72	27.000
TB37EF8-76	76	28.500
TB37EF8-80	80	30.000
TB37EF8-86	86	32.250
TB37EF8-92	92	34.500
TB37EF8-98	98	36.750
TB37EF8-104	104	39.000
TB37EF8-112	112	42.000
TB37EF8-120	120	45.000
TB37EF8-128	128	48.000
TB37EF8-136	136	51.000
TB37EF8-144	144	54.000
TB37EF8-160	160	60.000

• Temp Range 30°F To 185°F

CIRCULAR PITCH	BELT WIDTH	MATERIALS	BERG'S ® NAME	PULLEY
.375 (L)	3/4"	Nylon covered fiber reinforced neoprene	Max-M-Drive®	Operates with TP37 Series

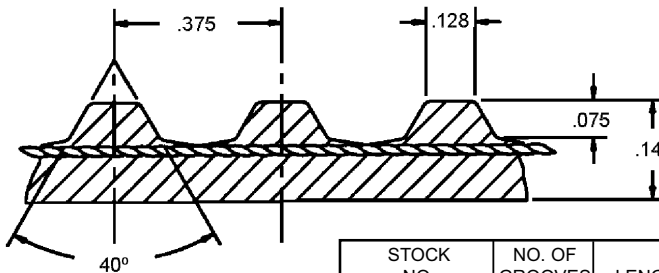

STOCK NO.	NO. OF GROOVES	LENGTH
TB37EF12-33	33	12.375
TB37EF12-40	40	15.000
TB37EF12-50	50	18.750
TB37EF12-56	56	21.000
TB37EF12-60	60	22.500
TB37EF12-64	64	24.000
TB37EF12-68	68	25.500
TB37EF12-72	72	27.000
TB37EF12-76	76	28.500
TB37EF12-80	80	30.000
TB37EF12-86	86	32.250
TB37EF12-92	92	34.500
TB37EF12-98	98	36.750
TB37EF12-104	104	39.000
TB37EF12-112	112	42.000
TB37EF12-120	120	45.000
TB37EF12-128	128	48.000
TB37EF12-136	136	51.000
TB37EF12-144	144	54.000
TB37EF12-160	160	60.000

• Temp Range 30°F To 185°F

TIMING PULLEYS

CIRCULAR PITCH	STYLE	BELT WIDTH	BORE	MATERIALS	BERG'S ® NAME	BELT
.375 (L)	Single Flange Pin Hub	1/2" & 3/4"	3/8"	Polycarbonate Lexan® with a fiberglass reinforced Aluminum Hub	Max-M-Drive®	Operates with Max-M-Drive® TB37 series.

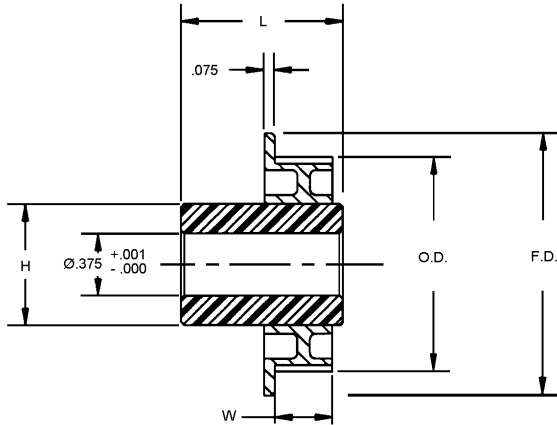

All core pulleys have 1/16" thick ribs, reinforcement.

STOCK NO.	NO. OF GROOVES	BELT WIDTH	O.D.	P.D.	F.D.	BORE	W	L	H
TP37L6U8-10	10	1/2	1.164	1.194	1.44	3/8	9/16	1.21	7/8
TP37L6U12-10	10	3/4	1.164	1.194	1.44		13/16	1.46	
TP37L6U8-12	12	1/2	1.402	1.432	1.69		9/16	1.21	
TP37L6U12-12	12	3/4	1.402	1.432	1.69		13/16	1.46	

CIRCULAR PITCH	STYLE	BELT WIDTH	BORE	MATERIALS	BERG'S ® NAME	BELT
.375 (L)	Single Flange Pin Hub	1/2" & 3/4"	1/2"	Polycarbonate Lexan® with a fiberglass reinforced Aluminum Hub	Max-M-Drive®	Operates with Max-M-Drive® TB37 series.

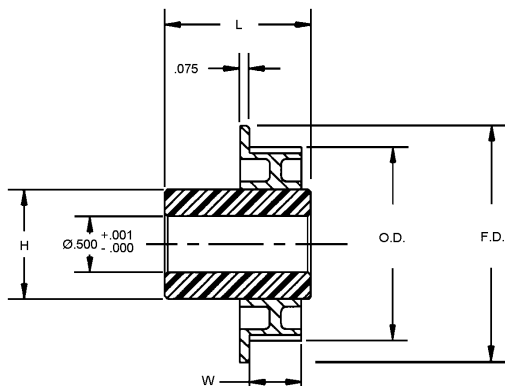

All core pulleys have 1/16" thick ribs, reinforcement.

STOCK NO.	NO. OF GROOVES	BELT WIDTH	O.D.	P.D.	F.D.	BORE	W	L	H
TP37L8U8-16	16	1/2	1.880	1.910	2.12	1/2	9/16	1.21	1 1/8
TP37L8U12-16	16	3/4	1.880	1.910	2.12		13/16	1.46	
TP37L8U8-18	18	1/2	2.119	2.149	2.37		9/16	1.21	
TP37L8U12-18	18	3/4	2.119	2.149	2.37		13/16	1.46	
TP37L8U8-20	20	1/2	2.357	2.387	2.62	1/2	9/16	1.21	1 1/8
TP37L8U12-20	20	3/4	2.357	2.387	2.62		13/16	1.46	
TP37L8U8-24	24	1/2	2.835	2.865	3.12		9/16	1.21	
TP37L8U12-24	24	3/4	2.835	2.865	3.12		13/16	1.46	
TP37L8U8-36	36	1/2	4.267	4.297	4.53	1/2	9/16	1.21	1 1/8
TP37L8U12-36	36	3/4	4.267	4.297	4.53		13/16	1.46	
TP37L8U8-40	40	1/2	4.745	4.775	5.00		9/16	1.21	
TP37L8U12-40	40	3/4	4.745	4.775	5.00		13/16	1.46	

TIMING PULLEYS

CIRCULAR PITCH	STYLE	BELT WIDTH	BORE	MATERIALS	BERG'S ® NAME	BELT
.375 (L)	Double Flange Pin Hub	1/2" & 3/4"	3/8"	Polycarbonate Lexan® with a fiberglass reinforced Aluminum Hub	Max-M-Drive®	Operates with Max-M-Drive® TB37 series.

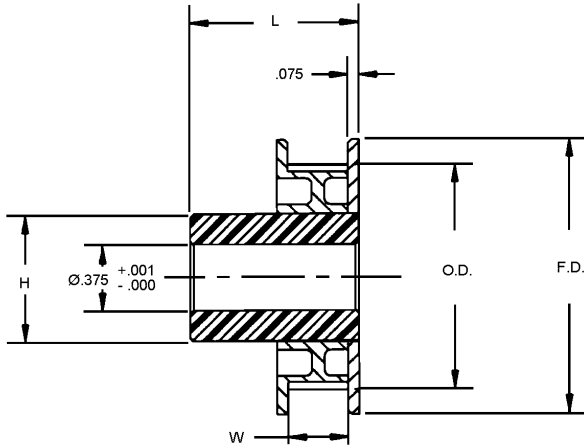

All core pulleys have 1/16" thick ribs, reinforcement.

STOCK NO.	NO. OF GROOVES	BELT WIDTH	O.D.	P.D.	F.D.	BORE	W	L	H
TP37L6W8-10	10	1/2	1.164	1.194	1.44	3/8	9/16	1.21	7/8
TP37L6W12-10	10	3/4	1.164	1.194	1.44		13/16	1.46	
TP37L6W8-12	12	1/2	1.402	1.432	1.69		9/16	1.21	
TP37L6W12-12	12	3/4	1.402	1.432	1.69		13/16	1.46	

CIRCULAR PITCH	STYLE	BELT WIDTH	BORE	MATERIALS	BERG'S ® NAME	BELT
.375 (L)	Double Flange Pin Hub	1/2" & 3/4"	1/2"	Polycarbonate Lexan® with a fiberglass reinforced Aluminum Hub	Max-M-Drive®	Operates with Max-M-Drive® TB37 series.

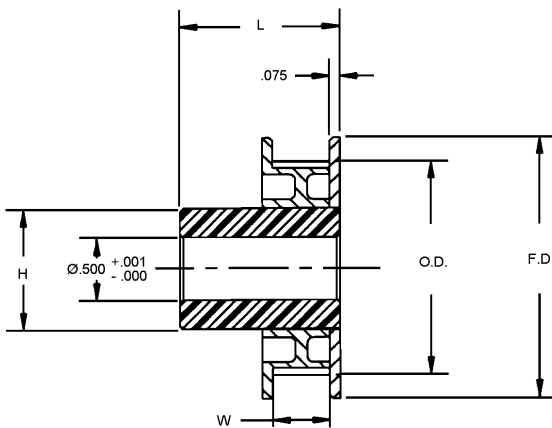

All core pulleys have 1/16" thick ribs, reinforcement.

STOCK NO.	NO. OF GROOVES	BELT WIDTH	O.D.	P.D.	F.D.	BORE	W	L	H
TP37L8W8-16	16	1/2	1.880	1.910	2.12	1/2	9/16	1.21	1 1/8
TP37L8W12-16	16	3/4	1.880	1.910	2.12		13/16	1.46	
TP37L8W8-18	18	1/2	2.119	2.149	2.37		9/16	1.21	
TP37L8W12-18	18	3/4	2.119	2.149	2.37		13/16	1.46	
TP37L8W8-20	20	1/2	2.357	2.387	2.62		9/16	1.21	
TP37L8W12-20	20	3/4	2.357	2.387	2.62		13/16	1.46	
TP37L8W8-24	24	1/2	2.835	2.865	3.12		9/16	1.21	
TP37L8W12-24	24	3/4	2.835	2.865	3.12		13/16	1.46	
TP37L8W8-36	36	1/2	4.267	4.297	4.53		9/16	1.21	
TP37L8W12-36	36	3/4	4.267	4.297	4.53		13/16	1.46	
TP37L8W8-40	40	1/2	4.745	4.775	5.09		9/16	1.21	
TP37L8W12-40	40	3/4	4.745	4.775	5.09		13/16	1.46	

TIMING PULLEY BAR STOCK

CIRCULAR PITCH	STYLE	MATERIAL	BERG'S ® NAME	BELT
.0816 (XXL) .200 (XL) .375 (L) and .500 (H)	BAR STOCK	ALUMINUM	MAX-M-DRIVE	TB40; TB20; TB37

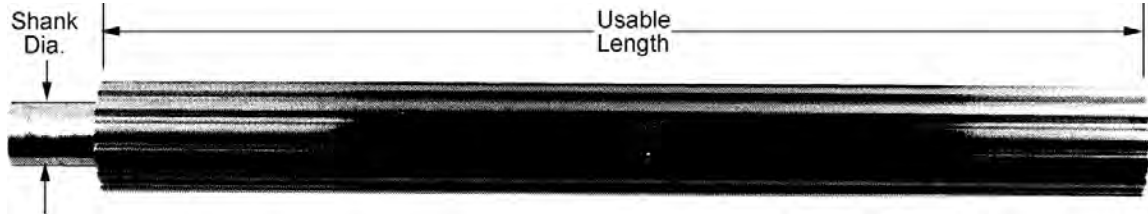

Material: Aluminum

Other numbers of grooves and materials available upon request.
For P.D. and O.D. dimensions see Max-M-Drive pulley pages.

.0816 (XXL) PITCH

STOCK NO.	NO. OF GROOVES
8TA-14-3A	14
8TA-15-3A	15
8TA-18-3A	18
8TA-20-4A	20
8TA-24-5A	24
8TA-25-5A	25
8TA-28-5A	28
8TA-30-6A	30
8TA-32-6A	32
8TA-34-6A	34
8TA-36-6A	36
8TA-38-6A	38
8TA-40-7A	40
8TA-42-7A	42
8TA-44-7A	44
8TA-48-7A	48
8TA-50-7A	50
8TA-54-7A	54
8TA-60-8A	60
8TA-72-8A	72
8TA-75-8A	75
8TA-80-8A	80
8TA-84-8A	84
8TA-88-8A	88
8TA-90-8A	90
8TA-96-8A	96
8TA-98-8A	98
8TA-100-8A	100
8TA-120-8A	120

Bar Stock Lengths:

Number of grooves - 14 to 18
useable length = 3" shank diameter = 7/16" to 1/2"

Number of grooves - 20
useable length = 4" shank diameter = 3/8"

Number of grooves - 24 to 28
useable length = 5" shank diameter = 1/2"

Number of grooves - 30 to 38
useable length = 6" shank diameter = 1/2"

Number of grooves - 40 to 54
useable length = 7" shank diameter = 1/2"

Number of grooves - 60 to 120
useable length = 8" shank diameter = 1/2" to 3/4"

.200 (XL) Pitch

STOCK NO.	NO. OF GROOVES
20TA-10-6A	10
20TA-11-6A	11
20TA-12-8A	12
20TA-14-8A	14
20TA-15-8A	15
20TA-16-8A	16
20TA-17-8A	17
20TA-18-8A	18
20TA-19-8A	19
20TA-20-8A	20
20TA-21-8A	21
20TA-22-8A	22
20TA-23-8A	23
20TA-24-8A	24
20TA-25-8A	25
20TA-27-8A	27
20TA-28-8A	28
20TA-29-8A	29
20TA-30-8A	30
20TA-32-8A	32
20TA-36-8A	36
20TA-40-8A	40
20TA-42-8A	42
20TA-44-8A	44
20TA-45-8A	45
20TA-48-8A	48
20TA-50-8A	50
20TA-60-8A	60
20TA-72-8A	72

Bar Stock Lengths:

Number of grooves - 10 to 11
useable length = 6" shank diameter = 1/2"

Number of grooves - 12 to 72
useable length = 8" shank diameter = 1/2" to 1"

.375 (L) PITCH

STOCK NO.	NO. OF GROOVES
37TA-10-8A	10
37TA-11-8A	11
37TA-12-8A	12
37TA-13-8A	13
37TA-14-8A	14
37TA-15-8A	15
37TA-16-8A	16
37TA-17-8A	17
37TA-18-8A	18
37TA-19-8A	19
37TA-20-8A	20
37TA-21-8A	21
37TA-22-8A	22
37TA-24-8A	24
37TA-26-8A	26
37TA-28-8A	28
37TA-30-8A	30
37TA-32-8A	32

Bar Stock Lengths:

Number of grooves - 10 to 36
useable length = 8" shank diameter = 3/4" to 1"

.500 (H) PITCH

STOCK NO.	NO. OF GROOVES
50TA-10-10A	10
50TA-11-10A	11
50TA-12-10A	12
50TA-13-10A	13
50TA-14-10A	14
50TA-15-10A	15
50TA-16-10A	16
50TA-17-10A	17
50TA-18-10A	18
50TA-19-10A	19
50TA-20-10A	20
50TA-21-10A	21
50TA-22-10A	22
50TA-24-10A	24
50TA-26-10A	26
50TA-28-10A	28
50TA-30-10A	30
50TA-32-10A	32
50TA-36-10A	36

Bar Stock Lengths:

Number of grooves - 10 to 32
useable length = 10" shank diameter = 3/4" to 1"

TIMING PULLEYS

CIRCULAR PITCH	STYLE	MATERIAL	BERG'S ® NAME	BELT
.0816 (XXL) .200 (XL) .080 (MXL)	BAR STOCK	6063-T6 ALUMINUM	MAX-M-DRIVE	TB20; TB40; TB7

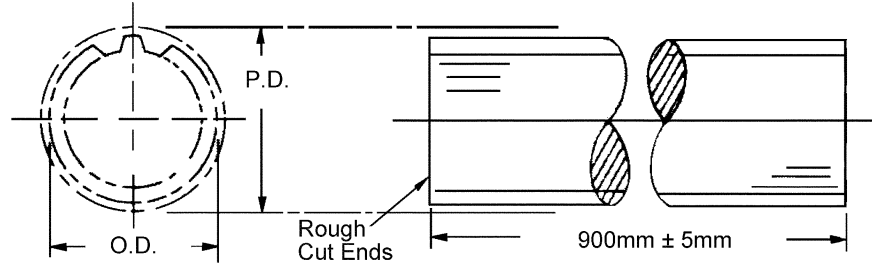

Material: 6063-T6 Aluminum

Fabricate your own pulleys.

W.M. Berg will fabricate custom orders, send us your print.

Available in custom lengths.

.200 CIRCULAR PITCH (XL)

STOCK NO.	NO. OF GROOVES	P.D.	O.D.
PW20TA-10	10	.637	.6170
PW20TA-11	11	.700	.6800
PW20TA-12	12	.764	.7440
PW20TA-14	14	.891	.8710
PW20TA-15	15	.955	.9350
PW20TA-16	16	1.019	.9990
PW20TA-17	17	1.082	1.0620
PW20TA-18	18	1.146	1.1260
PW20TA-20	20	1.273	1.2530
PW20TA-22	22	1.401	1.3810
PW20TA-23	23	1.464	1.4440
PW20TA-24	24	1.528	1.5080

.0816 CIRCULAR PITCH (XXL)

STOCK NO.	NO. OF GROOVES	P.D.	O.D.
PW8TA-10	10	.260	.2460
PW8TA-12	12	.312	.2980
PW8TA-14	14	.364	.3500
PW8TA-15	15	.390	.3760
PW8TA-18	18	.468	.4540
PW8TA-20	20	.520	.5060
PW8TA-24	24	.624	.6100
PW8TA-25	25	.650	.6360
PW8TA-28	28	.728	.7140
PW8TA-30	30	.780	.7660
PW8TA-32	32	.832	.8180
PW8TA-34	34	.884	.8700
PW8TA-36	36	.936	.9220
PW8TA-38	38	.988	.9740
PW8TA-40	40	1.040	1.0260
PW8TA-42	42	1.092	1.0780
PW8TA-44	44	1.144	1.1300
PW8TA-45	45	1.170	1.1560
PW8TA-48	48	1.248	1.2340
PW8TA-50	50	1.300	1.2860
PW8TA-54	54	1.404	1.3900
PW8TA-60	60	1.560	1.5460

.080 CIRCULAR PITCH (MXL)

STOCK NO.	NO. OF GROOVES	P.D.	O.D.
PW7TA-10	10	.255	.235
PW7TA-12	12	.306	.286
PW7TA-14	14	.357	.337
PW7TA-18	18	.458	.438
PW7TA-20	20	.509	.489
PW7TA-25	25	.637	.617
PW7TA-28	28	.713	.693
PW7TA-30	30	.764	.744
PW7TA-32	32	.815	.795
PW7TA-34	34	.866	.846
PW7TA-36	36	.917	.897
PW7TA-38	38	.986	.948
PW7TA-40	40	1.019	.999
PW7TA-42	42	1.070	1.050
PW7TA-44	44	1.120	1.100
PW7TA-45	45	1.146	1.126
PW7TA-48	48	1.222	1.202
PW7TA-50	50	1.273	1.253
PW7TA-54	54	1.375	1.355
PW7TA-60	60	1.528	1.508

TIMING BELTS

CIRCULAR PITCH	BELT WIDTH	MATERIALS	BERG'S ® NAME	PULLEY
.079 (GT) 2mm	.236" 6mm	Nylon covered Neoprene (Black) Fiberglass Reinforced	Max-M-Drive®	Operates with TP2 Series

STOCK NO.	NO. OF GROOVES	LENGTH (Ref.)
TB2EF6-50	50	3.94
TB2EF6-56	56	4.41
TB2EF6-62	62	4.88
TB2EF6-63	63	4.96
TB2EF6-67	67	5.28
TB2EF6-68	68	5.35
TB2EF6-70	70	5.51
TB2EF6-74	74	5.83
TB2EF6-76	76	5.98
TB2EF6-79	79	6.22
TB2EF6-80	80	6.30
TB2EF6-82	82	6.46
TB2EF6-83	83	6.54
TB2EF6-86	86	6.77
TB2EF6-90	90	7.09
TB2EF6-93	93	7.32
TB2EF6-96	96	7.56
TB2EF6-100	100	7.87
TB2EF6-101	101	7.95
TB2EF6-105	105	8.27
TB2EF6-106	106	8.35
TB2EF6-108	108	8.50
TB2EF6-110	110	8.66
TB2EF6-116	116	9.13
TB2EF6-118	118	9.29
TB2EF6-120	120	9.45
TB2EF6-125	125	9.84
TB2EF6-126	126	9.92
TB2EF6-129	129	10.16
TB2EF6-139	139	10.94
TB2EF6-140	140	11.02
TB2EF6-150	150	11.81
TB2EF6-160	160	12.60
TB2EF6-161	161	12.68
TB2EF6-166	166	13.07
TB2EF6-173	173	13.62
TB2EF6-175	175	13.78
TB2EF6-182	182	14.33
TB2EF6-185	185	14.57
TB2EF6-190	190	14.96
TB2EF6-193	193	15.20
TB2EF6-200	200	15.75
TB2EF6-203	203	15.98
TB2EF6-210	210	16.54
TB2EF6-228	228	17.95
TB2EF6-235	235	18.50
TB2EF6-237	237	18.66
TB2EF6-244	244	19.21
TB2EF6-252	252	19.84
TB2EF6-264	264	20.79
TB2EF6-276	276	21.73
TB2EF6-288	288	22.68
TB2EF6-300	300	23.62
TB2EF6-320	320	25.20
TB2EF6-348	348	27.40
TB2EF6-372	372	29.29
TB2EF6-424	424	33.39
TB2EF6-582	582	45.83

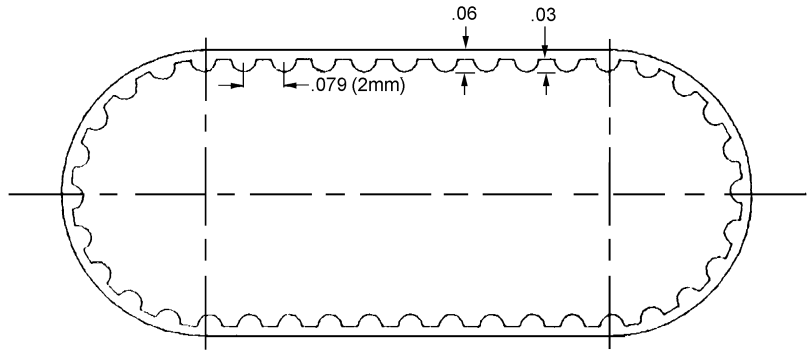

- Compact
- Light weight
- Durability
- Quiet Peration
- No lubrication
- Improved registration
- Corrosion resistant
- Clean operation
- Minimal elongation
- Recommended working strength 25 lbs. (111N) per 1" (25.4mm) belt width
- Recommended temperature range: -34°C to +85°C (-30°F to +185°F)

TIMING BELTS

CIRCULAR PITCH	BELT WIDTH	MATERIALS	BERG'S ® NAME	PULLEY
.079 (GT) 2mm	.354" 9mm	Nylon covered Neoprene (Black) Fiberglass Reinforced	Max-M-Drive®	Operates with TP2 Series

STOCK NO.	NO. OF GROOVES	LENGTH (Ref.)
TB2EF9-50	50	3.94
TB2EF9-56	56	4.41
TB2EF9-62	62	4.88
TB2EF9-63	63	4.96
TB2EF9-67	67	5.28
TB2EF9-68	68	5.35
TB2EF9-70	70	5.51
TB2EF9-76	76	5.98
TB2EF9-79	79	6.22
TB2EF9-80	80	6.30
TB2EF9-82	82	6.46
TB2EF9-83	83	6.54
TB2EF9-84	84	6.61
TB2EF9-86	86	6.77
TB2EF9-90	90	7.09
TB2EF9-93	93	7.32
TB2EF9-96	96	7.56
TB2EF9-100	100	7.87
TB2EF9-101	101	7.95
TB2EF9-105	105	8.27
TB2EF9-106	106	8.35
TB2EF9-108	108	8.50
TB2EF9-110	110	8.66
TB2EF9-116	116	9.13
TB2EF9-118	118	9.29
TB2EF9-120	120	9.45
TB2EF9-125	125	9.84
TB2EF9-126	126	9.92
TB2EF9-129	129	10.16
TB2EF9-139	139	10.94
TB2EF9-140	140	11.02
TB2EF9-150	150	11.81
TB2EF9-160	160	12.60
TB2EF9-161	161	12.68
TB2EF9-166	166	13.07
TB2EF9-173	173	13.62
TB2EF9-175	175	13.78
TB2EF9-182	182	14.33
TB2EF9-185	185	14.57
TB2EF9-190	190	14.96
TB2EF9-193	193	15.20
TB2EF9-200	200	15.75
TB2EF9-203	203	15.98
TB2EF9-210	210	16.54
TB2EF9-228	228	17.95
TB2EF9-235	235	18.50
TB2EF9-237	237	18.66
TB2EF9-244	244	19.21
TB2EF9-252	252	19.84
TB2EF9-264	264	20.79
TB2EF9-276	276	21.73
TB2EF9-288	288	22.68
TB2EF9-300	300	23.62
TB2EF9-320	320	25.20
TB2EF9-348	348	27.40
TB2EF9-372	372	29.29
TB2EF9-424	424	33.39
TB2EF9-582	582	45.83

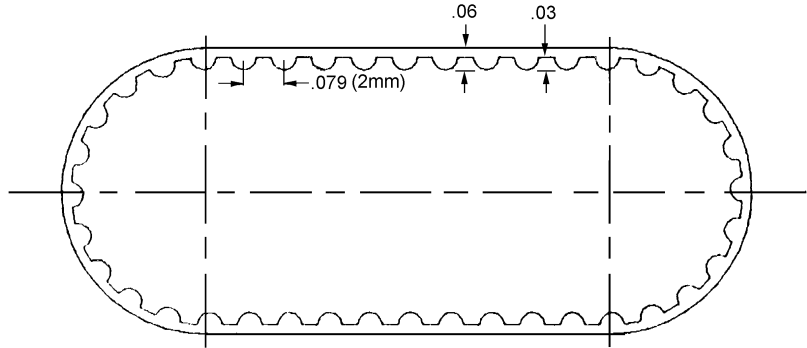

- Compact
- Light weight
- Durability
- Less width required vs. HTD
- Tooth jump resistance: Better than MXL-HTD
- Noise: Far less than HTD
- Positioning: Half (or more) the positioning error of MXL and HTD
- No lubrication
- Improved registration
- Corrosion resistant
- Clean operation
- Minimal elongation
- Recommended working strength 25 lbs. (111N) per 1" (25.4mm) belt width
- Recommended temperature range: -34°C to +85°C (-30°F to +185°F)

TIMING BELTS

CIRCULAR PITCH	BELT WIDTH	MATERIALS	BERG'S ® NAME	PULLEY
.118 (GT) 3mm	.354" 9mm	Nylon covered Neoprene (Black) Fiberglass Reinforced	Max-M-Drive®	Operates with TP3 Series

STOCK NO.	NO. OF GROOVES	LENGTH (Ref.)
TB3EF9-33	33	3.894
TB3EF9-37	37	4.366
TB3EF9-41	41	4.838
TB3EF9-43	43	5.074
TB3EF9-53	53	6.254
TB3EF9-55	55	6.490
TB3EF9-60	60	7.080
TB3EF9-61	61	7.198
TB3EF9-63	63	7.434
TB3EF9-67	67	7.906
TB3EF9-73	73	8.614
TB3EF9-75	75	8.850
TB3EF9-80	80	9.440
TB3EF9-81	81	9.558
TB3EF9-85	85	10.030
TB3EF9-89	89	10.502
TB3EF9-94	94	11.092
TB3EF9-97	97	11.446
TB3EF9-100	100	11.800
TB3EF9-113	113	13.334
TB3EF9-116	116	13.688
TB3EF9-119	119	14.042
TB3EF9-120	120	14.160
TB3EF9-125	125	14.750
TB3EF9-131	131	15.458
TB3EF9-138	138	16.284
TB3EF9-140	140	16.520
TB3EF9-149	149	17.582
TB3EF9-150	150	17.700
TB3EF9-158	158	18.644
TB3EF9-160	160	18.880
TB3EF9-161	161	18.998
TB3EF9-163	163	19.234
TB3EF9-168	168	19.824
TB3EF9-179	179	21.122
TB3EF9-184	184	21.712
TB3EF9-188	188	22.184
TB3EF9-200	200	23.600
TB3EF9-203	203	23.954
TB3EF9-210	210	24.780
TB3EF9-228	228	26.904
TB3EF9-245	245	28.910
TB3EF9-250	250	29.500
TB3EF9-262	262	30.916
TB3EF9-280	280	33.040
TB3EF9-315	315	37.170
TB3EF9-350	350	41.300
TB3EF9-360	360	42.480
TB3EF9-512	512	60.416
TB3EF9-529	529	62.422
TB3EF9-687	687	81.066

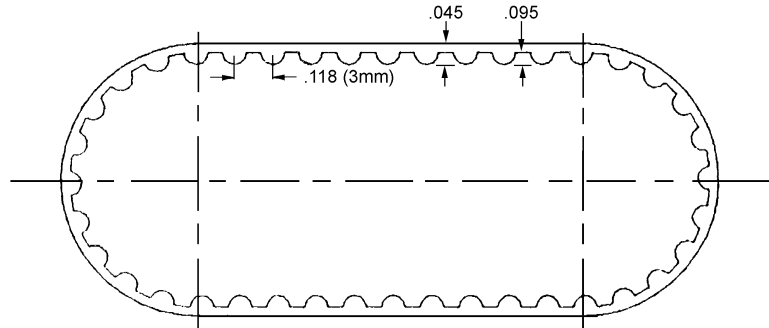

- Compact
- Light weight
- Durability
- Less width required vs. HTD
- Tooth jump resistance: Better than MXL-HTD
- Noise: Far less than HTD
- Positioning: Half (or more) the positioning error of MXL and HTD
- No lubrication
- Improved registration
- Corrosion resistant
- Clean operation
- Minimal elongation
- Recommended working strength 114 lbs. (507N) per 1" (25.4mm) belt width
- Recommended temperature range: -34°C to +85°C (-30°F to +185°F)

TIMING BELTS

CIRCULAR PITCH	BELT WIDTH	MATERIALS	BERG'S ® NAME	PULLEY
.118 (GT) 3mm	.590" 15mm	Nylon covered Neoprene (Black) Fiberglass Reinforced	Max-M-Drive®	Operates with TP3 Series

STOCK NO.	NO. OF GROOVES	LENGTH (Ref.)
TB3EF15-33	33	3.894
TB3EF15-37	37	4.366
TB3EF15-41	41	4.838
TB3EF15-43	43	5.074
TB3EF15-53	53	6.254
TB3EF15-55	55	6.490
TB3EF15-60	60	7.080
TB3EF15-61	61	7.198
TB3EF15-63	63	7.434
TB3EF15-67	67	7.906
TB3EF15-73	73	8.614
TB3EF15-75	75	8.850
TB3EF15-80	80	9.440
TB3EF15-81	81	9.558
TB3EF15-85	85	10.030
TB3EF15-89	89	10.502
TB3EF15-94	94	11.092
TB3EF15-97	97	11.446
TB3EF15-100	100	11.800
TB3EF15-113	113	13.334
TB3EF15-116	116	13.688
TB3EF15-119	119	14.042
TB3EF15-125	125	14.750
TB3EF15-131	131	15.458
TB3EF15-138	138	16.284
TB3EF15-140	140	16.520
TB3EF15-149	149	17.582
TB3EF15-150	150	17.700
TB3EF15-158	158	18.644
TB3EF15-160	160	18.880
TB3EF15-161	161	18.998
TB3EF15-163	163	19.234
TB3EF15-168	168	19.824
TB3EF15-179	179	21.122
TB3EF15-184	184	21.712
TB3EF15-188	188	22.184
TB3EF15-200	200	23.600
TB3EF15-203	203	23.954
TB3EF15-210	210	24.780
TB3EF15-228	228	26.904
TB3EF15-245	245	28.910
TB3EF15-250	250	29.500
TB3EF15-262	262	30.916
TB3EF15-280	280	33.040
TB3EF15-315	315	37.170
TB3EF15-350	350	41.300
TB3EF15-360	360	42.480
TB3EF15-512	512	60.416
TB3EF15-529	529	62.422
TB3EF15-687	687	81.066

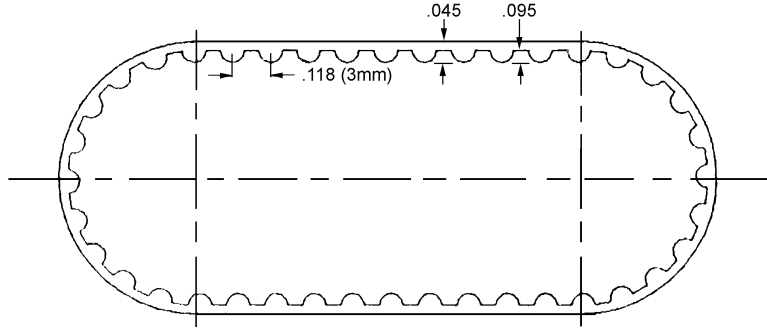

- Compact
- Light weight
- Durability
- Less width required vs. HTD
- Tooth jump resistance: Better than MXL-HTD
- Noise: Far less than HTD
- Positioning: Half (or more) the positioning error of MXL and HTD
- No lubrication
- Improved registration
- Corrosion resistant
- Clean operation
- Minimal elongation
- Recommended working strength 114 lbs. (507N) per 1" (25.4mm) belt width
- Recommended temperature range: -34°C to +85°C (-30°F to +185°F)

TIMING PULLEYS

CIRCULAR PITCH	STYLE	BELT WIDTH	BORE	MATERIALS	BERG'S ® NAME	BELT
.079 (GT) 2mm	Single Flange Pin Hub	.354" 9mm	1/8" - 1/4"	Aluminum Anodized	Max-M-Drive®	Operates with Max-M-Drive® TB2 series.

STOCK NO.	NO. OF GROOVES	P.D.	O.D.	F.D.	B*	F.W.	A	Ø H
TP2A1W9-12	12	0.301	0.281	0.480	1/8	0.446	0.687	0.480
TP2A1W9-13	13	0.326	0.306	0.505	1/8	0.446	0.687	0.505
TP2A1W9-14	14	0.351	0.331	0.530	1/8	0.446	0.687	0.530
TP2A1W9-15	15	0.376	0.356	0.555	3/16	0.446	0.687	0.555
TP2A2W9-16	16	0.401	0.381	0.580	3/16	0.446	0.687	0.580
TP2A2W9-17	17	0.426	0.406	0.635	1/4	0.446	0.687	0.635
TP2A2W9-18	18	0.451	0.431	0.635	1/4	0.446	0.687	0.635
TP2A2W9-19	19	0.476	0.456	0.635	1/4	0.446	0.687	0.635
TP2A2W9-20	20	0.501	0.481	0.685	1/4	0.446	0.687	0.685
TP2A2W9-21	21	0.526	0.506	0.710	1/4	0.446	0.687	0.710
TP2A2W9-22	22	0.551	0.531	0.740	1/4	0.446	0.687	0.740

CIRCULAR PITCH	STYLE	BELT WIDTH	BORE	MATERIALS	BERG'S ® NAME	BELT
.079 (GT) 2mm	Single Flange Pin Hub	.236" 6mm	1/8" - 1/4"	Aluminum Anodized	Max-M-Drive®	Operates with Max-M-Drive® TB2 series.

STOCK NO.	NO. OF GROOVES	P.D.	O.D.	F.D.	B*	F.W.	A	Ø H
TP2A1W6-12	12	0.301	0.281	0.480	1/8	0.327	0.562	0.480
TP2A1W6-13	13	0.326	0.306	0.505	1/8	0.327	0.562	0.505
TP2A1W6-14	14	0.351	0.331	0.530	1/8	0.327	0.562	0.530
TP2A2W6-15	15	0.376	0.356	0.555	3/16	0.327	0.562	0.555
TP2A2W6-16	16	0.401	0.381	0.580	3/16	0.327	0.562	0.580
TP2A2W6-17	17	0.426	0.406	0.635	1/4	0.327	0.562	0.635
TP2A2W6-18	18	0.451	0.431	0.635	1/4	0.327	0.562	0.635
TP2A2W6-19	19	0.476	0.456	0.635	1/4	0.327	0.562	0.635
TP2A2W6-20	20	0.501	0.481	0.685	1/4	0.327	0.562	0.685
TP2A2W6-21	21	0.526	0.506	0.710	1/4	0.327	0.562	0.710
TP2A2W6-22	22	0.551	0.531	0.740	1/4	0.327	0.562	0.740

CIRCULAR PITCH	STYLE	BELT WIDTH	BORE	MATERIALS	BERG'S ® NAME	BELT
.118 (GT) 3mm	Single Flange Pin Hub	.354" 9mm	3/16"	Aluminum Anodized	Max-M-Drive®	Operates with Max-M-Drive® TB3 series.

STOCK NO.	NO. OF GROOVES	P.D.	O.D.	F.D.	B*	F.W.	A	Ø H
TP3A2W9-16	16	0.602	0.572	0.710	3/16	0.453	0.691	0.710
TP3A2W9-17	17	0.639	0.609	0.740	3/16	0.453	0.691	0.740

CIRCULAR PITCH	STYLE	BELT WIDTH	BORE	MATERIALS	BERG'S ® NAME	BELT
.118 (GT) 3mm	Single Flange Pin Hub	.590" 15mm	3/16"	Aluminum Anodized	Max-M-Drive®	Operates with Max-M-Drive® TB3 series.

STOCK NO.	NO. OF GROOVES	P.D.	O.D.	F.D.	B*	F.W.	A	Ø H
TP3A2W15-16	16	0.602	0.572	0.710	3/16	0.689	0.927	0.710
TP3A2W15-17	17	0.639	0.609	0.740	3/16	0.689	0.927	0.710

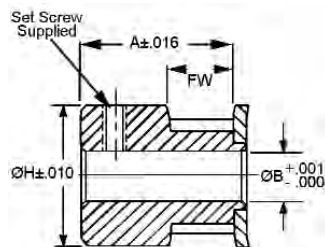

* Metric bore available on request.

TIMING PULLEYS

CIRCULAR PITCH	STYLE	BELT WIDTH	BORE	MATERIALS	BERG'S® NAME	BELT
.079 (GT) 2mm	Double Flange Pin Hub	.354" 9mm	3/16" to 1/4"	Aluminum Anodized	Max-M-Drive®	Operates with Max-M-Drive® TB2 series.

STOCK NO.	NO. OF GROOVES	P.D.	O.D.	F.D.	B*	F.W.	A	Ø H
TP2A3W9-17	17	0.426	0.406	0.635	3/16	0.514	0.750	0.312
TP2A3W9-18	18	0.451	0.431	0.635	3/16	0.514	0.750	0.312
TP2A3W9-19	19	0.476	0.456	0.635	3/16	0.514	0.750	0.338
TP2A3W9-20	20	0.501	0.481	0.685	3/16	0.514	0.750	0.364
TP2A3W9-21	21	0.526	0.506	0.710	3/16	0.514	0.750	0.390
TP2A3W9-22	22	0.551	0.531	0.740	3/16	0.514	0.750	0.390
TP2A3W9-24	24	0.602	0.582	0.790	1/4	0.514	0.812	0.442
TP2A3W9-25	25	0.627	0.607	0.815	1/4	0.514	0.812	0.468
TP2A3W9-26	26	0.652	0.632	0.840	1/4	0.514	0.812	0.490
TP2A3W9-28	28	0.702	0.682	0.895	1/4	0.514	0.812	0.494
TP2A3W9-30	30	0.752	0.732	0.945	1/4	0.514	0.812	0.546
TP2A3W9-32	32	0.802	0.782	1.000	1/4	0.514	0.812	0.598
TP2A3W9-36	36	0.902	0.882	1.105	1/4	0.514	0.812	0.676
TP2A3W9-40	40	1.003	0.983	1.210	1/4	0.530	0.843	0.754
TP2A3W9-42	42	1.053	1.033	1.260	1/4	0.530	0.843	0.806
TP2A3W9-44	44	1.103	1.083	1.315	1/4	0.530	0.843	0.858
TP2A3W9-45	45	1.128	1.108	1.340	1/4	0.530	0.843	0.900
TP2A3W9-48	48	1.203	1.183	1.420	1/4	0.530	0.843	0.936
TP2A3W9-50	50	1.253	1.233	1.470	1/4	0.530	0.843	0.936
TP2A3W9-56	56	1.404	1.384	1.575	1/4	0.530	0.843	1.030
TP2A3W9-60	60	1.504	1.484	1.730	1/4	0.530	0.843	1.222

CIRCULAR PITCH	STYLE	BELT WIDTH	BORE	MATERIALS	BERG'S® NAME	BELT
.079 (GT) 2mm	Double Flange Pin Hub	.236" 6mm	3/16" to 1/4"	Aluminum Anodized	Max-M-Drive®	Operates with Max-M-Drive® TB2 series.

STOCK NO.	NO. OF GROOVES	P.D.	O.D.	F.D.	B*	F.W.	A	Ø H
TP2A2W6-17	17	0.426	0.406	0.635	3/16	0.389	0.625	0.312
TP2A2W6-18	18	0.451	0.431	0.635	3/16	0.389	0.625	0.312
TP2A2W6-19	19	0.476	0.456	0.635	3/16	0.389	0.625	0.338
TP2A2W6-20	20	0.501	0.481	0.685	3/16	0.389	0.625	0.364
TP2A2W6-21	21	0.526	0.506	0.710	3/16	0.389	0.625	0.390
TP2A2W6-22	22	0.551	0.531	0.740	3/16	0.389	0.625	0.390
TP2A3W6-24	24	0.602	0.582	0.790	1/4	0.389	0.687	0.442
TP2A3W6-25	25	0.627	0.607	0.815	1/4	0.389	0.687	0.468
TP2A3W6-26	26	0.652	0.632	0.840	1/4	0.389	0.687	0.490
TP2A3W6-28	28	0.702	0.682	0.895	1/4	0.389	0.687	0.494
TP2A3W6-30	30	0.752	0.732	0.945	1/4	0.389	0.687	0.546
TP2A3W6-32	32	0.802	0.782	1.000	1/4	0.389	0.687	0.598
TP2A3W6-36	36	0.902	0.882	1.105	1/4	0.389	0.687	0.676
TP2A3W6-40	40	1.003	0.983	1.210	1/4	0.389	0.719	0.754
TP2A3W6-42	42	1.053	1.033	1.260	1/4	0.389	0.719	0.806
TP2A3W6-44	44	1.103	1.083	1.315	1/4	0.405	0.719	0.858
TP2A3W6-45	45	1.128	1.108	1.340	1/4	0.405	0.719	0.900
TP2A3W6-48	48	1.203	1.183	1.420	1/4	0.405	0.719	0.936
TP2A3W6-50	50	1.253	1.233	1.470	1/4	0.405	0.719	0.936
TP2A3W6-56	56	1.404	1.384	1.575	1/4	0.405	0.719	1.030
TP2A3W6-60	60	1.504	1.484	1.730	1/4	0.405	0.719	1.222

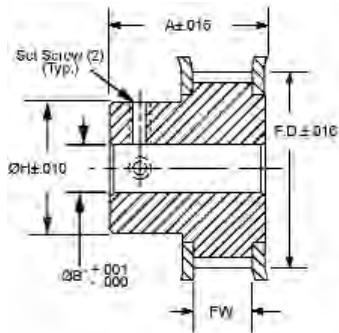

* Metric bore available on request.

TIMING PULLEYS

CIRCULAR PITCH	STYLE	BELT WIDTH	BORE	MATERIALS	BERG'S® NAME	BELT
.118 (GT) 3mm	Double Flange Pin Hub	.354" 9mm	3/16" to 1/4"	Aluminum Anodized	Max-M-Drive®	Operates with Max-M-Drive® TB2 series.

STOCK NO.	NO. OF GROOVES	P.D.	O.D.	F.D.	B*	F.W.	A	Ø H
TP3A3W9-18	18	0.677	0.684	0.790	3/16	0.506	0.812	0.442
TP3A3W9-19	19	0.714	0.722	0.815	3/16	0.506	0.812	0.468
TP3A3W9-20	20	0.752	0.760	0.895	3/16	0.506	0.812	0.500
TP3A3W9-21	21	0.790	0.797	0.895	3/16	0.506	0.812	0.500
TP3A3W9-22	22	0.827	0.872	0.945	3/16	0.506	0.812	0.562
TP3A3W9-24	24	0.902	0.910	1.025	1/4	0.506	0.812	0.625
TP3A3W9-25	25	0.940	0.947	1.060	1/4	0.506	0.812	0.625
TP3A3W9-26	26	0.977	1.023	1.105	1/4	0.506	0.812	0.625
TP3A3W9-28	28	1.053	1.098	1.173	1/4	0.506	0.812	0.701
TP3A3W9-30	30	1.128	1.173	1.250	1/4	0.506	0.812	0.776
TP3A3W9-32	32	1.203	1.248	1.323	1/4	0.506	0.812	0.851
TP3A3W9-34	34	1.248	1.323	1.398	1/4	0.527	0.833	0.921
TP3A3W9-36	36	1.353	1.399	1.473	1/4	0.527	0.833	1.000
TP3A3W9-38	38	1.429	1.399	1.549	1/4	0.527	0.833	1.075
TP3A3W9-40	40	1.504	1.474	1.625	1/4	0.527	0.833	1.150
TP3A3W9-44	44	1.654	1.624	1.775	1/4	0.527	0.833	1.300
TP3A3W9-45	45	1.692	1.662	1.775	1/4	0.527	0.833	1.250

CIRCULAR PITCH	STYLE	BELT WIDTH	BORE	MATERIALS	BERG'S® NAME	BELT
.118 (GT) 3mm	Double Flange Pin Hub	.590" 15mm	3/16" to 1/4"	Aluminum Anodized	Max-M-Drive®	Operates with Max-M-Drive® TB2 series.

STOCK NO.	NO. OF GROOVES	P.D.	O.D.	F.D.	B*	F.W.	A	Ø H
TP3A3W15-18	18	0.677	0.647	0.790	3/16	0.742	1.057	0.442
TP3A3W15-19	19	0.714	0.684	0.815	3/16	0.742	1.057	0.468
TP3A3W15-20	20	0.752	0.722	0.895	3/16	0.742	1.057	0.500
TP3A3W15-21	21	0.790	0.760	0.895	3/16	0.742	1.057	0.500
TP3A3W15-22	22	0.827	0.797	0.945	3/16	0.742	1.057	0.562
TP3A3W15-24	24	0.902	0.872	1.025	1/4	0.742	1.057	0.625
TP3A3W15-25	25	0.940	0.910	1.060	1/4	0.742	1.057	0.625
TP3A3W15-26	26	0.977	0.947	1.105	1/4	0.742	1.057	0.625
TP3A3W15-28	28	1.053	1.023	1.173	1/4	0.742	1.057	0.701
TP3A3W15-30	30	1.128	1.098	1.250	1/4	0.742	1.057	0.776
TP3A3W15-32	32	1.203	1.173	1.323	1/4	0.742	1.057	0.851
TP3A3W15-34	34	1.248	1.248	1.398	1/4	0.763	1.069	0.921
TP3A3W15-36	36	1.353	1.323	1.473	1/4	0.763	1.069	1.000
TP3A3W15-38	38	1.429	1.399	1.549	1/4	0.763	1.069	1.075
TP3A3W15-40	40	1.504	1.474	1.625	1/4	0.763	1.069	1.150
TP3A3W15-44	44	1.654	1.624	1.775	1/4	0.763	1.069	1.300

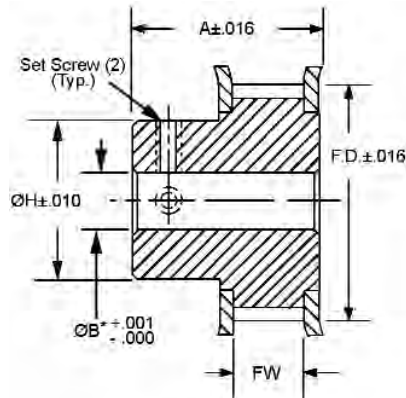

* Metric bore available on request.

TIMING PULLEYS

CIRCULAR PITCH	STYLE	BELT WIDTH	BORE	MATERIALS	BERG'S® NAME	BELT
.079 (GT) 2mm	Flangeless Pin Hub	.354" 9mm	1/4" to 3/8"	Aluminum Anodized	Max-M-Drive®	Operates with Max-M-Drive® TB2 series.

STOCK NO.	NO. OF GROOVES	P.D.	O.D.	B*	F.W.	A	Ø H
TP2A3H9-60	60	1.504	1.484	1/4	0.500	0.875	1.148
TP2A3H9-62	62	1.554	1.534	1/4	0.500	0.875	1.148
TP2A3H9-68	68	1.704	1.684	1/4	0.500	0.875	1.185
TP2A3H9-72	72	1.805	1.785	1/4	0.500	0.875	1.195
TP2A3H9-74	74	1.855	1.835	1/4	0.500	0.875	1.215
TP2A3H9-80	80	2.005	1.985	5/16	0.500	0.875	1.500
TP2A3H9-90	90	2.256	2.236	5/16	0.500	0.875	1.500
TP2A3H9-100	100	2.506	2.486	5/16	0.500	0.875	1.500
TP2A3H9-120	120	3.008	2.988	3/8	0.500	0.875	1.500

CIRCULAR PITCH	STYLE	BELT WIDTH	BORE	MATERIALS	BERG'S® NAME	BELT
.079 (GT) 2mm	Flangeless Pin Hub	.236" 6mm	1/4" to 3/8"	Aluminum Anodized	Max-M-Drive®	Operates with Max-M-Drive® TB2 series.

STOCK NO.	NO. OF GROOVES	P.D.	O.D.	B*	F.W.	A	Ø H
TP2A3H6-60	60	1.504	1.484	1/4	0.375	0.750	1.148
TP2A3H6-62	62	1.554	1.534	1/4	0.375	0.750	1.148
TP2A3H6-68	68	1.704	1.684	1/4	0.375	0.750	1.185
TP2A3H6-72	72	1.805	1.785	1/4	0.375	0.750	1.195
TP2A3H6-74	74	1.855	1.835	1/4	0.375	0.750	1.215
TP2A3H6-80	80	2.005	1.985	5/16	0.375	0.750	1.500
TP2A3H6-90	90	2.256	2.236	5/16	0.375	0.750	1.500
TP2A3H6-100	100	2.506	2.486	5/16	0.375	0.750	1.500
TP2A3H6-120	120	3.008	2.988	3/8	0.375	0.750	1.500

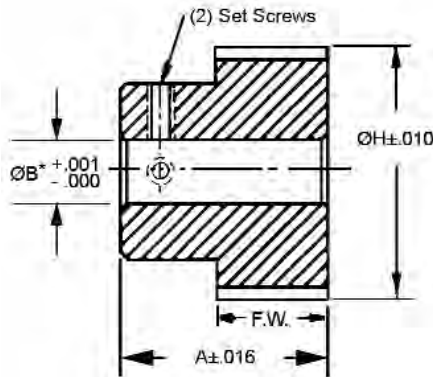

* Metric bore available on request.

TIMING PULLEYS

CIRCULAR PITCH	STYLE	BELT WIDTH	BORE	MATERIALS	BERG'S® NAME	BELT
.118 (GT) 3mm	Flangeless Pin Hub	.354" 9mm	5/16"	Aluminum Anodized	Max-M-Drive®	Operates with Max-M-Drive® TB2 series.

STOCK NO.	NO. OF GROOVES	P.D.	O.D.	B*	F.W.	A	Ø H
TP3A3H9-45	45	1.692	1.662	5/16	0.527	0.875	1.250
TP3A3H9-48	48	1.805	1.775	5/16	0.500	0.875	1.250
TP3A3H9-50	50	1.880	1.850	5/16	0.500	0.875	1.250
TP3A3H9-56	56	2.105	2.075	5/16	0.500	0.875	1.250
TP3A3H9-60	60	2.256	2.226	5/16	0.500	0.875	1.250
TP3A3H9-62	62	2.331	2.301	5/16	0.500	0.875	1.250
TP3A3H9-68	68	2.557	2.527	5/16	0.500	0.875	1.250
TP3A3H9-72	72	2.707	2.677	5/16	0.500	0.875	1.250
TP3A3H9-74	74	2.782	2.752	5/16	0.500	0.875	1.250
TP3A3H9-80	80	3.008	2.978	5/16	0.500	0.875	1.250

CIRCULAR PITCH	STYLE	BELT WIDTH	BORE	MATERIALS	BERG'S® NAME	BELT
.118 (GT) 3mm	Flangeless Pin Hub	.590" 15mm	1/4" to 5/16"	Aluminum Anodized	Max-M-Drive®	Operates with Max-M-Drive® TB2 series.

STOCK NO.	NO. OF GROOVES	P.D.	O.D.	B*	F.W.	A	Ø H
TP3A3H15-45	45	1.692	1.662	1/4	0.763	1.069	1.250
TP3A3H15-48	48	1.805	1.775	5/16	0.736	1.111	1.250
TP3A3H15-50	50	1.880	1.850	5/16	0.736	1.111	1.250
TP3A3H15-56	56	2.105	2.075	5/16	0.736	1.111	1.250
TP3A3H15-60	60	2.256	2.226	5/16	0.736	1.111	1.250
TP3A3H15-62	62	2.331	2.301	5/16	0.736	1.111	1.250
TP3A3H15-68	68	2.557	2.527	5/16	0.736	1.111	1.250
TP3A3H15-72	72	2.707	2.677	5/16	0.736	1.111	1.250
TP3A3H15-74	74	2.782	2.752	5/16	0.736	1.111	1.250
TP3A3H15-80	80	3.008	2.978	5/16	0.736	1.111	1.250

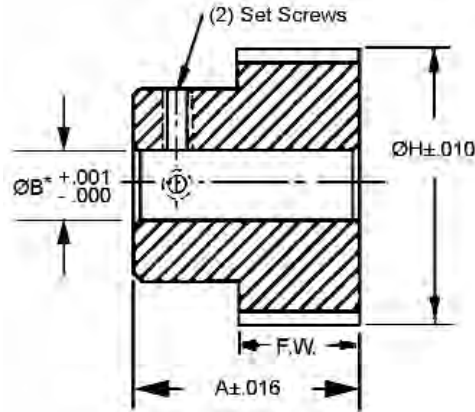

* Metric bore available on request.

60° V BELT

A

SERIES	WIDTH	HEIGHT	MATERIAL	BERG'S® NAME	PULLEY
V3M	1/8"	3/32"	Polyurethane (Black)	V-Flex	Operates with V3M Series

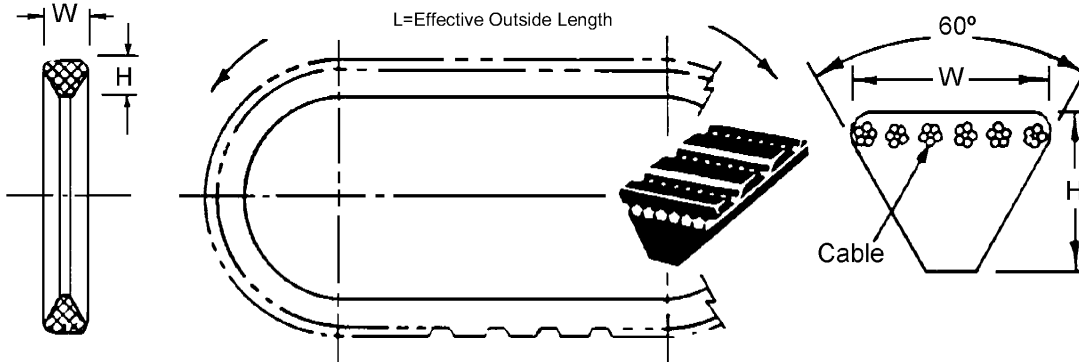

STOCK NO.	L (CIR.)
V3M180	7.09
V3M185	7.28
V3M190	7.48
V3M195	7.68
V3M200	7.87
V3M206	8.11
V3M212	8.35
V3M218	8.58
V3M224	8.82
V3M230	9.06
V3M243	9.57
V3M250	9.84
V3M265	10.43
V3M280	11.02
V3M300	11.81
V3M315	12.40
V3M325	12.80
V3M345	13.58
V3M365	14.37
V3M400	15.75
V3M425	16.73
V3M450	17.72
V3M475	18.70
V3M500	19.69
V3M530	20.87
V3M560	22.05
V3M600	23.62
V3M650	23.59
V3M710	27.95
V3M750	29.53

RPM Of Faster Shaft	Horsepower Ratings for 5000-10,000 Hours Service Life Range											
	V3M Small Sheave Diameter											
	.67	.71	.75	.79	.83	.88	.93	.98	1.04	1.10	1.17	1.24
200	.016	.019	.022	.024	.027	.031	.035	.039	.043	.048	.056	.059
400	.028	.033	.038	.044	.049	.056	.063	.070	.079	.088	.098	.11
600	.039	.046	.053	.061	.068	.078	.088	.099	.11	.12	.14	.15
800	.048	.057	.067	.076	.086	.099	.11	.13	.14	.16	.18	.20
1000	.057	.068	.079	.091	.10	.12	.13	.15	.17	.19	.21	.23
2000	-	.11	.13	.15	.17	.20	.23	.26	.29	.33	.37	.41
3000	-	-	.17	.20	.23	.27	.31	.35	.39	.44	.50	.55
4000	-	-	-	.23	.27	.32	.37	.42	.48	.54	.61	.68
5000	-	-	-	-	.31	.37	.42	.48	.55	.62	.70	.79

SERVICE FACTORS

Typical Units	Service Factor
Office Machines	1.2
Machine Tools	1.4
Woodworking Machines	1.5
Washing Machine Tumblers & Agitators	1.3
Dry Cleaning Tumblers	1.3
Clothes Dryer Tumblers	1.3
Ironers	1.0
Fans	1.0
Pumps:	
Centrifugal	1.1
Gear	1.3
Reciprocating	1.5
Compressors:	
Reciprocating	1.5
Rotary	1.3
Generators:	
Smooth Load	1.3
Welders	1.5
Lawn Mowers	1.5
Snow Blowers	1.5

- Superior Horsepower Life on smaller Diameter Sheaves
- More Compact Drives
- Smoother Running
- Last three digits in the Stock No. represent length in Millimeter



Design Horsepower = (Service Factor) x (Horsepower Requirement)

60° V BELT

SERIES	WIDTH	HEIGHT	MATERIAL	BERG'S ® NAME	PULLEY
V5M	3/16"	1/8"	Polyurethane (Black)	V-Flex	Operates with V5M Series

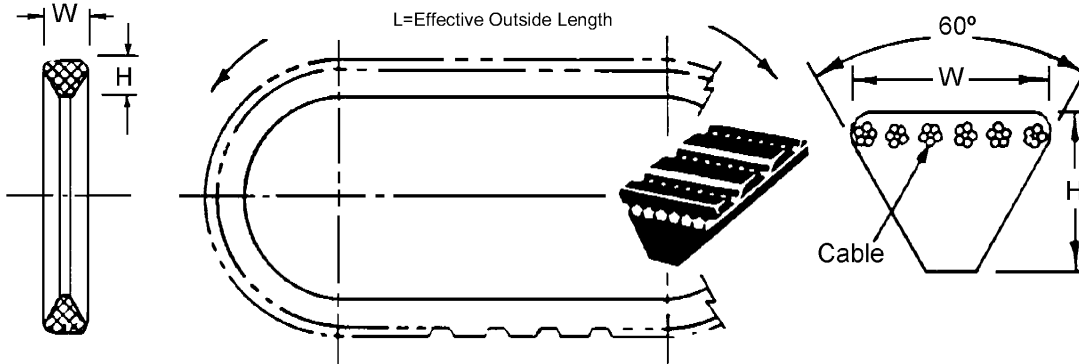

STOCK NO.	L (CIR.)
V5M280	11.02
V5M290	11.42
V5M300	11.81
V5M307	12.09
V5M315	12.40
V5M325	12.80
V5M335	13.19
V5M345	13.58
V5M375	14.76
V5M400	15.75
V5M425	16.73
V5M450	17.72
V5M475	18.70
V5M500	19.69
V5M530	20.87
V5M560	22.05
V5M580	22.83
V5M600	23.62
V5M650	23.59
V5M690	27.17
V5M750	29.53
V5M800	31.50
V5M850	33.46
V5M900	35.43
V5M950	37.40
V5M1000	39.37
V5M1060	41.73
V5M1250	49.21
V5M1400	55.12
V5M1500	59.06

RPM Of Faster Shaft	Horsepower Ratings for 5000-10,000 Hours Service Life Range												
	V5M Small Sheave Diameter												
	1.04	1.10	1.17	1.24	1.32	1.40	1.48	1.57	1.67	1.77	1.87	1.97	
200	.053	.061	.071	.081	.092	.10	.12	.13	.15	.16	.18	.20	
400	.007	.11	.13	.14	.17	.19	.22	.24	.27	.30	.33	.36	
600	.15	.16	.18	.21	.24	.27	.31	.34	.39	.43	.47	.52	
800	.17	.20	.23	.27	.31	.35	.39	.44	.50	.55	.61	.66	
1000	.20	.24	.28	.32	.37	.42	.47	.53	.60	.67	.74	.80	
2000	.35	.41	.48	.56	.65	.74	.83	.94	1.06	1.18	1.30	1.42	
3000	.46	.55	.65	.76	.88	1.01	1.14	1.28	1.45	1.61	1.78	1.95	
4000	-	.66	.80	.93	1.08	1.24	1.40	1.59	1.79	2.00	2.22	2.43	
5000	-	-	.92	1.08	1.26	1.45	1.64	1.86	2.11	2.36	2.61	2.87	

SERVICE FACTORS

Typical Units	Service Factor
Office Machines	1.2
Machine Tools	1.4
Woodworking Machines	1.5
Washing Machine Tumblers & Agitators	1.3
Dry Cleaning Tumblers	1.3
Clothes Dryer Tumblers	1.3
Ironers	1.0
Fans	1.0
Pumps:	
Centrifugal	1.1
Gear	1.3
Reciprocating	1.5
Compressors:	
Reciprocating	1.5
Rotary	1.3
Generators:	
Smooth Load	1.3
Welders	1.5
Lawn Mowers	1.5
Snow Blowers	1.5

- Superior Horsepower Life on smaller Diameter Sheaves
- More Compact Drives
- Smoother Running
- Last three digits in the Stock No. represent length in Millimeter



Design Horsepower = (Service Factor) x (Horsepower Requirement)

60° V BELT

A

SERIES	WIDTH	HEIGHT	MATERIAL	BERG'S® NAME	PULLEY
V7M	5/16"	7/32"	Polyurethane (Black)	V-Flex	Operates with V7M Series

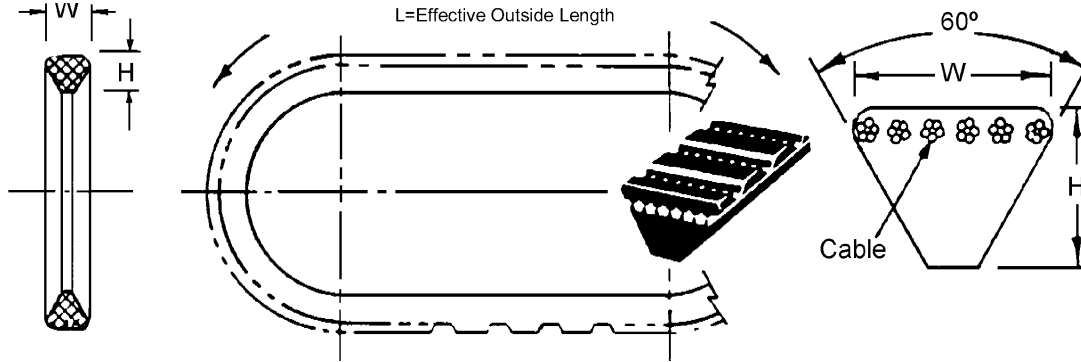

STOCK NO.	L (CIR.)
V7M500	19.69
V7M515	20.28
V7M530	20.87
V7M545	21.46
V7M560	22.05
V7M580	22.83
V7M600	23.62
V7M615	24.21
V7M650	23.59
V7M690	27.17
V7M710	27.95
V7M750	29.53
V7M800	31.50
V7M850	33.46
V7M900	35.43
V7M950	37.40
V7M1000	39.37
V7M1060	41.73
V7M1120	44.09
V7M1180	46.46
V7M1250	49.21
V7M1320	51.97
V7M1400	55.12
V7M1500	59.06
V7M1600	62.99
V7M1700	66.93
V7M1800	70.87
V7M1900	74.80
V7M2000	78.74
V7M2120	83.46
V7M2300	90.55

RPM Of Faster Shaft	Horsepower Ratings for 5000-10,000 Hours Service Life Range											
	V7M Small Sheave Diameter											
	1.67	1.77	1.87	1.97	2.08	2.20	2.34	2.48	2.64	2.80	2.95	3.15
200	.16	.19	.21	.24	.27	.30	.34	.38	.42	.47	.51	.57
400	.30	.34	.39	.44	.49	.55	.63	.70	.78	.87	.95	1.05
600	.42	.49	.56	.62	.70	.79	.89	1.00	1.12	1.24	1.35	1.50
800	.54	.62	.71	.80	.90	1.01	1.14	1.27	1.43	1.59	1.73	1.93
1000	.64	.75	.85	.96	1.08	1.22	1.38	1.54	1.73	1.91	2.09	2.33
2000	1.10	1.29	1.48	1.68	1.89	22.13	2.42	2.71	3.04	3.37	3.69	4.11
3000	1.47	1.73	2.00	2.27	2.57	2.91	3.30	3.71	4.17	4.64	5.08	5.67
4000	1.78	2.11	2.44	2.79	3.17	3.59	4.10	4.61	5.20	5.79	6.36	7.11
5000	2.03	2.43	2.83	3.24	3.70	4.21	4.82	5.43	6.14	6.86	7.53	8.43

SERVICE FACTORS

Typical Units	Service Factor
Office Machines	1.2
Machine Tools	1.4
Woodworking Machines	1.5
Washing Machine Tumblers & Agitators	1.3
Dry Cleaning Tumblers	1.3
Clothes Dryer Tumblers	1.3
Ironers	1.0
Fans	1.0
Pumps:	
Centrifugal	1.1
Gear	1.3
Reciprocating	1.5
Compressors:	
Reciprocating	1.5
Rotary	1.3
Generators:	
Smooth Load	1.3
Welders	1.5
Lawn Mowers	1.5
Snow Blowers	1.5

- Superior Horsepower Life on smaller Diameter Sheaves
- More Compact Drives
- Smoother Running
- Last three digits in the Stock No. represent length in Millimeter



Design Horsepower = (Service Factor) x (Horsepower Requirement)

60° V BELT PULLEYS

BORE	STYLE	MATERIAL	BERG'S ® NAME	BELT
1/8"	PIN HUB SINGLE GROOVE	303 Stainless Steel	V-Flex	Operates with V3M Series

STOCK NO.	B	O.D.	F	H	L
V3M14S-1		.67			
V3M14S-2		.75			
V3M14S-3		.83			
V3M14S-4	(1/8)	.93	3/16	5/16	3/8
V3M14S-5	.1248	1.04			
V3M14S-6		1.17			
V3M14S-7		1.24			

BORE	STYLE	MATERIAL	BERG'S ® NAME	BELT
3/16"	PIN HUB SINGLE GROOVE	303 Stainless Steel	V-Flex	Operates with V3M Series

STOCK NO.	B	O.D.	F	H	L
V3M21S-1		.67			
V3M21S-2		.75			
V3M21S-3		.83			
V3M21S-4	(3/16)	.93	3/16	3/8	13/32
V3M21S-5	.1873	1.04			
V3M21S-6		1.17			
V3M21S-7		1.24			

BORE	STYLE	MATERIAL	BERG'S ® NAME	BELT
1/4"	PIN HUB SINGLE GROOVE	303 Stainless Steel	V-Flex	Operates with V3M Series

STOCK NO.	B	O.D.	F	H	L
V3M28S-1		.67			
V3M28S-2		.75			
V3M28S-3		.79			
V3M28S-4		.88			
V3M28S-5		.93			
V3M28S-6		.98			
V3M28S-7		1.04			
V3M28S-8	(1/4)	1.10	3/16	1/2	7/16
V3M28S-9	.2498	1.17			
V3M28S-10		1.24			
V3M28S-11		1.57			
V3M28S-12		1.97			
V3M28S-13		2.48			
V3M28S-14		3.15			
V3M28S-15		3.94			

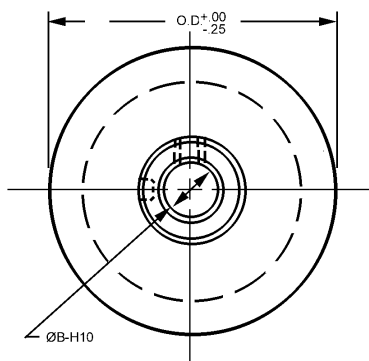
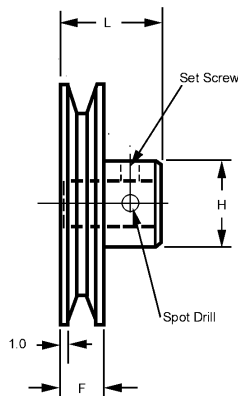

60° V BELT PULLEYS

BORE	STYLE	MATERIAL	BERG'S ® NAME	BELT
5/16"	PIN HUB SINGLE GROOVE	303 Stainless Steel	V-Flex	Operates with V5M Series

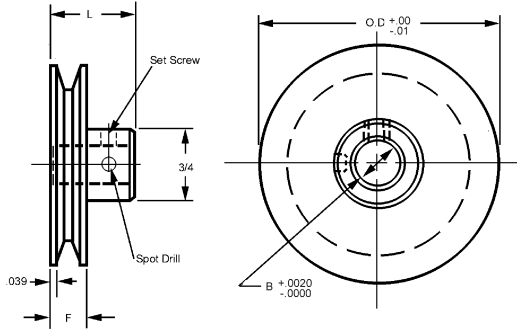

STOCK NO.	B	H	O.D.	F	L
V5M33S-1			1.04		
V5M33S-2			1.10		
V5M33S-3			1.17		
V5M33S-4			1.24		
V5M33S-5			1.32		
V5M33S-6			1.40		
V5M33S-7	.3123	3/4	1.48	1/4	5/8
V5M33S-8	(5/16)		1.57		
V5M33S-9			1.67		
V5M33S-10			1.77		
V5M33S-11			1.87		
V5M33S-12			1.97		
V5M33S-13			2.48		
V5M33S-14			3.15		
V5M33S-15			3.94		



Special sizes are available upon request.

BORE	STYLE	MATERIAL	BERG'S ® NAME	BELT
3/8"	PIN HUB SINGLE GROOVE	303 Stainless Steel	V-Flex	Operates with V5M Series

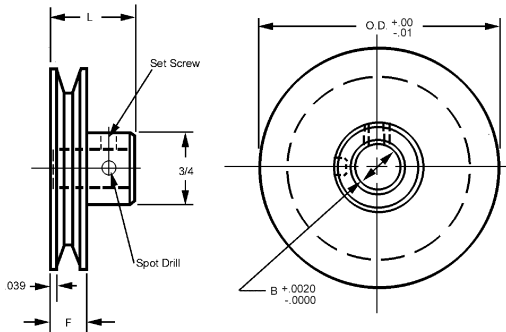

STOCK NO.	B	H	O.D.	F	L
V5M47S-1			1.04		
V5M47S-2			1.10		
V5M47S-3			1.17		
V5M47S-4			1.24		
V5M47S-5			1.32		
V5M47S-6			1.40		
V5M47S-7	.3748	3/4	1.48	1/4	5/8
V5M47S-8	(3/8)		1.57		
V5M47S-9			1.67		
V5M47S-10			1.77		
V5M47S-11			1.87		
V5M47S-12			1.97		
V5M47S-13			2.48		
V5M47S-14			3.15		
V5M47S-15			3.94		



Special sizes are available upon request.

60° V BELT PULLEYS

BORE	STYLE	MATERIAL	BERG'S® NAME	BELT
3/8"	PIN HUB SINGLE GROOVE	303 Stainless Steel	V-Flex	Operates with V7M Series

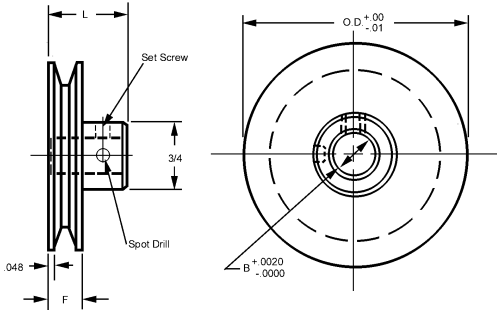

STOCK NO.	B	H	O.D.	F	L
V7M35S-1	.3748 (3/8)	3/4	1.67	3/8	7/8
V7M35S-2			1.77		
V7M35S-3			1.87		
V7M35S-4			1.97		
V7M35S-5			2.08		
V7M35S-6			2.20		
V7M35S-7			2.34		
V7M35S-8			2.48		
V7M35S-9			2.64		
V7M35S-10			2.80		
V7M35S-11			2.95		
V7M35S-12			3.15		
V7M35S-13			3.35		
V7M35S-14			3.64		
V7M35S-15			3.94		



Special sizes are available upon request.

BORE	STYLE	MATERIAL	BERG'S® NAME	BELT
1/2"	PIN HUB SINGLE GROOVE	303 Stainless Steel	V-Flex	Operates with V 7M Series

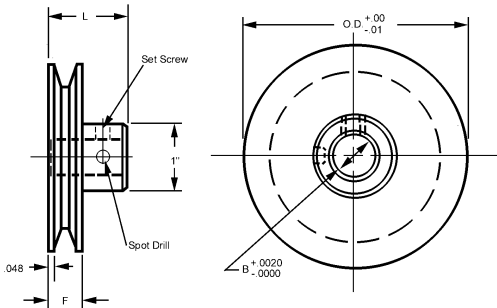

STOCK NO.	B	H	O.D.	F	L
V7M37S-1	.4998 (1/2)	1	1.67	3/8	7/8
V7M37S-2			1.77		
V7M37S-3			1.87		
V7M37S-4			1.97		
V7M37S-5			2.08		
V7M37S-6			2.20		
V7M37S-7			2.34		
V7M37S-8			2.48		
V7M37S-9			2.64		
V7M37S-10			2.80		
V7M37S-11			2.95		
V7M37S-12			3.15		
V7M37S-13			3.35		
V7M37S-14			3.64		
V7M37S-15			3.94		



Special sizes are available upon request.

POW-R-VEE® BELTS

A New Concept in V-Belt Drives

Advantages

Cable Design

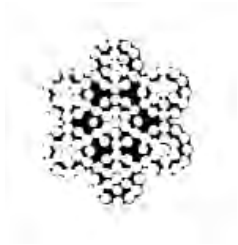

- Completely Non Corrosive
- Stainless Steel Cable Core Allows Maximum Strength.
- Lighter Weight
- Single Strand Cable Core Permits Complete Flexibility
- Power is Transferred Along The Pitch Line For Minimum Transmission Loss
- Can Be Spliced On Machine For Minimum Down Time
- Damaged Sections Can Be Replaced
- Infinite Lengths Are Available

Flexible Sidewall



- Can Be Used With Pulleys Of Any Angle
- Inherent Locking Action Offers A More Positive, Non Slip Drive & Allows For Tension On The Belt & Pulleys

Flexible Design

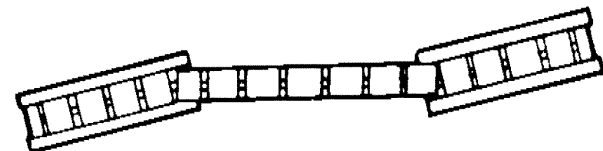

- Permits Odd Angle & Three Dimensional Drives
- Compensates For Misalignment
- Prevents "Turn Over" & "Lift Off"

Materials

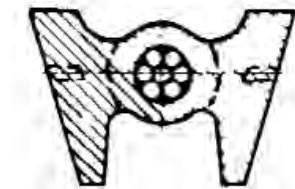

- The Combination Of Engineered Plastics & Stainless Steel Cable
- Offers High Heat Resistance, Smoother Operation, Light Weight, Less Inertia & Vibration.
- Pow-R-Vee Can Be Molded In Any Color For Sales Appeal

Cog Design

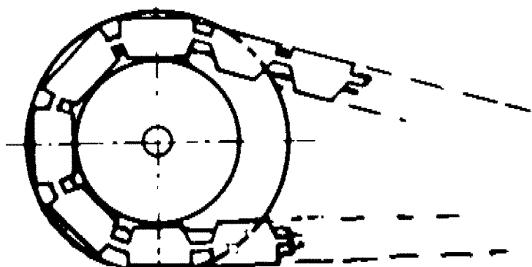

- No Stretch Or Compression Of Belt- Results In Less Fatigue, Longer Life, More Flexibility
- Segmented, Cog Design Permits Smaller Pulley Diameters, Larger Ratios, More Compact Design and Most Importantly Provides Positive Gripping at All Times.

TECHNICAL DATA

Operating Notes:

Due to the unique design of polyurethane molded over a stainless steel cable, this series offers high heat resistance, smooth operation, light weight, and less inertia. Because the design is cogged it allows for smaller pulley diameters and compensates for misalignment of pulleys by permitting an angle (7° maximum misalignment). The design also allows for the belt to be spliced to any length, (either in the field or at Berg) thus allowing belts to be replaced quickly.

2V Series

- Weight .21 oz./ft
- 1/32" Diameter
Stainless Steel Cable

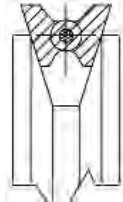

- 90A Durometer Polyurethane (Brown)
- Ultimate Tensile Strength 50 lbs.
- Recommended Operating Load 12 lbs.
- Recommended Maximum Operating Speed 1800 rpm
- Temperature Range +180°F to -15°F

3V Series

- Weight .60 oz/ft
- 3/64 Diameter
Stainless Steel Cable

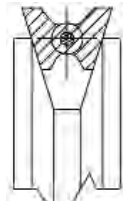

- 90A Durometer Polyurethane (Red)
- Ultimate Tensile Strength 125 lbs.
- Recommended Operating Load 30 lbs.
- Recommended Maximum Operating Speed 1800 rpm
- Temperature Range +180°F to -15°F

4V Series

- Weight 1.1 oz/ft
- 1/16" Diameter
Stainless Steel Cable

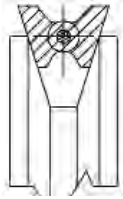

- 90A Durometer Polyurethane (Blue)
- Ultimate Tensile Strength 200 lbs.
- Recommended Operating Load 50 lbs.
- Recommended Maximum Operating Speed 1800 rpm
- Temperature Range + 180°F to -15°F

5V Series

- Weight 1.4 oz/ft
- 5/64" Diameter
Stainless Steel Cable

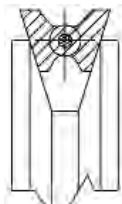

- 90A Durometer Polyurethane (Yellow)
- Ultimate Tensile Strength 350 lbs.
- Recommended Operating Load 85 lbs.
- Recommended Maximum Operating Speed 1800 rpm
- Temperature Range +180°F to -15°F



V-BELTS

A

SERIES	WIDTH	HEIGHT	MATERIAL	BERG'S ® NAME	PULLEY
2V	1/4"	7/32"	Polyurethane (Brown) with 1/32" Dia. Stainless Steel Cable	POW-R-VEE®	Operates with Pow-R-Vee 2V Series

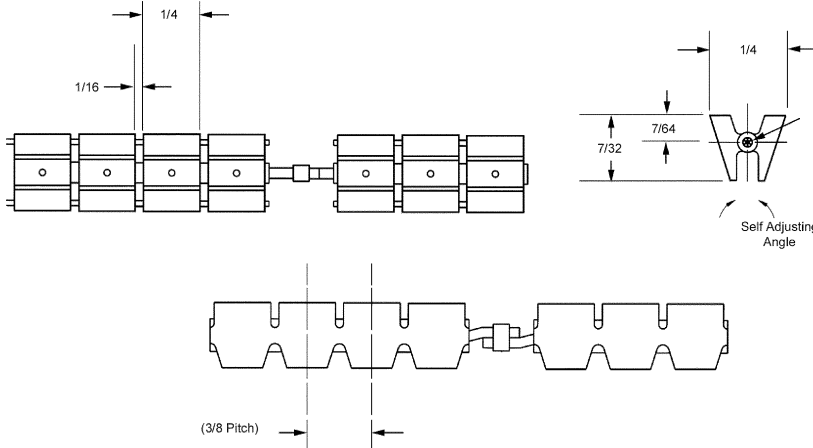

- More sidewall contact
- Less slippage
- Greater power transmission
- Infinite length variations
- Extra strong
- Light weight
- 90A Durometer
- Weight .21 oz./ft.
- Ultimate Tensile Strength 50 lbs.
- Temperature Range +180°F to -15°F
- Silent drive
- Recommended Operating Load 12 lbs.
- Recommended Max. Operating Speed 376 ft./min.
- For Field Splice Kit order 2V-7.



BULK FOOTAGE NOT SPLICED	
STOCK NO.	LENGTH
2V-5FT	5 Feet
2V-10FT	10 Feet
2V-25FT	25 Feet
2V-50FT	50 Feet
2V-100FT	100 Feet

STOCK NO.	LENGTH (Ref.)
2V-16	6.00
2V-18	6.75
2V-20	7.50
2V-22	8.25
2V-24	9.00
2V-26	9.75
2V-28	10.50
2V-30	11.25
2V-32	12.00
2V-34	12.75
2V-36	13.50
2V-38	14.25
2V-40	15.00
2V-42	15.75
2V-44	16.50
2V-46	17.25
2V-48	18.00
2V-50	18.75
2V-52	19.50
2V-54	20.25
2V-56	21.00
2V-58	21.75
2V-60	22.50
2V-62	23.25
2V-64	24.00
2V-66	24.75
2V-68	25.50
2V-70	26.25
2V-72	27.00
2V-74	27.75
2V-76	28.50
2V-78	29.25
2V-80	30.00
2V-82	30.75
2V-84	31.50
2V-86	32.25
2V-88	33.00
2V-90	33.75
2V-92	34.50
2V-94	35.25
2V-96	36.00
2V-98	36.75
2V-100	37.50
2V-102	38.25
2V-104	39.00
2V-106	39.75
2V-108	40.50
2V-110	41.25
2V-112	42.00
2V-114	42.75
2V-116	43.50
2V-118	44.25
2V-120	45.00
2V-122	45.75
2V-124	46.50
2V-126	47.25
2V-128	48.00
2V-130	48.75
2V-132	49.50
2V-134	50.25
2V-136	51.00
2V-140	52.50

V-BELT PULLEYS

SERIES	BORE	MATERIAL	BERG'S ® NAME	BELT
2V	3/8"	303 Stainless Steel	Pow-R-Vee®	Operates with Pow-R-Vee 2V Series (1/4"W X 7/32"D)

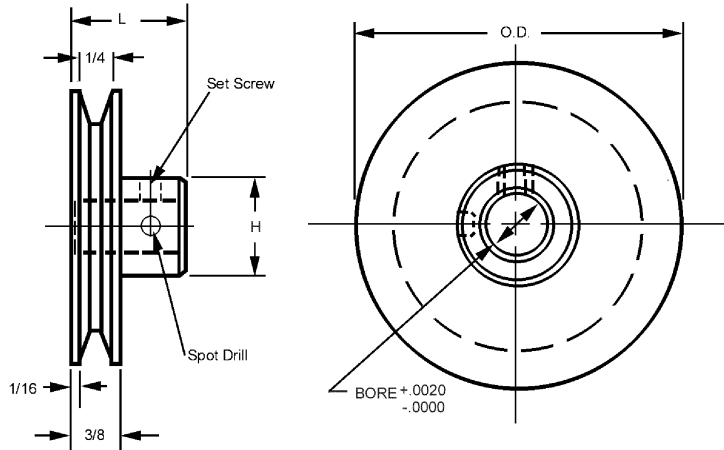

STOCK NO.	BORE	O.D.	H	L
V2M35S-1		1.67		
V2M35S-2		1.77		
V2M35S-3		1.87		
V2M35S-4		1.97		
V2M35S-5		2.08		
V2M35S-6		2.20		
V2M35S-7	(3/8)	2.34	3/4	7/8
V2M35S-8	.3748	2.48		
V2M35S-9		2.64		
V2M35S-10		2.80		
V2M35S-11		2.95		
V2M35S-12		3.15		
V2M35S-13		3.35		
V2M35S-14		3.64		
V2M35S-15		3.94		

Other sizes available upon request.

SERIES	BORE	MATERIAL	BERG'S ® NAME	BELT
2V	1/2"	303 Stainless Steel	Pow-R-Vee®	Operates with Pow-R-Vee 2V Series (1/4"W X 7/32"D)

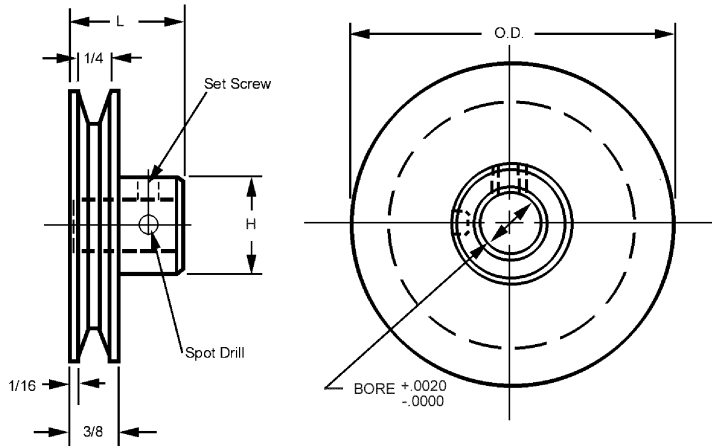

STOCK NO.	BORE	O.D.	H	L
V2M37S-1		1.67		
V2M37S-2		1.77		
V2M37S-3		1.87		
V2M37S-4		1.97		
V2M37S-5		2.08		
V2M37S-6		2.20		
V2M37S-7	(1/2)	2.34	1"	7/8
V2M37S-8	.4998	2.48		
V2M37S-9		2.64		
V2M37S-10		2.80		
V2M37S-11		2.95		
V2M37S-12		3.15		
V2M37S-13		3.35		
V2M37S-14		3.64		
V2M37S-15		3.94		

Other sizes available upon request.

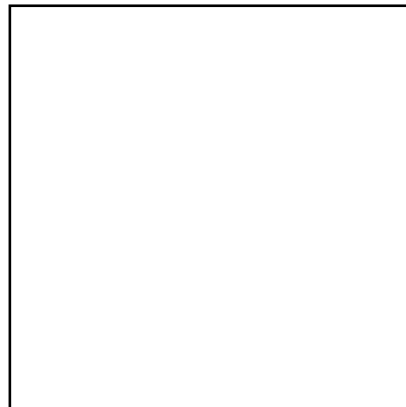

V-BELTS

SERIES	WIDTH	HEIGHT	MATERIAL	BERG'S ® NAME	PULLEY
3V	1/4"	11/32"	Polyurethane (Red) with 1/32" Dia. Stainless Steel Cable	POW-R-VEE®	Operates with Pow-R-Vee 3V Series

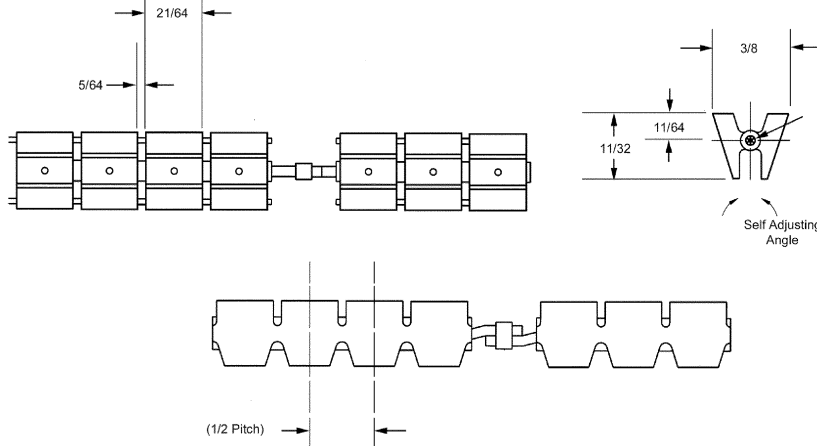

- More sidewall contact
- Less slippage
- Greater power transmission
- Infinite length variations
- Extra strong
- Silent drive
- 90A Durometer
- Weight .60 oz./ft.
- Ultimate Tensile Strength 125 lbs.
- Temperature Range +180°F to -15°F
- Recommended Operating Load 30 lbs.
- Recommended Max. Operating Speed 376 ft./min.
- For Field Splice Kit Order 3V-7.



STOCK NO.	LENGTH (Ref.)
3V-12	6.00
3V-13	6.50
3V-14	7.00
3V-15	7.50
3V-16	8.00
3V-17	8.50
3V-18	9.00
3V-19	9.50
3V-20	10.00
3V-21	10.50
3V-22	11.00
3V-23	11.50
3V-24	12.00
3V-25	12.50
3V-26	13.00
3V-27	13.50
3V-28	14.00
3V-29	14.50
3V-30	15.00
3V-31	15.50
3V-32	16.00
3V-33	16.50
3V-34	17.00
3V-35	17.50
3V-36	18.00
3V-37	18.50
3V-38	19.00
3V-39	19.50
3V-40	20.00
3V-41	20.50
3V-42	21.00
3V-43	21.50
3V-44	22.00
3V-45	22.50
3V-46	23.00
3V-47	23.50
3V-48	24.00
3V-49	24.50
3V-50	25.00
3V-51	25.50
3V-52	26.00
3V-53	26.50
3V-54	27.00
3V-55	27.50
3V-56	28.00
3V-57	28.50
3V-58	29.00
3V-59	29.50
3V-60	30.00
3V-61	30.50
3V-62	31.00
3V-63	31.50
3V-64	32.00
3V-65	32.50
3V-66	33.00
3V-67	33.50
3V-68	34.00
3V-69	34.50
3V-70	35.00
3V-71	35.50
3V-72	36.00
3V-74	37.00

BULK FOOTAGE NOT SPLICED	
STOCK NO.	LENGTH
3V-5FT	5 Feet
3V-10FT	10 Feet
3V-25FT	25 Feet
3V-50FT	50 Feet
3V-100FT	100 Feet

V-BELTS

SERIES	WIDTH	HEIGHT	MATERIAL	BERG'S® NAME	PULLEY
4V	1/2"	7/16"	Polyurethane (Blue) with 1/16" Dia. Stainless Steel Cable	POW-R-VEE®	Operates with Pow-R-Vee 4V Series

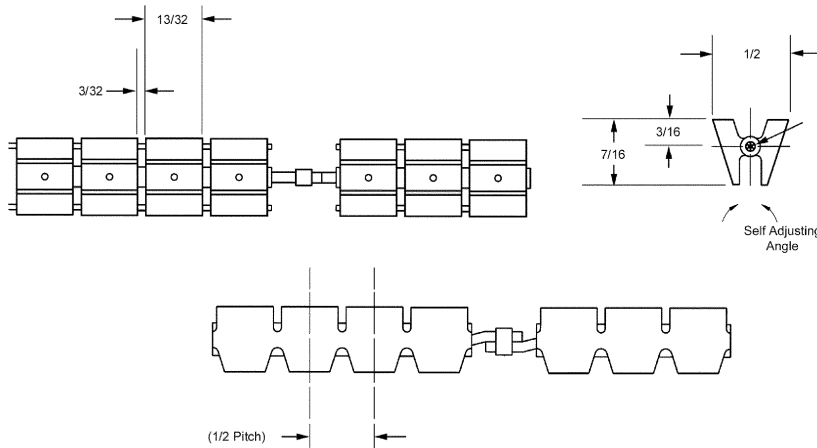

- More sidewall contact
- Less slippage
- Greater power transmission
- Infinite length variations
- Extra strong
- Silent drive
- 90A Durometer
- Weight 1.1 oz./ft.
- Ultimate Tensile Strength 200 lbs.
- Temperature Range +180°F to -15°F
- Recommended Operating Load 50 lbs.
- Recommended Max. Operating Speed 376 ft./min.
- For Field Splice Kit Order 4V-7.



BULK FOOTAGE NOT SPLICED	
STOCK NO.	LENGTH
4V-5FT	5 Feet
4V-10FT	10 Feet
4V-25FT	25 Feet
4V-50FT	50 Feet
4V-100FT	100 Feet

STOCK NO.	LENGTH (Ref.)
4V-15	7.50
4V-16	8.00
4V-17	8.50
4V-18	9.00
4V-19	9.50
4V-20	10.00
4V-21	10.50
4V-22	11.00
4V-23	11.50
4V-24	12.00
4V-25	12.50
4V-26	13.00
4V-27	13.50
4V-28	14.00
4V-29	14.50
4V-30	15.00
4V-31	15.50
4V-32	16.00
4V-33	16.50
4V-34	17.00
4V-35	17.50
4V-36	18.00
4V-37	18.50
4V-38	19.00
4V-39	19.50
4V-40	20.00
4V-41	20.50
4V-42	21.00
4V-43	21.50
4V-44	22.00
4V-45	22.50
4V-46	23.00
4V-47	23.50
4V-48	24.00
4V-49	24.50
4V-50	25.00
4V-51	25.50
4V-52	26.00
4V-53	26.50
4V-54	27.00
4V-55	27.50
4V-56	28.00
4V-57	28.50
4V-58	29.00
4V-59	29.50
4V-60	30.00
4V-61	30.50
4V-62	31.00
4V-63	31.50
4V-64	32.00
4V-65	32.50
4V-66	33.00
4V-67	33.50
4V-68	34.00
4V-69	34.50
4V-70	35.00
4V-72	36.00
4V-74	37.00
4V-76	38.00
4V-78	39.00
4V-80	40.00
4V-82	41.00
4V-84	42.00
4V-86	43.00
4V-88	44.00
4V-90	45.00
4V-92	46.00
4V-96	48.00

V-BELT PULLEYS

SERIES	BORE	MATERIAL	BERG'S ® NAME	BELT
3V	1/4"	Die Cast Zinc Alloy	Pow-R-Vee®	Operates with Pow-R-Vee 3V Series (3/8"W X 11/32"D)

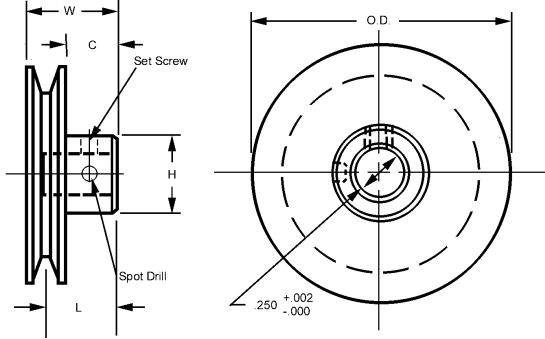

STOCK NO.	O.D. ± 5/64	W	C	L	H
V3-150-2	1 1/2	1	1/2	7/8	15/16
V3-200-2	2	1	1/2	7/8	1

All pulleys have set screws supplied.
Other bore sizes and keyways are available upon request.

SERIES	BORE	MATERIAL	BERG'S ® NAME	NOTE
3V	3/8"	Die Cast Zinc Alloy	Pow-R-Vee®	Operates with Pow-R-Vee 3V Series (3/8"W X 11/32"D)

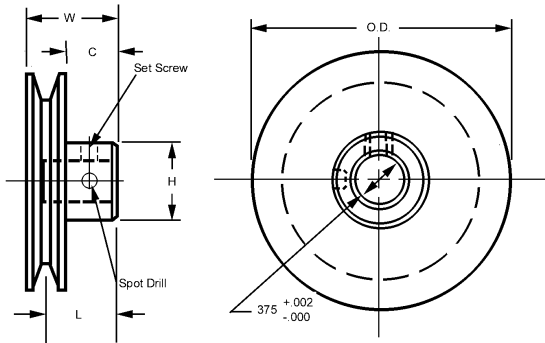

STOCK NO.	O.D. ± 5/64	W	C	L	H
V3-150-3	1 1/2	1	1/2	7/8	15/16
V3-200-3	2	1	1/2	7/8	1
V3-250-3	2 1/2	1	1/2	7/8	1 1/8
V3-300-3	3	1	1/2	7/8	1 1/8
V3-350-3	3 1/2	1	1/2	7/8	1 1/8
V3-400-3	4	1	1/2	7/8	1 1/8

All pulleys have set screws supplied.
Other bore sizes and keyways are available upon request.



V-BELT PULLEYS

SERIES	BORE	MATERIAL	BERG'S ® NAME	BELT
3V	1/2"	Die Cast Zinc Alloy	Pow-R-Vee®	Operates with Pow-R-Vee 3V Series (3/8"W X 11/32"D)

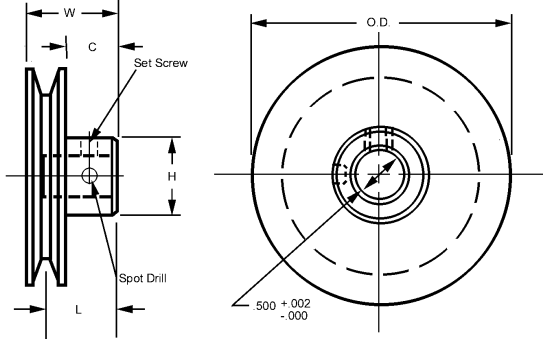

STOCK NO.	O.D. ± 5/64	W	C	L	H
V3-150-4	1 1/2				15/16
V3-200-4	2				1
V3-250-4	2 1/2	1	1/2	7/8	1 1/8
V3-300-4	3				1 1/8
V3-350-4	3 1/2				1 1/8
V3-400-4	4				1 1/8

All pulleys have set screws supplied.
Other bore sizes and keyways are available upon request.

SERIES	BORE	MATERIAL	BERG'S ® NAME	BELT
3V	5/8"	Die Cast Zinc Alloy	Pow-R-Vee®	Operates with Pow-R-Vee 3V Series (3/8"W X 11/32"D)

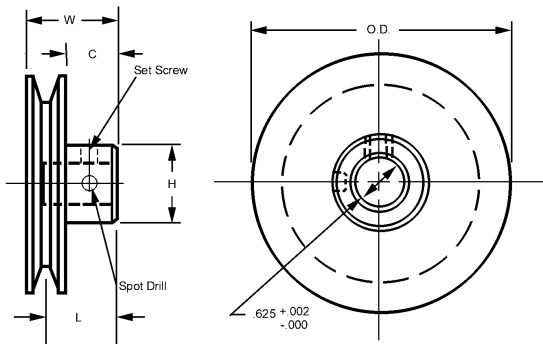

STOCK NO.	O.D. ± 5/64	W	C	L	H
V3-200-5	2				1
V3-250-5	2 1/2				1 1/8
V3-300-5	3	1	1/2	7/8	1 1/8
V3-350-5	3 1/2				1 1/8
V3-400-5	4				1 1/8

All pulleys have set screws supplied.
Other bore sizes and keyways are available upon request.



V-BELT PULLEYS

SERIES	BORE	MATERIAL	BERG'S ® NAME	BELT
4V	3/8"	Die Cast Zinc Alloy	Pow-R-Vee®	Operates with Pow-R-Vee 4V Series (1/2"W X 13/32"D)

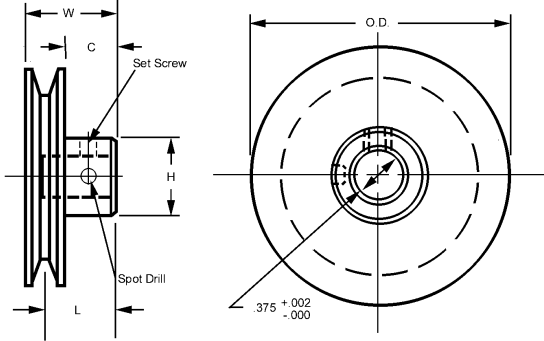

STOCK NO.	O.D. ± 5/64	W	C	L	H
V4-150-3	1 1/2				7/8
V4-175-3	1 3/4				1 1/16
V4-200-3	2	1-1/8	1/2	1	1 1/8
V4-225-3	2 1/4				1 1/8
V4-250-3	2 1/2				1 1/8

All pulleys have set screws supplied.
Other bore sizes and keyways are available upon request.

SERIES	BORE	MATERIAL	BERG'S ® NAME	BELT
4V	1/2"	Die Cast Zinc Alloy	Pow-R-Vee®	Operates with Pow-R-Vee 4V Series (1/2"W X 13/32"D)

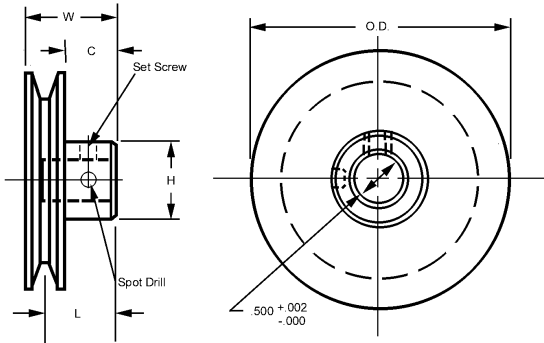

STOCK NO.	O.D. ± 5/64	W	C	L	H
V4-150-4	1 1/2	1 1/8	1/2	1	7/8
V4-175-4	1 3/4	1 1/8	1/2	1	1 1/16
V4-200-4	2	1 1/8	1/2	1	1 1/8
V4-225-4	2 1/4	1 1/8	1/2	1	1 1/8
V4-250-4	2 1/2	1 1/8	1/2	1	1 1/8
V4-300-4	3	1 1/8	1/2	1 1/8	1 1/4
V4-325-4	3 1/4	1 3/16	1/2	1 1/8	1 1/4
V4-350-4	3 1/2	1 1/4	5/8	1 1/8	1 1/4
V4-400-4	4	1 1/4	5/8	1 1/8	1 1/4
V4-500-4	5	1 3/8	7/8	1 3/16	1 9/16
V4-600-4	6	1 1/2	7/8	1 5/16	1 9/16
V4-700-4	7	1 1/2	7/8	1 5/16	1 9/16
V4-800-4	8	1 1/2	7/8	1 11/32	1 3/8
V4-900-4	9	1 1/2	13/16	1 11/32	2 1/16
V4-1000-4	10	1 1/2	13/16	1 11/32	2 1/16

All pulleys have set screws supplied.
Other bore sizes and keyways are available upon request.

SERIES	BORE	MATERIAL	BERG'S ® NAME	BELT
4V	5/8"	Die Cast Zinc Alloy	Pow-R-Vee®	Operates with Pow-R-Vee 4V Belt Series (1/2"W X 13/32"D)

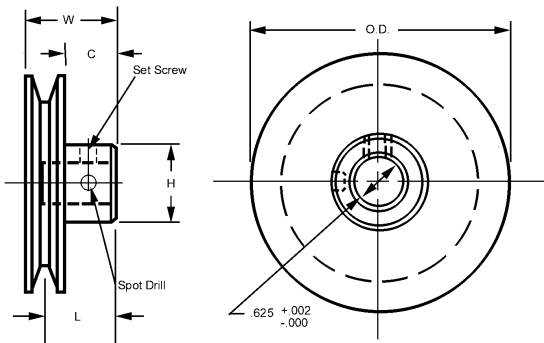

STOCK NO.	O.D. ± 5/64	W	C	L	H
V4-175-5	1-3/4	1 1/8	1/2	1	1 1/16
V4-200-5	2•	1 1/8	1/2	1	1 1/8
V4-225-5	2 1/4•	1 1/8	1/2	1	1 1/8
V4-250-5	2 1/2•	1 1/8	1/2	1	1 1/8
V4-300-5	3•	1 1/8	1/2	1 1/8	1 1/4
V4-325-5	3 1/4•	1 3/16	1/2	1 1/8	1 1/4
V4-350-5	3 1/2•	1 1/4	5/8	1 1/8	1 1/4
V4-400-5	4•	1 1/4	5/8	1 1/8	1 1/4
V4-500-5	5•	1 3/8	7/8	1 3/16	1 9/16
V4-600-5	6•	1 1/2	7/8	1 5/16	1 9/16
V4-700-5	7•	1 1/2	7/8	1 5/16	1 9/16
V4-800-5	8•	1 1/2	7/8	1 11/32	1 3/8
V4-900-5	9•	1 1/2	13/16	1 11/32	2 1/16
V4-1000-5	10•	1 1/2	13/16	1 11/32	2 1/16

• Keyway Supplied 3/16" - 3/32"
All pulleys have set screws supplied.
Other bore sizes and keyways are available upon request.

V-BELTS

SERIES	WIDTH	HEIGHT	MATERIAL	BERG'S ® NAME	PULLEY
5V	21/32"	1/2"	Polyurethane (Yellow) with 5/64" Dia. Stainless Steel Cable	POW-R-VEE®	Operates with Pow-R-Vee 5V Series

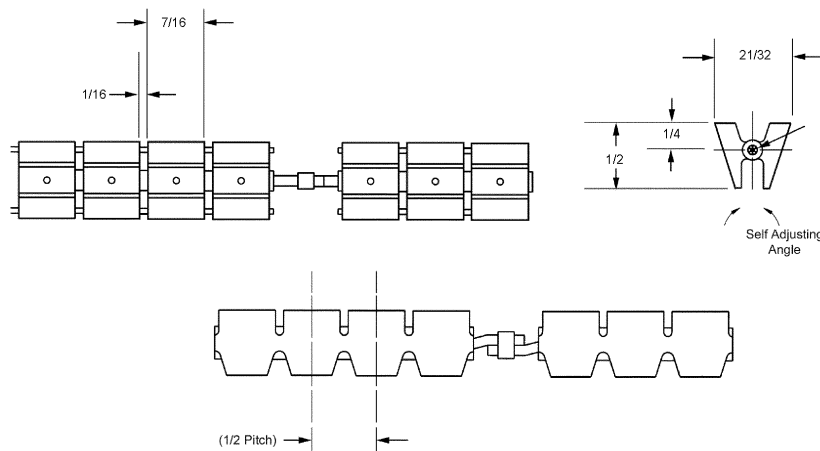

- More sidewall contact
- Less slippage
- Greater power transmission
- Infinite length variations
- Extra strong
- Silent drive
- 90A Durometer
- Weight 1.1 oz./ft.
- Ultimate Tensile Strength 350 lbs.
- Temperature Range +180°F to -15°F
- Recommended Operating Load 85 lbs.
- Recommended Max. Operating Speed 376 ft./min.
- For Field Splice Kit Order 5V-7.



STOCK NO.	LENGTH (Ref.)
5V-15	7.50
5V-16	8.00
5V-17	8.50
5V-18	9.00
5V-19	9.50
5V-20	10.00
5V-21	10.50
5V-22	11.00
5V-23	11.50
5V-24	12.00
5V-25	12.50
5V-26	13.00
5V-27	13.50
5V-28	14.00
5V-29	14.50
5V-30	15.00
5V-31	15.50
5V-32	16.00
5V-33	16.50
5V-34	17.00
5V-35	17.50
5V-36	18.00
5V-37	18.50
5V-38	19.00
5V-39	19.50
5V-40	20.00
5V-41	20.50
5V-42	21.00
5V-43	21.50
5V-44	22.00
5V-45	22.50
5V-46	23.00
5V-47	23.50
5V-48	24.00
5V-49	24.50
5V-50	25.00
5V-51	25.50
5V-52	26.00
5V-53	26.50
5V-54	27.00
5V-55	27.50
5V-56	28.00
5V-57	28.50
5V-58	29.00
5V-59	29.50
5V-60	30.00
5V-61	30.50
5V-62	31.00
5V-63	31.50
5V-64	32.00
5V-65	32.50
5V-66	33.00
5V-67	33.50
5V-68	34.00
5V-69	34.50
5V-70	35.00
5V-72	36.00
5V-74	37.00
5V-76	38.00
5V-78	39.00
5V-80	40.00
5V-82	41.00
5V-84	42.00
5V-86	43.00
5V-88	44.00
5V-90	45.00
5V-92	46.00
5V-96	48.00

BULK FOOTAGE NOT SPLICED	
STOCK NO.	LENGTH
5V-5FT	5 Feet
5V-10FT	10 Feet
5V-25FT	25 Feet
5V-50FT	50 Feet
5V-100FT	100 Feet

V-BELT PULLEYS

SERIES	BORE	MATERIAL	BERG'S® NAME	BELT
5V	1/2"	Die Cast Zinc Alloy	Pow-R-Vee®	Operates with Pow-R-Vee 5V Series (21/32"W X 1/2"D)

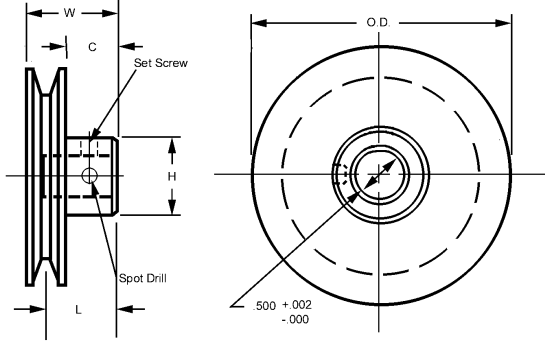

STOCK NO.	O.D. ± 5/64	W	C	L	H
V5-200-4	2	1 1/4	1/2	1 1/8	1 1/8
V5-225-4	2 1/4	1 1/4	3/8	1	1 1/8
V5-250-4	2 1/2	1 1/4	3/8	1	1 1/4
V5-275-4	2 3/4	1 1/4	1/2	1	1 1/4
V5-300-4	3	1 7/16	5/8	1 1/8	1 1/4
V5-325-4	3 1/4	1 1/4	1/2	1 1/8	1 1/4
V5-350-4	3 1/2	1 3/8	5/8	1 1/8	1 1/4
V5-400-4	4	1 3/8	5/8	1 1/8	1 5/16
V5-450-4	4 1/2	1 3/8	5/8	1 1/8	1 5/16
V5-500-4	5	1 9/16	3/4	1 5/16	1 3/8
V5-600-4	6	1 5/8	3/4	1 3/8	2 1/16

All pulleys have set screws supplied.
Other bore sizes and keyways are available upon request.

SERIES	BORE	MATERIAL	BERG'S® NAME	BELT
5V	5/8"	Die Cast Zinc Alloy	Pow-R-Vee®	Operates with Pow-R-Vee 5V Series (21/32"W X 1/2"D)

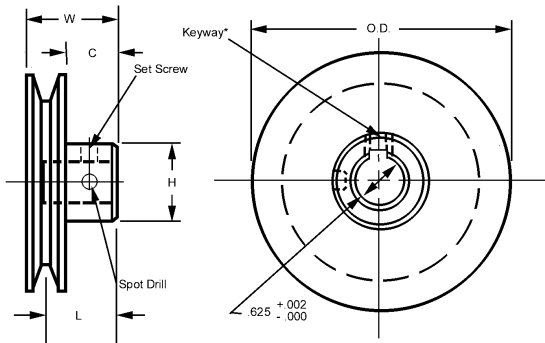

STOCK NO.	O.D. ± 5/64	W	C	L	H
V5-200-5	2	1 1/4	1/2	1 1/8	1 1/8
V5-225-5	2 1/4	1 1/4	3/8	1	1 1/8
V5-250-5	2 1/2	1 1/4	3/8	1	1 1/4
V5-275-5	2 3/4	1 1/4	1/2	1	1 1/4
V5-300-5	3	1 7/16	5/8	1 1/8	1 1/4
V5-325-5	3 1/4	1 1/4	1/2	1 1/8	1 1/4
V5-350-5	3 1/2	1 3/8	5/8	1 1/8	1 1/4
V5-500-5	4	1 3/8	5/8	1 1/8	1 5/16
V5-550-5	4 1/2	1 3/8	5/8	1 1/8	1 5/16
V5-500-5	5	1 9/16	3/4	1 5/16	1 3/8
V5-600-5	6	1 5/8	3/4	1 3/8	2 1/16

*5/8" Bore Pulleys have a 3/16 x 3/32 keyway.
All pulleys have set screws supplied.
Other bore sizes and keyways are available upon request.



V-BELT PULLEYS

SERIES	BORE	MATERIAL	BERG'S® NAME	BELT
5V	3/4"	Die Cast Zinc Alloy	Pow-R-Vee®	Operates with Pow-R-Vee 5V Series (21/32"W X 1/2"D)

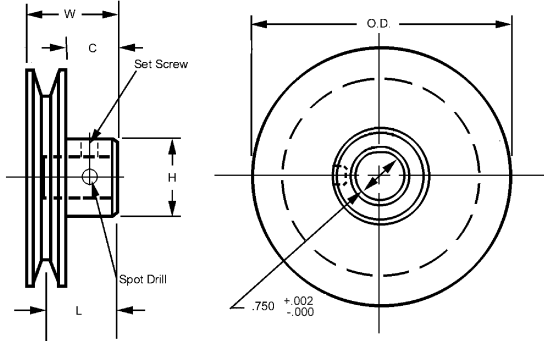

STOCK NO.	O.D. ± 5/64	W	C	L	H
V5-225-6	2 1/4	1 1/4	3/8	1	1 1/8
V5-250-6	2 1/2	1 1/4	3/8	1	1 1/4
V5-275-6	2 3/4	1 1/4	1/2	1	1 1/4
V5-300-6	3	1 7/16	5/8	1 1/8	1 1/4
V5-325-6	3 1/4	1 1/4	1/2	1 1/8	1 1/4
V5-350-6	3 1/2	1 3/8	5/8	1 1/8	1 1/4
V5-400-6	4	1 3/8	5/8	1 1/8	1 5/16
V5-650-6	4 1/2	1 3/8	5/8	1 1/8	1 5/16
V5-500-6	5	1 9/16	3/4	1 5/16	1 3/8
V5-600-6	6	1 5/8	3/4	1 3/8	2 1/16

* 3/4" Bore Pulleys have a 3/16 x 3/32 keyway.
 All pulleys have set screws supplied.
 Other bore sizes and keyways are available upon request.

SERIES	BORE	MATERIAL	BERG'S® NAME	BELT
5V	1"	Die Cast Zinc Alloy	Pow-R-Vee®	Operates with Pow-R-Vee 5V Series (21/32"W X 1/2"D)

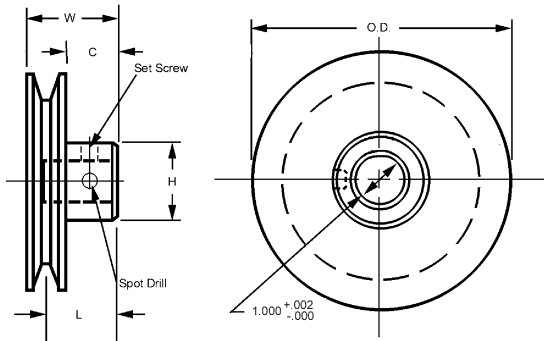

STOCK NO.	O.D. ± 5/64	W	C	L	H
V5-500-8	5	1 9/16	3/4	1 5/16	1 3/8
V5-600-8	6	1 5/8	3/4	1 3/8	2 1/16

*1" Bore Pulleys have a 1/4 X 1/8 keyway.
 All pulleys have set screws supplied.
 Other bore sizes and keyways are available upon request.



FIELD SPLICE KITS

Splicing Procedures

1. Cut BERG "Pow-R-Vee" sharp and square as shown, using cutter, to desired number of blocks, plus one block.



2. Cut plastic jacket lightly with sharp razor blade close to block as shown all around. **Caution:** Do not cut or nick cable. Strip or twist off block carefully.

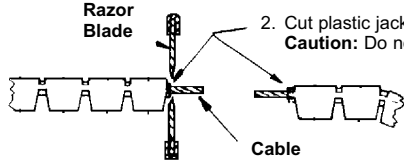

3. Slide stripped cable into oval splice bushing carefully. **Caution:** Do not fray cable. Feed cable into chamfered end of bushing last.

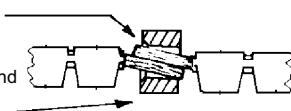

5. Position crimp tool over splice bushing and squeeze tightly for maximum splice strength.

4. Center bushing and be certain belt is straight before crimping.

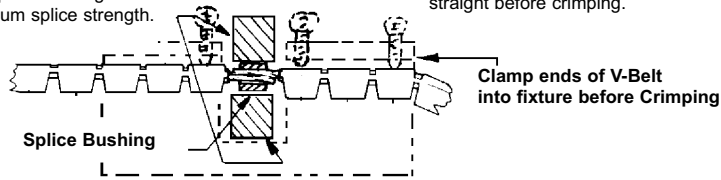

Cable Cutter



Crimp Tool

BELT SERIES	STOCK NUMBER	FIELD SPLICE KIT AND ACCESSORIES
2V 3V 4V 5V	2V-7 3V-7 4V-7 5V-7	Complete Kit Consists of: Crimp Tool, Crimp Fixture, Sample Belt Cable Cutter, Bushings, Razor Blades & Instructions
	TL-3 TL-3 TL-6	Crimp Tool for 2V Crimp Tool for 3V Crimp Tool for 4V AND 5V
	BU-032-S BU-046-S BU-062-C BU-078-S	Extra Splice Bushings for: 2V (1/32" Dia. Cable) 3V (3/64" Dia. Cable) 4V (1/16" Dia. Cable) 5V (5/64" Dia. Cable)
	TL-1 TL-2	Cable Cutter for up to 3/64" Cable Cable Cutter for up to 5/64" Cable

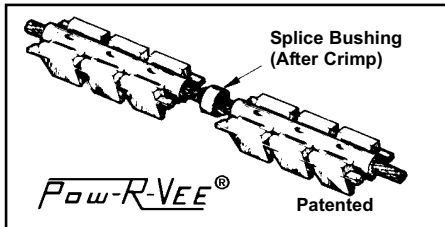

Field Splices offer only 50% of Catalog Rated Loads

W. M. Berg, Inc. will factory splice to order any length belt at a nominal charge.



O RING CORD

TYPE	MATERIAL	TEMPERATURE RANGE
Heat Spliceable	Extruded Polyurethane 83A	-40° to +180°

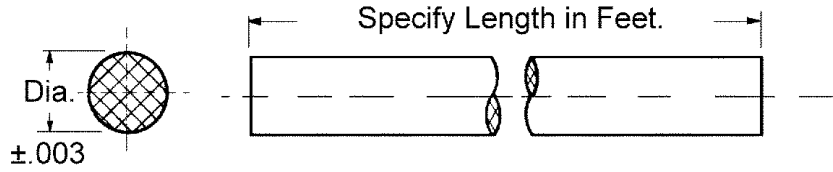

STOCK NO.	DIAMETER (ACTUAL)	FRACTIONAL SIZE
STS-C-1/FT	.062	1/16
STS-C-2/FT	.070	1/16
STS-C-3/FT	.103	3/32
STS-C-4/FT	.125	1/8
STS-C-6/FT	.187	3/16
STS-C-7/FT	.210	3/16
STS-C-9/FT	.250	1/4
STS-C-11/FT	.312	5/16
STS-C-12/FT	.375	3/8



Heat seal within temperatures from 525°F to 575°F.
Splices into endless belts with Berg's heat splice tool Berg P/N STS-U-5
Special O Rings spliced at a nominal charge.

NOTE: To order specific number and footage see below.

Example: STS-C-2/###Ft.

V-BELT CORD

TYPE	MATERIAL	TEMPERATURE RANGE
Heat Spliceable	Extruded Polyurethane 83A	-40° to +180°

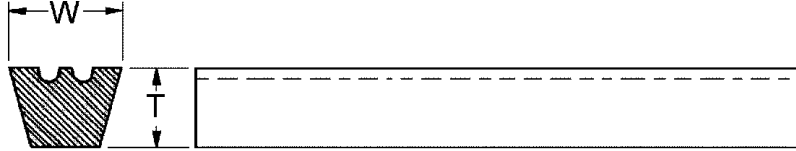

STOCK NO.	STANDARD BELT SIZE	W	T	USE WITH PULLEY SERIES
STS-V-1/FT	3L	3/8	7/32	V3-
STS-V-2/FT	A	1/2	5/16	V4-
STS-V-3/FT	B	21/32	13/32	V5-
STS-V-4/FT	C	7/8	17/32	-

- Coreless
- Ideal for odd sizes

Splice to suit. Order Berg heat splice tool Berg P/N STS-U-5. For a nominal charge, we will splice belting to your specific requirements.

Sold in 5, 10, 25 and 50 foot reels.

NOTE: To order specific number and footage see below.

Example: STS-V-2/###Ft.

Stock No. Be certain to indicate footage after / (slash) when ordering.

O RING BELTS - 70A DUROMETER

DIAMETER	MATERIAL	TEMPERATURE RANGE
3/64" (Cross Section)	ELASTOMER COMPOUND BUNA-N	-40° to +180°

- Low break-away friction
- No extrusion
- Higher temperature resistance
- No back up rings required
- Low permanent set
- No cold flow
- No special tool required
- STS-70 series stretch is 15% of belt length for proper tension.

STOCK NO.	NOMINAL SIZES			ACTUAL SIZES		
	D	I.D.	O.D.	D	I.D.	I.D. TOL.
STS-70-101	3/64	1/32	7/64	.040	.029	±.004
STS-70-102		3/64	9/64	.050 ±.003	.042	

DIAMETER	MATERIAL	TEMPERATURE RANGE	PULLEY
1/16" (Cross Section)	ELASTOMER COMPOUND BUNA-N	-40° to +180°	Operates with Grooved Pulley PG1 Series.

- Low break-away friction
- No extrusion
- Higher temperature resistance
- No back up rings required
- Low permanent set
- No cold flow
- No special tool required
- STS-70 series stretch is 15% of belt length for proper tension.

* Use in systems with variable center distance.

STOCK NO.	NOMINAL SIZES			ACTUAL SIZES					
	D	I.D.	O.D.	D	I.D.	I.D. TOL.			
STS-70-203	1/16	1/16	11/64	.060 ±.003	.056	±.004			
STS-70-204	1/16	5/64	7/32	.070 ±.003	.070	±.005			
STS-70-205		3/32	15/64		.101				
STS-70-207		5/32	9/32		.145				
STS-70-208		3/16	5/16		.176				
STS-70-209		7/32	11/32		.208				
STS-70-210		1/4	3/8		.239				
STS-70-211		5/16	7/16		.301				
STS-70-212		3/8	1/2		.364				
STS-70-213		7/16	9/16		.426				
STS-70-214		1/2	5/8		.489				
STS-70-215		9/16	11/16		.551				
STS-70-216		5/8	3/4		.614				
STS-70-217		11/16	13/16		.676				
STS-70-218		3/4	7/8		.739				
STS-70-219	1/16	13/16	15/16	.070 ±.003	.801	±.006			
STS-70-220		7/8	1		.864				
STS-70-221		15/16	1 1/16		.962				
STS-90-222		1	1 1/8		.989				
STS-70-224		1 1/8	1 1/4		1.114				
STS-70-225		1 3/16	1 5/16		1.176				
STS-70-226		1 1/4	1 3/8		1.239				
STS-70-228		1 3/8	1 1/2		1.364				
STS-70-229	1/16	1 1/2	1 5/8	.070 ±.003	1.489	±.010			
STS-70-230		1 5/8	1 3/4		1.614				
STS-70-231		1 3/4	1 7/8		1.739				
STS-70-233		2	2 1/8		1.989				
STS-70-234		2 1/8	2 1/4		2.114				
STS-70-235		2 1/4	2 3/8		2.239				
STS-70-236		2 3/8	2 1/2		2.364				
STS-70-237		2 1/2	2 5/8		2.489				
STS-70-238		2 5/8	2 3/4		2.614				
STS-70-239		2 3/4	2 7/8		2.739				
STS-70-240		2 7/8	3		2.864				
STS-70-241		3	3 1/8		2.989				
STS-70-242		1/16	3 1/4		3 3/8		.070 ±.003	3.239	±.015
STS-70-243			3 1/2		3 5/8			3.489	
STS-70-244	3 3/4		3 7/8	3.739					
STS-70-245	4		4 1/8	3.989					

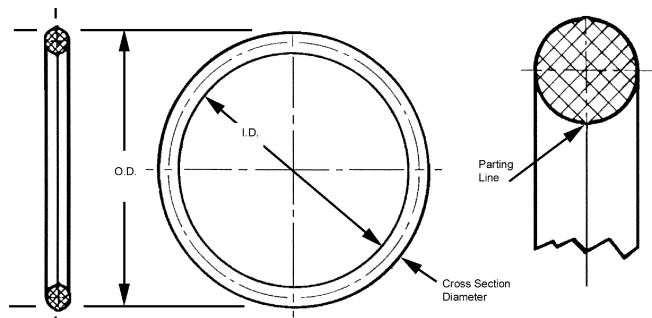

O RING BELTS - 70A DUROMETER

DIAMETER	MATERIAL	TEMPERATURE RANGE	PULLEY
3/32" (Cross Section)	ELASTOMER COMPOUND BUNA-N	-40° to +180°	Operates with Grooved Pulley PG2 Series.

- Low break-away friction
- No extrusion
- Higher temperature resistance
- No back up rings required
- Low permanent set
- No cold flow
- No special tool required
- STS-70 series stretch is 15% of belt length for proper tension.

* Use in systems with variable center distance.

STOCK NO.	NOMINAL SIZES			ACTUAL SIZES		
	D	I.D.	O.D.	D	I.D.	I.D. TOL.
STS-70-310 STS-70-311 STS-70-312	3/32	3/8 7/16 1/2	9/16 5/8 11/16	.103 ±.003	.362 .424 .487	±.005
STS-70-313 STS-70-315 STS-70-317 STS-70-318 STS-70-319 STS-70-321 STS-70-322 STS-70-323 STS-70-324 STS-70-325 STS-70-326 STS-70-328	3/32	9/16 11/16 13/16 7/8 15/16 1 1/16 1 1/8 1 3/16 1 1/4 1 5/16 1 3/8 1 1/2	3/4 7/8 1 1 1/16 1 1/8 1 1/4 1 5/16 1 3/8 1 7/16 1 1/2 1 9/16 1 11/16	.103 ±.003	.549 .674 .799 .862 .924 1.049 1.112 1.174 1.237 1.299 1.362 1.487	±.006
STS-70-329 STS-70-330 STS-70-332 STS-70-334 STS-70-340 STS-70-341 STS-70-344 STS-70-346 STS-70-347	3/32	1 9/16 1 5/8 1 3/4 1 7/8 2 1/4 2 5/16 2 1/2 2 5/8 2 11/16	1 3/4 1 13/16 1 15/16 2 1/16 2 7/16 2 1/2 2 11/16 2 13/16 2 7/8	.103 ±.003	1.549 1.612 1.737 1.862 2.237 2.300 2.487 2.612 2.675	±.010
STS-70-348 STS-70-349 STS-70-350 STS-70-351 STS-70-352 STS-70-353 STS-70-354 STS-70-355 STS-70-356 STS-70-357 STS-70-358 STS-70-359 STS-70-360 STS-70-361	3/32	2 3/4 2 13/16 2 7/8 3 3 1/4 3 1/2 3 3/4 4 4 1/4 4 1/2 4 3/4 5 5 1/4 5 1/2	2 15/16 3 3 1/16 3 3/16 3 7/16 3 11/16 3 15/16 4 3/16 4 7/16 4 11/16 4 15/16 5 3/16 5 7/16 5 11/16	.103 ±.003	2.737 2.800 2.862 2.987 3.237 3.487 3.737 3.987 4.237 4.487 4.737 4.987 5.237 5.487	±.015
STS-70-362 STS-70-363	3/32	5 3/4 6	5 15/16 6 3/16		5.737 5.987	±.023

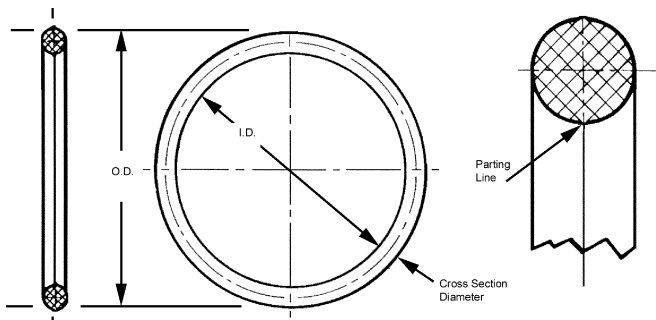

O RING BELTS - 70A DUROMETER

DIAMETER	MATERIAL	TEMPERATURE RANGE	PULLEY
1/8" (Cross Section)	ELASTOMER COMPOUND BUNA-N	-40° to +180°	Operates with Grooved Pulley PG3 Series.

- Low break-away friction
- No extrusion
- Higher temperature resistance
- No back up rings required
- Low permanent set
- No cold flow
- No special tool required
- STS-70 series stretch is 15% of belt length for proper tension.

* Use in systems with variable center distance.

STOCK NO.	NOMINAL SIZES			ACTUAL SIZES		
	D	I.D.	O.D.	D	I.D.	I.D. TOL.
STS-70-410	1/8	3/4	1	.139 ±.004	.734	±.006
STS-70-411		13/16	1 1/16		.796	
STS-70-412		7/8	1 1/8		.859	
STS-70-414		1	1 1/4		.984	
STS-70-415		1 1/16	1 5/16		1.046	
STS-70-417		1 3/16	1 7/16		1.171	
STS-70-418		1 1/4	1 1/2		1.234	
STS-70-419		1 5/16	1 9/16		1.296	
STS-70-420		1/8	1 3/8		1 5/8	
STS-70-421	1 7/16		1 11/16	1.421		
STS-70-422	1 1/2		1 3/4	1.484		
STS-70-423	1 5/8		1 7/8	1.609		
STS-70-424	1 3/4		2	1.737		
STS-70-425	1 7/8		2 1/8	1.859		
STS-70-426	2		2 1/4	1.984		
STS-70-427	2 1/8		2 3/8	2.109		
STS-70-428	2 1/4		2 1/2	2.234		
STS-70-429	2 3/8		2 5/8	2.359		
STS-70-430	2 1/2		2 3/4	2.484		
STS-70-431	2 5/8		2 7/8	2.609		
STS-70-432	2 3/4		3	2.734		
STS-70-433	1/8	2 7/8	3 1/8	.139 ±.004	2.859	±.015
STS-70-434		3	3 1/4		2.984	
STS-70-435		3 1/8	3 3/8		3.109	
STS-70-436		3 1/4	3 1/2		3.234	
STS-70-437		3 3/8	3 5/8		3.359	
STS-70-438		3 1/2	3 3/4		3.484	
STS-70-439		3 5/8	3 7/8		3.609	
STS-70-440		3 3/4	4		3.734	
STS-70-441		3 7/8	4 1/8		3.859	
STS-70-442	1/8	4	4 1/4	.139 ±.004	3.984	±.023
STS-70-444		4 1/4	4 1/2		4.234	
STS-70-445		4 3/8	4 5/8		4.359	
STS-70-446		4 1/2	4 3/4		4.484	
STS-70-448		4 3/4	5		4.734	
STS-70-449		4 7/8	5 1/8		4.859	
STS-70-450		5	5 1/4		4.984	
STS-70-452		5 1/4	5 1/2		5.234	
STS-70-454		5 1/2	5 3/4		5.484	
STS-70-456		5 3/4	6		5.734	
STS-70-458		6	6 1/4		5.984	
STS-70-459		6 1/4	6 1/2		6.234	
STS-70-460		6 1/2	6 3/4		6.484	
STS-70-462		7	7 1/4		6.984	
STS-70-464		1/8	7 1/2		7 3/4	
STS-70-465	7 3/4		8	7.734		
STS-70-466	8		8 1/4	7.984		
STS-70-468	8 1/2		8 3/4	8.484		
STS-70-470	9		9 1/4	8.984		
STS-70-471	9 1/4		9 1/2	9.234		
STS-70-472	9 1/2		9 3/4	9.484		
STS-70-474	10		10 1/4	9.984		
STS-70-475	10 1/2		10 3/4	10.484		
STS-70-476	11		11 1/4	10.984		
STS-70-477	11 1/2		11 3/4	11.484		
STS-70-478	12		12 1/4	11.984		
STS-70-479	13		13 1/4	12.984		
STS-70-480	14		14 1/4	13.984		
STS-70-481	15		15 1/4	14.984		

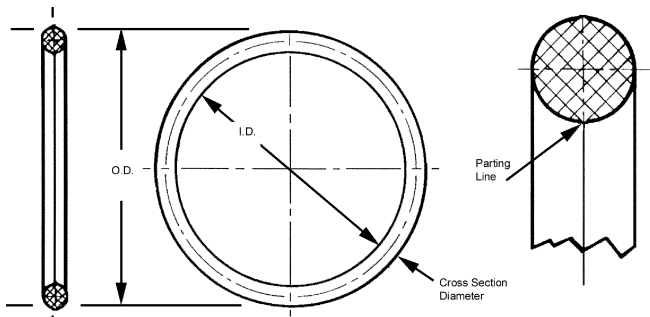

O RING BELTS - 70A DUROMETER

A

DIAMETER	MATERIAL	TEMPERATURE RANGE	PULLEY
3/16" (Cross Section)	ELASTOMER COMPOUND BUNA-N	-40° to +180°.	Operates with Grooved Pulley PG4 Series.

- Low break-away friction
- No extrusion
- Higher temperature resistance
- No back up rings required
- Low permanent set
- No cold flow
- No special tool required
- STS-70 series stretch is 15% of belt length for proper tension.

* Use in systems with variable center distance.

STOCK NO.	NOMINAL SIZES			ACTUAL SIZES		
	D	I.D.	O.D.	D	I.D.	I.D. TOL.
STS-70-525	3/16	1 1/2	1 7/8	.210 ±.005	1.475	±.010
STS-70-526		1 5/8	2		1.600	
STS-70-527		1 3/4	2 1/8		1.725	
STS-70-529		2	2 3/8		1.975	
STS-70-530		2 1/8	2 1/2		2.100	
STS-70-531		2 1/4	2 5/8		2.225	
STS-70-532		2 3/8	2 3/4		2.350	
STS-70-533		2 1/2	2 7/8		2.475	
STS-70-534	3/16	2 5/8	3	.210 ±.005	2.600	±.015
STS-70-535		2 3/4	3 1/8		2.750	
STS-70-537		3	3 3/8		2.975	
STS-70-539		3 1/4	3 5/8		3.225	
STS-70-541		3 1/2	3 7/8		3.475	
STS-70-542		3 5/8	4		3.600	
STS-70-543		3 3/4	4 1/8		3.725	
STS-70-545		4	4 3/8		3.975	
STS-70-547		4 1/4	4 5/8		4.225	
STS-70-549		4 1/2	4 7/8		4.475	

DIAMETER	MATERIAL	TEMPERATURE	PULLEY
1/4" (Cross Section)	ELASTOMER COMPOUND BUNA-N	-40° to +180°	Operates with Grooved Pulley PG5 Series.

- Low break-away friction
- No extrusion
- Higher temperature resistance
- No back up rings required
- Low permanent set
- No cold flow
- No special tool required
- STS-70 series stretch is 15% of belt length for proper tension.

* Use in systems with variable center distance.

STOCK NO.	NOMINAL SIZES			ACTUAL SIZES		
	D	I.D.	O.D.	D	I.D.	I.D. TOL.
STS-70-627	1/4	4 3/4	5 1/4	.275 ±.006	4.725	±.015
STS-70-631	1/4	5 1/4	5 3/4	.275 ±.006	5.225	±.023
STS-70-635		5 3/4	6 1/4		5.725	
STS-70-637		6	6 1/2		5.975	
STS-70-639		6 1/2	7		6.475	
STS-70-641	1/4	7	7 1/2	.275 ±.006	6.975	±.030
STS-70-645		8	8 1/2		7.975	
STS-70-646		8 1/2	9		8.475	
STS-70-647		9	9 1/2		8.975	
STS-70-648		9 1/2	10		9.475	
STS-70-649		10	10 1/2		9.975	
STS-70-650		10 1/2	11		10.475	
STS-70-653		12	12 1/2		11.975	
STS-70-655		13	13 1/2		12.975	
STS-70-657		14	14 1/2		13.975	
STS-70-659		15	15 1/2		14.975	

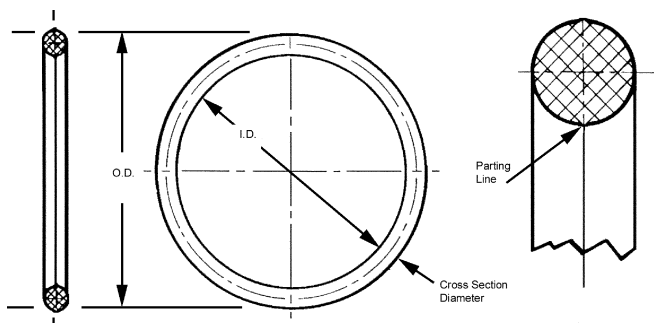

O RING BELTS - 70A DUROMETER

DIAMETER	MATERIAL	TEMPERATURE RANGE	PULLEY
1/8" (Cross Section)	NEOPRENE RUBBER 70A DUROMETER STRETCH BELTS	-40° to +250°	Operates with Grooved Pulley PG3 Series.

- Low break-away friction
- No extrusion
- Higher temperature resistance
- No back up rings required
- Low permanent set
- No cold flow
- No special tool required
- STS-70 series stretch is 15% of belt length for proper tension.

NOTE:
Ultimate Tensile Strength 2100 PSI
Minimum Pulley Dia. should be
4 x Belt Dia.

STOCK NO.	INSIDE CIRCUMFERENCE*
PP6-1	15.70
PP6-11	17.27
PP6-2	18.84
PP6-12	20.42
PP6-3	21.99
PP6-13	23.56
PP6-4	25.15
PP6-14	26.70
PP6-5	28.27
PP6-15	29.84
PP6-6	31.41
PP6-16	32.98
PP6-17	34.55
PP6-18	37.69
PP6-19	40.84

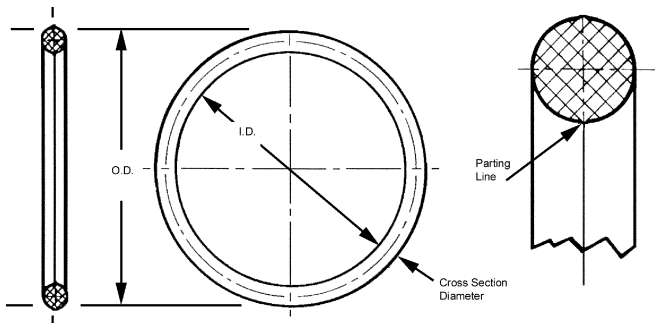

O RING BELTS - 90A DUROMETER

A

DIAMETER	MATERIAL	TEMPERATURE RANGE	PULLEY
3/64" (Cross Section)	ELASTOMER COMPOUND BUNA-N	-40° to +180°	Operates with Grooved Pulley PG1 Series.

- Low break-away friction
- No extrusion
- Higher temperature resistance
- No back up rings required
- Low permanent set
- No cold flow
- No special tool required
- STS-90 series stretch is 7% of belt length for proper tension.

STOCK NO.	NOMINAL SIZES			ACTUAL SIZES		
	D	I.D.	O.D.	D	I.D.	I.D. TOL.
STS-90-101	3/64	1/32	7/64	.040	.029	±.004
STS-90-102	3/64	3/64	9/64	.050 ±.003	.042	

DIAMETER	MATERIAL	TEMPERATURE RANGE	PULLEY
1/16" (Cross Section)	ELASTOMER COMPOUND BUNA-N	-40° to +180°	Operates with Grooved Pulley PG1 Series.

- Low break-away friction
- No extrusion
- Higher temperature resistance
- No back up rings required
- Low permanent set
- No cold flow
- No special tool required
- STS-90 series stretch is 7% of belt length for proper tension.

* Use in systems with variable center distance.

STOCK NO.	NOMINAL SIZES			ACTUAL SIZES		
	D	I.D.	O.D.	D	I.D.	I.D. TOL.
STS-70-203	1/16	1/16	11/64	.060 ±.003	.056	±.004
STS-90-204	1/16	5/64	7/32	.070 ±.003	.070	±.005
STS-90-205		3/32	15/64		.101	
STS-90-207		5/32	9/32		.145	
STS-90-208		3/16	5/16		.176	
STS-90-209		7/32	11/32		.208	
STS-90-210		1/4	3/8		.239	
STS-90-211		5/16	7/16		.301	
STS-90-212		3/8	1/2		.364	
STS-90-213		7/16	9/16		.426	
STS-90-214		1/2	5/8		.489	
STS-90-215		9/16	11/16		.551	
STS-90-216		5/8	3/4		.614	
STS-90-217		11/16	13/16		.676	
STS-90-218		3/4	7/8		.739	
STS-90-219	1/16	13/16	15/16	.070 ±.003	.801	±.006
STS-90-220		7/8	1		.864	
STS-90-221		15/16	1 1/16		.962	
STS-90-222		1	1 1/8		.989	
STS-90-224		1 1/8	1 1/4		1.114	
STS-90-225		1 3/16	1 5/16		1.176	
STS-90-226		1 1/4	1 3/8		1.239	
STS-90-228		1 3/8	1 1/2		1.364	
STS-90-229	1/16	1 1/2	1 5/8	.070 ±.003	1.489	±.010
STS-90-230		1 5/8	1 3/4		1.614	
STS-90-231		1 3/4	1 7/8		1.739	
STS-90-233		2	2 1/8		1.989	
STS-90-234		2 1/8	2 1/4		2.114	
STS-90-235		2 1/4	2 3/8		2.239	
STS-90-236		2 3/8	2 1/2		2.364	
STS-90-237		2 1/2	2 5/8		2.489	
STS-90-238		2 5/8	2 3/4		2.614	
STS-90-239		2 3/4	2 7/8		2.739	
STS-90-240		2 7/8	3		2.864	
STS-90-241		3	3 1/8		2.989	
STS-90-242	1/16	3 1/4	3 3/8	.070 ±.003	3.239	±.015
STS-90-243		3 1/2	3 5/8		3.489	
STS-90-244		3 3/4	3 7/8		3.739	
STS-90-245		4	4 1/8		3.989	

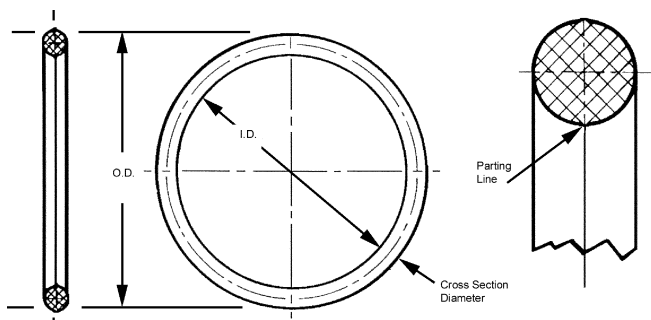

O RING BELTS - 90A DUROMETER

DIAMETER	MATERIAL	TEMPERATURE RANGE	PULLEY
3/32" (Cross Section)	ELASTOMER COMPOUND BUNA-N	-40° to +180°	Operates with Grooved Pulley PG2 Series.

- Low break-away friction
 - No extrusion
 - Higher temperature resistance
 - No back up rings required
 - Low permanent set
 - No cold flow
 - No special tool required
 - STS-90 series stretch is 7% of belt length for proper tension.
- * Use in systems with variable center distance.

STOCK NO.	NOMINAL SIZES			ACTUAL SIZES		
	D	I.D.	O.D.	D	I.D.	I.D. TOL.
STS-90-310	3/32	3/8	9/16	.103 ±.003	.362	±.005
STS-90-311		7/16	5/8		.424	
STS-90-312		1/2	11/16		.487	
STS-90-313	3/32	9/16	3/4	.103 ±.003	.549	±.006
STS-90-315		11/16	7/8		.674	
STS-90-317		13/16	1		.799	
STS-90-318		7/8	1 1/16		.862	
STS-90-319		15/16	1 1/8		.924	
STS-90-321		1 1/16	1 1/4		1.049	
STS-90-322		1 1/8	1 5/16		1.112	
STS-90-323		1 3/16	1 3/8		1.174	
STS-90-324		1 1/4	1 7/16		1.237	
STS-90-325		1 5/16	1 1/2		1.299	
STS-90-326		1 3/8	1 9/16		1.362	
STS-90-328		1 1/2	1 11/16		1.487	
STS-90-329	3/32	1 9/16	1 3/4	.103 ±.003	1.549	±.010
STS-90-330		1 5/8	1 13/16		1.612	
STS-90-332		1 3/4	1 15/16		1.737	
STS-90-334		1 7/8	2 1/16		1.862	
STS-90-340		2 1/4	2 7/16		2.237	
STS-90-341		2 5/16	2 1/2		2.300	
STS-90-344		2 1/2	2 11/16		2.487	
STS-90-346		2 5/8	2 13/16		2.612	
STS-90-347	2 11/16	2 7/8	2.675			
STS-90-348	3/32	2 3/4	2 15/16	.103 ±.003	2.737	±.015
STS-90-349		2 13/16	3		2.800	
STS-90-350		2 7/8	3 1/16		2.862	
STS-90-351		3	3 3/16		2.987	
STS-90-352		3 1/4	3 7/16		3.237	
STS-90-353		3 1/2	3 11/16		3.487	
STS-90-354		3 3/4	3 15/16		3.737	
STS-90-355		4	4 3/16		3.987	
STS-90-356		4 1/4	4 7/16		4.237	
STS-90-357		4 1/2	4 11/16		4.487	
STS-90-358	4 3/4	4 15/16	4.737			
STS-90-359	5	5 3/16	4.987			
STS-90-360	5 1/4	5 7/16	5.237			
STS-90-361	5 1/2	5 11/16	5.487			
STS-90-362	3/32	5 3/4	5 15/16	.103 ±.003	5.737	±.023
STS-90-363		6	6 3/16		5.987	

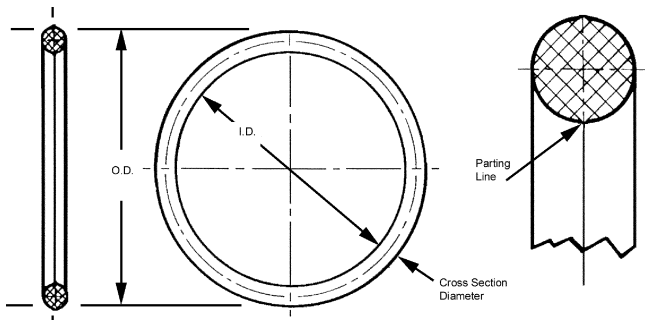

O RING BELTS - 90A DUROMETER

DIAMETER	MATERIAL	TEMPERATURE RANGE	PULLEY
1/8" (Cross Section)	ELASTOMER COMPOUND BUNA-N	-40° to +180°	Operates with Grooved Pulley PG3 Series.

- Low break-away friction
- No extrusion
- Higher temperature resistance
- No back up rings required
- Low permanent set
- No cold flow
- No special tool required
- STS-90 series stretch is 7% of belt length for proper tension.

* Use in systems with variable center distance.

STOCK NO.	NOMINAL SIZES			ACTUAL SIZES		
	D	I.D.	O.D.	D	I.D.	I.D. TOL.
STS-90-410	1/8	3/4	1	.139 ±.004	.734	±.006
STS-90-411		13/16	1 1/16		.796	
STS-90-412		7/8	1 1/8		.859	
STS-90-414		1	1 1/4		.984	
STS-90-415		1 1/16	1 5/16		1.046	
STS-90-417		1 3/16	1 7/16		1.171	
STS-90-418		1 1/4	1 1/2		1.234	
STS-90-419		1 5/16	1 9/16		1.296	
STS-90-420		1/8	1 3/8		1 5/8	
STS-90-421	1 7/16		1 11/16	1.421		
STS-90-422	1 1/2		1 3/4	1.484		
STS-90-423	1 5/8		1 7/8	1.609		
STS-90-424	1 3/4		2	1.737		
STS-90-425	1 7/8		2 1/8	1.859		
STS-90-426	2		2 1/4	1.984		
STS-90-427	2 1/8		2 3/8	2.109		
STS-90-428	2 1/4		2 1/2	2.234		
STS-90-429	2 3/8		2 5/8	2.359		
STS-90-430	2 1/2		2 3/4	2.484		
STS-90-431	2 5/8		2 7/8	2.609		
STS-90-432	2 3/4		3	2.734		
STS-90-433	1/8	2 7/8	3 1/8	.139 ±.004	2.859	±.015
STS-90-434		3	3 1/4		2.984	
STS-90-435		3 1/8	3 3/8		3.109	
STS-90-436		3 1/4	3 1/2		3.234	
STS-90-437		3 3/8	3 5/8		3.359	
STS-90-438		3 1/2	3 3/4		3.484	
STS-90-439		3 5/8	3 7/8		3.609	
STS-90-440		3 3/4	4		3.734	
STS-90-441		3 7/8	4 1/8		3.859	
STS-90-442	1/8	4	4 1/4	.139 ±.004	3.984	±.023
STS-90-444		4 1/4	4 1/2		4.234	
STS-90-445		4 3/8	4 5/8		4.359	
STS-90-446		4 1/2	4 3/4		4.484	
STS-90-448		4 3/4	5		4.734	
STS-90-449		4 7/8	5 1/8		4.859	
STS-90-450		5	5 1/4		4.984	
STS-90-452		5 1/4	5 1/2		5.234	
STS-90-454		5 1/2	5 3/4		5.484	
STS-90-456		5 3/4	6		5.734	
STS-90-458		6	6 1/4		5.984	
STS-90-459		6 1/4	6 1/2		6.234	
STS-90-460		6 1/2	6 3/4		6.484	
STS-90-462		7	7 1/4		6.984	
STS-90-464		1/8	7 1/2		7 3/4	
STS-90-465	7 3/4		8	7.734		
STS-90-466	8		8 1/4	7.984		
STS-90-468	8 1/2		8 3/4	8.484		
STS-90-470	9		9 1/4	8.984		
STS-90-471	9 1/4		9 1/2	9.234		
STS-90-472	9 1/2		9 3/4	9.484		
STS-90-474	10		10 1/4	9.984		
STS-90-475	10 1/2		10 3/4	10.484		
STS-90-476	11		11 1/4	10.984		
STS-90-477	11 1/2		11 3/4	11.484		
STS-90-478	12		12 1/4	11.984		
STS-90-479	13		13 1/4	12.984		
STS-90-480	14		14 1/4	13.984		
STS-90-481	15		15 1/4	14.984		

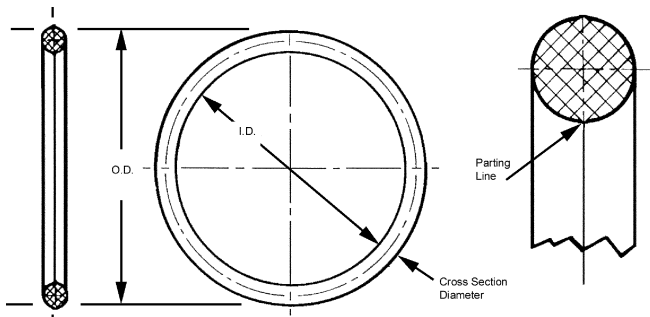

O RING BELTS - 90A DUROMETER

DIAMETER	MATERIAL	TEMPERATURE RANGE	PULLEY
3/16" (Cross Section)	ELASTOMER COMPOUND BUNA-N	-40° to +180°	Operates with Grooved Pulley PG4 Series.

- Low break-away friction
- No extrusion
- Higher temperature resistance
- No back up rings required
- Low permanent set
- No cold flow
- No special tool required
- STS-90 series stretch is 7% of belt length for proper tension.
- * Use in systems with variable center distance.

STOCK NO.	NOMINAL SIZES			ACTUAL SIZES		
	D	I.D.	O.D.	D	I.D.	I.D. TOL.
STS-90-525	3/16	1 1/2	1 7/8	.210 ±.005	1.475	±.010
STS-90-526		1 5/8	2		1.600	
STS-90-527		1 3/4	2 1/8		1.725	
STS-90-529		2	2 3/8		1.975	
STS-90-530		2 1/8	2 1/2		2.100	
STS-90-531		2 1/4	2 5/8		2.225	
STS-90-532		2 3/8	2 3/4		2.350	
STS-90-533		2 1/2	2 7/8		2.475	
STS-90-534	3/16	2 5/8	3	.210 ±.005	2.600	±.015
STS-90-535		2 3/4	3 1/8		2.750	
STS-90-537		3	3 3/8		2.975	
STS-90-539		3 1/4	3 5/8		3.225	
STS-90-541		3 1/2	3 7/8		3.475	
STS-90-542		3 5/8	4		3.600	
STS-90-543		3 3/4	4 1/8		3.725	
STS-90-545		4	4 3/8		3.975	
STS-90-547		4 1/4	4 5/8		4.225	
STS-90-549		4 1/2	4 7/8		4.475	

DIAMETER	MATERIAL	TEMPERATURE RANGE	PULLEY
1/4" (Cross Section)	ELASTOMER COMPOUND BUNA-N	-40° to +180°	Operates with Grooved Pulley PG5 Series.

- Low break-away friction
- No extrusion
- Higher temperature resistance
- No back up rings required
- Low permanent set
- No cold flow
- No special tool required
- STS-90 series stretch is 7% of belt length for proper tension.
- * Use in systems with variable center distance.

STOCK NO.	NOMINAL SIZES			ACTUAL SIZES		
	D	I.D.	O.D.	D	I.D.	I.D. TOL.
STS-90-627	1/4	4 3/4	5 1/4	.275 ±.006	4.725	±.015
STS-90-631	1/4	5 1/4	5 3/4	.275 ±.006	5.225	±.023
STS-90-635		5 3/4	6 1/4		5.725	
STS-90-637		6	6 1/2		5.975	
STS-90-639		6 1/2	7		6.475	
STS-90-641	1/4	7	7 1/2	.275 ±.006	6.975	±.030
STS-90-645		8	8 1/2		7.975	
STS-90-646		8 1/2	9		8.475	
STS-90-647		9	9 1/2		8.975	
STS-90-648		9 1/2	10		9.475	
STS-90-649		10	10 1/2		9.975	
STS-90-650		10 1/2	11		10.475	
STS-90-653		12	12 1/2		11.975	
STS-90-655		13	13 1/2		12.975	
STS-90-657		14	14 1/2		13.975	
STS-90-659						

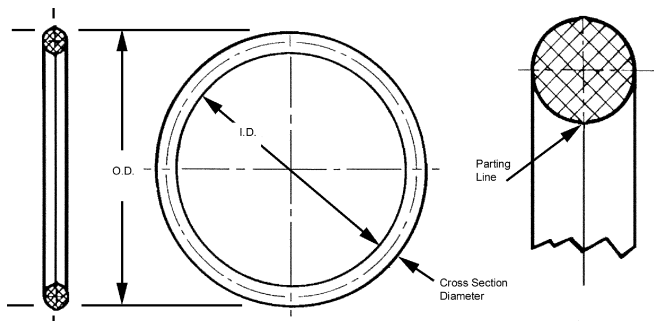

GROOVED PULLEYS

BELT DIA.	BORE	STYLE	MATERIAL	BELT
1/16"	1/8"	PIN HUB	303 Stainless Steel	Operates with the O Ring STS Series or the O Ring Belt PP Series

STOCK NO.	B	D	H	L	A
PG1-1		.500			
PG1-2	.1248	.750			
PG1-3	(1/8)	1.000	5/16	5/16	3/32
PG1-4		1.500			
PG1-5		2.000			

*Outside Diameter = Pitch Diameter
Special diameters available upon request.

BELT DIA.	BORE	STYLE	MATERIAL	BELT
1/16"	3/16"	PIN HUB	303 Stainless Steel	Operates with the O Ring STS Series or the O Ring Belt PP Series

STOCK NO.	B	D	H	L	A
PG1-6		.500			
PG1-7	.1873	.750			
PG1-8	(3/16)	1.000	3/8	11/32	7/64
PG1-9		1.500			
PG1-10		2.000			

*Outside Diameter = Pitch Diameter
Special diameters available upon request.

BELT DIA.	BORE	STYLE	MATERIAL	BELT
1/16"	1/4"	PIN HUB	303 Stainless Steel	Operates with the O Ring STS Series or the O Ring Belt PP Series

STOCK NO.	B	D	H	L	A
PG1-11		1.000			
PG1-12	.2498	1.500			
PG1-13	(1/4)	2.000	1/2	3/8	1/8
PG1-14		2.500			
PG1-15		3.000			

*Outside Diameter = Pitch Diameter
Special diameters available upon request.

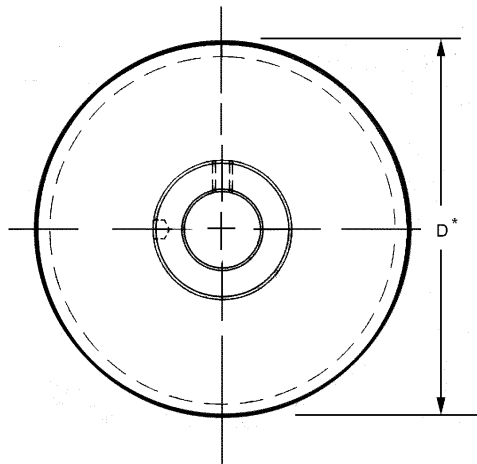
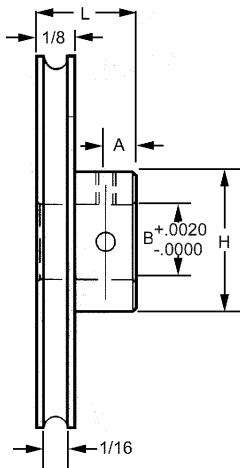

GROOVED PULLEYS

BELT DIA.	BORE	STYLE	MATERIAL	BELT
3/32"	1/8"	PIN HUB	303 Stainless Steel	Operates with the O Ring STS Series or the O Ring Belt PP Series

STOCK NO.	B	D	H	L	A
PG2-1		.500			
PG2-2	.1248	.750			
PG2-3	(1/8)	1.000	5/16	5/16	3/32
PG2-4		1.500			
PG2-5		2.000			

*Outside Diameter = Pitch Diameter
Special diameters available upon request.

BELT DIA.	BORE	STYLE	MATERIAL	BELT
3/32"	3/16"	PIN HUB	303 Stainless Steel	Operates with the O Ring STS Series or the O Ring Belt PP Series

STOCK NO.	B	D	H	L	A
PG2-6		.500			
PG2-7	.1873	.750			
PG2-8	(3/16)	1.000	3/8	11/32	7/64
PG2-9		1.500			
PG2-10		2.000			

*Outside Diameter = Pitch Diameter
Special diameters available upon request.

BELT DIA.	BORE	STYLE	MATERIAL	BELT
3/32"	1/4"	PIN HUB	303 Stainless Steel	Operates with the O Ring STS Series or the O Ring Belt PP Series

STOCK NO.	B	D	H	L	A
PG2-11		1.000			
PG2-12	.2498	1.500			
PG2-13	(1/4)	2.000	1/2	3/8	1/8
PG2-14		2.500			
PG2-15		3.000			

*Outside Diameter = Pitch Diameter
Special diameters available upon request.

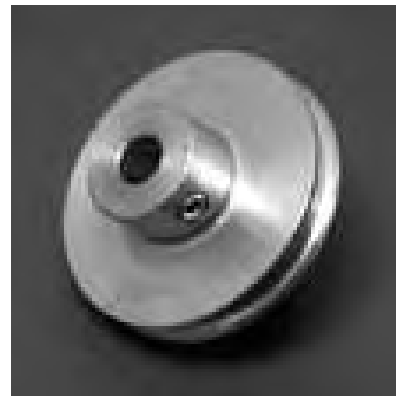
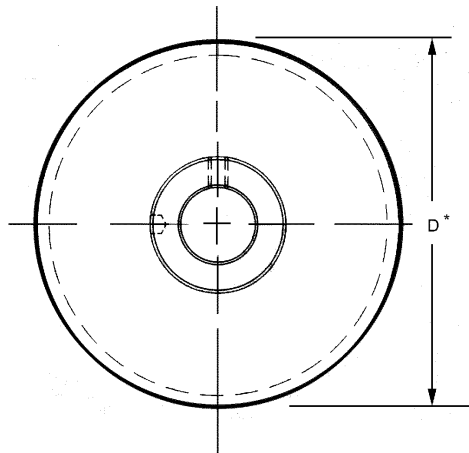
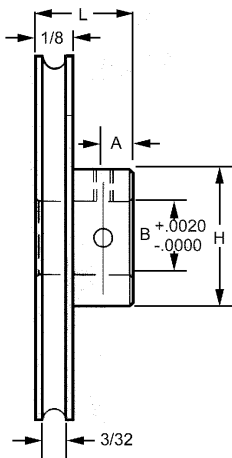

GROOVED PULLEYS

BELT DIA.	BORE	STYLE	MATERIAL	BELT
1/8"	1/8"	PIN HUB	303 Stainless Steel	Operates with the O Ring STS Series or the O Ring Belt PP Series

*Outside Diameter = Pitch Diameter
Special diameters available upon request.
Use in systems with variable or unknown center distances.

STOCK NO.	B	D	H	L	A
PG3-1		.500			
PG3-2	.1248	.750			
PG3-3	(1/8)	1.000	5/16	3/8	.09
PG3-4		1.500			
PG3-5		2.000			

BELT DIA.	BORE	STYLE	MATERIAL	BELT
1/8"	3/16"	PIN HUB	303 Stainless Steel	Operates with the O Ring STS Series or the O Ring Belt PP Series

*Outside Diameter = Pitch Diameter
Special diameters available upon request.
Use in systems with variable or unknown center distances.

STOCK NO.	B	D	H	L	A
PG3-6		.500			
PG3-7	.1873	.750			
PG3-8	(3/16)	1.000	3/8	13/32	.11
PG3-9		1.500			
PG3-10		2.000			

BELT DIA.	BORE	STYLE	MATERIAL	BELT
1/8"	1/4"	PIN HUB	303 Stainless Steel	Operates with the O Ring STS Series or the O Ring Belt PP Series

*Outside Diameter = Pitch Diameter
Special diameters available upon request.
Use in systems with variable or unknown center distances.

STOCK NO.	B	D	H	L	A
PG3-11		.500			
PG3-12	.2498	.750			
PG3-13	(1/4)	1.000	1/2	7/16	.12
PG3-20		1.500			
PG3-14		2.000			
PG3-21		2.500			
PG3-15		3.000			

BELT DIA.	BORE	STYLE	MATERIAL	BELT
1/8"	5/16"	PIN HUB	303 Stainless Steel	Operates with the O Ring STS Series or the O Ring Belt PP Series

*Outside Diameter = Pitch Diameter
Special diameters available upon request.
Use in systems with variable or unknown center distances.

STOCK NO.	B	D	H	L	A
PPG3-16		1.000			
PG3-17	.3123	2.000	1/2	7/16	.12
PG3-18	(5/16)	3.000			
PG3-19		4.000			

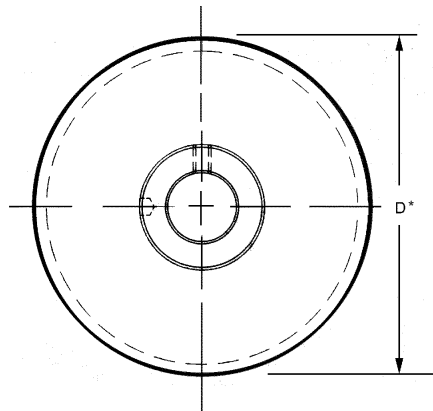
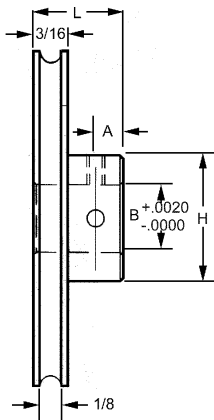

GROOVED PULLEYS

BELT DIA.	BORE	STYLE	MATERIAL	BELT
1/8"	1/8"	CLAMP HUB	303 Stainless Steel	Operates with the O Ring STS Series or the O Ring Belt PP Series

*Outside Diameter = Pitch Diameter
Special diameters available upon request.
Use in systems with variable or unknown center distances.

STOCK NO.	B	D	H +.000/-003	C	CLAMP NO.
PG3-1-C		.50			
PG3-2-C		.75			
PG3-3-C	.1248	1.00	.188	1/4	CG1-5
PG3-4-C	(1/8)	1.50			
PG3-5-C		2.00			

BELT DIA.	BORE	STYLE	MATERIAL	BELT
1/8"	3/16"	CLAMP HUB	303 Stainless Steel	Operates with the O Ring STS Series or the O Ring Belt PP Series

*Outside Diameter = Pitch Diameter
Special diameters available upon request.
Use in systems with variable or unknown center distances.

STOCK NO.	B	D	H +.000/-003	C	CLAMP NO.
PG3-6-C		.50			
PG3-7-C		.75			
PG3-8-C	.1873	1.00	.250	5/16	CG1-9
PG3-9-C	(3/16)	1.50			
PG3-10-C		2.00			

BELT DIA.	BORE	STYLE	MATERIAL	BELT
1/8"	1/4"	CLAMP HUB	303 Stainless Steel	Operates with the O Ring STS Series or the O Ring Belt PP Series

*Outside Diameter = Pitch Diameter
Special diameters available upon request.
Use in systems with variable or unknown center distances.

STOCK NO.	B	D	H +.000/-003	C	CLAMP NO.
PG3-11-C		.50			
PG3-12-C		.75			
PG3-13-C	.2498	1.00	.312	3/8	CG1-12
PG3-20-C	(1/4)	1.50			
PG3-14-C		2.00			
PG3-21-C		2.50			
PG3-15-C		3.00			

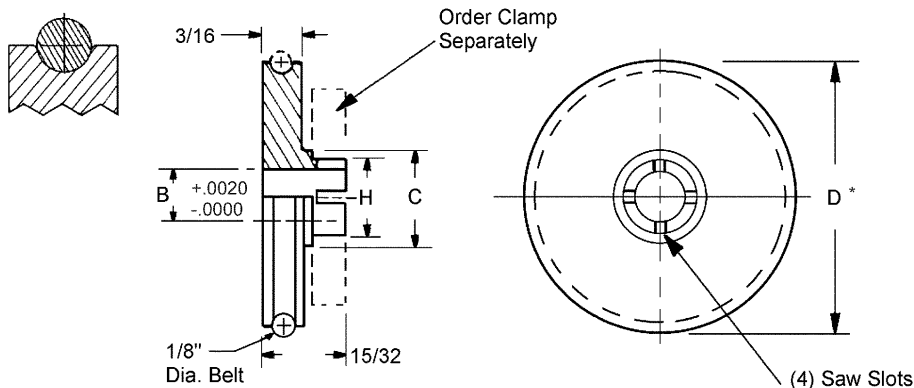

GROOVED PULLEYS

BELT DIA.	BORE	STYLE	MATERIAL	BELT
3/16"	5/16"	PIN HUB	303 Stainless Steel	Operates with the O Ring STS Series or the O Ring Belt PP Series

*Outside Diameter = Pitch Diameter
 Special diameters available upon request.
 Use in systems with variable or unknown center distances.

STOCK NO.	B	D	H	L	A
PG4-1		1.00			
PG4-2	.3123	1.50			
PG4-3	(5/16)	2.00	3/4	5/8	3/16
PG4-4		3.00			

BELT DIA.	BORE	STYLE	MATERIAL	BELT
3/16"	3/8"	PIN HUB	303 Stainless Steel	Operates with the O Ring STS Series or the O Ring Belt PP Series

*Outside Diameter = Pitch Diameter
 Special diameters available upon request.
 Use in systems with variable or unknown center distances.

STOCK NO.	B	D	H	L	A
PG4-5		1.00			
PG4-6	.3748	1.50			
PG4-7	(3/8)	2.00	3/4	3/4	1/4
PG4-8		3.00			

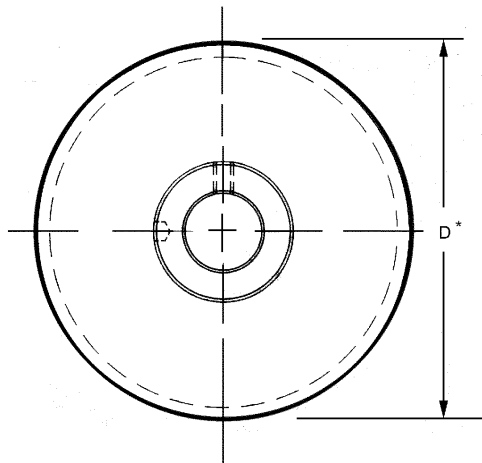
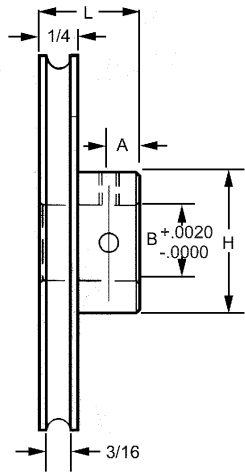

GROOVED PULLEYS

BELT DIA.	BORE	STYLE	MATERIAL	BELT
1/4"	3/8"	PIN HUB	303 Stainless Steel	Operates with the O Ring STS Series or the O Ring Belt PP Series

*Outside Diameter = Pitch Diameter
 Special diameters available upon request.
 Use in systems with variable or unknown center distances.

STOCK NO.	B	D	H	L	A
PG5-1		1.000			
PG5-2		1.500			
PG5-3	.3748	2.000	3/4	7/8	1/4
PG5-4	(3/8)	3.000			
PG5-5		4.000			

BELT DIA.	BORE	STYLE	MATERIAL	BELT
1/4"	1/2"	PIN HUB	303 Stainless Steel	Operates with the O Ring STS Series or the O Ring Belt PP Series

*Outside Diameter = Pitch Diameter
 Special diameters available upon request.
 Use in systems with variable or unknown center distances.

STOCK NO.	B	D	H	L	A
PG5-6		1.000			
PG5-7		1.500			
PG5-8	.4998	2.000	1	7/8	1/4
PG5-9	(1/2)	3.000			
PG5-10		4.000			

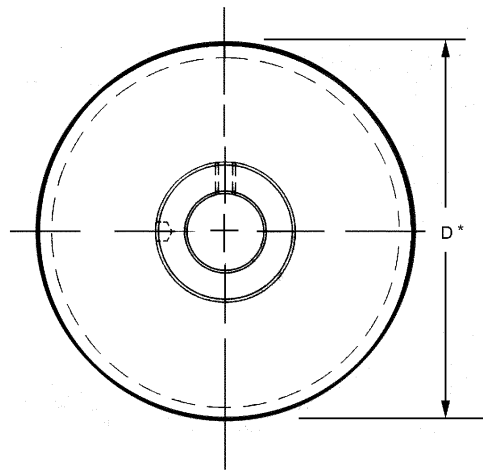
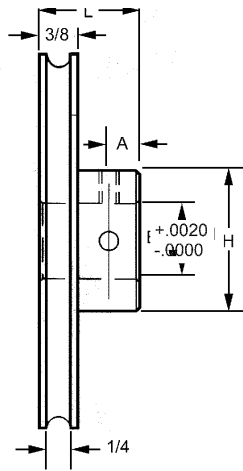

FRICITION DRIVE ROLLERS

BORE	STYLE	MATERIAL	TEMPERATURE RANGE
1/8"	PIN HUB	Wheel - 303 Stainless Steel Tire - Buna-N Elastomer Compound	Temperature Range -40°F to +180°F

•Other materials and diameters available on request.
•Ideal as a paper, tape or card drive.

STOCK NO.	B	D	H	L	A	F	E
G1-1	.1248 (1/8)	5/8	5/16	.375	.09	3/16	3/32
G1-2		7/8					1/8
G1-3		1 1/8					
G1-4		1 5/8					
G1-5		2 1/8					

BORE	STYLE	MATERIAL	TEMPERATURE RANGE
3/16"	PIN HUB	Wheel - 303 Stainless Steel Tire - Buna-N Elastomer Compound	Temperature Range -40°F to +180°F

•Other materials and diameters available on request.
•Ideal as a paper, tape or card drive.

STOCK NO.	B	D	H	L	A	F	E
G1-6	.1873 (3/16)	5/8	3/8	.406	.11	3/16	3/32
G1-7		7/8					1/8
G1-8		1 1/8					
G1-9		1 5/8					
G1-10		2 1/8					

BORE	STYLE	MATERIAL	TEMPERATURE RANGE
1/4"	PIN HUB	Wheel - 303 Stainless Steel Tire - Buna-N Elastomer Compound	Temperature Range -40°F to +180°F

•Other materials and diameters available on request.
•Ideal as a paper, tape or card drive.

STOCK NO.	B	D	H	L	A	F	E
G1-11	.2498 (1/4)	5/8	1/2	.437	.12	3/16	3/32
G1-12		7/8					1/8
G1-13		1 1/8					
G1-14		1 5/8					
G1-15		2 1/8					
G1-16		2 5/8					
G1-17		3 1/8					

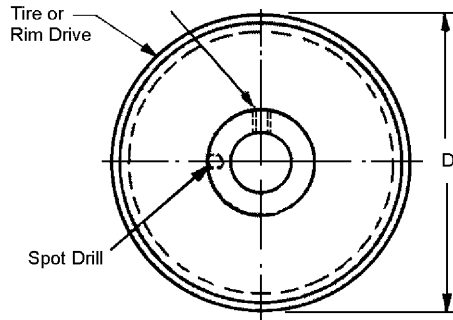
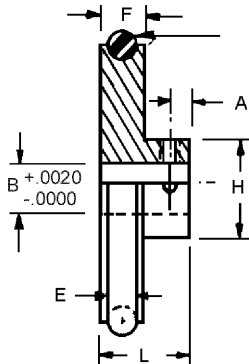

FRICTION DRIVE ROLLERS

BORE	STYLE	MATERIAL	TEMPERATURE RANGE
5/16"	PIN HUB	Wheel - 303 Stainless Steel Tire - Buna-N Elastomer Compound	-40°F to +180°F

•Other materials and diameters available on request.
•Ideal as a paper, tape or card drive.

STOCK NO.	B	D	H	L	A	F	E
G1-18		1 1/8					
G1-19	.3123	2 1/8	1/2	.437	.12	3/16	1/8
G1-20	(5/16)	3 1/8					
G1-21		4 1/8					

BORE	STYLE	MATERIAL	TEMPERATURE RANGE
3/8"	PIN HUB	Wheel - 303 Stainless Steel Tire - Buna-N Elastomer Compound	-40°F to +180°F

•Other materials and diameters available on request.
•Ideal as a paper, tape or card drive.

STOCK NO.	B	D	H	L	A	F	E
G1-22		1 1/8					
G1-23	.3748	2 1/8	3/4	.750	.25	1/4	1/8
G1-24	(3/8)	3 1/8					
G1-25		4 1/8					

BORE	STYLE	MATERIAL	TEMPERATURE RANGE
1/2"	PIN HUB	Wheel - 303 Stainless Steel Tire - Buna-N Elastomer Compound	-40°F to +180°F

•Other materials and diameters available on request.
•Ideal as a paper, tape or card drive.

STOCK NO.	B	D	H	L	A	F	E
G1-26		1 1/8					
G1-27	.4998	2 1/8	1	.875	.25	3/8	1/8
G1-28	(1/2)	3 1/8					
G1-29		4 1/8					

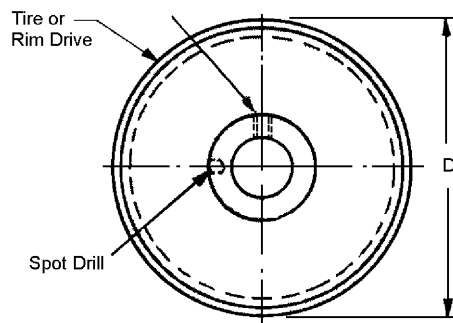
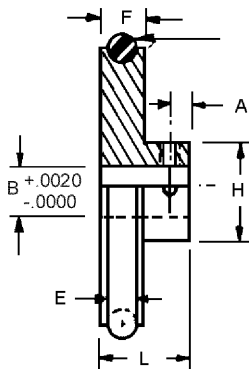

HEAT SPLICE KIT - EXTRUDED POLYURETHANE

Round or V-Belt Shapes

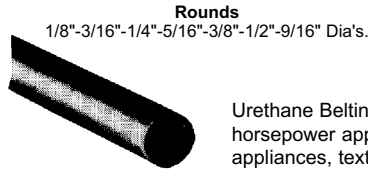

Urethane Belting is ideal for a wide range of fractional horsepower applications. It is suitable for light metalworking, small appliances, textile, printing and particularly adaptable to conveying systems. Send us your specifications.

-
1. To splice or weld Urethane Belting, the free ends are first locked in either side.
-
2. The heating blade is then inserted to soften the urethane.
-
3. The two softened ends are then pressed together with pressure.
-
4. The weld or splice is then cooled and trimmed to the original size.

STOCK NUMBER	TOOL DESCRIPTION
STS-U-5	COMPLETE - HEAT SPLICE KIT CONSISTING OF STS-U-2, STS-U-3, STS-U-9, STS-U-11 & TOOL BOX
STS-U-2	CUTTING TOOL
STS-U-6	CUTTER BLADE FOR STS-U-2 CUTTING TOOL
STS-U-3	HEAT-SPLICER FIXTURE
STS-U-11	HEATING TOOL-DOUBLE SURFACE
STS-U-12	HANDLE FOR STS-U-11 HEATING TOOL
STS-U-13	HOT BLADE FOR STS-U-11
STS-U-9	TRIMMING TOOL FOR ROUND BELTING

W. M. Berg, Inc. will factory splice to order, any length cord or belt at a nominal charge.

BELT TENSIONER GUIDES

Handy tools for checking belt tensions on your V-Belt and synchronous belt drives.

Push slowly on the pad to get an accurate reading. When you feel and hear the **CLICK** - stop immediately and remove the Kriket carefully so the indicator arm isn't moved. (A)

The illustrations below shows how to accurately read the Kriket to get the correct tension.

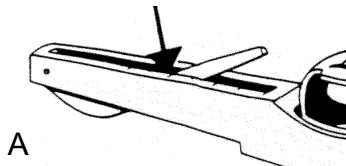

Position the Kriket on the belt - midway between the pulleys - with flange on the bottom of gauge against the edge of belt.

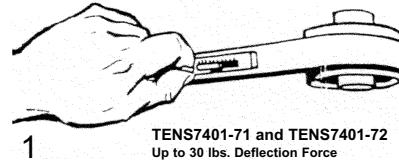

Detailed instructions are included with gauge.

How to use the Kriket V-Belt gauge.

1. Position the Kriket on the belt - midway between the pulleys - with flange on bottom gauge against the edge of belts.
2. Push slowly on the black pad to get an accurate reading. When you feel and hear the **CLICK** - stop immediately and remove the Kriket carefully so black indicator arm isn't moved.
3. Read the gauge to get the correct tension.

STOCK NO.	DESCRIPTION
TENS7401-71	Kriket IV belt tension gauge. Calibrated to measure tension from 30-150 lbs. (15-65 kg.)
TENS7401-72	Kriket II V belt tension gauge. Calibrated to measure tension from 100-320 lbs. (50-150 kg.)
TENS7401-75	Tension Tester Calibrated to measure tension up to 66 lbs. deflection force
TENS7401-76	Tension Tester Calibrated to measure tension up to 30 lbs. deflection force

TENS7401-76
Up to 30 lbs.
Deflection Force

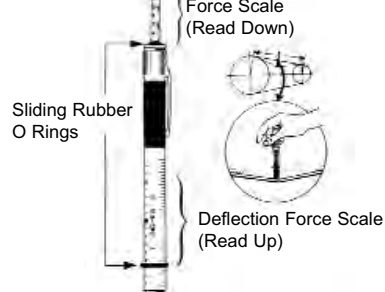

Read the scales at the bottom edge of the O Ring. Leave the upper O Ring in maximum "up" position.

TENS7401-76
Up to 66 lbs.
Deflection Force

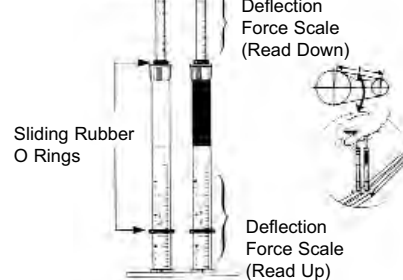

Read scales at the bottom edge of the O Rings. Leave the upper O Rings in maximum "down" position.

Compare the deflection force with the range of forces recommended. If **less** than **minimum** recommended force, belts should be tightened. If **more** than the **maximum** recommended deflection force, drive is tighter than necessary.

NOTE: There normally will be a rapid drop in tension during the "run-in period" for V-Belt drives. Check tension frequently during the first day of operation.

GEARS

Table of Contents

GEAR BLANKS

Hubless	B 2
Pin Hub	B 3 - B 4
Clamp Hub	B 5

SPUR GEARS

Hubless - 12 Pitch	B 6
Hubless - 16 Pitch	B 8 - B 9
Hubless - 20 Pitch	B 15
Hubless - 24 Pitch	B 23 - B 24
Hubless - 32 Pitch	B 50 - B 53
Hubless - 48 Pitch	B 77 - B 79
Hubless - 64 Pitch	B 122 - B 123
Hubless - 72 Pitch	B 158
Hubless - 80 Pitch	B 182 - B 184
Hubless - 96 Pitch	B 187
Hubless - 120 Pitch	B 210
Pin Hub - 12 Pitch	B 7
Pin Hub - 16 Pitch	B 10 - B 12
Pin Hub - 20 Pitch	B 16 - B 20
Pin Hub - 24 Pitch	B 26 - B 36
Pin Hub - 1/10 Pitch	B 44 - B 45
Pin Hub - 32 Pitch	B 55 - B 65
Pin Hub - 48 Pitch	B 82 - B 95
Pin Hub - 1/20 Pitch	B 117 - B 118
Pin Hub - 64 Pitch	B 126 - B 135
Pin Hub - 72 Pitch	B 161 - B 164
Pin Hub - 96 Pitch	B 189 - B 193
Pin Hub - 120 Pitch	B 213 - B 215
Clamp Hub - 16 Pitch	B 13
Clamp Hub - 20 Pitch	B 21
Clamp Hub - 32 Pitch	B 66 - B 67
Clamp Hub - 48 Pitch	B 96 - B 99
Clamp Hub - 64 Pitch	B 136 - B 138
Clamp Hub - 72 Pitch	B 165 - B 166
Clamp Hub - 96 Pitch	B 194

GEAR RACKS

16 Pitch	B 14
20 Pitch	B 22
24 Pitch	B 37 - B 38
1/10 Pitch	B 46 - B 47
32 Pitch	B 68 - B 69
48 Pitch	B 100 - B 101
1/20 Pitch	B 119 - B 120
64 Pitch	B 139 - B 140
72 Pitch	B 167 - B 168
80 Pitch	B 185
96 Pitch	B 195 - B 196
120 Pitch	B 216

CLUSTER GEAR AND HUB

24 Pitch	B 25
32 Pitch	B 54
48 Pitch	B 80 - B 81
64 Pitch	B 124 - B 125
72 Pitch	B 159 - B 160
96 Pitch	B 188
120 Pitch	B 211 - B 212

ANTI-BACKLASH GEARS

Pin Hub - 24 Pitch	B 39 - B 40
Pin Hub - 32 Pitch	B 70 - B 72
Pin Hub - 48 Pitch	B 102 - B 107
Pin Hub - 64 Pitch	B 141 - B 148
Pin Hub - 72 Pitch	B 169 - B 174
Pin Hub - 96 Pitch	B 197 - B 202

ANTI-BACKLASH GEARS (continued)

Clamp Hub - 24 Pitch	B 40 - B 41
Clamp Hub - 1/10 Pitch	B 48
Clamp Hub - 32 Pitch	B 73 - B 74
Clamp Hub - 48 Pitch	B 108 - B 113
Clamp Hub - 64 Pitch	B 148 - B 154
Clamp Hub - 72 Pitch	B 175 - B 180
Clamp Hub - 96 Pitch	B 203 - B 208

PINION SHAFTS

24 Pitch	B 42
1/10 Pitch	B 49
32 Pitch	B 75
48 Pitch	B 114 - B 115
1/20 Pitch	B 121
64 Pitch	B 155 - B 156
72 Pitch	B 181
80 Pitch	B 186
96 Pitch	B 209
120 Pitch	B 217

SPUR GEAR STOCK

24 Pitch	B 43
32 Pitch	B 76
48 Pitch	B 116
64 Pitch	B 157

HELICAL GEARS

16 Pitch	B 218
20 Pitch	B 218
24 Pitch	B 219
32 Pitch	B 219
48 Pitch	B 220 - B 221
64 Pitch	B 222 - B 223

MITER & BEVEL GEARS

16 Pitch	B 224
24 Pitch	B 225
32 Pitch	B 226
48 Pitch	B 227
64 Pitch	B 228
72 Pitch	B 229
96 Pitch	B 230

ANTI-BACKLASH MITER GEARS

48 Pitch	B 231
64 Pitch	B 231
72 Pitch	B 231

PRECISION WORMS

16 Pitch	B 232
24 Pitch	B 234
32 Pitch	B 236
48 Pitch	B 239-B240
64 Pitch	B 250

PRECISION WORM GEARS

16 Pitch	B 233
24 Pitch	B 235
32 Pitch	B 237- B 238
48 Pitch	B 241- B 243
48 Pitch	B 241- B 243

ANTI-BACKLASH WORM GEARS

48 Pitch	B 244 - B 249
64 Pitch	B 254 - B 259

INTERNAL GEARS

24 Pitch	B 260
32 Pitch	B 260
48 Pitch	B 261
64 Pitch	B 261
72 Pitch	B 262
96 Pitch	B 262
120 Pitch	B 263



GEAR BLANKS

STYLE	BORE	FACE	MATERIAL
HUBLESS	3/8"	1/8" TO 1/2"	2024-T4 ALUMINUM ANODIZED

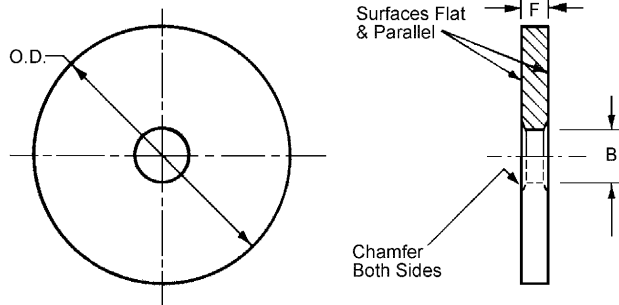

STOCK NO.	B BORE	F FACE	ANODIZED COLOR	MAX O.D.
FB79A*	.375	3/4	GREEN	5.166
FB78A*		1/2	BLUE	5.375
FB74A*		3/8	BROWN	6.000
FB77A*		1/4	RED	6.083
FB76A*		3/16	GOLD	4.063
FB75A*		1/8	BLACK	3.106

To order specify Blank Designator - Material Code - O.D. in inches.
Example: FB79 A - 2.750

Designator Number Material Code O.D.

STYLE	BORE	FACE	MATERIAL
HUBLESS	3/8" TO 1 3/8"	1/16" TO 1/2"	SEE MATERIAL CODES BELOW

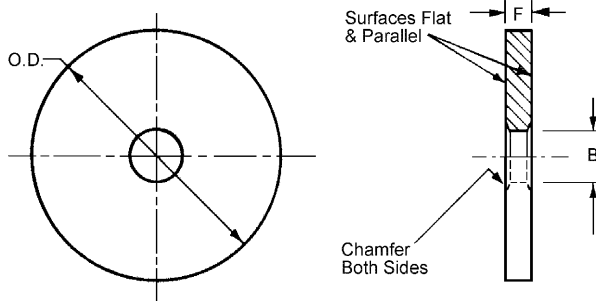

Ideal for:

- Gears
- Pulleys
- Cams
- Sprockets
- Handles
- Wheels
- Ratchets

Material Codes:

- A** - 2024-T4 Aluminum - Anodized
- B** - Tobin Bronze Alloy 464
- D** - Delrin®
- N** - Nylon - with Stainless Steel Bushing in Bore
- P** - Linen Phenolic
- S** - 303 Stainless Steel
- U** - Polyurethane

To order specify Blank Designator - Material Code - O.D. in inches.
Example: FB3 A - 2.750

Designator Number Material Code O.D.

BLANK DESIGNATOR	B BORE	F FACE	MAX. AVAILABLE MATERIAL	ANODIZE STOCK O.D.	COLOR (ALUM. ONLY)
FB1	+.0005 .3748	1/16	A, S	3.125	GRAY
FB2		3/32	A, S	4.250	GRAY
FB3		1/8	A, N, P, S, U*	4.250	GRAY
FB5		3/16	A, D**, S	4.250	GRAY
FB6		1/4	A, S, U*	7.500	GRAY
FB75		1/8	A	3.106	BLACK
FB76	3/16	A	4.063	GOLD	
FB77	1/4	A	6.083	RED	
FB74	3/8	A	6.000	BROWN	
FB78	1/2	A	5.375	BLUE	
FB79	3/4	A	5.166	GREEN	
FB17	1/8	1/8	A, S, U*	4.250	GRAY
FB19	3/16	3/16	A, D, S	4.250	GRAY
FB18	1/4	1/4	A, S, U*	7.500	GRAY
FB20	3/8	3/8	A, B, S, U*	5.750	GRAY
FB25	1/8	1/8	S	4.250	-
FB26	3/16	3/16	S	4.250	-
FB27	1/4	1/4	S	7.500	-
FB50	3/8	3/8	S	5.250	-
FB60	1/2	1/2	S	12.000	-

* Urethane Bore Tolerance ± 0.0005 for up to 1/2" bores and ± 0.001 for all bores over 1/2".

** FB5D Bore is .3750.

GEAR BLANKS

STYLE	BORE	FACE	MATERIAL
PIN HUB	1/8" TO 5/8"	1/8" TO 3/4"	2024-T4 ALUMINUM ANODIZED

B

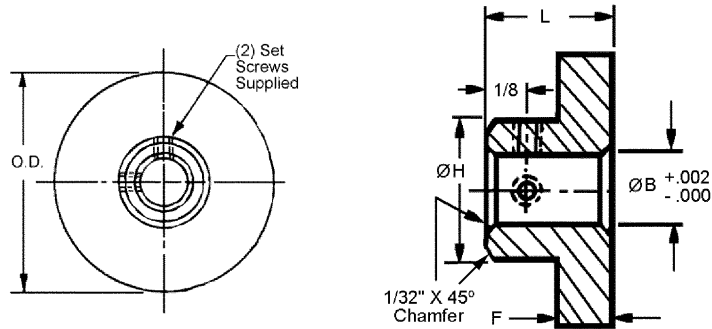

*To order specify Blank Designator - O.D. in inches.
Example: PBA74A - 2.750

Designator Number → O.D.

STOCK NO.	B BORE	F FACE	H HUB DIA.	L	SET SCREWS	ANODIZED COLOR	MAX OUTSIDE DIA.
PB72A-*	.375						3.125
PB73A-*	.500	3/4	1-1/4	1	#8-32	GREEN	5.250
PB74A-*	.625						5.250
PB69A-*	.250						2.125
PB70A-*	.375	1/2	1	3/4	#8-32	BLUE	5.500
PB71A-*	.500						5.500
PB57A-*	.250						
PB58A-*	.375	3/8	3/4	5/8	#8-32	BROWN	6.000
PB59A-*	.500						
PB66A-*	.250						
PB67A-*	.375	1/4	3/4	1/2	#8-32	RED	6.500
PB68A-*	.500						
PB65A-*	.125						
PB64A-*	.187	3/16	5/8	7/16	#4-40	GOLD	4.063
PB63A-*	.250						
PB62A-*	.125						
PB61A-*	.187	1/8	1/2	3/8	#4-40	BLACK	3.106
PB60A-*	.250						

- Ideal for:
- Gears
 - Pulleys
 - Cams
 - Sprockets
 - Handles
 - Wheels

GEAR BLANKS

STYLE	BORE	FACE	MATERIAL
PIN HUB	.1200 to .4998	1/16" TO 1/2"	SEE MATERIAL CODES BELOW

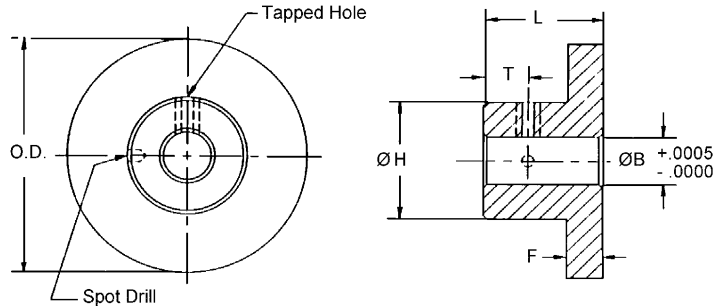

To order specify Blank Designator - Material Code - O.D. in inches.

Example: PB28 A - 2.250

Designator Number Material Code O.D.

STOCK NO.	B BORE	F FACE WIDTH	H	L	T	TAPPED HOLE	SPOT DRILL	MATERIALS AVAILABLE	MAX STOCK O.D.
PB3	.1200	1/16	5/16	1/4	.09	#2-56	#69	A, S	2.000
PB2		3/32		9/32				A, S	2.000
PB1		1/8		5/16				A, S	1.500
PB5	.1248	1/16	5/16	1/4	.09	#2-56	#69	A, S	2.000
PB7		3/32		9/32				A, S	2.000
PB10		1/8		5/16				A, N, P, S	2.625
PB13		3/16		13/32				B	2.625
PB14		3/16		3/8				A, S	1.750
PB15	.1562	1/8	5/16	5/16	.09	#2-66	#69	A, S	1.750
PB16	.1873	1/16	5/16	1/4	.09	#4-40	#60	A, S	1.375
PB17		3/32	3/8	5/16				A, S	2.500
PB19		1/8	3/8	11/32				A, S	3.250
PB21		3/16	3/8	13/32				A, B, N, P, S	4.500
PB24	.2405	3/16	3/8	13/32	.11	#4-40	#60	A, S	3.250
PB25	.2498	3/32	7/16	5/16	.12	#6-32	#50	A, S	2.000
PB26		1/8	1/2	3/8				A, S	4.250
PB28		3/16	1/2	7/16				A, N, P, S	4.500
PB29		3/16	1/2	13/32				B	5.750
PB30	.3123	3/16	1/2	13/32	.12	#6-32	#50	B	3.250
PB32		3/16	1/2	7/16				A, S	4.437
PB33		1/4	3/4	5/8				S	4.250
PB35	.3748	3/8	3/4	7/8	.25	#10-24	#31	A, B, S	4.250
PB36		1/2		1				S	4.250
PB34	.3750	3/8	3/4	3/4	.19	#10-32	-	B, S	2.000
PB37	.4998	3/8	1	7/8	.25	#10-24	#31	B, S	6.415
PB38		1/2		1				A, S	4.500

Ideal for:

- Gears
- Pulleys
- Cams
- Sprockets
- Handles
- Wheels
- Ratchets

Material Codes:

- A** - 2024-T4 Aluminum - Gray Chromic Anodized
- B** - Tobin Bronze Alloy 464
- N** - Nylon - with Stainless Steel Bushing in Bore
- P** - Linen Phenolic
- S** - 303 Stainless Steel

GEAR BLANKS

STYLE	BORE	FACE	MATERIAL
CLAMP HUB	.1200 to .4998	1/8" TO 3/8"	SEE MATERIAL CODES BELOW

B

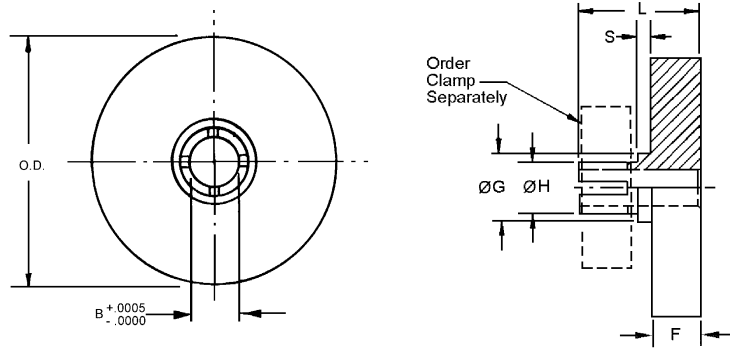

To order specify Blank Designator - Material Code - O.D. in inches.
Example: CB18 S - 1.250

Designator Number Material Code O.D.

BLANK STOCK NO.	B BORE	F FACE WIDTH	H +.000 -.003	L	G FLANGE	S DIA.	CLAMP STOCK NO.	AVAILABLE MATERIAL	MAX STOCK O.D.
CB36	.1200	1/8	.188	13/32	1/4	1/32	CG3-1	A,S	1.625
CB4		1/16		19/64			CG1-5	A,S	1.125
CB5	.1248	3/32	.188	21/64	1/4	1/32	CG1-5	A,S	1.625
CB7		1/8		13/32			CG3-1	A,S	2.375
CB8		3/16		15/32			CG3-1	B	2.000
CB10		3/32		21/64	5/16	1/32	CG1-8	A,S	1.500
CB14	.1873	1/8	.250	13/32	5/16	1/32	CG1-9	A,S	2.500
CB16		3/16		1/2	11/32	3/64	CG1-9	B,S	2.000
CB18		1/8		13/32	3/8	1/32	CG1-12	A,S	4.250
CB20	.2498	3/16	.312	1/2	13/32	3/64	CG1-12	A,B,S	5.750
CB22	.3123	1/4	.375	9/16	11/16	1/16	CG1-14	S	4.250
CB25	.3748	1/4	.437	5/8	11/16	1/16	CG1-17	S	4.250
CB29	.4998	3/8	.562	3/4	13/16	1/16	CG1-19	S	4.250

Ideal for:

- Gears
- Pulleys
- Cams
- Sprockets
- Handles
- Wheels
- Ratchets

Material Codes:

- A** - 2024-T4 Aluminum - Gray Chromic Anodized
- B** - Tobin Bronze Alloy 464
- S** - 303 Stainless Steel

SPUR GEARS

PITCH	STYLE	BORE	FACE	MATERIAL	AGMA QUALITY	PRESSURE ANGLE
12	HUBLESS	3/8"	3/4"	ALUMINUM ANODIZED (GREEN)	8	20°

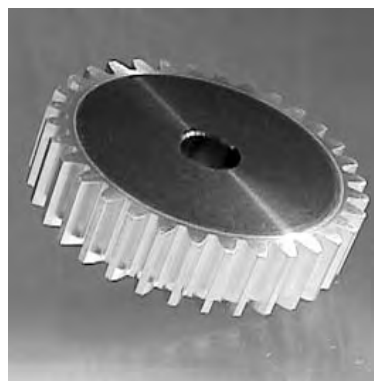
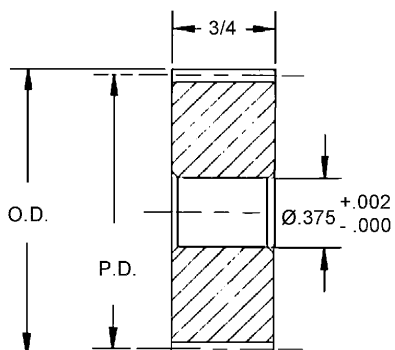

STOCK NO.	NO. OF TEETH	P.D.	O.D.
F12A79-12	12	1.0000	1.166
F12A79-13	13	1.0833	1.250
F12A79-14	14	1.1666	1.333
F12A79-15	15	1.2500	1.416
F12A79-16	16	1.3333	1.500
F12A79-18	18	1.5000	1.666
F12A79-20	20	1.6666	1.833
F12A79-21	21	1.7500	1.916
F12A79-22	22	1.8333	2.000
F12A79-24	24	2.0000	2.166
F12A79-30	30	2.5000	2.666
F12A79-32	32	2.6666	2.833
F12A79-36	36	3.0000	3.166

Available on request: other numbers of teeth; 14 - 1/2° pressure angle.

For Couplings See Section G.
For Shafts, Bearings and Collars See Section I.

SPUR GEARS

B

PITCH	STYLE	BORE	FACE	MATERIAL	AGMA QUALITY	PRES. ANGLE
12	PIN HUB	3/8"	3/4"	ALUMINUM ANODIZED (GREEN)	8	20°

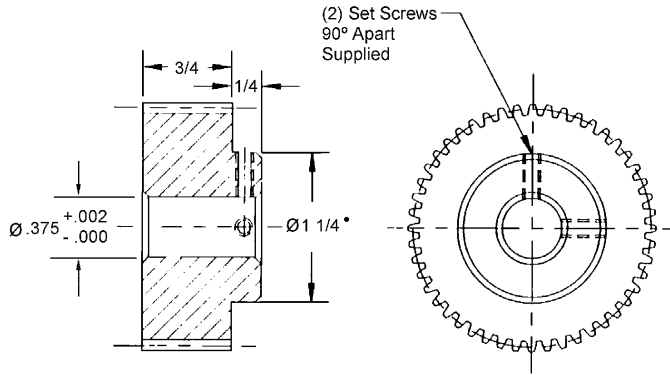

STOCK NO.	NO. OF TEETH	P.D.	O.D.
P12A72-12	12*	1.0000	1.166
P12A72-13	13*	1.0833	1.250
P12A72-14	14*	1.1666	1.333
P12A72-15	15*	1.2500	1.416
P12A72-16	16*	1.3333	1.500
P12A72-18	18	1.5000	1.666
P12A72-20	20	1.6666	1.833
P12A72-21	21	1.7500	1.916
P12A72-22	22	1.8333	2.000
P12A72-24	24	2.0000	2.166
P12A72-30	30	2.5000	2.666
P12A72-32	32	2.6666	2.833
P12A72-36	36	3.0000	3.166



* For 10 - 17 teeth hub diameter equals .62.
Available on request: other numbers of teeth; 14 - 1/2° pressure angle.

PITCH	STYLE	BORE	FACE	MATERIAL	AGMA QUALITY	PRES. ANGLE
12	PIN HUB	1/2"	3/4"	ALUMINUM ANODIZED (GREEN)	8	20°

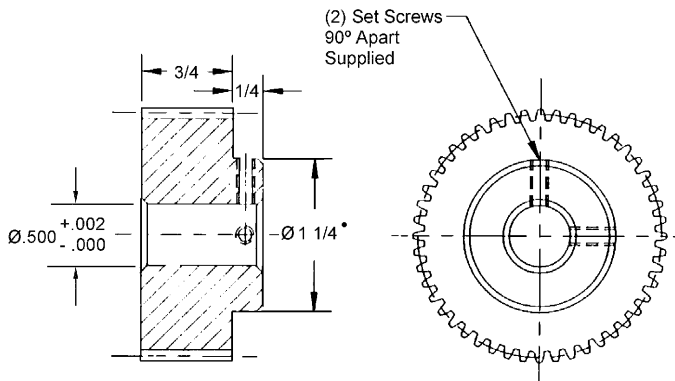

STOCK NO.	NO. OF TEETH	P.D.	O.D.
P12A73-12	12*	1.0000	1.166
P12A73-13	13*	1.0833	1.250
P12A73-14	14*	1.1666	1.333
P12A73-15	15*	1.2500	1.416
P12A73-16	16*	1.3333	1.500
P12A73-18	18	1.5000	1.666
P12A73-20	20	1.6666	1.833
P12A73-21	21	1.7500	1.916
P12A73-22	22	1.8333	2.000
P12A73-24	24	2.0000	2.166
P12A73-30	30	2.5000	2.666
P12A73-32	32	2.6666	2.833
P12A73-36	36	3.0000	3.166
P12A73-40	40	3.3333	3.500
P12A73-42	42	3.5000	3.666
P12A73-48	48	4.0000	4.166
P12A73-54	54	4.5000	4.666
P12A73-60	60	5.0000	5.166

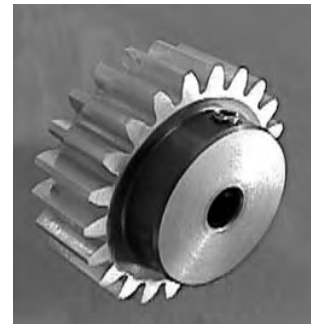

* For 11 - 17 teeth hub diameter equals .71.
Available on request: other numbers of teeth; 14 - 1/2° pressure angle.

PITCH	STYLE	BORE	FACE	MATERIAL	AGMA QUALITY	PRES. ANGLE
12	PIN HUB	5/8"	3/4"	ALUMINUM ANODIZED (GREEN)	8	20°

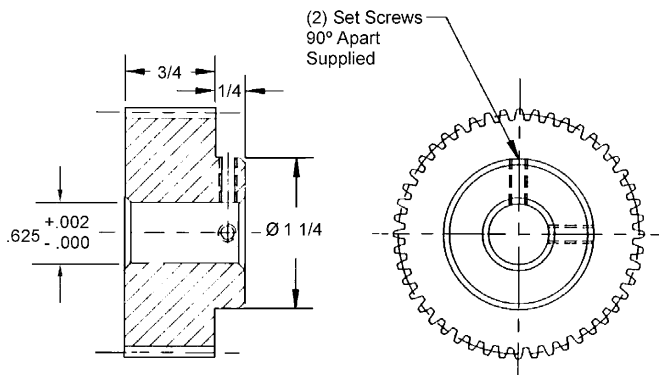

STOCK NO.	NO. OF TEETH	P.D.	O.D.
P12A74-18	18	1.5000	1.666
P12A74-20	20	1.6666	1.833
P12A74-21	21	1.7500	1.916
P12A74-22	22	1.8333	2.000
P12A74-24	24	2.0000	2.166
P12A74-30	30	2.5000	2.666
P12A74-32	32	2.6666	2.833
P12A74-36	36	3.0000	3.166
P12A74-40	40	3.3333	3.500
P12A74-42	42	3.5000	3.666
P12A74-48	48	4.0000	4.166
P12A74-54	54	4.5000	4.666
P12A74-60	60	5.0000	5.166

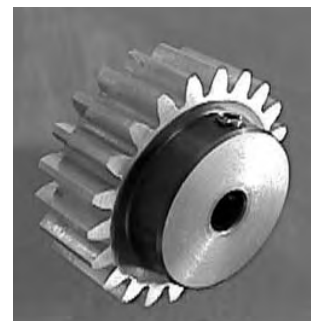

Available on request: other numbers of teeth; 14 - 1/2° pressure angle.

SPUR GEARS

PITCH	STYLE	BORE	FACE	MATERIAL	AGMA QUALITY	PRESSURE ANGLE
16	HUBLESS	3/8"	1/2"	ALUMINUM ANODIZED (BLUE)	8	20°

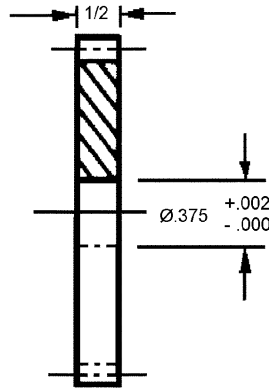
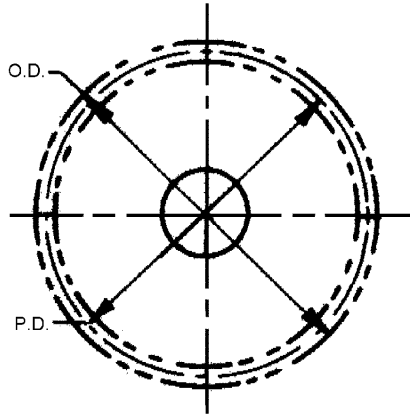

Available on request:
Other numbers of teeth;
14 - 1/2° pressure angle.

STOCK NO.	NO. OF TEETH	P.D.	O.D.
F16A78-12	12	.7500	.875
F16A78-13	13	.8125	.937
F16A78-14	14	.8750	1.000
F16A78-15	15	.9375	1.062
F16A78-16	16	1.0000	1.125
F16A78-18	18	1.1250	1.250
F16A78-20	20	1.2500	1.375
F16A78-22	22	1.3750	1.500
F16A78-24	24	1.5000	1.625
F16A78-26	26	1.6250	1.750
F16A78-28	28	1.7500	1.875
F16A78-30	30	1.8750	2.000
F16A78-32	32	2.0000	2.120
F16A78-36	36	2.2500	2.375
F16A78-40	40	2.5000	2.625
F16A78-48	48	3.0000	3.125
F16A78-54	54	3.3750	3.500
F16A78-56	56	3.5000	3.625
F16A78-60	60	3.7500	3.875
F16A78-64	64	4.0000	4.125
F16A78-72	72	4.5000	4.625
F16A78-80	80	5.0000	5.125
F16A78-84	84	5.2500	5.375

PITCH	STYLE	BORE	FACE	MATERIAL	AGMA QUALITY	PRESSURE ANGLE
16	HUBLESS	11/16"	3/8"	303 STAINLESS STEEL	9	20°

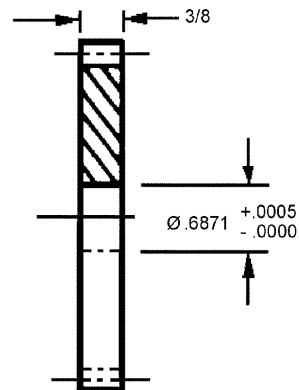
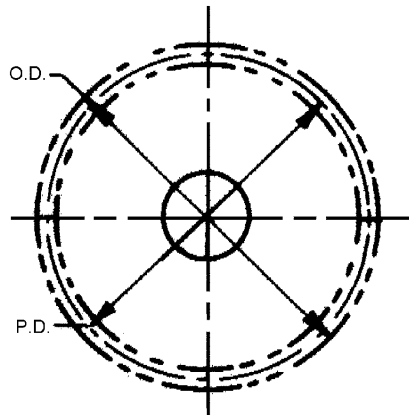

Available on request:
Other numbers of teeth;
Pin or Clamp hubs assembled;
14 - 1/2° pressure angle.

STOCK NO.	NO. OF TEETH	P.D.	O.D.
F16S20-18	18	1.1250	1.250
F16S20-20	20	1.2500	1.375
F16S20-24	24	1.5000	1.625
F16S20-28	28	1.7500	1.875
F16S20-30	30	1.8750	2.000
F16S20-32	32	2.0000	2.125
F16S20-36	36	2.2500	2.375
F16S20-40	40	2.5000	2.625
F16S20-48	48	3.0000	3.125
F16S20-56	56	3.5000	3.625
F16S20-60	60	3.7500	3.875
F16S20-64	64	4.0000	4.125



For Couplings See Section G.
For Shafts, Bearings and Collars See Section I.

SPUR GEARS

PITCH	STYLE	BORE	FACE	MATERIAL	AGMA QUALITY	PRESSURE ANGLE
16	HUBLESS	11/16"	3/8"	POLYURETHANE	8	20°

B

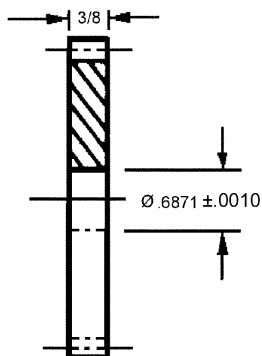
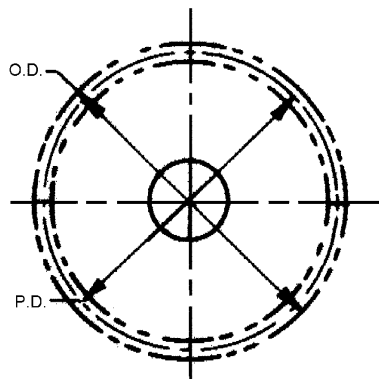

STOCK NO.	NO. OF TEETH	P.D.	O.D.
F16U20-18	18	1.1250	1.250
F16U20-20	20	1.2500	1.375
F16U20-24	24	1.5000	1.625
F16U20-28	28	1.7500	1.875
F16U20-30	30	1.8750	2.000
F16U20-32	32	2.0000	2.120
F16U20-36	36	2.2500	2.375
F16U20-40	40	2.5000	2.625
F16U20-48	48	3.0000	3.125
F16U20-56	56	3.5000	3.625
F16U20-60	60	3.7500	3.875
F16U20-64	64	4.0000	4.125

Available on request:
 Other numbers of teeth;
 Pin or Clamp hubs assembled;
 14 - 1/2° pressure angle.

For Couplings See Section G.
For Shafts, Bearings and Collars See Section I.



SPUR GEARS

PITCH	STYLE	BORE	FACE	MATERIAL	AGMA QUALITY	PRESSURE ANGLE
16	PIN HUB	1/4"	1/2"	ALUMINUM ANODIZED (BLUE)	8	20°

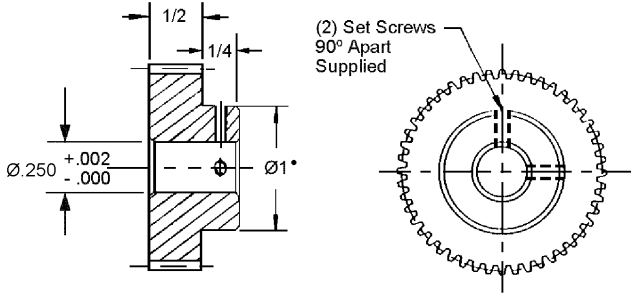

STOCK NO.	NO. OF TEETH	P.D.	O.D.
P16A69-12	12*	.7500	.875
P16A69-13	13*	.8125	.937
P16A69-14	14*	.8750	1.000
P16A69-15	15*	.9375	1.062
P16A69-16	16*	1.0000	1.125
P16A69-18	18*	1.1250	1.250
P16A69-20	20	1.2500	1.375
P16A69-22	22	1.3750	1.500
P16A69-24	24	1.5000	1.625
P16A69-26	26	1.6250	1.750
P16A69-28	28	1.7500	1.875
P16A69-30	30	1.8750	2.000
P16A69-32	32	2.0000	2.120

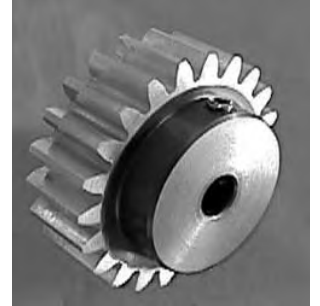

* For 10 - 18 teeth hub diameter equals .47.
Available on request: other numbers of teeth; 14 - 1/2° pressure angle.

PITCH	STYLE	BORE	FACE	MATERIAL	AGMA QUALITY	PRESSURE ANGLE
16	PIN HUB	3/8"	1/2"	303 STAINLESS STEEL	10	20°

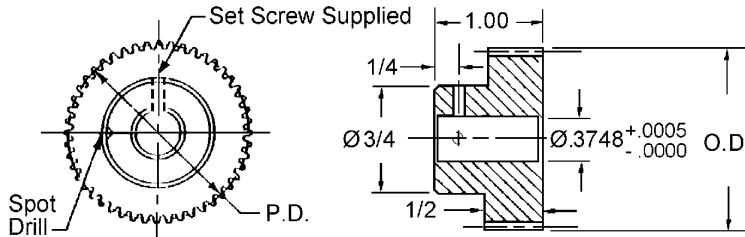

STOCK NO.	NO. OF TEETH	P.D.	O.D.
P16S36-18	18	1.1250	1.250
P16S36-20	20	1.2500	1.375
P16S36-24	24	1.5000	1.625
P16S36-28	28	1.7500	1.875
P16S36-30	30	1.8750	2.000
P16S36-32	32	2.0000	2.125
P16S36-36	36	2.2500	2.375
P16S36-40	40	2.5000	2.625
P16S36-48	48	3.0000	3.125
P16S36-56	56	3.5000	3.625
P16S36-64	64	4.0000	4.125

Available on request:
other numbers of teeth;
14 - 1/2° pressure angle.

PITCH	STYLE	BORE	FACE	MATERIAL	AGMA QUALITY	PRESSURE ANGLE
16	PIN HUB	3/8"	1/2"	ALUMINUM ANODIZED (BLUE)	8	20°

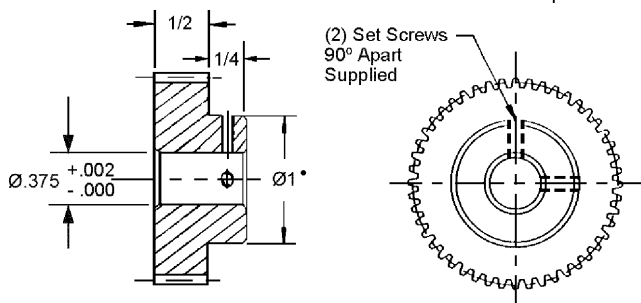

STOCK NO.	NO. OF TEETH	P.D.	O.D.
P16A70-12	12*	.7500	.875
P16A70-13	13*	.8125	.937
P16A70-14	14*	.8750	1.000
P16A70-15	15*	.9375	1.062
P16A70-16	16*	1.0000	1.125
P16A70-18	18*	1.1250	1.250
P16A70-20	20	1.2500	1.375
P16A70-22	22	1.3750	1.500
P16A70-24	24	1.5000	1.625
P16A70-26	26	1.6250	1.750
P16A70-28	28	1.7500	1.875
P16A70-30	30	1.8750	2.000
P16A70-32	32	2.0000	2.120
P16A70-36	36	2.2500	2.375
P16A70-40	40	2.5000	2.625
P16A70-48	48	3.0000	3.125
P16A70-54	54	3.3750	3.500
P16A70-56	56	3.5000	3.625
P16A70-60	60	3.7500	3.875
P16A70-64	64	4.0000	4.125
P16A70-72	72	4.5000	4.625
P16A70-80	80	5.0000	5.125
P16A70-84	84	5.2500	5.375



* For 12 - 18 teeth hub diameter equals .59.
Available on request: other numbers of teeth; 14 - 1/2° pressure angle.

For Couplings See Section G.
For Shafts, Bearings and Collars See Section I.

SPUR GEARS

PITCH	STYLE	BORE	FACE	MATERIAL	AGMA QUALITY	PRESSURE ANGLE
16	PIN HUB	1/2"	1/2"	303 STAINLESS STEEL	10	20°

B

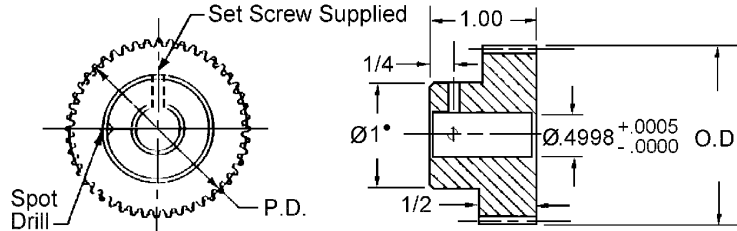

STOCK NO.	NO. OF TEETH	P.D.	O.D.
P16S38-18	18*	1.1250	1.250
P16S38-20	20	1.2500	1.375
P16S38-24	24	1.5000	1.625
P16S38-28	28	1.7500	1.875
P16S38-30	30	1.8750	2.000
P16S38-32	32	2.0000	2.125
P16S38-36	36	2.2500	2.375
P16S38-40	40	2.5000	2.625
P16S38-48	48	3.0000	3.125
P16S38-56	56	3.5000	3.625
P16S38-64	64	4.0000	4.125



* For 15-18 teeth hub diameter equals .78.
Available on request: other numbers of teeth; 14 - 1/2° pressure angle.

PITCH	STYLE	BORE	FACE	MATERIAL	AGMA QUALITY	PRESSURE ANGLE
16	PIN HUB	1/2"	1/2"	ALUMINUM ANODIZED (BLUE)	8	20°

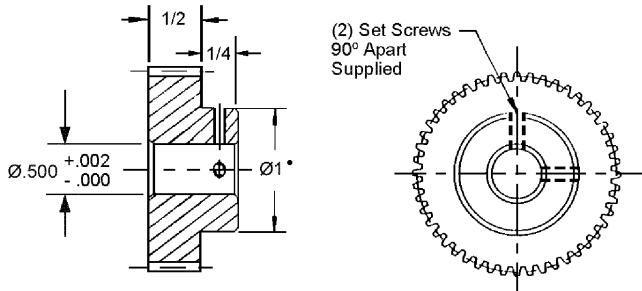

* For 16 - 18 teeth hub diameter equals .84.
Available on request: other numbers of teeth; 14 - 1/2° pressure angle.

STOCK NO.	NO. OF TEETH	P.D.	O.D.
P16A71-16	16*	1.0000	1.125
P16A71-18	18*	1.1250	1.250
P16A71-20	20	1.2500	1.375
P16A71-22	22	1.3750	1.500
P16A71-24	24	1.5000	1.625
P16A71-26	26	1.6250	1.750
P16A71-28	28	1.7500	1.875
P16A71-30	30	1.8750	2.000
P16A71-32	32	2.0000	2.120
P16A71-36	36	2.2500	2.375
P16A71-40	40	2.5000	2.625
P16A71-48	48	3.0000	3.125
P16A71-54	54	3.3750	3.500
P16A71-56	56	3.5000	3.625
P16A71-60	60	3.7500	3.875
P16A71-64	64	4.0000	4.125
P16A71-72	72	4.5000	4.625
P16A71-80	80	5.0000	5.125
P16A71-84	84	5.2500	5.375

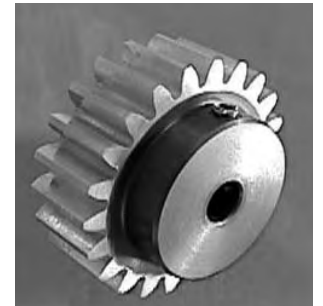

For Couplings See Section G.
For Shafts, Bearings and Collars See Section I.

SPUR GEARS

PITCH	STYLE	BORE	FACE	MATERIAL	AGMA QUALITY	PRESSURE ANGLE
16	PIN HUB	1/4"	3/8"	CAST POLYURETHANE GRAPHITE IMPREGNATED 70D DUROMETER, GREEN	8	20°

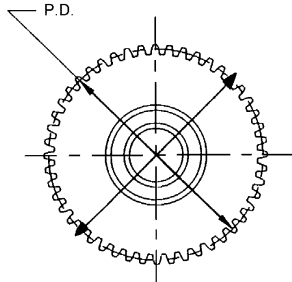
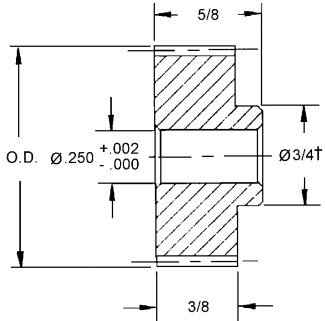

STOCK NO.	NO. OF TEETH	P.D.	O.D.
P16U57-12	12†	.7500	.875
P16U57-16	16	1.0000	1.125
P16U57-18	18	1.1250	1.250
P16U57-20	20	1.2500	1.375
P16U57-24	24	1.5000	1.625
P16U57-28	28	1.7500	1.875
P16U57-30	30	1.8750	2.000
P16U57-32	32	2.0000	2.125
P16U57-40	40	2.5000	2.625
P16U57-48	48	3.0000	3.125



† Teeth runout on hub.
Available on request: other numbers of teeth; 14 - 1/2° pressure angle.

PITCH	STYLE	BORE	FACE	MATERIAL	AGMA QUALITY	PRESSURE ANGLE
16	PIN HUB	3/8"	3/8"	CAST POLYURETHANE GRAPHITE IMPREGNATED 70D DUROMETER, GREEN	8	20°

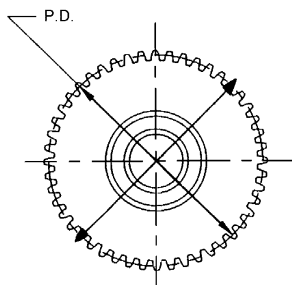
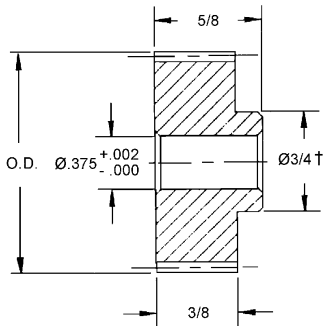

STOCK NO.	NO. OF TEETH	P.D.	O.D.
P16U58-12	12†	.7500	.875
P16U58-16	16	1.0000	1.125
P16U58-18	18	1.1250	1.250
P16U58-20	20	1.2500	1.375
P16U58-24	24	1.5000	1.625
P16U58-28	28	1.7500	1.875
P16U58-30	30	1.8750	2.000
P16U58-32	32	2.0000	2.125
P16U58-40	40	2.5000	2.625
P16U58-48	48	3.0000	3.125



† Teeth runout on hub.
Available on request: other numbers of teeth; 14 - 1/2° pressure angle.

PITCH	STYLE	BORE	FACE	MATERIAL	AGMA QUALITY	PRESSURE ANGLE
16	PIN HUB	1/2"	3/8"	CAST POLYURETHANE GRAPHITE IMPREGNATED 70D DUROMETER, GREEN	8	20°

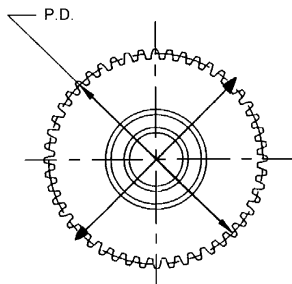
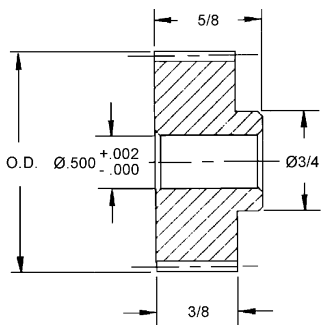

STOCK NO.	NO. OF TEETH	P.D.	O.D.
P16U59-16	16	1.0000	1.125
P16U59-18	18	1.1250	1.250
P16U59-20	20	1.2500	1.375
P16U59-24	24	1.5000	1.625
P16U59-28	28	1.7500	1.875
P16U59-30	30	1.8750	2.000
P16U59-32	32	2.0000	2.125
P16U59-40	40	2.5000	2.625
P16U59-48	48	3.0000	3.125



Available on request: other numbers of teeth; 14 - 1/2° pressure angle.

SPUR GEARS

PITCH	STYLE	BORE	FACE	MATERIAL	AGMA QUALITY	PRESSURE ANGLE
16	CLAMP HUB	3/8"	1/4"	303 STAINLESS STEEL	9	20°

B

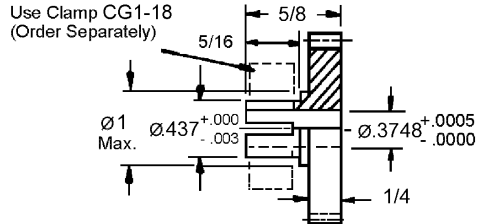
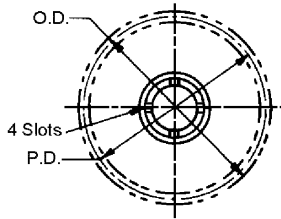

STOCK NO.	NO. OF TEETH	P.D.	O.D.
C16S25-16	16	1.0000	1.125
C16S25-18	18	1.1250	1.250
C16S25-20	20	1.2500	1.375
C16S25-24	24	1.5000	1.625
C16S25-32	32	2.0000	2.125
C16S25-40	40	2.5000	2.625
C16S25-48	48	3.0000	3.125

Available on request: other numbers of teeth;
 AGMA Quality 12 and 14;
 14 - 1/2° pressure angle.

PITCH	STYLE	BORE	FACE	MATERIAL	AGMA QUALITY	PRESSURE ANGLE
16	CLAMP HUB	1/2"	3/8"	303 STAINLESS STEEL	9	20°

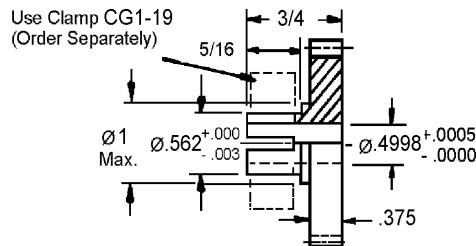
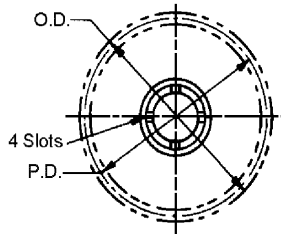

STOCK NO.	NO. OF TEETH	P.D.	O.D.
C16S29-16	16	1.0000	1.125
C16S29-18	18	1.1250	1.250
C16S29-20	20	1.2500	1.375
C16S29-24	24	1.5000	1.625
C16S29-32	32	2.0000	2.125
C16S29-40	40	2.5000	2.625
C16S29-48	48	3.0000	3.125

Available on request: other numbers of teeth;
 14 - 1/2° pressure angle.

For Couplings See Section G.
 For Shafts, Bearings and Collars See Section I.

GEAR RACKS

PITCH	STYLE	MATERIAL	AGMA QUALITY	PRESSURE ANGLE
16	ROUND & RECTANGULAR	416 SERIES STAINLESS STEEL STRESSED RELIEVED	8	20°

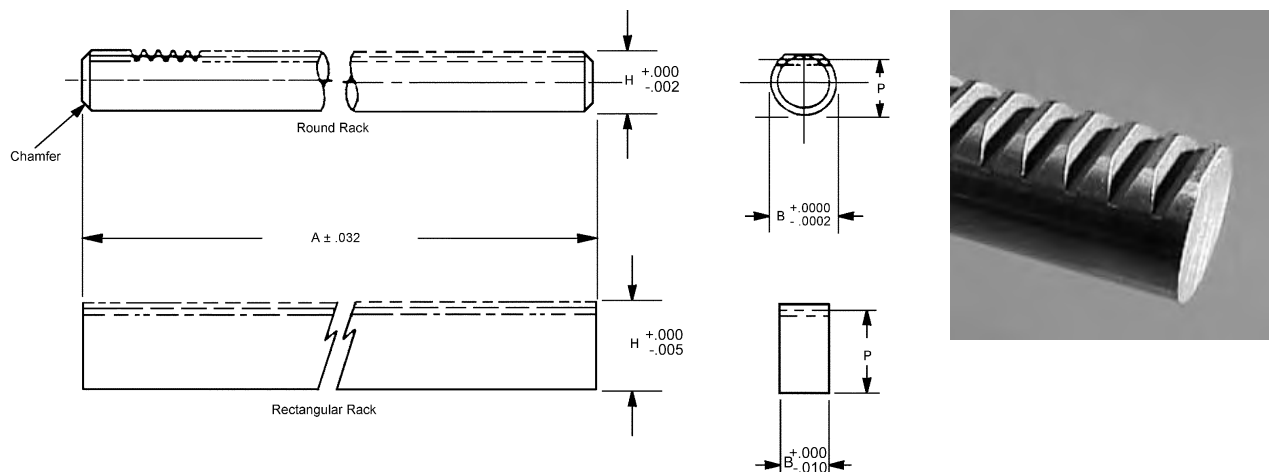

STOCK NO.	RACK STYLE	PITCH	P (Ref.)	B	A	H	AGMA QUALITY
R2-1	ROUND	16	.6175	.7497	.24	.680	8
R2-7	RECTANGULAR	16	.6625	.365	.24	.725	8

Available on request: 14 - 1/2° pressure angle, special, modified and custom racks.

PITCH	STYLE	MATERIAL	AGMA QUALITY	PRESSURE ANGLE
16	RECTANGULAR	416 SERIES STAINLESS STEEL STRESSED RELIEVED	10	20°

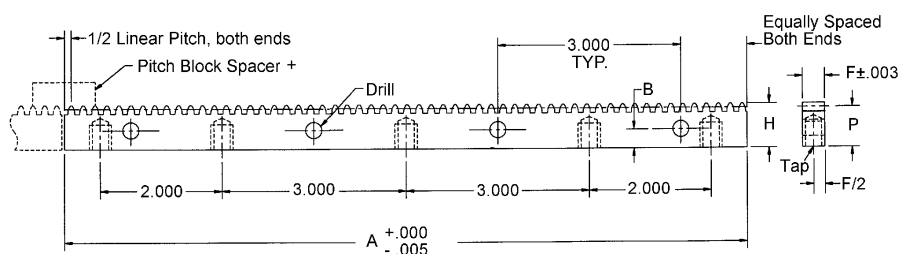

+Spacer block is designed for butting to achieve continuous lengths. On-Line pricing for AGMA 10 only.

RACKS	SPACER BLOCK	AGMA QTY. NO.	MAX ACCUM. ERROR	TOOTH TO TOOTH ERROR	PITCH	LINEAR PITCH	A INCH	P REF.	H +.000 / -.005	F	B	DRILL	TAP
R1-1-G1	R1-1-SB	10*	.0014	.0005	16	.1963	11.185	.6625	.725	.365	.312	17/64	#10-24 x 3/8

* Higher quality on request.

SPUR GEARS

PITCH	STYLE	BORE	FACE	MATERIAL	AGMA QUALITY	PRESSURE ANGLE
20	HUBLESS	11/16"	3/8"	303 STAINLESS STEEL	9	20°

B

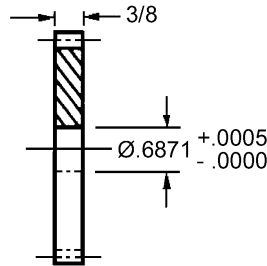
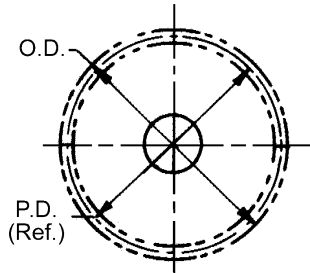

Available on request:
Pin or Clamp hubs assembled
Other numbers of teeth
14 - 1/2° Pressure Angle

STOCK NO.	NO. OF TEETH	PITCH DIA.	OUTSIDE DIA.
F20S20-24	24	1.2000	1.300
F20S20-25	25	1.2500	1.350
F20S20-30	30	1.5000	1.600
F20S20-35	35	1.7500	1.850
F20S20-40	40	2.0000	2.100
F20S20-45	45	2.2500	2.350
F20S20-50	50	2.5000	2.600
F20S20-60	60	3.0000	3.100
F20S20-70	70	3.5000	3.600
F20S20-80	80	4.0000	4.100

PITCH	STYLE	BORE	FACE	MATERIAL	AGMA QUALITY	PRESSURE ANGLE
20	HUBLESS	11/16"	3/8"	POLYURETHANE	8	20°

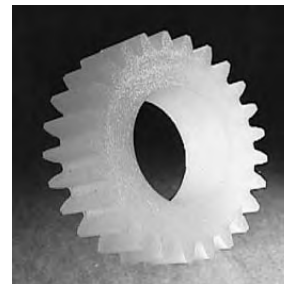
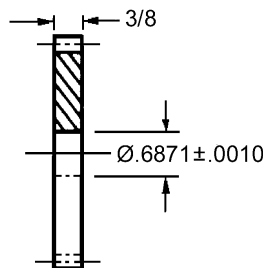
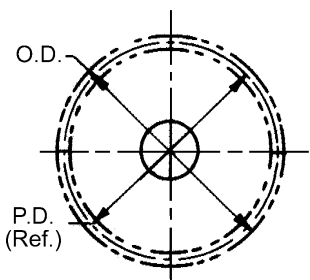

Available on request:
Pin or Clamp hubs assembled
Other numbers of teeth
14 - 1/2° Pressure Angle

STOCK NO.	NO. OF TEETH	PITCH DIA.	OUTSIDE DIA.
F20U20-24	24	1.2000	1.300
F20U20-25	25	1.2500	1.350
F20U20-30	30	1.5000	1.600
F20U20-35	35	1.7500	1.850
F20U20-40	40	2.0000	2.100
F20U20-45	45	2.2500	2.350
F20U20-50	50	2.5000	2.600
F20U20-60	60	3.0000	3.100
F20U20-70	70	3.5000	3.600
F20U20-80	80	4.0000	4.100

For Couplings See Section G.
For Shafts, Bearings and Collars See Section I.

SPUR GEARS

PITCH	STYLE	BORE	FACE	MATERIAL	AGMA QUALITY	PRESSURE ANGLE
20	PIN HUB	1/4"	3/16"	303 STAINLESS STEEL	10	20°

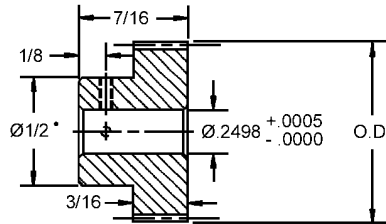
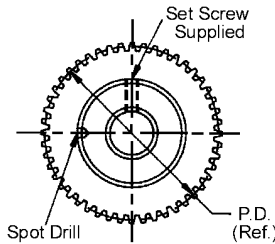

• For 14 - 16 teeth hub diameter equals .57.
Available on request, other numbers of teeth
and 14-1/2° Pressure Angle.

STOCK NO.	NO. OF TEETH	PITCH DIA.	OUTSIDE DIA.
P20S28-14	14•	.7000	.800
P20S28-15	15•	.7500	.850
P20S28-16	16•	.8000	.900
P20S28-18	18	.9000	1.000
P20S28-20	20	1.0000	1.100
P20S28-24	24	1.2000	1.300
P20S28-25	25	1.2500	1.350
P20S28-30	30	1.5000	1.600
P20S28-40	40	2.0000	2.100
P20S28-50	50	2.5000	2.600
P20S28-60	60	3.0000	3.100
P20S28-70	70	3.5000	3.600
P20S28-80	80	4.0000	4.100

PITCH	STYLE	BORE	FACE	MATERIAL	AGMA QUALITY	PRESSURE ANGLE
20	PIN HUB	5/16"	1/4"	303 STAINLESS STEEL	10	20°

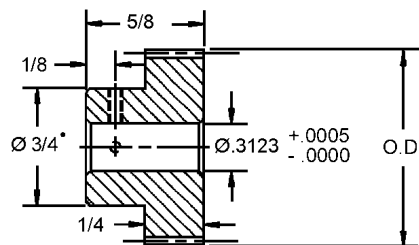
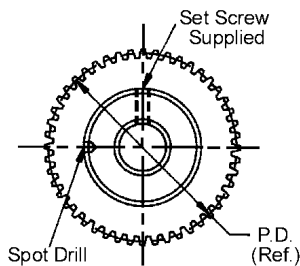

• For 14 - 16 teeth hub diameter equals .57.
Available on request, other numbers of teeth
and 14-1/2° Pressure Angle.

STOCK NO.	NO. OF TEETH	PITCH DIA.	OUTSIDE DIA.
P20S33-14	14•	.7000	.800
P20S33-15	15•	.7500	.850
P20S33-16	16•	.8000	.900
P20S33-18	18	.9000	1.000
P20S33-20	20	1.0000	1.100
P20S33-24	24	1.2000	1.300
P20S33-25	25	1.2500	1.350
P20S33-30	30	1.5000	1.600
P20S33-40	40	2.0000	2.100
P20S33-50	50	2.5000	2.600
P20S33-60	60	3.0000	3.100
P20S33-70	70	3.5000	3.600
P20S33-80	80	4.0000	4.100

For Couplings See Section G.
For Shafts, Bearings and Collars See Section I.

SPUR GEARS

PITCH	STYLE	BORE	FACE	MATERIAL	AGMA QUALITY	PRESSURE ANGLE
20	PIN HUB	3/8"	3/8"	303 STAINLESS STEEL	10	20°

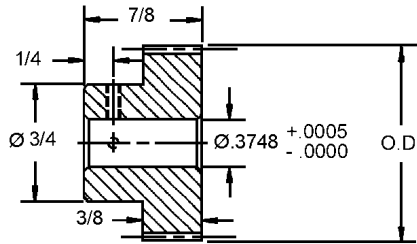
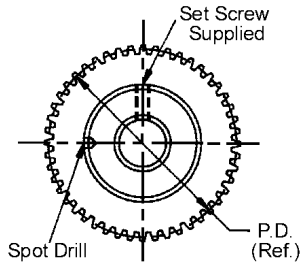

Available on request, other numbers of teeth and 14-1/2° Pressure Angle.

STOCK NO.	NO. OF TEETH	PITCH DIA.	OUTSIDE DIA.
P20S35-24	24	1.2000	1.300
P20S35-25	25	1.2500	1.350
P20S35-30	30	1.5000	1.600
P20S35-35	35	1.7500	1.850
P20S35-40	40	2.0000	2.100
P20S35-45	45	2.5000	2.350
P20S35-50	50	2.5000	2.600
P20S35-60	60	3.0000	3.100
P20S35-70	70	3.5000	3.600
P20S35-80	80	4.0000	4.100

PITCH	STYLE	BORE	FACE	MATERIAL	AGMA QUALITY	PRESSURE ANGLE
20	PIN HUB	3/8"	3/8"	303 STAINLESS STEEL OR BRONZE ALLOY 464	10	20°

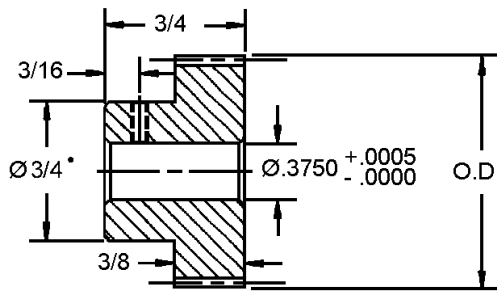
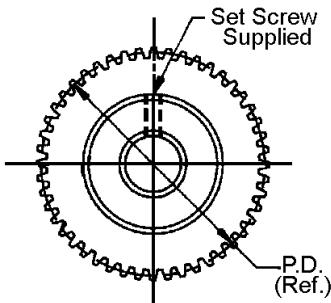

* For 14 - 16 teeth hub diameter equals .57
Available on request, other numbers of teeth and 14-1/2° Pressure Angle.

303 STAINLESS STEEL STOCK NO.	BRONZE ALLOY 464 STOCK NO.	NO. OF TEETH	PITCH DIA.	OUTSIDE DIA.
P20S34-14	P20B34-14	14*	.7000	.800
P20S34-15	P20B34-15	15*	.7500	.850
P20S34-16	P20B34-16	16*	.8000	.900
P20S34-18	P20B34-18	18	.9000	1.000
P20S34-20	P20B34-20	20	1.0000	1.100
P20S34-24	P20B34-24	24	1.2000	1.300
P20S34-28	P20B34-28	28	1.4000	1.500
P20S34-30	P20B34-30	30	1.5000	1.600
P20S34-36	P20B34-36	36	1.8000	1.900
P20S34X-40	P20B34X-40	40	2.0000	2.100
P20S34X-48	P20B34X-48	48	2.4000	2.500
P20S34X-56	P20B34X-56	56	2.8000	2.900
P20S34X-60	P20B34X-60	60	3.0000	3.100
P20S34X-72	P20B34X-72	72	3.6000	3.700
P20S34X-80	P20B34X-80	80	4.0000	4.100
P20S34X-84	P20B34X-84	84	4.2000	4.300
P20S34X-96	P20B34X-96	96	4.8000	4.900
P20S34X-100	P20B34X-100	100	5.0000	5.100

SPUR GEARS

PITCH	STYLE	BORE	FACE	MATERIAL	AGMA QUALITY	PRESSURE ANGLE
20	PIN HUB	1/2"	3/8"	303 STAINLESS STEEL	10	20°

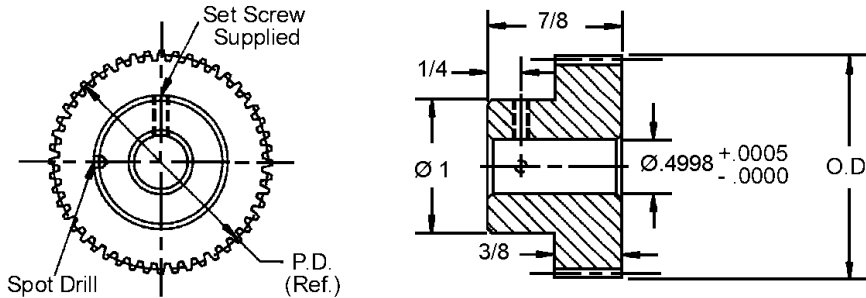

STOCK NO.	NO. OF TEETH	PITCH DIA.	OUTSIDE DIA.
P20S37-24	24	1.2000	1.300
P20S37-25	25	1.2500	1.350
P20S37-30	30	1.5000	1.600
P20S37-35	35	1.7500	1.850
P20S37-40	40	2.0000	2.100
P20S37-45	45	2.5000	2.350
P20S37-50	50	2.5000	2.600
P20S37-60	60	3.0000	3.100
P20S37-70	70	3.5000	3.600
P20S37-80	80	4.0000	4.100

Available on request, other numbers of teeth and 14-1/2° Pressure Angle.

PITCH	STYLE	BORE	FACE	MATERIAL	AGMA QUALITY	PRESSURE ANGLE
20	PIN HUB	1/4"	3/16"	17-4 PH STAINLESS STEEL RC 32-38	10	20°

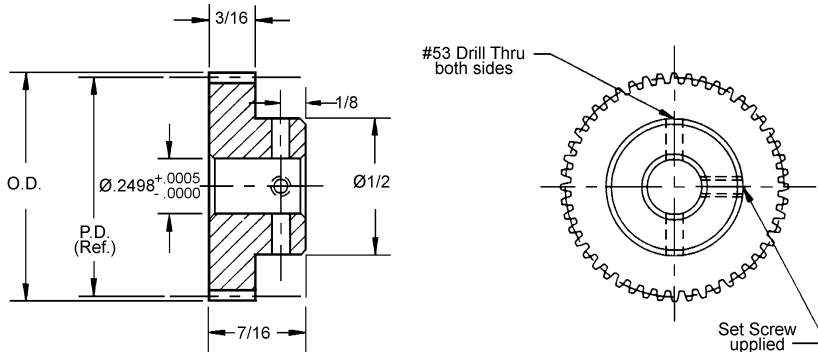

STOCK NO.	NO. OF TEETH	PITCH DIA.	OUTSIDE DIA.
P20PH28-12	12	.6000	.700
P20PH28-14	14	.7000	.800
P20PH28-15	15	.7500	.850
P20PH28-16	16	.8000	.900
P20PH28-18	18	.9000	1.000
P20PH28-20	20	1.0000	1.100
P20PH28-24	24	1.2000	1.300
P20PH28-25	25	1.2500	1.350

Available on request, other numbers of teeth, quality 12 and 14-1/2° Pressure Angle.

PITCH	STYLE	BORE	FACE	MATERIAL	AGMA QUALITY	PRESSURE ANGLE
20	PIN HUB	1/4"	3/8"	CAST POLYURETHANE GRAPHITE IMPREGNATED 70D DUROMETER, GREEN	8	20°

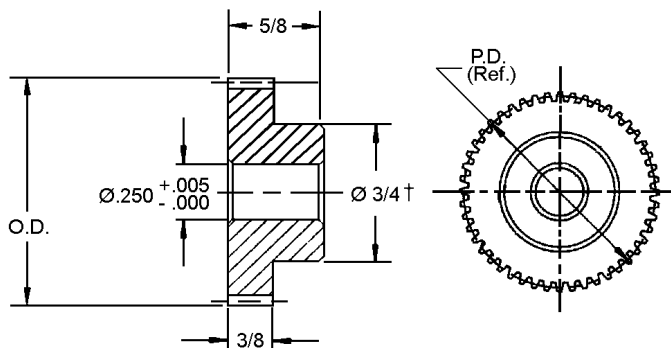

STOCK NO.	NO. OF TEETH	PITCH DIA.	OUTSIDE DIA.
P20U57-15	15†	.7500	.850
P20U57-16	16†	.8000	.900
P20U57-20	20	1.0000	1.100
P20U57-24	24	1.2000	1.300
P20U57-25	25	1.2500	1.350
P20U57-30	30	1.5000	1.600
P20U57-35	35	1.7500	1.850
P20U57-40	40	2.0000	2.100
P20U57-50	50	2.5000	2.600
P20U57-60	60	3.0000	3.100

† Teeth runout on hub.
Available on request, other numbers of teeth, quality 12 and 14-1/2° Pressure Angle.

SPUR GEARS

PITCH	STYLE	BORE	FACE	MATERIAL	AGMA QUALITY	PRESSURE ANGLE
20	PIN HUB	3/8"	3/8"	CAST POLYURETHANE GRAPHITE IMPREGNATED 70D DUROMETER	8	20°

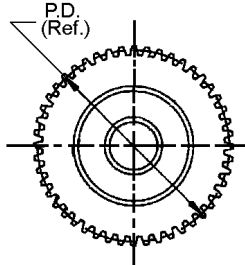
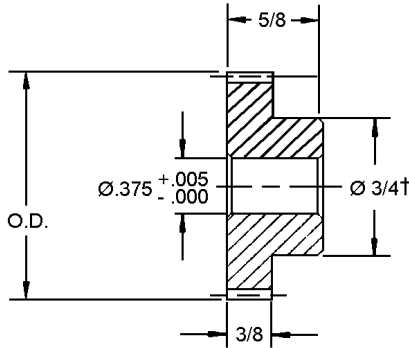

† Teeth runout on hub.
Available on request, other numbers of teeth,
quality 12 and 14-1/2° Pressure Angle.

STOCK NO.	NO. OF TEETH	PITCH DIA.	OUTSIDE DIA.
P20U58-15	15†	.7500	.850
P20U58-16	16†	.8000	.900
P20U58-20	20	1.0000	1.100
P20U58-24	24	1.2000	1.300
P20U58-25	25	1.2500	1.350
P20U58-30	30	1.5000	1.600
P20U58-35	35	1.7500	1.850
P20U58-40	40	2.0000	2.100
P20U58-50	50	2.5000	2.600
P20U58-60	60	3.0000	3.100

PITCH	STYLE	BORE	FACE	MATERIAL	AGMA QUALITY	PRESSURE ANGLE
20	PIN HUB	1/2"	3/8"	CAST POLYURETHANE GRAPHITE IMPREGNATED 70D DUROMETER	8	20°

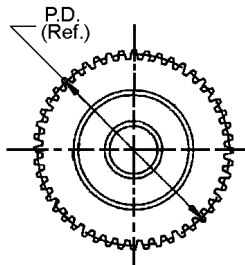
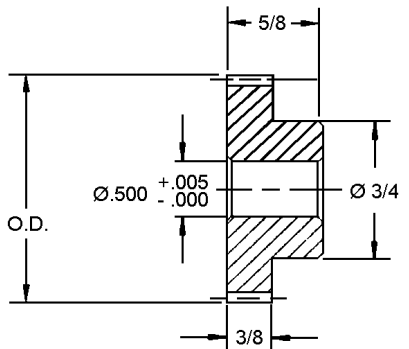

† Teeth runout on hub.
Available on request, other numbers of teeth,
quality 12 and 14-1/2° Pressure Angle.

STOCK NO.	NO. OF TEETH	PITCH DIA.	OUTSIDE DIA.
P20U59-16	16†	.8000	.900
P20U59-20	20	1.0000	1.100
P20U59-24	24	1.2000	1.300
P20U59-25	25	1.2500	1.350
P20U59-30	30	1.5000	1.600
P20U59-35	35	1.7500	1.850
P20U59-40	40	2.0000	2.100
P20U59-50	50	2.5000	2.600
P20U59-60	60	3.0000	3.100

For Couplings See Section G.
For Shafts, Bearings and Collars See Section I.

SPUR GEARS

PITCH	STYLE	BORE	FACE	MATERIAL	AGMA QUALITY	PRES. ANGLE
20	PIN HUB	1/4" TO 3/8"	3/8"	CAST POLYURETHANE GRAPHITE IMPREGNATED 70D DUROMETER	5	20°

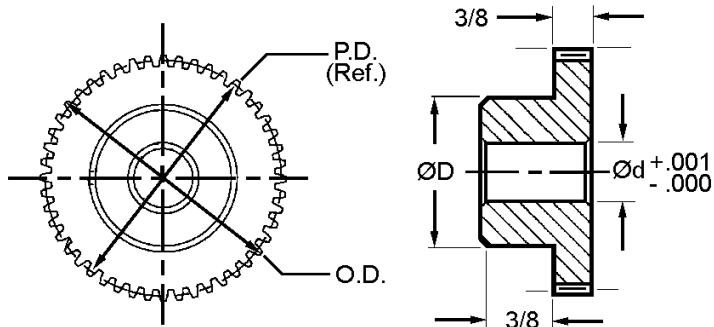

STOCK NO.	NO. OF TEETH	PITCH DIA.	OUTSIDE DIA.	Ød	ØD
P20D4P-12	12	.600	.700	1/4	15/32
P20D4P-13	13	.650	.750	1/4	1/2
P20D4P-14	14	.700	.800	5/16	9/16
P20D4P-15	15	.750	.850	5/16	19/32
P20D4P-16	16	.800	.900	5/16	39/64
P20D4P-17	17	.850	.950	5/16	43/64
P20D4P-18	18	.900	1.000	5/16	43/64
P20D4P-19	19	.950	1.050	3/8	47/64
P20D4P-20	20	1.000	1.100	3/8	47/64
P20D4P-21	21	1.050	1.150	3/8	47/64
P20D4P-22	22	1.100	1.200	3/8	3/4
P20D4P-23	23	1.150	1.250	3/8	47/64
P20D4P-24	24	1.200	1.300	3/8	47/64
P20D4P-25	25	1.250	1.350	3/8	47/64
P20D4P-26	26	1.300	1.400	3/8	47/64
P20D4P-28	28	1.400	1.500	3/8	47/64
P20D4P-30	30	1.500	1.600	3/8	47/64
P20D4P-32	32	1.600	1.700	3/8	47/64
P20D4P-34	34	1.700	1.800	3/8	47/64
P20D4P-35	35	1.750	1.850	3/8	47/64
P20D4P-36	36	1.800	1.900	3/8	47/64
P20D4P-38	38	1.900	2.000	3/8	47/64
P20D4P-40	40	2.000	2.100	3/8	47/64
P20D4P-41	41	2.050	2.150	3/8	47/64
P20D4P-42	42	2.100	2.200	3/8	47/64
P20D4P-44	44	2.200	2.300	3/8	47/64
P20D4P-45	45	2.250	2.350	3/8	47/64
P20D4P-46	46	2.300	2.400	3/8	47/64
P20D4P-48	48	2.400	2.500	3/8	47/64
P20D4P-50	50	2.500	2.600	3/8	3/4

Some molded gears may have webs.

**For Couplings See Section G.
For Shafts, Bearings and Collars See Section I.**

SPUR GEARS

B

PITCH	STYLE	BORE	FACE	MATERIAL	AGMA QUALITY	PRES. ANGLE
20	CLAMP HUB	5/16"	1/4"	303 STAINLESS STEEL	10	20°

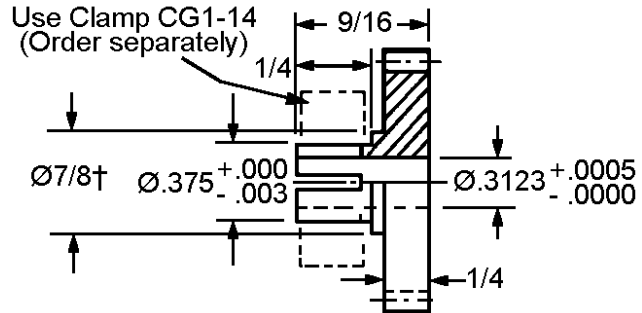
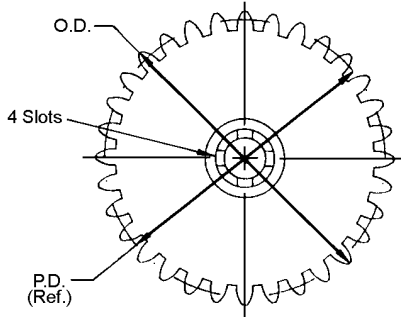

STOCK NO.	NO. OF TEETH	PITCH DIA.	OUTSIDE DIA.
C20S22-16	16†	.800	.900
C20S22-20	20	1.000	1.100
C20S22-24	24	1.200	1.300
C20S22-32	32	1.600	1.700
C20S22-40	40	2.000	2.100
C20S22-48	48	2.400	2.500
C20S22-50	50	2.500	2.600
C20S22-55	55	2.750	2.850
C20S22-60	60	3.000	3.100

† Teeth may runout on flange diameter
Available on request: Other numbers of teeth,
14-1/2° Pressure Angle.

PITCH	STYLE	BORE	FACE	MATERIAL	AGMA QUALITY	PRES. ANGLE
20	CLAMP HUB	3/8"	1/4"	303 STAINLESS STEEL	10	20°

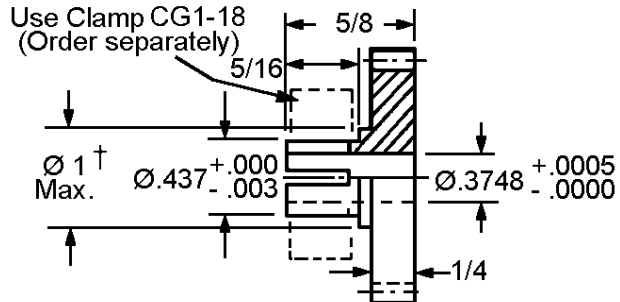
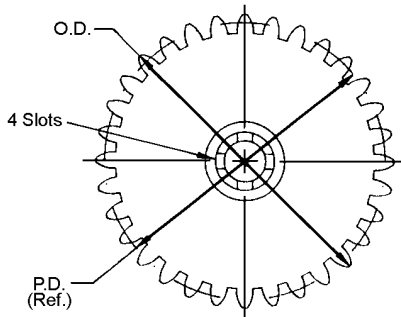

STOCK NO.	NO. OF TEETH	PITCH DIA.	OUTSIDE DIA.
C20S25-16	16†	.800	.900
C20S25-20	20	1.000	1.100
C20S25-24	24	1.200	1.300
C20S25-32	32	1.600	1.700
C20S25-40	40	2.000	2.100
C20S25-48	48	2.400	2.500
C20S25-50	50	2.500	2.600
C20S25-55	55	2.750	2.850
C20S25-60	60	3.000	3.100

† Teeth may runout on flange diameter
Available on request: Other numbers of teeth,
14-1/2° Pressure Angle.

GEAR RACKS

PITCH	STYLE	MATERIAL	AGMA QUALITY	PRESSURE ANGLE
20	ROUND & RECTANGULAR	416 SERIES STAINLESS STEEL STRESSED RELIEVED	8	20°

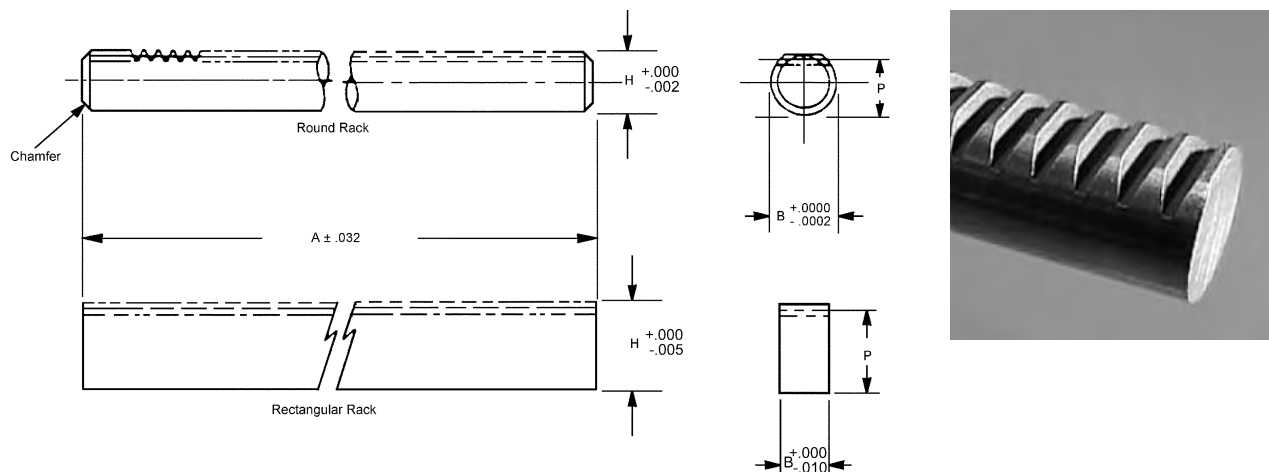

STOCK NO.	RACK STYLE	PITCH	P (Ref.)	B	A	H	AGMA QUALITY
R2-2	ROUND	20	.4800	.6247	24	.530	8
R2-8	RECTANGULAR	20	.6750	.365±.010	24	.725	8

Available on request: 14 - 1/2° pressure angle, special, modified and custom racks.

PITCH	STYLE	MATERIAL	AGMA QUALITY	PRESSURE ANGLE
20	RECTANGULAR	416 SERIES STAINLESS STEEL STRESSED RELIEVED	10	20°

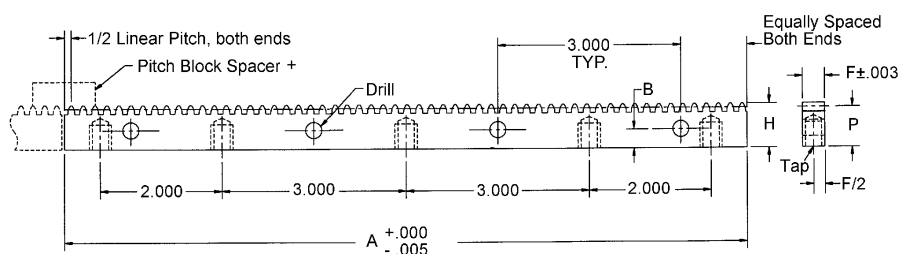

†Spacer block is designed for butting to achieve continuous lengths. On-Line pricing for AGMA 10 only.

RACKS	SPACER BLOCK	AGMA QTY. NO.	MAX ACCUM. ERROR	TOOTH TO TOOTH ERROR	PITCH	LINEAR PITCH	A INCH	P REF.	H +.000 / -.005	F	B	DRILL	TAP
R1-2-G1	R1-2-SB	10*	.0014	.0005	20	.1570	11.147	.6750	.725	.365	.312	17/64	#10-24 x 3/8

* Higher quality on request.

SPUR GEARS

PITCH	STYLE	BORE	FACE	MATERIAL	AGMA QUALITY	PRESSURE ANGLE
24	HUBLESS	3/8"	1/4"	303 STAINLESS STEEL AND 2024-T4 ALUMINUM ANODIZED	10	20°

B

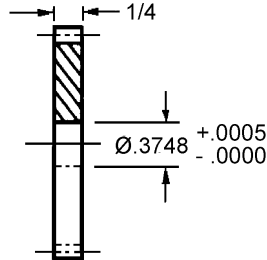
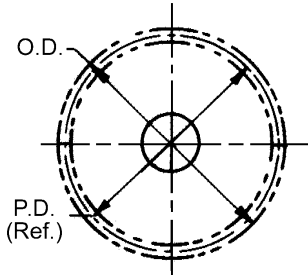

Available on request:
Pin or Clamp hubs assembled
Other numbers of teeth
14 - 1/2° Pressure Angle

303 STAINLESS STEEL STOCK NO.	2024-T4 ALUMINUM ANODIZED STOCK NO.	NO. OF TEETH	PITCH DIA.	OUTSIDE DIA.
F24S6-24	F24A6-24	24	1.0000	1.083
F24S6-30	F24A6-30	30	1.2500	1.333
F24S6-32	F24A6-32	32	1.3333	1.416
F24S6-36	F24A6-36	36	1.5000	1.583
F24S6-48	F24A6-48	48	2.0000	2.083
F24S6-60	F24A6-60	60	2.5000	2.583
F24S6-64	F24A6-64	64	2.6666	2.750
F24S6-72	F24A6-72	72	3.0000	3.083
F24S6-96	F24A6-96	96	4.0000	4.083

PITCH	STYLE	BORE	FACE	MATERIAL	AGMA QUALITY	PRESSURE ANGLE
24	HUBLESS	3/8"	1/4"	ALUMINUM RED ANODIZED	8	20°

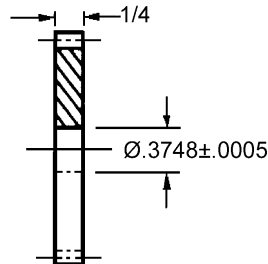
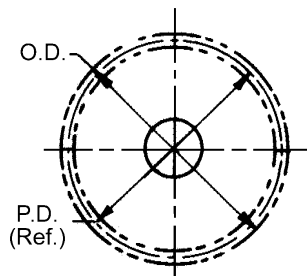

Available on request:
Other numbers of teeth
14 - 1/2° Pressure Angle

STOCK NO.	NO. OF TEETH	PITCH DIA.	OUTSIDE DIA.
F24A77-15	15	.6250	.708
F24A77-16	16	.6666	.750
F24A77-18	18	.7500	.833
F24A77-20	20	.8333	.916
F24A77-21	21	.8750	.958
F24A77-24	24	1.0000	1.083
F24A77-30	30	1.2500	1.333
F24A77-36	36	1.5000	1.583
F24A68-42	42	1.7500	1.833
F24A68-48	48	2.0000	2.083
F24A68-60	60	2.5000	2.583
F24A68-72	72	3.0000	3.083
F24A68-96	96	4.0000	4.083
F24A68-120	120	5.0000	5.083
F24A68-144	144	6.0000	6.083

For Couplings See Section G.
For Shafts, Bearings and Collars See Section I.

SPUR GEARS

PITCH	STYLE	BORE	FACE	MATERIAL	AGMA QUALITY	PRESSURE ANGLE
24	HUBLESS	3/8"	1/4"	POLYURETHANE	8	20°

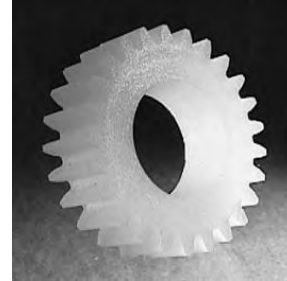
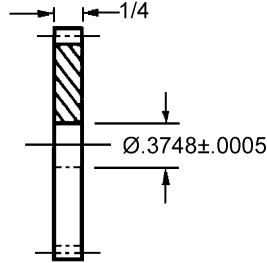
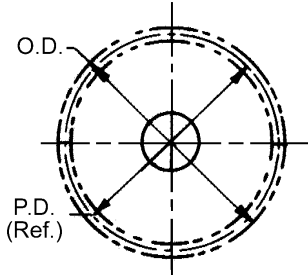

Available on request:
Other numbers of teeth
14 - 1/2° Pressure Angle

STOCK NO.	NO. OF TEETH	PITCH DIA.	OUTSIDE DIA.
F24U6-24	24	1.0000	1.083
F24U6-30	30	1.2500	1.333
F24U6-32	32	1.3333	1.416
F24U6-36	36	1.5000	1.583
F24U6-42	42	1.7500	1.833
F24U6-48	48	2.0000	2.083
F24U6-60	60	2.5000	2.583
F24U6-64	64	2.6666	2.750
F24U6-72	72	3.0000	3.083
F24U6-96	96	4.0000	4.083

PITCH	STYLE	BORE	FACE	MATERIAL	AGMA QUALITY	PRESSURE ANGLE
24	HUBLESS	3/8"	3/16"	DELTRIN	10	20°

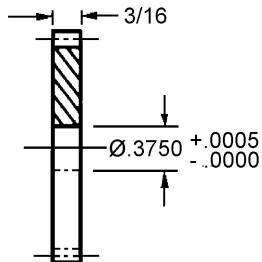
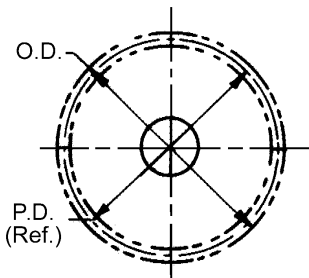

STOCK NO.	NO. OF TEETH	PITCH DIA.	OUTSIDE DIA.
F24D5-15	15	.6250	.708
F24D5-16	16	.6666	.750
F24D5-17	17	.7083	.791
F24D5-18	18	.7500	.833
F24D5-19	19	.7916	.875
F24D5-20	20	.8333	.916
F24D5-21	21	.8750	.958
F24D5-22	22	.9166	1.000
F24D5-23	23	.9583	1.041
F24D5-24	24	1.0000	1.083
F24D5-25	25	1.0416	1.125
F24D5-28	28	1.1666	1.250
F24D5-30	30	1.2500	1.333
F24D5-32	32	1.3333	1.416
F24D5-33	33	1.3750	1.458
F24D5-36	36	1.5000	1.583
F24D5-40	40	1.6666	1.750
F24D5-42	42	1.7500	1.833
F24D5-45	45	1.8750	1.958
F24D5-46	46	1.9166	2.000
F24D5-48	48	2.0000	2.083
F24D5-50	50	2.0833	2.166
F24D5-52	52	2.1666	2.250
F24D5-55	55	2.2916	2.375
F24D5-56	56	2.3333	2.416
F24D5-57	57	2.3750	2.458
F24D5-60	60	2.5000	2.583
F24D5-64	64	2.6666	2.750
F24D5-66	66	2.7500	2.833
F24D5-69	69	2.8750	2.958
F24D5-72	72	3.0000	3.083
F24D5-78	78	3.2500	3.333
F24D5-84	84	3.5000	3.583
F24D5-90	90	3.7500	3.833
F24D5-93	93	3.8750	3.958

Available on request:
Other numbers of teeth
14 - 1/2° Pressure Angle

CLUSTER GEAR AND HUB

B

PITCH	STYLE	BORE	MATERIAL	AGMA QUALITY	PRESSURE ANGLE
24	X	1/4"	303 STAINLESS STEEL	10	20°

STOCK NO.	PITCH	NO. OF TEETH	PITCH DIA.	OUTSIDE DIA.
DP24S14-12	24	12	.5000	.583
DP24S14-13		13	.5418	.625
DP24S14-15		15	.6250	.708

PITCH	STYLE	BORE	MATERIAL	AGMA QUALITY	PRESSURE ANGLE
24	Y	1/4"	303 STAINLESS STEEL	10	20°

STOCK NO.	PITCH	NO. OF TEETH	PITCH DIA.	OUTSIDE DIA.
DP24S16-12	24	12	.5000	.583
DP24S16-13		13	.5418	.625
DP24S16-15		15	.6250	.708

PITCH	STYLE	BORE	MATERIAL	AGMA QUALITY	PRESSURE ANGLE
24	Z	1/4"	303 STAINLESS STEEL	10	20°

STOCK NO.	PITCH	NO. OF TEETH	PITCH DIA.	OUTSIDE DIA.
DP24S16-12	24	12	.5000	.583
DP24S16-13		13	.5418	.625
DP24S16-15		15	.6250	.708

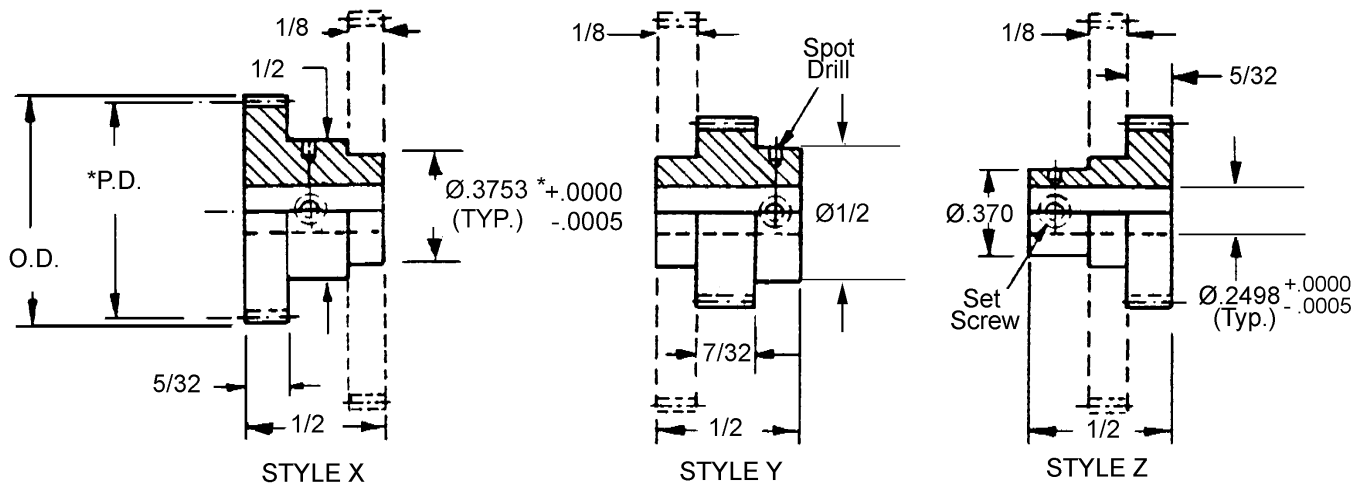

*Concentric within .0003
Order hubless gear separately.

For Couplings See Section G.
For Shafts, Bearings and Collars See Section I.

SPUR GEARS

PITCH	STYLE	BORE	FACE	MATERIAL	AGMA QUALITY	PRESSURE ANGLE
24	PIN HUB	3/16"	3/16"	303 STAINLESS STEEL OR ALUMINUM ANODIZED	10	20°

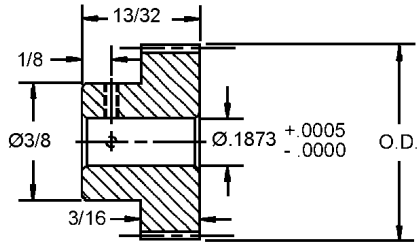
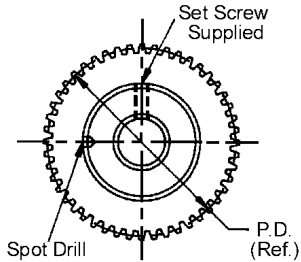

Available on request, other numbers of teeth and 14-1/2° Pressure Angle.

303 STAINLESS STEEL STOCK NO.	2024-T4 ALUMINUM ANODIZED STOCK NO.	NO. OF TEETH	PITCH DIA.	OUTSIDE DIA.
P24S21-15	P24A21-15	15	.6250	.708
P24S21-16	P24A21-16	16	.6666	.750
P24S21-18	P24A21-18	18	.7500	.833
P24S21-20	P24A21-20	20	.8333	.916
P24S21-22	P24A21-22	22	.9166	1.000
P24S21-24	P24A21-24	24	1.0000	1.083
P24S21-30	P24A21-30	30	1.2500	1.333
P24S21-36	P24A21-36	36	1.5000	1.583
P24S21-42	P24A21-42	42	1.7500	1.833
P24S21-48	P24A21-48	48	2.0000	2.083
P24S21-54	P24A21-54	54	2.2500	2.333
P24S21-60	P24A21-60	60	2.5000	2.583
P24S21-72	P24A21-72	72	3.0000	3.083
P24S21-84	P24A21-84	84	3.5000	3.583
P24S21-96	P24A21-96	96	4.0000	4.083

For Couplings See Section G.
For Shafts, Bearings and Collars See Section I.

SPUR GEARS

PITCH	STYLE	BORE	FACE	MATERIAL	AGMA QUALITY	PRESSURE ANGLE
24	PIN HUB	1/4"	3/16"	303 STAINLESS STEEL OR ALUMINUM ANODIZED	10	20°

B

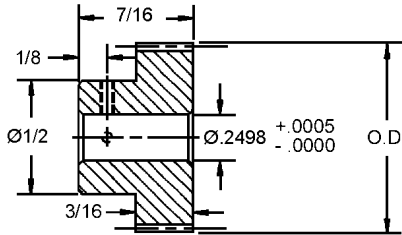
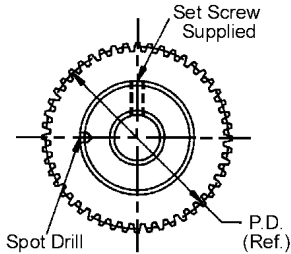

Available on request, other numbers of teeth and 14-1/2° Pressure Angle.

303 STAINLESS STEEL STOCK NO.	2024-T4 ALUMINUM ANODIZED STOCK NO.	NO. OF TEETH	PITCH DIA.	OUTSIDE DIA.
P24S28-15	P24A28-15	15	.6250	.708
P24S28-16	P24A28-16	16	.6666	.750
P24S28-18	P24A28-18	18	.7500	.833
P24S28-20	P24A28-20	20	.8333	.916
P24S28-21	P24A28-21	21	.8750	.958
P24S28-22	P24A28-22	22	.9166	1.000
P24S28-24	P24A28-24	24	1.0000	1.083
P24S28-27	P24A28-27	27	1.1250	1.208
P24S28-30	P24A28-30	30	1.2500	1.333
P24S28-33	P24A28-33	33	1.3750	1.458
P24S28-36	P24A28-36	36	1.5000	1.583
P24S28-39	P24A28-39	39	1.6250	1.708
P24S28-42	P24A28-42	42	1.7500	1.833
P24S28-45	P24A28-45	45	1.8750	1.958
P24S28-48	P24A28-48	48	2.0000	2.083
P24S28-51	P24A28-51	51	2.1250	2.208
P24S28-54	P24A28-54	54	2.2500	2.333
P24S28-57	P24A28-57	57	2.3750	2.458
P24S28-60	P24A28-60	60	2.5000	2.583
P24S28-63	P24A28-63	63	2.6250	2.708
P24S28-66	P24A28-66	66	2.7500	2.833
P24S28-69	P24A28-69	69	2.8750	2.958
P24S28-72	P24A28-72	72	3.0000	3.083
P24S28-75	P24A28-75	75	3.1250	3.208
P24S28-78	P24A28-78	78	3.2500	3.333
P24S28-81	P24A28-81	81	3.3750	3.458
P24S28-84	P24A28-84	84	3.5000	3.583
P24S28-87	P24A28-87	87	3.6250	3.708
P24S28-90	P24A28-90	90	3.7500	3.833
P24S28-93	P24A28-93	93	3.8750	3.958
P24S28-96	P24A28-96	96	4.0000	4.083
P24S28-99	P24A28-99	99	4.1250	4.208
P24S28-100	P24A28-100	100	4.1666	4.250
P24S28-105	P24A28-105	105	4.3750	4.458

For Couplings See Section G.
For Shafts, Bearings and Collars See Section I.

SPUR GEARS

PITCH	STYLE	BORE	FACE	MATERIAL	AGMA QUALITY	PRESSURE ANGLE
24	PIN HUB	1/4"	1/4"	ALUMINUM RED ANODIZED	8	20°

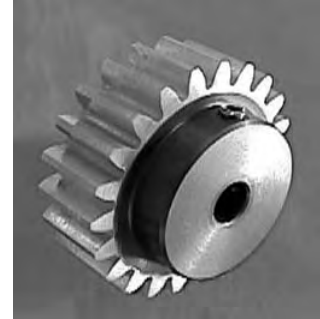
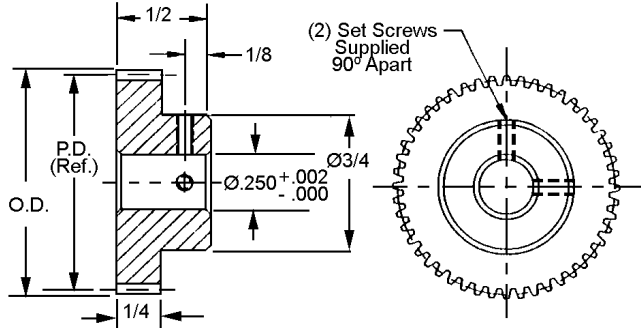

Available on request:
Other numbers of teeth
14 - 1/2° Pressure Angle

For 14-20 teeth
Hub diameter equals $\varnothing.44$

STOCK NO.	NO. OF TEETH	PITCH DIA.	OUTSIDE DIA.
P24A66-14	14	.5833	.666
P24A66-15	15	.6250	.708
P24A66-16	16	.6666	.750
P24A66-18	18	.7500	.833
P24A66-20	20	.8333	.916
P24A66-21	21	.8750	.958
P24A66-24	24	1.0000	1.083
P24A66-30	30	1.2500	1.333
P24A66-36	36	1.5000	1.583
P24A66-42	42	1.7500	1.833
P24A66-48	48	2.0000	2.083
P24A66-60	60	2.5000	2.583
P24A66-72	72	3.0000	3.083
P24A66-96	96	4.0000	4.083
P24A66-120	120	5.0000	5.083
P24A66-144	144	6.0000	6.083

PITCH	STYLE	BORE	FACE	MATERIAL	AGMA QUALITY	PRESSURE ANGLE
24	PIN HUB	5/16"	3/16"	303 STAINLESS STEEL	10	20°

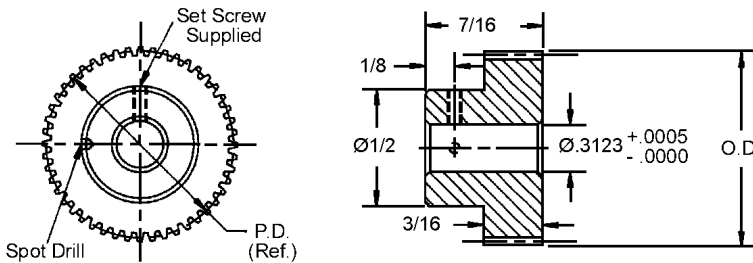

Available on request, other numbers of teeth
and 14-1/2° Pressure Angle.

STOCK NO.	NO. OF TEETH	PITCH DIA.	OUTSIDE DIA.
P24S32-15	15	.6250	.708
P24S32-18	18	.7500	.833
P24S32-21	21	.8750	.958
P24S32-24	24	1.0000	1.083
P24S32-30	30	1.2500	1.333
P24S32-36	36	1.5000	1.583
P24S32-48	48	2.0000	2.083
P24S32-72	72	3.0000	3.083
P24S32-84	84	3.5000	3.583
P24S32-96	96	4.0000	4.083

SPUR GEARS

PITCH	STYLE	BORE	FACE	MATERIAL	AGMA QUALITY	PRESSURE ANGLE
24	PIN HUB	3/8"	3/8"	303 STAINLESS STEEL	10	20°

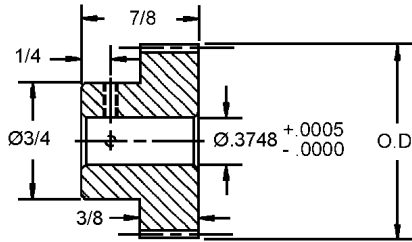
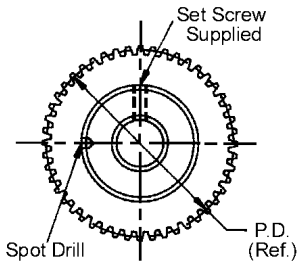

Available on request, other numbers of teeth and 14-1/2° Pressure Angle.

STOCK NO.	NO. OF TEETH	PITCH DIA.	OUTSIDE DIA.
P24S35-30	30	1.2500	1.333
P24S35-36	36	1.5000	1.583
P24S35-42	42	1.7500	1.833
P24S35-48	48	2.0000	2.083
P24S35-60	60	2.5000	2.583
P24S35-72	72	3.0000	3.083
P24S35-84	84	3.5000	3.583
P24S35-96	96	4.0000	4.083

PITCH	STYLE	BORE	FACE	MATERIAL	AGMA QUALITY	PRESSURE ANGLE
24	PIN HUB	3/8"	3/8"	303 STAINLESS STEEL OR BRONZE ALLOY 464	10	20°

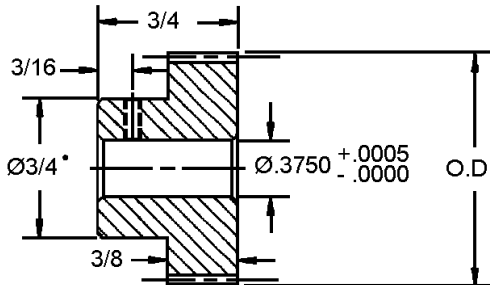
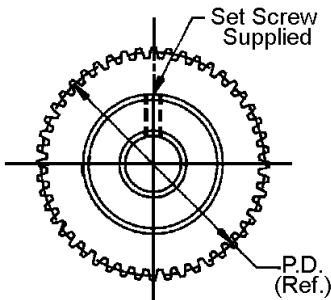

• For 16 - 20 teeth hub diameter equals .56

X In Part Number indicates that part may be supplied as two piece construction (some dimensions may vary.)

Available on request, other numbers of teeth and 14-1/2° Pressure Angle.

STOCK NO.	STOCK NO.	NO. OF TEETH	BERG QUALITY #10	
			PITCH DIA.	OUTSIDE DIA.
P24S34-16	P24B34-16	16•	.6666	.750
P24S34-18	P24B34-18	18•	.7500	.833
P24S34-20	P24B34-20	20•	.8333	.916
P24S34-24	P24B34-24	24	1.0000	1.083
P24S34-28	P24B34-28	28	1.1666	1.250
P24S34-30	P24B34-30	30	1.2500	1.333
P24S34-36	P24B34-36	36	1.5000	1.583
P24S34-40	P24B34-40	40	1.6666	1.750
P24S34X-48	P24B34X-48	48	2.0000	2.083
P24S34X-56	P24B34X-56	56	2.3333	2.416
P24S34X-60	P24B34X-60	60	2.5000	2.583
P24S34X-72	P24B34X-72	72	3.0000	3.083
P24S34X-80	P24B34X-80	80	3.3333	3.416
P24S34X-96	P24B34X-96	96	4.0000	4.083
P24S34X-112	P24B34X-112	112	4.6666	4.750
P24S34X-120	P24B34X-120	120	5.0000	5.083

For Couplings See Section G.
For Shafts, Bearings and Collars See Section I.

SPUR GEARS

PITCH	STYLE	BORE	FACE	MATERIAL	AGMA QUALITY	PRESSURE ANGLE
24	PIN HUB	3/8"	1/4"	ALUMINUM RED ANODIZED	8	20°

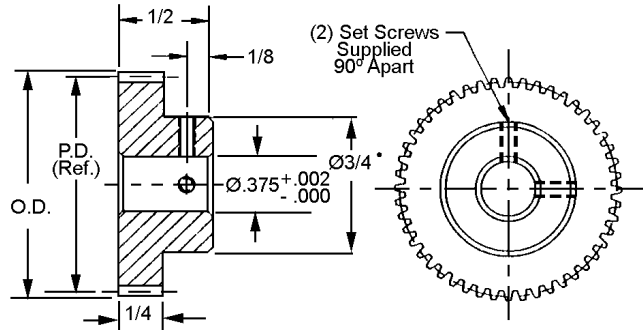

• For 16 - 20 teeth hub diameter equals .56

Available on request:
Other numbers of teeth
14 - 1/2° Pressure Angle

STOCK NO.	NO. OF TEETH	PITCH DIA.	OUTSIDE DIA.
P24A67-16	16*	.6666	.750
P24A67-18	18*	.7500	.833
P24A67-20	20*	.8333	.916
P24A67-21	21	.8750	.958
P24A67-24	24	1.0000	1.083
P24A67-30	30	1.2500	1.333
P24A67-36	36	1.5000	1.583
P24A67-42	42	1.7500	1.833
P24A67-48	48	2.0000	2.083
P24A67-60	60	2.5000	2.583
P24A67-72	72	3.0000	3.083
P24A67-96	96	4.0000	4.083
P24A67-120	120	5.0000	5.083
P24A67-144	144	6.0000	6.083

PITCH	STYLE	BORE	FACE	MATERIAL	AGMA QUALITY	PRESSURE ANGLE
24	PIN HUB	1/2"	1/4"	ALUMINUM RED ANODIZED	8	20°

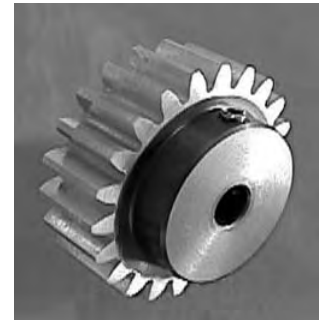
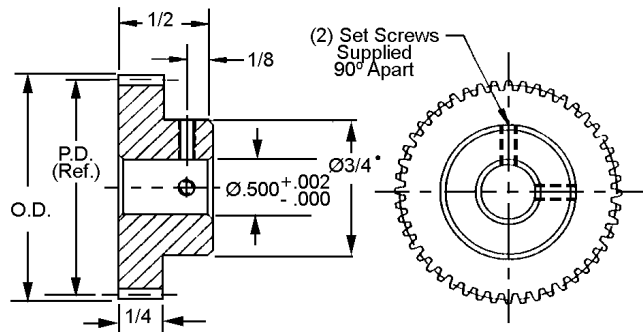

• For 19-20 teeth hub diameter equals .68

Available on request:
Other numbers of teeth
14 - 1/2° Pressure Angle

STOCK NO.	NO. OF TEETH	PITCH DIA.	OUTSIDE DIA.
P24A68-20	20*	.8333	.916
P24A68-21	21	.8750	.958
P24A68-24	24	1.0000	1.083
P24A68-30	30	1.2500	1.333
P24A68-36	36	1.5000	1.583
P24A68-42	42	1.7500	1.833
P24A68-48	48	2.0000	2.083
P24A68-60	60	2.5000	2.583
P24A68-72	72	3.0000	3.083
P24A68-96	96	4.0000	4.083
P24A68-120	120	5.0000	5.083
P24A68-144	144	6.0000	6.083

For Couplings See Section G.
For Shafts, Bearings and Collars See Section I.

SPUR GEARS

PITCH	STYLE	BORE	FACE	MATERIAL	AGMA QUALITY	PRESSURE ANGLE
24	PIN HUB	1/4"	3/16"	17-4PH STAINLESS STEEL RC 32-38	10	20°

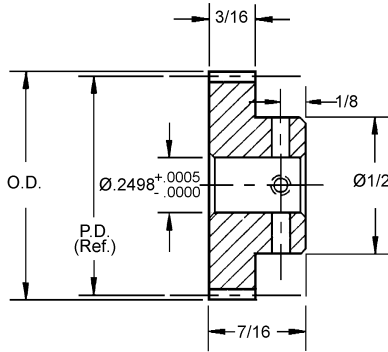

#53 Drill Thru both sides

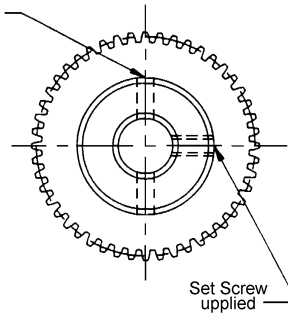

• For 13 - 14 teeth hub diameter equals .43

Available on request, other numbers of teeth, quality 12 and 14-1/2° Pressure Angle.

STOCK NO.	NO. OF TEETH	PITCH DIA.	OUTSIDE DIA.
P24PH28-13	13•	.5416	.625
P24PH28-14	14•	.5833	.666
P24PH28-15	15	.6250	.708
P24PH28-16	16	.6666	.750
P24PH28-18	18	.7500	.833
P24PH28-20	20	.8333	.916
P24PH28-21	21	.8750	.958
P24PH28-24	24	1.0000	1.083
P24PH28-26	26	1.0833	1.166
P24PH28-27	27	1.1250	1.208
P24PH28-28	28	1.1666	1.250
P24PH28-30	30	1.2500	1.333

PITCH	STYLE	BORE	FACE	MATERIAL	AGMA QUALITY	PRES. ANGLE
24	PIN HUB	1/8"	1/4"	COLD ROLLED STEEL C12L14 OR C12L15 WITH SELENIUM OR BRASS ALLOY 360	5	20°

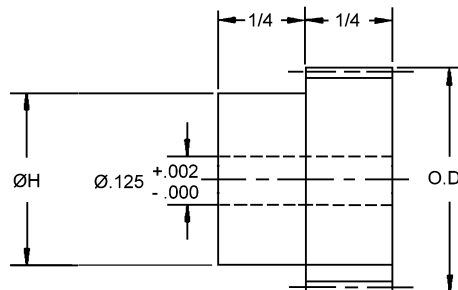
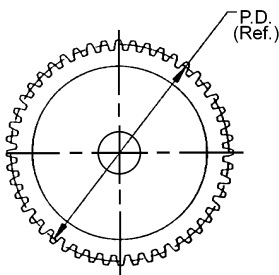

COLD ROLLED STEEL C12L14 OR C12L15 WITH SELENIUM	BRASS ALLOY 360	STOCK NO.	NO. OF TEETH	PITCH DIA.	OUTSIDE DIA.	H
PX24S-8	PX24B-8		8	.333	.416	.208
PX24S-9	PX24B-9		9	.375	.458	.250
PX24S-10	PX24B-10		10	.417	.500	.291
PX24S-12	PX24B-12		12	.500	.583	.375
PX24S-16	PX24B-16		16	.666	.750	.542
PX24S-18	PX24B-18		18	.750	.833	.625
-	PX24B-22		22	.916	1.000	.792

For Couplings See Section G.
For Shafts, Bearings and Collars See Section I.

SPUR GEARS

PITCH	STYLE	BORE	FACE	MATERIAL	AGMA QUALITY	PRESSURE ANGLE
24	PIN HUB	3/16"	3/16"	DELRIN WITH STAINLESS STEEL HUB	10	20°

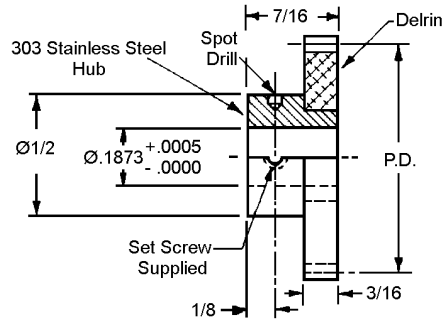

Available on request, other numbers of teeth, quality 12 and 14-1/2° Pressure Angle.

STOCK NO.	NO. OF TEETH	PITCH DIA.	OUTSIDE DIA.
P24D21X-15	15	.6250	.708
P24D21X-16	16	.6666	.750
P24D21X-17	17	.7083	.791
P24D21X-18	18	.7500	.833
P24D21X-19	19	.7916	.875
P24D21X-20	20	.8333	.916
P24D21X-21	21	.8750	.958
P24D21X-22	22	.9166	1.000
P24D21X-23	23	.9583	1.041
P24D21X-24	24	1.0000	1.083
P24D21X-25	25	1.0416	1.125
P24D21X-28	28	1.1666	1.250
P24D21X-30	30	1.2500	1.333
P24D21X-32	32	1.3333	1.416
P24D21X-33	33	1.3750	1.458
P24D21X-36	36	1.5000	1.583
P24D21X-40	40	1.6666	1.750
P24D21X-42	42	1.7500	1.833
P24D21X-45	45	1.8750	1.958
P24D21X-46	46	1.9166	2.000
P24D21X-48	48	2.0000	2.083
P24D21X-50	50	2.0833	2.166
P24D21X-52	52	2.1666	2.250
P24D21X-55	55	2.2916	2.375
P24D21X-56	56	2.3333	2.416
P24D21X-57	57	2.3750	2.458
P24D21X-60	60	2.5000	2.583
P24D21X-64	64	2.6666	2.750
P24D21X-66	66	2.7500	2.833
P24D21X-69	69	2.8750	2.958
P24D21X-72	72	3.0000	3.083
P24D21X-78	78	3.2500	3.333
P24D21X-84	84	3.5000	3.583
P24D21X-90	90	3.7500	3.833
P24D21X-93	93	3.8750	3.958

For Couplings See Section G.
For Shafts, Bearings and Collars See Section I.

SPUR GEARS

PITCH	STYLE	BORE	FACE	MATERIAL	AGMA QUALITY	PRESSURE ANGLE
24	PIN HUB	1/4"	3/16"	DELRIN WITH STAINLESS STEEL HUB	10	20°

B

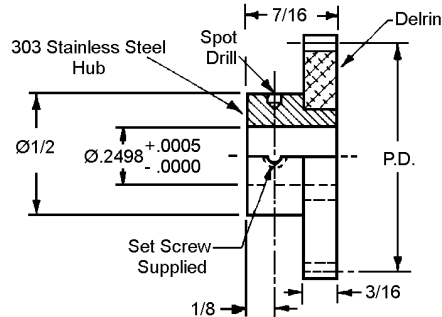

Available on request, other numbers of teeth, quality 12 and 14-1/2° Pressure Angle.

STOCK NO.	NO. OF TEETH	PITCH DIA.	OUTSIDE DIA.
P24D28X-15	15	.6250	.708
P24D28X-16	16	.6666	.750
P24D28X-17	17	.7083	.791
P24D28X-18	18	.7500	.833
P24D28X-19	19	.7916	.875
P24D28X-20	20	.8333	.916
P24D28X-21	21	.8750	.958
P24D28X-22	22	.9166	1.000
P24D28X-23	23	.9583	1.041
P24D28X-24	24	1.0000	1.083
P24D28X-25	25	1.0416	1.125
P24D28X-28	28	1.1666	1.250
P24D28X-30	30	1.2500	1.333
P24D28X-32	32	1.3333	1.416
P24D28X-33	33	1.3750	1.458
P24D28X-36	36	1.5000	1.583
P24D28X-40	40	1.6666	1.750
P24D28X-42	42	1.7500	1.833
P24D28X-45	45	1.8750	1.958
P24D28X-46	46	1.9166	2.000
P24D28X-48	48	2.0000	2.083
P24D28X-50	50	2.0833	2.166
P24D28X-52	52	2.1666	2.250
P24D28X-55	55	2.2916	2.375
P24D28X-56	56	2.3333	2.416
P24D28X-57	57	2.3750	2.458
P24D28X-60	60	2.5000	2.583
P24D28X-64	64	2.6666	2.750
P24D28X-66	66	2.7500	2.833
P24D28X-69	69	2.8750	2.958
P24D28X-72	72	3.0000	3.083
P24D28X-78	78	3.2500	3.333
P24D28X-84	84	3.5000	3.583
P24D28X-90	90	3.7500	3.833
P24D28X-93	93	3.8750	3.958

For Couplings See Section G.
For Shafts, Bearings and Collars See Section I.

SPUR GEARS

PITCH	STYLE	BORE	FACE	MATERIAL	AGMA QUALITY	PRESSURE ANGLE
24	PIN HUB	1/4"	1/4"	CAST POLYURETHANE GRAPHITE IMPREGNATED 70D DUROMETER	8	20°

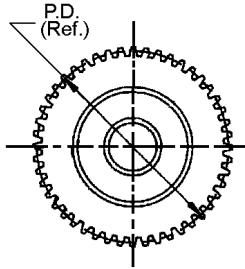
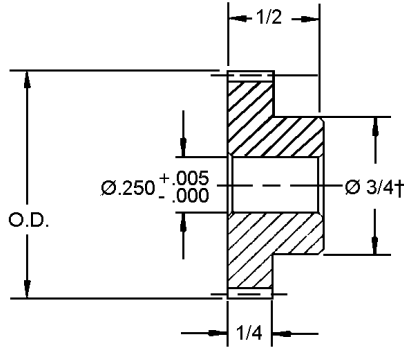

† Teeth runout on hub.
Available on request, other numbers of teeth,
quality 12 and 14-1/2° Pressure Angle.

STOCK NO.	NO. OF TEETH	PITCH DIA.	OUTSIDE DIA.
P24U66-15	15†	.6250	.708
P24U66-16	16†	.6666	.750
P24U66-18	18†	.7500	.833
P24U66-24	24	1.0000	1.083
P24U66-30	30	1.2500	1.333
P24U66-36	36	1.5000	1.583
P24U66-42	42	1.7500	1.833
P24U66-48	48	2.0000	2.083
P24U66-60	60	2.5000	2.583
P24U66-72	72	3.0000	3.083

PITCH	STYLE	BORE	FACE	MATERIAL	AGMA QUALITY	PRES. ANGLE
24	PIN HUB	1/4"	1/4"	MOLDED ACETAL	5	20°

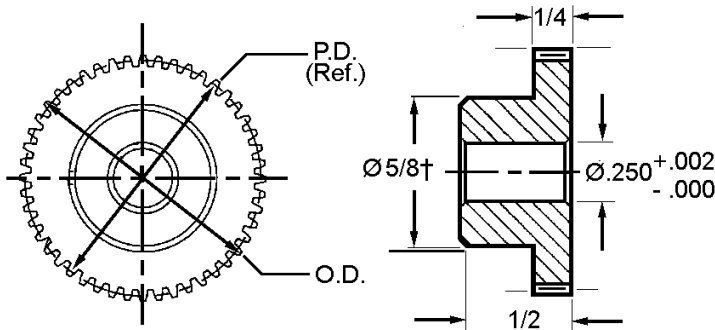

† Teeth runout on hub.
Available on request, other bore sizes and
numbers of teeth on request.

STOCK NO.	NO. OF TEETH	PITCH DIA.	OUTSIDE DIA.
P24D4M-15	15†	.6250	.71
P24D4M-16	16†	.6666	.75
P24D4M-18	18	.7500	.83
P24D4M-20	20	.8333	.92
P24D4M-21	21	.8750	.96
P24D4M-24	24	1.0000	1.08
P24D4M-30	30	1.2500	1.33
P24D4W-36	36	1.5000	1.58
P24D4M-42	42	1.7500	1.83
P24D4M-48	48	2.0000	2.08
P24D4M-54	54	2.2500	2.33
P24D4M-60	60	2.5000	2.58

SPUR GEARS

PITCH	STYLE	BORE	FACE	MATERIAL	AGMA QUALITY	PRESSURE ANGLE
24	PIN HUB	3/8"	1/4"	CAST POLYURETHANE GRAPHITE IMPREGNATED 70D DUROMETER	8	20°

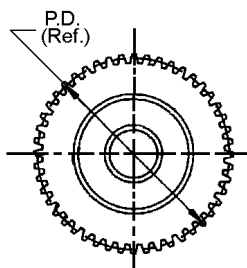
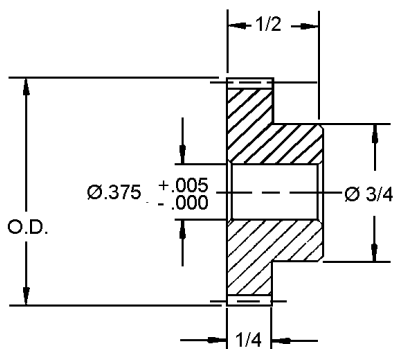

† Teeth runout on hub.
Available on request, other numbers of teeth,
quality 12 and 14-1/2° Pressure Angle.

STOCK NO.	NO. OF TEETH	PITCH DIA.	OUTSIDE DIA.
P24U67-15	15†	.6250	.708
P24U67-16	16†	.6666	.750
P24U67-18	18†	.7500	.833
P24U67-24	24	1.0000	1.083
P24U67-30	30	1.2500	1.333
P24U67-36	36	1.5000	1.583
P24U67-42	42	1.7500	1.833
P24U67-48	48	2.0000	2.083
P24U67-60	60	2.5000	2.583
P24U67-72	72	3.0000	3.083

PITCH	STYLE	BORE	FACE	MATERIAL	AGMA QUALITY	PRESSURE ANGLE
24	PIN HUB	1/2"	1/4"	CAST POLYURETHANE GRAPHITE IMPREGNATED 70D DUROMETER	8	20°

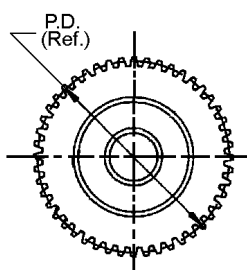
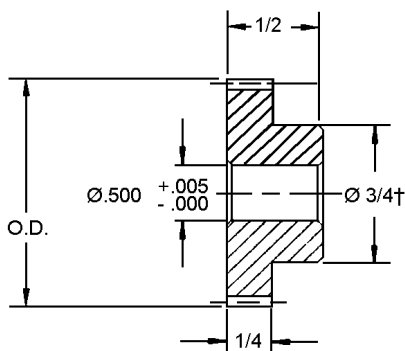

† Teeth runout on hub.
Available on request, other numbers of teeth,
quality 12 and 14-1/2° Pressure Angle.

STOCK NO.	NO. OF TEETH	PITCH DIA.	OUTSIDE DIA.
P24U68-16	16†	.6666	.750
P24U68-18	18†	.7500	.833
P24U68-24	24	1.0000	1.083
P24U68-30	30	1.2500	1.333
P24U68-36	36	1.5000	1.583
P24U68-42	42	1.7500	1.833
P24U68-48	48	2.0000	2.083
P24U68-60	60	2.5000	2.583
P24U68-72	72	3.0000	3.083

For Couplings See Section G.
For Shafts, Bearings and Collars See Section I.



SPUR GEARS

PITCH	STYLE	BORE	FACE	MATERIAL	AGMA QUALITY	PRES. ANGLE
24	PIN HUB	3/16" TO 5/16"	1/4"	MOLDED DELRIN	5	20°

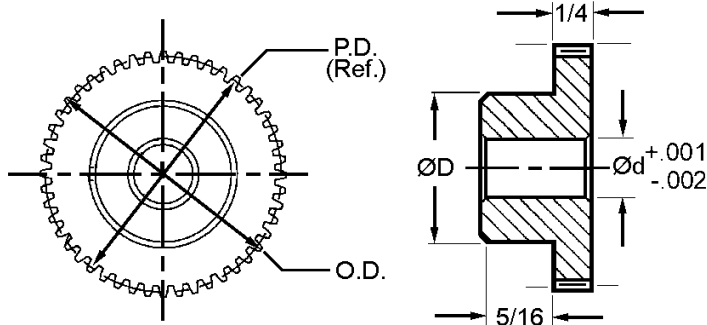

STOCK NO.	NO. OF TEETH	PITCH DIA.	OUTSIDE DIA.	$\varnothing d$	$\varnothing D$
P24D4P-12	12	.500	.583	3/16	3/8
P24D4P-14	14	.583	.667	3/16	7/16
P24D4P-15	15	.625	.709	3/16	31/64
P24D4P-16	16	.667	.750	3/16	31/64
P24D4P-17	17	.709	.791	3/16	35/64
P24D4P-18	18	.750	.833	3/16	35/64
P24D4P-19	19	.791	.875	3/16	35/64
P24D4P-20	20	.833	.917	3/16	35/64
P24D4P-21	21	.875	.959	3/16	35/64
P24D4P-22	22	.917	1.000	3/16	35/64
P24D4P-23	23	.959	1.041	3/16	35/64
P24D4P-24	24	1.000	1.083	1/4	5/8
P24D4P-25	25	1.041	1.125	1/4	39/64
P24D4P-26	26	1.083	1.167	1/4	5/8
P24D4P-27	27	1.125	1.208	1/4	5/8
P24D4P-28	28	1.167	1.250	1/4	5/8
P24D4P-30	30	1.250	1.333	1/4	5/8
P24D4P-32	32	1.333	1.416	1/4	39/64
P24D4P-33	33	1.375	1.458	1/4	39/64
P24D4P-34	34	1.416	1.500	1/4	39/64
P24D4P-36	36	1.500	1.583	1/4	5/8
P24D4P-39	39	1.625	1.708	5/16	43/64
P24D4P-40	40	1.666	1.750	5/16	43/64
P24D4P-42	42	1.750	1.833	5/16	43/64
P24D4P-44	44	1.833	1.917	5/16	43/64
P24D4P-45	45	1.875	1.958	5/16	43/64
P24D4P-48	48	2.000	2.083	5/16	43/64
P24D4P-50	50	2.083	2.166	5/16	43/64
P24D4P-52	52	2.166	2.250	5/16	43/64
P24D4P-54	54	2.250	2.333	5/16	43/64
P24D4P-56	56	2.333	2.416	5/16	43/64
P24D4P-60	60	2.500	2.583	5/16	43/64
P24D4P-72	72	3.000	3.083	5/16	43/64

Some molded gears may have webs.

For Couplings See Section G.
For Shafts, Bearings and Collars See Section I.

GEAR RACKS

PITCH	STYLE	MATERIAL	AGMA QUALITY	PRESSURE ANGLE
24	ROUND & RECTANGULAR	416 SERIES STAINLESS STEEL STRESSED RELIEVED	10	20°

B

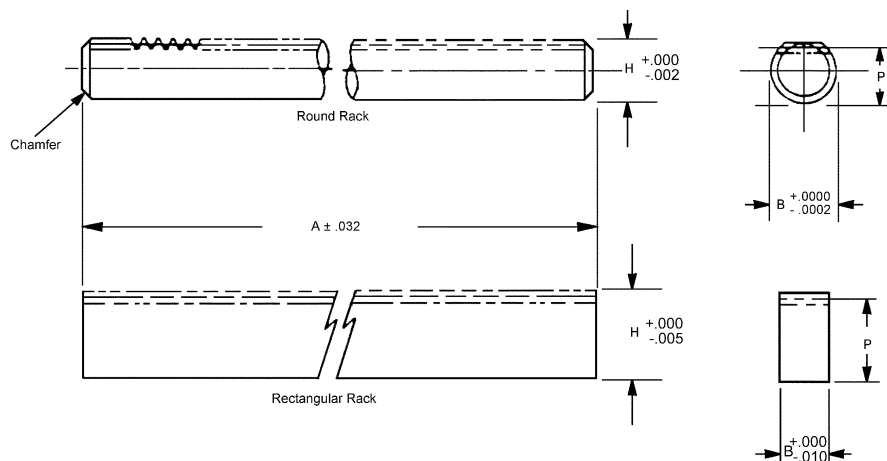

STOCK NO.	RACK STYLE	PITCH	P (Ref.)	B	A	H	AGMA QUALITY
R2-3	ROUND	24	.4383	.4997	18	.480	10
R2-9	RECTANGULAR	24	.4383	.230±.005	18	.480	10

Available on request:
14 - 1/2° pressure angle,
special, modified and custom racks.

PITCH	STYLE	MATERIAL	AGMA QUALITY	PRESSURE ANGLE
24	RECTANGULAR	416 SERIES STAINLESS STEEL AND 2024-T4 ALUMINUM ANODIZED	10	20°

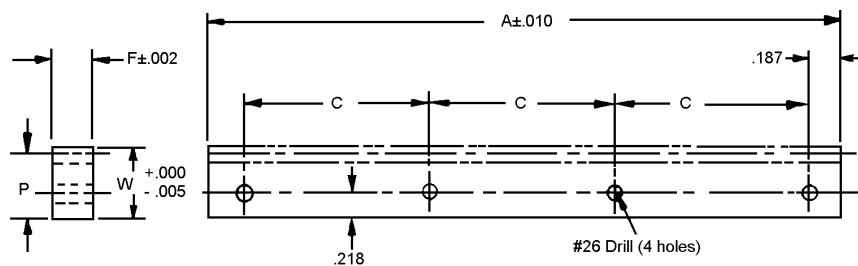

STOCK NO.	MATERIAL	A (Inch)	P (Ref.)	W	F	C
R4-5	STAINLESS ST.	10	.4383	.480	.230	3.208
R4-6	ALUMINUM					

Available on request: special,
modified and custom racks.

GEAR RACKS

PITCH	STYLE	MATERIAL	AGMA QUALITY	PRESSURE ANGLE
24	RECTANGULAR	416 SERIES STAINLESS STEEL STRESSED RELIEVED	10	20°

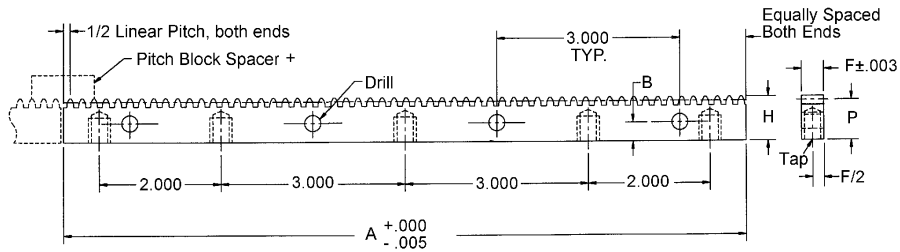

†Spacer block is designed for butting to achieve continuous lengths. On-Line pricing for AGMA 10 only.

RACKS	SPACER BLOCK												
		AGMA QTY. NO.	MAX ACCUM. ERROR	TOOTH TO TOOTH ERROR	PITCH	LINEAR PITCH	A INCH	P REF.	H +.000 / -.005	F	B	DRILL	TAP
STOCK NO.	STOCK NO.												
R1-3-G1	R1-3-SB	10*	.0014	.0005	24	.1309	11.120	.4333	.475	.230	.218	#26	#6-32 x 1/4

* Higher quality on request.

ANTI-BACKLASH GEARS

PITCH	STYLES	BORE	FACE	MATERIAL	AGMA QUALITY	PRES. ANGLE
24	PIN HUB	1/4"	3/16"	303 STAINLESS STEEL OR 2024-T4 ALUMINUM ANODIZED	10	20°

B

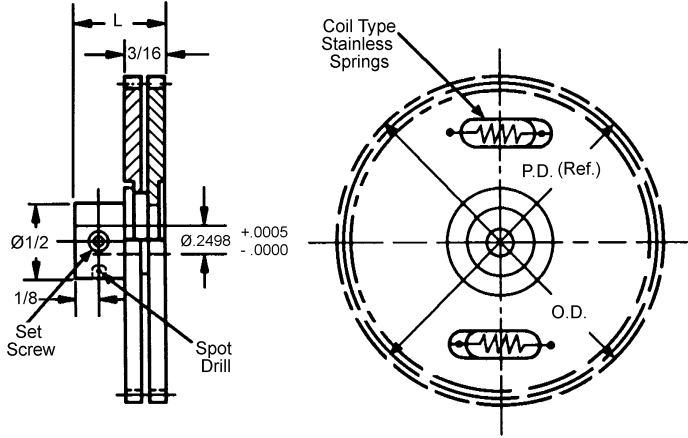

Hub Material: 303 Stainless Steel

303 STAINLESS STEEL STOCK NO.	2024-T4 ALUMINUM ANODIZED STOCK NO.	L	NO. OF TEETH	PITCH DIA.	OUTSIDE DIA.
AP24MS-24	AP24QS-24	15/32	24	1.0000	1.083
AP24MS-25	AP24QS-25		25	1.0417	1.125
AP24MS-26	AP24QS-26		26	1.0833	1.166
AP24MS-28	AP24QS-28		28	1.1667	1.250
AP24M-30	AP24Q-30	27/64	30	1.2500	1.333
AP24M-35	AP24Q-35		35	1.4583	1.541
AP24M-36	AP24Q-36		36	1.5000	1.583
AP24M-40	AP24Q-40		40	1.6667	1.750
AP24M-42	AP24Q-42		42	1.7500	1.833
AP24M-45	AP24Q-45		45	1.8750	1.958
AP24M-48	AP24Q-48		48	2.0000	2.083
AP24M-50	AP24Q-50		50	2.0833	2.166
AP24M-54	AP24Q-54		54	2.2500	2.333
AP24M-55	AP24Q-55		55	2.2917	2.375
AP24M-60	AP24Q-60		60	2.5000	2.583
AP24M-65	AP24Q-65		65	2.7083	2.791
AP24M-66	AP24Q-66		66	2.7500	2.833

Available on request:
 Other numbers of teeth,
 AGMA Quality 12 and 14 (some dimensions may vary),
 14-1/2° Pressure Angle

**For Couplings See Section G.
 For Shafts, Bearings and Collars See Section I.**

ANTI-BACKLASH GEARS

PITCH	STYLES	BORE	FACE	MATERIAL	AGMA QUALITY	PRES. ANGLE
24	PIN HUB	1/4"	1/4"	303 STAINLESS STEEL OR 2024-T4 ALUMINUM ANODIZED	10	20°

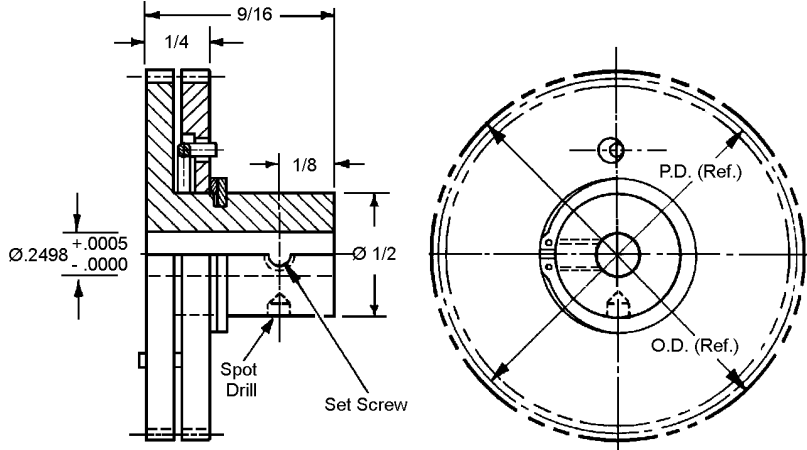

Hub Material:
303 Stainless Steel

STAINLESS STEEL STOCK NO.	ALUMINUM STOCK NO.	PITCH	NO. OF TEETH	PITCH DIA.	OUTSIDE DIA.
AP24BS-18	AP24DS-18	24	18	.7500	.833
AP24BS-21	AP24DS-21		21	.8750	.958
AP24BS-24	AP24DS-24		24	1.0000	1.083

Available on request:
Other numbers of teeth
AGMA Quality 12 and 14
14-1/2° Pressure Angle

PITCH	STYLES	BORE	FACE	MATERIAL	AGMA QUALITY	PRES. ANGLE
24	CLAMP STYLE	1/4"	1/4"	303 STAINLESS STEEL OR 2024-T4 ALUMINUM ANODIZED	10	20°

Hub Material:
303 Stainless Steel

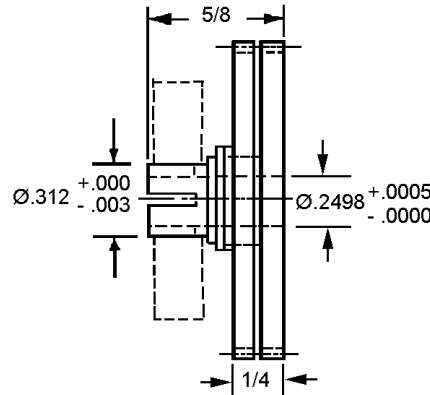

STAINLESS STEEL STOCK NO.	ALUMINUM STOCK NO.	PITCH	NO. OF TEETH	PITCH DIA.	OUTSIDE DIA.
AC24BS-18	AC24DS-18	24	18	.7500	.833
AC24BS-21	AC24DS-21		21	.8750	.958
AC24BS-24	AC24DS-24		24	1.0000	1.083

Available on request:
Other numbers of teeth
AGMA Quality 12 and 14
14-1/2° Pressure Angle

ANTI-BACKLASH GEARS

PITCH	STYLES	BORE	FACE	MATERIAL	AGMA QUALITY	PRES. ANGLE
24	CLAMP STYLE	1/4"	3/16"	303 STAINLESS STEEL OR 2024-T4 ALUMINUM ANODIZED	10	20°

B

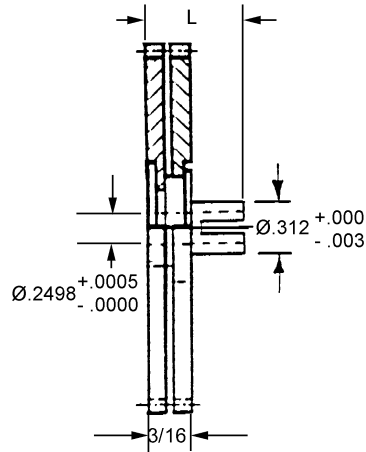

Hub Material:
303 Stainless Steel

303 STAINLESS STEEL STOCK NO.	2024-T4 ALUMINUM ANODIZED STOCK NO.	L	NO. OF TEETH	PITCH DIA.	OUTSIDE DIA.
AC24MS-24	AC24QS-24	15/32	24	1.0000	1.083
AC24MS-25	AC24QS-25		25	1.0417	1.125
AC24MS-26	AC24QS-26		26	1.0833	1.166
AC24MS-28	AC24QS-28		28	1.1667	1.250
AC24M-30	AC24Q-30	27/64	30	1.2500	1.333
AC24M-35	AC24Q-35		35	1.4583	1.541
AC24M-36	AC24Q-36		36	1.5000	1.583
AC24M-40	AC24Q-40		40	1.6667	1.750
AC24M-42	AC24Q-42		42	1.7500	1.833
AC24M-45	AC24Q-45		45	1.8750	1.958
AC24M-48	AC24Q-48		48	2.0000	2.083
AC24M-50	AC24Q-50		50	2.0833	2.166
AC24M-54	AC24Q-54		54	2.2500	2.333
AC24M-55	AC24Q-55		55	2.2917	2.375
AC24M-60	AC24Q-60		60	2.5000	2.583
AC24M-65	AC24Q-65		65	2.7083	2.791
AC24M-66	AC24Q-66		66	2.7500	2.833

Available on request:
Other numbers of teeth,
AGMA Quality 12 and 14 (some dimensions may vary),
14-1/2° Pressure Angle

For Couplings See Section G.
For Shafts, Bearings and Collars See Section I.

PINION SHAFTS

PITCH	MATERIAL	AGMA QUALITY	PRES. ANGLE
24	BRASS AND COLD ROLLED STEEL	5	20°

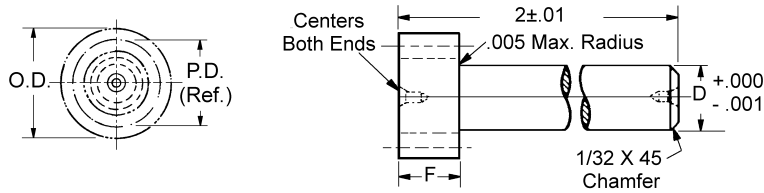

COLD ROLLED STEEL 12L14 OR 12L15 W/SELENIUM STOCK NO.	BRASS ALLOY 360 STOCK NO.	NUMBER OF TEETH	PITCH DIAMETER	OUTSIDE DIAMETER	D	F
PSX24S-8	PSX24B-8	8	.3333	.416	.187	
PSX24S-9	PSX24B-9	9	.3750	.458	.250	
PSX24S-10	PSX24B-10	10	.4167	.500	.250	5/16
PSX24S-12	PSX24B-12	12	.5000	.583	.375	

PITCH	MATERIAL	AGMA QUALITY	PRES. ANGLE
24	BRASS AND COLD ROLLED STEEL	5	20°

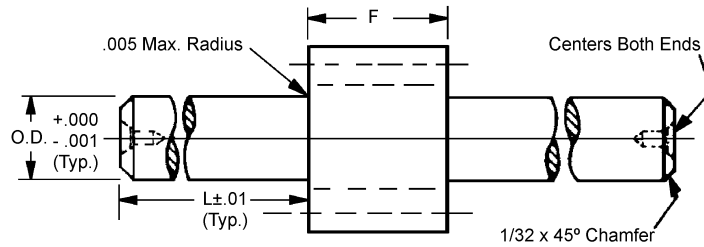

COLD ROLLED STEEL 12L14 OR 12L15 W/SELENIUM STOCK NO.	BRASS ALLOY 360 STOCK NO.	NUMBER OF TEETH	PITCH DIAMETER	OUTSIDE DIAMETER	D	F	L
PSW24S-8	PSW24B-8	8	.3333	.416	.187		
PSW24S-9	PSW24B-9	9	.3750	.458	.250		
PSW24S-10	PSW24B-10	10	.4167	.500	.250	5/16	3/4
PSW24S-12	PSW24B-12	12	.5000	.583	.375		

PITCH	MATERIAL	AGMA QUALITY	PRES. ANGLE
24	303 STAINLESS STEEL	5	20°

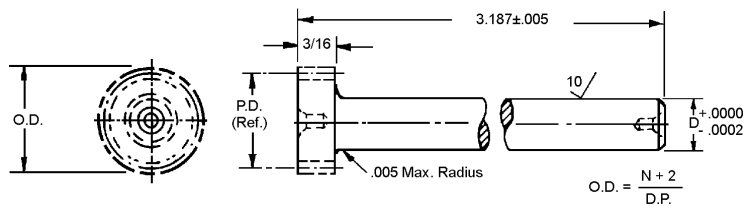

STOCK NO.	PITCH	NO. OF TEETH	PITCH DIA.	D
PS24S4-10H	24	10	.4166	.2497
PS24S4-12H	24	12	.5000	.2497

SPUR GEAR STOCK

PITCH	TYPE	MATERIAL	PRESSURE ANGLE
24	PINION WIRE	BRASS AND COLD ROLLED STEEL	20°

B

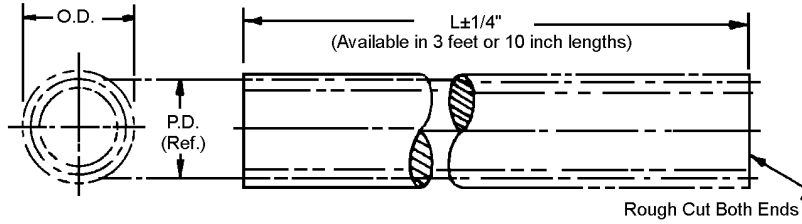

BRASS ALLOY 360		COLD ROLLED STEEL C12L14 or C12L15 WITH SELENIUM		NO. OF TEETH	PITCH DIA.	OUTSIDE DIA.
3FT. LONG STOCK NO.	10 IN. LONG STOCK NO.	3FT. LONG STOCK NO.	10 IN. LONG STOCK NO.			
PW24B-8X	PW24B-8A	PW24S-8X	PW24S-8A	8	.3333	.416
PW24B-9X	PW24B-9A	PW24S-9X	PW24S-9A	9	.3750	.458
PW24B-10X	PW24B-10A	PW24S-10X	PW24S-10A	10	.4166	.500
-	-	PW24S-11	PW24S-11A	11	.4583	.541
PW24B-12X	PW24B-12A	PW24S-12X	PW24S-12A	12	.5000	.583
PW24B-14	PW24B-14A	PW24S-14	PW24S-14A	14	.5833	.666
PW24B-15	PW24B-15A	PW24S-15	PW24S-15A	15	.6250	.708
PW24B-16	PW24B-16A	PW24S-16	PW24S-16A	16	.6666	.750
PW24B-18	PW24B-18A	PW24S-18	PW24S-18A	18	.7500	.833
PW24B-22	PW24B-22A	-	-	22	.9166	1.000

SPUR GEARS

PITCH	STYLE	BORE	FACE	MATERIAL	AGMA QUALITY	PRESSURE ANGLE
1/10	PIN HUB	3/16"	3/16"	303 STAINLESS STEEL AND ALUMINUM ANODIZED	10	20°

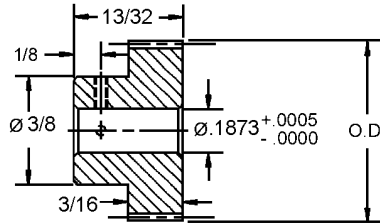
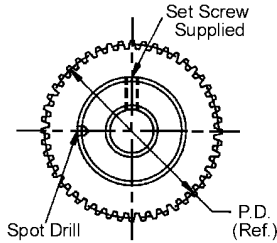

Available on request, other numbers of teeth,
AGMA Quality 12 and 14-1/2° Pressure Angle.

303 STAINLESS STEEL STOCK NO.	2024-T4 ALUMINUM ANODIZED STOCK NO.	BERG QUALITY #10		
		NO. OF TEETH	PITCH DIA.	OUTSIDE DIA.
P31S21-20	P31A21-20	20	.6366	.700
P31S21-25	P31A21-25	25	.7957	.859
P31S21-30	P31A21-30	30	.9549	1.018
P31S21-35	P31A21-35	35	1.1140	1.177
P31S21-40	P31A21-40	40	1.2732	1.336
P31S21-45	P31A21-45	45	1.4323	1.496
P31S21-50	P31A21-50	50	1.5915	1.655

PITCH	STYLE	BORE	FACE	MATERIAL	AGMA QUALITY	PRESSURE ANGLE
1/10	PIN HUB	1/4"	1/8"	303 STAINLESS STEEL AND ALUMINUM ANODIZED	10	20°

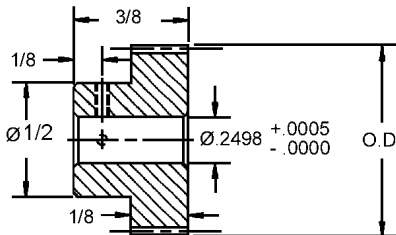
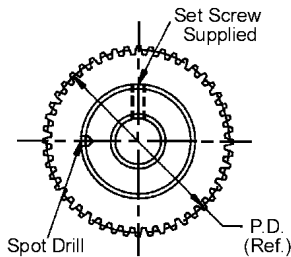

Available on request, other numbers of teeth,
AGMA Quality 12 and 14-1/2° Pressure Angle.

303 STAINLESS STEEL STOCK NO.	2024-T4 ALUMINUM ANODIZED STOCK NO.	BERG QUALITY #10		
		NO. OF TEETH	PITCH DIA.	OUTSIDE DIA.
P31S26-20	P31A26-20	20	.6366	.700
P31S26-25	P31A26-25	25	.7957	.859
P31S26-30	P31A26-30	30	.9549	1.018
P31S26-35	P31A26-35	35	1.1140	1.177
P31S26-40	P31A26-40	40	1.2732	1.336
P31S26-45	P31A26-45	45	1.4323	1.496
P31S26-50	P31A26-50	50	1.5915	1.655

**For Couplings See Section G.
For Shafts, Bearings and Collars See Section I.**

SPUR GEARS

B

PITCH	STYLE	BORE	FACE	MATERIAL	AGMA QUALITY	PRESSURE ANGLE
1/10	PIN HUB	1/4"	3/16"	303 STAINLESS STEEL AND ALUMINUM ANODIZED	10	20°

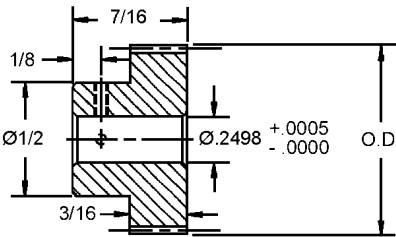
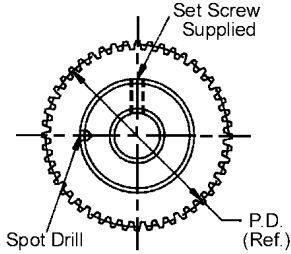

Available on request, other numbers of teeth, 14-1/2° Pressure Angle.

303 STAINLESS STEEL STOCK NO.	2024-T4 ALUMINUM ANODIZED STOCK NO.	BERG QUALITY #10		
		NO. OF TEETH	PITCH DIA.	OUTSIDE DIA.
P31S28-20	P31A28-20	20	.6366	.700
P31S28-25	P31A28-25	25	.7957	.859
P31S28-30	P31A28-30	30	.9549	1.018
P31S28-35	P31A28-35	35	1.1140	1.177
P31S28-40	P31A28-40	40	1.2732	1.336
P31S28-45	P31A28-45	45	1.4323	1.496
P31S28-50	P31A28-50	50	1.5915	1.655

PITCH	STYLE	BORE	FACE	MATERIAL	AGMA QUALITY	PRESSURE ANGLE
1/10	PIN HUB	1/4"	3/16"	17-4PH STAINLESS STEEL HARDENED RC 32-38	10	20°

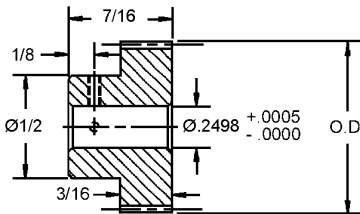
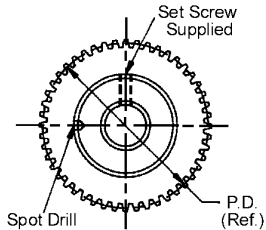

STOCK NO.	NO. OF TEETH	PITCH DIA.	OUTSIDE DIA.
P31PH28-20	20	.6366	.700
P31PH28-25	25	.7957	.859
P31PH28-30	30	.9549	1.019
P31PH28-40	40	1.2732	1.337

PITCH	STYLE	BORE	FACE	MATERIAL	AGMA QUALITY	PRESSURE ANGLE
1/10	PIN HUB	1/4"	1/4"	17-4PH STAINLESS STEEL HARDENED RC 32-38	13	20°

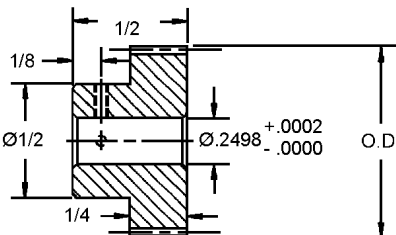
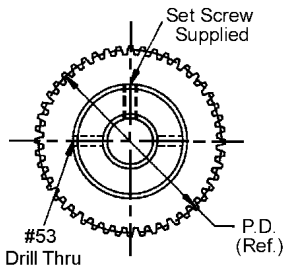

STOCK NO.	NO. OF TEETH	PITCH DIA.	OUTSIDE DIA.
P31PH41-20-Q13	20	.6366	.700
P31PH41-40-Q13	40	1.2732	1.337

GEAR RACKS

PITCH	STYLE	MATERIAL	AGMA QUALITY	PRESSURE ANGLE
1/10	ROUND & RECTANGULAR	416 SERIES STAINLESS STEEL STRESSED RELIEVED	10	20°

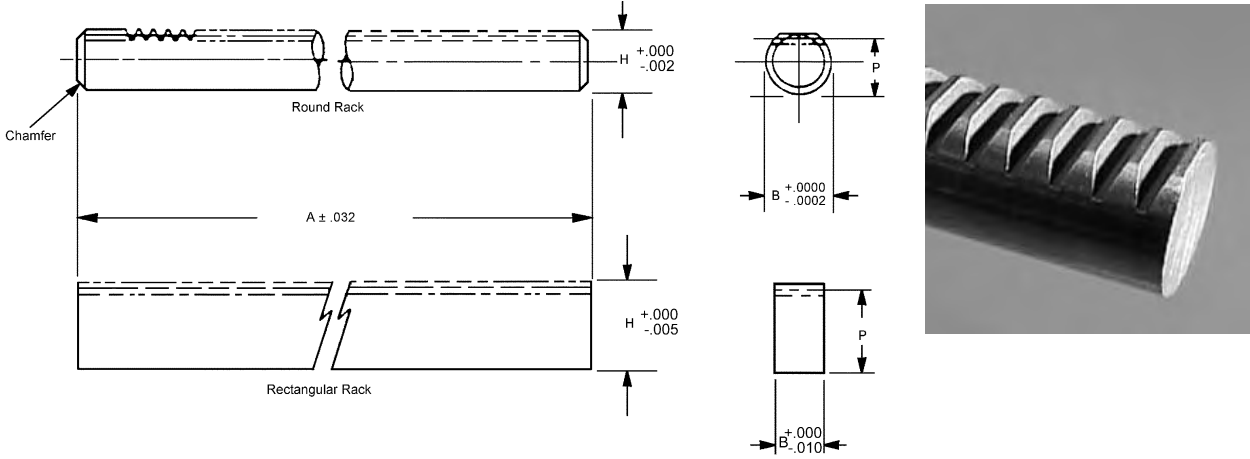

STOCK NO.	RACK STYLE	PITCH	P (Ref.)	B	A	H	AGMA QUALITY
R2-4	ROUND	1/10	.3082	.3747	18	.340	10
R2-10	RECTANGULAR	1/10	.4482	.230±.005	18	.480	10

Available on request:
14 - 1/2° pressure angle,
special, modified and custom racks.

PITCH	STYLES	MATERIAL	AGMA QUALITY	PRESSURE ANGLE
1/10	Order With or Without Spacer Block	416 SERIES STAINLESS STEEL RC26-36	10	20°

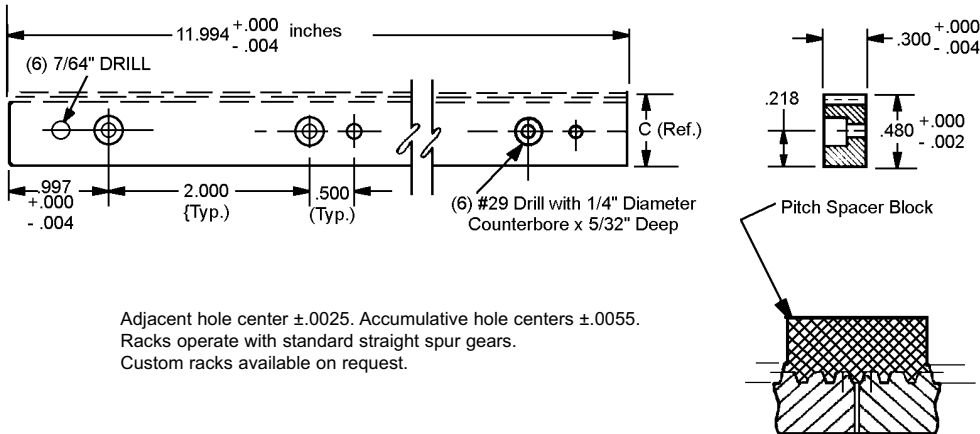

Adjacent hole center ±.0025. Accumulative hole centers ±.0055.
Racks operate with standard straight spur gears.
Custom racks available on request.

WITHOUT SPACER BLOCK STOCK NO.	SPACER BLOCK STOCK NO.	AGMA QUALITY NO.	TOTAL COMPOSITE ERROR	TOTAL TOOTH ERROR	PITCH PLANE PARALLELISM TO BASE SURFACE	LINEAR PITCH	C REF
R8-2-G1	R8-2-G1-SB	Q10*	.0014	.0005	.0015	1/10	.4480

* Higher quality on request.

GEAR RACKS

PITCH	STYLES	MATERIAL	AGMA QUALITY	PRESSURE ANGLE
1/10	RECTANGULAR	416 SERIES STAINLESS STEEL STRESSED RELIEVED	10	20°

B

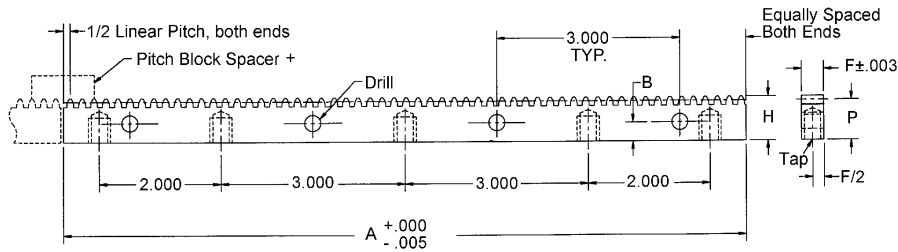

† Spacer block is designed for butting to achieve continuous lengths. On-Line pricing for AGMA 10 only.

RACKS	SPACER BLOCK	AGMA QTY. NO.	MAX ACCUM. ERROR	TOOTH TO TOOTH ERROR	PITCH	LINEAR PITCH	A INCH	P REF.	H +.000 -.005	F	B	DRILL	TAP
R1-4-G1	R1-4-SB	10*	.0014	.0005	1/10	.1000	10.994	.4432	.475	.230	.218	#26	#6-32 x 1/4
R3-2G1	R3-2-SB	10*	.0014	.0005	1/10	.1000	10.994	.4482	.480	.230	.218	#26	#6-32 x 1/4

* Higher quality on request.

ANTI-BACKLASH GEARS

PITCH	STYLES	MATERIAL	AGMA QUALITY	PRESSURE ANGLE
1/10	CLAMP STYLE	303 STAINLESS STEEL OR 2024-T4 ALUMINUM ANODIZED	10	20°

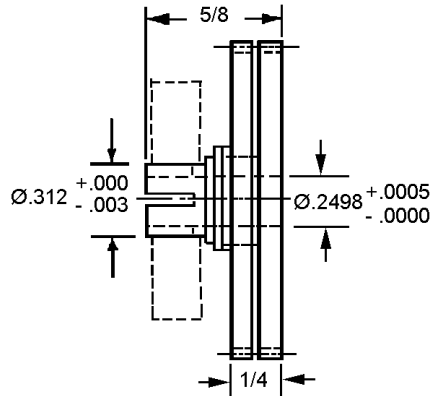

STAINLESS STEEL STOCK NO.	ALUMINUM STOCK NO.	PITCH	NO. OF TEETH	PITCH DIA.	OUTSIDE DIA.
AC31BS-25	AC31DS-25	1/10	25	.7958	.859
AC31BS-30	AC31DS-30		30	.9549	1.018

Available on request:
Other numbers of teeth
AGMA Quality 12 and 14
14-1/2° Pressure Angle

**For Couplings See Section G.
For Shafts, Bearings and Collars See Section I.**

PINION SHAFTS

PITCH	MATERIAL	AGMA QUALITY	PRES. ANGLE
1/10	303 STAINLESS STEEL	10	20°

B

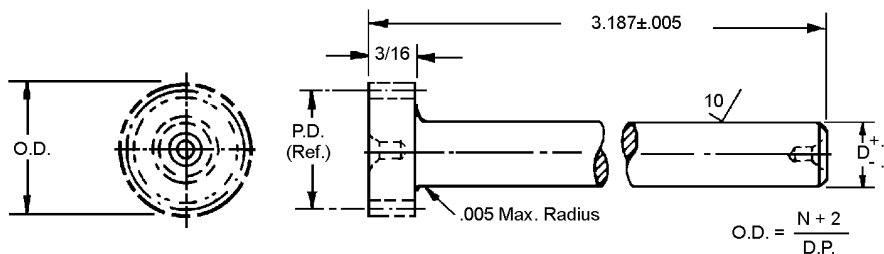

STOCK NO.	PITCH	NO. OF TEETH	PITCH DIA.	D
PS31S4-10H	1/10	10	.3183	.2497

Other numbers of teeth available on request.

SPUR GEARS

PITCH	STYLE	BORE	FACE	MATERIAL	AGMA QUALITY	PRESSURE ANGLE
32	HUBLESS	3/8"	1/8"	303 STAINLESS STEEL AND 2024-T4 ALUMINUM ANODIZED	10	20°

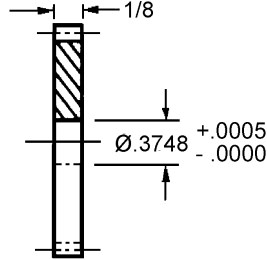
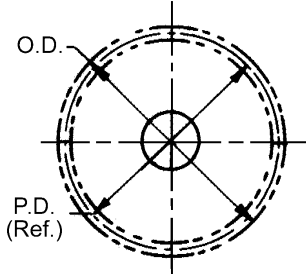

Available on request:
Pin or Clamp hubs assembled
Other numbers of teeth
14 - 1/2° Pressure Angle

303 STAINLESS STEEL STOCK NO.	2024-T4 ALUMINUM ANODIZED STOCK NO.	NO. OF TEETH	PITCH DIA.	OUTSIDE DIA.
F32S3-20	F32A3-20	20	.6250	.687
F32S3-24	F32A3-24	24	.7500	.812
F32S3-26	F32A3-26	26	.8125	.875
F32S3-28	F32A3-28	28	.8750	.937
F32S3-30	F32A3-30	30	.9375	1.000
F32S3-32	F32A3-32	32	1.0000	1.062
F32S3-36	F32A3-36	36	1.1250	1.187
F32S3-40	F32A3-40	40	1.2500	1.312
F32S3-42	F32A3-42	42	1.3125	1.375
F32S3-44	F32A3-44	44	1.3750	1.437
F32S3-48	F32A3-48	48	1.5000	1.562
F32S3-60	F32A3-60	60	1.8750	1.937
F32S3-64	F32A3-64	64	2.0000	2.062
F32S3-72	F32A3-72	72	2.2500	2.312
F32S3-75	F32A3-75	75	2.3437	2.406
F32S3-76	F32A3-76	76	2.3750	2.437
F32S3-80	F32A3-80	80	2.5000	2.562
F32S3-81	F32A3-81	81	2.5312	2.593
F32S3-86	F32A3-86	86	2.6875	2.750
F32S3-88	F32A3-88	88	2.7500	2.812
F32S3-90	F32A3-90	90	2.8125	2.875
F32S3-92	F32A3-92	92	2.8750	2.937
F32S3-95	F32A3-95	95	2.9687	3.031
F32S3-96	F32A3-96	96	3.0000	3.062
F32S3-100	F32A3-100	100	3.1250	3.187
F32S3-105	F32A3-105	105	3.2812	3.343
F32S3-108	F32A3-108	108	3.3750	3.437
F32S3-110	F32A3-110	110	3.4375	3.500
F32S3-112	F32A3-112	112	3.5000	3.562
F32S3-115	F32A3-115	115	3.5937	3.656
F32S3-116	F32A3-116	116	3.6250	3.687
F32S3-120	F32A3-120	120	3.7500	3.812
F32S3-124	F32A3-124	124	3.8750	3.937
F32S3-126	F32A3-126	126	3.9375	4.000
F32S3-128	F32A3-128	128	4.0000	4.062
F32S3-132	F32A3-132	132	4.1250	4.187

For Couplings See Section G.
For Shafts, Bearings and Collars See Section I.

SPUR GEARS

PITCH	STYLE	BORE	FACE	MATERIAL	AGMA QUALITY	PRESSURE ANGLE
32	HUBLESS	3/8"	1/4"	303 STAINLESS STEEL AND 2024-T4 ALUMINUM ANODIZED	10	20°

B

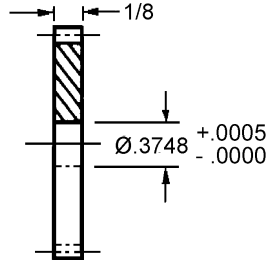
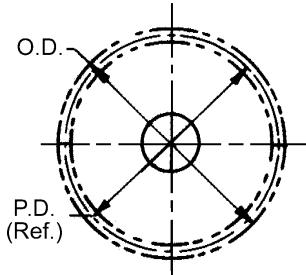

Available on request:
Pin or Clamp hubs assembled
Other numbers of teeth
14 - 1/2° Pressure Angle

303 STAINLESS STEEL STOCK NO.	2024-T4 ALUMINUM ANODIZED STOCK NO.	NO. OF TEETH	PITCH DIA.	OUTSIDE DIA.
F32S6-32	F32A6-32	32	1.0000	1.062
F32S6-36	F32A6-36	36	1.1250	1.187
F32S6-40	F32A6-40	40	1.2500	1.312
F32S6-48	F32A6-48	48	1.5000	1.562
F32S6-60	F32A6-60	60	1.8750	1.937
F32S6-64	F32A6-64	64	2.0000	2.062
F32S6-72	F32A6-72	72	2.2500	2.312
F32S6-75	F32A6-75	75	2.3437	2.406
F32S6-80	F32A6-80	80	2.5000	2.562
F32S6-96	F32A6-96	96	3.0000	3.062
F32S6-120	F32A6-120	120	3.7500	3.812
F32S6-128	F32A6-128	128	4.0000	4.062

PITCH	STYLE	BORE	FACE	MATERIAL	AGMA QUALITY	PRESSURE ANGLE
32	HUBLESS	3/8"	1/4"	ALUMINUM RED ANODIZED	8	20°

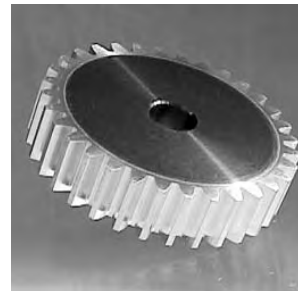
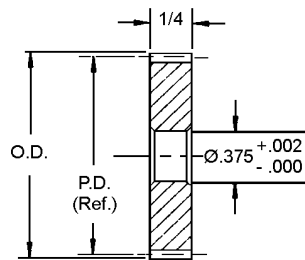

Available on request:
Other numbers of teeth
14 - 1/2° Pressure Angle

STOCK NO.	NO. OF TEETH	PITCH DIA.	OUTSIDE DIA.
F32A77-20	20	.6250	.687
F32A77-24	24	.7500	.812
F32A77-30	30	.9375	1.000
F32A77-32	32	1.0000	1.062
F32A77-36	36	1.1250	1.187
F32A77-40	40	1.2500	1.312
F32A77-48	48	1.5000	1.562
F32A77-56	56	1.7500	1.812
F32A77-60	60	1.8750	1.937
F32A77-64	64	2.0000	2.062
F32A77-80	80	2.5000	2.562
F32A77-96	96	3.0000	3.062
F32A77-112	112	3.5000	3.562
F32A77-128	128	4.0000	4.062
F32A77-160	160	5.0000	5.062
F32A77-192	192	6.0000	6.062

SPUR GEARS

PITCH	STYLE	BORE	FACE	MATERIAL	AGMA QUALITY	PRESSURE ANGLE
32	HUBLESS	3/8"	1/8"	POLYURETHANE	8	20°

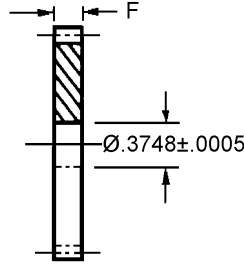
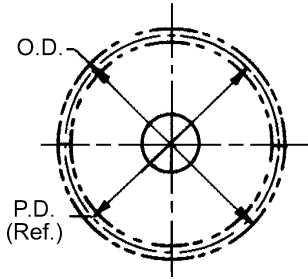

Available on request:
Other numbers of teeth
14 - 1/2° Pressure Angle

STOCK NO.	NO. OF TEETH	PITCH DIA.	OUTSIDE DIA.
F32U3-32	32	1.0000	1.062
F32U3-36	36	1.1250	1.187
F32U3-40	40	1.2500	1.312
F32U3-48	48	1.5000	1.562
F32U3-60	60	1.8750	1.937
F32U3-64	64	2.0000	2.062
F32U3-72	72	2.2500	2.312

PITCH	STYLE	BORE	FACE	MATERIAL	AGMA QUALITY	PRESSURE ANGLE
32	HUBLESS	3/8"	3/16"	DELRIN	10	20°

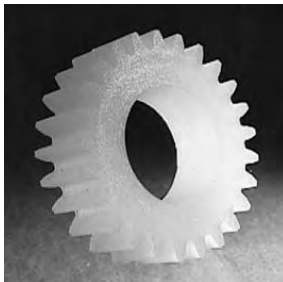
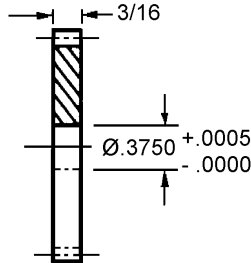
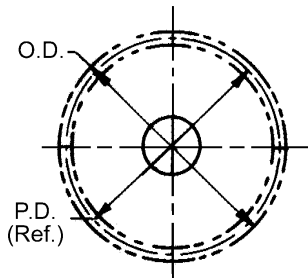

Available on request:
Other numbers of teeth
14 - 1/2° Pressure Angle

STOCK NO.	NO. OF TEETH	PITCH DIA.	OUTSIDE DIA.
F32D5-20	20	.6250	.687
F32D5-21	21	.6562	.718
F32D5-22	22	.6875	.750
F32D5-23	23	.7187	.781
F32D5-24	24	.7500	.812
F32D5-25	25	.7812	.843
F32D5-26	26	.8125	.875
F32D5-28	28	.8750	.937
F32D5-30	30	.9375	1.000
F32D5-32	32	1.0000	1.062
F32D5-36	36	1.1250	1.187
F32D5-40	40	1.2500	1.312
F32D5-42	42	1.3125	1.375
F32D5-44	44	1.3750	1.437
F32D5-46	46	1.4375	1.500
F32D5-48	48	1.5000	1.562
F32D5-50	50	1.5625	1.625
F32D5-52	52	1.6250	1.687
F32D5-56	56	1.7500	1.812
F32D5-60	60	1.8750	1.937
F32D5-63	63	1.9687	2.031
F32D5-64	64	2.0000	2.062
F32D5-66	66	2.0625	2.125
F32D5-69	69	2.1562	2.218
F32D5-72	72	2.2500	2.312
F32D5-75	75	2.3437	2.406
F32D5-80	80	2.5000	2.562
F32D5-84	84	2.6250	2.687
F32D5-88	88	2.7500	2.812
F32D5-92	92	2.8750	2.937
F32D5-96	96	3.0000	3.062
F32D5-104	104	3.2500	3.312
F32D5-108	108	3.3750	3.437
F32D5-112	112	3.5000	3.562
F32D5-124	124	3.8750	3.937

For Couplings See Section G.
For Shafts, Bearings and Collars See Section I.

SPUR GEARS

PITCH	STYLE	BORE	FACE	MATERIAL	AGMA QUALITY	PRESSURE ANGLE
32	HUBLESS	3/8"	1/4"	POLYURETHANE	8	20°

B

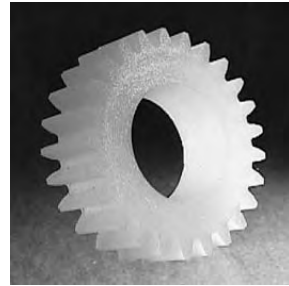
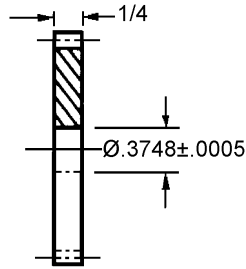
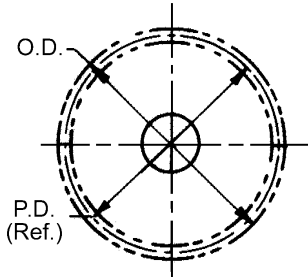

Available on request:
Other numbers of teeth
14 - 1/2° Pressure Angle

STOCK NO.	NO. OF TEETH	PITCH DIA.	OUTSIDE DIA.
F32U6-32	32	1.00	1.062
F32U6-36	36	1.13	1.187
F32U6-40	40	1.25	1.312
F32U6-48	48	1.50	1.562
F32U6-60	60	1.88	1.937
F32U6-64	64	2.00	2.062
F32U6-72	72	2.25	2.312
F32U6-75	75	2.34	2.406
F32U6-80	80	2.50	2.562
F32U6-96	96	3.00	3.062
F32U6-112	112	3.50	3.562
F32U6-120	120	3.75	3.812
F32U6-128	128	4.00	4.062

For Couplings See Section G.
For Shafts, Bearings and Collars See Section I.

CLUSTER GEAR AND HUB

PITCH	STYLE	BORE	MATERIAL	AGMA QUALITY	PRESSURE ANGLE
32	X	1/4"	303 STAINLESS STEEL	10	20°

STOCK NO.	PITCH	NO. OF TEETH	PITCH DIA.	OUTSIDE DIA.
DP32S14-15	32	15	.4688	.531
DP32S14-16		16	.5000	.563
DP32S14-18		18	.5625	.625
DP32S14-19		19	.5983	.656
DP32S14-20		20	.6250	.688

PITCH	STYLE	BORE	MATERIAL	AGMA QUALITY	PRESSURE ANGLE
32	Y	1/4"	303 STAINLESS STEEL	10	20°

STOCK NO.	PITCH	NO. OF TEETH	PITCH DIA.	OUTSIDE DIA.
DP32S16-15	32	15	.4688	.531
DP32S16-16		16	.5000	.563
DP32S16-18		18	.5625	.625
DP32S16-19		19	.5983	.656
DP32S16-20		20	.6250	.688

PITCH	STYLE	BORE	MATERIAL	AGMA QUALITY	PRESSURE ANGLE
32	Z	1/4"	303 STAINLESS STEEL	10	20°

STOCK NO.	PITCH	NO. OF TEETH	PITCH DIA.	OUTSIDE DIA.
DP32S18-15	32	15	.4688	.531
DP32S18-16		16	.5000	.563
DP32S18-18		18	.5625	.625
DP32S18-19		19	.5983	.656
DP32S18-20		20	.6250	.688

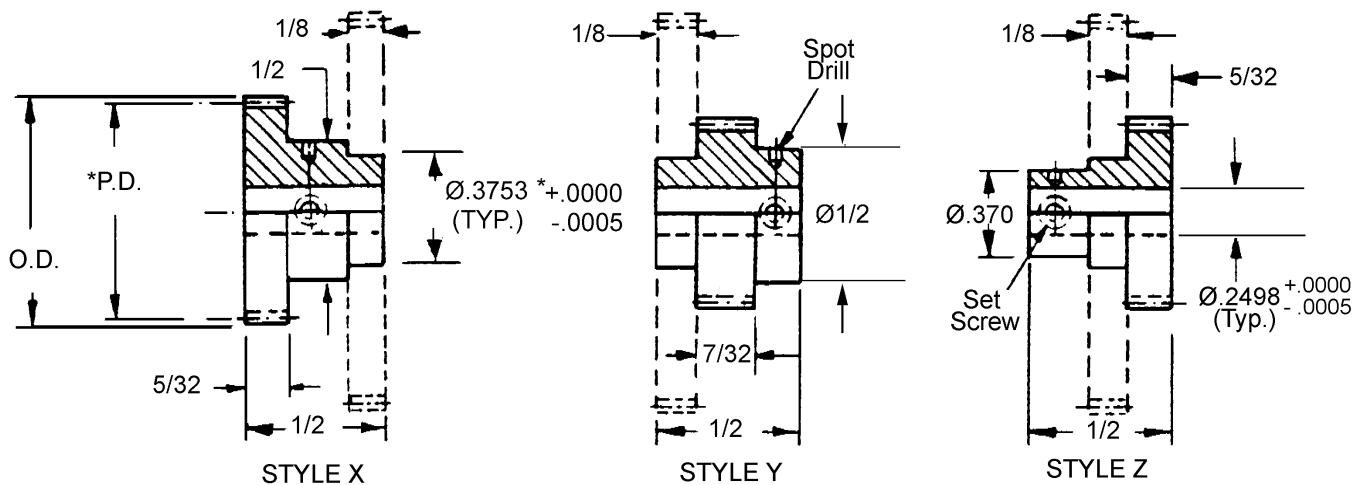

*Concentric within .0003
Order hubless gear separately.

SPUR GEARS

PITCH	STYLE	BORE	FACE	MATERIAL	AGMA QUALITY	PRESSURE ANGLE
32	PIN HUB	3/16"	3/16"	303 STAINLESS STEEL AND ALUMINUM ANODIZED	10	20°

B

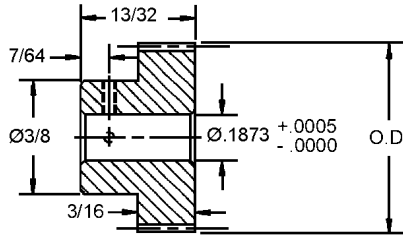
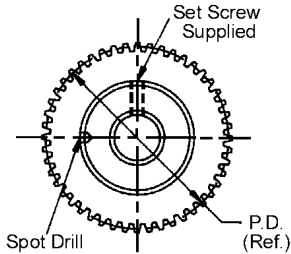

Available on request, other numbers of teeth and 14-1/2° Pressure Angle.

303 STAINLESS STEEL STOCK NO.	2024-T4 ALUMINUM ANODIZED STOCK NO.	NO. OF TEETH	PITCH DIA.	OUTSIDE DIA.
P32S21-15	P32A21-15	15	.4687	.531
P32S21-16	P32A21-16	16	.5000	.562
P32S21-17	P32A21-17	17	.5312	.593
P32S21-18	P32A21-18	18	.5625	.625
P32S21-20	P32A21-20	20	.6250	.687
P32S21-22	P32A21-22	22	.6875	.750
P32S21-24	P32A21-24	24	.7500	.812
P32S21-26	P32A21-26	26	.8125	.875
P32S21-28	P32A21-28	28	.8750	.937
P32S21-30	P32A21-30	30	.9375	1.000
P32S21-32	P32A21-32	32	1.0000	1.062
P32S21-36	P32A21-36	36	1.1250	1.187
P32S21-40	P32A21-40	40	1.2500	1.312
P32S21-48	P32A21-48	48	1.5000	1.562
P32S21-52	P32A21-52	52	1.6250	1.687
P32S21-56	P32A21-56	56	1.7500	1.812
P32S21-60	P32A21-60	60	1.8750	1.937
P32S21-64	P32A21-64	64	2.0000	2.062
P32S21-68	P32A21-68	68	2.1250	2.187
P32S21-72	P32A21-72	72	2.2500	2.312
P32S21-80	P32A21-80	80	2.5000	2.562
P32S21-84	P32A21-84	84	2.6250	2.687
P32S21-88	P32A21-88	88	2.7500	2.812
P32S21-92	P32A21-92	92	2.8750	2.937
P32S21-96	P32A21-96	96	3.0000	3.062
P32S21-100	P32A21-100	100	3.1250	3.187
P32S21-104	P32A21-104	104	3.2500	3.312
P32S21-108	P32A21-108	108	3.3750	3.437
P32S21-112	P32A21-112	112	3.5000	3.562
P32S21-116	P32A21-116	116	3.6250	3.687
P32S21-120	P32A21-120	120	3.7500	3.812
P32S21-128	P32A21-128	128	4.0000	4.062
P32S21-130	P32A21-130	130	4.0625	4.125
P32S21-135	P32A21-135	135	4.2187	4.281
P32S21-140	P32A21-140	140	4.3750	4.437

For Couplings See Section G.
For Shafts, Bearings and Collars See Section I.

SPUR GEARS

PITCH	STYLE	BORE	FACE	MATERIAL	AGMA QUALITY	PRESSURE ANGLE
32	PIN HUB	1/4"	3/16"	303 STAINLESS STEEL AND ALUMINUM ANODIZED	10	20°

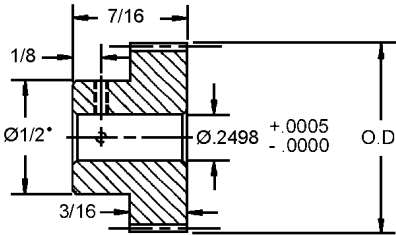
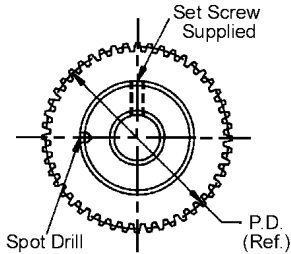

• For tooth counts 17-18 new hub diameter is .44.
Available on request, other numbers of teeth,
Agma Quality 12 and 14-1/2° Pressure Angle.

303 STAINLESS STEEL STOCK NO.	2024-T4 ALUMINUM ANODIZED STOCK NO.	NO. OF TEETH	PITCH DIA.	OUTSIDE DIA.
P32S28-18	P32A28-18	18*	.5625	.625
P32S28-20	P32A28-20	20*	.6250	.687
P32S28-24	P32A28-24	24	.7500	.812
P32S28-26	P32A28-26	26	.8125	.875
P32S28-28	P32A28-28	28	.8750	.937
P32S28-30	P32A28-30	30	.9375	1.000
P32S28-32	P32A28-32	32	1.0000	1.062
P32S28-36	P32A28-36	36	1.1250	1.187
P32S28-40	P32A28-40	40	1.2500	1.312
P32S28-48	P32A28-48	48	1.5000	1.562
P32S28-52	P32A28-52	52	1.6250	1.687
P32S28-56	P32A28-56	56	1.7500	1.812
P32S28-60	P32A28-60	60	1.8750	1.937
P32S28-64	P32A28-64	64	2.0000	2.062
P32S28-72	P32A28-72	72	2.2500	2.312
P32S28-80	P32A28-80	80	2.5000	2.562
P32S28-88	P32A28-88	88	2.7500	2.812
P32S28-92	P32A28-92	92	2.8750	2.937
P32S28-96	P32A28-96	96	3.0000	3.062
P32S28-100	P32A28-100	100	3.1250	3.187
P32S28-112	P32A28-112	112	3.5000	3.562
P32S28-120	P32A28-120	120	3.7500	3.812
P32S28-128	P32A28-128	128	4.0000	4.062
P32S28-132	P32A28-132	132	4.1250	4.187

For Couplings See Section G.
For Shafts, Bearings and Collars See Section I.

SPUR GEARS

PITCH	STYLE	BORE	FACE	MATERIAL	AGMA QUALITY	PRESSURE ANGLE
32	PIN HUB	1/4"	1/8"	303 STAINLESS STEEL AND ALUMINUM ANODIZED	10	20°

B

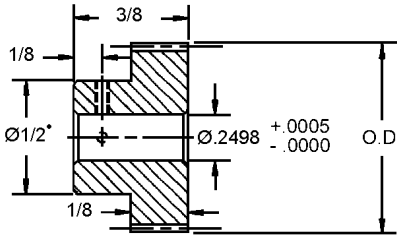
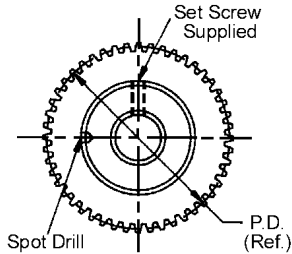

• For 17 - 18 teeth hub diameter equals .45.
Available on request, other numbers of teeth,
Agma Quality 12 and 14-1/2° Pressure Angle.

303 STAINLESS STEEL STOCK NO.	2024-T4 ALUMINUM ANODIZED STOCK NO.	NO. OF TEETH	PITCH DIA.	OUTSIDE DIA.
P32S26-18	P32A26-18	18•	.5625	.625
P32S26-20	P32A26-20	20	.6250	.687
P32S26-22	P32A26-22	22	.6875	.750
P32S26-24	P32A26-24	24	.7500	.812
P32S26-25	P32A26-25	25	.7812	.843
P32S26-26	P32A26-26	26	.8125	.875
P32S26-28	P32A26-28	28	.8750	.937
P32S26-30	P32A26-30	30	.9375	1.000
P32S26-32	P32A26-32	32	1.0000	1.062
P32S26-36	P32A26-36	36	1.1250	1.187
P32S26-40	P32A26-40	40	1.2500	1.312
P32S26-42	P32A26-42	42	1.3125	1.375
P32S26-45	P32A26-45	45	1.4062	1.468
P32S26-48	P32A26-48	48	1.5000	1.562
P32S26-50	P32A26-50	50	1.5625	1.625
P32S26-54	P32A26-54	54	1.6875	1.750
P32S26-56	P32A26-56	56	1.7500	1.812
P32S26-60	P32A26-60	60	1.8750	1.937
P32S26-64	P32A26-64	64	2.0000	2.062
P32S26-70	P32A26-70	70	2.1875	2.250
P32S26-72	P32A26-72	72	2.2500	2.312
P32S26-75	P32A26-75	75	2.3437	2.406
P32S26-76	P32A26-76	76	2.3750	2.437
P32S26-80	P32A26-80	80	2.5000	2.562
P32S26-88	P32A26-88	88	2.7500	2.812
P32S26-90	P32A26-90	90	2.8125	2.875
P32S26-96	P32A26-96	96	3.0000	3.062
P32S26-100	P32A26-100	100	3.1250	3.187
P32S26-110	P32A26-110	110	3.4375	3.500
P32S26-120	P32A26-120	120	3.7500	3.812
P32S26-124	P32A26-124	124	3.8750	3.937
P32S26-128	P32A26-128	128	4.0000	4.062

**For Couplings See Section G.
For Shafts, Bearings and Collars See Section I.**

SPUR GEARS

PITCH	STYLE	BORE	FACE	MATERIAL	AGMA QUALITY	PRESSURE ANGLE
32	PIN HUB	1/4"	1/4"	ALUMINUM ANODIZED	8	20°

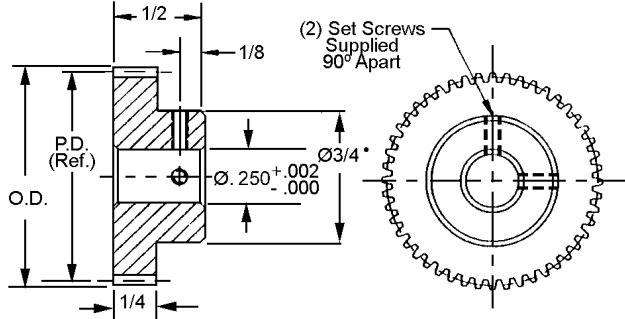

• For 17 - 24 teeth hub diameter equals .45

Available on request, other numbers of teeth, quality 12 and 14-1/2° Pressure Angle.

STOCK NO.	NO. OF TEETH	PITCH DIA.	OUTSIDE DIA.
P32A66-18	18*	.5625	.625
P32A66-20	20*	.6250	.687
P32A66-24	24*	.7500	.812
P32A66-30	30	.9375	1.000
P32A66-32	32	1.0000	1.062
P32A66-36	36	1.1250	1.187
P32A66-40	40	1.2500	1.312
P32A66-48	48	1.5000	1.562
P32A66-56	56	1.7500	1.812
P32A66-60	60	1.8750	1.937
P32A66-64	64	2.0000	2.062
P32A66-80	80	2.5000	2.562
P32A66-96	96	3.0000	3.062
P32A66-112	112	3.5000	3.562
P32A66-128	128	4.0000	4.062
P32A66-160	160	5.0000	5.062
P32A66-192	192	6.0000	6.062

PITCH	STYLE	BORE	FACE	MATERIAL	AGMA QUALITY	PRESSURE ANGLE
32	PIN HUB	3/8"	1/4"	ALUMINUM ANODIZED	8	20°

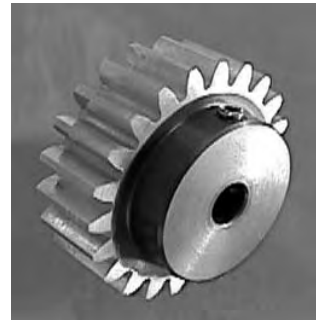
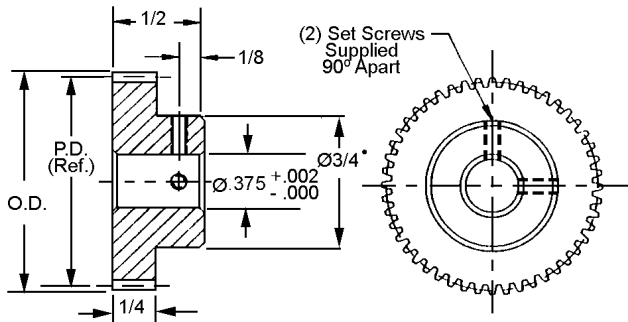

• For 21-24 teeth hub diameter equals .57

Available on request, other numbers of teeth, quality 12 and 14-1/2° Pressure Angle.

STOCK NO.	NO. OF TEETH	PITCH DIA.	OUTSIDE DIA.
P32A67-24	24*	.7500	.812
P32A67-30	30	.9375	1.000
P32A67-32	32	1.0000	1.062
P32A67-36	36	1.1250	1.187
P32A67-40	40	1.2500	1.312
P32A67-48	48	1.5000	1.562
P32A67-56	56	1.7500	1.812
P32A67-60	60	1.8750	1.937
P32A67-64	64	2.0000	2.062
P32A67-80	80	2.5000	2.562
P32A67-96	96	3.0000	3.062
P32A67-112	112	3.5000	3.562
P32A67-128	128	4.0000	4.062
P32A67-160	160	5.0000	5.062
P32A67-192	192	6.0000	6.062

SPUR GEARS

PITCH	STYLE	BORE	FACE	MATERIAL	AGMA QUALITY	PRESSURE ANGLE
32	PIN HUB	3/8"	3/8"	303 STAINLESS STEEL OR BRONZE ALLOY 464	10	20°

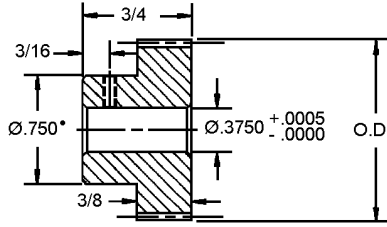
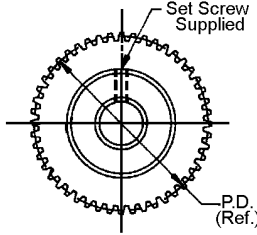

• For 21 - 24 teeth hub diameter equals .57

X In part number indicates part may be supplied as a two piece construction (some dimensions may vary.)

Available on request, other numbers of teeth and 14-1/2° Pressure Angle.

303 STAINLESS STEEL		NO. OF TEETH	PITCH DIA.	OUTSIDE DIA.
STOCK NO.	BRONZE ALLOY 464 STOCK NO.			
P32S34-24	P32B34-24	24	.7500	.812
P32S34-28	P32B34-28	28	.8750	.937
P32S34-30	P32B34-30	30	.9375	1.000
P32S34-32	P32B34-32	32	1.0000	1.062
P32S34-36	P32B34-36	36	1.1250	1.187
P32S34-40	P32B34-40	40	1.2500	1.312
P32S34-48	P32B34-48	48	1.5000	1.562
P32S34-56	P32B34-56	56	1.7500	1.812
P32S34-60	P32B34-60	60	1.8750	1.937
P32S34X-64	P32B34X-64	64	2.0000	2.062
P32S34X-72	P32B34X-72	72	2.2500	2.312
P32S34X-80	P32B34X-80	80	2.5000	2.562
P32S34X-96	P32B34X-96	96	3.0000	3.062
P32S34X-112	P32B34X-112	112	3.5000	3.562
P32S34X-128	P32B34X-128	128	4.0000	4.062
P32S34X-160	P32B34X-160	160	5.0000	5.062

PITCH	STYLE	BORE	FACE	MATERIAL	AGMA QUALITY	PRESSURE ANGLE
32	PIN HUB	1/2"	1/4"	ALUMINUM ANODIZED	8	20°

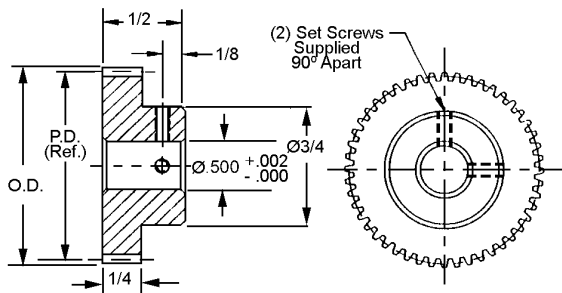

Available on request, other numbers of teeth, quality 12 and 14-1/2° Pressure Angle.

STOCK NO.	NO. OF TEETH	PITCH DIA.	OUTSIDE DIA.
P32A68-30	30	.9375	1.000
P32A68-32	32	1.0000	1.062
P32A68-36	36	1.1250	1.187
P32A68-40	40	1.2500	1.312
P32A68-48	48	1.5000	1.562
P32A68-56	56	1.7500	1.812
P32A68-60	60	1.8750	1.937
P32A68-64	64	2.0000	2.062
P32A68-80	80	2.5000	2.562
P32A68-96	96	3.0000	3.062
P32A68-112	112	3.5000	3.562
P32A68-128	128	4.0000	4.062
P32A68-160	160	5.0000	5.062
P32A68-192	192	6.0000	6.062

SPUR GEARS

PITCH	STYLE	BORE	FACE	MATERIAL	AGMA QUALITY	PRESSURE ANGLE
32	PIN HUB	1/4"	3/16"	17-4 PH STAINLESS STEEL RC26 - 32	10	20°

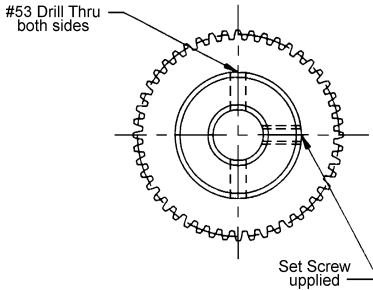
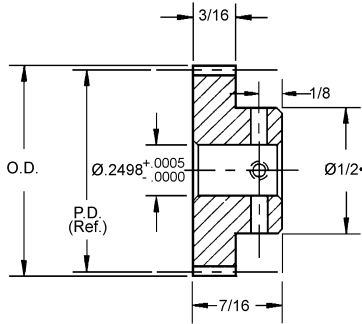

• For 14 - 17 teeth hub diameter equals .35

Available on request, other numbers of teeth, quality 12 and 14-1/2° Pressure Angle.

STOCK NO.	NO. OF TEETH	PITCH DIA.	OUTSIDE DIA.
P32PH28-14	14•	.4375	.500
P32PH28-15	15•	.4687	.531
P32PH28-16	16•	.5000	.562
P32PH28-17	17•	.5312	.593
P32PH28-18	18	.5625	.625
P32PH28-19	19	.5937	.656
P32PH28-20	20	.6250	.687
P32PH28-24	24	.7500	.812
P32PH28-28	28	.8750	.937
P32PH28-32	32	1.0000	1.062
P32PH28-34	34	1.0625	1.125
P32PH28-36	36	1.1250	1.187
P32PH28-38	38	1.1875	1.250
P32PH28-40	40	1.2500	1.312

PITCH	STYLE	BORE	FACE	MATERIAL	AGMA QUALITY	PRES. ANGLE
32	PIN HUB	1/8"	1/4"	COLD ROLLED STEEL C12L14 OR C12L15 WITH SELENIUM OR BRASS ALLOY 360	5	20°

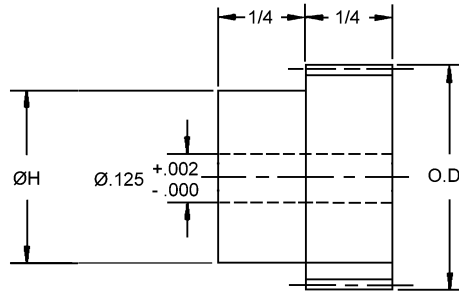
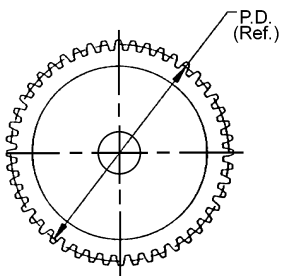

COLD ROLLED STEEL C12L14 OR C12L15 WITH SELENIUM	BRASS ALLOY 360	NO. OF TEETH	PITCH DIA.	OUTSIDE DIA.	H
STOCK NO.	STOCK NO.				
PX32S-10	PX32B-10	10	.312	.375	.218
PX32S-11	PX32B-11	11	.344	.406	.250
PX32S-12	PX32B-12	12	.375	.437	.281
PX32S-14	PX32B-14	14	.438	.500	.343
PX32S-15	PX32B-15	15	.469	.531	.375
PX32S-16	PX32B-16	16	.500	.562	.406
PX32S-18	PX32B-18	18	.563	.625	.468
PX32S-20	PX32B-20	20	.625	.688	.532
-	PX32B-24	24	.750	.813	.656

SPUR GEARS

PITCH	STYLE	BORE	FACE	MATERIAL	AGMA QUALITY	PRESSURE ANGLE
32	PIN HUB	3/16"	3/16"	DELTRIN WITH STAINLESS STEEL HUB	10	20°

B

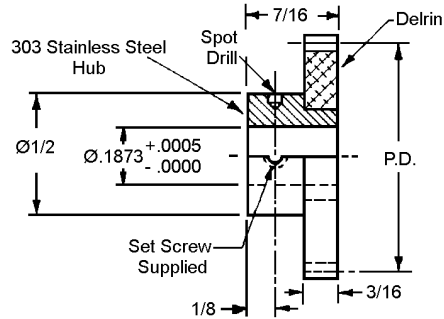

STOCK NO.	NO. OF TEETH	PITCH DIA.	OUTSIDE DIA.
P32D21X-20	20	.6250	.687
P32D21X-21	21	.6562	.718
P32D21X-22	22	.6875	.750
P32D21X-23	23	.7187	.781
P32D21X-24	24	.7500	.812
P32D21X-25	25	.7812	.843
P32D21X-26	26	.8125	.875
P32D21X-28	28	.8750	.937
P32D21X-30	30	.9375	1.000
P32D21X-32	32	1.0000	1.062
P32D21X-36	36	1.1250	1.187
P32D21X-40	40	1.2500	1.312
P32D21X-42	42	1.3125	1.375
P32D21X-44	44	1.3750	1.437
P32D21X-46	46	1.4375	1.500
P32D21X-48	48	1.5000	1.562
P32D21X-50	50	1.5625	1.625
P32D21X-52	52	1.6250	1.687
P32D21X-56	56	1.7500	1.812
P32D21X-60	60	1.8750	1.937
P32D21X-63	63	1.9687	2.031
P32D21X-64	64	2.0000	2.062
P32D21X-66	66	2.0625	2.125
P32D21X-69	69	2.1562	2.218
P32D21X-72	72	2.2500	2.312
P32D21X-75	75	2.3437	2.406
P32D21X-80	80	2.5000	2.562
P32D21X-84	84	2.6250	2.687
P32D21X-88	88	2.7500	2.812
P32D21X-92	92	2.8750	2.937
P32D21X-96	96	3.0000	3.062
P32D21X-104	104	3.2500	3.312
P32D21X-108	108	3.3750	3.437
P32D21X-112	112	3.5000	3.562
P32D21X-124	124	3.8750	3.937

Available on request, other numbers of teeth,
14-1/2° Pressure Angle.

**For Couplings See Section G.
For Shafts, Bearings and Collars See Section I.**

SPUR GEARS

PITCH	STYLE	BORE	FACE	MATERIAL	AGMA QUALITY	PRESSURE ANGLE
32	PIN HUB	1/4"	3/16"	DELRIN WITH STAINLESS STEEL HUB	10	20°

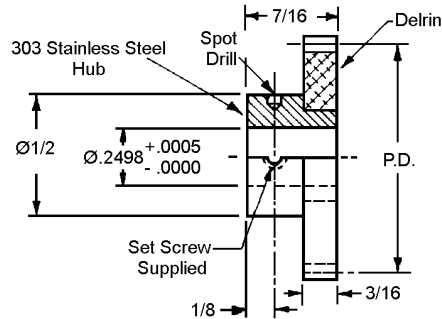

Available on request, other numbers of teeth,
14-1/2° Pressure Angle.

STOCK NO.	NO. OF TEETH	PITCH DIA.	OUTSIDE DIA.
P32D28X-20	20	.6250	.687
P32D28X-21	21	.6562	.718
P32D28X-22	22	.6875	.750
P32D28X-23	23	.7187	.781
P32D28X-24	24	.7500	.812
P32D28X-25	25	.7812	.843
P32D28X-26	26	.8125	.875
P32D28X-28	28	.8750	.937
P32D28X-30	30	.9375	1.000
P32D28X-32	32	1.0000	1.062
P32D28X-36	36	1.1250	1.187
P32D28X-40	40	1.2500	1.312
P32D28X-42	42	1.3125	1.375
P32D28X-44	44	1.3750	1.437
P32D28X-46	46	1.4375	1.500
P32D28X-48	48	1.5000	1.562
P32D28X-50	50	1.5625	1.625
P32D28X-52	52	1.6250	1.687
P32D28X-56	56	1.7500	1.812
P32D28X-60	60	1.8750	1.937
P32D28X-63	63	1.9687	2.031
P32D28X-64	64	2.0000	2.062
P32D28X-66	66	2.0625	2.125
P32D28X-69	69	2.1562	2.218
P32D28X-72	72	2.2500	2.312
P32D28X-75	75	2.3437	2.406
P32D28X-80	80	2.5000	2.562
P32D28X-84	84	2.6250	2.687
P32D28X-88	88	2.7500	2.812
P32D28X-92	92	2.8750	2.937
P32D28X-96	96	3.0000	3.062
P32D28X-104	104	3.2500	3.312
P32D28X-108	108	3.3750	3.437
P32D28X-112	112	3.5000	3.562
P32D28X-124	124	3.8750	3.937

**For Couplings See Section G.
For Shafts, Bearings and Collars See Section I.**

SPUR GEARS

PITCH	STYLE	BORE	FACE	MATERIAL	AGMA QUALITY	PRESSURE ANGLE
32	PIN HUB	1/4"	1/4"	CAST POLYURETHANE GRAPHITE IMPREGNATED 70D DUROMETER	8	20°

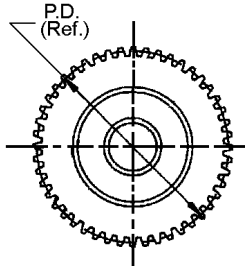
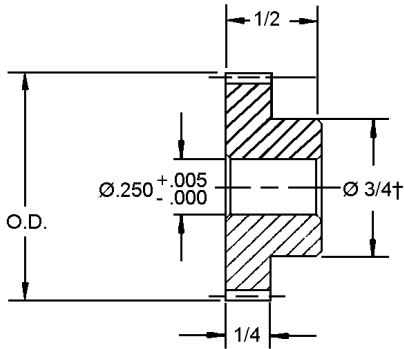

† Teeth runout on hub.
Available on request, other numbers of teeth,
quality 12 and 14-1/2° Pressure Angle.

STOCK NO.	NO. OF TEETH	PITCH DIA.	OUTSIDE DIA.
P32U66-16	16†	.5000	.562
P32U66-20	20†	.6250	.687
P32U66-24	24†	.7500	.812
P32U66-30	30	.9375	1.000
P32U66-32	32	1.0000	1.062
P32U66-40	40	1.2500	1.312
P32U66-48	48	1.5000	1.562
P32U66-64	64	2.0000	2.062
P32U66-72	72	2.2500	2.313
P32U66-96	96	3.0000	3.062

PITCH	STYLE	BORE	FACE	MATERIAL	AGMA QUALITY	PRES. ANGLE
32	PIN HUB	1/4"	3/16"	MOLDED ACETAL	5	20°

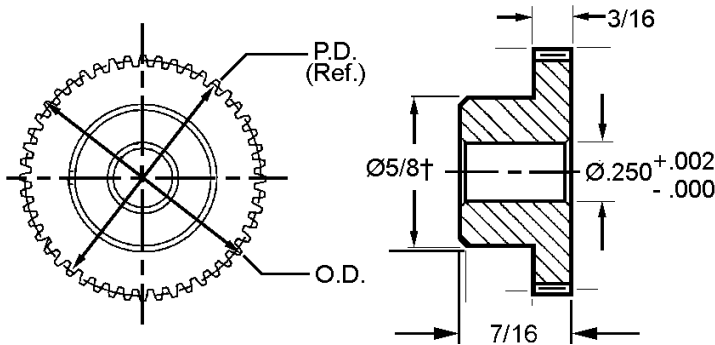

† Teeth runout on hub.
Available on request, other bore sizes and
numbers of teeth on request.

STOCK NO.	NO. OF TEETH	PITCH DIA.	OUTSIDE DIA.
P32D4M-20	20†	.6250	.69
P32D4M-24	24	.7500	.81
P32D4M-28	28	.8750	.94
P32D4M-30	30	.9375	1.00
P32D4M-32	32	1.0000	1.06
P32D4M-40	40	1.2500	1.31
P32D4M-48	48	1.5000	1.56
P32D4M-50	50	1.5625	1.63
P32D4M-56	56	1.7500	1.81
P32D4M-60	60	1.8750	1.94
P32D4M-64	64	2.0000	2.06
P32D4M-70	70	2.1875	2.25
P32D4M-72	72	2.2500	2.31
P32D4M-76	76	2.3750	2.44
P32D4M-80	80	2.5000	2.56
P32D4M-88	88	2.7500	2.81
P32D4M-90	90	2.8125	2.88

SPUR GEARS

PITCH	STYLE	BORE	FACE	MATERIAL	AGMA QUALITY	PRESSURE ANGLE
32	PIN HUB	3/8"	1/4"	CAST POLYURETHANE GRAPHITE IMPREGNATED 70D DUROMETER	8	20°

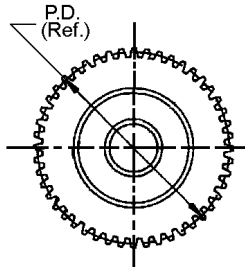
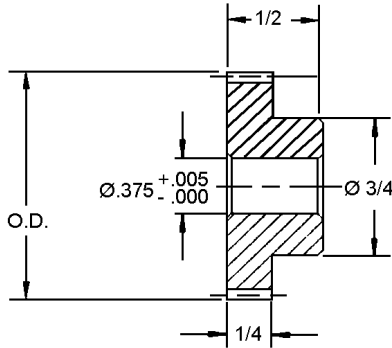

† Teeth runout on hub.
Available on request, other numbers of teeth,
quality 12 and 14-1/2° Pressure Angle.

STOCK NO.	NO. OF TEETH	PITCH DIA.	OUTSIDE DIA.
P32U67-20	20†	.6250	.687
P32U67-24	24†	.7500	.812
P32U67-30	30	.9375	1.000
P32U67-32	32	1.0000	1.062
P32U67-40	40	1.2500	1.312
P32U67-48	48	1.5000	1.562
P32U67-64	64	2.0000	2.062
P32U67-72	72	2.2500	2.313
P32U67-96	96	3.0000	3.062

PITCH	STYLE	BORE	FACE	MATERIAL	AGMA QUALITY	PRESSURE ANGLE
32	PIN HUB	1/2"	1/4"	CAST POLYURETHANE GRAPHITE IMPREGNATED 70D DUROMETER	8	20°

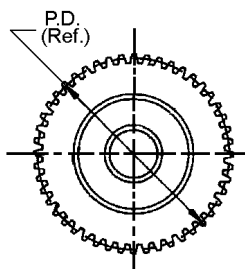
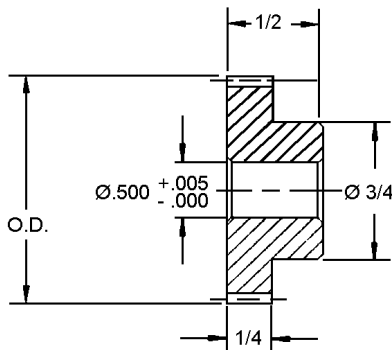

† Teeth runout on hub.
Available on request, other numbers of teeth,
quality 12 and 14-1/2° Pressure Angle.

STOCK NO.	NO. OF TEETH	PITCH DIA.	OUTSIDE DIA.
P32U68-24	24†	.7500	.812
P32U68-30	30	.9375	1.000
P32U68-32	32	1.0000	1.062
P32U68-40	40	1.2500	1.312
P32U68-48	48	1.5000	1.562
P32U68-64	64	2.0000	2.062
P32U68-72	72	2.2500	2.313
P32U68-96	96	3.0000	3.062

For Couplings See Section G.
For Shafts, Bearings and Collars See Section I.

SPUR GEARS

PITCH	STYLE	BORE	FACE	MATERIAL	AGMA QUALITY	PRES. ANGLE
32	PIN HUB	5/32" TO 5/16	3/16"	MOLDED DELRIN	5	20°

B

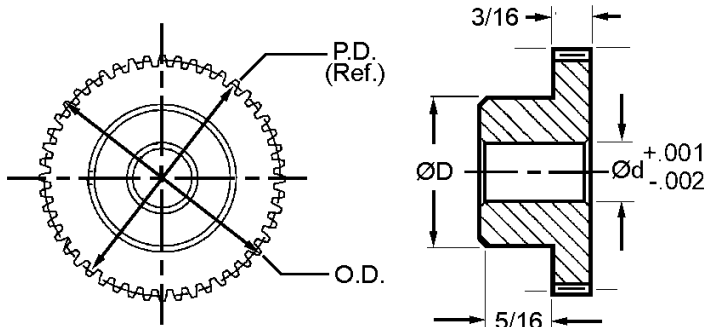

STOCK NO.	NO. OF TEETH	PITCH DIA.	OUTSIDE DIA.	$\varnothing d$	$\varnothing D$
P32D4P-12	12	.375	.438	5/32	9/32
P32D4P-14	14	.438	.500	5/32	5/16
P32D4P-15	15	.469	.532	5/32	5/16
P32D4P-16	16	.500	.562	5/32	11/32
P32D4P-18	18	.562	.625	5/32	11/32
P32D4P-20	20	.625	.688	3/16	15/32
P32D4P-22	22	.688	.750	3/16	1/2
P32D4P-24	24	.750	.812	3/16	1/2
P32D4P-25	25	.782	.844	3/16	9/16
P32D4P-26	26	.813	.875	3/16	9/16
P32D4P-28	28	.875	.938	3/16	1/2
P32D4P-30	30	.938	1.000	3/16	9/16
P32D4P-32	32	1.000	1.062	1/4	5/8
P32D4P-34	34	1.062	1.125	1/4	39/64
P32D4P-36	36	1.125	1.187	1/4	39/64
P32D4P-38	38	1.187	1.250	1/4	39/64
P32D4P-40	40	1.250	1.312	1/4	39/64
P32D4P-42	42	1.312	1.375	1/4	39/64
P32D4P-44	44	1.375	1.438	1/4	39/64
P32D4P-48	48	1.500	1.562	1/4	5/8
P32D4P-52	52	1.625	1.688	5/16	43/64
P32D4P-56	56	1.750	1.812	5/16	43/64
P32D4P-64	64	2.000	2.062	5/16	43/64
P32D4P-72	72	2.250	2.312	5/16	13/16
P32D4P-80	80	2.500	2.562	5/16	13/16
P32D4P-96	96	3.000	3.062	5/16	13/16

Some molded gears may have webs.

**For Couplings See Section G.
For Shafts, Bearings and Collars See Section I.**

SPUR GEARS

PITCH	STYLE	BORE	FACE	MATERIAL	AGMA QUALITY	PRESSURE ANGLE
32	CLAMP STYLE	1/4"	1/8"	303 STAINLESS STEEL AND ALUMINUM ANODIZED	10	20°

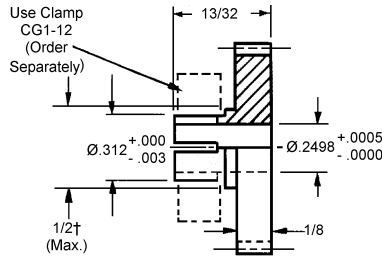
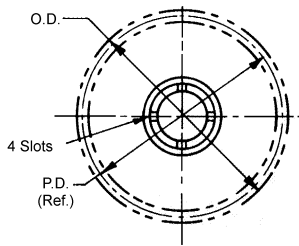

† Teeth may runout on flange diameter
Available on request, other numbers of teeth,
Agma Quality 12 and 14-1/2° Pressure Angle.

303 STAINLESS STEEL STOCK NO.	2024-T4 ALUMINUM ANODIZED 5 STOCK NO.	BERG QUALITY #10		
		NO. OF TEETH	PITCH DIA.	OUTSIDE DIA.
C32S18-14	C32A18-14	14†	.4375	.500
C32S18-15	C32A18-15	15†	.4687	.531
C32S18-16	C32A18-16	16†	.5000	.562
C32S18-17	C32A18-17	17†	.5312	.593
C32S18-18	C32A18-18	18†	.5625	.625
C32S18-19	C32A18-19	19	.5937	.656
C32S18-20	C32A18-20	20	.6250	.687
C32S18-22	C32A18-22	22	.6875	.750
C32S18-24	C32A18-24	24	.7500	.812
C32S18-25	C32A18-25	25	.7812	.843
C32S18-26	C32A18-26	26	.8125	.875
C32S18-28	C32A18-28	28	.8750	.937
C32S18-30	C32A18-30	30	.9375	1.000
C32S18-32	C32A18-32	32	1.0000	1.062
C32S18-34	C32A18-34	34	1.0625	1.125
C32S18-36	C32A18-36	36	1.1250	1.187
C32S18-38	C32A18-38	38	1.1875	1.250
C32S18-39	C32A18-39	39	1.2187	1.281
C32S18-40	C32A18-40	40	1.2500	1.312
C32S18-45	C32A18-45	45	1.4062	1.468
C32S18-48	C32A18-48	48	1.5000	1.562
C32S18-50	C32A18-50	50	1.5625	1.625
C32S18-54	C32A18-54	54	1.6875	1.750
C32S18-55	C32A18-55	55	1.7187	1.781
C32S18-56	C32A18-56	56	1.7500	1.812
C32S18-60	C32A18-60	60	1.8750	1.937
C32S18-64	C32A18-64	64	2.0000	2.062
C32S18-65	C32A18-65	65	2.0312	2.093
C32S18-68	C32A18-68	68	2.1250	2.187
C32S18-70	C32A18-70	70	2.1875	2.250
C32S18-72	C32A18-72	72	2.2500	2.312
C32S18-76	C32A18-76	76	2.3750	2.437
C32S18-80	C32A1 8-80	80	2.5000	2.562
C32S18-88	C32A18-88	88	2.7500	2.812
C32S18-90	C32A18-90	90	2.8125	2.875
C32S18-96	C32A18-96	96	3.0000	3.062
C32S18-112	C32A18-112	112	3.5000	3.562
C32S18-127	C32A18-127	127	3.9687	4.031
C32S18-128	C32A1 8-128	128	4.0000	4.062
C32S18-132	C32A18-132	132	4.1250	4.187

For Couplings See Section G.
For Shafts, Bearings and Collars See Section I.

SPUR GEARS

PITCH	STYLE	BORE	FACE	MATERIAL	AGMA QUALITY	PRESSURE ANGLE
32	CLAMP STYLE	1/4"	3/16"	303 STAINLESS STEEL	10	20°

B

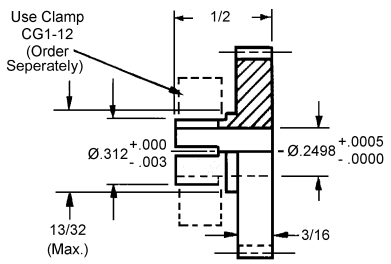
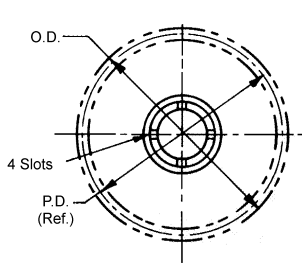

Available on request, other numbers of teeth, Agma Quality 12 and 14-1/2° Pressure Angle.

STOCK NO.	NO. OF TEETH	PITCH DIA.	OUTSIDE DIA.
C32S20-20	20	.6250	.687
C32S20-21	21	.6562	.718
C32S20-22	22	.6875	.750
C32S20-23	23	.7187	.781
C32S20-24	24	.7500	.812
C32S20-25	25	.7812	.843
C32S20-28	28	.8750	.937
C32S20-30	30	.9375	1.000
C32S20-32	32	1.0000	1.062
C32S20-36	36	1.1250	1.187
C32S20-40	40	1.2500	1.312
C32S20-48	48	1.5000	1.562
C32S20-56	56	1.7500	1.812
C32S20-60	60	1.8750	1.937
C32S20-64	64	2.0000	2.062
C32S20-72	72	2.2500	2.312
C32S20-80	80	2.5000	2.562
C32S20-96	96	3.0000	3.062
C32S20-112	112	3.5000	3.562
C32S20-128	128	4.0000	4.062
C32S20-132	132	4.1250	4.187

For Couplings See Section G.
For Shafts, Bearings and Collars See Section I.

GEAR RACKS

PITCH	STYLE	MATERIAL	AGMA QUALITY	PRESSURE ANGLE
32	ROUND & RECTANGULAR	416 SERIES STAINLESS STEEL STRESSED RELIEVED	10	20°

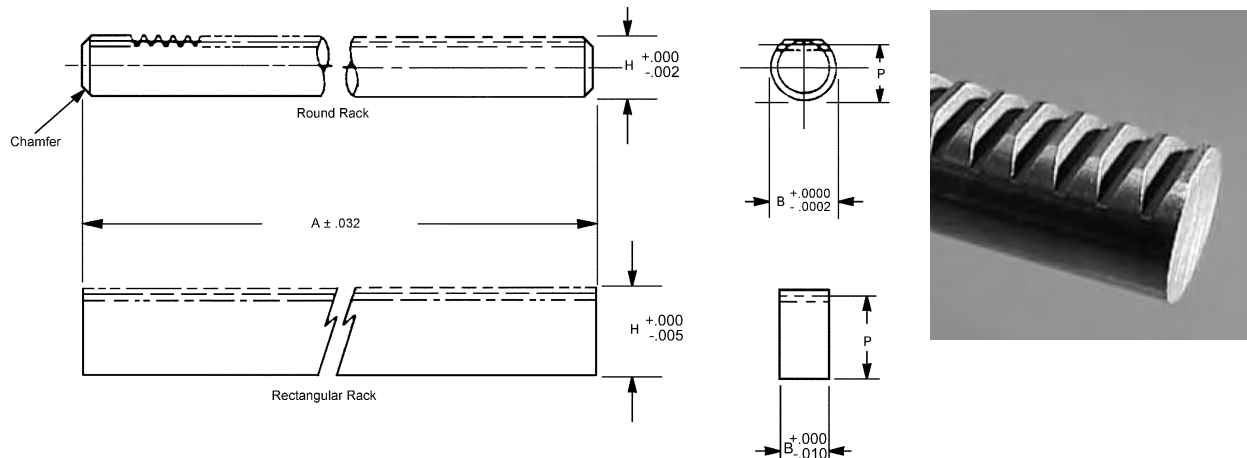

STOCK NO.	RACK STYLE	PITCH	P (Ref.)	B	A	H	AGMA QUALITY
R2-5	ROUND	32	.3087	.3747	18	.340	10
R2-11	RECTANGULAR	32	.4487	.230±.005	18	.480	10

Available on request:
14 - 1/2° pressure angle,
special, modified and custom racks.

PITCH	STYLE	MATERIAL	AGMA QUALITY	PRESSURE ANGLE
32	RECTANGULAR	416 SERIES STAINLESS STEEL AND 2024-T4 ALUMINUM ANODIZED	10	20°

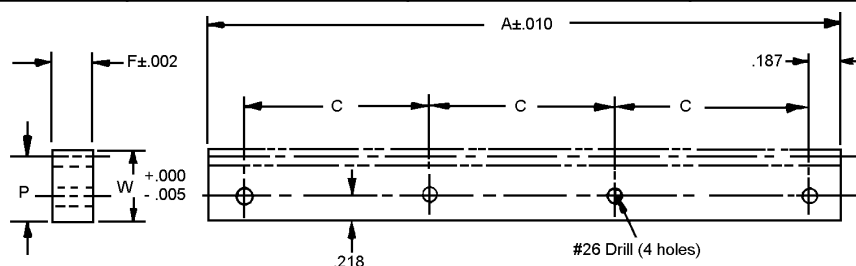

STOCK NO.	MATERIAL	A (Inch)	P (Ref.)	W	F	C
R4-9	STAINLESS ST.	10	.4487	.480	.230	3.208
R4-10	ALUMINUM					

Available on request: special,
modified and custom racks.

* Higher quality on request.

GEAR RACKS

PITCH	STYLES	MATERIAL	AGMA QUALITY	PRESSURE ANGLE
32	RECTANGULAR	416 SERIES STAINLESS STEEL STRESSED RELIEVED	10	20°

B

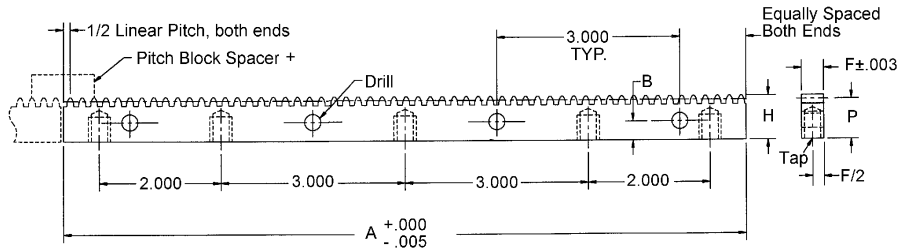

†Spacer block is designed for butting to achieve continuous lengths. On-Line pricing for AGMA 10 only.

RACKS	SPACER BLOCK	AGMA QTY. NO.	MAX ACCUM. ERROR	TOOTH TO TOOTH ERROR	PITCH	LINEAR PITCH	A INCH	P REF.	H +.000 -.005	F	B	DRILL	TAP
R1-5-G1	R1-5-SB	10*	.0014	.0005	32	.0982	11.087	.4437	.475	.230	.218	#26	#6-32 x 1/4
R3-3-G1	R3-3-SB	10*	.0014	.0005	32	.0982	11.087	.4487	.480	.230	.218	#26	#6-32 x 1/4

* Higher quality on request.

ANTI-BACKLASH GEARS

PITCH	STYLE	BORE	FACE	MATERIAL	AGMA QUALITY	PRES. ANGLE
32	PIN HUB	1/4"	.104	303 STAINLESS STEEL OR 2024-T4 ALUMINUM ANODIZED	10	20°

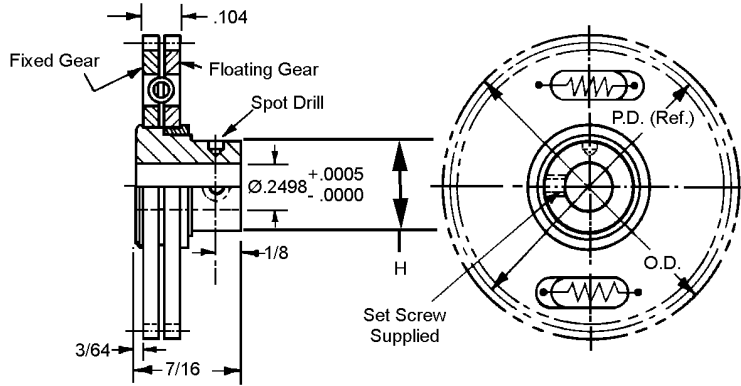

Hub Material: 303 Stainless Steel

STAINLESS STEEL STOCK NO.	ALUMINUM ANODIZED STOCK NO.	NO. OF TEETH	PITCH DIA.	OUTSIDE DIA.	SPRING STYLE	H
AP32ES-20	-	20	.6250	.687	SCISSOR	3/8
AP32ES-24	AP32RS-24	24	.7500	.812		
AP32ES-28	AP32RS-28	28	.8750	.937		
AP32ES-30	AP32RS-30	30	.9375	1.000	COIL	7/16
AP32E-32	AP32R-32	32	1.0000	1.062		
AP32E-36	AP32R-36	36	1.1250	1.187		
AP32E-40	AP32R-40	40	1.2500	1.312		
AP32E-42	AP32R-42	42	1.3125	1.375		
AP32E-48	AP32R-48	48	1.5000	1.562		
AP32E-50	AP32R-50	50	1.5625	1.625		
AP32E-54	AP32R-54	54	1.6875	1.750		
AP32E-56	AP32R-56	56	1.7500	1.812		
AP32E-60	AP32R-60	60	1.8750	1.937		
AP32E-64	AP32R-64	64	2.0000	2.062		
AP32E-70	AP32R-70	70	2.1875	2.250		
AP32E-72	AP32R-72	72	2.2500	2.312		
AP32E-80	AP32R-80	80	2.5000	2.562		
AP32E-96	AP32R-96	96	3.0000	3.062		

Available on request:

Other numbers of teeth;
AGMA Quality 12 and 14;
14-12° pressure angle.

For Couplings See Section G.
For Shafts, Bearings and Collars See Section I.

ANTI-BACKLASH GEARS

PITCH	STYLE	BORE	FACE	MATERIAL	AGMA QUALITY	PRES. ANGLE
32	PIN HUB	1/4"	3/16"	303 STAINLESS STEEL OR 2024-T4 ALUMINUM ANODIZED	10	20°

B

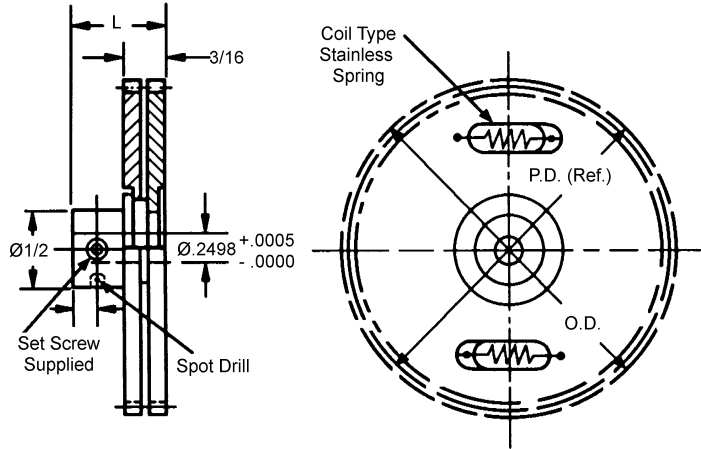

Hub Material: 303 Stainless Steel

303 STAINLESS STEEL STOCK NO.	2024-T4 ALUMINUM ANODIZED STOCK NO.	L	NO. OF TEETH	PITCH DIA.	OUTSIDE DIA.	
AP32MS-32	AP32QS-32	15/32	32	1.000	1.062	
AP32MS-34	AP32QS-34		34	1.062	1.125	
AP32MS-36	AP32QS-36		36	1.125	1.187	
AP32MS-38	AP32QS-38		38	1.187	1.250	
AP32M-40	AP32Q-40		27/64	40	1.250	1.312
AP32M-45	AP32Q-45			45	1.406	1.468
AP32M-48	AP32Q-48			48	1.500	1.562
AP32M-50	AP32Q-50			50	1.562	1.625
AP32M-55	AP32Q-55	55		1.718	1.781	
AP32M-56	AP32Q-56	56		1.750	1.812	
AP32M-60	AP32Q-60	60		1.875	1.937	
AP32M-64	AP32Q-64	64		2.000	2.062	
AP32M-65	AP32Q-65		65	2.031	2.093	
AP32M-70	AP32Q-70		70	2.187	2.250	
AP32M-72	AP32Q-72		72	2.250	2.312	
AP32M-75	AP32Q-75		75	2.343	2.406	
AP32M-80	AP32Q-80		80	2.500	2.562	
AP32M-85	AP32Q-85		85	2.656	2.718	

Available on request:

- Other numbers of teeth;
- AGMA Quality 12 and 14 (some dimensions may vary);
- 14-12° pressure angle.

**For Couplings See Section G.
For Shafts, Bearings and Collars See Section I.**

ANTI-BACKLASH GEARS

PITCH	STYLE	BORE	FACE	MATERIAL	AGMA QUALITY	PRES. ANGLE
32	PIN HUB	1/4"	1/4"	303 STAINLESS STEEL OR 2024-T4 ALUMINUM ANODIZED	10	20°

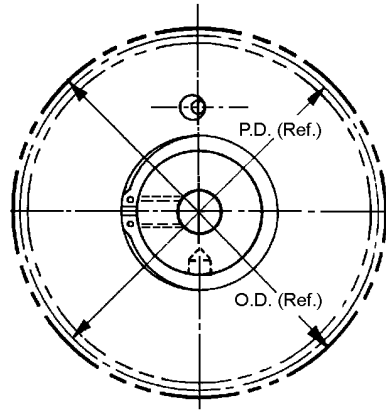
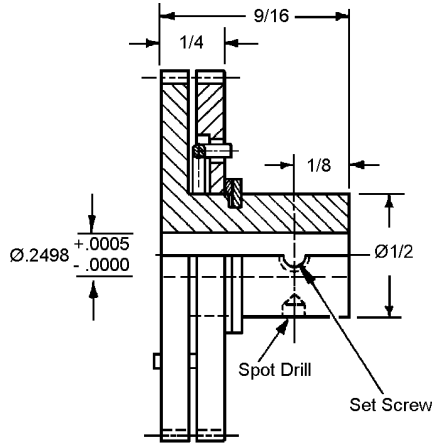

Hub Material: 303 Stainless Steel

STAINLESS STEEL STOCK NO.	ALUMINUM STOCK NO.	PITCH	NO. OF TEETH	PITCH DIA.	OUTSIDE DIA.
AP32BS-24	AP32DS-24	32	24	.7500	.813
AP32BS-28	AP32DS-28		28	.8750	.938
AP32BS-32	AP32DS-32		32	1.0000	1.063

Available on request:

Other numbers of teeth;
AGMA Quality 12 and 14 (some dimensions may vary);
14-12° pressure angle.

For Couplings See Section G.
For Shafts, Bearings and Collars See Section I.

ANTI-BACKLASH GEARS

PITCH	STYLE	BORE	FACE	MATERIAL	AGMA QUALITY	PRES. ANGLE
32	CLAMP STYLE	1/4"	.104	303 STAINLESS STEEL OR 2024-T4 ALUMINUM ANODIZED	10	20°

B

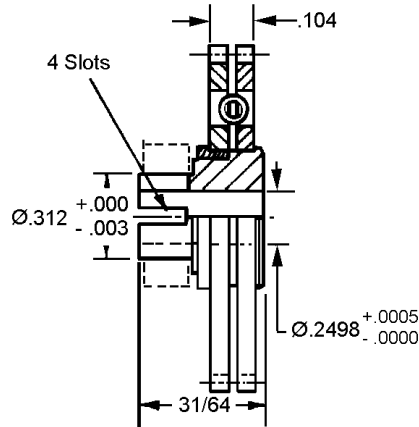

Hub Material: 303 Stainless Steel

STAINLESS STEEL STOCK NO.	ALUMINUM ANODIZED STOCK NO.	NO. OF TEETH	PITCH DIA.	OUTSIDE DIA.	SPRING STYLE
AC32ES-20	-	20	.6250	.687	SCISSOR
AC32ES-24	AC32RS-24	24	.7500	.812	
AC32ES-28	AC32RS-28	28	.8750	.937	
AC32ES-30	AC32RS-30	30	.9375	1.000	
AC32E-32	AC32R-32	32	1.0000	1.062	COIL
AC32E-36	AC32R-36	36	1.1250	1.187	
AC32E-40	AC32R-40	40	1.2500	1.312	
AC32E-42	AC32R-42	42	1.3125	1.375	
AC32E-48	AC32R-48	48	1.5000	1.562	
AC32E-50	AC32R-50	50	1.5625	1.625	
AC32E-54	AC32R-54	54	1.6875	1.750	
AC32E-56	AC32R-56	56	1.7500	1.812	
AC32E-60	AC32R-60	60	1.8750	1.937	
AC32E-64	AC32R-64	64	2.0000	2.062	
AC32E-70	AC32R-70	70	2.1875	2.250	
AC32E-72	AC32R-72	72	2.2500	2.312	
AC32E-80	AC32R-80	80	2.5000	2.562	
AC32E-96	AC32R-96	96	3.0000	3.062	

Available on request:

Other numbers of teeth;
AGMA Quality 12 and 14;
14-12° pressure angle.

**For Couplings See Section G.
For Shafts, Bearings and Collars See Section I.**

ANTI-BACKLASH GEARS

PITCH	STYLE	BORE	FACE	MATERIAL	AGMA QUALITY	PRES. ANGLE
32	CLAMP STYLE	1/4"	3/16"	303 STAINLESS STEEL OR 2024-T4 ALUMINUM ANODIZED	10	20°

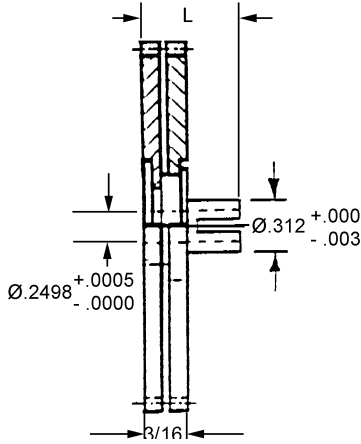

Available on request:
Other numbers of teeth;
AGMA Quality 12 and 14
(some dimensions may vary);
14-12° pressure angle.

303 STAINLESS STEEL STOCK NO.	2024-T4 ALUMINUM ANODIZED STOCK NO.	L	NO. OF TEETH	PITCH DIA.	OUTSIDE DIA.
AC32MS-32	AC32QS-32	15/32	32	1.000	1.062
AC32MS-34	AC32QS-34		34	1.062	1.125
AC32MS-36	AC32QS-36		36	1.125	1.187
AC32MS-38	AC32QS-38		38	1.187	1.250
AC32M-40	AC32Q-40		40	1.250	1.312
AC32M-45	AC32Q-45	27/64	45	1.406	1.468
AC32M-48	AC32Q-48		48	1.500	1.562
AC32M-50	AC32Q-50		50	1.562	1.625
AC32M-55	AC32Q-55		55	1.718	1.781
AC32M-56	AC32Q-56		56	1.750	1.812
AC32M-60	AC32Q-60		60	1.875	1.937
AC32M-64	AC32Q-64		64	2.000	2.062
AC32M-65	AC32Q-65		65	2.031	2.093
AC32M-70	AC32Q-70		70	2.187	2.250
AC32M-72	AC32Q-72		72	2.250	2.312
AC32M-75	AC32Q-75	75	2.343	2.406	
AC32M-80	AC32Q-80	80	2.500	2.562	
AC32M-85	AC32Q-85	85	2.656	2.718	

Hub Material: 303 Stainless Steel

PITCH	STYLE	BORE	FACE	MATERIAL	AGMA QUALITY	PRES. ANGLE
32	CLAMP STYLE	1/4"	1/4"	303 STAINLESS STEEL OR 2024-T4 ALUMINUM ANODIZED	10	20°

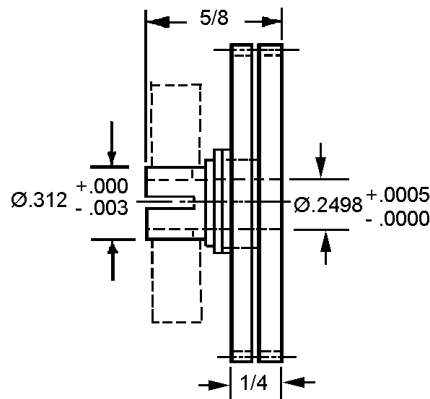

Hub Material: 303 Stainless Steel

STAINLESS STEEL STOCK NO.	ALUMINUM STOCK NO.	PITCH	NO. OF TEETH	PITCH DIA.	OUTSIDE DIA.
AC32BS-24	AC32DS-24	32	24	.7500	.813
AC32BS-28	AC32DS-28		28	.8750	.938
AC32BS-32	AC32DS-32		32	1.0000	1.063

Available on request:
Other numbers of teeth
AGMA Quality 12 and 14
14-1/2° Pressure Angle

For Couplings See Section G.
For Shafts, Bearings and Collars See Section I.

PINION SHAFTS

PITCH	MATERIAL	AGMA QUALITY	PRES. ANGLE
32	BRASS AND COLD ROLLED STEEL	4	20°

B

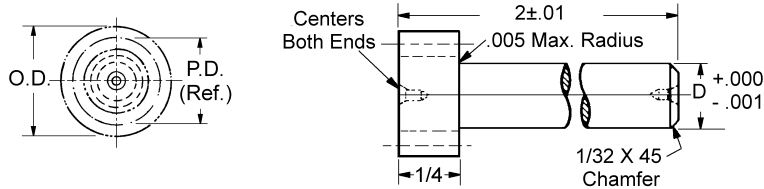

303 STAINLESS STEEL STOCK NO.	BRASS ALLOY 360 STOCK NO.	NUMBER OF TEETH	PITCH DIAMETER	OUTSIDE DIAMETER	D
PSX32S-11	PSX32B-11	11	.3438	.406	.250
PSX32S-12	PSX32B-12	12	.3750	.437	.250
PSX32S-14	PSX32B-14	14	.4375	.500	.312
PSX32S-15	PSX32B-15	15	.4688	.531	.375
PSX32S-16	PSX32B-16	16	.5000	.562	.375

PITCH	MATERIAL	AGMA QUALITY	PRES. ANGLE
32	BRASS AND COLD ROLLED STEEL	10	20°

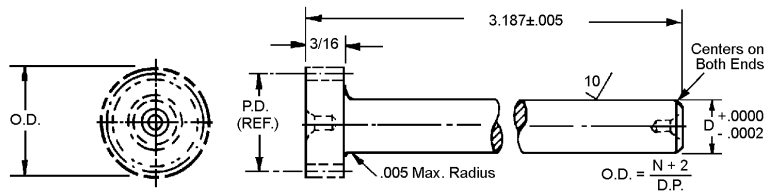

STOCK NO.	PITCH	NO. OF TEETH	PITCH DIA.	D
PS32S4-12H	32	12	.3750	.2497
PS32S4-14H		14	.4375	.2497
PS32S4-16H		16	.5000	.2497

SPUR GEAR STOCK

PITCH	TYPE	MATERIAL	AGMA QUALITY	PRESSURE ANGLE
32	PINION WIRE	BRASS AND COLD ROLLED STEEL	4	20°

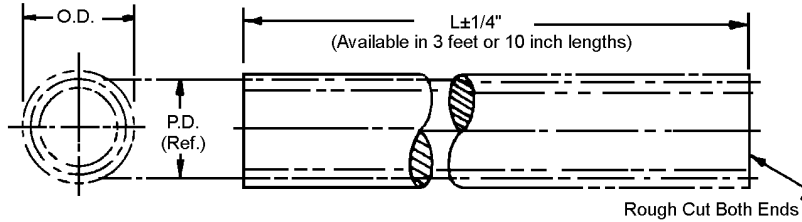

BRASS ALLOY 360		COLD ROLLED STEEL 12L14 or 12L15 WITH SELENIUM		NO. OF TEETH	PITCH DIA.	OUTSIDE DIA.
3FT. LONG STOCK NO.	10 IN. LONG STOCK NO.	3FT. LONG STOCK NO.	10 IN. LONG STOCK NO.			
PW32B-6	PW32B-6A	PW32S-6	PW32S-6A	6	.1875	.250
PW32B-8	PW32B-8A	PW32S-8	PW32S-8A	8	.2500	.312
PW32B-9	PW32B-9A	PW32S-9	PW32S-9A	9	.2812	.343
PW32B-10	PW32B-10A	PW32S-10	PW32S-10A	10	.3125	.375
PW32B-11	PW32B-11A	PW32S-11	PW32S-11A	11	.3437	.406
PW32B-12X	PW32B-12A	PW32S-12X	PW32S-12A	12	.3750	.437
PW32B-14X	PW32B-14A	PW32S-14X	PW32S-14A	14	.4375	.500
PW32B-15X	PW32B-15A	PW32S-15X	PW32S-15A	15	.4687	.531
PW32B-16X	PW32B-16A	PW32S-16X	PW32S-16A	16	.5000	.562
PW32B-18	PW32B-18A	PW32S-18	PW32S-18A	18	.5625	.625
PW32B-20	PW32B-20A	PW32S-20	PW32S-20A	20	.6250	.687
PW32B-24	PW32B-24A	-	-	24	.7500	.812

SPUR GEARS

PITCH	STYLE	BORE	FACE	MATERIAL	AGMA QUALITY	PRESSURE ANGLE
48	HUBLESS	3/8"	1/8"	303 STAINLESS STEEL AND 2024-T4 ALUMINUM ANODIZED	10	20°

B

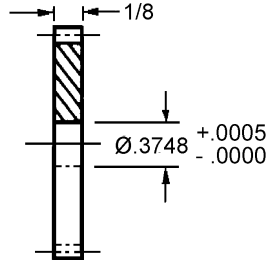
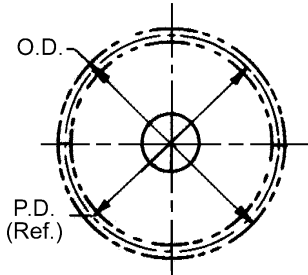

Available on request:
Pin or Clamp hubs assembled
Other numbers of teeth
14 - 1/2° Pressure Angle

303 STAINLESS STEEL STOCK NO.	2024-T4 ALUMINUM ANODIZED STOCK NO.	NO. OF TEETH	PITCH DIA.	OUTSIDE DIA.
F48S3-30	F48A3-30	30	.6250	.666
F48S3-32	F48A3-32	32	.6666	.708
F48S3-40	F48A3-40	40	.8333	.875
F48S3-42	F48A3-42	42	.8750	.916
F48S3-44	F48A3-44	44	.9166	.958
F48S3-48	F48A3-48	48	1.0000	1.041
F48S3-50	F48A3-50	50	1.0416	1.083
F48S3-54	F48A3-54	54	1.1250	1.166
F48S3-60	F48A3-60	60	1.2500	1.291
F48S3-64	F48A3-64	64	1.3333	1.375
F48S3-65	F48A3-65	65	1.3541	1.395
F48S3-70	F48A3-70	70	1.4583	1.500
F48S3-72	F48A3-72	72	1.5000	1.541
F48S3-75	F48A3-75	75	1.5625	1.604
F48S3-80	F48A3-80	80	1.6666	1.708
F48S3-84	F48A3-84	84	1.7500	1.791
F48S3-85	F48A3-85	85	1.7708	1.812
F48S3-90	F48A3-90	90	1.8750	1.916
F48S3-96	F48A3-96	96	2.0000	2.041
F48S3-100	F48A3-100	100	2.0833	2.125
F48S3-105	F48A3-105	105	2.1875	2.229
F48S3-108	F48A3-108	108	2.2500	2.291
F48S3-110	F48A3-110	110	2.2916	2.333
F48S3-114	F48A3-114	114	2.3750	2.416
F48S3-120	F48A3-120	120	2.5000	2.541
F48S3-125	F48A3-125	125	2.6041	2.645
F48S3-130	F48A3-130	130	2.7083	2.750
F48S3-132	F48A3-132	132	2.7500	2.791
F48S3-135	F48A3-135	135	2.8125	2.854
F48S3-138	F48A3-138	138	2.8750	2.916
F48S3-140	F48A3-140	140	2.9166	2.958
F48S3-144	F48A3-144	144	3.0000	3.041
F48S3-150	F48A3-150	150	3.1250	3.166
F48S3-156	F48A3-156	156	3.2500	3.291
F48S3-160	F48A3-160	160	3.3333	3.375
F48S3-168	F48A3-168	168	3.5000	3.541
F48S3-170	F48A3-170	170	3.5416	3.583
F48S3-180	F48A3-180	180	3.7500	3.791
F48S3-186	F48A3-186	186	3.8750	3.916
F48S3-190	F48A3-190	190	3.9583	4.000
F48S3-192	F48A3-192	192	4.0000	4.041

For Couplings See Section G.
For Shafts, Bearings and Collars See Section I.

SPUR GEARS

PITCH	STYLE	BORE	FACE	MATERIAL	AGMA QUALITY	PRESSURE ANGLE
48	HUBLESS	3/8"	3/16"	ALUMINUM GOLD ANODIZED	8	20°

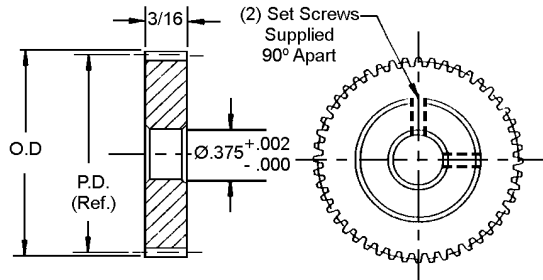

Available on request:
Other numbers of teeth
14 - 1/2° Pressure Angle

STOCK NO.	NO. OF TEETH	PITCH DIA.	OUTSIDE DIA.
F48A76-28	28	.5833	.625
F48A76-30	30	.6250	.666
F48A76-36	36	.7500	.791
F48A76-40	40	.8333	.875
F48A76-46	46	.9583	1.000
F48A76-48	48	1.0000	1.041
F48A76-60	60	1.2500	1.291
F48A76-70	70	1.4583	1.500
F48A76-72	72	1.5000	1.541
F48A76-80	80	1.6666	1.708
F48A76-90	90	1.8750	2.041
F48A76-96	96	2.0000	2.125
F48A76-100	100	2.0833	2.333
F48A76-110	110	2.2916	2.541
F48A76-132	132	2.7500	2.791
F48A76-144	144	3.0000	3.041
F48A76-150	150	3.1250	3.166
F48A76-168	168	3.5000	3.541
F48A76-192	192	4.0000	4.041

PITCH	STYLE	BORE	FACE	MATERIAL	AGMA QUALITY	PRESSURE ANGLE
48	HUBLESS	3/8"	1/8" AND 1/4"	POLYURETHANE	8	20°

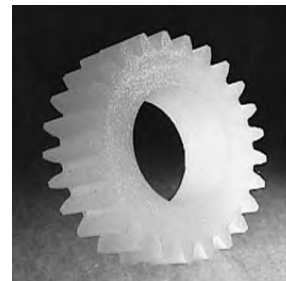
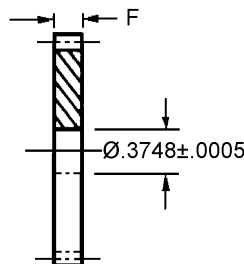
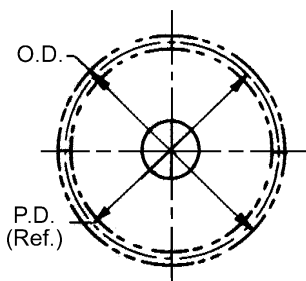

Available on request:
Other numbers of teeth
14 - 1/2° Pressure Angle

STOCK NO.	NO. OF TEETH	PITCH DIA.	OUTSIDE DIA.	F
F48U3-48	48	1.0000	1.041	.125
F48U3-60	60	1.2500	1.291	.125
F48U3-72	72	1.5000	1.541	.125
F48U3-84	84	1.7500	1.791	.125
F48U3-96	96	2.0000	2.041	.125
F48U3-108	108	2.2500	2.291	.125
F48U6-120	120	2.5000	2.541	.250
F48U6-144	144	3.0000	3.041	.250
F48U6-168	168	3.5000	3.541	.250
F48U6-192	192	4.0000	4.041	.250

SPUR GEARS

PITCH	STYLE	BORE	FACE	MATERIAL	AGMA QUALITY	PRESSURE ANGLE
48	HUBLESS	3/8"	3/16"	DELTRIN	10	20°

B

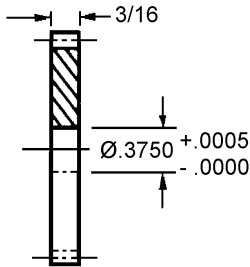
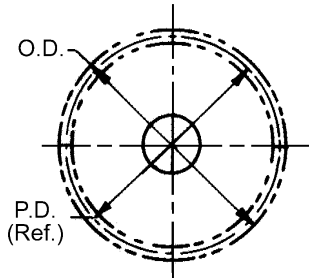

Available on request:
Other numbers of teeth
14 - 1/2° Pressure Angle

STOCK NO.	NO. OF TEETH	PITCH DIA.	OUTSIDE DIA.
F48D5-28	28	.5833	.625
F48D5-29	29	.6041	.645
F48D5-30	30	.6250	.666
F48D5-32	32	.6666	.708
F48D5-34	34	.7083	.750
F48D5-36	36	.7500	.791
F48D5-38	38	.7916	.833
F48D5-40	40	.8333	.875
F48D5-42	42	.8750	.916
F48D5-44	44	.9166	.958
F48D5-46	46	.9583	1.000
F48D5-48	48	1.0000	1.041
F48D5-50	50	1.0416	1.083
F48D5-55	55	1.1458	1.187
F48D5-56	56	1.1666	1.208
F48D5-60	60	1.2500	1.291
F48D5-64	64	1.3333	1.375
F48D5-68	68	1.4166	1.458
F48D5-72	72	1.5000	1.541
F48D5-75	75	1.5625	1.604
F48D5-80	80	1.6666	1.708
F48D5-84	84	1.7500	1.791
F48D5-90	90	1.8750	1.916
F48D5-92	92	1.9166	1.958
F48D5-96	96	2.0000	2.041
F48D5-100	100	2.0833	2.125
F48D5-110	110	2.2916	2.333
F48D5-120	120	2.5000	2.541
F48D5-132	132	2.7500	2.791
F48D5-138	138	2.8750	2.916
F48D5-144	144	3.0000	3.041
F48D5-156	156	3.2500	3.291
F48D5-168	168	3.5000	3.541
F48D5-180	180	3.7500	3.791
F48D5-186	186	3.8750	3.916

For Couplings See Section G.
For Shafts, Bearings and Collars See Section I.

CLUSTER GEAR AND HUB

PITCH	STYLE	BORE	MATERIAL	AGMA QUALITY	PRESSURE ANGLE
48	X	1/4"	303 STAINLESS STEEL	10	20°

STOCK NO.	PITCH	NO. OF TEETH	PITCH DIA.	OUTSIDE DIA.
DP48S14-20	48	20	.4166	.458
DP48S14-21		21	.4375	.479
DP48S14-22		22	.4583	.500
DP48S14-23		23	.4791	.521
DP48S14-24		24	.5000	.542
DP48S14-25		25	.5208	.563
DP48S14-26		26	.5416	.583
DP48S14-30		30	.6250	.667
DP48S14-32		32	.6666	.708
DP48S14-40		40	.8333	.875
DP48S14-48		48	1.0000	1.041
DP48S14-50		50	1.0416	1.083

PITCH	STYLE	BORE	MATERIAL	AGMA QUALITY	PRESSURE ANGLE
48	Y	1/4"	303 STAINLESS STEEL	10	20°

STOCK NO.	PITCH	NO. OF TEETH	PITCH DIA.	OUTSIDE DIA.
DP48S16-20	48	20	.4166	.458
DP48S16-21		21	.4375	.479
DP48S16-22		22	.4583	.500
DP48S16-23		23	.4791	.521
DP48S16-24		24	.5000	.542
DP48S16-25		25	.5208	.563
DP48S16-26		26	.5416	.583
DP48S16-30		30	.6250	.667
DP48S16-32		32	.6666	.708
DP48S16-40		40	.8333	.875
DP48S16-48		48	1.0000	1.041
DP48S16-50		50	1.0416	1.083

PITCH	STYLE	BORE	MATERIAL	AGMA QUALITY	PRESSURE ANGLE
48	Z	1/4"	303 STAINLESS STEEL	10	20°

STOCK NO.	PITCH	NO. OF TEETH	PITCH DIA.	OUTSIDE DIA.
DP48S18-20	48	20	.4166	.458
DP48S18-21		21	.4375	.479
DP48S18-22		22	.4583	.500
DP48S18-23		23	.4791	.521
DP48S18-24		24	.5000	.542
DP48S18-25		25	.5208	.563
DP48S18-26		26	.5416	.583
DP48S18-30		30	.6250	.667
DP48S18-32		32	.6666	.708
DP48S18-40		40	.8333	.875
DP48S18-48		48	1.0000	1.041
DP48S18-50		50	1.0416	1.083

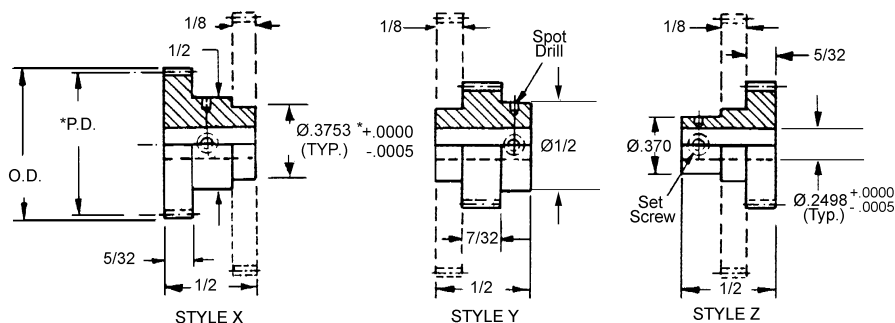

*Concentric within .0003
Order hubless gear separately.

CLUSTER GEAR AND HUB

B

PITCH	STYLE	BORE	MATERIAL	AGMA QUALITY	PRESSURE ANGLE
48	X	3/16"	303 STAINLESS STEEL	10	20°

STOCK NO.	PITCH	NO. OF TEETH	PITCH DIA.	OUTSIDE DIA.
DP48S8-20	48	20	.4166	.458
DP48S8-21		21	.4375	.479
DP48S8-23		23	.4701	.521
DP48S8-24		24	.5000	.542
DP48S8-40		40	.8333	.875

PITCH	STYLE	BORE	MATERIAL	AGMA QUALITY	PRESSURE ANGLE
48	Y	3/16"	303 STAINLESS STEEL	10	20°

STOCK NO.	PITCH	NO. OF TEETH	PITCH DIA.	OUTSIDE DIA.
DP48S10-20	48	20	.4166	.458
DP48S10-21		21	.4375	.479
DP48S10-23		23	.4701	.521
DP48S10-24		24	.5000	.542
DP48S10-40		40	.8333	.875

PITCH	STYLE	BORE	MATERIAL	AGMA QUALITY	PRESSURE ANGLE
48	Z	3/16"	303 STAINLESS STEEL	10	20°

STOCK NO.	PITCH	NO. OF TEETH	PITCH DIA.	OUTSIDE DIA.
DP48S12-20	48	20	.4166	.458
DP48S12-21		21	.4375	.479
DP48S12-23		23	.4701	.521
DP48S12-24		24	.5000	.542
DP48S12-40		40	.8333	.875

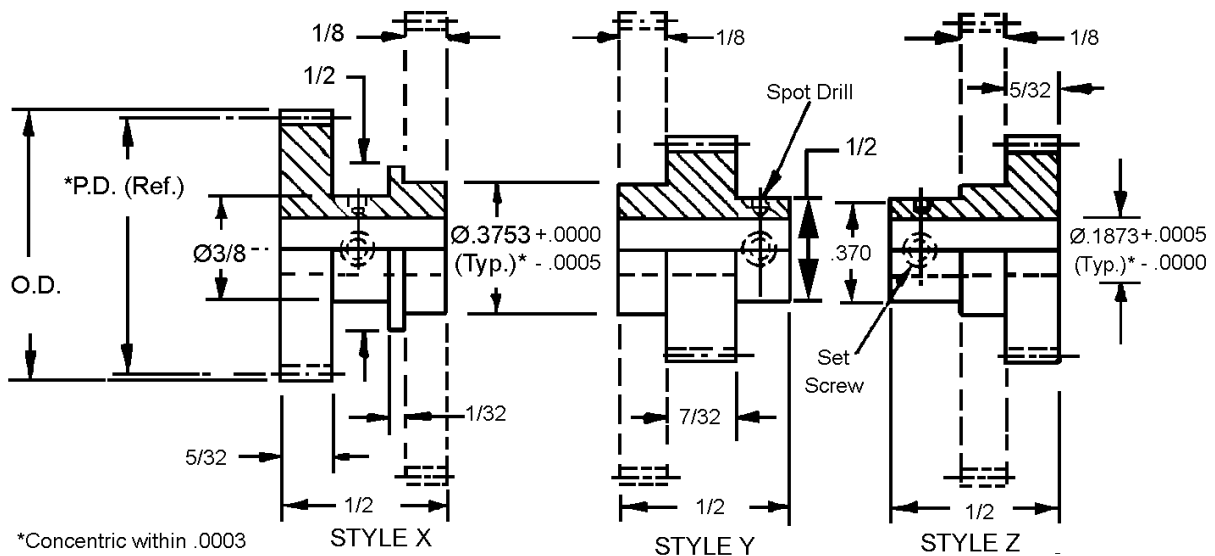

Order hubless gear separately

Available on request:

Other numbers of teeth; AGMA quality 12 and 14; 14-1/2° Pressure Angle.

SPUR GEARS

PITCH	STYLE	BORE	FACE	MATERIAL	AGMA QUALITY	PRESSURE ANGLE
48	PIN HUB	1/8"	1/8"	303 STAINLESS STEEL AND ALUMINUM ANODIZED	10	20°

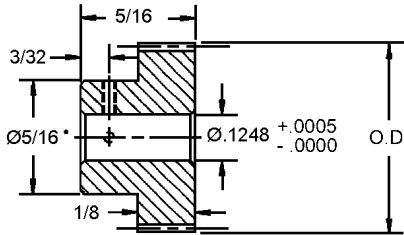
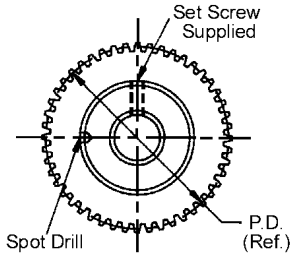

• For 14-15 teeth hub diameter equals .23
Available on request, other numbers of teeth
and 14-1/2° Pressure Angle.

303 STAINLESS STEEL STOCK NO.	2024-T4 ALUMINUM ANODIZED STOCK NO.	NO. OF TEETH	PITCH DIA.	OUTSIDE DIA.
P48S10-15	P48A10-15	15*	.3125	.354
P48S10-18	P48A10-18	18	.3750	.416
P48S10-19	P48A10-19	19	.3958	.437
P48S10-20	P48A10-20	20	.4166	.458
P48S10-21	P48A10-21	21	.4375	.479
P48S10-22	P48A10-22	22	.4583	.500
P48S10-24	P48A10-24	24	.5000	.541
P48S10-25	P48A10-25	25	.5208	.562
P48S10-26	P48A10-26	26	.5416	.583
P48S10-27	P48A10-27	27	.5625	.604
P48S10-28	P48A10-28	28	.5833	.625
P48S10-30	P48A10-30	30	.6250	.666
P48S10-32	P48A10-32	32	.6666	.708
P48S10-34	P48A10-34	34	.7083	.750
P48S10-36	P48A10-36	36	.7500	.791
P48S10-40	P48A10-40	40	.8333	.875
P48S10-42	P48A10-42	42	.8750	.916
P48S10-46	P48A10-46	46	.9583	1.000
P48S10-48	P48A10-48	48	1.0000	1.041
P48S10-50	P48A10-50	50	1.0416	1.083
P48S10-55	P48A10-55	55	1.1458	1.187
P48S10-56	P48A10-56	56	1.1666	1.208
P48S10-60	P48A10-60	60	1.2500	1.291
P48S10-64	P48A10-64	64	1.3333	1.375
P48S10-65	P48A10-65	65	1.3541	1.395
P48S10-70	P48A10-70	70	1.4583	1.500
P48S10-72	P48A10-72	72	1.5000	1.541
P48S10-75	P48A10-75	75	1.5625	1.604
P48S10-80	P48A10-80	80	1.6666	1.708
P48S10-84	P48A10-84	84	1.7500	1.791
P48S10-85	P48A10-85	85	1.7708	1.812
P48S10-90	P48A10-90	90	1.8750	1.916
P48S10-96	P48A10-96	96	2.0000	2.041
P48S10-100	P48A10-100	100	2.0833	2.125
P48S10-102	P48A10-102	102	2.1250	2.166
P48S10-105	P48A10-105	105	2.1875	2.229
P48S10-110	P48A10-110	110	2.2916	2.333
P48S10-120	P48A10-120	120	2.5000	2.541

For Couplings See Section G.
For Shafts, Bearings and Collars See Section I.

SPUR GEARS

PITCH	STYLE	BORE	FACE	MATERIAL	AGMA QUALITY	PRESSURE ANGLE
48	PIN HUB	1/8"	3/16"	ALUMINUM ANODIZED	8	20°

B

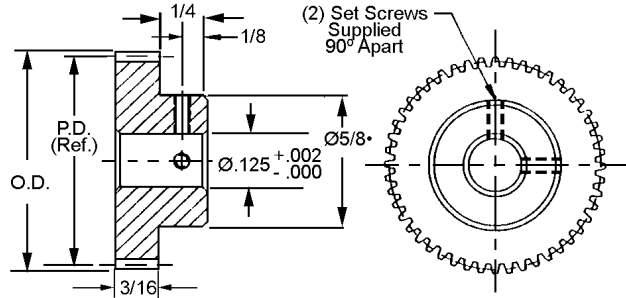

• For 16-32 teeth hub diameter equals .27

Available on request, other numbers of teeth and 14-1/2° Pressure Angle.

STOCK NO.	NO. OF TEETH	PITCH DIA.	OUTSIDE DIA.
P48A65-16	16•	.3333	.375
P48A65-18	18•	.3750	.416
P48A65-20	20•	.4166	.458
P48A65-22	22•	.4583	.500
P48A65-24	24•	.5000	.541
P48A65-28	28•	.5833	.625
P48A65-30	30•	.6250	.666
P48A65-36	36	.7500	.79
P48A65-40	40	.8333	.875
P48A65-46	46	.9583	1.000
P48A65-48	48	1.0000	1.041
P48A65-60	60	1.2500	1.291
P48A65-70	70	1.4583	1.500
P48A65-72	72	1.5000	1.541
P48A65-80	80	1.6666	1.708
P48A65-90	90	1.8750	1.916
P48A65-96	96	2.0000	2.041
P48A65-100	100	2.0833	2.125
P48A65-110	110	2.2916	2.333
P48A65-120	120	2.5000	2.541
P48A65-132	132	2.7500	2.791
P48A65-144	144	3.0000	3.041
P48A65-150	150	3.1250	3.166
P48A65-168	168	3.5000	3.541
P48A65-192	192	4.0000	4.041

For Couplings See Section G.
For Shafts, Bearings and Collars See Section I.

SPUR GEARS

PITCH	STYLE	BORE	FACE	MATERIAL	AGMA QUALITY	PRESSURE ANGLE
48	PIN HUB	3/16"	3/16"	ALUMINUM ANODIZED	8	20°

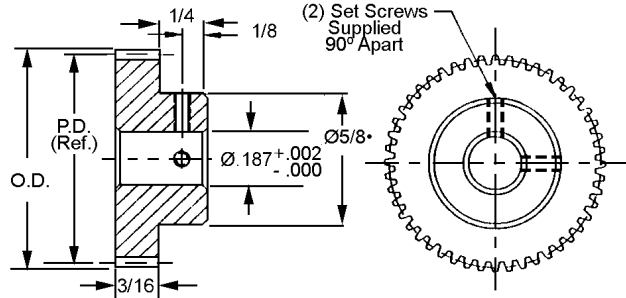

• For 19-32 teeth hub diameter equals .34

Available on request, other numbers of teeth and 14-1/2° Pressure Angle.

STOCK NO.	NO. OF TEETH	PITCH DIA.	OUTSIDE DIA.
P48A64-20	20•	.4166	.458
P48A64-22	22•	.4583	.500
P48A64-24	24•	.5000	.541
P48A64-28	28•	.5833	.625
P48A64-30	30•	.6250	.666
P48A64-36	36	.7500	.79
P48A64-40	40	.8333	.875
P48A64-46	46	.9583	1.000
P48A64-48	48	1.0000	1.041
P48A64-60	60	1.2500	1.291
P48A64-70	70	1.4583	1.500
P48A64-72	72	1.5000	1.541
P48A64-80	80	1.6666	1.708
P48A64-90	90	1.8750	1.916
P48A64-96	96	2.0000	2.041
P48A64-100	100	2.0833	2.125
P48A64-110	110	2.2916	2.333
P48A64-120	120	2.5000	2.541
P48A64-132	132	2.7500	2.791
P48A64-144	144	3.0000	3.041
P48A64-150	150	3.1250	3.166
P48A64-168	168	3.5000	3.541
P48A64-192	192	4.0000	4.041

For Couplings See Section G.
For Shafts, Bearings and Collars See Section I.

SPUR GEARS

PITCH	STYLE	BORE	FACE	MATERIAL	AGMA QUALITY	PRESSURE ANGLE
48	PIN HUB	3/16"	1/8"	303 STAINLESS STEEL AND ALUMINUM ANODIZED	10	20°

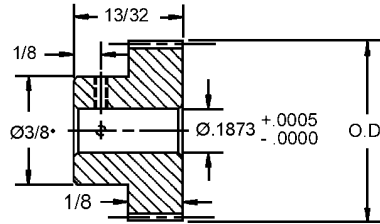
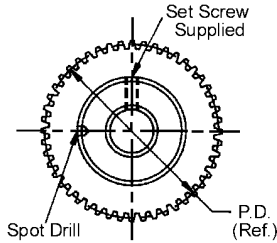

B

• For 19-20 teeth hub diameter equals .34

Available on request, other numbers of teeth, AGMA quality 12 and 14, and 14-1/2° Pressure Angle.

X in part number indicates part may be supplied as two piece construction (some dimensions may vary).

303 STAINLESS STEEL STOCK NO.	2024-T4 ALUMINUM ANODIZED STOCK NO.	NO. OF TEETH	PITCH DIA.	OUTSIDE DIA.
P48S19-19	P48A19-19	19•	.3958	.437
P48S19-20	P48A19-20	20•	.4166	.458
P48S19-21	P48A19-21	21	.4375	.479
P48S19-22	P48A19-22	22	.4583	.500
P48S19-23	P48A19-23	23	.4791	.520
P48S19-24	P48A19-24	24	.5000	.541
P48S19-25	P48A19-25	25	.5208	.562
P48S19-28	P48A19-28	28	.5833	.625
P48S19-30	P48A19-30	30	.6250	.666
P48S19-32	P48A19-32	32	.6666	.708
P48S19-34	P48A19-34	34	.7083	.750
P48S19-36	P48A19-36	36	.7500	.791
P48S19-40	P48A19-40	40	.8333	.875
P48S19-42	P48A19-42	42	.8750	.916
P48S19-46	P48A19-46	46	.9583	1.000
P48S19-48	P48A19-48	48	1.0000	1.041
P48S19-50	P48A19-50	50	1.0416	1.083
P48S19-60	P48A19-60	60	1.2500	1.291
P48S19-64	P48A19-64	64	1.3333	1.375
P48S19-70	P48A19-70	70	1.4583	1.500
P48S19-72	P48A19-72	72	1.5000	1.541
P48S19-80	P48A19-80	80	1.6666	1.708
P48S19-84	P48A19-84	84	1.7500	1.791
P48S19-90	P48A19-90	90	1.8750	1.916
P48S19-96	P48A19-96	96	2.0000	2.041
P48S19-105	P48A19-105	105	2.1875	2.229
P48S19-120	P48A19-120	120	2.5000	2.541
P48S19-132	P48A19-132	132	2.7500	2.791
P48S19-144	P48A19-144	144	3.0000	3.041
P48S19X-156	P48A19X-156	156	3.2500	3.291
P48S19X-168	P48A19X-168	168	3.5000	3.541
P48S19X-190	P48A19X-190	190	3.9583	4.000
P48S19X-192	P48A19X-192	192	4.0000	4.041

**For Couplings See Section G.
For Shafts, Bearings and Collars See Section I.**

SPUR GEARS

PITCH	STYLE	BORE	FACE	MATERIAL	AGMA QUALITY	PRESSURE ANGLE
48	PIN HUB	3/16"	3/16"	303 STAINLESS STEEL AND ALUMINUM ANODIZED	10	20°

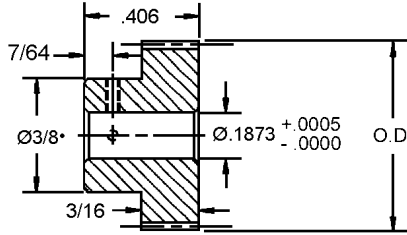
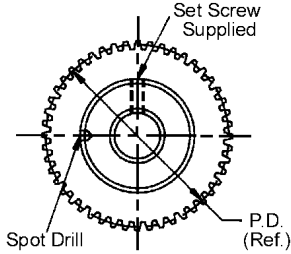

• For 19-20 teeth hub diameter equals .34

Available on request, other numbers of teeth, AGMA quality 12 and 14, and 14-1/2° Pressure Angle.

303 STAINLESS STEEL STOCK NO.	2024-T4 ALUMINUM ANODIZED STOCK NO.	NO. OF TEETH	PITCH DIA.	OUTSIDE DIA.
P48S21-20	P48A21-20	20•	.4166	.458
P48S21-21	P48A21-21	21	.4375	.479
P48S21-22	P48A21-22	22	.4583	.500
P48S21-23	P48A21-23	23	.4791	.520
P48S21-24	P48A21-24	24	.5000	.541
P48S21-25	P48A21-25	25	.5208	.562
P48S21-26	P48A21-26	26	.5416	.583
P48S21-27	P48A21-27	27	.5625	.604
P48S21-28	P48A21-28	28	.5833	.625
P48S21-29	P48A21-29	29	.6041	.645
P48S21-30	P48A21-30	30	.6250	.666
P48S21-32	P48A21-32	32	.6666	.708
P48S21-34	P48A21-34	34	.7083	.750
P48S21-36	P48A21-36	36	.7500	.791
P48S21-40	P48A21-40	40	.8333	.875
P48S21-44	P48A21-44	44	.9166	.958
P48S21-48	P48A21-48	48	1.0000	1.041
P48S21-50	P48A21-50	50	1.0416	1.083
P48S21-55	P48A21-55	55	1.1458	1.187
P48S21-60	P48A21-60	60	1.2500	1.291
P48S21-64	P48A21-64	64	1.3333	1.375
P48S21-65	P48A21-65	65	1.3541	1.395
P48S21-72	P48A21-72	72	1.5000	1.541
P48S21-84	P48A21-84	84	1.7500	1.791
P48S21-85	P48A21-85	85	1.7708	1.812
P48S21-90	P48A21-90	90	1.8750	1.916
P48S21-92	P48A21-92	92	1.9166	1.958
P48S21-95	P48A21-95	95	1.9791	2.020
P48S21-96	P48A21-96	96	2.0000	2.041
P48S21-100	P48A21-100	100	2.0833	2.125
P48S21-108	P48A21-108	108	2.2500	2.291
P48S21-120	P48A21-120	120	2.5000	2.541
P48S21-127	P48A21-127	127	2.6458	2.687
P48S21-144	P48A21-144	144	3.0000	3.041
P48S21-156	P48A21-156	156	3.2500	3.291
P48S21-180	P48A21-180	180	3.7500	3.791
P48S21-192	P48A21-192	192	4.0000	4.041

**For Couplings See Section G.
For Shafts, Bearings and Collars See Section I.**

SPUR GEARS

PITCH	STYLE	BORE	FACE	MATERIAL	AGMA QUALITY	PRESSURE ANGLE
48	PIN HUB	1/4"	3/16"	303 STAINLESS STEEL AND ALUMINUM ANODIZED	10	20°

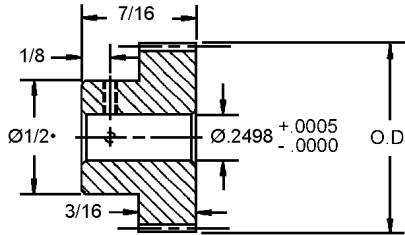
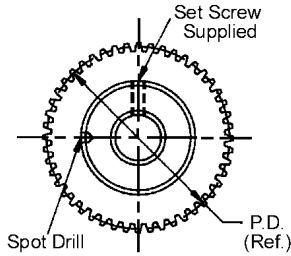

• For 24-26 teeth hub diameter equals .44

Available on request, other numbers of teeth, AGMA quality 12 and 14, and 14-1/2° Pressure Angle.

303 STAINLESS STEEL STOCK NO.	2024-T4 ALUMINUM ANODIZED STOCK NO.	NO. OF TEETH	PITCH DIA.	OUTSIDE DIA.
P48S28-24	P48A28-24	24•	.5000	.541
P48S28-25	P48A28-25	25•	.5208	.562
P48S28-26	P48A28-26	26•	.5416	.583
P48S28-27	P48A28-27	27	.5625	.604
P48S28-28	P48A28-28	28	.5833	.625
P48S28-29	P48A28-29	29	.6041	.645
P48S28-30	P48A28-30	30	.6250	.666
P48S28-32	P48A28-32	32	.6666	.708
P48S28-34	P48A28-34	34	.7083	.750
P48S28-36	P48A28-36	36	.7500	.791
P48S28-40	P48A28-40	40	.8333	.875
P48S28-42	P48A28-42	42	.8750	.916
P48S28-45	P48A28-45	45	.9375	.979
P48S28-48	P48A28-48	48	1.0000	1.041
P48S28-50	P48A28-50	50	1.0416	1.083
P48S28-55	P48A28-55	55	1.1458	1.187
P48S28-56	P48A28-56	56	1.1666	1.208
P48S28-60	P48A28-60	60	1.2500	1.291
P48S28-64	P48A28-64	64	1.3333	1.375
P48S28-65	P48A28-65	65	1.3541	1.395
P48S28-70	P48A28-70	70	1.4583	1.500
P48S28-72	P48A28-72	72	1.5000	1.541
P48S28-75	P48A28-75	75	1.5625	1.604
P48S28-80	P48A28-80	80	1.6666	1.708
P48S28-84	P48A28-84	84	1.7500	1.791
P48S28-85	P48A28-85	85	1.7708	1.812
P48S28-90	P48A28-90	90	1.8750	1.916
P48S28-95	P48A28-95	95	1.9791	2.020
P48S28-96	P48A28-96	96	2.0000	2.041
P48S28-100	P48A28-100	100	2.0833	2.125
P48S28-105	P48A28-105	105	2.1875	2.229
P48S28-108	P48A28-108	108	2.2500	2.291
P48S28-110	P48A28-110	110	2.2916	2.333
P48S28-120	P48A28-120	120	2.5000	2.541
P48S28-128	P48A28-128	128	2.6666	2.708
P48S28-168	P48A28-168	168	3.5000	3.541
P48S28-192	P48A28-192	192	4.0000	4.041
P48S28-198	P48A28-198	198	4.1250	4.166

**For Couplings See Section G.
For Shafts, Bearings and Collars See Section I.**

SPUR GEARS

PITCH	STYLE	BORE	FACE	MATERIAL	AGMA QUALITY	PRESSURE ANGLE
48	PIN HUB	1/4"	1/8"	303 STAINLESS STEEL AND ALUMINUM ANODIZED	10	20°

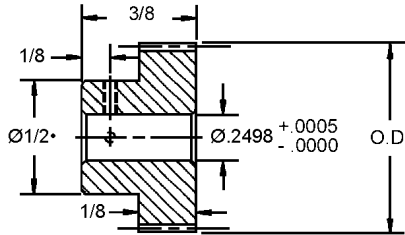
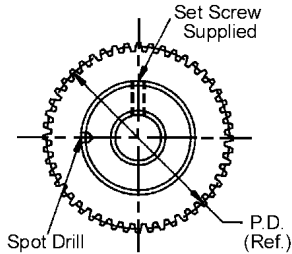

• For 24-26 teeth hub diameter equals .44

Available on request, other numbers of teeth, AGMA quality 12 and 14, and 14-1/2° Pressure Angle.

303 STAINLESS STEEL STOCK NO.	2024-T4 ALUMINUM ANODIZED STOCK NO.	NO. OF TEETH	PITCH DIA.	OUTSIDE DIA.
P48S26-24	P48A26-24	24•	.5000	.541
P48S26-25	P48A26-25	25•	.5208	.562
P48S26-26	P48A26-26	26•	.5416	.583
P48S26-28	P48A26-28	28	.5833	.625
P48S26-30	P48A26-30	30	.6250	.666
P48S26-32	P48A26-32	32	.6666	.708
P48S26-35	P48A26-35	35	.7291	.770
P48S26-36	P48A26-36	36	.7500	.791
P48S26-40	P48A26-40	40	.8333	.875
P48S26-42	P48A26-42	42	.8750	.916
P48S26-44	P48A26-44	44	.9166	.958
P48S26-45	P48A26-45	45	.9375	.979
P48S26-46	P48A26-46	46	.9583	1.000
P48S26-48	P48A26-48	48	1.0000	1.041
P48S26-50	P48A26-50	50	1.0416	1.083
P48S26-54	P48A26-54	54	1.1250	1.166
P48S26-55	P48A26-55	55	1.1458	1.187
P48S26-56	P48A26-56	56	1.1666	1.208
P48S26-60	P48A26-60	60	1.2500	1.291
P48S26-64	P48A26-64	64	1.3333	1.375
P48S26-65	P48A26-65	65	1.3541	1.395
P48S26-70	P48A26-70	70	1.4583	1.500
P48S26-72	P48A26-72	72	1.5000	1.541
P48S26-75	P48A26-75	75	1.5625	1.604
P48S26-78	P48A26-78	78	1.6250	1.666
P48S26-80	P48A26-80	80	1.6666	1.708
P48S26-84	P48A26-84	84	1.7500	1.791
P48S26-85	P48A26-85	85	1.7708	1.812
P48S26-90	P48A26-90	90	1.8750	1.916
P48S26-96	P48A26-96	96	2.0000	2.041
P48S26-100	P48A26-100	100	2.0833	2.125
P48S26-105	P48A26-105	105	2.1875	2.229
P48S26-108	P48A26-108	108	2.2500	2.291
P48S26-110	P48A26-110	110	2.2916	2.333
P48S26-120	P48A26-120	120	2.5000	2.541
P48S26-126	P48A26-126	126	2.6250	2.666
P48S26-132	P48A26-132	132	2.7500	2.791
P48S26-140	P48A26-140	140	2.9166	2.958
P48S26-144	P48A26-144	144	3.0000	3.041
P48S26-145	P48A26-145	145	3.0208	3.062
P48S26-150	P48A26-150	150	3.1250	3.166
P48S26-156	P48A26-156	156	3.2500	3.291
P48S26-160	P48A26-160	160	3.3333	3.375
P48S26-168	P48A26-168	168	3.5000	3.541
P48S26-180	P48A26-180	180	3.7500	3.791
P48S26-192	P48A26-192	192	4.0000	4.041

**For Couplings See Section G.
For Shafts, Bearings and Collars See Section I.**

SPUR GEARS

PITCH	STYLE	BORE	FACE	MATERIAL	AGMA QUALITY	PRESSURE ANGLE
48	PIN HUB	1/4"	3/16"	ALUMINUM ANODIZED	8	20°

B

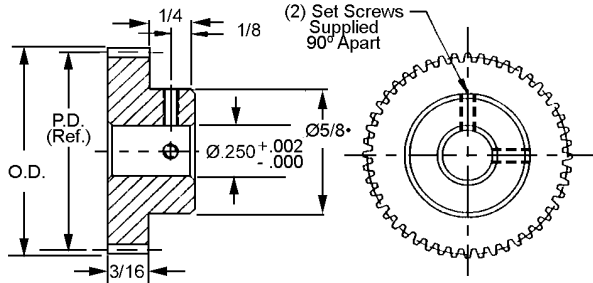

Available on request, other numbers of teeth and 14-1/2° Pressure Angle.

• For tooth counts 22-32 new hub diameter is .40.

STOCK NO.	NO. OF TEETH	PITCH DIA.	OUTSIDE DIA.
P48A63-22	22*	.4583	.500
P48A63-24	24*	.5000	.541
P48A63-28	28*	.5833	.625
P48A63-30	30*	.6250	.666
P48A63-36	36	.7500	.79
P48A63-40	40	.8333	.875
P48A63-46	46	.9583	1.000
P48A63-48	48	1.0000	1.041
P48A63-60	60	1.2500	1.291
P48A63-70	70	1.4583	1.500
P48A63-72	72	1.5000	1.541
P48A63-80	80	1.6666	1.708
P48A63-90	90	1.8750	1.916
P48A63-96	96	2.0000	2.041
P48A63-100	100	2.0833	2.125
P48A63-110	110	2.2916	2.333
P48A63-120	120	2.5000	2.541
P48A63-132	132	2.7500	2.791
P48A63-144	144	3.0000	3.041
P48A63-150	150	3.1250	3.166
P48A63-168	168	3.5000	3.541
P48A63-192	192	4.0000	4.041

For Couplings See Section G.
For Shafts, Bearings and Collars See Section I.

SPUR GEARS

PITCH	STYLE	BORE	FACE	MATERIAL	AGMA QUALITY	PRESSURE ANGLE
48	PIN HUB	1/4"	3/16"	17-4 PH STAINLESS STEEL RC26-32	10	20°

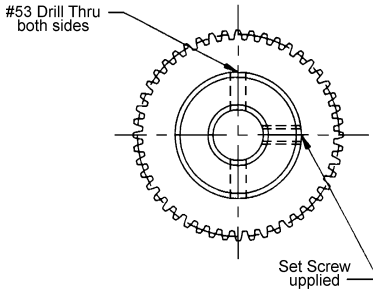
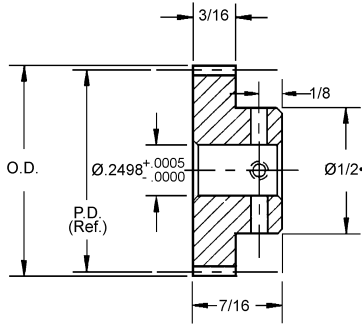

• For 24-26 teeth hub diameter equals .44

Available on request, other numbers of teeth, quality 12 and 14-1/2° Pressure Angle.

STOCK NO.	NO. OF TEETH	PITCH DIA.	OUTSIDE DIA.
P48PH28-24	24*	.5000	.542
P48PH28-25	25*	.5208	.563
P48PH28-26	26*	.5416	.583
P48PH28-27	27	.5625	.604
P48PH28-28	28	.5833	.625
P48PH28-29	29	.6041	.646
P48PH28-30	30	.6250	.667
P48PH28-32	32	.6666	.708
P48PH28-36	36	.7500	.792
P48PH28-40	40	.8333	.875
P48PH28-42	42	.8750	.917
P48PH28-48	48	1.0000	1.042
P48PH28-50	50	1.0416	1.083

PITCH	STYLE	BORE	MATERIAL	AGMA QUALITY	PRESSURE ANGLE
48	PIN HUB	1/8"	COLD ROLLED STEEL C12L14 OR C12L15 WITH SELENIUM OR BRASS ALLOY 360	5	20°

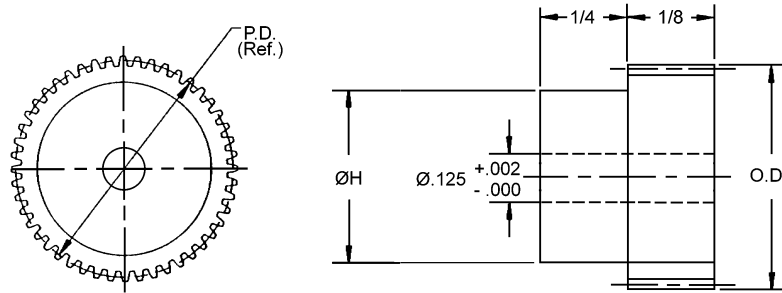

COLD ROLLED STEEL C12L14 OR C12L15 WITH SELENIUM	BRASS ALLOY 360	NO. OF TEETH	PITCH DIA.	OUTSIDE DIA.	H
PX48S-14	PX48B-14	14	.292	.333	.229
PX48S-15	PX48B-15	15	.312	.353	.250
PX48S-16	PX48B-16	16	.333	.375	.271
PX48S-18	PX48B-18	18	.375	.417	.312
PX48S-24	PX48B-24	24	.500	.542	.437
PX48S-32	PX48B-32	32	.666	.708	.604
-	PX48B-36	36	.750	.792	.687
-	PX48B-40	40	.833	.875	.770

SPUR GEARS

PITCH	STYLE	BORE	FACE	MATERIAL	AGMA QUALITY	PRESSURE ANGLE
48	PIN HUB	3/16"	3/16"	DELTRIN WITH STAINLESS STEEL HUB	10	20°

B

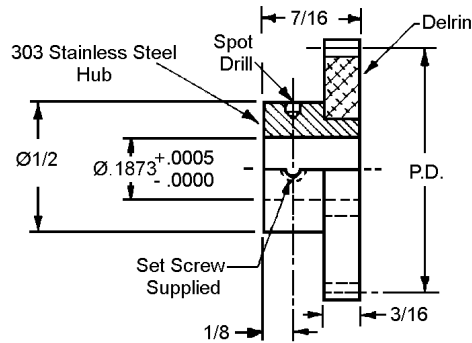

Available on request, other numbers of teeth,
14-1/2° Pressure Angle.

STOCK NO.	NO. OF TEETH	PITCH DIA.	OUTSIDE DIA.
P48D21X-28	28	.5833	.625
P48D21X-29	29	.6041	.645
P48D21X-30	30	.6250	.666
P48D21X-32	32	.6666	.708
P48D21X-34	34	.7083	.750
P48D21X-36	36	.7500	.791
P48D21X-38	38	.7916	.833
P48D21X-40	40	.8333	.875
P48D21X-42	42	.8750	.916
P48D21X-44	44	.9166	.958
P48D21X-46	46	.9583	1.000
P48D21X-48	48	1.0000	1.041
P48D21X-50	50	1.0416	1.083
P48D21X-55	55	1.1458	1.187
P48D21X-56	56	1.1666	1.208
P48D21X-60	60	1.2500	1.291
P48D21X-64	64	1.3333	1.375
P48D21X-68	68	1.4166	1.458
P48D21X-72	72	1.5000	1.541
P48D21X-75	75	1.5625	1.604
P48D21X-80	80	1.6666	1.708
P48D21X-84	84	1.7500	1.791
P48D21X-90	90	1.8750	1.916
P48D21X-92	92	1.9166	1.958
P48D21X-96	96	2.0000	2.041
P48D21X-100	100	2.0833	2.125
P48D21X-110	110	2.2916	2.333
P48D21X-120	120	2.5000	2.541
P48D21X-132	132	2.7500	2.791
P48D21X-138	138	2.8750	2.916
P48D21X-144	144	3.0000	3.041
P48D21X-156	156	3.2500	3.291
P48D21X-168	168	3.5000	3.541
P48D21X-180	180	3.7500	3.791
P48D21X-186	186	3.8750	3.916

For Couplings See Section G.
For Shafts, Bearings and Collars See Section I.

SPUR GEARS

PITCH	STYLE	BORE	FACE	MATERIAL	AGMA QUALITY	PRESSURE ANGLE
48	PIN HUB	1/4"	3/16"	DELRIN WITH STAINLESS STEEL HUB	10	20°

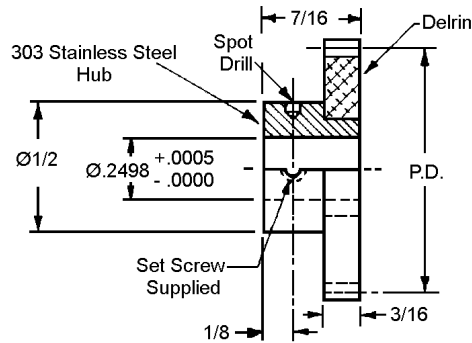

Available on request, other numbers of teeth,
14-1/2° Pressure Angle.

STOCK NO.	NO. OF TEETH	PITCH DIA.	OUTSIDE DIA.
P48D28X-28	28	.5833	.625
P48D28X-29	29	.6041	.645
P48D28X-30	30	.6250	.666
P48D28X-32	32	.6666	.708
P48D28X-34	34	.7083	.750
P48D28X-36	36	.7500	.791
P48D28X-38	38	.7916	.833
P48D28X-40	40	.8333	.875
P48D28X-42	42	.8750	.916
P48D28X-44	44	.9166	.958
P48D28X-46	46	.9583	1.000
P48D28X-48	48	1.0000	1.041
P48D28X-50	50	1.0416	1.083
P48D28X-55	55	1.1458	1.187
P48D28X-56	56	1.1666	1.208
P48D28X-60	60	1.2500	1.291
P48D28X-64	64	1.3333	1.375
P48D28X-68	68	1.4166	1.458
P48D28X-72	72	1.5000	1.541
P48D28X-75	75	1.5625	1.604
P48D28X-80	80	1.6666	1.708
P48D28X-84	84	1.7500	1.791
P48D28X-90	90	1.8750	1.916
P48D28X-92	92	1.9166	1.958
P48D28X-96	96	2.0000	2.041
P48D28X-100	100	2.0833	2.125
P48D28X-110	110	2.2916	2.333
P48D28X-120	120	2.5000	2.541
P48D28X-132	132	2.7500	2.791
P48D28X-138	138	2.8750	2.916
P48D28X-144	144	3.0000	3.041
P48D28X-156	156	3.2500	3.291
P48D28X-168	168	3.5000	3.541
P48D28X-180	180	3.7500	3.791
P48D28X-186	186	3.8750	3.916

For Couplings See Section G.
For Shafts, Bearings and Collars See Section I.

SPUR GEARS

PITCH	STYLE	BORE	FACE	MATERIAL	AGMA QUALITY	PRES. ANGLE
48	PIN HUB	1/4"	3/16"	MOLDED ACETAL	5	20°

B

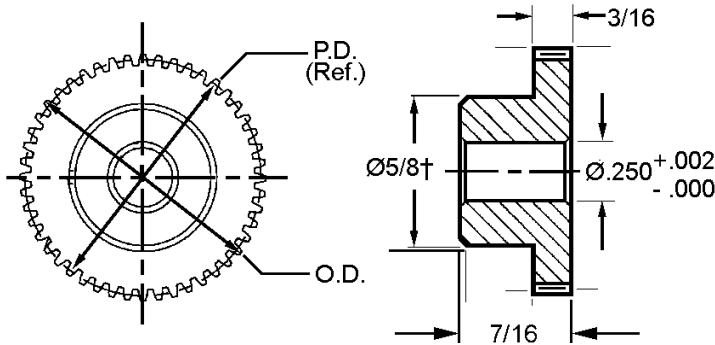

† Teeth runout on hub.

Available on request, other bore sizes and numbers of teeth on request.

STOCK NO.	NO. OF TEETH	PITCH DIA.	OUTSIDE DIA.
P48D4M-28	28†	.5833	.63
P48D4M-30	30†	.6250	.66
P48D4M-36	36	.7500	.79
P48D4M-40	40	.8333	.87
P48D4M-42	42	.8750	.92
P48D4M-48	48	1.0000	1.04
P48D4M-50	50	1.0416	1.08
P48D4M-60	60	1.2500	1.29
P48D4M-70	70	1.4583	1.50
P48D4M-72	72	1.5000	1.54
P48D4M-80	80	1.6666	1.71
P48D4M-84	84	1.7500	1.79
P48D4M-90	90	1.8750	1.92
P48D4M-96	96	2.0000	2.04
P48D4M-100	100	2.0833	2.12
P48D4M-108	108	2.2500	2.29
P48D4M-120	120	2.5000	2.54

PITCH	STYLE	BORE	FACE	MATERIAL	AGMA QUALITY	PRESSURE ANGLE
48	PIN HUB	1/4"	1/4"	CAST POLYURETHANE GRAPHITE IMPREGNATED 70D DUROMETER, GREEN	8	20°

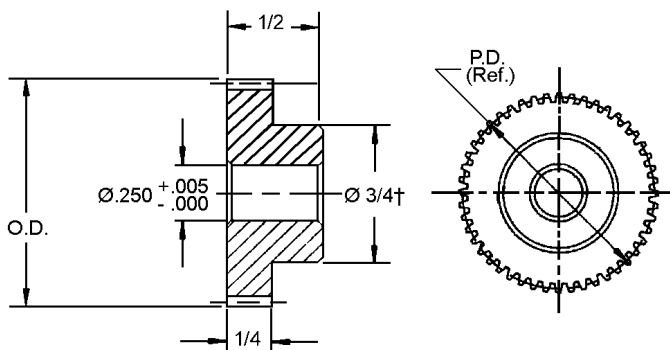

† Teeth runout on hub.

Available on request, other numbers of teeth.

STOCK NO.	NO. OF TEETH	PITCH DIA.	OUTSIDE DIA.
P48U66-24	24†	.5000	.541
P48U66-28	28†	.5833	.625
P48U66-30	30†	.6250	.666
P48U66-36	36†	.7500	.791
P48U66-42	42	.8750	.917
P48U66-48	48	1.0000	1.041
P48U66-60	60	1.2500	1.291
P48U66-72	72	1.5000	1.541
P48U66-84	84	1.1750	1.791
P48U66-96	96	2.0000	2.041

SPUR GEARS

PITCH	STYLE	BORE	FACE	MATERIAL	AGMA QUALITY	PRESSURE ANGLE
48	PIN HUB	3/8"	1/4"	CAST POLYURETHANE GRAPHITE IMPREGNATED 70D DUROMETER	8	20°

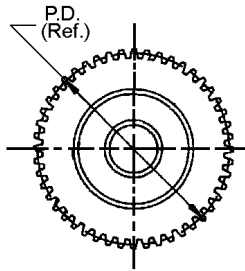
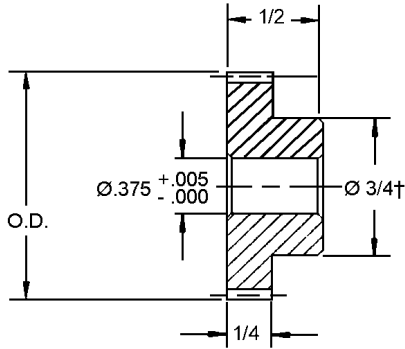

† Teeth runout on hub.
Available on request, other numbers of teeth.

STOCK NO.	NO. OF TEETH	PITCH DIA.	OUTSIDE DIA.
P48U67-24	24†	.5000	.541
P48U67-28	28†	.5833	.625
P48U67-30	30†	.6250	.666
P48U67-36	36†	.7500	.791
P48U67-42	42	.8750	.917
P48U67-48	48	1.0000	1.041
P48U67-60	60	1.2500	1.291
P48U67-72	72	1.5000	1.541
P48U67-84	84	1.7500	1.791
P48U67-96	96	2.0000	2.041

For Couplings See Section G.
For Shafts, Bearings and Collars See Section I.

SPUR GEARS

PITCH	STYLE	BORE	FACE	MATERIAL	AGMA QUALITY	PRES. ANGLE
48	PIN HUB	5/32 TO 1/4"	1/8"	MOLDED DELRIN	5	20°

B

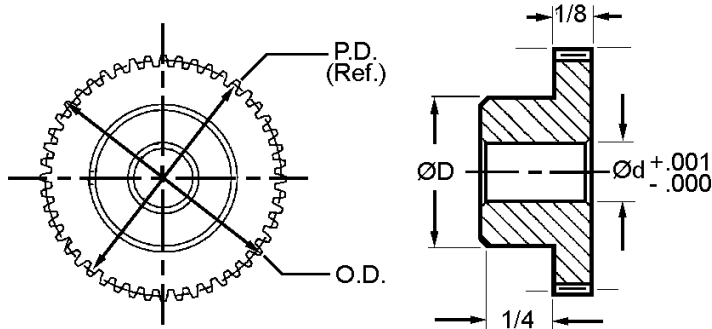

STOCK NO.	NO. OF TEETH	PITCH DIA.	OUTSIDE DIA.	Ød	ØD
P48D4P-18	18	.375	.417	5/32	5/16
P48D4P-19	19	.396	.438	5/32	5/16
P48D4P-20	20	.417	.458	5/32	11/32
P48D4P-21	21	.438	.479	5/32	11/32
P48D4P-22	22	.458	.500	5/32	3/8
P48D4P-23	23	.479	.521	5/32	3/8
P48D4P-24	24	.500	.542	5/32	13/32
P48D4P-25	25	.521	.562	5/32	13/32
P48D4P-26	26	.542	.583	5/32	29/64
P48D4P-27	27	.562	.604	5/32	29/64
P48D4P-28	28	.583	.625	5/32	31/64
P48D4P-29	29	.604	.646	5/32	31/64
P48D4P-30	30	.625	.667	5/32	1/2
P48D4P-31	31	.646	.688	3/16	35/64
P48D4P-32	32	.667	.708	3/16	35/64
P48D4P-33	33	.688	.729	3/16	35/64
P48D4P-34	34	.708	.750	3/16	35/64
P48D4P-35	35	.729	.771	3/16	35/64
P48D4P-36	36	.750	.792	3/16	35/64
P48D4P-37	37	.771	.813	3/16	35/64
P48D4P-38	38	.792	.833	3/16	35/64
P48D4P-39	39	.813	.854	3/16	35/64
P48D4P-40	40	.833	.875	3/16	35/64
P48D4P-42	42	.875	.917	3/16	35/64
P48D4P-44	44	.917	.958	3/16	35/64
P48D4P-45	45	.938	.979	3/16	35/64
P48D4P-48	48	1.000	1.042	1/4	39/64
P48D4P-52	52	1.083	1.125	1/4	39/64
P48D4P-54	54	1.125	1.168	1/4	39/64
P48D4P-56	56	1.168	1.208	1/4	39/64
P48D4P-60	60	1.250	1.292	1/4	39/64
P48D4P-64	64	1.333	1.375	1/4	39/64
P48D4P-66	66	1.375	1.416	1/4	39/64
P48D4P-72	72	1.500	1.542	1/4	39/64
P48D4P-80	80	1.667	1.708	1/4	39/64
P48D4P-84	84	1.750	1.792	1/4	39/64
P48D4P-96	96	2.000	2.042	1/4	39/64
P48D4P-100	100	2.083	2.125	1/4	39/64
P48D4P-108	108	2.250	2.292	1/4	39/64
P48D4P-120	120	2.500	2.542	1/4	39/64

Some molded gears may have webs.

**For Couplings See Section G.
For Shafts, Bearings and Collars See Section I.**

SPUR GEARS

PITCH	STYLE	BORE	FACE	MATERIAL	AGMA QUALITY	PRESSURE ANGLE
48	CLAMP STYLE	3/16"	1/8"	303 STAINLESS STEEL AND ALUMINUM ANODIZED	10	20°

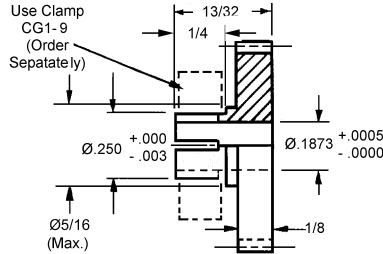
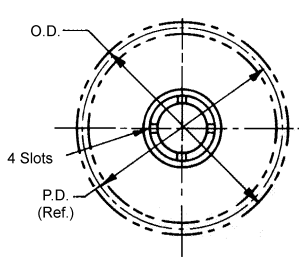

Available on request, other numbers of teeth, Agma Quality 12 and 14-1/2° Pressure Angle.

X in part number indicates part may be supplied in two piece construction with stainless steel hub (some dimensions may vary).

303 STAINLESS STEEL STOCK NO.	2024-T4 ALUMINUM ANODIZED STOCK NO.	NO. OF TEETH	PITCH DIA.	OUTSIDE DIA.
C48S14-20	C48A14-20	20	.4166	.458
C48S14-24	C48A14-24	24	.5000	.541
C48S14-28	C48A14-28	28	.5833	.625
C48S14-30	C48A14-30	30	.6250	.666
C48S14-32	C48A14-32	32	.6666	.708
C48S14-40	C48A14-40	40	.8333	.875
C48S14-46	C48A14-46	46	.9583	1.000
C48S14-48	C48A14-48	48	1.0000	1.041
C48S14-56	C48A14-56	56	1.1666	1.208
C48S14-60	C48A14-60	60	1.2500	1.291
C48S14-66	C48A14-66	66	1.3750	1.416
C48S14-70	C48A14-70	70	1.4583	1.500
C48S14-72	C48A14-72	72	1.5000	1.541
C48S14-84	C48A14-84	84	1.7500	1.791
C48S14-90	C48A14-90	90	1.8750	1.916
C48S14-96	C48A14-96	96	2.0000	2.041
C48S14-100	C48A14-100	100	2.0833	2.125
C48S14-102	C48A14-102	102	2.1250	2.166
C48S14-105	C48A14-105	105	2.1875	2.229
C48S14-108	C48A14-108	108	2.2500	2.291
C48S14-110	C48A14-110	110	2.2916	2.333
C48S14-114	C48A14-114	114	2.3750	2.416
C48S15X-120	C48A15X-120	120	2.5000	2.541
C48S15X-126	C48A15X-126	126	2.6250	2.666
C48S15X-132	C48A15X-132	132	2.7500	2.791
C48S15X-138	C48A15X-138	138	2.8750	2.916
C48S15X-140	C48A15X-140	140	2.9166	2.958
C48S15X-144	C48A15X-144	144	3.0000	3.041
C48S15X-150	C48A15X-150	150	3.1250	3.166
C48S15X-156	C48A15X-156	156	3.2500	3.291
C48S15X-160	C48A15X-160	160	3.3333	3.375
C48S15X-168	C48A15X-168	168	3.5000	3.541
C48S15X-170	C48A15X-170	170	3.5416	3.583
C48S15X-180	C48A15X-180	180	3.7500	3.791
C48S15X-190	C48A15X-190	190	3.9583	4.000
C48S15X-192	C48A15X-192	192	4.0000	4.041

For Couplings See Section G.
For Shafts, Bearings and Collars See Section I.

SPUR GEARS

PITCH	STYLE	BORE	FACE	MATERIAL	AGMA QUALITY	PRESSURE ANGLE
48	CLAMP STYLE	1/4"	1/8"	303 STAINLESS STEEL AND ALUMINUM ANODIZED	10	20°

B

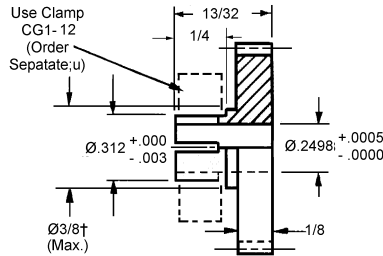
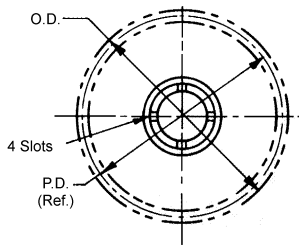

† Teeth may runout on flange diameter.

Available on request, other numbers of teeth, Agma Quality 12 and 14-1/2° Pressure Angle.

X in part number indicates part may be supplied in two piece construction with stainless steel hub (some dimensions may vary).

303 STAINLESS STEEL STOCK NO.	2024-T4 ALUMINUM ANODIZED STOCK NO.	NO. OF TEETH	PITCH DIA.	OUTSIDE DIA.
C48S18-20	C48A18-20	20†	.4166	.458
C48S18-21	C48A18-21	21	.4375	.479
C48S18-22	C48A18-22	22	.4583	.500
C48S18-23	C48A18-23	23	.4791	.520
C48S18-24	C48A18-24	24	.5000	.541
C48S18-25	C48A18-25	25	.5208	.562
C48S18-26	C48A18-26	26	.5416	.583
C48S18-27	C48A18-27	27	.5625	.604
C48S18-28	C48A18-28	28	.5833	.625
C48S18-29	C48A18-29	29	.6041	.645
C48S18-30	C48A18-30	30	.6250	.666
C48S18-32	C48A18-32	32	.6666	.708
C48S18-34	C48A18-34	34	.7083	.750
C48S18-35	C48A18-35	35	.7291	.770
C48S18-36	C48A18-36	36	.7500	.791
C48S18-38	C48A18-38	38	.7916	.833
C48S18-40	C48A18-40	40	.8333	.875
C48S18-42	C48A18-42	42	.8750	.916
C48S18-44	C48A18-44	44	.9166	.958
C48S18-45	C48A18-45	45	.9375	.979
C48S18-46	C48A18-46	46	.9583	1.000
C48S18-47	C48A18-47	47	.9791	1.020
C48S18-48	C48A18-48	48	1.0000	1.041
C48S18-50	C48A18-50	50	1.0416	1.083
C48S18-54	C48A18-54	54	1.1250	1.166
C48S18-55	C48A18-55	55	1.1458	1.187
C48S18-56	C48A18-56	56	1.1666	1.208
C48S18-60	C48A18-60	60	1.2500	1.291
C48S18-64	C48A18-64	64	1.3333	1.375
C48S18-66	C48A18-66	66	1.3750	1.416
C48S18-68	C48A18-68	68	1.4166	1.458
C48S18-70	C48A18-70	70	1.4583	1.500
C48S18-72	C48A18-72	72	1.5000	1.541
C48S18-75	C48A18-75	75	1.5625	1.604
C48S18-78	C48A18-78	78	1.6250	1.666

**For Couplings See Section G.
For Shafts, Bearings and Collars See Section I.**

SPUR GEARS

PITCH	STYLE	BORE	FACE	MATERIAL	AGMA QUALITY	PRESSURE ANGLE
48	CLAMP STYLE	1/4"	1/8"	303 STAINLESS STEEL AND ALUMINUM ANODIZED	10	20°

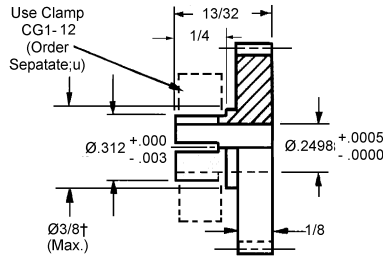
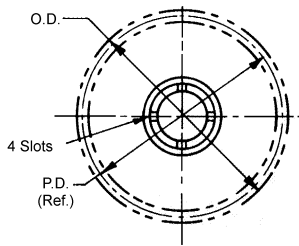

† Teeth may runout on flange diameter.

Available on request, other numbers of teeth, Agma Quality 12 and 14-1/2° Pressure Angle.

X in part number indicates part may be supplied in two piece construction with stainless steel hub (some dimensions may vary).

303 STAINLESS STEEL STOCK NO.	2024-T4 ALUMINUM ANODIZED STOCK NO.	NO. OF TEETH	PITCH DIA.	OUTSIDE DIA.
C48S18-80	C48A18-80	80	1.6666	1.708
C48S18-81	C48A18-81	81	1.6875	1.729
C48S18-84	C48A18-84	84	1.7500	1.791
C48S18-85	C48A18-85	85	1.7708	1.812
C48S18-88	C48A18-88	88	1.8333	1.875
C48S18-90	C48A18-90	90	1.8750	1.916
C48S18-91	C48A18-91	91	1.8958	1.937
C48S18-92	C48A18-92	92	1.9166	1.958
C48S18-93	C48A18-93	93	1.9375	1.979
C48S18-96	C48A18-96	96	2.0000	2.041
C48S18-100	C48A18-100	100	2.0833	2.125
C48S18-102	C48A18-102	102	2.1250	2.166
C48S18-104	C48A18-104	104	2.1666	2.208
C48S18-105	C48A18-105	105	2.1875	2.229
C48S18-108	C48A18-108	108	2.2500	2.291
C48S18-112	C48A18-112	112	2.3333	2.375
C48S18-114	C48A18-114	114	2.3750	2.416
C48S18-120	C48A18-120	120	2.5000	2.541
C48S18-126	C48A18-126	126	2.6250	2.666
C48S18-127	C48A18-127	127	2.6458	2.687
C48S18-128	C48A18-128	128	2.6666	2.708
C48S18-132	C48A18-132	132	2.7500	2.791
C48S18-136	C48A18-136	136	2.8333	2.875
C48S18-138	C48A18-138	138	2.8750	2.916
C48S18-144	C48A18-144	144	3.0000	3.041
C48S18-150	C48A18-150	150	3.1250	3.166
C48S18-152	C48A18-152	152	3.1666	3.208
C48S18-156	C48A18-156	156	3.2500	3.291
C48S18-162	C48A18-162	162	3.3750	3.416
C48S18-168	C48A18-168	168	3.5000	3.541
C48S18-171	C48A18-171	171	3.5625	3.604
C48S18-175	C48A18-175	175	3.6458	3.687
C48S18-180	C48A18-180	180	3.7500	3.791
C48S18-186	C48A18-186	186	3.8750	3.916
C48S18-192	C48A18-192	192	4.0000	4.041

**For Couplings See Section G.
For Shafts, Bearings and Collars See Section I.**

SPUR GEARS

PITCH	STYLE	BORE	FACE	MATERIAL	AGMA QUALITY	PRESSURE ANGLE
48	CLAMP STYLE	1/4"	3/16"	303 STAINLESS STEEL	10	20°

B

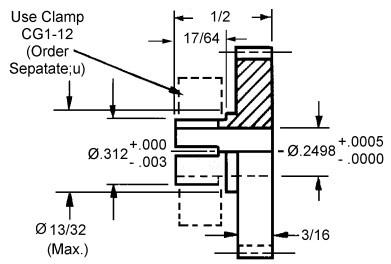
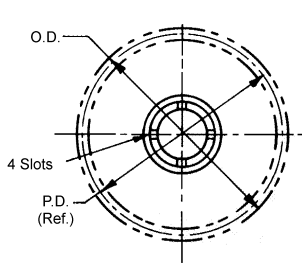

Available on request, other numbers of teeth, Agma Quality 12 and 14-1/2° Pressure Angle.

STOCK NO.	NO. OF TEETH	PITCH DIA.	OUTSIDE DIA.
C48S20-23	23	.4791	.520
C48S20-24	24	.5000	.541
C48S20-25	25	.5208	.562
C48S20-28	28	.5833	.625
C48S20-30	30	.6250	.666
C48S20-32	32	.6666	.708
C48S20-36	36	.7500	.791
C48S20-40	40	.8333	.875
C48S20-42	42	.8750	.916
C48S20-45	45	.9375	.979
C48S20-48	48	1.0000	1.041
C48S20-50	50	1.0416	1.083
C48S20-54	54	1.1250	1.166
C48S20-60	60	1.2500	1.291
C48S20-70	70	1.4583	1.500
C48S20-72	72	1.5000	1.541
C48S20-75	75	1.5625	1.604
C48S20-78	78	1.6250	1.666
C48S20-80	80	1.6666	1.708
C48S20-84	84	1.7500	1.791
C48S20-88	88	1.8333	1.875
C48S20-90	90	1.8750	1.916
C48S20-96	96	2.0000	2.041
C48S20-100	100	2.0833	2.125
C48S20-108	108	2.2500	2.291
C48S20-112	112	2.3333	2.375
C48S20-120	120	2.5000	2.541
C48S20-128	128	2.6666	2.708
C48S20-132	132	2.7500	2.791
C48S20-144	144	3.0000	3.041
C48S20-150	150	3.1250	3.166
C48S20-162	162	3.3750	3.416
C48S20-168	168	3.5000	3.541
C48S20-180	180	1.7500	1.791
C48S20-192	192	4.0000	4.041
C48S20-198	198	4.1250	4.066

For Couplings See Section G.
For Shafts, Bearings and Collars See Section I.

GEAR RACKS

PITCH	STYLE	MATERIAL	AGMA QUALITY	PRESSURE ANGLE
48	ROUND & RECTANGULAR	416 SERIES STAINLESS STEEL STRESSED RELIEVED	10	20°

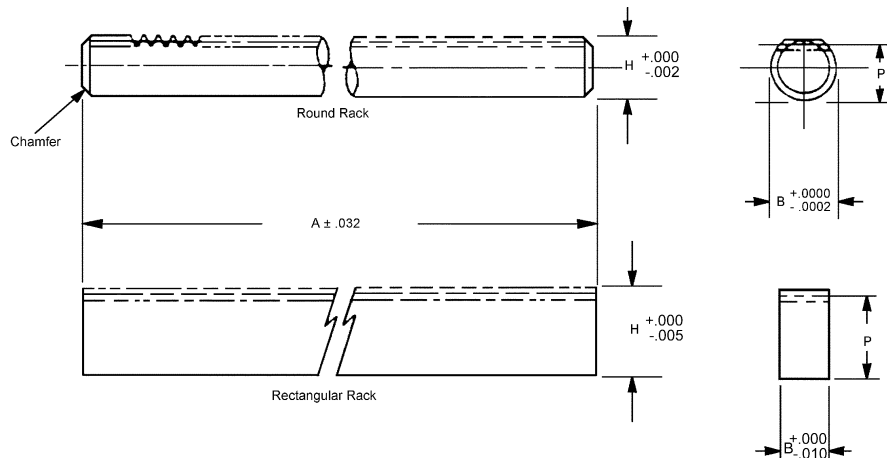

STOCK NO.	RACK STYLE	PITCH	P (Ref.)	B	A	H	AGMA QUALITY
R2-6	ROUND	48	.1992	.2497	18	.220	10
R2-12	RECTANGULAR	48	.4592	.230±.005	18	.480	10

Available on request:
14 - 1/2° pressure angle,
special, modified and custom racks.

PITCH	STYLE	MATERIAL	AGMA QUALITY	PRESSURE ANGLE
32	RECTANGULAR	416 SERIES STAINLESS STEEL AND 2024-T4 ALUMINUM ANODIZED	10	20°

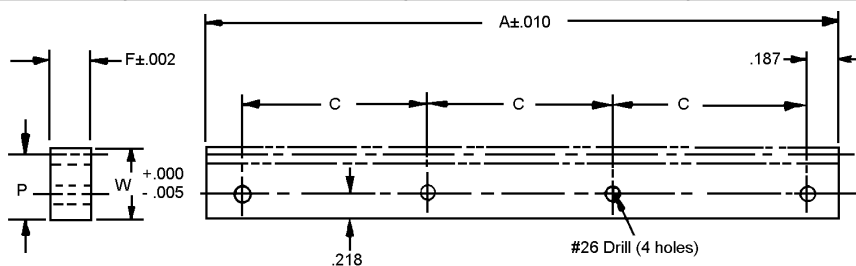

STOCK NO.	MATERIAL	A (Inch)	P (Ref.)	W	F	C
R4-11	STAINLESS ST.	9	.4592	.480	.230	2.879
R4-12	ALUMINUM					

Available on request: special,
modified and custom racks.

GEAR RACKS

PITCH	STYLE	MATERIAL	AGMA QUALITY	PRESSURE ANGLE
48	RECTANGULAR	416 SERIES STAINLESS STEEL STRESSED RELIEVED	10	20°

B

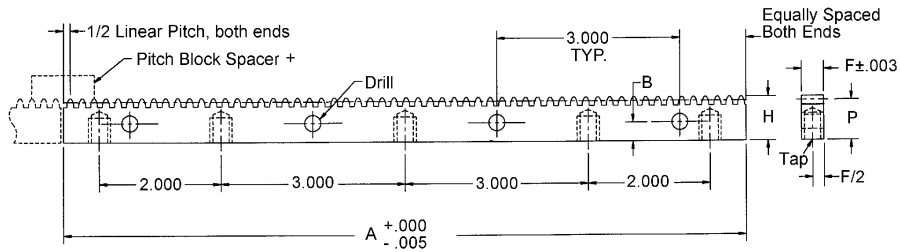

† Spacer block is designed for butting to achieve continuous lengths. On-Line pricing for AGMA 10 only.

RACKS	SPACER BLOCK	AGMA QTY. NO.	MAX ACCUM. ERROR	TOOTH TO TOOTH ERROR	PITCH	LINEAR PITCH	A INCH	P REF.	H +.000 -.005	F	B	DRILL	TAP
R1-6-G1	R1-6-SB	10*	.0014	.0005	48	.0354	11.055	.4542	.475	.230	.218	#26	#6-32 x 1/4
R3-4-G1	R3-4-SB	10*	.0014	.0005	48	.0654	11.055	.4542	.480	.230	.218	#26	#6-32 x 1/4

* Higher quality on request.

ANTI-BACKLASH GEARS

PITCH	STYLE	BORE	FACE	MATERIAL	AGMA QUALITY	PRES. ANGLE
48	PIN HUB	1/8"	.104	303 STAINLESS STEEL OR 2024-T4 ALUMINUM ANODIZED	10	20°

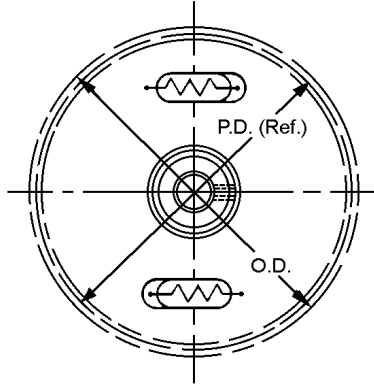
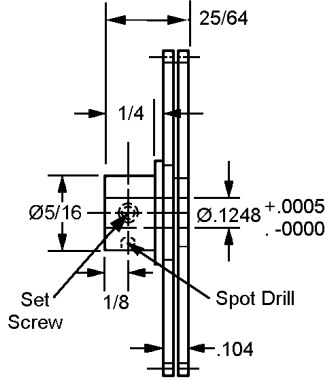

Hub Material: 303 Stainless Steel

303 STAINLESS STEEL STOCK NO.	2024-T4 ALUMINUM ANODIZED STOCK NO.	NO. OF TEETH	PITCH DIAMETER
AP48SS-40	AP48TS-40	40	.8333
AP48SS-42	AP48TS-42	42	.8750
AP48SS-44	AP48TS-44	44	.9166
AP48SS-46	AP48TS-46	46	.9583
AP48SS-48	AP48TS-48	48	1.0000
AP48SS-50	AP48TS-50	50	1.0416
AP48SS-55	AP48TS-55	55	1.1458
AP48SS-56	AP48TS-56	56	1.1666
AP48SS-60	AP48TS-60	60	1.2500
AP48SS-64	AP48TS-64	64	1.3333
AP48S-65	AP48T-65	65	1.3541
AP48S-70	AP48T-70	70	1.4583
AP48S-72	AP48T-72	72	1.5000
AP48S-75	AP48T-75	75	1.5625
AP48S-80	AP48T-80	80	1.6666
AP48S-84	AP48T-84	84	1.7500
AP48S-85	AP48T-85	85	1.7708
AP48S-90	AP48T-90	90	1.8750
AP48S-95	AP48T-95	95	1.9791
AP48S-96	AP48T-96	96	2.0000
AP48S-100	AP48T-100	100	2.0833
AP48S-105	AP48T-105	105	2.1875
AP48S-110	AP48T-110	110	2.2916
AP48S-115	AP48T-115	115	2.3958
AP48S-120	AP48T-120	120	2.5000
AP48S-125	AP48T-125	125	2.6041
AP48S-130	AP48T-130	130	2.7083
AP48S-132	AP48T-132	132	2.7500
AP48S-140	AP48T-140	140	2.9166
AP48S-144	AP48T-144	144	3.0000
AP48S-150	AP48T-150	150	3.1250

Available on request:

Other numbers of teeth;
AGMA Quality 12 and 14 (some dimensions may vary);
14-12° pressure angle.

For Couplings See Section G.
For Shafts, Bearings and Collars See Section I.

ANTI-BACKLASH GEARS

PITCH	STYLE	BORE	FACE	MATERIAL	AGMA QUALITY	PRES. ANGLE
48	PIN HUB	3/16"	.104	303 STAINLESS STEEL OR 2024-T4 ALUMINUM ANODIZED	10	20°

B

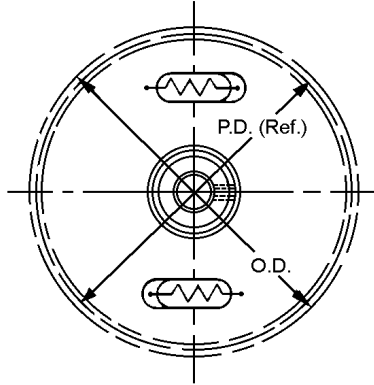
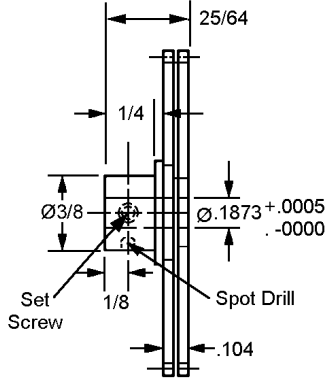

Hub Material: 303 Stainless Steel

303 STAINLESS STEEL STOCK NO.	2024-T4 ALUMINUM ANODIZED STOCK NO.	NO. OF TEETH	PITCH DIAMETER
AP48US-46	AP48VS-46	46	.9583
AP48US-48	AP48VS-48	48	1.0000
AP48US-50	AP48VS-50	50	1.0416
AP48US-55	AP48VS-55	55	1.1458
AP48US-56	AP48VS-56	56	1.1666
AP48US-60	AP48VS-60	60	1.2500
AP48US-64	AP48VS-64	64	1.3333
AP48U-65	AP48V-65	65	1.3541
AP48U-70	AP48V-70	70	1.4583
AP48U-72	AP48V-72	72	1.5000
AP48U-75	AP48V-75	75	1.5625
AP48U-80	AP48V-80	80	1.6666
AP48U-84	AP48V-84	84	1.7500
AP48U-85	AP48V-85	85	1.7708
AP48U-90	AP48V-90	90	1.8750
AP48U-95	AP48V-95	95	1.9791
AP48U-96	AP48V-96	96	2.0000
AP48U-100	AP48V-100	100	2.0833
AP48U-105	AP48V-105	105	2.1875
AP48U-110	AP48V-110	110	2.2916
AP48U-115	AP48V-115	115	2.3958
AP48U-120	AP48V-120	120	2.5000
AP48U-125	AP48V-125	125	2.6041
AP48U-130	AP48V-130	130	2.7083
AP48U-132	AP48V-132	132	2.7500
AP48U-140	AP48V-140	140	2.9166
AP48U-144	AP48V-144	144	3.0000
AP48U-150	AP48V-150	150	3.1250

Available on request:

Other numbers of teeth;
 AGMA Quality 12 and 14 (some dimensions may vary);
 14-12° pressure angle.

**For Couplings See Section G.
 For Shafts, Bearings and Collars See Section I.**

ANTI-BACKLASH GEARS

PITCH	STYLE	BORE	FACE	MATERIAL	AGMA QUALITY	PRES. ANGLE
48	PIN HUB	3/16"	.104	303 STAINLESS STEEL OR 2024-T4 ALUMINUM ANODIZED	10	20°

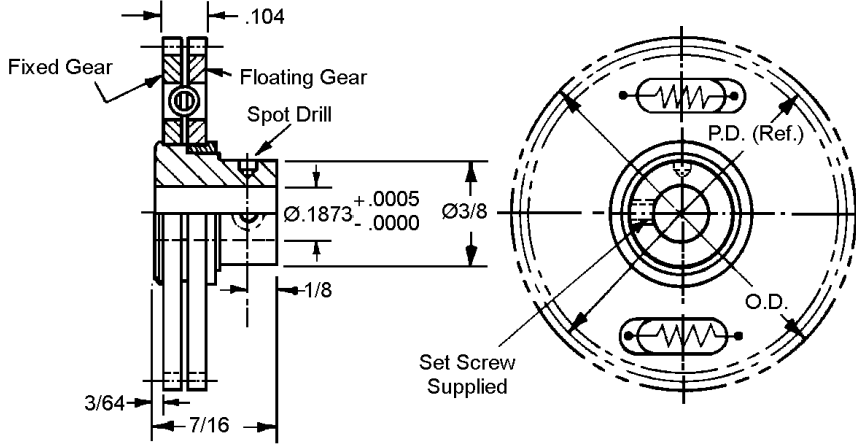

Hub Material: 303 Stainless Steel

STAINLESS STEEL STOCK NO.	ALUMINUM ANODIZED STOCK NO.	NO. OF TEETH	PITCH DIA.	OUTSIDE DIA.	SPRING STYLE
AP48CS-28	-	28	.5833	.625	SCISSOR
AP48CS-30	-	30	.6250	.666	
AP48CS-32	-	32	.6666	.708	
AP48CS-36	AP48PS-36	36	.7500	.791	
AP48CS-40	AP48PS-40	40	.8333	.875	
AP48CS-44	AP48PS-42	42	.8750	.916	
AP48C-48	AP48P-48	48	1.0000	1.041	COIL
AP48C-50	AP48P-50	50	1.0416	1.083	
AP48C-54	AP48P-54	54	1.1250	1.166	
AP48C-60	AP48P-60	60	1.2500	1.291	
AP48C-64	AP48P-64	64	1.3333	1.375	
AP48C-70	AP48P-70	70	1.4583	1.500	
AP48C-72	AP48P-72	72	1.5000	1.541	
AP48C-80	AP48P-80	80	1.6666	1.708	
AP48C-90	AP48P-90	90	1.8750	1.916	
AP48C-96	AP48P-96	96	2.0000	2.041	
AP48C-100	AP48P-100	100	2.0833	2.125	
AP48C-108	AP48P-108	108	2.2500	2.291	
AP48C-120	AP48P-120	120	2.5000	2.541	
AP48C-144	AP48P-144	144	3.0000	3.041	

Available on request:

Other numbers of teeth;
AGMA Quality 12 and 14;
14-12° pressure angle.

**For Couplings See Section G.
For Shafts, Bearings and Collars See Section I.**

ANTI-BACKLASH GEARS

B

PITCH	STYLE	BORE	FACE	MATERIAL	AGMA QUALITY	PRES. ANGLE
48	PIN HUB	3/16"	1/8"	303 STAINLESS STEEL OR 2024-T4 ALUMINUM ANODIZED	10	20°

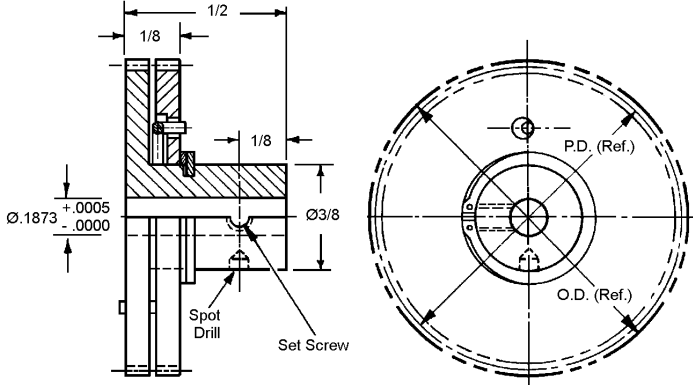

Hub Material:
303 Stainless Steel

STAINLESS STEEL STOCK NO.	ALUMINUM STOCK NO.	NO. OF TEETH	PITCH DIA.	OUTSIDE DIA.
AP48HS-30	AP48JS-30	30	.6250	.666
AP48HS-32	AP48JS-32	32	.6666	.708
AP48HS-36	AP48JS-36	36	.7500	.792
AP48HS-48	AP48JS-48	48	1.0000	1.042

Available on request:
Other numbers of teeth
AGMA Quality 12 and 14
14-1/2° Pressure Angle

PITCH	STYLE	BORE	FACE	MATERIAL	AGMA QUALITY	PRES. ANGLE
48	PIN HUB	1/4"	.104	303 STAINLESS STEEL OR 2024-T4 ALUMINUM ANODIZED	10	20°

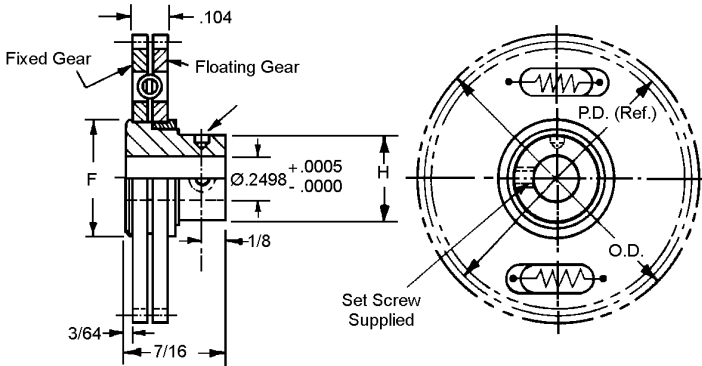

Hub Material: 303 Stainless Steel

Available on request:
Other numbers of teeth;
AGMA Quality 12 and 14;
14-12° pressure angle.

STAINLESS STEEL STOCK NO.	ALUMINUM ANODIZED STOCK NO.	NO. OF TEETH	PITCH DIA.	OUTSIDE DIA.	SPRING STYLE	H
AP48ES-28	-	28	.5833	.625	SCISSOR	3/8
AP48ES-30	-	30	.6250	.666		
AP48ES-32	-	32	.6666	.708		
AP48ES-36	AP48RS-36	36	.7500	.791		
AP48ES-40	AP48RS-40	40	.8333	.875		
AP48ES-42	AP48RS-42	42	.8750	.916		
AP48ES-45	AP48RS-45	45	.9375	.979	COIL	7/16
AP48E-48	AP48R-48	48	1.0000	1.041		
AP48E-50	AP48R-50	50	1.0416	1.083		
AP48E-54	AP48R-54	54	1.1250	1.166		
AP48E-56	AP48R-56	56	1.1666	1.208		
AP48E-60	AP48R-60	60	1.2500	1.291		
AP48E-64	AP48R-64	64	1.3333	1.375		
AP48E-65	AP48R-65	65	1.3541	1.395		
AP48E-70	AP48R-70	70	1.4583	1.500		
AP48E-72	AP48R-72	72	1.5000	1.541		
AP48E-75	AP48R-75	75	1.5625	1.604		
AP48E-78	AP48R-78	78	1.6250	1.666		
AP48E-80	AP48R-80	80	1.6666	1.708		
AP48E-90	AP48R-90	90	1.8750	1.916		
AP48E-96	AP48R-96	96	2.0000	2.041		
AP48E-100	AP48R-100	100	2.0833	2.125		
AP48E-105	AP48R-105	105	2.1875	2.229		
AP48E-108	AP48R-108	108	2.2500	2.291		
AP48E-120	AP48R-120	120	2.5000	2.541		
AP48E-144	AP48R-144	144	3.0000	3.041		



For Couplings See Section G.
For Shafts, Bearings and Collars See Section I.

ANTI-BACKLASH GEARS

PITCH	STYLE	BORE	FACE	MATERIAL	AGMA QUALITY	PRES. ANGLE
48	PIN HUB	1/4"	.104	303 STAINLESS STEEL OR 2024-T4 ALUMINUM ANODIZED	10	20°

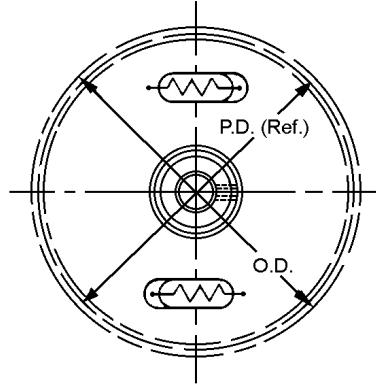
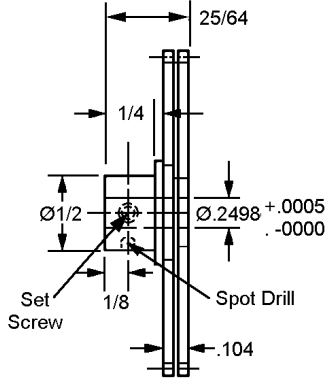

Hub Material: 303 Stainless Steel

303 STAINLESS STEEL STOCK NO.	2024-T4 ALUMINUM ANODIZED STOCK NO.	NO. OF TEETH	PITCH DIAMETER
AP48WS-50	AP48XS-50	50	1.0416
AP48WS-55	AP48XS-55	55	1.1458
AP48WS-56	AP48XS-56	56	1.1666
AP48WS-60	AP48XS-60	60	1.2500
AP48WS-64	AP48XS-64	64	1.3333
AP48W-65	AP48X-65	65	1.3541
AP48W-70	AP48X-70	70	1.4583
AP48W-72	AP48X-72	72	1.5000
AP48W-75	AP48X-75	75	1.5625
AP48W-80	AP48X-80	80	1.6666
AP48W-84	AP48X-84	84	1.7500
AP48W-85	AP48X-85	85	1.7708
AP48W-90	AP48X-90	90	1.8750
AP48W-95	AP48X-95	95	1.9791
AP48W-96	AP48X-96	96	2.0000
AP48W-100	AP48X-100	100	2.0833
AP48W-105	AP48X-105	105	2.1875
AP48W-110	AP48X-110	110	2.2916
AP48W-115	AP48X-115	115	2.3958
AP48W-120	AP48X-120	120	2.5000
AP48W-125	AP48X-125	125	2.6041
AP48W-130	AP48X-130	130	2.7083
AP48W-132	AP48X-132	132	2.7500
AP48W-140	AP48X-140	140	2.9166
AP48W-144	AP48X-144	144	3.0000
AP48W-150	AP48X-150	150	3.1250

Available on request:

- Other numbers of teeth;
- AGMA Quality 12 and 14 (some dimensions may vary);
- 14-12° pressure angle.

**For Couplings See Section G.
For Shafts, Bearings and Collars See Section I.**

ANTI-BACKLASH GEARS

PITCH	STYLE	BORE	FACE	MATERIAL	AGMA QUALITY	PRES. ANGLE
48	PIN HUB	1/4"	1/8"	303 STAINLESS STEEL OR 2024-T4 ALUMINUM ANODIZED	10	20°

B

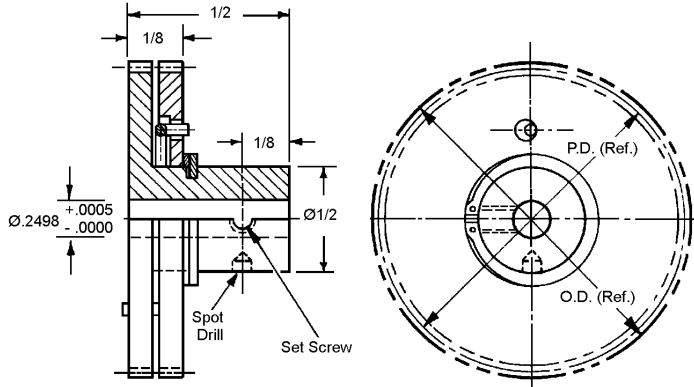

Hub Material:
303 Stainless Steel

STAINLESS STEEL STOCK NO.	ALUMINUM STOCK NO.	NO. OF TEETH	BORE	PITCH DIA.	OUTSIDE DIA.
AP48KS-32	AP48LS-32	32	.2498	.6666	.708
AP48KS-36	AP48LS-36	36		.7500	.792
AP48KS-48	AP48LS-48	48		1.0000	1.042

Available on request:
Other numbers of teeth
AGMA Quality 12 and 14
14-1/2° Pressure Angle

For Couplings See Section G.
For Shafts, Bearings and Collars See Section I.

ANTI-BACKLASH GEARS

PITCH	STYLE	BORE	FACE	MATERIAL	AGMA QUALITY	PRES. ANGLE
48	CLAMP STYLE	1/8"	.104	303 STAINLESS STEEL OR 2024-T4 ALUMINUM ANODIZED	10	20°

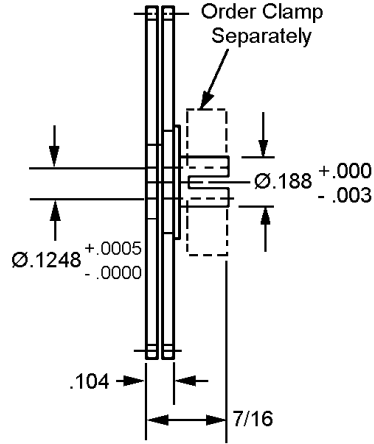

Hub Material: 303 Stainless Steel

303 STAINLESS STEEL STOCK NO.	2024-T4 ALUMINUM ANODIZED STOCK NO.	NO. OF TEETH	PITCH DIAMETER
AC48SS-40	AC48TS-40	40	.8333
AC48SS-42	AC48TS-42	42	.8750
AC48SS-44	AC48TS-44	44	.9166
AC48SS-46	AC48TS-46	46	.9583
AC48SS-48	AC48TS-48	48	1.0000
AC48SS-50	AC48TS-50	50	1.0416
AC48SS-55	AC48TS-55	55	1.1458
AC48SS-56	AC48TS-56	56	1.1666
AC48SS-60	AC48TS-60	60	1.2500
AC48SS-64	AC48TS-64	64	1.3333
AC48S-65	AC48T-65	65	1.3541
AC48S-70	AC48T-70	70	1.4583
AC48S-72	AC48T-72	72	1.5000
AC48S-75	AC48T-75	75	1.5625
AC48S-80	AC48T-80	80	1.6666
AC48S-84	AC48T-84	84	1.7500
AC48S-85	AC48T-85	85	1.7708
AC48S-90	AC48T-90	90	1.8750
AC48S-95	AC48T-95	95	1.9791
AC48S-96	AC48T-96	96	2.0000
AC48S-100	AC48T-100	100	2.0833
AC48S-105	AC48T-105	105	2.1875
AC48S-110	AC48T-110	110	2.2916
AC48S-115	AC48T-115	115	2.3958
AC48S-120	AC48T-120	120	2.5000
AC48S-125	AC48T-125	125	2.6041
AC48S-130	AC48T-130	130	2.7083
AC48S-132	AC48T-132	132	2.7500
AC48S-140	AC48T-140	140	2.9166
AC48S-144	AC48T-144	144	3.0000
AC48S-150	AC48T-150	150	3.1250

Available on request:
Other numbers of teeth
AGMA Quality 12 and 14 (some dimensions may vary)
14-1/2° Pressure Angle

For Couplings See Section G.
For Shafts, Bearings and Collars See Section I.

ANTI-BACKLASH GEARS

PITCH	STYLE	BORE	FACE	MATERIAL	AGMA QUALITY	PRES. ANGLE
48	CLAMP STYLE	3/16"	.104	303 STAINLESS STEEL OR 2024-T4 ALUMINUM ANODIZED	10	20°

B

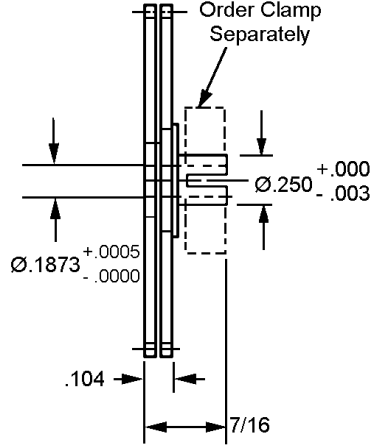

Hub Material: 303 Stainless Steel

303 STAINLESS STEEL STOCK NO.	2024-T4 ALUMINUM ANODIZED STOCK NO.	NO. OF TEETH	PITCH DIAMETER
AC48US-46	AC48VS-46	46	.9583
AC48US-48	AC48VS-48	48	1.0000
AC48US-50	AC48VS-50	50	1.0416
AC48US-55	AC48VS-55	55	1.1458
AC48US-56	AC48VS-56	56	1.1666
AC48US-60	AC48VS-60	60	1.2500
AC48US-64	AC48VS-64	64	1.3333
AC48U-65	AC48V-65	65	1.3541
AC48U-70	AC48V-70	70	1.4583
AC48U-72	AC48V-72	72	1.5000
AC48U-75	AC48V-75	75	1.5625
AC48U-80	AC48V-80	80	1.6666
AC48U-84	AC48V-84	84	1.7500
AC48U-85	AC48V-85	85	1.7708
AC48U-90	AC48V-90	90	1.8750
AC48U-95	AC48V-95	95	1.9791
AC48U-96	AC48V-96	96	2.0000
AC48U-100	AC48V-100	100	2.0833
AC48U-105	AC48V-105	105	2.1875
AC48U-110	AC48V-110	110	2.2916
AC48U-115	AC48V-115	115	2.3958
AC48U-120	AC48V-120	120	2.5000
AC48U-125	AC48V-125	125	2.6041
AC48U-130	AC48V-130	130	2.7083
AC48U-132	AC48V-132	132	2.7500
AC48U-140	AC48V-140	140	2.9166
AC48U-144	AC48V-144	144	3.0000
AC48U-150	AC48V-150	150	3.1250

Available on request:
 Other numbers of teeth
 AGMA Quality 12 and 14 (some dimensions may vary)
 14-1/2° Pressure Angle

**For Couplings See Section G.
 For Shafts, Bearings and Collars See Section I.**

ANTI-BACKLASH GEARS

PITCH	STYLE	BORE	FACE	MATERIAL	AGMA QUALITY	PRES. ANGLE
48	CLAMP STYLE	3/16"	.104	303 STAINLESS STEEL OR 2024-T4 ALUMINUM ANODIZED	10	20°

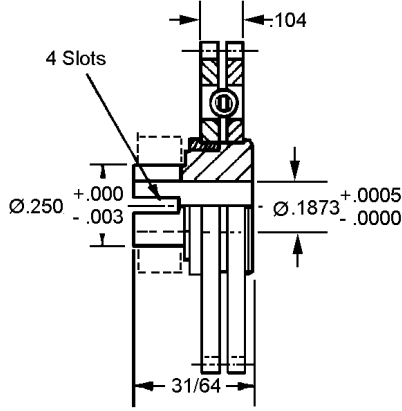

Hub Material: 303 Stainless Steel

STAINLESS STEEL STOCK NO.	ALUMINUM ANODIZED STOCK NO.	NO. OF TEETH	PITCH DIA.	OUTSIDE DIA.	SPRING STYLE
AC48CS-28	---	28	.5833	.625	SCISSOR
AC48CS-30	---	30	.6250	.666	
AC48CS-32	---	32	.6666	.708	
AC48CS-34	AC48PS-34	34	.7083	.750	
AC48CS-36	AC48PS-36	36	.7500	.791	
AC48CS-40	AC48PS-40	40	.8333	.875	
AC48CS-44	AC48PS-44	44	.9166	.958	COIL
AC48C-48	AC48P-48	48	1.0000	1.041	
AC48C-50	AC48P-50	50	1.0416	1.083	
AC48C-54	AC48P-54	54	1.1250	1.166	
AC48C-60	AC48P-60	60	1.2500	1.291	
AC48C-64	AC48P-64	64	1.3333	1.375	
AC48C-70	AC48P-70	70	1.4583	1.500	
AC48C-72	AC48P-72	72	1.5000	1.541	
AC48C-80	AC48P-80	80	1.6666	1.708	
AC48C-90	AC48P-90	90	1.8750	1.916	
AC48C-96	AC48P-96	96	2.0000	2.041	
AC48C-100	AC48P-100	100	2.0833	2.125	
AC48C-108	AC48P-108	108	2.2500	2.291	
AC48C-120	AC48P-120	120	2.5000	2.541	
AC48C-144	AC48P-144	144	3.0000	3.041	

Available on request:

Other numbers of teeth;
AGMA Quality 12 and 14;
14-12° pressure angle.

For Couplings See Section G.
For Shafts, Bearings and Collars See Section I.

ANTI-BACKLASH GEARS

PITCH	STYLE	BORE	FACE	MATERIAL	AGMA QUALITY	PRES. ANGLE
48	CLAMP STYLE	3/16"	1/8"	303 STAINLESS STEEL OR 2024-T4 ALUMINUM ANODIZED	10	20°

B

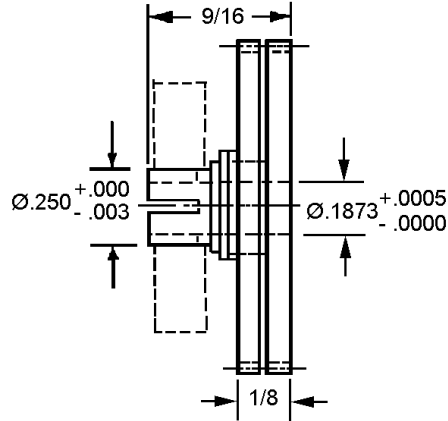

Hub Material:
303 Stainless Steel

STAINLESS STEEL STOCK NO.	ALUMINUM STOCK NO.	PITCH	NO. OF TEETH	PITCH DIA.	OUTSIDE DIA.
AC48HS-30	AC48JS-30	48	30	.6250	.666
AC48HS-32	AC48JS-32		32	.6666	.708
AC48HS-36	AC48JS-36		36	.7500	.792
AC48HS-48	AC48JS-48		48	1.0000	1.042

Available on request:
Other numbers of teeth
AGMA Quality 12 and 14
14-1/2° Pressure Angle

For Couplings See Section G.
For Shafts, Bearings and Collars See Section I.

ANTI-BACKLASH GEARS

PITCH	STYLE	BORE	FACE	MATERIAL	AGMA QUALITY	PRES. ANGLE
48	CLAMP STYLE	1/4"	.104	303 STAINLESS STEEL OR 2024-T4 ALUMINUM ANODIZED	10	20°

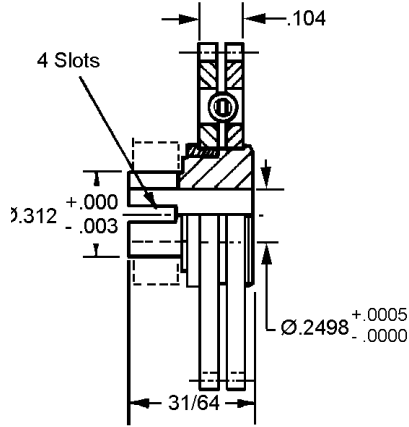

Hub Material: 303 Stainless Steel

STAINLESS STEEL STOCK NO.	ALUMINUM ANODIZED STOCK NO.	NO. OF TEETH	PITCH DIA.	OUTSIDE DIA.	SPRING STYLE
AC48ES-28	-	28	.5833	.625	SCISSOR
AC48ES-30	-	30	.6250	.666	
AC48ES-32	-	32	.6666	.708	
AC48ES-36	AC48RS-36	36	.7500	.791	
AC48ES-40	AC48RS-40	40	.8333	.875	
AC48ES-42	AC48RS-42	42	.8750	.916	
AC48ES-45	AC48RS-45	45	.9375	.979	COIL
AC48E-48	AC48R-48	48	1.0000	1.041	
AC48E-50	AC48R-50	50	1.0416	1.083	
AC48E-54	AC48R-54	54	1.1250	1.166	
AC48E-56	AC48R-56	56	1.1666	1.208	
AC48E-60	AC48R-60	60	1.2500	1.291	
AC48E-64	AC48R-64	64	1.3333	1.375	
AC48E-65	AC48R-65	65	1.3541	1.395	
AC48E-70	AC48R-70	70	1.4583	1.500	
AC48E-72	AC48R-72	72	1.5000	1.541	
AC48E-75	AC48R-75	75	1.5625	1.604	
AC48E-78	AC48R-78	78	1.6250	1.666	
AC48E-80	AC48R-80	80	1.6666	1.708	
AC48E-90	AC48R-90	90	1.8750	1.916	
AC48E-96	AC48R-96	96	2.0000	2.041	
AC48E-100	AC48R-100	100	2.0833	2.125	
AC48E-105	AC48R-105	105	2.1875	2.229	
AC48E-108	AC48R-108	108	2.2500	2.291	
AC48E-120	AC48R-120	120	2.5000	2.541	
AC48E-144	AC48R-144	144	3.0000	3.041	

Available on request:

- Other numbers of teeth;
- AGMA Quality 12 and 14;
- 14-12° pressure angle.

**For Couplings See Section G.
For Shafts, Bearings and Collars See Section I.**

ANTI-BACKLASH GEARS

B

PITCH	STYLE	BORE	FACE	MATERIAL	AGMA QUALITY	PRES. ANGLE
48	CLAMP STYLE	1/4"	1/4"	303 STAINLESS STEEL OR 2024-T4 ALUMINUM ANODIZED	10	20°

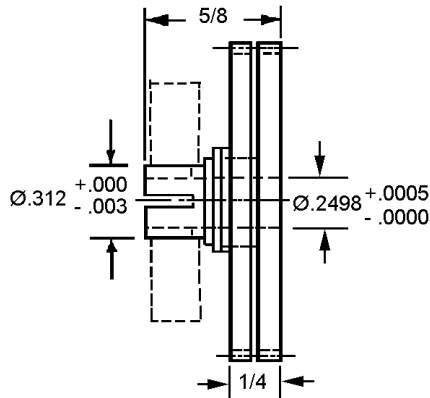

Hub Material:
303 Stainless Steel

STAINLESS STEEL STOCK NO.	ALUMINUM STOCK NO.	PITCH	NO. OF TEETH	PITCH DIA.	OUTSIDE DIA.
AC48BS-36	AC48DS-36	48	36	.7500	.792
AC48BS-42	AC48DS-42		42	.8750	.917
AC48BS-48	AC48DS-48		48	1.0000	1.042

Available on request:
Other numbers of teeth
AGMA Quality 12 and 14
14-1/2° Pressure Angle

PITCH	STYLE	BORE	FACE	MATERIAL	AGMA QUALITY	PRES. ANGLE
48	CLAMP STYLE	1/4"	1/8"	303 STAINLESS STEEL OR 2024-T4 ALUMINUM ANODIZED	10	20°

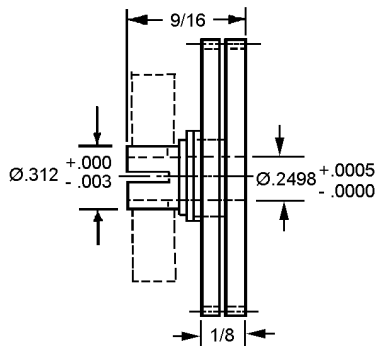

Hub Material: 303 Stainless Steel

STAINLESS STEEL STOCK NO.	ALUMINUM STOCK NO.	NO. OF TEETH	PITCH DIA.	OUTSIDE DIA.
AC48KS-32	AC48LS-32	32	.6666	.708
AC48KS-36	AC48LS-36	36	.7500	.792
AC48KS-48	AC48LS-48	48	1.0000	1.042

Available on request:
Other numbers of teeth
AGMA Quality 12 and 14
14-1/2° Pressure Angle

PINION SHAFTS

PITCH	MATERIAL	AGMA QUALITY	PRES. ANGLE
48	BRASS AND COLD ROLLED STEEL	5	20°

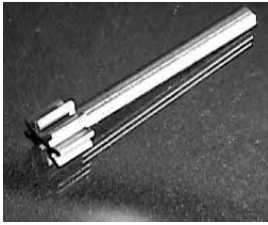
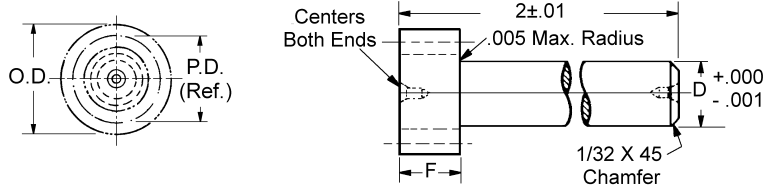

303 STAINLESS STEEL STOCK NO.	BRASS ALLOY 360 STOCK NO.	NUMBER OF TEETH	PITCH DIAMETER	OUTSIDE DIAMETER	D	F
PSX48S-9	PSX48B-9	9	.1875	.230	.125	3/16
PSX48S-10	PSX48B-10	10	.2083	.250	.125	
PSX48S-12	PSX48B-12	12	.2500	.291	.187	
PSX48S-14	PSX48B-14	14	.2917	.333	.187	
PSX48S-15	PSX48B-15	15	.3125	.353	.250	
PSX48S-16	PSX48B-16	16	.3333	.375	.250	
PSX48S-18	PSX48B-18	18	.3750	.417	.312	

PITCH	MATERIAL	AGMA QUALITY	PRES. ANGLE
48	BRASS AND COLD ROLLED STEEL	5	20°

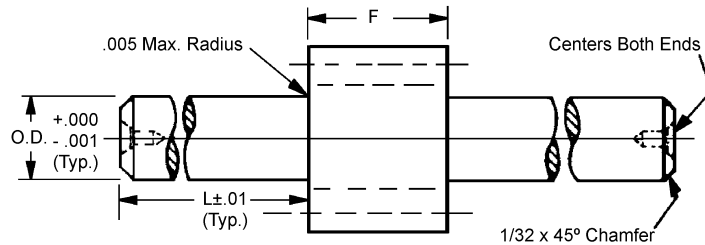

COLD ROLLED STEEL 12L14 OR 12L15 W/SELENIUM STOCK NO.	BRASS ALLOY 360 STOCK NO.	NUMBER OF TEETH	PITCH DIAMETER	OUTSIDE DIAMETER	D	F	L
PSW48S-9	PSW48B-9	9	.1875	.416	.230	3/16	1/2
PSW48S-10	PSW48B-10	10	.2083	.458	.250		
PSW48S-12	PSW48B-12	12	.2500	.500	.291		
PSW48S-14	PSW48B-14	14	.2917	.583	.333		
PSW48S-15	PSW48B-15	15	.3125	.500	.353		
PSW48S-16	PSW48B-16	16	.3333	.583	.375		
PSW48S-18	PSW48B-18	18	.3750	.500	.417		

PINION SHAFTS

PITCH	MATERIAL	AGMA QUALITY	PRES. ANGLE
48	303 STAINLESS STEEL	10	20°

B

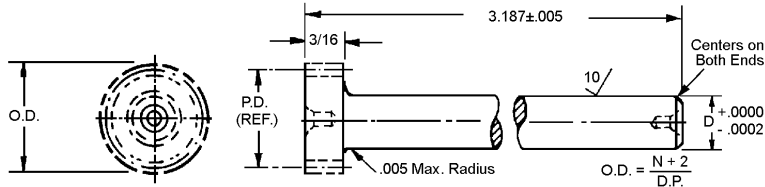

STOCK NO.	PITCH	NO. OF TEETH	PITCH DIA.	D
PS48S3-12H	48	12	.2500	.1872
PS48S4-12H		12	.2500	.2497
PS48S4-14H		14	.2917	.2497
PS48S4-16H		16	.3333	.2497
PS48S4-18H		18	.3750	.2497
PS48S4-20H		20	.4166	.2497
PS48S4-24H		24	.5000	.2497

Other numbers of teeth available on request.

PITCH	MATERIAL	AGMA QUALITY	PRES. ANGLE
48	303 STAINLESS STEEL	10	20°

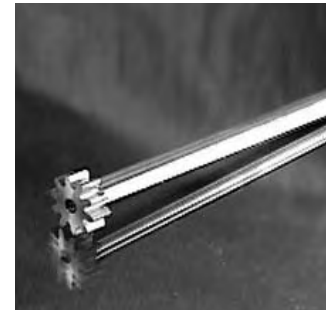
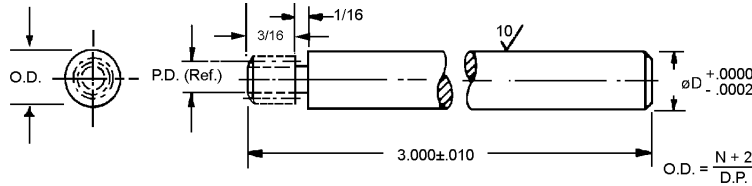

STOCK NO.	PITCH	NO. OF TEETH	PITCH DIA.	D
PS48S4-10	48	10	.2083	.2497

Other numbers of teeth available on request.

PITCH	MATERIAL	AGMA QUALITY	PRES. ANGLE
48	303 STAINLESS STEEL	10	20°

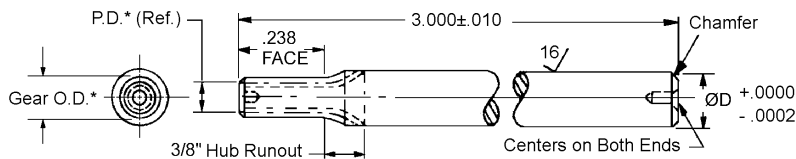

STOCK NO.	PITCH	NO. OF TEETH	D	ENLARGED	
				PITCH DIAMETER	OUTSIDE DIA.
B-PS48S5-10	48	10	.3122	.2256	.267
B-PS48S5-11		11	.3122	.2440	.285
B-PS48S5-12		12	.3122	.2624	.304

Other numbers of teeth available on request.

SPUR GEAR STOCK

PITCH	TYPE	MATERIAL	PRESSURE ANGLE
48	PINION WIRE	BRASS AND COLD ROLLED STEEL	20°

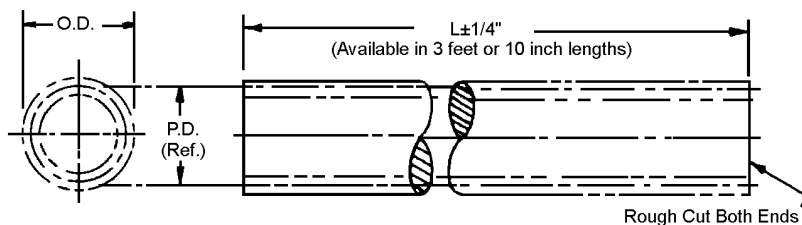

BRASS ALLOY 360		COLD ROLLED STEEL 12L14 or 12L15 WITH SELENIUM		NO. OF TEETH	PITCH DIA.	OUTSIDE DIA.
3FT. LONG STOCK NO.	10 IN. LONG STOCK NO.	3FT. LONG STOCK NO.	10 IN. LONG STOCK NO.			
PW48B-6	PW48B-6A	PW48S-6	PW48S-6A	6	.1250	.166
PW48B-7	PW48B-7A	PW48S-7	PW48S-7A	7	.1458	.187
PW48B-8	PW48B-8A	PW48S-8	PW48S-8A	8	.1666	.208
PW48B-9	PW48B-9A	PW48S-9	PW48S-9A	9	.1875	.229
PW48B-10	PW48B-10A	PW48S-10	PW48S-10A	10	.2083	.250
PW48B-11	PW48B-11A	PW48S-11	PW48S-11A	11	.2291	.270
PW48B-12	PW48B-12A	PW48S-12	PW48S-12A	12	.2500	.291
PW48B-14	PW48B-14A	PW48S-14	PW48S-14A	14	.2916	.333
PW48B-15	PW48B-15A	PW48S-15	PW48S-15A	15	.3125	.354
PW48B-16	PW48B-16A	PW48S-16	PW48S-16A	16	.3333	.375
PW48B-18X	PW48B-18A	PW48S-18X	PW48S-18A	18	.3750	.416
PW48B-20	PW48B-20A	PW48S-20	PW48S-20A	20	.4166	.458
PW48B-22	PW48B-22A	PW48S-22	PW48S-22A	22	.4583	.500
PW48B-24	PW48B-24A	PW48S-24	PW48S-24A	24	.5000	.541
PW48B-30	PW48B-30A	PW48S-30	PW48S-30A	30	.6250	.666
PW48B-32	PW48B-32A	PW48S-32	PW48S-32A	32	.6666	.708
PW48B-36	PW48B-36A	-	-	36	.7500	.791
PW48B-40	PW48B-40A	-	-	40	.8333	.875

SPUR GEARS

PITCH	STYLE	BORE	FACE	MATERIAL	AGMA QUALITY	PRESSURE ANGLE
1/20	PIN HUB	3/16"	3/16"	303 STAINLESS STEEL	10	20°

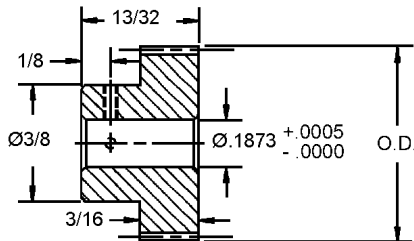
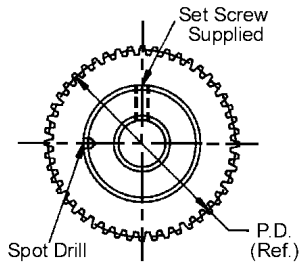

Available on request, other numbers of teeth and 14-1/2° Pressure Angle.

303 STAINLESS STEEL STOCK NO.	NO. OF TEETH	PITCH DIA.	OUTSIDE DIA.
P62S21-40	40	.6366	.668
P62S21-50	50	.7957	.827
P62S21-60	60	.9549	.986
P62S21-70	70	1.1140	1.145
P62S21-80	80	1.2732	1.305
P62S21-90	90	1.4323	1.464
P62S21-100	100	1.5915	1.623

PITCH	STYLE	BORE	FACE	MATERIAL	AGMA QUALITY	PRESSURE ANGLE
1/20	PIN HUB	1/4"	3/16"	303 STAINLESS STEEL	10	20°

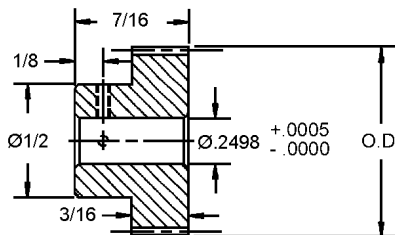
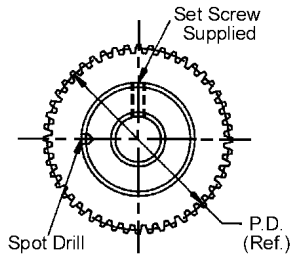

Available on request, other numbers of teeth and 14-1/2° Pressure Angle.

303 STAINLESS STEEL STOCK NO.	NO. OF TEETH	PITCH DIA.	OUTSIDE DIA.
P62S28-40	40	.6366	.668
P62S28-50	50	.7957	.827
P62S28-60	60	.9549	.986
P62S28-70	70	1.1140	1.145
P62S28-80	80	1.2732	1.305
P62S28-90	90	1.4323	1.464
P62S28-100	100	1.5915	1.623

For Couplings See Section G.
For Shafts, Bearings and Collars See Section I.

SPUR GEARS

PITCH	STYLE	BORE	FACE	MATERIAL	AGMA QUALITY	PRESSURE ANGLE
1/20	PIN HUB	1/4"	3/16"	17-4 PH STAINLESS STEEL HARDENED RC 26-32	10	20°

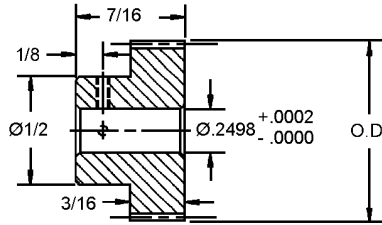
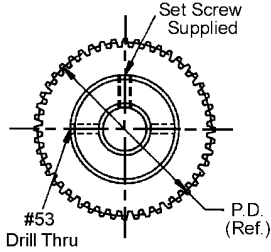

STOCK NO.	NO. OF TEETH	PITCH DIA.	OUTSIDE DIA.
P62PH28-40	40	.6366	.668
P62PH28-50	50	.7958	.828
P62PH28-60	60	.9549	.987
P62PH28-70	70	1.1141	1.146
P62PH28-80	80	1.2732	1.305



PITCH	STYLE	BORE	FACE	MATERIAL	AGMA QUALITY	PRESSURE ANGLE
1/20	PIN HUB	1/4"	1/4"	17-4 PH STAINLESS STEEL HARDENED RC26-32	13	20°

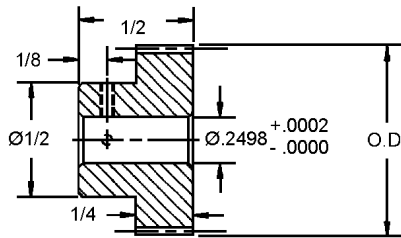
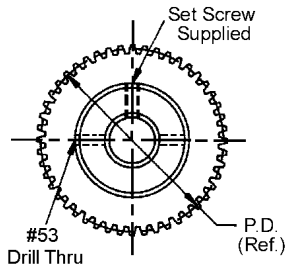

STOCK NO.	NO. OF TEETH	PITCH DIA.	OUTSIDE DIA.
P62PH41-40-Q13	40	.6366	.668
P62PH41-80-Q13	80	1.2732	1.305



GEAR RACKS

B

PITCH	STYLE	MATERIAL	AGMA QUALITY	PRESSURE ANGLE
1/20	RECTANGULAR	416 SERIES STAINLESS STEEL STRESSED RELIEVED	10	20°

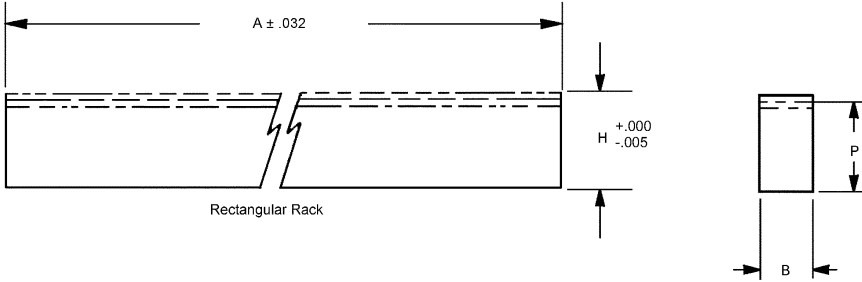

STOCK NO.	RACK STYLE	PITCH	P (Ref.)	B	A	H	AGMA QUALITY
R2-13	RECTANGULAR	1/20	.4641	.230 ±.005	11	.480	10

Available on request: 14 - 1/2° pressure angle, special, modified and custom racks.

PITCH	STYLES	MATERIAL	AGMA QUALITY	PRESSURE ANGLE
1/20	RECTANGULAR	416 SERIES STAINLESS STEEL RC26-36	10	20°

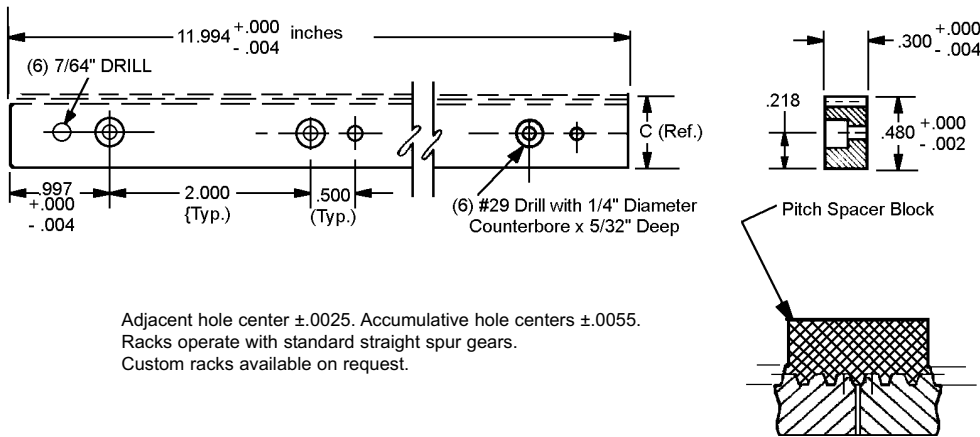

Adjacent hole center ±.0025. Accumulative hole centers ±.0055.
Racks operate with standard straight spur gears.
Custom racks available on request.

WITHOUT SPACER BLOCK STOCK NO.	WITH SPACER BLOCK STOCK NO.	AGMA QUALITY NO.	TOTAL COMPOSITE ERROR	TOTAL TOOTH ERROR	PITCH PLANE PARALLELISM TO BASE SURFACE	LINEAR PITCH	C REF
R8-3-G1	R8-3-G1-SB	Q10*	.0014	.0005	.0015	1/20	.4639

* Higher quality on request.

GEAR RACKS

PITCH	STYLE	MATERIAL	AGMA QUALITY	PRESSURE ANGLE
1/20	RECTANGULAR	MOLDED DELRIN	10	20°

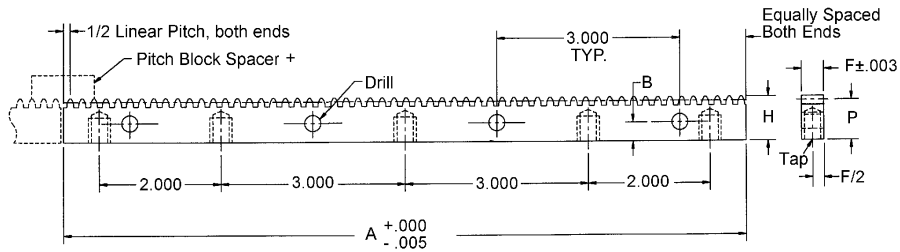

Spacer block is designed for butting to achieve continuous lengths. On-Line pricing for AGMA 10 only.

RACKS	SPACER BLOCK	AGMA QTY. NO.	MAX ACCUM. ERROR	TOOTH TO TOOTH ERROR	PITCH	LINEAR PITCH	A INCH	P REF.	H +.000 / -.005	F	B	DRILL	TAP
R1-7-G1	R1-7-SB	10*	.0014	.0005	1/20	.0500	10.994	.4592	.475	.230	.218	#26	#6-32 x 1/4

* Higher quality on request.

PINION SHAFTS

PITCH	MATERIAL	AGMA QUALITY	PRES. ANGLE
1/20	303 STAINLESS STEEL	10	20°

B

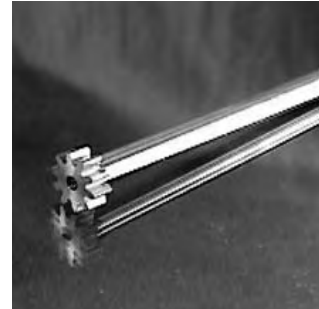
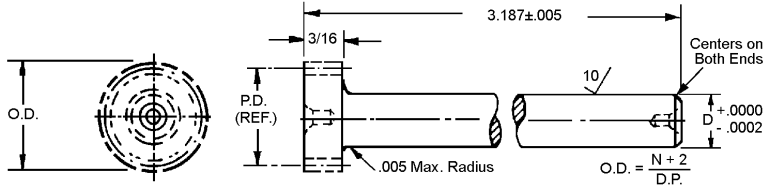

STOCK NO.	PITCH	NO. OF TEETH	PITCH DIA.	D
PS62S4-20H	1/20	20	.3183	.2497

Other numbers of teeth available on request.

SPUR GEARS

PITCH	STYLE	BORE	FACE	MATERIAL	AGMA QUALITY	PRESSURE ANGLE
64	HUBLESS	3/8"	1/8"	303 STAINLESS STEEL AND 2024-T4 ALUMINUM ANODIZED	10	20°

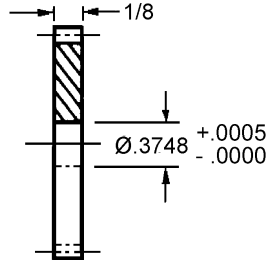
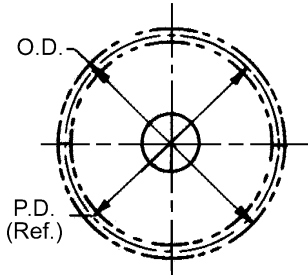

Available on request:
Pin or Clamp hubs assembled
Other numbers of teeth
14 - 1/2° Pressure Angle

303 STAINLESS STEEL STOCK NO.	2024-T4 ALUMINUM ANODIZED STOCK NO.	NO. OF TEETH	PITCH DIA.	OUTSIDE DIA.
F64S3-38	F64A3-38	38	.5937	.625
F64S3-40	F64A3-40	40	.6250	.656
F64S3-48	F64A3-48	48	.7500	.781
F64S3-50	F64A3-50	50	.7812	.812
F64S3-64	F64A3-64	64	1.0000	1.031
F64S3-66	F64A3-66	66	1.0312	1.062
F64S3-70	F64A3-70	70	1.0937	1.125
F64S3-72	F64A3-72	72	1.1250	1.156
F64S3-75	F64A3-75	75	1.1718	1.203
F64S3-80	F64A3-80	80	1.2500	1.281
F64S3-84	F64A3-84	84	1.3125	1.343
F64S3-90	F64A3-90	90	1.4062	1.437
F64S3-96	F64A3-96	96	1.5000	1.531
F64S3-100	F64A3-100	100	1.5625	1.593
F64S3-110	F64A3-110	110	1.7187	1.750
F64S3-120	F64A3-120	120	1.8750	1.906
F64S3-128	F64A3-128	128	2.0000	2.031
F64S3-130	F64A3-130	130	2.0312	2.062
F64S3-140	F64A3-140	140	2.1875	2.218
F64S3-144	F64A3-144	144	2.2500	2.281
F64S3-150	F64A3-150	150	2.3437	2.375
F64S3-155	F64A3-155	155	2.4218	2.453
F64S3-160	F64A3-160	160	2.5000	2.531
F64S3-165	F64A3-165	165	2.5781	2.609
F64S3-170	F64A3-170	170	2.6562	2.687
F64S3-176	F64A3-176	176	2.7500	2.781
F64S3-180	F64A3-180	180	2.8125	2.843
F64S3-190	F64A3-190	190	2.9687	3.000
F64S3-192	F64A3-192	192	3.0000	3.031
F64S3-224	F64A3-224	224	3.5000	3.531
F64S3-256	F64A3-256	256	4.0000	4.031
F64S3-264	F64A3-264	264	4.1250	4.156

For Couplings See Section G.
For Shafts, Bearings and Collars See Section I.

SPUR GEARS

PITCH	STYLE	BORE	FACE	MATERIAL	AGMA QUALITY	PRESSURE ANGLE
64	HUBLESS	3/8"	1/8" & 1/4"	POLYURETHANE	8	20°

B

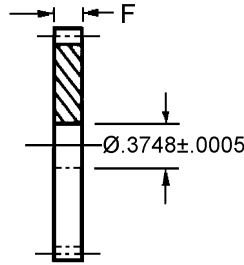
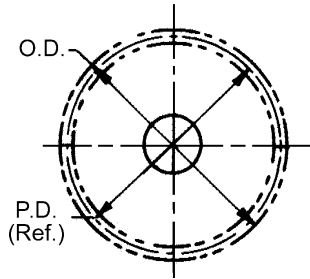

Available on request:
Other numbers of teeth
14 - 1/2° Pressure Angle

STOCK NO.	NO. OF TEETH	PITCH DIA.	OUTSIDE DIA.	F
F64U3-64	64	1.0000	1.031	.125
F64U3-80	80	1.2500	1.281	.125
F64U3-96	96	1.5000	1.531	.125
F64U3-112	112	1.7500	1.781	.125
F64U3-128	128	2.0000	2.031	.125
F64U3-144	144	2.2500	2.281	.125
F64U6-160	160	2.5000	2.531	.250
F64U6-192	192	3.0000	3.031	.250
F64U6-224	224	3.5000	3.531	.250
F64U6-256	256	4.0000	4.031	.250

PITCH	STYLE	BORE	FACE	MATERIAL	AGMA QUALITY	PRESSURE ANGLE
64	HUBLESS	3/8"	3/16"	DELTRIN	10	20°

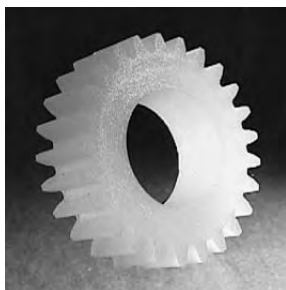
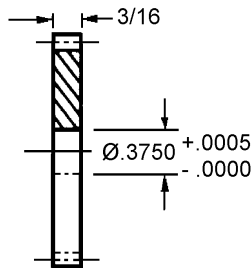
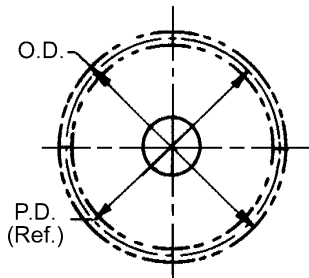

Available on request:
Other numbers of teeth
14 - 1/2° Pressure Angle

STOCK NO.	NO. OF TEETH	PITCH DIA.	OUTSIDE DIA.
F64D5-36	36	.5625	.593
F64D5-37	37	.5781	.609
F64D5-38	38	.5937	.625
F64D5-40	40	.6250	.656
F64D5-42	42	.6562	.687
F64D5-44	44	.6875	.718
F64D5-46	46	.7187	.750
F64D5-48	48	.7500	.781
F64D5-50	50	.7812	.812
F64D5-56	56	.8750	.906
F64D5-60	60	.9375	.968
F64D5-64	64	1.0000	1.031
F64D5-72	72	1.1250	1.156
F64D5-74	74	1.1562	1.187
F64D5-80	80	1.2500	1.281
F64D5-84	84	1.3125	1.343
F64D5-88	88	1.3750	1.406
F64D5-90	90	1.4062	1.437
F64D5-96	96	1.5000	1.531
F64D5-100	100	1.5625	1.593
F64D5-112	112	1.7500	1.781
F64D5-120	120	1.8750	1.906
F64D5-127	127	1.9843	2.015
F64D5-128	128	2.0000	2.031
F64D5-144	144	2.2500	2.281
F64D5-152	152	2.3750	2.406
F64D5-160	160	2.5000	2.531
F64D5-168	168	2.6250	2.656
F64D5-176	176	2.7500	2.781
F64D5-184	184	2.8750	2.906
F64D5-192	192	3.0000	3.031
F64D5-224	224	3.5000	3.531

For Couplings See Section G.
For Shafts, Bearings and Collars See Section I.

CLUSTER GEAR AND HUB

PITCH	STYLE	BORE	MATERIAL	AGMA QUALITY	PRESSURE ANGLE
64	X	1/4"	303 STAINLESS STEEL	10	20°

STOCK NO.	PITCH	NO. OF TEETH	PITCH DIA.	OUTSIDE DIA.
DP64S14-27	64	27	.4218	.453
DP64S14-28		28	.4375	.469
DP64S14-30		30	.4687	.500
DP64S14-32		32	.5000	.531
DP64S14-34		34	.5312	.563
DP64S14-36		36	.5625	.594
DP64S14-40		40	.6250	.656
DP64S14-50		50	.7812	.812

PITCH	STYLE	BORE	MATERIAL	AGMA QUALITY	PRESSURE ANGLE
64	Y	1/4"	303 STAINLESS STEEL	10	20°

STOCK NO.	PITCH	NO. OF TEETH	PITCH DIA.	OUTSIDE DIA.
DP64S16-27	64	27	.4218	.453
DP64S16-28		28	.4375	.469
DP64S16-30		30	.4687	.500
DP64S16-32		32	.5000	.531
DP64S16-34		34	.5312	.563
DP64S16-36		36	.5625	.594
DP64S16-40		40	.6250	.656
DP64S16-50		50	.7812	.812

PITCH	STYLE	BORE	MATERIAL	AGMA QUALITY	PRESSURE ANGLE
64	Z	1/4"	303 STAINLESS STEEL	10	20°

STOCK NO.	PITCH	NO. OF TEETH	PITCH DIA.	OUTSIDE DIA.
DP64S18-27	64	27	.4218	.453
DP64S18-28		28	.4375	.469
DP64S18-30		30	.4687	.500
DP64S18-32		32	.5000	.531
DP64S18-34		34	.5312	.563
DP64S18-36		36	.5625	.594
DP64S18-40		40	.6250	.656
DP64S18-50		50	.7812	.812

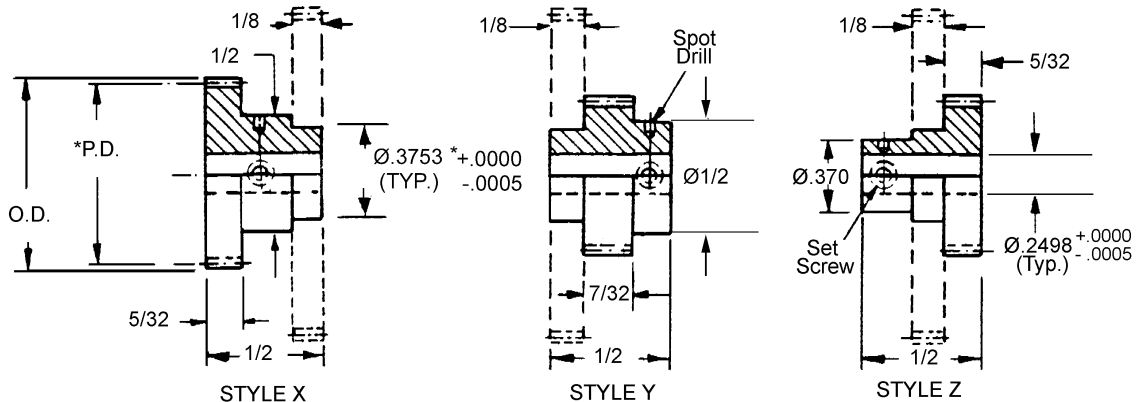

*Concentric within .0003
Order hubless gear separately.

CLUSTER GEAR AND HUB

B

PITCH	STYLE	BORE	MATERIAL	AGMA QUALITY	PRESSURE ANGLE
64	X	3/16"	303 STAINLESS STEEL	10	20°

STOCK NO.	PITCH	NO. OF TEETH	PITCH DIA.	OUTSIDE DIA.
DP64S8-25	64	25	.3906	.422
DP64S8-26		26	.4062	.438
DP64S8-28		28	.4375	.469
DP64S8-30		30	.4687	.500
DP64S8-31		31	.4843	.516
DP64S8-32		32	.4531	.531
DP64S8-40		40	.6250	.656

PITCH	STYLE	BORE	MATERIAL	AGMA QUALITY	PRESSURE ANGLE
64	Y	3/16"	303 STAINLESS STEEL	10	20°

STOCK NO.	PITCH	NO. OF TEETH	PITCH DIA.	OUTSIDE DIA.
*DP64S10-25	64	25	.3906	.422
*DP64S10-26		26	.4062	.438
DP64S10-28		28	.4375	.469
DP64S10-30		30	.4687	.500
DP64S10-31		31	.4843	.516
DP64S10-32		32	.4531	.531
DP64S10-40		40	.6250	.656

PITCH	STYLE	BORE	MATERIAL	AGMA QUALITY	PRESSURE ANGLE
64	Z	3/16"	303 STAINLESS STEEL	10	20°

STOCK NO.	PITCH	NO. OF TEETH	PITCH DIA.	OUTSIDE DIA.
*DP64S12-25	64	25	.3906	.422
*DP64S12-26		26	.4062	.438
DP64S12-28		28	.4375	.469
DP64S12-30		30	.4687	.500
DP64S12-31		31	.4843	.516
DP64S12-32		32	.4531	.531
DP64S12-40		40	.6250	.656

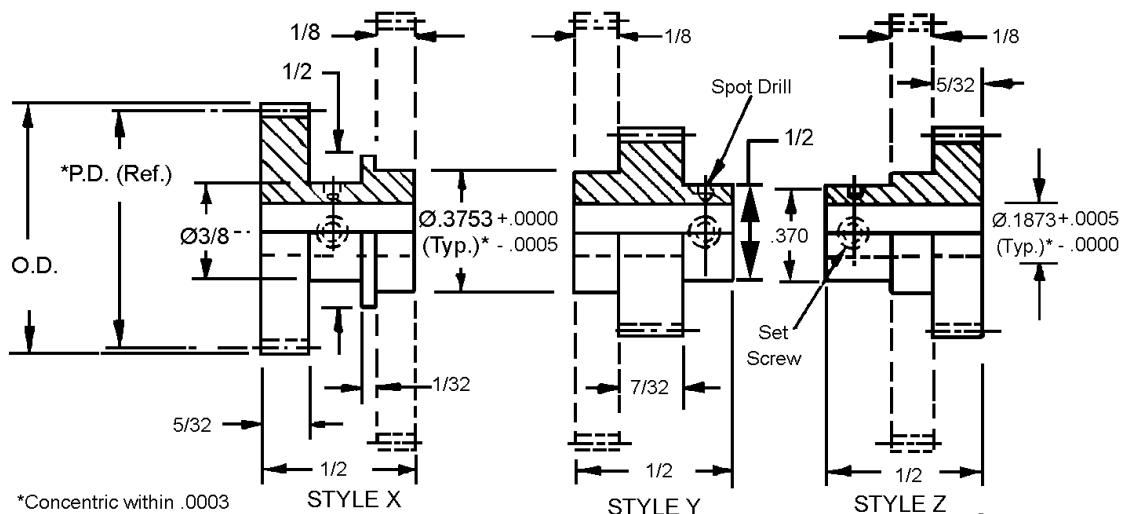

*Concentric within .0003

• Hub runout cuts thru shoulder.

Available on request: Other numbers of teeth; AGMA quality 12 and 14; 14-1/2° Pressure Angle.

SPUR GEARS

PITCH	STYLE	BORE	FACE	MATERIAL	AGMA QUALITY	PRESSURE ANGLE
64	PIN HUB	1/8"	1/8"	303 STAINLESS STEEL AND ALUMINUM ANODIZED	10	20°

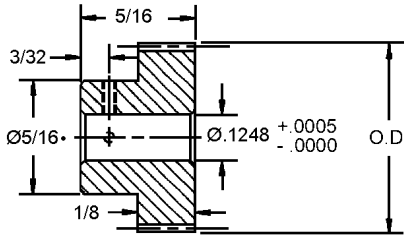
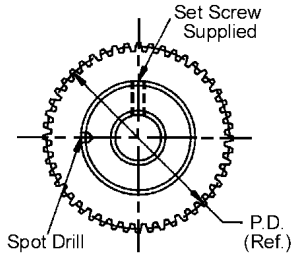

• For 18-23 teeth hub diameter equals .23
Available on request, other numbers of teeth
and 14-1/2° Pressure Angle.

303 STAINLESS STEEL STOCK NO.	2024-T4 ALUMINUM ANODIZED STOCK NO.	NO. OF TEETH	PITCH DIA.	OUTSIDE DIA.
P64S10-18	P64A10-18	18•	.2812	.312
P64S10-19	P64A10-19	19•	.2968	.328
P64S10-20	P64A10-20	20•	.3125	.343
P64S10-21	P64A10-21	21•	.3281	.359
P64S10-22	P64A10-22	22•	.3437	.375
P64S10-23	P64A10-23	23•	.3593	.390
P64S10-24	P64A10-24	24	.3750	.406
P64S10-25	P64A10-25	25	.3906	.421
P64S10-26	P64A10-26	26	.4062	.437
P64S10-27	P64A10-27	27	.4218	.453
P64S10-28	P64A10-28	28	.4375	.468
P64S10-29	P64A10-29	29	.4531	.484
P64S10-30	P64A10-30	30	.4687	.500
P64S10-32	P64A10-32	32	.5000	.531
P64S10-34	P64A10-34	34	.5312	.562
P64S10-36	P64A10-36	36	.5625	.593
P64S10-38	P64A10-38	38	.5937	.625
P64S10-40	P64A10-40	40	.6250	.656
P64S10-42	P64A10-42	42	.6562	.687
P64S10-44	P64A10-44	44	.6875	.718
P64S10-46	P64A10-46	46	.7187	.750
P64S10-48	P64A10-48	48	.7500	.781
P64S10-50	P64A10-50	50	.7812	.812
P64S10-55	P64A10-55	55	.8593	.890
P64S10-56	P64A10-56	56	.8750	.906
P64S10-60	P64A10-60	60	.9375	.968
P64S10-64	P64A10-64	64	1.0000	1.031
P64S10-65	P64A10-65	65	1.0156	1.046
P64S10-70	P64A10-70	70	1.0937	1.125
P64S10-72	P64A10-72	72	1.1250	1.156
P64S10-75	P64A10-75	75	1.1718	1.203
P64S10-80	P64A10-80	80	1.2500	1.281
P64S10-84	P64A10-84	84	1.3125	1.343
P64S10-85	P64A10-85	85	1.3281	1.359
P64S10-88	P64A10-88	88	1.3750	1.406
P64S10-90	P64A10-90	90	1.4062	1.437
P64S10-92	P64A10-92	92	1.4375	1.468
P64S10-95	P64A10-95	95	1.4843	1.515
P64S10-96	P64A10-96	96	1.5000	1.531
P64S10-104	P64A10-104	104	1.6250	1.656
P64S10-105	P64A10-105	105	1.6406	1.671
P64S10-112	P64A10-112	112	1.7500	1.781
P64S10-120	P64A10-120	120	1.8750	1.906
P64S10-121	P64A10-121	121	1.8906	1.921
P64S10-127	P64A10-127	127	1.9843	2.015
P64S10-128	P64A10-128	128	2.0000	2.031
P64S10-136	P64A10-136	136	2.1250	2.156

For Couplings See Section G.
For Shafts, Bearings and Collars See Section I.

SPUR GEARS

PITCH	STYLE	BORE	FACE	MATERIAL	AGMA QUALITY	PRESSURE ANGLE
64	PIN HUB	3/16"	1/8"	303 STAINLESS STEEL AND ALUMINUM ANODIZED	10	20°

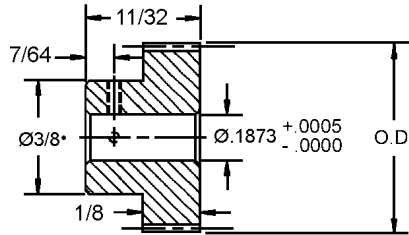
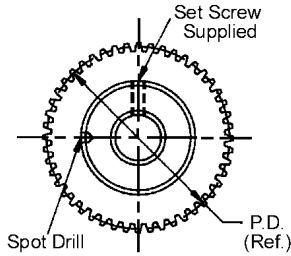

• For 25-26 teeth hub diameter equals .34

Available on request, other numbers of teeth, AGMA quality 12 and 14, and 14-1/2° Pressure Angle.

303 STAINLESS STEEL STOCK NO.	2024-T4 ALUMINUM ANODIZED STOCK NO.	NO. OF TEETH	PITCH DIA.	OUTSIDE DIA.
P64S19-25	P64A19-25	25	.3906	.421
P64S19-26	P64A19-26	26	.4062	.437
P64S19-28	P64A19-28	28	.4375	.468
P64S19-29	P64A19-29	29	.4531	.484
P64S19-30	P64A19-30	30	.4687	.500
P64S19-31	P64A19-31	31	.4843	.515
P64S19-32	P64A19-32	32	.5000	.531
P64S19-34	P64A19-34	34	.5312	.562
P64S19-35	P64A19-35	35	.5468	.578
P64S19-36	P64A19-36	36	.5625	.593
P64S19-38	P64A19-38	38	.5937	.625
P64S19-40	P64A19-40	40	.6250	.656
P64S19-42	P64A19-42	42	.6562	.687
P64S19-44	P64A19-44	44	.6875	.718
P64S19-45	P64A19-45	45	.7031	.734
P64S19-46	P64A19-46	46	.7187	.750
P64S19-48	P64A19-48	48	.7500	.781
P64S19-50	P64A19-50	50	.7812	.812
P64S19-55	P64A19-55	55	.8593	.890
P64S19-56	P64A19-56	56	.8750	.906
P64S19-60	P64A19-60	60	.9375	.968
P64S19-64	P64A19-64	64	1.0000	1.031
P64S19-65	P64A19-65	65	1.0156	1.046
P64S19-70	P64A19-70	70	1.0937	1.125
P64S19-72	P64A19-72	72	1.1250	1.156
P64S19-75	P64A19-75	75	1.1718	1.203
P64S19-80	P64A19-80	80	1.2500	1.281
P64S19-84	P64A19-84	84	1.3125	1.343
P64S19-85	P64A19-85	85	1.3281	1.359
P64S19-88	P64A19-88	88	1.3750	1.406

**For Couplings See Section G.
For Shafts, Bearings and Collars See Section I.**

SPUR GEARS

PITCH	STYLE	BORE	FACE	MATERIAL	AGMA QUALITY	PRESSURE ANGLE
64	PIN HUB	3/16"	1/8"	303 STAINLESS STEEL AND ALUMINUM ANODIZED	10	20°

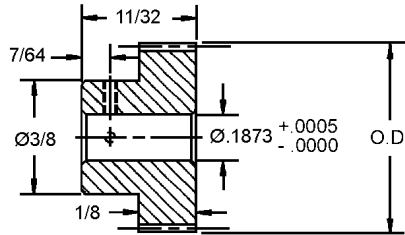
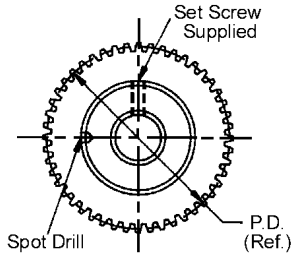

• For 25-26 teeth hub diameter equals .34

Available on request, other numbers of teeth, AGMA quality 12 and 14, and 14-1/2° Pressure Angle.

X in part number indicates part may be supplied as two piece construction (some dimensions may vary).

303 STAINLESS STEEL STOCK NO.	2024-T4 ALUMINUM ANODIZED STOCK NO.	NO. OF TEETH	PITCH DIA.	OUTSIDE DIA.
P64S19-90	P64A19-90	90	1.0462	1.437
P64S19-92	P64A19-92	92	1.4375	1.468
P64S19-95	P64A19-95	95	1.4843	1.515
P64S19-96	P64A19-96	96	1.5000	1.531
P64S19-100	P64A19-100	100	1.5625	1.593
P64S19-105	P64A19-105	105	1.6406	1.671
P64S19-110	P64A19-110	110	1.7187	1.750
P64S19-115	P64A19-115	115	1.7968	1.828
P64S19-120	P64A19-120	120	1.8750	1.906
P64S19-122	P64A19-122	122	1.9062	1.937
P64S19-124	P64A19-124	124	1.9375	1.968
P64S19-127	P64A19-127	127	1.9843	2.015
P64S19-128	P64A19-128	128	2.0000	2.031
P64S19-130	P64A19-130	130	2.0312	2.062
P64S19-136	P64A19-136	136	2.1250	2.156
P64S19-140	P64A19-140	140	2.1875	2.218
P64S19-144	P64A19-144	144	2.2500	2.281
P64S19-150	P64A19-150	150	2.3437	2.375
P64S19-152	P64A19-152	152	2.3750	2.406
P64S19-156	P64A19-156	156	2.4375	2.468
P64S19-160	P64A19-160	160	2.5000	2.531
P64S19-164	P64A19-164	164	2.5625	2.593
P64S19-168	P64A19-168	168	2.6250	2.656
P64S19-170	P64A19-170	170	2.6562	2.687
P64S19-176	P64A19-176	176	2.7500	2.781
P64S19-180	P64A19-180	180	2.8125	2.843
P64S19-184	P64A19-184	184	2.8750	2.906
P64S19-190	P64A19-190	190	2.9687	3.000
P64S19-192	P64A19-192	192	3.0000	3.031
P64S19-200	P64A19-200	200	3.1250	3.156
P64S19X-224	P64A19X-224	224	3.5000	3.531
P64S19X-256	P64A19X-256	256	4.0000	4.031

For Couplings See Section G.
For Shafts, Bearings and Collars See Section I.

SPUR GEARS

PITCH	STYLE	BORE	FACE	MATERIAL	AGMA QUALITY	PRESSURE ANGLE
64	PIN HUB	3/16"	3/16"	303 STAINLESS STEEL AND ALUMINUM ANODIZED	10	20°

B

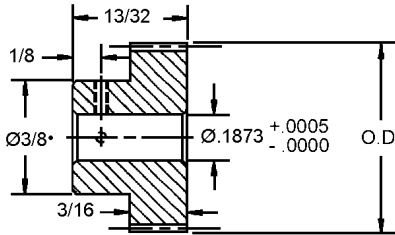
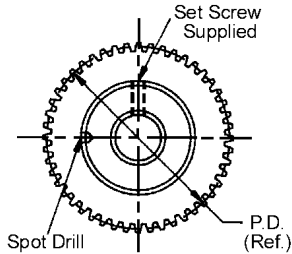

• For 25-26 teeth hub diameter equals .34

Available on request, other numbers of teeth, AGMA quality 12 and 14, and 14-1/2° Pressure Angle.

303 STAINLESS STEEL STOCK NO.	2024-T4 ALUMINUM ANODIZED STOCK NO.	NO. OF TEETH	PITCH DIA.	OUTSIDE DIA.
P64S21-25	P64A21-25	25•	.3906	.421
P64S21-26	P64A21-26	26•	.4062	.437
P64S21-28	P64A21-28	28	.4375	.468
P64S21-30	P64A21-30	30	.4687	.500
P64S21-32	P64A21-32	32	.5000	.531
P64S21-36	P64A21-36	36	.5625	.593
P64S21-40	P64A21-40	40	.6250	.656
P64S21-44	P64A21-44	44	.6875	.718
P64S21-46	P64A21-46	46	.7187	.750
P64S21-48	P64A21-48	48	.7500	.781
P64S21-50	P64A21-50	50	.7812	.812
P64S21-56	P64A21-56	56	.8750	.906
P64S21-60	P64A21-60	60	.9375	.968
P64S21-64	P64A21-64	64	1.0000	1.031
P64S21-70	P64A21-70	70	1.0937	1.125
P64S21-75	P64A21-75	75	1.1718	1.203
P64S21-80	P64A21-80	80	1.2500	1.281
P64S21-88	P64A21-88	88	1.3750	1.406
P64S21-90	P64A21-90	90	1.4062	1.437
P64S21-96	P64A21-96	96	1.5000	1.531
P64S21-100	P64A21-100	100	1.5625	1.593
P64S21-110	P64A21-110	110	1.7187	1.750
P64S21-112	P64A21-112	112	1.7500	1.781
P64S21-120	P64A21-120	120	1.8750	1.906
P64S21-128	P64A21-128	128	2.0000	2.031
P64S21-136	P64A21-136	136	2.1250	2.156
P64S21-144	P64A21-144	144	2.2500	2.281
P64S21-152	P64A21-152	152	2.3750	2.406
P64S21-160	P64A21-160	160	2.5000	2.531
P64S21-176	P64A21-176	176	2.7500	2.781
P64S21-192	P64A21-192	192	3.0000	3.031
P64S21-200	P64A21-200	200	3.1250	3.156
P64S21-208	P64A21-208	208	3.2500	3.281
P64S21-224	P64A21-224	224	3.5000	3.531
P64S21-240	P64A21-240	240	3.7500	3.781
P64S21-256	P64A21-256	256	4.0000	4.031

**For Couplings See Section G.
For Shafts, Bearings and Collars See Section I.**

SPUR GEARS

PITCH	STYLE	BORE	FACE	MATERIAL	AGMA QUALITY	PRESSURE ANGLE
64	PIN HUB	1/4"	3/16"	303 STAINLESS STEEL AND ALUMINUM ANODIZED	10	20°

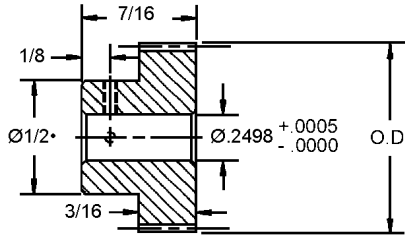
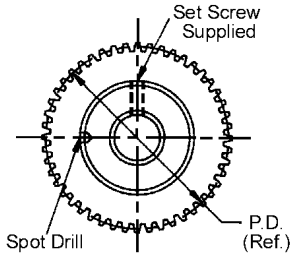

• For 31-34 teeth hub diameter equals .44

Available on request, other numbers of teeth, AGMA quality 12 and 14, and 14-1/2° Pressure Angle.

303 STAINLESS STEEL STOCK NO.	2024-T4 ALUMINUM ANODIZED STOCK NO.	NO. OF TEETH	PITCH DIA.	OUTSIDE DIA.
P64S28-32	P64A28-32	32•	.5000	.531
P64S28-34	P64A28-34	34•	.5312	.562
P64S28-36	P64A28-36	36	.5625	.593
P64S28-38	P64A28-38	38	.5937	.625
P64S28-40	P64A28-40	40	.6250	.656
P64S28-42	P64A28-42	42	.6562	.687
P64S28-48	P64A28-48	48	.7500	.781
P64S28-50	P64A28-50	50	.7812	.812
P64S28-56	P64A28-56	56	.8750	.906
P64S28-60	P64A28-60	60	.9375	.968
P64S28-64	P64A28-64	64	1.0000	1.031
P64S28-70	P64A28-70	70	1.0937	1.125
P64S28-72	P64A28-72	72	1.1250	1.156
P64S28-75	P64A28-75	75	1.1718	1.203
P64S28-80	P64A28-80	80	1.2500	1.281
P64S28-84	P64A28-84	84	1.3125	1.343
P64S28-88	P64A28-88	88	1.3750	1.406
P64S28-90	P64A28-90	90	1.4062	1.437
P64S28-96	P64A28-96	96	1.5000	1.531
P64S28-104	P64A28-104	104	1.6250	1.656
P64S28-112	P64A28-112	112	1.7500	1.781
P64S28-120	P64A28-120	120	1.8750	1.906
P64S28-128	P64A28-128	128	2.0000	2.031
P64S28-130	P64A28-130	130	2.0312	2.062
P64S28-144	P64A28-144	144	2.2500	2.281
P64S28-160	P64A28-160	160	2.5000	2.531
P64S28-176	P64A28-176	176	2.7500	2.781
P64S28-192	P64A28-192	192	3.0000	3.031
P64S28-208	P64A28-208	208	3.2500	3.281
P64S28-224	P64A28-224	224	3.5000	3.531
P64S28-240	P64A28-240	240	3.7500	3.781
P64S28-256	P64A28-256	256	4.0000	4.031
P64S28-264	P64A28-264	264	4.1250	4.156

**For Couplings See Section G.
For Shafts, Bearings and Collars See Section I.**

SPUR GEARS

PITCH	STYLE	BORE	FACE	MATERIAL	AGMA QUALITY	PRESSURE ANGLE
64	PIN HUB	1/4"	1/8"	303 STAINLESS STEEL AND ALUMINUM ANODIZED	10	20°

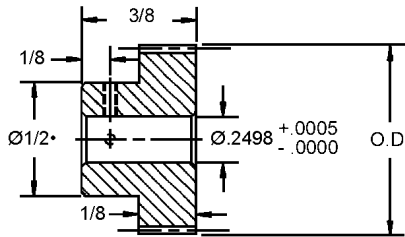
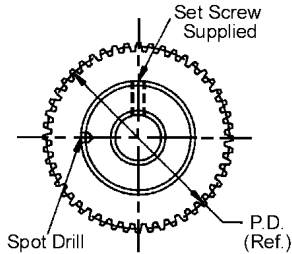

• For 31-34 teeth hub diameter equals .44

Available on request, other numbers of teeth, AGMA quality 12 and 14, and 14-1/2° Pressure Angle.

303 STAINLESS STEEL STOCK NO.	2024-T4 ALUMINUM ANODIZED STOCK NO.	NO. OF TEETH	PITCH DIA.	OUTSIDE DIA.
P64S26-32	P64A26-32	32•	.5000	.531
P64S26-34	P64A26-34	34•	.5312	.562
P64S26-35	P64A26-35	35	.5468	.578
P64S26-36	P64A26-36	36	.5625	.593
P64S26-40	P64A26-40	40	.6250	.656
P64S26-42	P64A26-42	42	.6562	.687
P64S26-44	P64A26-44	44	.6875	.718
P64S26-45	P64A26-45	45	.7031	.734
P64S26-46	P64A26-46	46	.7187	.750
P64S26-48	P64A26-48	48	.7500	.781
P64S26-50	P64A26-50	50	.7812	.812
P64S26-54	P64A26-54	54	.8437	.875
P64S26-55	P64A26-55	55	.8593	.890
P64S26-56	P64A26-56	56	.8750	.906
P64S26-60	P64A26-60	60	.9375	.968
P64S26-64	P64A26-64	64	1.0000	1.031
P64S26-70	P64A26-70	70	1.0937	1.125
P64S26-72	P64A26-72	72	1.1250	1.156
P64S26-75	P64A26-75	75	1.1718	1.203
P64S26-80	P64A26-80	80	1.2500	1.281
P64S26-84	P64A26-84	84	1.3125	1.343
P64S26-85	P64A26-85	85	1.3281	1.359
P64S26-86	P64A26-86	86	1.3437	1.375
P64S26-90	P64A26-90	90	1.4062	1.437
P64S26-95	P64A26-95	95	1.4843	1.515

**For Couplings See Section G.
For Shafts, Bearings and Collars See Section I.**

SPUR GEARS

PITCH	STYLE	BORE	FACE	MATERIAL	AGMA QUALITY	PRESSURE ANGLE
64	PIN HUB	1/4"	1/8"	303 STAINLESS STEEL AND ALUMINUM ANODIZED	10	20°

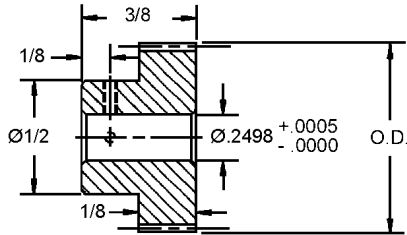
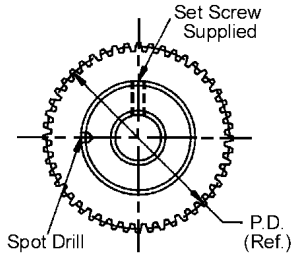

Available on request, other numbers of teeth, AGMA quality 12 and 14, and 14-1/2° Pressure Angle.

303 STAINLESS STEEL STOCK NO.	2024-T4 ALUMINUM ANODIZED STOCK NO.	NO. OF TEETH	PITCH DIA.	OUTSIDE DIA.
P64S26-100	P64A26-100	100	1.5625	1.593
P64S26-105	P64A26-105	105	1.6406	1.671
P64S26-110	P64A26-110	110	1.7187	1.750
P64S26-112	P64A26-112	112	1.7500	1.781
P64S26-120	P64A26-120	120	1.8750	1.906
P64S26-124	P64A26-124	124	1.9375	1.968
P64S26-128	P64A26-128	128	2.0000	2.031
P64S26-130	P64A26-130	130	2.0312	2.062
P64S26-140	P64A26-140	140	2.1875	2.218
P64S26-144	P64A26-144	144	2.2500	2.281
P64S26-150	P64A26-150	150	2.3437	2.375
P64S26-160	P64A26-160	160	2.5000	2.531
P64S26-168	P64A26-168	168	2.6250	2.656
P64S26-170	P64A26-170	170	2.6562	2.687
P64S26-176	P64A26-176	176	2.7500	2.781
P64S26-180	P64A26-180	180	2.8125	2.843
P64S26-184	P64A26-184	184	2.8750	2.906
P64S26-190	P64A26-190	190	2.9687	3.000
P64S26-192	P64A26-192	192	3.0000	3.031
P64S26-200	P64A26-200	200	3.1250	3.156
P64S26-208	P64A26-208	208	3.2500	3.281
P64S26-216	P64A26-216	216	3.3750	3.406
P64S26-224	P64A26-224	224	3.5000	3.531
P64S26-232	P64A26-232	232	3.6250	3.656
P64S26-240	P64A26-240	240	3.7500	3.781
P64S26-248	P64A26-248	248	3.8750	3.906
P64S26-256	P64A26-256	256	4.0000	4.031
P64S26-264	P64A26-264	264	4.1250	4.156

**For Couplings See Section G.
For Shafts, Bearings and Collars See Section I.**

SPUR GEARS

B

PITCH	STYLE	BORE	FACE	MATERIAL	AGMA QUALITY	PRESSURE ANGLE
64	PIN HUB	1/4"	3/16"	17-4 STAINLESS STEEL RC 28 - 35	10	20°

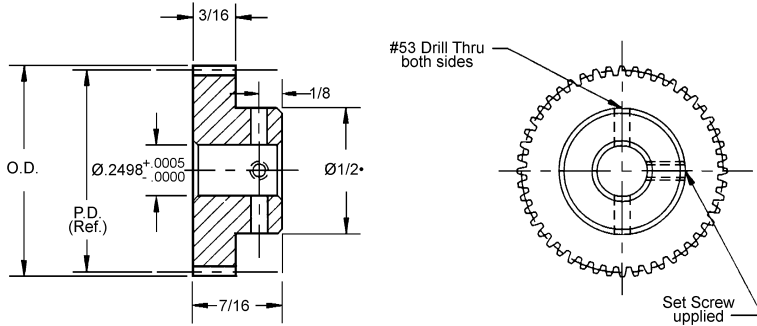

• For 32-34 teeth hub diameter equals .45.
Available on request, other numbers of teeth, quality 12 and 14-1/2° Pressure Angle.

STOCK NO.	NO. OF TEETH	PITCH DIA.	OUTSIDE DIA.
P64PH28-32	32*	.5000	.531
P64PH28-34	34*	.5312	.563
P64PH28-36	36	.5625	.594
P64PH28-38	38	.5937	.625
P64PH28-40	40	.6250	.656
P64PH28-42	42	.6562	.687
P64PH28-44	44	.6875	.719
P64PH28-48	48	.7500	.781
P64PH28-50	50	.7812	.813
P64PH28-56	56	.8750	.906
P64PH28-64	60	1.0000	1.031
P64PH28-72	72	1.1250	1.156

PITCH	STYLE	BORE	FACE	MATERIAL	AGMA QUALITY	PRESSURE ANGLE
64	PIN HUB	1/8"	1/8"	COLD ROLLED STEEL C12L14 OR C12L15 WITH SELENIUM OR BRASS ALLOY 360	4	20°

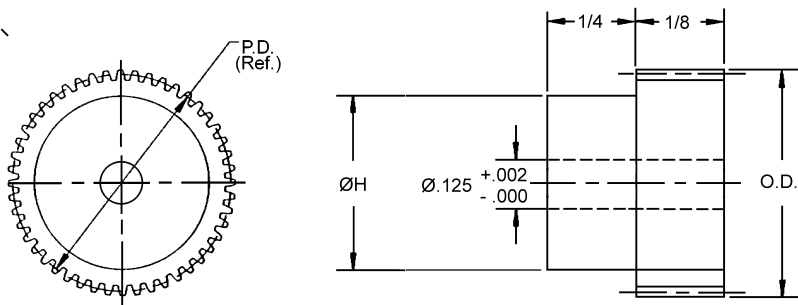

COLD ROLLED STEEL C12L14 OR C12L15 WITH SELENIUM	BRASS ALLOY 360	STOCK NO.	NO. OF TEETH	PITCH DIA.	OUTSIDE DIA.	H
		PX64S-15	15	.234	.265	.187
		PX64S-16	16	.250	.281	.203
		PX64S-18	18	.281	.312	.234
		-	24	.375	.406	.328
		-	40	.625	.656	.578
		-	48	.750	.781	.703

**For Couplings See Section G.
For Shafts, Bearings and Collars See Section I.**

SPUR GEARS

PITCH	STYLE	BORE	FACE	MATERIAL	AGMA QUALITY	PRESSURE ANGLE
64	PIN HUB	3/16"	3/16"	DELRIN WITH STAINLESS STEEL HUB	10	20°

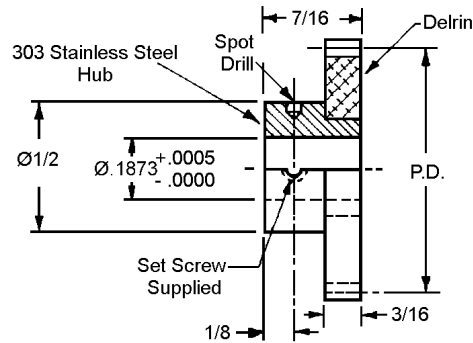

Available on request, other numbers of teeth,
14-1/2° Pressure Angle.

STOCK NO.	NO. OF TEETH	PITCH DIA.	OUTSIDE DIA.
P64D21X-36	36	.5625	.593
P64D21X-37	37	.5781	.609
P64D21X-38	38	.5937	.625
P64D21X-40	40	.6250	.656
P64D21X-42	42	.6562	.687
P64D21X-44	44	.6875	.718
P64D21X-46	46	.7187	.750
P64D21X-48	48	.7500	.781
P64D21X-50	50	.7812	.812
P64D21X-56	56	.8750	.906
P64D21X-60	60	.9375	.968
P64D21X-64	64	1.0000	1.031
P64D21X-72	72	1.1250	1.156
P64D21X-74	74	1.1562	1.187
P64D21X-80	80	1.2500	1.281
P64D21X-84	84	1.3125	1.343
P64D21X-88	88	1.3750	1.406
P64D21X-90	90	1.4062	1.437
P64D21X-96	96	1.5000	1.531
P64D21X-100	100	1.5625	1.593
P64D21X-112	112	1.7500	1.781
P64D21X-120	120	1.8750	1.906
P64D21X-127	127	1.9843	2.015
P64D21X-128	128	2.0000	2.031
P64D21X-144	144	2.2500	2.281
P64D21X-152	152	2.3750	2.406
P64D21X-160	160	2.5000	2.531
P64D21X-168	168	2.6250	2.656
P64D21X-176	176	2.7500	2.781
P64D21X-184	184	2.8750	2.906
P64D21X-192	192	3.0000	3.031
P64D21X-224	224	3.5000	3.531

For Couplings See Section G.
For Shafts, Bearings and Collars See Section I.

SPUR GEARS

PITCH	STYLE	BORE	FACE	MATERIAL	AGMA QUALITY	PRESSURE ANGLE
64	PIN HUB	1/4"	3/16"	DELRIN WITH STAINLESS STEEL HUB	10	20°

B

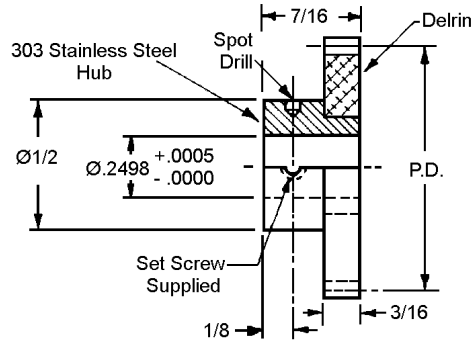

Available on request, other numbers of teeth,
14-1/2° Pressure Angle.

STOCK NO.	NO. OF TEETH	PITCH DIA.	OUTSIDE DIA.
P64D28X-36	36	.5625	.593
P64D28X-37	37	.5781	.609
P64D28X-38	38	.5937	.625
P64D28X-40	40	.6250	.656
P64D28X-42	42	.6562	.687
P64D28X-44	44	.6875	.718
P64D28X-46	46	.7187	.750
P64D28X-48	48	.7500	.781
P64D28X-50	50	.7812	.812
P64D28X-56	56	.8750	.906
P64D28X-60	60	.9375	.968
P64D28X-64	64	1.0000	1.031
P64D28X-72	72	1.1250	1.156
P64D28X-74	74	1.1562	1.187
P64D28X-80	80	1.2500	1.281
P64D28X-84	84	1.3125	1.343
P64D28X-88	88	1.3750	1.406
P64D28X-90	90	1.4062	1.437
P64D28X-96	96	1.5000	1.531
P64D28X-100	100	1.5625	1.593
P64D28X-112	112	1.7500	1.781
P64D28X-120	120	1.8750	1.906
P64D28X-127	127	1.9843	2.015
P64D28X-128	128	2.0000	2.031
P64D28X-144	144	2.2500	2.281
P64D28X-152	152	2.3750	2.406
P64D28X-160	160	2.5000	2.531
P64D28X-168	168	2.6250	2.656
P64D28X-176	176	2.7500	2.781
P64D28X-184	184	2.8750	2.906
P64D28X-192	192	3.0000	3.031
P64D28X-224	224	3.5000	3.531

For Couplings See Section G.
For Shafts, Bearings and Collars See Section I.

SPUR GEARS

PITCH	STYLE	BORE	FACE	MATERIAL	AGMA QUALITY	PRESSURE ANGLE
64	CLAMP STYLE	1/8"	1/8"	303 STAINLESS STEEL AND ALUMINUM ANODIZED	10	20°

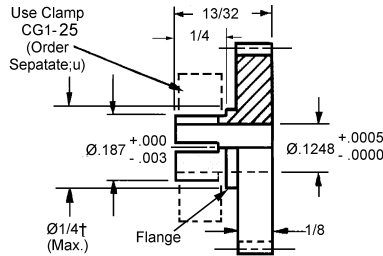
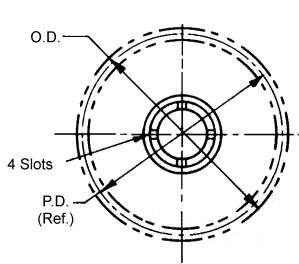

† Teeth may runout on flange diameter.

Available on request, other numbers of teeth, Agma Quality 12 and 14-1/2° Pressure Angle.

303 STAINLESS STEEL STOCK NO.	2024-T4 ALUMINUM ANODIZED STOCK NO.	NO. OF TEETH	PITCH DIA.	OUTSIDE DIA.
C64S7-18	C64A7-18	18†	.2812	.312
C64S7-19	C64A7-19	19	.2968	.328
C64S7-20	C64A7-20	20	.3125	.343
C64S7-21	C64A7-21	21	.3281	.359
C64S7-22	C64A7-22	22	.3437	.375
C64S7-23	C64A7-23	23	.3593	.390
C64S7-24	C64A7-24	24	.3750	.406
C64S7-25	C64A7-25	25	.3906	.421
C64S7-26	C64A7-26	26	.4062	.437
C64S7-27	C64A7-27	27	.4218	.453
C64S7-28	C64A7-28	28	.4375	.468
C64S7-29	C64A7-29	29	.4531	.484
C64S7-30	C64A7-30	30	.4687	.500
C64S7-32	C64A7-32	32	.5000	.531
C64S7-34	C64A7-34	34	.5312	.562
C64S7-36	C64A7-36	36	.5625	.593
C64S7-38	C64A7-38	38	.5937	.625
C64S7-40	C64A7-40	40	.6250	.656
C64S7-42	C64A7-42	42	.6562	.687
C64S7-44	C64A7-44	44	.6875	.718
C64S7-46	C64A7-46	46	.7187	.750
C64S7-48	C64A7-48	48	.7500	.781
C64S7-50	C64A7-50	50	.7812	.812
C64S7-55	C64A7-55	55	.8593	.890
C64S7-56	C64A7-56	56	.8750	.906
C64S7-60	C64A7-60	60	.9375	.968
C64S7-64	C64A7-64	64	1.0000	1.031
C64S7-72	C64A7-72	72	1.1250	1.156
C64S7-80	C64A7-80	80	1.2500	1.281
C64S7-88	C64A7-88	88	1.3750	1.406
C64S7-96	C64A7-96	96	1.5000	1.531
C64S7-104	C64A7-104	104	1.6250	1.656
C64S7-112	C64A7-112	112	1.7500	1.781
C64S7-120	C64A7-120	120	1.8750	1.906

For Couplings See Section G.
For Shafts, Bearings and Collars See Section I.

SPUR GEARS

PITCH	STYLE	BORE	FACE	MATERIAL	AGMA QUALITY	PRESSURE ANGLE
64	CLAMP STYLE	3/16"	1/8"	303 STAINLESS STEEL AND ALUMINUM ANODIZED	10	20°

B

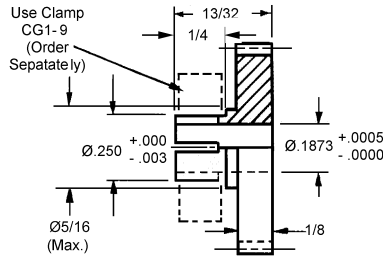
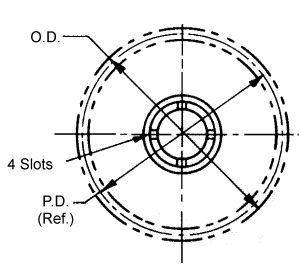

Available on request, other numbers of teeth, Agma Quality 12 and 14-1/2° Pressure Angle.

X in part number indicates part may be supplied in two piece construction with stainless steel hub (some dimensions may vary).

303 STAINLESS STEEL STOCK NO.	2024-T4 ALUMINUM ANODIZED STOCK NO.	NO. OF TEETH	PITCH DIA.	OUTSIDE DIA.
C64S14-24	C64A14-24	24	.3750	.406
C64S14-25	C64A14-25	25	.3906	.421
C64S14-28	C64A14-28	28	.4375	.468
C64S14-30	C64A14-30	30	.4687	.500
C64S14-32	C64A14-32	32	.5000	.531
C64S14-40	C64A14-40	40	.6250	.656
C64S14-42	C64A14-42	42	.6562	.687
C64S14-44	C64A14-44	44	.6875	.718
C64S14-46	C64A14-46	46	.7187	.750
C64S14-48	C64A14-48	48	.7500	.781
C64S14-50	C64A14-50	50	.7812	.812
C64S14-52	C64A14-52	52	.8125	.843
C64S14-56	C64A14-56	56	.8750	.906
C64S14-60	C64A14-60	60	.9375	.968
C64S14-64	C64A14-64	64	1.0000	1.031
C64S14-72	C64A14-72	72	1.1250	1.156
C64S14-76	C64A14-76	76	1.1875	1.218
C64S14-80	C64A14-80	80	1.2500	1.281
C64S14-84	C64A14-84	84	1.3125	1.343
C64S14-85	C64A14-85	85	1.3281	1.359
C64S14-88	C64A14-88	88	1.3750	1.406
C94S14-90	C64A14-90	90	1.4062	1.437
C64S14-96	C64A14-96	96	1.5000	1.531
C64S14-100	C64A14-100	100	1.5625	1.593
C64S14-104	C64A14-104	104	1.6250	1.656
C64S14-112	C64A14-112	112	1.7500	1.781
C64S14-120	C64A14-120	120	1.8750	1.906
C64S14-128	C64A14-128	128	2.0000	2.031
C64S14-130	C64A14-130	130	2.0312	2.062
C64S14-144	C64A14-144	144	2.2500	2.281
C64S14-152	C64A14-152	152	2.3750	2.406
C64S15X-160	C64A15X-160	160	2.5000	2.531
C64S15X-176	C64A15X-176	176	2.7500	2.781
C64S15X-180	C64A15X-180	180	2.8125	2.843
C64S15X-192	C64A15X-192	192	3.0000	3.031
C64S15X-224	C64A15X-224	224	3.5000	3.531
C64S15X-256	C64A1 5X-256	256	4.0000	4.031

For Couplings See Section G.
For Shafts, Bearings and Collars See Section I.

SPUR GEARS

PITCH	STYLE	BORE	FACE	MATERIAL	AGMA QUALITY	PRESSURE ANGLE
64	CLAMP STYLE	1/4"	1/8"	303 STAINLESS STEEL AND ALUMINUM ANODIZED	10	20°

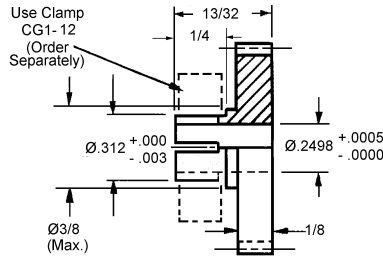
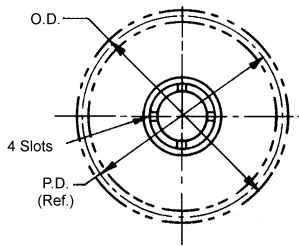

Available on request, other numbers of teeth, Agma Quality 12 and 14-1/2° Pressure Angle.

303 STAINLESS STEEL STOCK NO.	2024-T4 ALUMINUM ANODIZED STOCK NO.	NO. OF TEETH	PITCH DIA.	OUTSIDE DIA.
C64S18-30	C64A18-30	30	.4687	.500
C64S18-32	C64A18-32	32	.5000	.531
C64S18-35	C64A18-35	35	.5468	.578
C64S18-36	C64A 8-36	36	.5625	.593
C64S18-40	C64A18-40	40	.6250	.656
C64S18-45	C64A18-45	45	.7031	.734
C64S18-48	C64A18-48	48	.7500	.781
C64S18-50	C64A18-50	50	.7812	.812
C64S18-60	C64A18-60	60	.9375	.968
C64S18-64	C64A18-64	64	1.0000	1.031
C64S18-70	C64A18-70	70	1.0937	1.125
C64S18-72	C64A18-72	72	1.1250	1.156
C64S18-75	C64A18-75	75	1.1718	1.203
C64S18-80	C64A18-80	80	1.2500	1.281
C64S18-84	C64A18-84	84	1.3125	1.343
C64S18-88	C64A18-88	88	1.3750	1.406
C64S18-90	C64A18-90	90	1.4062	1.437
C64S18-96	C64A18-96	96	1.5000	1.531
C64S18-112	C64A18-112	112	1.7500	1.781
C64S18-120	C64A18-120	120	1.8750	1.906
C64S18-125	C64A18-125	125	1.9531	1.984
C64S18-128	C64A18-128	128	2.0000	2.031
C64S18-130	C64A18-130	130	2.0312	2.062
C64S18-140	C64A18-140	140	2.1875	2.218
C64S18-144	C64A18-144	144	2.2500	2.281
C64S18-160	C64A18-160	160	2.5000	2.531
C64S18-176	C64A18-176	176	2.7500	2.781
C64S18-180	C64A18-180	180	2.8125	2.843
C64S18-192	C64A18-192	192	3.0000	3.031
C64S18-224	C64A18-224	224	3.5000	3.531
C64S18-256	C64A18-256	256	4.0000	4.031

For Couplings See Section G.
For Shafts, Bearings and Collars See Section I.

GEAR RACKS

PITCH	STYLE	MATERIAL	AGMA QUALITY	PRESSURE ANGLE
64	ROUND & RECTANGULAR	416 SERIES STAINLESS STEEL STRESSED RELIEVED	10	20°

B

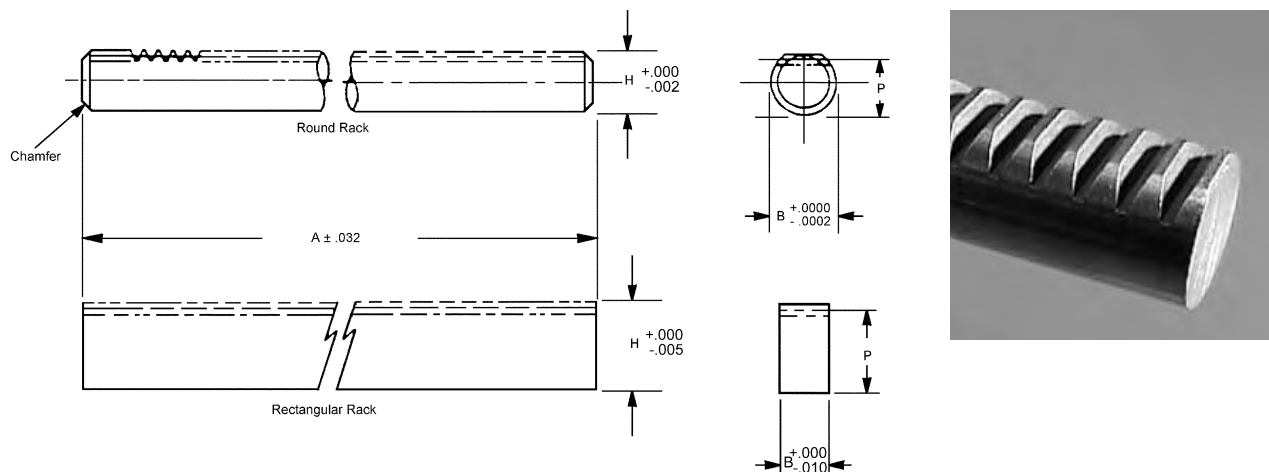

STOCK NO.	RACK STYLE	PITCH	P (Ref.)	B	A	H	AGMA QUALITY
R2-18	ROUND	64	.2044	.2497	11	.220	10
R2-14	RECTANGULAR	64	.4644	230±.005	11	.480	10

Available on request: 14 - 1/2° pressure angle, special, modified and custom racks.

PITCH	STYLE	MATERIAL	AGMA QUALITY	PRESSURE ANGLE
64	RECTANGULAR	416 SERIES STAINLESS STEEL AND 2024-T4 ALUMINUM ANODIZED	10	20°

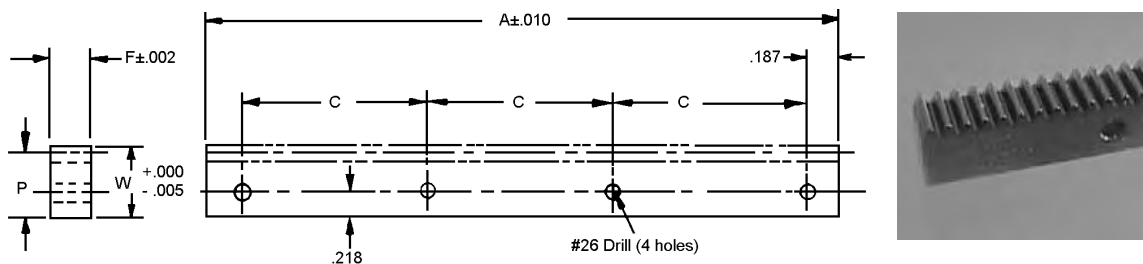

STOCK NO.	MATERIAL	A (Inch)	P (Ref.)	W	F	C
R4-15 R4-16	STAINLESS ST. ALUMINUM	7"	.4644	.480	.230	2.208

Available on request: special, modified and custom racks.

GEAR RACKS

PITCH	STYLES	MATERIAL	AGMA QUALITY	PRESSURE ANGLE
64	RECTANGULAR	416 SERIES STAINLESS STEEL STRESSED RELIEVED	10	20°

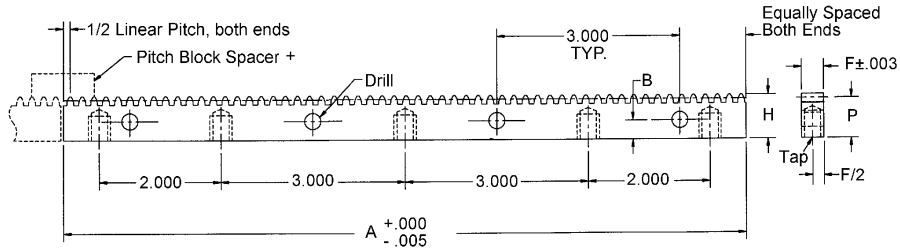

† Spacer block is designed for butting to achieve continuous lengths. On-Line pricing for AGMA 10 only.

RACKS	SPACER BLOCK												
		AGMA QTY. NO.	MAX ACCUM. ERROR	TOOTH TO TOOTH ERROR	PITCH	LINEAR PITCH	A INCH	P REF.	H +.000 -.005	F	B	DRILL	TAP
R1-8-G1	R1-8-SB	10*	.0014	.0005	64	.0491	11.038	.4594	.475	.230	.218	#26	#6-32 X 1/4
R3-5-G1	R3-5-SB	10*	.0014	.0005	64	.0491	11.038	.4644	.480	.230	.218	#26	#6-32 X 1/4

* Higher quality on request.

ANTI-BACKLASH GEARS

PITCH	STYLE	BORE	FACE	MATERIAL	AGMA QUALITY	PRES. ANGLE
64	PIN HUB	1/8"	.104"	303 STAINLESS STEEL OR 2024-T4 ALUMINUM ANODIZED	10	20°

B

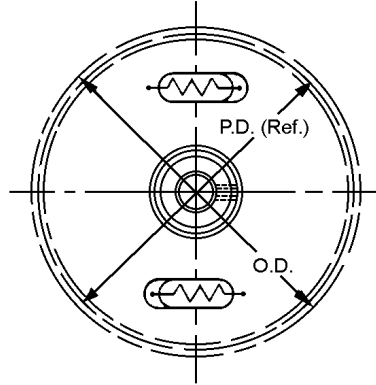
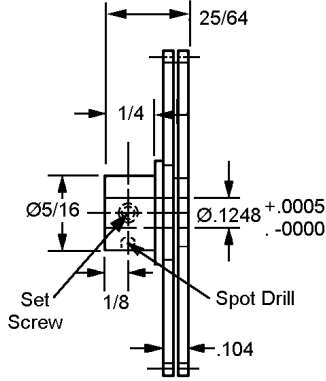

Hub Material: 303 Stainless Steel

303 STAINLESS STEEL STOCK NO.	2024-T4 ALUMINUM ANODIZED STOCK NO.	NO. OF TEETH	PITCH DIAMETER
AP64SS-52	AP64TS-52	52	.8125
AP64SS-55	AP64TS-55	55	.8593
AP64SS-56	AP64TS-56	56	.8750
AP64SS-60	AP64TS-60	60	.9375
AP64SS-64	AP64TS-64	64	1.0000
AP64SS-68	AP64TS-68	68	1.0625
AP64SS-70	AP64TS-70	70	1.0937
AP64SS-75	AP64TS-75	75	1.1718
AP64SS-80	AP64TS-80	80	1.2500
AP64S-85	AP64T-85	85	1.3281
AP64S-90	AP64T-90	90	1.4062
AP64S-95	AP64T-95	95	1.4843
AP64S-96	AP64T-96	96	1.5000
AP64S-100	AP64T-100	100	1.5625
AP64S-105	AP64T-105	105	1.6406
AP64S-108	AP64T-108	108	1.6875
AP64S-110	AP64T-110	110	1.7187
AP64S-115	AP64T-115	115	1.7968
AP64S-120	AP64T-120	120	1.8750
AP64S-125	AP64T-125	125	1.9531
AP64S-128	AP64T-128	128	2.0000
AP64S-130	AP64T-130	130	2.0312
AP64S-140	AP64T-140	140	2.1875
AP64S-150	AP64T-150	150	2.3437
AP64S-160	AP64T-160	160	2.5000
AP64S-170	AP64T-170	170	2.6562
AP64S-176	AP64T-176	176	2.7500
AP64S-180	AP64T-180	180	2.8125
AP64S-190	AP64T-190	190	2.9687
AP64S-192	AP64T-192	192	3.0000
AP64S-200	AP64T-200	200	3.1250

O.D. = P.D. +.031

Available on request:

- Other numbers of teeth;
- AGMA Quality 12 and 14 (some dimensions may vary);
- 14-12° pressure angle.

For Couplings See Section G.
For Shafts, Bearings and Collars See Section I.

ANTI-BACKLASH GEARS

PITCH	STYLE	BORE	FACE	MATERIAL	AGMA QUALITY	PRES. ANGLE
64	PIN HUB	3/16"	.104"	303 STAINLESS STEEL OR 2024-T4 ALUMINUM ANODIZED	10	20°

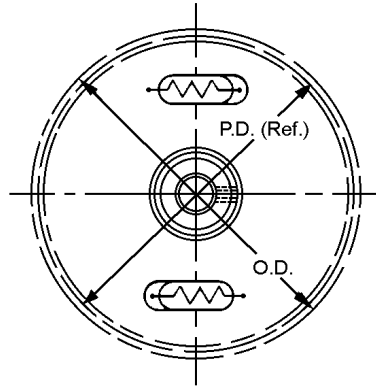
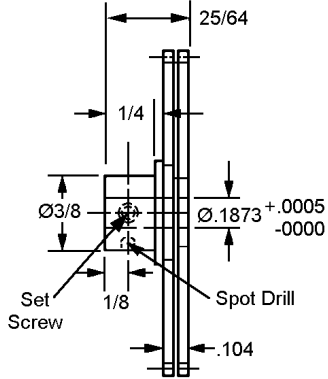

Hub Material: 303 Stainless Steel

303 STAINLESS STEEL STOCK NO.	2024-T4 ALUMINUM ANODIZED STOCK NO.	NO. OF TEETH	PITCH DIAMETER
AP64US-60	AP64VS-60	60	.9375
AP64US-64	AP64VS-64	64	1.0000
AP64US-68	AP64VS-68	68	1.0625
AP64US-70	AP64VS-70	70	1.0937
AP64US-75	AP64VS-75	75	1.1718
AP64US-80	AP64VS-80	80	1.2500
AP64U-85	AP64V-85	85	1.3281
AP64U-90	AP64V-90	90	1.4062
AP64U-95	AP64V-95	95	1.4843
AP64U-96	AP64V-96	96	1.5000
AP64U-100	AP64V-100	100	1.5625
AP64U-105	AP64V-105	105	1.6406
AP64U-108	AP64V-108	108	1.6875
AP64U-110	AP64V-110	110	1.7187
AP64U-115	AP64V-115	115	1.7968
AP64U-120	AP64V-120	120	1.8750
AP64U-125	AP64V-125	125	1.9531
AP64U-128	AP64V-128	128	2.0000
AP64U-130	AP64V-130	130	2.0312
AP64U-140	AP64V-140	140	2.1875
AP64U-150	AP64V-150	150	2.3437
AP64U-160	AP64V-160	160	2.5000
AP64U-170	AP64V-170	170	2.6562
AP64U-176	AP64V-176	176	2.7500
AP64U-180	AP64V-180	180	2.8125
AP64U-190	AP64V-190	190	2.9687
AP64U-192	AP64V-192	192	3.0000
AP64U-200	AP64V-200	200	3.1250

O.D. = P.D. +.031

Available on request:

Other numbers of teeth;
AGMA Quality 12 and 14 (some dimensions may vary);
14-12° pressure angle.

For Couplings See Section G.
For Shafts, Bearings and Collars See Section I.

ANTI-BACKLASH GEARS

PITCH	STYLE	BORE	FACE	MATERIAL	AGMA QUALITY	PRES. ANGLE
64	PIN HUB	3/16"	.104	303 STAINLESS STEEL OR 2024-T4 ALUMINUM ANODIZED	10	20°

B

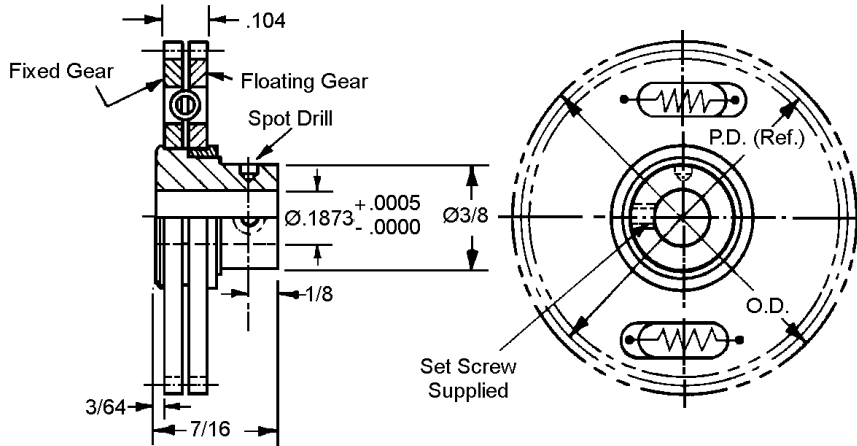

Hub Material: 303 Stainless Steel

STAINLESS STEEL STOCK NO.	ALUMINUM ANODIZED STOCK NO.	NO. OF TEETH	PITCH DIA.	OUTSIDE DIA.	SPRING STYLE
AP64CS-37	-	37	.5781	.609	SCISSOR
AP64CS-40	-	40	.6250	.656	
AP64CS-48	AP64PS-48	48	.7500	.781	
AP64CS-56	AP64PS-56	56	.8750	.906	
AP64CS-60	AP64PS-60	60	.9375	.968	
AP64C-64	AP64P-64	64	1.0000	1.031	
AP64C-72	AP64P-72	72	1.1250	1.156	COIL
AP64C-80	AP64P-80	80	1.2500	1.281	
AP64C-88	AP64P-88	88	1.3750	1.406	
AP64C-90	AP64P-90	90	1.4062	1.437	
AP64C-92	AP64P-92	92	1.4375	1.468	
AP64C-96	AP64P-96	96	1.5000	1.531	
AP64C-100	AP64P-100	100	1.5625	1.593	
AP64C-110	AP64P-110	110	1.7187	1.750	
AP64C-120	AP64P-120	120	1.8750	1.906	
AP64C-128	AP64P-128	128	2.0000	2.031	
AP64C-130	AP64P-130	130	2.0312	2.062	
AP64C-140	AP64P-140	140	2.1875	2.218	
AP64C-150	AP64P-150	150	2.3437	2.375	
AP64C-160	AP64P-160	160	2.5000	2.531	
AP64C-180	AP64P-180	180	2.8125	2.843	
AP64C-192	AP64P-192	192	3.0000	3.031	

Available on request:

- Other numbers of teeth;
- AGMA Quality 12 and 14;
- 14-12° pressure angle.

**For Couplings See Section G.
For Shafts, Bearings and Collars See Section I.**

ANTI-BACKLASH GEARS

PITCH	STYLE	BORE	FACE	MATERIAL	AGMA QUALITY	PRES. ANGLE
64	PIN HUB	3/16"	1/8"	303 STAINLESS STEEL OR 2024-T4 ALUMINUM ANODIZED	10	20°

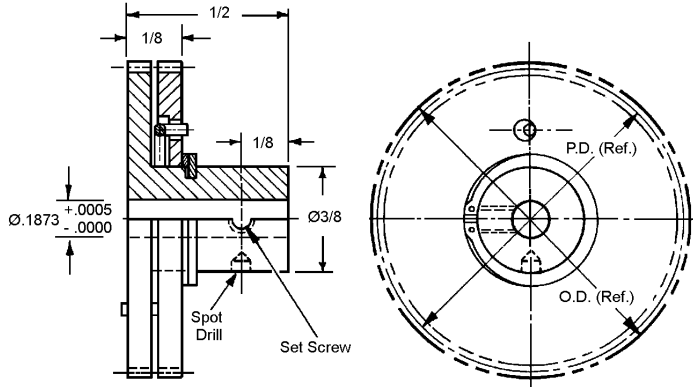

Hub Material: 303 Stainless Steel

STAINLESS STEEL STOCK NO.	ALUMINUM STOCK NO.	NO. OF TEETH	BORE	PITCH DIA.	OUTSIDE DIA.
AP64HS-40	AP64JS-40	40	.1873	.6250	.656
AP64HS-48	AP64JS-48	48		.7500	.781
AP64HS-64	AP64JS-64	64		1.0000	1.031

Available on request:
Other numbers of teeth
AGMA Quality 12 and 14
14-1/2° Pressure Angle

**For Couplings See Section G.
For Shafts, Bearings and Collars See Section I.**

ANTI-BACKLASH GEARS

PITCH	STYLE	BORE	FACE	MATERIAL	AGMA QUALITY	PRES. ANGLE
64	PIN HUB	1/4"	.104"	303 STAINLESS STEEL OR 2024-T4 ALUMINUM ANODIZED	10	20°

B

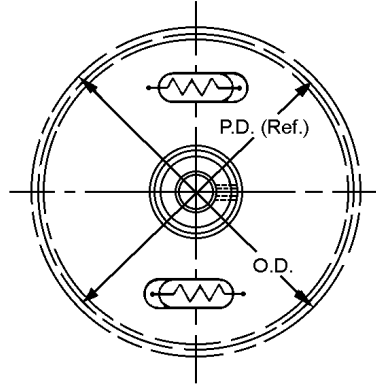
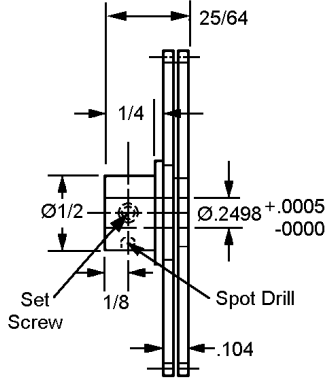

Hub Material: 303 Stainless Steel

303 STAINLESS STEEL STOCK NO.	2024-T4 ALUMINUM ANODIZED STOCK NO.	NO. OF TEETH	PITCH DIAMETER
AP64WS-68	AP64XS-68	68	1.0625
AP64WS-70	AP64XS-70	70	1.0937
AP64WS-75	AP64XS-75	75	1.1718
AP64WS-80	AP64XS-80	80	1.2500
AP64W-85	AP64X-85	85	1.3281
AP64W-90	AP64X-90	90	1.4062
AP64W-95	AP64X-95	95	1.4843
AP64W-96	AP64X-96	96	1.5000
AP64W-100	AP64X-100	100	1.5625
AP64W-105	AP64X-105	105	1.6406
AP64W-108	AP64X-108	108	1.6875
AP64W-110	AP64X-110	110	1.7187
AP64W-115	AP64X-115	115	1.7968
AP64W-120	AP64X-120	120	1.8750
AP64W-125	AP64X-125	125	1.9531
AP64W-128	AP64X-128	128	2.0000
AP64W-130	AP64X-130	130	2.0312
AP64W-140	AP64X-140	140	2.1875
AP64W-150	AP64X-150	150	2.3437
AP64W-160	AP64X-160	160	2.5000
AP64W-170	AP64X-170	170	2.6562
AP64W-176	AP64X-176	176	2.7500
AP64W-180	AP64X-180	180	2.8125
AP64W-190	AP64X-190	190	2.9687
AP64W-192	AP64X-192	192	3.0000
AP64W-200	AP64X-200	200	3.1250

O.D. = P.D. + .031

Available on request:

- Other numbers of teeth;
- AGMA Quality 12 and 14 (some dimensions may vary);
- 14-12° pressure angle.

**For Couplings See Section G.
For Shafts, Bearings and Collars See Section I.**

ANTI-BACKLASH GEARS

PITCH	STYLE	BORE	FACE	MATERIAL	AGMA QUALITY	PRES. ANGLE
64	PIN HUB	1/4"	1/8"	303 STAINLESS STEEL OR 2024-T4 ALUMINUM ANODIZED	10	20°

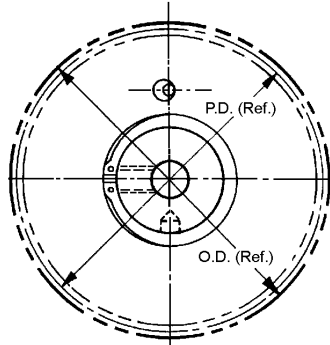
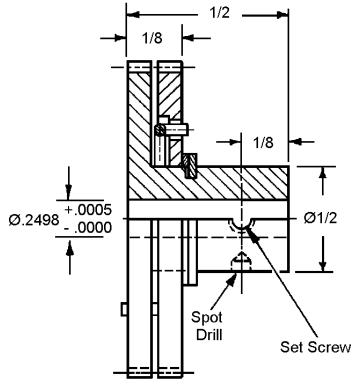

Hub Material: 303 Stainless Steel

STAINLESS STEEL STOCK NO.	ALUMINUM STOCK NO.	NO. OF TEETH	BORE	PITCH DIA.	OUTSIDE DIA.
AP64KS-48	AP64LS-48	48	.2498	.7500	.781
AP64KS-64	AP64LS-64	64		1.0000	1.031

Available on request:
Other numbers of teeth
AGMA Quality 12 and 14
14-1/2° Pressure Angle

**For Couplings See Section G.
For Shafts, Bearings and Collars See Section I.**

ANTI-BACKLASH GEARS

PITCH	STYLE	BORE	FACE	MATERIAL	AGMA QUALITY	PRES. ANGLE
64	PIN HUB	1/4"	.104	303 STAINLESS STEEL OR 2024-T4 ALUMINUM ANODIZED	10	20°

B

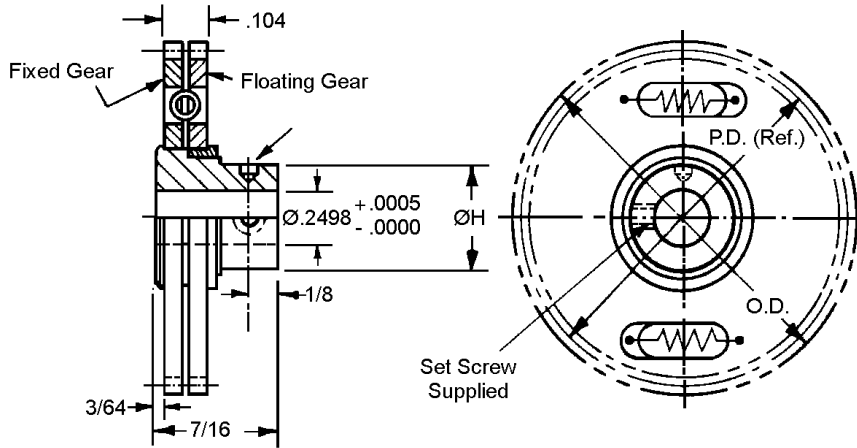

HUB MATERIAL: 303 Stainless Steel

STAINLESS STEEL STOCK NO.	ALUMINUM ANODIZED STOCK NO.	NO. OF TEETH	PITCH DIA.	OUTSIDE DIA.	SPRING STYLE	H
AP64ES-38	-	38	.5937	.625	SCISSOR	3/8
AP64ES-40	-	40	.6250	.656		
AP64ES-48	AP64RS-48	48	.7500	.781		
AP64ES-56	AP64RS-56	56	.8750	.906		
AP64ES-60	AP64RS-60	60	.9375	.968		
AP64ES-62	AP64RS-62	62	.9687	1.000		
AP64E-64	AP64R-64	64	1.0000	1.031	COIL	7/16
AP64E-70	AP64R-70	70	1.0937	1.125		
AP64E-72	AP64R-72	72	1.1250	1.156		
AP64E-80	AP64R-80	80	1.2500	1.281		
AP64E-84	AP64R-84	84	1.3125	1.343		
AP64E-88	AP64R-88	88	1.3750	1.406		
AP64E-96	AP64R-96	96	1.5000	1.531		
AP64E-100	AP64R-100	100	1.5625	1.593		
AP64E-105	AP64R-105	105	1.6406	1.671		
AP64E-110	AP64R-110	110	1.7187	1.750		
AP64E-120	AP64R-120	120	1.8750	1.906		
AP64E-128	AP64R-128	128	2.0000	2.031		
AP64E-140	AP64R-140	140	2.1875	2.218		
AP64E-144	AP64R-144	144	2.2500	2.281		
AP64E-160	AP64R-160	160	2.5000	2.531		
AP64E-176	AP64R-176	176	2.7500	2.781		
AP64E-180	AP64R-180	180	2.8125	2.843		
AP64E-192	AP64R-192	192	3.0000	3.031		

Available on request:

- Other numbers of teeth;
- AGMA Quality 12 and 14;
- 14-12° pressure angle.

**For Couplings See Section G.
For Shafts, Bearings and Collars See Section I.**

ANTI-BACKLASH GEARS

PITCH	STYLE	BORE	FACE	MATERIAL	AGMA QUALITY	PRES. ANGLE
64	CLAMP STYLE	1/8"	.104	303 STAINLESS STEEL OR 2024-T4 ALUMINUM ANODIZED	10	20°

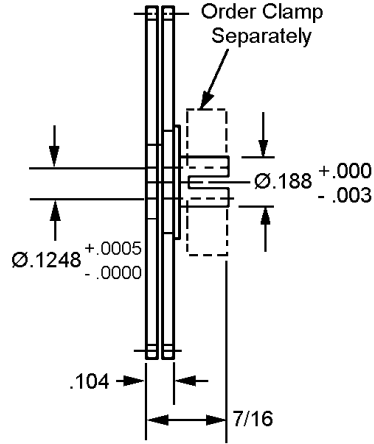

O.D. = P.D. + .031

Hub Material: 303 Stainless Steel

303 STAINLESS STEEL STOCK NO.	2024-T4 ALUMINUM ANODIZED STOCK NO.	NO. OF TEETH	PITCH DIAMETER
AC64SS-52	AC64TS-52	52	.8125
AC64SS-55	AC64TS-55	55	.8593
AC64SS-56	AC64TS-56	56	.8750
AC64SS-60	AC64TS-60	60	.9375
AC64SS-64	AC64TS-64	64	1.0000
AC64SS-68	AC64TS-68	68	1.0625
AC64SS-70	AC64TS-70	70	1.0937
AC64SS-75	AC64TS-75	75	1.1718
AC64SS-80	AC64TS-80	80	1.2500
AC64S-85	AC64T-85	85	1.3281
AC64S-90	AC64T-90	90	1.4062
AC64S-95	AC64T-95	95	1.4843
AC64S-96	AC64T-96	96	1.5000
AC64S-100	AC64T-100	100	1.5625
AC64S-105	AC64T-105	105	1.6406
AC64S-108	AC64T-108	108	1.6875
AC64S-110	AC64T-110	110	1.7187
AC64S-115	AC64T-115	115	1.7968
AC64S-120	AC64T-120	120	1.8750
AC64S-125	AC64T-125	125	1.9531
AC64S-128	AC64T-128	128	2.0000
AC64S-130	AC64T-130	130	2.0312
AC64S-140	AC64T-140	140	2.1875
AC64S-150	AC64T-150	150	2.3437
AC64S-160	AC64T-160	160	2.5000
AC64S-170	AC64T-170	170	2.6562
AC64S-176	AC64T-176	176	2.7500
AC64S-180	AC64T-180	180	2.8125
AC64S-190	AC64T-190	190	2.9687
AC64S-192	AC64T-192	192	3.0000
AC64S-200	AC64T-200	200	3.1250

Available on request:
 Other numbers of teeth
 AGMA Quality 12 and 14 (some dimensions may vary)
 14-1/2° Pressure Angle

**For Couplings See Section G.
 For Shafts, Bearings and Collars See Section I.**

ANTI-BACKLASH GEARS

PITCH	STYLE	BORE	FACE	MATERIAL	AGMA QUALITY	PRES. ANGLE
64	CLAMP STYLE	3/16"	1/8"	303 STAINLESS STEEL OR 2024-T4 ALUMINUM ANODIZED	10	20°

B

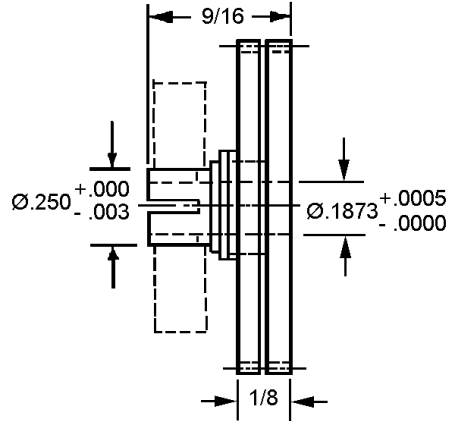

Hub Material:
303 Stainless Steel

STAINLESS STEEL STOCK NO.	ALUMINUM STOCK NO.	PITCH	NO. OF TEETH	PITCH DIA.	OUTSIDE DIA.
AC64HS-40	AC64JS-40	64	40	.6250	.656
AC64HS-48	AC64JS-48		48	.7500	.781
AC64HS-64	AC64JS-64		64	1.0000	1.031

Available on request:
Other numbers of teeth
AGMA Quality 12 and 14
14-1/2° Pressure Angle

For Couplings See Section G.
For Shafts, Bearings and Collars See Section I.

ANTI-BACKLASH GEARS

PITCH	STYLE	BORE	FACE	MATERIAL	AGMA QUALITY	PRES. ANGLE
64	CLAMP STYLE	1/4"	1/8"	303 STAINLESS STEEL OR 2024-T4 ALUMINUM ANODIZED	10	20°

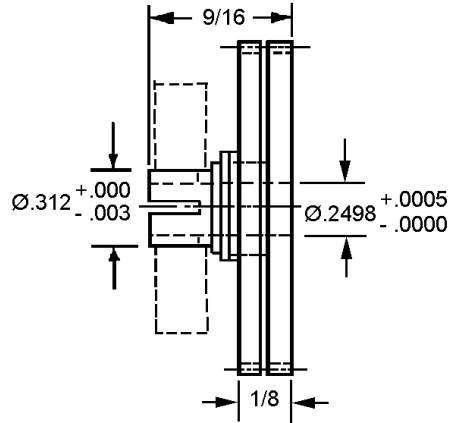

Hub Material: 303 Stainless Steel

STAINLESS STEEL STOCK NO.	ALUMINUM STOCK NO.	PITCH	NO. OF TEETH	PITCH DIA.	OUTSIDE DIA.
AC64KS-48	AC64LS-48	64	48	0.7500	.781
AC64KS-64	AC64LS-64	64	64	1.0000	1.031

Available on request:
Other numbers of teeth
AGMA Quality 12 and 14
14-1/2° Pressure Angle

For Couplings See Section G.
For Shafts, Bearings and Collars See Section I.

ANTI-BACKLASH GEARS

PITCH	STYLE	BORE	FACE	MATERIAL	AGMA QUALITY	PRES. ANGLE
64	CLAMP STYLE	3/16"	.104	303 STAINLESS STEEL OR 2024-T4 ALUMINUM ANODIZED	10	20°

B

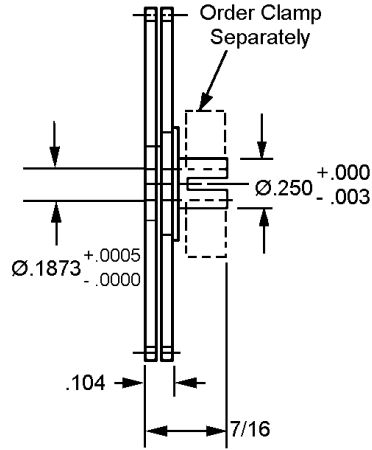

Hub Material: 303 Stainless Steel

O.D. = P.D. + .031

303 STAINLESS STEEL STOCK NO.	2024-T4 ALUMINUM ANODIZED STOCK NO.	NO. OF TEETH	PITCH DIAMETER
AC64US-60	AC64VS-60	60	.9375
AC64US-64	AC64VS-64	64	1.0000
AC64US-68	AC64VS-68	68	1.0625
AC64US-70	AC64VS-70	70	1.0937
AC64US-75	AC64VS-75	75	1.1718
AC64US-80	AC64VS-80	80	1.2500
AC64U-85	AC64V-85	85	1.3281
AC64U-90	AC64V-90	90	1.4062
AC64U-95	AC64V-95	95	1.4843
AC64U-96	AC64V-96	96	1.5000
AC64U-100	AC64V-100	100	1.5625
AC64U-105	AC64V-105	105	1.6406
AC64U-108	AC64V-108	108	1.6875
AC64U-110	AC64V-110	110	1.7187
AC64U-115	AC64V-115	115	1.7968
AC64U-120	AC64V-120	120	1.8750
AC64U-125	AC64V-125	125	1.9531
AC64U-128	AC64V-128	128	2.0000
AC64U-130	AC64V-130	130	2.0312
AC64U-140	AC64V-140	140	2.1875
AC64U-150	AC64V-150	150	2.3437
AC64U-160	AC64V-160	160	2.5000
AC64U-170	AC64V-170	170	2.6562
AC64U-176	AC64V-176	176	2.7500
AC64U-180	AC64V-180	180	2.8125
AC64U-190	AC64V-190	190	2.9687
AC64U-192	AC64V-192	192	3.0000
AC64U-200	AC64V-200	200	3.1250

Available on request:
 Other numbers of teeth
 AGMA Quality 12 and 14 (some dimensions may vary)
 14-1/2° Pressure Angle

**For Couplings See Section G.
 For Shafts, Bearings and Collars See Section I.**

ANTI-BACKLASH GEARS

PITCH	STYLE	BORE	FACE	MATERIAL	AGMA QUALITY	PRES. ANGLE
64	CLAMP STYLE	3/16"	.104	303 STAINLESS STEEL OR 2024-T4 ALUMINUM ANODIZED	10	20°

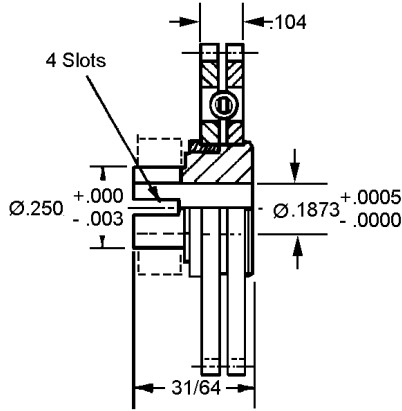

Hub Material: 303 Stainless Steel

STAINLESS STEEL STOCK NO.	ALUMINUM ANODIZED STOCK NO.	NO.OF TEETH	PITCH DIA.	OUTSIDE DIA.	SPRING STYLE
AC64CS-37	-	37	.5781	.609	SCISSOR
AC64CS-40	-	40	.6250	.656	
AC64CS-48	AC64PS-48	48	.7500	.781	
AC64CS-56	AC64PS-56	56	.8750	.906	
AC64CS-60	AC64PS-60	60	.9375	.968	
AC64C-64	AC64P-64	64	1.0000	1.031	
AC64C-72	AC64P-72	72	1.1250	1.156	COIL
AC64C-80	AC64P-80	80	1.2500	1.281	
AC64C-88	AC64P-88	88	1.3750	1.406	
AC64C-90	AC64P-90	90	1.4062	1.437	
AC64C-92	AC64P-92	92	1.4375	1.468	
AC64C-96	AC64P-96	96	1.5000	1.531	
AC64C-100	AC64P-100	100	1.5625	1.593	
AC64C-110	AC64P-110	110	1.7187	1.750	
AC64C-120	AC64P-120	120	1.8750	1.906	
AC64C-128	AC64P-128	128	2.0000	2.031	
AC64C-130	AC64P-130	130	2.0312	2.062	
AC64C-140	AC64P-140	140	2.1875	2.218	
AC64C-150	AC64P-150	150	2.3437	2.375	
AC64C-160	AC64P-160	160	2.5000	2.531	
AC64C-180	AC64P-180	180	2.8125	2.843	
AC64C-192	AC64P-192	192	3.0000	3.031	

Available on request:

Other numbers of teeth;
AGMA Quality 12 and 14;
14-12° pressure angle.

For Couplings See Section G.
For Shafts, Bearings and Collars See Section I.

ANTI-BACKLASH GEARS

PITCH	STYLE	BORE	FACE	MATERIAL	AGMA QUALITY	PRES. ANGLE
64	CLAMP STYLE	1/4"	.104	303 STAINLESS STEEL OR 2024-T4 ALUMINUM ANODIZED	10	20°

B

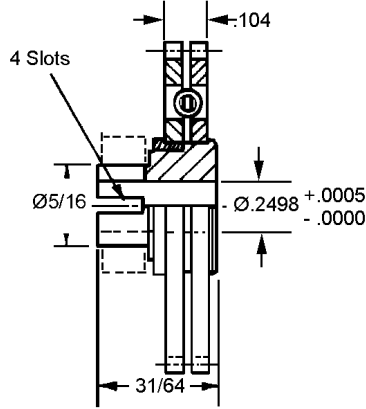

Hub Material: 303 Stainless Steel

STAINLESS STEEL STOCK NO.	ALUMINUM ANODIZED STOCK NO.	NO.OF TEETH	PITCH DIA.	OUTSIDE DIA.	SPRING STYLE
AC64ES-38	-	38	.5937	.625	SCISSOR
AC64ES-40	-	40	.6250	.656	
AC64ES-48	AC64RS-48	48	.7500	.781	
AC64ES-56	AC64RS-56	56	.8750	.906	
AC64ES-60	AC64RS-60	60	.9375	.968	
AC64ES-62	AC64RS-62	62	.9687	1.000	
AC64E-64	AC64R-64	64	1.0000	1.031	COIL
AC64E-70	AC64R 70	70	1.0937	1.125	
AC64E-72	AC64R-72	72	1.1250	1.156	
AC64E-80	AC64R-80	80	1.2500	1.281	
AC64E-84	AC64R-84	84	1.3125	1.343	
AC64E-88	AC64R-88	88	1.3750	1.406	
AC64E-96	AC64R-96	96	1.5000	1.531	
AC64E-100	AC64R-100	100	1.5625	1.593	
AC64E-105	AC64R-105	105	1.6406	1.671	
AC64E-110	AC64R-110	110	1.7187	1.750	
AC64E-120	AC64R-120	120	1.8750	1.906	
AC64E-128	AC64R-128	128	2.0000	2.031	
AC64E-140	AC64R-140	140	2.1875	2.218	
AC64E-144	AC64R-144	144	2.2500	2.281	
AC64E-160	AC64R-160	160	2.5000	2.531	
AC64E-176	AC64R-176	176	2.7500	2.781	
AC64E-180	AC64R-180	180	2.8125	2.843	
AC64E-192	AC64R-192	192	3.0000	3.031	

Available on request:

- Other numbers of teeth;
- AGMA Quality 12 and 14;
- 14-12° pressure angle.

**For Couplings See Section G.
For Shafts, Bearings and Collars See Section I.**

ANTI-BACKLASH GEARS

PITCH	STYLE	BORE	FACE	MATERIAL	AGMA QUALITY	PRES. ANGLE
64	CLAMP STYLE	1/4"	.104	303 STAINLESS STEEL OR 2024-T4 ALUMINUM ANODIZED	10	20°

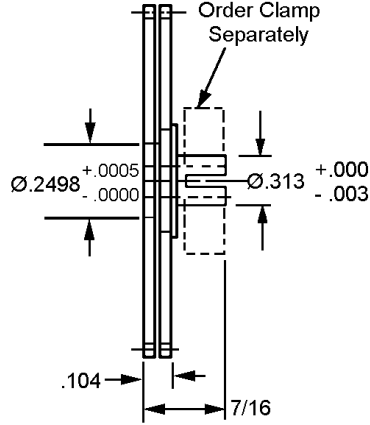

Hub Material: 303 Stainless Steel

303 STAINLESS STEEL STOCK NO.	2024-T4 ALUMINUM ANODIZED STOCK NO.	NO. OF TEETH	PITCH DIAMETER
AC64WS-68	AC64XS-68	68	1.0625
AC64WS-70	AC64XS-70	70	1.0937
AC64WS-75	AC64XS-75	75	1.1718
AC64WS-80	AC64XS-80	80	1.2500
AC64W-85	AC64X-85	85	1.3281
AC64W-90	AC64X-90	90	1.4062
AC64W-95	AC64X-95	95	1.4843
AC64W-96	AC64X-96	96	1.5000
AC64W-100	AC64X-100	100	1.5625
AC64W-105	AC64X-105	105	1.6406
AC64W-108	AC64X-108	108	1.6875
AC64W-110	AC64X-110	110	1.7187
AC64W-115	AC64X-115	115	1.7968
AC64W-120	AC64X-120	120	1.8750
AC64W-125	AC64X-125	125	1.9531
AC64W-128	AC64X-128	128	2.0000
AC64W-130	AC64X-130	130	2.0312
AC64W-140	AC64X-140	140	2.1875
AC64W-150	AC64X-150	150	2.3437
AC64W-160	AC64X-160	160	2.5000
AC64W-170	AC64X-170	170	2.6562
AC64W-176	AC64X-176	176	2.7500
AC64W-180	AC64X-180	180	2.8125
AC64W-190	AC64X-190	190	2.9687
AC64W-192	AC64X-192	192	3.0000
AC64W-200	AC64X-200	200	3.1250

O.D. = P.D. +.031

Available on request:

Other numbers of teeth;
 AGMA Quality 12 and 14 (some dimensions may vary);
 14-12° pressure angle.

For Couplings See Section G.
For Shafts, Bearings and Collars See Section I.

PINION SHAFTS

PITCH	MATERIAL	AGMA QUALITY	PRES. ANGLE
64	BRASS AND COLD ROLLED STEEL	5	20°

B

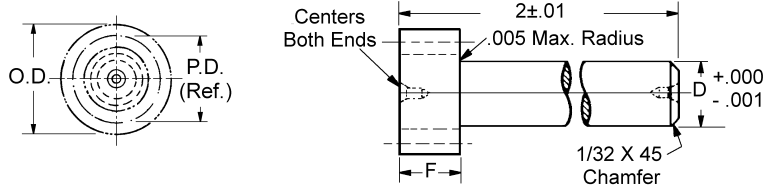

303 STAINLESS STEEL STOCK NO.	BRASS ALLOY 360 STOCK NO.	NUMBER OF TEETH	PITCH DIAMETER	OUTSIDE DIAMETER	D	F
PSX64S-12	PSX64B-12	12	.1875	.218	.125	3/16
PSX64S-14	PSX64B-14	14	.2188	.250	.125	
PSX64S-15	PSX64B-15	15	.2344	.265	.187	
PSX64S-16	PSX64B-16	16	.2500	.281	.187	
PSX64S-18	PSX64B-18	18	.2813	.312	.187	

Made from extruded pinion stock.
Specials made to order - send sketch.

PITCH	MATERIAL	AGMA QUALITY	PRES. ANGLE
64	BRASS AND COLD ROLLED STEEL	5	20°

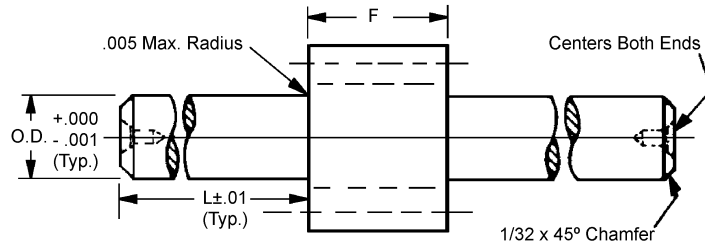

COLD ROLLED STEEL 12L14 OR 12L15 W/SELENIUM STOCK NO.	BRASS ALLOY 360 STOCK NO.	NUMBER OF TEETH	PITCH DIAMETER	OUTSIDE DIAMETER	D	F	L
PSW64S-12	PSW64B-12	12	.1875	.218	.125	3/16	3/8
PSW64S-14	PSW64B-14	14	.2188	.250			
PSW64S-15	PSW64B-15	15	.2344	.265			
PSW64S-16	PSW64B-16	16	.2500	.281			
PSW64S-18	PSW64B-18	18	.2813	.312			

Made from extruded pinion stock.
Specials made to order - send sketch.

PINION SHAFTS

PITCH	MATERIAL	AGMA QUALITY	PRES. ANGLE
64	303 STAINLESS STEEL	10	20°

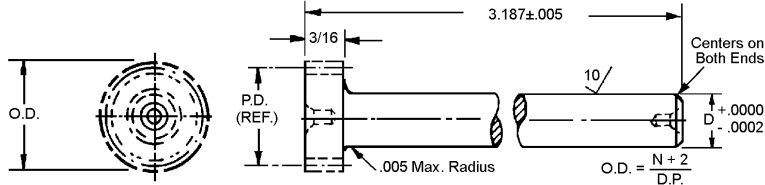

STOCK NO.	PITCH	NO. OF TEETH	PITCH DIA.	D
PS64S2-16H	64	16	.2500	.1247
PS64S3-16H		16	.2500	.1872
PS64S4-16H		16	.2500	.2497
PS64S4-18H		18	.2812	.2497
PS64S2-20H		20	.3125	.1247
PS64S3-20H		20	.3125	.1872
PS64S4-20H		20	.3125	.2497
PS64S4-22H		22	.3437	.2497
PS64S4-24H		24	.3750	.2497

Other numbers of teeth available on request.

PITCH	MATERIAL	AGMA QUALITY	PRES. ANGLE
64	303 STAINLESS STEEL	10	20°

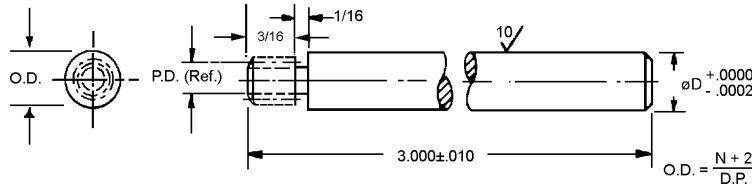

STOCK NO.	PITCH	NO. OF TEETH	PITCH DIA.	D
PS64S4-12	64	12	.1875	.2497
PS64S4-14	64	14	.2187	.2497

Other numbers of teeth available on request.

PITCH	MATERIAL	AGMA QUALITY	PRES. ANGLE
64	303 STAINLESS STEEL	10	20°

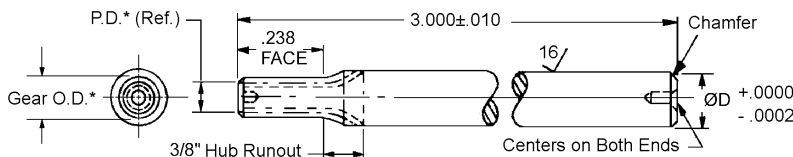

STOCK NO.	PITCH	NO. OF TEETH	D	ENLARGED	
				PITCH DIAMETER	OUTSIDE DIA.
B-PS64S4-10	64	10	.2497	.1692	.200
B-PS64S4-11		11		.1830	.214
B-PS64S4-12		12		.1968	.228
B-PS64S4-13		13		.2106	.241
B-PS64S5-15	64	15	.3122	.2382	.269

Other numbers of teeth available on request.

SPUR GEAR STOCK

PITCH	TYPE	MATERIAL	AGMA QUALITY	PRESSURE ANGLE
64	PINION WIRE	BRASS AND COLD ROLLED STEEL	4	20°

B

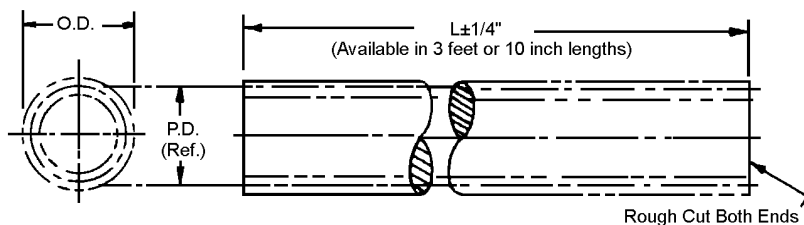

BRASS ALLOY 360		COLD ROLLED STEEL 12L-14 or 12L-15 WITH SELENIUM		NO. OF TEETH	PITCH DIA.	OUTSIDE DIA.
3FT. LONG STOCK NO.	10 IN. LONG STOCK NO.	3FT. LONG STOCK NO.	10 IN. LONG STOCK NO.			
PW64B-8	PW64B-8A	PW64S-8	PW64S-8A	8	.1250	.156
PW64B-9	PW64B-9A	PW64S-9	PW64S-9A	9	.1406	.171
PW64B-10	PW64B-10A	PW64S-10	PW64S-10A	10	.1562	.187
PW64B-11	PW64B-11A	PW64S-11	PW64S-11A	11	.1718	.203
PW64B-12	PW64B-12A	PW64S-12	PW64S-12A	12	.1875	.218
PW64B-14	PW64B-14A	PW64S-14	PW64S-14A	14	.2187	.250
PW64B-15	PW64B-15A	PW64S-15	PW64S-15A	15	.2343	.265
PW64B-16	PW64B-16A	PW64S-16	PW64S-16A	16	.2500	.281
PW64B-18	PW64B-18A	PW64S-18	PW64S-18A	18	.2812	.312
PW64B-20	PW64B-20A	PW64S-20	PW64S-20A	20	.3125	.343
PW64B-24	PW64B-24A	-	-	24	.3750	.406
PW64B-28	PW64B-28A	-	-	28	.4375	.468
PW64B-36	PW64B-36A	-	-	36	.5625	.593
PW64B-40	PW64B-40A	-	-	40	.6250	.656
PW64B-48	PW64B-48A	-	-	48	.7500	.781

SPUR GEARS

PITCH	STYLE	BORE	FACE	MATERIAL	AGMA QUALITY	PRESSURE ANGLE
72	HUBLESS	3/8"	1/8"	303 STAINLESS STEEL AND 2024-T4 ALUMINUM ANODIZED	10	20°

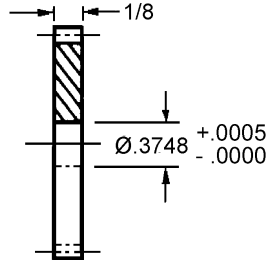
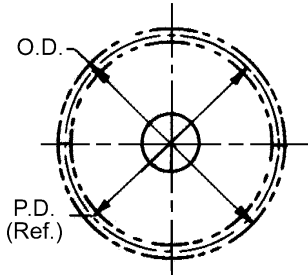

Available on request:
Pin or Clamp hubs assembled
Other numbers of teeth
14 - 1/2° Pressure Angle

303 STAINLESS STEEL STOCK NO.	2024-T4 ALUMINUM ANODIZED STOCK NO.			
		NO. OF TEETH	PITCH DIA.	OUTSIDE DIA.
F72S3-72	F72A3-72	72	1.0000	1.027
F72S3-80	F72A3-80	80	1.1111	1.138
F72S3-81	F72A3-81	81	1.1250	1.152
F72S3-90	F72A3-90	90	1.2500	1.277
F72S3-96	F72A3-96	96	1.3333	1.361
F72S3-99	F72A3-99	99	1.3750	1.402
F72S3-100	F72A3-100	100	1.3888	1.416
F72S3-108	F72A3-108	108	1.5000	1.527
F72S3-115	F72A3-115	115	1.5972	1.625
F72S3-130	F72A3-130	130	1.8055	1.833
F72S3-135	F72A3-135	135	1.8750	1.902
F72S3-140	F72A3-140	140	1.9444	1.972
F72S3-144	F72A3-144	144	2.0000	2.027
F72S3-150	F72A3-150	150	2.0833	2.111
F72S3-160	F72A3-160	160	2.2222	2.250
F72S3-180	F72A3-180	180	2.5000	2.527
F72S3-192	F72A3-192	192	2.6666	2.694
F72S3-200	F72A3-200	200	2.7777	2.805
F72S3-216	F72A3-216	216	3.0000	3.027
F72S3-288	F72A3-288	288	4.0000	4.027

PITCH	STYLE	BORE	FACE	MATERIAL	AGMA QUALITY	PRESSURE ANGLE
72	HUBLESS	3/8"	1/8"	POLYURETHANE	8	20°

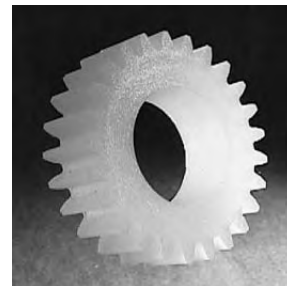
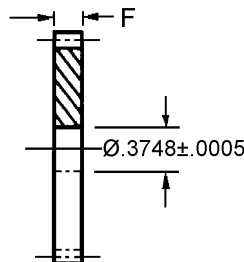
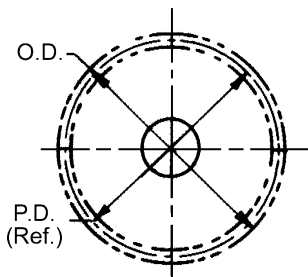

Available on request:
Other numbers of teeth
14 - 1/2° Pressure Angle

STOCK NO.	NO. OF TEETH	PITCH DIA.	OUTSIDE DIA.
F72U3-72	72	1.0000	1.027
F72U3-96	96	1.3333	1.361
F72U3-100	100	1.3888	1.416
F72U3-108	108	1.5000	1.527
F72U3-120	120	1.6666	1.694
F72U3-125	125	1.7361	1.763
F72U3-135	135	1.8750	1.902
F72U3-140	140	1.9444	1.972
F72U3-150	150	2.0833	2.111

CLUSTER GEAR AND HUB

B

PITCH	STYLE	BORE	MATERIAL	AGMA QUALITY	PRESSURE ANGLE
72	X	1/4"	303 STAINLESS STEEL	10	20°

STOCK NO.	PITCH	NO. OF TEETH	PITCH DIA.	OUTSIDE DIA.
DP72S14-30	72	30	.4166	.444
DP72S14-36		36	.5000	.528
DP72S14-40		40	.5555	.583

PITCH	STYLE	BORE	MATERIAL	AGMA QUALITY	PRESSURE ANGLE
72	Y	1/4"	303 STAINLESS STEEL	10	20°

STOCK NO.	PITCH	NO. OF TEETH	PITCH DIA.	OUTSIDE DIA.
DP72S16-30	72	30	.4166	.444
DP72S16-36		36	.5000	.528
DP72S16-40		40	.5555	.583

PITCH	STYLE	BORE	MATERIAL	AGMA QUALITY	PRESSURE ANGLE
72	Z	1/4"	303 STAINLESS STEEL	10	20°

STOCK NO.	PITCH	NO. OF TEETH	PITCH DIA.	OUTSIDE DIA.
DP72S18-30	72	30	.4166	.444
DP72S18-36		36	.5000	.528
DP72S18-40		40	.5555	.583

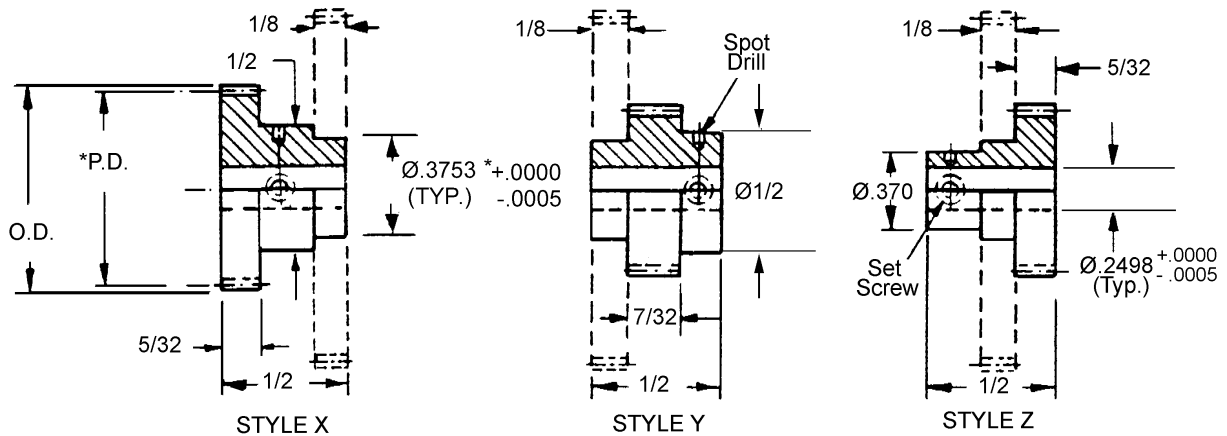

*Concentric within .0003
Order hubless gear separately.

CLUSTER GEAR AND HUB

PITCH	STYLE	BORE	MATERIAL	AGMA QUALITY	PRESSURE ANGLE
72	X	3/16"	303 STAINLESS STEEL	10	20°

STOCK NO.	PITCH	NO. OF TEETH	PITCH DIA.	OUTSIDE DIA.
DP72S8-30	72	30	.4166	.444
DP72S8-32		32	.4444	.472
DP72S8-34		34	.4722	.500
DP72S8-35		35	.4861	.514
DP72S8-36		36	.5000	.528

PITCH	STYLE	BORE	MATERIAL	AGMA QUALITY	PRESSURE ANGLE
72	Y	3/16"	303 STAINLESS STEEL	10	20°

STOCK NO.	PITCH	NO. OF TEETH	PITCH DIA.	OUTSIDE DIA.
DP72S10-30	72	30	.4166	.444
DP72S10-32		32	.4444	.472
DP72S10-34		34	.4722	.500
DP72S10-35		35	.4861	.514
DP72S10-36		36	.5000	.528

PITCH	STYLE	BORE	MATERIAL	AGMA QUALITY	PRESSURE ANGLE
72	Z	3/16"	303 STAINLESS STEEL	10	20°

STOCK NO.	PITCH	NO. OF TEETH	PITCH DIA.	OUTSIDE DIA.
DP72S12-30	72	30	.4166	.444
DP72S12-32		32	.4444	.472
DP72S12-34		34	.4722	.500
DP72S12-35		35	.4861	.514
DP72S12-36		36	.5000	.528

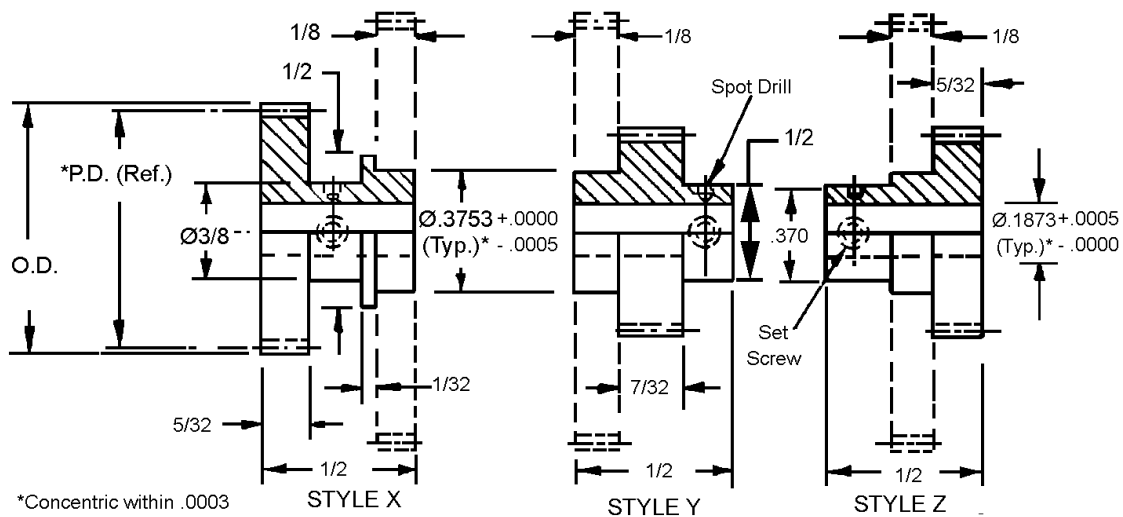

SPUR GEARS

PITCH	STYLE	BORE	FACE	MATERIAL	AGMA QUALITY	PRESSURE ANGLE
72	PIN HUB	1/8"	1/8"	303 STAINLESS STEEL AND ALUMINUM ANODIZED	10	20°

B

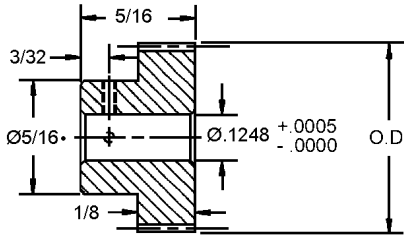
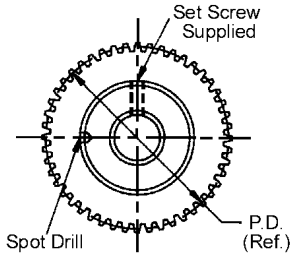

• For 20-25 teeth hub diameter equals .24
Available on request, other numbers of teeth
and 14-1/2° Pressure Angle.

303 STAINLESS STEEL STOCK NO.	2024-T4 ALUMINUM ANODIZED STOCK NO.	NO. OF TEETH	PITCH DIA.	OUTSIDE DIA.
P72S10-20	P72A10-20	20•	.2777	.305
P72S10-22	P72A10-22	22•	.3055	.333
P72S10-23	P72A10-23	23•	.3194	.347
P72S10-24	P72A10-24	24•	.3333	.361
P72S10-25	P72A10-25	25•	.3472	.375
P72S10-26	P72A10-26	26	.3611	.388
P72S10-27	P72A10-27	27	.3750	.402
P72S10-28	P72A10-28	28	.3888	.416
P72S10-29	P72A10-29	29	.4027	.430
P72S10-30	P72A10-30	30	.4166	.444
P72S10-32	P72A10-32	32	.4444	.472
P72S10-34	P72A10-34	34	.4722	.500
P72S10-36	P72A10-36	36	.5000	.527
P72S10-38	P72A10-38	38	.5277	.555
P72S10-40	P72A10-40	40	.5555	.583
P72S10-42	P72A10-42	42	.5833	.611
P72S10-44	P72A10-44	44	.6111	.638
P72S10-45	P72A10-45	45	.6250	.652
P72S10-46	P72A10-46	46	.6388	.666
P72S10-48	P72A10-48	48	.6666	.694
P72S10-50	P72A10-50	50	.6944	.722
P72S10-54	P72A10-54	54	.7500	.777
P72S10-56	P72A10-56	56	.7777	.805
P72S10-60	P72A10-60	60	.8333	.861
P72S10-64	P72A10-64	64	.8888	.916
P72S10-70	P72A10-70	70	.9722	1.000
P72S10-72	P72A10-72	72	1.0000	1.027
P72S10-75	P72A10-75	75	1.0416	1.069
P72S10-80	P72A10-80	80	1.1111	1.138
P72S10-84	P72A10-84	84	1.1666	1.194
P72S10-85	P72A10-85	85	1.1805	1.208
P72S10-90	P72A10-90	90	1.2500	1.277
P72S10-92	P72A10-92	92	1.2777	1.305
P72S10-96	P72A10-96	96	1.3333	1.361
P72S10-100	P72A10-100	100	1.3888	1.416
P72S10-110	P72A10-110	110	1.5277	1.555
P72S10-117	P72A10-117	117	1.6250	1.652
P72S10-120	P72A10-120	120	1.6666	1.694
P72S10-130	P72A10-130	130	1.8055	1.833
P72S10-144	P72A10-144	144	2.0000	2.027
P72S10-150	P72A10-150	150	2.0833	2.111
P72S10-153	P72A10-153	153	2.1250	2.152

For Couplings See Section G.
For Shafts, Bearings and Collars See Section I.

SPUR GEARS

PITCH	STYLE	BORE	FACE	MATERIAL	AGMA QUALITY	PRESSURE ANGLE
72	PIN HUB	3/16"	3/16"	303 STAINLESS STEEL AND ALUMINUM ANODIZED	10	20°

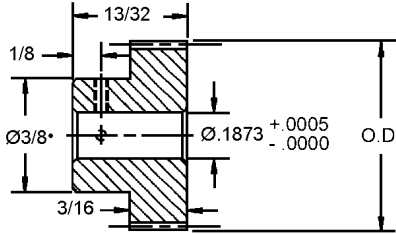
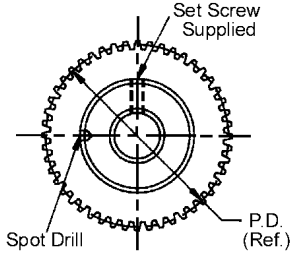

• For 27-29 teeth hub diameter equals .33

Available on request, other numbers of teeth, AGMA quality 12 and 14, and 14-1/2° Pressure Angle.

303 STAINLESS STEEL STOCK NO.	2024-T4 ALUMINUM ANODIZED STOCK NO.	NO. OF TEETH	PITCH DIA.	OUTSIDE DIA.
P72S21-27	P72A21-27	27•	.3750	.402
P72S21-28	P72A21-28	28•	.3888	.416
P72S21-30	P72A21-30	30	.4166	.444
P72S21-32	P72A21-32	32	.4444	.472
P72S21-34	P72A21-34	34	.4722	.500
P72S21-36	P72A21-36	36	.5000	.527
P72S21-38	P72A21-38	38	.5277	.555
P72S21-40	P72A21-40	40	.5555	.583
P72S21-42	P72A21-42	42	.5833	.611
P72S21-44	P72A21-44	44	.6111	.638
P72S21-46	P72A21-46	46	.6388	.666
P72S21-48	P72A21-48	48	.6666	.694
P72S21-50	P72A21-50	50	.6944	.722
P72S21-54	P72A21-54	54	.7500	.777
P72S21-56	P72A21-56	56	.7777	.805
P72S21-60	P72A21-60	60	.8333	.861
P72S21-63	P72A21-63	63	.8750	.902
P72S21-64	P72A21-64	64	.8888	.916
P72S21-70	P72A21-70	70	.9722	1.000
P72S21-72	P72A21-72	72	1.0000	1.027
P72S21-80	P72A21-80	80	1.1111	1.138
P72S21-90	P72A21-90	90	1.2500	1.277
P72S21-96	P72A21-96	96	1.3333	1.361
P72S21-100	P72A21-100	100	1.3888	1.416
P72S21-105	P72A21-105	105	1.4583	1.486
P72S21-108	P72A21-108	108	1.5000	1.527
P72S21-144	P72A21-144	144	2.0000	2.027

**For Couplings See Section G.
For Shafts, Bearings and Collars See Section I.**

SPUR GEARS

PITCH	STYLE	BORE	FACE	MATERIAL	AGMA QUALITY	PRESSURE ANGLE
72	PIN HUB	3/16"	1/8"	303 STAINLESS STEEL AND ALUMINUM ANODIZED	10	20°

B

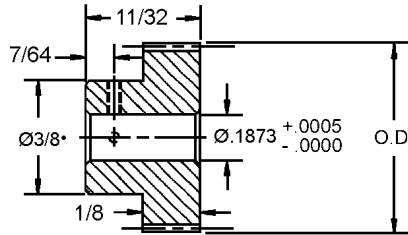
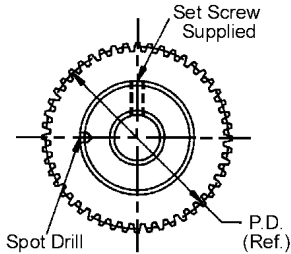

• For 27-29 teeth hub diameter equals .33

Available on request, other numbers of teeth, AGMA quality 12 and 14, and 14-1/2° Pressure Angle.

303 STAINLESS STEEL STOCK NO.	2024-T4 ALUMINUM ANODIZED STOCK NO.	NO. OF TEETH	PITCH DIA.	OUTSIDE DIA.
P72S19-28	P72A19-28	28*	.3888	.416
P72S19-30	P72A19-30	30	.4166	.444
P72S19-32	P72A19-32	32	.4444	.472
P72S19-36	P72A19-36	36	.5000	.527
P72S19-38	P72A19-38	38	.5277	.555
P72S19-40	P72A19-40	40	.5555	.583
P72S19-42	P72A19-42	42	.5833	.611
P72S19-44	P72A19-44	44	.6111	.638
P72S19-45	P72A19-45	45	.6250	.652
P72S19-46	P72A19-46	46	.6388	.666
P72S19-48	P72A19-48	48	.6666	.694
P72S19-50	P72A19-50	50	.6944	.722
P72S19-54	P72A19-54	54	.7500	.777
P72S19-55	P72A19-55	55	.7638	.791
P72S19-56	P72A19-56	56	.7777	.805
P72S19-60	P72A10-60	60	.8333	.861
P72S19-64	P72A19-64	64	.8888	.916
P72S19-70	P72A19-70	70	.9722	1.000
P72S19-72	P72A19-72	72	1.0000	1.027
P72S19-75	P72A19-75	76	1.0416	1.069
P72S19-80	P72A19-80	80	1.1111	1.138
P72S19-81	P72A19-81	81	1.1250	1.152
P72S19-90	P72A19-90	90	1.2500	1.277
P72S19-96	P72A19-96	96	1.3333	1.361
P72S19-99	P72A19-99	99	1.3750	1.402
P72S19-100	P72A19-100	100	1.3888	1.416
P72S19-108	P72A19-108	108	1.5000	1.527
P72S19-110	P72A19-110	110	1.5277	1.555
P72S19-120	P72A19-120	120	1.6666	1.694
P72S19-126	P72A19-126	126	1.7500	1.777
P72S19-130	P72A19-130	130	1.8055	1.833
P72S19-140	P72A19-140	140	1.9444	1.972
P72S19-144	P72A19-144	144	2.0000	2.027
P72S19-150	P72A19-150	150	2.0833	2.111
P72S19-153	P72A19-153	153	2.1250	2.152
P72S19-162	P72A19-162	162	2.2500	2.277
P72S19-168	P72A19-168	168	2.3333	2.361
P72S19-170	P72A19-170	170	2.3611	2.388
P72S19-180	P72A19-180	180	2.5000	2.527
P72S19-198	P72A19-198	198	2.7500	2.777
P72S19-200	P72A19-200	200	2.7777	2.805
P72S19-216	P72A19-216	216	3.0000	3.027
P72S19-288	P72A19-288	288	4.0000	4.027

For Couplings See Section G.
For Shafts, Bearings and Collars See Section I.

SPUR GEARS

PITCH	STYLE	BORE	FACE	MATERIAL	AGMA QUALITY	PRESSURE ANGLE
72	PIN HUB	1/4"	3/16"	303 STAINLESS STEEL AND ALUMINUM ANODIZED	10	20°

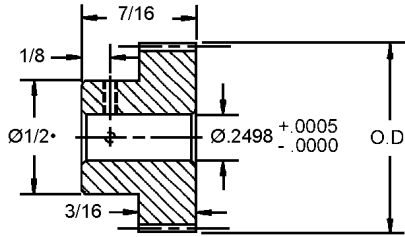
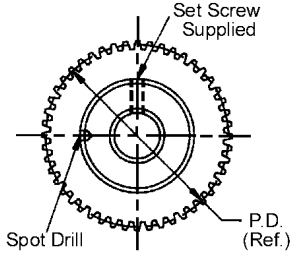

• For 35-38 teeth hub diameter equals .44

Available on request, other numbers of teeth, AGMA quality 12 and 14, and 14-1/2° Pressure Angle.

303 STAINLESS STEEL STOCK NO.	2024-T4 ALUMINUM ANODIZED STOCK NO.	NO. OF TEETH	PITCH DIA.	OUTSIDE DIA.
P72S28-38	P72A28-38	38•	.5277	.555
P72S28-40	P72A28-40	40	.5555	.583
P72S28-42	P72A28-42	42	.5833	.611
P72S28-44	P72A28-44	44	.6111	.638
P72S28-45	P72A28-45	45	.6250	.652
P72S28-46	P72A28-46	46	.6388	.666
P72S28-48	P72A28-48	48	.6666	.694
P72S28-50	P72A28-50	50	.6944	.722
P72S28-54	P72A28-54	54	.7500	.777
P72S28-55	P72A28-55	55	.7638	.791
P72S28-60	P72A28-60	60	.8333	.861
P72S28-63	P72A28-63	63	.8750	.902
P72S28-64	P72A28-64	64	.8888	.916
P72S28-65	P72A28-65	65	.9027	.930
P72S28-70	P72A28-70	70	.9722	1.000
P72S28-72	P72A28-72	72	1.0000	1.027
P72S28-80	P72A28-80	80	1.1111	1.138
P72S28-90	P72A28-90	90	1.2500	1.277
P72S28-96	P72A28-96	96	1.3333	1.361
P72S28-100	P72A28-100	100	1.3888	1.416
P72S28-105	P72A28-105	105	1.4583	1.486
P72S28-110	P72A28-110	110	1.5277	1.555
P72S28-120	P72A28-120	120	1.6666	1.694
P72S28-126	P72A28-126	126	1.7500	1.777
P72S28-130	P72A28-130	130	1.8055	1.833
P72S28-136	P72A28-136	136	1.8888	1.916
P72S28-140	P72A28-140	140	1.9444	1.972
P72S28-150	P72A28-150	150	2.0833	2.111
P72S28-160	P72A28-160	160	2.2222	2.250
P72S28-170	P72A28-170	170	2.3611	2.388
P72S28-180	P72A28-180	180	2.5000	2.527

**For Couplings See Section G.
For Shafts, Bearings and Collars See Section I.**

SPUR GEARS

PITCH	STYLE	BORE	FACE	MATERIAL	AGMA QUALITY	PRESSURE ANGLE
72	CLAMP STYLE	1/8"	1/8"	303 STAINLESS STEEL AND ALUMINUM ANODIZED	10	20°

B

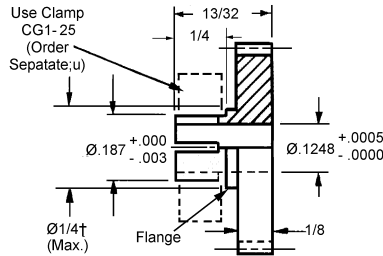
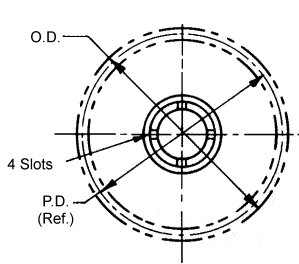

† Teeth may runout on flange diameter.

Available on request, other numbers of teeth, Agma Quality 12 and 14-1/2° Pressure Angle.

303 STAINLESS STEEL STOCK NO.	2024-T4 ALUMINUM ANODIZED STOCK NO.	NO. OF TEETH	PITCH DIA.	OUTSIDE DIA.
C72S7-20	C72A7-20	20†	.2777	.305
C72S7-22	C72A7-22	22	.3055	.333
C72S7-23	C72A7-23	23	.3194	.347
C72S7-25	C72A7-25	25	.3472	.375
C72S7-26	C72A7-26	26	.3611	.388
C72S7-27	C72A7-27	27	.3750	.402
C72S7-28	C72A7-28	28	.3888	.416
C72S7-30	C72A7-30	30	.4166	.444
C72S7-32	C72A7-32	32	.4444	.472
C72S7-34	C72A7-34	34	.4722	.500
C72S7-36	C72A7-36	36	.5000	.527
C72S7-38	C72A7-38	38	.5277	.555
C72S7-40	C72A7-40	40	.5555	.583
C72S7-42	C72A7-42	42	.5833	.611
C72S7-50	C72A7-50	50	.6944	.722
C72S7-56	C72A7-56	56	.7777	.805
C72S7-60	C72A7-60	60	.8333	.861
C72S7-64	C72A7-64	64	.8888	.916
C72S7-70	C72A7-70	70	.9722	1.000
C72S7-72	C72A7-72	72	1.0000	1.027
C72S7-75	C72A7-75	75	1.0416	1.069
C72S7-80	C72A7-80	80	1.1111	1.138
C72S7-81	C72A7-81	81	1.1250	1.152
C72S7-85	C72A7-85	85	1.1805	1.208
C72S7-90	C72A7-90	90	1.2500	1.277
C72S7-96	C72A7-96	96	1.3333	1.361

**For Couplings See Section G.
For Shafts, Bearings and Collars See Section I.**

SPUR GEARS

PITCH	STYLE	BORE	FACE	MATERIAL	AGMA QUALITY	PRESSURE ANGLE
72	CLAMP STYLE	3/16"	1/8"	303 STAINLESS STEEL AND ALUMINUM ANODIZED	10	20°

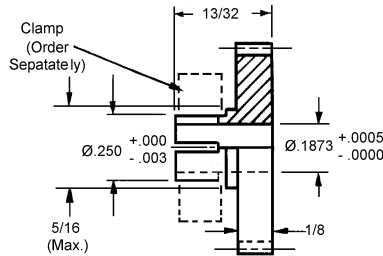
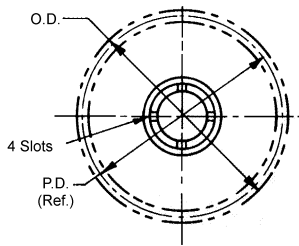

Available on request, other numbers of teeth, Agma Quality 12 and 14-1/2° Pressure Angle.

X in part number indicates part may be supplied in two piece construction with stainless steel hub (some dimensions may vary).

303 STAINLESS STEEL STOCK NO.	2024-T4 ALUMINUM ANODIZED STOCK NO.	NO. OF TEETH	PITCH DIA.	OUTSIDE DIA.
C72S14-30	C72A14-30	30	.4166	.444
C72S14-36	C72A14-36	36	.5000	.527
C72S14-72	C72A14-72	72	1.0000	1.027
C72S14-100	C72A14-100	100	1.3888	1.416
C72S14-126	C72A14-126	126	1.7500	1.777
C72S14-160	C72A14-160	160	2.2222	2.250
C72S15X-180	C72A15X-180	180	2.5000	2.527
C72S15X-216	C72A15X-216	216	3.0000	3.027
C72S15X-288	C72A15X-288	288	4.0000	4.027

PITCH	STYLE	BORE	FACE	MATERIAL	AGMA QUALITY	PRESSURE ANGLE
72	CLAMP STYLE	1/4"	1/8"	303 STAINLESS STEEL AND ALUMINUM ANODIZED	10	20°

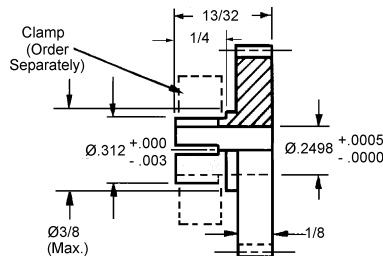
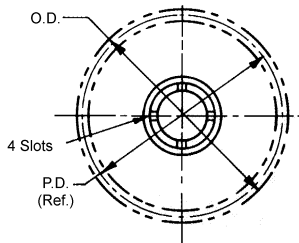

Available on request, other numbers of teeth, Agma Quality 12 and 14-1/2° Pressure Angle.

303 STAINLESS STEEL STOCK NO.	2024-T4 ALUMINUM ANODIZED STOCK NO.	NO. OF TEETH	PITCH DIA.	OUTSIDE DIA.
C72S18-45	C72A18-45	45	.6250	.652
C72S18-63	C72A18-63	63	.8750	.902
C72S18-72	C72A18-72	72	1.0000	1.027
C72S18-90	C72A18-90	90	1.2500	1.277
C72S18-99	C72A18-99	99	1.3750	1.402
C72S18-108	C72A18-108	108	1.5000	1.527
C72S18-126	C72A18-126	126	1.7500	1.777
C72S18-144	C72A18-144	144	2.0000	2.027
C72S18-180	C72A18-180	180	2.5000	2.527
C72S18-216	C72A18-216	216	3.0000	3.027
C72S18-288	C72A18-288	288	4.0000	4.027

GEAR RACKS

PITCH	STYLE	MATERIAL	AGMA QUALITY	PRESSURE ANGLE
72	ROUND & RECTANGULAR	416 SERIES STAINLESS STEEL STRESSED RELIEVED	10	20°

B

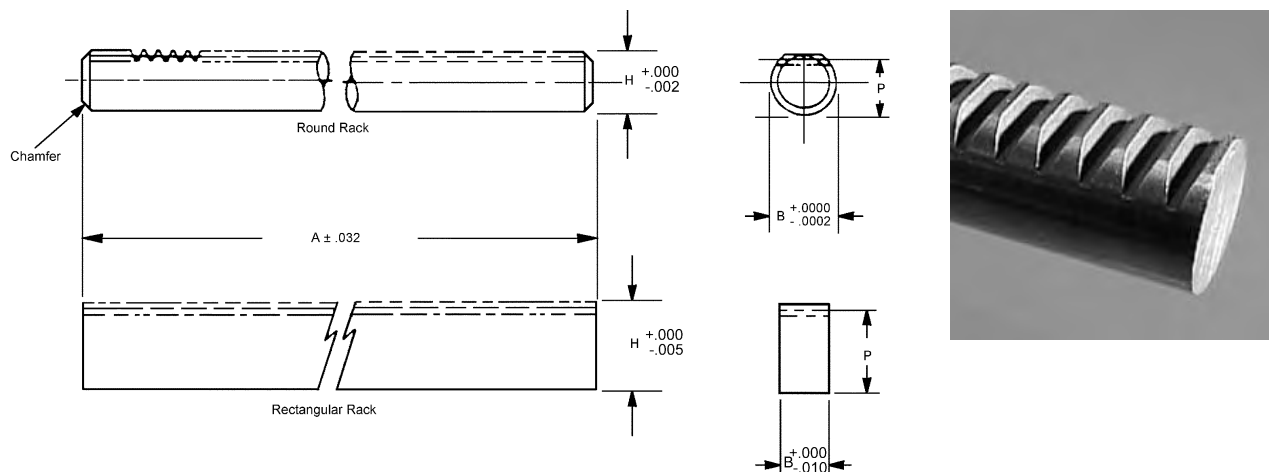

STOCK NO.	RACK STYLE	PITCH	P (Ref.)	B	A	H	AGMA QUALITY
R2-19	ROUND	72	.1421	.1872	11	.156	10
R2-15	RECTANGULAR	72	.3411	.167±.005	11	.355	10

Available on request: 14 - 1/2° pressure angle, special, modified and custom racks.

PITCH	STYLE	MATERIAL	AGMA QUALITY	PRESSURE ANGLE
72	RECTANGULAR	416 SERIES STAINLESS STEEL AND 2024-T4 ALUMINUM ANODIZED	10	20°

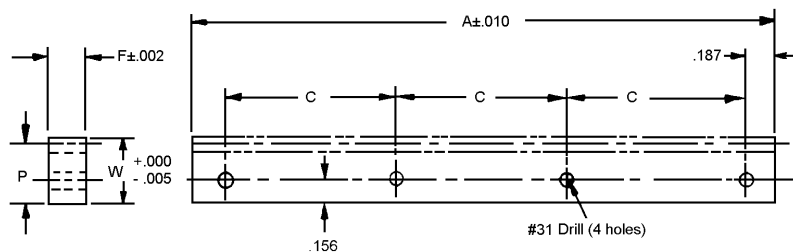

STOCK NO.	MATERIAL	A (Inch)	P (Ref.)	W	F	C
R4-17	STAINLESS ST.	5"	.3411	.355	.167	1.541
R4-18	ALUMINUM					

Available on request: special, modified and custom racks.

GEAR RACKS

PITCH	STYLES	MATERIAL	AGMA QUALITY	PRESSURE ANGLE
72	RECTANGULAR	416 SERIES STAINLESS STEEL STRESSED RELIEVED	10	20°

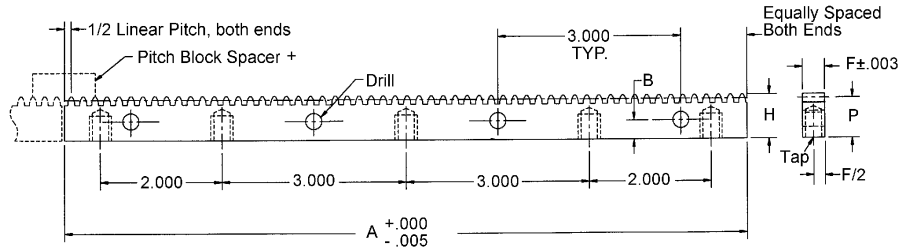

† Spacer block is designed for butting to achieve continuous lengths. On-Line pricing for AGMA 10 only.

RACKS	SPACER BLOCK	AGMA QTY. NO.	MAX ACCUM. ERROR	TOOTH TO TOOTH ERROR	PITCH	LINEAR PITCH	A INCH	P REF.	H +.000 / -.005	F	B	DRILL	TAP
R1-9-G1	R1-9-SB	10*	.0014	.0005	72	.0436	11.033	.3361	.350	.167	.156	#31	#4-40 X 3/16
R3-6-G1	R3-6-SB	10*	.0014	.0005	72	.0436	11.033	.3411	.355	.167	.156	#31	#4-40 X 3/16

* Higher quality on request.

ANTI-BACKLASH GEARS

PITCH	STYLE	BORE	FACE	MATERIAL	AGMA QUALITY	PRES. ANGLE
72	PIN HUB	1/8"	.104"	303 STAINLESS STEEL OR 2024-T4 ALUMINUM ANODIZED	10	20°

B

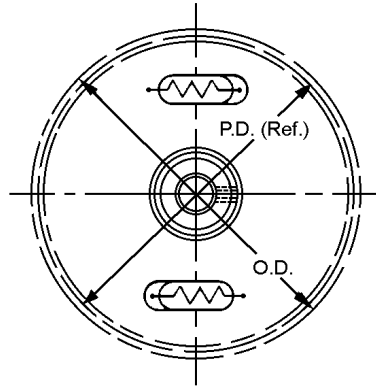
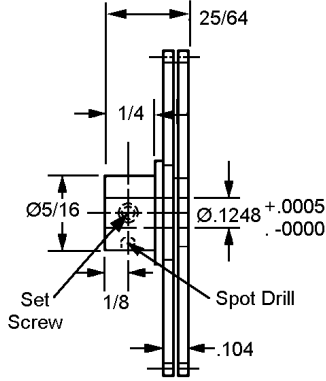

Hub Material: 303 Stainless Steel

303 STAINLESS STEEL STOCK NO.	2024-T4 ALUMINUM ANODIZED STOCK NO.	NO. OF TEETH	PITCH DIAMETER
AP72SS-58	AP72TS-58	58	.8055
AP72SS-60	AP72TS-60	60	.8333
AP72SS-64	AP72TS-64	64	.8888
AP72SS-68	AP72TS-68	68	.9444
AP72SS-70	AP72TS-70	70	.9722
AP72SS-72	AP72TS-72	72	1.0000
AP72SS-75	AP72TS-75	75	1.0416
AP72SS-80	AP72TS-80	80	1.1111
AP72SS-84	AP72TS-84	84	1.1666
AP72SS-90	AP72TS-90	90	1.2500
AP72SS-96	AP72TS-96	96	1.3333
AP72S-100	AP72T-100	100	1.3888
AP72S-105	AP72T-105	105	1.4583
AP72S-108	AP72T-108	108	1.5000
AP72S-110	AP72T-110	110	1.5277
AP72S-115	AP72T-115	115	1.5972
AP72S-120	AP72T-120	120	1.6666
AP72S-125	AP72T-125	125	1.7361
AP72S-130	AP72T-130	130	1.8055
AP72S-140	AP72T-140	140	1.9444
AP72S-144	AP72T-144	144	2.0000
AP72S-150	AP72T-150	150	2.0833
AP72S-160	AP72T-160	160	2.2222
AP72S-170	AP72T-170	170	2.3611
AP72S-180	AP72T-180	180	2.5000
AP72S-190	AP72T-190	190	2.6388
AP72S-200	AP72T-200	200	2.7777
AP72S-210	AP72T-210	210	2.9166
AP72S-216	AP72T-216	216	3.0000
AP72S-220	AP72T-220	220	3.0555
AP72S-225	AP72T-225	225	3.1250

O.D. = P.D. +.031

Available on request:

- Other numbers of teeth;
- AGMA Quality 12 and 14 (some dimensions may vary);
- 14-12° pressure angle.

For Couplings See Section G.
For Shafts, Bearings and Collars See Section I.

ANTI-BACKLASH GEARS

PITCH	STYLE	BORE	FACE	MATERIAL	AGMA QUALITY	PRES. ANGLE
72	PIN HUB	1/8"	.104	303 STAINLESS STEEL OR 2024-T4 ALUMINUM ANODIZED	10	20°

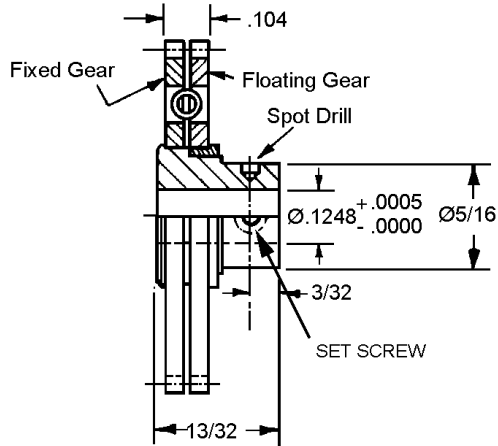

Hub Material: 303 Stainless Steel

303 STAINLESS STEEL STOCK NO.	2024-T4 ALUMINUM ANODIZED STOCK NO.	NO. OF TEETH	PITCH DIAMETER	OUTSIDE DIA.
AP72AS-45	-	45	.6250	.652
AP72AS-56	AP72NS-56	56	.7777	.805
AP72AS-60	AP72NS-60	60	.8333	.861
AP72AS-63	AP72NS-63	63	.8750	.902
AP72AS-65	AP72NS-65	65	.9027	.930
AP72AS-70	AP72NS-70	70	.9722	1.000

Available on request:

Other numbers of teeth;
AGMA Quality 12 and 14 (some dimensions may vary);
14-12° pressure angle.

**For Couplings See Section G.
For Shafts, Bearings and Collars See Section I.**

ANTI-BACKLASH PINIONS

PITCH	STYLE	BORE	FACE	MATERIAL	AGMA QUALITY	PRES. ANGLE
72	PIN HUB	1/8"	1/8"	303 STAINLESS STEEL OR 2024-T4 ALUMINUM ANODIZED	10	20°

B

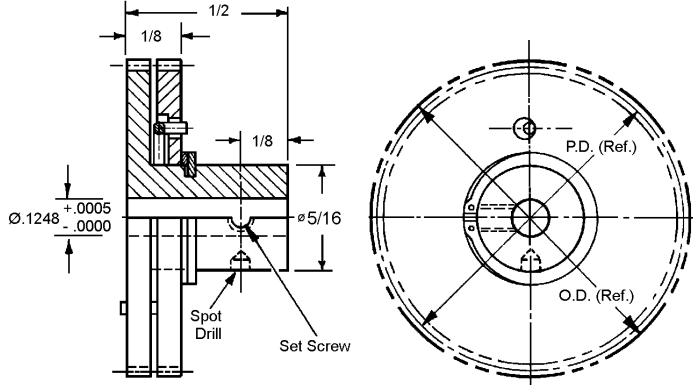

Hub Material:
303 Stainless Steel

STAINLESS STEEL STOCK NO.	ALUMINUM STOCK NO.	NO. OF TEETH	BORE	PITCH DIA.	OUTSIDE DIA.
AP72FS-44	AP72GS-44	44	.1248	.6111	.639
AP72FS-56	AP72GS-56	56		.7777	.805
AP72FS-72	AP72GS-72	72		1.0000	1.028

Available on request:
Other numbers of teeth
AGMA Quality 12 and 14
14-1/2° Pressure Angle

For Couplings See Section G.
For Shafts, Bearings and Collars See Section I.

ANTI-BACKLASH GEARS

PITCH	STYLE	BORE	FACE	MATERIAL	AGMA QUALITY	PRES. ANGLE
72	PIN HUB	3/16"	.104"	303 STAINLESS STEEL OR 2024-T4 ALUMINUM ANODIZED	10	20°

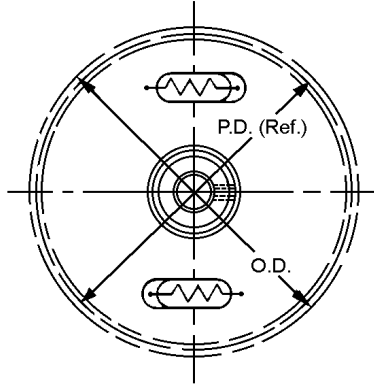
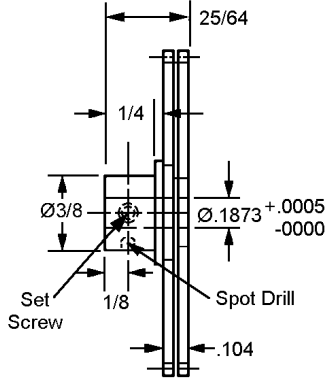

Hub Material: 303 Stainless Steel

303 STAINLESS STEEL STOCK NO.	2024-T4 ALUMINUM ANODIZED STOCK NO.	NO. OF TEETH	PITCH DIAMETER
AP72US-68	AP72VS-68	68	.9444
AP72US-70	AP72VS-70	70	.9722
AP72US-72	AP72VS-72	72	1.0000
AP72US-75	AP72VS-75	75	1.0416
AP72US-80	AP72VS-80	80	1.1111
AP72US-84	AP72VS-84	84	1.1666
AP72US-90	AP72VS-90	90	1.2500
AP72US-96	AP72VS-96	96	1.3333
AP72U-100	AP72V-100	100	1.3888
AP72U-105	AP72V-105	105	1.4583
AP72U-108	AP72V-108	108	1.5000
AP72U-110	AP72V-110	110	1.5277
AP72U-115	AP72V-115	115	1.5972
AP72U-120	AP72V-120	120	1.6666
AP72U-125	AP72V-125	125	1.7361
AP72U-130	AP72V-130	130	1.8055
AP72U-140	AP72V-140	140	1.9444
AP72U-144	AP72V-144	144	2.0000
AP72U-150	AP72V-150	150	2.0833
AP72U-160	AP72V-160	160	2.2222
AP72U-170	AP72V-170	170	2.3611
AP72U-180	AP72V-180	180	2.5000
AP72U-190	AP72V-190	190	2.6388
AP72U-200	AP72V-200	200	2.7777
AP72U-210	AP72V-210	210	2.9166
AP72U-216	AP72V-216	216	3.0000
AP72U-220	AP72V-220	220	3.0555
AP72U-225	AP72V-225	225	3.1250

O.D. = P.D. +.031

Available on request:

Other numbers of teeth;
 AGMA Quality 12 and 14 (some dimensions may vary);
 14-12° pressure angle.

For Couplings See Section G.
For Shafts, Bearings and Collars See Section I.

ANTI-BACKLASH GEARS

PITCH	STYLE	BORE	FACE	MATERIAL	AGMA QUALITY	PRES. ANGLE
72	PIN HUB	3/16"	.104	303 STAINLESS STEEL OR 2024-T4 ALUMINUM ANODIZED	10	20°

B

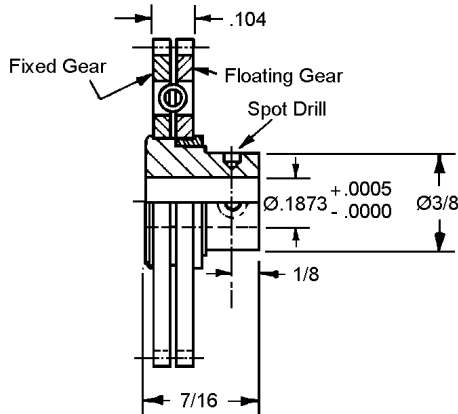

Hub Material: 303 Stainless Steel

303 STAINLESS STEEL STOCK NO.	2024-T4 ALUMINUM ANODIZED STOCK NO.	NO. OF TEETH	PITCH DIAMETER	OUTSIDE DIA.
AP72CS-50	-	50	.6944	.722
AP72CS-52	AP72PS-52	52	.7222	.750
AP72CS-54	AP72PS-54	54	.7500	.777
AP72CS-60	AP72PS-60	60	.8333	.861
AP72CS-63	AP72PS-63	63	.8750	.902
AP72CS-65	AP72PS-65	65	.9027	.930
AP72CS-70	AP72PS-70	70	.9722	1.000

Available on request:

Other numbers of teeth;
AGMA Quality 12 and 14 (some dimensions may vary);
14-12° pressure angle.

PITCH	STYLE	BORE	FACE	MATERIAL	AGMA QUALITY	PRES. ANGLE
72	PIN HUB	3/16"	1/8"	303 STAINLESS STEEL OR 2024-T4 ALUMINUM ANODIZED	10	20°

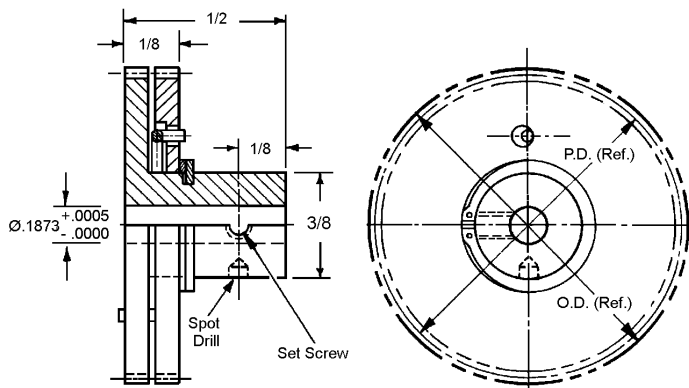

Hub Material: 303 Stainless Steel

STAINLESS STEEL STOCK NO.	ALUMINUM STOCK NO.	NO. OF TEETH	PITCH DIA.	OUTSIDE DIA.
AP72HS-44	AP72JS-44	44	.6111	.639
AP72HS-56	AP72JS-56	56	.7777	.805
AP72HS-72	AP72JS-72	72	1.0000	1.028

Available on request:
Other numbers of teeth
AGMA Quality 12 and 14
14-1/2° Pressure Angle

ANTI-BACKLASH GEARS

PITCH	STYLE	BORE	FACE	MATERIAL	AGMA QUALITY	PRES. ANGLE
72	PIN HUB	1/4"	.104"	303 STAINLESS STEEL OR 2024-T4 ALUMINUM ANODIZED	10	20°

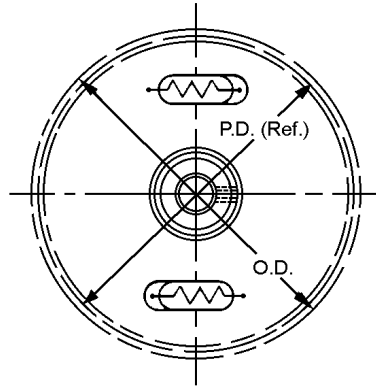
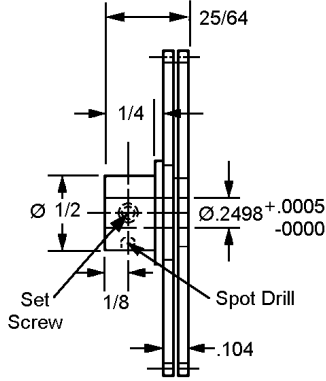

Hub Material: 303 Stainless Steel

303 STAINLESS STEEL STOCK NO.	2024-T4 ALUMINUM ANODIZED STOCK NO.	NO. OF TEETH	PITCH DIAMETER
AP72WS-72	AP72XS-72	72	1.0000
AP72WS-75	AP72XS-75	75	1.0416
AP72WS-80	AP72XS-80	80	1.1111
AP72WS-84	AP72XS-84	84	1.1666
AP72WS-90	AP72XS-90	90	1.2500
AP72WS-96	AP72XS-96	96	1.3333
AP72W-100	AP72X-100	100	1.3888
AP72W-105	AP72X-105	105	1.4583
AP72W-108	AP72X-108	108	1.5000
AP72W-110	AP72X-110	110	1.5277
AP72W-115	AP72X-115	115	1.5972
AP72W-120	AP72X-120	120	1.6666
AP72W-125	AP72X-125	125	1.7361
AP72W-130	AP72X-130	130	1.8055
AP72W-140	AP72X-140	140	1.9444
AP72W-144	AP72X-144	144	2.0000
AP72W-150	AP72X-150	150	2.0833
AP72W-160	AP72X-160	160	2.2222
AP72W-170	AP72X-170	170	2.3611
AP72W-180	AP72X-180	180	2.5000
AP72W-190	AP72X-190	190	2.6388
AP72W-200	AP72X-200	200	2.7777
AP72W-210	AP72X-210	210	2.9166
AP72W-216	AP72X-216	216	3.0000
AP72W-220	AP72X-220	220	3.0555
AP72W-225	AP72X-225	225	3.1250

O.D. = P.D. +.031

Available on request:

- Other numbers of teeth;
- AGMA Quality 12 and 14 (some dimensions may vary);
- 14-12° pressure angle.

For Couplings See Section G.
For Shafts, Bearings and Collars See Section I.

ANTI-BACKLASH PINIONS

PITCH	STYLE	BORE	FACE	MATERIAL	AGMA QUALITY	PRES. ANGLE
72	CLAMP STYLE	1/8"	1/8"	303 STAINLESS STEEL OR 2024-T4 ALUMINUM ANODIZED	10	20°

B

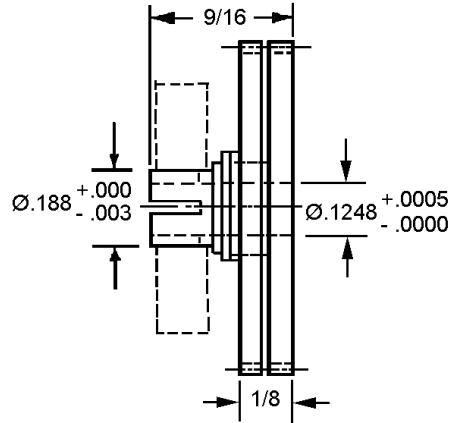

Hub Material:
303 Stainless Steel

STAINLESS STEEL STOCK NO.	ALUMINUM STOCK NO.	NO. OF TEETH	PITCH DIA.	OUTSIDE DIA.
AC72FS-44	AC72GS-44	44	.6111	.639
AC72FS-56	AC72GS-56	56	.7777	.805
AC72FS-72	AC72GS-72	72	1.0000	1.028

Available on request:
Other numbers of teeth
AGMA Quality 12 and 14
14-1/2° Pressure Angle

**For Couplings See Section G.
For Shafts, Bearings and Collars See Section I.**

ANTI-BACKLASH GEARS

PITCH	STYLE	BORE	FACE	MATERIAL	AGMA QUALITY	PRES. ANGLE
72	CLAMP STYLE	1/8"	.104	303 STAINLESS STEEL OR 2024-T4 ALUMINUM ANODIZED	10	20°

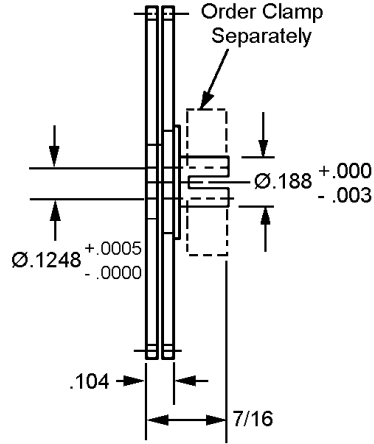

Hub Material: 303 Stainless Steel

303 STAINLESS STEEL STOCK NO.	2024-T4 ALUMINUM ANODIZED STOCK NO.	NO. OF TEETH	PITCH DIAMETER
AC72SS-58	AC72TS-58	58	.8055
AC72SS-60	AC72TS-60	60	.8333
AC72SS-64	AC72TS-64	64	.8888
AC72SS-68	AC72TS-68	68	.9444
AC72SS-70	AC72TS-70	70	.9722
AC72SS-72	AC72TS-72	72	1.0000
AC72SS-75	AC72TS-75	75	1.0416
AC72SS-80	AC72TS-80	80	1.1111
AC72SS-84	AC72TS-84	84	1.1666
AC72SS-90	AC72TS-90	90	1.2500
AC72SS-96	AC72TS-96	96	1.3333
AC72S-100	AC72T-100	100	1.3888
AC72S-105	AC72T-105	105	1.4583
AC72S-108	AC72T-108	108	1.5000
AC72S-110	AC72T-110	110	1.5277
AC72S-115	AC72T-115	115	1.5972
AC72S-120	AC72T-120	120	1.6666
AC72S-125	AC72T-125	125	1.7361
AC72S-130	AC72T-130	130	1.8055
AC72S-140	AC72T-140	140	1.9444
AC72S-144	AC72T-144	144	2.0000
AC72S-150	AC72T-150	150	2.0833
AC72S-160	AC72T-160	160	2.2222
AC72S-170	AC72T-170	170	2.3611
AC72S-180	AC72T-180	180	2.5000
AC72S-190	AC72T-190	190	2.6388
AC72S-200	AC72T-200	200	2.7777
AC72S-210	AC72T-210	210	2.9166
AC72S-216	AC72T-216	216	3.0000
AC72S-220	AC72T-220	220	3.0555
AC72S-225	AC72T-225	225	3.1250

Available on request:

Other numbers of teeth;
 AGMA Quality 12 and 14 (some dimensions may vary);
 14-12° pressure angle.

**For Couplings See Section G.
 For Shafts, Bearings and Collars See Section I.**

ANTI-BACKLASH GEARS

B

PITCH	STYLE	BORE	FACE	MATERIAL	AGMA QUALITY	PRES. ANGLE
72	CLAMP STYLE	1/8"	.104	303 STAINLESS STEEL OR 2024-T4 ALUMINUM ANODIZED	10	20°

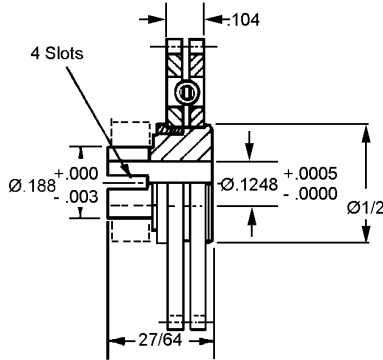

Hub Material: 303 Stainless Steel

303 STAINLESS STEEL STOCK NO.	2024-T4 ALUMINUM ANODIZED STOCK NO.	NO. OF TEETH	PITCH DIAMETER	OUTSIDE DIA.
AC72AS-56	AC72NS-56	56	.7777	.805
AC72AS-60	AC72NS-60	60	.8333	.861
AC72AS-63	AC72NS-63	63	.8750	.902
AC72AS-65	AC72NS-65	65	.9027	.930
AC72AS-70	AC72NS-70	70	.9722	1.000

Available on request:

Other numbers of teeth;
AGMA Quality 12 and 14 (some dimensions may vary);
14-12° pressure angle.

PITCH	STYLE	BORE	FACE	MATERIAL	AGMA QUALITY	PRES. ANGLE
72	CLAMP STYLE	3/16"	.104	303 STAINLESS STEEL OR 2024-T4 ALUMINUM ANODIZED	10	20°

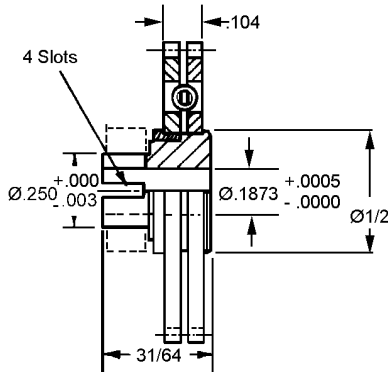

Hub Material:
303 Stainless Steel

Available on request:

Other numbers of teeth;
AGMA Quality 12 and 14
(some dimensions may vary);
14-12° pressure angle.

303 STAINLESS STEEL STOCK NO.	2024-T4 ALUMINUM ANODIZED STOCK NO.	NO. OF TEETH	PITCH DIAMETER	OUTSIDE DIA.
AC72CS-50	-	50	.6944	.722
AC72CS-52	AC72PS-52	52	.7222	.750
AC72CS-54	AC72PS-54	54	.7500	.777
AC72CS-60	AC72PS-60	60	.8333	.861
AC72CS-63	AC72PS-63	63	.8750	.902
AC72CS-65	AC72PS-65	65	.9027	.930
AC72CS-70	AC72PS-70	70	.9722	1.000

ANTI-BACKLASH GEARS

PITCH	STYLE	BORE	FACE	MATERIAL	AGMA QUALITY	PRES. ANGLE
72	CLAMP STYLE	3/16"	1/8	303 STAINLESS STEEL OR 2024-T4 ALUMINUM ANODIZED	10	20°

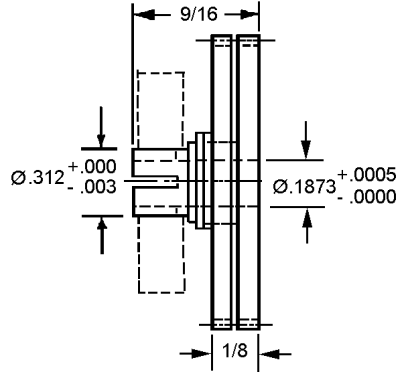

Hub Material: 303 Stainless Steel

STAINLESS STEEL STOCK NO.	ALUMINUM STOCK NO.	NO. OF TEETH	PITCH DIA.	OUTSIDE DIA.
AC72HS-44	AC72JS-44	44	.6111	.639
AC72HS-56	AC72JS-56	56	.7777	.805
AC72HS-72	AC72JS-72	72	1.0000	1.028

Available on request:
Other numbers of teeth
AGMA Quality 12 and 14
14-1/2° Pressure Angle

For Couplings See Section G.
For Shafts, Bearings and Collars See Section I.

ANTI-BACKLASH GEARS

PITCH	STYLE	BORE	FACE	MATERIAL	AGMA QUALITY	PRES. ANGLE
72	CLAMP STYLE	3/16"	.104	303 STAINLESS STEEL OR 2024-T4 ALUMINUM ANODIZED	10	20°

B

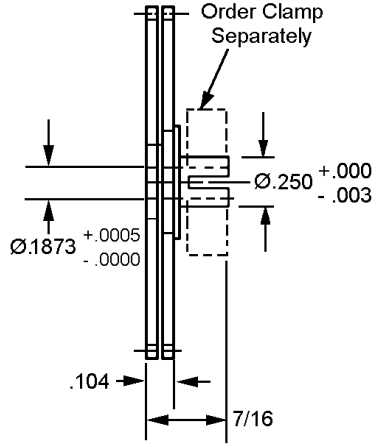

Hub Material: 303 Stainless Steel

303 STAINLESS STEEL STOCK NO.	2024-T4 ALUMINUM ANODIZED STOCK NO.	NO. OF TEETH	PITCH DIAMETER
AC72US-68	AC72VS-68	68	.9444
AC72US-70	AC72VS-70	70	.9722
AC72US-72	AC72VS-72	72	1.0000
AC72US-75	AC72VS-75	75	1.0416
AC72US-80	AC72VS-80	80	1.1111
AC72US-84	AC72VS-84	84	1.1666
AC72US-90	AC72VS-90	90	1.2500
AC72US-96	AC72VS-96	96	1.3333
AC72U-100	AC72V-100	100	1.3888
AC72U-105	AC72V-105	105	1.4583
AC72U-108	AC72V-108	108	1.5000
AC72U-110	AC72V-110	110	1.5277
AC72U-115	AC72V-115	115	1.5972
AC72U-120	AC72V-120	120	1.6666
AC72U-125	AC72V-125	125	1.7361
AC72U-130	AC72V-130	130	1.8055
AC72U-140	AC72V-140	140	1.9444
AC72U-144	AC72V-144	144	2.0000
AC72U-150	AC72V-150	150	2.0833
AC72U-160	AC72V-160	160	2.2222
AC72U-170	AC72V-170	170	2.3611
AC72U-180	AC72V-180	180	2.5000
AC72U-190	AC72V-190	190	2.6388
AC72U-200	AC72V-200	200	2.7777
AC72U-210	AC72V-210	210	2.9166
AC72U-216	AC72V-216	216	3.0000
AC72U-220	AC72V-220	220	3.0555
AC72U-225	AC72V-225	225	3.1250

Available on request:

- Other numbers of teeth;
- AGMA Quality 12 and 14 (some dimensions may vary);
- 14-12° pressure angle.

**For Couplings See Section G.
For Shafts, Bearings and Collars See Section I.**

ANTI-BACKLASH GEARS

PITCH	STYLE	BORE	FACE	MATERIAL	AGMA QUALITY	PRES. ANGLE
72	CLAMP STYLE	1/4"	.104	303 STAINLESS STEEL OR 2024-T4 ALUMINUM ANODIZED	10	20°

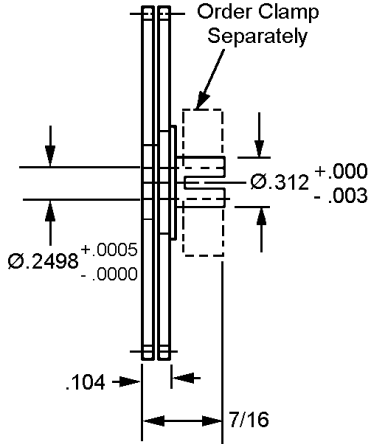

Hub Material: 303 Stainless Steel

303 STAINLESS STEEL STOCK NO.	2024-T4 ALUMINUM ANODIZED STOCK NO.	NO. OF TEETH	PITCH DIAMETER
AC72WS-72	AC72XS-72	72	1.0000
AC72WS-75	AC72XS-75	75	1.0416
AC72WS-80	AC72XS-80	80	1.1111
AC72WS-84	AC72XS-84	84	1.1666
AC72WS-90	AC72XS-90	90	1.2500
AC72WS-96	AC72XS-96	96	1.3333
AC72W-100	AC72X-100	100	1.3888
AC72W-105	AC72X-105	105	1.4583
AC72W-108	AC72X-108	108	1.5000
AC72W-110	AC72X-110	110	1.5277
AC72W-115	AC72X-115	115	1.5972
AC72W-120	AC72X-120	120	1.6666
AC72W-125	AC72X-125	125	1.7361
AC72W-130	AC72X-130	130	1.8055
AC72W-140	AC72X-140	140	1.9444
AC72W-144	AC72X-144	144	2.0000
AC72W-150	AC72X-150	150	2.0833
AC72W-160	AC72X-160	160	2.2222
AC72W-170	AC72X-170	170	2.3611
AC72W-180	AC72X-180	180	2.5000
AC72W-190	AC72X-190	190	2.6388
AC72W-200	AC72X-200	200	2.7777
AC72W-210	AC72X-210	210	2.9166
AC72W-216	AC72X-216	216	3.0000
AC72W-220	AC72X-220	220	3.0555
AC72W-225	AC72X-225	225	3.1250

Available on request:

- Other numbers of teeth;
- AGMA Quality 12 and 14 (some dimensions may vary);
- 14-12° pressure angle.

**For Couplings See Section G.
For Shafts, Bearings and Collars See Section I.**

PINION SHAFTS

PITCH	MATERIAL	AGMA QUALITY	PRES. ANGLE
72	303 STAINLESS STEEL	10	20°

B

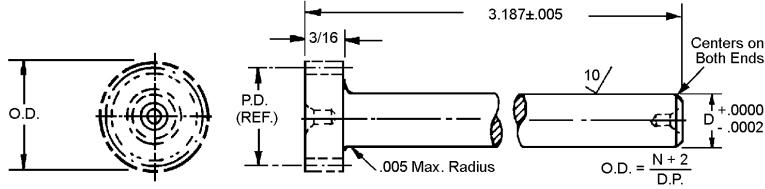

STOCK NO.	PITCH	NO. OF TEETH	PITCH DIA.	D
PS72S3-18H	72	18	.2500	.1872
PS72S2-24H	72	24	.3333	.1247
PS72S3-24H	72	24	.3333	.1872

Other numbers of teeth available on request.

PITCH	MATERIAL	AGMA QUALITY	PRES. ANGLE
72	303 STAINLESS STEEL	10	20°

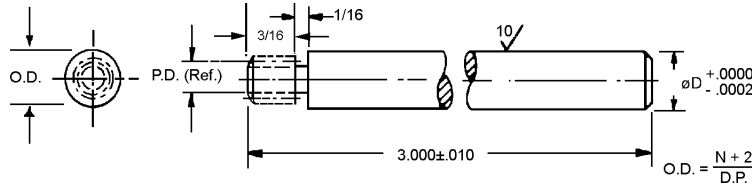

STOCK NO.	PITCH	NO. OF TEETH	PITCH DIA.	D
PS72S3-10	72	10	.1388	.1872
PS72S4-14	72	14	.1944	.2497

Other numbers of teeth available on request.

PITCH	MATERIAL	AGMA QUALITY	PRES. ANGLE
72	303 STAINLESS STEEL	10	20°

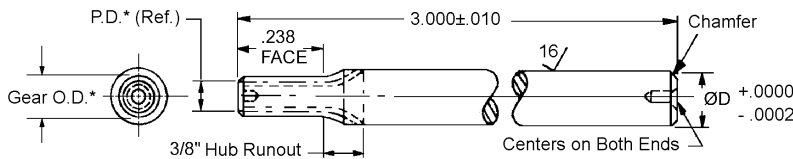

STOCK NO.	PITCH	NO. OF TEETH	D	ENLARGED	
				PITCH DIAMETER	OUTSIDE DIA.
B-PS72S3-10		10	.1872	.1504	.178
B-PS72S4-12	72	12	.1750	.1750	.202
B-PS72S4-15		15	.2497	.2117	.239

Other numbers of teeth available on request.

SPUR GEARS

PITCH	STYLE	BORE	FACE	MATERIAL	AGMA QUALITY	PRESSURE ANGLE
80	HUBLESS	3/8"	1/8"	303 STAINLESS STEEL AND 2024-T4 ALUMINUM ANODIZED	10	20°

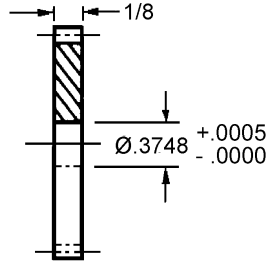
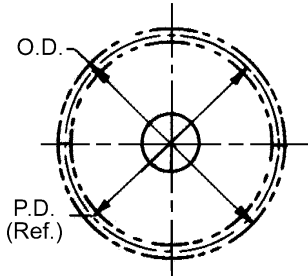

Available on request:
Pin or Clamp hubs assembled
Other numbers of teeth
14 - 1/2° Pressure Angle

303 STAINLESS STEEL STOCK NO.	2024-T4 ALUMINUM ANODIZED STOCK NO.			
		NO. OF TEETH	PITCH DIA.	OUTSIDE DIA.
F80S3-80	F80A3-80	80	1.0000	1.025
F80S3-90	F80A3-90	90	1.1250	1.150
F80S3-100	F80A3-100	100	1.2500	1.275
F80S3-110	F80A3-110	110	1.3750	1.400
F80S3-120	F80A3-120	120	1.5000	1.525
F80S3-140	F80A3-140	140	1.7500	1.775
F80S3-150	F80A3-150	150	1.8750	1.900
F80S3-160	F80A3-160	160	2.0000	2.025
F80S3-180	F80A3-180	180	2.2500	2.275
F80S3-200	F80A3-200	200	2.5000	2.525
F80S3-240	F80A3-240	240	3.0000	3.025
F80S3-280	F80A3-280	280	3.5000	3.525
F80S3-320	F80A3-320	320	4.0000	4.025

**For Couplings See Section G.
For Shafts, Bearings and Collars See Section I.**

SPUR GEARS

PITCH	STYLE	BORE	FACE	MATERIAL	AGMA QUALITY	PRESSURE ANGLE
80	PIN HUB	1/8"	1/8"	303 STAINLESS STEEL AND ALUMINUM ANODIZED	10	20°

B

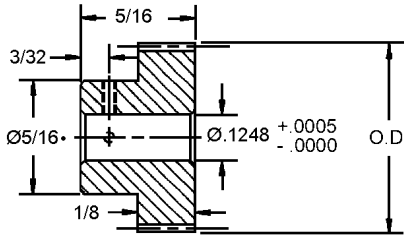
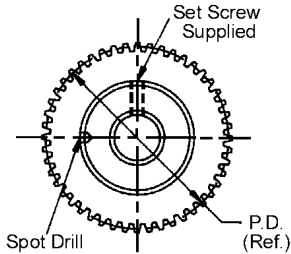

• For 22-27 teeth hub diameter equals .24
Available on request, other numbers of teeth
and 14-1/2° Pressure Angle.

303 STAINLESS STEEL STOCK NO.	2024-T4 ALUMINUM ANODIZED STOCK NO.			
		NO. OF TEETH	PITCH DIA.	OUTSIDE DIA.
P80S10-24	P80A10-24	24*	.3000	.325
P80S10-26	P80A10-26	26*	.3250	.350
P80S10-27	P80A10-27	27*	.3375	.362
P80S10-28	P80A10-28	28	.3500	.375
P80S10-30	P80A10-30	30	.3750	.400
P80S10-32	P80A10-32	32	.4000	.425
P80S10-36	P80A10-36	36	.4500	.475
P80S10-40	P80A10-40	40	.5000	.525
P80S10-42	P80A10-42	42	.5250	.550
P80S10-44	P80A10-44	44	.5500	.575
P80S10-50	P80A10-50	50	.6250	.650
P80S10-60	P80A10-60	60	.7500	.775
P80S10-80	P80A10-80	80	1.0000	1.025
P80S10-90	P80A10-90	90	1.1250	1.150
P80S10-100	P80A10-100	100	1.2500	1.275
P80S10-110	P80A10-110	110	1.3750	1.400
P80S10-120	P80A10-120	120	1.5000	1.525
P80S10-130	P80A10-130	130	1.6250	1.650
P80S10-140	P80A10-140	140	1.7500	1.775
P80S10-150	P80A10-150	150	1.8750	1.900
P80S10-160	P80A10-160	160	2.0000	2.025
P80S10-170	P80A10-170	170	2.1250	2.150
P80S10-180	P80A10-180	180	2.2500	2.275

**For Couplings See Section G.
For Shafts, Bearings and Collars See Section I.**

SPUR GEARS

PITCH	STYLE	BORE	FACE	MATERIAL	AGMA QUALITY	PRESSURE ANGLE
80	PIN HUB	3/16"	1/8"	303 STAINLESS STEEL AND ALUMINUM ANODIZED	10	20°

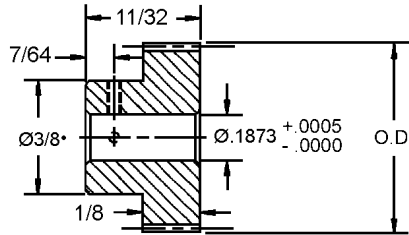
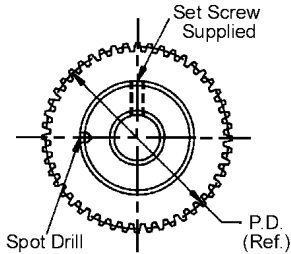

• For 30 teeth hub diameter equals .34

Available on request, other numbers of teeth, AGMA quality 12 and 14, and 14-1/2° Pressure Angle.

303 STAINLESS STEEL STOCK NO.	2024-T4 ALUMINUM ANODIZED STOCK NO.			
		NO. OF TEETH	PITCH DIA.	OUTSIDE DIA.
P80S19-30	P80A19-30	30*	.3750	.400
P80S19-40	P80A19-40	40	.5000	.525
P80S19-44	P80A19-44	44	.5500	.575
P80S19-50	P80A19-50	50	.6250	.650
P80S19-60	P80A19-60	60	.7500	.775
P80S19-65	P80A19-65	65	.8125	.837
P80S19-70	P80A19-70	70	.8750	.900
P80S19-80	P80A19-80	80	1.0000	1.025
P80S19-85	P80A19-85	85	1.0625	1.087
P80S19-90	P80A19-90	90	1.1250	1.150
P80S19-100	P80A19-100	100	1.2500	1.275
P80S19-110	P80A19-110	110	1.3750	1.400
P80S19-120	P80A19-120	120	1.5000	1.525
P80S19-130	P80A19-130	130	1.6250	1.650
P80S19-140	P80A19-140	140	1.7500	1.775
P80S19-150	P80A19-150	150	1.8750	1.900
P80S19-160	P80A19-160	160	2.0000	2.025

**For Couplings See Section G.
For Shafts, Bearings and Collars See Section I.**

GEAR RACKS

PITCH	STYLE	MATERIAL	AGMA QUALITY	PRESSURE ANGLE
80	RECTANGULAR	416 SERIES STAINLESS STEEL AND 2024-T4 ALUMINUM ANODIZED	10	20°

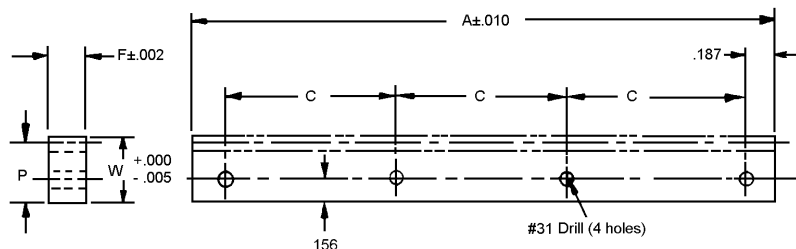

STOCK NO.	MATERIAL	A (Inch)	P (Ref.)	W	F	C
R4-19	STAINLESS ST.	5"	.3425	.355	.167	1.541
R4-20	ALUMINUM					

Available on request: special, modified and custom racks.

B

PITCH	STYLE	MATERIAL	AGMA QUALITY	PRESSURE ANGLE
80	RECTANGULAR	416 SERIES STAINLESS STEEL STRESSED RELIEVED	10	20°

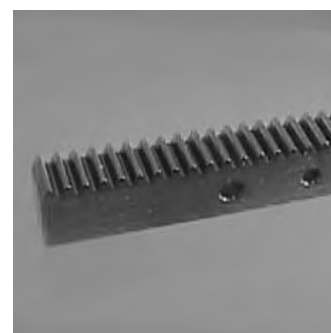
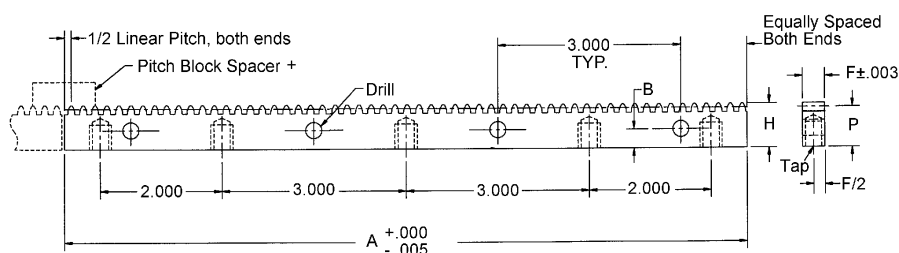

† Spacer block is designed for butting to achieve continuous lengths. On-Line pricing for AGMA 10 only.

RACKS	SPACER BLOCK	AGMA QTY. NO.	MAX ACCUM. ERROR	TOOTH TO TOOTH ERROR	PITCH	LINEAR PITCH	A INCH	P REF.	H +.000 -.005	F	B	DRILL	TAP
R1-10-G1	R1-10-SB	10*	.0014	.0005	80	.0393	11.028	.3375	.350	.167	.156	#31	#4-40 X 3/16

* Higher quality on request.

PINION SHAFTS

PITCH	MATERIAL	AGMA QUALITY	PRES. ANGLE
80	303 STAINLESS STEEL	10	20°

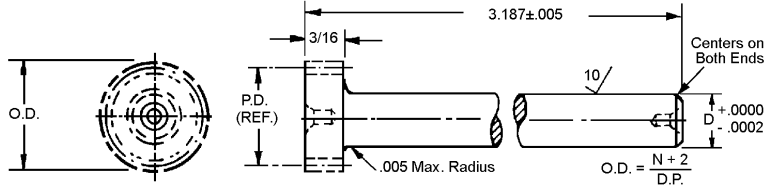

STOCK NO.	PITCH	NO. OF TEETH	PITCH DIA.	D
PS80S3-20H	80	20	.2500	.1872

Other numbers of teeth available on request.



PITCH	MATERIAL	AGMA QUALITY	PRES. ANGLE
80	303 STAINLESS STEEL	10	20°

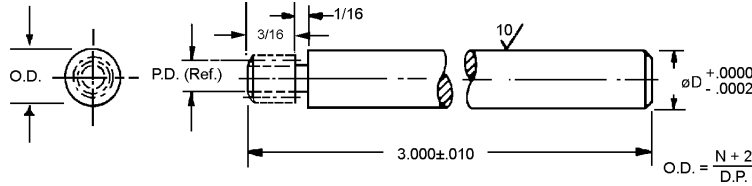

STOCK NO.	PITCH	NO. OF TEETH	PITCH DIA.	D
PS80S4-10	80	10	.1250	.2497
PS80S4-12	80	12	.1500	.2497

Other numbers of teeth available on request.



SPUR GEARS

PITCH	STYLE	BORE	FACE	MATERIAL	AGMA QUALITY	PRESSURE ANGLE
96	HUBLESS	3/8"	3/32"	303 STAINLESS STEEL AND 2024-T4 ALUMINUM ANODIZED	10	20°

B

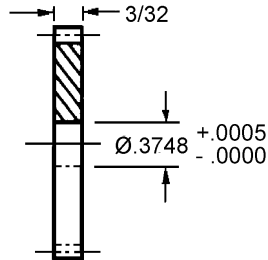
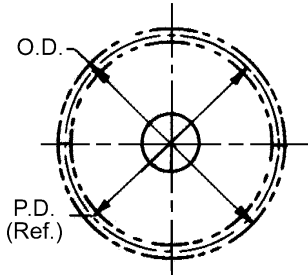

Available on request:
Pin or Clamp hubs assembled
Other numbers of teeth
14 - 1/2° Pressure Angle
1/16" Face

303 STAINLESS STEEL STOCK NO.	2024-T4 ALUMINUM ANODIZED STOCK NO.	NO. OF TEETH	PITCH DIA.	OUTSIDE DIA.
F96S2-96	F96A2-96	96	1.0000	1.020
F96S2-100	F96A2-100	100	1.0416	1.062
F96S2-105	F96A2-105	105	1.0937	1.114
F96S2-108	F96A2-108	108	1.1250	1.145
F96S2-110	F96A2-110	110	1.1458	1.166
F96S2-120	F96A2-120	120	1.2500	1.270
F96S2-125	F96A2-125	125	1.3020	1.322
F96S2-132	F96A2-132	132	1.3750	1.395
F96S2-140	F96A2-140	140	1.4583	1.479
F96S2-144	F96A2-144	144	1.5000	1.520
F96S2-150	F96A2-150	150	1.5625	1.583
F96S2-160	F96A2-160	160	1.6666	1.687
F96S2-180	F96A2-180	180	1.8750	1.895
F96S2-190	F96A2-190	190	1.9791	2.000
F96S2-192	F96A2-192	192	2.0000	2.020

For Couplings See Section G.
For Shafts, Bearings and Collars See Section I.

CLUSTER GEAR AND HUB

PITCH	STYLE	BORE	MATERIAL	AGMA QUALITY	PRESSURE ANGLE
96	X	3/16"	303 STAINLESS STEEL	10	20°

STOCK NO.	PITCH	NO. OF TEETH	PITCH DIA.	OUTSIDE DIA.
DP96S8-40	96	40	.4166	.428
DP96S8-42		42	.4375	.458
DP96S8-44		44	.4583	.479
DP96S8-45		45	.4687	.490
DP96S8-46		46	.4791	.500
DP96S8-48		48	.5000	.521
DP96S8-50		50	.5208	.542

PITCH	STYLE	BORE	MATERIAL	AGMA QUALITY	PRESSURE ANGLE
96	Y	3/16"	303 STAINLESS STEEL	10	20°

STOCK NO.	PITCH	NO. OF TEETH	PITCH DIA.	OUTSIDE DIA.
DP96S10-40	96	40	.4166	.428
DP96S10-42		42	.4375	.458
DP96S10-44		44	.4583	.479
DP96S10-45		45	.4687	.490
DP96S10-46		46	.4791	.500
DP96S10-48		48	.5000	.521
DP96S10-50		50	.5208	.542

PITCH	STYLE	BORE	MATERIAL	AGMA QUALITY	PRESSURE ANGLE
96	Z	3/16"	303 STAINLESS STEEL	10	20°

STOCK NO.	PITCH	NO. OF TEETH	PITCH DIA.	OUTSIDE DIA.
DP96S12-40	96	40	.4166	.428
DP96S12-42		42	.4375	.458
DP96S12-44		44	.4583	.479
DP96S12-45		45	.4687	.490
DP96S12-46		46	.4791	.500
DP96S12-48		48	.5000	.521
DP96S12-50		50	.5208	.542

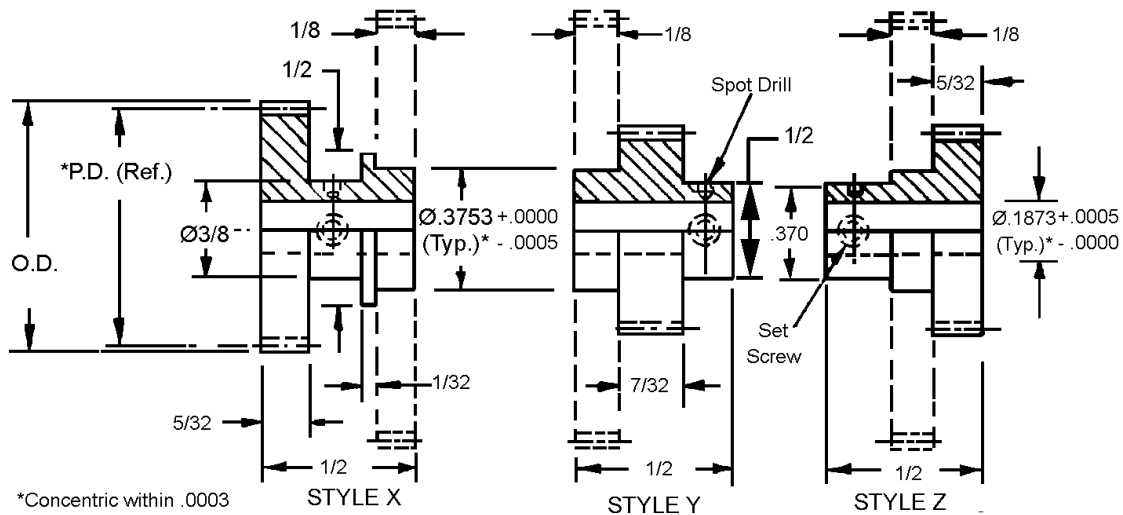

• Hub runout cuts thru shoulder.

Available on request: Other numbers of teeth; AGMA quality 12 and 14; 14-1/2° Pressure Angle.

SPUR GEARS

PITCH	STYLE	BORE	FACE	MATERIAL	AGMA QUALITY	PRESSURE ANGLE
96	PIN HUB	1/8"	1/16"	303 STAINLESS STEEL AND ALUMINUM ANODIZED	10	20°

B

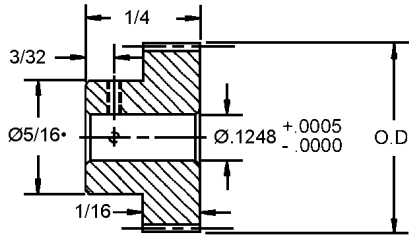
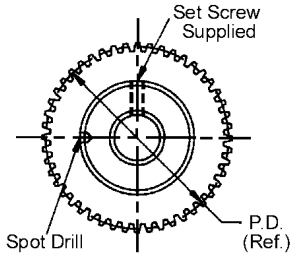

• For 26-30 teeth hub diameter equals .24

Available on request, other numbers of teeth, AGMA quality 12 and 14, and 14-1/2° Pressure Angle.

303 STAINLESS STEEL STOCK NO.	2024-T4 ALUMINUM ANODIZED STOCK NO.	NO. OF TEETH	PITCH DIA.	OUTSIDE DIA.
P96S5-30	P96A5-30	30•	.3125	.333
P96S5-34	P96A5-34	34	.3541	.375
P96S5-35	P96A5-35	35	.3645	.385
P96S5-36	P96A5-36	36	.3750	.395
P96S5-38	P96A5-38	38	.3958	.416
P96S5-40	P96A5-40	40	.4166	.437
P96S5-45	P96A5-45	45	.4687	.489
P96S5-50	P96A5-50	50	.5208	.541
P96S5-52	P96A5-52	52	.5416	.562
P96S5-54	P96A5-54	54	.5625	.583
P96S5-55	P96A5-55	55	.5729	.593
P96S5-56	P96A5-56	56	.5833	.604
P96S5-57	P96A5-57	57	.5937	.614
P96S5-58	P96A5-58	58	.6041	.625
P96S5-60	P96A5-60	60	.6250	.645
P96S5-61	P96A5-61	61	.6354	.656
P96S5-64	P96A5-64	64	.6666	.687
P96S5-65	P96A5-65	65	.6770	.697
P96S5-66	P96A5-66	66	.6875	.708
P96S5-67	P96A5-67	67	.6979	.718
P96S5-70	P96A5-70	70	.7291	.750
P96S5-72	P96A5-72	72	.7500	.770
P96S5-75	P96A5-75	75	.7812	.802
P96S5-76	P96A5-76	76	.7916	.812
P96S5-78	P96A5-78	78	.8125	.833
P96S5-80	P96A5-80	80	.8333	.854
P96S5-82	P96A5-82	82	.8541	.875
P96S5-85	P96A5-85	85	.8854	.906
P96S5-86	P96A5-86	86	.8958	.916
P96S5-88	P96A5-88	88	.9166	.937
P96S5-90	P96A5-90	90	.9375	.958
P96S5-95	P96A5-95	95	.9895	1.010
P96S5-96	P96A5-96	96	1.0000	1.020
P96S5-100	P96A5-100	100	1.0416	1.062
P96S5-102	P96A5-102	102	1.0625	1.083
P96S5-105	P96A5-105	105	1.0937	1.114
P96S5-108	P96A5-108	108	1.1250	1.145
P96S5-110	P96A5-110	110	1.1458	1.166
P96S5-111	P96A5-111	111	1.1562	1.177
P96S5-120	P96A5-120	120	1.2500	1.270
P96S5-140	P96A5-140	140	1.4583	1.479
P96S5-160	P96A5-160	160	1.6666	1.687
P96S5-180	P96A5-180	180	1.8750	1.895

For Couplings See Section G.
For Shafts, Bearings and Collars See Section I.

SPUR GEARS

PITCH	STYLE	BORE	FACE	MATERIAL	AGMA QUALITY	PRESSURE ANGLE
96	PIN HUB	1/8"	3/32"	303 STAINLESS STEEL AND ALUMINUM ANODIZED	10	20°

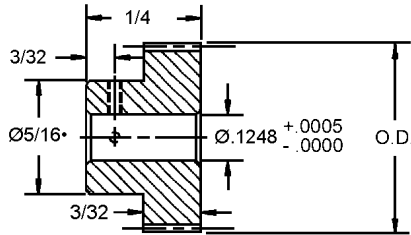
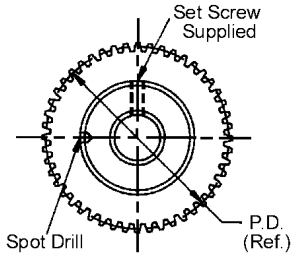

• For 26-32 teeth hub diameter equals .24

Available on request, other numbers of teeth, AGMA quality 12 and 14, and 14-1/2° Pressure Angle.

303 STAINLESS STEEL STOCK NO.	2024-T4 ALUMINUM ANODIZED STOCK NO.	NO. OF TEETH	PITCH DIA.	OUTSIDE DIA.
P96S7-26	P96A7-26	26•	.2708	.291
P96S7-28	P96A7-28	28•	.2916	.312
P96S7-30	P96A7-30	30•	.3125	.333
P96S7-32	P96A7-32	32•	.3333	.354
P96S7-34	P96A7-34	34	.3541	.375
P96S7-35	P96A7-35	35	.3645	.385
P96S7-36	P96A7-36	36	.3750	.395
P96S7-38	P96A7-38	38	.3958	.416
P96S7-40	P96A7-40	40	.4166	.437
P96S7-42	P96A7-42	42	.4375	.458
P96S7-45	P96A7-45	45	.4687	.489
P96S7-46	P96A7-46	46	.4791	.500
P96S7-48	P96A7-48	48	.5000	.520
P96S7-50	P96A7-50	50	.5208	.541
P96S7-54	P96A7-54	54	.5625	.583
P96S7-55	P96A7-55	55	.5729	.593
P96S7-56	P96A7-56	56	.5833	.604
P96S7-60	P96A7-60	60	.6250	.645
P96S7-62	P96A7-62	62	.6458	.666
P96S7-64	P96A7-64	64	.6666	.687
P96S7-65	P96A7-65	65	.6770	.697
P96S7-70	P96A7-70	70	.7291	.750
P96S7-72	P96A7-72	72	.7500	.770
P96S7-75	P96A7-75	75	.7812	.802
P96S7-78	P96A7-78	78	.8125	.833
P96S7-80	P96A7-80	80	.8333	.854
P96S7-84	P96A7-84	84	.8750	.895
P96S7-90	P96A7-90	90	.9375	.958
P96S7-96	P96A7-96	96	1.0000	1.020
P96S7-100	P96A7-100	100	1.0416	1.062
P96S7-105	P96A7-105	105	1.0937	1.114
P96S7-108	P96A7-108	108	1.1250	1.145
P96S7-120	P96A7-120	120	1.2500	1.270
P96S7-125	P96A7-125	125	1.3020	1.322
P96S7-132	P96A7-132	132	1.3750	1.395
P96S7-140	P96A7-140	140	1.4583	1.479
P96S7-144	P96A7-144	144	1.5000	1.520
P96S7-150	P96A7-150	150	1.5625	1.583
P96S7-160	P96A7-160	160	1.6666	1.687
P96S7-180	P96A7-180	180	1.8750	1.895
P96S7-190	P96A7-190	190	1.9791	2.000
P96S7-192	P96A7-192	192	2.0000	2.020

**For Couplings See Section G.
For Shafts, Bearings and Collars See Section I.**

SPUR GEARS

PITCH	STYLE	BORE	FACE	MATERIAL	AGMA QUALITY	PRESSURE ANGLE
96	PIN HUB	1/8"	1/8"	303 STAINLESS STEEL AND ALUMINUM ANODIZED	10	20°

B

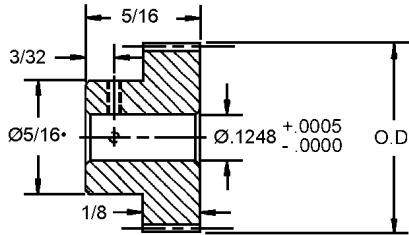
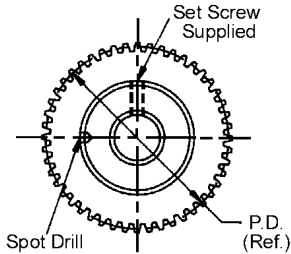

• For 26-32 teeth hub diameter equals .24

Available on request, other numbers of teeth, AGMA quality 12 and 14, and 14-1/2° Pressure Angle.

303 STAINLESS STEEL STOCK NO.	2024-T4 ALUMINUM ANODIZED STOCK NO.	NO. OF TEETH	PITCH DIA.	OUTSIDE DIA.
P96S10-26	P96A10-26	26*	.2708	.291
P96S10-27	P96A10-27	27*	.2812	.302
P96S10-28	P96A10-28	28*	.2916	.312
P96S10-29	P96A10-29	29*	.3020	.322
P96S10-30	P96A10-30	30*	.3125	.333
P96S10-32	P96A10-32	32*	.3333	.354
P96S10-34	P96A10-34	34	.3541	.375
P96S10-35	P96A10-35	35	.3645	.385
P96S10-36	P96A10-36	36	.3750	.395
P96S10-38	P96A10-38	38	.3958	.416
P96S10-39	P96A10-39	39	.4062	.427
P96S10-40	P96A10-40	40	.4166	.437
P96S10-42	P96A10-42	42	.4375	.458
P96S10-44	P96A10-44	44	.4583	.479
P96S10-46	P96A10-46	46	.4791	.500
P96S10-47	P96A10-47	47	.4895	.510
P96S10-48	P96A10-48	48	.5000	.520
P96S10-50	P96A10-50	50	.5208	.541
P96S10-52	P96A10-52	52	.5416	.562
P96S10-54	P96A10-54	54	.5625	.583
P96S10-56	P96A10-56	56	.5833	.604
P96S10-58	P96A10-58	58	.6041	.625
P96S10-60	P96A10-60	60	.6250	.645
P96S10-62	P96A10-62	62	.6458	.666
P96S10-64	P96A10-64	64	.6666	.687
P96S10-65	P96A10-65	65	.6770	.697
P96S10-67	P96A10-67	67	.6979	.718
P96S10-70	P96A10-70	70	.7291	.750
P96S10-72	P96A10-72	72	.7500	.770
P96S10-74	P96A10-74	74	.7708	.791
P96S10-75	P96A10-75	75	.7812	.802
P96S10-80	P96A10-80	80	.8333	.854
P96S10-84	P96A10-84	84	.8750	.895
P96S10-88	P96A10-88	88	.9166	.937
P96S10-90	P96A10-90	90	.9375	.958
P96S10-96	P96A10-96	96	1.0000	1.020
P96S10-100	P96A10-100	100	1.0416	1.062
P96S10-105	P96A10-105	105	1.0937	1.114
P96S10-127	P96A10-127	127	1.3229	1.343
P96S10-144	P96A10-144	144	1.5000	1.520
P96S10-156	P96A10-156	156	1.6250	1.645
P96S10-168	P96A10-168	168	1.7500	1.770

For Couplings See Section G.
For Shafts, Bearings and Collars See Section I.

SPUR GEARS

PITCH	STYLE	BORE	FACE	MATERIAL	AGMA QUALITY	PRESSURE ANGLE
96	PIN HUB	3/16"	3/32"	303 STAINLESS STEEL AND ALUMINUM ANODIZED	10	20°

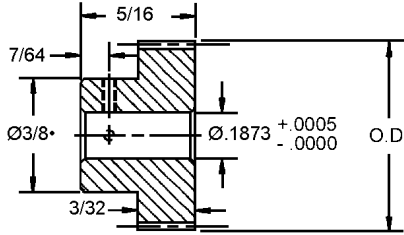
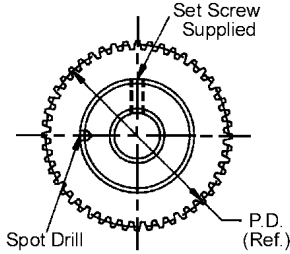

• For 36 teeth hub diameter equals .34

Available on request, other numbers of teeth, AGMA quality 12 and 14, and 14-1/2° Pressure Angle.

303 STAINLESS STEEL STOCK NO.	2024-T4 ALUMINUM ANODIZED STOCK NO.	NO. OF TEETH	PITCH DIA.	OUTSIDE DIA.
P96S17-36	P96A17-36	36•	.3750	.395
P96S17-40	P96A17-40	40	.4166	.437
P96S17-42	P96A17-42	42	.4375	.458
P96S17-44	P96A17-44	44	.4583	.479
P96S17-45	P96A17-45	45	.4687	.489
P96S17-48	P96A17-48	48	.5000	.520
P96S17-50	P96A17-50	50	.5208	.541
P96S17-54	P96A17-54	54	.5625	.583
P96S17-60	P96A17-60	60	.6250	.645
P96S17-61	P96A17-61	61	.6354	.656
P96S17-64	P96A17-64	64	.6666	.687
P96S17-70	P96A17-70	70	.7291	.750
P96S17-72	P96A17-72	72	.7500	.770
P96S17-77	P96A17-77	77	.8020	.822
P96S17-79	P96A17-79	79	.8229	.843
P96S17-80	P96A17-80	80	.8333	.854
P96S17-85	P96A17-85	85	.8854	.906
P96S17-90	P96A17-90	90	.9375	.958
P96S17-92	P96A17-92	92	.9583	.979
P96S17-95	P96A17-95	95	.9895	1.010
P96S17-96	P96A17-96	96	1.0000	1.020
P96S17-100	P96A17-100	100	1.0416	1.062
P96S17-108	P96A17-108	108	1.1250	1.145
P96S17-110	P96A17-110	110	1.1458	1.166
P96S17-120	P96A17-120	120	1.2500	1.270
P96S17-130	P96A17-130	130	1.3541	1.375
P96S17-132	P96A17-132	132	1.3750	1.395
P96S17-140	P96A17-140	140	1.4583	1.479
P96S17-144	P96A17-144	144	1.5000	1.520
P96S17-150	P96A17-150	150	1.5625	1.583
P96S17-156	P96A17-156	156	1.6250	1.645
P96S17-160	P96A17-160	160	1.6666	1.687
P96S17-168	P96A17-168	168	1.7500	1.770
P96S17-180	P96A17-180	180	1.8750	1.895
P96S17-190	P96A17-190	190	1.9791	2.000
P96S17-192	P96A17-192	192	2.0000	2.020

For Couplings See Section G.
For Shafts, Bearings and Collars See Section I.

SPUR GEARS

PITCH	STYLE	BORE	FACE	MATERIAL	AGMA QUALITY	PRESSURE ANGLE
96	PIN HUB	3/16"	1/8"	303 STAINLESS STEEL AND ALUMINUM ANODIZED	10	20°

B

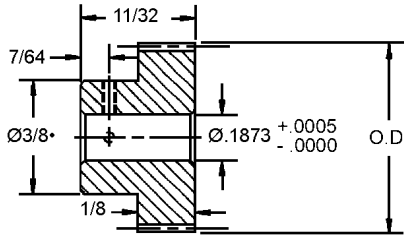
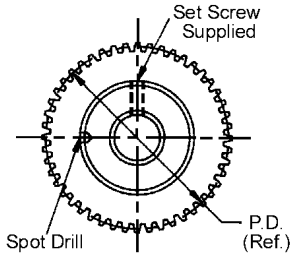

• For 36-38 teeth hub diameter equals .34
Available on request, other numbers of teeth, AGMA quality 12 and 14, and 14-1/2° Pressure Angle.

303 STAINLESS STEEL STOCK NO.	2024-T4 ALUMINUM ANODIZED STOCK NO.	NO. OF TEETH	PITCH DIA.	OUTSIDE DIA.
P96S19-36	P96A19-36	36•	.3750	.395
P96S19-38	P96A19-38	38•	.3958	.416
P96S19-40	P96A19-40	40	.4166	.437
P96S19-42	P96A19-42	42	.4375	.458
P96S19-44	P96A19-44	44	.4583	.479
P96S19-45	P96A19-45	45	.4687	.489
P96S19-48	P96A19-48	48	.5000	.520
P96S19-50	P96A19-50	50	.5208	.541
P96S19-52	P96A19-52	52	.5416	.562
P96S19-54	P96A19-54	54	.5625	.583
P96S19-60	P96A19-60	60	.6250	.645
P96S19-64	P96A19-64	64	.6666	.687
P96S19-66	P96A19-66	66	.6875	.708
P96S19-70	P96A19-70	70	.7291	.750
P96S19-72	P96A19-72	72	.7500	.770
P96S19-75	P96A19-75	75	.7812	.802
P96S19-77	P96A19-77	77	.8020	.822
P96S19-80	P96A19-80	80	.8333	.854
P96S19-85	P96A19-85	85	.8854	.906
P96S19-90	P96A19-90	90	.9375	.958
P96S19-95	P96A19-95	95	.9895	1.010
P96S19-96	P96A19-96	96	1.0000	1.020
P96S19-100	P96A19-100	100	1.0416	1.062
P96S19-105	P96A19-105	105	1.0937	1.114
P96S19-110	P96A19-110	110	1.1485	1.166
P96S19-120	P96A19-120	120	1.2500	1.270
P96S19-130	P96A19-130	130	1.3541	1.375
P96S19-140	P96A19-140	140	1.4583	1.479
P96S19-160	P96A19-160	160	1.6666	1.687
P96S19-180	P96A19-180	180	1.8750	1.895
P96S19-192	P96A19-192	192	2.0000	2.020

For Couplings See Section G.
For Shafts, Bearings and Collars See Section I.

SPUR GEARS

PITCH	STYLE	BORE	FACE	MATERIAL	AGMA QUALITY	PRESSURE ANGLE
96	CLAMP STYLE	1/8"	1/8"	303 STAINLESS STEEL AND ALUMINUM ANODIZED	10	20°

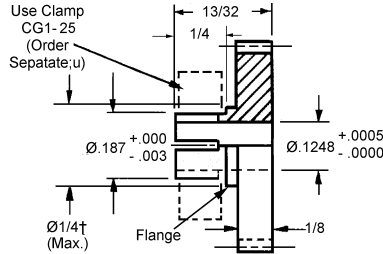
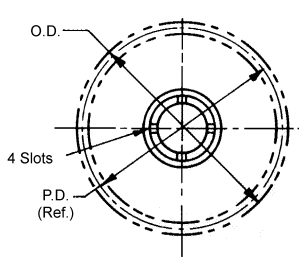

† Teeth may runout on flange diameter.

Available on request, other numbers of teeth, Agma Quality 12 and 14-1/2° Pressure Angle.

303 STAINLESS STEEL STOCK NO.	2024-T4 ALUMINUM ANODIZED STOCK NO.	NO. OF TEETH	PITCH DIA.	OUTSIDE DIA.
C96S7-24	C96A7-24	24†	.2500	.270
C96S7-25	C96A7-25	25†	.2604	.281
C96S7-26	C96A7-26	26†	.2708	.291
C96S7-28	C96A7-28	28	.2916	.312
C96S7-30	C96A7-30	30	.3125	.333
C96S7-32	C96A7-32	32	.3333	.354
C96S7-33	C96A7-33	33	.3437	.364
C96S7-34	C96A7-34	34	.3541	.375
C96S7-35	C96A7-35	35	.3645	.385
C96S7-36	C96A7-36	36	.3750	.395
C96S7-38	C96A7-38	38	.3958	.416
C96S7-40	C96A7-40	40	.4166	.437
C96S7-42	C96A7-42	42	.4375	.458
C96S7-44	C96A7-44	44	.4583	.479
C96S7-48	C96A7-48	48	.5000	.520
C96S7-50	C96A7-50	50	.5208	.541
C96S7-52	C96A7-52	52	.5416	.562
C96S7-54	C96A7-54	54	.5625	.583
C96S7-56	C96A7-56	56	.5833	.604
C96S7-58	C96A7-58	58	.6041	.625
C96S7-60	C96A7-60	60	.6250	.645
C96S7-64	C96A7-64	64	.6666	.687
C96S7-70	C96A7-70	70	.7291	.750
C96S7-72	C96A7-72	72	.7500	.770
C96S7-76	C96A7-76	76	.7916	.812
C96S7-78	C96A7-78	78	.8125	.833
C96S7-80	C96A7-80	80	.8333	.854
C96S7-84	C96A7-84	84	.8750	.895
C96S7-90	C96A7-90	90	.9375	.958
C96S7-95	C96A7-95	95	.9895	1.010
C96S7-96	C96A7-96	96	1.0000	1.020
C96S7-100	C96A7-100	100	1.0416	1.062
C96S7-105	C96A7-105	105	1.0937	1.114
C96S7-108	C96A7-108	108	1.1250	1.145
C96S7-110	C96A7-110	110	1.1458	1.166
C96S7-115	C96A7-115	115	1.1979	1.218
C96S7-120	C96A7-120	120	1.2500	1.270
C96S7-127	C96A7-127	127	1.3229	1.343
C96S7-132	C96A7-132	132	1.3750	1.395
C96S7-144	C96A7-144	144	1.5000	1.520
C96S7-168	C96A7-168	168	1.7500	1.770
C96S7-180	C96A7-180	180	1.8750	1.895

For Couplings See Section G.
For Shafts, Bearings and Collars See Section I.

GEAR RACKS

PITCH	STYLE	MATERIAL	AGMA QUALITY	PRESSURE ANGLE
96	ROUND & RECTANGULAR	416 SERIES STAINLESS STEEL STRESSED RELIEVED	10	20°

B

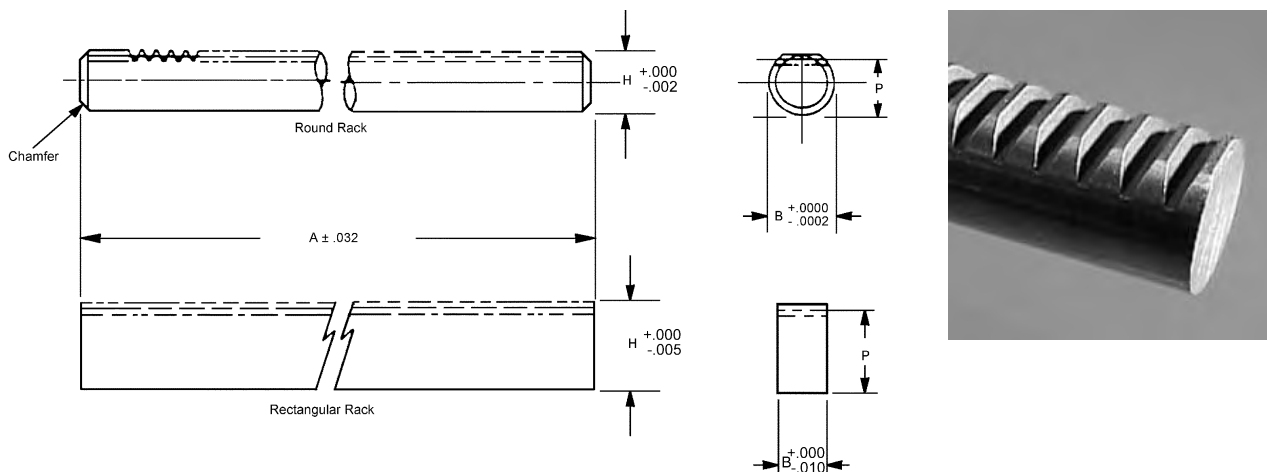

STOCK NO.	RACK STYLE	PITCH	P (Ref.)	B	A	H	AGMA QUALITY
R2-20	ROUND	96	.1456	.1872	.11	.156	10
R2-16	RECTANGULAR	96	.3466	.167±.005	.11	.355	10

Available on request: 14 - 1/2° pressure angle, special, modified and custom racks.

PITCH	STYLE	MATERIAL	AGMA QUALITY	PRESSURE ANGLE
96	RECTANGULAR	416 SERIES STAINLESS STEEL AND 2024-T4 ALUMINUM ANODIZED	10	20°

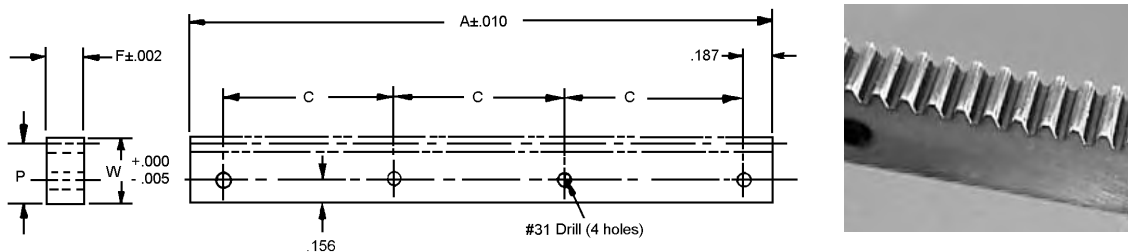

STOCK NO.	MATERIAL	A (Inch)	P (Ref.)	W	F	C
R4-21 R4-22	STAINLESS ST. ALUMINUM	3"	.3446	.355	.167	.875

Available on request: special, modified and custom racks.

GEAR RACKS

PITCH	STYLE	MATERIAL	AGMA QUALITY	PRESSURE ANGLE
96	RECTANGULAR	416 SERIES STAINLESS STEEL STRESSED RELIEVED	10	20°

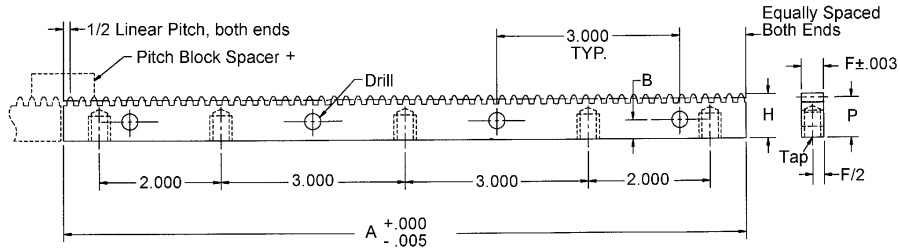

† Spacer block is designed for butting to achieve continuous lengths. On-Line pricing for AGMA 10 only.

RACKS	SPACER BLOCK												
		AGMA QTY. NO.	MAX ACCUM. ERROR	TOOTH TO TOOTH ERROR	PITCH	LINEAR PITCH	A INCH	P REF.	H +.000 / -.005	F	B	DRILL	TAP
R1-11-G1	R1-11-SB	10*	.0014	.0005	96	.0327	11.022	.3396	.350	.167	.156	#31	#4-40 X 3/16
R3-8-G1	R3-8-SB	10*	.0014	.0005	96	.0327	11.022	.3446	.355	.167	.156	#31	#4-40 X 3/16

* Higher quality on request.

ANTI-BACKLASH PINIONS

PITCH	STYLE	BORE	FACE	MATERIAL	AGMA QUALITY	PRES. ANGLE
96	PIN HUB	1/8"	1/8"	303 STAINLESS STEEL OR 2024-T4 ALUMINUM ANODIZED	10	20°

B

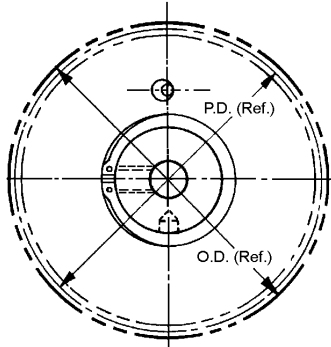
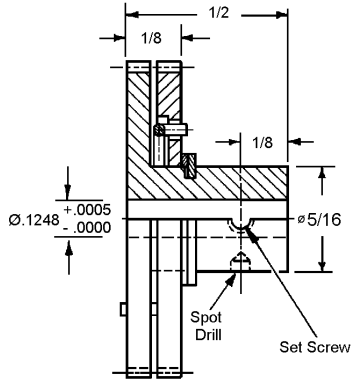

STAINLESS STEEL STOCK NO.	ALUMINUM STOCK NO.	NO. OF TEETH	BORE	PITCH DIA.	OUTSIDE DIA.
AP96FS-60	AP96GS-60	60	.1248	.6250	.646
AP96FS-72	AP96GS-72	72	.1248	.7500	.771
AP96FS-96	AP96GS-96	96	.1248	1.0000	1.021

Available on request:
Other numbers of teeth
AGMA Quality 12 and 14
14-1/2° Pressure Angle

HUB MATERIAL:
303 Stainless Steel

ANTI-BACKLASH GEARS

PITCH	STYLE	BORE	FACE	MATERIAL	AGMA QUALITY	PRES. ANGLE
96	PIN HUB	1/8"	.104	303 STAINLESS STEEL OR 2024-T4 ALUMINUM ANODIZED	10	20°

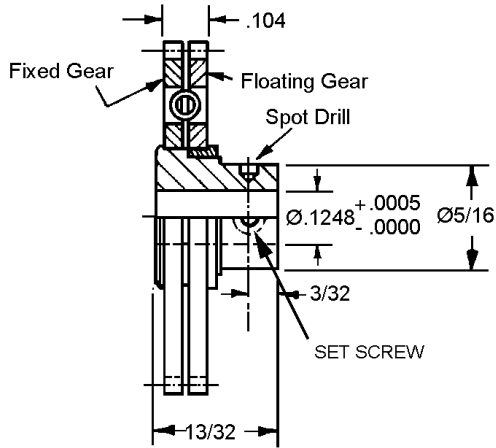

HUB MATERIAL: 303 Stainless Steel

303 STAINLESS STEEL STOCK NO.	2024-T4 ALUMINUM ANODIZED STOCK NO.	NO. OF TEETH	PITCH DIAMETER	OUTSIDE DIA.	SPRING STYLE
AP96AS-54	-	54	.5625	.583	SCISSOR
AP96AS-55	-	55	.5729	.593	
AP96AS-56	-	56	.5833	.604	
AP96AS-60	-	60	.6250	.645	
AP96AS-64	-	64	.6666	.687	
AP96AS-66	-	66	.6875	.708	
AP96AS-72	AP96NS-72	72	.7500	.770	
AP96AS-80	AP96NS-80	80	.8333	.854	
AP96AS-84	AP96NS-84	84	.8750	.895	
AP96AS-90	AP96NS-90	90	.9375	.958	
AP96AS-95	AP96NS-95	95	.9895	1.010	
AP96A-96	AP96N-96	96	1.0000	1.020	COIL
AP96A-105	AP96N-105	105	1.0937	1.114	
AP96A-108	AP96N-108	108	1.1250	1.145	
AP96A-112	AP96N-112	112	1.1666	1.187	
AP96A-120	AP96N-120	120	1.2500	1.270	
AP96A-126	AP96N-126	126	1.3125	1.333	
AP96A-128	AP96N-128	128	1.3333	1.354	
AP96A-140	AP96N-140	140	1.4583	1.479	
AP96A-144	AP96N-144	144	1.5000	1.520	
AP96A-150	AP96N-150	150	1.5625	1.583	
AP96A-155	AP96N-155	155	1.6145	1.635	
AP96A-160	AP96N-160	160	1.6666	1.687	
AP96A-165	AP96N-165	165	1.7187	1.739	
AP96A-168	AP96N-168	168	1.7500	1.770	
AP96A-192	AP96N-192	192	2.0000	2.020	
AP96A-216	AP96N-216	216	2.2500	2.270	
AP96A-240	AP96N-240	240	2.5000	2.520	
AP96A-264	AP96N-264	264	2.7500	2.770	

Available on request:

- Other numbers of teeth;
- AGMA Quality 12 and 14 (some dimensions may vary);
- 14-12° pressure angle.

For Couplings See Section G.
For Shafts, Bearings and Collars See Section I.

ANTI-BACKLASH GEARS

PITCH	STYLE	BORE	FACE	MATERIAL	AGMA QUALITY	PRES. ANGLE
96	PIN HUB	1/8"	.104"	303 STAINLESS STEEL OR 2024-T4 ALUMINUM ANODIZED	10	20°

B

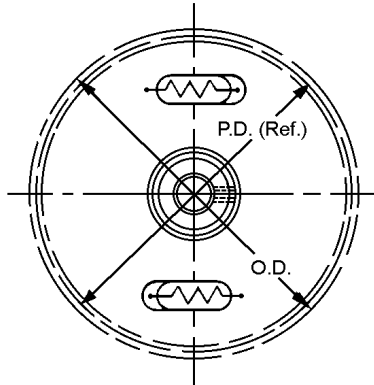
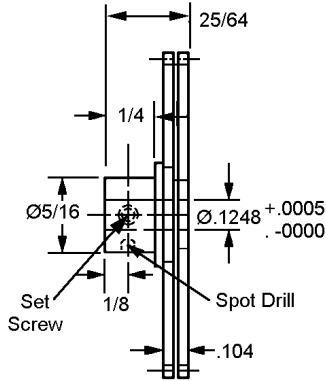

303 STAINLESS STEEL STOCK NO.	2024-T4 ALUMINUM ANODIZED STOCK NO.	NO. OF TEETH	PITCH DIAMETER
AP96SS-76	AP96TS-76	76	.7916
AP96SS-80	AP96TS-80	80	.8333
AP96SS-84	AP96TS-84	84	.8750
AP96SS-90	AP96TS-90	90	.9375
AP96SS-96	AP96TS-96	96	1.0000
AP96SS-100	AP96TS-100	100	1.0416
AP96SS-108	AP96TS-108	108	1.1250
AP96SS-112	AP96TS-112	112	1.1666
AP96SS-120	AP96TS-120	120	1.2500
AP96SS-125	AP96TS-125	125	1.3020
AP96S-130	AP96T-130	130	1.3541
AP96S-135	AP96T-135	135	1.4062
AP96S-140	AP96T-140	140	1.4583
AP96S-144	AP96T-144	144	1.5000
AP96S-145	AP96T-145	145	1.5104
AP96S-150	AP96T-150	150	1.5625
AP96S-160	AP96T-160	160	1.6666
AP96S-170	AP96T-170	170	1.7708
AP96S-180	AP96T-180	180	1.8750
AP96S-190	AP96T-190	190	1.9791
AP96S-192	AP96T-192	192	2.0000
AP96S-200	AP96T-200	200	2.0833
AP96S-210	AP96T-210	210	2.1875
AP96S-220	AP96T-220	220	2.2916
AP96S-230	AP96T-230	230	2.3958
AP96S-240	AP96T-240	240	2.5000
AP96S-250	AP96T-250	250	2.6041
AP96S-260	AP96T-260	260	2.7083
AP96S-264	AP96T-264	264	2.7500
AP96S-270	AP96T-270	270	2.8125
AP96S-288	AP96T-288	288	3.0000
AP96S-300	AP96T-300	300	3.1250

O.D. = P.D. + .031

HUB MATERIAL: 303 Stainless Steel

Available on request:

- Other numbers of teeth;
- AGMA Quality 12 and 14 (some dimensions may vary);
- 14-12° pressure angle.

**For Couplings See Section G.
For Shafts, Bearings and Collars See Section I.**

ANTI-BACKLASH GEARS

PITCH	STYLE	BORE	FACE	MATERIAL	AGMA QUALITY	PRES. ANGLE
96	PIN HUB	3/16"	.104"	303 STAINLESS STEEL OR 2024-T4 ALUMINUM ANODIZED	10	20°

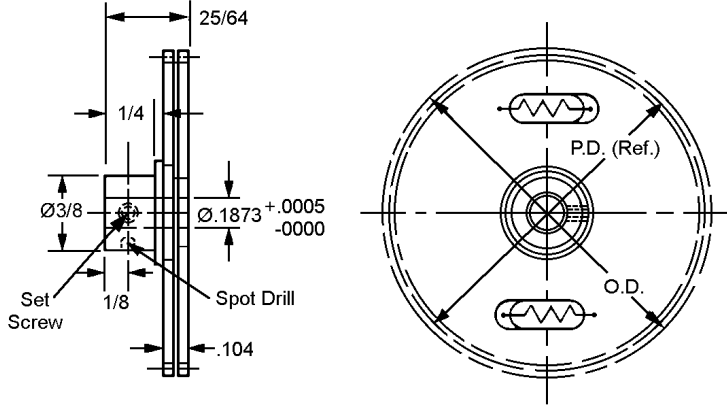

O.D. = P.D. + .031

HUB MATERIAL: 303 Stainless Steel

303 STAINLESS STEEL STOCK NO.	2024-T4 ALUMINUM ANODIZED STOCK NO.	NO. OF TEETH	PITCH DIAMETER
AP96US-90	AP96VS-90	90	.9375
AP96US-96	AP96VS-96	96	1.0000
AP96US-100	AP96VS-100	100	1.0416
AP96US-108	AP96VS-108	108	1.1250
AP96US-112	AP96VS-112	112	1.1666
AP96US-120	AP96VS-120	120	1.2500
AP96US-125	AP96VS-125	125	1.3020
AP96U-130	AP96V-130	130	1.3541
AP96U-135	AP96V-135	135	1.4062
AP96U-140	AP96V-140	140	1.4583
AP96U-144	AP96V-144	144	1.5000
AP96U-145	AP96V-145	145	1.5104
AP96U-150	AP96V-150	150	1.5625
AP96U-160	AP96V-160	160	1.6666
AP96U-170	AP96V-170	170	1.7708
AP96U-180	AP96V-180	180	1.8750
AP96U-190	AP96V-190	190	1.9791
AP96U-192	AP96V-192	192	2.0000
AP96U-200	AP96V-200	200	2.0833
AP96U-210	AP96V-210	210	2.1875
AP96U-220	AP96V-220	220	2.2916
AP96U-230	AP96V-230	230	2.3958
AP96U-240	AP96V-240	240	2.5000
AP96U-250	AP96V-250	250	2.6041
AP96U-260	AP96V-260	260	2.7083
AP96U-264	AP96V-264	264	2.7500
AP96U-270	AP96V-270	270	2.8125
AP96U-288	AP96V-288	288	3.0000
AP96U-300	AP96V-300	300	3.1250

Available on request:

Other numbers of teeth;
AGMA Quality 12 and 14 (some dimensions may vary);
14-12° pressure angle.

**For Couplings See Section G.
For Shafts, Bearings and Collars See Section I.**

ANTI-BACKLASH PINIONS

PITCH	STYLE	BORE	FACE	MATERIAL	AGMA QUALITY	PRES. ANGLE
96	PIN HUB	3/16"	1/8"	303 STAINLESS STEEL OR 2024-T4 ALUMINUM ANODIZED	10	20°

B

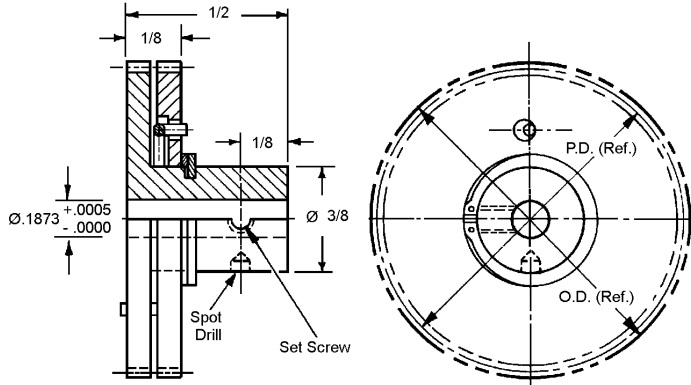

STAINLESS STEEL STOCK NO.	ALUMINUM STOCK NO.	NO. OF TEETH	BORE	PITCH DIA.	OUTSIDE DIA.
AP96HS-60	AP96JS-60	60	.1873	.6250	.646
AP96HS-72	AP96JS-72	72	.1873	.7500	.771
AP96HS-96	AP96JS-96	96	.1873	1.0000	1.021

Available on request:
Other numbers of teeth
AGMA Quality 12 and 14
14-1/2° Pressure Angle

For Couplings See Section G.
For Shafts, Bearings and Collars See Section I.

ANTI-BACKLASH GEARS

PITCH	STYLE	BORE	FACE	MATERIAL	AGMA QUALITY	PRES. ANGLE
96	PIN HUB	1/4"	.104"	303 STAINLESS STEEL OR 2024-T4 ALUMINUM ANODIZED	10	20°

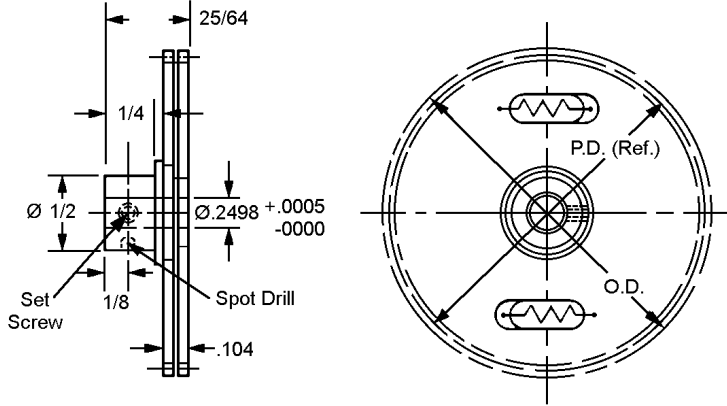

303 STAINLESS STEEL STOCK NO.	2024-T4 ALUMINUM ANODIZED STOCK NO.	NO. OF TEETH	PITCH DIAMETER
AP96WS-96	AP96XS-96	96	1.0000
AP96WS-100	AP96XS-100	100	1.0416
AP96WS-108	AP96XS-108	108	1.1250
AP96WS-112	AP96XS-112	112	1.1666
AP96WS-120	AP96XS-120	120	1.2500
AP96WS-125	AP96XS-125	125	1.3020
AP96W-130	AP96X-130	130	1.3541
AP96W-135	AP96X-135	135	1.4062
AP96W-140	AP96X-140	140	1.4583
AP96W-144	AP96X-144	144	1.5000
AP96W-145	AP96X-145	145	1.5104
AP96W-150	AP96X-150	150	1.5625
AP96W-160	AP96X-160	160	1.6666
AP96W-170	AP96X-170	170	1.7708
AP96W-180	AP96X-180	180	1.8750
AP96W-190	AP96X-190	190	1.9791
AP96W-192	AP96X-192	192	2.0000
AP96W-200	AP96X-200	200	2.0833
AP96W-210	AP96X-210	210	2.1875
AP96W-220	AP96X-220	220	2.2916
AP96W-230	AP96X-230	230	2.3958
AP96W-240	AP96X-240	240	2.5000
AP96W-250	AP96X-250	250	2.6041
AP96W-260	AP96X-260	260	2.7083
AP96W-264	AP96X-264	264	2.7500
AP96W-270	AP96X-270	270	2.8125
AP96W-288	AP96X-288	288	3.0000
AP96W-300	AP96X-300	300	3.1250

O.D. = P.D. + .031

HUB MATERIAL: 303 Stainless Steel

Available on request:

Other numbers of teeth;
AGMA Quality 12 and 14 (some dimensions may vary);
14-12° pressure angle.

**For Couplings See Section G.
For Shafts, Bearings and Collars See Section I.**

ANTI-BACKLASH GEARS

PITCH	STYLE	BORE	FACE	MATERIAL	AGMA QUALITY	PRES. ANGLE
96	CLAMP STYLE	1/8"	.104	303 STAINLESS STEEL OR 2024-T4 ALUMINUM ANODIZED	10	20°

B

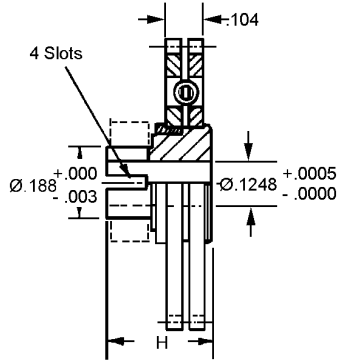

Hub Material: 303 Stainless Steel

303 STAINLESS STEEL STOCK NO.	2024-T4 ALUMINUM ANODIZED STOCK NO.	NO. OF TEETH	PITCH DIAMETER	OUTSIDE DIA.	SPRING STYLE	H
AC96AS-54	-	54	.5625	.583	SCISSOR	27/64
AC96AS-55	-	55	.5729	.593		
AC96AS-56	-	56	.5833	.604		
AC96AS-60	-	60	.6250	.645		
AC96AS-64	-	64	.6666	.687		
AC96AS-66	-	66	.6875	.708		
AC96AS-72	AC96NS-72	72	.7500	.770		
AC96AS-80	AC96NS-80	80	.8333	.854		
AC96AS-84	AC96NS-84	84	.8750	.895		
AC96AS-90	AC96NS-90	90	.9375	.958		
AC96AS-95	AC96NS-95	95	.9895	1.010		
AC96A-96	AC96N-96	96	1.0000	1.020	COIL	25/64
AC96A-105	AC96N-105	105	1.0937	1.114		
AC96A-108	AC96N-108	108	1.1250	1.145		
AC96A-112	AC96N-112	112	1.1666	1.187		
AC96A-120	AC96N-120	120	1.2500	1.270		
AC96A-126	AC96N-126	126	1.3125	1.333		
AC96A-128	AC96N-128	128	1.3333	1.354		
AC96A-140	AC96N-140	140	1.4583	1.479		
AC96A-144	AC96N-144	144	1.5000	1.520		
AC96A-150	AC96N-150	150	1.5625	1.583		
AC96A-155	AC96N-155	155	1.6145	1.635		
AC96A-160	AC96N-160	160	1.6666	1.687		
AC96A-165	AC96N-165	165	1.7187	1.739		
AC96A-168	AC96N-168	168	1.7500	1.770		
AC96A-192	AC96N-192	192	2.0000	2.020		
AC96A-216	AC96N-216	216	2.2500	2.270		
AC96A-240	AC96N-240	240	2.5000	2.520		
AC96A-264	AC96N-264	264	2.7500	2.770		

Available on request:

- Other numbers of teeth;
- AGMA Quality 12 and 14 (some dimensions may vary);
- 14-12° pressure angle.

**For Couplings See Section G.
For Shafts, Bearings and Collars See Section I.**

ANTI-BACKLASH GEARS

PITCH	STYLE	BORE	FACE	MATERIAL	AGMA QUALITY	PRES. ANGLE
96	CLAMP STYLE	1/8"	.104	303 STAINLESS STEEL OR 2024-T4 ALUMINUM ANODIZED	10	20°

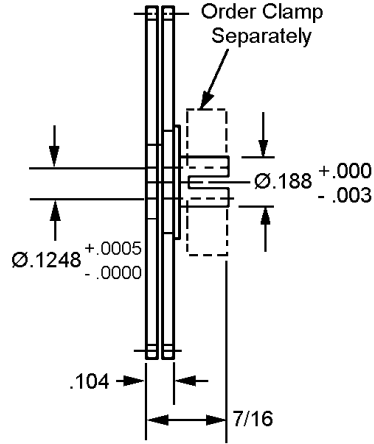

HUB MATERIAL: 303 Stainless Steel

303 STAINLESS STEEL STOCK NO.	2024-T4 ALUMINUM ANODIZED STOCK NO.	NO. OF TEETH	PITCH DIAMETER
AC96SS-76	AC96TS-76	76	.7916
AC96SS-80	AC96TS-80	80	.8333
AC96SS-84	AC96TS-84	84	.8750
AC96SS-90	AC96TS-90	90	.9375
AC96SS-96	AC96TS-96	96	1.0000
AC96SS-100	AC96TS-100	100	1.0416
AC96SS-108	AC96TS-108	108	1.1250
AC96SS-112	AC96TS-112	112	1.1666
AC96SS-120	AC96TS-120	120	1.2500
AC96SS-125	AC96TS-125	125	1.3020
AC96S-130	AC96T-130	130	1.3541
AC96S-135	AC96T-135	135	1.4062
AC96S-140	AC96T-140	140	1.4583
AC96S-144	AC96T-144	144	1.5000
AC96S-145	AC96T-145	145	1.5104
AC96S-150	AC96T-150	150	1.5625
AC96S-160	AC96T-160	160	1.6666
AC96S-170	AC96T-170	170	1.7708
AC96S-180	AC96T-180	180	1.8750
AC96S-190	AC96T-190	190	1.9791
AC96S-192	AC96T-192	192	2.0000
AC96S-200	AC96T-200	200	2.0833
AC96S-210	AC96T-210	210	2.1875
AC96S-220	AC96T-220	220	2.2916
AC96S-230	AC96T-230	230	2.3958
AC96S-240	AC96T-240	240	2.5000
AC96S-250	AC96T-250	250	2.6041
AC96S-260	AC96T-260	260	2.7083
AC96S-264	AC96T-264	264	2.7500
AC96S-270	AC96T-270	270	2.8125
AC96S-288	AC96T-288	288	3.0000
AC96S-300	AC96T-300	300	3.1250

Available on request:

Other numbers of teeth;
AGMA Quality 12 and 14 (some dimensions may vary);
14-12° pressure angle.

For Couplings See Section G.
For Shafts, Bearings and Collars See Section I.

ANTI-BACKLASH GEARS

PITCH	STYLE	BORE	FACE	MATERIAL	AGMA QUALITY	PRES. ANGLE
96	CLAMP STYLE	1/8"	1/8"	303 STAINLESS STEEL OR 2024-T4 ALUMINUM ANODIZED	10	20°

B

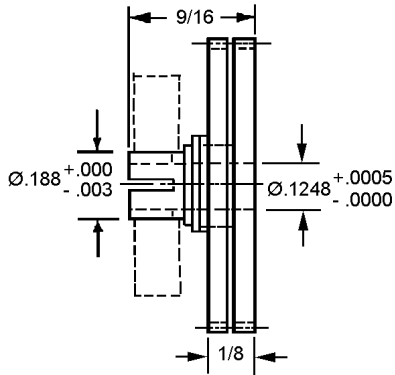

HUB MATERIAL:
303 Stainless Steel

STAINLESS STEEL STOCK NO.	ALUMINUM STOCK NO.	NO. OF TEETH	BORE	PITCH DIA.	OUTSIDE DIA.
AC96FS-60	AC96GS-60	60	.1248	.6250	.646
AC96FS-72	AC96GS-72	72	.1248	.7500	.771
AC96FS-96	AC96GS-96	96	.1248	1.0000	1.021

Available on request:
Other numbers of teeth
AGMA Quality 12 and 14
14-1/2° Pressure Angle

For Couplings See Section G.
For Shafts, Bearings and Collars See Section I.

ANTI-BACKLASH GEARS

PITCH	STYLE	BORE	FACE	MATERIAL	AGMA QUALITY	PRES. ANGLE
96	CLAMP STYLE	3/16"	.104	303 STAINLESS STEEL OR 2024-T4 ALUMINUM ANODIZED	10	20°

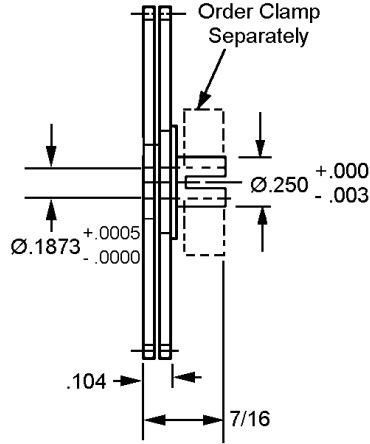

303 STAINLESS STEEL STOCK NO.	2024-T4 ALUMINUM ANODIZED STOCK NO.	NO. OF TEETH	PITCH DIAMETER
AC96US-90	AC96VS-90	90	.9375
AC96US-96	AC96VS-96	96	1.0000
AC96US-100	AC96VS-100	100	1.0416
AC96US-108	AC96VS-108	108	1.1250
AC96US-112	AC96VS-112	112	1.1666
AC96US-120	AC96VS-120	120	1.2500
AC96US-125	AC96VS-125	125	1.3020
AC96U-130	AC96V-130	130	1.3541
AC96U-135	AC96V-135	135	1.4062
AC96U-140	AC96V-140	140	1.4583
AC96U-144	AC96V-144	144	1.5000
AC96U-145	AC96V-145	145	1.5104
AC96U-150	AC96V-150	150	1.5625
AC96U-160	AC96V-160	160	1.6666
AC96U-170	AC96V-170	170	1.7708
AC96U-180	AC96V-180	180	1.8750
AC96U-190	AC96V-190	190	1.9791
AC96U-192	AC96V-192	192	2.0000
AC96U-200	AC96V-200	200	2.0833
AC96U-210	AC96V-210	210	2.1875
AC96U-220	AC96V-220	220	2.2916
AC96U-230	AC96V-230	230	2.3958
AC96U-240	AC96V-240	240	2.5000
AC96U-250	AC96V-250	250	2.6041
AC96U-260	AC96V-260	260	2.7083
AC96U-264	AC96V-264	264	2.7500
AC96U-270	AC96V-270	270	2.8125
AC96U-288	AC96V-288	288	3.0000
AC96U-300	AC96V-300	300	3.1250

HUB MATERIAL: 303 Stainless Steel

Available on request:

- Other numbers of teeth;
- AGMA Quality 12 and 14 (some dimensions may vary);
- 14-12° pressure angle.

**For Couplings See Section G.
For Shafts, Bearings and Collars See Section I.**

ANTI-BACKLASH GEARS

PITCH	STYLE	BORE	FACE	MATERIAL	AGMA QUALITY	PRES. ANGLE
96	CLAMP STYLE	3/16"	1/8"	303 STAINLESS STEEL OR 2024-T4 ALUMINUM ANODIZED	10	20°

B

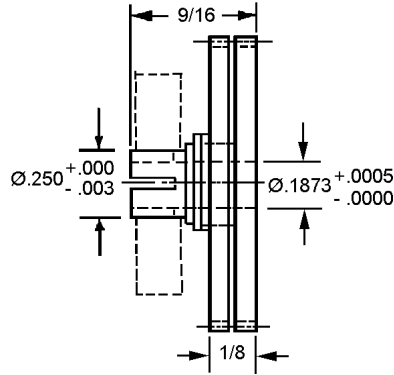

STAINLESS STEEL STOCK NO.	ALUMINUM STOCK NO.	NO. OF TEETH	BORE	PITCH DIA.	OUTSIDE DIA.
AC96HS-60	AC96JS-60	60		.6250	.646
AC96HS-72	AC96JS-72	72	.1873	.7500	.771
AC96HS-96	AC96JS-96	96		1.0000	1.021

Available on request:
Other numbers of teeth
AGMA Quality 12 and 14
14-1/2° Pressure Angle

For Couplings See Section G.
For Shafts, Bearings and Collars See Section I.

ANTI-BACKLASH GEARS

PITCH	STYLE	BORE	FACE	MATERIAL	AGMA QUALITY	PRES. ANGLE
96	CLAMP STYLE	1/4"	.104	303 STAINLESS STEEL OR 2024-T4 ALUMINUM ANODIZED	10	20°

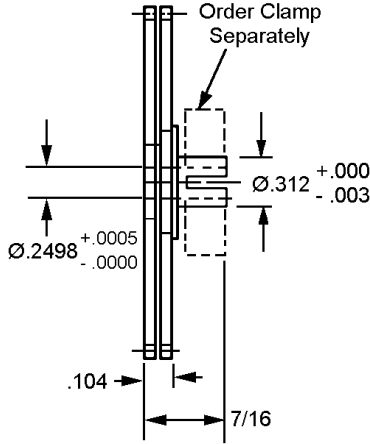

303 STAINLESS STEEL STOCK NO.	2024-T4 ALUMINUM ANODIZED STOCK NO.	NO. OF TEETH	PITCH DIAMETER
AC96WS-96	AC96XS-96	96	1.0000
AC96WS-100	AC96XS-100	100	1.0416
AC96WS-108	AC96XS-108	108	1.1250
AC96WS-112	AC96XS-112	112	1.1666
AC96WS-120	AC96XS-120	120	1.2500
AC96WS-125	AC96XW-125	125	1.3020
AC96W-130	AC96X-130	130	1.3541
AC96W-135	AC96X-135	135	1.4062
AC96W-140	AC96X-140	140	1.4583
AC96W-144	AC96X-144	144	1.5000
AC96W-145	AC96X-145	145	1.5104
AC96W-150	AC96X-150	150	1.5625
AC96W-160	AC96X-160	160	1.6666
AC96W-170	AC96X-170	170	1.7708
AC96W-180	AC96X-180	180	1.8750
AC96W-190	AC96X-190	190	1.9791
AC96W-192	AC96X-192	192	2.0000
AC96W-200	AC96X-200	200	2.0833
AC96W-210	AC96X-210	210	2.1875
AC96W-220	AC96X-220	220	2.2916
AC96W-230	AC96X-230	230	2.3958
AC96W-240	AC96X-240	240	2.5000
AC96W-250	AC96X-250	250	2.6041
AC96W-260	AC96X-260	260	2.7083
AC96W-264	AC96X-264	264	2.7500
AC96W-270	AC96X-270	270	2.8125
AC96W-288	AC96X-288	288	3.0000
AC96W-300	AC96X-300	300	3.1250

HUB MATERIAL: 303 Stainless Steel

Available on request:

Other numbers of teeth;
 AGMA Quality 12 and 14 (some dimensions may vary);
 14-12° pressure angle.

For Couplings See Section G.
For Shafts, Bearings and Collars See Section I.

PINION SHAFTS

PITCH	MATERIAL	AGMA QUALITY	PRES. ANGLE
96	303 STAINLESS STEEL	10	20°

B

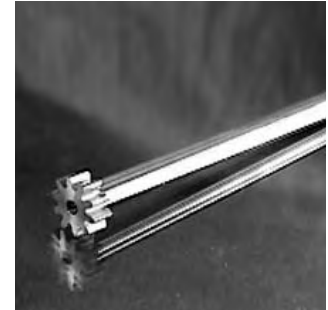
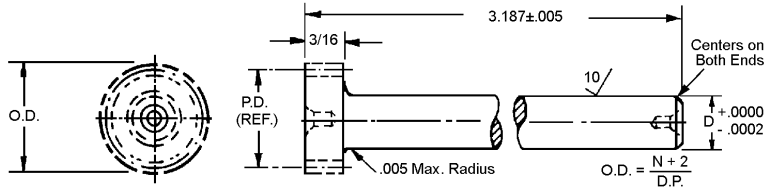

STOCK NO.	PITCH	NO. OF TEETH	PITCH DIA.	D
PS96S2-24H	96	24	.2500	.1247

Other numbers of teeth available on request.

PITCH	MATERIAL	AGMA QUALITY	PRES. ANGLE
96	303 STAINLESS STEEL	10	20°

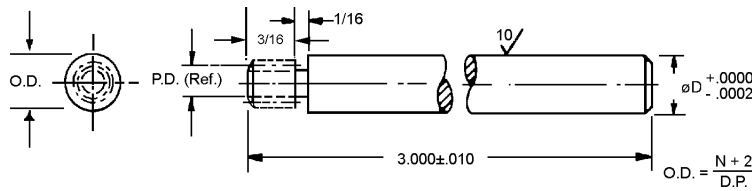

STOCK NO.	PITCH	NO. OF TEETH	PITCH DIA.	D
PS96S2-10	96	10	.1042	.1247
PS96S3-10		10	.1042	.1872
PS96S3-12		12	.1250	.1872
PS96S3-14		14	.1458	.1872
PS96S4-16		16	.1666	.2497
PS96S4-18		18	.1875	.2497
PS96S4-20		20	.2083	.2497

Other numbers of teeth available on request.

PITCH	MATERIAL	AGMA QUALITY	PRES. ANGLE
96	303 STAINLESS STEEL	10	20°

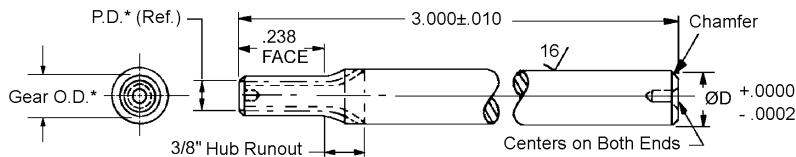

STOCK NO.	PITCH	NO. OF TEETH	D	ENLARGED	
				PITCH DIAMETER	OUTSIDE DIA.
B-PS96S3-10	96	10	.1872	.1128	.133
B-PS96S3-11		11		.1220	.142
B-PS96S3-12		12		.1312	.152
B-PS96S3-13		13		.1404	.161
B-PS96S3-14		14		.1496	.170
B-PS96S3-15		15		.1588	.179
B-PS96S3-16		16		.1680	.187
B-PS96S4-17	96	17	.2497	.1772	.198

Other numbers of teeth available on request.

SPUR GEARS

PITCH	STYLE	BORE	FACE	MATERIAL	AGMA QUALITY	PRESSURE ANGLE
120	HUBLESS	3/8"	3/32"	303 STAINLESS STEEL AND 2024-T4 ALUMINUM ANODIZED	10	20°

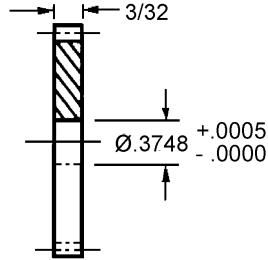
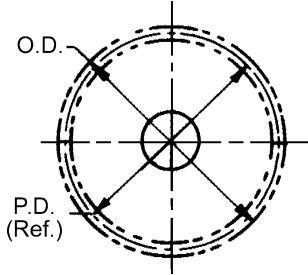

Available on request:
Pin or Clamp hubs assembled
Other numbers of teeth
14 - 1/2° Pressure Angle
1/16" Face

303 STAINLESS STEEL STOCK NO.	2024-T4 ALUMINUM ANODIZED STOCK NO.	NO. OF TEETH	PITCH DIA.	OUTSIDE DIA.
F120S2-96	F120A2-96	96	.8000	.816
F120S2-108	F120A2-108	108	.9000	.916
F120S2-120	F120A2-120	120	1.0000	1.016
F120S2-132	F120A2-132	132	1.1000	1.116
F120S2-144	F120A2-144	144	1.2000	1.216
F120S2-168	F120A2-168	168	1.4000	1.416
F120S2-180	F120A2-180	180	1.5000	1.516
F120S2-192	F120A2-192	192	1.6000	1.616

**For Couplings See Section G.
For Shafts, Bearings and Collars See Section I.**

CLUSTER GEAR AND HUB

B

PITCH	STYLE	BORE	MATERIAL	AGMA QUALITY	PRESSURE ANGLE
120	X	1/4"	303 STAINLESS STEEL	10	20°

STOCK NO.	PITCH	NO. OF TEETH	PITCH DIA.	OUTSIDE DIA.
DP120S14-48	120	48	.4000	.417
DP120S14-50		50	.4166	.433
DP120S14-60		60	.5000	.517

PITCH	STYLE	BORE	MATERIAL	AGMA QUALITY	PRESSURE ANGLE
120	Y	1/4"	303 STAINLESS STEEL	10	20°

STOCK NO.	PITCH	NO. OF TEETH	PITCH DIA.	OUTSIDE DIA.
DP120S16-48	120	48	.4000	.417
DP120S16-50		50	.4166	.433
DP120S16-60		60	.5000	.517

PITCH	STYLE	BORE	MATERIAL	AGMA QUALITY	PRESSURE ANGLE
120	Z	1/4"	303 STAINLESS STEEL	10	20°

STOCK NO.	PITCH	NO. OF TEETH	PITCH DIA.	OUTSIDE DIA.
DP120S18-48	120	48	.4000	.417
DP120S18-50		50	.4166	.433
DP120S18-60		60	.5000	.517

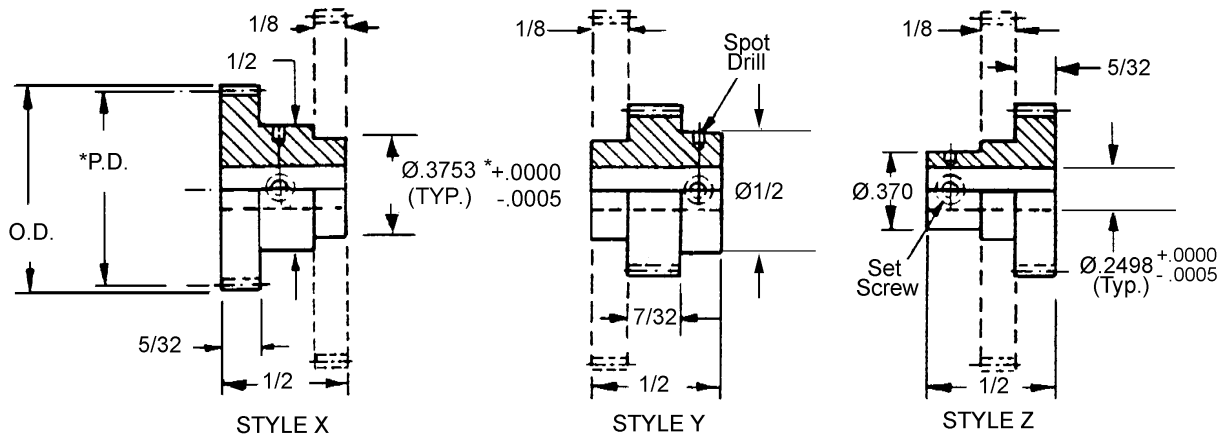

*Concentric within .0003
Order hubless gear separately.

CLUSTER GEAR AND HUB

PITCH	STYLE	BORE	MATERIAL	AGMA QUALITY	PRESSURE ANGLE
120	X	3/16"	303 STAINLESS STEEL	10	20°

STOCK NO.	PITCH	NO. OF TEETH	PITCH DIA.	OUTSIDE DIA.
DP120S8-48	120	48	.4000	.417
DP120S8-50		50	.4166	.433
DP120S8-54		54	.4500	.467
DP120S8-55		55	.4583	.475
DP120S8-60		60	.5000	.517
DP120S8-80		80	.6666	.683

PITCH	STYLE	BORE	MATERIAL	AGMA QUALITY	PRESSURE ANGLE
120	Y	3/16"	303 STAINLESS STEEL	10	20°

STOCK NO.	PITCH	NO. OF TEETH	PITCH DIA.	OUTSIDE DIA.
DP120S10-48	120	48	.4000	.417
DP120S10-50		50	.4166	.433
DP120S10-54		54	.4500	.467
DP120S10-55		55	.4583	.475
DP120S10-60		60	.5000	.517
DP120S10-80		80	.6666	.683

PITCH	STYLE	BORE	MATERIAL	AGMA QUALITY	PRESSURE ANGLE
120	Z	3/16"	303 STAINLESS STEEL	10	20°

STOCK NO.	PITCH	NO. OF TEETH	PITCH DIA.	OUTSIDE DIA.
DP120S12-48	120	48	.4000	.417
DP120S12-50		50	.4166	.433
DP120S12-54		54	.4500	.467
DP120S12-55		55	.4583	.475
DP120S12-60		60	.5000	.517
DP120S12-80		80	.6666	.683

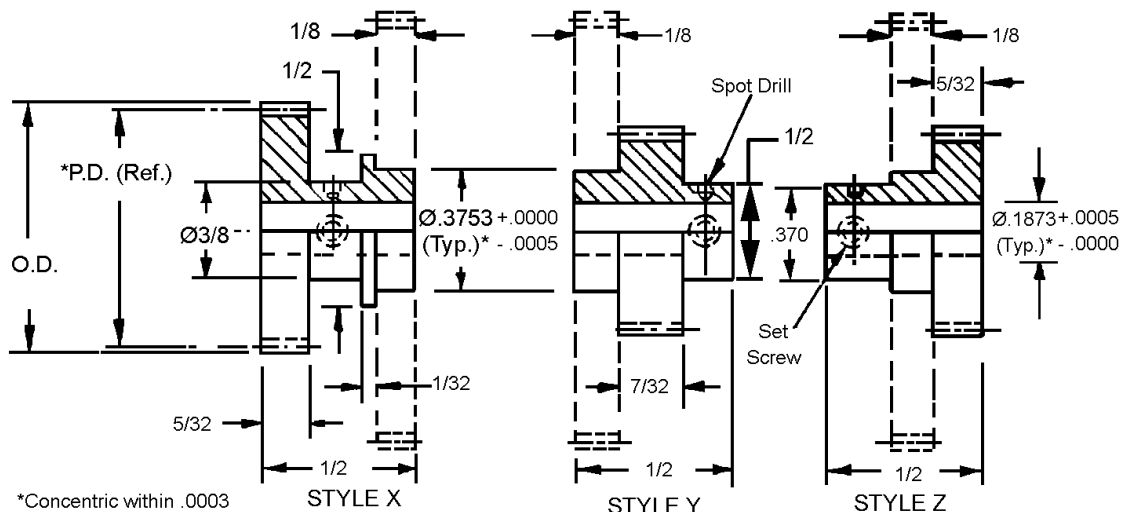

• Hub runout cuts thru shoulder.
 Available on request: Other numbers of teeth; AGMA quality 12 and 14; 14-1/2° Pressure Angle.

SPUR GEARS

PITCH	STYLE	BORE	FACE	MATERIAL	AGMA QUALITY	PRESSURE ANGLE
120	PIN HUB	1/8"	1/16"	303 STAINLESS STEEL AND ALUMINUM ANODIZED	10	20°

B

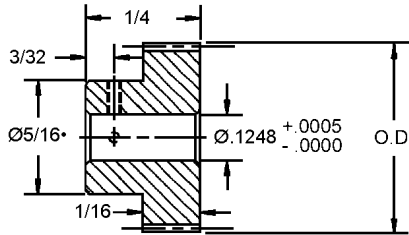
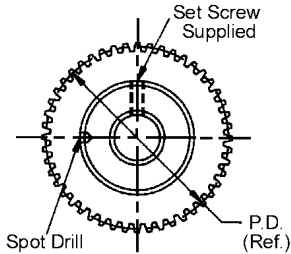

• For 31-40 teeth hub diameter equals .23
Available on request, other numbers of teeth, AGMA quality 12 and 14, and 14-1/2° Pressure Angle.

303 STAINLESS STEEL STOCK NO.	2024-T4 ALUMINUM ANODIZED STOCK NO.	NO. OF TEETH	PITCH DIA.	OUTSIDE DIA.
P120S5-32	P120A5-32	32•	.2666	.283
P120S5-33	P120A5-33	33•	.2750	.291
P120S5-34	P120A5-34	34•	.2833	.300
P120S5-36	P120A5-36	36•	.3000	.316
P120S5-39	P120A5-39	39•	.3250	.341
P120S5-40	P120A5-40	40•	.3333	.350
P120S5-42	P120A5-42	42	.3500	.366
P120S5-44	P120A5-44	44	.3666	.383
P120S5-45	P120A5-45	45	.3750	.391
P120S5-48	P120A5-48	48	.4000	.416
P120S5-50	P120A5-50	50	.4166	.433
P120S5-54	P120A5-54	54	.4500	.466
P120S5-60	P120A5-60	60	.5000	.516
P120S5-65	P120A5-65	65	.5416	.558
P120S5-66	P120A5-66	66	.5500	.566
P120S5-70	P120A5-70	70	.5833	.600
P120S5-72	P120A5-72	72	.6000	.616
P120S5-75	P120A5-75	75	.6250	.641
P120S5-78	P120A5-78	78	.6500	.666
P120S5-80	P120A5-80	80	.6666	.683
P120S5-84	P120A5-84	84	.7000	.716
P120S5-90	P120A5-90	90	.7500	.766
P120S5-96	P120A5-96	96	.8000	.816
P120S5-100	P120A5-100	100	.8333	.850
P120S5-102	P120A5-102	102	.8500	.866
P120S5-108	P120A5-108	108	.9000	.916
P120S5-114	P120A5-114	114	.9500	.966
P120S5-120	P120A5-120	120	1.0000	1.016
P120S5-126	P120A5-126	126	1.0500	1.066
P120S5-127	P120A5-127	127	1.0583	1.075
P120S5-130	P120A5-130	130	1.0833	1.100
P120S5-132	P120A5-132	132	1.1000	1.116
P120S5-138	P120A5-138	138	1.1500	1.166
P120S5-140	P120A5-140	140	1.1666	1.183
P120S5-144	P120A5-144	144	1.2000	1.216
P120S5-150	P120A5-150	150	1.2500	1.266
P120S5-156	P120A5-156	156	1.3000	1.316
P120S5-162	P120A5-162	162	1.3500	1.366
P120S5-180	P120A5-180	180	1.5000	1.516

For Couplings See Section G.
For Shafts, Bearings and Collars See Section I.

SPUR GEARS

PITCH	STYLE	BORE	FACE	MATERIAL	AGMA QUALITY	PRESSURE ANGLE
120	PIN HUB	1/8"	3/32"	303 STAINLESS STEEL AND ALUMINUM ANODIZED	10	20°

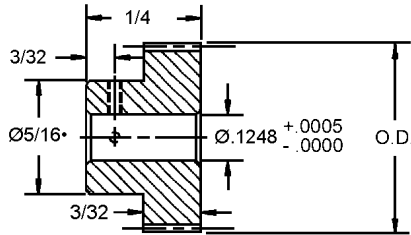
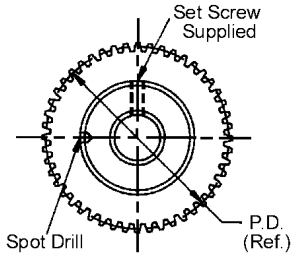

• For 31-40 teeth hub diameter equals .23

Available on request, other numbers of teeth, AGMA quality 12 and 14, and 14-1/2° Pressure Angle.

303 STAINLESS STEEL STOCK NO.	2024-T4 ALUMINUM ANODIZED STOCK NO.	NO. OF TEETH	PITCH DIA.	OUTSIDE DIA.
P120S7-35	P120A7-35	35•	.2916	.308
P120S7-40	P120A7-40	40•	.3333	.350
P120S7-41	P120A7-41	41	.3416	.358
P120S7-45	P120A7-45	45	.3750	.391
P120S7-48	P120A7-48	48	.4000	.416
P120S7-50	P120A7-50	50	.4166	.433
P120S7-52	P120A7-52	52	.4333	.450
P120S7-56	P120A7-56	56	.4666	.483
P120S7-57	P120A7-57	57	.4750	.491
P120S7-59	P120A7-59	59	.4916	.508
P120S7-60	P120A7-60	60	.5000	.516
P120S7-61	P120A7-61	61	.5083	.525
P120S7-64	P120A7-64	64	.5333	.550
P120S7-65	P120A7-65	65	.5416	.558
P120S7-67	P120A7-67	67	.5583	.575
P120S7-70	P120A7-70	70	.5833	.600
P120S7-72	P120A7-72	72	.6000	.616
P120S7-73	P120A7-73	73	.6083	.625
P120S7-90	P120A7-90	90	.7500	.766
P120S7-96	P120A7-96	96	.8000	.816
P120S7-100	P120A7-100	100	.8333	.850
P120S7-108	P120A7-108	108	.9000	.916
P120S7-110	P120A7-110	110	.9166	.933
P120S7-120	P120A7-120	120	1.0000	1.016
P120S7-130	P120A7-130	130	1.0833	1.100
P120S7-140	P120A7-140	140	1.1666	1.183
P120S7-144	P120A7-144	144	1.2000	1.216
P120S7-150	P120A7-150	150	1.2500	1.266
P120S7-156	P120A7-156	156	1.3000	1.316
P120S7-160	P120A7-160	160	1.3333	1.350
P120S7-162	P120A7-162	162	1.3500	1.366
P120S7-168	P120A7-168	168	1.4000	1.416
P120S7-170	P120A7-170	170	1.4166	1.433
P120S7-174	P120A7-174	174	1.4500	1.466
P120S7-180	P120A7-180	180	1.5000	1.516
P120S7-185	P120A7-185	185	1.5416	1.558

For Couplings See Section G.
For Shafts, Bearings and Collars See Section I.

SPUR GEARS

PITCH	STYLE	BORE	FACE	MATERIAL	AGMA QUALITY	PRESSURE ANGLE
120	PIN HUB	1/8"	1/8"	303 STAINLESS STEEL AND ALUMINUM ANODIZED	10	20°

B

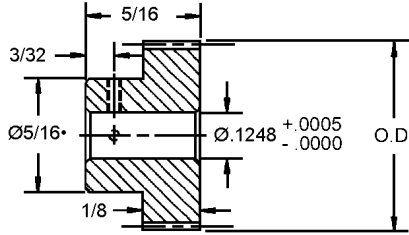
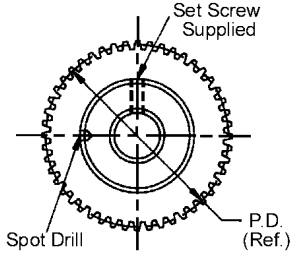

• For 31-40 teeth hub diameter equals .23
Available on request, other numbers of teeth, AGMA quality 12 and 14, and 14-1/2° Pressure Angle.

303 STAINLESS STEEL STOCK NO.	2024-T4 ALUMINUM ANODIZED STOCK NO.	NO. OF TEETH	PITCH DIA.	OUTSIDE DIA.
P120S10-32	P120A10-32	32•	.2666	.283
P120S10-34	P120A10-34	34•	.2833	.300
P120S10-36	P120A10-36	36•	.3000	.316
P120S10-38	P120A10-38	38•	.3166	.333
P120S10-40	P120A10-40	40•	.3333	.350
P120S10-41	P120A10-41	41	.3416	.358
P120S10-43	P120A10-43	43	.3583	.375
P120S10-44	P120A10-44	44	.3666	.383
P120S1045	P120A10-45	45	.3750	.391
P120S10-47	P120A10-47	47	.3916	.408
P120S10-48	P120A10-48	48	.4000	.416
P120S10-50	P120A10-50	50	.4166	.433
P120S10-55	PI 20A10-55	55	.4583	.475
P120S10-59	P120A10-59	59	.4916	.508
P120S10-60	P120A10-60	60	.5000	.516
P120S10-61	PI 20A10-61	61	.5083	.525
P120S10-64	P120A10-64	64	.5333	.550
P120S10-65	P120A10-65	65	.5416	.558
P120S10-70	P120A10-70	70	.5833	.600
P120S10-72	P120A10-72	72	.6000	.616
P120S10-75	P120A10-75	75	.6250	.641
P120S10-80	P120A10-80	80	.6666	.683
P120S10-85	P120A10-85	85	.7083	.725
P120S10-90	P120A10-90	90	.7500	.766
P120S10-96	P120A10-96	96	.8000	.816
P120S10-100	P120A10-100	100	.8333	.850
P120S10-110	P120A10-110	110	.9166	.933
P120S10-120	P120A10-120	120	1.0000	1.016
P120S10-130	P120A10-130	130	1.0833	1.100
P120S10-140	P120A10-140	140	1.1666	1.183
P120S10-150	P120A10-150	150	1.2500	1.266
P120S10-160	P120A10-160	160	1.3333	1.350
P120S10-170	P120A10-170	170	1.4166	1.433
P120S10-180	P120A10-180	180	1.5000	1.516

For Couplings See Section G.
For Shafts, Bearings and Collars See Section I.

GEAR RACKS

PITCH	STYLE	MATERIAL	AGMA QUALITY	PRESSURE ANGLE
120	ROUND & RECTANGULAR	416 SERIES STAINLESS STEEL STRESSED RELIEVED	10	20°

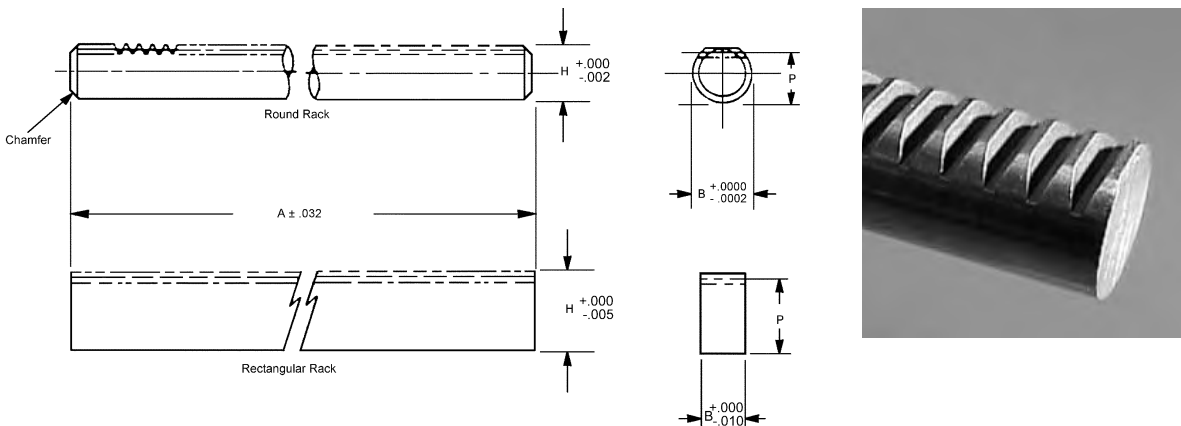

STOCK NO.	RACK STYLE	PITCH	P (Ref.)	B	A	H	AGMA QUALITY
R2-21	ROUND	120	.1067	.1247	11	.115	10
R2-17	RECTANGULAR	120	.3467	.167±.005	11	.355	10

Available on request: 14 - 1/2° pressure angle, special, modified and custom racks.

PITCH	STYLE	MATERIAL	AGMA QUALITY	PRESSURE ANGLE
120	RECTANGULAR	416 SERIES STAINLESS STEEL AND 2024-T4 ALUMINUM ANODIZED	10	20°

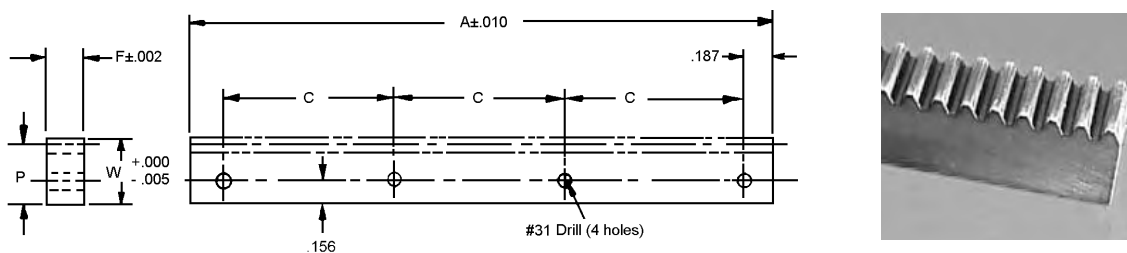

STOCK NO.	MATERIAL	A (Inch)	P (Ref.)	W	F	C
R4-23	STAINLESS ST.	3"	.3467	.355	.167	.875
R4-24	ALUMINUM					

Available on request: special, modified and custom racks.

PINION SHAFTS

PITCH	MATERIAL	AGMA QUALITY	PRES. ANGLE
120	303 STAINLESS STEEL	10	20°

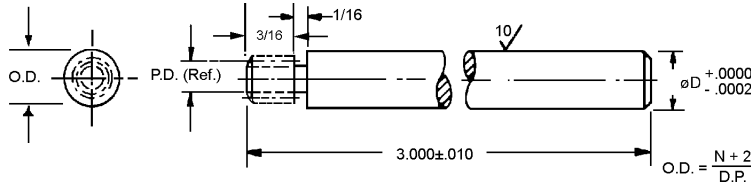

STOCK NO.	PITCH	NO. OF TEETH	PITCH DIA.	D
PS120S2-12	120	12	.10000	.1247

Other numbers of teeth available on request.



B

PITCH	MATERIAL	AGMA QUALITY	PRES. ANGLE
120	303 STAINLESS STEEL	10	20°

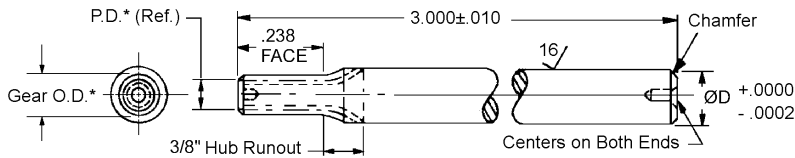

STOCK NO.	PITCH	NO. OF TEETH	D	ENLARGED	
				PITCH DIAMETER	OUTSIDE DIA.
B-PS120S2-10	120	10	.1247	.0902	.106
B-PS120S2-12		12		.1050	.121
B-PS120S3-15	120	15	.1872	.1270	.143
B-PS120S3-17		17		.1418	.158

Other numbers of teeth available on request.



HELICAL GEARS

PITCH	STYLE	BORE	MATERIAL	AGMA QUALITY	PRES. ANGLE	HELIX ANGLE
16	R & L Hand PIN HUB	1/2"	303 Stainless Steel	9	20°	45°

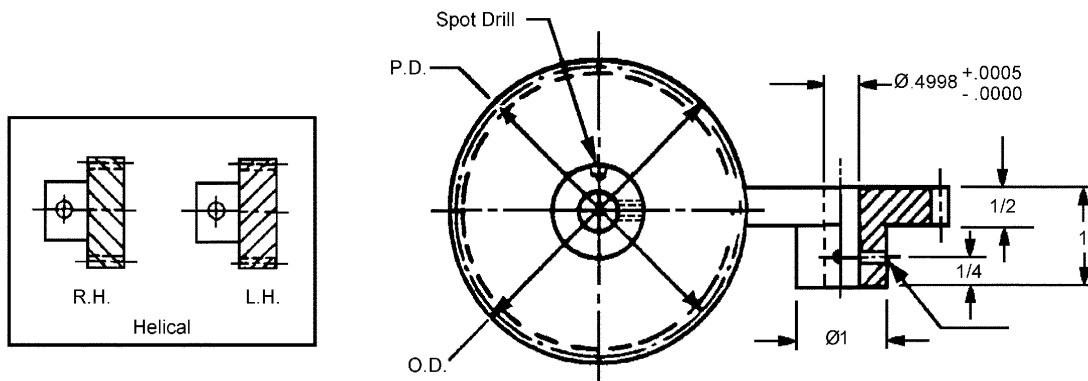

RIGHT HAND STOCK NO.	LEFT HAND STOCK NO.	NO. OF TEETH	P.D.	O.D.
H16S38-R12	H16S38-L12	12*	1.0600	1.185
H16S38-R16	H16S38-L16	16	1.4142	1.539
H16S38-R20	H16S38-L20	20	1.7677	1.892
H16S38-R24	H16S38-L24	24	2.1213	2.246
H16S38-R32	H16S38-L32	32	2.8284	2.953
H16S38-R40	H16S38-L40	40	3.5355	3.660
H16S38-R48	H16S38-L48	48	4.2426	4.367

* For 11-12 teeth hub diameter is .81



PITCH	STYLE	BORE	MATERIAL	AGMA QUALITY	PRES. ANGLE	HELIX ANGLE
20	R & L Hand PIN HUB	3/8"	303 Stainless Steel	9	20°	45°

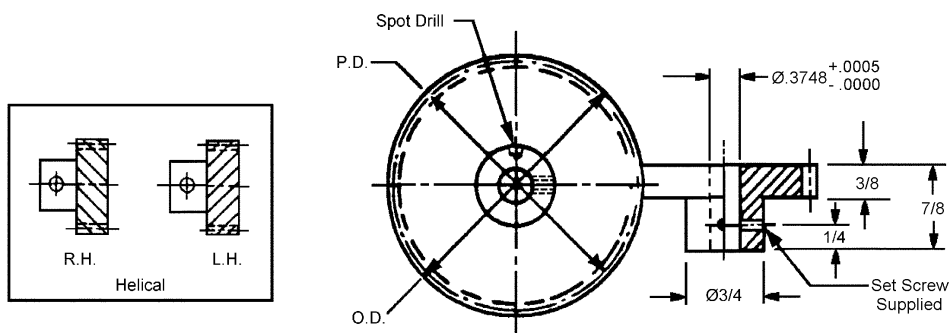

RIGHT HAND STOCK NO.	LEFT HAND STOCK NO.	NO. OF TEETH	P.D.	O.D.
H20S35-R11	H20S35-L11	11*	.7778	.877
H20S35-R15	H20S35-L15	15	1.0606	1.160
H20S35-R20	H20S35-L20	20	1.4142	1.514
H20S35-R25	H20S35-L25	25	1.7677	1.867
H20S35-R30	H20S35-L30	30	2.1213	2.221
H20S35-R40	H20S35-L40	40	2.8284	2.928
H20S35-R50	H20S35-L50	50	3.5355	3.635
H20S35-R60	H20S35-L60	60	4.2426	4.342

* For 11-12 teeth hub diameter equals .65



HELICAL GEARS

B

PITCH	STYLE	BORE	MATERIAL	AGMA QUALITY	PRES. ANGLE	HELIX ANGLE
24	R & L Hand PIN HUB	5/16"	303 Stainless Steel or 2024-T4 Aluminum Anodized	10	20°	45°

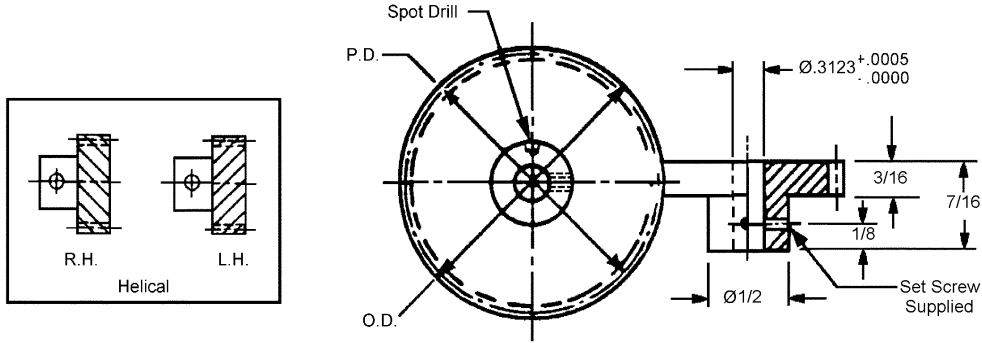

RIGHT HAND		LEFT HAND		NO. OF TEETH	P.D.	O.D.
STAINLESS	ALUMINUM	STAINLESS	ALUMINUM			
STOCK NO.	STOCK NO.	STOCK NO.	STOCK NO.			
H24S32-R12	H24A32-R12	H24S32-L12	H24A32-L12	12	.7071	.790
H24S32-R18	H24A32-R18	H24S32-L18	H24A32-L18	18	1.0606	1.143
H24S32-R24	H24A32-R24	H24S32-L24	H24A32-L24	24	1.4142	1.497
H24S32-R30	H24A32-R30	H24S32-L30	H24A32-L30	30	1.7677	1.850
H24S32-R36	H24A32-R36	H24S32-L36	H24A32-L36	36	2.1213	2.204
H24S32-R48	H24A32-R48	H24S32-L48	H24A32-L48	48	2.8284	2.911
H24S32-R60	H24A32-R60	H24S32-L60	H24A32-L60	60	3.5355	3.618
H24S32-R72	H24A32-R72	H24S32-L72	H24A32-L72	72	4.2426	4.325



PITCH	STYLE	BORE	MATERIAL	AGMA QUALITY	PRES. ANGLE	HELIX ANGLE
32	R & L Hand PIN HUB	1/4"	303 Stainless Steel or 2024-T4 Aluminum Anodized	10	20°	45°

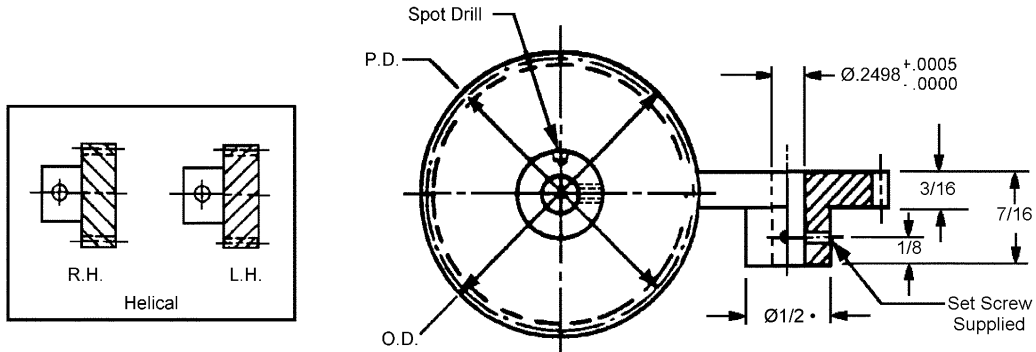

RIGHT HAND		LEFT HAND		NO. OF TEETH	P.D.	O.D.
STAINLESS	ALUMINUM	STAINLESS	ALUMINUM			
STOCK NO.	STOCK NO.	STOCK NO.	STOCK NO.			
H32S28-R16	H32A28-R16	H32S28-L16	H32A28-L16	16	.7071	.769
H32S28-R24	H32A28-R24	H32S28-L24	H32A28-L24	24	1.0606	1.122
H32S28-R32	H32A28-R32	H32S28-L32	H32A28-L32	32	1.4142	1.476
H32S28-R40	H32A28-R40	H32S28-L40	H32A28-L40	40	1.7677	1.829
H32S28-R48	H32A28-R48	H32S28-L48	H32A28-L48	48	2.1213	2.183
H32S28-R64	H32A28-R64	H32S28-L64	H32A28-L64	64	2.8284	2.890
H32S28-R80	H32A28-R80	H32S28-L80	H32A28-L80	80	3.5355	3.597
H32S28-R96	H32A28-R96	H32S28-L96	H32A28-L96	96	4.2426	4.304



* For 12-13 teeth hub diameter is .45

HELICAL GEARS

PITCH	STYLE	BORE	MATERIAL	AGMA QUALITY	PRES. ANGLE	HELIX ANGLE
48	R & L Hand PIN HUB	3/16"	303 Stainless Steel or 2024-T4 Aluminum Anodized	10	20°	45°

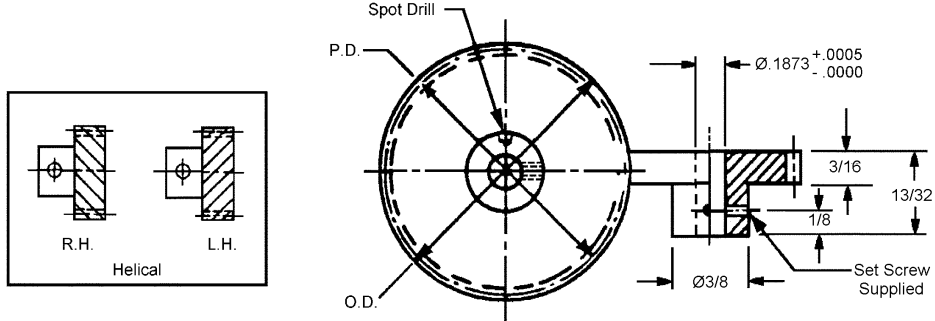

STAINLESS STEEL		ALUMINUM		NO. OF TEETH	P.D.
RIGHT HAND	LEFT HAND	RIGHT HAND	LEFT HAND		
STOCK NO.	STOCK NO.	STOCK NO.	STOCK NO.		
H48S21-R20	H48S21-L20	H48A21-R20	H48A21-L20	20	.5892
H48S21-R24	H48S21-L24	H48A21-R24	H48A21-L24	24	.7071
H48S21-R25	H48S21-L25	H48A21-R25	H48A21-L25	25	.7365
H48S21-R30	H48S21-L30	H48A21-R30	H48A21-L30	30	.8838
H48S21-R35	H48S21-L35	H48A21-R35	H48A21-L35	35	1.0311
H48S21-R36	H48S21-L36	H48A21-R36	H48A21-L36	36	1.0606
H48S21-R40	H48S21-L40	H48A21-R40	H48A21-L40	40	1.1785
H48S21-R45	H48S21-L45	H48A21-R45	H48A21-L45	45	1.3258
H48S21-R48	H48S21-L48	H48A21-R48	H48A21-L48	48	1.4142
H48S21-R50	H48S21-L50	H48A21-R50	H48A21-L50	50	1.4731
H48S21-R60	H48S21-L60	H48A21-R60	H48A21-L60	60	1.7677
H48S21-R70	H48S21-L70	H48A21-R70	H48A21-L70	70	2.0623
H48S21-R72	H48S21-L72	H48A21-R72	H48A21-L72	72	2.1213
H48S21-R80	H48S21-L80	H48A21-R80	H48A21-L80	80	2.3568
H48S21-R90	H48S21-L90	H48A21-R90	H48A21-L90	90	2.6516
H48S21-R96	H48S21-L96	H48A21-R96	H48A21-L96	96	2.8282
H48S21-R100	H48S21-L100	H48A21-R100	H48A21-L100	100	2.9462
H48S21-R120	H48S21-L120	H48A21-R120	H48A21-L120	120	3.5355
H48S21-R144	H48S21-L144	H48A21-R144	H48A21-L144	144	4.2426



HELICAL GEARS

PITCH	STYLE	BORE	MATERIAL	AGMA QUALITY	PRES. ANGLE	HELIX ANGLE
48	R & L Hand PIN HUB	1/4"	303 Stainless Steel or 2024-T4 Aluminum Anodized	10	20°	45°

B

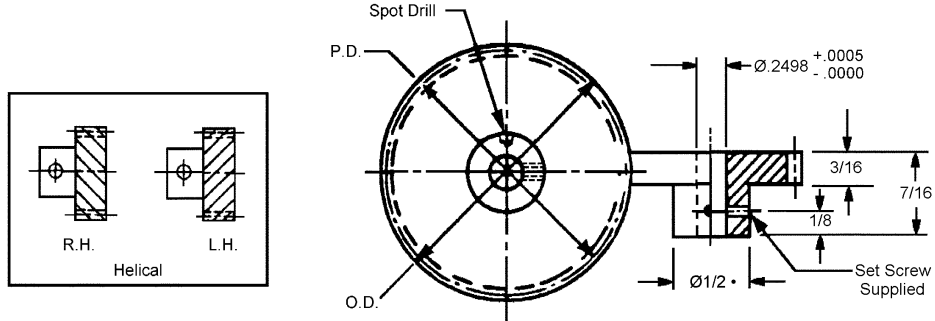

STAINLESS STEEL		ALUMINUM		NO. OF TEETH	P.D.
RIGHT HAND	LEFT HAND	RIGHT HAND	LEFT HAND		
STOCK NO.	STOCK NO.	STOCK NO.	STOCK NO.		
H48S28-R20	H48S28-L20	H48A28-R20	H48A28-L20	20	.5892
H48S28-R24	H48S28-L24	H48A28-R24	H48A28-L24	24	.7071
H48S28-R25	H48S28-L25	H48A28-R25	H48A28-L25	25	.7365
H48S28-R30	H48S28-L30	H48A28-R30	H48A28-L30	30	.8838
H48S28-R35	H48S28-L35	H48A28-R35	H48A28-L35	35	1.0311
H48S28-R36	H48S28-L36	H48A28-R36	H48A28-L36	36	1.0606
H48S28-R40	H48S28-L40	H48A28-R40	H48A28-L40	40	1.1785
H48S28-R45	H48S28-L45	H48A28-R45	H48A28-L45	45	1.3258
H48S28-R48	H48S28-L48	H48A28-R48	H48A28-L48	48	1.4142
H48S28-R50	H48S28-L50	H48A28-R50	H48A28-L50	50	1.4731
H48S28-R60	H48S28-L60	H48A28-R60	H48A28-L60	60	1.7677
H48S28-R70	H48S28-L70	H48A28-R70	H48A28-L70	70	2.0623
H48S28-R72	H48S28-L72	H48A28-R72	H48A28-L72	72	2.1213
H48S28-R80	H48S28-L80	H48A28-R80	H48A28-L80	80	2.3568
H48S28-R90	H48S28-L90	H48A28-R90	H48A28-L90	90	2.6516
H48S28-R96	H48S28-L96	H48A28-R96	H48A28-L96	96	2.8282
H48S28-R100	H48S28-L100	H48A28-R100	H48A28-L100	100	2.9462
H48S28-R120	H48S28-L120	H48A28-R120	H48A28-L120	120	3.5355
H48S28-R144	H48S28-L144	H48A28-R144	H48A28-L144	144	4.2426



• For 17-19 teeth hub diameter is .44

**For Couplings See Section G.
For Shafts, Bearings and Collars See Section I.**

HELICAL GEARS

PITCH	STYLE	BORE	MATERIAL	AGMA QUALITY	PRES. ANGLE	HELIX ANGLE
64	R & L Hand PIN HUB	1/8"	303 Stainless Steel or 2024-T4 Aluminum Anodized	10	20°	45°

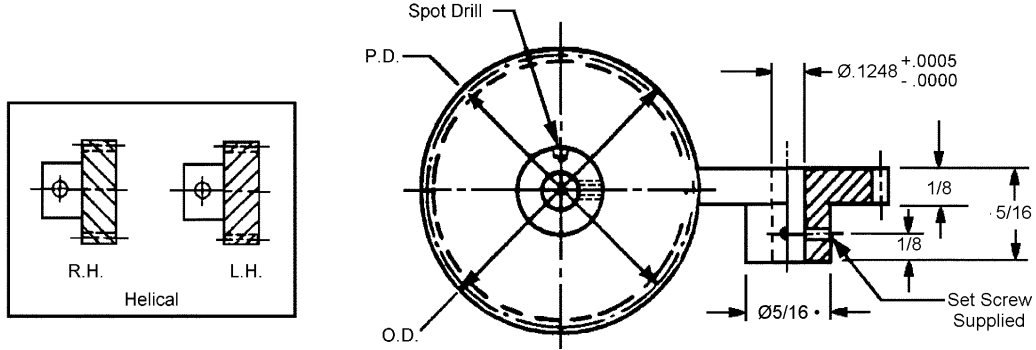

STAINLESS STEEL		ALUMINUM		NO. OF TEETH	P.D.
RIGHT HAND	LEFT HAND	RIGHT HAND	LEFT HAND		
STOCK NO.	STOCK NO.	STOCK NO.	STOCK NO.		
H64S10-R20	H64S10-L20	H64A10-R20	H64A10-L20	20	.4419
H64S10-R25	H64S10-L25	H64A10-R25	H64A10-L25	25	.5524
H64S10-R30	H64S10-L30	H64A10-R30	H64A10-L30	30	.6629
H64S10-R32	H64S10-L32	H64A10-R32	H64A10-L32	32	.7071
H64S10-R35	H64S10-L35	H64A10-R35	H64A10-L35	35	.7733
H64S10-R40	H64S10-L40	H64A10-R40	H64A10-L40	40	.8838
H64S10-R45	H64S10-L45	H64A10-R45	H64A10-L45	45	.9943
H64S10-R48	H64S10-L48	H64A10-R48	H64A10-L48	48	1.0606
H64S10-R50	H64S10-L50	H64A10-R50	H64A10-L50	50	1.1048
H64S10-R60	H64S10-L60	H64A10-R60	H64A10-L60	60	1.3258
H64S10-R64	H64S10-L64	H64A10-R64	H64A10-L64	64	1.4142
H64S10-R70	H64S10-L70	H64A10-R70	H64A10-L70	70	1.5467
H64S10-R80	H64S10-L80	H64A10-R80	H64A10-L80	80	1.7677
H64S10-R90	H64S10-L90	H64A10-R90	H64A10-L90	90	1.9886
H64S10-R96	H64S10-L96	H64A10-R96	H64A10-L96	96	2.1213
H64S10-R100	H64S10-L100	H64A10-R100	H64A10-L100	100	2.2096
H64S10-R128	H64S10-L128	H64A10-R128	H64A10-L128	128	2.8284
H64S10-R160	H64S10-L160	H64A10-R160	H64A10-L160	160	3.5355



• For 13-15 teeth hub diameter equals .24

**For Couplings See Section G.
For Shafts, Bearings and Collars See Section I.**

HELICAL GEARS

PITCH	STYLE	BORE	MATERIAL	AGMA QUALITY	PRES. ANGLE	HELIX ANGLE
64	R & L Hand PIN HUB	3/16"	303 Stainless Steel or 2024-T4 Aluminum Anodized	10	20°	45°

B

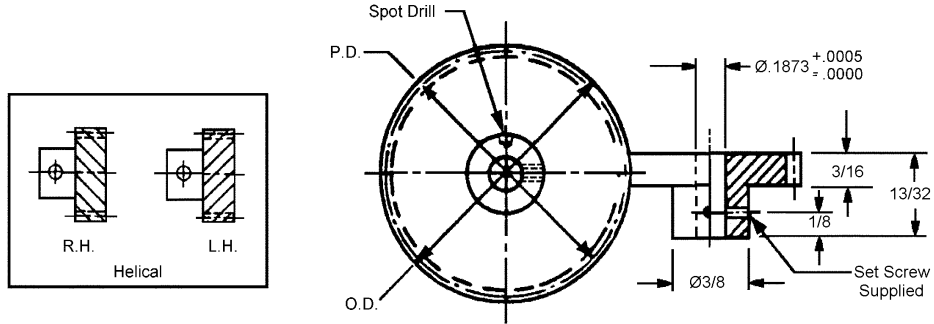

STAINLESS STEEL		ALUMINUM		NO. OF TEETH	P.D.
RIGHT HAND	LEFT HAND	RIGHT HAND	LEFT HAND		
STOCK NO.	STOCK NO.	STOCK NO.	STOCK NO.		
H64S21-R20	H64S21-L20	H64A21-R20	H64A21-L20	20	.4419
H64S21-R25	H64S21-L25	H64A21-R25	H64A21-L25	25	.5524
H64S21-R30	H64S21-L30	H64A21-R30	H64A21-L30	30	.6629
H64S21-R32	H64S21-L32	H64A21-R32	H64A21-L32	32	.7071
H64S21-R35	H64S21-L35	H64A21-R35	H64A21-L35	35	.7733
H64S21-R40	H64S21-L40	H64A21-R40	H64A21-L40	40	.8838
H64S21-R45	H64S21-L45	H64A21-R45	H64A21-L45	45	.9943
H64S21-R48	H64S21-L48	H64A21-R48	H64A21-L48	48	1.0606
H64S21-R50	H64S21-L50	H64A21-R50	H64A21-L50	50	1.1048
H64S21-R60	H64S21-L60	H64A21-R60	H64A21-L60	60	1.3258
H64S21-R64	H64S21-L64	H64A21-R64	H64A21-L64	64	1.4142
H64S21-R70	H64S21-L70	H64A21-R70	H64A21-L70	70	1.5467
H64S21-R80	H64S21-L80	H64A21-R80	H64A21-L80	80	1.7677
H64S21-R90	H64S21-L90	H64A21-R90	H64A21-L90	90	1.9886
H64S21-R96	H64S21-L96	H64A21-R96	H64A21-L96	96	2.1213
H64S21-R100	H64S21-L100	H64A21-R100	H64A21-L100	100	2.2096
H64S21-R128	H64S21-L128	H64A21-R128	H64A21-L128	128	2.8284
H64S21-R160	H64S21-L160	H64A21-R160	H64A21-L160	160	3.5355



For Couplings See Section G.
For Shafts, Bearings and Collars See Section I.

MITER & BEVEL GEARS

PITCH	STYLE	BORE	FACE	MATERIAL	AGMA QUALITY	PRES. ANGLE
16	Matched Sets PIN HUB	1/2"	5/16"	303 Stainless Steel or 2024-T4 Aluminum Anodized	10	20°

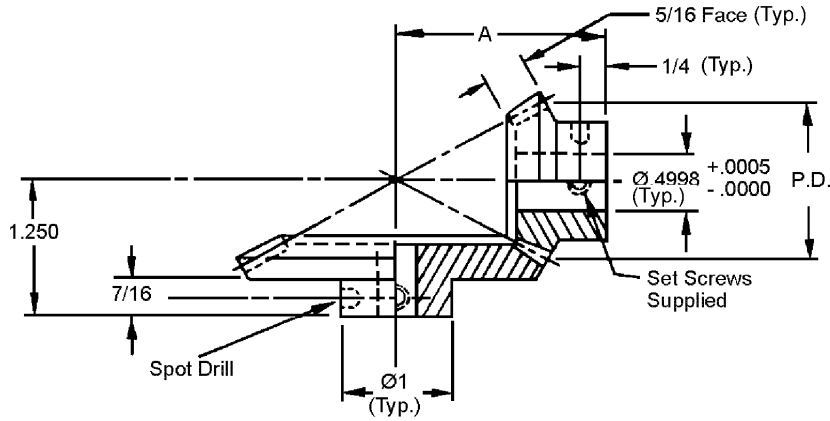

STOCK NO.	P.D.	RATIO	NO. OF TEETH	A	MATERIAL
M16P-1	1.250 1.250	1 to 1	20 20	1.250	STAINLESS STEEL ALUMINUM
M16P-1S	1.250 1.250	1 to 1	20 20	1.250	STAINLESS STEEL STAINLESS STEEL
M16P-1A	1.250 1.250	1 to 1	20 20	1.250	ALUMINUM ALUMINUM
M16P-2	1.250 (PINION) 2.500 (GEAR)	1 to 2	20 40	1.875	STAINLESS STEEL ALUMINUM
M16P-3	1.250 (PINION) 3.750 (GEAR)	1 to 3	20 60	2.500	STAINLESS STEEL ALUMINUM
M16P-1P	1.250	1 to 1	20	1.250	STAINLESS STEEL
M16P-1G	1.250	1 to 1	20	1.250	ALUMINUM

Note: Gears will mesh at right angles only when used as sets described in chart.

For Couplings See Section G.
For Shafts, Bearings and Collars See Section I.

MITER & BEVEL GEARS

PITCH	STYLE	BORE	FACE	MATERIAL	AGMA QUALITY	PRES. ANGLE
24	Matched Sets PIN HUB	3/8"	9/32"	303 Stainless Steel or 2024-T4 Aluminum Anodized	10	20°

B

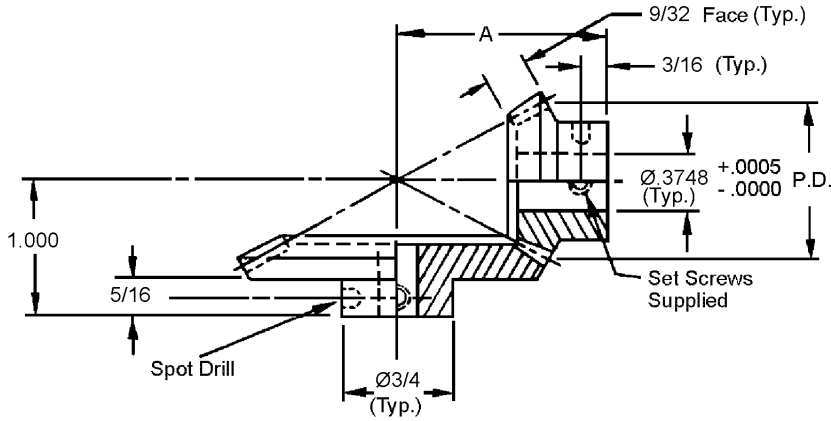

STOCK NO.	P.D.	RATIO	NO. OF TEETH	A	MATERIAL
M24P-1	1.000 1.000	1 to 1	24 24	1.000	STAINLESS STEEL ALUMINUM
M24P-1S	1.000 1.000	1 to 1	24 24	1.000	STAINLESS STEEL STAINLESS STEEL
M24P-1A	1.000 1.000	1 to 1	24 24	1.000	ALUMINUM ALUMINUM
M24P-2	1.000 (PINION) 2.000 (GEAR)	1 to 2	24 48	1.500	STAINLESS STEEL ALUMINUM
M24P-3	1.000 (PINION) 3.000 (GEAR)	1 to 3	24 72	2.000	STAINLESS STEEL ALUMINUM
M24P-4	1.000 (PINION) 4.000 (GEAR)	1 to 4	24 96	2.500	ST STEEL ALUMINUM
M24P-1P	1.000	1 to 1	24	1.000	STAINLESS STEEL
M24P-1G	1.000	1 to 1	24	1.000	ALUMINUM

Note: Gears will mesh at right angles only when used as sets described in chart.

For Couplings See Section G.
For Shafts, Bearings and Collars See Section I.

MITER & BEVEL GEARS

PITCH	STYLE	BORE	FACE	MATERIAL	AGMA QUALITY	PRES. ANGLE
32	Matched Sets PIN HUB	5/16"	1/4"	303 Stainless Steel or 2024-T4 Aluminum Anodized	10	20°

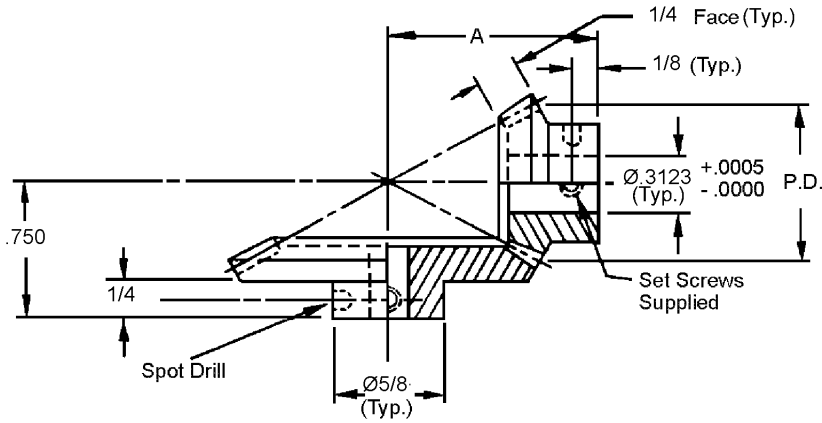

STOCK NO.	P.D.	RATIO	NO. OF TEETH	A	MATERIAL
M32P-1	.750	1 to 1	24	.750	STAINLESS STEEL ALUMINUM
M32P-1S	.750	1 to 1	24	.750	STAINLESS STEEL STAINLESS STEEL
M32P-1A	.750	1 to 1	24	.750	ALUMINUM ALUMINUM
M32P-2	.750 (PINION) 1.500 (GEAR)	1 to 2	24 48	1.125	STAINLESS STEEL ALUMINUM
M32P-3	.750 (PINION) 2.250 (GEAR)	1 to 3	24 72	1.500	STAINLESS STEEL ALUMINUM
M32P-4	.750 (PINION) 3.000 (GEAR)	1 to 4	24 96	1.875	STAINLESS STEEL ALUMINUM
M32P-1P	.750	1 to 1	24	.750	STAINLESS STEEL
M32P-1G	.750	1 to 1	24	.750	ALUMINUM

Note: Gears will mesh at right angles only when used as sets described in chart.

For Couplings See Section G.
For Shafts, Bearings and Collars See Section I.

MITER & BEVEL GEARS

PITCH	STYLE	BORE	FACE	MATERIAL	AGMA QUALITY	PRES. ANGLE
48	Matched Sets PIN OR CLAMP	1/4"	3/16"	303 Stainless Steel or 2024-T4 Aluminum Anodized	10	20°

B

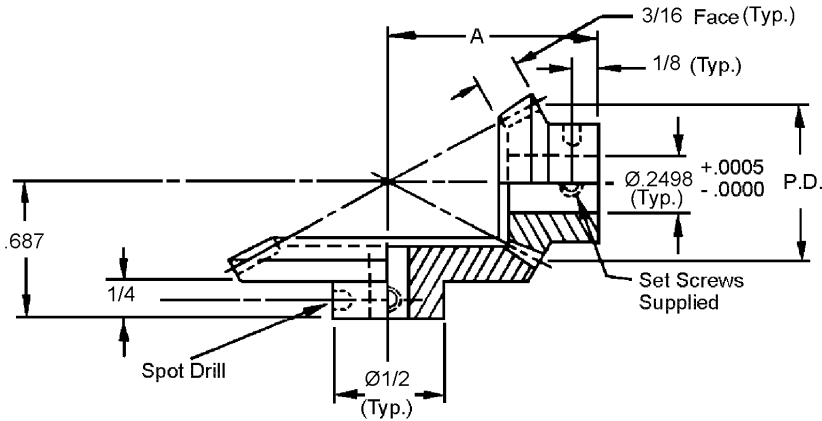

PIN HUB STOCK NO.	CLAMP STYLE STOCK NO.	P.D.	RATIO	NO. OF TEETH	A	MATERIAL
M48N-1	M48N-1-C	.625 .625	1 to 1	30 30	.687	STAINLESS STEEL ALUMINUM
M48N-1S	M48N-1S-C	.625 .625	1 to 1	30 30	.687	STAINLESS STEEL
M48N-1A	M48N-1A-C	.625 .625	1 to 1	30 30	.687	ALUMINUM
M48N-5	M48N-5-C	.625 (PINION) .937 (GEAR)	1 to 1-1/2	30 45	.812	STAINLESS STEEL ALUMINUM
M48N-5S	M48N-5-CS	.625 (PINION) .937 (GEAR)	1 to 1-1/2	30 45	.812	STAINLESS STEEL
M48N-5A	M48N-5-CA	.625 (PINION) .937 (GEAR)	1 to 1-1/2	30 45	.812	ALUMINUM
M48N-2	M48N-2-C	.625 (PINION) 1.250 (GEAR)	1 to 2	30 60	.937	STAINLESS STEEL ALUMINUM
M48N-2S	M48N-2S-C	.625 (PINION) 1.250 (GEAR)	1 to 2	30 60	.937	STAINLESS STEEL
M48N-2A	M48N-2A-C	.625 (PINION) 1.250 (GEAR)	1 to 2	30 60	.937	ALUMINUM
M48N-3	M48N-3-C	.625 (PINION) 1.875 (GEAR)	1 to 3	30 90	1.250	STAINLESS STEEL ALUMINUM
M48N-3S	M48N-3-CS	.625 (PINION) 1.875 (GEAR)	1 to 3	30 90	1.250	STAINLESS STEEL
M48N-3A	M48N-3-CA	.625 (PINION) 1.875 (GEAR)	1 to 3	30 90	1.250	ALUMINUM
M48N-4	M48N-4-C	.625 (PINION) 2.500 (GEAR)	1 to 4	30 120	1.531	STAINLESS STEEL ALUMINUM
M48N-4S	M48N-4-CS	.625 (PINION) 2.500 (GEAR)	1 to 4	30 120	1.531	STAINLESS STEEL
M48N-4A	M48N-4-CA	.625 (PINION) 2.500 (GEAR)	1 to 4	30 120	1.531	ALUMINUM
M48N-1P	M48N-1P-C	.625	1 to 1	30	.687	STAINLESS STEEL
M48N-1G	M48N-1G-C	.625	1 to 1	30	.687	ALUMINUM

Note: Gears will mesh at right angles only when used as sets described in chart.

MITER & BEVEL GEARS

PITCH	STYLE	BORE	FACE	MATERIAL	AGMA QUALITY	PRES. ANGLE
64	Matched Sets PIN OR CLAMP	3/16"	5/32"	303 Stainless Steel or 2024-T4 Aluminum Anodized	10	20°

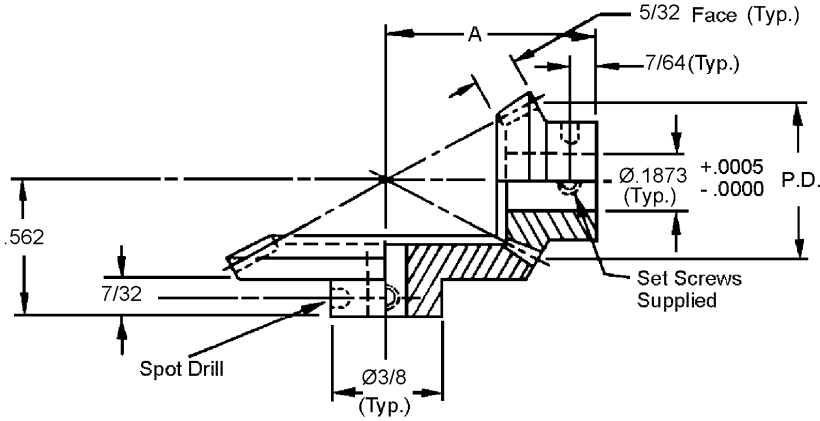

PIN HUB STOCK NO.	CLAMP STYLE STOCK NO.	P.D.	RATIO	NO. OF TEETH	A	MATERIAL
M64N-1	M64N-1-C	.500 .500	1 to 1	32 32	.562	STAINLESS STEEL ALUMINUM
M64N-1S	M64N-1S-C	.500 .500	1 to 1	32 32	.562	STAINLESS STEEL
M64N-1A	M64N-1A-C	.500 .500	1 to 1	32 32	.562	ALUMINUM
M64N-2	M64N-2-C	.500 (PINION) 1.000 (GEAR)	1 to 2	32 64	.750	STAINLESS STEEL ALUMINUM
M64N-2S	M64N-2-CS	.500 (PINION) 1.000 (GEAR)	1 to 2	30 64	.750	STAINLESS STEEL
M64N-2A	M64N-2-CA	.500 (PINION) 1.000 (GEAR)	1 to 2	30 64	.750	ALUMINUM
M64N-3	M64N-3-C	.500 (PINION) 1.500 (GEAR)	1 to 3	32 96	1.000	STAINLESS STEEL ALUMINUM
M64N-3S	M64N-3S-C	.500 (PINION) 1.500 (GEAR)	1 to 3	32 96	1.000	STAINLESS STEEL
M64N-3A	M64N-3A-C	.500 (PINION) 1.500 (GEAR)	1 to 3	32 96	1.000	ALUMINUM
M64N-4	M64N-4-C	.500 (PINION) 2.000 (GEAR)	1 to 4	32 128	1.250	STAINLESS STEEL ALUMINUM
M64N-4S	M64N-4S-C	.500 (PINION) 2.000 (GEAR)	1 to 4	32 128	1.250	STAINLESS STEEL
M64N-4A	M64N-4A-C	.500 (PINION) 2.000 (GEAR)	1 to 4	32 128	1.250	ALUMINUM
M64N-5	M64N-5-C	.500 .500	1 to 1	32	.562	STAINLESS STEEL ALUMINUM
M64N-6	M64N-6-CS	.500 (PINION) 1.000 (GEAR)	1 to 2	32 64	.750	STAINLESS STEEL ALUMINUM
M64N-1P	M64N-1P-C	.500	1 to 1	32	.562	STAINLESS STEEL
M64N-1G	M64N-1G-C	.500	1 to 1	32	.562	ALUMINUM

Note: Gears will mesh at right angles only when used as sets described in chart.
Clamp hubs are 1/32" longer than pin hubs.

For Couplings See Section G.
For Shafts, Bearings and Collars See Section I.

MITER & BEVEL GEARS

PITCH	STYLE	BORE	FACE	MATERIAL	AGMA QUALITY	PRES. ANGLE
72	Matched Sets PIN OR CLAMP	1/8"	1/8"	303 Stainless Steel or 2024-T4 Aluminum Anodized	10	20°

B

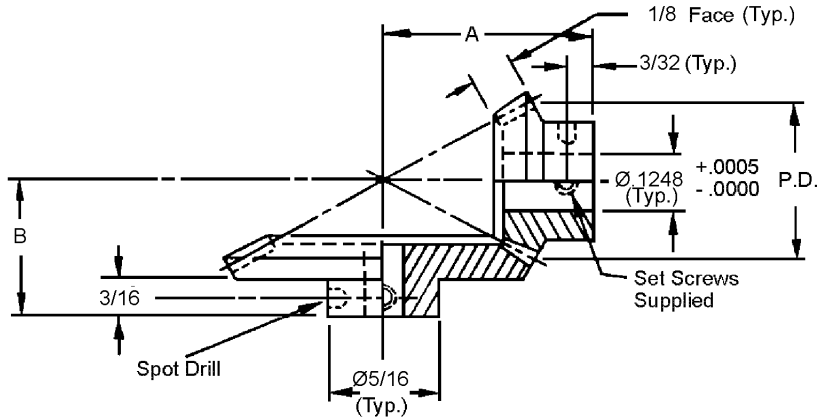

PIN HUB STOCK NO.	CLAMP STYLE STOCK NO.	PITCH DIA.	RATIO	NO. OF TEETH	A	B	MATERIAL
M72N-7	M72N-7-C	.333 .333	1 to 1	24 24	.437	.437	STAINLESS STEEL ALUMINUM
M72N-7S	M72N-7S-C	.333 .333	1 to 1	24 24	.437	.437	STAINLESS STEEL STAINLESS STEEL
M72N-7A	M72N-7A-C	.333 .333	1 to 1	24 24	.437	.437	ALUMINUM ALUMINUM
M72N-1	M72N-1-C	.500 .500	1 to 1	36 36	.531	.531	STAINLESS STEEL ALUMINUM
M72N-1S	M72N-1S-C	.500 .500	1 to 1	36 36	.531	.531	STAINLESS STEEL STAINLESS STEEL
M72N-1A	M72N-1A-C	.500 .500	1 to 1	36 36	.531	.531	ALUMINUM ALUMINUM
M72N-8	M72N-8-C	.500 (PINION) .750 (GEAR)	1 to 1-1/2	36 54	.640	.531	STAINLESS STEEL ALUMINUM
M72N-2	M72N-2-C	.500 (PINION) 1.000 (GEAR)	1 to 2	36 72	.750	.531	STAINLESS STEEL ALUMINUM
M72N-2S	M72N-2S-C	.500 (PINION) 1.000 (GEAR)	1 to 2	36 72	.750	.531	STAINLESS STEEL STAINLESS STEEL
M72N-2A	M72N-2A-C	.500 (PINION) 1.000 (GEAR)	1 to 2	36 72	.750	.531	ALUMINUM ALUMINUM
M72N-3	M72N-3-C	.500 (PINION) 1.500 (GEAR)	1 to 3	36 108	1.000	.531	STAINLESS STEEL ALUMINUM
M72N-3S	M72N-3S-C	.500 (PINION) 1.500 (GEAR)	1 to 3	36 108	1.000	.531	STAINLESS STEEL STAINLESS STEEL
M72N-3A	M72N-3A-C	.500 (PINION) 1.500 (GEAR)	1 to 3	36 108	1.000	.531	ALUMINUM ALUMINUM
M72N-9	M72N-9-C	.500 (PINION) 2.000 (GEAR)	1 to 4	36 144	1.250	.531	STAINLESS STEEL ALUMINUM
M72N-1P	M72N-1P-C	.500	1 to 1	36	.531	.531	STAINLESS STEEL
M72N-1G	M72N-1G-C	.500	1 to 1	36	.531	.531	ALUMINUM

Note: Gears will mesh at right angles only when used as sets described in chart.
Clamp hubs are 1/32" longer than pin hubs.

MITER & BEVEL GEARS

PITCH	STYLE	BORE	FACE	MATERIAL	AGMA QUALITY	PRES. ANGLE
96	Matched Sets PIN HUB	1/8"	3/32"	303 Stainless Steel or 2024-T4 Aluminum Anodized	10	20°

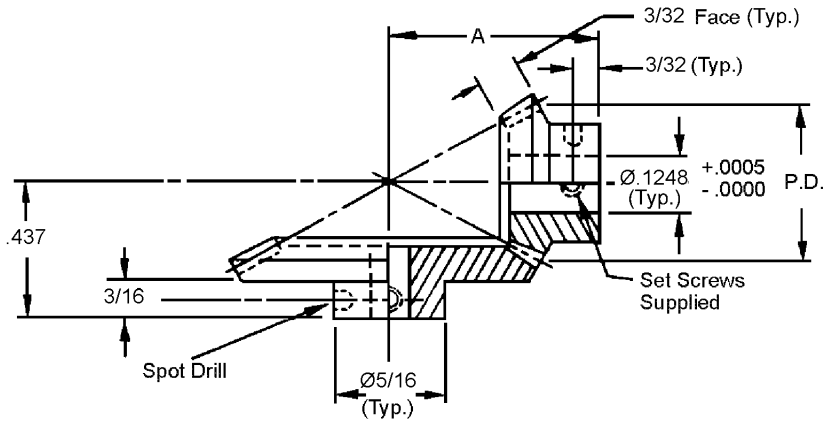

STOCK NO.	PITCH DIA.	RATIO	NO. OF TEETH	A	MATERIAL
M96P-1	.375 .375	1 to 1	36 36	.437	STAINLESS STEEL ALUMINUM
M96P-1S	.375 .375	1 to 1	36 36	.437	STAINLESS STEEL STAINLESS STEEL
M96P-1A	.375 .375	1 to 1	36 36	.437	ALUMINUM ALUMINUM
M96P-2	.375 (PINION) .750 (GEAR)	1 to 2	36 72	.687	STAINLESS STEEL ALUMINUM
M96P-3	.375 (PINION) 1.125 (GEAR)	1 to 3	36 108	.875	STAINLESS STEEL ALUMINUM
M96P-1P	.375	1 to 1	36	.437	STAINLESS STEEL
M96P-1G	.375	1 to 1	36	.437	ALUMINUM

Note: Gears will mesh at right angles only when used as sets described in chart.

**For Couplings See Section G.
For Shafts, Bearings and Collars See Section I.**

ANTI-BACKLASH MITER GEARS

B

PITCH	STYLE	BORE	MATERIAL	AGMA QUALITY	PRES. ANGLE
48	Matched Sets PIN HUB	1/4"	303 Stainless Steel or 2024-T4 Aluminum Anodized	10	20°

STOCK NO.	PITCH DIA.	D BORE	FACE	T	PITCH	NO. OF TEETH	A	G	H	MATERIAL
M48N-1AB	.625 .625	.2498	3/16	1/8	48	30 30	.687	1/2	3/8	STAINLESS STEEL ALUMINUM
M48N-1ABS	.625 .625	.2498	3/16	1/8	48	30 30	.687	1/2	3/8	STAINLESS STEEL STAINLESS STEEL

Note: Gears will mesh at right angles only when used as sets described in chart.

PITCH	STYLE	BORE	MATERIAL	AGMA QUALITY	PRES. ANGLE
64	Matched Sets PIN HUB	3/16"	303 Stainless Steel or 2024-T4 Aluminum Anodized	10	20°

STOCK NO.	PITCH DIA.	D BORE	FACE	T	PITCH	NO. OF TEETH	A	G	H	MATERIAL
M64N-1-ABS	.500 .500	.1873	5/32	7/64	64	32 32	.562	3/8	17/64	STAINLESS STEEL STAINLESS STEEL

Note: Gears will mesh at right angles only when used as sets described in chart.

PITCH	STYLE	BORE	MATERIAL	AGMA QUALITY	PRES. ANGLE
72	Matched Sets PIN HUB	1/8"	303 Stainless Steel or 2024-T4 Aluminum Anodized	10	20°

STOCK NO.	PITCH DIA.	D BORE	FACE	T	PITCH	NO. OF TEETH	A	G	H	MATERIAL
M72N-1AB	.500 .500	.1248	1/8	3/32	72	36 36	.531	5/16	1/4	STAINLESS STEEL ALUMINUM
M72N-1-ABS	.500 .500	.1248	1/8	3/32	72	36 36	.531	5/16	1/4	STAINLESS STEEL STAINLESS STEEL

Note: Gears will mesh at right angles only when used as sets described in chart.

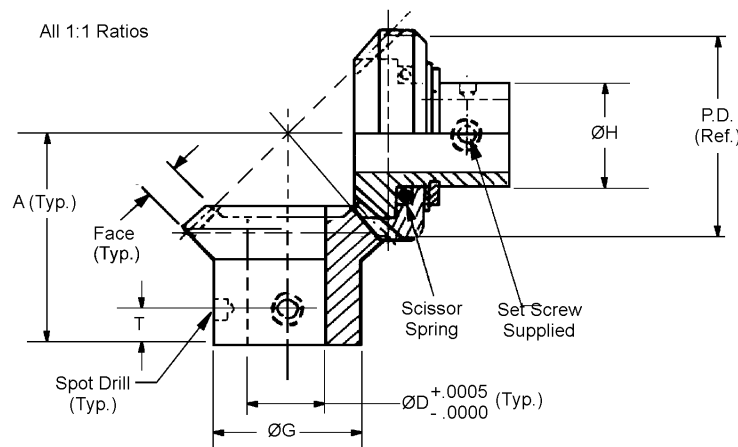

**For Couplings See Section G.
For Shafts, Bearings and Collars See Section I.**

PRECISION WORMS

PITCH	STYLE	BORE	MATERIAL	AGMA QUALITY	TYPE
16	SINGLE, DOUBLE OR FOUR THREAD	1/4"	303 STAINLESS STEEL	8	RIGHT HAND

STOCK NO.	B	THREAD	LEAD	LEAD ANGLE	PRESSURE ANGLE
W16S-4S	.2498	SINGLE	.1963	5° - 43'	14-1/2°
W16S-4D		DOUBLE	.3927	11° - 19'	14-1/2°
W16S-4F		FOUR	.7854	21° - 48'	20°

PITCH	STYLE	BORE	MATERIAL	AGMA QUALITY	TYPE
16	SINGLE, DOUBLE OR FOUR THREAD	5/16"	303 STAINLESS STEEL	8	RIGHT HAND

STOCK NO.	B	THREAD	LEAD	LEAD ANGLE	PRESSURE ANGLE
W16S-5S	.3123	SINGLE	.1963	5° - 43'	14-1/2°
W16S-5D		DOUBLE	.3927	11° - 19'	14-1/2°
W16S-5F		FOUR	.7854	21° - 48'	20°

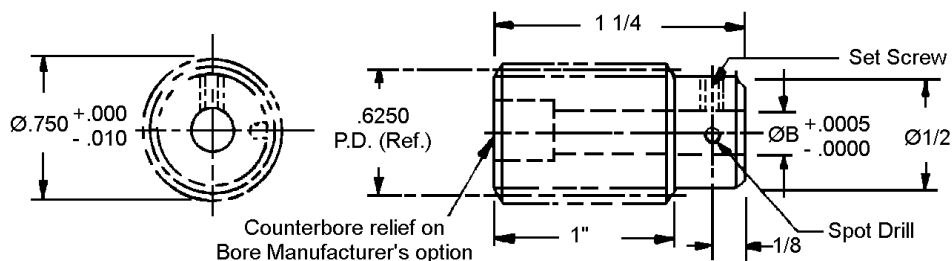

WORM GEARS

B

PITCH	STYLE	BORE	FACE	MATERIAL	AGMA QUALITY	TYPE
16	SINGLE, DOUBLE OR FOUR THREAD PIN HUB	3/8"	3/8"	BRONZE QQ-B-637 ALLOY 464	8	RIGHT HAND

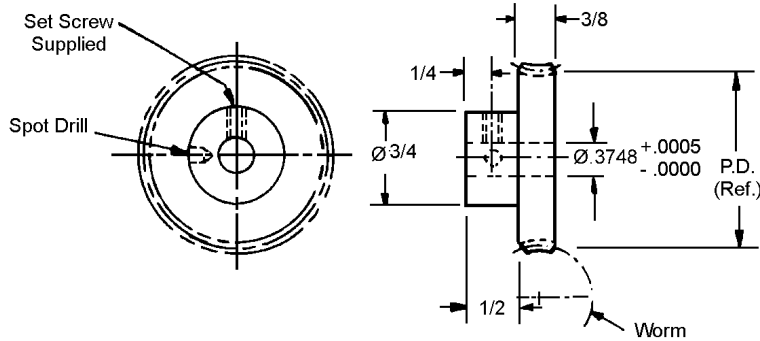

SINGLE THREAD WORM	DOUBLE THREAD WORM	FOUR THREAD WORM	NO. OF TEETH	PITCH DIA.
CIRCULAR PITCH .1963 HELIX ANGLE 5° - 43' PRESSURE ANGLE 14-1/2°	CIRCULAR PITCH .3927 HELIX ANGLE 11° - 19' PRESSURE ANGLE 14-1/2°	CIRCULAR PITCH .7854 HELIX ANGLE 21°-48' PRESSURE ANGLE 20°		
STOCK NO.	STOCK NO.	STOCK NO.		
W16B35-S20	W16B35-D20	W16B35-F20	20	1.250
W16B35-S30	W16B35-D30	W16B35-F30	30	1.875
W16B35-S40	W16B35-D40	W16B35-F40	40	2.500
W16B35-S50	W16B35-D50	W16B35-F50	50	3.125
W16B35-S60	W16B35-D60	W16B35-F60	60	3.750
W16B35-S80	W16B35-D80	W16B35-F80	80	5.000
W16B35-S100	W16B35-D100	W16B35-F100	100	6.250

$$\text{Ratio} = \frac{\# \text{ of Teeth}}{\text{Worm Threads}}$$

May be two piece construction.

PITCH	STYLE	BORE	FACE	MATERIAL	AGMA QUALITY	TYPE
16	SINGLE, DOUBLE OR FOUR THREAD PIN HUB	1/2"	3/8"	BRONZE QQ-B-637 ALLOY 464	8	RIGHT HAND

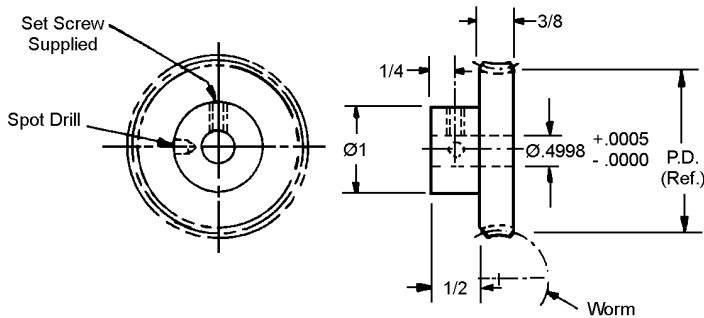

SINGLE THREAD WORM	DOUBLE THREAD WORM	FOUR THREAD WORM	NO. OF TEETH	PITCH DIA.
CIRCULAR PITCH .1963 HELIX ANGLE 5° - 43' PRESSURE ANGLE 14-1/2°	CIRCULAR PITCH .3927 HELIX ANGLE 11° - 19' PRESSURE ANGLE 14-1/2°	CIRCULAR PITCH .7854 HELIX ANGLE 21°-48' PRESSURE ANGLE 20°		
STOCK NO.	STOCK NO.	STOCK NO.		
W16B37-S20	W16B37-D20	W16B37-F20	20	1.250
W16B37-S30	W16B37-D30	W16B37-F30	30	1.875
W16B37-S40	W16B37-D40	W16B37-F40	40	2.500
W16B37-S50	W16B37-D50	W16B37-F50	50	3.125
W16B37-S60	W16B37-D60	W16B37-F60	60	3.750
W16B37-S80	W16B37-D80	W16B37-F80	80	5.000
W16B37-S100	W16B37-D100	W16B37-F100	100	6.250

$$\text{Ratio} = \frac{\# \text{ of Teeth}}{\text{Worm Threads}}$$

May be two piece construction.

PRECISION WORMS

PITCH	STYLE	BORE	MATERIAL	AGMA QUALITY	TYPE
24	SINGLE, DOUBLE OR FOUR THREAD	1/4"	303 STAINLESS STEEL	10	RIGHT HAND

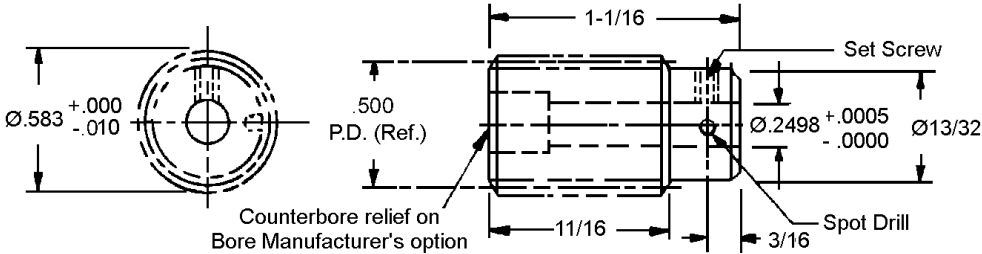

STOCK NO.	THREAD	LEAD	LEAD ANGLE	PRESSURE ANGLE
W24S-4S	SINGLE	.1309	4° - 46'	14-1/2°
W24S-4D	DOUBLE	.2618	9° - 28'	20°
W24S-4F	FOUR	.5236	18° - 26'	25°

PRECISION WORM GEARS

B

PITCH	STYLE	BORE	FACE	MATERIAL	AGMA QUALITY	TYPE
24	SINGLE, DOUBLE OR FOUR THREAD PIN HUB	3/8"	3/8"	BRONZE QQ-B-637 ALLOY 464	10	RIGHT HAND

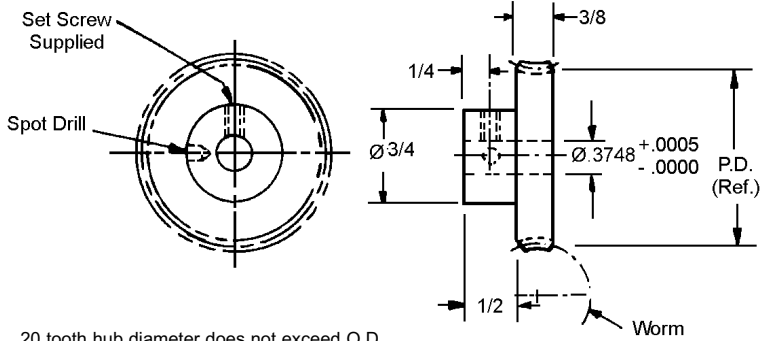

20 tooth hub diameter does not exceed O.D.

SINGLE THREAD WORM	DOUBLE THREAD WORM	FOUR THREAD WORM	NO. OF TEETH	PITCH DIA.
CIRCULAR PITCH .1309 HELIX ANGLE 4° - 46' PRESSURE ANGLE 14-1/2°	CIRCULAR PITCH .2518 HELIX ANGLE 9° - 28' PRESSURE ANGLE 20°	CIRCULAR PITCH .5236 HELIX ANGLE 18°-26' PRESSURE ANGLE 25°		
STOCK NO.	STOCK NO.	STOCK NO.		
W24B35-S20	W24B35-D20	W24B35-F20	20	.833
W24B35-S30	W24B35-D30	W24B35-F30	30	1.250
W24B35-S40	W24B35-D40	W24B35-F40	40	1.667
W24B35-S50	W24B35-D50	W24B35-F50	50	2.083
W24B35-S60	W24B35-D60	W24B35-F60	60	2.500
W24B35-S72	W24B35-D72	W24B35-F72	72	3.000
W24B35-S80	W24B35-D80	W24B35-F80	80	3.333
W24B35-S90	W24B35-D90	W24B35-F90	90	4.000
W24B35-S100	W24B35-D100	W24B35-F100	100	4.167

$$\text{Ratio} = \frac{\# \text{ of Teeth}}{\text{Worm Threads}}$$

PITCH	STYLE	BORE	FACE	MATERIAL	AGMA QUALITY	TYPE
24	SINGLE, DOUBLE OR FOUR THREAD PIN HUB	1/2"	3/8"	BRONZE QQ-B-637 ALLOY 464	10	RIGHT HAND

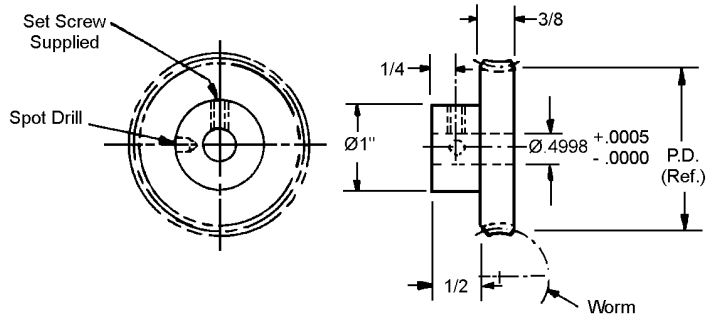

20 tooth hub diameter does not exceed O.D.

SINGLE THREAD WORM	DOUBLE THREAD WORM	FOUR THREAD WORM	NO. OF TEETH	PITCH DIA.
CIRCULAR PITCH .1309 HELIX ANGLE 4° - 46' PRESSURE ANGLE 14-1/2°	CIRCULAR PITCH .2518 HELIX ANGLE 9° - 28' PRESSURE ANGLE 20°	CIRCULAR PITCH .5236 HELIX ANGLE 18°-26' PRESSURE ANGLE 25°		
STOCK NO.	STOCK NO.	STOCK NO.		
W24B37-S20	W24B37-D20	W24B37-F20	20	.833
W24B37-S30	W24B37-D30	W24B37-F30	30	1.250
W24B37-S40	W24B37-D40	W24B37-F40	40	1.667
W24B37-S50	W24B37-D50	W24B37-F50	50	2.083
W24B37-S60	W24B37-D60	W24B37-F60	60	2.500
W24B37-S72	W24B37-D72	W24B37-F72	72	3.000
W24B37-S80	W24B37-D80	W24B37-F80	80	3.333
W24B37-S90	W24B37-D90	W24B37-F90	90	4.000
W24B37-S100	W24B37-D100	W24B37-F100	100	4.167

$$\text{Ratio} = \frac{\# \text{ of Teeth}}{\text{Worm Threads}}$$

PRECISION WORMS

PITCH	STYLE	BORE	MATERIAL	AGMA QUALITY	TYPE
32	SINGLE, DOUBLE OR FOUR THREAD	3/16"	303 STAINLESS STEEL	10	RIGHT HAND

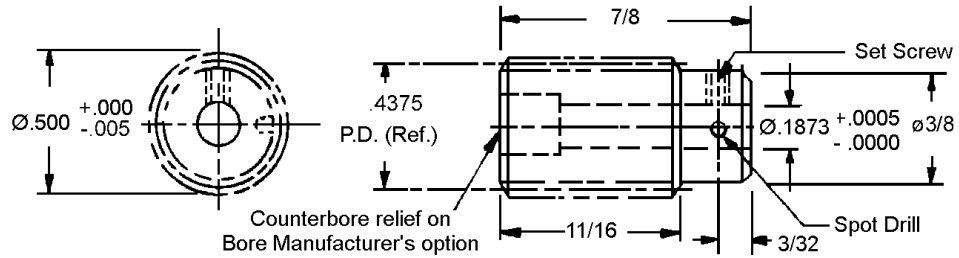

STOCK NO.	THREAD	LEAD	LEAD ANGLE	PRESSURE ANGLE
W32S-3S	SINGLE	.0982	4° - 5'	14-1/2°
W32S-3D	DOUBLE	.1963	8° - 8'	20°
W32S-3F	FOUR	.3927	15° - 57'	25°

AGMA Quality 12 on request.

PRECISION WORM GEARS

B

PITCH	STYLE	BORE	FACE	MATERIAL	AGMA QUALITY	TYPE
32	SINGLE, DOUBLE OR FOUR THREAD PIN HUB	3/16"	3/16"	BRONZE QQ-B-637 ALLOY 464	10	RIGHT HAND

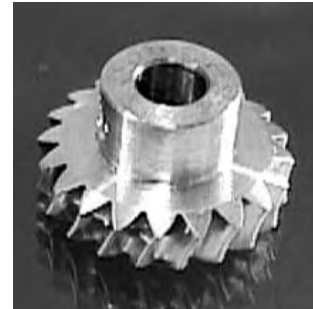
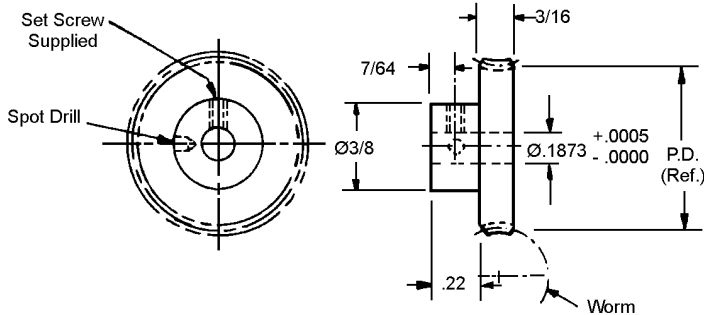

SINGLE THREAD WORM	DOUBLE THREAD WORM	FOUR THREAD WORM	NO. OF TEETH	PITCH DIA.
CIRCULAR PITCH .0982 HELIX ANGLE 4° - 5' PRESSURE ANGLE 14-1/2°	CIRCULAR PITCH .1963 HELIX ANGLE 8° - 8' PRESSURE ANGLE 20°	CIRCULAR PITCH .3927 HELIX ANGLE 15°-57' PRESSURE ANGLE 25°		
STOCK NO.	STOCK NO.	STOCK NO.		
W32B21-S20	W32B21-D20	W32B21-F20	20	.625
W32B21-S30	W32B21-D30	W32B21-F30	30	.938
W32B21-S40	W32B21-D40	W32B21-F40	40	1.250
W32B21-S50	W32B21-D50	W32B21-F50	50	1.562
W32B21-S60	W32B21-D60	W32B21-F60	60	1.875
W32B21-S80	W32B21-D80	W32B21-F80	80	2.500
W32B21-S96	W32B21-D96	W32B21-F96	96	3.000
W32B21-S100	W32B21-D100	W32B21-F100	100	3.125
W32B21-S120	W32B21-D120	W32B21-F120	120	3.750
W32B21-S180	W32B21-D180	W32B21-F180	180	5.625

$$\text{Ratio} = \frac{\text{\# of Teeth}}{\text{Worm Threads}}$$

PITCH	STYLE	BORE	FACE	MATERIAL	AGMA QUALITY	TYPE
32	SINGLE, DOUBLE OR FOUR THREAD PIN HUB	1/4"	3/16"	BRONZE QQ-B-637 ALLOY 464	10	RIGHT HAND

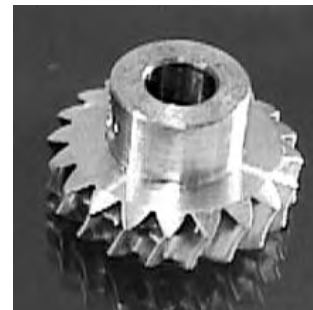
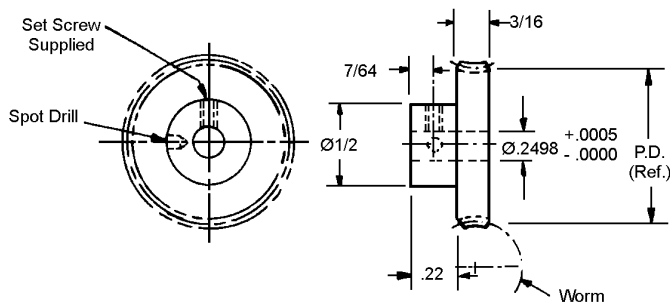

SINGLE THREAD WORM	DOUBLE THREAD WORM	FOUR THREAD WORM	NO. OF TEETH	PITCH DIA.
CIRCULAR PITCH .0982 HELIX ANGLE 4° - 5' PRESSURE ANGLE 14-1/2°	CIRCULAR PITCH .1963 HELIX ANGLE 8° - 8' PRESSURE ANGLE 20°	CIRCULAR PITCH .3927 HELIX ANGLE 15°-57' PRESSURE ANGLE 25°		
STOCK NO.	STOCK NO.	STOCK NO.		
W32B29-S20	W32B29-D20	W32B29-F20	20	.625
W32B29-S30	W32B29-D30	W32B29-F30	30	.938
W32B29-S40	W32B29-D40	W32B29-F40	40	1.250
W32B29-S50	W32B29-D50	W32B29-F50	50	1.562
W32B29-S60	W32B29-D60	W32B29-F60	60	1.875
W32B29-S80	W32B29-D80	W32B29-F80	80	2.500
W32B29-S96	W32B29-D96	W32B29-F96	96	3.000
W32B29-S100	W32B29-D100	W32B29-F100	100	3.125
W32B29-S120	W32B29-D120	W32B29-F120	120	3.750
W32B29-S180	W32B29-D180	W32B29-F180	180	5.625

$$\text{Ratio} = \frac{\text{\# of Teeth}}{\text{Worm Threads}}$$

PRECISION WORM GEARS

PITCH	STYLE	BORE	FACE	MATERIAL	AGMA QUALITY	TYPE
32	SINGLE, DOUBLE OR FOUR THREAD PIN HUB	5/16"	3/16"	BRONZE QQ-B-637 ALLOY 464	10	RIGHT HAND

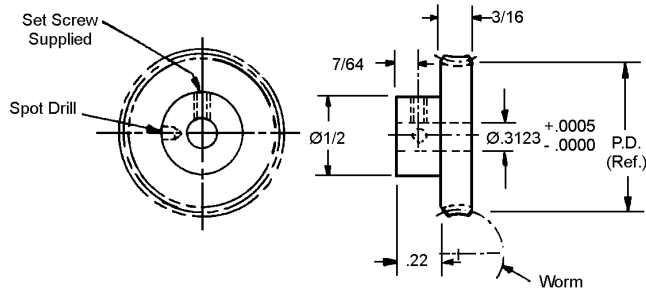

SINGLE THREAD WORM	DOUBLE THREAD WORM	FOUR THREAD WORM	NO. OF TEETH	PITCH DIA.
CIRCULAR PITCH .0982 HELIX ANGLE 4° - 5' PRESSURE ANGLE 14-1/2°	CIRCULAR PITCH .1963 HELIX ANGLE 8° - 8' PRESSURE ANGLE 20°	CIRCULAR PITCH .3927 HELIX ANGLE 15°-57' PRESSURE ANGLE 25°		
STOCK NO.	STOCK NO.	STOCK NO.		
W32B30-S20	W32B30-D20	W32B30-F20	20	.625
W32B30-S30	W32B30-D30	W32B30-F30	30	.938
W32B30-S40	W32B30-D40	W32B30-F40	40	1.250
W32B30-S50	W32B30-D50	W32B30-F50	50	1.562
W32B30-S60	W32B30-D60	W32B30-F60	60	1.875
W32B30-S80	W32B30-D80	W32B30-F80	80	2.500
W32B30-S96	W32B30-D96	W32B30-F96	96	3.000
W32B30-S100	W32B30-D100	W32B30-F100	100	3.125

$$\text{Ratio} = \frac{\text{\# of Teeth}}{\text{Worm Threads}}$$

**For Couplings See Section G.
For Shafts, Bearings and Collars See Section I.**

PRECISION WORMS

PITCH	STYLE	BORE	MATERIAL	AGMA QUALITY	TYPE
48	SINGLE, DOUBLE OR FOUR THREAD	1/8"	303 STAINLESS STEEL	10	RIGHT HAND

B

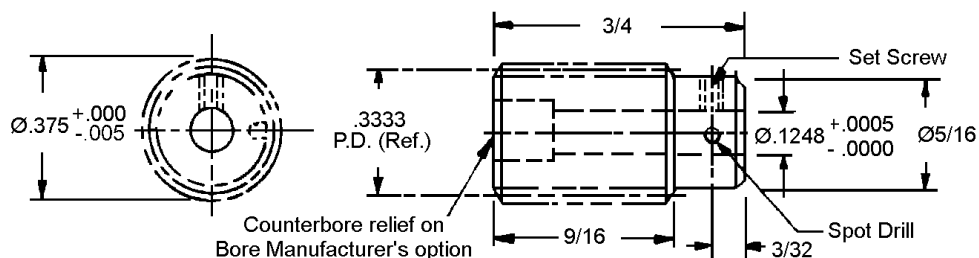

STOCK NO.	THREAD	LEAD	LEAD ANGLE	PRESSURE ANGLE
W48S-2S	SINGLE	.0654	3° - 35'	14-1/2°
W48S-2D	DOUBLE	.1309	7° - 7'	20°
W48S-2F	FOUR	.2618	14° - 2'	25°

AGMA Quality 12 and 14 on request.

PITCH	STYLE	BORE	MATERIAL	AGMA QUALITY	TYPE
48	SINGLE, DOUBLE OR FOUR THREAD	3/16"	303 STAINLESS STEEL	10	RIGHT HAND

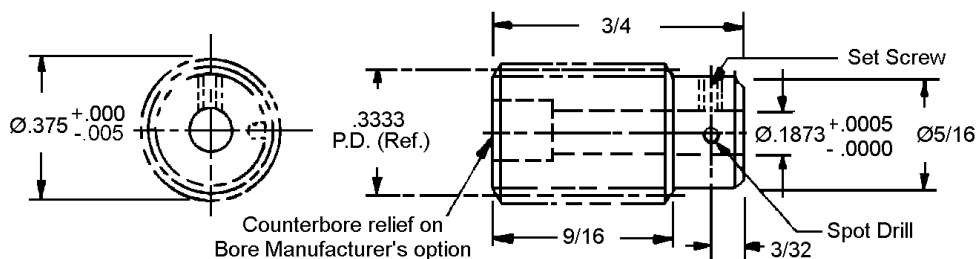

STOCK NO.	THREAD	LEAD	LEAD ANGLE	PRESSURE ANGLE
W48S-3S	SINGLE	.0654	3° - 35'	14-1/2°
W48S-3D	DOUBLE	.1309	7° - 7'	20°
W48S-3F	FOUR	.2618	14° - 2'	25°

AGMA Quality 12 and 14 on request.

PRECISION WORM SHAFT

PITCH	STYLE	SHAFT DIA.	MATERIAL	AGMA QUALITY	TYPE
48	SINGLE START 14.5 P.A.	1/4"	303 STAINLESS STEEL	10 AND 12	RIGHT HAND

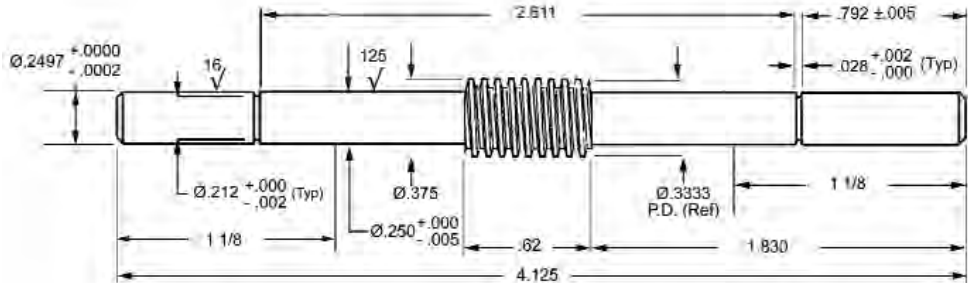

STOCK NO.	AGMA QUALITY
WS48S-4S	10
WS48S-4S-Q12	12

PRECISION WORM GEARS

B

PITCH	STYLE	BORE	FACE	MATERIAL	AGMA QUALITY	TYPE
48	SINGLE, DOUBLE OR FOUR THREAD PIN HUB	1/8"	3/16"	BRONZE QQ-B-637 ALLOY 464	10	RIGHT HAND

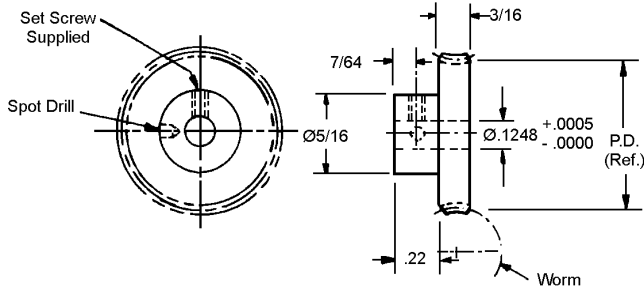

SINGLE THREAD WORM	DOUBLE THREAD WORM	FOUR THREAD WORM	NO. OF TEETH	PITCH DIA.
CIRCULAR PITCH .0654 HELIX ANGLE 3° - 35' PRESSURE ANGLE 14-1/2°	CIRCULAR PITCH .1309 HELIX ANGLE 7° - 7' PRESSURE ANGLE 20°	CIRCULAR PITCH .2618 HELIX ANGLE 14°-2' PRESSURE ANGLE 25°		
STOCK NO.	STOCK NO.	STOCK NO.		
W48B13-S30	W48B13-D30	W48B13-F30	30	.625
W48B13-S40	W48B13-D40	W48B13-F40	40	.833
W48B13-S50	W48B13-D50	W48B13-F50	50	1.042
W48B13-S60	W48B13-D60	W48B13-F60	60	1.250
W48B13-S70	W48B13-D70	W48B13-F70	70	1.458
W48B13-S80	W48B13-D80	W48B13-F80	80	1.667
W48B13-S90	W48B13-D90	W48B13-F90	90	1.875
W48B13-S100	W48B13-D100	W48B13-F100	100	2.083
W48B13-S120	W48B13-D120	W48B13-F120	120	2.500

$$\text{Ratio} = \frac{\text{\# of Teeth}}{\text{Worm Threads}}$$

PITCH	STYLE	BORE	FACE	MATERIAL	AGMA QUALITY	TYPE
48	SINGLE, DOUBLE OR FOUR THREAD PIN HUB	3/16"	3/16"	BRONZE QQ-B-637 ALLOY 464	10	RIGHT HAND

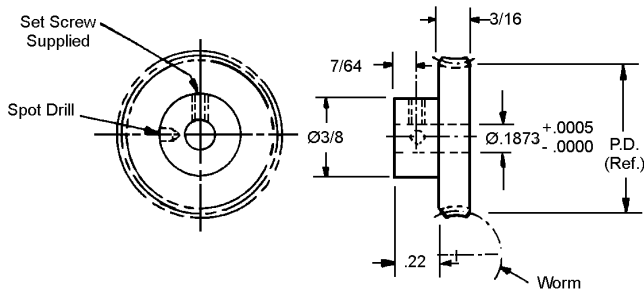

SINGLE THREAD WORM	DOUBLE THREAD WORM	FOUR THREAD WORM	NO. OF TEETH	PITCH DIA.
CIRCULAR PITCH .0654 HELIX ANGLE 3° - 35' PRESSURE ANGLE 14-1/2°	CIRCULAR PITCH .1309 HELIX ANGLE 7° - 7' PRESSURE ANGLE 20°	CIRCULAR PITCH .2618 HELIX ANGLE 14°-2' PRESSURE ANGLE 25°		
STOCK NO.	STOCK NO.	STOCK NO.		
W48B21-S30	W48B21-D30	W48B21-F30	30	.625
W48B21-S40	W48B21-D40	W48B21-F40	40	.833
W48B21-S50	W48B21-D50	W48B21-F50	50	1.042
W48B21-S60	W48B21-D60	W48B21-F60	60	1.250
W48B21-S70	W48B21-D70	W48B21-F70	70	1.458
W48B21-S80	W48B21-D80	W48B21-F80	80	1.667
W48B21-S90	W48B21-D90	W48B21-F90	90	1.875
W48B21-S100	W48B21-D100	W48B21-F100	100	2.083
W48B21-S120	W48B21-D120	W48B21-F120	120	2.500

$$\text{Ratio} = \frac{\text{\# of Teeth}}{\text{Worm Threads}}$$

PRECISION WORM GEARS

PITCH	STYLE	BORE	FACE	MATERIAL	AGMA QUALITY	TYPE
48	SINGLE, DOUBLE OR FOUR THREAD PIN HUB	1/4"	3/16"	BRONZE QQ-B-637 ALLOY 464	10	RIGHT HAND

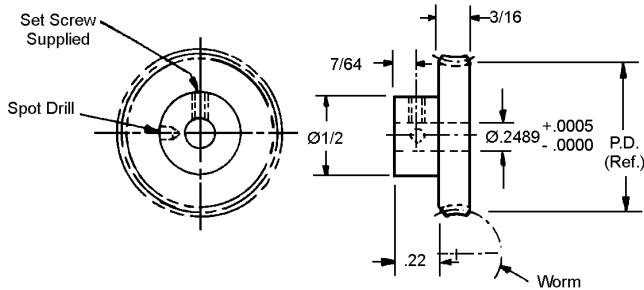

SINGLE THREAD WORM CIRCULAR PITCH .0654 HELIX ANGLE 3° - 35' PRESSURE ANGLE 14-1/2°	DOUBLE THREAD WORM CIRCULAR PITCH .1309 HELIX ANGLE 7° - 7' PRESSURE ANGLE 20°	FOUR THREAD WORM CIRCULAR PITCH .2618 HELIX ANGLE 14°-2' PRESSURE ANGLE 25°	NO. OF TEETH	PITCH DIA.
STOCK NO.	STOCK NO.	STOCK NO.		
W48B29-S30	W48B29-D30	W48B29-F30	30	.625
W48B29-S40	W48B29-D40	W48B29-F40	40	.833
W48B29-S50	W48B29-D50	W48B29-F50	50	1.042
W48B29-S60	W48B29-D60	W48B29-F60	60	1.250
W48B29-S70	W48B29-D70	W48B29-F70	70	1.458
W48B29-S80	W48B29-D80	W48B29-F80	80	1.667
W48B29-S90	W48B29-D90	W48B29-F90	90	1.875
W48B29-S100	W48B29-D100	W48B29-F100	100	2.083
W48B29-S120	W48B29-D120	W48B29-F120	120	2.500
W48B29-S180	W48B29-D180	W48B29-F180	180	3.750

$$\text{Ratio} = \frac{\text{\# of Teeth}}{\text{Worm Threads}}$$

PITCH	STYLE	BORE	FACE	MATERIAL	AGMA QUALITY	TYPE
48	SINGLE, DOUBLE OR FOUR THREAD CLAMP STYLE	1/8"	3/16"	BRONZE QQ-B-637 ALLOY 464	10	RIGHT HAND

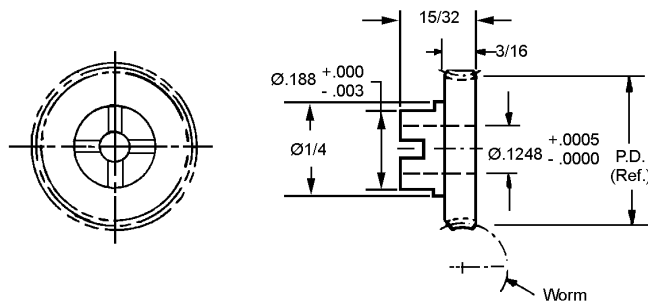

SINGLE THREAD WORM CIRCULAR PITCH .0654 HELIX ANGLE 3° - 35' PRESSURE ANGLE 14-1/2°	DOUBLE THREAD WORM CIRCULAR PITCH .1309 HELIX ANGLE 7° - 7' PRESSURE ANGLE 20°	FOUR THREAD WORM CIRCULAR PITCH .2618 HELIX ANGLE 14°-2' PRESSURE ANGLE 25°	NO. OF TEETH	PITCH DIA.
STOCK NO.	STOCK NO.	STOCK NO.		
W48B13-S30-C	W48B13-D30-C	W48B13-F30-C	30	.625
W48B13-S40-C	W48B13-D40-C	W48B13-F40-C	40	.833
W48B13-S50-C	W48B13-D50-C	W48B13-F50-C	50	1.042
W48B13-S60-C	W48B13-D60-C	W48B13-F60-C	60	1.250
W48B13-S70-C	W48B13-D70-C	W48B13-F70-C	70	1.458
W48B13-S80-C	W48B13-D80-C	W48B13-F80-C	80	1.667
W48B13-S90-C	W48B13-D90-C	W48B13-F90-C	90	1.875
W48B13-S100-C	W48B13-D100-C	W48B13-F100-C	100	2.083
W48B13-S120-C	W48B13-D120-C	W48B13-F120-C	120	2.500

$$\text{Ratio} = \frac{\text{\# of Teeth}}{\text{Worm Threads}}$$

PRECISION WORM GEARS

B

PITCH	STYLE	BORE	FACE	MATERIAL	AGMA QUALITY	TYPE
48	SINGLE, DOUBLE OR FOUR THREAD CLAMP STYLE	3/16"	3/16"	BRONZE QQ-B-637 ALLOY 464	10	RIGHT HAND

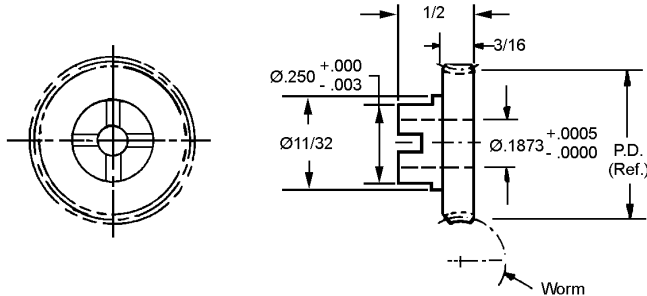

SINGLE THREAD WORM		DOUBLE THREAD WORM		FOUR THREAD WORM		NO. OF TEETH	PITCH DIA.
CIRCULAR PITCH .0654		CIRCULAR PITCH .1309		CIRCULAR PITCH .2618			
HELIX ANGLE 3° - 35'		HELIX ANGLE 7° - 7'		HELIX ANGLE 14°-2'			
PRESSURE ANGLE 14-1/2°		PRESSURE ANGLE 20°		PRESSURE ANGLE 25°			
STOCK NO.	STOCK NO.	STOCK NO.	STOCK NO.	STOCK NO.	STOCK NO.		
W48B21-S30-C	W48B21-D30-C	W48B21-F30-C	30	.625			
W48B21-S40-C	W48B21-D40-C	W48B21-F40-C	40	.833			
W48B21-S50-C	W48B21-D50-C	W48B21-F50-C	50	1.042			
W48B21-S60-C	W48B21-D60-C	W48B21-F60-C	60	1.250			
W48B21-S70-C	W48B21-D70-C	W48B21-F70-C	70	1.458			
W48B21-S80-C	W48B21-D80-C	W48B21-F80-C	80	1.667			
W48B21-S90-C	W48B21-D90-C	W48B21-F90-C	90	1.875			
W48B21-S100-C	W48B21-D100-C	W48B21-F100-C	100	2.083			
W48B21-S120-C	W48B21-D120-C	W48B21-F120-C	120	2.500			

$$\text{Ratio} = \frac{\text{\# of Teeth}}{\text{Worm Threads}}$$

PITCH	STYLE	BORE	FACE	MATERIAL	AGMA QUALITY	TYPE
48	SINGLE, DOUBLE OR FOUR THREAD CLAMP STYLE	1/4"	3/16"	BRONZE QQ-B-637 ALLOY 464	10	RIGHT HAND

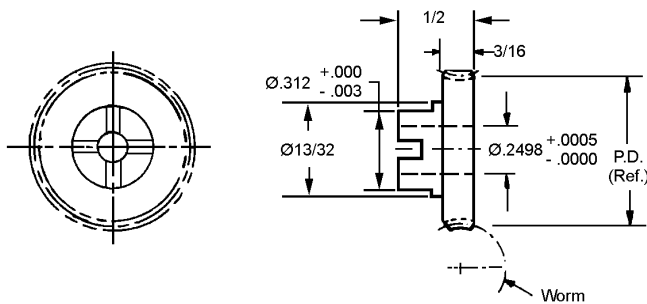

SINGLE THREAD WORM		DOUBLE THREAD WORM		FOUR THREAD WORM		NO. OF TEETH	PITCH DIA.
CIRCULAR PITCH .0654		CIRCULAR PITCH .1309		CIRCULAR PITCH .2618			
HELIX ANGLE 3° - 35'		HELIX ANGLE 7° - 7'		HELIX ANGLE 14°-2'			
PRESSURE ANGLE 14-1/2°		PRESSURE ANGLE 20°		PRESSURE ANGLE 25°			
STOCK NO.	STOCK NO.	STOCK NO.	STOCK NO.	STOCK NO.	STOCK NO.		
W48B29-S30-C	W48B29-D30-C	W48B29-F30-C	30	.625			
W48B29-S40-C	W48B29-D40-C	W48B29-F40-C	40	.833			
W48B29-S50-C	W48B29-D50-C	W48B29-F50-C	50	1.042			
W48B29-S60-C	W48B29-D60-C	W48B29-F60-C	60	1.250			
W48B29-S70-C	W48B29-D70-C	W48B29-F70-C	70	1.458			
W48B29-S80-C	W48B29-D80-C	W48B29-F80-C	80	1.667			
W48B29-S90-C	W48B29-D90-C	W48B29-F90-C	90	1.875			
W48B29-S100-C	W48B29-D100-C	W48B29-F100-C	100	2.083			
W48B29-S120-C	W48B29-D120-C	W48B29-F120-C	120	2.500			
W48B29-S180-C	W48B29-D180-C	W48B29-F180-C	180	3.750			

$$\text{Ratio} = \frac{\text{\# of Teeth}}{\text{Worm Threads}}$$

ANTI-BACKLASH WORM GEARS

PITCH	STYLE	BORE	MATERIAL	AGMA QUALITY	TYPE
48	SINGLE THREAD PIN HUB	1/8"	BRONZE QQ-B-637 ALLOY 464	10	RIGHT HAND

STOCK NO.	NO. OF TEETH	PITCH DIA.
AW48BS13-S40	40	.833
AW48BS13-S48	48	1.000
AW48BS13-S50	50	1.042
AW48BS13-S56	56	1.167
AW48BS13-S60	60	1.250
AW48BC13-S70	70	1.458
AW48BC13-S72	72	1.500
AW48BC13-S80	80	1.667
AW48BC13-S90	90	1.875
AW48BC13-S96	96	2.000
AW48BC13-S100	100	2.083

$$\text{Ratio} = \frac{\# \text{ of Teeth}}{\text{Worm Threads}}$$

Pressure Angle
14 1/2°

Runs with worm #
W48S-2S
OR
W48S-3S

PITCH	STYLE	BORE	MATERIAL	AGMA QUALITY	TYPE
48	DOUBLE THREAD PIN HUB	1/8"	BRONZE QQ-B-637 ALLOY 464	10	RIGHT HAND

STOCK NO.	NO. OF TEETH	PITCH DIA.
AW48BS13-D40	40	.833
AW48BS13-D48	48	1.000
AW48BS13-D50	50	1.042
AW48BS13-D56	56	1.167
AW48BS13-D60	60	1.250
AW48BC13-D70	70	1.458
AW48BC13-D72	72	1.500
AW48BC13-D80	80	1.667
AW48BC13-D90	90	1.875
AW48BC13-D96	96	2.000
AW48BC13-D100	100	2.083

$$\text{Ratio} = \frac{\# \text{ of Teeth}}{\text{Worm Threads}}$$

Pressure Angle 20°

Runs with worm #
W48S-2D
OR
W48S-3D

PITCH	STYLE	BORE	MATERIAL	AGMA QUALITY	TYPE
48	FOUR THREAD PIN HUB	1/8"	BRONZE QQ-B-637 ALLOY 464	10	RIGHT HAND

STOCK NO.	NO. OF TEETH	PITCH DIA.
AW48BS13-F40	40	.833
AW48BS13-F48	48	1.000
AW48BS13-F50	50	1.042
AW48BS13-F56	56	1.167
AW48BS13-F60	60	1.250
AW48BC13-F70	70	1.458
AW48BC13-F72	72	1.500
AW48BC13-F80	80	1.667
AW48BC13-F90	90	1.875
AW48BC13-F96	96	2.000
AW48BC13-F100	100	2.083

$$\text{Ratio} = \frac{\# \text{ of Teeth}}{\text{Worm Threads}}$$

Pressure Angle 25°

Runs with worm #
W48S-2F
OR
W48S-3F

Hub Material: 303 Stainless Steel

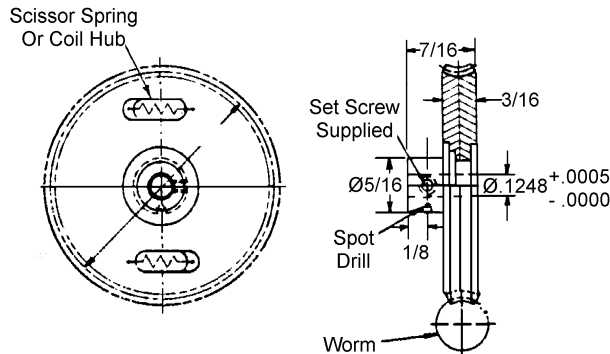

Other numbers of teeth are available on request.



ANTI-BACKLASH WORM GEARS

B

PITCH	STYLE	BORE	MATERIAL	AGMA QUALITY	TYPE
48	SINGLE THREAD PIN HUB	3/16"	BRONZE QQ-B-637 ALLOY 464	10	RIGHT HAND

STOCK NO.	NO. OF TEETH	PITCH DIA.
AW48BS21-S40	40	.833
AW48BS21-S48	48	1.000
AW48BS21-S50	50	1.042
AW48BS21-S56	56	1.167
AW48BS21-S60	60	1.250
AW48BC21-S70	70	1.458
AW48BC21-S72	72	1.500
AW48BC21-S80	80	1.667
AW48BC21-S90	90	1.875
AW48BC21-S96	96	2.000
AW48BC21-S100	100	2.083

$$\text{Ratio} = \frac{\# \text{ of Teeth}}{\text{Worm Threads}}$$

Pressure Angle
14/1/2°

Runs with worm #
W48S-2S
OR
W48S-3S

PITCH	STYLE	BORE	MATERIAL	AGMA QUALITY	TYPE
48	DOUBLE THREAD PIN HUB	3/16"	BRONZE QQ-B-637 ALLOY 464	10	RIGHT HAND

STOCK NO.	NO. OF TEETH	PITCH DIA.
AW48BS21--D40	40	.833
AW48BS21--D48	48	1.000
AW48BS21--D50	50	1.042
AW48BS21--D56	56	1.167
AW48BS21--D60	60	1.250
AW48BC21-D70	70	1.458
AW48BC21-D72	72	1.500
AW48BC21-D80	80	1.667
AW48BC21-D90	90	1.875
AW48BC21-D96	96	2.000
AW48BC21-D100	100	2.083

$$\text{Ratio} = \frac{\# \text{ of Teeth}}{\text{Worm Threads}}$$

Pressure Angle 20°

Runs with worm #
W48S-2D
OR
W48S-3D

PITCH	STYLE	BORE	MATERIAL	AGMA QUALITY	TYPE
48	FOUR THREAD PIN HUB	3/16"	BRONZE QQ-B-637 ALLOY 464	10	RIGHT HAND

STOCK NO.	NO. OF TEETH	PITCH DIA.
AW48BS21-F40	40	.833
AW48BS21-F48	48	1.000
AW48BS21-F50	50	1.042
AW48BS21-F56	56	1.167
AW48BS21-F60	60	1.250
AW48BC21-F70	70	1.458
AW48BC21-F72	72	1.500
AW48BC21-F80	80	1.667
AW48BC21-F90	90	1.875
AW48BC21-F96	96	2.000
AW48BC21-F100	100	2.083

$$\text{Ratio} = \frac{\# \text{ of Teeth}}{\text{Worm Threads}}$$

Pressure Angle 25°

Runs with worm #
W48S-2F
OR
W48S-3F

Hub Material: 303 Stainless Steel

Scissor Spring
Or Coil Hub

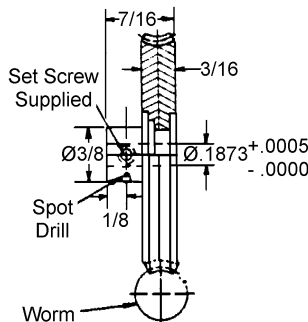
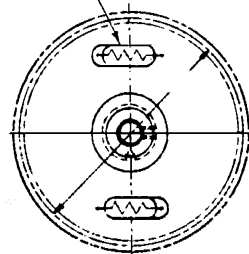

Other numbers of teeth are available on request.

ANTI-BACKLASH WORM GEARS

PITCH	STYLE	BORE	MATERIAL	AGMA QUALITY	TYPE
48	SINGLE THREAD PIN HUB	1/4"	BRONZE QQ-B-637 ALLOY 464	10	RIGHT HAND

STOCK NO.	NO. OF TEETH	PITCH DIA.
AW48BS29-S40	40	.833
AW48BS29-S48	48	1.000
AW48BS29-S50	50	1.042
AW48BS29-S56	56	1.167
AW48BS29-S60	60	1.250
AW48BC29-S70	70	1.458
AW48BC29-S72	72	1.500
AW48BC29-S80	80	1.667
AW48BC29-S90	90	1.875
AW48BC29-S96	96	2.000
AW48BC29-S100	100	2.083

$$\text{Ratio} = \frac{\# \text{ of Teeth}}{\text{Worm Threads}}$$

Pressure Angle
14 1/2°

Runs with worm #
W48S-2S
OR
W48S-3S

PITCH	STYLE	BORE	MATERIAL	AGMA QUALITY	TYPE
48	DOUBLE THREAD PIN HUB	1/4"	BRONZE QQ-B-637 ALLOY 464	10	RIGHT HAND

STOCK NO.	NO. OF TEETH	PITCH DIA.
AW48BS29-D40	40	.833
AW48BS29-D48	48	1.000
AW48BS29-D50	50	1.042
AW48BS29-D56	56	1.167
AW48BS29-D60	60	1.250
AW48BC29-D70	70	1.458
AW48BC29-D72	72	1.500
AW48BC29-D80	80	1.667
AW48BC29-D90	90	1.875
AW48BC29-D96	96	2.000
AW48BC29-D100	100	2.083

$$\text{Ratio} = \frac{\# \text{ of Teeth}}{\text{Worm Threads}}$$

Pressure Angle 20°

Runs with worm #
W48S-2D
OR
W48S-3D

PITCH	STYLE	BORE	MATERIAL	AGMA QUALITY	TYPE
48	FOUR THREAD PIN HUB	1/4"	BRONZE QQ-B-637 ALLOY 464	10	RIGHT HAND

STOCK NO.	NO. OF TEETH	PITCH DIA.
AW48BS29-F40	40	.833
AW48BS29-F48	48	1.000
AW48BS29-F50	50	1.042
AW48BS29-F56	56	1.167
AW48BS29-F60	60	1.250
AW48BC29-F70	70	1.458
AW48BC29-F72	72	1.500
AW48BC29-F80	80	1.667
AW48BC29-F90	90	1.875
AW48BC29-F96	96	2.000
AW48BC29-F100	100	2.083

$$\text{Ratio} = \frac{\# \text{ of Teeth}}{\text{Worm Threads}}$$

Pressure Angle 25°

Runs with worm #
W48S-2F
OR
W48S-3F

Hub Material: 303 Stainless Steel

Scissor Spring
Or Coil Hub

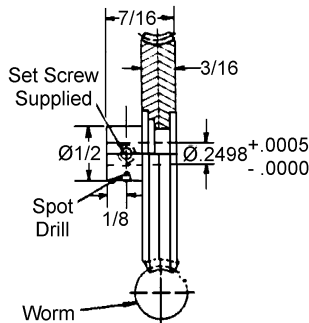
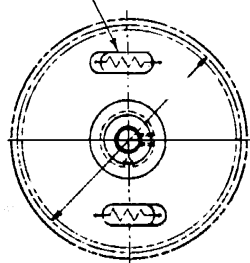

Other numbers of teeth are available on request.



ANTI-BACKLASH WORM GEARS

B

PITCH	STYLE	BORE	MATERIAL	AGMA QUALITY	TYPE
48	SINGLE THREAD CLAMP STYLE	1/8"	BRONZE QQ-B-637 ALLOY 464	10	RIGHT HAND

STOCK NO.	NO. OF TEETH	PITCH DIA.
AW48BS13-S40-C	40	.833
AW48BS13-S48-C	48	1.000
AW48BS13-S50-C	50	1.042
AW48BS13-S56-C	56	1.167
AW48BS13-S60-C	60	1.250
AW48BC13-S70-C	70	1.458
AW48BC13-S72-C	72	1.500
AW48BC13-S80-C	80	1.667
AW48BC13-S90-C	90	1.875
AW48BC13-S96-C	96	2.000
AW48BC13-S100-C	100	2.083

$$\text{Ratio} = \frac{\# \text{ of Teeth}}{\text{Worm Threads}}$$

Pressure Angle
14 1/2°

Runs with worm #
W48S-2S
OR
W48S-3S

PITCH	STYLE	BORE	MATERIAL	AGMA QUALITY	TYPE
48	DOUBLE THREAD CLAMP STYLE	1/8"	BRONZE QQ-B-637 ALLOY 464	10	RIGHT HAND

STOCK NO.	NO. OF TEETH	PITCH DIA.
AW48BS13-D40-C	40	.833
AW48BS13-D48-C	48	1.000
AW48BS13-D50-C	50	1.042
AW48BS13-D56-C	56	1.167
AW48BS13-D60-C	60	1.250
AW48BC13-D70-C	70	1.458
AW48BC13-D72-C	72	1.500
AW48BC13-D80-C	80	1.667
AW48BC13-D90-C	90	1.875
AW48BC13-D96-C	96	2.000
AW48BC13-D100-C	100	2.083

$$\text{Ratio} = \frac{\# \text{ of Teeth}}{\text{Worm Threads}}$$

Pressure Angle 20°

Runs with worm #
W48S-2D
OR
W48S-3D

PITCH	STYLE	BORE	MATERIAL	AGMA QUALITY	TYPE
48	FOUR THREAD CLAMP STYLE	1/8"	BRONZE QQ-B-637 ALLOY 464	10	RIGHT HAND

STOCK NO.	NO. OF TEETH	PITCH DIA.
AW48BS13-F40-C	40	.833
AW48BS13-F48-C	48	1.000
AW48BS13-F50-C	50	1.042
AW48BS13-F56-C	56	1.167
AW48BS13-F60-C	60	1.250
AW48BC13-F70-C	70	1.458
AW48BC13-F72-C	72	1.500
AW48BC13-F80-C	80	1.667
AW48BC13-F90-C	90	1.875
AW48BC13-F96-C	96	2.000
AW48BC13-F100-C	100	2.083

$$\text{Ratio} = \frac{\# \text{ of Teeth}}{\text{Worm Threads}}$$

Pressure Angle 25°

Runs with worm #
W48S-2F
OR
W48S-3F

Hub Material: 303 Stainless Steel

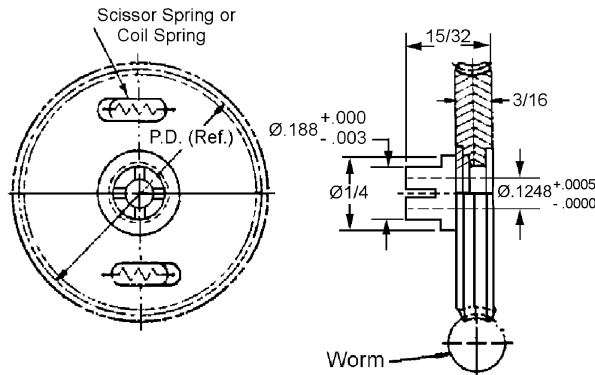

ANTI-BACKLASH WORM GEARS

PITCH	STYLE	BORE	MATERIAL	AGMA QUALITY	TYPE
48	SINGLE THREAD CLAMP STYLE	3/16"	BRONZE QQ-B-637 ALLOY 464	10	RIGHT HAND

STOCK NO.	NO. OF TEETH	PITCH DIA.
AW48BS21-S40-C	40	.833
AW48BS21-S48-C	48	1.000
AW48BS21-S50-C	50	1.042
AW48BS21-S56-C	56	1.167
AW48BS21-S60-C	60	1.250
AW48BC21-S70-C	70	1.458
AW48BC21-S72-C	72	1.500
AW48BC21-S80-C	80	1.667
AW48BC21-S90-C	90	1.875
AW48BC21-S96-C	96	2.000
AW48BC21-S100-C	100	2.083

$$\text{Ratio} = \frac{\# \text{ of Teeth}}{\text{Worm Threads}}$$

Pressure Angle
14/1/2°

Runs with worm #
W48S-2S
OR
W48S-3S

PITCH	STYLE	BORE	MATERIAL	AGMA QUALITY	TYPE
48	DOUBLE THREAD CLAMP STYLE	3/16"	BRONZE QQ-B-637 ALLOY 464	10	RIGHT HAND

STOCK NO.	NO. OF TEETH	PITCH DIA.
AW48BS21-D40-C	40	.833
AW48BS21-D48-C	48	1.000
AW48BS21-D50-C	50	1.042
AW48BS21-D56-C	56	1.167
AW48BS21-D60-C	60	1.250
AW48BC21-D70-C	70	1.458
AW48BC21-D72-C	72	1.500
AW48BC21-D80-C	80	1.667
AW48BC21-D90-C	90	1.875
AW48BC21-D96-C	96	2.000
AW48BC21-D100-C	100	2.083

$$\text{Ratio} = \frac{\# \text{ of Teeth}}{\text{Worm Threads}}$$

Pressure Angle 20°

Runs with worm #
W48S-2D
OR
W48S-3D

PITCH	STYLE	BORE	MATERIAL	AGMA QUALITY	TYPE
48	FOUR THREAD CLAMP STYLE	3/16"	BRONZE QQ-B-637 ALLOY 464	10	RIGHT HAND

STOCK NO.	NO. OF TEETH	PITCH DIA.
AW48BS21-F40-C	40	.833
AW48BS21-F48-C	48	1.000
AW48BS21-F50-C	50	1.042
AW48BS21-F56-C	56	1.167
AW48BS21-F60-C	60	1.250
AW48BC21-F70-C	70	1.458
AW48BC21-F72-C	72	1.500
AW48BC21-F80-C	80	1.667
AW48BC21-F90-C	90	1.875
AW48BC21-F96-C	96	2.000
AW48BC21-F100-C	100	2.083

$$\text{Ratio} = \frac{\# \text{ of Teeth}}{\text{Worm Threads}}$$

Pressure Angle 25°

Runs with worm #
W48S-2F
OR
W48S-3F

Hub Material: 303 Stainless Steel

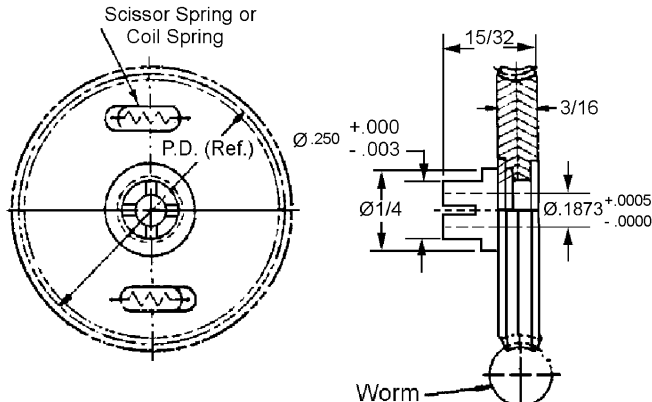

ANTI-BACKLASH WORM GEARS

B

PITCH	STYLE	BORE	MATERIAL	AGMA QUALITY	TYPE
48	SINGLE THREAD CLAMP STYLE	1/4"	BRONZE QQ-B-637 ALLOY 464	10	RIGHT HAND

STOCK NO.	NO. OF TEETH	PITCH DIA.
AW48BS29-S40-C	40	.833
AW48BS29-S48-C	48	1.000
AW48BS29-S50-C	50	1.042
AW48BS29-S56-C	56	1.167
AW48BS29-S60-C	60	1.250
AW48BC29-S70-C	70	1.458
AW48BC29-S72-C	72	1.500
AW48BC29-S80-C	80	1.667
AW48BC29-S90-C	90	1.875
AW48BC29-S96-C	96	2.000
AW48BC29-S100-C	100	2.083

$$\text{Ratio} = \frac{\# \text{ of Teeth}}{\text{Worm Threads}}$$

Pressure Angle
14 1/2°

Runs with worm #
W48S-2S
OR
W48S-3S

PITCH	STYLE	BORE	MATERIAL	AGMA QUALITY	TYPE
48	DOUBLE THREAD CLAMP STYLE	1/4"	BRONZE QQ-B-637 ALLOY 464	10	RIGHT HAND

STOCK NO.	NO. OF TEETH	PITCH DIA.
AW48BS29-D40-C	40	.833
AW48BS29-D48-C	48	1.000
AW48BS29-D50-C	50	1.042
AW48BS29-D56-C	56	1.167
AW48BS29-D60-C	60	1.250
AW48BC29-D70-C	70	1.458
AW48BC29-D72-C	72	1.500
AW48BC29-D80-C	80	1.667
AW48BC29-D90-C	90	1.875
AW48BC29-D96-C	96	2.000
AW48BC29-D100-C	100	2.083

$$\text{Ratio} = \frac{\# \text{ of Teeth}}{\text{Worm Threads}}$$

Pressure Angle 20°

Runs with worm #
W48S-2D
OR
W48S-3D

PITCH	STYLE	BORE	MATERIAL	AGMA QUALITY	TYPE
48	FOUR THREAD CLAMP STYLE	1/4"	BRONZE QQ-B-637 ALLOY 464	10	RIGHT HAND

STOCK NO.	NO. OF TEETH	PITCH DIA.
AW48BS29-F40-C	40	.833
AW48BS29-F48-C	48	1.000
AW48BS29-F50-C	50	1.042
AW48BS29-F56-C	56	1.167
AW48BS29-F60-C	60	1.250
AW48BC29-F70-C	70	1.458
AW48BC29-F72-C	72	1.500
AW48BC29-F80-C	80	1.667
AW48BC29-F90-C	90	1.875
AW48BC29-F96-C	96	2.000
AW48BC29-F100-C	100	2.083

$$\text{Ratio} = \frac{\# \text{ of Teeth}}{\text{Worm Threads}}$$

Pressure Angle 25°

Runs with worm #
W48S-2F
OR
W48S-3F

Hub Material: 303 Stainless Steel

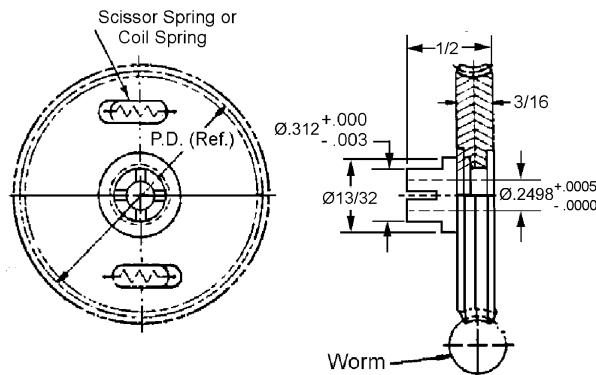

PRECISION WORMS

PITCH	STYLE	BORE	MATERIAL	AGMA QUALITY	TYPE
64	SINGLE, DOUBLE OR FOUR THREAD	1/8"	303 STAINLESS STEEL	10	RIGHT HAND

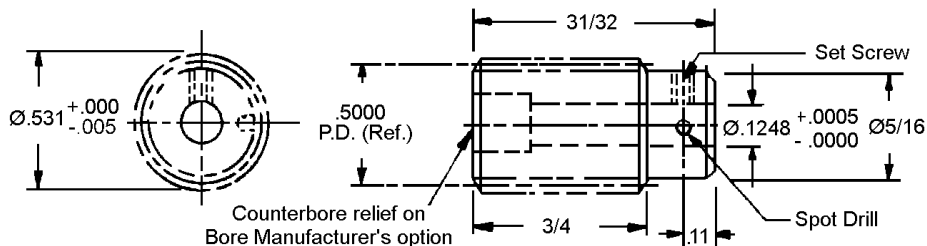

STOCK NO.	THREAD	LEAD	LEAD ANGLE	PRESSURE ANGLE
W64S-2S	SINGLE	.04908	1° - 47'	14-1/2°
W64S-2D	DOUBLE	.09817	3° - 35'	
W64S-2F	FOUR	.19635	7° - 8'	

Counterbore relief on bore manufacturer's option.

PITCH	STYLE	BORE	MATERIAL	AGMA QUALITY	TYPE
64	SINGLE, DOUBLE OR FOUR THREAD	3/16"	303 STAINLESS STEEL	10	RIGHT HAND

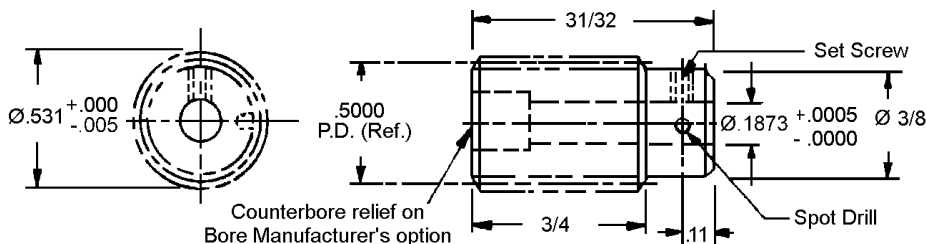

STOCK NO.	THREAD	LEAD	LEAD ANGLE	PRESSURE ANGLE
W64S-3S	SINGLE	.04908	1° - 47'	14-1/2°
W64S-3D	DOUBLE	.09817	3° - 35'	
W64S-3F	FOUR	.19635	7° - 8'	

Counterbore relief on bore manufacturer's option.

PITCH	STYLE	BORE	MATERIAL	AGMA QUALITY	TYPE
64	SINGLE, DOUBLE OR FOUR THREAD	1/4"	303 STAINLESS STEEL	10	RIGHT HAND

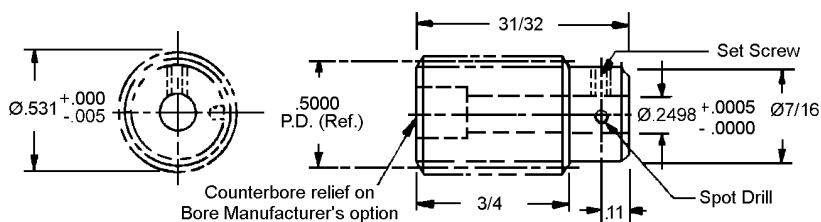

STOCK NO.	THREAD	LEAD	LEAD ANGLE	PRESSURE ANGLE
W64S-4S	SINGLE	.04908	1° - 47'	14-1/2°
W64S-4D	DOUBLE	.09817	3° - 35'	
W64S-4F	FOUR	.19635	7° - 8'	

Counterbore relief on bore manufacturer's option.

PRECISION WORM GEARS

B

PITCH	STYLE	BORE	FACE	MATERIAL	AGMA QUALITY	TYPE
64	SINGLE, DOUBLE OR FOUR THREAD PIN HUB	1/8"	3/16"	BRONZE QQ-B-637 ALLOY 464	10	RIGHT HAND

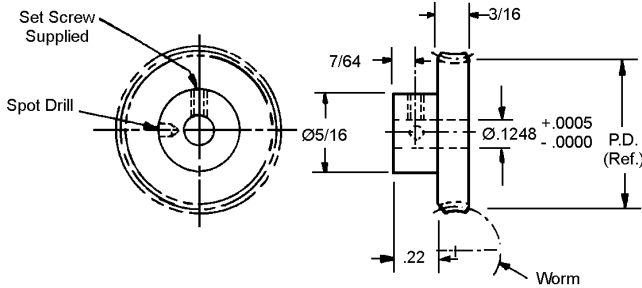

SINGLE THREAD WORM	DOUBLE THREAD WORM	FOUR THREAD WORM	NO. OF TEETH	PITCH DIA.
CIRCULAR PITCH .04908 HELIX ANGLE 1° - 47' PRESSURE ANGLE 14-1/2°	CIRCULAR PITCH .09817 HELIX ANGLE 3° - 35' PRESSURE ANGLE 14-1/2°	CIRCULAR PITCH .19635 HELIX ANGLE 7°-8' PRESSURE ANGLE 14-1/2°		
STOCK NO.	STOCK NO.	STOCK NO.		
W64B13-S40	W64B13-D40	W64B13-F40	40	.625
W64B13-S50	W64B13-D50	W64B13-F50	50	.781
W64B13-S60	W64B13-D60	W64B13-F60	60	.937
W64B13-S70	W64B13-D70	W64B13-F70	70	1.093
W64B13-S80	W64B13-D80	W64B13-F80	80	1.250
W64B13-S90	W64B13-D90	W64B13-F90	90	1.406
W64B13-S100	W64B13-D100	W64B13-F100	100	1.562
W64B13-S110	W64B13-D110	W64B13-F110	110	1.719
W64B13-S120	W64B13-D120	W64B13-F120	120	1.875
W64B13-S180	W64B13-D180	W64B13-F180	180	2.813
W64B13-S360	W64B13-D360	W64B13-F360	360	5.625

$$\text{Ratio} = \frac{\text{\# of Teeth}}{\text{Worm Threads}}$$

PITCH	STYLE	BORE	FACE	MATERIAL	AGMA QUALITY	TYPE
64	SINGLE, DOUBLE OR FOUR THREAD PIN HUB	3/16"	3/16"	BRONZE QQ-B-637 ALLOY 464	10	RIGHT HAND

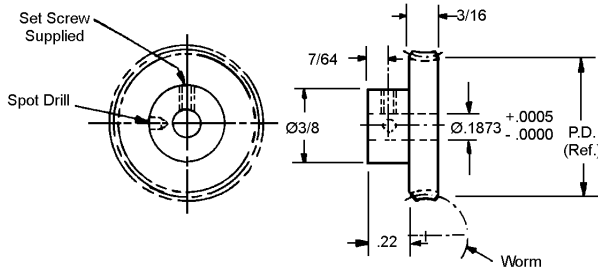

SINGLE THREAD WORM	DOUBLE THREAD WORM	FOUR THREAD WORM	NO. OF TEETH	PITCH DIA.
CIRCULAR PITCH .04908 HELIX ANGLE 1° - 47' PRESSURE ANGLE 14-1/2°	CIRCULAR PITCH .09817 HELIX ANGLE 3° - 35' PRESSURE ANGLE 14-1/2°	CIRCULAR PITCH .19635 HELIX ANGLE 7°-8' PRESSURE ANGLE 14-1/2°		
STOCK NO.	STOCK NO.	STOCK NO.		
W64B21-S40	W64B21-D40	W64B21-F40	40	.625
W64B21-S50	W64B21-D50	W64B21-F50	50	.781
W64B21-S60	W64B21-D60	W64B21-F60	60	.937
W64B21-S70	W64B21-D70	W64B21-F70	70	1.093
W64B21-S80	W64B21-D80	W64B21-F80	80	1.250
W64B21-S90	W64B21-D90	W64B21-F90	90	1.406
W64B21-S100	W64B21-D100	W64B21-F100	100	1.562
W64B21-S110	W64B21-D110	W64B21-F110	110	1.719
W64B21-S120	W64B21-D120	W64B21-F120	120	1.875

$$\text{Ratio} = \frac{\text{\# of Teeth}}{\text{Worm Threads}}$$

Other numbers of teeth and AGMA Quality 12 and 14 are available on request.

PRECISION WORM GEARS

PITCH	STYLE	BORE	FACE	MATERIAL	AGMA QUALITY	TYPE
64	SINGLE, DOUBLE OR FOUR THREAD PIN HUB	1/4"	3/16"	BRONZE QQ-B-637 ALLOY 464	10	RIGHT HAND

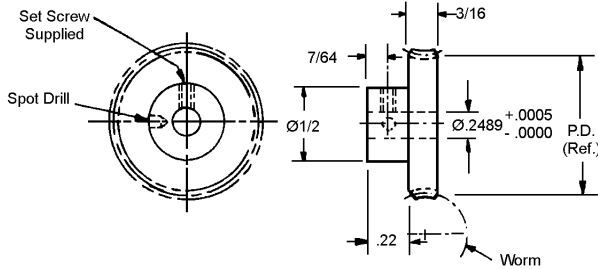

SINGLE THREAD WORM CIRCULAR PITCH .04908 HELIX ANGLE 1° - 47' PRESSURE ANGLE 14-1/2°	DOUBLE THREAD WORM CIRCULAR PITCH .09817 HELIX ANGLE 3° - 35' PRESSURE ANGLE 14-1/2°	FOUR THREAD WORM CIRCULAR PITCH .19635 HELIX ANGLE 7°-8' PRESSURE ANGLE 14-1/2°	NO. OF TEETH	PITCH DIA.
STOCK NO.	STOCK NO.	STOCK NO.		
W64B29-S40	W64B29-D40	W64B29-F40	40	.625
W64B29-S50	W64B29-D50	W64B29-F50	50	.781
W64B29-S60	W64B29-D60	W64B29-F60	60	.937
W64B29-S70	W64B29-D70	W64B29-F70	70	1.093
W64B29-S80	W64B29-D80	W64B29-F80	80	1.250
W64B29-S90	W64B29-D90	W64B29-F90	90	1.406
W64B29-S100	W64B29-D100	W64B29-F100	100	1.562
W64B29-S110	W64B29-D110	W64B29-F110	110	1.719
W64B29-S120	W64B29-D120	W64B29-F120	120	1.875

$$\text{Ratio} = \frac{\# \text{ of Teeth}}{\text{Worm Threads}}$$

PITCH	STYLE	BORE	FACE	MATERIAL	AGMA QUALITY	TYPE
64	SINGLE, DOUBLE OR FOUR THREAD CLAMP STYLE	1/8"	3/16"	BRONZE QQ-B-637 ALLOY 464	10	RIGHT HAND

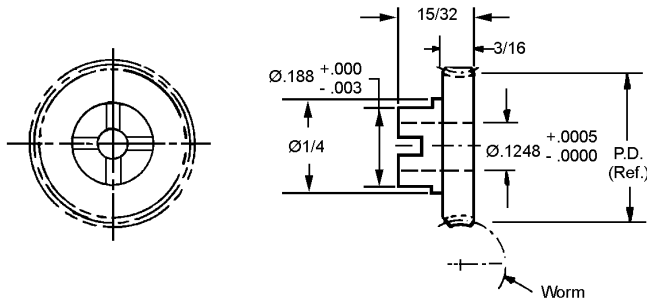

SINGLE THREAD WORM CIRCULAR PITCH .04908 HELIX ANGLE 1° - 47' PRESSURE ANGLE 14-1/2°	DOUBLE THREAD WORM CIRCULAR PITCH .09817 HELIX ANGLE 3° - 35' PRESSURE ANGLE 14-1/2°	FOUR THREAD WORM CIRCULAR PITCH .19635 HELIX ANGLE 7°-8' PRESSURE ANGLE 14-1/2°	NO. OF TEETH	PITCH DIA.
STOCK NO.	STOCK NO.	STOCK NO.		
W64B13-S40-C	W64B13-D40-C	W64B13-F40-C	40	.625
W64B13-S50-C	W64B13-D50-C	W64B13-F50-C	50	.781
W64B13-S60-C	W64B13-D60-C	W64B13-F60-C	60	.937
W64B13-S70-C	W64B13-D70-C	W64B13-F70-C	70	1.093
W64B13-S80-C	W64B13-D80-C	W64B13-F80-C	80	1.250
W64B13-S90-C	W64B13-D90-C	W64B13-F90-C	90	1.406
W64B13-S100-C	W64B13-D100-C	W64B13-F100-C	100	1.562
W64B13-S110-C	W64B13-D110-C	W64B13-F110-C	110	1.719
W64B13-S120-C	W64B13-D120-C	W64B13-F120-C	120	1.875
W64B13-S180-C	W64B13-D180-C	W64B13-F180-C	180	2.813
W64B13-S360-C	W64B13-D360-C	W64B13-F360-C	360	5.625

$$\text{Ratio} = \frac{\# \text{ of Teeth}}{\text{Worm Threads}}$$

Other numbers of teeth and AGMA Quality 12 and 14 are available on request.

PRECISION WORM GEARS

B

PITCH	STYLE	BORE	FACE	MATERIAL	AGMA QUALITY	TYPE
64	SINGLE, DOUBLE OR FOUR THREAD CLAMP STYLE	3/16"	3/16"	BRONZE QQ-B-637 ALLOY 464	10	RIGHT HAND

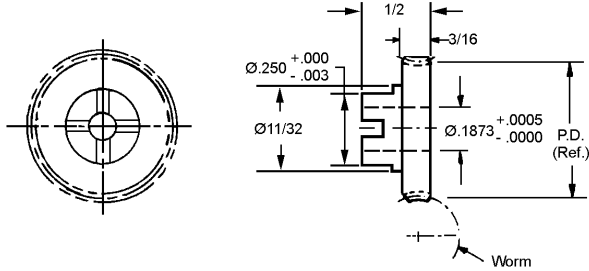

SINGLE THREAD WORM	DOUBLE THREAD WORM	FOUR THREAD WORM	NO. OF TEETH	PITCH DIA.
CIRCULAR PITCH .04908 HELIX ANGLE 1° - 47' PRESSURE ANGLE 14-1/2°	CIRCULAR PITCH .09817 HELIX ANGLE 3° - 35' PRESSURE ANGLE 14-1/2°	CIRCULAR PITCH .19635 HELIX ANGLE 7°-8' PRESSURE ANGLE 14-1/2°		
STOCK NO.	STOCK NO.	STOCK NO.		
W64B21-S40-C	W64B21-D40-C	W64B21-F40-C	40	.625
W64B21-S50-C	W64B21-D50-C	W64B21-F50-C	50	.781
W64B21-S60-C	W64B21-D60-C	W64B21-F60-C	60	.937
W64B21-S70-C	W64B21-D70-C	W64B21-F70-C	70	1.093
W64B21-S80-C	W64B21-D80-C	W64B21-F80-C	80	1.250
W64B21-S90-C	W64B21-D90-C	W64B21-F90-C	90	1.406
W64B21-S100-C	W64B21-D100-C	W64B21-F100-C	100	1.562
W64B21-S110-C	W64B21-D110-C	W64B21-F110-C	110	1.719
W64B21-S120-C	W64B21-D120-C	W64B21-F120-C	120	1.875

$$\text{Ratio} = \frac{\# \text{ of Teeth}}{\text{Worm Threads}}$$

PITCH	STYLE	BORE	FACE	MATERIAL	AGMA QUALITY	TYPE
64	SINGLE, DOUBLE OR FOUR THREAD CLAMP STYLE	1/4"	3/16"	BRONZE QQ-B-637 ALLOY 464	10	RIGHT HAND

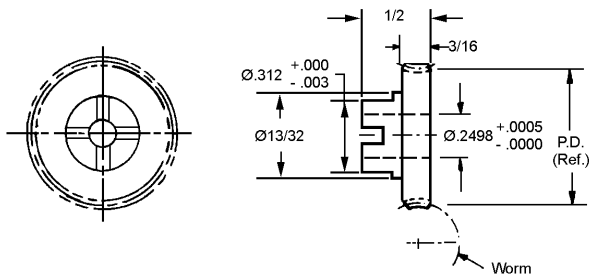

SINGLE THREAD WORM	DOUBLE THREAD WORM	FOUR THREAD WORM	NO. OF TEETH	PITCH DIA.
CIRCULAR PITCH .04908 HELIX ANGLE 1° - 47' PRESSURE ANGLE 14-1/2°	CIRCULAR PITCH .09817 HELIX ANGLE 3° - 35' PRESSURE ANGLE 14-1/2°	CIRCULAR PITCH .19635 HELIX ANGLE 7°-8' PRESSURE ANGLE 14-1/2°		
STOCK NO.	STOCK NO.	STOCK NO.		
W64B29-S40-C	W64B29-D40-C	W64B29-F40-C	40	.625
W64B29-S50-C	W64B29-D50-C	W64B29-F50-C	50	.781
W64B29-S60-C	W64B29-D60-C	W64B29-F60-C	60	.937
W64B29-S70-C	W64B29-D70-C	W64B29-F70-C	70	1.093
W64B29-S80-C	W64B29-D80-C	W64B29-F80-C	80	1.250
W64B29-S90-C	W64B29-D90-C	W64B29-F90-C	90	1.406
W64B29-S100-C	W64B29-D100-C	W64B29-F100-C	100	1.562
W64B29-S110-C	W64B29-D110-C	W64B29-F110-C	110	1.719
W64B29-S120-C	W64B29-D120-C	W64B29-F120-C	120	1.875

$$\text{Ratio} = \frac{\# \text{ of Teeth}}{\text{Worm Threads}}$$

Other numbers of teeth and AGMA Quality 12 and 14 are available on request.

ANTI-BACKLASH WORM GEARS

PITCH	STYLE	BORE	MATERIAL	AGMA QUALITY	TYPE
64	SINGLE THREAD PIN HUB	1/8"	BRONZE QQ-B-637 ALLOY 464	10	RIGHT HAND

STOCK NO.	NO. OF TEETH	PITCH DIA.
AW64BS13-S50	50	.781
AW64BS13-S52	52	.812
AW64BS13-S60	60	.937
AW64BS13-S64	64	1.000
AW64BS13-S70	70	1.094
AW64BS13-S72	72	1.125
AW64BS13-S80	80	1.250
AW64BC13-S96	96	1.500
AW64BC13-S100	100	1.563
AW64BC13-S110	110	1.719
AW64BC13-S120	120	1.875
AW64BC13-S130	130	2.031
AW64BC13-S140	140	2.187

$$\text{Ratio} = \frac{\# \text{ of Teeth}}{\text{Worm Threads}}$$

Pressure Angle
14/1/2°

Runs with worm # W64S-2S

PITCH	STYLE	BORE	MATERIAL	AGMA QUALITY	TYPE
64	DOUBLE THREAD PIN HUB	1/8"	BRONZE QQ-B-637 ALLOY 464	10	RIGHT HAND

STOCK NO.	NO. OF TEETH	PITCH DIA.
AW64BS13-D50	50	.781
AW64BS13-D52	52	.812
AW64BS13-D60	60	.937
AW64BS13-D64	64	1.000
AW64BS13-D70	70	1.094
AW64BS13-D72	72	1.125
AW64BS13-D80	80	1.250
AW64BC13-D96	96	1.500
AW64BC13-D100	100	1.563
AW64BC13-D110	110	1.719
AW64BC13-D120	120	1.875
AW64BC13-D130	130	2.031
AW64BC13-D140	140	2.187

$$\text{Ratio} = \frac{\# \text{ of Teeth}}{\text{Worm Threads}}$$

Pressure Angle
14/1/2°

Runs with worm # W64S-2D

PITCH	STYLE	BORE	MATERIAL	AGMA QUALITY	TYPE
64	FOUR THREAD PIN HUB	1/8"	BRONZE QQ-B-637 ALLOY 464	10	RIGHT HAND

STOCK NO.	NO. OF TEETH	PITCH DIA.
AW64BS13-F50	50	.781
AW64BS13-F52	52	.812
AW64BS13-F60	60	.937
AW64BS13-F64	64	1.000
AW64BS13-F70	70	1.094
AW64BS13-F72	72	1.125
AW64BS13-F80	80	1.250
AW64BC13-F96	96	1.500
AW64BC13-F100	100	1.563
AW64BC13-F110	110	1.719
AW64BC13-F120	120	1.875
AW64BC13-F130	130	2.031
AW64BC13-F140	140	2.187

$$\text{Ratio} = \frac{\# \text{ of Teeth}}{\text{Worm Threads}}$$

Pressure Angle
14/1/2°

Runs with worm # W64S-2F

Hub Material: 303 Stainless Steel

Scissor Spring 50T to 80T
Coil Spring 96T to 140T

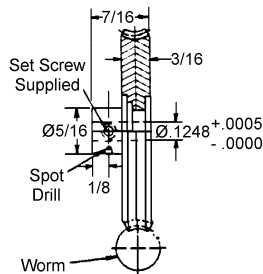
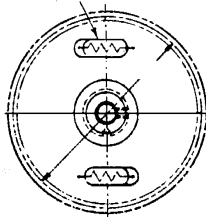

Other numbers of teeth are available on request.

ANTI-BACKLASH WORM GEARS

B

PITCH	STYLE	BORE	MATERIAL	AGMA QUALITY	TYPE
64	SINGLE THREAD PIN HUB	3/16"	BRONZE QQ-B-637 ALLOY 464	10	RIGHT HAND

STOCK NO.	NO. OF TEETH	PITCH DIA.
AW64BS21-S50	50	.781
AW64BS21-S52	52	.812
AW64BS21-S60	60	.937
AW64BS21-S64	64	1.000
AW64BS21-S70	70	1.094
AW64BS21-S72	72	1.125
AW64BS21-S80	80	1.250
AW64BC21-S96	96	1.500
AW64BC21-S100	100	1.563
AW64BC21-S110	110	1.719
AW64BC21-S120	120	1.875
AW64BC21-S130	130	2.031
AW64BC21-S140	140	2.187

$$\text{Ratio} = \frac{\# \text{ of Teeth}}{\text{Worm Threads}}$$

Pressure Angle
14/1/2°

Runs with worm # W64S-3S

PITCH	STYLE	BORE	MATERIAL	AGMA QUALITY	TYPE
64	DOUBLE THREAD PIN HUB	3/16"	BRONZE QQ-B-637 ALLOY 464	10	RIGHT HAND

STOCK NO.	NO. OF TEETH	PITCH DIA.
AW64BS21-D50	50	.781
AW64BS21-D52	52	.812
AW64BS21-D60	60	.937
AW64BS21-D64	64	1.000
AW64BS21-D70	70	1.094
AW64BS21-D72	72	1.125
AW64BS21-D80	80	1.250
AW64BC21-D96	96	1.500
AW64BC21-D100	100	1.563
AW64BC21-D110	110	1.719
AW64BC21-D120	120	1.875
AW64BC21-D130	130	2.031
AW64BC21-D140	140	2.187

$$\text{Ratio} = \frac{\# \text{ of Teeth}}{\text{Worm Threads}}$$

Pressure Angle
14/1/2°

Runs with worm # W64S-3D

PITCH	STYLE	BORE	MATERIAL	AGMA QUALITY	TYPE
64	FOUR THREAD PIN HUB	3/16"	BRONZE QQ-B-637 ALLOY 464	10	RIGHT HAND

STOCK NO.	NO. OF TEETH	PITCH DIA.
AW64BS21-F50	50	.781
AW64BS21-F52	52	.812
AW64BS21-F60	60	.937
AW64BS21-F64	64	1.000
AW64BS21-F70	70	1.094
AW64BS21-F72	72	1.125
AW64BS21-F80	80	1.250
AW64BC21-F96	96	1.500
AW64BC21-F100	100	1.563
AW64BC21-F110	110	1.719
AW64BC21-F120	120	1.875
AW64BC21-F130	130	2.031
AW64BC21-F140	140	2.187

$$\text{Ratio} = \frac{\# \text{ of Teeth}}{\text{Worm Threads}}$$

Pressure Angle
14/1/2°

Runs with worm # W64S-3F

Hub Material: 303 Stainless Steel

Scissor Spring 50T to 80T
Coil Spring 96T to 140T

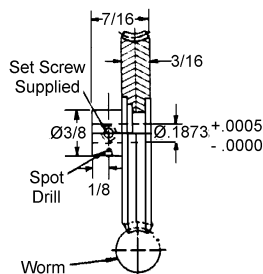
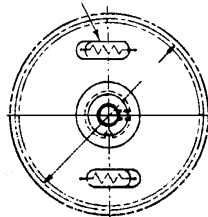

Other numbers of teeth are available on request.

ANTI-BACKLASH WORM GEARS

PITCH	STYLE	BORE	MATERIAL	AGMA QUALITY	TYPE
64	SINGLE THREAD PIN HUB	1/4"	BRONZE QQ-B-637 ALLOY 464	10	RIGHT HAND

STOCK NO.	NO. OF TEETH	PITCH DIA.
AW64BS29-S50	50	.781
AW64BS29-S52	52	.812
AW64BS29-S60	60	.937
AW64BS29-S64	64	1.000
AW64BS29-S70	70	1.094
AW64BS29-S72	72	1.125
AW64BS29-S80	80	1.250
AW64BC29-S96	96	1.500
AW64BC29-S100	100	1.563
AW64BC29-S110	110	1.719
AW64BC29-S120	120	1.875
AW64BC29-S130	130	2.031
AW64BC29-S140	140	2.187

$$\text{Ratio} = \frac{\# \text{ of Teeth}}{\text{Worm Threads}}$$

Pressure Angle
14/1/2°

Runs with worm # W64S-4S

PITCH	STYLE	BORE	MATERIAL	AGMA QUALITY	TYPE
64	DOUBLE THREAD PIN HUB	1/4"	BRONZE QQ-B-637 ALLOY 464	10	RIGHT HAND

STOCK NO.	NO. OF TEETH	PITCH DIA.
AW64BS29-D50	50	.781
AW64BS29-D52	52	.812
AW64BS29-D60	60	.937
AW64BS29-D64	64	1.000
AW64BS29-D70	70	1.094
AW64BS29-D72	72	1.125
AW64BS29-D80	80	1.250
AW64BC29-D96	96	1.500
AW64BC29-D100	100	1.563
AW64BC29-D110	110	1.719
AW64BC29-D120	120	1.875
AW64BC29-D130	130	2.031
AW64BC29-D140	140	2.187

$$\text{Ratio} = \frac{\# \text{ of Teeth}}{\text{Worm Threads}}$$

Pressure Angle
14/1/2°

Runs with worm # W64S-4D

PITCH	STYLE	BORE	MATERIAL	AGMA QUALITY	TYPE
64	FOUR THREAD PIN HUB	1/4"	BRONZE QQ-B-637 ALLOY 464	10	RIGHT HAND

STOCK NO.	NO. OF TEETH	PITCH DIA.
AW64BS29-F50	50	.781
AW64BS29-F52	52	.812
AW64BS29-F60	60	.937
AW64BS29-F64	64	1.000
AW64BS29-F70	70	1.094
AW64BS29-F72	72	1.125
AW64BS29-F80	80	1.250
AW64BC29-F96	96	1.500
AW64BC29-F100	100	1.563
AW64BC29-F110	110	1.719
AW64BC29-F120	120	1.875
AW64BC29-F130	130	2.031
AW64BC29-F140	140	2.187

$$\text{Ratio} = \frac{\# \text{ of Teeth}}{\text{Worm Threads}}$$

Pressure Angle
14/1/2°

Runs with worm # W64S-4F

Hub Material: 303 Stainless Steel

Scissor Spring 50T to 80T
Coil Spring 96T to 140T

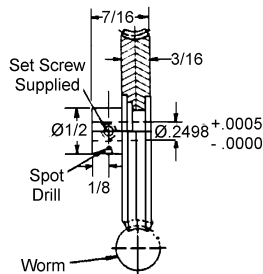
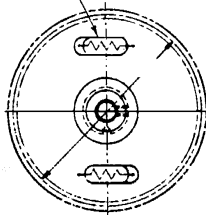

Other numbers of teeth are available on request.

ANTI-BACKLASH WORM GEARS

B

PITCH	STYLE	BORE	MATERIAL	AGMA QUALITY	TYPE
64	SINGLE THREAD CLAMP STYLE	1/8"	BRONZE QQ-B-637 ALLOY 464	10	RIGHT HAND

STOCK NO.	NO. OF TEETH	PITCH DIA.
AW64BS13-S50-C	50	.781
AW64BS13-S52-C	52	.812
AW64BS13-S60-C	60	.937
AW64BS13-S64-C	64	1.000
AW64BS13-S70-C	70	1.094
AW64BS13-S72-C	72	1.125
AW64BS13-S80-C	80	1.250
AW64BC13-S96-C	96	1.500
AW64BC13-S100-C	100	1.563
AW64BC13-S110-C	110	1.719
AW64BC13-S120-C	120	1.875
AW64BC13-S130-C	130	2.031
AW64BC13-S140-C	140	2.187

$$\text{Ratio} = \frac{\# \text{ of Teeth}}{\text{Worm Threads}}$$

Pressure Angle
14/1/2°

Runs with worm # W64S-2S

PITCH	STYLE	BORE	MATERIAL	AGMA QUALITY	TYPE
64	DOUBLE THREAD CLAMP STYLE	1/8"	BRONZE QQ-B-637 ALLOY 464	10	RIGHT HAND

STOCK NO.	NO. OF TEETH	PITCH DIA.
AW64BS13 -D50-C	50	.781
AW64BS13 -D52-C	52	.812
AW64BS13 -D60-C	60	.937
AW64BS13 -D64-C	64	1.000
AW64BS13 -D70-C	70	1.094
AW64BS13 -D72-C	72	1.125
AW64BS13 -D80-C	80	1.250
AW64BC13 -D96-C	96	1.500
AW64BC13 -D100-C	100	1.563
AW64BC13 -D110-C	110	1.719
AW64BC13 -D120-C	120	1.875
AW64BC13 -D130-C	130	2.031
AW64BC13 -D140-C	140	2.187

$$\text{Ratio} = \frac{\# \text{ of Teeth}}{\text{Worm Threads}}$$

Pressure Angle
14/1/2°

Runs with worm # W64S-2D

PITCH	STYLE	BORE	MATERIAL	AGMA QUALITY	TYPE
64	FOUR THREAD CLAMP STYLE	1/8"	BRONZE QQ-B-637 ALLOY 464	10	RIGHT HAND

STOCK NO.	NO. OF TEETH	PITCH DIA.
AW64BS13-F50-C	50	.781
AW64BS13-F52-C	52	.812
AW64BS13-F60-C	60	.937
AW64BS13-F64-C	64	1.000
AW64BS13-F70-C	70	1.094
AW64BS13-F72-C	72	1.125
AW64BS13-F80-C	80	1.250
AW64BC13-F96-C	96	1.500
AW64BC13-F100-C	100	1.563
AW64BC13-F110-C	110	1.719
AW64BC13-F120-C	120	1.875
AW64BC13-F130-C	130	2.031
AW64BC13-F140-C	140	2.187

$$\text{Ratio} = \frac{\# \text{ of Teeth}}{\text{Worm Threads}}$$

Pressure Angle
14/1/2°

Runs with worm # W64S-2F

Hub Material: 303 Stainless Steel

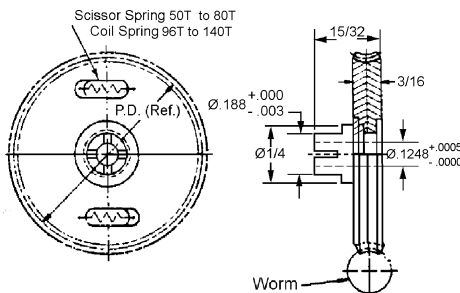

Other numbers of teeth are available on request.

ANTI-BACKLASH WORM GEARS

PITCH	STYLE	BORE	MATERIAL	AGMA QUALITY	TYPE
64	SINGLE THREAD CLAMP STYLE	3/16"	BRONZE QQ-B-637 ALLOY 464	10	RIGHT HAND

STOCK NO.	NO. OF TEETH	PITCH DIA.
AW64BS21-S50-C	50	.781
AW64BS21-S52-C	52	.812
AW64BS21-S60-C	60	.937
AW64BS21-S64-C	64	1.000
AW64BS21-S70-C	70	1.094
AW64BS21-S72-C	72	1.125
AW64BS21-S80-C	80	1.250
AW64BC21-S96-C	96	1.500
AW64BC21-S100-C	100	1.563
AW64BC21-S110-C	110	1.719
AW64BC21-S120-C	120	1.875
AW64BC21-S130-C	130	2.031
AW64BC21-S140-C	140	2.187

$$\text{Ratio} = \frac{\# \text{ of Teeth}}{\text{Worm Threads}}$$

Pressure Angle
14/1/2°

Runs with worm # W64S-3S

PITCH	STYLE	BORE	MATERIAL	AGMA QUALITY	TYPE
64	DOUBLE THREAD CLAMP STYLE	3/16"	BRONZE QQ-B-637 ALLOY 464	10	RIGHT HAND

STOCK NO.	NO. OF TEETH	PITCH DIA.
AW64BS21-D50-C	50	.781
AW64BS21-D52-C	52	.812
AW64BS21-D60-C	60	.937
AW64BS21-D64-C	64	1.000
AW64BS21-D70-C	70	1.094
AW64BS21-D72-C	72	1.125
AW64BS21-D80-C	80	1.250
AW64BC21-D96-C	96	1.500
AW64BC21-D100-C	100	1.563
AW64BC21-D110-C	110	1.719
AW64BC21-D120-C	120	1.875
AW64BC21-D130-C	130	2.031
AW64BC21-D140-C	140	2.187

$$\text{Ratio} = \frac{\# \text{ of Teeth}}{\text{Worm Threads}}$$

Pressure Angle
14/1/2°

Runs with worm # W64S-3D

PITCH	STYLE	BORE	MATERIAL	AGMA QUALITY	TYPE
64	FOUR THREAD CLAMP STYLE	3/16"	BRONZE QQ-B-637 ALLOY 464	10	RIGHT HAND

STOCK NO.	NO. OF TEETH	PITCH DIA.
AW64BS21-F50-C	50	.781
AW64BS21-F52-C	52	.812
AW64BS21-F60-C	60	.937
AW64BS21-F64-C	64	1.000
AW64BS21-F70-C	70	1.094
AW64BS21-F72-C	72	1.125
AW64BS21-F80-C	80	1.250
AW64BC21-F96-C	96	1.500
AW64BC21-F100-C	100	1.563
AW64BC21-F110-C	110	1.719
AW64BC21-F120-C	120	1.875
AW64BC21-F130-C	130	2.031
AW64BC21-F140-C	140	2.187

$$\text{Ratio} = \frac{\# \text{ of Teeth}}{\text{Worm Threads}}$$

Pressure Angle
14/1/2°

Runs with worm # W64S-3F

Hub Material: 303 Stainless Steel

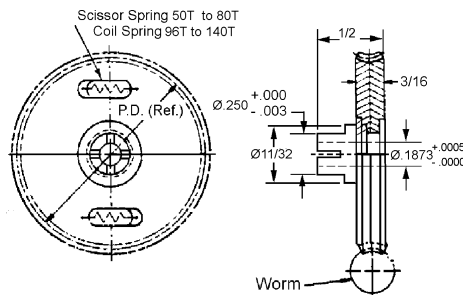

Other numbers of teeth are available on request.

ANTI-BACKLASH WORM GEARS

B

PITCH	STYLE	BORE	MATERIAL	AGMA QUALITY	TYPE
64	SINGLE THREAD CLAMP STYLE	1/4"	BRONZE QQ-B-637 ALLOY 464	10	RIGHT HAND

STOCK NO.	NO. OF TEETH	PITCH DIA.
AW64BS29-S50-C	50	.781
AW64BS29-S52-C	52	.812
AW64BS29-S60-C	60	.937
AW64BS29-S64-C	64	1.000
AW64BS29-S70-C	70	1.094
AW64BS29-S72-C	72	1.125
AW64BS29-S80-C	80	1.250
AW64BC29-S96-C	96	1.500
AW64BC29-S100-C	100	1.563
AW64BC29-S110-C	110	1.719
AW64BC29-S120-C	120	1.875
AW64BC29-S130-C	130	2.031
AW64BC29-S140-C	140	2.187

$$\text{Ratio} = \frac{\# \text{ of Teeth}}{\text{Worm Threads}}$$

Pressure Angle
14/1/2°

Runs with worm # W64S-4S

PITCH	STYLE	BORE	MATERIAL	AGMA QUALITY	TYPE
64	DOUBLE THREAD CLAMP STYLE	1/4"	BRONZE QQ-B-637 ALLOY 464	10	RIGHT HAND

STOCK NO.	NO. OF TEETH	PITCH DIA.
AW64BS29-D50-C	50	.781
AW64BS29-D52-C	52	.812
AW64BS29-D60-C	60	.937
AW64BS29-D64-C	64	1.000
AW64BS29-D70-C	70	1.094
AW64BS29-D72-C	72	1.125
AW64BS29-D80-C	80	1.250
AW64BC29-D96-C	96	1.500
AW64BC29-D100-C	100	1.563
AW64BC29-D110-C	110	1.719
AW64BC29-D120-C	120	1.875
AW64BC29-D130-C	130	2.031
AW64BC29-D140-C	140	2.187

$$\text{Ratio} = \frac{\# \text{ of Teeth}}{\text{Worm Threads}}$$

Pressure Angle
14/1/2°

Runs with worm # W64S-4D

PITCH	STYLE	BORE	MATERIAL	AGMA QUALITY	TYPE
64	FOUR THREAD CLAMP STYLE	1/4"	BRONZE QQ-B-637 ALLOY 464	10	RIGHT HAND

STOCK NO.	NO. OF TEETH	PITCH DIA.
AW64BS29-F50-C	50	.781
AW64BS29-F52-C	52	.812
AW64BS29-F60-C	60	.937
AW64BS29-F64-C	64	1.000
AW64BS29-F70-C	70	1.094
AW64BS29-F72-C	72	1.125
AW64BS29-F80-C	80	1.250
AW64BC29-F96-C	96	1.500
AW64BC29-F100-C	100	1.563
AW64BC29-F110-C	110	1.719
AW64BC29-F120-C	120	1.875
AW64BC29-F130-C	130	2.031
AW64BC29-F140-C	140	2.187

$$\text{Ratio} = \frac{\# \text{ of Teeth}}{\text{Worm Threads}}$$

Pressure Angle
14/1/2°

Runs with worm # W64S-4F

Hub Material: 303 Stainless Steel

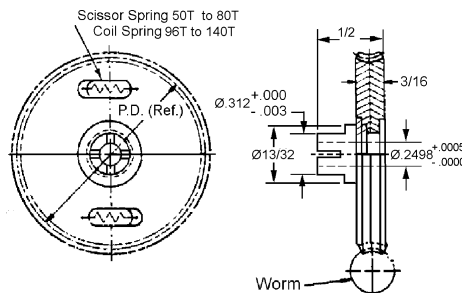

Other numbers of teeth are available on request.

INTERNAL GEARS

PITCH	I.D.	O.D.	MATERIAL	AGMA QUALITY	PRESSURE ANGLE
24	.750 TO 3.166	1.9980 TO 3.9980	303 STAINLESS STEEL OR 2024-T4 ALUMINUM ANODIZED	10	20°

303 STAINLESS STEEL STOCK NO.	2024-T4 ALUMINUM ANODIZED STOCK NO.	NO. OF TEETH	PITCH DIA.	INSIDE DIA.	OUTSIDE DIA.
N24S2-20	N24A2-20	20	.8333	.750	1.9980
N24S2-25	N24A2-25	25	1.0417	.958	
N24S2-30	N24A2-30	30	1.2500	1.166	
N24S2-35	N24A2-35	35	1.4583	1.375	
N24S3-35	N24A3-35	35	1.4583	1.375	2.9980
N24S3-40	N24A3-40	40	1.6667	1.583	
N24S3-45	N24A3-45	45	1.8750	1.791	
N24S3-50	N24A3-50	50	2.0833	2.000	
N24S3-60	N24A3-60	60	2.5000	2.416	3.9980
N24S4-60	N24A4-60	60	2.5000	2.416	
N24S4-65	N24A4-65	65	2.7083	2.625	
N24S4-70	N24A4-70	70	2.9167	2.834	
N24S4-72	N24A4-72	72	3.0000	2.916	3.9980
N24S4-78	N24A4-78	78	3.2500	3.166	

PITCH	I.D.	O.D.	MATERIAL	AGMA QUALITY	PRESSURE ANGLE
32	.718 TO 3.062	1.9980 TO 3.9980	303 STAINLESS STEEL OR 2024-T4 ALUMINUM ANODIZED	10	20°

303 STAINLESS STEEL STOCK NO.	2024-T4 ALUMINUM ANODIZED STOCK NO.	NO. OF TEETH	PITCH DIA.	INSIDE DIA.	OUTSIDE DIA.
N32S2-25	N32A2-25	25	.7813	.718	1.9980
N32S2-30	N32A2-30	30	.9375	.875	
N32S2-35	N32A2-35	35	1.0938	1.031	
N32S2-40	N32A2-40	40	1.2500	1.187	
N32S2-45	N32A2-45	45	1.4063	1.343	
N32S3-45	N32A3-45	45	1.4063	1.343	2.9980
N32S3-50	N32A3-50	50	1.5625	1.500	
N32S3-60	N32A3-60	60	1.8750	1.812	
N32S3-70	N32A3-70	70	2.1875	2.125	
N32S3-80	N32A3-80	80	2.5000	2.437	
N32S4-80	N32A4-80	80	2.5000	2.437	3.9980
N32S4-85	N32A4-85	85	2.6563	2.593	
N32S4-90	N32A4-90	90	2.8125	2.750	
N32S4-96	N32A4-96	96	3.0000	2.937	
N32S4-100	N32A4-100	100	3.1250	3.062	

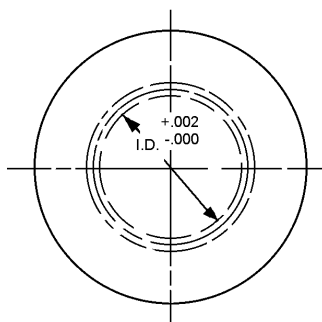
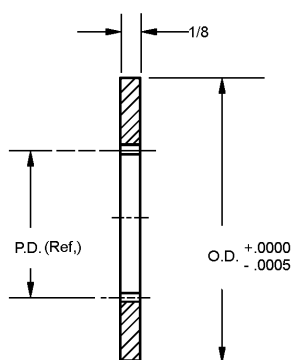

Drawing and dimensions apply to all pitches.
Special internal gears on request.

INTERNAL GEARS

B

PITCH	I.D.	O.D.	MATERIAL	AGMA QUALITY	PRESSURE ANGLE
48	.791 TO 3.208	1.9980 TO 3.9980	303 STAINLESS STEEL OR 2024-T4 ALUMINUM ANODIZED	10	20°

303 STAINLESS STEEL STOCK NO.	2024-T4 ALUMINUM ANODIZED STOCK NO.	NO. OF TEETH	PITCH DIA.	INSIDE DIA.	OUTSIDE DIA.
N48S2-40	N48A2-40	40	.8333	.791	1.9980
N48S2-50	N48A2-50	50	1.0417	1.000	
N48S2-60	N48A2-60	60	1.2500	1.208	
N48S2-70	N48A2-70	70	1.4583	1.416	
N48S3-70	N48A3-70	70	1.4583	1.416	2.9980
N48S3-80	N48A3-80	80	1.6667	1.625	
N48S3-90	N48A3-90	90	1.8750	1.833	
N48S3-100	N48A3-100	100	2.0833	2.041	
N48S3-120	N48A3-120	120	2.5000	2.458	3.9980
N48S4-120	N48A4-120	120	2.5000	2.458	
N48S4-130	N48A4-130	130	2.7083	2.666	
N48S4-140	N48A4-140	140	2.9167	2.875	
N48S4-144	N48A4-144	144	3.0000	2.958	
N48S4-156	N48A4-156	156	3.2500	3.208	

PITCH	I.D.	O.D.	MATERIAL	AGMA QUALITY	PRESSURE ANGLE
64	.750 TO 3.093	1.9980 TO 3.9980	303 STAINLESS STEEL OR 2024-T4 ALUMINUM ANODIZED	10	20°

303 STAINLESS STEEL STOCK NO.	2024-T4 ALUMINUM ANODIZED STOCK NO.	NO. OF TEETH	PITCH DIA.	INSIDE DIA.	OUTSIDE DIA.
N64S2-50	N64A2-50	50	.7813	.750	1.9980
N64S2-60	N64A2-60	60	.9375	.906	
N64S2-70	N64A2-70	70	1.0938	1.062	
N64S2-80	N64A2-80	80	1.2500	1.219	
N64S2-90	N64A2-90	90	1.4063	1.375	
N64S3-90	N64A3-90	90	1.4063	1.375	2.9980
N64S3-100	N64A3-100	100	1.5625	1.531	
N64S3-120	N64A3-120	120	1.8750	1.843	
N64S3-140	N64A3-140	140	2.1875	2.156	
N64S3-160	N64A3-160	160	2.5000	2.468	
N64S4-160	N64A4-160	160	2.5000	2.468	3.9980
N64S4-170	N64A4-170	170	2.6563	2.625	
N64S4-180	N64A4-180	180	2.8125	2.781	
N64S4-192	N64A4-192	192	3.0000	2.968	
N64S4-200	N64A4-200	200	3.1250	3.093	

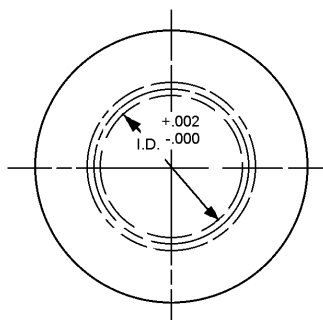
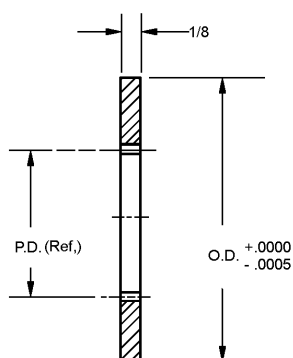

Drawing and dimensions apply to all pitches.
Special internal gears on request.

INTERNAL GEARS

PITCH	I.D.	O.D.	MATERIAL	AGMA QUALITY	PRESSURE ANGLE
72	.805 TO 3.027	1.9980 TO 3.9980	303 STAINLESS STEEL OR 2024-T4 ALUMINUM ANODIZED	10	20°

303 STAINLESS STEEL STOCK NO.	2024-T4 ALUMINUM ANODIZED STOCK NO.	NO. OF TEETH	PITCH DIA.	INSIDE DIA.	OUTSIDE DIA.
N72S2-60	N72A2-60	60	.8333	.805	1.9980
N72S2-80	N72A2-80	80	1.1111	1.083	
N72S2-100	N72A2-100	100	1.3889	1.361	
N72S2-110	N72A2-110	110	1.5278	1.500	
N72S3-110	N72A3-110	110	1.5278	1.500	2.9980
N72S3-120	N72A3-120	120	1.6667	1.639	
N72S3-140	N72A3-140	140	1.9444	1.916	
N72S3-160	N72A3-160	160	2.2222	2.194	
N72S3-180	N72A3-180	180	2.5000	2.472	3.9980
N72S4-180	N72A4-180	180	2.5000	2.472	
N72S4-190	N72A4-190	190	2.6389	2.611	
N72S4-200	N72A4-200	200	2.7778	2.750	
N72S4-216	N72A4-216	216	3.0000	2.972	3.9980
N72S4-220	N72A4-220	220	3.0556	3.027	

PITCH	I.D.	O.D.	MATERIAL	AGMA QUALITY	PRESSURE ANGLE
96	.812 TO 3.3.105	1.9980 TO 3.9980	303 STAINLESS STEEL OR 2024-T4 ALUMINUM ANODIZED	10	20°

303 STAINLESS STEEL STOCK NO.	2024-T4 ALUMINUM ANODIZED STOCK NO.	NO. OF TEETH	PITCH DIA.	INSIDE DIA.	OUTSIDE DIA.
N96S2-80	N96A2-80	80	.8333	.812	1.9980
N96S2-100	N96A2-100	100	1.0416	1.021	
N96S2-120	N96A2-120	120	1.2500	1.230	
N96S2-140	N96A2-140	140	1.4583	1.438	
N96S2-150	N96A2-150	150	1.5625	1.542	
N96S3-150	N96A3-150	150	1.5625	1.542	2.9980
N96S3-160	N96A3-160	160	1.6667	1.646	
N96S3-180	N96A3-180	180	1.8750	1.855	
N96S3-200	N96A3-200	200	2.0833	2.063	
N96S3-240	N96A3-240	240	2.5000	2.480	
N96S4-240	N96A4-240	240	2.5000	2.480	3.9980
N96S4-250	N96A4-250	250	2.6042	2.584	
N96S4-260	N96A4-260	260	2.7083	2.688	
N96S4-280	N96A4-280	280	2.9167	2.896	
N96S4-288	N96A4-288	288	3.0000	2.980	
N96S4-300	N96A4-300	300	3.1250	3.105	

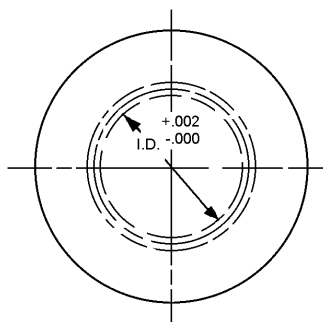
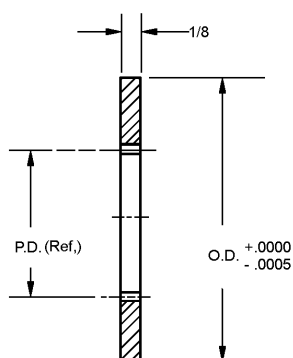

Drawing and dimensions apply to all pitches.
Special internal gears on request.

INTERNAL GEARS

PITCH	I.D.	O.D.	MATERIAL	AGMA QUALITY	PRESSURE ANGLE
120	.816 TO 3.149	1.9980 TO 3.9980	303 STAINLESS STEEL OR 2024-T4 ALUMINUM ANODIZED	10	20°

B

303 STAINLESS STEEL STOCK NO.	2024-T4 ALUMINUM ANODIZED STOCK NO.	NO. OF TEETH	PITCH DIA.	INSIDE DIA.	OUTSIDE DIA.
N120S2-100	N120A2-100	100	.8333	.816	1.9980
N120S2-120	N120A2-120	120	1.0000	.983	
N120S2-140	N120A2-140	140	1.1667	1.149	
N120S2-160	N120A2-160	160	1.3333	1.316	
N120S2-180	N120A2-180	180	1.5000	1.483	
N120S3-180	N120A3-180	180	1.5000	1.483	2.9980
N120S3-200	N120A3-200	200	1.6667	1.649	
N120S3-240	N120A3-240	240	2.0000	1.983	
N120S3-250	N120A3-250	250	2.0833	2.066	
N120S3-270	N120A3-270	270	2.2500	2.233	
N120S3-300	N120A3-300	300	2.5000	2.483	3.9980
N120S4-300	N120A4-300	300	2.5000	2.483	
N120S4-320	N120A4-320	320	2.6667	2.649	
N120S4-340	N120A4-340	340	2.8333	2.816	
N120S4-350	N120A4-350	350	2.9167	2.900	
N120S4-360	N120A4-360	360	3.0000	2.983	3.9980
N120S4-380	N120A4-380	380	3.1667	3.149	

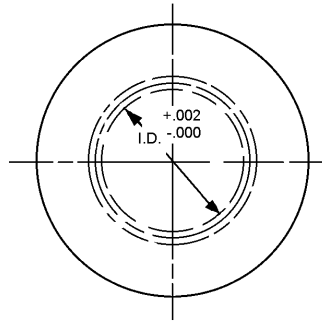
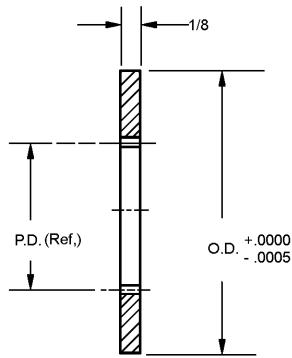

Drawing and dimensions apply to all pitches.
Special internal gears on request.

For Couplings See Section G.
For Shafts, Bearings and Collars See Section I.

ASSEMBLIES

Table of Contents

GEARBOXES - WORM WHEEL AND HELICAL GEARS	
TECHNICAL DATA - SPEED REDUCERS	C 2
WORM & WORM WHEEL GEARS	
SHAFT SIZE - 1/8", 3/16" AND 1/4"	C3 - C 4
HELICAL GEARS	
SHAFT SIZE - 1/8", 3/16" AND 1/4"	C5
BEVEL GEARBOX	C 6
SHAFT SIZE - 1/8", 3/16" AND 1/4"	C 10
MINIATURE MITER GEARBOX	C 7, C 9
MITER GEARBOX	
SHAFT SIZE - 1/8", 3/16" AND 1/4"	C 8
SERVO GEARBOX	
SHAFT SIZE - 1/8"	C 11
SHAFT SIZE - 3/16"	C 12
SHAFT SIZE - 1/4"	C 13
SPEED REDUCER	
SHAFT SIZE - 1/8"	C 14
SHAFT SIZE - 1/4"	C 15
PRECISION PLANETARY GEAR HEADS	
SHAFT SIZE - 3/8", 1/2" AND 5/8"	C 16
INTERMITTENT MOTION ASSEMBLY	
SHAFT SIZE - 1/4"	C 17
GENEVA MECHANISM	
SHAFT SIZE - 1/4"	C 18
CAM FOLLOWERS	C 19
ROLLER BEARING CAM FOLLOWER	C 20
ADJUSTABLE CAM ASSEMBLY	C 21
RATCHETS AND PAWLS	C 22

C

GEARBOXES - WORM WHEEL AND HELICAL GEARS

TECHNICAL INFORMATION PRECISION SPEED REDUCERS 1/8", 3/16" and 1/4" Shafts

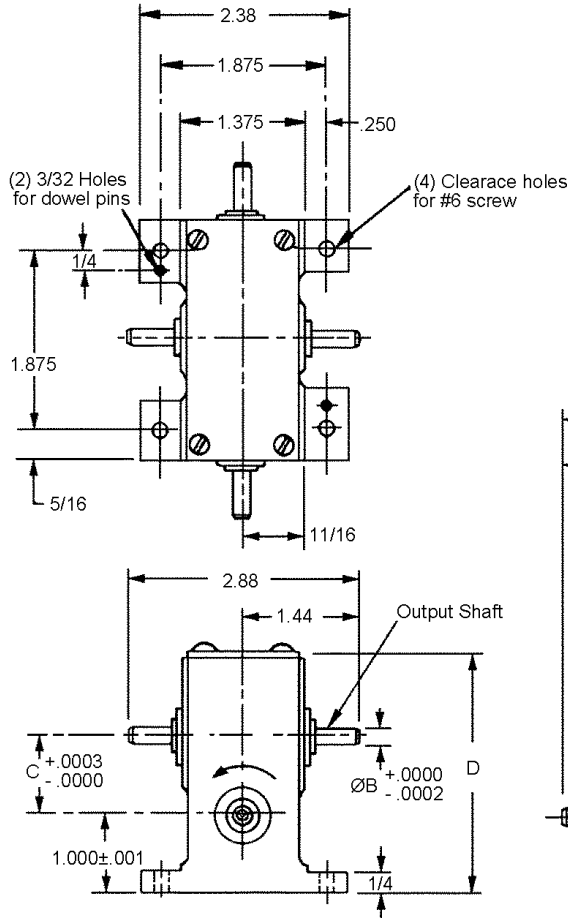

Materials

Housing	Cast Aluminum (Anodized)
Worm Wheel	Bronze
Worm	Stainless Steel
Helical Gear	Aluminum
Helical Pinion	Stainless Steel

Bearings	Stainless Steel or Bronze
Shafts	Stainless Steel
Lubrication	MIL. Spec. Oil and Grease
Housing Cover	Aluminum
All other parts	Stainless Steel

Backlash

Ball Bearing Unit 20 Minutes Max.
Bronze Bearing Unit 30 Minutes Max.

Maximum Speed

2000 RPM

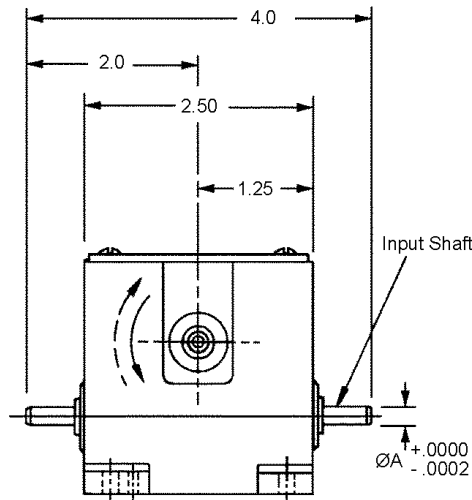

Worm and Wheel units can only be driven from input shaft and will only operate as a Speed Reducer.
Helical Gear units can be driven from input shaft as a Speed Reducer or from output shaft as a Speed Increaser.
Other ratios available on request.
Anti-Backlash unit available on request.



WORM & WORM WHEEL GEARS

SHAFT SIZE	TYPE
ØA= 1/8 ØB= 1/8	BALL BEARING OR BRONZE BEARING

BALL BEARINGS UNITS STOCK NO.	BRONZE BEARINGS UNITS STOCK NO.	PITCH	SHAFT SIZE		NOMINAL RATIO	C CENTER	D HEIGHT	MAXIMUM OUTPUT TORQUE (OZ.-IN.)
			ØA	ØB				
WX64B2-1	WX64P2-1	64 WORM & WHEEL	.1247	.1247	15:1	.7191	2-11/32	112
WX64B2-2	WX64P2-2				20:1	.8753	2-5/8	160
WX64B2-3	WX64P2-3				25:1	1.0315	2-31/32	192
WX64B2-4	WX64P2-4				30:1	1.1878	3-1/4	240
WX64B2-5	WX64P2-5				30:1	.7190	2-11/32	144
WX64B2-6	WX64P2-6				40:1	.8753	2-5/8	192
WX64B2-7	WX64P2-7				50:1	1.0315	2-31/32	240
WX64B2-8	WX64P2-8				60:1	1.1878	3-1/4	288
WX64B2-9	WX64P2-9				60:1	.7190	2-11/32	144
WX64B2-10	WX64P2-10				80:1	.8753	2-5/8	192
WX64B2-11	WX64P2-11				100:1	1.0315	2-31/32	240
WX64B2-12	WX64P2-12				120:1	1.1873	3-1/4	288



SHAFT SIZE	TYPE
ØA= 3/16 ØB= 3/16	BALL BEARING OR BRONZE BEARING

BALL BEARINGS UNITS STOCK NO.	BRONZE BEARINGS UNITS STOCK NO.	PITCH	SHAFT SIZE		NOMINAL RATIO	C CENTER	D HEIGHT	MAXIMUM OUTPUT TORQUE (OZ.-IN.)
			ØA	ØB				
WX64B3-1	WX64P3-1	64 WORM & WHEEL	.1872	.1872	15:1	.7190	2-11/32	112
WX64B3-2	WX64P3-2				20:1	.8753	2-5/8	160
WX64B3-3	WX64P3-3				25:1	1.0315	2-31/32	192
WX64B3-4	WX64P3-4				30:1	1.1878	3-1/4	240
WX64B3-5	WX64P3-5				30:1	.7190	2-11/32	144
WX64B3-6	WX64P3-6				40:1	.8753	2-5/8	192
WX64B3-7	WX64P3-7				50:1	1.0315	2-31/32	240
WX64B3-8	WX64P3-8				60:1	1.1878	3-1/4	288
WX64B3-9	WX64P3-9				60:1	.7190	2-11/32	144
WX64B3-10	WX64P3-10				80:1	.8753	2-5/8	192
WX64B3-11	WX64P3-11				100:1	1.0315	2-31/32	240
WX64B3-12	WX64P3-12				120:1	1.1878	3-1/4	288

SHAFT SIZE	TYPE
ØA= 1/4 ØB= 1/4	BALL BEARING OR BRONZE BEARING

BALL BEARINGS UNITS STOCK NO.	BRONZE BEARINGS UNITS STOCK NO.	PITCH	SHAFT SIZE		NOMINAL RATIO	C CENTER	D HEIGHT	MAXIMUM OUTPUT TORQUE (OZ.-IN.)
			ØA	ØB				
WX64B4-1	WX64P4-1	64 WORM & WHEEL	.2497	.2497	15:1	.7190	2-11/32	112
WX64B4-2	WX64P4-2				20:1	.8753	2-5/8	160
WX64B4-3	WX64P4-3				25:1	1.0315	2-31/32	192
WX64B4-4	WX64P4-4				30:1	1.1878	3-1/4	240
WX64B4-5	WX64P4-5				30:1	.7190	2-11/32	144
WX64B4-6	WX64P4-6				40:1	.8753	2-5/8	192
WX64B4-7	WX64P4-7				50:1	1.0315	2-31/32	240
WX64B4-8	WX64P4-8				60:1	1.1878	3-1/4	288
WX64B4-9	WX64P4-9				60:1	.7190	2-11/32	144
WX64B4-10	WX64P4-10				80:1	.8753	2-5/8	192
WX64B4-11	WX64P4-11				100:1	1.0315	2-31/32	240
WX64B4-12	WX64P4-12				120:1	1.1878	3-1/4	288

WORM & WORM WHEEL GEARS

SHAFT SIZE	TYPE
ØA= 1/8 ØB= 1/8	BALL BEARING OR BRONZE BEARING

BALL BEARINGS UNITS STOCK NO.	BRONZE BEARINGS UNITS STOCK NO.	PITCH	SHAFT SIZE		NOMINAL RATIO	C CENTER	D HEIGHT	MAXIMUM OUTPUT TORQUE (OZ.-IN.)
			ØA	ØB				
WX48B2-1	WX48P2-1	48 WORM & WHEEL	.1247	.1247	12.5:1	.6878	2-11/32	144
WX48B2-2	WX48P2-2				15:1	.7920	2-35/64	176
WX48B2-3	WX48P2-3				20:1	1.0003	2-31/32	240
WX48B2-4	WX48P2-4				22.5:1	1.1045	3-11/64	272
WX48B2-5	WX48P2-5				25:1	.6878	2-11/32	176
WX48B2-6	WX48P2-6				30:1	.7920	2-35/64	208
WX48B2-7	WX48P2-7				40:1	1.0003	2-31/32	288
WX48B2-8	WX48P2-8				45:1	1.1045	3-11/64	320
WX48B2-9	WX48P2-9				50:1	.6878	2-11/32	176
WX48B2-10	WX48P2-10				60:1	.7920	2-35/64	208
WX48B2-11	WX48P2-11				80:1	1.0003	2-31/32	288
WX48B2-12	WX48P2-12				90:1	1.1045	3-11/64	320

SHAFT SIZE	TYPE
ØA= 3/16 ØB= 3/16	BALL BEARING OR BRONZE BEARING

BALL BEARINGS UNITS STOCK NO.	BRONZE BEARINGS UNITS STOCK NO.	PITCH	SHAFT SIZE		NOMINAL RATIO	C CENTER	D HEIGHT	MAXIMUM OUTPUT TORQUE (OZ.-IN.)
			ØA	ØB				
WX48B3-1	WX48P3-1	48 WORM & WHEEL	.1872	.1872	12.5:1	.6878	2-11/32	144
WX48B3-2	WX48P3-2				15:1	.7920	2-35/64	176
WX48B3-3	WX48P3-3				20:1	1.0003	2-31/32	240
WX48B3-4	WX48P3-4				22.5:1	1.1045	3-11/64	272
WX48B3-5	WX48P3-5				25:1	.6878	2-11/32	176
WX48B3-6	WX48P3-6				30:1	.7920	2-35/64	208
WX48B3-7	WX48P3-7				40:1	1.0003	2-31/32	288
WX48B3-8	WX48P3-8				45:1	1.1045	3-11/64	320
WX48B3-9	WX48P3-9				50:1	.6878	2-11/32	176
WX48B3-10	WX48P3-10				60:1	.7920	2-35/64	208
WX48B3-11	WX48P3-11				80:1	1.0003	2-31/32	288
WX48B3-12	WX48P3-12				90:1	1.1045	3-11/64	320

SHAFT SIZE	TYPE
ØA= 3/16 ØB= 1/4	BALL BEARING OR BRONZE BEARING

BALL BEARINGS UNITS STOCK NO.	BRONZE BEARINGS UNITS STOCK NO.	PITCH	SHAFT SIZE		NOMINAL RATIO	C CENTER	D HEIGHT	MAXIMUM OUTPUT TORQUE (OZ.-IN.)
			ØA	ØB				
WX48B43-1	WX48P43-1	48 WORM & WHEEL	.1872	.2497	12.5:1	.6878	2-11/32	144
WX48B43-2	WX48P43-2				15:1	.7920	2-35/64	176
WX48B43-3	WX48P43-3				20:1	1.0003	2-31/32	240
WX48B43-4	WX48P43-4				22.5:1	1.1045	3-11/64	272
WX48B43-5	WX48P43-5				25:1	.6878	2-11/32	176
WX48B43-6	WX48P43-6				30:1	.7920	2-35/64	208
WX48B43-7	WX48P43-7				40:1	1.0003	2-31/32	288
WX48B43-8	WX48P43-8				45:1	1.1040	3-11/64	320
WX48B43-9	WX48P43-9				50:1	.6878	2-11/32	176
WX48B43-10	WX48P43-10				60:1	.7920	2-35/64	208
WX48B43-11	WX48P43-11				80:1	1.0003	2-31/32	288
WX48B43-12	WX48P43-12				90:1	1.1045	3-11/64	320

HELICAL GEARS

SHAFT SIZE					TYPE			
ØA= 1/8 ØB= 1/8					BALL BEARING OR BRONZE BEARING			

BALL BEARINGS UNITS STOCK NO.	BRONZE BEARINGS UNITS STOCK NO.	PITCH	SHAFT SIZE		NOMINAL RATIO	C CENTER	D HEIGHT	MAXIMUM OUTPUT TORQUE (OZ.-IN.)
			ØA	ØB				
HX64B2-1	HX64P2-1	64 HELICAL	.1247	.1247	1:1	.4422	1-25/32	49
HX64B2-2	HX64P2-2				2:1	.6632	2-15/64	
HX64B2-3	HX64P2-3				3:1	.8841	2-43/64	
HX64B2-4	HX64P2-4				4:1	1.1051	3-7/64	



SHAFT SIZE					TYPE			
ØA= 3/16 ØB= 3/16					BALL BEARING OR BRONZE BEARING			

BALL BEARINGS UNITS STOCK NO.	BRONZE BEARINGS UNITS STOCK NO.	PITCH	SHAFT SIZE		NOMINAL RATIO	C CENTER	D HEIGHT	MAXIMUM OUTPUT TORQUE (OZ.-IN.)
			ØA	ØB				
HX64B3-1	HX64P3-1	64 HELICAL	.1872	.1872	1:1	.4422	1-25/32	73
HX64B3-2	HX64P3-2				2:1	.6632	2-15/16	
HX64B3-3	HX64P3-3				3:1	.8841	2-43/64	
HX64B3-4	HX64P3-4				4:1	1.1051	3-7/64	

SHAFT SIZE					TYPE			
ØA= 3/16 ØB= 3/16					BALL BEARING OR BRONZE BEARING			

BALL BEARINGS UNITS STOCK NO.	BRONZE BEARINGS UNITS STOCK NO.	PITCH	SHAFT SIZE		NOMINAL RATIO	C CENTER	D HEIGHT	MAXIMUM OUTPUT TORQUE (OZ.-IN.)
			ØA	ØB				
HX48B3-1	HX48P3-1	48 HELICAL	.1872	.1872	1:1	.5895	2-1/64	73
HX48B3-2	HX48P3-2				2:1	.8841	2-19/32	
HX48B3-3	HX48P3-3				3:1	1.1787	3-3/16	

SHAFT SIZE					TYPE			
ØA= 1/4 ØB= 1/4					BALL BEARING OR BRONZE BEARING			

BALL BEARINGS UNITS STOCK NO.	BRONZE BEARINGS UNITS STOCK NO.	PITCH	SHAFT SIZE		NOMINAL RATIO	C CENTER	D HEIGHT	MAXIMUM OUTPUT TORQUE (OZ.-IN.)
			ØA	ØB				
HX48B4-1	HX48P4-1	48 HELICAL	.2497	.2497	1:1	.5895	2-1/64	130
HX48B4-2	HX48P4-2				2:1	.8841	2-19/32	
HX48B4-3	HX49P4-3				3:1	1.1787	3-3/16	

BEVEL GEARBOX

SHAFT SIZE	RATIOS	TYPE
1/4" OR 5MM	1:1 and 1:2	BRONZE BEARING

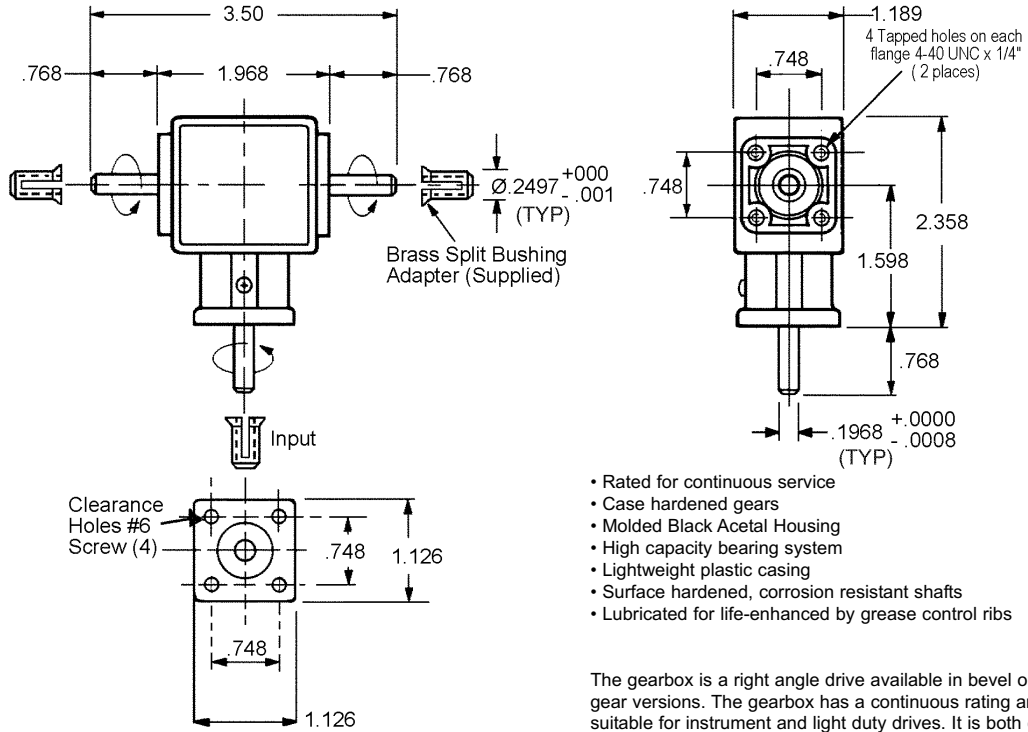

- Rated for continuous service
- Case hardened gears
- Molded Black Acetal Housing
- High capacity bearing system
- Lightweight plastic casing
- Surface hardened, corrosion resistant shafts
- Lubricated for life-enhanced by grease control ribs

The gearbox is a right angle drive available in bevel or miter gear versions. The gearbox has a continuous rating and is suitable for instrument and light duty drives. It is both economical and reliable.

STOCK NO.	RATIO	RPM MAX.	OPERATING TORQUE	BACKLASH MAX.
MX-16	1:1	1500	48 OZ. IN.	2°
MX-17	1:2	1500	96 OZ. IN.	2°

MINIATURE MITER GEARBOX

SHAFT SIZE	RATIOS	TYPE
1/4" OR 4mm	1:1	BRONZE BEARING

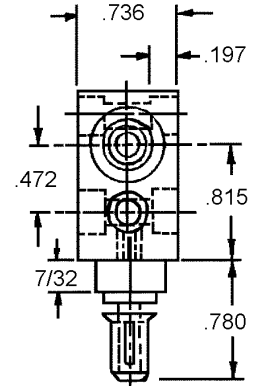
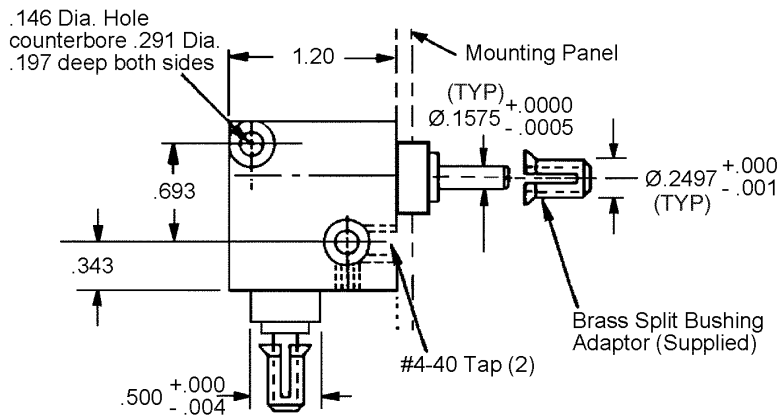

STOCK NO.	GEAR MATERIAL	OPERATING TORQUE
MX-14	HARDENED STEEL	98 OZ. IN.

- Molded Black Acetal Housing
- Ground and hardened steel shaft
- Sintered bronze bearing system
- Gearbox and bearings lubricated for life
- 1000 RPM Maximum

C

MITER GEARBOX

SHAFT SIZE	RATIO	TYPE
1/8"	1:1	BALL BEARING OR BRONZE BEARING

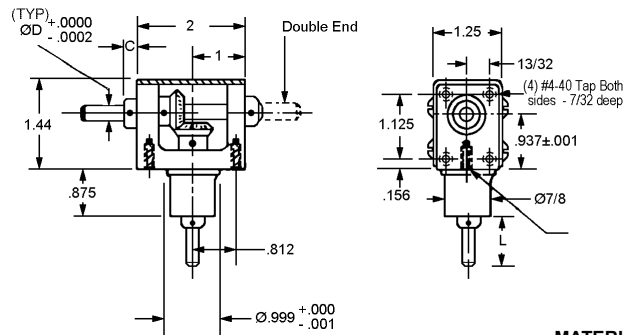

Consult Berg's Engineering Department for higher torque units.

ABEC 7 BALL BEARING	OIL-LESS BRONZE BEARING UNIT	ØD	C	L	SHAFT END STYLE	R.P.M. (MAX.)	TORQUE (MAX.)
STOCK NO.	STOCK NO.						
MX-1	MX-1B	.1247	.187	.71	SINGLE	1000	200
MX-1-D	MX-1B-D				DOUBLE		OZ.IN.

MATERIAL:
Housing Aluminum
Shafts and Hardware Stainless Steel
Bearings Stainless Steel or Bronze
Gears Stainless Steel and Aluminum
Lubrication MIL. Spec. Oil and Grease

SHAFT SIZE	RATIO	TYPE
3/16"	1:1	BALL BEARING OR BRONZE BEARING

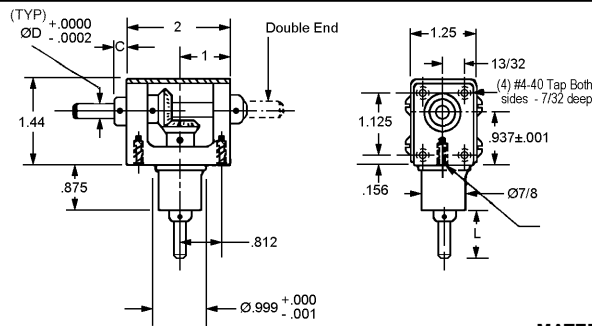

Consult Berg's Engineering Department for higher torque units.

ABEC 7 BALL BEARING	OIL-LESS BRONZE BEARING UNIT	ØD	C	L	SHAFT END STYLE	R.P.M. (MAX.)	TORQUE (MAX.)
STOCK NO.	STOCK NO.						
MX-2	MX-2B	.1872	.220	.87	SINGLE	2000	300
MX-2-D	MX-2B-D				DOUBLE		OZ.IN.

MATERIAL:
Housing Aluminum
Shafts and Hardware Stainless Steel
Bearings Stainless Steel or Bronze
Gears Stainless Steel and Aluminum
Lubrication MIL. Spec. Oil and Grease

SHAFT SIZE	RATIO	TYPE
1/4"	1:1	BALL BEARING OR BRONZE BEARING

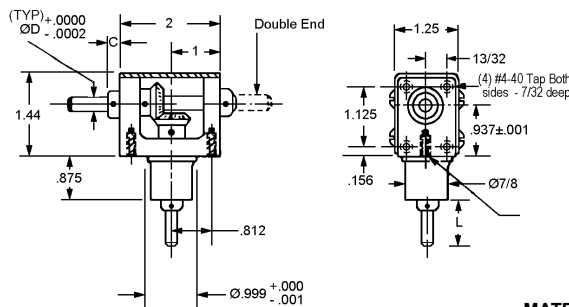

Consult Berg's Engineering Department for higher torque units.

ABEC 7 BALL BEARING	OIL-LESS BRONZE BEARING UNIT	ØD	C	L	SHAFT END STYLE	R.P.M. (MAX.)	TORQUE (MAX.)
STOCK NO.	STOCK NO.						
MX-3	MX-3B	.2497	.250	1.03	SINGLE	2500	500
MX-3-D	MX-3B-D				DOUBLE		OZ.IN.

MATERIAL:
Housing Aluminum
Shafts and Hardware Stainless Steel
Bearings Stainless Steel or Bronze
Gears Stainless Steel and Aluminum
Lubrication MIL. Spec. Oil and Grease

MINIATURE MITER GEARBOX

SHAFT SIZE	RATIO	TYPE
1/8"	1:1	BALL BEARING OR BRONZE BEARING

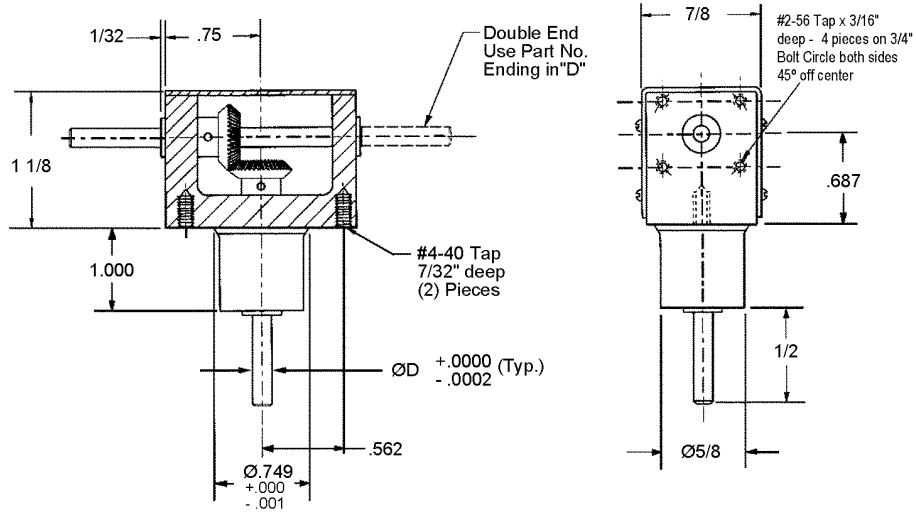

MATERIAL:
Housing Aluminum
Shafts and Hardware Stainless Steel
Bearings Stainless Steel or Bronze
Gears Stainless Steel
Lubrication MIL. Spec. Oil and Grease

ABEC 7 BALL BEARING	OIL-LESS BRONZE BEARING UNIT	ØD	SHAFT END STYLE	R.P.M. (MAX.)	TORQUE (MAX.)
STOCK NO.	STOCK NO.				
MX-4	MX-4B	.1247	SINGLE	1000	100
MX-4-D	MX-4B-D	.1247	DOUBLE		OZ. IN.

Consult Berg's Engineering Department for higher torque units.
 Anti-Backlash units available on request.



BEVEL GEARBOX

SHAFT SIZE	RATIO	TYPE
1/8"	FROM 1:1 TO 1:3	BALL BEARING OR BRONZE BEARING

ABEC 7 BALL BEARING	OIL-LESS BRONZE BEARING UNIT	NOMINAL RATIO	ØD	B	C	E	F	G	H	A	RPM (MAX.)	STATIC TORQUE (MAX.)
MX-5	MX-5B	1:1	.1247	2 3/4	1 7/8	1 5/8	1 7/8	13/16	1 7/16 1 11/16 1 15/16	1.000	1000	60 OZ. IN.
MX-6	MX-6B	1:2										
MX-7	MX-7B	1:3										

- Maximum backlash 10 minutes
- Units can be driven in either direction from any shaft

MATERIAL: Housing Aluminum
 Shafts and Hardware Stainless Steel
 Bearings Stainless Steel or Bronze
 Gears Stainless Steel and Aluminum
 Lubrication MIL. Spec. Oil and Grease

SHAFT SIZE	RATIO	TYPE
3/16"	FROM 1:1 TO 1:3	BALL BEARING OR BRONZE BEARING

ABEC 7 BALL BEARING	OIL-LESS BRONZE BEARING UNIT	NOMINAL RATIO	ØD	B	C	E	F	G	H	A	RPM (MAX.)	STATIC TORQUE (MAX.)
MX-8	MX-8B	1:1	.1872	2 3/4	1 7/8	1 5/8	1 7/8	13/16	1 7/16 1 11/16 1 15/16	1.000	2000	80 OZ. IN.
MX-9	MX-9B	1:2										
MX-10	MX-10B	1:3										

- Maximum backlash 10 minutes
- Units can be driven in either direction from any shaft

MATERIAL: Housing Aluminum
 Shafts and Hardware Stainless Steel
 Bearings Stainless Steel or Bronze
 Gears Stainless Steel and Aluminum
 Lubrication MIL. Spec. Oil and Grease

SHAFT SIZE	RATIO	TYPE
1/4"	FROM 1:1 TO 1:3	BALL BEARING OR BRONZE BEARING

ABEC 7 BALL BEARING	OIL-LESS BRONZE BEARING UNIT	NOMINAL RATIO	ØD	B	C	E	F	G	H	A	RPM (MAX.)	STATIC TORQUE (MAX.)
MX-11	MX-11B	1:1	.2498	3 1/2	2 5/8	2	2 1/4	15/16	2 2 5/16 2 9/16	1.500	2500	100 OZ. IN.
MX-12	MX-12B	1:2										
MX-13	MX-13B	1:3										

- Maximum backlash 10 minutes
- Units can be driven in either direction from any shaft

MATERIAL: Housing Aluminum
 Shafts and Hardware Stainless Steel
 Bearings Stainless Steel or Bronze
 Gears Stainless Steel and Aluminum
 Lubrication MIL. Spec. Oil and Grease

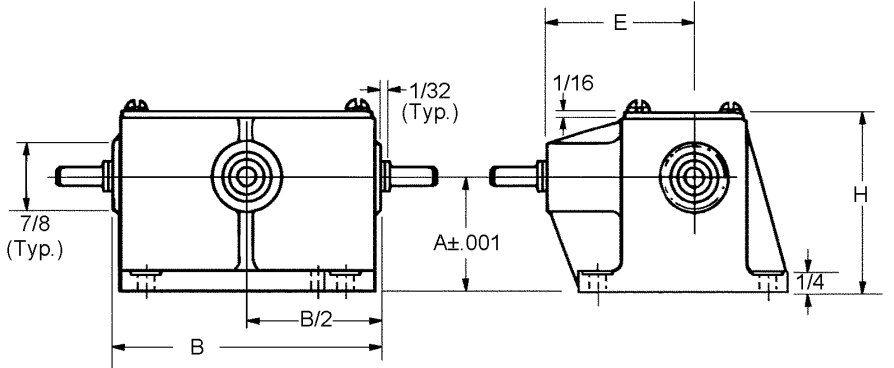
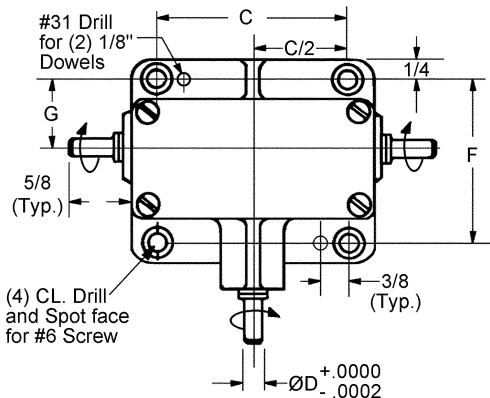

SERVO GEARBOX - PRECISION SPEED REDUCER

SHAFT SIZE	RATIO	TYPE
1/8"	2:1 TO 625:1	BALL BEARING OR BRONZE BEARING

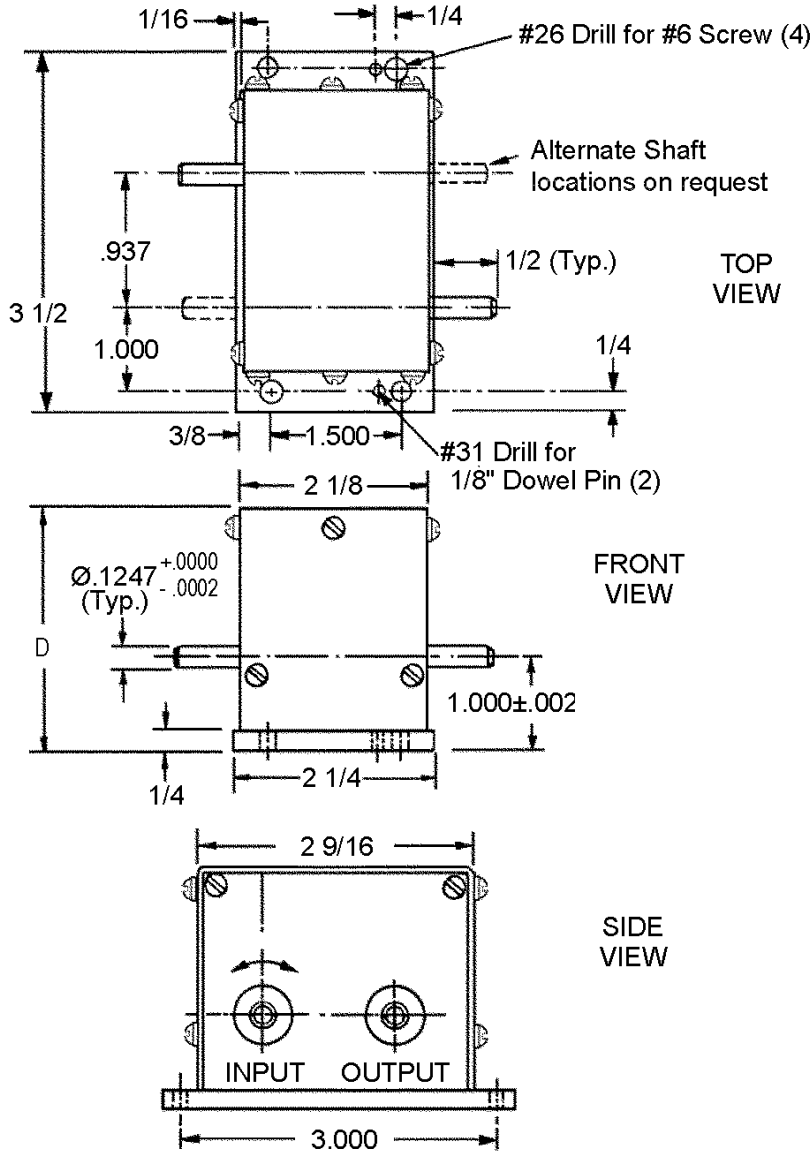

Special units available on request.

Anti-Backlash gear - Output End

Slip Clutch included - Input End

Contact Berg's Engineering Department for recommendations for use as a Speed Increaser.

• See instructions below to order alternate shaft locations.

ABEC 7 BALL BEARINGS UNITS	BRONZE BEARINGS UNITS	NOMINAL RATIO	D HEIGHT	DIRECTION ROTATION
SX-B2-1	SX-P2-1	2:1	2-1/2	SAME
SX-B2-2	SX-P2-2	3:1		
SX-B2-3	SX-P2-3	4:1		
SX-B2-4	SX-P2-4	5:1		
SX-B2-5	SX-P2-5	6:1		
SX-B2-6	SX-P2-6	7:1		
SX-B2-7	SX-P2-7	8:1		
SX-B2-8	SX-P2-8	9:1		
SX-B2-9	SX-P2-9	10:1		
SX-B2-10	SX-P2-10	12:1		
SX-B2-11	SX-P2-11	15:1		
SX-B2-12	SX-P2-12	16:1		
SX-B2-13	SX-P2-13	20:1		
SX-B2-14	SX-P2-14	25:1		
SX-B2-15	SX-P2-15	30:1	2-5/8	OPPOSITE
SX-B2-16	SX-P2-16	32:1		
SX-B2-17	SX-P2-17	36:1		
SX-B2-18	SX-P2-18	40:1		
SX-B2-19	SX-P2-19	45:1		
SX-B2-20	SX-P2-20	48:1		
SX-B2-21	SX-P2-21	50:1		
SX-B2-22	SX-P2-22	60:1		
SX-B2-23	SX-P2-23	64:1		
SX-B2-24	SX-P2-24	75:1		
SX-B2-25	SX-P2-25	80:1		
SX-B2-26	SX-P2-26	100:1		
SX-B2-27	SX-P2-27	125:1		
SX-B2-28	SX-P2-28	72:1	3-5/16	SAME
SX-B2-29	SX-P2-29	90:1		
SX-B2-30	SX-P2-30	96:1		
SX-B2-31	SX-P2-31	128:1		
SX-B2-32	SX-P2-32	150:1		
SX-B2-33	SX-P2-33	180:1		
SX-B2-34	SX-P2-34	200:1		
SX-B2-35	SX-P2-35	250:1		
SX-B2-36	SX-P2-36	256:1		
SX-B2-37	SX-P2-37	300:1		
SX-B2-38	SX-P2-38	375:1		
SX-B2-39	SX-P2-39	400:1		
SX-B2-40	SX-P2-40	500:1		
SX-B2-41	SX-P2-41	625:1		

Alternate Shaft Locations

Add **Style Letter** to complete stock number, if different from that shown.

Style:

- O** = Opposite of as shown
- R** = In and Out on R.H. side only
- L** = In and Out on L.H. side only
- A** = In and Out on all sides

Send drawing if other than listed above.

Backlash

At Output Shaft

- Ball Bearing - 15 Minutes Max.
- Bronze Bearing - 30 Minutes Max.

Materials

Housing and Cover Aluminum Anodized

Gears Stainless Steel and Aluminum

Shafts and Hardware Stainless Steel

Bearings Stainless Steel or Bronze

Lubrication MIL. Spec. Oil and Grease

Maximum Speed

5000 RPM

Maximum Output Torque

300 Oz. In.



SERVO GEARBOXES

SHAFT SIZE	RATIO	TYPE
3/16"	2:1 TO 625:1	BALL BEARING OR BRONZE BEARING

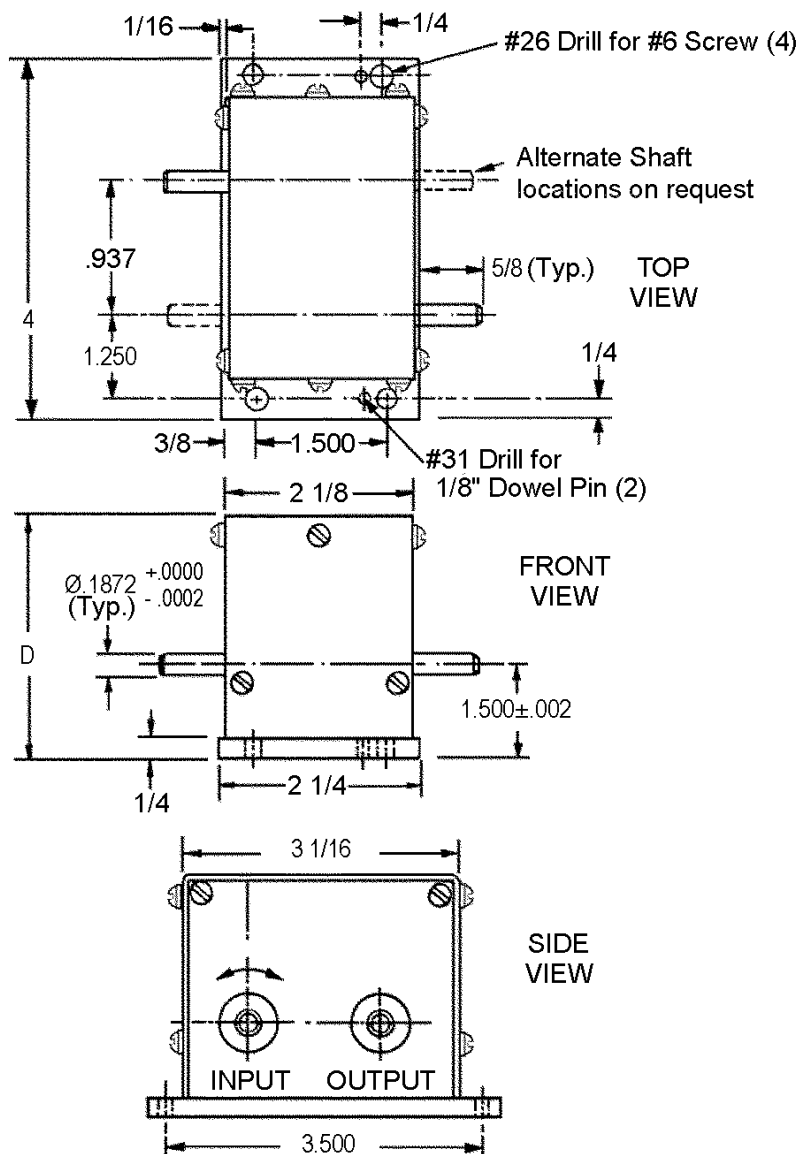

Special units available on request.

Anti-Backlash gear - Output End

Slip Clutch included - Input End

Contact Berg's Engineering Department for recommendations for use as a Speed Increaser.

• See instructions below to order alternate shaft locations.

ABEC 7 BALL BEARINGS UNITS	BRONZE BEARINGS UNITS	NOMINAL RATIO	D HEIGHT	DIRECTION ROTATION
STOCK NO.	STOCK NO.			
SX-B3-1	SX-P3-1	2:1	3 3/8	SAME
SX-B3-2	SX-P3-2	3:1		
SX-B3-3	SX-P3-3	4:1		
SX-B3-4	SX-P3-4	5:1		
SX-B3-5	SX-P3-5	6:1		
SX-B3-6	SX-P3-6	7:1		
SX-B3-7	SX-P3-7	8:1		
SX-B3-8	SX-P3-8	9:1		
SX-B3-9	SX-P3-9	10:1		
SX-B3-10	SX-P3-10	12:1		
SX-B3-11	SX-P3-11	15:1		
SX-B3-12	SX-P3-12	16:1		
SX-B3-13	SX-P3-13	20:1		
SX-B3-14	SX-P3-14	25:1		
SX-B3-15	SX-P3-15	30:1	3 3/8	OPPOSITE
SX-B3-16	SX-P3-16	32:1		
SX-B3-17	SX-P3-17	36:1		
SX-B3-18	SX-P3-18	40:1		
SX-B3-19	SX-P3-19	45:1		
SX-B3-20	SX-P3-20	48:1		
SX-B3-21	SX-P3-21	50:1		
SX-B3-22	SX-P3-22	60:1		
SX-B3-23	SX-P3-23	64:1		
SX-B3-24	SX-P3-24	75:1		
SX-B3-25	SX-P3-25	80:1		
SX-B3-26	SX-P3-26	100:1		
SX-B3-27	SX-P3-27	125:1		
SX-B3-28	SX-P3-28	72:1	4 9/32	SAME
SX-B3-29	SX-P3-29	90:1		
SX-B3-30	SX-P3-30	96:1		
SX-B3-31	SX-P3-31	128:1		
SX-B3-32	SX-P3-32	150:1		
SX-B3-33	SX-P3-33	180:1		
SX-B3-34	SX-P3-34	200:1		
SX-B3-35	SX-P3-35	250:1		
SX-B3-36	SX-P3-36	256:1		
SX-B3-37	SX-P3-37	300:1		
SX-B3-38	SX-P3-38	375:1		
SX-B3-39	SX-P3-39	400:1		
SX-B3-40	SX-P3-40	500:1		
SX-B3-41	SX-P3-41	625:1		

Alternate Shaft Locations

Add **Style Letter** to complete stock number, if different from that shown.

Style:

- O** = Opposite of as shown
- R** = In and Out on R.H. side only
- L** = In and Out on L.H. side only
- A** = In and Out on all sides

Send drawing if other than listed above.

Backlash

At Output Shaft

Ball Bearing - 15 Minutes Max.

Bronze Bearing - 30 Minutes Max.

Materials

Housing and Cover Aluminum Anodized

Gears Stainless Steel and Aluminum

Shafts and Hardware Stainless Steel

Bearings Stainless Steel or Bronze

Lubrication MIL. Spec. Oil and Grease

Maximum Speed

5000 RPM

Maximum Output Torque

400 Oz. In.



SERVO GEARBOXES

SHAFT SIZE	RATIO	TYPE
1/4"	2:1 TO 625:1	BALL BEARING OR BRONZE BEARING

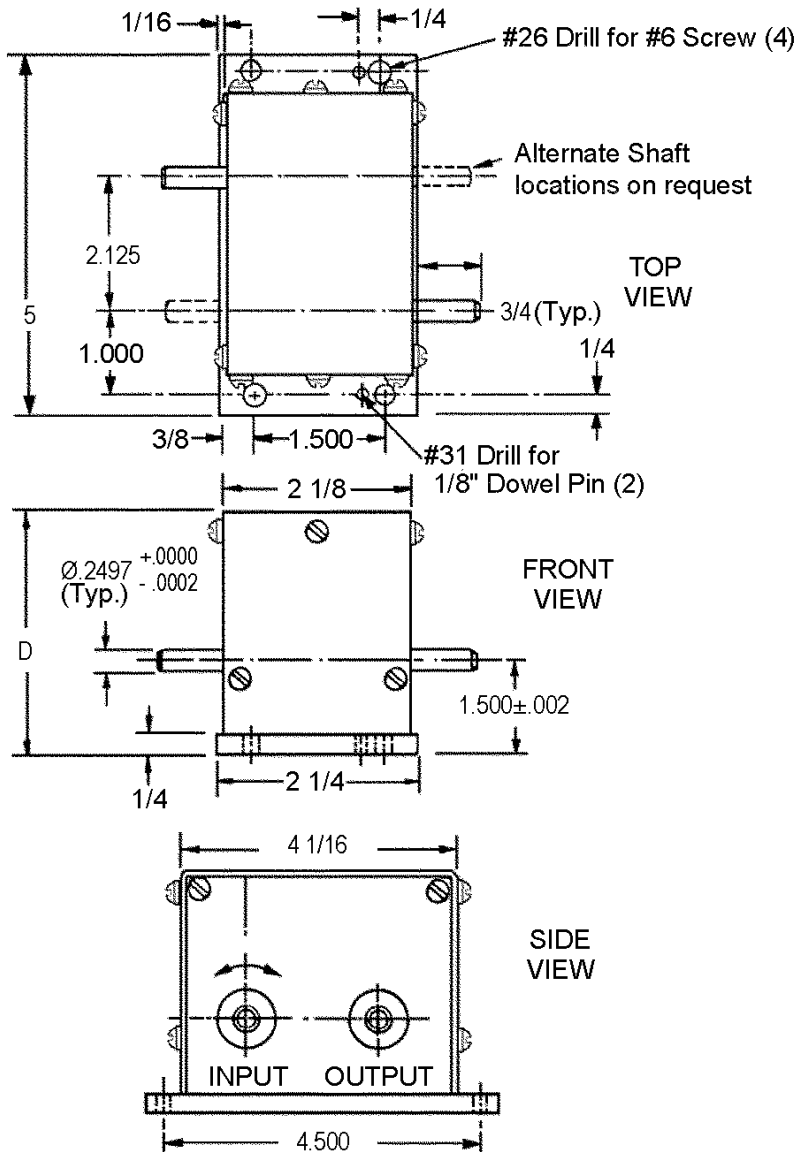

Special units available on request.

Anti-Backlash gear - Output End

Slip Clutch included - Input End

Contact Berg's Engineering Department for recommendations for use as a Speed Increaser.

• See instructions below to order alternate shaft locations.

ABEC 7 BALL BEARINGS UNITS	BRONZE BEARINGS UNITS	NOMINAL RATIO	D HEIGHT	DIRECTION ROTATION
STOCK NO.	STOCK NO.			
SX-B4-1	SX-P4-1	2:1	3 9/32	SAME
SX-B4-2	SX-P4-2	3:1		
SX-B4-3	SX-P4-3	4:1		
SX-B4-4	SX-P4-4	5:1		
SX-B4-5	SX-P4-5	6:1		
SX-B4-6	SX-P4-6	7:1		
SX-B4-7	SX-P4-7	8:1		
SX-B4-8	SX-P4-8	9:1		
SX-B4-9	SX-P4-9	10:1		
SX-B4-10	SX-P4-10	12:1		
SX-B4-11	SX-P4-11	15:1		
SX-B4-12	SX-P4-12	16:1		
SX-B4-13	SX-P4-13	20:1		
SX-B4-14	SX-P4-14	25:1		
SX-B4-15	SX-P4-15	30:1	3 13/16	OPPOSITE
SX-B4-16	SX-P4-16	32:1		
SX-B4-17	SX-P4-17	36:1		
SX-B4-18	SX-P4-18	40:1		
SX-B4-19	SX-P4-19	45:1		
SX-B4-20	SX-P4-20	48:1		
SX-B4-21	SX-P4-21	50:1		
SX-B4-22	SX-P4-22	60:1		
SX-B4-23	SX-P4-23	64:1		
SX-B4-24	SX-P4-24	75:1		
SX-B4-25	SX-P4-25	80:1		
SX-B4-26	SX-P4-26	100:1		
SX-B4-27	SX-P4-27	125:1		
SX-B4-28	SX-P4-28	72:1	4 13/16	SAME
SX-B4-29	SX-P4-29	90:1		
SX-B4-30	SX-P4-30	96:1		
SX-B4-31	SX-P4-31	128:1		
SX-B4-32	SX-P4-32	150:1		
SX-B4-33	SX-P4-33	180:1		
SX-B4-34	SX-P4-34	200:1		
SX-B4-35	SX-P4-35	250:1		
SX-B4-36	SX-P4-36	256:1		
SX-B4-37	SX-P4-37	300:1		
SX-B4-38	SX-P4-38	375:1		
SX-B4-39	SX-P4-39	400:1		
SX-B4-40	SX-P4-40	500:1		
SX-B4-41	SX-P4-41	625:1		

Alternate Shaft Locations

Add **Style Letter** to complete stock number, if different from that shown.

Style:

- O** = Opposite of as shown
- R** = In and Out on R.H. side only
- L** = In and Out on L.H. side only
- A** = In and Out on all sides

Send drawing if other than listed above.

Backlash

At Output Shaft

Ball Bearing - 15 Minutes Max.

Bronze Bearing - 30 Minutes Max.

Materials

Housing and Cover Aluminum Anodized

Gears Stainless Steel and Aluminum

Shafts and Hardware Stainless Steel

Bearings Stainless Steel or Bronze

Lubrication MIL. Spec. Oil and Grease

Maximum Speed

5000 RPM

Maximum Output Torque

600 Oz. In.



SPEED REDUCER

SHAFT	SIZE	DIAMETER	BEARINGS	RATIOS
1/8"	11	1 1/16"	ABEC -5	9:1 to 3600:1

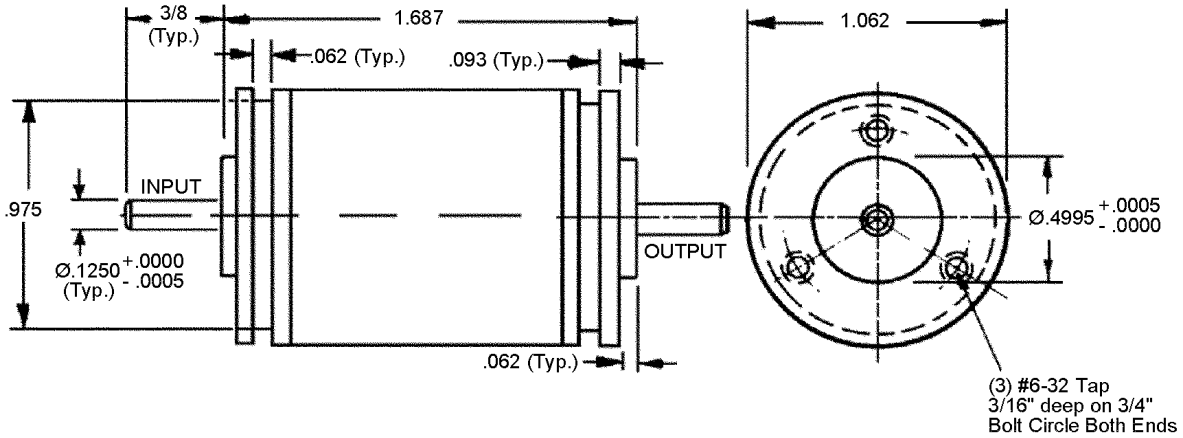

- Starting Torque (Max.) .005 Oz. In.
- Rated Output Torque 65 Oz. In.
- Maximum Backlash 0° 30'
- Moment of Inertia at Input Shaft .015 gm-cm²
- Approximate Weight 3 Oz.
- Ball Bearings On All Cluster Shafts



STOCK NO.	NOMINAL RATIO	NO. OF SHAFT ROTATION	GEAR CLUSTERS
RX11-1	9:1	SAME	1
RX11-2	10:1		
RX11-3	12:1		
RX11-4	15:1		
RX11-5	20:1		
RX11-6	25:1		
RX11-7	30:1	OPPOSITE	2
RX11-8	40:1	SAME	3
RX11-9	50:1		
RX11-10	60:1	OPPOSITE	2
RX11-11	80:1	SAME	3
RX11-12	90:1		
RX11-13	100:1		
RX11-14	180:1		
RX11-15	200:1	OPPOSITE	4
RX11-16	300:1		
RX11-17	360:1		
RX11-18	400:1		
RX11-19	500:1		
RX11-20	600:1	SAME	5
RX11-21	800:1		
RX11-22	1000:1		
RX11-23	2000:1		
RX11-24	3000:1	OPPOSITE	6
RX11-25	3600:1	SAME	5

SPEED REDUCER

SHAFT	SIZE	DIAMETER	BEARINGS	RATIOS
1/4"	18	1 3/4"	ABEC -5	4.96:1 to 3000:1

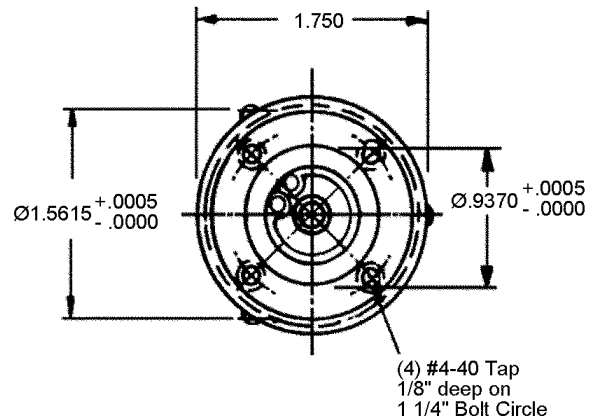
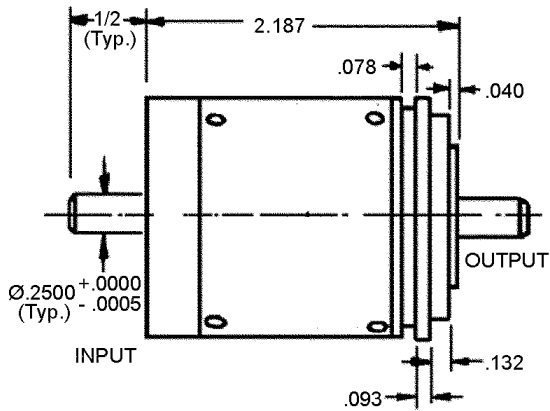

- Starting Torque (Max.) .03 Oz. In.
- Rated Output Torque 125 Oz. In.
- Maximum Backlash 0° 30'
- Moment of Inertia at Input Shaft .035 gm-cm²
- Approximate Weight 8 Oz.
- Ball Bearings On All Cluster Shafts



STOCK NO.	NOMINAL RATIO	NO. OF SHAFT ROTATION	GEAR CLUSTERS
RX18-1	4.96:1	SAME	1
RX18-2	6:1		
RX18-3	9.93:1	OPPOSITE	2
RX18-4	15.27:1		
RX18-5	20:1	SAME	1
RX18-6	30:1	OPPOSITE	2
RX18-7	40:1		
RX18-8	50.9:1		
RX18-9	80:1		
RX18-10	100:1		
RX18-11	124.8:1	SAME	3
RX18-12	150:1		
RX18-13	200:1		
RX18-14	248.16:1		
RX18-15	300.3:1		
RX18-16	400:1		
RX18-17	500:1		
RX18-18	600:1	OPPOSITE	4
RX18-19	1000:1		
RX18-20	1600:1		
RX18-21	1800:1	OPPOSITE	6
RX18-22	2000:1	OPPOSITE	4
RX18-23	2300:1	SAME	5
RX18-24	2500:1	OPPOSITE	4
RX18-25	3000:1	SAME	5

PRECISION PLANETARY GEAR HEADS

SHAFT SIZES			RATIOS		
3/8	1/2	5/8	3:1 TO 100:1		

NEMA PLANETARY GEARHEADS

STOCK NO.	RATIO	A	B	C	D	ØE	F	G	H	I	J	K	L	M	N	O	P
GHNE23-3	3:1	2.27	.195	2.625	1.500	.375	1.00	.062	.19	3.00	1.501	.125	2.30	-	.75	.15	-
GHNE23-5	5:1	2.27	.195	2.625	1.500	.375	1.00	.062	.19	3.00	1.501	.125	2.30	-	.75	.15	-
GHNE23-8	8:1	2.27	.195	2.625	1.500	.375	1.00	.062	.19	3.00	1.501	.125	2.30	-	.75	.15	-
GHNE23-10	10:1	2.27	.195	2.625	1.500	.375	1.00	.062	.19	3.00	1.501	.125	2.30	-	.75	.15	-
GHNE23-15	15:1	2.27	.195	2.625	1.500	.375	1.00	.062	.19	3.00	1.501	.125	2.30	-	.75	.15	-
GHNE23-20	20:1	2.27	.195	2.625	1.500	.375	1.00	.062	.19	3.00	1.501	.125	2.30	-	.75	.15	-
GHNE23-30	30:1	2.27	.195	2.625	1.500	.375	1.00	.062	.19	3.00	1.501	.125	2.30	-	.75	.15	-
GHNE23-50	50:1	2.27	.195	2.625	1.500	.375	1.00	.062	.19	3.00	1.501	.125	2.30	-	.75	.15	-
GHNE23-100	100:1	2.27	.195	2.625	1.500	.375	1.00	.062	.19	3.00	1.501	.125	2.30	-	.75	.15	-
GHNE34-3	3:1	3.25	.218	3.875	2.875	.500	1.25	.062	0.38	4.38	2.876	.200	3.00	-	1.06	.07	.125
GHNE34-5	5:1	3.25	.218	3.875	2.875	.500	1.25	.062	0.38	4.38	2.876	.200	3.00	-	1.06	.07	.125
GHNE34-8	8:1	3.25	.218	3.875	2.875	.500	1.25	.062	0.38	4.38	2.876	.200	3.00	-	1.06	.07	.125
GHNE34-10	10:1	3.25	.218	3.875	2.875	.500	1.25	.062	0.38	4.38	2.876	.200	3.00	-	1.06	.07	.125
GHNE34-15	15:1	3.25	.218	3.875	2.875	.500	1.25	.062	0.38	4.38	2.876	.200	3.00	-	1.06	.07	.125
GHNE34-20	20:1	3.25	.218	3.875	2.875	.500	1.25	.062	0.38	4.38	2.876	.200	3.00	-	1.06	.07	.125
GHNE34-30	30:1	3.25	.218	3.875	2.875	.500	1.25	.062	0.38	4.38	2.876	.200	3.00	-	1.06	.07	.125
GHNE34-50	50:1	3.25	.218	3.875	2.875	.500	1.25	.062	0.38	4.38	2.876	.200	3.00	-	1.06	.07	.125
GHNE34-100	100:1	3.25	.218	3.875	2.875	.500	1.25	.062	0.38	4.38	2.876	.200	3.00	-	1.06	.07	.125
GHNE42-3	3:1	4.25	.281	4.950	2.187	.625	1.50	.093	0.50	5.63	2.188	.188	3.75	-	1.13	.11	.188
GHNE42-5	5:1	4.25	.281	4.950	2.187	.625	1.50	.093	0.50	5.63	2.188	.188	3.75	-	1.13	.11	.188
GHNE42-8	8:1	4.25	.281	4.950	2.187	.625	1.50	.093	0.50	5.63	2.188	.188	3.75	-	1.13	.11	.188
GHNE42-10	10:1	4.25	.281	4.950	2.187	.625	1.50	.093	0.50	5.63	2.188	.188	3.75	-	1.13	.11	.188
GHNE42-15	15:1	4.25	.281	4.950	2.187	.625	1.50	.093	0.50	5.63	2.188	.188	3.75	-	1.13	.11	.188
GHNE42-20	20:1	4.25	.281	4.950	2.187	.625	1.50	.093	0.50	5.63	2.188	.188	3.75	-	1.13	.11	.188
GHNE42-30	30:1	4.25	.281	4.950	2.187	.625	1.50	.093	0.50	5.63	2.188	.188	3.75	-	1.13	.11	.188
GHNE42-50	50:1	4.25	.281	4.950	2.187	.625	1.50	.093	0.50	5.63	2.188	.188	3.75	-	1.13	.11	.188
GHNE42-100	100:1	4.25	.281	4.950	2.187	.625	1.50	.093	0.50	5.63	2.188	.188	3.75	-	1.13	.11	.188

PLANETARY GEAR HEADS PERFORMANCE SPECIFICATIONS

STOCK NO.	RATED OUTPUT TOR. In-Lbs	PEAK OUTPUT TOR. In-Lbs	RATED INPUT SP. RPM	BACK LASH MIN.	*LOW BACK LASH MIN.	AVE. EFF. %	MOM. OF IN. Oz-in-sec ²	MAX. WEIGHT lbs	RAD LOAD ⁽¹⁾ lbs	AXIAL LOAD lbs
GHNE23	50	100	4000	20	10	92	7x10 ⁻⁵	1.2	20	40
GHNE34	250	500	4000	20	10	92	5x10 ⁻⁴	3.0	50	100
GHNE42	500	1000	4000	20	10	92	4x10 ⁻³	6.0	250	250

⁽¹⁾ Radial loads are at 0.5 inches from the face of the gear head.

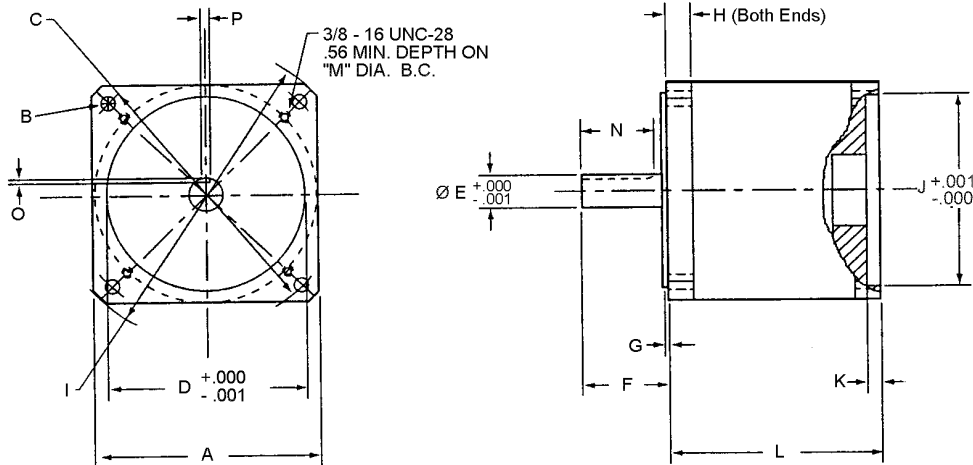

Materials:

- Housing** - Anodized Aluminum
- Gears** - Stainless Steel Q12 / DIN 7 Quality Class
- Shafts** - Stainless Steel
- Bearings** - Stainless Steel or Bronze
- Lubrication** - Sny. Grease

• Low Backlash available on request.

INTERMITTENT MOTION ASSEMBLY

SHAFT	PITCH GEARS	TYPE
1/4"	48	BALL BEARING

Precision Geneva Mechanism

Materials:

Housing and Cover - Anodized Aluminum

Geneva - Stainless Steel

Gears - Stainless Steel and Aluminum

Shafts and Hardware - Stainless Steel

Bearings - Stainless Steel - ABEC 7

Lubrication - MIL Spec. Oil and Grease

Max. Input Speed - 300 RPM

Backlash at Output Shaft - 30 Minutes Max.

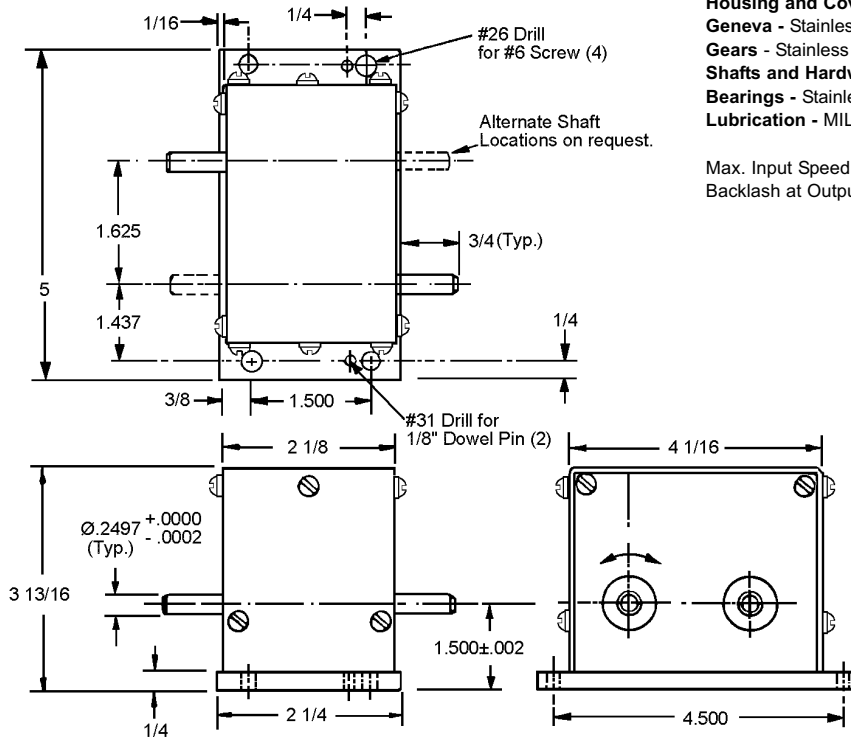

PRECISION BALL BEARING UNIT	ROTATION OF OUTPUT SHAFT PER EACH 360° REV. OF INPUT
STOCK NUMBER	
GX-1	90 DEGREES
GX-2	60 DEGREES
GX-3	45 DEGREES
GX-4	30 DEGREES
GX-5	22.5 DEGREES
GX-6	10 DEGREES

PRECISION BALL BEARING UNIT	ROTATION OF OUTPUT SHAFT PER EACH 180° REV. OF INPUT
STOCK NUMBER	
GX-7	90 DEGREES
GX-8	60 DEGREES
GX-9	45 DEGREES
GX-10	30 DEGREES
GX-11	22.5 DEGREES
GX-12	10 DEGREES



GENEVA MECHANISM

SHAFT	POINTS	MATERIAL
1/4"	4, 5, 6 AND 8	STAINLESS STEEL

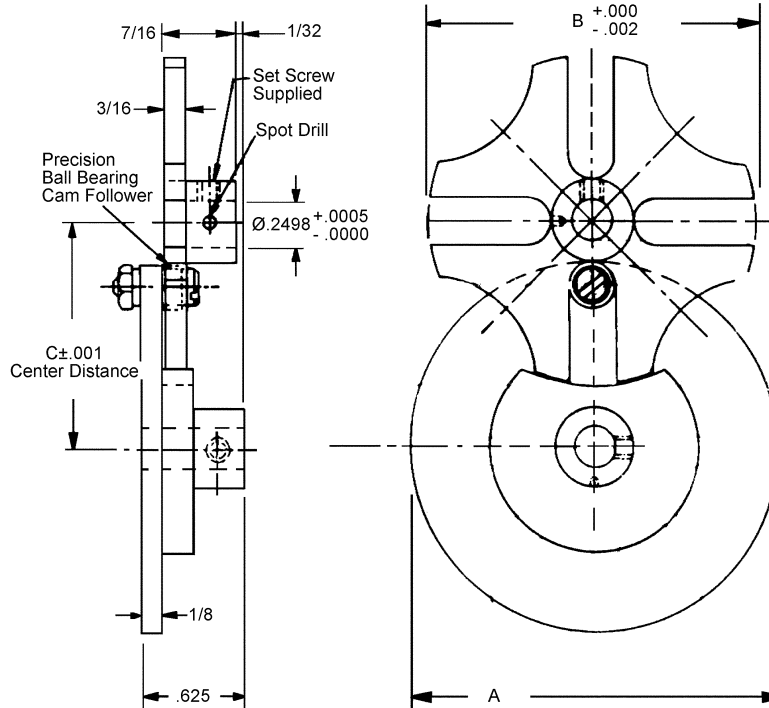

4 POINT DRIVE ILLUSTRATED

STOCK NO.	NO. ROLLERS ON DRIVER	RELATIVE ROTATION DRIVER TO DRIVEN		POINTS ON DRIVEN	MAX. TORQUE (IN OZ.)	MAX OPER. TORQUE (IN OZ.)	A	B	C
GM-1 GM-1A	ONE TWO	360° 180°	90°	4	71	35	2-1/4	1.971	1.3824
GM-2 GM-2A	ONE TWO	360° 180°	72°	5	110	55	2-1/4	2.470	1.5187
GM-3 GM-3A	ONE TWO	360° 180°	60°	6	175	87	2-1/2	3.468	1.9970
GM-4 GM-4A	ONE TWO	360° 180°	45°	8	240	120	2	4.083	2.2056

STOCK NO.	DESCRIPTION
JE-1-PH	REPLACEMENT CAM FOLLOWER

5/16" Bore available, call for price, to order, add an "L" to end of Stock Number.



CAM FOLLOWER

TYPE	MATERIAL	ABEC
BALL BEARING OR BRONZE BEARING	303 STAINLESS STEEL	5

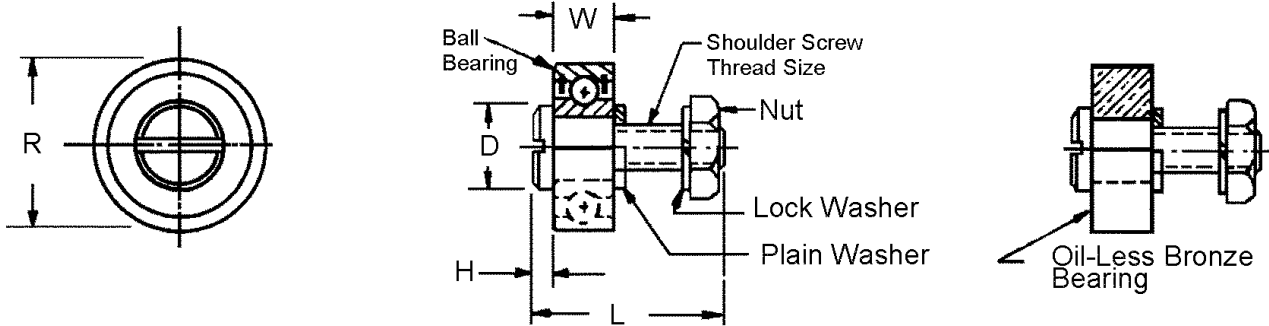

STOCK NO.	R	W	L	D	H	SCREW THREAD	BEARING
JE-1	.2500	.109	.484	3/16	1/8	#4-40	BALL BEARING
JE-2	.3125	.140	.578	7/32	1/8	#4-40	
JE-3	.3750	.156	.593	1/4	1/8	#4-40	
JE-4	.5000	.196	.727	5/16	5/32	#8-32	
JE-5	.6250	.196	.852	3/8	5/32	#10-32	
JE-6	.2500	.140	.484	5/32	3/32	#1-64	
JE-7	.3125	.140	.484	3/16	3/32	#2-56	
JE-1-PH*	.2500	.109	.484	3/16	1/8	#4-40	BRONZE BEARING
JE-B-1	.2500	.093	.483	3/16	1/8	#4-40	
JE-B-3	.3750	.140	.593	1/4	1/8	#4-40	
JE-B-4	.5000	.180	.727	5/16	5/32	#8-32	
JE-B-5	.6250	.180	.852	3/8	5/32	#10-32	

*Hardened shoulder screw, material is 416 Stainless Steel.



ROLLER BEARING CAM FOLLOWER

TYPE
HEAVY DUTY

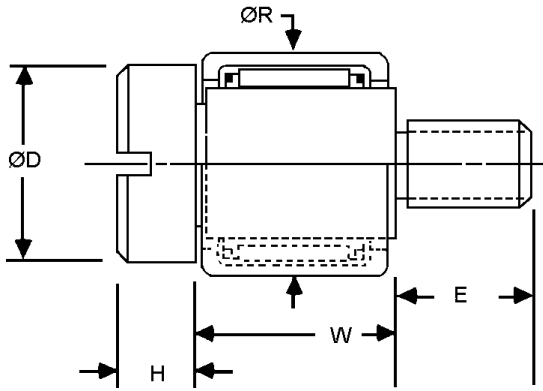

Materials:

Screw - 416 Stainless Steel

Roller Cup - Case Hardened Steel

Needle Bearings - 52100 Hardened Steel

Bearing Cage - Low Carbon Steel

See the Bearings Section of this book for Bearings Specifications.

- High Load
- Low Profile
- Low Friction

STOCK NO.	ØR	W	ØD	H	E	SCREW THREAD
JE-R-1	.2500	.250	7/32	1/8	5/32	#4-40
JE-R-2	.3438	.250	5/16	5/32	3/16	#8-32
JE-R-3	.3438	.375	5/16	5/32	3/16	#8-32
JE-R-4	.4375	.250	3/8	3/16	1/4	#10-32
JE-R-5	.5000	.312	7/16	7/32	7/16	#1/4-20
JE-R-6	.5625	.312	1/2	1/4	1/2	#5/16-18
JE-R-7	.5625	.625	1/2	1/4	1/2	#5/16-18
JE-R-8	.6875	.750	5/8	5/16	5/8	#3/8-16

ADJUSTABLE CAM ASSEMBLY

BORE SIZES	TYPE	MATERIAL
1/8" TO 1/2"	PIN HUB	303 STAINLESS STEEL

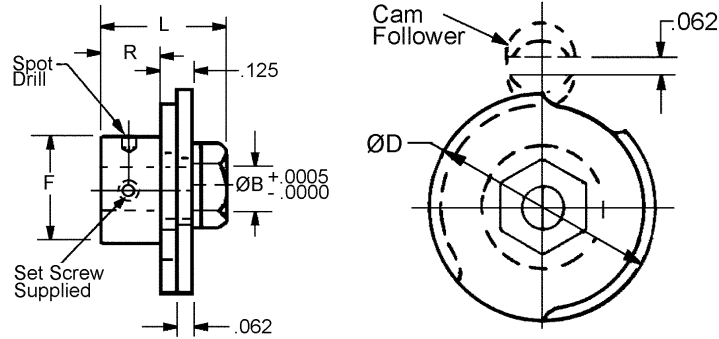

Cam plates are adjustable from 0° to 180°. Order Cam Follower Separately.

STOCK NO.	B	D	F	L	R
JD-1-P	.1248	11/16	5/16	.61	1/4
JD-2-P	.1873		3/8		
JD-3-P	.2498		1/2		
JD-4-P	.1248	1-1/4	5/16	.61	1/4
JD-5-P	.1873		3/8		
JD-6-P	.2498		1/2		
JD-7-P	.3123	2	1-1/4	1.50	1/2
JD-8-P	.3748		1-1/4		
JD-9-P	.4998		1-1/4		

BORE SIZES	TYPE	MATERIAL
1/8" TO 1/2"	CLAMP STYLE	303 STAINLESS STEEL

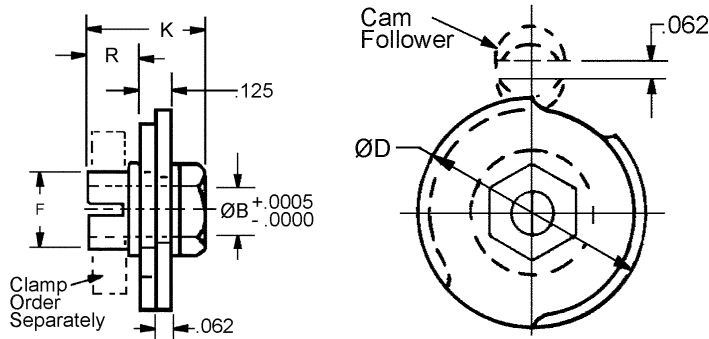

Cam plates are adjustable from 0° to 180°. Order Cam Follower Separately.

STOCK NO.	B	D	F	K	R
CA-1C	.1248	11/16	.188	.61	1/4
CA-2C	.1873		.250		
CA-3C	.2498		.312		
CA-4C	.1248	1-1/4	.188	.61	1/4
CA-5C	.1873		.250		
CA-6C	.2498		.312		
CA-7C	.3123	2	.375	1.25	1/2
CA-8C	.3748		.437		
CA-9C	.4998		.562		

RATCHETS AND PAWLS

PITCH	STYLE	MATERIAL
16 to 48	RIGHT HAND OPERATION	STAINLESS STEEL

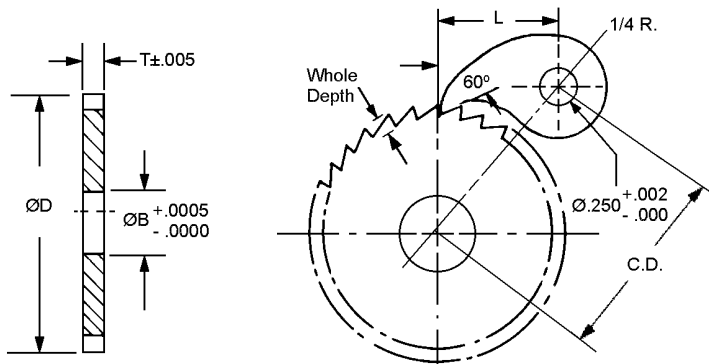

17-4 PH STAINLESS STEEL HARDENED RC 32-38			416 STAINLESS STEEL
STOCK PAWLS			MOUNTING SHOULDER SCREW (Order Separately)
STOCK NO.	T THICKNESS	L LENGTH	
RP-2	.245	3/4	PL-19
RP-375	.370	1-5/16	PL-21

- For Shoulder Screw Dimensions - See Index
- Ratchets Material - 303 Stainless Steel
- Last number in Stock No. indicate the total number of teeth. Special ratchets and pawls made to order, contact us.

RATCHET STOCK NO.	DIAMETRAL PITCH	OUTSIDE DIA.	BORE	T	C.D. +.06 -.00	WHOLE DEPTH
R16S20-20	16 (.1963 CIRC. PITCH)	1.250	.6871	.375		1.53
R16S20-24		1.500				1.60
R16S20-32		2.000				1.75
R16S20-48		3.000				2.10
R16S20-56		3.500				2.30
R16S20-64		4.000			2.50	
R24S6-24	24 (.1309 CIRC. PITCH)	1.000	.3748	.250		1.11
R24S6-30		1.250				1.18
R24S6-36		1.500				1.26
R24S6-48		2.000				1.45
R24S6-72		3.000				1.86
R32S3-24	32 (.0932 CIRC. PITCH)	.750	.3748	.125		1.04
R32S3-32		1.000				1.11
R32S3-40		1.250				1.18
R32S3-48		1.500				1.26
R32S3-64		2.000				1.45
R32S3-96		3.000			1.86	
R48S3-36	48 (.0654 CIRC. PITCH)	.750	.3748	.125		1.05
R48S3-48		1.000				1.12
R48S3-60		1.250				1.20
R48S3-72		1.500				1.28
R48S3-96		2.000				1.47
R48S3-144		3.000			1.88	



BREADBOARD COMPONENTS

Table of Contents

PRECISION BREADBOARD KITS	D 2 - D 3	COMPONENT PLATE POSTS	D 25
BREADBOARD PLATES	D 4	HOUSING COVER POSTS	D 26
HANGERS		INSTRUMENT PLATE PILLAR POSTS	D 27
Shaft Hangers	D 5 - D 7	DIALS	
Double Shaft Hangers	D 8	Dial Clamp	D 28
Micro Switch Hangers	D 9	Drum Dials	D 29 - D 30
Dial Index Hangers	D 10	Flat Dials	D 31
Motor Mounting Brackets	D 11	Engraved Flat Disks	D 32
Component Hangers	D 12 - D 14	Flat Dial Index	D 33
Pillow Blocks	D 15	Engraved Index	D 34
Adjustable Shaft Hanger	D 16	KNURLED HANDWHEELS	D 35 - D 36
BEARING MOUNTING PLATE	D 17	KNURLED HAND CRANKS	D 37
BEARING ADAPTERS	D 18	HAND CRANKS	D 38
RECTANGULAR POST	D 19	KNOBS	D 39
"T" NUT & CLAMP	D 20	SYNCRO MOUNT CLAMPS	D 40 - D 44
SPACER POSTS	D 21 - D 22	MINIATURE SYNCRO MOUNT CLAMPS	D 45
STAND OFF	D 23 - D 24		

D

PRECISION BREADBOARD KITS

Research and Prototype Development Kits

Designed by practical engineers for use in all mechanical and electro-mechanical breadboard prototype work, test fixture and servo control system applications...

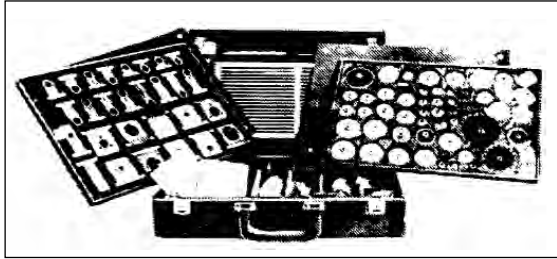

- All Kits may be enlarged at a later date by the addition of parts from this catalog (see Parts List).
- Kits are supplied with an attractive carrying case, felt lined to protect the high quality precision gears and associated parts.
- The supplemental parts kit is a complete precision parts stock room that complements all of the master parts kits. It has a basic selection of the most commonly used parts.
- Replacement parts are always available from stock.

Ideal For Use In:

- Military Applications
- Industrial Operations
- Test Evaluation
- University Research

Send For Lists of Materials

48 Pitch Spur Gear Kits 1/4" Shaft Size

STOCK NO.	NUMBER OF COMPONENTS	KIT TYPE
KIT-4L KIT-4M KIT-4S	OVER 660 PARTS OVER 520 PARTS OVER 420 PARTS	MASTER PARTS KIT
KIT-4G	OVER 900 PARTS	SUPPLEMENTAL PARTS KIT

64 Pitch Spur Gear Kits 3/16" Shaft Size

STOCK NO.	NUMBER OF COMPONENTS	KIT TYPE
KIT-3L KIT-3M KIT-3S	OVER 660 PARTS OVER 520 PARTS OVER 420 PARTS	MASTER PARTS KIT
KIT-3G	OVER 900 PARTS	SUPPLEMENTAL PARTS KIT

96 Pitch Spur Gear Kits 1/8" Shaft Size

STOCK NO.	NUMBER OF COMPONENTS	KIT TYPE
KIT-2L KIT-2M KIT-2S	OVER 660 PARTS OVER 520 PARTS OVER 420 PARTS	MASTER PARTS KIT
KIT-2G	OVER 900 PARTS	SUPPLEMENTAL PARTS KIT

Select high quality Berg parts for your designs. W. M. Berg's Precision Mechanical Components are well stocked assuring fast delivery.

Solves many design problems quickly in a hands-on environment.

- Cuts Development Cost
- Engineers
- Reduces Expensive Delays
- Designers
- Simplifies Preliminary Test Phase
- Educational and Research Facilities

After the final sketches have been worked out the designer can duplicate the mechanism with actual working kit parts.

Always design the gear layout so that the assembly gear and shafts are at right angles to the slots in the breadboard plate. This will permit perfect adjustment of the gear centers, etc.

Where this is not practical, parallel positioning is permissible. Step shaft hangers are supplied to permit compact over-hanging of gear meshes when assembling hangers do not align over slots, we have provided for a special hanger clamp BC13-2. Shaft hangers are adjusted in the slotted plate by hand tightening wing screws. Breadboard plates are supported by a series of legs supplied with rubber bumpers to eliminate scratching of table surface while working on the assembly critical parts.

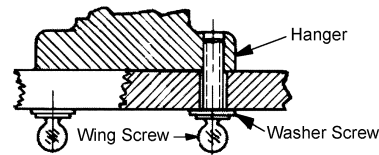
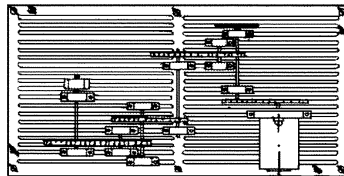
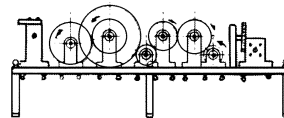
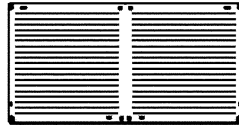

PRECISION BREADBOARD KITS (continued)

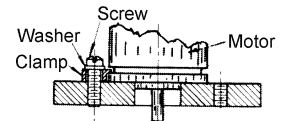
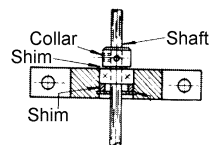
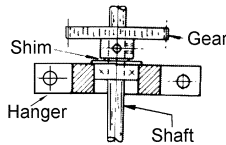
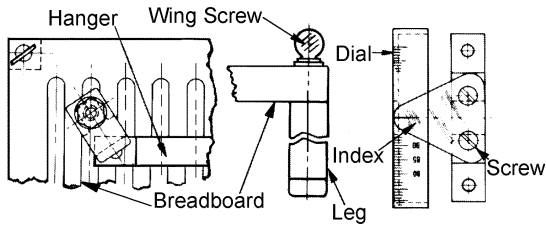
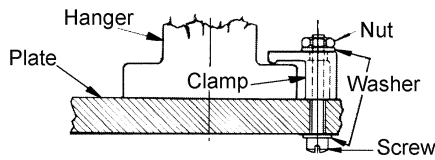

Each kit has a wide variety of shaft lengths, bearings, spur gears, precision engraved disc and drum dials, and a broad selection of couplings to make most rotating component and drive shaft connections.

All parts are designed for simple assembly and dis-assembly for reuse at another time. Thousands of additional parts are available from stock. Special components can be manufactured to meet your specifications.

Caution should be taken -- handle all parts with care. Do not permit parts to bang or drop to avoid damage to critical parts

Kits are supplied in 3 gear pitch selections, 48, 64 and 96 each in 3 basic kit sizes; small medium and large. Small and medium kits can be built up as time and usage require.

Over 65,000 items are available from Berg stock. For all practical purposes, this makes any configuration or application possible. We also have other size breadboard plates available for that extra large or small unit application.

Typical Kit Parts Below are a few of the Typical Breadboard Kit Parts

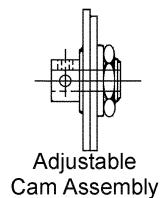
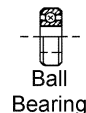
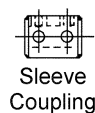
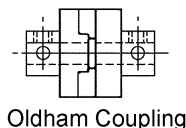
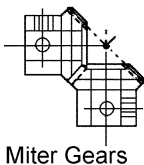
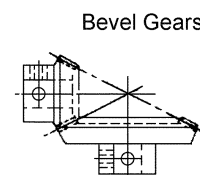
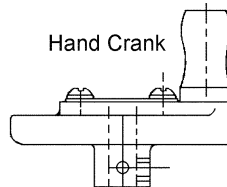
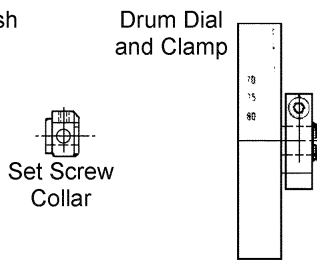
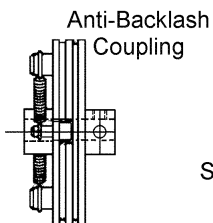
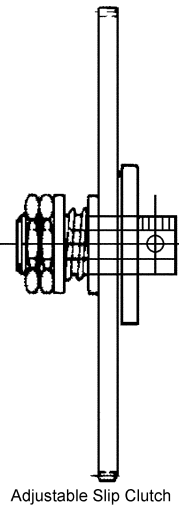
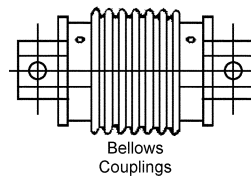
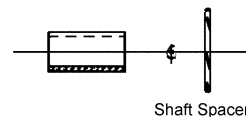
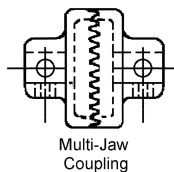
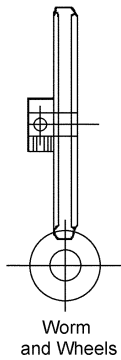
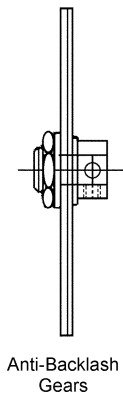
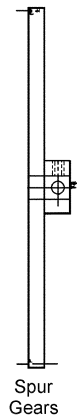
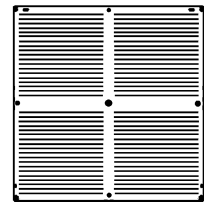
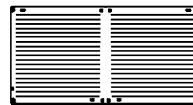
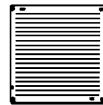

BREADBOARD PLATES

SIZES	MATERIAL
4" X 8" TO 16" X 16"	ALUMINUM ANODIZED

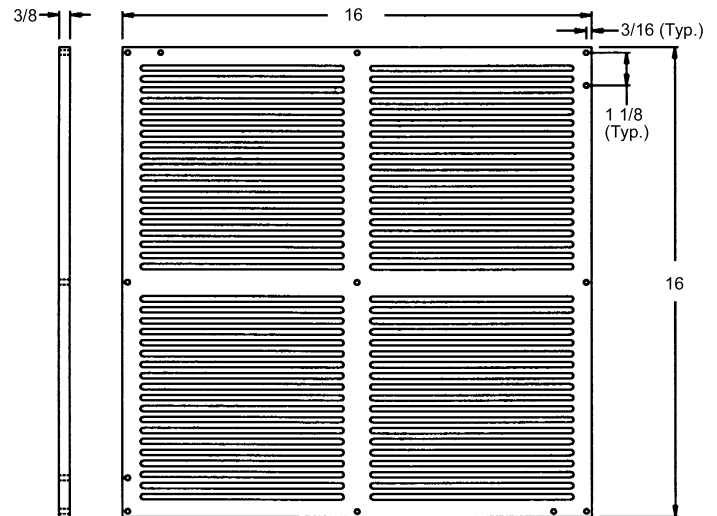
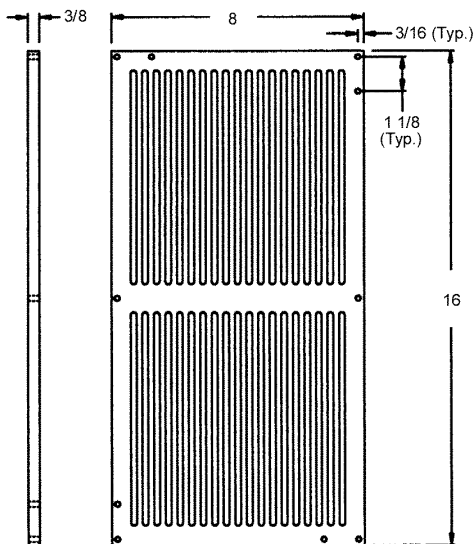
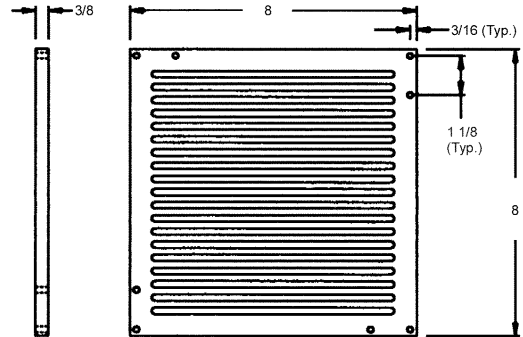
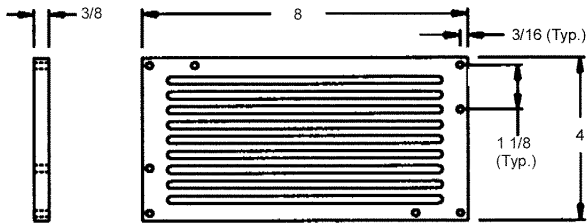

Notes:

All Dimensions Typical
 Slot Pitch = 3/8
 Slot Width = 3/16
 Clearance Slots For #6 Screws
 Double Disc Ground and
 Machine Finished All Six Sides.

Also listed:

Hanger Screws, Post Screws, Washers and Rubber Foot Pads

STOCK NO.	DESCRIPTION
BC1-1	4X8 BREADBOARD
BC1-2	8X8 BREADBOARD
BC1-3	8X16 BREADBOARD
BC1-4	16X16 BREADBOARD
BC1-RB	RUBBER FOOT PAD AND SCREW
BC1-HS	HANGER SCREW
BC1-PS	POST SCREW
Z4-6	HANGER SCREW WASHER
Z4-8	POST SCREW WASHER

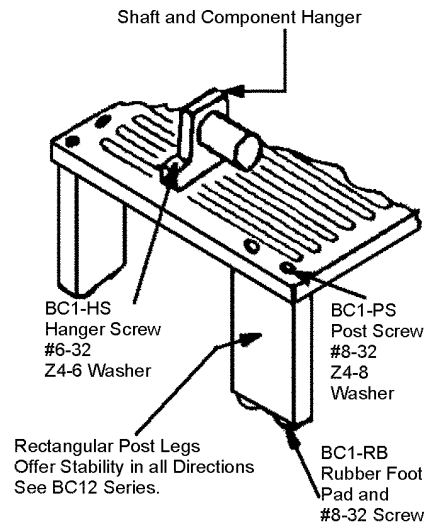

SHAFT HANGERS

SHAFT SIZE	MATERIAL
1/8"	ALUMINUM ANODIZED

TAPPED HOLES STOCK NO.	CLEAR HOLES STOCK NO.	ØB	A	H	RECOMMENDED			
					SHAFT	BALL BEARINGS	OIL-LESS BRONZE BEARINGS	RETAINER RING
BC2-1T	BC2-1C	.3750	1 1/2	1.000	1/8 (.1247)	FLANGED B2-5-S	FLANGED B4-13	-
BC2-2T	BC2-2C		2	1.500				
BC2-3T	BC2-3C		2 1/2	2.000				
BC2-4T	BC2-4C		2 3/4	2.250				
BC2-5T	BC2-5C		3	2.500				
					FLANGELESS B1-5	FLANGELESS B3-13	Q4-37	

SHAFT SIZE	MATERIAL
3/16"	ALUMINUM ANODIZED

TAPPED HOLES STOCK NO.	CLEAR HOLES STOCK NO.	ØB	A	H	RECOMMENDED			
					SHAFT	BALL BEARINGS	OIL-LESS BRONZE BEARINGS	RETAINER RING
BC3-1T	BC3-1C	.5000	1 1/2	1.000	3/16 (.1872)	FLANGED B2-6-S	FLANGED B4-14	-
BC3-2T	BC3-2C		2	1.500				
BC3-3T	BC3-3C		2 1/2	2.000				
BC3-4T	BC3-4C		2 3/4	2.250				
BC3-5T	BC3-5C		3	2.500				
					FLANGELESS B1-7	FLANGELESS B3-15	Q4-50	

SHAFT SIZE	MATERIAL
1/4"	ALUMINUM ANODIZED

TAPPED HOLES STOCK NO.	CLEAR HOLES STOCK NO.	ØB	A	H	RECOMMENDED			
					SHAFT	BALL BEARINGS	OIL-LESS BRONZE BEARINGS	RETAINER RING
BC4-1T	BC4-1C	.6250	1 1/2	1.000	1/4 (.2497)	FLANGED B2-7-S	FLANGED B4-15	-
BC4-2T	BC4-2C		2	1.500				
BC4-3T	BC4-3C		2 1/2	2.000				
BC4-4T	BC4-4C		2 3/4	2.250				
BC4-5T	BC4-5C		3	2.500				
					FLANGELESS B1-9	FLANGELESS B3-16	Q4-62	

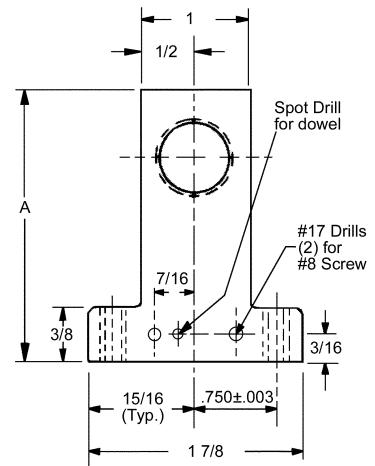
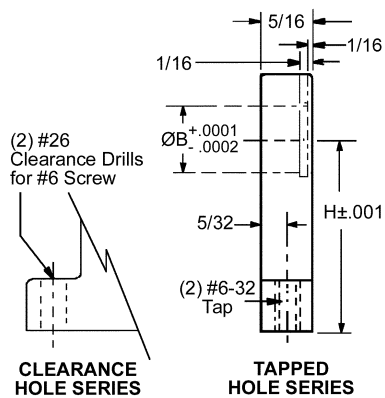

SAMPLE APPLICATION

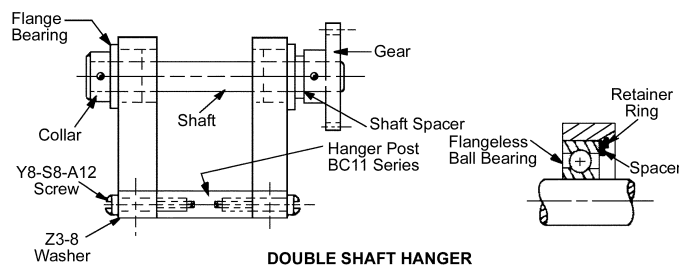

SHAFT HANGERS

SHAFT SIZE	MATERIAL
1/8"	ALUMINUM ANODIZED

TAPPED HOLES STOCK NO.	CLEAR HOLES STOCK NO.	ØB	H	SHAFT	RECOMMENDED		
					BALL BEARINGS	BRONZE BEARINGS	OIL-LESS RETAINER RING
BC16-1T	BC16-1C	.3750	1.000	1/8 (.1247)	FLANGED B2-5-S FLANGELESS B1-5	FLANGED B2-5-S FLANGELESS B1-5	FOR FLANGELESS BEARINGS Q4-37
BC16-2T	BC16-2C		1.500				
BC16-3T	BC16-3C		2.000				
BC16-13T	BC16-13C		2.250				
BC16-4T	BC16-4C		2.500				

SHAFT SIZE	MATERIAL
3/16"	ALUMINUM ANODIZED

TAPPED HOLES STOCK NO.	CLEAR HOLES STOCK NO.	ØB	H	SHAFT	RECOMMENDED		
					BALL BEARINGS	BRONZE BEARINGS	OIL-LESS RETAINER RING
BC16-5T	BC16-5C	.5000	1.000	3/16 (.1872)	FLANGED B2-6-S FLANGELESS B1-7	FLANGED B4-14 FLANGELESS B3-15	FOR FLANGELESS BEARINGS Q4-50
BC16-6T	BC16-6C		1.500				
BC16-7T	BC16-7C		2.000				
BC16-14T	BC16-14C		2.250				
BC16-8T	BC16-8C		2.500				

SHAFT SIZE	MATERIAL
1/4"	ALUMINUM ANODIZED

TAPPED HOLES STOCK NO.	CLEAR HOLES STOCK NO.	ØB	H	SHAFT	RECOMMENDED		
					BALL BEARINGS	BRONZE BEARINGS	OIL-LESS RETAINER RING
BC16-9T	BC16-9C	.6250	1.000	1/4 (.2497)	FLANGED B2-7-S FLANGELESS B1-9	FLANGED B4-15 FLANGELESS B3-16	FOR FLANGELESS BEARINGS Q4-62
BC16-10T	BC16-10C		1.500				
BC16-11T	BC16-11C		2.000				
BC16-15T	BC16-15C		2.250				
BC16-12T	BC16-12C		2.500				

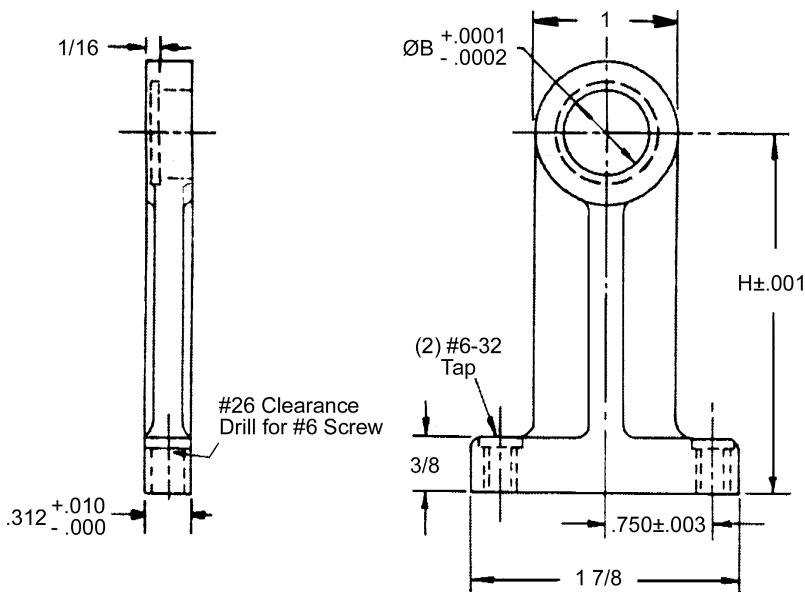

CLEARANCE HOLE SERIES

TAPPED HOLE SERIES



SHAFT HANGERS

SHAFT SIZE	MATERIAL
3/8"	ALUMINUM ANODIZED

TAPPED HOLES STOCK NO.	CLEAR HOLES STOCK NO.	ØB	H	RECOMMENDED			
				SHAFT	BALL BEARINGS	BRONZE BEARINGS	OIL-LESS RETAINER RING
BC24-1T	BC24-1C	.8750	2.000	3/8 (.3750)	FLANGED B2-8-S	FLANGED B4-11	-
BC24-2T	BC24-2C		2.500				
BC24-3T	BC24-3C		3.000				
BC24-4T	BC24-4C		3.500				
BC24-5T	BC24-5C		4.000				

SHAFT SIZE	MATERIAL
1/2"	ALUMINUM ANODIZED

TAPPED HOLES STOCK NO.	CLEAR HOLES STOCK NO.	ØB	H	RECOMMENDED			
				SHAFT	BALL BEARINGS	BRONZE BEARINGS	OIL-LESS RETAINER RING
BC25-1T	BC25-1C	1.1250	2.000	1/2 (.5000)	FLANGED B2-22-S	FLANGED B4-12	-
BC25-2T	BC25-2C		2.500				
BC25-3T	BC25-3C		3.000				
BC25-4T	BC25-4C		3.500				
BC25-5T	BC25-5C		4.000				

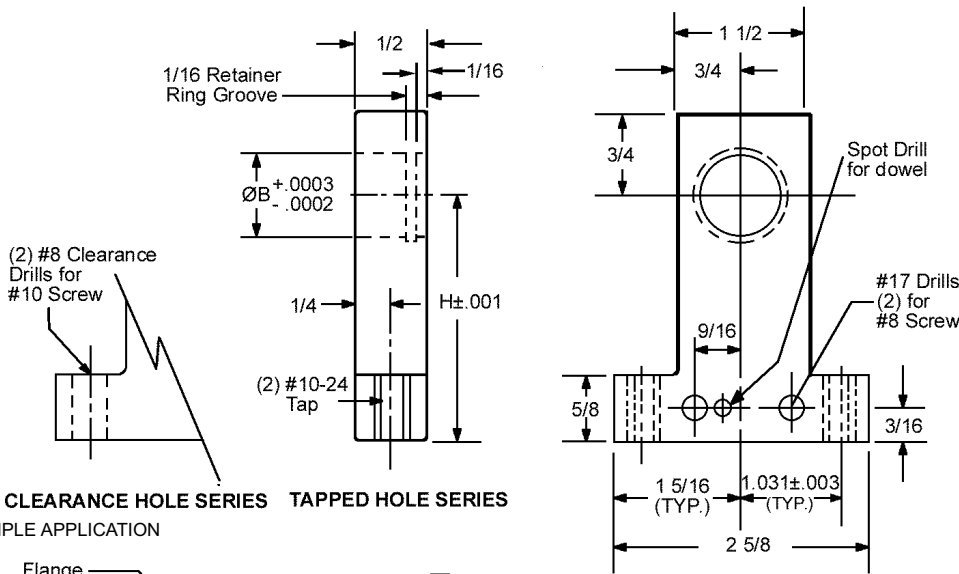

CLEARANCE HOLE SERIES TAPPED HOLE SERIES
SAMPLE APPLICATION

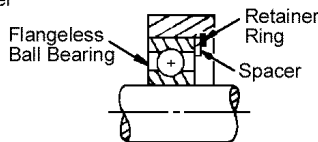
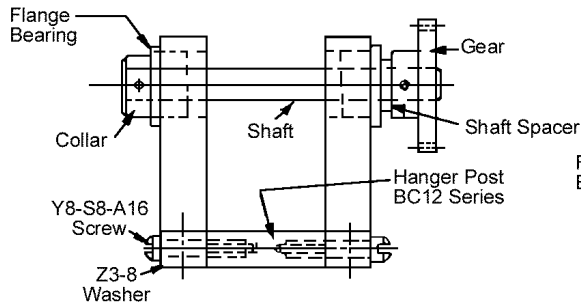

DOUBLE SHAFT HANGERS

SHAFT SIZE	MATERIAL
1/8"	ALUMINUM ANODIZED

TAPPED HOLES STOCK NO.	CLEAR HOLES STOCK NO.	ØB	A	H	RECOMMENDED			
					SHAFT	BALL BEARINGS	OIL-LESS BRONZE BEARINGS	RETAINER RING
BC17-1T	BC17-1C	.3750	.187	1.000	1/8 (.1247)	FLANGED B2-5-S FLANGELESS B1-5	FLANGED B4-13 FLANGELESS B3-13	FOR FLANGELESS BEARINGS Q4-37
BC17-2T	BC17-2C			1.500				
BC17-3T	BC17-3C			2.000				
BC17-4T	BC17-4C			2.250				
BC17-5T	BC17-5C			2.500				

SHAFT SIZE	MATERIAL
3/16"	ALUMINUM ANODIZED

TAPPED HOLES STOCK NO.	CLEAR HOLES STOCK NO.	ØB	A	H	RECOMMENDED			
					SHAFT	BALL BEARINGS	OIL-LESS BRONZE BEARINGS	RETAINER RING
BC17-6T	BC17-6C	.5000	.218	1.000	3/16 (.1872)	FLANGED B2-6-S FLANGELESS B1-7	FLANGED B4-14 FLANGELESS B3-15	FOR FLANGELESS BEARINGS Q4-50
BC17-7T	BC17-7C			1.500				
BC17-8T	BC17-8C			2.000				
BC17-9T	BC17-9C			2.250				
BC17-10T	BC17-10C			2.500				

SHAFT SIZE	MATERIAL
1/4"	ALUMINUM ANODIZED

TAPPED HOLES STOCK NO.	CLEAR HOLES STOCK NO.	ØB	A	H	RECOMMENDED			
					SHAFT	BALL BEARINGS	OIL-LESS BRONZE BEARINGS	RETAINER RING
BC17-11T	BC17-11C	.6250	.218	1.000	1/4 (.2497)	FLANGED B2-7-S FLANGELESS B1-9	FLANGED B4-15 FLANGELESS B3-16	FOR FLANGELESS BEARINGS Q4-62
BC17-12T	BC17-12C			1.500				
BC17-13T	BC17-13C			2.000				
BC17-14T	BC17-14C			2.250				
BC17-15T	BC17-15C			2.500				

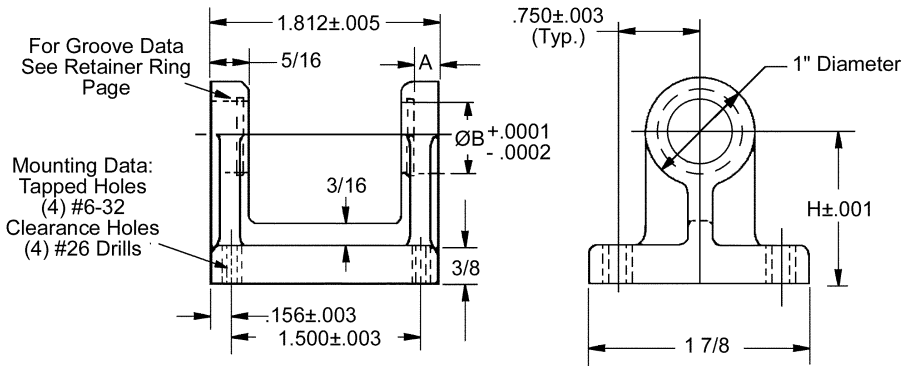

MICRO SWITCH HANGERS

TYPE	MATERIAL
CLEARANCE MOUNT AND TAPPED MOUNT	ALUMINUM ANODIZED

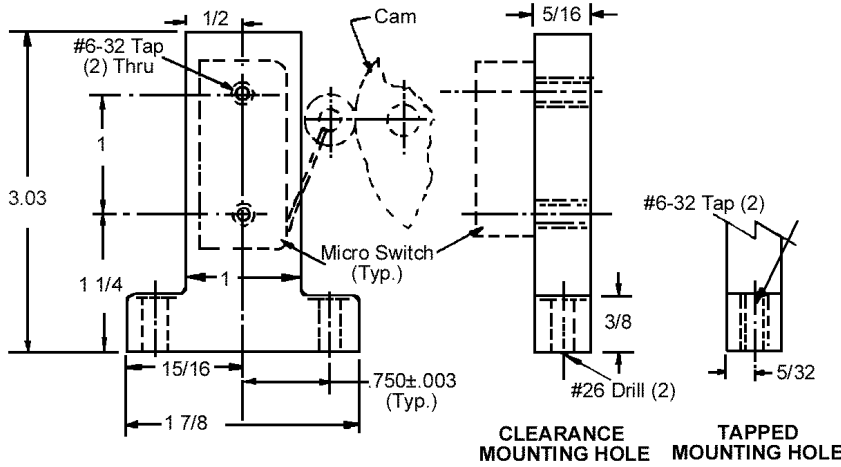

D

CLEARANCE MOUNTING HOLES	TAPPED MOUNTING HOLES
STOCK NO.	STOCK NO.
BC5-1C	BC5-1T

DIAL INDEX HANGERS

TYPE	MATERIAL
CLEARANCE MOUNT AND TAPPED MOUNT	ALUMINUM ANODIZED

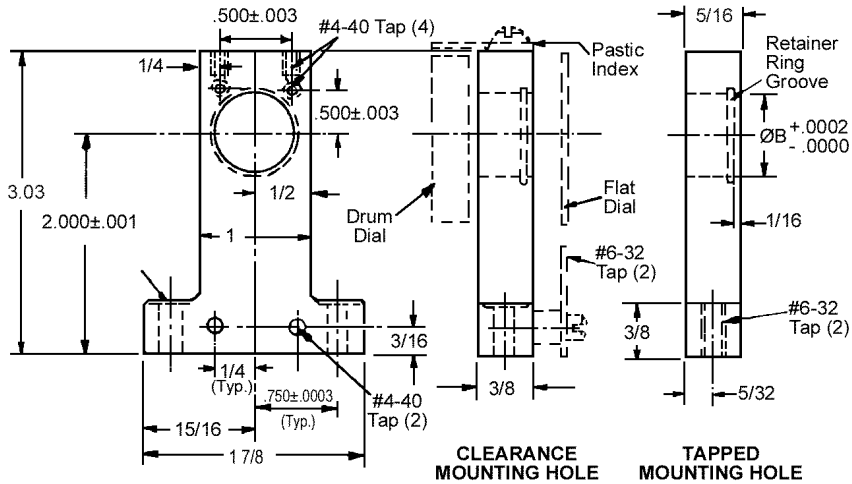

CLEARANCE MOUNTING HOLE STOCK NO.	TAP MOUNTING HOLES STOCK NO.	SHAFT SIZE	ØB BORE	RECOMMENDED RETAINER RINGS*
BC6-2C	BC6-2T	1/8	.3750	Q4-37
BC6-3C	BC6-3T	3/16	.5000	Q4-50
BC6-1C	BC6-1T	1/4	.6250	Q4-62

For components such as dials, indexes, screws and spacers, see index.
*Order separately.

MOTOR MOUNTING BRACKETS

TYPE	MATERIAL
CLEARANCE MOUNT AND TAPPED MOUNT	ALUMINUM ANODIZED

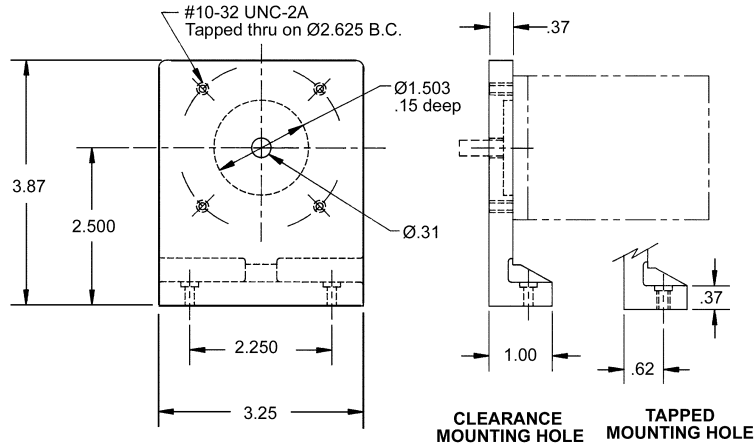

STOCK NO.	DESCRIPTION	HOLE DATA
BC8-3C	CLEARANCE MOUNTING HOLES	#26 DRILL (#6 SCR.)
BC8-3T	TAPPED MOUNTING HOLES	#6-32 TAP



COMPONENT HANGERS

TYPES	MATERIAL
WIDE RANGE OF CONFIGURATIONS	ALUMINUM ANODIZED

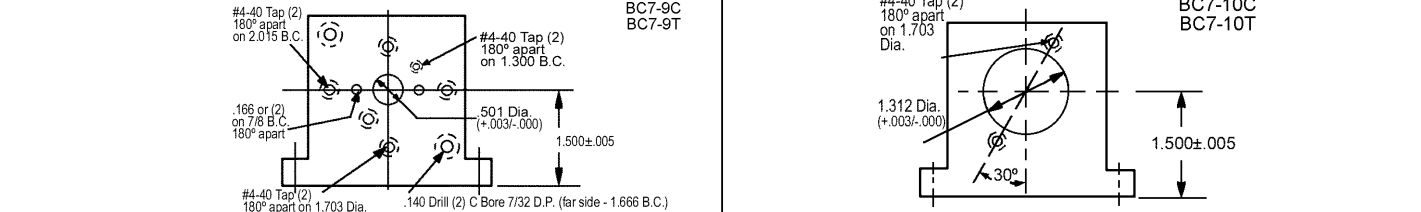
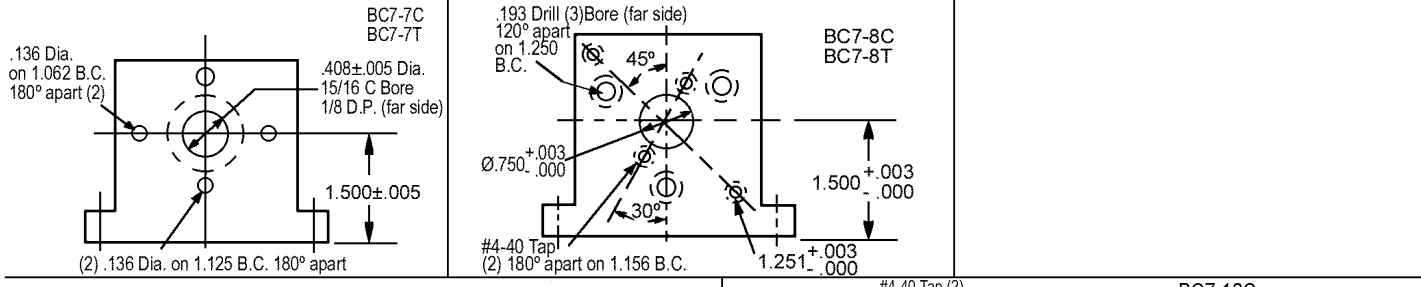
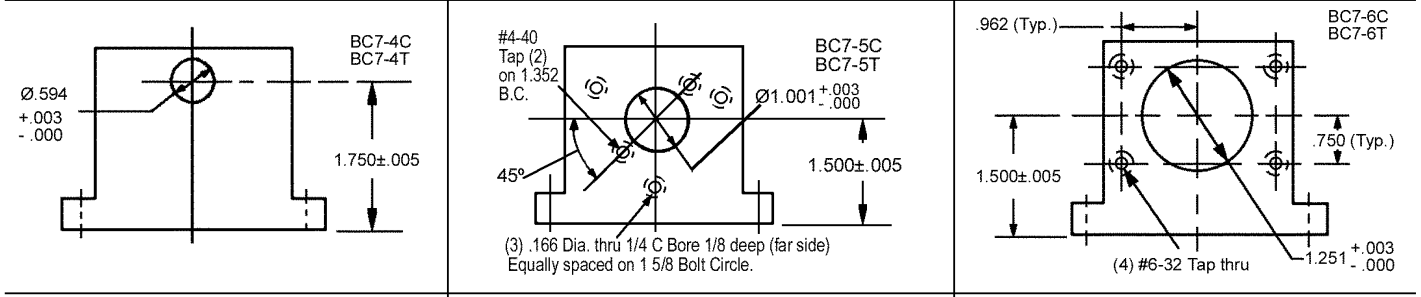
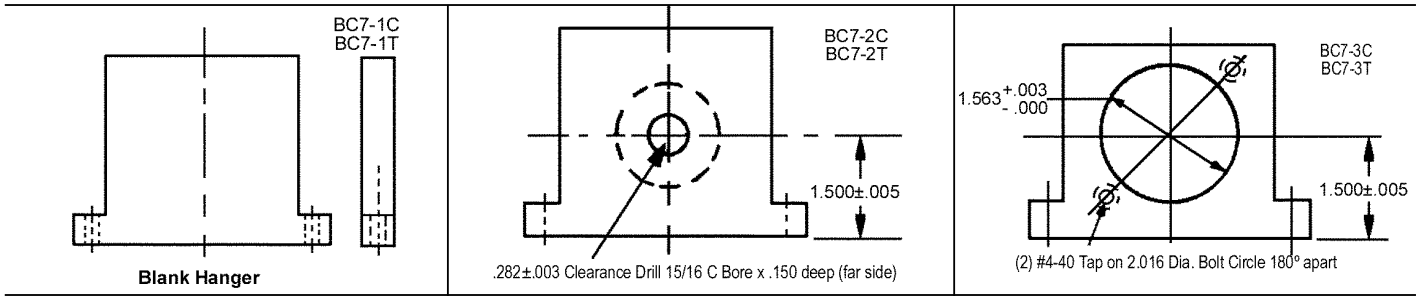
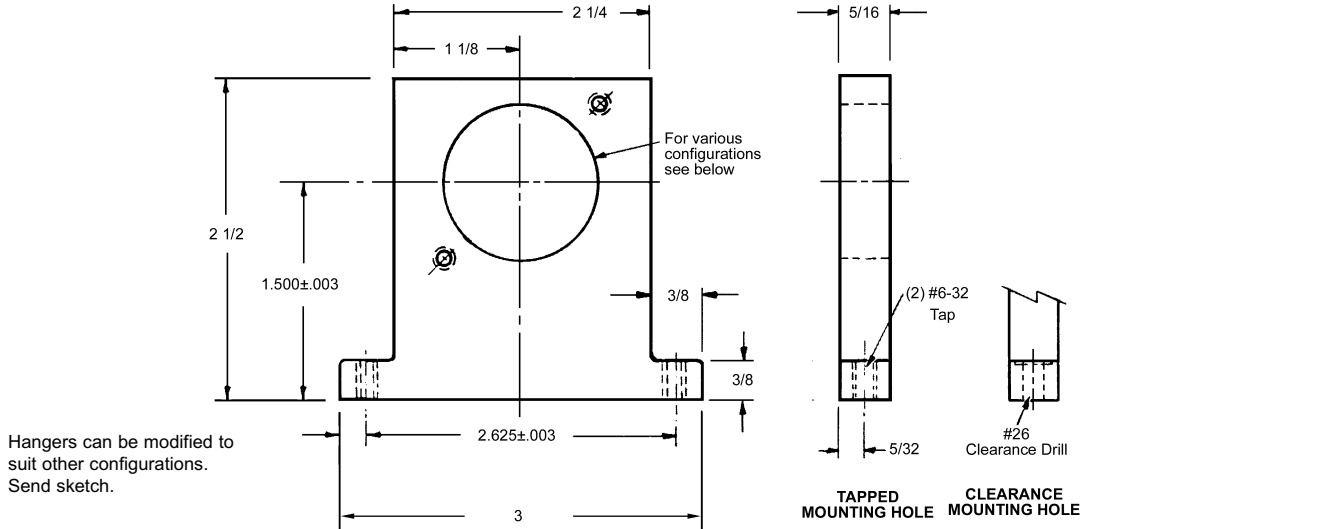

COMPONENT HANGERS

TYPES	MATERIAL
CLEARANCE MOUNT AND TAPPED MOUNT	ALUMINUM ANODIZED

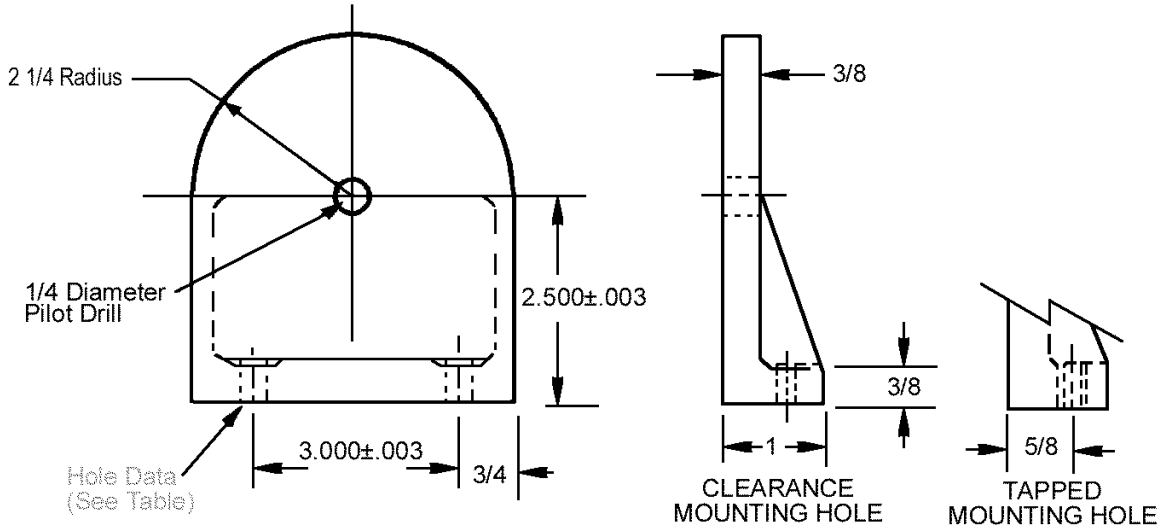

STOCK NO.	DESCRIPTION	HOLE DATA
BC8-1C	CLEARANCE MOUNTING HOLES	#26 DRILL (#6 SCR.) & SPOT FACE
BC8-1T	TAPPED MOUNTING HOLES	#6-32 TAP

Hangers modified on request.



D

COMPONENT HANGERS

TYPES	MATERIAL
CLEARANCE MOUNT AND TAPPED MOUNT	ALUMINUM ANODIZED

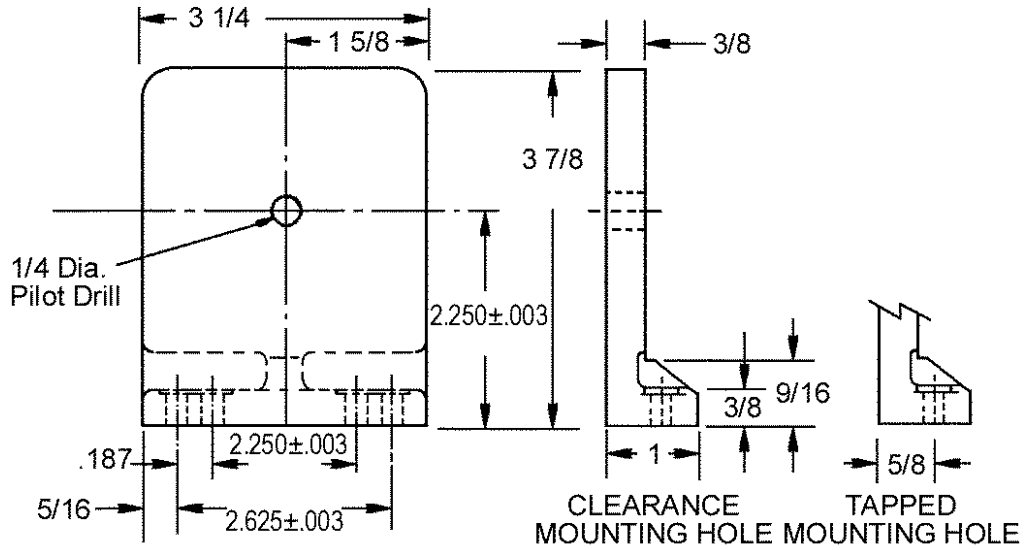

STOCK NO.	DESCRIPTION	HOLE DATA
BC8-2C	CLEARANCE MOUNTING HOLES	#26 DRILL (#6 SCR.) & SPOT FACE
BC8-2T	TAPPED MOUNTING HOLES	#6-32 TAP

Hangers modified on request.



PILLOW BLOCKS

BORE	TYPES	MATERIAL
1/8" TO 1/2"	OIL-LESS BRONZE BEARINGS OR TEFLON BEARINGS	ALUMINUM ANODIZED

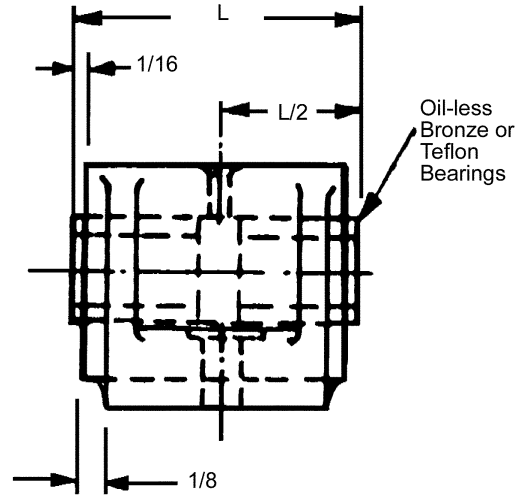
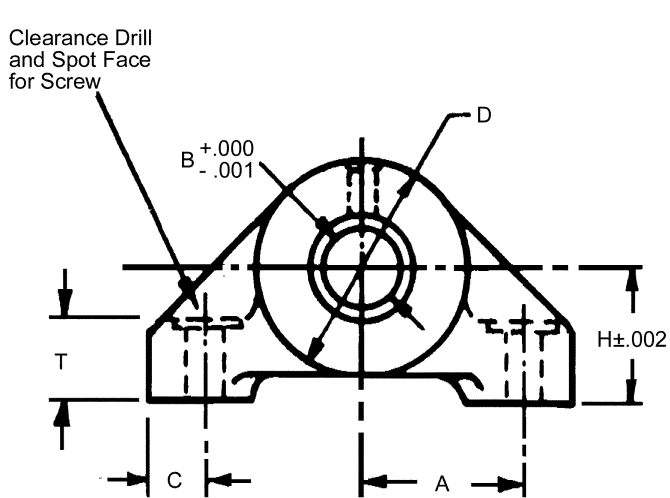

BRONZE BEARINGS STOCK NO.	TEFLON® BEARING STOCK NO.	B	D	H	T	A	C	L	SCREW
BC9-1	BC9-1T	.127							
BC9-2	BC9-2T	.189	3/4	.500	1/4	.625	1/4	7/8	#8
BC9-3	BC9-3T	.252							
BC9-4	BC9-4T	.314							
BC9-5	BC9-5T	.377	1 1/8	.750	3/8	.937	5/16	1 5/8	#10
BC9-6	BC9-6T	.502							



D

ADJUSTABLE SHAFT HANGER

BORE	MATERIAL
1/8" TO 1/2"	ALUMINUM ANODIZED WITH STAINLESS STEEL SHAFT

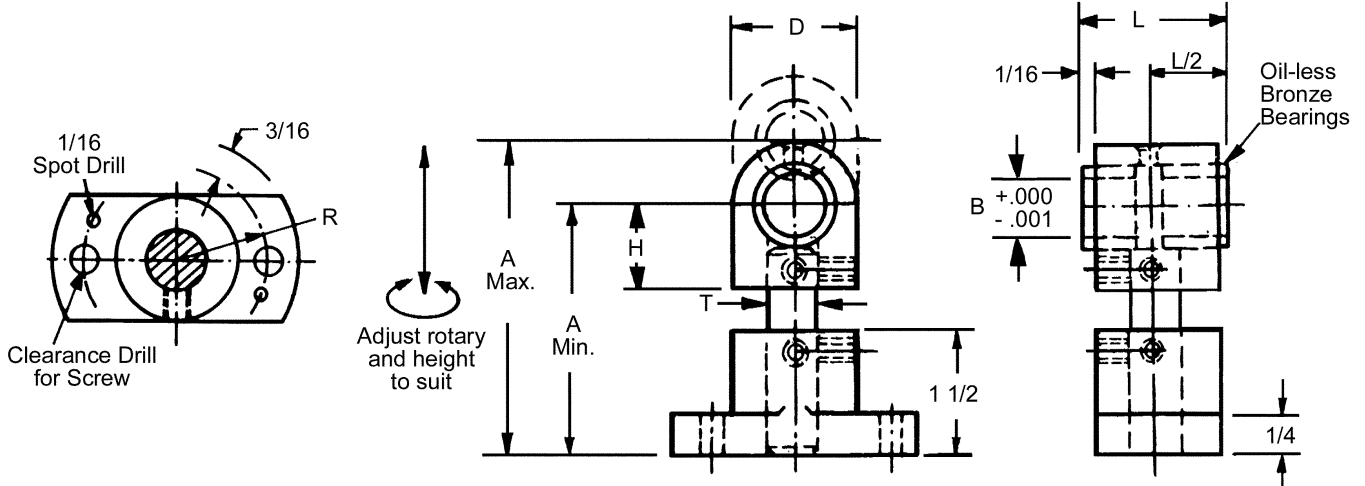

STOCK NO	B	D	H	T	A (Max.)	A (Min.)	L	SCREW	R
BC10-1	.127								
BC10-2	.189	3/4	5/8	.375	3 1/8	2 1/8	7/8	#6	.562
BC10-3	.252								
BC10-4	.314								
BC10-5	.377	15/16	1	.625	3 1/2	2 1/2	1 1/16	#10	.687
BC10-6	.502								

Special extension shafts available on request.



BEARING MOUNTING PLATE

SHAFT	TYPES	MATERIAL
1/8" TO 1/4"	OIL-LESS BRONZE BEARINGS OR BALL BEARINGS	ALUMINUM ANODIZED

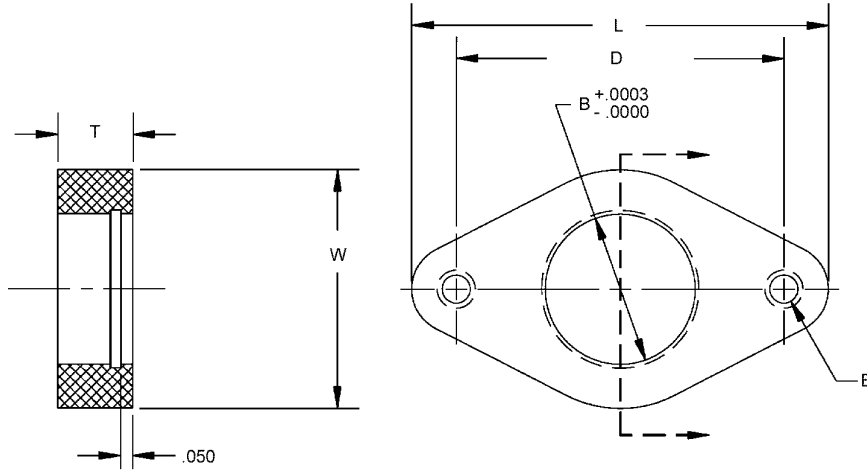

TAP HOLES STOCK NO.	CLEARANCE HOLES STOCK NO.	FOR SHAFT	B	L	W	T	D	S	
								TAP	CLEARANCE DRILL
BC22-1T	BC22-1C	1/8	.3748	1 3/16	3/4	.250	.875	#2-56	#41
BC22-2T	BC22-2C	3/16	.4998	1 5/8	7/8	.312	1.250	#4-40	#31
BC22-3T	BC22-3C	1/4	.6248	1 3/4	1	.312	1.375	#6-32	#26

RECOMMENDED

STOCK NUMBER	BALL BEARINGS	OIL-LESS BRONZE BEARINGS	RETAINER RINGS	SHAFTS
BC22-1T BC22-1C	FLANGED B2-5-S FLANGELESS B1-5	FLANGED B4-13 FLANGELESS B3-13	Q4-37	S2-SERIES OR .1247 DIAMETER S1-SERIES
BC22-2T BC22-2C	FLANGED B2-6-S FLANGELESS B1-7	FLANGED B4-14 FLANGELESS B3-15	Q4-50	S3-SERIES OR .1872 DIAMETER S1-SERIES
BC22-3T BC22-3C	FLANGED B2-7-S FLANGELESS B1-9	FLANGED B4-15 FLANGELESS B3-16	Q4-62	S4-SERIES OR .2497 DIAMETER S1-SERIES



For groove dimensions see index for rings.

BEARING ADAPTERS

SHAFTS	STYLE	MATERIAL
1/8", 3/16" AND 1/4"	STYLE X	ALUMINUM ANODIZED

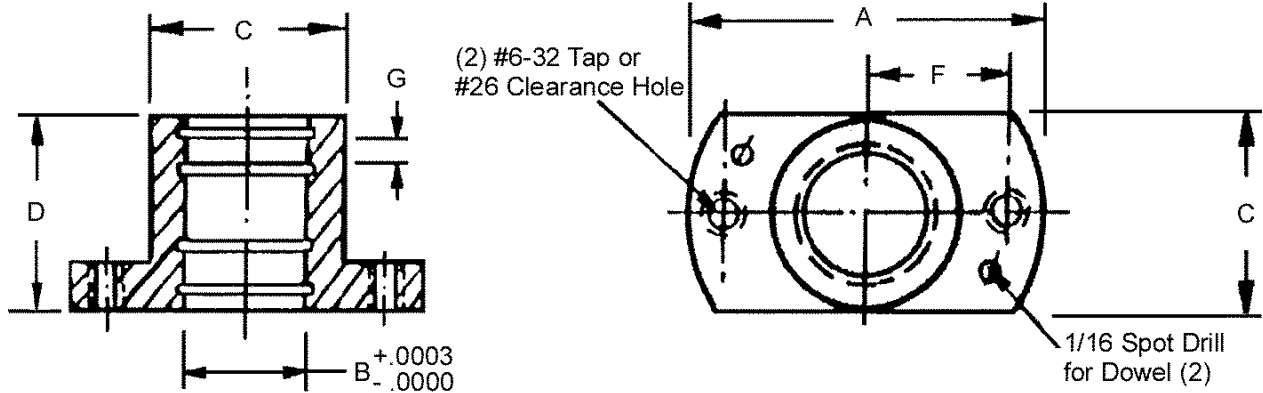

TAPPED HOLE STOCK NO.	CLEAR HOLE STOCK NO.	B	D	C	A	F	G	RECOMMENDED		
								BALL	OIL-LESS BRONZE	BEARINGS RETAINER RING
BC21-1T BC21-2T BC21-3T	BC21-1C BC21-2C BC21-3C	.3748 FOR 1/8 SHAFT	3/4* 1 1 1/2	3/4	1 1/2	9/16	3/16	B1-5	B3-13	Q4-37
BC21-7T BC21-8T BC21-9T	BC21-7C BC21-8C BC21-9C	.4998 FOR 3/16 SHAFT	3/4* 1 1 1/2	7/8	1 5/8	5/8	1/4	B1-7	B3-15	Q4-50
BC21-13T BC21-14T BC21-15T	BC21-13C BC21-14C BC21-15C	.6248 FOR 1/4 SHAFT	3/4* 1 1 1/2	15/16	1 3/4	11/16	1/4	B1-9	B3-16	Q4-62



*No center grooves in 3/4" long units. 4 grooves in all others.

SHAFTS	STYLE	MATERIAL
1/8", 3/16" AND 1/4"	STYLE Y	ALUMINUM ANODIZED

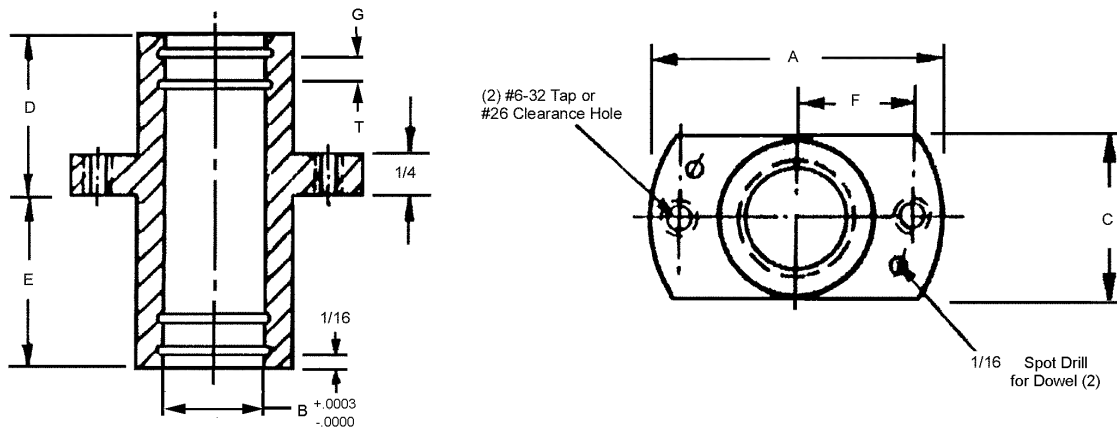

TAPPED HOLE STOCK NO.	CLEAR HOLE STOCK NO.	B	D	E	C	A	F	G	RECOMMENDED		
									BALL	OIL-LESS BRONZE	BEARINGS RETAINER RING
BC21-4T BC21-5T BC21-6T	BC21-4C BC21-5C BC21-6C	.3748 FOR 1/8 SHAFT	3/4 1 1 1/2	3/4 1 1 1/2	3/4	1 1/2	9/16	3/16	B1-5	B3-13	Q4-37
BC21-10T BC21-11T BC21-12T	BC21-10C BC21-11C BC21-12C	.4998 FOR 3/16 SHAFT	3/4 1 1 1/2	3/4 1 1 1/2	7/8	1 5/8	5/8	1/4	B1-7	B3-15	Q4-50
BC21-16T BC21-17T BC21-18T	BC21-16C BC21-17C BC21-18C	.6248 FOR 1/4 SHAFT	3/4 1 1 1/2	3/4 1 1 1/2	15/16	1 3/4	11/16	1/4	B1-9	B3-16	Q4-62

RECTANGULAR POST

STYLE	MATERIAL
HANGER POST	ALUMINUM ANODIZED

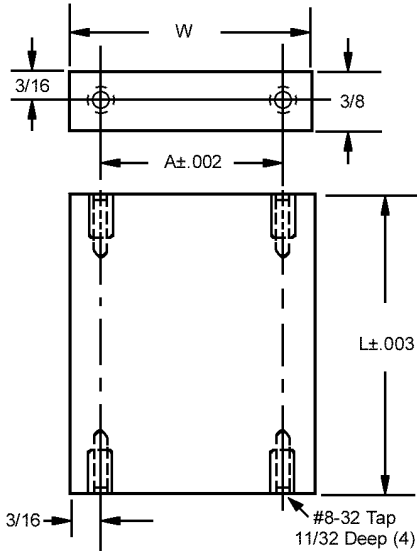

STOCK NO.	W	L	A
BC11-1		1.000	
BC11-2		1.500	
BC11-3		2.000	
BC11-4	1 1/4	2.500	7/8
BC11-5		3.000	
BC11-6		4.000	



D

STYLE	MATERIAL
BREADBOARD POSTS	ALUMINUM ANODIZED

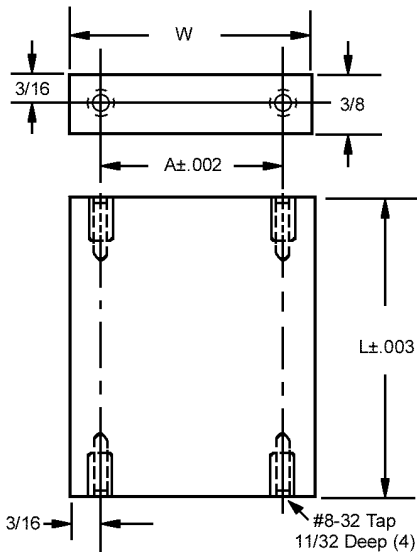

STOCK NO.	W	L	A
BC12-1		1.000	
BC12-2		1.500	
BC12-3		2.000	
BC12-4	1 1/2	2.500	1 1/8
BC12-5		3.000	
BC12-6		4.000	



"T" NUT & CLAMP

MATERIAL

HEAT TREATED STAINLESS STEEL

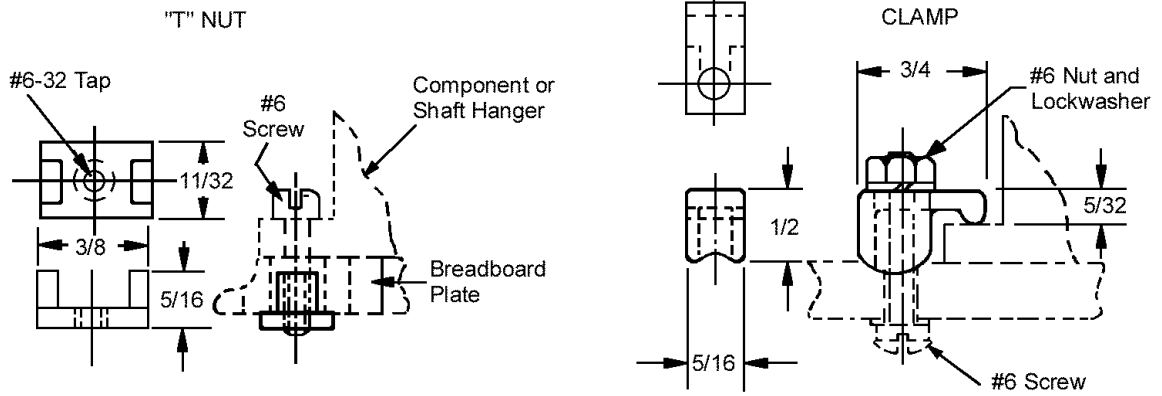

STOCK NO.	DESCRIPTION
BC13-1	T-NUT - USED WITH BREADBOARD PLATES FOR TOP LOCK AND ADJUSTMENT
BC13-2	CLAMP- USED WITH BREADBOARD PLATES TO PERMIT ANGULAR LOCATION OF HANGERS, ETC.

SPACER POSTS

SIZE	MATERIAL
1/8 SQUARE	ALUMINUM ANODIZED



STOCK NO.	D	B	SCREW THREAD	THREAD DEPTH
BC14-29G	1/8	.500	#0-80 UNC-2B	1/8
BC14-30G		.625		
BC14-31G		.750		
BC14-32G		.875		
BC14-33G		1.000		
BC14-34G		1.250		
BC14-35G		1.500		
BC14-36G		1.750		
BC14-37G	2.000			

Drawing with dimensions on next page

SIZE	MATERIAL
3/16 SQUARE	ALUMINUM ANODIZED



STOCK NO.	D	B	SCREW THREAD	THREAD DEPTH
BC14-39G	3/16	.625	#2-56 UNC-2B	3/16
BC14-40G		.750		
BC14-41G		1.000		
BC14-42G		1.250		
BC14-43G		1.500		
BC14-44G		1.750		
BC14-45G		2.000		
BC14-46G		2.500		
BC14-47G		3.000		

Drawing with dimensions on next page

SIZE	MATERIAL
1/4 SQUARE	ALUMINUM ANODIZED



GRAY ANODIZED STOCK NO.	BLACK ANODIZED STOCK NO.	D	B	SCREW THREAD	THREAD DEPTH
BC14-1G	BC14-1	1/4	1.000	#6-32 UNC 2B	1/4
BC14-2G	BC14-2		1.500		
BC14-3G	BC14-3		2.000		
BC14-4G	BC14-4		2.500		
BC14-5G	BC14-5		3.000		
BC14-6G	BC14-6		3.500		
BC14-7G	BC14-7		4.000		
BC14-27G	-		4.500		
BC14-28G	-		5.000		

Drawing with dimensions on next page

SIZE	MATERIAL
5/16 SQUARE	ALUMINUM ANODIZED



GRAY ANODIZED STOCK NO.	BLACK ANODIZED STOCK NO.	D	B	SCREW THREAD	THREAD DEPTH
BC14-8G	BC14-8	5/16	.750	#6-32 UNC-2B	1/4
BC14-9G	BC14-9		1.000		
BC14-10G	BC14-10		1.250		
BC14-11G	BC14-11		1.500		
BC14-12G	BC14-12		1.750		
BC14-13G	BC14-13		2.000		
BC14-52G	-		2.500		
BC14-53G	-		3.000		
BC14-54G	-		3.500		

Drawing with dimensions on next page

SPACER POSTS

SIZE	MATERIAL
3/8 SQUARE	ALUMINUM ANODIZED



GRAY ANODIZED STOCK NO.	BLACK ANODIZED STOCK NO.	D	B	SCREW THREAD	THREAD DEPTH
BC14-14G	BC14-14	3/8	1.500	#8-32 UNC-2B	5/16
BC14-15G	BC14-15		2.000		
BC14-16G	BC14-16		2.500		
BC14-17G	BC14-17		3.000		
BC14-18G	BC14-18		3.500		
BC14-19G	BC14-19		4.000		
BC14-38G	-		4.500		
BC14-20G	BC14-20		5.000		
BC14-21G	BC14-21		5.500		

SIZE	MATERIAL
1/2 SQUARE	ALUMINUM ANODIZED



GRAY ANODIZED STOCK NO.	BLACK ANODIZED STOCK NO.	D	B	SCREW THREAD	THREAD DEPTH
BC14-22G	BC14-22	1/2	2.000	#10-32UNC-2B	3/8
BC14-23G	BC14-23		2.500		
BC14-24G	BC14-24		3.000		
BC14-25G	BC14-25		3.500		
BC14-26G	BC14-26		4.000		
BC14-48G	-		4.500		
BC14-49G	-		5.000		
BC14-50G	-		5.500		
BC14-51G	-		6.000		

SIZE	MATERIAL
5/8 SQUARE	ALUMINUM ANODIZED



STOCK NO.	D	B	SCREW THREAD	THREAD DEPTH
BC14-55G	5/8	2.000	#1/4-20 UNC-2B	7/16
BC14-56G		2.500		
BC14-57G		3.000		
BC14-58G		3.500		
BC14-59G		4.000		
BC14-60G		4.500		
BC14-61G		5.000		
BC14-62G		5.500		
BC14-63G		6.000		

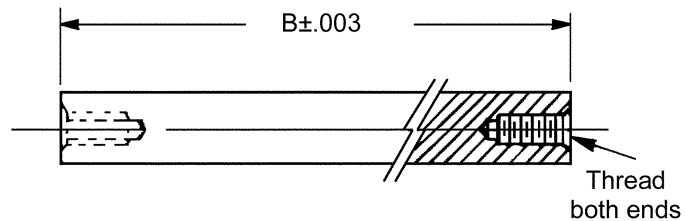
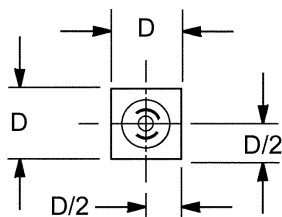

Special Spacer Posts are available on request.

STAND OFF

HEIGHT SIZE	TYPE	MATERIAL
.250	SWAGE	303 STAINLESS STEEL

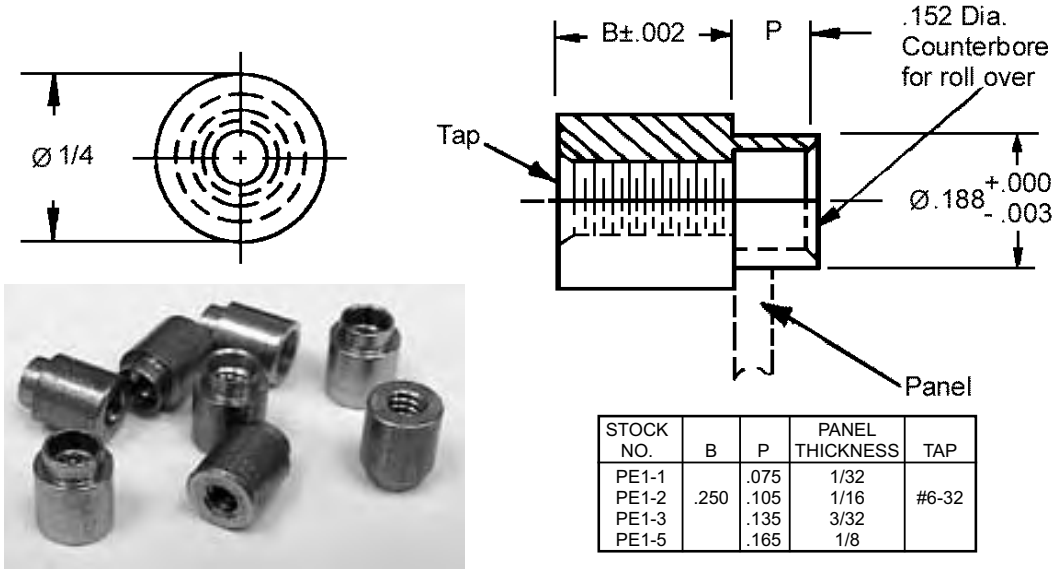

HEIGHT SIZE	TYPE	MATERIAL
.375	SWAGE	303 STAINLESS STEEL

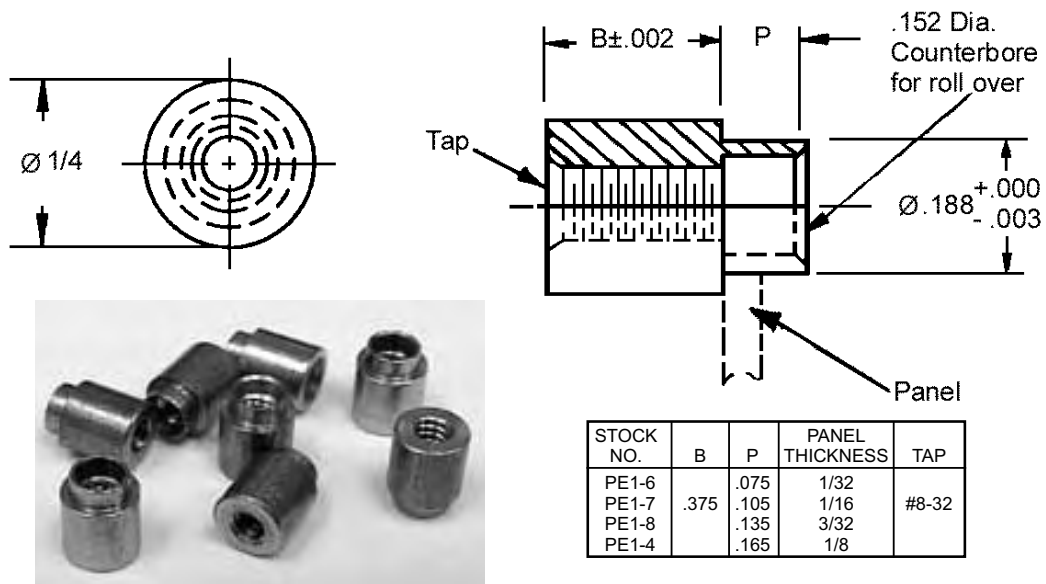

STAND OFF

BODY SIZE	TYPE	MATERIAL
Ø.187	THREADED	303 STAINLESS STEEL

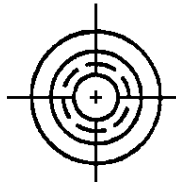
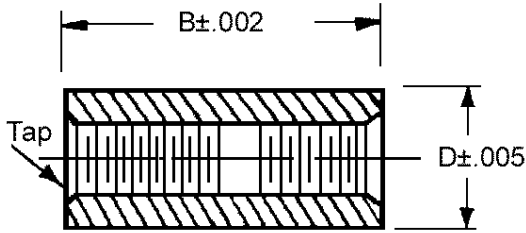

STOCK NO.	B	ØD	TAP
PE2-1	.250	.187	#4-40
PE2-2	.375		
PE2-3	.500		
PE2-13	.750		

BODY SIZE	TYPE	MATERIAL
Ø.250	THREADED	303 STAINLESS STEEL

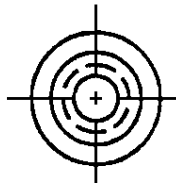
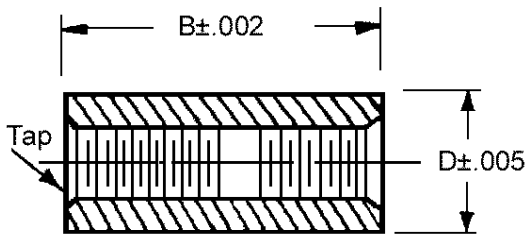

STOCK NO.	B	ØD	TAP
PE2-12	.250	.250	#6-32
PE2-4	.375		
PE2-5	.500		
PE2-6	.625		
PE2-7	.750		
PE2-14	1.000		

BODY SIZE	TYPE	MATERIAL
Ø.375	THREADED	303 STAINLESS STEEL

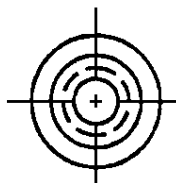
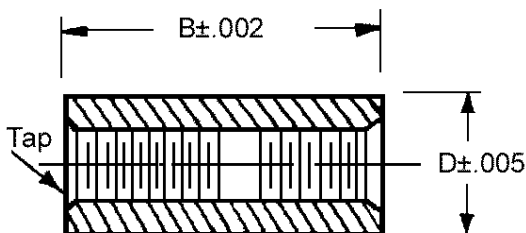

STOCK NO.	B	ØD	TAP
PE2-8	.375	.375	#8-32
PE2-9	.500		
PE2-10	.625		
PE2-11	.750		
PE2-15	1.000		

COMPONENT PLATE POSTS

BODY SIZE	MATERIAL
Ø9/32	303 STAINLESS STEEL

STOCK NO.	ØA	ØB	L	THREAD	T	S
PA2-1	.187	9/32	.781	#4-40	1/4	1/16
PA2-2			1.000			
PA2-3			1.500			

BODY SIZE	MATERIAL
Ø3/8	303 STAINLESS STEEL

STOCK NO.	ØA	ØB	L	THREAD	T	S
PA2-4	.250	3/8	.875	#10-32	3/8	3/32
PA2-5			1.250			
PA2-6			1.750			

BODY SIZE	MATERIAL
Ø1/2	303 STAINLESS STEEL

STOCK NO.	ØA	ØB	L	THREAD	T	S
PA2-7	.312	1/2	.875	1/4-28	1/2	1/8
PA2-8			1.500			
PA2-9			1.750			
PA2-10			2.500			

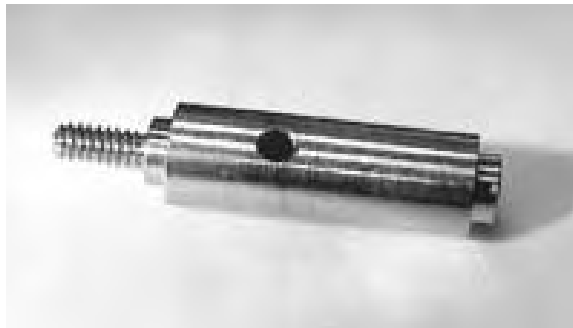
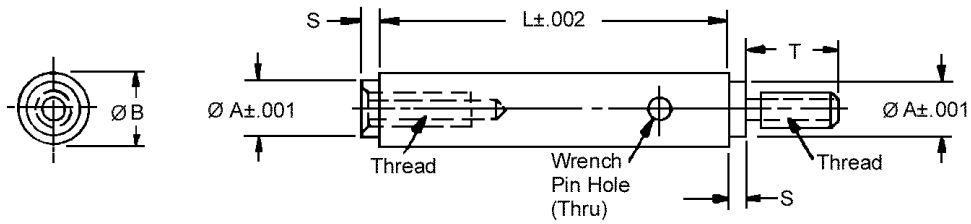

HOUSING COVER POSTS

BODY SIZE	MATERIAL
9/32	303 STAINLESS STEEL

STOCK NO.	ØA	ØB	L	THREAD	T	S
PA3-1	.187	9/32	2.000	#4-40	1/4	1/16
PA3-2			2.312			
PA3-3			3.000			

BODY SIZE	MATERIAL
3/8	303 STAINLESS STEEL

STOCK NO.	ØA	ØB	L	THREAD	T	S
PA3-4	.250	3/8	2.500	#10-32	3/8	3/32
PA3-5			3.000			
PA3-6			3.750			

BODY SIZE	MATERIAL
1/2	303 STAINLESS STEEL

STOCK NO.	ØA	ØB	L	THREAD	T	S
PA3-7	.312	1/2	2.625	1/4-28	1/2	1/8
PA3-8			3.000			
PA3-9			4.125			
PA3-10			4.750			

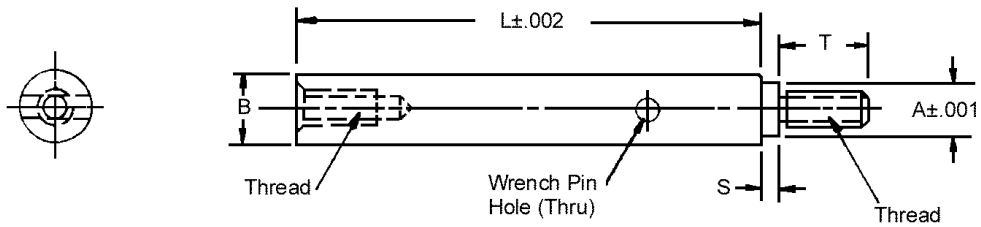

INSTRUMENT PLATE PILLAR POSTS

BODY SIZE	MATERIAL
Ø9/32	303 STAINLESS STEEL

STOCK NO.	ØA	ØB	L	THREAD	S
PA1-1	.187	9/32	.875	#4-40	1/16
PA1-2			1.250		
PA1-3			1.580		
PA1-4			2.000		

BODY SIZE	MATERIAL
Ø3/8	303 STAINLESS STEEL

STOCK NO.	ØA	ØB	L	THREAD	S
PA1-5	.250	3/8	.875	#10-32	3/32
PA1-6			1.250		
PA1-7			1.500		
PA1-8			1.750		
PA1-9			2.240		

BODY SIZE	MATERIAL
Ø1/2	303 STAINLESS STEEL

STOCK NO.	ØA	ØB	L	THREAD	S
PA1-10	.312	1/2	1.000	1/4-28	1/8
PA1-11			1.750		
PA1-12			2.500		
PA1-13			3.280		

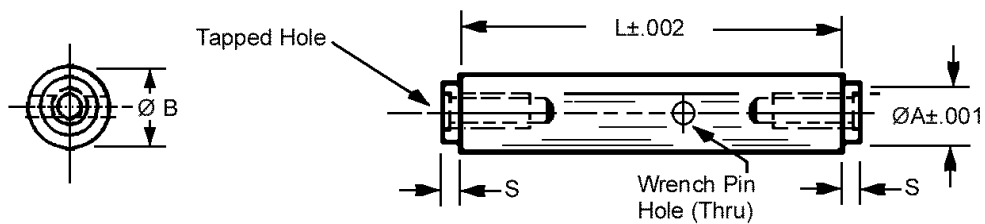

D

DIAL CLAMP

MATERIAL

STAINLESS STEEL

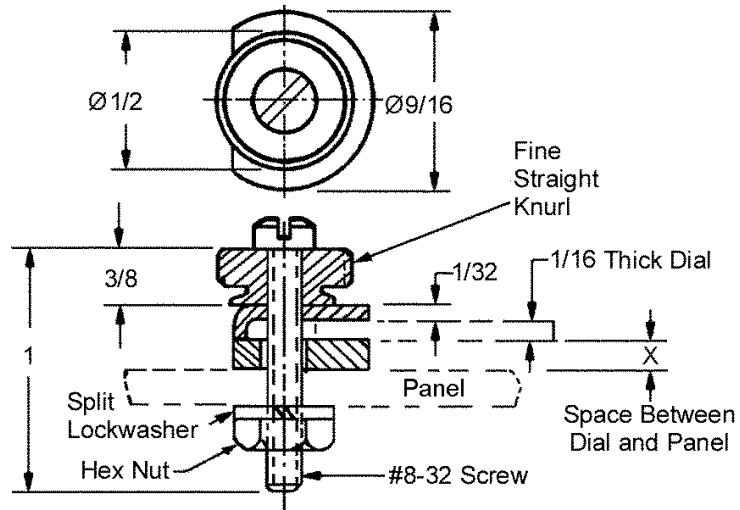

STOCK NO.	X
A16-1	1/16
A16-2	1/8

Supplied complete with all hardware.



DRUM DIALS

DIAMETER	TYPE	MATERIAL
1 1/2" TO 3"	SETS, DIALS OR VERNIERS	ALUMINUM BLACK ANODIZED

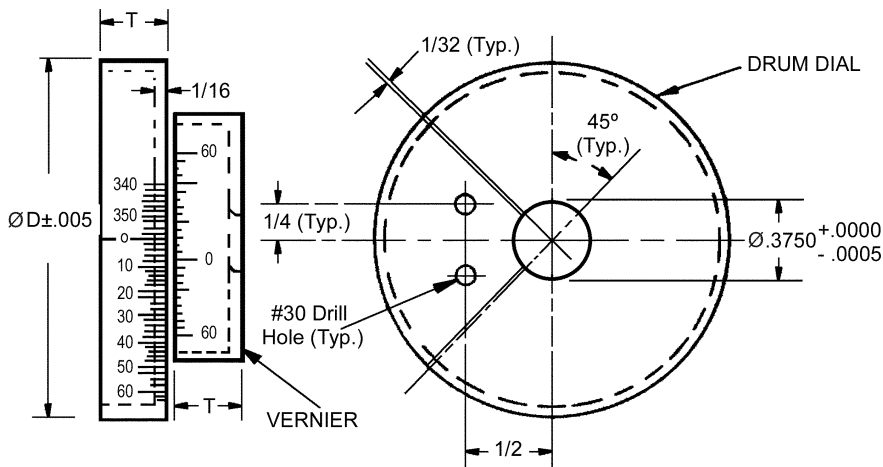

SET STOCK NO.	DIAL STOCK NO.	VERNIER STOCK NO.	D DIAL DIA.	T WIDTH	VERNIER READING	GRADUATIONS
A1-1*	A1-1-D	A1-1-V	1.490	3/8	12 MIN.	180 IN 2° STEPS
A1-2*	A1-2-D	A1-2-V	1.990	3/8	12 MIN.	180 IN 2° STEPS
A1-3	A1-3-D	A1-3-V	2.490	1/2	6 MIN.	360 IN 1° STEPS
A1-4	A1-4-D	A1-4-V	2.990	1/2	6 MIN.	360 IN 1° STEPS

* Dials and Verniers are numbered every 20°.

Engraving filled with white.
Range of Graduations - 0 to 360°

- Available on request:
- Pin or Clamp Hubs assembled to drum
 - Counter Clockwise numbering
 - Special Engraving

For Pin and Clamp Hubs see index.



DRUM DIALS

DIAMETER	MATERIAL
1" TO 3"	ALUMINUM BLACK ANODIZED

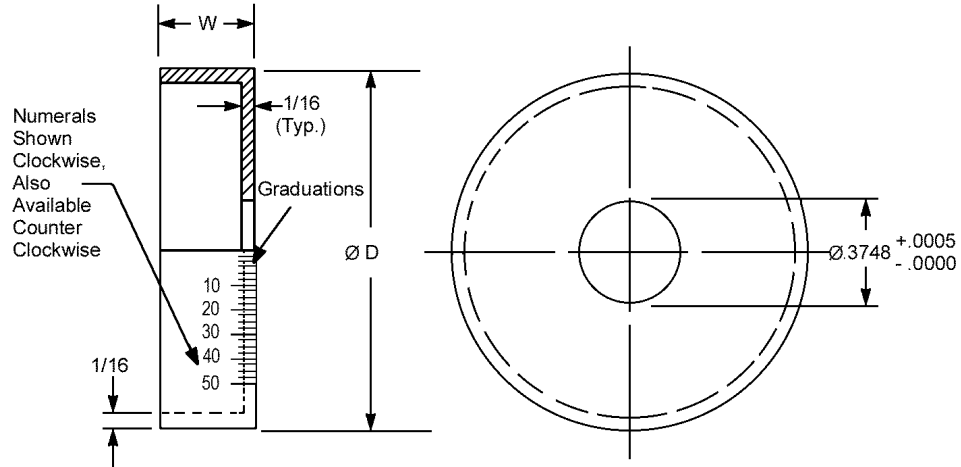

STOCK NO.	W WIDTH	D DIAL DIA.	DIRECTION OF NUMBERING	GRADUATIONS RANGE	NO. OF GRAD.S	STEPS IN DEGREES
A3-1	3/8	1 (.990)	BLANK	-	-	-
A3-2*			CW	0 TO 360	180	2°
A3-3			CW	0 TO 100	100	3°-36'
A4-1	3/8	1 1/2 (1.490)	BLANK	-	-	-
A4-2*			CW	0 TO 360	180	2°
A4-3			CW	0 TO 100	100	3°-36'
A4-4			CW	0 TO 60	60	6°
A5-1	3/8	2 (1.990)	BLANK	-	-	-
A5-2*			CW	0 TO 360	180	2°
A5-3			CW	0 TO 50	50	7°-12'
A5-4			CW	0 TO 25	25	14°-24'
A6-1	1/2	2 1/2 (2.490)	BLANK	-	-	-
A6-2			CW	0 TO 360	360	1°
A6-3			CW	0 TO 100	100	3°-36'
A6-4			CCW	0 TO 360	360	1°
A7-1	1/2	3 (2.990)	BLANK	-	-	-
A7-2			CW	0 TO 360	360	1°
A7-3*			CW	0 TO 360	180	2°
A7-4			CW	0 TO 100	100	3°-36'
A7-5			CCW	0 TO 360	360	1°

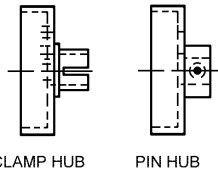

* Dials are numbered every 20°.

Engraving filled with white.
Range of Graduations - 0 to 360°

Available on request:
• Pin or Clamp Hubs assembled to drum
• Special Engraving



For Pin and Clamp Hubs see index.

FLAT DIALS

DIAMETER	TYPE	MATERIAL
1 1/2" TO 4"	SETS, DIALS OR VERNIERS	ALUMINUM BLACK ANODIZED

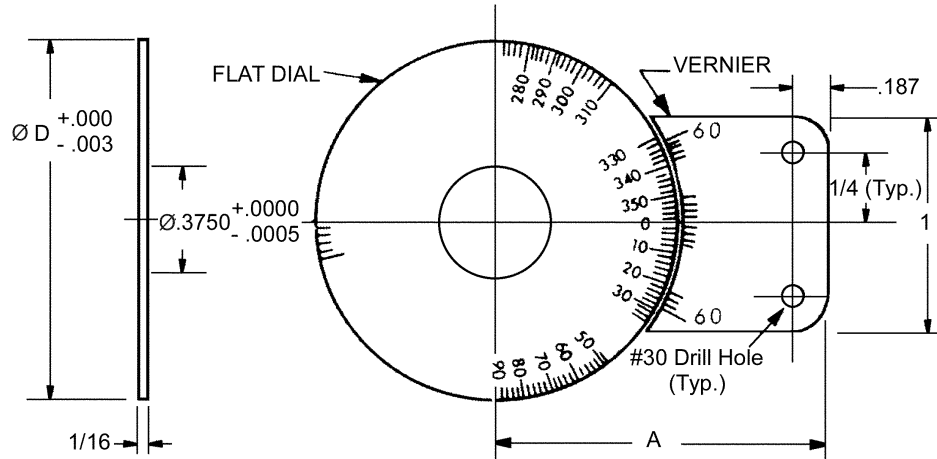

SET STOCK NO.	DIAL STOCK NO.	VERNIER STOCK NO.	A	D DIAL DIA.	VERNIER READING	GRADUATIONS
A2-1*	A2-1-D	A2-1-V	1.760	1 1/2	12 MIN.	180 IN 2° STEPS
A2-2*	A2-2-D	A2-2-V	2.010	2	12 MIN.	180 IN 2° STEPS
A2-3	A2-3-D	A2-3-V	2.510	3	6 MIN.	360 IN 1° STEPS
A2-4	A2-4-D	A2-4-V	3.010	4	6 MIN.	360 IN 1° STEPS

* Dials and Verniers are numbered every 20°.

Engraving filled with white.
Range of Graduations - 0 to 360°

Available on request:

- Pin or Clamp Hubs assembled to drum
- Read at 12 o'clock
- Counter Clockwise numbering
- Special Engraving

For Pin and Clamp Hubs see index.



ENGRAVED FLAT DISKS

DIAMETER	MATERIAL
1 1/2" TO 4"	ALUMINUM BLACK ANODIZED

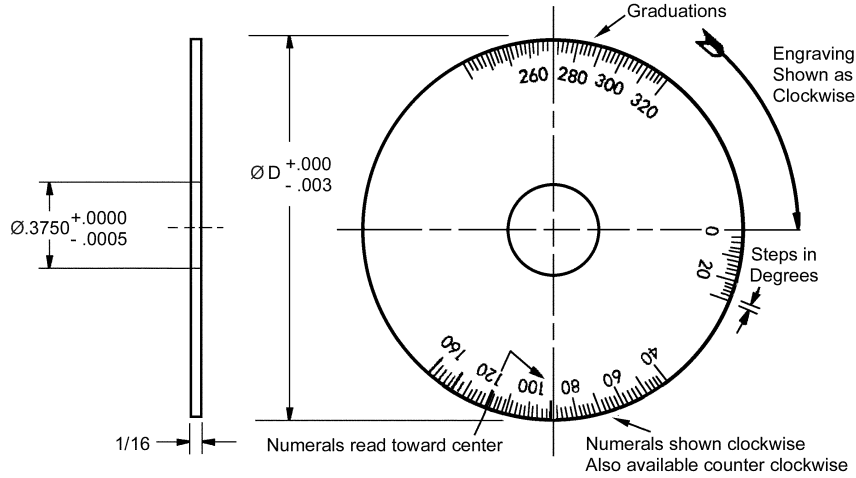

STOCK NO.	D DIAL DIA.	DIRECTION OF NUMBERING	GRADUATIONS RANGE	NO. OF GRAD.S	STEPS IN DEGREES
A8-1	1 1/2	BLANK	-	-	-
A8-2*		CW	0 TO 360	180	2°
A8-3		CW	0 TO 100	100	3°-36'
A8-4		CW	0 TO 50	50	7°-12'
A8-5		CW	0 TO 10	10	36°
A9-1	2	BLANK	-	-	-
A9-2*		CW	0 TO 360	180	2°
A9-3*		CCW	0 TO 360	180	2°
A9-4		CW	0 TO 100	100	3°-36'
A9-5		CCW	0 TO 100	100	3°-36'
A9-6		CW	0 TO 72	72	5°
A9-7		CW	0 TO 60	60	6°
A9-8		CW	0 TO 50	50	7°-12'
A10-1	3	BLANK	-	-	-
A10-2		CW	0 TO 360	360	1°
A10-3*		CW	0 TO 360	180	2°
A10-4		CW	0 TO 200	200	1°-48'
A10-5		CW	0 TO 120	120	3°
A10-6		CW	0 TO 100	100	3°-36'
A10-7		CW	0 TO 72	72	5°
A10-8		CCW	0 TO 360	360	1°
A10-9		CCW	0 TO 100	100	3°-36'
A11-1	4	BLANK	-	-	-
A11-2		CW	0 TO 360	360	1°
A11-3*		CW	0 TO 360	180	2°
A11-4		CW	0 TO 200	200	1°-48'
A11-5		CW	0 TO 100	100	3°-36'
A11-6		CW	0 TO 1000	500	43°-12'
A11-7		CCW	0 TO 360	360	1°
A11-8*		CCW	0 TO 360	180	2°

* Dials are numbered every 20°.

Engraving filled with white.
Range of Graduations - 0 to 1000°

Available on request:
• Pin or Clamp Hubs assembled to drum
• Special Engraving

For Pin and Clamp Hubs see index.



FLAT DIAL INDEX

MATERIAL

ALUMINUM BLACK ANODIZED

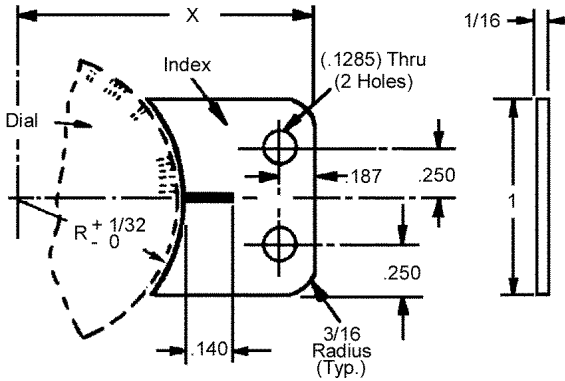

STOCK NO.	X	R
A13-1	1 3/4	.750
A13-2	2	1.000
A13-3	2 1/2	1.500
A13-4	3	2.000



D

DRUM DIAL INDEX

MATERIAL

ALUMINUM BLACK ANODIZED

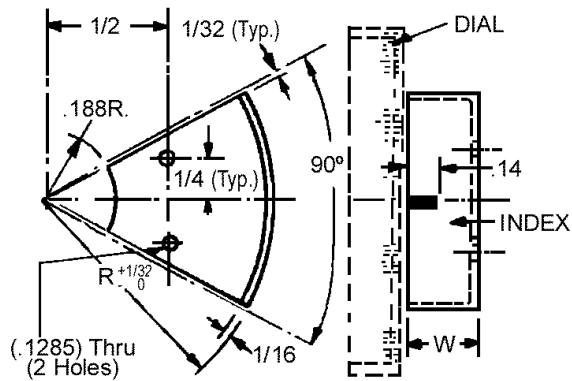

STOCK NO.	X	R
A14-1	.745	.375
A14-2	.995	.375
A14-3	1.245	.500
A14-4	1.495	.500

ENGRAVED INDEX

MATERIAL

PLEXIGLASS

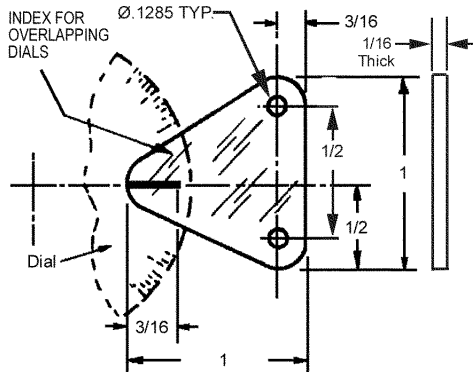

STOCK NO.	MATERIAL & FINISH
A12-1	PLEXIGLASS (CLEAR) MIL-P-5425



MATERIAL

ALUMINUM BLACK ANODIZED

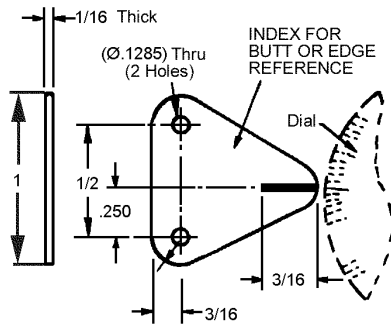

STOCK NO.	MATERIAL & FINISH
A12-2	24 ST. ALUMINUM, BLACK ANODIZED

KNURLED HANDWHEELS

MATERIAL

303 STAINLESS STEEL

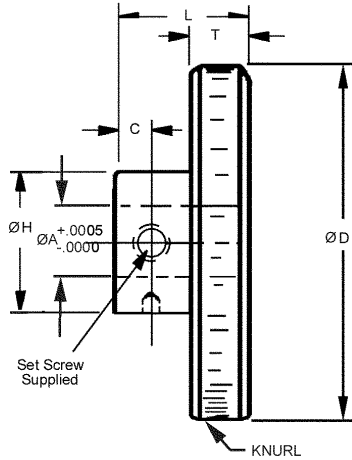

D

STOCK NO.	ØA	ØD	ØH	T	L	C
CN1-1	.1248	1				
CN1-2	(1/8)	1 1/2	5/16	3/16	.375	.09
CN1-3		2				
CN1-4	.1873	1				
CN1-5	(3/16)	1 1/2	3/8	3/16	.406	.11
CN1-6		2				
CN1-7	.2498	1				
CN1-8	(1/4)	1 1/2	1/2	3/16	.437	.12
CN1-9		2				
CN1-10	.3123	1				
CN1-11	(5/16)	1 1/2	1/2	3/16	.437	.12
CN1-12		2				
CN1-13	.3748	2				
CN1-14	(3/8)	2 1/2	3/4	3/8	.875	.25
CN1-15		3				
CN1-16	.4998	2 1/2				
CN1-17	(1/2)	3	1	3/8	.875	.25
CN1-18		4				

KNURLED HANDWHEELS

MATERIAL

ALUMINUM BLACK ANODIZED

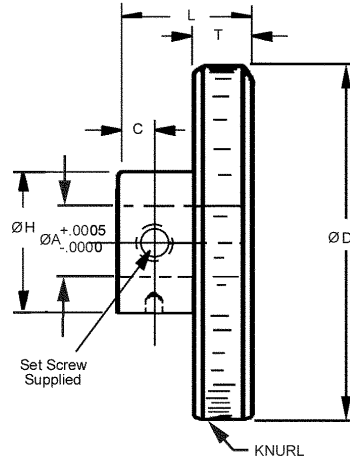

STOCK NO.	$\varnothing A$	$\varnothing D$	$\varnothing H$	T	L	C
CN11-1	.125	1 1/8				
CN11-2	(1/8)	1 5/8	5/8	3/16	7/16	1/8
CN11-3	.187	1 1/8				
CN11-4	(3/16)	2 1/8	5/8	3/16	7/16	1/8
CN11-5	.250	1 5/8				
CN11-6	(1/4)	2 1/8	5/8	3/16	7/16	1/8
CN11-7	.375	1 5/8				
CN11-8	(3/8)	2 5/8	1	1/2	3/4	1/8
CN11-9	.500	2 5/8				
CN11-10	(1/2)	3 1/2	1	1/2	3/4	1/8

KNURLED HAND CRANKS

MATERIAL

303 STAINLESS STEEL

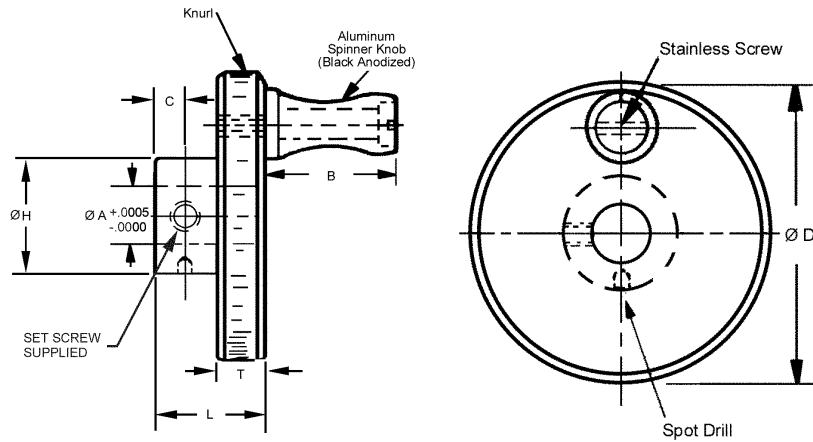

STOCK NO.	$\varnothing A$	$\varnothing D$	$\varnothing H$	T	L	C	B
CN2-1	.1248	1					
CN2-2	(1/8)	1 1/2	5/16	3/16	.375	.09	3/4
CN2-3		2					
CN2-4	.1873	1					
CN2-5	(3/16)	1 1/2	3/8	3/16	.406	.11	3/4
CN2-6		2					
CN2-7	.2498	1					
CN2-8	(1/4)	1 1/2	1/2	3/16	.437	.12	3/4
CN2-9		2					
CN2-10	.3123	1					
CN2-11	(5/16)	1 1/2	1/2	3/16	.437	.12	3/4
CN2-12		2					
CN2-13	.3748	2					
CN2-14	(3/8)	2 1/2	3/4	3/8	.875	.25	31/32
CN2-15		3					
CN2-16	.4998	2 1/2					
CN2-17	(1/2)	3	1	3/8	.875	.25	31/32
CN2-18		4					

HAND CRANKS

MATERIAL

ALUMINUM BLACK ANODIZED

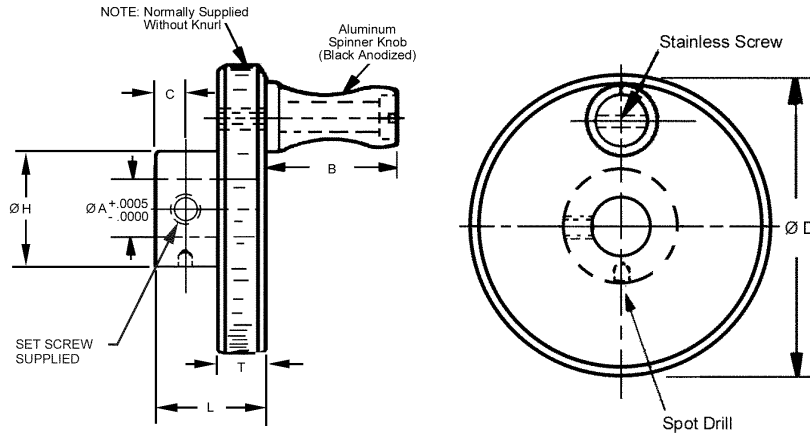

STOCK NO.	$\varnothing A$	$\varnothing D$	$\varnothing H$	T	L	B	C
CN12-1	.125	1 1/8					
CN12-2	(1/8)	1 5/8	5/8	3/16	7/16	3/4	1/8
CN12-3	.187	1 1/8					
CN12-4	(3/16)	2 1/8	5/8	3/16	7/16	3/4	1/8
CN12-5	.250	1 5/8					
CN12-6	(1/4)	2 1/8	5/8	3/16	7/16	3/4	1/8
CN12-7	.375	1 5/8				3/4	
CN12-8	(3/8)	2 5/8	1	1/2	3/4	31/32	1/8
CN12-9	.500	2 5/8					
CN12-10	(1/2)	3 1/2	1	1/2	3/4	31/32	1/8

KNOBS

TYPE	MATERIAL
SPINNER KNOB AND SCREW	ALUMINUM BLACK ANODIZED WITH 303 STAINLESS STEEL SCREW

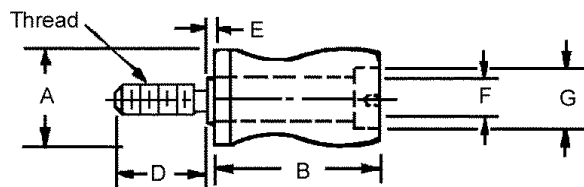

STOCK NO.	A	B	THREAD	D	E	F	G
CN8-1	1/2	3/4	#8-32	3/16	1/64	3/16	5/16
CN8-2	11/16	31/32	1/4-20	7/16	1/64	5/16	1/2
CN8-3	15/16	1 1/4	3/8-16	5/8	11/32	1/2	3/4



TYPE	MATERIAL
SPINNER KNOB WITH RIBBED GRIPPING SURFACE	THERMOPLASTIC BLACK MATTE FINISH WITH ALUMINUM INSERTS

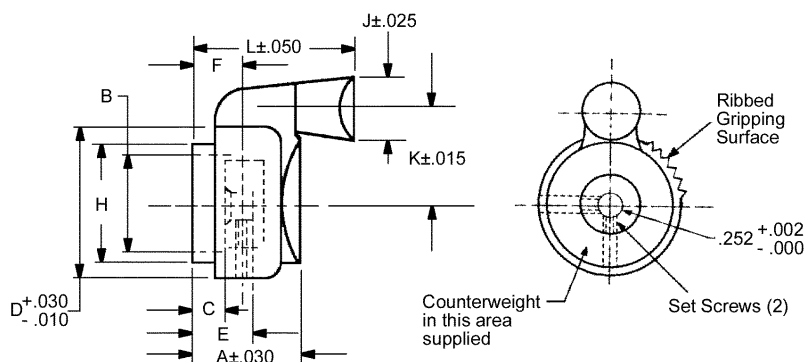

Meets MIL-K-3926 B and MS91528J

STOCK NO.	MS PART NO.	D	NUT CLEARANCE B MIN.	C MIN.	F MAX.	SHAFT HOLE DEPTH E MIN.	A	H MAX.	L	J	K	SET SCREW
CN5-22	-3S2B	1.250	.685	.250	.427	.605	.850	1.185	1.350	.580	.800	#8-32
CN5-23	-4S2B	1.750	.685	.320	.489	.740	1.070	1.690	1.758	.780	1.094	#8-32



TYPE	MATERIAL
ROUND KNOBS	ALUMINUM BLACK ANODIZED WITH 303 STAINLESS STEEL SCREW

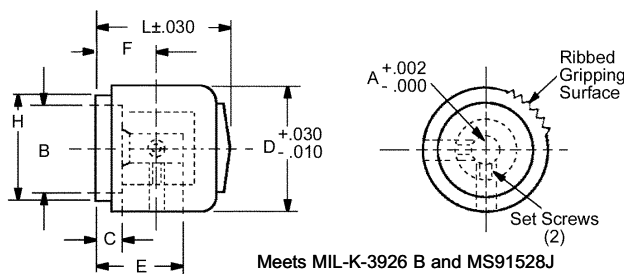

Meets MIL-K-3926 B and MS91528J

STOCK NO.	MS PART NO.	A	D	NUT CLEARANCE B MIN.	C MIN.	F MAX.	E MIN.	L	H MAX.	SET SCREW
CN5-14	-0D1B	.127	.500	.300	.177	.325	.560	.655	.460	#4-40
CN5-15	-1D2B	.252	.700	.485	.188	.369	.568	.782	.680	#4-40
CN5-16	-2D2B	.252	.900	.640	.320	.484	.730	1.010	.845	#8-32
CN5-17	-3D2B	.252	1.250	.750	.250	.427	.605	.850	1.185	#8-32



SYNCRO MOUNT CLAMPS

SHAFTS	MATERIAL
1/8" TO 1/4"	416 STAINLESS STEEL HEAT TREATED - ROCKWELL C28-32 (CAST)

STOCK NO.	T	C	F
SM-11	.062	.052	.100
SM-12	.093	.081	.131
SM-13	.125	.109	.160
SM-14	.250	.238	.288
SM-15	.072	.063	.113
SM-16	.125	.112	.162
SM-17	.156	.143	.193
SM-18	.225	.213	.263

SHAFTS	MATERIAL
1/8" TO 1/4"	303 STAINLESS STEEL

STOCK NO.	T	C	F
SM-1	.062	.052	.100
SM-2	.093	.081	.131
SM-3	.125	.109	.160
SM-4	.250	.238	.288
SM-5	.072	.063	.113
SM-6	.125	.112	.162
SM-7	.156	.143	.193
SM-8	.225	.213	.263

SHAFTS	MATERIAL
1/8" TO 1/4"	2024-T4 ALUMINUM

STOCK NO.	T	C	F
SM-1-A	.062	.052	.100
SM-2-A	.093	.081	.131
SM-3-A	.125	.109	.160
SM-4-A	.250	.238	.288

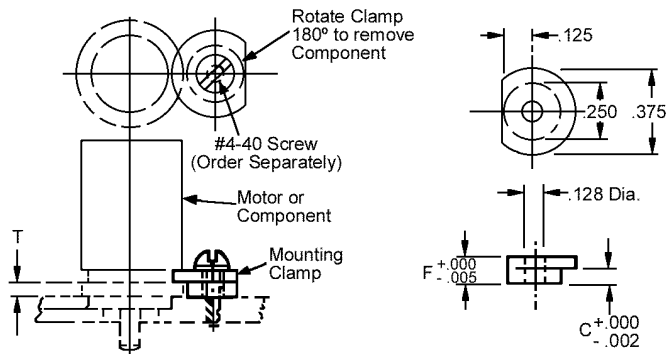

SYNCRO MOUNT CLAMPS

MOUNT STYLES	MATERIAL
TOP AND REVERSE	316 STAINLESS STEEL (SINTERED) WITH NYLON INSERTS

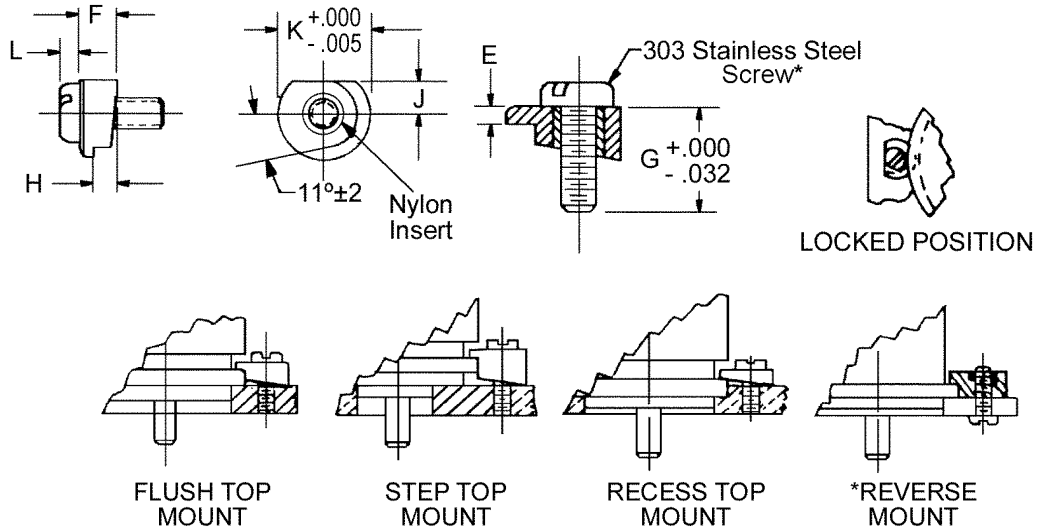

STOCK NO.	MOUNT STYLE	+.003 H	REF J	+.003 E	REF F	G	SCREW SIZE	+.000 -.005 K	L MAX	BOLT CIRCLE FOR CLEATS
										USE THE LARGER OF THE FOLLOWING TWO BOLT CIRCLES
SQ-1 SQ-2 SQ-3 SQ-4 SQ-5	TOP	.031 .047 .062 .093 .125	.091	.040 .040 .040 .040 .040	.071 .087 .102 .133 .165	1/4 1/4 1/4 5/16 5/16	#2-56	.265	.053	ADD .192" TO MAX FLANGE DIA., OR ADD .275" TO MAX GROOVE BASE DIA.
SQ-6 SQ-7 SQ-8 SQ-9 SQ-10 SQ-11 SQ-12 SQ-13 SQ-14 SQ-15 SQ-16 SQ-17	TOP	.031 .062 .062 .078 .093 .093 .093 .125 .156 .225 .250	.125	.040 .040 .050 .063 .063 .040 .050 .143 .156 .175 .196 .288 .312	.071 .102 .112 .125 .141 .133 .143 .156 .175 .196 .288 .312	5/16 5/16 3/8 3/8 3/8 3/8 3/8 3/8 3/8 3/8 7/16 5/8	#4-40	.390	.068	ADD .270" TO MAX FLANGE DIA., OR ADD .400" TO MAX GROOVE BASE DIA.
SQ-18	TOP	.250 +.005	.187	.187 +.005	.437	7/8	#10-32	.625 +.000	.110	ADD .406" TO MAX FLANGE DIA., OR ADD .630" TO MAX GROOVE BASE DIA.
SQ-19 SQ-20 SQ-26	REVERSE	.062 .093 .125	.125	.063 .063 .063	.125 .156 .187	- - -	*#4-40	.390	- - -	ADD .270" TO MAX FLANGE DIA., OR ADD .400" TO GROOVE BASE DIA.

- Quick Releasing
- Faster Nulling of Clamped Component
- Self Locking

Meets ASTM B525 Clamp and ASTM B4066 Insert

* 303 Stainless Steel slotted pan head screw supplied (except reverse mount).

Phillips pan head screw (MIL Standard) available on request

SYNCRO MOUNT CLAMPS

SHAFTS	MATERIAL
1/8" TO 1/4"	303 STAINLESS STEEL AND ALUMINUM

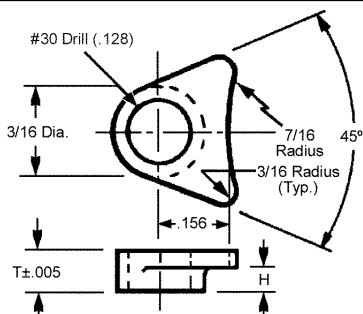

303 STAINLESS STEEL STOCK NO.	ALUMINUM STOCK NO.	H	T
SM-20	SM-20-A	.047	.093
SM-21	SM-21-A	.110	.156
SM-22	SM-22-A	.210	.272

SHAFTS	MATERIAL
1/8" TO 1/4"	302 STAINLESS STEEL AND ALUMINUM

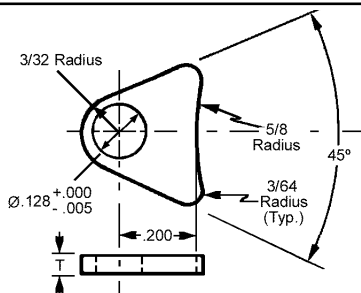

302 STAINLESS STEEL STOCK NO.	ALUMINUM STOCK NO.	T
SM-23	SM-23-A	.040

SHAFTS	MATERIAL
1/8" TO 1/4"	303 STAINLESS STEEL AND ALUMINUM

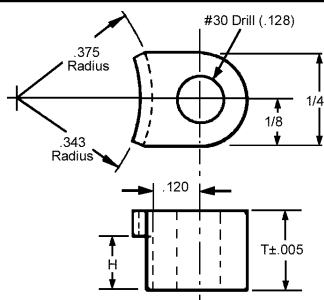

303 STAINLESS STEEL STOCK NO.	ALUMINUM STOCK NO.	H	T
SM-24	SM-24-A	.020	.065
SM-25	SM-25-A	.050	.095
SM-26	SM-26-A	.115	.160
SM-27	SM-27-A	.175	.220

SHAFTS	MATERIAL
1/8" TO 1/4"	302 STAINLESS STEEL

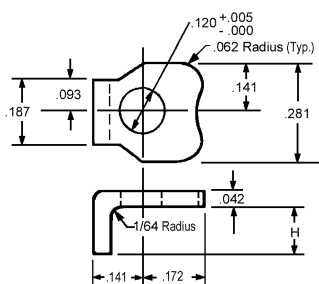

302 STAINLESS STEEL STOCK NO.	H
SM-28	FLAT
SM-29	.047
SM-30	.078
SM-31	.110
SM-32	.142



SYNCRO MOUNT CLAMPS

THREAD	MATERIAL
#2-56, #4-40 AND #6-32	303 STAINLESS STEEL SCREW 302 STAINLESS STEEL CLAMP & LOCKWASHER

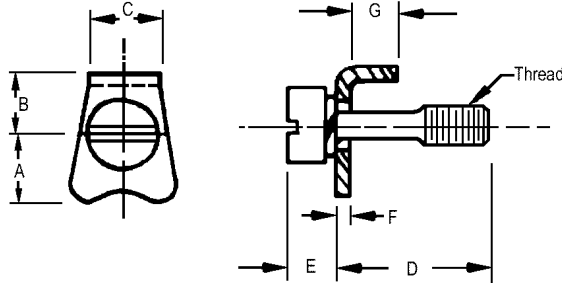

STOCK NO.	COMPONENT SIZE	THREAD	A	B	C	D	E	F	G
SQ-27	08 & 10	#2-56	.150	.080	.125	.192	.093	.028	.070
SQ-28	11, 15 & 18	#4-40	.172	.110	.187	.289	.113	.032	.093
SQ-29	23	#6-32	.250	.156	.250	.475	.138	.062	.255

D

THREAD	MATERIAL
#2-64, #4-48 AND #6-40	303 STAINLESS STEEL SCREW 302 STAINLESS STEEL CLAMP & LOCKWASHER

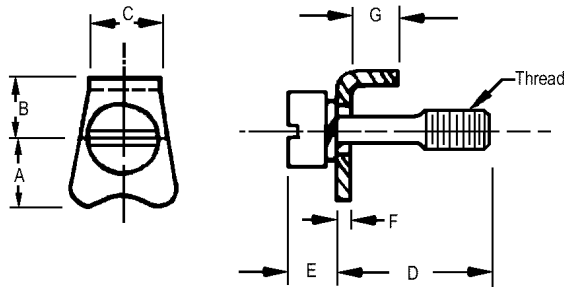

STOCK NO.	COMPONENT SIZE	THREAD	A	B	C	D	E	F	G
SQ-30	08 & 10	#2-64	.150	.080	.125	.192	.093	.028	.070
SQ-31	11, 15 & 18	#4-48	.172	.110	.187	.289	.113	.032	.093
SQ-32	23	#6-40	.250	.156	.250	.475	.138	.062	.255

SYNCRO MOUNT CLAMPS

MATERIAL

303 STAINLESS STEEL

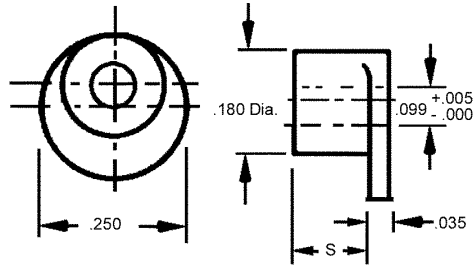

STOCK NO.	S
SM-47	.057
SM-48	.088
SM-49	.104
SM-50	.117



MATERIAL

303 STAINLESS STEEL AND ALUMINUM

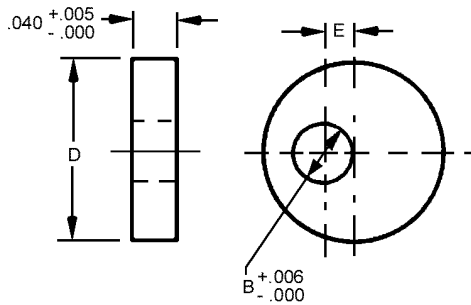

303 STAINLESS STEEL STOCK NO.	ALUMINUM STOCK NO.	E	D	B
SM-43	SM-43-A	.011	.187	.103
SM-44	SM-44-A	.031	.250	.127
SM-45	SM-45-A	.062	.310	.127
SM-46	SM-46-A	.062	.370	.127

MINIATURE SYNCRO MOUNT CLAMPS

MATERIAL

**316 STAINLESS STEEL (SINTERED)
WITH NYLON INSERT**

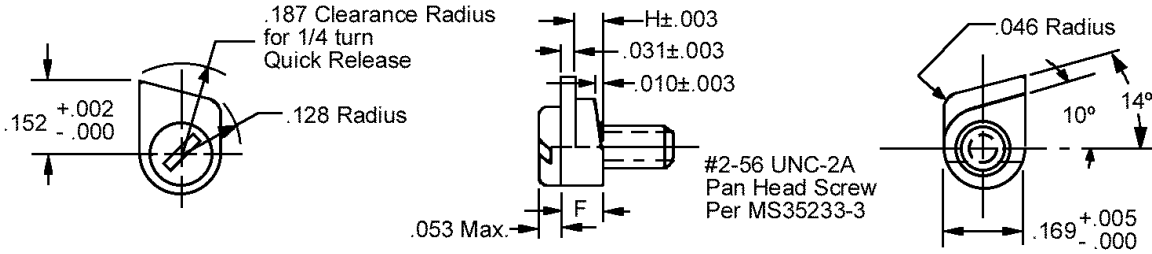

STOCK NO.	COMP. SIZE	MOUNT STYLE	H	F
SQ-21	5, 8, 10	TOP	.031	.062
SQ-22	5	TOP	.047	.078
SQ-23	8, 10	TOP	.062	.093

- Quick Releasing
- Self Locking

D

LINEAR COMPONENTS

Table of Contents

ACME LEAD SCREWS, NUTS & FLANGES E 2 - E 13

Technical Data	E 2
Lead Screw, Nuts & Flanges	E 3 - E 13
Lubricating Spray	E 14
Lubricating Grease	E 14

HIGH PRECISION AND PRECISION LEAD SCREWS

Technical Data	E 15
Anti-Backlash Lead Screw Assemblies	E 16
Lead Screws	E 17
Lead Screw Assemblies	E 18 - E 19

LINEAR CLUTCH - LINEAR ACTUATORS E 20

LINEAR SLIDES

Technical Data Linear Slides	E 21
Linear Ball Slides	E 22 - E 23
Linear Crossed Roller Slides	E 24
Rack Driven Ball Slides	E 25
Linear Tables	E 26

ULTRA PRECISION ROLLER SLIDES

Technical Data	E 27
----------------	------

SSX SLIDES E 28

Lead Screw Driven SSX Slides	E 29
Motor Driven SSX Slides	E 30

CROSS ROLLER BEARING RAIL SET E 31

NEEDLE ROLLER BEARING RAILS E 32 - E 33

Needle Roller Bearing / Needle Cages	E 34
End Tabs for Needle Roller Bearing	E 35

ULTRA PRECISION CROSS ROLLER BEARINGS

Double V Rail Sets	E 36
"Recirculating" Bearings & Rail Sets	E 37 - E 39

ULTRA-PRECISION CROSS ROLLER SLIDES

Slide Assemblies, Long Travel	E 40
Slide Assemblies, Low Profile	E 41
Flange Based, Slide Assemblies	E 42
"Recirculating" Slide Assemblies, Long Travel	E 43
Plain Style Slide Assemblies, Long Travel	E 44
Lead Screw Driven Slide Assemblies	E 45 - E 46

LINEAR-ROTARY BEARINGS

Pre-Loaded, General Purpose	E 47
-----------------------------	------

ROLLER RAIL E 48 - 49

BEARINGS

Linear Motion Adjustable Bearings	E 50
Precision Linear "Gear Drive" Bearings	E 51

LINEAR DRIVE GEAR RACKS E 52

SELF-ALIGNING ROD ENDS E 53

ROD END AND STUD ASSEMBLIES E 54 - E 56

THERMOPLASTIC ROD ENDS E 57 - E 58

LINEAR BEARINGS

Flanged Type	E 59
Ball Bearings	E 60 - E 61, E 65 - 66
Ball Bearings With Shaft Wipers	E 62
Self-Aligning - Barrel Style	E 63
Rotating (Set)	E 64
Closed Style	E 67
Open Style	E 68
Thermoplastic	E 72
Thermoplastic Self-Aligning	E 73

FLANGE MOUNTS E 69

No Lube	E 70 - E 71
---------	-------------

CERAMIC COATED SHAFTING E 74

CERAMIC BEARINGS E 75

Self-Aligning	E 76
---------------	------

COMPOSITE BEARINGS E 77

LOGLIFE BEARINGS E 78

SHAFT SUPPORT E 79

LINEAR PILLOW BLOCK ASSEMBLIES E 80

With Shaft Wipers	E 81
-------------------	------

PILLOW BLOCKS E 82

Linear With Shaft Wipers	E 83
--------------------------	------

SQUARE BEARINGS E 84 - 86

Plugs	E 87
-------	------

SQUARE SHAFTING & ACCESSORIES E 88

LINEAR BEARING BRACKETS E 89 - E 90

LINEAR BEARING CARRIAGE E 91

LINEAR BEARING MAINTENANCE E 92

SHAFT HANGERS E 93 - E 94

SHAFTING E 95 - E 102

Case Hardened and Ground	E 95
Ground	E 96
Seals	E 97
Wiper - Retainer	E 98
Wipers	E 101 - 102
Retainer Rings External	E 99
Retainer Rings Push In	100

ACME LEAD SCREWS, NUTS & FLANGE

TECHNICAL DATA - See Reference Section for more information.

ROLLED ACME SCREWS

Rolled thread acme screws offer the largest selection of size and pitch choices in the industry. Rolled thread screws are cost effective.



MATERIAL	THREAD CLASS	LEAD ACCURACY	SCREW DIAMETER	SCREW LENGTHS
4140 Alloy Steel	Centralizing 2C or Stub	±.0003" per Inch up to 1"	1/4" To 1"	Available up to 6 feet
300 Series Stainless Steel	Centralizing 2C or Stub	±.0003" per Inch up to 1"	1/4" To 1"	Available up to 6 feet

Special end configurations are available on request, call Berg TSR Group for special quotes. Materials used in these acme nuts have been selected for low friction, minimum wear, long life and clean operation.

BRONZE ACME & ISO NUT

Special high tensile bronze is selected for our smooth running, anti-wedging bronze nuts.



MATERIAL	BRONZE
TENSILE YIELD	50,000 psi
TENSILE ULTIMATE	65,000 psi
HARDNESS	RB75
DYNAMIC CO-EFFICIENT OF FRICTION	0.125 with Lubricant

PLASTIC ACME ISO NUTS

The high strength and inherent lubricity of this material can result in product life that can equal or exceed conventional nut materials.



TENSILE STRENGTH @ 70°F	8,000 psi
COMPRESSIVE STRENGTH @ 70°F	16,000 psi
PV LIMIT @ ft-lbs./in ² -min.	10,000
CO-EFFICIENT OF FRICTION	0.10

FLANGES FOR BRONZE & PLASTIC NUTS

Made of carbon steel alloy with black oxide finish.



LEAD SCREW SPECIFICATIONS	ALLOY	STAINLESS STEEL
MATERIAL	4140 Series	300 Series
MINIMUM HARDNESS	200 Brinell	170 Brinell
TENSILE ULTIMATE STRENGTH	95,000 psi	85,000 psi
FINISH	Black Oxide	Natural

ACME LEAD SCREWS

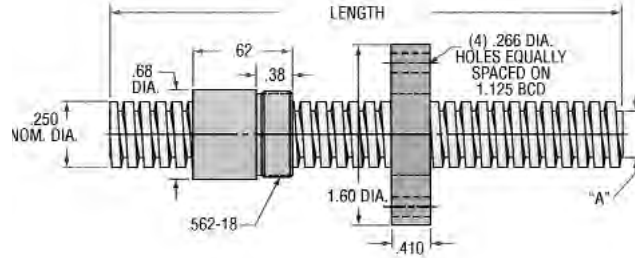

To extend the life of these lead screws we recommend that you lubricate with either spray lubricant (Stock No. E-100) or grease (Stock No. PAG-1). See Page E 14.

SIZE (O.D.)	TURNS PER INCH (TPI)	FORM	LEAD	STARTS
1/4"	3	STUB RIGHT HAND	0.333	4

LEAD SCREW STOCK NO.	LENGTH (INCH)	MATERIAL	BACKLASH	"A" ROOT DIA.
AT4SS3-6	6	300 STAINLESS STEEL	0.005	0.192
AT4SS3-8	8			
AT4SS3-10	10			
AT4SS3-12	12			
AT4SS3-36	36			
AT4SS3-72	72			
AT4AS3-6	6	4140 ALLOY STEEL		
AT4AS3-8	8			
AT4AS3-10	10			
AT4AS3-12	12			
AT4AS3-36	36			
AT4AS3-72	72			

NUT(S) / FLANGE - ARE TO BE ORDERED SEPARATELY

NUT STOCK NO.	O.D.-TPI	MATERIAL	EFFICIENCY	TORQUE* (IN.-LBS.)	DYNAMIC LOAD	STATIC LOAD
AT4B3-NT	1/4-3	BRONZE PLASTIC	73%	.073	312	1000
AT4P3-NT			79%	.067	156	156

FLANGE STOCK NO.	MATERIAL	FINISH
AT1S-FL**	CARBON ALLOY STEEL	BLACK OXIDE

*TORQUE TO RAISE ONE (1) POUND.

** STAINLESS STEEL FLANGES AVAILABLE ON REQUEST.

SIZE (O.D.)	TURNS PER INCH (TPI)	FORM	LEAD	STARTS
1/4"	4	2C RIGHT HAND	0.250	4

LEAD SCREW STOCK NO.	LENGTH (INCH)	MATERIAL	BACKLASH	"A" ROOT DIA.
AT4SS4-6	6	300 STAINLESS STEEL	0.007	0.162
AT4SS4-8	8			
AT4SS4-10	10			
AT4SS4-12	12			
AT4SS4-36	36			
AT4SS4-72	72			

NUT(S) / FLANGE - ARE TO BE ORDERED SEPARATELY

NUT STOCK NO.	O.D.-TPI	MATERIAL	EFFICIENCY	TORQUE* (IN.-LBS.)	DYNAMIC LOAD	STATIC LOAD
AT4B4-NT	1/4-4	BRONZE PLASTIC	71%	.056	312	1000
AT4P4-NT			75%	.053	156	156

FLANGE STOCK NO.	MATERIAL	FINISH
AT1S-FL**	CARBON ALLOY STEEL	BLACK OXIDE

*TORQUE TO RAISE ONE (1) POUND.

** STAINLESS STEEL FLANGES AVAILABLE ON REQUEST.

SIZE (O.D.)	TURNS PER INCH (TPI)	FORM	LEAD	STARTS
1/4"	16	2C RIGHT HAND	0.062	1

LEAD SCREW STOCK NO.	LENGTH (INCH)	MATERIAL	BACKLASH	"A" ROOT DIA.
AT4SS16-6	6	300 STAINLESS STEEL	0.005	0.162
AT4SS16-8	8			
AT4SS16-10	10			
AT4SS16-12	12			
AT4SS16-36	36			
AT4SS16-72	72			
AT4AS16-6	6	4140 ALLOY STEEL		
AT4AS16-8	8			
AT4AS16-10	10			
AT4AS16-12	12			
AT4AS16-36	36			
AT4AS16-72	72			

NUT(S) / FLANGE - ARE TO BE ORDERED SEPARATELY

NUT STOCK NO.	O.D.-TPI	MATERIAL	EFFICIENCY	TORQUE* (IN.-LBS.)	DYNAMIC LOAD	STATIC LOAD
AT4B16-NT	1/4-16	BRONZE PLASTIC	39%	.026	312	1000
AT4P16-NT			46%	.021	156	156

FLANGE STOCK NO.	MATERIAL	FINISH
AT1S-FL**	CARBON ALLOY STEEL	BLACK OXIDE

*TORQUE TO RAISE ONE (1) POUND.

** STAINLESS STEEL FLANGES AVAILABLE ON REQUEST.

ACME LEAD SCREWS

SIZE (O.D.)	TURNS PER INCH (TPI)	FORM	LEAD	STARTS
1/4"	20	2C RIGHT HAND	0.050	1

LEAD SCREW STOCK NO.	LENGTH (INCH)	MATERIAL	BACKLASH	"A" ROOT DIA.
AT4SS20-6	6	300 STAINLESS STEEL	0.006	0.175
AT4SS20-8	8			
AT4SS20-10	10			
AT4SS20-12	12			
AT4SS20-36	36			
AT4SS20-72	72			

NUT(S) / FLANGE - ARE TO BE ORDERED SEPARATELY

NUT STOCK NO.	O.D.-TPI	MATERIAL	EFFICIENCY	TORQUE* (IN.-LBS.)	DYNAMIC LOAD	STATIC LOAD
AT4B20-NT	1/4-20	BRONZE	36%	.022	312	1000
AT4P20-NT		PLASTIC	40%	.020	156	156

FLANGE STOCK NO.	MATERIAL	FINISH
AT1S-FL**	CARBON ALLOY STEEL	BLACK OXIDE

*TORQUE TO RAISE ONE (1) POUND.

** STAINLESS STEEL FLANGES AVAILABLE ON REQUEST.

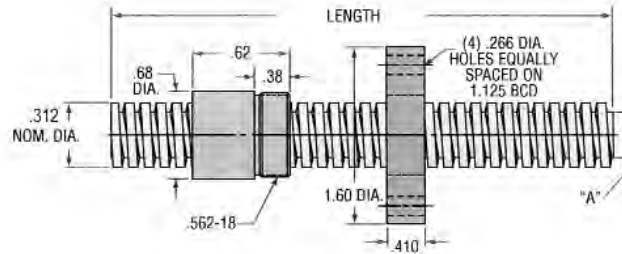

To extend the life of these lead screws we recommend that you lubricate with either spray lubricant (Stock No. E-100) or grease (Stock No. PAG-1). See Page E 14.

SIZE (O.D.)	TURNS PER INCH (TPI)	FORM	LEAD	STARTS
5/16"	2	STUB RIGHT HAND	0.500	4

LEAD SCREW STOCK NO.	LENGTH (INCH)	MATERIAL	BACKLASH	"A" ROOT DIA.
AT5SS2-6	6	300 STAINLESS STEEL	0.008	0.216
AT5SS2-8	8			
AT5SS2-10	10			
AT5SS2-12	12			
AT5SS2-36	36			
AT5SS2-72	72			

NUT(S) / FLANGE - ARE TO BE ORDERED SEPARATELY

NUT STOCK NO.	O.D.-TPI	MATERIAL	EFFICIENCY	TORQUE* (IN.-LBS.)	DYNAMIC LOAD	STATIC LOAD
AT5P2-NT	5/16-2	PLASTIC	81%	.099	205	205

FLANGE STOCK NO.	MATERIAL	FINISH
AT1S-FL**	CARBON ALLOY STEEL	BLACK OXIDE

*TORQUE TO RAISE ONE (1) POUND.

** STAINLESS STEEL FLANGES AVAILABLE ON REQUEST.

SIZE (O.D.)	TURNS PER INCH (TPI)	FORM	LEAD	STARTS
5/16"	4	STUB RIGHT HAND	0.250	2

LEAD SCREW STOCK NO.	LENGTH (INCH)	MATERIAL	BACKLASH	"A" ROOT DIA.
AT5SS4-6	6	300 STAINLESS STEEL	0.008	0.216
AT5SS4-8	8			
AT5SS4-10	10			
AT5SS4-12	12			
AT5SS4-36	36			
AT5SS4-72	72			
AT5AS4-6	6	4140 ALLOY STEEL	0.008	0.216
AT5AS4-8	8			
AT5AS4-10	10			
AT5AS4-12	12			
AT5AS4-36	36			
AT5AS4-72	72			

NUT(S) / FLANGE - ARE TO BE ORDERED SEPARATELY

NUT STOCK NO.	O.D.-TPI	MATERIAL	EFFICIENCY	TORQUE* (IN.-LBS.)	DYNAMIC LOAD	STATIC LOAD
AT5B4-NT	5/16-4	BRONZE	67%	.059	510	1625
AT5P4-NT		PLASTIC	73%	.054	205	205

FLANGE STOCK NO.	MATERIAL	FINISH
AT1S-FL**	CARBON ALLOY STEEL	BLACK OXIDE

*TORQUE TO RAISE ONE (1) POUND.

** STAINLESS STEEL FLANGES AVAILABLE ON REQUEST.

ACME LEAD SCREWS

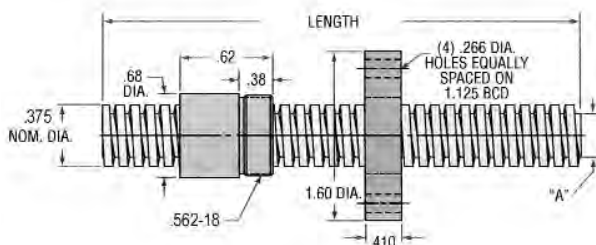

To extend the life of these lead screws we recommend that you lubricate with either spray lubricant (Stock No. E-100) or grease (Stock No. PAG-1). See Page E 14.

SIZE (O.D.)	TURNS PER INCH (TPI)	FORM	LEAD	STARTS
3/8"	2	STUB RIGHT HAND	0.500	4

LEAD SCREW STOCK NO.	LENGTH (INCH)	MATERIAL	BACKLASH	"A" ROOT DIA.
AT6SS2-6	6	300 STAINLESS STEEL	0.009	0.278
AT6SS2-8	8			
AT6SS2-10	10			
AT6SS2-12	12			
AT6SS2-36	36			
AT6SS2-72	72			
AT6AS2-6	6	4140 ALLOY STEEL		
AT6AS2-8	8			
AT6AS2-10	10			
AT6AS2-12	12			
AT6AS2-36	36			
AT6AS2-72	72			

NUT(S) / FLANGE - ARE TO BE ORDERED SEPARATELY

NUT STOCK NO.	O.D.-TPI	MATERIAL	EFFICIENCY	TORQUE* (IN.-LBS.)	DYNAMIC LOAD	STATIC LOAD
AT6B2-NT	3/8-2	BRONZE	74%	.107	703	2250
AT6P2-NT		PLASTIC	79%	.101	351	351

FLANGE STOCK NO.	MATERIAL	FINISH
AT1S-FL**	CARBON ALLOY STEEL	BLACK OXIDE

*TORQUE TO RAISE ONE (1) POUND.

** STAINLESS STEEL FLANGES AVAILABLE ON REQUEST.

SIZE (O.D.)	TURNS PER INCH (TPI)	FORM	LEAD	STARTS
3/8"	4	STUB RIGHT HAND	0.250	2

LEAD SCREW STOCK NO.	LENGTH (INCH)	MATERIAL	BACKLASH	"A" ROOT DIA.
AT6SS4-6	6	300 STAINLESS STEEL	0.009	0.278
AT6SS4-8	8			
AT6SS4-10	10			
AT6SS4-12	12			
AT6SS4-36	36			
AT6SS4-72	72			
AT6AS4-6	6	4140 ALLOY STEEL		
AT6AS4-8	8			
AT6AS4-10	10			
AT6AS4-12	12			
AT6AS4-36	36			
AT6AS4-72	72			

NUT(S) / FLANGE - ARE TO BE ORDERED SEPARATELY

NUT STOCK NO.	O.D.-TPI	MATERIAL	EFFICIENCY	TORQUE* (IN.-LBS.)	DYNAMIC LOAD	STATIC LOAD
AT6B4-NT	3/8-4	BRONZE	63%	.063	703	2250
AT6P4-NT		PLASTIC	69%	.057	351	351

FLANGE STOCK NO.	MATERIAL	FINISH
AT1S-FL**	CARBON ALLOY STEEL	BLACK OXIDE

*TORQUE TO RAISE ONE (1) POUND.

** STAINLESS STEEL FLANGES AVAILABLE ON REQUEST.

SIZE (O.D.)	TURNS PER INCH (TPI)	FORM	LEAD	STARTS
3/8"	5	STUB RIGHT HAND	0.200	2

LEAD SCREW STOCK NO.	LENGTH (INCH)	MATERIAL	BACKLASH	"A" ROOT DIA.
AT6SS5-6	6	300 STAINLESS STEEL	0.008	0.282
AT6SS5-8	8			
AT6SS5-10	10			
AT6SS5-12	12			
AT6SS5-36	36			
AT6SS5-72	72			
AT6AS5-6	6	4140 ALLOY STEEL		
AT6AS5-8	8			
AT6AS5-10	10			
AT6AS5-12	12			
AT6AS5-36	36			
AT6AS5-72	72			

NUT(S) / FLANGE - ARE TO BE ORDERED SEPARATELY

NUT STOCK NO.	O.D.-TPI	MATERIAL	EFFICIENCY	TORQUE* (IN.-LBS.)	DYNAMIC LOAD	STATIC LOAD
AT6B5-NT	3/8-5	BRONZE	59%	.054	703	2250
AT6P5-NT		PLASTIC	64%	.050	351	351

FLANGE STOCK NO.	MATERIAL	FINISH
AT1S-FL**	CARBON ALLOY STEEL	BLACK OXIDE

*TORQUE TO RAISE ONE (1) POUND.

** STAINLESS STEEL FLANGES AVAILABLE ON REQUEST.



ACME LEAD SCREWS

SIZE (O.D.)	TURNS PER INCH (TPI)	FORM	LEAD	STARTS
3/8"	6	2C RIGHT HAND	0.166	2

LEAD SCREW STOCK NO.	LENGTH (INCH)	MATERIAL	BACKLASH	"A" ROOT DIA.
AT6SS6-6	6	300 STAINLESS STEEL	0.006	0.263
AT6SS6-8	8			
AT6SS6-10	10			
AT6SS6-12	12			
AT6SS6-36	36			
AT6SS6-72	72			
AT6AS6-6	6	4140 ALLOY STEEL		
AT6AS6-8	8			
AT6AS6-10	10			
AT6AS6-12	12			
AT6AS6-36	36			
AT6AS6-72	72			

NUT(S) / FLANGE - ARE TO BE ORDERED SEPARATELY

NUT STOCK NO.	O.D.-TPI	MATERIAL	EFFICIENCY	TORQUE* (IN.-LBS.)	DYNAMIC LOAD	STATIC LOAD
AT6B6-NT	3/8-6	BRONZE	54%	.049	703	2250
AT6P6-NT		PLASTIC	60%	.044	351	351

FLANGE STOCK NO.	MATERIAL	FINISH
AT1S-FL**	CARBON ALLOY STEEL	BLACK OXIDE

*TORQUE TO RAISE ONE (1) POUND.

** STAINLESS STEEL FLANGES AVAILABLE ON REQUEST.

SIZE (O.D.)	TURNS PER INCH (TPI)	FORM	LEAD	STARTS
3/8"	8	STUB RIGHT HAND	0.125	1

LEAD SCREW STOCK NO.	LENGTH (INCH)	MATERIAL	BACKLASH	"A" ROOT DIA.
AT6SS8-6	6	300 STAINLESS STEEL	0.009	0.278
AT6SS8-8	8			
AT6SS8-10	10			
AT6SS8-12	12			
AT6SS8-36	36			
AT6SS8-72	72			
AT6AS8-6	6	4140 ALLOY STEEL		
AT6AS8-8	8			
AT6AS8-10	10			
AT6AS8-12	12			
AT6AS8-36	36			
AT6AS8-72	72			

NUT(S) / FLANGE - ARE TO BE ORDERED SEPARATELY

NUT STOCK NO.	O.D.-TPI	MATERIAL	EFFICIENCY	TORQUE* (IN.-LBS.)	DYNAMIC LOAD	STATIC LOAD
AT6B8-NT	3/8-8	BRONZE	48%	.042	703	2250
AT6P8-NT		PLASTIC	54%	.037	351	351

FLANGE STOCK NO.	MATERIAL	FINISH
AT1S-FL**	CARBON ALLOY STEEL	BLACK OXIDE

*TORQUE TO RAISE ONE (1) POUND.

** STAINLESS STEEL FLANGES AVAILABLE ON REQUEST.

SIZE (O.D.)	TURNS PER INCH (TPI)	FORM	LEAD	STARTS
3/8"	10	STUB RIGHT HAND	0.100	1

LEAD SCREW STOCK NO.	LENGTH (INCH)	MATERIAL	BACKLASH	"A" ROOT DIA.
AT6SS10-6	6	300 STAINLESS STEEL	0.008	0.282
AT6SS10-8	8			
AT6SS10-10	10			
AT6SS10-12	12			
AT6SS10-36	36			
AT6SS10-72	72			
AT6AS10-6	6	4140 ALLOY STEEL		
AT6AS10-8	8			
AT6AS10-10	10			
AT6AS10-12	12			
AT6AS10-36	36			
AT6AS10-72	72			

NUT(S) / FLANGE - ARE TO BE ORDERED SEPARATELY

NUT STOCK NO.	O.D.-TPI	MATERIAL	EFFICIENCY	TORQUE* (IN.-LBS.)	DYNAMIC LOAD	STATIC LOAD
AT6B10-NT	3/8-10	BRONZE	42%	.038	703	2250
AT6P10-NT		PLASTIC	48%	.033	351	351

FLANGE STOCK NO.	MATERIAL	FINISH
AT1S-FL**	CARBON ALLOY STEEL	BLACK OXIDE

*TORQUE TO RAISE ONE (1) POUND.

** STAINLESS STEEL FLANGES AVAILABLE ON REQUEST.

ACME LEAD SCREWS

SIZE (O.D.)	TURNS PER INCH (TPI)	FORM	LEAD	STARTS
3/8"	12	2C RIGHT HAND	0.083	1

LEAD SCREW STOCK NO.	LENGTH (INCH)	MATERIAL	BACKLASH	"A" ROOT DIA.
AT6SS12-6	6	300 STAINLESS STEEL	0.006	0.263
AT6SS12-8	8			
AT6SS12-10	10			
AT6SS12-12	12			
AT6SS12-36	36			
AT6SS12-72	72			
AT6AS12-6	6	4140 ALLOY STEEL	0.006	0.263
AT6AS12-8	8			
AT6AS12-10	10			
AT6AS12-12	12			
AT6AS12-36	36			
AT6AS12-72	72			

NUT(S) / FLANGE - ARE TO BE ORDERED SEPARATELY

NUT STOCK NO.	O.D.-TPI	MATERIAL	EFFICIENCY	TORQUE* (IN.-LBS.)	DYNAMIC LOAD	STATIC LOAD
AT6B12-NT	3/8-12	BRONZE	37%	.036	703	2250
AT6P12-NT		PLASTIC	43%	.031	351	351

FLANGE STOCK NO.	MATERIAL	FINISH
AT1S-FL**	CARBON ALLOY STEEL	BLACK OXIDE

*TORQUE TO RAISE ONE (1) POUND.

** STAINLESS STEEL FLANGES AVAILABLE ON REQUEST.

SIZE (O.D.)	TURNS PER INCH (TPI)	FORM	LEAD	STARTS
3/8"	16	STUB RIGHT HAND	0.062	1

LEAD SCREW STOCK NO.	LENGTH (INCH)	MATERIAL	BACKLASH	"A" ROOT DIA.
AT6SS16-6	6	300 STAINLESS STEEL	0.007	0.286
AT6SS16-8	8			
AT6SS16-10	10			
AT6SS16-12	12			
AT6SS16-36	36			
AT6SS16-72	72			
AT6AS16-6	6	4140 ALLOY STEEL	0.007	0.286
AT6AS16-8	8			
AT6AS16-10	10			
AT6AS16-12	12			
AT6AS16-36	36			
AT6AS16-72	72			

NUT(S) / FLANGE - ARE TO BE ORDERED SEPARATELY

NUT STOCK NO.	O.D.-TPI	MATERIAL	EFFICIENCY	TORQUE* (IN.-LBS.)	DYNAMIC LOAD	STATIC LOAD
AT6B16-NT	3/8-16	BRONZE	37%	.036	703	2250
AT6P16-NT		PLASTIC	43%	.031	351	351

FLANGE STOCK NO.	MATERIAL	FINISH
AT1S-FL**	CARBON ALLOY STEEL	BLACK OXIDE

*TORQUE TO RAISE ONE (1) POUND.

** STAINLESS STEEL FLANGES AVAILABLE ON REQUEST.

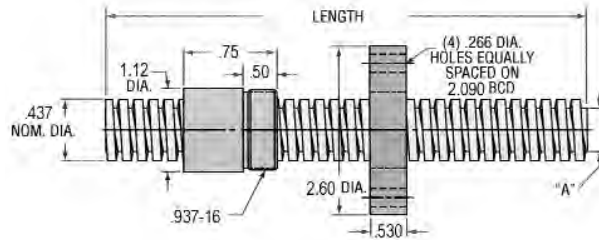

To extend the life of these lead screws we recommend that you lubricate with either spray lubricant (Stock No. E-100) or grease (Stock No. PAG-1). See Page E 14.

SIZE (O.D.)	TURNS PER INCH (TPI)	FORM	LEAD	STARTS
7/16"	2	STUB RIGHT HAND	0.500	4

LEAD SCREW STOCK NO.	LENGTH (INCH)	MATERIAL	BACKLASH	"A" ROOT DIA.
AT7SS2-6	6	300 STAINLESS STEEL	0.009	0.340
AT7SS2-8	8			
AT7SS2-10	10			
AT7SS2-12	12			
AT7SS2-36	36			
AT7SS2-72	72			
AT7AS2-6	6	4140 ALLOY STEEL	0.009	0.340
AT7AS2-8	8			
AT7AS2-10	10			
AT7AS2-12	12			
AT7AS2-36	36			
AT7AS2-72	72			

NUT(S) / FLANGE - ARE TO BE ORDERED SEPARATELY

NUT STOCK NO.	O.D.-TPI	MATERIAL	EFFICIENCY	TORQUE* (IN.-LBS.)	DYNAMIC LOAD	STATIC LOAD
AT7B2-NT	7/16-2	PLASTIC	77%	.103	450	450
AT7P2-NT						

FLANGE STOCK NO.	MATERIAL	FINISH
AT2S-FL**	CARBON ALLOY STEEL	BLACK OXIDE

*TORQUE TO RAISE ONE (1) POUND.

** STAINLESS STEEL FLANGES AVAILABLE ON REQUEST.

ACME LEAD SCREWS

SIZE (O.D.)	TURNS PER INCH (TPI)	FORM	LEAD	STARTS
7/16"	4	STUB RIGHT HAND	0.250	2

LEAD SCREW STOCK NO.	LENGTH (INCH)	MATERIAL	BACKLASH	"A" ROOT DIA.
AT7SS4-6	6	300 STAINLESS STEEL	0.009	0.340
AT7SS4-8	8			
AT7SS4-10	10			
AT7SS4-12	12			
AT7SS4-36	36			
AT7SS4-72	72			
AT7AS4-6	6	4140 ALLOY STEEL		
AT7AS4-8	8			
AT7AS4-10	10			
AT7AS4-12	12			
AT7AS4-36	36			
AT7AS4-72	72			

NUT(S) / FLANGE - ARE TO BE ORDERED SEPARATELY

NUT STOCK NO.	O.D.-TPI	MATERIAL	EFFICIENCY	TORQUE* (IN.-LBS.)	DYNAMIC LOAD	STATIC LOAD
AT7B4-NT	7/16-4	BRONZE	60%	.067	975	3000
AT7P4-NT		PLASTIC	66%	.060	450	450

FLANGE STOCK NO.	MATERIAL	FINISH
AT2S-FL**	CARBON ALLOY STEEL	BLACK OXIDE

*TORQUE TO RAISE ONE (1) POUND.

** STAINLESS STEEL FLANGES AVAILABLE ON REQUEST.

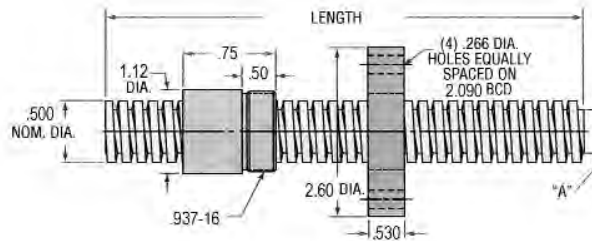

To extend the life of these lead screws we recommend that you lubricate with either spray lubricant (Stock No. E-100) or grease (Stock No. PAG-1). See Page E 14.

SIZE (O.D.)	TURNS PER INCH (TPI)	FORM	LEAD	STARTS
1/2"	1	STUB RIGHT HAND	1.000	8

LEAD SCREW STOCK NO.	LENGTH (INCH)	MATERIAL	BACKLASH	"A" ROOT DIA.
AT8SS1-6	6	300 STAINLESS STEEL	0.007	0.392
AT8SS1-8	8			
AT8SS1-10	10			
AT8SS1-12	12			
AT8SS1-36	36			
AT8SS1-72	72			

NUT(S) / FLANGE - ARE TO BE ORDERED SEPARATELY

NUT STOCK NO.	O.D.-TPI	MATERIAL	EFFICIENCY	TORQUE* (IN.-LBS.)	DYNAMIC LOAD	STATIC LOAD
AT8P1-NT	1/2-1	PLASTIC	75%	.106	625	625

FLANGE STOCK NO.	MATERIAL	FINISH
AT2S-FL**	CARBON ALLOY STEEL	BLACK OXIDE

*TORQUE TO RAISE ONE (1) POUND.

** STAINLESS STEEL FLANGES AVAILABLE ON REQUEST.

SIZE (O.D.)	TURNS PER INCH (TPI)	FORM	LEAD	STARTS
1/2"	2	STUB RIGHT HAND	0.500	5

LEAD SCREW STOCK NO.	LENGTH (INCH)	MATERIAL	BACKLASH	"A" ROOT DIA.
AT8SS2-6	6	300 STAINLESS STEEL	0.006	0.406
AT8SS2-8	8			
AT8SS2-10	10			
AT8SS2-12	12			
AT8SS2-36	36			
AT8SS2-72	72			
AT8AS2-6	6	4140 ALLOY STEEL		
AT8AS2-8	8			
AT8AS2-10	10			
AT8AS2-12	12			
AT8AS2-36	36			
AT8AS2-72	72			

NUT(S) / FLANGE - ARE TO BE ORDERED SEPARATELY

NUT STOCK NO.	O.D.-TPI	MATERIAL	EFFICIENCY	TORQUE* (IN.-LBS.)	DYNAMIC LOAD	STATIC LOAD
AT8B2-NT	1/2-2	BRONZE	69%	.115	1250	4000
AT8P2-NT		PLASTIC	75%	.107	625	625

FLANGE STOCK NO.	MATERIAL	FINISH
AT2S-FL**	CARBON ALLOY STEEL	BLACK OXIDE

*TORQUE TO RAISE ONE (1) POUND.

** STAINLESS STEEL FLANGES AVAILABLE ON REQUEST.

ACME LEAD SCREWS

SIZE (O.D.)	TURNS PER INCH (TPI)	FORM	LEAD	STARTS
1/2"	4	2C RIGHT HAND	.250	2

LEAD SCREW STOCK NO.	LENGTH (INCH)	MATERIAL	BACKLASH	"A" ROOT DIA.
AT8SS4-6	6	300 STAINLESS STEEL	0.007	0.332
AT8SS4-8	8			
AT8SS4-10	10			
AT8SS4-12	12			
AT8SS4-36	36			
AT8SS4-72	72			
AT8AS4-6	6	4140 ALLOY STEEL	0.007	0.332
AT8AS4-8	8			
AT8AS4-10	10			
AT8AS4-12	12			
AT8AS4-36	36			
AT8AS4-72	72			

NUT(S) / FLANGE - ARE TO BE ORDERED SEPARATELY

NUT STOCK NO.	O.D.-TPI	MATERIAL	EFFICIENCY	TORQUE* (IN.-LBS.)	DYNAMIC LOAD	STATIC LOAD
AT8B4-NT	1/2-4	BRONZE	57%	.070	1250	4000
AT8P4-NT		PLASTIC	63%	.064	625	625

FLANGE STOCK NO.	MATERIAL	FINISH
AT2S-FL**	CARBON ALLOY STEEL	BLACK OXIDE

*TORQUE TO RAISE ONE (1) POUND.
** STAINLESS STEEL FLANGES AVAILABLE ON REQUEST.

SIZE (O.D.)	TURNS PER INCH (TPI)	FORM	LEAD	STARTS
1/2"	5	STUB RIGHT HAND	.200	2

LEAD SCREW STOCK NO.	LENGTH (INCH)	MATERIAL	BACKLASH	"A" ROOT DIA.
AT8SS5-6	6	300 STAINLESS STEEL	0.009	0.391
AT8SS5-8	8			
AT8SS5-10	10			
AT8SS5-12	12			
AT8SS5-36	36			
AT8SS5-72	72			
AT8AS5-6	6	4140 ALLOY STEEL	0.009	0.391
AT8AS5-8	8			
AT8AS5-10	10			
AT8AS5-12	12			
AT8AS5-36	36			
AT8AS5-72	72			

NUT(S) / FLANGE - ARE TO BE ORDERED SEPARATELY

NUT STOCK NO.	O.D.-TPI	MATERIAL	EFFICIENCY	TORQUE* (IN.-LBS.)	DYNAMIC LOAD	STATIC LOAD
AT8B5-NT	1/2-5	BRONZE	52%	.061	1250	4000
AT8P5-NT		PLASTIC	57%	.056	625	625

FLANGE STOCK NO.	MATERIAL	FINISH
AT2S-FL**	CARBON ALLOY STEEL	BLACK OXIDE

*TORQUE TO RAISE ONE (1) POUND.
** STAINLESS STEEL FLANGES AVAILABLE ON REQUEST.

SIZE (O.D.)	TURNS PER INCH (TPI)	FORM	LEAD	STARTS
1/2"	10	2C RIGHT HAND	.100	1

LEAD SCREW STOCK NO.	LENGTH (INCH)	MATERIAL	BACKLASH	"A" ROOT DIA.
AT8SS10-6	6	300 STAINLESS STEEL	0.007	0.359
AT8SS10-8	8			
AT8SS10-10	10			
AT8SS10-12	12			
AT8SS10-36	36			
AT8SS10-72	72			
AT8AS10-6	6	4140 ALLOY STEEL	0.007	0.359
AT8AS10-8	8			
AT8AS10-10	10			
AT8AS10-12	12			
AT8AS10-36	36			
AT8AS10-72	72			

NUT(S) / FLANGE - ARE TO BE ORDERED SEPARATELY

NUT STOCK NO.	O.D.-TPI	MATERIAL	EFFICIENCY	TORQUE* (IN.-LBS.)	DYNAMIC LOAD	STATIC LOAD
AT8B10-NT	1/2-10	BRONZE	34%	.047	1250	4000
AT8P10-NT		PLASTIC	40%	.039	625	625

FLANGE STOCK NO.	MATERIAL	FINISH
AT2S-FL**	CARBON ALLOY STEEL	BLACK OXIDE

*TORQUE TO RAISE ONE (1) POUND.
** STAINLESS STEEL FLANGES AVAILABLE ON REQUEST.



ACME LEAD SCREWS

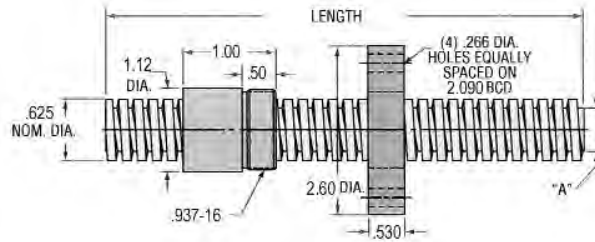

To extend the life of these lead screws we recommend that you lubricate with either spray lubricant (Stock No. E-100) or grease (Stock No. PAG-1). See Page E 14

SIZE (O.D.)	TURNS PER INCH (TPI)	FORM	LEAD	STARTS
5/8"	5	2C RIGHT HAND	0.200	2

LEAD SCREW STOCK NO.	LENGTH (INCH)	MATERIAL	BACKLASH	"A" ROOT DIA.
AT10SS5-6	6	300 STAINLESS STEEL	0.009	0.484
AT10SS5-8	8			
AT10SS5-10	10			
AT10SS5-12	12			
AT10SS5-36	36			
AT10SS5-72	72			
AT10AS5-6	6	4140 ALLOY STEEL		
AT10AS5-8	8			
AT10AS5-10	10			
AT10AS5-12	12			
AT10AS5-36	36			
AT10AS5-72	72			

NUT(S) / FLANGE - ARE TO BE ORDERED SEPARATELY

NUT STOCK NO.	O.D.-TPI	MATERIAL	EFFICIENCY	TORQUE* (IN.-LBS.)	DYNAMIC LOAD	STATIC LOAD
AT10B5-NT	5/8-5	BRONZE	46%	.069	1953	6250
AT10P5-NT		PLASTIC	51%	.062	976	976

FLANGE STOCK NO.	MATERIAL	FINISH
AT2S-FL**	CARBON ALLOY STEEL	BLACK OXIDE

*TORQUE TO RAISE ONE (1) POUND.

** STAINLESS STEEL FLANGES AVAILABLE ON REQUEST.

SIZE (O.D.)	TURNS PER INCH (TPI)	FORM	LEAD	STARTS
5/8"	8	2C RIGHT HAND	0.125	1

LEAD SCREW STOCK NO.	LENGTH (INCH)	MATERIAL	BACKLASH	"A" ROOT DIA.
AT10SS8-6	6	300 STAINLESS STEEL	0.008	0.457
AT10SS8-8	8			
AT10SS8-10	10			
AT10SS8-12	12			
AT10SS8-36	36			
AT10SS8-72	72			
AT10AS8-6	6	4140 ALLOY STEEL		
AT10AS8-8	8			
AT10AS8-10	10			
AT10AS8-12	12			
AT10AS8-36	36			
AT10AS8-72	72			

NUT(S) / FLANGE - ARE TO BE ORDERED SEPARATELY

NUT STOCK NO.	O.D.-TPI	MATERIAL	EFFICIENCY	TORQUE* (IN.-LBS.)	DYNAMIC LOAD	STATIC LOAD
AT10B8-NT	5/8-8	BRONZE	34%	.058	1953	6250
AT10P8-NT		PLASTIC	40%	.049	976	976

FLANGE STOCK NO.	MATERIAL	FINISH
AT2S-FL**	CARBON ALLOY STEEL	BLACK OXIDE

*TORQUE TO RAISE ONE (1) POUND.

** STAINLESS STEEL FLANGES AVAILABLE ON REQUEST.

SIZE (O.D.)	TURNS PER INCH (TPI)	FORM	LEAD	STARTS
5/8"	10	STUB RIGHT HAND	0.100	1

LEAD SCREW STOCK NO.	LENGTH (INCH)	MATERIAL	BACKLASH	"A" ROOT DIA.
AT10SS10-6	6	300 STAINLESS STEEL	0.009	0.516
AT10SS10-8	8			
AT10SS10-10	10			
AT10SS10-12	12			
AT10SS10-36	36			
AT10SS10-72	72			
AT10AS10-6	6	4140 ALLOY STEEL		
AT10AS10-8	8			
AT10AS10-10	10			
AT10AS10-12	12			
AT10AS10-36	36			
AT10AS10-72	72			

NUT(S) / FLANGE - ARE TO BE ORDERED SEPARATELY

NUT STOCK NO.	O.D.-TPI	MATERIAL	EFFICIENCY	TORQUE* (IN.-LBS.)	DYNAMIC LOAD	STATIC LOAD
AT10B10-NT	5/8-10	BRONZE	30%	.053	1953	6250
AT10P10-NT		PLASTIC	35%	.046	976	976

FLANGE STOCK NO.	MATERIAL	FINISH
AT2S-FL**	CARBON ALLOY STEEL	BLACK OXIDE

*TORQUE TO RAISE ONE (1) POUND.

** STAINLESS STEEL FLANGES AVAILABLE ON REQUEST.

ACME LEAD SCREWS

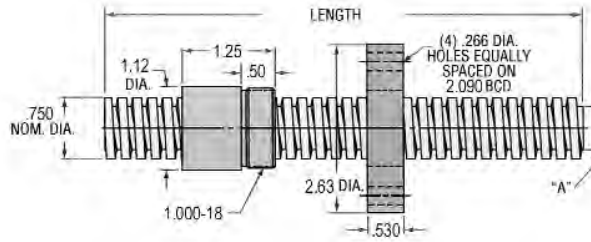

To extend the life of these lead screws we recommend that you lubricate with either spray lubricant (Stock No. E-100) or grease (Stock No. PAG-1). See Page E 14.

SIZE (O.D.)	URNS PER INCH (TPI)	FORM	LEAD	STARTS
3/4"	5	2C RIGHT HAND	0.200	1

LEAD SCREW STOCK NO.	LENGTH (INCH)	MATERIAL	BACKLASH	"A" ROOT DIA.
AT12SS5-6	6	300 STAINLESS STEEL	0.009	0.502
AT12SS5-8	8			
AT12SS5-10	10			
AT12SS5-12	12			
AT12SS5-36	36			
AT12SS5-72	72			
AT12AS5-6	6	4140 ALLOY STEEL		
AT12AS5-8	8			
AT12AS5-10	10			
AT12AS5-12	12			
AT12AS5-36	36			
AT12AS5-72	72			

NUT(S) / FLANGE - ARE TO BE ORDERED SEPARATELY

NUT STOCK NO.	O.D.-TPI	MATERIAL	EFFICIENCY	TORQUE* (IN.-LBS.)	DYNAMIC LOAD	STATIC LOAD
AT12B5-NT	3/4-5	BRONZE	40%	.080	2812	9000
AT12P5-NT		PLASTIC	35%	.046	1406	1406

FLANGE STOCK NO.	MATERIAL	FINISH
AT3S-FL**	CARBON ALLOY STEEL	BLACK OXIDE

*TORQUE TO RAISE ONE (1) POUND.

** STAINLESS STEEL FLANGES AVAILABLE ON REQUEST.

SIZE (O.D.)	URNS PER INCH (TPI)	FORM	LEAD	STARTS
3/4"	6	2C RIGHT HAND	0.166	1

LEAD SCREW STOCK NO.	LENGTH (INCH)	MATERIAL	BACKLASH	"A" ROOT DIA.
AT12SS6-6	6	300 STAINLESS STEEL	0.008	0.537
AT12SS6-8	8			
AT12SS6-10	10			
AT12SS6-12	12			
AT12SS6-36	36			
AT12SS6-72	72			
AT12AS6-6	6	4140 ALLOY STEEL		
AT12AS6-8	8			
AT12AS6-10	10			
AT12AS6-12	12			
AT12AS6-36	36			
AT12AS6-72	72			

NUT(S) / FLANGE - ARE TO BE ORDERED SEPARATELY

NUT STOCK NO.	O.D.-TPI	MATERIAL	EFFICIENCY	TORQUE* (IN.-LBS.)	DYNAMIC LOAD	STATIC LOAD
AT12B6-NT	3/4-6	BRONZE	36%	.073	2812	9000
AT12P6-NT		PLASTIC	43%	.061	1406	1406

FLANGE STOCK NO.	MATERIAL	FINISH
AT3S-FL**	CARBON ALLOY STEEL	BLACK OXIDE

*TORQUE TO RAISE ONE (1) POUND.

** STAINLESS STEEL FLANGES AVAILABLE ON REQUEST.

SIZE (O.D.)	URNS PER INCH (TPI)	FORM	LEAD	STARTS
3/4"	10	2C RIGHT HAND	0.100	1

LEAD SCREW STOCK NO.	LENGTH (INCH)	MATERIAL	BACKLASH	"A" ROOT DIA.
AT12SS10-6	6	300 STAINLESS STEEL	0.007	0.608
AT12SS10-8	8			
AT12SS10-10	10			
AT12SS10-12	12			
AT12SS10-36	36			
AT12SS10-72	72			
AT12AS10-6	6	4140 ALLOY STEEL		
AT12AS10-8	8			
AT12AS10-10	10			
AT12AS10-12	12			
AT12AS10-36	36			
AT12AS10-72	72			

NUT(S) / FLANGE - ARE TO BE ORDERED SEPARATELY

NUT STOCK NO.	O.D.-TPI	MATERIAL	EFFICIENCY	TORQUE* (IN.-LBS.)	DYNAMIC LOAD	STATIC LOAD
AT12B10-NT	3/4-10	BRONZE	25%	.064	2812	9000
AT12P10-NT		PLASTIC	30%	.052	1406	1406

FLANGE STOCK NO.	MATERIAL	FINISH
AT3S-FL**	CARBON ALLOY STEEL	BLACK OXIDE

*TORQUE TO RAISE ONE (1) POUND.

** STAINLESS STEEL FLANGES AVAILABLE ON REQUEST.

ACME LEAD SCREWS

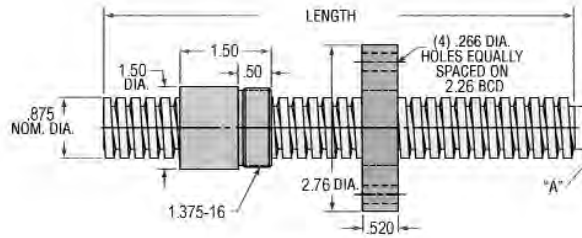

To extend the life of these lead screws we recommend that you lubricate with either spray lubricant (Stock No. E-100) or grease (Stock No. PAG-1). See Page E 14.

SIZE (O.D.)	TURNS PER INCH (TPI)	FORM	LEAD	STARTS
7/8"	6	2C RIGHT HAND	0.166	1

LEAD SCREW STOCK NO.	LENGTH (INCH)	MATERIAL	BACKLASH	"A" ROOT DIA.
AT14AS6-6	6	4140 ALLOY STEEL	0.009	0.661
AT14AS6-8	8			
AT14AS6-10	10	ALLOY STEEL	0.009	0.661
AT14AS6-12	12			
AT14AS6-36	36	STEEL	0.009	0.661
AT14AS6-72	72			

NUT(S) / FLANGE - ARE TO BE ORDERED SEPARATELY

NUT STOCK NO.	O.D.-TPI	MATERIAL	EFFICIENCY	TORQUE* (IN.-LBS.)	DYNAMIC LOAD	STATIC LOAD
AT14B6-NT	7/8-6	BRONZE	39%	.068	3828	12250
AT14P6-NT		PLASTIC	44%	.060	1914	1914

FLANGE STOCK NO.	MATERIAL	FINISH
AT4S-FL**	CARBON ALLOY STEEL	BLACK OXIDE

*TORQUE TO RAISE ONE (1) POUND.

** STAINLESS STEEL FLANGES AVAILABLE ON REQUEST.

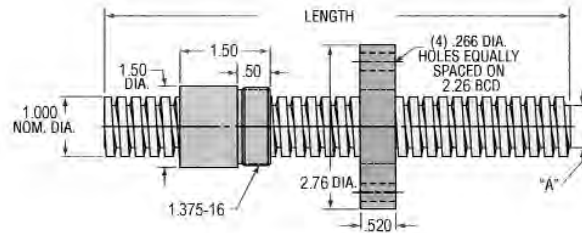

To extend the life of these lead screws we recommend that you lubricate with either spray lubricant (Stock No. E-100) or grease (Stock No. PAG-1). See Page E 14.

SIZE (O.D.)	TURNS PER INCH (TPI)	FORM	LEAD	STARTS
1"	4	2C RIGHT HAND	0.250	1

LEAD SCREW STOCK NO.	LENGTH (INCH)	MATERIAL	BACKLASH	"A" ROOT DIA.
AT16SS4-6	6	300 STAINLESS STEEL	0.010	0.698
AT16SS4-8	8			
AT16SS4-10	10	ALLOY STEEL	0.010	0.698
AT16SS4-12	12			
AT16SS4-36	36	STEEL	0.010	0.698
AT16SS4-72	72			
AT16AS4-6	6	4140 ALLOY STEEL	0.010	0.698
AT16AS4-8	8			
AT16AS4-10	10	STEEL	0.010	0.698
AT16AS4-12	12			
AT16AS4-36	36	STEEL	0.010	0.698
AT16AS4-72	72			

NUT(S) / FLANGE - ARE TO BE ORDERED SEPARATELY

NUT STOCK NO.	O.D.-TPI	MATERIAL	EFFICIENCY	TORQUE* (IN.-LBS.)	DYNAMIC LOAD	STATIC LOAD
AT16B4-NT	1-4	BRONZE	46%	.086	5000	16000
AT16P4-NT		PLASTIC	51%	.078	2500	2500

FLANGE STOCK NO.	MATERIAL	FINISH
AT4S-FL**	CARBON ALLOY STEEL	BLACK OXIDE

*TORQUE TO RAISE ONE (1) POUND.

** STAINLESS STEEL FLANGES AVAILABLE ON REQUEST.

ACME LEAD SCREWS

SIZE (O.D.)	TURNS PER INCH (TPI)	FORM	LEAD	STARTS
1"	5	2C RIGHT HAND	0.200	1

LEAD SCREW STOCK NO.	LENGTH (INCH)	MATERIAL	BACKLASH	"A" ROOT DIA.
AT16SS5-6	6	300 STAINLESS STEEL	0.009	0.750
AT16SS5-8	8			
AT16SS5-10	10			
AT16SS5-12	12			
AT16SS5-36	36			
AT16SS5-72	72			
AT16AS5-6	6	4140 ALLOY STEEL	0.009	0.750
AT16AS5-8	8			
AT16AS5-10	10			
AT16AS5-12	12			
AT16AS5-36	36			
AT16AS5-72	72			

NUT(S) / FLANGE - ARE TO BE ORDERED SEPARATELY

NUT STOCK NO.	O.D.-TPI	MATERIAL	EFFICIENCY	TORQUE* (IN.-LBS.)	DYNAMIC LOAD	STATIC LOAD
AT16B5-NT	1-5	BRONZE	40%	.079	5000	16000
AT16P5-NT		PLASTIC	46%	.069	2500	2500

FLANGE STOCK NO.	MATERIAL	FINISH
AT4S-FL**	CARBON ALLOY STEEL	BLACK OXIDE

*TORQUE TO RAISE ONE (1) POUND.

** STAINLESS STEEL FLANGES AVAILABLE ON REQUEST.

SIZE (O.D.)	TURNS PER INCH (TPI)	FORM	LEAD	STARTS
1"	6	2C RIGHT HAND	0.167	1

LEAD SCREW STOCK NO.	LENGTH (INCH)	MATERIAL	BACKLASH	"A" ROOT DIA.
AT16SS6-6	6	300 STAINLESS STEEL	0.009	0.786
AT16SS6-8	8			
AT16SS6-10	10			
AT16SS6-12	12			
AT16SS6-36	36			
AT16SS6-72	72			
AT16AS6-6	6	4140 ALLOY STEEL	0.009	0.786
AT16AS6-8	8			
AT16AS6-10	10			
AT16AS6-12	12			
AT16AS6-36	36			
AT16AS6-72	72			

NUT(S) / FLANGE - ARE TO BE ORDERED SEPARATELY

NUT STOCK NO.	O.D.-TPI	MATERIAL	EFFICIENCY	TORQUE* (IN.-LBS.)	DYNAMIC LOAD	STATIC LOAD
AT16B6-NT	1-6	BRONZE	36%	.074	5000	16000
AT16P6-NT		PLASTIC	41%	.064	2500	2500

FLANGE STOCK NO.	MATERIAL	FINISH
AT4S-FL**	CARBON ALLOY STEEL	BLACK OXIDE

*TORQUE TO RAISE ONE (1) POUND.

** STAINLESS STEEL FLANGES AVAILABLE ON REQUEST.

SIZE (O.D.)	TURNS PER INCH (TPI)	FORM	LEAD	STARTS
1"	10	2C RIGHT HAND	0.100	1

LEAD SCREW STOCK NO.	LENGTH (INCH)	MATERIAL	BACKLASH	"A" ROOT DIA.
AT16SS10-6	6	300 STAINLESS STEEL	0.008	0.857
AT16SS10-8	8			
AT16SS10-10	10			
AT16SS10-12	12			
AT16SS10-36	36			
AT16SS10-72	72			
AT16AS10-6	6	4140 ALLOY STEEL	0.008	0.857
AT16AS10-8	8			
AT16AS10-10	10			
AT16AS10-12	12			
AT16AS10-36	36			
AT16AS10-72	72			

NUT(S) / FLANGE - ARE TO BE ORDERED SEPARATELY

NUT STOCK NO.	O.D.-TPI	MATERIAL	EFFICIENCY	TORQUE* (IN.-LBS.)	DYNAMIC LOAD	STATIC LOAD
AT16B10-NT	1-10	BRONZE	24%	.065	5000	16000
AT16P10-NT		PLASTIC	30%	.053	2500	2500

FLANGE STOCK NO.	MATERIAL	FINISH
AT4S-FL**	CARBON ALLOY STEEL	BLACK OXIDE

*TORQUE TO RAISE ONE (1) POUND.

** STAINLESS STEEL FLANGES AVAILABLE ON REQUEST.



LUBRICATION FOR ACME LEAD SCREWS & NUTS

Proper lubrication is the key to continued performance and reliability of acme screw assemblies.



12 oz. Acme Screw (Spray) Lubricant = STOCK NO. E-100
1 Pound Can of Acme Screw Grease = STOCK NO. PAG-1

SPECIFICATIONS:

NLGI Grade No.	2
Penetration (worked)	285
Dropping Point	550°F
Gelling Agent	Synthetic
Oil Viscosity	cst @ 104°F is 96 / cst @ 212°F is 11.3
Temperature Range	15°F to 400°F

HIGH PRECISION & PRECISION LEAD SCREWS

TECHNICAL DATA

Lead Screws and Components

Berg is a pioneer in the development of lead screws. Providing cost effective solutions to linear actuation problems. The close tolerance, free running nuts are ideal for miniature applications requiring rotary to linear or linear to rotary actuation.

For applications requiring precision positioning, Berg also manufactures Anti-Backlash Nuts. This device, consisting of only three components, utilizes the constant force of a compression spring to push two nut halves apart. This action eliminates any play (backlash) which exists between the internal thread of the nut and the external screw thread. To ensure accuracy and repeatability the nut can be fine tuned through the use of the many available spring constants, to meet any pre-load design requirements.

Lead Screw Specification	High Precision
Lead Error	+/- .006 in./ft.
Repeatability	.00005 in.
Straightness	.003 in./ft.
Backlash	.003 in. (zero when using Anti-Backlash nut)
Temperature Range	-50°F to + 200°F
Breakaway Torque	0-3 oz-in. (standard nut)



Figure 9.1



Figure 9.2



Figure 9.3



Figure 9.4

Load - In order to properly incorporate a lead screw into a design, load requirements must be taken into account. Maximum load values for the nuts are listed in the tables on the following pages. These numbers are based on the shear of the nuts and does not take shaft buckling into account (see Max. Column Load formula below). Wherever possible, nuts should be positioned so as to be put in tension, pulling the load. This eliminates the need for buckling considerations. Listed below are some helpful formulas to assist in proper lead screw selection.

$$\text{Maximum Column Load (F)} = K \times C \times 10^6 \times d^4 / D^2$$

Where:

- K = End support factor
 - .025 one end fixed, other free (Figure 9.1)
 - 1.00 simple supports both ends (Figure 9.2)
 - 2.00 one end fixed, one simple (Figure 9.3)
 - 4.00 both ends fixed (Figure 9.4)
- C = Material factor
 - 13.4 for Stainless Steel screws
 - 4.8 for Aluminum screws
- d = Root diameter of the screw
- D = Length between the nut and the support bearing

$$\text{Torque to Move a Load (T)} = (F \times L) / (2 \times \xi \times E)$$

Where:

- F = Load
- L = Lead
- E = Efficiency (consult Berg Engineering Department for efficiency values)

$$\text{Horsepower (HP)} = \text{Torque (in. lbs.)} \times \text{RPM} / 63,025$$



ANTI-BACKLASH LEAD SCREW ASSEMBLIES

SERIES	MATERIAL
HIGH PRECISION	NUT - DELRIN, SPRING - STEEL PLATED ZINC, SCREW - STAINLESS STEEL

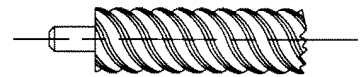
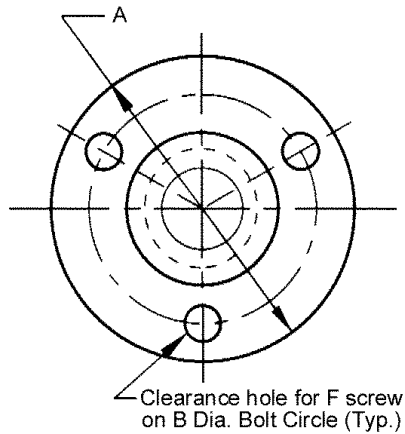
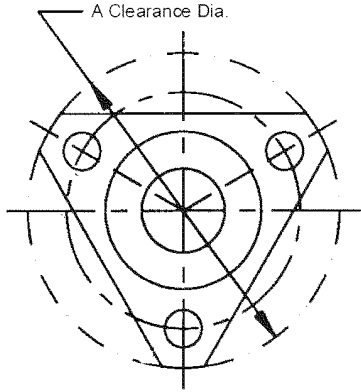
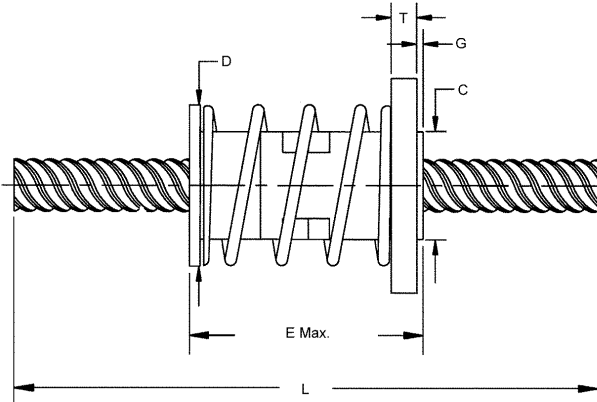

Special end configurations available on request.

Lead Screw Specifications

HIGH PRECISION LEAD SCREW SERIES	PITCH DIA.	LEAD	A	B ±.010	C ±.010	D	E	F	L	T	G
HTSP4ABS1-12 HTSP4ABS2-12 HTSP4ABS4-12	1/4	.0500 .0625 .2500	1.00	.750	.437	.582	1.13	#6-32	12	.19	.06
HTSP5ABS1-12 HTSP5ABS2-12	5/16	.0833 .2500	1.500	1.125	.625	.770	1.50	#10-24	24	.19	.06
HTSP6ABS1-24 HTSP6ABS2-24 HTSP6ABS8-24	3/8	.1000 .2500 1.0000									
HTSP7ABS1-24	7/16	.2500									
HTSP8ABS4-24 HTSP8ABS8-24	1/2	.5000 1.0000									
HTSP10ABS4-36*	5/8	.5000	1.750	1.375	.875	1.03	2.09	#10-24	36	.25	.08
HTSP12ABS4-36	3/4	.5000	2.180	1.800	1.18	1.58	2.50	#10	36	.25	.08

* Lead Screws can also be supplied in footage up to 5 ft.
Spare Nuts are also available on request
W. M. Berg rolling capabilities up to 2.00" dia. 16 d.p.

LEAD SCREWS

MATERIAL

NUT - DELRIN SHAFT - ALUMINUM

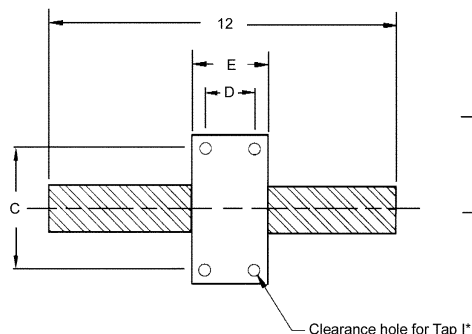

LEAD SCREW WITH SQUARE NUT

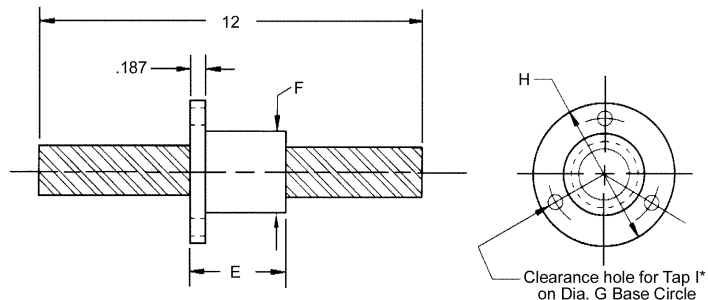

LEAD SCREW WITH ROUND NUT

Lead Screw Specifications - With Rectangular Nut

LEAD SCREW PITCH DIA.	STOCK NUMBER	LEAD	STOCK NUMBER	LEAD	STOCK NUMBER	LEAD
	PRECISION		PRECISION		PRECISION	
3/16	HTP3KA2-12	.3750	HTP3KA3-12	.5625	HTP3KA4-12	.7500
1/4	HTP4KA2-12	.5000	HTP4KA3-12	.7500	HTP4KA4-12	1.0000
3/8	HTP6KA2-12	.7500	HTP6KA3-12	1.1250	HTP6KA4-12	1.5000
1/2	HTP8KA2-12	1.0000	HTP8KA3-12	1.5000	HTP8KA4-12	2.0000
5/8	HTP10KA2-12	1.2500	HTP10KA3-12	1.8750	HTP10KA4-12	2.5000

Lead Screw Specifications - With Round Nut

LEAD SCREW PITCH DIA.	STOCK NUMBER	LEAD	STOCK NUMBER	LEAD	STOCK NUMBER	LEAD
	PRECISION		PRECISION		PRECISION	
3/16	HTP3LA2-12	.3750	HTP3LA3-12	.5625	HTP3LA4-12	.7500
1/4	HTP4LA2-12	.5000	HTP4LA3-12	.7500	HTP4LA4-12	1.0000
3/8	HTP6LA2-12	.7500	HTP6LA3-12	1.1250	HTP6LA4-12	1.5000
1/2	HTP8LA2-12	1.0000	HTP8LA3-12	1.5000	HTP8LA4-12	2.0000
5/8	HTP10LA2-12	1.2500	HTP10LA3-12	1.8750	HTP10LA4-12	2.5000

Nut Specifications

LEAD SCREW PITCH DIA.	A	B	C	D	E	F	G	H	I*	LOAD
3/16	.500	1.250	1.000	#	.750	.437	.750	1.06	#6-32	16 Lbs.
1/4	.500	1.313	1.000	#	.750	.500	.812	1.12	#6-32	22 Lbs.
3/8	.625	1.750	1.313	#	.750	.625	1.000	1.37	#8-32	32 Lbs.
1/2	.750	1.813	1.437	.625	1.000	.750	1.125	1.50	#8-32	44 Lbs.
5/8	.875	1.937	1.562	.625	1.000	1.000	1.375	1.75	#8-32	55 Lbs.

Note: Special lengths, ends, diameters, or material available on request. Load ratings, based on shear of nut does not account for buckling.

- These items are supplied with one mounting hole @ E/2 on each side.

* Note: some clearance holes may be slotted to accept a range of sizes.

Spare nuts available on request.

LEAD SCREW ASSEMBLY

MATERIAL

SHAFT HANGERS - ALUMINUM ANODIZED • LEAD SCREWS - HIGH HELIX - ALUMINUM (UNCUNF - STAINLESS)
SUPPORT SHAFT - STAINLESS STEEL • BEARINGS - STD. SERIES - TEFLON (ADJUSTABLE SERIES - CHROME STEEL) • FOLLOWER NUT - DELRIN

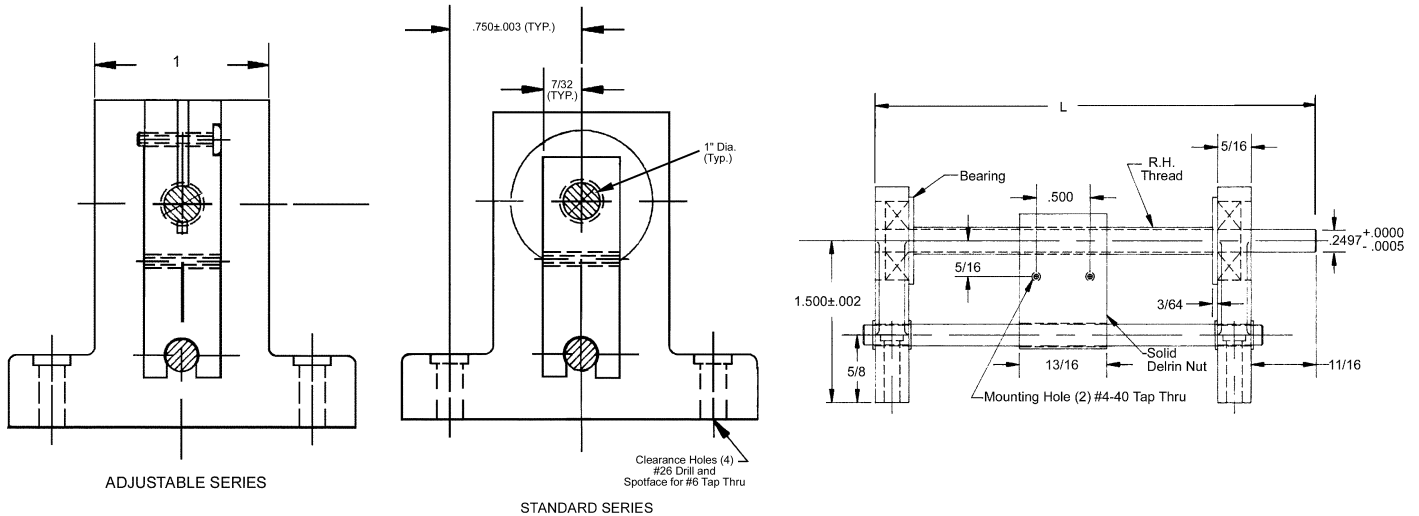

Non-Self-Locking HIGH HELIX FAST LEAD



STANDARD SERIES STOCK NO.	ADJUSTABLE SERIES STOCK NO.	LEAD PER REV.	L (Inch)	TOTAL TRAVEL
LS6A2-6	LS7A2-6	.500	6 1/8	3.79
LS6A2-12	LS7A2-12		12 1/8	9.79
LS6A2-18	LS7A2-18		18 1/8	15.79
LS6A3-6	LS7A3-6	.750	6 1/8	3.79
LS6A3-12	LS7A3-12		12 1/8	9.79
LS6A3-18	LS7A3-18		18 1/8	15.79
LS6A4-6	LS7A4-6	1.000	6 1/8	3.79
LS6A4-12	LS7A4-12		12 1/8	9.79
LS6A4-18	LS7A4-18		18 1/8	15.79

Units can also be used as linear to rotary drive.

Self-Locking UNC/UNF THREAD



STANDARD SERIES STOCK NO.	ADJUSTABLE SERIES STOCK NO.	LEAD PER REV.	L (Inch)	TOTAL TRAVEL
LS1-30	LS1-36	.0393	6 1/8	3.79
LS1-31	LS1-37		12 1/8	9.79
LS1-32	LS1-38		18 1/8	15.79
LS1-33	LS1-39	.0500	6 1/8	3.79
LS1-34	LS1-40		12 1/8	9.79
LS1-35	LS1-41		18 1/8	15.79

Parts can be reassembled with shaft on opposite end.
Left hand threads, other lengths, diameters, leads and shaft heights are available on request.

LEAD SCREW ASSEMBLY

MATERIAL

**LEAD SCREW - 303 STAINLESS STEEL • SUPPORT SHAFT - 303 STAINLESS STEEL
SHAFT HANGER - ANODIZED ALUMINUM, FOLLOWER NUT-DELRIN**

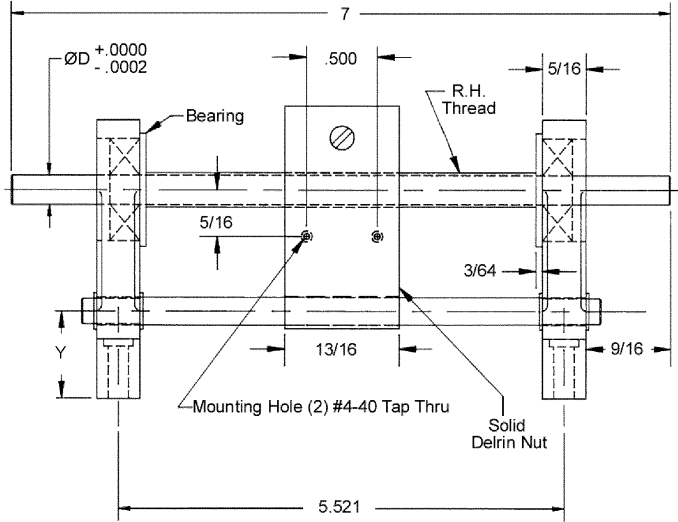
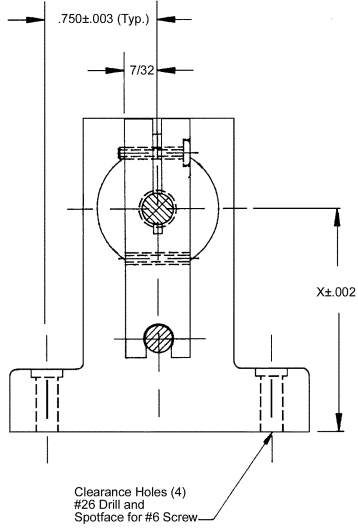

STOCK NO.	LEAD PER REV.	SHAFT DIA. D	X	Y	TYPE BEARING
LS1-8	.0500	.1247	1.500	.625	PRECISION BALL
LS1-9	.0394	.1247	1.500	.625	
LS1-3	.0500	.1872	1.500	.625	
LS1-4	.0357	.1872	1.500	.625	
LS1-12	.0500	.2497	2.000	1.125	
LS1-13	.0357	.2497	2.000	1.125	
LS1-20	.0500	.1247	1.500	.625	OIL-LESS BRONZE
LS1-21	.0357	.1247	1.500	.625	
LS1-22	.0500	.1872	1.500	.625	
LS1-23	.0357	.1872	1.500	.625	
LS1-24	.0500	.2497	2.000	1.125	
LS1-25	.0357	.2497	2.000	1.125	

• Minimum Backlash
Precision Ball Bearing Units or Oil-Less Bronze Bearing Units
Longer Lead screws and quantity discounts are available on request.



E

LINEAR CLUTCH - LINEAR ACTUATORS

SHAFT SIZE	STYLES	MATERIAL
3/8" - 1"	A & B	ALUMINUM HOUSING STEEL BALL BEARINGS AND SCREWS

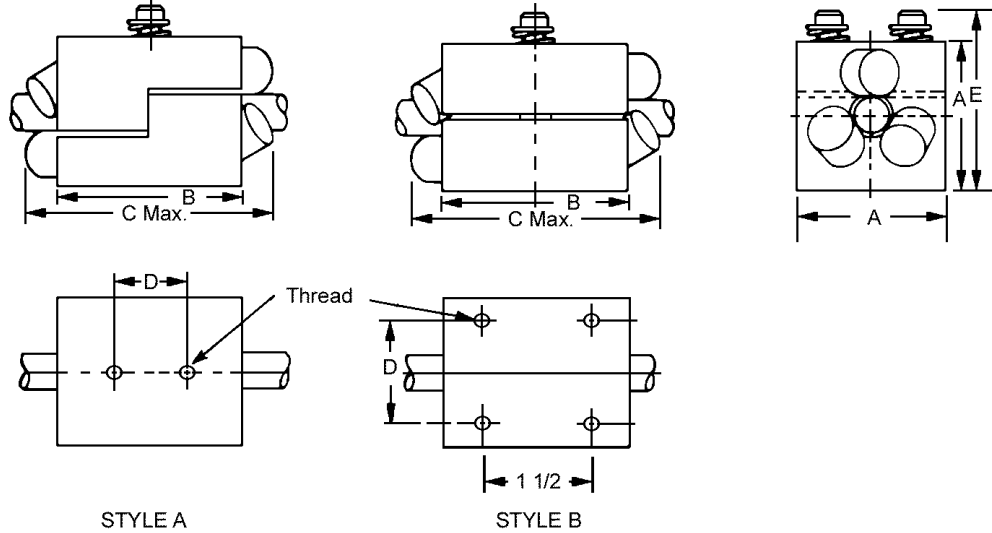

- Translates rotating motion into linear motion
- Built In Safety - Adjustable tension allows device to slip free when overloaded
- Infinite Travel - On threadless shafting
- Ends Backlash Problems - Free axial backlash less than .001
- No Lubrication - Shaft runs dry - Bearing factory lubricated
- Installs Fast, Two halves assemble around shaft
- Longer Life for shafts and actuators
- Greatly reduces maintenance
- Operates on standard Berg ground shafting (hard or soft)



STOCK NO.	SHAFT DIA.	LEAD* (Inches)	THRUST RATING	A	B	C	D	AVG. HEIGHT AT RATED THRUST E	THREAD	STYLE										
LCA-1 LCA-2	3/8	.030	15 LBS	1 1/8	1 5/8	2 1/4	3/4	1 11/16	6-32NC-2B	A										
LCA-3 LCA-4 LCA-5		.100 .200 .500	30 LBS	1 1/2	2	2 13/16	1	2	10-32NF-2B	A										
LCA-6 LCA-7 LCA-8		.100 .200 .500																		
LCA-9		1.000																		
LCA-10 LCA-11 LCA-12		1/2	.200 .500 1.000	60 LBS	2	2 1/2	3 3/8	1 1/4	2 9/16	1/4-20NC-2B	A									
LCA-13 LCA-14			.100 .500																	
LCA-15 LCA-16 LCA-17			.100 .750 1.000																	
LCA-18 LCA-19 LCA-20 LCA-21			1									.200 .500 1.000 2.000	100 LBS	3	2 1/2	3 1/2	2 1/2	3 5/16	1/4-20NC-2B	B

*Lateral movement per rotation.

LINEAR SLIDES

TECHNICAL DATA

W. M. Berg, Inc. manufactures a complete line of off the shelf linear ball slides and linear crossed roller slide bearings. Made to the highest quality standards, components must pass strict inspection requirements at each stage of manufacturing. These Quality Control steps ensure precise, uniform, linear movement with low friction and minimum side-play.

Available in inch or metric sizes, and in travel lengths ranging from 1/2 inch to 24 inches, slides have flat, parallel, and smooth mounting surfaces. Equipped with mounting holes, they are shipped ready to install, with no need for modifications or adjustments.

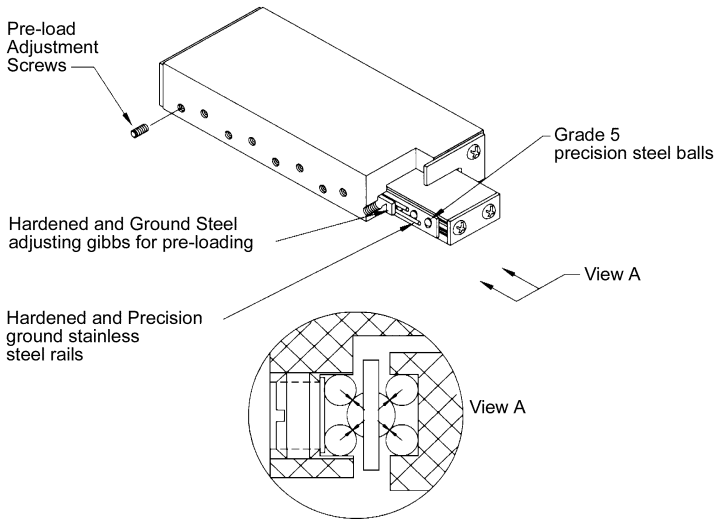

FIGURE 1

Linear Ball Slides

W. M. Berg Inc. Linear Ball Slides are designed to provide precise linear movement for **light to medium loads**. Their construction, as shown in Figure 1, consists of precision Grade 5 balls rolling along ground wire ways. Since the rolling contact surface is a point, the bearing ways are self cleaning, expelling matter which may deposit on their surfaces.

Linear Crossed Roller Slides

W. M. Berg Inc. Linear Crossed Roller Slides are designed to provide precise linear movement for medium to heavy loads. Their improved stiffness and rigidity mean long term reliability under the punishment of vibration and shock conditions. Their construction as shown in Figure 2 consists of precision rollers rolling along ground flat ways. Since the rolling contact surface is a line, they can support greater loads than the ball slides

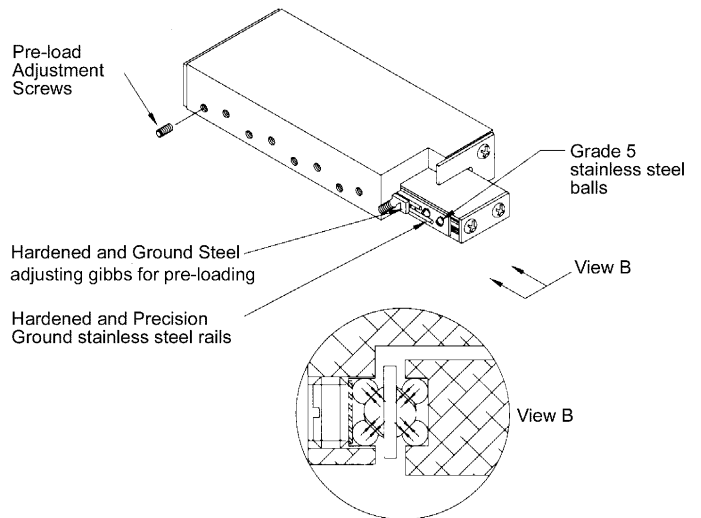

FIGURE 2

- Straightness of Travel = Precision Series - .0005 in./in.
* Ultra-precision Series - .0004 in./in
- Repeatability of Travel = Precision Series - .0001 in.
Ultra-precision Series - .00005 in.
- Life = 10×10^6 in. of Travel at Safe Load Capacity
= 100×10^6 in. of Travel at 1/2 Safe Load Capacity
Coefficient of Friction - .003
- Safe Load Capacity = $\frac{\text{Rated Load Capacity}}{\text{Safety Factor (SF)}}$

* Inspection Report Available for This Accuracy



ULTRA-PRECISION LINEAR BALL SLIDES

TRAVEL	MATERIAL
.50" TO 10.00"	ALUMINUM BLACK ANODIZED

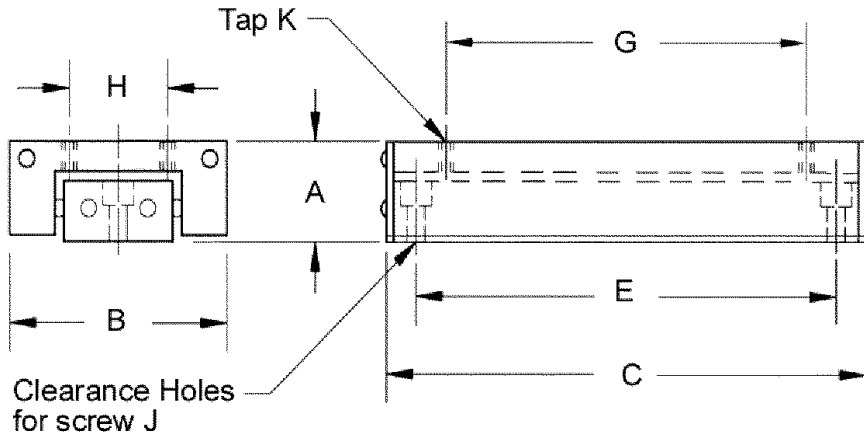

STOCK NO.	TRAVEL	A	B	C	E	G	H	J	K	RATED LOAD (lbs.)
LPSB-5A	.5			1.56	1.250	1.250				10
LPSB-10A	1.0	.500	1.00	2.56	2.250	2.250	.437	#4	#6-32	15
LPSB-15A	1.5			3.06	2.750	2.750				20
LPSB-20A	2.0			3.56	3.250	3.250				30
LPSC-10A	1.0			2.00	1.625	1.375				25
LPSC-15A	1.5	.750	1.75	2.75	2.250	2.126	.875	#6	#6-32	30
LPSC-20A	2.0			3.25	2.750	2.625				35
LPSC-30A	3.0			4.00	3.500	3.375				40
LPSC-10A	1.0			2.62	2.125	2.125				70
LPSC-20A	2.0			4.00	3.375	3.000				90
LPSC-30A	3.0	1.000	2.62	5.00	4.375	4.000	1.250	#10	#10-32	110
LPSC-40A	4.0			6.00	5.375	5.000				130
LPSC-50A	5.0			8.00	7.375	7.000				180
LPSJ-20A	2.0			4.00	2.500	2.000				130
LPSJ-30A	3.0			5.75	4.250	3.750				180
LPSJ-50A	5.0	1.375	3.50	8.00	6.500	6.000	2.000	#10	#10-32	220
LPSJ-65A	6.5			10.25	8.750	8.250				280
LPSJ-90A	9.5			14.00	12.500	12.000				375
LPSK-50A	5.0			8.25	6.250	6.250				300
LPSK-70A	7.0	2.000	5.75	12.00	10.000	10.000	4.000	1/4	1/4-20	420
LPSK-100A	10.0			15.00	13.000	13.000				520

LINEAR BALL SLIDES

TRAVEL	MATERIAL
.50" TO 24.00"	ALUMINUM BLACK ANODIZED

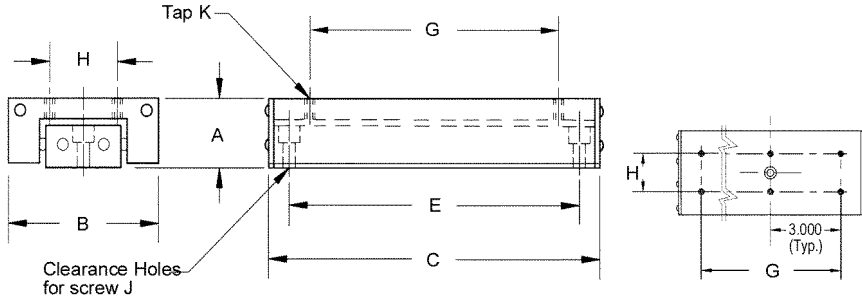

STOCK NO.	TRAVEL	A	B	C	E	G	H	J	K	RATED LOAD (lbs.)
LBSG-5	.5			.75	.375	.375				1.50
LBSG-10	1.0	.23	.38	1.25	.875	.875	.156	#2-56 TAP	#2-56*	1.50
LBSG-15	1.5			1.75	1.375	1.375				1.50
LBSA-5	.5			1.06	.750	.625				4
LBSA-10	1.0			2.06	1.375	1.625				8
LBSA-20	2.0	.32	.56	3.06	2.375	2.625	.218	#2	#2-56	12
LBSA-30	3.0			4.06	3.375	3.625				14
LBSA-40	4.0			5.06	3.500	4.625				16
LBSA-50	5.0			6.06	4.500	5.625				18
LBSE-5	.5			1.06	.750	.625				5
LBSE-10	1.0			2.06	1.375	1.625				9
LBSE-20	2.0	.40	.75	3.06	2.375	2.625	.375	#4	#4-40	12
LBSE-30	3.0			4.06	3.375	3.625				14
LBSE-40	4.0			5.06	3.500	4.625				16
LBSE-50	5.0			6.06	4.500	5.625				18
LBSB-5	.5			1.56	1.250	1.250				10
LBSB-10	1.0			2.56	2.250	2.250				15
LBSB-15	1.5			3.06	2.750	2.750				20
LBSB-20	2.0	.50	1.00	3.56	3.250	3.250	.437	4	#6-32	25
LBSB-30	3.0			4.56	4.250	4.250				30
LBSB-40	4.0			5.56	5.250	5.250				35
LBSB-50	5.0			6.56	6.250	3.250				40
LBSF-7	.8			1.56	1.125	1.250				10
LBSF-15	1.5			2.56	2.125	2.250				15
LBSF-20	2.0			3.56	3.125	3.250				20
LBSF-30	3.0	.53	1.06	4.56	3.250	4.000	.437	6	#6-32	25
LBSF-40	4.0			6.00	4.000	5.500				30
LBSF-60	6.0			8.00	5.000	7.500				35
LBSF-80	8.0			10.00	7.000	9.500				40
LBSH-10	1.0			2.00	1.500	1.375				15
LBSH-20	2.0			3.00	2.500	2.375				20
LBSH-30	3.0			4.00	3.500	3.375				25
LBSH-35	3.5	.62	1.50	5.00	3.500	4.375	.625	6	#6-32	30
LBSH-40	4.0			6.00	4.000	5.375				35
LBSH-60	6.0			8.00	5.000	7.375				45
LBSH-80	8.0			10.00	7.000	9.375				55
LBSC-10	1.0			2.00	1.625	1.375				25
LBSC-15	1.5			2.75	2.250	2.125				30
LBSC-20	2.0			3.25	2.750	2.625				35
LBSC-30	3.0	.75	1.75	4.00	3.500	3.375	.875	6	#6-32	40
LBSC-40	4.0			5.00	4.500	4.375				45
LBSC-60	6.0			7.00	6.500	6.375				55
LBSD-10	1.0			2.60	2.125	2.125				70
LBSD-20	2.0			4.60	3.000	3.000				90
LBSD-30	3.0			5.00	4.000	4.000				110
LBSD-40	4.0			6.00	5.000	5.000				130
LBSD-50	5.0			8.00	7.000	7.000				180
LBSD-60**	6.0			9.00	6.000	6.000				120
LBSD-90**	9.0	1.00	2.62	12.00	9.000	9.000	1.250	#10	#10-32	130
LBSD-120**	12.0			15.00	12.000	12.000				145
LBSD-150**	15.0			18.00	15.000	15.000				160
LBSD-180**	18.0			21.00	18.000	18.000				170
LBSD-210**	21.0			24.00	21.000	21.000				150
LBSD-240**	24.0			27.00	24.000	24.000				120

See Linear Slides Technical Data at beginning of this section for additional specifications.

* Tapped hole is supplied.

** Top Mounting hole configuration for slides LBSD-60 thru LBSD-240

LINEAR CROSSED ROLLER SLIDES

TRAVEL	MATERIAL
.50" TO 6.00"	ALUMINUM BLACK ANODIZED

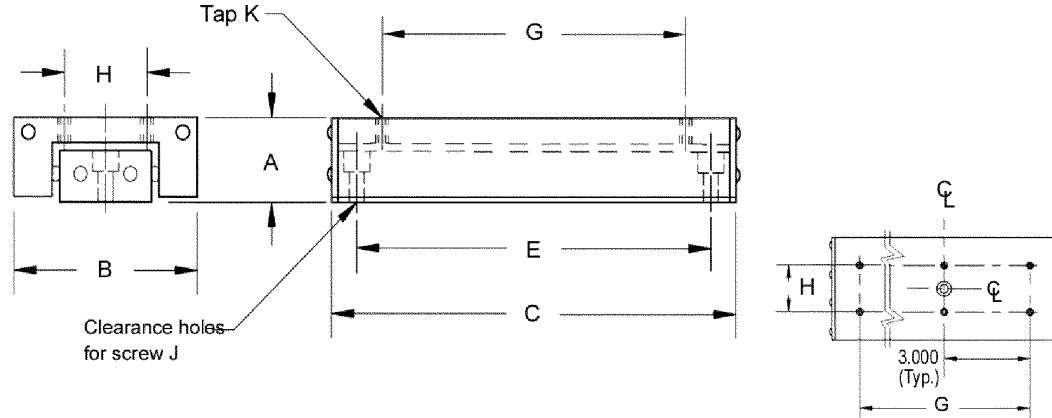

STOCK NO.	TRAVEL	A	B	C	E	G	H	K	RATED CAPACITY(Lbs.)
LRSA-5	.50			1.06	.750	.625			32
LRSA-10	1.00	.32	.56	2.06	1.375	1.625	.218	#2-56	56
LRSA-20	2.00			3.06	2.375	2.625			68
LRSB-5	.50			1.06	.750	.625			50
LRSB-10	1.00	.40	.75	2.06	1.375	1.625	.375	#4-40	80
LRSB-20	2.00			3.06	2.375	2.625			100
LRSC-15	1.50			2.56	2.125	2.250			135
LRSC-20	2.00	.53	1.06	3.56	3.125	3.250	.437	#6-32	225
LRSC-30	3.00			4.56	3.250	4.000			265
LRSD-10	1.00			2.00	1.500	1.375			135
LRSD-20	2.00	.62	1.50	3.00	2.500	2.375	.625	#6-32	180
LRSD-30	3.00			4.00	3.500	3.375			180
LRSD-40	4.00			6.00	4.000	5.375			310
LRSE-10	1.00			2.00	1.625	1.375			180
LRSE-20	2.00	.75	1.75	3.25	2.750	2.625	.875	#6-32	210
LRSE-30	3.00			4.00	3.500	3.375			240
LRSE-40	4.00			6.00	4.000	5.500			310
LRSF-15	1.50			2.62	1.875	1.625			330
LRSF-20	2.00			4.00	3.375	3.000			420
LRSF-30	3.00	1.00	2.62	5.00	4.375	4.000	1.250	#10-32	450
LRSF-40	4.00			6.00	5.375	5.000			500
LRSF-60**	6.00			9.00	7.000	6.000			705



** Top mounting hole configuration for LRSF-60.

See Linear Slides Technical Data at beginning of this section for additional specifications.

RACK DRIVEN BALL SLIDES

TRAVEL	MATERIAL
.50" TO 18.00"	RACK - 416 STAINLESS STEEL

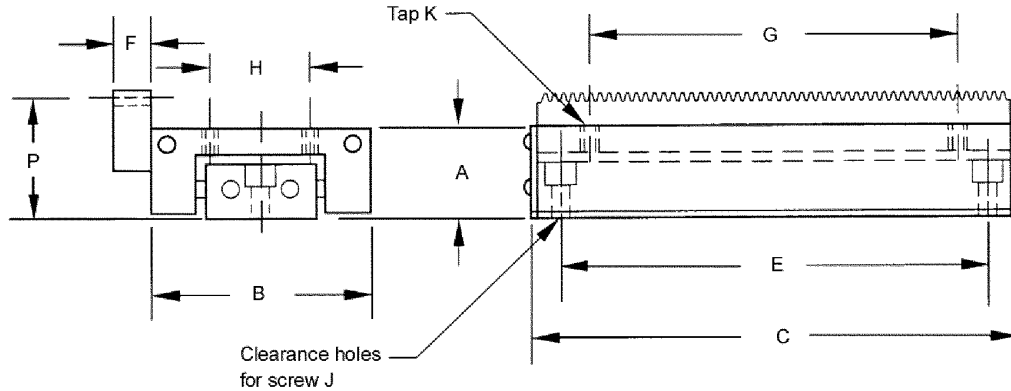

STOCK NO.	MAX. TRAVEL (Inch)	A	B	C	E	G	H	J	K	P	F	RATED LOAD (lbs.)	DIAMETRAL PITCH
LRDB-5	0.5			1.56	1.250	1.250						5	1/20 20°PA
LRDB-10	1.0			2.56	2.250	2.250						10	
LRDB-15	1.5			3.06	2.750	2.750						15	
LRDB-20	2.0	.50	1.00	3.56	3.250	3.250	.437	#4	#6-32	.562		20	
LRDB-30	3.0			4.56	4.250	4.250						30	
LRDB-40	4.0			5.56	5.250	5.250						35	
LRDB-50	5.0			6.56	6.250	6.250						40	
LRDD-10	1.0			2.62	2.125	2.125					.230	40	1/10 20°PA
LRDD-20	2.0			4.00	3.375	3.000						60	
LRDD-30	3.0			5.00	4.375	4.000						90	
LRDD-40	4.0			6.00	5.375	5.000						116	
LRDD-50	5.0			8.00	7.375	7.000						120	
LRDD-60	6.0	1.00	2.62	9.00	7.000	6.000	1.250	#10	#10-32	1.093		120	
LRDD-90	9.0			12.00	10.000	9.000						130	
LRDD-120	12.0			15.00	13.000	12.000						145	
LRDD-150	15.0			18.00	16.000	15.000						160	
LRDD-180	18.0			21.00	19.000	18.000						170	

See Linear Slides Technical Data at beginning of this section for additional specifications.



LINEAR TABLES

TRAVEL	MATERIAL
3.00" TO 8.00"	CARRIAGE & BASE - BLACK ANODIZED ALUMINUM • NUT - DELRIN ROLLING ELEMENTS - HARDENED STAINLESS STEEL • ACME LEADSCREW - 303 STAINLESS STEEL

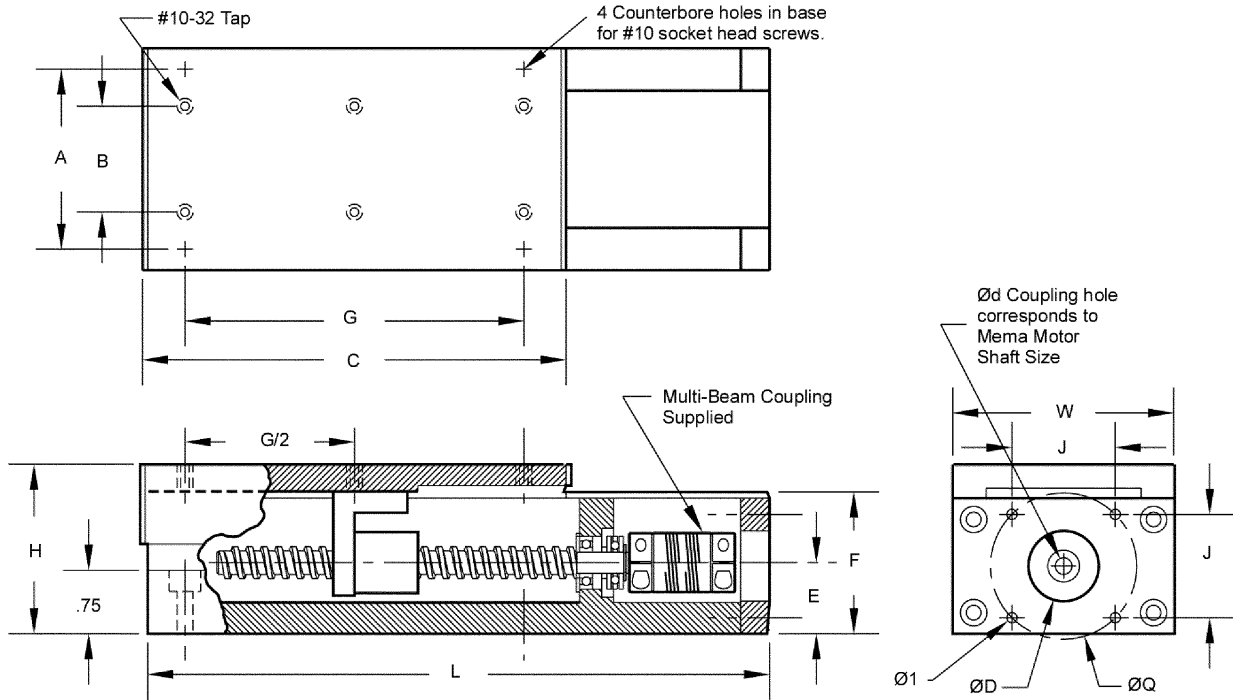

ROLLER SERIES	BALL SERIES	TRAVEL	LOAD RATING (lbs.)		A	B	C	G	H	W	L	MOUNTING REFERENCE DATA							
			ROLLER SERIES	BALL SERIES								MOTOR SIZE	NEMA® Ød	E	F	ØD	I	ØQ	J
TRSD-30	TBSD-30	3.00	450	110			5.00	4.000			7.34								
TRSD-40	TBSD-40	4.00	500	130	2.125	1.250	6.00	5.000	2.00	2.62	8.34	17	5mm H7	.840	1.675	22mm H7	Ø.120	(1.73)	1.220
TRSD-60	TBSD-60	6.00	700	120			9.00	6.000			11.34								
TRSK-40	TBSK-40	4.00	400	130			6.00	5.000			8.56								
TRSK-60	TBSK-60	6.00	500	120	3.000	3.000	8.00	7.000	2.75	4.00	10.56	23	.2498 + .0005	1.140	2.260	1.502 + .001	#10-32	2.625	(1.86)
TRSK-80	TBSK-80	8.00	620	140			10.00	9.000			12.56								

Travel = .0833 Inch per revolution
Lead Accuracy = .003 in./ft.

Other sizes and materials available on request.

ULTRA PRECISION ROLLER SLIDES

TECHNICAL DATA

W.M. Berg, Inc. introduces its newest line of precision roller slides which allow the designer the opportunity to incorporate an off-the-shelf component to meet his requirements for accuracy and load carrying capabilities. Our Ultra Precision family of slides are fabricated with hardened and ground steel rails and rollers, to provide extended service life within the parameters described in this catalog.

ULTRA PRECISION CONSTRUCTION

Bearing Rail Sets - Rails and Rollers - Hardened (Rc60 - 62) Tool Steel.
Retainers - Brass

Complete assemblies - Base and Top - 6061 T6 Aluminum Alloy, Clear Anodized.
or G2 Close Grain Iron, Electroless Nickel Plated.
Rail and Rollers - Hardened (Rc60 - 62) Tool Steel.
Retainers - Brass

ULTRA PRECISION ACCURACY

Straightness - Defined as the maximum lateral or horizontal error an assembly will introduce during its axial travel. Standard assemblies in either material can exhibit values as low as .00008"/in.

Flatness - The maximum variation of the top surface plane. Some units have error values not exceeding .00008".

Parallelism - The Vertical error introduced during axial travel. This parameter is a measure of flatness (as described above) plus the vertical component of the axial travel. On some units this will not exceed .0002".

Repeatability - within .00005"

The accuracy tolerances vary with the assembly type and size. Please check with the Engineering Department of W.M.Berg,Inc. for specific values.

ULTRA PRECISION OPERATING TEMPERATURE

Normal operating conditions = - 40°F to +176°F

Short intervals = up to +212°F

ULTRA PRECISION LUBRICATION

No lubrication is required below an operating speed of 50"/min. (1.3 m/min). Above this speed lubrication is recommended.

ULTRA PRECISION COEFFICIENT OF FRICTION

Bearing Rail Sets and Slide Assemblies = .003

Recirculating sets and Assemblies = .005

ULTRA PRECISION LIFE

At maximum dynamic load = 10,000,000"

At 1/2 dynamic load = 100,000,000"

At 1/4 dynamic load = 900,000,000"

ULTRA PRECISION MOUNTING HOLES

Factory machined mounting holes are available from W.M.Berg,Inc. Clearance or tapped holes can be included in the slide base and/or top.

Detailed information concerning the Precision range of Slides is available from the Engineering Department of W.M.Berg, Inc. Call (516) 596-1700 and select engineering.

NON-STANDARD MATERIAL

Rail sets can be fabricated in Stainless Steel for corrosive or vacuum environments. Assemblies can be made from any available material that will be consistent with the accuracies and strength requirements.

MOTOR MOUNTS

Motor mounting brackets, designed to NEMA® standards, are available for the screw driven slides. These can be supplied with any one of the many types of couplings offered by W.M. Berg, Inc.

SSX SLIDES

AVAILABILITY

SPECIAL CARRIAGE AND/OR RAIL LENGTHS AVAILABLE ON REQUEST

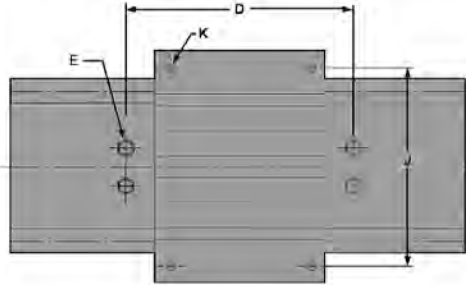

All Dimensions in Inches.

Special Carriage and/or rail lengths available upon request.

- Low Sliding Friction
- Tolerates Shock Loads
- Will Not Rust or Corrode
- Tolerates Severe Contamination
- No Maintenance Required
- Low Cost
- Self Lubricating
- No Roller Elements
- No Grease or Oil Necessary
- RC70 Ceramic Coated Rail
- No Metal to Metal Contact
- Clear Anodized with FrelonJ
- Weld, Splatter, Paints, etc. will not Stick to the Rail

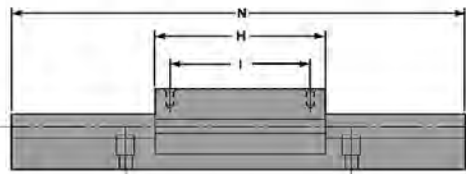
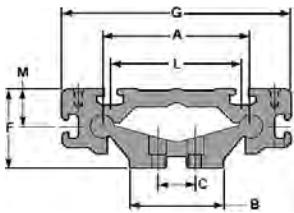

STOCK NO.	A	B	C	D	Bolt Size E	F	G	H	I	J	K	L	M	N
LDS75-12														12
LDS75-24	2.95	2	0.75	4	1/4	1.63	4.6	4	3	4	#10-32	2.6	0.81	24
LDS75-36														36
LDS100-12														12
LDS100-24	3.94	2.6	1	6	5/16	2.13	6.1	5	3.8	5.3	1/4-20	3.5	1.024	24
LDS100-36														36
LDS125-12														12
LDS125-24	4.92	3.3	1.25	6	3/8	2.63	7.6	6	5.3	6.8	5/16-18	4.3	1.3	24
LDS125-36														36

TECHNICAL DATA

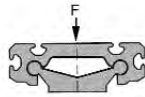
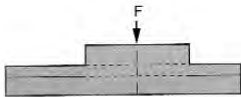

Size	F Max. Load (Lbs.)
LDS75	500
LDS100	750
LDS125	1000

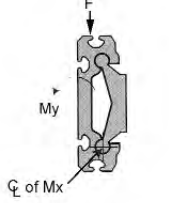
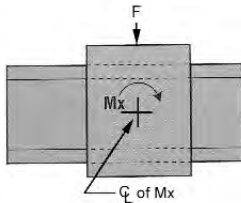

Size	F Max. Load (Lbs.)	Mx (In-Lbs)	My (In-Lbs)
LDS75	250	340	350
LDS100	375	650	730
LDS125	500	1200	1225

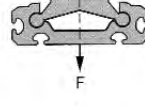
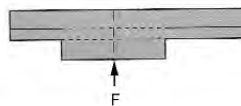

Size	F Max. Load (Lbs.)
LDS75	125
LDS100	190
LDS125	250

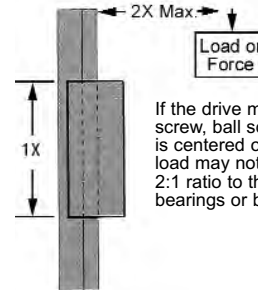

If the drive mechanism (lead screw, ball screw, cylinder, etc.) is centered on the carriage, the load may not exceed a 2:1 ratio to the length of the bearings or binding will occur.

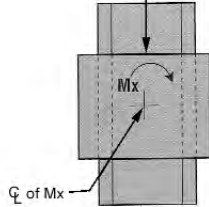
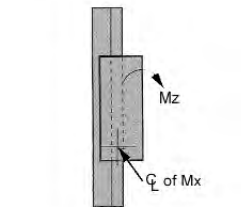

Size	Mx Max. Load (Lbs.)	Mz (In-Lbs)
LDS75	340	350
LDS100	650	730
LDS125	1200	1225

Designs must also operate within the following dynamic parameters.

- Maximum Loads (P) = F from charts above
- Maximum Speed Dry (V) = 300 ft./min.
- Maximum PV (pressure x velocity) = 20,000
- PV Example: Load = 85 lbs.
Speed = 180 ft./min.
PV = 85 x 180 = 15,300 PV

Note: Coefficient of friction is .125.

LEAD SCREW DRIVEN SSX SLIDES

AVAILABILITY

SPECIAL CARRIAGE AND/OR RAIL LENGTHS AVAILABLE ON REQUEST

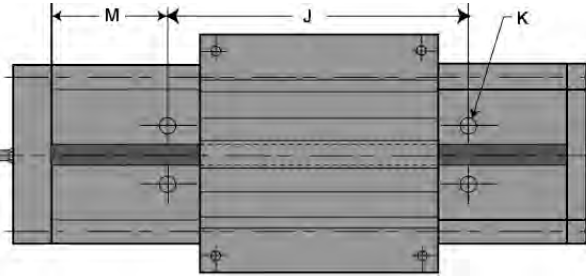

- Special lengths available upon request.
- Self lubricating.
- Also see our motor driven styles.
- Fewer components than conventional ball slides.
- Lightweight construction.
- Tolerates contamination.
- Smooth running operation.
- Special mounting dimensions (fax or email sketch).
- High load capacities.
- Integrate you own drive mechanism or use Berg's.

All dimensions in inches.

Leadscrew standard lead = .25.

Other leads available. Fax or Email your request.

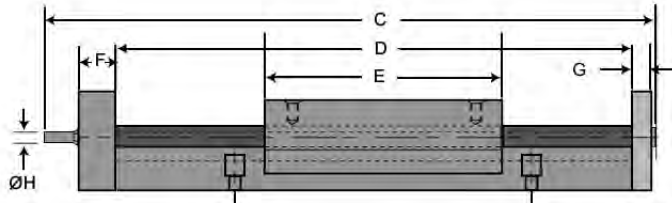
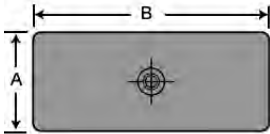

STOCK NO.	A	B	C	D	E	F	G	ØH	J	K	M	Travel	Nom. Screw Ø
LDSM75-12			13	12								8.5	
LDSM75-16	1.75	3.42	17	16	3.5	0.625	0.375	0.187	4	1/4	2	12.5	3/8"
LDSM75-20			21	20								16.5	
LDSM75-24			25	24								20.5	
LDSM100-12			13.3	12								7.5	
LDSM100-18	2.50	4.56	19.3	18	4.5	1	0.5	0.314	6	5/16	3	13.5	1/2"
LDSM100-24			25.3	24								19.5	
LDSM100-30			31.3	30								25.5	
LDSM125-18			19.5	18								12.0	
LDSM125-24	3.50	5.78	25.5	24	6	1	0.5	0.314	6	3/8	3	18.0	5/8"
LDSM125-30			31.5	30								24.0	
LDSM125-36			37.5	36								30.0	

E

MOTOR DRIVEN SSX SLIDES

AVAILABILITY

SPECIAL CARRIAGE AND/OR RAIL LENGTHS AVAILABLE ON REQUEST

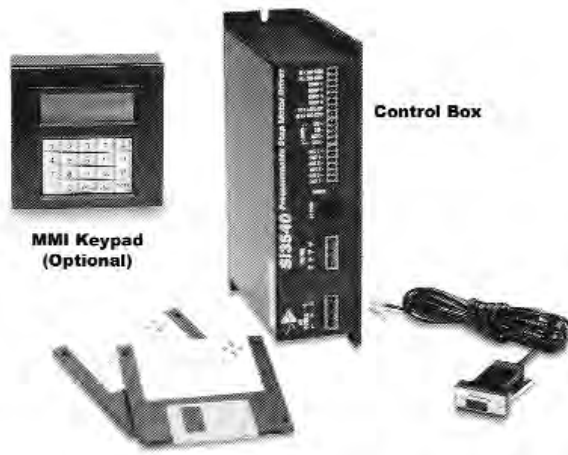
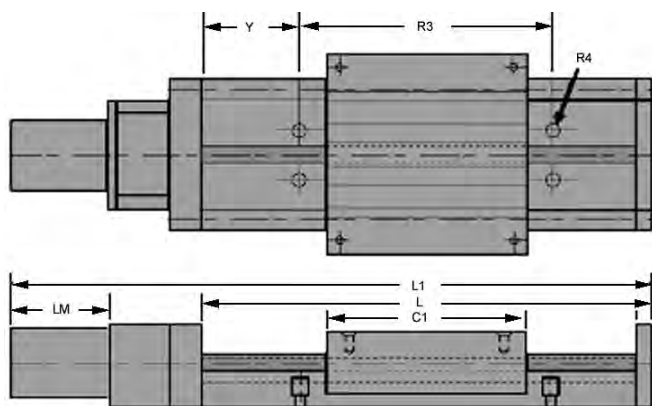
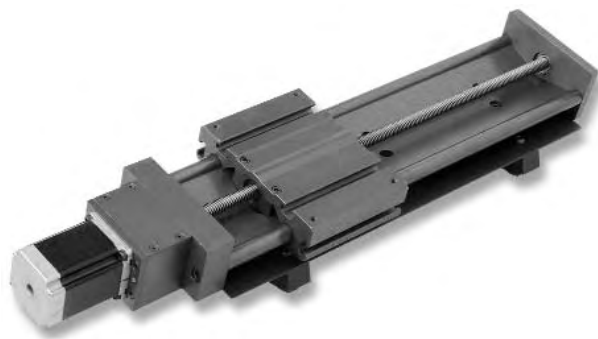

- Kit Includes:
1. Leadscrew Driven SSX Slide
 2. Programmable Controller
 3. Programming Download Cable
 4. Programming Software
 5. Stepper Motor
 6. Motor Mount Bracket
 7. Motor to Leadscrew Coupling
 8. Integrated Homing Proximity Switch

Motors and Controllers:

- Includes 110v Power and 10' cable from controller to slide
- RS232 Connection to the optional MMI (Man-to-Machine Interface)

Refer to our leadscrew driven SSX slides for dimensions not given.

Call the factory for non-standard lengths, optional screws, limit switches or other accessories.

STOCK NO.	STROKE (L-C1)	L	L1	C1	NOMINAL LEAD SCREW DIA.	Y	R3	R4	MOTOR SIZE	LM
MDLDSM75-12	8.5	12	16.66	3.5	3/8"	2	4	1/4"	NEMA 17	1.85
MDLDSM75-16	12.5	16	20.66	3.5	3/8"	2	4	1/4"	NEMA 17	1.85
MDLDSM75-20	16.5	20	24.66	3.5	3/8"	2	4	1/4"	NEMA 17	1.85
MDLDSM75-24	20.5	24	28.66	3.5	3/8"	2	4	1/4"	NEMA 17	1.85
MDLDSM100-12	7.5	12	18.3	4.5	1/2"	3	6	5/16"	NEMA 23	3
MDLDSM100-18	13.5	18	24.3	4.5	1/2"	3	6	5/16"	NEMA 23	3
MDLDSM100-24	19.5	24	30.3	4.5	1/2"	3	6	5/16"	NEMA 23	3
MDLDSM100-30	25.5	30	36.3	4.5	1/2"	3	6	5/16"	NEMA 23	3
MDLDSM125-18	12	18	27.5	6	5/8"	3	6	3/8"	NEMA 34	5.1
MDLDSM125-24	18	24	33.5	6	5/8"	3	6	3/8"	NEMA 34	5.1
MDLDSM125-30	24	30	39.5	6	5/8"	3	6	3/8"	NEMA 34	5.1
MDLDSM125-36	30	36	45.5	6	5/8"	3	6	3/8"	NEMA 34	5.1

Leadscrew standard lead = .25. Other leads available Fax or Email your request.
Special carriage and rail lengths available upon request.

CROSS ROLLER BEARINGS RAIL SET

MATERIAL

RAILS & ROLLERS - HARDENED & GROUND TOOL STEEL • RETAINERS - BRASS

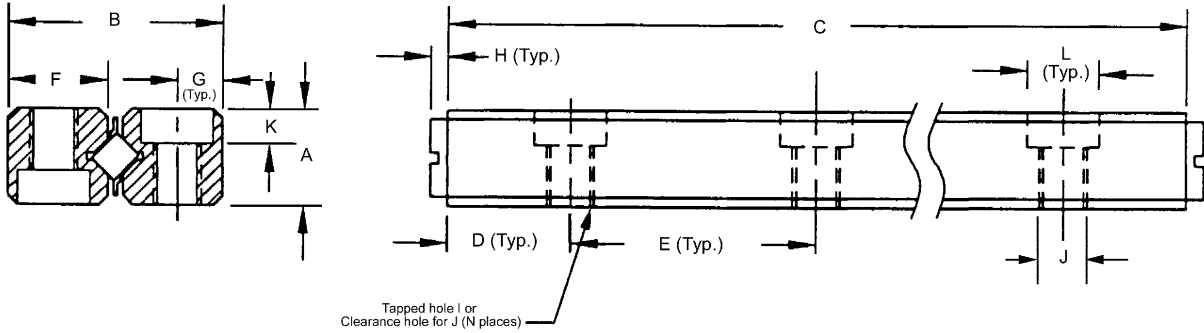

STOCK NO.	TRAVEL MAX.	A	B +.000 -.008	C	D	E	F	G	H	I	J	K	L	N	RATED CAPACITY (lbs.)
LR1-02	.94			1.968										2	232
LR1-03	1.33			2.952										3	348
LR1-04	1.33			3.936										4	464
LR1-05	1.33			4.920										5	638
LR1-06	2.12			5.904										6	696
LR1-07	2.11	.315	.707	6.888	.492	.984	.328	.137	.078	#8-32	#5	.133	.218	7	870
LR1-08	2.11			7.872										8	986
LR1-09	3.29			8.856										9	1044
LR1-10	4.08			9.840										10	1160
LR1-11	4.08			10.824										11	1276
LR1-12	4.07			11.808										12	1450
LR2-04	1.74			3.937										2	720
LR2-06	2.84			5.906										3	1200
LR2-08	3.95			7.875										4	1440
LR2-10	5.06			9.844										5	1920
LR2-12	6.16			11.813										6	2160
LR2-14	7.27			13.782										7	2640
LR2-16	8.37			15.751										8	2880
LR2-18	8.54			17.720										9	3360
LR2-20	8.70	.591	1.217	19.969	.984	1.969	.544	.239	.120	1/4-28	#10	.200	.375	10	3840
LR2-22	8.86			21.658										11	4320
LR2-24	9.02			23.627										12	4800
LR2-26	16.25			25.590										13	4320
LR2-28	17.36			27.559										14	4800
LR2-30	18.46			29.528										15	5040
LR2-32	19.57			31.496										16	5522
LR2-34	20.67			33.464										17	5760
LR2-36	22.72			35.433										18	6000

Part number represents two sets of parts shown in diagram.

NEEDLE ROLLER BEARING RAILS

STYLES

“M” (See Illustration, for Style “V” see next page)

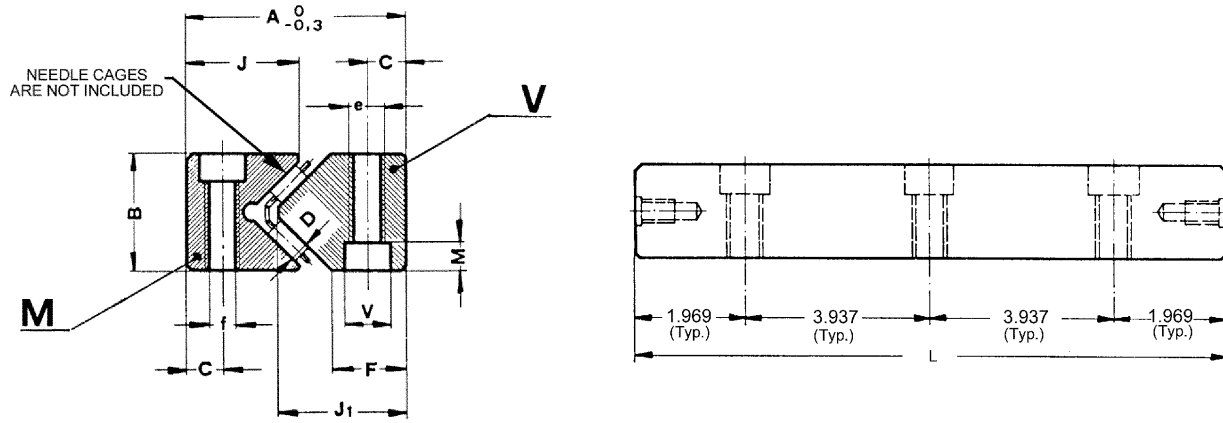

STOCK NO.	L	Z	D* (Ref.)	A	B +.000 -.004	F	J1	J	C	e	f	V	M
LNRM92025-2	7.874	2											
LNRM92025-3	11.811	3											
LNRM92025-4	15.748	4											
LNRM92025-5	19.685	5											
LNRM92025-6	23.622	6	.0787	1.732	.866	.591	.965	.945	.354	M8	.268	.413	.244
LNRM92025-7	27.559	7											
LNRM92025-8	31.496	8											
LNRM92025-9	35.433	9											
LNRM92025-10	39.370	10											
LNRM92025-11	43.307	11											
LNRM92025-12	47.244	12											
LNRM2025-2	7.874	2											
LNRM2025-3	11.811	3											
LNRM2025-4	15.748	4											
LNRM2025-5	19.685	5											
LNRM2025-6	23.622	6	.0787	2.047	.984	.709	1.142	1.102	.394	M10	.335	.532	.323
LNRM2025-7	27.559	7											
LNRM2025-8	31.496	8											
LNRM2025-9	35.433	9											
LNRM2025-10	39.370	10											
LNRM2025-11	43.307	11											
LNRM2025-12	47.244	12											
LNRM2535-3	11.811	3											
LNRM2535-4	15.748	4											
LNRM2535-5	19.685	5											
LNRM2535-6	23.622	6	.0984	2.441	1.181	.866	1.378	1.339	.472	M12	.413	.650	.402
LNRM2535-7	27.559	7											
LNRM2535-8	31.496	8											
LNRM2535-9	35.433	9											
LNRM2535-10	39.370	10											
LNRM2535-11	43.307	11											
LNRM2535-12	47.244	12											
LNRM3045-4	15.748	4											
LNRM3045-5	19.685	5											
LNRM3045-6	23.622	6											
LNRM3045-7	27.559	7											
LNRM3045-8	31.496	8	.1181	2.913	1.378	.984	1.575	1.673	.551	M14	.492	.728	.480
LNRM3045-9	35.433	9											
LNRM3045-10	39.370	10											
LNRM3045-11	43.307	11											
LNRM3045-12	47.244	12											
LNRM3555-5	19.685	5											
LNRM3555-6	23.622	6											
LNRM3555-7	27.559	7											
LNRM3555-8	31.496	8											
LNRM3555-9	35.433	9	.1378	3.071	1.772	.984	1.772	1.772	.551	M14	.492	.728	.480
LNRM3555-10	39.370	10											
LNRM3555-11	43.307	11											
LNRM3555-12	47.244	12											

Needle Bearing Cages sold separately. See page E34 for parts.

NEEDLE ROLLER BEARING RAILS

STYLES

“V” (See Illustration, for Style “M” see previous page)

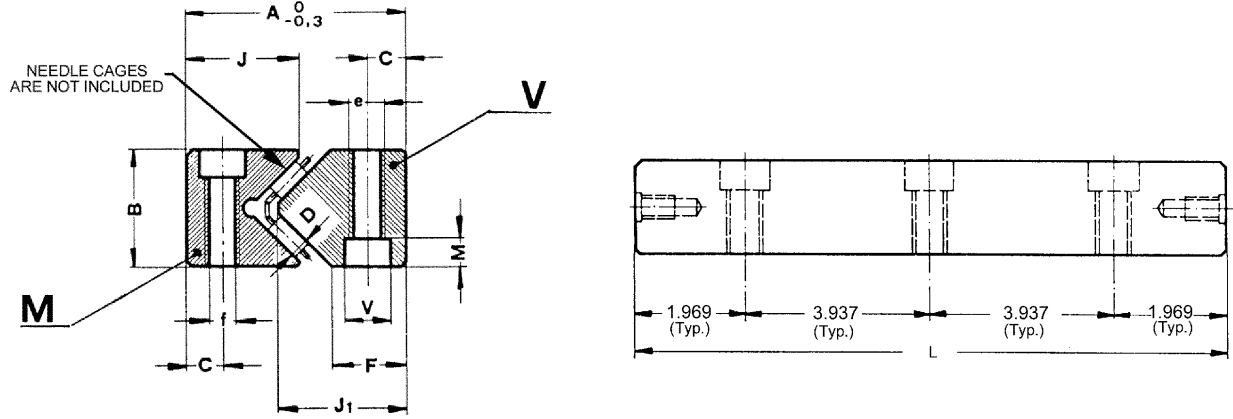

STOCK NO.	L	Z	D* (Ref.)	A	B +0.000 -0.004	F	J1	J	C	e	f	V	M
LNRV92025-2	7.874	2											
LNRV92025-3	11.811	3											
LNRV92025-4	15.748	4											
LNRV92025-5	19.685	5											
LNRV92025-6	23.622	6	.0787	1.732	.866	.591	.965	.945	.354	M8	.268	.413	.244
LNRV92025-7	27.559	7											
LNRV92025-8	31.496	8											
LNRV92025-9	35.433	9											
LNRV92025-10	39.370	10											
LNRV92025-11	43.307	11											
LNRV92025-12	47.244	12											
LNRV2025-2	7.874	2											
LNRV2025-3	11.811	3											
LNRV2025-4	15.748	4											
LNRV2025-5	19.685	5											
LNRV2025-6	23.622	6	.0787	2.047	.984	.709	1.142	1.102	.394	M10	.335	.532	.323
LNRV2025-7	27.559	7											
LNRV2025-8	31.496	8											
LNRV2025-9	35.433	9											
LNRV2025-10	39.370	10											
LNRV2025-11	43.307	11											
LNRV2025-12	47.244	12											
LNRV2535-3	11.811	3											
LNRV2535-4	15.748	4											
LNRV2535-5	19.685	5											
LNRV2535-6	23.622	6	.0984	2.441	1.181	.866	1.378	1.339	.472	M12	.413	.650	.402
LNRV2535-7	27.559	7											
LNRV2535-8	31.496	8											
LNRV2535-9	35.433	9											
LNRV2535-10	39.370	10											
LNRV2535-11	43.307	11											
LNRV2535-12	47.244	12											
LNRV3045-4	15.748	4											
LNRV3045-5	19.685	5											
LNRV3045-6	23.622	6											
LNRV3045-7	27.559	7											
LNRV3045-8	31.496	8	.1181	2.913	1.378	.984	1.575	1.673	.551	M14	.492	.728	.480
LNRV3045-9	35.433	9											
LNRV3045-10	39.370	10											
LNRV3045-11	43.307	11											
LNRV3045-12	47.244	12											
LNRV3555-5	19.685	5											
LNRV3555-6	23.622	6											
LNRV3555-7	27.559	7											
LNRV3555-8	31.496	8											
LNRV3555-9	35.433	9	.1378	3.071	1.772	.984	1.772	1.772	.551	M14	.492	.728	.480
LNRV3555-10	39.370	10											
LNRV3555-11	43.307	11											
LNRV3555-12	47.244	12											

Needle Bearing Cages sold separately. See page E 34 for parts.

NEEDLE ROLLER BEARING / NEEDLE CAGES

MATERIAL

MOLDED PLASTIC

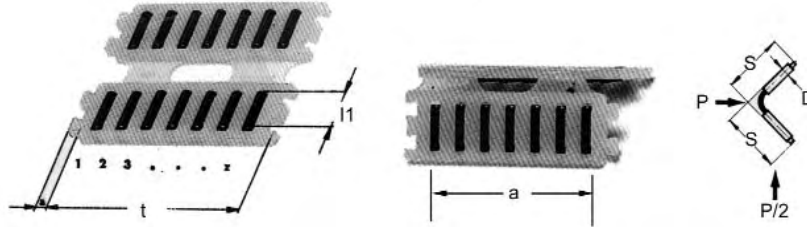

STOCK NO.	DIA. D (Ref.)	l1	s	t	a	nr/t	P (lbs.)
LFF2025ZW	.0787	.267	.591	1.260	.079	7	1.91
LFF2035ZW	.0984	.386	.807	1.772	.095	8	3.95
LFF2045ZW	.1181	.543	1.024	2.362	.118	9	7.43
LFF2055ZW	.1378	.701	1.240	2.953	.126	10	12.11

MATERIAL

ALUMINUM SERIES

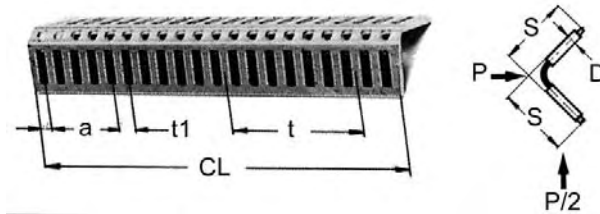

STOCK NO.	DIA. D (Ref.)	l1	s	t	a	t1	nr/t	P (lbs.)
LHW15	.0787	.267	.591	1.260	.079	.12	7	1.91
LHW20	.0984	.386	.807	1.772	.095	.22	8	3.95
LHW25	.1181	.543	1.024	2.362	.118	.24	9	7.43
LHW30	.1378	.701	1.240	2.953	.126	.28	10	12.11

Determining Cage Length and Quantities

The cages are made up of one or more elements which are made of plastic, aluminum and brass. The plastic cages series LFF are molded in single elements which can be assembled by means of dovetail snap in ends. They are intended for use in horizontal applications. This type of cage is supplied in the flat state. The angle necessary during assembly can be obtained by submerging the cage in oil at 175°F and cooling it. For vertical applications the aluminum cage series LHW is recommended.

$$\text{Cage Length } CL = L - C/2$$

L = Rail Length

C = Stroke Required

P = Maximum load on cage length

nr/t = number of rollers / t

The condition $P > F$ must be satisfied when selecting your Rail design.

$$\text{Number of Elements required } NE = CL/t$$

t = Length of a single element

F = Load applied by user

LHW series has a maximum length (CL) of 39.37. Higher lengths can be obtained by joining together several elements. *When ordering LHW series cages please specify length of cages, Example: LHW15-1.26CL.

END TABS FOR NEEDLE ROLLER BEARING

STYLE	MATERIAL
GM	STAINLESS STEEL

STOCK NO.	a4	a5	a6	e	f	r
GM92025	.315	.158	.394	M4	.394	.394
GM2025	.354	.118	.433	M6	.551	.492
GM2535	.433	.118	.520	M8	.630	.551
GM3045	.433	.118	.520	M8	.709	.551
GM3555	.433	.118	.520	M8	.866	.551

STYLE	MATERIAL
GV	STAINLESS STEEL

STOCK NO.	a4	a5	a6	e	f	r
GV92025	.315	.158	.394	M4	.394	.394
GV2025	.354	.118	.433	M6	.551	.492
GV2535	.433	.118	.520	M8	.630	.551
GV3045	.433	.118	.520	M8	.709	.551
GV3555	.433	.118	.520	M8	.866	.551

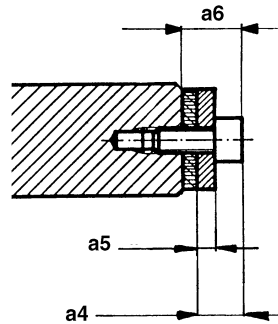
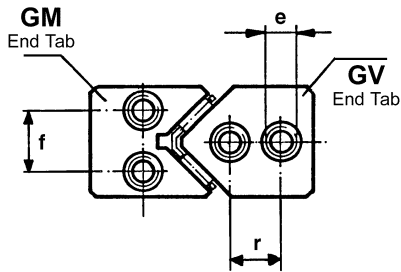

ULTRA PRECISION CROSS ROLLER BEARINGS DOUBLE V RAIL SETS

TRAVEL	MATERIAL
.94" TO 2.12"	RAILS & ROLLERS - HARDENED AND GROUND TOOL STEEL • RETAINERS - BRASS

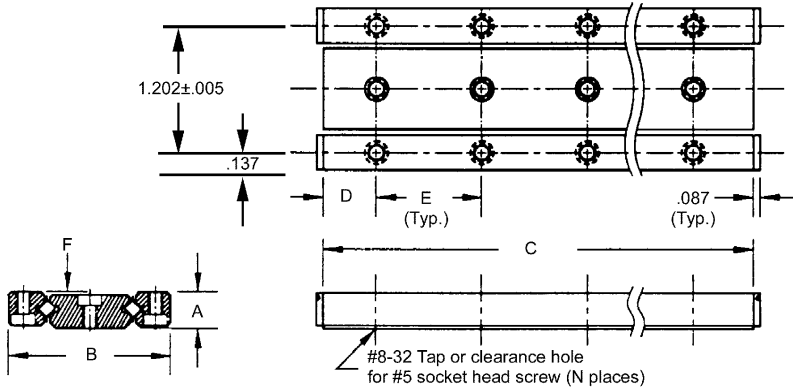

STOCK NO.	TRAVEL	A	B	C	D	E	F	N	RATED CAPACITY (lbs.)
LVL-01	.94			1.968				2	232
LVL-02	1.33			2.952				3	348
LVL-03	1.33	.322	1.479	3.936	.492	.984	.006	4	464
LVL-04	1.33			4.920				5	638
LVL-05	2.12			5.904				6	696

TRAVEL	MATERIAL
5" TO 35"	RAILS & ROLLERS - HARDENED AND GROUND TOOL STEEL • RETAINERS - BRASS

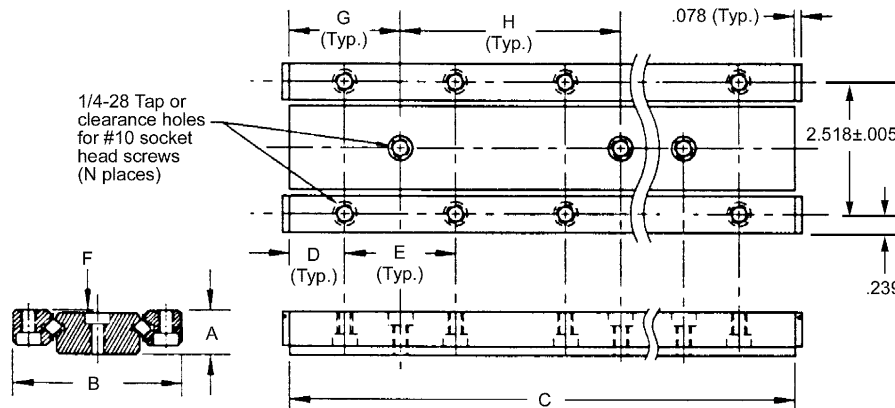

STOCK NO.	TRAVEL	A	B	C	D	E	F	G	H	N		RATED CAPACITY (lbs.)
										SIDE RAILS	CENTER RAILS	
LVH-05	5.00			5.906				0.984	1.968	3	3	1200
LVH-11	11.00			11.811						6	3	2160
LVH-15	15.00	.749	2.991	15.748	.984	1.968	0.007	1.968	3.937	8	4	2880
LVH-23	23.00			23.622						12	6	4320
LVH-35	35.00			35.433						18	9	6480

ULTRA PRECISION CROSS ROLLER "RECIRCULATING" BEARINGS & RAIL SETS

UNIT	MATERIAL
BEARINGS	RAILS & ROLLERS HARDENED AND GROUND TOOL STEEL

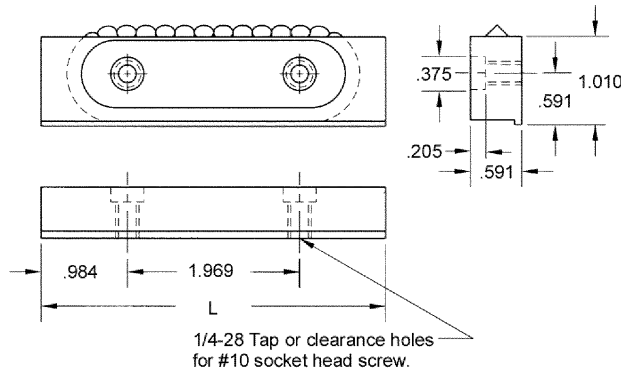

STOCK NO.	L
RW-100	3.937
RW-150	5.818

UNIT	MATERIAL
RAIL SETS	RAILS & ROLLERS HARDENED AND GROUND TOOL STEEL

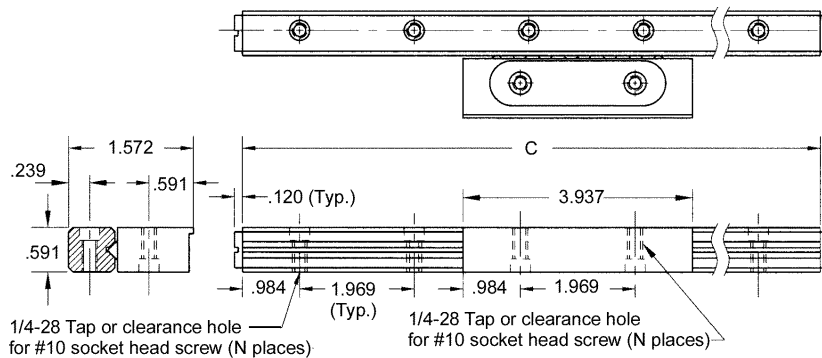

STOCK NO.	TRAVEL	C	N	RATED CAPACITY (lbs.)
SRWS-05	5.50	9.844	5	480
SRWS-07	7.50	11.813	6	
SRWS-09	9.50	13.782	7	
SRWS-11	11.50	15.751	8	
SRWS-13	13.50	17.720	9	
SRWS-15	15.50	19.689	10	
SRWS-17	17.50	21.658	11	
SRWS-19	19.50	23.627	12	

ULTRA PRECISION CROSS ROLLER "RECIRCULATING" BEARINGS & RAIL SETS

TRAVEL	MATERIAL
8" TO 32"	RAILS & ROLLERS HARDENED AND GROUND TOOL STEEL

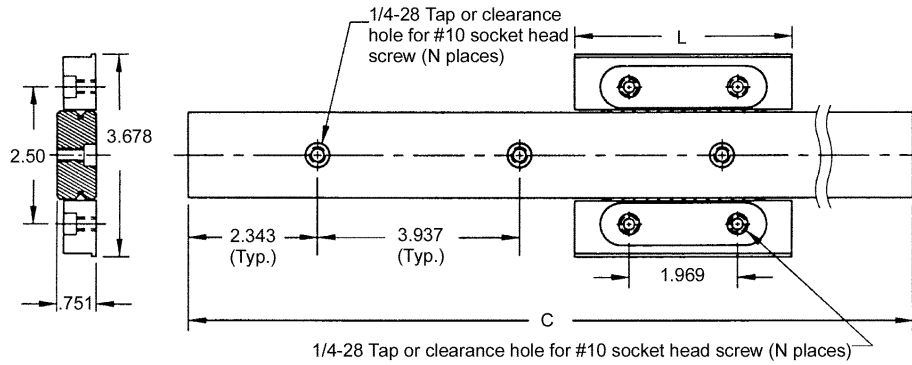

STOCK NO.	TRAVEL	C	L	N	RATED CAPACITY (lbs.)
DRWA-08	8.00	12.561		3	960
DRWA-20	20.00	24.372	3.937	6	
DRWA-32	32.00	36.183		9	
DRWB-06	6.00	12.561		3	1920
DRWB-18	18.00	24.373	5.818	6	
DRWB-30	30.00	36.183		9	

ULTRA PRECISION CROSS ROLLER "RECIRCULATING" BEARINGS & RAIL SETS

TRAVEL	MATERIAL
8" TO 32"	RAILS & ROLLERS - HARDENED AND GROUND TOOL STEEL TOP CARRIAGE - 6061-T6 ALUMINUM, CLEAR ANODIZED

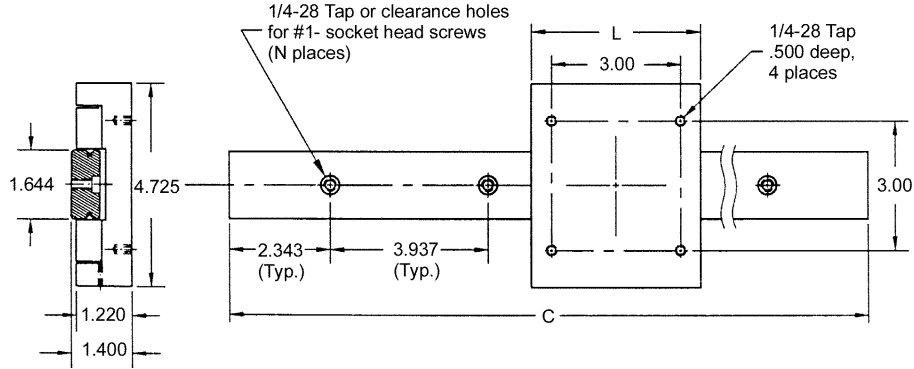

STOCK NO.	TRAVEL	C	L	N	RATED CAPACITY (lbs.)
RWSA-08	8.00	12.561		3	960
RWSA-20	20.00	24.372	3.937	6	
RWSA-32	32.00	36.183		9	
RSWB-06	6.00	12.561		3	1920
RSWB-18	18.00	24.373	5.818	6	
RSWB-30	30.00	36.183		9	



ULTRA-PRECISION CROSS ROLLER SLIDE ASSEMBLIES, LONG TRAVEL

TRAVEL	MATERIAL
1" TO 23"	RAILS & ROLLERS - HARDENED AND GROUND TOOL STEEL TOP CARRIAGE 6061-T6 ALUMINUM, CLEAR ANODIZED OR G2 CLOSE GRAIN CAST IRON • RETAINERS - BRASS

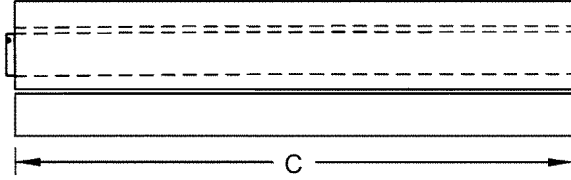
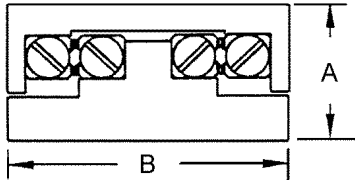

ALUMINUM STOCK NO.	CAST IRON STOCK NO.	TRAVEL	A	B	C	RATED CAPACITY (lbs.)
LWAA-01	LWSA-01	1.00			2.00	174
LWAA-02	LWSA-02	2.00			3.00	232
LWAA-03	LWSA-03	3.00			4.00	348
LWAA-04	LWSA-04	4.00			5.00	406
LWAA-05	LWSA-05	5.00			6.00	464
LWAA-06	LWSA-06	6.00	.984	2.00	7.00	522
LWAA-07	LWSA-07	7.00			8.00	638
LWAA-08	LWSA-08	8.00			9.00	696
LWAA-09	LWSA-09	9.00			10.00	754
LWAA-10	LWSA-10	10.00			11.00	812
LWAA-11	LWSA-11	11.00			12.00	928
LWAB-02	LWSB-02	2.00			3.00	232
LWAB-03	LWSB-03	3.00			4.00	348
LWAB-04	LWSB-04	4.00			5.00	406
LWAB-05	LWSB-05	5.00			6.00	464
LWAB-06	LWSB-06	6.00			7.00	522
LWAB-07	LWSB-07	7.00	1.250	3.00	8.00	638
LWAB-08	LWSB-08	8.00			9.00	696
LWAB-09	LWSB-09	9.00			10.00	754
LWAB-10	LWSB-10	10.00			11.00	812
LWAB-11	LWSB-11	11.00			12.00	928
LWAC-03	LWSC-03	3.00			4.00	480
LWAC-05	LWSC-05	5.00			6.00	720
LWAC-07	LWSC-07	7.00			8.00	960
LWAC-09	LWSC-09	9.00			10.00	1200
LWAC-11	LWSC-11	11.00			12.00	1440
LWAC-13	LWSC-13	13.00	1.440	4.00	14.00	1680
LWAC-15	LWSC-15	15.00			16.00	1920
LWAC-17	LWSC-17	17.00			18.00	2160
LWAC-19	LWSC-19	19.00			20.00	2400
LWAC-21	LWSC-21	21.00			22.00	2640
LWAC-23	LWSC-23	23.00			24.00	2880
LWAD-04	LWSD-04	4.75			6.00	720
LWAD-06	LWSD-06	6.75			8.00	960
LWAD-08	LWSD-08	8.75			10.00	1200
LWAD-10	LWSD-10	10.75			12.00	1440
LWAD-12	LWSD-12	12.75	2.00	6.00	14.00	1680
LWAD-14	LWSD-14	14.75			16.00	1920
LWAD-16	LWSD-16	16.75			18.00	2160
LWAD-18	LWSD-18	18.75			20.00	2400
LWAD-20	LWSD-20	20.75			22.00	2640
LWAD-22	LWSD-22	22.75			24.00	2880



Mounting holes can be supplied at an additional cost, contact Customer Service.

ULTRA-PRECISION CROSSED ROLLER SLIDE ASSEMBLIES, LOW PROFILE

TRAVEL	MATERIAL
1" TO 5"	RAILS & ROLLERS - HARDENED AND GROUND TOOL STEEL TOP & BASE - 6061-T6 ALUMINUM, CLEAR ANODIZED RETAINERS - PLASTIC

STOCK NO.	TRAVEL	A	B	C	D	E	I	J	N	RATED CAPACITY (lbs.)
LPA-01	1.00			2.00					2	75
LPA-02	2.00			3.00					3	75
LPA-03	3.00	.625	1.48	4.00	.492	.984	#8-32	#5	4	100
LPA-04	4.00			5.00					5	100
LPA-05	5.00			6.00					6	100

TRAVEL	MATERIAL
1" TO 5"	RAILS & ROLLERS - HARDENED AND GROUND TOOL STEEL TOP & BASE - 6061-T6 ALUMINUM, CLEAR ANODIZED RETAINERS - BRASS

STOCK NO.	TRAVEL	A	B	C	D	E	I	J	N	RATED CAPACITY (lbs.)
LPB-01	1.00			2.00					2	75
LPB-02	2.00			3.00					3	75
LPB-03	3.00	.625	2.00	4.00	.492	.984	#8-32	#5	4	100
LPB-04	4.00			5.00					5	100
LPB-05	5.00			6.00					6	100

TRAVEL	MATERIAL
6" TO 36"	RAILS & ROLLERS - HARDENED AND GROUND TOOL STEEL TOP & BASE - 6061-T6 ALUMINUM, CLEAR ANODIZED RETAINERS - PLASTIC

STOCK NO.	TRAVEL	A	B	C	D	E	I	J	N	RATED CAPACITY (lbs.)
LPC-06	6.00			6.02	.984	1.968			3	960
LPC-12	12.00			12.02					3	1920
LPC-24	24.00	1.250	3.75	24.02	1.968	3.937	1/4-28	#10	6	4080
LPC-36	36.00			36.02					9	6000

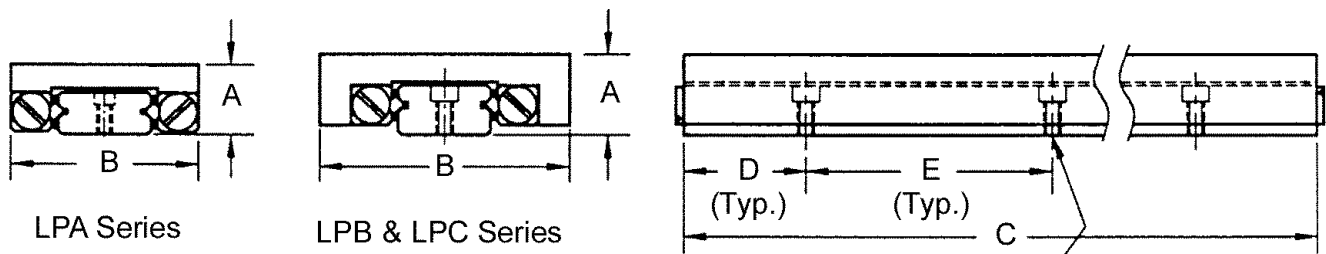

Tapped hole I or clearance hole for screw J (N places)

ULTRA-PRECISION CROSS ROLLER FLANGE BASED SLIDE ASSEMBLIES

TRAVEL	MATERIAL
1" TO 6"	RAILS & ROLLERS - HARDENED AND GROUND TOOL STEEL TOP CARRIAGE 6061-T6 ALUMINUM, CLEAR ANODIZED OR G2 CLOSE GRAIN CAST IRON • RETAINERS - BRASS

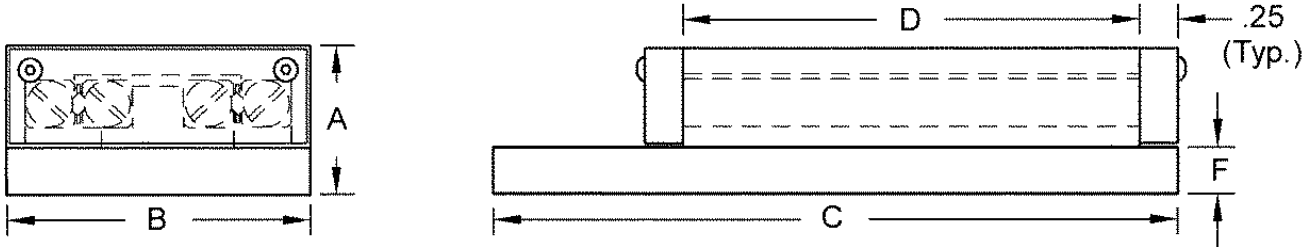

ALUMINUM STOCK NO.	CAST IRON STOCK NO.	TRAVEL	A	B	C	D	F	RATED CAPACITY (lbs.)
LFA-01	LFS-01	1.00	.98	2.00	4.50	3.00	.20	232
LFA-02	LFS-02	1.00			5.50	4.00		348
LFA-03	LFS-03	2.00			8.50	6.00		464
LFA-04	LFS-04	1.00	1.25	3.00	5.50	4.00	.41	348
LFA-05	LFS-05	1.00			6.50	5.00		522
LFA-06	LFS-06	2.00			8.50	6.00		464
LFA-07	LFS-07	1.00	1.44	4.00	7.50	6.00	.47	638
LFA-08	LFS-08	2.00			10.50	8.00		754
LFA-09	LFS-09	2.00			12.50	10.00		1044
LFA-10	LFS-10	3.00			15.50	12.00		1102
LFA-11	LFS-11	2.00	2.00	6.00	10.50	8.00	.81	1200
LFA-12	LFS-12	4.00			16.50	12.00		1440
LFA-13	LFS-13	6.00			22.50	16.00		1680

Mounting holes can be supplied at an additional cost, contact Customer Service.

ULTRA-PRECISION CROSS ROLLER "RECIRCULATING" SLIDE ASSEMBLIES, LONG TRAVEL

TRAVEL	MATERIAL
6" TO 20"	RAILS & ROLLERS - HARDENED AND GROUND TOOL STEEL TOP CARRIAGE 6061-T6 ALUMINUM, CLEAR ANODIZED OR G2 CLOSE GRAIN CAST IRON • RETAINERS - BRASS

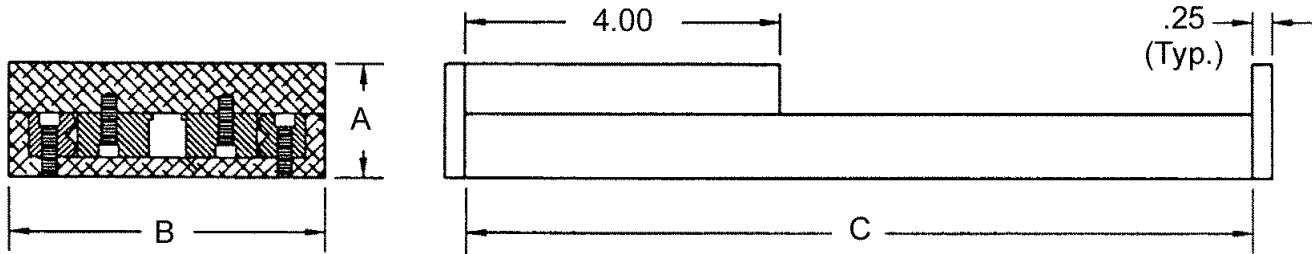

ALUMINUM STOCK NO.	CAST IRON STOCK NO.	TRAVEL	A	B	C	RATED CAPACITY (lbs.)
RWAA-06	RWAS-06	6.00			10.00	960
RWAA-08	RWAS-08	8.00			12.00	
RWAA-10	RWAS-10	10.00			14.00	
RWAA-12	RWAS-12	12.00	1.44	4.00	16.00	
RWAA-14	RWAS-14	14.00			18.00	
RWAA-16	RWAS-16	16.00			20.00	
RWAA-18	RWAS-18	18.00			22.00	
RWAA-20	RWAS-20	20.00			24.00	
RWBA-06	RWBS-06	6.00			10.00	960
RWBA-08	RWBS-08	8.00			12.00	
RWBA-10	RWBS-10	10.00			14.00	
RWBA-12	RWBS-12	12.00	2.00	6.00	16.00	
RWBA-14	RWBS-14	14.00			18.00	
RWBA-16	RWBS-16	16.00			20.00	
RWBA-18	RWBS-18	18.00			22.00	
RWBA-20	RWBS-20	20.00			24.00	

Mounting holes can be supplied at an additional cost, contact Customer Service.



ULTRA-PRECISION CROSS ROLLER PLAIN STYLE SLIDE ASSEMBLIES, LONG TRAVEL

TRAVEL	MATERIAL
1" TO 6"	RAILS & ROLLERS - HARDENED AND GROUND TOOL STEEL TOP CARRIAGE 6061-T6 ALUMINUM, CLEAR ANODIZED OR G2 CLOSE GRAIN CAST IRON • RETAINERS - BRASS

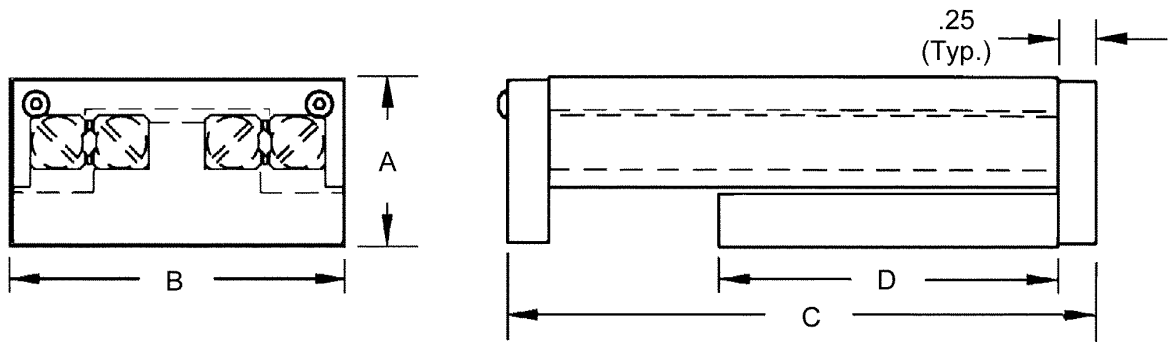

ALUMINUM STOCK NO.	CAST IRON STOCK NO.	TRAVEL	A	B	C	D	RATED CAPACITY (lbs.)
LAA-01	LAS-01	1.00					232
LAA-02	LAS-02	1.00	.98	2.00	3.50	2.00	348
LAA-03	LAS-03	2.00			4.50	3.00	464
LAA-04	LAS-04	1.00			6.50	4.00	464
LAA-05	LAS-05	1.00	1.25	3.00	3.00	3.48	522
LAA-06	LAS-06	2.00			5.50	4.00	464
LAA-07	LAS-07	1.00			6.50	5.00	638
LAA-08	LAS-08	2.00			8.50	6.00	754
LAA-09	LAS-09	2.00	1.44	4.00	10.50	8.00	1044
LAA-10	LAS-10	3.00			12.50	9.00	1102
LAA-11	LAS-11	2.00			8.50	6.00	1200
LAA-12	LAS-12	4.00	2.00	6.00	12.50	8.00	1440
LAA-13	LAS-13	6.00			16.50	10.00	1680

Mounting holes can be supplied at an additional cost, contact Customer Service.

ULTRA-PRECISION CROSS ROLLER LEAD SCREW DRIVEN SLIDE ASSEMBLIES

STYLE	TRAVEL	MATERIAL
KNOB	1" TO 6"	RAILS & ROLLERS - HARDENED AND GROUND TOOL STEEL TOP CARRIAGE 6061-T6 ALUMINUM, CLEAR ANODIZED OR G2 CLOSE GRAIN CAST IRON • RETAINERS - BRASS

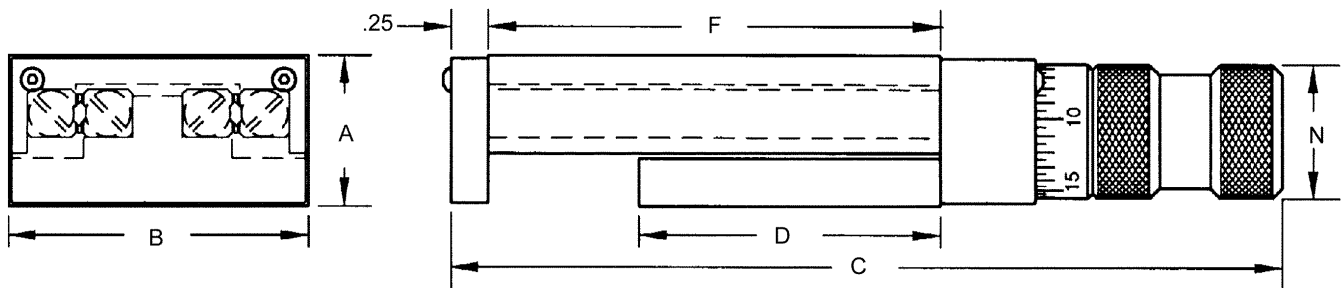

ALUMINUM STOCK NO.	CAST IRON STOCK NO.	TRAVEL	A	B	C KNOB STYLE	D	F	N	RATED CAPACITY (lbs.)
LDA-01K	LDS-01K	1			5.5	2	3		232
LDA-02K	LDS-02K	1	.98	2.00	6.5	3	4	7/8	348
LDA-03K	LDS-03K	2			7.5	4	6		464
LDA-04K	LDS-04K	1			6.87	3	4		348
LDA-05K	LDS-05K	1	1.25	3.00	7.87	4	5		522
LDA-06K	LDS-06K	2			8.87	4	6		464
LDA-07K	LDS-07K	1			8.87	5	6	1 3/32	638
LDA-08K	LDS-08K	2			10.87	6	8		754
LDA-09K	LDS-09K	2	1.44	4.00	12.87	8	10		1044
LDA-10K	LDS-10K	3			14.87	9	12		1102
LDA-11K	LDS-11K	2			11.37	6	8		1200
LDA-12K	LDS-12K	4	2.00	6.00	15.37	8	12	1 3/8	1440
LDA-13K	LDS-13K	6			19.37	10	16		1680

Mounting holes can be supplied at an additional cost, contact Customer Service.

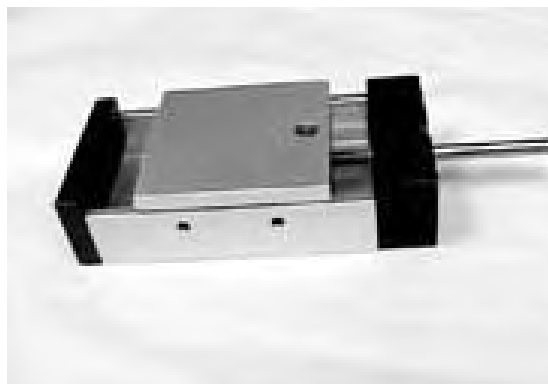

ULTRA-PRECISION CROSS ROLLER LEAD SCREW DRIVEN SLIDE ASSEMBLIES

STYLE	TRAVEL	MATERIAL
CRANK	1" TO 6"	RAILS & ROLLERS - HARDENED AND GROUND TOOL STEEL TOP CARRIAGE 6061-T6 ALUMINUM, CLEAR ANODIZED OR G2 CLOSE GRAIN CAST IRON • RETAINERS - BRASS

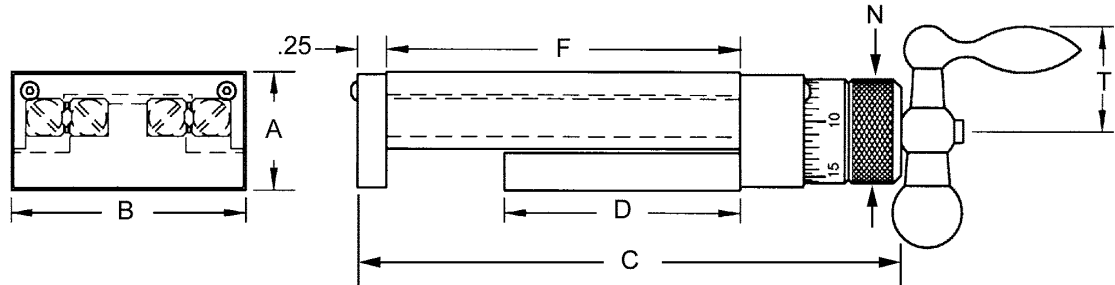

ALUMINUM STOCK NO.	CAST IRON STOCK NO.	TRAVEL	A	B	C CRANK STYLE	D	F	N	T	RATED CAPACITY (lbs.)
LDA-01C	LDS-01C	1	.98	2.00	6.12	2	3	7/8	1.00	232
LDA-02C	LDS-02C	1			7.12	3	4			348
LDA-03C	LDS-03C	2			8.12	4	6			464
LDA-04C	LDS-04C	1	1.25	3.00	7.25	3	4	1.00	348	
LDA-05C	LDS-05C	1			8.25	4	5		522	
LDA-06C	LDS-06C	2			9.25	4	6		464	
LDA-07C	LDS-07C	1	1.44	4.00	9.25	5	6	1 3/32	1.00	638
LDA-08C	LDS-08C	2			11.25	6	8			754
LDA-09C	LDS-09C	2			13.25	8	10			1044
LDA-10C	LDS-10C	3			15.25	9	12			1102
LDA-11C	LDS-11C	2	2.00	6.00	12.31	6	8	1 3/8	1.50	1200
LDA-12C	LDS-12C	4			16.31	8	12			1440
LDA-13C	LDS-13C	6			20.31	10	16			1680

Mounting holes can be supplied at an additional cost, contact Customer Service.

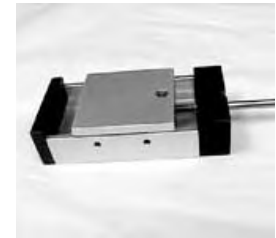

STYLE	TRAVEL	MATERIAL
SHAFT	1" TO 6"	RAILS & ROLLERS - HARDENED AND GROUND TOOL STEEL TOP CARRIAGE 6061-T6 ALUMINUM, CLEAR ANODIZED OR G2 CLOSE GRAIN CAST IRON • RETAINERS - BRASS

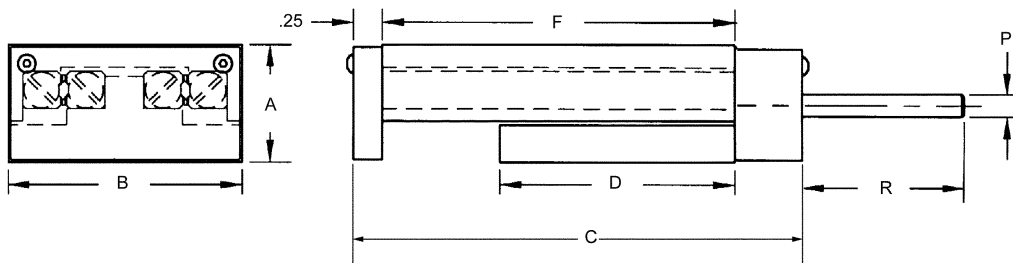

ALUMINUM STOCK NO.	CAST IRON STOCK NO.	TRAVEL	A	B	C SHAFT STYLE	D	F	R	P +.0000 -.0002	RATED CAPACITY (lbs.)
LDA-01S	LDS-01S	1	.98	2.00	5.25	2	3	1.38	.1873	232
LDA-02S	LDS-02S	1			6.26	3	4			348
LDA-03S	LDS-03S	2			7.25	4	6			464
LDA-04S	LDS-04S	1	1.25	3.00	6.50	3	4	1.50	.1873	348
LDA-05S	LDS-05S	1			7.50	4	5			522
LDA-06S	LDS-06S	2			8.50	4	6			464
LDA-07S	LDS-07S	1	1.44	4.00	8.50	5	6	1.50	.1873	638
LDA-08S	LDS-08S	2			10.50	6	8			754
LDA-09S	LDS-09S	2			12.50	8	10			1044
LDA-10S	LDS-10S	3			14.50	9	12			1102
LDA-11S	LDS-11S	2	2.00	6.00	11.00	6	8	2.13	.2498	1200
LDA-12S	LDS-12S	4			15.00	8	12			1440
LDA-13S	LDS-13S	6			19.00	10	16			1680

Mounting holes can be supplied at an additional cost, contact Customer Service.

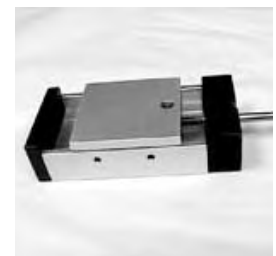

LINEAR-ROTARY BEARINGS PRE-LOADED, GENERAL PURPOSE

BORE	TRAVEL	MATERIAL
1/2" TO 2"	1" TO 6"	RETAINER 1/2" BORE BRASS, 3/4-2" BORES ALUMINUM SEALS - NITRITE RUBBER

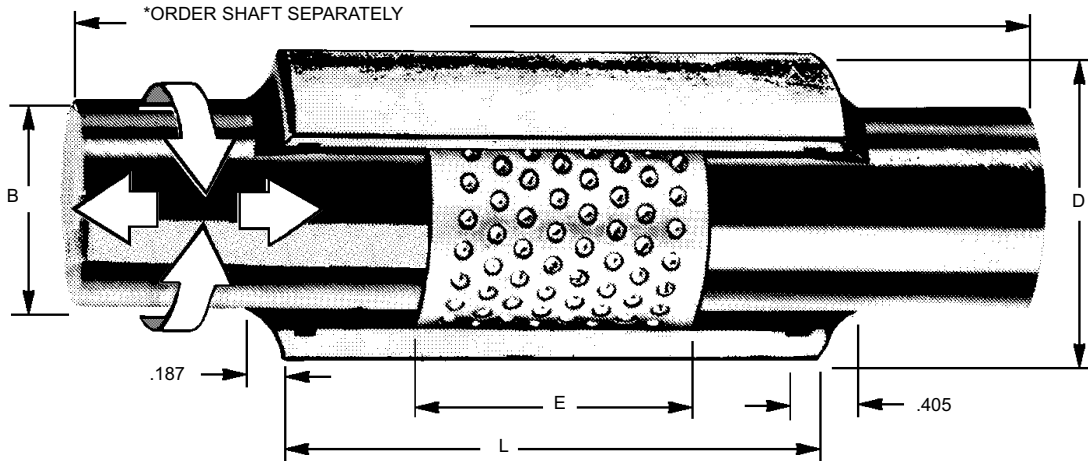

STOCK NO.	B	OUTSIDE DIA.	E	+0.000 -.005 L	MAX. LINEAR TRAVEL	CAP. (lbs.)	HARDENED SHAFTING STOCK LENGTH 12 INCHES OTHER LENGTHS ON REQUEST		
							STOCK NO.	DIAMETER	
LRM-3-1	-.0002	+.0002	.500	1.625	1.00	230	LMS-48-12	-.0002	
LRM-3-2	.4997	.8753		2.125	2.00		.5000		
LRM-4-1	-.0002	+.0003	.843	2.000	1.00	490	LMS-52-12	-.0002	
LRM-4-2	.7497	1.2504		2.500	2.00		.7500		
LRM-5-1	-.0002	+.0003	1.281	2.500	1.00	720	LMS-56-12	-.0002	
LRM-5-2				3.000	2.00				1.0000
LRM-5-3				3.500	3.00				
LRM-5-4				4.000	1.00				
LRM-6-1	-.0002	+.0003	1.781	3.000	1.00	1010	LMS-60-12	-.0002	
LRM-6-2				3.500	2.00				1.2500
LRM-6-3				4.000	3.00				
LRM-6-4				4.500	4.00				
LRM-6-6	5.000	6.00							
LRM-7-1	-.0002	+.0003	2.000	3.250	1.00	1200	LMS-64-12	-.0002	
LRM-7-2				3.750	2.00				1.5000
LRM-7-3				4.250	3.00				
LRM-7-4				4.750	4.00				
LRM-7-6				5.750	6.00				
LRM-8-1	-.0002	+.0003	2.687	4.000	1.00	2400	LMS-72-12	-.0002	
LRM-8-2				4.500	2.00				2.0000
LRM-8-3				5.000	3.00				
LRM-8-4				5.500	4.00				
LRM-8-6				6.000	6.00				

- Seals can be hand removed to reduce friction
- Supporting combinations of linear and rotary motion bearings
- Temperature ranges -40°F to +248°F



ROLLER RAIL

STYLE	NOTE
THREE SET UP STYLES AVAILABLE	SEE OPERATING SUGGESTIONS BELOW

FIG. 1

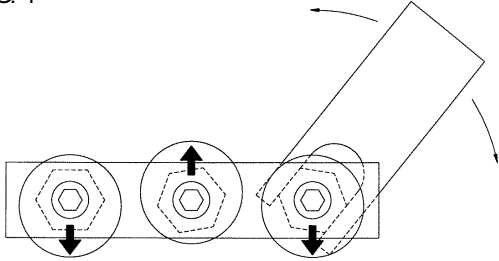

Operating Suggestions:

Slider Selection

If your load is always acting in one direction on the slider, then choose the unit with three (3) rollers (RRSS-3 or RRLS-3). Adjust the slider so the two outer rollers carry the load and center roller removes the free-play against the opposite flange (see fig. 1).

If your application requires load capacity in two directions, choose the slider with four (4) rollers (RRSS-4 or RRLS-4) and configure them alternately against opposing flanges of the track.

For maximum stability or moment loading, choose the slider with five (5) rollers (RRSS-5 or RRLS-5). As with the other styles, adjust the rollers alternately against opposing flanges.

FIG. 2

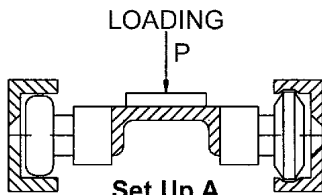

Set Up A
Concentrated load halfway between the sides.

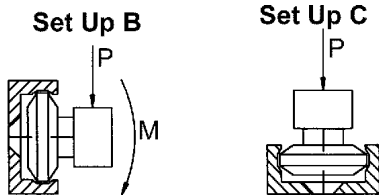

Set Up B
Set Up C
Concentrated load on the center line of slide.

Load Capacity

The load capacity of Berg's Roller Rail is dependent on the mounting configuration of your load with respect to the slider. Use fig. 2, the corresponding setup and the chart below to determine the maximum suggested operation load for your application.

Adjustment

Berg Roller Rail sliders are provided with an adjustment wrench. This wrench allows you to adjust the eccentric roller mount to achieve the desired free-play, friction and pre-load.

The rollers are adjusted by placing the slider on the track and attaching the wrench to the hex nut between the roller and the body of the slider. The mounting cap screw is then loosened with a hex key and the roller is turned into place with the supplied wrench. The cap screw is then tightened to secure the assembly. (fig. 1)

Proper Mounting

Berg Roller Rails are designed to be mounted on either a vertical surface (figs. 3-1 & 3-2) or horizontal surface (fig. 3-3). As shown in the illustration, when mounting on a vertical surface it is important to provide support for the load under the rail.

When mounting for horizontal motion and high loads, it is suggested that you mount the slide as shown in figure 4. By using one grooved flange track and one flat flange track, you get a self-positioning set-up which makes precision assembly not required.

Lubrication

While the rollers on the slider are lubricated for life, it is useful to lubricate the track with oil or a light grease prior to beginning operation. This will extend the life of the assembly considerably. The lubrication should be replaced or replenished occasionally.

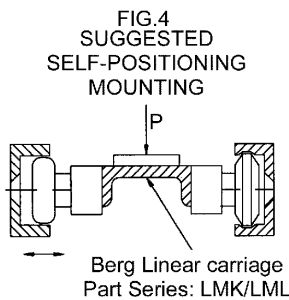
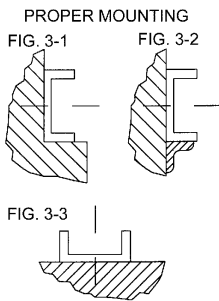

STOCK NO.	LOAD CAPACITY P (lbs.) SETUP LETTER			MAX. MOMENT M (in. lbs.)
	A	B	C	
RRSS-3	70	7	7	442
RRSS-4	75	7	7	
RRSS-5	80	8	8	
RRLS-3	185	14	18	1106
RRLS-4	200	15	19	
RRLS-5	210	16	21	

- Economical linear positioning
- High load capacity
- Low friction
- Long life
- Versatile mounting configurations
- Infinite travel length variations
- Easy Adjustability
- Easy replacement of worn components
- Low maintenance

ROLLER RAIL

MATERIAL

BODY - ALUMINUM, ANODIZED • BEARINGS - STAINLESS STEEL
ROLLERS - 416 STAINLESS STEEL C26-32 • RAILS - CORROSION RESISTANT COLD ROLLED STEEL

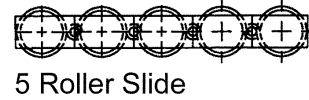
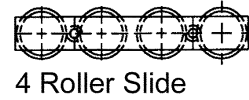
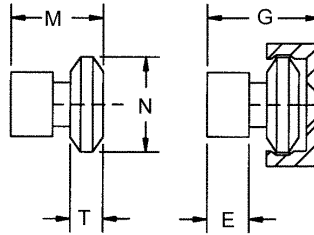
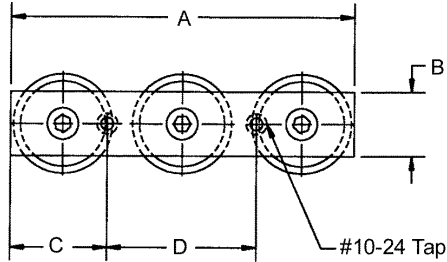

Hole for Flat Head Screw
 #6-21 for RRS Series
 #8-32 for RRL Series

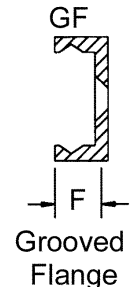
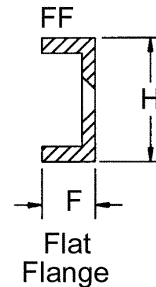
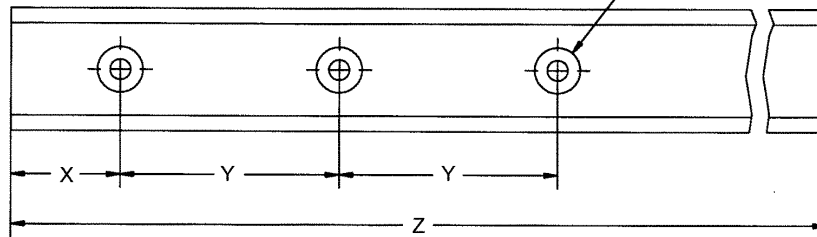

STOCK NO.	A	B	C	D	NO. OF MOUNTING HOLES	E	F	G	H	M	N	T	NO. OF ROLLERS
RRSS-3	2.38			.78	2								3
RRSS-4	3.15	.375	.787	1.57	2	.225	.328	.600	.708	.435	.551	.157	4
RRSS-5	3.94			.78	4								5
RRLS-3	3.15		.887	1.37	2								3
RRLS-4	3.94	.750	1.000	2.00	2	.375	.485	1.000	1.100	.750	.912	.234	4
RRLS-5	5.00		1.000	1.00	4								5

	FLAT FLANGE STOCK NO.	GROOVED FLANGE STOCK NO.	NO. OF MOUNTING HOLES	Z	X	Y
USE WITH RRSS-SERIES SLIDER	RRSFF-1	RRSGF-1	3	9.45		
	RRSFF-2	RRSGF-2	4	12.60		
	RRSFF-3	RRSGF-3	5	15.75		
	RRSFF-4	RRSGF-4	6	18.90		
	RRSFF-5	RRSGF-5	7	22.05		
	RRSFF-6	RRSGF-6	8	25.20		
	RRSFF-7	RRSGF-7	9	28.35	1.575	3.150
	RRSFF-8	RRSGF-8	10	31.50		
	RRSFF-9	RRSGF-9	12	37.80		
	RRSFF-10	RRSGF-10	14	44.10		
	RRSFF-11	RRSGF-11	16	50.40		
	RRSFF-12	RRSGF-12	18	56.70		
	RRSFF-13	RRSGF-13	20	63.00		
USE WITH RRLS-SERIES SLIDER	RRLFF-1	RRLGF-1	5	15.75		
	RRLFF-2	RRLGF-2	6	18.90	1.575	3.150
	RRLFF-3	RRLGF-3	10	31.50		
	RRLFF-4	RRLGF-4	15	47.25	1.575	3.150
	RRLFF-5	RRLGF-5	20	63.00		
	RRLFF-6	RRLGF-6	25	78.74		

Roller adjustment wrench supplied.

Additional and replacement rollers available on request.

See previous page for operating suggestions.

Other rail lengths available on request.



LINEAR MOTION ADJUSTABLE BEARINGS

STYLE	MATERIAL
F, W, FS & WS	HOUSING - STAINLESS STEEL OR MILD STEEL, BLACK OXIDE FINISH BEARINGS & SPINDLES - STAINLESS STEEL

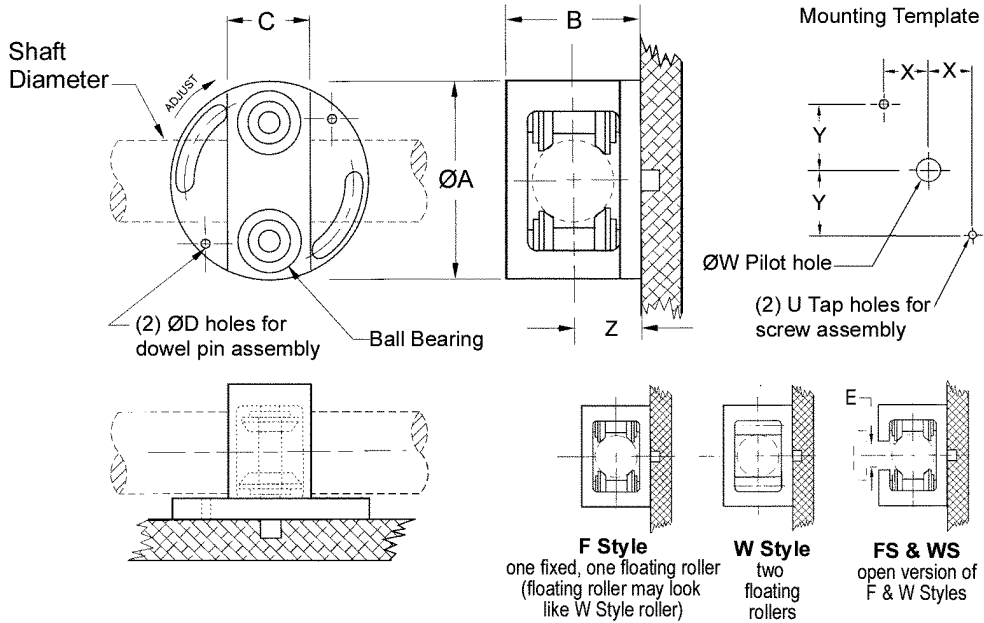

STAINLESS STEEL STOCK NO.	MILD STEEL STOCK NO.	SHAFT DIA. MIN.-MAX.	ØA	B	C	D	E	U	ØW	X	Y	Z	RATED LOAD lbs.
- -	LMX-4-F LMX-4-W	.2485-.2500	.62	.56	.25	-	-	#4-40	.127	.093	.200	.279	22
LMA-6-F LMA-6-W	LMX-6-F LMX-6-W	.375-.500	1.25	.93	.50	.10	-	#6-32	.252	.312	.370	.453	90
LMA-12-F LMA-12-W	LMX-12-F LMX-12-W	.750-1.000	2.37	1.62	1.00	.10	.56	#8-32	.252	.664	.776	.796	460
LMA-12-FS LMA-12-WS	LMX-12-FS LMX-12-WS	1.000 ±.010											
LMA-20-F LMA-20-W LMA-20-FS LMA-20-WS	LMX-20-F LMX-20-W LMX-20-FS LMX-20-WS	1.250 ±.010	3.25	2.12	1.38	.15	.63	#8-32	.377	.860	1.027	1.008	750
- - - -	LMX-24-F LMX-24-W LMX-24-FS LMX-24-WS	1.500 ±.020	3.59	2.75	*	.15	.75	1/4-20	.377	1.000	.990	1.382	1250
- - - -	LMX-32-F LMX-32-W LMX-32-FS LMX-32-WS	1.500 ±.020	4.75	3.06	*	.15	1.00	1/4-28	.502	1.115	1.850	1.517	3000

* 1 1/2 and 2" shaft units are round. C = A.



PRECISION LINEAR "GEAR DRIVE" BEARINGS

MATERIAL

STAINLESS STEEL

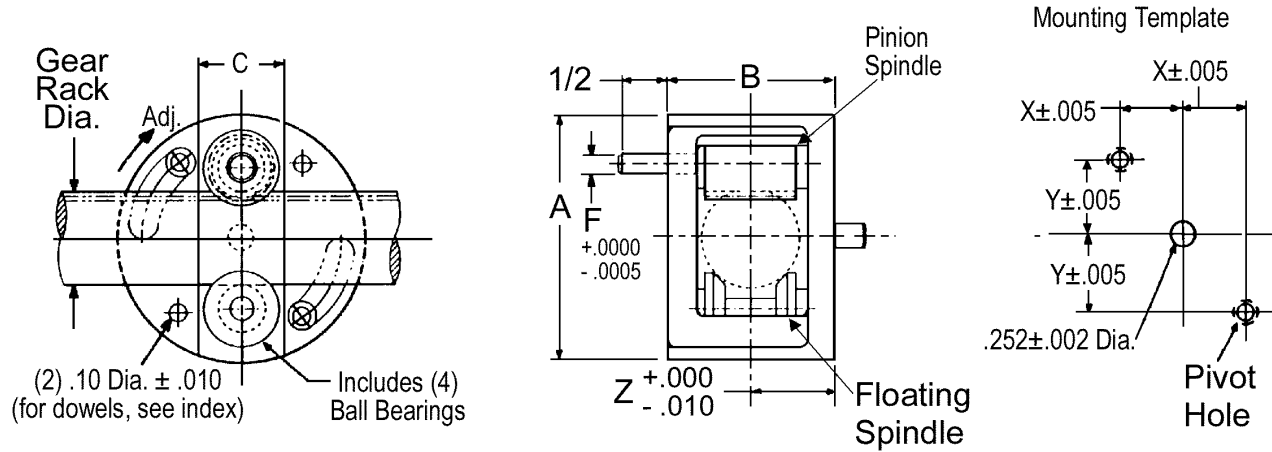

STOCK NO.	LINEAR DRIVE GEAR RACK STOCK NO.	GEAR RACK DIA.	A	B	C	U	X	Y	Z	F	PINION DATA 1/20" CIRCULAR PITCH 20° PRESSURE ANGLE		
											# TEETH	PITCH DIA. (Ref.)	TRAVEL PER REV.
LMA-G-6	R12-1	1/2	1 1/4	15/16	1/2	#6-32	.316	.370	.453	.1247	20	.3183	1.000
LMA-G-12	R12-2	1	2 3/8	1 5/8	1	#8-32	.664	.776	.796	.1872	40	.6366	2.000

- Power take off for encoders, feedback systems, etc.
- Power drive. Direct drive through stepper motors, etc.
- Mount with Dial and Vernier for simple, accurate positioning.
- Backlash adjustable by rotating housing against gear rack.
- Mounting screws and washers supplied.



LINEAR DRIVE GEAR RACKS

PITCH	MATERIAL	PRESSURE ANGLE
1/20	400 SERIES STAINLESS STEEL HRC 45	20°

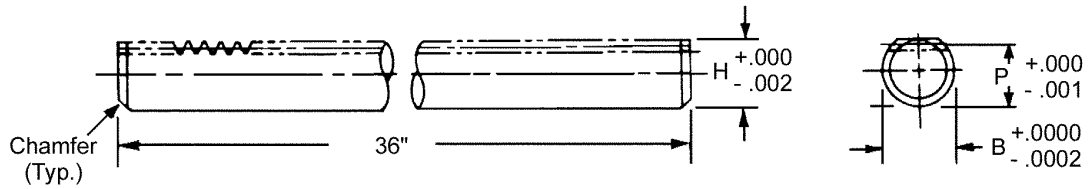

STOCK NO.	PITCH	P	B	H	USE WITH DRIVE BEARING
R12-1	1/20	.4443	.4997	.460	LMA-G-6
R12-2	1/20	.9060	.9997	.922	LMA-G-12

- Use with linear "gear drive" bearings
- Can be butted for longer lengths.
- High Precision, High Performance



SELF-ALIGNING ROD ENDS

STYLE	BORE	MATERIAL
RIGHT HAND THREAD FEMALE ENDS	3/16" TO 5/8"	STAINLESS STEEL OR CARBON ZINC PLATED

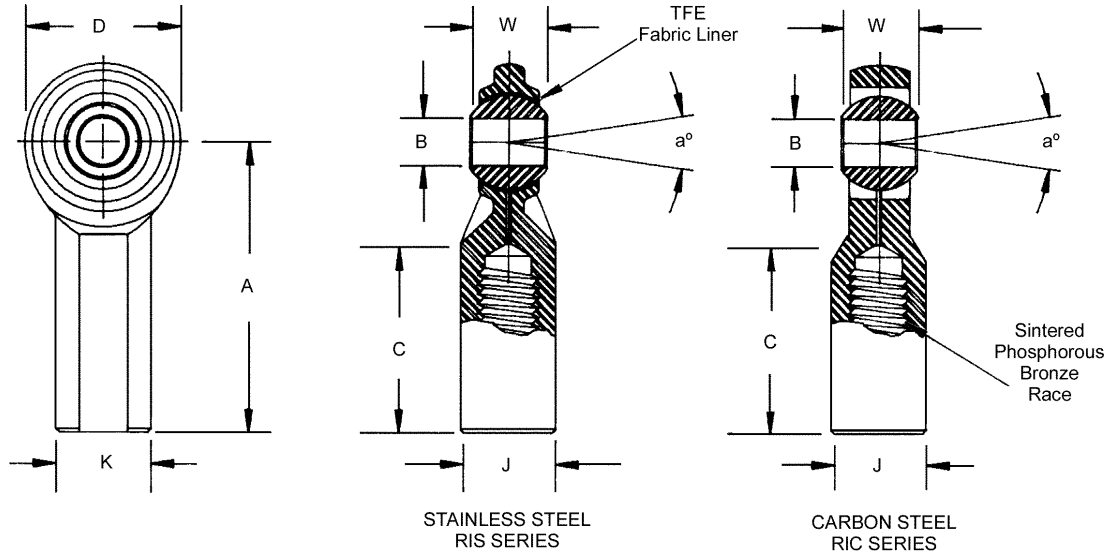

STAINLESS STEEL STOCK NO.	CARBON STEEL STOCK NO.	DIMENSIONS IN INCHES								THREAD	a° Misalign. Angle	RADICAL* STATIC LOAD CAP. (lbs.)
		B +.0015 -.0015	W +.000 -.005	A ±.015	D ±.010	K ±.010	J ±.010	C +.062 -.031				
RIS-3	RIC-3	.1900	.312	1.062	.625	.406	.312	.500	#10-32	17	900	
RIS-4	RIC-4	.2500	.375	1.312	.750	.469	.375	.687	1/4-28	21	1,350	
RIS-5	RIC-5	.3125	.437	1.375	.875	.500	.437	.687	5/16-24	17	2,000	
RIS-6	RIC-6	.3750	.500	1.625	1.000	.687	.562	.812	3/8-24	19	3,000	
RIS-7	RIC-7	.4375	.562	1.812	1.125	.750	.625	.937	7/16-20	18	3,750	
RIS-8	RIC-8	.5000	.625	2.125	1.312	.875	.750	1.062	1/2-20	17	4,650	
RIS-10	RIC-10	.6250	.750	2.500	1.500	1.000	.875	1.375	5/8-18	22	5,850	

* Load is higher and the angle is lower for carbon steel units.
Consult Berg Engineering Department.

- High radical and thrust loads
- Long life cycle
- Temperature range -65°F to +250°F



ROD END AND STUD ASSEMBLIES

STYLE	BORE END SIZE	MATERIAL
RIGHT HAND THREAD	3 TO 10	STAINLESS STEEL OR CARBON STEEL

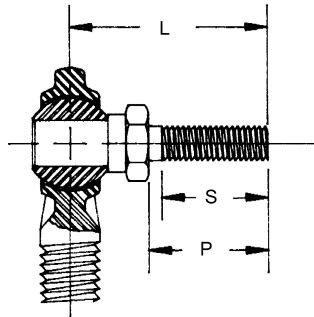

STAINLESS STEEL		CARBON STEEL		STUD DIMENSIONS					
STOCK NO.	STUD ASSEMBLED WITH:	STOCK NO.	STUD ASSEMBLED WITH:	ROD END BORE SIZE	L ±.015	P Ref.	S. MIN	THREAD	HEX
RISS-3	RIS-3	RICS-3	RIC-3	3	.875	.437	.375	10-32	.312
RISS-4	RIS-4	RICS-4	RIC-4	4	1.031	.562	.500	1/4-28	.375
RISS-5	RIS-5	RICS-5	RIC-5	5	1.218	.687	.593	5/16-24	.437
RISS-6	RIS-6	RICS-6	RIC-6	6	1.500	.875	.781	3/8-24	.500
RISS-7	RIS-7	RICS-7	RIC-7	7	1.906	1.062	.937	7/16-20	.625
RISS-8	RIS-8	RICS-8	RIC-8	8	2.000	1.125	1.000	1/2-20	.625
RISS-10	RIS-10	RICS-10	RIC-10	10	2.125	1.125	1.000	5/8-18	.750

MATERIALS				
SERIES	BALL	RACE	BODY	STUD
RIS Stainless Steel	400C Stainless Steel Heat Treated	Teflon Fabric Permanently Bonded to Race I.D.	Type 303 Stainless Steel	Low Carbon Steel, Zinc Plated
RIC Carbon Steel	Carbon Steel Case Hardened Chrome Plated	Sintered Phosphorous Bronze	Low Carbon Steel Zinc Plated Chromate Treated	Low Carbon Steel Zinc Plated Chromate Treated

Options Available:

- Left hand threads
- Other bore diameters
- Other materials
- Grease ball check fittings on rod ends, RIC series.

ROD END AND STUD ASSEMBLIES

STYLE	BORE	MATERIAL
RIGHT HAND THREAD FEMALE ENDS	3/16" TO 5/8"	STAINLESS STEEL OR CARBON STEEL ZINC PLATED

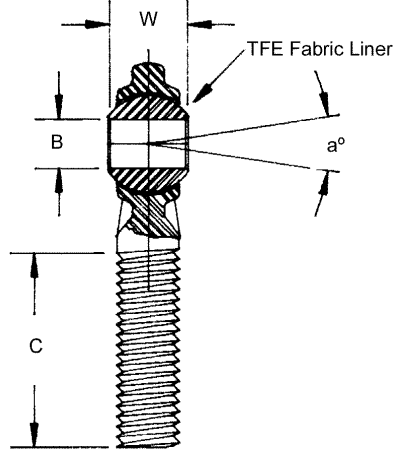
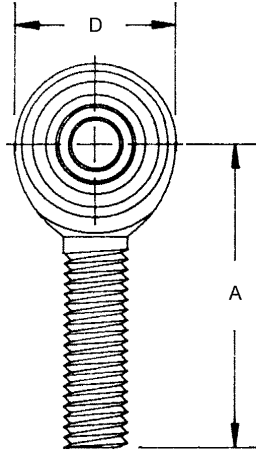

STAINLESS STEEL
RES SERIES

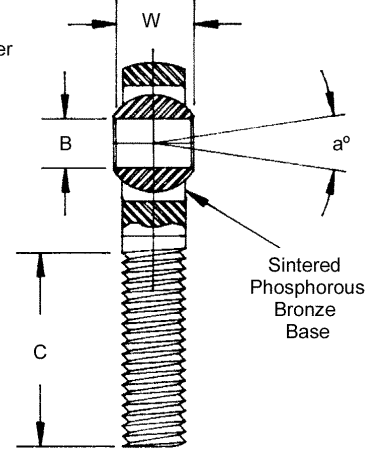

CARBON STEEL
REC SERIES

STAINLESS STEEL STOCK NO.	CARBON STEEL STOCK NO.	DIMENSIONS IN INCHES							a° Misalign. Angle	RADICAL* STATIC LOAD CAP. (lbs.)
		B +.0015 -.0015	W +.000 -.005	A ±.015	D ±.010	C +.062 -.031	THREAD			
RES-3	REC-3	.1900	.312	1.250	.625	.750	10-32	17	900	
RES-4	REC-4	.2500	.375	1.562	.750	1.000	1/4-28	21	1,350	
RES-5	REC-5	.3125	.437	1.875	.875	1.250	5/16-24	17	2,000	
RES-6	REC-6	.3750	.500	1.938	1.000	1.250	3/8-24	19	3,000	
RES-7	REC-7	.4375	.562	2.125	1.125	1.375	7/16-20	18	3,750	
RES-8	REC-8	.5000	.625	2.438	1.312	1.500	1/2-20	17	4,650	
RES-10	REC-10	.6250	.750	2.625	1.500	1.625	5/8-18	22	5,850	

* Load is higher and the angle is lower for carbon steel units.
Consult Berg Engineering Department.

- High radical and thrust loads
- Long life cycle
- Temperature range -65°F to +250°F



ROD END AND STUD ASSEMBLIES

STYLE	MATERIAL
RIGHT HAND THREAD	STAINLESS STEEL OR CARBON STEEL

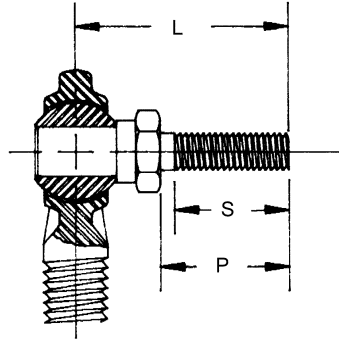

STAINLESS STEEL		CARBON STEEL		STUD DIMENSIONS				
STOCK NO.	STUD ASSEMBLED WITH:	STOCK NO.	STUD ASSEMBLED WITH:	L ±.015	P Ref.	S MIN	THREAD	HEX
RESS-3	RES-3	RECS-3	REC-3	.875	.437	.375	#10-32	.312
RESS-4	RES-4	RECS-4	REC-4	1.031	.562	.500	1/4-28	.375
RESS-5	RES-5	RECS-5	REC-5	1.218	.687	.593	5/16-24	.437
RESS-6	RES-6	RECS-6	REC-6	1.500	.875	.781	3/8-24	.500
RESS-7	RES-7	RECS-7	REC-7	1.906	1.062	.937	7/16-20	.625
RESS-8	RES-8	RECS-8	REC-8	2.000	1.125	1.000	1/2-20	.625
RESS-10	RES-10	RECS-10	REC-10	2.125	1.125	1.000	5/8-18	.750

MATERIALS				
SERIES	BALL	RACE	BODY	STUD
RES Stainless Steel	400C Stainless Steel Heat Treated	Teflon Fabric Permanently Bonded to Race I.D.	Type 303 Stainless Steel	Low Carbon Steel, Zinc Plated
REC Carbon Steel	Carbon Steel Case Hardened Chrome Plated	Sintered Phosphorous Bronze	Low Carbon Steel Zinc Plated Chromate Treated	Low Carbon Steel Zinc Plated Chromate Treated

Options Available:

- Left hand threads
- Other bore diameters
- Other materials
- Grease ball check fittings on rod ends, REC series.

THERMOPLASTIC ROD ENDS

STYLE	MATERIAL
EXTERNAL THREAD	HOUSING - REINFORCED THERMOPLASTIC RACE - B15 BEARING

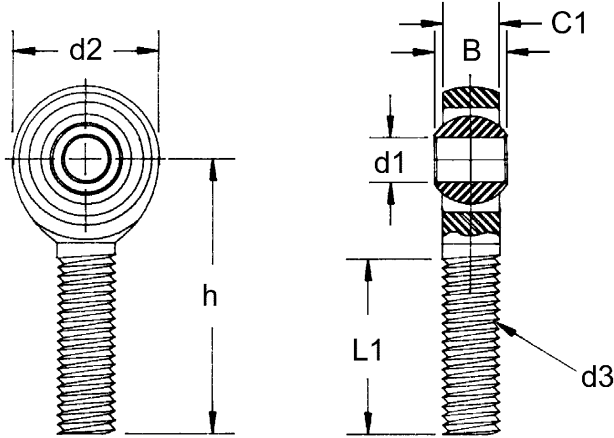

RIGHT THREAD STOCK NO.	LEFT THREAD STOCK NO.	d_1 +.0025 -.0005	d_2	d_3 -.031	c_1	B	h	L_1 +.062 -.031
RKARI-03	RKALI-03	.190	.625	10-32	.234	.312	1.250	.750
RKARI-04	RKALI-04	.250	.750	1/4-28	.250	.375	1.562	1.000
RKARI-05	RKALI-05	.312	.875	5/16-24	.312	.437	1.875	1.250
RKARI-06	RKALI-06	.375	1.000	3/8-24	.359	.500	1.938	1.250
RKARI-07	RKALI-07	.437	1.125	7/16-20	.406	.562	2.125	1.375
RKARI-08	RKALI-08	.500	1.312	1/2-20	.453	.625	2.438	1.500
RKARI-10	RKALI-10	.625	1.500	5/8-18	.484	.750	2.625	1.625
RKARI-12	RKALI-12	.750	1.750	3/4-16	.593	.875	2.875	1.750

E

THERMOPLASTIC ROD ENDS

STYLE	MATERIAL
INTERNAL THREAD	HOUSING - REINFORCED THERMOPLASTIC RACE - B15 BEARING

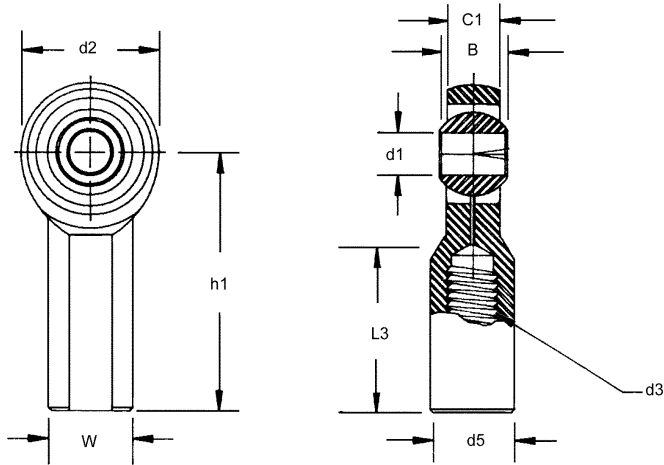

RIGHT THREAD STOCK NO.	LEFT THREAD STOCK NO.	d1 +.0025 -.0005	d2	d3	W	c1	B	h1	L3 +.062 -.031	d5
RKBRI-03	RKBLI-03	.190	.625	10-32	.406	.250	.312	1.062	.500	0.312
RKBRI-04	RKBLI-04	.250	.750	1/4-28	.469	.281	.375	1.312	.687	.375
RKBRI-05	RKBLI-05	.312	.875	5/16-24	.500	.348	.437	1.375	.687	.437
RKBRI-06	RKBLI-06	.750	1.000	3/8-24	.687	.406	.500	1.625	.812	.562
RKBRI-07	RKBLI-07	.437	1.125	7/16-20	.750	.451	.562	1.812	.937	.625
RKBRI-08	RKBLI-08	.500	1.312	1/2-20	.875	.500	.625	2.125	1.062	.750
RKBRI-10	RKBLI-10	.625	1.500	5/8-18	1.000	.562	.750	2.500	1.375	.875
RKBRI-12	RKBLI-12	.750	1.750	3/4-16	1.125	.687	.875	2.875	1.562	1.000

FLANGED TYPE LINEAR BEARINGS

STYLE	MATERIAL
SQUARE OR ROUND FLANGE	HOUSING & BALLS - 52100 CHROME STEEL RETAINER - DELRIN

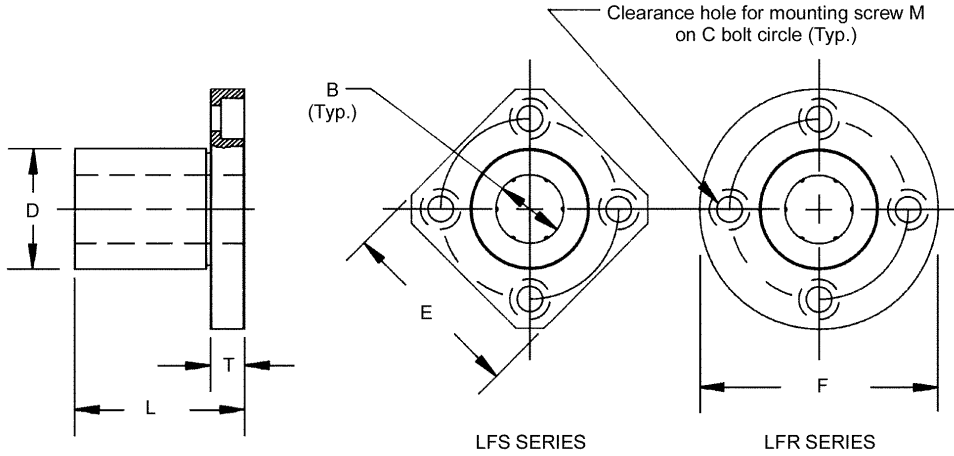

SQUARE FLANGE STOCK NO.	ROUND FLANGE STOCK NO.	WORKING BORE B	OUTSIDE DIA. D	L ±.012 MAX.	T	F	E	USE SHAFT SERIES	C	MOUNTING SCREW M	RADIAL LOAD RATING (lbs.)
LFS-1	LFR-1	.2500 -0.0004	.5000 -0.0005	.750	.22	1.250	1.00	LMS-4-36	.875	#6	6
LFS-2	LFR-2	.3750 -0.0004	.6250 -0.0005	.875	.25	1.500	1.25	LMS-6-36	1.062	#8	7
LFS-3	LFR-3	.5000 -0.0004	.8750 -0.0005	1.250	.25	1.750	1.37	LMS-8-36	1.312	#8	18
LFS-4	LFR-4	.7500 -0.0004	1.2500 -0.0007	1.625	.31	2.187	1.68	LMS-12-36	1.718	#10	31
LFS-5	LFR-5	1.0000 -0.0004	1.5625 -0.0007	2.250	.31	2.500	2.00	LMS-16-36	2.031	#10	36
LFS-6	LFR-6	1.2500 -0.0005	2.0000 -0.0008	2.625	.37	3.125	2.50	LMS-20-36	2.562	1/4	63
LFS-7	LFR-7	1.5000 -0.0005	2.3750 -0.0008	3.000	.50	3.750	3.00	LMS-24-36	3.062	5/16	92
LFS-8	LFR-8	2.0000 -0.0005	3.0000 -0.0009	4.000	.50	4.375	3.50	LMS-32-36	3.687	5/16	182



LINEAR BALL BEARINGS

SHAFT SIZE	MATERIAL
1/4" TO 2"	CHROME STEEL OUTER SLEEVE HARDENED & GROUND STEEL BALLS - HARDENED STEEL

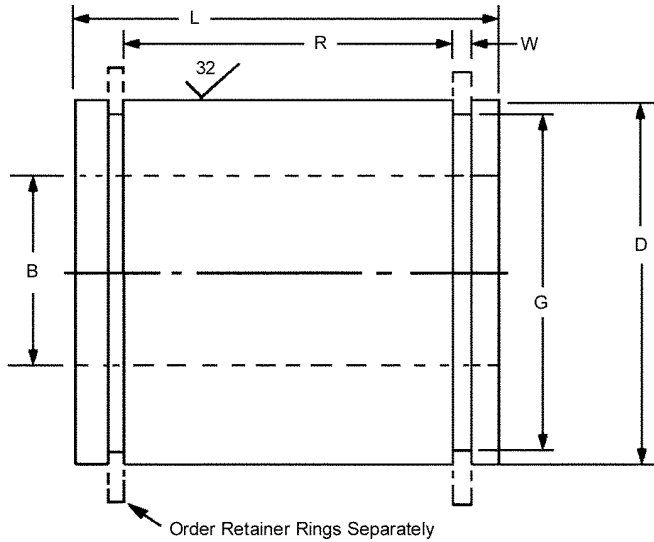

STOCK NO.	WORKING BORE B	OUTSIDE DIAMETER D	L	±.015 R	+.005 - .000 W	+.000 - .008 G	MAXIMUM SHAFT DIAMETER	USE SHAFT SERIES	REC. FITS		MAX ROLLING LOAD (lbs.)	RETAINER RING STOCK NO.
									NORM +.0005	PRESS +.0005		
LMB-1	.2500-.0005	.5000-.0004	3/4	.433	.039	.468	.2490	LMS-4-*	.5000	.4990	25	Q2-50-CP
LMB-2	.3750-.0005	.6250-.0004	7/8	.558	.039	.588	.3740	LMS-6-*	.6250	.6240	51	Q2-62-CP
LMB-3	.5000-.0005	.8750-.0004	1 1/4	.871	.046	.821	.4990	LMS-8-*	.8750	.8740	102	Q2-87-CP
LMB-4	.7500-.0005	1.2500-.0004	1 5/8	1.054	.056	1.176	.7490	LMS-12-*	1.2500	1.2490	205	Q2-125-CP
LMB-5	1.0000-.0005	1.5625-.0004	2 1/4	1.619	.068	1.468	.9990	LMS-16-*	1.5625	1.5615	385	Q2-156-CP
LMB-6	1.2500-.0006	2.0000-.0005	2 5/8	1.869	.068	1.886	1.2490	LMS-20-*	2.0000	1.9983	540	Q2-200-CP
LMB-7	1.5000-.0006	2.3750-.0005	3	2.240	.086	2.239	1.4989	LMS-24-*	2.3750	2.3733	750	Q2-237-CP
LMB-8	2.0000-.0008	3.0000-.0006	4	3.000	.103	2.838	1.9987	LMS-32-*	3.0000	2.99982	1080	Q2-300-CP

* Specify Length Required.

LINEAR BALL BEARINGS

SHAFT SIZE	MATERIAL
1/8" TO 1"	STAINLESS STEEL OUTER SLEEVE HARDENED & GROUND STEEL BALLS - HARDENED STEEL

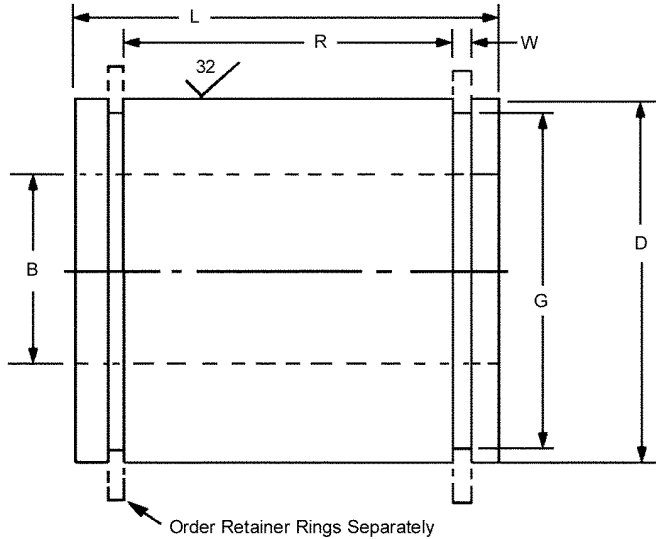

E

STOCK NO.	WORKING BORE B	OUTSIDE DIAMETER D	L	±.015 R	+.005 -.000 W	+.005 -.000 G	MAXIMUM SHAFT DIAMETER	USE SHAFT SERIES	REC. FITS		MAX ROLLING LOAD (lbs.)	RETAINER RING STOCK NO.
									NORM +.0005	PRESS +.0005		
LMB-125SS	.1250-.0003	.3125-.0004	1/2	.312	.029	.290	.1247	S1-8	.3125	.3115	7	Q2-31
LMB-187SS	.1875-.0003	.3750-.0004	9/16	.375	.029	.352	.1872	S1-11	.3750	.3740	9	Q2-37
LMB-1SS	.2500-.0005	.5000-.0004	3/4	.433	.039	.468	.2490	LMS-4*	.5000	.4999	25	Q2-50
LMB-2SS	.3750-.0005	.6250-.0004	7/8	.558	.039	.588	.3740	LMS-6*	.6250	.6240	51	Q2-62
LMB-3SS	.5000-.0005	.8750-.0004	1 1/4	.871	.046	.821	.4990	LMS-8*	.8750	.8740	102	Q2-87
LMB-4SS	.7500-.0005	1.2500-.0004	1 5/8	1.054	.056	1.176	.7490	LMS-12*	1.2500	1.2490	205	Q2-125
LMB-5SS	1.0000-.0005	1.5625-.0004	2 1/4	1.619	.068	1.468	.9990	LMS-16*	1.5625	1.5615	385	Q2-156

LINEAR BALL BEARINGS WITH SHAFT WIPERS

SHAFT SIZE	MATERIAL
1/4" TO 1 1/2"	CHROME STEEL OUTER SLEEVE HARDENED & GROUND STEEL BALLS - HARDENED STEEL

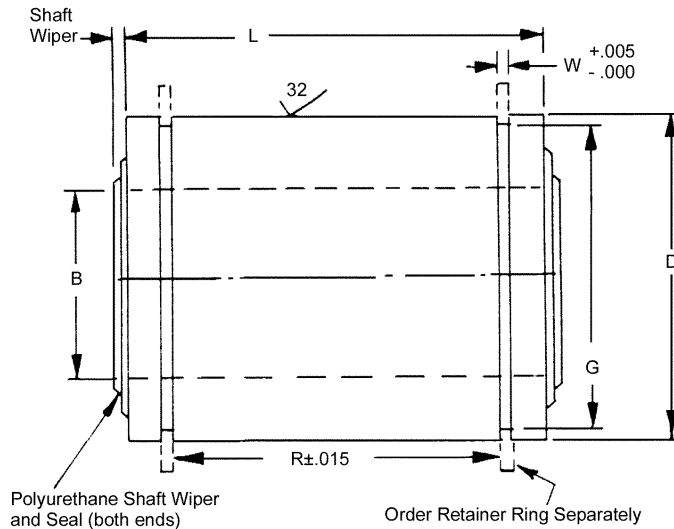

STOCK NO.	WORKING BORE B	HOUSING BORE D	L	±.015 R	+.005 -.000 W	+.005 -.000 G	MAX. SHAFT SIZE	USE SHAFT SERIES	REC. HOUSING		RATED ROLLING LOAD (lbs.)	REPLACEMENT WHIPERS (2) REQ'D	RETAINER RING STOCK NO.
									NORMAL +.0005	PRESS +.0005			
LMB-1-W	.2500-.0005	.5000-.0004	3/4	.433	.039	.468	.2490	LMS-4-*	.5000	.4990	25	U-W1	Q2-50-CP
LMB-2-W	.3750-.0005	.6250-.0004	7/8	.558	.039	.588	.3740	LMS-6-*	.6250	.6240	51	U-W2	Q2-62-CP
LMB-3-W	.5000-.0005	.8750-.0004	1 1/4	.871	.046	.821	.4990	LMS-8-*	.8750	.8740	102	U-W3	Q2-87-CP
LMB-4-W	.7500-.0005	1.2500-.0004	1 5/8	1.054	.056	1.176	.7490	LMS-12-*	1.2500	1.2490	205	U-W4	Q2-125-CP
LMB-5-W	1.0000-.0005	1.5625-.0004	2 1/4	1.619	.068	1.468	.9990	LMS-16-*	1.5625	1.5615	385	U-W5	Q2-156-CP
LMB-6-W	1.2500-.0006	2.0000-.0005	2 5/8	1.869	.068	1.886	1.2490	LMS-20-*	2.0000	1.9983	540	U-W6	Q2-200-CP
LMB-7-W	1.5000-.0006	2.3750-.0005	3	2.240	.086	2.239	1.4989	LMS-24-*	2.3750	2.3733	750	U-W7	Q2-237-CP

- * Specify Length Required.
- Low coefficient of friction

LINEAR BALL BEARINGS SELF-ALIGNING-BARREL STYLE

SHAFT SIZE	MATERIAL
1/4" TO 1 1/2"	CHROME STEEL OUTER SLEEVE HARDENED & GROUND STEEL BALLS - HARDENED STEEL

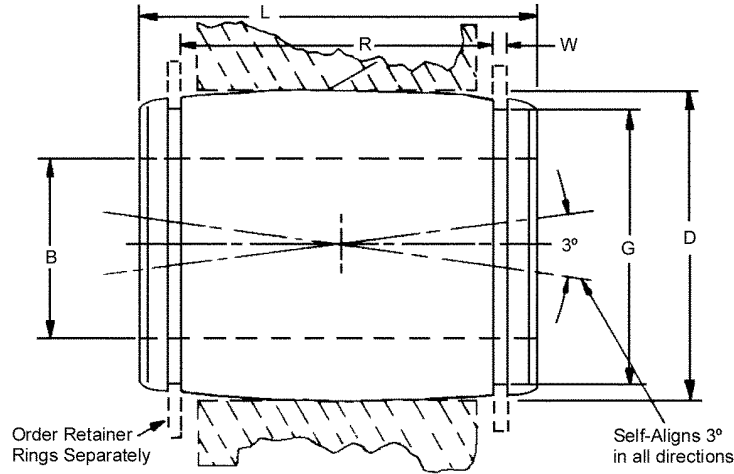

WORKING STOCK NO.	BORE B	HOUSING BORE D	L	$\pm .015$ R	$+ .005$ $- .000$ W	$+ .005$ $- .000$ G	MAX. SHAFT SIZE
LMB-1-B	.2500-.0005	.5000-.0004	3/4	.437	.039	.468	.2490
LMB-2-B	.3750-.0005	.6250-.0004	7/8	.562	.039	.588	.3740
LMB-3-B	.5000-.0005	.8750-.0004	1 1/4	.875	.046	.821	.4990
LMB-4-B	.7500-.0005	1.2500-.0004	1 5/8	1.062	.056	1.176	.7490
LMB-5-B	1.0000-.0005	1.5625-.0004	2 1/4	1.625	.068	1.468	.9990
LMB-6-B	1.2500-.0006	2.0000-.0005	2 5/8	1.875	.068	1.886	1.2490
LMB-7-B	1.5000-.0006	2.3750-.0005	3	2.250	.086	2.239	1.4989

Self-aligning-barrel shape allows bearing to accommodate parallel misalignment of up to 3°.

E

ROTATING LINEAR BEARING SET

SHAFT SIZE	MATERIAL
1/8" TO 2"	CHROME STEEL OUTER SLEEVE HARDENED & GROUND STEEL BALLS - HARDENED STEEL

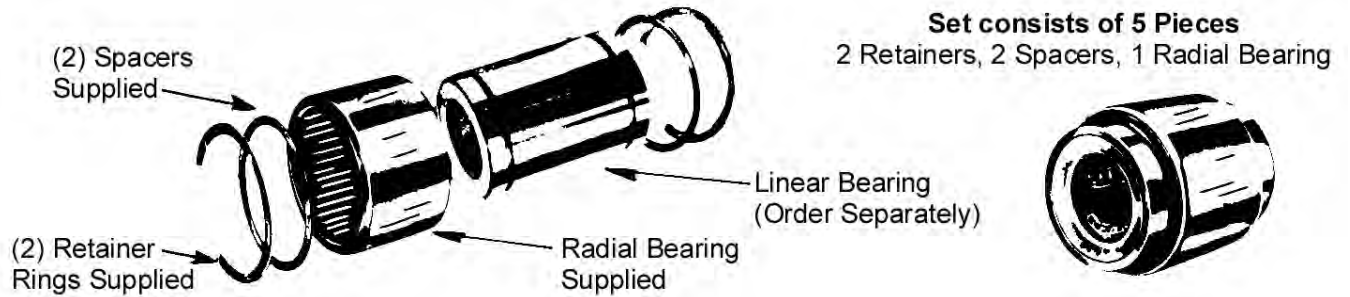

STOCK NO.	USE WITH LINEAR BRG. STOCK NO.	HOUSING BORE FOR PRESS FIT OF RADIAL BEARING	LENGTH OF RADIAL BEARING	LINEAR BRG. SHAFT SIZE
LMW-125	LMB-125SS	.4995	5/16	1/8
LMW-187	LMB-187SS	.5620	5/16	3/16
LMW-250	LMB-1	.6870	3/8	1/4
LMW-375	LMB-2	.8120	1/2	3/8
LMW-500	LMB-3	1.1245 +.001	3/4	1/2
LMW-750	LMB-4	1.4995 -.000	1	3/4
LMW-1000	LMB-5	2.1234	1 1/4	1
LMW-1250	LMB-6	2.3745	1 3/4	1 1/4
LMW-1500	LMB-7	3.7482	1 3/4	1 1/2
LMW-2000	LMB-8	3.7482	1 3/4	2

THIS PRODUCT HAS BEEN DISCONTINUED

LINEAR BALL BEARINGS

STYLE	SHAFT SIZE	MATERIAL
ADJUSTABLE DIAMETER SERIES	1/2" TO 2"	CHROME STEEL OUTER SLEEVE HARDENED & GROUND STEEL BALLS - HARDENED STEEL

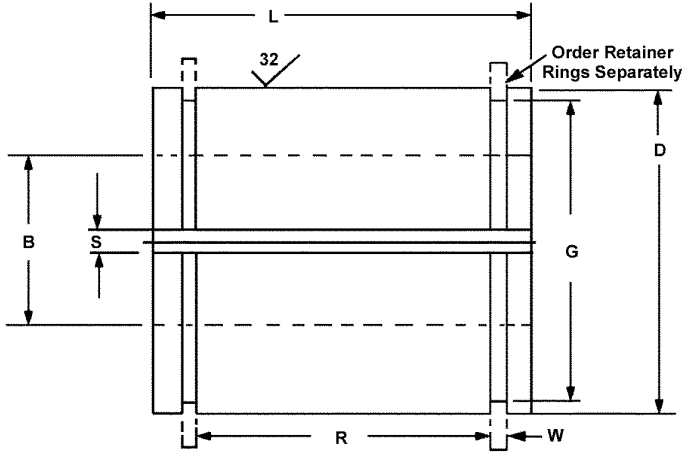

STOCK NO.	BORE B BEFORE ADJUSTMENT	HOUSING BORE BEFORE ADJUSTMENT D*	L	±.015 R	+0.005 -.000 W	+0.005 -.000 G	MAX. SHAFT DIA.	USE SHAFT SERIES	MINIMUM SLOT WIDTH S	MAXIMUM ROLLING LOAD (lbs.)	RETAINER RING STOCK NO.
LMC-3	.5000±.0005	.8750+.0010	1 1/4	.875	.046	.821	.4995	LMS-9-*	1/16	102	Q2-87-CP
LMC-4	.7500±.0005	1.2500+.0010	1 5/8	1.062	.056	1.176	.7495	LMS-13-*	3/32	205	Q2-125-CP
LMC-5	1.0000±.0005	1.5625+.0010	2 1/4	1.625	.068	1.468	.9995	LMS-17-*	3/32	385	Q2-156-CP
LMC-6	1.2500±.0006	2.0000+.0010	2 5/8	1.875	.068	1.886	1.2495	LMS-21-*	3/32	540	Q2-200-CP
LMC-7	1.5000±.0006	2.3750+.0010	3	2.250	.086	2.239	1.4994	LMS-25-*	1/8	750	Q2-237-CP
LMC-8	2.0000±.0008	3.0000+.0010	4	3.000	.103	2.838	1.4994	LMS-33-*	1/8	1080	Q2-300-CP

* Use adjustable type housing to obtain optimum operating fit.

* Specify Length Required.

E

LINEAR BALL BEARINGS

STYLE	SHAFT SIZE	MATERIAL
OPEN	1/2" TO 2"	CHROME STEEL, OUTER SLEEVE HARDENED & GROUND, BALLS - HARDENED STEEL, PLASTIC BALL RETAINER

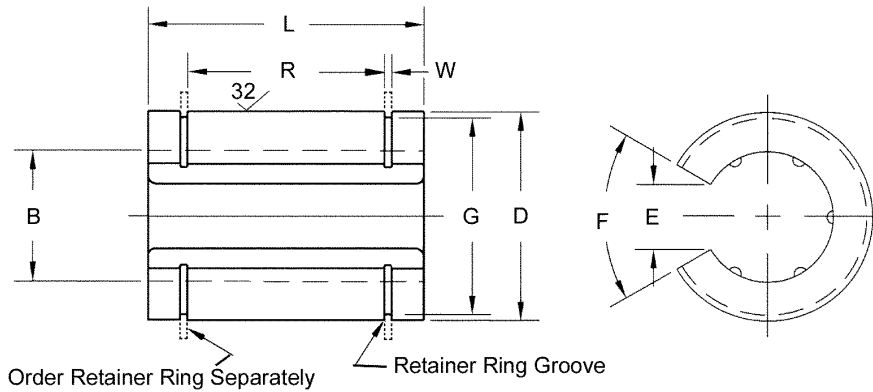

STOCK NO.	BORE B BEFORE ADJUSTMENT	HOUSING BORE BEFORE ADJUSTMENT D*	L	±.015 R	+.005 -.000 W	+.005 -.000 G	MAX. SHAFT DIA.	USE SHAFT SERIES	MINIMUM SLOT		RATED ROLLING LOAD (lbs.)	RETAINER RING STOCK NO.
									Width E	Angle F		
LMD-3	.5000±.0005	.8750+.0010	1 1/4	.875	.046	.821	.4995	LMS-9-*	9/32	60°	102	Q2-87-CP
LMD-4	.7500±.0005	1.2500+.0010	1 5/8	1.062	.056	1.176	.7495	LMS-13-*	13/32	60°	205	Q2-125-CP
LMD-5	1.0000±.0005	1.5625+.0010	2 1/4	1.625	.068	1.468	.9995	LMS-17-*	9/16	60°	385	Q2-156-CP
LMD-6	1.2500±.0006	2.0000+.0010	2 5/8	1.875	.068	1.886	1.2495	LMS-21-*	7/8	50°	540	Q2-200-CP
LMD-7	1.5000±.0006	2.3750+.0010	3	2.250	.086	2.239	1.4994	LMS-25-*	3/4	50°	750	Q2-237-CP
LMD-8	2.0000±.0008	3.0000+.0010	4	3.000	.103	2.838	1.4994	LMS-33-*	1	50°	1080	Q2-300-CP

• Use adjustable type housing to obtain optimum operating fit.

* Specify Length Required.

CLOSED STYLE LINEAR BEARINGS

MATERIAL

6061-T6 ANODIZED ALUMINUM - SELF LUBRICATING FRELON®

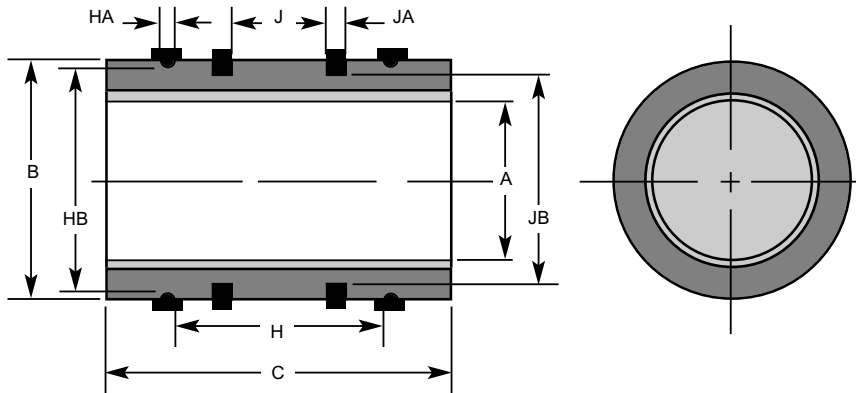

STOCK NO.	NOMINAL SIZE	A BEARING I.D.		B O.D.		C LENGTH O.D.		CONCENTRICITY	BEARING WEIGHT (Lbs.)
		Min.	Max.	Min.	Max.	Min.	Max.		
LB-FL-03	3/16	0.1877	0.1884	0.3740	0.3750	0.547	0.562	0.0010	0.003
LB-FL-04	1/4	0.2502	0.2511	0.4990	0.5000	0.735	0.750	0.0010	0.009
LB-FL-06	3/8	0.3752	0.3761	0.6240	0.6250	0.860	0.875	0.0010	0.016
LB-FL-08	1/2	0.5002	0.5013	0.8740	0.8750	1.235	1.250	0.0010	0.041
LB-FL-10	5/8	0.6252	0.6263	1.1240	1.1250	1.485	1.500	0.0010	0.091
LB-FL-12	3/4	0.7503	0.7516	1.2490	1.2500	1.610	1.625	0.0010	0.109
LB-FL-16	1	1.0003	1.0016	1.5613	1.5625	2.235	2.250	0.0010	0.228

MOUNTING DIMENSIONAL INFORMATION

STOCK NO.	NOMINAL SIZE	H BETWEEN RETAINING RINGS	HA RETAINING RING GROOVE WIDTH	HB RETAINING RING GROOVE DIA.	J BETWEEN O RING GROOVES	JA O RING GROOVE WIDTH	JB O RING GROOVE DIA.
LB-FL-03	3/16	0.375	0.030	0.352	N/A	N/A	N/A
LB-FL-04	1/4	0.437	0.041	0.467	0.125	0.080	0.399
LB-FL-06	3/8	0.562	0.041	0.587	0.187	0.080	0.524
LB-FL-08	1/2	0.875	0.048	0.820	0.250	0.125	0.712
LB-FL-10	5/8	1.000	0.058	1.060	0.312	0.125	0.962
LB-FL-12	3/4	1.062	0.058	1.177	0.312	0.125	1.087
LB-FL-16	1	1.625	0.070	1.471	0.500	0.125	1.399

Speed Characteristics

Exceeding these speeds causes frictional heat and accelerates liner wear.

Bearing Material	No Lube Continuous Motion	No Lube Intermittent Motion	With Lubrication
Frelon® Gold	300 sfm 60 in/sec. 1.524 m/sec.	825 sfm 165 in/sec. 4.19 m/sec.	825 sfm 165 in/sec. 4.19 m/sec.

Speed & Load Data

STOCK NO.	EFFECTIVE SURFACE AREA (SQ. IN)	MAX. STATIC LOAD (LBS.)
LB-FL-03	0.110	220
LB-FL-04	0.200	600
LB-FL-06	0.340	1020
LB-FL-08	0.650	1950
LB-FL-10	0.980	2940
LB-FL-12	1.270	3810
LB-FL-16	2.350	7050

Performance Ratings (For Linear Motion)

Plane bearings are rated by their limiting PV which is a combination of load over a given surface area and velocity.

Bearing Material	Max. "PV"	Max. "P"	Max. "V" (No Lubrication)
Frelon® Gold	20,000 (psi) x ft/Min or 430 (kgf/cm²) x m/min	3000 psi or 210.9 (kgf/cm²) x m/min	300 sfm or 91.44 m/min.

PV = The performance measurement of plane bearings. P x V where P = pressure (load) in psi (kgf/cm²). V = velocity (speed) in sfm (m/min.)

Factors Affecting Wear Rate / Life

Shafting requirements for Frelon® bearing material.

Best Performance:

- Finish of 8-12 RMS / Hardness of RC60

Acceptable Performance:

- Finish of 8-16 RMS / Hardness of RC35
- Rougher shafting can be used, but both bearing and shafting will wear at accelerated rates and binding may occur.

Chrome Plated Shafting Is Not Recommended!

Lubrication - Reduces friction 50%, and reduces heat buildup allowing greater speeds.

Recommended:

- Waylube Oil, Light Weight Oils, Petroleum Based Grease; 3-in-1 Oils

Not Recommended

- WD-40, PTFE Sprays, Fluorocarbons, Silicon

Running Clearance

Tightest running clearance approximately .001" (.25mm). Use in applications that require high precision. **Caution:** *Not recommended for all parallel shaft applications. Any misalignment can cause binding on the shaft.*

Liner Material

Frelon® is a compound of Teflon® and fillers developed for improved performance over other bearings.

Features: Self-lubricating, Embeddability of hard particulate, Chemically inert, Vibration dampening, Wide Temperature Range (-400°F/+500°F -240°C /+260°C)

Benefits: Will not Rust, Maintenance free operation, Will not damage shafting, Smooth quiet operation, Will not catastrophically fail.

OPEN STYLE LINEAR BEARINGS

MATERIAL

6061-T6 ANODIZED ALUMINUM - SELF LUBRICATING FRELON®

LB-FLN-03 - LB-FLN-06

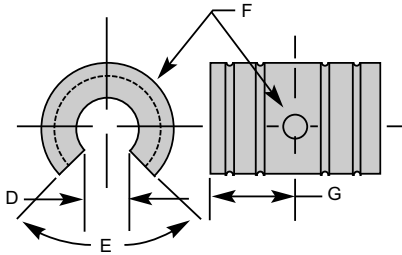

LB-FLN-08

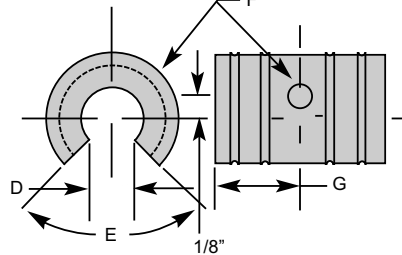

LB-FLN-10

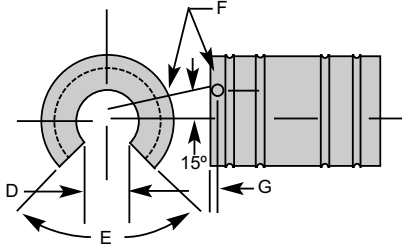

LB-FLN-12 thru LB-FLN-16

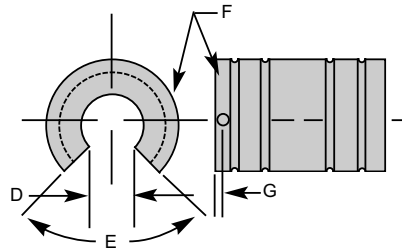

Factors Affecting Wear Rate / Life
Shafting requirements for Frelon® bearing material.

Best Performance:

- Finish of 8-12 RMS / Hardness of RC60

Acceptable Performance:

- Finish of 8-16 RMS / Hardness of RC35
- Rougher shafting can be used, but both bearing and shafting will wear at accelerated rates and binding may occur.

Chrome Plated Shafting Is Not Recommended!

6061-T6 Anodized Aluminum - Self Lubricating Frelon®

STOCK NO.	NOMINAL SIZE	A BEARING I.D.		B O.D.		C LENGTH O.D.		CONCENTRICITY	BEARING WEIGHT (Lbs.)
		Min.	Max.	Min.	Max.	Min.	Max.		
LB-FLN-03	3/16	0.1877	0.1884	0.3740	0.3750	0.547	0.562	0.0010	0.003
LB-FLN-04	1/4	0.2502	0.2511	0.4990	0.5000	0.735	0.750	0.0010	0.009
LB-FLN-06	3/8	0.3752	0.3761	0.6240	0.6250	0.860	0.875	0.0010	0.016
LB-FLN-08	1/2	0.5002	0.5013	0.8740	0.8750	1.235	1.250	0.0010	0.041
LB-FLN-10	5/8	0.6252	0.6263	1.1240	1.1250	1.485	1.500	0.0010	0.091
LB-FLN-12	3/4	0.7503	0.7516	1.2490	1.2500	1.610	1.625	0.0010	0.109
LB-FLN-16	1	1.0003	1.0016	1.5613	1.5625	2.235	2.250	0.0010	0.228

Lubrication - Reduces friction 50%, and reduces heat buildup allowing greater speeds.

Recommended: Waylube Oil, Light Weight Oils, Petroleum Based Grease; 3-in-1 Oils. **Not Recommended:** WD-40, PTFE Sprays, Fluorocarbons, Silicon

MOUNTING DIMENSIONAL INFORMATION

STOCK NO.	NOMINAL SIZE	H BETWEEN RETAINING RINGS	HA RETAINING RING GROOVE WIDTH	HB RETAINING RING GROOVE DIA.	J BETWEEN O RING GROOVES	JA O RING GROOVE WIDTH	JB O RING GROOVE DIA.	D	E	F	G
LB-FL-03	3/16	0.375	0.030	0.352	N/A	N/A	N/A	0.125	60°	0.094	9/32
LB-FL-04	1/4	0.437	0.041	0.467	0.125	0.080	0.399	0.188			3/8
LB-FL-06	3/8	0.562	0.041	0.587	0.187	0.080	0.524	0.250			7/16
LB-FL-08	1/2	0.875	0.048	0.820	0.250	0.125	0.712	0.313		5/8	
LB-FL-10	5/8	1.000	0.058	1.060	0.312	0.125	0.962	0.375	0.136	1/8	
LB-FL-12	3/4	1.062	0.058	1.177	0.312	0.125	1.087	0.438			
LB-FL-16	1	1.625	0.070	1.471	0.500	0.125	1.399	0.563			

Speed Characteristics

Exceeding these speeds causes frictional heat and accelerates liner wear.

Bearing Material	No Lube Continuous Motion	No Lube Intermittent Motion	With Lubrication
Frelon® Gold	300 sfm 60 in/sec. 1.524 m/sec.	825 sfm 165 in/sec. 4.19 m/sec.	825 sfm 165 in/sec. 4.19 m/sec.

Speed & Load Data

STOCK NO.	EFFECTIVE SURFACE AREA (SQ. IN.)	MAX. STATIC LOAD (LBS.)
LB-FL-03	0.110	220
LB-FL-04	0.200	600
LB-FL-06	0.340	1020
LB-FL-08	0.650	1950
LB-FL-10	0.980	2940
LB-FL-12	1.270	3810
LB-FL-16	2.350	7050

Running Clearance

Tightest running clearance approximately .001" (.25mm). Use in applications that require high precision. **Caution:** Not recommended for all parallel shaft applications. Any misalignment can cause binding on the shaft.

Liner Material

Frelon® is a compound of Teflon® and fillers developed for improved performance over other bearings.

Features: Self-lubricating, Embeddability of hard particulate, Chemically inert, Vibration damping, Wide Temperature Range (-400°F/+500°F -240°C/+260°C)

Benefits: Will not Rust, Maintenance free operation, Will not damage shafting, Smooth quiet operation, Will not catastrophically fail.

Performance Ratings (For Linear Motion)

Plane bearings are rated by their limiting PV which is a combination of load over a given surface area and velocity.

Bearing Material	Max. "PV"	Max. "P"	Max. "V" (No Lubrication)
Frelon® Gold	20,000 (psi) x ft/Min or 430 (kgf/cm²) x m/min	3000 psi or 210.9 (kgf/cm²) x m/min	300 sfm or 91.44 m/min.

PV = The performance measurement of plane bearings. P x V where P = pressure (load) in psi (kgf/cm²). V = velocity (speed) in sfm (m/min).

FLANGE MOUNTS

STYLE	MATERIAL
SINGLE	CLEAR ANODIZED 6061-T6 ALUMINUM

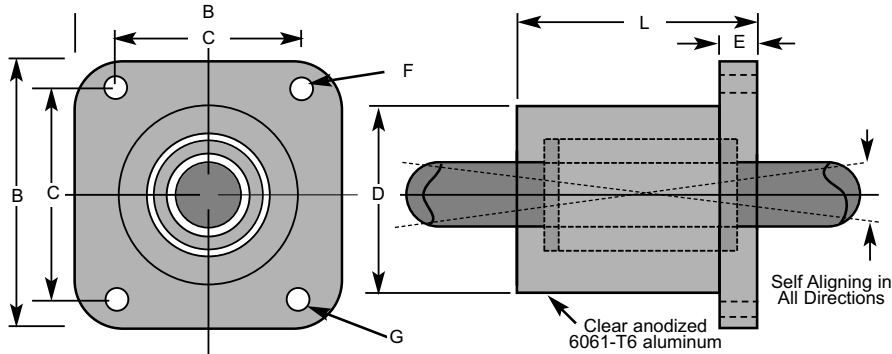

SINGLE MOUNT

Basic Dimensional Information

STOCK NO.	BEARING NOMINAL SIZE	B FLANGE SQUARE	C HOLE SPACING	D BARREL DIA.	E FLANGE LENGTH	F BOLT SIZE	G HOLE SIZE	L LENGTH OVERALL	MAX. STATIC LOAD (LBS.)	ASSEMBLY WEIGHT (LBS.)
LF-SFP-08	1/2"	1.63	1.25	1.25	0.250	#8	0.187	1.687	1950	0.175
LF-SFP-12	3/4"	2.38	1.75	1.75	0.375	#10	0.219	2.067	2940	0.463
LF-SFP-16	1"	2.75	2.125	2.25	0.500	1/4"	0.281	2.812	3810	1.206



STYLE	MATERIAL
DOUBLE	CLEAR ANODIZED 6061-T6 ALUMINUM

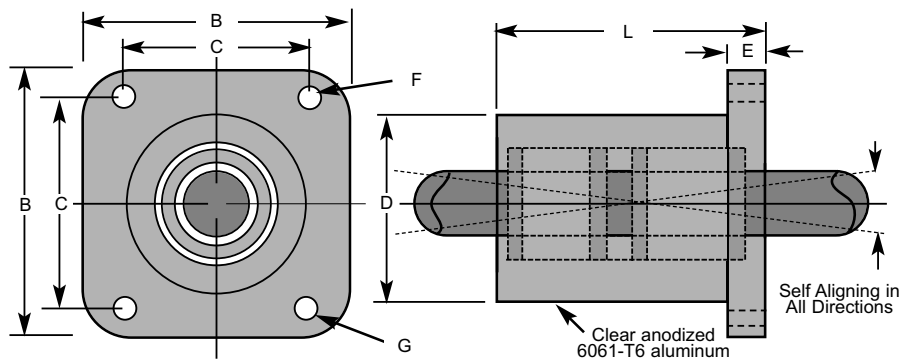

DOUBLE MOUNT

Basic Dimensional Information

STOCK NO.	BEARING NOMINAL SIZE	B FLANGE SQUARE	C HOLE SPACING	D BARREL DIA.	E FLANGE LENGTH	F BOLT SIZE	G HOLE SIZE	L LENGTH OVERALL	MAX. STATIC LOAD (LBS.)	ASSEMBLY WEIGHT (LBS.)
LF-DFP-08	1/2"	1.63	1.25	1.25	0.250	#8	0.187	3.375	3900	0.325
LF-DFP-12	3/4"	2.38	1.75	1.75	0.375	#10	0.219	4.188	5880	0.825
LF-DFP-16	1"	2.75	2.125	2.25	0.500	1/4"	0.281	5.625	7620	1.750

NOTE: All standard, pre-assembled LF-SFP & LF-DFP assemblies include a self-aligning housing and standard FL bearing.

LINEAR "NO LUBE" BEARINGS

STYLE	SHAFT SIZE	MATERIAL
CLOSED	1/4" TO 1 1/4"	MOLYBDENUM DISULFIDE FILLED NYLON

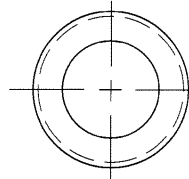
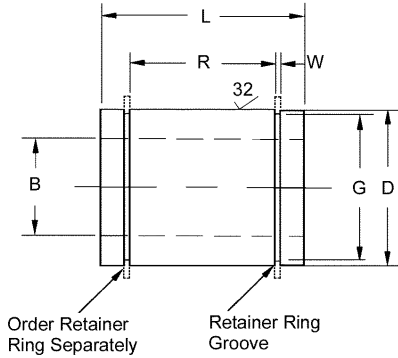

May be used with either hard or soft ground shafting



STOCK NO.	BORE B	HOUSING DIA. D	L	±.015 R	+0.010 -.000 W	+0.010 -.000 G	BEARING WEIGHT OZ.	USE WITH HARD SHAFTS	USE WITH SOFT S.S. SHAFTS	RETAINER RING
LMN-1	.250+.003	.500-.002	3/4	.437	.039	.468	0.10	LMS-4-*	S1-72	Q2-50-CP
LMN-2	.375+.003	.625-.002	7/8	.562	.039	.588	0.10	LMS-6-*	S1-74	Q2-62-CP
LMN-3	.500+.004	.875-.002	1 1/4	.875	.046	.821	0.40	LMS-8-*	S1-76	Q2-87-CP
LMN-4	.750+.004	1.250-.002	1 5/8	1.062	.056	1.176	0.80	LMS-12-*	S1-78	Q2-125-CP
LMN-5	1.000+.004	1.563-.003	2 1/4	1.625	.068	1.468	2.10	LMS-16-*	S1-80	Q2-156-CP
LMN-6	1.250+.006	2.000-.003	2 5/8	1.875	.068	1.886	3.30	LMS-20-*	S1-82	Q2-200-CP

- PV = 10,000 psi fpm
- Self lubricating
- Interchangeable with all makes of linear ball bearings
- Good for linear and/or rotation motion

*Specify Lengths Required.

STYLE	SHAFT SIZE	MATERIAL
ADJUSTABLE	1/4" TO 1 1/4"	MOLYBDENUM DISULFIDE FILLED NYLON

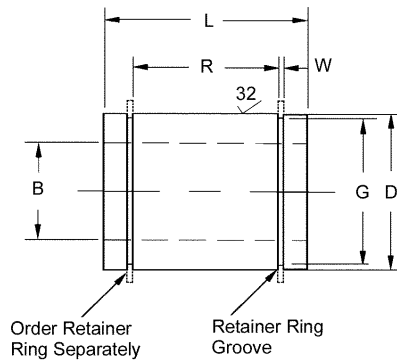

STOCK NO.	BORE B	HOUSING DIA. D	L	±.015 R	+0.010 -.000 W	+0.010 -.000 G	BEARING WEIGHT OZ.	USE WITH HARD SHAFTS	USE WITH SOFT S.S. SHAFTS	RETAINER RING
LMN-1-ADJ	.250+.003	.500-.002	3/4	.437	.039	.468	0.10	LMS-4-*	S1-72	Q2-50-CP
LMN-2-ADJ	.375+.003	.625-.002	7/8	.562	.039	.588	0.10	LMS-6-*	S1-74	Q2-62-CP
LMN-3-ADJ	.500+.004	.875-.002	1 1/4	.875	.046	.821	0.40	LMS-8-*	S1-76	Q2-87-CP
LMN-4-ADJ	.750+.004	1.250-.002	1 5/8	1.062	.056	1.176	0.80	LMS-12-*	S1-78	Q2-125-CP
LMN-5-ADJ	1.000+.004	1.563-.003	2 1/4	1.625	.068	1.468	2.10	LMS-16-*	S1-80	Q2-156-CP
LMN-6-ADJ	1.250+.006	2.000-.003	2 5/8	1.875	.068	1.886	3.30	LMS-20-*	S1-82	Q2-200-CP

- PV = 10,000 psi fpm
- Self lubricating
- Interchangeable with all makes of linear ball bearings
- Good for linear and/or rotation motion

*Specify Lengths Required.

LINEAR "NO LUBE" BEARINGS

STYLE	SHAFT SIZE	MATERIAL
OPEN	1/4" TO 1 1/4"	MOLYBDENUM DISULFIDE FILLED NYLON

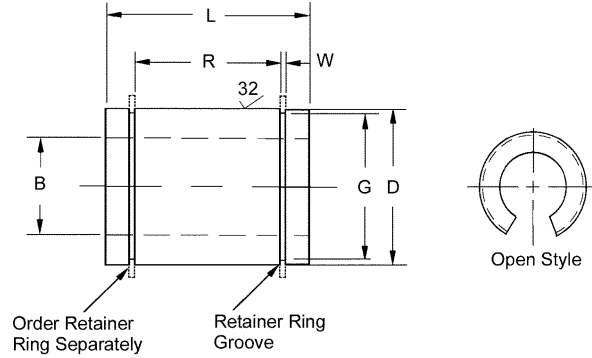

STOCK NO.	BORE B	HOUSING DIA. D	L	±.015 R	+.010 -.000 W	+.010 -.000 G	BEARING WEIGHT OZ.	USE WITH HARD SHAFTS	USE WITH SOFT S.S. SHAFTS	RETAINER RING
LMN-1-OPN	.250+.003	.500-.002	3/4	.437	.039	.468	0.10	LMS-4-*	S1-72	Q2-50-CP
LMN-2-OPN	.375+.003	.625-.002	7/8	.562	.039	.588	0.10	LMS-6-*	S1-74	Q2-62-CP
LMN-3-OPN	.500+.004	.875-.002	1 1/4	.875	.046	.821	0.40	LMS-8-*	S1-76	Q2-87-CP
LMN-4-OPN	.750+.004	1.250-.002	1 5/8	1.062	.056	1.176	0.80	LMS-12-*	S1-78	Q2-125-CP
LMN-5-OPN	1.000+.004	1.563-.003	2 1/4	1.625	.068	1.468	2.10	LMS-16-*	S1-80	Q2-156-CP
LMN-6-OPN	1.250+.006	2.000-.003	2 5/8	1.875	.068	1.886	3.30	LMS-20-*	S1-82	Q2-200-CP

- PV = 10,000 psi fpm
- Self lubricating
- Interchangeable with all makes of linear ball bearings
- Good for linear and/or rotation motion

*Specify Lengths Required.



THERMOPLASTIC LINEAR BEARINGS

STYLE	SHAFT SIZE	MATERIAL
CLOSED	1/4" TO 2"	SHELL - ALUMINUM LINER - THERMOPLASTIC POLYMER

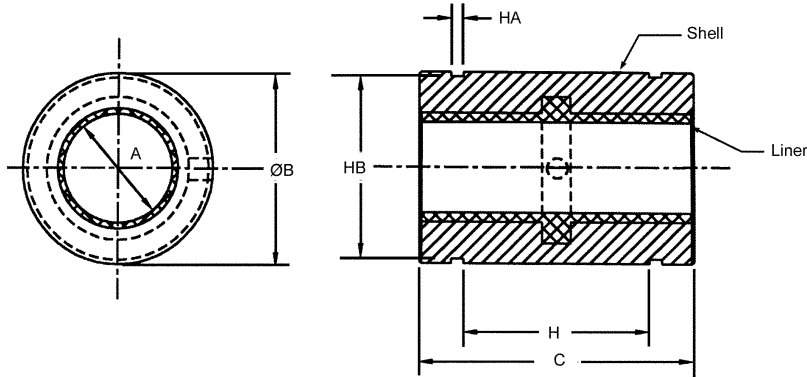

STOCK NO.	ØA	ØB	C	H	HA	HB	NOMINAL SIZE
LBRJZI-01-04	.2516/.2532	.5000	.750	.437	.041	.467	1/4
LBRJZI-01-06	.3766/.3782	.6250	.875	.562	.041	.587	3/8
LBRJUI-01-08	.5016/.5032	.8750	1.250	.875	.048	.820	1/2
LBRJUI-01-10	.6266/.6282	1.1250	1.500	1.000	.058	1.060	5/8
LBRJUI-01-12	.7516/.7532	1.2500	1.625	1.062	.058	1.177	3/4
LBRJUI-01-16	1.0016/1.0032	1.5625	2.250	1.625	.070	1.471	1
LBRJUI-01-20	1.2520/1.2541	2.0000	2.625	1.875	.070	1.889	1 1/4
LBRJUI-01-24	1.5020/1.5041	2.3750	3.000	2.250	.089	2.241	1 1/2
LBRJUI-01-32	2.0020/2.0041	3.0000	4.000	3.000	.105	2.839	2

STYLE	SHAFT SIZE	MATERIAL
OPEN	1/2" TO 2"	SHELL - ALUMINUM LINER - THERMOPLASTIC POLYMER

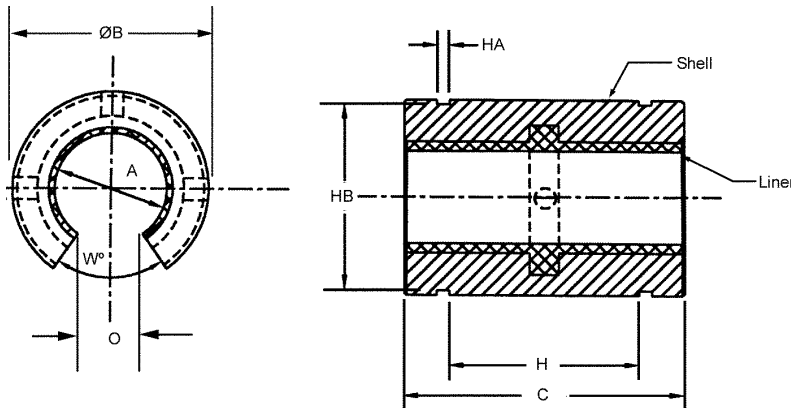

STOCK NO.	ØA	ØB	C	W°	O ±.012	H	HA	HB	NOMINAL SIZE
LBOJUI-01-08	.5016/.5032	.875	1.250	30°	.394	.875	.048	.820	1/2
LBOJUI-01-10	.6266/.6282	1.125	1.500	30°	.433	1.000	.058	1.060	5/8
LBOJUI-01-12	.7516/.7532	1.250	1.625	30°	.492	1.062	.058	1.177	3/4
LBOJUI-01-16	1.0016/1.0032	1.562	2.250	30°	.630	1.625	.070	1.471	1
LBOJUI-01-20	1.2520/1.2541	2.000	2.625	30°	.709	1.875	.070	1.889	1 1/4
LBOJUI-01-24	1.5020/1.5041	2.375	3.000	30°	.866	2.250	.089	2.241	1 1/2
LBOJUI-01-32	2.0020/2.0041	3.000	4.000	30°	1.181	3.000	.105	2.839	2

THERMOPLASTIC SELF ALIGNING LINEAR BEARINGS

STYLE	SHAFT SIZE	MATERIAL
CLOSED	1/4" TO 2"	SHELL - ALUMINUM LINER - THERMOPLASTIC POLYMER

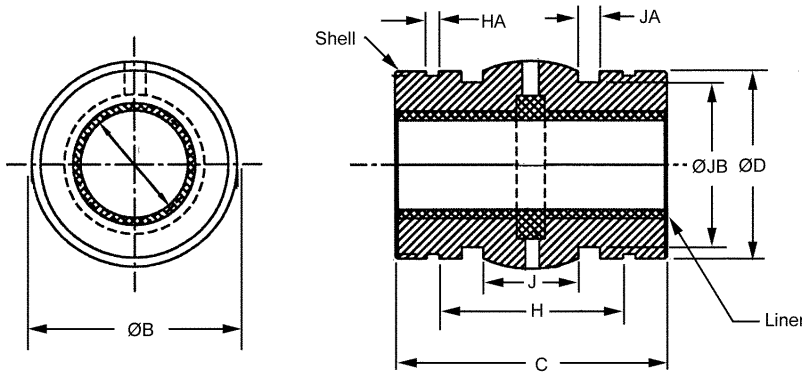

STOCK NO.	ØA	ØB	C	H	HA	ØD ±.005	JB	JA	J	NOMINAL SIZE
LBRJZI-03-04*	.2520/.2508	.500	.746	.439	.0410	.4935	.399	.080	.125	1/4
LBRJZI-03-06*	.3770/.3758	.625	.871	.565	.0410	.6174	.524	.080	.187	3/8
LBRJUI-03-08	.5020/.5008	.875	1.242	.879	.0480	.8641	.712	.125	.250	1/2
LBRJUI-03-10	.6270/.6258	1.125	1.492	1.005	.0580	1.1119	.962	.125	.312	5/8
LBRJUI-03-12	.7524/.7508	1.250	1.617	1.067	.0580	1.2356	1.087	.125	.312	3/4
LBRJUI-03-16	1.0024/1.0008	1.562	2.238	1.632	.0700	1.5429	1.399	.125	.500	1
LBRJUI-03-20	1.2528/1.2512	2.000	2.613	1.884	.0700	1.9771	1.837	.125	.625	1 1/4
LBRJUI-03-24	1.5028/1.5012	2.375	2.984	2.260	.0890	2.3448	2.152	.162	.750	1 1/2
LBRJUI-03-32	2.0035/2.0016	3.000	3.980	3.013	.1050	2.9651	2.775	.189	1.000	2

* Available only with Press Fit-Style Thermoplastic Bearing.

STYLE	SHAFT SIZE	MATERIAL
OPEN	1/2" TO 2"	SHELL - ALUMINUM LINER - THERMOPLASTIC POLYMER

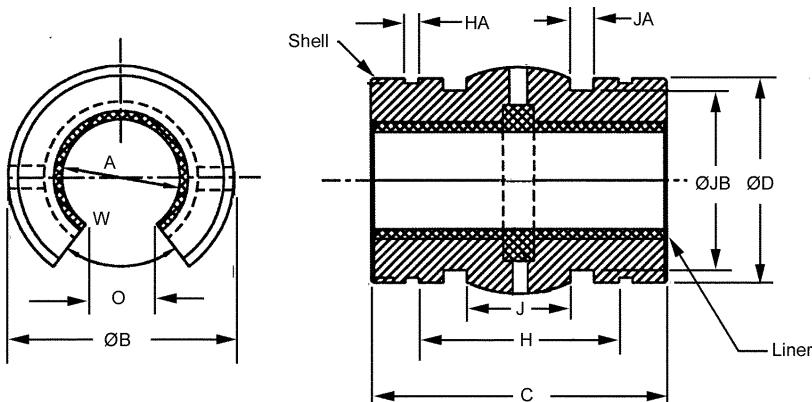

STOCK NO.	ØA	ØB	C	H	HA	ØJB	JA	J	W°	ØD ±.005	O ±.012	Nominal Size
LBOJUI-03-08	.5020/.5008	.8750	1.242	.879	.048	.712	.125	.250	30°	.8641	.3937	1/2
LBOJUI-03-10	.6270/.6258	1.1250	1.492	1.005	.058	.962	.125	.312	30°	1.1119	.4331	5/8
LBOJUI-03-12	.7524/.7508	1.2500	1.617	1.067	.058	1.087	.125	.312	30°	1.2356	.4921	3/4
LBOJUI-03-16	1.0024/1.0008	1.5620	2.238	1.632	.070	1.399	.125	.500	30°	1.5429	.6299	1
LBOJUI-03-20	1.2528/1.2512	2.0000	2.613	1.884	.070	1.837	.125	.625	30°	1.9771	.7087	1 1/4
LBOJUI-03-24	1.5028/1.5012	2.3750	2.984	2.260	.089	2.152	.162	.750	30°	2.3488	.8661	1 1/2
LBOJUI-03-32	2.0035/2.0016	3.0000	3.980	3.013	.105	2.775	.189	1.000	30°	2.9651	1.1811	2

CERAMIC COATED SHAFTING

SIZES	STYLES	MATERIAL
3/16" TO 2"	SOLID AND PRE-DRILLED OR TAPPED	RC70 CERAMIC COATED 6061-T6 ALUMINUM

Solid

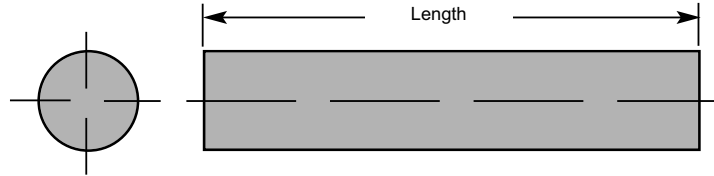

STOCK NO.	NOMINAL SHAFT SIZE	DIAMETER TOLERANCES		LENGTH (Inches)	MAX. LENGTH (ft.) (SPECIAL)*	WEIGHT PER INCH (LBS.)
		MIN.	MAX.			
LSCA-03-36	3/16"	0.1863	0.1871	36"	4	0.003
LSCA-04-36	1/4"	0.2488	0.2496		6	0.005
LSCA-06-36	3/8"	0.3738	0.3746		8	0.010
LSCA-08-36	1/2"	0.4988	0.4996		12	0.019
LSCA-10-36	5/8"	0.6238	0.6246		12	0.030
LSCA-12-36	3/4"	0.7488	0.7496		12	0.043
LSCA-16-36	1"	0.9988	0.9996		12	0.077
LSCA-20-36	1 1/4"	1.2488	1.2496		12	0.120
LSCA-24-36	1 1/2"	1.4987	1.4995		12	0.173
LSCA-32-36	2"	1.9985	1.9995		12	0.308

Pre-drilled and Tapped

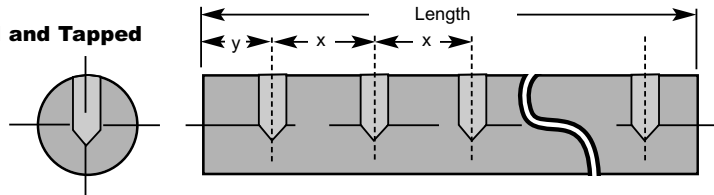

STOCK NO.	NOMINAL SHAFT SIZE	DIAMETER TOLERANCES		HOLE SPACING		THREAD	THREAD DEPTH (Inches)	LENGTH (Inches)	MAX. LENGTH (Special)*	WEIGHT PER INCH (LBS.)
		MIN.	MAX.	x	y					
LSCA-PD-08-36	1/2"	0.4988	0.4996	4	2	6-32	.29	36"	12 ft.	0.019
LSCA-PD-10-36	5/8"	0.6238	0.6246	4	2	8-32	.35		0.030	
LSCA-PD-12-36	3/4"	0.7488	0.7496	6	3	10-32	.40		0.043	
LSCA-PD-16-36	1"	0.9988	0.9996	6	3	1/4-20	.56		0.077	
LSCA-PD-20-36	1 1/4"	1.2488	1.2496	6	3	5/16-18	.74		0.120	
LSCA-PD-24-36	1 1/2"	1.4987	1.4995	8	4	3/8-16	.88		0.173	
LSCA-PD-32-36	2"	1.9985	1.9995	8	4	1/2-13	1.15		0.308	

NOTE:

For non-standard lengths, the "y" dimension will be held to one end. It may not be equal at both ends.

Solid



NOTE:

* Special lengths are available upon request, please call for pricing. Ends of cut-to-length shafting are not coated. Fully coated shafting is available upon special request.

Pre-drilled and Tapped



- Designed to run with Frelon® lined bearings.
- Non-Magnetic and vibration resistant.
- Weld splatter, paints, contaminants will not stick.
- Special end configurations available upon request.
- For use with Berg Bearing series LB-FL, LB-FLN, BPS, BPSF, LF-SFP, and LF-DFP.

CERAMIC BEARINGS

STYLE	SHAFT SIZE	MATERIAL
CLOSED	1/4" TO 2"	CERAMIC COATED ALUMINUM HOUSING

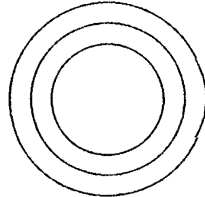
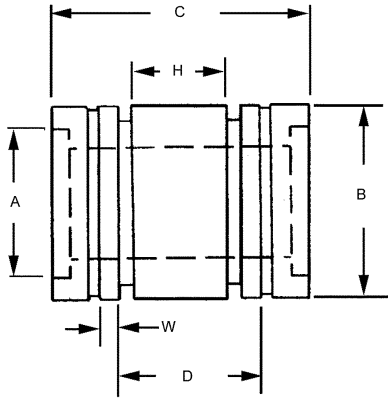

Maximum PV (continuous) 40,000
 Maximum P (static) 50,000 PSI
 Maximum V SGM (no load) unlimited
 Shaft Hardness RC 58-63
 Shaft Finish (RMS) 8-10
 Coefficient of Friction .04-.08
 Temperature Limits (Typ.) -200°F to +400°F



STOCK NO.	WORKING BORE		OUTSIDE DIA.		LENGTH		RETAINING RING		MAX. SHAFT DIA.	HOUSING BORE DIA. TOL.		H ±.010
	A	TOL.	B	TOL.	C	TOL.	D	W				
L408-6	.2505	.0010	.5000	.0010	.750	.015	.437	.029	.2495	.5000	.0005	.180
L610-7	.3755	.0010	.6250	.0010	.875	.015	.562	.029	.3745	.6250	.0005	.260
L814-10	.5005	.0010	.8750	.0010	1.250	.015	.875	.039	.4995	.8750	.0005	.490
L1018-12	.6255	.0010	1.1250	.0010	1.500	.015	1.000	.039	.6245	1.1250	.0005	.550
L1220-13	.7508	.0010	1.2500	.0010	1.625	.015	1.062	.046	.7495	1.2500	.0005	.612
L1625-18	1.0008	.0010	1.5625	.0010	2.250	.015	1.625	.046	.9995	1.5625	.0005	1.180
L2032-21	1.2508	.0010	2.0000	.0010	2.625	.020	1.875	.050	1.2495	2.0000	.0010	1.425
L2438-24	1.5008	.0015	2.3750	.0015	3.000	.020	2.250	.068	1.4994	2.3750	.0010	1.670
L3248-32	2.0012	.0015	3.0000	.0015	4.000	.020	3.000	.068	1.9994	3.0000	.0010	1.450

Recommended Shafting Hardness RC 58-63.

STYLE	SHAFT SIZE	MATERIAL
OPEN	1/4" TO 2"	CERAMIC COATED ALUMINUM HOUSING

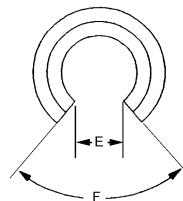
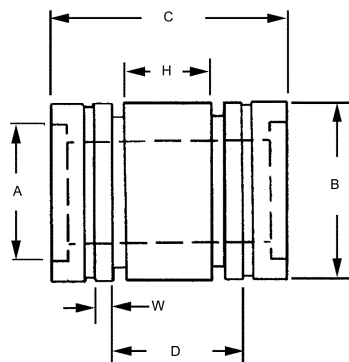

Maximum PV (continuous) 40,000
 Maximum P (static) 50,000 PSI
 Maximum V SGM (no load) unlimited
 Shaft Hardness RC 58-63
 Shaft Finish (RMS) 8-10
 Coefficient of Friction .04-.08
 Temperature Limits (Typ.) -200°F to +400°F

STOCK NO.	WORKING BORE		OUTSIDE DIA.		LENGTH		RETAINING RING		MAX. SHAFT DIA.	HOUSING BORE DIA. TOL.		H ±.010	E +.020 -.000	F
	A	TOL.	B	TOL.	C	TOL.	D	W						
LX408-6	.2505	.0010	.5000	.0010	.750	.015	.437	.029	.2495	.5000	.0005	.180	.094	60°
LX610-7	.3755	.0010	.6250	.0010	.875	.015	.562	.029	.3745	.6250	.0005	.260	.156	
LX814-10	.5005	.0010	.8750	.0010	1.250	.015	.875	.039	.4995	.8750	.0005	.490	.312	
LX1018-12	.6255	.0010	1.1250	.0010	1.500	.015	1.000	.039	.6245	1.1250	.0005	.550	.375	
LX1220-13	.7508	.0010	1.2500	.0010	1.625	.015	1.062	.046	.7495	1.2500	.0005	.612	.438	
LX1625-18	1.0008	.0010	1.5625	.0010	2.250	.015	1.625	.046	.9995	1.5625	.0005	1.180	.563	
LX2032-21	1.2508	.0010	2.0000	.0010	2.625	.020	1.875	.050	1.2495	2.0000	.0010	1.425	.625	
LX2438-24	1.5008	.0015	2.3750	.0015	3.000	.020	2.250	.068	1.4994	2.3750	.0010	1.670	.750	
LX3248-32	2.0012	.0015	3.0000	.0015	4.000	.020	3.000	.068	1.9994	3.0000	.0010	1.450	1.000	

SELF ALIGNING CERAMIC BEARINGS

STYLE	SHAFT SIZE	MATERIAL
CLOSED	1/4" TO 2"	CERAMIC COATED ALUMINUM HOUSING

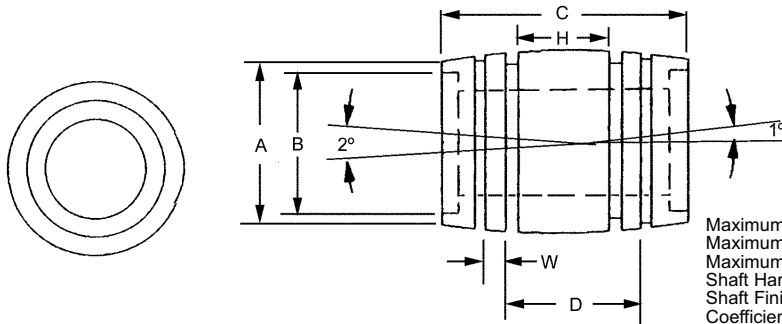

Maximum PV (continuous) 40,000
 Maximum P (static) 50,000 PSI
 Maximum V SGM (no load) unlimited
 Shaft Hardness (minimum) RC 35-63
 Shaft Finish (RMS) 8-10
 Coefficient of Friction .04-.08
 Temperature Limits (Typ.) -200°F to +400°F

STOCK NO.	WORKING BORE		OUTSIDE DIA.		LENGTH		RETAINING RING		MAX. SHAFT DIA.	HOUSING BORE DIA.		H ±.010
	A	TOL.	B	TOL.	C	TOL.	D	W		TOL.		
L408-6SA	.2505	.0010	.5000	.0010	.750	.015	.437	.029	.2495	.5000	.0005	.180
L610-7SA	.3755	.0010	.6250	.0010	.875	.015	.562	.029	.3745	.6250	.0005	.260
L814-10SA	.5005	.0010	.8750	.0010	1.250	.015	.875	.039	.4995	.8750	.0005	.490
L1018-12SA	.6255	.0010	1.1250	.0010	1.500	.015	1.000	.039	.6245	1.1250	.0005	.550
L1220-13SA	.7508	.0010	1.2500	.0010	1.625	.015	1.062	.046	.7495	1.2500	.0005	.612
L1625-18SA	1.0008	.0010	1.5625	.0010	2.250	.015	1.625	.046	.9995	1.5625	.0005	1.180
L2032-21SA	1.2508	.0010	2.0000	.0010	2.625	.020	1.875	.050	1.2495	2.0000	.0010	1.425
L2438-24SA	1.5008	.0015	2.3750	.0015	3.000	.020	2.250	.068	1.4994	2.3750	.0010	1.670
L3248-32SA	2.0012	.0015	3.0000	.0015	4.000	.020	3.000	.068	1.9994	3.0000	.0010	1.450

Recommended Shafting Hardness RC 58-63.

STYLE	SHAFT SIZE	MATERIAL
OPEN	1/4" TO 2"	CERAMIC COATED ALUMINUM HOUSING

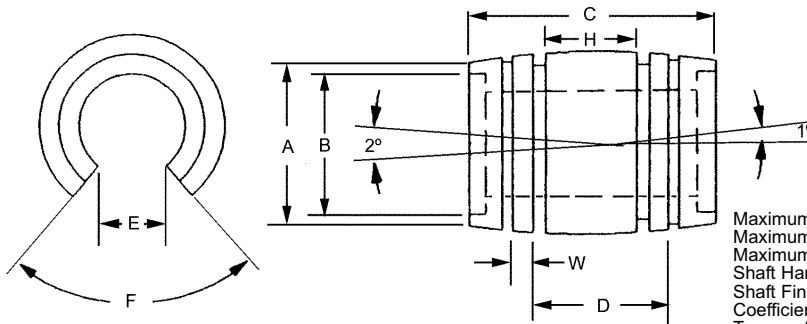

Maximum PV (continuous) 40,000
 Maximum P (static) 50,000 PSI
 Maximum V SGM (no load) unlimited
 Shaft Hardness (minimum) RC 35-63
 Shaft Finish (RMS) 8-10
 Coefficient of Friction .04-.08
 Temperature Limits (Typ.) -200°F to +400°F

STOCK NO.	WORKING BORE		OUTSIDE DIA.		LENGTH		RETAINING RING		MAX. SHAFT DIA.	HOUSING BORE DIA.		H ±.010	E +.020 -.000	F
	A	TOL.	B	TOL.	C	TOL.	D	W		TOL.				
LX408-6SA	.2505	.0010	.5000	.0010	.750	.015	.437	.029	.2495	.5000	.0005	.180	.094	60°
LX610-7SA	.3755	.0010	.6250	.0010	.875	.015	.562	.029	.3745	.6250	.0005	.260	.156	
LX814-10SA	.5005	.0010	.8750	.0010	1.250	.015	.875	.039	.4995	.8750	.0005	.490	.312	
LX1018-12SA	.6255	.0010	1.1250	.0010	1.500	.015	1.000	.039	.6245	1.1250	.0005	.550	.375	
LX1220-13SA	.7508	.0010	1.2500	.0010	1.625	.015	1.062	.046	.7495	1.2500	.0005	.612	.438	
LX1625-18SA	1.0008	.0010	1.5625	.0010	2.250	.015	1.625	.046	.9995	1.5625	.0005	1.180	.563	
LX2032-21SA	1.2508	.0010	2.0000	.0010	2.625	.020	1.875	.050	1.2495	2.0000	.0010	1.425	.625	
LX2438-24SA	1.5008	.0015	2.3750	.0015	3.000	.020	2.250	.068	1.4994	2.3750	.0010	1.670	.750	
LX3248-32SA	2.0012	.0015	3.0000	.0015	4.000	.020	3.000	.068	1.9994	3.0000	.0010	1.450	1.000	

Recommended Shafting Hardness RC 58-63.

COMPOSITE BEARINGS

SHAFT SIZE	MATERIAL
1/4" TO 4"	TEFLON® / DURALON®

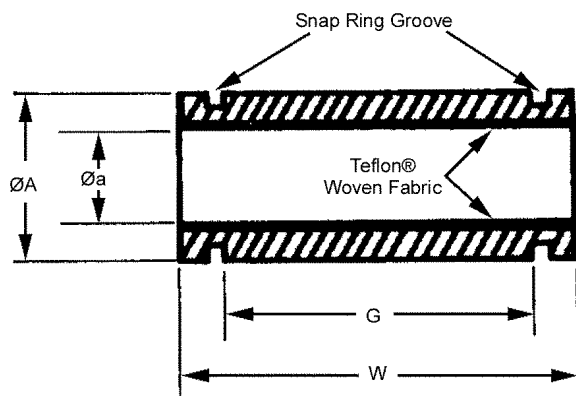

STOCK NO.	Øa	ØA +.000 -.001	W +.000 -.020	G	ØA-Øa CONCENTRICITY
701-66004-024	.2515 .2505	.5006	.750	.447 .427	.001 TIR
701-66006-028	.3765 .3755	.6256	.875	.572 .552	
701-66008-040	.5015 .5005	.8756	1.250	.885 .865	
701-66010-048	.6265 .6255	1.1256	1.500	1.010 .990	
701-66012-052	.7515 .7505	1.2506	1.625	1.072 1.052	
701-66016-072	1.0015 1.0005	1.5631	2.250	1.635 1.615	
701-66020-084	1.2515 1.2505	2.0006	2.625	1.890 1.860	
701-66024-096	1.5015 1.5005	2.3756	3.001	2.265 2.235	
701-66032-128	2.0015 2.0005	3.0006	4.000	3.015 2.985	
701-60040-160	2.5060 2.5050	3.7506	5.000	3.765 3.735	
701-60048-192	3.0070 3.0050	4.5006	6.000	4.515 4.485	
701-60064-256	4.0080 4.0050	6.0006	8.000	6.020 5.980	

Teflon® is a registered trademark of E.I. DuPont.
Duralon® is a registered trademark of Rexnord Corporation.



LOGLIFE® BEARINGS

SERIES	FOR SHAFT SIZES	MATERIAL
DRY UNLUBRICATED	1/8" TO 1"	STEEL BACKED POROUS BRONZE AND PTFE-LEAD

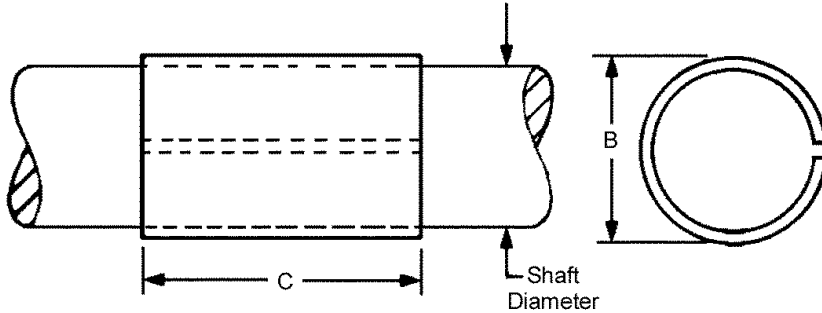

- Lasts up to 10x longer than oil impregnated porous bronze bearings
- High loads
- Runs cool - excellent heat dissipation
- Operates in extreme temperatures
- Reduce costs - lower maintenance, eliminate hardened shafting and expensive shaft preparations
- Excellent for rotating, sliding or oscillating motion and both thrust and radial loading
- In fully lubricated environments provides protection during dry starts and from lubrication system failure

Maximum Continuous Load: 50,000 PV's Unlubricated
2,000,000 PV's Lubricated
PV Factor = psi x sfpm

Maximum Continuous Speed: 1,000 sfpm Unlubricated
2,000 sfpm Lubricated

Temperature Range: +536°F to -328°F

Compressive Strength: 44,000 psi

STOCK NO.	NOMINAL SHAFT SIZE	ACTUAL SHAFT DIA.	NOMINAL OUTSIDE DIA. B	HOUSING BORE	C	REC. SHAFT
DU14-1 DU14-2	1/8	.1247/.1240	3/16	.1882/.1877	1/8 3/16	S1-8
DU14-5 DU14-6 DU14-7	3/16	.1872/.1865	1/4	.2510/.2504	3/16 1/4 3/8	S1-11
DU14-8 DU14-9	1/4	.2497/.2488	5/16	.3135/.3129	1/4 3/8	S1-14
DU14-10 DU14-11	5/16	.3122/.3113	3/8	.3760/.3754	3/8 1/2	S1-16
DU14-12 DU14-13 DU14-14 DU14-15 DU14-16 DU14-17	3/8	.3747/.3738	15/32	.4698/.4691	3/16 1/4 3/8 1/2 5/8 3/4	S1-18
DU14-18 DU14-19	7/16	.4372/.4362	17/32	.5323/.5315	1/2 3/4	-
DU14-21 DU14-22 DU14-23 DU14-24 DU14-25	1/2	.4997/.4987	19/32	.5948/.5941	1/4 3/8 1/2 5/8 7/8	S1-20
DU14-31 DU14-32 DU14-33	5/8	.6247/.6237	23/32	.7199/.7191	1/4 1/2 3/4	S1-22
DU14-38 DU14-39 DU14-40 DU14-41 DU14-42	3/4	.7497/.7485	7/8	.8761/.8753	3/8 1/2 5/8 3/4 1	S1-23
DU14-51 DU14-53 DU14-54	1	.9997/.9985	1-1/8	1.1261/1.1253	1/2 1 1-1/4	S1-24

LongLife® is a trademark of Glacier Metal Co.

SHAFT SUPPORT

FOR SHAFT SIZES	MATERIAL	USE WITH
1/2" TO 2"	EXTRUDED ALUMINUM	LMD, LMA & LMX OPEN STYLE LINEAR BEARINGS

EXAMPLES

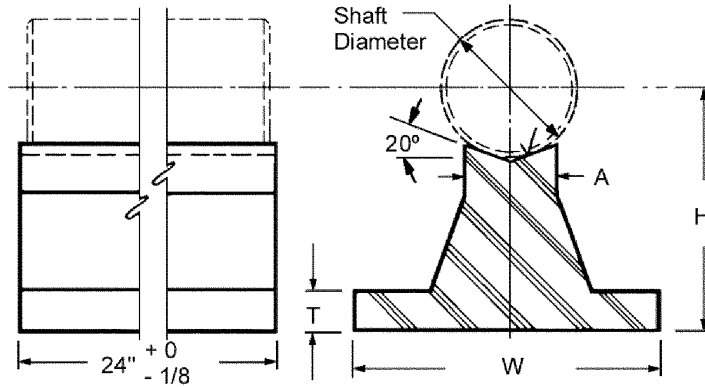
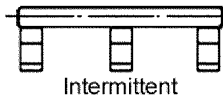
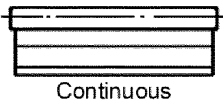

STOCK NO.	SHAFT DIA.	H ±.002	T	W	A	WEIGHT PER FT. (lbs.)
LMR-1	1/2	1.125	3/16	1 1/2	1/4	.6
LMR-2	3/4	1.500	1/4	1 3/4	3/8	1.0
LMR-3	1	1.750	1/4	2 1/8	1/2	1.4
LMR-4	1 1/4	2.125	5/16	2 1/2	9/16	2.1
LMR-5	1 1/2	2.500	3/8	3	11/16	2.6
LMR-6	2	3.250	1/2	3 3/4	7/8	4.2



FOR SHAFT SIZES	MATERIAL
1/2" TO 2"	EXTRUDED ALUMINUM

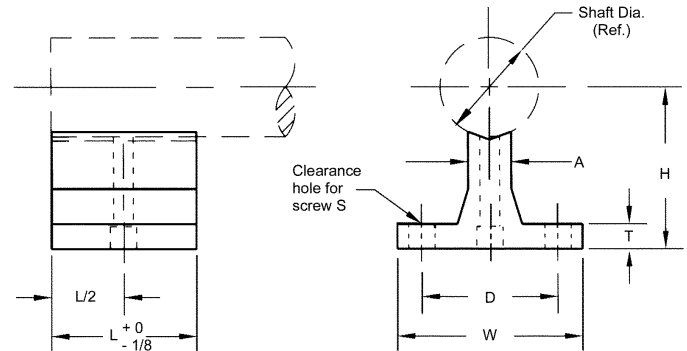
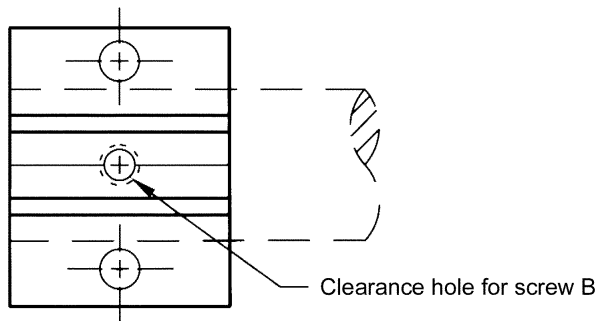

STOCK NO.	SHAFT DIA. (Ref.)	H ±.002	T	W	A	L	S	B THREAD	LENGTH	D
LMR-1H	1/2	1.125	.187	1.50	.25	4	#6	#6	7/8	1
LMR-2H	3/4	1.500	.250	1.75	.38	6	#10	#10	1 1/4	1 1/4
LMR-3H	1	1.750	.250	2.13	.50	6	1/4	1/4	1 1/2	1 1/2
LMR-4H	1 1/4	2.125	.312	2.50	.56	6	5/16	5/16	1 3/4	1 7/8
LMR-5H	1 1/2	2.500	.375	3.00	.69	8	5/16	3/8	1 3/4	2 1/4
LMR-6H	2	3.250	.500	3.75	.88	8	3/8	1/2	2 1/2	2 3/4



LINEAR PILLOW BLOCK ASSEMBLIES

STYLE	SHAFT SIZE	MATERIAL
CLOSED (SEE FIG. 1)	1/8" TO 1 1/4"	HOUSING - BLACK ANODIZED ALUMINUM, BEARING HOUSING & BALLS - CHROME STEEL, BALL RETAINER - PLASTIC, RETAINER RING - CARBON STEEL, WIPER-SYNTHETIC RUBBER

STOCK NO.	SHAFT SIZE	D	E	F	G	H	K	L	M	RATED LOAD (lbs.)	SHAFT STOCK NO.	MOUNTING SCREW STOCK NO.
LPA-125	1/8	.94	.31	.39	.54	.281	.50	*	.684	7	S1-8	Y9-S4-A10
LPA-187	3/16	1.10	.38	.43	.60	.312	.56	*	.812	9	S1-11	Y9-S6-A12
LPA-1	1/4	1.13	.44	.65	.81	.437	.75	*	.875	25	LMS-4-36	Y9-S6-A14-R
LPA-2	3/8	1.25	.56	.78	.94	.500	.88	*	1.000	51	LMS-6-36	Y9-S6-A16-R
LPA-3	1/2	1.50	.88	1.00	1.18	.625	1.25	.562	1.187	102	LMS-8-36	Y9-S6-A20-R
LPA-4	3/4	1.88	1.06	1.43	1.65	.875	1.63	.750	1.562	205	LMS-12-36	Y9-S8-A28-R
LPA-5	1	2.38	1.63	1.62	1.93	1.000	2.25	1.250	2.000	385	LMS-16-36	Y9-S10-A32-R
LPA-6	1 1/4	2.75	1.88	2.06	2.50	1.312	2.63	1.500	2.375	540	LMS-20-36	Y9-S10-A40-R

* Only 2 mounting holes, centered at E/2.

STYLE	SHAFT SIZE	MATERIAL
OPEN (SEE FIG. 2)	1/2" TO 1 1/4"	HOUSING - BLACK ANODIZED ALUMINUM, BEARING HOUSING & BALLS - CHROME STEEL, BALL RETAINER - PLASTIC, RETAINER RING - CARBON STEEL, WIPER-SYNTHETIC RUBBER

STOCK NO.	SHAFT SIZE	D	E	F	G	H	K	L	M	N	LOAD (lbs.)	STOCK NO.	SCREW STOCK NO.
LPA-13	1/2	1.50	.88	1.00	1.06	.625	1.25	.562	1.187	.31	102	LMS-8-36	Y9-S6-A20-R
LPA-14	3/4	1.88	1.06	1.43	1.57	.875	1.63	.750	1.562	.44	205	LMS-12-36	Y9-S8-A28-R
LPA-15	1	2.38	1.63	1.62	1.64	1.000	2.25	1.250	2.000	.56	385	LMS-16-36	Y9-S10-A32-R
LPA-16	1 1/4	2.75	1.88	2.06	2.25	1.312	2.63	1.500	2.375	.62	540	LMS-20-36	Y9-S10-A40-R

STYLE	SHAFT SIZE	MATERIAL
ADJUSTABLE (SEE FIG. 3)	1/2" TO 1 1/4"	HOUSING - BLACK ANODIZED ALUMINUM, BEARING HOUSING & BALLS - CHROME STEEL, BALL RETAINER - PLASTIC, RETAINER RING - CARBON STEEL, WIPER-SYNTHETIC RUBBER

STOCK NO.	SHAFT SIZE	D	E	F	G	H	K	L	M	RATED LOAD (lbs.)	SHAFT STOCK NO.	MOUNTING SCREW STOCK NO.
LPA-23	1/2	1.50	.88	1.00	1.18	.625	1.25	.562	1.187	102	LMS-8-36	Y9-S6-A8
LPA-24	3/4	1.88	1.06	1.44	1.65	.875	1.63	.750	1.562	205	LMS-12-36	Y9-S8-A12
LPA-25	1	2.38	1.63	1.63	1.93	1.000	2.25	1.250	2.000	385	LMS-16-36	Y9-S10-A12
LPA-26	1 1/4	2.75	1.88	2.06	2.50	1.312	2.63	1.500	2.375	540	LMS-20-36	Y9-S10-A116

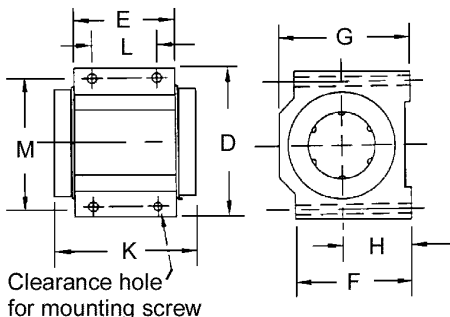

CLOSED STYLE
FIGURE 1

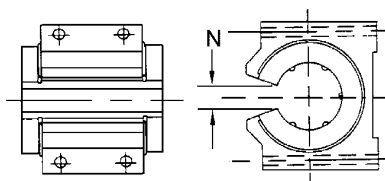

OPEN STYLE
FIGURE 2

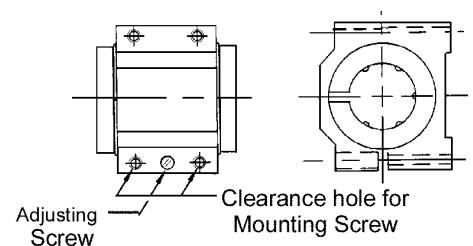

ADJUSTABLE STYLE
FIGURE 3

PILLOW BLOCK ASSEMBLIES WITH SHAFT WIPERS

STYLE	SHAFT SIZE	MATERIAL
CLOSED (SEE FIG. 1)	1/4" TO 1 1/4"	HOUSING - BLACK ANODIZED ALUMINUM, BEARING HOUSING & BALLS - CHROME STEEL, BALL RETAINER - PLASTIC, RETAINER RING - CARBON STEEL

STOCK NO.	SHAFT SIZE	D	E	F	G	H ±.001	L	M	RATED LOAD (lbs.)	SHAFT STOCK NO.	MOUNTING SCREW STOCK NO.	REPLACEMENT SHAFT WIPER STOCK NO.
LPW-1A	1/4	1.13	1.00	.65	.81	.437	.687	.875	25	LMS-4-36	Y9-S6-A14-R	LMG-R-1
LPW-2A	3/8	1.25	1.12	.78	.93	.500	.812	1.000	51	LMS-6-36	Y9-S6-A16-R	LMG-R-2
LPW-3A	1/2	1.50	1.50	1.00	1.18	.625	1.187	1.187	102	LMS-8-36	Y9-S6-A20-R	LMG-R-3
LPW-4A	3/4	1.88	1.88	1.44	1.65	.875	1.562	1.562	205	LMS-12-36	Y9-S8-A28-R	LMG-R-4
LPW-5A	1	2.38	2.62	1.63	1.93	1.000	2.250	2.000	385	LMS-16-36	Y9-S10-A32-R	LMG-R-5
LPW-6A	1 1/4	2.75	3.38	2.06	2.50	1.312	3.000	2.375	540	LMS-20-36	Y9-S10-A40-R	LMG-R-6

STYLE	SHAFT SIZE	MATERIAL
OPEN (SEE FIG. 2)	1/2" TO 1 1/4"	HOUSING - BLACK ANODIZED ALUMINUM, BEARING HOUSING & BALLS - CHROME STEEL, BALL RETAINER - PLASTIC, RETAINER RING - CARBON STEEL

STOCK NO.	SHAFT SIZE	D	E	F	G	H ±.001	L	M	N	RATED LOAD (lbs.)	SHAFT STOCK NO.	MOUNTING SCREW STOCK NO.	REPLACEMENT SHAFT WIPER STOCK NO.
LPW-13A	1/2	1.50	1.50	1.00	1.06	.625	1.187	1.187	.28	102	LMS-8-36	Y9-S6-A20-R	LMG-P-3
LPW-14A	3/4	1.88	1.88	1.44	1.56	.875	1.562	1.562	.44	205	LMS-12-36	Y9-S8-A28-R	LMG-P-4
LPW-15A	1	2.38	2.62	1.63	1.64	1.000	2.250	2.000	.56	385	LMS-16-36	Y9-S10-A32-R	LMG-P-5
LPW-16A	1 1/4	2.75	3.38	2.06	2.25	1.312	2.375	2.375	.75	540	LMS-20-36	Y9-S10-A40-R	LMG-P-6

STYLE	SHAFT SIZE	MATERIAL
ADJUSTABLE (SEE FIG. 3)	1/2" TO 1 1/4"	HOUSING - BLACK ANODIZED ALUMINUM, BEARING HOUSING & BALLS - CHROME STEEL, BALL RETAINER - PLASTIC, RETAINER RING - CARBON STEEL

STOCK NO.	SHAFT SIZE	D	E	F	G	H ±.001	L	M	RATED LOAD (lbs.)	SHAFT STOCK NO.	MOUNTING SCREW STOCK NO.	REPLACEMENT SHAFT WIPER STOCK NO.
LPW-23A	1/2	1.50	1.50	1.00	1.18	.625	1.187	1.187	102	LMS-8-36	Y9-S6-A8	LMG-A-3
LPW-24A	3/4	1.88	1.88	1.44	1.65	.875	1.562	1.562	205	LMS-12-36	Y9-S8-A12	LMG-A-4
LPW-25A	1	2.38	2.62	1.63	1.93	1.000	2.000	2.000	385	LMS-16-36	Y9-S10-A12	LMG-A-5
LPW-26A	1 1/4	2.75	3.38	2.06	2.50	1.312	2.375	2.375	540	LMS-20-36	Y9-S10-A16	LMG-A-6

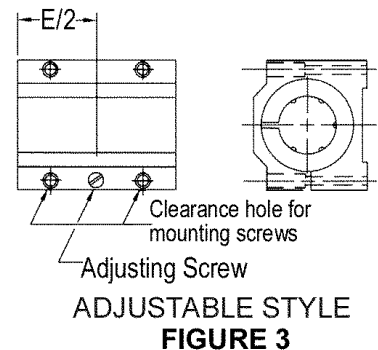
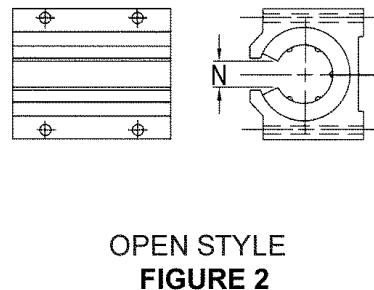
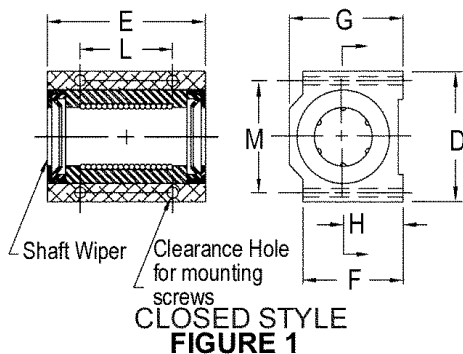

PILLOW BLOCKS

TYPE	FOR SHAFT SIZES	MATERIAL
CLOSED	1/4" TO 2"	ALUMINUM

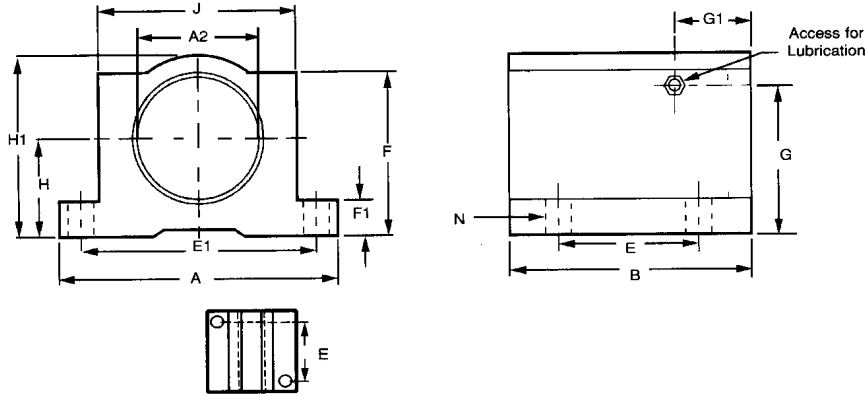

STOCK NO.	NOMINAL SHAFT DIA.	H (±.001)	H1	A	B	E (±.010)	E1 (±.010)	F	F1	G	G1	N Hole	Bolt	+0.005 A -0.000	J
BPB-4	.250	.437	.81	1.63	1.19	.750	1.313	.75	.19	.61	.22	.16	#6	.5000	1.00
BPB-6	.375	.500	.94	1.75	1.31	.875	1.438	.88	.19	.72	.22	.16	#6	.6250	1.13
BPB-8	.500	.687	1.25	2.00	1.69	1.000	1.688	1.13	.25	.69	.84	.16	#6	.8750	1.38
BPB-10	.625	.875	1.63	2.50	1.94	1.125	2.125	1.44	.28	.70	.68	.19	#8	1.1250	1.75
BPB-12	.750	.937	1.75	2.75	2.06	1.250	2.375	1.56	.31	.94	.72	.19	#8	1.2500	1.88
BPB-16	1.000	1.187	2.19	3.25	2.81	1.750	2.875	1.94	.38	1.20	.86	.22	#10	1.5625	2.38
BPB-20	1.250	1.500	2.81	4.00	3.63	2.000	3.500	2.50	.44	1.50	1.20	.22	#10	2.0000	3.00
BPB-24	1.500	1.750	3.25	4.75	4.00	2.500	4.125	2.88	.50	1.75	1.25	.28	1/4	2.3750	3.50
BPB-32	2.000	2.125	4.06	6.00	5.00	3.250	5.250	3.63	.63	2.12	1.58	.41	3/8	3.0000	4.50

Bearing not supplied.

TYPE	FOR SHAFT SIZES	MATERIAL
OPEN	1/2" TO 2"	ALUMINUM

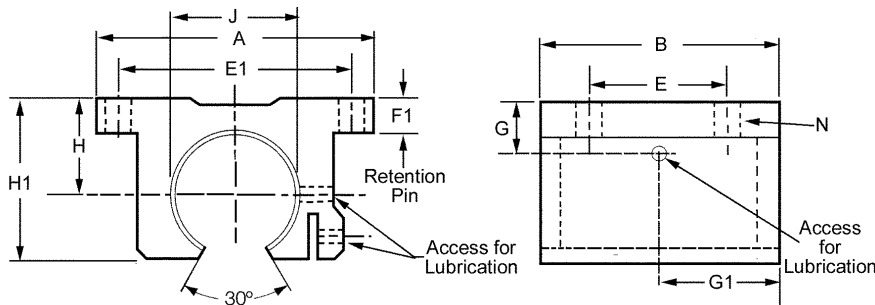

STOCK NO.	NOMINAL SHAFT DIA.	H ±.003	H1	A	B	E ±.010	E1 ±.010	F1	G	G1	N		J	J TOL.
											HOLE	BOLT		
BPB-8-OPN	.500	.687	1.13	2.00	1.50	1.000	1.688	.25	.69	.75	.16	#6	.8750	
BPB-10-OPN	.625	.875	1.44	2.50	1.75	1.125	2.125	.28	.42	.53	.19	#8	1.1250	+0.02
BPB-12-OPN	.750	.937	1.56	2.75	1.88	1.250	2.375	.31	1.08	.55	.19	#8	1.2500	-.000
BPB-16-OPN	1.000	1.187	2.00	3.25	2.63	1.750	2.875	.38	1.37	.76	.22	#10	1.5625	
BPB-20-OPN	1.250	1.500	2.56	4.00	3.38	2.000	3.500	.44	1.73	1.05	.22	#10	2.0000	
BPB-24-OPN	1.500	1.750	2.94	4.75	3.75	2.500	4.125	.50	2.03	1.12	.28	1/4	2.3750	+0.03
BPB-32-OPN	2.000	2.125	3.63	6.00	4.75	3.250	5.250	.63	2.50	1.44	.41	3/8	3.0000	-.000

LINEAR PILLOW BLOCKS WITH SHAFT WIPERS

TYPE	FOR SHAFT SIZES	MATERIAL
STANDARD BEARINGS	1/2" TO 2"	HOUSING - ALUMINUM BLACK ANODIZED, STANDARD BEARING - HARDENED STEEL, WIPER - POLYURETHANE

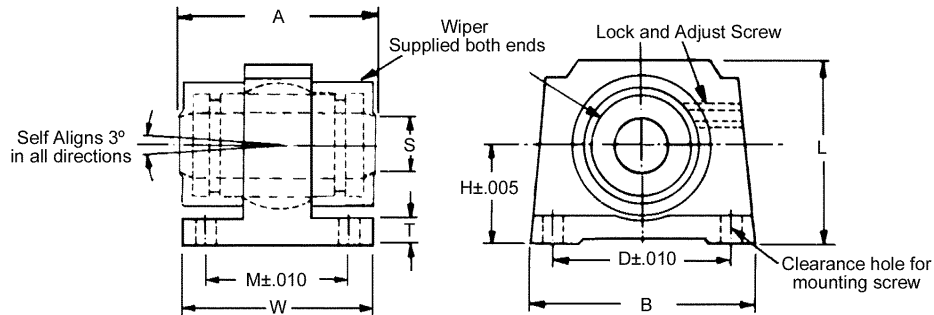

STOCK NO.	SHAFT DIA.	H	T	W	B	A	M	D	L	MTG. SCREW
LMP-A8	1/2	.875	1/4	1.56	2.04	1.42	1	1 1/2	1.68	#8
LMP-A12	3/4	1.125	5/16	2.07	2.80	1.83	1 3/8	2	2.15	#10
LMP-A16	1	1.375	3/8	2.24	3.33	2.50	1 1/2	2 1/2	2.62	1/4
LMP-A20	1 1/4	1.750	7/16	2.84	4.05	2.81	1 7/8	3	2.90	5/16
LMP-A24	1 1/2	2.000	1/2	3.00	4.65	3.13	2	3 1/2	3.75	5/16
LMP-A32	2	2.500	5/8	3.52	6.00	4.15	2 1/2	4 1/2	4.75	3/8



TYPE	FOR SHAFT SIZES	MATERIAL
OPEN BEARINGS	1/2" TO 2"	HOUSING - ALUMINUM BLACK ANODIZED, STANDARD BEARING - HARDENED STEEL, WIPER - POLYURETHANE

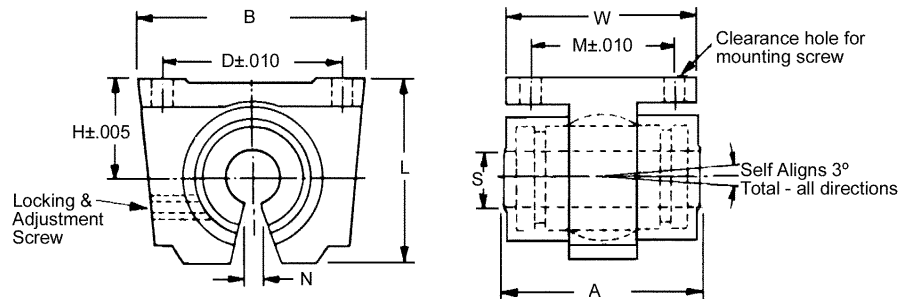

STOCK NO.	SHAFT DIA.	H ±.005	N	W	B	A	M ±.010	D ±.010	L	MTG. SCREW
LMP-OPN8	1/2	0.875	9/32	1.56	2.04	1.42	1	1 1/2	1.68	#8
LMP-OPN12	3/4	1.125	13/32	2.07	2.80	1.83	1 3/8	2	2.15	#10
LMP-OPN16	1	1.375	9/16	2.24	3.33	2.50	1 1/2	2 1/2	2.62	1/4
LMP-OPN20	1 1/4	1.750	5/8	2.84	4.05	2.81	1 7/8	3	2.90	5/16
LMP-OPN24	1 1/2	2.000	3/4	3.00	4.65	3.13	2	3 1/2	3.75	5/16
LMP-OPN32	2	2.500	1	3.52	6.00	4.15	2-1/2	4 1/2	4.75	3/8

SQUARE BEARINGS

SIZE	MATERIAL
1.0"	6061-T6 ANODIZED ALUMINUM

Ordering Information

STOCK NO.	Description
SB16-2E	Standard 1.0" 2-sided adj. square bearing with FrelonJ™ plugs for stainless steel shafting.
SB16-4E	Standard 1.0" 4-sided adj. square bearing with FrelonJ™ plugs for stainless steel shafting.

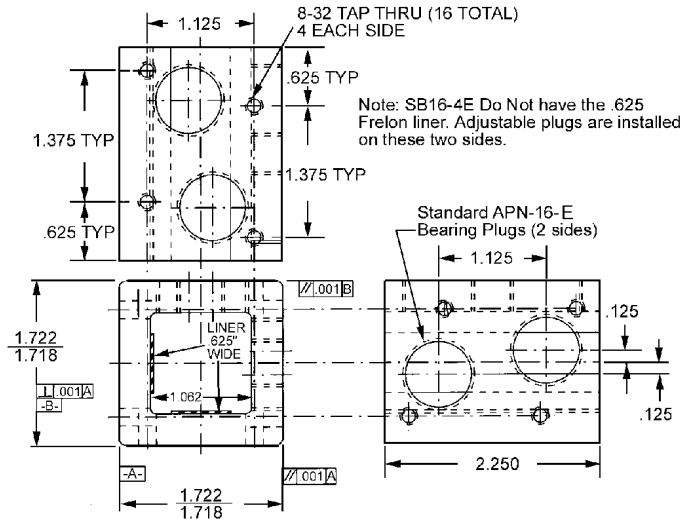
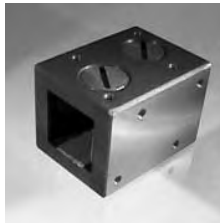

SIZE	MATERIAL
1.0"	6061-T6 ANODIZED ALUMINUM

Ordering Information

STOCK NO.	Description
SBL16-2E	1.0" extended length 2-sided adj. square bearing with FrelonJ™ plugs for stainless steel shafting.
SBL16-4E	1.0" extended length 4-sided adj. square bearing with FrelonJ™ plugs for stainless steel shafting.

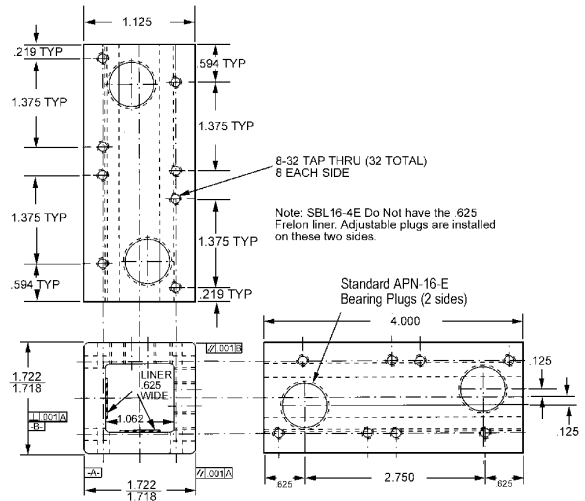

SQUARE BEARINGS

SIZE	MATERIAL
1.5"	6061-T6 ANODIZED ALUMINUM

Ordering Information

STOCK NO.	Description
SB24-2E	Standard 1.5" 2-sided adj. square bearing with FrelonJ™ plugs for stainless steel shafting.
SB24-4E	Standard 1.5" 4-sided adj. square bearing with FrelonJ™ plugs for stainless steel shafting

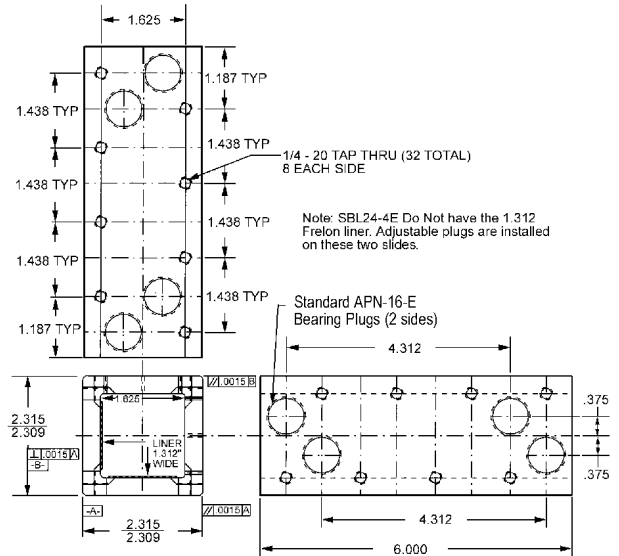
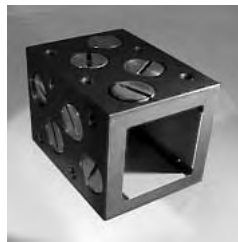

See Technical data on next page for these parts.

SIZE	MATERIAL
1.5"	6061-T6 ANODIZED ALUMINUM

Ordering Information

STOCK NO.	Description
SBL24-2E	1.5" Extended length 2-sided adj. square bearing with FrelonJ™ plugs for stainless steel shafting.
SBL24-4E	1.5" Extended length 4-sided adj. square bearing with FrelonJ™ plugs for stainless steel shafting

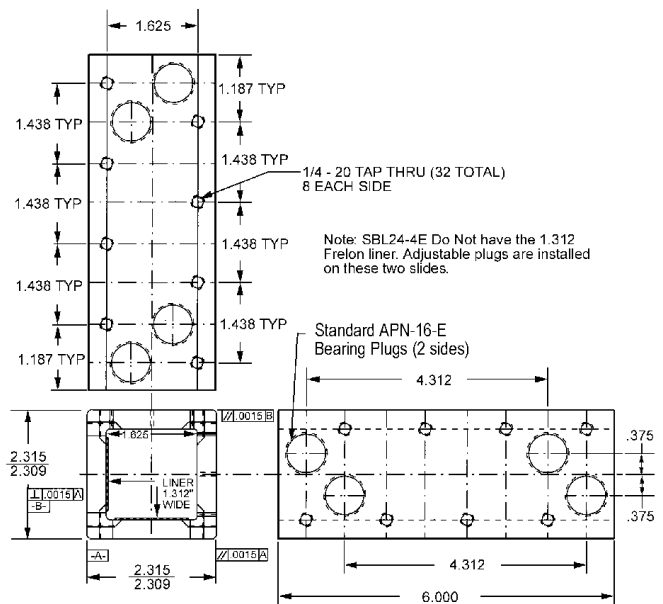

SQUARE BEARINGS

SIZES	NOTES
1.0" AND 1.5"	TECHNICAL DATA



Square Bearing Loading Information

Stock No.	Maximum Moments (torsional cap. in-lbs.)		Maximum Force (lbs.)
	Mx	My	
SB16	74	165	920
SBL16	74	475	920
SB24	416	402	1840
SBL24	416	1413	1840

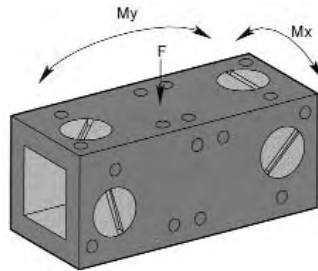

Application Notes

The use of green Loctite is recommended to hold the adjustable bearing plugs in position. Two parameters must be met in the design and use of square bearings:

1. The 2:1 ratio for cantilevered loads applies to square bearings in the same way as roundway bearings. Binding will occur if the ratio is exceeded. If only one bearing is used, the 2:1 applies from plug centers.

This principal is not load dependent.

2. The maximum load and moment load must be met. To calculate the acceptable cantilever or lever arm, multiply the length (from center of the bearing to the center of the load) times the weight. The result must be less than the moment load for that orientation.

Example: Distance of cantilever = 3"

Amount of load = 40 lbs.

3" x 40 lbs. = 120 in-lbs

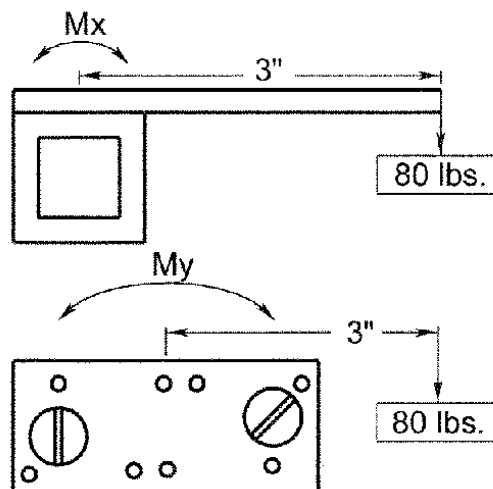
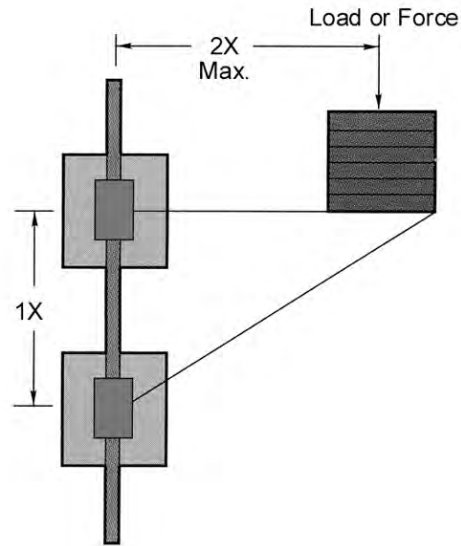
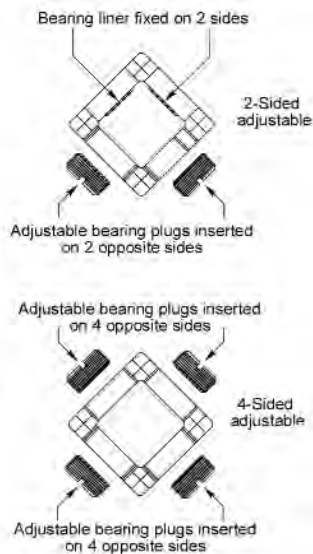

SQUARE BEARING PLUGS

SIZES	INCLUDES
1.0" AND 1.5"	TECHNICAL DATA

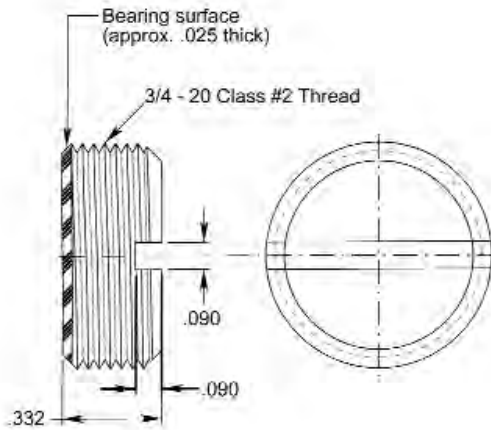

Stock No.	Description
APN-16-E	Adjustable bearing plug with FrelonJ™ bearing liner. Use with 300 Series stainless of soft shafting.

Adjustable Bearing Plugs

- Plug material is 316 stainless steel
- Bearing surface area equals .300 in².
- Maximum Static Load Capacity Per Plug = 450 lbs.
- The use of green Loctite is recommended to hold the adjustable bearing plugs in position.

Square Bearing Benefits & Features

- Runs on a single, square shaft eliminating costly components
- Maintains radial integrity and can eliminate the need for parallel shafting
- Can be mounted in any orientation
- Adjustable to maintain tight running clearances
- Self-lubricating
- High load capacity
- Wide temperature range (-400°F/+500°F)
- Excel in contaminated environments
- High shock loading abilities
- Low wear rates
- 6061-T6 Aluminum Housing
- Bearing Plugs easily replaced

SQUARE SHAFTING & ACCESSORIES

SIZES	MATERIALS
1.0" AND 1.5"	304 STAINLESS STEEL SHAFTING AND CAST 356-T6 ALUMINUM ACCESSORIES

Square Shafting

STOCK NO.	Description
S-SQ16-36	1.0" 304 Stainless Steel Square Shafting
S-SQ24-36	1.5" 304 Stainless Steel Square Shafting

- Highly corrosion resistant
- Buffed and polished to provide an excellent running surface
- Both 1" and 1.5" available cut to any length up to 36"

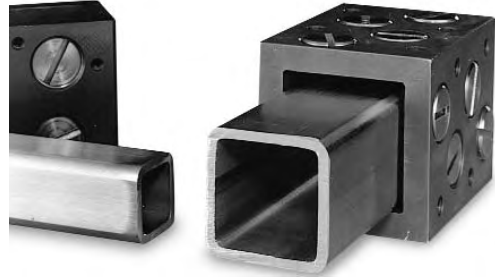

Square Mounting Accessories

All mounting accessories are made from cast 356-T6 aluminum for good strength and corrosion resistance.

STOCK NO.	SQUARE CLAMPS							
	A	B	C	D	E	F	G	H
CL-SQ-1000	1.00	0.984	1.968	0.630	2.362	0.197	0.200	0.787
CL-SQ-1500	1.50	1.338	2.677	0.787	2.953	0.276	0.256	1.024

STOCK NO.	FLANGED BASE									
	A	B	C	D	E	F	G	H	J	
FBH-1000	1.00	0.984	1.890	2.362	2.520	0.472	0.256	3.228	2.874	
FBH-1500	1.50	1.338	2.440	2.756	2.992	0.551	0.256	3.740	3.347	

CL-SQ

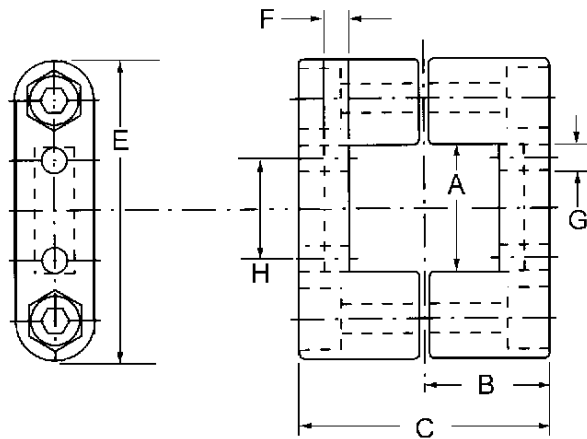

FBH

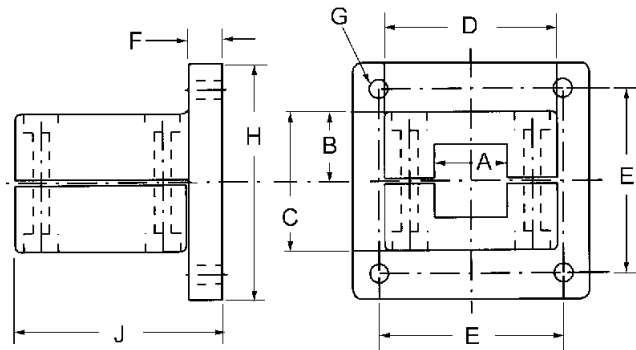

LINEAR BEARING BRACKETS

TYPE	FOR SHAFT SIZES	MATERIAL
CLOSED RETAINER RING DESIGN	1/8" TO 1 1/4"	6061 ALUMINUM BLACK ANODIZED

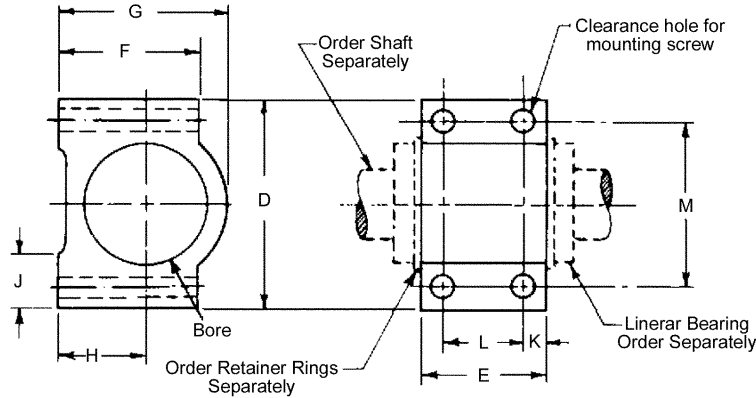

STOCK NO.	SHAFT SIZE	USE WITH SHAFT SERIES	BORE +.005	USE WITH LINEAR BEARING	USE WITH RETAINER RING NO.	USE WITH MOUNTING SCREW	G	D	+0.000 -0.005	E	F	H ±.001	J	K	L ±.005	M ±.005	MTG. SCREW TAP
LME-125	18	SI-8	.3125	LMB-125SS	Q2-31	Y9-S4-A10	.54	.94	.312	.39	.281	.25	.16	*	*	.687	#4-40
LME-187	3/16	SI-11	.3750	LMB-187SS	Q2-37	Y9-S6-A12	.60	1.10	.375	.43	.312	.31	.19	*	*	.812	#6-32
LME-1	1/4	LMS-4	.5000	LMB-1	Q2-50	Y9-S6-A14-R	.81	1.12	.437	.65	.437	.31	.21	*	*	.875	#6-32
LME-2	3/8	LMS-6	.6250	LMB-2	Q2-62	Y9-S6-A16-R	.93	1.25	.562	.78	.500	.31	.28	*	*	1.000	#6-32
LME-3	1/2	LMS-8	.8750	LMB-3	Q2-87	Y9-S6-A20-R	1.18	1.50	.875	1.00	.625	.37	.15	.562	1.187	#6-32	
LME-4	3/4	LMS-12	1.2500	LMB-4	Q2-125	Y9-S8-A28-R	1.65	1.87	1.062	1.43	.875	.43	.15	.750	1.562	#8-32	
LME-5	1	LMS-16	1.5625	LMB-5	Q2-156	Y9-S10-A32-R	1.93	2.37	1.625	1.62	1.000	.50	.18	1.250	2.000	#10-24	
LME-6	1 1/4	LMS-20	2.0000	LMB-6	Q2-200	Y9-S10-A40-R	2.50	2.75	1.875	2.06	1.312	.50	.18	1.500	2.375	#10-24	

* 2 Mounting holes centered on length.

TYPE	FOR SHAFT SIZES	MATERIAL
OPEN RETAINER RING DESIGN	1/2" TO 1 1/4"	6061 ALUMINUM BLACK ANODIZED

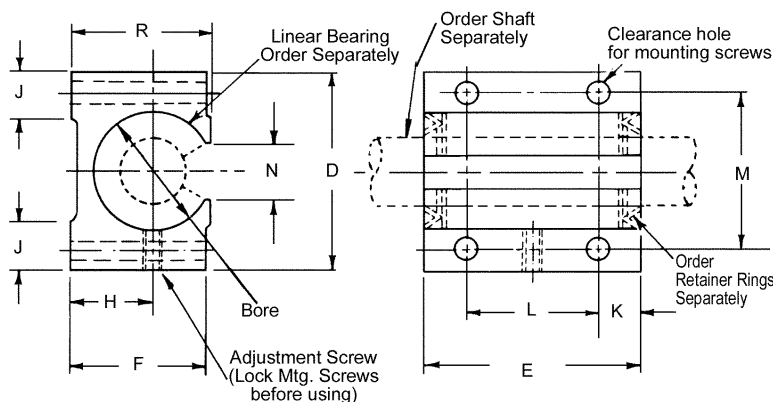

STOCK NO.	SHAFT SIZE	USE WITH SHAFT SERIES	BORE +.001	USE WITH LINEAR BEARING	USE WITH RETAINER RING NO.	USE WITH MOUNTING SCREW	D	+0.000 -0.005	F	H ±.001	J	K	L ±.005	M ±.005	N	R	MTG. SCREW TAP
LME-13	1/2	LMS-9	.8750	LMD-3	Q5-87-CP	Y9-S6-A20-R	1.50	.875	1.00	.625	.37	.15	.562	1.187	.28	1.06	#6-32
LME-14	3/4	LMS-13	1.2500	LMD-4	Q5-125-CP	Y9-S8-A28-R	1.87	1.062	1.43	.875	.43	.15	.750	1.562	.44	1.56	#8-32
LME-15	1	LMS-17	1.5625	LMD-5	Q5-156-CP	Y9-S10-A32-R	2.37	1.625	1.62	1.000	.50	.18	1.250	2.000	.56	1.68	#10-24
LME-16	1 1/4	LMS-21	2.0000	LMD-6	Q5-200-CP	Y9-S10-A40-R	2.75	1.875	2.06	1.312	.50	.18	1.500	2.375	.75	2.25	#10-24

LINEAR BEARING BRACKET

TYPE	FOR SHAFT SIZES	MATERIAL
CLOSED WIPER STYLE	1/4" TO 1 1/4"	6061 ALUMINUM BLACK ANODIZED

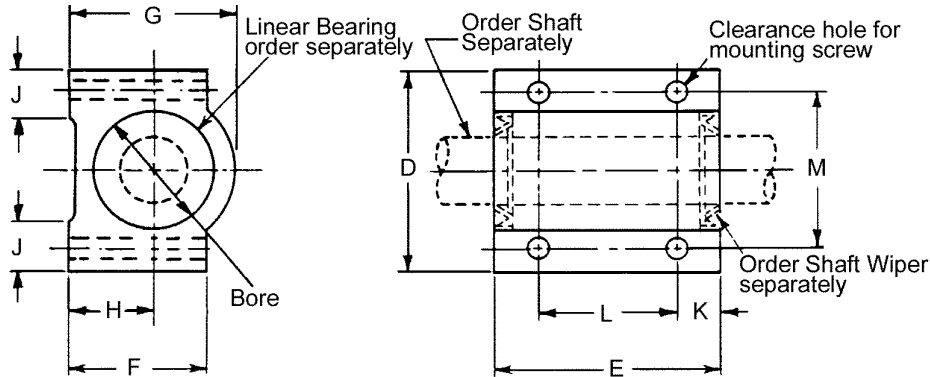

STOCK NO.	SHAFT SIZE	USE WITH SHAFT SERIES	BORE +.005	USE WITH LINEAR BEARING	USE WITH RETAINER RING NO.	USE WITH MOUNTING SCREW	G	D	E +.000 -.005	F	H ±.001	J	K	L ±.005	M ±.005	MTG. SCREW TAP
LMF-1	1/4	LMS-4	.5000	LMB-1	LMG-R1	Y9-S6-A14-R	.81	1.12	1.00	.65	.437	.31	.15	.687	.875	#6-32
LMF-2	3/8	LMS-6	.6250	LMB-2	LMG-R2	Y9-S6-A16-R	.93	1.25	1.12	.78	.500	.31	.15	.812	1.000	#6-32
LMF-3	1/2	LMS-8	.8750	LMB-3	LMG-R3	Y9-S6-A20-R	1.18	1.50	1.50	1.00	.625	.37	.15	1.187	1.187	#6-32
LMF-4	3/4	LMS-12	1.2500	LMB-4	LMG-R4	Y9-S8-A28-R	1.65	1.87	1.87	1.43	.875	.43	.15	1.562	1.562	#8-32
LMF-5	1	LMS-16	1.5625	LMB-5	LMG-R5	Y9-S10-A32-R	1.93	2.37	2.62	1.62	1.000	.50	.18	2.250	2.000	#10-24
LMF-6	1 1/4	LMS-20	2.0000	LMB-6	LMG-R6	Y9-S10-A40-R	2.50	2.75	3.37	2.06	1.312	.50	.18	3.000	2.375	#10-24

TYPE	FOR SHAFT SIZES	MATERIAL
OPEN WIPER STYLE	1/2" TO 1 1/4"	6061 ALUMINUM BLACK ANODIZED

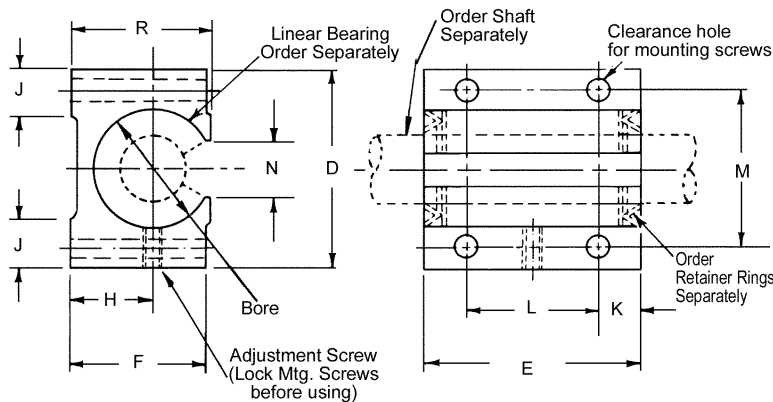

STOCK NO.	SHAFT SIZE	USE WITH SHAFT SERIES	BORE +.005	USE WITH LINEAR BEARING	USE WITH RETAINER RING NO.	USE WITH MOUNTING SCREW	D	E	F	H ±.001	J	K	L ±.005	M	N	R	MTG. SCREW TAP
LMF-13	1/2	LMS-9	.875	LMD-3	LMG-P3	Y9-S6-A20-R	1.50	1.50	1.00	.625	.37	.15	1.187	1.187	.28	1.06	#6-32
LMF-14	3/4	LMS-13	1.250	LMD-4	LMG-P4	Y9-S8-A28-R	1.87	1.87	1.43	.875	.43	.15	1.562	1.562	.44	1.56	#8-32
LMF-15	1	LMS-17	1.563	LMD-5	LMG-P5	Y9-S10-A32-R	2.37	2.62	1.62	1.000	.50	.18	2.250	2.000	.56	1.68	#10-24
LMF-16	1 1/4	LMS-21	2.000	LMD-6	LMG-P6	Y9-S10-A40-R	2.75	3.37	2.06	1.312	.50	.18	3.000	2.375	.75	2.25	#10-24

LINEAR BEARING CARRIAGE

MATERIAL

6061 ALUMINUM BLACK ANODIZED

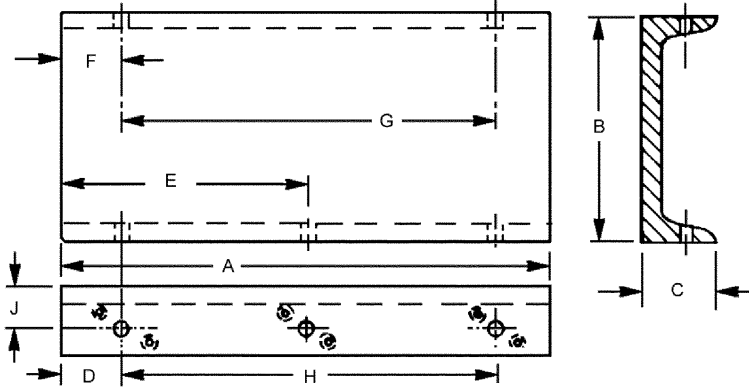

STOCK NO.	A	B	C	D	E	F	G	H	J	LINEAR BEARING	
										STOCK NO.	USE
LMK-1	5	3.937	1 3/8	-	2 1/2	5/8	3.75	-	.687	LMA(LMX)-6	3
LMK-2	10	7.908	2 1/2	1 1/4	-	1 1/4	7.50	7.50	1.250	LMA(LMX)-12	4
LML-1	5	3.937	1 3/8		BLANK					ALL	AS
LML-2	10	7.908	2 1/2		FURNISHED WITHOUT HOLES					SERIES	REQ.

E

LINEAR BEARING MAINTENANCE

PRODUCT USE

LUBRICANT



STOCK NO.	SIZE	DESCRIPTION
CE-12	16 OZ. CAN	"SLICK ACTION" A SPECIALLY FORMULATED DRY LUBRICATION DESIGNED FOR LINEAR BALLBEARINGS & ASSOCIATED COMPONENTS HELPS PREVENT SEIZURE & GALLING OF BEARING SURFACES.

- "Slick Action"
- Dry film lubricant & anti-stick agent
- No grease
- Contains no silicones
- Stainless and colorless
- Odorless, waxless

PRODUCT USE

CLEANER & DEGREASER

STOCK NO.	SIZE	DESCRIPTION
CE-16	16 OZ. CAN	INSTANT CONTACT CLEANER & DEGREASER FOR HARDENED SHAFTS, BEARING, ETC. CAN BE USED ON EQUIPMENT WHILE IN OPERATION.

- Instant contact cleaner and degrease
- No oil
- No residue
- Non-toxic
- Non-flammable
- Non-conductive



SHAFT HANGERS

FOR SHAFT SIZES	MATERIAL
1/4" TO 1 1/4"	ALUMINUM BLACK ANODIZED

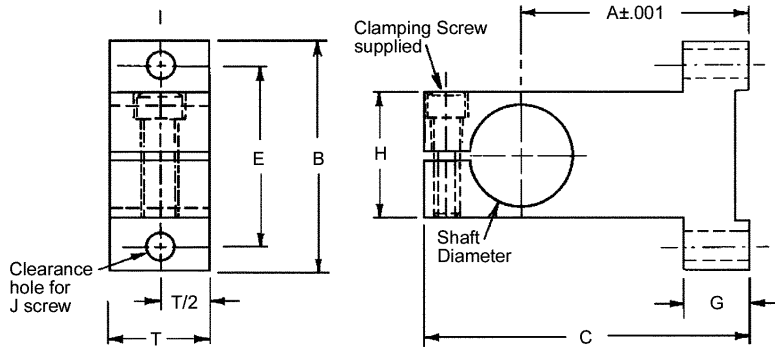

STOCK NO.	SHAFT DIA.	A	B	C	E	T	G	H	J
LMH-1	1/4	.562	1 1/8	1 1/8	.875	3/8	3/16	5/8	#6
LMH-2	3/8	.687	1 1/4	1 5/16	.937	1/2	3/16	5/8	#8
LMH-3	1/2	.750	1 1/2	1 7/16	1.125	5/8	1/4	3/4	#10
LMH-4	5/8	1.000	1 3/4	1 3/4	1.375	3/4	3/8	7/8	#10
LMH-5	3/4	1.062	1 7/8	1 7/8	1.500	7/8	1/2	1	1/4
LMH-6	1	2.125	2 1/4	3 1/16	1.750	1	5/8	1 1/4	1/4
LMH-7	1 1/4	2.375	2 1/2	3 3/8	2.000	1 1/4	3/4	1 3/8	1/4

E

SHAFT HANGERS

FOR SHAFT SIZES	MATERIAL
1/2" TO 2"	ALUMINUM ANODIZED

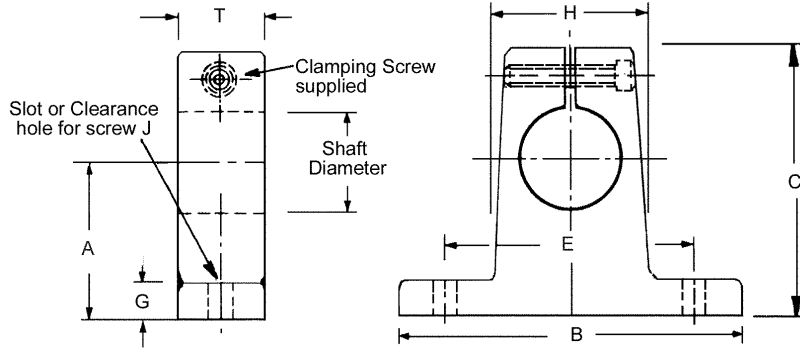

STOCK NO.	SHAFT DIA.	A	G	B	T	H	J	C	E
LMH-13	1/2	1.000	1/4	2	5/8	1	#8	1 11/16	1 1/2
LMH-15	3/4	1.250	5/16	2 3/4	3/4	1 1/4	#10	2 1/8	2
LMH-16	1	1.500	3/8	3 1/4	1	1 3/4	1/4	2 9/16	2 1/2
LMH-17	1 1/4	1.750	7/16	4	1 1/8	2 1/8	5/16	3	3
LMH-18	1 1/2	2.000	1/2	4 3/4	1 1/4	2 1/2	5/16	3 1/2	3 1/2
LMH-20	2	2.500	5/8	6	1 1/2	3 3/8	3/8	4 1/2	4 1/2

CASE HARDENED & GROUND SHAFTS

FOR DIAMETER	MATERIAL
1/4" TO 2"	C1060 STEEL OR 440 STAINLESS STEEL

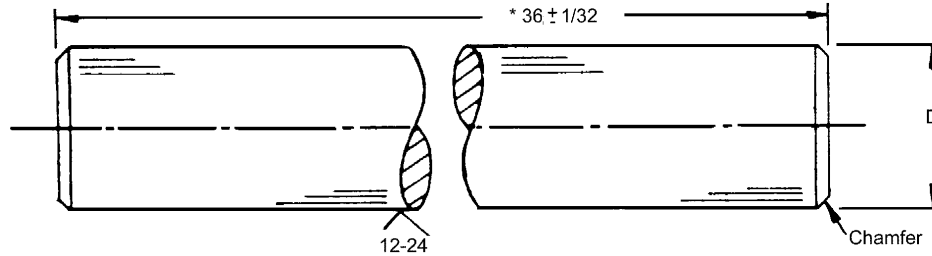

C1060 STEEL	440 STAINLESS STEEL		NOM. DIA.	D DIAMETER	MAX. LENGTH AVAILABLE TO ORDER
	STOCK NO. (36" long)	STOCK NO. (12" long)			
LMS-4-36 LMS-5-36	-	-	1/4	.2490-.0005 .2495-.0005	8 ft.
LMS-6-36 LMS-7-36	-	-	3/8	.3740-.0005 .3745-.0005	11 ft
LMS-46-36 LMS-8-36 LMS-9-36	LMS-46-12 -	- LMT-8-36 LMT-9-36	1/2	.3750-.0005 .4990-.0005 .4995-.0005	
LMS-48-36 LMS-50-36 LMS-12-36 LMS-13-36	LMS-48-12 LMS-50-12 -	- -	5/8	.5000-.0005 .6250-.0005	
	-	LMT-12-36 LMT-13-36	3/4	.7490-.0005 .7495-.0005	
LMS-52-36 LMS-16-36 LMS-17-36	LMS-52-12 -	- LMT-16-36 LMT-17-36	1	.7500-.0005 .9990-.0005 .9995-.0005	
LMS-56-36 LMS-20-36 LMS-21-36	LMS-56-12 -	- -	1 1/4	1.0000-.0005 1.2490-.0005 1.2495-.0005	
LMS-60-36 LMS-24-36 LMS-25-36	LMS-60-12 -	- -	1 1/2	1.2500-.0005 1.4989-.0005 1.4994-.0005	11 ft.
LMS-64-36 LMS-32-36 LMS-33-36 LMS-72-36	LMS-64-12 -	- -	2	1.5000-.0005 1.9987-.0005 1.9994-.0007 2.0000-.0005	

Straightness
LMS-4 & 5 Best effort basis
LMS-6 to 72 within .001-.002/ft.

*Shafting made to any length within 1/16"
Specify by similar stock number and length required
Example: LMS-21-56" (1.2495 Diameter, 56" long)

CALL FOR PRICING

GROUND STOCK

FOR SHAFT SIZES	MATERIAL
1/8" TO 1 1/4"	303 STAINLESS STEEL ROCKWELL B75-90

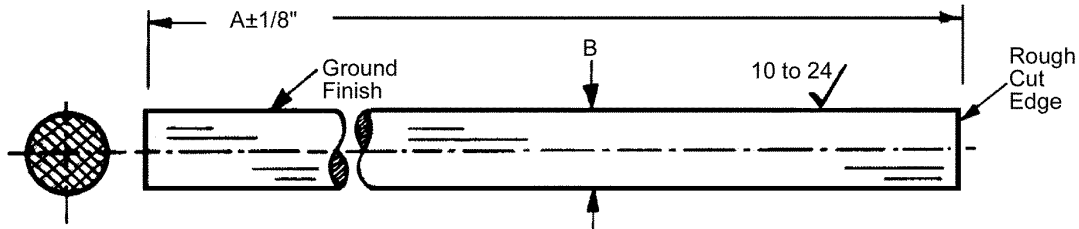

Modification on request
send drawings

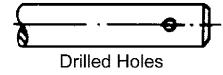
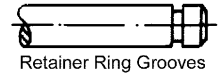

STOCK NO.	NOMINAL DIA.*	B	A	B TOL.
S1-8	1/8	.1247	24	+ .0000
S1-11	3/16	.1872	24	- .0002
S1-72	1/4	.2490	36	+ .0000 - .0003
S1-73	1/4	.2495	36	
S1-74	3/8	.3740	36	
S1-75	3/8	.3745	36	
S1-76	1/2	.4990	36	
S1-77	1/2	.4995	36	+ .0000 - .0005
S1-78	3/4	.7490	36	
S1-79	3/4	.7495	36	
S1-80	1	.9990	36	
S1-81	1	.9995	36	
S1-82	1 1/4	1.2490	36	
S1-83	1 1/4	1.2495	36	

* Straightness: up to 3/16" diameter on best effort basis, 1/4" diameter and up .0004 in/in.

SHAFT SEALS

STYLE	FOR SHAFT SIZES
REGULAR	1/4" TO 2"

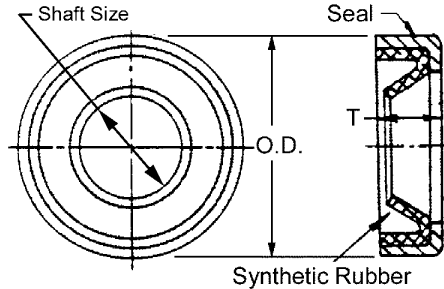

STOCK NO.	SHAFT SIZE	OUTSIDE DIA.	T
LMG-R-1	1/4	.504	.125
LMG-R-2	3/8	.629	.125
LMG-R-3	1/2	.879	.125
LMG-R-4	3/4	1.254	.125
LMG-R-5	1	1.567	.187
LMG-R-6	1 1/4	2.004	.375
LMG-R-7	1 1/2	2.379	.375
LMG-R-8	2	3.004	.375

STYLE	FOR SHAFT SIZES
ADJUSTABLE	1/2" TO 2"

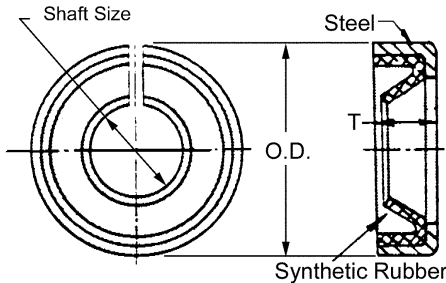

STOCK NO.	SHAFT SIZE	OUTSIDE DIA.	T
LMG-A-3	1/2	.879	.125
LMG-A-4	3/4	1.254	.125
LMG-A-5	1	1.567	.187
LMG-A-6	1 1/4	2.004	.375
LMG-A-7	1 1/2	2.379	.375
LMG-A-8	2	3.004	.375

STYLE	FOR SHAFT SIZES
OPEN	1/2" TO 2"

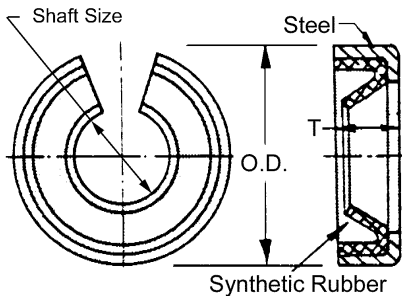

STOCK NO.	SHAFT SIZE	OUTSIDE DIA.	T
LMG-P-3	1/2	.879	.125
LMG-P-4	3/4	1.254	.125
LMG-P-5	1	1.567	.187
LMG-P-6	1 1/4	2.004	.375
LMG-P-7	1 1/2	2.379	.375
LMG-P-8	2	3.004	.375



LINEAR BEARING WIPER - RETAINER

TYPES	FOR SHAFT SIZES	MATERIAL
CLOSED AND OPEN	1/4" TO 1 1/4"	POLYURETHANE

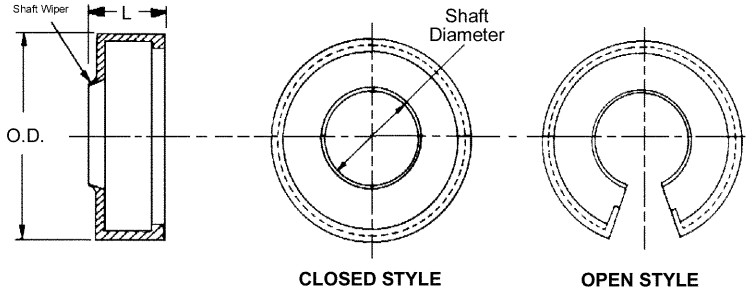

STOCK NO.	SHAFT DIA.	STYLE	OUTSIDE DIA.	L	USE WITH LINEAR BEARING
LMZ-1	1/4	CLOSED	.63	.25	LMB-1
LMZ-2	3/8		.74	.24	LMB-2
LMZ-3	1/2		.99	.25	LMB-3 OR LMC-3
LMZ-4	3/4		1.37	.39	LMB-4 OR LMC-4
LMZ-5	1		1.68	.40	LMB-5 OR LMC-5
LMZ-6	1 1/4		2.12	.49	LMB-6 OR LMC-6
LMZ-13	1/2	OPEN	.99	.25	LMD-3
LMZ-14	3/4		1.37	.39	LMD-4
LMZ-15	1		1.68	.40	LMD-5
LMZ-16	1 1/4		2.12	.49	LMD-6



- Simple assembly
- Economical to use
- Quick and easy to replace, snap on design
- Eliminates the need for retainer ring and spacer
- Acts as a shaft wiper and bearing dust shield
- Fits all major brands of linear recirculating ball bearings

RETAINER RINGS EXTERNAL DESIGN

STYLE	FOR SHAFT SIZES	MATERIAL
CLOSED	1/2" TO 3"	CARBON STEEL PLATED

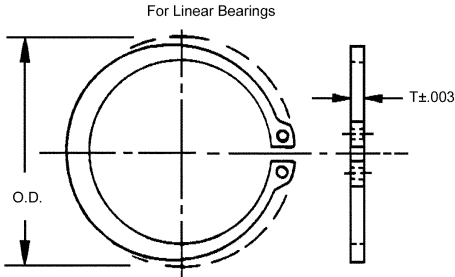

STOCK NO.	SHAFT DIA. (REF)	OUTSIDE DIA.	T	GROOVE DIA.	LINEAR BEARING
Q2-50-CP	1/2	.740	.035	.468	1/4
Q2-62-CP	5/8	.870	.035	.588	3/8
Q2-87-CP	7/8	1.160	.042	.821	1/2
Q2-112-CP	1 1/8	1.490	.050	1.059	5/8
Q2-125-CP	1 1/4	1.620	.050	1.176	3/4
Q2-156-CP	1 9/16	2.010	.062	1.468	1
Q2-200-CP	2	2.440	.062	1.886	1 1/4
Q2-237-CP	2 3/8	2.880	.078	2.239	1 1/2
Q2-300-CP	3	3.530	.093	2.838	2



STYLE	FOR SHAFT SIZES	MATERIAL
CLOSED	1/2" TO 3"	STAINLESS STEEL

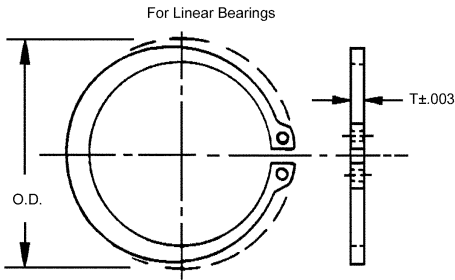

STOCK NO.	SHAFT DIA. (REF)	OUTSIDE DIA.	T	GROOVE DIA.	LINEAR BEARING
Q2-50	1/2	.740	.035	.468	1/4
Q2-62	5/8	.870	.035	.588	3/8
Q2-87	7/8	1.160	.042	.821	1/2
Q2-112	1 1/8	1.490	.050	1.059	5/8
Q2-125	1 1/4	1.620	.050	1.176	3/4
Q2-156	1 9/16	2.010	.062	1.468	1
Q2-200	2	2.440	.062	1.886	1 1/4
Q2-237	2 3/8	2.880	.078	2.239	1 1/2
Q2-300	3	3.530	.093	2.838	2



STYLE	FOR SHAFT SIZES	MATERIAL
OPEN	1/2" TO 2 3/8"	CARBON STEEL

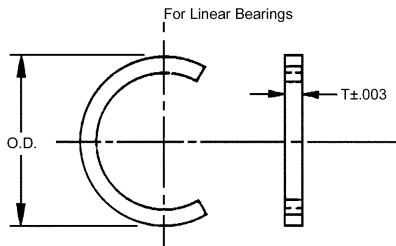

STOCK NO.	SHAFT DIA. (REF)	OUTSIDE DIA.	T	GROOVE DIA.	LINEAR BEARING
Q5-50-CP	1/2	.550	.035	.468	1/4
Q5-62-CP	5/8	.673	.035	.588	3/8
Q5-87-CP	7/8	.923	.042	.821	1/2
Q5-112-CP	1 1/8	1.180	.050	1.059	5/8
Q5-125-CP	1 1/4	1.301	.050	1.176	3/4
Q5-156-CP	1 9/16	1.620	.062	1.468	1
Q5-200-CP	2	2.040	.062	1.886	1 1/4
Q5-237-CP	2 3/8	2.429	.078	2.239	1 1/2

STYLE	FOR SHAFT SIZES	MATERIAL
OPEN	1/2" TO 2 3/8"	STAINLESS STEEL

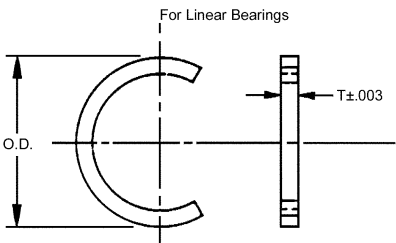

STOCK NO.	SHAFT DIA. (REF)	OUTSIDE DIA.	T	GROOVE DIA.	LINEAR BEARING
Q5-50	1/2	.550	.035	.468	1/4
Q5-62	5/8	.673	.035	.588	3/8
Q5-87	7/8	.923	.042	.821	1/2
Q5-112	1 1/8	1.180	.050	1.059	5/8
Q5-125	1 1/4	1.301	.050	1.176	3/4
Q5-156	1 9/16	1.620	.062	1.468	1
Q5-200	2	2.040	.062	1.886	1 1/4
Q5-237	2 3/8	2.429	.078	2.239	1 1/2

FOR ADDITIONAL RETAINER RINGS, SEE INDEX.

BEARING RETAINER - PUSH IN DESIGN

FOR SHAFT SIZES	MATERIAL
1/8" TO 2"	CARBON STEEL PLATED

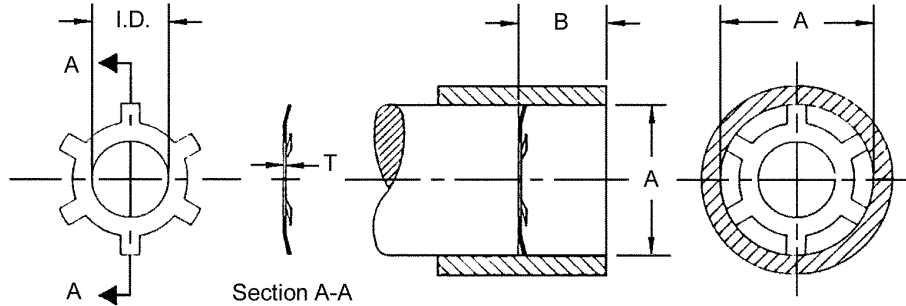

STOCK NO.	LINEAR SHAFT SIZE	A HOUSING BORE	B MINIMUM END SPACE	T±.002	I.D. REF. ONLY
Q6-37-CP	1/8	3/8	.040	.010	3/16
Q6-50-CP	1/4	1/2	.060	.010	1/4
Q6-62-CP	3/8	5/8	.060	.010	3/8
Q6-87-CP	1/2	7/8	.080	.010	5/8
Q6-125-CP	3/4	1 1/4	.080	.015	15/16
Q6-156-CP	1	1 9/16	.080	.015	1 3/16
Q6-200-CP	1 1/4	2	.080	.015	1 9/16
Q6-237-CP	1 1/2	2 3/8	.100	.015	1 7/8
Q6-300-CP	2	3	.100	.015	2 1/4



SHAFT WIPERS

FOR SHAFT SIZES	MATERIAL	TEMPERATURE RANGE
1/2" TO 4"	POLYURETHANE 90A DURO	-40°F TO +190°F

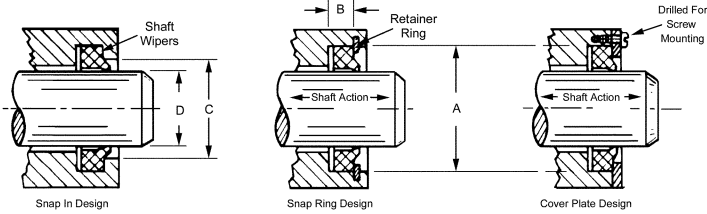
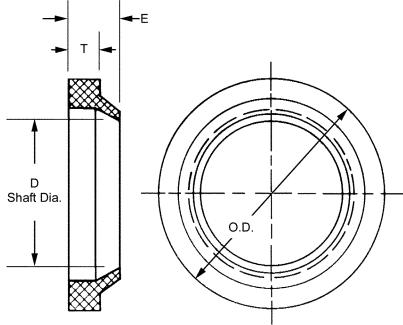

STOCK NO.	WIPER DIMENSIONS					HOUSING DIMENSIONS		
	SHAFT (REF.)	D (+.000/- .002)	O.D.	T	E (MAX)	A (+.004 /-.000)	B (+/- .003)	C (+.005 /-.000)
ANW-9	1/2	.498	.766	.104	.187	.760	.107	.647
ANW-10	9/16	.560	.829	.104	.187	.823	.107	.710
ANW-11	5/8	.623	.891	.104	.187	.885	.107	.772
ANW-12	11/16	.685	.954	.104	.187	.948	.107	.834
ANW-13	3/4	.748	1.016	.104	.187	1.010	.107	.897
ANW-14	13/16	.810	1.090	.104	.187	1.084	.107	.960
ANW-15	7/8	.873	1.153	.104	.187	1.147	.107	1.023
ANW-16	15/16	.935	1.215	.104	.187	1.209	.107	1.085
ANW-17	1	.998	1.278	.104	.187	1.272	.107	1.148
ANW-18	1 1/16	1.060	1.340	.104	.187	1.334	.107	1.210
ANW-19	1 1/8	1.123	1.403	.104	.187	1.397	.107	1.273
ANW-20	1 3/16	1.185	1.465	.104	.187	1.459	.107	1.335
ANW-21	1 1/4	1.248	1.528	.104	.187	1.522	.107	1.398
ANW-22	1 5/16	1.310	1.622	.104	.187	1.614	.107	1.480
ANW-23	1 3/8	1.373	1.685	.104	.187	1.677	.107	1.542
ANW-24	1 7/16	1.435	1.747	.104	.187	1.739	.107	1.605
ANW-25	1 1/2	1.498	1.810	.104	.187	1.802	.107	1.668
ANW-26	1 5/8	1.623	1.935	.104	.187	1.927	.107	1.793
ANW-27	1 3/4	1.748	2.060	.104	.187	2.052	.107	1.918
ANW-28	1 7/8	1.873	2.185	.104	.187	2.177	.107	2.043
ANW-29	2	1.998	2.310	.104	.187	2.302	.107	2.178
ANW-30	2 1/8	2.123	2.435	.104	.187	2.427	.107	2.303
ANW-31	2 1/4	2.248	2.560	.104	.187	2.552	.107	2.428
ANW-32	2 3/8	2.373	2.685	.104	.187	2.677	.107	2.553
ANW-33	2 1/2	2.498	2.810	.104	.187	2.802	.107	2.678
ANW-34	2 5/8	2.623	2.999	.119	.211	2.989	.122	2.834
ANW-35	2 3/4	2.748	3.124	.119	.211	3.114	.122	2.959
ANW-36	2 7/8	2.873	3.249	.119	.211	3.239	.122	3.084
ANW-37	3	2.997	3.374	.119	.211	3.364	.122	3.209
ANW-38	3 1/8	3.122	3.499	.119	.211	3.489	.122	3.334
ANW-39	3 1/4	3.247	3.624	.199	.211	3.614	.122	3.459
ANW-40	3 3/8	3.372	3.749	.199	.211	3.739	.122	3.584
ANW-41	3 1/2	3.497	3.874	.199	.211	3.864	.122	3.709
ANW-42	3 5/8	3.622	3.999	.199	.211	3.989	.122	3.834
ANW-43	3 3/4	3.747	4.124	.199	.211	4.114	.122	3.959
ANW-44	3 7/8	3.872	4.249	.199	.211	4.239	.122	4.084
ANW-45	4	3.997	4.439	.135	.238	4.427	.138	4.240

SHAFT WIPERS

FOR SHAFT SIZES	MATERIAL	TEMPERATURE RANGE
1/4" TO 4"	MOLYBDENUM DISULFIDE IMPREGNATED POLYURETHANE 90A DURO	-65°F TO +200°F

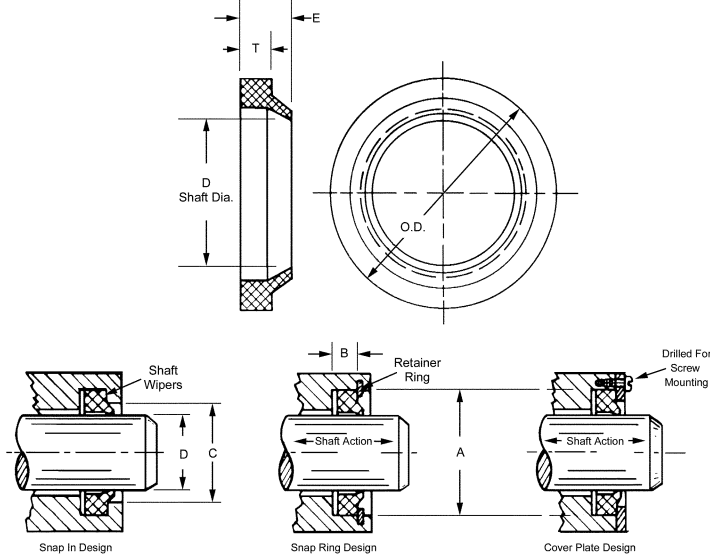

STOCK NO.	WIPER DIMENSIONS				HOUSING DIMENSIONS		
	D	O.D.	T	E (MAX)	A (+.006 /-.000)	B (+.004 /-.000)	C (+.010 /-.000)
USW-4	1/4	1/2	1/8	.210	.497	.124	.410
USW-6	3/8	5/8	1/8	.210	.622	.124	.535
USW-8	1/2	3/4	1/8	.210	.747	.124	.660
USW-10	5/8	7/8	1/8	.210	.872	.124	.785
USW-12	3/4	1 1/8	3/16	.305	1.122	.187	.995
USW-14	7/8	1 1/4	3/16	.305	1.247	.187	1.120
USW-16	1	1 3/8	3/16	.305	1.372	.187	1.245
USW-18	1 1/8	1 1/2	3/16	.305	1.497	.187	1.370
USW-20	1 1/4	1 5/8	3/16	.305	1.622	.187	1.495
USW-22	1 3/8	1 3/4	3/16	.305	1.747	.187	1.620
USW-24	1 1/2	1 7/8	3/16	.305	1.872	.187	1.745
USW-26	1 5/8	2	3/16	.305	1.997	.187	1.870
USW-27	1 11/16	2 1/16	3/16	.305	2.060	.187	1.935
USW-28	1 3/4	2 1/8	3/16	.305	2.122	.187	1.995
USW-29	1 13/16	2 3/16	3/16	.305	2.185	.187	2.060
USW-30	1 7/8	2 1/4	3/16	.305	2.247	.187	2.120
USW-31	1 15/16	2 5/16	3/16	.305	2.310	.187	2.185
USW-32	2	2 1/2	1/4	.395	2.497	.249	2.327
USW-34	2 1/8	2 5/8	1/4	.395	2.622	.249	2.452
USW-36	2 1/4	2 3/4	1/4	.395	2.747	.249	2.577
USW-37	2 5/16	2 13/16	1/4	.395	2.810	.249	2.640
USW-38	2 3/8	2 7/8	1/4	.395	2.872	.249	2.702
USW-40	2 1/2	3	1/4	.395	2.997	.249	2.827
USW-42	2 5/8	3 1/8	1/4	.395	3.122	.249	2.952
USW-44	2 3/4	3 1/4	1/4	.395	3.247	.249	3.077
USW-45	2 13/16	3 5/16	1/4	.395	3.310	.249	3.140
USW-46	2 7/8	3 3/8	1/4	.395	3.372	.249	3.202
USW-48	3	3 1/2	1/4	.395	3.497	.249	3.327
USW-49	3 1/8	3 5/8	1/4	.395	3.622	.249	3.452
USW-50	3 1/4	3 3/4	1/4	.395	3.747	.249	3.577
USW-51	3 3/8	3 7/8	1/4	.395	3.872	.249	3.702
USW-52	3 1/2	4	1/4	.395	3.997	.249	3.827
USW-53	3 5/8	4 1/8	1/4	.395	4.122	.249	3.952
USW-54	3 3/4	4 1/4	1/4	.395	4.247	.249	4.077
USW-56	4	4 1/2	1/4	.395	4.497	.249	4.327

HARDWARE AND FASTENERS

Table of Contents

HARDWARE KIT	
Plastic	F 2
PARTS BOXES	
Natural Wood	F 3
Plastic	F 3
SCREW HEAD TECHNICAL DATA	F 4
MACHINE SCREWS	
Stainless Steel, Flat, Round and Fillister Head	F 5 - F 7
Stainless Steel, Flat, Round Fillister Head Kit	F 2
Stainless Steel, Binding, Socket Head, and Button	F 7
Long-Lok® and Nyloc® Flat, Round and Fillister Head	F 8 - F 9
Long-Lok® and Nyloc® Binding and Socket Head	F 8 - 9
Nylon, Flat, Round and Fillister Head	F 10 - F 11
Nylon, Pan and Socket Cap	F 10 - F 11
INTEGRAL SEAL SCREWS	
Slotted Pan Head	F 12 - F 13
SET SCREWS	
Slotted and Hex Head, Stainless Steel and Nylon	F 14
Set Screw Kits - Slotted and Hex Head, Stainless Steel and Nylon	F 2
Ball Button	F 15
Brass Soft Tip, Hex Socket	F 16
Silver Solder Tip, Slotted Head and Hex Socket	F 17
Set Screw Kits - Silver Solder Tip, Slotted Head and Hex Socket	F 17
Soft Tip, Slotted Head and Hex Socket	F 18 - F 20
Set Screw Kits	F 19
SHOULDER SCREWS	
Stainless Steel, Slotted Head	F 21 - F 22
Stainless Steel, Hex Socket Head	F 23 - F 24
PRECISION CAPTIVE SCREWS	
Slotted, Hex Socket and Knurled Head, Stainless Steel	F 25
PRECISION JIG BUTTONS	
Stainless Steel	F 26
THUMB SCREWS	
Plastic Head, Knurled	F 27 - F 28
Stainless Steel, Knurled	F 29 - F 31
Stainless Steel, Knurled, Socket Head	F 32 - F 33
THUMB NUTS	
Stainless Steel, Knurled	F 34 - F 35
THREADED STUDS	
Stainless Steel, Double Ended	F 36 - F 37
HEX NUTS	
Stainless Steel and Molded Nylon	F 38
Hex Nut Kits	F 38
WASHERS	
Nylon and Stainless Steel	F 39 - F 40
LOCK WASHERS	
Stainless Steel, External and Internal Tooth	F 41
Lock Washer Kits	F 41
THRUST WASHERS AND DISKS	
Stainless Steel, Plastic, Bronze and Tool Steel	F 42
SWIVEL WASHERS	
Stainless Steel, Male and Female	F 43
Belleville Washers	F 44
Curved Washers	F 44
THREAD INSERTS	
Stainless Steel, Free Running and Locking	F 45
Thread Insert Kits	F 45
THREAD INSERT TAPS	
Bottoming and Plug	F 46
THREAD INSERT TOOLS	
Production Tool and Prototype	F 46
TANG BREAK-OFF TOOL	F 47
PINS	
Tapper, Stainless Steel	F 48
Grooved, Stainless Steel	F 49
Roller or Spring Pins, Stainless Steel	F 49
Spiral Pins, Stainless Steel	F 50
Assorted Pins Kit	F 50
Clevis Pins, Stainless Steel	F 51
Cotter Pins, Stainless Steel	F 51
Cotter Pins Kit	F 51
DOWEL PINS	
Soft Pins, Stainless Steel	F 52
Dowel Pin Kit	F 52
Hardened Pins, Stainless Steel	F 53
TAPER AND DOWEL PIN REAMERS	
Spiral and Straight, High Speed Steel	F 54
HEX WRENCH	
Steel Alloy	F 55
Hex Wrench Kit	F 55
MISCELLANEOUS ITEMS	
Grease, Oil, Inspection Mirrors, Screw Drivers, Plastic Hammers, Scale, Hex Wrenches, Tweezers, Loupes, Cable Cutters	
Adhesives, Liquid Pin, Solvent, Lubricants	F 56 - F 57
RETAINER RINGS	
External Lug Design, Stainless Steel, Copper Plated	F 58
Assorted Retainer Rings Kit	F 58
External Snap On Design	F 59
External Power Grip Design	F 59
External Bowed Snap On Design	F 60
External, Carbon Steel and Stainless Steel	F 60
Internal and External, High Carbon Spring Steel	F 61 - F 63
Retainer Ring Pliers	F 58 - F 59
Bearings, Internal Push In Design	F 64
Internal Lug Design	F 64
BEARING PRE-LOAD SPRINGS	F 65
SPACERS	
Inner and Outer Race Shim	F 66
Shaft Spacers	F 67 - F 68
Assorted Inner Race Shaft Spacers Kit	F 68
BEARING SPACERS	F 69
Bearing Spacers Kit	F 69
BALLS	
Hardened Steel, Plastic, Brass and Titanium	F 70
SPRINGS	
Compression	F 71
Compression Springs Kit	F 71
Experimental	F 72
Extension	F 72
Torsion	F 73
Anti-backlash	F 73
Anti-backlash Torsion	F 74
Spring Posts	F 74
CHASSIS HANDLES	
Tap and stud styles	F 75

HARDWARE KITS

MATERIAL

PLASTIC

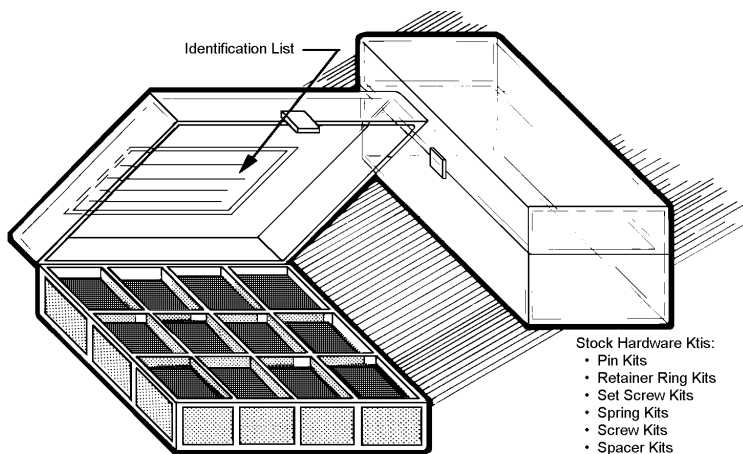

STOCK NUMBER	DESCRIPTION OF KIT CONTENTS	NO. OF PARTS
KIT-CP1	Cotter Pins - Stainless Steel - 3/8" to 2" Long	280
KIT-CP3	Taper Pins - Stainless Steel - #9/0 to #2/0 To 1-1/4" Long	240
KIT-CP5	Pins - Taper, Roll & Dowel - Stainless Steel - .047 To .125 Diameter	530
KIT-D11	Dowel Pins - 303 Stainless Steel - 1/32" To 1/4" Diameter	135
KIT-D23	Dowel Pins - Hardened Stainless Steel - 1/16" To 3/8" Diameter	135
KIT-Q2	Retainer Rings - St. St. - Int. & Ext. - 1/8", 3/16" & 1/4" Shafts	450
KIT-SCA	Set Screws - Stainless Steel - Cup Point & Soft Tip #0-80 To 1/4"	256
KIT-SC2	Set Screws - Stainless Steel, Cup Point - Socket Hd. #2 To 1/4"	180
KIT-SC8-A	Set Screws - Stainless Steel, Soft Tip - Socket Hd. #2 To 10	90
KIT-SC8-B	Set Screws - Stainless Steel, Soft Tip - Socket Hd. #10 To 1/2"	60
KIT-SPR9	Compression Springs - Stain. St. - .057 To .240 Dia. To 2" Long	141
KIT-SPR10	Extension Springs - Stain. St. - 1/6" To 1/2" Dia. To 2" Long	134
KIT-SS1	Shaft Spacers - Stain.St., Inner Race - 1/8", 3/16" & 1/4" Shaft	330
KIT-SS3	Bearing Spacers - Stain.St., Outer Race - 1/8", 3/16" & 1/4" Shaft	330
KIT-ST	Belleville Spring Washers - Stainless st. 3/32" To 1/2" I.D.	160
KIT-Z2	Lockwashers - Stain. St. - Internal & External Tooth - #2 To 3/8"	480
KIT-Z5	Hex Nuts, Washers, Lock Washers - Stainless St. - #0-80 To #10-32	1800
KIT-Z6N	Flat Head Nylon Screws, Nuts & Washers #4 To 1/4"	480
KIT-Z8S	Fillister Head Screws - Stainless Steel #0-80 To #10-32	360
KIT-Z9N	Socket Head Nylon Screws, Nuts & Washers #4 To 1/4"	480
KIT-Z9S	Socket Head Cap Screws - Stainless Steel - #0-80 To #10-32	216
KIT-Z11N	Pan Head Nylon Screws, Nuts & Washers #4 To 1/4"	480
SC5-B	Set Screws - Silver Tip, Stainless Steel, Slotted Hd. #6-32 To 1/4-20	60
SC5-C	Set Screws - Silver Tip, Stainless Steel, Slotted Hd. #10 To 3/8-16	60
SC6-A	Set Screws - Silver Tip, Stainless Steel, Hex Hd. - #4-40 To #8-32	60
SC6-B	Set Screws - Silver Tip, Stainless Steel, Hex Hd. - #8-32 To 1/4-20	60
SC6-C	Set Screws - Silver Tip, Stain. Steel, Slotted Hd. - 1/4-20 To 3/8-16	60
TR-35	Hex Key Set With Plastic Case .050 To 5/32	8

Available From Stock:
 Replacement Parts
 Special Kits

PARTS BOX

MATERIAL

**SELECTED HARDWOOD - NATURAL VARNISH SEALER WITH SOFT FLOCK-LINING
THIS PRODUCT IS DISCONTINUED**

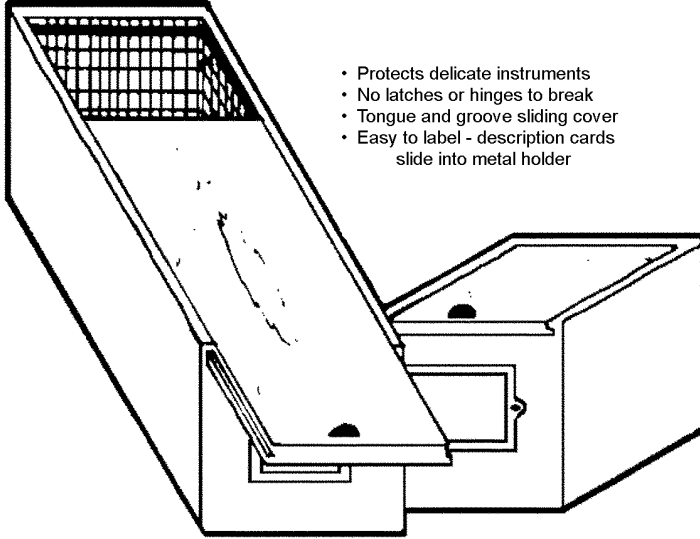

- Protects delicate instruments
- No latches or hinges to break
- Tongue and groove sliding cover
- Easy to label - description cards slide into metal holder

STOCK NO.	OUTSIDE DIMENSIONS HEIGHT x WIDTH x LENGTH	INSIDE DIMENSIONS HEIGHT x WIDTH x LENGTH
X-1	3 1/4 x 4 x 4	2 1/2 x 3 x 3
X-2	4 3/8 x 4 x 6	3 5/8 x 3 x 5
X-3	4 3/8 x 5 x 8	3 5/8 x 4 x 7
X-4	4 x 5 x 11 1/2	3 1/4 x 4 x 10 1/2
X-5	5 1/8 x 6 x 8	4 3/8 x 5 x 7
X-6	5 7/8 x 6 x 9 1/2	5 1/8 x 5 x 8 1/2
X-7	5 7/8 x 6 x 11 1/2	5 1/8 x 5 x 10 1/2
X-8	7 x 7 x 11 1/2	6 1/4 x 6 x 10 1/2

MATERIAL

PLASTIC

- Ideal storage boxes for small parts
 - Sectioned and nin-sectioned boxes
- Other sizes available on request.

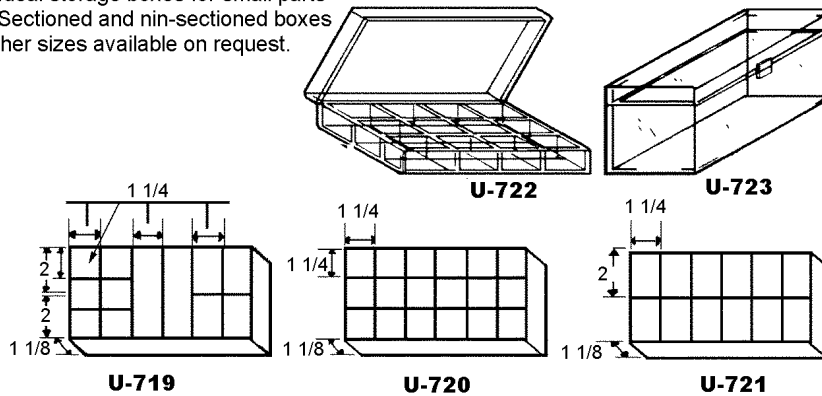

STOCK NO.	OUTSIDE DIMENSIONS HEIGHT x WIDTH x LENGTH	NO. OF COMPARTMENTS	MATERIAL
U-719	1 3/8 x 4 1/2 x 8 1/4	12	Clear Styrene
U-720		18	
U-721		12	
U-722	4 x 5 1/2 x 10	1	Tan Polypropylene
U-723	1 1/16 x 4 1/2 x 8 3/8	1	

SCREW HEAD

Technical Data

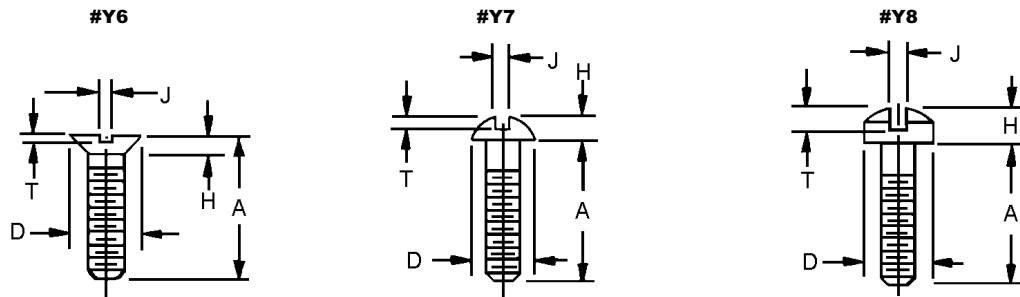

S SCREW SIZE	#Y6-FLAT HEAD 82°				#Y7-ROUND HEAD				#Y8- FILLISTER HEAD			
	D MAX	H MAX	J MAX	T MAX	D	H	J	T	D MAX	H MAX	J MAX	T MAX
#000	.064	.016	.011	.009	.062	.031	.012	.018	.059	.035	.012	.017
#00	.092	.028	.017	.014	.089	.045	.017	.026	.082	.047	.017	.022
#0	.119	.035	.023	.015	.113	.053	.023	.039	.096	.055	.023	.025
#2	.172	.051	.031	.023	.162	.069	.031	.048	.140	.083	.031	.037
#4	.225	.067	.039	.030	.211	.086	.039	.058	.183	.107	.039	.048
#6	.279	.083	.048	.038	.260	.103	.048	.068	.226	.132	.048	.060
#8	.332	.100	.054	.045	.309	.120	.054	.077	.270	.156	.054	.071
#10	.385	.116	.060	.053	.359	.137	.060	.087	.313	.180	.060	.083
1/4	.507	.153	.075	.070	.472	.175	.075	.109	.414	.237	.075	.109

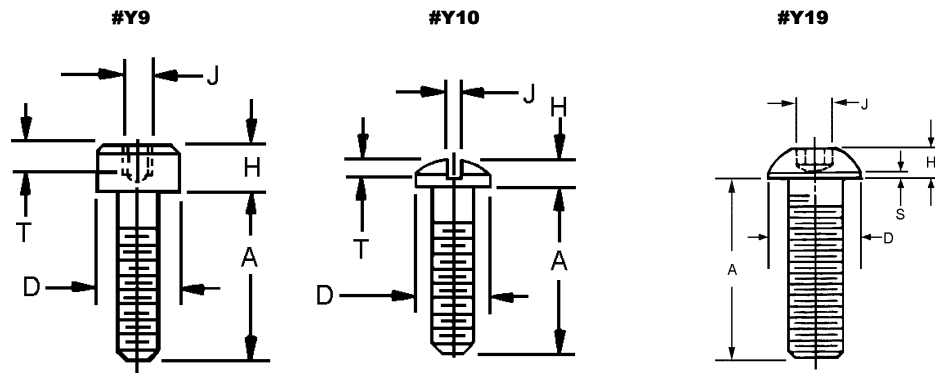

SCREW SIZE	# Y9-CAP SOCKET HEAD				#Y10-BINDING HEAD				#Y19-BUTTON HEAD			
	D MAX	H MAX	J MAX	T MIN	D MAX	H MAX	J MAX	T MAX	D MAX	H MAX	S MAX	J MAX
#000	-	-	-	-	.073	.021	.012	.013	-	-	-	-
#00	-	-	-	-	.098	.028	.017	.018	-	-	-	-
#0	.096	.060	.050	.025	.126	.032	.023	.018	.144	.032	.010	.035
#2	.140	.086	5/64	.038	.181	.050	.031	.030	.164	.046	.010	.050
#4	.183	.112	3/32	.051	.235	.068	.039	.042	.213	.059	.015	1/6
#6	.226	.138	7/64	.064	.290	.087	.048	.053	.262	.073	.015	5/64
#8	.270	.164	9/64	.077	.344	.105	.054	.065	.312	.087	.015	3/32
#10	.312	.190	5/32	.090	.390	.123	.060	.077	.361	.101	.020	1/8
1/4	.375	.250	3/16	.120	.525	.165	.075	.105	.437	.132	.031	5/32

MACHINE SCREWS

THREAD	STYLE	MATERIAL
#000-120	BINDING, FLAT, ROUND AND FILLISTER	STAINLESS STEEL TYPE 18-8

HEAD STYLE				CLASS 2A THREAD	A LENGTH
BINDING STOCK NO.	FLAT STOCK NO.	ROUND STOCK NO.	FILLISTER STOCK NO.		
Y10-S000-A2	Y6-S000-A2	Y7-S000-A2	Y8-S000-A2	#000-120	1/8
Y10-S000-A3	Y6-S000-A3	Y7-S000-A3	Y8-S000-A3		3/16
Y10-S000-A4	Y6-S000-A4	Y7-S000-A4	Y8-S000-A4		1/4
Y10-S000-A5	Y6-S000-A5	Y7-S000-A5	Y8-S000-A5		5/16

THREAD	STYLE	MATERIAL
#00-96	BINDING, FLAT, ROUND AND FILLISTER	STAINLESS STEEL TYPE 18-8

HEAD STYLE				CLASS 2A THREAD	A LENGTH
BINDING STOCK NO.	FLAT STOCK NO.	ROUND STOCK NO.	FILLISTER STOCK NO.		
Y10-S00-A2	Y6-S00-A2	Y7-S00-A2	Y8-S00-A2	#00-96	1/8
Y10-S00-A3	Y6-S00-A3	Y7-S00-A3	Y8-S00-A3		3/16
Y10-S00-A4	Y6-S00-A4	Y7-S00-A4	Y8-S00-A4		1/4
Y10-S00-A5	Y6-S00-A5	Y7-S00-A5	Y8-S00-A5		5/16
Y10-S00-A6	Y6-S00-A6	Y7-S00-A6	Y8-S00-A6		3/8

THREAD	STYLE	MATERIAL
#0-80	SOCKET CAP, BINDING, BUTTON, FLAT, ROUND AND FILLISTER	STAINLESS STEEL TYPE 18-8

HEAD STYLE						CLASS 2A THREAD	A LENGTH
SOCKET CAP STOCK NO.	BINDING STOCK NO.	BUTTON STOCK NO.	FLAT STOCK NO.	ROUND STOCK NO.	FILLISTER STOCK NO.		
Y9-S0-A2	Y10S0-A2	Y19-S0-A2	Y6-S0-A2	Y7-S0-A2	Y8-S0-A2	#0-80	1/8
Y9-S0-A3	Y10S0-A3	Y19-S0-A3	Y6-S0-A3	Y7-S0-A3	Y8-S0-A3		3/16
Y9-S0-A4	Y10S0-A4	Y19-S0-A4	Y6-S0-A4	Y7-S0-A4	Y8-S0-A4		1/4
Y9-S0-A5	Y10S0-A5	Y19-S0-A5	Y6-S0-A5	Y7-S0-A5	Y8-S0-A5		5/16
Y9-S0-A6	Y10S0-A6	Y19-S0-A6	Y6-S0-A6	Y7-S0-A6	Y8-S0-A6		3/8
Y9-S0-A8	Y10S0-A8	Y19-S0-A8	Y6-S0-A8	Y7-S0-A8	Y8-S0-A8		1/2

THREAD	STYLE	MATERIAL
#2-56	SOCKET CAP, BINDING, BUTTON, FLAT, ROUND AND FILLISTER	STAINLESS STEEL TYPE 18-8

HEAD STYLE						CLASS 2A THREAD	A LENGTH
SOCKET CAP STOCK NO.	BINDING STOCK NO.	BUTTON STOCK NO.	FLAT STOCK NO.	ROUND STOCK NO.	FILLISTER STOCK NO.		
Y9-S2-A3	Y10-S2-A3	Y19-S2-A3	Y6-S2-A3	Y7-S2-A3	Y8-S2-A3	#2-56	3/16
Y9-S2-A4	Y10-S2-A4	Y19-S2-A4	Y6-S2-A4	Y7-S2-A4	Y8-S2-A4		1/4
Y9-S2-A5	Y10-S2-A5	Y19-S2-A5	Y6-S2-A5	Y7-S2-A5	Y8-S2-A5		5/16
Y9-S2-A6	Y10-S2-A6	Y19-S2-A6	Y6-S2-A6	Y7-S2-A6	Y8-S2-A6		3/8
Y9-S2-A8	Y10-S2-A8	Y19-S2-A8	Y6-S2-A8	Y7-S2-A8	Y8-S2-A8		1/2

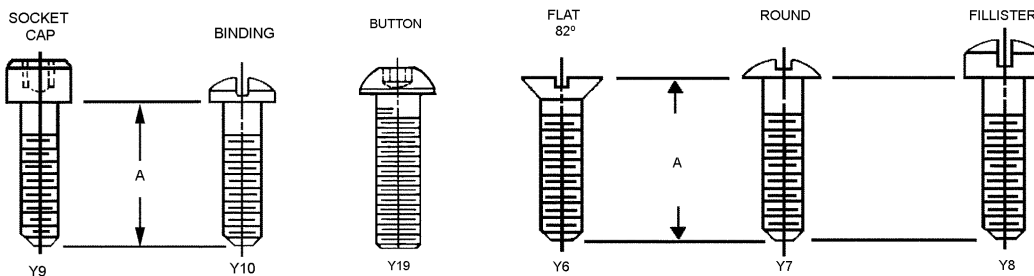

MACHINE SCREWS

THREAD	STYLE	MATERIAL
#4-40	SOCKET CAP, BINDING, BUTTON, FLAT, ROUND AND FILLISTER	STAINLESS STEEL TYPE 18-8

HEAD STYLE						CLASS 2A THREAD	A LENGTH
SOCKET CAP STOCK NO.	BINDING STOCK NO.	BUTTON STOCK NO.	FLAT STOCK NO.	ROUND STOCK NO.	FILLISTER STOCK NO.		
Y9-S4-A3	Y10-S4-A3	Y19-S4-A3	Y6-S4-A3	Y7-S4-A3	Y8-S4-A3	#4-40 UNC	3/16
Y9-S4-A4	Y10-S4-A4	Y19-S4-A4	Y6-S4-A4	Y7-S4-A4	Y8-S4-A4		1/4
Y9-S4-A5	Y10-S4-A5	Y19-S4-A5	Y6-S4-A5	Y7-S4-A5	Y8-S4-A5		5/16
Y9-S4-A6	Y10-S4-A6	Y19-S4-A6	Y6-S4-A6	Y7-S4-A6	Y8-S4-A6		3/8
Y9-S4-A8	Y10-S4-A8	Y19-S4-A8	Y6-S4-A8	Y7-S4-A8	Y8-S4-A8		1/2
Y9-S4-A10	Y10-S4-A10	Y19-S4-A10	Y6-S4-A10	Y7-S4-A10	Y8-S4-A10		5/8

THREAD	STYLE	MATERIAL
#6-32	SOCKET CAP, BINDING, BUTTON, FLAT, ROUND AND FILLISTER	STAINLESS STEEL TYPE 18-8

HEAD STYLE						CLASS 2A THREAD	A LENGTH
SOCKET CAP STOCK NO.	BINDING STOCK NO.	BUTTON STOCK NO.	FLAT STOCK NO.	ROUND STOCK NO.	FILLISTER STOCK NO.		
Y9-S6-A4	Y10-S6-A4	Y19-S6-A4	Y6-S6-A4	Y7-S6-A4	Y8-S6-A4	#6-32 UNC	1/4
Y9-S6-A5	Y10-S6-A5	Y19-S6-A5	Y6-S6-A5	Y7-S6-A5	Y8-S6-A5		5/16
Y9-S6-A6	Y10-S6-A6	Y19-S6-A6	Y6-S6-A6	Y7-S6-A6	Y8-S6-A6		3/8
Y9-S6-A8	Y10-S6-A8	Y19-S6-A8	Y6-S6-A8	Y7-S6-A8	Y8-S6-A8		1/2
Y9-S6-A10	Y10-S6-A10	Y19-S6-A10	Y6-S6-A10	Y7-S6-A10	Y8-S6-A10		5/8
Y9-S6-A12	Y10-S6-A12	Y19-S6-A12	Y6-S6-A12	Y7-S6-A12	Y8-S6-A12		3/4

THREAD	STYLE	MATERIAL
#8-32	SOCKET CAP, BINDING, BUTTON, FLAT, ROUND AND FILLISTER	STAINLESS STEEL TYPE 18-8

HEAD STYLE						CLASS 2A THREAD	A LENGTH
SOCKET CAP STOCK NO.	BINDING STOCK NO.	BUTTON STOCK NO.	FLAT STOCK NO.	ROUND STOCK NO.	FILLISTER STOCK NO.		
Y9-S8-A4	Y10-S8-A4	Y19-S8-A4	Y6-S8-A4	Y7-S8-A4	Y8-S8-A4	#8-32 UNC	1/4
Y9-S8-A5	Y10-S8-A5	Y19-S8-A5	Y6-S8-A5	Y7-S8-A5	Y8-S8-A5		5/16
Y9-S8-A6	Y10-S8-A6	Y19-S8-A6	Y6-S8-A6	Y7-S8-A6	Y8-S8-A6		3/8
Y9-S8-A8	Y10-S8-A8	Y19-S8-A8	Y6-S8-A8	Y7-S8-A8	Y8-S8-A8		1/2
Y9-S8-A10	Y10-S8-A10	Y19-S8-A10	Y6-S8-A10	Y7-S8-A10	Y8-S8-A10		5/8
Y9-S8-A12	Y10-S8-A12	Y19-S8-A12	Y6-S8-A12	Y7-S8-A12	Y8-S8-A12		3/4
Y9-S8-A16	Y10-S8-A16	Y19-S8-A16	Y6-S8-A16	Y7-S8-A16	Y8-S8-A16		1

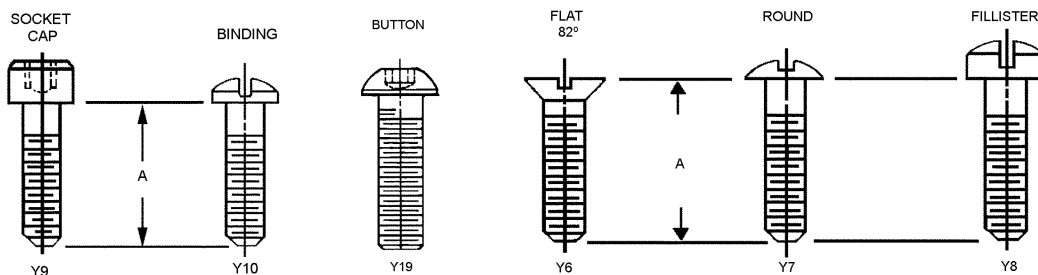

MACHINE SCREWS

THREAD	STYLE	MATERIAL
#10-24	SOCKET CAP, BINDING, BUTTON, FLAT, ROUND AND FILLISTER	STAINLESS STEEL TYPE 18-8

HEAD STYLE						CLASS 2A THREAD	A LENGTH
SOCKET CAP STOCK NO.	BINDING STOCK NO.	BUTTON STOCK NO.	FLAT STOCK NO.	ROUND STOCK NO.	FILLISTER STOCK NO.		
Y9-S10-A4	Y10-S10-A4	Y19-S10-A4	Y6-S10-A4	Y7-S10-A4	Y8-S10-A4	#10-24 UNC	1/4
Y9-S10-A5	Y10-S10-A5	Y19-S10-A5	Y6-S10-A5	Y7-S10-A5	Y8-S10-A5		5/16
Y9-S10-A6	Y10-S10-A6	Y19-S10-A6	Y6-S10-A6	Y7-S10-A6	Y8-S10-A6		3/8
Y9-S10-A8	Y10-S10-A8	Y19-S10-A8	Y6-S10-A8	Y7-S10-A8	Y8-S10-A8		1/2
Y9-S10-A10	Y10-S10-A10	Y19-S10-A10	Y6-S10-A10	Y7-S10-A10	Y8-S10-A10		5/8
Y9-S10-A12	Y10-S10-A12	Y19-S10-A12	Y6-S10-A12	Y7-S10-A12	Y8-S10-A12		3/4
Y9-S10-A16	Y10-S10-A16	Y19-S10-A16	Y6-S10-A16	Y7-S10-A16	Y8-S10-A16		1

THREAD	STYLE	MATERIAL
#10-32	SOCKET CAP, BINDING, BUTTON, FLAT, ROUND AND FILLISTER	STAINLESS STEEL TYPE 18-8

HEAD STYLE						CLASS 2A THREAD	A LENGTH
SOCKET CAP STOCK NO.	BINDING STOCK NO.	BUTTON STOCK NO.	FLAT STOCK NO.	ROUND STOCK NO.	FILLISTER STOCK NO.		
Y9-S11-A4	Y10-S11-A4	Y19-S11-A4	Y6-S11-A4	Y7-S11-A4	Y8-S11-A4	#10-32 UNC	1/4
Y9-S11-A5	Y10-S11-A5	Y19-S11-A5	Y6-S11-A5	Y7-S11-A5	Y8-S11-A5		5/16
Y9-S11-A6	Y10-S11-A6	Y19-S11-A6	Y6-S11-A6	Y7-S11-A6	Y8-S11-A6		3/8
Y9-S11-A8	Y10-S11-A8	Y19-S11-A8	Y6-S11-A8	Y7-S11-A8	Y8-S11-A8		1/2
Y9-S11-A10	Y10-S11-A10	Y19-S11-A10	Y6-S11-A10	Y7-S11-A10	Y8-S11-A10		5/8
Y9-S11-A12	Y10-S11-A12	Y19-S11-A12	Y6-S11-A12	Y7-S11-A12	Y8-S11-A12		3/4
Y9-S11-A16	Y10-S11-A16	Y19-S11-A16	Y6-S11-A16	Y7-S11-A16	Y8-S11-A16		1

THREAD	STYLE	MATERIAL
1/4-20	SOCKET CAP, BINDING, BUTTON, FLAT, ROUND AND FILLISTER	STAINLESS STEEL TYPE 18-8

HEAD STYLE						CLASS 2A THREAD	A LENGTH
SOCKET CAP STOCK NO.	BINDING STOCK NO.	BUTTON STOCK NO.	FLAT STOCK NO.	ROUND STOCK NO.	FILLISTER STOCK NO.		
-	Y10-S12-A4	-	-	Y7-S12-A4	-	1/4-20 UNC	1/4
-	Y10-S12-A5	-	-	Y7-S12-A5	-		5/16
Y9-S12-A6	Y10-S12-A6	Y19-S12-A6	Y6-S12-A6	Y7-S12-A6	Y8-S12-A6		3/8
Y9-S12-A8	Y10-S12-A8	Y19-S12-A8	Y6-S12-A8	Y7-S12-A8	Y8-S12-A8		1/2
Y9-S12-A10	Y10-S12-A10	Y19-S12-A10	Y6-S12-A10	Y7-S12-A10	Y8-S12-A10		5/8
Y9-S12-A12	Y10-S12-A12	Y19-S12-A12	Y6-S12-A12	Y7-S12-A12	Y8-S12-A12		3/4
Y9-S12-A16	Y10-S12-A16	Y19-S12-A16	Y6-S12-A16	Y7-S12-A16	Y8-S12-A16		1

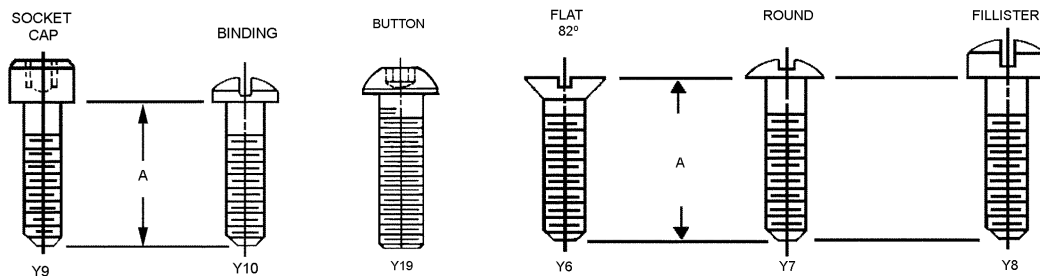

LONG-LOK® AND NYLOC® MACHINE SCREWS

THREAD	STYLE	MATERIAL
#0-80	SELF LOCKING - VIBRATION PROOF FLAT, ROUND, FILLISTER, BINDING AND SOCKET CAP	STAINLESS STEEL TYPE 18-8 WITH NYLON INSERT

LONG-LOCK®				NYLOC®	CLASS A THREAD	A LENGTH
FLAT STYLE STOCK NO.	ROUND STYLE STOCK NO.	FILLISTER STYLE STOCK NO.	BINDING STYLE STOCK NO.	SOCKET CAP STYLE STOCK NO.		
Y6-S0-A2-L	Y7-S0-A2-L	Y8-S0-A2-L	Y10-S0-A2-L	Y9-S0-A2-N	#0-80	1/8
Y6-S0-A3-L	Y7-S0-A3-L	Y8-S0-A3-L	Y10-S0-A3-L	Y9-S0-A3-N		3/16
Y6-S0-A4-L	Y7-S0-A4-L	Y8-S0-A4-L	Y10-S0-A4-L	Y9-S0-A4-N		1/4
Y6-S0-A5-L	Y7-S0-A5-L	Y8-S0-A5-L	Y10-S0-A5-L	Y9-S0-A5-N		5/16
Y6-S0-A6-L	Y7-S0-A6-L	Y8-S0-A6-L	Y10-S0-A6-L	Y9-S0-A6-N		3/8
Y6-S0-A8-L	Y7-S0-A8-L	Y8-S0-A8-L	Y10-S0-A8-L	Y9-S0-A8-N		1/2

THREAD	STYLE	MATERIAL
#2-56	SELF LOCKING - VIBRATION PROOF FLAT, ROUND, FILLISTER, BINDING AND SOCKET CAP	STAINLESS STEEL TYPE 18-8 WITH NYLON INSERT

LONG-LOCK®				NYLOC®	CLASS A THREAD	A LENGTH
FLAT STYLE STOCK NO.	ROUND STYLE STOCK NO.	FILLISTER STYLE STOCK NO.	BINDING STYLE STOCK NO.	SOCKET CAP STYLE STOCK NO.		
Y6-S2-A3-L	Y7-S2-A3-L	Y8-S2-A3-L	Y10-S2-A3-L	Y9-S2-A3-N	#2-56	3/16
Y6-S2-A4-L	Y7-S2-A4-L	Y8-S2-A4-L	Y10-S2-A4-L	Y9-S2-A4-N		1/4
Y6-S2-A5-L	Y7-S2-A5-L	Y8-S2-A5-L	Y10-S2-A5-L	Y9-S2-A5-N		5/16
Y6-S2-A6-L	Y7-S2-A6-L	Y8-S2-A6-L	Y10-S2-A6-L	Y9-S2-A6-N		3/8
Y6-S2-A8-L	Y7-S2-A8-L	Y8-S2-A8-L	Y10-S2-A8-L	Y9-S2-A8-N		1/2

THREAD	STYLE	MATERIAL
#4-40	SELF LOCKING - VIBRATION PROOF FLAT, ROUND, FILLISTER, BINDING AND SOCKET CAP	STAINLESS STEEL TYPE 18-8 WITH NYLON INSERT

LONG-LOCK®				NYLOC®	CLASS A THREAD	A LENGTH
FLAT STYLE STOCK NO.	ROUND STYLE STOCK NO.	FILLISTER STYLE STOCK NO.	BINDING STYLE STOCK NO.	SOCKET CAP STYLE STOCK NO.		
Y6-S4-A3-L	Y7-S4-A3-L	Y8-S4-A3-L	Y10-S4-A3-L	Y9-S4-A3-N	#4-40	3/16
Y6-S4-A4-L	Y7-S4-A4-L	Y8-S4-A4-L	Y10-S4-A4-L	Y9-S4-A4-N		1/4
Y6-S4-A5-L	Y7-S4-A5-L	Y8-S4-A5-L	Y10-S4-A5-L	Y9-S4-A5-N		5/16
Y6-S4-A6-L	Y7-S4-A6-L	Y8-S4-A6-L	Y10-S4-A6-L	Y9-S4-A6-N		3/8
Y6-S4-A8-L	Y7-S4-A8-L	Y8-S4-A8-L	Y10-S4-A8-L	Y9-S4-A8-N		1/2
Y6-S4-A10-L	Y7-S4-A10-L	Y8-S4-A10-L	Y10-S4-A10-L	Y9-S4-A10-N		5/8

THREAD	STYLE	MATERIAL
#6-32	CLASS A SELF LOCKING - VIBRATION PROOF BINDING AND SOCKET CAP	STAINLESS STEEL TYPE 18-8 WITH NYLON INSERT

LONG-LOCK®	NYLOC®		THREAD	LENGTH
BINDING STYLE STOCK NO.	SOCKET CAP STYLE STOCK NO.	BINDING STYLE STOCK NO.		
Y10-S6-A4-L	Y9-S6-A4-N	Y10-S6-A4-N	#6-32	1/4
Y10-S6-A5-L	Y9-S6-A5-N	Y10-S6-A5-N		5/16
Y10-S6-A6-L	Y9-S6-A6-N	Y10-S6-A6-N		3/8
Y10-S6-A8-L	Y9-S6-A8-N	Y10-S6-A8-N		1/2
Y10-S6-A10-L	Y9-S6-A10-N	Y10-S6-A10-N		5/8
Y10-S6-A12-L	Y9-S6-A12-N	Y10-S6-A12-N		3/4

See drawings on page F4

LONG-LOK® AND NYLOC® MACHINE SCREWS

THREAD	STYLE	MATERIAL
#8-32	SELF LOCKING - VIBRATION PROOF FLAT, ROUND, FILLISTER, BINDING AND SOCKET CAP	STAINLESS STEEL TYPE 18-8 WITH NYLON INSERT

LONG-LOCK®				NYLOC®	CLASS A THREAD	A LENGTH
FLAT STYLE STOCK NO.	ROUND STYLE STOCK NO.	FILLISTER STYLE STOCK NO.	BINDING STYLE STOCK NO.	SOCKET CAP STYLE STOCK NO.		
Y6-S8-A4-L	Y7-S8-A4-L	Y8-S8-A4-L	Y10-S8-A4-L	Y9-S8-A4-N	#8-32	1/4
Y6-S8-A5-L	Y7-S8-A5-L	Y8-S8-A5-L	Y10-S8-A5-L	Y9-S8-A5-N		5/16
Y6-S8-A6-L	Y7-S8-A6-L	Y8-S8-A6-L	Y10-S8-A6-L	Y9-S8-A6-N		3/8
Y6-S8-A8-L	Y7-S8-A8-L	Y8-S8-A8-L	Y10-S8-A8-L	Y9-S8-A8-N		1/2
Y6-S8-A10-L	Y7-S8-A10-L	Y8-S8-A10-L	Y10-S8-A10-L	Y9-S8-A10-N		5/8
Y6-S8-A12-L	Y7-S8-A12-L	Y8-S8-A12-L	Y10-S8-A12-L	Y9-S8-A12-N		3/4
Y6-S8-A16-L	Y7-S8-A16-L	Y8-S8-A16-L	Y10-S8-A16-L	Y9-S8-A16-N		1

THREAD	STYLE	MATERIAL
#10-24	SELF LOCKING - VIBRATION PROOF FLAT, ROUND, FILLISTER, BINDING AND SOCKET CAP	STAINLESS STEEL TYPE 18-8 WITH NYLON INSERT

LONG-LOCK®				NYLOC®	CLASS A THREAD	A LENGTH
FLAT STYLE STOCK NO.	ROUND STYLE STOCK NO.	FILLISTER STYLE STOCK NO.	BINDING STYLE STOCK NO.	SOCKET CAP STYLE STOCK NO.		
Y6-S10-A4-L	Y7-S10-A4-L	Y8-S10-A4-L	Y10-S10-A4-L	Y9-S10-A4-N	#10-24	1/4
Y6-S10-A5-L	Y7-S10-A5-L	Y8-S10-A5-L	Y10-S10-A5-L	Y9-S10-A5-N		5/16
Y6-S10-A6-L	Y7-S10-A6-L	Y8-S10-A6-L	Y10-S10-A6-L	Y9-S10-A6-N		3/8
Y6-S10-A8-L	Y7-S10-A8-L	Y8-S10-A8-L	Y10-S10-A8-L	Y9-S10-A8-N		1/2
Y6-S10-A10-L	Y7-S10-A10-L	Y8-S10-A10-L	Y10-S10-A10-L	Y9-S10-A10-N		5/8
Y6-S10-A12-L	Y7-S10-A12-L	Y8-S10-A12-L	Y10-S10-A12-L	Y9-S10-A12-N		3/4
Y6-S10-A16-L	Y7-S10-A16-L	Y8-S10-A16-L	Y10-S10-A16-L	Y9-S10-A16-N		1

THREAD	STYLE	MATERIAL
#10-32	SELF LOCKING - VIBRATION PROOF FLAT, ROUND, FILLISTER, BINDING AND SOCKET CAP	STAINLESS STEEL TYPE 18-8 WITH NYLON INSERT

LONG-LOCK®				NYLOC®	CLASS A THREAD	A LENGTH
FLAT STYLE STOCK NO.	ROUND STYLE STOCK NO.	FILLISTER STYLE STOCK NO.	BINDING STYLE STOCK NO.	SOCKET CAP STYLE STOCK NO.		
Y6-S11-A4-L	Y7-S11-A4-L	Y8-S11-A4-L	Y10-S11-A4-L	Y9-S11-A4-N	#10-32	1/4
Y6-S11-A5-L	Y7-S11-A5-L	Y8-S11-A5-L	Y10-S11-A5-L	Y9-S11-A5-N		5/16
Y6-S11-A6-L	Y7-S11-A6-L	Y8-S11-A6-L	Y10-S11-A6-L	Y9-S11-A6-N		3/8
Y6-S11-A8-L	Y7-S11-A8-L	Y6-S11-A8-L	Y10-S11-A8-L	Y9-S11-A8-N		1/2
Y6-S11-A10-L	Y7-S11-A10-L	Y8-S11-A10-L	Y10-S11-A10-L	Y9-S11-A10-N		5/8
Y6-S11-A12-L	Y7-S11-A12-L	Y8-S11-A12-L	Y10-S11-A12-L	Y9-S11-A12-N		3/4
Y6-S11-A16-L	Y7-S11-A16-L	Y8-S11-A16-L	Y10-S11-A16-L	Y9-S11-A16-N		1

THREAD	STYLE	MATERIAL
#1/4-20	SELF LOCKING - VIBRATION PROOF FLAT, ROUND, FILLISTER, BINDING AND SOCKET CAP	STAINLESS STEEL TYPE 18-8 WITH NYLON INSERT

LONG-LOCK®				NYLOC®	CLASS A THREAD	A LENGTH
FLAT STYLE STOCK NO.	ROUND STYLE STOCK NO.	FILLISTER STYLE STOCK NO.	BINDING STYLE STOCK NO.	SOCKET CAP STYLE STOCK NO.		
Y6-S12-A6-L	Y7-S12-A6-L	Y8-S12-A6-L	Y10-S12-A6-L	Y9-S12-A6-N	1/4-20	3/8
Y6-S12-A8-L	Y7-S12-A8-L	Y8-S12-A8-L	Y10-S12-A8-L	Y9-S12-A8-N		1/2
Y6-S12-A10-L	Y7-S12-A10-L	Y8-S12-A10-L	Y10-S12-A10-L	Y9-S12-A10-N		5/8
Y6-S12-A12-L	Y7-S12-A12-L	Y8-S12-A12-L	Y10-S12-A12-L	Y9-S12-A12-N		3/4
Y6-S12-A16-L	Y7-S12-A16-L	Y8-S12-A16-L	Y10-S12-A16-L	Y9-S12-A16-N		1

See drawings on page F4

NYLON MACHINE SCREWS

THREAD	STYLE	MATERIAL
#2-56	FLAT, ROUND, FILLISTER AND PAN	MOLDED NYLON, WHITE

FLAT 82°	ROUND	FILLISTER	PAN	THREAD	A LENGTH
STOCK NO.	STOCK NO.	STOCK NO.	STOCK NO.		
Z6-N2-A2	Z7-N2-A2	Z8-N2-A2	Z11-N2-A2	#2-56	1/8
Z6-N2-A3	Z7-N2-A3	Z8-N2-A3	Z11-N2-A3		3/16
Z6-N2-A4	Z7-N2-A4	Z8-N2-A4	Z11-N2-A4		1/4
Z6-N2-A5	Z7-N2-A5	Z8-N2-A5	Z11-N2-A5		5/16
Z6-N2-A6	Z7-N2-A6	Z8-N2-A6	Z11-N2-A6		3/8
Z6-N2-A8	Z7-N2-A8	Z8-N2-A8	Z11-N2-A8		1/2
Z6-N2-A10	Z7-N2-A10	Z8-N2-A10	Z11-N2-A10		5/8
Z6-N2-A12	Z7-N2-A12	Z8-N2-A12	Z11-N2-A12		3/4

THREAD	STYLE	MATERIAL
#4-40	FLAT, ROUND, FILLISTER, PAN AND SOCKET CAP	MOLDED NYLON, WHITE

FLAT 82°	ROUND	FILLISTER	PAN	SOCKET CAP	THREAD	A LENGTH
STOCK NO.	STOCK NO.	STOCK NO.	STOCK NO.	STOCK NO.		
Z6-N4-A3	Z7-N4-A3	Z8-N4-A3	Z11-N4-A3	Z9-N4-A3	#4-40	3/16
Z6-N4-A4	Z7-N4-A4	Z8-N4-A4	Z11-N4-A4	Z9-N4-A4		1/4
Z6-N4-A5	Z7-N4-A5	Z8-N4-A5	Z11-N4-A5	Z9-N4-A5		5/16
Z6-N4-A6	Z7-N4-A6	Z8-N4-A6	Z11-N4-A6	Z9-N4-A6		3/8
Z6-N4-A8	Z7-N4-A8	Z8-N4-A8	Z11-N4-A8	Z9-N4-A8		1/2
Z6-N4-A10	Z7-N4-A10	Z8-N4-A10	Z11-N4-A10	Z9-N4-A10		5/8
Z6-N4-A12	Z7-N4-A12	Z8-N4-A12	Z11-N4-A12	Z9-N4-A12		3/4

THREAD	STYLE	MATERIAL
#6-32	FLAT, ROUND, FILLISTER, PAN AND SOCKET CAP	MOLDED NYLON, WHITE

FLAT 82°	ROUND	FILLISTER	PAN	SOCKET CAP	THREAD	A LENGTH
STOCK NO.	STOCK NO.	STOCK NO.	STOCK NO.	STOCK NO.		
Z6-N6-A4	Z7-N6-A4	Z8-N6-A4	Z11-N6-A4	Z9-N6-A4	#6-32	1/4
Z6-N6-A5	Z7-N6-A5	Z8-N6-A5	Z11-N6-A5	Z9-N6-A5		5/16
Z6-N6-A6	Z7-N6-A6	Z8-N6-A6	Z11-N6-A6	Z9-N6-A6		3/8
Z6-N6-A8	Z7-N6-A8	Z8-N6-A8	Z11-N6-A8	Z9-N6-A8		1/2
-	Z7-N6-A10	Z8-N6-A10	Z11-N6-A10	Z9-N6-A10		5/8
-	Z7-N6-A12	Z8-N6-A12	Z11-N6-A12	Z9-N6-A12		3/4

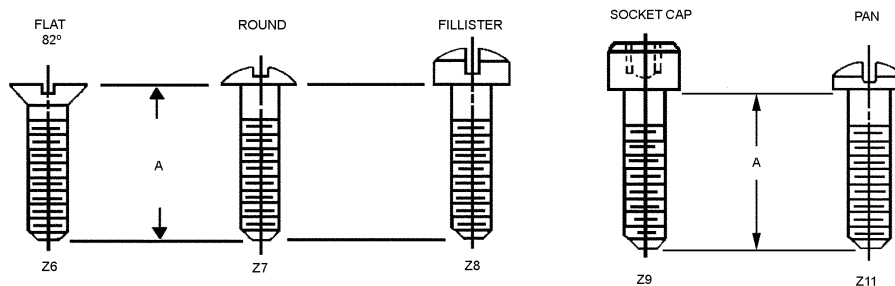

NYLON MACHINE SCREWS

THREAD	STYLE	MATERIAL
#8-32	FLAT, ROUND, FILLISTER, PAN AND SOCKET CAP	MOLDED NYLON, WHITE

FLAT 82°	ROUND	FILLISTER	PAN	SOCKET CAP	THREAD	A LENGTH
STOCK NO.	STOCK NO.	STOCK NO.	STOCK NO.	STOCK NO.		
Z6-N8-A4	Z7-N8-A4	Z8-N8-A4	Z11-N8-A4	Z9-N8-A4	#8-32	1/4
Z6-N8-A5	Z7-N8-A5	Z8-N8-A5	Z11-N8-A5	Z9-N8-A5		5/16
Z6-N8-A6	Z7-N8-A6	Z8-N8-A6	Z11-N8-A6	Z9-N8-A6		3/8
Z6-N8-A8	Z7-N8-A8	Z8-N8-A8	Z11-N8-A8	Z9-N8-A8		1/2
Z6-N8-A10	Z7-N8-A10	Z8-N8-A10	Z11-N8-A10	Z9-N8-A10		5/8
Z6-N8-A12	Z7-N8-A12	Z8-N8-A12	Z11-N8-A12	Z9-N8-A12		3/4
Z6-N8-A16	Z7-N8-A16	Z8-N8-A16	Z11-N8-A16	Z9-N8-A16		1

THREAD	STYLE	MATERIAL
#10-24	FLAT, ROUND, FILLISTER, PAN AND SOCKET CAP	MOLDED NYLON, WHITE

FLAT 82°	ROUND	FILLISTER	PAN	SOCKET CAP	THREAD	A LENGTH
STOCK NO.	STOCK NO.	STOCK NO.	STOCK NO.	STOCK NO.		
Z6-N10-A4	Z7-N10-A4	Z8-N10-A4	Z11-N10-A4	Z9-N10-A4	#10-24	1/4
Z6-N10-A6	Z7-N10-A6	Z8-N10-A6	Z11-N10-A6	Z9-N10-A6		3/8
Z6-N10-A8	Z7-N10-A8	Z8-N10-A8	Z11-N10-A8	Z9-N10-A8		1/2
Z6-N10-A12	Z7-N10-A12	Z8-N10-A12	Z11-N10-A12	Z9-N10-A12		3/4
Z6-N10-A16	Z7-N10-A16	Z8-N10-A16	Z11-N10-A16	Z9-N10-A16		1

THREAD	STYLE	MATERIAL
#10-32	FLAT, ROUND, FILLISTER, PAN AND SOCKET CAP	MOLDED NYLON, WHITE

FLAT 82°	ROUND	FILLISTER	PAN	SOCKET CAP	THREAD	A LENGTH
STOCK NO.	STOCK NO.	STOCK NO.	STOCK NO.	STOCK NO.		
Z6-N11-A4	Z7-N11-A4	Z8-N11-A4	Z11-N11-A4	Z9-N11-A4	#10-32	1/4
Z6-N11-A6	Z7-N11-A6	Z8-N11-A6	Z11-N11-A6	Z9-N11-A6		3/8
Z6-N11-A8	Z7-N11-A8	Z8-N11-A8	Z11-N11-A8	Z9-N11-A8		1/2
Z6-N11-A12	Z7-N11-A12	Z8-N11-A12	Z11-N11-A12	Z9-N11-A12		3/4
Z6-N11-A16	Z7-N11-A16	Z8-N11-A16	Z11-N11-A16	Z9-N11-A16		1

THREAD	STYLE	MATERIAL
1/4-20	FLAT, ROUND, FILLISTER, PAN AND SOCKET CAP	MOLDED NYLON, WHITE

FLAT 82°	ROUND	FILLISTER	PAN	SOCKET CAP	THREAD	A LENGTH
STOCK NO.	STOCK NO.	STOCK NO.	STOCK NO.	STOCK NO.		
Z6-N12-A4	Z7-N12-A4	Z8-N12-A4	Z11-N12-A4	Z9-N12-A4	1/4-20	1/4
Z6-N12-A6	Z7-N12-A6	Z8-N12-A6	Z11-N12-A6	Z9-N12-A6		3/8
Z6-N12-A8	Z7-N12-A8	Z8-N12-A8	Z11-N12-A8	Z9-N12-A8		1/2
Z6-N12-A12	Z7-N12-A12	Z8-N12-A12	Z11-N12-A12	Z9-N12-A12		3/4
Z6-N12-A16	Z7-N12-A16	Z8-N12-A16	Z11-N12-A16	Z9-N12-A16		1

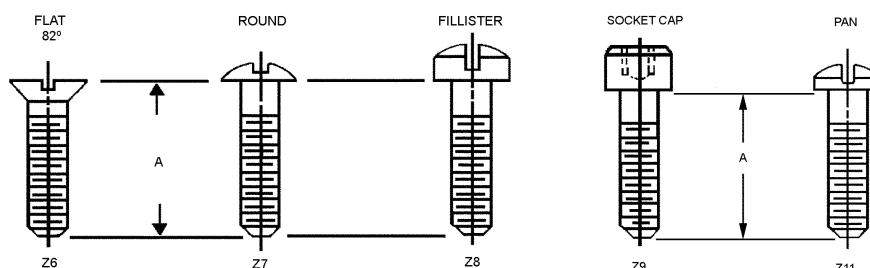

INTEGRAL SEAL SCREWS

THREAD	STYLE	MATERIAL
#2-56	SLOTTED PAN HEAD	300 SERIES STAINLESS STEEL SCREW WITH SILICONE O RING

STOCK NO.	THREAD SIZE	LENGTH	A	B	CLEARANCE HOLE	
					MIN.	MAX.
Y18-S2-A4	#2-56	1/4	.055	.168	.091	.095
Y18-S2-A6		3/8				
Y18-S2-A8		1/2				
Y18-S2-A10		5/8				

THREAD	STYLE	MATERIAL
#4-40	SLOTTED PAN HEAD	300 SERIES STAINLESS STEEL SCREW WITH SILICONE O RING

STOCK NO.	THREAD SIZE	LENGTH	A	B	CLEARANCE HOLE	
					MIN.	MAX.
Y18-S4-A4	#4-40	1/4	.069	.220	.125	.129
Y18-S4-A8		1/2				
Y18-S4-A12		3/4				
Y18-S4-A16		1				

THREAD	STYLE	MATERIAL
#6-32	SLOTTED PAN HEAD	300 SERIES STAINLESS STEEL SCREW WITH SILICONE O RING

STOCK NO.	THREAD SIZE	LENGTH	A	B	CLEARANCE HOLE	
					MIN.	MAX.
Y18-S6-A4	#6-32	1/4	.083	.271	.147	.152
Y18-S6-A8		1/2				
Y18-S6-A12		3/4				
Y18-S6-A16		1				

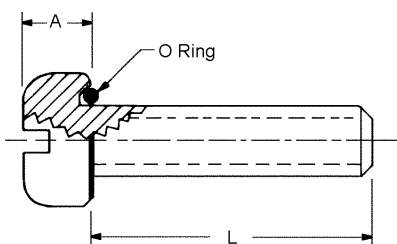
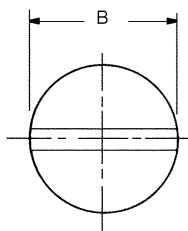

- Reusable
- Clearance holes recommended for maximum sealing
- Maximum temperature range +500°F to -160°F
- Pressure range - up to 6000 psi

INTEGRAL SEAL SCREWS

THREAD	STYLE	MATERIAL
#8-32	SLOTTED PAN HEAD	300 SERIES STAINLESS STEEL SCREW WITH SILICONE O RING

STOCK NO.	THREAD SIZE	LENGTH	A	B	CLEARANCE HOLE	
					MIN.	MAX.
Y18-S8-A4	#8-32	1/4	.097	.323	.173	.179
Y18-S8-A8		1/2				
Y18-S8-A12		3/4				
Y18-S8-A16		1				

THREAD	STYLE	MATERIAL
#10-24	SLOTTED PAN HEAD	300 SERIES STAINLESS STEEL SCREW WITH SILICONE O RING

STOCK NO.	THREAD SIZE	LENGTH	A	B	CLEARANCE HOLE	
					MIN.	MAX.
Y18-S10-A6	#10-24	3/8	.113	.374	.199	.204
Y18-S10-A8		1/2				
Y18-S10-A12		3/4				
Y18-S10-A16		1				

THREAD	STYLE	MATERIAL
#10-32	SLOTTED PAN HEAD	300 SERIES STAINLESS STEEL SCREW WITH SILICONE O RING

STOCK NO.	THREAD SIZE	LENGTH	A	B	CLEARANCE HOLE	
					MIN.	MAX.
Y18-S11-A6	#10-32	3/8	.113	.374	.199	.204
Y18-S11-A8		1/2				
Y18-S11-A12		3/4				
Y18-S11-A16		1				

THREAD	STYLE	MATERIAL
1/4-20	SLOTTED PAN HEAD	300 SERIES STAINLESS STEEL SCREW WITH SILICONE O RING

STOCK NO.	THREAD SIZE	LENGTH	A	B	CLEARANCE HOLE	
					MIN.	MAX.
Y18-S12-A6	1/4-20	3/8	.148	.493	.265	.269
Y18-S12-A8		1/2				
Y18-S12-A12		3/4				
Y18-S12-A16		1				
Y18-S12-A20		1 1/4				

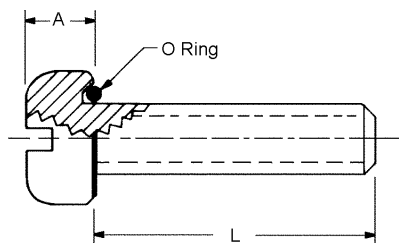
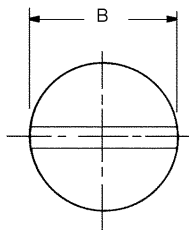

- Reusable
- Clearance holes recommended for maximum sealing
- Maximum temperature range +500°F to -160°F
- Pressure range - up to 6000 psi

F

SET SCREWS

THREAD	STYLE	MATERIAL
#0-80 TO 3/4-10	SLOTTED HEAD AND HEX SOCKET	STAINLESS STEEL 18-8 AND NYLON (SLOTTED HEAD ONLY)

SLOTTED HEAD STAINLESS STEEL	HEX SOCKET HEAD STAINLESS STEEL	SLOTTED HEAD NYLON	THREAD	L
STOCK NO.	STOCK NO.	STOCK NO.		
SC1-18	SC2-18	-	#0-80	1/8
SC1-19	SC2-19	-	#0-80	3/16
SC1-50	SC2-50	-	#2-56	3/32
SC1-1	SC2-1	-	#2-56	1/8
SC1-24	SC2-24	SC11-24	#2-56	3/16
-	SC2-25	SC11-25	#2-56	1/4
-	SC2-59*	-	#2-64	1/16
SC1-14	SC2-14	-	#2-64	1/8
SC1-51	SC2-51	-	#4-40	3/32
SC1-2	SC2-2	-	#4-40	1/8
-	SC2-27	-	#4-40	3/16
-	SC2-28	SC11-28	#4-40	1/4
-	SC2-15	-	#5-40	3/16
-	SC2-52	-	#6-32	3/32
SC1-3	SC2-3	-	#6-32	1/8
-	SC2-30	SC11-30	#6-32	1/4
-	SC2-31	SC11-31	#6-32	3/8
-	SC2-32	SC11-32	#6-32	1/2
-	SC2-53	-	#8-32	1/8
SC1-4	SC2-4	-	#8-32	3/16
-	SC2-33	SC11-33	#8-32	1/4
SC1-54	-	SC11-54	#8-32	5/16
-	SC2-34	SC11-34	#8-32	3/8
-	SC2-35	SC11-35	#8-32	1/2
-	SC2-36	SC11-36	#8-32	5/8
-	SC2-16	-	#10-24	3/16
-	SC2-62	-	#10-24	1/4
SC1-60	SC2-60	SC11-60	#10-24	5/16
SC1-61	SC2-61	SC11-61	#10-24	3/8
SC1-5	SC2-5	-	#10-32	3/16
-	SC2-37	SC11-37	#10-32	1/4
SC1-55	SC2-55	SC11-55	#10-32	3/8
-	SC2-38	SC11-38	#10-32	1/2
-	SC2-39	-	#10-32	3/4
-	SC2-40	-	#10-32	1
-	SC2-41	SC 11-41	1/4-20	1/4
-	SC2-56	-	1/4-20	5/16
SC1-6	SC2-6	SC11-6	1/4-20	3/8
-	SC2-42	SC11-42	1/4-20	1/2
-	SC2-43	-	1/4-20	3/4
-	SC2-44	-	1/4-20	1
-	SC2-45	-	1/4-20	1 1/4
-	SC2-17	-	1/4-28	5/16
-	SC2-64	-	1/4-28	3/8
SC1-7	SC2-7	-	5/16-18	1/2
-	SC2-65	-	5/16-18	3/4
SC1-8	SC2-8	-	3/8-16	1/2
-	SC2-57	-	3/8-16	3/8
-	SC2-58	-	3/8-16	1/4
-	SC2-66	-	3/8-16	1
SC1-10	SC2-10	-	1/2-13	1/2
SC1-12	SC2-12	-	5/8-11	3/4
SC1-13	SC2-13	-	3/4-10	3/4

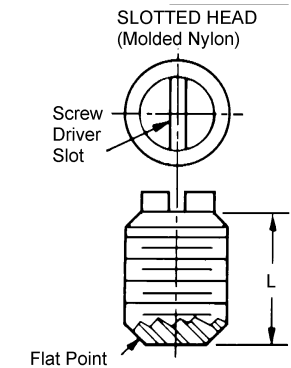
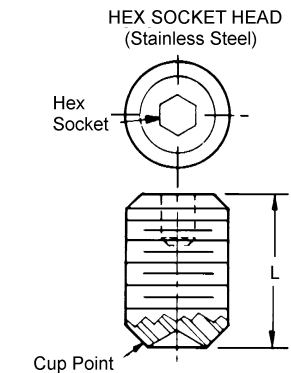
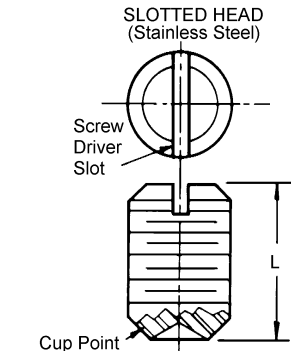

See Index for Allen Socket Head Keys.

These parts are sold in packages of 10.

* Plated Steel

Also available

STOCK NO.	DESCRIPTION OF KIT
KIT-SC2	STAINLESS HEX HEAD SET SCREWS #2 TO 1/4"
KIT-SCA	SET SCREWS - STAINLESS STEEL - CUP POINT AND SOFT TIP #0-80 TO 1/4"



SET SCREWS

THREAD	STYLE	MATERIAL
#4-48 TO 1/4-20	BALL BUTTON	440 STAINLESS STEEL

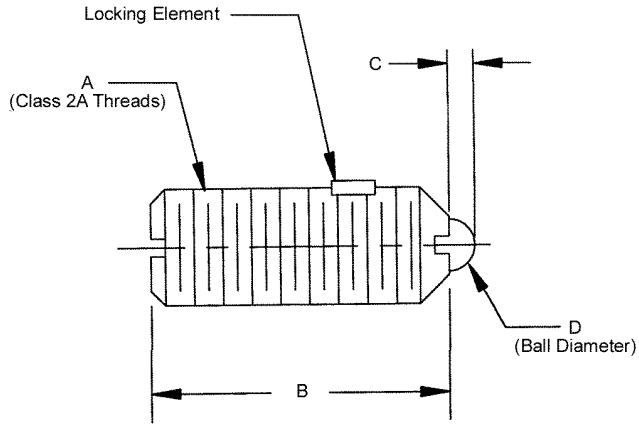

STOCK NO.	END FORCE (lbs.) INITIAL	FINAL	A	B	C	D
SC12-1	1/8	1/2	#4-48	.187	.020	.062
SC12-2	1/4	3/4	#5-40	.250	.020	.062
SC12-3	1/2	1	#6-40	.312	.023	.078
SC12-4	1/2	1 1/4	#8-36	.344	.025	.0937
SC12-5	1/2	1 1/2	#10-32	.513	.025	.0937
SC12-6	3	7	1/4-20	.531	.035	.125

Other materials available on request.

F

SET SCREWS

THREAD	STYLE	MATERIAL
#2-56 TO 3/8-16	BRASS SOFT TIP HEX SOCKET	STAINLESS STEEL AND HEAT TREATED ALLOY STEEL

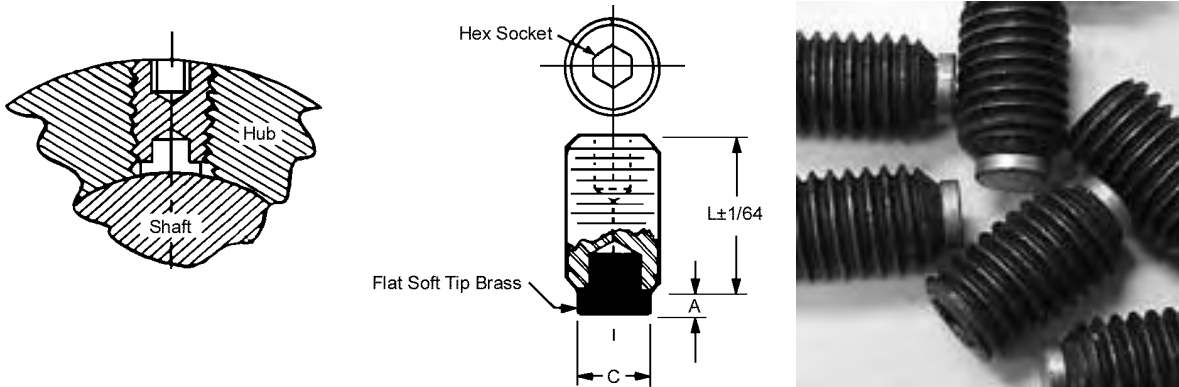

STOCK NO.	THREAD	L	C	A	MATERIAL
SC10-30	#2-56	1/8	1/32	1/32	303 STAINLESS STEEL
SC10-31	UNC-2A	1/4			
SC10-32	#4-40 UNC-2A	1/8	1/16	1/32	
SC10-33		1/4			
SC10-34		3/8			
SC10-35	#6-32 UNC-2A	1/8	1/16	1/32	
SC10-36		1/4			
SC10-37		3/8			
SC10-38	#8-32 UNC-2A	3/16	3/32	3/64	ALLOY STEEL BLACK OXIDE FINISH ROCKWELL C48-52
SC10-39		1/4			
SC10-40		3/8			
SC10-41	#10-24 / UNC-2A	1/4	1/8	3/64	
SC10-1	#10-32 UNF-2A	1/4	1/8	3/64	
SC10-2		3/8			
SC10-3		1/2			
SC10-4	1/4-20 UNC-2A	3/16	1/8	3/64	
SC10-5		1/4			
SC10-6		5/16			
SC10-7		3/8			
SC10-8		1/2			
SC10-10		3/4			
SC10-12	5/16-18 UNC-2A	1/4	3/16	3/64	
SC10-14		3/8			
SC10-15		1/2			
SC10-16		5/8			
SC10-21	3/8-16 UNC-2A	3/8	3/16	3/64	
SC10-22		1/2			
SC10-24		3/4			

- Non marring
- Self locking
- Also used as position adjustment screw
- Screws may be used over and over
- Conforms to shaft surface for positive grip

Length is exclusive of brass tip.

SET SCREWS

THREAD	STYLE	MATERIAL
#2-56 TO 3/4-10	SILVER SOLDER TIP SLOTTED HEAD AND HEX SOCKET	STAINLESS STEEL TYPE 18-8

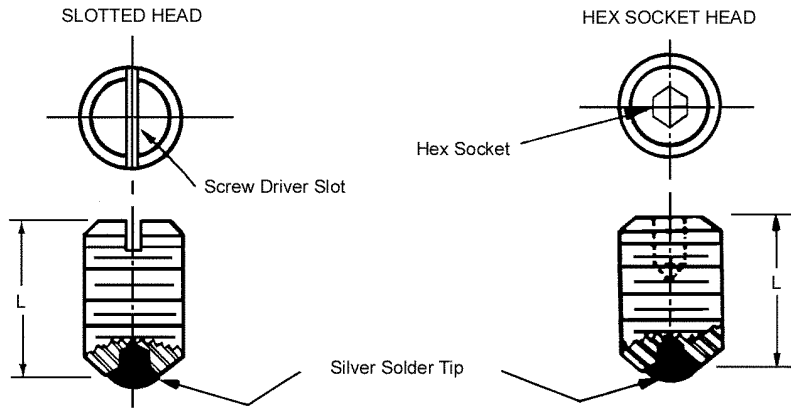

SLOTTED HEAD STOCK NO.	HEX SOCKET HEAD STOCK NO.	SCREW SIZE	L LENGTH
-	SC6-1	#2-56	1/8
-	SC6-2	#4-40	1/8
-	SC6-28	#4-40	1/4
SC5-3	SC6-3	#6-32	1/8
SC5-30	SC6-30	#6-32	1/4
SC5-4	SC6-4	#8-32	3/16
SC5-34	SC6-34	#8-32	3/8
SC5-61	SC6-61	#10-24	3/8
SC5-5	SC6-5	#10-32	3/16
SC5-55	SC6-55	#10-32	3/8
SC5-41	SC6-41	1/4-20	1/4
SC5-6	SC6-6	1/4-20	3/8
-	SC6-64	1/4-28	3/8
SC5-7	SC6-7	5/16-18	1/2
-	SC6-65	5/16-18	3/4
SC5-8	SC6-8	3/8-16	1/2
-	SC6-66	3/8-16	1
SC5-10	SC6-10	1/2-13	1/2
SC5-12	SC6-12	5/8-11	3/4
SC5-13	SC6-13	3/4-10	3/4

- Also used as position adjustment screw
- Conforms to shaft surface for positive grip
- Non marring
- Self locking

Special sizes are available on request.

Length is exclusive of silver tip.

Also available

SLOTTED HEAD KIT ASSORTMENT (IN LUCITE BOX)		
STOCK NO.	SCREW RANGE	NO. OF PIECES
SC5-B	#6-32 TO 1/4-20	60
SC5-C	#10 TO 3/8-16	60

HEX SOCKET HEAD KIT ASSORTMENT (IN LUCITE BOX)		
STOCK NO.	SCREW RANGE	NO. OF PIECES
SC6-A	#4-40 TO #8-32	60
SC6-B	#8-32 TO 1/4-20	60
SC6-C	1/4-20 TO 3/8-16	60

SET SCREWS

THREAD	STYLE	MATERIAL
#2-56 TO 1/2-13	SOFT TIP SLOTTED HEAD	STAINLESS STEEL TYPE 18-8 WITH NYLON TIP

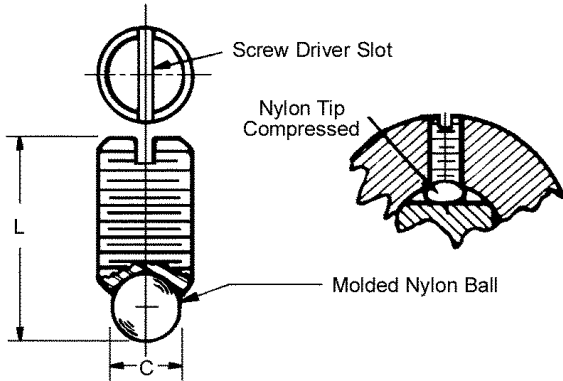

SLOTTED HEAD			
STOCK NO.	THREAD	L	C
SC3-1	#2-56	5/32	1/16
SC3-2	#4-40	11/64	1/16
SC3-3	#6-32	11/64	1/16
SC3-4	#8-32	17/64	3/32
SC3-5	#10-32	17/64	3/32
SC3-6	1/4-20	15/32	1/8
SC3-7	5/16-18	19/32	1/8
SC3-8	3/8-16	5/8	3/16
SC3-10	1/2-13	11/16	1/4

- Will not damage shafts
- Nylon compresses to make full face contact with surface



THREAD	STYLE	MATERIAL
#2-56 TO 1/2-13	SOFT TIP HEX SOCKET HEAD	STAINLESS STEEL TYPE 18-8 WITH NYLON TIP

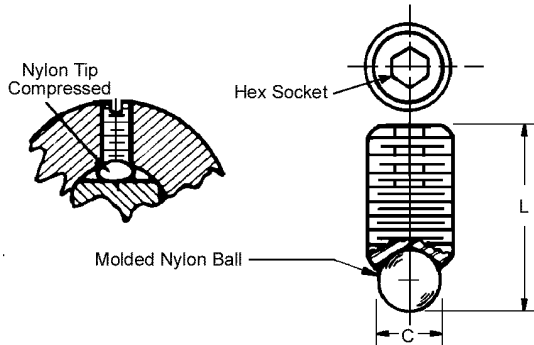

HEX SLOTTED HEAD			
STOCK NO.	THREAD	L	C
SC4-1	#2-56	5/32	1/16
SC4-2	#4-40	11/64	1/16
SC4-3	#6-32	11/64	1/16
SC4-4	#8-32	17/64	3/32
SC4-5	#10-32	17/64	3/32
SC4-6	1/4-20	15/32	1/8
SC4-7	5/16-18	19/32	1/8
SC4-8	3/8-16	5/8	3/16
SC4-10	1/2-13	11/16	1/4

- Will not damage shafts
- Nylon compresses to make full face contact with surface



SET SCREWS

THREAD	STYLE	MATERIAL
#2-56 TO 1/2-13	SOFT TIP HEX SOCKET HEAD	STAINLESS STEEL TYPE 18-8 WITH NYLON TIP

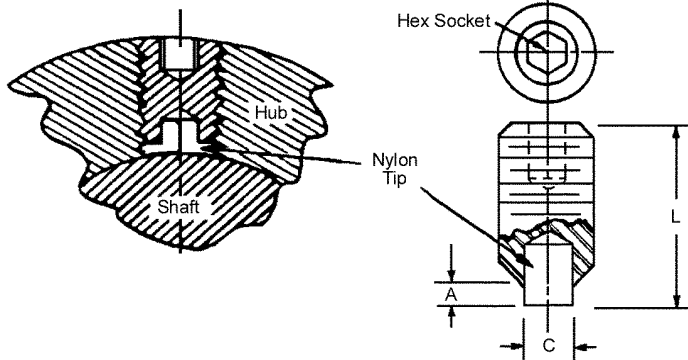

STOCK NO.	THREAD	L	C	A
SC8-1 SC8-2 SC8-31	#2-56	5/32 1/4 9/32	1/32	1/32
SC8-4 SC8-5 SC8-32	#3-48	1/4 5/32 9/32	1/32	1/32
SC8-6 SC8-33	#4-40	3/8 13/32	1/16	1/32
SC8-7 SC8-8	#5-40	5/32 3/8	1/16	1/32
SC8-17 SC8-9 SC8-29 SC8-10 SC8-34	#6-32	5/32 7/32 9/32 5/16 17/32	1/16	1/32
SC8-11 SC8-12 SC8-30 SC8-35	#8-32	15/64 3/8 27/64 43/64	3/32	3/64
SC8-19 SC8-20	#10-24	15/64 27/64	3/32	3/64
SC8-13 SC8-14 SC8-21 SC8-36	#10-32	15/64 5/16 27/64 43/64	3/32	3/64
SC8-15 SC8-22 SC8-16 SC8-37 SC8-38	1/4-20	5/16 7/16 1/2 13/16 1 1/16	1/8	1/16
SC8-23	1/4-28	7/16	1/8	1/16
SC8-24 SC8-39 SC8-40	5/16-18	19/32 27/32 1 3/32	3/16	3/32
SC8-25 SC8-41 SC8-42	3/8-16	19/32 27/32 1 3/32	3/16	3/32
SC8-26 SC8-43	1/2-13	3/4 1 1/8	1/4	1/8

- Self locking
- Extra holding power from full face control
- Will not mar or damage shaft
- Nylon "soft tip" conforms to shape of shaft

F

Also available

STOCK NO.	DESCRIPTION OF KIT	NO. OF PARTS
KITSC8-A	SOFT TIP SET SCREW KIT #2-56 TO #10	90 PIECES
KIT-SC8-B	SOFT TIP SET SCREW #10-24 TO 1/2-13	60 PIECES

SET SCREWS

THREAD	STYLE	MATERIAL
#2-56 TO 1/4-20	SOFT TIP SLOTTED HEAD	STAINLESS STEEL TYPE 18-8 WITH NYLON TIP

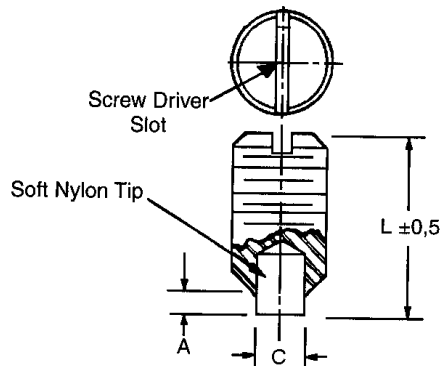

STOCK NO.	THREAD	L	C	A
SC7-1	#2-56	5/32	1/32	1/32
SC7-5 SC7-17	#4-40 #6-32	5/32	1/16	
SC7-11 SC7-19 SC7-13	#8-32 #10-24 #10-32	15/64	3/32	3/64
SC7-15	1/4-20	5/16	1/8	1/16

- Self locking
- Non marring
- Also used as position adjustment screw
- Screw may be used over and over
- Conforms to shaft surface for positive grip

SHOULDER SCREWS

THREAD	STYLE	MATERIAL
#4-40 UNC-2A	SLOTTED HEAD	303 STAINLESS STEEL AND 416 STAINLESS STEEL HARDENED RC 26-36

416 STAINLESS STEEL HARDENED RC 26-36 STOCK NO.	303 STAINLESS STEEL STOCK NO.	THREAD	d +.000 -.001	L +.002 -.000	D	H	E
PL-1 PL-2 PL-3 PL-4 PL-5	PL-1-3 PL-2-3 PL-3-3 PL-4-3 PL-5-3	#4-40 UNC-2A	.1245	.1255 .1880 .2505 .3130 .3755	1/4	1/8	5/32

THREAD	STYLE	MATERIAL
#8-32 UNC-2A	SLOTTED HEAD	303 STAINLESS STEEL AND 416 STAINLESS STEEL HARDENED RC 26-36

416 STAINLESS STEEL HARDENED RC 26-36 STOCK NO.	303 STAINLESS STEEL STOCK NO.	THREAD	d +.000 -.001	L +.002 -.000	D	H	E
PL-6 PL-7 PL-8 PL-9 PL-10 PL-11 PL-12 PL-13 PL-14 PL-15 PL-16	PL-6-3 PL-7-3 PL-8-3 PL-9-3 PL-10-3 PL-11-3 PL-12-3 PL-13-3 PL-14-3 PL-15-3 PL-16-3	#8-32 UNC-2A	.1870	.1255 .1880 .2505 .3130 .3755 .5005 .6255 .7505 1.0005 1.2605 1.5005	5/16	5/32	3/16

THREAD	STYLE	MATERIAL
#10-32 UNC-2A	SLOTTED HEAD	303 STAINLESS STEEL AND 416 STAINLESS STEEL HARDENED RC 26-36

416 STAINLESS STEEL HARDENED RC 26-36 STOCK NO.	303 STAINLESS STEEL STOCK NO.	THREAD	d +.000 -.001	L +.002 -.000	D	H	E
PL-17 PL-18 PL-19 PL-20 PL-21 PL-22 PL-23 PL-24 PL-25 PL-26 PL-27	PL-17-3 PL-18-3 PL-19-3 PL-20-3 PL-21-3 PL-22-3 PL-23-3 PL-24-3 PL-25-3 PL-26-3 PL-27-3	#10-32 UNF-2A	.2495	.1255 .1880 .2505 .3130 .3755 .5005 .6255 .7505 1.0005 1.2505 1.5005	3/8	3/16	1/4

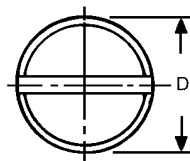
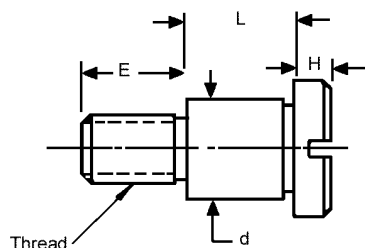

SHOULDER SCREWS

THREAD	STYLE	MATERIAL
1/4-20 UNC-2A	SLOTTED HEAD	303 STAINLESS STEEL AND 416 STAINLESS STEEL HARDENED RC 26-36

416 STAINLESS STEEL HARDENED RC 26-36	303 STAINLESS STEEL	THREAD	d + .000 - .001	L + .002 - .000	D	H	E
STOCK NO.	STOCK NO.						
PL-28 PL-29 PL-30 PL-31 PL-32 PL-33	PL-28-3 PL-29-3 PL-30-3 PL-31-3 PL-32-3 PL-33-3	1/4-20 UNC-2A	.3120	.2505 .3130 .3755 .5005 .6255 .7505	1/2	7/32	7/16

THREAD	STYLE	MATERIAL
1/4-20 UNC-2A	SLOTTED HEAD	303 STAINLESS STEEL AND 416 STAINLESS STEEL HARDENED RC 26-36

416 STAINLESS STEEL HARDENED RC 26-36	303 STAINLESS STEEL	THREAD	d + .000 - .001	L + .002 - .000	D	H	E
STOCK NO.	STOCK NO.						
PL-34 PL-35 PL-36 PL-37	PL-34-3 PL-35-3 PL-36-3 PL-37-3	1/4-20 UNC-2A	.3745	.3130 .3755 .5005 .6255	1/2	7/32	7/16

THREAD	STYLE	MATERIAL
5/16-18 UNC-2A	SLOTTED HEAD	303 STAINLESS STEEL AND 416 STAINLESS STEEL HARDENED RC 26-36

416 STAINLESS STEEL HARDENED RC 26-36	303 STAINLESS STEEL	THREAD	d + .000 - .001	L + .002 - .000	D	H	E
STOCK NO.	STOCK NO.						
PL-38 PL-39 PL-40 PL-41	PL-38-3 PL-39-3 PL-40-3 PL-41-3	5/16-18 UNC-2A	.3745	.3130 .3755 .5005 .6255	9/16	1/4	1/2

THREAD	STYLE	MATERIAL
3/8-16 UNC-2A	SLOTTED HEAD	303 STAINLESS STEEL AND 416 STAINLESS STEEL HARDENED RC 26-36

416 STAINLESS STEEL HARDENED RC 26-36	303 STAINLESS STEEL	THREAD	d + .000 - .001	L + .002 - .000	D	H	E
STOCK NO.	STOCK NO.						
PL-42 PL-43 PL-44 PL-45	PL-42-3 PL-43-3 PL-44-3 PL-45-3	3/8-16 UNC-2A	.4995	.5005 .6255 .7505 1.0005	3/4	5/16	5/8

Drawing on previous page.

SHOULDER SCREWS

THREAD	STYLE	MATERIAL
#4-40 UNC-2A	HEX SOCKET HEAD	303 STAINLESS STEEL AND 416 STAINLESS STEEL HARDENED RC 26-36

416 STAINLESS STEEL HARDENED RC 26-36	303 STAINLESS STEEL	THREAD	d + .000 - .001	L + .002 - .000	D	H	E	S
STOCK NO.	STOCK NO.							
PZ-1	PZ-1-3	#4-40 UNC-2A	.1245	.1255	1/4	1/8	5/32	5/64
PZ-2	PZ-2-3			.1880				
PZ-3	PZ-3-3			.2505				
PZ-4	PZ-4-3			.3130				
PZ-5	PZ-5-3			.3755				

THREAD	STYLE	MATERIAL
#8-32 UNC-2A	HEX SOCKET HEAD	303 STAINLESS STEEL AND 416 STAINLESS STEEL HARDENED RC 26-36

416 STAINLESS STEEL HARDENED RC 26-36	303 STAINLESS STEEL	THREAD	d + .000 - .001	L + .002 - .000	D	H	E	S
STOCK NO.	STOCK NO.							
PZ-6	PZ-6-3	#8-32 UNC-2A	.1870	.1255	5/16	5/32	3/16	3/32
PZ-7	PZ-7-3			.1880				
PZ-8	PZ-8-3			.2505				
PZ-9	PZ-9-3			.3130				
PZ-10	PZ-10-3			.3755				
PZ-11	PZ-11-3			.5005				
PZ-12	PZ-12-3			.6255				
PZ-13	PZ-13-3			.7505				
PZ-14	PZ-14-3			1.0005				
PZ-15	PZ-15-3			1.2505				
PZ-16	PZ-16-3			1.5005				

THREAD	STYLE	MATERIAL
#10-32 UNC-2A	HEX SOCKET HEAD	303 STAINLESS STEEL AND 416 STAINLESS STEEL HARDENED RC 26-36

416 STAINLESS STEEL HARDENED RC 26-36	303 STAINLESS STEEL	THREAD	d + .000 - .001	L + .002 - .000	D	H	E	S
STOCK NO.	STOCK NO.							
PZ-17	PZ-17-3	#10-32 UNF-2A	.2495	.1255	3/8	3/16	1/4	1/8
PZ-18	PZ-18-3			.1880				
PZ-19	PZ-19-3			.2505				
PZ-20	PZ-20-3			.3130				
PZ-21	PZ-21-3			.3755				
PZ-22	PZ-22-3			.5005				
PZ-23	PZ-23-3			.6255				
PZ-24	PZ-24-3			.7505				
PZ-25	PZ-25-3			1.0005				
PZ-26	PZ-26-3			1.2505				
PZ-27	PZ-27-3			1.5005				

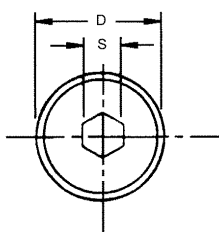
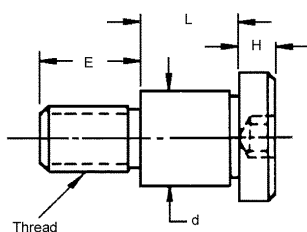

SHOULDER SCREWS

THREAD	STYLE	MATERIAL
1/4-20 UNC-2A	HEX SOCKET HEAD	303 STAINLESS STEEL AND 416 STAINLESS STEEL HARDENED RC 26-36

416 STAINLESS STEEL HARDENED RC 26-36	303 STAINLESS STEEL	THREAD	d + .000 - .001	L + .002 - .000	D	H	E	S
STOCK NO.	STOCK NO.							
PZ-28 PZ-29 PZ-30 PZ-31 PZ-32 PZ-33	PZ-28-3 PZ-29-3 PZ-30-3 PZ-31-3 PZ-32-3 PZ-33-3	1/4-20 UNC-2A	.3120	.2505 .3130 .3755 .5005 .6255 .7505	1/2	7/32	7/16	5/32

THREAD	STYLE	MATERIAL
1/4-20 UNC-2A	HEX SOCKET HEAD	303 STAINLESS STEEL AND 416 STAINLESS STEEL HARDENED RC 26-36

416 STAINLESS STEEL HARDENED RC 26-36	303 STAINLESS STEEL	THREAD	d + .000 - .001	L + .002 - .000	D	H	E	S
STOCK NO.	STOCK NO.							
PZ-34 PZ-35 PZ-36 PZ-37	PZ-34-3 PZ-35-3 PZ-36-3 PZ-37-3	1/4-20 UNC-2A	.3745	.3130 .3755 .5005 .6255	1/2	7/32	7/16	5/32

THREAD	STYLE	MATERIAL
5/16-18 UNC-2A	HEX SOCKET HEAD	303 STAINLESS STEEL AND 416 STAINLESS STEEL HARDENED RC 26-36

416 STAINLESS STEEL HARDENED RC 26-36	303 STAINLESS STEEL	THREAD	d + .000 - .001	L + .002 - .000	D	H	E	S
STOCK NO.	STOCK NO.							
PZ-38 PZ-39 PZ-40 PZ-41	PZ-38-3 PZ-39-3 PZ-40-3 PZ-41-3	5/16-18 UNC-2A	.3745	.3130 .3755 .5005 .6255	9/16	1/4	1/2	3/16

THREAD	STYLE	MATERIAL
3/8-16 UNC-2A	HEX SOCKET HEAD	303 STAINLESS STEEL AND 416 STAINLESS STEEL HARDENED RC 26-36

416 STAINLESS STEEL HARDENED RC 26-36	303 STAINLESS STEEL	THREAD	d + .000 - .001	L + .002 - .000	D	H	E	S
STOCK NO.	STOCK NO.							
PZ-42 PZ-43 PZ-44 PZ-45	PZ-42-3 PZ-43-3 PZ-44-3 PZ-45-3	3/8-16 UNC-2A	.4995	.5005 .6255 .7505 1.0005	3/4	5/16	5/8	1/4

Drawing on previous page. See index for hex wrenches.

PRECISION CAPTIVE SCREWS

THREAD	STYLE	MATERIAL
#4-40 TO 10-32 UNC-2A	SLOTTED HEAD	303 STAINLESS STEEL

SLOTTED HEAD STOCK NO.	L	M	H	E	D	THREAD UN-2A
Z12-1	.281	.187	1/8	.072	1/4	#4-40
Z12-2	.343	.187	1/8	.072	1/4	#4-40
Z12-3	.312	.218	1/8	.086	9/32	#6-32
Z12-4	.375	.218	1/8	.086	9/32	#6-32
Z12-5	.437	.218	1/8	.086	9/32	#6-32
Z12-6	.406	.250	5/32	.114	5/16	#8-32
Z12-7	.468	.250	5/32	.114	5/16	#8-32
Z12-8	.531	.250	5/32	.114	5/16	#8-32
Z12-9	.531	.312	3/16	.136	3/8	#10-32
Z12-10	.593	.312	3/16	.136	3/8	#10-32

THREAD	STYLE	MATERIAL
#4-40 TO 10-32 UNC-2A	HEX SOCKET HEAD	303 STAINLESS STEEL

HEX SOCKET HEAD STOCK NO.	L	M	H	E	D	THREAD UN-2A	W
Z12-1-H	.281	.187	1/8	.072	1/4	#4-40	5/64
Z12-2-H	.343	.187	1/8	.072	1/4	#4-40	5/64
Z12-3-H	.312	.218	1/8	.086	9/32	#6-32	5/64
Z12-4-H	.375	.218	1/8	.086	9/32	#6-32	5/64
Z12-5-H	.437	.218	1/8	.086	9/32	#6-32	5/64
Z12-6-H	.406	.250	5/32	.114	5/16	#8-32	3/32
Z12-7-H	.468	.250	5/32	.114	5/16	#8-32	3/32
Z12-8-H	.531	.250	5/32	.114	5/16	#8-32	3/32
Z12-9-H	.531	.312	3/16	.136	3/8	#10-32	1/8
Z12-10-H	.593	.312	3/16	.136	3/8	#10-32	1/8

See index for hex wrenches.



THREAD	STYLE	MATERIAL
#4-40 TO 10-32 UNC-2A	KNURLED HEAD	303 STAINLESS STEEL

KNURLED HEAD STOCK NO.	L	M	H	E	D	THREAD UN-2A
Z12-1-K	.281	.187	1/8	.072	1/4	#4-40
Z12-2-K	.343	.187	1/8	.072	1/4	#4-40
Z12-3-K	.312	.218	1/8	.086	9/32	#6-32
Z12-4-K	.375	.218	1/8	.086	9/32	#6-32
Z12-5-K	.437	.218	1/8	.086	9/32	#6-32
Z12-6-K	.406	.250	5/32	.114	5/16	#8-32
Z12-7-K	.468	.250	5/32	.114	5/16	#8-32
Z12-8-K	.531	.250	5/32	.114	5/16	#8-32
Z12-9-K	.531	.312	3/16	.136	3/8	#10-32
Z12-10-K	.593	.312	3/16	.136	3/8	#10-32

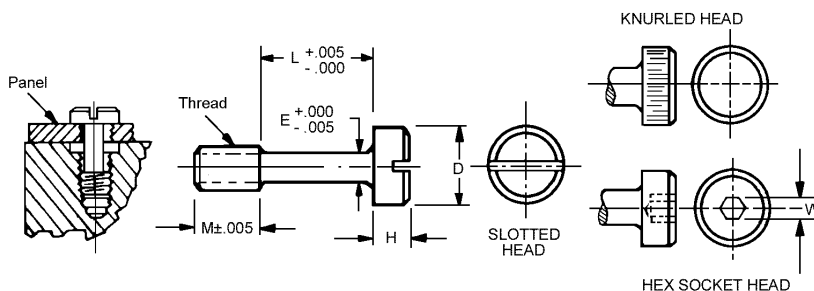

PRECISION JIG BUTTONS

MATERIAL
416 STAINLESS STEEL HARDENED ROCKWELL C28-32

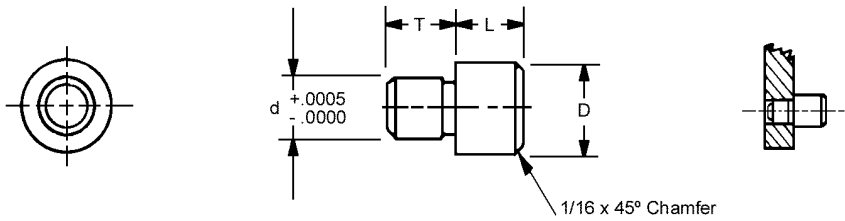

STOCK NO.	L	T	D	d
PM-1	1/4	1/4	3/8	.1875
PM-2	3/8	1/4	3/8	.1875
PM-3	1/2	1/4	3/8	.1875
PM-4	1/4	5/16	1/2	.2500
PM-5	3/8	5/16	1/2	.2500
PM-6	1/2	5/16	1/2	.3125
PM-7	3/4	5/16	1/2	.3125
PM-8	1	5/16	1/2	.3125

THUMB SCREWS

THREAD	STYLE	MATERIAL
#4-40 UNC-2A	PLASTIC HEAD, KNURLED	303 STAINLESS STEEL WITH BLACK PLASTIC HEAD

STOCK NO.	THREAD	A	B	C	D	L
PQC-1	#4-40 UNC-2A	5/16	11/64	9/32	.112	1/4
PQC-2						5/16
PQC-3						3/8
PQC-4						1/2
PQC-5						5/8

THREAD	STYLE	MATERIAL
#6-32 UNC-2A	PLASTIC HEAD, KNURLED	303 STAINLESS STEEL WITH BLACK PLASTIC HEAD

STOCK NO.	THREAD	A	B	C	D	L
PQC-6	#6-32 UNC-2A	3/8	3/16	21/64	.138	5/16
PQC-7						3/8
PQC-8						1/2
PQC-9						5/8
PQC-10						3/4

THREAD	STYLE	MATERIAL
#8-32 UNC-2A	PLASTIC HEAD, KNURLED	303 STAINLESS STEEL WITH BLACK PLASTIC HEAD

STOCK NO.	THREAD	A	B	C	D	L
PQC-11	#8-32 UNC-2A	1/2	7/32	3/8	.164	3/8
PQC-12						1/2
PQC-13						5/8
PQC-14						3/4
PQC-15						1

THREAD	STYLE	MATERIAL
#10-24 UNC-2A	PLASTIC HEAD, KNURLED	303 STAINLESS STEEL WITH BLACK PLASTIC HEAD

STOCK NO.	THREAD	A	B	C	D	L
PQC-16	#10-24 UNC-2A	5/8	1/4	27/64	.190	3/8
PQC-17						1/2
PQC-18						5/8
PQC-19						3/4
PQC-20						1

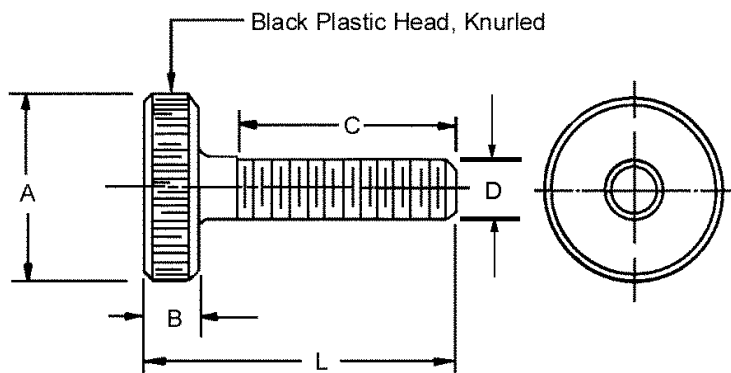

Other sizes, special lengths and non-stainless screws available on request.



THUMB SCREWS

THREAD	STYLE	MATERIAL
10-32 UNF-2A	PLASTIC HEAD, KNURLED	303 STAINLESS STEEL WITH BLACK PLASTIC HEAD

STOCK NO.	THREAD	A	B	C	D	L
PQC-21	#10-32 UNF-2A	5/8	1/4	27/64	.190	3/8
PQC-22						1/2
PQC-23						5/8
PQC-24						3/4
PQC-25						1

THREAD	STYLE	MATERIAL
1/4-20 UNC-2A	PLASTIC HEAD, KNURLED	303 STAINLESS STEEL WITH BLACK PLASTIC HEAD

STOCK NO.	THREAD	A	B	C	D	L
PQC-26	#1/4-20 UNC-2A	3/4	5/16	1/2	.250	3/8
PQC-27						1/2
PQC-28						5/8
PQC-29						3/4
PQC-30						1

THREAD	STYLE	MATERIAL
1/4-20 UNC-2A	PLASTIC HEAD, KNURLED	303 STAINLESS STEEL WITH BLACK PLASTIC HEAD

STOCK NO.	THREAD	A	B	C	D	L
PQC-31	#1/4-20 UNC-2A	1	5/16	1/2	.250	3/8
PQC-32						1/2
PQC-33						5/8
PQC-34						3/4
PQC-35						1

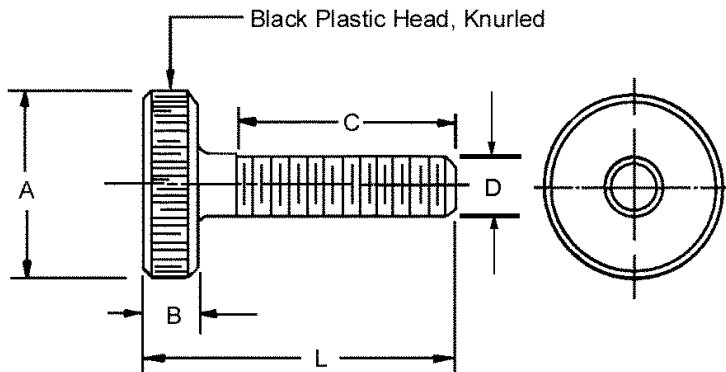

Other sizes, special lengths and non-stainless screws available on request.



THUMB SCREWS

THREAD	STYLE	MATERIAL
#4-40 UNC-2A	KNURLED	303 STAINLESS STEEL OR 416 STAINLESS STEEL HARDENED RC 26-32

416 STAINLESS STEEL STOCK NO.	303 STAINLESS STEEL STOCK NO.	THREAD	D	L	F	E
PQ-1	PQ-1-3	#4-40 UNC-2A	1/4	1/2	5/16	1/8
PQ-2	PQ-2-3		1/4	1	7/16	1/2
PQ-3	PQ-3-3		1/4	1 1/4	5/8	1/2
PQ-4	-	#4-40 UNC-2A	3/8	1/2	5/16	1/8
-	PQ-4-3		3/8	1/2	5/16	1/8
PQ-5	PQ-5-3		3/8	5/8	7/16	1/8

THREAD	STYLE	MATERIAL
#6-32 UNC-2A	KNURLED	303 STAINLESS STEEL OR 416 STAINLESS STEEL HARDENED RC 26-32

416 STAINLESS STEEL STOCK NO.	303 STAINLESS STEEL STOCK NO.	THREAD	D	L	F	E
PQ-6	PQ-6-3	#6-32 UNC-2A	1/4	1	7/16	1/2
PQ-7	PQ-7-3		1/4	1 1/4	5/8	1/2
PQ-8	PQ-8-3		1/4	1 1/2	13/16	1/2
PQ-9	PQ-9-3	#6-32 UNC-2A	3/8	1/2	5/16	1/8
PQ-10	PQ-10-3		3/8	5/8	3/8	1/8

THREAD	STYLE	MATERIAL
#8-32 UNC-2A	KNURLED	303 STAINLESS STEEL OR 416 STAINLESS STEEL HARDENED RC 26-32

416 STAINLESS STEEL STOCK NO.	303 STAINLESS STEEL STOCK NO.	THREAD	D	L	F	E
PQ-11	PQ-11-3	#8-32 UNC-2A	1/4	1	7/16	1/2
PQ-12	PQ-12-3		1/4	1 1/4	5/8	1/2
PQ-13	PQ-13-3		1/4	1 1/2	13/16	1/2
PQ-14	PQ-14-3	#8-32 UNC-2A	3/8	1/2	5/16	1/8
PQ-15	PQ-15-3		3/8	5/8	3/8	1/8

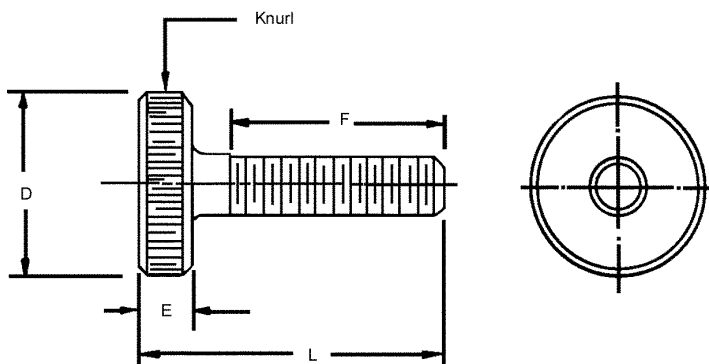

F

THUMB SCREWS

THREAD	STYLE	MATERIAL
#10-24 UNC-2A	KNURLED	303 STAINLESS STEEL OR 416 STAINLESS STEEL HARDENED RC 26-32

416 STAINLESS STEEL STOCK NO.	303 STAINLESS STEEL STOCK NO.	THREAD	D	L	F	E
PQ-16	PQ-16-3	#10-24 UNC-2A	3/8	11/16	7/16	3/16
PQ-17	PQ-17-3		3/8	15/16	5/8	3/16
PQ-18	PQ-18-3		3/8	1 3/16	13/16	3/16
PQ-19	PQ-19-3		3/8	1 7/16	1	3/16
PQ-20	PQ-20-3	#10-24 UNC-2A	1/2	15/16	5/8	3/16
PQ-21	PQ-21-3		1/2	1 3/16	13/16	3/16
PQ-22	PQ-22-3		1/2	1 7/16	1	3/16
PQ-23	PQ-23-3		1/2	1 11/16	1 1/4	3/16
PQ-24	PQ-24-3	#10-24 UNC-2A	3/4	15/16	5/8	3/16
PQ-25	PQ-25-3		3/4	1 3/16	13/16	3/16
PQ-26	PQ-26-3		3/4	1 7/16	1	3/16
PQ-27	PQ-27-3		3/4	1 11/16	1 1/4	3/16

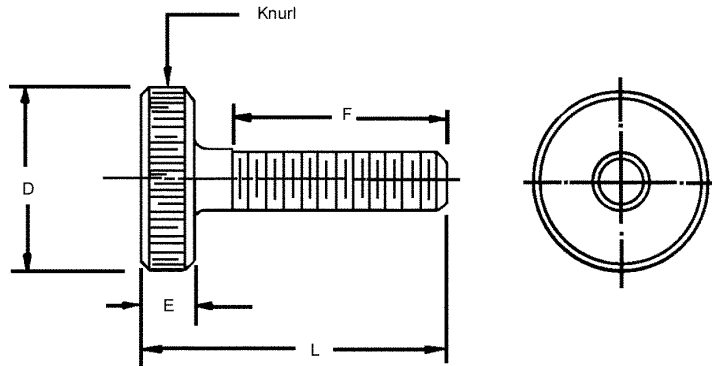

THUMB SCREWS

THREAD	STYLE	MATERIAL
#10-32 UNF-2A	KNURLED	303 STAINLESS STEEL OR 416 STAINLESS STEEL HARDENED RC 26-32

416 STAINLESS STEEL STOCK NO.	303 STAINLESS STEEL STOCK NO.	THREAD	D	L	F
PQ-28	PQ-28-3	#10-32 UNF-2A	3/8	11/16	7/16
PQ-29	PQ-29-3			15/16	5/8
PQ-30	PQ-30-3			1 3/16	13/16
PQ-31	PQ-31-3			1 7/16	1
PQ-32	PQ-32-3	#10-32 UNF-2A	1/2	15/16	5/8
PQ-33	PQ-33-3			1 3/16	13/16
PQ-34	PQ-34-3			1 7/16	1
PQ-35	PQ-35-3			1 11/16	1 1/4
PQ-36	PQ-36-3	#10-32 UNF-2A	3/4	15/16	5/8
PQ-37	PQ-37-3			1 3/16	13/16
PQ-38	PQ-38-3			1 7/16	1
PQ-39	PQ-39-3			1 11/16	1 1/4

THREAD	STYLE	MATERIAL
#1/4-20 UNC-2A	KNURLED	303 STAINLESS STEEL OR 416 STAINLESS STEEL HARDENED RC 26-32

416 STAINLESS STEEL STOCK NO.	303 STAINLESS STEEL STOCK NO.	THREAD	D	L	F
PQ-40	PQ-40-3	1/4-20 UNC-2A	3/4	15/16	5/8
PQ-41	PQ-41-3			1 3/16	13/16
PQ-42	PQ-42-3			1 7/16	1
PQ-43	PQ-43-3			1 11/16	1 1/4
PQ-44	PQ-44-3			2 3/16	1 5/8
PQ-45	PQ-45-3	1/4-20 UNC-2A	1	15/16	5/8
PQ-46	PQ-46-3			1 3/16	13/16
PQ-47	PQ-47-3			1 7/16	1
PQ-48	PQ-48-3			1 11/16	1 1/4
PQ-49	PQ-49-3			2 3/16	1 5/8

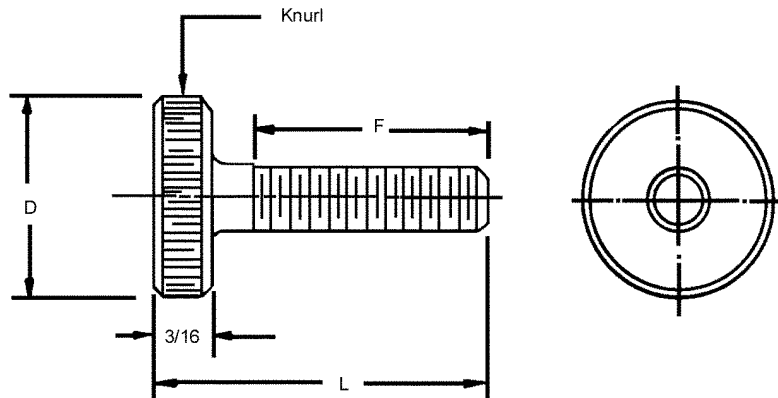

F

THUMB SCREWS

THREAD	STYLE	MATERIAL
#4-40 UNC-2A	KNURLED SOCKET HEAD	303 STAINLESS STEEL

STOCK NO.	THREAD	A	C	D	B	E	F
PQH-1	#4-40	1/2	1/4	1/2	7/16	5/64	1/16
PQH-2	UNC-2A	3/4			5/8		
PQH-3	#4-40	1/2	5/16	1/2	7/16	3/32	5/64
PQH-4	UNC-2A	3/4			5/8		
PQH-5	#4-40	3/8	3/8	1/2	5/16	1/8	3/32
PQH-6	UNC-2A	1/2			7/16		

THREAD	STYLE	MATERIAL
#6-32 UNC-2A	KNURLED SOCKET HEAD	303 STAINLESS STEEL

STOCK NO.	THREAD	A	C	D	B	E	F
PQH-7	#6-32	1/2	1/4	1/2	7/16	5/64	1/16
PQH-8	UNC-2A	3/4			5/8		
PQH-9		1			13/16		
PQH-10	#6-32	1/2	5/16	1/2	7/16	3/32	5/64
PQH-11	UNC-2A	3/4			5/8		
PQH-12		1			13/16		
PQH-13	#6-32	3/8	3/8	1/2	5/16	1/8	3/32
PQH-14	UNC-2A	1/2			3/8		

THREAD	STYLE	MATERIAL
#8-32 UNC-2A	KNURLED SOCKET HEAD	303 STAINLESS STEEL

STOCK NO.	THREAD	A	C	D	B	E	F
PQH-15	#8-32	1/2	1/4	1/2	7/16	5/64	1/16
PQH-16	UNC-2A	3/4			5/8		
PQH-17		1			13/16		
PQH-18	#8-32	1/2	5/16	1/2	7/16	3/32	5/64
PQH-19	UNC-2A	3/4			5/8		
PQH-20		1			13/16		
PQH-21	#8-32	3/8	3/8	1/2	5/16	1/8	3/32
PQH-22	UNC-2A	1/2			3/8		

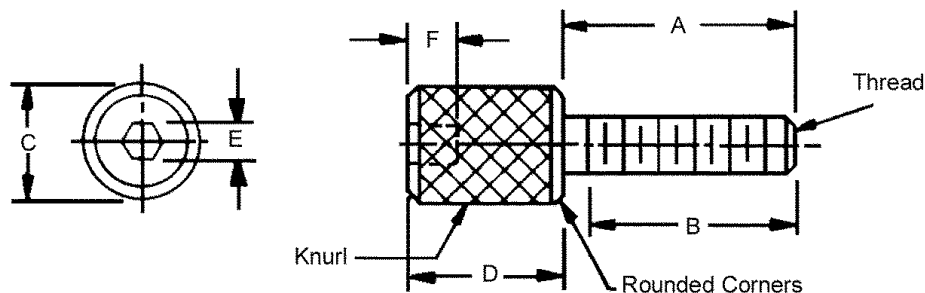

THUMB SCREWS

THREAD	STYLE	MATERIAL
#10-24 UNC-2A #10-32 UNF-2A	KNURLED SOCKET HEAD	303 STAINLESS STEEL OR 416 STAINLESS STEEL HARDENED RC 26-32

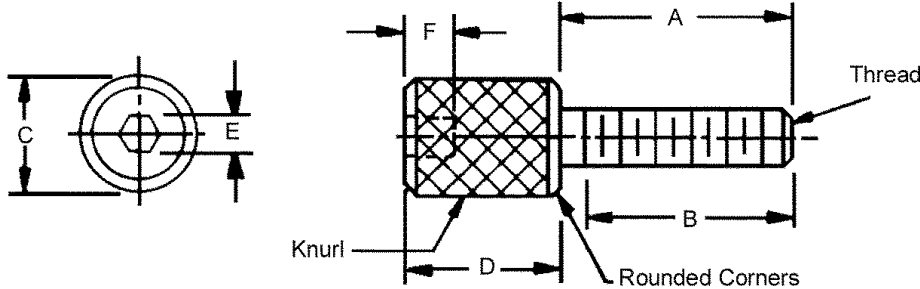

STOCK NO.	THREAD	A	C	D	B	E	F
PQH-23	#10-24 UNC-2A	1/2	5/16	3/16	7/16	3/32	5/64
PQH-24		3/4			5/8		
PQH-25		1			13/16		
PQH-26		1 1/4			1		
PQH-27	#10-24 UNC-2A	1/2	3/8	1/2	7/16	1/8	3/32
PQH-28		3/4			5/8		
PQH-29		1			13/16		
PQH-30		1 1/4			1		
PQH-31	#10-32 UNF-2A	1/2	5/16	3/16	7/16	3/32	5/64
PQH-32		3/4			5/8		
PQH-33		1			13/16		
PQH-34		1 1/4			1		
PQH-35	#10-32 UNF-2A	1/2	3/8	1/2	7/16	1/8	3/32
PQH-36		3/4			5/8		
PQH-37		1			13/16		
PQH-38		1 1/4			1		

F

THUMB NUTS

THREAD	STYLE	MATERIAL
#4-40 UNC-2B	KNURLED	303 STAINLESS STEEL

STOCK NO.	THREAD	A	B	C	D	COUNTERBORE			
						DIA.	DEEP		
PD1-1	#4-40 UNC-2B	1/2	1/4	1/8	1/4	1/8	1/8		
PD1-2		1/2			1/8	3/8			
PD1-3		3/4			1/4	1/8	1/4	1/8	1/8
PD1-4		3/4			1/2	1/8	1/8	3/8	

THREAD	STYLE	MATERIAL
#6-32 UNC-2B	KNURLED	303 STAINLESS STEEL

STOCK NO.	THREAD	A	B	C	D	COUNTERBORE			
						DIA.	DEEP		
PD1-5	#6-32 UNC-2B	1/2	1/4	1/8	1/4	#26	3/32		
PD1-6		1/2			1/2	#26	11/32		
PD1-7		3/4			1/4	1/8	1/4	#26	3/32
PD1-8		3/4			1/2	1/8	1/4	#26	11/32

THREAD	STYLE	MATERIAL
#8-32 UNC-2B	KNURLED	303 STAINLESS STEEL

STOCK NO.	THREAD	A	B	C	D	COUNTERBORE	
						DIA.	DEEP
PD1-9	#8-32 UNC-2B	1/2	5/16	1/8	1/4	-	-
PD1-10		1/2			1/2	#15	1/4
PD1-11		3/4			1/4	-	-
PD1-12		3/4			1/2	#15	1/4

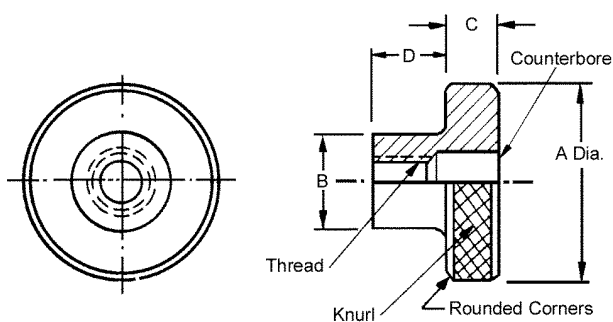

THUMB NUTS

THREAD	STYLE	MATERIAL
#10-24 UNC-2B	KNURLED	303 STAINLESS STEEL

STOCK NO.	THREAD	A	B	C	D	COUNTERBORE	
						DIA.	DEEP
PD1-13	#10-24 UNC-2B	1/2	3/8	3/16	1/4	-	-
PD1-14		1/2			1/4	13/64	1/4
PD1-15		1	1/4	-	-		
PD1-16		1	1/2	13/64	1/4		

THREAD	STYLE	MATERIAL
#10-32 UNF-2B	KNURLED	303 STAINLESS STEEL

STOCK NO.	THREAD	A	B	C	D	COUNTERBORE	
						DIA.	DEEP
PD1-17	#10-32 UNF-2B	1/2	3/8	3/16	1/4	-	-
PD1-18		1/2			1/2	13/64	1/4
PD1-19		1	1/4	-	-		
PD1-20		1	1/2	13/64	1/4		

THREAD	STYLE	MATERIAL
#1/4-20 UNC-2B	KNURLED	303 STAINLESS STEEL

STOCK NO.	THREAD	A	B	C	D	COUNTERBORE	
						DIA.	DEEP
PD1-21	1/4-20 UNC-2B	3/4	1/2	1/4	1/4	-	-
PD1-22		3/4			1/2	17/64	1/4
PD1-23		1	1/4	-	-		
PD1-24		1	1/2	17/64	1/4		
PD1-25		1	3/4	17/64	1/2		

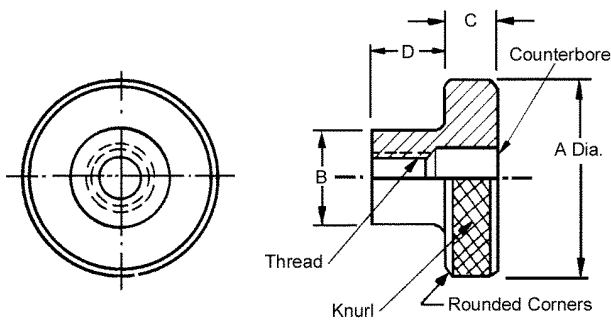

F

THREADED STUDS

THREAD	STYLE	MATERIAL
#6-32	DOUBLE ENDED	303 STAINLESS STEEL

STOCK NO.	L	THREAD SIZE BOTH ENDS	D	d	B
PV-1	1	#6-32	7/32	1/2	.138 DIA.
PV-2	1 1/4			5/8	
PV-30	1 1/2			3/4	
PV-3	1 3/4			3/4	
PV-4	2			3/4	

THREAD	STYLE	MATERIAL
#8-32	DOUBLE ENDED	303 STAINLESS STEEL

STOCK NO.	L	THREAD SIZE BOTH ENDS	D	d	B
PV-5	1	#8-32	7/32	1/2	.164 DIA.
PV-6	1 1/4			5/8	
PV-7	1 1/2			3/4	
PV-8	1 3/4			3/4	
PV-9	2			3/4	

THREAD	STYLE	MATERIAL
#10-24	DOUBLE ENDED	303 STAINLESS STEEL

STOCK NO.	L	THREAD SIZE BOTH ENDS	D	d	B
PV-10	1	#10-24	7/32	1/2	.190 DIA.
PV-11	1 1/4			5/8	
PV-12	1 1/2			3/4	
PV-13	1 3/4			3/4	
PV-31	2			3/4	

THREAD	STYLE	MATERIAL
#10-32	DOUBLE ENDED	303 STAINLESS STEEL

STOCK NO.	L	THREAD SIZE BOTH ENDS	D	d	B
PV-14	1	#10-32	7/32	1/2	.190 DIA.
PV-15	1 1/4			5/8	
PV-16	1 1/2			3/4	
PV-17	1 3/4			3/4	
PV-18	2			3/4	

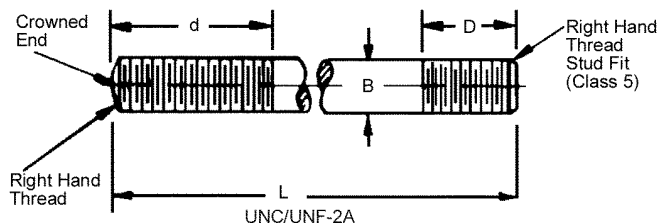

THREADED STUDS

THREAD	STYLE	MATERIAL
1/4-20	DOUBLE ENDED	303 STAINLESS STEEL

STOCK NO.	L	THREAD SIZE BOTH ENDS	D	d	B
PV-19	1 1/4	1/4-20	9/32	5/8	.250 DIA.
PV-20	1 1/2			5/8	
PV-21	1 3/4			3/4	
PV-22	2			3/4	
PV-23	2 1/2			3/4	
PV-24	1			1	

THREAD	STYLE	MATERIAL
5/16-18	DOUBLE ENDED	303 STAINLESS STEEL

STOCK NO.	L	THREAD SIZE BOTH ENDS	D	d	B
PV-25	1 1/2	5/16-18	11/32	5/8	.312 DIA.
PV-26	2			1	
PV-27	2 1/2			1 1/4	
PV-28	1			1 3/8	
PV-32	3 1/2			1 1/2	
PV-29	4			1 1/2	

THREAD	STYLE	MATERIAL
3/8-16	DOUBLE ENDED	303 STAINLESS STEEL

STOCK NO.	L	THREAD SIZE BOTH ENDS	D	d	B
PV-33	1 5/8	3/8-16	11/32	3/4	.375 DIA.
PV-34	2			1	
PV-35	2 1/2			1 1/4	
PV-36	1			1 3/8	
PV-37	3 1/2			1 1/2	
PV-38	4			1 1/2	

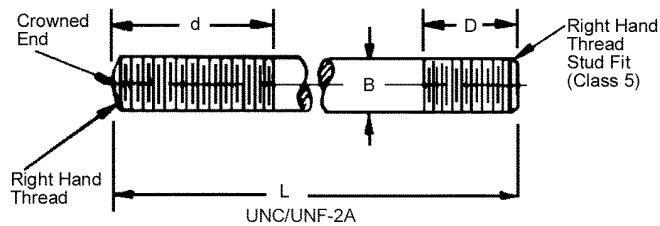

F

HEX NUTS

SCREW SIZE	MATERIAL
#000 TO 1/4-20	STAINLESS STEEL TYPE 18-8

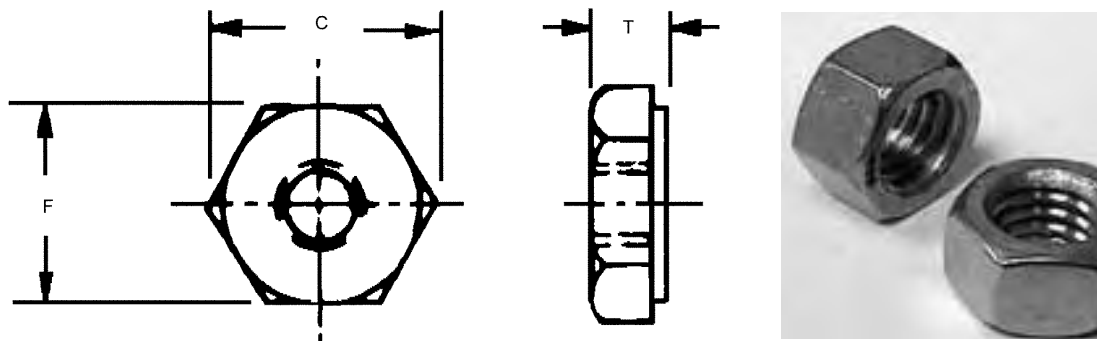

SCREW STOCK NO.	SIZE UN-2B	T	C (Ref.)	F
Y5-000	#000-120	3/64	7/64	3/32
Y5-00	#00-96	3/64	7/64	3/32
Y5-0	#0-80	3/64	3/16	5/32
Y5-164	#1-64	3/64	3/16	5/32
Y5-1	#1-72	3/64	3/16	5/32
Y5-2	#2-56	1/16	7/32	3/16
Y5-4	#4-40	3/32	9/32	1/4
Y5-6	#6-32	7/64	23/64	5/16
Y5-8	#8-32	1/8	25/64	11/32
Y5-11	#10-24	1/8	7/16	3/8
Y5-10	#10-24	1/8	7/16	3/8
Y5-12	1/4-20	3/16	1/2	7/16

SCREW STOCK NO.	SIZE UN-2B	T	C (Ref.)	F
Y5-23	1/4-28	3/16	1/2	7/16
Y5-13	5/16-18	17/64	37/64	1/2
Y5-14	5/16-24	17/64	37/64	1/2
Y5-15	3/8-16	21/64	41/64	9/16
Y5-16	3/8-24	21/64	41/64	9/16
Y5-24	3/8-32	3/32	41/64	9/16
Y5-17	1/2-13	7/16	7/8	55/64
Y5-18	1/2-20	7/16	55/64	3/4
Y5-19	5/8-11	35/64	1 5/64	15/16
Y5-20	5/8-18	35/64	1 5/64	15/16
Y5-21	3/4-10	41/64	1 17/64	1 1/8
Y5-22	3/4-16	41/64	1 17/64	1 1/8

SCREW SIZE	MATERIAL
#2-56 TO 5/16-24	MOLDED NYLON - WHITE

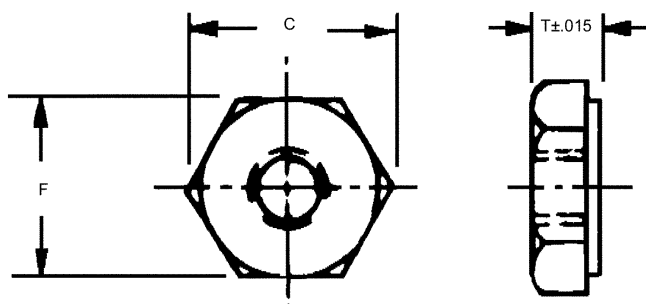

SCREW STOCK NO.	THREAD SIZE	T	C (Ref.)	F
Z5-N-2	#2-56	.066	.217	3/16
Z5-N-1	#4-40	.098	.289	1/4
Z5-N-3	#6-32	.114	.361	5/16
Z5-N-5	#8-32	.130	.397	11/32
Z5-N-7	#10-24	.130	.433	3/8
Z5-N-9	#10-32	.130	.433	3/8
Z5-N-11	1/4-20	.226	.505	7/16
Z5-N-12	5/16-18	.273	.577	1/2
Z5-N-13	5/16-24	.293	.577	1/2

SOLD IN PACKAGES OF 10.

Also available

STOCK NO.	DESCRIPTION OF KIT	NO. OF PIECES
KIT-Z5	HEX NUTS, WASHERS, LOCK WASHERS, STAINLESS STEEL #0 TO #10	1800
KIT-Z11N	NYLON PAN HEAD SCREW KIT	480
KIT-Z9N	NYLON SOCKET HEAD SCREW KIT	480
KIT-Z6N	NYLON FLAT HEAD SCREW KIT	480

WASHERS

SCREW SIZE	MATERIAL	TYPE
#4 TO 1/4	MOLDED NYLON - WHITE	PLAIN

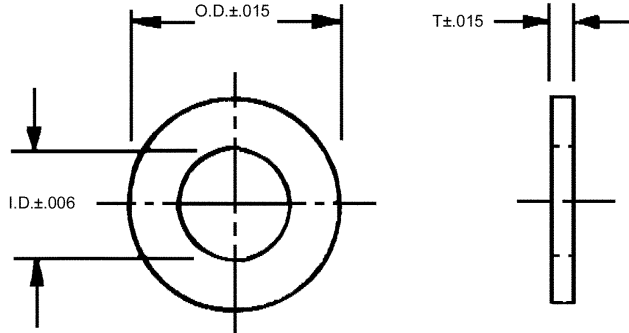

STOCK NO.	SCREW SIZE	OUTSIDE DIA.	I.D.	T
Z4-N-1	# 4	.281	.115	.047
Z4-N-3	# 6	.312	.140	.047
Z4-N-5	# 8	.375	.170	.062
Z4-N-7	# 10	.437	.200	.062
Z4-N-9	1/4	.562	.260	.062

SOLD IN PACKAGES OF 10.

SCREW SIZE	MATERIAL	TYPE
#000 TO 1/2	STAINLESS STEEL TYPE 18-8	SPLIT LOCK

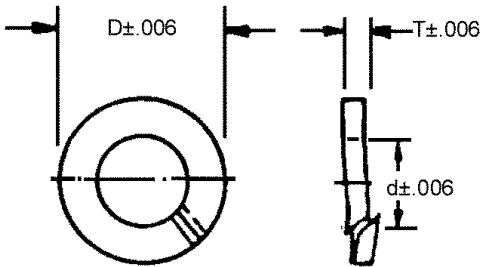

SOLD IN PACKAGES OF 10.

STOCK NO.	SCREW SIZE	D	d	T
Z3-000	#000	.093	.043	.020
Z3-00	#00	.093	.056	.020
Z3-0	#0	.130	.066	.020
Z3-1	#1	.150	.075	.020
Z3-2	#2	.166	.093	.020
Z3-4	#4	.203	.120	.025
Z3-6	#6	.244	.146	.031
Z3-8	#8	.287	.173	.040
Z3-10	#10	.327	.199	.047
Z3-12	1/4	.483	.261	.062
Z3-13	5/16	.580	.326	.078
Z3-14	3/8	.676	.390	.094
Z3-15	1/2	.875	.506	.125

F

SCREW SIZE	MATERIAL	TYPE
#000 TO 1/2	STAINLESS STEEL TYPE 18-8	PLAIN

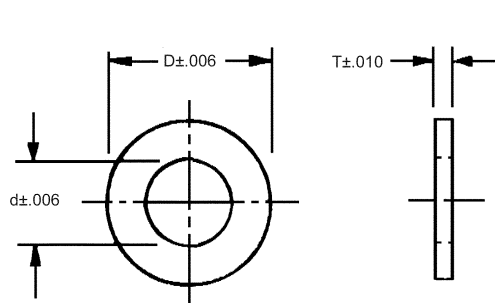

SOLD IN PACKAGES OF 10.

STOCK NO.	SCREW SIZE	D	d	T
Z4-000	#000	.090	.040	.012
Z4-00	#00	.108	.053	.015
Z4-0	#0	.156	.062	.020
Z4-1	#1	.187	.078	.020
Z4-2	#2	.187	.089	.031
Z4-4	#4	.312	.125	.031
Z4-6	#6	.375	.149	.031
Z4-8	#8	.375	.174	.031
Z4-10	#10	.438	.203	.063
Z4-12	1/4	.500	.265	.063
Z4-13	5/16	.562	.328	.063
Z4-14	3/8	.625	.390	.063
Z4-15	1/2	.750	.516	.093

WASHERS

SCREW SIZE	MATERIAL	TYPE
#4 TO 3/8	303 STAINLESS STEEL	PLAIN

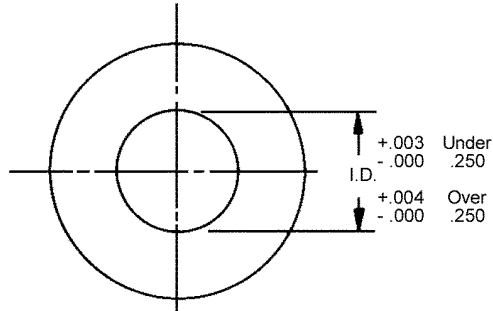
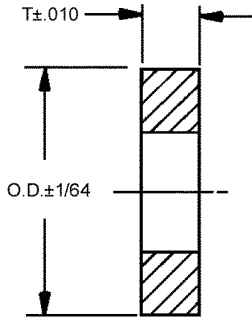

STOCK NO.	SCREW SIZE	I.D.	O.D.	T
PC5-1	#4	.116	1/4	1/16
PC5-2	#6	.144	5/16	1/16
PC5-3	#8	.169	3/8	1/16
PC5-4	#10	.196	7/16	5/64
PC5-5	1/4	.257	1/2	5/64
PC5-6	5/16	.323	5/8	3/32
PC5-7	3/8	.386	3/4	3/32

SOLD IN PACKAGES OF 10.

LOCK WASHERS

THREAD	STYLE	MATERIAL
#4 TO 1/2	EXTERNAL TOOTH	410 STAINLESS STEEL

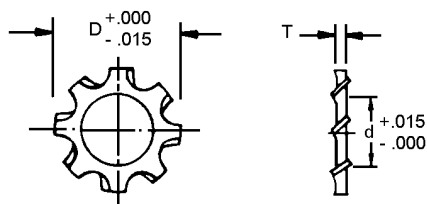

STOCK NO.	THREAD	D	d	T
Z1-4	#4	.255	.120	.015
Z1-6	#6	.317	.146	.018
Z1-8	#8	.381	.173	.020
Z1-10	#10	.406	.200	.022
Z1-25	1/4	.506	.260	.025
Z1-31	5/16	.601	.326	.030
Z1-37	3/8	.695	.390	.035
Z1-50	1/2	.898	.530	.040

THREAD	STYLE	MATERIAL
#2 TO 1/2	INTERNAL TOOTH	410 STAINLESS STEEL

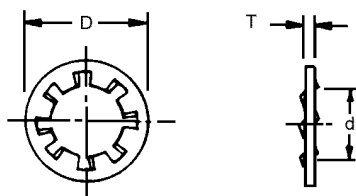

STOCK NO.	THREAD	D	d	T
Z2-2	#2	.185	.093	.013
Z2-4	#4	.265	.120	.015
Z2-6	#6	.288	.146	.018
Z2-8	#8	.336	.173	.020
Z2-10	#10	.381	.200	.022
Z2-25	1/4	.478	.260	.025
Z2-31	5/16	.607	.326	.030
Z2-37	3/8	.692	.390	.035
Z2-50	1/2	.883	.530	.090



Also available

STOCK NO.	DESCRIPTION OF KIT	PIECES
KIT-Z2	LOCK WASHER KIT, ASSORTED SIZES, STAINLESS STEEL, INTERNAL AND EXTERNAL TOOTH	480

THRUST WASHERS AND DISKS

SHAFT SIZE	TYPE	MATERIAL
1/8 TO 1 1/4	PLAIN HARDENED GROUND	410 STAINLESS STEEL RC 38-42 OR 1080 CARBON STEEL RC 61-63

410 STAINLESS STEEL STOCK NO.	CARBON STEEL STOCK NO.	I.D. DIA. +.003 -.008	O.D. DIA. +.003 -.008	T	SHAFT SIZE
CD1-1-SS	CD1-1	1/8	7/16	.050	1/8
CD1-2-SS	CD1-2	3/16	1/2	.050	3/16
CD1-3-SS	CD1-3	1/4	9/16	.050 ±.002	1/4
CD1-4-SS	CD1-4	5/16	5/8	.050	5/16
CD1-5-SS	CD1-5	3/8	13/16	.062	3/8
CD1-6-SS	CD1-6	1/2	15/16	.062 ±.003	1/2
CD1-7-SS	CD1-7	5/8	1 1/8	.093	5/8
CD1-8-SS	CD1-8	3/4	1 1/4	.093	3/4
CD1-9-SS	CD1-9	1	1 5/8	.125 ±.005	1
CD1-10-SS	CD1-10	1 1/4	1 7/8	.125	1 1/4

SHAFT SIZE	TYPE	MATERIAL
3/16 TO 1 1/4	PLAIN PLASTIC THRUST	NYLON AND TEFLON

NYLON STOCK NO.	TEFLON® STOCK NO.	I.D. +.010 -.005	O.D. ±1/64	T ±.005	SHAFT SIZE
CD7-3	CD8-3	.188	3/4	.062	3/16
CD7-4	CD8-4	.250	5/8	.093	1/4
CD7-5	CD8-5	.500	13/16	.093	1/2
CD7-9	CD8-9	.562	1	.093	9/16
CD7-10	CD8-10	.625	1 1/16	.093	5/8
CD7-12	CD8-12	.750	1 1/8	.093	3/4
CD7-14	CD8-14	.875	2 1/8	.093	7/8
CD7-20	CD8-20	1.250	2 1/16	.093	1 1/4

SHAFT SIZE	TYPE	MATERIAL
1/8 TO 1/2	PLAIN DISK AND WASHER	BRONZE (OIL-IMPREGNATED) OR TOOL STEEL

BRONZE OIL-IMPREGNATED		TOOL STEEL		WASHER I.D. +.004 -.000	O.D. BRONZE +0.000 -0.004	O.D. TOOL STEEL +0.008 -0.004	±.002 T	SHAFT SIZE
DISK	WASHER	DISK	WASHER					
CD2-1	CD3-1	CD4-1	CD5-1	.128	.372	.252	.062	1/8
CD2-2	CD3-2	CD4-2	CD5-2	.190	.497	.377	.062	3/16
CD2-3	CD3-3	CD4-3	CD5-3	.253	.622	.502	.062	1/4
CD2-4	CD3-4	CD4-4	CD5-4	.316	.747	.627	.093	5/16
CD2-5	CD3-5	CD4-5	CD5-5	.378	.872	.752	.125	3/8
CD2-6	CD3-6	CD4-6	CD5-6	.503	1.127	1.002	.187	1/2

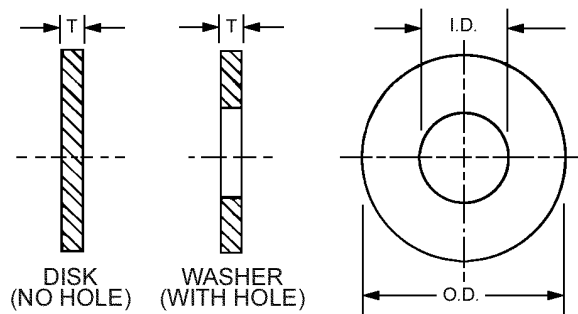

SWIVEL WASHERS

SCREW SIZE	TYPE	MATERIAL
#4 TO 3/8	MALE	303 STAINLESS STEEL MACHINED

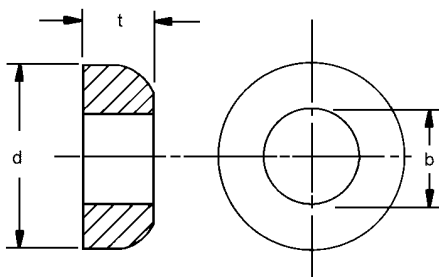

STOCK NO.	SCREW SIZE	d	b	t
PC6-1	#4	9/32	.116	1/8
PC6-2	#6	9/32	.144	1/8
PC6-3	#8	5/16	.169	1/8
PC6-4	#10	3/8	.196	5/32
PC6-5	1/4	7/16	.257	3/16
PC6-6	5/16	1/2	.323	3/16
PC6-7	3/8	5/8	.386	1/4

ASSEMBLED HEIGHT
13/64
13/64
13/64
15/64
17/64
21/64
25/64

TYPE	MATERIAL
FEMALE	303 STAINLESS STEEL MACHINED

F

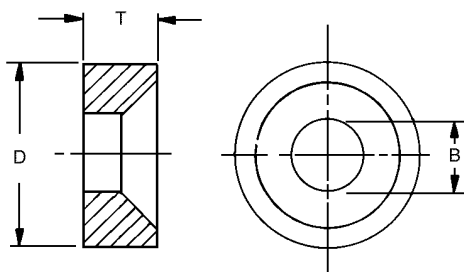

STOCK NO.	D	B	T
PC7-1	3/8	5/32	1/8
PC7-2	3/8	11/64	1/8
PC7-3	3/8	3/16	1/8
PC7-4	7/16	7/32	1/8
PC7-5	1/2	9/32	5/32
PC7-6	9/16	11/32	3/16
PC7-7	11/16	13/32	1/4

ASSEMBLED HEIGHT
13/64
13/64
13/64
15/64
17/64
21/64
25/64

WASHERS

STYLE	SHAFT SIZE	MATERIALS
BELLEVILLE	3/32 TO 3/4	302 STAINLESS STEEL *1095 CARBON STEEL

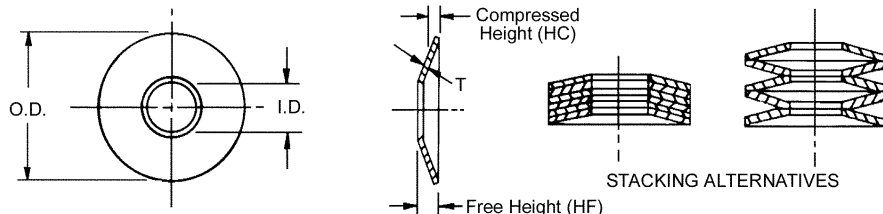

STOCK NO.	O.D. ±.010	I.D. +0.01 -.000	T ± 10%	HF (Ref.)	HC	FORCE TO COMPRESS TO HC ± 15%
ST-1	.187	.093	.010	.015	.012	15 LBS
ST-2	.250	.125	.013	.020	.017	26 LBS
ST-3	.312	.156	.016	.025	.021	41 LBS
ST-4	.375	.190	.020	.030	.025	60 LBS
ST-5	.500	.255	.025	.038	.031	95 LBS
ST-6	.625	.317	.032	.048	.040	145 LBS
ST-7	.750	.380	.040	.059	.049	235 LBS
ST-8	1.000	.505	.050	.075	.062	340 LBS
ST-9	1.250	.630	.062	.092	.077	475 LBS
ST-10*	1.500	.750	.072	.107	.089	660 LBS



Sold in packages of 10.

STYLE	SHAFT SIZE	MATERIALS
CURVED	3/32 TO 3/4	302 STAINLESS STEEL *1095 CARBON STEEL

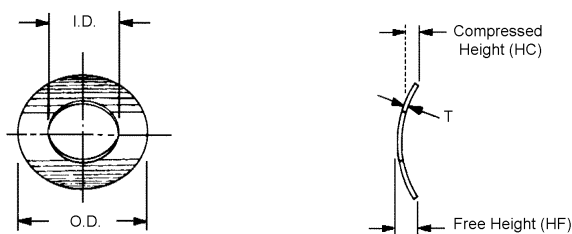

STOCK NO.	SCREW OR ROD SIZE	HOLE SIZE	O.D. ± .010	I.D.† + .010 -.000	HF REF	T ± 10%	HC	FORCE TO COMPRESS TO HC ± 15%
SU-1	#5	1/4	.245	.135	.034	.006	.020	2 LBS
SU-2	#6	9/32	.270	.148	.035	.007	.022	2 LBS
SU-3	#8	11/32	.322	.174	.042	.007	.025	3 LBS
SU-4	#10	3/8	.370	.200	.047	.009	.028	4 LBS
SU-5	#12	7/16	.423	.231	.053	.010	.032	5 LBS
SU-6	1/4	1/2	.490	.265	.063	.011	.034	7 LBS
SU-7*	9/32	9/16	.551	.296	.070	.012	.038	8 LBS
SU-8	5/16	5/8	.612	.327	.077	.013	.042	9 LBS
SU-9*	11/32	11/16	.672	.363	.081	.015	.047	11 LBS
SU-10	3/8	3/4	.735	.395	.086	.016	.050	12 LBS
SU-11*	7/16	7/8	.857	.462	.100	.018	.057	15 LBS
SU-12	1/2	1	.980	.525	.110	.021	.063	20 LBS



† I.D. Based in long axis providing free fit on normal screw.

Sold in packages of 10.

THREAD INSERTS

THREAD SIZE	TYPE	MATERIAL
#2-56 TO 1/4-20	FREE RUNNING OR LOCKING	STAINLESS STEEL

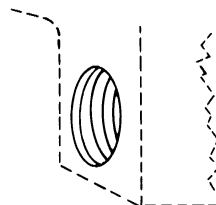
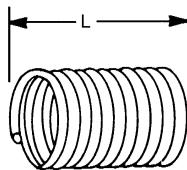
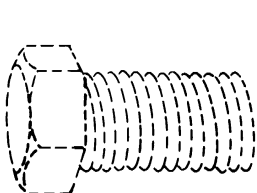

FREE RUNNING STOCK NO.	LOCKING STOCK NO.	THREAD SIZE	LENGTH L
Y12-S2-09	-	#2-56	.086
Y12-S2-13	Y13-S2-13		.129
Y12-S2-17	Y13-S2-17		.172
Y12-S2-22	-		.215
Y12-S4-11	-	#4-40	.112
Y12-S4-17	Y13-S4-17		.168
Y12-S4-22	Y13-S4-22		.224
Y12-S4-28	-		.280
Y12-S6-14	-	#6-32	.138
Y12-S6-21	Y13-S6-21		.207
Y12-S6-28	Y13-S6-28		.276
Y12-S6-35	-		.345
Y12-S8-16	-	#8-32	.164
Y12-S8-25	Y13-S8-25		.246
Y12-S8-33	Y13-S8-33		.328
Y12-S8-41	-		.410
Y12-S10-19	-	#10-24	.190
Y12-S10-29	Y13-S10-29		.285
Y12-S10-38	Y13-S10-38		.380
Y12-S10-48	-		.475
Y12-S11-19	-	#10-32	.190
Y12-S11-29	Y13-S11-29		.285
Y12-S11-38	Y13-S11-38		.380
Y12-S11-48	-		.475
Y12-S12-25	-	#1/4-20	.250
Y12-S12-38	Y13-S12-38		.375
Y12-S12-50	Y13-S12-50		.500
Y12-S12-63	-		.625

- Increased holding power
- Positive locking
- Eliminates stripping, seizing, corrosion
- Long life without thread wear
- Saves space, weight, material
- no more lock nuts, etc.

NOTE: SEE PAGE # F54 FOR DRILL SIZES AND TAPS

Also available

STOCK NO.	DESCRIPTION OF KIT
Y17-4	#4-40 THREAD INSERTS (24), (1) PRODUCTION STYLE INSERTING TOOL, (1) TAP, (1) DRILL BIT
Y17-6	#6-32 THREAD INSERTS (24), (1) PROTOTYPE STYLE INSERTING TOOL, (1) TAP, (1) DRILL BIT
Y17-8	#8-32 THREAD INSERTS (24), (1) PROTOTYPE STYLE INSERTING TOOL, (1) TAP, (1) DRILL BIT
Y17-10	#10-24 THREAD INSERTS (24), (1) PROTOTYPE STYLE INSERTING TOOL, (1) TAP, (1) DRILL BIT
Y17-11	#10-32 THREAD INSERTS (24), (1) PROTOTYPE STYLE INSERTING TOOL, (1) TAP, (1) DRILL BIT
Y17-12	1/4-20 THREAD INSERTS (24), (1) PROTOTYPE STYLE INSERTING TOOL, (1) TAP, (1) DRILL BIT



THREAD INSERT TAPS

THREAD SIZE	TYPE
#2-56 TO 1/4-20	BOTTOMING TAP AND PLUG TAP

BOTTOMING TAP STOCK NO.	PLUG TAP STOCK NO.	INSERT THREAD SIZE	DRILLING DATA		
			DRILL SIZE	HOLE SIZE	
				MIN.	MAX.
Y14-BT2	Y14-PT2	# 2-56	3/32	.0899	.0961
Y14-BT4	Y14-PT4	# 4-40	31	.1175	.1252
Y14-BT6	Y14-PT6	# 6-32	26	.1448	.1527
Y14-BT8	Y14-PT8	# 8-32	17	.1708	.1781
Y14-BT10	Y14-PT10	# 10-24	13/64	.1990	.2080
Y14-BT11	Y14-PT11	# 10-32	7	.1968	.2041
Y14-BT12	Y14-PT12	1/4-20	17/64	.2608	.2704



Taps can be used for limited production in steel by drilling to maximum tap hole size.

THREAD INSERT TOOL

THREAD SIZE	TYPE
#2-56 TO 1/4-20	PRODUCTION TOOL AND PROTOTYPE TOOL

PRODUCTION TOOL STOCK NO.	PROTOTYPE TOOL STOCK NO.	THREAD SIZE
Y15-P2	-	#2-56
Y15-P4	-	#4-40
Y15-P6	Y15-T6	#6-32
Y15-P8	Y15-T8	#8-32
Y15-P10	Y15-T10	#10-24
Y15-P11	Y15-T11	#10-32
Y15-P12	Y15-T12	1/4-20



Taps can be used for limited production in steel by drilling to maximum tap hole size.

TANG BREAK-OFF TOOL

THREAD SIZE

#2-56 TO 1/4-20



STOCK NO.	THREAD SIZE
Y16-T2	# 2-56
Y16-T4	# 4-40
Y16-T6	# 6-32
Y16-T8	# 8-32
Y16-T10	#10-24 10-32
Y16-T12	1/4-20

Remove tang to avoid interference with the screw.

F

PINS

TYPE	MATERIALS
TAPER ANSI-B18.2-1978 (R1995)	303 STAINLESS STEEL

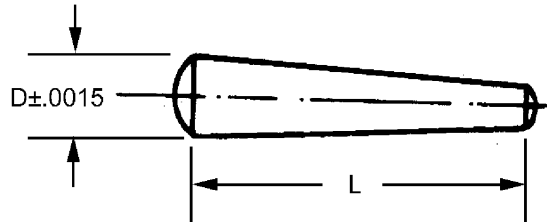

STOCK NO.	TAPER PIN NO.	D	L
CP3-20*	#9/0	.031	1/4
CP3-22*			3/8
CP3-21*	#8/0	.047	1/4
CP3-1*			3/8
CP3-2*			1/2
CP3-24	#7/0	.0625	3/8
CP3-3			7/16
CP3-4			1/2
CP3-25			9/16
CP3-26			5/8
CP3-27	#6/0	.078	7/16
CP3-5			1/2
CP3-6			9/16
CP3-28			5/8
CP3-29			3/4
CP3-7	#5/0	.094	9/16
CP3-8			5/8
CP3-32			3/4
CP3-33			7/8
CP3-34	#4/0	.109	5/8
CP3-35			3/4
CP3-36			7/8
CP3-37			1
CP3-9	#3/0	.125	5/8
CP3-10			3/4
CP3-38			7/8
CP3-39			1
CP3-11	#2/0	.141	3/4
CP3-40			7/8
CP3-12			1
CP3-41			1 1/4

* ANSI B18.8.2-1978 (R1989) Does not apply.
Taper 1/4" per foot
Sold in packages of 10.

Also available

STOCK NO.	DESCRIPTION OF KIT
KIT-CP3	ASSORTED TAPER PIN KIT 240 PIECES

PINS

TYPE	MATERIALS
GROOVED HALF LENGTH TYPE B ANSI-B18.2-1978 (R1995)	303 STAINLESS STEEL

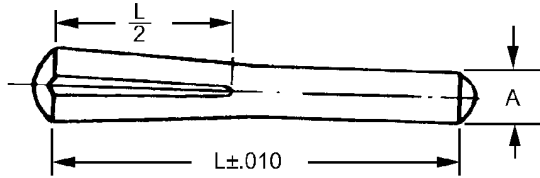

STOCK NO.	A	L	DRILL SIZE
CP4-1	.0469 +.0000 -.0010	3/8	3/64
CP4-2		1/2	
CP4-17		5/8	
CP4-3	.0625 +.0000 -.0010	3/8	1/16
CP4-4		1/2	
CP4-18		5/8	
CP4-5	.0781 +.0000 -.0010	3/8	5/64
CP4-6		1/2	
CP4-22		5/8	
CP4-7	.0938 +.0000 -.0010	3/8	3/32
CP4-8		1/2	
CP4-23	.0938 +.0000 -.0010	5/8	3/32
CP4-24		3/4	
CP4-25	.1250 +.0000 -.0020	1/2	1/8
CP4-9		5/8	
CP4-10		3/4	
CP4-26		1	
CP4-27	.1563 +.0000 -.0020	1/2	5/32
CP4-28		5/8	
CP4-11		3/4	
CP4-12		1	

Other sizes available on request.
Sold in packages of 10.

TYPE	MATERIALS
ROLL OR SPRING	420 STAINLESS STEEL

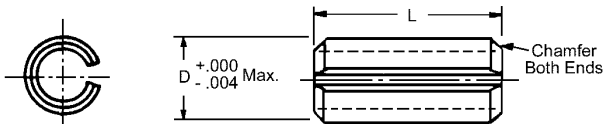

STOCK NO.	D	L (Inch)	DRILL SIZE	REF. SHAFT DIA.
CP5-2	.069	1/4	1/16	3/16
CP5-21		5/16		
CP5-3		3/8		
CP5-12		7/16		
CP5-10		1/2		
CP5-22	.086	9/16	5/64	1/4
CP5-23		5/8		
CP5-4	.103	9/16	3/32	1/4
CP5-24		3/8		
CP5-25	7/16			
CP5-26	.103	1/2	3/32	1/4
CP5-5		5/8		
CP5-13	.135	3/8	1/8	3/8
CP5-14		7/16		
CP5-15		1/2		
CP5-16		9/16		
CP5-17		5/8		
CP5-18		11/16		
CP5-6	.167	3/4	5/32	1/2
CP5-7		1		



Sold in packages of 10.

PINS

TYPE	MATERIALS
SPIRAL STANDARD DUTY	302 STAINLESS STEEL

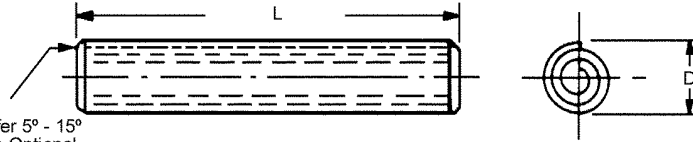

STOCK NO.	D	L	DRILL SIZE	(Ref.) SHAFT
CP6-17	.033	1/8	.031	3/32
CP6-18		3/16		
CP6-19		1/4		
CP6-20		5/16		
CP6-21		3/8		
CP6-23	.041	1/4	.039	1/8
CP6-24		5/16		
CP6-10		3/8		
CP6-25		7/16		
CP6-11	1/2			
CP6-26	.049	3/16	.047	1/8
CP6-27		1/4		
CP6-1		5/16		
CP6-29		3/8		
CP6-30		7/16		
CP6-31	1/2			
CP6-32	.054	3/16	.051	1/8
CP6-33		1/4		
CP6-34		5/16		
CP6-35		3/8		
CP6-36		7/16		
CP6-37		1/2		
CP6-38	.067	1/4	.061	3/16
CP6-39		5/16		
CP6-12		3/8		
CP6-2		7/16		
CP6-13		1/2		
CP6-41		9/16		
CP6-42	5/8			
CP6-3	.083	1/2	.077	1/4
CP6-43	.099	3/8	.093	1/4 & 5/16
CP6-44		7/16		
CP6-4		1/2		
CP6-15		9/16		
CP6-45		5/8		
CP6-46		11/16		
CP6-5	.114	3/4	.108	3/8
CP6-47	.124	3/8	.124	3/8 7/16 & 1/2
CP6-48		7/16		
CP6-49		1/2		
CP6-50		9/16		
CP6-51		5/8		
CP6-52		11/16		
CP6-53		3/4		
CP6-6	1			



Sold in packages of 10.

Also available

STOCK NO.	DESCRIPTION OF KIT
KIT-CP5	ASSORTED SIZES ROLL, TAPER, & DOWEL PINS - 530 PIECES

PINS

TYPE	MATERIALS
CLEVIS ANSI-B18-8.1-1972 (R 1983)	416 STAINLESS STEEL HARDENED ROCKWELL C28-32

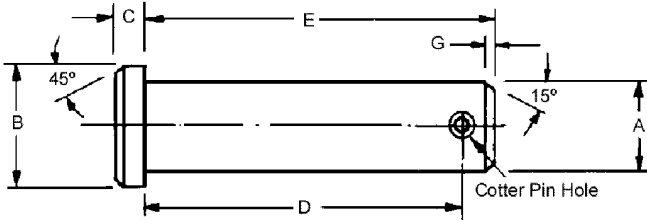

STOCK NO.	A +.000 -.005	B	C	D +.000 -.020	E +.020 +.000	G	COTTER PIN HOLE H
CP2-1	.186	5/16	1/16	.504	19/32	3/64	5/64
CP2-2	.248	3/8	3/32	.692	51/64	3/64	5/64
CP2-3	.311	7/16	3/32	.832	31/32	1/16	7/64
CP2-4	.373	1/2	1/8	.958	1 1/16	1/16	7/64
CP2-5	.436	9/16	5/32	1.082	1 15/64	1/16	7/64
CP2-6	.496	5/8	5/32	1.223	1 27/64	5/64	9/64



TYPE	MATERIALS
COTTER ANSI-B18-8.1-1972 (R 1983)	STAINLESS STEEL

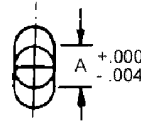
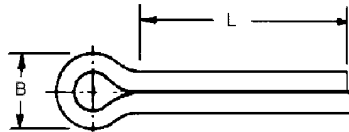

STOCK NO.	A	B MIN.	L (Inch)	HOLE SIZE
CP1-31	.032	1/16	3/8	3/64
CP1-32			1/2	
CP1-1			3/4	
CP1-34			1	
CP1-2	.048	3/32	1	1/16
CP1-35	.060	1/8	3/8	5/64
CP1-36			1/2	
CP1-37			3/4	
CP1-3			1	
CP1-9			1 1/2	
CP1-4	.076	5/32	1 1/4	3/32
CP1-10	.090	3/16	1/2	7/64
CP1-11			3/4	
CP1-12			1	
CP1-5			1 1/2	
CP1-14	.120	1/4	1/2	9/64
CP1-15			3/4	
CP1-16			1	
CP1-17			1 1/2	
CP1-7			2	
CP1-19	.150	5/16	3/4	11/64
CP1-20			1	
CP1-21			1 1/2	
CP1-22			2	
CP1-23	.176	3/8	1	13/64
CP1-24			1 1/2	
CP1-25			2	
CP1-26			2 1/2	
CP1-27	.225*	1/2	1 1/2	17/64
CP1-28			2	
CP1-29			2 1/2	

* Tolerance is +.000/-.005

SOLD IN PACKAGES OF 10.

Also available

STOCK NO.	DESCRIPTION OF KIT
KIT-CP1	COTTER PIN KIT, ASSORTED SIZES 3/8" TO 2" (280 PIECES)

PINS

TYPE	DIAMETER SIZE	MATERIALS
DOWEL SOFT PINS	1/32 TO 5/32	303 STAINLESS STEEL (NOT HARDENED)

DIAMETER = d						B
(1/32") .0312 STOCK NO.	(1/16") .0625 STOCK NO.	(5/64") .0780 STOCK NO.	(3/32") .0937 STOCK NO.	(1/8") .1250 STOCK NO.	(5/32") .1561 STOCK NO.	
D11-1	D12-1	D18-1	D13-1	D14-1	-	3/32
D11-2	D12-2	D18-2	D13-2	D14-2	-	1/8
D11-3	D12-3	D18-3	D13-3	D14-3	-	5/32
D11-4	D12-4	D18-4	D13-4	D14-4	D15-4	3/16
D11-5	D12-5	-	D13-5	D14-5	-	7/32
D11-6	D12-6	D18-6	D13-6	D14-6	D15-6	1/4
D11-7	D12-7	D18-7	D13-7	D14-7	D15-7	5/16
D11-8	D12-8	D18-8	D13-8	D14-8	D15-8	3/8
D11-9	D12-9	-	D13-9	D14-9	D15-9	7/16
D11-10	D12-10	-	D13-10	D14-10	D15-10	1/2
D11-11	D12-11	-	D13-11	D14-11	D15-11	5/8
D11-12	D12-12	-	D13-12	D14-12	-	3/4
D11-13	D12-13	-	D13-13	D14-13	-	7/8
D11-14	D12-14	-	D13-14	D14-14	-	1

Sold in packages of 10.

TYPE	DIAMETER SIZE	MATERIALS
DOWEL SOFT PINS	3/16 TO 1/2	303 STAINLESS STEEL (NOT HARDENED)

DIAMETER = d						B
(3/16") .1874 STOCK NO.	(7/32") .2186 STOCK NO.	(1/4") .2499 STOCK NO.	(5/16") .3124 STOCK NO.	(3/8") .3749 STOCK NO.	(1/2") .4999 STOCK NO.	
D16-6	-	-	-	-	-	1/4
D16-7	D19-7	-	-	-	-	5/16
D16-8	D19-8	D17-8	-	-	-	3/8
D16-9	D19-9	D17-9	D20-9	-	-	7/16
D16-10	D19-10	D17-10	D20-10	-	-	1/2
-	-	D17-20	D20-20	D21-20	-	9/16
D16-11	D19-11	D17-11	D20-11	D21-11	-	5/8
D16-12	D19-12	D17-12	D20-12	D21-12	D22-12	3/4
D16-13	D19-13	D17-13	D20-13	D21-13	D22-13	7/8
D16-14	D19-14	D17-14	D20-14	D21-14	D22-14	1
-	-	-	D20-15	D21-15	D22-15	1 1/4
-	-	-	-	D21-16	D22-16	1 1/2
-	-	-	-	-	D22-17	1 3/4
-	-	-	-	-	D22-18	2

Sold in packages of 10.

Also available

STOCK NO.	DESCRIPTION OF KIT
KIT-D11	DOWEL PIN KIT, ASSORTED SIZES 1/32" TO 1/4" DIA. (135 PIECES)

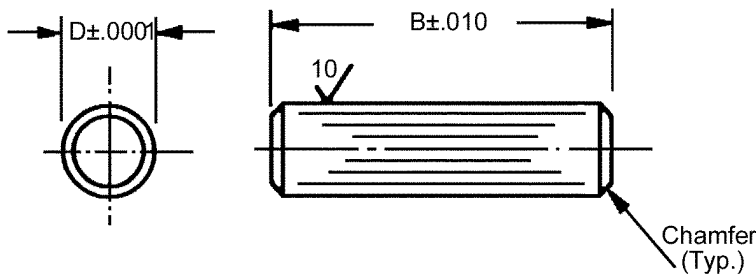

PINS

TYPE	DIAMETER SIZE	MATERIALS
DOWEL	1/16" TO 3/8"	416 STAINLESS STEEL ROCKWELL C36-42

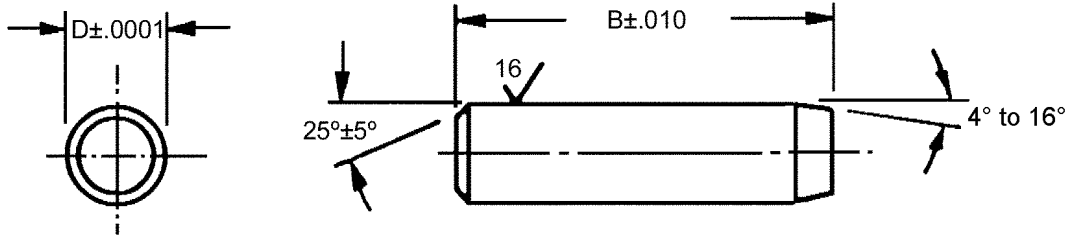

Conforms to Mil. Standard MS16555.

DIAMETER = d								B
(1/16") STOCK NO.	(3/32") .0940 STOCK NO.	(1/8") .1252 STOCK NO.	(5/32") .1564 STOCK NO.	(3/16") .1877 STOCK NO.	(1/4") .2502 STOCK NO.	(5/16") .3127 STOCK NO.	(3/8") .3752 STOCK NO.	
D23-1	D24-1	-	-	-	-	-	-	3/16
D23-2	D24-2	D25-2	-	-	-	-	-	1/4
D23-15	D24-15	D25-15	-	-	-	-	-	5/16
D23-3	D24-3	D25-3	D26-3	D27-3	-	-	-	3/8
D23-17	D24-17	D25-17	D26-17	-	-	-	-	7/16
D23-4	D24-4	D25-4	D26-4	D27-4	D28-4	-	-	1/2
D23-5	D24-5	D25-5	D26-5	D27-5	D28-5	D29-5	-	5/8
D23-6	D24-6	D25-6	D26-6	D27-6	D28-6	D29-6	D30-6	3/4
D23-7	D24-7	D25-7	D26-7	-	-	-	-	7/8
D23-8	D24-8	D25-8	D26-8	D27-8	D28-8	D29-8	D30-8	1"
-	-	-	-	D27-9	D28-9	D29-9	D30-9	1-1/4
-	-	-	-	-	D28-10	D29-10	D30-10	1-1/2



Sold in packages of 10.

F

Also available

STOCK NO.	DESCRIPTION OF KIT
KIT-D23	DOWEL PIN KIT, ASSORTED SIZES 1/16" TO 3/8" DIA. (135 PIECES)

TYPE	DIAMETER SIZE	MATERIALS
DOWEL	1/16" TO 3/8"	CARBON STEEL CARBONIZED ROCKWELL C58-62 CASE DEPTH .010 TO .020

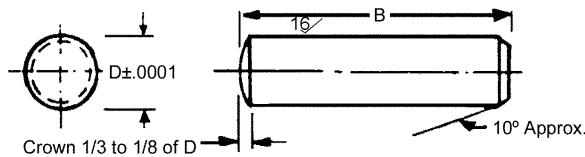

D=.0627 STOCK NO.	D=.0940 STOCK NO.	D=.1252 STOCK NO.	D=.1877 STOCK NO.	D=.2502 STOCK NO.	D=.3127 STOCK NO.	D=.3752 STOCK NO.	B (Inch)
D1-1	-	-	-	-	-	-	3/16
D1-2	D2-2	-	-	-	-	-	1/4
D1-3	D2-3	D3-3	-	-	-	-	3/8
D1-4	D2-4	D3-4	D4-4	D5-4	D6-4	D7-4	1/2
D1-5	D2-5	D3-5	D4-5	D5-5	D6-5	D7-5	5/8
D1-6	D2-6	D3-6	D4-6	D5-6	D6-6	D7-6	3/4
D1-7	D2-7	D3-7	D4-7	D5-7	D6-7	D7-7	7/8
D1-8	D2-8	D3-8	D4-8	D5-8	D6-8	D7-8	1
-	-	D3-9	D4-9	D5-9	D6-9	D7-9	1 1/4
-	D2-10	D3-10	D4-10	D5-10	D6-10	D7-10	1 1/2

Sold in packages of 10.



TAPER PIN AND DOWEL PIN REAMERS

MATERIAL

HIGH SPEED STEEL

TAPER PIN REAMERS (SPIRAL) HIGH SPEED STEEL	
STOCK NO.	SIZE
TR-24	#9/0
TR-1	8/0
TR-2	7/0
TR-25	6/0
TR-3	5/0
TR-26	4/0
TR-27	3/0
TR-28	2/0

DOWEL PIN REAMERS (STRAIGHT) HIGH SPEED STEEL	
STOCK NO.	SIZE
TR-4	1/32" DIA. (.0312)
TR-5	1/16" DIA. (.0625)
TR-6	3/32" DIA. (.0937)
TR-7	1/8" DIA. (.1250)
TR-29	5/32" DIA. (.1562)
TR-30	3/16" DIA. (.1875)
TR-31	1/4" DIA. (.2500)
TR-32	5/16" DIA. (.3125)
TR-33	3/8" DIA. (.3750)

HEX WRENCH

SET SCREW SIZE	MATERIALS
#0 TO 1/2	ALLOY STEEL

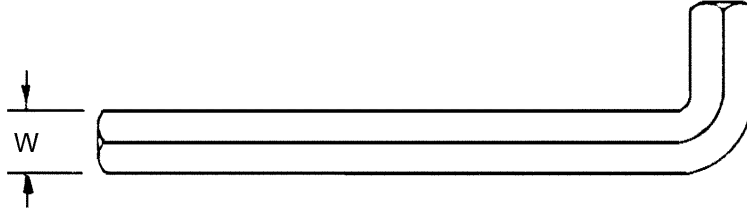

STOCK NO.	W ACROSS FLATS	CAP SCREW SIZE	SET SCREW SIZE
SC9-10	.028	-	#0
SC9-1	.035	-	#1 & 2
SC9-2	.050	#0	#3 & 4
SC9-3	1/16	#1	#5 & 6
SC9-4	5/64	#2 & 3	#8
SC9-5	3/32	#4 & 5	#10
SC9-11	7/64	#6	-
SC9-6	1/8	-	1/4
SC9-12	9/64	#8	-
SC9-7	5/32	#10	5/16
SC9-8	3/16	1/4	3/8
SC9-13	7/32	-	7/16
SC9-9	1/4	5/16	1/2
SC9-14	5/16	3/8	5/8
SC9-15	3/8	1/2	3/4



Also available

STOCK NO.	DESCRIPTION OF KIT
TR-35	HEX KEY SET WITH PLASTIC CASE - 8 KEYS (.050 TO 5/32")

F

MISCELLANEOUS ITEMS

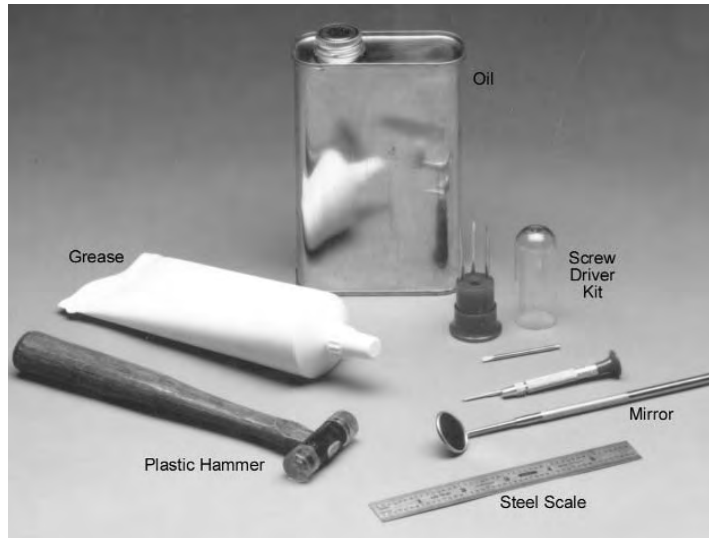

STOCK NO.	ITEM	DESCRIPTION
TR-8 TR-34	GREASE	INSTRUMENT (-65°F TO +250°F) RECOMMENDED FOR GEAR MESHES & BALL BEARINGS. -MIL-G-23827 (-65°F TO +250°F) RECOMMENDED FOR GEAR MESHES & BALL BEARINGS
TR-9	OIL	-MIL-L-6085 (-65°F TO +250°F) RECOMMENDED FOR ALL PRECISION APPLICATIONS
TR-18 TR-19	INSP & ASSEMBLY MIRROR	3/4" DIAMETER MIRROR WITH HANDLE 3/4" DIAMETER MAGNIFYING MIRROR WITH HANDLE
TR-20	INSTR. SCREW DRIVERS	SET OF ASSTD. SMALL PRECISION INSTR. SCREW DRIVER IN PLASTIC CASE AND COVER
TR-21	PLASTIC HAMMER	INSTR. STYLE TO PREVENT MARKING FACES OF WORKING SURFACE
TR-22	STEEL SCALE	6" STAINLESS STEEL 1/32 & 1/64 GRAD'S WITH DECIMAL CHART

MISCELLANEOUS ITEMS



STOCK NO.	ITEM	DESCRIPTION
TR-35	HEX WRENCHES	PLASTIC CASE WITH 8 KEYS (.050 TO 5/32")
TR-23	TWEEZERS	STAINLESS STEEL FOR INSTR. PARTS HANDLING
TR-36	LOUPE	2.5 INCHES - 4X
TL-1	CABLE CUTTERS	CUTTER FOR UP TO 3/64" CABLE
TL-2	CABLE CUTTERS	CUTTER FOR UP TO 5/64" CABLE
CE-1	ADHESIVE	1 OZ. BOTTLE USE WHEN METAL IS ONE OR BOTH OF THE BONDED PARTS
CE-3		1 OZ. BOTTLE USE WHEN PLASTIC, RUBBER, CERAMIC OR GLASS IS TO BE BONDED
CE-24		1/3 OZ. CONTAINER
CE-6	LIQUID PIN	50 cc BOTTLE
CE-7		250 cc BOTTLE
CE-28	SOLVENT	12 OZ. CLEANER-SOLVENT SPRAY CAN
CE-10	LUBRICANT 12 OZ. CAN	SILICONE LUBRICANT & RELEASE AGENT NON TOXIC, NON FLAMMABLE & FOOD GRADE
CE-12	LUBRICANT 12 OZ. CAN	DRY LUBRICANT & ANTI STICK AGENT SLICK ACTION, CONTAINS NO OIL, NO GREASE, & NO SILICONE
CE-14	LUBRICANT 16 OZ. CAN	RUST INHIBITING LUBRICANT & PENETRANT ACTION LUBE, DISPLACES WATER, CLEANS AND PROTECTS
CE-16		INSTANT CLEANER & DEGREASER FOR CONTACTS, SWITCHES ETC. MAYBE APPLIED TO EQUIPMENT WHILE IN OPERATION



RETAINER RINGS

TYPE	MATERIALS
EXTERNAL LUG DESIGN	STAINLESS STEEL PH 15-7 MO (SS), CARBON STEEL PLATED (CP), BERYLLIUM COPPER (BC)

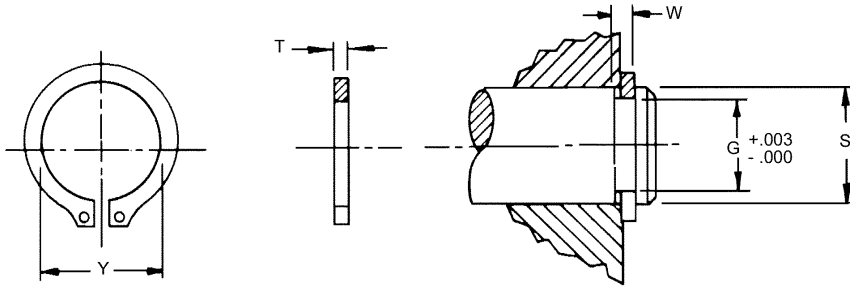

Retainer Ring Pliers. Order separately.

STOCK NO.	S SHAFT SIZE	G GROOVE DIA.	W GROOVE WIDTH	T	MATERIAL	Y RING I.D.	PLIERS
Q2-12	1/8	.117	.012	.010	BC	.112	S11-12P
Q2-15	5/32 & 4mm	.146	.012 +.002	.010	BC	.142	S11-12P
Q2-18	3/16	.175	.018 -.000	.015	BC	.168	S11-18P
Q2-23	6mm	.222	.018	.015	BC	.215	S11-18P
Q2-25	1/4	.230	.029	.025	SS	.225	S11-25P
Q2-31	5/16 & 8mm	.290	.029	.025	SS	.281	S11-25P
Q2-34	11/32	.321	.029	.025	SS	.309	S11-25P
Q2-37	3/8	.352	.029	.025	SS	.338	S11-25P
Q2-39	10mm	.369	.029	.025	SS	.354	S11-25P
Q2-50	1/2	.468	.039 +.003	.035	SS	.461	S11-25P
Q2-50-CP	1/2	.468	.039 -.000	.035 ±.002	CP	.461	S11-25P
Q2-62-P	5/8 & 16mm	.588	.039	.035	SS	.579	S11-25P
Q2-62-CP	5/8 & 16mm	.588	.039	.035	CP	.579	S11-25P
Q2-75	3/4 & 19mm	.704	.046	.042	SS	.693	S11-25P
Q2-87	7/8	.821	.046	.042	SS	.810	S11-25P
Q2-87-CP	7/8	.821	.046	.042	CP	.810	S11-25P
Q2-100	1	.940	.046	.042	SS	.925	S11-100P
Q2-112	1 1/8	1.059	.056	.050	SS	1.041	S11-100P
Q2-112-CP	1 1/8	1.059	.056	.050	CP	1.041	S11-100P
Q2-125	1 1/4 & 32mm	1.176	.056 +.004	.050	SS	1.156	S11-100P
Q2-125-CP	1 1/4 & 32mm	1.176	.056 -.000	.050	CP	1.156	S11-100P
Q2-156	1 9/16	1.468	.068	.062	SS	1.446	-
Q2-156-CP	1 9/16	1.468	.068	.062	CP	1.446	-
Q2-200-CP	2	1.886	.068	.062 ±.003	CP	1.850	-
Q2-237-CP	2 3/8	2.239	.086 +.005	.078	CP	2.197	-
Q2-300-CP	3	2.838	.103 -.000	.093	CP	2.775	-



Sold in packages of 10.

Also available

STOCK NO.	DESCRIPTION OF KIT
KIT-Q2	RETAINER RINGS, STAINLESS STEEL, INTERNAL AND EXTERNAL, 1/8", 3/16" AND 1/4" SHAFTS (450 PIECES)

RETAINER RINGS

TYPE	MATERIALS
EXTERNAL SNAP ON DESIGN	STAINLESS STEEL PH 15-7 MO

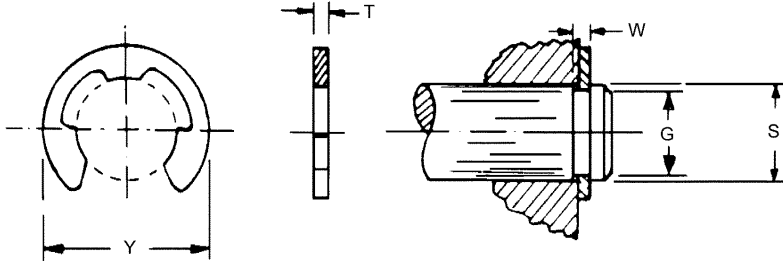

Retainer Ring Pliers. Order separately.

STOCK NO.	SHAFT SIZE S	GROOVE DIA. G	GROOVE WIDTH W	T RING THICKNESS	O.D. RING Y	APPLICATOR TOOL NO.
Q1-6	5/64 & 1/16	.052	.012	.010	.14	S10-6T
Q1-9	3/32	.074 +0.002	.018	.015	.19	S10-9T
Q1-12	1/8	.095 -.0000	.018	.015	.23	S10-12T
Q1-15	5/32 & 4mm	.116	.029	.025	.29	-
Q1-18	3/16	.147	.029	.025	.34	S10-18T
Q1-25	1/4	.210	.029	.025	.53	S10-25T
Q1-31	5/16 & 8mm	.250	.029	.025	.50	S10-31T
Q1-37	3/8	.303	.039	.035	.66	S10-37T
Q1-43	7/16 & 11mm	.343	.039	.035	.69	-
Q1-50	1/2	.396 +003	.046	.044	.80	S10-50T
Q1-62	5/8 & 16mm	.485 -.000	.046	.044	.94	S10-62T
Q1-75	3/4 & 19mm	.580	.056	.050	1.12	S10-75T
Q1-87	7/8	.675	.056	.050	1.30	S10-87T
Q1-98	1	.835	.056	.050	1.50	S10-98T



Sold in packages of 10.

F

TYPE	MATERIALS
EXTERNAL POWER GRIP DESIGN	STAINLESS STEEL PH 15-7 MO AMS 5520

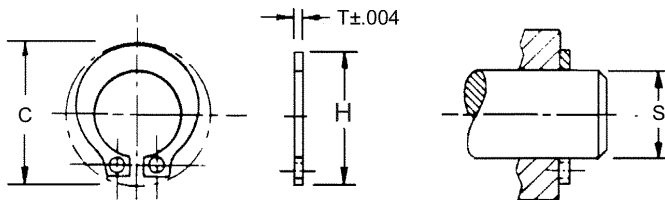

Retainer Ring Pliers. Order separately.

STOCK NO.	SHAFT SIZE S	T RING THICKNESS	H RING HEIGHT	CLEARANCE DIA. C	ASSEMBLY PLIER STOCK NO.
Q7-12	1/8	.025	.268	.33	S14-12P
Q7-15	5/32 & 4mm	.025	.307	.36	
Q7-18	3/16	.035	.364	.44	S14-25P
Q7-25	1/4	.035	.437	.49	
Q7-31	5/16 & 8mm	.042	.553	.68	S14-37P
Q7-37	3/8	.042	.620	.74	
Q7-43	7/16 & 11mm	.050	.701	.81	
Q7-50	1/2	.050	.768	.90	
Q7-62	5/8 & 16mm	.062	.948	1.06	
Q7-75	3/4 & 19mm	.062	1.115	1.32	



Sold in packages of 10.

RETAINER RINGS

TYPE	MATERIALS
EXTERNAL BOWED SNAP ON DESIGN	STAINLESS STEEL PH 15-7 MO

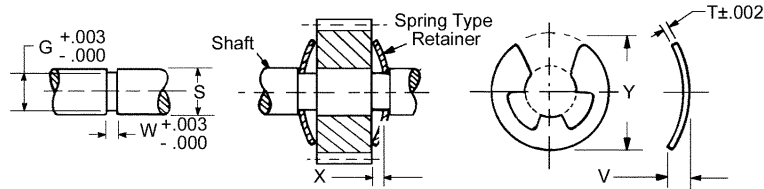

STOCK NO.	S SHAFT SIZE	Y	T	V	X MAX. TAKE UP	W	G
Q3-12	1/8	.230	.010	.025	.013	.022	.095
Q3-18	3/16	.335	.015	.033	.015	.030	.147
Q3-25	1/4	.527	.025	.052	.024	.049	.210
Q3-31	5/16 & 8mm	.500	.025	.050	.022	.047	.250
Q3-37	3/8	.660	.035	.060	.022	.060	.303
Q3-50	1/2	.800	.042	.075	.030	.073	.396
Q3-62	5/8 & 16mm	.940	.042	.080	.035	.077	.485
Q3-75	3/4 & 19mm	1.000	.050	.088	.035	.085	.625
Q3-98	1	1.500	.050	.088	.035	.085	.835



Sold in packages of 10.

TYPE	MATERIALS
EXTERNAL DESIGN	CARBON STEEL OR STAINLESS STEEL

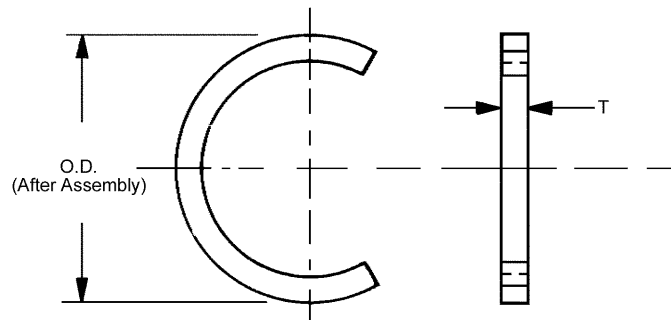

CARBON STEEL STOCK NO.	STAINLESS STEEL STOCK NO.	SHAFT SIZE	O.D.	T	GROOVE DIMENSIONS	
					WIDTH +.005 -.000	DIAMETER +.005 -.000
Q5-50-CP	Q5-50	1/2	.550	.035	.039	.468
Q5-62-CP	Q5-62	5/8	.673	.035	.039	.588
Q5-87-CP	Q5-87	7/8	.923	.042	.046	.821
Q5-112-CP	Q5-112	1 1/8	1.180	.050	.056	1.061
Q5-125-CP	Q5-125	1 1/4	1.301	.050	.056	1.176
Q5-156-CP	Q5-156	1 9/16	1.620	.062	.068	1.468
Q5-200-CP	-	2	2.040	.062	.068	1.886
Q5-237-CP	-	2 3/8	2.429	.078	.086	2.239



Sold in packages of 10.

RETAINER RINGS

TYPE	MATERIALS
INTERNAL	302 STAINLESS STEEL

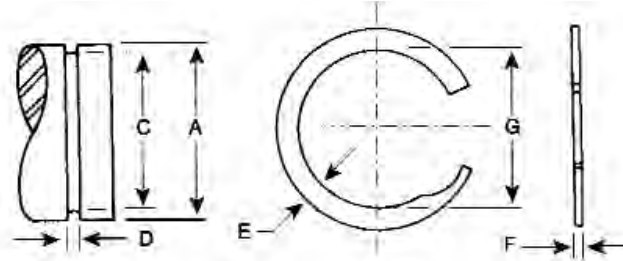

STOCK NO.	A HOUSING DIA.		C GROOVE DIA.	D GROOVE WIDTH	F RING THICKNESS	G RING OUTER DIA.	E RADIAL WALL	THRUST LOAD BASED ON RING SHEAR	THRUST LOAD BASED ON GROOVE YIELD (45,000 P.S.I.)	MAX. CORNER RADIUS OR CHAMFER		WEIGHT lbs./M		
	INCHES	MM.								*X	*CH			
Q9-50	.500	12.7	.526	.030 +.003 -.000	.025 ±.002	.532	.045	2,000	405	.015	.012	.41		
Q9-51	.512	13.0	.538			.544		2,050	420			.42		
Q9-53	.531	13.5	.557			.564		2,130	455			.44		
Q9-56	.562	14.3	.588			.594		2,250	495			.46		
Q9-59	.594	15.1	.619			.626		2,380	535			.49		
Q9-62	.625	15.9	.651 ±.002			.658		2,500	610			.52		
Q9-65	.656	16.7	.682			.689		2,630	670			.55		
Q9-68	.687	17.5	.713			.720		2,750	725			.58		
Q9-71	.718	18.3	.744			.751		2,870	790			.61		
Q9-75	.750	19.0	.782			.790		3,360	800			1.14		
Q9-77	.777	19.7	.808	.817	3,480	835	.024	.019	1.19					
Q9-78	.781	19.8	.812	.036 +.003 -.000	.031 ±.002	.821	.065	3,500	840	.022	.018	1.20		
Q9-81	.812	20.6	.843			.853 +.013 -.000		3,640	915			1.25		
Q9-84	.843	21.4	.880			.889		3,780	1,155			1.32		
Q9-86	.866	22.0	.903			.913		3,880	1,250			1.35		
Q9-87	.875	22.2	.912 ±.003			.922		3,920	1,250			1.36		
Q9-90	.906	22.9	.939			.949		4,060	1,335			1.41		
Q9-93	.938	23.8	.975			.986		4,200	1,430			1.48		
Q9-96	.968	24.4	1.015			1.025		4,340	1,950			.025	.020	2.11
Q9-98	.987	25.0	1.030			1.041		4,420	1,865			.026	.021	2.15
Q9-100	1.000	25.4	1.043			1.054		4,480	1,910					2.19

*For calculation of Groove Yield.

TYPE	MATERIALS
EXTERNAL	302 STAINLESS STEEL

STOCK NO.	A HOUSING DIA.		C GROOVE DIA.	D GROOVE WIDTH	F RING THICKNESS	G RING OUTER DIA.	E RADIAL WALL	THRUST LOAD BASED ON RING SHEAR	THRUST LOAD BASED ON GROOVE YIELD (45,000 P.S.I.)	MAX. CORNER RADIUS OR CHAMFER		WEIGHT lbs./M		
	INCHES	MM.								*X	*CH			
Q11-50	.500	12.7	.474	.030 +.003 -.000	.025 ±.002	.467	.045	2,000	550	.015	.012	.44		
Q11-53	.531	13.5	.505 ±.002			.498		2,130	640			.48		
Q11-55	.551	14.0	.525			.518		2,210	700			.50		
Q11-56	.532	14.3	.536			.529		2,250	730			.51		
Q11-59	.594	15.1	.569			.561		2,380	740			.54		
Q11-62	.625	15.9	.594			.585		2,500	970			.70		
Q11-65	.656	16.7	.625			.617		2,630	1,020			.74		
Q11-66	.669	17.0	.638			.629		2,680	1,040			.75		
Q11-68	.687	17.5	.656			.647		2,750	1,060			.77		
Q11-71	.718	18.3	.687			.679		2,870	1,110			.81		
Q11-75	.750	19.0	.719	.710 +.000 -.013	3,360	1,100	1.27							
Q11-78	.781	19.8	.750 ±.003	.741	3,500	1,210	.024	.019	1.32					
Q11-81	.812	20.6	.781	.036 +.003 -.000	.031 ±.002	.771	.065	3,640	1,260	.022	.018	1.38		
Q11-84	.843	21.4	.812			.803		3,780	1,310			1.43		
Q11-87	.875	22.2	.838			.828		3,920	1,620			1.48		
Q11-90	.906	23.0	.869			.860		4,060	1,680			1.53		
Q11-93	.937	23.8	.900			.889		4,200	1,740			1.57		
Q11-96	.968	24.4	.925			.916		5,180	2,080			2.26		
Q11-98	.984	25.0	.941			.930		5,260	2,120			.026	.021	2.31
Q11-100	1.000	25.4	.957			.946		5,350	2,150					2.34

*For calculation of Groove Yield.

RETAINER RINGS

TYPE	MATERIALS
INTERNAL	CARBON SPRING STEEL WITH OIL-DIP FINISH

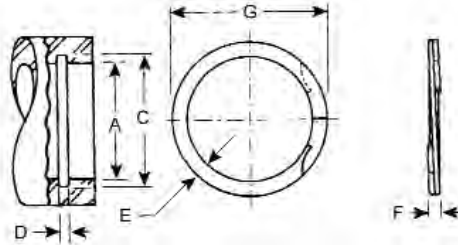

STOCK NO.	A HOUSING DIA.		C GROOVE DIA.	D GROOVE WIDTH	F RING THICKNESS	G RING OUTER DIA.	E RADIAL WALL	THRUST LOAD BASED ON RING SHEAR	THRUST LOAD BASED ON GROOVE YIELD (45,000 P.S.I.)	MAX. CORNER RADIUS OR CHAMFER		WEIGHT lbs./M
	INCHES	MM.								*X	*CH	
Q9-50C	.500	12.7	.526	.030 +.003 -.000	.025 ±.002	.532	.045	2,000	405	.015	.012	.41
Q9-51C	.512	13.0	.538			.544		2,050	420			.42
Q9-53C	.531	13.5	.557			.564		2,130	455			.44
Q9-56C	.562	14.3	.588			.594		2,250	495			.46
Q9-59C	.594	15.1	.619			.626		2,380	535			.49
Q9-62C	.625	15.9	.651 ±.002			.658		2,500	610			.52
Q9-65C	.656	16.7	.682			.689		2,630	670			.55
Q9-68C	.687	17.5	.713			.720		2,750	725			.58
Q9-71C	.718	18.3	.744			.751		2,870	790			.61
Q9-75C	.750	19.0	.782			.790		3,360	800			1.14
Q9-77C	.777	19.7	.808	.817	3,480	835	.024	.019	1.19			
Q9-78C	.781	19.8	.812	.036 +.003 -.000	.031 ±.002	.821	.065	3,500	840	.022	.018	1.20
Q9-81C	.812	20.6	.843			.853 +.013 -.000		3,640	915			1.25
Q9-84C	.843	21.4	.880	.889	3,780	1,155	.025	.021	1.32			
Q9-86C	.866	22.0	.903	.913	3,880	1,250			1.35			
Q9-87C	.875	22.2	.912 ±.003	.922	3,920	1,250	.026	.021	1.36			
Q9-90C	.906	22.9	.939	.949	4,060	1,335			1.41			
Q9-93C	.938	23.8	.975	.986	4,200	1,430	.026	.021	1.48			
Q9-96C	.968	24.4	1.015	1.025	4,340	1,950			2.11			
Q9-98C	.987	25.0	1.030	.042 +.003 -.000	.037 ±.002	1.041	.075	4,420	1,865	2.15		
Q9-100C	1.000	25.4	1.043	1.054	4,480	1,910		2.19				

*For calculation of Groove Yield.

TYPE	MATERIALS
EXTERNAL	CARBON SPRING STEEL WITH OIL-DIP FINISH

STOCK NO.	A HOUSING DIA.		C GROOVE DIA.	D GROOVE WIDTH	F RING THICKNESS	G RING OUTER DIA.	E RADIAL WALL	THRUST LOAD BASED ON RING SHEAR	THRUST LOAD BASED ON GROOVE YIELD (45,000 P.S.I.)	MAX. CORNER RADIUS OR CHAMFER		WEIGHT lbs./M		
	INCHES	MM.								*X	*CH			
Q11-50C	.500	12.7	.474	.030 +.003 -.000	.025 ±.002	.467	.045	2,000	550	.015	.012	.44		
Q11-53C	.531	13.5	.505 ±.002			.498		2,130	640			.48		
Q11-55C	.551	14.0	.525			.518		2,210	700			.50		
Q11-56C	.532	14.3	.536			.529		2,250	730			.51		
Q11-59C	.594	15.1	.569			.561		2,380	740			.54		
Q11-62C	.625	15.9	.594			.585		2,500	970			.70		
Q11-65C	.656	16.7	.625			.617		2,630	1,020			.74		
Q11-66C	.669	17.0	.638			.629		2,680	1,040			.019	.015	.75
Q11-68C	.687	17.5	.656			.647		2,750	1,060					.77
Q11-71C	.718	18.3	.687			.679		2,870	1,110			.024	.019	.81
Q11-75C	.750	19.0	.719	.710 +.000 -.013	3,360	1,100	1.27							
Q11-78C	.781	19.8	.750 ±.003	.741	3,500	1,210	.022	.018	1.32					
Q11-81C	.812	20.6	.781	.771	3,640	1,260			1.38					
Q11-84C	.843	21.4	.812	.803	3,780	1,310	.026	.021	1.43					
Q11-87C	.875	22.2	.838	.828	3,920	1,620			1.48					
Q11-90C	.906	23.0	.869	.860	4,060	1,680	.026	.021	1.53					
Q11-93C	.937	23.8	.900	.889	4,200	1,740			1.57					
Q11-96C	.968	24.4	.925	.916	5,180	2,080	.026	.021	2.26					
Q11-98C	.984	25.0	.941	.930	5,260	2,120			2.31					
Q11-100C	1.000	25.4	.957	.946	5,350	2,150	2.34							

RETAINER RINGS

TYPE	MATERIALS
EXTERNAL	CARBON SPRING STEEL WITH OIL-DIP FINISH

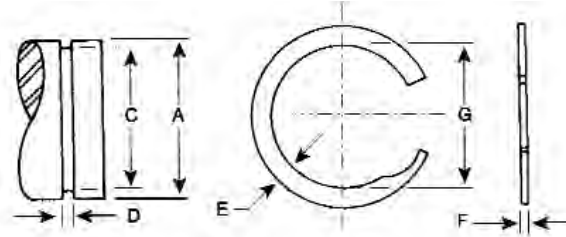

STOCK NO.	A HOUSING DIA.		C GROOVE DIA.	D GROOVE WIDTH	F RING THICKNESS	G RING OUTER DIA.	E RADIAL WALL	THRUST LOAD BASED ON RING SHEAR	THRUST LOAD BASED ON GROOVE YIELD (45,000 P.S.I.)	MAX. CORNER RADIUS OR CHAMFER		WEIGHT lbs./M
	INCHES	MM.								*X	*CH	
Q10-50	.500	12.7	.472	.022	.018 +/- .0015	.467	.045	1,300	380	.007	.005	.32
Q10-56	.562	14.3	.534	.022		.529		1,460	500			
Q10-62	.625	15.9	.597 +/- .002	.022 +.002		.591 +.000		1,630	630			
Q10-68	.687	17.5	.659	.022 -.000		.652 -.013		1,790	770			
Q10-75	.750	19.0	.722	.022	.021 +/- .0015	.715	.065	1,950	940	.011	.008	.48
Q10-81	.812	20.6	.770	.026		.762		2,460	1,330			
Q10-87	.875	22.2	.833	.026 +.002		.825		2,660	1,590			
Q10-93	.937	23.8	.895 +/- .003	.026 -.000		.886		2,840	1,840			
Q10-100	1.000	25.4	.958	.026	.025	.949	.088	3,030	2,100	.016	.012	1.12
Q10-106	1.062	27.0	1.018	.031		1.008 +.000 -.015		3,500	1,820			

*For calculation of Groove Yield.

F

TYPE	MATERIALS
INTERNAL	CARBON SPRING STEEL WITH OIL-DIP FINISH

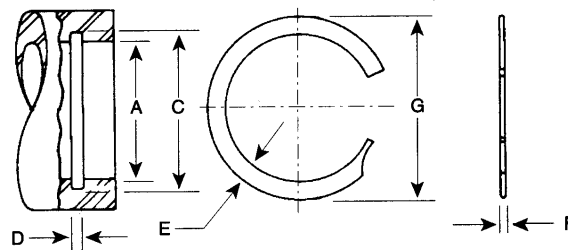

STOCK NO.	A HOUSING DIA.		C GROOVE DIA.	D GROOVE WIDTH	F RING THICKNESS	G RING OUTER DIA.	E RADIAL WALL	THRUST LOAD BASED ON RING SHEAR	THRUST LOAD BASED ON GROOVE YIELD (45,000 P.S.I.)	MAX. CORNER RADIUS OR CHAMFER		WEIGHT lbs./M
	INCHES	MM.								*X	*CH	
Q8-50	.500	12.7	.528	.022 +.002 -.000	.018	.531	.045	1,300	530	.007	.005	.28
Q8-56	.562	14.3	.590			.593		1,460	660			
Q8-62	.625	15.9	.653 ±.002			.656 +.013		1,630	810			
Q8-68	.687	17.5	.715			.719 -.000		1,790	960			
Q8-75	.750	19.0	.779	.026 +.002 -.000	±.0015	.783	.065	1,950	1,090	.011	.008	.46
Q8-81	.812	20.6	.854			.862		2,460	1,705			
Q8-87	.875	22.2	.917			.926		2,660	1,840			
Q8-93	.937	23.8	.979 ±.003			.989		2,840	1,970			
Q8-100	1.000	25.4	1.042 ±.003	.031	.025	1.052	.088	3,030	2,100	.016	.012	1.04
Q8-106	1.062	27.0	1.106 ±.004			1.117 +.015 -.000		3,500	2,340			

*For calculation of Groove Yield.

RETAINER RINGS

TYPE	HOUSING BORE SIZE	MATERIALS
BEARING INTERNAL PUSH IN DESIGN	3/8 TO 3	CARBON SPRING STEEL PLATED

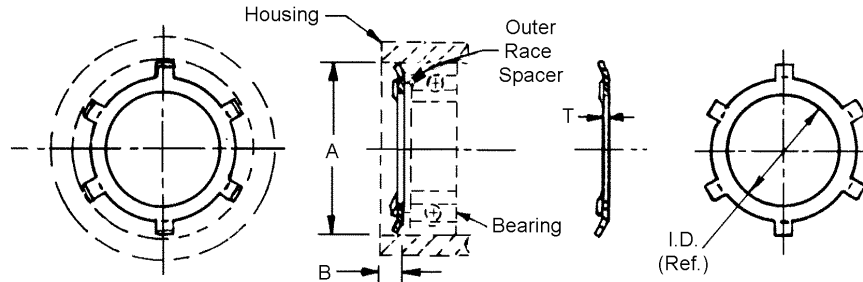

STOCK NO.	A HOUSING	B MIN. END SPACE	T±.002	I.D. (REF. ONLY)
Q6-37-CP	3/8	.040	.010	3/16
Q6-50-CP	1/2	.060	.010	1/4
Q6-61-CP	5/8	.060	.010	3/8
Q6-82-CP	7/8	.080	.015	5/8
Q6-125-CP	1 1/4	.080	.015	15/16
Q6-156-CP	1 9/16	.080	.015	1 1/8
Q6-200-CP	2	.080	.015	1 9/16
Q6-237-CP	2 3/8	.100	.015	1 7/8
Q6-300-CP	3	.100	.015	2 1/4

Sold in packages of 10.



TYPE	HOUSING BORE SIZE	MATERIALS
INTERNAL LUG DESIGN	1/4 TO 1	PH15-7 STAINLESS STEEL

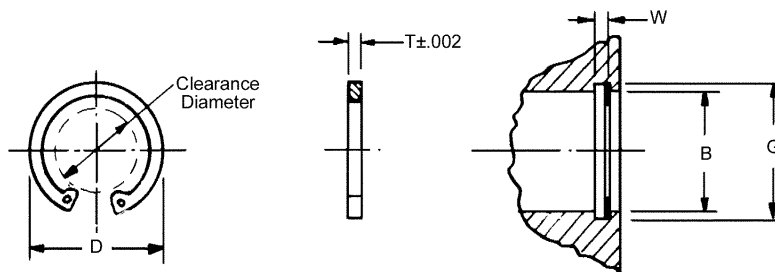

STOCK NO.	HOUSING BORE B	GROOVE DIA. G	GROOVE WIDTH W	RING THICKNESS T	FREE DIA. D	MAX. CLEAR. DIA.	PLIERS
Q4-25	1/4	.268	.020	.015	.280	.133	S13-25P
Q4-31	5/16	.330 ±.001	.020 ±.002	.015	.346	.191	S13-25P
Q4-37	3/8	.397	.029	.025	.415	.226	S13-37P
Q4-50	1/2	.530	.039	.035	.548	.290	S13-37P
Q4-62	5/8	.665 ±.002	.039 ±.003	.035	.694	.380	S13-37P
Q4-75	3/4	.796	.039	.035	.831	.490	S13-37P
Q4-87	7/8	.931	.046	.042	.971	.600	S13-37P
Q4-100	1	1.066 ±.003	.046	.042	1.111	.730	S13-37P
Q4-112	1 1/8	1.197 ±.004	.056 ±.004	.050	1.249	.815	S13-37P



SPRINGS

TYPE	MATERIALS
FOR OUTER RACE BALL BEARING PRE-LOAD	302 STAINLESS STEEL - SPRING TEMPERED

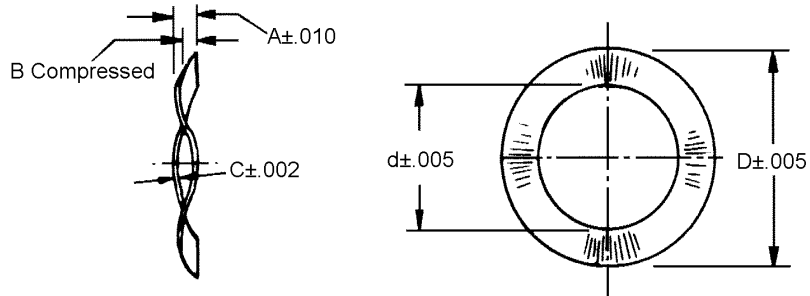

STOCK NO.	BEARING OUTSIDE DIA. (REF.)	D	d	A	B	C	LOAD IN (lbs.) TO DEFLECT TO B
SV-7	.375	.367	.265	.030	.015	.006	2-4
SV-8	.500	.492	.350	.035	.020	.007	3-5
SV-9	.625	.618	.440	.040	.025	.008	3-5
SV-4	.750	.734	.531	.050	.030	.009	4-7
SV-5	.875	.855	.650	.060	.030	.010	4-7
SV-6	1.125	1.102	.856	.075	.037	.012	9-13

Sold in packages of 10.
D & d dimensions before loading.



SPACERS

TYPE	SHAFT SIZE	MATERIALS
LAMINATED INNER RACE SHIM	1/8" TO 3/8"	BRASS - MIL-S-22499C COMP. 2 TYPE 1 CL.-1

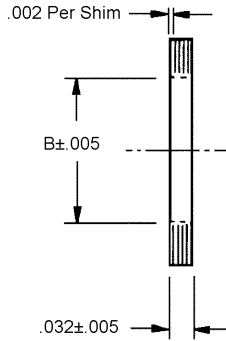
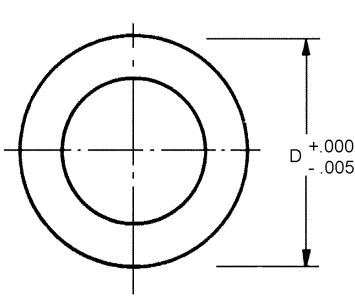

STOCK NO.	SHAFT SIZE	D	B
SS8-1	1/8	.234	.135
SS8-2	3/16	.375	.193
SS8-3	1/4	.500	.255
SS8-4	3/8	.625	.380

Sold in packages of 10.

The inner race spacer fits on shaft and pre-loads inner race of ball bearing.



TYPE	SHAFT SIZE	MATERIALS
LAMINATED OUTER RACE SHIM	1/8" TO 3/8"	BRASS - MIL-S-22499C COMP. 2 TYPE 1 CL.-1

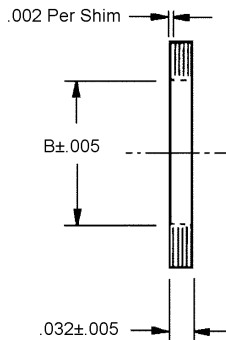
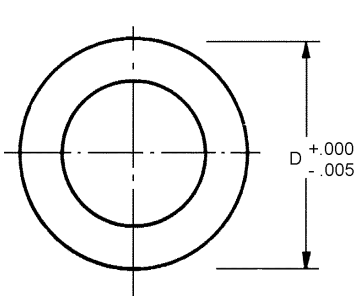

STOCK NO.	D	B
SS7-1	.370	.312
SS7-2	.498	.375
SS7-3	.623	.437
SS7-4	.873	.687

Sold in packages of 10.

The outer race spacer fits in housing and pre-loads outer race of ball bearing.



SHAFT SPACERS

TYPE	SHAFT SIZE	MATERIALS
INNER RACE SHAFT	5/64 TO 3/16	18-8 STAINLESS STEEL OR ANODIZED ALUMINUM

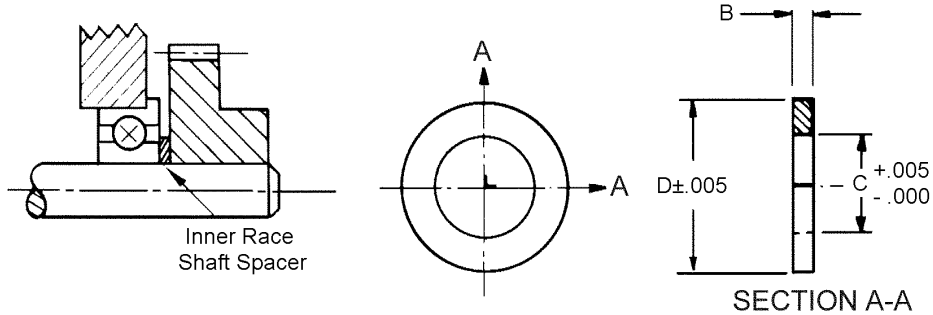

STOCK NO.	C	D	B	
SS1-49	.078	.164	.002	±.001
SS1-1			.004	
SS1-2			.006	
SS1-46			.008	
SS1-3	.078	.164	.010	±.002
SS1-47			.012	
SS1-48			.014	
SS1-4			.016	
SS1-50	.093	.203	.002	±.001
SS1-5			.004	
SS1-6			.006	
SS1-43			.008	
SS1-7	.093	.203	.010	±.002
SS1-44			.012	
SS1-45			.014	
SS1-8			.016	
SS1-51	.125	.187	.002	±.001
SS1-9			.004	
SS1-10			.006	
SS1-27			.008	
SS1-11	.125	.187	.010	±.002
SS1-28			.012	
SS1-29			.014	
SS1-12			.016	



Sold in packages of 10.

STAINLESS STOCK NO.	ALUMINUM STOCK NO.	C	D	B	
SS1-13	SS1-13-A	.125	.187	.031	±.003
SS1-14	SS1-14-A			.063	
SS1-30	SS1-30-A			.094	
SS1-15	SS1-15-A			.125	
SS1-31	SS1-31-A			.188	
SS1-16	SS1-16-A			.250	
SS1-32	SS1-32-A			.375	
SS1-17	SS1-17-A		.500		
SS1-52	-	.187	.250	.002	±.001
SS1-18	-			.004	
SS1-19	-			.006	
SS1-36	-			.008	±.002
SS1-20	-			.010	
SS1-37	-			.012	
SS1-38	-			.014	
SS1-21	-			.016	±.003
SS1-22	SS1-22-A			.031	
SS1-23	SS1-23-A			.063	
SS1-40	SS1-40-A	.094			
SS1-24	SS1-24-A	.125			
SS1-41	SS1-41-A	.188			
SS1-25	SS1-25-A	.250			
SS1-42	SS1-42-A	.375			
SS1-26	SS1-26-A		.500		

Also available

STOCK NO.	DESCRIPTION OF KIT
KIT-SS1	STAINLESS STEEL SHAFT SPACERS, INNER RACE, 1/8, 3/16 AND 1/4" SHAFT SIZES (330 PIECES)

SHAFT SPACERS

TYPE	SHAFT SIZE	MATERIALS
INNER RACE SHAFT	1/4 TO 1/2	18-8 STAINLESS STEEL OR ANODIZED ALUMINUM

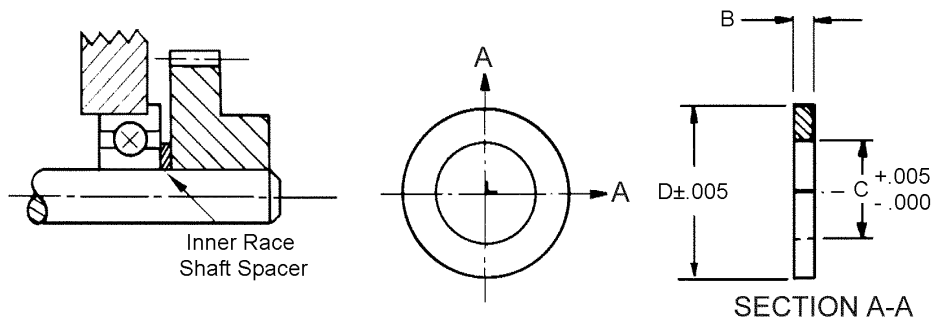

STAINLESS STOCK NO.	ALUMINUM STOCK NO.	C	D	B	
SS2-66	-	.250	.375	.002	±.001
SS2-27	-			.004	
SS2-28	-			.006	
SS2-60	-			.008	
SS2-29	-			.010	±.002
SS2-61	-			.012	
SS2-62	-			.014	
SS2-30	-			.016	±.003
SS2-31	SS2-31-A			.031	
SS2-32	SS2-32-A			.063	
SS2-63	SS2-63-A	.094			
SS2-33	SS2-33-A	.125			
SS2-64	SS2-64-A	.188			
SS2-34	SS2-34-A	.250			
SS2-65	SS2-65-A	.375			
SS2-35	SS2-35-A	.500			
SS2-80	-	.313	.500	.002	
SS2-81	-			.004	
SS2-82	-			.006	
SS2-83	-			.008	
SS2-36	-			.010	±.002
SS2-84	-			.012	
SS2-85	-			.014	
SS2-37	-			.016	±.003
SS2-38	-			.031	
SS2-39	-			.062	
SS2-40	-	.125			

STAINLESS STOCK NO.	ALUMINUM STOCK NO.	C	D	B	
SS2-67	-	.375	.562	.002	±.001
SS2-68	-			.004	
SS2-69	-			.006	
SS2-70	-			.008	
SS2-41	-			.010	±.002
SS2-71	-			.012	
SS2-72	-			.014	
SS2-42	-			.016	±.003
SS2-43	SS2-43-A			.031	
SS2-44	SS2-44-A			.063	
SS2-73	SS2-73-A	.094			
SS2-45	SS2-45-A	.125			
SS2-74	SS2-74-A	.188			
SS2-75	SS2-75-A	.250			
SS2-76	SS2-76-A	.375			
SS2-77	SS2-77-A	.500			
SS2-90	-	.500	.750	.002	
SS2-91	-			.004	
SS2-92	-			.006	
SS2-93	-			.008	
SS2-46	-			.010	±.002
SS2-94	-			.012	
SS2-95	-			.014	
SS2-47	-			.016	±.003
SS2-48	-			.031	
SS2-49	-			.062	
SS2-50	-	.125			

Sold in packages of 10.

Also available

STOCK NO.	DESCRIPTION OF KIT
KIT-SS1	STAINLESS STEEL SHAFT SPACERS, INNER RACE, 1/8, 3/16 AND 1/4" SHAFT SIZES (330 PIECES)

BEARING SPACERS

TYPE	SHAFT SIZE	MATERIALS
OUTER RACE	5/32 TO 1 1/8	18-8 STAINLESS STEEL OR ANODIZED ALUMINUM

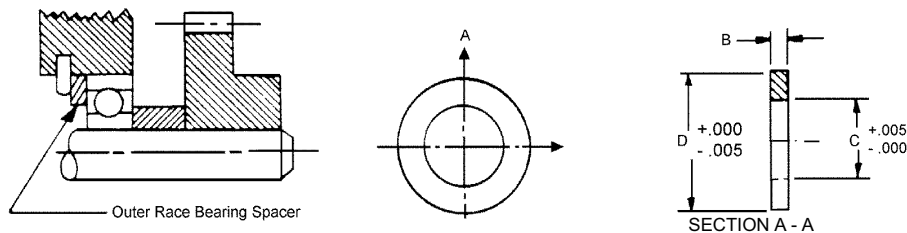

STAINLESS STOCK NO.	ALUMINUM STOCK NO.	D	C	B	
SS3-51	-	.153	.088	.003	±.001
SS3-52	-			.005	
SS3-53	-			.007	
SS3-54	-			.010	±.002
SS3-55	-			.020	
SS3-56	-	.178	.123	.003	±.001
SS3-57	-			.005	
SS3-58	-			.007	
SS3-59	-			.010	±.002
SS3-60	-			.020	
SS3-50	-	.248	.167	.003	±.003
SS3-1	-			.005	
SS3-32	-			.007	
SS3-2	-			.010	
SS3-71	-			.020	
SS3-33	-	.310	.206	.003	±.001
SS3-3	-			.005	
SS3-34	-			.007	
SS3-4	-			.010	±.002
SS3-72	-			.020	
SS3-35	-	.373	.253	.003	±.001
SS3-5	-			.005	
SS3-36	-			.007	
SS3-6	-			.010	±.002
SS3-7	-			.020	
SS3-8	SS3-8-A			.032	±.003
SS3-9	SS3-9-A			.062	
SS3-10	SS3-10-A			.125	
SS3-41	SS3-41-A			.250	
SS3-42	SS3-42-A			.375	
SS3-43	SS3-43-A			.500	
SS3-37	-			.003	
SS3-11	-			.005	±.001
SS3-38	-	.007			
SS3-12	-	.498	.378	.010	±.002
SS3-13	-			.020	

STAINLESS STOCK NO.	ALUMINUM STOCK NO.	D	C	B	
SS3-14	SS3-14-A	.498	.378	.032	±.003
SS3-15	SS3-15-A			.062	
SS3-16	SS3-16-A			.125	
SS3-44	SS3-44-A			.250	
SS3-45	SS3-45-A			.375	
SS3-46	SS3-46-A			.500	
SS3-39	-	.623	.503	.003	±.001
SS3-17	-			.005	
SS3-40	-			.007	
SS3-18	-			.010	±.002
SS3-19	-			.020	
SS3-20	SS3-20-A			.032	±.003
SS3-21	SS3-21-A	.062			
SS3-22	SS3-22-A	.125			
SS3-47	SS3-47-A	.250			
SS3-48	SS3-48-A	.375	±.003		
SS3-49	SS3-49-A	.500			
SS3-23	-	.685	.562	.016	±.02
SS3-24	-			.032	±.003
SS3-25	-			.062	
SS3-61	-	.873	.687	.003	±.001
SS3-62	-			.005	
SS3-63	-			.007	
SS3-64	-			.010	±.002
SS3-26	-			.016	
SS3-65	-			.020	
SS3-27	SS3-27-A			.032	±.003
SS3-28	SS3-28-A			.062	
SS3-67	SS3-67-A			.125	
SS3-68	SS3-68-A			.250	
SS3-69	SS3-69-A			.375	
SS3-70	SS3-70-A			.500	
SS3-29	-			1.120	
SS3-30	-	.032	±.003		
SS3-31	-	.062			

Sold in packages of 10.

Also available

STOCK NO.	DESCRIPTION OF KIT
KIT-SS3	STAINLESS STEEL BEARING SPACERS, OUTER RACE, 1/8, 3/16 AND 1/4" SHAFT SIZES (330 PIECES)

BALLS

TYPE	DIAMETER	MATERIALS
HARDENED STEEL	1/16" TO 1/2"	ROCKWELL C55 TO C62 440 STAINLESS STEEL AND 52100 CHROME STEEL

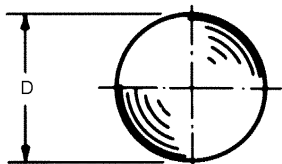

STAINLESS STEEL STOCK NO.	CHROME STEEL STOCK NO.	D DIA.
PT4-2	PT5-2	1/16
PT4-3	PT5-3	3/32
PT4-4	PT5-4	1/8
PT4-5	PT5-5	5/32
PT4-6	PT5-6	3/16
-	PT5-7	7/32
PT4-8	PT5-8	1/4
PT4-10	PT5-10	5/16
PT4-12	PT5-12	3/8
PT4-16	PT5-16	1/2

DIAMETER TOLERANCE:

440 Stainless Steel, Grade #50±.0002
52100 Chrome Steel, Grade #25±.0001

SPHERICITY TOLERANCE:

440 Stainless Steel, Grade #50±.000050
52100 Chrome Steel, Grade #25±.00025

Sold in packages of 10.



TYPE	DIAMETER	MATERIALS
PLASTIC	1/16" TO 1/2"	NYLON, POLYURETHANE, AND TEFLON

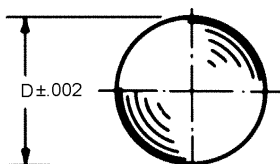

NYLON STOCK NO.	POLYURETHANE STOCK NO.	TEFLON STOCK NO.	D DIA.
PT1-2	-	-	1/16
PT1-3	-	-	3/32
PT1-4	-	PT3-4	1/8
PT1-6	-	PT3-6	3/16
PT1-8	PT2-8	PT3-8	1/4
PT1-12	PT2-12	PT3-12	3/8
PT1-16	PT2-16	PT3-16	1/2

- Ideal for float, check, relief valves
- Non-corrosive, quiet running and self lubricating

Sold in packages of 10.



TYPE	DIAMETER	MATERIALS
BRASS	1/8" TO 1/2"	BRASS HARDNESS 75-87 RB (TYP.)

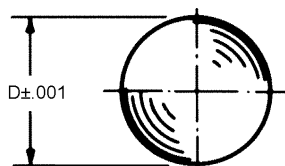

STOCK NO.	SIZE	DIAMETER D
PT9-4	1/8	.125
PT9-5	5/32	.15625
PT9-6	3/16	.1875
PT9-7	7/32	.21875
PT9-8	1/4	.250
PT9-9	9/32	.28125
PT9-10	5/16	.3125
PT9-11	11/32	.34375
PT9-12	3/8	.375
PT9-14	7/16	.4375
PT9-16	1/2	.500

CHARACTERISTICS

Resistance to corrosion by water.
Electrical conductivity.

NOTE: Other sizes available upon request.
Brass surface finish 6-8 microfinish.

Sold in packages of 10.



TYPE	DIAMETER	MATERIALS
TITANIUM	1/8" TO 3/8"	TITANIUM 6A4V ELI PER ASTM F136

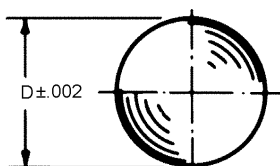

STOCK NO.	SIZE	DIAMETER D
PT8-4	1/8	.125
PT8-5	5/32	.15625
PT8-6	3/16	.1875
PT8-7	7/32	.21875
PT8-8	1/4	.250
PT8-10	5/16	.3125
PT8-12	3/8	.375

CHARACTERISTICS

Exceptional anti-corrosive properties.
Operates effectively under high temperatures.
High level of tension/compression strength.

NOTE: Other sizes available upon request.

Sold in packages of 10.



SPRINGS

TYPE	STYLE	MATERIALS
COMPRESSION	RIGHT HAND - OPEN WOUND ENDS SQUARED	302 STAINLESS STEEL SPRING TEMPERED

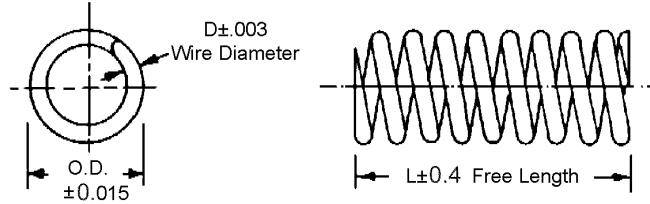

STOCK NO.	OUTSIDE DIA.	D	L	COILS	K $\pm 10\%$
SPR1-1	.057	.007	3/8	18	1.58
SPR9-1		.008	1/4	13	4.41
SPR9-2		.008	1/2	24	2.08
SPR9-3	.088	.010	1/4	9	4.16
SPR1-2		.010	1/2	17	1.91
SPR9-5		.012	3/8	14	5.41
SPR9-6	.120	.012	3/4	24	2.66
SPR9-7		.016	1/4	7	14.57
SPR9-8		.016	1/2	13	6.91
SPR9-9		.018	3/8	10	14.91
SPR1-3		.018	5/8	16	8.82
SPR9-10		.018	3/4	19	7.08
SPR9-11		.020	3/8	11	23.07
SPR9-12	.180	.020	3/4	20	10.99
SPR9-13		.022	1/2	14	25.90
SPR9-14		.022	1	27	12.24
SPR9-15		.018	1/2	8	5.58
SPR9-16		.018	1	14	2.66
SPR9-17		.020	1/2	8	8.08
SPR9-18		.020	1	15	3.83
SPR1-4	.180	.022	1/2	8	11.82
SPR9-20		.022	1	16	5.41
SPR9-21		.024	1/2	9	15.74
SPR9-22		.024	1	17	7.49
SPR9-23		.026	1/2	9	22.32
SPR9-24		.026	1	17	10.16
SPR9-25		.029	3/4	14	21.49
SPR9-26		.029	1 1/2	26	10.32
SPR9-27		.032	3/4	14	34.40
SPR9-28		.032	1 1/2	27	15.66
SPR9-29	.240	.026	1/2	6	17.40
SPR1-5		.026	5/8	8	10.57
SPR9-30		.026	1	12	6.16
SPR9-31		.035	1/2	8	40.40
SPR9-32		.035	1	14	18.65
SPR9-33		.038	3/4	10	38.40
SPR9-34		.038	1 1/2	20	17.82
SPR9-35		.040	1	14	32.48
SPR9-36		.040	2	27	15.57
SPR1-6		.300	.032	5/8	6
SPR1-7	.360	.042	7/8	8	21.24
SPR1-8	.420	.045	1	7	16.66
SPR1-9	.480	.055	1 1/4	8	22.49
SPR1-10	.600	.063	1 1/2	8	19.99
SPR1-11	.720	.072	2	9	16.66

K = Average Spring Rate lbs./in.

Sold in packages of 10.

F

Also available

STOCK NO.	DESCRIPTION OF KIT
KIT-SPR9	COMPRESSION SPRING KIT - ASSORTED SIZES .057 TO .240 DIAMETER TO 2" LONG (141 PIECES)

SPRINGS

TYPE	LENGTHS	MATERIALS
EXPERIMENTAL	1 1/2 TO 2 1/2	302 STAINLESS STEEL SPRING TEMPERED

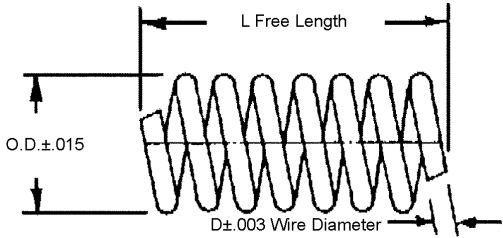

STOCK NO.	OUTSIDE DIA.	D	L	APPROX. NO. COILS	K ±10%
SPR7-1	.093	.016	1 1/2	32	5.98
SPR7-2	.125	.018	2	37	3.06
SPR7-7	.140	.016	11	17	3.32
SPR7-8	.172	.018	1 1/4	19	2.15
SPR7-3	.187	.023	2 1/2	37	2.26
SPR7-4	.250	.025	3	29	1.67
SPR7-9	.250	.023	1 1/2	22	1.59
SPR7-10	.328	.025	1 3/4	19	1.06
SPR7-11	.390	.032	2	16	2.11
SPR7-12	.468	.040	2 1/4	12	4.11
SPR7-13	.609	.047	2 1/2	15	2.43

- Cut you own length
 - Ends can be ground or looped
- K = Average Spring Rate lbs./in.
Sold in packages of 10.

TYPE	LENGTHS	MATERIALS
EXTENSION - FULL TWIST LOOPS CLOSE WOUND	1/4" TO 5"	302 STAINLESS STEEL SPRING TEMPERED

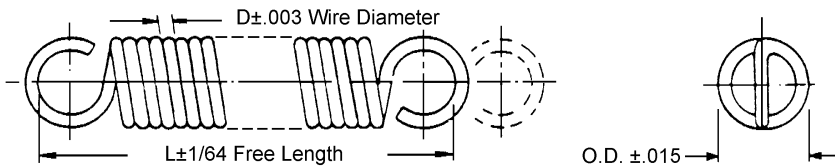

Sold in packages of 10.

STOCK NO.	OUTSIDE DIA.	D	L	K ± 10%
SPR10-1	.063	.008	1/4	1.7
SPR2-1	.063	.008	3/8	.9
SPR10-2	.063	.008	1/2	.6
SPR10-3	.093	.010	3/8	1.0
SPR2-2	.093	.012	1/2	1.7
SPR10-4	.093	.010	3/4	.3
SPR2-3	.120	.018	1	2.7
SPR10-5	.120	.016	3/4	2.5
SPR10-6	.120	.016	1 1/4	1.1
SPR10-7	.120	.020	3/4	6.9
SPR10-8	.120	.020	1 1/4	3.7
SPR2-4	.180	.026	1 1/4	4.2
SPR10-9	.180	.022	3/4	3.6
SPR10-10	.180	.022	1 1/4	1.7
SPR10-11	.180	.026	3/4	8.8
SPR10-13	.180	.031	3/4	22.5
SPR10-14	.180	.031	1 1/4	10.9
SPR2-5	.240	.031	1 1/2	3.5
SPR10-15	.240	.026	3/4	4.7
SPR10-16	.240	.026	1 1/4	1.7
SPR10-17	.240	.029	3/4	8.2
SPR10-18	.240	.029	1 1/4	3.2
SPR10-19	.240	.031	3/4	11.5
SPR10-20	.240	.031	1 1/4	4.4
SPR10-21	.240	.034	3/4	18.4
SPR10-22	.240	.034	1 1/4	7.4
SPR2-6	.360	.055	2	15.2
SPR10-27	.360	.031	1	2.7
SPR10-28	.360	.031	1 1/2	1.2
SPR10-29	.360	.037	1	6.6
SPR10-30	.360	.037	1 1/2	2.8
SPR10-31	.360	.045	1 1/4	11.3
SPR10-32	.360	.045	2	5.2
SPR10-33	.360	.055	1 1/4	32.2
SPR10-35	.500	.037	1 1/4	2.3
SPR10-36	.500	.037	2	.8
SPR2-7	.500	.055	2 1/2	4.2
SPR2-8	.650	.055	3	1.6
SPR2-9	.750	.063	4	1.4
SPR2-10	.580	.075	4 1/2	2.1
SPR2-11	1.000	.075	5	1.2

SPRINGS

TYPE	LENGTHS	MATERIALS
TORSION LEFT HAND WOUND	1/2" TO 2"	STAINLESS STEEL

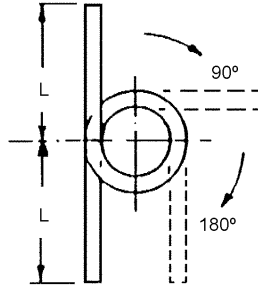
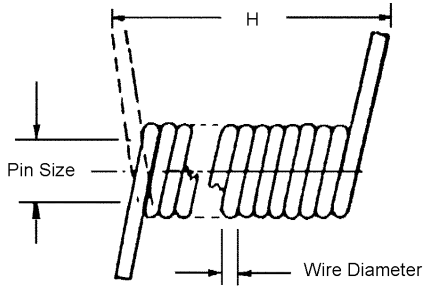

STOCK NO.	WIRE DIA.	OUTSIDE DIA.	L	PIN SIZE	H	TORQUE IN.LBS. @ 180
SPR3-1	.012	.166	.50	.109	.059	.047
SPR3-2	.015	.183	.75	.109	.075	.093
SPR3-3	.018	.216	.75	.140	.109	.140
SPR3-4	.021	.247	1.00	.156	.127	.218
SPR3-5	.025	.304	1.00	.203	.151	.375
SPR3-6	.030	.394	1.00	.250	.181	.625
SPR3-7	.035	.450	1.25	.281	.212	1.000
SPR3-8	.040	.518	2.00	.343	.242	1.375
SPR3-9	.048	.618	2.00	.406	.292	2.500

Special springs on request, send sketch.

Right hand wound on request.

Sold in packages of 10.

F

TYPE	LENGTHS	MATERIALS
ANTI-BACKLASH EXTENSION	3/8 TO 27/64	302 STAINLESS STEEL

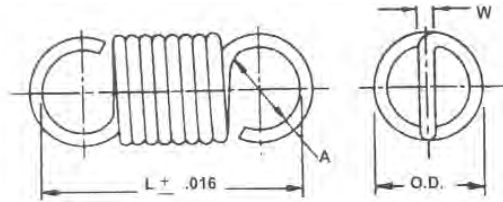

Extension Spring

STOCK NO.	OUTSIDE DIA.	W	NO. OF COILS	L	A	K LBS./IN.
SPR5-1	.105	.008	19	.375	.11	0.3
SPR5-9	.120	.010	17	.375	.10	0.5
SPR5-2	.105	.012	13	.375	.10	2.5
SPR5-6	.120	.012	14	.375	.09	1.4
SPR5-5	.090	.012	20	.375	.07	2.6
SPR5-3	.105	.015	11	.375	.09	7.7
SPR5-10	.120	.015	11	.350	.09	5.0
SPR5-3-A	.120	.016	11	.426	.12	6.5
SPR5-11	.120	.018	9	.350	.09	14.0
SPR5-4	.105	.020	10	.375	.09	32.0

Sold in packages of 10.

SPRINGS

TYPE	MATERIALS
ANTI-BACKLASH TORSION	302 STAINLESS STEEL

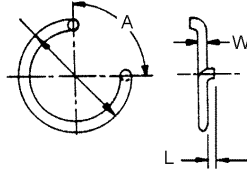

STOCK NO.	OUTSIDE DIA.	W	L	A	K LBS./IN.
SPR6-3	.37	.030	.045	90	7.6
SPR6-1	.51	.015	.045	90	0.3
SPR6-2	.51	.020	.045	90	1.0
SPR6-5	.53	.028	.045	90	4.0
SPR6-10	.55	.032	.045	90	6.3
SPR6-12	.62	.026	.031	135	2.5
SPR6-14	.65	.022	.045	135	1.3
SPR6-15	.65	.026	.045	135	2.4
SPR6-16	.72	.024	.031	135	1.5
SPR6-6	.81	.026	.062	135	2.0

Sold in packages of 10.

SPRING POSTS

DIAMETER	MATERIALS
1/8" TO 1/4"	CARBON STEEL - ZINC PLATED QQ-Z325 TYPE 1-C1.3

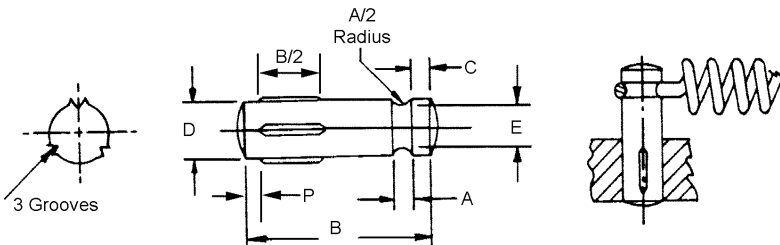

STOCK NO.	D	A	B	E	C	CROWN RADIUS	CROWN HEIGHT	P
CL-1	1/8	1/16	1/2	.083	1/32	5/32	.013	1/32
CL-2	3/16	1/16	5/8	.125	3/64	1/4	.018	1/16
CL-3	1/4	3/32	3/4	.167	1/16	5/16	.026	1/16



Sold in packages of 10.

CHASSIS HANDLES

TYPE	MATERIALS
TAP	303 STAINLESS STEEL

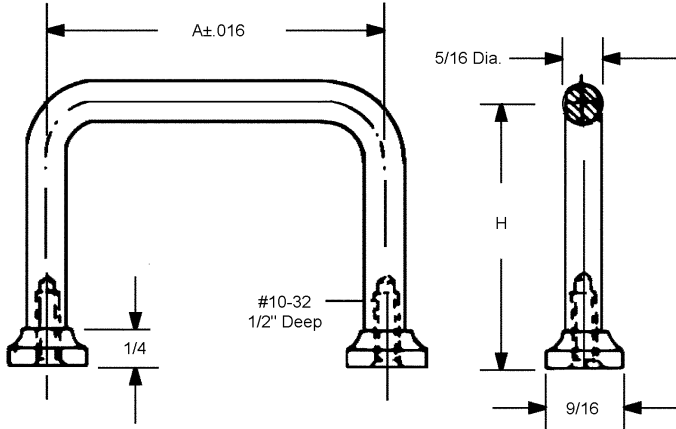

STOCK NO.	A	H
HA-1	3.000	1 1/2
HA-2	4.500	1 1/2
HA-3	5.500	1 5/8
HA-4	6.500	1 3/4



TYPE	MATERIALS
STUD	303 STAINLESS STEEL

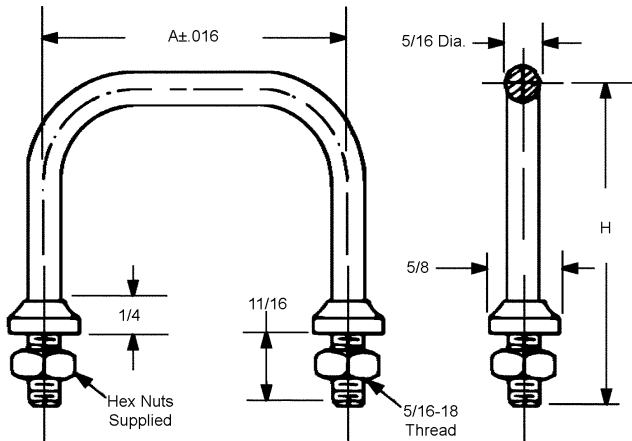

STOCK NO.	A	H
HB-1	3.000	1 1/2
HB-2	4.500	1 1/2
HB-3	5.500	1 5/8
HB-4	6.500	1 3/4



F

COUPLINGS AND CLUTCHES

Table of Contents

COUPLINGS

Guide for Couplings Selection - Technical DataG 2
Thin Wall CouplingsG 3 - G 6
Polyurethane CouplingsG 7
Six Beam FlexibleG 8 - G 13
Three Beam FlexibleG 14 - G 17
Single Beam FlexibleG 18 - G 19
Reli-A-Flex®G 20 - G 23
Flex-Thane -G 24, G 49
Absorbathane FlexibleG 25
Neo-FlexG 26 - G 27
SleeveG 28
Split SleeveG 29 - G 30
SpiderG 31
Multi-JawG 32
BellowsG 33 - G 35
OldhamG 36 - G 39
Universal LateralG 40 - G 41
Wafer SpringG 42 - G 43
Disc Couplings - Ratings and Mass DataG 44
Disc CouplingsG 45 - G 48

UNIVERSAL JOINTSG 50 - G 53

TELESCOPIC UNIVERSAL JOINTSG 54

FLEXIBLE SHAFT COUPLINGS

Technical DataG 55, G 58
Flexible Shaft CouplingsG 56 - G 57, G 59

SHAFT ADAPTERS

Clamp StyleG 60
Metric Male / Inch Male - PlainG 61 - G 62
Inch Femal / Metric Male - Clamp HubG 63 - G 64
Inch Male / Metric Female - Clamp HubG 65
Inch Female / Metric Male - Pin HubG 66 - G 68
Inch Male / Metric Female - Pin HubG 69 - G 71

SHAFT EXTENSIONS (CLAMP HUB)G 72

OVERRUNNING COUPLINGG 73

SLIP COUPLINGSG 74 - G 77

OLDHAM SLIP COUPLINGSG 77

TORQUE LIMITERSG 78

INLINE COUPLING SLIP CLUTCHG 79

SLIP CLUTCHG 80 - G 82

MINIATURE SLIP CLUTCHG 83

SLIP CLUTCHES AND COUPLINGSG 84

ROLLER CLUTCHESG 85



GUIDE FOR COUPLING SELECTION

TECHNICAL DATA

Dimensional Parameters				Environmental Parameters					
COUPLING TYPE		TORQUE RANGE IN.-OZ.	RANGE OF MAXIMUM PARALLEL MISALIGN.	RANGE OF MAXIMUM ANGULAR MISALIGN.	HIGH TORSIONAL STIFFNESS	VIBRATION DAMPENING	VACUUM COMPATIBILITY	ELECTRICAL INSULATION	CLEAN ROOM ENVIRONMENT
INFORMATION TRANSMITTING COUPLINGS	MULTIBEAM: -ST/ST+AL -PLASTIC	64-7200 35-1273	.005-.038 .005-.038	5p-7p 5p-10p	E G	- -	E -	- E	E G
	BEAMED	56-1488	.004-.005	5p	E	-	E	-	E
	WAFER SPRING	165-440	.018-.030	8p	E	-	E	-	E
	BELLOWS	40-175	.012-.027	4p-7p	E	-	E	-	E
	SLEEVE	5-5833	0	0p	E	-	E	-	E
SHOCK ABSORBING COUPLINGS	SPIDER	42-3520	.031-.078	1p	-	G	-	E	G
	NEO-FLEX	150	.005	1p	-	E	-	E	G
	ABSORBATHANE	48-640	.094-.125	10p-15p	-	E	-	E	G
MISALIGNMENT COUPLINGS	UNIVERSAL LATERAL	38-607	.050	5p-10p	G	-	-	E	-
	OLDHAM	16-3200	.030-.200	1/2p-1 1/4p	G	-	-	E	-
HIGH MISALIGNMENT COUPLINGS	FLEX-THANE	400-3200	.063-1.250	10p-30p	-	E	-	E	G
	UNIVERSAL JOINTS: - ST/ST - DELRIN®, SINGLE JOINT - DELRIN®, DOUBLE JOINT	480-4240	0	30p	G	-	E	-	-
		16-239	0	45p	-	-	-	E	-
		11-183	.220-.610	90p	-	-	-	E	-
	TELESCOPIC UNIVERSAL JOINT	55-239	1.920-3.770	60p	-	-	-	E	-
FLEXIBLE SHAFT	*	*	*	E	E	-	-	G	

E = Excellent

G = Good

- = Not Recommended

W.M. Berg Inc. manufactures a complete line of precision made, high quality couplings. Available in inch and metric sizes and many styles to accommodate any design requirement. Couplings can be placed into the following four categories;

- 1. Information Transmitting Couplings** - These zero backlash high torsional rigidity couplings, are for precision positioning applications where constant velocity is required for accurate feedback control.
- 2. Shock Absorbing Couplings** - As a result of flexible plastic members connecting their hubs, these couplings dampen vibrations and shock loads and electrically insulate shafting.
- 3. Misalignment Couplings** - The sliding center elements of these couplings compensate for lateral and angular misalignment caused by tolerance buildup or as a result of mounting.
- 4. High Misalignment Couplings** - These couplings allow the designer to have shafts that are intentionally offset, laterally or angularly, by a large amount.

The above chart is a guide for the proper selection of the Berg coupling best suited for your particular application.

THIN WALL COUPLINGS

BORE	O.D.	TORQUE	MATERIAL
1/8" TO 5/16"	.85	28 IN. LBS.	ALUMINUM HUBS

- Shaft to shaft couplings
- Pin to pin phase adjustment
- No lubrication required
- Positive drive
- 3° max. angular misalignment
- 1/32 max. lateral misalignment
- -65° to 180° F temperature range
- Quick Disconnect

STOCK NO.	B1	H1	L1	B2	H2	L2
CC6-1	.1248			.1248	5/16	5/16
CC6-2	.1248			.1562	5/16	5/16
CC6-3	.1248	5/16	5/16	.1873	3/8	11/32
CC6-4	.1248			.2498	1/2	3/8
CC6-5	.1873			.1873	3/8	11/32
CC6-6	.1873	3/8	11/32	.2498	1/2	3/8
CC6-7	.2498			.2405	3/8	11/32
CC6-8	.2498	1/2	3/8	.2498	1/2	3/8
CC6-9	.3123			.1873	3/8	11/32
CC6-10	.3123			.2498	1/2	3/8
CC6-11	.3123	1/2	3/8	.3123	1/2	3/8

BORE	O.D.	TORQUE	MATERIAL
1/8" TO 1/2"	1.09"	50 IN. LBS.	ALUMINUM HUBS

- Shaft to shaft couplings
- Pin to pin phase adjustment
- No lubrication required
- Positive drive
- 3° max. angular misalignment
- 1/32 max. lateral misalignment
- -65° to 180° F temperature range
- Quick Disconnect

STOCK NO.	B1	H1	L1	B2	H2	L2
CC6-20	.1248			.1248	5/16	5/16
CC6-21	.1248			.1562	5/16	5/16
CC6-22	.1248	5/16	5/16	.1873	3/8	11/32
CC6-23	.1248			.2498	1/2	3/8
CC6-24	.1873			.1873	3/8	11/32
CC6-25	.1873	3/8	11/32	.2498	1/2	3/8
CC6-26	.2498			.2405	3/8	11/32
CC6-27	.2498	1/2	3/8	.2498	1/2	3/8
CC6-28	.3123			.1873	3/8	11/32
CC6-29	.3123			.2498	1/2	3/8
CC6-30	.3123	1/2	3/8	.3123	1/2	3/8
CC6-31	.3748*			.2498	1/2	3/8
CC6-32	.3748*			.3123	1/2	3/8
CC6-33	.3748*	1	5/8	.3748*	1	5/8
CC6-34	.4998*			.2498	1/2	3/8
CC6-37	.4998*	1 1/4	5/8	.4998*	1 1/4	5/8

* Two piece construction - Aluminum Sprocket with Stainless Steel Hubs

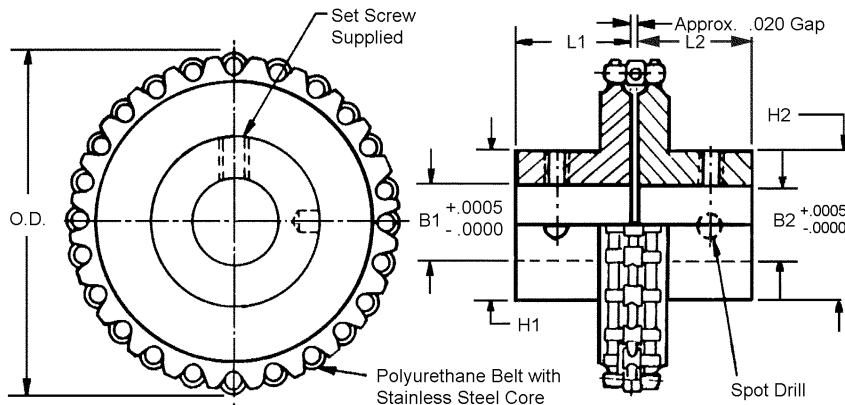

Available on request: Other bore sizes, larger torque ratings

THIN WALL COUPLINGS

BORE	O.D.	TORQUE	MATERIAL
1/8" TO 1/2"	1.35"	80 IN. LBS.	ALUMINUM HUBS

- Shaft to shaft couplings
- Pin to pin phase adjustment
- No lubrication required
- Positive drive
- 3° max. angular misalignment
- 1/32 max. lateral misalignment
- -65° to 180° F temperature range
- Quick Disconnect

STOCK NO.	B1	H1	L1	B2	H2	L2
CC6-40	.1248			.1248	5/16	5/16
CC6-41	.1248	5/16	5/16	.1562	5/16	5/16
CC6-42	.1248			.1873	3/8	11/32
CC6-43	.1248			.2498	1/2	3/8
CC6-44	.1873	3/8	11/32	.1873	3/8	11/32
CC6-45	.1873			.2498	1/2	3/8
CC6-46	.2498	1/2	3/8	.2405	3/8	11/32
CC6-47	.2498			.2498	1/2	3/8
CC6-48	.3123	1/2	3/8	.1873	3/8	11/32
CC6-49	.3123			.2498	1/2	3/8
CC6-50	.3123			.3123	1/2	3/8
CC6-51	.3748	1	5/8	.2498	1/2	3/8
CC6-52	.3748			.3123	1/2	3/8
CC6-53	.3748			.3748	1	5/8
CC6-54	.4998	1 1/4	5/8	.2498	1/2	3/8
CC6-55	.4998			.3123	1 1/2	3/8
CC6-56	.4998			.3748	1	5/8
CC6-57	.4998			.4998	1 1/4	5/8

BORE	O.D.	TORQUE	MATERIAL
1/4" TO 1/2"	1.60"	115 IN. LBS.	ALUMINUM HUBS

- Shaft to shaft couplings
- Pin to pin phase adjustment
- No lubrication required
- Positive drive
- 3° max. angular misalignment
- 1/32 max. lateral misalignment
- -65° to 180° F temperature range
- Quick Disconnect

STOCK NO.	B1	H1	L1	B2	H2	L2
CC6-67	.2498	1/2	3/8	.2498	1/2	3/8
CC6-68	.3123	1/2	3/8	.1873	3/8	11/32
CC6-69	.3123			.2498	1/2	3/8
CC6-70	.3123			.3123	1/2	3/8
CC6-71	.3748*	1	5/8	.2498	1/2	3/8
CC6-72	.3748*			.3123	1/2	3/8
CC6-73	.3748*			.3748*	1	5/8
CC6-74	.4998*	1 1/4	5/8	.2498	1/2	3/8
CC6-75	.4998*			.3123	1 1/2	3/8
CC6-76	.4998*			.3748*	1	5/8
CC6-77	.4998*			.4998*	1 1/4	5/8

* Two piece construction - Aluminum Sprocket with Stainless Steel Hubs

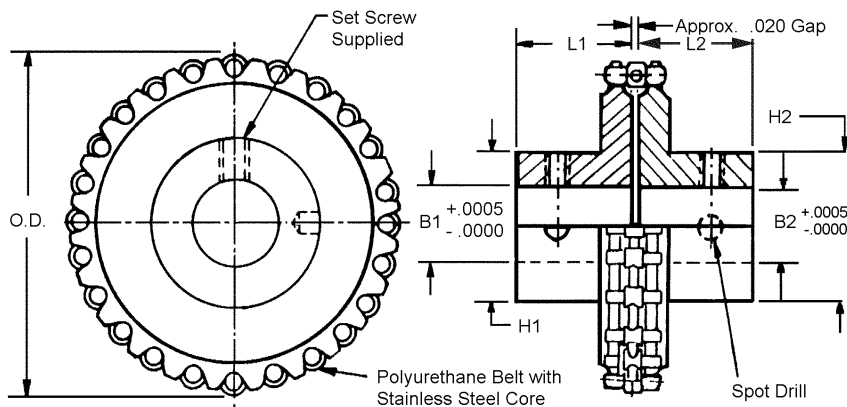

Available on request: Other bore sizes, larger torque ratings

THIN WALL COUPLINGS

BORE	O.D.	TORQUE	MATERIAL
1/8" TO 5/16"	.85"	28 IN. LBS.	STAINLESS STEEL HUBS

- Shaft to shaft couplings
- Pin to pin phase adjustment
- No lubrication required
- Positive drive
- 3° max. angular misalignment
- 1/32 max. lateral misalignment
- -65° to 180° F temperature range
- Quick Disconnect

STOCK NO.	B1	H1	L1	B2	H2	L2
CC7-1	.1248			.1248	5/16	5/16
CC7-2	.1248			.1562	5/16	5/16
CC7-3	.1248	5/16	5/16	.1873	3/8	11/32
CC7-4	.1248			.2498	1/2	3/8
CC7-5	.1873			.1873	3/8	11/32
CC7-6	.1873	3/8	11/32	.2498	1/2	3/8
CC7-7	.2498			.2405	3/8	11/32
CC7-8	.2498	1/2	3/8	.2498	1/2	3/8
CC7-9	.3123			.1873	3/8	11/32
CC7-10	.3123			.2498	1/2	3/8
CC7-11	.3123	1/2	3/8	.3123	1/2	3/8

BORE	O.D.	TORQUE	MATERIAL
1/8" TO 1/2"	1.09"	50 IN. LBS.	STAINLESS STEEL

- Shaft to shaft couplings
- Pin to pin phase adjustment
- No lubrication required
- Positive drive
- 3° max. angular misalignment
- 1/32 max. lateral misalignment
- -65° to 180° F temperature range
- Quick Disconnect

STOCK NO.	B1	H1	L1	B2	H2	L2
CC7-20	.1248			.1248	5/16	5/16
CC7-21	.1248			.1562	5/16	5/16
CC7-22	.1248	5/16	5/16	.1873	3/8	11/32
CC7-23	.1248			.2498	1/2	3/8
CC7-24	.1873			.1873	3/8	11/32
CC7-25	.1873	3/8	11/32	.2498	1/2	3/8
CC7-26	.2498			.2405	3/8	11/32
CC7-27	.2498	1/2	3/8	.2498	1/2	3/8
CC7-28	.3123			.1873	3/8	11/32
CC7-29	.3123			.2498	1/2	3/8
CC7-30	.3123	1/2	3/8	.3123	1/2	3/8
CC7-31	.3748*			.2498	1/2	3/8
CC7-32	.3748*	1	5/8	.3123	1/2	3/8
CC7-33	.3748*			.3748*	1	5/8
CC7-34	.4998*			.2498	1/2	3/8
CC7-37	.4998*	1 1/4	5/8	.4998*	1 1/4	5/8

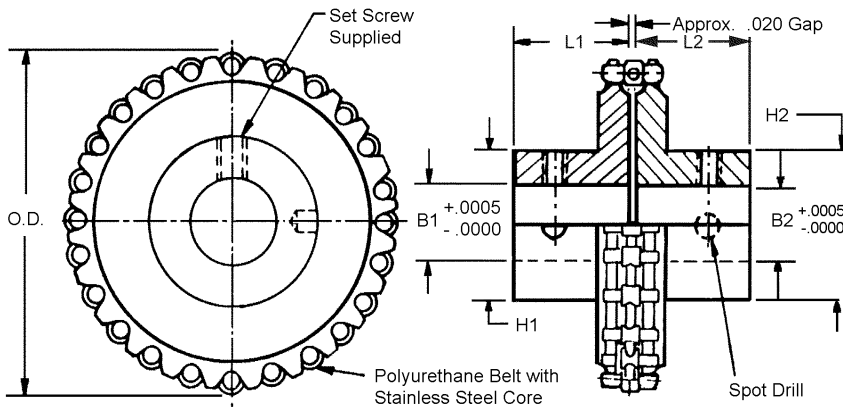

Available on request: Other bore sizes, larger torque ratings

THIN WALL COUPLINGS

BORE	O.D.	TORQUE	MATERIAL
1/8" TO 1/2"	1.35"	80 IN. LBS.	STAINLESS STEEL HUBS

- Shaft to shaft couplings
- Pin to pin phase adjustment
- No lubrication required
- Positive drive
- 3° max. angular misalignment
- 1/32 max. lateral misalignment
- -65° to 180° F temperature range
- Quick Disconnect

STOCK NO.	B1	H1	L1	B2	H2	L2
CC7-40	.1248			.1248	5/16	5/16
CC7-41	.1248	5/16	5/16	.1562	5/16	5/16
CC7-42	.1248			.1873	3/8	11/32
CC7-43	.1248			.2498	1/2	3/8
CC7-44	.1873	3/8	11/32	.1873	3/8	11/32
CC7-45	.1873			.2498	1/2	3/8
CC7-46	.2498	1/2	3/8	.2405	3/8	11/32
CC7-47	.2498			.2498	1/2	3/8
CC7-48	.3123	1/2	3/8	.1873	3/8	11/32
CC7-49	.3123			.2498	1/2	3/8
CC7-50	.3123			.3123	1/2	3/8
CC7-51	.3748	1	5/8	.2498	1/2	3/8
CC7-52	.3748			.3123	1/2	3/8
CC7-53	.3748			.3748	1	5/8
CC7-54	.4998	1 1/4	5/8	.2498	1/2	3/8
CC7-55	.4998			.3123	1 1/2	3/8
CC7-56	.4998			.3748	1	5/8
CC7-57	.4998			.4998	1 1/4	5/8

BORE	O.D.	TORQUE	MATERIAL
1/4" TO 1/2"	1.60"	115 IN. LBS.	STAINLESS STEEL

- Shaft to shaft couplings
- Pin to pin phase adjustment
- No lubrication required
- Positive drive
- 3° max. angular misalignment
- 1/32 max. lateral misalignment
- -65° to 180° F temperature range
- Quick Disconnect

STOCK NO.	B1	H1	L1	B2	H2	L2
CC7-67	.2498	1/2	3/8	.2498	1/2	3/8
CC7-68	.3123	1/2	3/8	.1873	3/8	11/32
CC7-69	.3123			.2498	1/2	3/8
CC7-70	.3123			.3123	1/2	3/8
CC7-71	.3748*	1	5/8	.2498	1/2	3/8
CC7-72	.3748*			.3123	1/2	3/8
CC7-73	.3748*			.3748	1	5/8
CC7-74	.4998*	1 1/4	5/8	.2498	1/2	3/8
CC7-75	.4998*			.3123	1 1/2	3/8
CC7-76	.4998*			.3748*	1	5/8
CC7-77	.4998*			.4998*	1 1/4	5/8

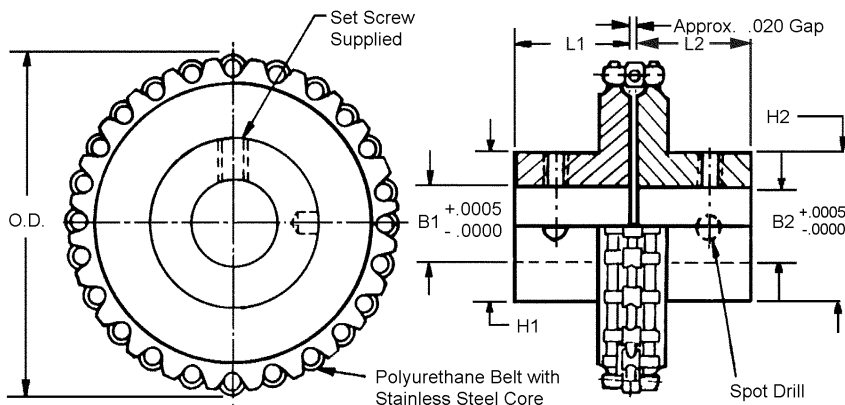

Available on request: Other bore sizes, larger torque ratings

COUPLINGS

BORE	MATERIAL	BERG'S® NAME
1/8" TO 1/2"	POLYURETHANE WITH ANODIZED ALUMINUM HUBS	FLEX-E-GRIP

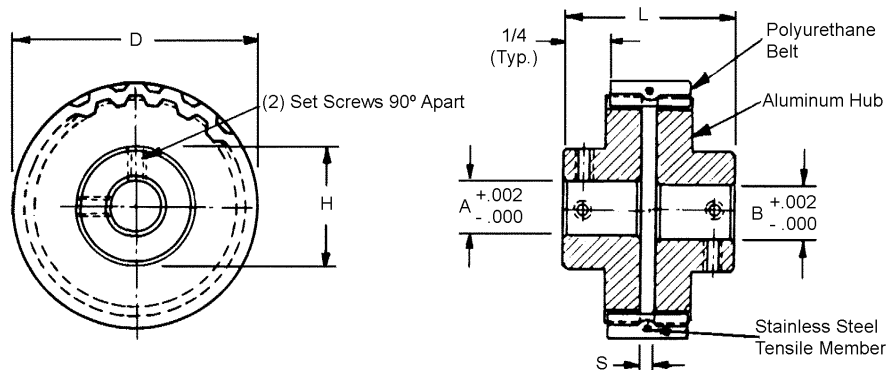

STOCK NO.	BORES A & B	D	H	L	S	MAXIMUM ANGULAR MISALIGN.	MAXIMUM SHAFT MISALIGN	MAXIMUM TORQUE (IN LBS.)
CC9-20-2	.125	.56	1/2	5/8	3/64	3°	.005	25
CC9-20-3	.188							
CC9-20-4	.250							
CC9-40-2	.125	1.08	1/2	5/8	3/64	4°	.006	50
CC9-40-3	.188							
CC9-40-4	.250							
CC9-60-2	.125	1.60	1/2	5/8	3/64	5°	.008	100
CC9-60-3	.188							
CC9-60-4	.250							
CC9-120-2	.125	3.16	1/2	5/8	3/64	6°	.010	150
CC9-120-3	.188							
CC9-120-4	.250							
CC10-14-4	.250	.95	3/4	3/4	3/32	3°	.005	50
CC10-14-6	.375							
CC10-14-8	.500							
CC10-24-4	.250	1.58	3/4	3/4	3/32	4°	.006	100
CC10-24-6	.375							
CC10-24-8	.500							
CC10-36-4	.250	2.35	3/4	3/4	3/32	5°	.008	150
CC10-36-6	.375							
CC10-36-8	.500							
CC10-48-4	.250	3.12	3/4	3/4	3/32	6°	.010	200
CC10-48-6	.375							
CC10-48-8	.500							
CC8-10-4	.250	1.28	1	1	1/8	3°	.005	50
CC8-10-6	.375							
CC8-10-8	.500							
CC8-15-4	.250	1.88	1	1	1/8	4°	.006	100
CC8-15-6	.375							
CC8-15-8	.500							
CC8-20-4	.250	2.48	1	1	1/8	5°	.008	200
CC8-20-6	.375							
CC8-20-8	.500							
CC8-24-4	.250	2.96	1	1	1/8	6°	.010	300
CC8-24-6	.375							
CC8-24-8	.500							

- Shaft to shaft couplings
- Pin to pin phase adjustment
- -65° to 180° F temperature range
- Positive drive
- Minimal backlash
- Silent operation
- Acid and chemical resistant

- Shaft to shaft synchronization
- Simple assembly and disassembly
- No lubrication required
- Quick disconnect
- Cushioned drive

Other bore combinations available on request.



SIX BEAM FLEXIBLE COUPLING

BORE	STYLE	MATERIAL
.120 TO 1.000	PIN HUB	2024 ANODIZED ALUMINUM

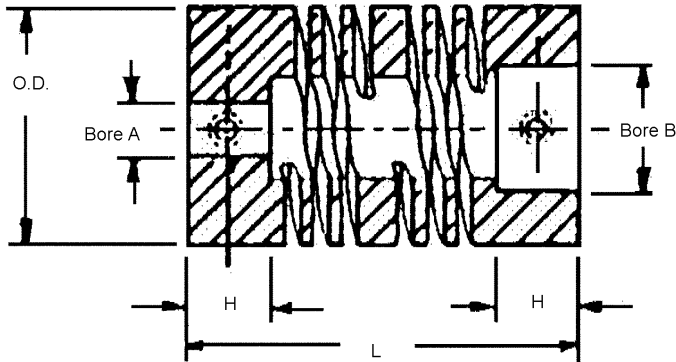

STOCK NO.	BORE A +.002	BORE B +.002	OD	L	H	ANGLE OFF SET	PARALLEL OFF SET	NON-REVERSING WORKING TORQUE* (LB-IN)
CO36A-1	.120	.125	.375	.770	.23	5°	.005	5
CO36A-2	.125	.125						
CO36A-3	.125	.187						
CO36A-4	.187	.187						
CO38A-1	.120	.125	.500	1.000	.27	5°	.007	10
CO38A-2	.125	.125						
CO38A-3	.187	.187						
CO38A-4	.250	.250						
CO40A-1	.187	.250	.750	1.100	.25	7°	.010	25
CO40A-2	.250	.250						
CO40A-3	.250	.375						
CO40A-4	.375	.375						
CO42A-1	.250	.250	1.000	1.500	.43	7°	.015	44
CO42A-2	.312	.312						
CO42A-3	.375	.375						
CO42A-4	.500	.500						
CO44A-1	.250	.375	1.250	2.250	.62	7°	.020	62
CO44A-2	.375	.375						
CO44A-3	.500	.500						
CO44A-4	.625	.625						
CO50A-1	.500	.500	1.500	2.625	.71	7°	.020	97
CO50A-2	.625	.625						
CO50A-3	.750	.750						
CO52A-1	.500	.500	1.750	3.000	.79	7°	.031	130
CO52A-2	.625	.625						
CO52A-3	.750	.750						
CO54A-1	.750	.750	2.250	5.125	1.26	7°	.038	230
CO54A-2	.875	.875						
CO54A-3	1.000	1.000						

* For reversing torque use factor 2.

Available on request - Key ways in bores 1/2" and larger
 Special bores or bore combinations
 Operating temperature -40° F to 248° F

Central internal chamber diameter may be smaller than bore in some cases.

Advantages

- One Piece construction. no mechanical joints
- No Backlash
- Constant velocity
- Torsionally rigid
- High Flexibility
- Small and lightweight
- High or low speeds
- Not temperature sensitive
- No lubrication
- Unaffected by climactic conditions
- Reversible

Applications

Encoders • Stepper Motors • Precision Ball Screws • Machine Tools • Robotics • Scientific Equipment
 • Measuring Instruments • Computers • Servo Systems • Optical Telescopes • Defense Systems
 • Medical Equipment • Appliances • Pumps • Valves • Fans

SIX BEAM FLEXIBLE COUPLING

BORE	STYLE	MATERIAL
.120 TO 1.000	PIN HUB	303 STAINLESS STEEL

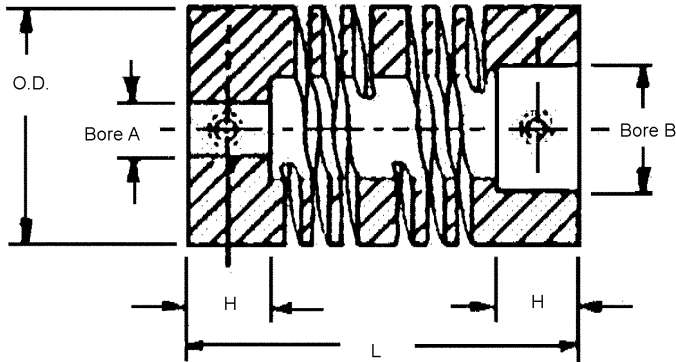

STOCK NO.	BORE A +.002 -.000	BORE B +.002 -.000	OD	L	H	ANGLE OFF SET	PARALLEL OFF SET	NON-REVERSING WORKING TORQUE* (LB-IN)
CO36S-1	.120	.125	.375	.770	.230	5°	.005	8
CO36S-2	.125	.125						
CO36S-3	.125	.187						
CO36S-4	.187	.187						
CO38S-1	.120	.125	.500	1.000	.270	5°	.007	15
CO38S-2	.125	.125						
CO38S-3	.187	.187						
CO38S-4	.250	.250						
CO40S-1	.187	.250	.750	1.100	.250	7°	.010	40
CO40S-2	.250	.250						
CO40S-3	.250	.375						
CO40S-4	.375	.375						
CO42S-1	.250	.250	1.000	1.500	.430	7°	.015	85
CO42S-2	.312	.312						
CO42S-3	.375	.375						
CO42S-4	.500	.500						
CO44S-1	.250	.375	1.250	2.250	.620	7°	.020	115
CO44S-2	.375	.375						
CO44S-3	.500	.500						
CO44S-4	.625	.625						
CO50S-1	.500	.500	1.500	2.625	.710	7°	.020	170
CO50S-2	.625	.625						
CO50S-3	.750	.750						
CO52S-1	.500	.500	1.750	3.000	.790	7°	.031	200
CO52S-2	.625	.625						
CO52S-3	.750	.750						
CO54S-1	.750	.750	2.250	5.125	1.260	7°	.038	400
CO54S-2	.875	.875						
CO54S-3	1.000	1.000						

* For reversing torque use factor 2.

Available on request - Key ways in bores 1/2" and larger
 Special bores or bore combinations
 Operating temperature -40°F to 248°F

Central internal chamber diameter may be smaller than bore in some cases.

Advantages

- One Piece construction. no mechanical joints
- No Backlash
- Constant velocity
- Torsionally rigid
- High Flexibility
- Small and lightweight
- High or low speeds
- Not temperature sensitive
- No lubrication
- Unaffected by climactic conditions
- Reversible

Applications

Encoders • Stepper Motors • Precision Ball Screws • Machine Tools • Robotics • Scientific Equipment
 • Measuring Instruments • Computers • Servo Systems • Optical Telescopes • Defense Systems
 • Medical Equipment • Appliances • Pumps • Valves • Fans



SIX BEAM FLEXIBLE COUPLING

BORE	STYLE	MATERIAL
.120 TO 1.000	PIN HUB	DELRIN

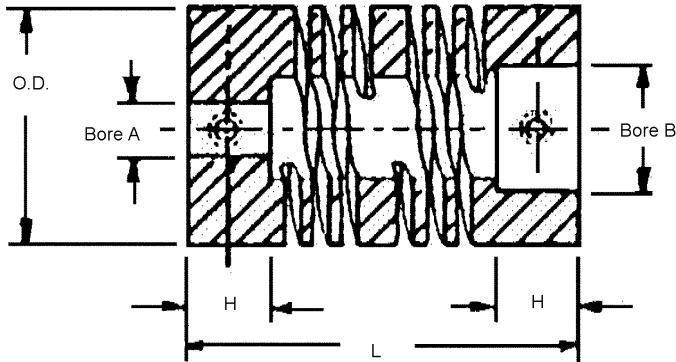

STOCK NO.	BORE A +.002	BORE B +.002	OD	L	H	ANGLE OFF SET	PARALLEL OFF SET	NON-REVERSING WORKING TORQUE* (LB-IN)
CO36D-1	.120	.125						
CO36D-2	.125	.125						
CO36D-3	.125	.187	.375	.770	.230	5°	.005	-
CO36D-4	.187	.187						
CO38D-1	.120	.125						
CO38D-2	.125	.125	.500	1.000	.270	5°	.007	2.5
CO38D-3	.187	.187						
CO38D-4	.250	.250						
CO40D-1	.187	.250						
CO40D-2	.250	.250	.750	1.100	.250	7°	.010	7.5
CO40D-3	.250	.375						
CO40D-4	.375	.375						
CO42D-1	.250	.250						
CO42D-2	.312	.312	1.000	1.500	.430	7°	.015	14.0
CO42D-3	.375	.375						
CO42D-4	.500	.500						
CO44D-1	.250	.375						
CO44D-2	.375	.375	1.250	2.250	.620	7°	.020	21.0
CO44D-3	.500	.500						
CO44D-4	.625	.625						
CO50D-1	.500	.500						
CO50D-2	.625	.625	1.500	2.625	.710	7°	.020	25.0
CO50D-3	.750	.750						
CO52D-1	.500	.500						
CO52D-2	.625	.625	1.750	3.000	.790	7°	.031	30.0
CO52D-3	.750	.750						
CO54D-1	.750	.750						
CO54D-2	.875	.875	2.250	5.125	1.260	7°	.038	35.0
CO54D-3	1.000	1.000						

* For reversing torque use factor 2.

Available on request - Key ways in bores 1/2" and larger
Special bores or bore combinations
Operating temperature -4°F to 140°F

Central internal chamber diameter may be smaller than bore in some cases.

Advantages

- One Piece construction. no mechanical joints
- No Backlash
- Constant velocity
- Torsionally rigid
- High Flexibility
- Small and lightweight
- High or low speeds
- Not temperature sensitive
- No lubrication
- Unaffected by climactic conditions
- Reversible

Applications

Encoders • Stepper Motors • Precision Ball Screws • Machine Tools • Robotics • Scientific Equipment
• Measuring Instruments • Computers • Servo Systems • Optical Telescopes • Defense Systems
• Medical Equipment • Appliances • Pumps • Valves • Fans

SIX BEAM FLEXIBLE COUPLING

BORE	STYLE	MATERIAL
.120 TO 1.000	CLAMP	2024 ANODIZED ALUMINUM

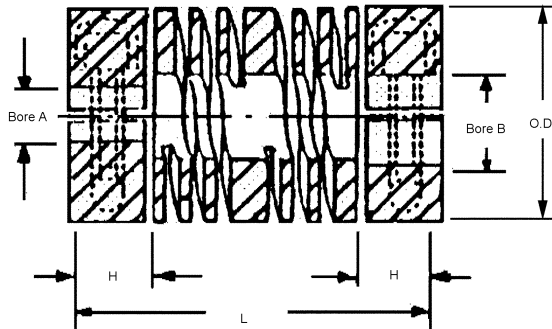

STOCK NO.	BORE A +.002 -.000	BORE B +.002 -.000	OD	L	H	ANGLE OFF SET	PARALLEL OFF SET	NON-REVERSING WORKING TORQUE* (LB-IN)
CO37A-1	.120	.125	.375	.770	.230	5°	.005	5
CO37A-2	.125	.125						
CO37A-3	.125	.187						
CO37A-4	.187	.187						
CO39A-1	.120	.125	.500	1.000	.270	5°	.007	10
CO39A-2	.125	.125						
CO39A-3	.187	.187						
CO39A-4	.250	.250						
CO41A-1	.187	.250	.750	1.100	.250	7°	.010	25
CO41A-2	.250	.250						
CO41A-3	.250	.375						
CO41A-4	.375	.375						
CO43A-1	.250	.250	1.000	1.500	.430	7°	.015	44
CO43A-2	.312	.312						
CO43A-3	.375	.375						
CO43A-4	.500	.500						
CO45A-1	.250	.375	1.250	2.250	.620	7°	.020	62
CO45A-2	.375	.375						
CO45A-3	.500	.500						
CO45A-4	.625	.625						
CO51A-1	.500	.500	1.500	2.625	.710	7°	.020	97
CO51A-2	.625	.625						
CO51A-3	.750	.750						
CO53A-1	.500	.500	1.750	3.000	.790	7°	.031	130
CO53A-2	.625	.625						
CO53A-3	.750	.750						
CO55A-1	.750	.750	2.250	5.125	1.260	7°	.038	230
CO55A-2	.875	.875						
CO55A-3	1.000	1.000						

* For reversing torque use factor 2.

Available on request - Key ways in bores 1/2" and larger
 Special bores or bore combinations
 Operating temperature -40°F to 248°F

Central internal chamber diameter may be smaller than bore in some cases.

Advantages

- One Piece construction. no mechanical joints
- No Backlash
- Constant velocity
- Torsionally rigid
- High Flexibility
- Small and lightweight
- High or low speeds
- Not temperature sensitive
- No lubrication
- Unaffected by climactic conditions
- Reversible

Applications

Encoders • Stepper Motors • Precision Ball Screws • Machine Tools • Robotics • Scientific Equipment
 • Measuring Instruments • Computers • Servo Systems • Optical Telescopes • Defense Systems
 • Medical Equipment • Appliances • Pumps • Valves • Fans



SIX BEAM FLEXIBLE COUPLING

BORE	STYLE	MATERIAL
.120 TO 1.000	CLAMP	303 STAINLESS STEEL

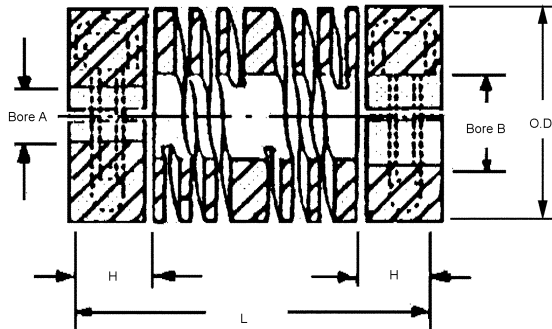

STOCK NO.	BORE A +.002 -.000	BORE B +.002 -.000	OD	L	H	ANGLE OFF SET	PARALLEL OFF SET	NON-REVERSING WORKING TORQUE* (LB-IN)
CO37S-1 CO37S-2 CO37S-3 CO37S-4	.120 .125 .125 .187	.125 .125 .187 .187	.375	.770	.230	5°	.005	8
CO39S-1 CO39S-2 CO39S-3 CO39S-4	.120 .125 .187 .250	.125 .125 .187 .250	.500	1.000	.270	5°	.007	15
CO41S-1 CO41S-2 CO41S-3 CO41S-4	.187 .250 .250 .375	.250 .250 .375 .375	.750	1.100	.250	7°	.010	40
CO43S-1 CO43S-2 CO43S-3 CO43S-4	.250 .312 .375 .500	.250 .312 .375 .500	1.000	1.500	.430	7°	.015	85
CO45S-1 CO45S-2 CO45S-3 CO45S-4	.250 .375 .500 .625	.375 .375 .500 .625	1.250	2.250	.620	7°	.020	115
CO51S-1 CO51S-2 CO51S-3	.500 .625 .750	.500 .625 .750	1.500	2.625	.710	7°	.020	170
CO53S-1 CO53S-2 CO53S-3	.500 .625 .750	.500 .625 .750	1.750	3.000	.790	7°	.031	200
CO55S-1 CO55S-2 CO55S-3	.750 .875 1.000	.750 .875 1.000	2.250	5.125	1.260	7°	.038	400

* For reversing torque use factor 2.

Available on request - Key ways in bores 1/2" and larger
Special bores or bore combinations
Operating temperature -40°F to 248°F

Central internal chamber diameter may be smaller than bore in some cases.

Advantages

- One Piece construction. no mechanical joints
- No Backlash
- Constant velocity
- Torsionally rigid
- High Flexibility
- Small and lightweight
- High or low speeds
- Not temperature sensitive
- No lubrication
- Unaffected by climactic conditions
- Reversible

Applications

Encoders • Stepper Motors • Precision Ball Screws • Machine Tools • Robotics • Scientific Equipment
• Measuring Instruments • Computers • Servo Systems • Optical Telescopes • Defense Systems
• Medical Equipment • Appliances • Pumps • Valves • Fans

SIX BEAM FLEXIBLE COUPLING

BORE	STYLE	MATERIAL
.120 TO 1.000	CLAMP	DELRIN

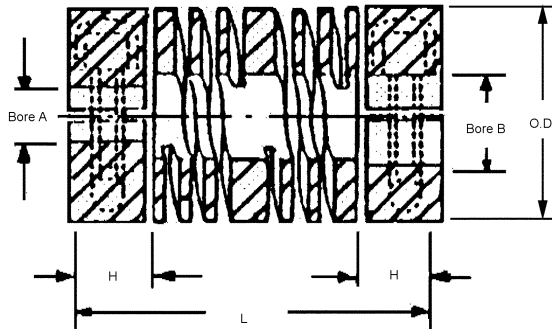

STOCK NO.	BORE A +.002 -.000	BORE B +.002 -.000	OD	L	H	ANGLE OFF SET	PARALLEL OFF SET	NON-REVERSING WORKING TORQUE* (LB-IN)
CO37D-1	.120	.125						
CO37D-2	.125	.125						
CO37D-3	.125	.187	.375	.770	.230	5°	.005	-
CO37D-4	.187	.187						
CO39D-1	.120	.125						
CO39D-2	.125	.125	.500	1.000	.270	5°	.007	2.5
CO39D-3	.187	.187						
CO39D-4	.250	.250						
CO41D-1	.187	.250						
CO41D-2	.250	.250	.750	1.100	.250	7°	.010	7.5
CO41D-3	.250	.375						
CO41D-4	.375	.375						
CO43D-1	.250	.250	1.000	1.500	.430	7°	.015	14
CO43D-2	.312	.312						
CO43D-3	.375	.375						
CO43D-4	.500	.500						
CO45D-1	.250	.375						
CO45D-2	.375	.375	1.250	2.250	.620	7°	.020	21
CO45D-3	.500	.500						
CO45D-4	.625	.625						
CO51D-1	.500	.500	1.500	2.625	.710	7°	.020	25
CO51D-2	.625	.625						
CO51D-3	.750	.750						
CO53D-1	.500	.500	1.750	3.000	.790	7°	.031	30
CO53D-2	.625	.625						
CO53D-3	.750	.750						
CO55D-1	.750	.750	2.250	5.125	1.260	7°	.038	35
CO55D-2	.875	.875						
CO55D-3	1.000	1.000						

* For reversing torque use factor 2.

Available on request - Key ways in bores 1/2" and larger
 Special bores or bore combinations
 Operating temperature -4°F to 140°F

Central internal chamber diameter may be smaller than bore in some cases.

Advantages

- One Piece construction. no mechanical joints
- No Backlash
- Constant velocity
- Torsionally rigid
- High Flexibility
- Small and lightweight
- High or low speeds
- Not temperature sensitive
- No lubrication
- Unaffected by climactic conditions
- Reversible

Applications

Encoders • Stepper Motors • Precision Ball Screws • Machine Tools • Robotics • Scientific Equipment
 • Measuring Instruments • Computers • Servo Systems • Optical Telescopes • Defense Systems
 • Medical Equipment • Appliances • Pumps • Valves • Fans



THREE BEAM FLEXIBLE COUPLING

BORE	STYLE	MATERIAL
3/32" TO 1"	PIN HUB	ALUMINUM 2024-T6 ANODIZED

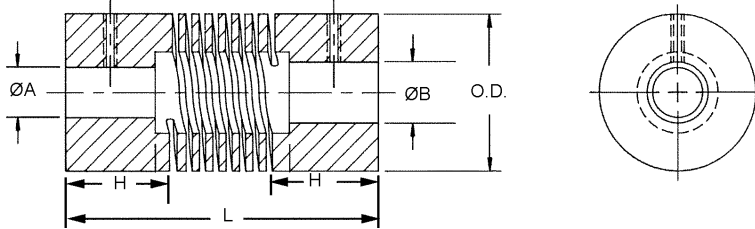

- Couplings can be supplied with a keyway
- Non-standard bore sizes available
- All couplings contain an integral relief chamber
- Operating temperature -40°F to 248°F

STOCK NO.	BORE A +.002 -.000	BORE B +.002 -.000	OD	L MAX.	H	MAXIMUM WORKING TORQUE (LB-IN)	ALLOWABLE MISALIGNMENT	
							ANGLE OFFSET	PARALLEL OFFSET
CO71A-1	.094	.094	.38	.56	.11	3.5	5°	.004
CO73A-1	.094	.094	.50	.75	.21	8	5°	.005
CO73A-2	.094	.125						
CO73A-3	.125	.125						
CO75A-1	.125	.125	.63	.80	.24	13	5°	.005
CO75A-2	.125	.157						
CO75A-3	.125	.188						
CO75A-4	.157	.157						
CO75A-5	.157	.188						
CO75A-6	.188	.188						
CO77A-1	.125	.125	.75	.90	.28	22	5°	.005
CO77A-2	.125	.157						
CO77A-3	.125	.188						
CO77A-4	.125	.250						
CO77A-5	.157	.157						
CO77A-6	.157	.188						
CO77A-7	.157	.250						
CO77A-8	.188	.188						
CO77A-9	.188	.188						
CO77A-10	.250	.250						
CO79A-1	.250	.250	1.00	1.25	.33	35	5°	.005
CO79A-2	.250	.313						
CO79A-3	.250	.375						
CO79A-4	.313	.313						
CO79A-5	.313	.375						
CO79A-6	.375	.375						
CO81A-1	.250	.250	1.25	1.75	.44	53	5°	.005
CO81A-2	.250	.375						
CO81A-3	.250	.500						
CO81A-4	.250	.625						
CO81A-5	.375	.375						
CO81A-6	.375	.500						
CO81A-7	.375	.625						
CO81A-8	.500	.500						
CO81A-9	.500	.625						
CO81A-10	.625	.625						
CO83A-1	.500	.500	1.50	2.63	.71	59	5°	.010
CO83A-2	.625	.625						
CO83A-3	.750	.750						
CO85A-1	.500	.500	1.75	3.00	.79	70	5°	.010
CO85A-2	.625	.625						
CO85A-3	.750	.750						
CO87A-1	.750	.750	2.25	5.13	1.26	80	5°	.010
CO87A-2	.875	.875						
CO87A-3	1.000	1.000						

Central internal chamber diameter may be smaller than bore in some cases.

THREE BEAM FLEXIBLE COUPLING

BORES	STYLE	MATERIAL
3/32" TO 1"	PIN HUB	303 STAINLESS STEEL

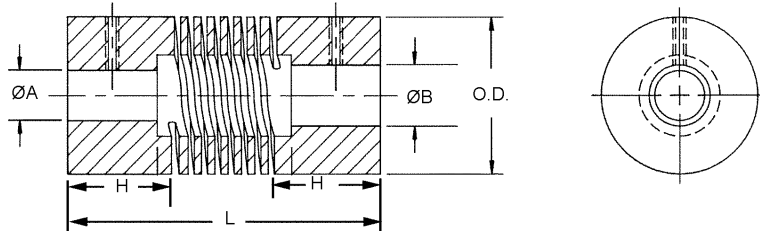

- Couplings can be supplied with a keyway
- Non-standard bore sizes available
- All couplings contain an integral relief chamber
- Operating temperature -40°F to 248°F

STOCK NO.	BORE A +.002 -.000	BORE B +.002 -.000	OD	L MAX.	H	MAXIMUM WORKING TORQUE (LB-IN)	ALLOWABLE MISALIGNMENT	
							ANGLE OFFSET	PARALLEL OFFSET
CO71S-1	.094	.094	.38	.56	.11	4	3°	.004
CO73S-1	.094	.094	.50	.75	.21	8	5°	.005
CO73S-2	.094	.125						
CO73S-3	.125	.125						
CO75S-1	.125	.125	.63	.80	.24	16	5°	.005
CO75S-2	.125	.157						
CO75S-3	.125	.188						
CO75S-4	.157	.157						
CO75S-5	.157	.188						
CO75S-6	.188	.188						
CO77S-1	.125	.125	.75	.90	.28	23	5°	.005
CO77S-2	.125	.157						
CO77S-3	.125	.188						
CO77S-4	.125	.250						
CO77S-5	.157	.157						
CO77S-6	.157	.188						
CO77S-7	.157	.250						
CO77S-8	.188	.188						
CO77S-9	.188	.188						
CO77S-10	.250	.250						
CO79S-1	.250	.250	1.00	1.25	.33	53	5°	.005
CO79S-2	.250	.313						
CO79S-3	.250	.375						
CO79S-4	.313	.313						
CO79S-5	.313	.375						
CO79S-6	.375	.375						
CO81S-1	.250	.250	1.25	1.75	.44	88	5°	.005
CO81S-2	.250	.375						
CO81S-3	.250	.500						
CO81S-4	.250	.625						
CO81S-5	.375	.375						
CO81S-6	.375	.500						
CO81S-7	.375	.625						
CO81S-8	.500	.500						
CO81S-9	.500	.625						
CO81S-10	.625	.625						
CO83S-1	.500	.500	1.50	2.63	.71	100	5°	.010
CO83S-2	.625	.625						
CO83S-3	.750	.750						
CO85S-1	.500	.500	1.75	3.00	.79	120	5°	.010
CO85S-2	.625	.625						
CO85S-3	.750	.750						
CO87S-1	.750	1.750	2.25	5.13	1.26	145	5°	.010
CO87S-2	.875	.875						
CO87S-3	1.000	1.000						

Central internal chamber diameter may be smaller than bore in some cases.



THREE BEAM FLEXIBLE COUPLING

BORES	STYLE	MATERIAL
3/32" TO 1"	CLAMP	ALUMINUM 2024-T6 ANODIZED

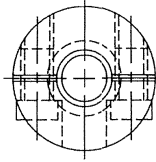
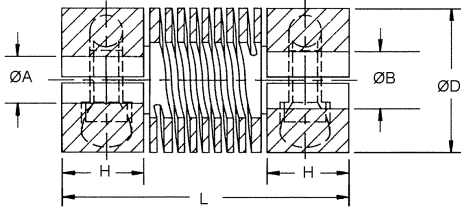

- Couplings can be supplied with a keyway
- Non-standard bore sizes available
- All couplings contain an integral relief chamber
- Operating temperature -40°F to 248°F

STOCK NO.	BORE A	BORE B	OD	L MAX.	H	MAXIMUM WORKING TORQUE (LB-IN)	ALLOWABLE MISALIGNMENT	
							ANGLE OFFSET	PARALLEL OFFSET
CO72A-1	.094	.094	.50	.75	.21	8	5°	.005
CO72A-2	.094	.125						
CO72A-3	.125	.125						
CO74A-1	.125	.125	.63	.80	.24	13	5°	.005
CO74A-2	.125	.157						
CO74A-3	.125	.188						
CO74A-4	.157	.157						
CO74A-5	.157	.188						
CO74A-6	.188	.188						
CO76A-1	.125	.125	.75	.90	.28	22	5°	.005
CO76A-2	.125	.157						
CO76A-3	.125	.188						
CO76A-4	.125	.250						
CO76A-5	.157	.157						
CO76A-6	.157	.188						
CO76A-7	.157	.250						
CO76A-8	.188	.188						
CO76A-9	.188	.188						
CO76A-10	.250	.250						
CO78A-1	.250	.250	1.00	1.25	.33	35	5°	.005
CO78A-2	.250	.313						
CO78A-3	.250	.375						
CO78A-4	.313	.313						
CO78A-5	.313	.375						
CO78A-6	.375	.375						
CO80A-1	.250	.250	1.25	1.75	.44	53	5°	.005
CO80A-2	.250	.375						
CO80A-3	.250	.500						
CO80A-4	.250	.625						
CO80A-5	.375	.375						
CO80A-6	.375	.500						
CO80A-7	.375	.625						
CO80A-8	.500	.500						
CO80A-9	.500	.625						
CO80A-10	.625	.625						
CO82A-1	.500	.500	1.50	2.63	.71	59	5°	.010
CO82A-2	.625	.625						
CO82A-3	.750	.750						
CO84A-1	.500	.500	1.75	3.00	.79	70	5°	.010
CO84A-2	.625	.625						
CO84A-3	.750	.750						
CO86A-1	.750	1.750	2.25	5.13	1.26	80	5°	.010
CO86A-2	.875	.875						
CO86A-3	1.000	1.000						

Central internal chamber diameter may be smaller than bore in some cases.

THREE BEAM FLEXIBLE COUPLING

BORE	STYLE	MATERIAL
3/32" TO 1"	CLAMP	303 STAINLESS STEEL

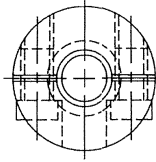
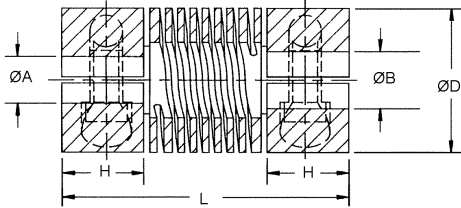

- Couplings can be supplied with a keyway
- Non-standard bore sizes available
- All couplings contain an integral relief chamber
- Operating temperature -40°F to 248°F

STOCK NO.	BORE A	BORE B	OD	L MAX.	H	MAXIMUM WORKING TORQUE (LB-IN)	ALLOWABLE MISALIGNMENT	
							ANGLE OFFSET	PARALLEL OFFSET
CO72S-1	.094	.094	.50	.75	.21	8	5°	.005
CO72S-2	.094	.125						
CO72S-3	.125	.125						
CO74S-1	.125	.125	.63	.80	.24	16	5°	.005
CO74S-2	.125	.157						
CO74S-3	.125	.188						
CO74S-4	.157	.157						
CO74S-5	.157	.188						
CO74S-6	.188	.188						
CO76S-1	.125	.125	.75	.90	.28	23	5°	.005
CO76S-2	.125	.157						
CO76S-3	.125	.188						
CO76S-4	.125	.250						
CO76S-5	.157	.157						
CO76S-6	.157	.188						
CO76S-7	.157	.250						
CO76S-8	.188	.188						
CO76S-9	.188	.188						
CO76S-10	.250	.250						
CO78S-1	.250	.250	1.00	1.25	.33	53	5°	.010
CO78S-2	.250	.313						
CO78S-3	.250	.375						
CO78S-4	.313	.313						
CO78S-5	.313	.375						
CO78S-6	.375	.375						
CO80S-1	.250	.250	1.25	1.75	.44	88	5°	.010
CO80S-2	.250	.375						
CO80S-3	.250	.500						
CO80S-4	.250	.625						
CO80S-5	.375	.375						
CO80S-6	.375	.500						
CO80S-7	.375	.625						
CO80S-8	.500	.500						
CO80S-9	.500	.625						
CO80S-10	.625	.625						
CO82S-1	.500	.500	1.50	2.63	.71	100	5°	.010
CO82S-2	.625	.625						
CO82S-3	.750	.750						
CO84S-1	.500	.500	1.75	3.00	.79	120	5°	.010
CO84S-2	.625	.625						
CO84S-3	.750	.750						
CO86S-1	.750	1.750	2.25	5.13	1.26	145	5°	.010
CO86S-2	.875	.875						
CO86S-3	1.000	1.000						

Central internal chamber diameter may be smaller than bore in some cases.

Central internal chamber diameter may be smaller than bore in some cases.



SINGLE BEAM FLEXIBLE COUPLING

BORES	STYLE	MATERIAL
3/32" TO 1"	PIN HUB	ALUMINUM 7075 ANODIZED

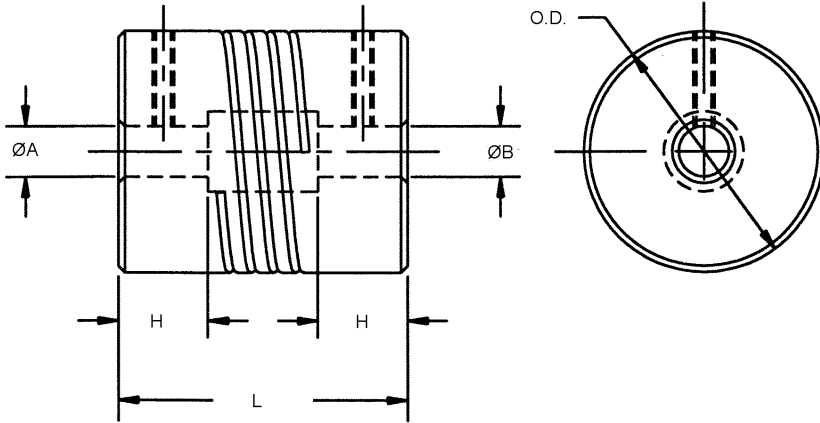

STOCK NO.	A +.002 -.000	B +.002 -.000	OD	L MAX.	H	MAXIMUM WORKING TORQUE (LB-IN)	ALLOWABLE MISALIGNMENT	
							ANGLE OFFSET	PARALLEL OFFSET
COS71A-1	.094	.094	.38	.56	.11	1.50	5	.005
COS73A-1	.094	.094	.50	.75	.21	4	5	.010
COS73A-2	.125	.125						
COS73A-3	.125	.125						
COS75A-1	.125	.125	.63	.80	.24	6	5	.010
COS75A-2	.125	.157						
COS75A-3	.125	.188						
COS75A-4	.157	.157						
COS75A-5	.157	.188						
COS75A-6	.188	.188						
COS77A-1	.125	.125	.75	.90	.25	10.5	5	.010
COS77A-2	.125	.157						
COS77A-3	.125	.188						
COS77A-4	.125	.250						
COS77A-5	.157	.157						
COS77A-6	.157	.157						
COS77A-7	.157	.157						
COS77A-8	.188	.188						
COS77A-9	.188	.188						
COS77A-10	.250	.250						
COS79A-1	.250	.250	1.00	1.25	.33	15	5	.010
COS79A-2	.250	.313						
COS79A-3	.250	.375						
COS79A-4	.313	.313						
COS79A-5	.313	.375						
COS79A-6	.375	.375						
COS81A-1	.250	.250	1.25	1.75	.44	31	5	.010
COS81A-2	.250	.375						
COS81A-3	.250	.500						
COS81A-4	.250	.625						
COS81A-5	.375	.375						
COS81A-6	.375	.500						
COS81A-7	.375	.625						
COS81A-8	.500	.500						
COS81A-9	.500	.625						
COS81A-10	.625	.625						
COS83A-1	.500	.500	1.50	2.63	.71	45	5	.010
COS83A-2	.625	.625						
COS83A-3	.750	.750						
COS85A-1	.500	.500	1.75	3.00	.79	60	5	.010
COS85A-2	.625	.625						
COS85A-3	.750	.750						
COS87A-1	.750	.750	2.25	5.13	1.26	100	5	.010
COS87A-2	.875	.875						
COS87A-3	1.000	1.000						

Central internal chamber diameter may be smaller than bore in some cases.

SINGLE BEAM FLEXIBLE COUPLING

BORES	STYLE	MATERIAL
3/32" TO 1"	CLAMP	ALUMINUM 7075 ANODIZED

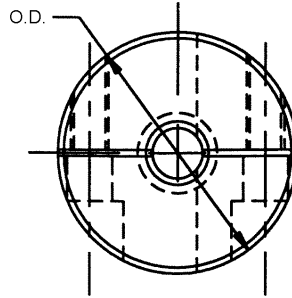
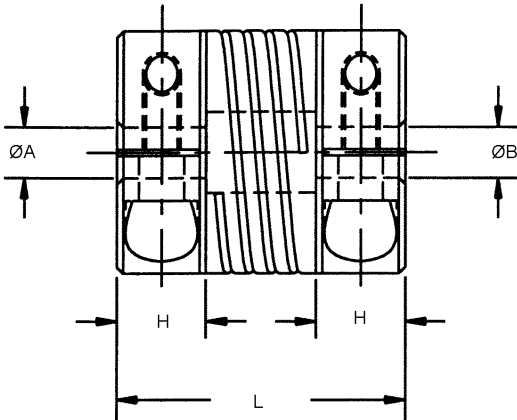

STOCK NO.	A +.002 - .000	B +.002 - .000	OD	L MAX.	H	MAXIMUM WORKING TORQUE (LB-IN)	ALLOWABLE MISALIGNMENT	
							ANGLE OFFSET	PARALLEL OFFSET
COS72A-1	.094	.094	.50	.75	.21	4	5	.010
COS72A-2	.094	.125						
COS72A-3	.125	.125						
COS74A-1	.125	.125	.63	.80	.24	6	5	.010
COS74A-2	.125	.157						
COS74A-3	.125	.188						
COS74A-4	.157	.157						
COS74A-5	.157	.188						
COS74A-6	.188	.188						
COS76A-1	.125	.125	.75	.90	.25	10.5	5	.010
COS76A-2	.125	.157						
COS76A-3	.125	.188						
COS76A-4	.125	.250						
COS76A-5	.157	.157						
COS76A-6	.157	.157						
COS76A-7	.157	.157						
COS76A-8	.188	.188						
COS76A-9	.188	.188						
COS76A-10	.250	.250						
COS78A-1	.250	.250	1.00	1.25	.33	15	5	.010
COS78A-2	.250	.313						
COS78A-3	.250	.375						
COS78A-4	.313	.313						
COS78A-5	.313	.375						
COS78A-6	.375	.375						
COS80A-1	.250	.250	1.25	1.75	.44	31	5	.010
COS80A-2	.250	.375						
COS80A-3	.250	.500						
COS80A-4	.250	.625						
COS80A-5	.375	.375						
COS80A-6	.375	.500						
COS80A-7	.375	.625						
COS80A-8	.500	.500						
COS80A-9	.500	.625						
COS80A-10	.625	.625						
COS82A-1	.500	.500	1.50	2.63	.71	45	5	.010
COS82A-2	.625	.625						
COS82A-3	.750	.750						
COS84A-1	.500	.500	1.75	3.00	.79	60	5	.010
COS84A-2	.625	.625						
COS84A-3	.750	.750						
COS86A-1	.750	.750	2.25	5.13	1.26	100	5	.010
COS86A-2	.875	.875						
COS86A-3	1.000	1.000						

Central internal chamber diameter may be smaller than bore in some cases.



RELI-A-FLEX COUPLINGS

BORES	STYLE	MATERIAL
1/8" TO 1/2"	CLAMP, SHORT	ALUMINUM 7075 ALOCROM FINISH

STOCK NO.	L	ØD	ØB1 +.002 -.000	ØB2 +.002 -.000	E	SOCKET SCREW SIZE	ØH
RCSA13C-1	0.661	0.512	0.125	0.125	0.197	#0-80	0.571
RCSA13C-2	0.661	0.512	0.125	0.188	0.197	#0-80	0.571
RCSA13C-3	0.661	0.512	0.125	0.250	0.197	#0-80	0.571
RCSA13C-4	0.661	0.512	0.188	0.188	0.197	#0-80	0.571
RCSA13C-5	0.661	0.512	0.188	0.250	0.197	#0-80	0.571
RCSA13C-6	0.661	0.512	0.250	0.250	0.197	#0-80	0.571
RCSA16C-1	0.778	0.630	0.125	0.125	0.232	#2-56	0.709
RCSA16C-2	0.778	0.630	0.125	0.188	0.232	#2-56	0.709
RCSA16C-3	0.778	0.630	0.125	0.250	0.232	#2-56	0.709
RCSA16C-4	0.778	0.630	0.188	0.188	0.232	#2-56	0.709
RCSA16C-5	0.778	0.630	0.188	0.250	0.232	#2-56	0.709
RCSA16C-6	0.778	0.630	0.250	0.250	0.232	#2-56	0.709
RCSA16C-7	0.778	0.630	0.313	0.250	0.232	#2-56	0.709
RCSA16C-8	0.778	0.630	0.313	0.313	0.232	#2-56	0.709
RCSA20C-1	0.846	0.787	0.188	0.188	0.260	#2-56	0.858
RCSA20C-2	0.846	0.787	0.188	0.250	0.260	#2-56	0.858
RCSA20C-3	0.846	0.787	0.250	0.250	0.260	#2-56	0.858
RCSA20C-4	0.846	0.787	0.313	0.250	0.260	#2-56	0.858
RCSA20C-5	0.846	0.787	0.313	0.313	0.260	#2-56	0.858
RCSA20C-6	0.846	0.787	0.313	0.375	0.260	#2-56	0.858
RCSA20C-7	0.846	0.787	0.375	0.375	0.260	#2-56	0.858
RCSA25C-1	1.016	0.984	0.250	0.250	0.299	#4-40	1.059
RCSA25C-2	1.016	0.984	0.313	0.250	0.299	#4-40	1.059
RCSA25C-3	1.016	0.984	0.313	0.313	0.299	#4-40	1.059
RCSA25C-4	1.016	0.984	0.313	0.375	0.299	#4-40	1.059
RCSA25C-5	1.016	0.984	0.375	0.375	0.299	#4-40	1.059
RCSA25C-6	1.016	0.984	0.375	0.500	0.299	#4-40	1.059
RCSA25C-7	1.016	0.984	0.500	0.500	0.299	#4-40	1.059

TECHNICAL FEATURES

- Zero backlash, reliable one-piece construction
- Unique design maximises torsional stiffness without including high bearing loads
- Minimal velocity and positional fluctuations
- Over 50,000,000 test cycles at test load and 80% offset without failure
- Maintenance free
- Recommended temperature range -112°F to +176°F

TECHNICAL SPECIFICATIONS

SIZE	TORSIONAL STIFFNESS OZ./IN	RADIAL COMPLIANCE IN/OZ ARCMIN	MISALIGNMENT			MAX. INERTIA OZ.IN ²	MAX. MASS OZ	TYPICAL TORQUE CAPACITY			MAX. SPEED RPM
			PARALLEL IN	ANGULAR DEG.	AXIAL IN			REVERSING IN-LB.	NONREV. IN-LB.	PEAK IN-LB.	
13C	1.85	.0003	.003	2.5	±.011	.006	.16	3.09	3.98	4.42	12000
16C	2.88	.0003	.004	2.5	±.015	.016	.30	4.88	7.32	11.06	10000
20C	4.74	.0003	.005	3.0	±.020	.043	.53	8.41	12.83	21.68	7500
25C	7.50	.0002	.006	3.0	±.027	.127	.97	13.72	20.80	34.32	5000

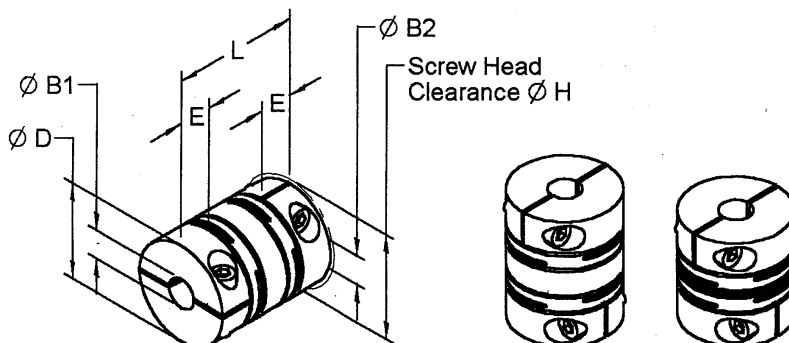

RELI-A-FLEX COUPLINGS

BORES	STYLE	MATERIAL
1/8" TO 1/2"	CLAMP, LONG	ALUMINUM 7075 ALOCROM FINISH

STOCK NO.	L	ØD	ØB1 +.002 -.000	ØB2 +.002 -.000	E	SOCKET SCREW SIZE	ØH
RCLA13C-1	0.787	0.512	0.125	0.125	0.197	#0-80	0.571
RCLA13C-2	0.787	0.512	0.125	0.188	0.197	#0-80	0.571
RCLA13C-3	0.787	0.512	0.125	0.250	0.197	#0-80	0.571
RCLA13C-4	0.787	0.512	0.188	0.188	0.197	#0-80	0.571
RCLA13C-5	0.787	0.512	0.188	0.250	0.197	#0-80	0.571
RCLA13C-6	0.787	0.512	0.250	0.250	0.197	#0-80	0.571
RCLA16C-1	0.925	0.630	0.125	0.125	0.232	#2-56	0.709
RCLA16C-2	0.925	0.630	0.125	0.188	0.232	#2-56	0.709
RCLA16C-3	0.925	0.630	0.125	0.250	0.232	#2-56	0.709
RCLA16C-4	0.925	0.630	0.188	0.188	0.232	#2-56	0.709
RCLA16C-5	0.925	0.630	0.188	0.250	0.232	#2-56	0.709
RCLA16C-6	0.925	0.630	0.250	0.250	0.232	#2-56	0.709
RCLA16C-7	0.925	0.630	0.313	0.250	0.232	#2-56	0.709
RCLA16C-8	0.925	0.630	0.313	0.313	0.232	#2-56	0.709
RCLA20C-1	1.024	0.787	0.188	0.188	0.260	#2-56	0.858
RCLA20C-2	1.024	0.787	0.188	0.250	0.260	#2-56	0.858
RCLA20C-3	1.024	0.787	0.250	0.250	0.260	#2-56	0.858
RCLA20C-4	1.024	0.787	0.313	0.250	0.260	#2-56	0.858
RCLA20C-5	1.024	0.787	0.313	0.313	0.260	#2-56	0.858
RCLA20C-6	1.024	0.787	0.313	0.375	0.260	#2-56	0.858
RCLA20C-7	1.024	0.787	0.375	0.375	0.260	#2-56	0.858
RCLA25C-1	1.339	0.984	0.250	0.250	0.299	#4-40	1.059
RCLA25C-2	1.339	0.984	0.313	0.250	0.299	#4-40	1.059
RCLA25C-3	1.339	0.984	0.313	0.313	0.299	#4-40	1.059
RCLA25C-4	1.339	0.984	0.313	0.375	0.299	#4-40	1.059
RCLA25C-5	1.339	0.984	0.375	0.375	0.299	#4-40	1.059
RCLA25C-6	1.339	0.984	0.375	0.500	0.299	#4-40	1.059
RCLA25C-7	1.339	0.984	0.500	0.500	0.299	#4-40	1.059

TECHNICAL FEATURES

- Zero backlash, reliable one-piece construction
- Unique design maximises torsional stiffness without including high bearing loads
- Minimal velocity and positional fluctuations
- Over 50,000,000 test cycles at test load and 80% offset without failure
- Maintenance free
- Recommended temperature range -112°F to +176°F

TECHNICAL SPECIFICATIONS

SIZE	TORSIONAL STIFFNESS OZ./IN	RADIAL COMPLIANCE IN/OZ ARCMIN	MISALIGNMENT			MAX. INERTIA OZ.IN ²	MAX. MASS OZ	TYPICAL TORQUE CAPACITY			MAX. SPEED RPM
			PARALLEL IN	ANGULAR DEG.	AXIAL IN			REVERSING IN-LB.	NONREV. IN-LB.	PEAK IN-LB.	
13C	2.20	.0007	.006	2.5	±.011	.007	.19	3.09	3.98	4.42	12000
16C	3.46	.0007	.007	2.5	±.015	.018	.37	4.88	7.32	11.06	10000
20C	5.73	.0007	.009	3.0	±.020	.050	.66	8.41	12.83	21.68	7500
25C	9.35	.0009	.015	3.0	±.027	.171	1.36	13.72	20.80	34.32	5000

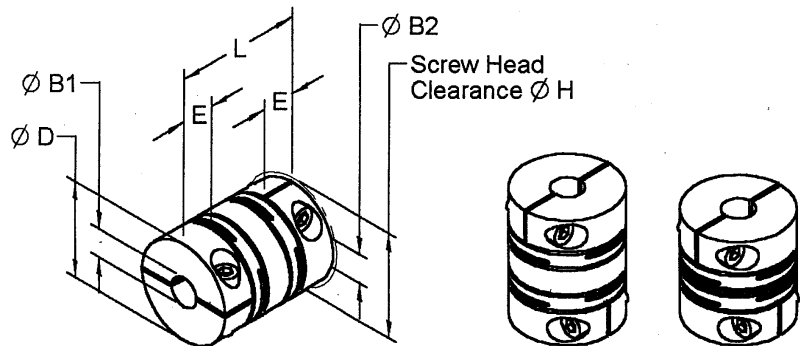

RELI-A-FLEX COUPLINGS

BORES	STYLE	MATERIAL
3/32" TO 1/2"	SET SCREW, SHORT	ALUMINUM 7075 ALOCROM FINISH

STOCK NO.	L	ØD	ØB1 +.002 -.000	ØB2 +.002 -.000	E	SET SCREW SIZE
RCSA6-1	0.368	0.236	0.094	0.094	0.110	#0-80
RCSA6-2	0.368	0.236	0.094	0.125	0.110	#0-80
RCSA6-3	0.368	0.236	0.125	0.125	0.110	#0-80
RCSA8-1	0.461	0.315	0.094	0.094	0.1259	#0-80
RCSA8-2	0.461	0.315	0.094	0.125	0.1259	#0-80
RCSA8-3	0.461	0.315	0.125	0.125	0.1259	#0-80
RCSA10-1	0.537	0.394	0.094	0.094	0.1574	#0-80
RCSA10-2	0.537	0.394	0.094	0.125	0.1574	#0-80
RCSA10-3	0.537	0.394	0.125	0.125	0.1574	#2-56
RCSA10-4	0.537	0.394	0.125	0.188	0.1574	#2-56
RCSA10-5	0.537	0.394	0.188	0.188	0.1574	#4-40
RCSA13-1	0.661	0.512	0.125	0.125	0.1968	#2-56
RCSA13-2	0.661	0.512	0.125	0.188	0.1968	#2-56
RCSA13-3	0.661	0.512	0.125	0.250	0.1968	#2-56
RCSA13-4	0.661	0.512	0.188	0.188	0.1968	#4-40
RCSA13-5	0.661	0.512	0.188	0.250	0.1968	#4-40
RCSA13-6	0.661	0.512	0.250	0.250	0.1968	#6-32
RCSA16-1	0.778	0.630	0.125	0.125	0.2322	#2-56
RCSA16-2	0.778	0.630	0.125	0.188	0.2322	#2-56
RCSA16-3	0.778	0.630	0.125	0.250	0.2322	#2-56
RCSA16-4	0.778	0.630	0.125	0.313	0.2322	#2-56
RCSA16-5	0.778	0.630	0.188	0.188	0.2322	#4-40
RCSA16-6	0.778	0.630	0.188	0.250	0.2322	#4-40
RCSA16-7	0.778	0.630	0.188	0.313	0.2322	#4-40
RCSA16-8	0.778	0.630	0.250	0.250	0.2322	#6-32
RCSA16-9	0.778	0.630	0.250	0.313	0.2322	#6-32
RCSA16-10	0.778	0.630	0.313	0.313	0.2322	#8-32
RCSA20-1	0.846	0.787	0.188	0.188	0.2598	#4-40
RCSA20-2	0.846	0.787	0.188	0.250	0.2598	#4-40
RCSA20-3	0.846	0.787	0.188	0.313	0.2598	#4-40
RCSA20-4	0.846	0.787	0.250	0.250	0.2598	#6-32
RCSA20-5	0.846	0.787	0.250	0.313	0.2598	#6-32
RCSA20-6	0.846	0.787	0.313	0.313	0.2598	#8-32
RCSA20-7	0.846	0.787	0.313	0.375	0.2598	#8-32
RCSA20-8	0.846	0.787	0.375	0.375	0.2598	#10-32
RCSA25-1	1.016	0.984	0.250	0.250	0.3385	#6-32
RCSA25-2	1.016	0.984	0.250	0.313	0.3385	#6-32
RCSA25-3	1.016	0.984	0.250	0.375	0.3385	#6-32
RCSA25-4	1.016	0.984	0.250	0.500	0.3385	#6-32
RCSA25-5	1.016	0.984	0.313	0.313	0.3385	#8-32
RCSA25-6	1.016	0.984	0.313	0.375	0.3385	#8-32
RCSA25-7	1.016	0.984	0.313	0.500	0.3385	#8-32
RCSA25-8	1.016	0.984	0.375	0.375	0.3385	#10-32
RCSA25-9	1.016	0.984	0.375	0.500	0.3385	#10-32
RCSA25-10	1.016	0.984	0.500	0.500	0.3385	#1/4-20

TECHNICAL FEATURES

- Zero backlash, reliable one-piece construction
- Unique design maximises torsional stiffness without including high bearing loads
- Minimal velocity and positional fluctuations
- Over 50,000,000 test cycles at test load and 80% offset without failure
- Maintenance free
- Recommended temperature range -112°F to +176°F

TECHNICAL SPECIFICATIONS

SIZE	TORSIONAL STIFFNESS OZ./IN	RADIAL COMPLIANCE IN/OZ ARCMIN	MISALIGNMENT			MAX. INERTIA OZ.IN ²	MAX. MASS OZ	TYPICAL TORQUE CAPACITY			MAX. SPEED RPM
			PARALLEL IN	ANGULAR DEG.	AXIAL IN			REVERSING IN-LB.	NON REV. IN-LB.	PEAK IN-LB.	
6	.172	2.3 X 10 ⁻⁴	7.8 X 10 ⁻⁴	1.7	±2.3 X 10 ⁻³	1.6 X 10 ⁻⁴	.023	.88	1.32	2.21	7000
8	.358	3.8 X 10 ⁻⁴	1.9 X 10 ⁻³	2.0	±3.9 X 10 ⁻³	6.0 X 10 ⁻⁴	.046	1.77	2.65	4.43	40000
10	.692	3.0 X 10 ⁻⁴	2.3 X 10 ⁻³	2.0	±6.7 X 10 ⁻³	1.8 X 10 ⁻³	.082	2.65	3.98	6.63	35000

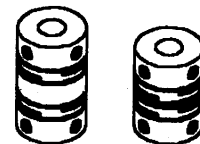
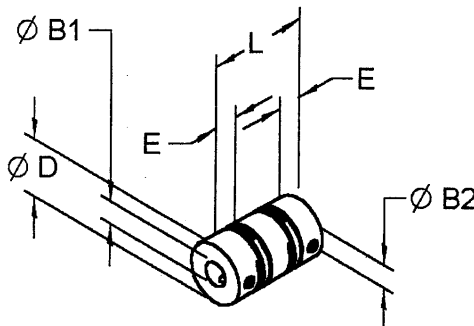

RELI-A-FLEX COUPLINGS

BORES	STYLE	MATERIAL
3/32" TO 1/2"	SET SCREW, LONG	ALUMINUM 7075 ALOCROM FINISH

STOCK NO.	L	ØD	ØB1 +.002 -.000	ØB2 +.002 -.000	E	SET SCREW SIZE
RCLA6-1	0.492	0.236	0.094	0.094	0.110	#0-80
RCLA6-2	0.492	0.236	0.094	0.125	0.110	#0-80
RCLA6-3	0.492	0.236	0.125	0.125	0.110	#0-80
RCLA8-1	0.571	0.315	0.094	0.094	0.1259	#0-80
RCLA8-2	0.571	0.315	0.094	0.125	0.1259	#0-80
RCLA8-3	0.571	0.315	0.125	0.125	0.1259	#0-80
RCLA10-1	0.669	0.394	0.094	0.094	0.1574	#0-80
RCLA10-2	0.669	0.394	0.094	0.125	0.1574	#0-80
RCLA10-3	0.669	0.394	0.125	0.125	0.1574	#2-56
RCLA10-4	0.669	0.394	0.125	0.188	0.1574	#2-56
RCLA10-5	0.669	0.394	0.188	0.188	0.1574	#4-40
RCLA13-1	0.787	0.512	0.125	0.125	0.1968	#2-56
RCLA13-2	0.787	0.512	0.125	0.188	0.1968	#2-56
RCLA13-3	0.787	0.512	0.125	0.250	0.1968	#2-56
RCLA13-4	0.787	0.512	0.188	0.188	0.1968	#4-40
RCLA13-5	0.787	0.512	0.188	0.250	0.1968	#4-40
RCLA13-6	0.787	0.512	0.250	0.250	0.1968	#6-32
RCLA16-1	0.925	0.630	0.125	0.125	0.2322	#2-56
RCLA16-2	0.925	0.630	0.125	0.188	0.2322	#2-56
RCLA16-3	0.925	0.630	0.125	0.250	0.2322	#2-56
RCLA16-4	0.925	0.630	0.125	0.313	0.2322	#2-56
RCLA16-5	0.925	0.630	0.188	0.188	0.2322	#4-40
RCLA16-6	0.925	0.630	0.188	0.250	0.2322	#4-40
RCLA16-7	0.925	0.630	0.188	0.313	0.2322	#4-40
RCLA16-8	0.925	0.630	0.250	0.250	0.2322	#6-32
RCLA16-9	0.925	0.630	0.250	0.313	0.2322	#6-32
RCLA16-10	0.925	0.630	0.313	0.313	0.2322	#8-32
RCLA20-1	1.024	0.787	0.188	0.188	0.2598	#4-40
RCLA20-2	1.024	0.787	0.188	0.250	0.2598	#4-40
RCLA20-3	1.024	0.787	0.188	0.313	0.2598	#4-40
RCLA20-4	1.024	0.787	0.250	0.250	0.2598	#6-32
RCLA20-5	1.024	0.787	0.250	0.313	0.2598	#6-32
RCLA20-6	1.024	0.787	0.313	0.313	0.2598	#8-32
RCLA20-7	1.024	0.787	0.313	0.375	0.2598	#8-32
RCLA20-8	1.024	0.787	0.375	0.375	0.2598	#10-32
RCLA25-1	1.339	0.984	0.250	0.250	0.3385	#6-32
RCLA25-2	1.339	0.984	0.250	0.313	0.3385	#6-32
RCLA25-3	1.339	0.984	0.250	0.375	0.3385	#6-32
RCLA25-4	1.339	0.984	0.250	0.500	0.3385	#6-32
RCLA25-5	1.339	0.984	0.313	0.313	0.3385	#8-32
RCLA25-6	1.339	0.984	0.313	0.375	0.3385	#8-32
RCLA25-7	1.339	0.984	0.313	0.500	0.3385	#8-32
RCLA25-8	1.339	0.984	0.375	0.375	0.3385	#10-32
RCLA25-9	1.339	0.984	0.375	0.500	0.3385	#10-32
RCLA25-10	1.339	0.984	0.500	0.500	0.3385	#1/4-20

TECHNICAL FEATURES

- Zero backlash, reliable one-piece construction
- Unique design maximises torsional stiffness without including high bearing loads
- Minimal velocity and positional fluctuations
- Over 50,000,000 test cycles at test load and 80% offset without failure
- Maintenance free
- Recommended temperature range -112°F to +176°F

TECHNICAL SPECIFICATIONS

SIZE	TORSIONAL STIFFNESS OZ./IN ARCMIN	RADIAL COMPLIANCE IN/OZ	MISALIGNMENT			MAX. INERTIA OZ.IN ²	MAX. MASS OZ	TYPICAL TORQUE CAPACITY			MAX. SPEED RPM
			PARALLEL IN	ANGULAR DEG	AXIAL IN			REVERSING IN-LB.	NONREV. IN-LB	PEAK IN-LB	
6	.177	8.6 X 10 ⁻⁴	1.5 X 10 ⁻³	1.7	±2.3 X 10 ⁻³	2.7 X 10 ⁻⁴	.034	.88	1.32	2.21	32000
8	.358	1.1 X 10 ⁻³	3.9 X 10 ⁻³	2.0	±3.9 X 10 ⁻³	8.2 X 10 ⁻⁴	.060	1.77	2.65	4.43	24000
10	.692	9.0 X 10 ⁻⁴	4.7 X 10 ⁻³	2.0	±6.7 X 10 ⁻³	2.3 X 10 ⁻³	.106	2.65	3.98	6.63	22000

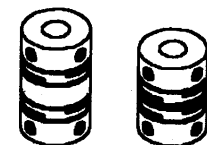
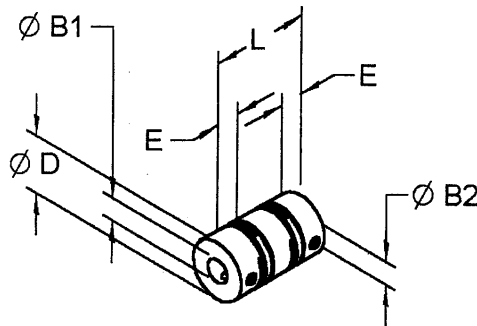

FLEX-THANE COUPLINGS

BORE	FOR GEAR PITCH	MATERIAL
1/8" TO 1/2"	32	MOLDED POLYURETHANE WITH 303 STAINLESS STEEL HUBS

STOCK NO.	B1	B2	H	L	F	NO. OF PINS	P.D.	MAXIMUM MISALIGNMENT		APPROX. MAX TORQUE	A	P	O.D.
								LATERAL	ANGULAR				
CC4-S14	.1248	.1248	5/16	3/8	3/16	24	.750	1/32	15°	100 in.oz.	3/8	.049	15/16
CC4-S21	.1873	.1873	3/8	13/32	3/16	24	.750	1/32	15°	100 in.oz.	3/8	.049	15/16

BORE	FOR GEAR PITCH	MATERIAL
1/8" TO 1/2"	24	MOLDED POLYURETHANE WITH 303 STAINLESS STEEL HUBS

STOCK NO.	B1	B2	H	L	F	NO. OF PINS	P.D.	MAXIMUM MISALIGNMENT		APPROX. MAX TORQUE	A	P	O.D.
								LATERAL	ANGULAR				
CC4-S28	.2498	.2498	1/2	7/16	3/16	24	1.000	1/16	15°	300 in.oz.	1/2	.065	1 3/16
CC4-S32	.3123	.3123	1/2	7/16	3/16	24	1.000	1/16	15°	300 in.oz.	1/2	.065	1 3/16

BORE	FOR GEAR PITCH	MATERIAL
1/8" TO 1/2"	16	MOLDED POLYURETHANE WITH 303 STAINLESS STEEL HUBS

STOCK NO.	B1	B2	H	L	F	NO. OF PINS	P.D.	MAXIMUM MISALIGNMENT		APPROX. MAX TORQUE	A	P	O.D.
								LATERAL	ANGULAR				
CC4-S35	.3748	.3748	3/4	7/8	3/8	20	1.250	1/8	15°	500 in.oz.	3/4	.098	1 1/2
CC4-S37	.4998	.4998	1	7/8	3/8	20	1.250	1/8	15°	500 in.oz.	3/4	.098	1 1/2

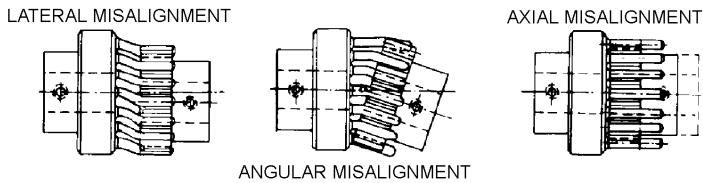
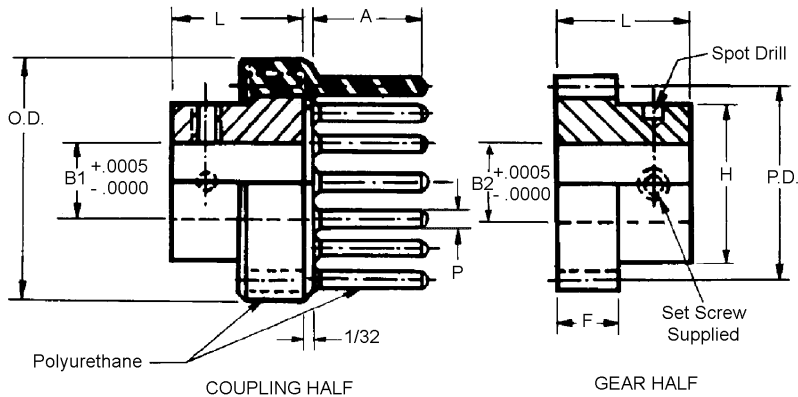

Other bore sizes and combinations are available.



ABSORBATHANE FLEXIBLE COUPLINGS

BORE	STYLE	MATERIAL
3/16" TO 3/8"	EXTERNAL HUB	BLACK POLYURETHANE PLATED MILD STEEL HUB

STOCK NO.	BORES B1 AND B2	A	C	D	MAX. WORKING TORQUE lb-in	MAX. PARALLEL MISALIGN	MAX. ANGULAR MISALIGN
CC3-10	3/16	1 1/8	1 1/8	11/16	3	3/32	10°
CC3-11	1/4						
CC3-12	5/16						
CC3-13	3/8						

BORE	STYLE	MATERIAL
1/4" TO 7/16"	INTERNAL HUB	BLACK POLYURETHANE PLATED MILD STEEL HUB

STOCK NO.	BORES 1 AND B2	A	C	D	MAX. WORKING TORQUE lb-in	MAX. PARALLEL MISALIGN	MAX. ANGULAR MISALIGN
CC3-1	1/4	1 7/8	1 3/4	1	12	1/8	15°
CC3-2	5/16						
CC3-3	3/8						
CC3-14	7/16						
CC3-5	1/2						

BORE	STYLE	MATERIAL
1/2" TO 5/8"	INTERNAL HUB	BLACK POLYURETHANE PLATED MILD STEEL HUB

STOCK NO.	BORES B1 AND B2	A	C	D	MAX. WORKING TORQUE lb-in	MAX. PARALLEL MISALIGN	MAX. ANGULAR MISALIGN
CC3-4	3/8	2 1/8	2 1/4	1 1/4	28	3/16	15°
CC3-15	7/16						
CC3-6	1/2						
CC3-16	9/16						
CC3-8	5/8						

BORES	STYLE	MATERIAL
1/2" TO 5/8"	INTERNAL HUB	BLACK POLYURETHANE PLATED MILD STEEL HUB

STOCK NO.	BORES B1 AND B2	A	C	D	MAX. WORKING TORQUE lb-in	MAX. PARALLEL MISALIGN	MAX. ANGULAR MISALIGN
CC3-7	1/2	2 1/8	2 3/8	1 1/4	40	1/8	15°
CC3-17	9/16						
CC3-9	5/8						

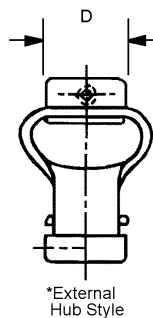
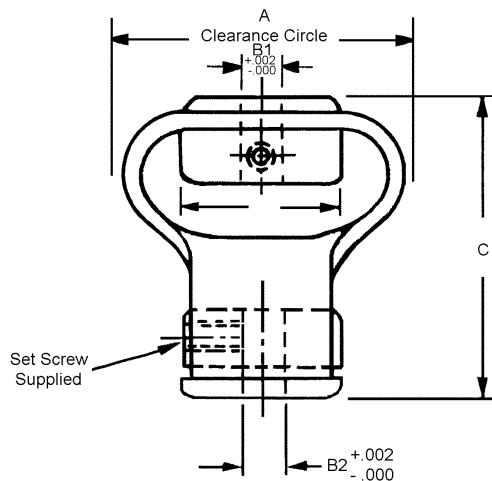

Available on request:
Other bore sizes
or bore combinations.

- Absorbs end play
- Quiet running
- Maintenance free (No moving parts)
- 3600 R.P.M. Maximum



NEO-FLEX COUPLINGS

BORE	STYLE	MATERIAL
.1200 TO .3748	PIN HUB	303 STAINLESS STEEL HUB MOLDED NEOPRENE BODY

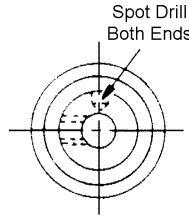
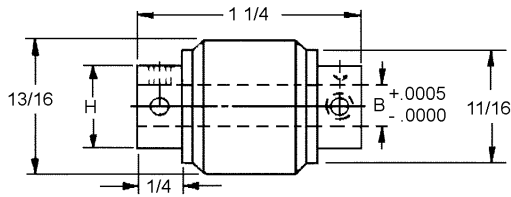

STOCK NO.	B	H	SET SCREW	SPOT DRILL
CO14-7	.1200 .1248	5/16 5/16	#2-56 #2-56	#69 #69
CO14-10	.1200 .1873	5/16 3/8	#2-56 #4-40	#69 #60
CO14-9	.1200 .2498	5/16 1/2	#2-56 #6-32	#69 #50
CO14-1	.1248 .1248	5/16 5/16	#2-56 #2-56	#69 #69
CO14-4	.1248 .1873	5/16 3/8	#2-56 #4-40	#69 #60
CO14-5	.1248 .2498	5/16 1/2	#2-56 #6-32	#69 #50
CO14-8	.1562 .1873	5/16 3/8	#2-56 #4-40	#69 #60
CO14-2	.1873 .1873	3/8 3/8	#4-40 #4-40	#60 #60
CO14-6	.1873 .2498	3/8 1/2	#4-40 #6-32	#60 #50
CO14-3	.2498 .2498	1/2 1/2	#6-32 #6-32	#50 #50
CO14-11	.3123 .3123	1/2 1/2	#6-32 #6-32	#50 #50
CO14-12	.3748 .3748	5/8 5/8	#8-32 #8-32	#31 #31

- Isolates torsional vibration
- Insulates between shafts
- 1° angular misalignment (Max.)
- .005 Shaft misalignment (Max.)
- Maximum working torque 9 in-lb

BORES	STYLE	MATERIAL
.1873 TO .4998	PIN HUB	303 STAINLESS STEEL HUB POLYURETHANE BODY

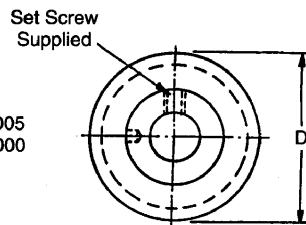
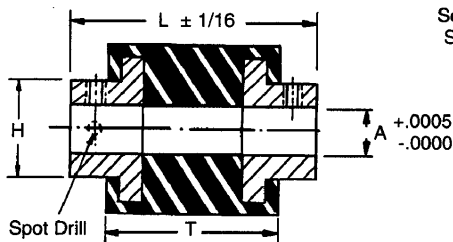

STOCK NO.	A	H	D	L	T
CC1-3	.1873	3/8	15/16	1 1/4	3/4
CC1-14	.2498	5/8	1 1/8	1 9/16	15/16
CC1-15	.3123	5/8	1 1/8	1 9/16	15/16
CC1-16	.3748	5/8	1 1/8	1 9/16	15/16
CC1-8	.4998	1	1 5/8	2 1/4	1 3/8

Combination bores are available on request.

NEO-FLEX COUPLINGS

BORES	STYLE	MATERIAL
.1200 TO .3748	CLAMP	303 STAINLESS STEEL HUB MOLDED NEOPRENE BODY

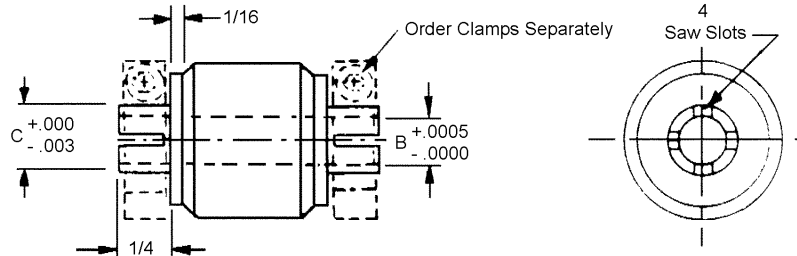

STOCK NO.	B	C	CLAMP STOCK NO.
CO15-7	.1200 .1248	.187 .187	CG1-25 CG1-25
CO15-10	.1200 .1873	.187 .250	CG1-25 CG1-9
CO15-9	.1200 .2498	.187 .312	CG1-25 CG1-12
CO15-1	.1248 .1248	.187 .187	CG1-25 CG1-25
CO15-4	.1248 .1873	.187 .250	CG1-25 CG1-9
CO15-5	.1248 .2498	.187 .312	CG1-25 CG1-12
CO15-8	.1562 .1873	.250 .250	CG1-9 CG1-9
CO15-2	.1873 .1873	.250 .250	CG1-9 CG1-9
CO15-6	.1873 .2498	.250 .312	CG1-9 CG1-12
CO15-3	.2498 .2498	.312 .312	CG1-12 CG1-12
CO15-11	.3123 .3123	.375 .375	CG1-14 CG1-14
CO15-12	.3748 .3748	.437 .437	CG1-17 CG1-17

- Isolates torsional vibration
- Insulates between shafts
- 1° angular misalignment (Max.)
- .005 Shaft misalignment (Max.)
- Maximum working torque 9 in-lb



BORES	STYLE	MATERIAL
.1873 TO .4998	CLAMP	303 STAINLESS STEEL HUB POLYURETHANE BODY

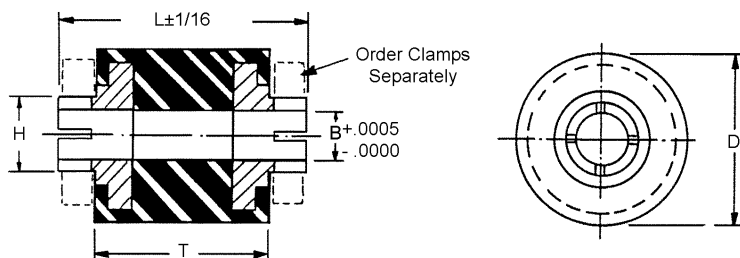

STOCK NO.	B	C	D	L	T
CC2-3	.1873	1/4	15/16	1 1/4	3/4
CC2-14	.2498	5/16	1 1/8	1 9/16	15/16
CC2-5*	.3123	3/8	1 1/8	1 1/4	7/8
CC2-15	.3123	3/8	1 1/8	1 9/16	15/16
CC2-16	.3748	7/16	1 1/8	1 9/16	15/16
CC2-8	.4998	9/16	1 5/8	2	1 3/8

*Limited supply available.
Combination bores are available on request.

SLEEVE COUPLINGS

BORE	STYLE	MATERIAL
.0779 TO .9998	SET SCREW	303 STAINLESS STEEL

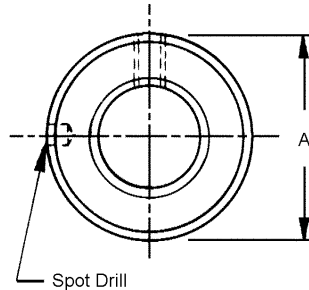
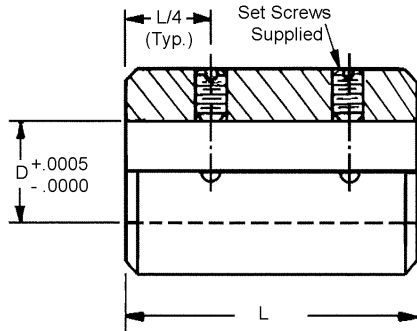

STOCK NO.	SHAFT SIZE	D	L	A	SPOT DRILL	SET SCREW
CT-14	5/64	.0779	3/8	7/32	#78	#0-80
CT-15	3/32	.0935	3/8	1/4	#78	#0-80
CT-1	1/8	.1248	7/16	5/16	#69	#2-56
CT-2	3/16	.1873	1/2	3/8	#60	#4-40
CT-3	1/4	.2498	9/16	1/2	#50	#6-32
CT-4	5/16	.3123	9/16	1/2	#50	#6-32
CT-22	3/8	.3748	3/4	3/4	#31	#10-32
CT-5	3/8	.3748	1	3/4	#31	#10-24
CT-23	1/2	.4998	1	1	#25	1/4-20
CT-6	1/2	.4998	1 1/2	1	#25	1/4-20
CT-7	5/8	.6248	2	1 1/4	#25	1/4-20
CT-8	3/4	.7498	2	1 1/2	#22	3/8-16
CT-9	1	.9998	3	2	#22	3/8-16
CT-10	1/8 to .1200	.1248 .1200	7/16	1/4	#69	#2-56
CT-16	1/8 to 5/32	.1248 .1562	7/16	1/4	#69	#2-56
CT-11	1/8 to 3/16	.1248 .1873	1/2	3/8	#69 #60	#2-56 #4-40
CT-12	1/8 to 1/4	.1248 .2498	9/16	1/2	#69 #50	#2-56 #6-32
CT-17	3/16 to .2405	.1873 .2405	1/2	3/8	#60 #50	#4-40 #6-32
CT-13	3/16 to 1/4	.1873 .2498	9/16	1/2	#60 #50	#4-40 #6-32
CT-18	1/4 to 5/16	.2498 .3123	9/16	9/16	#50	#6-32
CT-19	1/4 to 3/8	.2498 .3748	3/4	3/4	#50 #31	#6-32 #10-32
CT-20	5/16 to 3/8	.3123 .3748	3/4	3/4	#50 #31	#6-32 #10-32
CT-21	3/8 to 1/2	.3748 .4998	1	1	#31 #25	#10-32 1/4-20

Modified or specials are available on request.

SPLIT SLEEVE COUPLINGS

BORE	DESCRIPTION	MATERIAL
3/8" TO 1 1/4"	ONE-PIECE CONSTRUCTION WITH KEYWAY	303 STAINLESS STEEL

STOCK NO.	A +.002 -.000	B +.002 -.000	O.D. (D)	W	K	RECOMMENDED MAX. SCREW TORQUE IN./LBS.	
						ALLOY STEEL	STAINLESS STEEL
CLC-6-6-SS	.375	.375	7/8	1 3/8	3/32	28	15
CLC-8-8-SS	.500	.500	1 1/8	1 3/4	1/8	49	28
CLC-10-10-SS	.625	.625	1 5/16	2	3/16	76	45
CLC-12-12-SS	.750	.750	1 1/2	2 1/4	3/16	170	110
CLC-14-14-SS	.875	.875	1 5/8	2 1/2	3/16	170	110
CLC-16-16-SS	1.000	1.000	1 3/4	3	1/4	170	110
CLC-18-18-SS	1.125	1.125	1 7/8	3 1/8	1/4	170	110
CLC-20-20-SS	1.250	1.250	2 1/16	3 1/4	1/4	170	110

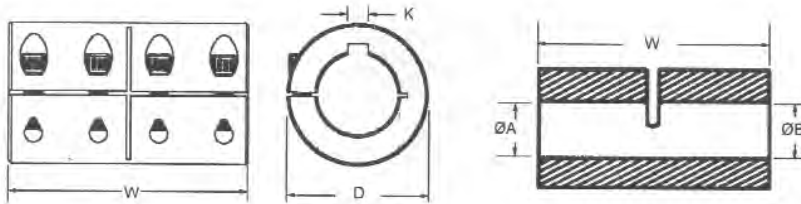

BORE	DESCRIPTION	MATERIAL
1/4" TO 1 1/4"	ONE-PIECE CONSTRUCTION WITHOUT KEYWAY	303 STAINLESS STEEL

STOCK NO.	A +.002 -.000	B +.002 -.000	O.D. (D)	W	RECOMMENDED MAX. SCREW TORQUE IN./LBS.	
					ALLOY STEEL	STAINLESS STEEL
CLX-4-4-SS	.250	.250	5/8	1	15	8
CLX-6-6-SS	.375	.375	7/8	1 3/8	28	15
CLX-8-8-SS	.500	.500	1 1/8	1 3/4	49	28
CLX-10-10-SS	.625	.625	1 5/16	2	76	45
CLX-12-12-SS	.750	.750	1 1/2	2 1/4	170	110
CLX-14-14-SS	.875	.875	1 5/8	2 1/2	170	110
CLX-16-16-SS	1.000	1.000	1 3/4	3	170	110
CLX-18-18-SS	1.125	1.125	1 7/8	3 1/8	170	110
CLX-20-20-SS	1.250	1.250	2 1/16	3 1/4	170	110

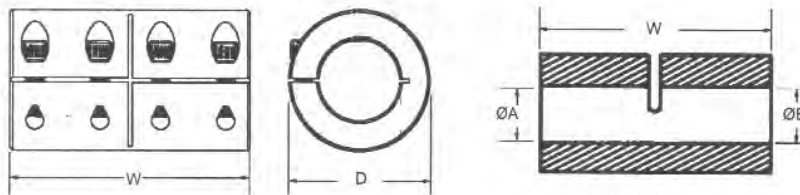

G

SPLIT SLEEVE COUPLINGS

BORE	DESCRIPTION	MATERIAL
3/8" TO 1 1/4"	ONE-PIECE CONSTRUCTION WITHOUT KEYWAYS	303 STAINLESS STEEL

STOCK NO.	A +.002 -.000	B +.002 -.000	O.D. (D)	LENGTH (W)	FORGED CLAMP SCREW
CLX-6-4-SS	.375	.250	7/8	1 3/8	6-32x3/8
CLX-8-6-SS	.500	.375	1 1/8	1 3/4	8-32x1/2
CLX-10-8-SS	.625	.500	1 5/16	2 1/4	10-32x1/2
CLX-12-10-SS	.750	.625	1 5/8	2 1/2	1/4-28x5/8
CLX-14-12-SS	.875	.750	1 5/8	2 1/2	1/4-28x5/8
CLX-16-12-SS	1.000	.750	1 3/4	3	1/4-28x11/16
CLX-16-14-SS	1.000	.875	1 3/4	3	1/4-28x11/16
CLX-18-16-SS	1.125	1.000	1 7/8	3 1/8	1/4-28x11/16
CLX-20-16-SS	1.250	1.000	2 1/16	3 1/4	1/4-28x3/4

BORE	DESCRIPTION	MATERIAL
3/8" TO 1 1/4"	TWO-PIECE CONSTRUCTION WITHOUT KEYWAYS	303 STAINLESS STEEL

STOCK NO.	A +.002 -.000	B +.002 -.000	O.D. (D)	LENGTH (W)	FORGED CLAMP SCREW
SPX-6-4-SS	.375	.250	7/8	1 3/8	6-32x3/8
SPX-8-6-SS	.500	.375	1 1/8	1 3/4	8-32x1/2
SPX-10-8-SS	.625	.500	1 5/16	2 1/4	10-32x1/2
SPX-12-10-SS	.750	.625	1 5/8	2 1/2	1/4-28x5/8
SPX-14-12-SS	.875	.750	1 5/8	2 1/2	1/4-28x5/8
SPX-16-12-SS	1.000	.750	1 3/4	3	1/4-28x11/16
SPX-16-14-SS	1.000	.875	1 3/4	3	1/4-28x11/16
SPX-18-16-SS	1.125	1.000	1 7/8	3 1/8	1/4-28x11/16
SPX-20-16-SS	1.250	1.000	2 1/16	3 1/4	1/4-28x3/4

BORE	DESCRIPTION	MATERIAL
3/8" TO 1 1/4"	TWO-PIECE CONSTRUCTION WITH KEYWAYS	303 STAINLESS STEEL

STOCK NO.	A +.002 -.000	B +.002 -.000	O.D. (D)	LENGTH (W)	KEYWAY A	KEYWAY B	FORGED CLAMP SCREW
SPC-6-4-SS	.375	.250	7/8	1 3/8	3/32	N/A	6-32x3/8
SPC-8-6-SS	.500	.375	1 1/8	1 3/4	1/8	3/32	8-32x1/2
SPC-10-8-SS	.625	.500	1 5/16	2 1/4	3/16	1/8	10-32x1/2
SPC-12-10-SS	.750	.625	1 5/8	2 1/2	3/16	3/16	1/4-28x5/8
SPC-14-12-SS	.875	.750	1 5/8	2 1/2	3/16	3/16	1/4-28x5/8
SPC-16-12-SS	1.000	.750	1 3/4	3	1/4	3/16	1/4-28x11/16
SPC-16-14-SS	1.000	.875	1 3/4	3	1/4	3/16	1/4-28x11/16
SPC-18-16-SS	1.125	1.000	1 7/8	3 1/8	1/4	1/4	1/4-28x11/16
SPC-20-16-SS	1.250	1.000	2 1/16	3 1/4	1/4	1/4	1/4-28x3/4

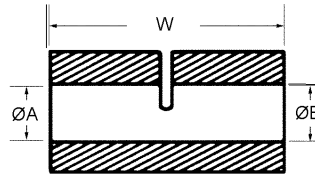
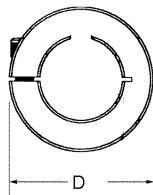
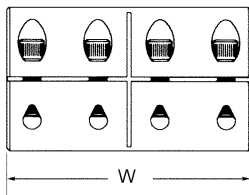

SPIDER COUPLINGS

BORE	DESCRIPTION	MATERIAL
1/8" TO 1/2"	SOFT 80 DURO SPIDER	ALUMINUM HUBS POLYURETHANE SPIDER

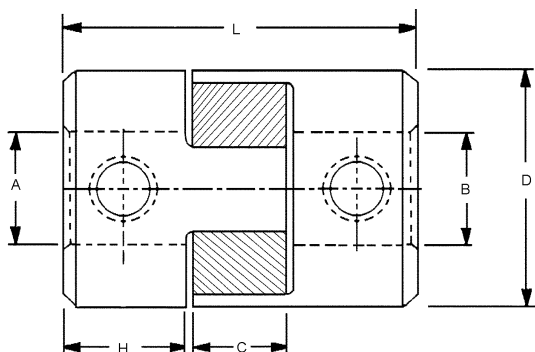

STOCK NO.	A +.002 -.000	B +.002 -.000	D	H	L	C	MISALIGNMENT		MAXIMUM TORQUE in-lb.	SET SCREW
							PARALLEL IN.	ANGULAR DEG.		
CO46-1A CO46-2A	.125 .187	.125 .187	.394	.20	.59	.16	.031	1°	2.6	#2-56 #4-40
CO47-1A CO47-2A CO47-3A	.125 .187 .250	.125 .187 .250	.551	.28	.87	.24	.047	1°	12	#2-56 #4-40 #6-32
CO48-1A CO48-2A CO48-3A	.250 .312 .375	.250 .312 .375	.787	.39	1.18	.32	.062	1°	32	#6-32 #8-32 #10-32
CO49-1A CO49-2A CO49-3A	.312 .375 .500	.312 .375 .500	1.18	.43	1.36	.39	.078	1°	70	#8-32 #10-32 1/4-20

- Torsional rigidity
- Contoured and machined components for quick assembly and minimum wear over extended use. Components assembled with pre-load.
- Bearing protection from parallel and angular misalignment
- Allowance for axial shaft float
- Small size, low WR, electrical isolation and light weight aluminum hubs.

Other bore sizes and combinations are available on request. Clamp style couplings are available on request.

BORE	DESCRIPTION	MATERIAL
1/8" TO 1/2"	RIGID 98 DURO SPIDER	ALUMINUM HUBS POLYURETHANE SPIDER

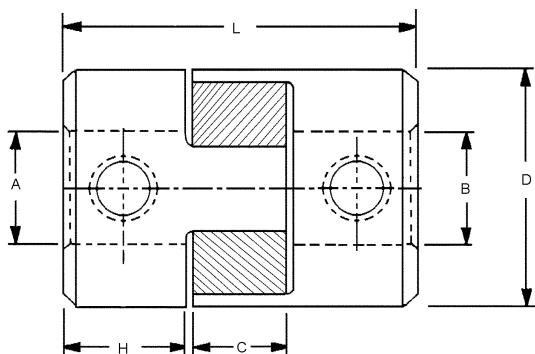

STOCK NO.	A +.002 -.000	B +.002 -.000	D	H	L	C	MISALIGNMENT		MAXIMUM TORQUE in-lb.	SET SCREW
							PARALLEL IN.	ANGULAR DEG.		
CO46-1B CO46-2B	.125 .187	.125 .187	.394	.20	.59	.16	.031	1°	8.6	#2-56 #4-40
CO47-1B CO47-2B CO47-3B	.125 .187 .250	.125 .187 .250	.551	.28	.87	.24	.047	1°	34	#2-56 #4-40 #6-32
CO48-1B CO48-2B CO48-3B	.250 .312 .375	.250 .312 .375	.787	.39	1.18	.32	.062	1°	86	#6-32 #8-32 #10-32
CO49-1B CO49-2B CO49-3B	.312 .375 .500	.312 .375 .500	1.18	.43	1.36	.39	.078	1°	220	#8-32 #10-32 1/4-20

- Torsional rigidity
- Contoured and machined components for quick assembly and minimum wear over extended use. Components assembled with pre-load.
- Bearing protection from parallel and angular misalignment
- Allowance for axial shaft float
- Small size, low WR, electrical isolation and light weight aluminum hubs.

Other bore sizes and combinations are available on request. Clamp style couplings are available on request.



MULTI-JAW COUPLINGS

BORE	MATERIAL
.1200 TO .4998	303 STAINLESS STEEL

STOCK NO.	B1 +.0005 -.0000	B2 +.0005 -.0000	H1	H2	L	C	P	OUTSIDE DIA.	NO. OF TEETH	MAX. TORQUE
CM3-4	.1200	.1200	.31	.31						
CM3-5	.1200	.1248	.31	.31						
CM3-1	.1248	.1248	.31	.31						
CM3-6	.1248	.1873	.31	.37	.79	.21	.22	17/32	32	300 OZ. IN.
CM3-7	.1248	.2498	.37	.50						
CM3-2	.1873	.1873	.37	.37						
CM3-8	.1873	.2498	.50	.50						
CM3-3	.2498	.2498	.50	.50						
CM1-15	.1200	.1248	.31	.31						
CM1-2	.1248	.1248	.31	.31						
CM1-16	.1248	.1873	.31	.37						
CM1-17	.1248	.2498	.31	.50	.87	.21	.25	3/4	48	500 OZ. IN.
CM1-3	.1873	.1873	.37	.37						
CM1-18	.1873	.2498	.37	.50						
CM1-4	.2498	.2498	.50	.50						
CM1-5	.3123	.3123	.50	.50						
CM1-6	.3748	.3748	.68	.68	1.25	.43	.31			
CM1-8	.4998	.4998	.93	.93	1.50	.56	.43	1	64	900

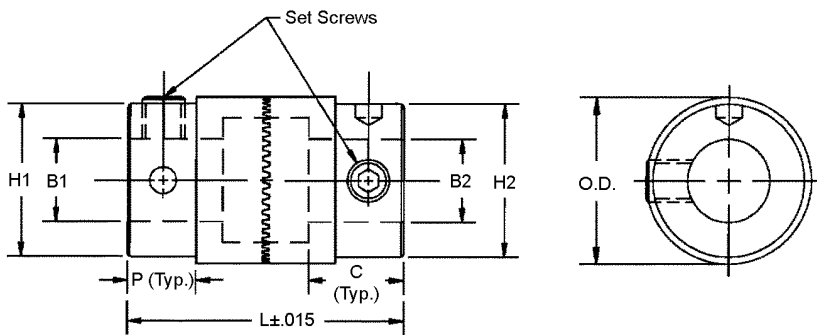

BORES	MATERIAL
3/16" TO 1/2"	COLD ROLLED STEEL

STOCK NO.	B1 +.0005 -.0000	B2 +.0005 -.0000	O.D.	L	C	H	P	NO. OF TEETH	MAX. TORQUE
CM2-3	3/16	3/16	1/2	1 1/8	1/2	.43	7/16	10	400 OZ. IN.
CM2-4	1/4	1/4	1/2	1 1/8	1/2	.43	7/16	10	400 OZ. IN.
CM2-5	5/16	5/16	3/4	1 1/2	5/8	.68	33/34	10	650 OZ. IN.
CM2-6	3/8	3/8	3/4	1 1/2	5/8	.68	33/64	10	650 OZ. IN.
CM2-8	1/2	1/2	1	2	7/8	.93	3/4	12	1100 OZ. IN.

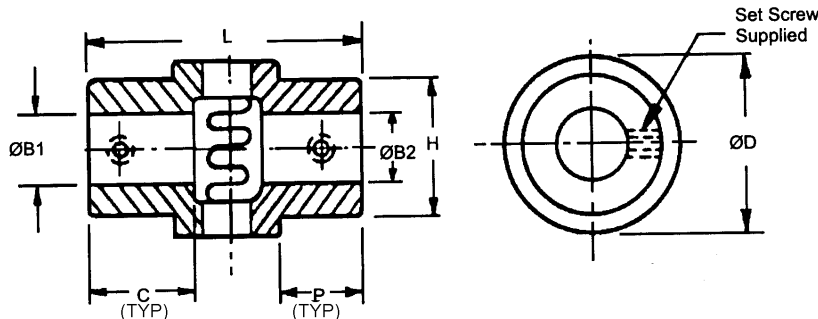

BELLOWS COUPLINGS

BORE	STYLE	MATERIAL
.128 TO .503	PIN HUB	303 STAINLESS STEEL HUB 321 STAINLESS STEEL BELLOWS

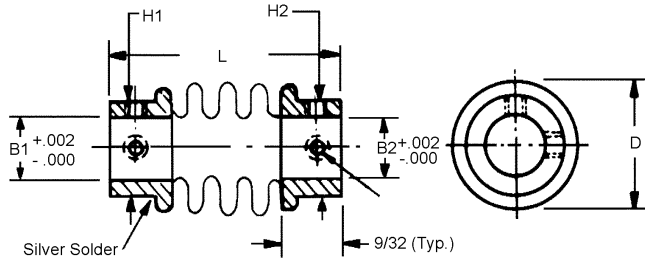

STOCK NO.	SHAFT SIZE	BORES B1 & B2	D	L	H1 & H2	MAXIMUM RATED TORQUE Oz. In.	MAXIMUM ANGULAR MISALIGNMENT	MAXIMUM PARALLEL MISALIGNMENT
CO4-2	1/8	.128	1/2	63/64	.34	40	4°	.027
CO4-3	3/16	.190			.43	55	6°	.012
CO4-4	1/4	.253			.53	105	7°	.017
CO4-5	5/16	.315	3/4	1 5/64	.55	115	7°	.017
CO4-6	3/8	.378			.61	150	5°	.015
CO4-7	7/16	.441			.67	175	5°	.015
CO4-8	1/2	.503			.80	175	5°	.025

- Eliminates end play
- Zero backlash
- Provides uniform angular velocity
- Absorbs vibration, noise and shock

BORE	STYLE	MATERIAL
.128 TO .503	PIN HUB	HUBS AND SPACER - ALUMINUM 2011T3 ANODIZED BELLOWS - SPRING STAINLESS STEEL JOINT ASSEMBLY - COPPER C 106, ZINC PLATE, BLACK CHROMATE TEMPERATURE RANGE -40°C TO +120°C

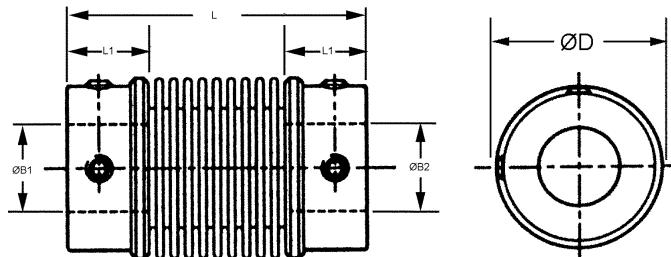

Peak Torque: Select a size where peak torque exceeds the application torque x service factor.

STOCK NO.	L	ØB1, ØB2 +.002 -.000	ØD	L1	PEAK TORQUE (± in/lb)	MAXIMUM MISALIGNMENT				
						ANGULAR (± degree)	RADIAL (± in)	AXIAL (± in)		
CO5H-1	1.70	.187	1.02		28.3	2	.002	.014		
CO5H-2	2.14	.187			14.2	6	.020	.040		
CO5H-3	1.70	.250			28.3	2	.002	.014		
CO5H-4	2.14	.250			14.2	6	.020	.040		
CO5H-5	1.70	.375			28.3	2	.002	.014		
CO5H-6	2.14	.375			14.2	6	.020	.040		
CO5H-7	1.57	.250	1.34	.55	66.4	2.5	.004	.024		
CO5H-8	2.24	.250			33.6	8	.040	.075		
CO5H-9	1.57	.375			66.4	2.5	.004	.024		
CO5H-10	2.24	.375			33.6	8	.040	.075		
CO5H-11	1.57	.500			66.4	2.5	.004	.024		
CO5H-12	2.24	.500			33.6	8	.040	.075		
CO5H-13	1.57	.625			66.4	2.5	.004	.031		
CO5H-14	2.24	.625			33.6	8	.040	.098		
CO5H-15	1.96	.250			1.61	.71	88.5	2.5	.006	.031
CO5H-16	2.81	.250					44.3	8	.047	.098
CO5H-17	1.96	.375	88.5	2.5			.006	.031		
CO5H-18	2.81	.375	44.3	8			.047	.098		
CO5H-19	1.96	.500	88.5	2.5			.006	.031		
CO5H-20	2.81	.500	44.3	8			.047	.098		
CO5H-21	1.96	.625	88.5	2.5			.006	.031		
CO5H-22	2.81	.625	44.3	8			.047	.098		
CO5H-23	1.96	.750	88.5	2.5			.006	.031		
CO5H-24	2.81	.750	44.3	8			.047	.098		

Service Factor	
Nature of Load	Factor
Uniform load	1.5
Non-uniform load	2
Shock load	3
Reversing shock load	4

BELLOWS COUPLINGS

BORE	STYLE	MATERIAL
.187 TO .750	CLAMP HUB	HUBS AND SPACER - ALUMINUM 2011T3 ANODIZED BELLOWS - SPRING STAINLESS STEEL JOINT ASSEMBLY - COPPER C 106, ZINC PLATE, BLACK CHROMATE TEMPERATURE RANGE -40°C TO +120°C

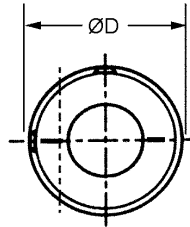
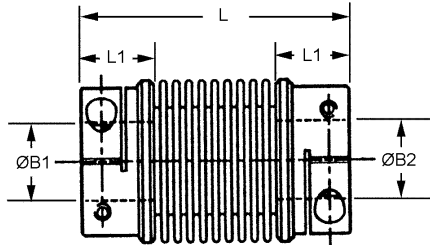

Peak Torque: Select a size where peak torque exceeds the application torque x service factor.

STOCK NO.	L	ØB1, ØB2 + .002 - .000	ØD	L1	PEAK TORQUE (± in/lb)	MAXIMUM MISALIGNMENT		
						ANGULAR (± degree)	RADIAL (± in)	AXIAL (± in)
CO5H-1C	1.70	.187	1.02	.55	28.3	2	.002	.014
CO5H-2C	2.14	.187			14.2	6	.020	.040
CO5H-3C	1.70	.250			28.3	2	.002	.014
CO5H-4C	2.14	.250			14.2	6	.020	.040
CO5H-5C	1.70	.375	1.34	.55	28.3	2	.002	.014
CO5H-6C	2.14	.375			14.2	6	.020	.040
CO5H-7C	1.57	.250			66.4	2.5	.004	.024
CO5H-8C	2.24	.250			33.6	8	.040	.075
CO5H-9C	1.57	.375	1.61	.71	66.4	2.5	.004	.024
CO5H-10C	2.24	.375			33.6	8	.040	.075
CO5H-11C	1.57	.500			66.4	2.5	.004	.024
CO5H-12C	2.24	.500			33.6	8	.040	.075
CO5H-13C	1.57	.625	1.61	.71	66.4	2.5	.004	.031
CO5H-14C	2.24	.625			33.6	8	.040	.098
CO5H-15C	1.96	.250			88.5	2.5	.006	.031
CO5H-16C	2.81	.250			44.3	8	.047	.098
CO5H-17C	1.96	.375	1.61	.71	88.5	2.5	.006	.031
CO5H-18C	2.81	.375			44.3	8	.047	.098
CO5H-19C	1.96	.500			88.5	2.5	.006	.031
CO5H-20C	2.81	.500			44.3	8	.047	.098
CO5H-21C	1.96	.625	1.61	.71	88.5	2.5	.006	.031
CO5H-22C	2.81	.625			44.3	8	.047	.098
CO5H-23C	1.96	.750			88.5	2.5	.006	.031
CO5H-24C	2.81	.750			44.3	8	.047	.098

Service Factor	
Nature of Load	Factor
Uniform load	1.5
Non-uniform load	2
Shock load	3
Reversing shock load	4

PRECISION BELLOWS COUPLINGS

BORE	STYLE	MATERIAL
.1200 TO .3748	PIN HUB	STAINLESS STEEL

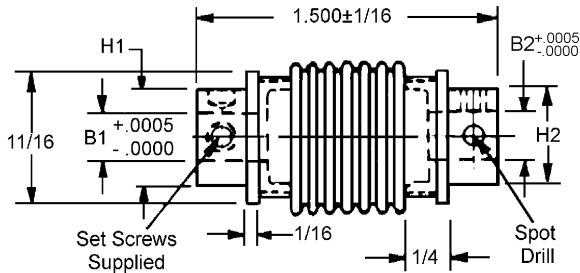

STOCK NO.	B1	B2	H1	H2
CO5-7	.1200	.1200	5/16	5/16
CO5-8	.1200	.1248	5/16	5/16
CO5-11	.1200	.1873	5/16	3/8
CO5-12	.1200	.2498	5/16	1/2
CO5-1	.1248	.1248	5/16	5/16
CO5-4	.1248	.1873	5/16	3/8
CO5-5	.1248	.2498	5/16	1/2
CO5-2	.1873	.1873	3/8	3/8
CO5-6	.1873	.2498	3/8	1/2
CO5-9	.2405	.2498	3/8	1/2
CO5-3	.2498	.2498	1/2	1/2
CO5-10	.3123	.3123	1/2	1/2
CO5-13	.3748	.3748	5/8	5/8



Maximum Rated Torque 75 oz./in.

Metric bore sizes and other bore combinations available on request.

BORE	STYLE	MATERIAL
.1200 TO .3748	CLAMP HUB	STAINLESS STEEL

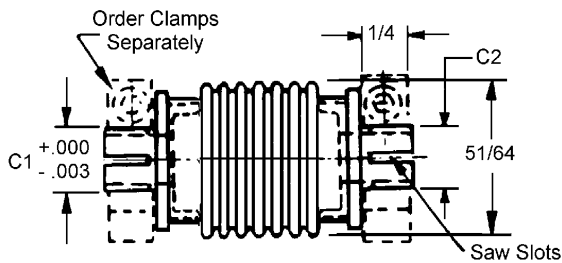

STOCK NO.	B1 +.0005 -.0000	B2 +.0005 -.0000	C1	C2
CO5-7C	.1200	.1200	3/16	3/16
CO5-8C	.1200	.1248	3/16	3/16
CO5-11C	.1200	.1873	3/16	1/4
CO5-12C	.1200	.2498	3/16	5/16
CO5-1C	.1248	.1248	3/16	3/16
CO5-4C	.1248	.1873	3/16	1/4
CO5-5C	.1248	.2498	3/16	5/16
CO5-2C	.1873	.1873	1/4	1/4
CO5-6C	.1873	.2498	1/4	5/16
CO5-9C	.2405	.2498	5/16	5/16
CO5-3C	.2498	.2498	5/16	5/16
CO5-10C	.3123	.3123	3/8	3/8
CO5-13C	.3748	.3748	7/16	7/16

Metric bore sizes and other bore combinations available on request.



OLDHAM COUPLINGS

BORES	STYLE	MATERIAL
.1200 TO .4998	PIN HUB	303 STAINLESS STEEL HUBS CENTER BLOCK: U = POLYURETHANE B = BRONZE OR N = NYLON

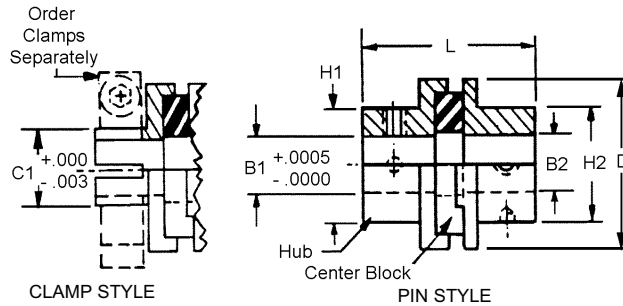

STOCK NO.	B1	B2	D	H1	H2	L	TORQUE Oz. In.
CO3-13-B CO3-13-N	.1200	.1248	5/8	5/16	5/16	21/32	90 28
CO3-2-U CO3-2-B CO3-2-N	.1248	.1248	5/8	5/16	5/16	21/32	20 90 28
CO3-10-U CO3-10-B CO3-10-N	.1248	.1873	5/8	5/16	3/8	11/16	20 90 28
CO3-11-U CO3-11-B CO3-11-N	.1248	.2498	5/8	5/16	1/2	23/32	20 90 28
CO3-3-U CO3-3-B CO3-3-N	.1873	.1873	5/8	3/8	3/8	23/32	80 360 112
CO3-12-U CO3-12-B CO3-12-N	.1873	.2498	5/8	3/8	1/2	3/4	80 360 112
CO3-4-U CO3-4-B CO3-4-N	.2498	.2498	5/8	1/2	1/2	25/32	80 360 112
CO3-5-U CO3-5-B CO3-5-N	.3123	.3123	5/8	1/2	1/2	25/32	80 360 112
CO3-6-U CO3-6-B CO3-6-N	.3748	.3748	1 3/8	3/4	3/4	1 9/16	300 1350 420
CO3-8-U CO3-8-B CO3-8-N	.4998	.4998	1 1/2	1	1	1 13/16	400 1800 560

* Limiting factor is strength of hub-to-shaft connection.

- Shaft to shaft misalignment .010 maximum
- Angular misalignment 1° maximum
- Maximum backlash 10 minutes

OLDHAM COUPLINGS

BORE	STYLE	MATERIAL
.1200 TO .2500	PIN HUB	BRASS HUB ACETAL CENTER BLOCK

STOCK NO.	BORE TO BORE		E	O.D.	L	RATED WORKING TORQUE Oz. In.	ANGULAR	PARALLEL
	SOLID	SOLID						
CO31-B	SOLID	SOLID	-	.37	1/2	64	1/2°	.05
CO31-1	.1200	.1250	.15					
CO31-2	.1250	.1250						
CO31-3	.1562	.1562						
CO31-4	.1875	.1875						
CO32-B	SOLID	SOLID	-	.50	5/8	120	3/4°	.06
CO32-1	.1250	.1250	.17					
CO32-2	.1562	.1562						
CO32-3	.1875	.1875						
CO32-4	.2500	.2500						

BORE	STYLE	MATERIAL
.1875 TO .6250	PIN HUB	ALUMINUM HUB ACETAL CENTER BLOCK

STOCK NO.	BORE TO BORE		E	O.D.	L	RATED WORKING TORQUE Oz. In.	ANGULAR	PARALLEL
	SOLID	SOLID						
CO33-B	SOLID	SOLID	-	.75	7/8	334	3/4°	.09
CO33-1	.1875	.1875	.25					
CO33-2	.2500	.2500						
CO33-3	.3125	.3125						
CO34-B	SOLID	SOLID	-	1	1-1/8	640	1°	.12
CO34-1	.2500	.2500	.34					
CO34-2	.3125	.3125						
CO34-3	.3750	.3750						
CO34-4	.4375	.4375						
CO60-B	SOLID	SOLID	-	1.31	1.91	2200	1-1/4°	.16
CO60-1	.3125	.3125	.51					
CO60-2	.3750	.3750						
CO60-3	.5000	.5000						
CO35-B	SOLID	SOLID	-	1.62	2.00	3200	1-1/4°	.20
CO35-1	.3750	.3750	.66					
CO35-2	.4375	.4375						
CO35-3	.5000	.5000						
CO35-4	.6250	.6250						

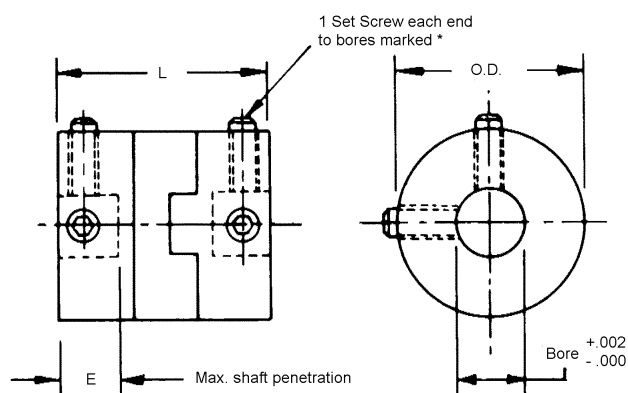

Blank hubs, set screw hubs, and clamp hubs are interchangeable within the same series, special combinations will be assembled to order.



- Simple construction
- * No backlash
- Corrosion resistant
- Reduces vibration
- Electrical Isolation
- No lubrication required



OLDHAM COUPLINGS

BORE	STYLE	MATERIAL
.1200 TO .2498	CLAMP	303 STAINLESS STEEL HUBS CENTER BLOCK: U = POLYURETHANE B = BRONZE OR N = NYLON

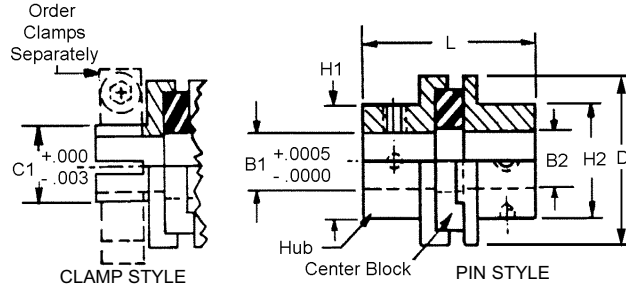

See previous pages for Stock Nos. and descriptions for Pin Hub Oldham Couplings.

STOCK NO.	B1	B2	D	C1	C2	L	TORQUE Oz. In.
CO6-8-B CO6-8-N	.1200	.1248	5/8	3/16	3/16	27/32	90 28
CO6-1-U CO6-1-B CO6-1-N	.1248	.1248	5/8	3/16	3/16	27/32	20 90 28
CO6-5-U CO6-5-B CO6-5-N	.1248	.1873	5/8	3/16	1/4	27/32	20 90 28
CO6-6-U CO6-6-B CO6-6-N	.1248	.2498	5/8	3/16	5/16	27/32	20 90 28
CO6-2-U CO6-2-B CO6-2-N	.1873	.1873	5/8	1/4	1/4	27/32	80 360 112
CO6-7-U CO6-7-B CO6-7-N	.1873	.2498	5/8	1/4	5/16	27/32	80 360 112
CO6-3-U CO6-3-B CO6-3-N	.2498	.2498	5/8	5/16	5/16	27/32	80 360 112

* Limiting factor is strength of hub-to-shaft connection.

- Shaft to shaft misalignment .010 maximum
- Angular misalignment 1° maximum
- Maximum backlash 10 minutes

OLDHAM COUPLINGS

BORE	STYLE	MATERIAL
.1875 TO .6250	CLAMP HUB	ALUMINUM HUB ACETAL CENTER BLOCK

STOCK NO.	BORE TO BORE		E	O.D.	L	RATED WORKING TORQUE Oz. In.	ANGULAR	PARALLEL
CO33-1C	.1875	.1875	.25	.75	7/8	334	3/4°	.09
CO33-2C	.2500	.2500						
CO34-1C	.2500	.2500	.34	1	1-1/8	640	1°	.12
CO34-2C	.3125	.3125						
CO34-3C	.3750	.3750						
CO60-1C	.3125	.3125	.51	1.31	1.91	2200	1-1/4°	.16
CO60-2C	.3750	.3750						
CO60-3C	.5000	.5000						
CO35-1C	.3750	.3750	.66	1.62	2.00	3200	1-1/4°	.20
CO35-2C	.4375	.4375						
CO35-3C	.5000	.5000						
CO35-4C	.6250	.6250						

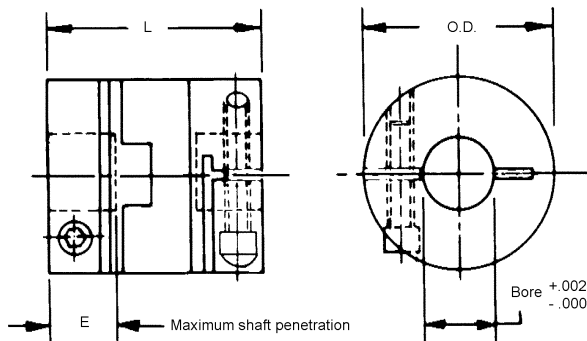

- Simple construction
- * No backlash
- Corrosion resistant
- Reduces vibration
- Electrical Isolation
- No lubrication required

Blank hubs, set screw hubs, and clamp hubs are interchangeable within the same series, special combinations will be assembled to order.

UNIVERSAL LATERAL COUPLINGS

BORE		STYLE		MATERIAL	
.1200 TO .3750		PIN HUB		DELRIN OUTER RING BRASS HUBS	

STOCK NO.	B1 +.002 +.000	B2 +.002 +.000	D1	D2	E1	E2	L	WORKING TORQUE Oz. In.	A
CO26-1	.1200	.1250	.35	.35	.16	.16	.56	38	23/32
CO26-2	.1250	.1250	.35	.35	.16	.16	.56		
CO26-3	.1250	.1575	.35	.35	.16	.16	.56		
CO26-4	.1250	.1875	.35	.35	.16	.16	.56		
CO26-7	.1250	.2500	.35	.44	.16	.26	.66		
CO26-5	.1575	.1575	.35	.35	.16	.16	.56		
CO26-8	.1575	.2500	.35	.44	.16	.26	.66		
CO26-6	.1875	.1875	.35	.35	.16	.16	.56		
CO26-9	.1875	.2500	.35	.44	.16	.26	.66		
CO26-10	.2500	.2500	.44	.44	.26	.26	.75		
CO23-1	.1250	.1250	.50	.50	.19	.19	.75	1-1/16	
CO23-2	.1250	.1875	.50	.50	.19	.19	.75		
CO23-3	.1250	.2500	.50	.50	.19	.19	.75		
CO23-8	.1575	.1575	.50	.50	.19	.19	.75		
CO23-4	.1875	.1875	.50	.50	.19	.19	.75		
CO23-5	.1875	.2500	.50	.50	.19	.19	.75		
CO23-10	.1875	.3750	.50	.59	.19	.31	.88		
CO23-6	.2500	.2500	.50	.50	.19	.19	.75		
CO23-9**	.2500	.3125	.50	.50	.19	.19	.75		
CO23-11**	.2500	.3750	.50	.59	.19	.31	.88		
CO23-7**	.3125	.3125	.50	.50	.19	.19	.75		
CO23-12**	.3125	.3750	.50	.59	.19	.31	.88		
CO23-13**	.3750	.3750	.59	.59	.31	.31	1.00		

- Zero backlash
- Offers simultaneous lateral & angular misalignment
- Corrosion resistant
- No lubrication required
- Resonance damping
- Low inertia
- Shafts can pass through for easy installation
- Maximum operating temperature 185°F
- Misalignment (**)
Angular 10° maximum
Lateral .050 maximum

**Misalignment: Angular 5° maximum, Lateral .025 maximum.

BORE		STYLE		MATERIAL	
.2500 TO .6250		PIN HUB		DELRIN OUTER RING ALUMINUM HUBS	

STOCK NO.	B1 +.002 +.000	B2 +.002 +.000	D1	D2	E1	E2	L	WORKING TORQUE Oz. In.	A
CO25X-1	.2500	.2500	.69	.69	.30	.30	.99	444	1-21/64
CO25X-2	.2500	.3750	.69	.69	.30	.30	.99		
CO25X-3	.3750	.3750	.69	.69	.30	.30	.99		
CO25X-4	.3750	.5000	.69	.79	.30	.40	1.10		
CO25X-5	.5000	.5000	.79	.79	.40	.40	1.21		
CO25-1	.2500	.2500	.87	.87	.30	.30	1.12	607	1-5/8
CO25-2	.2500	.3125	.87	.87	.30	.30	1.12		
CO25-3	.2500	.3750	.87	.87	.30	.30	1.12		
CO25-8	.2500	.5000	.87	.87	.30	.30	1.12		
CO25-4	.3125	.3125	.87	.87	.30	.30	1.12		
CO25-9	.3125	.5000	.87	.87	.30	.30	1.12		
CO25-5	.3750	.3750	.87	.87	.30	.30	1.12		
CO25-6	.3750	.5000	.87	.87	.30	.30	1.12		
CO25-7	.5000	.5000	.87	.87	.30	.30	1.12		
CO25-10	.6250	.6250	.95	.95	.49	.49	1.50		

- Zero backlash
- Offers simultaneous lateral & angular misalignment
- Corrosion resistant
- No lubrication required
- Resonance damping
- Low inertia
- Shafts can pass through for easy installation
- Maximum operating temperature 185°F
- Misalignment
Angular 10° maximum
Lateral .050 maximum

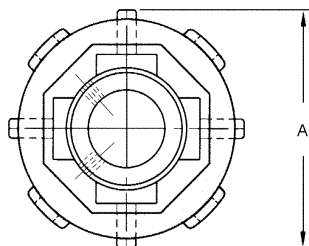
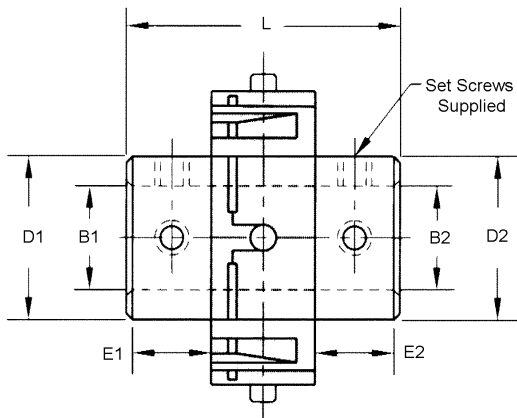

UNIVERSAL LATERAL COUPLINGS

BORE		STYLE		MATERIAL	
.1200 TO .3750		CLAMP		DELTRIN OUTER RING BRASS HUBS	

STOCK NO.	B1 +.002 -.000	B2 +.002 -.000	D	E	L	MAXIMUM WORKING TORQUE Oz. In.	OUTSIDE DIA.
CO27-1	.1200	.1250	.75	.26	.75	38	3/4
CO27-2	.1250	.1250					
CO27-3	.1250	.2500					
CO27-4	.1575	.1575					
CO27-5	.1875	.1875					
CO27-6	.2500	.2500					
CO28-1	.1575	.1575	1.00	.31	1.00	222	1-1/16
CO28-2	.1875	.1875				222	
CO28-3	.2500	.2500				222	
CO28-4**	.2500	.3750				122	
CO28-5**	.3125	.3125				222	
CO28-6**	.3750	.3750				122	

- Low inertia
- Resonance damping
- Electrically insulated
- Zero backlash
- Offers simultaneous lateral & angular misalignment
- Corrosion resistant
- No lubrication required
- Shafts can pass through for easy installation
- Maximum operating temperature 185°F
- Misalignment (**)
Angular 10° maximum
Lateral .050 maximum

**Misalignment: Angular 5° maximum, Lateral .025 maximum.

Additional sizes and bore combinations available on request.

BORE		STYLE		MATERIAL	
.2500 TO .5000		CLAMP		DELTRIN OUTER RING ALUMINUM HUBS	

STOCK NO.	B1 +.002 -.000	B2 +.002 -.000	D	E	L	MAXIMUM WORKING TORQUE Oz. In.	OUTSIDE DIA.
CO29X-1	.2500	.2500	.79	.40	1.21	444	1 21/64
CO29X-2	.2500	.3750					
CO29X-3	.3750	.3750					
CO29-1*	.2500	.2500	.95	.49	1.50	607	1 5/8
CO29-2*	.2500	.5000					
CO29-3*	.3125	.3125					
CO29-4*	.3125	.5000					
CO29-5*	.3750	.3750					
CO29-6*	.3750	.5000					
CO29-7*	.5000	.5000					

- Low inertia
- Resonance damping
- Electrically insulated
- Zero backlash
- Offers simultaneous lateral & angular misalignment
- Corrosion resistant
- No lubrication required
- Shafts can pass through for easy installation
- Maximum operating temperature 185°F
- Misalignment
Angular 10° maximum
Lateral .050 maximum

*Clamp hub is integral to hub on CO29 series.

Additional sizes and bore combinations available on request.

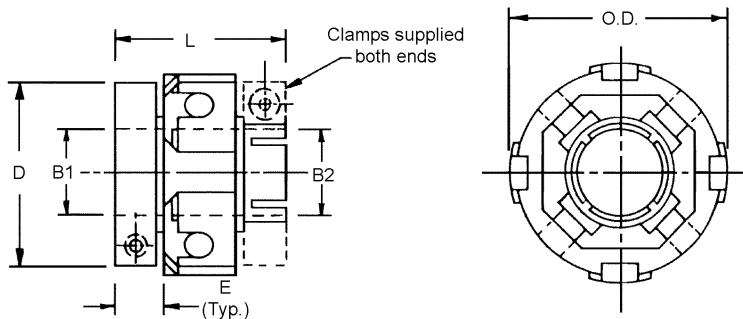

WAFER SPRING COUPLINGS

BORES	STYLE	MATERIAL
.1200 TO .5000	PIN HUB	HUB AND CENTER BLOCK: ALUMINUM LEAVES: BERYLLIUM COPPER

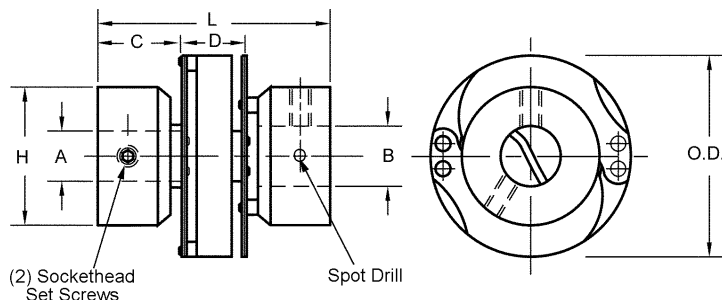

STOCK NO.	A +.0010	B +.0010	L	H	C	D	MAX. WORKING OUTSIDE DIA.	MAX. TORQUE (IN.OZ)	MAX. PARALLEL MISALIGNMENT	ANGULAR MISALIGNMENT
CO20-1P	.1200	.1250								8°
CO20-2P	.1200	.1562								
CO20-3P	.1200	.1875								
CO20-4P	.1200	.2500								
CO20-5P	.1250	.1250								
CO20-6P	.1250	.1562								
CO20-7P	.1250	.1875	.94	.56	.33	.28	.75	165	.018	
CO20-8P	.1250	.2500								
CO20-9P	.1562	.1562								
CO20-10P	.1562	.1875								
CO20-11P	.1562	.2500								
CO20-12P	.1875	.1875								
CO20-13P	.1875	.2500								
CO20-14P	.2500	.2500								
CO20-22P	.1875	.1875								
CO20-23P	.1875	.2500								
CO20-24P	.2500	.2500	1.21	.75	.44	.33	1.00	225	.020	
CO20-25P	.2500	.3125								
CO20-26P	.3125	.3125								
CO20-15P	.2500	.3125								
CO20-16P	.2500	.3750								
CO20-17P	.3125	.3125								
CO20-18P	.3125	.3750	1.82	1.00	.66	.50	1.50	440	.030	
CO20-19P	.3750	.3750								
CO20-20P	.3750	.5000								
CO20-21P	.5000	.5000								

TECHNICAL SPECIFICATIONS	3/4 O.D.	1 O.D.	1 1/2 O.D.
Maximum Lateral Deflection	.018	.020	.030
Moment of inertia (oz.in ²)	0.19	.66	.630
Torque (oz.in)	165	225	44
Weight (oz)	.22	.56	1.60

- Zero backlash
- 8° maximum angular misalignment
- 10,000 RPM maximum

Torque ratings are based on maximum lateral angular and axial misalignment combined.

WAFER SPRING COUPLINGS

BORE	STYLE	MATERIAL
.1200 TO .5000	CLAMP	HUB AND CENTER BLOCK: ALUMINUM LEAVES: BERYLLIUM COPPER

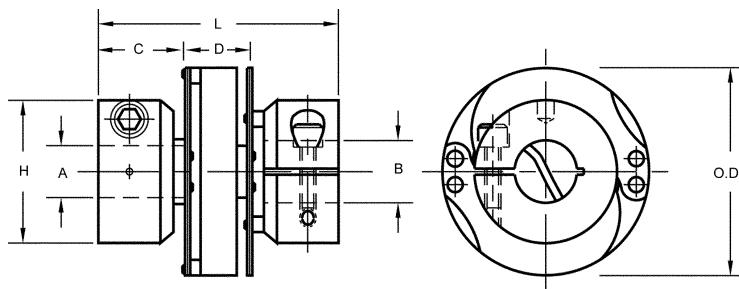

STOCK NO.	A +.0010	B +.0010	L	H	C	D	MAX. WORKING OUTSIDE DIA.	MAX. TORQUE (IN.OZ)	MAX. PARALLEL MISALIGNMENT	ANGULAR MISALIGNMENT
CO20-1	.1200	.1250								8°
CO20-2	.1200	.1562								
CO20-3	.1200	.1875								
CO20-4	.1200	.2500								
CO20-5	.1250	.1250								
CO20-6	.1250	.1562								
CO20-7	.1250	.1875	.88	.56	.30	.28	.75	165	.018	
CO20-8	.1250	.2500								
CO20-9	.1562	.1562								
CO20-10	.1562	.1875								
CO20-11	.1562	.2500								
CO20-12	.1875	.1875								
CO20-13	.1875	.2500								
CO20-14	.2500	.2500								
CO20-22	.1875	.1875								8°
CO20-23	.1875	.2500								
CO20-24	.2500	.2500	1.21	.75	.44	.33	1.00	225	.020	
CO20-25	.2500	.3125								
CO20-26	.3125	.3125								
CO20-15	.2500	.3125								
CO20-16	.2500	.3750								
CO20-17	.3125	.3125								
CO20-18	.3125	.3750	1.82	1.00	.66	.50	1.50	440	.030	
CO20-19	.3750	.3750								
CO20-20	.3750	.5000								
CO20-21	.5000	.5000								

TECHNICAL SPECIFICATIONS	3/4 O.D.	1 O.D.	1 1/2 O.D.
Maximum Lateral Deflection	.018	.020	.030
Moment of inertia (oz.in ²)	0.19	.66	.630
Torque (oz.in)	165	225	44
Weight (oz)	.22	.56	1.60

- Zero backlash
- 8° maximum angular misalignment
- 10,000 RPM maximum

Torque ratings are based on maximum lateral angular and axial misalignment combined.



DISC COUPLINGS

Ratings and Mass Data for disc couplings CTCC, CTCA, CTCB and CTCBC

SIZE NO.	MAX. RPM	APPROX. WEIGHT (OZ.)	APPROX. WR (OZ. IN. ²)	TORSIONAL RIGIDITY (K) (MILLIRADIANS PER OZ. IN.)	MAX. ANGULAR MISALIGNMENT, CONTINUOUS PER FLEXING ELEMENT	MAX. PARALLEL MISALIGNMENT, CONTINUOUS IN.	END FLOAT ² IN.	TORQUE CAPACITY (lb-in)
12	150,000	.09	.0026	.148	2°	.015	±.016	1.1
18	100,000	.29	.0177	.0908	2°	.015	±.016	2.2
25	80,000	.74	.0799	.03700	2°	.028	±.031	4.7
37	55,000	2.02	.474	.00554	1.5°	.028	±.031	19.0
50	45,000	4.02	1.418	.00362	1°	.028	±.031	75.0
62	35,000	9.36	4.99	.00139	.67°	.028	±.031	300.0
75	30,000	11.57	8.61	.00089	.67°	.028	±.031	440.0
100	25,000	20.00	23.00	.00066	.50°	.020	±.031	700.0



• Size number determination

Example: CTCC _ _ _ -
CTCB _ _ _ -



CTCC: Both hubs inside
CTCA: One hub inside
CTCB: Both hubs out
CTCBC: Same as CB but Clamp style

DISC COUPLINGS

BORE	STYLE	MATERIAL
.0781 TO 1.005	CTCC PIN HUB	ANODIZED ALUMINUM HUBS AND CENTER, RIVETS AND WASHERS - BRASS DISCS STAINLESS STEEL

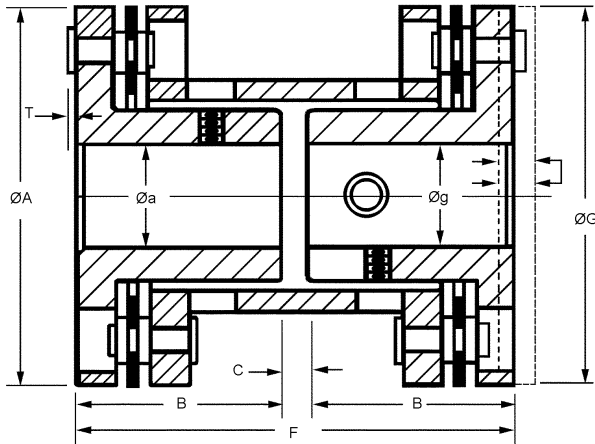

STOCK NO.	Øa ±.0005	Øg ±.0005	ØA	ØG	B	C	F	T	TORQUE CAPACITY (LB.-IN.)
CTCC12-1	.0781	.0781	1/2	1/2	1/4	1/32	17/32	.018	1.1
CTCC12-2	.0937	.0937	1/2	1/2	1/4	1/32	17/32	.018	1.1
CTCC12-3	.1200	.1200	1/2	1/2	1/4	1/32	17/32	.018	1.1
CTCC12-4	.1250	.1250	1/2	1/2	1/4	1/32	17/32	.018	1.1
CTCC18-1	.0937	.0937	3/4	3/4	3/8	1/16	13/16	.023	2.2
CTCC18-2	.1200	.1200	3/4	3/4	3/8	1/16	13/16	.023	2.2
CTCC18-3	.1250	.1250	3/4	3/4	3/8	1/16	13/16	.023	2.2
CTCC18-4	.1562	.1562	3/4	3/4	3/8	1/16	13/16	.023	2.2
CTCC18-5	.1875	.1875	3/4	3/4	3/8	1/16	13/16	.023	2.2
CTCC25-1	.1255	.1255	1	1	1/2	1/16	1 1/16	.025	4.7
CTCC25-2	.1880	.1880	1	1	1/2	1/16	1 1/16	.025	4.7
CTCC25-3	.2505	.2505	1	1	1/2	1/16	1 1/16	.025	4.7
CTCC37-1	.1255	.1255	1 7/16	1 7/16	11/16	1/8	1 1/2	.035	19.0
CTCC37-2	.1880	.1880	1 7/16	1 7/16	11/16	1/8	1 1/2	.035	19.0
CTCC37-3	.2505	.2505	1 7/16	1 7/16	11/16	1/8	1 1/2	.035	19.0
CTCC37-4	.3130	.3130	1 7/16	1 7/16	11/16	1/8	1 1/2	.035	19.0
CTCC37-5	.3755	.3755	1 7/16	1 7/16	11/16	1/8	1 1/2	.035	19.0
CTCC50-1	.2505	.2505	1 7/16	1 7/16	15/16	1/8	2	.045	75.0
CTCC50-2	.3130	.3130	1 3/4	1 3/4	15/16	1/8	2	.045	75.0
CTCC50-3	.3755	.3755	1 3/4	1 3/4	15/16	1/8	2	.045	75.0
CTCC50-4	.4380	.4380	1 3/4	1 3/4	15/16	1/8	2	.045	75.0
CTCC50-5	.5005	.5005	1 3/4	1 3/4	15/16	1/8	2	.045	75.0
CTCC62-1	.3755	.3755	1 3/4	1 3/4	1 1/16	1/8	2 1/4	.060	300.0
CTCC62-2	.4380	.4380	2 1/4	2 1/4	1 1/16	1/8	2 1/4	.060	300.0
CTCC62-3	.5005	.5005	2 1/4	2 1/4	1 1/16	1/8	2 1/4	.060	300.0
CTCC62-4	.6255	.6255	2 1/4	2 1/4	1 1/16	1/8	2 1/4	.060	300.0
CTCC75-1	.4380	.4380	2 1/4	2 1/4	1 3/16	1/8	2 1/2	.060	440.0
CTCC75-2	.5005	.5005	2 1/2	2 1/2	1 3/16	1/8	2 1/2	.060	440.0
CTCC75-3	.6255	.6255	2 1/2	2 1/2	1 3/16	1/8	2 1/2	.060	440.0
CTCC75-4	.7505	.7505	2 1/2	2 1/2	1 3/16	1/8	2 1/2	.060	440.0
CTCC100-1	.6255	.6255	2 1/2	2 1/2	1 3/8	1/4	3	.060	700.0
CTCC100-2	.7505	.7505	3	3	1 3/8	1/4	3	.060	700.0
CTCC100-3	.8755	.8755	3	3	1 3/8	1/4	3	.060	700.0
CTCC100-4	1.0050	1.0050	3	3	1 3/8	1/4	3	.060	700.0

Torque capacities are based on smooth drives with moderate torque fluctuations. Reduce ratings 1/3 the value shown for severe applications such as indexing drives where torque reversals occur.



DISC COUPLINGS

BORE	STYLE	MATERIAL
.0781 TO 1.2505	PIN HUB	ANODIZED ALUMINUM HUBS AND CENTER, RIVETS AND WASHERS - BRASS DISCS STAINLESS STEEL

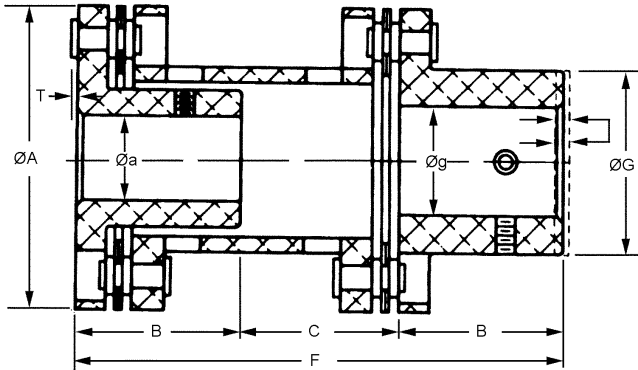

STOCK NO.	Øa ±.0005	Øg ±.0005	ØA	ØG	B	C	F	T	TORQUE CAPACITY (LB.-IN.)
CTCA12-1	.0781	.1200	1/2	5/16	1/4	15/64	47/64	.018	1.1
CTCA12-2	.0937	.1250	1/2	5/16	1/4	15/64	47/64	.018	1.1
CTCA12-3	.1200	.1562	1/2	5/16	1/4	15/64	47/64	.018	1.1
CTCA12-4	.1250	.1875	1/2	5/16	1/4	15/64	47/64	.018	1.1
CTCA18-1	.0937	.1250	3/4	15/32	3/8	3/8	1 1/8	.023	2.2
CTCA18-2	.1200	.1562	3/4	15/32	3/8	3/8	1 1/8	.023	2.2
CTCA18-3	.1250	.1875	3/4	15/32	3/8	3/8	1 1/8	.023	2.2
CTCA18-4	.1562	.2500	3/4	15/32	3/8	3/8	1 1/8	.023	2.2
CTCA18-5	.1875	.2500	3/4	15/32	3/8	3/8	1 1/8	.023	2.2
CTCA25-1	.1255	.1255	1	5/8	1/2	15/32	1 15/32	.025	4.7
CTCA25-2	.1880	.1880	1	5/8	1/2	15/32	1 15/32	.025	4.7
CTCA25-3	.2505	.2505	1	5/8	1/2	15/32	1 15/32	.025	4.7
CTCA25-4	.2505	.3130	1	5/8	1/2	15/32	1 15/32	.025	4.7
CTCA25-5	.2505	.3755	1	5/8	1/2	15/32	1 15/32	.025	4.7
CTCA37-1	.1255	.1880	1 7/16	7/8	11/16	11/16	2 1/16	.035	19.0
CTCA37-2	.1880	.2505	1 7/16	7/8	11/16	11/16	2 1/16	.035	19.0
CTCA37-3	.2505	.3130	1 7/16	7/8	11/16	11/16	2 1/16	.035	19.0
CTCA37-4	.3130	.3755	1 7/16	7/8	11/16	11/16	2 1/16	.035	19.0
CTCA37-5	.3755	.4380	1 7/16	7/8	11/16	11/16	2 1/16	.035	19.0
CTCA37-6	.3755	.5005	1 7/16	7/8	11/16	11/16	2 1/16	.035	19.0
CTCA50-1	.2505	.2505	1 3/4	1 1/16	15/16	29/32	2 25/32	.045	75.0
CTCA50-2	.3130	.3130	1 3/4	1 1/16	15/16	29/32	2 25/32	.045	75.0
CTCA50-3	.3755	.3755	1 3/4	1 1/16	15/16	29/32	2 25/32	.045	75.0
CTCA50-4	.4380	.4380	1 3/4	1 1/16	15/16	29/32	2 25/32	.045	75.0
CTCA50-5	.5005	.5005	1 3/4	1 1/16	15/16	29/32	2 25/32	.045	75.0
CTCA50-6	.5005	.6255	1 3/4	1 1/16	15/16	29/32	2 25/32	.045	75.0
CTCA62-1	.3755	.4380	2 1/4	1 3/8	1 1/16	1	3 1/8	.060	300.0
CTCA62-2	.4380	.5005	2 1/4	1 3/8	1 1/16	1	3 1/8	.060	300.0
CTCA62-3	.5005	.6255	2 1/4	1 3/8	1 1/16	1	3 1/8	.060	300.0
CTCA62-4	.6255	.7505	2 1/4	1 3/8	1 1/16	1	3 1/8	.060	300.0
CTCA75-1	.4380	.5005	2 1/2	1 5/8	1 3/16	1 1/8	3 1/2	.060	440.0
CTCA75-2	.5005	.6255	2 1/2	1 5/8	1 3/16	1 1/8	3 1/2	.060	440.0
CTCA75-3	.6255	.7505	2 1/2	1 5/8	1 3/16	1 1/8	3 1/2	.060	440.0
CTCA75-4	.7505	.8755	2 1/2	1 5/8	1 3/16	1 1/8	3 1/2	.060	440.0
CTCA75-5	.7505	1.0005	2 1/2	1 5/8	1 3/16	1 1/8	3 1/2	.060	440.0
CTCA100-1	.6255	.7505	3	1 7/8	1 3/8	1 3/8	4 1/8	.060	700.0
CTCA100-2	.7505	.8755	3	1 7/8	1 3/8	1 3/8	4 1/8	.060	700.0
CTCA100-3	.8755	1.0005	3	1 7/8	1 3/8	1 3/8	4 1/8	.060	700.0
CTCA100-4	1.0050	1.1255	3	1 7/8	1 3/8	1 3/8	4 1/8	.060	700.0
CTCA100-5	1.0050	1.2505	3	1 7/8	1 3/8	1 3/8	4 1/8	.060	700.0

Torque capacities are based on smooth drives with moderate torque fluctuations. Reduce ratings 1/3 the value shown for severe applications such as indexing drives where torque reversals occur.

DISC COUPLINGS

BORE	STYLE	MATERIAL
.1200 TO 1.2505	CTCB PIN HUB	ANODIZED ALUMINUM HUBS AND CENTER, RIVETS AND WASHERS - BRASS DISCS STAINLESS STEEL

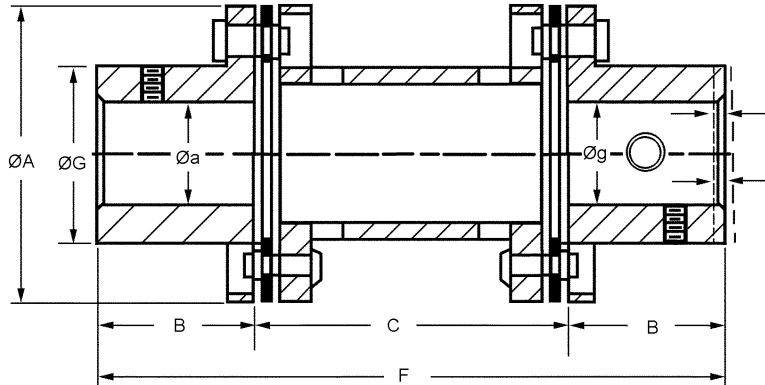

STOCK NO.	Øa and Øg +.0005 -.0005	ØA	ØG	B	C	F	TORQUE CAPACITY (Lb. In.)
CTCB12-1	.1200	1/2	5/16	1/4	7/16	15/16	1.1
CTCB12-2	.1250	1/2	5/16	1/4	7/16	15/16	1.1
CTCB12-3	.1562	1/2	5/16	1/4	7/16	15/16	1.1
CTCB12-4	.1875	1/2	5/16	1/4	7/16	15/16	1.1
CTCB18-1	.1250	3/4	15/32	3/8	11/16	1 7/16	2.2
CTCB18-2	.1562	3/4	15/32	3/8	11/16	1 7/16	2.2
CTCB18-3	.1875	3/4	15/32	3/8	11/16	1 7/16	2.2
CTCB18-4	.2500	3/4	15/32	3/8	11/16	1 7/16	2.2
CTCB25-1	.1255	1	5/8	1/2	7/8	1 7/8	4.7
CTCB25-2	.1880	1	5/8	1/2	7/8	1 7/8	4.7
CTCB25-3	.2505	1	5/8	1/2	7/8	1 7/8	4.7
CTCB25-4	.3130	1	5/8	1/2	7/8	1 7/8	4.7
CTCB25-5	.3755	1	5/8	1/2	7/8	1 7/8	4.7
CTCB37-1	.1880	1 7/16	7/8	11/16	1 1/4	2 5/8	19.0
CTCB37-2	.2505	1 7/16	7/8	11/16	1 1/4	2 5/8	19.0
CTCB37-3	.3130	1 7/16	7/8	11/16	1 1/4	2 5/8	19.0
CTCB37-4	.3755	1 7/16	7/8	11/16	1 1/4	2 5/8	19.0
CTCB37-5	.4380	1 7/16	7/8	11/16	1 1/4	2 5/8	19.0
CTCB37-6	.5005	1 7/16	7/8	11/16	1 1/4	2 5/8	19.0
CTCB50-1	.2505	1 3/4	1 1/16	15/16	1 11/16	3 9/16	75.0
CTCB50-2	.3130	1 3/4	1 1/16	15/16	1 11/16	3 9/16	75.0
CTCB50-3	.3755	1 3/4	1 1/16	15/16	1 11/16	3 9/16	75.0
CTCB50-4	.4380	1 3/4	1 1/16	15/16	1 11/16	3 9/16	75.0
CTCB50-5	.5005	1 3/4	1 1/16	15/16	1 11/16	3 9/16	75.0
CTCB50-6	.6255	1 3/4	1 1/16	15/16	1 11/16	3 9/16	75.0
CTCB62-1	.4380	2 1/4	1 3/8	1 1/16	1 7/8	4	300.0
CTCB62-2	.5005	2 1/4	1 3/8	1 1/16	1 7/8	4	300.0
CTCB62-3	.6255	2 1/4	1 3/8	1 1/16	1 7/8	4	300.0
CTCB62-4	.7505	2 1/4	1 3/8	1 1/16	1 7/8	4	300.0
CTCB75-1	.5005	2 1/2	1 5/8	1 3/16	2 1/8	4 1/2	440.0
CTCB75-2	.6255	2 1/2	1 5/8	1 3/16	2 1/8	4 1/2	440.0
CTCB75-3	.7505	2 1/2	1 5/8	1 3/16	2 1/8	4 1/2	440.0
CTCB75-4	.8755	2 1/2	1 5/8	1 3/16	2 1/8	4 1/2	440.0
CTCB75-5	1.0005	2 1/2	1 5/8	1 3/16	2 1/8	4 1/2	440.0
CTCB100-1	.7505	3	1 7/8	1 3/8	2 1/2	5 1/4	700.0
CTCB100-2	.8755	3	1 7/8	1 3/8	2 1/2	5 1/4	700.0
CTCB100-3	1.0005	3	1 7/8	1 3/8	2 1/2	5 1/4	700.0
CTCB100-4	1.1255	3	1 7/8	1 3/8	2 1/2	5 1/4	700.0
CTCB100-5	1.2505	3	1 7/8	1 3/8	2 1/2	5 1/4	700.0

Torque capacities are based on smooth drives with moderate torque fluctuations. Reduce ratings 1/3 the value shown for severe applications such as indexing drives where torque reversals occur.



DISC COUPLINGS

BORE	STYLE	MATERIAL
.1200 TO 1.2505	CTCBC CLAMP	ANODIZED ALUMINUM HUBS AND CENTER, RIVETS AND WASHERS - BRASS DISCS STAINLESS STEEL

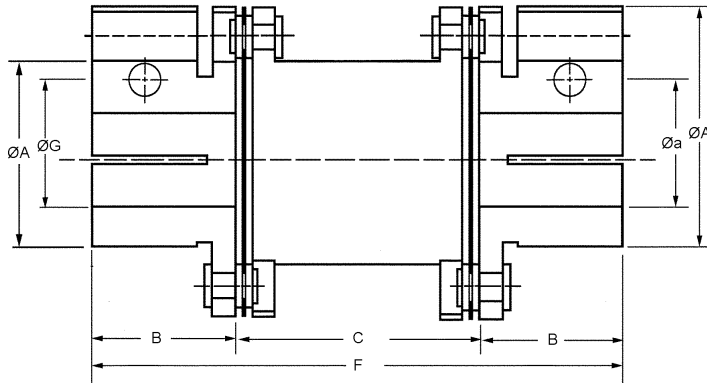

STOCK NO.	Øa and Øg +.0005 -.0005	ØA	ØG	B	C	F	TORQUE CAPACITY (Lb. In.)
CTCBC12-1	.1200	1/2	5/16	1/4	7/16	15/16	1.1
CTCBC12-2	.1250	1/2	5/16	1/4	7/16	15/16	1.1
CTCBC12-3	.1562	1/2	5/16	1/4	7/16	15/16	1.1
CTCBC12-4	.1875	1/2	5/16	1/4	7/16	15/16	1.1
CTCBC18-1	.1250	3/4	15/32	3/8	11/16	1 7/16	2.2
CTCBC18-2	.1562	3/4	15/32	3/8	11/16	1 7/16	2.2
CTCBC18-3	.1875	3/4	15/32	3/8	11/16	1 7/16	2.2
CTCBC18-4	.2500	3/4	15/32	3/8	11/16	1 7/16	2.2
CTCBC25-1	.1255	1	5/8	1/2	7/8	1 7/8	4.7
CTCBC25-2	.1880	1	5/8	1/2	7/8	1 7/8	4.7
CTCBC25-3	.2505	1	5/8	1/2	7/8	1 7/8	4.7
CTCBC25-4	.3130	1	5/8	1/2	7/8	1 7/8	4.7
CTCBC25-5	.3755	1	5/8	1/2	7/8	1 7/8	4.7
CTCBC37-1	.1880	1 7/16	7/8	11/16	1 1/4	2 5/8	19.0
CTCBC37-2	.2505	1 7/16	7/8	11/16	1 1/4	2 5/8	19.0
CTCBC37-3	.3130	1 7/16	7/8	11/16	1 1/4	2 5/8	19.0
CTCBC37-4	.3755	1 7/16	7/8	11/16	1 1/4	2 5/8	19.0
CTCBC37-5	.4380	1 7/16	7/8	11/16	1 1/4	2 5/8	19.0
CTCBC37-6	.5005	1 7/16	7/8	11/16	1 1/4	2 5/8	19.0
CTCBC50-1	.2505	1 3/4	1 1/16	15/16	1 11/16	3 9/16	75.0
CTCBC50-2	.3130	1 3/4	1 1/16	15/16	1 11/16	3 9/16	75.0
CTCBC50-3	.3755	1 3/4	1 1/16	15/16	1 11/16	3 9/16	75.0
CTCBC50-4	.4380	1 3/4	1 1/16	15/16	1 11/16	3 9/16	75.0
CTCBC50-5	.5005	1 3/4	1 1/16	15/16	1 11/16	3 9/16	75.0
CTCBC50-6	.6255	1 3/4	1 1/16	15/16	1 11/16	3 9/16	75.0
CTCBC62-1	.4380	2 1/4	1 3/8	1 1/16	1 7/8	4	300.0
CTCBC62-2	.5005	2 1/4	1 3/8	1 1/16	1 7/8	4	300.0
CTCBC62-3	.6255	2 1/4	1 3/8	1 1/16	1 7/8	4	300.0
CTCBC62-4	.7505	2 1/4	1 3/8	1 1/16	1 7/8	4	300.0
CTCBC75-1	.5005	2 1/2	1 5/8	1 3/16	2 1/8	4 1/2	440.0
CTCBC75-2	.6255	2 1/2	1 5/8	1 3/16	2 1/8	4 1/2	440.0
CTCBC75-3	.7505	2 1/2	1 5/8	1 3/16	2 1/8	4 1/2	440.0
CTCBC75-4	.8755	2 1/2	1 5/8	1 3/16	2 1/8	4 1/2	440.0
CTCBC75-5	1.0005	2 1/2	1 5/8	1 3/16	2 1/8	4 1/2	440.0
CTCBC100-1	.7505	3	1 7/8	1 3/8	2 1/2	5 1/4	700.0
CTCBC100-2	.8755	3	1 7/8	1 3/8	2 1/2	5 1/4	700.0
CTCBC100-3	1.0005	3	1 7/8	1 3/8	2 1/2	5 1/4	700.0
CTCBC100-4	1.1255	3	1 7/8	1 3/8	2 1/2	5 1/4	700.0
CTCBC100-5	1.2505	3	1 7/8	1 3/8	2 1/2	5 1/4	700.0

Torque capacities are based on smooth drives with moderate torque fluctuations. Reduce ratings 1/3 the value shown for severe applications such as indexing drives where torque reversals occur.

FLEX-THANE COUPLINGS

BORE	MATERIAL
1/8" TO 1/2"	PINS: POLYURETHANE HUBS: 2024-T4 ANODIZED ALUMINUM

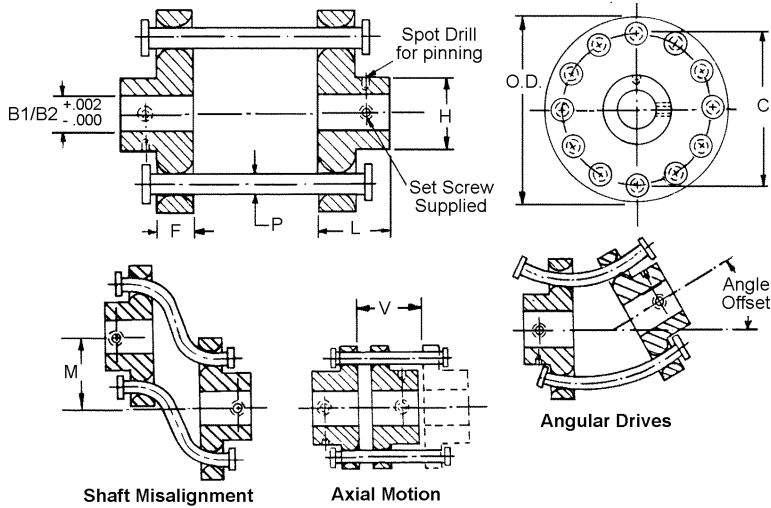

STOCK NO.	B1	B2	P	H	L	F	O.D.	C	M MAX.	V MAX.	MAX. TORQUE LB.-IN.	MAX. ANGLE OFFSET
CC5-10-L	1/8	1/8	1/16	5/16	5/16	1/8	.687	9/16	1/16	9/64	25	10°
CC5-19-L	3/16	3/16	1/8	3/8	11/32	1/8	1.000	3/4	1/8	3/16	35	
CC5-28-L	1/4	1/4	1/8	1/2	7/16	3/16	1.250	1	1/4	1/4	50	
CC5-32-L	5/16	5/16	3/16	1/2	7/16	3/16	1.500	1 1/8	7/32	5/16	60	
CC5-35-L	3/8	3/8	1/4	3/4	3/4	3/8	2.000	1 1/2	5/32	3/8	100	
CC5-37-L	1/2	1/2	5/16	1	7/8	3/8	2.500	1 7/8	1/8	1/2	200	
CC5-10-A	1/8	1/8	1/16	5/16	5/16	1/8	.687	9/16	1/2	7/16	25	30°
CC5-19-A	3/16	3/16	1/8	3/8	11/32	1/8	1.000	3/4	5/8	5/8	35	
CC5-28-A	1/4	1/4	1/8	1/2	7/16	3/16	1.250	1	3/4	7/8	50	
CC5-32-A	5/16	5/16	3/16	1/2	7/16	3/16	1.500	1 1/8	7/8	1 1/8	60	
CC5-35-A	3/8	3/8	1/4	3/4	3/4	3/8	2.000	1 1/2	1	1 3/8	100	
CC5-37-A	1/2	1/2	5/16	1	7/8	3/8	2.500	1 7/8	1 1/4	2	200	

- Can drive shafts to 1 1/4" out of line
- Runs at angles to 30°
- Silent running operation
- Maintenance free
- Long life
- Absorbs start up shock

Central internal chamber diameter may be smaller than bore in some cases.



UNIVERSAL JOINTS

BORE	STYLE	MATERIAL
1/8" TO 3/16"	PIN HUB	303 STAINLESS STEEL

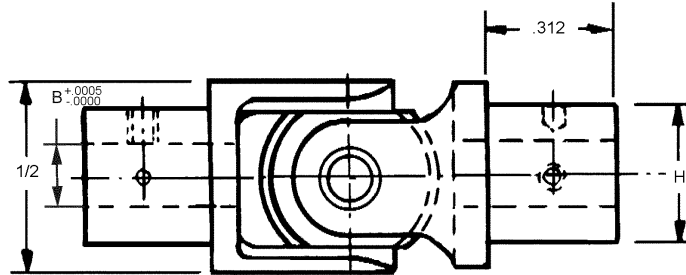

STOCK NO.	SHAFT SIZE	B BORE	H HUB DIA.	L	A BORE LENGTH
UJ-1	1/8	.1248	5/16	1 1/2	.44
UJ-2	3/16	.1873	3/8	1 1/2	.44

- Maximum operating angle 30° at 500 RPM
- Ideal operating angle 10° at 1000 RPM
- Lubrication required at all times

Special bore and bore-to-bore connections available on request.

BORES	STYLE	MATERIAL
1/4" TO 1/2"	PIN HUB	303 STAINLESS STEEL

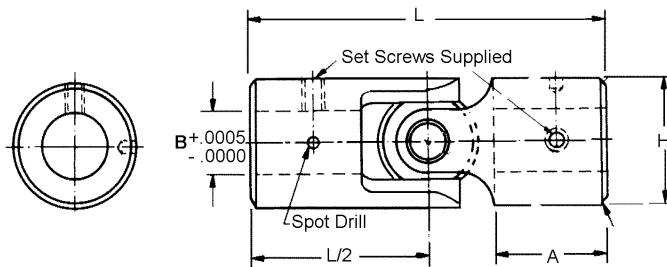

STOCK NO.	SHAFT SIZE	B BORE	H HUB DIA.	L	A BORE LENGTH
UJ-3	1/4	.2498	1/2	1 1/2	.44
UJ-4	5/16	.3123	1/2	1 1/2	.44
UJ-5	3/8	.3748	3/4	2 5/8	.92
UJ-6	1/2	.4998	1	3 3/8	1.17

- Maximum operating angle 30° at 500 RPM
- Ideal operating angle 10° at 1000 RPM
- Lubrication required at all times

Special bore and bore-to-bore connections available on request.

UNIVERSAL JOINTS

BORES	STYLE	MATERIAL
1/8" TO 1/4"	CLAMP	303 STAINLESS STEEL

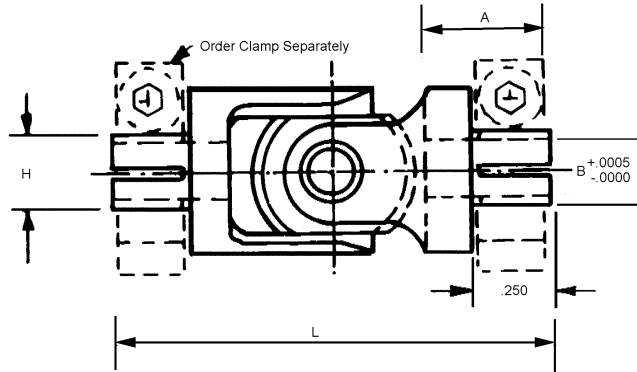

STOCK NO.	SHAFT SIZE	B BORE	H HUB DIA.	L OVERALL	A BORE LG.	CLAMP (2) ORDER SEPARATELY STOCK NO.
UJ-10	1/8	.1248	3/16	1 3/8	.37	CG1-25
UJ-11	3/16	.1873	1/4	1 3/8	.37	CG1-9
UJ-12	1/4	.2498	5/16	1 3/8	.37	CG1-12

- Maximum operating angle 30° at 500 RPM
- Ideal operating angle 10° at 1000 RPM
- Lubrication required at all times

Special bore and bore-to-bore connections available on request.

UNIVERSAL JOINTS

BORES	STYLE	MATERIAL
1/8" TO 3/8"	SINGLE JOINT	DELIRIN BODY BRASS HUB AND SPIDER

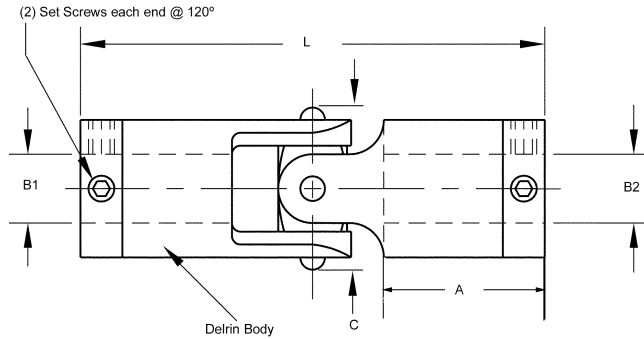

SINGLE JOINT

STOCK NO.	+0.001 +0.000 B1	+0.001 +0.000 B2	L	A	C	SET SCREW	RATED TORQUE (OZ. IN.)
UJS-9	.1250*	.1250*	1 1/16	1/4	9/32	#4-40	16
UJS-1	.1250*	.1250*	1 31/64	3/8	7/16	#4-40	55
UJS-2	.1250*	.1875					
UJS-3	.1875	.1875					
UJS-4	.1875	.1875	1 13/16	1/2	9/16	#6-32	151
UJS-5	.1875	.2500					
UJS-6	.2500	.2500					
UJS-10	.2500	.2500	2 21/32	5/8	11/16	#8-32	239
UJS-11	.2500	.3125					
UJS-12	.2500	.3750					
UJS-13	.3125	.3125					
UJS-14	.3125	.3750					
UJS-15	.3750	.3750					

- Needs no lubrication
- Can be submersed in water
- Resists corrosion and chemical attack
- Electrically isolates input from output
- Zero backlash
- Lightweight
- Shock absorbent
- Non contaminant
- Temperature Range -40° F to +185° F

* 1 Set screw each end on these bore sizes.

UNIVERSAL JOINTS

BORES	STYLE	MATERIAL
1/8" TO 3/8"	DOUBLE JOINT	DELRIN BODY BRASS HUB ENDS AND SPIDER

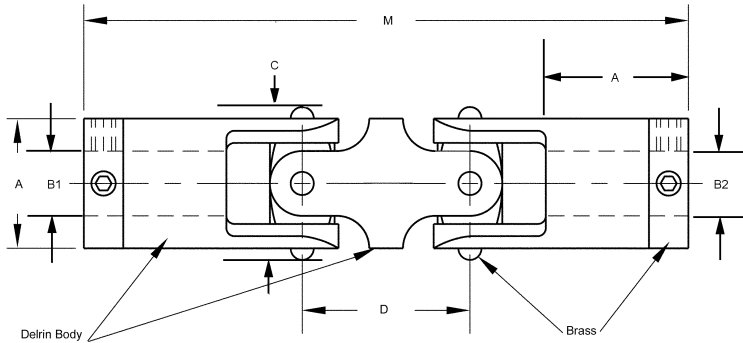

DOUBLE JOINT

STOCK NO.	+001 +000 B1	+001 +000 B2	A	C	D	M	SET SCREW	RATED TORQUE (OZ. IN.)
UJD-9	.1250*	.1250*	1/4	9/32	5/16	1 25/64	#4-40	11
UJD-1	.1250*	.1250*	3/8	7/16	33/64	2	#4-40	23
UJD-2	.1250*	.1875						
UJD-3	.1875	.1875						
UJD-4	.1875	.1875	1/2	9/16	5/8	2 7/16	#6-32	83
UJD-5	.1875	.2500						
UJD-6	.2500	.2500						
UJD-10	.2500	.2500	5/8	11/16	7/8	3 17/32	#8-32	183
UJD-11	.2500	.3125						
UJD-12	.2500	.3750						
UJD-13	.3125	.3125						
UJD-14	.3125	.3750						
UJD-15	.3750	.3750						

- Needs no lubrication
- Can be submersed in water
- Resists corrosion and chemical attack
- Electrically isolates input from output
- Zero backlash
- Lightweight
- Shock absorbent
- Non contaminant
- Temperature Range -40° F to +185° F

* 1 Set screw each end on these bore sizes.

TELESCOPIC UNIVERSAL JOINTS

BORES	MATERIAL
1/8" TO 3/8"	DELRIN BODY BRASS ENDS, SPIDER AND TELESCOPIC SECTIONS

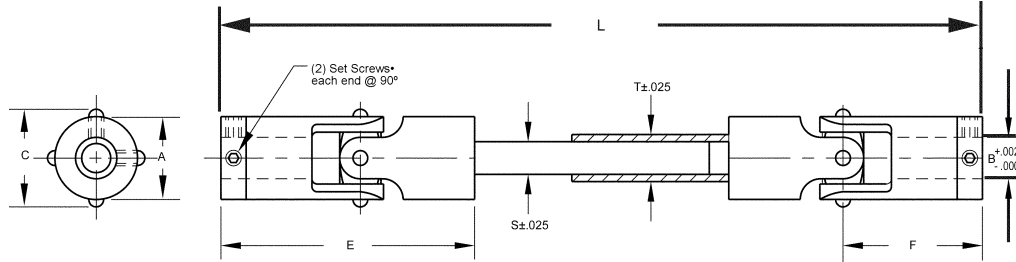

STOCK NO.	BORES		A	C	L		E	F	SET SCREW	RATED TORQUE OZ.IN.	S SQ.	T SQ.
	1	2			MAX.	MIN.						
UJT-1	.1250*	.1250*	3/8	7/16	5 19/64	4 5/64	1 19/64	47/64	#4-40	55	.118	.165
UJT-2	.1250*	.1875										
UJT-3	.1875	.1875										
UJT-4	.1875	.1875	1/2	9/16	7 11/32	5 31/64	1 39/64	29/32	#6-32	151	.165	.236
UJT-5	.1875	.2500										
UJT-6	.2500	.2500										
UJT-10	.2500	.2500	5/8	11/16	10 7/32	7 25/32	2 3/8	1 21/64	#8-32	239	.236	.315
UJT-11	.2500	.3125										
UJT-12	.2500	.3750										
UJT-13	.3125	.3125										
UJT-14	.3125	.3750										
UJT-15	.3750	.3750										

- Temperature Range -40° F to +185° F
- Needs no lubrication
- Can be submersed in water
- Resists corrosion
- Electrically isolates input from output
- Minimum Backlash
- Lightweight
- Non contaminant (e.g. food, textiles and paper handling)
- Non-magnetic
- Resists chemical attack
- Shock absorbent

• Note: 1/8" bore coupling ends are supplied with (1) set screw each end.
Maximum length can be reduced by cutting equal lengths off both telescoping halves.



FLEXIBLE SHAFT COUPLINGS

TECHNICAL DATA

Remote Control (bi-directional) cores are designed to transmit rotary motion in both directions of operation at slow speeds (less than 100 rpm) or intermittent power drive applications. They also exhibit a minimal amount of angular deflection (wind up) in both directions of operation. The construction of a remote control core differs from a power drive by the fact that it has a larger number of wires and layers. This has been precisely calculated to result in nearly identical properties of deflection and strength in both directions of operation.

OPERATING RADIUS

Minimum operating radius, or the smallest radius in which a core can be operated, is given in the following Tables for each individual core. Do not exceed this radius without consulting Berg's Customer Service Department.

DEFLECTION

Torsional deflection or the angular wind up of a core is given for all remote control cores in the following Tables. Consider this carefully for it may dictate the diameter core needed for your application.

REMOTE CONTROL

In choosing the proper diameter core for remote control or bi-directional Flexible Shaft applications, you must know:

1. Torque to be transmitted by core
2. Minimum radius of bend
3. rpm of operation (if applicable)
4. Maximum allowable torsional deflection (if applicable)

With this information, go to the Table below and in the proper column of Radius of Operation, locate a torque figure applicable to your application. Read across for the properties of that particular core. If the deflection list is unacceptable, move to the next largest size. Special consideration must be given when using bi-directional cores for power drive applications both continuous and intermittent. For continuous power drive applications, reduce torque values listed by 70%. On intermittent power drive installations, core can be operated for a short period of time limited by heat build up. If you have any questions when choosing a core, contact Berg's Customer Service Department for assistance.

NOM. DIA.	WT/ 100 FT.	MAX. TOR. LB-IN	MAX. RPM	MAX. TORSIONAL DEFLECTION AT GIVEN TOR. IN DEG. PER FT			TORQUE RATING (LB-IN) FOR BOTH DIRECTIONS OF OPERATION AT GIVEN RADIUS (NOTE A) RADIUS OF OPERATION									
				TORQUE	DEFLECTION WIND	UNWIND	3	4	6	8	10	12	15	20	25	50
5/32	4.8	20	20,000	1 LB-IN	7P	9P	6.0	7.0	8.0	9.0	10.0	11.0	12.0	12.0	12.0	12.0
3/16	6.9	45	20,000	1 LB-IN	3.5P	4P	--	14.0	16.0	18.0	22.0	24.0	26.0	26.0	26.0	26.0
1/4	12.8	95	20,000	5 LB-IN	5P	6P	--	28.0	32.0	36.0	44.0	48.0	55.0	55.0	55.0	55.0
5/16	19.7	150	20,000	10 LB-IN	6P	7.5P	--	56.0	64.0	72.0	88.0	96.0	110.0	110.0	110.0	110.0
3/8	28.8	220	20,000	10 LB-IN	3.5P	5P	--	--	102.0	116.0	124.0	132.0	140.0	140.0	140.0	140.0
1/2	54	340	10,000	100 LB-IN	10P	13P	--	--	--	200.0	220.0	240.0	260.0	280.0	280.0	280.0

- A) Each core can transmit this torque in both directions of operation for remote control applications (less than 100 rpm) and intermittent power drive applications (no longer what it takes to raise core temp 70P above ambient with rest duration allowing for core to cool within 30P of ambient). For continuous power drive applications in both directions, use only 30% of these torques.
- B) Each core will either break or helix under this load. For short term overloads do not exceed 75% of this value.
- C) Standard remote control cores are wound in the right hand direction.



FLEXIBLE SHAFT COUPLINGS

BORES	STYLE	MATERIAL
.188" TO .501	REMOTE CONTROL WITHOUT CASTING	ENDS - STEEL CABLE; FLEXIBLE CABLE - STEEL; SCREWS - STEEL PLATED

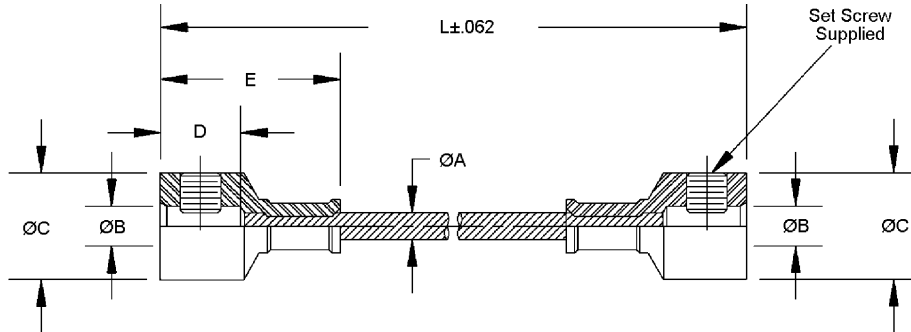

STOCK NO.	ØA	ØB +.003 -.000	ØC	D	E	L	MIN. RAD.	MAX. TORQUE IN-LB. (STATIC OR DYNAMIC) FOR GIVEN LENGTH OF UNSUPPORTED CORE					
								2"	4"	6"	8"	10"	12"
FS8257-8 FS8257-12	5/32	.188 .251	Ø.500	.375	.844	8.00 12.00	3.50	5.5	2.8	1.8	1.2	.8	-
FS8258-8 FS8258-12	3/16	.188 .251	Ø.500	.375	.812	8.00 12.00	4.00	9.4	4.6	3.0	2.2	1.6	1.1
FS8259-8 FS8259-12	1/4	.188 .251	Ø.500	.375	.906	8.00 12.00	4.50	25.0	12.5	8.0	5.8	4.4	3.5
FS8260-8 FS8260-12	5/16	.251 .313	Ø.625	.500	1.062	8.00 12.00	6.00	84.0	42.0	24.0	18.2	14.0	10.8
FS8261-6 FS8261-12	3/8	.313 .376	Ø.750	.625	1.344	6.00 12.00	8.00	120.0	62.0	45.0	32.0	24.0	18.0
FS8262-8 FS8262-12	1/2	.376 .501	Ø.875	.750	1.438	8.00 12.00	10.00	220.0	149.0	97.0	70.0	52.0	36.0

Flexible shafts are ideally suited for avoidance of obstacles, change of direction, to isolate vibration, positional flexibility, parallel offsets and areas with limited access.

BORES	STYLE	MATERIAL
.125" TO .625"	REMOTE CONTROL WITH CASTING	ENDS - STEEL CABLE; FLEXIBLE CABLE - STEEL; SCREWS - STEEL PLATED; CASING - GALVANIZED STEEL

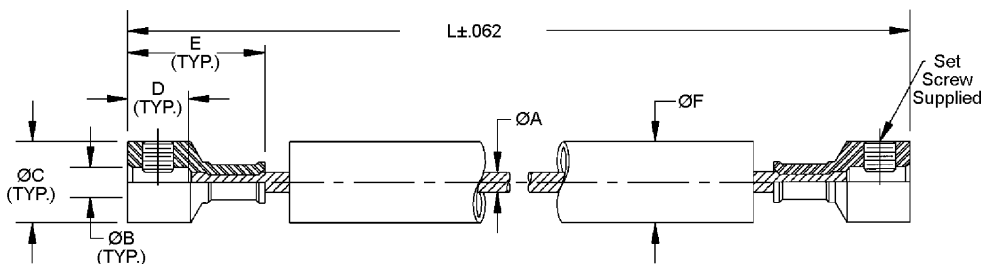

STOCK NO.	ØA	ØB +.003 -.000	ØC	D	E	F	L	MIN. RAD.	MAX. TORQUE CAPACITY (IN-LB)
FSC15597-12 FSC15597-24	.188	Ø.125 Ø.250	Ø.50	.380	.81	.365	12 24	4.0	1.1
FSC15579-12 FSC15579-24	.250	Ø.250 Ø.375	Ø.50 Ø.62	.380	.91	.440	12 24	4.5	3.5
FSC15598-12 FSC15598-24	.312	Ø.250 Ø.375	Ø.62	.380	.94	.500	12 24	6.0	10.8
FSC15599-12 FSC15599-24	.375	Ø.250 Ø.375	Ø.75 Ø.87	.750	1.38	.560	12 24	8.0	18.0
FSC15600-12 FSC15600-24	.500	Ø.375 Ø.625	Ø.87	.880	1.56	.699	12 24	10.0	49.0

To determine the proper core diameter and torque rating at a given radius of perations see flexible shaft couplings technical data covered on page G 51.

Other bore sizes and custom lengths available on request. Examples P/N FS8257-24 for 24" length.

FLEXIBLE SHAFT COUPLINGS

BORES	STYLE	MATERIAL
.125" TO .375"	REMOTE CONTROL PANEL MOUNT WITHOUT CASING	ENDS - STEEL/ZINC PLATED; FLEXIBLE CABLE - STEEL/PHOSPHATE; SCREWS - STEEL/ZINC PLATED

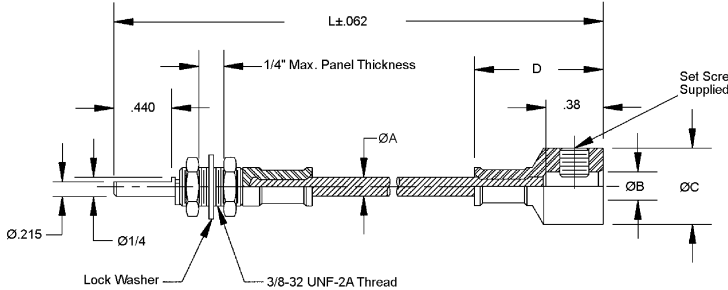

STOCK NO.	ØA	ØB +.002 -.000	ØC	D	L	MIN. RAD.	MAX. TORQUE CAPACITY (STATIC OR DYNAMIC) FOR GIVEN: LENGTH OF UNSUPPORTED CORE (IN.)			
							4"	6"	8"	10"
FSP26199-3	3/16	Ø.125	.50	TBD	3	4.0	4.6	3.0	2.2	1.6
FSP26199-4		Ø.187			4					
FSP26199-14		Ø.250			14					
FSP26199-8		Ø.310			8					
FSP26202-3	1/4	Ø.125	.62	TBD	3	4.5	12.5	8.0	5.8	4.4
FSP26202-4		Ø.187			4					
FSP26202-14		Ø.250			14					
FSP26202-8		Ø.375			8					

BORES	STYLE	MATERIAL
.125" TO .375"	REMOTE CONTROL PANEL MOUNT WITH CASING	ENDS - STEEL/ZINC PLATED; FLEXIBLE CABLE - STEEL/PHOSPHATE; SCREWS - STEEL/ZINC PLATED; CASING - POLYETHYLENE

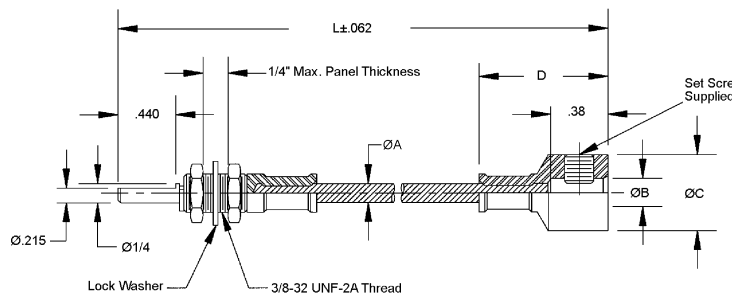

STOCK NO.	ØA	ØB +.002 -.000	ØC	D	L	MIN. RAD.	MAX. TORQUE CAPACITY (IN./LBS.)
FSPC10361-12	3/16	Ø.125	.50	TBD	12	4.0	1.1
FSPC10361-16		Ø.187			16		
FSPC10361-24		Ø.250			24		
FSPC10361-16L		Ø.310			16		
FSPC10362-12	1/4	Ø.125	.50	TBD	12	4.5	3.5
FSPC10362-16		Ø.187			16		
FSPC10362-24		Ø.250			24		
FSPC10362-16L		Ø.375			16		

To determine the proper core diameter and torque rating at a given radius of operations see flexible shaft couplings technical data covered on page G 51.

Other bore sizes and custom lengths available on request. Examples P/N FSPC10361-24 for 24" length.



FLEXIBLE SHAFT COUPLINGS

TECHNICAL DATA

Power Drive cores are designed to transmit rotary motion continuously in one direction of operation. They are constructed of quality high carbon Flexible Shaft wire and wound on most modern automatic winding machines. Precisely controlled stress relieving is utilized to provide optimum flexibility and smoothness.

OPERATING RADIUS

Minimum operating radius, or the smallest radius in which a core can be operated, is given in the following Tables for each individual core. Do not exceed this radius without consulting Berg's Customer Service Department.

DEFLECTION

Torsional deflection or the angular wind up of a core is given for all remote control cores in the following Tables. Consider this carefully for it may dictate the diameter core needed for your application.

POWER DRIVE

In choosing the proper diameter core for Power Drive (over 100 rpm) Flexible Shaft applications, you must know:

1. hp and torque to be transmitted by core
2. rpm
3. Minimum radius of bend
4. Maximum torque (starting or stopping)
5. Direction of rotation

With this information, go to the Table below and in the proper column of Radius of Operation, locate hp value applicable to your application. Compare your actual torque to the maximum dynamic torque capacity being sure not to exceed it. If you have exceeded the maximum dynamic torque capacity, continue down the column of Radius of Operation until you reach a value large enough for your application. If your hp is too large, ruling out the use of a flexible shaft, check to see if your actual torque requirements are within the range of Flexible Shafting. Use the following formulas to calculate your power requirements.

$$\text{torque} = \frac{\text{hp} \times 63,000}{\text{rpm}}$$

$$\text{hp} = \frac{\text{torque} \times \text{rpm}}{63,000}$$

NOM. DIA.	WT/100 FT.	MIN. RADIUS OF OPERATION (INCHES)	H.P. RATING MAXIMUM DYNAMIC TORQUE (LB-IN) AT GIVEN RADIUS											
			H.P. VALUES											
			RADIUS OF OPERATION (INCHES)											
			3	4	6	8	10	12	15	20	25	50		
1/8	3.3	3	.04	.05	.08	.10	.12	.14	.15	.16	.17	.18	.19	
5/32	4.5	4	.10	.15	.24	.28	.32	.34	.37	.40	.44	.48	.52	
3/16	6.8	4	.19	.34	.55	.70	.85	.99	1.14	1.29	1.44	1.59	1.74	
1/4	12.5	5	.44	.70	1.10	1.40	1.70	2.00	2.30	2.60	2.90	3.20	3.50	
1/4	12.4	3	.28	.46	.70	1.00	1.30	1.60	1.90	2.20	2.50	2.80	3.10	
5/16	19.2	5	.51	.82	1.24	1.66	2.08	2.50	2.92	3.34	3.76	4.18	4.60	

- A) Each core can transmit up to it's maximum rpm, as long as the maximum dynamic torque capacity is not exceeded (for higher rpm's consult Berg's Customer Service Department.)
- B) Each core will either break or helix under this load. For short term overloads (shock loads) do not exceed 50% of this value
- C) Direction of operation is always determined by observing from behind the driving end.

FLEXIBLE SHAFT COUPLINGS

BORES	STYLE	MATERIAL
.188" TO .500"	REMOTE CONTROL PANEL MOUNT WITHOUT CASING	FLEXIBLE CABLE - STEEL; END FITTINGS - PLATED STEEL; FLEXIBLE CASINGS - VINYL COVERED STEEL; BEARINGS - SINTERED

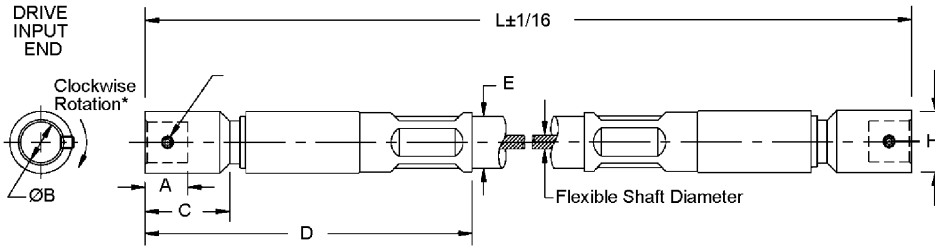

STOCK NO.	FLEX. SHAFT DIA. (REF.)	L. IN.	A	ØB ^{+0.002} / _{-0.000}	C	D	E	SET SCREW	H
FSPD8053-24	.188	24	.50	Ø.188	1.00	3.00	.35	#8-32	.75
FSPD8053-36		36							
FSPDS12779-24	.250	24	.56	Ø.250	1.19	4.12	.65	TBD	
FSPDS12779-60		36							
FSPDS12785-24	.312	24	.75	Ø.500	1.44	4.88	.75	TBD	.88
FSPDS12785-36		36							

SHAFT DIA.	MINIMUM OPERATING RADIUS	DYNAMIC TORQUE CAPACITY WINDING DIRECTION (LB. IN.) INPUT RADIUS OF CURVATURE								RPM	TORSIONAL BREAKING LOAD FOR STRAIGHT SHAFTS WINDING DIRECTION (LB. IN.) (See note 1)
		25"	20"	15"	12"	10"	8"	6"	4"		
.188	4"	9.5	9.0	8.5	8.0	7.5	7.0	5.5	4.0	2000	48
.250	5"	23.0	20.0	18.0	16.0	15.0	14.0	12.0	--		96
.312	5"	35.0	32.0	30.0	26.0	24.0	20.0	18.0	--		190

Clockwise or Counterclockwise rotation available upon request

BORES	STYLE	MATERIAL
.250"	POWER DRIVE WITH CASING	FLEXIBLE CABLE - STEEL; END FITTINGS - PLATED STEEL; FLEXIBLE CASINGS - VINYL COVERED STEEL; BEARINGS - BALL

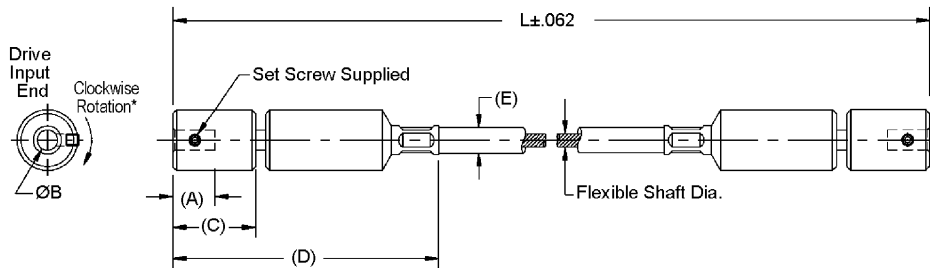

STOCK NO.	FLEX. SHAFT DIA. (REF.)	L. IN.	A	ØB ^{+0.002} / _{-0.000}	C	D	E	SET SCREW
FSPD7614-12R	.188	12	.63	Ø.250	1.26	3.38	.35	#10-32
FSPD7614-16R		16						
FSPD7614-24R		24						
FSPD7614-60R		60						

SHAFT DIA.	MINIMUM OPERATING RADIUS	DYNAMIC TORQUE CAPACITY WINDING DIRECTION (LB. IN.) INPUT RADIUS OF CURVATURE								RPM	TORSIONAL BREAKING LOAD FOR STRAIGHT SHAFTS WINDING DIRECTION (LB. IN.) (See note 1)
		25"	20"	15"	12"	10"	8"	6"	4"		
.188	4"	9.5	9.0	8.5	8.0	7.5	7.0	5.5	4.0	6000	48
.250*	5"	23.0	20.0	18.0	16.0	15.0	14.0	12.0	--		96
.312*	5"	35.0	32.0	30.0	26.0	24.0	20.0	18.0	--		190

NOTE 1: For short term overload (shock load) do not exceed 50% of the corresponding values.
Other bore sizes and custom lengths available on request. Counterclockwise or bi-directional rotation available on request.
*These shaft diameters and characteristics are available on request.

SHAFT ADAPTERS

BORES	STYLE	MATERIAL
.1200 TO .1873	CLAMP	303 STAINLESS STEEL

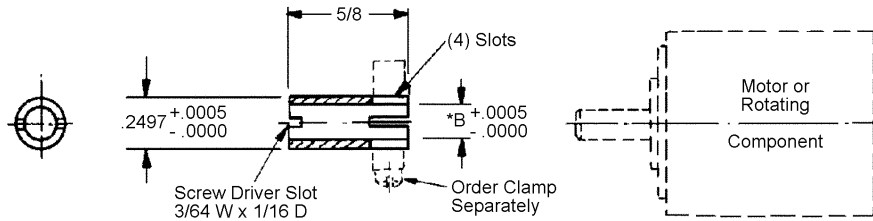

STOCK NO.	B BORE SIZE	ROTATING COMPONENT SHAFT DIA.	CLAMP (ORDER SEPARATELY) STOCK NO.
SA-3	.1200	.1200	CG1-8
SA-4	.1248	1/8	
SA-1	.1560	5/32	
SA-5	.1772	.1772	
SA-2	.1873	3/16	

* Concentric within .0003

PRECISION SHAFT ADAPTERS

SHAFT SIZES	STYLE	MATERIAL
2MM TO 6MM	INCH MALE - METRIC FEMALE - CLAMP HUB	303 STAINLESS STEEL

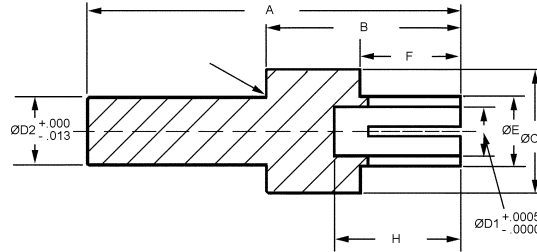

STOCK NO.	Metric Female ØD1 (mm)		Inch Male ØD2 (Inches)		A	B	ØC	ØE mm	F	H	Use With Clamp
	Nom	Actual	Decimal	Fraction							
SAIMMF-1-C	2	1.996	0.0467	3/64	0.441	0.220	0.350	4.6	0.181	0.16	CG1M-4
SAIMMF-2-C	2	1.996	0.0623	1/16	0.441	0.220	0.350	4.6	0.181	0.16	CG1M-4
SAIMMF-3-C	2	1.996	0.0779	5/64	0.441	0.220	0.350	4.6	0.181	0.16	CG1M-4
SAIMMF-4-C	2	1.996	0.0936	3/32	0.441	0.220	0.350	4.6	0.181	0.16	CG1M-4
SAIMMF-5-C	2	1.996	0.1092	7/64	0.441	0.220	0.350	4.6	0.181	0.16	CG1M-4
SAIMMF-6-C	2	1.996	0.1248	1/8	0.441	0.220	0.350	4.6	0.181	0.16	CG1M-4
SAIMMF-7-C	3	2.996	0.0779	5/64	0.661	0.331	0.350	4.6	0.181	0.24	CG1M-4
SAIMMF-8-C	3	2.996	0.0936	3/32	0.661	0.331	0.350	4.6	0.181	0.24	CG1M-4
SAIMMF-9-C	3	2.996	0.1092	7/64	0.661	0.331	0.350	4.6	0.181	0.24	CG1M-4
SAIMMF-10-C	3	2.996	0.1248	1/8	0.661	0.331	0.350	4.6	0.181	0.24	CG1M-4
SAIMMF-11-C	3	2.996	0.1404	9/64	0.661	0.331	0.350	4.6	0.181	0.24	CG1M-4
SAIMMF-12-C	3	2.996	0.1561	5/32	0.661	0.331	0.350	4.6	0.181	0.24	CG1M-4
SAIMMF-13-C	3	2.996	0.1717	11/64	0.661	0.331	0.350	4.6	0.181	0.24	CG1M-4
SAIMMF-14-C	3	2.996	0.1873	3/16	0.661	0.331	0.350	4.6	0.181	0.24	CG1M-4
SAIMMF-15-C	3	2.996	0.2029	13/64	0.661	0.331	0.350	4.6	0.181	0.24	CG1M-4
SAIMMF-16-C	3	2.996	0.2186	7/32	0.661	0.331	0.350	4.6	0.181	0.24	CG1M-4
SAIMMF-17-C	3	2.996	0.2342	15/64	0.661	0.331	0.350	4.6	0.181	0.24	CG1M-4
SAIMMF-18-C	3	2.996	0.2498	1/4	0.661	0.331	0.350	4.6	0.181	0.24	CG1M-4
SAIMMF-19-C	4	3.996	0.0936	3/32	0.882	0.441	0.350	5.6	0.220	0.31	CG1M-5
SAIMMF-20-C	4	3.996	0.1092	7/64	0.882	0.441	0.350	5.6	0.220	0.31	CG1M-5
SAIMMF-21-C	4	3.996	0.1248	1/8	0.882	0.441	0.350	5.6	0.220	0.31	CG1M-5
SAIMMF-22-C	4	3.996	0.1404	9/64	0.882	0.441	0.350	5.6	0.220	0.31	CG1M-5
SAIMMF-23-C	4	3.996	0.1561	5/32	0.882	0.441	0.350	5.6	0.220	0.31	CG1M-5
SAIMMF-24-C	4	3.996	0.1717	11/64	0.882	0.441	0.350	5.6	0.220	0.31	CG1M-5
SAIMMF-25-C	4	3.996	0.1873	3/16	0.882	0.441	0.350	5.6	0.220	0.31	CG1M-5
SAIMMF-26-C	4	3.996	0.2029	13/64	0.882	0.441	0.350	5.6	0.220	0.31	CG1M-5
SAIMMF-27-C	4	3.996	0.2186	7/32	0.882	0.441	0.350	5.6	0.220	0.31	CG1M-5
SAIMMF-28-C	4	3.996	0.2342	15/64	0.882	0.441	0.350	5.6	0.220	0.31	CG1M-5
SAIMMF-29-C	4	3.996	0.2498	1/4	0.882	0.441	0.350	5.6	0.220	0.31	CG1M-5
SAIMMF-30-C	4	3.996	0.2654	17/64	0.882	0.441	0.350	5.6	0.220	0.31	CG1M-5
SAIMMF-31-C	4	3.996	0.2811	9/32	0.882	0.441	0.350	5.6	0.220	0.31	CG1M-5
SAIMMF-32-C	4	3.996	0.2967	19/64	0.882	0.441	0.350	5.6	0.220	0.31	CG1M-5
SAIMMF-33-C	4	3.996	0.3123	5/16	0.882	0.441	0.350	5.6	0.220	0.31	CG1M-5
SAIMMF-34-C	5	4.996	0.1248	1/8	1.102	0.551	0.350	6.6	0.260	0.39	CG1M-10
SAIMMF-35-C	5	4.996	0.1404	9/64	1.102	0.551	0.350	6.6	0.260	0.39	CG1M-10
SAIMMF-36-C	5	4.996	0.1561	5/32	1.102	0.551	0.350	6.6	0.260	0.39	CG1M-10
SAIMMF-37-C	5	4.996	0.1717	11/64	1.102	0.551	0.350	6.6	0.260	0.39	CG1M-10
SAIMMF-38-C	5	4.996	0.1873	3/16	1.102	0.551	0.350	6.6	0.260	0.39	CG1M-10
SAIMMF-39-C	5	4.996	0.2029	13/64	1.102	0.551	0.350	6.6	0.260	0.39	CG1M-10
SAIMMF-40-C	5	4.996	0.2186	7/32	1.102	0.551	0.350	6.6	0.260	0.39	CG1M-10
SAIMMF-41-C	5	4.996	0.2342	15/64	1.102	0.551	0.350	6.6	0.260	0.39	CG1M-10
SAIMMF-42-C	5	4.996	0.2498	1/4	1.102	0.551	0.350	6.6	0.260	0.39	CG1M-10
SAIMMF-43-C	5	4.996	0.2654	17/64	1.102	0.551	0.350	6.6	0.260	0.39	CG1M-10
SAIMMF-44-C	5	4.996	0.2811	9/32	1.102	0.551	0.350	6.6	0.260	0.39	CG1M-10
SAIMMF-45-C	5	4.996	0.2967	19/64	1.102	0.551	0.350	6.6	0.260	0.39	CG1M-10
SAIMMF-46-C	5	4.996	0.3123	5/16	1.102	0.551	0.350	6.6	0.260	0.39	CG1M-10
SAIMMF-47-C	5	4.996	0.3436	11/32	1.102	0.551	0.350	6.6	0.260	0.39	CG1M-10
SAIMMF-48-C	5	4.996	0.3748	3/8	1.102	0.551	0.350	6.6	0.260	0.39	CG1M-10
SAIMMF-49-C	6	5.996	0.1248	1/8	1.323	0.661	0.350	7.6	0.299	0.47	CG1M-11
SAIMMF-50-C	6	5.996	0.1404	9/64	1.323	0.661	0.350	7.6	0.299	0.47	CG1M-11
SAIMMF-51-C	6	5.996	0.1561	5/32	1.323	0.661	0.350	7.6	0.299	0.47	CG1M-11
SAIMMF-52-C	6	5.996	0.1717	11/64	1.323	0.661	0.350	7.6	0.299	0.47	CG1M-11

•ØD1 & ØD2 are concentric within .0005.
 •All dimensions are in inches, except where noted.
 •Order Clamp Separately.

Continued on next page.

PRECISION SHAFT ADAPTERS

SHAFT SIZES	STYLE	MATERIAL
2MM TO 7MM	INCH FEMALE - METRIC MALE - PIN HUB	303 STAINLESS STEEL

STOCK NO.	Inch Female ØD1 (Inches)		Metric Male ØD2 (mm)		ØC	H	B	A	E	G UNC-2B
	Decimal	Fraction	Nom	Actual						
SAIFMM-1	0.0779	5/64	2	1.995	0.250	0.117	0.164	0.327	0.058	#0-80
SAIFMM-2	0.0936	3/32	2	1.995	0.250	0.140	0.196	0.393	0.070	#2-56
SAIFMM-3	0.1092	7/64	2	1.995	0.375	0.164	0.229	0.459	0.082	#2-56
SAIFMM-4	0.1248	1/8	2	1.995	0.500	0.187	0.262	0.524	0.094	#2-56
SAIFMM-5	0.0779	5/64	3	2.995	0.250	0.117	0.164	0.327	0.058	#0-80
SAIFMM-6	0.0936	3/32	3	2.995	0.250	0.140	0.196	0.393	0.070	#2-56
SAIFMM-7	0.1092	7/64	3	2.995	0.375	0.164	0.229	0.459	0.082	#2-56
SAIFMM-8	0.1248	1/8	3	2.995	0.500	0.187	0.262	0.524	0.094	#2-56
SAIFMM-9	0.1404	9/64	3	2.995	0.500	0.211	0.295	0.590	0.105	#4-40
SAIFMM-10	0.1561	5/32	3	2.995	0.500	0.234	0.328	0.655	0.117	#4-40
SAIFMM-11	0.1717	11/64	3	2.995	0.500	0.258	0.361	0.721	0.129	#4-40
SAIFMM-12	0.1873	3/16	3	2.995	0.500	0.281	0.393	0.787	0.140	#4-40
SAIFMM-13	0.2029	13/64	3	2.995	0.625	0.304	0.426	0.852	0.152	#6-32
SAIFMM-14	0.2186	7/32	3	2.995	0.625	0.328	0.459	0.918	0.164	#6-32
SAIFMM-15	0.2342	15/64	3	2.995	0.750	0.351	0.492	0.984	0.176	#6-32
SAIFMM-16	0.2498	1/4	3	2.995	0.750	0.375	0.525	1.049	0.187	#6-32
SAIFMM-17	0.0936	3/32	4	3.995	0.250	0.140	0.196	0.393	0.070	#2-56
SAIFMM-18	0.1092	7/64	4	3.995	0.250	0.164	0.229	0.459	0.082	#2-56
SAIFMM-19	0.1248	1/8	4	3.995	0.500	0.187	0.262	0.524	0.094	#2-56
SAIFMM-20	0.1404	9/64	4	3.995	0.500	0.211	0.295	0.590	0.105	#4-40
SAIFMM-21	0.1561	5/32	4	3.995	0.500	0.234	0.328	0.655	0.117	#4-40
SAIFMM-22	0.1717	11/64	4	3.995	0.500	0.258	0.361	0.721	0.129	#4-40
SAIFMM-23	0.1873	3/16	4	3.995	0.500	0.281	0.393	0.787	0.140	#4-40
SAIFMM-24	0.2029	13/64	4	3.995	0.625	0.304	0.426	0.852	0.152	#6-32
SAIFMM-25	0.2186	7/32	4	3.995	0.625	0.328	0.459	0.918	0.164	#6-32
SAIFMM-26	0.2342	15/64	4	3.995	0.750	0.351	0.492	0.984	0.176	#6-32
SAIFMM-27	0.2498	1/4	4	3.995	0.750	0.375	0.525	1.049	0.187	#6-32
SAIFMM-28	0.2654	17/64	4	3.995	0.750	0.398	0.557	1.115	0.199	#8-32
SAIFMM-29	0.2811	9/32	4	3.995	0.750	0.422	0.590	1.180	0.211	#8-32
SAIFMM-30	0.2967	19/64	4	3.995	0.750	0.445	0.623	1.246	0.223	#8-32
SAIFMM-31	0.3123	5/16	4	3.995	1.000	0.468	0.656	1.312	0.234	#8-32
SAIFMM-32	0.1248	1/8	5	4.995	0.500	0.187	0.262	0.524	0.094	#2-56
SAIFMM-33	0.1404	9/64	5	4.995	0.500	0.211	0.295	0.590	0.105	#4-40
SAIFMM-34	0.1561	5/32	5	4.995	0.500	0.234	0.328	0.655	0.117	#4-40
SAIFMM-35	0.1717	11/64	5	4.995	0.500	0.258	0.361	0.721	0.129	#4-40
SAIFMM-36	0.1873	3/16	5	4.995	0.500	0.281	0.393	0.787	0.140	#4-40
SAIFMM-37	0.2029	13/64	5	4.995	0.625	0.304	0.426	0.852	0.152	#6-32
SAIFMM-38	0.2186	7/32	5	4.995	0.625	0.328	0.459	0.918	0.164	#6-32
SAIFMM-39	0.2342	15/64	5	4.995	0.750	0.351	0.492	0.984	0.176	#6-32
SAIFMM-40	0.2498	1/4	5	4.995	0.750	0.375	0.525	1.049	0.187	#6-32
SAIFMM-41	0.2654	17/64	5	4.995	0.750	0.398	0.557	1.115	0.199	#8-32
SAIFMM-42	0.2811	9/32	5	4.995	0.750	0.422	0.590	1.180	0.211	#8-32
SAIFMM-43	0.2967	19/64	5	4.995	0.750	0.445	0.623	1.246	0.223	#8-32
SAIFMM-44	0.3123	5/16	5	4.995	1.000	0.468	0.656	1.312	0.234	#8-32
SAIFMM-45	0.3436	11/32	5	4.995	1.000	0.515	0.721	1.443	0.258	#10-32
SAIFMM-46	0.3748	3/8	5	4.995	1.000	0.562	0.787	1.574	0.281	#10-32
SAIFMM-47	0.1248	1/8	6	5.995	0.500	0.187	0.262	0.524	0.094	#2-56
SAIFMM-48	0.1404	9/64	6	5.995	0.500	0.211	0.295	0.590	0.105	#4-40
SAIFMM-49	0.1561	5/32	6	5.995	0.500	0.234	0.328	0.655	0.117	#4-40
SAIFMM-50	0.1717	11/64	6	5.995	0.500	0.258	0.361	0.721	0.129	#4-40
SAIFMM-51	0.1873	3/16	6	5.995	0.500	0.281	0.393	0.787	0.140	#4-40
SAIFMM-52	0.2029	13/64	6	5.995	0.625	0.304	0.426	0.852	0.152	#6-32
SAIFMM-53	0.2186	7/32	6	5.995	0.625	0.328	0.459	0.918	0.164	#6-32
SAIFMM-54	0.2342	15/64	6	5.995	0.750	0.351	0.492	0.984	0.176	#6-32
SAIFMM-55	0.2498	1/4	6	5.995	0.750	0.375	0.525	1.049	0.187	#6-32
SAIFMM-56	0.2654	17/64	6	5.995	0.750	0.398	0.557	1.115	0.199	#8-32
SAIFMM-57	0.2811	9/32	6	5.995	0.750	0.422	0.590	1.180	0.211	#8-32
SAIFMM-58	0.2967	19/64	6	5.995	0.750	0.445	0.623	1.246	0.223	#8-32
SAIFMM-59	0.3123	5/16	6	5.995	1.000	0.468	0.656	1.312	0.234	#8-32
SAIFMM-60	0.3436	11/32	6	5.995	1.000	0.515	0.721	1.443	0.258	#10-32
SAIFMM-61	0.3748	3/8	6	5.995	1.000	0.562	0.787	1.574	0.281	#10-32
SAIFMM-62	0.1248	1/8	7	6.995	0.500	0.187	0.262	0.524	0.094	#2-56
SAIFMM-63	0.1561	5/32	7	6.995	0.500	0.234	0.328	0.655	0.117	#4-40
SAIFMM-64	0.1873	3/16	7	6.995	0.500	0.281	0.393	0.787	0.140	#4-40
SAIFMM-65	0.2186	7/32	7	6.995	0.625	0.328	0.459	0.918	0.164	#6-32
SAIFMM-66	0.2498	1/4	7	6.995	0.750	0.375	0.525	1.049	0.187	#6-32
SAIFMM-67	0.2811	9/32	7	6.995	0.750	0.422	0.590	1.180	0.211	#8-32
SAIFMM-68	0.3123	5/16	7	6.995	1.000	0.468	0.656	1.312	0.234	#8-32
SAIFMM-69	0.3436	11/32	7	6.995	1.000	0.515	0.721	1.443	0.258	#10-32
SAIFMM-70	0.3748	3/8	7	6.995	1.000	0.562	0.787	1.574	0.281	#10-32

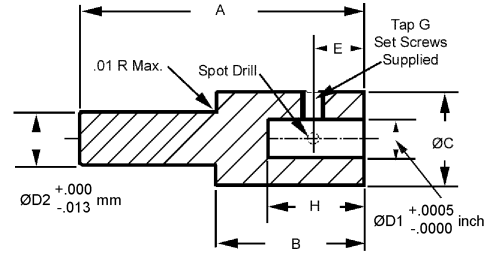

Continued on next page.

PRECISION SHAFT ADAPTERS

SHAFT SIZES	STYLE	MATERIAL
20MM TO 30MM	INCH FEMALE - METRIC MALE - PIN HUB	303 STAINLESS STEEL

STOCK NO.	Inch Female ØD1 (Inches)		Metric Male ØD2 (mm)		ØC	H	B	A	E	G
	Decimal	Fraction	Nom	Actual						
SAIFMM-156	0.4998	1/2	20	20	1.250	0.750	1.050	2.099	0.375	1/4-20
SAIFMM-157	0.5623	9/16	20	20	1.250	0.843	1.181	2.362	0.422	1/4-20
SAIFMM-158	0.6248	5/8	20	20	1.250	0.937	1.312	2.624	0.469	1/4-20
SAIFMM-159	0.6873	11/16	20	20	1.500	1.031	1.443	2.887	0.515	1/4-20
SAIFMM-160	0.7498	3/4	20	20	1.625	1.125	1.575	3.149	0.562	1/4-20
SAIFMM-161	0.8123	13/16	20	20	1.750	1.218	1.706	3.412	0.609	1/4-20
SAIFMM-162	0.8748	7/8	20	20	1.750	1.312	1.837	3.674	0.656	1/4-20
SAIFMM-163	0.9373	15/16	20	20	2.000	1.406	1.968	3.937	0.703	1/4-20
SAIFMM-164	0.9998	1	20	20	2.000	1.500	2.100	4.199	0.750	1/4-20
SAIFMM-165	1.1248	1 1/8	20	20	2.250	1.687	2.362	4.724	0.844	3/8-16
SAIFMM-166	1.2498	1 1/4	20	20	2.250	1.875	2.625	5.249	0.937	3/8-16
SAIFMM-167	0.4998	1/2	25	25	1.250	0.750	1.050	2.099	0.375	1/4-20
SAIFMM-168	0.5623	9/16	25	25	1.250	0.843	1.181	2.362	0.422	1/4-20
SAIFMM-169	0.6248	5/8	25	25	1.250	0.937	1.312	2.624	0.469	1/4-20
SAIFMM-170	0.6873	11/16	25	25	1.500	1.031	1.443	2.887	0.515	1/4-20
SAIFMM-171	0.7498	3/4	25	25	1.625	1.125	1.575	3.149	0.562	1/4-20
SAIFMM-172	0.8123	13/16	25	25	1.750	1.218	1.706	3.412	OM9	1/4-20
SAIFMM-173	0.8748	7/8	25	25	1.750	1.312	1.837	3.674	0.656	1/4-20
SAIFMM-174	0.9373	15/16	25	25	2.000	1.406	1.968	3.937	0.703	1/4-20
SAIFMM-175	0.9998	1	25	25	2.000	1.500	2.100	4.199	0.750	1/4-20
SAIFMM-176	1.1248	1 1/8	25	25	2.250	1.687	2.362	4.724	0.844	3/8-16
SAIFMM-177	1.2498	1 1/4	25	25	2.250	1.875	2.625	5.249	0.937	3/8-16
SAIFMM-178	1.3748	1 3/8	25	25	2.250	2.062	2.887	5.774	1.031	3/8-16
SAIFMM-179	1.4998	1 1/2	25	25	2.500	2.250	3.150	6.299	1.125	3/8-16
SAIFMM-180	0.4998	1/2	30	30	1.250	0.750	1.050	2.099	0.375	1/4-20
SAIFMM-181	0.5623	9/16	30	30	1.250	0.843	1.181	2.362	0.422	1/4-20
SAIFMM-182	0.6248	5/8	30	30	1.250	0.937	1.312	2.624	0.469	1/4-20
SAIFMM-183	0.6873	11/16	30	30	1.500	1.031	1.443	2.887	0.515	1/4-20
SAIFMM-184	0.7498	3/4	30	30	1.625	1.125	1.575	3.149	0.562	1/4-20
SAIFMM-185	0.8123	13/16	30	30	1.750	1.218	1.706	3.412	0.609	1/4-20
SAIFMM-186	0.8748	7/8	30	30	1.750	1.312	1.837	3.674	0.656	1/4-20
SAIFMM-187	0.9373	15/16	30	30	2.000	1.406	1.968	3.937	0.703	1/4-20
SAIFMM-188	0.9998	1	30	30	2.000	1.500	2.100	4.199	0.750	1/4-20
SAIFMM-189	1.1248	1 1/8	30	30	2.250	1.687	2.362	4.724	0.844	3/8-16
SAIFMM-190	1.2498	1 1/4	30	30	2.250	1.875	2.625	5.249	0.937	3/8-16
SAIFMM-191	1.3748	1 3/8	30	30	2.250	2.062	2.887	5.774	1.031	3/8-16
SAIFMM-192	1.4998	1 1/2	30	30	2.500	2.250	3.150	6.299	1.125	3/8-16
SAIFMM-193	1.6248	1 5/8	30	30	2.750	2.437	3.412	6.824	1.219	3/8-16

See drawing on page G66.

PRECISION SHAFT ADAPTERS

SHAFT SIZES	STYLE	MATERIAL
8MM TO 16MM	INCH MALE - METRIC FEMALE - PIN HUB	303 STAINLESS STEEL

STOCK NO.	Inch Male ØD1 (Inches)		Metric Female ØD2 (mm)		ØC	H	B	A	E	G
	Decimal	Fraction	Nom	Actual						
SAIMMF-75	0.1248	1/8	8	7.996	0.787	0.630	0.882	1.764	0.315	M4x0.7
SAIMMF-76	0.1561	5/32	8	7.996	0.787	0.630	0.882	1.764	0.315	M4x0.7
SAIMMF-77	0.1873	3/16	8	7.996	0.787	0.630	0.882	1.764	0.315	M4x0.7
SAIMMF-78	0.2186	7/32	8	7.996	0.787	0.630	0.882	1.764	0.315	M4x0.7
SAIMMF-79	0.2498	1/4	8	7.996	0.787	0.630	0.882	1.764	0.315	M4x0.7
SAIMMF-80	0.2811	9/32	8	7.996	0.787	0.630	0.882	1.764	0.315	M4x0.7
SAIMMF-81	0.3123	5/16	8	7.996	0.787	0.630	0.882	1.764	0.315	M4x0.7
SAIMMF-82	0.3436	11/32	8	7.996	0.787	0.630	0.882	1.764	0.315	M4x0.7
SAIMMF-83	0.3748	3/8	8	7.996	0.787	0.630	0.882	1.764	0.315	M4x0.7
SAIMMF-84	0.4061	13/32	8	7.996	0.787	0.630	0.882	1.764	0.315	M4x0.7
SAIMMF-85	0.4373	7/16	8	7.996	0.787	0.630	0.882	1.764	0.315	M4x0.7
SAIMMF-86	0.4998	1/2	8	7.996	0.787	0.630	0.882	1.764	0.315	M4x0.7
SAIMMF-87	0.1248	1/8	9	8.996	0.787	0.709	0.992	1.984	0.354	M5x0.8
SAIMMF-88	0.1561	5/32	9	8.996	0.787	0.709	0.992	1.984	0.354	M5x0.8
SAIMMF-89	0.1873	3/16	9	8.996	0.787	0.709	0.992	1.984	0.354	M5x0.8
SAIMMF-90	0.2186	7/32	9	8.996	0.787	0.709	0.992	1.984	0.354	M5x0.8
SAIMMF-91	0.2498	1/4	9	8.996	0.787	0.709	0.992	1.984	0.354	M5x0.8
SAIMMF-92	0.2811	9/32	9	8.996	0.787	0.709	0.992	1.984	0.354	M5x0.8
SAIMMF-93	0.3123	5/16	9	8.996	0.787	0.709	0.992	1.984	0.354	M5x0.8
SAIMMF-94	0.3436	11/32	9	8.996	0.787	0.709	0.992	1.984	0.354	M5x0.8
SAIMMF-95	0.3748	3/8	9	8.996	0.787	0.709	0.992	1.984	0.354	M5x0.8
SAIMMF-96	0.4061	13/32	9	8.996	0.787	0.709	0.992	1.984	0.354	M5x0.8
SAIMMF-97	0.4373	7/16	9	8.996	0.787	0.709	0.992	1.984	0.354	M5x0.8
SAIMMF-98	0.4998	1/2	9	8.996	0.787	0.709	0.992	1.984	0.354	M5x0.8
SAIMMF-99	0.1873	3/16	10	9.996	0.866	0.787	1.102	2.205	0.394	M5x0.8
SAIMMF-100	0.2186	7/32	10	9.996	0.866	0.787	1.102	2.205	0.394	M5x0.8
SAIMMF-101	0.2498	1/4	10	9.996	0.866	0.787	1.102	2.205	0.394	M5x0.8
SAIMMF-102	0.2811	9/32	10	9.996	0.866	0.787	1.102	2.205	0.394	M5x0.8
SAIMMF-103	0.3123	5/16	10	9.996	0.866	0.787	1.102	2.205	0.394	M5x0.8
SAIMMF-104	0.3436	11/32	10	9.996	0.866	0.787	1.102	2.205	0.394	M5x0.8
SAIMMF-105	0.3748	3/8	10	9.996	0.866	0.787	1.102	2.205	0.394	M5x0.8
SAIMMF-106	0.4061	13/32	10	9.996	0.866	0.787	1.102	2.205	0.394	M5x0.8
SAIMMF-107	0.4373	7/16	10	9.996	0.866	0.787	1.102	2.205	0.394	M5x0.8
SAIMMF-108	0.4998	1/2	10	9.996	0.866	0.787	1.102	2.205	0.394	M5x0.8
SAIMMF-109	0.5623	9/16	10	9.996	0.866	0.787	1.102	2.205	0.394	M5x0.8
SAIMMF-110	0.6248	5/8	10	9.996	0.866	0.787	1.102	2.205	0.394	M5x0.8
SAIMMF-111	0.1873	3/16	12	11.996	1.024	0.945	1.323	2.646	0.472	M6x1.0
SAIMMF-112	0.2186	7/32	12	11.996	1.024	0.945	1.323	2.646	0.472	M6x1.0
SAIMMF-113	0.2498	1/4	12	11.996	1.024	0.945	1.323	2.646	0.472	M6x1.0
SAIMMF-114	0.2811	9/32	12	11.996	1.024	0.945	1.323	2.646	0.472	M6x1.0
SAIMMF-115	0.3123	5/16	12	11.996	1.024	0.945	1.323	2.646	0.472	M6x1.0
SAIMMF-116	0.3436	11/32	12	11.996	1.024	0.945	1.323	2.646	0.472	M6x1.0
SAIMMF-117	0.3748	3/8	12	11.996	1.024	0.945	1.323	2.646	0.472	M6x1.0
SAIMMF-118	0.4061	13/32	12	11.996	1.024	0.945	1.323	2.646	0.472	M6x1.0
SAIMMF-119	0.4373	7/16	12	11.996	1.024	0.945	1.323	2.646	0.472	M6x1.0
SAIMMF-120	0.4998	1/2	12	11.996	1.024	0.945	1.323	2.646	0.472	M6x1.0
SAIMMF-121	0.5623	9/16	12	11.996	1.024	0.945	1.323	2.646	0.472	M6x1.0
SAIMMF-122	0.6248	5/8	12	11.996	1.024	0.945	1.323	2.646	0.472	M6x1.0
SAIMMF-123	0.6873	11/16	12	11.996	1.024	0.945	1.323	2.646	0.472	M6x1.0
SAIMMF-124	0.1873	3/16	14	13.996	1.181	1.102	1.543	3.087	0.551	M6x1.0
SAIMMF-125	0.2498	1/4	14	13.996	1.181	1.102	1.543	3.087	0.551	M6x1.0
SAIMMF-126	0.3123	5/16	14	13.996	1.181	1.102	1.543	3.087	0.551	M6x1.0
SAIMMF-127	0.3748	3/8	14	13.996	1.181	1.102	1.543	3.087	0.551	M6x1.0
SAIMMF-128	0.4373	7/16	14	13.996	1.181	1.102	1.543	3.087	0.551	M6x1.0
SAIMMF-129	0.4998	1/2	14	13.996	1.181	1.102	1.543	3.087	0.551	M6x1.0
SAIMMF-130	0.5623	9/16	14	13.996	1.181	1.102	1.543	3.087	0.551	M6x1.0
SAIMMF-131	0.6248	5/8	14	13.996	1.181	1.102	1.543	3.087	0.551	M6x1.0
SAIMMF-132	0.6873	11/16	14	13.996	1.181	1.102	1.543	3.087	0.551	M6x1.0
SAIMMF-133	0.7498	3/4	14	13.996	1.181	1.102	1.543	3.087	0.551	M6x1.0
SAIMMF-134	0.8123	13/16	14	13.996	1.181	1.102	1.543	3.087	0.551	M6x1.0
SAIMMF-135	0.3748	3/8	16	15.996	1.339	1.260	1.764	3.528	0.630	M6x1.0
SAIMMF-136	0.4373	7/16	16	15.996	1.339	1.260	1.764	3.528	0.630	M6x1.0
SAIMMF-137	0.4998	1/2	16	15.996	1.339	1.260	1.764	3.528	0.630	M6x1.0
SAIMMF-138	0.5623	9/16	16	15.996	1.339	1.260	1.764	3.528	0.630	M6x1.0
SAIMMF-139	0.6248	5/8	16	15.996	1.339	1.260	1.764	3.528	0.630	M6x1.0
SAIMMF-140	0.6873	11/16	16	15.996	1.339	1.260	1.764	3.528	0.630	M6x1.0
SAIMMF-141	0.7498	3/4	16	15.996	1.339	1.260	1.764	3.528	0.630	M6x1.0
SAIMMF-142	0.8123	13/16	16	15.996	1.339	1.260	1.764	3.528	0.630	M6x1.0
SAIMMF-143	0.8748	7/8	16	15.996	1.339	1.260	1.764	3.528	0.630	M6x1.0
SAIMMF-144	0.9373	15/16	16	15.996	1.339	1.260	1.764	3.528	0.630	M6x1.0
SAIMMF-145	0.9998	1	16	15.996	1.339	1.260	1.764	3.528	0.630	M6x1.0

See drawing on previous page.

Continued on next page.

PRECISION SHAFT ADAPTERS

SHAFT SIZES	STYLE	MATERIAL
18MM TO 30MM	INCH MALE - METRIC FEMALE - PIN HUB	303 STAINLESS STEEL

STOCK NO.	Inch Male ØD1 (Inches)		Metric Female ØD2 (mm)		ØC	H	B	A	E	G 6H
	Decimal	Fraction	Nom	Actual						
SAIMMF-146	0.3748	3/8	18	17.996	1.575	1.417	1.984	3.969	0.709	M6x1.0
SAIMMF-147	0.4373	7/16	18	17.996	1.575	1.417	1.984	3.969	0.709	M6x1.0
SAIMMF-148	0.4998	1/2	18	17.996	1.575	1.417	1.984	3.969	0.709	M6x1.0
SAIMMF-149	0.5623	9/16	18	17.996	1.575	1.417	1.984	3.969	0.709	M6x1.0
SAIMMF-150	0.6248	5/8	18	17.996	1.575	1.417	1.984	3.969	0.709	M6x1.0
SAIMMF-151	0.6873	11/16	18	17.996	1.575	1.417	1.984	3.969	0.709	M6x1.0
SAIMMF-152	0.7498	3/4	18	17.996	1.575	1.417	1.984	3.969	0.709	M6x1.0
SAIMMF-153	0.8123	13/16	18	17.996	1.575	1.417	1.984	3.969	0.709	M6x1.0
SAIMMF-154	0.8748	7/8	18	17.996	1.575	1.417	1.984	3.969	0.709	M6x1.0
SAIMMF-155	0.9373	15/16	18	17.996	1.575	1.417	1.984	3.969	0.709	M6x1.0
SAIMMF-156	0.9998	1	18	17.996	1.575	1.417	1.984	3.969	0.709	M6x1.0
SAIMMF-157	1.1248	1 1/8	18	17.996	1.575	1.417	1.984	3.969	0.709	M6x1.0
SAIMMF-158	0.4998	1/2	20	19.996	1.575	1.575	2.205	4.409	0.787	M8x1.25
SAIMMF-159	0.5623	9/16	20	19.996	1.575	1.575	2.205	4.409	0.787	M8x1.25
SAIMMF-160	0.6248	5/8	20	19.996	1.575	1.575	2.205	4.409	0.787	M8x1.25
SAIMMF-161	0.6873	11/16	20	19.996	1.575	1.575	2.205	4.409	0.787	M8x1.25
SAIMMF-162	0.7498	3/4	20	19.996	1.575	1.575	2.205	4.409	0.787	M8x1.25
SAIMMF-163	0.8123	13/16	20	19.996	1.575	1.575	2.205	4.409	0.787	M8x1.25
SAIMMF-164	0.8748	7/8	20	19.996	1.575	1.575	2.205	4.409	0.787	M8x1.25
SAIMMF-165	0.9373	15/16	20	19.996	1.575	1.575	2.205	4.409	0.787	M8x1.25
SAIMMF-166	0.9998	1	20	19.996	1.575	1.575	2.205	4.409	0.787	M8x1.25
SAIMMF-167	1.1248	1 1/8	20	19.996	1.575	1.575	2.205	4.409	0.787	M8x1.25
SAIMMF-168	1.2498	1 1/4	20	19.996	1.575	1.575	2.205	4.409	0.787	M8x1.25
SAIMMF-169	0.4998	1/2	25	24.996	1.969	1.969	2.756	5.512	0.984	M10x1.5
SAIMMF-170	0.5623	9/16	25	24.996	1.969	1.969	2.756	5.512	0.984	M10x1.5
SAIMMF-171	0.6248	5/8	25	24.996	1.969	1.969	2.756	5.512	0.984	M10x1.5
SAIMMF-172	0.6873	11/16	25	24.996	1.969	1.969	2.756	5.512	0.984	M10x1.5
SAIMMF-173	0.7498	3/4	25	24.996	1.969	1.969	2.756	5.512	0.984	M10x1.5
SAIMMF-174	0.8123	13/16	25	24.996	1.969	1.969	2.756	5.512	0.984	M10x1.5
SAIMMF-175	0.8748	7/8	25	24.996	1.969	1.969	2.756	5.512	0.984	M10x1.5
SAIMMF-176	0.9373	15/16	25	24.996	1.969	1.969	2.756	5.512	0.984	M10x1.5
SAIMMF-177	0.9998	1	25	24.996	1.969	1.969	2.756	5.512	0.984	M10x1.5
SAIMMF-178	1.1248	1 1/8	25	24.996	1.969	1.969	2.756	5.512	0.984	M10x1.5
SAIMMF-179	1.2498	1 1/4	25	24.996	1.969	1.969	2.756	5.512	0.984	M10x1.5
SAIMMF-180	1.3748	1 3/8	25	24.996	1.969	1.969	2.756	5.512	0.984	M10x1.5
SAIMMF-181	1.4998	1 1/2	25	24.996	1.969	1.969	2.756	5.512	0.984	M10x1.5
SAIMMF-182	0.4998	1/2	30	29.996	2.205	2.362	3.307	6.614	1.181	M10x1.5
SAIMMF-183	0.5623	9/16	30	29.996	2.205	2.362	3.307	6.614	1.181	M10x1.5
SAIMMF-184	0.6248	5/8	30	29.996	2.205	2.362	3.307	6.614	1.181	M10x1.5
SAIMMF-185	0.6873	11/16	30	29.996	2.205	2.362	3.307	6.614	1.181	M10x1.5
SAIMMF-186	0.7498	3/4	30	29.996	2.205	2.362	3.307	6.614	1.181	M10x1.5
SAIMMF-187	0.8123	13/16	30	29.996	2.205	2.362	3.307	6.614	1.181	M10x1.5
SAIMMF-188	0.8748	7/8	30	29.996	2.205	2.362	3.307	6.614	1.181	M10x1.5
SAIMMF-189	0.9373	15/16	30	29.996	2.205	2.362	3.307	6.614	1.181	M10x1.5
SAIMMF-190	0.9998	1	30	29.996	2.205	2.362	3.307	6.614	1.181	M10x1.5
SAIMMF-191	1.1248	1 1/8	30	29.996	2.205	2.362	3.307	6.614	1.181	M10x1.5
SAIMMF-192	1.2498	1 1/4	30	29.996	2.205	2.362	3.307	6.614	1.181	M10x1.5
SAIMMF-193	1.3748	1 3/8	30	29.996	2.205	2.362	3.307	6.614	1.181	M10x1.5
SAIMMF-194	1.4998	1 1/2	30	29.996	2.205	2.362	3.307	6.614	1.181	M10x1.5
SAIMMF-195	1.6248	1 5/8	30	29.996	2.205	2.362	3.307	6.614	1.181	M10x1.5

See drawing on page.G69.



SHAFT EXTENSIONS

SHAFT SIZES	STYLE	MATERIAL
.1200 TO .3748	CLAMP HUB	303 STAINLESS STEEL

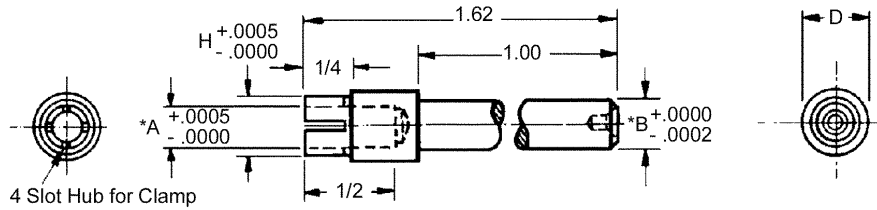

STOCK NO.	ØA (FEMALE END)	ØB (MALE END)	D	H	CLAMP (ORDER SEPARATELY)
PE3-10	.1200	.1247	1/4	.188	CG3-7
PE3-1	.1248	.1247	1/4	.188	
PE3-7	.1248	.1872	1/4	.188	
PE3-8	.1248	.2497	1/4	.188	
PE3-4	.1873	.1247	5/16	.250	CG3-9
PE3-2	.1873	.1872	5/16	.250	
PE3-9	.1873	.2497	5/16	.250	
PE3-5	.2498	.1247	3/8	.312	CG3-11
PE3-6	.2498	.1872	3/8	.312	
PE3-3	.2498	.2497	3/8	.312	
PE3-12	.2498	.3747	3/8	.312	
PE3-11	.3748	.2497	1/2	.437	CG3-15
PE3-13	.3748	.3747	1/2	.437	

*Concentric within .0005

Modifications and specials available on request.

OVERRUNNING COUPLING

BORE SIZES	STYLE	MATERIAL
1/8" TO 1/2"	CLOCKWISE	416 STAINLESS STEEL HUB RC26-32 DELRIN CENTER

STOCK NO.	A	B	MAX DRIVE TORQUE	MAX DRAG TORQUE	C	D	E	F	G	H	SET SCREW
JB-R-4	.1248	.1248									
JB-R-5	.1248	.1873									
JB-R-6	.1248	.2498	10.0	.10							
JB-R-17	.1873	.1873	IN.	IN.	1.00	.75	.56	.21	.11	.47	#4-40
JB-R-8	.1873	.2498	LBS	LBS							
JB-R-9	.2498	.2498									
JB-R-10	.3123	.3123									
JB-R-11	.3123	.3748									
JB-R-12	.3123	.4998	80.0	.25							
JB-R-13	.3748	.3748	IN.	IN.	1.48	1.38	1.00	.33	.20	.73	#10-32
JB-R-14	.3748	.4998	LBS	LBS							
JB-R-15	.4998	.4998									

Locking R.H. Hub, L.H. drives clockwise

BORE SIZES	STYLE	MATERIAL
1/8" TO 1/2"	COUNTER-CLOCKWISE	416 STAINLESS STEEL HUB RC26-32 DELRIN CENTER

STOCK NO.	A	B	MAX DRIVE TORQUE	MAX DRAG TORQUE	C	D	E	F	G	H	SET SCREW
JB-L-4	.1248	.1248									
JB-L-5	.1248	.1873									
JB-L-6	.1248	.2498	10.0	.10							
JB-L-17	.1873	.1873	IN.	IN.	1.00	.75	.56	.21	.11	.47	#4-40
JB-L-8	.1873	.2498	LBS	LBS							
JB-L-9	.2498	.2498									
JB-L-10	.3123	.3123									
JB-L-11	.3123	.3748									
JB-L-12	.3123	.4998	80.0	.25							
JB-L-13	.3748	.3748	IN.	IN.	1.48	1.38	1.00	.33	.20	.73	#10-32
JB-L-14	.3748	.4998	LBS	LBS							
JB-L-15	.4998	.4998									

G

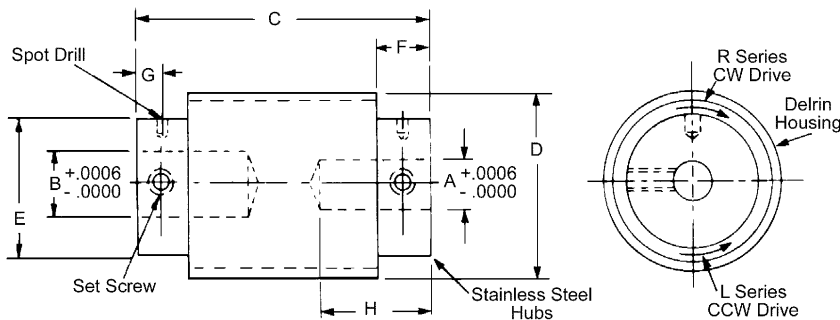

Locking R.H. Hub, L.H. drives counter-clockwise

Drive load in one direction.
Clutch rotates freely in opposite direction

Note: Backlash is less than 1° (degree) in driving direction.

SLIP COUPLINGS

BORE SIZES	TORQUE	MATERIAL
1/8" TO 1/4"	ADJUSTABLE SEE GRAPH BELOW	STAINLESS STEEL HOUSING

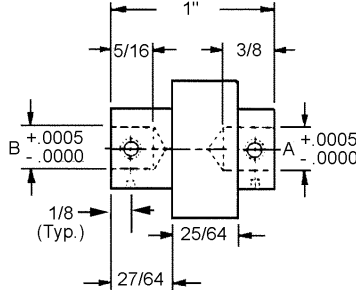
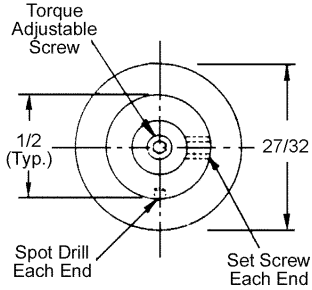

PIN HUB STOCK NUMBER	A BORE	B BORE
JK-1	.1250	.1250
JK-2	.1250	.1875
JK-3	.1250	.2500
JK-4	.1875	.1875
JK-5	.1875	.2500
JK-7	.2500	.2500

CLAMP HUB STOCK NUMBER	A BORE	B BORE	CLAMP
JK-2C	.1250	.1875	CG1-5/-8
JK-3C	.1250	.2500	CG1-5/-12
JK-4C	.1875	.1875	CG1-8/-8
JK-5C	.1875	.2500	CG1-8/-12
JK-7C	.2500	.2500	CG1-12/-12

- Bi-Directional
- No Lubrication required
- Rulon clutch faces for smooth operation and long life at high speeds
- Consistent breakaway torques and performance at slip speeds up to 1200 R.P.M
- Slip torque is set and may be adjusted

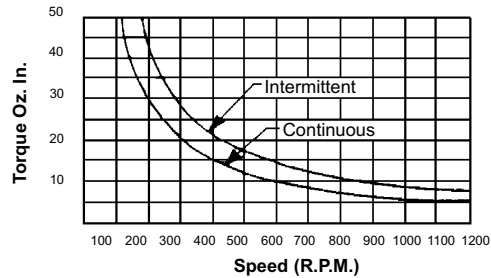

Note:
Clutch capacity can be determined by use of the chart. The curves are based on a predetermined maximum temperature rise in the clutch when operated in an ambient temperature of 70°F. The intermittent curve applies to applications where the slipping period is 10 minutes or less and the cooling period is equal or greater.

Torque settings are maintained within plus or minus 20% over the full speed range. Stability is improved for constant speed applications.

SLIP COUPLINGS

BORE SIZES	TORQUE	MATERIAL
1/4" AND 5/16"	ADJUSTABLE FROM 3.402 OZ.IN. TO 187.4 OZ.IN.	HOUSING ADJUSTER PINS: ALUMINUM ALLOY WITH ALOCROM FINISH ADAPTERS, HUBS AND PLATES: HEAT TREATED STEEL, BRONZE BEARING

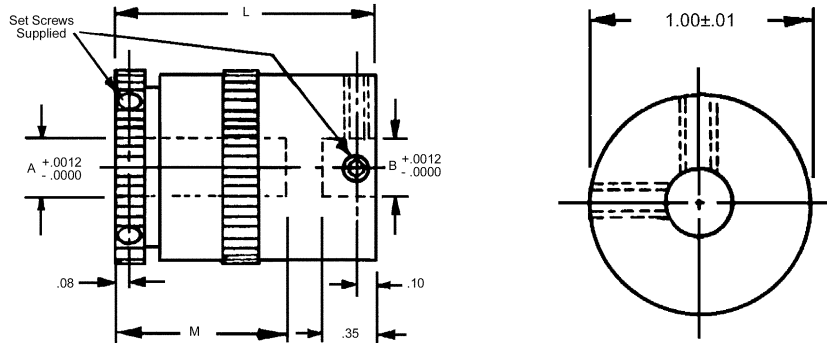

STOCK NUMBER	A BORE	B BORE	L	M	ADJUSTABLE TORQUE RANGE		WEIGHT
					MIN.	MAX.	
JJ-25	.2500	.2500	1.42	.98	3.4	76.0	50g
JJ-26	.3125	.3125			IN. OZ.	IN. OZ.	
JJ-27	.2500	.2500	1.65	1.22	11.0	187.4	61g
JJ-28	.3125	.3125			IN. OZ.	IN. OZ.	



SLIP COUPLINGS

BORE SIZES	TORQUE	MATERIAL
1/8" AND 3/4"	ADJUSTABLE 5 OZ.IN. TO 320 OZ.IN.	STAINLESS STEEL

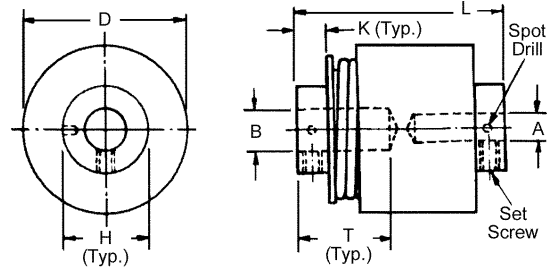

STOCK NO.	BORE $+0.0006$ -0.0000		L ± 0.02	D ± 0.02	H ± 0.02	K ± 0.02	T	TORQUE Bi DIRECTION (OZ. IN.)
	A	B						
JJ-1	.1250	.1250	.89	.50	.37	.17	.43	5 \pm .7
JJ-2	.1250	.1875						
JJ-3	.1875	.1875						
JJ-4	.1875	.1875	1.11	.75	.50	.19	.50	12 \pm 1.2
JJ-5	.1875	.2500						
JJ-6	.2500	.2500						
JJ-7	.1875	.1875	1.26	1.00	.50	.19	.55	20 \pm 2
JJ-8	.1875	.2500						
JJ-9	.2500	.2500						
JJ-10	.2500	.2500	1.43	1.25	.62	.25	.62	48 \pm 5
JJ-11	.2500	.3750						
JJ-12	.3750	.3750						
JJ-13	.3125	.3125	1.59	1.50	.75	.25	.73	88 \pm 9
JJ-14	.3750	.3750						
JJ-15	.3750	.3750	1.84	1.87	.87	.28	.85	120 \pm 12
JJ-16	.3750	.5000						
JJ-17	.5000	.5000						
JJ-18	.3750	.3750	2.25	2.25	1.25	.38	1.00	240 \pm 24
JJ-19	.3750	.5000						
JJ-20	.5000	.5000						
JJ-21	.5000	.6250						
JJ-22	.6250	.6250						
JJ-23	.6250	.7500						
JJ-24	.7500	.7500						
JJ-18-X	.3750	.3750						
JJ-19-X	.3750	.5000						
JJ-20-X	.5000	.5000						
JJ-21-X	.5000	.6250						
JJ-22-X	.6250	.6250						
JJ-23-X	.6250	.7500						
JJ-24-X	.7500	.7500						

- Shaft to Shaft misalignment to .010 max.
- Angular misalignment 3° max.
- Can run under continuous slip operation

Torque limits calibrated to 5% torques from 1/2 oz./in. to 480 oz./in. available on request.

OLDHAM SLIP COUPLINGS

BORE SIZES	TORQUE	MATERIAL
1/4" AND 5/16"	ADJUSTABLE 3.4 OZ.IN. TO 187.4 OZ.IN.	HOUSING ADJUSTER PINS: ALUMINUM ALLOY WITH ALOCROM; FINISH ADAPTERS, HUBS AND PLATES: HEAT TREATED STEEL; BRONZE BEARING

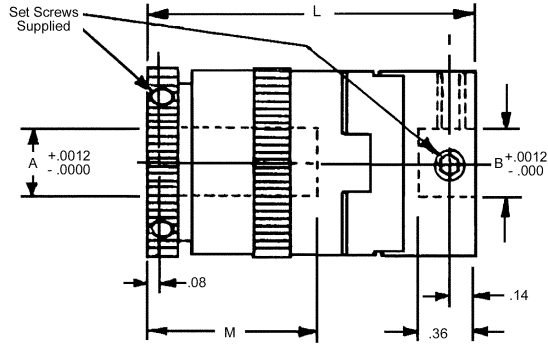

STOCK NUMBER	A BORE	B BORE	L	M	ADJUSTABLE TORQUE RANGE		WEIGHT
					MIN.	MAX.	
JJ-29	.2500	.2500	1.83	.98	3.4	76.0	57g
JJ-30	.3125	.3125			IN. OZ.	IN. OZ.	
JJ-31	.2500	.2500	2.07	1.22	11.0	187.4	68g
JJ-32	.3125	.3125			IN. OZ.	IN. OZ.	

- Bi-Directional
- Maximum operating temperature 175°F
- Maximum backlash 2°

TORQUE LIMITERS

BORE SIZES	TORQUE	MATERIAL
1/2" AND 3/4"	BIDIRECTIONAL 18 IN.-LBS TO 100 IN.-LBS.	6151 STEEL

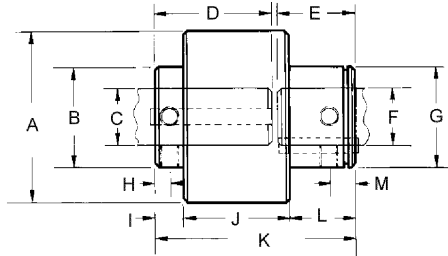

STOCK NO.	C	F	A REF.	D	G	I REF.	J	K REF.	L	TORQUE (IN.-LBS.)	B	E	H/M
JTT2X18-1 JTT2X18-2 JTT2X18-3	.500 .625 .750	.500 .625 .750	2.500	1.805	1.625	0.455	1.500	2.950	1.000	18	1.500	1.110	.312
JTT2X24-1 JTT2X24-2 JTT2X24-3	.500 .625 .750	.500 .625 .750	2.500	1.805	1.625	0.455	1.500	2.950	1.000	24	1.500	1.110	.312
JTT2X28-1 JTT2X28-2 JTT2X28-3	.500 .625 .750	.500 .625 .750	2.500	1.805	1.625	0.455	1.500	2.950	1.000	28	1.500	1.110	.312
JTT2X40-1 JTT2X40-2 JTT2X40-3	.500 .625 .750	.500 .625 .750	2.500	1.805	1.625	0.455	1.500	2.950	1.000	40	1.500	1.110	.312
JTT2X50-1 JTT2X50-2 JTT2X50-3	.500 .625 .750	.500 .625 .750	2.500	1.805	1.625	0.455	1.500	2.950	1.000	50	1.500	1.110	.312
JTT2X60-1 JTT2X60-2 JTT2X60-3	.500 .625 .750	.500 .625 .750	2.500	1.805	1.625	0.455	1.500	2.950	1.000	60	1.500	1.110	.312
JTT2X90-1 JTT2X90-2 JTT2X90-3	.500 .625 .750	.500 .625 .750	2.500	1.805	1.625	0.455	1.500	2.950	1.000	90	1.500	1.110	.312
JTT2X100-1 JTT2X100-2 JTT2X100-3	.500 .625 .750	.500 .625 .750	2.500	1.805	1.625	0.455	1.500	2.950	1.000	100	1.500	1.110	.312

Other Bores/Torques are available.



INLINE COUPLING SLIP CLUTCH

BORE	STYLE	TORQUE	MATERIAL
1/8" TO 1/4"	PIN HUB	ADJUSTABLE 0-25 OZ.IN.	303 STAINLESS STEEL

STOCK NO.	B1	B2	H	ADJUSTABLE SLIP TORQUE
CO16-1	.1248	.1248	5/16	0-25 OZ. IN.
CO16-2	.1873	.1873	3/8	
CO16-3	.2498	.2498	1/2	
CO16-4	.1248	.1873	3/8	
CO16-5	.1248	.2498	1/2	
CO16-6	.1873	.2498	1/2	

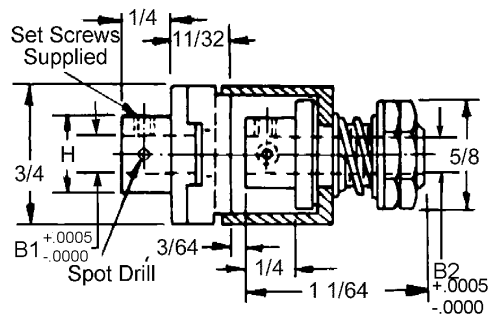

PIN HUB

BORE	STYLE	TORQUE	MATERIAL
1/8" TO 1/4"	CLAMP HUB	ADJUSTABLE 0-25 OZ.IN.	303 STAINLESS STEEL

STOCK NO.	B1	B2	H	ADJUSTABLE SLIP TORQUE
CO17-1	.1248	.1248	3/16	0-25 OZ. IN.
CO17-2	.1873	.1873	1/4	
CO17-3	.2498	.2498	5/16	
CO17-4	.1248	.1873	1/4	
CO17-5	.1248	.2498	5/16	
CO17-6	.1873	.2498	5/16	

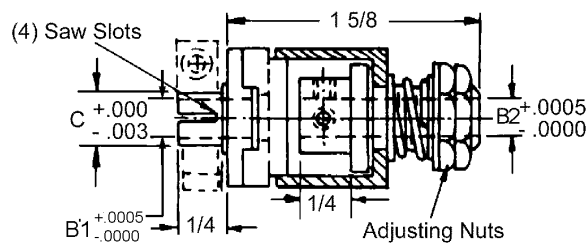

CLAMP HUB

SLIP CLUTCH

BORE	STYLE	TORQUE	MATERIAL
1/8" TO 1/4"	PIN HUB	ADJUSTABLE 0 OZ.IN. TO 50 OZ.IN	303 STAINLESS STEEL

STOCK NO.	BORE SIZE	H	D	FRICION FACE	ADJUSTABLE SLIP TORQUE
JC-10 JC-11 JC-12	.1248 .1873 .2498	5/16 3/8 1/2	5/8	FRICION RING	0 TO 10 OZ. IN.
JC-10-50 JC-11-50 JC-12-50	.1248 .1873 .2498	5/16 3/8 1/2	5/8	FRICION RING	10 TO 50 OZ. IN.
JA-1 JA-2 JA-3	.1248 .1873 .2498	5/16 3/8 1/2	1	FRICION RING	10 TO 50 OZ. IN.
JC-1 JC-2 JC-3	.1248 .1873 .2498	5/16 3/8 1/2	1	FRICION PADS	0 TO 10 OZ. IN.
JC-1-50 JC-2-50 JC-3-50	.1248 .1873 .2498	5/16 3/8 1/2	1	FRICION PADS	10 TO 50 OZ. IN.

BORE	STYLE	TORQUE	MATERIAL
1/8" TO 1/4"	CLAMP HUB	ADJUSTABLE 10 OZ.IN. TO 50 OZ.IN	303 STAINLESS STEEL

STOCK NO.	BORE SIZE	C	D	FRICION FACE	ADJUSTABLE SLIP TORQUE
JA-1C JA-2C JA-3C	.1248 .1873 .2498	3/16 1/4 5/16	1	FRICION RING	10 TO 50 OZ. IN.
JC-1C JC-2C JC-3C	.1248 .1873 .2498	3/16 1/4 5/16	1	FRICION PADS	0 TO 10 OZ. IN.
JC-1-50C JC-2-50C JC-3-50C	.1248 .1873 .2498	3/16 1/4 5/16	1	FRICION PADS	10 TO 50 OZ. IN.

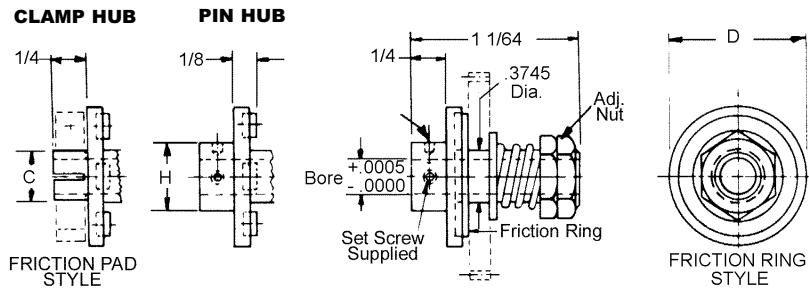

Order gears and clamps separately.

SLIP CLUTCH

BORE	STYLE	TORQUE	MATERIAL
1/8" TO 1/4"	CLAMP HUB	ADJUSTABLE 0 OZ.IN. TO 100 OZ.IN.*	303 STAINLESS STEEL

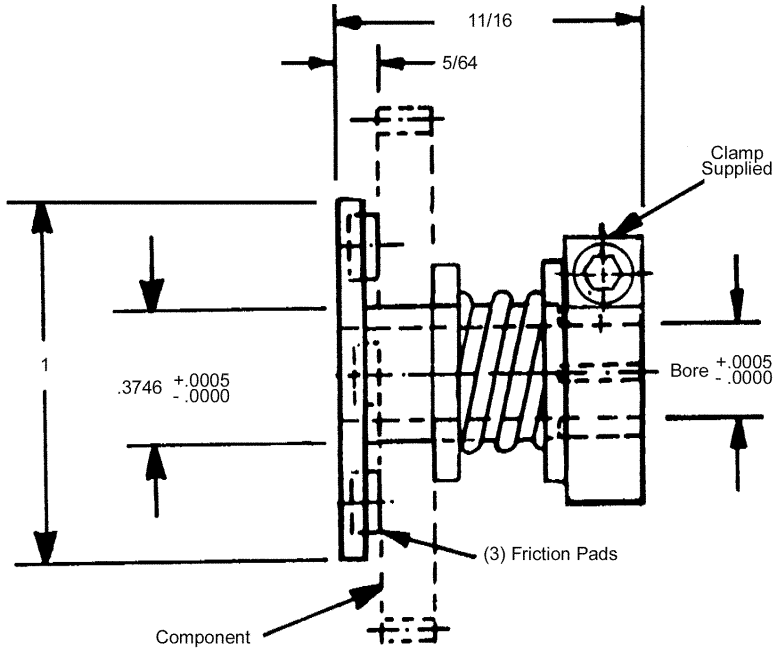

- Use with gears, sprockets, pulleys, ratchets, cams, or other components with 3/8" bores.

STOCK NO.	BORE	COMPONENT THICKNESS (IN.)	ADJUSTABLE SLIP TORQUE (IN.)
JC-7	.1248	1/16 THROUGH 1/8	1/16 - 0 TO 15 OZ. IN.
JC-8	.1873		1/8 - 5 TO 30 OZ. IN.
JC-9	.2498		
JC-7-50	.1248	1/16 THROUGH 1/8	1/16 - 15 TO 50 OZ. IN.
JC-8-50	.1873		1/8 - 25 TO 100 OZ.IN.
JC-9-50	.2498		

* Adjustable by varying spring force.

G

SLIP CLUTCH

MBORE	STYLE	TORQUE	MATERIAL
1/8" TO 1/2"	1 AND 2	BI-DIRECTIONAL 9 OZ. IN. TO 320 OZ. IN.	STAINLESS STEEL BRONZE BEARINGS

STOCK NO.	B BORE +.0007 -.0000	TORQUE BI-DIRECTIONAL	K DIA. -.0008	L	A	C	STYLE	D	T (DEPTH)	B.C.	F	Q (MAX.)	E	H
JH-1	.1248	9 OZ. IN. ± 1	.3740	1.05	.72	.18	1	.63	#0-80 x .08	.500	.080	.45	.03	.38
JH-1A	.1873	9 OZ. IN. ± 1	.3740	1.05	.72	.18	1	.63	#0-80 x .08	.500	.080	.33	.03	.38
JH-2	.1873	20 OZ. IN. ± 2	.4990	1.24	.85	.21	1	1.00	#1-72 x .10	.650	.095	.68	.04	.50
JH-3	.2498	20 OZ. IN. ± 2	.4990	1.24	.85	.21	1	1.00	#1-72 x .10	.650	.095	.68	.04	.50
JH-3A	.3123	20 OZ. IN. ± 2	.4990	1.24	.85	.21	1	1.00	#1-72 x .10	.650	.095	.68	.04	.50
JH-4	.2498	48 OZ. IN. ± 5	.4990	1.39	.94	.23	1	1.25	#2-56 x .11	.925	.130	.68	.04	.50
JH-4A	.3123	48 OZ. IN. ± 5	.4990	1.39	.94	.23	1	1.25	#2-56 x .11	.925	.130	.68	.04	.50
JH-5	.2498	80 OZ. IN. ± 8	.4990	1.39	.94	.23	1	1.50	#2-56 x .11	.925	.130	.68	.04	.63
JH-5A	.3123	80 OZ. IN. ± 8	.4990	1.39	.94	.23	1	1.50	#2-56 x .11	.925	.130	.68	.04	.63
JH-6	.2498	120 OZ. IN. ± 12	.4990	1.67	1.20	.25	1	1.87	#4-40 x .15	.750	.130	.68	.04	.63
JH-6A	.3123	120 OZ. IN. ± 12	.4990	1.67	1.20	.25	1	1.87	#4-40 x .15	.750	.130	.68	.04	.63
JH-7	.2498	240 OZ. IN. ± 24	.7490	1.88	1.34	.29	2	2.25	#4-40 x .17	1.170	.130	.74	.04	1.00
JH-8	.3123													
JH-9	.3748													
JH-10	.4998													
JH-7-X	.2498	320 OZ. IN. ± 24	.7490	1.88	1.34	.29	2	2.25	#4-40 x .17	1.170	.130	.74	.04	1.00
JH-8-X	.3123													
JH-9-X	.3748													
JH-10-X	.4998													

- Torques from 1/2 oz. in. to 480 oz. in. are available on request.
- Torque limits calibrated to 5% on request.

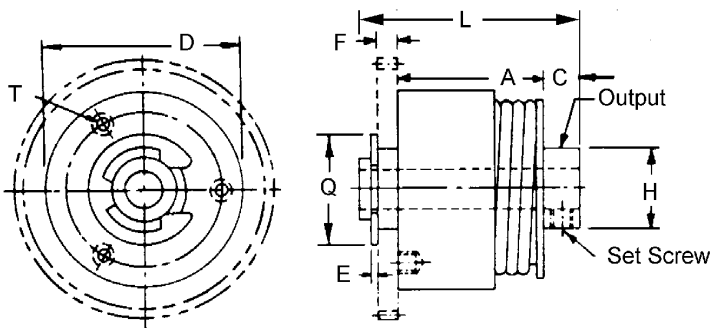

STYLE 1

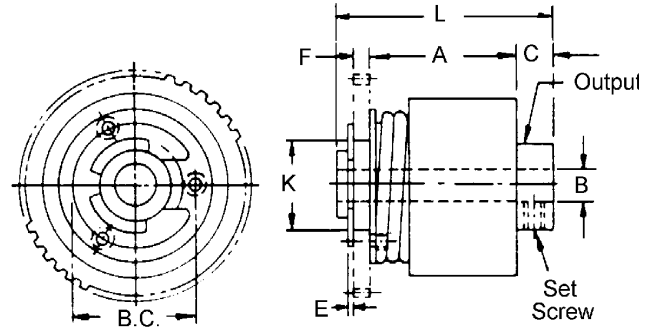

STYLE 2

MINIATURE SLIP CLUTCH

BORE	STYLE	TORQUE	MATERIAL
1/8" TO 1/4"	CLAMP HUB	ADJUSTABLE 0 OZ.IN. TO 50 OZ.IN.*	ANODIZED ALUMINUM

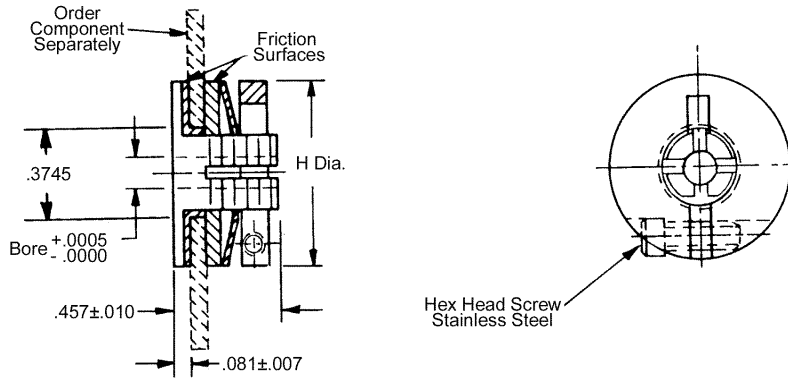

STOCK NO.	H	BORE	COMPONENT THICKNESS (IN.)
JA-4	.625	.1248	1/16 THROUGH 1/8
JA-5	.625	.1873	
JA-6	.750	.2498	

- Use with gears, sprockets, pulleys, ratchets, cams, or other components with 3/8" bores.

Special bore sizes available on request.

* Adjusted by varying spring force.

SLIP CLUTCHES AND COUPLINGS

BORE	TORQUE	MATERIAL
1/4" TO 5/16"	ADJUSTABLE 3.4 OZ.IN. TO 187.4 OZ.IN.	STAINLESS STEEL BRONZE BEARING

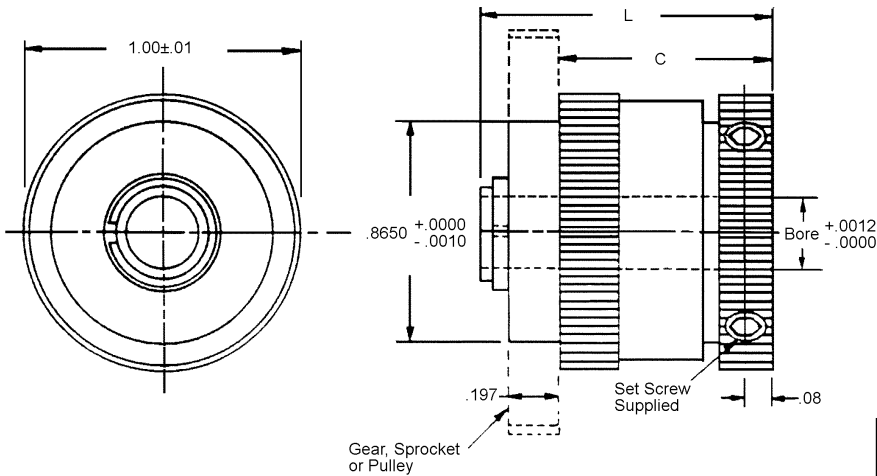

- Maximum operating temperature 175°F
- Maximum backlash 2°
- Bi-directional
- Fine-knurled torque adjustment rings

STOCK NO.	BORE	L	C	ADJUSTABLE TORQUE RANGE		WEIGHT
				MIN.	MAX.	
JH-11	.2500			3.4	76.0	37g
JH-12	.3125	1.04	.79	IN. OZ.	IN. OZ.	
JH-13	.2500			11.0	187.4	48g
JH-14	.3125	1.28	1.03	IN. OZ.	N. OZ.	

BORE	STYLE	TORQUE	MATERIAL
1/8" TO 1/2"	OPEN OR CLOSED	ADJUSTABLE 4.80 OZ.IN. TO 400 OZ.IN.	STAINLESS STEEL BRONZE BEARING

SHAFT TO COMPONENT	SHAFT TO SHAFT	ØB +.002 -.000	ØA	C	ØD	E	ØG	ADJUSTABLE TORQUE RANGE	STYLE
JCL-1 JCL-2 JCL-3	JCO-1 JCO-2 JCO-3	.125 .187 .250	1.00	1.31	.50	.25	.750	4.8 TO 160 IN. OZ.	CLOSED
JCL-4 JCL-5 JCL-6	JCO-4 JCO-5 JCO-6	.250 .375 .500	1.50	2.50	1.00	.37	1.250	8 TO 400 IN. OZ.	OPEN

**SLIP COUPLING
JCO SERIES - CLOSED**

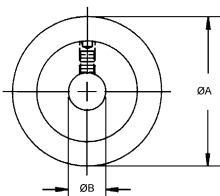

**SLIP CLUTCH
JCL SERIES - CLOSED**

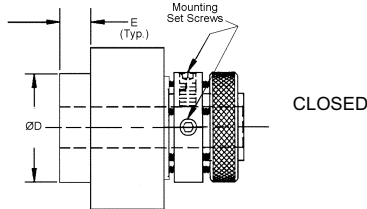
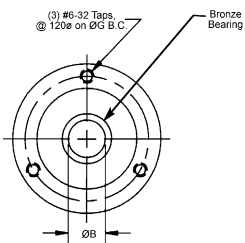

**SLIP COUPLING
JCO SERIES - OPEN**

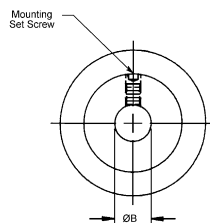

**SLIP CLUTCH
JCL SERIES - OPEN**

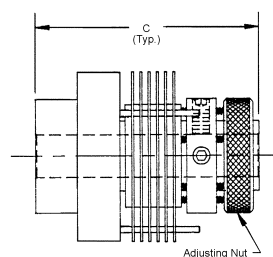
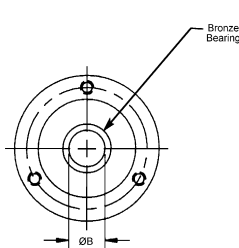

ROLLER CLUTCHES

BORE	STYLE	MATERIAL
1/8" TO 3/4"	DRAWN CUP DESIGN ONE DIRECTIONAL DRIVE	ROLLER CUP - CASE HARDENED STEEL; NEEDLE BEARINGS - 52100 HARDENED CHROME STEEL; SPRINGS - STAINLESS STEEL; CAGE - NYLON 66 (or Equiv.)

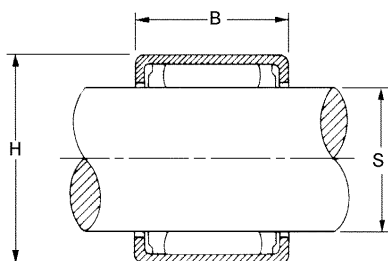

- Ideal For Indexing, Backstopping Or Overrunning Operations
- Free Rolling One Way, Drives In Opposite Direction
- Light Weight, Low Profile
- High Indexing, Frequency
- Temp. Range, Grease - 50°F To + 160°F

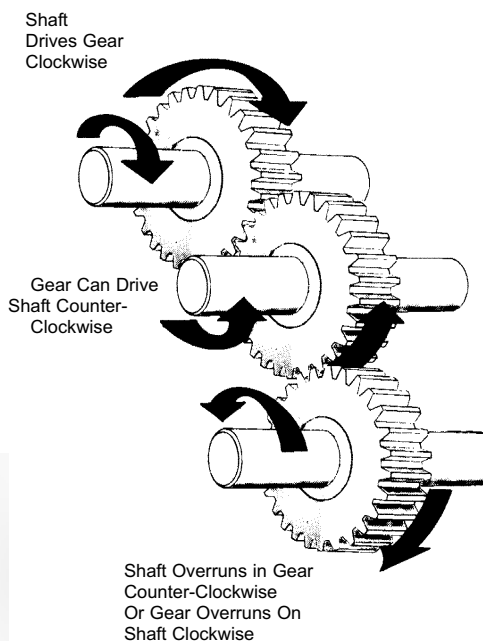

STOCK NO.	BORE	H CLUTCH (O.D.)	B + .000 - .008	MAX TORQ LB. IN.	HOUSING DIAMETER + .0010 - .0000	OVERRUN SPEED (MAX) (RPM)
NRC-2**	1/8	9/32	.250	2.86	.2812	50,000
NRC-4	1/4	7/16	.500	18.6	.4370	21,000
NRC-6	3/8	5/8	.500	50.4	.6245	14,000
NRC-8	1/2	3/4	.500	85.9	.7495	11,000
NRC-10	5/8	7/8	.625	175.2	.8745	8,500
NRC-12	3/4	1"	.625	247.8	.9995	7,000

* HARDENED SHAFTING STOCK LENGTH 12 INCHES OTHER LENGTHS ON REQUEST	
SHAFTING STOCK NO.	SHAFT DIAMETER S + .0000 - .0005
---	.1250
---	.2500
LMS-46-12	.3750
LMS-48-12	.5000
LMS-50-12	.6250
LMS-52-12	.7500

*Order Shaft Separately.

** Utilizes a one-piece cage of acetal resin plastic with integral leaf style spring.



BEARING, SHAFTS, CLAMPS, COLLARS, HUBS & KEYS

Table of Contents

HUBS

Gear, Dial and Sprocket Assemblies - Tech Info.	2
Phase Adjustable Hub	3
Hubs - Quick To Lock	4
Gear, Sprocket and Dial Hubs	5 - 17
Dual Gear Hubs	8

CLAMPS

Split Hub Clamps	9 - 13
Shaft Clamp	14
Threaded Shaft Clamp	15
Squeeze Clamp	16

COLLARS

Set Screw Collars	17 - 18
-----------------------------	---------

SHAFTS

Plastic Rod Stock	19
Threaded Stock	20
Case Hardened and Ground Shafts	21
Stainless Ground Shafts	22 - 26
Ultra Ground Shafting	27

WOODRUFF KEYS	28
--------------------------------	----

BEARINGS

Dyna-Speed Needle Roller Bearings	29
Ball Bearings	30 - 36
Angular Contact Ball Bearings	37
Oil-Less Bearings	38 - 41
Precision Bearings	42 - 43
Thermoplastic Bearings - Reference Chart	44
Thermoplastic Bearings	45 - 46
Journal Bearings	47 - 48
Composit Annular Bearings	49
Composit Spherical Bearings	50
Spherical Bearings	51
Thermoplastic Spherical Bearings	52
Thrust Bearings	53
Roller Thrust Bearings	54



GEAR, DIAL AND SPROCKET ASSEMBLIES

Technical Information

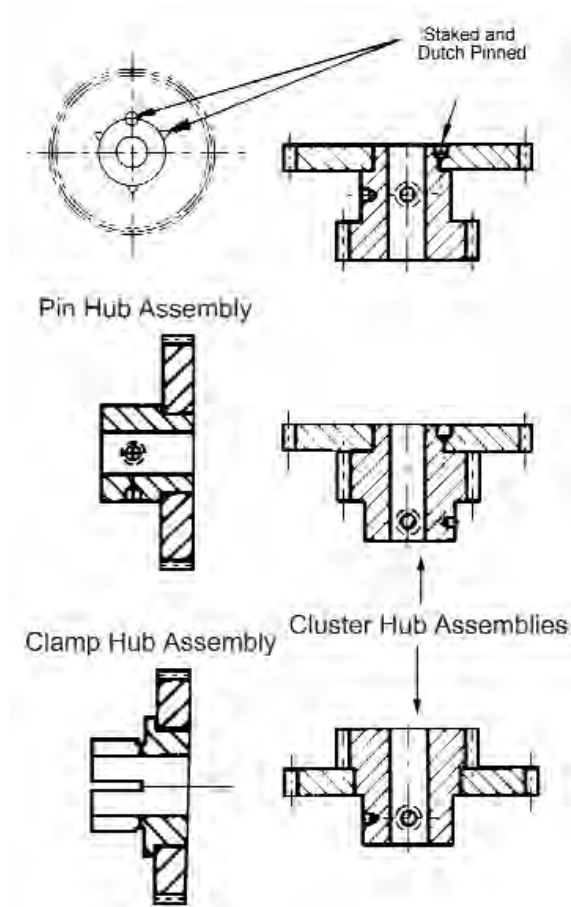

W.M. Berg has a wide selection of hub sizes and styles to select from. Our all stainless steel hubs are available in bore diameters ranging from 5/64" to 1 1/4".

See the following pages for pin hub, clamp hubs and dual hubs, see index for cluster gears. W.M. Berg assembles hubless gears, sprockets or dials to hubs for a nominal assembly charge. Contact our Customer Service Department for more information.

PHASE ADJUSTABLE HUB

BORE	TYPE	MATERIAL
.1200" TO .2498"	PIN HUB 360° ADJUSTABLE BI-DIRECTIONAL	303 STAINLESS STEEL

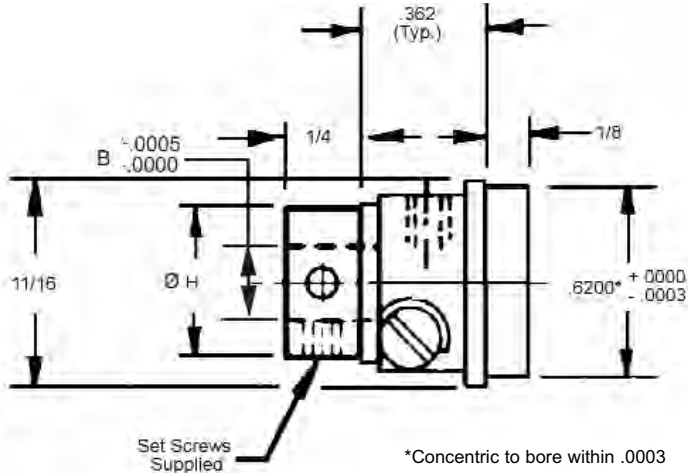

STOCK NO.	B BORE	ØH
PH6-4	.1200	5/16
PH6-1	.1248	5/16
PH6-2	.1873	3/8
PH6-3	.2498	1/2

BORE	TYPE	MATERIAL
.1200" TO .2498"	CLAMP HUB 360° ADJUSTABLE BI-DIRECTIONAL	303 STAINLESS STEEL

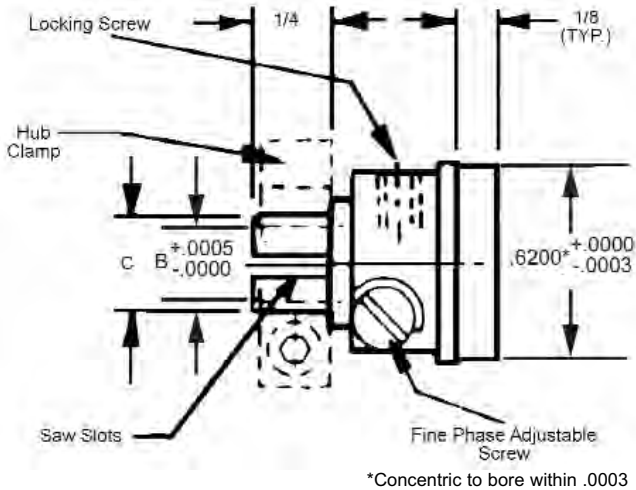

STOCK NO.	B BORE	C	HUB CLAMP NO. (ORDER SEPARATELY)
CH6-4	.1200	3/16	CG1-25
CH6-1	.1248	3/16	CG1-25
CH6-2	.1873	1/4	CG1-9
CH6-3	.2498	5/16	CG1-12

HUBS - QUICK TO LOCK

BORE	TYPE	MATERIAL
3/16" TO 3/4"	CLAMP HUB	303 STAINLESS STEEL

STOCK NO.	ØB	ØD	L	E	A	C	MAX. TRANSMISSIBLE		CONTACT PRESSURE		INSTALLATION TORQUE ON NUT IN. LBS	WT. OZ.
							TORQUE IN. LBS.	THRUST LBS.	ON HUB LBS./SQ.IN	ON SHAFT LBS./SQ.IN		
QH-3S	3/16	5/8	3/4	3/8	1/2	1/8	100	700	5200	6800	125	1/2
QH-4S	1/4	5/8	3/4	3/8	1/2	1/8	150	788	5200	5700	125	1/2
QH-5S	5/16	3/4	7/8	7/16	5/8	1/8	200	892	3700	3650	150	1
QH-6S	3/8	3/4	7/8	7/16	5/8	1/8	250	925	3700	3050	150	1
QH-8S	1/2	7/8	1	1/2	3/4	3/16	350	980	2700	2500	175	1 1/2
QH-10S	5/8	1	1 1/8	5/8	7/8	3/16	450	995	1800	1580	200	2
QH-11S	11/16	1 1/2	1 1/2	3/4	1 1/4	3/16	1800	3500	5000	5500	1200	8
QH-12S	3/4	1 1/2	1 1/2	3/4	1 1/4	3/16	1800	4000	5000	5000	1200	8

BORE	TYPE	MATERIAL
3/16" TO 3/4"	CLAMP HUB	TOOL STEEL

STOCK NO.	ØB	ØD	L	E	A	C	MAX. TRANSMISSIBLE		CONTACT PRESSURE		INSTALLATION TORQUE ON NUT IN. LBS	WT. OZ.
							TORQUE IN. LBS.	THRUST LBS.	ON HUB LBS./SQ.IN	ON SHAFT LBS./SQ.IN		
QH-3T	3/16	5/8	3/4	3/8	1/2	1/8	100	700	5200	6800	125	1/2
QH-4T	1/4	5/8	3/4	3/8	1/2	1/8	150	788	5200	5700	125	1/2
QH-5T	5/16	3/4	7/8	7/16	5/8	1/8	200	892	3700	3650	150	1
QH-6T	3/8	3/4	7/8	7/16	5/8	1/8	250	925	3700	3050	150	1
QH-8T	1/2	7/8	1	1/2	3/4	3/16	350	980	2700	2500	175	1 1/2
QH-10T	5/8	1	1 1/8	5/8	7/8	3/16	450	995	1800	1580	200	2
QH-11T	11/16	1 1/2	1 1/2	3/4	1 1/4	3/16	1800	3500	5000	5500	1200	8
QH-12T	3/4	1 1/2	1 1/2	3/4	1 1/4	3/16	1800	4000	5000	5000	1200	8

- Quick and easy installation - just tighten the nut
 - Positive release for removal or adjustment
 - Eliminates expensive machining operations such as cutting of keyways, turning of snap ring grooves, splines, shoulders and threads for lock nuts, drilling and pinning
 - Drastically relaxes shaft and hub tolerances, permitting the use of commercially finished shafting
 - Smaller diameter shafts (and bearings) may be used, offering equal strength and stiffness because of the rigidizing effect of quick-2-lock and because of the elimination of keyways
 - Infinite lateral and easy circumference positioning
 - Quick and easy removal
 - Excellent concentricity ØB to ØD within .002"
 - Greater shaft strength and stiffness
 - Unaffected by vibration and torque reversal
 - Available in metric shaft sizes 5mm through 16mm
- The "torque on nut" column represents values which are necessary to obtain the maximum transmissible torque/thrust.

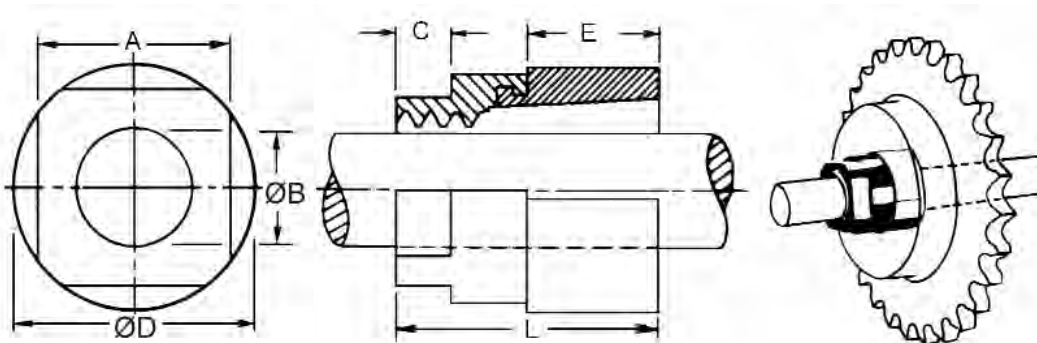

GEAR, SPROCKET AND DIAL HUBS

BORE					TYPE				MATERIAL															
5/64" TO 1 1/4"					PIN HUB				303 STAINLESS STEEL															
STOCK NO.	B +.0005 +.0000	A +.0005 +.0000	T	L	H	SPOT DRILL	SET SCREW	STOCK NO.	B +.0005 +.0000	A +.0005 +.0000	T	L	H	SPOT DRILL	SET SCREW									
PH4-27 PH4-28	.0781	.3750	.062 .125	.22	7/16	#69	#2-56	PH1-20 PH1-62 PH4-62 PH4-63 PH2-7 PH2-5 PH2-23	.3748	.6875	.062 .093 .125 .187 .250 .375 .575	.50	1	#42	#8-32									
PH4-29 PH4-30	.0900		.062 .125					.46																
PH4-31 PH4-32	.0937		.062 .125																					
PH4-7 PH4-8	.1200		.062 .125																					
PH4-1 PH1-3 PH4-2 PH2-12 PH2-1 PH2-10	.1248	.3750	.062 .093 .125 .187 .250 .575	.22 .23 .22 .22 .22 .19	7/16	#69 #60 #69 #69 #69 #60	#2-56 #4-40 #2-56 #2-56 #2-56 #4-40		PH1-24 PH1-64 PH4-64 PH4-65 PH1-27 PH1-28 PH1-36 PH2-29	.4998	.6875	.062 .093 .125 .187 .250 .375 .500 .575	.50	1 1/4	#42 #42 #31 #31 #42 #42 #42 #42	#8-32 #8-32 #10-32 #8-32 #8-32 #8-32 #8-32								
PH4-33 PH4-34			.1562	.062 .125	.46																			
PH4-3 PH1-8 PH4-4 PH2-13 PH2-2 PH2-11			.1873	.3750		.062 .093 .125 .187 .250 .575	.22 .23 .22 .22 .22 .19	7/16 7/16 7/16 1/2 7/16 7/16	#60 #60 #60 #50 #60 #50			#4-40 #4-40 #4-40 #4-40 #4-40 #6-32					PH1-30 PH1-31 PH1-32 PH1-33 PH1-34 PH2-35	.6250	1.374	1/8 3/16 1/4 3/8 1/2 .575	.75	1 1/2	#31	1/4-20
PH4-35 PH4-36						.2405	.062 .125	.70																
PH4-5 PH1-13 PH4-6 PH2-14 PH2-3 PH2-15	.2498	.3750				.062 .093 .125 .187 .250 .575	.25 .22 .25 .25 .22 .18		1/2 7/16 1/2 1/2 1/2 7/16	#50	#6-32	PH1-38 PH1-39 PH1-40 PH1-41 PH1-42 PH2-43	.7500	1.374	1/8 3/16 1/4 3/8 1/2 .575	.75	1 1/2			#31				
PH2-4					.3123	.250	.96																	
PH1-16 PH1-60 PH4-61 PH2-8 PH2-9 PH2-19			.3123	.6875	.062 .093 .125 .187 .250 .375 .575	.50			7/8	#42 #42 #50 #50 #42 #42 #42	#8-32 #8-32 #6-32 #6-32 #8-32 #8-32 #8-32	PH1-54 PH1-55 PH1-56 PH1-57 PH1-58 PH2-59			1.0000			1.374	1/8 3/16 1/4 3/8 1/2 .575		1.00	1 3/4	#22	3/8-16
PH1-54 PH1-55 PH1-56 PH1-57 PH1-58 PH2-59					1.2500			1.374				1/8 3/16 1/4 3/8 1/2 .575							.96					

* Diameters A & B are concentric within .0005.

- Fasten component to hub with epoxy cement or stake and dutch pin
- Assembly by Berg available.

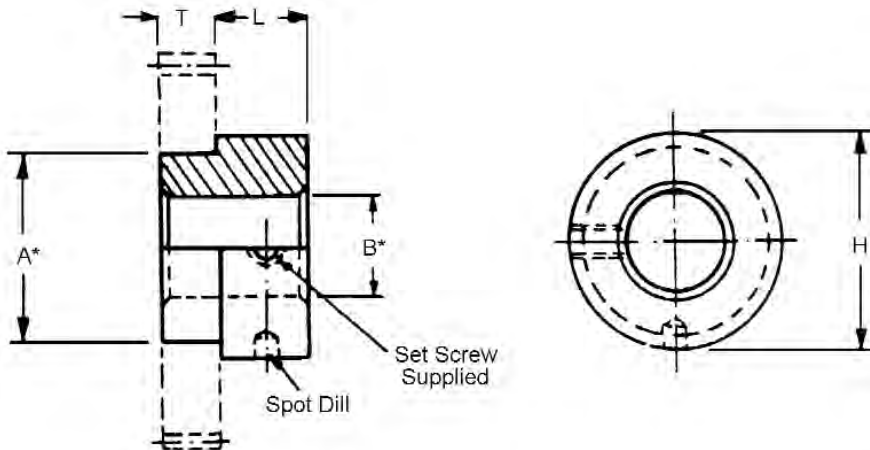

GEAR, SPROCKET AND DIAL HUBS

BORE	TYPE	MATERIAL
.0900 TO .2498	PIN HUB	303 STAINLESS STEEL

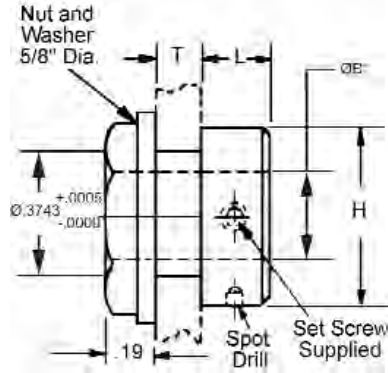

* Concentric within .0005

STOCK NO.	ØB +.0005 -.0000	T	H	L
PH4-19 PH4-20	.0900	.062 .125	7/16	.22
PH4-21 PH4-22	.0937	.062 .125		
PH4-15 PH4-16	.1200	.062 .125		
PH4-9 PH4-10	.1248	.062 .125		
PH4-23 PH4-24	.1562	.062 .125		
PH4-11 PH4-12	.1873	.062 .125		
PH4-25 PH4-26	.2405	.062 .125	1/2	.25
PH4-13 PH4-14	.2498	.062 .125		

BORE	TYPE	MATERIAL
.0900 TO .2498	CLAMP HUB	303 STAINLESS STEEL

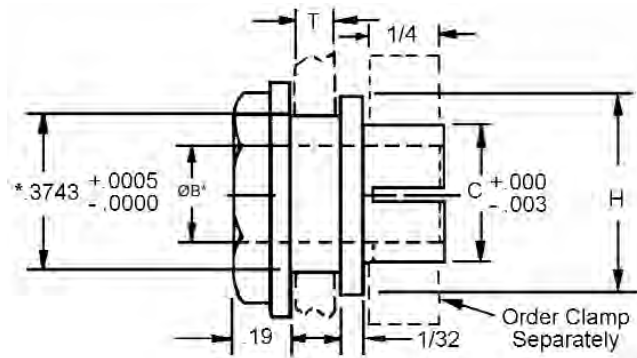

* Concentric within .0005

STOCK NO.	ØB +.0005 -.0000	T	H	C	CLAMP STOCK NO.
CH2-19 CH2-20	.0900	.062 .125	7/16	.188	CG1-5
CH2-21 CH2-22	.0937	.062 .125			
CH2-15 CH2-16	.1200	.062 .125			
CH2-9 CH2-10	.1248	.062 .125			
CH2-23 CH2-24	.1562	.062 .125			
CH2-11 CH2-12	.1873	.062 .125			
CH2-25 CH2-26	.2405	.062 .125	1/2	.312	CG1-12
CH2-13 CH2-14	.2498	.062 .125			

GEAR, SPROCKET AND DIAL HUBS

BORE	TYPE	MATERIAL
5/64" TO 1/2"	CLAMP HUB	303 STAINLESS STEEL

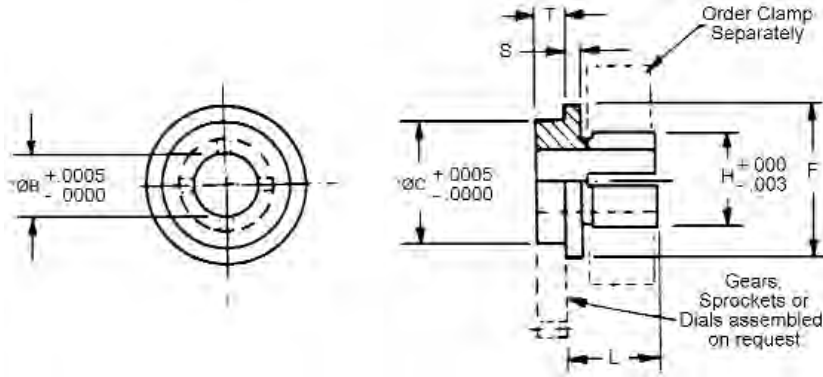

* Concentric within .0005



STOCK NO.	B	C	T	L	H	F	S	CLAMP STOCK NO.
CH2-27 CH2-28	.0781	.3750	.062 .125	.281	3/16	7/16	.031	CG1-5
CH2-29 CH2-30	.0900	.3750	.062 .125	.281	3/16	7/16	.031	CG1-5
CH2-31 CH2-32	.0937	.3750	.062 .125	.281	3/16	7/16	.031	CG1-5
CH2-7 CH2-8	.1200	.3750	.062 .125	.281	3/16	7/16	.031	CG1-5
CH2-1 CH1-3 CH2-2 CH1-35	.1248	.3750	.062 .093 .125 .187	.281 .250 .281 .281	3/16	7/16	.031 .046 .031 .046	CG1-5
CH2-33 CH2-34	.1562	.3750	.062 .125	.281	1/4	7/16	.031	CG1-9
CH2-3 CH1-7 CH2-4 CH1-40	.1873	.3750	.062 .093 .125 .187	.281 .313 .281 .281	1/4	7/16	.031 .046 .031 .046	CG1-9
CH2-35 CH2-36	.2405	.3750	.062 .125	.281	5/16	1/2	.031	CG1-12
CH2-5 CH1-11 CH2-6 CH1-43	.2498	.3750	.062 .093 .125 .187	.281 .313 .281 .344	5/16	1/2 7/16 1/2 7/16	.031 .046 .031 .046	CG1-12
CH1-13 CH1-52 CH2-60 CH2-61	.3123	.6875	.062 .093 .125 .187	.375	3/8	7/8	.062	CG1-15
CH1-16 CH1-54 CH2-62 CH2-63	.3748	.6875	.062 .093 .125 .187	.375	7/16	1	.062	CG1-18
CH1-19 CH1-56 CH2-64 CH2-65 CH1-22 CH1-23	.4998	.6875	.062 .093 .125 .187 .250 .375	.375	9/16	1 1/4	.062	CG1-19

DUAL GEAR HUBS

BORE	TYPE	MATERIAL
1/8" TO 1/2"	PIN HUB	303 STAINLESS STEEL

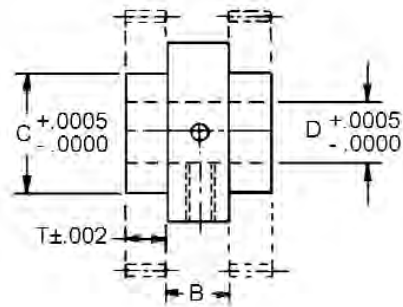
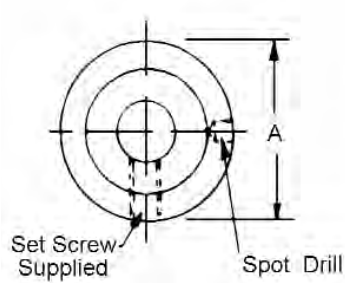

STOCK NO.	D	C	T	A	B
PH3-1	.1248	.3750	1/8	7/16	1/4
PH3-2	.1873	.3750	1/8	7/16	1/4
PH3-3	.2498	.3750	1/8	1/2	1/4
PH3-4	.3123	.3750	1/8	1/2	1/4
PH3-5	.3748	.6872	3/8	1	1/2
PH3-6	.4998	.6872	1/4	1 1/4	1/2

- Assembly available
- Gears are triple staked and dutch pinned at assembly
- Components may also be assembled to hubs with epoxy cement
- Order gears separately

SPLIT HUB CLAMPS

BORE	TYPE	MATERIAL
.103" TO .562"	COMPACT CLAMP DESIGN	303 STAINLESS STEEL OR ALUMINUM ANODIZED

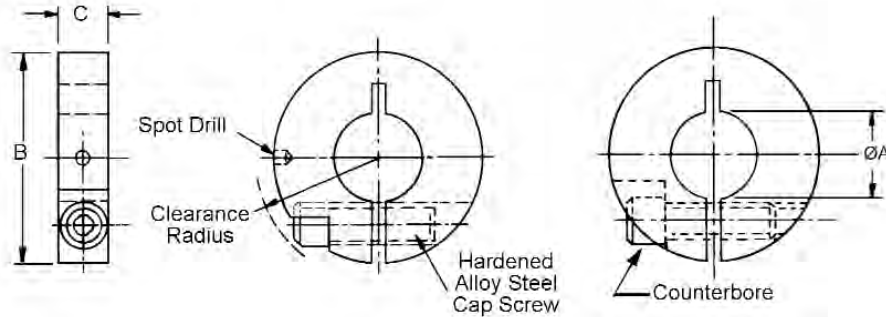

Note: Some sizes may be full or semi-counterbored or step cut at manufacturer's option.

STAINLESS STEEL STOCK NO.	ANODIZED ALUMINUM STOCK NO.	ØA DIA.	B DIA.	C	CLEAR. RADIUS	CAP SCREW THREAD	SPOT DRILL DIA.	SPLIT HUB INSIDE DIA. (Ref.)
CG1-1	CG1-1-A	.103	1/2	5/32	5/16	#3-48	1/16	-
CG1-2	CG1-2-A	.125	1/2	5/32	5/16	#3-48	1/16	-
CG1-20	CG1-20-A	.125	9/16	5/32	3/8	#2-56	-	-
CG1-21	CG1-21-A	.125	5/8	5/32	3/8	#2-56	-	-
CG1-3	CG1-3-A	.141	1/2	5/32	5/16	#3-48	1/16	-
CG1-22	CG1-22-A	.188	9/16	1/8	3/8	#1-72	-	-
CG1-23	CG1-23-A	.188	9/16	5/32	3/8	#2-56	-	5/64
CG1-4	CG1-24-A	.188	5/8	5/32	11/32	#2-56	-	TO
CG1-5	-	.188	5/8	3/16	3/8	#4-40	1/16	1/8
CG1-25	CG1-25-A	.188	7/8	1/4	33/64	#6-32	-	-
CG1-6	-	.219	5/8	5/32	11/32	#2-56	1/16	-
CG1-26	CG1-26-A	.250	9/16	1/8	3/8	#1-72	-	-
CG1-27	CG1-27-A	.250	9/16	5/32	3/8	#2-56	-	5/32
CG1-28	CG1-28-A	.250	5/8	5/32	3/8	#2-56	-	& 3/16
CG1-8	CG1-8-A	.250	7/8	3/16	31/64	#4-40	1/8	-
CG1-9	CG1-9-A	.250	7/8	1/4	33/64	#6-32	-	-
CG1-10	-	.281	7/8	1/4	33/64	#6-32	1/8	-
CG1-11	-	.312	7/8	3/16	31/64	#4-40	1/8	.2405
CG1-12	CG1-12-A	.312	7/8	1/4	33/64	#6-32	-	& 1/4
CG1-14	CG1-14-A	.375	1 1/8	1/4	21/32	#8-32	3/16	-
CG1-15	CG1-15-A	.375	1 1/4	5/16	11/16	#8-32	-	5/16
CG1-31	-	.375	1 1/4	5/16	5/8	#8-32	-	-
CG1-17	CG1-17-A	.437	1 1/8	1/4	21/32	#8-32	3/16	-
CG1-18	CG1-18-A	.437	1 1/4	5/16	11/16	#8-32	-	3/8
CG1-32	-	.437	1 1/4	5/16	5/8	#8-32	-	-
CG1-19	CG1-19-A	.562	1 1/4	5/16	11/16	#8-32	-	1/2
CG1-33	-	.562	1 1/4	5/16	5/8	#8-32	-	-

Special clamps are available on request.

SPLIT HUB CLAMPS

SHAFT SIZE	MATERIAL
1/8" TO 3/8"	STAINLESS STEEL AND MILD STEEL

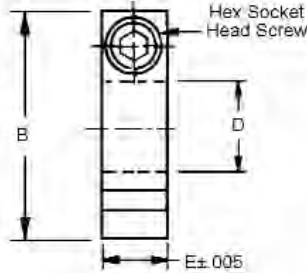
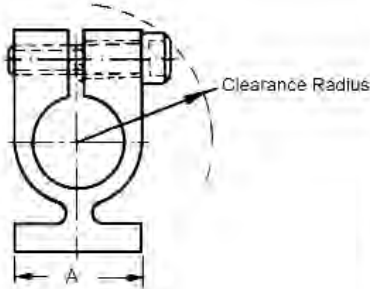

STOCK NO.	MATERIAL	D	A	B	CLEAR. RADIUS	E	SCREW	FINISH	SHAFT SIZE
CG3-1	416 STAINLESS STEEL	.188	.312	.687	7/16	.240	# 6-32	CLEAR PASS.	1/8
CG3-2	416 STAINLESS STEEL					.240	# 6-32	BLACK PASS	
CG3-7	303 STAINLESS STEEL					.250	# 6-32	CLEAR PASS.	
CG3-28	MILD STEEL					.140	# 2-56	CAD.PLATE	
CG3-3	416 STAINLESS STEEL	.251	.378	.812	33/64	.240	# 6-32	CLEAR PASS.	3/16
CG3-4	416 STAINLESS STEEL					.240	# 6-32	BLACK PASS	
CG3-9	303 STAINLESS STEEL					.250	# 6-32	CLEAR PASS.	
CG3-30	MILD STEEL					.140	# 2-56	CAD. PLATE	
CG3-5	416 STAINLESS STEEL	.313	.437	.812	9/16	.240	# 6-32	CLEAR PASS.	1/4
CG3-6	416 STAINLESS STEEL					.240	# 6-32	BLACK PASS	
CG3-11	303 STAINLESS STEEL					.250	# 6-32	CLEAR PASS.	
CG3-32	MILD STEEL					.140	# 2-56	CAD.PLATE	
CG3-13	303 STAINLESS STEEL	.376	.500	.875	9/16	.250	# 6-32	CLEAR PASS.	5/16
CG3-14	MILD STEEL					.250	# 6-32	CAD.PLATE	
CG3-34	MILD STEEL					.140	# 2-56	CAD.PLATE	
CG3-15	303 STAINLESS STEEL	.438	.625	1.032	43/64	.250	# 6-32	CLEAR PASS.	3/8
CG3-16	MILD STEEL					.250	# 6-32	CAD. PLATE	
CG3-36	MILD STEEL					.140	# 2-56	CAD. PLATE	

SHAFT SIZE	TYPE	MATERIAL
1/8" TO 3/8"	BALANCED CLAMP	STAINLESS STEEL AND MILD STEEL

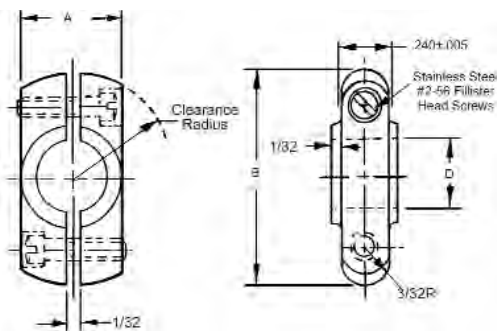

STOCK NO.	D	A	B	TYPE CLEAR. RADIUS	SPLIT HUB OF BALANCE	INSIDE DIA. (REF.)
CG2-1	.188	.312	.718	3/8	DYNAMICALLY BALANCED	1/8
CG2-3	.251	.374	.750	13/32		3/16
CG2-5	.313	.436	.875	15/32		1/4
CG2-2	.188	.312	.718	3/8	AS CAST	1/8
CG2-4	.251	.374	.750	13/32		3/16
CG2-6	.313	.436	.875	15/32		1/4

SPLIT HUB CLAMPS

SHAFT SIZE	TYPE	MATERIAL
1/8" TO 3/8"	BALANCED CLAMP	416 STAINLESS STEEL AND 303 STAINLESS STEEL

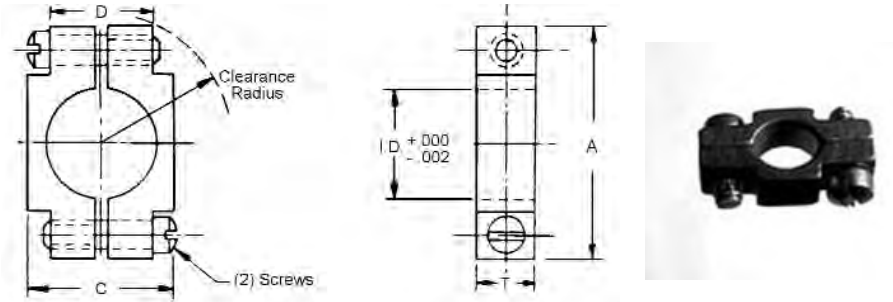

STOCK NO.	MATERIAL	INSIDE DIA.	T	A	C	D	SCREW	SPLIT HUB CLEARANCE RADIUS	INSIDE DIA. (Ref.)
CG2-7	416 STAINLESS STEEL	.187	.156	.500	.286	.176	#2-56	9/32	1/8
CG2-8		.250	.187	.590	.350	.235	#3-48	11/32	3/16
CG2-9		.312	.187	.687	.420	.286	#4-40	13/32	1/4
CG2-10		.375	.187	.781	.510	.336	#4-40	15/32	5/16
CG2-11		.437	.250	.890	.636	.365	#6-32	35/64	3/8
CG2-27	303 STAINLESS STEEL	.187	.156	.500	.286	.176	#2-56	9/32	1/8
CG2-28		.250	.187	.590	.350	.235	#3-48	11/32	3/16
CG2-29		.312	.187	.687	.420	.286	#4-40	13/32	1/4
CG2-30		.375	.187	.781	.510	.336	#4-40	15/32	5/16
CG2-31		.437	.250	.890	.636	.365	#6-32	35/64	3/8

SHAFT SIZE	TYPE	MATERIAL
1/8" TO 1/4"	BALANCED CLAMP	303 STAINLESS STEEL OR 2024 ALUMINUM ANODIZED

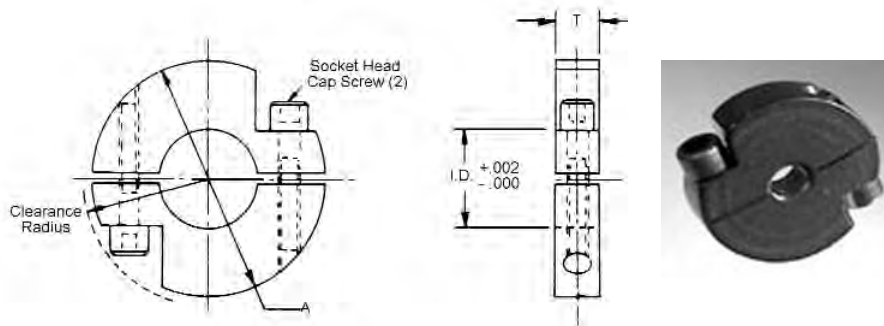

STOCK NO.	MATERIAL	INSIDE DIA.	T	A	SCREW	SPLIT HUB CLEARANCE RADIUS	SPLIT HUB INSIDE DIA. (REF.)
CG2-12-S	STAINLESS STEEL	.125	.156	.562	#2-56	25/64	-
CG2-12-A	ALUMINUM	.125					-
CG2-13-S	STAINLESS STEEL	.188	.250	.875	#6-32	33/64	1/8
CG2-13-A	ALUMINUM	.188					1/8
CG2-15-S	STAINLESS STEEL	.250	.250	.875	#6-32	33/64	3/16
CG2-15-A	ALUMINUM	.250					3/16
CG2-14-S	STAINLESS STEEL	.188	.250	.875	#6-32	33/64	1/8
CG2-14-A	ALUMINUM	.188					1/8
CG2-16-S	STAINLESS STEEL	.250	.250	.875	#6-32	33/64	3/16
CG2-16-A	ALUMINUM	.250					3/16
CG2-17-S	STAINLESS STEEL	.313	.250	.875	#6-32	33/64	1/4
CG2-17-A	ALUMINUM	.313					1/4

SPLIT HUB CLAMPS

SHAFT SIZE	TYPE	MATERIAL
1/8" TO 1/2"	SCREW TYPE CLAMP	303 STAINLESS STEEL OR 2024 ALUMINUM ANODIZED

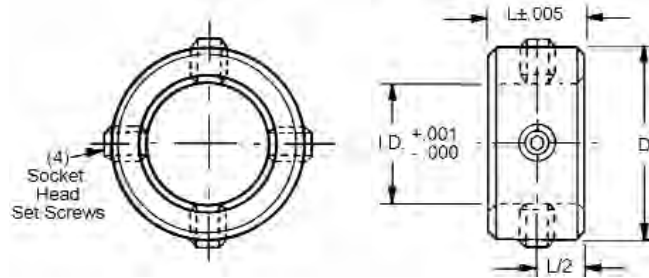

STAINLESS STEEL STOCK NO.	ALUMINUM STOCK NO.	INSIDE DIA.	D	L	SET SCREW	SPLIT HUB INSIDE DIA. (Ref.)
CS-36	-	.0995	.312	.125	#2-56	-
CS-28	CS-32	.1255	.375	.250	#4-40	-
CS-29	CS-33	.1880	.375	.250	#4-40	1/8
CS-30	CS-34	.2505	.500	.250	#6-32	3/16
CS-31	CS-35	.3130	.500	.250	#6-32	1/4
CS-40	CS-43	.3750	.750	.312	#10-32	5/16
CS-41	CS-44	.4370	.750	.312	#10-32	3/8
CS-42	CS-45	.5620	.875	.312	#10-32	1/2



SHAFT SIZE	TYPE	MATERIAL
1/8" TO 3/16"	SCREW TYPE CLAMP	416 STAINLESS STEEL

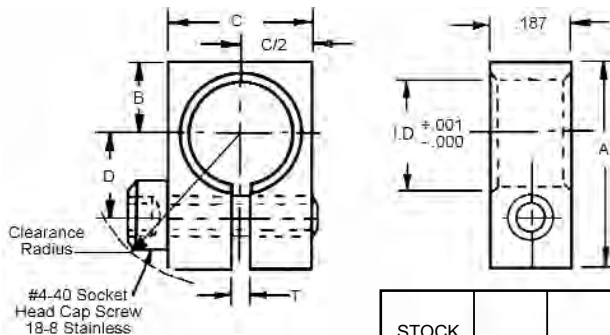

STOCK NO.	I.D.	A	C	D	B	T	CLEAR. RADIUS	SPLIT HUB INSIDE DIA. (Ref.)
CG4-1	.125	23/64	.218	.133	.109	.031	21/64	-
CG4-2	.187	27/64	.281	.165	.141	.040	25/64	1/8
CG4-3	.250	31/64	.344	.196	.172	.040	7/16	3/16

SPLIT HUB CLAMPS

SHAFT SIZE	TYPE	MATERIAL
1/8" TO 3/8"	TYPE I AND TYPE II	303 STAINLESS STEEL, MILD STEEL CADMIUM PLATED OR 416 STAINLESS STEEL RC 38-45

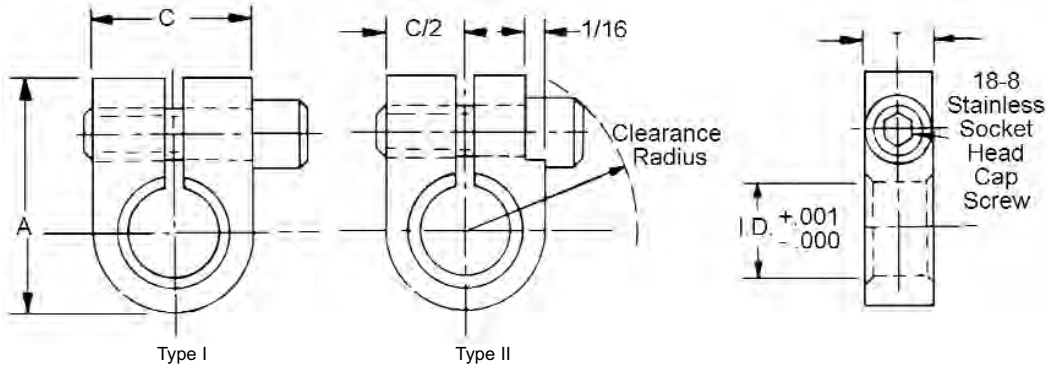

TYPE I								
STOCK NO.	MATERIAL	INSIDE DIA.	C	A	T	SCREW THREAD	SPLIT HUB CLEARANCE RADIUS	INSIDE DIA. (Ref.)
CG5-24	MILD STEEL	.188	.312	.468	.140	#2-56	11/32	1/8
CG5-25	MILD STEEL	.251	.375	.500	.140	#2-56	25/64	3/16
CG5-26	MILD STEEL	.313	.437	.593	.140	#2-56	7/16	1/4
CG5-27	MILD STEEL	.376	.500	.656	.140	#2-56	15/32	5/16
CG5-28	MILD STEEL	.438	.625	.781	.140	#2-56	9/16	3/8
CG5-14	MILD STEEL	.188	.312	.468	.250	#6-32	27/64	1/8
CG5-15	MILD STEEL	.251	.375	.562	.250	#6-32	1/2	3/16
CG5-16	MILD STEEL	.313	.437	.593	.250	#6-32	33/64	1/4
CG5-17	MILD STEEL	.376	.500	.656	.250	#6-32	9/16	5/16
CG5-18	MILD STEEL	.438	.625	.781	.250	#6-32	41/64	3/8
CG5-29	303	.188	.312	.468	.250	#6-32	27/64	1/8
CG5-30	303	.251	.375	.562	.250	#6-32	1/2	3/16
CG5-31	303	.313	.437	.593	.250	#6-32	33/64	1/4
CG5-32	303	.376	.500	.656	.250	#6-32	9/16	5/16
CG5-33	303	.438	.625	.781	.250	#6-32	41/64	3/8
CG5-34	416	.188	.312	.468	.250	#6-32	27/64	1/8
CG5-35	416	.251	.375	.562	.250	#6-32	1/2	3/16
CG5-36	416	.313	.437	.593	.250	#6-32	33/64	1/4
CG5-37	416	.376	.500	.656	.250	#6-32	9/16	5/16
CG5-38	416	.438	.625	.781	.250	#6-32	41/64	3/8

TYPE II								
STOCK NO.	MATERIAL	INSIDE DIA.	C	A	T	SCREW THREAD	SPLIT HUB CLEARANCE RADIUS	INSIDE DIA. (Ref.)
CG5-19	MILD STEEL	.188	.312	.468	.140	#2-56	5/16	1/8
CG5-20	MILD STEEL	.251	.375	.500	.140	#2-56	23/64	3/16
CG5-21	MILD STEEL	.313	.437	.593	.140	#2-56	25/64	1/4
CG5-22	MILD STEEL	.376	.500	.656	.140	#2-56	7/16	5/16
CG5-23	MILD STEEL	.438	.625	.781	.140	#2-56	33/64	3/8
CG5-9	MILD STEEL	.188	.312	.468	.250	#6-32	3/8	1/8
CG5-10	MILD STEEL	.251	.375	.562	.250	#6-32	29/64	3/16
CG5-11	MILD STEEL	.313	.437	.593	.250	#6-32	15/32	1/4
CG5-12	MILD STEEL	.376	.500	.656	.250	#6-32	33/64	5/16
CG5-13	MILD STEEL	.438	.625	.781	.250	#6-32	19/32	3/8
CG5-39	303	.188	.312	.468	.250	#6-32	3/8	1/8
CG5-40	303	.251	.375	.562	.250	#6-32	29/64	3/16
CG5-41	303	.313	.437	.593	.250	#6-32	15/32	1/4
CG5-42	303	.376	.500	.656	.250	#6-32	33/64	5/16
CG5-43	303	.438	.625	.781	.250	#6-32	19/32	3/8
CG5-44	416	.188	.312	.468	.250	#6-32	3/8	1/8
CG5-45	416	.251	.375	.562	.250	#6-32	29/64	3/16
CG5-46	416	.313	.437	.593	.250	#6-32	15/32	1/4
CG5-47	416	.376	.500	.656	.250	#6-32	33/64	5/16
CG5-48	416	.438	.625	.781	.250	#6-32	19/32	3/8

SHAFT CLAMP

SHAFT SIZE	MATERIAL
3/32" TO 3/16"	416 STAINLESS STEEL

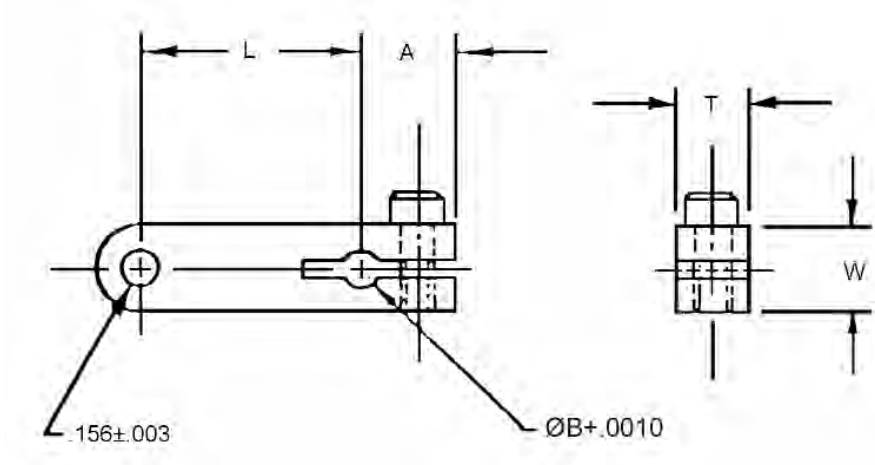

STOCK NO	A	ØB	L	T	W
CG7-1	.250	.0938	.625	.190	.250
CG7-2	.250	.1250	.625	.190	.250
CG7-3	.250	.1875	.625	.190	.312



THREADED SHAFT CLAMP

THREAD SIZE	MATERIAL
1/4 X 20 TO 3/4 X 10	12L14 STEEL

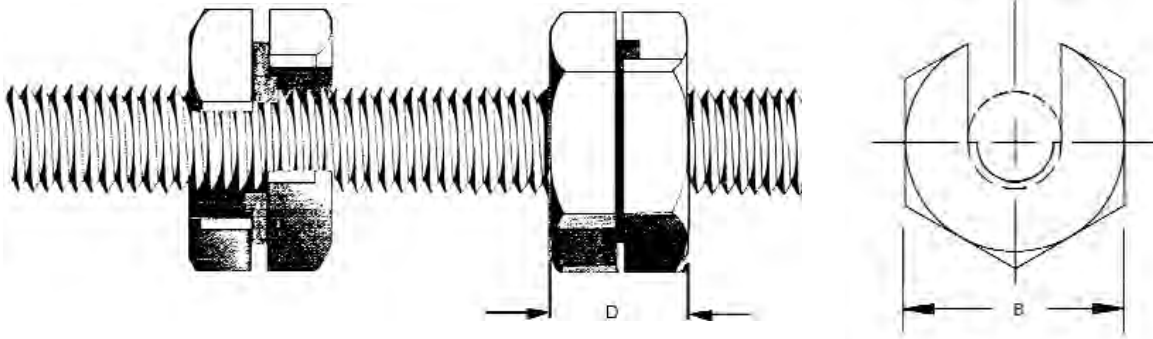

STOCK NO.	THREAD	B	D (APPROX)	MAX.* LOAD (lbs.)
TSC-25	1/4 x 20	.63	.38	650
TSC-37	3/8 x 16	.88	.47	2,000
TSC-50	1/2 x 13	1.06	.63	4,000
TSC-62	5/8 x 11	1.31	.66	5,000
TSC-75	3/4 x 10	1.63	.83	8,000

* Or as limited by rod.



SQUEEZE CLAMP

SHAFT SIZE	MATERIAL
3/16" TO 9/16"	NUT - STAINLESS STEEL BUSHING - BRONZE

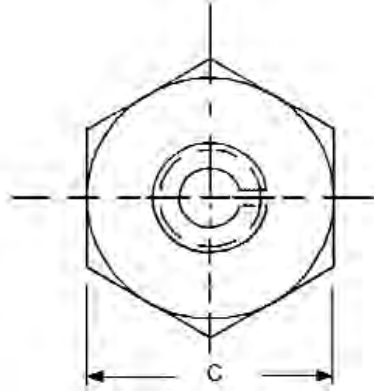
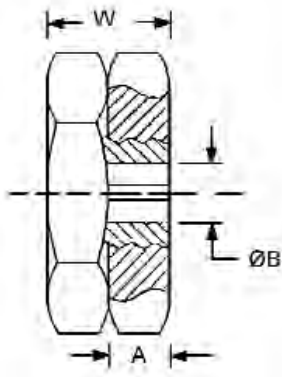

STOCK NO.	ØB	A	W	C	REF. SHAFT SIZE	SPLIT HUB INSIDE DIA. (Ref.)
SCL-1	.187	.125	.250	5/8	3/16	5/64 - 1/8
SCL-2	.250	.125	.250	5/8	1/4	5/32 - 3/16
SCL-3	.312	.125	.250	3/4	5/16	.2405 - 1/4
SCL-4	.375	.125	.250	3/4	3/8	5/16
SCL-5	.437	.155	.310	7/8	7/16	3/8
SCL-6	.562	.155	.310	7/8	9/16	1/2

- High clamping force
- Clamp directly to shafting or over a split hub

SET SCREW COLLARS

BORE SIZE	MATERIAL
5/64" TO 1 1/4" PRECISION BORE	303 STAINLESS STEEL

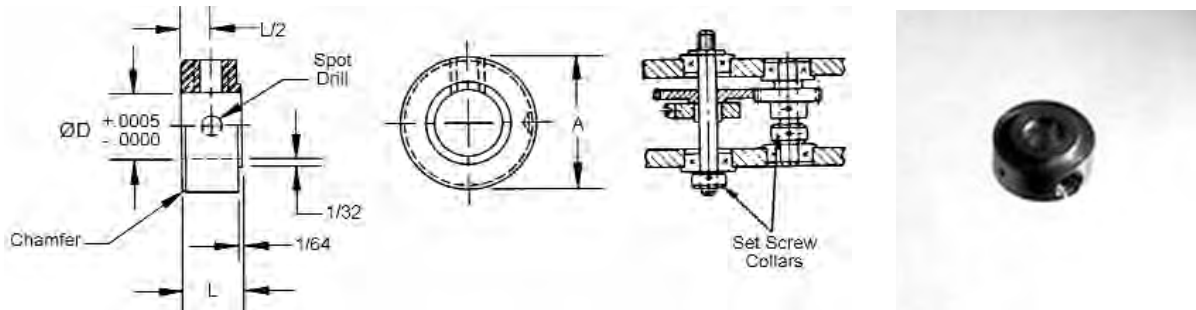

STOCK NO.	SHAFT SIZE	ØD	L	A	SPOT DRILL	SET SCREW
CS-1	5/64	.0779	.120	7/32	#78 (.016)	#0-80
CS-2	3/32	.0935	.120	1/4	#78 (.016)	#0-80
CS-3	1/8	.1248	.180	5/16	#69 (.028)	#2-56
CS-4	5/32	.1560	.180	5/16	#69 (.028)	#2-56
CS-5	3/16	.1873	.220	3/8	#60 (.040)	#4-40
CS-6	.2405	.2405	.250	1/2	#50 (.070)	#6-32
CS-7	1/4	.2498	.250	1/2	#50 (.070)	#6-32
CS-8	5/16	.3123	.250	1/2	#50 (.070)	#6-32
CS-9	3/8	.3748	.375	3/4	#31 (.120)	#10-24
CS-10	1/2	.4998	.437	1	#25 (.149)	1/4-20
CS-11	5/8	.6248	.500	1 1/4	#25 (.149)	1/4-20
CS-12	3/4	.7498	.562	1 1/2	#22 (.157)	3/8-16
CS-13	1	.9998	.625	2	#22 (.157)	3/8-16
CS-14	1 1/4	1.2498	.750	2 1/4	#22 (.157)	3/8-16

- No shim spacers required
- Used to pre-load bearing

BORE SIZE	MATERIAL
1/8" TO 1 1/4" COMMERCIAL BORE	COLD ROLLED STEEL ZINC PLATED

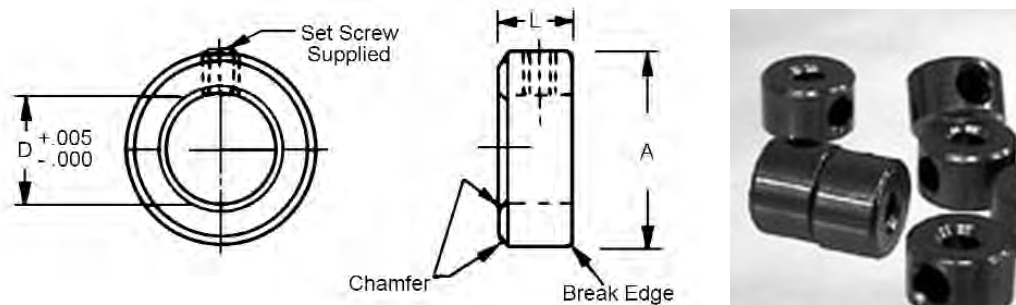

STOCK NO.	D	A	L	SET SCREW
CS-50	.125	3/8	1/4	#6
CS-51	.188	7/16	1/4	#8
CS-52	.250	1/2	9/32	#10
CS-53	.313	5/8	5/16	#10
CS-54	.375	3/4	3/8	1/4
CS-55	.500	1	7/16	1/4
CS-56	.625	1 1/8	1/2	5/16
CS-57	.750	1 1/4	9/16	5/16
CS-58	1.000	1 5/8	5/8	5/16
CS-59	1.250	2	11/16	3/8

SET SCREW COLLARS

BORE SIZE	MATERIAL
5/64" TO 1/2" PRECISION BORE	303 STAINLESS STEEL

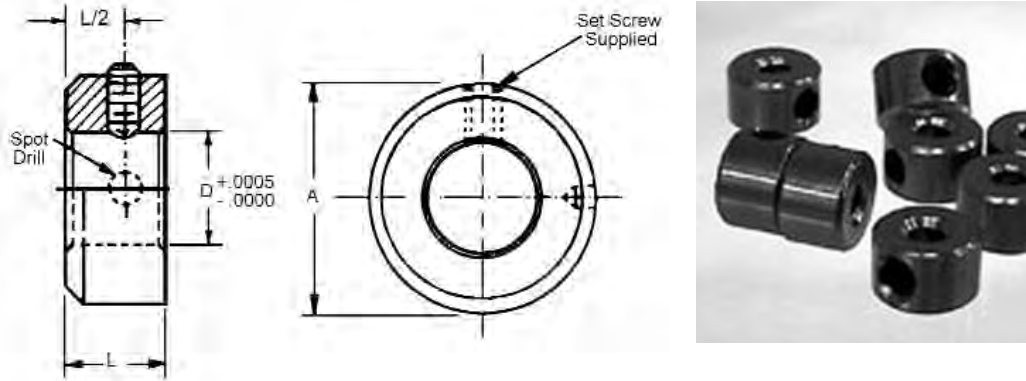

STOCK NO.	SHAFT SIZE	D	L	A	SPOT DRILL	SET SCREW
CS-26	5/64	.0779	.120	7/32	#78 (.016)	#0-80
CS-27	3/32	.0935	.120	1/4	#78 (.016)	#0-80
CS-23	.1200	.1200	.180	5/16	#69 (.028)	#2-56
CS-20	1/8	.1248	.180	5/16	#69 (.028)	#2-56
CS-24	5/32	.1560	.180	5/16	#69 (.028)	#2-56
CS-21	3/16	.1873	.220	3/8	#60 (.040)	#4-40
CS-25	.2405	.2405	.250	1/2	#50 (.070)	#6-32
CS-22	1/4	.2498	.250	1/2	#50 (.070)	#6-32
CS-37	5/16	.3123	.280	9/16	#50 (.070)	#6-32
CS-38	3/8	.3748	.375	3/4	#31 (.120)	#10-32
CS-39	1/2	.4998	.500	1	#25 (.149)	1/4-20

BORE SIZE	MATERIAL
1/8" TO 1/2" COMMERCIAL BORE	303 STAINLESS STEEL OR 2024T-4 ALUMINUM ANODIZED

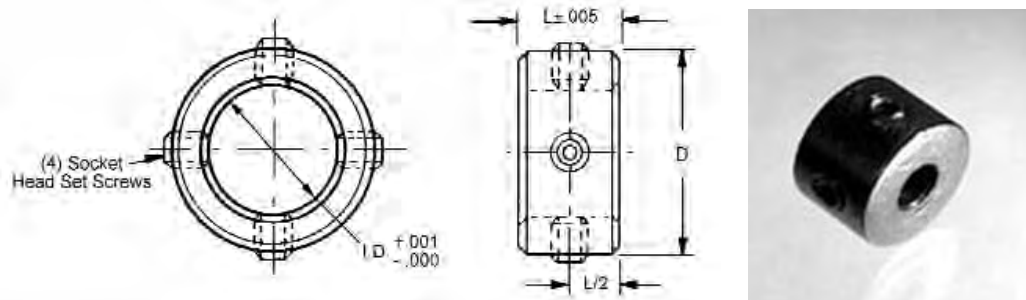

STAINLESS STEEL STOCK NO.	ALUMINUM STOCK NO.	SHAFT SIZE	I.D.	D	L	SET SCREW
CS-28	CS-32	1/8	.1255	.375	.250	#4-40
CS-29	CS-33	3/16	.1880	.375	.250	#4-40
CS-30	CS-34	1/4	.2505	.500	.250	#6-32
CS-31	CS-35	5/16	.3130	.500	.250	#6-32
CS-40	CS-43	3/8	.3750	.750	.312	#10-32
CS-41	CS-44	7/16	.4370	.750	.312	#10-32
CS-46	CS-47	1/2	.5000	.875	.312	#10-32

PLASTIC ROD STOCK

DIAMETER	MATERIAL
1/16" TO 3"	NYLON 101 OR DELRIN

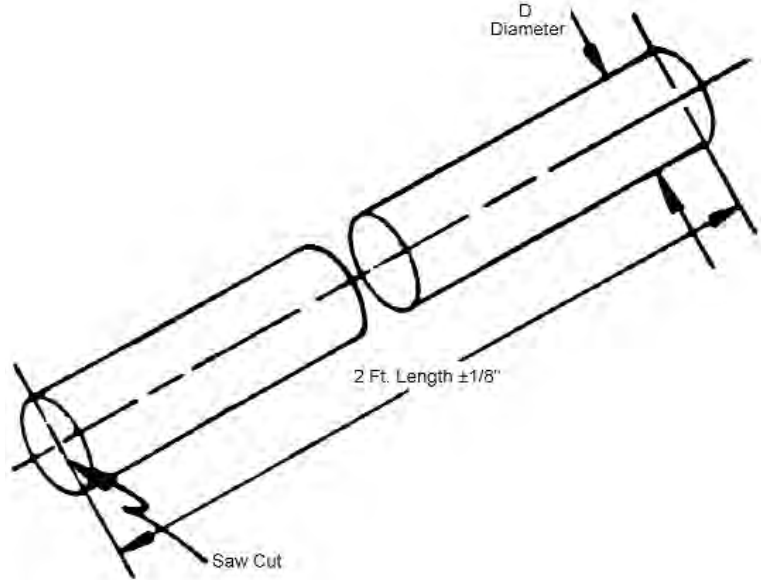

NYLON 101 STOCK NO.	DELRIN 500 STOCK NO.	D
PR-N-1	-	1/16
PR-N-51	-	3/32
PR-N-2	-	1/8
PR-N-3	PR-D-3	3/16
PR-N-4	PR-D-4	1/4
PR-N-6	PR-D-6	3/8
PR-N-8	PR-D-8	1/2
PR-N-10	PR-D-10	5/8
PR-N-12	PR-D-12	3/4
PR-N-16	PR-D-16	1
PR-N-20	PR-D-20	1 1/4
PR-N-24	PR-D-24	1 1/2
PR-N-28	PR-D-28	1 3/4
PR-N-32	PR-D-32	2
PR-N-40	PR-D-40	2 1/2
PR-N-48	PR-D-48	3

THREADED STOCK

THREAD	MATERIAL
#2-56 TO 1-14	18-8 STAINLESS STEEL

STOCK NO.	THREAD SIZE	LENGTH	DIA.	THREAD PITCH
T1-1	#2-56	12	.086	.018
T1-2	#4-40	12	.112	.025
T1-23	#4-40	24	.112	.025
T1-3	#6-32	12	.138	.031
T1-24	#6-32	24	.138	.031
T1-4	#8-32	12	.164	.031
T1-25	#8-32	24	.164	.031
T1-20	#10-24	16	.190	.042
T1-5	#10-24	24	.190	.042
T1-21	#10-32	16	.190	.031
T1-6	#10-32	24	.190	.031
T1-7	1/4-20	24	1/4	.050
T1-8	1/4-28	24	1/4	.036
T1-9	5/16-18	24	5/16	.055
T1-26	5/16-24	24	5/16	.042
T1-10	3/8-16	24	3/8	.062
T1-27	3/8-24	24	3/8	.042
T1-22	3/8-32	24	3/8	.031
T1-12	1/2-13	36	1/2	.077
T1-13	1/2-20	36	1/2	.050
T1-14	5/8-11	36	5/8	.091
T1-15	5/8-18	36	5/8	.056
T1-16	3/4-10	36	3/4	.100
T1-17	3/4-16	36	3/4	.062
T1-18	1-8	36	1	.125
T1-19	1-14	36	1	.071

THREAD	MATERIAL
#4-40 TO 1/2-13	MOLDED NYLON

STOCK NO.	THREAD SIZE	LENGTH	DIA.	THREAD PITCH
T2-1	#4-40	24	.112	.025
T2-2	#6-32	24	.138	.031
T2-3	#8-32	24	.164	.031
T2-4	#10-24	24	.190	.042
T2-5	#10-32	24	.190	.031
T2-6	1/4 - 20	24	1/4	.050
T2-7	5/16 - 18	24	5/16	.055
T2-8	3/8 - 16	24	3/8	.062
T2-9	1/2 - 13	24	1/2	.077

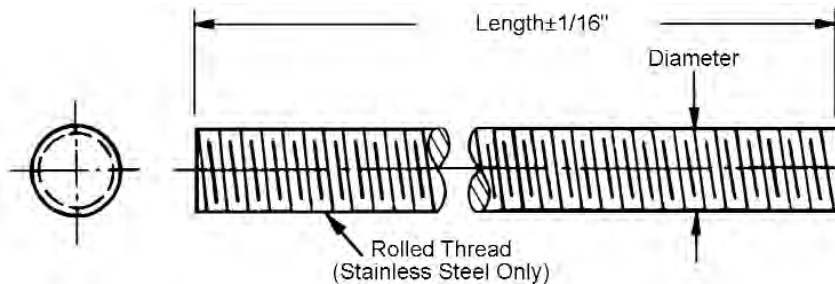

Special sizes and lengths are available on request. See index for threaded studs.
Straightness: .001 in/in

CASE HARDENED AND GROUND SHAFTS

DIAMETER	MATERIAL
1/4" TO 2"	C1060 STEEL HARDENED C60-65 OR 440 STAINLESS STEEL HARDENED C50-55

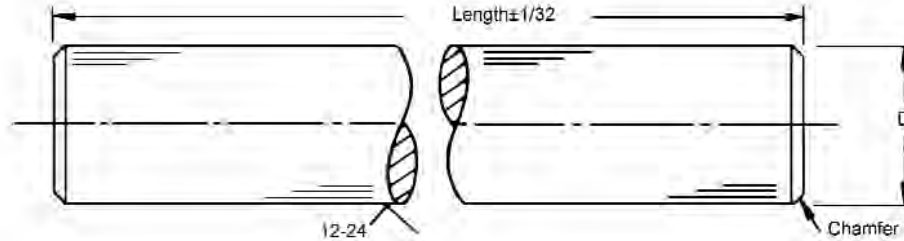

C1060 STEEL STOCK NO. (36" long)	C1060 STEEL STOCK NO. (12" long)	440 STAINLESS STEEL STOCK NO. (36" long)	NOM. DIA.	D DIAMETER	MAX. LENGTH AVAILABLE TO ORDER
LMS-4-36	-	-	1/4	.2490-.0005	8 ft.
LMS-5-36	-	-		.2495-.0005	
LMS-6-36	-	-	3/8	.3740-.0005	11 ft.
LMS-7-36	-	-		.3745-.0005	
LMS-46-36	LMS-46-12	-		.3750-.0005	
LMS-8-36	-	LMT-8-36	1/2	.4990-.0005	11 ft.
LMS-9-36	-	LMT-9-36		.4995-.0005	
LMS-48-36	LMS-48-12	-		.5000-.0005	
LMS-50-36	LMS-50-12	-	5/8	.6250-.0005	11 ft.
LMS-12-36	-	LMT-12-36	3/4	.7490-.0005	11 ft.
LMS-13-36	-	LMT-13-36		.7495-.0005	
LMS-52-36	LMS-52-12	-		.7500-.0005	
LMS-16-36	-	LMT-16-36	1	.9990-.0005	12 ft.
LMS-17-36	-	LMT-17-36		.9995-.0005	
LMS-56-36	LMS-56-12	-		1.0000-.0005	
LMS-20-36	-	-	1 1/4	1.2490-.0005	11 ft.
LMS-21-36	-	-		1.2495-.0005	
LMS-60-36	LMS-60-12	-		1.2500-.0005	
LMS-24-36	-	-	1 1/2	1.4989-.0005	11 ft.
LMS-25-36	-	-		1.4994-.0005	
LMS-64-36	LMS-64-12	-		1.5000-.0005	
LMS-32-36	-	-	2	1.9987-.0005	11 ft.
LMS-33-36	-	-		1.9994-.0007	
LMS-72-36	LMS-72-12	-		2.0000-.0005	

Straightness

LMS-4, LMS-5 best efforts basis

LMS-6 to LMS-72 within .001"-.002"/FT.

Note: Shafting available in other lengths. Specify by similar stock number and length required.

Example: LMS-21-56" (1.2495 Diameter 56" Long)

STAINLESS GROUND SHAFTS

DIAMETER	MATERIAL
1/32" TO 1 1/4"	303 STAINLESS STEEL ROCKWELL B75-90

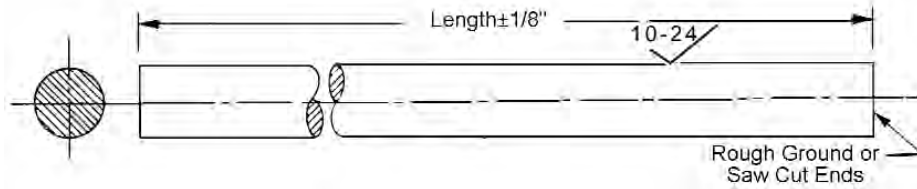

STOCK NO.	FRACT. DIA. (Ref.)*	ACTUAL DIA.	DIA. TOL. +.0000	L
S1-1	1/32	.0313	-.0002	12
S1-39		.0317	-.0002	12
S1-84	3/64	.0467	-.0002	12
S1-85	1/16	.0548	-.0002	12
S1-40		.0622	-.0002	12
S1-2		.0626	-.0002	12
S1-41		.0630	-.0002	12
S1-36	5/64	.0778	-.0002	12
S1-3		.0778	-.0002	14
S1-38		.0781	-.0002	12
S1-4		.0781	-.0002	14
S1-42		.0786	-.0002	12
S1-37	3/32	.0934	-.0002	12
S1-5		.0934	-.0002	18
S1-30		.0938	-.0002	12
S1-6		.0938	-.0002	18
S1-43		.0942	-.0002	12
S1-8	1/8	.1247	-.0002	24
S1-9		.1250	-.0002	24
S1-31		.1251	-.0002	12
S1-7		.1251	-.0002	24
S1-44		.1255	-.0002	24
S1-45	5/32	.1559	-.0002	24
S1-10		.1562	-.0002	24
S1-46		.1567	-.0002	24
S1-11	3/16	.1872	-.0002	24
S1-12		.1875	-.0002	24
S1-47		.1880	-.0002	24
S1-48	7/32	.2184	-.0002	24
S1-13		.2187	-.0002	24
S1-49		.2192	-.0002	24
S1-72		.2490	-.0003	36
S1-73	1/4	.2495	-.0003	36
S1-14		.2497	-.0002	24
S1-50		.2497	-.0002	36
S1-15		.2500	-.0002	24
S1-51		.2500	-.0002	36
S1-52		.2505	-.0002	36

STOCK NO.	FRACT. DIA. (Ref.)*	ACTUAL DIA.	DIA. TOL. +.0000	L
S1-16	5/16	.3122	-.0002	24
S1-17		.3125	-.0002	24
S1-53		.3130	-.0002	24
S1-74	3/8	.3740	-.0003	36
S1-75		.3745	-.0003	36
S1-33		.3747	-.0002	16
S1-18		.3747	-.0002	36
S1-32		.3750	-.0002	16
S1-19		.3750	-.0002	36
S1-54		.3755	-.0002	36
S1-76	1/2	.4990	-.0005	36
S1-77		.4995	-.0005	36
S1-35		.4997	-.0002	16
S1-20		.4997	-.0002	36
S1-34		.5000	-.0002	16
S1-21	.5000	-.0002	36	
S1-55	.5005	-.0002	36	
S1-22	5/8	.6247	-.0004	36
S1-56		.6250	-.0004	36
S1-57		.6255	-.0004	36
S1-78	3/4	.7490	-.0005	36
S1-79		.7495	-.0005	36
S1-23		.7497	-.0004	36
S1-58		.7500	-.0004	36
S1-59		.7505	-.0004	36
S1-80	1	.9990	-.0005	36
S1-81		.9995	-.0005	36
S1-24		.9997	-.0004	36
S1-60		1.0000	-.0004	36
S1-61		1.0005	-.0004	36
S1-82	1 1/4	1.2490	-.0005	36
S1-83		1.2495	-.0005	36
S1-25		1.2497	-.0004	36

* Straightness: Best efforts basis up to 3/16" diameter, straightness .0004 in/in for 7/32" diameter and up.

STAINLESS GROUND SHAFTS

DIAMETER	MATERIAL
1/8"	303 STAINLESS STEEL

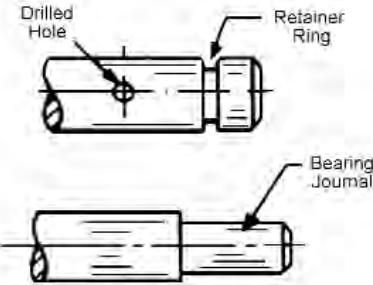
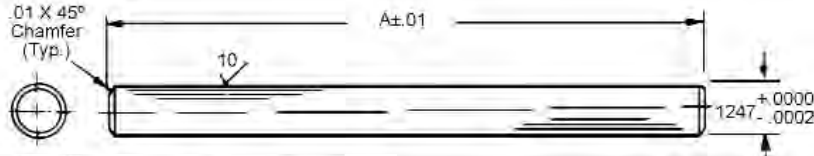

TYPICAL MODIFICATIONS

- Precision ground finish
- Straight within .0003 in./in.
- Send sketch for quotation on modifications

Available on request:

- Retainer ring grooves
- Special shaft lengths
- Journals
- Drilled holes
- Milled flats

STOCK NO.	A
S2-10	1.000
S2-11	1.125
S2-12	1.250
S2-13	1.375
S2-15	1.500
S2-16	1.625
S2-17	1.750
S2-18	1.875
S2-20	2.000
S2-21	2.125
S2-22	2.250
S2-23	2.375
S2-25	2.500
S2-26	2.625
S2-27	2.750
S2-28	2.875
S2-30	3.000
S2-31	3.125
S2-32	3.250
S2-33	3.375
S2-35	3.500
S2-36	3.625

STOCK NO.	A
S2-37	3.750
S2-38	3.875
S2-40	4.000
S2-41	4.125
S2-42	4.250
S2-43	4.375
S2-45	4.500
S2-46	4.625
S2-47	4.750
S2-48	4.875
S2-50	5.000
S2-51	5.125
S2-52	5.250
S2-53	5.375
S2-55	5.500
S2-56	5.625
S2-57	5.750
S2-60	6.000
S2-62	6.250
S2-63	6.375
S2-65	6.500
S2-66	6.625

STOCK NO.	A
S2-67	6.750
S2-70	7.000
S2-72	7.250
S2-75	7.500
S2-77	7.750
S2-80	8.000
S2-82	8.250
S2-83	8.375
S2-85	8.500
S2-90	9.000
S2-95	9.500
S2-100	10.000
S2-110	11.000
S2-120	12.000
S2-130	13.000
S2-140	14.000
S2-150	15.000
S2-160	16.000
S2-180	18.000
S2-200	20.000
S2-220	22.000
S2-240	24.000

DIAMETER	MATERIAL
3/16"	303 STAINLESS STEEL

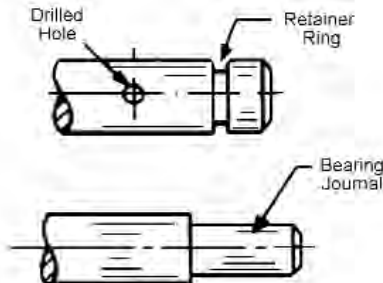
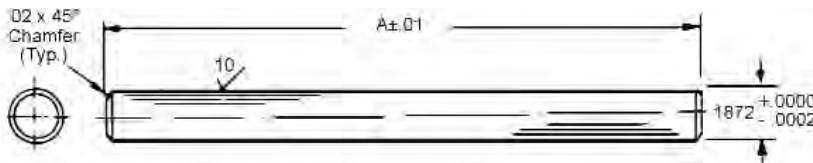

TYPICAL MODIFICATIONS

- Precision ground finish
- Straight within .0003 in./in.
- Send sketch for quotation on modifications

Available on request:

- Retainer ring grooves
- Special shaft lengths
- Journals
- Drilled holes
- Milled flats

STOCK NO.	A
S3-10	1.000
S3-11	1.125
S3-12	1.250
S3-13	1.375
S3-15	1.500
S3-16	1.625
S3-17	1.750
S3-18	1.875
S3-20	2.000
S3-21	2.125
S3-22	2.250
S3-23	2.375
S3-25	2.500
S3-26	2.625
S3-27	2.750
S3-28	2.875
S3-30	3.000
S3-31	3.125
S3-32	3.250
S3-33	3.375
S3-35	3.500
S3-36	3.625
S3-37	3.750

STOCK NO.	A
S3-38	3.875
S3-40	4.000
S3-41	4.125
S3-42	4.250
S3-43	4.375
S3-45	4.500
S3-46	4.625
S3-47	4.750
S3-48	4.875
S3-50	5.000
S3-51	5.125
S3-52	5.250
S3-53	5.375
S3-55	5.500
S3-57	5.750
S3-60	6.000
S3-62	6.250
S3-63	6.375
S3-65	6.500
S3-66	6.625
S3-67	6.750
S3-68	6.875
S3-70	7.000

STOCK NO.	A
S3-71	7.125
S3-72	7.250
S3-75	7.500
S3-77	7.750
S3-80	8.000
S3-81	8.125
S3-85	8.500
S3-90	9.000
S3-95	9.500
S3-100	10.000
S3-108	10.875
S3-110	11.000
S3-113	11.375
S3-120	12.000
S3-126	12.625
S3-130	13.000
S3-140	14.000
S3-150	15.000
S3-160	16.000
S3-180	18.000
S3-200	20.000
S3-220	22.000
S3-240	24.000

STAINLESS GROUND SHAFTS

DIAMETER	MATERIAL
1/4"	303 STAINLESS STEEL

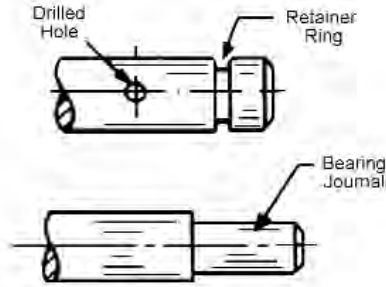
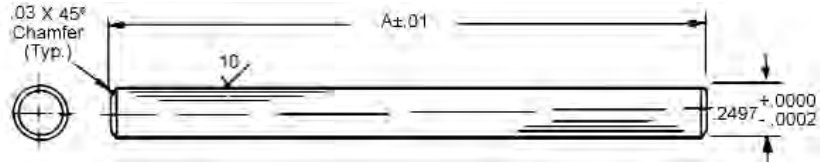

TYPICAL MODIFICATIONS

- Precision ground finish
- Straight within .0003 in./in.
- Send sketch for quotation on modifications

Available on request:

- Retainer ring grooves
- Special shaft lengths
- Journals
- Drilled holes
- Milled flats

STOCK NO.	A
S4-10	1.000
S4-11	1.125
S4-12	1.250
S4-13	1.375
S4-15	1.500
S4-16	1.625
S4-17	1.750
S4-18	1.875
S4-20	2.000
S4-21	2.125
S4-22	2.250
S4-23	2.375
S4-25	2.500
S4-26	2.625
S4-27	2.750
S4-28	2.875
S4-30	3.000
S4-31	3.125
S4-32	3.250
S4-33	3.375
S4-35	3.500
S4-36	3.625

STOCK NO.	A
S4-37	3.750
S4-38	3.875
S4-40	4.000
S4-41	4.125
S4-42	4.250
S4-43	4.375
S4-45	4.500
S4-46	4.625
S4-47	4.750
S4-48	4.875
S4-50	5.000
S4-51	5.125
S4-52	5.250
S4-53	5.375
S4-55	5.500
S4-56	5.625
S4-57	5.750
S4-58	5.875
S4-60	6.000
S4-62	6.250
S4-65	6.500
S4-67	6.750

STOCK NO.	A
S4-70	7.000
S4-72	7.250
S4-75	7.500
S4-77	7.750
S4-80	8.000
S4-82	8.250
S4-85	8.500
S4-90	9.000
S4-95	9.500
S4-100	10.000
S4-105	10.500
S4-110	11.000
S4-117	11.750
S4-120	12.000
S4-130	13.000
S4-140	14.000
S4-150	15.000
S4-160	16.000
S4-180	18.000
S4-200	20.000
S4-220	22.000
S4-240	24.000

DIAMETER	MATERIAL
5/16"	303 STAINLESS STEEL

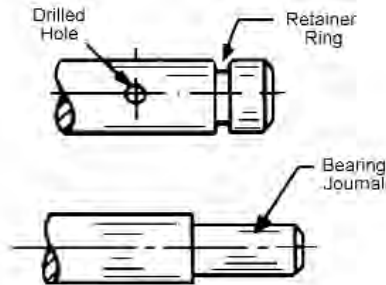
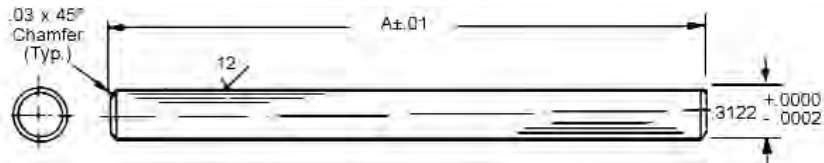

TYPICAL MODIFICATIONS

- Precision ground finish
- Straight within .0004 in./in.
- Send sketch for quotation on modifications

Available on request:

- Retainer ring grooves
- Special shaft lengths
- Journals
- Drilled holes
- Milled flats

STOCK NO.	A
S5-13	1.375
S5-15	1.500
S5-16	1.625
S5-17	1.750
S5-18	1.875
S5-20	2.000
S5-21	2.125
S5-22	2.250
S5-23	2.375
S5-25	2.500
S5-26	2.625
S5-27	2.750
S5-28	2.875
S5-30	3.000
S5-31	3.125
S5-32	3.250
S5-33	3.375
S5-35	3.500
S5-37	3.750

STOCK NO.	A
S5-38	3.875
S5-40	4.000
S5-41	4.125
S5-42	4.250
S5-43	4.375
S5-45	4.500
S5-47	4.750
S5-48	4.875
S5-50	5.000
S5-51	5.125
S5-53	5.375
S5-55	5.500
S5-56	5.625
S5-57	5.750
S5-58	5.875
S5-60	6.000
S5-62	6.250
S5-65	6.500
S5-67	6.750

STOCK NO.	A
S5-70	7.000
S5-72	7.250
S5-75	7.500
S5-77	7.750
S5-80	8.000
S5-85	8.500
S5-90	9.000
S5-95	9.500
S5-100	10.000
S5-110	11.000
S5-120	12.000
S5-130	13.000
S5-140	14.000
S5-150	15.000
S5-160	16.000
S5-180	18.000
S5-200	20.000
S5-220	22.000
S5-240	24.000

STAINLESS GROUND SHAFTS

DIAMETER	MATERIAL
3/8"	303 STAINLESS STEEL

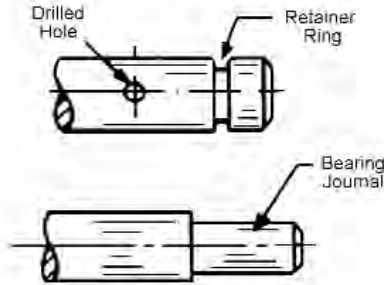
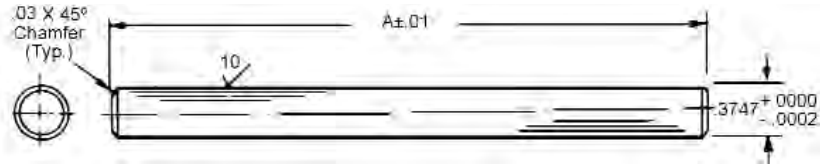

TYPICAL MODIFICATIONS

- Precision ground finish
- Straight within .0004 in./in.
- Send sketch for quotation on modifications

Available on request:

- Retainer ring grooves
- Special shaft lengths
- Journals
- Drilled holes
- Milled flats

STOCK NO.	A
S6-18	1.875
S6-20	2.000
S6-21	2.125
S6-22	2.250
S6-23	2.375
S6-25	2.500
S6-26	2.625
S6-27	2.750
S6-28	2.875
S6-30	3.000
S6-31	3.125
S6-32	3.250
S6-33	3.375
S6-35	3.500
S6-36	3.625
S6-37	3.750
S6-38	3.875
S6-40	4.000
S6-41	4.125
S6-42	4.250

STOCK NO.	A
S6-43	4.375
S6-45	4.500
S6-46	4.625
S6-47	4.750
S6-48	4.875
S6-50	5.000
S6-52	5.250
S6-55	5.500
S6-57	5.750
S6-60	6.000
S6-62	6.250
S6-65	6.500
S6-67	6.750
S6-70	7.000
S6-72	7.250
S6-75	7.500
S6-77	7.750
S6-80	8.000
S6-82	8.250
S6-85	8.500

STOCK NO.	A
S6-87	8.750
S6-90	9.000
S6-95	9.500
S6-100	10.000
S6-110	11.000
S6-120	12.000
S6-130	13.000
S6-140	14.000
S6-150	15.000
S6-160	16.000
S6-180	18.000
S6-200	20.000
S6-220	22.000
S6-240	24.000
S6-260	26.000
S6-280	28.000
S6-300	30.000
S6-320	32.000
S6-340	34.000
S6-360	36.000

DIAMETER	MATERIAL
1/2"	303 STAINLESS STEEL

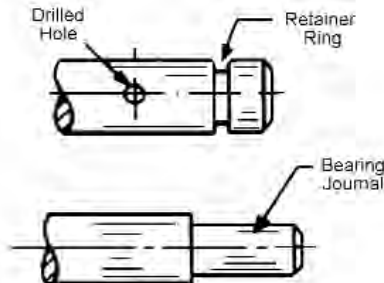
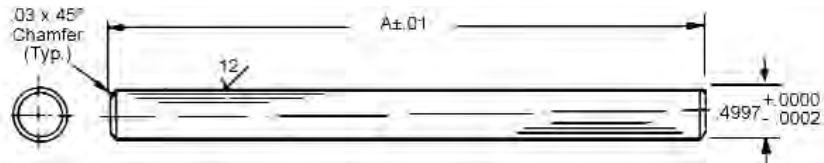

TYPICAL MODIFICATIONS

- Precision ground finish
- Straight within .0004 in./in.
- Send sketch for quotation on modifications

Available on request:

- Retainer ring grooves
- Special shaft lengths
- Journals
- Drilled holes
- Milled flats

STOCK NO.	A
S8-20	2.000
S8-21	2.125
S8-22	2.250
S8-23	2.375
S8-25	2.500
S8-26	2.625
S8-27	2.750
S8-28	2.875
S8-30	3.000
S8-31	3.125
S8-32	3.250
S8-33	3.375
S8-35	3.500
S8-36	3.625
S8-37	3.750
S8-38	3.875
S8-40	4.000
S8-41	4.125
S8-42	4.250

STOCK NO.	A
S8-43	4.375
S8-45	4.500
S8-46	4.625
S8-47	4.750
S8-48	4.875
S8-50	5.000
S8-52	5.250
S8-55	5.500
S8-57	5.750
S8-60	6.000
S8-62	6.250
S8-65	6.500
S8-67	6.750
S8-70	7.000
S8-72	7.250
S8-75	7.500
S8-77	7.750
S8-80	8.000
S8-85	8.500

STOCK NO.	A
S8-90	9.000
S8-95	9.500
S8-100	10.000
S8-110	11.000
S8-120	12.000
S8-130	13.000
S8-140	14.000
S8-150	15.000
S8-160	16.000
S8-180	18.000
S8-200	20.000
S8-220	22.000
S8-240	24.000
S8-260	26.000
S8-280	28.000
S8-300	30.000
S8-320	32.000
S8-340	34.000
S8-360	36.000

GROUND SHAFTING

DIAMETER	MATERIAL
1/8" TO 1 1/4"	COLD ROLLED STEEL 12L14 OR 12L15 ROCKWELL B75-95 (OILED TO PREVENT RUSTING)

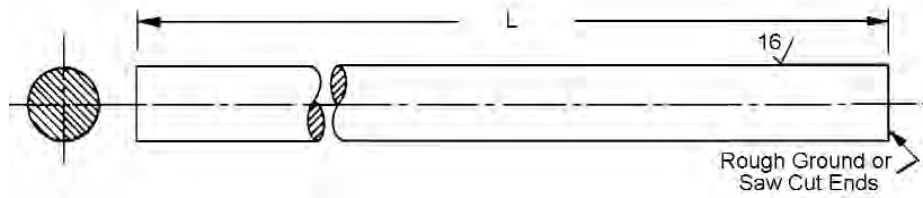

STOCK NO.	FRACT. DIA. (Ref.)	ACTUAL DIA.	L ± 1/8
S20-1	1/8	.1247	35
S20-2	3/16	.1872 +.0000	
S20-3	1/4	.2497 -.0002	
S20-4	5/16	.3122	
S20-5	3/8	.3747	
S20-6	1/2	.4997	35
S20-7	5/8	.6247 +.0000	
S20-8	3/4	.7497 -.0004	
S20-9	1	.9997	
S20-10	1 1/4	1.2497	

ULTRA GROUND SHAFTING

DIAMETER	MATERIAL
1/8"	303 STAINLESS STEEL

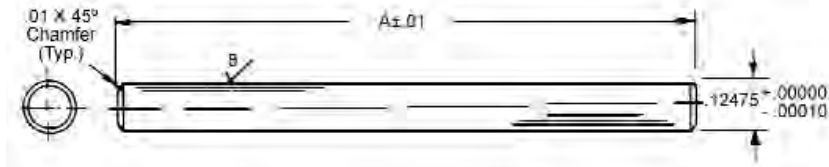

Straight within .0002 in./in.

STOCK NO.	A
S2-10-U	1.000
S2-11-U	1.125
S2-12-U	1.250
S2-13-U	1.375
S2-15-U	1.500
S2-16-U	1.625
S2-17-U	1.750
S2-18-U	1.875
S2-20-U	2.000
S2-21-U	2.125

STOCK NO.	A
S2-22-U	2.250
S2-23-U	2.375
S2-25-U	2.500
S2-26-U	2.625
S2-27-U	2.750
S2-28-U	2.875
S2-30-U	3.000
S2-31-U	3.125
S2-32-U	3.250
S2-35-U	3.500

STOCK NO.	A
S2-37-U	3.750
S2-40-U	4.000
S2-45-U	4.500
S2-50-U	5.000
S2-55-U	5.500
S2-60-U	6.000
S2-65-U	6.500
S2-70-U	7.000
S2-75-U	7.500
S2-80-U	8.000

DIAMETER	MATERIAL
3/16"	303 STAINLESS STEEL

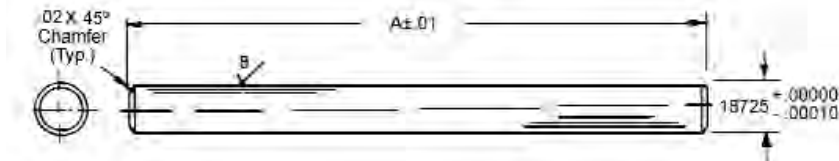

Straight within .00015 in./in.

STOCK NO.	A
S3-10-U	1.000
S3-11-U	1.125
S3-12-U	1.250
S3-13-U	1.375
S3-15-U	1.500
S3-16-U	1.625
S3-17-U	1.750
S3-18-U	1.875
S3-20-U	2.000
S3-21-U	2.125

STOCK NO.	A
S3-22-U	2.250
S3-23-U	2.375
S3-25-U	2.500
S3-26-U	2.625
S3-27-U	2.750
S3-28-U	2.875
S3-30-U	3.000
S3-31-U	3.125
S3-32-U	3.250
S3-35-U	3.500

STOCK NO.	A
S3-37-U	3.750
S3-40-U	4.000
S3-45-U	4.500
S3-50-U	5.000
S3-55-U	5.500
S3-60-U	6.000
S3-65-U	6.500
S3-70-U	7.000
S3-75-U	7.500
S3-80-U	8.000

DIAMETER	MATERIAL
1/4"	303 STAINLESS STEEL

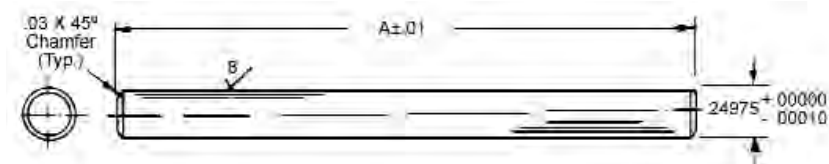

Straight within .0002 in./in.

STOCK NO.	A
S4-10-U	1.000
S4-11-U	1.125
S4-12-U	1.250
S4-13-U	1.375
S4-15-U	1.500
S4-16-U	1.625
S4-17-U	1.750
S4-18-U	1.875
S4-20-U	2.000
S4-21-U	2.125
S4-22-U	2.250

STOCK NO.	A
S4-23-U	2.375
S4-25-U	2.500
S4-27-U	2.750
S4-30-U	3.000
S4-31-U	3.125
S4-32-U	3.250
S4-33-U	3.375
S4-35-U	3.500
S4-36-U	3.625
S4-37-U	3.750
S4-40-U	4.000

STOCK NO.	A
S4-45-U	4.500
S4-50-U	5.000
S4-55-U	5.500
S4-60-U	6.000
S4-65-U	6.500
S4-70-U	7.000
S4-75-U	7.500
S4-80-U	8.000
S4-85-U	8.500
S4-90-U	9.000
S4-100-U	10.000

Special shaft length and modifications are available on request. Send sketch or print for quotation.

WOODRUFF KEYS

TYPE	MATERIAL
ANSI B17.2 - 1967, R 1978	303 STAINLESS STEEL

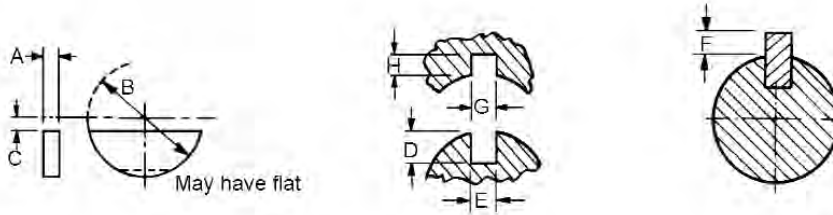

STOCK NO.	ANSI KEY NO. (Ref.)	KEY SIZE		C	D +.005	F +.010	H +.005	G +.002	E +.0015
		A +.001	B -.010						
K1-1	202	.0625	.250	.016	.0728	.0262	.0372	.0635	.0615
K1-2	202.5	.0625	.312	.016	.1038	.0262	.0372	.0635	.0615
K1-3	302.5	.0938	.312	.016	.0882	.0419	.0529	.0948	.0928
K1-4	203	.0625	.375	.016	.1358	.0262	.0372	.0635	.0615
K1-5	303	.0938	.375	.016	.1202	.0419	.0529	.0948	.0928
K1-6	403	.1250	.375	.016	.1045	.0575	.0685	.1260	.1240
K1-7	204	.0625	.500	.047	.1668	.0262	.0372	.0635	.0615
K1-8	304	.0938	.500	.047	.1511	.0419	.0529	.0948	.0928
K1-10	404	.1250	.500	.047	.1355	.0575	.0685	.1260	.1240
K1-11	305	.0938	.625	.062	.1981	.0419	.0529	.0948	.0928
K1-12	405	.1250	.625	.062	.1825	.0575	.0685	.1260	.1240
K1-9	505	.1563	.625	.062	.1669	.0731	.0841	.1573	.1553

DYNA-SPEED NEEDLE ROLLER BEARING

TYPE	MATERIAL
DRAWN CUP DESIGN FOR 1/8" TO 1" HARDENED SHAFTS	ROLLER CUP - CASE HARDENED STEEL NEEDLE ROLLERS - 52100 HARDENED STEEL BEARING CAGE - LOW HARDENED STEEL (**PLASTIC)

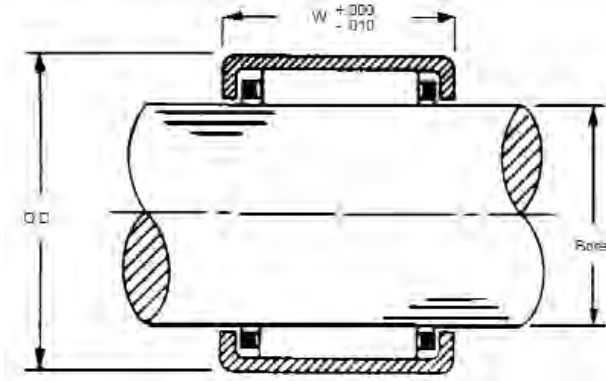

STOCK NO.	BORE	BEARING OUTSIDE DIA. (Ref.)	HOUSING BORE DIA.	BEARING W	MAX. SPEED RPM	LOAD CAPACITIES DYNAMIC (lbs.)	STATIC (lbs.)	HARDENED SHAFTING (ORDER SEPARATELY) STOCK LENGTH 12 INCHES OTHER LENGTHS ON REQUEST	
								SHAFTING STOCK NO.	SHAFT DIA.
NRB-24	1/8	.250	.2500- .2505	.250	70,000	240	165	-	.1250- .1247
NRB-34	3/16	.343	.3432- .3437	.250	70,000	400	305	-	.1875- .1872
NRB-36	3/16	.343	.3432- .3437	.375	70,000	620	530	-	.1875- .1872
NRB-44	1/4	.437	.4370- .4380	.250	55,000	360	260	-	.2500- .2495
NRB-47	1/4	.437	.4370- .4380	.438	55,000	920	870	-	.2500- .2495
NRB-55	5/16	.500	.4995- .5005	.312	44,000	650	590	-	.3125- .3120
NRB-59	5/16	.500	.4995- .5005	.562	44,000	1340	1480	-	.3125- .3120
NRB-65	3/8	.562	.5620- .5630	.312	37,000	650	610	LMS-46-12	.3750- .3745
NRB-610	3/8	.562	.5620- .5630	.625	37,000	1660	2040	LMS-46-12	.3750- .3745
NRB-86	1/2	.687	.6870- .6880	.375	27,000	1040	1210	LMS-48-12	.5000- .4995
NRB-812	1/2	.687	.6870- .6880	.750	27,000	2230	3200	LMS-48-12	.5000- .4995
NRB-107	5/8	.812	.8120- .8130	.438	22,000	1480	2100	LMS-50-12	.6250- .6245
NRB-1012	5/8	.812	.8120- .8130	.750	22,000	2700	4450	LMS-50-12	.6250- .6245
NRB-126	3/4	1.000	.9995- 1.0005	.375	18,000	1600	1860	LMS-52-12	.7500- .7495
NRB-1212	3/4	1.000	.9995- 1.0005	.750	18,000	4150	5300	LMS-52-12	.7500- .7495
NRB-168	1	1.250	1.2495- 1.2505	.500	14,000	2850	4300	LMS-56-12	1.0000- .9995
NRB-1616	1	1.250	1.2495- 1.2505	1.000	14,000	6500	10,400	LMS-56-12	1.0000- .9995

- Extremely high speed
- High load capacity
- Low profile, Light weight
- Caged needle bearings offer up to 3 times the speed of uncaged designs
- Extremely low rolling friction
- High lubrication capacity
- Low sensitivity to misalignment

BALL BEARINGS

BORE SIZE	TYPE	MATERIAL
3/64" TO 1/2"	SINGLE ROW PRECISION ABEC-3 AND ABEC-7	440C STAINLESS STEEL

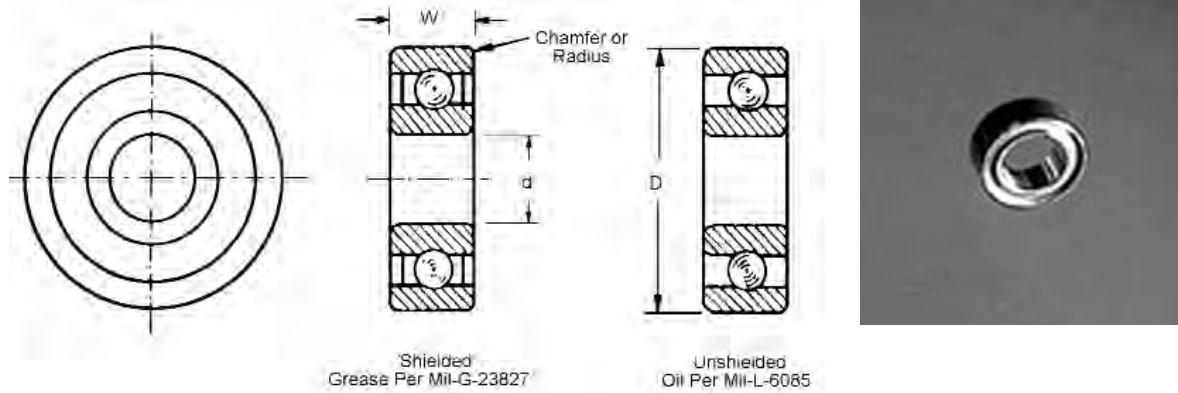

ABEC-3 STOCK NO.	ABEC-7 STOCK NO.	d	D	w	SHIELD DATA	DYNAMIC LOAD (LBS.)	STATIC LOAD (LBS.)
B1-37-Q3 B1-37-S-Q3	B1-37 B1-37-S	.0469	.1562	.0625 .0937	UNSHIELDED SHIELDED	17	6
B1-38-Q3 B1-38-S-Q3	B1-38 B1-38-S	.0550	.1875	.0781 .1094	UNSHIELDED SHIELDED	26	9
B1-33-Q3 B1-33-S-Q3	B1-33 B1-33-S	.0781	.2500	.0937 .1406	UNSHIELDED SHIELDED	36	14
B1-34-Q3 B1-34-S-Q3	B1-34 B1-34-S	.0937	.3125	.1094 .1406	UNSHIELDED SHIELDED	60	24
B1-35-Q3 B1-35-S-Q3 B1-36-Q3 B1-36-S-Q3 B1-24-Q3 B1-5-Q3	B1-35 B1-35-S B1-36 B1-36-S B1-24 B1-5	.1250	.2500 .3125 .3750	.0937 .1094 .1094 .1406 .1562 .1562	UNSHIELDED SHIELDED UNSHIELDED SHIELDED UNSHIELDED SHIELDED	33 60 68	13 24 28
B1-42-Q3 B1-42-S-Q3	B1-42 B1-42-S	.1562	.3125	.1094 .1250	UNSHIELDED SHIELDED	33	14
B1-40-Q3 B1-40-S-Q3 B1-25-Q3 B1-27-Q3 B1-26-Q3 B1-7-Q3	B1-40 B1-40-S B1-25 B1-27 B1-26 B1-7	.1875	.3125 .3750 .5000	.1094 .1250 .1250 .1562 .1960	UNSHIELDED SHIELDED UNSHIELDED SHIELDED UNSHIELDED SHIELDED	33 76 141	14 33 67
B1-29-Q3 B1-30-Q3 B1-31-Q3 B1-32-Q3 B1-28-Q3 B1-9-Q3	B1-29 B1-30 B1-31 B1-32 B1-28 B1-9	.2500	.3750 .5000 .6250	.1250 .1250 .1250 .1875 .1960 .1960	UNSHIELDED SHIELDED UNSHIELDED SHIELDED UNSHIELDED SHIELDED	37 114 158	17 57 78
B1-43-Q3 B1-43-S-Q3	B1-43 B1-43-S	.3125	.5000	.1562 .1562	UNSHIELDED SHIELDED	56	31
B1-39-Q3 B1-13-Q3	B1-39 B1-13	.3750	.8750	.2188 .2812	UNSHIELDED SHIELDED	356	176
B1-44-Q3 B1-44-S-Q3 B1-15-Q3	B1-44 B1-44-S B1-15	.5000	.8750 1.1250	.2188 .2812 .3125	UNSHIELDED SHIELDED SHIELDED	203 827	114 464

See Section K (Reference Section) for Bearing Tolerances.

BALL BEARINGS

BORE SIZE	TYPE	MATERIAL
3/64" TO 1/2"	SINGLE ROW - FLANGED PRECISION ABEC-3 AND ABEC-7	440C STAINLESS STEEL

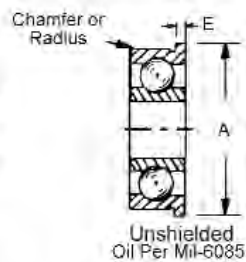
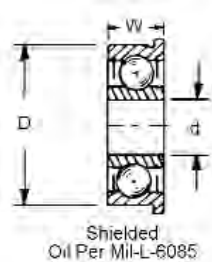
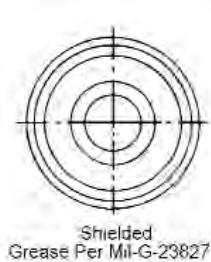

ABEC-3 STOCK NO.	ABEC-7 STOCK NO.	d	D	w	A	SHIELD DATA	E	DYNAMIC LOAD (LBS.)	STATIC LOAD (LBS.)
B2-16-Q3 B2-16-S-Q3	B2-16 B2-16-S	.0469	.1562	.0625 .0937	.203	UNSHIELDED SHIELDED	.013 .031	17	6
B2-17-Q3 B2-17-S-Q3	B2-17 B2-17-S	.0550	.1875	.0781 .1094	.234	UNSHIELDED SHIELDED	.023 .031	26	9
B2-12-Q3 B2-12-S-Q3	B2-12 B2-12-S	.0781	.2500	.0937 .1406	.296	UNSHIELDED SHIELDED	.023 .031	36	14
B2-13-Q3 B2-13-S-Q3	B2-13 B2-13-S	.0937	.3125	.1094 .1406	.359	UNSHIELDED SHIELDED	.023 .031	60	24
B2-14-Q3 B2-14-S-Q3	B2-14 B2-14-S	.1250	.2500	.0937 .1094	.296	UNSHIELDED SHIELDED	.023 .031	33	13
B2-15-Q3 B2-15-S-Q3	B2-15 B2-15-S		.3125	.1094 .1406	.359	UNSHIELDED SHIELDED	.023 .031	60	24
B2-5-Q3 B2-5-S-Q3	B2-5 B2-5-S		.3750	.1562 .1562	.440	UNSHIELDED SHIELDED	.030 .030	68	28
B2-20-Q3 B2-20-S-Q3	B2-20 B2-20-S	.1562	.3125	.1094 .1250	.359	UNSHIELDED SHIELDED	.023 .036	33	14
B2-18-Q3 B2-18-S-Q3	B2-18 B2-18-S	.1875	.3125	.1094 .1250	.359	UNSHIELDED SHIELDED	.023 .036	33	14
B2-9-Q3 B2-9-S-Q3	B2-9 B2-9-S		.3750	.1250 .1250	.422	UNSHIELDED SHIELDED	.023 .031	76	33
B2-6-Q3 B2-6-S-Q3	B2-6 B2-6-S		.5000	.1960 .1960	.565	UNSHIELDED SHIELDED	.042 .042	141	67
B2-10-Q3 B2-10-S-Q3	B2-10 B2-10-S	.2500	.3750	.1250 .1250	.422	UNSHIELDED SHIELDED	.023 .036	37	17
B2-11-Q3 B2-11-S-Q3	B2-11 B2-11-S		.5000	.1250 .1875	.547	UNSHIELDED SHIELDED	.023 .045	114	57
B2-7-Q3 B2-7-S-Q3	B2-7 B2-7-S		.6250	.1960 .1960	.690	UNSHIELDED SHIELDED	.042 .042	158	78
B2-21-Q3 B2-21-S-Q3	B2-21 B2-21-S		.3125	.5000	.1562 .1562	.547	UNSHIELDED SHIELDED	.031 .031	56
B2-8-Q3 B2-8-S-Q3	B2-8 B2-8-S	.3750	.8750	.2812 .2812	.969	UNSHIELDED SHIELDED	.062 .062	356	176
B2-22-S-Q3	B2-22-S	.5000	1.1250	.3125	1.225	SHIELDED	.062	827	464

See Section K (Reference Section) for Bearing Tolerances.

BALL BEARINGS

BORE SIZE	TYPE	MATERIAL
1/8" TO 3/4"	OPEN - PLAIN PRECISION ABEC-5	440C STAINLESS STEEL

Lubrication: Oil Per Mil-L-6085

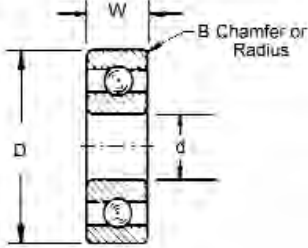
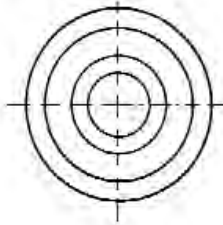

STOCK NO.	d	D	W	DYNAMIC LOAD (LBS)	STATIC LOAD (LBS)
B10-5	.1250	.3125	.1094	62	24
B10-6	.1875	.3750	.1250	79	33
B10-7	.2500	.5000	.1250	128	55
B10-8	.3125	.5000	.1562	95	47
B10-1	.3750	.6250	.1562	95	49
B10-2	.5000	.7500	.1562	111	66
B10-3	.6250	.8750	.1562	114	75
B10-4	.7500	1.0000	.1562	126	92

See Section K (Reference Section) for Bearing Tolerances.

BORE SIZE	TYPE	MATERIAL
1/8" TO 5/16"	SHIELDED - FLANGED PRECISION ABEC-3	440C STAINLESS STEEL

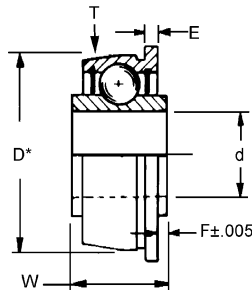
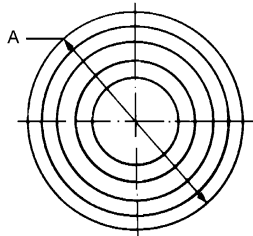

STOCK NO.	SHAFT SIZE	d	D	w	A	F	E	DYNAMIC LOAD (LBS)	STATIC T IN/FT.	TAPER
B2-1	1/8	.1250	.3757	.189	.4380		.037	69	16	.075
B2-2	3/16	.1875	.5632	.251	.6250	.015	.042	198	51	.068
B2-3	1/4	.2500	.6257	.251	.6875		.042	233	68	.068
B2-4	5/16	.3125	.6882	.251	.7500		.042	240	72	.068

*Measured at the midpoint of the raceway.

See Section K (Reference Section) for Bearing Tolerances.

BALL BEARINGS

BORE SIZE	TYPE	MATERIAL
1/8" TO 1 1/4"	SINGLE ROW - UNFLANGED PRECISION ABEC-1	52100 CHROME STEEL

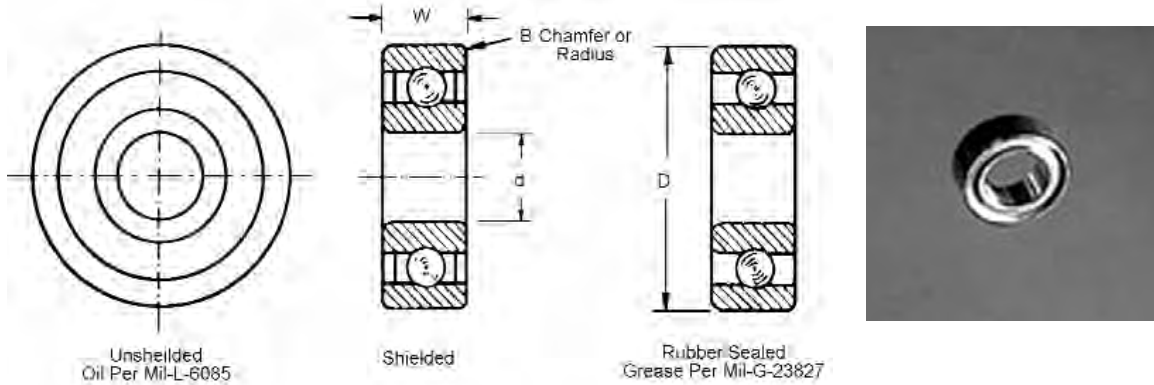

STOCK NO.	d	D	W	B	SHIELD AND LUBE DATA	DYNAMIC LOAD (LBS) CAPACITY	STATIC LOAD (LBS) CAPACITY
B11-1	.1250	.3750	.156	.005	UNSHIELDED	71	29
B11-2			.156	.005	SHIELDED		
B11-3			.156	.005	RUBBER SEALED		
B11-4	.1875	.5000	.156	.012	UNSHIELDED	139	60
B11-5			.196	.012	SHIELDED		
B11-6			.196	.012	RUBBER SEALED		
B11-7	.2500	.6250	.196	.012	UNSHIELDED	159	71
B11-8			.196	.012	SHIELDED		
B11-9			.196	.012	RUBBER SEALED		
B11-10	.3750	.8750	.218	.016	UNSHIELDED	451	219
B11-11			.281	.016	SHIELDED		
B11-12			.281	.016	RUBBER SEALED		
B11-13	.5000	1.1250	.250	.016	UNSHIELDED	880	500
B11-14			.312	.016	SHIELDED		
B11-15			.312	.016	RUBBER SEALED		
B1-17	.6250	1.3750	.343	.031	SHIELDED	1175	710
B1-19	.7500	1.6250	.437	.031	SHIELDED	1630	1073
B1-21	1.0000	2.0000	.500	.031	SHIELDED	2015	1408
B1-23	1.2500	2.2500	.375	.031	UNSHIELDED	1940	1582

See Section K (Reference Section) for Bearing Tolerances.

BALL BEARINGS

BORE SIZE	TYPE	MATERIAL
1/8" TO 3/8"	SINGLE ROW - FLANGED PRECISION ABEC-1	52100 CHROME STEEL

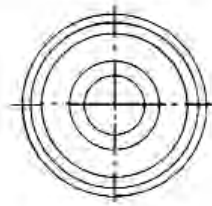

Unshielded
Oil Per MIL-L-6085

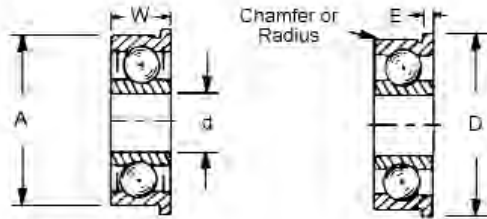

Shielded
Grease Per MIL-G-23827



STOCK NO.	d	D	W	A	SHIELD AND LUBE DATA	E	DYNAMIC LOAD (LBS) CAPACITY	STATIC LOAD (LBS) CAPACITY
B13-1			.156		UNSHIELDED			
B13-2	.1250	.3750	.156	.440	SHIELDED	.030	71	29
B13-4			.156		UNSHIELDED			
B13-5	.1875	.5000	.196	.565	SHIELDED	.042	139	60
B13-7			.196		UNSHIELDED			
B13-8	.2500	.6250	.196	.690	SHIELDED	.042	159	71
B13-10			.281		UNSHIELDED			
B13-11	.3750	.8750	.281	.969	SHIELDED	.062	451	219

See Section K (Reference Section) for Bearing Tolerances.

BORE SIZE	TYPE	MATERIAL
1/4" TO 1"	SINGLE ROW	316 STAINLESS STEEL RACEWAYS AND BALLS

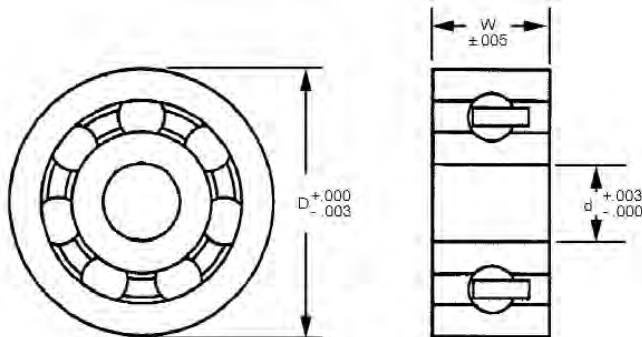

STOCK NO.	d	D	w	MAXIMUM RPM WITH NO LOAD	DYNAMIC LOAD (LBS) CAPACITY	STATIC LOAD (LBS) CAPACITY
B11-7-6	1/4	5/8	.196	2,352	89	51
B11-8-6	1/4	3/4	7/32	2,352	78	51
B11-9-6	1/4	3/4	9/32	2,352	78	51
B11-10-6	3/8	7/8	7/32	1,600	126	99
B11-11-6	3/8	7/8	9/32	1,600	126	99
B11-13-6	1/2	1 1/8	1/4	1,142	165	129
B11-14-6	5/8	1 1/8	1/4	1,142	165	129
B11-15-6	3/8	1 1/8	3/8	1,142	165	129
B11-16-6	1/2	1 1/8	3/8	1,142	165	129
B11-18-6	5/8	1 3/8	7/16	1,069	207	138
B11-19-6	3/4	1 5/8	5/16	840	234	156
B11-21-6	1	2	1/2	729	276	183

Load and speed calculations are for reference only. W.M. Berg recommends testing in actual environment to be encountered.

BALL BEARINGS

BORE SIZE	TYPE	MATERIAL
1/4" TO 1"	DOUBLE ROW	316 STAINLESS STEEL RACEWAYS AND BALLS

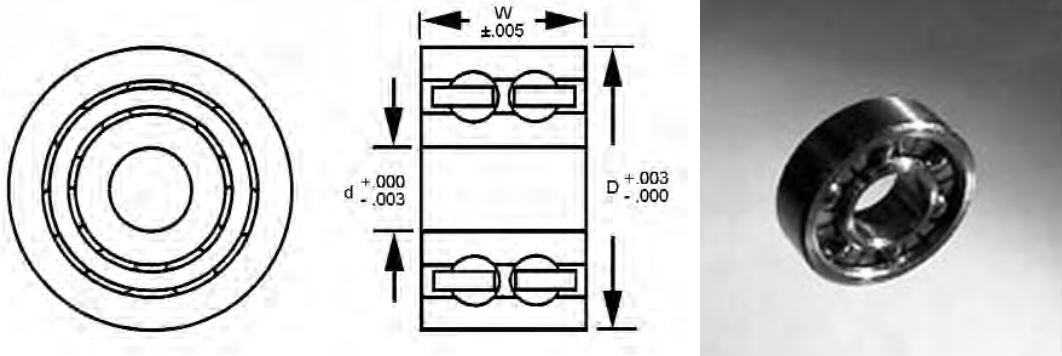

STOCK NO.	d	D	W	MAXIMUM RPM WITH NO LOAD	DYNAMIC LOAD (LBS) CAPACITY	STATIC LOAD (LBS) CAPACITY
B11D-7-6	1/4	5/8	3/8	2,352	117	76
B11D-10-6	3/8	7/8	1/2	1,600	189	148
B11D-13-6	1/2	1 1/8	7/16	1,142	247	193
B11D-17-6	5/8	1 3/8	7/16	1,069	310	207
B11D-19-6	3/4	1 5/8	5/8	840	351	234
B11D-21-6	1	2	3/4	729	414	274

Load and speed calculations are for reference only. W.M. Berg recommends testing in actual environment to be encountered.

BALL BEARINGS

BORE SIZE	TYPE	MATERIAL
3/16" TO 1"	SINGLE ROW	316 STAINLESS STEEL BALLS ACETAL PLASTIC RACEWAYS

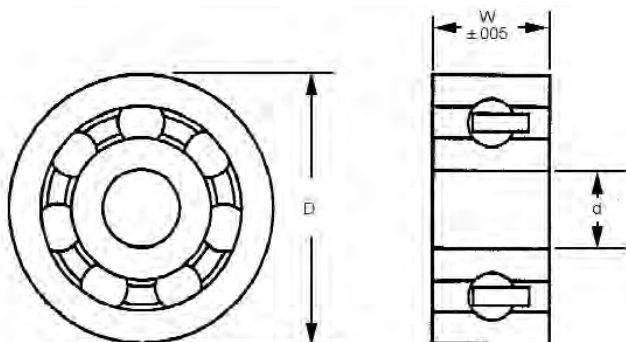

STOCK NO.	d*	D*	W	MAXIMUM RPM WITH NO LOAD	DYNAMIC LOAD (LBS) CAPACITY	STATIC LOAD (LBS) CAPACITY
B11A-4-6	3/16	1/2	5/32	3,167	17	11
B11A-5-6	3/16	5/8	.196	2,352	26	17
B11A-7-6	1/4	5/8	.196	2,352	26	17
B11A-8-6	1/4	3/4	7/32	2,352	26	17
B11A-9-6	1/4	3/4	9/32	2,352	26	17
B11A-10-6	3/8	7/8	7/32	1,600	42	33
B11A-11-6	3/8	7/8	9/32	1,600	42	33
B11A-13-6	1/2	1 1/8	1/4	1,142	55	43
B11A-15-6	3/8	1 1/8	3/8	1,142	55	43
B11A-17-6	5/8	1 3/8	3/8	1,069	69	46
B11A-18-6	5/8	1 3/8	7/16	1,069	69	46
B11A-19-6	3/4	1 5/8	5/16	840	78	52
B11A-21-6	1	2	1/2	729	92	61

* Inner and Outer Diameter Tolerancing:
 $D = 1/2" - 7/8" +.000 / -.003$
 $D = 1 1/8" - 2" +.000 / -.004$
 $d = 3/16" - 3/4" +.003 / -.000$
 $d = 1" +.004 / -.000$

Load and speed calculations are for reference only. W.M. Berg recommends testing in actual environment to be encountered.

BORE SIZE	TYPE	MATERIAL
1/4" TO 1"	DOUBLE ROW	316 STAINLESS STEEL BALLS ACETAL PLASTIC RACEWAYS

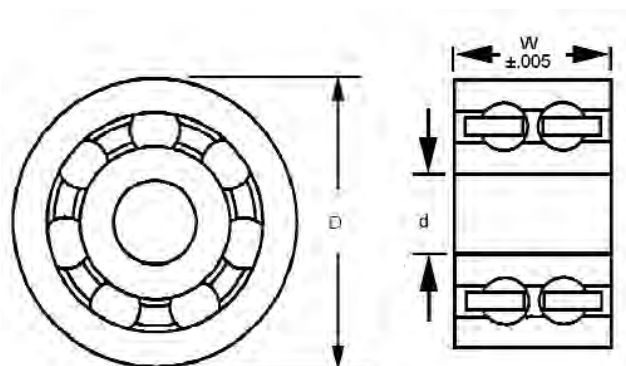

STOCK NO.	d*	D*	W	MAXIMUM RPM WITH NO LOAD	DYNAMIC LOAD (LBS) CAPACITY	STATIC LOAD (LBS) CAPACITY
B11AD-7-6	1/4	5/8	3/8	1,881	37	20
B11AD-8-6	1/4	3/4	3/8	1,881	37	20
B11AD-10-6	3/8	7/8	1/2	1,280	60	43
B11AD-13-6	1/2	1 1/8	7/16	913	78	61
B11AD-17-6	5/8	1 3/8	7/16	855	85	68
B11AD-19-6	3/4	1 5/8	5/8	672	92	75
B11AD-21-6	1	2	3/4	583	127	110

* Inner and Outer Diameter Tolerancing:
 $D = 5/8" - 7/8" +.000 / -.003$
 $D = 1 1/8" - 2" +.000 / -.004$
 $d = 1/4" - 3/4" +.003 / -.000$
 $d = 1" +.004 / -.000$

Load and speed calculations are for reference only. W.M. Berg recommends testing in actual environment to be encountered.

ANGULAR CONTACT BALL BEARINGS

BORE SIZE	TYPE	MATERIAL
1/8" TO 1/4"	NON-SEPARABLE ABEC-7	400 SERIES MARTENSITIC STAINLESS STEEL

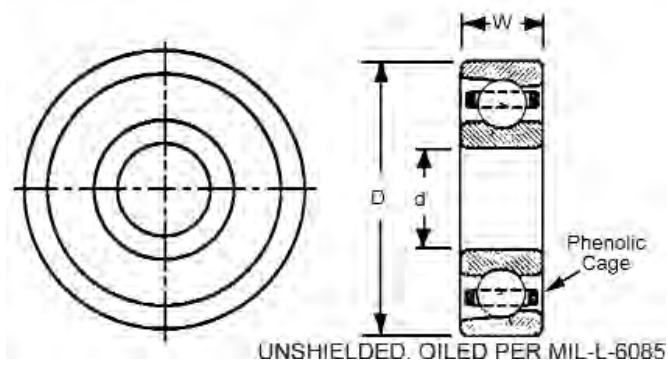

STOCK NO.	d	D	W	MAX. SPEED (RPM)	STATIC RADIAL LOAD (LBS.)	DYNAMIC RADIAL LOAD (LBS.)	STATIC THRUST LOAD (LBS)
B14-1	.1250	.3750	.1562	85,000	27	97	76
B14-2	.1875	.5000	.1562	55,000	52	190	167
B14-3	.2500	.6250	.1960	49,000	63	229	229

See Section K (Reference Section) for Bearing Tolerances.

OIL-LESS BEARINGS

BORE SIZE	TYPE	MATERIAL
3/64" TO 1/2"	PLAIN ULTRA PRECISION	SINTERED BRONZE MIL-B-5687A TYPE 1 VACUUM IMPREGNATED MIL-L-6085

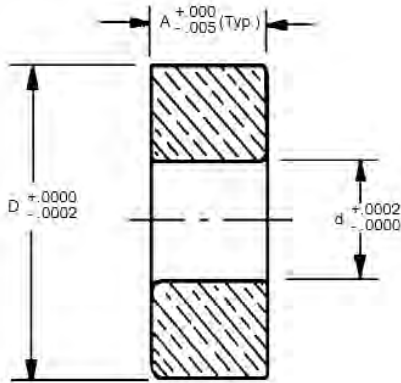

STOCK NO.	SHAFT SIZE	d	D	A
B3-1	3/64	.0469	.1563	.093
B3-2	1.4 MM	.0550	.1876	.109
B3-3	1/16	.0627	.2501	.093
B3-17	5/64	.0781	.2500	.094
B3-4	5/64	.0783	.2501	.093
B3-18	3/32	.0937	.3125	.109
B3-5	3/32	.0939	.3126	.109
B3-19	1/8	.1250	.2500	.094
B3-20	1/8	.1250	.3125	.109
B3-13	1/8	.1250	.3750	.156
B3-6	1/8	.1252	.3751	.140
B3-7	5/32	.1564	.3126	.125
B3-14	3/16	.1875	.5000	.156
B3-15	3/16	.1875	.5000	.196
B3-21	3/16	.1875	.3750	.125
B3-8	3/16	.1877	.5001	.156
B3-16	1/4	.2500	.6250	.196
B3-22	1/4	.2500	.5000	.188
B3-9	1/4	.2502	.6251	.196
B3-10	5/16	.3127	.6876	.250
B3-11	3/8	.3752	.8751	.281
B3-12	1/2	.5002	1.1251	.312



BORE SIZE	TYPE	MATERIAL
3/64" TO 1/2"	FLANGED ULTRA PRECISION	SINTERED BRONZE MIL-B-5687A TYPE 1 VACUUM IMPREGNATED MIL-L-6085

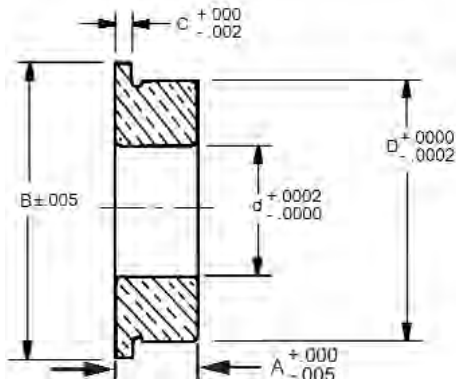

STOCK NO.	SHAFT SIZE	d	D	A	B	C
B4-1	3/64	.0469	.1563	.093	.203	.031
B4-2	1.4 MM	.0550	.1876	.109	.234	.031
B4-3	1/16	.0627	.2501	.093	.296	.031
B4-16	5/64	.0781	.2500	.094	.296	.023
B4-4	5/64	.0783	.2501	.093	.296	.031
B4-17	3/32	.0937	.3125	.109	.359	.023
B4-5	3/32	.0939	.3126	.109	.359	.031
B4-18	1/8	.1250	.2500	.094	.296	.023
B4-19	1/8	.1250	.3125	.109	.359	.023
B4-13	1/8	.1250	.3750	.156	.440	.030
B4-6	1/8	.1252	.3751	.140	.422	.031
B4-7	5/32	.1564	.3126	.125	.359	.036
B4-14	3/16	.1875	.5000	.196	.565	.042
B4-21	3/16	.1875	.3750	.125	.422	.031
B4-8	3/16	.1877	.5001	.156	.565	.042
B4-15	1/4	.2500	.6250	.196	.690	.042
B4-22	1/4	.2500	.5000	.188	.547	.045
B4-9	1/4	.2502	.6251	.196	.690	.042
B4-10	5/16	.3127	.6876	.250	.750	.042
B4-11	3/8	.3752	.8751	.281	.969	.062
B4-12	1/2	.5002	1.1251	.312	1.250	.062

OIL-LESS BEARINGS

SHAFT SIZE	TYPE	MATERIAL
1/8" TO 1/2"	PLAIN GRADE S.A.E 30	SINTERED BRONZE MIL-B-5687 TYPE 1 OIL IMPREGNATED

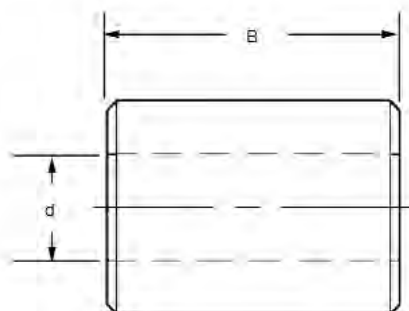
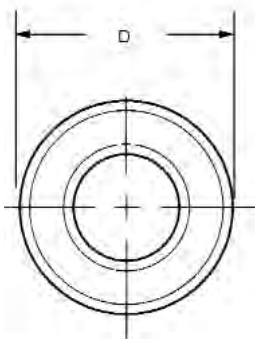

STOCK NO.	SHAFT SIZE	d +.002	D -.002	B ±.005	SHAFT STOCK NO.
B6-1 B6-2 B6-3 B6-4	1/8	.125	.252	.125 .250 .375 .500	S1-8
B6-5 B6-6 B6-7 B6-30 B6-8	3/16	* * * * .1875	.315	.250 .375 .500 .625 .750	S1-11
B6-9 B6-10 B6-11 B6-12 B6-54	1/4	.250	.378	.250 .375 .500 .625 .750	LMS-5-36
B6-37 B6-13 B6-14 B6-15 B6-16 B6-55	5/16	** *** *** ** .3125 .3125	.440	.250 .375 .500 .625 .750 1.000	S1-16
B6-41 B6-42 B6-17 B6-18 B6-19 B6-20	3/8	.375	.503	.250 .375 .500 .625 .750 1.000	LMS-7-36
B6-46 B6-21 B6-22 B6-23 B6-24 B6-57	1/2	.500	.628	.375 .500 .625 .750 1.000 1.250	LMS-9-36

* d = .1875 - .1895
 ** d = .3135 - .3155
 *** d = .3135 - .3155

OIL-LESS BEARINGS

SHAFT SIZE	TYPE	MATERIAL
1/8" TO 1/2"	PLAIN AND FLANGED STYLE	TEFLON-MIL-P-19468

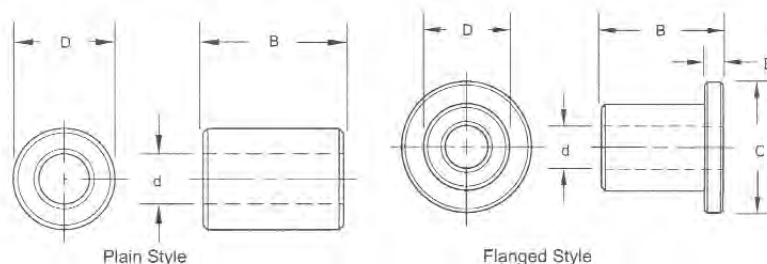

- Long Life
- Smooth Operation
- No Lubrication Required
- Minimal Breakaway Torque Resistance
- Max. PV = 10,000
- 450° F Max. Temperature Use

PLAIN STYLE	FLANGED STYLE					FLANGED ONLY		
STOCK NO.	STOCK NO.	SHAFT SIZE	d +.005	D -.000 -.003	B ±.010	C ±.010	E ±.005	SHAFT STOCK NO.
B8-1 --- B8-2 B8-3	B9-1 B9-2 B9-3 ---	1/8	.126	.254	.125 .187 .250 .375	.312	.047	S1-8
--- B8-5 B8-6 B8-7	B9-5 B9-6 B9-7 ---	3/16	.188	.317	.125 .250 .375 .500	.375	.047	S1-11
B8-9 B8-10 B8-11 B8-12	B9-9 B9-10 B9-11 ---	1/4	.251	.379	.250 .375 .500 .625	.500	.047	S1-73
--- B8-13 B8-14 B8-15 B8-16	B9-13 B9-14 B9-15 B9-16 ---	5/16	.313	.441	.250 .375 .500 .625 .750	.562	.093	S1-16
B8-17 B8-18 B8-19 B8-20	B9-17 B9-18 B9-19 B9-20	3/8	.376	.504	.375 .500 .625 .750		.093	S1-75
B8-21 B8-22 B8-23 B8-24	B9-21 B9-22 B9-23 B9-24	1/2	.501	.629	.500 .625 .750 1.000	.875	.125	S1-77

OIL-LESS BEARINGS

SHAFT SIZE	TYPE	MATERIAL
1/8" TO 1/2"	FLANGED GRADE S.A.E 30	SINTERED BRONZE MIL-B-5687 TYPE 1 OIL IMPREGNATED

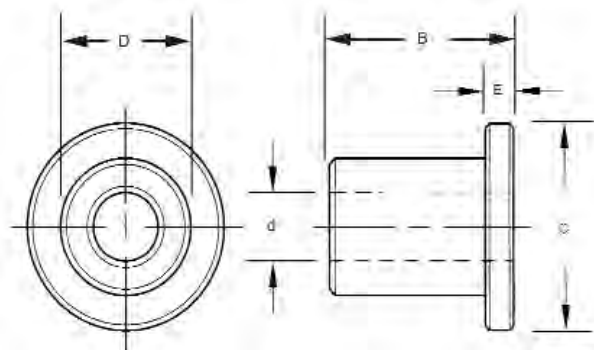

STOCK NO.	SHAFT SIZE	d + .002	D - .002	B ± .005	C ± .005	E ± .005	SHAFT STOCK NO.
B7-30 B7-31 B7-32	1/8	.125	.252	.125 .250 .375	.360	.047	S1-8
B7-1 B7-2	1/8	.125	.315	.250 .375	.375	.047	
B7-6 B7-7 B7-8 B7-35 B7-36	3/16	.187 * * * *	.315	.125 .250 .375 .500 .625	.370	.047	S1-11
B7-9 B7-10 B7-11 B7-12 B7-52	1/4	.250	.378	.250 .375 .500 .625 .750	.500	.047	LMS-5-36
B7-37 B7-38 B7-39 B7-40 B7-53	5/16	** *** *** ** .3125	.440	.250 .375 .500 .625 .750	.563 .560 .560 .563 .625	.062	S1-16 ----- ----- S1-16
B7-41 B7-42 B7-43 B7-44 B7-45 B7-54		3/8		.375	.503		.250 .375 .500 .625 .750 1.000
B7-46 B7-47 B7-48 B7-49 B7-50	1/2	.500	.628	.375 .500 .625 .750 1.000	.875	.062	LMS-9-36

* d = .188 - .189
 ** d = .313 - .314
 *** d = .3115 - .3125

PRECISION BEARINGS

SHAFT SIZE	TYPE	MATERIAL
3/16" TO 1/2"	FLANGED	6061-T6 ALUMINUM BODY WITH FRELON LINING

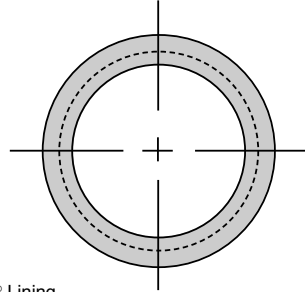
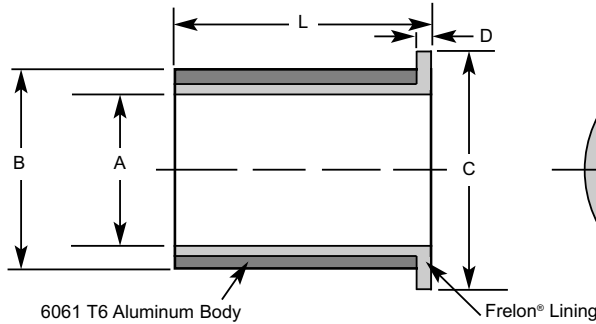

STOCK NO.	NOMINAL BEARING SIZE			A BEARING I.D.		B O.D.		C FLANGE O.D.	D FLANGE	L LENGTH	
	A	B	L	Min.	Max.	Min.	Max.	Max.	Max.	Min.	Max.
BPSF0305-2	3/16	5/16	1/4	0.1890	0.1900	0.3135	0.3145	0.4370	.0625	0.230	0.250
BPSF0305-4	3/16	5/16	1/2	0.1890	0.1900	0.3135	0.3145	0.4370	.0625	0.480	0.500
BPSF0405-2	1/4	3/8	1/4	0.2515	0.2525	0.3760	0.3770	0.5000	.0625	0.230	0.250
BPSF0405-3	1/4	3/8	3/8	0.2515	0.2525	0.3760	0.3770	0.5000	.0625	0.355	0.375
BPSF0405-4	1/4	3/8	1/2	0.2515	0.2525	0.3760	0.3770	0.5000	.0625	0.480	0.500
BPSF0610-4	3/8	5/8	1/2	0.3765	0.3775	0.6260	0.6270	0.8750	0.125	0.480	0.500
BPSF0610-6	3/8	5/8	3/4	0.3765	0.3775	0.6260	0.6270	0.8750	0.125	0.730	0.750
BPSF0710-6	7/16	5/8	3/4	0.4390	0.4400	0.6260	0.6270	0.9375	0.125	0.730	0.750
BPSF0812-4	1/2	3/4	1/2	0.5015	0.5025	0.7510	0.7520	1.0000	0.125	0.980	1.000
BPSF0812-6	1/2	3/4	3/4	0.5015	0.5025	0.7510	0.7520	1.0000	0.125	0.730	0.750
BPSF0812-8	1/2	3/4	1	0.5015	0.5025	0.7510	0.7520	1.0000	0.125	0.980	1.000

Factors Affecting Wear Rate / Life

Shafting requirements for Frelon® bearing material.

Best Performance:

- Finish of 8-12 RMS / Hardness of RC60

Acceptable Performance:

- Finish of 8-16 RMS / Hardness of RC35
- Rougher shafting can be used, but both bearing and shafting will wear at accelerated rates and binding may occur.

Chrome Plated Shafting Is Not Recommended!

Lubrication

Reduces friction 50%, and reduces heat buildup allowing greater speeds.

Recommended:

- Waylube Oil, Light Weight Oils, Petroleum Based Grease; 3-in-1 Oils

Not Recommended

- WD-40, PTFE Sprays, Fluorocarbon, Silicon

SHAFT SIZE	TYPE	MATERIAL
3/16" TO 1/2"	SLEEVE	6061-T6 ALUMINUM BODY WITH FRELON LINING

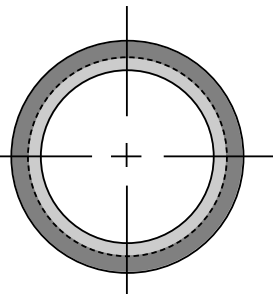
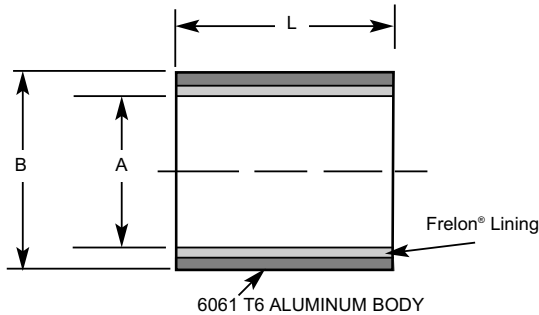

STOCK NO.	NOMINAL BEARING SIZE			A BEARING I.D.		B O.D.		L LENGTH	
	A	B	L	Min.	Max.	Min.	Max.	Min.	Max.
BPS0305-2	3/16	5/16	1/4	0.1890	0.1900	0.3135	0.3145	0.230	0.250
BPS0305-4	3/16	5/16	1/2	0.1890	0.1900	0.3135	0.3145	0.480	0.500
BPS0406-2	1/4	3/8	1/4	0.2515	0.2525	0.3760	0.3770	0.230	0.250
BPS0406-3	1/4	3/8	3/8	0.2515	0.2525	0.3760	0.3770	0.355	0.375
BPS0406-4	1/4	3/8	1/2	0.2515	0.2525	0.3760	0.3770	0.480	0.500
BPS0610-4	3/8	5/8	1/2	0.3765	0.3775	0.6260	0.6270	0.480	0.500
BPS0610-6	3/8	5/8	3/4	0.3765	0.3775	0.6260	0.6270	0.730	0.750
BPS0710-6	7/16	5/8	3/4	0.4390	0.4400	0.6260	0.6270	0.730	0.750
BPS0812-4	1/2	3/4	1/2	0.5015	0.5025	0.7510	0.7520	0.480	0.500
BPS0812-6	1/2	3/4	3/4	0.5015	0.5025	0.7510	0.7520	0.730	0.750
BPS0812-8	1/2	3/4	1	0.5015	0.5025	0.7510	0.7520	0.980	1.000

Factors Affecting Wear Rate / Life

Shafting requirements for Frelon® bearing material.

Best Performance:

- Finish of 8-12 RMS / Hardness of RC60

Acceptable Performance:

- Finish of 8-16 RMS / Hardness of RC35
- Rougher shafting can be used, but both bearing and shafting will wear at accelerated rates and binding may occur.

Chrome Plated Shafting Is Not Recommended!

Lubrication

Reduces friction 50%, and reduces heat buildup allowing greater speeds.

Recommended:

- Waylube Oil, Light Weight Oils, Petroleum Based Grease; 3-in-1 Oils

Not Recommended

- WD-40, PTFE Sprays, Fluorocarbon, Silicon

PRECISION BEARINGS

Additional Dimensional Information

STOCK NO.		MAXIMUM STATIC LOAD (LBS.)	BEARING WEIGHT	RECOMMENDED HOUSING BORE			
				SLIP FIT & EPOXY		PRESS FIT	
FLANGED	SLEEVE		OZ.	Min.	Max.	Max.	Max.
BPSF0305-2	BPS0305-2	130	0.023	.3145	0.3155	0.3125	0.3130
BPSF0305-4	BPS0305-4	272	0.044	.3145	0.3155	0.3125	0.3130
BPSF0406-2	BPS0406-2	174	0.031	.3770	0.3780	0.3750	0.3755
BPSF0406-3	BPS0406-3	268	0.044	.3770	0.3780	0.3750	0.3755
BPSF0406-4	BPS0406-4	362	0.055	.3770	0.3780	0.3750	0.3755
BPSF0610-4	BPS0610-4	542	0.20	0.6270	0.6280	0.6250	0.6255
BPSF0610-6	BPS0610-6	824	0.25	0.6270	0.6280	0.6250	0.6255
BPSF0710-6	BPS0710-6	962	0.20	0.6270	0.6280	0.6250	0.6255
BPSF0812-4	BPS0812-4	722	0.25	0.7520	0.7530	0.7500	0.7505
BPSF0812-6	BPS0812-6	1098	0.30	0.7520	0.7530	0.7500	0.7505
BPSF0812-8	BPS0812-8	1474	0.40	0.7520	0.7530	0.7500	0.7505

Installation Instructions

- Slip the bearing sleeve into the housing and epoxy into place with bonding agent. CAUTION: Do NOT let any of the adhesive touch the bearing liner. It will harden and interfere with the running clearance.
- Freeze the bearing at 0°F (-17.75°C) for 30-45 minutes. Using gloves, remove the bearings from the freezer and slip them into housing. As they heat to room temperature, full contact between the bearing and housing will be achieved. The greatest advantage to his technique over traditional pressing is greater accuracy in alignment.
- Temperature Range (-400°F/+500°F, -240°C/+260°C)

Speed Characteristics

Exceeding these speeds causes frictional heat and accelerates liner wear.

Bearing Material	No Lube Continuous Motion	No Lube Intermittent Motion	With Lubrication
Frelon® Gold	300 sfm 60 in/sec. 1.524 m/sec.	825 sfm 165 in/sec. 4.19 m/sec.	825 sfm 165 in/sec. 4.19 m/sec.

Performance Ratings (For Linear Motion)

Plane bearings are rated by their limiting PV which is a combination of load over a given surface area and velocity.

Bearing Material	Max. "PV"	Max. "P"	Max. "V" (No Lubrication)
Frelon® Gold	20,000 (psi) x ft/Min or 430 (kgf/cm ² x m/min)	3000 psi or 210.9 (kgf/cm ² x m/min)	300 sfm or 91.44 m/min.

PV = The performance measurement of plane bearings. P x V where P = pressure (load) in psi (kgf/cm²). V = velocity (speed) in sfm (m/min.)

THERMOPLASTIC BEARING

Reference Chart

The B15/16 Series is a thick-walled light-duty bearing used in many types of machinery to dampen vibration and shock loads. They are dimensionally interchangeable with most sintered metal bearings, and can be retro-fitted without changing the housing bore or shaft. Typically they're used in agricultural and exercise equipment and machinery such as woodworking, packaging, and welding equipment.

The B17/18 Series is available for situations where even the excellent abrasion resistance of the B19/20 Series is insufficient. It's superior characteristics are especially well suited for high performance requirements. Applications include, for example, pneumatic cylinders, lifting equipment, fitness machinery, industrial brakes, clutches and automotive components in general.

The B19/20 Series was initially designed for applications in chemical processing equipment. This material is a unique combination of exotic materials best suited for high load, temperature and speed applications. It is resistant to virtually any substance except for concentrated sulfuric acids. At present, this material is unique and unequalled. Applications include chemical mountings and pumps, oven manufacture, semi-conductors, film developing equipment, equipment for industrial-sized kitchens, etc.

	B15/16 SERIES	B17/18 SERIES	B19/20 SERIES
MAX. LOAD (PSI)	2,300	9,425	21,750
TEMP. RANGE			
LONG TERM.	-40f	-40f	-149f
SHORT TERM.	240f	275f	485f
WEAR BARRIER	390f	410f	600f
	175f	250f	410f
MAX. PV (NO LUB.)	9,800	28,000	100,000
SPEEDS (FPM)			
OSCILLATING (CONTINUOUS)	195	390	585
OSCILLATING (SHORT TERM)	390	590	780
ROTATIONAL (CONTINUOUS)	195	295	295
ROTATIONAL (SHORT TERM)	390	490	685
LINEAR (CONTINUOUS)	585	975	975
LINEAR (SHORT TERM)	975	1,180	1,170
COEFFICIENT OF FRICTION. DYNAMIC STEEL, DRY.	.18-.30	.08-.15	.11-.17
MAINTENANCE FREE	YES	YES	YES
DRY OPERATION	YES	YES	YES
COMPRESSIVE STRENGTH	2610 PSI	9425 PSI	21,750 PSI
SPACE REQUIREMENTS	MEDIUM WALL THICKNESS	THIN WALLED	THIN WALLED
DENSITY 1B/IN3	.040	.051	.053
MODULUS OF ELASTICITY PSI	246,500	797,500	957,000
H ₂ O ABSORPTION @50% HUM. & 72 ° F (%)	1.6	.65	.10

THERMOPLASTIC BEARINGS

BORE SIZE	SHAFT SIZE	TYPE
1/8" TO 1/2"	.1250 TO .5000	SLEEVE AND FLANGED

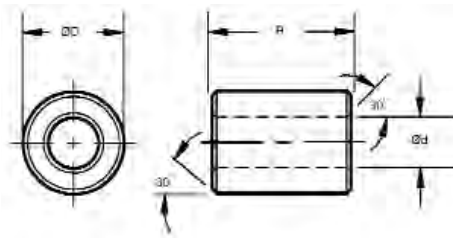

Sleeve

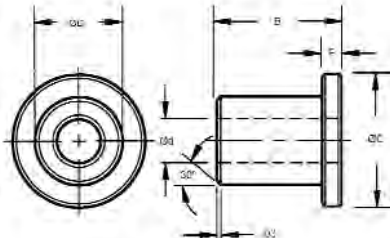

Flanged



SLEEVE STOCK NO.	FLANGED STOCK NO.	NOMINAL SIZES Ød	ØD	B	ØC	E (+0,-/-.0055)	I.D. AFTER PRESS FIT		HOUSING BORE		SHAFT SIZE	
							MAX.	MIN.	MAX.	MIN.	MAX.	MIN.
B15-1	B16-1	1/8	1/4	1/8	.360	.047	.1280	.1262	.2515	.2510	.1250	.1241
B15-2	B16-2	1/8	1/4	3/16	.360	.047	.1280	.1262	.2515	.2510	.1250	.1241
B15-3	B16-3	1/8	1/4	1/4	.360	.047	.1280	.1262	.2515	.2510	.1250	.1241
B15-4	B16-4	1/8	1/4	3/8	.360	.047	.1280	.1262	.2515	.2510	.1250	.1241
B15-5	B16-5	3/16	1/4	1/4	.375	.032	.1905	.1887	.2515	.2510	.1875	.1866
B15-6	B16-6	3/16	1/4	3/8	.375	.032	.1905	.1887	.2515	.2510	.1875	.1866
B15-7	B16-7	3/16	1/4	1/2	.375	.032	.1905	.1887	.2515	.2510	.1875	.1866
B15-8	B16-8	3/16	5/16	3/16	.370	.047	.1905	.1887	.3140	.3135	.1875	.1866
B15-9	B16-9	3/16	5/16	1/4	.370	.047	.1905	.1887	.3140	.3135	.1875	.1866
B15-10	B16-10	3/16	5/16	5/16	.370	.047	.1905	.1887	.3140	.3135	.1875	.1866
B15-11	B16-11	3/16	5/16	3/8	.370	.047	.1905	.1887	.3140	.3135	.1875	.1866
B15-12	B16-12	3/16	5/16	1/2	.370	.047	.1905	.1887	.3140	.3135	.1875	.1866
B15-13	B16-13	1/4	5/16	1/4	.438	.032	.2539	.2516	.3140	.3135	.2500	.2491
B15-14	B16-14	1/4	5/16	3/8	.438	.032	.2539	.2516	.3140	.3135	.2500	.2491
B15-15	B16-15	1/4	5/16	1/2	.438	.032	.2539	.2516	.3140	.3135	.2500	.2491
B15-16	B16-16	1/4	3/8	3/16	.560	.047	.2539	.2516	.3765	.3760	.2500	.2491
B15-17	B16-17	1/4	3/8	1/4	.560	.047	.2539	.2516	.3765	.3760	.2500	.2491
B15-18	B16-18	1/4	3/8	5/16	.560	.047	.2539	.2516	.3765	.3760	.2500	.2491
B15-19	B16-19	1/4	3/8	3/8	.560	.047	.2539	.2516	.3765	.3760	.2500	.2491
B15-20	B16-20	1/4	3/8	1/2	.560	.047	.2539	.2516	.3765	.3760	.2500	.2491
B15-21	B16-21	1/4	3/8	5/8	.560	.047	.2539	.2516	.3765	.3760	.2500	.2491
B15-22	B16-22	1/4	3/8	3/4	.560	.047	.2539	.2516	.3765	.3760	.2500	.2491
B15-23	B16-23	5/16	3/8	1/4	.500	.032	.3164	.3141	.3765	.3760	.3125	.3116
B15-24	B16-24	5/16	3/8	3/8	.500	.032	.3164	.3141	.3765	.3760	.3125	.3116
B15-25	B16-25	5/16	3/8	1/2	.500	.032	.3164	.3141	.3765	.3760	.3125	.3116
B15-26	B16-26	5/16	7/16	3/16	.560	.062	.3164	.3141	.4390	.4385	.3125	.3116
B15-27	B16-27	5/16	7/16	1/4	.560	.062	.3164	.3141	.4390	.4385	.3125	.3116
B15-28	B16-28	5/16	7/16	5/16	.560	.062	.3164	.3141	.4390	.4385	.3125	.3116
B15-29	B16-29	5/16	7/16	3/8	.560	.062	.3164	.3141	.4390	.4385	.3125	.3116
B15-30	B16-30	5/16	7/16	1/2	.560	.062	.3164	.3141	.4390	.4385	.3125	.3116
B15-31	B16-31	5/16	7/16	5/8	.560	.062	.3164	.3141	.4390	.4385	.3125	.3116
B15-32	B16-32	5/16	7/16	3/4	.560	.062	.3164	.3141	.4390	.4385	.3125	.3116
B15-33	B16-33	3/8	7/16	1/4	.563	.032	.3789	.3766	.4390	.4385	.3750	.3741
B15-34	B16-34	3/8	7/16	3/8	.563	.032	.3789	.3766	.4390	.4385	.3750	.3741
B15-35	B16-35	3/8	7/16	1/2	.563	.032	.3789	.3766	.4390	.4385	.3750	.3741
B15-36	B16-36	3/8	1/2	3/16	.625	.062	.3789	.3766	.5015	.5010	.3750	.3741
B15-37	B16-37	3/8	1/2	1/4	.625	.062	.3789	.3766	.5015	.5010	.3750	.3741
B15-38	B16-38	3/8	1/2	5/16	.625	.062	.3789	.3766	.5015	.5010	.3750	.3741
B15-39	B16-39	3/8	1/2	3/8	.625	.062	.3789	.3766	.5015	.5010	.3750	.3741
B15-40	B16-40	3/8	1/2	1/2	.625	.062	.3789	.3766	.5015	.5010	.3750	.3741
B15-41	B16-41	3/8	1/2	5/8	.625	.062	.3789	.3766	.5015	.5010	.3750	.3741
B15-42	B16-42	3/8	1/2	3/4	.625	.062	.3789	.3766	.5015	.5010	.3750	.3741
B15-43	B16-43	3/8	1/2	1	.625	.062	.3789	.3766	.5015	.5010	.3750	.3741
B15-44	B16-44	7/16	9/16	3/8	.687	.062	.4422	.4395	.5635	.5625	.4375	.4365
B15-45	B16-45	7/16	9/16	1/2	.687	.062	.4422	.4395	.5635	.5625	.4375	.4365
B15-46	B16-46	1/2	5/8	1/4	.875	.062	.5047	.5020	.6260	.6250	.5000	.4990
B15-47	B16-47	1/2	5/8	5/16	.875	.062	.5047	.5020	.6260	.6250	.5000	.4990
B15-48	B16-48	1/2	5/8	3/8	.875	.062	.5047	.5020	.6260	.6250	.5000	.4990
B15-49	B16-49	1/2	5/8	1/2	.875	.062	.5047	.5020	.6260	.6250	.5000	.4990
B15-50	B16-50	1/2	5/8	5/8	.875	.062	.5047	.5020	.6260	.6250	.5000	.4990
B15-51	B16-51	1/2	5/8	3/4	.875	.062	.5047	.5020	.6260	.6250	.5000	.4990
B15-52	B16-52	1/2	5/8	1	.875	.062	.5047	.5020	.6260	.6250	.5000	.4990

THERMOPLASTIC BEARINGS

BORE SIZE	SHAFT SIZE	TYPE
1/8" TO 1/2"	.1250 TO .5000	SLEEVE AND FLANGED

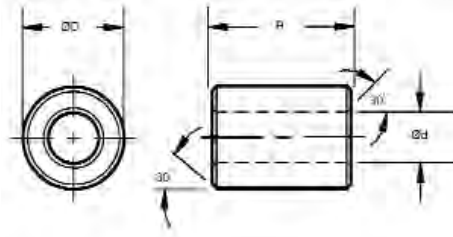

Sleeve

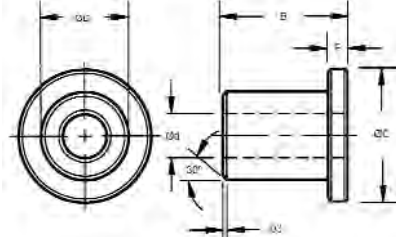

Flanged



SLEEVE STOCK NO.	FLANGED STOCK NO.	NOMINAL SIZES Ød	ØD	B	ØC	E (+0./-0055)	I.D. AFTER PRESS FIT		HOUSING BORE		SHAFT SIZE	
							MAX.	MIN.	MAX.	MIN.	MAX.	MIN.
B17-1	B18-1	1/8	3/16	3/16	.312	.032	.1269	.1251	.1878	.1873	.1243	.1236
B17-2	B18-2	1/8	3/16	1/4	.312	.032	.1269	.1251	.1878	.1873	.1243	.1236
B17-3	B18-3	1/8	3/16	3/8	.312	.032	.1269	.1251	.2503	.1873	.1243	.1236
B17-4	B18-4	3/16	1/4	1/4	.375	.032	.1892	.1873	.2503	.2497	.1865	.1858
B17-5	B18-5	3/16	1/4	3/8	.375	.032	.1892	.1873	.2503	.2497	.1865	.1858
B17-6	B18-6	3/16	1/4	1/2	.375	.032	.1892	.1873	.2503	.2497	.1865	.1858
B17-7	B18-7	1/4	5/16	1/4	.500	.032	.2521	.2498	.3128	.3122	.2490	.2481
B17-8	B18-8	1/4	5/16	3/8	.500	.032	.2521	.2498	.3128	.3122	.2490	.2481
B17-9	B18-9	1/4	5/16	1/2	.500	.032	.2521	.2498	.3128	.3122	.2490	.2481
B17-10	B18-10	5/16	3/8	1/4	.562	.032	.3148	.3125	.3753	.3747	.3115	.3106
B17-11	B18-11	5/16	3/8	3/8	.562	.032	.3148	.3125	.3753	.3747	.3115	.3106
B17-12	B18-12	5/16	3/8	1/2	.562	.032	.3148	.3125	.3753	.3747	.3115	.3106
B17-13	B18-13	5/16	3/8	3/4	.562	.032	.3148	.3125	.3753	.3747	.3115	.3106
B17-14	B18-14	3/8	15/32	1/4	.687	.046	.3773	.3750	.4691	.4684	.3740	.3731
B17-15	B18-15	3/8	15/32	3/8	.687	.046	.3773	.3750	.4691	.4684	.3740	.3731
B17-16	B18-16	3/8	15/32	1/2	.687	.046	.3773	.3750	.4691	.4684	.3740	.3731
B17-17	B18-17	3/8	15/32	3/4	.687	.046	.3773	.3750	.4691	.4684	.3740	.3731
B17-18	B18-18	7/16	17/32	1/2	.750	.046	.4406	.4379	.5316	.5309	.4365	.4355
B17-19	B18-19	1/2	19/32	1/4	.875	.046	.5030	.5003	.5941	.5934	.4990	.4980
B17-20	B18-20	1/2	19/32	3/8	.875	.046	.5030	.5003	.5941	.5934	.4990	.4980
B17-21	B18-21	1/2	19/32	1/2	.875	.046	.5030	.5003	.5941	.5934	.4990	.4980
B17-22	B18-22	1/2	19/32	3/4	.875	.046	.5030	.5003	.5941	.5934	.4990	.4980
B17-23	B18-23	1/2	19/32	1	.875	.046	.5030	.5003	.5941	.5934	.4990	.4980
B19-1	B20-1	1/8	3/16	3/16	.312	.032	.1269	.1251	.1878	.1873	.1243	.1236
B19-2	B20-2	1/8	3/16	3/8	.312	.032	.1269	.1251	.1878	.1873	.1243	.1236
B19-3	B20-3	3/16	1/4	1/4	.375	.032	.1892	.1873	.2503	.2497	.1865	.1858
B19-4	B20-4	3/16	1/4	3/8	.375	.032	.1892	.1873	.2503	.2497	.1865	.1858
B19-5	B20-5	3/16	1/4	1/2	.375	.032	.1892	.1873	.2503	.2497	.1865	.1858
B19-6	B20-6	1/4	5/16	1/4	.500	.032	.2521	.2498	.3128	.3122	.2490	.2481
B19-7	B20-7	1/4	5/16	3/8	.500	.032	.2521	.2498	.3128	.3122	.2490	.2481
B19-8	B20-8	1/4	5/16	1/2	.500	.032	.2521	.2498	.3128	.3122	.2490	.2481
B19-9	B20-9	5/16	3/8	1/4	.562	.032	.3148	.3125	.3753	.3747	.3115	.3106
B19-10	B20-10	5/16	3/8	3/8	.562	.032	.3148	.3125	.3753	.3747	.3115	.3106
B19-11	B20-11	5/16	3/8	1/2	.562	.032	.3148	.3125	.3753	.3747	.3115	.3106
B19-12	B20-12	3/8	15/32	1/4	.687	.046	.3773	.3750	.4691	.4684	.3740	.3731
B19-13	B20-13	3/8	15/32	3/8	.687	.046	.3773	.3750	.4691	.4684	.3740	.3731
B19-14	B20-14	3/8	15/32	1/2	.687	.046	.3773	.3750	.4691	.4684	.3740	.3731
B19-15	B20-15	3/8	15/32	3/4	.687	.046	.3773	.3750	.4691	.4684	.3740	.3731
B19-16	B20-16	7/16	17/32	1/2	.750	.046	.4406	.4379	.5316	.5309	.4365	.4355
B19-17	B20-17	1/2	19/32	3/8	.875	.046	.5030	.5003	.5941	.5934	.4990	.4980
B19-18	B20-18	1/2	19/32	1/2	.875	.046	.5030	.5003	.5941	.5934	.4990	.4980
B19-19	B20-19	1/2	19/32	3/4	.875	.046	.5030	.5003	.5941	.5934	.4990	.4980
B19-20	B20-20	1/2	19/32	1	.875	.046	.5030	.5003	.5941	.5934	.4990	.4980

JOURNAL BEARINGS

BORE SIZE	TYPE	MATERIAL
.2530 TO .6280	PLAIN THIN WALL	DURALON WITH TFE LINER

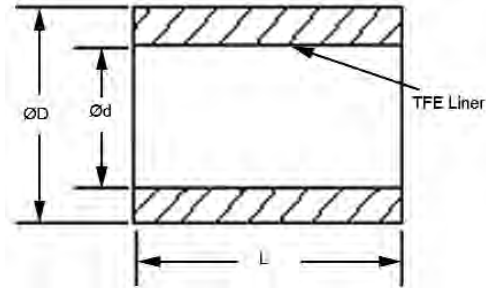

STOCK NO.	$\varnothing d$ +.001 -.000	$\varnothing D$ +.000 -.001	HOUSING BORE	WT.(REF) LB./IN.	BEARING AREA FACTOR*	L +.000 -.020
701-00004-008	.2530	.3767		.0043	.082	.250
701-00004-012	.2530	.3767		.0043	.145	.375
701-00004-016	.2530	.3767		.0043	.209	.500
701-00004-020	.2530	.3767	.3755	.0043	.273	.625
701-00004-024	.2530	.3767	.3745	.0043	.337	.750
701-00004-028	.2530	.3767		.0043	.400	.875
701-00004-032	.2530	.3767		.0043	.464	1.000
701-00004-036	.2530	.3767		.0043	.528	1.125
701-00006-008	.3780	.5017		.0060	.099	.250
701-00006-012	.3780	.5017		.0060	.177	.375
701-00006-016	.3780	.5017		.0060	.255	.500
701-00006-020	.3780	.5017	.5005	.0060	.332	.625
701-00006-024	.3780	.5017	.4995	.0060	.410	.750
701-00006-028	.3780	.5017		.0060	.488	.875
701-00006-032	.3780	.5017		.0060	.565	1.000
701-00006-036	.3780	.5017		.0060	.643	1.125
701-00008-008	.5030	.6267		.0077	.114	.250
701-00008-012	.5030	.6267		.0077	.204	.375
701-00008-016	.5030	.6267		.0077	.293	.500
701-00008-020	.5030	.6267	.6255	.0077	.382	.625
701-00008-024	.5030	.6267	.6245	.0077	.471	.750
701-00008-028	.5030	.6267		.0077	.561	.875
701-00008-032	.5030	.6267		.0077	.650	1.000
701-00008-036	.5030	.6267		.0077	.739	1.125
701-00010-012	.6280	.7517		.0094	.227	.375
701-00010-016	.6280	.7517		.0094	.326	.500
701-00010-020	.6280	.7517		.0094	.426	.625
701-00010-024	.6280	.7517		.0094	.526	.750
701-00010-028	.6280	.7517	.7505	.0094	.625	.875
701-00010-032	.6280	.7517	.7495	.0094	.725	1.000
701-00010-036	.6280	.7517		.0094	.824	1.125
701-00010-040	.6280	.7517		.0094	.924	1.250
701-00010-044	.6280	.7517		.0094	1.023	1.375

*The Bearing Area Factor is a numerical index of a bearing's dynamic performance ability and is based upon effective bearing area.

JOURNAL BEARINGS

BORE SIZE	TYPE	MATERIAL
.7530 TO 1.0030	PLAIN THIN WALL	DURALON WITH TFE LINER

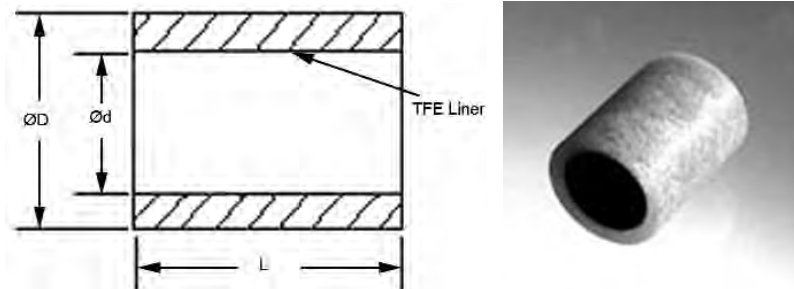

STOCK NO.	Ød +.001 -.000	ØD +.000 -.001	HOUSING BORE	WT.(REF) LB./IN.	BEARING AREA FACTOR*	L +.000 -.020
701-00012-012	.7530	.8767		.0111	.248	.375
701-00012-016	.7530	.8767		.0111	.357	.500
701-00012-020	.7530	.8767		.0111	.466	.625
701-00012-024	.7530	.8767		.0111	.574	.750
701-00012-028	.7530	.8767	.8755	.0111	.683	.875
701-00012-032	.7530	.8767	.8745	.0111	.792	1.000
701-00012-036	.7530	.8767		.0111	.901	1.125
701-00012-040	.7530	.8767		.0111	1.010	1.250
701-00012-044	.7530	.8767		.0111	1.119	1.375
701-00014-016	.8780	1.0642		.0199	.385	.500
701-00014-020	.8780	1.0642		.0199	.502	.625
701-00014-024	.8780	1.0642		.0199	.620	.750
701-00014-028	.8780	1.0642	1.0630	.0199	.737	.875
701-00014-032	.8780	1.0642	1.0620	.0199	.854	1.000
701-00014-036	.8780	1.0642		.0199	.971	1.125
701-00014-040	.8780	1.0642		.0199	1.089	1.250
701-00014-044	.8780	1.0642		.0199	1.206	1.375
701-00014-048	.8780	1.0642		.0199	1.323	1.500
701-00016-016	1.0030	1.1892		.0224	.411	.500
701-00016-020	1.0030	1.1892		.0224	.536	.625
701-00016-024	1.0030	1.1892		.0224	.661	.750
701-00016-028	1.0030	1.1892		.0224	.786	.875
701-00016-032	1.0030	1.1892	1.1880	.0224	.912	1.000
701-00016-036	1.0030	1.1892	1.1870	.0224	1.037	1.125
701-00016-040	1.0030	1.1892		.0224	1.162	1.250
701-00016-044	1.0030	1.1892		.0224	1.288	1.375
701-00016-048	1.0030	1.1892		.0224	1.413	1.500
701-00016-056	1.0030	1.1892		.0224	1.663	1.750
701-00016-064	1.0030	1.1892		.0224	1.914	2.000

*The Bearing Area Factor is a numerical index of a bearing's dynamic performance ability and is based upon effective bearing area.

COMPOSITE ANNULAR BEARINGS

BORE SIZE	TYPE	MATERIAL
.504 TO 1.254	SPLIT OUTER RACE	DURALON WITH TFE LINER

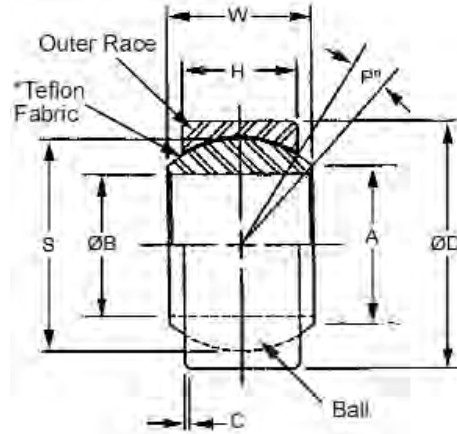

STOCK NO.	ØB MAX / MIN	ØD MAX / MIN	W +.000 -.005	H +.000 -.005	A (REF)	C HOUSING FILLET RADIUS (MAX)	P DEG MAX	S BALL OUTSIDE DIA. REF	RADIAL LIMIT LOADING RATING (LB.)
831-08-14-01	.504 .503	.8750 .8745	.437	.375	.571	.022	6	.7190	3,750
831-12-20-01	.754 .753	1.2500 1.2495	.656	.562	.858	.032	6	1.0800	8,430
831-14-23-01	.879 .878	1.4375 1.4370	.765	.656	.999	.032	6	1.2580	11,480
831-16-26-01	1.004 1.003	1.6250 1.6245	.875	.750	1.140	.032	6	1.4370	15,000
831-20-32-01	1.254 1.253	2.0000 1.9995	1.093	.937	1.424	.032	6	1.7950	23,425
838-08-14-01	.504 .503	.8750 .8745	.437	.375	.571	.022	6	.7190	3,750
838-12-20-01	.754 .753	1.2500 1.2495	.656	.562	.858	.032	6	1.0800	8,430
838-14-23-01	.879 .878	1.4375 1.4370	.765	.656	.999	.032	6	1.2580	11,480
838-16-26-01	1.004 1.003	1.6250 1.6245	.875	.750	1.140	.032	6	1.4370	15,000
838-20-32-01	1.254 1.253	2.0000 1.9995	1.093	.937	1.424	.032	6	1.7950	23,425

* Model Nos. 831 indicates no teflon fabric on the ball O.D. Model Nos. 838 indicates teflon fabric on the ball O.D.

Note: Duralon is a registered trademark of Rexnord Corporation.
Teflon is a registered trademark of E.I. DuPont.

COMPOSITE SPHERICAL BEARINGS

BORE SIZE	TYPE	MATERIAL
.252 TO 1.002	SELF LUBRICATING SPHERICAL ANNULAR	17-4 STAINLESS STEEL OUTER RACE

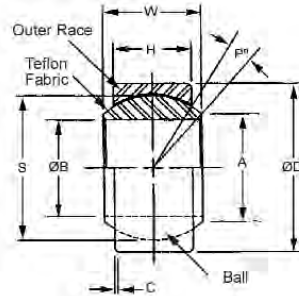

STOCK NO.	ØB +.000 -.001	ØD +.0000 -.0005	W +.000 -.010	H ±.003	A (REF)	C ±.005	P DEG MAX	S BALL OUTSIDE DIA. REF	LIMIT LOAD RATING (LB.)
821-04-10-01	.252	.6562	.343	.250	.405	.020	12	.5300	6,300
821-05-12-01	.315	.7500	.375	.281	.419	.020	11	.5625	7,490
821-06-13-01	.377	.8125	.406	.312	.475	.025	10	.6250	9,060
821-07-14-01	.440	.9062	.437	.343	.529	.025	9	.6865	11,380
821-08-16-01	.502	1.0000	.500	.390	.640	.030	9	.8125	15,750
821-09-18-01	.565	1.0937	.562	.437	.671	.030	10	.8750	18,980
821-10-19-01	.627	1.1875	.625	.500	.739	.030	9	.9680	24,180
821-12-23-01	.752	1.4375	.750	.593	.920	.030	9	1.1870	36,170
821-14-25-01	.877	1.5625	.875	.703	.978	.030	9	1.3120	48,160
821-16-28-01	1.002	1.7500	1.000	1.000	.797	.030	9	1.5000	63,100

Note: Duralon is a registered trademark of Rexnord Corporation.
Teflon is a registered trademark of E.I. DuPont.

BORE SIZE	TYPE	MATERIAL
.500 TO 2.000	SELF ALIGNING SPHERICAL ANNULAR	17-4 STAINLESS STEEL OUTER RACE

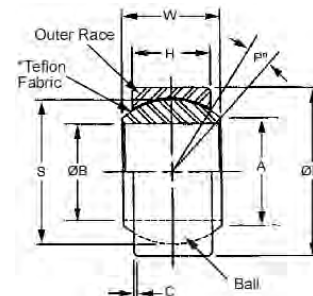

STOCK NO.	ØB +.000 -.001	ØD +.001 -.000	W +.000 -.005	H +.000 -.005	A (REF)	C +.010 -.010	P DEG MAX	S BALL OUTSIDE DIA. REF	LIMIT LOAD RATING (LB.)
801-08-14-01	.500	.8750	.437	.375	.571	.015	6	.719	5,400
801-12-20-01	.750	1.2500	.656	.562	.858	.015	6	1.080	12,140
801-14-23-01	.875	1.4375	.765	.656	.999	.015	6	1.258	16,500
801-16-26-01	1.000	1.6250	.875	.750	1.140	.015	6	1.437	21,560
801-20-32-01	1.250	2.0000	1.093	.937	1.424	.015	6	1.795	33,640
801-22-35-01	1.375	2.1875	1.187	1.031	1.531	.015	6	1.937	40,000
801-24-39-01	1.500	2.4375	1.312	1.125	1.710	.015	6	2.155	48,480
801-28-45-01	1.750	2.8125	1.531	1.312	1.995	.015	6	2.515	66,000
801-32-51-01	2.000	3.1875	1.750	1.500	2.281	.015	6	2.875	86,250

Note: Duralon is a registered trademark of Rexnord Corporation.
Teflon is a registered trademark of E.I. DuPont.

SPHERICAL BEARINGS

BORE SIZE	TYPE	MATERIAL
.1900 TO .6250	SELF LUBRICATING	440C R/C 55-62 BALL, 410 RC 23-25 HOUSING, RACE TEFLON FABRIC COATED PERM. BONDE (I.D.)

- High radial and thrust load
- Long life cycle
- Temperature range
-65°F to + 250° F

Options Available:
Bore diameters under .1900
and other materials.

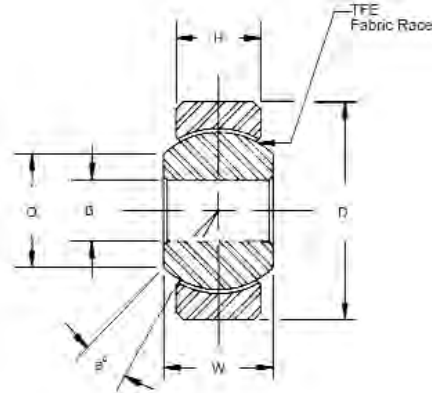

STAINLESS STEEL STOCK NUMBER	B +.0000 -.0005	D +.0000 -.0005	W +.000 -.002	H ±.005	O FLAT DIA. REF.	BALL DIA REF.	a/b	RADIAL STATIC LOAD LIMIT Lbs.
RJS-3	.1900	.5625	.281	.218	.293	.406	10	3,975
RJS-4	.2500	.6562	.343	.250	.364	.500	10	6,040
RJS-5	.3125	.7500	.375	.281	.419	.562	10	8,750
RJS-6	.3750	.8125	.406	.312	.515	.656	9	10,540
RJS-7	.4375	.9062	.437	.343	.570	.718	8	13,200
RJS-8	.5000	1.0000	.500	.390	.641	.813	8	17,900
RJS-10	.6250	1.1875	.625	.500	.739	.968	8	30,500

BORE SIZE	TYPE	MATERIAL
.1900 TO .6250	LUBRICATION REQUIRED	52100 STEEL R/C 56 MIN. HARD CHROME PLATED BALL, LOW CARBON STEEL HOUSING, RACE BRASS

- High radial and thrust load
- Long life cycle
- Temperature range
-65°F to + 250° F

Options Available:
Bore diameters under .1900 and
other materials.

** Bore diameter .3765/3745,
Housing material is low carbon
steel oil coated on outside
diameter, and race material is
low carbon steel.

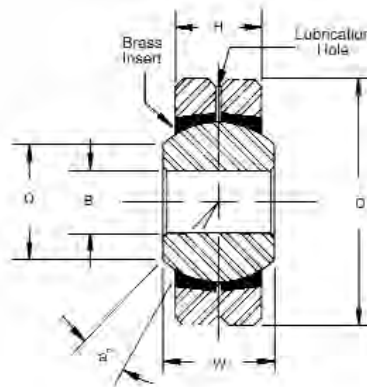

CARBON STEEL STOCK NUMBER	B +.0000 -.0005	D +.0000 -.0005	W +.000 -.005	H +.005	O FLAT DIA. REF.	BALL DIA REF.	a/b	RADIAL STATIC LOAD LIMIT Lbs.
RJC-3	.1900	.6250	.281	.187	.293	.406	12.0	2,961
RJC-4	.2500	.7500	.375	.281	.354	.515	12.5	5,246
RJC-5	.3125	.8750	.437	.313	.447	.625	12.0	6,554
RJC-6**	-	1.0000	.500	.375	.517	.718	10.5	10,785
RJC-7	.4375	1.1875	.562	.437	.586	.812	8.5	11,100
RJC-8	.5000	1.3125	.687	.531	.637	.937	10.0	15,600
RJC-10	.6250	1.5625	.875	.687	.802	1.187	10.0	25,700

THERMOPLASTIC SPHERICAL BEARINGS

BORE SIZE	TYPE	MATERIAL
.1900 TO .7500	SELF LUBRICATING	REINFORCED THERMOPLASTIC HOUSING, BALL B15/16 BEARING THERMOPLASTIC

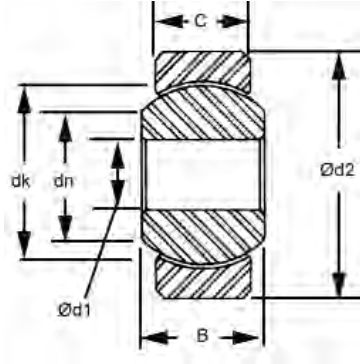

STOCK NUMBER	Ød1	Ød2	dn	dk REF	B	C
SKGLI-03	.1900	.5625	.307	.438	.312	.218
SKGLI-04	.2500	.6562	.354	.516	.375	.250
SKGLI-05	.3125	.7500	.447	.625	.437	.281
SKGLI-06	.3750	.8125	.504	.718	.500	.312
SKGLI-07	.4375	.9062	.600	.828	.562	.343
SKGLI-08	.5000	1.0000	.700	.938	.625	.390
SKGLI-10	.6250	1.1875	.838	1.125	.750	.500
SKGLI-12	.7500	1.4375	.978	1.312	.875	.593

THRUST BEARINGS

BORE SIZE	MATERIAL
.128 TO 1.253	410 STAINLESS STEEL OR C1075 CARBON STEEL

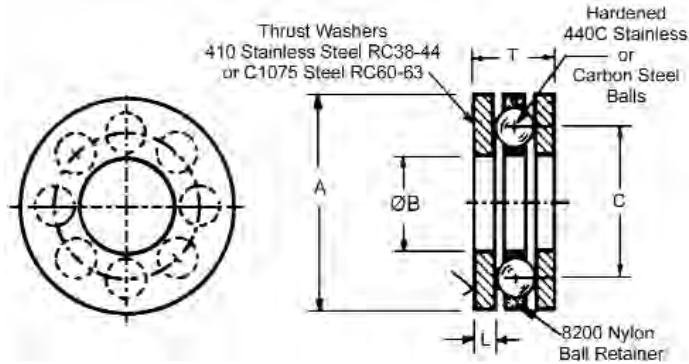

STAINLESS STEEL STOCK NUMBER	CARBON STEEL STOCK NUMBER	ØB ⁺ .005 - .000	A ⁺ .000 - .005	C	T	L ± .002	NO. OF BALLS	STAINLESS STEEL LOAD RATING AT 15 RPM	CARBON STEEL LOAD RATING AT 15 RPM
B5-1-SS	B5-1	.128	.434	9/32	.195	.050	6	63 LBS.	89 LBS.
B5-2-SS	B5-2	.190	.497	11/32	.195	.050	7	73 LBS.	104 LBS.
B5-3-SS	B5-3	.253	.559	13/32	.195	.050	8	83 LBS.	119 LBS.
B5-4-SS	B5-4	.315	.622	15/32	.195	.050	9	94 LBS.	134 LBS.
B5-5-SS	B5-5	.378	.809	19/32	.249	.062	6	104 LBS.	149 LBS.
B5-6-SS	B5-6	.503	.934	23/32	.249	.062	8	139 LBS.	198 LBS.
B5-7-SS	B5-7	.628	1.122	7/8	.342	.093	6	170 LBS.	243 LBS.
B5-8-SS	B5-8	.753	1.247	1"	.342	.093	8	255 LBS.	322 LBS.
B5-10-SS	B5-10	1.003	1.622	1-5/16	.437	.125	10	347 LBS.	496 LBS.
B5-12-SS	B5-12	1.253	1.872	1-9/16	.437	.125	14	486 LBS.	694 LBS.

ROLLER THRUST BEARINGS

BORE SIZE	MATERIAL
.252 TO 1.252	52100 CHROME STEEL ROLLERS CAGE 1008 CARBON STEEL, WASHERS 1074 STEEL

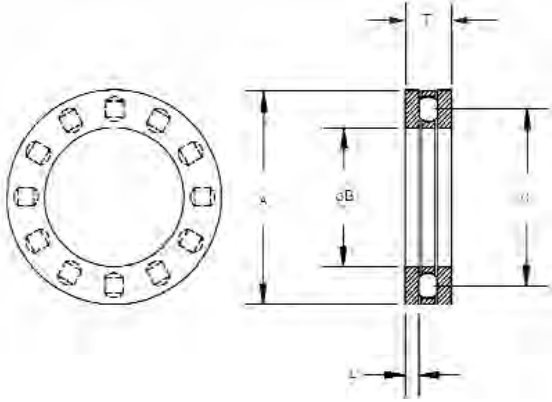

STOCK NUMBER	ØB +.005 -.000	A +.000 -.020	C	T	L +.000 -.003	DYNAMIC LOAD RATING (Lbs.)
BR5-1	.252	.677	.45	.142	.032	1,100
BR5-2	.377	.802	.58	.142	.032	1,300
BR5-3	.502	.927	.71	.142	.032	1,550
BR5-4	.627	1.115	.87	.268	.095	1,750
BR5-5	.752	1.240	.99	.268	.095	1,950
BR5-6	.877	1.427	1.14	.330	.126	2,480
BR5-7	1.002	1.552	1.27	.330	.126	2,700
BR5-8	1.252	1.927	1.58	.330	.126	3,850

CHAIN AND BELT DRIVES

Table of Contents

FLEX-E-GEAR® DRIVE CHAINS	
FLEX-E-GEAR DRIVE CHAIN - 2.50mm C.P.	MA 1
FLEX-E-GEAR DRIVE CHAIN - 2.54mm C.P.	MA 5
FLEX-E-GEAR DRIVE CHAIN - 3.325mm C.P.	MA 8
SPROCKET GEARS	
PIN HUB - 2.5mm	MA 2 - MA 4
PIN HUB - 2.54mm	MA 6
HUBLESS - 2.54mm	MA 7
PIN HUB - 3.325mm	MA 9
HUBLESS - 3.325mm	MA 10
DRIVE BELTS	
DRIVE BELT - 2.5mm	MA 12 - MA 13
DRIVE BELT - 2.54mm	MA 16
BELT PULLEYS (E-Z ENTRY)	
HUBLESS	MA 14
PIN HUB	MA 14 - MA 15
FLEX-E-BELT® DRIVE BELTS	
FLEX-E-BELT DRIVE BELTS - 2.54mm	MA 16
FLEX-E-BELT DRIVE BELTS - 3.325mm	MA 19
BELT PULLEYS (E-Z ENTRY)	
HUBLESS - 2.54mm	MA 17
PIN HUB - 2.54mm	MA 18
HUBLESS - 3.325mm	MA 20
PIN HUB - 3.325mm	MA 21
MIN-E-PITCH® CABLE CHAINS	
MIN-E-PITCH CABLE CHAIN - 4mm	MA 22
CHAIN SPROCKETS	
PIN HUB - 4mm	MA 23 - MA 27
HUBLESS - 4mm	MA 28
DUAL CHAINS	
MIN-E-PITCH - 4mm	MA 29
MIN-E-PITCH BELT	
MIN-E-PITCH BELT - 4mm C.P.	MA 30
DOUBLE SPROCKETS	
PIN HUB - 4mm C.P.	MA 31 - MA 33
HUBLESS - 4mm C.P.	MA 34
3-D BELT	
MIN-E-PITCH 3-D BELT - 4mm C.P.	MA 35
3-D PULLEYS	
PIN HUB - 4mm	MA 36 - MA 38
HUBLESS - 4mm	MA 39
IDLER - 4mm	MA 40 - MA 42
SUPPORT & GUIDE RAILS	MA 43
FLEX-E-PITCH® LINK CHAINS	MA 44 - MA 64
CABLE CHAINS	
FLEX-E-PITCH - 3.747 CIRCULAR PITCH	MA 44
FLEX-E-PITCH - 6.35 CIRCULAR PITCH	MA 50
FLEX-E-PITCH - 9.525 CIRCULAR PITCH	MA 55
FLEX-E-PITCH - 12.7 CIRCULAR PITCH	MA 58 - MA 59
CHAIN SPROCKETS	
PIN HUB - 3.747 CIRCULAR PITCH	MA 45, MA 47 - MA 49
PIN HUB - 6.35 CIRCULAR PITCH	MA 51, MA 53 - MA 54
PIN HUB - 9.525 CIRCULAR PITCH	MA 57
PIN HUB - 12.7 CIRCULAR PITCH	MA 61 - MA 63
HUBLESS - 3.747 CIRCULAR PITCH	MA 46
HUBLESS - 6.35 CIRCULAR PITCH	MA 52
HUBLESS - 9.525 CIRCULAR PITCH	MA 56
HUBLESS - 12.7 CIRCULAR PITCH	MA 60
FIELD SPLICE KIT (FLEX-E-PITCH)	MA 64
BELT TENSIONER	MA 65
ROW-L-ER CHAIN LINK	MA 66 - MA 87
TECHNICAL DATA	MA 66
LINK CHAINS	
ROW-L-ER - 3.75 CIRCULAR PITCH	MA 67
ROW-L-ER - 6.35 CIRCULAR PITCH	MA 74, MA 81
ROW-L-ER - 9.53 CIRCULAR PITCH	MA 84
ROW-L-ER - 12.7 CIRCULAR PITCH	MA 86
SPROCKETS	
PIN HUB - 3.75 CIRCULAR PITCH	MA 68, MA 70 - MA 72
PIN HUB - 6.35 CIRCULAR PITCH	MA 75, MA 77 - MA 79, MA 82 - 83
PIN HUB - 9.53 CIRCULAR PITCH	MA 85
PIN HUB - 12.7 CIRCULAR PITCH	MA 87
HUBLESS - 3.75 CIRCULAR PITCH	MA 69, MA 73
HUBLESS - 6.35 CIRCULAR PITCH	MA 76, MA 80
FLEX-E-GRIP	
Technical Data	MA 88 - MA 89
Timing Belts - 2mm	MA 90
Timing Belts - 5mm	MA 94
Timing Belts - 9.525mm	MA 98
Timing Pulleys - 2mm	MA 91 - MA 93
Timing Pulleys - 5mm	MA 95 - MA 97
Timing Pulleys - 9.525mm	MA 99
MAX-M-DRIVE	
Technical Data	MA 100
Timing Belts - 2mm	MA 101
Timing Belts - 3mm	MA 102 - MA 103
Timing Belts - 5mm	MA 111 - MA 112
Timing Pulleys - 3mm	MA 104 - MA 110
Timing Pulleys - 5mm	MA 113 - MA 117
Timing Pulleys - 2.032mm	MA 118
60° V BELT	
V3M	MA 119
V5M	MA 120
V7M	MA 121
60° V PULLEYS	
3mm Bore	MA 122
5mm Bore	MA 122
8mm Bore	MA 122, MA 123
10mm Bore	MA 123 - MA 124
POW-R-VEE BELTS	
Technical Data	MA 125 - MA 126
2V	MA 127 - MA 128
3V	MA 129
4V	MA 130
5V	MA 131
POW-R-VEE PULLEYS	
3V	MA 132 - MA 133
4V	MA 134
5V	MA 135
FIELD SPLICE KITS	MA 136

GEAR DRIVE CHAINS

CIRCULAR PITCH	MATERIALS	BERG'S ® NAME	SPROCKET
2.50mm	Polyurethane (Blue) 0.5mm Dia. Stainless Steel Cable*	Flex-E-Gear®	Operates with 32B, GG33 and GGF33 series.

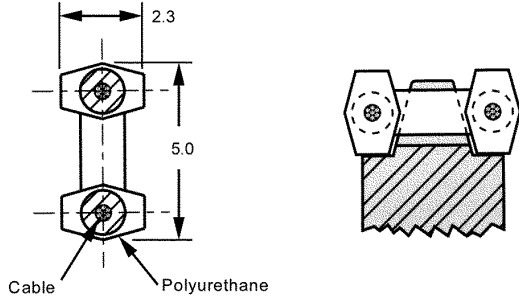
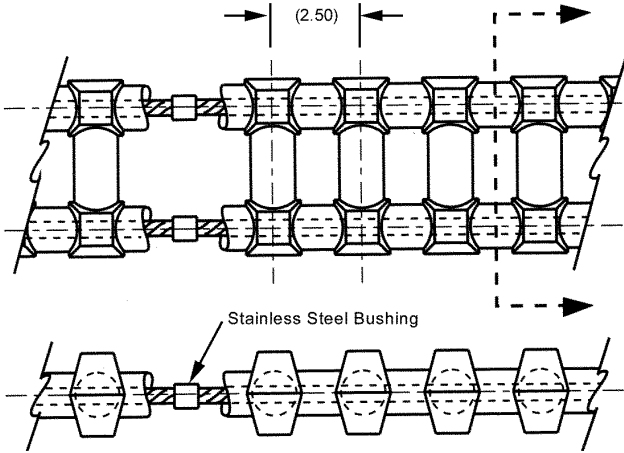

STOCK NO.	NO. OF PITCHES	LENGTH (Ref.)
32GCF-49-E	49	122.2
32GCF-52-E	52	129.7
32GCF-53-E	53	132.2
32GCF-64-E	64	159.6
32GCF-67-E	67	167.1
32GCF-75-E	75	187.0
32GCF-80-E	80	199.5
32GCF-95-E	95	236.9
32GCF-112-E	112	279.3
32GCF-126-E	126	314.2
32GCF-128-E	128	319.2
32GCF-144-E	144	359.1
32GCF-158-E	158	394.1
32GCF-176-E	176	438.9
32GCF-189-E	189	471.4
32GCF-208-E	208	518.8
32GCF-220-E	220	548.7
32GCF-240-E	240	598.6
32GCF-252-E	252	628.5
32GCF-272-E	272	678.4
32GCF-283-E	283	705.8
32GCF-304-E	304	758.2
32GCF-315-E	315	785.6
32GCF-336-E	336	838.0
32GCF-346-E	346	862.9
32GCF-377-E	377	940.2
32GCF-400-E	400	997.6
32GCF-408-E	408	1017.6
32GCF-432-E	432	1077.4
32GCF-440-E	440	1097.4
32GCF-464-E	464	1157.2
32GCF-471-E	471	1174.7
32GCF-480-E	480	1197.1
32GCF-512-E	512	1276.9
32GCF-544-E	544	1356.7
32GCF-592-E	592	1476.4
32GCF-608-E	608	1516.4

BULK LENGTH - NOT SPLICED	
STOCK NO.	LENGTH
32GCF-1.5M	1.5 M
32GCF-3.0M	3.0 M
32GCF-7.5M	7.5 M
32GCF-15.0M	15.0 M
32GCF-30.0M	30.0 M

- For Field Splice Kit order 32GCF-7.
- * Available with Aramid Core. See page A-2 for alternative belt construction or reverse bending applications.
- ** Reduce operating load rating by 50% for field splices.

- Infinite Lengths
- Silent Drive
- Mass 12 Grams/Meter
- Positive Drive
- Zero Backlash
- No Lubrication
- 90A Durometer
- Ultimate Tensile Strength 130N 17N/PIN when belt is used in open loop configuration (without splice, no crimp bushing)
- Temperature Range +82°C to -26°C
- Recommended Operating Load 36N
- Recommended Max. Operating Speed 1.91 m/s

Other numbers of pitches available on request.



SPROCKET GEARS

CIR. PITCH	BORE	STYLE	MATERIAL	BERG'S ® NAME	CHAIN
2.50mm	Ø7	PIN HUB	ACETAL	Flex-E-Gear® Chain Drive	Operates with 32GCF Series

† Teeth runout on hub.
Other numbers of teeth available on request.

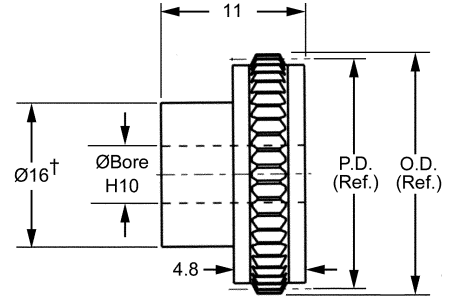
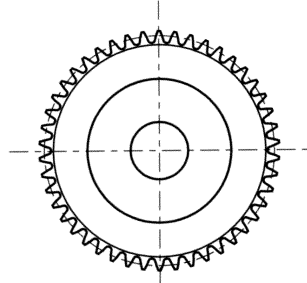
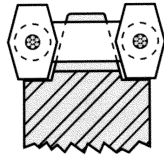

STOCK NO.	NO. OF TEETH	PITCH DIA.	OUTSIDE DIA.
32B107M-18	18†	14.29	15.88
32B107M-20	20†	15.88	17.47
32B107M-22	22†	17.46	19.05
32B107M-24	24†	19.05	20.64
32B107M-26	26	20.64	22.23
32B107M-28	28	22.23	23.82
32B107M-30	30	23.81	25.40
32B107M-32	32	25.40	26.99
32B107M-36	36	28.58	30.17
32B107M-40	40	31.75	33.34
32B107M-48	48	38.10	39.69
32B107M-56	56	44.45	46.04
32B107M-64	64	50.80	52.39
32B107M-72	72	57.15	58.74
32B107M-80	80	63.50	65.09



CIR. PITCH	BORE	STYLE	MATERIAL	BERG'S ® NAME	CHAIN
2.50mm	Ø8	PIN HUB	ACETAL	Flex-E-Gear® Chain Drive	Operates with 32GCF Series

† Teeth runout on hub.
Other numbers of teeth available on request.

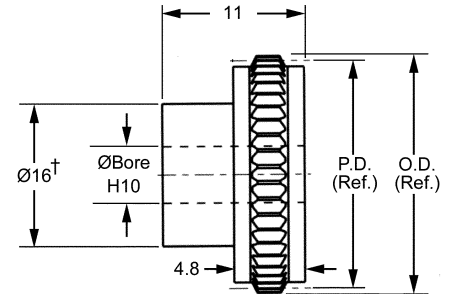
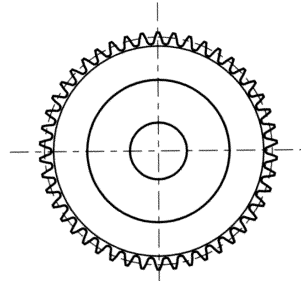
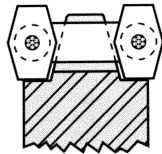

STOCK NO.	NO. OF TEETH	PITCH DIA.	OUTSIDE DIA.
32B108M-18	18†	14.29	15.88
32B108M-20	20†	15.88	17.47
32B108M-22	22†	17.46	19.05
32B108M-24	24†	19.05	20.64
32B108M-26	26	20.64	22.23
32B108M-28	28	22.23	23.82
32B108M-30	30	23.81	25.40
32B108M-32	32	25.40	26.99
32B108M-36	36	28.58	30.17
32B108M-40	40	31.75	33.34
32B108M-48	48	38.10	39.69
32B108M-56	56	44.45	46.04
32B108M-64	64	50.80	52.39
32B108M-72	72	57.15	58.74
32B108M-80	80	63.50	65.09



SPROCKET GEARS

CIR. PITCH	BORE	STYLE	MATERIAL	BERG'S ® NAME	CHAIN
2.50mm	Ø4	PIN HUB	Aluminum per DIN 3.1355 Anodized	Flex-E-Gear® Chain Drive	Operates with 32GCF Series

• For 18-24 teeth, hub diameter equals 11.9.
Other numbers of teeth available on request.

Teeth could be anodized.

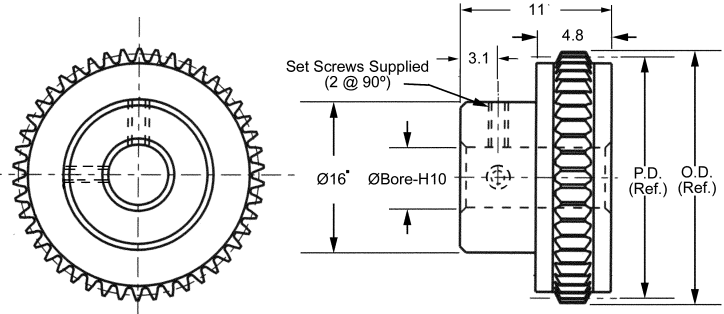

STOCK NO.	NO. OF TEETH	PITCH DIA.	OUTSIDE DIA.
32B104-18	18•	14.29	15.88
32B104-20	20•	15.88	17.47
32B104-22	22•	17.46	19.05
32B104-24	24•	19.05	20.64
32B104-26	26	20.64	22.23
32B104-28	28	22.23	23.82
32B104-30	30	23.81	25.40
32B104-32	32	25.40	26.99
32B104-36	36	28.58	30.17
32B104-40	40	31.75	33.34
32B104-48	48	38.10	39.69
32B104-56	56	44.45	46.04
32B104-64	64	50.80	52.39
32B104-72	72	57.15	58.74
32B104-80	80	63.50	65.09
32B104-88	88	69.85	71.44
32B104-96	96	76.20	77.79
32B104-112	112	88.90	90.49
32B104-128	128	101.60	103.19

CIR. PITCH	BORE	STYLE	MATERIAL	BERG'S ® NAME	CHAIN
2.50mm	Ø10	HUBLESS	Aluminum per DIN 3.1355 Anodized	Flex-E-Gear® Chain Drive	Operates with 32GCF Series

Other numbers of teeth available on request.

Teeth could be anodized.

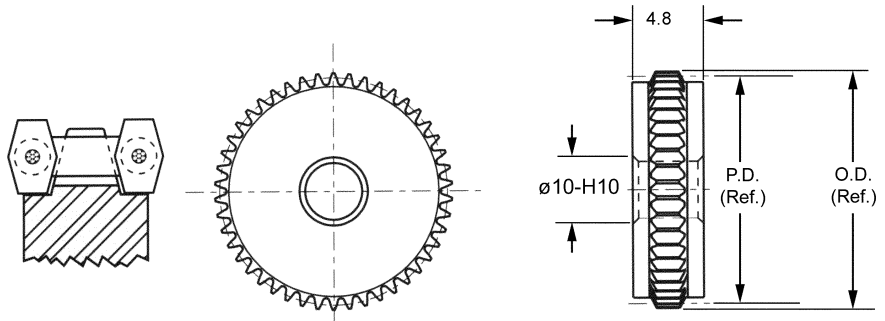

STOCK NO.	NO. OF TEETH	PITCH DIA.	OUTSIDE DIA.
32A110-32	32	25.40	26.99
32A110-36	36	28.58	30.17
32A110-40	40	31.75	33.34
32A110-48	48	38.10	39.69
32A110-56	56	44.45	46.04
32A110-64	64	50.80	52.39
32A110-72	72	57.15	58.74
32A110-80	80	63.50	65.09
32A110-88	88	69.85	71.44
32A110-96	96	76.20	77.79
32A110-112	112	88.90	90.49
32A110-128	128	101.60	103.19

SPROCKET GEARS

CIR. PITCH	BORE	STYLE	MATERIAL	BERG'S ® NAME	CHAIN
2.50mm	Ø6	PIN HUB	Aluminum per DIN 3.1355 Anodized	Flex-E-Gear® Chain Drive	Operates with 32GCF Series

• For 18-24 teeth, hub diameter equals 11.9.
Other numbers of teeth available on request.

Teeth could be anodized.

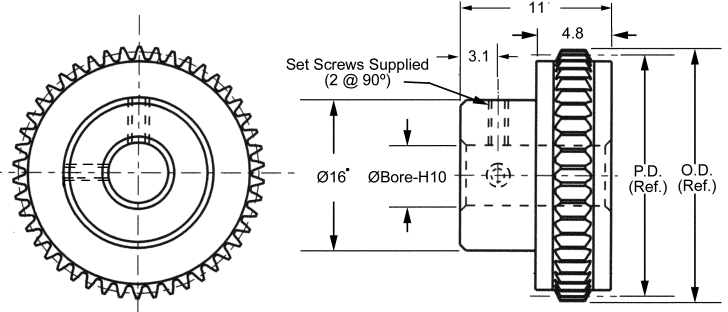

STOCK NO.	NO. OF TEETH	PITCH DIA.	OUTSIDE DIA.
32B106-18	18•	14.29	15.88
32B106-20	20•	15.88	17.47
32B106-22	22•	17.46	19.05
32B106-24	24•	19.05	20.64
32B106-26	26	20.64	22.23
32B106-28	28	22.23	23.82
32B106-30	30	23.81	25.40
32B106-32	32	25.40	26.99
32B106-36	36	28.58	30.17
32B106-40	40	31.75	33.34
32B106-48	48	38.10	39.69
32B106-56	56	44.45	46.04
32B106-64	64	50.80	52.39
32B106-72	72	57.15	58.74
32B106-80	80	63.50	65.09
32B106-88	88	69.85	71.44
32B106-96	96	76.20	77.79
32B106-112	112	88.90	90.49
32B106-128	128	101.60	103.19

CIR. PITCH	BORE	STYLE	MATERIAL	BERG'S ® NAME	CHAIN
2.50mm	Ø8	PIN HUB	Aluminum per DIN 3.1355 Anodized	Flex-E-Gear® Chain Drive	Operates with 32GCF Series

• For 18-24 teeth, hub diameter equals 11.9.
Other numbers of teeth available on request.

Teeth could be anodized.

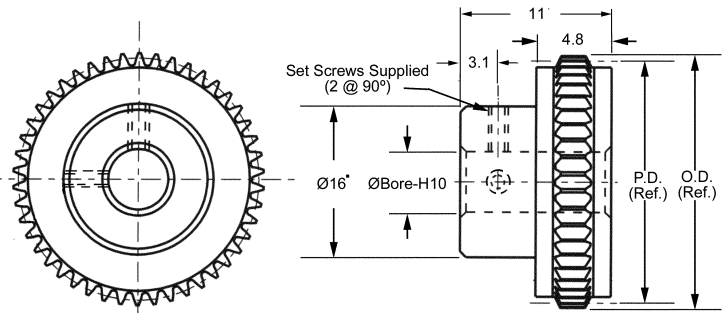

STOCK NO.	NO. OF TEETH	PITCH DIA.	OUTSIDE DIA.
32B108-18	18•	14.29	15.88
32B108-20	20•	15.88	17.47
32B108-22	22•	17.46	19.05
32B108-24	24•	19.05	20.64
32B108-26	26	20.64	22.23
32B108-28	28	22.23	23.82
32B108-30	30	23.81	25.40
32B108-32	32	25.40	26.99
32B108-36	36	28.58	30.17
32B108-40	40	31.75	33.34
32B108-48	48	38.10	39.69
32B108-56	56	44.45	46.04
32B108-64	64	50.80	52.39
32B108-72	72	57.15	58.74
32B108-80	80	63.50	65.09
32B108-88	88	69.85	71.44
32B108-96	96	76.20	77.79
32B108-112	112	88.90	90.49
32B108-128	128	101.60	103.19

GEAR DRIVE CHAINS

CIRCULAR PITCH	MATERIALS	BERG'S ® NAME	SPROCKET
2.54mm	Polyurethane (Green) 0.5mm Dia. Stainless Steel Cable*	Flex-E-Gear®	Operates with 31A and 31B series.

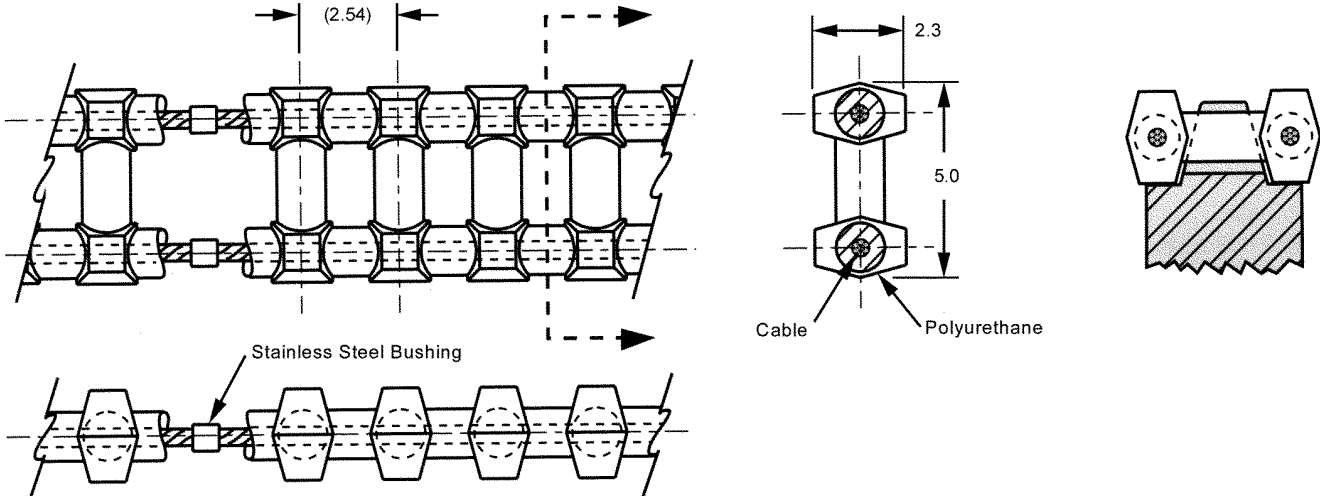

STOCK NO.	NO. OF PITCHES	LENGTH (Ref.)
31GCF-45-E	45	114.3
31GCF-50-E	50	127.0
31GCF-55-E	55	139.7
31GCF-60-E	60	152.4
31GCF-65-E	65	165.1
31GCF-70-E	70	177.8
31GCF-75-E	75	190.5
31GCF-80-E	80	203.2
31GCF-85-E	85	215.9
31GCF-90-E	90	228.6
31GCF-95-E	95	241.3
31GCF-100-E	100	254.0
31GCF-105-E	105	266.7
31GCF-110-E	110	279.4
31GCF-115-E	115	292.1
31GCF-120-E	120	304.8
31GCF-125-E	125	317.5
31GCF-130-E	130	330.2
31GCF-135-E	135	342.9
31GCF-140-E	140	355.6
31GCF-150-E	150	381.0
31GCF-160-E	160	406.4
31GCF-170-E	170	431.8
31GCF-180-E	180	457.2
31GCF-190-E	190	482.6
31GCF-200-E	200	508.0
31GCF-210-E	210	533.4
31GCF-220-E	220	558.8
31GCF-230-E	230	584.2
31GCF-240-E	240	609.6
31GCF-250-E	250	635.0
31GCF-300-E	300	762.0
31GCF-360-E	360	914.4
31GCF-420-E	420	1066.8
31GCF-480-E	480	1219.2
31GCF-540-E	540	1371.6
31GCF-600-E	600	1524.0

BULK LENGTH - NOT SPLICED	
STOCK NO.	LENGTH
31GCF-1.5M	1.5 M
31GCF-3.0M	3.0 M
31GCF-7.5M	7.5 M
31GCF-15.0M	15.0 M
31GCF-30.0M	30.0 M

- For Field Splice Kit order 32GCF-7.
- * Available with Aramid Core. See page A-2 for alternative belt construction or reverse bending applications.
- ** Reduce operating load rating by 50% for field splices.

- Infinite Lengths
- Silent Drive
- Mass 12 Grams/Meter
- Positive Drive
- Zero Backlash
- No Lubrication
- 90A Durometer
- Ultimate Tensile Strength 130 N. (15N/PIN)
When belt is used in open loop configuration (without splice, no crimp bushing)
- Temperature Range +82°C to -26°C
- Recommended Operating Load 36N
- Recommended Max. Operating Speed 1.91 m/s

Other numbers of pitches available on request.

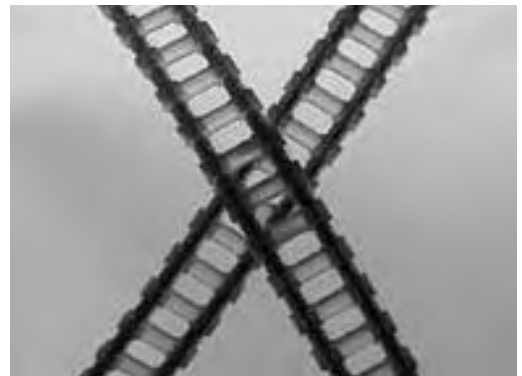

SPROCKET GEARS

CIR. PITCH	BORE	STYLE	MATERIAL	BERG'S ® NAME	CHAIN
2.54mm	Ø4	PIN HUB	Per DIN 3.1355 Aluminum Anodized	Flex-E-Gear® Chain Drive	Operates with 31GCF Series

STOCK NO.	NO. OF TEETH	PITCH DIA.	OUTSIDE DIA.
31B104-14	14*	11.32	12.94
31B104-16	16*	12.94	14.55
31B104-20	20*	16.17	17.79
31B104-22	22*	17.79	19.41
31B104-24	24	19.40	21.02
31B104-26	26	21.02	22.64
31B104-28	28	22.64	24.26
31B104-30	30	24.26	25.87
31B104-32	32	25.87	27.49
31B104-36	36	29.11	30.72
31B104-40	40	32.34	33.96
31B104-48	48	38.81	40.43
31B104-56	56	45.28	46.89
31B104-64	64	51.74	53.36
31B104-72	72	58.21	59.83
31B104-96	96	77.62	79.23
31B104-112	112	90.55	92.17

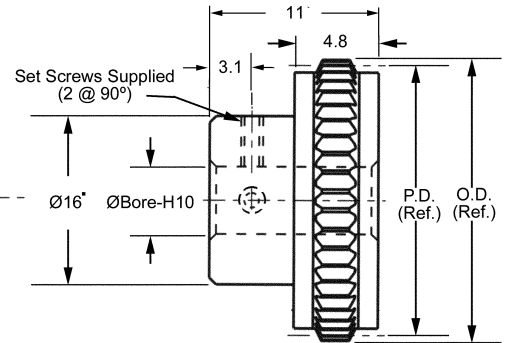
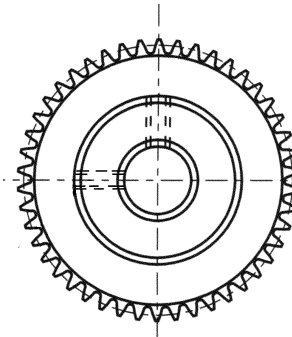

* For 14-22 teeth, hub diameter equals 8.9.
 * Sprockets Ø12.7 P.D. and smaller are recommended for idler use only.

Other numbers of teeth available on request.
 Teeth could be anodized.

CIR. PITCH	BORE	STYLE	MATERIAL	BERG'S ® NAME	CHAIN
2.54mm	Ø6	PIN HUB	Per DIN 3.1355 Aluminum Anodized	Flex-E-Gear® Chain Drive	Operates with 31GCF Series

STOCK NO.	NO. OF TEETH	PITCH DIA.	OUTSIDE DIA.
31B106-20	20*	16.17	17.79
31B106-22	22*	17.79	19.41
31B106-24	24	19.40	21.02
31B106-26	26	21.02	22.64
31B106-28	28	22.64	24.26
31B106-30	30	24.26	25.87
31B106-32	32	25.87	27.49
31B106-36	36	29.11	30.72
31B106-40	40	32.34	33.96
31B106-48	48	38.81	40.43
31B106-56	56	45.28	46.89
31B106-64	64	51.74	53.36
31B106-72	72	58.21	59.83
31B106-96	96	77.62	79.23
31B106-112	112	90.55	92.17

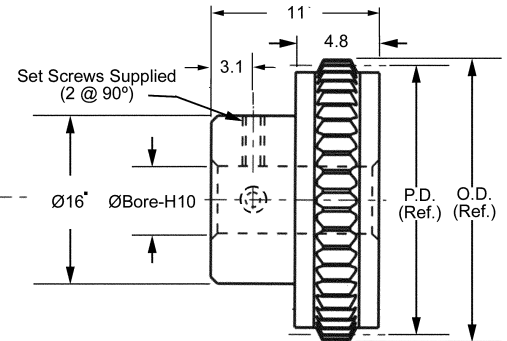
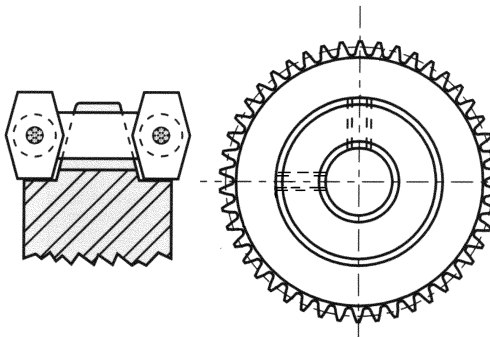

* For 20-22 teeth, hub diameter equals 13.8. Other numbers of teeth available on request.
 Teeth could be anodized.

CIR. PITCH	BORE	STYLE	MATERIAL	BERG'S ® NAME	CHAIN
2.54mm	Ø8	PIN HUB	Per DIN 3.1355 Aluminum Anodized	Flex-E-Gear® Chain Drive	Operates with 31GCF Series

STOCK NO.	NO. OF TEETH	PITCH DIA.	OUTSIDE DIA.
31B108-20	20*	16.17	17.79
31B108-22	22*	17.79	19.41
31B108-24	24	19.40	21.02
31B108-26	26	21.02	22.64
31B108-28	28	22.64	24.26
31B108-30	30	24.26	25.87
31B108-32	32	25.87	27.49
31B108-36	36	29.11	30.72
31B108-40	40	32.34	33.96
31B108-48	48	38.81	40.43
31B108-56	56	45.28	46.89
31B108-64	64	51.74	53.36
31B108-72	72	58.21	59.83
31B108-96	96	77.62	79.23
31B108-112	112	90.55	92.17

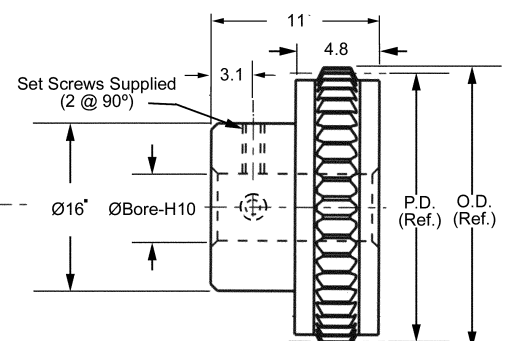
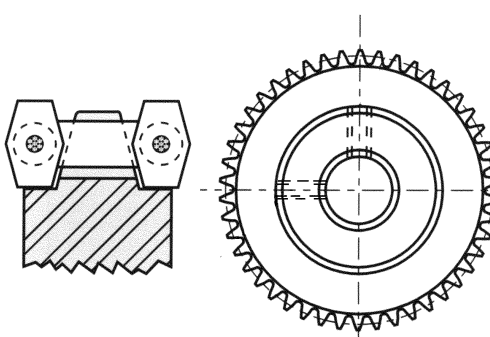

* For 20-22 teeth, hub diameter equals 13.8. Other numbers of teeth available on request.
 Teeth could be anodized.

SPROCKET GEARS

CIR. PITCH	BORE	STYLE	MATERIAL	BERG'S ® NAME	CHAIN
2.54mm	Ø10	HUBLESS	Per DIN 3.1355 Aluminum Anodized	Flex-E-Gear® Chain Drive	Operates with 31GCF Series

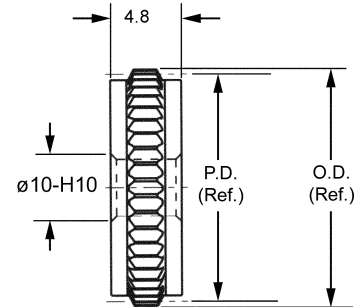
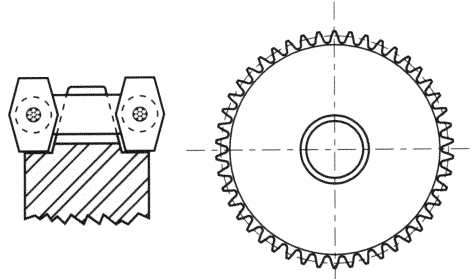

Other numbers of teeth available on request.

Teeth could be anodized.

STOCK NO.	NO. OF TEETH	PITCH DIA.	OUTSIDE DIA.
31A110-22	22	17.79	19.41
31A110-24	24	19.40	21.02
31A110-26	26	21.02	22.64
31A110-28	28	22.64	24.26
31A110-30	30	24.26	25.87
31A110-32	32	25.87	27.49
31A110-36	36	29.11	30.72
31A110-40	40	32.34	33.96
31A110-48	48	38.81	40.43
31A110-56	56	45.28	46.89
31A110-64	64	51.74	53.36
31A110-72	72	58.21	59.83
31A110-96	96	77.62	79.23
31A110-112	112	90.55	92.17

GEAR DRIVE CHAINS

CIRCULAR PITCH	MATERIALS	BERG'S ® NAME	SPROCKET
3.325mm	Polyurethane (Red) 0.8mm Dia. Stainless Steel Cable*	Flex-E-Gear®	Operates with 24A and 24B series.

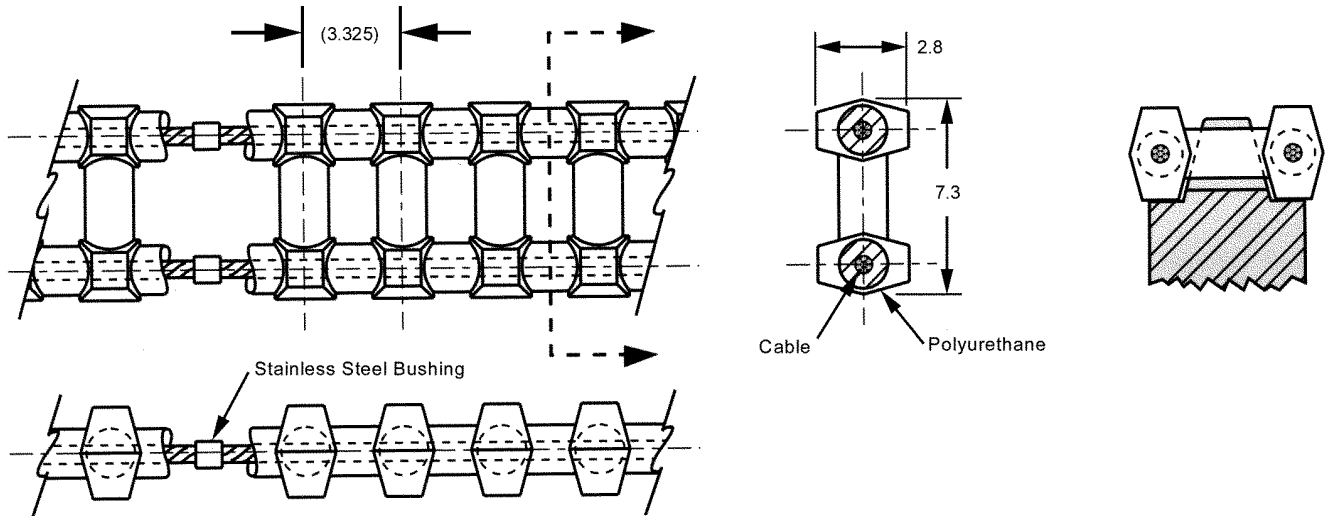

STOCK NO.	NO. OF PITCHES	LENGTH (Ref.)
24GCF-50-E	50	166.3
24GCF-52-E	52	172.9
24GCF-54-E	54	179.6
24GCF-56-E	56	186.2
24GCF-58-E	58	192.9
24GCF-60-E	60	199.5
24GCF-62-E	62	206.2
24GCF-64-E	64	212.8
24GCF-66-E	66	219.5
24GCF-68-E	68	226.1
24GCF-70-E	70	232.8
24GCF-75-E	75	249.4
24GCF-80-E	80	266.0
24GCF-85-E	85	282.6
24GCF-90-E	90	299.3
24GCF-95-E	95	315.9
24GCF-100-E	100	332.5
24GCF-105-E	105	349.1
24GCF-110-E	110	365.8
24GCF-115-E	115	382.4
24GCF-120-E	120	399.0
24GCF-130-E	130	432.3
24GCF-140-E	140	465.5
24GCF-150-E	150	498.8
24GCF-160-E	160	532.0
24GCF-170-E	170	565.3
24GCF-180-E	180	598.5
24GCF-190-E	190	631.8
24GCF-200-E	200	665.0
24GCF-220-E	220	731.5
24GCF-240-E	240	798.0
24GCF-260-E	260	864.5
24GCF-280-E	280	931.0
24GCF-300-E	300	997.5
24GCF-320-E	320	1064.0
24GCF-380-E	380	1263.5
24GCF-420-E	420	1396.5

BULK LENGTH - NOT SPLICED	
STOCK NO.	LENGTH
24GCF-1.5M	1.5 M
24GCF-3.0M	3.0 M
24GCF-7.5M	7.5 M
24GCF-15.0M	15.0 M
24GCF-30.0M	30.0 M

- For Field Splice Kit order 24GCF-7.
- * Available with Aramid Core. See page A-2 for alternative belt construction or reverse bending applications.
- **Reduce operating load rating by 50% for field splices.

- Infinite Lengths
- Mass 13 Grams/Meter
- Positive Drive
- Zero Backlash
- No Lubrication
- Silent Drive
- Extra Strong
- 90A Durometer
- Ultimate Tensile Strength 440N (40 N/PIN)
- when belt is used in open loop configuration (without splice, no crimp bushing).
- Temperature Range +82°C to -26°C
- Recommended Operating Load 108N
- Recommended Max. Operating Speed 1.91 m/s

Other numbers of pitches available on request.

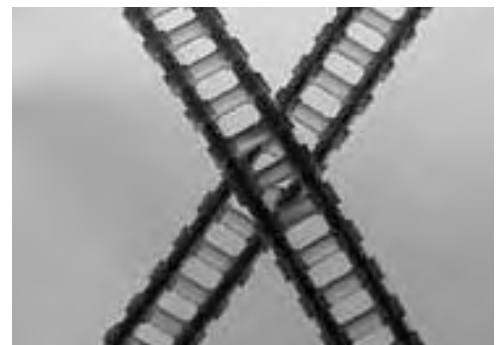

SPROCKET GEARS

CIR. PITCH	BORE	STYLE	MATERIAL	BERG'S® NAME	CHAIN
3.325mm	Ø7	PIN HUB	Delrin®	Flex-E-Gear® Chain Drive	Operates with 24GCF Series

STOCK NO.	NO. OF TEETH	PITCH DIA.	OUTSIDE DIA.
24B107M-15	15†	15.86	17.97
24B107M-16	16†	16.91	19.03
24B107M-18	18	19.03	21.14
24B107M-20	20	21.14	23.26
24B107M-21	21	22.20	24.32
24B107M-24	24	25.37	27.49
24B107M-30	30	31.71	33.83
24B107M-36	36	38.06	40.17
24B107M-42	42	44.40	46.52
24B107M-48	48	50.74	52.86
24B107M-60	60	63.43	65.54

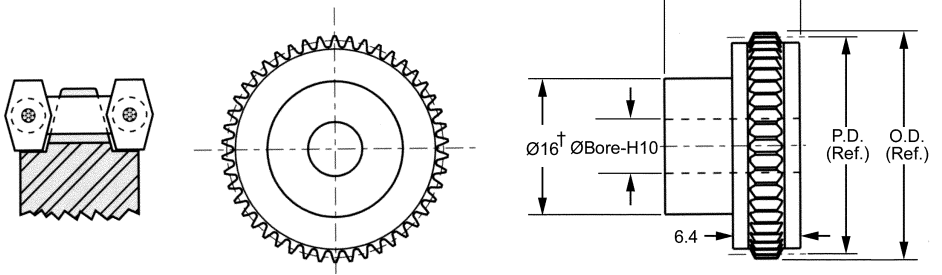

† Teeth runout on hub.
Other bore sizes and numbers of teeth available on request.

CIR. PITCH	BORE	STYLE	MATERIAL	BERG'S® NAME	CHAIN
3.325mm	Ø8	PIN HUB	Delrin®	Flex-E-Gear® Chain Drive	Operates with 24GCF Series

STOCK NO.	NO. OF TEETH	PITCH DIA.	OUTSIDE DIA.
24B108M-15	15†	15.86	17.97
24B108M-16	16†	16.91	19.03
24B108M-18	18	19.03	21.14
24B108M-20	20	21.14	23.26
24B108M-21	21	22.20	24.32
24B108M-24	24	25.37	27.49
24B108M-30	30	31.71	33.83
24B108M-36	36	38.06	40.17
24B108M-42	42	44.40	46.52
24B108M-48	48	50.74	52.86
24B108M-60	60	63.43	65.54

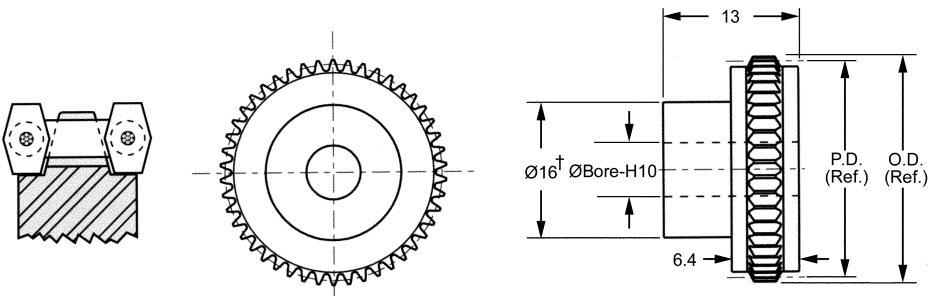

† Teeth runout on hub.
Other bore sizes and numbers of teeth available on request.



SPROCKET GEARS

CIR. PITCH	BORE	STYLE	MATERIAL	BERG'S ® NAME	CHAIN
3.325mm	Ø10	HUBLESS	ALUMINUM PER DIN 3.1355 - ANODIZED	Flex-E-Gear® Chain Drive	Operates with 24GCF Series

• Sprockets Ø19.0mm P.D. and smaller for idler use only.
Other numbers of teeth available on request.
Teeth could be anodized.

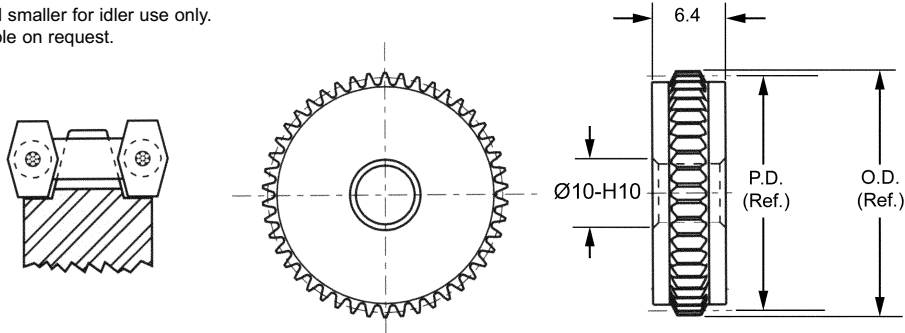

STOCK NO.	NO. OF TEETH	PITCH DIA.	OUTSIDE DIA.
24A110-15	15*	15.86*	17.97
24A110-16	16*	16.91*	19.03
24A110-18	18*	19.03*	21.14
24A110-20	20	21.14	23.26
24A110-21	21	22.20	24.32
24A110-24	24	25.37	27.49
24A110-30	30	31.71	33.83
24A110-36	36	38.06	40.17
24A110-42	42	44.40	46.52
24A110-48	48	50.74	52.86
24A110-60	60	63.43	65.54
24A110-72	72	76.11	78.23
24A110-96	96	101.49	103.60
24A110-120	120	126.86	128.97
24A110-144	144	152.23	154.35



SPROCKET GEARS

CIR. PITCH	BORE	STYLE	MATERIAL	BERG'S ® NAME	CHAIN
3.325mm	Ø8	PIN HUB	Aluminum PER DIN 3.1355 Anodized	Flex-E-Gear® Chain Drive	Operates with 24GCF Series

STOCK NO.	NO. OF TEETH	PITCH DIA.	OUTSIDE DIA.
24B108-15	15*	15.86*	17.97
24B108-16	16*	16.91*	19.03
24B108-18	18*	19.03*	21.14
24B108-20	20*	21.14	23.26
24B108-21	21	22.20	24.32
24B108-24	24	25.37	27.49
24B108-30	30	31.71	33.83
24B108-36	36	38.06	40.17
24B108-42	42	44.40	46.52
24B108-48	48	50.74	52.86
24B108-60	60	63.43	65.54
24B108-72	72	76.11	78.23
24B108-96	96	101.49	103.60
24B108-120	120	126.86	128.97
24B108-144	144	152.23	154.35

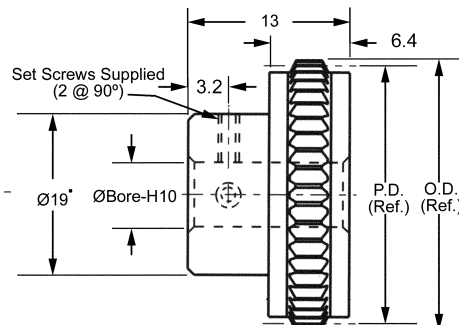
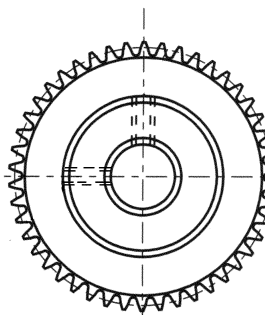
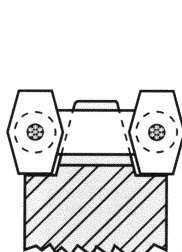

* For 15-20 teeth, hub diameter equals 12.9.

* Sprockets Ø19.0mm P.D. and smaller for idler use only.

Other numbers of teeth available on request.
Teeth could be anodized.

CIR. PITCH	BORE	STYLE	MATERIAL	BERG'S ® NAME	CHAIN
3.325mm	Ø10	PIN HUB	Aluminum per DIN 3.1355 Anodized	Flex-E-Gear® Chain Drive	Operates with 24GCF Series

STOCK NO.	NO. OF TEETH	PITCH DIA.	OUTSIDE DIA.
24B110-18	18*	19.03*	21.14
24B110-20	20*	21.14	23.26
24B110-21	21	22.20	24.32
24B110-24	24	25.37	27.49
24B110-30	30	31.71	33.83
24B110-36	36	38.06	40.17
24B110-42	42	44.40	46.52
24B110-48	48	50.74	52.86
24B110-60	60	63.43	65.54
24B110-72	72	76.11	78.23
24B110-96	96	101.49	103.60
24B110-120	120	126.86	128.97
24B110-144	144	152.23	154.35

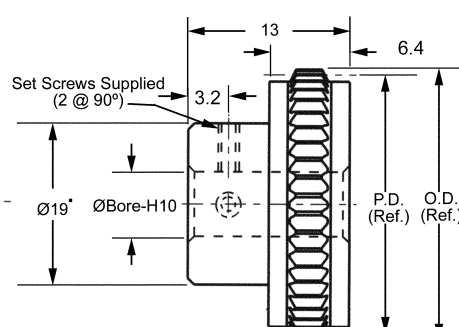
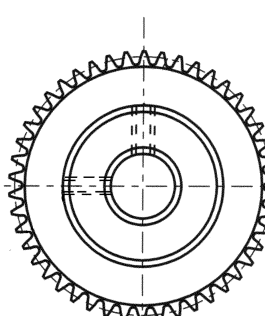
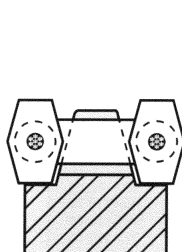

Teeth could be anodized.

* For 18-20 teeth, hub diameter equals 16.2.

* Sprockets Ø19.0mm P.D. and smaller for idler use only.

Other numbers of teeth available on request.

CIR. PITCH	BORE	STYLE	MATERIAL	BERG'S ® NAME	CHAIN
3.325mm	Ø12	PIN HUB	Aluminum per DIN 3.1355 Anodized	Flex-E-Gear® Chain Drive	Operates with 24GCF Series

STOCK NO.	NO. OF TEETH	PITCH DIA.	OUTSIDE DIA.
24B112-18	18*	19.03*	21.14
24B112-20	20*	21.14	23.26
24B112-21	21	22.20	24.32
24B112-24	24	25.37	27.49
24B112-30	30	31.71	33.83
24B112-36	36	38.06	40.17
24B112-42	42	44.40	46.52
24B112-48	48	50.74	52.86
24B112-60	60	63.43	65.54
24B112-72	72	76.11	78.23
24B112-96	96	101.49	103.60
24B112-120	120	126.86	128.97
24B112-144	144	152.23	154.35

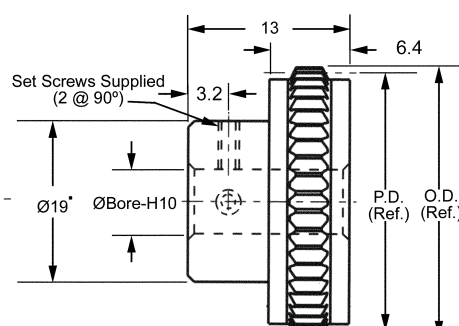
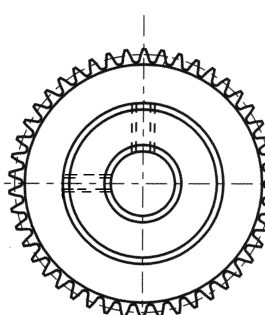
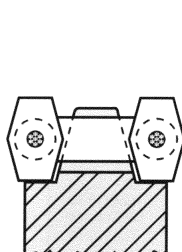

Teeth could be anodized.

* For 18-20 teeth, hub diameter equals 16.2.

* Sprockets Ø19.0mm P.D. and smaller for idler use only.

Other numbers of teeth available on request.

GEAR DRIVE BELTS

CIRCULAR PITCH	MATERIALS	BERG'S ® NAME	PULLEY
2.5mm	Polyurethane (Blue) 0.8mm Dia. Stainless Steel Cable*	Flex-E-Belt®	Operates with 32C, 32D, GPS, GP32, GF32 and GC32 series.

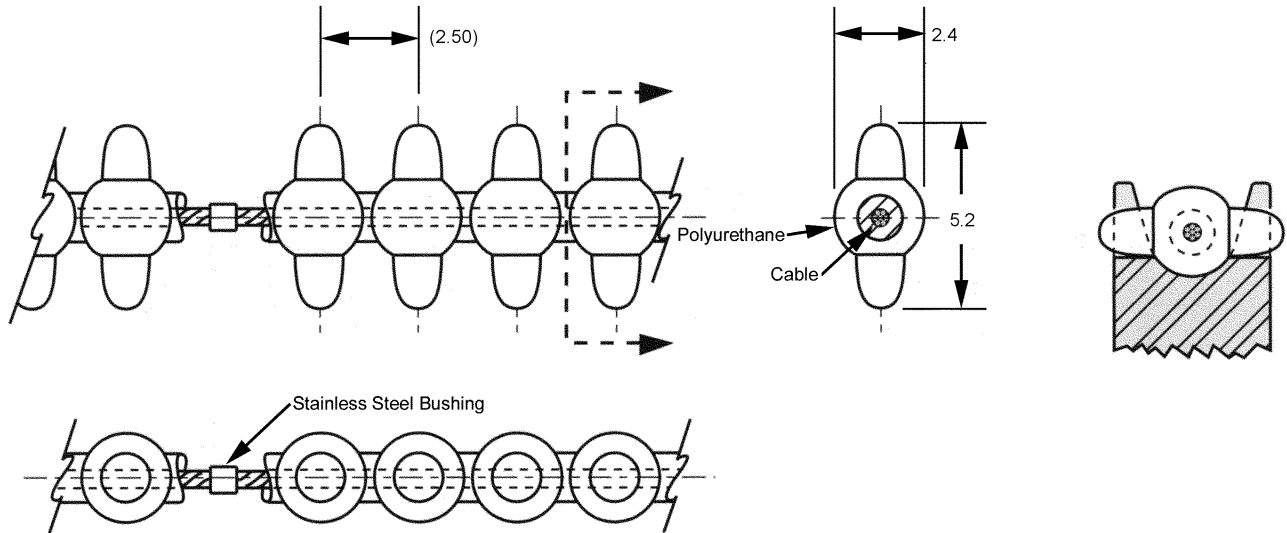

STOCK NO.	NO. OF PITCHES	LENGTH (Ref.)
32GBF-49-E	49	122.2
32GBF-52-E	52	129.7
32GBF-53-E	53	132.2
32GBF-64-E	64	159.6
32GBF-67-E	67	167.1
32GBF-75-E	75	187.1
32GBF-80-E	80	199.5
32GBF-95-E	95	236.9
32GBF-112-E	112	279.3
32GBF-126-E	126	314.2
32GBF-128-E	128	319.2
32GBF-144-E	144	359.1
32GBF-158-E	158	394.1
32GBF-176-E	176	438.9
32GBF-189-E	189	471.4
32GBF-208-E	208	518.8
32GBF-220-E	220	548.7
32GBF-240-E	240	598.6
32GBF-252-E	252	628.5
32GBF-272-E	272	678.4
32GBF-283-E	283	705.8
32GBF-304-E	304	758.2
32GBF-315-E	315	785.6
32GBF-336-E	336	838.0
32GBF-346-E	346	862.9
32GBF-377-E	377	940.2
32GBF-400-E	400	997.6
32GBF-408-E	408	1017.6
32GBF-432-E	432	1077.4
32GBF-440-E	440	1097.4
32GBF-464-E	464	1157.2
32GBF-471-E	471	1174.7
32GBF-480-E	480	1197.1
32GBF-496-E	496	1237.0
32GBF-512-E	512	1276.9
32GBF-544-E	544	1356.7
32GBF-560-E	560	1396.6
32GBF-576-E	576	1436.5
32GBF-640-E	640	1596.2

- For Field Splice Kit order 32GBF-7.
- * Available with Aramid Core. See page A-2 for alternative belt construction or reverse bending applications.
- ** Reduce operating load rating by 50% for field splices.

Other numbers of pitches available on request.

- Accommodates twists and turns
- Odd Angles
- Infinite Lengths
- Silent Drive
- Mass 10 grams/meter
- Positive Drive
- Zero Backlash
- No Lubrication
- 90A Durometer
- Ultimate Tensile Strength 222N -40N/PIN when belt is used in open loop configuration (without splice, no crimp bushing).
- Temperature Range +82°C to -26°C
- Recommended Operating Load 53N
- Recommended Max. Operating Speed 1.91 m/s

BULK FOOTAGE - NOT SPLICED	
STOCK NO.	LENGTH
32GBF-1.5M	1.5 M
32GBF-3.0M	3.0M
32GBF-7.5M	7.5M
32GBF-15.0M	15.0M
32GBF-30.0M	30.0M



GEAR DRIVE BELTS

CIRCULAR PITCH	MATERIALS	BERG'S ® NAME	PULLEY
2.5mm	Polyurethane (Light Brown) 0.5mm Dia. Stainless Steel Cable*	Flex-E-Belt®	Operates with 32C, 32D, GPS, GP32, GF32 and GC32 series.

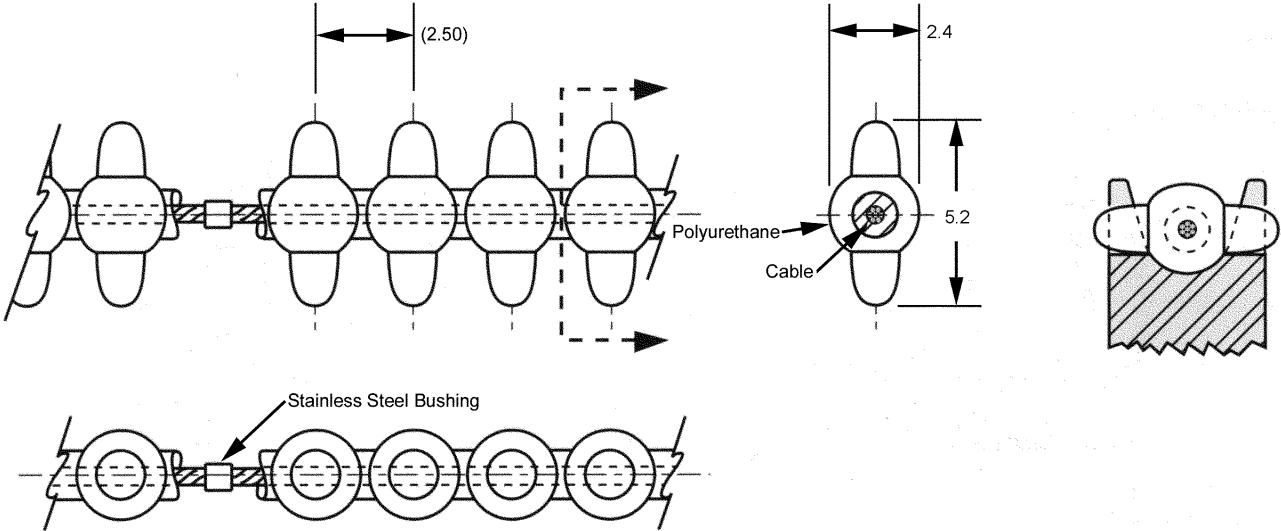

STOCK NO.	NO. OF PITCHES	LENGTH (Ref.)
33GBF-49-E	49	122.2
33GBF-52-E	52	129.7
33GBF-53-E	53	132.2
33GBF-64-E	64	159.6
33GBF-67-E	67	167.1
33GBF-75-E	75	187.1
33GBF-80-E	80	199.5
33GBF-95-E	95	236.9
33GBF-112-E	112	279.3
33GBF-126-E	126	314.2
33GBF-128-E	128	319.2
33GBF-144-E	144	359.1
33GBF-158-E	158	394.1
33GBF-176-E	176	438.9
33GBF-189-E	189	471.4
33GBF-208-E	208	518.8
33GBF-220-E	220	548.7
33GBF-240-E	240	598.6
33GBF-252-E	252	628.5
33GBF-272-E	272	678.4
33GBF-283-E	283	705.8
33GBF-304-E	304	758.2
33GBF-315-E	315	785.6
33GBF-336-E	336	838.0
33GBF-346-E	346	862.9
33GBF-377-E	377	940.2
33GBF-400-E	400	997.6
33GBF-408-E	408	1017.6
33GBF-432-E	432	1077.4
33GBF-440-E	440	1097.4
33GBF-464-E	464	1157.2
33GBF-471-E	471	1174.7
33GBF-480-E	480	1197.1
33GBF-496-E	496	1237.0
33GBF-512-E	512	1276.9
33GBF-544-E	544	1356.7
33GBF-560-E	560	1396.6
33GBF-576-E	576	1436.5
33GBF-640-E	640	1596.2

- For Field Splice Kit order 33GBF-7.
- * Available with Aramid Core. See page A-2 for alternative belt construction or reverse bending applications.
- ** Reduce operating load rating by 50% for field splice.
- Other numbers of pitches available on request.

- Accommodates twists and turns
- Odd Angles
- Infinite Lengths
- Silent Drive
- Mass 10 Grams/Meter
- Positive Drive
- Zero Backlash
- No Lubrication
- 90A Durometer
- Ultimate Tensile Strength 89N - 31N/PIN when belt is used in open loop configuration (without splice, no crimp bushing).
- Temperature Range +82°C TO -26°C
- Recommended Operating Load 22N
- Recommended Max. Operating Speed 1.91 m/s

BULK FOOTAGE - NOT SPLICED	
STOCK NO.	LENGTH
33GBF-1.5M	1.5 M
33GBF-3.0M	3.0M
33GBF-7.5M	7.5M
33GBF-15.0M	15.0M
33GBF-30.0M	30.0M



E-Z ENTRY BELT PULLEYS

CIR. PITCH	BORE	STYLE	MATERIAL	BERG'S ® NAME	BELT
2.5MM	Ø10	HUBLESS	Aluminum per DIN 3.1355 Anodized	Flex-E-Belt®	Operates with 32GBF or 33GBF Series

STOCK NO.	NO. OF TEETH	PITCH DIA.	OUTSIDE DIA.
32C110-20	20 •	15.88	17.47
32C110-22	22 •	17.46	19.05
32C110-24	24 •	19.05	20.64
32C110-26	26	20.64	22.23
32C110-28	28	22.23	23.82
32C110-30	30	23.81	25.40
32C110-32	32	25.40	26.99
32C110-36	36	28.58	30.17
32C110-40	40	31.75	33.34
32C110-48	48	38.10	39.69
32C110-56	56	44.45	46.04
32C110-64	64	50.80	52.39
32C110-72	72	57.15	58.74
32C110-80	80	63.50	65.09
32C110-88	88	69.85	71.44
32C110-96	96	76.20	77.79
32C110-112	112	88.90	90.49
32C110-128	128	101.60	103.19

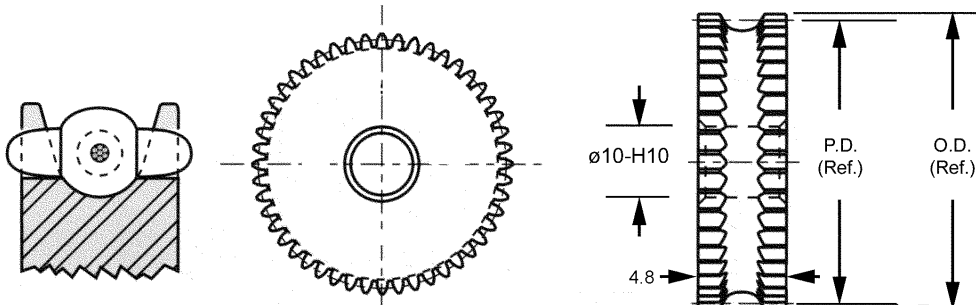

• May be used with 33GBF Belt as a drive gear. When used with 32GBF belt, use as an idler only. Other numbers of teeth available on request.

Teeth could be anodized.

CIR. PITCH	BORE	STYLE	MATERIAL	BERG'S ® NAME	BELT
2.5mm	Ø4	PIN HUB	Aluminum DIN 3.1355 Anodized	Flex-E-Belt®	Operates with 32GBF or 33GBF Series

STOCK NO.	NO. OF TEETH	PITCH DIA.	OUTSIDE DIA.
32D104-16	16 •*	12.70	14.29
32D104-18	18 •*	14.29	15.88
32D104-20	20 •*	15.88	17.47
32D104-22	22 •*	17.46	19.05
32D104-24	24 •*	19.05	20.64
32D104-26	26	20.64	22.23
32D104-28	28	22.23	23.82
32D104-30	30	23.81	25.40
32D104-32	32	25.40	26.99
32D104-36	36	28.58	30.17
32D104-40	40	31.75	33.34
32D104-48	48	38.10	39.69
32D104-56	56	44.45	46.04
32D104-64	64	50.80	52.39
32D104-72	72	57.15	58.74
32D104-80	80	63.50	65.09
32D104-88	88	69.85	71.44
32D104-96	96	76.20	77.79
32D104-112	112	88.90	90.49
32D104-128	128	101.60	103.19

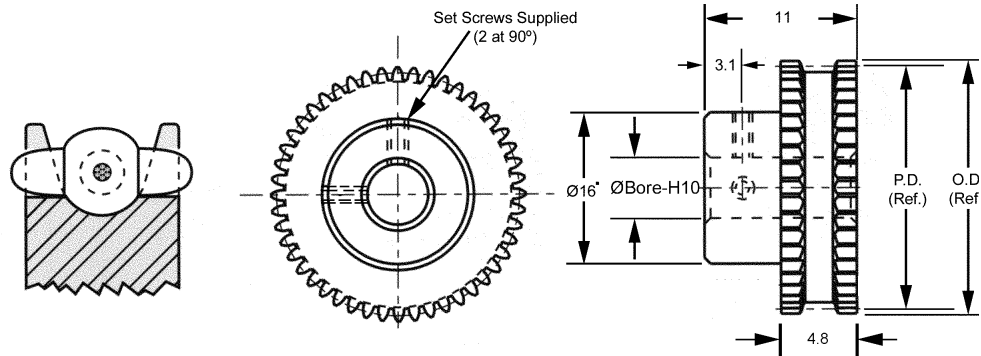

• For 16-22 teeth, hub diameter equals 10.4.
 * May be used with 33GBF Belt as a drive gear. When used with 32GBF belt, use as an idler only. Other numbers of teeth available on request.

Teeth could be anodized.

E-Z ENTRY BELT PULLEYS

CIR. PITCH	BORE	STYLE	MATERIAL	BERG'S ® NAME	BELT
2.5mm	Ø6	PIN HUB	Aluminum per DIN 3.1355 Anodized	Flex-E-Belt®	Operates with 32GBF or 33GBF Series

STOCK NO.	NO. OF TEETH	PITCH DIA.	OUTSIDE DIA.
32D106-16	16 *	12.70	14.29
32D106-18	18 *	14.29	15.88
32D106-20	20 *	15.88	17.47
32D106-22	22 *	17.46	19.05
32D106-24	24 *	19.05	20.64
32D106-26	26	20.64	22.23
32D106-28	28	22.23	23.82
32D106-30	30	23.81	25.40
32D106-32	32	25.40	26.99
32D106-36	36	28.58	30.17
32D106-40	40	31.75	33.34
32D106-48	48	38.10	39.69
32D106-56	56	44.45	46.04
32D106-64	64	50.80	52.39
32D106-72	72	57.15	58.74
32D106-80	80	63.50	65.09
32D106-88	88	69.85	71.44
32D106-96	96	76.20	77.79
32D106-112	112	88.90	90.49
32D106-128	128	101.60	103.19

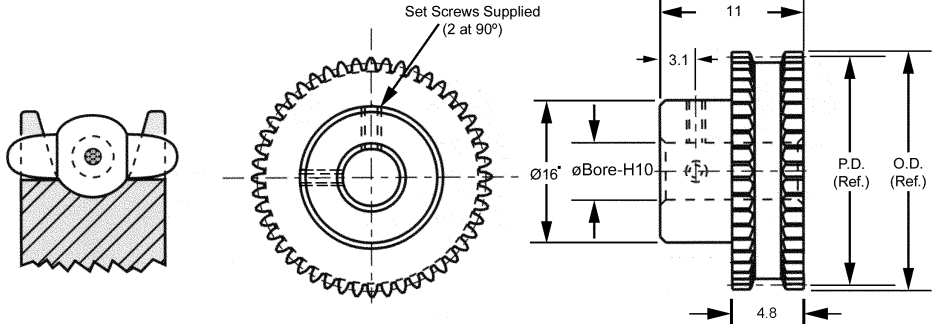

• For 16-22 teeth, hub diameter equals 10.4.
 * May be used with 33GBF Belt as a drive gear.
 When used with 32GBF belt, use as an idler only.
 Other numbers of teeth available on request.
 Teeth could be anodized.

CIR. PITCH	BORE	STYLE	MATERIAL	BERG'S ® NAME	BELT
2.5mm	Ø8	PIN HUB	Aluminum per DIN 3.1355 Anodized	Flex-E-Belt®	Operates with 32GBF or 33GBF Series

STOCK NO.	NO. OF TEETH	PITCH DIA.	OUTSIDE DIA.
32D108-16	16 *	12.70	14.29
32D108-18	18 *	14.29	15.88
32D108-20	20 *	15.88	17.47
32D108-22	22 *	17.46	19.05
32D108-24	24 *	19.05	20.64
32D108-26	26	20.64	22.23
32D108-28	28	22.23	23.82
32D108-30	30	23.81	25.40
32D108-32	32	25.40	26.99
32D108-36	36	28.58	30.17
32D108-40	40	31.75	33.34
32D108-48	48	38.10	39.69
32D108-56	56	44.45	46.04
32D108-64	64	50.80	52.39
32D108-72	72	57.15	58.74
32D108-80	80	63.50	65.09
32D108-88	88	69.85	71.44
32D108-96	96	76.20	77.79
32D108-112	112	88.90	90.49
32D108-128	128	101.60	103.19

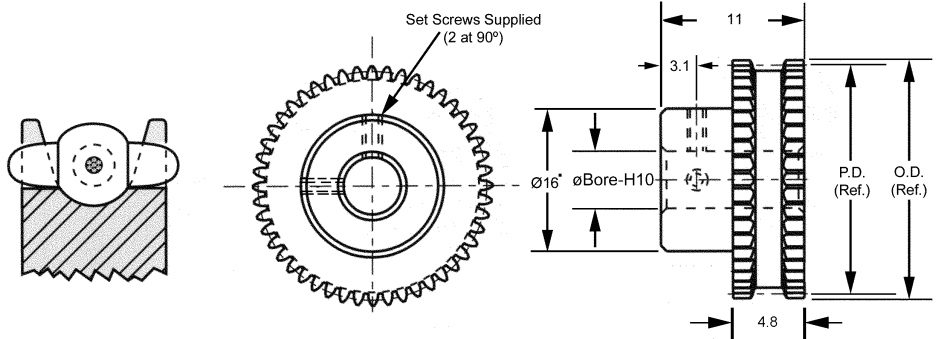

• For 16-22 teeth, hub diameter equals 10.4.
 * May be used with 33GBF Belt as a drive gear.
 When used with 32GBF belt, use as an idler only.
 Other numbers of teeth available on request.
 Teeth could be anodized.

GEAR DRIVE BELTS

CIRCULAR PITCH	MATERIALS	BERG'S ® NAME	PULLEY
2.54mm	Polyurethane (Red) 0.8mm Dia. Stainless Steel Cable*	Flex-E-Belt®	Operates with GP31 and GF31 series.

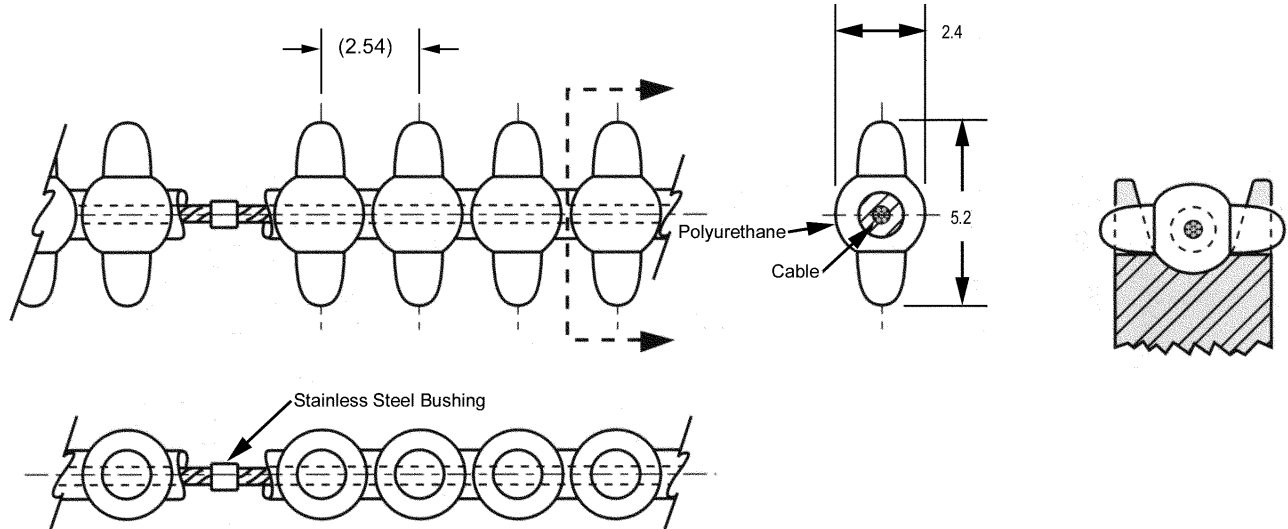

STOCK NO.	NO. OF PITCHES	LENGTH (Ref.)
31GBF-50-E	50	127.0
31GBF-52-E	52	132.1
31GBF-54-E	54	137.2
31GBF-56-E	56	142.2
31GBF-58-E	58	147.3
31GBF-60-E	60	152.4
31GBF-65-E	65	165.1
31GBF-70-E	70	177.8
31GBF-75-E	75	190.5
31GBF-80-E	80	203.2
31GBF-85-E	85	215.9
31GBF-90-E	90	228.6
31GBF-100-E	100	254.0
31GBF-110-E	110	279.4
31GBF-120-E	120	304.8
31GBF-130-E	130	330.2
31GBF-140-E	140	355.6
31GBF-150-E	150	381.0
31GBF-160-E	160	406.4
31GBF-170-E	170	431.8
31GBF-180-E	180	457.2
31GBF-190-E	190	482.6
31GBF-200-E	200	508.0
31GBF-210-E	210	533.4
31GBF-220-E	220	558.8
31GBF-230-E	230	584.2
31GBF-240-E	240	609.6
31GBF-250-E	250	635.0
31GBF-260-E	260	660.4
31GBF-270-E	270	685.8
31GBF-280-E	280	711.2
31GBF-300-E	300	762.0
31GBF-350-E	350	889.0
31GBF-400-E	400	1016.0
31GBF-480-E	480	1143.0
31GBF-500-E	500	1270.0
31GBF-800-E	800	2032.0

- For Field Splice Kit order 32GBF-7.
- * Available with Aramid Core. See page A-2 for alternative belt construction or reverse bending applications.
- **Reduce operating load rating by 50% for field splices.

- Odd Angles
- Infinite Lengths
- Accommodates twists and turns
- Positive Drive
- Zero Backlash
- No Lubrication
- Mass 10 grams/meter
- 90A Durometer
- Ultimate Tensile Strength 222N - 40N/PIN
When belt is used in open loop configuration (without splice, no crimp bushing).
- Temperature Range +85°C to -26°C
- Recommended Operating Load 53N
- Recommended Max. Operating Speed 1.91 M/S

BULK FOOTAGE - NOT SPLICED	
STOCK NO.	LENGTH
31GBF-1.5M	1.5 M
31GBF-3.0M	3.0M
31GBF-7.5M	7.5M
31GBF-15.0M	15.0M
31GBF-30.0M	30.0M



E-Z-ENTRY BELT PULLEYS

CIR. PITCH	BORE	STYLE	MATERIAL	BERG'S ® NAME	BELT
2.54mm	Ø10	HUBLESS	Aluminum per DIN 3.1355 Anodized	Flex-E-Belt®	Operates with 31GBF Series

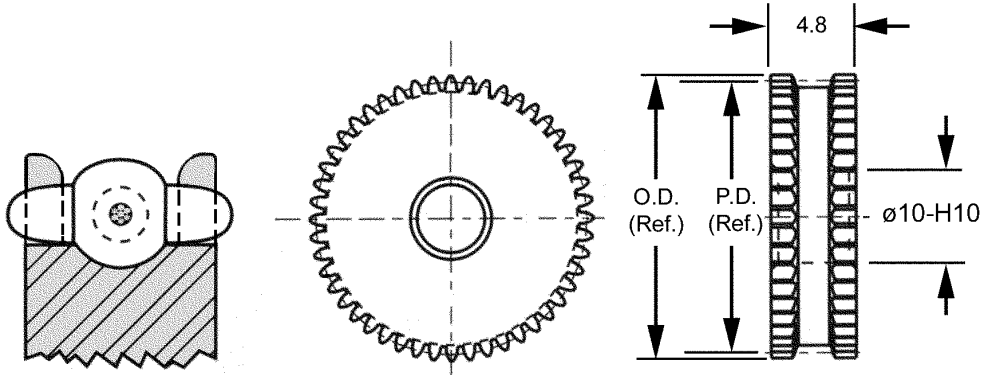

STOCK NO.	NO. OF TEETH	PITCH DIA.	OUTSIDE DIA.
31C110-24	24	19.40	21.02
31C110-26	26	21.02	22.64
31C110-28	28	22.64	24.26
31C110-30	30	24.26	25.87
31C110-32	32	25.87	27.49
31C110-36	36	29.11	30.72
31C110-40	40	32.34	33.96
31C110-48	48	38.81	40.43
31C110-56	56	45.28	46.89
31C110-64	64	51.74	53.36
31C110-72	72	58.21	59.83
31C110-80	80	64.68	66.30
31C110-88	88	71.15	72.77
31C110-96	96	77.62	79.23
31C110-112	112	90.55	92.17
31C110-128	128	103.48	105.11



Teeth could be anodized.

E-Z-ENTRY BELT PULLEYS

CIR. PITCH	BORE	STYLE	MATERIAL	BERG'S ® NAME	BELT
2.54mm	Ø4	PIN HUB	Aluminum per DIN 3.1355 Anodized	Flex-E-Belt®	Operates with 31GBF Series

STOCK NO.	NO. OF TEETH	PITCH DIA.	OUTSIDE DIA.
31D104-20	20*	16.17	17.79
31D104-22	22*	17.79	19.41
31D104-24	24	19.40	21.02
31D104-26	26	21.02	22.64
31D104-28	28	22.64	24.26
31D104-30	30	24.26	25.87
31D104-32	32	25.87	27.49
31D104-36	36	29.11	30.72
31D104-40	40	32.34	33.96
31D104-48	48	38.81	40.43
31D104-56	56	45.28	46.89
31D104-64	64	51.74	53.36
31D104-72	72	58.21	59.83
31D104-80	80	64.68	66.30
31D104-88	88	71.15	72.77
31D104-96	96	77.62	79.23
31D104-112	112	90.55	92.17
31D104-128	128	103.48	105.11

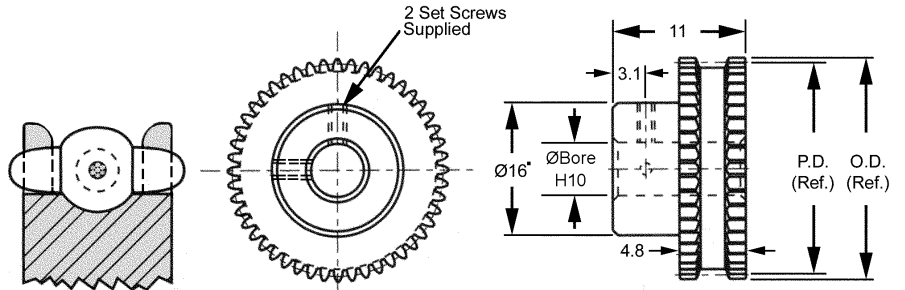

• For 20-22 teeth, hub diameter equals 13.9.
 * Sprockets 19.0mm and smaller for idler use only.
 Other numbers of teeth are available on request.
 Teeth could be anodized.

CIR. PITCH	BORE	STYLE	MATERIAL	BERG'S ® NAME	BELT
2.54mm	Ø6	PIN HUB	Aluminum per DIN 3.1355 Anodized	Flex-E-Belt®	Operates with 31GBF Series

STOCK NO.	NO. OF TEETH	PITCH DIA.	OUTSIDE DIA.
31D106-20	20*	16.17	17.79
31D106-22	22*	17.79	19.41
31D106-24	24	19.40	21.02
31D106-26	26	21.02	22.64
31D106-28	28	22.64	24.26
31D106-30	30	24.26	25.87
31D106-32	32	25.87	27.49
31D106-36	36	29.11	30.72
31D106-40	40	32.34	33.96
31D106-48	48	38.81	40.43
31D106-56	56	45.28	46.89
31D106-64	64	51.74	53.36
31D106-72	72	58.21	59.83
31D106-80	80	64.68	66.30
31D106-88	88	71.15	72.77
31D106-96	96	77.62	79.23
31D106-112	112	90.55	92.17
31D106-128	128	103.48	105.11

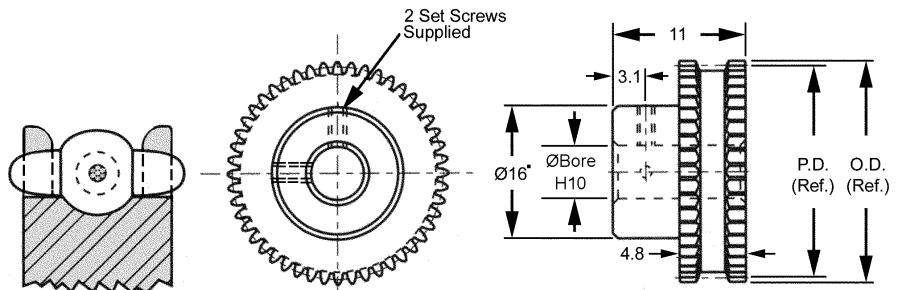

• For 20-22 teeth, hub diameter equals 13.9.
 * Sprockets 19.0mm and smaller for idler use only.
 Other numbers of teeth are available on request.
 Teeth could be anodized.

CIR. PITCH	BORE	STYLE	MATERIAL	BERG'S ® NAME	BELT
2.54mm	Ø8	PIN HUB	Aluminum per DIN 3.1355 Anodized	Flex-E-Belt®	Operates with 31GBF Series

STOCK NO.	NO. OF TEETH	PITCH DIA.	OUTSIDE DIA.
31D108-20	20*	16.17	17.79
31D108-22	22*	17.79	19.41
31D108-24	24	19.40	21.02
31D108-26	26	21.02	22.64
31D108-28	28	22.64	24.26
31D108-30	30	24.26	25.87
31D108-32	32	25.87	27.49
31D108-36	36	29.11	30.72
31D108-40	40	32.34	33.96
31D108-48	48	38.81	40.43
31D108-56	56	45.28	46.89
31D108-64	64	51.74	53.36
31D108-72	72	58.21	59.83
31D108-80	80	64.68	66.30
31D108-88	88	71.15	72.77
31D108-96	96	77.62	79.23
31D108-112	112	90.55	92.17
31D108-128	128	103.48	105.11

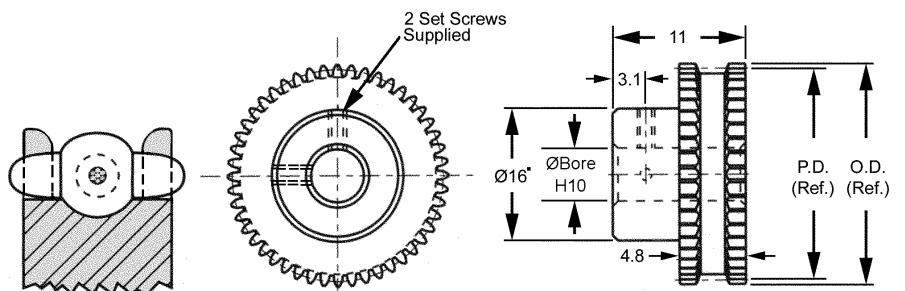

• For 20-22 teeth, hub diameter equals 13.9.
 * Sprockets 19.0mm and smaller for idler use only.
 Other numbers of teeth are available on request.
 Teeth could be anodized.

GEAR DRIVE BELTS

CIRCULAR PITCH	MATERIALS	BERG'S ® NAME	PULLEY
3.325mm	Polyurethane (Red) 0.8mm Dia. Stainless Steel Cable	Flex-E-Belt®	Operates with 24C and 24D series.

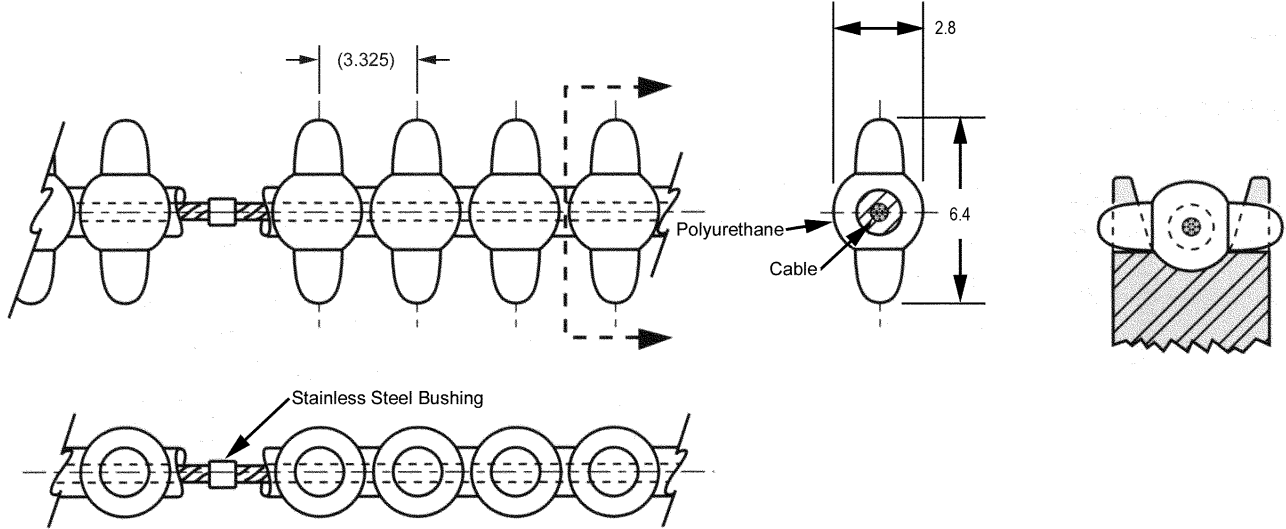

STOCK NO.	NO. OF PITCHES	LENGTH (Ref.)
24GBF-50-E	50	166.3
24GBF-52-E	52	172.9
24GBF-54-E	54	179.6
24GBF-56-E	56	186.2
24GBF-58-E	58	192.9
24GBF-60-E	60	199.5
24GBF-62-E	62	206.2
24GBF-64-E	64	212.8
24GBF-66-E	66	219.5
24GBF-68-E	68	226.1
24GBF-70-E	70	232.8
24GBF-75-E	75	249.4
24GBF-80-E	80	266.0
24GBF-85-E	85	282.6
24GBF-90-E	90	299.3
24GBF-95-E	95	315.9
24GBF-100-E	100	332.5
24GBF-105-E	105	349.1
24GBF-110-E	110	365.8
24GBF-115-E	115	382.4
24GBF-120-E	120	399.0
24GBF-130-E	130	432.3
24GBF-140-E	140	465.5
24GBF-150-E	150	498.8
24GBF-160-E	160	532.0
24GBF-170-E	170	565.3
24GBF-180-E	180	598.5
24GBF-190-E	190	631.8
24GBF-200-E	200	665.0
24GBF-220-E	220	731.5
24GBF-240-E	240	798.0
24GBF-260-E	260	864.5
24GBF-280-E	280	931.0
24GBF-300-E	300	997.5
24GBF-320-E	320	1064.0
24GBF-360-E	360	1197.0
24GBF-420-E	420	1396.0

• For Field Splice Kit order 24GBF-7.
 ** Reduce operating load rating by 50% for field splices.

- Positive Drive
- Accommodates twists and turns
- Odd Angles
- No Lubrication
- Infinite Lengths
- Zero Backlash
- Mass 12 Grams/Meter
- 90A Durometer
- Ultimate Tensile Strength 222N - 40N/PIN
- Recommended Operating Load 53N
- Recommended Max. Operating Speed 1.91 M/S
- Temperature Range +82°C to -26°C

Other numbers of pitches available on request.

BULK FOOTAGE - NOT SPLICED	
STOCK NO.	LENGTH
24GBF-1.5M	1.5M
24GBF-3.0M	3.0M
24GBF-7.5M	7.5M
24GBF-15.0M	15.0M
24GBF-30.0M	30.0M



E-Z-ENTRY BELT PULLEYS

CIR. PITCH	BORE	STYLE	MATERIAL	BERG'S ® NAME	BELT
3.325mm	Ø10	HUBLESS	Aluminum per DIN 3.1355 Anodized	Flex-E-Belt®	Operates with 24GBF Series

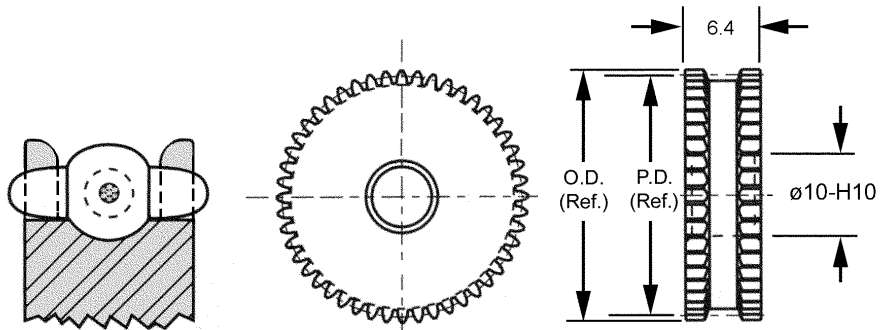

STOCK NO.	NO. OF TEETH	PITCH DIA.	OUTSIDE DIA.
24C110-15	15•	15.88	17.99
24C110-16	16•	16.93	19.05
24C110-18	18•	19.05	21.17
24C110-20	20	21.17	23.28
24C110-21	21	22.23	24.34
24C110-24	24	25.40	27.52
24C110-30	30	31.75	33.87
24C110-36	36	38.10	40.22
24C110-42	42	44.45	46.57
24C110-48	48	50.80	52.92
24C110-60	60	63.50	65.62
24C110-72	72	76.20	78.32
24C110-96	96	101.60	103.72
24C110-120	120	127.00	129.12
24C110-144	144	152.40	154.52



• Pulleys with 19.0mm P.D. and smaller for idler use only.

Teeth could be anodized.

E-Z-ENTRY BELT PULLEYS

CIR. PITCH	BORE	STYLE	MATERIAL	BERG'S ® NAME	BELT
3.325mm	Ø8	PIN HUB	Aluminum per DIN 3.1355 Anodized	Flex-E-Belt®	Operates with 24GBF Series

STOCK NO.	NO. OF TEETH	PITCH DIA.	OUTSIDE DIA.
24D108-15	15*	15.88	17.99
24D108-16	16*	16.93	19.05
24D108-18	18*	19.05	21.17
24D108-20	20	21.17	23.28
24D108-21	21	22.23	24.34
24D108-24	24	25.40	27.52
24D108-30	30	31.75	33.87
24D108-36	36	38.10	40.22
24D108-42	42	44.45	46.57
24D108-48	48	50.80	52.92
24D108-60	60	63.50	65.62
24D108-72	72	76.20	78.32
24D108-96	96	101.60	103.72
24D108-120	120	127.00	129.12
24D108-144	144	152.40	154.52

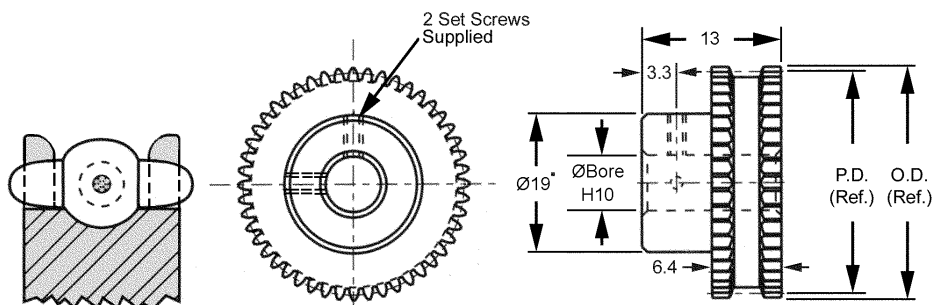

* For 15-18 teeth, hub diameter equals 13.1.
 * Pulleys Ø19.0mm P.D. and smaller for idler use only.

Teeth could be anodized.

CIR. PITCH	BORE	STYLE	MATERIAL	BERG'S ® NAME	BELT
3.325mm	Ø10	PIN HUB	Aluminum per DIN 3.1355 Anodized	Flex-E-Belt®	Operates with 24GBF Series

STOCK NO.	NO. OF TEETH	PITCH DIA.	OUTSIDE DIA.
24D110-18	18*	19.05	21.17
24D110-20	20	21.17	23.28
24D110-21	21	22.23	24.34
24D110-24	24	25.40	27.52
24D110-30	30	31.75	33.87
24D110-36	36	38.10	40.22
24D110-42	42	44.45	46.57
24D110-48	48	50.80	52.92
24D110-60	60	63.50	65.62
24D110-72	72	76.20	78.32
24D110-96	96	101.60	103.72
24D110-120	120	127.00	129.12
24D110-144	144	152.40	154.52

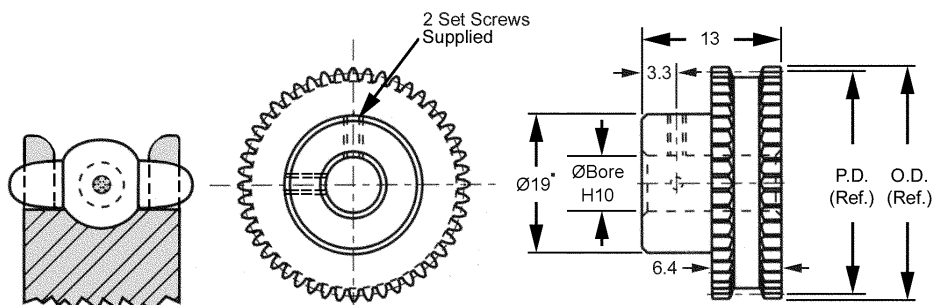

* For 18 teeth, hub diameter equals 16.3.
 * Pulleys Ø19.0mm P.D. and smaller for idler use only.

Teeth could be anodized.

CIR. PITCH	BORE	STYLE	MATERIAL	BERG'S ® NAME	BELT
3.325mm	Ø12	PIN HUB	Aluminum per DIN 3.1355 Anodized	Flex-E-Belt®	Operates with 24GBF Series

STOCK NO.	NO. OF TEETH	PITCH DIA.	OUTSIDE DIA.
24D112-20	20	21.17	23.28
24D112-21	21	22.23	24.34
24D112-24	24	25.40	27.52
24D112-30	30	31.75	33.87
24D112-36	36	38.10	40.22
24D112-42	42	44.45	46.57
24D112-48	48	50.80	52.92
24D112-60	60	63.50	65.62
24D112-72	72	76.20	78.32
24D112-96	96	101.60	103.72
24D112-120	120	127.00	129.12
24D112-144	144	152.40	154.52

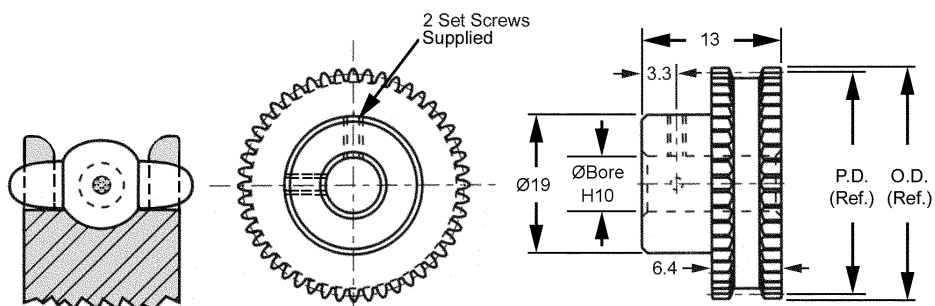

Teeth could be anodized.

CABLE CHAINS

CIRCULAR PITCH	MATERIALS	BERG'S ® NAME	SPROCKET
4mm	Polyurethane (Red) 0.8mm Dia. Stainless Steel Cable*	Min-E-Pitch®	Operates with 3C, 3MP, 3MF, and 3MC series.

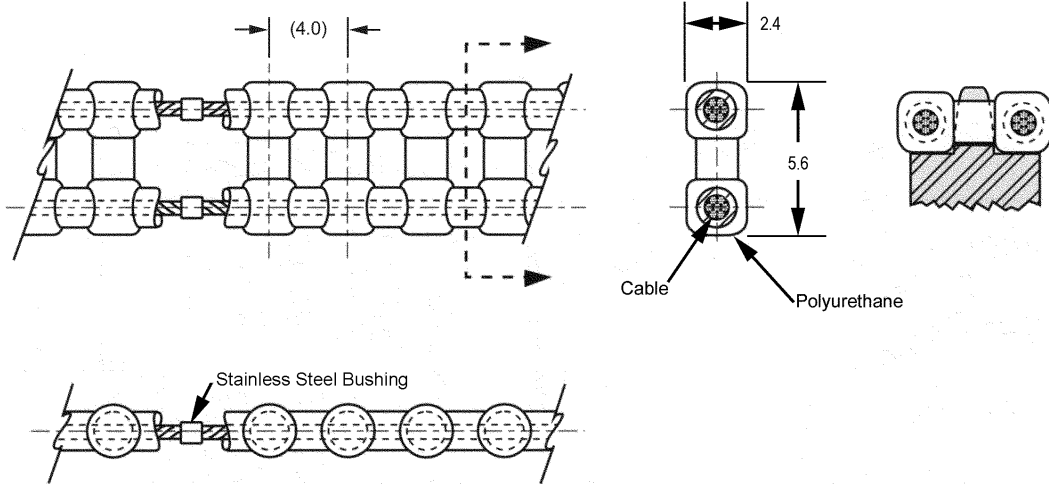

STOCK NO.	NO. OF PITCHES	LENGTH (Ref.)
3CCF-30-E	30	120.0
3CCF-35-E	35	140.0
3CCF-40-E	40	160.0
3CCF-45-E	45	180.0
3CCF-50-E	50	200.0
3CCF-55-E	55	220.0
3CCF-60-E	60	240.0
3CCF-70-E	70	280.0
3CCF-80-E	80	320.0
3CCF-90-E	90	360.0
3CCF-100-E	100	400.0
3CCF-110-E	110	440.0
3CCF-120-E	120	480.0
3CCF-130-E	130	520.0
3CCF-140-E	140	560.0
3CCF-150-E	150	600.0
3CCF-160-E	160	640.0
3CCF-170-E	170	680.0
3CCF-180-E	180	720.0
3CCF-190-E	190	760.0
3CCF-200-E	200	800.0
3CCF-210-E	210	840.0
3CCF-220-E	220	880.0
3CCF-230-E	230	920.0
3CCF-240-E	240	960.0
3CCF-250-E	250	1000.0
3CCF-260-E	260	1040.0
3CCF-270-E	270	1080.0
3CCF-280-E	280	1120.0
3CCF-290-E	290	1160.0
3CCF-300-E	300	1200.0
3CCF-310-E	310	1240.0
3CCF-320-E	320	1280.0
3CCF-330-E	330	1320.0
3CCF-340-E	340	1360.0
3CCF-350-E	350	1520.0
3CCF-370-E	370	1600.0
3CCF-400-E	400	1680.0
3CCF-440-E	440	1760.0

- For Field Splice Kit order 3CCR-7.
- * Available with Aramid Core. See page A-2 for alternative belt construction or reverse bending applications.
- **Reduce Operating Load Rating by 50% for field splices.

- Infinite Lengths
- Silent Drive
- Mass 12 Grams/Meter
- Non-Magnetic
- Positive Drive
- Zero Backlash
- No Lubrication
- 90A Durometer
- Ultimate Tensile Strength 445N - 89N/PIN when belt is used in open loop configuration (without splice, no crimp bushings).
- Temperature Range +82°C to -26°C
- Recommended Operating Load 111N
- Recommended Max. Operating Speed 1.91 M/S
- Other numbers of pitches available on request.

BULK FOOTAGE - NOT SPLICED	
STOCK NO.	LENGTH
3CCF-1.5M	1.5M
3CCF-3.0M	3.0M
3CCF-7.5M	7.5M
3CCF-15.0M	15.0M
3CCF-30.0M	30.0M



CHAIN SPROCKETS

CIR. PITCH	BORE	STYLE	MATERIAL	BERG'S ® NAME	CHAIN
4mm	Ø7	PIN HUB	Polyacetal	Min-E-Pitch® Chain Drive	Operates with 3CCF Series

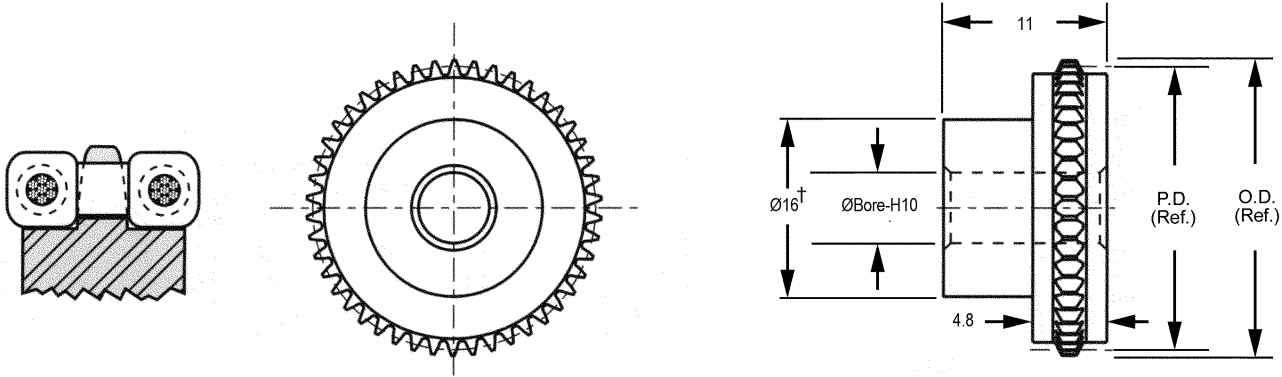

STOCK NO.	NO. OF TEETH	PITCH DIA.	OUTSIDE DIA.
3CC107M-13	13*†	16.49	18.07
3CC107M-14	14*†	17.76	19.34
3CC107M-15	15	19.03	20.61
3CC107M-16	16	20.29	21.87
3CC107M-18	18	22.83	24.41
3CC107M-20	20	25.37	26.95
3CC107M-22	22	27.90	29.48
3CC107M-24	24	30.44	32.02
3CC107M-26	26	32.98	34.56
3CC107M-28	28	35.51	37.09
3CC107M-30	30	38.05	39.63
3CC107M-32	32	40.59	42.17
3CC107M-35	35	44.39	45.97
3CC107M-36	36	45.66	47.24
3CC107M-40	40	50.74	52.32
3CC107M-45	45	57.08	58.66
3CC107M-50	50	63.42	64.00
3CC107M-55	55	69.76	71.34



† Teeth runout on hub.
 * Sprockets with Ø19.0mm P.D. and smaller are recommended for idler use only.
 Other numbers of teeth available on request.

CHAIN SPROCKETS

CIR. PITCH	BORE	STYLE	MATERIAL	BERG'S ® NAME	CHAIN
4mm	Ø8	PIN HUB	Polyacetal	Min-E-Pitch® Chain Drive	Operates with 3CCF Series

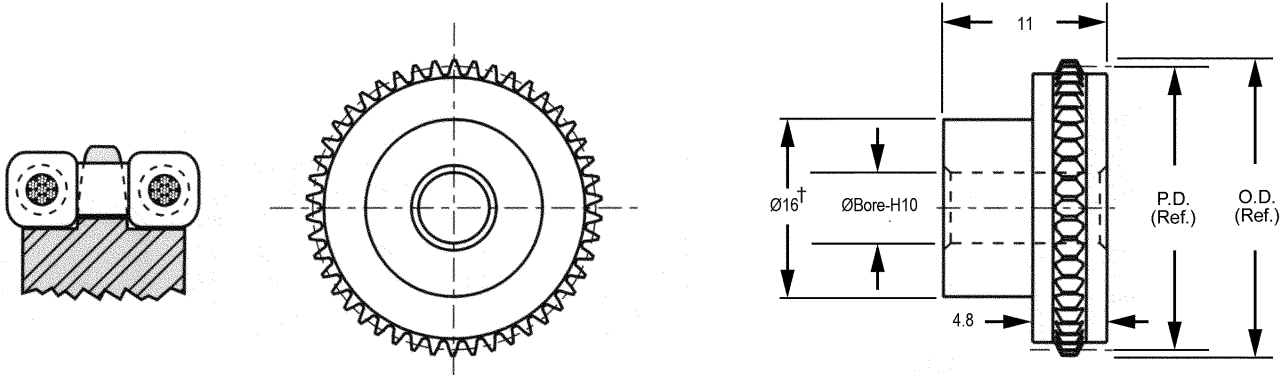

STOCK NO.	NO. OF TEETH	PITCH DIA.	OUTSIDE DIA.
3CC108M-13	13*†	16.49	18.07
3CC108M-14	14*†	17.76	19.34
3CC108M-15	15	19.03	20.61
3CC108M-16	16	20.29	21.87
3CC108M-18	18	22.83	24.41
3CC108M-20	20	25.37	26.95
3CC108M-22	22	27.90	29.48
3CC108M-24	24	30.44	32.02
3CC108M-26	26	32.98	34.56
3CC108M-28	28	35.51	37.09
3CC108M-30	30	38.05	39.63
3CC108M-32	32	40.59	42.17
3CC108M-35	35	44.39	45.97
3CC108M-36	36	45.66	47.24
3CC108M-40	40	50.74	52.32
3CC108M-45	45	57.08	58.66
3CC108M-50	50	63.42	64.00
3CC108M-55	55	69.76	71.34



† Teeth runout on hub.

* Sprockets with Ø19.0mm P.D. and smaller are recommended for idler use only.
Other numbers of teeth available on request.

CHAIN SPROCKETS

CIR. PITCH	BORE	STYLE	MATERIALS	BERG'S ® NAME	CHAIN
4mm	Ø4	PIN HUB	Aluminum per DIN 3.1355 Anodized	Min-E-Pitch® Chain Drive	Operates with 3CCF Series

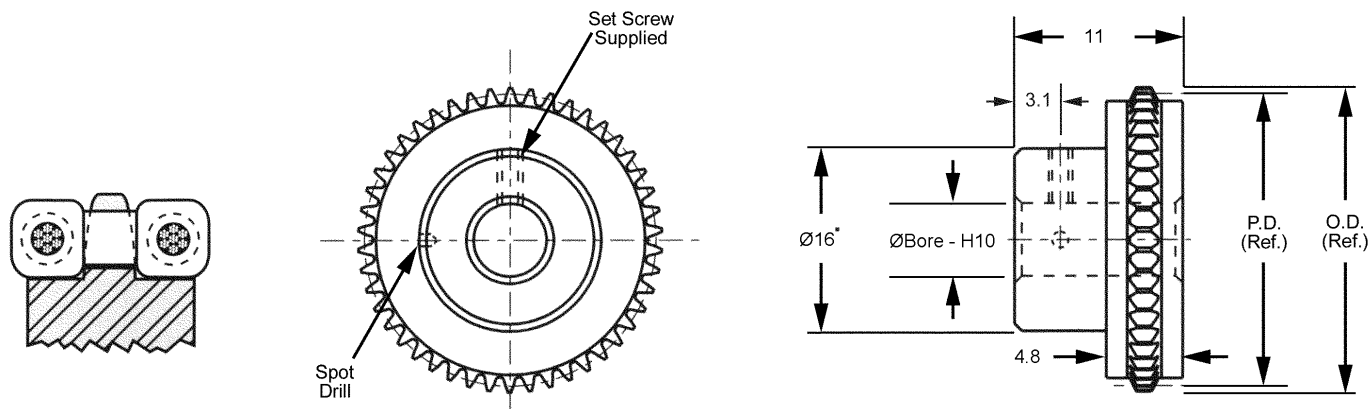

STOCK NO.	NO. OF TEETH	PITCH DIA.	OUTSIDE DIA.
3MP165A-13	13	16.49	18.07
3MP165A-14	14	17.76	19.34
3MP165A-15	15	19.03	20.61
3MP165A-16	16	20.29	21.87
3MP165A-17	17	21.56	23.14
3MP165A-18	18	22.83	24.41
3MP165A-19	19	24.10	25.68
3MP165A-20	20	25.37	26.95
3MP165A-22	22	27.90	29.48
3MP165A-24	24	30.44	32.02
3MP165A-25	26	31.71	33.29
3MP165A-26	26	32.98	34.56
3MP165A-28	28	35.51	37.09
3MP165A-30	30	38.05	39.63
3MP165A-32	32	40.59	42.17
3MP165A-35	35	44.39	45.97
3MP165A-36	36	45.66	47.24
3MP165A-40	40	50.74	52.32
3MP165A-45	45	57.08	58.66
3MP165A-50	50	63.42	65.00
3MP165A-55	55	69.76	71.34
3MP165A-60	60	76.10	77.68
3MP165A-65	65	82.45	84.02
3MP165A-70	70	88.79	90.37
3MP165A-75	75	95.13	96.71
3MP165A-80	80	101.47	103.05

• For 13-14 teeth, hub diameter equals 14.0.
 Other numbers of teeth are available upon request.
 Stainless Steel equivalent available.
 Teeth could be anodized.

CHAIN SPROCKETS

CIR. PITCH	BORE	STYLE	MATERIALS	BERG'S ® NAME	CHAIN
4mm	Ø6	PIN HUB	Aluminum per DIN 3.1355 Anodized	Min-E-Pitch® Chain Drive	Operates with 3CCF Series

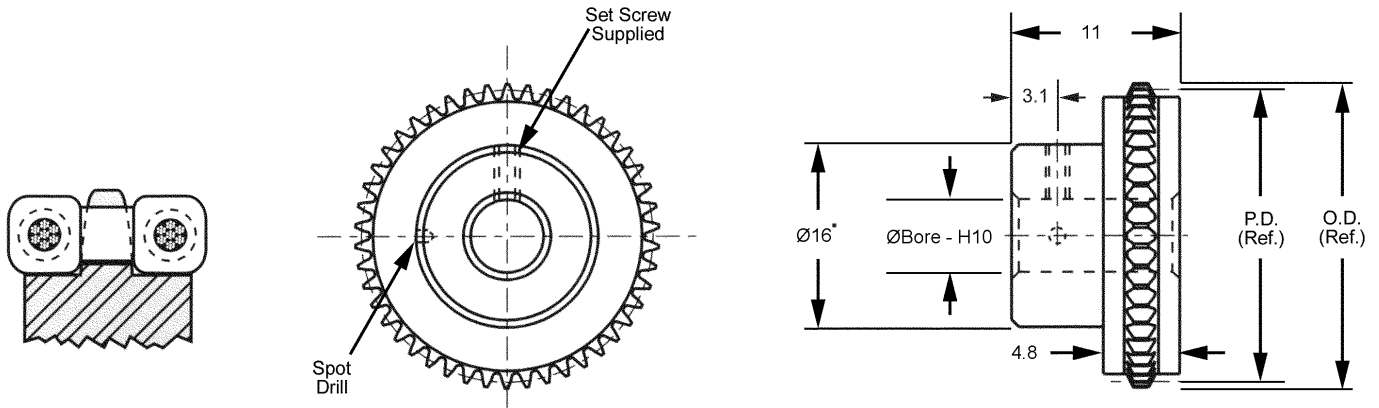

STOCK NO.	NO. OF TEETH	PITCH DIA.	OUTSIDE DIA.
3MP164A-13	13*	16.49	18.07
3MP164A-14	14*	17.76	19.34
3MP164A-15	15	19.03	20.61
3MP164A-16	16	20.29	21.87
3MP164A-17	17	21.56	23.14
3MP164A-18	18	22.83	24.41
3MP164A-19	19	24.10	25.68
3MP164A-20	20	25.37	26.95
3MP164A-22	22	27.90	29.48
3MP164A-24	24	30.44	32.02
3MP164A-25	26	31.71	33.29
3MP164A-26	26	32.98	34.56
3MP164A-28	28	35.51	37.09
3MP164A-30	30	38.05	39.63
3MP164A-32	32	40.59	42.17
3MP164A-35	35	44.39	45.97
3MP164A-36	36	45.66	47.24
3MP164A-40	40	50.74	52.32
3MP164A-45	45	57.08	58.66
3MP164A-50	50	63.42	65.00
3MP164A-55	55	69.76	71.34
3MP164A-60	60	76.10	77.68
3MP164A-65	65	82.45	84.02
3MP164A-70	70	88.79	90.37
3MP164A-75	75	95.13	96.71
3MP164A-80	80	101.47	103.05

• For 13-14 teeth, hub diameter equals 14.0.
 Other numbers of teeth are available upon request.
 Stainless Steel equivalent available.
 Teeth could be anodized.

CHAIN SPROCKETS

CIR. PITCH	BORE	STYLE	MATERIALS	BERG'S ® NAME	CHAIN
4mm	Ø8	PIN HUB	Aluminum per DIN 3.1355 Anodized	Min-E-Pitch® Chain Drive	Operates with 3CCF Series

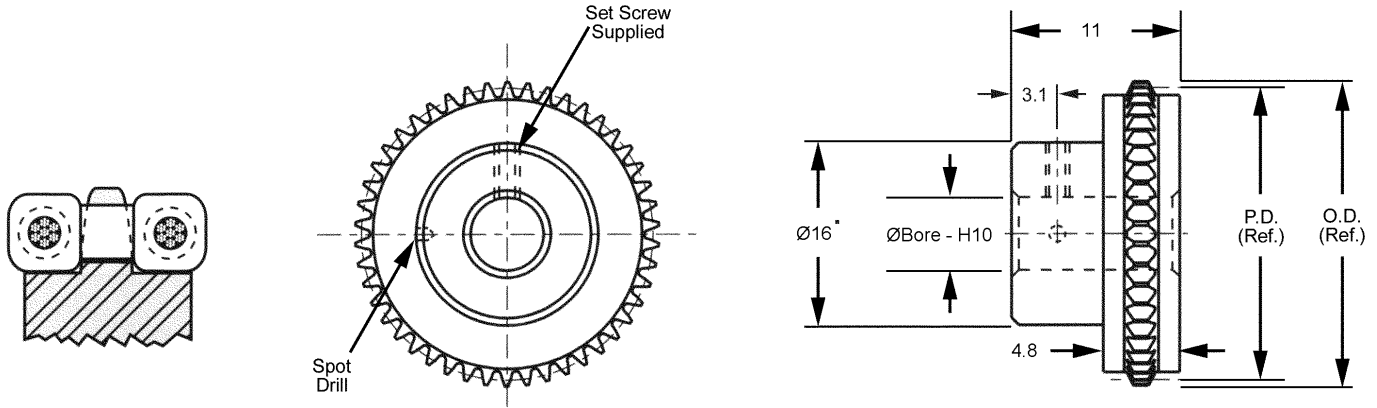

STOCK NO.	NO. OF TEETH	PITCH DIA.	OUTSIDE DIA.
3MP263A-13	13*	16.49	18.07
3MP263A-14	14*	17.76	19.34
3MP263A-15	15	19.03	20.61
3MP263A-16	16	20.29	21.87
3MP263A-17	17	21.56	23.14
3MP263A-18	18	22.83	24.41
3MP263A-19	19	24.10	25.68
3MP263A-20	20	25.37	26.95
3MP263A-22	22	27.90	29.48
3MP263A-24	24	30.44	32.02
3MP263A-25	26	31.71	33.29
3MP263A-26	26	32.98	34.56
3MP263A-28	28	35.51	37.09
3MP263A-30	30	38.05	39.63
3MP263A-32	32	40.59	42.17
3MP263A-35	35	44.39	45.97
3MP263A-36	36	45.66	47.24
3MP263A-40	40	50.74	52.32
3MP263A-45	45	57.08	58.66
3MP263A-50	50	63.42	65.00
3MP263A-55	55	69.76	71.34
3MP263A-60	60	76.10	77.68
3MP263A-65	65	82.45	84.02
3MP263A-70	70	88.79	90.37
3MP263A-75	75	95.13	96.71
3MP263A-80	80	101.47	103.05

• For 13-14 teeth, hub diameter equals 14.0.
 Other numbers of teeth are available upon request.
 Stainless Steel equivalent available.
 Teeth could be anodized.

CHAIN SPROCKETS

CIR. PITCH	BORE	STYLE	MATERIALS	BERG'S ® NAME	CHAIN
4mm	Ø10	HUBLESS	Aluminum per DIN 3.1355 Anodized	Min-E-Pitch® Chain Drive	Operates with 3CCF Series

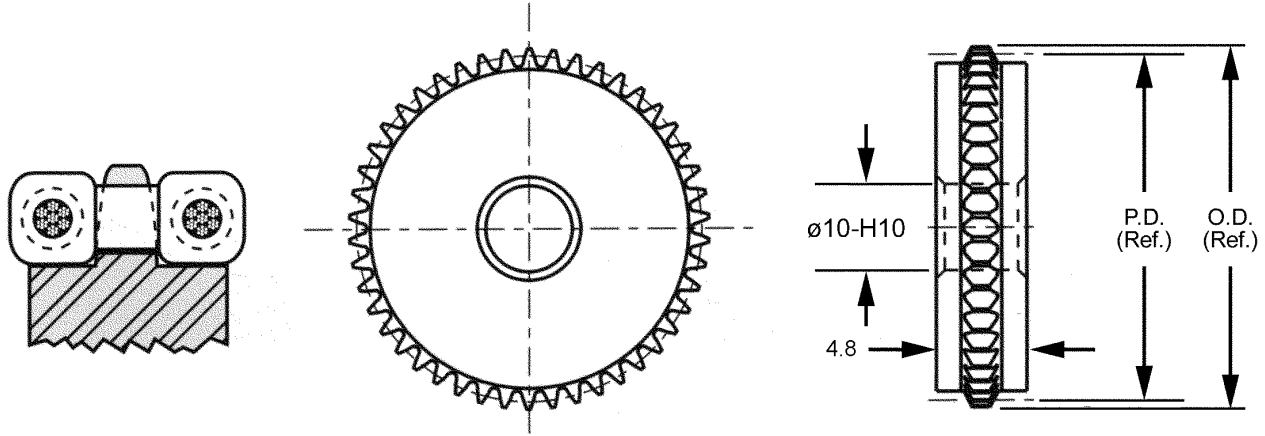

STOCK NO.	NO. OF TEETH	PITCH DIA.	OUTSIDE DIA.
3MF176A-14	14*	17.76	19.34
3MF176A-15	15	19.03	20.61
3MF176A-16	16	20.29	21.87
3MF176A-17	17	21.56	23.14
3MF176A-18	18	22.83	24.41
3MF176A-19	19	24.10	25.68
3MF176A-20	20	25.37	26.95
3MF176A-22	22	27.90	29.48
3MF176A-24	24	30.44	32.02
3MF176A-25	26	31.71	33.29
3MF176A-26	26	32.98	34.56
3MF176A-28	28	35.51	37.09
3MF176A-30	30	38.05	39.63
3MF176A-32	32	40.59	42.17
3MF176A-35	35	44.39	45.97
3MF176A-36	36	45.66	47.24
3MF176A-40	40	50.74	52.32
3MF176A-45	45	57.08	58.66
3MF176A-50	50	63.42	65.00
3MF176A-55	55	69.76	71.34
3MF176A-60	60	76.10	77.68
3MF176A-65	65	82.45	84.02
3MF176A-70	70	88.79	90.37
3MF176A-75	75	95.13	96.71
3MF176A-80	80	101.47	103.05



* Sprockets Ø19.0mm P.D. and smaller are recommended for idler use only.
Other numbers of teeth are available on request.
Stainless Steel equivalent available.
Teeth could be anodized.

DUAL CHAINS

CIRCULAR PITCH	MATERIALS	BERG'S ® NAME	SPROCKET
4mm	Polyurethane (Brown) 0.8mm Dia. Stainless Steel Cable*	Min-E-Pitch® Dual Chain	Operates with 3MDP, and 3MDF series.

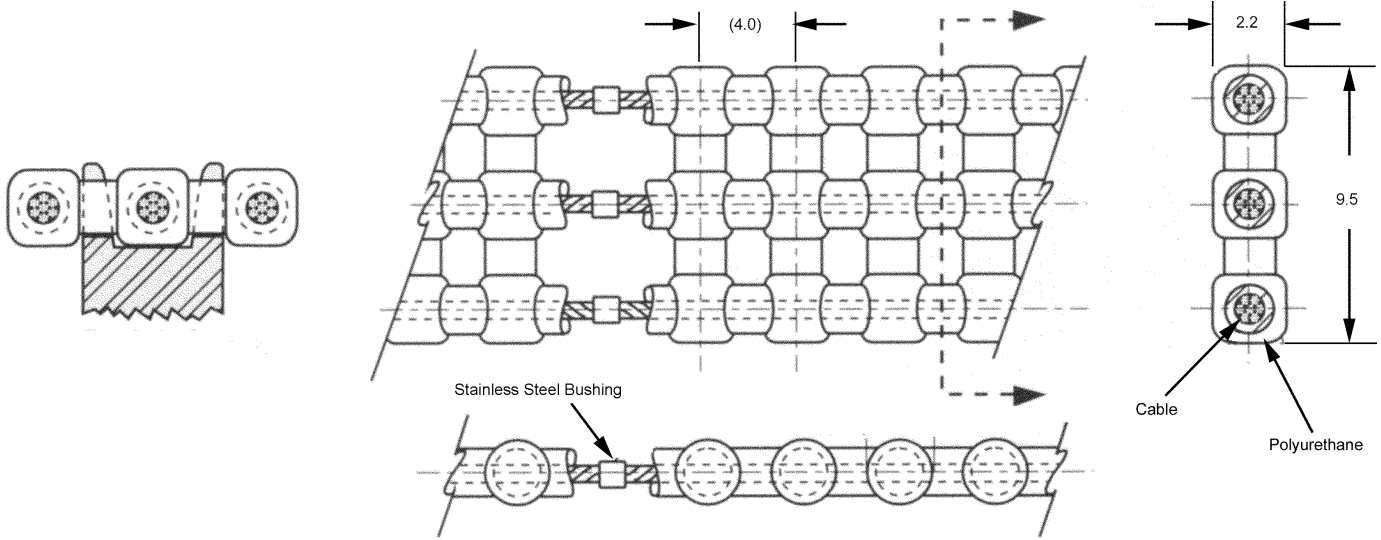

STOCK NO.	NO. OF PITCHES	LENGTH (Ref.)
3DCF-30-E	30	120.0
3DCF-35-E	35	140.0
3DCF-40-E	40	160.0
3DCF-45-E	45	180.0
3DCF-50-E	50	200.0
3DCF-55-E	55	220.0
3DCF-60-E	60	240.0
3DCF-70-E	70	280.0
3DCF-80-E	80	320.0
3DCF-90-E	90	360.0
3DCF-100-E	100	400.0
3DCF-110-E	110	440.0
3DCF-120-E	120	480.0
3DCF-130-E	130	520.0
3DCF-140-E	140	560.0
3DCF-150-E	150	600.0
3DCF-160-E	160	640.0
3DCF-170-E	170	680.0
3DCF-180-E	180	720.0
3DCF-190-E	190	760.0
3DCF-200-E	200	800.0
3DCF-210-E	210	840.0
3DCF-220-E	220	880.0
3DCF-230-E	230	920.0
3DCF-240-E	240	960.0
3DCF-250-E	250	1000.0
3DCF-260-E	260	1040.0
3DCF-270-E	270	1080.0
3DCF-280-E	280	1120.0
3DCF-290-E	290	1160.0
3DCF-300-E	300	1200.0
3DCF-310-E	310	1240.0
3DCF-320-E	320	1280.0
3DCF-330-E	330	1320.0
3DCF-340-E	340	1360.0
3DCF-350-E	350	1520.0
3DCF-370-E	370	1600.0
3DCF-400-E	400	1680.0
3DCF-440-E	440	1760.0

* This series is not available with alternate core configuration.
 ** Reduce Operating Load Rating by 50% for field splices.

- For Field Splice Kit order 3CCR-7.
- Zero Backlash
- Mass 20 Grams/Meter
- Silent Drive
- No Lubrication
- Infinite Lengths
- 90A Durometer
- Positive Drive
- Non-Magnetic
- Ultimate Tensile Strength 533N - 133N/PIN
- When belt is used in open loop configuration (without splice, no crimp bushing)
- Temperature Range +82°C to -26°C
- Recommended Operating Load 133N
- Recommended Max. Operating Speed 1.91M/S

BULK FOOTAGE - NOT SPLICED	
STOCK NO.	LENGTH
3DCF-1.5M	1.5M
3DCF-3.0M	3.0M
3DCF-7.5M	7.5M
3DCF-15.0M	15.0M
3DCF-30.0M	30.0M



MIN-E-PITCH BELT

CIRCULAR PITCH	MATERIALS	BERG'S ® NAME	SPROCKET
4mm	Polyurethane (Yellow) .8mm Dia. Stainless Steel Cable*	Min-E-Pitch® Belt Drive	Operates with 3MDP, and 3MDF series.

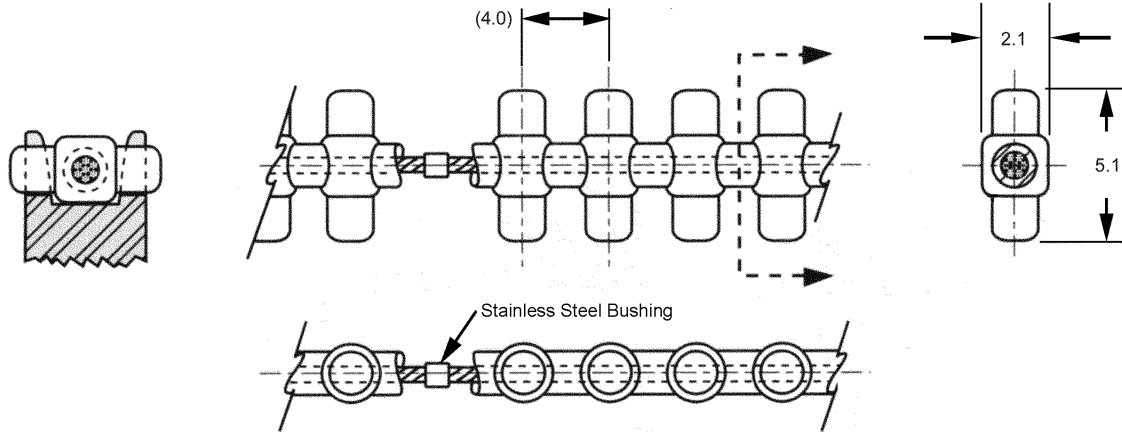

STOCK NO.	NO. OF PITCHES	LENGTH (Ref.)
3CBF-30-E	30	120.0
3CBF-35-E	35	140.0
3CBF-40-E	40	160.0
3CBF-45-E	45	180.0
3CBF-50-E	50	200.0
3CBF-55-E	55	220.0
3CBF-60-E	60	240.0
3CBF-70-E	70	280.0
3CBF-80-E	80	320.0
3CBF-90-E	90	360.0
3CBF-100-E	100	400.0
3CBF-110-E	110	440.0
3CBF-120-E	120	480.0
3CBF-130-E	130	520.0
3CBF-140-E	140	560.0
3CBF-150-E	150	600.0
3CBF-160-E	160	640.0
3CBF-170-E	170	680.0
3CBF-180-E	180	720.0
3CBF-190-E	190	760.0
3CBF-200-E	200	800.0
3CBF-210-E	210	840.0
3CBF-220-E	220	880.0
3CBF-230-E	230	920.0
3CBF-240-E	240	960.0
3CBF-250-E	250	1000.0
3CBF-260-E	260	1040.0
3CBF-270-E	270	1080.0
3CBF-280-E	280	1120.0
3CBF-290-E	290	1160.0
3CBF-300-E	300	1200.0
3CBF-310-E	310	1240.0
3CBF-320-E	320	1280.0
3CBF-330-E	330	1320.0
3CBF-340-E	340	1360.0
3CBF-350-E	350	1520.0
3CBF-370-E	370	1600.0
3CBF-400-E	400	1680.0
3CBF-440-E	440	1760.0

* This series is not available with alternate core configuration.
** Reduce Operating Load Rating by 50% for field splices.

- For Field Splice Kit order 3CCR-7.
- Zero Backlash
- Odd Angles
- Silent Drive
- Infinite Lengths
- 90A Durometer
- No Lubrication
- Mass 11 Grams/Meter
- Positive Drive
- Ultimate Tensile Strength 222N - 40N/PIN
- When belt is used in open loop configuration (without splice, no crimp bushing)
- Temperature Range +82°C to -26°C
- Recommended Operating Load 53N
- Recommended Max. Operating Speed 1.91 M/S

BULK FOOTAGE - NOT SPLICED	
STOCK NO.	LENGTH
3CBF-1.5M	1.5M
3CBF-3.0M	3.0M
3CBF-7.5M	7.5M
3CBF-15.0M	15.0M
3CBF-30.0M	30.0M



DOUBLE SPROCKETS

CIR. PITCH	BORE	STYLE	MATERIALS	BERG'S ® NAME	BELT/CHAIN
4mm	Ø4	PIN HUB	Aluminum per DIN 3.1355 Anodized	Min-E-Pitch®	Operates with 3CBF & 3DCF Series

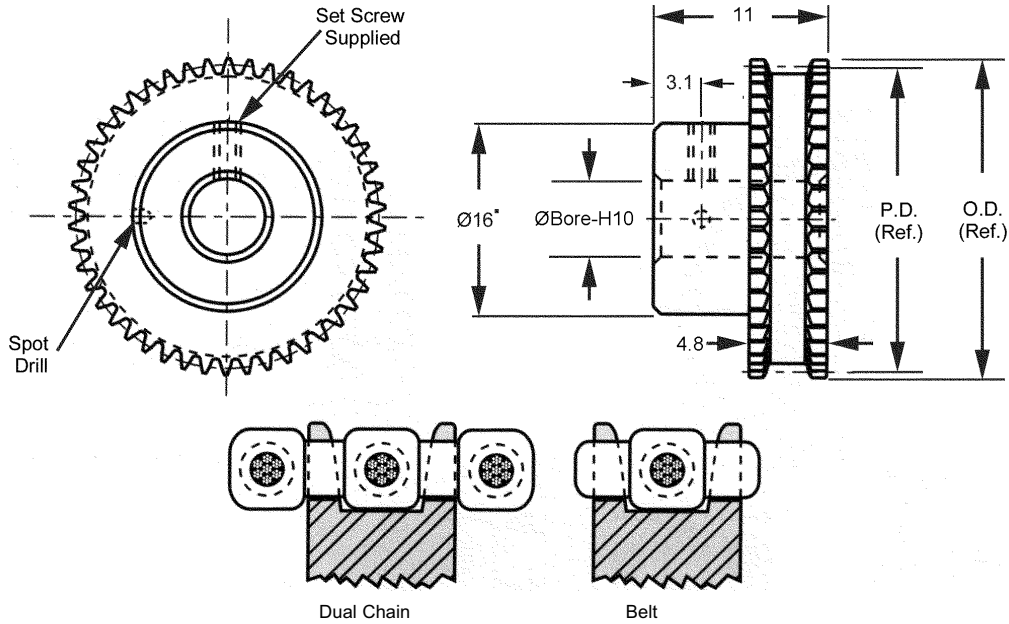

STOCK NO.	NO. OF TEETH	PITCH DIA.	OUTSIDE DIA.
3MDP165A-12	12*	15.33	16.79
3MDP165A-13	13*	16.49	18.06
3MDP165A-14	14*	17.76	19.33
3MDP165A-15	15*	19.02	20.57
3MDP165A-16	16	20.29	21.87
3MDP165A-17	17	21.56	23.11
3MDP165A-18	18	22.83	24.38
3MDP165A-19	19	24.10	25.65
3MDP165A-20	20	25.37	26.92
3MDP165A-22	22	27.90	29.46
3MDP165A-24	24	30.44	32.00
3MDP165A-25	25	31.71	33.27
3MDP165A-26	26	32.98	34.54
3MDP165A-28	28	35.51	37.08
3MDP165A-30	30	38.05	39.62
3MDP165A-32	32	40.59	42.16
3MDP165A-35	35	44.39	45.95
3MDP165A-36	36	45.66	47.22
3MDP165A-40	40	50.73	52.30
3MDP165A-45	45	57.08	58.65
3MDP165A-50	50	63.42	64.97
3MDP165A-55	55	69.76	71.32
3MDP165A-60	60	76.10	77.67
3MDP165A-65	65	82.44	84.00
3MDP165A-70	70	88.79	90.35
3MDP165A-75	75	95.13	96.70
3MDP165A-80	80	101.47	103.02



* Sprockets with Ø19.0mm P.D. and smaller are recommended for idler use only.
 • For 12-14 teeth, hub diameter equals 12.9.
 Other numbers of teeth are available on request.
 Stainless Steel equivalent available.
 Teeth could be anodized.

DOUBLE SPROCKETS

CIR. PITCH	BORE	STYLE	MATERIALS	BERG'S ® NAME	BELT/CHAIN
4mm	Ø6	PIN HUB	Aluminum per DIN 3.1355 Anodized	Min-E-Pitch®	Operates with 3CBF & 3DCF Series

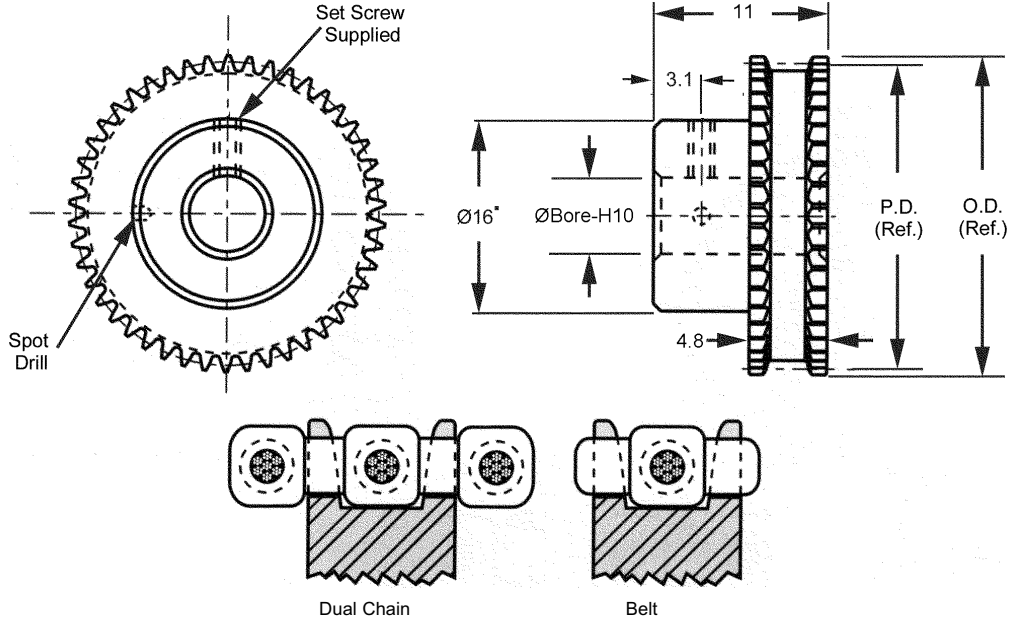

STOCK NO.	NO. OF TEETH	PITCH DIA.	OUTSIDE DIA.
3MDP164A-12	12*	15.33	16.79
3MDP164A-13	13*	16.49	18.06
3MDP164A-14	14*	17.76	19.33
3MDP164A-15	15*	19.02	20.57
3MDP164A-16	16	20.29	21.87
3MDP164A-17	17	21.56	23.11
3MDP164A-18	18	22.83	24.38
3MDP164A-19	19	24.10	25.65
3MDP164A-20	20	25.37	26.92
3MDP164A-22	22	27.90	29.46
3MDP164A-24	24	30.44	32.00
3MDP164A-25	25	31.71	33.27
3MDP164A-26	26	32.98	34.54
3MDP164A-28	28	35.51	37.08
3MDP164A-30	30	38.05	39.62
3MDP164A-32	32	40.59	42.16
3MDP164A-35	35	44.39	45.95
3MDP164A-36	36	45.66	47.22
3MDP164A-40	40	50.73	52.30
3MDP164A-45	45	57.08	58.65
3MDP164A-50	50	63.42	64.97
3MDP164A-55	55	69.76	71.32
3MDP164A-60	60	76.10	77.67
3MDP164A-65	65	82.44	84.00
3MDP164A-70	70	88.79	90.35
3MDP164A-75	75	95.13	96.70
3MDP164A-80	80	101.47	103.02



* Sprockets with Ø19.0mm P.D. and smaller are recommended for idler use only.
 • For 12-14 teeth, hub diameter equals 12.9.
 Other numbers of teeth are available on request.
 Stainless Steel equivalent available.
 Teeth could be anodized.

DOUBLE SPROCKETS

CIR. PITCH	BORE	STYLE	MATERIALS	BERG'S ® NAME	BELT/CHAIN
4mm	Ø8	PIN HUB	Aluminum per DIN 3.1355 Anodized	Min-E-Pitch®	Operates with 3CBF & 3DCF Series

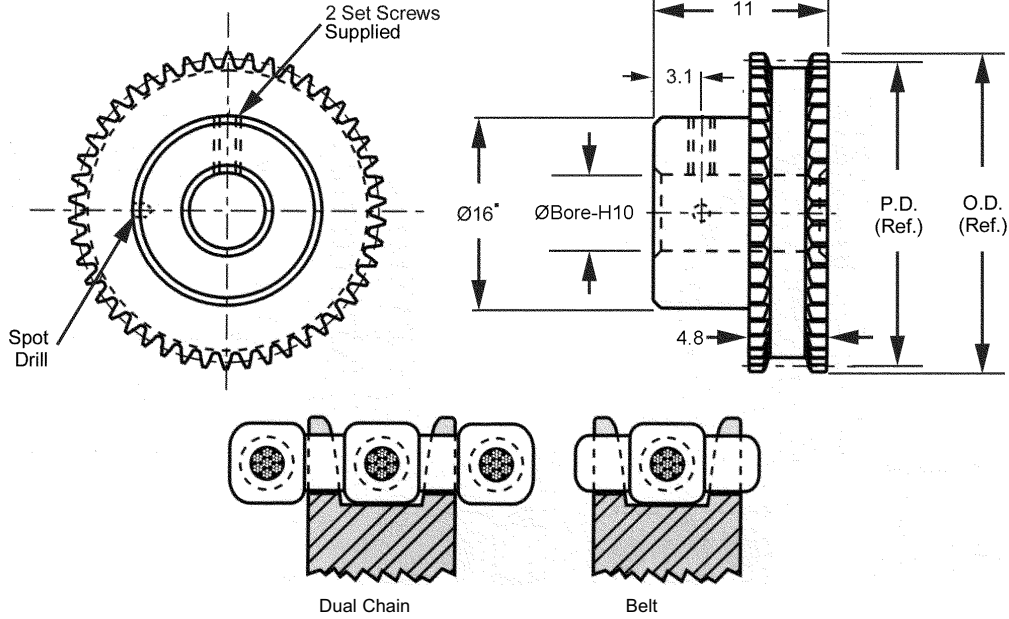

STOCK NO.	NO. OF TEETH	PITCH DIA.	OUTSIDE DIA.
3MDP263A-12	12*	15.33	16.79
3MDP263A-13	13*	16.49	18.06
3MDP263A-14	14*	17.76	19.33
3MDP263A-15	15*	19.02	20.57
3MDP263A-16	16	20.29	21.87
3MDP263A-17	17	21.56	23.11
3MDP263A-18	18	22.83	24.38
3MDP263A-19	19	24.10	25.65
3MDP263A-20	20	25.37	26.92
3MDP263A-22	22	27.90	29.46
3MDP263A-24	24	30.44	32.00
3MDP263A-25	25	31.71	33.27
3MDP263A-26	26	32.98	34.54
3MDP263A-28	28	35.51	37.08
3MDP263A-30	30	38.05	39.62
3MDP263A-32	32	40.59	42.16
3MDP263A-35	35	44.39	45.95
3MDP263A-36	36	45.66	47.22
3MDP263A-40	40	50.73	52.30
3MDP263A-45	45	57.08	58.65
3MDP263A-50	50	63.42	64.97
3MDP263A-55	55	69.76	71.32
3MDP263A-60	60	76.10	77.67
3MDP263A-65	65	82.44	84.00
3MDP263A-70	70	88.79	90.35
3MDP263A-75	75	95.13	96.70
3MDP263A-80	80	101.47	103.02



* Sprockets with Ø19.0mm P.D. and smaller are recommended for idler use only.
 • For 12-14 teeth, hub diameter equals 12.9.
 Other numbers of teeth are available on request.
 Stainless Steel equivalent available.
 Teeth could be anodized.

DOUBLE SPROCKETS

CIR. PITCH	BORE	STYLE	MATERIALS	BERG'S ® NAME	BELT/CHAIN
4mm	Ø10	HUBLESS	Aluminum per DIN 3.1355 Anodized	Min-E-Pitch®	Operates with 3CBF & 3DCF Series

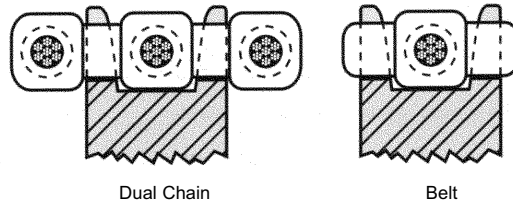
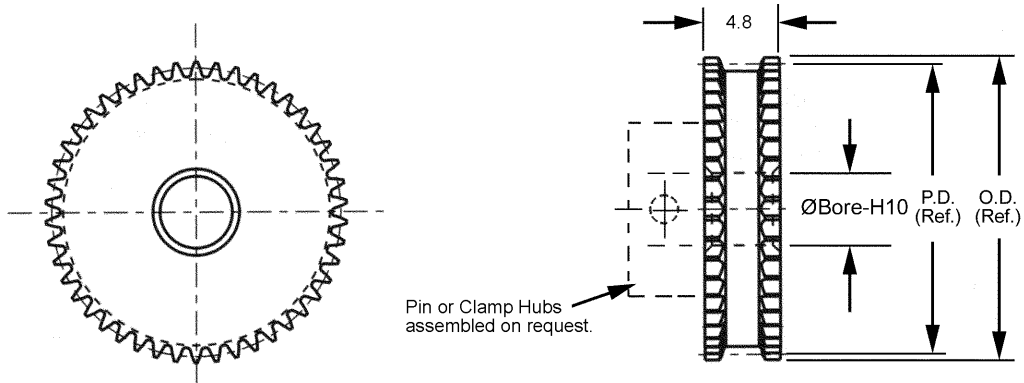

STOCK NO.	NO. OF TEETH	PITCH DIA.	OUTSIDE DIA.
3MDF176A-14	14*	17.76	19.33
3MDF176A-15	15*	19.02	20.57
3MDF176A-16	16	20.29	21.87
3MDF176A-17	17	21.56	23.11
3MDF176A-18	18	22.83	24.38
3MDF176A-19	19	24.10	25.65
3MDF176A-20	20	25.37	26.92
3MDF176A-22	22	27.90	29.46
3MDF176A-24	24	30.44	32.00
3MDF176A-25	25	31.71	33.27
3MDF176A-26	26	32.98	34.54
3MDF176A-28	28	35.51	37.08
3MDF176A-30	30	38.05	39.62
3MDF176A-32	32	40.59	42.16
3MDF176A-35	35	44.39	45.95
3MDF176A-36	36	45.66	47.22
3MDF176A-40	40	50.73	52.30
3MDF176A-45	45	57.08	58.65
3MDF176A-50	50	63.42	64.97
3MDF176A-55	55	69.76	71.32
3MDF176A-60	60	76.10	77.67
3MDF176A-65	65	82.44	84.00
3MDF176A-70	70	88.79	90.35
3MDF176A-75	75	95.13	96.70
3MDF176A-80	80	101.47	103.02



* Sprockets Ø19.0mm P.D. and smaller are recommended for idler use only.
Other numbers of teeth are available on request.
Stainless Steel equivalent available.
Teeth could be anodized.

3-D BELT

CIRCULAR PITCH	MATERIALS	BERG'S ® NAME	PULLEY
4mm	Polyurethane (Green) 8mm Dia. Stainless Steel Cable*	Min-E-Pitch®	Operates with 3TDP, 3TF, and 3MTB series.

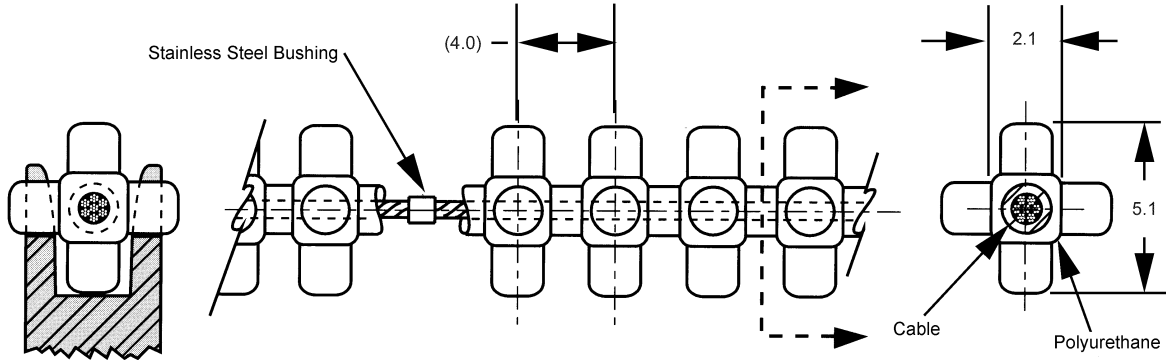

STOCK NO.	NO. OF PITCHES	LENGTH (Ref.)
3TDF-30-E	30	120.0
3TDF-35-E	36	144.0
3TDF-40-E	40	160.0
3TDF-45-E	46	184.0
3TDF-50-E	50	200.0
3TDF-55-E	56	224.0
3TDF-60-E	60	240.0
3TDF-70-E	70	280.0
3TDF-80-E	80	320.0
3TDF-90-E	90	360.0
3TDF-100-E	100	400.0
3TDF-110-E	110	440.0
3TDF-120-E	120	480.0
3TDF-130-E	130	520.0
3TDF-140-E	140	560.0
3TDF-150-E	150	600.0
3TDF-160-E	160	640.0
3TDF-170-E	170	680.0
3TDF-180-E	180	720.0
3TDF-190-E	190	760.0
3TDF-200-E	200	800.0
3TDF-210-E	210	840.0
3TDF-220-E	220	880.0
3TDF-230-E	230	920.0
3TDF-240-E	240	960.0
3TDF-250-E	250	1000.0
3TDF-260-E	260	1040.0
3TDF-270-E	270	1080.0
3TDF-280-E	280	1120.0
3TDF-290-E	290	1160.0
3TDF-300-E	300	1200.0
3TDF-310-E	310	1240.0
3TDF-320-E	320	1280.0
3TDF-330-E	330	1320.0
3TDF-340-E	340	1360.0
3TDF-350-E	350	1400.0
3TDF-370-E	360	1440.0
3TDF-400-E	400	1600.0
3TDF-440-E	440	1760.0

• For Field Splice Kit order 3CCR-7.

* Available with Aramid Core. See page A-2 for alternate belt construction and reverse bending applications.

** Reduce Operating Load Rating by 50% for field splices.

- Three Dimensional Drive
- Zero Backlash
- Silent Drive
- Infinite Lengths
- 90A Durometer
- No Lubrication
- Mass 11 Grams/Meter
- Positive Drive
- Ultimate Tensile Strength 222N - 40N/PIN
When belt is used in open loop configuration (without splice, no crimp bushing).
- Temperature Range +82°C to -26°C
- Recommended Operating Load 53N
- Recommended Max. Operating Speed 1.91 M/S

BULK FOOTAGE - NOT SPLICED	
STOCK NO.	LENGTH
3TDF-1.5M	1.5M
3TDF-3.0M	3.0M
3TDF-7.5M	7.5M
3TDF-15.0M	15.0M
3TDF-30.0M	30.0M



3-D PULLEYS

CIR. PITCH	BORE	STYLE	MATERIALS	BERG'S ® NAME	BELT
4mm	Ø4	PIN HUB	Aluminum per DIN 3.1355 Anodized	Min-E-Pitch® Three D Drive	Operates with 3TDF Series

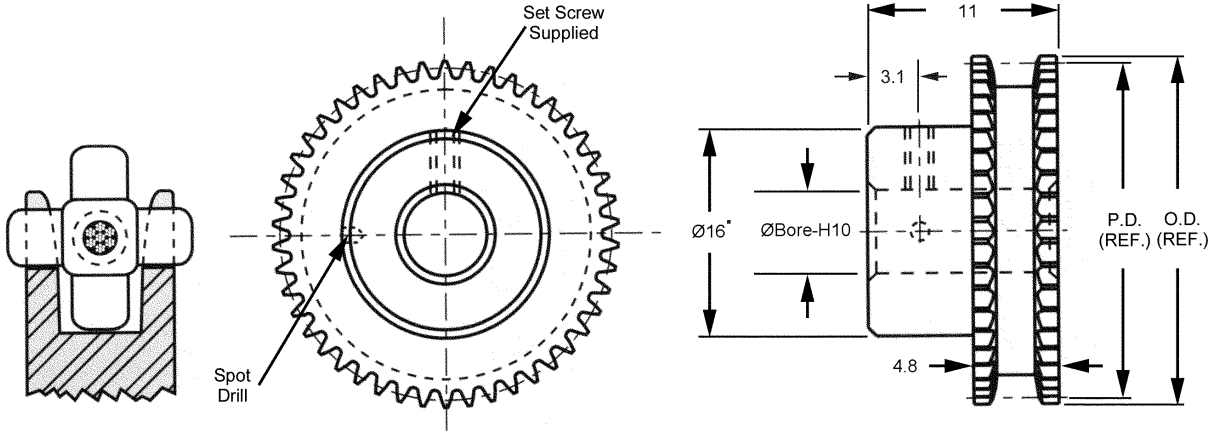

STOCK NO.	NO. OF TEETH	PITCH DIA.	OUTSIDE DIA.
3TDP165A-12	12*	15.22	16.80
3TDP165A-13	13*	16.49	18.07
3TDP165A-14	14*	17.76	19.34
3TDP165A-15	15*	19.03	20.61
3TDP165A-16	16*	20.29	21.87
3TDP165A-17	17	21.56	23.14
3TDP165A-18	18	22.83	24.41
3TDP165A-19	19	24.10	25.68
3TDP165A-20	20	25.37	26.95
3TDP165A-22	22	27.90	29.48
3TDP165A-24	24	30.44	32.02
3TDP165A-25	25	31.71	33.26
3TDP165A-26	26	32.98	34.56
3TDP165A-28	28	35.51	37.09
3TDP165A-30	30	38.05	39.63
3TDP165A-32	32	40.59	42.17
3TDP165A-35	35	44.39	45.97
3TDP165A-36	36	45.66	47.24
3TDP165A-40	40	50.47	52.32
3TDP165A-45	45	57.10	58.66
3TDP165A-50	50	63.42	65.00
3TDP165A-55	55	69.76	71.34
3TDP165A-60	60	76.10	77.68
3TDP165A-65	65	82.45	84.02
3TDP165A-70	70	88.79	90.37
3TDP165A-75	75	95.13	96.71
3TDP165A-80	80	101.47	103.05



* Sprockets with Ø19.0mm P.D. and smaller are recommended for idler use only.

• For 12-16 teeth, hub diameter equals 10.0.

Other numbers of teeth are available on request.

Stainless Steel equivalent available.

Teeth could be anodized.

3-D PULLEYS

CIR. PITCH	BORE	STYLE	MATERIALS	BERG'S ® NAME	BELT
4mm	Ø6	PIN HUB	Aluminum per DIN 3.1355 Anodized	Min-E-Pitch® Three D Drive	Operates with 3TDF Series

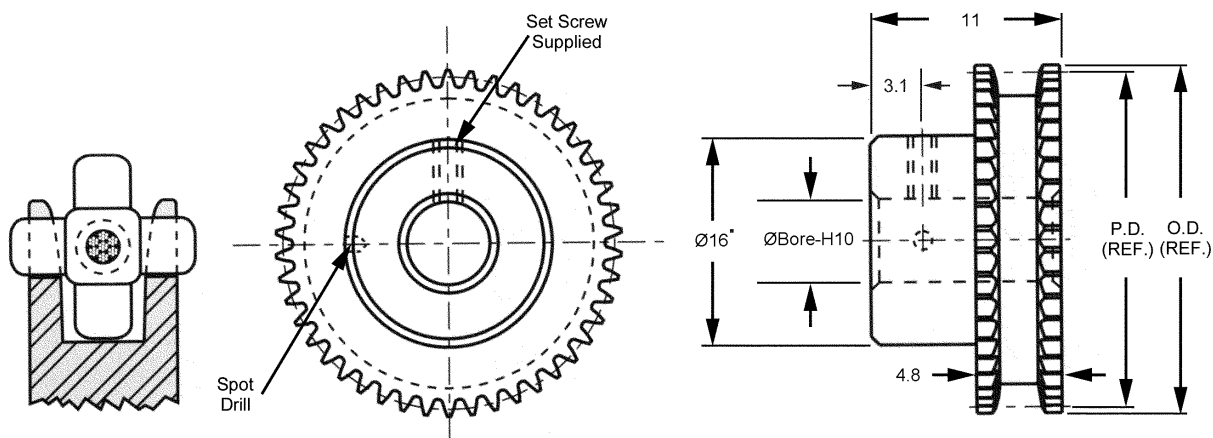

STOCK NO.	NO. OF TEETH	PITCH DIA.	OUTSIDE DIA.
3TDP164A-12	12*	15.22	16.80
3TDP164A-13	13*	16.49	18.07
3TDP164A-14	14*	17.76	19.34
3TDP164A-15	15*	19.03	20.61
3TDP164A-16	16*	20.29	21.87
3TDP164A-17	17	21.56	23.14
3TDP164A-18	18	22.83	24.41
3TDP164A-19	19	24.10	25.68
3TDP164A-20	20	25.37	26.95
3TDP164A-22	22	27.90	29.48
3TDP164A-24	24	30.44	32.02
3TDP164A-25	25	31.71	33.26
3TDP164A-26	26	32.98	34.56
3TDP164A-28	28	35.51	37.09
3TDP164A-30	30	38.05	39.63
3TDP164A-32	32	40.59	42.17
3TDP164A-35	35	44.39	45.97
3TDP164A-36	36	45.66	47.24
3TDP164A-40	40	50.47	52.32
3TDP164A-45	45	57.10	58.66
3TDP164A-50	50	63.42	65.00
3TDP164A-55	55	69.76	71.34
3TDP164A-60	60	76.10	77.68
3TDP164A-65	65	82.45	84.02
3TDP164A-70	70	88.79	90.37
3TDP164A-75	75	95.13	96.71
3TDP164A-80	80	101.47	103.05



* Sprockets with Ø19.0mm P.D. and smaller are recommended for idler use only.
 • For 12-16 teeth, hub diameter equals 10.0.
 Other numbers of teeth are available on request.
 Stainless Steel equivalent available.
 Teeth could be anodized.

3-D PULLEYS

CIR. PITCH	BORE	STYLE	MATERIALS	BERG'S ® NAME	BELT
4mm	Ø8	PIN HUB	Aluminum per DIN 3.1355 Anodized	Min-E-Pitch® Three D Drive	Operates with 3TDF Series

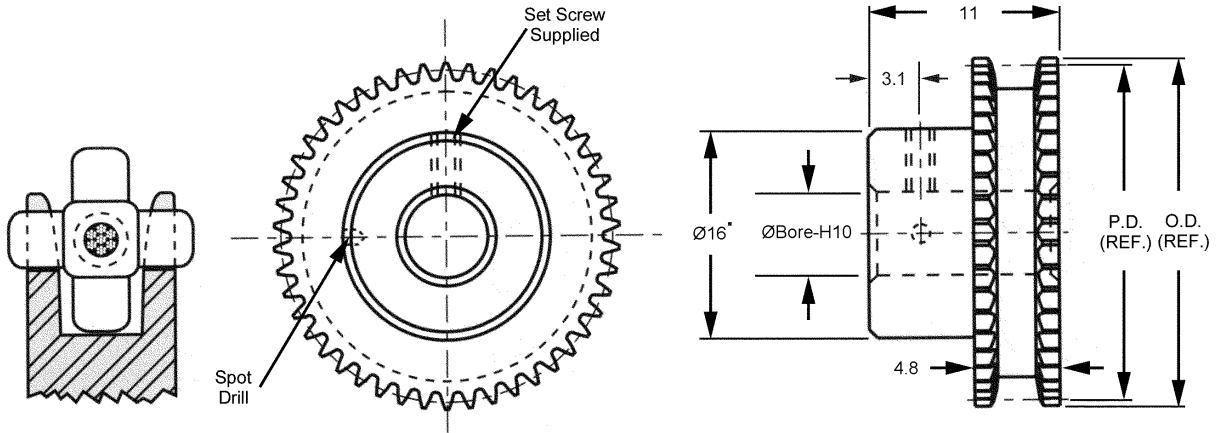

STOCK NO.	NO. OF TEETH	PITCH DIA.	OUTSIDE DIA.
3TDP263A-12	12*	15.22	16.80
3TDP263A-13	13*	16.49	18.07
3TDP263A-14	14*	17.76	19.34
3TDP263A-15	15*	19.03	20.61
3TDP263A-16	16*	20.29	21.87
3TDP263A-17	17	21.56	23.14
3TDP263A-18	18	22.83	24.41
3TDP263A-19	19	24.10	25.68
3TDP263A-20	20	25.37	26.95
3TDP263A-22	22	27.90	29.48
3TDP263A-24	24	30.44	32.02
3TDP263A-25	25	31.71	33.26
3TDP263A-26	26	32.98	34.56
3TDP263A-28	28	35.51	37.09
3TDP263A-30	30	38.05	39.63
3TDP263A-32	32	40.59	42.17
3TDP263A-35	35	44.39	45.97
3TDP263A-36	36	45.66	47.24
3TDP263A-40	40	50.47	52.32
3TDP263A-45	45	57.10	58.66
3TDP263A-50	50	63.42	65.00
3TDP263A-55	55	69.76	71.34
3TDP263A-60	60	76.10	77.68
3TDP263A-65	65	82.45	84.02
3TDP263A-70	70	88.79	90.37
3TDP263A-75	75	95.13	96.71
3TDP263A-80	80	101.47	103.05



* Sprockets with Ø19.0mm P.D. and smaller are recommended for idler use only.

• For 12-16 teeth, hub diameter equals 10.0.

Other numbers of teeth are available on request.

Stainless Steel equivalent available.

Teeth could be anodized.

3-D PULLEYS

CIR. PITCH	BORE	STYLE	MATERIALS	BERG'S ® NAME	BELT
4mm	Ø10	HUBLESS	Aluminum per DIN 3.1355 Anodized	Min-E-Pitch® Three D Drive	Operates with 3TDF Series

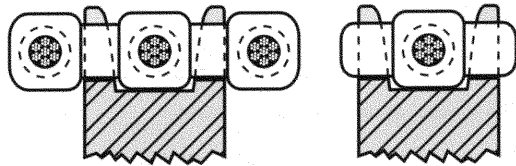
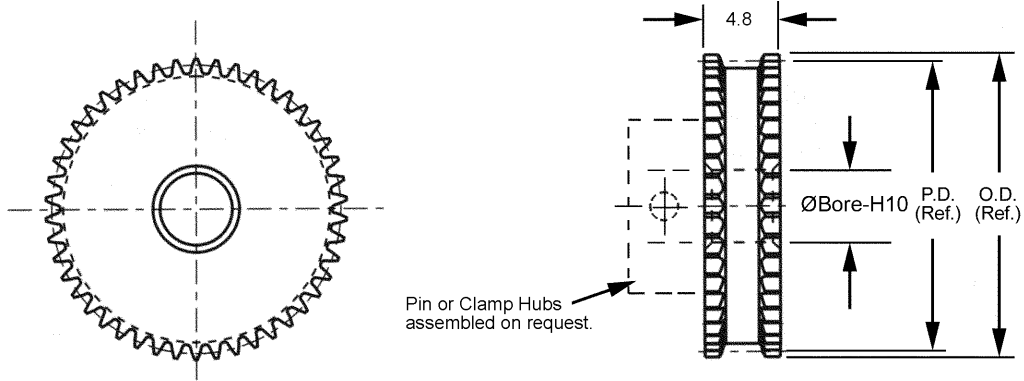

STOCK NO.	NO. OF TEETH	PITCH DIA.	OUTSIDE DIA.
3MDF176A-12	12*	15.22	16.80
3MDF176A-13	13*	16.49	18.07
3MDF176A-14	14*	17.76	19.34
3MDF176A-15	15*	19.03	20.61
3MDF176A-16	16*	20.29	21.87
3MDF176A-17	17	21.56	23.14
3MDF176A-18	18	22.83	24.41
3MDF176A-19	19	24.10	25.68
3MDF176A-20	20	25.37	26.95
3MDF176A-22	22	27.90	29.48
3MDF176A-24	24	30.44	32.02
3MDF176A-25	25	31.71	33.26
3MDF176A-26	26	32.98	34.56
3MDF176A-28	28	35.51	37.09
3MDF176A-30	30	38.05	39.63
3MDF176A-32	32	40.59	42.17
3MDF176A-35	35	44.39	45.97
3MDF176A-36	36	45.66	47.24
3MDF176A-40	40	50.47	52.32
3MDF176A-45	45	57.10	58.66
3MDF176A-50	50	63.42	65.00
3MDF176A-55	55	69.76	71.34
3MDF176A-60	60	76.10	77.68
3MDF176A-65	65	82.45	84.02
3MDF176A-70	70	88.79	90.37
3MDF176A-75	75	95.13	96.71
3MDF176A-80	80	101.47	103.05



* Sprockets with Ø19.0mm P.D. and smaller are recommended for idler use only.
Other numbers of teeth are available on request.
Stainless Steel equivalent available.
Teeth could be anodized.

3-D PULLEYS

CIR. PITCH	SHAFT SIZE	STYLE	MATERIALS	BERG'S ® NAME	BELT
4mm	Ø4	IDLER	Aluminum Pulley w/Teflon® Bushings	Min-E-Pitch® Three D Drive	Operates with 3TDF Series

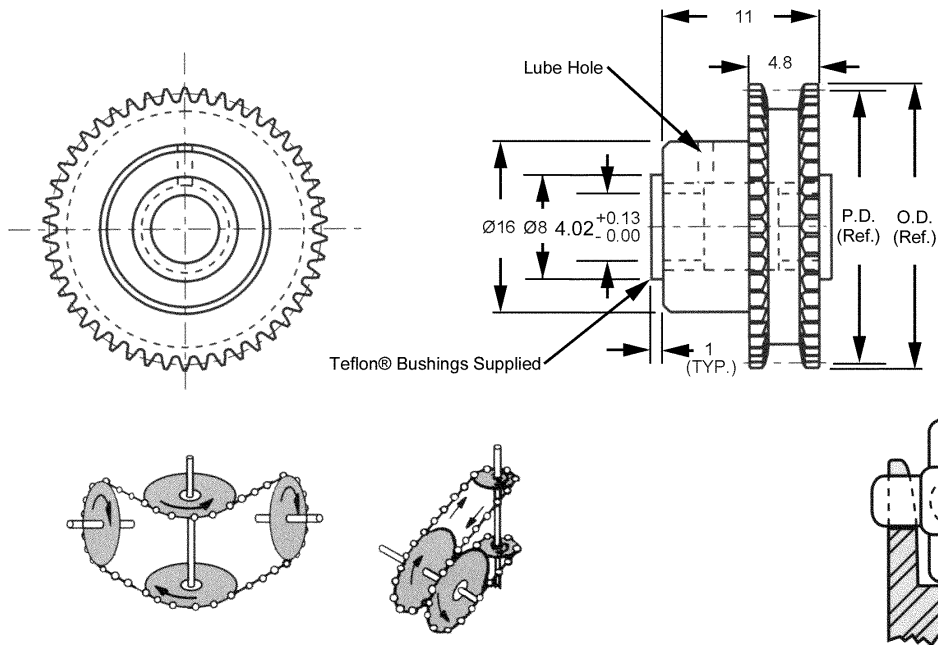

STOCK NO.	NO. OF TEETH	PITCH DIA.	OUTSIDE DIA.
3MTB163A-25	25	31.71	33.27
3MTB163A-26	26	32.98	34.54
3MTB163A-28	28	35.51	37.08
3MTB163A-30	30	38.05	39.62
3MTB163A-32	32	40.59	40.64
3MTB163A-34	34	43.13	44.70
3MTB163A-35	35	44.39	45.95
3MTB163A-36	36	45.66	47.22
3MTB163A-38	38	48.20	49.78
3MTB163A-40	40	50.74	52.30
3MTB163A-44	44	55.81	57.38
3MTB163A-45	45	57.08	58.65
3MTB163A-50	50	63.42	64.97
3MTB163A-55	55	69.75	71.12
3MTB163A-60	60	76.10	77.67
3MTB163A-65	65	82.45	84.02
3MTB163A-70	70	88.79	90.37
3MTB163A-75	75	95.13	96.70
3MTB163A-80	80	101.47	103.05

Other numbers of teeth are available on request.

Teeth could be anodized.

3-D PULLEYS

CIR. PITCH	SHAFT SIZE	STYLE	MATERIALS	BERG'S ® NAME	BELT
4mm	Ø6	IDLER	Aluminum Pulley w/Teflon® Bushings	Min-E-Pitch® Three D Drive	Operates with 3TDF Series

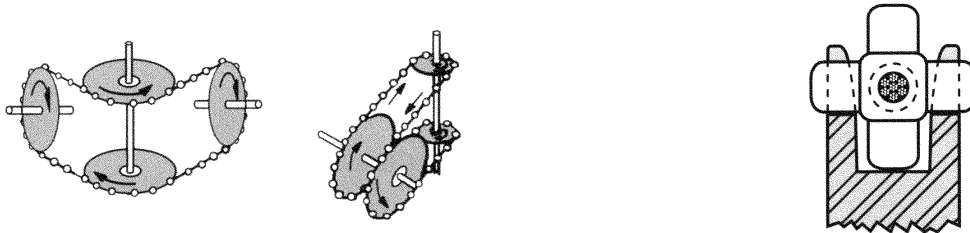
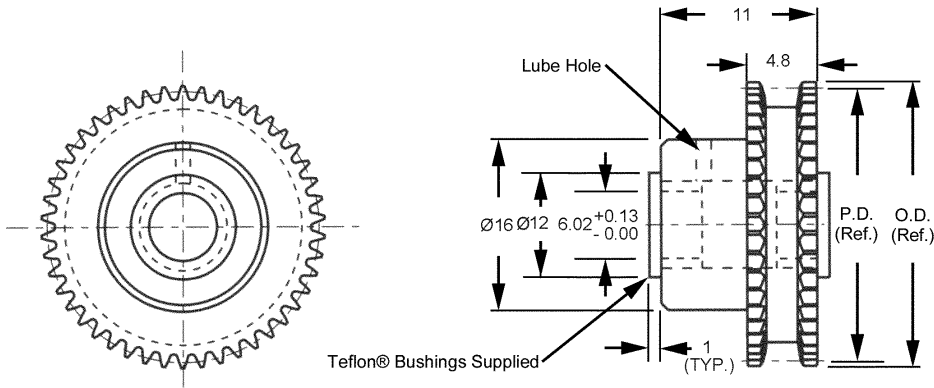

STOCK NO.	NO. OF TEETH	PITCH DIA.	OUTSIDE DIA.
3MTB183A-25	25	31.71	33.27
3MTB183A-26	26	32.98	34.54
3MTB183A-28	28	35.51	37.08
3MTB183A-30	30	38.05	39.62
3MTB183A-32	32	40.59	40.64
3MTB183A-34	34	43.13	44.70
3MTB183A-35	35	44.39	45.95
3MTB183A-36	36	45.66	47.22
3MTB183A-38	38	48.20	49.78
3MTB183A-40	40	50.74	52.30
3MTB183A-44	44	55.81	57.38
3MTB183A-45	45	57.08	58.65
3MTB183A-50	50	63.42	64.97
3MTB183A-55	55	69.75	71.12
3MTB183A-60	60	76.10	77.67
3MTB183A-65	65	82.45	84.02
3MTB183A-70	70	88.79	90.37
3MTB183A-75	75	95.13	96.70
3MTB183A-80	80	101.47	103.05

Other numbers of teeth are available on request.
Teeth could be anodized.

3-D PULLEYS

CIR. PITCH	SHAFT SIZE	STYLE	MATERIALS	BERG'S ® NAME	BELT
4mm	Ø8	IDLER	Aluminum Pulley w/Teflon® Bushings	Min-E-Pitch® Three D Drive	Operates with 3TDF Series

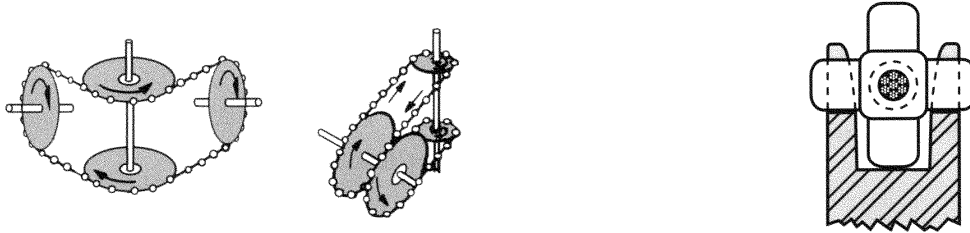
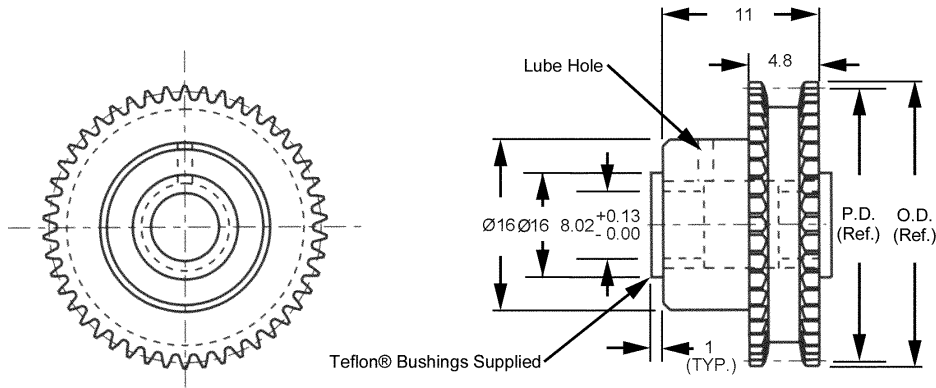

STOCK NO.	NO. OF TEETH	PITCH DIA.	OUTSIDE DIA.
3MTB293A-25	25	31.71	33.27
3MTB293A-26	26	32.98	34.54
3MTB293A-28	28	35.51	37.08
3MTB293A-30	30	38.05	39.62
3MTB293A-32	32	40.59	40.64
3MTB293A-34	34	43.13	44.70
3MTB293A-35	35	44.39	45.95
3MTB293A-36	36	45.66	47.22
3MTB293A-38	38	48.20	49.78
3MTB293A-40	40	50.74	52.30
3MTB293A-44	44	55.81	57.38
3MTB293A-45	45	57.08	58.65
3MTB293A-50	50	63.42	64.97
3MTB293A-55	55	69.75	71.12
3MTB293A-60	60	76.10	77.67
3MTB293A-65	65	82.45	84.02
3MTB293A-70	70	88.79	90.37
3MTB293A-75	75	95.13	96.70
3MTB293A-80	80	101.47	103.05

Other numbers of teeth are available on request.
Teeth could be anodized.

SUPPORT & GUIDE RAILS

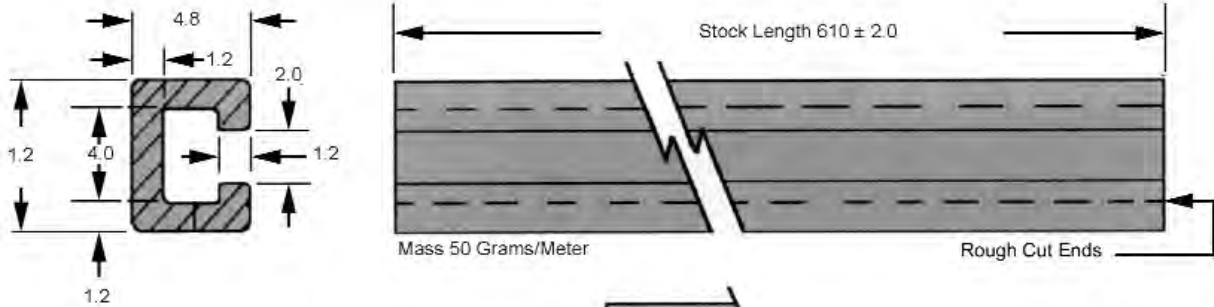

After cutting guide to suit your application, always file and funnel ends for easy entrance.

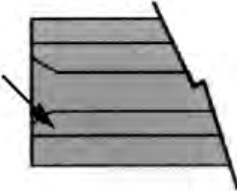

APPLICATIONS:

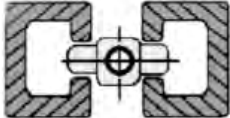

Cable Belt Guides

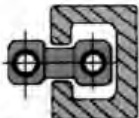

Cable Chain Guides



Three-D Guides

STOCK NO.
3CRR



CABLE CHAINS

CIRCULAR PITCH	PIN DIAMETER	MATERIALS	BERG'S ® NAME	SPROCKET
3.747mm	2.3mm	Polyurethane (Blue) 0.8mm Stainless Steel Cable*	Flex-E-Pitch®	Operates with 14LC, and 14LP series.

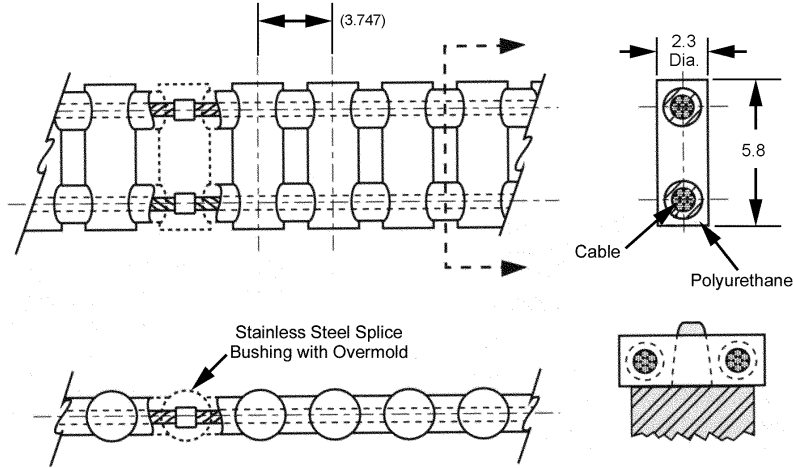

STOCK NO.	NO. OF PITCHES	LENGTH MM
14CCF-40-E	40	149.9
14CCF-50-E	50	187.4
14CCF-60-E	60	224.8
14CCF-70-E	70	262.3
14CCF-80-E	80	299.8
14CCF-90-E	90	337.2
14CCF-100-E	100	374.7
14CCF-110-E	110	412.2
14CCF-120-E	120	449.6
14CCF-130-E	130	487.1
14CCF-140-E	140	524.6
14CCF-150-E	150	562.1
14CCF-160-E	160	599.5
14CCF-170-E	170	637.0
14CCF-180-E	180	674.5
14CCF-190-E	190	711.9
14CCF-200-E	200	749.4
14CCF-210-E	210	786.9
14CCF-220-E	220	824.3
14CCF-230-E	230	861.8
14CCF-240-E	240	899.3
14CCF-250-E	250	936.8
14CCF-260-E	260	974.2
14CCF-270-E	270	1011.7
14CCF-280-E	280	1049.2
14CCF-290-E	290	1086.6
14CCF-300-E	300	1124.1
14CCF-310-E	310	1161.6
14CCF-320-E	320	1199.0
14CCF-330-E	330	1236.5
14CCF-340-E	340	1274.0
14CCF-370-E	370	1386.4
14CCF-390-E	390	1461.3

• For Field Splice Kit order 14CCF-7.

*Available with Aramid Core construction. See page A-2 for alternate belt construction and reverse belt bending applications.

** Reduce Operating Load Rating by 50% for field splices.

Designed to replace standard metal roller chain systems:

- No multiple link joints to bind.
- Lubrication is never required.
- Easily modified to any length.
- Large selection of mating sprockets.
- Infinite Lengths
- Silent Drive
- Rust Proof
- 90A Durometer
- Non-Magnetic
- Positive Drive
- Zero Backlash
- Mass 14 Grams/Meter
- Ultimate Tensile Strength 445N - 53N/ PIN - when belt is used in an open configuration (without splice, no crimp bushing)
- Temperature Range +82°C to -26°C
- Recommended Operating Load 111N
- Recommended Max. Operating Speed 1.91 m/s

BULK FOOTAGE-NOT SPLICED	
STOCK NO.	LENGTH
14CCF-1.5M	1.5 M
14CCF-3.0M	3.0 M
14CCF-7.5M	7.5 M
14CCF-15.0M	15.0 M
14CCF-30.0M	30.0 M



CHAIN SPROCKETS

CIR. PITCH	BORE	STYLE	MATERIALS	BERG'S ® NAME	CHAIN
3.747mm	Ø7	PIN HUB	Acetal	Flex-E-Pitch®	Operates with 14CCF Series

STOCK NO.	NO. OF TEETH	PITCH DIA.	OUTSIDE DIA.
14LC107M-14	14 [†] *	16.80	18.83
14LC107M-15	15 [†] *	18.00	20.03
14LC107M-16	16	19.20	21.23
14LC107M-18	18	21.60	23.63
14LC107M-20	20	24.00	26.03
14LC107M-22	22	26.40	28.43
14LC107M-24	24	28.80	30.83
14LC107M-26	26	31.20	33.23
14LC107M-30	30	35.99	38.03
14LC107M-32	32	38.39	40.42
14LC107M-36	36	43.19	45.23
14LC107M-40	40	47.99	50.03
14LC107M-42	42	50.39	52.42
14LC107M-44	44	52.79	54.83
14LC107M-45	45	53.99	56.02
14LC107M-50	50	59.99	62.02
14LC107M-60	60	71.99	74.02

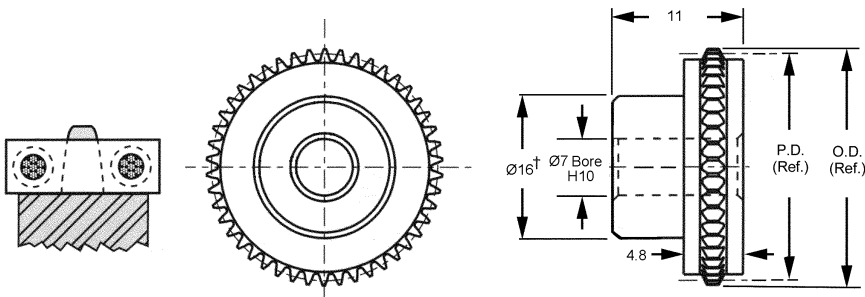

† Teeth runout on hub.
 • Sprockets with Ø19.0mm P.D. and smaller are recommended for idler use only.
 Other numbers of teeth available on request.

CIR. PITCH	BORE	STYLE	MATERIALS	BERG'S ® NAME	CHAIN
3.747mm	Ø8	PIN HUB	Acetal	Flex-E-Pitch®	Operates with 14CCF Series

STOCK NO.	NO. OF TEETH	PITCH DIA.	OUTSIDE DIA.
14LC108M-14	14 [†] *	16.80	18.83
14LC108M-15	15 [†] *	18.00	20.03
14LC108M-16	16	19.20	21.23
14LC108M-18	18	21.60	23.63
14LC108M-20	20	24.00	26.03
14LC108M-22	22	26.40	28.43
14LC108M-24	24	28.80	30.83
14LC108M-26	26	31.20	33.23
14LC108M-30	30	35.99	38.03
14LC108M-32	32	38.39	40.42
14LC108M-36	36	43.19	45.23
14LC108M-40	40	47.99	50.03
14LC108M-42	42	50.39	52.42
14LC108M-44	44	52.79	54.83
14LC108M-45	45	53.99	56.02
14LC108M-50	50	59.99	62.02
14LC108M-60	60	71.99	74.02

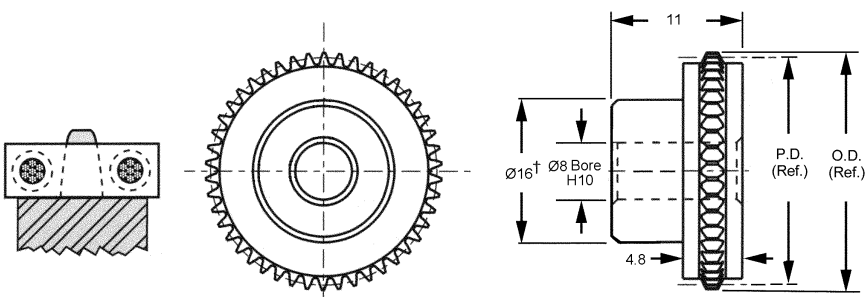

† Teeth runout on hub.
 • Sprockets with Ø19.0mm P.D. and smaller are recommended for idler use only.
 Other numbers of teeth available on request.



CHAIN SPROCKETS

CIR. PITCH	BORE	STYLE	MATERIALS	BERG'S ® NAME	CHAIN
3.747mm	Ø10	HUBLESS	Aluminum per DIN 3.1355 Anodized	Flex-E-Pitch®	Operates with 14CCF Series

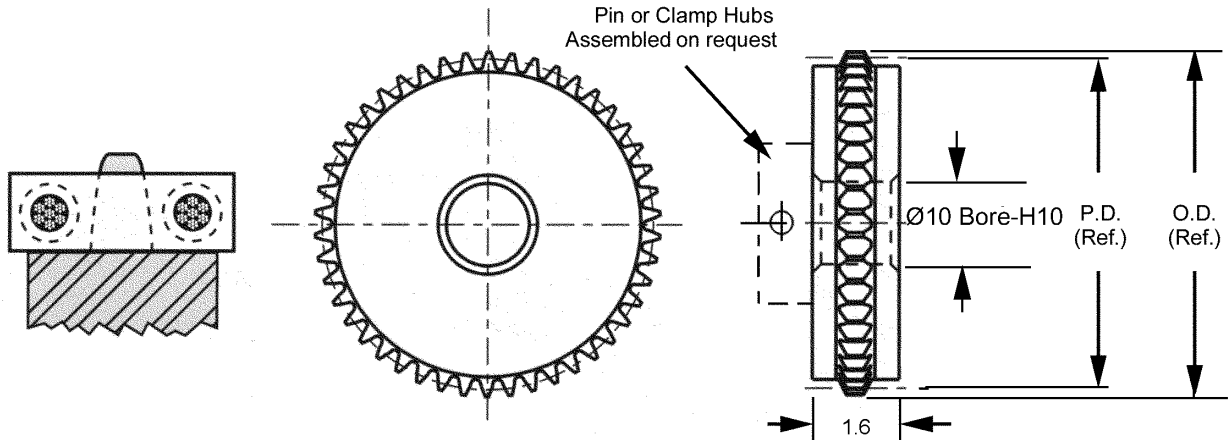

STOCK NO.	NO. OF TEETH	PITCH DIA.	OUTSIDE DIA.
14LP176A-14	14*	16.80	18.82
14LP176A-15	15*	18.00	20.03
14LP176A-16	16	19.20	21.23
14LP176A-18	18	21.60	23.63
14LP176A-20	20	24.00	26.03
14LP176A-24	24	28.80	30.83
14LP176A-25	25	30.00	32.03
14LP176A-27	27	32.40	34.43
14LP176A-28	28	33.60	35.63
14LP176A-29	29	34.80	36.83
14LP176A-30	30	35.99	38.03
14LP176A-32	32	38.39	40.43
14LP176A-34	34	40.79	42.83
14LP176A-36	36	43.19	45.23
14LP176A-38	38	45.59	47.63
14LP176A-40	40	47.99	50.03
14LP176A-42	42	50.39	52.42
14LP176A-44	44	52.79	54.82
14LP176A-48	48	57.59	59.62
14LP176A-50	50	59.99	62.02
14LP176A-52	52	62.39	64.42
14LP176A-54	54	64.79	66.82
14LP176A-56	56	67.19	69.22
14LP176A-60	60	71.99	74.02
14LP176A-65	65	77.99	80.02
14LP176A-70	70	83.99	86.02
14LP176A-80	80	95.99	98.02



* Sprockets with Ø19.0mm P.D. and smaller are recommended for idler use only.

Other numbers of teeth available on request.

Teeth could be anodized.

CHAIN SPROCKETS

CIR. PITCH	BORE	STYLE	MATERIALS	BERG'S ® NAME	CHAIN
3.747mm	Ø4	PIN HUB	Aluminum per DIN 3.1355 Anodized	Flex-E-Pitch®	Operates with 14CCF Series

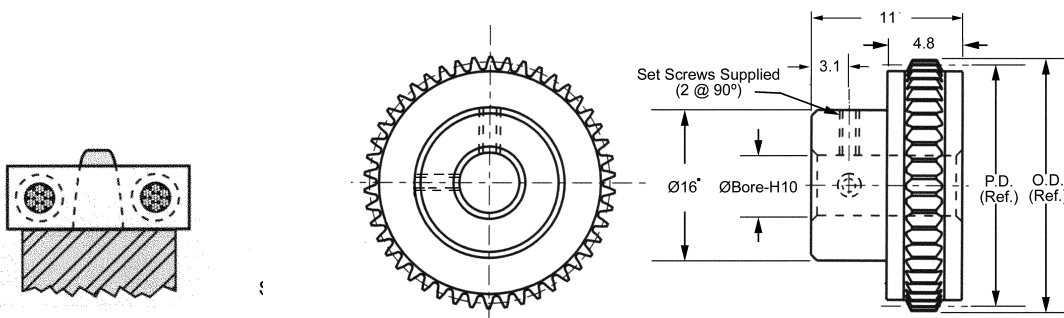

STOCK NO.	NO. OF TEETH	PITCH DIA.	OUTSIDE DIA.
14LC165A-13	13*	15.60	17.63
14LC165A-14	14*	16.80	18.82
14LC165A-15	15*	18.00	20.03
14LC165A-16	16	19.20	21.23
14LC165A-18	18	21.60	23.63
14LC165A-20	20	24.00	26.03
14LC165A-24	24	28.80	30.83
14LC165A-25	25	30.00	32.03
14LC165A-27	27	32.40	34.43
14LC165A-28	28	33.60	35.63
14LC165A-29	29	34.80	36.83
14LC165A-30	30	35.99	38.03
14LC165A-32	32	38.39	40.43
14LC165A-34	34	40.79	42.83
14LC165A-36	36	43.19	45.23
14LC165A-38	38	45.59	47.63
14LC165A-40	40	47.99	50.03
14LC165A-42	42	50.39	52.42
14LC165A-44	44	52.79	54.82
14LC165A-48	48	57.59	59.62
14LC165A-50	50	59.99	62.02
14LC165A-52	52	62.39	64.42
14LC165A-54	54	64.79	66.82
14LC165A-56	56	67.19	69.22
14LC165A-60	60	71.99	74.02
14LC165A-65	65	77.99	80.02
14LC165A-70	70	83.99	86.02
14LC165A-80	80	95.99	98.02



* For 13-15 teeth, hub diameter equals 13.3.
 * Sprockets with Ø19.0mm P.D. and smaller are recommended for idler use only.

Other numbers of teeth available on request.
 Teeth could be anodized.

CHAIN SPROCKETS

CIR. PITCH	BORE	STYLE	MATERIALS	BERG'S ® NAME	CHAIN
3.747mm	Ø6	PIN HUB	Aluminum per DIN 3.1355 Anodized	Flex-E-Pitch®	Operates with 14CCF Series

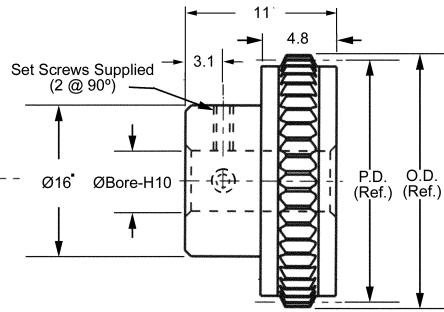
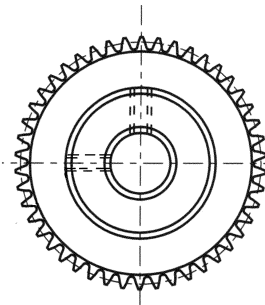
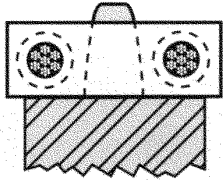

STOCK NO.	NO. OF TEETH	PITCH DIA.	OUTSIDE DIA.
14LC164A-13	13*	15.60	17.63
14LC164A-14	14*	16.80	18.82
14LC164A-15	15*	18.00	20.03
14LC164A-16	16	19.20	21.23
14LC164A-18	18	21.60	23.63
14LC164A-20	20	24.00	26.03
14LC164A-24	24	28.80	30.83
14LC164A-25	25	30.00	32.03
14LC164A-27	27	32.40	34.43
14LC164A-28	28	33.60	35.63
14LC164A-29	29	34.80	36.83
14LC164A-30	30	35.99	38.03
14LC164A-32	32	38.39	40.43
14LC164A-34	34	40.79	42.83
14LC164A-36	36	43.19	45.23
14LC164A-38	38	45.59	47.63
14LC164A-40	40	47.99	50.03
14LC164A-42	42	50.39	52.42
14LC164A-44	44	52.79	54.82
14LC164A-48	48	57.59	59.62
14LC164A-50	50	59.99	62.02
14LC164A-52	52	62.39	64.42
14LC164A-54	54	64.79	66.82
14LC164A-56	56	67.19	69.22
14LC164A-60	60	71.99	74.02
14LC164A-65	65	77.99	80.02
14LC164A-70	70	83.99	86.02
14LC164A-80	80	95.99	98.02



* For 13-15 teeth, hub diameter equals 13.3.

* Sprockets with Ø19.0mm P.D. and smaller are recommended for idler use only.

Other numbers of teeth available on request.

Teeth could be anodized.

CHAIN SPROCKETS

CIR. PITCH	BORE	STYLE	MATERIALS	BERG'S ® NAME	CHAIN
3.747mm	Ø8	PIN HUB	Aluminum per DIN 3.1355 Anodized	Flex-E-Pitch®	Operates with 14CCF Series

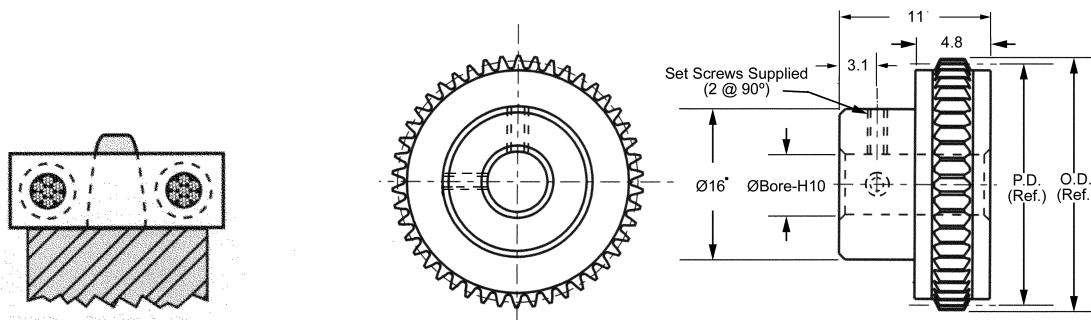

STOCK NO.	NO. OF TEETH	PITCH DIA.	OUTSIDE DIA.
14LC263A-13	13*	15.60	17.63
14LC263A-14	14*	16.80	18.82
14LC263A-15	15*	18.00	20.03
14LC263A-16	16	19.20	21.23
14LC263A-18	18	21.60	23.63
14LC263A-20	20	24.00	26.03
14LC263A-24	24	28.80	30.83
14LC263A-25	25	30.00	32.03
14LC263A-27	27	32.40	34.43
14LC263A-28	28	33.60	35.63
14LC263A-29	29	34.80	36.83
14LC263A-30	30	35.99	38.03
14LC263A-32	32	38.39	40.43
14LC263A-34	34	40.79	42.83
14LC263A-36	36	43.19	45.23
14LC263A-38	38	45.59	47.63
14LC263A-40	40	47.99	50.03
14LC263A-42	42	50.39	52.42
14LC263A-44	44	52.79	54.82
14LC263A-48	48	57.59	59.62
14LC263A-50	50	59.99	62.02
14LC263A-52	52	62.39	64.42
14LC263A-54	54	64.79	66.82
14LC263A-56	56	67.19	69.22
14LC263A-60	60	71.99	74.02
14LC263A-65	65	77.99	80.02
14LC263A-70	70	83.99	86.02
14LC263A-80	80	95.99	98.02



• For 13-15 teeth, hub diameter equals 13.3.
 * Sprockets with Ø19.0mm P.D. and smaller are recommended for idler use only.

Other numbers of teeth available on request.
 Teeth could be anodized.

CABLE CHAINS

CIRCULAR PITCH	PIN DIAMETER	MATERIALS	BERG'S ® NAME	SPROCKET
6.35mm	3.3mm	Polyurethane (Yellow) 0.8mm Dia. Stainless Steel Cable*	Flex-E-Pitch®	Operates with 25CF, 25CP, and 25LC series.

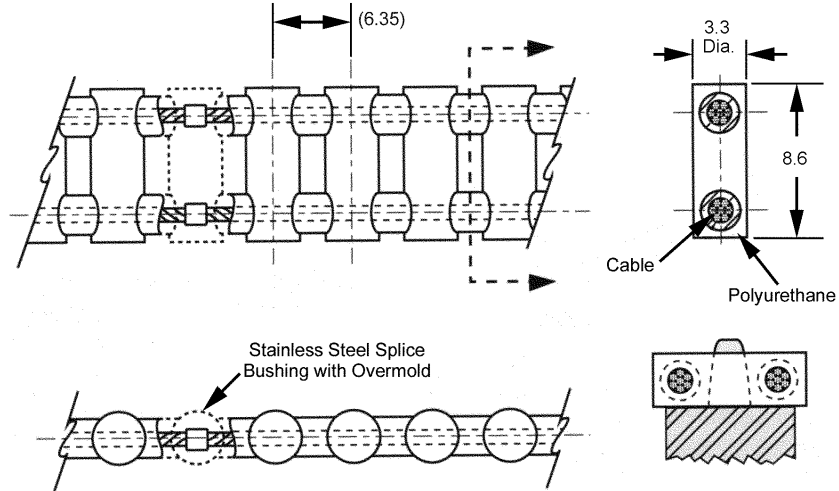

STOCK NO.	NO. OF PITCHES	LENGTH (Ref.)
25CCF-40-E	40	254.0
25CCF-50-E	50	317.5
25CCF-60-E	60	381.0
25CCF-70-E	70	444.5
25CCF-80-E	80	508.0
25CCF-90-E	90	571.5
25CCF-100-E	100	635.0
25CCF-110-E	110	698.5
25CCF-120-E	120	762.0
25CCF-130-E	130	825.5
25CCF-140-E	140	889.0
25CCF-150-E	150	952.5
25CCF-160-E	160	1016.0
25CCF-170-E	170	1079.5
25CCF-180-E	180	1143.0
25CCF-190-E	190	1206.5
25CCF-200-E	200	1270.0
25CCF-210-E	210	1333.5
25CCF-220-E	220	1397.0
25CCF-230-E	230	1460.5
25CCF-240-E	240	1524.0
25CCF-250-E	250	1587.5
25CCF-260-E	260	1651.0
25CCF-270-E	270	1714.5
25CCF-280-E	280	1778.0
25CCF-290-E	290	1841.5
25CCF-300-E	300	1905.0
25CCF-310-E	310	1968.5
25CCF-320-E	320	2032.0
25CCF-330-E	330	2095.5
25CCF-370-E	370	2349.5
25CCF-380-E	380	2413.0
25CCF-390-E	390	2476.5

- For Field Splice Kit order 25CCF-7.
- *Available with Aramid Core construction.
- ** Reduce Operating Load Rating by 50% for Field Splices.
- Alternate belt construction and reverse belt bending applications available.

Designed to replace standard metal roller chain systems:

- No multiple link joints to bind.
- Lubrication is never required.
- Easily modified to any length.
- Large selection of mating sprockets.
- Infinite Lengths
 - Silent Drive
 - Rust Proof
 - 90A Durometer
 - Non-Magnetic
 - Positive Drive
 - Zero Backlash
 - Mass 28 Grams/Meter
 - Ultimate Tensile Strength 445N - (22 lbs./Pin)
- When belt is used in open loop configuration (without splice, no crimp bushing)
 - Temperature Range + 82°C to -26°C
- Recommended Operating Load 111N
- Recommended Max. Operating Speed 1.91 m/s

BULK FOOTAGE-NOT SPLICED	
STOCK NO.	LENGTH
25CCF-1.5M	1.5 M
25CCF-3.0M	3.0 M
25CCF-7.5M	7.5 M
25CCF-15.0M	15.0 M
25CCF-30.0M	30.0 M



CHAIN SPROCKETS

CIR. PITCH	BORE	STYLE	MATERIALS	BERG'S ® NAME	CHAIN
6.35mm	Ø7	PIN HUB	ACETAL	Flex-E-Pitch®	Operates with 25CCF Series

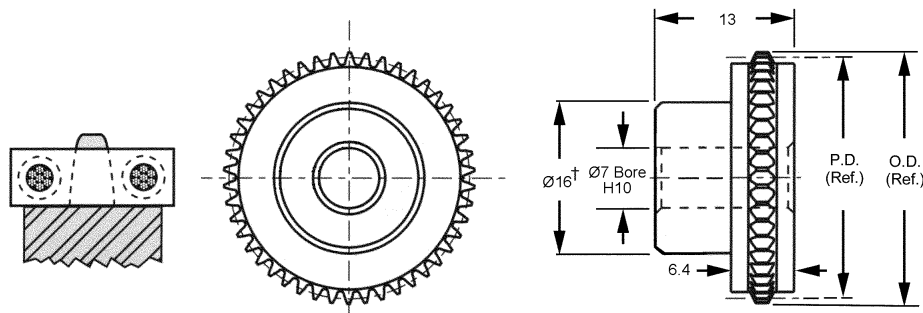

STOCK NO.	NO. OF TEETH	PITCH DIA.	OUTSIDE DIA.
25LC107M-9	9*	18.19	21.24
25LC107M-10	10	20.21	23.26
25LC107M-12	12	24.26	27.30
25LC107M-13	13	26.28	29.32
25LC107M-14	14	28.30	31.35
25LC107M-15	15	30.32	33.37
25LC107M-16	16	32.34	35.39
25LC107M-18	18	36.38	39.43
25LC107M-20	20	40.43	43.47
25LC107M-24	24	48.51	51.56
25LC107M-25	25	50.53	53.58
25LC107M-28	28	56.60	59.64
25LC107M-30	30	60.64	63.69
25LC107M-36	36	72.77	75.81



† Teeth runout on hub.
 * Sprockets with Ø19.0mm P.D. and smaller are recommended for idler use only. Other numbers of teeth available on request.

CIR. PITCH	BORE	STYLE	MATERIALS	BERG'S ® NAME	CHAIN
6.35mm	Ø8	PIN HUB	ACETAL	Flex-E-Pitch®	Operates with 25CCF Series

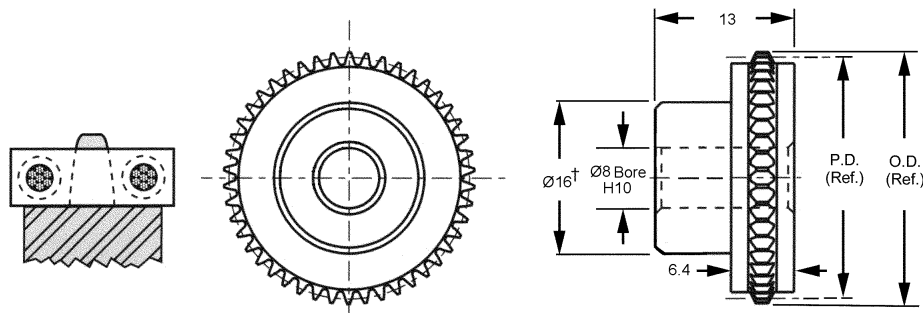

STOCK NO.	NO. OF TEETH	PITCH DIA.	OUTSIDE DIA.
25LC108M-9	9*	18.19	21.24
25LC108M-10	10	20.21	23.26
25LC108M-12	12	24.26	27.30
25LC108M-13	13	26.28	29.32
25LC108M-14	14	28.30	31.35
25LC108M-15	15	30.32	33.37
25LC108M-16	16	32.34	35.39
25LC108M-18	18	36.38	39.43
25LC108M-20	20	40.43	43.47
25LC108M-24	24	48.51	51.56
25LC108M-25	25	50.53	53.58
25LC108M-28	28	56.60	59.64
25LC108M-30	30	60.64	63.69
25LC108M-36	36	72.77	75.81



† Teeth runout on hub.
 * Sprockets with Ø19.0mm P.D. and smaller are recommended for idler use only. Other numbers of teeth available on request.

CHAIN SPROCKETS

CIR. PITCH	BORE	STYLE	MATERIALS	BERG'S ® NAME	CHAIN
6.35mm	Ø10	HUBLESS	Aluminum per DIN 3.1355 Anodized	Flex-E-Pitch®	Operates with 25CCF Series

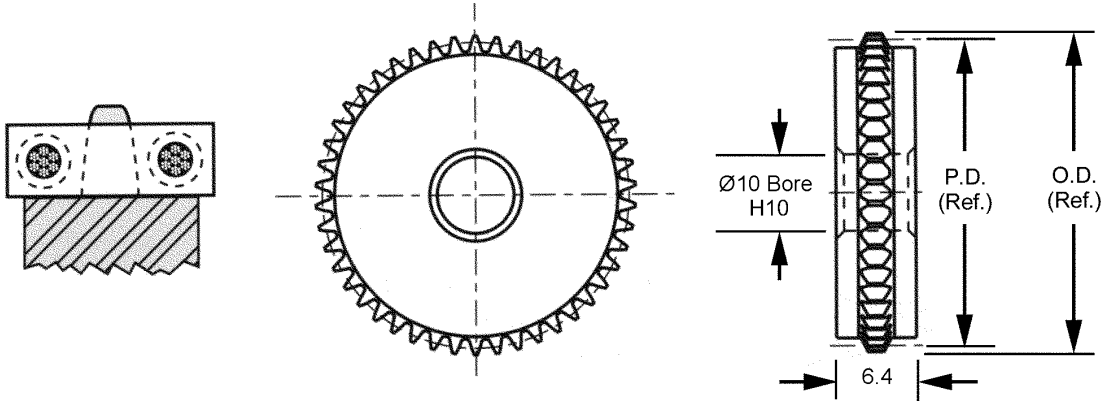

STOCK NO.	NO. OF TEETH	PITCH DIA.	OUTSIDE DIA.
25CF177A-9	9*	18.19	21.24
25CF177A-10	10	20.21	23.26
25CF177A-12	12	24.26	27.30
25CF177A-13	13	28.28	29.32
25CF177A-14	14	28.30	31.35
25CF177A-15	15	30.32	33.37
25CF177A-16	16	32.34	35.39
25CF177A-18	18	36.38	39.43
25CF177A-20	20	40.43	43.47
25CF177A-24	24	48.51	51.56
25CF177A-25	25	50.53	53.58
25CF177A-28	28	56.60	59.64
25CF177A-30	30	60.64	63.69
25CF177A-36	36	72.77	75.81
25CF177A-40	40	80.85	83.90
25CF177A-48	48	97.02	100.07
25CF177A-60	60	121.28	124.32
25CF177A-72	72	145.53	148.58



* Sprockets with Ø19.0mm P.D. and smaller are recommended for idler use only.

Other numbers of teeth available on request.

Teeth could be anodized.

CHAIN SPROCKETS

CIR. PITCH	BORE	STYLE	MATERIALS	BERG'S ® NAME	CHAIN
6.35mm	Ø8	PIN HUB	Aluminum per DIN 3.1355 Anodized	Flex-E-Pitch®	Operates with 25CCF Series

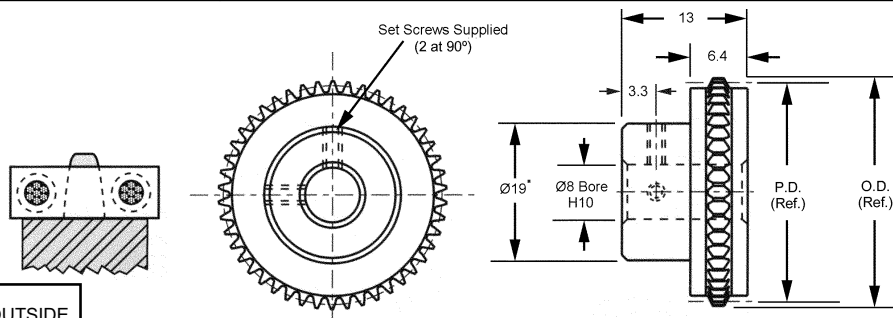

STOCK NO.	NO. OF TEETH	PITCH DIA.	OUTSIDE DIA.
25CP266A-9	9*	18.19	21.24
25CP266A-10	10*	20.21	23.26
25CP266A-12	12	24.26	27.30
25CP266A-13	13	28.28	29.32
25CP266A-14	14	28.30	31.35
25CP266A-15	15	30.32	33.37
25CP266A-16	16	32.34	35.39
25CP266A-18	18	36.38	39.43
25CP266A-20	20	40.43	43.47
25CP266A-24	24	48.51	51.56
25CP266A-25	25	50.53	53.58
25CP266A-28	28	56.60	59.64
25CP266A-30	30	60.64	63.69
25CP266A-36	36	72.77	75.81
25CP266A-40	40	80.85	83.90
25CP266A-48	48	97.02	100.07
25CP266A-60	60	121.28	124.32
25CP266A-72	72	145.53	148.58



• For 9-10 teeth, hub diameter equals 14.5.
 * Sprockets with Ø19.0mm P.D. and smaller are recommended for idler use only.
 Other numbers of teeth available on request.
 Teeth could be anodized.

CIR. PITCH	BORE	STYLE	MATERIALS	BERG'S ® NAME	NOTE
6.35mm	Ø10	PIN HUB	Aluminum per DIN 3.1355 Anodized	Flex-E-Pitch®	Operates with 25CCF Series

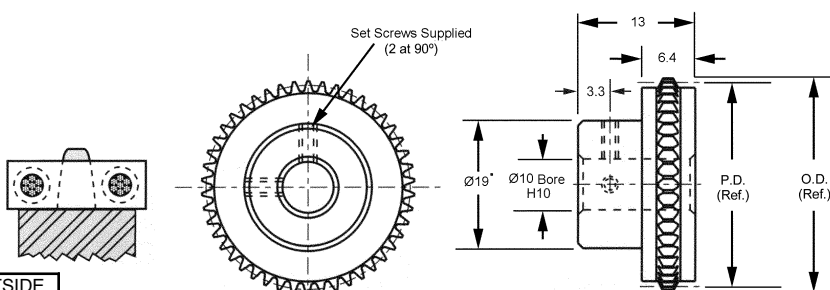

STOCK NO.	NO. OF TEETH	PITCH DIA.	OUTSIDE DIA.
25CP167A-10	10*	20.21	23.26
25CP167A-12	12	24.26	27.30
25CP167A-13	13	28.28	29.32
25CP167A-14	14	28.30	31.35
25CP167A-15	15	30.32	33.37
25CP167A-16	16	32.34	35.39
25CP167A-18	18	36.38	39.43
25CP167A-20	20	40.43	43.47
25CP167A-24	24	48.51	51.56
25CP167A-25	25	50.53	53.58
25CP167A-28	28	56.60	59.64
25CP167A-30	30	60.64	63.69
25CP167A-36	36	72.77	75.81
25CP167A-40	40	80.85	83.90
25CP167A-48	48	97.02	100.07
25CP167A-60	60	121.28	124.32
25CP167A-72	72	145.53	148.58



• For 10 teeth, hub diameter equals 16.9.
 Other numbers of teeth available on request.
 Teeth could be anodized.

CHAIN SPROCKETS

CIR. PITCH	BORE	STYLE	MATERIALS	BERG'S ® NAME	CHAIN
6.35mm	Ø12	PIN HUB	Aluminum per DIN 3.1355 Anodized	Flex-E-Pitch®	Operates with 25CCF Chain

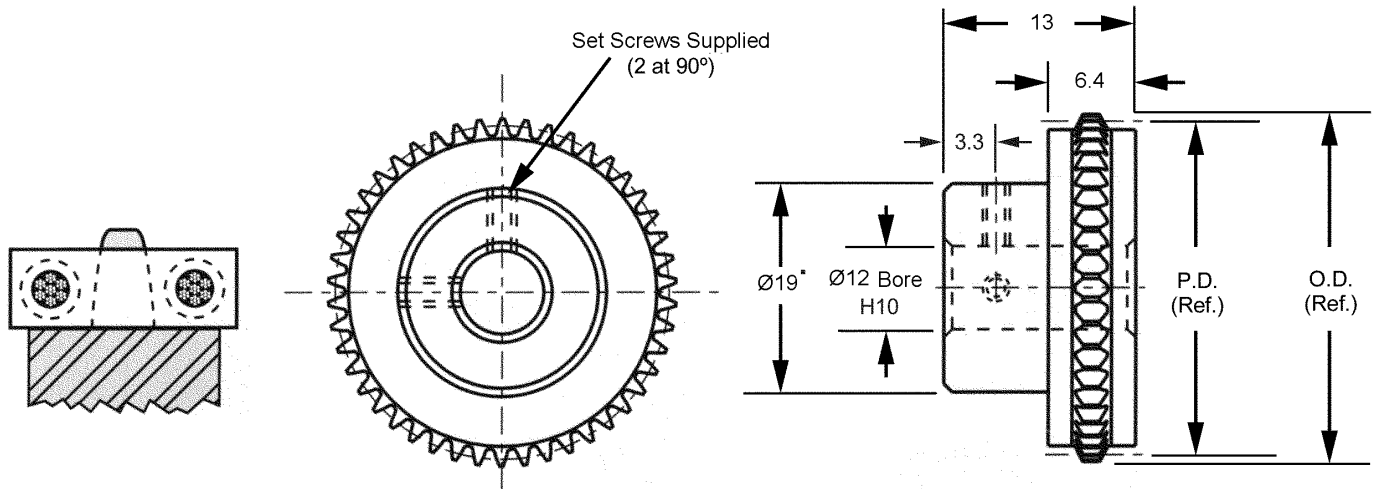

STOCK NO.	NO. OF TEETH	PITCH DIA.	OUTSIDE DIA.
25CP168A-10	10*	20.21	23.26
25CP168A-12	12	24.26	27.30
25CP168A-13	13	28.28	29.32
25CP168A-14	14	28.30	31.35
25CP168A-15	15	30.32	33.37
25CP168A-16	16	32.34	35.39
25CP168A-18	18	36.38	39.43
25CP168A-20	20	40.43	43.47
25CP168A-24	24	48.51	51.56
25CP168A-25	25	50.53	53.58
25CP168A-28	28	56.60	59.64
25CP168A-30	30	60.64	63.69
25CP168A-36	36	72.77	75.81
25CP168A-40	40	80.85	83.90
25CP168A-48	48	97.02	100.07
25CP168A-60	60	121.28	124.32
25CP168A-72	72	145.53	148.58



* For 10 teeth, hub diameter equals 16.9.
Other numbers of teeth available on request.

Teeth could be anodized.

CABLE CHAINS

CIRCULAR PITCH	ROLL DIAMETER	MATERIALS	BERG'S ® NAME	SPROCKET
9.525mm	5.1mm	Polyurethane (Brown) 1.2mm Dia. Stainless Steel Cable*	Flex-E-Pitch®	Operates with 25LC, 25CF, and 25CP series.

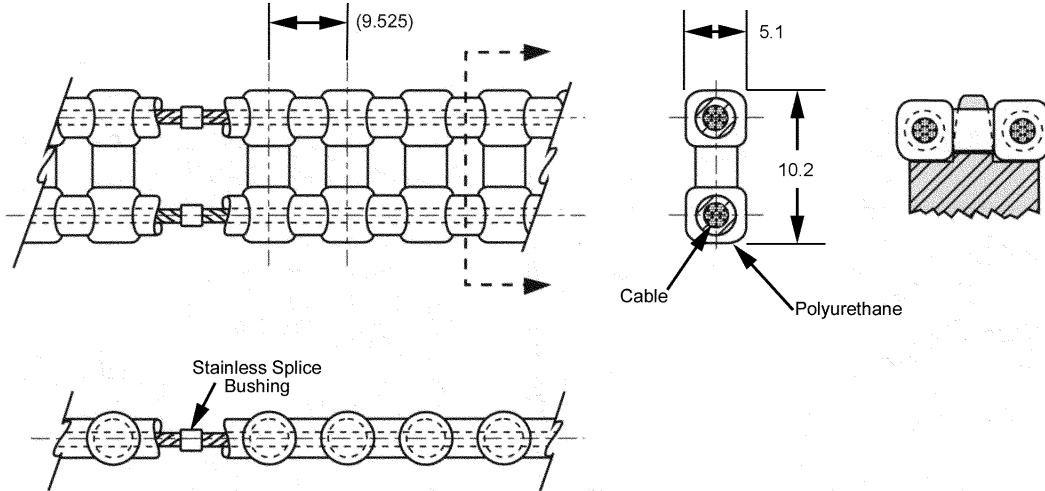

STOCK NO.	NO. OF PITCHES	LENGTH (Ref.)
35CCF-40-E	40	381.0
35CCF-50-E	50	476.2
35CCF-60-E	60	571.5
35CCF-70-E	70	666.7
35CCF-80-E	80	762.0
35CCF-90-E	90	857.2
35CCF-100-E	100	952.5
35CCF-110-E	110	1047.7
35CCF-120-E	120	1143.0
35CCF-130-E	130	1238.2
35CCF-140-E	140	1333.5
35CCF-150-E	150	1428.7
35CCF-160-E	160	1524.0
35CCF-170-E	170	1617.2
35CCF-180-E	180	1714.5
35CCF-190-E	190	1809.7
35CCF-200-E	200	1905.0
35CCF-210-E	210	2000.2
35CCF-220-E	220	2095.5
35CCF-230-E	230	2190.7
35CCF-240-E	240	2286.0
35CCF-250-E	250	2381.2
35CCF-260-E	260	2476.5
35CCF-270-E	270	2571.7
35CCF-280-E	280	2667.0
35CCF-290-E	290	2762.2
35CCF-300-E	300	2857.5
35CCF-310-E	310	2952.7
35CCF-320-E	320	3048.0
35CCF-330-E	330	3143.2
35CCF-370-E	370	3429.0
35CCF-380-E	380	3524.2
35CCF-390-E	390	3714.7

• For Field Splice Kit order 7CCF-7.
 *Available with Aramid Core construction.
 ** Reduce Operating Load Rating by 50% for Field Splices.
 Alternate belt construction and reverse belt bending applications available.

Designed to replace standard metal roller chain systems:

- No multiple link joints to bind.
 - Lubrication is never required.
 - Easily modified to any length.
 - Large selection of mating sprockets.
 - Infinite Lengths
 - Silent Drive
 - Rust Proof
 - 90A Durometer
 - Non-Magnetic
 - Positive Drive
 - Zero Backlash
 - Mass 46.5 Grams/Meter
 - Ultimate Tensile Strength 890N (222N/PIN)
- When belt is used in open loop configuration (without splice, no crimp bushing)
- Temperature Range +82°C to -26°C
 - Recommended Operating Load 245N
- Recommended Max. Operating Speed 1.91 M/S

BULK FOOTAGE-NOT SPLICED	
STOCK NO.	LENGTH
35CCF-1.5M	1.5 M
35CCF-3.0M	3.0 M
35CCF-7.5M	7.5 M
35CCF-15.0M	15.0 M
35CCF-30.0M	30.0 M



CHAIN SPROCKETS

CIR. PITCH	BORE	STYLE	MATERIALS	BERG'S ® NAME	CHAIN
9.525mm	Ø10	HUBLESS	Aluminum per DIN 3.1355 Anodized	Flex-E-Pitch®	Operates with 35CCF Series

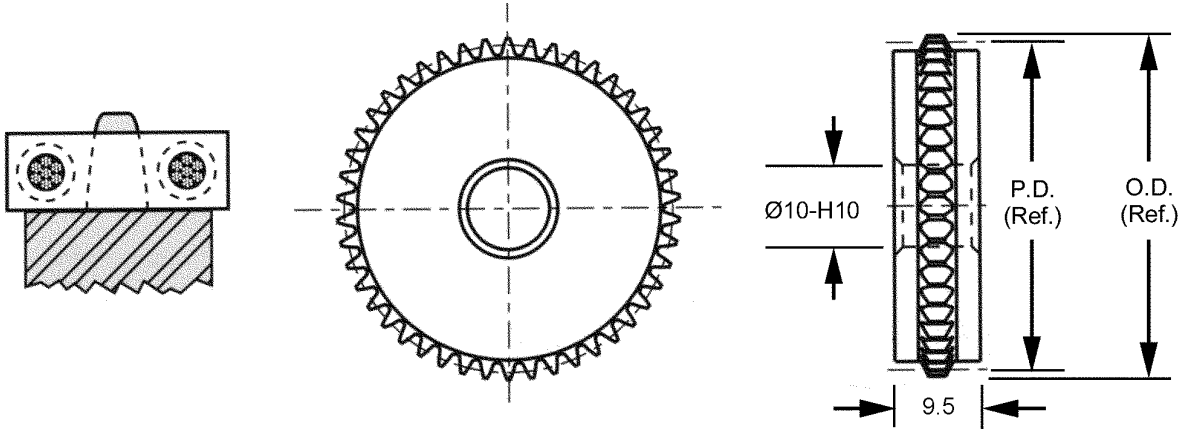

STOCK NO.	NO. OF TEETH	PITCH DIA.	OUTSIDE DIA.
35CF174A-8	8*	24.19	29.27
35CF174A-9	9*	27.22	32.30
35CF174A-10	10*	30.24	35.32
35CF174A-11	11*	33.27	38.35
35CF174A-12	12	36.29	41.37
35CF174A-14	14	42.34	47.42
35CF174A-15	15	45.36	50.44
35CF174A-16	16	48.39	53.47
35CF174A-18	18	54.43	59.51
35CF174A-20	20	60.48	65.56
35CF174A-24	24	72.58	77.66
35CF174A-25	25	75.60	80.68
35CF174A-30	30	90.72	95.80
35CF174A-32	32	96.77	101.85
35CF174A-36	36	108.87	113.95
35CF174A-40	40	120.96	126.04
35CF174A-48	48	145.16	150.24

* Sprockets with Ø35.0mm P.D. and smaller are recommended for idler use only.
Other numbers of teeth available on request.
Teeth could be anodized.

CHAIN SPROCKETS

CIR. PITCH	BORE	STYLE	MATERIALS	BERG'S ® NAME	CHAIN
9.525mm	Ø8	PIN HUB	Aluminum per DIN 3.1355 Anodized	Flex-E-Pitch®	Operates with 35CCF Series

STOCK NO.	NO. OF TEETH	PITCH DIA.	OUTSIDE DIA.
35CP257A-8	8*	24.19	29.27
35CP257A-9	9*	27.22	32.30
35CP257A-10	10*	30.24	35.32
35CP257A-11	11*	33.27	38.35
35CP257A-12	12	36.29	41.37
35CP257A-14	14	42.34	47.42
35CP257A-15	15	45.36	50.44
35CP257A-16	16	48.39	53.47
35CP257A-18	18	54.43	59.51
35CP257A-20	20	60.48	65.56
35CP257A-24	24	72.58	77.66
35CP257A-25	25	75.60	80.68
35CP257A-30	30	90.72	95.80
35CP257A-32	32	96.77	101.85
35CP257A-36	36	108.87	113.95
35CP257A-40	40	120.96	126.04
35CP257A-48	48	145.16	150.24

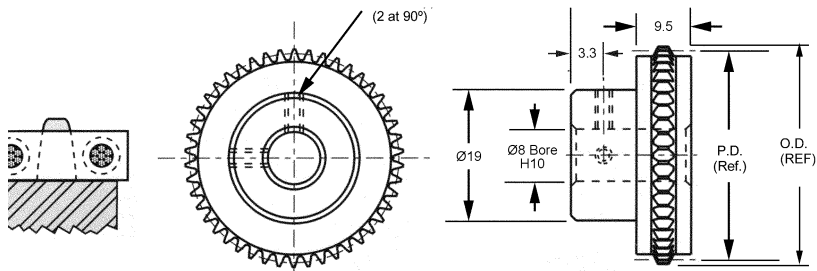

* Sprockets with Ø35.0mm P.D. and smaller are recommended for idler use only. Other numbers of teeth available on request. Teeth could be anodized.

CIR. PITCH	BORE	STYLE	MATERIALS	BERG'S ® NAME	CHAIN
9.525mm	Ø10	PIN HUB	Aluminum per DIN 3.1355 Anodized	Flex-E-Pitch®	Operates with 35CCF Series

STOCK NO.	NO. OF TEETH	PITCH DIA.	OUTSIDE DIA.
35CP158A-8	8*	24.19	29.27
35CP158A-9	9*	27.22	32.30
35CP158A-10	10*	30.24	35.32
35CP158A-11	11*	33.27	38.35
35CP158A-12	12	36.29	41.37
35CP158A-14	14	42.34	47.42
35CP158A-15	15	45.36	50.44
35CP158A-16	16	48.39	53.47
35CP158A-18	18	54.43	59.51
35CP158A-20	20	60.48	65.56
35CP158A-24	24	72.58	77.66
35CP158A-25	25	75.60	80.68
35CP158A-30	30	90.72	95.80
35CP158A-32	32	96.77	101.85
35CP158A-36	36	108.87	113.95
35CP158A-40	40	120.96	126.04
35CP158A-48	48	145.16	150.24

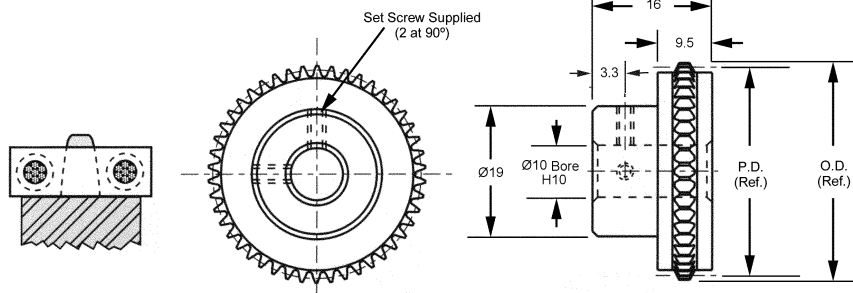

* Sprockets with Ø35.0mm P.D. and smaller are recommended for idler use only. Other numbers of teeth available on request. Teeth could be anodized.

CIR. PITCH	BORE	STYLE	MATERIALS	BERG'S ® NAME	CHAIN
9.525mm	Ø12	PIN HUB	Aluminum per DIN 3.1355 Anodized	Flex-E-Pitch®	Operates with 35CCF Series

STOCK NO.	NO. OF TEETH	PITCH DIA.	OUTSIDE DIA.
35CP159A-8	8*	24.19	29.27
35CP159A-9	9*	27.22	32.30
35CP159A-10	10*	30.24	35.32
35CP159A-11	11*	33.27	38.35
35CP159A-12	12	36.29	41.37
35CP159A-14	14	42.34	47.42
35CP159A-15	15	45.36	50.44
35CP159A-16	16	48.39	53.47
35CP159A-18	18	54.43	59.51
35CP159A-20	20	60.48	65.56
35CP159A-24	24	72.58	77.66
35CP159A-25	25	75.60	80.68
35CP159A-30	30	90.72	95.80
35CP159A-32	32	96.77	101.85
35CP159A-36	36	108.87	113.95
35CP159A-40	40	120.96	126.04
35CP159A-48	48	145.16	150.24

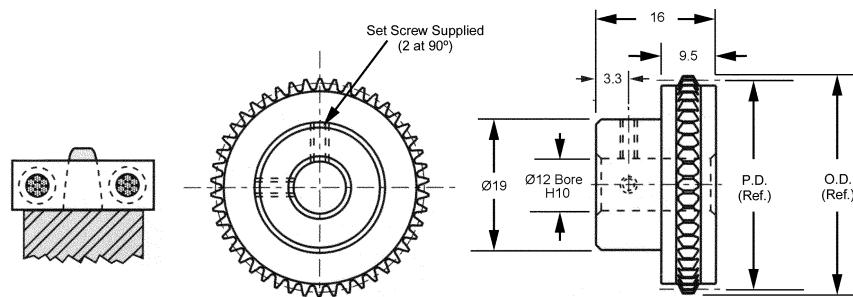

* Sprockets with Ø35.0mm P.D. and smaller are recommended for idler use only. Other numbers of teeth available on request. Teeth could be anodized.

CHAIN CABLE

CIRCULAR PITCH	PIN DIAMETER	MATERIALS	BERG'S ® NAME	SPROCKET
12.7mm	7.8mm	Polyurethane (Red) 1.6mm Dia. Stainless Steel Cable*	Flex-E-Pitch®	Operates with 7CF, and 7CP series.

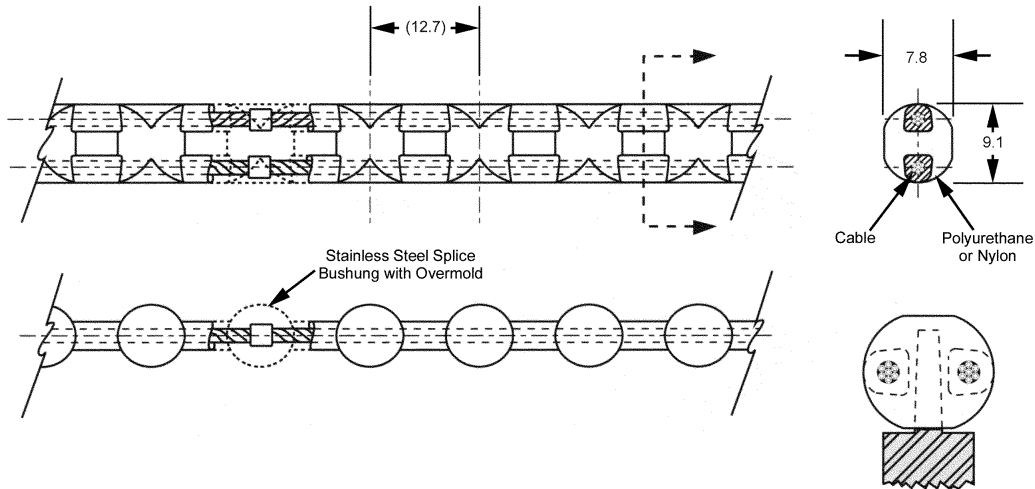

STOCK NO.	NO. OF PITCHES	LENGTH (Ref.)
7CCF-20-U	20	254.0
7CCF-22-U	22	279.4
7CCF-24-U	24	304.8
7CCF-26-U	26	330.2
7CCF-28-U	28	355.6
7CCF-30-U	30	381.0
7CCF-32-U	32	406.4
7CCF-34-U	34	431.8
7CCF-36-U	36	457.2
7CCF-38-U	38	482.6
7CCF-40-U	40	508.0
7CCF-42-U	42	533.4
7CCF-44-U	44	558.8
7CCF-46-U	46	584.2
7CCF-48-U	48	609.6
7CCF-50-U	50	635.0
7CCF-52-U	52	660.4
7CCF-54-U	54	685.8
7CCF-56-U	56	711.2
7CCF-60-U	60	762.0
7CCF-64-U	64	685.8
7CCF-68-U	68	863.6
7CCF-72-U	72	914.4
7CCF-76-U	76	965.2
7CCF-80-U	80	1016.0
7CCF-84-U	84	1066.8
7CCF-88-U	88	1117.6
7CCF-92-U	92	1168.4
7CCF-96-U	96	1219.2
7CCF-100-U	100	1270.0
7CCF-104-U	104	1320.8
7CCF-108-U	108	1371.6
7CCF-112-U	112	1422.4
7CCF-116-U	116	1473.2
7CCF-130-U	130	1651.0
7CCF-140-U	140	1778.0
7CCF-200-U	200	2540.0

• Aramid & Anti-Static alternate construction available.
Aramid Core and/or Anti-Static Materials, and reverse belt bending applications available.

- For Field Splice Kit order 7CCF-7.
- Infinite Lengths
- Rust Proof
- Non Magnetic
- Zero Backlash
- No Lubrication Required
- Positive Drive
- Mass 111 Grams/Meter
- 90A Durometer
- Ultimate Tensile Strength 1335N (311N/Pin)
When belt is used in an open loop configuration (without splice, no crimp bushing)
- Temperature Range +82°C to -26°C
- Recommended Operating Load 334N
- Recommended Operating Speed 1.91m/s

Other lengths available on request.

BULK FOOTAGE-NOT SPLICED	
STOCK NO.	LENGTH
7CCF-U-1.5M	1.5 M
7CCF-U-3.0M	3.0 M
7CCF-U-7.5M	7.5 M
7CCF-U-15.0M	15.0 M
7CCF-U-30.0M	30.0 M



CHAIN CABLE

CIRCULAR PITCH	ROLL DIAMETER	MATERIALS	BERG'S ® NAME	SPROCKET
12.7mm	7.8mm	Nylon (Green) 1.6mm Dia. Stainless Steel Cable*	Flex-E-Pitch®	Operates with 7CP, and 7CF series.

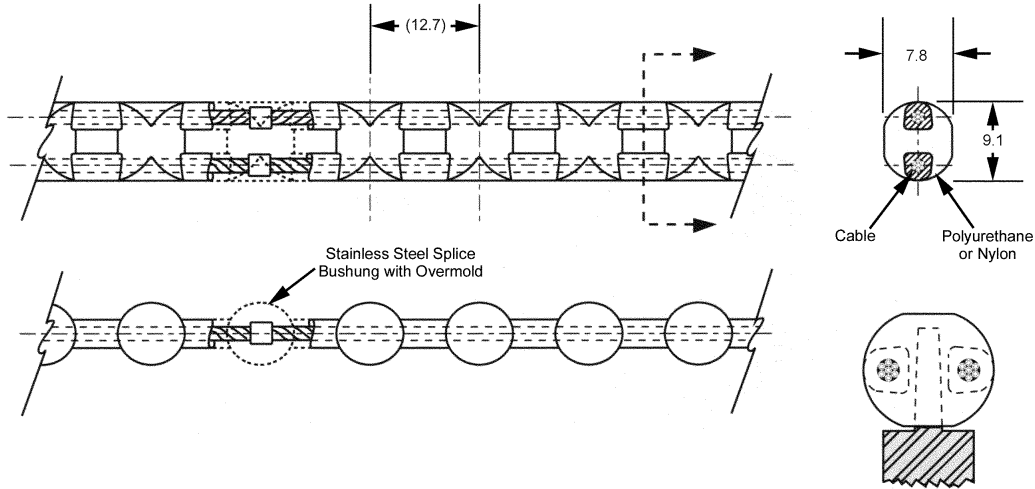

STOCK NO.	NO. OF PITCHES	LENGTH (Ref.)
7CCF-20-N	20	254.0
7CCF-22-N	22	279.4
7CCF-24-N	24	304.8
7CCF-26-N	26	330.2
7CCF-28-N	28	355.6
7CCF-30-N	30	381.0
7CCF-32-N	32	406.4
7CCF-34-N	34	431.8
7CCF-36-N	36	457.2
7CCF-38-N	38	482.6
7CCF-40-N	40	508.0
7CCF-42-N	42	533.4
7CCF-44-N	44	558.8
7CCF-46-N	46	584.2
7CCF-48-N	48	609.6
7CCF-50-N	50	635.0
7CCF-52-N	52	660.4
7CCF-54-N	54	685.8
7CCF-56-N	56	711.2
7CCF-60-N	60	762.0
7CCF-64-N	64	685.8
7CCF-68-N	68	863.6
7CCF-72-N	72	914.4
7CCF-76-N	76	965.2
7CCF-80-N	80	1016.0
7CCF-84-N	84	1066.8
7CCF-88-N	88	1117.6
7CCF-92-N	92	1168.4
7CCF-96-N	96	1219.2
7CCF-100-N	100	1270.0
7CCF-104-N	104	1320.8
7CCF-108-N	108	1371.6
7CCF-112-N	112	1422.4
7CCF-116-N	116	1473.2
7CCF-130-N	130	1651.0
7CCF-140-N	140	1778.0
7CCF-200-N	200	2540.0

• Aramid & Anti-Static alternate construction available.
Aramid Core and/or Anti-Static Materials, and reverse belt bending applications available.

- For Field Splice Kit order 7CCF-7.
- Infinite Lengths
- Rust Proof
- Non Magnetic
- Zero Backlash
- No Lubrication Required
- Positive Drive
- Mass 111 Grams/Meter
- 90A Durometer
- Ultimate Tensile Strength 1335N (311N/Pin)
When belt is used in an open loop configuration (without splice, no crimp bushing)
- Temperature Range +121°C to -40°C
- Recommended Operating Load 334N
- Recommended Operating Speed 1.91m/s

Other lengths available on request.

BULK FOOTAGE-NOT SPLICED	
STOCK NO.	LENGTH
7CCF-N-1.5M	1.5 M
7CCF-N-3.0M	3.0 M
7CCF-N-7.5M	7.5 M
7CCF-N-15.0M	15.0 M
7CCF-N-30.0M	30.0 M



CHAIN SPROCKETS

CIR. PITCH	BORE	STYLE	MATERIALS	BERG'S ® NAME	CHAIN
12.7mm	Ø10	HUBLESS	Aluminum per DIN 3.1355 Anodized	Flex-E-Pitch®	Operates with 7CCF Series

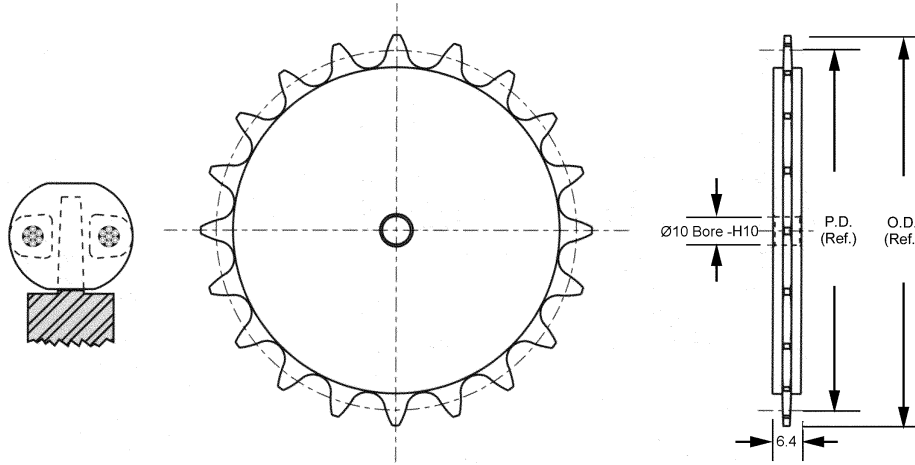

STOCK NO.	NO. OF TEETH	PITCH DIA.	OUTSIDE DIA.
7CF177A-8	8*	32.51	38.86
7CF177A-9	9*	36.58	42.93
7CF177A-10	10*	40.64	46.99
7CF177A-11	11*	44.70	51.05
7CF177A-12	12	48.77	55.12
7CF177A-13	13	52.83	59.18
7CF177A-14	14	56.90	63.25
7CF177A-15	15	60.96	67.31
7CF177A-16	16	65.02	71.37
7CF177A-18	18	73.15	79.50
7CF177A-20	20	81.28	87.63
7CF177A-22	22	89.41	95.76
7CF177A-24	24	97.54	103.89
7CF177A-25	25	101.60	107.95
7CF177A-28	28	113.79	120.14
7CF177A-30	30	121.92	128.27
7CF177A-32	32	130.05	136.40
7CF177A-34	34	138.18	144.53
7CF177A-36	36	146.30	152.65
7CF177A-38	38	154.43	160.78

* Sprockets with Ø45.0mm P.D. and smaller are recommended for idler use only. Other numbers of teeth available on request.

Teeth could be anodized.

CHAIN SPROCKETS

CIR. PITCH	BORE	STYLE	MATERIALS	BERG'S ® NAME	CHAIN
12.7mm	Ø8	PIN HUB	Aluminum per DIN 3.1355 Anodized	Flex-E-Pitch®	Operates with 7CCF Series

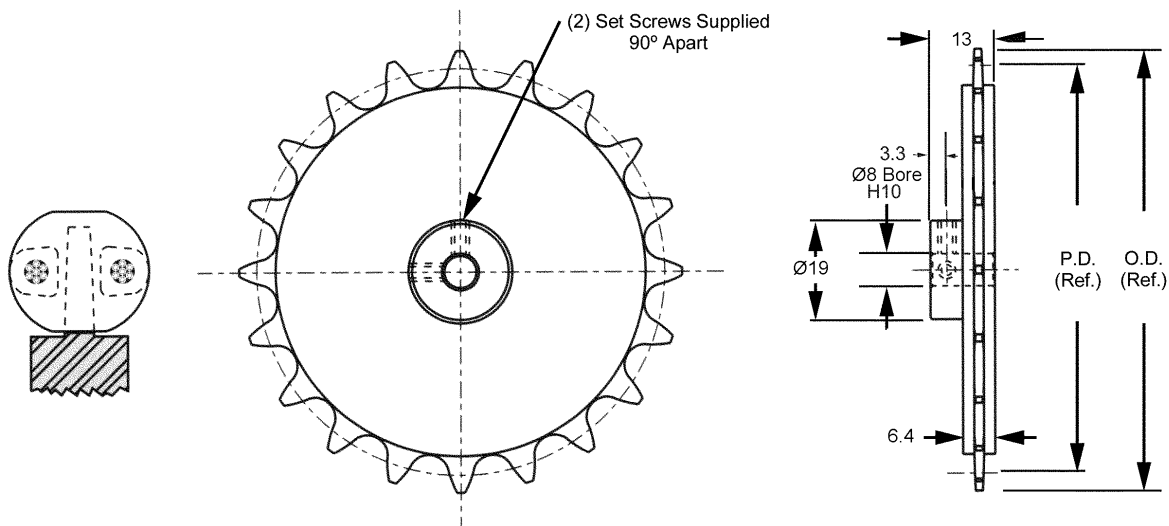

STOCK NO.	NO. OF TEETH	PITCH DIA.	OUTSIDE DIA.
7CP266A-8	8*	32.51	38.86
7CP266A-9	9*	36.58	42.93
7CP266A-10	10*	40.64	46.99
7CP266A-11	11*	44.70	51.05
7CP266A-12	12	48.77	55.12
7CP266A-13	13	52.83	59.18
7CP266A-14	14	56.90	63.25
7CP266A-15	15	60.96	67.31
7CP266A-16	16	65.02	71.37
7CP266A-18	18	73.15	79.50
7CP266A-20	20	81.28	87.63
7CP266A-22	22	89.41	95.76
7CP266A-24	24	97.54	103.89
7CP266A-25	25	101.60	107.95
7CP266A-28	28	113.79	120.14
7CP266A-30	30	121.92	128.27
7CP266A-32	32	130.05	136.40
7CP266A-34	34	138.18	144.53
7CP266A-36	36	146.30	152.65
7CP266A-38	38	154.43	160.78

* Sprockets with Ø45.0mm P.D. and smaller are recommended for idler use only. Other numbers of teeth available on request.

Teeth could be anodized.

CHAIN SPROCKETS

CIR. PITCH	BORE	STYLE	MATERIALS	BERG'S ® NAME	CHAIN
12.7mm	Ø10	PIN HUB	Aluminum per DIN 3.1355 Anodized	Flex-E-Pitch®	Operates with 7CCF Series

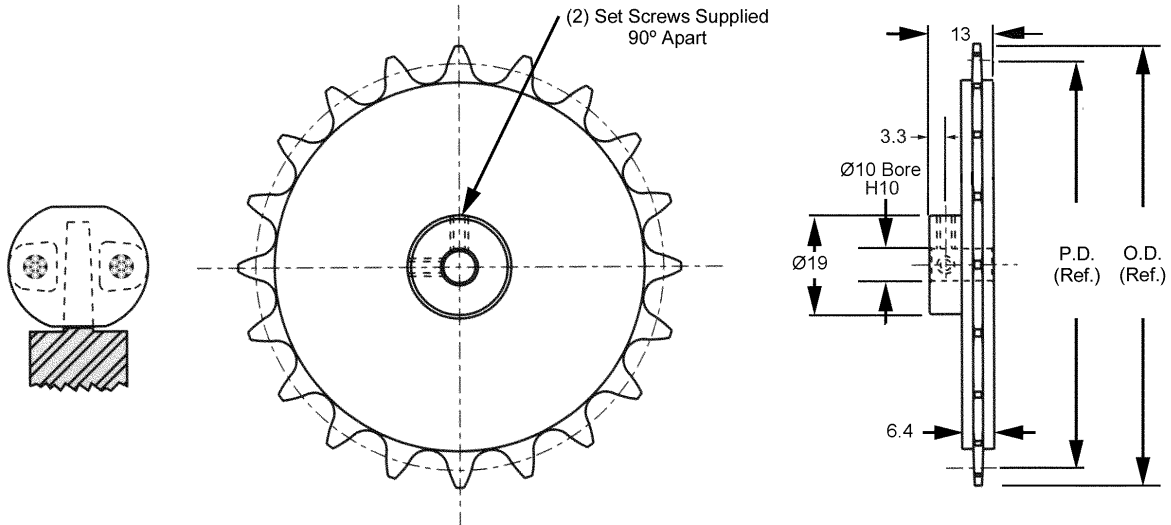

STOCK NO.	NO. OF TEETH	PITCH DIA.	OUTSIDE DIA.
7CP167A-8	8*	32.51	38.86
7CP167A-9	9*	36.58	42.93
7CP167A-10	10*	40.64	46.99
7CP167A-11	11*	44.70	51.05
7CP167A-12	12	48.77	55.12
7CP167A-13	13	52.83	59.18
7CP167A-14	14	56.90	63.25
7CP167A-15	15	60.96	67.31
7CP167A-16	16	65.02	71.37
7CP167A-18	18	73.15	79.50
7CP167A-20	20	81.28	87.63
7CP167A-22	22	89.41	95.76
7CP167A-24	24	97.54	103.89
7CP167A-25	25	101.60	107.95
7CP167A-28	28	113.79	120.14
7CP167A-30	30	121.92	128.27
7CP167A-32	32	130.05	136.40
7CP167A-34	34	138.18	144.53
7CP167A-36	36	146.30	152.65
7CP167A-38	38	154.43	160.78

* Sprockets with Ø45.0mm P.D. and smaller are recommended for idler use only.
Other numbers of teeth available on request.

Teeth could be anodized.

CHAIN SPROCKETS

CIR. PITCH	BORE	STYLE	MATERIALS	BERG'S ® NAME	CHAIN
12.7mm	Ø12	PIN HUB	Aluminum per DIN 3.1355 Anodized	Flex-E-Pitch®	Operates with 7CCF Series

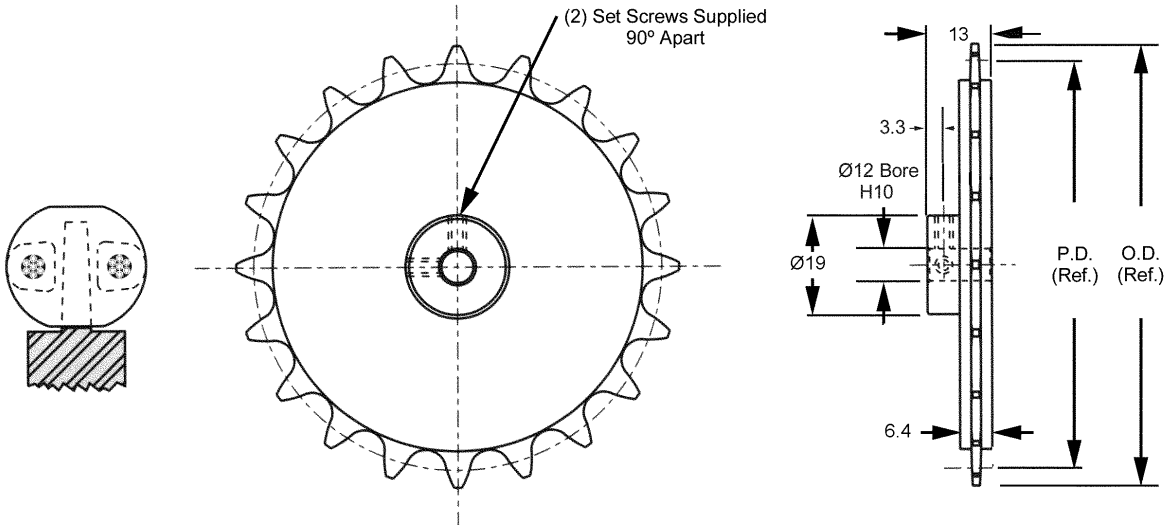

STOCK NO.	NO. OF TEETH	PITCH DIA.	OUTSIDE DIA.
7CP168A-8	8*	32.51	38.86
7CP168A-9	9*	36.58	42.93
7CP168A-10	10*	40.64	46.99
7CP168A-11	11*	44.70	51.05
7CP168A-12	12	48.77	55.12
7CP168A-13	13	52.83	59.18
7CP168A-14	14	56.90	63.25
7CP168A-15	15	60.96	67.31
7CP168A-16	16	65.02	71.37
7CP168A-18	18	73.15	79.50
7CP168A-20	20	81.28	87.63
7CP168A-22	22	89.41	95.76
7CP168A-24	24	97.54	103.89
7CP168A-25	25	101.60	107.95
7CP168A-28	28	113.79	120.14
7CP168A-30	30	121.92	128.27
7CP168A-32	32	130.05	136.40
7CP168A-34	34	138.18	144.53
7CP168A-36	36	146.30	152.65
7CP168A-38	38	154.43	160.78

* Sprockets with Ø45.0mm P.D. and smaller are recommended for idler use only.
Other numbers of teeth available on request.

Teeth could be anodized.

FIELD SPLICE KITS

Splicing Procedures:

1. Cut "BERG" *FLEX-E-PITCH*[®] sharp and square as shown, using cutter, to desired number of pitches, plus one pitch.

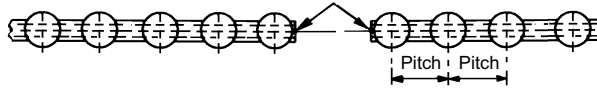

2. Cut plastic jacket (one pitch each side) lightly, with a sharp razor blade, as shown (all around). Caution: do not nick cable. Strip or twist off jacket carefully.

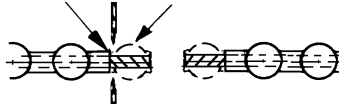

3. Slide stripped cable into oval splice bushing carefully. **Caution:** Do not fray cable. Feed cable into chamfered end of bushing last.

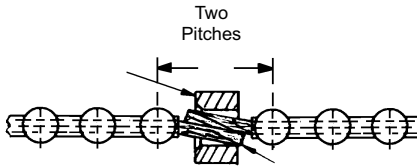

4. Center bushing and be certain chain is straight before crimping.

5. Position crimp tool over splice bushing and squeeze tightly for maximum splice strength.

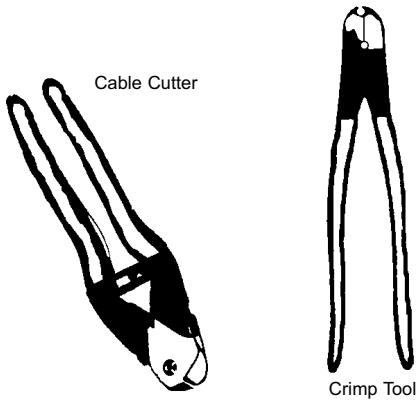
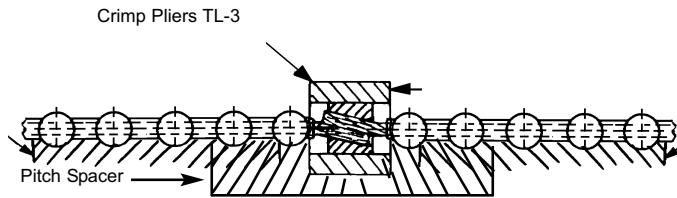

CHAIN SERIES	STOCK NO.	FIELD SPLICE KIT AND ACCESSORIES
14CCF 25CCF 35CCF 7CCF	14CCF-7 25CCF-7 35CCF-7 7CCF-7	Complete Kit Consists of: Crimp tool, Pitch Spacer, Sample Chain Cable cutter, Bushings, Razor Blades & Instructions
	TL-3 TL-7	Crimp Tool For 14CCF,25CCF,35CCF Crimp Tool 7CCF
	BU-032-S BU-046-S BU-062-S	Extra Splice Bushings for: 14CCF & 25CCF (0.8 Dia. Cable) 35CCF (1.2 Dia. Cable) 7CCF (1.6 Dia. Cable)
	TL-1 TL-2	Cable Cutter for up to 1.2 Dia. Cable Cable Cutter for 7CCF (1.6 Dia. Cable)
	TL-9	7CCF Pitch Space Fixture

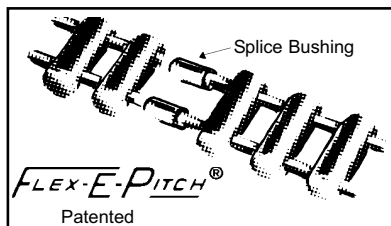

**Field Splices Offer Only
50% of Catalog Rated Loads**

BELT TENSIONER

MATERIALS

HOUSING - DIN 3.1355 Aluminum Black Anodized **Shafting** - DIN 1.4305 Stainless Steel

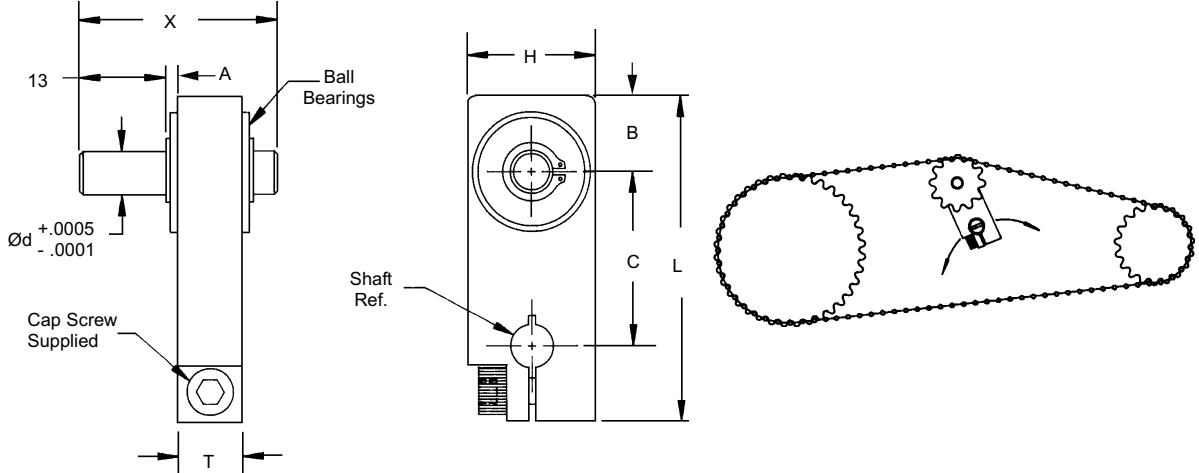

- Berg's Belt Tensioner installs quickly into existing or new belting systems. Its clamp style design allows for mounting on shoulder screws or shafts.
- Tension is easily adjusted by pivoting tensioner about mounting surface.
- The Belt Tensioner has been designed to handle most of Berg's Belt and Sprocket series as well as available similar products.

STOCK NO.	d	SHAFT REF.	X	L	T	H	C	A	B
TENS-1M	1.000	4.0	30.0	48	9.5	19	25	1.8	11.2
TENS-2M	6.000	6.0	30.0	48	9.5	19	25	1.8	11.2
TENS-3M	8.000	8.0	35.0	64	12.5	25	40	2.2	12.5

ROW-L-ER® CHAIN TECHNICAL DATA

Operating Notes:

ROW-L-ER Chain offers no slippage due to the positive drive between chain and tooth. This series will also have negligible stretch, long life, and the ability to operate in many different hostile environments such as high temperature, high moisture, high dust or dirty areas, and corrosive atmospheres.

CIRCULAR PITCH	ROLLER DIAMETER	MATERIAL	SPROCKET
3.75mm	2.3mm	Stainless Steel, Non-Magnetic, Prestretched Single Strand	Operates with 14EM and 14SP series.

3.75 Pitch Series

- Ultimate tensile 801N - Max operating load 89N
- Mass 52 gms/m

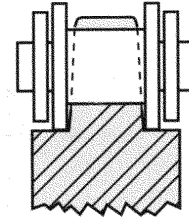

CIRCULAR PITCH	ROLLER DIAMETER	MATERIAL	SPROCKET
6.35mm	3.3mm	Stainless Steel, Mild Steel Single Strand, Delrin and Nylatron	Operates with 25EM and 25SP series.

6.35 Pitch Series

- Ultimate tensile 3113N, for Stainless Steel - Max. operating load 342N
3892N, for Mild Steel - Max. operating load 431N
280N, for Delrin - Max operating load 93N
290N for Nylatron - Max. operating load 98N
- Mass 133gms/m (Stainless and Mild Steel) - Must be lubricated

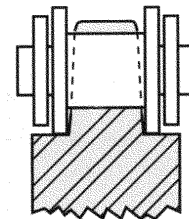

CIRCULAR PITCH	ROLLER DIAMETER	MATERIAL	SPROCKET
9.53mm	5.1mm	Delrin and Nylatron	Operates with 35EM and 35SP series.

9.53 Pitch Series

- Ultimate tensile 605N, for Delrin - Max. operating load 200N
605N, for Nylatron - Max. operating load 200N

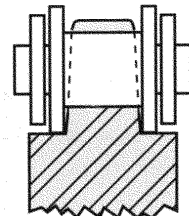

CIRCULAR PITCH	ROLLER DIAMETER	MATERIAL	SPROCKET
12.7mm	7.9mm	Delrin and Nylatron	Operates with 40EM series.

12.70 Pitch Series

- Ultimate tensile 779N, for Delrin - Max. operating load 258N
779N, for Nylatron - Max. operating load 258N

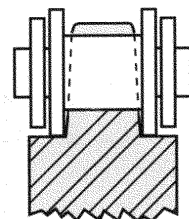

LINK CHAIN

CIRCULAR PITCH	ROLLER DIAMETER	BERG NAME	MATERIAL	SPROCKET
3.75mm	2.3mm	ROW-L-ER®	Stainless Steel, Non-Magnetic, Prestretched Single Strand	Operates with 14EM and 14SP series.

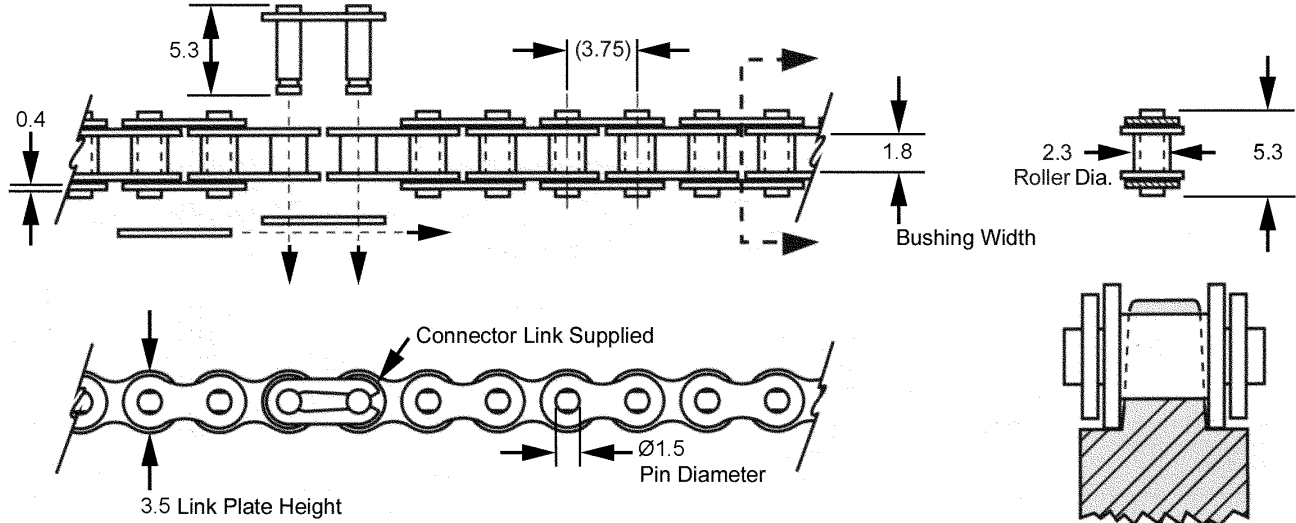

STOCK NO.	NO. OF PITCHES	LENGTH MM
RC14SS-40	40	150.0
RC14SS-50	50	187.5
RC14SS-60	60	225.0
RC14SS-70	70	262.5
RC14SS-80	80	300.0
RC14SS-90	90	337.5
RC14SS-100	100	375.0
RC14SS-110	110	412.5
RC14SS-120	120	450.0
RC14SS-130	130	487.5
RC14SS-140	140	525.0
RC14SS-150	150	562.5
RC14SS-160	160	600.0
RC14SS-170	170	637.5
RC14SS-180	180	675.0
RC14SS-190	190	712.5
RC14SS-200	200	750.0
RC14SS-210	210	787.5
RC14SS-220	220	825.0
RC14SS-230	230	862.5
RC14SS-240	240	900.0
RC14SS-250	250	937.5
RC14SS-260	260	975.0
RC14SS-270	270	1012.5
RC14SS-280	280	1050.0
RC14SS-290	290	1087.5
RC14SS-300	300	1125.0
RC14SS-310	310	1162.5
RC14SS-320	320	1200.0
RC14SS-330	330	1237.5
RC14SS-340	340	1275.0
RC14SS-350	350	1312.5
RC14SS-360	360	1350.0
RC14SS-370	370	1387.5
RC14SS-380	380	1425.0
RC14SS-390	390	1462.5

* Maximum recommended operating load is for a slip fit connecting link, which is standard. A press fit connecting link is a special available on request.

Special lengths available on request (only even numbers of links).

Maximum recommended Operating Load = 89N

Ultimate Tensile Strength = 801N

52gms/m - Must be lubricated.

Use Connector Link Berg P/N RC14SS-CL.



STOCK NO.	LENGTH
RC14SS-1.5M	1.5M
RC14SS-3.0M	3.0M
RC14SS-7.5M	7.5M
RC14SS-15.0M	15.0M
RC14SS-30.0M	30.0M

SPROCKETS

CIR. PITCH	BORE	STYLE	MATERIALS	BERG'S ® NAME	CHAIN
3.75mm	Ø7	PIN HUB	ACETAL	ROW-L-ER®	Operates with RC14SS Series

STOCK NO.	NO. OF TEETH	P.D.	O.D.
14EM107M-15	15†	18.02	19.33
14EM107M-16	16†	19.22	20.52
14EM107M-18	18	21.60	22.89
14EM107M-20	20	23.97	25.25
14EM107M-22	22	26.35	27.64
14EM107M-24	24	28.73	30.02
14EM107M-26	26	31.11	32.39
14EM107M-30	30	35.88	37.39
14EM107M-32	32	38.26	39.52
14EM107M-36	36	43.03	44.30
14EM107M-40	40	47.80	49.07
14EM107M-42	42	50.18	51.44
14EM107M-44	44	52.57	53.82
14EM107M-45	45	53.76	55.02
14EM107M-50	50	59.72	60.99
14EM107M-55	55	65.69	66.93
14EM107M-60	60	71.65	72.90

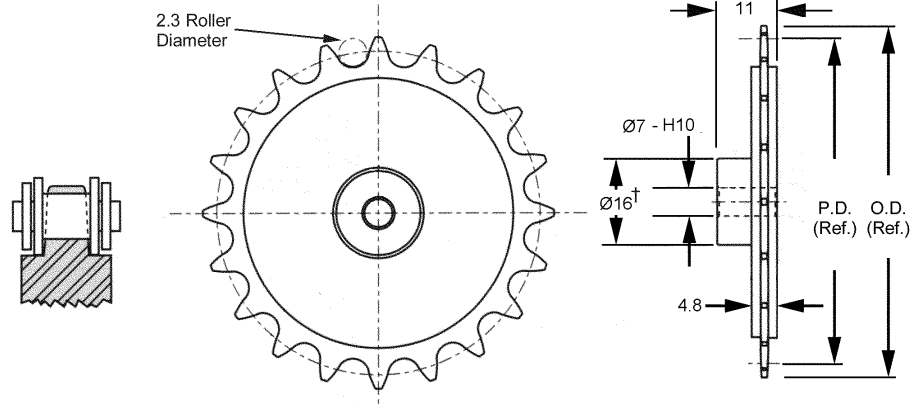

† Teeth runout on hub.
Other Bore sizes and other numbers of teeth are available on request.

CIR. PITCH	BORE	STYLE	MATERIALS	BERG'S ® NAME	CHAIN
3.75mm	Ø8	PIN HUB	ACETAL	ROW-L-ER®	Operates with RC14SS Series

STOCK NO.	NO. OF TEETH	P.D.	O.D.
14EM108M-15	15†	18.02	19.33
14EM108M-16	16†	19.22	20.52
14EM108M-18	18	21.60	22.89
14EM108M-20	20	23.97	25.25
14EM108M-22	22	26.35	27.64
14EM108M-24	24	28.73	30.02
14EM108M-26	26	31.11	32.39
14EM108M-30	30	35.88	37.39
14EM108M-32	32	38.26	39.52
14EM108M-36	36	43.03	44.30
14EM108M-40	40	47.80	49.07
14EM108M-42	42	50.18	51.44
14EM108M-44	44	52.57	53.82
14EM108M-45	45	53.76	55.02
14EM108M-50	50	59.72	60.99
14EM108M-55	55	65.69	66.93
14EM108M-60	60	71.65	72.90

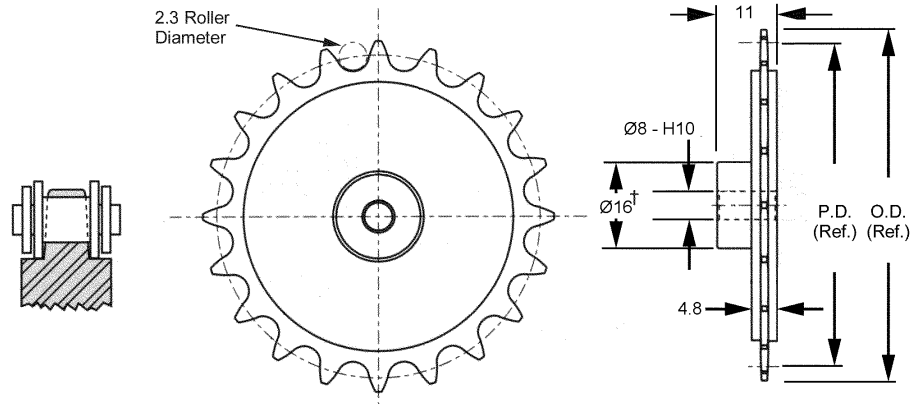

† Teeth runout on hub.
Other Bore sizes and other numbers of teeth are available on request.



SPROCKETS

CIR. PITCH	BORE	STYLE	MATERIALS	BERG'S ® NAME	CHAIN
3.75mm	Ø10	HUBLESS	Aluminum per DIN 3.1355 Anodized	ROW-L-ER®	Operates with RC14SS Series

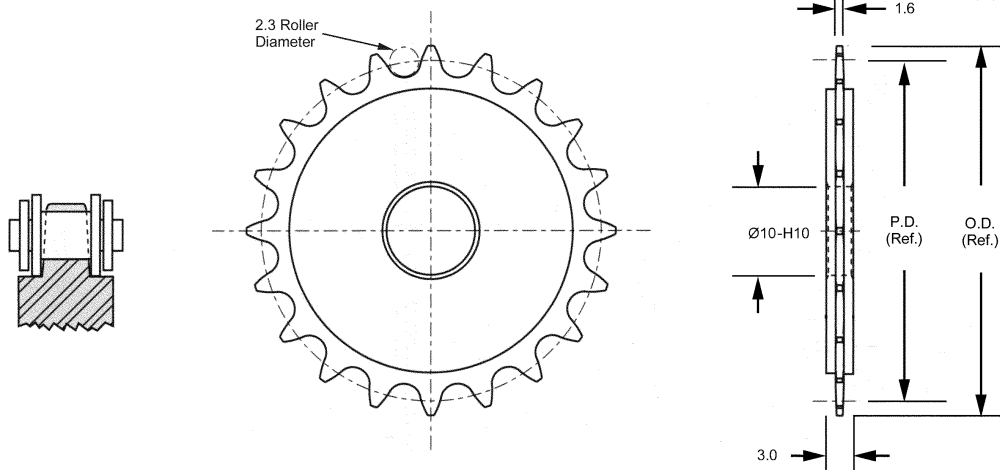

STOCK NO.	NO. OF TEETH	PITCH DIA.	OUTSIDE DIA.
14SP175A-16	16	19.22	20.52
14SP175A-17	17	20.41	21.72
14SP175A-18	18	21.60	22.89
14SP175A-19	19	22.78	24.08
14SP175A-20	20	23.97	25.27
14SP175A-21	21	25.16	26.47
14SP175A-22	22	26.35	27.63
14SP175A-23	23	27.54	28.83
14SP175A-24	24	28.73	30.02
14SP175A-25	25	29.92	31.22
14SP175A-26	26	31.11	32.41
14SP175A-27	27	32.30	33.58
14SP175A-28	28	33.49	34.77
14SP175A-29	29	34.68	35.97
14SP175A-30	30	35.88	37.16
14SP175A-31	31	37.07	38.35
14SP175A-32	32	38.26	39.55
14SP175A-33	33	39.45	40.75
14SP175A-34	34	40.64	41.91
14SP175A-35	35	41.83	43.12
14SP175A-36	36	43.03	44.30



Other Bore sizes and other numbers of teeth are available on request.
Teeth could be anodized.

SPROCKETS

CIR. PITCH	BORE	STYLE	MATERIALS	BERG'S ® NAME	CHAIN
3.75mm	Ø4	PIN HUB	Aluminum per DIN 3.1355 Anodized	ROW-L-ER®	Operates with RC14SS Series

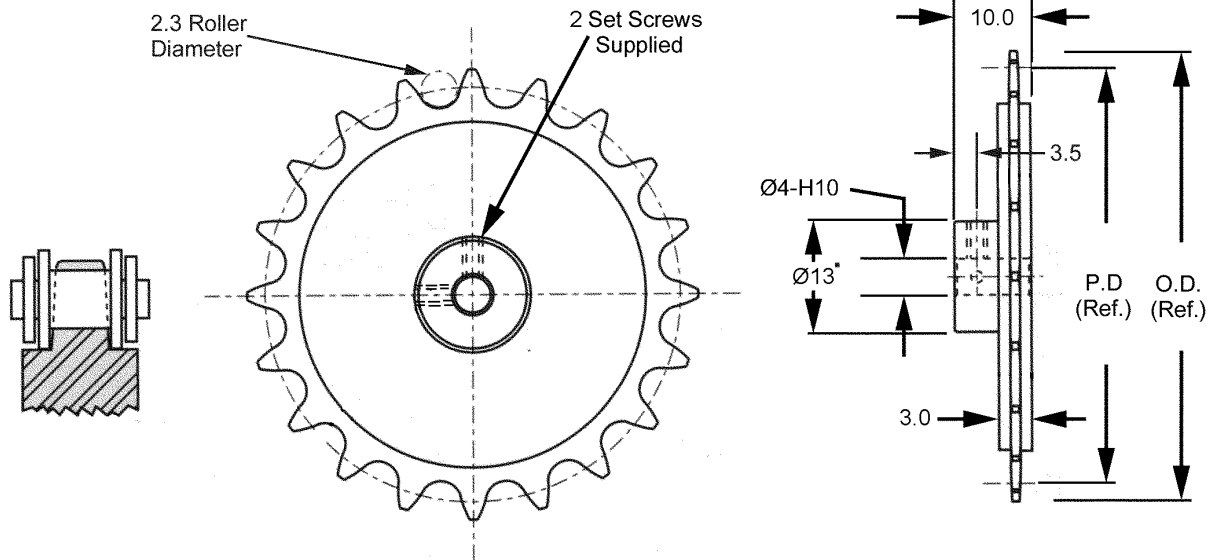

STOCK NO.	NO. OF TEETH	PITCH DIA.	OUTSIDE DIA.
14EM162A-10	10•	12.14	13.44
14EM162A-11	11•	13.31	14.63
14EM162A-12	12•	14.49	15.80
14EM162A-13	13•	15.67	16.97
14EM162A-14	14•	16.85	18.16
14EM162A-15	15	18.04	19.33
14EM162A-16	16	19.22	20.52
14EM162A-17	17	20.41	21.72
14EM162A-18	18	21.60	22.89
14EM162A-19	19	22.78	24.08
14EM162A-20	20	23.97	25.27
14EM162A-21	21	25.16	26.47
14EM162A-22	22	26.35	27.63
14EM162A-23	23	27.54	28.83
14EM162A-24	24	28.73	30.02
14EM162A-25	25	29.92	31.22
14EM162A-26	26	31.11	32.41
14EM162A-27	27	32.30	33.58
14EM162A-28	28	33.49	34.77
14EM162A-29	29	34.68	35.97
14EM162A-30	30	35.88	37.16
14EM162A-31	31	37.07	38.35
14EM162A-32	32	38.26	39.55
14EM162A-33	33	39.45	40.75
14EM162A-34	34	40.64	41.91
14EM162A-35	35	41.83	43.12
14EM162A-36	36	43.03	44.30



• For 10-14 teeth, hub diameter equals 7.1.
Other Bore sizes and other numbers of teeth are available on request.
Teeth could be anodized.

SPROCKETS

CIR. PITCH	BORE	STYLE	MATERIALS	BERG'S ® NAME	CHAIN
3.75mm	Ø6	PIN HUB	Aluminum per DIN 3.1355 Anodized	ROW-L-ER®	Operates with RC14SS Series

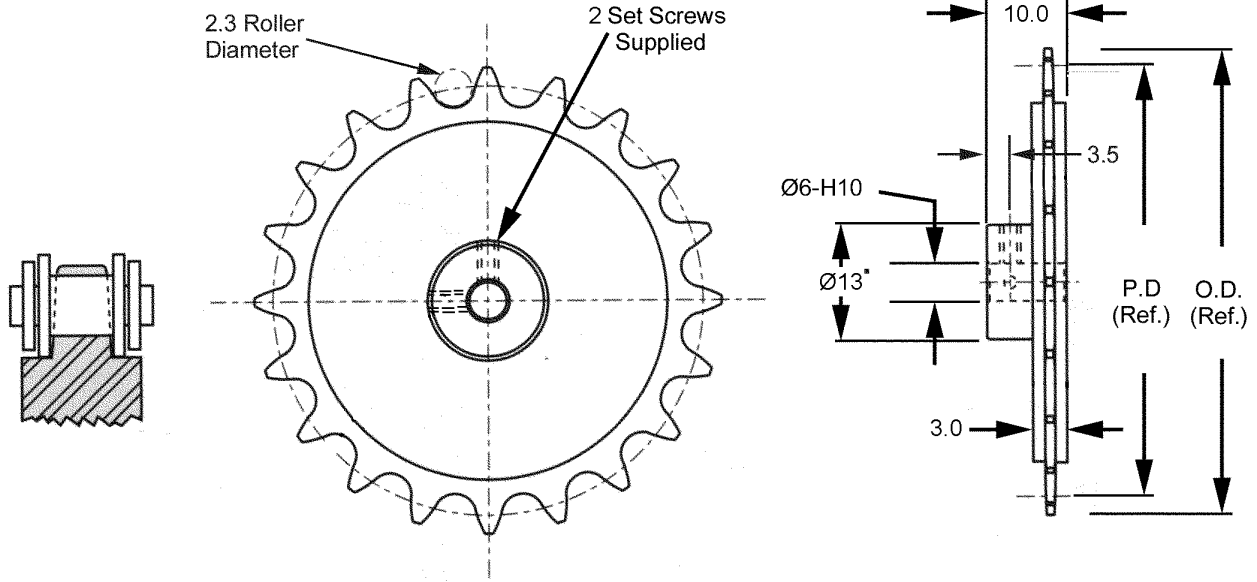

STOCK NO.	NO. OF TEETH	PITCH DIA.	OUTSIDE DIA.
14EM161A-13	13*	15.67	16.97
14EM161A-14	14*	16.85	18.16
14EM161A-15	15	18.04	19.33
14EM161A-16	16	19.22	20.52
14EM161A-17	17	20.41	21.72
14EM161A-18	18	21.60	22.89
14EM161A-19	19	22.78	24.08
14EM161A-20	20	23.97	25.27
14EM161A-21	21	25.16	26.47
14EM161A-22	22	26.35	27.63
14EM161A-23	23	27.54	28.83
14EM161A-24	24	28.73	30.02
14EM161A-25	25	29.92	31.22
14EM161A-26	26	31.11	32.41
14EM161A-27	27	32.30	33.58
14EM161A-28	28	33.49	34.77
14EM161A-29	29	34.68	35.97
14EM161A-30	30	35.88	37.16
14EM161A-31	31	37.07	38.35
14EM161A-32	32	38.26	39.55
14EM161A-33	33	39.45	40.75
14EM161A-34	34	40.64	41.91
14EM161A-35	35	41.83	43.12
14EM161A-36	36	43.03	44.30



• For 13-14 teeth, hub diameter equals 10.7.
 Other Bore sizes and other numbers of teeth are available on request.
 Teeth could be anodized.

SPROCKETS

CIR. PITCH	BORE	STYLE	MATERIALS	BERG'S ® NAME	CHAIN
3.75mm	Ø8	PIN HUB	Aluminum per DIN 3.1355 Anodized	ROW-L-ER®	Operates with RC14SS Series

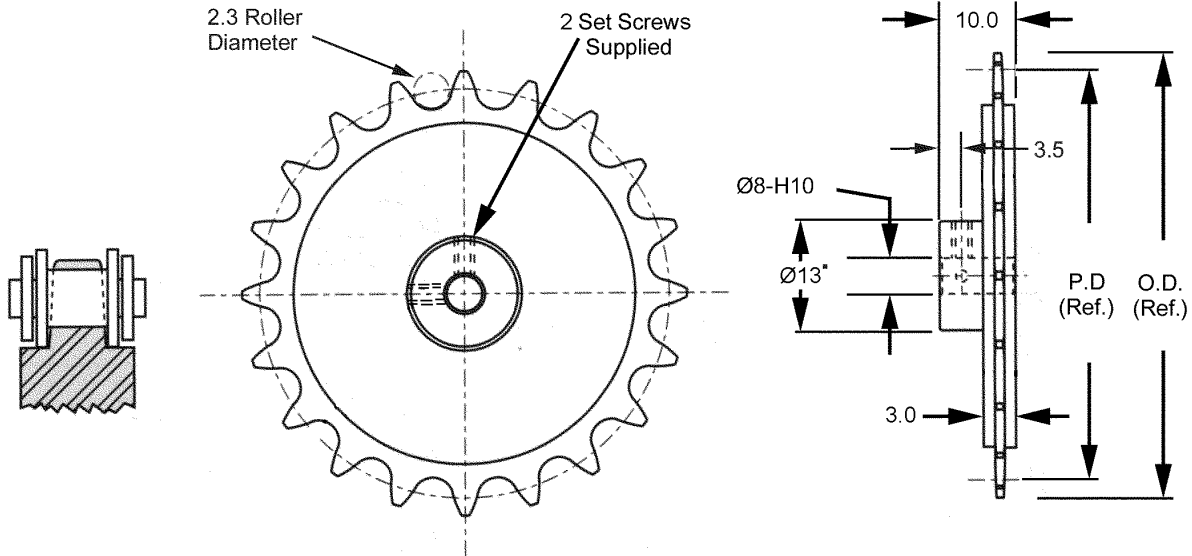

STOCK NO.	NO. OF TEETH	PITCH DIA.	OUTSIDE DIA.
14EM260A-13	13	15.67	16.97
14EM260A-14	14	16.85	18.16
14EM260A-15	15	18.04	19.33
14EM260A-16	16	19.22	20.52
14EM260A-17	17	20.41	21.72
14EM260A-18	18	21.60	22.89
14EM260A-19	19	22.78	24.08
14EM260A-20	20	23.97	25.27
14EM260A-21	21	25.16	26.47
14EM260A-22	22	26.35	27.63
14EM260A-23	23	27.54	28.83
14EM260A-24	24	28.73	30.02
14EM260A-25	25	29.92	31.22
14EM260A-26	26	31.11	32.41
14EM260A-27	27	32.30	33.58
14EM260A-28	28	33.49	34.77
14EM260A-29	29	34.68	35.97
14EM260A-30	30	35.88	37.16
14EM260A-31	31	37.07	38.35
14EM260A-32	32	38.26	39.55
14EM260A-33	33	39.45	40.75
14EM260A-34	34	40.64	41.91
14EM260A-35	35	41.83	43.12
14EM260A-36	36	43.03	44.30



• For 13-14 teeth, hub diameter equals 10.7.
Other Bore sizes and other numbers of teeth are available on request.
Teeth could be anodized.

SPROCKETS

CIR. PITCH	BORE	STYLE	MATERIALS	BERG'S ® NAME	CHAIN
3.75mm	Ø10	HUBLESS	Aluminum DIN-3.1355 Anodized	ROW-L-ER®	Operates with RC14SS Series

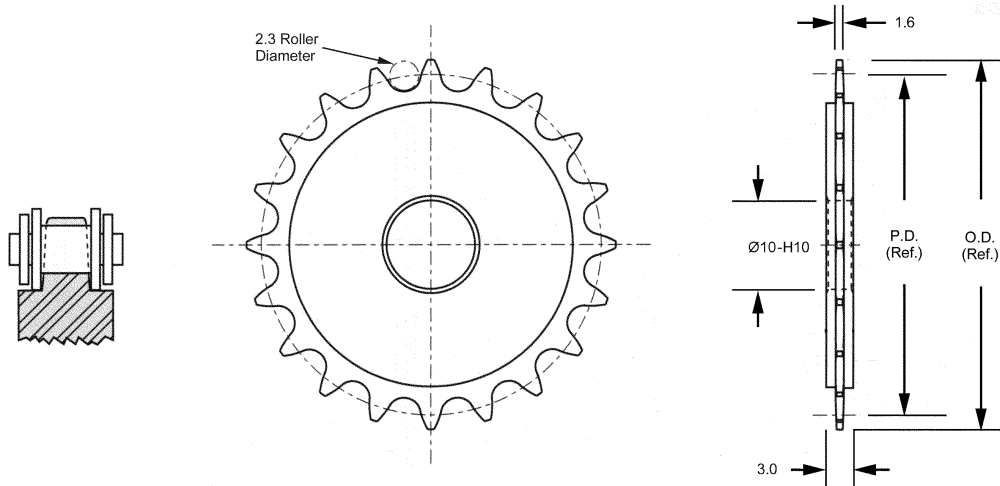

STOCK NO.	NO. OF TEETH	PITCH DIA.	OUTSIDE DIA.
14SP175A-16	16	19.22	20.52
14SP175A-17	17	20.41	21.72
14SP175A-18	18	21.60	22.89
14SP175A-19	19	22.78	24.08
14SP175A-20	20	23.97	25.27
14SP175A-21	21	25.16	26.47
14SP175A-22	22	26.35	27.63
14SP175A-23	23	27.54	28.83
14SP175A-24	24	28.73	30.02
14SP175A-25	25	29.92	31.22
14SP175A-26	26	31.11	32.41
14SP175A-27	27	32.30	33.58
14SP175A-28	28	33.49	34.77
14SP175A-29	29	34.68	35.97
14SP175A-30	30	35.88	37.16
14SP175A-31	31	37.07	38.35
14SP175A-32	32	38.26	39.55
14SP175A-33	33	39.45	40.75
14SP175A-34	34	40.64	41.91
14SP175A-35	35	41.83	43.12
14SP175A-36	36	43.03	44.30



Other Bore sizes and other numbers of teeth are available on request.
Teeth could be anodized.

LINK CHAIN

CIRCULAR PITCH	ROLLER DIAMETER	BERG NAME	MATERIAL	SPROCKET
6.35mm	3.3mm	ROW-L-ER®	Stainless Steel or Mild Steel Single Strand	Operates with 25EM and 25SP series.

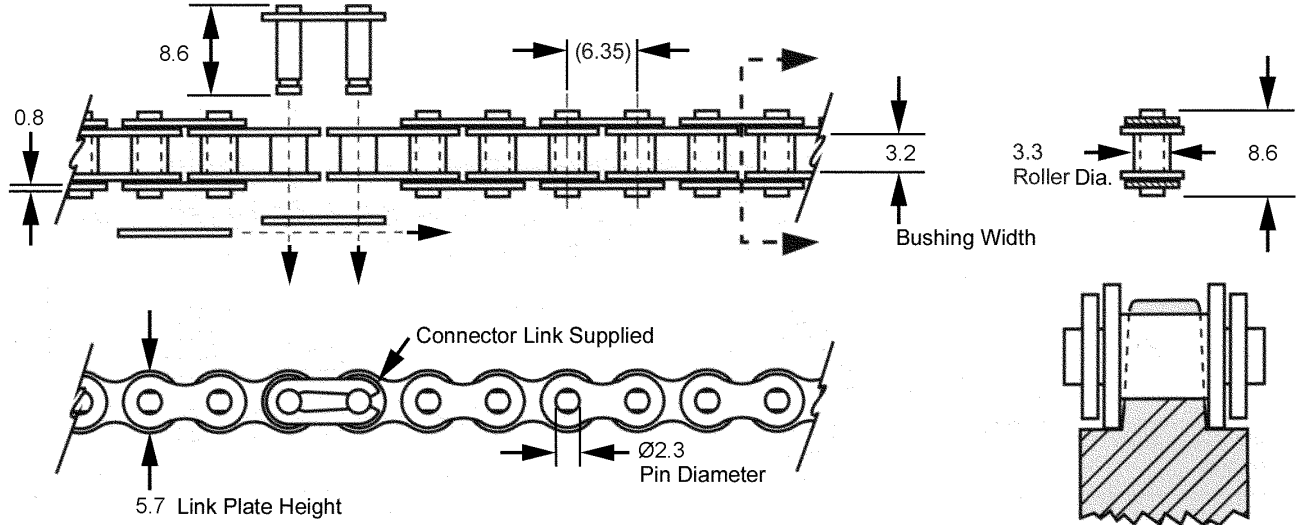

STAINLESS STEEL STOCK NO.	MILD STEEL STOCK NO.	NO. OF PITCHES	LENGTH MM
RC25SS-40	RC25-40	40	150.0
RC25SS-50	RC25-50	50	187.5
RC25SS-60	RC25-60	60	225.0
RC25SS-70	RC25-70	70	262.5
RC25SS-80	RC25-80	80	300.0
RC25SS-90	RC25-90	90	337.5
RC25SS-100	RC25-100	100	375.0
RC25SS-110	RC25-110	110	412.5
RC25SS-120	RC25-120	120	450.0
RC25SS-130	RC25-130	130	487.5
RC25SS-140	RC25-140	140	525.0
RC25SS-150	RC25-150	150	562.5
RC25SS-160	RC25-160	160	600.0
RC25SS-170	RC25-170	170	637.5
RC25SS-180	RC25-180	180	675.0
RC25SS-190	RC25-190	190	712.5
RC25SS-200	RC25-200	200	750.0
RC25SS-210	RC25-210	210	787.5
RC25SS-220	RC25-220	220	825.0
RC25SS-230	RC25-230	230	862.5
RC25SS-240	RC25-240	240	900.0
RC25SS-250	RC25-250	250	937.5
RC25SS-260	RC25-260	260	975.0
RC25SS-270	RC25-270	270	1012.5
RC25SS-280	RC25-280	280	1050.0

STAINLESS STEEL STOCK NO.	MILD STEEL STOCK NO.	LENGTH
RC25SS-1.5M	RC25-1.5M	1.5M
RC25SS-3.0M	RC25-3.0M	3.0M
RC25SS-7.5M	RC25-7.5M	7.5M
RC25SS-15.0M	RC25-15.0M	15.0M
RC25SS-30.0M	RC25-30.0M	30.0M

* Maximum recommended operating load is for a slip fit connecting link, which is standard. A press fit connecting link is a special available on request.

Special lengths available on request (only even numbers of links).

Max. recommended operating load =
342N for Stainless Steel
431N for Mild Steel

Ultimate Tensile Strength =
3113N - Stainless Steel
3892N - Mild Steel

133gms/m - Must be lubricated.

Use Connector Link Berg P/N RC25SS-CL for Stainless Steel, P/N RC25-CL for Mild Steel.



SPROCKETS

CIR. PITCH	BORE	STYLE	MATERIALS	BERG'S ® NAME	CHAIN
6.35mm	Ø8	PIN HUB	Cast Polyurethane Graphite Impregnated 70D Durometer	ROW-L-ER®	Operates with RC25 and RC25SS series

STOCK NO.	NO. OF TEETH	P.D.	O.D.
25EM266U-12	12†	24.53	27.51
25EM266U-13	13†	26.53	29.57
25EM266U-14	14†	28.54	31.62
25EM266U-15	15†	30.54	33.68
25EM266U-18	18	36.57	39.80
25EM266U-20	20	40.59	43.89
25EM266U-24	24	48.65	52.02
25EM266U-26	26	52.68	56.08
25EM266U-30	30	60.75	54.21
25EM266U-36	36	72.86	76.38

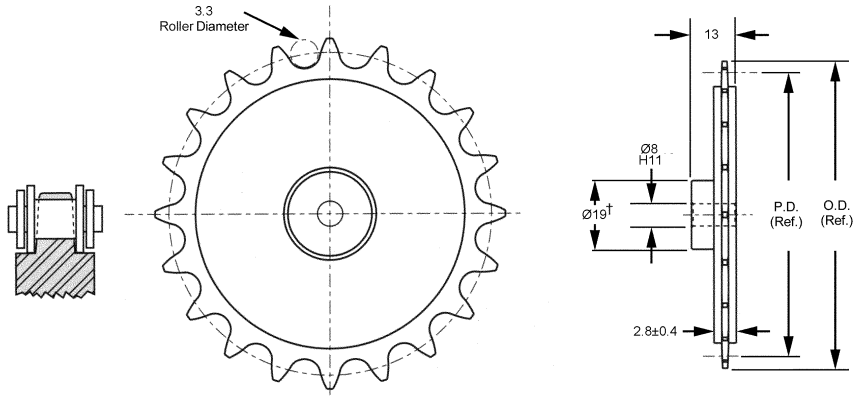

† Teeth run out on hub.
Other Bore sizes and other numbers of teeth are available on request.

CIR. PITCH	BORE	STYLE	MATERIALS	BERG'S ® NAME	NOTE
6.35mm	Ø10	PIN HUB	Cast Polyurethane Graphite Impregnated 70D Durometer	ROW-L-ER®	Operates with RC25 and RC25SS series

STOCK NO.	NO. OF TEETH	P.D.	O.D.
25EM167U-12	12†	24.53	27.51
25EM167U-13	13†	26.53	29.57
25EM167U-14	14†	28.54	31.62
25EM167U-15	15†	30.54	33.68
25EM167U-18	18	36.57	39.80
25EM167U-20	20	40.59	43.89
25EM167U-24	24	48.65	52.02
25EM167U-26	26	52.68	56.08
25EM167U-30	30	60.75	54.21
25EM167U-36	36	72.86	76.38

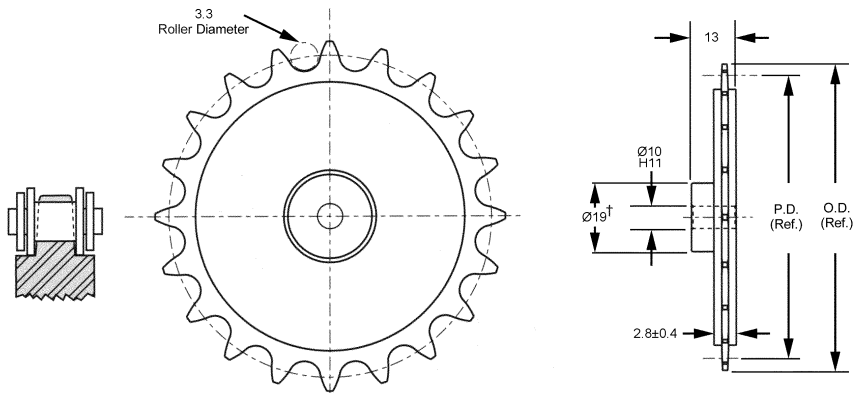

† Teeth run out on hub.
Other Bore sizes and other numbers of teeth are available on request.

CIR. PITCH	BORE	STYLE	MATERIALS	BERG'S ® NAME	CHAIN
6.35mm	Ø12	PIN HUB	Cast Polyurethane Graphite Impregnated 70D Durometer	ROW-L-ER®	Operates with RC25 and RC25SS series

STOCK NO.	NO. OF TEETH	P.D.	O.D.
25EM168U-13	13†	26.53	29.57
25EM168U-14	14†	28.54	31.62
25EM168U-15	15†	30.54	33.68
25EM168U-18	18	36.57	39.80
25EM168U-20	20	40.59	43.89
25EM168U-24	24	48.65	52.02
25EM168U-26	26	52.68	56.08
25EM168U-30	30	60.75	54.21
25EM168U-36	36	72.86	76.38

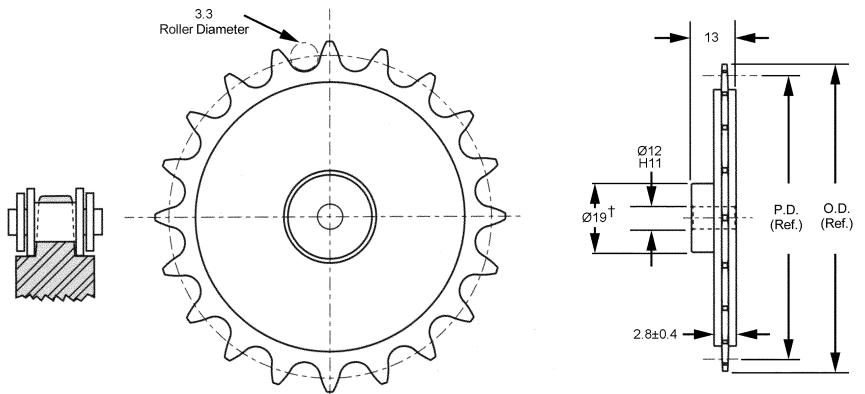

† Teeth run out on hub.
Other Bore sizes and other numbers of teeth are available on request.

SPROCKETS

CIR. PITCH	BORE	STYLE	MATERIALS	BERG'S ® NAME	CHAIN
6.35mm	Ø10	HUBLESS	Aluminum per DIN 3.1355 Anodized	ROW-L-ER®	Operates with RC25 and RC25SS series

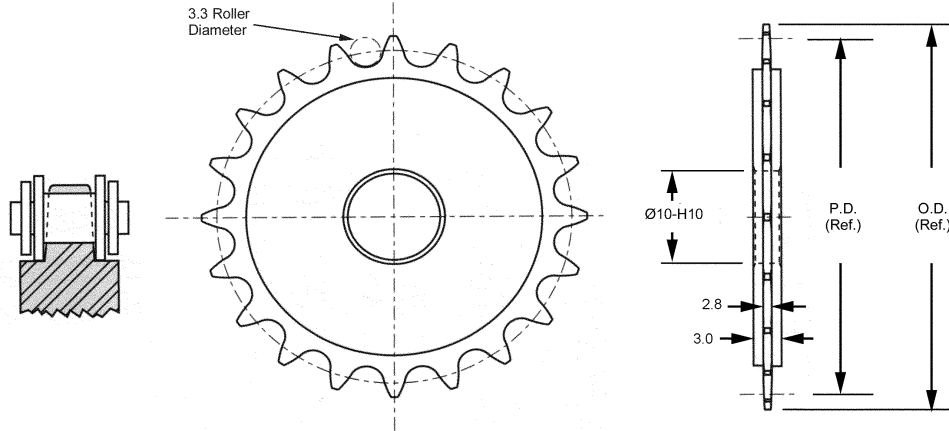

STOCK NO.	NO. OF TEETH	PITCH DIA.	OUTSIDE DIA.
25SP175A-9	9	18.57	21.23
25SP175A-10	10	20.55	23.34
25SP175A-11	11	22.54	25.43
25SP175A-12	12	24.53	27.51
25SP175A-13	13	26.53	29.57
25SP175A-14	14	28.54	31.62
25SP175A-15	15	30.54	33.68
25SP175A-16	16	32.55	35.71
25SP175A-18	18	36.57	39.80
25SP175A-20	20	40.59	43.89
25SP175A-21	21	42.61	45.92
25SP175A-22	22	44.62	47.96
25SP175A-24	24	48.65	52.02
25SP175A-25	25	50.66	54.05
25SP175A-26	26	52.68	56.08
25SP175A-28	28	56.71	60.15
25SP175A-30	30	60.75	64.21
25SP175A-32	32	64.78	68.28
25SP175A-36	36	72.86	76.38



Other Bore sizes and other numbers of teeth are available on request.
Teeth could be anodized.

SPROCKETS

CIR. PITCH	BORE	STYLE	MATERIALS	BERG'S ® NAME	CHAIN
6.35mm	Ø4	PIN HUB	Aluminum per DIN 3.1355 Anodized	ROW-L-ER®	Operates with RC25 and RC25SS series

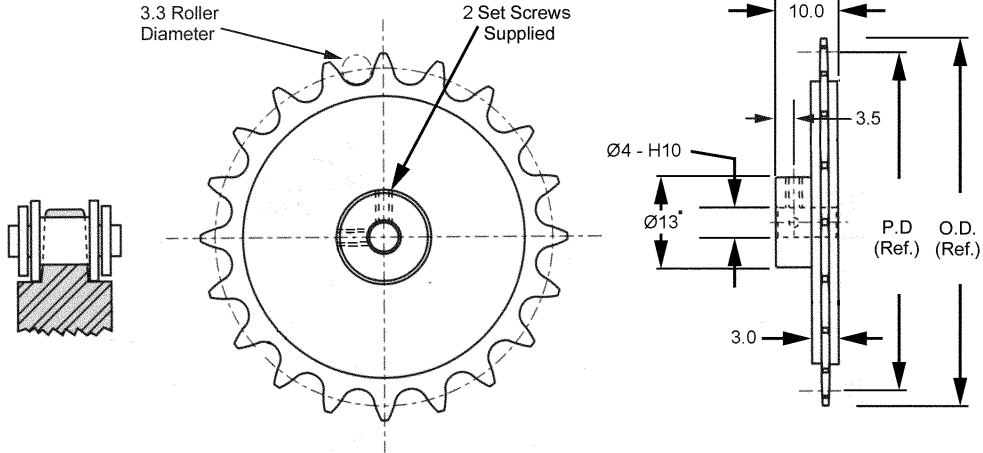

STOCK NO.	NO. OF TEETH	PITCH DIA.	OUTSIDE DIA.
25EM162A-9	9	18.57	21.23
25EM162A-10	10	20.55	23.34
25EM162A-11	11	22.54	25.43
25EM162A-12	12	24.53	27.51
25EM162A-13	13	26.53	29.57
25EM162A-14	14	28.54	31.62
25EM162A-15	15	30.54	33.68
25EM162A-16	16	32.55	35.71
25EM162A-18	18	36.57	39.80
25EM162A-20	20	40.59	43.89
25EM162A-21	21	42.61	45.92
25EM162A-22	22	44.62	47.96
25EM162A-24	24	48.65	52.02
25EM162A-25	25	50.66	54.05
25EM162A-26	26	52.68	56.08
25EM162A-28	28	56.71	60.15
25EM162A-30	30	60.75	64.21
25EM162A-32	32	64.78	68.28
25EM162A-36	36	72.86	76.38



• For 9 teeth, hub diameter equals 11.7.
Other Bore sizes and other numbers of teeth are available on request.
Teeth could be anodized.

SPROCKETS

CIR. PITCH	BORE	STYLE	MATERIALS	BERG'S ® NAME	CHAIN
6.35mm	Ø6	PIN HUB	Aluminum per DIN 3.1355 Anodized	ROW-L-ER®	Operates with RC25 and RC25SS series

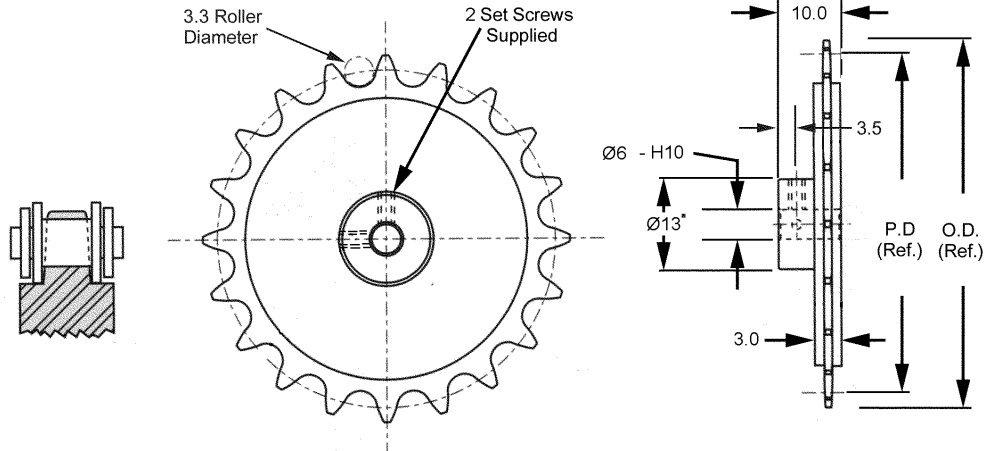

STOCK NO.	NO. OF TEETH	PITCH DIA.	OUTSIDE DIA.
25EM161A-9	9	18.57	21.23
25EM161A-10	10	20.55	23.34
25EM161A-11	11	22.54	25.43
25EM161A-12	12	24.53	27.51
25EM161A-13	13	26.53	29.57
25EM161A-14	14	28.54	31.62
25EM161A-15	15	30.54	33.68
25EM161A-16	16	32.55	35.71
25EM161A-18	18	36.57	39.80
25EM161A-20	20	40.59	43.89
25EM161A-21	21	42.61	45.92
25EM161A-22	22	44.62	47.96
25EM161A-24	24	48.65	52.02
25EM161A-25	25	50.66	54.05
25EM161A-26	26	52.68	56.08
25EM161A-28	28	56.71	60.15
25EM161A-30	30	60.75	64.21
25EM161A-32	32	64.78	68.28
25EM161A-36	36	72.86	76.38



- For 9 teeth, hub diameter equals 11.7.
- Other Bore sizes and other numbers of teeth are available on request.
- Teeth could be anodized.

SPROCKETS

CIR. PITCH	BORE	STYLE	MATERIALS	BERG'S ® NAME	CHAIN
6.35mm	Ø8	PIN HUB	Aluminum per DIN 3.1355 Anodized	ROW-L-ER®	Operates with RC25 and RC25SS series

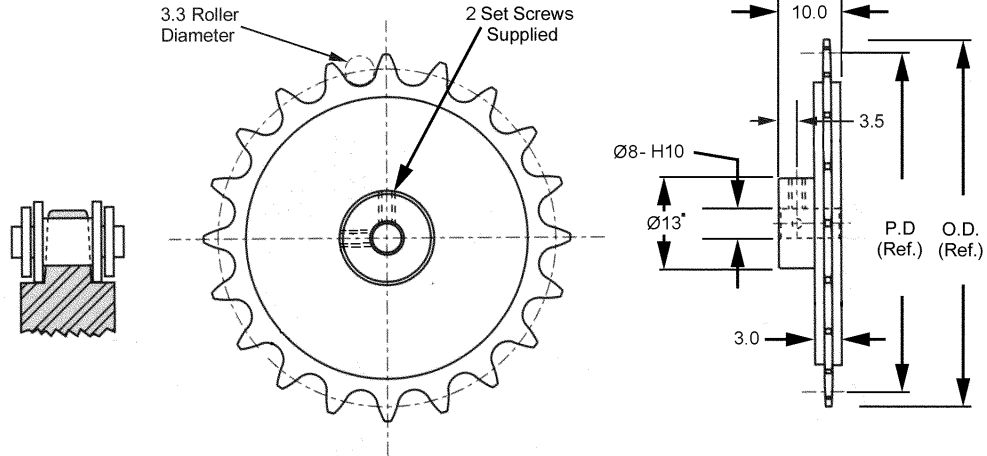

STOCK NO.	NO. OF TEETH	PITCH DIA.	OUTSIDE DIA.
25EM260A-9	9*	18.57	21.23
25EM260A-10	10	20.55	23.34
25EM260A-11	11	22.54	25.43
25EM260A-12	12	24.53	27.51
25EM260A-13	13	26.53	29.57
25EM260A-14	14	28.54	31.62
25EM260A-15	15	30.54	33.68
25EM260A-16	16	32.55	35.71
25EM260A-18	18	36.57	39.80
25EM260A-20	20	40.59	43.89
25EM260A-21	21	42.61	45.92
25EM260A-22	22	44.62	47.96
25EM260A-24	24	48.65	52.02
25EM260A-25	25	50.66	54.05
25EM260A-26	26	52.68	56.08
25EM260A-28	28	56.71	60.15
25EM260A-30	30	60.75	64.21
25EM260A-32	32	64.78	68.28
25EM260A-36	36	72.86	76.38



• For 9 teeth, hub diameter equals 11.7.
Other Bore sizes and other numbers of teeth are available on request.
Teeth could be anodized.

SPROCKETS

CIR. PITCH	BORE	STYLE	MATERIALS	BERG'S ® NAME	CHAIN
6.35mm	Ø10	HUBLESS	Stainless Steel DIN 1.4305	ROW-L-ER®	Operates with RC25 and RC25SS series

STOCK NO.	NO. OF TEETH	P.D.	O.D.
25SP110S-10	10	20.55	23.34
25SP110S-11	11	22.54	25.43
25SP110S-12	12	24.53	27.51
25SP110S-13	13	26.53	29.57
25SP110S-14	14	28.54	31.62
25SP110S-15	15	30.54	33.68
25SP110S-16	16	32.55	35.71
25SP110S-17	17	34.56	37.77
25SP110S-18	18	36.57	39.80
25SP110S-19	19	38.58	41.86
25SP110S-20	20	40.59	43.89
25SP110S-21	21	42.61	45.92
25SP110S-22	22	44.62	47.96
25SP110S-24	24	48.65	52.02
25SP110S-25	25	50.66	54.08
25SP110S-26	26	52.68	56.08
25SP110S-30	30	60.75	64.21
25SP110S-32	32	64.78	68.28
25SP110S-36	36	72.86	76.38

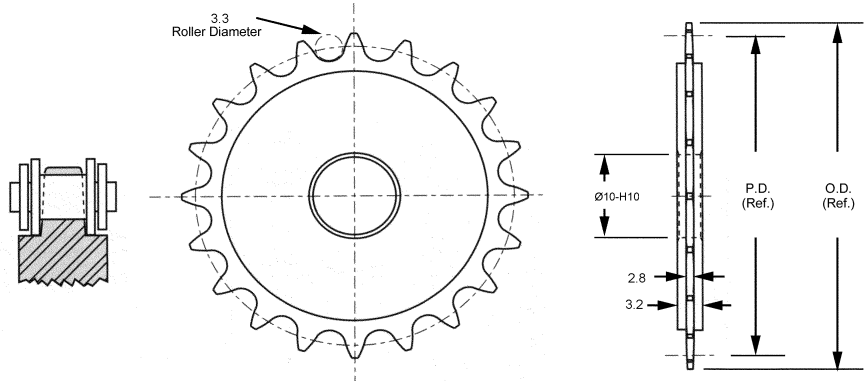

Other Bore sizes and other numbers of teeth are available on request.
Hubs assembled on request. Specify hub by stock number see index for page number.

CIR. PITCH	BORE	STYLE	MATERIALS	BERG'S ® NAME	CHAIN
6.35mm	Ø16	HUBLESS	Stainless Steel DIN 1.4305	ROW-L-ER®	Operates with RC25 and RC25SS series

STOCK NO.	NO. OF TEETH	P.D.	O.D.
25SP116S-15	15	30.54	33.68
25SP116S-16	16	32.55	35.71
25SP116S-17	17	34.56	37.77
25SP116S-18	18	36.57	39.80
25SP116S-19	19	38.58	41.86
25SP116S-20	20	40.59	43.89
25SP116S-21	21	42.61	45.92
25SP116S-22	22	44.62	47.96
25SP116S-24	24	48.65	52.02
25SP116S-25	25	50.66	54.08
25SP116S-26	26	52.68	56.08
25SP116S-30	30	60.75	64.21
25SP116S-32	32	64.78	68.28
25SP116S-36	36	72.86	76.38

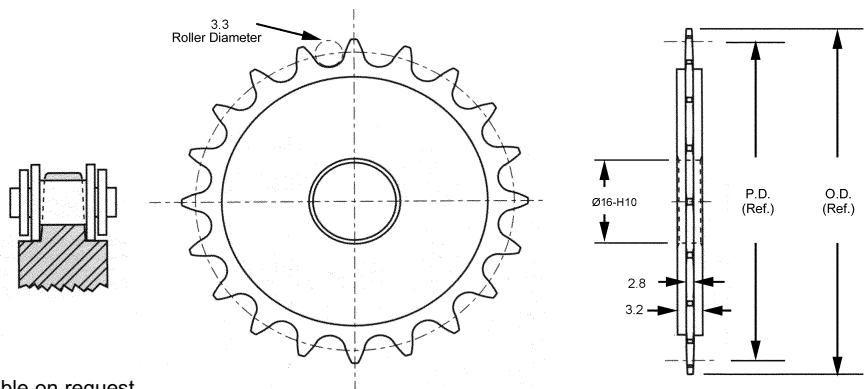

Other Bore sizes and other numbers of teeth are available on request.
Hubs assembled on request. Specify hub by stock number see index for page number.



LINK CHAIN

CIRCULAR PITCH	ROLLER DIAMETER	BERG NAME	MATERIAL	SPROCKET
6.35mm	3.3mm	ROW-L-ER®	Delrin and Nylatron	Operates with 25EM and 25SP series.

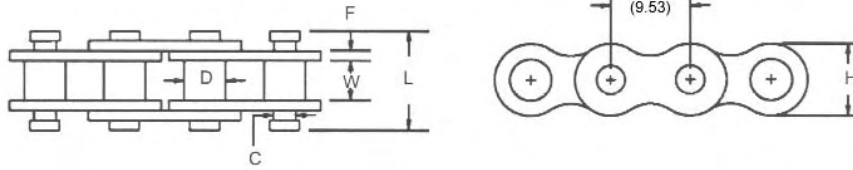

DELRIN® STOCK NO.	NYLATRON® STOCK NO.	NO. OF PITCHES	LENGTH (MM)	PITCH	W	D	C	F	L	H
RC25D-40	RC25N-40	40	254.0	6.35	3.2	3.30	2.68	1.02	9.12	6.35
RC25D-50	RC25N-50	50	317.5							
RC25D-60	RC25N-60	60	381.0							
RC25D-70	RC25N-70	70	444.5							
RC25D-80	RC25N-80	80	508.0							
RC25D-90	RC25N-90	90	571.5							
RC25D-100	RC25N-100	100	635.0							
RC25D-120	RC25N-120	120	762.0							
RC25D-130	RC25N-130	130	825.5							
RC25D-140	RC25N-140	140	889.0							
RC25D-150	RC25N-150	150	925.5							
RC25D-160	RC25N-160	160	1016.0							
RC25D-170	RC25N-170	170	1079.5							
RC25D-180	RC25N-180	180	1143.0							
RC25D-190	RC25N-190	190	1206.5							
RC25D-200	RC25N-200	200	1270.0							
RC25D-210	RC25N-210	210	1333.5							
RC25D-220	RC25N-220	220	1397.0							
RC25D-230	RC25N-230	230	1460.5							
RC25D-240	RC25N-240	240	1524.0							
RC25D-250	RC25N-250	250	1587.5							
RC25D-260	RC25N-260	260	1651.0							
RC25D-270	RC25N-270	270	1714.5							
RC25D-280	RC25N-280	280	1778.0							

Chain Material Data:

Chain Tensile Strength @ Break (N)	Delrin = 280	Nylatron GS = 289
Max. operating load (N)	Delrin = 93	Nylatron GS = 98
Tensile (KG/CM ²)	Delrin = 682	Nylatron GS = 963
Compressive (KG/CM ²)	Delrin = 1097	Nylatron GS = 879
Flexural (KG/CM ²)	Delrin = 956	Nylatron GS = 1195
Water Absorption %	Delrin = 0.25	Nylatron GS = 0.8
Chain Elongation % (ultimate)	Delrin = 9	Nylatron GS = 34
@ 75% Ultimate	Delrin = 5	Nylatron GS = 14

Other materials available upon request. Other lengths available upon request.

For material data on Polypropylene (RC25PP) and/or Kynar (RC25K) contact our technical support department.

SPROCKETS

CIR. PITCH	BORE	STYLE	MATERIALS	BERG'S ® NAME	CHAIN
6.35mm	Ø8.0	PIN HUB	Delrin®	ROW-L-ER®	Operates with RC25 and RC25SS series

STOCK NO.	NO. OF TEETH	OUTSIDE DIA. (O.D.)	PITCH DIA. (P.D.)	MINOR DIA. (M.D.)	HUB DIA. (H)
25EM4EM-10	10	23.34	20.55	17.25	13.5
25EM4EM-12	12	27.51	24.53	21.23	
25EM4EM-15	15	33.68	30.54	27.25	15.5
25EM4EM-16	16	35.74	32.55	29.26	
25EM4EM-17	17	37.77	34.56	33.55	
25EM4EM-18	18	39.83	36.57	33.27	
25EM4EM-19	19	41.86	38.58	35.28	
25EM4EM-20	20	43.92	40.59	37.29	
25EM4EM-21	21	45.95	42.61	39.29	17.0
25EM5EM-24	24	52.04	48.65	45.34	
25EM5EM-25	25	54.08	50.66	47.37	
25EM5EM-30	30	64.24	60.75	57.45	

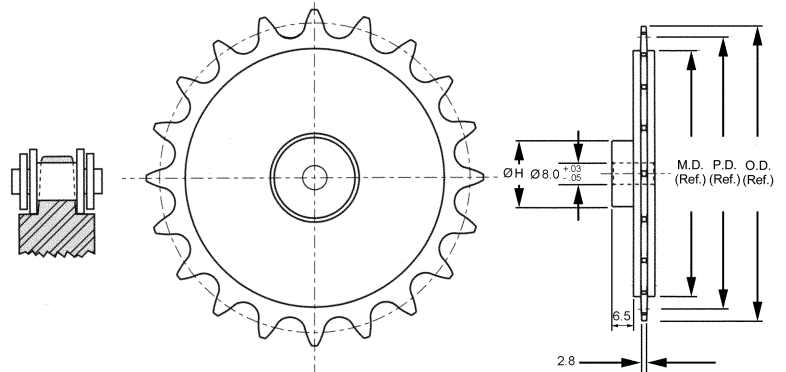

CIR. PITCH	BORE	STYLE	MATERIALS	BERG'S ® NAME	CHAIN
6.35mm	Ø10.0	PIN HUB	Delrin®	ROW-L-ER®	Operates with RC25 and RC25SS series

STOCK NO.	NO. OF TEETH	OUTSIDE DIA. (O.D.)	PITCH DIA. (P.D.)	MINOR DIA. (M.D.)	+DIA. (H)
25EM6EM-32	32	68.28	64.78	61.49	17.0
25EM6EM-36	36	76.40	72.86	69.57	
25EM6EM-40	40	84.51	81.93	77.65	

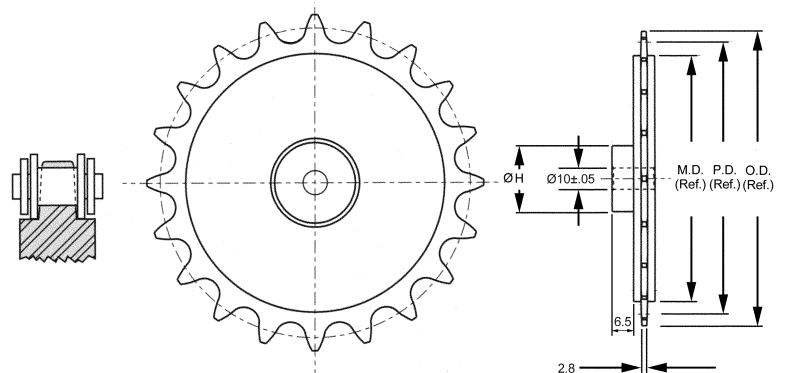

SPROCKETS

CIR. PITCH	BORE	STYLE	MATERIALS	BERG'S ® NAME	CHAIN
6.35mm	Ø8.0	PIN HUB	NYLATRON®	ROW-L-ER®	Operates with RC25 and RC25SS series

STOCK NO.	NO. OF TEETH	OUTSIDE DIA. (O.D.)	PITCH DIA. (P.D.)	MINOR DIA. (M.D.)	BORE +.05/-05	HUB DIA. (H)	HUB PROJ. (P)
25EM4GSM-10	10	23.34	20.55	17.25	8.0	14.0	9.5
25EM4GSM-11	11	24.45	22.55	19.23		14.0	9.5
25EM5GSM-12	12	27.51	24.53	21.23		17.5	9.5
25EM5GSM-13	13	31.65	26.53	23.24		19.0	9.5
25EM5GSM-14	14	33.68	28.54	25.22		19.0	9.5
25EM5GSM-15	15	35.74	30.54	27.25		19.0	9.5
25EM5GSM-16	16	37.77	32.55	29.26		20.5	9.5
25EM5GSM-17	17	39.83	34.56	33.55		23.0	9.5

CIR. PITCH	BORE	STYLE	MATERIALS	BERG'S ® NAME	CHAIN
6.35mm	Ø10.0	PIN HUB	NYLATRON®	ROW-L-ER®	Operates with RC25 and RC25SS series

STOCK NO.	NO. OF TEETH	OUTSIDE DIA. (O.D.)	PITCH DIA. (P.D.)	MINOR DIA. (M.D.)	BORE +.05/-05	HUB DIA. (H)	HUB PROJ. (P)
25EM6GSM-18	18	39.83	36.57	33.27	10.0	25.5	9.5
25EM6GSM-19	19	41.86	38.58	35.28		27.0	9.5
25EM6GSM-20	20	43.92	40.59	37.29		29.5	9.5
25EM6GSM-21	21	45.95	42.61	39.29		29.5	9.5
25EM6GSM-22	22	47.98	44.62	41.33		29.5	9.5
25EM6GSM-24	24	52.04	48.65	45.34		32.5	9.5
25EM6GSM-26	26	56.11	52.68	49.38		32.5	9.5
25EM6GSM-27	27	60.17	56.70	53.42		32.5	9.5
25EM6GSM-30	30	64.40	60.75	57.45		31.0	9.5

CIR. PITCH	BORE	STYLE	MATERIALS	BERG'S ® NAME	CHAIN
6.35mm	Ø16.0	PIN HUB	NYLATRON®	ROW-L-ER®	Operates with RC25 and RC25SS series

STOCK NO.	NO. OF TEETH	OUTSIDE DIA. (O.D.)	PITCH DIA. (P.D.)	MINOR DIA. (M.D.)	BORE +.05/-05	HUB DIA. (H)	HUB PROJ. (P)
25EM8GSM-36	36	76.40	72.86	69.57	16.0	35.0	12.7
25EM8GSM-40	40	84.51	81.93	77.65		35.0	12.7
25EM8GSM-48	48	100.69	97.09	93.80		35.0	12.7
25EM8GSM-54	54	112.83	109.21	106.68		35.0	12.7
25EM8GSM-60	60	124.97	121.33	118.03		35.0	12.7

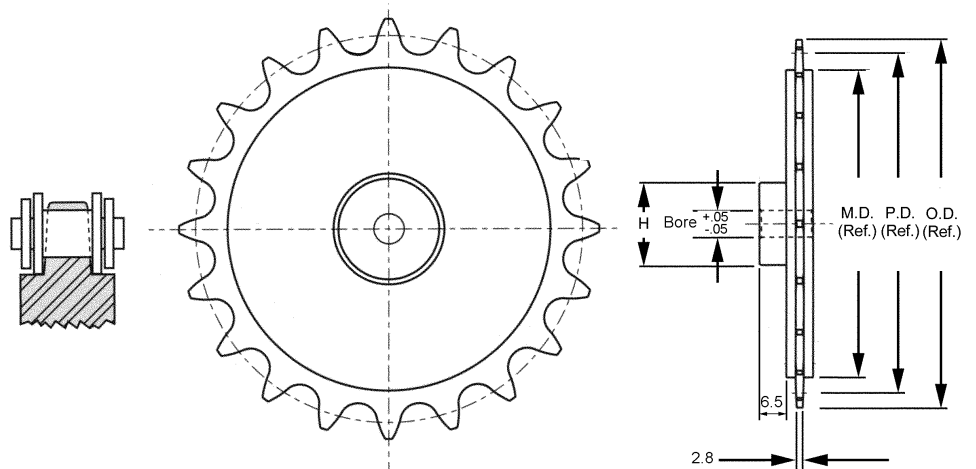

LINK CHAIN

CIRCULAR PITCH	ROLLER DIAMETER	BERG NAME	MATERIAL	SPROCKET
9.53mm	5.1mm	ROW-L-ER®	Delrin and Nylatron	Operates with 35EM and 35SP series.

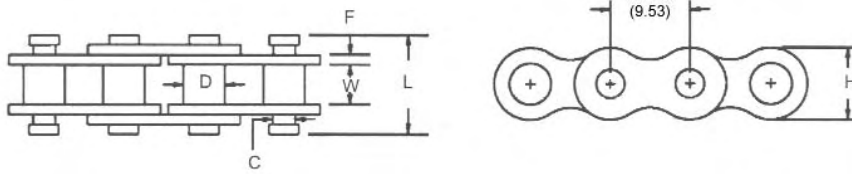

DELIRIN® STOCK NO.	NYLATRON® STOCK NO.	NO. OF PITCHES	LENGTH (MM)	W	D	C	F	L	H
RC35D-40	RC35N-40	40	381.0						
RC35D-50	RC35N-50	50	476.3						
RC35D-60	RC35N-60	60	571.5						
RC35D-70	RC35N-70	70	666.8						
RC35D-80	RC35N-80	80	762.0						
RC35D-90	RC35N-90	90	857.3						
RC35D-100	RC35N-100	100	952.5						
RC35D-120	RC35N-120	120	1143.0						
RC35D-130	RC35N-130	130	1238.3	4.8	5.08	3.58	1.9	13.8	8.9
RC35D-140	RC35N-140	140	1333.5						
RC35D-150	RC35N-150	150	1428.8						
RC35D-160	RC35N-160	160	1524.0						
RC35D-170	RC35N-170	170	1619.3						
RC35D-180	RC35N-180	180	1714.5						
RC35D-190	RC35N-190	190	1809.8						
RC35D-200	RC35N-200	200	1905.0						
RC35D-210	RC35N-210	210	2000.3						
RC35D-220	RC35N-220	220	2095.5						
RC35D-230	RC35N-230	230	2190.3						

Chain Material Data:

Chain Tensile Strength @ Break (N)	Delrin = 605	Nylatron GS = 605
Max. operating load (N)	Delrin = 200	Nylatron GS = 200
Tensile (KG/CM ²)	Delrin = 682	Nylatron GS = 963
Chain Elongation % (ultimate)	Delrin = 6	Nylatron GS = 11
@ 75% Ultimate	Delrin = 5	Nylatron GS = 9
Compressive (KG/CM ²)	Delrin = 1097	Nylatron GS = 879
Flexural (KG/CM ²)	Delrin = 956	Nylatron GS = 1195
Water Absorption %	Delrin = 0.25	Nylatron GS = 0.8

Other materials available upon request. Other lengths available upon request.

SPROCKETS

CIR. PITCH	STOCK BORE	STYLE	MATERIALS	BERG'S ® NAME	CHAIN
9.53mm	Ø10	PIN HUB	FILLED NYLATRON® GS-51	ROW-L-ER®	Operates with RC35 and RC35SS series

STOCK NO.	NO. OF TEETH	OUTSIDE DIA. (O.D.)	PITCH DIA. (P.D.)	MINOR DIA. (M.D.)	L	HUB DIA. (H)	MAX. BORE
35EM6GSM-9	9	31.90	27.84	22.76	19	16.0	10
35EM6GSM-10	10	35.05	30.84	25.76		20.6	12
35EM6GSM-11	11	38.15	33.81	28.73		22.2	12

CIR. PITCH	BORE	STYLE	MATERIALS	BERG'S ® NAME	CHAIN
9.53mm	Ø16	PIN HUB	FILLED NYLATRON® GS-51	ROW-L-ER®	Operates with RC35 and RC35SS series

STOCK NO.	NO. OF TEETH	OUTSIDE DIA. (O.D.)	PITCH DIA. (P.D.)	MINOR DIA. (M.D.)	L	HUB DIA. (H)	MAX. BORE
35EM8GSM-12	12	41.28	36.80	31.72	19.0	25.5	19
35EM8GSM-14	14	47.45	42.80	37.72	19.0	27.0	19
35EM8GSM-15	15	50.55	45.82	40.74	19.0	35.0	20
35EM8GSM-16	16	53.62	48.82	43.74	19.0	38.0	24
35EM8GSM-18	18	59.84	54.84	49.56	19.0	31.8	27
35EM8GSM-20	20	65.86	60.88	55.80	22.2	38.0	30
35EM8GSM-24	24	78.08	72.97	67.89	22.2	50.8	30
35EM8GSM-26	26	84.18	79.02	73.94	22.2	52.4	36.5
35EM8GSM-30	30	96.34	91.14	86.06	22.2	57.0	36.5
35EM8GSM-35	35	111.56	105.11	101.17	22.2	57.0	36.5
35EM10GSM-36	36	114.58	109.30	104.22	22.2	57.0	36.5
35EM10GSM-40	40	126.75	121.41	116.33	22.2	63.5	45
35EM10GSM-45	45	141.94	136.55	131.47	25.5	70.0	45

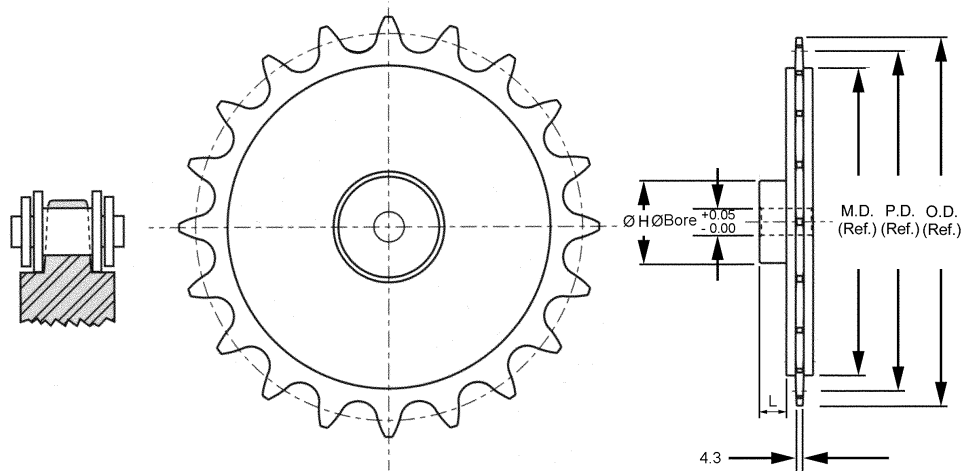

LINK CHAIN

CIRCULAR PITCH	ROLLER DIAMETER	BERG NAME	MATERIAL	SPROCKET
12.7mm	7.9mm	ROW-L-ER®	Delrin and Nylatron	Operates with 40EM series.

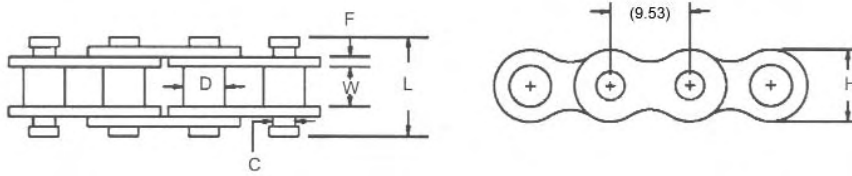

DELRIN® STOCK NO.	NYLATRON® STOCK NO.	NO. OF PITCHES	LENGTH (MM)	PITCH	W	D	C	F	L	H
RC40D-40	RC40N-40	40	508.0	12.7	7.9	7.9	3.96	2.2	18.4	11.7
RC40D-50	RC40N-50	50	635.0							
RC40D-60	RC40N-60	60	762.0							
RC40D-70	RC40N-70	70	889.0							
RC40D-80	RC40N-80	80	1016.0							
RC40D-90	RC40N-90	90	1143.0							
RC40D-100	RC40N-100	100	1270.0							
RC40D-120	RC40N-120	120	1524.0							
RC40D-130	RC40N-130	130	1651.0							
RC40D-140	RC40N-140	140	1778.0							
RC40D-150	RC40N-150	150	1905.0							
RC40D-160	RC40N-160	160	2032.0							
RC40D-170	RC40N-170	170	2159.0							
RC40D-180	RC40N-180	180	2286.0							
RC40D-190	RC40N-190	190	2413.0							
RC40D-200	RC40N-200	200	2540.0							

Chain Material Data:

Chain Tensile Strength @ Break (N)	Delrin = 778	Nylatron GS = 769
Max. operating load (N)	Delrin = 258	Nylatron GS = 254
Tensile (KG/CM ²)	Delrin = 682	Nylatron GS = 963
Chain Elongation % (ultimate)	Delrin = 4	Nylatron GS = 9
@ 75% Ultimate	Delrin = 3	Nylatron GS = 7
Compressive (KG/CM ²)	Delrin = 1097	Nylatron GS = 879
Flexural (KG/CM ²)	Delrin = 956	Nylatron GS = 1195
Water Absorption %	Delrin = 0.25	Nylatron GS = 0.8

Other materials available upon request. Other lengths available upon request.

SPROCKETS

CIR. PITCH	STOCK BORE	STYLE	MATERIALS	BERG'S ® NAME	CHAIN
12.7mm	Ø16	PIN HUB	FILLED NYLATRON® GS-51	ROW-L-ER®	Operates with RC40D and RC40N series

STOCK NO.	NO. OF TEETH	OUTSIDE DIA. (O.D.)	PITCH DIA. (P.D.)	MINOR DIA. (M.D.)	L	HUB DIA. (H)	MAX. BORE
40EM8GSM-9	9	42.52	37.13	29.21	22.2	22.2	16
40EM8GSM-10	10	46.71	41.10	33.17	22.2	28.5	16
40EM8GSM-12	12	55.20	49.07	41.15	22.2	35.0	21.5
40EM8GSM-15	15	67.35	61.08	53.16	22.2	47.5	30
40EM10GSM-16	16	71.48	65.10	57.18	22.2	47.5	32
40EM10GSM-24	24	104.09	97.30	89.38	25.5	63.5	44.5

CIR. PITCH	STOCK BORE	STYLE	MATERIALS	BERG'S ® NAME	CHAIN
12.7MM	Ø19	PIN HUB	FILLED NYLATRON® GS-51	ROW-L-ER®	Operates with RC40D and RC40N series

STOCK NO.	NO. OF TEETH	OUTSIDE DIA. (O.D.)	PITCH DIA. (P.D.)	MINOR DIA. (M.D.)	L	HUB DIA. (H)	MAX. BORE
40EM10GSM-32	32	136.58	129.57	121.64	25.5	50.8	44.5

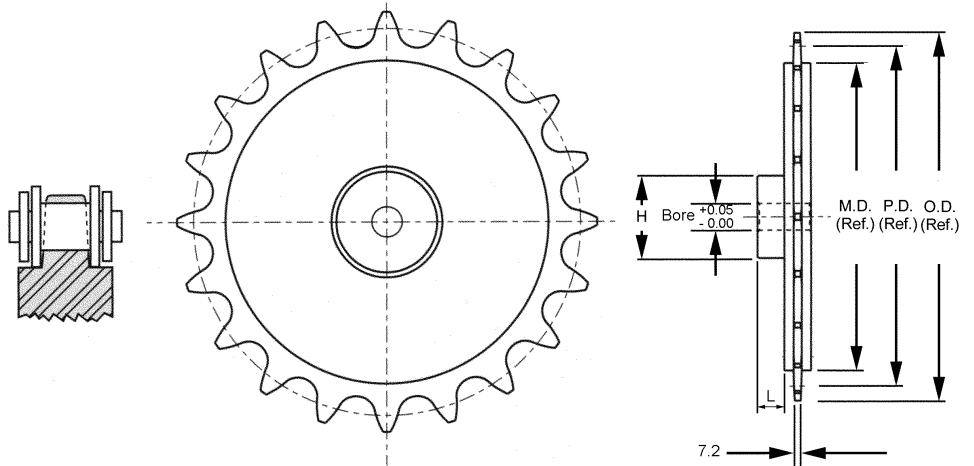

FLEX-E-GRIP TIMING BELTS TECHNICAL DATA

Features

- No Side Flanges Necessary
- Infinite Lengths
- Higher Load Capacities and Narrower Widths
- Positive Drives (Non-slip Engagement)
- No Lubrication
- Minimum Backlash
- High Mechanical Efficiency
- Extra Light Weight
- Silent Operation (No Side Flange Noise)
- Economical
- Wide Speed Range
- Broader Ratio Selection

Installation Notes

- (A)** All Shafts Must Be Parallel
(B) Use Adjustable Centers Wherever Possible
(C) If Adjustable Centers are not Possible Use Idler Pulley Inside The Belt
(D) Never Force Belt Over Pulleys
(E) Avoid Reverse Bending (See Page A 2)

4 Compact Width Sizes

2.073 Pitch (XXL) Miniature 3.2 Wide

Equal to or stronger than conventional Timing Belts up to 19.0 wide

5.080 Pitch (XL) Extra Light 6.4 Wide

Equal to or stronger than conventional Timing Belts up to 25.4 wide

9.525 Pitch (L) Light 12.7 Wide

Equal to or stronger than conventional Timing Belts up to 50.8 wide

12.700 Pitch (H) Heavy 19.0 Wide

Equal to or stronger than conventional Timing Belts up to 50.8 wide

Construction

Belts - Molded in Polyurethane to meet Acid, Chemical and Environmental Conditions.

Cable - Steel Preformed Aircraft Standard Cable of both 7x7 and 7x19 Construction.

Pulleys - Aluminum 2024 (bar) MIL QQ-Q-225/6 Cond. T4 Anodized

Operating Parameters

Minimum Pulley Diameters

SIZE	MAX. SPEED R.P.M.	MIN. NO. OF. GROOVES	PITCH DIAMETER
2.073 D.P. 8TB-SERIES	1750	18	11.89
5.080 PITCH 20TB-SERIES	1750	11	17.78
9.525 PITCH 37TB-SERIES	1750 1160	14 12	42.44 36.37
12.700 PITCH 50TB-SERIES	1750 1160	18 16	72.77 65.13

Will Not Slip, Slide, Jump, Creep or Walk Off Timing Pulley

FLEX-E-GRIP TIMING BELTS TECHNICAL DATA

Technical Data and Comparison With Standard Timing Belts

Miniature (MXL) 2.073 C.P. 3.2mm timing belts - equal to standard 15.9mm wide xxl belts Ultimate tensile

Berg 8 TB Series

Flex-E-Grip® XXL Timing Belts 3.2mm wide 89N ultimate tensile strength.

Conventional Belt	Tensile Strength
3.2mm WIDE	17N
4.8mm WIDE	26N
6.4mm WIDE	34N
15.9mm WIDE	89N

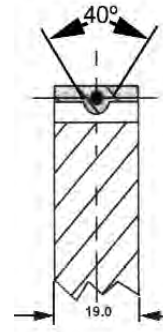

Berg 20TB Series

Flex-E-Grip® (XL) 5.080 C.P. 6.4mm timing belts - equal to standard 25.4mm wide XL belts. XL Timing Belts 6.4mm wide 222N ultimate tensile strength.

Conventional Belt	Tensile Strength
6.4mm WIDE	45N
12.7mm WIDE	55N
15.9mm WIDE	69N
19.0mm WIDE	99N
25.4mm WIDE	102N
63.5mm WIDE	182N

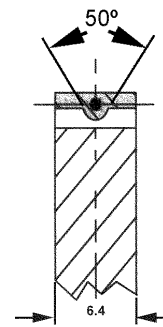

Berg 37TB Series

Flex-E-Grip® (L) 9.525 C.P. 12.7mm timing belts - equal to standard 50.8mm wide L belts. L Timing Belts 12.7mm wide 556N ultimate tensile strength.

Conventional Belt	Tensile Strength
9.5mm WIDE	71N
12.7mm WIDE	107N
5.9mm WIDE	138N
19.0mm WIDE	173N
25.4mm WIDE	245N
63.5mm WIDE	667N

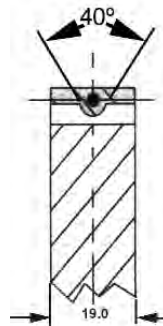

Berg 50TB Series

Flex-E-Grip® (H) 12.700 C.P. 19mm timing belts - equal to standard 50.8mm wide H belts. H Timing Belts 19mm wide 1335N ultimate tensile strength.

Conventional Belt	Tensile Strength
12.7mm WIDE	262N
15.9mm WIDE	356N
19.0mm WIDE	440N
25.4mm WIDE	623N
50.8mm WIDE	1335N

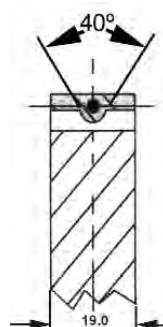

TIMING BELTS

CIRCULAR PITCH	BELT WIDTH	MATERIALS	BERG'S ® NAME	PULLEY
2mm	3.2mm	Polyurethane (Black) 90A Duro 0.5mm Dia. Stainless Steel Cable*	Flex-E-Grip®	Operates with 8TP series

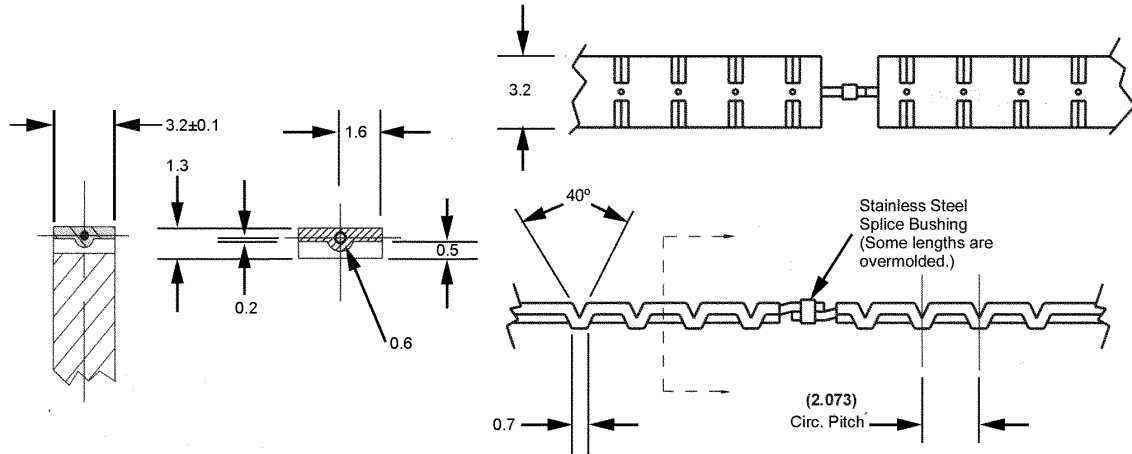

STOCK NO.	NO. OF PITCHES	LENGTH (Ref.)
8TB-24*	24	49.7
8TB-44	44	91.2
8TB-45	45	93.3
8TB-48	48	99.5
8TB-51	51	105.7
8TB-52	52	107.8
8TB-53	53	109.9
8TB-60	60	124.4
8TB-64	64	132.7
8TB-66	66	136.8
8TB-67	67	138.9
8TB-72	72	149.2
8TB-77	77	159.6
8TB-88	88	182.4
8TB-96	96	199.0
8TB-98	98	203.1
8TB-102	102	211.4
8TB-109	109	225.9
8TB-110	110	228.0
8TB-114	114	236.3
8TB-120	120	248.7
8TB-123	123	254.9
8TB-126	126	261.2
8TB-132	132	273.6
8TB-139	139	288.1
8TB-140	140	290.2
8TB-150	150	310.9
8TB-162	162	335.8
8TB-175	175	362.7
8TB-184	184	381.4
8TB-193	193	400.0
8TB-214	214	443.5
8TB-228	228	472.6
8TB-245	245	507.8
8TB-249	249	516.1
8TB-251	251	520.2
8TB-264	264	541.2

- No Flanges Required
- Infinite Lengths
- Silent Drive
- No-Walk Feature
- No Lubrication
- Mass 4.7 Grams/Meter
- Compact Design
- Positive Drive
- Light Weight
- Extra Strong
- Ultimate Tensile Strength 89N
- Temperature Range +82°C to -26°C
- Recommended Operating Load 22N.
- Recommended Max. Operating Speed 1.91 m/s
- For Field Splice Kit Order 8TB-7.

* Splices are factory overmolded



BULK FOOTAGE - NOT SPLICED	
STOCK NO.	LENGTH
8TB-1.5M	1.5 METERS
8TB-3.0M	3.0 METERS
8TB-7.5M	7.5 METERS
8TB-15.0M	15.0 METERS
8TB-30.0M	30.0 METERS

TIMING PULLEYS

CIR. PITCH	BORE	STYLE	MATERIAL	BERG'S ® NAME	BELT
2mm	Ø4	PIN HUB	Aluminum DIN 3.1355 Anodized	Flex-E-Grip®	Operates with Flex-E-Grip Belt 8TB Series

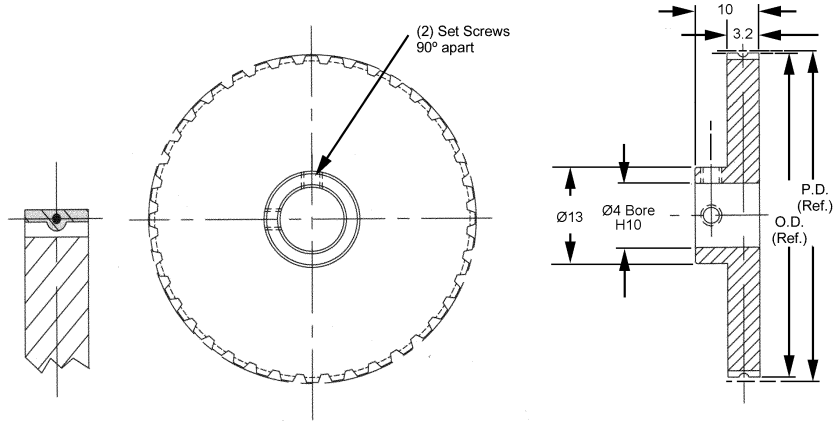

STOCK NO.	NO. OF TEETH	PITCH DIA.	OUTSIDE DIA.
8TP104-14	14*	9.24	8.86
8TP104-15	15*	9.90	9.53
8TP104-18	18*	11.88	11.51
8TP104-20	20	13.19	12.83
8TP104-24	24	15.83	15.47
8TP104-25	25	16.49	16.13
8TP104-28	28	18.47	18.11
8TP104-30	30	19.79	19.43
8TP104-32	32	21.11	20.75
8TP104-34	34	22.43	22.07
8TP104-36	36	23.75	23.39
8TP104-38	38	25.07	24.69
8TP104-40	40	26.39	26.01
8TP104-42	42	27.71	27.33
8TP104-44	44	29.03	28.65
8TP104-48	48	31.67	31.29
8TP104-50	50	32.99	32.61
8TP104-54	54	35.63	35.26
8TP104-60	60	39.58	39.22
8TP104-72	72	47.50	47.14
8TP104-75	75	49.48	49.12
8TP104-80	80	52.78	52.40
8TP104-84	84	55.42	55.04
8TP104-88	88	58.06	57.68
8TP104-90	90	59.38	59.00
8TP104-96	96	63.34	62.97
8TP104-98	98	64.65	64.29
8TP104-100	100	65.97	65.61
8TP104-120	120	79.17	78.79



* For 14-18 teeth, hub diameter equals 8.1.
 * Pulleys Ø12.0mm and smaller for idler use only.
 Teeth could be anodized.

TIMING PULLEYS

CIR. PITCH	BORE	STYLE	MATERIAL	BERG'S ® NAME	BELT
2mm	Ø6	PIN HUB	Aluminum DIN 3.1355 Anodized	Flex-E-Grip®	Operates with Flex-E-Grip Belt 8TB Series

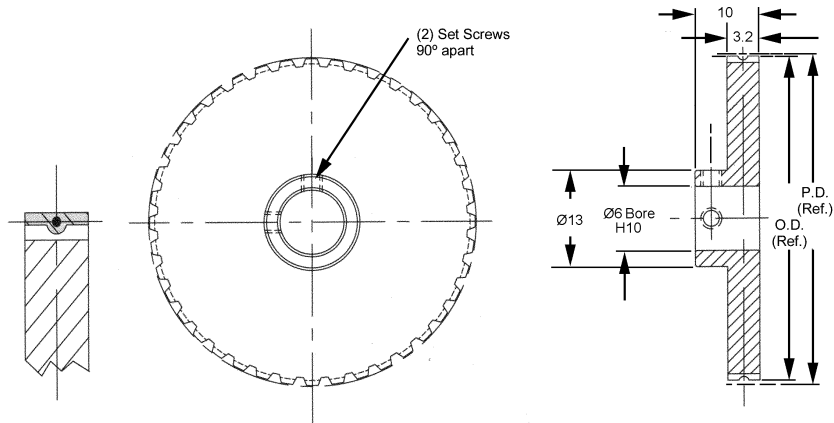

STOCK NO.	NO. OF TEETH	PITCH DIA.	OUTSIDE DIA.
8TP106-14	14*	9.24	8.86
8TP106-15	15*	9.90	9.53
8TP106-18	18*	11.88	11.51
8TP106-20	20	13.19	12.83
8TP106-24	24	15.83	15.47
8TP106-25	25	16.49	16.13
8TP106-28	28	18.47	18.11
8TP106-30	30	19.79	19.43
8TP106-32	32	21.11	20.75
8TP106-34	34	22.43	22.07
8TP106-36	36	23.75	23.39
8TP106-38	38	25.07	24.69
8TP106-40	40	26.39	26.01
8TP106-42	42	27.71	27.33
8TP106-44	44	29.03	28.65
8TP106-48	48	31.67	31.29
8TP106-50	50	32.99	32.61
8TP106-54	54	35.63	35.26
8TP106-60	60	39.58	39.22
8TP106-72	72	47.50	47.14
8TP106-75	75	49.48	49.12
8TP106-80	80	52.78	52.40
8TP106-84	84	55.42	55.04
8TP106-88	88	58.06	57.68
8TP106-90	90	59.38	59.00
8TP106-96	96	63.34	62.97
8TP106-98	98	64.65	64.29
8TP106-100	100	65.97	65.61
8TP106-120	120	79.17	78.79



* For 14-18 teeth, hub diameter equals 8.1
 * Pulleys Ø12.0mm and smaller for idler use only.
 Teeth could be anodized.

TIMING PULLEYS

CIR. PITCH	BORE	STYLE	MATERIAL	BERG'S ® NAME	BELT
2mm	Ø8	PIN HUB	Aluminum DIN 3.1355 Anodized	Flex-E-Grip®	Operates with Flex-E-Grip Belt 8TB Series

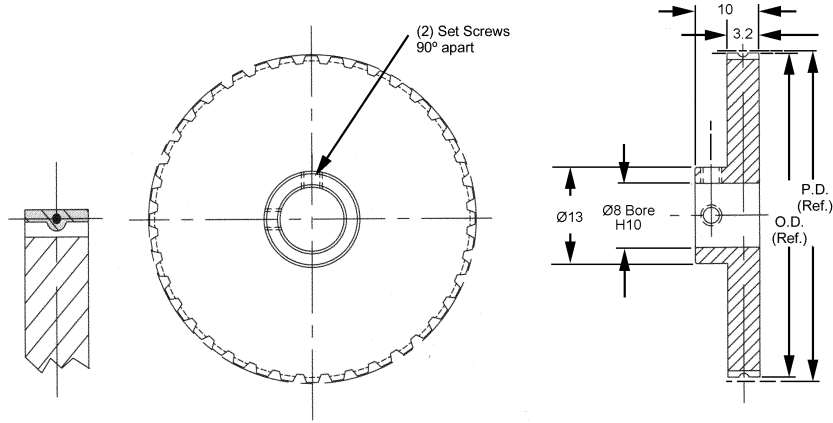

STOCK NO.	NO. OF TEETH	PITCH DIA.	OUTSIDE DIA.
8TP108-20	20*	13.19	12.83
8TP108-24	24	15.83	15.47
8TP108-25	25	16.49	16.13
8TP108-28	28	18.47	18.11
8TP108-30	30	19.79	19.43
8TP108-32	32	21.11	20.75
8TP108-34	34	22.43	22.07
8TP108-36	36	23.75	23.39
8TP108-38	38	25.07	24.69
8TP108-40	40	26.39	26.01
8TP108-42	42	27.71	27.33
8TP108-44	44	29.03	28.65
8TP108-48	48	31.67	31.29
8TP108-50	50	32.99	32.61
8TP108-54	54	35.63	35.26
8TP108-60	60	39.58	39.22
8TP108-72	72	47.50	47.14
8TP108-75	75	49.48	49.12
8TP108-80	80	52.78	52.40
8TP108-84	84	55.42	55.04
8TP108-88	88	58.06	57.68
8TP108-90	90	59.38	59.00
8TP108-96	96	63.34	62.97
8TP108-98	98	64.65	64.29
8TP108-100	100	65.97	65.61
8TP108-120	120	79.17	78.79



* For 20 teeth, hub diameter equals 12.1.
 * Pulleys Ø12.0mm and smaller for idler use only.
 Teeth could be anodized.

TIMING BELTS

CIRCULAR PITCH	BELT WIDTH	MATERIALS	BERG'S ® NAME	PULLEY
5mm	6.4mm	Polyurethane (Red) 90A Duro 0.8mm Dia. Stainless Steel Cable*	Flex-E-Grip®	Operates with 20TP series

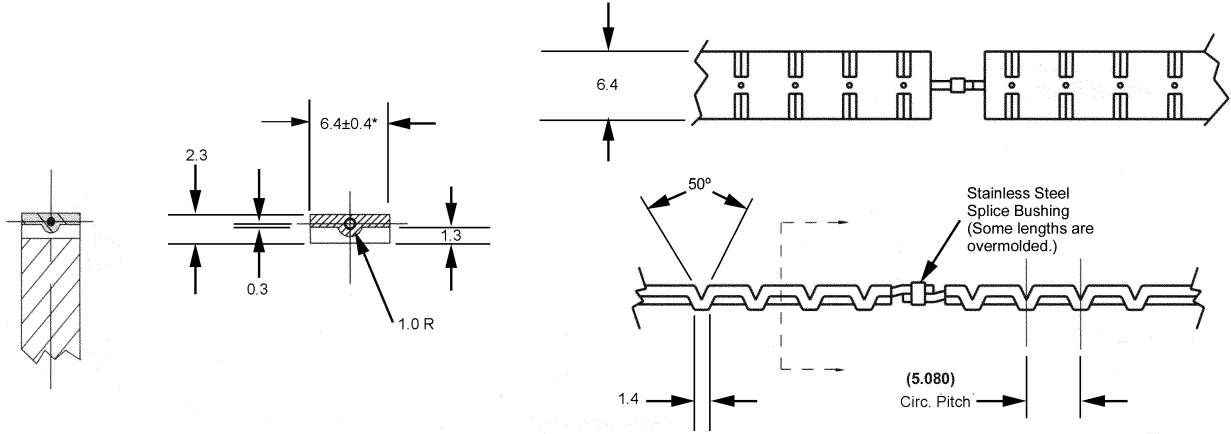

STOCK NO.	NO. OF PITCHES	LENGTH (Ref.)
20TB-10	10*	50.8
20TB-15	15*	76.2
20TB-20	20*	101.6
20TB-25	25	127.0
20TB-30	30	152.4
20TB-35	35	177.8
20TB-40	40	203.2
20TB-45	45	228.6
20TB-50	50	254.0
20TB-55	55	279.4
20TB-60	60	304.8
20TB-65	65	330.2
20TB-70	70	355.6
20TB-80	80	406.4
20TB-85	85	431.8
20TB-90	90	457.2
20TB-95	95	482.6
20TB-100	100	508.0
20TB-105	105	533.4
20TB-110	110	558.8
20TB-115	115	584.2
20TB-120	120	609.6
20TB-125	125	635.0
20TB-130	130	660.4
20TB-135	135	685.8
20TB-140	140	711.2
20TB-145	145	736.6
20TB-150	150	762.0
20TB-155	155	787.4
20TB-160	160	812.8
20TB-175	175	889.0
20TB-180	180	914.4
20TB-185	185	939.8
20TB-190	190	965.2
20TB-200	200	1016.0
20TB-210	210	1066.8

*Aramid Core. Alternate construction available.

- No Flanges Required
- Infinite Lengths
- Silent Drive
- No-Walk Feature
- No Lubrication
- Mass 9 Grams/Meter
- Compact Design
- Positive Drive
- Light Weight
- Extra Strong
- Ultimate Tensile Strength 222N
- Temperature Range +82°C to -26°C
- Recommended Operating Load 53N
- Recommended Max. Operating Speed 1.91 m/s
- For Field Splice Kit Order 20TB-7

* Splices are factory overmolded

BULK FOOTAGE - NOT SPLICED	
STOCK NO.	LENGTH
20TB-1.5M	1.5 METERS
20TB-3.0M	3.0 METERS
20TB-7.5M	7.5 METERS
20TB-15.0M	15.0 METERS
20TB-30.0M	30.0 METERS



TIMING PULLEYS

CIR. PITCH	BORE	STYLE	MATERIAL	BERG'S® NAME	BELT
5mm	Ø8	PIN HUB	Aluminum DIN 3.1355 Anodized	Flex-E-Grip®	Operates with Flex-E-Grip Belt 20TB Series

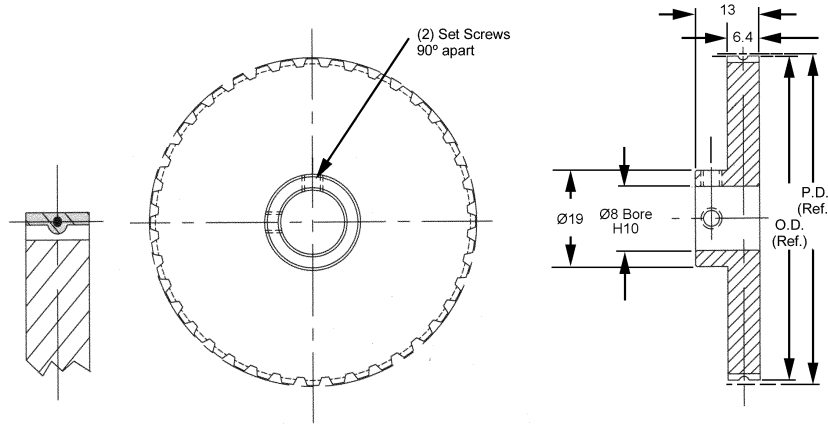

STOCK NO.	NO. OF TEETH	PITCH DIA.	OUTSIDE DIA.
20TP108-10	10*	16.17	15.65
20TP108-11	11*	17.79	17.27
20TP108-12	12*	19.40	18.87
20TP108-14	14	22.64	22.12
20TP108-15	15	24.26	23.72
20TP108-16	16	25.87	25.35
20TP108-17	17	27.49	26.97
20TP108-18	18	29.11	28.58
20TP108-19	19	30.72	30.20
20TP108-20	20	32.34	31.83
20TP108-21	21	33.96	33.43
20TP108-22	22	35.57	35.05
20TP108-23	23	37.19	36.68
20TP108-24	24	38.81	38.28
20TP108-25	25	40.43	39.90
20TP108-27	27	43.66	43.13
20TP108-28	28	45.28	44.75
20TP108-29	29	46.89	46.38
20TP108-30	30	48.51	47.98
20TP108-32	32	51.74	51.23
20TP108-36	36	58.21	57.68
20TP108-40	40	64.68	64.16
20TP108-42	42	67.91	67.39
20TP108-44	44	71.15	70.64
20TP108-45	45	72.77	72.24
20TP108-48	48	77.62	77.09
20TP108-50	50	80.85	80.34
20TP108-60	60	97.02	96.49
20TP108-72	72	116.43	115.90



• For 10-12 teeth, hub diameter equals 14.1.
 * Pulleys Ø19.0mm P.D. and smaller for idler use only.
 Other numbers of teeth available upon request.
 Teeth could be anodized.

TIMING PULLEYS

CIR. PITCH	BORE	STYLE	MATERIAL	BERG'S ® NAME	BELT
5mm	Ø10	PIN HUB	Aluminum DIN 3.1355 Anodized	Flex-E-Grip®	Operates with Flex-E-Grip Belt 20TB Series

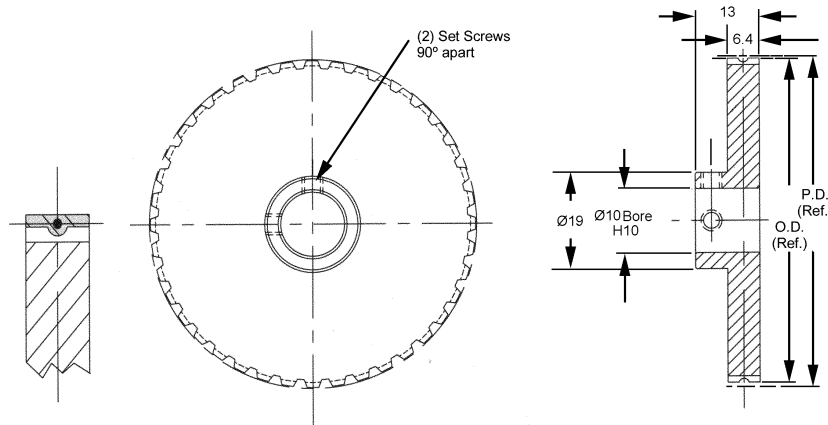

STOCK NO.	NO. OF TEETH	PITCH DIA.	OUTSIDE DIA.
20TP110-11	11*	17.79	17.27
20TP110-12	12*	19.40	18.87
20TP110-14	14	22.64	22.12
20TP110-15	15	24.26	23.72
20TP110-16	16	25.87	25.35
20TP110-17	17	27.49	26.97
20TP110-18	18	29.11	28.58
20TP110-19	19	30.72	30.20
20TP110-20	20	32.34	31.83
20TP110-21	21	33.96	33.43
20TP110-22	22	35.57	35.05
20TP110-23	23	37.19	36.68
20TP110-24	24	38.81	38.28
20TP110-25	25	40.43	39.90
20TP110-27	27	43.66	43.13
20TP110-28	28	45.28	44.75
20TP110-29	29	46.89	46.38
20TP110-30	30	48.51	47.98
20TP110-32	32	51.74	51.23
20TP110-36	36	58.21	57.68
20TP110-40	40	64.68	64.16
20TP110-42	42	67.91	67.39
20TP110-44	44	71.15	70.64
20TP110-45	45	72.77	72.24
20TP110-48	48	77.62	77.09
20TP110-50	50	80.85	80.34
20TP110-60	60	97.02	96.49
20TP110-72	72	116.43	115.90



• For 11-12 teeth, hub diameter equals 15.7.
 * Pulleys Ø19.0mm P.D. and smaller for idler use only.
 Other numbers of teeth available upon request.
 Teeth could be anodized.

TIMING PULLEYS

CIR. PITCH	BORE	STYLE	MATERIAL	BERG'S ® NAME	BELT
5mm	Ø12	PIN HUB	Aluminum DIN 3.1355 Anodized	Flex-E-Grip®	Operates with Flex-E-Grip Belt 20TB Series

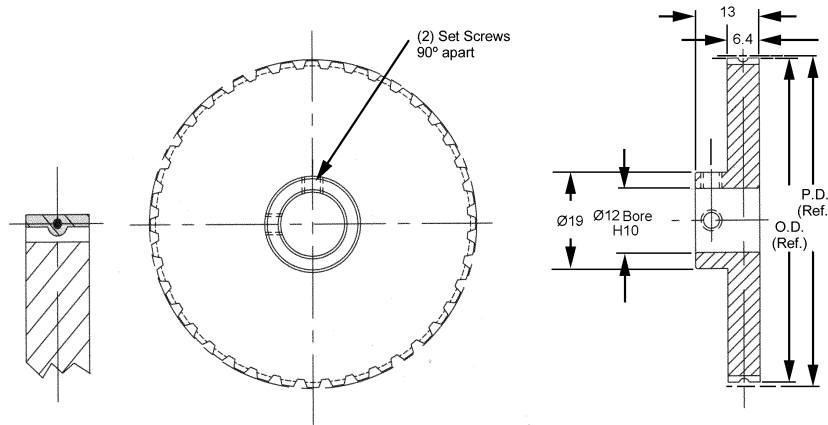

STOCK NO.	NO. OF TEETH	PITCH DIA.	OUTSIDE DIA.
20TP112-12	12*	19.40	18.87
20TP112-14	14	22.64	22.12
20TP112-15	15	24.26	23.72
20TP112-16	16	25.87	25.35
20TP112-17	17	27.49	26.97
20TP112-18	18	29.11	28.58
20TP112-19	19	30.72	30.20
20TP112-20	20	32.34	31.83
20TP112-21	21	33.96	33.43
20TP112-22	22	35.57	35.05
20TP112-23	23	37.19	36.68
20TP112-24	24	38.81	38.28
20TP112-25	25	40.43	39.90
20TP112-27	27	43.66	43.13
20TP112-28	28	45.28	44.75
20TP112-29	29	46.89	46.38
20TP112-30	30	48.51	47.98
20TP112-32	32	51.74	51.23
20TP112-36	36	58.21	57.68
20TP112-40	40	64.68	64.16
20TP112-42	42	67.91	67.39
20TP112-44	44	71.15	70.64
20TP112-45	45	72.77	72.24
20TP112-48	48	77.62	77.09
20TP112-50	50	80.85	80.34
20TP112-60	60	97.02	96.49
20TP112-72	72	116.43	115.90



* For 12 teeth, hub diameter equals 17.4.
Other numbers of teeth available upon request.

Teeth could be anodized.

TIMING BELTS

CIRCULAR PITCH	BELT WIDTH	MATERIALS	BERG'S ® NAME	PULLEY
9.525mm	12.7mm	Polyurethane (Blue) 90A Duro 1.2mm Dia. Stainless Steel Cable*	Flex-E-Grip®	Operates with 37TP series

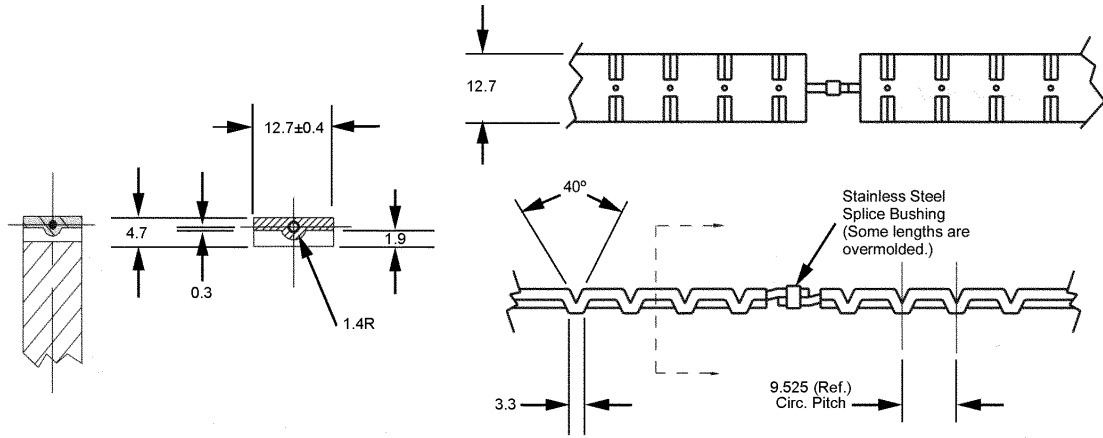

STOCK NO.	NO. OF PITCHES	LENGTH (Ref.)
37TB-20	20	190.5
37TB-22	22	209.5
37TB-24	24	228.6
37TB-26	26	247.6
37TB-28	28	266.7
37TB-30	30	285.7
37TB-33	33	314.3
37TB-36	36	342.9
37TB-40	40	381.0
37TB-45	45	428.6
37TB-50	50	476.2
37TB-56	56	533.4
37TB-60	60	571.5
37TB-64	64	609.6
37TB-68	68	647.7
37TB-72	72	685.8
37TB-80	80	765.0
37TB-86	86	819.1
37TB-92	92	876.3
37TB-98	98	933.4
37TB-100	100	952.5
37TB-104	104	990.6
37TB-108	108	1028.7
37TB-112	112	1066.8
37TB-116	116	1104.9
37TB-120	120	1143.0
37TB-124	124	1181.1
37TB-128	128	1219.2
37TB-132	132	1257.3
37TB-136	136	1295.4
37TB-140	140	1333.5
37TB-144	144	1371.6
37TB-148	148	1409.7
37TB-152	152	1447.8
37TB-156	156	1485.9
37TB-160	160	1524.0
37TB-176	176	1676.4

Aramid Core. Alternate construction available.

- No Flanges Required
- Infinite Lengths
- Silent Drive
- No-Walk Feature
- No Lubrication
- Mass 38 Grams/Meter
- Compact Design
- Positive Drive
- Light Weight
- Extra Strong
- Ultimate Tensile Strength 556N
- Temperature Range +82°C to -26°C
- Recommended Max. Operating Speed 1.91m/s
- For Field Splice Kit Order 37TB-7

* Splices are factory overmolded

BULK FOOTAGE - NOT SPLICED	
STOCK NO.	LENGTH
37TB-1.5M	1.5 METERS
37TB-3.0M	3.0 METERS
37TB-7.5M	7.5 METERS
37TB-15.0M	15.0 METERS
37TB-30.0M	30.0 METERS

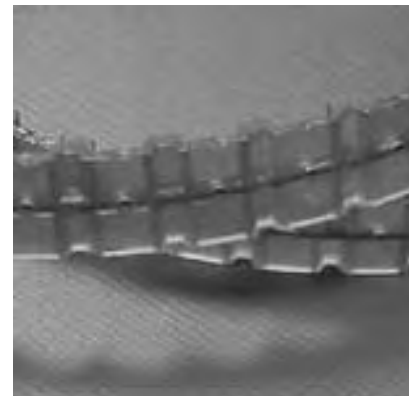

TIMING PULLEYS

CIR. PITCH	BORE	STYLE	MATERIAL	BERG'S ® NAME	BELT
9.525mm	Ø8	PIN HUB	Aluminum DIN 3.1355 Anodized	Flex-E-Grip®	Operates with Flex-E-Grip Belt 37TB Series

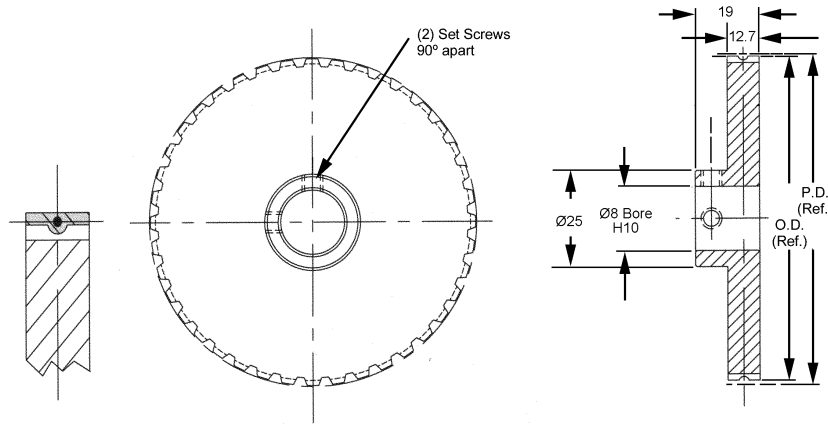

STOCK NO.	NO. OF TEETH	PITCH DIA.	OUTSIDE DIA.
37TP108-10	10*	30.32	29.57
37TP108-11	11*	33.35	32.59
37TP108-12	12	36.38	35.64
37TP108-13	13	39.42	38.66
37TP108-14	14	42.45	41.71
37TP108-15	15	45.48	44.73
37TP108-16	16	48.51	47.75
37TP108-17	17	51.54	50.80
37TP108-18	18	54.57	53.82
37TP108-19	19	57.61	56.87
37TP108-20	20	60.64	59.89
37TP108-21	21	63.67	62.92
37TP108-22	22	66.70	65.96
37TP108-24	24	72.77	72.01
37TP108-26	26	78.83	78.08
37TP108-28	28	84.89	84.15
37TP108-30	30	90.96	90.22
37TP108-32	32	97.02	96.27
37TP108-36	36	109.15	108.41

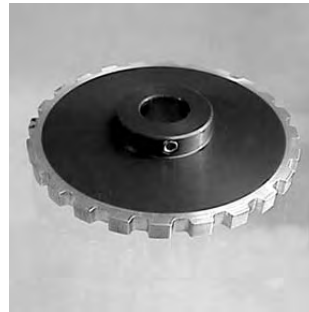

* Pulleys Ø35.0mm P.D. and smaller for idler use only.
Other numbers of teeth available upon request.

Teeth could be anodized.

Max-M-Drive® CABLE DRIVE CHAIN TECHNICAL DATA

Operating Notes

Timing Belts also known as Synchronous Belts are basically flat belts with evenly spaced or pitched grooves. These grooves when matched with the grooves in the pulleys provide a positive no-slip engagement. These belts will not stretch and require no lubrication.

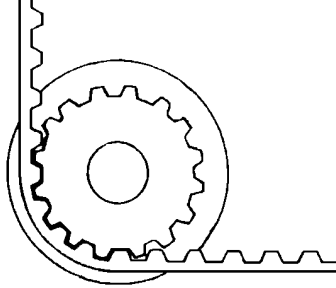

TB7 Series

- Trapezoidal Profile
- 2.03 Pitch
- Maximum Operating Speed 20,000 RPM
- Minimum Pulley Diameter 6.48 (10 grooves)
- Maximum Operating Tension 7N

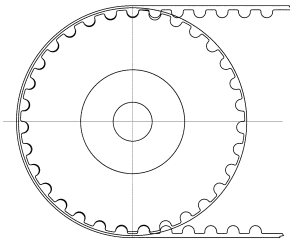

TB3 Series

- HTD Profile
- 3mm Pitch
- Maximum Operating Tension 33N
- Maximum Operating Speed 20,000RPM
- Minimum Pulley Diameter 9.5mm (10 grooves)

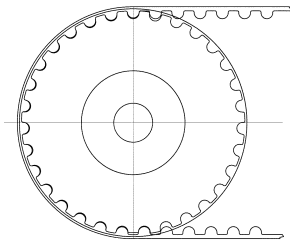

TB5 Series

- HTD Profile
- 5mm Pitch
- Maximum Operating Tension 145N
- Maximum Operating Speed 10,000RPM
- Minimum Pulley Diameter 17.5mm (11 grooves)

TIMING BELTS

CIRCULAR PITCH	BELT WIDTH	MATERIALS	BERG'S ® NAME	PULLEY
2mm	3mm	Neoprene (Black) Fiberglass reinforced	Max-M-Drive®	Operates with TP7 Series

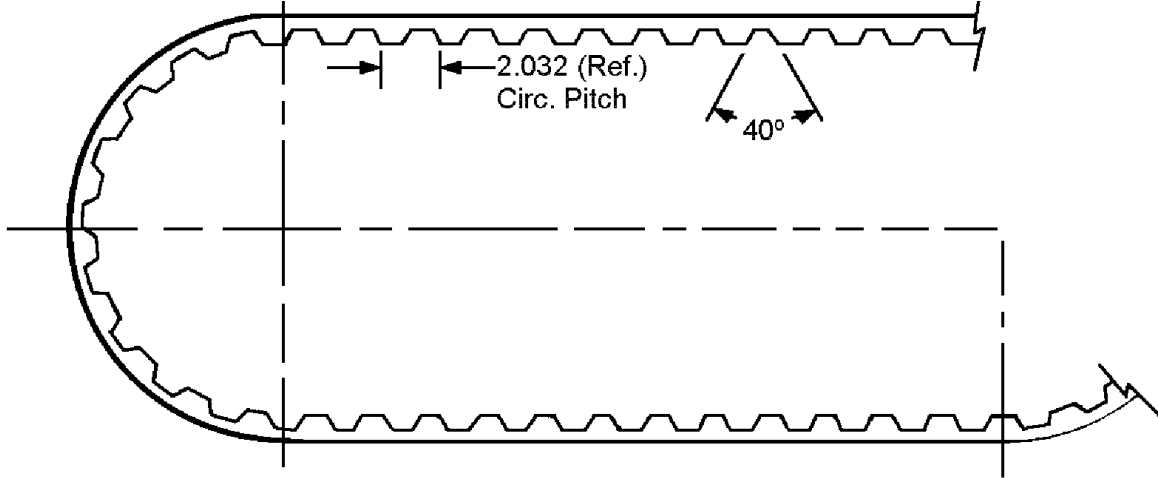

STOCK NO.	NO. OF GROOVES	LENGTH (Ref.)
TB7EF2-40	40	81.3
TB7EF2-42	42	85.3
TB7EF2-45	45	91.4
TB7EF2-50	50	101.6
TB7EF2-54	54	109.7
TB7EF2-55	55	111.8
TB7EF2-57	57	115.8
TB7EF2-60	60	121.9
TB7EF2-64	64	130.0
TB7EF2-67	67	136.1
TB7EF2-70	70	142.2
TB7EF2-73	73	148.3
TB7EF2-80	80	162.6
TB7EF2-90	90	182.9
TB7EF2-100	100	203.2
TB7EF2-105	105	213.4
TB7EF2-110	110	223.5
TB7EF2-120	120	243.8
TB7EF2-130	130	264.2
TB7EF2-150	150	304.8
TB7EF2-160	160	325.1
TB7EF2-170	170	345.4
TB7EF2-175	175	355.6
TB7EF2-190	190	386.1
TB7EF2-200	200	406.4
TB7EF2-225	225	457.2
TB7EF2-250	250	508.0
TB7EF2-300	300	609.6
TB7EF2-400	400	812.8

- High Ratios
- Allows use of small diameter pulleys
- High Speeds
- High Power Transmission
- Long Life
- Wear Resistant Nylon Facing
- Low Profile
- Quiet Operation
- Maximum speed up to 20,000 RPM
- Minimum pulley diameter 6.4 (10 grooves)
- Temperature Range +85°C to -34°C



TIMING BELTS

CIRCULAR PITCH	BELT WIDTH	MATERIALS	BERG'S ® NAME	PULLEY
3mm (HTD)	6mm	Neoprene (Black) Fiberglass reinforced	Max-M-Drive®	Operates with TP3 Series

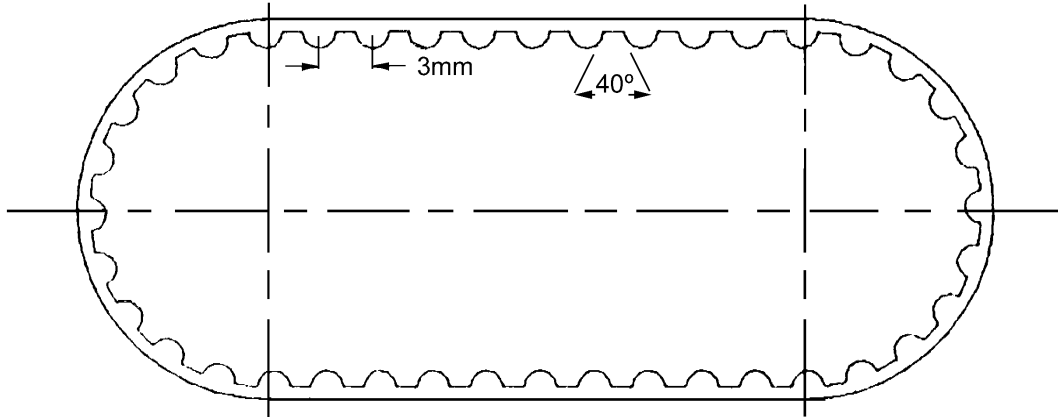

STOCK NO.	NO. OF GROOVES	LENGTH (Ref.)
TB3EF6M-48	48	144
TB3EF6M-49	49	147
TB3EF6M-50	50	150
TB3EF6M-53	53	159
TB3EF6M-59	59	177
TB3EF6M-67	67	201
TB3EF6M-70	70	210
TB3EF6M-71	71	213
TB3EF6M-75	75	225
TB3EF6M-84	84	252
TB3EF6M-85	85	255
TB3EF6M-88	88	264
TB3EF6M-89	89	267
TB3EF6M-92	92	276
TB3EF6M-95	95	285
TB3EF6M-96	96	288
TB3EF6M-99	99	297
TB3EF6M-100	100	300
TB3EF6M-104	104	312
TB3EF6M-106	106	318
TB3EF6M-111	111	333
TB3EF6M-113	113	339
TB3EF6M-119	119	357
TB3EF6M-121	121	363
TB3EF6M-128	128	384
TB3EF6M-130	130	390
TB3EF6M-140	140	420
TB3EF6M-149	149	447
TB3EF6M-153	153	459
TB3EF6M-158	158	474
TB3EF6M-162	162	486
TB3EF6M-163	163	489
TB3EF6M-171	171	513
TB3EF6M-179	179	537
TB3EF6M-188	188	564
TB3EF6M-211	211	633
TB3EF6M-237	237	711
TB3EF6M-294	294	882
TB3EF6M-315	315	945
TB3EF6M-369	369	1107
TB3EF6M-375	375	1125
TB3EF6M-415	415	1245
TB3EF6M-421	421	1263
TB3EF6M-500	500	1500

- High Ratios
- Allows use of small diameter pulleys
- High Speeds
- High Power Transmission
- Long Life
- Wear Resistant Nylon Facing
- Low Profile
- Quiet Operation
- Maximum speed up to 20,000 RPM
- Maximum Operating Tension 60N
- Minimum pulley diameter 9.5 (10 grooves)
- Temperature Range +85°C to -18°C



TIMING BELTS

CIRCULAR PITCH	BELT WIDTH	MATERIALS	BERG'S ® NAME	PULLEY
3mm (HTD)	9mm	Neoprene (Black) Fiberglass reinforced	Max-M-Drive®	Operates with TP3 Series

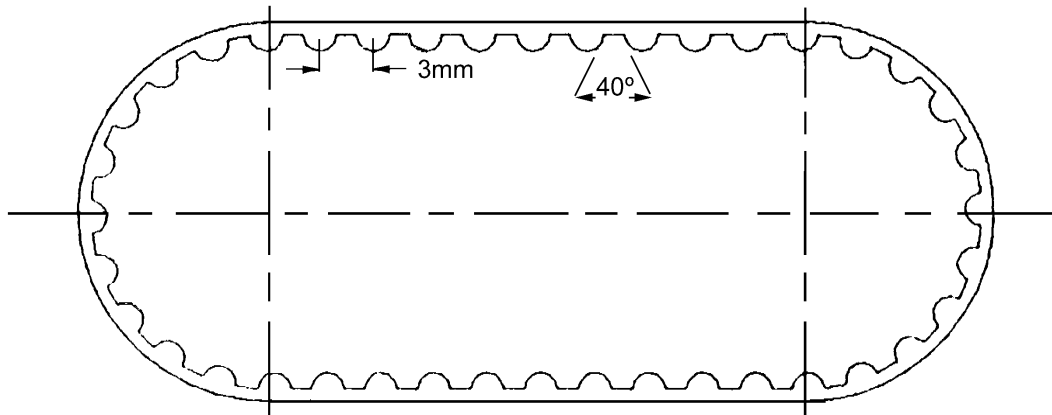

STOCK NO.	NO. OF GROOVES	LENGTH (Ref.)
TB3EF9M-48	48	144
TB3EF9M-49	49	147
TB3EF9M-50	50	150
TB3EF9M-53	53	159
TB3EF9M-56	56	168
TB3EF9M-59	59	177
TB3EF9M-67	67	201
TB3EF9M-70	70	210
TB3EF9M-71	71	213
TB3EF9M-75	75	225
TB3EF9M-80	80	240
TB3EF9M-84	84	252
TB3EF9M-85	85	255
TB3EF9M-88	88	264
TB3EF9M-89	89	267
TB3EF9M-90	90	270
TB3EF9M-92	92	276
TB3EF9M-95	95	285
TB3EF9M-96	96	288
TB3EF9M-99	99	297
TB3EF9M-100	100	300
TB3EF9M-104	104	312
TB3EF9M-106	106	318
TB3EF9M-111	111	333
TB3EF9M-113	113	339
TB3EF9M-119	119	357
TB3EF9M-121	121	363
TB3EF9M-128	128	384
TB3EF9M-130	130	390
TB3EF9M-140	140	420
TB3EF9M-145	145	435
TB3EF9M-149	149	447
TB3EF9M-153	153	459
TB3EF9M-155	155	465
TB3EF9M-158	158	474
TB3EF9M-162	162	486
TB3EF9M-163	163	489
TB3EF9M-171	171	513
TB3EF9M-179	179	537
TB3EF9M-188	188	564
TB3EF9M-199	199	597
TB3EF9M-211	211	633
TB3EF9M-223	223	669
TB3EF9M-237	237	711
TB3EF9M-251	251	753
TB3EF9M-294	294	882
TB3EF9M-315	315	945
TB3EF9M-369	369	1107
TB3EF9M-375	375	1125
TB3EF9M-415	415	1245
TB3EF9M-421	421	1263
TB3EF9M-500	500	1500

- High Ratios
- Allows use of small diameter pulleys
- High Speeds
- High Power Transmission
- Long Life
- Wear Resistant Nylon Facing
- Low Profile
- Quiet Operation
- Maximum speed up to 20,000 RPM
- Maximum Operating Tension 90N
- Minimum pulley diameter 9.5 (10 grooves)
- Temperature Range +85°C to -18°C



TIMING PULLEYS

CIRCULAR PITCH	STYLE	BELT WIDTH	BORE	MATERIALS	BERG'S ® NAME	BELT
3mm (HTD)	Single Flange Pin Hub	6mm to 9mm	6mm	10% Glass Filled Polycarbonate (Black) Hub = Aluminum	Max-M-Drive®	Operates with TB3 Series

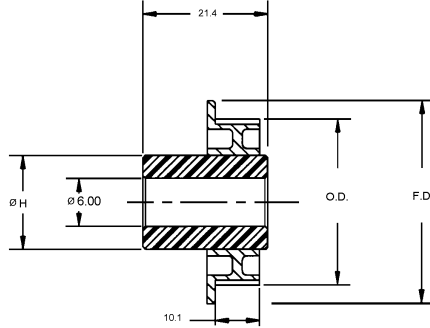

STOCK NO.	BORE + .04 - .00	NO. OF GROOVES	P.D.	O.D.	F.D.	ØH HUB DIA.
TP3P6U9M-24	6.00	24	22.92	22.16	25.9	19
TP3P6U9M-28		28	26.74	25.98	29.7	
TP3P6U9M-30		30	28.65	27.89	31.8	
TP3P6U9M-32		32	30.56	29.80	33.5	
TP3P6U9M-36		36	34.38	33.62	37.3	
TP3P6U9M-40		40	38.20	37.44	41.1	
TP3P6U9M-48	6.00	48	45.84	45.07	48.8	22
TP3P6U9M-50		50	47.7	46.98	50.8	

Other materials, bores and hub styles available on request.
Made solid without lightening grooves.

CIRCULAR PITCH	STYLE	BELT WIDTH	BORE	MATERIALS	BERG'S ® NAME	BELT
3mm (HTD)	Single Flange Pin Hub	6mm to 9mm	8mm	10% Glass Filled Polycarbonate (Black) Hub = Aluminum	Max-M-Drive®	Operates with TB3 Series

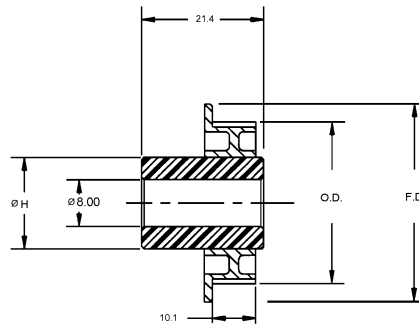

STOCK NO.	BORE + .04 - .00	NO. OF GROOVES	P.D.	O.D.	F.D.	ØH HUB DIA.
TP3P8U9M-60	8.00	60	57.30	56.53	60.2	22
TP3P8U9M-72		72	68.75	67.99	71.9	

Other materials, bores and hub styles available on request.
Made solid without lightening grooves available on request.

TIMING PULLEYS

CIRCULAR PITCH	STYLE	BELT WIDTH	BORE	MATERIALS	BERG'S ® NAME	BELT
3mm (HTD)	Double Flange Pin Hub	6mm to 9mm	4mm	10% Glass Filled Polycarbonate (Black)	Max-M-Drive®	Operates with TB3 Series

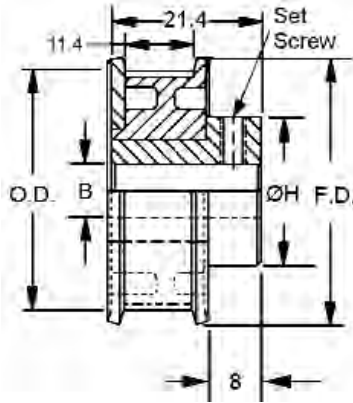

STOCK NO.	B + .04 - .00	NO. OF GROOVES	P.D.	O.D.	F.D.	HUB DIA.
TP3P4W9M-14	4.00	14	13.37	12.61	16.0	17.5
TP3P4W9M-15		15	14.32	13.56	20.0	
TP3P4W9M-16		16	15.28	14.52	18.0	

Other materials, bores and hub styles available on request.
 Made solid without lightening grooves available on request.

CIRCULAR PITCH	STYLE	BELT WIDTH	BORE	MATERIALS	BERG'S ® NAME	BELT
3mm (HTD)	Double Flange Pin Hub	6mm to 9mm	6.35mm	10% Glass Filled Polycarbonate (Black) Aluminum Insert	Max-M-Drive®	Operates with TB3 Series

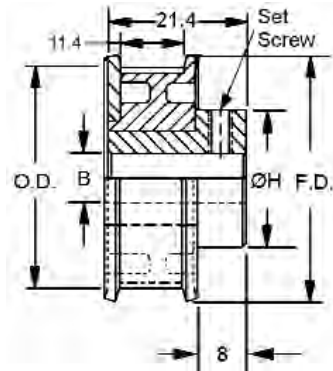

STOCK NO.	B + .04 - .00	NO. OF GROOVES	P.D.	O.D.	F.D.	HUB DIA.
TP3P4W9M-18	6.35	18	17.19	16.43	20.1	17.5
TP3P4W9M-20		20	19.10	18.34	22.6	
TP3P4W9M-22		22	21.01	20.25	23.9	

Other materials, bores and hub styles available on request.
 Made solid without lightening grooves available on request.

TIMING PULLEYS

CIRCULAR PITCH	STYLE	BELT WIDTH	BORE	MATERIALS	BERG'S ® NAME	BELT
3mm (HTD)	Double Flange Pin Hub	6mm to 9mm	6mm	10% Glass Filled Polycarbonate (Black) Aluminum Insert	Max-M-Drive®	Operates with TB3 Series

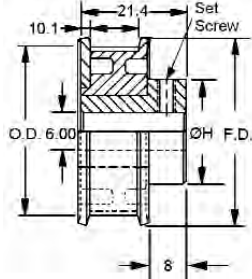

STOCK NO.	BORE + .04 - .00	NO. OF GROOVES	P.D.	O.D.	F.D.	HUB DIA.
TP3P6W9M-28	6.00	28	26.74	25.98	29.7	19
TP3P6W9M-30		30	28.65	27.89	31.8	
TP3P6W9M-32		32	30.56	29.80	33.5	
TP3P6W9M-36		36	34.38	33.62	37.3	
TP3P6W9M-40		40	38.20	37.44	41.1	22
TP3P6W9M-42		42	40.11	39.35	43.2	
TP3P6W9M-48		48	45.84	45.07	48.8	
TP3P6W9M-50		50	47.75	46.98	50.8	

Other materials, bores and hub styles available on request.
Made solid without lightening grooves.

CIRCULAR PITCH	STYLE	BELT WIDTH	BORE	MATERIALS	BERG'S ® NAME	BELT
3mm (HTD)	Double Flange Pin Hub	6mm to 9mm	8.00mm	10% Glass Filled Polycarbonate (Black) Aluminum Insert	Max-M-Drive®	Operates with TB3 Series

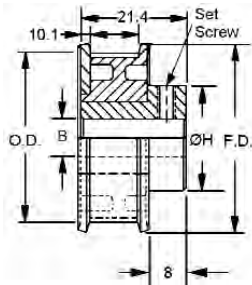

STOCK NO.	B + .04 - .00	NO. OF GROOVES	P.D.	O.D.	F.D.	HUB DIA.
TP3P8W9M-60	8.00	60	57.30	56.53	60.2	22
TP3P8W9M-72		72	68.75	67.99	71.9	

Other materials, bores and hub styles available on request.
Made solid without lightening grooves.

TIMING PULLEYS

CIRCULAR PITCH	STYLE	BELT WIDTH	BORE	MATERIALS	BERG'S ® NAME	BELT
3mm (HTD)	Double Flange Pin Hub	6mm to 9mm	3.00	Aluminum Alloy Din 3.1355 Anodized	Max-M-Drive®	Operates with Max-M-Drive® TB3 series.

Other numbers of grooves, bores or hub styles available on request.

STOCK NO.	NO. OF GROOVES	ØP.D	ØF.D. ±0.4	A ±0.4	Ø H ±0.3	Ø B +.03/-0.00	ØO.D.
TP3A3W9M-10	10	9.5	12.8	17.3	12.8	3.0	8.8
TP3A3W9M-11	11	10.5	13.4	17.3	13.4	3.0	9.7

Supplied with 1 set screw.

Teeth could be anodized.

CIRCULAR PITCH	STYLE	BELT WIDTH	BORE	MATERIALS	BERG'S ® NAME	BELT
3mm (HTD)	Double Flange Pin Hub	6mm to 9mm	4.00	Aluminum Alloy Din 3.1355 Anodized	Max-M-Drive®	Operates with Max-M-Drive® TB3 series.

Other numbers of grooves, bores or hub styles available on request.

STOCK NO.	NO. OF GROOVES	ØP.D	ØF.D. ±0.4	A ±0.4	Ø H ±0.3	Ø B +.03/-0.00	ØO.D.
TP3A4W9M-12	12	11.5	14.7	17.3	14.7	4.0	10.7

Supplied with 1 set screw.

CIRCULAR PITCH	STYLE	BELT WIDTH	BORE	MATERIALS	BERG'S ® NAME	BELT
3mm (HTD)	Double Flange Pin Hub	6mm to 9mm	6.00	Aluminum Alloy Din 3.1355 Anodized	Max-M-Drive®	Operates with Max-M-Drive® TB3 series.

Other numbers of grooves, bores or hub styles available on request.

STOCK NO.	NO. OF GROOVES	ØP.D	ØF.D. ±0.4	A ±0.4	Ø H ±0.3	Ø B +.03/-0.00	ØO.D.
TP3A6W9M-14	14	13.4	16.1	17.6	16.1	6.0	12.6
TP3A6W9M-15	15	14.3	17.4	17.6	17.4	6.0	13.6
TP3A6W9M-16	16	15.3	18.0	17.6	18.0	6.0	14.5

Supplied with 1 set screw.

Teeth could be anodized.

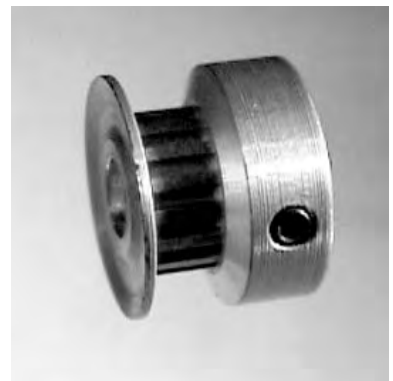
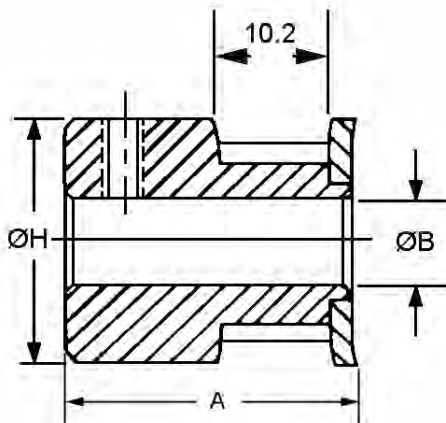

TIMING PULLEYS

CIRCULAR PITCH	STYLE	BELT WIDTH	BORE	MATERIALS	BERG'S ® NAME	BELT
3mm (HTD)	Double Flange Pin Hub	6mm to 9mm	6.00	Aluminum Alloy Din 3.1355 Anodized	Max-M-Drive®	Operates with Max-M-Drive® TB3 series.

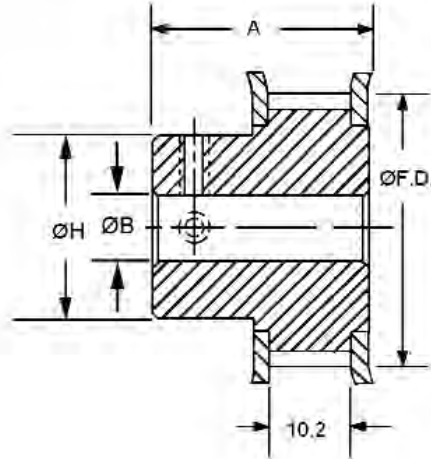

STOCK NO.	NO. OF GROOVES	ØP.D.	ØF.D. ±0.4	A ±0.4	Ø H ±0.3	Ø B +.03/-0.00	ØO.D.
TP3A6W9M-18	18	17.2	20.1	20.8	11.2	6.0	16.4
TP3A6W9M-20	20	19.1	22.7	20.8	12.7	6.0	18.3
TP3A6W9M-22	22	21.0	24.0	20.8	14.3	6.0	20.2
TP3A6W9M-24	24	22.9	26.0	20.8	15.9	6.0	22.2
TP3A6W9M-28	28	26.7	29.8	20.8	17.8	6.0	26.0
TP3A6W9M-30	30	28.6	31.8	20.8	19.7	6.0	27.9
TP3A6W9M-32	32	30.6	33.6	20.8	21.6	6.0	29.8
TP3A6W9M-36	36	34.4	37.4	21.2	25.4	6.0	33.6
TP3A6W9M-40	40	38.2	41.3	21.2	29.2	6.0	37.4
TP3A6W9M-44	44	42.0	45.1	21.2	33.0	6.0	41.3

Other numbers of grooves, bores or hub styles available on request.

Supplied with 2 set screws.

Teeth could be anodized.

TIMING PULLEYS

CIRCULAR PITCH	STYLE	BELT WIDTH	BORE	MATERIALS	BERG'S ® NAME	BELT
3mm (HTD)	Single Flange Pin Hub	6mm to 9mm	4.00	Polycarbonate Lexan® with Fiberglass Reinforcement 94 V-O UL Rated	Max-M-Drive®	Operates with Max-M-Drive® TB3 series.

STOCK NO.	NO. OF GROOVES	O.D.	P.D.	F.D.	B +.036/-.000	H
TP3L4U9M-17	17	15.4	16.2	22	4	17
TP3L4U9M-18	18	16.4	17.2	24		
TP3L4U9M-19	19	17.4	18.2	24		
TP3L4U9M-20	20	18.3	19.1	24		
TP3L4U9M-22	22	20.2	21.0	27		

CIRCULAR PITCH	STYLE	BELT WIDTH	BORE	MATERIALS	BERG'S ® NAME	BELT
3mm (HTD)	Single Flange Pin Hub	6mm to 9mm	6.00	Polycarbonate Lexan® with Fiberglass Reinforcement 94 V-O UL Rated	Max-M-Drive®	Operates with Max-M-Drive® TB3 series.

STOCK NO.	NO. OF GROOVES	O.D.	P.D.	F.D.	B +.036/-.000	H
TP3L4U9M-25	25	23.1	23.9	30	6	19
TP3L6U9M-28	28	26.0	26.8	32		
TP3L6U9M-32	32	29.8	30.6	32		
TP3L6U9M-36	36	33.6	34.4	40	6	22
TP3L6U9M-40	40	37.4	38.2	45		
TP3L6U9M-48	48	45.0	45.8	51		

CIRCULAR PITCH	STYLE	BELT WIDTH	BORE	MATERIALS	BERG'S ® NAME	BELT
3mm (HTD)	Single Flange Pin Hub	6mm to 9mm	8.00	Polycarbonate Lexan® with Fiberglass Reinforcement 94 V-O UL Rated	Max-M-Drive®	Operates with Max-M-Drive® TB3 series.

STOCK NO.	NO. OF GROOVES	O.D.	P.D.	F.D.	B +.036/-.000	H
TP3L8U9M-60	60	56.5	57.3	63	8	22
TP3L8U9M-72	72	68.0	68.8	74		
TP3L8U9M-80	80	75.6	76.4	84		

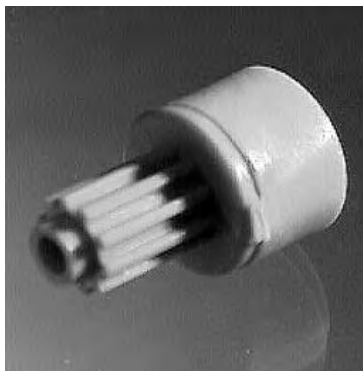
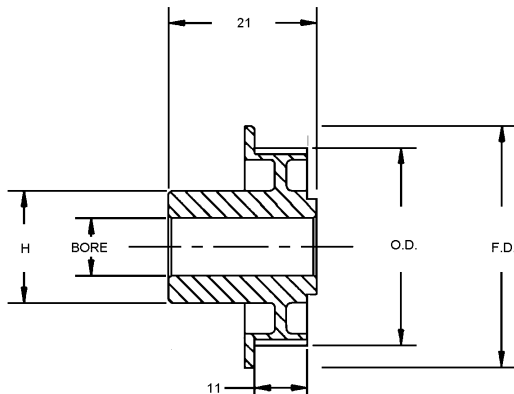

All flanges 1/16" thick.

One or two set screws are optional.

Lexan® Material Specs:

Tensile Strength (PSI) 16,000
 Compressive Strength (PSI) 16,000
 Flexural Strength (PSI) 19,000
 Impact (ft.-lbs./in. notch) 2.0
 Water Absorption (24 hrs.) Equilibrium 73% 0.29%

Examples of specials:

- a. Bores: D shaped, key slots, square or spline.
- b. Face widths other than standard.
- c. Hubless or hub diameters other than standard.
- d. Aluminum, brass or stainless steel inserts thru bore with pulley overmolded.
- e. Non-standard bores including metric bores are available upon request.

TIMING PULLEYS

CIRCULAR PITCH	STYLE	BELT WIDTH	BORE	MATERIALS	BERG'S ® NAME	BELT
3mm (HTD)	Double Flange Pin Hub	6mm to 9mm	4.00	Polycarbonate Lexan® with Fiberglass Reinforcement 94 V-O UL Rated	Max-M-Drive®	Operates with Max-M-Drive® TB3 series.

STOCK NO.	NO. OF GROOVES	O.D.	P.D.	F.D.	B +.036/-0.000	H
TP3L4W9M-17	17	15.4	16.2	22	4	17
TP3L4W9M-18	18	16.4	17.2	24	4	17
TP3L4W9M-19	19	17.4	18.2	24	4	17
TP3L4W9M-20	20	18.3	19.1	24	4	17
TP3L4W9M-22	22	20.2	21.0	27	4	17

CIRCULAR PITCH	STYLE	BELT WIDTH	BORE	MATERIALS	BERG'S ® NAME	BELT
3mm (HTD)	Double Flange Pin Hub	6mm to 9mm	6.00	Polycarbonate Lexan® with Fiberglass Reinforcement 94 V-O UL Rated	Max-M-Drive®	Operates with Max-M-Drive® TB3 series.

STOCK NO.	NO. OF GROOVES	O.D.	P.D.	F.D.	B +.036/-0.000	H
TP3L4W9M-25	25	23.1	23.9	30	6	19
TP3L6W9M-28	28	26.0	26.8	32	6	19
TP3L6W9M-32	32	29.8	30.6	32	6	19
TP3L6W9M-36	36	33.6	34.4	40	6	22
TP3L6W9M-48	48	45.0	45.8	51	6	22

CIRCULAR PITCH	STYLE	BELT WIDTH	BORE	MATERIALS	BERG'S ® NAME	BELT
3mm (HTD)	Double Flange Pin Hub	6mm to 9mm	8.00	Polycarbonate Lexan® with Fiberglass Reinforcement 94 V-O UL Rated	Max-M-Drive®	Operates with Max-M-Drive® TB3 series.

STOCK NO.	NO. OF GROOVES	O.D.	P.D.	F.D.	B +.036/-0.000	H
TP3L8W9M-60	60	56.5	57.3	63	8	22
TP3L8W9M-72	72	68.0	68.8	74	8	22
TP3L8W9M-80	80	75.6	76.4	84	8	22

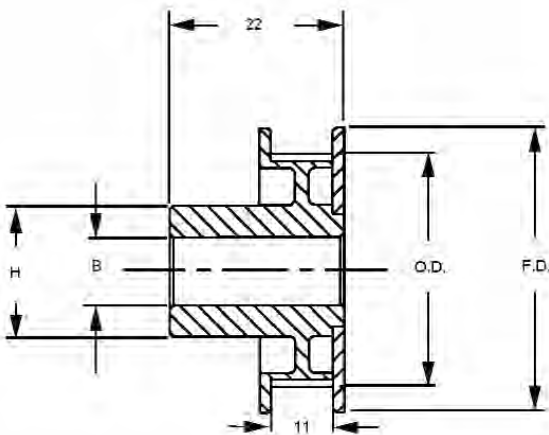

All flanges 1/16" thick.

One or two set screws are optional.

Lexan® Material Specs:

Tensile Strength (PSI) 16,000
 Compressive Strength (PSI) 16,000
 Flexural Strength (PSI) 19,000
 Impact (ft.-lbs./in. notch) 2.0
 Water Absorption (24 hrs.) Equilibrium 73% 0.29%

Examples of specials:

- a. Bores: D shaped, key slots, square or spline.
- b. Face widths other than standard.
- c. Hubless or hub diameters other than standard.
- d. Aluminum, brass or stainless steel inserts thru bore with pulley overmolded.
- e. Non-standard bores including metric bores are available upon request.

TIMING BELTS

CIRCULAR PITCH	BELT WIDTH	MATERIALS	BERG'S ® NAME	PULLEY
5mm (HTD)	6mm	Neoprene (Black) Fiberglass reinforced	Max-M-Drive®	Operates with TP5 Series

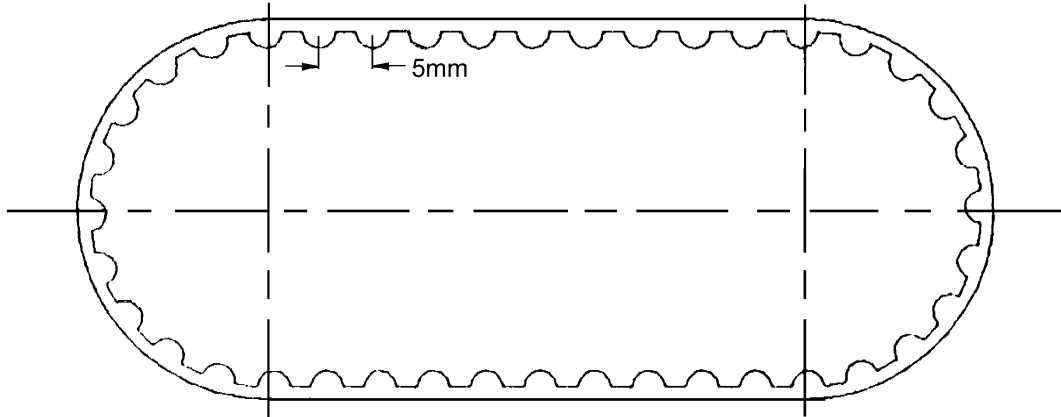

STOCK NO.	NO. OF GROOVES	PITCH LENGTH
TB5EF6M-64	64	320
TB5EF6M-70	70	350
TB5EF6M-75	75	375
TB5EF6M-80	80	400
TB5EF6M-85	85	425
TB5EF6M-90	90	450
TB5EF6M-100	100	500
TB5EF6M-104	104	520
TB5EF6M-107	107	535
TB5EF6M-113	113	565
TB5EF6M-120	120	600
TB5EF6M-127	127	635
TB5EF6M-133	133	665
TB5EF6M-142	142	710
TB5EF6M-148	148	740
TB5EF6M-160	160	800
TB5EF6M-166	166	830
TB5EF6M-178	178	890
TB5EF6M-185	185	925
TB5EF6M-190	190	950
TB5EF6M-200	200	1000
TB5EF6M-210	210	1050
TB5EF6M-225	225	1125
TB5EF6M-254	254	1270
TB5EF6M-284	284	1420
TB5EF6M-319	319	1595
TB5EF6M-358	358	1790
TB5EF6M-360	360	1800
TB5EF6M-379	379	1895
TB5EF6M-400	400	2000
TB5EF6M-505	505	2525

- Large Ratios
- Allows use of small diameter pulleys
- High Speeds
- High Power Transmission
- Long Life
- Wear resistant Nylon facing
- Low Profile
- Quiet operation
- Maximum speed up to 10,000 RPM
- Maximum operating tension 105N
- Minimum pulley diameter 17.5mm (11 grooves)
- Temperature Range +85°C to -34°C



TIMING BELTS

CIRCULAR PITCH	BELT WIDTH	MATERIALS	BERG'S ® NAME	PULLEY
5mm (HTD)	9mm	Neoprene (Black) Fiberglass reinforced	Max-M-Drive®	Operates with TP5 Series

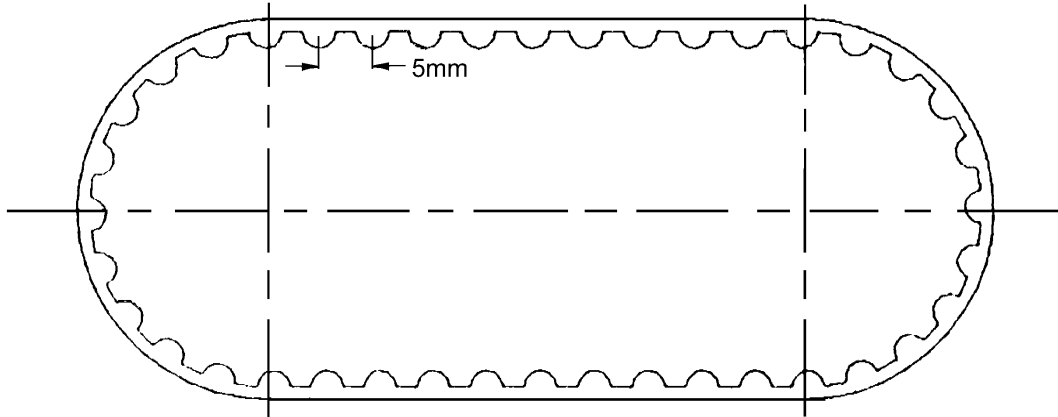

STOCK NO.	NO. OF GROOVES	PITCH LENGTH
TB5EF9M-33	33	165
TB5EF9M-37	37	185
TB5EF9M-40	40	200
TB5EF9M-45	45	225
TB5EF9M-52	52	260
TB5EF9M-54	54	270
TB5EF9M-55	55	275
TB5EF9M-56	56	280
TB5EF9M-60	60	300
TB5EF9M-64	64	320
TB5EF9M-65	65	325
TB5EF9M-66	66	330
TB5EF9M-68	68	340
TB5EF9M-70	70	350
TB5EF9M-72	72	360
TB5EF9M-75	75	375
TB5EF9M-80	80	400
TB5EF9M-85	85	425
TB5EF9M-90	90	450
TB5EF9M-100	100	500
TB5EF9M-104	104	520
TB5EF9M-107	107	535
TB5EF9M-113	113	565
TB5EF9M-120	120	600
TB5EF9M-127	127	635
TB5EF9M-133	133	665
TB5EF9M-142	142	710
TB5EF9M-148	148	740
TB5EF9M-160	160	800
TB5EF9M-166	166	830
TB5EF9M-178	178	890
TB5EF9M-185	185	925
TB5EF9M-190	190	950
TB5EF9M-200	200	1000
TB5EF9M-210	210	1050
TB5EF9M-225	225	1125
TB5EF9M-254	254	1270
TB5EF9M-284	284	1420
TB5EF9M-319	319	1595
TB5EF9M-358	358	1790
TB5EF9M-360	360	1800
TB5EF9M-379	379	1895
TB5EF9M-400	400	2000
TB5EF9M-505	505	2525

- Large Ratios
- Allows use of small diameter pulleys
- High Speeds
- High Power Transmission
- Long Life
- Wear resistant Nylon facing
- Low Profile
- Quiet operation
- Maximum speed up to 10,000 RPM
- Maximum operating tension 155N
- Minimum pulley diameter 17.5mm (11 grooves)
- Temperature Range +85°C to -34°C



TIMING PULLEYS

CIRCULAR PITCH	STYLE	BELT WIDTH	BORE	MATERIALS	BERG'S ® NAME	BELT
5mm (HTD)	Single Flange Pin Hub	6mm to 9mm	4.00	10% Glass filled Polycarbonate (Black) Hub = Aluminum	Max-M-Drive®	Operates with Max-M-Drive® TB5 series

STOCK NO.	B +0.04	NO. OF GROOVES	P.D.	O.D.	F.D.	øH
TP5P4U9M-14	4.00	14	22.28	21.14	25.40	15

Other numbers of grooves, bores or hub styles available on request.

CIRCULAR PITCH	STYLE	BELT WIDTH	BORE	MATERIALS	BERG'S ® NAME	BELT
5mm (HTD)	Single Flange Pin Hub	6mm to 9mm	6.00	10% Glass filled Polycarbonate (Black) Hub = Aluminum	Max-M-Drive®	Operates with Max-M-Drive® TB5 series

STOCK NO.	B +0.04	NO. OF GROOVES	P.D.	O.D.	F.D.	øH
TP5P6U9M-15	6.00	15	23.87	22.73	26.90	22
TP5P6U9M-16		16	25.46	24.32	27.70	
TP5P6U9M-18		18	28.65	27.50	31.80	
TP5P6U9M-19		19	30.24	29.10	33.30	32
TP5P6U9M-20		20	31.83	30.69	34.80	
TP5P6U9M-22		22	35.01	33.87	38.10	
TP5P6U9M-28		28	44.55	43.42	47.50	
TP5P6U9M-30	30	47.75	46.60	50.80		

Other numbers of grooves, bores or hub styles available on request.

CIRCULAR PITCH	STYLE	BELT WIDTH	BORE	MATERIALS	BERG'S ® NAME	BELT
5mm (HTD)	Single Flange Pin Hub	6mm to 9mm	8.00	10% Glass filled Polycarbonate (Black) Hub = Aluminum	Max-M-Drive®	Operates with Max-M-Drive® TB5 series

STOCK NO.	B +0.04	NO. OF GROOVES	P.D.	O.D.	F.D.	øH
TP5P8U9M-40	8.00	40	63.66	62.52	67.60	32
TP5P8U9M-44		44	70.03	68.89	73.90	
TP5P8U9M-50		50	79.58	78.43	82.80	

Other numbers of grooves, bores or hub styles available on request.

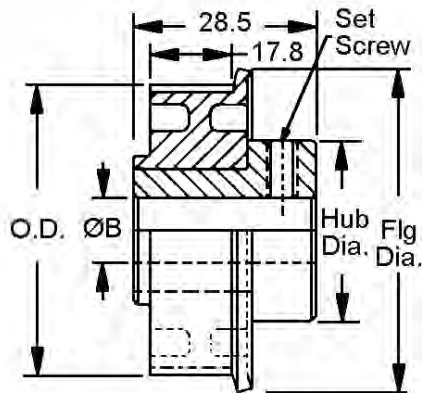

TIMING PULLEYS

CIRCULAR PITCH	STYLE	BELT WIDTH	BORE	MATERIALS	BERG'S ® NAME	BELT
5mm (HTD)	Double Flange Pin Hub	6mm to 9mm	4.00	10% Glass filled Polycarbonate (Black) Hub = Aluminum	Max-M-Drive®	Operates with Max-M-Drive® TB5 series

STOCK NO.	B +0.04	NO. OF GROOVES	P.D.	O.D.	F.D.	øH
TP5P4W9M-14	4.00	14	22.28	21.14	25.40	15

Other numbers of grooves, bores or hub styles available on request.

CIRCULAR PITCH	STYLE	BELT WIDTH	BORE	MATERIALS	BERG'S ® NAME	BELT
5mm (HTD)	Double Flange Pin Hub	6mm to 9mm	6.00	10% Glass filled Polycarbonate (Black) Hub = Aluminum	Max-M-Drive®	Operates with Max-M-Drive® TB5 series

STOCK NO.	B +0.04	NO. OF GROOVES	P.D.	O.D.	F.D.	øH
TP5P6W9M-15	6.00	15	23.87	22.73	26.90	22
TP5P6W9M-16		16	25.46	24.32	27.70	
TP5P6W9M-18		18	28.65	27.50	31.80	
TP5P6W9M-19		19	30.24	29.10	33.30	
TP5P6W9M-20		20	31.83	30.69	34.80	
TP5P6W9M-22		22	35.01	33.87	38.10	
TP5P6W9M-28		28	44.55	43.42	47.50	
TP5P6W9M-30	30	47.75	46.60	50.80	32	

Other numbers of grooves, bores or hub styles available on request.

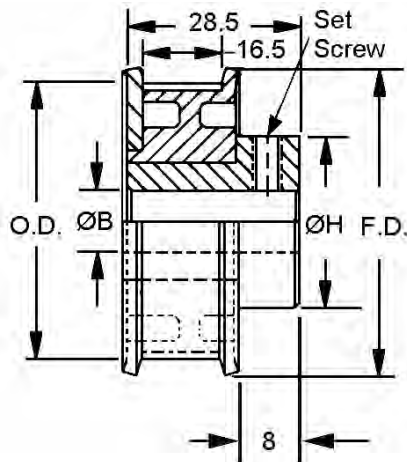

TIMING PULLEYS

CIRCULAR PITCH	STYLE	BELT WIDTH	BORE	MATERIALS	BERG'S ® NAME	BELT
5mm (HTD)	Double Flange Pin Hub	6mm to 9mm	6.00	Aluminum DIN 3.1355 Anodized	Max-M-Drive®	Operates with Max-M-Drive® TB5 series.

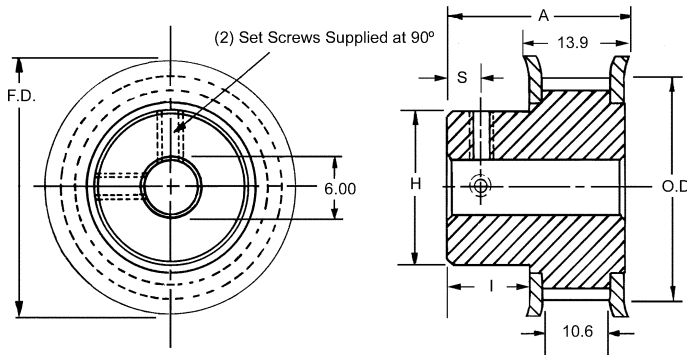

STOCK NO.	NO. OF GROOVES	P.D.	F.D.	A	H	BORE +0.04/-0.00	O.D.	I	S
TP5A6W9M-12	12*	19.1	22.2	20.1	11.1	6.0	18.0	6.3	3.2
TP5A6W9M-13	13*	20.7	23.8		12.7		19.5		
TP5A6W9M-14	14	22.3	25.0		12.7		21.1		
TP5A6W9M-15	15	23.9	27.0		14.3		22.7		
TP5A6W9M-16	16	25.5	27.8		15.9		24.3		

* One set screw supplied.
Other numbers of grooves, bores or hub styles available on request.

Teeth could be anodized.

CIRCULAR PITCH	STYLE	BELT WIDTH	BORE	MATERIALS	BERG'S ® NAME	BELT
5mm (HTD)	Double Flange Pin Hub	6mm to 9mm	8.00	Aluminum DIN 3.1355 Anodized	Max-M-Drive®	Operates with Max-M-Drive® TB5 series.

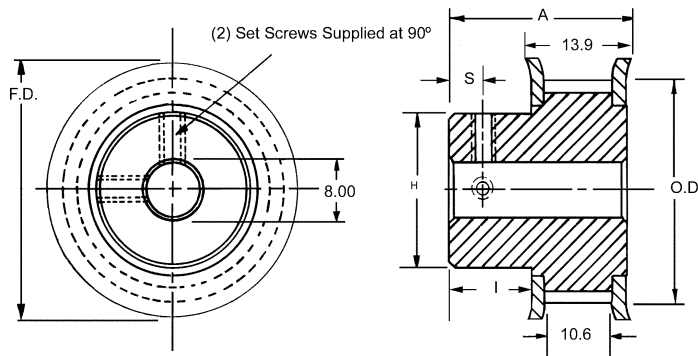

STOCK NO.	NO. OF GROOVES	P.D.	F.D.	A	H	BORE +0.04/-0.00	O.D.	I	S
TP5A8W9M-18	18	28.6	31.8	21.6	17.5	8.0	27.5	6.3	3.2
TP5A8W9M-20	20	31.8	34.9		20.6		30.7		
TP5A8W9M-22	22	35.0	38.1		23.8		33.9		
TP5A8W9M-24	24	38.2	41.3		25.0		37.1		
TP5A8W9M-26	26	41.4	44.5		27.0		40.2		
TP5A8W9M-28	28	44.6	47.6	30.2	43.4				
TP5A8W9M-30	30	47.7	50.8	30.2	46.6				

Other numbers of grooves, bores or hub styles available on request.

Teeth could be anodized.

TIMING PULLEYS

CIRCULAR PITCH	STYLE	BELT WIDTH	BORE	MATERIALS	BERG'S ® NAME	BELT
5mm (HTD)	Single Flange Pin Hub	6mm to 9mm	4.00	Polycarbonate Lexan® with a fiberglass reinforced	Max-M-Drive®	Operates with Max-M-Drive® TB5 series.

STOCK NO.	NO. OF GROOVES	O.D.	P.D.	F.D.	B +.036/-0.000	H
TP5L4U9M-11	11	16.4	17.5	22	4	17
TP5L4U9M-12	12	18.0	19.1	24		
TP5L4U9M-13	13	19.6	20.7	25		
TP5L4U9M-14	14	21.1	22.2	27		

CIRCULAR PITCH	STYLE	BELT WIDTH	BORE	MATERIALS	BERG'S ® NAME	BELT
5mm (HTD)	Single Flange Pin Hub	6mm to 9mm	6.00	Polycarbonate Lexan® with a fiberglass reinforced	Max-M-Drive®	Operates with Max-M-Drive® TB5 series.

STOCK NO.	NO. OF GROOVES	O.D.	P.D.	F.D.	B +.036/-0.000	H
TP5L6U9M-15	15	22.7	23.8	30	6	19
TP5L6U9M-16	16	24.3	25.4	30		
TP5L6U9M-17	17	25.9	27.0	32		
TP5L6U9M-18	18	27.5	28.6	33		
TP5L6U9M-19	19	29.1	30.2	35		22
TP5L6U9M-20	20	30.7	31.8	37		
TP5L6U9M-22	22	33.9	35.0	40		
TP5L6U9M-25	27	38.7	39.8	45		
TP5L6U9M-28	28	43.4	44.5	50	22	
TP5L6U9M-29	29	45.0	46.1	51		
TP5L6U9M-30	30	46.6	47.7	53		

CIRCULAR PITCH	STYLE	BELT WIDTH	BORE	MATERIALS	BERG'S ® NAME	BELT
5mm (HTD)	Single Flange Pin Hub	6mm to 9mm	8.00	Polycarbonate Lexan® with a fiberglass reinforced	Max-M-Drive®	Operates with Max-M-Drive® TB5 series.

STOCK NO.	NO. OF GROOVES	O.D.	P.D.	F.D.	BORE +.036/-0.000	H
TP5L8U9M-40	40	62.5	63.6	69	8	22
TP5L8U9M-50	50	78.4	79.5	84		

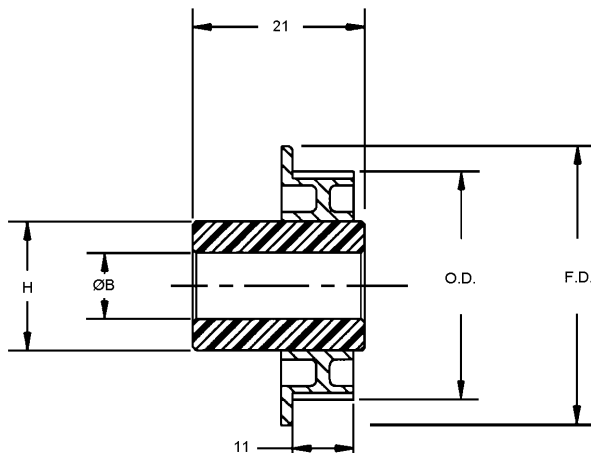

TIMING PULLEYS

CIRCULAR PITCH	STYLE	BELT WIDTH	BORE	MATERIALS	BERG'S ® NAME	BELT
5mm (HTD)	Double Flange Pin Hub	6mm to 9mm	4.00	Polycarbonate Lexan® with a fiberglass reinforced	Max-M-Drive®	Operates with Max-M-Drive® TB5 series.

STOCK NO.	NO. OF GROOVES	O.D.	P.D.	F.D.	B + .036/- .000	H
TP5L4W9M-11	11	16.4	17.5	22	4	17
TP5L4W9M-12	12	18.0	19.1	24		
TP5L4W9M-13	13	19.6	20.7	25		
TP5L4W9M-14	14	21.1	22.2	27		

CIRCULAR PITCH	STYLE	BELT WIDTH	BORE	MATERIALS	BERG'S ® NAME	BELT
5mm (HTD)	Double Flange Pin Hub	6mm to 9mm	6.00	Polycarbonate Lexan® with a fiberglass reinforced	Max-M-Drive®	Operates with Max-M-Drive® TB5 series.

STOCK NO.	NO. OF GROOVES	O.D.	P.D.	F.D.	B + .036/- .000	H
TP5L6W9M-15	15	22.7	23.8	30	6	19
TP5L6W9M-16	16	24.3	25.4	30		
TP5L6W9M-17	17	25.9	27.0	32		
TP5L6W9M-18	18	27.5	28.6	33		
TP5L6W9M-19	19	29.1	30.2	35		
TP5L6W9M-20	20	30.7	31.8	37		22
TP5L6W9M-22	22	33.9	35.0	40		
TP5L6W9M-25	27	38.7	39.8	45		
TP5L6W9M-28	28	43.4	44.5	50		
TP5L6W9M-29	29	45.0	46.1	51		
TP5L6W9M-30	30	46.6	47.7	53		

CIRCULAR PITCH	STYLE	BELT WIDTH	BORE	MATERIALS	BERG'S ® NAME	BELT
5mm (HTD)	Double Flange Pin Hub	6mm to 9mm	8.00	Polycarbonate Lexan® with a fiberglass reinforced	Max-M-Drive®	Operates with Max-M-Drive® TB5 series.

STOCK NO.	NO. OF GROOVES	O.D.	P.D.	F.D.	B* + .036/- .000	H
TP5L8W9M-40	40	62.5	63.6	69	8	22
TP5L8W9M-50	50	78.4	79.5	84		

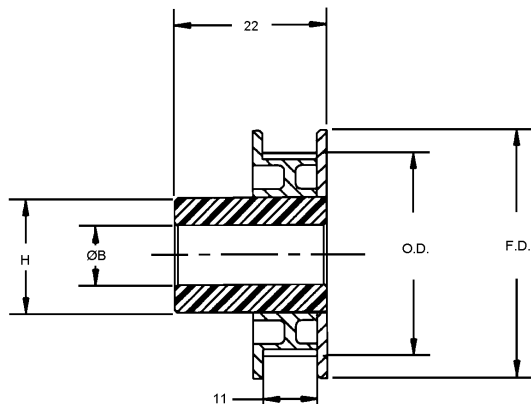

TIMING PULLEY BAR STOCK

CIRCULAR PITCH	STYLE	MATERIALS	BERG'S ® NAME	BELT
2.032mm (MXL)	Barstock	6063-T6 Aluminum	Max-M-Drive®	Operates with TB7 series.

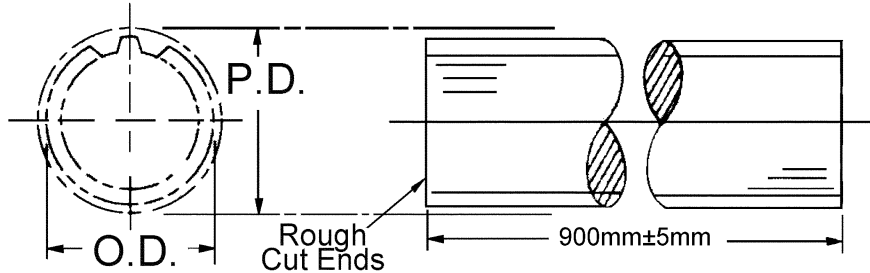

Material: 6063-T6 Aluminum

Fabricate your own pulleys.

W.M. Berg will fabricate custom orders, send us your print.

Available in custom lengths.

Teeth could be anodized.

2.032 CIRCULAR PITCH (MXL)

STOCK NO.	NO. OF GROOVES	P.D.	O.D.
PW7TA-10	10	6.48	5.97
PW7TA-12	12	7.77	7.26
PW7TA-14	14	9.07	8.56
PW7TA-20	20	12.93	12.42
PW7TA-28	28	18.11	17.60
PW7TA-30	30	19.41	18.90
PW7TA-34	34	22.00	21.49
PW7TA-36	36	23.29	22.78
PW7TA-38	38	25.04	24.08
PW7TA-40	40	25.88	25.37
PW7TA-42	42	27.18	26.67
PW7TA-44	44	28.45	27.94
PW7TA-45	45	29.11	28.60
PW7TA-50	50	32.33	31.83

60° V BELT

A

SERIES	WIDTH	HEIGHT	MATERIAL	BERG'S ® NAME	PULLEY
V3M	3mm	2.5mm	Polyurethane (Black)	V-Flex	Operates with V3M Series

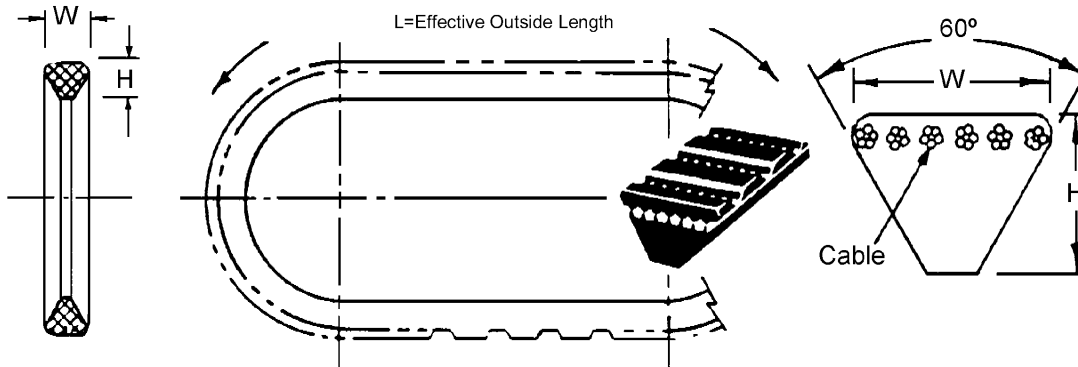

STOCK NO.	L (CIR.)
V3M180	180
V3M185	185
V3M190	190
V3M195	195
V3M200	200
V3M206	206
V3M212	212
V3M218	218
V3M224	224
V3M230	230
V3M243	248
V3M250	250
V3M265	265
V3M280	280
V3M300	300
V3M315	315
V3M325	325
V3M345	345
V3M365	365
V3M400	400
V3M425	425
V3M450	450
V3M475	475
V3M500	500
V3M530	530
V3M560	560
V3M600	600
V3M650	650
V3M710	710
V3M750	750

RPM Of FASTER Shaft	Horsepower Ratings for 5000-10,000 Hours Service Life Range											
	V3M Small Sheave Diameter											
	.67	.71	.75	.79	.83	.88	.93	.98	1.04	1.10	1.17	1.24
200	.016	.019	.022	.024	.027	.031	.035	.039	.043	.048	.056	.059
400	.028	.033	.038	.044	.049	.056	.063	.070	.079	.088	.098	.11
600	.039	.046	.053	.061	.068	.078	.088	.099	.11	.12	.14	.15
800	.048	.057	.067	.076	.086	.099	.11	.13	.14	.16	.18	.20
1000	.057	.068	.079	.091	.10	.12	.13	.15	.17	.19	.21	.23
2000	-	.11	.13	.15	.17	.20	.23	.26	.29	.33	.37	.41
3000	-	-	.17	.20	.23	.27	.31	.35	.39	.44	.50	.55
4000	-	-	-	.23	.27	.32	.37	.42	.48	.54	.61	.68
5000	-	-	-	-	.31	.37	.42	.48	.55	.62	.70	.79

SERVICE FACTORS

Typical Units	Service Factor
Office Machines	1.2
Machine Tools	1.4
Woodworking Machines	1.5
Washing Machine Tumblers & Agitators	1.3
Dry Cleaning Tumblers	1.3
Clothes Dryer Tumblers	1.3
Ironers	1.0
Fans	1.0
Pumps:	
Centrifugal	1.1
Gear	1.3
Reciprocating	1.5
Compressors:	
Reciprocating	1.5
Rotary	1.3
Generators:	
Smooth Load	1.3
Welders	1.5
Lawn Mowers	1.5
Snow Blowers	1.5

- Superior Horsepower Life on smaller Diameter Sheaves
- More Compact Drives
- Smoother Running
- Last three digits in the Stock No. represent length in Millimeter



Design Horsepower = (Service Factor) x (Horsepower Requirement)

60° V BELT

SERIES	WIDTH	HEIGHT	MATERIAL	BERG'S ® NAME	PULLEY
V5M	5mm	3mm	Polyurethane (Black)	V-Flex	Operates with V5M Series

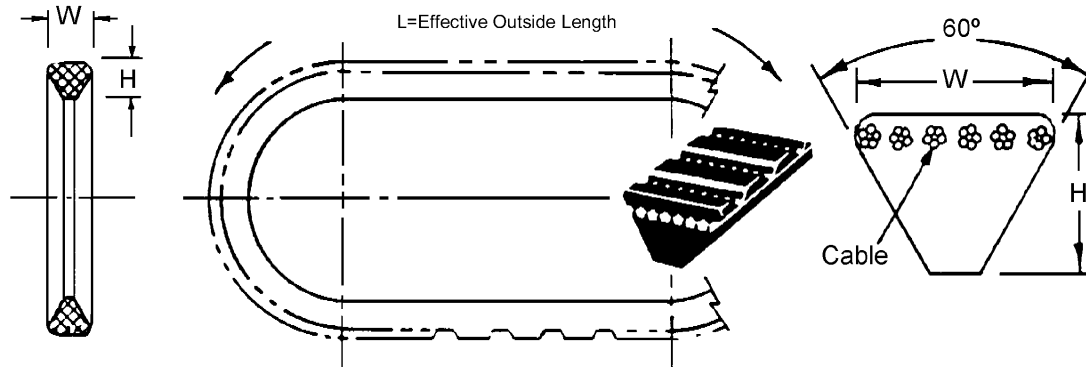

STOCK NO.	L (CIR.)
V5M280	280
V5M290	290
V5M300	300
V5M307	307
V5M315	315
V5M325	325
V5M335	335
V5M345	345
V5M375	375
V5M400	400
V5M425	425
V5M450	450
V5M475	475
V5M500	500
V5M530	530
V5M560	560
V5M580	580
V5M600	600
V5M650	650
V5M690	690
V5M750	750
V5M800	800
V5M850	850
V5M900	900
V5M950	950
V5M1000	1000
V5M1060	1060
V5M1250	1250
V5M1400	1400
V5M1500	1500

RPM Of FASTER Shaft	Horsepower Ratings for 5000-10,000 Hours Service Life Range											
	V5M Small Sheave Diameter											
	1.04	1.10	1.17	1.24	1.32	1.40	1.48	1.57	1.67	1.77	1.87	1.97
200	.053	.061	.071	.081	.092	.10	.12	.13	.15	.16	.18	.20
400	.007	.11	.13	.14	.17	.19	.22	.24	.27	.30	.33	.36
600	.15	.16	.18	.21	.24	.27	.31	.34	.39	.43	.47	.52
800	.17	.20	.23	.27	.31	.35	.39	.44	.50	.55	.61	.66
1000	.20	.24	.28	.32	.37	.42	.47	.53	.60	.67	.74	.80
2000	.35	.41	.48	.56	.65	.74	.83	.94	1.06	1.18	1.30	1.42
3000	.46	.55	.65	.76	.88	1.01	1.14	1.28	1.45	1.61	1.78	1.95
4000	-	.66	.80	.93	1.08	1.24	1.40	1.59	1.79	2.00	2.22	2.43
5000	-	-	.92	1.08	1.26	1.45	1.64	1.86	2.11	2.36	2.61	2.87

SERVICE FACTORS

Typical Units	Service Factor
Office Machines	1.2
Machine Tools	1.4
Woodworking Machines	1.5
Washing Machine Tumblers & Agitators	1.3
Dry Cleaning Tumblers	1.3
Clothes Dryer Tumblers	1.3
Ironers	1.0
Fans	1.0
Pumps:	
Centrifugal	1.1
Gear	1.3
Reciprocating	1.5
Compressors:	
Reciprocating	1.5
Rotary	1.3
Generators:	
Smooth Load	1.3
Welders	1.5
Lawn Mowers	1.5
Snow Blowers	1.5

- Superior Horsepower Life on smaller Diameter Sheaves
- More Compact Drives
- Smoother Running
- Last three digits in the Stock No. represent length in Millimeter



Design Horsepower = (Service Factor) x (Horsepower Requirement)

60° V BELT

A

SERIES	WIDTH	HEIGHT	MATERIAL	BERG'S® NAME	PULLEY
V7M	8mm	5.5mm	Polyurethane (Black)	V-Flex	Operates with V7M Series

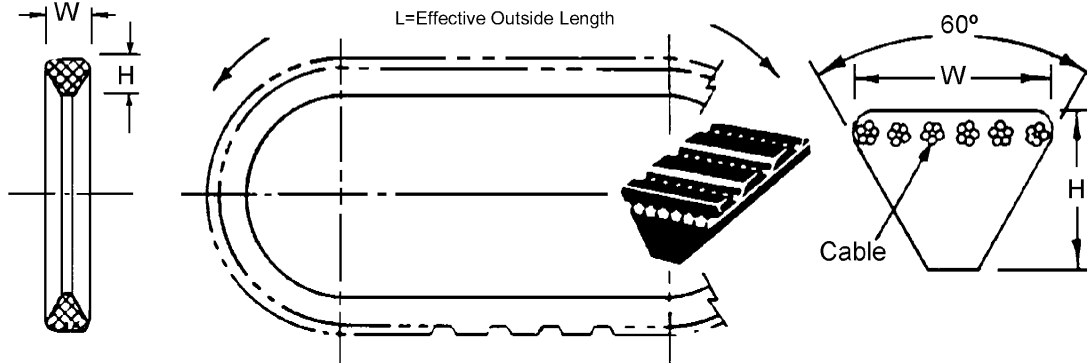

STOCK NO.	L (CIR.)
V7M500	500
V7M515	515
V7M530	530
V7M545	545
V7M560	560
V7M580	580
V7M600	600
V7M615	615
V7M650	650
V7M690	690
V7M710	710
V7M750	750
V7M800	800
V7M850	850
V7M900	900
V7M950	950
V7M1000	1000
V7M1060	1060
V7M1120	1120
V7M1180	1180
V7M1250	1250
V7M1320	1320
V7M1400	1400
V7M1500	1500
V7M1600	1600
V7M1700	1700
V7M1800	1800
V7M1900	1900
V7M2000	2000
V7M2120	2120
V7M2300	2300

RPM Of Faster Shaft	Horsepower Ratings for 5000-10,000 Hours Service Life Range											
	V7M Small Sheave Diameter											
	1.67	1.77	1.87	1.97	2.08	2.20	2.34	2.48	2.64	2.80	2.95	3.15
200	.16	.19	.21	.24	.27	.30	.34	.38	.42	.47	.51	.57
400	.30	.34	.39	.44	.49	.55	.63	.70	.78	.87	.95	1.05
600	.42	.49	.56	.62	.70	.79	.89	1.00	1.12	1.24	1.35	1.50
800	.54	.62	.71	.80	.90	1.01	1.14	1.27	1.43	1.59	1.73	1.93
1000	.64	.75	.85	.96	1.08	1.22	1.38	1.54	1.73	1.91	2.09	2.33
2000	1.10	1.29	1.48	1.68	1.89	22.13	2.42	2.71	3.04	3.37	3.69	4.11
3000	1.47	1.73	2.00	2.27	2.57	2.91	3.30	3.71	4.17	4.64	5.08	5.67
4000	1.78	2.11	2.44	2.79	3.17	3.59	4.10	4.61	5.20	5.79	6.36	7.11
5000	2.03	2.43	2.83	3.24	3.70	4.21	4.82	5.43	6.14	6.86	7.53	8.43

SERVICE FACTORS

Typical Units	Service Factor
Office Machines	1.2
Machine Tools	1.4
Woodworking Machines	1.5
Washing Machine Tumblers & Agitators	1.3
Dry Cleaning Tumblers	1.3
Clothes Dryer Tumblers	1.3
Ironers	1.0
Fans	1.0
Pumps:	
Centrifugal	1.1
Gear	1.3
Reciprocating	1.5
Compressors:	
Reciprocating	1.5
Rotary	1.3
Generators:	
Smooth Load	1.3
Welders	1.5
Lawn Mowers	1.5
Snow Blowers	1.5

- Superior Horsepower Life on smaller Diameter Sheaves
- More Compact Drives
- Smoother Running
- Last three digits in the Stock No. represent length in Millimeter



Design Horsepower = (Service Factor) x (Horsepower Requirement)

60° V BELT PULLEYS

BORE	STYLE	MATERIAL	BERG'S ® NAME	BELT
Ø3	PIN HUB SINGLE GROOVE	DIN 1.4305 Stainless Steel	V-Flex	Operates with V3M Series

STOCK NO.	B	O.D.	F	H	L
V3M81S-1	3	17.0	5	10	12
V3M81S-2		19.0			
V3M81S-3		21.0			
V3M81S-4		23.0			
V3M81S-5		26.0			
V3M81S-6		29.0			
V3M81S-7		31.0			

BORE	STYLE	MATERIAL	BERG'S ® NAME	BELT
Ø5	PIN HUB SINGLE GROOVE	DIN 1.4305 Stainless Steel	V-Flex	Operates with V3M Series

STOCK NO.	B	O.D.	F	H	L
V3M83S-1	5	17.0	5	10	12
V3M83S-2		19.0			
V3M83S-3		21.0			
V3M83S-4		23.0			
V3M83S-5		26.0			
V3M83S-6		29.0			
V3M83S-7		31.0			

BORE	STYLE	MATERIAL	BERG'S ® NAME	BELT
Ø8	PIN HUB SINGLE GROOVE	DIN 1.4305 Stainless Steel	V-Flex	Operates with V3M Series

STOCK NO.	B	O.D.	F	H	L
V3M95S-1	8	17.0	5	12	12
V3M95S-2		19.0			
V3M95S-3		20.0			
V3M95S-4		22.0			
V3M95S-5		23.0			
V3M95S-6		24.0			
V3M95S-7		26.0			
V3M95S-8		27.0			
V3M95S-9		29.0			
V3M95S-10		31.0			
V3M95S-11		39.0			
V3M95S-12		50.0			
V3M95S-13		62.0			
V3M95S-14		80.0			
V3M95S-15		100.0			

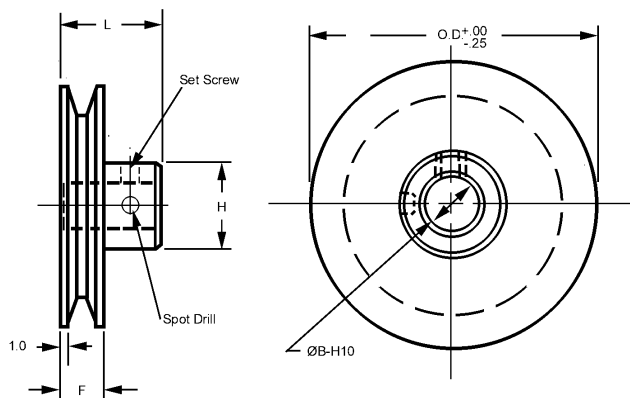

60° V BELT PULLEYS

A

BORE	STYLE	MATERIAL	BERG'S ® NAME	BELT
Ø8	PIN HUB SINGLE GROOVE	DIN 1.4305 Stainless Steel	V-Flex	Operates with V5M Series

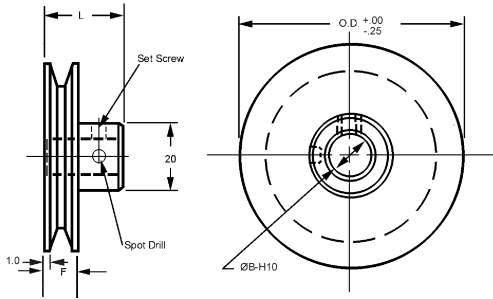

STOCK NO.	B	H	O.D.	F	L
V5M90S-1			26.42		
V5M90S-2			27.94		
V5M90S-3			29.72		
V5M90S-4			31.50		
V5M90S-5			33.53		
V5M90S-6			35.56		
V5M90S-7	8	20	37.59	7	16
V5M90S-8			39.88		
V5M90S-9			42.42		
V5M90S-10			44.96		
V5M90S-11			47.49		
V5M90S-12			50.03		
V5M90S-13			62.99		
V5M90S-14			80.01		
V5M90S-15			100.08		



Special sizes are available upon request.

BORE	STYLE	MATERIAL	BERG'S ® NAME	BELT
Ø10	PIN HUB SINGLE GROOVE	DIN 1.4305 Stainless Steel	V-Flex	Operates with V5M Series

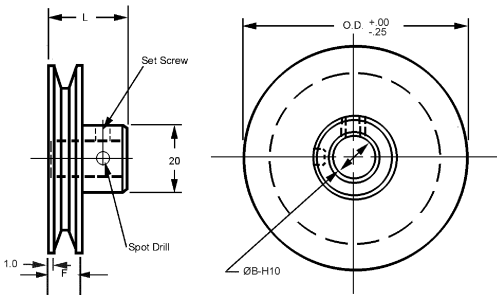

STOCK NO.	B	H	O.D.	F	L
V5M91S-1			26.42		
V5M91S-2			27.94		
V5M91S-3			29.72		
V5M91S-4			31.50		
V5M91S-5			33.53		
V5M91S-6			35.56		
V5M91S-7	10	20	37.59	7	16
V5M91S-8			39.88		
V5M91S-9			42.42		
V5M91S-10			44.96		
V5M91S-11			47.49		
V5M91S-12			50.03		
V5M91S-13			62.99		
V5M91S-14			80.01		
V5M91S-15			100.08		



Special sizes are available upon request.

60° V BELT PULLEYS

BORE	STYLE	MATERIAL	BERG'S ® NAME	BELT
Ø10	PIN HUB SINGLE GROOVE	DIN 1.4305 Stainless Steel	V-Flex	Operates with V7M Series

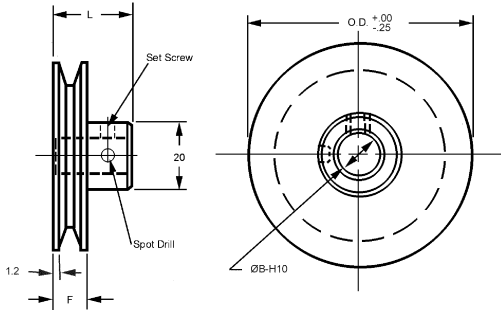

STOCK NO.	B	H	O.D.	F	L
V7M86S-1	10	20	42.42	10	20
V7M86S-2			44.96		
V7M86S-3			47.50		
V7M86S-4			50.04		
V7M86S-5			52.83		
V7M86S-6			55.88		
V7M86S-7			59.44		
V7M86S-8			62.99		
V7M86S-9			67.06		
V7M86S-10			71.12		
V7M86S-11			74.93		
V7M86S-12			80.01		
V7M86S-13			85.09		
V7M86S-14			92.46		
V7M86S-15			100.08		



Special sizes are available upon request.

BORE	STYLE	MATERIAL	BERG'S ® NAME	BELT
Ø12	PIN HUB SINGLE GROOVE	DIN 1.4305 Stainless Steel	V-Flex	Operates with V7M Series

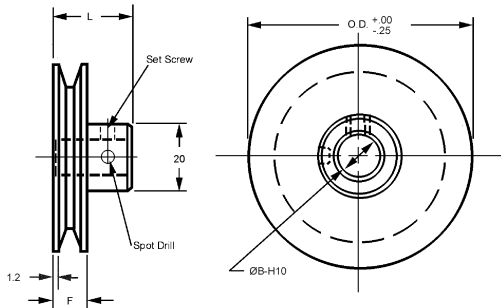

STOCK NO.	B	H	O.D.	F	L
V7M88S-1	12	20	42.42	10	20
V7M88S-2			44.96		
V7M88S-3			47.50		
V7M88S-4			50.04		
V7M88S-5			52.83		
V7M88S-6			55.88		
V7M88S-7			59.44		
V7M88S-8			62.99		
V7M88S-9			67.06		
V7M88S-10			71.12		
V7M88S-11			74.93		
V7M88S-12			80.01		
V7M88S-13			85.09		
V7M88S-14			92.46		
V7M88S-15			100.08		



Special sizes are available upon request.

POW-R-VEE® BELTS

A New Concept in V-Belt Drives

Advantages

Cable Design

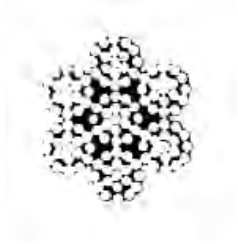

- Completely Non Corrosive
- Stainless Steel Cable Core Allows Maximum Strength.
- Lighter Weight
- Single Strand Cable Core Permits Complete Flexibility
- Power is Transferred Along The Pitch Line For Minimum Transmission Loss
- Can Be Spliced On Machine For Minimum Down Time
- Damaged Sections Can Be Replaced
- Infinite Lengths Are Available

Flexible Sidewall

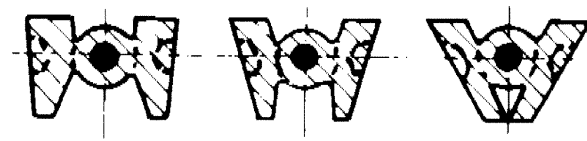

- Can Be Used With Pulleys Of Any Angle
- Inherent Locking Action Offers A More Positive, Non Slip Drive & Allows For Tension On The Belt & Pulleys

Flexible Design

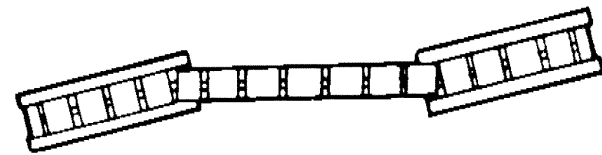

- Permits Odd Angle & Three Dimensional Drives
- Compensates For Misalignment
- Prevents "Turn Over" & "Lift Off"

Materials

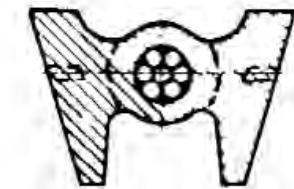

- The Combination Of Engineered Plastics & Stainless Steel Cable
- Offers High Heat Resistance, Smoother Operation, Light Weight, Less Inertia & Vibration.
- Pow-R-Vee Can Be Molded In Any Color For Sales Appeal

Cog Design

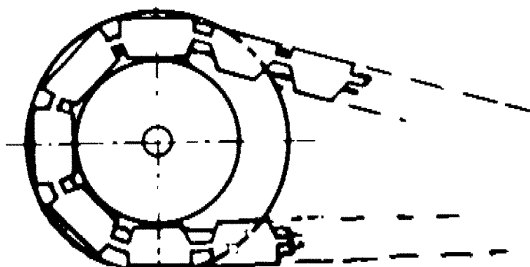

- No Stretch Or Compression Of Belt- Results In Less Fatigue, Longer Life, More Flexibility
- Segmented, Cog Design Permits Smaller Pulley Diameters, Larger Ratios, More Compact Design and Most Importantly Provides Positive Gripping at All Times.

TECHNICAL DATA

Operating Notes:

Due to the unique design of polyurethane molded over a stainless steel cable, this series offers high heat resistance, smooth operation, light weight, and less inertia. Because the design is cogged it allows for smaller pulley diameters and compensates for misalignment of pulleys by permitting an angle (7° maximum misalignment). The design also allows for the belt to be spliced to any length, (either in the field or at Berg) thus allowing belts to be replaced quickly.

2V Series

- Mass 20 Grams/Meter
- 0.8mm Diameter
Stainless Steel Cable

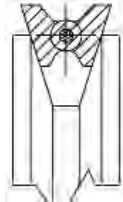

- 90A Durometer Polyurethane (Brown)
- Ultimate Tensile Strength 222N
- Recommended Operating Load 53N
- Recommended Maximum Operating Speed 1.91 m/s
- Temperature Range +82°C to -26°C

3V Series

- Mass 55 Grams/Meter
- 1.2mm Diameter
Stainless Steel Cable

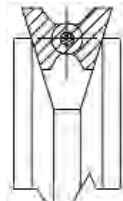

- 90A Durometer Polyurethane (Brown)
- Ultimate Tensile Strength 555N
- Recommended Operating Load 133N
- Recommended Maximum Operating Speed 1.91m/s
- Temperature Range +82°C to -26°C

4V Series

- Mass 102 Grams/Meter
- 1.6mm Diameter
Stainless Steel Cable

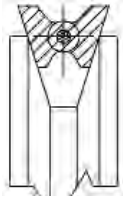

- 90A Durometer Polyurethane (Brown)
- Ultimate Tensile Strength 880N
- Recommended Operating Load 133N
- Recommended Maximum Operating Speed 1.91m/s
- Temperature Range +82°C to -26°C

5V Series

- Mass 130 Grams/Meter
- 2.0mm Diameter
Stainless Steel Cable

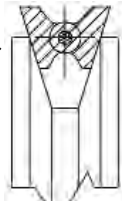

- 90A Durometer Polyurethane (Brown)
- Ultimate Tensile Strength 1550N
- Recommended Operating Load 378N
- Recommended Maximum Operating Speed 1.91m/s
- Temperature Range +82°C to -26°C

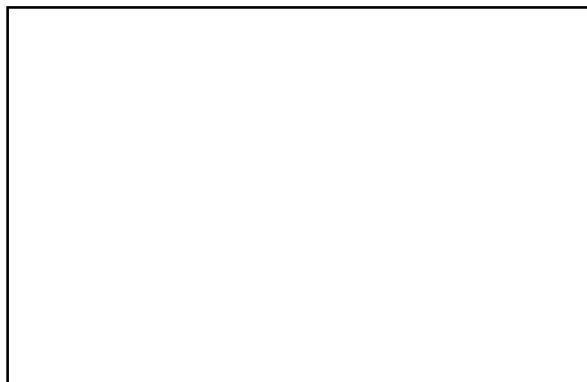

V-BELTS

SERIES	WIDTH	HEIGHT	MATERIAL	BERG'S ® NAME	PULLEY
2V	6.4	5.6	Polyurethane (Brown) with 0.8mm Dia. Stainless Steel Cable	POW-R-VEE®	Operates with Pow-R-Vee 2V Series

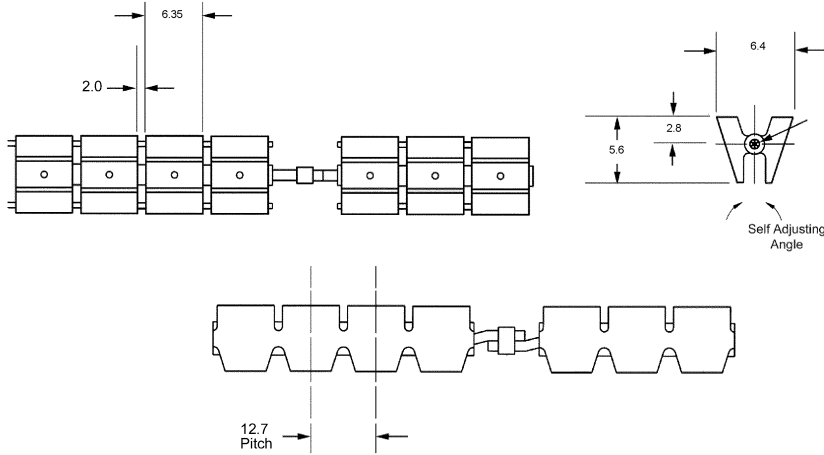

- More sidewall contact
- Less slippage
- Greater power transmission
- Infinite length variations
- Extra strong
- Light weight
- Silent drive
- 90A Durometer
- Mass 20 Grams/Meter
- Ultimate Tensile Strength 222N
- Temperature Range +82°C to -26°C
- Recommended Operating Load 53N
- Recommended Max. Operating Speed 1.91 m/s
- For Field Splice Order 2V-7.



BULK FOOTAGE NOT SPLICED	
STOCK NO.	LENGTH
2V-1.5M	1.5 Meters
2V-3.0M	3.0 Meters
2V-7.5m	7.5 Meters
2V-15.0M	15.0 Meters
2V-30.0M	30.0 Meters

STOCK NO.	LENGTH (Ref.)
2V-16	152.4
2V-18	171.5
2V-20	190.5
2V-22	209.6
2V-24	228.6
2V-26	247.7
2V-28	266.7
2V-30	285.6
2V-32	304.8
2V-34	323.9
2V-36	342.9
2V-38	362.0
2V-40	381.0
2V-42	400.1
2V-44	419.1
2V-46	438.2
2V-48	457.2
2V-50	476.3
2V-52	495.3
2V-54	514.4
2V-56	533.4
2V-58	552.5
2V-60	571.5
2V-62	590.6
2V-64	609.6
2V-66	628.7
2V-68	647.7
2V-70	666.8
2V-72	685.8
2V-74	704.9
2V-76	723.9
2V-78	743.0
2V-80	762.0
2V-82	781.1
2V-84	800.1
2V-86	819.2
2V-88	838.2
2V-90	857.3
2V-92	876.3
2V-94	895.4
2V-96	914.4
2V-98	933.5
2V-100	952.5
2V-102	971.6
2V-104	990.6
2V-106	1009.7
2V-108	1028.7
2V-110	1047.8
2V-112	1066.8
2V-114	1085.9
2V-116	1104.9
2V-118	1124.0
2V-120	1143.0
2V-122	1162.1
2V-124	1181.1
2V-126	1200.2
2V-128	1219.2
2V-130	1238.3
2V-132	1257.3
2V-134	1276.4
2V-136	1295.4
2V-140	1333.5

V-BELT PULLEYS

SERIES	BORE	MATERIAL	BERG'S ® NAME	BELT
V2	Ø10	DIN 1.4303 Stainless Steel	Pow-R-Vee®	Operates with Pow-R-Vee 2V Series (6.4W X 5.6D)

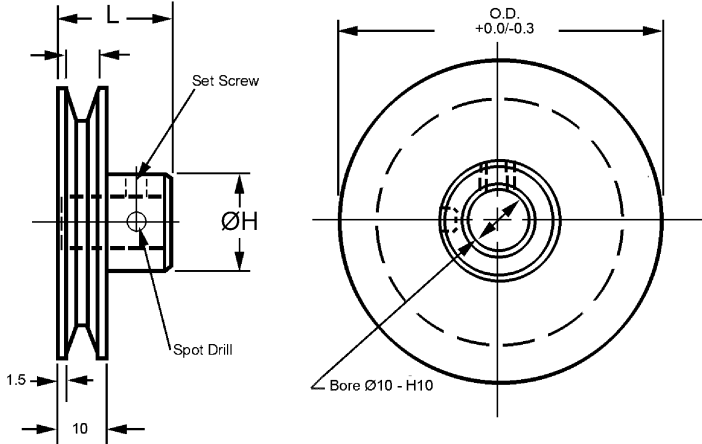

STOCK NO.	BORE	O.D.	H	L
V2M86S-1	10	42.5	20	20
V2M86S-2		45.0		
V2M86S-3		47.5		
V2M86S-4		50.0		
V2M86S-5		52.5		
V2M86S-6		56.0		
V2M86S-7		60.0		
V2M86S-8		63.0		
V2M86S-9		67.0		
V2M86S-10		71.0		
V2M86S-11		75.0		
V2M86S-12		80.0		
V2M86S-13		85.0		
V2M86S-14		92.5		
V2M86S-15		100.0		

Other sizes available upon request.

SERIES	BORE	MATERIAL	BERG'S ® NAME	BELT
V2	Ø12	DIN 1.4303 Stainless Steel	Pow-R-Vee®	Operates with Pow-R-Vee 2V Series (6.4W X 5.6D)

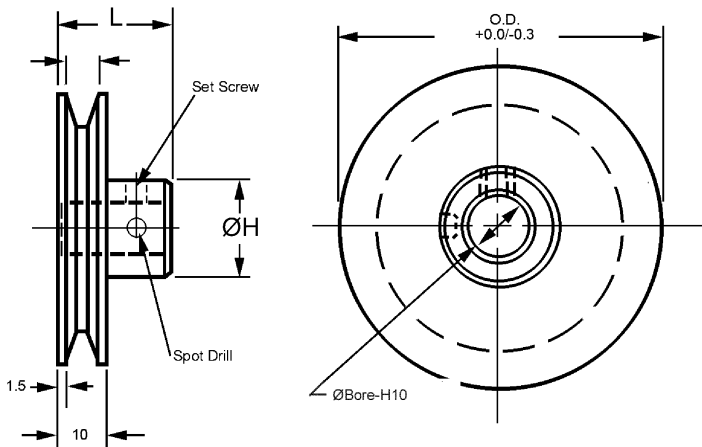

STOCK NO.	BORE	O.D.	H	L
V2M88S-1	12	42.5	20	20
V2M88S-2		45.0		
V2M88S-3		47.5		
V2M88S-4		50.0		
V2M88S-5		52.5		
V2M88S-6		56.0		
V2M88S-7		60.0		
V2M88S-8		63.0		
V2M88S-9		67.0		
V2M88S-10		71.0		
V2M88S-11		75.0		
V2M88S-12		80.0		
V2M88S-13		85.0		
V2M88S-14		92.5		
V2M88S-15		100.0		

Other sizes available upon request.



V-BELTS

SERIES	WIDTH	HEIGHT	MATERIAL	BERG'S ® NAME	PULLEY
3V	9.4	8.8	Polyurethane (Red) with 1.2 Dia. Stainless Steel Cable	POW-R-VEE®	Operates with Pow-R-Vee 3V Series

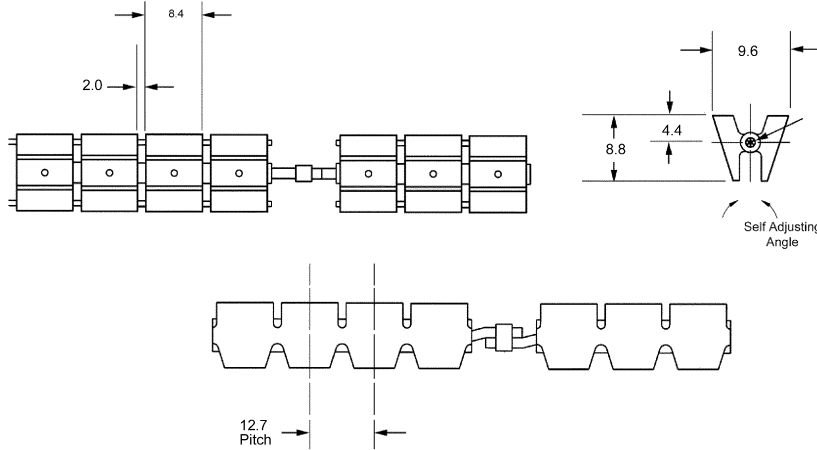

- More sidewall contact
- Less slippage
- Greater power transmission
- Infinite length variations
- Extra strong
- Silent drive
- 90A Durometer
- Mass 55 Gram/Meter
- Ultimate Tensile Strength 555N
- Temperature Range +82°C to -26°C
- Recommended Operating Load 133N
- Recommended Max. Operating Speed 1.91 m/s
- For Field Splice Kit Order 3V-7.



BULK FOOTAGE NOT SPLICED	
STOCK NO.	LENGTH
3V-1.5M	1.5 Meters
3V-3.0M	3.0 Meters
3V-7.5M	7.5 Meters
3V-15.0M	15.0 Meters
3V-30.0M	30.0 Meters

STOCK NO.	LENGTH (Ref.)
3V-12	304.8
3V-13	330.2
3V-14	355.6
3V-15	381.0
3V-16	406.4
3V-17	431.8
3V-18	457.2
3V-19	482.6
3V-20	508.0
3V-21	533.4
3V-22	558.8
3V-23	584.2
3V-24	609.6
3V-25	635.0
3V-26	660.4
3V-27	685.8
3V-28	711.2
3V-29	736.6
3V-30	762.0
3V-31	787.4
3V-32	812.8
3V-33	838.2
3V-34	863.6
3V-35	889.0
3V-36	914.4
3V-37	939.8
3V-38	965.2
3V-39	990.6
3V-40	1016.0
3V-41	1041.4
3V-42	1366.8
3V-43	1092.2
3V-44	1117.6
3V-45	1143.0
3V-46	1168.4
3V-47	1193.8
3V-48	1219.2
3V-49	1244.6
3V-50	1270.0
3V-51	1295.4
3V-52	1320.8
3V-53	1346.2
3V-54	1371.6
3V-55	1397.0
3V-56	1422.4
3V-57	1447.8
3V-58	1473.2
3V-59	1498.6
3V-60	1524.0
3V-61	1549.4
3V-62	1574.8
3V-63	1600.2
3V-64	1625.5
3V-65	1651.0
3V-66	1676.4
3V-67	1701.8
3V-68	1727.2
3V-69	1752.6
3V-70	1778.0
3V-71	1803.4
3V-72	1828.8
3V-74	1879.6

V-BELTS

SERIES	WIDTH	HEIGHT	MATERIAL	BERG'S ® NAME	PULLEY
V4	12.7	11.1	Polyurethane (Blue) with 1.6mm Dia. Stainless Steel Cable	POW-R-VEE®	Operates with Pow-R-Vee 4V Series

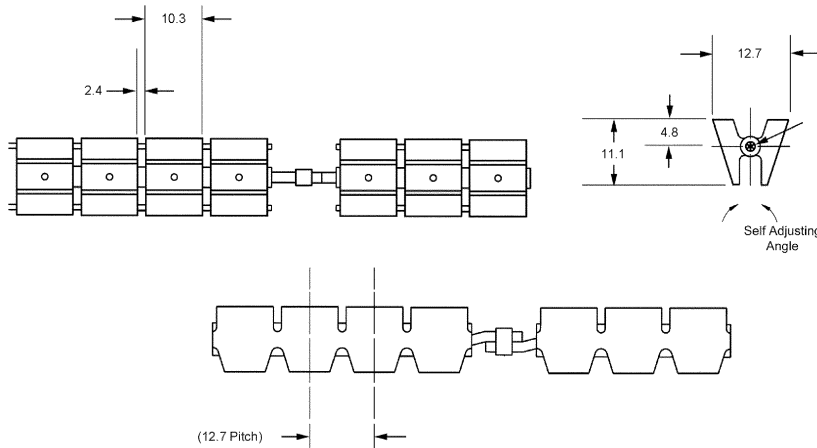

- More sidewall contact
- Less slippage
- Greater power transmission
- Infinite length variations
- Extra strong
- Silent drive
- 90A Durometer
- Mass 102 Grams/Meter
- Ultimate Tensile Strength 880N
- Temperature Range +82°C to -26°C
- Recommended Operating Load 133N
- Recommended Max. Operating Speed 1.91 m/s
- For Field Splice Order 4V-7.



BULK FOOTAGE NOT SPLICED	
STOCK NO.	LENGTH
4V-1.5M	1.5 Meters
4V-3.0M	3.0 Meters
4V-7.5M	7.5 Meters
4V-15.0M	15.0 Meters
4V-30.0M	30.0 Meters

STOCK NO.	LENGTH (Ref.)
4V-15	381.0
4V-16	406.4
4V-17	431.8
4V-18	457.2
4V-19	482.6
4V-20	508.0
4V-21	533.4
4V-22	558.8
4V-23	584.2
4V-24	609.6
4V-25	635.0
4V-26	660.4
4V-27	685.8
4V-28	711.2
4V-29	736.6
4V-30	762.0
4V-31	787.4
4V-32	812.8
4V-33	838.2
4V-34	863.6
4V-35	889.0
4V-36	914.4
4V-37	939.8
4V-38	965.2
4V-39	990.6
4V-40	1016.0
4V-41	1041.4
4V-42	1066.8
4V-43	1092.2
4V-44	1117.6
4V-45	1143.0
4V-46	1168.4
4V-47	1193.8
4V-48	1219.2
4V-49	1244.6
4V-50	1270.0
4V-51	1295.4
4V-52	1320.8
4V-53	1346.2
4V-54	1371.6
4V-55	1397.0
4V-56	1422.4
4V-57	1447.8
4V-58	1473.2
4V-59	1498.6
4V-60	1524.0
4V-61	1549.4
4V-62	1574.8
4V-63	1600.2
4V-64	1625.6
4V-65	1651.0
4V-66	1676.4
4V-67	1701.8
4V-68	1727.2
4V-69	1752.6
4V-70	1778.0
4V-72	1828.8
4V-74	1879.6
4V-76	1930.4
4V-78	1981.2
4V-80	2032.0
4V-82	2082.8
4V-84	2133.6
4V-86	2184.4
4V-88	2235.2
4V-90	2286.0
4V-92	2336.8
4V-96	2438.4

V-BELTS

SERIES	WIDTH	HEIGHT	MATERIAL	BERG'S ® NAME	PULLEY
5V	16.6	12.7	Polyurethane (Yellow) with 2.0mm Dia. Stainless Steel Cable	POW-R-VEE®	Operates with Pow-R-Vee 5V Series

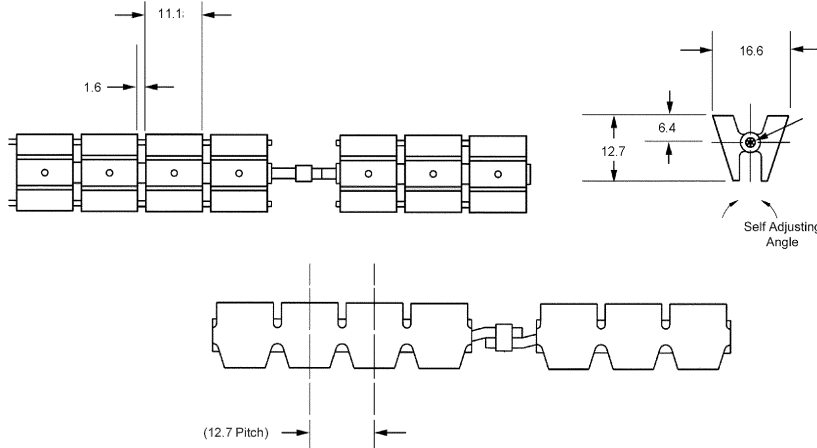

- More sidewall contact
- Less slippage
- Greater power transmission
- Infinite length variations
- Extra strong
- Silent drive
- 90A Durometer
- Mass 130 Grams/Meter
- Ultimate Tensile Strength 1550N
- Temperature Range +82°C to -26°C
- Recommended Operating Load 378N
- Recommended Max. Operating Speed 1.91 m/s
- For Field Splice Order 5V-7.



BULK FOOTAGE NOT SPLICED	
STOCK NO.	LENGTH
5V-1.5M	1.5 Meters
5V-3.0M	3.0 Meters
5V-7.5M	7.5 Meters
5V-15.0M	15.0 Meters
5V-30.0M	30.0 Meters

STOCK NO.	LENGTH (Ref.)
5V-15	381.0
5V-16	406.4
5V-17	431.8
5V-18	457.2
5V-19	482.6
5V-20	508.0
5V-21	533.4
5V-22	558.8
5V-23	584.2
5V-24	609.6
5V-25	635.0
5V-26	660.4
5V-27	685.8
5V-28	711.2
5V-29	736.6
5V-30	762.0
5V-31	787.4
5V-32	812.8
5V-33	838.2
5V-34	863.6
5V-35	889.0
5V-36	914.4
5V-37	939.8
5V-38	965.2
5V-39	990.6
5V-40	1016.0
5V-41	1041.4
5V-42	1066.8
5V-43	1092.2
5V-44	1117.6
5V-45	1143.0
5V-46	1168.4
5V-47	1193.8
5V-48	1219.2
5V-49	1244.6
5V-50	1270.0
5V-51	1295.4
5V-52	1320.8
5V-53	1346.2
5V-54	1371.6
5V-55	1397.0
5V-56	1422.4
5V-57	1447.8
5V-58	1473.2
5V-59	1498.6
5V-60	1524.0
5V-61	1549.4
5V-62	1574.8
5V-63	1600.2
5V-64	1625.6
5V-65	1651.0
5V-66	1676.4
5V-67	1701.8
5V-68	1727.2
5V-69	1752.6
5V-70	1778.0
5V-72	1828.8
5V-74	1879.6
5V-76	1930.4
5V-78	1981.2
5V-80	2032.0
5V-82	2082.8
5V-84	2133.6
5V-86	2184.4
5V-88	2235.2
5V-90	2286.0
5V-92	2336.8
5V-96	2438.4

V-BELT PULLEYS

SERIES	BORE	MATERIAL	BERG'S ® NAME	BELT
3V	Ø8	Zinc Alloy	Pow-R-Vee®	Operates with Pow-R-Vee 3V Series (10mmW X 9mmD)

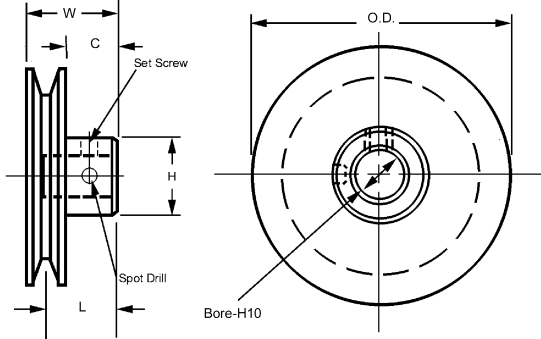

STOCK NO.	O.D.	W	C	L	H
V3-150-8M	38	25	13	22	24
V3-200-8M	51				25

All pulleys have set screws supplied.
Other bore sizes and keyways are available upon request.

SERIES	BORE	MATERIAL	BERG'S ® NAME	BELT
3V	Ø10	Zinc Alloy	Pow-R-Vee®	Operates with Pow-R-Vee 3V Series (10mmW X 9mmD)

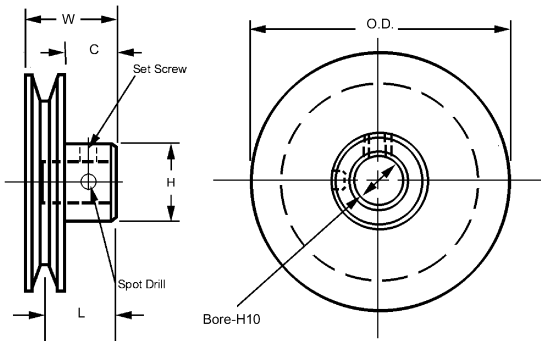

STOCK NO.	O.D.	W	C	L	H
V3-150-10M	38	25	13	22	24
V3-200-10M	51				25
V3-250-10M	64				29
V3-300-10M	76				29
V3-350-10M	89				29
V3-400-10M	102				29

All pulleys have set screws supplied.
Other bore sizes and keyways are available upon request.



V-BELT PULLEYS

SERIES	BORE	MATERIAL	BERG'S ® NAME	BELT
3V	Ø13	Zinc Alloy	Pow-R-Vee®	Operates with Pow-R-Vee 3V Series (10mmW X 9mmD)

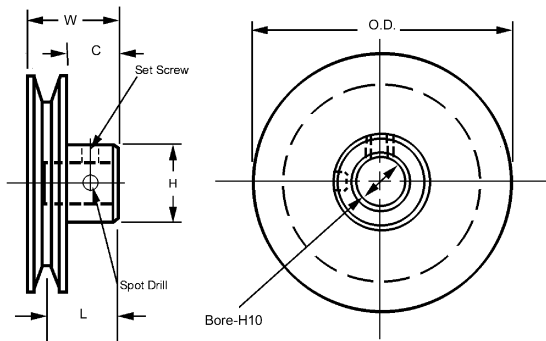

STOCK NO.	O.D.	W	C	L	H
V3-150-13M	38				24
V3-200-13M	51				25
V3-250-13M	64				29
V3-300-13M	76	25	13	22	29
V3-350-13M	89				29
V3-400-13M	102				29

All pulleys have set screws supplied.
Other bore sizes and keyways are available upon request.

SERIES	BORE	MATERIAL	BERG'S ® NAME	BELT
3V	Ø16	Zinc Alloy	Pow-R-Vee®	Operates with Pow-R-Vee 3V Series (10mmW X 9mmD)

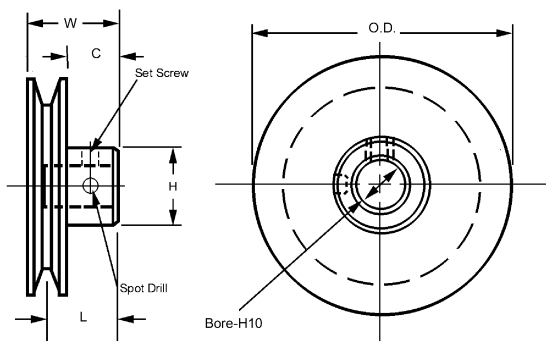

STOCK NO.	O.D.	W	C	L	H
V3-200-16M	51				24
V3-250-16M	64				25
V3-300-16M	76	25	13	22	29
V3-350-16M	89				29
V3-400-16M	102				29

All pulleys have set screws supplied.
Other bore sizes and keyways are available upon request.



V-BELT PULLEYS

SERIES	BORE	MATERIAL	BERG'S ® NAME	BELT
4V	Ø10	Zinc Alloy	Pow-R-Vee®	Operates with Pow-R-Vee 4V Series (13mmW X 10mmD)

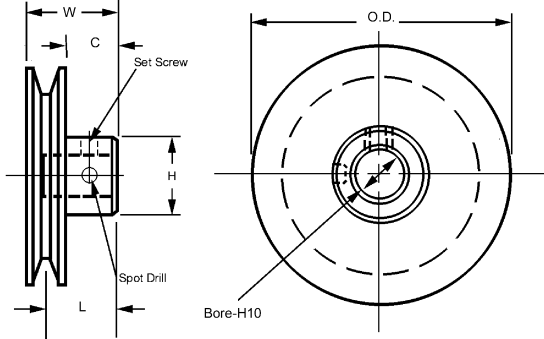

STOCK NO.	O.D.	W	C	L	H
V4-150-10M	38				22
V4-175-10M	44				27
V4-200-10M	51	29	13	25	29
V4-225-10M	57				29
V4-250-10M	64				29

All pulleys have set screws supplied.
Other bore sizes and keyways are available upon request.

SERIES	BORE	MATERIAL	BERG'S ® NAME	BELT
4V	Ø13	Zinc Alloy	Pow-R-Vee®	Operates with Pow-R-Vee 4V Series (13mmW X 10mmD)

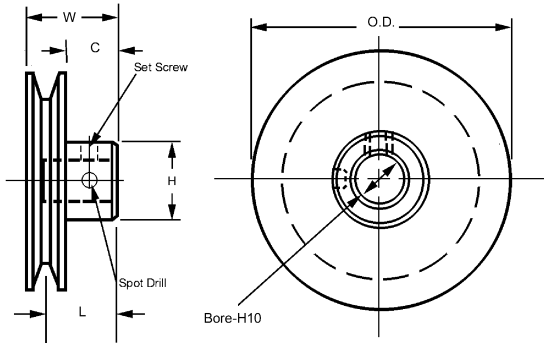

STOCK NO.	O.D.	W	C	L	H
V4-150-13M	38	29	13	25	22
V4-175-13M	44	29	13	25	27
V4-200-13M	51	29	13	25	29
V4-225-13M	57	29	13	25	29
V4-250-13M	64	29	13	25	29
V4-300-13M	76	29	13	29	32
V4-325-13M	83	30	13	29	32
V4-350-13M	89	32	16	29	32
V4-400-13M	102	32	16	29	32
V4-500-13M	127	35	22	30	40
V4-600-13M	152	38	22	33	40
V4-700-13M	178	38	22	33	40
V4-800-13M	203	38	22	34	35
V4-900-13M	229	38	21	34	52
V4-1000-13M	254	38	21	34	52

All pulleys have set screws supplied.
Other bore sizes and keyways are available upon request.

SERIES	BORE	MATERIAL	BERG'S ® NAME	BELT
4V	Ø16	Zinc Alloy	Pow-R-Vee®	Operates with Pow-R-Vee 4V Series (13mmW X 10mmD)

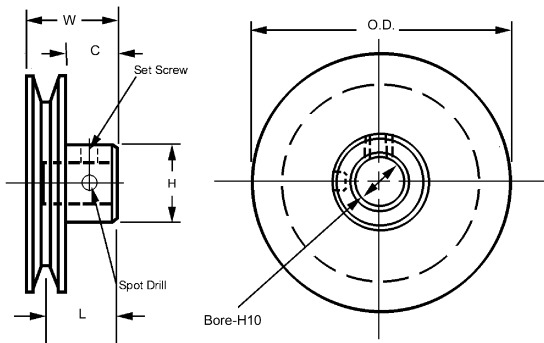

STOCK NO.	O.D.	W	C	L	H
V4-175-16M	44	29	13	25	22
V4-200-16M	51	29	13	25	27
V4-225-16M	57	29	13	25	29
V4-250-16M	64	29	13	25	29
V4-300-16M	76	29	13	29	32
V4-325-16M	83	30	13	29	32
V4-350-16M	89	32	16	29	32
V4-400-16M	102	32	16	29	32
V4-500-16M	127	35	22	30	40
V4-600-16M	152	38	22	33	40
V4-700-16M	178	38	22	33	40
V4-800-16M	203	38	22	34	35
V4-900-16M	229	38	21	34	52
V4-1000-16M	254	38	21	34	52

All pulleys have set screws supplied.
Other bore sizes and keyways are available upon request.

V-BELT PULLEYS

SERIES	BORE	MATERIAL	BERG'S ® NAME	BELT
5V	Ø13	Die Cast Zinc Alloy	Pow-R-Vee®	Operates with Pow-R-Vee 5V Series (17mmW X 13mmD)

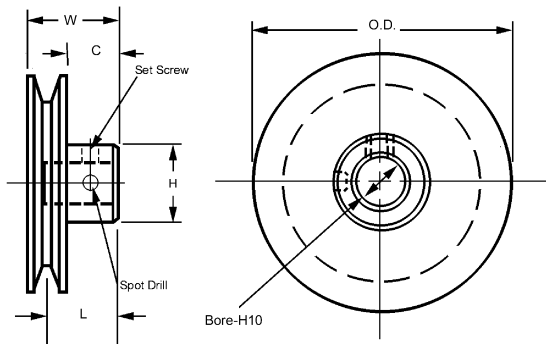

STOCK NO.	O.D.	W	C	L	H
V5-200-13M	51	32	13	29	29
V5-225-13M	57	32	10	25	29
V5-250-13M	64	32	10	25	32
V5-275-13M	70	32	13	25	32
V5-300-13M	76	37	16	29	32
V5-325-13M	83	32	13	29	32
V5-350-13M	89	35	16	29	32
V5-400-13M	102	35	16	29	33
V5-450-13M	114	35	16	29	33
V5-500-13M	127	40	19	33	35
V5-600-13M	152	41	19	35	52

All pulleys have set screws supplied.
Other bore sizes and keyways are available upon request.

SERIES	BORE	MATERIAL	BERG'S ® NAME	BELT
5V	Ø16	Die Cast Zinc Alloy	Pow-R-Vee®	Operates with Pow-R-Vee 5V Series (17mmW X 13mmD)

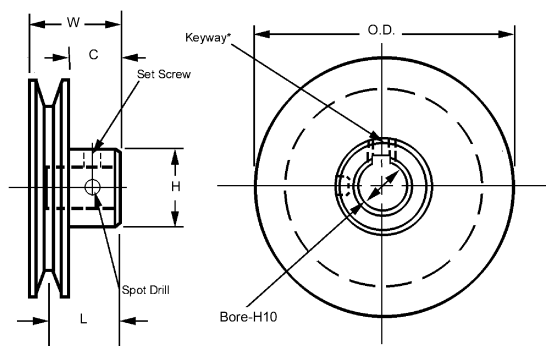

STOCK NO.	O.D.	W	C	L	H
V5-200-16M	51	32	13	29	29
V5-225-16M	57	32	10	25	29
V5-250-16M	64	32	10	25	32
V5-275-16M	70	32	13	25	32
V5-300-16M	76	37	16	29	32
V5-325-16M	83	32	13	29	32
V5-350-16M	89	35	16	29	32
V5-400-16M	102	35	16	29	33
V5-450-16M	114	35	16	29	33
V5-500-16M	127	40	19	33	35
V5-600-16M	152	41	19	35	52

*Ø16 Bore Pulleys have a 5mm x 2mm keyway.
All pulleys have set screws supplied.
Other bore sizes and keyways are available upon request.

SERIES	BORE	MATERIAL	BERG'S ® NAME	BELT
5V	Ø19	Die Cast Zinc Alloy	Pow-R-Vee®	Operates with Pow-R-Vee 5V Series (17mmW X 13mmD)

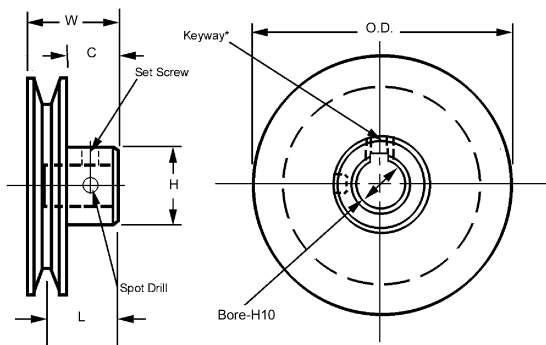

STOCK NO.	O.D.	W	C	L	H
V5-225-19M	57	32	10	25	29
V5-250-19M	64	32	10	25	32
V5-275-19M	70	32	13	25	32
V5-300-19M	76	37	16	29	32
V5-325-19M	83	32	13	29	32
V5-350-19M	89	35	16	29	32
V5-400-19M	102	35	16	29	33
V5-450-19M	114	35	16	29	33
V5-500-19M	127	40	19	33	35
V5-600-19M	152	41	19	35	52

*Ø19 Bore Pulleys have a 5mm x 2mm keyway.
All pulleys have set screws supplied.
Other bore sizes and keyways are available upon request.

FIELD SPLICE KITS

Splicing Procedures

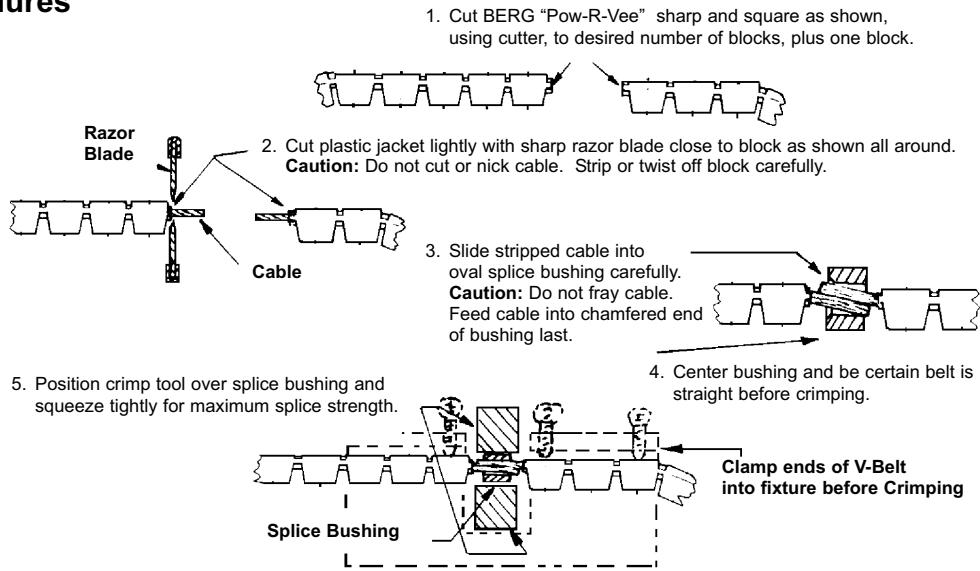

BELT SERIES	STOCK NUMBER	FIELD SPLICE KIT AND ACCESSORIES
2V	2V-7	Complete Kit Consists of: Crimp Tool, Crimp Fixture, Sample Belt Cable Cutter, Bushings, Razor Blades & Instructions
3V	3V-7	
4V	4V-7	
5V	5V-7	
	TL-3	Crimp Tool for 2V Crimp Tool for 3V Crimp Tool for 4V AND 5V
	TL-3	
	TL-6	
	BU-032-S	Extra Splice Bushings for: 2V (Ø 0.8 Dia. Cable) 3V (Ø 1.2 Dia. Cable) 4V (Ø 1.6 Dia. Cable) 5V (Ø 2.0 Dia. Cable)
	BU-046-S	
	BU-062-C	
	BU-078-S	
	TL-1	Cable Cutter for up to 1.2 Cable Cable Cutter for up to 2.0 Cable
	TL-2	

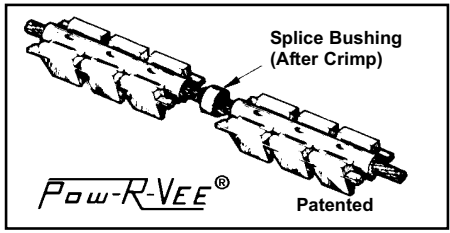

Field Splices offer only 50% of Catalog Rated Loads

W. M. Berg, Inc. will factory splice to order any length belt at a nominal charge.



GEARS

Table of Contents

SPUR GEARS

Hubless - 1.5 Module	.MB 2
Hubless - 1.25 Module	.MB 8
Hubless - 1.0 Module	.MB 14 - MB 15
Hubless - 0.8 Module	.MB 28 - MB 31
Hubless - 0.5 Module	.MB 58 - MB 59
Hubless - 0.4 Module	.MB 79 - MB 80
Hubless - 0.3 Module	.MB 100
Pin Hub - 1.5 Module	.MB 3 - MB 4
Pin Hub - 1.25 Module	.MB 9 - MB 10
Pin Hub - 1.0 Module	.MB 16 - MB 21
Pin Hub - 0.8 Module	.MB 32 - MB 37
Pin Hub - 0.6 Module	.MB 46 - MB 47
Pin Hub - 0.5 Module	.MB 60 - MB 68
Pin Hub - 0.4 Module	.MB 81 - MB 87
Pin Hub - 0.3 Module	.MB 101 - MB 104
Pin Hub - 0.25 Module	.MB 114 - MB 115
Clamp Hub - 1.5 Module	.MB 5
Clamp Hub - 1.25 Module	.MB 11
Clamp Hub - 1.0 Module	.MB 22
Clamp Hub - 0.8 Module	.MB 38 - MB 39
Clamp Hub - 0.6 Module	.MB 48 - MB 50
Clamp Hub - 0.4 Module	.MB 88 - MB 90
Clamp Hub - 0.3 Module	.MB 105 - MB 106
Clamp Hub - 0.25 Module	.MB 116

GEAR RACKS

1.5 Module	.MB 6 - MB 7
1.25 Module	.MB 12 - MB 13
1.0 Module	.MB 23 - MB 24
0.8 Module	.MB 40 - MB 41
0.6 Module	.MB 51 - MB 52
0.5 Module	.MB 69 - MB 70
0.4 Module	.MB 91 - MB 92
0.3 Module	.MB 107 - MB 108
0.25 Module	.MB 117 - MB 118

ANTI-BACKLASH GEARS

Pin Hub - 1.0 Module	.MB 25 - MB 26
Pin Hub - 0.8 Module	.MB 42 - MB 43
Pin Hub - 0.6 Module	.MB 53 - MB 55
Pin Hub - 0.5 Module	.MB 71 - MB 74
Pin Hub - 0.4 Module	.MB 93 - MB 96
Pin Hub - 0.3 Module	.MB 109 - MB 110
Pin Hub - 0.25 Module	.MB 119 - MB 120
Clamp Hub - 1.0 Module	.MB 26 - MB 27
Clamp Hub - 0.8 Module	.MB 43 - MB 44
Clamp Hub - 0.6 Module	.MB 55 - MB 57
Clamp Hub - 0.5 Module	.MB 75 - MB 77
Clamp Hub - 0.4 Module	.MB 97 - MB 98
Clamp Hub - 0.3 Module	.MB 111 - MB 112
Clamp Hub - 0.25 Module	.MB 121 - MB 122

SPUR GEAR STOCK

0.8 Module	.MB 45
0.5 Module	.MB 78
0.4 Module	.MB 99
0.3 Module	.MB 113

HELICAL GEARS

1.5 Module	.MB 123
1.25 Module	.MB 123
1.0 Module	.MB 124
0.8 Module	.MB 125
0.5 Module	.MB 126 - MB 127
0.4 Module	.MB 128 - MB 129

MITER & BEVEL GEARS

1.5 Module	.MB 130
1.0 Module	.MB 131
0.8 Module	.MB 132
0.6 Module	.MB 133
0.5 Module	.MB 134
0.4 Module	.MB 135
0.3 Module	.MB 136

PRECISION WORMS

1.5 Module	.MB 137 - MB 138
1.0 Module	.MB 139 - MB 140
0.8 Module	.MB 141 - MB 142
0.5 Module	.MB 143 - MB 144
0.4 Module	.MB 145

WORM GEARS

0.4 Module	.MB 146 - MB 147
------------	------------------

ANTI-BACKLASH WORM GEARS

Pin Hub - 0.5 Module	.MB 148 - MB 149
Pin Hub - 0.4 Module	.MB 150 - MB 151
Clamp Hub - 0.5 Module	.MB 152 - MB 153
Clamp Hub - 0.4 Module	.MB 154 - MB 155

B

SPUR GEARS

MODULE	STYLE	BORE	FACE	MATERIAL	QUALITY	PRESSURE ANGLE
1.5	PIN HUB	10	12	STAINLESS STEEL DIN 1.4305	DIN 8/AGMA 9	20°

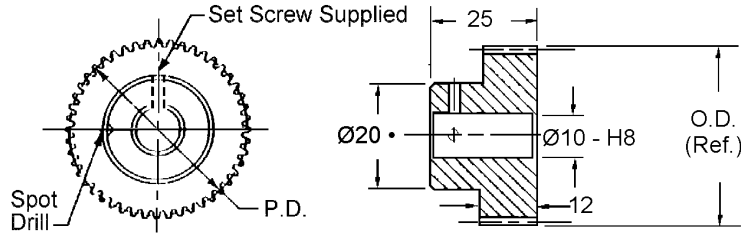

STOCK NO.	NO. OF TEETH	PITCH DIA.	OUTSIDE DIA.
PAS87-18	18	27.00	30.00
PAS87-20	20	30.00	33.00
PAS87-24	24	36.00	39.00
PAS87-28	28	42.00	45.00
PAS87-30	30	45.00	48.00
PAS87-32	32	48.00	51.00
PAS87-36	36	54.00	57.00
PAS87-40	40	60.00	63.00
PAS87-48	48	72.00	75.00
PAS87-56	56	84.00	87.00
PAS87-64	64	96.00	99.00

• For 13-15 teeth hub diameter is 15.7

Available on request:
Other numbers of teeth;
14 - 1/2° pressure angle.

MODULE	STYLE	BORE	FACE	MATERIAL	QUALITY	PRESSURE ANGLE
1.5	PIN HUB	12	12	STAINLESS STEEL DIN 1.4305	DIN 8/AGMA 9	20°

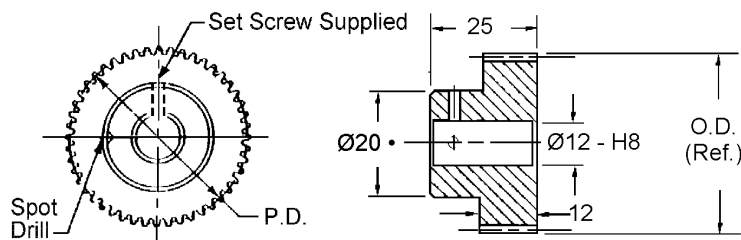

STOCK NO.	NO. OF TEETH	PITCH DIA.	OUTSIDE DIA.
PAS89-18	18	27.00	30.00
PAS89-20	20	30.00	33.00
PAS89-24	24	36.00	39.00
PAS89-28	28	42.00	45.00
PAS89-30	30	45.00	48.00
PAS89-32	32	48.00	51.00
PAS89-36	36	54.00	57.00
PAS89-40	40	60.00	63.00
PAS89-48	48	72.00	75.00
PAS89-56	56	84.00	87.00
PAS89-64	64	96.00	99.00

• For 15 teeth hub diameter equals 18.0

Available on request:
Other numbers of teeth;
14 - 1/2° pressure angle.

For Couplings See Section MG.
For Shafts, Bearings and Collars See Section MI.

Other bore sizes, styles and materials available.
Check our website or call us.

SPUR GEARS

B

MODULE	STYLE	BORE	FACE	MATERIAL	QUALITY	PRESSURE ANGLE
1.25	PIN HUB	10	10	STAINLESS STEEL DIN 1.4305	DIN 7/AGMA 10	20°

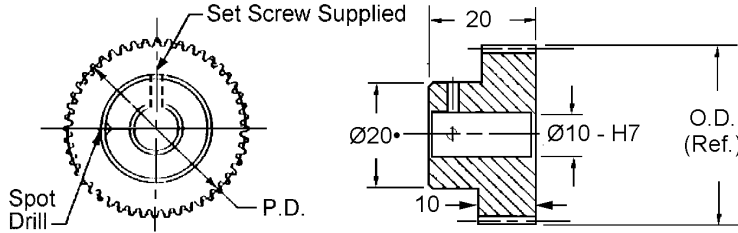

Available on request:
Other numbers of teeth;
14 - 1/2° pressure angle.

• For 15-18 teeth hub diameter equals 15.6

STOCK NO.	NO. OF TEETH	PITCH DIA.	OUTSIDE DIA.
PBS86-15	15	18.75	21.25
PBS86-16	16	20.00	22.50
PBS86-18	18	22.50	25.00
PBS86-20	20	25.00	27.50
PBS86-24	24	30.00	32.50
PBS86-25	25	31.25	33.75
PBS86-28	28	35.00	37.50
PBS86-30	30	37.50	40.00
PBS86-35	35	43.75	46.25
PBS86-36	36	45.00	47.50
PBS86-40	40	50.00	52.50
PBS86-45	45	56.25	58.75
PBS86-48	48	60.00	62.50
PBS86-50	50	62.50	65.00
PBS86-56	56	70.00	72.50
PBS86-60	60	75.00	77.50
PBS86-70	70	87.50	90.00
PBS86-72	72	90.00	92.50
PBS86-80	80	100.00	102.50
PBS86-84	84	105.00	107.50

MODULE	STYLE	BORE	FACE	MATERIAL	QUALITY	PRESSURE ANGLE
1.25	PIN HUB	12	10	STAINLESS STEEL DIN 1.4305	DIN 7/AGMA 10	20°

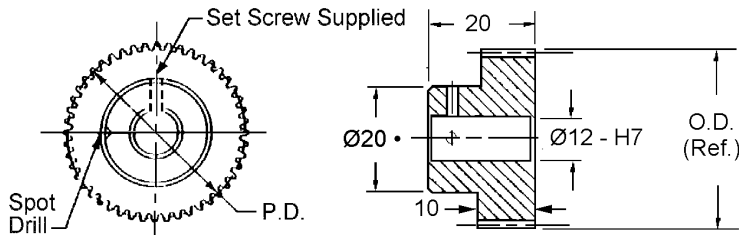

• For 12-13 teeth hub diameter is 16.3

STOCK NO.	NO. OF TEETH	PITCH DIA.	OUTSIDE DIA.
PBS88-24	24	30.00	32.50
PBS88-25	25	31.25	33.75
PBS88-30	30	37.50	40.00
PBS88-35	35	43.75	46.25
PBS88-40	40	50.00	52.50
PBS88-45	45	56.25	58.75
PBS88-50	50	62.50	65.00
PBS88-60	60	75.00	77.50
PBS88-70	70	87.50	90.00
PBS88-80	80	100.00	102.50

Available on request:
Other numbers of teeth;
14 - 1/2° pressure angle.

For Couplings See Section MG.
For Shafts, Bearings and Collars See Section MI.

Other bore sizes, styles and materials available.
Check our website or call us.

SPUR GEARS

MODULE	STYLE	BORE	FACE	MATERIAL	QUALITY	PRESSURE ANGLE
1.0	PIN HUB	8	5	STAINLESS STEEL DIN 1.4305 OR ALUMINUM DIN 3.1355 ANODIZED	DIN 7/AGMA 10	20°

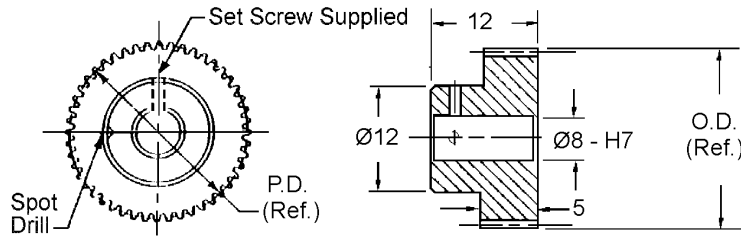

STAINLESS STEEL STOCK NO.	ALUMINUM STOCK NO.	NO. OF TEETH	PITCH DIA.	OUTSIDE DIA.
PCS95-15	PCA95-15	15	15.00	17.00
PCS95-16	PCA95-16	16	16.00	18.00
PCS95-18	PCA95-18	18	18.00	20.00
PCS95-20	PCA95-20	20	20.00	22.00
PCS95-21	PCA95-21	21	21.00	23.00
PCS95-22	PCA95-22	22	22.00	24.00
PCS95-24	PCA95-24	24	24.00	26.00
PCS95-27	PCA95-27	27	27.00	29.00
PCS95-30	PCA95-30	30	30.00	32.00
PCS95-33	PCA95-33	33	33.00	35.00
PCS95-36	PCA95-36	36	36.00	38.00
PCS95-39	PCA95-39	39	39.00	41.00
PCS95-42	PCA95-42	42	42.00	44.00
PCS95-45	PCA95-45	45	45.00	47.00
PCS95-48	PCA95-48	48	48.00	50.00
PCS95-51	PCA95-51	51	51.00	53.00
PCS95-54	PCA95-54	54	54.00	56.00
PCS95-57	PCA95-57	57	57.00	59.00
PCS95-60	PCA95-60	60	60.00	62.00
PCS95-63	PCA95-63	63	63.00	65.00
PCS95-66	PCA95-66	66	66.00	68.00
PCS95-69	PCA95-69	69	69.00	71.00
PCS95-72	PCA95-72	72	72.00	74.00
PCS95-75	PCA95-75	75	75.00	77.00
PCS95-78	PCA95-78	78	78.00	80.00
PCS95-81	PCA95-81	81	81.00	83.00
PCS95-84	PCA95-84	84	84.00	86.00
PCS95-87	PCA95-87	87	87.00	89.00
PCS95-90	PCA95-90	90	90.00	92.00
PCS95-93	PCA95-93	93	93.00	95.00
PCS95-96	PCA95-96	96	96.00	98.00

Available on request:
Other numbers of teeth;
14 - 1/2° pressure angle;
Quality Class AGMA 12 and 14 / DIN 5 and 3

**Other bore sizes, styles and materials available.
Check our website or call us.**

**For Couplings See Section MG.
For Shafts, Bearings and Collars See Section MI.**

SPUR GEARS

MODULE	STYLE	BORE	FACE	MATERIAL	QUALITY	PRESSURE ANGLE
0.8	PIN HUB	5	5	STAINLESS STEEL DIN 1.4305 OR ALUMINUM DIN 3.1355 ANODIZED	DIN 7/AGMA 10	20°

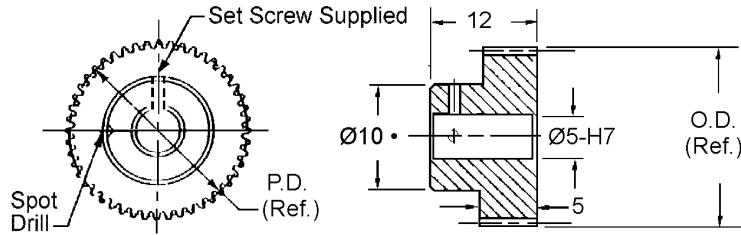

STAINLESS STEEL STOCK NO.	ALUMINUM STOCK NO.	NO. OF TEETH	PITCH DIA.	OUTSIDE DIA.
PDS83-15	PDA83-15	15*	12.00	13.60
PDS83-16	PDA83-16	16	12.80	14.40
PDS83-17	PDA83-17	17	13.60	15.20
PDS83-18	PDA83-18	18	14.40	16.00
PDS83-20	PDA83-20	20	16.00	17.60
PDS83-22	PDA83-22	22	17.60	19.20
PDS83-24	PDA83-24	24	19.20	20.80
PDS83-26	PDA83-26	26	20.80	22.40
PDS83-28	PDA83-28	28	22.40	24.00
PDS83-30	PDA83-30	30	24.00	25.60
PDS83-32	PDA83-32	32	25.60	27.20
PDS83-36	PDA83-36	36	28.80	30.40
PDS83-40	PDA83-40	40	32.00	33.60
PDS83-48	PDA83-48	48	38.40	40.00
PDS83-52	PDA83-52	52	41.60	43.20
PDS83-56	PDA83-56	56	44.80	46.40
PDS83-60	PDA83-60	60	48.00	49.60
PDS83-64	PDA83-64	64	51.20	52.80
PDS83-68	PDA83-68	68	54.40	56.00
PDS83-72	PDA83-72	72	57.60	59.20
PDS83-80	PDA83-80	80	64.00	65.60
PDS83-84	PDA83-84	84	67.20	68.80
PDS83-88	PDA83-88	88	70.40	72.00
PDS83-92	PDA83-92	92	73.60	75.20
PDS83-96	PDA83-96	96	76.80	78.40
PDS83-100	PDA83-100	100	80.00	81.60
PDS83-104	PDA83-104	104	83.20	84.80
PDS83-108	PDA83-108	108	86.40	88.00
PDS83-112	PDA83-112	112	89.60	91.20
PDS83-116	PDA83-116	116	92.80	94.40
PDS83-120	PDA83-120	120	96.00	97.60
PDS83-128	PDA83-128	128	102.40	104.00

Available on request:
Other numbers of teeth;
14 - 1/2° pressure angle;
Quality Class AGMA 12 and 14 / DIN 5 and 3

* For 13-15 teeth hub diameter equals 8.3

**Other bore sizes, styles and materials available.
Check our website or call us.**

**For Couplings See Section MG.
For Shafts, Bearings and Collars See Section MI.**

SPUR GEARS

MODULE	STYLE	BORE	FACE	MATERIAL	QUALITY	PRESSURE ANGLE
0.6	PIN HUB	5	5	STAINLESS STEEL DIN 1.4305 OR ALUMINUM DIN 3.1355 ANODIZED	DIN 7/AGMA 10	20°

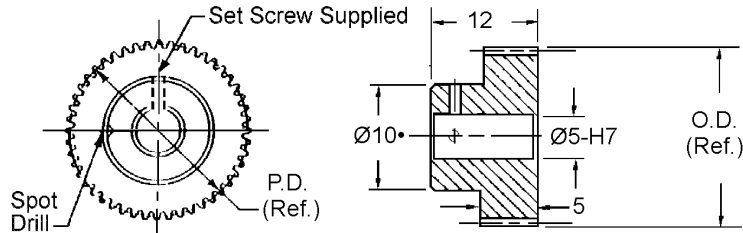

STAINLESS STEEL STOCK NO.	ALUMINUM STOCK NO.	NO. OF TEETH	PITCH DIA.	OUTSIDE DIA.
PES83-18	PEA83-18	18	10.80	12.00
PES83-20	PEA83-20	20	12.00	13.20
PES83-22	PEA83-22	22	13.20	14.40
PES83-24	PEA83-24	24	14.40	15.60
PES83-25	PEA83-25	25	15.00	16.20
PES83-26	PEA83-26	26	15.60	16.80
PES83-28	PEA83-28	28	16.80	18.00
PES83-30	PEA83-30	30	18.00	19.20
PES83-32	PEA83-32	32	19.20	20.40
PES83-36	PEA83-36	36	21.60	22.80
PES83-40	PEA83-40	40	24.00	25.20
PES83-42	PEA83-42	42	25.20	26.40
PES83-45	PEA83-45	45	27.00	28.20
PES83-48	PEA83-48	48	28.80	30.00
PES83-50	PEA83-50	50	30.00	31.20
PES83-54	PEA83-54	54	32.40	33.60
PES83-56	PEA83-56	56	33.60	34.80
PES83-60	PEA83-60	60	36.00	37.20
PES83-64	PEA83-64	64	38.40	39.60
PES83-70	PEA83-70	70	42.00	43.20
PES83-72	PEA83-72	72	43.20	44.40
PES83-75	PEA83-75	75	45.00	46.20
PES83-76	PEA83-76	76	45.60	46.80
PES83-80	PEA83-80	80	48.00	49.20
PES83-88	PEA83-88	88	52.80	54.00
PES83-90	PEA83-90	90	54.00	55.20
PES83-96	PEA83-96	96	57.60	58.80
PES83-100	PEA83-100	100	60.00	61.20
PES83-110	PEA83-110	110	66.00	67.20
PES83-120	PEA83-120	120	72.00	73.20
PES83-124	PEA83-124	124	74.40	75.60
PES83-128	PEA83-128	128	76.80	78.00

Available on request:
Other numbers of teeth;
14 - 1/2° pressure angle;
Quality Class AGMA 12 and 14 / DIN 5 and 3

• For 16-18 teeth hub diameter equals 8.0

**Other bore sizes, styles and materials available.
Check our website or call us.**

**For Couplings See Section MG.
For Shafts, Bearings and Collars See Section MI.**

SPUR GEARS

MODULE	STYLE	BORE	FACE	MATERIAL	QUALITY	PRESSURE ANGLE
0.5	PIN HUB	5	5	STAINLESS STEEL DIN 1.4305 OR ALUMINUM DIN 3.1355 ANODIZED	DIN 7/AGMA 10	20°

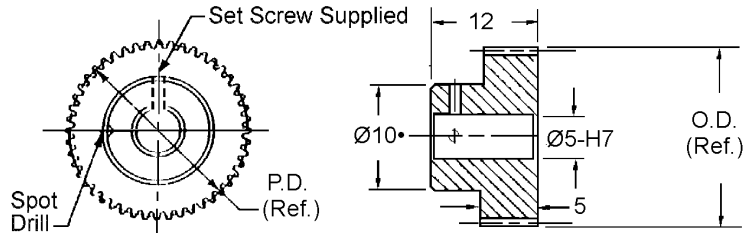

STAINLESS STEEL STOCK NO.	ALUMINUM STOCK NO.	NO. OF TEETH	PITCH DIA.	OUTSIDE DIA.
PFS83-20	PFA83-20	20•	10.00	11.00
PFS83-21	PFA83-21	21•	10.50	11.50
PFS83-22	PFA83-22	22•	11.00	12.00
PFS83-23	PFA83-23	23	11.50	12.50
PFS83-24	PFA83-24	24	12.00	13.00
PFS83-25	PFA83-25	25	12.50	13.50
PFS83-28	PFA83-28	28	14.00	15.00
PFS83-30	PFA83-30	30	15.00	16.00
PFS83-32	PFA83-32	32	16.00	17.00
PFS83-34	PFA83-34	34	17.00	18.00
PFS83-36	PFA83-36	36	18.00	19.00
PFS83-40	PFA83-40	40	20.00	21.00
PFS83-42	PFA83-42	42	21.00	22.00
PFS83-46	PFA83-46	46	23.00	24.00
PFS83-48	PFA83-48	48	24.00	25.00
PFS83-50	PFA83-50	50	25.00	26.00
PFS83-60	PFA83-60	60	30.00	31.00
PFS83-64	PFA83-64	64	32.00	33.00
PFS83-70	PFA83-70	70	35.00	36.00
PFS83-72	PFA83-72	72	36.00	37.00
PFS83-80	PFA83-80	80	40.00	41.00
PFS83-84	PFA83-84	84	42.00	43.00
PFS83-90	PFA83-90	90	45.00	46.00
PFS83-96	PFA83-96	96	48.00	49.00
PFS83-105	PFA83-105	105	52.50	53.50
PFS83-120	PFA83-120	120	60.00	61.00
PFS83-132	PFA83-132	132	66.00	67.00
PFS83-144	PFA83-144	144	72.00	73.00
PFS83-156	PFA83-156	156	78.00	79.00
PFS83-190	PFA83-190	190	95.00	96.00
PFS83-192	PFA83-192	192	96.00	97.00

Available on request:
Other numbers of teeth;
14 - 1/2° pressure angle;
Quality Class AGMA 12 and 14 / DIN 5 and 3

• For 20-22 teeth hub diameter equals 8.1

**Other bore sizes, styles and materials available.
Check our website or call us.**

**For Couplings See Section MG.
For Shafts, Bearings and Collars See Section MI.**

SPUR GEARS

MODULE	STYLE	BORE	FACE	MATERIAL	QUALITY	PRESSURE ANGLE
0.4	PIN HUB	5	5	STAINLESS STEEL DIN 1.4305 OR ALUMINUM DIN 3.1355 ANODIZED	DIN 7/AGMA 10	20°

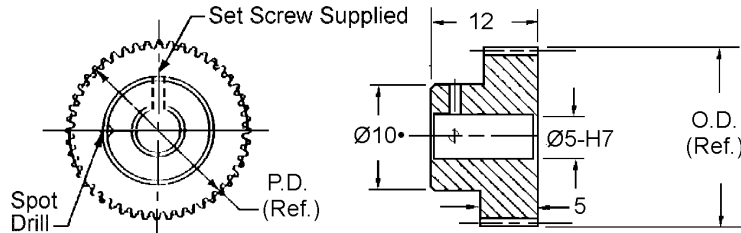

STAINLESS STEEL STOCK NO.	ALUMINUM STOCK NO.	NO. OF TEETH	PITCH DIA.	OUTSIDE DIA.
PGS83-24	PGA83-24	24•	9.60	10.40
PGS83-25	PGA83-25	25•	10.00	10.80
PGS83-26	PGA83-26	26•	10.40	11.20
PGS83-28	PGA83-28	28	11.20	12.00
PGS83-30	PGA83-30	30	12.00	12.80
PGS83-32	PGA83-32	32	12.80	13.60
PGS83-36	PGA83-36	36	14.40	15.20
PGS83-40	PGA83-40	40	16.00	16.80
PGS83-44	PGA83-44	44	17.60	18.40
PGS83-46	PGA83-46	46	18.40	19.20
PGS83-48	PGA83-48	48	19.20	20.00
PGS83-50	PGA83-50	50	20.00	20.80
PGS83-56	PGA83-56	56	22.40	23.20
PGS83-60	PGA83-60	60	24.00	24.80
PGS83-64	PGA83-64	64	25.60	26.40
PGS83-70	PGA83-70	70	28.00	28.80
PGS83-75	PGA83-75	75	30.00	30.80
PGS83-80	PGA83-80	80	32.00	32.80
PGS83-88	PGA83-88	88	35.20	36.00
PGS83-90	PGA83-90	90	36.00	36.80
PGS83-96	PGA83-96	96	38.40	39.20
PGS83-100	PGA83-100	100	40.00	40.80
PGS83-110	PGA83-110	110	44.00	44.80
PGS83-112	PGA83-112	112	44.80	45.60
PGS83-120	PGA83-120	120	48.00	48.80
PGS83-128	PGA83-128	128	51.20	52.00
PGS83-136	PGA83-136	136	54.40	55.20
PGS83-144	PGA83-144	144	57.60	58.40
PGS83-152	PGA83-152	152	60.80	61.60
PGS83-160	PGA83-160	160	64.00	64.80
PGS83-176	PGA83-176	176	70.40	71.20
PGS83-192	PGA83-192	192	76.80	77.60
PGS83-200	PGA83-200	200	80.00	80.80
PGS83-208	PGA83-208	208	83.20	84.00
PGS83-224	PGA83-224	224	89.60	90.40
PGS83-240	PGA83-240	240	96.00	96.80
PGS83-256	PGA83-256	256	102.40	103.20

Available on request:
Other numbers of teeth;
14 - 1/2° pressure angle;
Quality Class AGMA 12 and 14 / DIN 5 and 3

• For 24-27 teeth hub diameter equals 8.1

**Other bore sizes, styles and materials available.
Check our website or call us.**

**For Couplings See Section MG.
For Shafts, Bearings and Collars See Section MI.**

SPUR GEARS

MODULE	STYLE	BORE	FACE	MATERIAL	QUALITY	PRESSURE ANGLE
0.3	PIN HUB	5	5	STAINLESS STEEL DIN 1.4305 OR ALUMINUM DIN 3.1355 ANODIZED	DIN 7/AGMA 10	20°

B

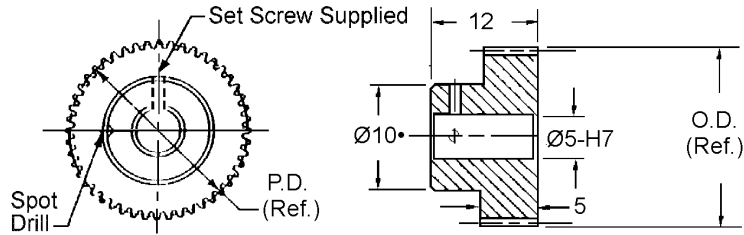

STAINLESS STEEL STOCK NO.	ALUMINUM STOCK NO.	NO. OF TEETH	PITCH DIA.	OUTSIDE DIA.
PHS83-30	PHA83-30	30•	9.00	9.60
PHS83-32	PHA83-32	32•	9.60	10.20
PHS83-34	PHA83-34	34•	10.20	10.80
PHS83-36	PHA83-36	36•	10.80	11.40
PHS83-38	PHA83-38	38	11.40	12.00
PHS83-40	PHA83-40	40	12.00	12.60
PHS83-42	PHA83-42	42	12.60	13.20
PHS83-44	PHA83-44	44	13.20	13.80
PHS83-46	PHA83-46	46	13.80	14.40
PHS83-48	PHA83-48	48	14.40	15.00
PHS83-50	PHA83-50	50	15.00	15.60
PHS83-54	PHA83-54	54	16.20	16.80
PHS83-56	PHA83-56	56	16.80	17.40
PHS83-60	PHA83-60	60	18.00	18.60
PHS83-63	PHA83-63	63	18.90	19.50
PHS83-64	PHA83-64	64	19.20	19.80
PHS83-70	PHA83-70	70	21.00	21.60
PHS83-72	PHA83-72	72	21.60	22.20
PHS83-80	PHA83-80	80	24.00	24.60
PHS83-90	PHA83-90	90	27.00	27.60
PHS83-96	PHA83-96	96	28.80	29.40
PHS83-100	PHA83-100	100	30.00	30.60
PHS83-105	PHA83-105	105	31.50	32.10
PHS83-108	PHA83-108	108	32.40	33.00
PHS83-144	PHA83-144	144	43.20	43.80

Available on request:
Other numbers of teeth;
14 - 1/2° pressure angle;
Quality Class AGMA 12 and 14 / DIN 5 and 3

• For 30-36 teeth hub diameter equals 8.1

**Other bore sizes, styles and materials available.
Check our website or call us.**

**For Couplings See Section MG.
For Shafts, Bearings and Collars See Section MI.**

SPUR GEARS

MODULE	STYLE	BORE	FACE	MATERIAL	QUALITY	PRESSURE ANGLE
0.25	PIN HUB	3	3	STAINLESS STEEL DIN 1.4305 OR ALUMINUM DIN 3.1355 ANODIZED	DIN 7/AGMA 10	20°

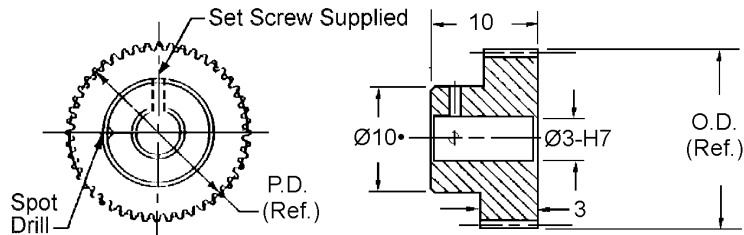

STAINLESS STEEL STOCK NO.	ALUMINUM STOCK NO.	NO. OF TEETH	PITCH DIA.	OUTSIDE DIA.
PJS80-32	PJA80-32	32	8.00	8.50
PJS80-34	PJA80-34	34	8.50	9.00
PJS80-35	PJA80-35	35	8.75	9.25
PJS80-36	PJA80-36	36	9.00	9.50
PJS80-38	PJA80-38	38	9.50	10.00
PJS80-39	PJA80-39	39	9.75	10.25
PJS80-40	PJA80-40	40	10.00	10.50
PJS80-42	PJA80-42	42	10.50	11.00
PJS80-44	PJA80-44	44	11.00	11.50
PJS80-46	PJA80-46	46	11.50	12.00
PJS80-47	PJA80-47	47	11.75	12.25
PJS80-48	PJA80-48	48	12.00	12.50
PJS80-50	PJA80-50	50	12.50	13.00
PJS80-52	PJA80-52	52	13.00	13.50
PJS80-54	PJA80-54	54	13.50	14.00
PJS80-56	PJA80-56	56	14.00	14.50
PJS80-58	PJA80-58	58	14.50	15.00
PJS80-60	PJA80-60	60	15.00	15.50
PJS80-62	PJA80-62	62	15.50	16.00
PJS80-64	PJA80-64	64	16.00	16.50
PJS80-65	PJA80-65	65	16.25	16.75
PJS80-67	PJA80-67	67	16.75	17.25
PJS80-70	PJA80-70	70	17.50	18.00
PJS80-72	PJA80-72	72	18.00	18.50
PJS80-74	PJA80-74	74	18.50	19.00
PJS80-75	PJA80-75	75	18.75	19.25
PJS80-80	PJA80-80	80	20.00	20.50
PJS80-84	PJA80-84	84	21.00	21.50
PJS80-88	PJA80-88	88	22.00	22.50
PJS80-90	PJA80-90	90	22.50	23.00
PJS80-96	PJA80-96	96	24.00	24.50
PJS80-100	PJA80-100	100	25.00	25.50
PJS80-105	PJA80-105	105	26.25	26.75
PJS80-127	PJA80-127	127	31.75	32.25
PJS80-144	PJA80-144	144	36.00	36.50
PJS80-156	PJA80-156	156	39.00	39.50
PJS80-168	PJA80-168	168	42.00	42.50

Available on request:
Other numbers of teeth;
14 - 1/2° pressure angle;
Quality Class AGMA 12 and 14 / DIN 5 and 3

• For 25-42 teeth hub diameter equals 5.5

**Other bore sizes, styles and materials available.
Check our website or call us.**

**For Couplings See Section MG.
For Shafts, Bearings and Collars See Section MI.**

MITER & BEVEL GEARS

MODULE	STYLE	BORE	FACE	MATERIAL	QUALITY	PRES. ANGLE
1.5	Matched Sets PIN HUB	12	8	STAINLESS STEEL DIN 1.4305 OR ALUMINUM DIN 3.1555	DIN 7/AGMA 10	20°

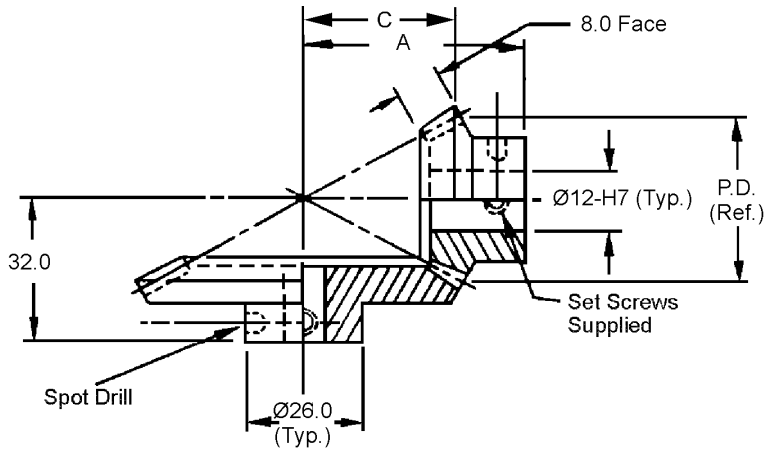

STOCK NO.	PITCH DIA.	RATIO	NO. OF TEETH	A	MATERIAL	CROWN TO APEX (C)
MAN-1	30.00	1 to 1	20	32.0	STAINLESS STEEL	13.94
	30.00				ALUMINUM	13.94
MAN-1S	30.00	1 to 1	20	32.0	STAINLESS STEEL	13.94
	30.00				ALUMINUM	13.94
MAN-1A	30.00	1 to 1	20	32.0	ALUMINUM	13.94
	30.00				ALUMINUM	13.94
MAN-2	30.00 (PINION)	1 to 2	20	47.5	STAINLESS STEEL	29.10
	60.00 (GEAR)				ALUMINUM	14.12
MAN-3	30.00 (PINION)	1 to 3	20	63.5	STAINLESS STEEL	44.33
	90.00 (GEAR)				ALUMINUM	14.16
MAN-1P	30.00	1 to 1	20	32.0	STAINLESS STEEL	13.94
MAN-1G	30.00	1 to 1	20	32.0	ALUMINUM	13.94

Note: Gears will mesh at right angles only when used as sets described in chart.

For Couplings See Section MG.
For Shafts, Bearings and Collars See Section MI.

MITER & BEVEL GEARS

MODULE	STYLE	BORE	FACE	MATERIAL	QUALITY	PRES. ANGLE
1.0	Matched Sets PIN HUB	10	7	STAINLESS STEEL DIN 1.4305 OR ALUMINUM DIN 3.1555	DIN 7/AGMA 10	20°

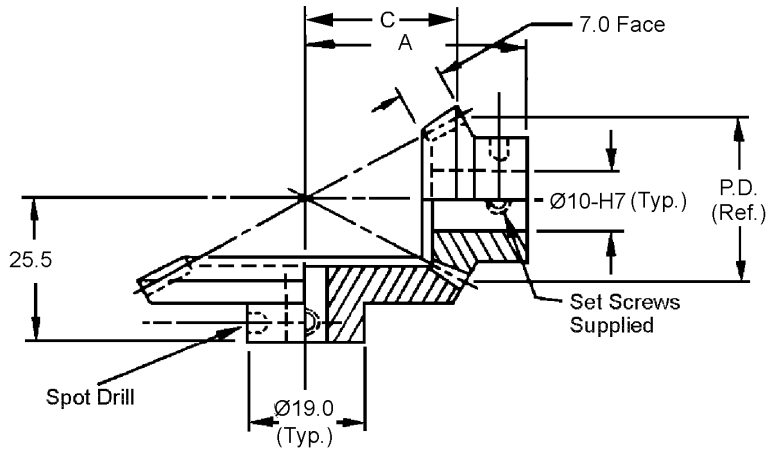

STOCK NO.	PITCH DIA.	RATIO	NO. OF TEETH	A	MATERIAL	CROWN TO APEX (C)
MCN-1	24.00	1 to 1	24	25.5	STAINLESS STEEL	11.29
	24.00				ALUMINUM	11.29
MCN-1S	24.00	1 to 1	24	25.5	STAINLESS STEEL	11.29
MCN-1A	24.00	1 to 1	24	25.5	ALUMINUM	11.29
	24.00				ALUMINUM	11.29
MCN-2	24.00 (PINION)	1 to 2	24	38.0	STAINLESS STEEL	23.40
	48.00 (GEAR)				ALUMINUM	11.42
MCN-3	24.00 (PINION)	1 to 3	24	51.0	STAINLESS STEEL	35.56
	72.00 (GEAR)				ALUMINUM	11.44
MCN-4	24.00 (PINION)	1 to 4	24	63.5	STAINLESS STEEL	47.65
	96.00 (GEAR)				ALUMINUM	11.45
MCN-1P	24.00	1 to 1	24	25.5	STAINLESS STEEL	11.29
MCN-1G	24.00	1 to 1	24	25.5	ALUMINUM	11.29

Note: Gears will mesh at right angles only when used as sets described in chart.

For Couplings See Section MG.
For Shafts, Bearings and Collars See Section MI.

MITER & BEVEL GEARS

MODULE	STYLE	BORE	FACE	MATERIAL	QUALITY	PRES. ANGLE
0.8	Matched Sets PIN HUB	8	7	STAINLESS STEEL DIN 1.4305 OR ALUMINUM DIN 3.1555	DIN 7/AGMA 10	20°

B

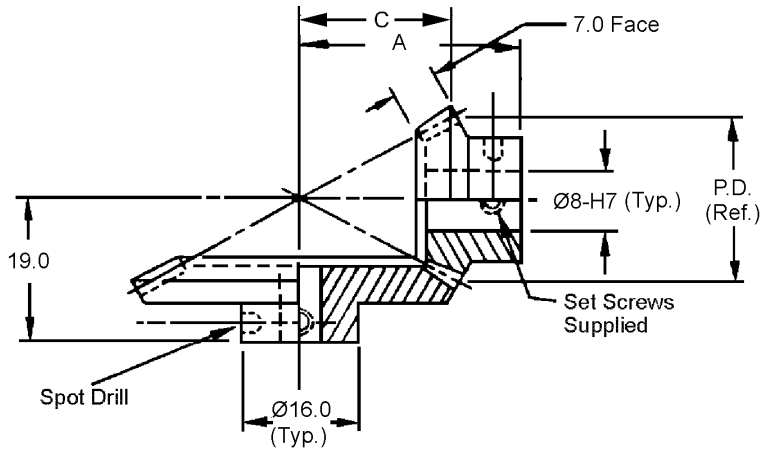

STOCK NO.	PITCH DIA.	RATIO	NO. OF TEETH	A	MATERIAL	CROWN TO APEX (C)
MDN-1	19.20	1 to 1	24	19.0	STAINLESS STEEL	9.03
	19.20		24		ALUMINUM	9.03
MDN-1S	19.20	1 to 1	24	19.0	STAINLESS STEEL	9.03
	19.20		24		ALUMINUM	9.03
MDN-1A	19.20 (PINION)	1 to 2	24	19.0	STAINLESS STEEL	18.72
	38.40 (GEAR)		48		ALUMINUM	9.13
MDN-2	19.20 (PINION)	1 to 3	24	38.0	STAINLESS STEEL	28.44
	57.60 (GEAR)		72		ALUMINUM	9.15
MDN-3	19.20 (PINION)	1 to 4	24	47.5	STAINLESS STEEL	38.12
	76.80 (GEAR)		96		ALUMINUM	9.16
MDN-1P	19.20	1 to 1	24	19.0	STAINLESS STEEL	9.03
MDN-1G	19.20	1 to 1	24	19.0	ALUMINUM	9.03

Note: Gears will mesh at right angles only when used as sets described in chart.

For Couplings See Section MG.
For Shafts, Bearings and Collars See Section MI.

MITER & BEVEL GEARS

MODULE	STYLE	BORE	FACE	MATERIAL	QUALITY	PRES. ANGLE
0.6	Matched Sets PIN HUB	8	5	STAINLESS STEEL DIN 1.4305 OR ALUMINUM DIN 3.1555	DIN 7/AGMA 10	20°

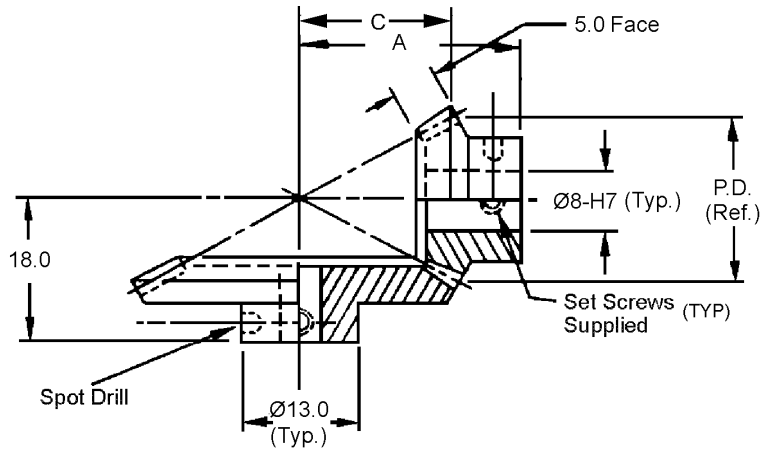

STOCK NO.	PITCH DIA.	RATIO	NO. OF TEETH	A	MATERIAL	CROWN TO APEX (C)
MEN-1	18.00	1 to 1	30	18.0	STAINLESS STEEL	8.58
	18.00				ALUMINUM	8.58
MEN-1S	18.00	1 to 1	30	18.0	STAINLESS STEEL	8.58
	18.00				ALUMINUM	8.58
MEN-1A	18.00	1 to 1	30	18.0	ALUMINUM	8.58
	18.00				ALUMINUM	8.58
MEN-2	18.00 (PINION)	1 to 2	30	26.0	STAINLESS STEEL	17.64
	36.00 (GEAR)				ALUMINUM	8.65
MEN-3	18.00 (PINION)	1 to 3	30	36.0	STAINLESS STEEL	26.73
	54.00 (GEAR)				ALUMINUM	8.66
MEN-4	18.00 (PINION)	1 to 4	30	44.0	STAINLESS STEEL	35.79
	72.00 (GEAR)				ALUMINUM	8.67
MEN-1P	18.00	1 to 1	30	18.0	STAINLESS STEEL	8.58
MEN-1G	18.00	1 to 1	30	18.0	ALUMINUM	8.58

Note: Gears will mesh at right angles only when used as sets described in chart.

For Couplings See Section MG.
For Shafts, Bearings and Collars See Section MI.

MITER & BEVEL GEARS

MODULE	STYLE	BORE	FACE	MATERIAL	QUALITY	PRES. ANGLE
0.5	Matched Sets PIN HUB	5	4	STAINLESS STEEL DIN 1.4305 OR ALUMINUM DIN 3.1555	DIN 7/AGMA 10	20°

B

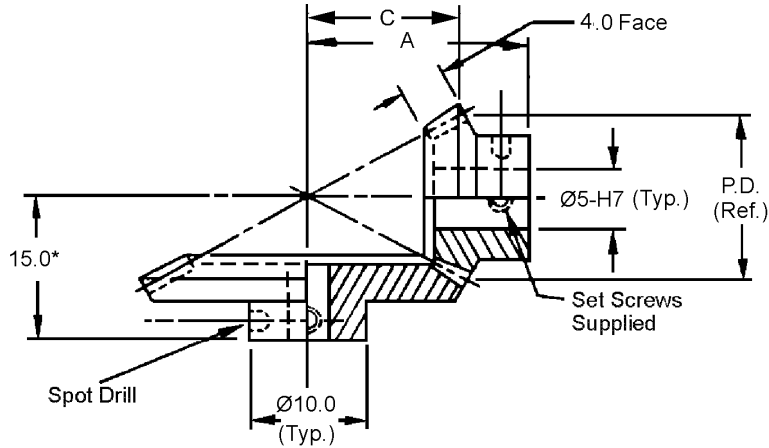

STOCK NO.	PITCH DIA.	RATIO	NO. OF TEETH	A	MATERIAL	CROWN TO APEX (C)
MFN-1	16.00	1 to 1	32	15.0	STAINLESS STEEL	7.65
	16.00		32		ALUMINUM	7.65
MFN-1S	16.00	1 to 1	32	15.0	STAINLESS STEEL	7.65
MFN-1A	16.00	1 to 1	32	15.0	ALUMINUM	7.65
	16.00		32		ALUMINUM	7.65
MFN-2*	16.00 (PINION)	1 to 2	32	23.0	STAINLESS STEEL	15.70
	32.00 (GEAR)		64		ALUMINUM	7.71
MFN-3*	16.00 (PINION)	1 to 3	32	32.0	STAINLESS STEEL	23.78
	48.00 (GEAR)		96		ALUMINUM	7.72
MFN-4	16.00 (PINION)	1 to 4	32	39.0	STAINLESS STEEL	31.83
	64.00 (GEAR)		128		ALUMINUM	7.72
MFN-1P	16.00	1 to 1	32	15.0	STAINLESS STEEL	7.65
MFN-1G	16.00	1 to 1	32	15.0	ALUMINUM	7.65

Note: Gears will mesh at right angles only when used as sets described in chart.

*Back to apex dimension for MFN-2 and MFN-3 is 17.0

**For Couplings See Section MG.
For Shafts, Bearings and Collars See Section MI.**

MITER & BEVEL GEARS

MODULE	STYLE	BORE	FACE	MATERIAL	QUALITY	PRES. ANGLE
0.4	Matched Sets PIN HUB	5	4	STAINLESS STEEL DIN 1.4305 OR ALUMINUM DIN 3.1555	DIN 7/AGMA 10	20°

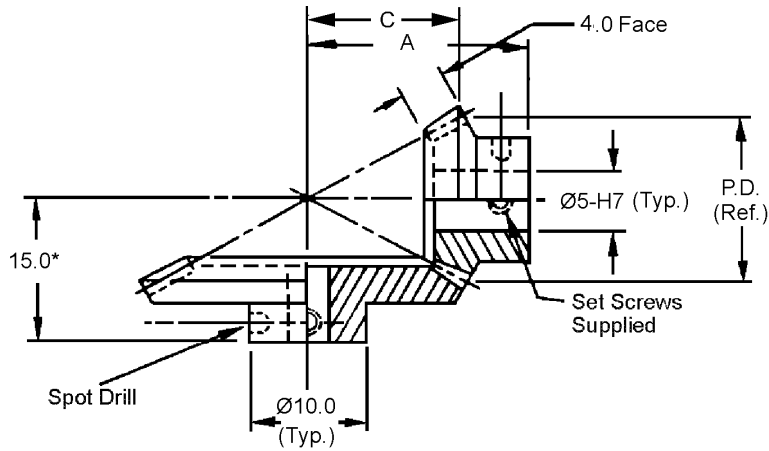

STOCK NO.	PITCH DIA.	RATIO	NO. OF TEETH	A	MATERIAL	CROWN TO APEX (C)
MGN-1	14.40	1 to 1	36	15.0	STAINLESS STEEL	6.92
	14.40		ALUMINUM		6.92	
MGN-1S	14.40	1 to 1	36	15.0	STAINLESS STEEL	6.92
	14.40		ALUMINUM		6.92	
MGN-1A	14.40	1 to 1	36	15.0	ALUMINUM	6.92
	14.40		ALUMINUM		6.92	
MGN-2	14.40 (PINION)	1 to 2	36	22.0	STAINLESS STEEL	14.16
	28.80 (GEAR)		ALUMINUM		6.97	
MGN-3	14.40 (PINION)	1 to 3	36	29.5	STAINLESS STEEL	21.42
	43.20 (GEAR)		ALUMINUM		6.97	
MGN-1P	14.40	1 to 1	36	15.0	STAINLESS STEEL	6.92
MGN-1G	14.40	1 to 1	36	15.0	ALUMINUM	6.92

Note: Gears will mesh at right angles only when used as sets described in chart.

For Couplings See Section MG.
For Shafts, Bearings and Collars See Section MI.

MITER & BEVEL GEARS

MODULE	STYLE	BORE	FACE	MATERIAL	QUALITY	PRES. ANGLE
0.3	Matched Sets PIN HUB	3	3	STAINLESS STEEL DIN 1.4305 OR ALUMINUM DIN 3.1555	DIN 7/AGMA 10	20°

B

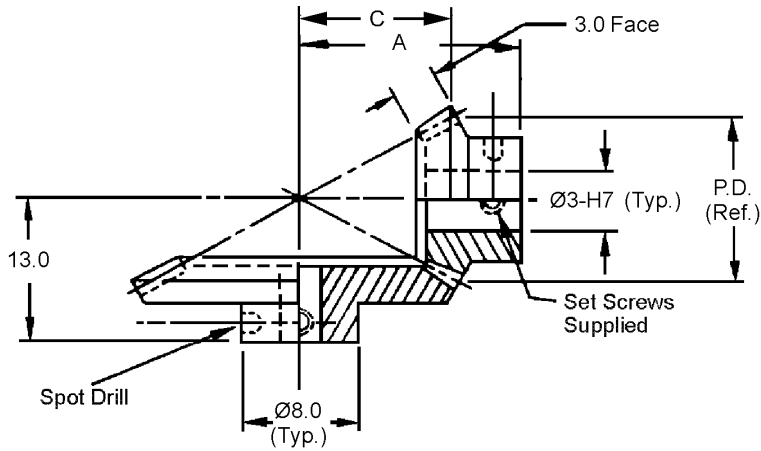

STOCK NO.	PITCH DIA.	RATIO	NO. OF TEETH	A	MATERIAL	CROWN TO APEX (C)
MHN-1	10.80	1 to 1	36	13.0	STAINLESS STEEL	5.19
	10.80		ALUMINUM		5.19	
MHN-1S	10.80	1 to 1	36	13.0	STAINLESS STEEL	5.19
MHN-1A	10.80	1 to 1	36	13.0	ALUMINUM	5.19
	10.80		ALUMINUM		5.19	
MHN-2	10.80 (PINION)	1 to 2	36	18.5	STAINLESS STEEL	10.62
	21.60 (GEAR)		ALUMINUM		5.23	
MHN-3	10.80 (PINION)	1 to 3	36	24.0	STAINLESS STEEL	16.07
	32.40 (GEAR)		ALUMINUM		5.23	
MHN-1P	10.80	1 to 1	36	13.0	STAINLESS STEEL	5.19
MHN-1G	10.80	1 to 1	36	13.0	ALUMINUM	5.19

Note: Gears will mesh at right angles only when used as sets described in chart.

For Couplings See Section MG.
For Shafts, Bearings and Collars See Section MI.

PRECISION WORMS

MODULE	STYLE	BORE	MATERIAL	QUALITY	TYPE
1.5	SINGLE, DOUBLE OR FOUR THREAD	7	STAINLESS STEEL DIN 1.4305	DIN 7/AGMA 10	RIGHT HAND

STOCK NO.	B	THREAD	LEAD	LEAD ANGLE	PRESSURE ANGLE
WAS-7S	B	SINGLE	4.712	5° 21'	14-1/2°
WAS-7D	7	DOUBLE	9.425	10° 37'	14-1/2°
WAS-7F		FOUR	18.850	20° 33'	20°

Quality Class AGMA 12 & 14 / Din 5 & 3 are available on request.

MODULE	STYLE	BORE	MATERIAL	QUALITY	TYPE
1.5	SINGLE, DOUBLE OR FOUR THREAD	8	STAINLESS STEEL DIN 1.4305	DIN 7/AGMA 10	RIGHT HAND

STOCK NO.	B	THREAD	LEAD	LEAD ANGLE	PRESSURE ANGLE
WAS-8S	B	SINGLE	4.712	5° 21'	14-1/2°
WAS-8D	8	DOUBLE	9.425	10° 37'	14-1/2°
WAS-8F		FOUR	18.850	20° 33'	20°

Quality Class AGMA 12 & 14 / Din 5 & 3 are available on request.

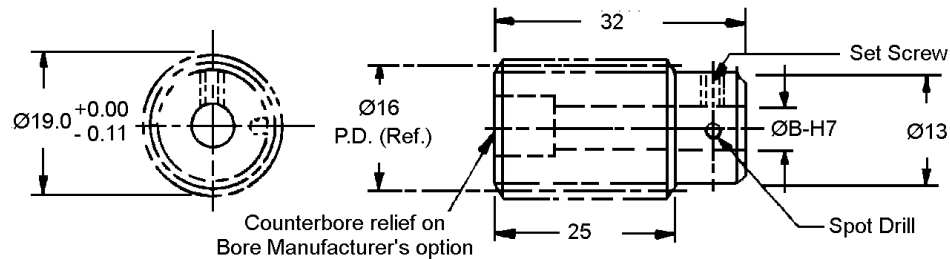

WORM GEARS

B

MODULE	STYLE	BORE	FACE	MATERIAL	QUALITY	TYPE
1.5	SINGLE, DOUBLE OR FOUR THREAD PIN HUB	10	10	464 BRASS ALLOY	DIN 7/AGMA 10	RIGHT HAND

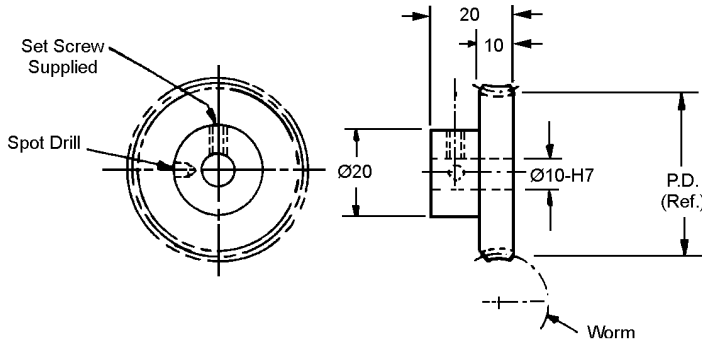

SINGLE THREAD WORM	DOUBLE THREAD WORM	FOUR THREAD WORM	NO. OF TEETH	PITCH DIA.
Circular Pitch 4.712	Circular Pitch 9.425	Circular Pitch 18.850		
Helix Angle 5° 21'	Helix Angle 10° 37'	Helix Angle 20° 33'		
Pressure Angle 14-1/2°	Pressure Angle 14-1/2°	Pressure Angle 20°		
STOCK NO.	STOCK NO.	STOCK NO.		
WAB86-S20	WAB86-D20	WAB86-F20	20	30.00
WAB86-S30	WAB86-D30	WAB86-F30	30	45.00
WAB86-S40	WAB86-D40	WAB86-F40	40	80.00
WAB86-S50	WAB86-D50	WAB86-F50	50	75.00
WAB86-S60	WAB86-D60	WAB86-F60	60	90.00
WAB86-S80	WAB86-D80	WAB86-F80	80	120.00
WAB86-S100	WAB86-D100	WAB86-F100	100	150.00

$$\text{Ratio} = \frac{\# \text{ of Teeth}}{\text{Worm Threads}}$$

May be two piece construction. Hub diameter never exceeds O.D.
Other number of teeth AGMA 12 ir 14 / DIN 5 or 3 available on request.

MODULE	STYLE	BORE	FACE	MATERIAL	QUALITY	TYPE
1.5	SINGLE, DOUBLE OR FOUR THREAD PIN HUB	12	10	464 BRASS ALLOY	DIN 7/AGMA 10	RIGHT HAND

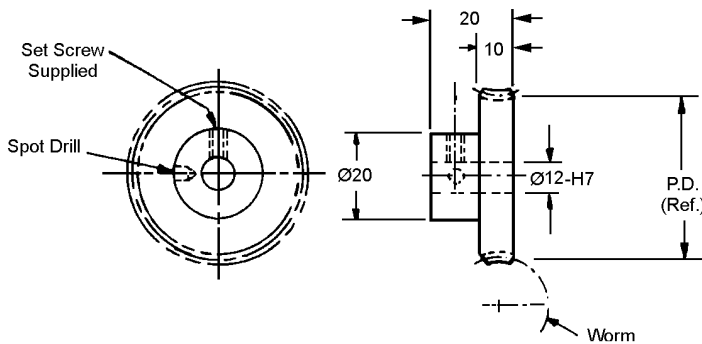

SINGLE THREAD WORM	DOUBLE THREAD WORM	FOUR THREAD WORM	NO. OF TEETH	PITCH DIA.
Circular Pitch 4.712	Circular Pitch 9.425	Circular Pitch 18.850		
Helix Angle 5° 21'	Helix Angle 10° 37'	Helix Angle 20° 33'		
Pressure Angle 14-1/2°	Pressure Angle 14-1/2°	Pressure Angle 20°		
STOCK NO.	STOCK NO.	STOCK NO.		
WAB88-S20	WAB88-D20	WAB88-F20	20	30.00
WAB88-S30	WAB88-D30	WAB88-F30	30	45.00
WAB88-S40	WAB88-D40	WAB88-F40	40	80.00
WAB88-S50	WAB88-D50	WAB88-F50	50	75.00
WAB88-S60	WAB88-D60	WAB88-F60	60	90.00
WAB88-S80	WAB88-D80	WAB88-F80	80	120.00
WAB88-S100	WAB88-D100	WAB88-F100	100	150.00

$$\text{Ratio} = \frac{\# \text{ of Teeth}}{\text{Worm Threads}}$$

May be two piece construction. Hub diameter never exceeds O.D.
Other number of teeth AGMA 12 ir 14 / DIN 5 or 3 available on request.

PRECISION WORMS

MODULE	STYLE	BORE	MATERIAL	QUALITY	TYPE
1.0	SINGLE, DOUBLE OR FOUR THREAD	7	STAINLESS STEEL DIN 1.4305	DIN 7/AGMA 10	RIGHT HAND

STOCK NO.	B	THREAD	LEAD	LEAD ANGLE	PRESSURE ANGLE
WCS-7S	7	SINGLE	3.142	4° 45'	14-1/2°
WCS-7D	7	DOUBLE	6.283	9° 27'	20°
WCS-7F	7	FOUR	12.566	18° 26'	25°

Quality Class AGMA 12 & 14 / Din 5 & 3 are available on request.

MODULE	STYLE	BORE	MATERIAL	QUALITY	TYPE
1.0	SINGLE, DOUBLE OR FOUR THREAD	8	STAINLESS STEEL DIN 1.4305	DIN 7/AGMA 10	RIGHT HAND

STOCK NO.	B	THREAD	LEAD	LEAD ANGLE	PRESSURE ANGLE
WCS-8S	7	SINGLE	3.142	4° 45'	14-1/2°
WCS-8D	7	DOUBLE	6.283	9° 27'	20°
WCS-8F	7	FOUR	12.566	18° 26'	25°

Quality Class AGMA 12 & 14 / Din 5 & 3 are available on request.

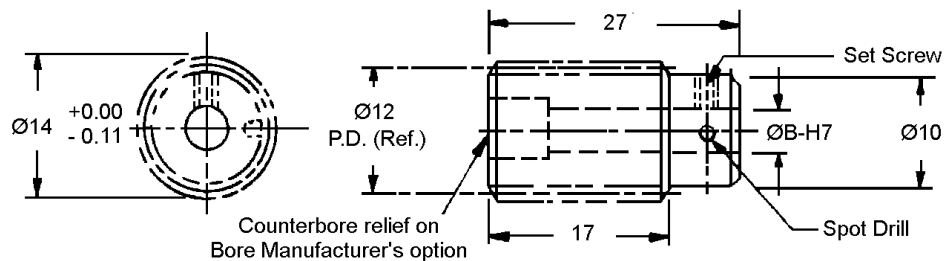

WORM GEARS

B

MODULE	STYLE	BORE	FACE	MATERIAL	QUALITY	TYPE
1.0	SINGLE, DOUBLE OR FOUR THREAD PIN HUB	10	10	464 BRASS ALLOY	DIN 7/AGMA 10	RIGHT HAND

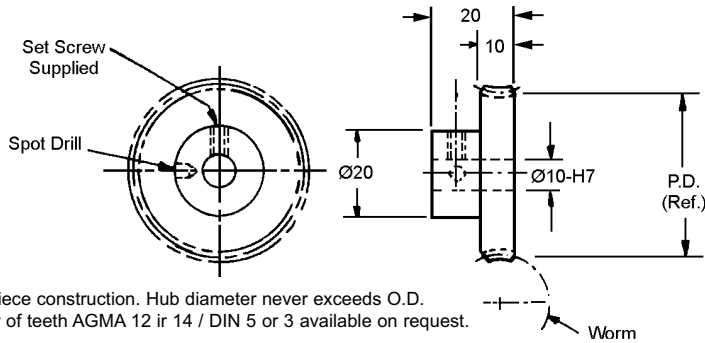

May be two piece construction. Hub diameter never exceeds O.D.
Other number of teeth AGMA 12 or 14 / DIN 5 or 3 available on request.

SINGLE THREAD WORM		DOUBLE THREAD WORM		FOUR THREAD WORM		NO. OF TEETH	PITCH DIA.
Circular Pitch	3.142	Circular Pitch	6.283	Circular Pitch	12.566		
Helix Angle	4° 45'	Helix Angle	9° 27'	Helix Angle	18° 26'		
Pressure Angle	14-1/2°	Pressure Angle	20°	Pressure Angle	25°		
STOCK NO.		STOCK NO.		STOCK NO.			
WCB86-S20		WCB86-D20		WCB86-F20		20	20.00
WCB86-S30		WCB86-D30		WCB86-F30		30	30.00
WCB86-S40		WCB86-D40		WCB86-F40		40	40.00
WCB86-S50		WCB86-D50		WCB86-F50		50	50.00
WCB86-S60		WCB86-D60		WCB86-F60		60	60.00
WCB86-S72		WCB86-D72		WCB86-F72		72	72.00
WCB86-S80		WCB86-D80		WCB86-F80		80	80.00
WCB86-S96		WCB86-D96		WCB86-F96		96	96.00
WCB86-S100		WCB86-D100		WCB86-F100		100	100.00

$$\text{Ratio} = \frac{\# \text{ of Teeth}}{\text{Worm Threads}}$$

MODULE	STYLE	BORE	FACE	MATERIAL	QUALITY	TYPE
1.0	SINGLE, DOUBLE OR FOUR THREAD PIN HUB	12	10	464 BRASS ALLOY	DIN 7/AGMA 10	RIGHT HAND

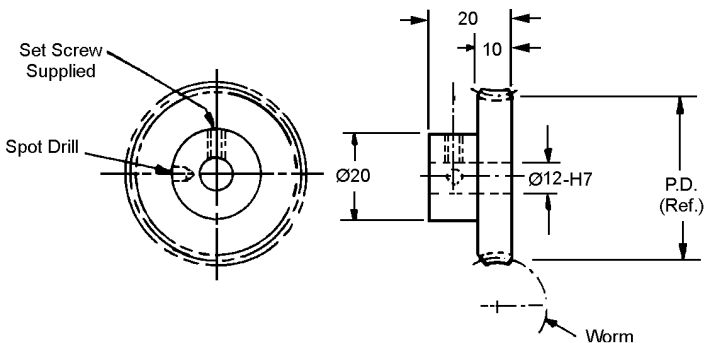

SINGLE THREAD WORM		DOUBLE THREAD WORM		FOUR THREAD WORM		NO. OF TEETH	PITCH DIA.
Circular Pitch	3.142	Circular Pitch	6.283	Circular Pitch	12.566		
Helix Angle	4° 45'	Helix Angle	9° 27'	Helix Angle	18° 26'		
Pressure Angle	14-1/2°	Pressure Angle	20°	Pressure Angle	25°		
STOCK NO.		STOCK NO.		STOCK NO.			
WCB88-S20		WCB88-D20		WCB88-F20		20	20.00
WCB88-S30		WCB88-D30		WCB88-F30		30	30.00
WCB88-S40		WCB88-D40		WCB88-F40		40	40.00
WCB88-S50		WCB88-D50		WCB88-F50		50	50.00
WCB88-S60		WCB88-D60		WCB88-F60		60	60.00
WCB88-S72		WCB88-D72		WCB88-F72		72	72.00
WCB88-S80		WCB88-D80		WCB88-F80		80	80.00
WCB88-S96		WCB88-D96		WCB88-F96		96	96.00
WCB88-S100		WCB88-D100		WCB88-F100		100	100.00

$$\text{Ratio} = \frac{\# \text{ of Teeth}}{\text{Worm Threads}}$$

May be two piece construction. Hub diameter never exceeds O.D.
Other number of teeth AGMA 12 or 14 / DIN 5 or 3 available on request.

PRECISION WORMS

MODULE	STYLE	BORE	MATERIAL	QUALITY	TYPE
0.8	SINGLE, DOUBLE OR FOUR THREAD	5	STAINLESS STEEL DIN 1.4305	DIN 7/AGMA 10	RIGHT HAND

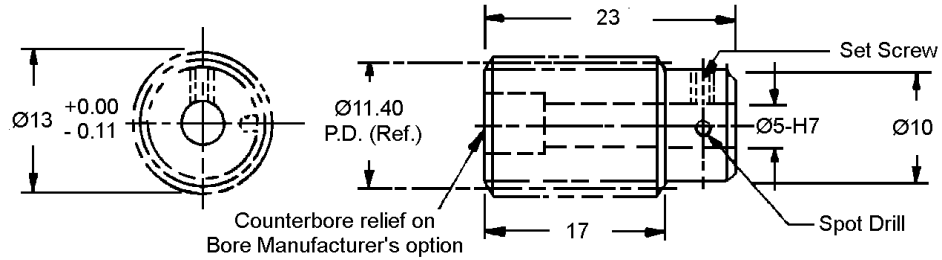

STOCK NO.	THREAD	LEAD	LEAD ANGLE	PRESSURE ANGLE
WDS-5S	SINGLE	3.142	4° 45'	14-1/2°
WDS-5D	DOUBLE	6.283	9° 27'	20°
WDS-5F	FOUR	12.566	18° 26'	25°

Quality Class AGMA 12 & 14 / Din 5 & 3 are available on request.

WORM GEARS

B

MODULE	STYLE	BORE	FACE	MATERIAL	QUALITY	TYPE
0.8	SINGLE, DOUBLE OR FOUR THREAD PIN HUB	5	5	464 BRASS ALLOY	DIN 7/AGMA 10	RIGHT HAND

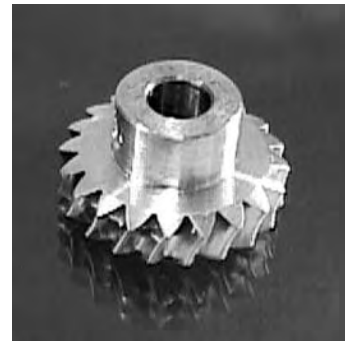
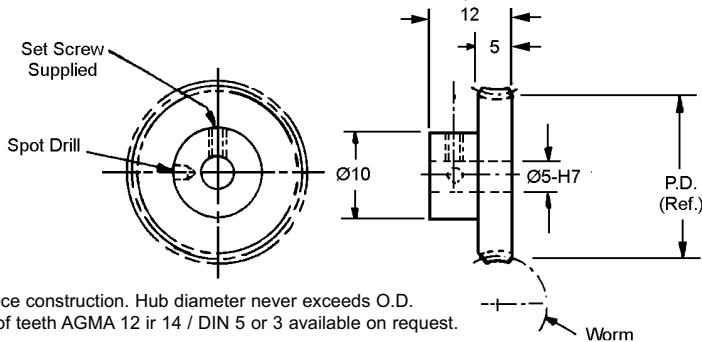

May be two piece construction. Hub diameter never exceeds O.D.
Other number of teeth AGMA 12 ir 14 / DIN 5 or 3 available on request.

SINGLE THREAD WORM		DOUBLE THREAD WORM		FOUR THREAD WORM		NO. OF TEETH	PITCH DIA.
Circular Pitch	2.513	Circular Pitch	5.027	Circular Pitch	10.053		
Helix Angle	4° - 0'	Helix Angle	7° - 59'	Helix Angle	15° - 40'		
Pressure Angle	14-1/2°	Pressure Angle	20°	Pressure Angle	25°		
STOCK NO.		STOCK NO.		STOCK NO.			
WDB83-S20		WDB83-D20		WDB83-F20		20	16.00
WDB83-S30		WDB83-D30		WDB83-F30		30	24.00
WDB83-S40		WDB83-D40		WDB83-F40		40	32.00
WDB83-S50		WDB83-D50		WDB83-F50		50	40.00
WDB83-S60		WDB83-D60		WDB83-F60		60	48.00
WDB83-S80		WDB83-D80		WDB83-F80		80	64.00
WDB83-S96		WDB83-D96		WDB83-F96		96	76.80
WDB83-S100		WDB83-D100		WDB83-F100		100	80.00

$$\text{Ratio} = \frac{\# \text{ of Teeth}}{\text{Worm Threads}}$$

MODULE	STYLE	BORE	FACE	MATERIAL	QUALITY	TYPE
0.8	SINGLE, DOUBLE OR FOUR THREAD PIN HUB	8	5	464 BRASS ALLOY	DIN 7/AGMA 10	RIGHT HAND

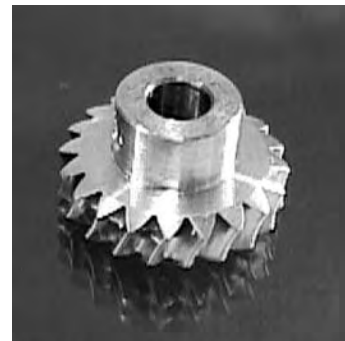
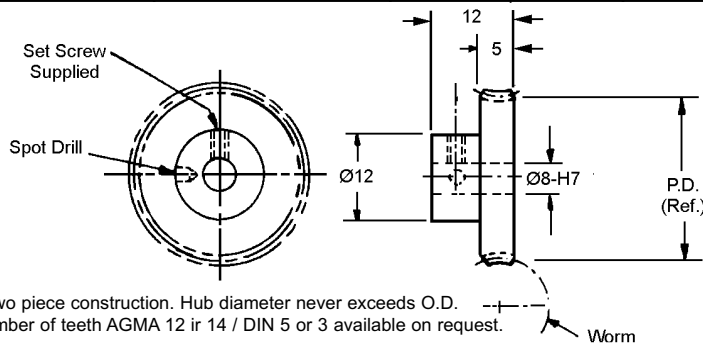

May be two piece construction. Hub diameter never exceeds O.D.
Other number of teeth AGMA 12 ir 14 / DIN 5 or 3 available on request.

SINGLE THREAD WORM		DOUBLE THREAD WORM		FOUR THREAD WORM		NO. OF TEETH	PITCH DIA.
Circular Pitch	2.513	Circular Pitch	5.027	Circular Pitch	10.053		
Helix Angle	4° - 0'	Helix Angle	7° - 59'	Helix Angle	15° - 40'		
Pressure Angle	14-1/2°	Pressure Angle	20°	Pressure Angle	25°		
STOCK NO.		STOCK NO.		STOCK NO.			
WDB95-S20		WDB95-D20		WDB95-F20		20	16.00
WDB95-S30		WDB95-D30		WDB95-F30		30	24.00
WDB95-S40		WDB95-D40		WDB95-F40		40	32.00
WDB95-S50		WDB95-D50		WDB95-F50		50	40.00
WDB95-S60		WDB95-D60		WDB95-F60		60	48.00
WDB95-S80		WDB95-D80		WDB95-F80		80	64.00
WDB95-S96		WDB95-D96		WDB95-F96		96	76.80
WDB95-S100		WDB95-D100		WDB95-F100		100	80.00

$$\text{Ratio} = \frac{\# \text{ of Teeth}}{\text{Worm Threads}}$$

PRECISION WORMS

MODULE	STYLE	BORE	MATERIAL	QUALITY	TYPE
0.5	SINGLE, DOUBLE OR FOUR THREAD	3	STAINLESS STEEL DIN 1.4305	DIN 7/AGMA 10	RIGHT HAND

STOCK NO.	THREAD	LEAD	LEAD ANGLE	PRESSURE ANGLE
WFS-3S	SINGLE	1.571	3° 10'	14-1/2°
WFS-3D	DOUBLE	3.142	6° 20'	20°
WFS-3F	FOUR	6.283	12° 31'	25°

Quality Class AGMA 12 & 14 / Din 5 & 3 are available on request.

MODULE	STYLE	BORE	MATERIAL	QUALITY	TYPE
0.5	SINGLE, DOUBLE OR FOUR THREAD	5	STAINLESS STEEL DIN 1.4305	DIN 7/AGMA 10	RIGHT HAND

STOCK NO.	THREAD	LEAD	LEAD ANGLE	PRESSURE ANGLE
WFS-5S	SINGLE	1.571	3° 10'	14-1/2°
WFS-5D	DOUBLE	3.142	6° 20'	20°
WFS-5F	FOUR	6.283	12° 31'	25°

Quality Class AGMA 12 & 14 / Din 5 & 3 are available on request.

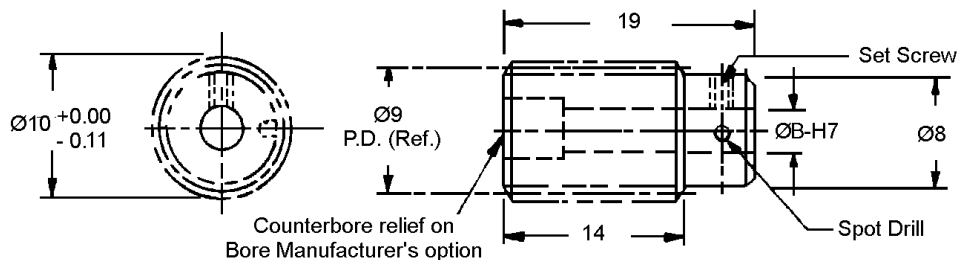

WORM GEARS

B

MODULE	STYLE	BORE	FACE	MATERIAL	QUALITY	TYPE
0.5	SINGLE, DOUBLE OR FOUR THREAD PIN HUB	5	5	464 BRASS ALLOY	DIN 7/AGMA 10	RIGHT HAND

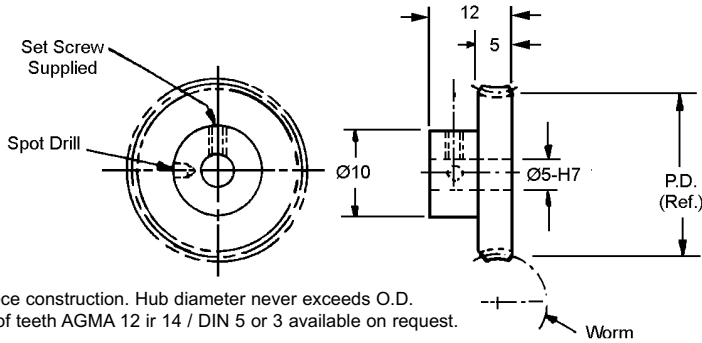

May be two piece construction. Hub diameter never exceeds O.D.
Other number of teeth AGMA 12 ir 14 / DIN 5 or 3 available on request.

SINGLE THREAD WORM		DOUBLE THREAD WORM		FOUR THREAD WORM		NO. OF TEETH	PITCH DIA.
Circular Pitch	1.571	Circular Pitch	3.142	Circular Pitch	6.283		
Helix Angle	3° 10'	Helix Angle	6° 20'	Helix Angle	12° 31'		
Pressure Angle	14-1/2°	Pressure Angle	20°	Pressure Angle	25°		
STOCK NO.	STOCK NO.	STOCK NO.					
WFB83-S30	WFB83-D30	WFB83-F30			30	15.00	
WFB83-S40	WFB83-D40	WFB83-F40			40	20.00	
WFB83-S50	WFB83-D50	WFB83-F50			50	25.00	
WFB83-S60	WFB83-D60	WFB83-F60			60	30.00	
WFB83-S70	WFB83-D70	WFB83-F70			70	35.00	
WFB83-S80	WFB83-D80	WFB83-F80			80	40.00	
WFB83-S90	WFB83-D90	WFB83-F90			90	45.00	
WFB83-S100	WFB83-D100	WFB83-F100			100	50.00	
WFB83-S120	WFB83-D120	WFB83-F120			120	60.00	

$$\text{Ratio} = \frac{\# \text{ of Teeth}}{\text{Worm Threads}}$$

MODULE	STYLE	BORE	FACE	MATERIAL	QUALITY	TYPE
0.5	SINGLE, DOUBLE OR FOUR THREAD PIN HUB	8	5	464 BRASS ALLOY	DIN 7/AGMA 10	RIGHT HAND

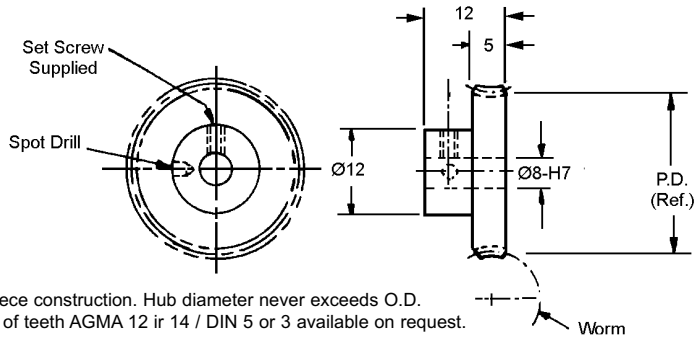

May be two piece construction. Hub diameter never exceeds O.D.
Other number of teeth AGMA 12 ir 14 / DIN 5 or 3 available on request.

SINGLE THREAD WORM		DOUBLE THREAD WORM		FOUR THREAD WORM		NO. OF TEETH	PITCH DIA.
Circular Pitch	1.571	Circular Pitch	3.142	Circular Pitch	6.283		
Helix Angle	3° 10'	Helix Angle	6° 20'	Helix Angle	12° 31'		
Pressure Angle	14-1/2°	Pressure Angle	20°	Pressure Angle	25°		
STOCK NO.	STOCK NO.	STOCK NO.					
WFB95-S30	WFB95-D30	WFB95-F30			30	15.00	
WFB95-S40	WFB95-D40	WFB95-F40			40	20.00	
WFB95-S50	WFB95-D50	WFB95-F50			50	25.00	
WFB95-S60	WFB95-D60	WFB95-F60			60	30.00	
WFB95-S70	WFB95-D70	WFB95-F70			70	35.00	
WFB95-S80	WFB95-D80	WFB95-F80			80	40.00	
WFB95-S90	WFB95-D90	WFB95-F90			90	45.00	
WFB95-S100	WFB95-D100	WFB95-F100			100	50.00	
WFB95-S120	WFB95-D120	WFB95-F120			120	60.00	

$$\text{Ratio} = \frac{\# \text{ of Teeth}}{\text{Worm Threads}}$$

PRECISION WORMS

MODULE	STYLE	BORE	MATERIAL	QUALITY	TYPE
0.4	SINGLE, DOUBLE OR FOUR THREAD	3	STAINLESS STEEL DIN 1.4305	DIN 7/AGMA 10	RIGHT HAND

STOCK NO.	THREAD	LEAD	LEAD ANGLE	ØH	PRESSURE ANGLE
WGS-3S	SINGLE	1.257	1° 44'	8	14-1/2°
WGS-3D	DOUBLE	2.513	3° 28'		
WGS-3F	FOUR	5.027	6° 54'		

Quality Class AGMA 12 & 14 / Din 5 & 3 are available on request.

MODULE	STYLE	BORE	MATERIAL	QUALITY	TYPE
0.4	SINGLE, DOUBLE OR FOUR THREAD	5	STAINLESS STEEL DIN 1.4305	DIN 7/AGMA 10	RIGHT HAND

STOCK NO.	THREAD	LEAD	LEAD ANGLE	ØH	PRESSURE ANGLE
WGS-5S	SINGLE	1.257	1° 44'	10	14-1/2°
WGS-5D	DOUBLE	2.513	3° 28'		
WGS-5F	FOUR	5.027	6° 54'		

Quality Class AGMA 12 & 14 / Din 5 & 3 are available on request.

MODULE	STYLE	BORE	MATERIAL	QUALITY	TYPE
0.4	SINGLE, DOUBLE OR FOUR THREAD	7	STAINLESS STEEL DIN 1.4305	DIN 7/AGMA 10	RIGHT HAND

STOCK NO.	THREAD	LEAD	LEAD ANGLE	ØH	PRESSURE ANGLE
WGS-7S	SINGLE	1.257	1° 44'	11	14-1/2°
WGS-7D	DOUBLE	2.513	3° 28'		
WGS-7F	FOUR	5.027	6° 54'		

Quality Class AGMA 12 & 14 / Din 5 & 3 are available on request.

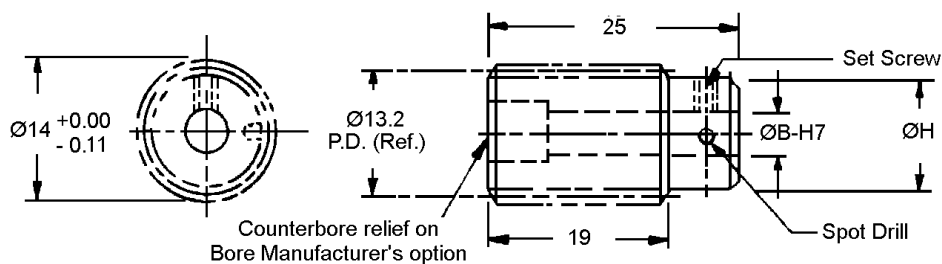

WORM GEARS

B

MODULE	STYLE	BORE	FACE	MATERIAL	QUALITY	TYPE
0.4	SINGLE, DOUBLE OR FOUR THREAD PIN HUB	5	5	464 BRASS ALLOY	DIN 7/AGMA 10	RIGHT HAND

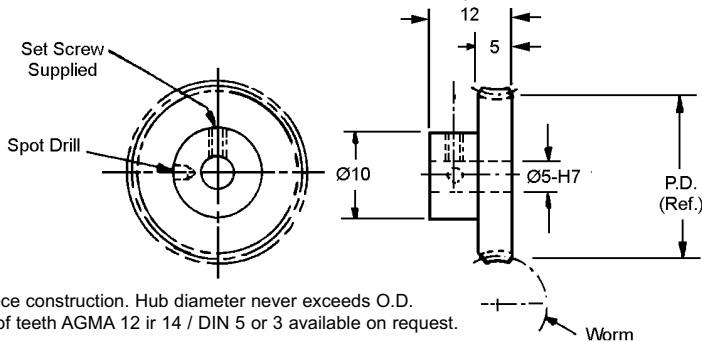

May be two piece construction. Hub diameter never exceeds O.D.
Other number of teeth AGMA 12 ir 14 / DIN 5 or 3 available on request.

SINGLE THREAD WORM		DOUBLE THREAD WORM		FOUR THREAD WORM		NO. OF TEETH	PITCH DIA.
Circular Pitch	1.257	Circular Pitch	2.513	Circular Pitch	5.027		
Helix Angle	1° 44'	Helix Angle	3° 28'	Helix Angle	6° 54'		
Pressure Angle	14-1/2°	Pressure Angle	14-1/2°	Pressure Angle	14-1/2°		
STOCK NO.		STOCK NO.		STOCK NO.			
WGB83-S40		WGB83-D40		WGB83-F40		40	16.00
WGB83-S50		WGB83-D50		WGB83-F50		50	20.00
WGB83-S60		WGB83-D60		WGB83-F60		60	24.00
WGB83-S70		WGB83-D70		WGB83-F70		70	28.00
WGB83-S80		WGB83-D80		WGB83-F80		80	32.00
WGB83-S90		WGB83-D90		WGB83-F90		90	36.00
WGB83-S100		WGB83-D100		WGB83-F100		100	40.00
WGB83-S110		WGB83-D110		WGB83-F110		110	44.00
WGB83-S120		WGB83-D120		WGB83-F120		120	48.00

$$\text{Ratio} = \frac{\# \text{ of Teeth}}{\text{Worm Threads}}$$

MODULE	STYLE	BORE	FACE	MATERIAL	QUALITY	TYPE
0.4	SINGLE, DOUBLE OR FOUR THREAD PIN HUB	8	5	464 BRASS ALLOY	DIN 7/AGMA 10	RIGHT HAND

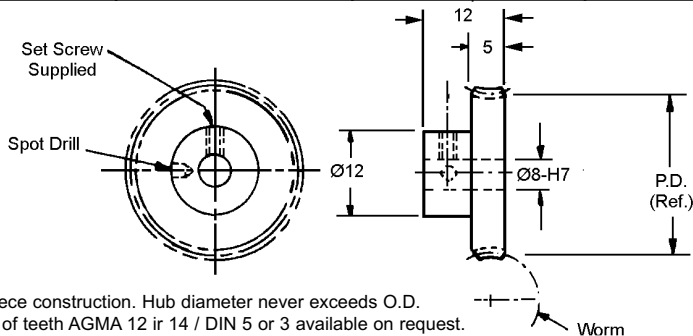

May be two piece construction. Hub diameter never exceeds O.D.
Other number of teeth AGMA 12 ir 14 / DIN 5 or 3 available on request.

SINGLE THREAD WORM		DOUBLE THREAD WORM		FOUR THREAD WORM		NO. OF TEETH	PITCH DIA.
Circular Pitch	1.257	Circular Pitch	2.513	Circular Pitch	5.027		
Helix Angle	1° 44'	Helix Angle	3° 28'	Helix Angle	6° 54'		
Pressure Angle	14-1/2°	Pressure Angle	14-1/2°	Pressure Angle	14-1/2°		
STOCK NO.		STOCK NO.		STOCK NO.			
WGB95-S40		WGB95-D40		WGB95-F40		40	16.00
WGB95-S50		WGB95-D50		WGB95-F50		50	20.00
WGB95-S60		WGB95-D60		WGB95-F60		60	24.00
WGB95-S70		WGB95-D70		WGB95-F70		70	28.00
WGB95-S80		WGB95-D80		WGB95-F80		80	32.00
WGB95-S90		WGB95-D90		WGB95-F90		90	36.00
WGB95-S100		WGB95-D100		WGB95-F100		100	40.00
WGB95-S110		WGB95-D110		WGB95-F110		110	44.00
WGB95-S120		WGB95-D120		WGB95-F120		120	48.00
WGB95-S180		WGB95-D180		WGB95-F180		180	72.00

$$\text{Ratio} = \frac{\# \text{ of Teeth}}{\text{Worm Threads}}$$

SPUR GEARS

B

MODULE	STYLE	BORE	FACE	MATERIAL	QUALITY	PRESSURE ANGLE
1.5	HUBLESS	16	10	STAINLESS STEEL DIN 1.4305	DIN 8/AGMA 9	20°

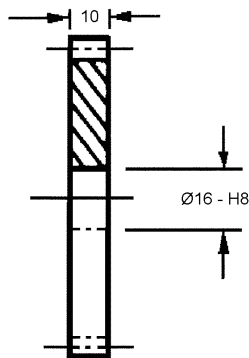
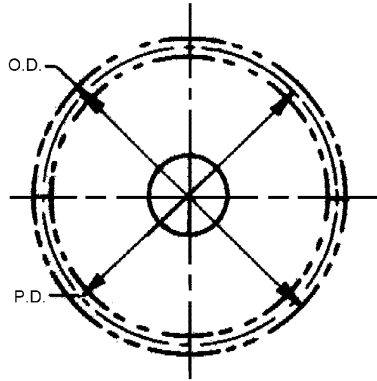

STOCK NO.	NO. OF TEETH	PITCH DIA.	OUTSIDE DIA.
FAS120-18	18	27.00	30.00
FAS120-20	20	30.00	33.00
FAS120-24	24	36.00	39.00
FAS120-28	28	42.00	45.00
FAS120-30	30	45.00	48.00
FAS120-32	32	48.00	51.00
FAS120-36	36	54.00	57.00
FAS120-40	40	60.00	63.00
FAS120-48	48	72.00	75.00
FAS120-56	56	84.00	87.00
FAS120-60	60	90.00	93.00
FAS120-64	64	96.00	99.00

Available on request:
Other numbers of teeth;
14 - 1/2° pressure angle.

MODULE	STYLE	BORE	FACE	MATERIAL	QUALITY	PRESSURE ANGLE
1.5	HUBLESS	16	10	POLYURETHANE WITH LUBRICANT	DIN 9/AGMA 8	20°

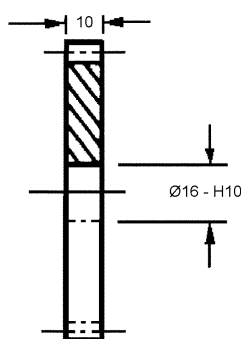
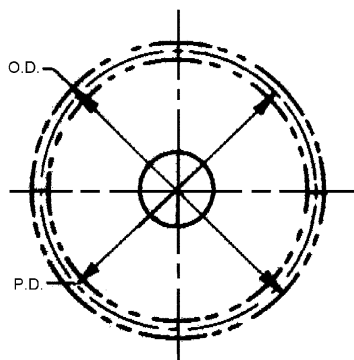

STOCK NO.	NO. OF TEETH	PITCH DIA.	OUTSIDE DIA.
FAU120-18	18	27.00	30.00
FAU120-20	20	30.00	33.00
FAU120-24	24	36.00	39.00
FAU120-28	28	42.00	45.00
FAU120-30	30	45.00	48.00
FAU120-32	32	48.00	51.00
FAU120-36	36	54.00	57.00
FAU120-40	40	60.00	63.00
FAU120-48	48	72.00	75.00
FAU120-56	56	84.00	87.00
FAU120-60	60	90.00	93.00
FAU120-64	64	96.00	99.00

Available on request:
Other numbers of teeth;
14 - 1/2° pressure angle.

SPUR GEARS

MODULE	STYLE	BORE	FACE	MATERIAL	QUALITY	PRESSURE ANGLE
1.5	PIN HUB	6	10	CAST POLYURETHANE GRAPHITE IMPREGNATED 70D DURO	DIN 9/AGMA 8	20°

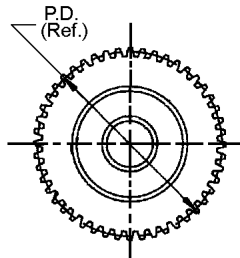
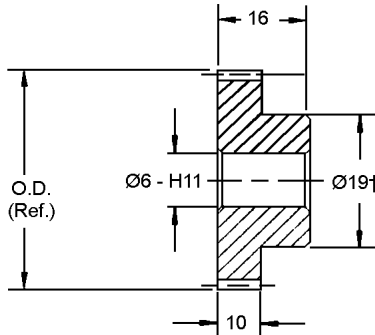

STOCK NO.	NO. OF TEETH	PITCH DIA.	OUTSIDE DIA.
PAU157-12	12†	18.00	21.00
PAU157-16	16	24.00	27.00
PAU157-18	18	27.00	30.00
PAU157-20	20	30.00	33.00
PAU157-24	24	36.00	39.00
PAU157-28	28	42.00	45.00
PAU157-30	30	45.00	48.00
PAU157-32	32	48.00	51.00
PAU157-40	40	60.00	63.00
PAU157-48	48	72.00	75.00

†Teeth runout on hub.

Available on request: Other numbers of teeth; 14 - 1/2° pressure angle.

MODULE	STYLE	BORE	FACE	MATERIAL	QUALITY	PRESSURE ANGLE
1.5	PIN HUB	10	10	CAST POLYURETHANE GRAPHITE IMPREGNATED 70D DURO	DIN 9/AGMA 8	20°

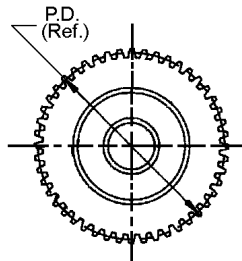
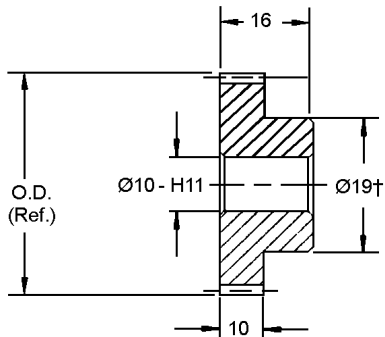

STOCK NO.	NO. OF TEETH	PITCH DIA.	OUTSIDE DIA.
PAU158-12	12†	18.00	21.00
PAU158-16	16	24.00	27.00
PAU158-18	18	27.00	30.00
PAU158-20	20	30.00	33.00
PAU158-24	24	36.00	39.00
PAU158-28	28	42.00	45.00
PAU158-30	30	45.00	48.00
PAU158-32	32	48.00	51.00
PAU158-40	40	60.00	63.00
PAU158-48	48	72.00	75.00

†Teeth runout on hub.

Available on request: Other numbers of teeth; 14 - 1/2° pressure angle.

MODULE	STYLE	BORE	FACE	MATERIAL	QUALITY	PRESSURE ANGLE
1.5	PIN HUB	12	10	CAST POLYURETHANE GRAPHITE IMPREGNATED 70D DURO	DIN 9/AGMA 8	20°

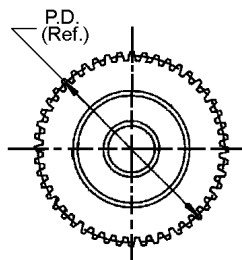
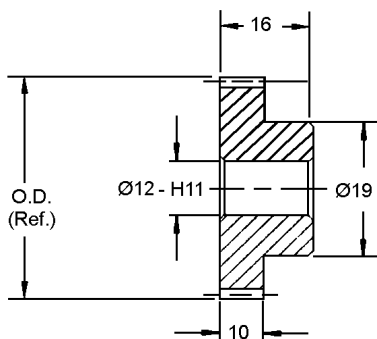

STOCK NO.	NO. OF TEETH	PITCH DIA.	OUTSIDE DIA.
PAU159-16	16	24.00	27.00
PAU159-18	18	27.00	30.00
PAU159-20	20	30.00	33.00
PAU159-24	24	36.00	39.00
PAU159-28	28	42.00	45.00
PAU159-30	30	45.00	48.00
PAU159-32	32	48.00	51.00
PAU159-40	40	60.00	63.00
PAU159-48	48	72.00	75.00

Available on request: Other numbers of teeth; 14 - 1/2° pressure angle.

For Couplings See Section MG.
For Shafts, Bearings and Collars See Section MI.

SPUR GEARS

MODULE	STYLE	BORE	FACE	MATERIAL	QUALITY	PRESSURE ANGLE
1.5	CLAMP STYLE	10	6	STAINLESS STEEL DIN 1.4305	DIN 8/AGMA 9	20°

B

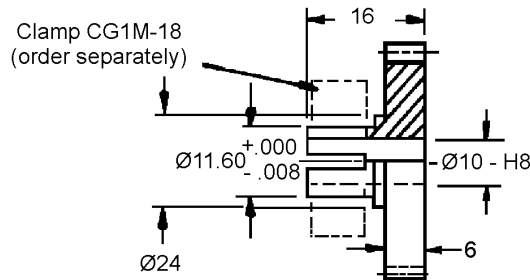
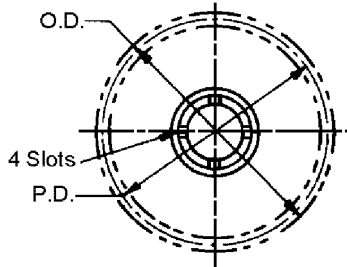

STOCK NO.	NO. OF TEETH	PITCH DIA.	OUTSIDE DIA.
CAS56-16	16	24.00	27.00
CAS56-18	18	27.00	30.00
CAS56-20	20	30.00	33.00
CAS56-24	24	36.00	39.00
CAS56-32	32	48.00	51.00
CAS56-40	40	60.00	63.00
CAS56-48	48	72.00	75.00

Available on request: Other numbers of teeth; 14 - 1/2° pressure angle.

MODULE	STYLE	BORE	FACE	MATERIAL	QUALITY	PRESSURE ANGLE
1.5	CLAMP STYLE	12	10	STAINLESS STEEL DIN 1.4305	DIN 8/AGMA 9	20°

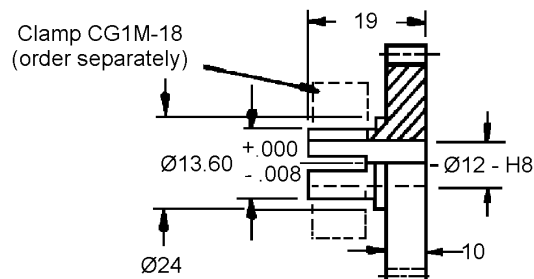
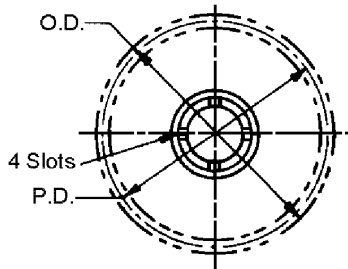

STOCK NO.	NO. OF TEETH	PITCH DIA.	OUTSIDE DIA.
CAS57-16	16	24.00	27.00
CAS57-18	18	27.00	30.00
CAS57-20	20	30.00	33.00
CAS57-24	24	36.00	39.00
CAS57-32	32	48.00	51.00
CAS57-40	40	60.00	63.00
CAS57-48	48	72.00	75.00

Available on request: Other numbers of teeth; 14 - 1/2° pressure angle.

**For Couplings See Section MG.
For Shafts, Bearings and Collars See Section MI.**

GEAR RACKS

MODULE	STYLE	MATERIAL	QUALITY	PRESSURE ANGLE
1.5	ROUND & RECTANGULAR	STAINLESS STEEL DIN 1.4005	DIN 7/AGMA 10	20°

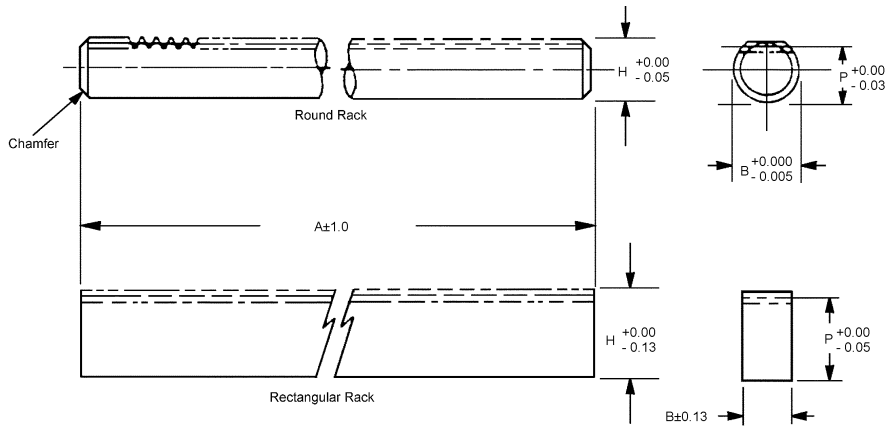

STOCK NO.	RACK STYLE	MOD.	P (Ref.)	B	A	H
R2M-1	ROUND	1.5	15.77	19.974	600	17.27
R3M-1	RECTANGULAR	1.5	17.04	9.02	600	18.54

Available on request: Special, modified and custom racks.

MODULE	STYLE	MATERIAL	QUALITY	PRESSURE ANGLE
1.5	RECTANGULAR	STAINLESS STEEL DIN 1.4005	DIN 7/AGMA 10	20°

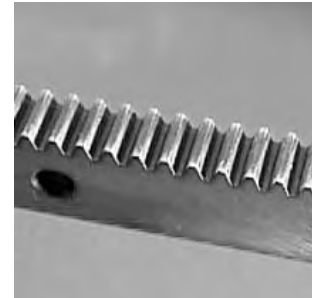
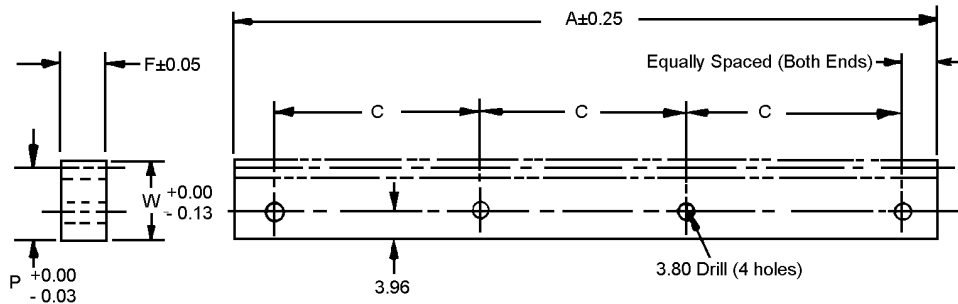

STOCK NO.	A	P (Ref.)	W	F	C
R4M-15	248.8	11.4	12.2	5.8	80.0

Available on request: special, modified and custom racks.

Quality Class AGMA12/DIN 5 available on request.

GEAR RACKS

MODULE	STYLE	MATERIAL	QUALITY	PRESSURE ANGLE
1.5	RECTANGULAR	STAINLESS STEEL DIN 1.4005	DIN 7/AGMA 10	20°

B

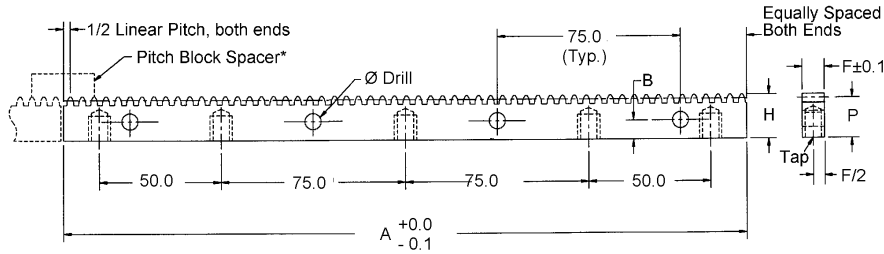

Spacer block is designed for butting to achieve continuous lengths.

RACKS	SPACER BLOCK		LINEAR PITCH	A	P (REF.)	H +0.00 -0.13	F	B	Ø DRILL	TAP
	STOCK NO.	STOCK NO.								
R1M-1	R1M-SB	4.71	282.7	16.91	18.42	9.0	7.9	7.0	M5.0 X 0.8	

Quality Class AGMA 12/Din 5 available on request. Custom racks available on request.

SPUR GEARS

MODULE	STYLE	BORE	FACE	MATERIAL	QUALITY	PRESSURE ANGLE
1.25	HUBLESS	16	10	STAINLESS STEEL DIN 1.4305	DIN 8/AGMA 9	20°

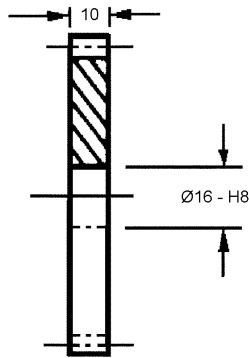
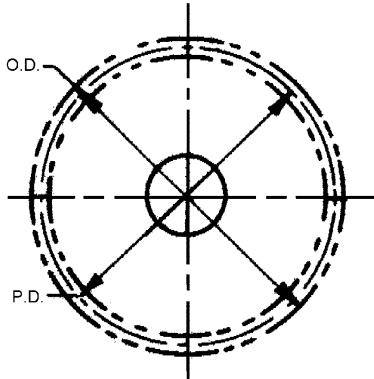

STOCK NO.	NO. OF TEETH	PITCH DIA.	OUTSIDE DIA.
FBS120-24	24	30.00	32.50
FBS120-25	25	31.25	33.75
FBS120-30	30	37.50	40.00
FBS120-35	35	43.75	46.25
FBS120-40	40	50.00	52.50
FBS120-45	45	56.25	58.75
FBS120-50	50	62.50	65.00
FBS120-60	60	75.00	77.50
FBS120-70	70	87.50	90.00
FBS120-80	80	100.00	102.50

Available on request:
Other numbers of teeth;
14 - 1/2° pressure angle.

MODULE	STYLE	BORE	FACE	MATERIAL	QUALITY	PRESSURE ANGLE
1.25	HUBLESS	16	10	POLYURETHANE WITH LUBRICANT	DIN 9/AGMA 8	20°

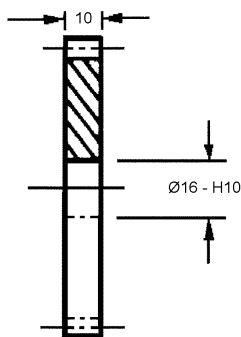
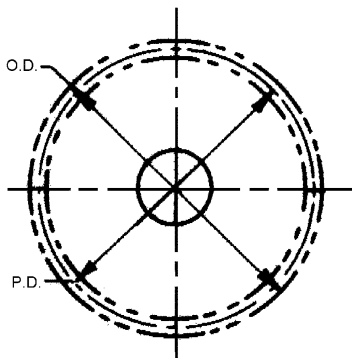

STOCK NO.	NO. OF TEETH	PITCH DIA.	OUTSIDE DIA.
FBU120-24	24	30.00	32.50
FBU120-25	25	31.25	33.75
FBU120-30	30	37.50	40.00
FBU120-35	35	43.75	46.25
FBU120-40	40	50.00	52.50
FBU120-45	45	56.25	58.75
FBU120-50	50	62.50	65.00
FBU120-60	60	75.00	77.50
FBU120-70	70	87.50	90.00
FBU120-80	80	100.00	102.50

Available on request:
Other numbers of teeth;
14 - 1/2° pressure angle.

For Couplings See Section MG.
For Shafts, Bearings and Collars See Section MI.

SPUR GEARS

MODULE	STYLE	BORE	FACE	MATERIAL	QUALITY	PRESSURE ANGLE
1.25	PIN HUB	6	10	CAST POLYURETHANE GRAPHITE IMPREGNATED 70D DURO	DIN 9/AGMA 8	20°

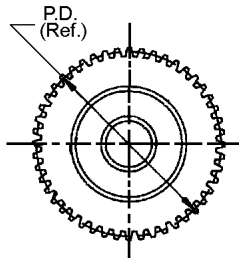
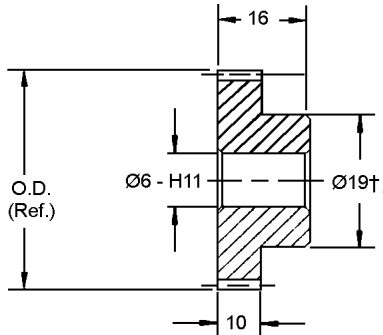

STOCK NO.	NO. OF TEETH	PITCH DIA.	OUTSIDE DIA.
PBU157-15	15†	18.75	21.25
PBU157-16	16†	20.00	22.50
PBU157-20	20	25.00	27.50
PBU157-24	24	30.00	32.50
PBU157-25	25	31.25	33.75
PBU157-30	30	37.50	40.00
PBU157-35	35	43.75	46.25
PBU157-40	40	50.00	52.50
PBU157-50	50	62.50	65.00
PBU157-60	60	75.00	77.50

†Teeth runout on hub.

Available on request: Other numbers of teeth; 14 - 1/2° pressure angle.

MODULE	STYLE	BORE	FACE	MATERIAL	QUALITY	PRESSURE ANGLE
1.25	PIN HUB	10	10	CAST POLYURETHANE GRAPHITE IMPREGNATED 70D DURO	DIN 9/AGMA 8	20°

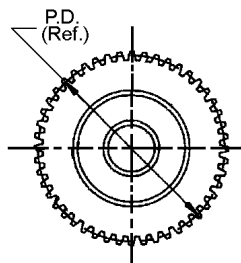
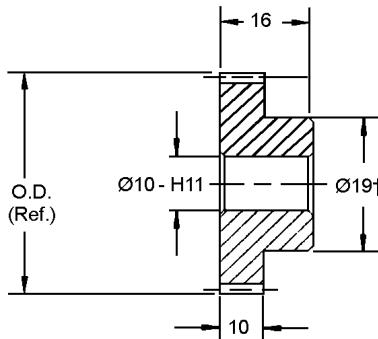

STOCK NO.	NO. OF TEETH	PITCH DIA.	OUTSIDE DIA.
PBU158-15	15†	18.75	21.25
PBU158-16	16†	20.00	22.50
PBU158-20	20	25.00	27.50
PBU158-24	24	30.00	32.50
PBU158-25	25	31.25	33.75
PBU158-30	30	37.50	40.00
PBU158-35	35	43.75	46.25
PBU158-40	40	50.00	52.50
PBU158-50	50	62.50	65.00
PBU158-60	60	75.00	77.50

†Teeth runout on hub.

Available on request: Other numbers of teeth; 14 - 1/2° pressure angle.

MODULE	STYLE	BORE	FACE	MATERIAL	QUALITY	PRESSURE ANGLE
1.25	PIN HUB	12	10	CAST POLYURETHANE GRAPHITE IMPREGNATED 70D DURO	DIN 9/AGMA 8	20°

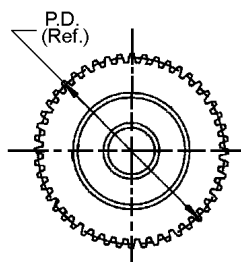
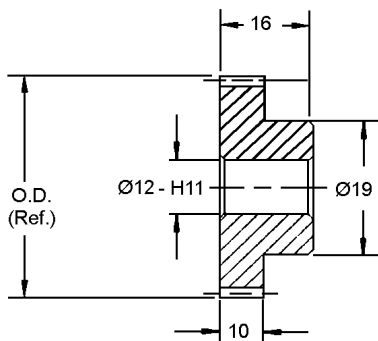

STOCK NO.	NO. OF TEETH	PITCH DIA.	OUTSIDE DIA.
PBU159-16	16†	20.00	22.50
PBU159-20	20	25.00	27.50
PBU159-24	24	30.00	32.50
PBU159-25	25	31.25	33.75
PBU159-30	30	37.50	40.00
PBU159-35	35	43.75	46.25
PBU159-40	40	50.00	52.50
PBU159-50	50	62.50	65.00
PBU159-60	60	75.00	77.50

†Teeth runout on hub.

Available on request: Other numbers of teeth; 14 - 1/2° pressure angle.

For Couplings See Section MG.
For Shafts, Bearings and Collars See Section MI.

SPUR GEARS

MODULE	STYLE	BORE	FACE	MATERIAL	QUALITY	PRESSURE ANGLE
1.25	CLAMP STYLE	8	5	STAINLESS STEEL DIN 1.4305	DIN 8/AGMA 9	20°

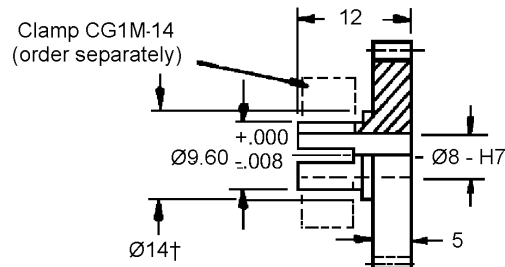
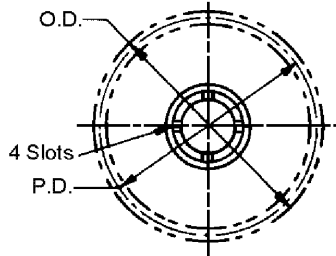

STOCK NO.	NO. OF TEETH	PITCH DIA.	OUTSIDE DIA.
CBS65-16	16†	20.00	22.50
CBS65-20	20	25.00	27.50
CBS65-24	24	30.00	32.50
CBS65-32	32	40.00	42.50
CBS65-40	40	50.00	52.50
CBS65-48	48	60.00	62.50
CBS65-50	50	62.00	65.00
CBS65-55	55	68.00	71.25
CBS65-60	60	75.00	77.50

Available on request: Other numbers of teeth;
14 - 1/2° pressure angle; Quality Class DIN 5 / AGMA 12

† Teeth may runout on flange diameter.

MODULE	STYLE	BORE	FACE	MATERIAL	QUALITY	PRESSURE ANGLE
1.25	CLAMP STYLE	10	6	STAINLESS STEEL DIN 1.4305	DIN 8/AGMA 9	20°

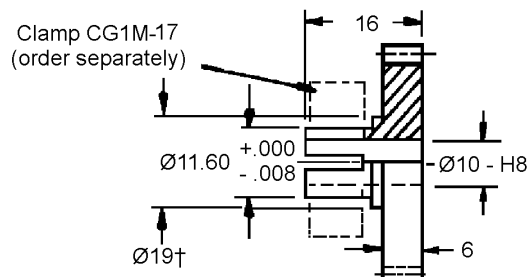
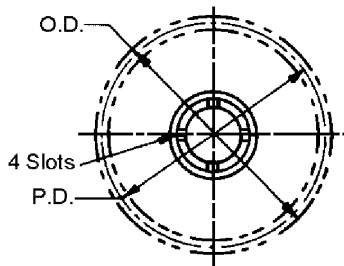

STOCK NO.	NO. OF TEETH	PITCH DIA.	OUTSIDE DIA.
CBS56-16	16†	20.00	22.50
CBS56-20	20	25.00	27.50
CBS56-24	24	30.00	32.50
CBS56-32	32	40.00	42.50
CBS56-40	40	50.00	52.50
CBS56-48	48	60.00	62.50
CBS56-50	50	62.00	65.00
CBS56-55	55	68.00	71.25
CBS56-60	60	75.00	77.50

Available on request: Other numbers of teeth;
14 - 1/2° pressure angle; Quality Class DIN 5 / AGMA 12

† Teeth may runout on flange diameter.

GEAR RACKS

MODULE	STYLE	MATERIAL	QUALITY	PRESSURE ANGLE
1.25	ROUND & RECTANGULAR	STAINLESS STEEL DIN 1.4005	DIN 7/AGMA 10	20°

B

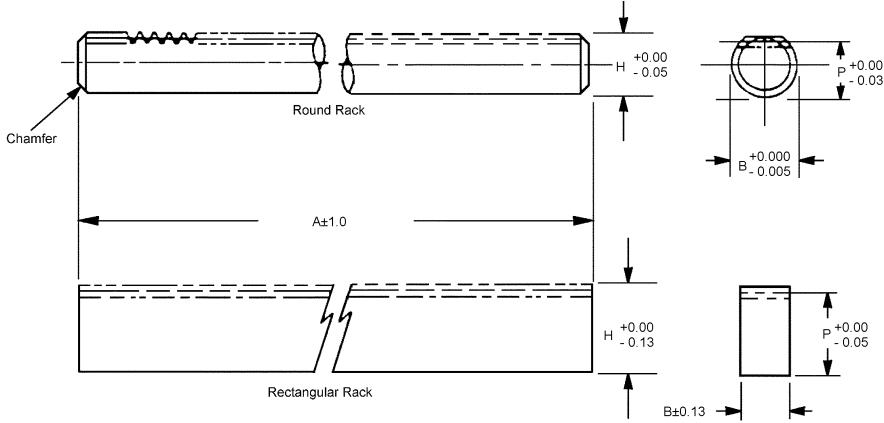

STOCK NO.	RACK STYLE	MOD.	P (Ref.)	B	A	H
R2M-2	ROUND	1.25	12.21	19.974	600	13.46
R3M-3	RECTANGULAR	1.25	17.24	9.02	600	18.54

Available on request: Special, modified and custom racks.

MODULE	STYLE	MATERIAL	QUALITY	PRESSURE ANGLE
1.25	RECTANGULAR	STAINLESS STEEL DIN 1.4005	DIN 7/AGMA 10	20°

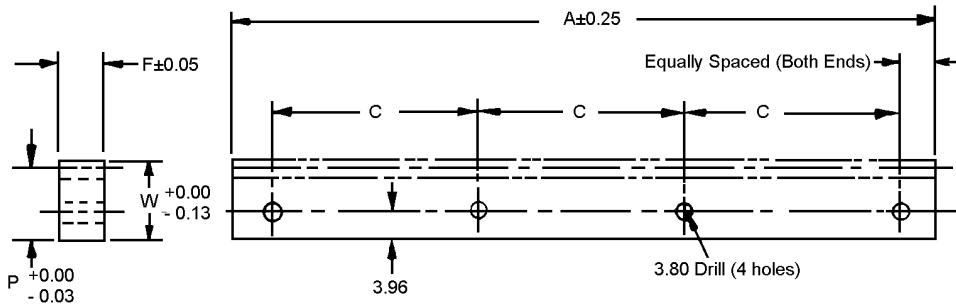

STOCK NO.	A	P (Ref.)	W	F	C
R4M-9	247.4	10.9	12.2	5.8	80.0

Available on request: special, modified and custom racks.

Quality Class AGMA12/DIN 5 available on request.

GEAR RACKS

MODULE	STYLE	MATERIAL	QUALITY	PRESSURE ANGLE
1.25	RECTANGULAR	STAINLESS STEEL DIN 1.4005	DIN 7/AGMA 10	20°

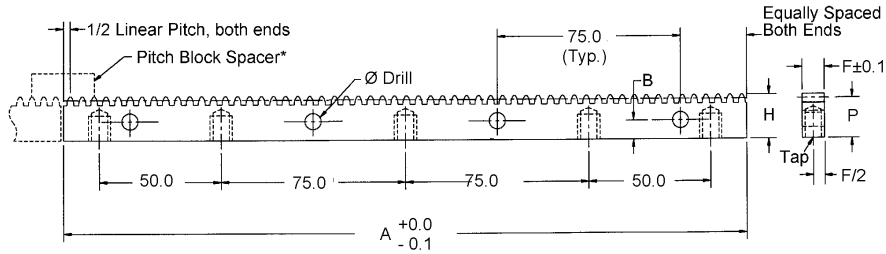

Spacer block is designed for butting to achieve continuous lengths.

RACKS	SPACER BLOCK		LINEAR PITCH	A	P (REF.)	H +0.00 -0.13	F	B	Ø DRILL	TAP
	STOCK NO.	STOCK NO.								
R1M-2	R1M-2-SB		3.93	282.8	17.17	18.42	9.0	7.9	7.0	M5.0 X 0.8

Quality Class AGMA 12/Din 5 available on request. Custom racks available on request.

SPUR GEARS

B

MODULE	STYLE	BORE	FACE	MATERIAL	QUALITY	PRESSURE ANGLE
1.0	HUBLESS	10	6	STAINLESS STEEL DIN 1.4305 OR ALUMINUM DIN 3.1355 ANODIZED	DIN 7/AGMA 10	20°

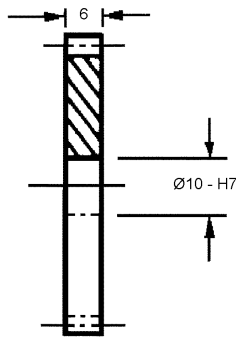
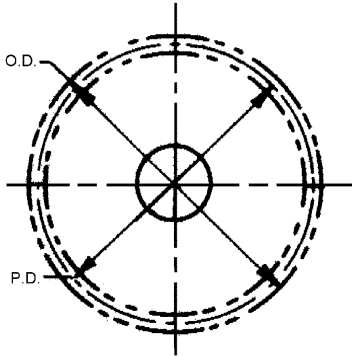

STAINLESS STEEL STOCK NO.	ALUMINUM STOCK NO.	NO. OF TEETH	PITCH DIA.	OUTSIDE DIA.
FCS106-24	FCA106-24	24	24.00	26.00
FCS106-30	FCA106-30	30	30.00	32.00
FCS106-32	FCA106-32	32	32.00	34.00
FCS106-36	FCA106-36	36	36.00	38.00
FCS106-48	FCA106-48	48	48.00	50.00
FCS106-60	FCA106-60	60	60.00	62.00
FCS106-64	FCA106-64	64	64.00	66.00
FCS106-72	FCA106-72	72	72.00	74.00
FCS106-96	FCA106-96	96	96.00	98.00

Available on request:
Other numbers of teeth;
14 - 1/2° pressure angle.

MODULE	STYLE	BORE	FACE	MATERIAL	QUALITY	PRESSURE ANGLE
1.0	HUBLESS	10	6	POLYURETHANE WITH LUBRICANT	DIN 9/AGMA 8	20°

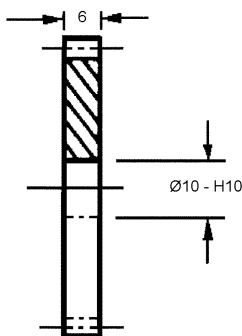
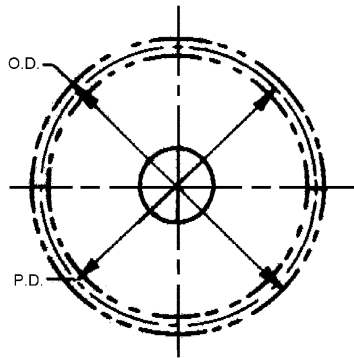

STOCK NO.	NO. OF TEETH	PITCH DIA.	OUTSIDE DIA.
FCU106-24	24	24.00	26.00
FCU106-30	30	30.00	32.00
FCU106-32	32	32.00	34.00
FCU106-36	36	36.00	38.00
FCU106-48	48	48.00	50.00
FCU106-60	60	60.00	62.00
FCU106-64	64	64.00	66.00
FCU106-72	72	72.00	74.00
FCU106-96	96	96.00	98.00

Available on request:
Other numbers of teeth;
14 - 1/2° pressure angle.

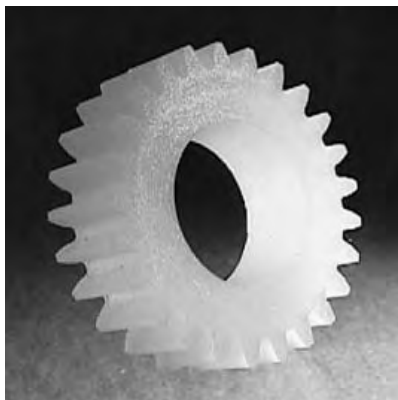

For Couplings See Section MG.
For Shafts, Bearings and Collars See Section MI.

SPUR GEARS

MODULE	STYLE	BORE	FACE	MATERIAL	QUALITY	PRESSURE ANGLE
1.0	HUBLESS	10	5	DELRIN	DIN 8/AGMA 9	20°

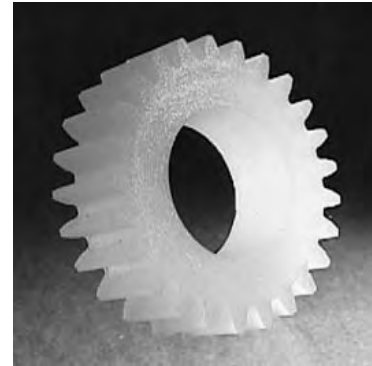
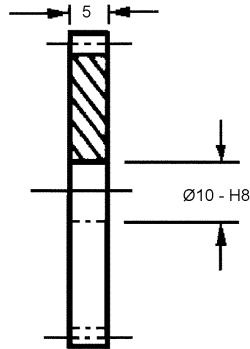
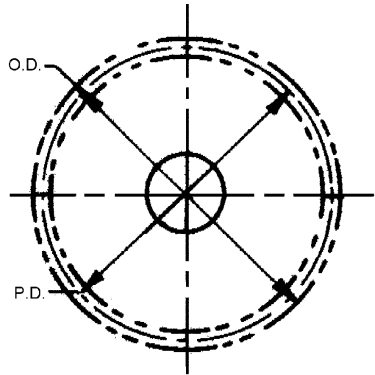

STOCK NO.	NO. OF TEETH	PITCH DIA.	OUTSIDE DIA.
FCD105-15	15	15.00	17.00
FCD105-16	16	16.00	18.00
FCD105-17	17	17.00	19.00
FCD105-18	18	18.00	20.00
FCD105-19	19	19.00	21.00
FCD105-20	20	20.00	22.00
FCD105-21	21	21.00	23.00
FCD105-22	22	22.00	24.00
FCD105-23	23	23.00	25.00
FCD105-24	24	24.00	26.00
FCD105-25	25	25.00	27.00
FCD105-28	28	28.00	30.00
FCD105-30	30	30.00	32.00
FCD105-32	32	32.00	34.00
FCD105-33	33	33.00	35.00
FCD105-36	36	36.00	38.00
FCD105-40	40	40.00	42.00
FCD105-42	42	42.00	44.00
FCD105-45	45	45.00	47.00
FCD105-46	46	46.00	48.00
FCD105-48	48	48.00	50.00
FCD105-50	50	50.00	52.00
FCD105-52	52	52.00	54.00
FCD105-55	55	55.00	57.00
FCD105-56	56	56.00	58.00
FCD105-57	57	57.00	59.00
FCD105-60	60	60.00	62.00
FCD105-64	64	64.00	66.00
FCD105-66	66	66.00	68.00
FCD105-69	69	69.00	71.00
FCD105-72	72	72.00	74.00
FCD105-78	78	78.00	80.00
FCD105-84	84	84.00	86.00
FCD105-90	90	90.00	92.00
FCD105-93	93	93.00	95.00

Available on request:
Other numbers of teeth;
14 - 1/2° pressure angle.

For Couplings See Section MG.
For Shafts, Bearings and Collars See Section MI.

SPUR GEARS

MODULE	STYLE	BORE	FACE	MATERIAL	QUALITY	PRESSURE ANGLE
1.0	PIN HUB	10	5	STAINLESS STEEL DIN 1.4305	DIN 7/AGMA 10	20°

B

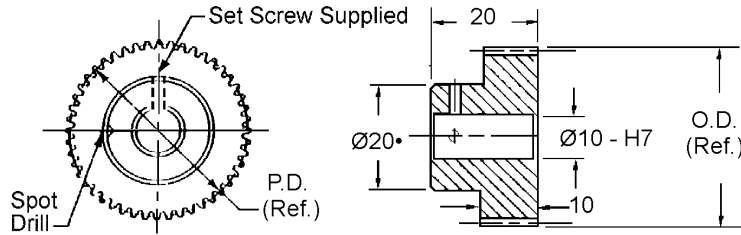

STOCK NO.	NO. OF TEETH	PITCH DIA.	OUTSIDE DIA.
PCS86-18	18	18.00	20.00
PCS86-20	20	20.00	22.00
PCS86-24	24	24.00	26.00
PCS86-28	28	28.00	30.00
PCS86-30	30	30.00	32.00
PCS86-36	36	36.00	38.00
PCS86-40	40	40.00	42.00
PCS86-48	48	48.00	50.00
PCS86-56	56	56.00	58.00
PCS86-60	60	60.00	62.00
PCS86-72	72	72.00	74.00
PCS86-80	80	80.00	82.00
PCS86-96	96	96.00	98.00

Available on request:
Other numbers of teeth;
14 - 1/2° pressure angle;
Quality Class AGMA 12 and 14 / DIN 5 and 3

• For 18 - 22 teeth hub diameter equals 15.5

MODULE	STYLE	BORE	FACE	MATERIAL	QUALITY	PRESSURE ANGLE
1.0	PIN HUB	5	5	STAINLESS STEEL DIN 1.4305 OR ALUMINUM DIN 3.1355 ANODIZED	DIN 7/AGMA 10	20°

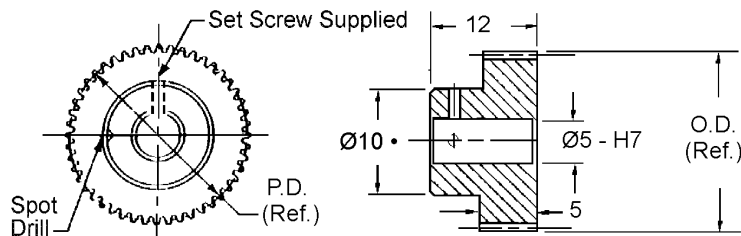

STAINLESS STEEL STOCK NO.	ALUMINUM STOCK NO.	NO. OF TEETH	PITCH DIA.	OUTSIDE DIA.
PCS83-15	PCA83-15	15	15.00	17.00
PCS83-16	PCA83-16	16	16.00	18.00
PCS83-18	PCA83-18	18	18.00	20.00
PCS83-20	PCA83-20	20	20.00	22.00
PCS83-22	PCA83-22	22	22.00	24.00
PCS83-24	PCA83-24	24	24.00	26.00
PCS83-30	PCA83-30	30	30.00	32.00
PCS83-36	PCA83-36	36	36.00	38.00
PCS83-42	PCA83-42	42	42.00	44.00
PCS83-48	PCA83-48	48	48.00	50.00
PCS83-54	PCA83-54	54	54.00	56.00
PCS83-60	PCA83-60	60	60.00	62.00
PCS83-72	PCA83-72	72	72.00	74.00
PCS83-84	PCA83-84	84	84.00	86.00
PCS83-96	PCA83-96	96	96.00	98.00

Available on request:
Other numbers of teeth;
14 - 1/2° pressure angle;
Quality Class AGMA 12 and 14 / DIN 5 and 3

• For 11 - 12 teeth hub diameter is 8.1

SPUR GEARS

MODULE	STYLE	BORE	FACE	MATERIAL	QUALITY	PRESSURE ANGLE
1.0	PIN HUB	5	5	DELRIN	DIN 8/AGMA 9	20°

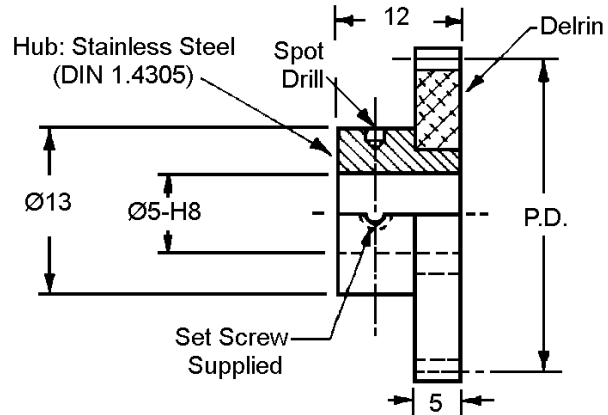

STOCK NO.	NO. OF TEETH	PITCH DIA.	OUTSIDE DIA.
PCD121X-15	15	15.00	17.00
PCD121X-16	16	16.00	18.00
PCD121X-17	17	17.00	19.00
PCD121X-18	18	18.00	20.00
PCD121X-19	19	19.00	21.00
PCD121X-20	20	20.00	22.00
PCD121X-21	21	21.00	23.00
PCD121X-22	22	22.00	24.00
PCD121X-23	23	23.00	25.00
PCD121X-24	24	24.00	26.00
PCD121X-25	25	25.00	27.00
PCD121X-28	28	28.00	30.00
PCD121X-30	30	30.00	32.00
PCD121X-32	32	32.00	34.00
PCD121X-33	33	33.00	35.00
PCD121X-36	36	36.00	38.00
PCD121X-40	40	40.00	42.00
PCD121X-42	42	42.00	44.00
PCD121X-45	45	45.00	47.00
PCD121X-46	46	46.00	48.00
PCD121X-48	48	48.00	50.00
PCD121X-50	50	50.00	52.00
PCD121X-52	52	52.00	54.00
PCD121X-55	55	55.00	57.00
PCD121X-56	56	56.00	58.00
PCD121X-57	57	57.00	59.00
PCD121X-60	60	60.00	62.00
PCD121X-64	64	64.00	66.00
PCD121X-66	66	66.00	68.00
PCD121X-69	69	69.00	71.00
PCD121X-72	72	72.00	74.00
PCD121X-78	78	78.00	80.00
PCD121X-84	84	84.00	86.00
PCD121X-90	90	90.00	92.00
PCD121X-93	93	93.00	95.00

Available on request:
Other numbers of teeth;
14 - 1/2° pressure angle

For Couplings See Section MG.
For Shafts, Bearings and Collars See Section MI.

SPUR GEARS

B

MODULE	STYLE	BORE	FACE	MATERIAL	QUALITY	PRESSURE ANGLE
1.0	PIN HUB	6	6	DELTRIN	DIN 12/AGMA 5	20°

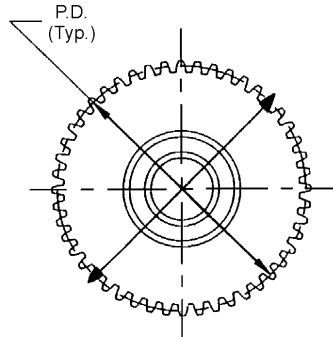
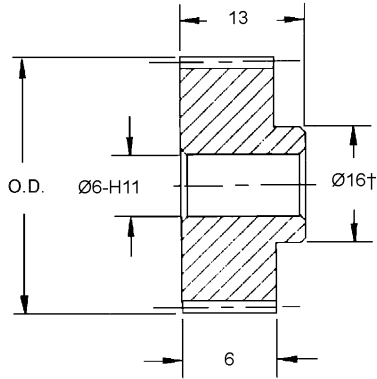

STOCK NO.	NO. OF TEETH	PITCH DIA.	OUTSIDE DIA.
PCD106M-15	15†	15.00	17.00
PCD106M-16	16†	16.00	18.00
PCD106M-18	18	18.00	20.00
PCD106M-20	20	20.00	22.00
PCD106M-21	21	21.00	23.00
PCD106M-24	24	24.00	26.00
PCD106M-30	30	30.00	32.00
PCD106M-36	36	36.00	38.00
PCD106M-42	42	42.00	44.00
PCD106M-48	48	48.00	50.00
PCD106M-54	54	54.00	56.00
PCD106M-60	60	60.00	62.00

Available on request:
Other bore sizes, numbers of teeth

† Teeth runout on hub.

MODULE	STYLE	BORE	FACE	MATERIAL	QUALITY	PRESSURE ANGLE
1.0	PIN HUB	6	6	CAST POLYURETHANE GRAPHITE IMPREGNATED 70D DURO	DIN 12/AGMA 5	20°

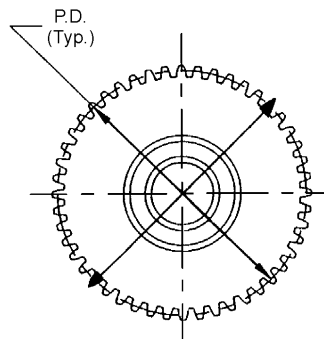
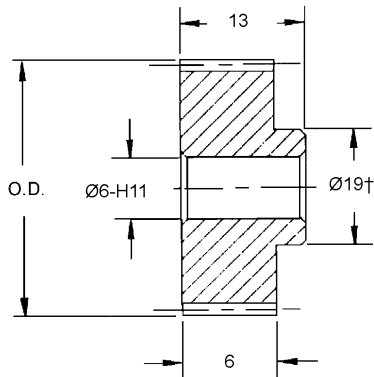

STOCK NO.	NO. OF TEETH	PITCH DIA.	OUTSIDE DIA.
PCU166-15	15†	15.00	17.00
PCU166-16	16†	16.00	18.00
PCU166-18	18†	18.00	20.00
PCU166-24	24	24.00	26.00
PCU166-30	30	30.00	32.00
PCU166-36	36	36.00	38.00
PCU166-42	42	42.00	44.00
PCU166-48	48	48.00	50.00
PCU166-60	60	60.00	62.00
PCU166-72	72	72.00	74.00

Available on request:
Other bore sizes, numbers of teeth;
14-12° Pressure Angle

† Teeth runout on hub.

SPUR GEARS

MODULE	STYLE	BORE	FACE	MATERIAL	QUALITY	PRESSURE ANGLE
1.0	PIN HUB	8	5	DELRIN	DIN 8/AGMA 9	20°

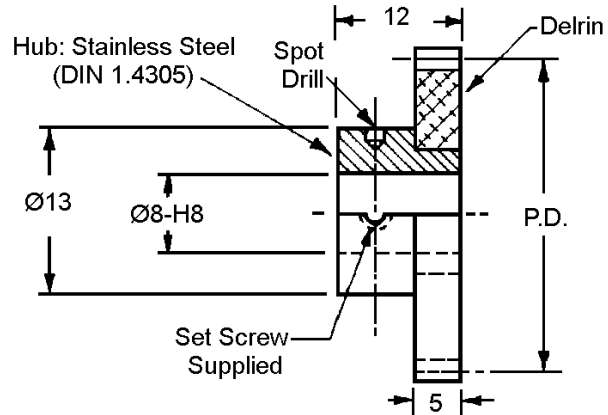

STOCK NO.	NO. OF TEETH	PITCH DIA.	OUTSIDE DIA.
PCD138X-15	15	15.00	17.00
PCD138X-16	16	16.00	18.00
PCD138X-17	17	17.00	19.00
PCD138X-18	18	18.00	20.00
PCD138X-19	19	19.00	21.00
PCD138X-20	20	20.00	22.00
PCD138X-21	21	21.00	23.00
PCD138X-22	22	22.00	24.00
PCD138X-23	23	23.00	25.00
PCD138X-24	24	24.00	26.00
PCD138X-25	25	25.00	27.00
PCD138X-28	28	28.00	30.00
PCD138X-30	30	30.00	32.00
PCD138X-32	32	32.00	34.00
PCD138X-33	33	33.00	35.00
PCD138X-36	36	36.00	38.00
PCD138X-40	40	40.00	42.00
PCD138X-42	42	42.00	44.00
PCD138X-45	45	45.00	47.00
PCD138X-46	46	46.00	48.00
PCD138X-48	48	48.00	50.00
PCD138X-50	50	50.00	52.00
PCD138X-52	52	52.00	54.00
PCD138X-55	55	55.00	57.00
PCD138X-56	56	56.00	58.00
PCD138X-57	57	57.00	59.00
PCD138X-60	60	60.00	62.00
PCD138X-64	64	64.00	66.00
PCD138X-66	66	66.00	68.00
PCD138X-69	69	69.00	71.00
PCD138X-72	72	72.00	74.00
PCD138X-78	78	78.00	80.00
PCD138X-84	84	84.00	86.00
PCD138X-90	90	90.00	92.00
PCD138X-93	93	93.00	95.00

Available on request:
Other numbers of teeth;
14 - 1/2° pressure angle

For Couplings See Section MG.
For Shafts, Bearings and Collars See Section MI.

SPUR GEARS

B

MODULE	STYLE	BORE	FACE	MATERIAL	QUALITY	PRESSURE ANGLE
1.0	PIN HUB	10	6	CAST POLYURETHANE GRAPHITE IMPREGNATED 70D DURO	DIN 12/AGMA 5	20°

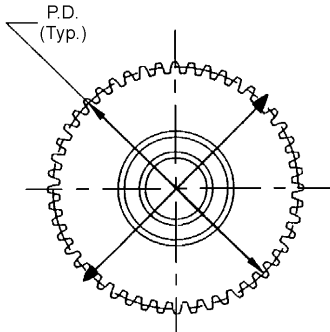
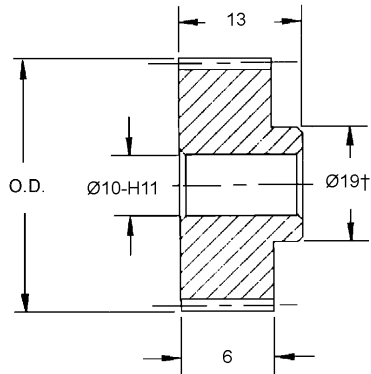

STOCK NO.	NO. OF TEETH	PITCH DIA.	OUTSIDE DIA.
PCU167-15	15†	15.00	17.00
PCU167-16	16†	16.00	18.00
PCU167-18	18†	18.00	20.00
PCU167-24	24	24.00	26.00
PCU167-30	30	30.00	32.00
PCU167-36	36	36.00	38.00
PCU167-42	42	42.00	44.00
PCU167-48	48	48.00	50.00
PCU167-60	60	60.00	62.00
PCU167-72	72	72.00	74.00

Available on request:
Other bore sizes, numbers of teeth;
14-12° Pressure Angle

† Teeth runout on hub.

MODULE	STYLE	BORE	FACE	MATERIAL	QUALITY	PRESSURE ANGLE
1.0	PIN HUB	12	6	CAST POLYURETHANE GRAPHITE IMPREGNATED 70D DURO	DIN 12/AGMA 5	20°

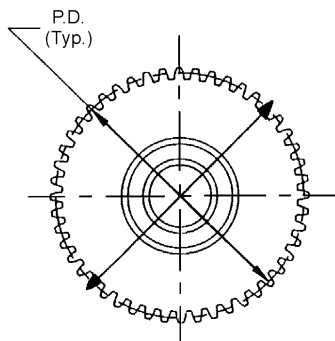
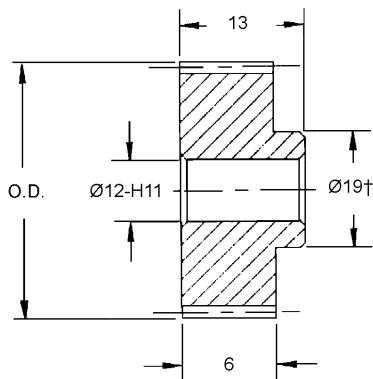

STOCK NO.	NO. OF TEETH	PITCH DIA.	OUTSIDE DIA.
PCU168-16	16†	16.00	18.00
PCU168-18	18†	18.00	20.00
PCU168-24	24	24.00	26.00
PCU168-30	30	30.00	32.00
PCU168-36	36	36.00	38.00
PCU168-42	42	42.00	44.00
PCU168-48	48	48.00	50.00
PCU168-60	60	60.00	62.00
PCU168-72	72	72.00	74.00

Available on request:
Other bore sizes, numbers of teeth;
14-12° Pressure Angle

† Teeth runout on hub.

SPUR GEARS

MODULE	STYLE	BORE	FACE	MATERIAL	QUALITY	PRESSURE ANGLE
1.0	CLAMP HUB	8	3	STAINLESS STEEL DIN 1.4305 OR ALUMINUM DIN 3.1355 ANODIZED	DIN 8/AGMA 9	20°

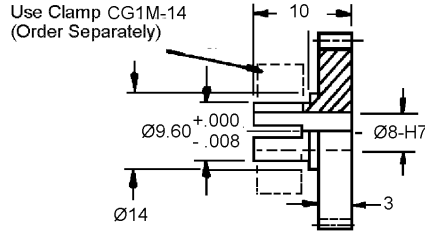
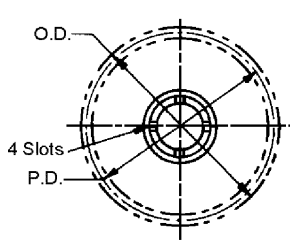

STAINLESS STEEL STOCK NO.	ALUMINUM STOCK NO.	NO. OF TEETH	PITCH DIA.	OUTSIDE DIA.
CCS64-12	CCA64-12	12	12.00	14.00
CCS64-13	CCA64-13	13	13.00	15.00
CCS64-14	CCA64-14	14	14.00	16.00
CCS64-15	CCA64-15	15	15.00	17.00
CCS64-16	CCA64-16	16	16.00	18.00
CCS64-17	CCA64-17	17	17.00	19.00
CCS64-18	CCA64-18	18	18.00	20.00
CCS64-19	CCA64-19	19	19.00	21.00
CCS64-20	CCA64-20	20	20.00	22.00
CCS64-21	CCA64-21	21	21.00	23.00
CCS64-22	CCA64-22	22	22.00	24.00
CCS64-23	CCA64-23	23	23.00	25.00
CCS64-24	CCA64-24	24	24.00	26.00
CCS64-27	CCA64-27	27	27.00	29.00
CCS64-30	CCA64-30	30	30.00	32.00
CCS64-33	CCA64-33	33	33.00	35.00
CCS64-36	CCA64-36	36	36.00	38.00
CCS64-39	CCA64-39	39	39.00	41.00
CCS64-42	CCA64-42	42	42.00	44.00
CCS64-45	CCA64-45	45	45.00	47.00
CCS64-48	CCA64-48	48	48.00	50.00
CCS64-51	CCA64-51	51	51.00	53.00
CCS64-54	CCA64-54	54	54.00	56.00
CCS64-57	CCA64-57	57	57.00	59.00
CCS64-60	CCA64-60	60	60.00	62.00
CCS64-63	CCA64-63	63	63.00	65.00
CCS64-66	CCA64-66	66	66.00	68.00
CCS64-69	CCA64-69	69	69.00	71.00
CCS64-72	CCA64-72	72	72.00	74.00
CCS64-75	CCA64-75	75	75.00	77.00
CCS64-78	CCA64-78	78	78.00	80.00
CCS64-81	CCA64-81	81	81.00	83.00
CCS64-84	CCA64-84	84	84.00	86.00
CCS64-87	CCA64-87	87	87.00	89.00
CCS64-90	CCA64-90	90	90.00	92.00
CCS64-93	CCA64-93	93	93.00	95.00
CCS64-96	CCA64-96	96	96.00	98.00
CCS64-99	CCA64-99	99	99.00	101.00

Available on request:
 Other bore sizes;
 numbers of teeth;
 14-12° Pressure Angle;
 Quality Class DIN 5/AGMA12

For Couplings See Section MG.
 For Shafts, Bearings and Collars See Section MI.

GEAR RACKS

MODULE	STYLE	MATERIAL	QUALITY	PRESSURE ANGLE
1.0	ROUND & RECTANGULAR	STAINLESS STEEL DIN 1.4005	DIN 7/AGMA 10	20°

B

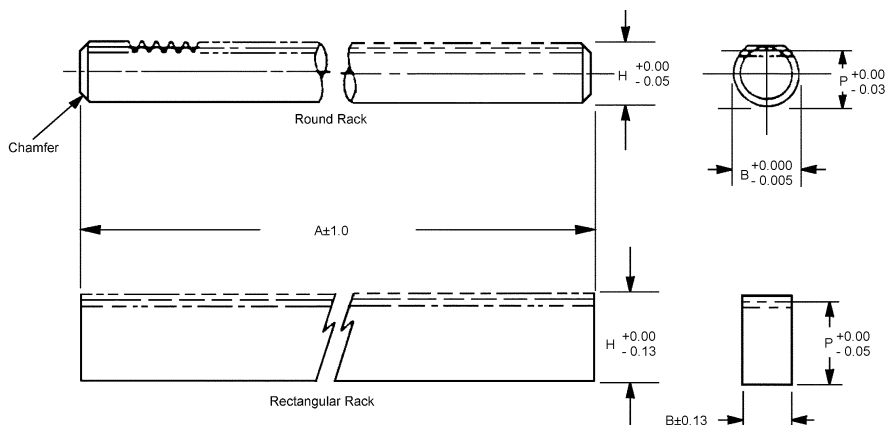

STOCK NO.	RACK STYLE	MOD.	P (Ref.)	B	A	H
R2M-3	ROUND	1.0	11.19	12.974	450	12.19
R3M-3	RECTANGULAR	1.0	11.19	5.84	450	12.19

Available on request: Special, modified and custom racks.

MODULE	STYLE	MATERIAL	QUALITY	PRESSURE ANGLE
1.0	RECTANGULAR	STAINLESS STEEL DIN 1.4005	DIN 7/AGMA 10	20°

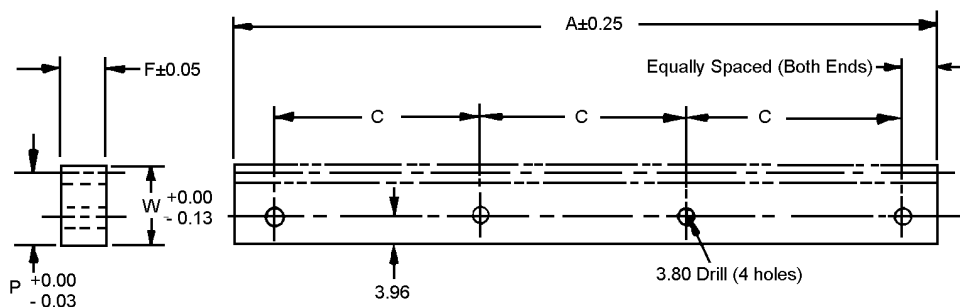

STOCK NO.	A	P (Ref.)	W	F	C
R4M-11	248.2	11.2	12.2	5.8	80.0

Available on request: special, modified and custom racks.

Quality Class AGMA12/DIN 5 available on request.

GEAR RACKS

MODULE	STYLE	MATERIAL	QUALITY	PRESSURE ANGLE
1.0	RECTANGULAR	STAINLESS STEEL DIN 1.4005	DIN 7/AGMA 10	20°

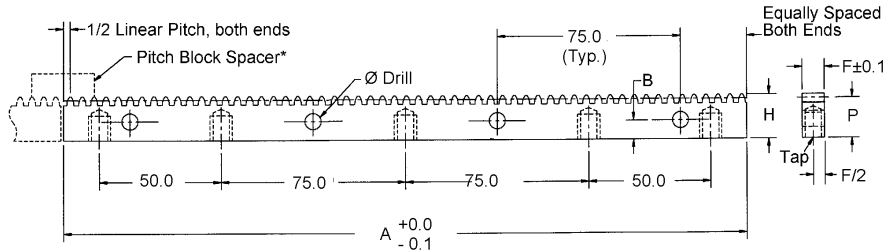

Spacer block is designed for butting to achieve continuous lengths.

RACKS	SPACER BLOCK								
STOCK NO.	STOCK NO.	LINEAR PITCH	A	P (REF.)	H +0.00 -0.13	F	B	Ø DRILL	TAP
R1M-3	R1M-3-SB	3.14	279.6	11.07	12.07	5.8	5.5	3.8	M4.0 X 0.7

Quality Class AGMA 12/Din 5 available on request. Custom racks available on request.

ANTI-BACKLASH GEARS

MODULE	STYLE	BORE	FACE	MATERIAL	QUALITY	PRESSURE ANGLE
1.0	PIN HUB	8	5	STAINLESS STEEL DIN 1.4305 OR ALUMINUM DIN 3.1355 ANODIZED	DIN 7/AGMA 10	20°

B

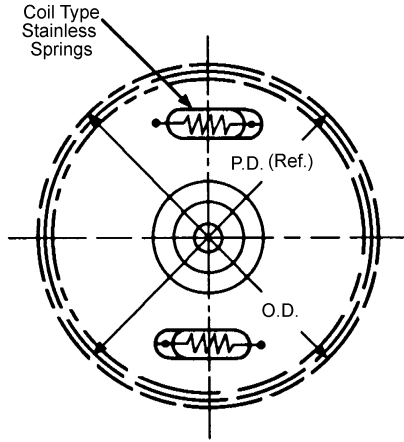
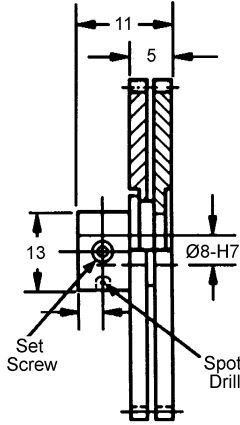

STAINLESS STEEL DIN 1.4305 STOCK NO.	ALUMINUM DIN 3.1355 STOCK NO.	NO. OF TEETH	PITCH DIA.	OUTSIDE DIA.
APCMM-30-X	APCQM-30-X	30	30.00	32.0
APCMM-35-X	APCQM-35-X	35	35.00	37.0
APCMM-36-X	APCQM-36-X	36	36.00	38.0
APCMM-40-X	APCQM-40-X	40	40.00	42.0
APCMM-42-X	APCQM-42-X	42	42.00	44.0
APCMM-45-X	APCQM-45-X	45	45.00	47.0
APCMM-48-X	APCQM-48-X	48	48.00	50.0
APCMM-50-X	APCQM-50-X	50	50.00	52.0
APCMM-54-X	APCQM-54-X	54	54.00	56.0
APCMM-55-X	APCQM-55-X	55	55.00	57.0
APCMM-60-X	APCQM-60-X	60	60.00	62.0
APCMM-65-X	APCQM-65-X	65	65.00	67.0
APCMM-66-X	APCQM-66-X	66	66.00	68.0

Available on request:
 Other numbers of teeth;
 Quality Class AGMA12 & 14 / DIN 5 & 3;
 14-1/2° Pressure Angle

Hub Material: Stainless Steel DIN 1.4305

For Couplings See Section MG.
 For Shafts, Bearings and Collars See Section MI.

ANTI-BACKLASH GEARS

MODULE	STYLE	BORE	FACE	MATERIAL	QUALITY	PRESSURE ANGLE
1.0	PIN HUB	8	6	STAINLESS STEEL DIN 1.4305 OR ALUMINUM DIN 3.1355 ANODIZED	DIN 7/AGMA 10	20°

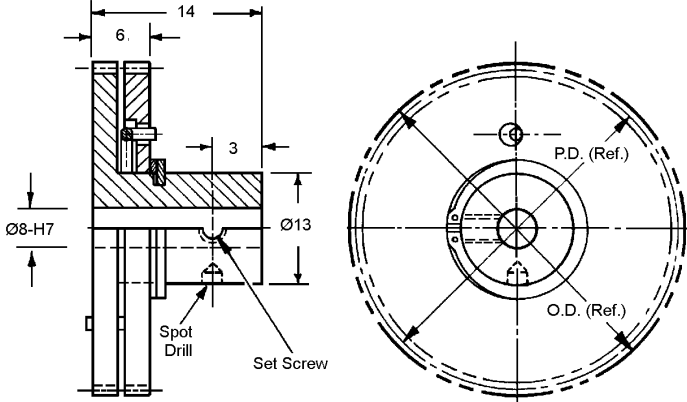

STAINLESS STEEL DIN 1.4305 STOCK NO.	ALUMINUM DIN 3.1355 STOCK NO.	NO. OF TEETH	PITCH DIA.	OUTSIDE DIA.
APCBSM-18-X	APCDSM-18-X	18	18.00	20.00
APCBSM-21-X	APCDSM-21-X	21	21.00	23.00
APCBSM-24-X	APCDSM-24-X	24	24.00	26.00

Available on request:
Other numbers of teeth;
Other Quality Classes;
14-1/2° Pressure Angle

Hub Material: Stainless Steel DIN 1.4305

MODULE	STYLE	BORE	FACE	MATERIAL	QUALITY	PRESSURE ANGLE
1.0	CLAMP HUB	8	6	STAINLESS STEEL DIN 1.4305 OR ALUMINUM DIN 3.1355 ANODIZED	DIN 7/AGMA 10	20°

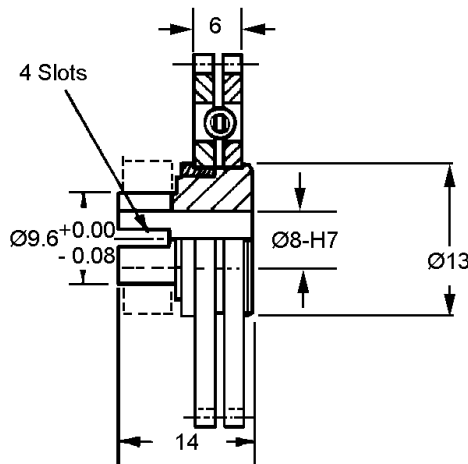

STAINLESS STEEL DIN 1.4305 STOCK NO.	ALUMINUM DIN 3.1355 STOCK NO.	NO. OF TEETH	PITCH DIA.	OUTSIDE DIA.
ACCBSM-18-X	ACCDSM-18-X	18	18.00	20.00
ACCBSM-21-X	ACCDSM-21-X	21	21.00	23.00
ACCBSM-24-X	ACCDSM-24-X	24	24.00	26.00

Available on request:
Other numbers of teeth;
Other Quality Classes;
14-1/2° Pressure Angle

Hub Material: Stainless Steel DIN 1.4305

ANTI-BACKLASH GEARS

MODULE	STYLE	BORE	FACE	MATERIAL	QUALITY	PRESSURE ANGLE
1.0	CLAMP HUB	8	5	STAINLESS STEEL DIN 1.4305 OR ALUMINUM DIN 3.1355 ANODIZED	DIN 7/AGMA 10	20°

B

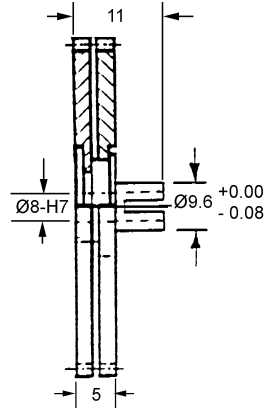

STAINLESS STEEL DIN 1.4305 STOCK NO.	ALUMINUM DIN 3.1355 STOCK NO.	NO. OF TEETH	PITCH DIA.	OUTSIDE DIA.
ACCMM-30-X	ACCQM-30-X	30	30.00	32.0
ACCMM-35-X	ACCQM-35-X	35	35.00	37.0
ACCMM-36-X	ACCQM-36-X	36	36.00	38.0
ACCMM-40-X	ACCQM-40-X	40	40.00	42.0
ACCMM-42-X	ACCQM-42-X	42	42.00	44.0
ACCMM-45-X	ACCQM-45-X	45	45.00	47.0
ACCMM-48-X	ACCQM-48-X	48	48.00	50.0
ACCMM-50-X	ACCQM-50-X	50	50.00	52.0
ACCMM-54-X	ACCQM-54-X	54	54.00	56.0
ACCMM-55-X	ACCQM-55-X	55	55.00	57.0
ACCMM-60-X	ACCQM-60-X	60	60.00	62.0
ACCMM-65-X	ACCQM-65-X	65	65.00	67.0
ACCMM-66-X	ACCQM-66-X	66	66.00	68.0

Available on request:
Other numbers of teeth;
Other Quality Classes;
14-1/2° Pressure Angle

Hub Material: Stainless Steel DIN 1.4305

For Couplings See Section MG.
For Shafts, Bearings and Collars See Section MI.

SPUR GEARS

MODULE	STYLE	BORE	FACE	MATERIAL	QUALITY	PRESSURE ANGLE
0.8	HUBLESS	10	3	STAINLESS STEEL DIN 1.4305 OR ALUMINUM DIN 3.1355 ANODIZED	DIN 7/AGMA 10	20°

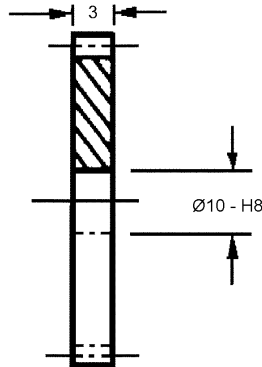
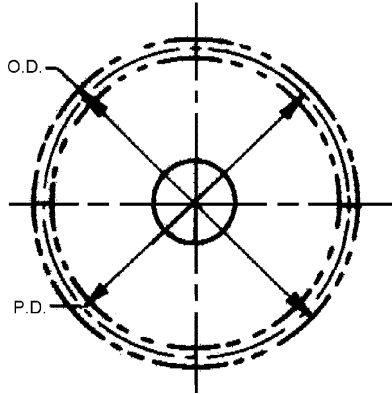

STAINLESS STEEL DIN 1.4305 STOCK NO.	ALUMINUM DIN 3.1355 ANODIZED STOCK NO.	NO. OF TEETH	PITCH DIA.	OUTSIDE DIA.
FDS103-20	FDA103-20	20	16.00	17.60
FDS103-24	FDA103-24	24	19.20	20.80
FDS103-26	FDA103-26	26	20.80	22.40
FDS103-28	FDA103-28	28	22.40	24.00
FDS103-30	FDA103-30	30	24.00	25.60
FDS103-32	FDA103-32	32	25.60	27.20
FDS103-36	FDA103-36	36	28.80	30.40
FDS103-40	FDA103-40	40	32.00	33.60
FDS103-42	FDA103-42	42	33.60	35.20
FDS103-44	FDA103-44	44	35.20	36.80
FDS103-48	FDA103-48	48	38.40	40.00
FDS103-60	FDA103-60	60	48.00	49.60
FDS103-64	FDA103-64	64	51.20	52.80
FDS103-72	FDA103-72	72	57.60	59.20
FDS103-75	FDA103-75	75	60.00	61.60
FDS103-76	FDA103-76	76	60.80	62.40
FDS103-80	FDA103-80	80	64.00	65.60
FDS103-81	FDA103-81	81	64.80	66.40
FDS103-86	FDA103-86	86	68.80	70.40
FDS103-88	FDA103-88	88	70.40	72.00
FDS103-90	FDA103-90	90	72.00	73.60
FDS103-92	FDA103-92	92	73.60	75.20
FDS103-95	FDA103-95	95	76.00	77.60
FDS103-96	FDA103-96	96	76.80	78.40
FDS103-100	FDA103-100	100	80.00	81.60
FDS103-105	FDA103-105	105	84.00	85.60
FDS103-108	FDA103-108	108	86.40	88.00
FDS103-110	FDA103-110	110	88.00	89.60
FDS103-112	FDA103-112	112	89.60	91.20
FDS103-115	FDA103-115	115	92.00	93.60
FDS103-116	FDA103-116	116	92.80	94.40
FDS103-120	FDA103-120	120	96.00	97.60
FDS103-124	FDA103-124	124	99.20	100.80
FDS103-126	FDA103-126	126	100.80	102.40
FDS103-128	FDA103-128	128	102.40	104.00
FDS103-132	FDA103-132	132	105.60	107.20

Available on request:
Other numbers of teeth;
Quality Class AGMA 12 & 14 / DIN 5 & 3;
14-1/2° Pressure Angle

**For Couplings See Section MG.
For Shafts, Bearings and Collars See Section MI.**

SPUR GEARS

MODULE	STYLE	BORE	FACE	MATERIAL	QUALITY	PRESSURE ANGLE
0.8	HUBLESS	10	6	STAINLESS STEEL DIN 1.4305 OR ALUMINUM DIN 3.1355 ANODIZED	DIN 7/AGMA 10	20°

B

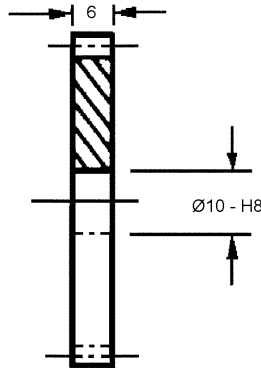
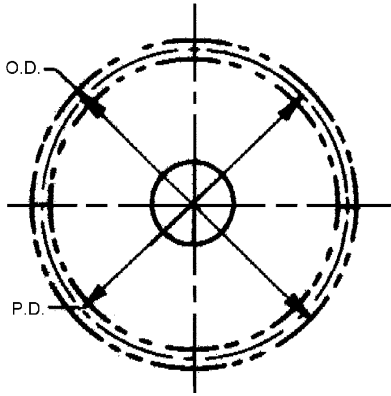

STAINLESS STEEL DIN 1.4305 STOCK NO.	ALUMINUM DIN 3.1355 ANODIZED STOCK NO.	NO. OF TEETH	PITCH DIA.	OUTSIDE DIA.
FDS106-32	FDA106-32	32	25.60	27.20
FDS106-36	FDA106-36	36	28.80	30.40
FDS106-40	FDA106-40	40	32.00	33.60
FDS106-48	FDA106-48	48	38.40	40.00
FDS106-60	FDA106-60	60	48.00	49.60
FDS106-64	FDA106-64	64	51.20	52.80
FDS106-72	FDA106-72	72	57.60	59.20
FDS106-75	FDA106-75	75	60.00	61.60
FDS106-80	FDA106-80	80	64.00	65.60
FDS106-96	FDA106-96	96	76.80	78.40
FDS106-120	FDA106-120	120	96.00	97.60
FDS106-128	FDA106-128	128	102.40	104.00

Available on request:
Other numbers of teeth;
14-1/2° Pressure Angle

For Couplings See Section MG.
For Shafts, Bearings and Collars See Section MI.

SPUR GEARS

MODULE	STYLE	BORE	FACE	MATERIAL	QUALITY	PRESSURE ANGLE
0.8	HUBLESS	10	3	POLYURETHANE WITH LUBRICANT	DIN 8/AGMA 9	20°

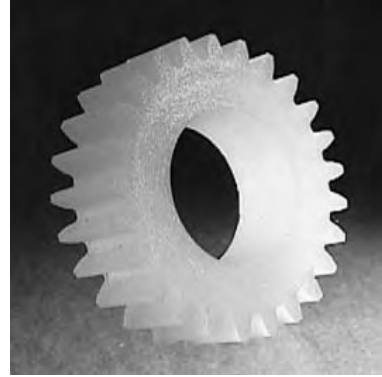
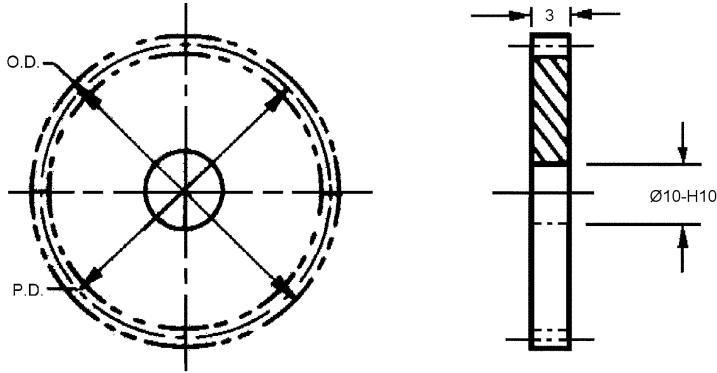

STOCK NO.	NO. OF TEETH	PITCH DIA.	OUTSIDE DIA.
FDU103-32	32	25.60	27.20
FDU103-36	36	28.80	30.40
FDU103-40	40	32.00	33.60
FDU103-48	48	38.40	40.00
FDU103-60	60	48.00	49.60
FDU103-64	64	51.20	52.80
FDU103-72	72	57.60	59.20

Available on request:
Other numbers of teeth;
14 - 1/2° pressure angle.

MODULE	STYLE	BORE	FACE	MATERIAL	QUALITY	PRESSURE ANGLE
0.8	HUBLESS	10	5	DELTRIN	DIN 8/AGMA 9	20°

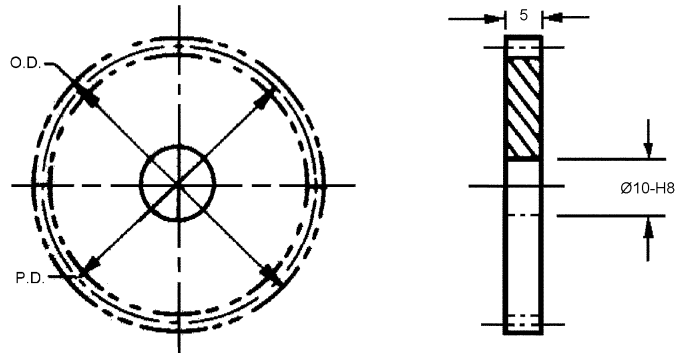

STOCK NO.	NO. OF TEETH	PITCH DIA.	OUTSIDE DIA.
FDD105-20	20	16.00	17.60
FDD105-21	21	16.80	18.40
FDD105-22	22	17.60	19.20
FDD105-23	23	18.40	20.00
FDD105-24	24	19.20	20.80
FDD105-25	25	20.00	21.60
FDD105-26	26	20.80	22.40
FDD105-28	28	22.40	24.00
FDD105-30	30	24.00	25.60
FDD105-32	32	25.60	27.20
FDD105-36	36	28.80	30.40
FDD105-40	40	32.00	33.60
FDD105-42	42	33.60	35.20
FDD105-44	44	35.20	36.80
FDD105-46	46	36.80	38.40
FDD105-48	48	38.40	40.00
FDD105-50	50	40.00	41.60

Available on request:
Other numbers of teeth;
14 - 1/2° pressure angle

SPUR GEARS

MODULE	STYLE	BORE	FACE	MATERIAL	QUALITY	PRESSURE ANGLE
0.8	HUBLESS	10	6	POLYURETHANE WITH LUBRICANT	DIN 9/AGMA 8	20°

B

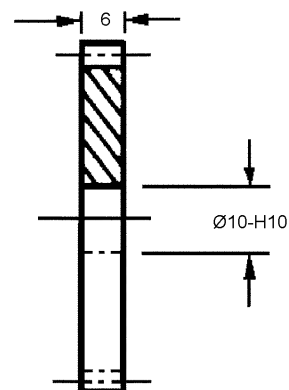
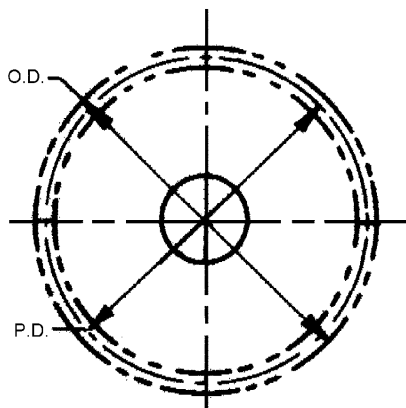
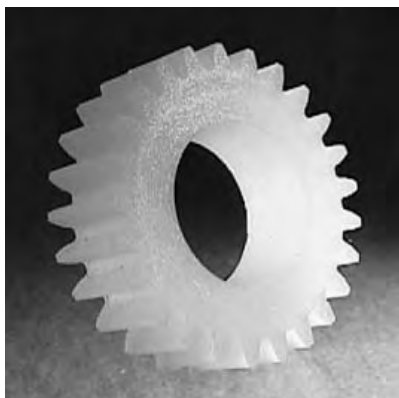

STOCK NO.	NO. OF TEETH	PITCH DIA.	OUTSIDE DIA.
FDU106-32	32	25.60	27.20
FDU106-36	36	28.80	30.40
FDU106-40	40	32.00	33.60
FDU106-48	48	38.40	40.00
FDU106-60	60	48.00	49.60
FDU106-64	64	51.20	52.80
FDU106-72	72	57.60	59.20
FDU106-75	75	60.00	61.60
FDU106-80	80	64.00	65.60
FDU106-96	96	76.80	78.40
FDU106-112	112	89.60	91.20
FDU106-120	120	96.00	97.60
FDU106-128	128	102.40	104.00

Available on request:
Other numbers of teeth;
14 - 1/2° pressure angle

For Couplings See Section MG.
For Shafts, Bearings and Collars See Section MI.

SPUR GEARS

MODULE	STYLE	BORE	FACE	MATERIAL	QUALITY	PRESSURE ANGLE
0.8	PIN HUB	8	5	STAINLESS STEEL DIN 1.4305 OR ALUMINUM DIN 3.1355 ANODIZED	DIN 7/AGMA 10	20°

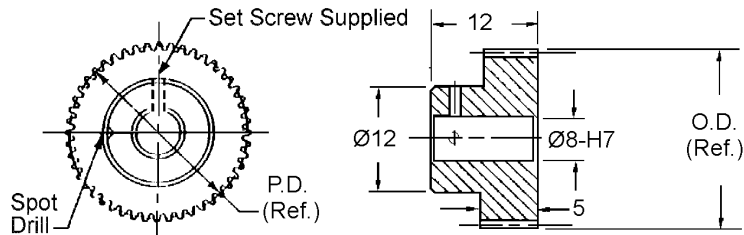

STAINLESS STEEL STOCK NO.	ALUMINUM STOCK NO.	NO. OF TEETH	PITCH DIA.	OUTSIDE DIA.
PDS95-18	PDA95-18	18	14.40	16.00
PDS95-20	PDA95-20	20	16.00	17.60
PDS95-24	PDA95-24	24	19.20	20.80
PDS95-26	PDA95-26	26	20.80	22.40
PDS95-28	PDA95-28	28	22.40	24.00
PDS95-30	PDA95-30	30	24.00	25.60
PDS95-32	PDA95-32	32	25.60	27.20
PDS95-36	PDA95-36	36	28.80	30.40
PDS95-40	PDA95-40	40	32.00	33.60
PDS95-48	PDA95-48	48	38.40	40.00
PDS95-52	PDA95-52	52	41.60	43.20
PDS95-56	PDA95-56	56	44.80	46.40
PDS95-60	PDA95-60	60	48.00	49.60
PDS95-64	PDA95-64	64	51.20	52.80
PDS95-72	PDA95-72	72	57.60	59.20
PDS95-80	PDA95-80	80	64.00	65.60
PDS95-88	PDA95-88	88	70.40	72.00
PDS95-92	PDA95-92	92	73.60	75.20
PDS95-96	PDA95-96	96	76.80	78.40
PDS95-100	PDA95-100	100	80.00	81.60
PDS95-112	PDA95-112	112	89.60	91.20
PDS95-120	PDA95-120	120	96.00	97.60
PDS95-128	PDA95-128	128	102.40	104.00

Available on request:
Other numbers of teeth;
14 - 1/2° pressure angle;
Quality Class AGMA 12 and 14 / DIN 5 and 3

For Couplings See Section MG.
For Shafts, Bearings and Collars See Section MI.

SPUR GEARS

MODULE	STYLE	BORE	FACE	MATERIAL	QUALITY	PRESSURE ANGLE
0.8	PIN HUB	5	5	DELRIN	DIN 8/AGMA 9	20°

B

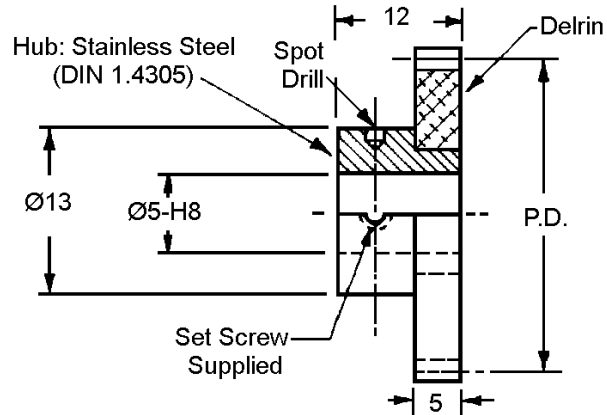

STOCK NO.	NO. OF TEETH	PITCH DIA.	OUTSIDE DIA.
PDD121X-20	20	16.00	17.60
PDD121X-21	21	16.80	18.40
PDD121X-22	22	17.60	19.20
PDD121X-23	23	18.40	20.00
PDD121X-24	24	19.20	20.80
PDD121X-25	25	20.00	21.60
PDD121X-26	26	20.80	22.40
PDD121X-28	28	22.40	24.00
PDD121X-30	30	24.00	25.60
PDD121X-32	32	25.60	27.20
PDD121X-36	36	28.80	30.40
PDD121X-40	40	32.00	33.60
PDD121X-42	42	33.60	35.20
PDD121X-44	44	35.20	36.80
PDD121X-46	46	36.80	38.40
PDD121X-48	48	38.40	40.00
PDD121X-50	50	40.00	41.60
PDD121X-52	52	41.60	43.20
PDD121X-56	56	44.80	46.40
PDD121X-60	60	48.00	49.60
PDD121X-63	63	50.40	52.00
PDD121X-64	64	51.20	52.80
PDD121X-66	66	52.80	54.40
PDD121X-69	69	55.20	56.80
PDD121X-72	72	57.60	59.20
PDD121X-75	75	60.00	61.60
PDD121X-80	80	64.00	65.60
PDD121X-84	84	67.20	68.80
PDD121X-88	88	70.40	72.00
PDD121X-92	92	73.60	75.20
PDD121X-96	96	76.80	78.40
PDD121X-104	104	83.20	84.80
PDD121X-108	108	86.40	88.00
PDD121X-112	112	89.60	91.20
PDD121X-124	124	99.20	100.80

Available on request:
Other numbers of teeth;
14 - 1/2° pressure angle

For Couplings See Section MG.
For Shafts, Bearings and Collars See Section MI.

SPUR GEARS

MODULE	STYLE	BORE	FACE	MATERIAL	QUALITY	PRESSURE ANGLE
0.8	PIN HUB	6	6	CAST POLYURETHANE GRAPHITE IMPREGNATED 70D DURO	DIN 9/AGMA 8	20°

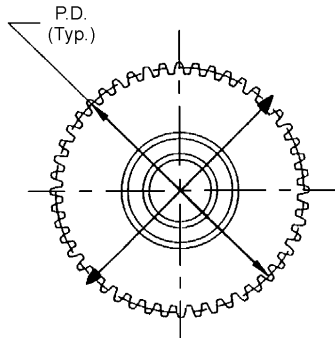
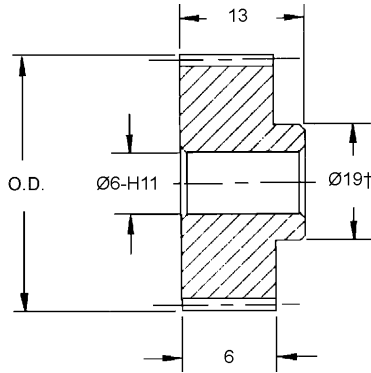

STOCK NO.	NO. OF TEETH	PITCH DIA.	OUTSIDE DIA.
PDU166-16	16†	12.80	14.40
PDU166-20	20†	16.00	17.60
PDU166-24	24†	19.20	20.80
PDU166-30	30	24.00	25.60
PDU166-32	32	25.60	27.20
PDU166-40	40	32.00	33.60
PDU166-48	48	38.40	40.00
PDU166-64	64	51.20	52.80
PDU166-72	72	57.60	59.20
PDU166-96	96	76.80	78.40

Available on request:
Other bore sizes, numbers of teeth;
14-12° Pressure Angle

† Teeth runout on hub.

MODULE	STYLE	BORE	FACE	MATERIAL	QUALITY	PRESSURE ANGLE
0.8	PIN HUB	6	6	DELTRIN	DIN 12/AGMA 5	20°

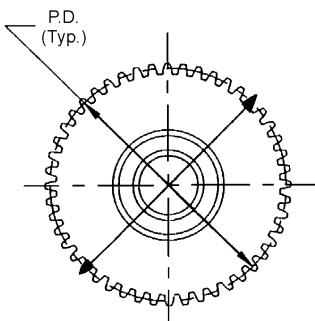
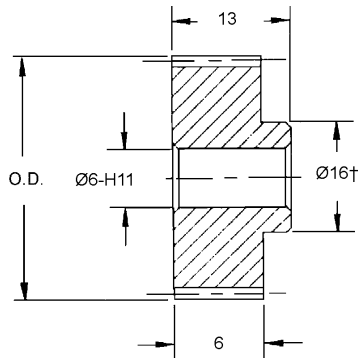

STOCK NO.	NO. OF TEETH	PITCH DIA.	OUTSIDE DIA.
PDD106M-20	20†	16.00	17.60
PDD106M-24	24	19.20	20.80
PDD106M-28	28	22.40	24.00
PDD106M-30	30	24.00	25.60
PDD106M-32	32	25.60	27.20
PDD106M-40	40	32.00	33.60
PDD106M-48	48	38.40	40.00
PDD106M-50	50	40.00	41.60
PDD106M-56	56	44.80	46.40
PDD106M-60	60	48.00	49.60
PDD106M-64	64	51.20	52.80
PDD106M-70	70	56.00	57.60
PDD106M-72	72	57.60	59.20
PDD106M-76	76	60.80	62.40
PDD106M-80	80	64.00	65.60
PDD106M-88	88	70.40	72.00
PDD106M-90	90	72.00	73.60

Available on request:
Other bore sizes, numbers of teeth

† Teeth runout on hub.

SPUR GEARS

MODULE	STYLE	BORE	FACE	MATERIAL	QUALITY	PRESSURE ANGLE
0.8	PIN HUB	8	5	DELRIN	DIN 8/AGMA 9	20°

B

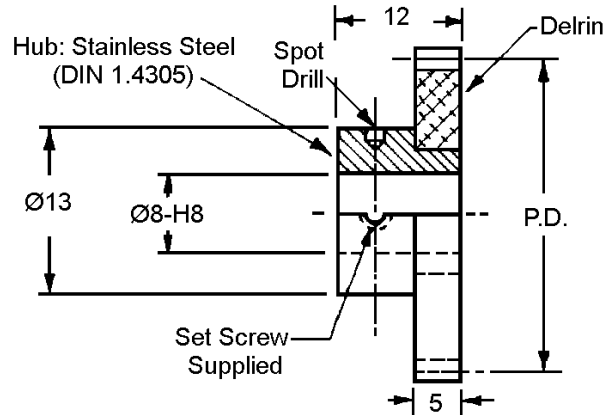

STOCK NO.	NO. OF TEETH	PITCH DIA.	OUTSIDE DIA.
PDD138X-20	20	16.00	17.60
PDD138X-21	21	16.80	18.40
PDD138X-22	22	17.60	19.20
PDD138X-23	23	18.40	20.00
PDD138X-24	24	19.20	20.80
PDD138X-25	25	20.00	21.60
PDD138X-26	26	20.80	22.40
PDD138X-28	28	22.40	24.00
PDD138X-30	30	24.00	25.60
PDD138X-32	32	25.60	27.20
PDD138X-36	36	28.80	30.40
PDD138X-40	40	32.00	33.60
PDD138X-42	42	33.60	35.20
PDD138X-44	44	35.20	36.80
PDD138X-46	46	36.80	38.40
PDD138X-48	48	38.40	40.00
PDD138X-50	50	40.00	41.60
PDD138X-52	52	41.60	43.20
PDD138X-56	56	44.80	46.40
PDD138X-60	60	48.00	49.60
PDD138X-63	63	50.40	52.00
PDD138X-64	64	51.20	52.80
PDD138X-66	66	52.80	54.40
PDD138X-69	69	55.20	56.80
PDD138X-72	72	57.60	59.20
PDD138X-75	75	60.00	61.60
PDD138X-80	80	64.00	65.60
PDD138X-84	84	67.20	68.80
PDD138X-88	88	70.40	72.00
PDD138X-92	92	73.60	75.20
PDD138X-96	96	76.80	78.40
PDD138X-104	104	83.20	84.80
PDD138X-108	108	86.40	88.00
PDD138X-112	112	89.60	91.20
PDD138X-124	124	99.20	100.80

Available on request:
Other numbers of teeth;
14 - 1/2° pressure angle

For Couplings See Section MG.
For Shafts, Bearings and Collars See Section MI.

SPUR GEARS

MODULE	STYLE	BORE	FACE	MATERIAL	QUALITY	PRESSURE ANGLE
0.8	PIN HUB	10	6	CAST POLYURETHANE GRAPHITE IMPREGNATED 70D DURO	DIN 9/AGMA 8	20°

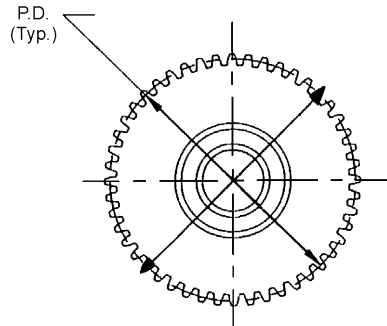
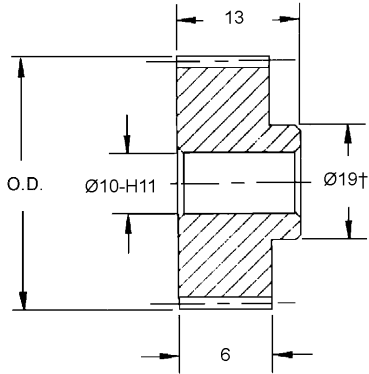

STOCK NO.	NO. OF TEETH	PITCH DIA.	OUTSIDE DIA.
PDU167-20	20†	16.00	17.60
PDU167-24	24†	19.20	20.80
PDU167-30	30	24.00	25.60
PDU167-32	32	25.60	27.20
PDU167-40	40	32.00	33.60
PDU167-48	48	38.40	40.00
PDU167-64	64	51.20	52.80
PDU167-72	72	57.60	59.20
PDU167-96	96	76.80	78.40

Available on request:
Other bore sizes, numbers of teeth;
14-12° Pressure Angle

† Teeth runout on hub.

MODULE	STYLE	BORE	FACE	MATERIAL	QUALITY	PRESSURE ANGLE
0.8	PIN HUB	12	6	CAST POLYURETHANE GRAPHITE IMPREGNATED 70D DURO	DIN 9/AGMA 8	20°

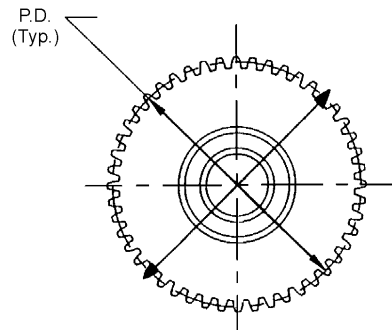
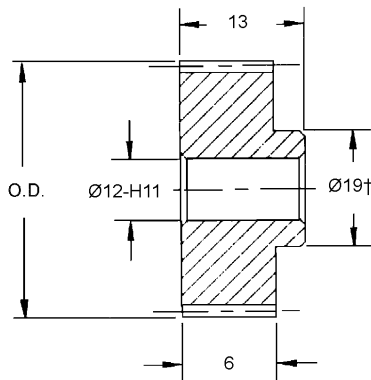

STOCK NO.	NO. OF TEETH	PITCH DIA.	OUTSIDE DIA.
PDU168-20	20†	16.00	17.60
PDU168-24	24†	19.20	20.80
PDU168-30	30	24.00	25.60
PDU168-32	32	25.60	27.20
PDU168-40	40	32.00	33.60
PDU168-48	48	38.40	40.00
PDU168-64	64	51.20	52.80
PDU168-72	72	57.60	59.20
PDU168-96	96	76.80	78.40

Available on request:
Other bore sizes, numbers of teeth;
14-12° Pressure Angle

† Teeth runout on hub.

For Couplings See Section MG.
For Shafts, Bearings and Collars See Section MI.

SPUR GEARS

MODULE	STYLE	BORE	FACE	MATERIAL	QUALITY	PRESSURE ANGLE
0.8	CLAMP HUB	8	3	STAINLESS STEEL DIN 1.4305 OR ALUMINUM DIN 3.1355 ANODIZED	DIN 7/AGMA 10	20°

B

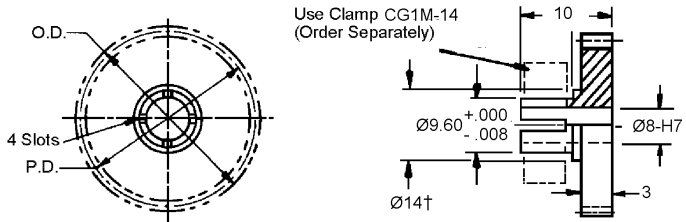

STAINLESS STEEL STOCK NO.	ALUMINUM STOCK NO.	NO. OF TEETH	PITCH DIA.	OUTSIDE DIA.
CDS64-14	CDA64-14	14†	11.20	12.80
CDS64-15	CDA64-15	15†	12.00	13.60
CDS64-16	CDA64-16	16†	12.80	14.40
CDS64-17	CDA64-17	17†	13.60	15.20
CDS64-18	CDA64-18	18†	14.40	16.00
CDS64-19	CDA64-19	19†	15.20	16.80
CDS64-20	CDA64-20	20	16.00	17.60
CDS64-22	CDA64-22	22	17.60	19.20
CDS64-24	CDA64-24	24	19.20	20.80
CDS64-25	CDA64-25	25	20.00	21.60
CDS64-26	CDA64-26	26	20.80	22.40
CDS64-28	CDA64-28	28	22.40	24.00
CDS64-30	CDA64-30	30	24.00	25.60
CDS64-32	CDA64-32	32	25.60	27.20
CDS64-34	CDA64-34	34	27.20	28.80
CDS64-36	CDA64-36	36	28.80	30.40
CDS64-38	CDA64-38	38	30.40	32.00
CDS64-39	CDA64-39	39	31.20	32.80
CDS64-40	CDA64-40	40	32.00	33.60
CDS64-45	CDA64-45	45	36.00	37.60
CDS64-48	CDA64-48	48	38.40	40.00
CDS64-50	CDA64-50	50	40.00	41.60
CDS64-54	CDA64-54	54	43.20	44.80
CDS64-55	CDA64-55	55	44.00	45.60
CDS64-56	CDA64-56	56	44.80	46.40
CDS64-60	CDA64-60	60	48.00	49.60
CDS64-64	CDA64-64	64	51.20	52.80
CDS64-65	CDA64-65	65	52.00	53.60
CDS64-68	CDA64-68	68	54.40	56.00
CDS64-70	CDA64-70	70	56.00	57.60
CDS64-72	CDA64-72	72	57.60	59.20
CDS64-76	CDA64-76	76	60.80	62.40
CDS64-80	CDA64-80	80	64.00	65.60
CDS64-88	CDA64-88	88	70.40	72.00
CDS64-90	CDA64-90	90	72.00	73.60
CDS64-96	CDA64-96	96	76.80	78.40
CDS64-112	CDA64-112	112	89.60	91.20
CDS64-127	CDA64-127	127	101.60	103.20
CDS64-128	CDA64-128	128	102.40	104.00
CDS64-132	CDA64-132	132	105.60	107.20

Available on request:
 Other bore sizes;
 numbers of teeth;
 14-12° Pressure Angle;
 Quality Class DIN 5/AGMA12

†Teeth may runout on flange diameter.

**For Couplings See Section MG.
 For Shafts, Bearings and Collars See Section MI.**

SPUR GEARS

MODULE	STYLE	BORE	FACE	MATERIAL	QUALITY	PRESSURE ANGLE
0.8	CLAMP HUB	8	5	STAINLESS STEEL DIN 1.4305	DIN 7/AGMA 10	20°

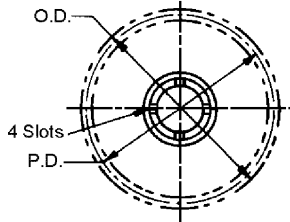

Use Clamp CG1M-14
(Order Separately)

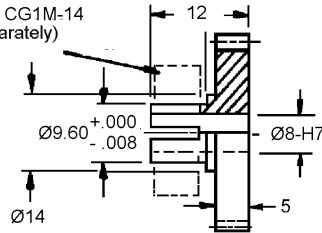

STAINLESS STEEL STOCK NO.	NO. OF TEETH	PITCH DIA.	OUTSIDE DIA.
CDS65-20	20	16.00	17.60
CDS65-21	21	16.80	18.40
CDS65-22	22	17.60	19.20
CDS65-23	23	18.40	20.00
CDS65-24	24	19.20	20.80
CDS65-25	25	20.00	21.60
CDS65-28	28	22.40	24.00
CDS65-30	30	24.00	25.60
CDS65-32	32	25.60	27.20
CDS65-36	36	28.80	30.40
CDS65-40	40	32.00	33.60
CDS65-48	48	38.40	40.00
CDS65-56	56	44.80	46.40
CDS65-60	60	48.00	49.60
CDS65-64	64	51.20	52.80
CDS65-72	72	57.60	59.20
CDS65-80	80	64.00	65.60
CDS65-96	96	76.80	78.40
CDS65-112	112	89.60	91.20
CDS65-128	128	102.40	104.00
CDS65-132	132	105.60	107.20

Available on request:
Other numbers of teeth;
14-12° Pressure Angle;
Quality Class DIN 5/AGMA12

†Teeth may runout on flange diameter.

**For Couplings See Section MG.
For Shafts, Bearings and Collars See Section MI.**

GEAR RACKS

MODULE	STYLE	MATERIAL	QUALITY	PRESSURE ANGLE
0.8	ROUND & RECTANGULAR	STAINLESS STEEL DIN 1.4005	DIN 7/AGMA 10	20°

B

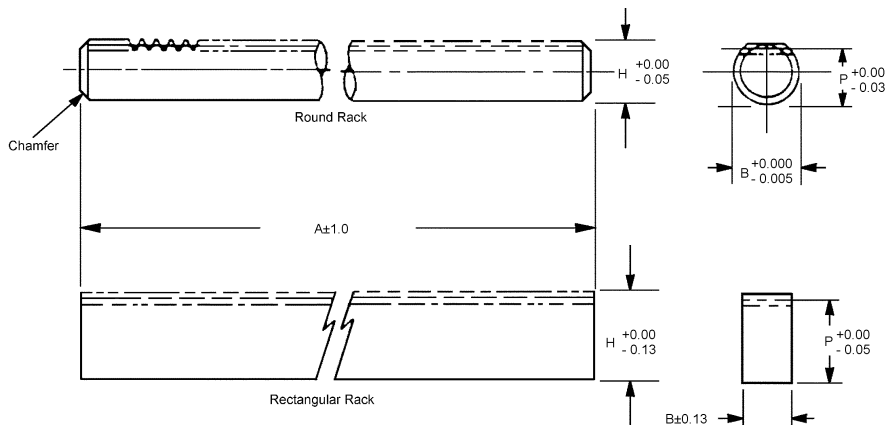

STOCK NO.	RACK STYLE	MOD.	P (Ref.)	B	A	H
R2M-4	ROUND	0.8	7.84	9.974	450	12.19
R3M-4	RECTANGULAR	0.8	11.39	5.84	450	12.19

Available on request: Special, modified and custom racks.

MODULE	STYLE	MATERIAL	QUALITY	PRESSURE ANGLE
0.8	RECTANGULAR	STAINLESS STEEL DIN 1.4005	DIN 7/AGMA 10	20°

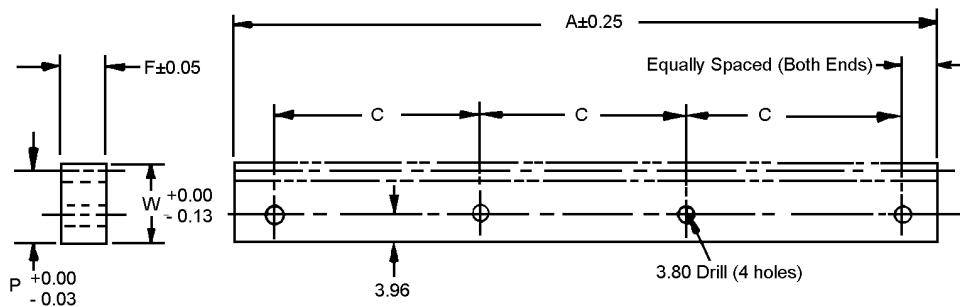

STOCK NO.	A	P (Ref.)	W	F	C
R4M-15	248.8	11.4	12.2	5.8	80.0

Available on request: special, modified and custom racks.

Quality Class AGMA12/DIN 5 available on request.

GEAR RACKS

MODULE	STYLE	MATERIAL	QUALITY	PRESSURE ANGLE
0.8	RECTANGULAR	STAINLESS STEEL DIN 1.4005	DIN 7/AGMA 10	20°

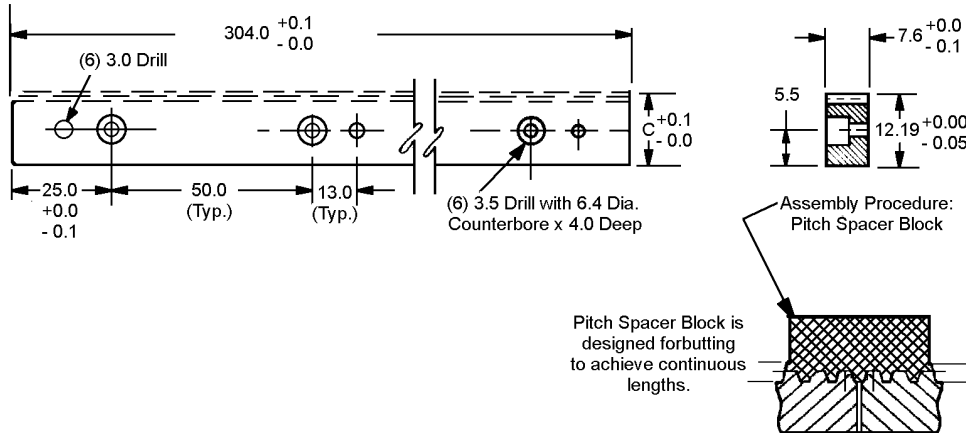

RACKS STOCK NO.	SPACER BLOCKS STOCK NO.	MODULE	LINEAR PITCH	C
R8M-1-G1	R8M-1-SB	0.8	2.51	11.39

Available on request: special, modified and custom racks.

Quality Class AGMA12/DIN 5 available on request.

Adjacent hole center ± 0.06
Accumulative hole centers ± 0.14

MODULE	STYLE	MATERIAL	QUALITY	PRESSURE ANGLE
0.8	RECTANGULAR	STAINLESS STEEL DIN 1.4005	DIN 7/AGMA 10	20°

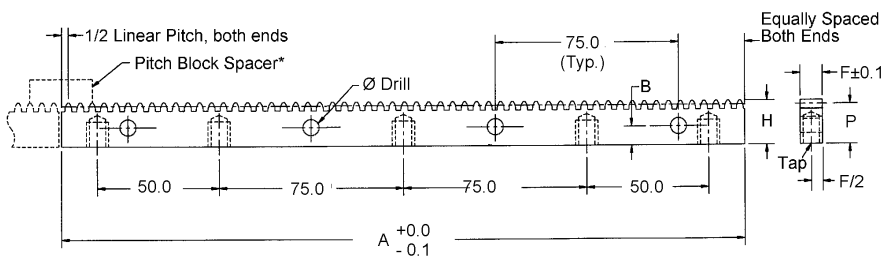

Spacer block is designed for butting to achieve continuous lengths.

RACKS STOCK NO.	SPACER BLOCK STOCK NO.	LINEAR PITCH	A	P (REF.)	H +0.00 -0.13	F	B	Ø DRILL	TAP
R1M-4	R1M-4-SB	2.51	281.5	11.26	12.07	5.8	5.5	3.8	M4.0 X 0.7

Quality Class AGMA 12/Din 5 available on request. Custom racks available on request.

ANTI-BACKLASH GEARS

MODULE	STYLE	BORE	FACE	MATERIAL	QUALITY	PRESSURE ANGLE
0.8	PIN HUB	8	5	STAINLESS STEEL DIN 1.4305 OR ALUMINUM DIN 3.1355 ANODIZED	DIN 7/AGMA 10	20°

B

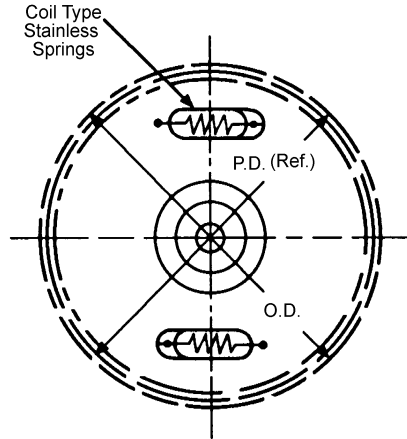
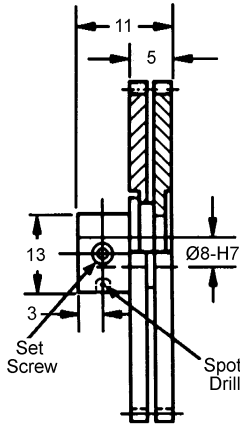

STAINLESS STEEL DIN 1.4305 STOCK NO.	ALUMINUM DIN 3.1355 STOCK NO.	NO. OF TEETH	PITCH DIA.	OUTSIDE DIA.
APDMM-40-X	APDQM-40-X	40	32.00	33.6
APDMM-45-X	APDOM-45-X	45	36.00	37.6
APDMM-48-X	APDQM-48-X	48	38.40	40.0
APDMM-50-X	APDQM-50-X	50	40.00	41.6
APDMM-55-X	APDQM-55-X	55	44.00	45.6
APDMM-56-X	APDQM-56-X	56	44.80	46.4
APDMM-60-X	APDQM-60-X	60	48.00	49.6
APDMM-64-X	APDQM-64-X	64	51.20	52.8
APDMM-65-X	APDQM-65-X	65	52.00	53.6
APDMM-70-X	APDQM-70-X	70	56.00	57.6
APDMM-72-X	APDQM-72-X	72	57.60	59.2
APDMM-75-X	APDQM-75-X	75	60.00	61.6
APDMM-80-X	APDQM-80-X	80	64.00	65.6
APDMM-85-X	APDQM-85-X	85	66.00	69.6

Available on request:
 Other numbers of teeth;
 Quality Class AGMA12 & 14 / DIN 5 & 3;
 14-1/2° Pressure Angle

Hub Material: Stainless Steel DIN 1.4305

For Couplings See Section MG.
For Shafts, Bearings and Collars See Section MI.

ANTI-BACKLASH GEARS

MODULE	STYLE	BORE	FACE	MATERIAL	QUALITY	PRESSURE ANGLE
0.8	PIN HUB	8	6	STAINLESS STEEL DIN 1.4305 OR ALUMINUM DIN 3.1355 ANODIZED	DIN 7/AGMA 10	20°

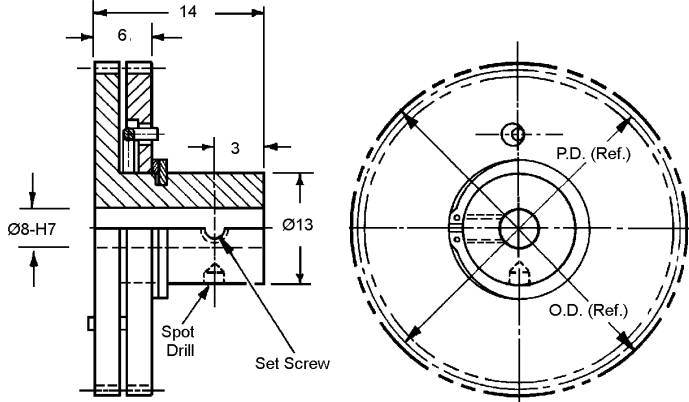

STAINLESS STEEL DIN 1.4305 STOCK NO.	ALUMINUM DIN 3.1355 STOCK NO.	NO. OF TEETH	PITCH DIA.	OUTSIDE DIA.
APDBSM-24-X	APDDSM-24-X	24	19.20	20.80
APDBSM-28-X	APDDSM-28-X	28	22.40	24.00
APDBSM-32-X	APDDSM-32-X	32	25.60	27.20

Available on request:
Other numbers of teeth;
Other Quality Classes;
14-1/2° Pressure Angle

Hub Material: Stainless Steel DIN 1.4305

MODULE	STYLE	BORE	FACE	MATERIAL	QUALITY	PRESSURE ANGLE
0.8	CLAMP HUB	8	6	STAINLESS STEEL DIN 1.4305 OR ALUMINUM DIN 3.1355 ANODIZED	DIN 7/AGMA 10	20°

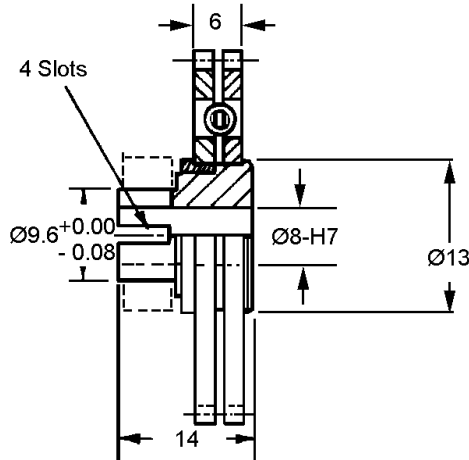

STAINLESS STEEL DIN 1.4305 STOCK NO.	ALUMINUM DIN 3.1355 STOCK NO.	NO. OF TEETH	PITCH DIA.	OUTSIDE DIA.
ACDBSM-24-X	ACDDSM-24-X	24	19.20	20.80
ACDBSM-28-X	ACDDSM-28-X	28	22.40	24.00
ACDBSM-32-X	ACDDSM-32-X	32	25.60	27.20

Available on request:
Other numbers of teeth;
Other Quality Classes;
14-1/2° Pressure Angle

Hub Material: Stainless Steel DIN 1.4305

ANTI-BACKLASH GEARS

MODULE	STYLE	BORE	FACE	MATERIAL	QUALITY	PRESSURE ANGLE
0.8	CLAMP HUB	8	5	STAINLESS STEEL DIN 1.4305 OR ALUMINUM DIN 3.1355 ANODIZED	DIN 7/AGMA 10	20°

B

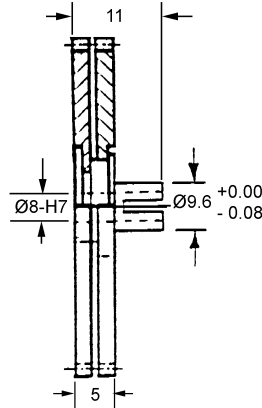

STAINLESS STEEL DIN 1.4305 STOCK NO.	ALUMINUM DIN 3.1355 STOCK NO.	NO. OF TEETH	PITCH DIA.	OUTSIDE DIA.
ACDMM-40-X	ACDQM-40-X	40	32.00	33.6
ACDMM-45-X	ACDOM-45-X	45	36.00	37.6
ACDMM-48-X	ACDQM-48-X	48	38.40	40.0
ACDMM-50-X	ACDQM-50-X	50	40.00	41.6
ACDMM-55-X	ACDQM-55-X	55	44.00	45.6
ACDMM-56-X	ACDQM-56-X	56	44.80	46.4
ACDMM-60-X	ACDQM-60-X	60	48.00	49.6
ACDMM-64-X	ACDQM-64-X	64	51.20	52.8
ACDMM-65-X	ACDQM-65-X	65	52.00	53.6
ACDMM-70-X	ACDQM-70-X	70	56.00	57.6
ACDMM-72-X	ACDQM-72-X	72	57.60	59.2
ACDMM-75-X	ACDQM-75-X	75	60.00	61.6
ACDMM-80-X	ACDQM-80-X	80	64.00	65.6
ACDMM-85-X	ACDQM-85-X	85	66.00	69.6

Available on request:
Other numbers of teeth;
Other Quality Classes;
14-1/2° Pressure Angle

Hub Material: Stainless Steel DIN 1.4305

For Couplings See Section MG.
For Shafts, Bearings and Collars See Section MI.

SPUR GEAR STOCK

MODULE	STYLE	MATERIAL	PRESSURE ANGLE
0.8	PINION WIRE	BRASS ALLOY	20°

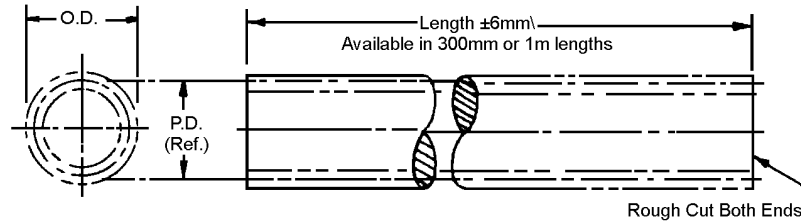

1 METER. LONG STOCK NO.	300mm LONG STOCK NO.	NO. OF TEETH	PITCH DIA.	OUTSIDE DIA.
PWPDB-6	PWPDB-6A	6	4.80	6.40
PWPDB-8	PWPDB-8A	8	6.40	8.00
PWPDB-12	PWPDB-12A	12	9.60	11.20
PWPDB-16	PWPDB-16A	16	12.80	14.40

Available on request:
Other numbers of teeth;
14-1/2° Pressure Angle

Hub Material: Stainless Steel DIN 1.4305

SPUR GEARS

MODULE	STYLE	BORE	FACE	MATERIAL	QUALITY	PRESSURE ANGLE
0.6	PIN HUB	5	5	STAINLESS STEEL DIN 1.4305 OR ALUMINUM DIN 3.1355 ANODIZED	DIN 7/AGMA 10	20°

B

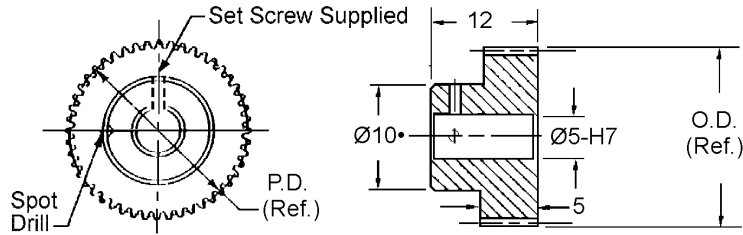

STAINLESS STEEL STOCK NO.	ALUMINUM STOCK NO.	NO. OF TEETH	PITCH DIA.	OUTSIDE DIA.
PES83-18	PEA83-18	18*	10.80	12.00
PES83-20	PEA83-20	20	12.00	13.20
PES83-22	PEA83-22	22	13.20	14.40
PES83-24	PEA83-24	24	14.40	15.60
PES83-25	PEA83-25	25	15.00	16.20
PES83-26	PEA83-26	26	15.60	16.80
PES83-28	PEA83-28	28	16.80	18.00
PES83-30	PEA83-30	30	18.00	19.20
PES83-32	PEA83-32	32	19.20	20.40
PES83-36	PEA83-36	36	21.60	22.80
PES83-40	PEA83-40	40	24.00	25.20
PES83-42	PEA83-42	42	25.20	26.40
PES83-45	PEA83-45	45	27.00	28.20
PES83-48	PEA83-48	48	28.80	30.00
PES83-50	PEA83-50	50	30.00	31.20
PES83-54	PEA83-54	54	32.40	33.60
PES83-56	PEA83-56	56	33.60	34.80
PES83-60	PEA83-60	60	36.00	37.20
PES83-64	PEA83-64	64	38.40	39.60
PES83-70	PEA83-70	70	42.00	43.20
PES83-72	PEA83-72	72	43.20	44.40
PES83-75	PEA83-75	75	45.00	46.20
PES83-76	PEA83-76	76	45.60	46.80
PES83-80	PEA83-80	80	48.00	49.20
PES83-88	PEA83-88	88	52.80	54.00
PES83-90	PEA83-90	90	54.00	55.20
PES83-96	PEA83-96	96	57.60	58.80
PES83-100	PEA83-100	100	60.00	61.20
PES83-110	PEA83-110	110	66.00	67.20
PES83-120	PEA83-120	120	72.00	73.20
PES83-124	PEA83-124	124	74.40	75.60
PES83-128	PEA83-128	128	76.80	78.00

Available on request:
Other numbers of teeth;
14 - 1/2° pressure angle;
Quality Class AGMA 12 and 14 / DIN 5 and 3

* For 17 - 18 teeth hub diameter equals 8.0

For Couplings See Section MG.
For Shafts, Bearings and Collars See Section MI.

SPUR GEARS

MODULE	STYLE	BORE	FACE	MATERIAL	QUALITY	PRESSURE ANGLE
0.6	CLAMP HUB	5	3	STAINLESS STEEL DIN 1.4305 OR ALUMINUM DIN 3.1355 ANODIZED	DIN 7/AGMA 10	20°

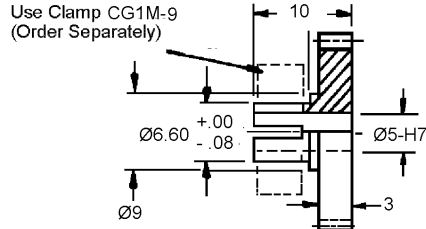
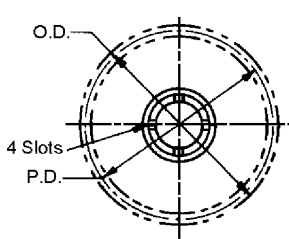

STAINLESS STEEL STOCK NO.	ALUMINUM STOCK NO.	NO. OF TEETH	PITCH DIA.	OUTSIDE DIA.
CEA52-20	CEA52-20	20	12.00	13.20
CEA52-24	CEA52-24	24	14.40	15.60
CEA52-28	CEA52-28	28	16.80	18.00
CEA52-30	CEA52-30	30	18.00	19.20
CEA52-32	CEA52-32	32	19.20	20.40
CEA52-40	CEA52-40	40	24.00	25.20
CEA52-46	CEA52-46	46	27.60	28.80
CEA52-48	CEA52-48	48	28.80	30.00
CEA52-56	CEA52-56	56	33.60	34.80
CEA52-60	CEA52-60	60	36.00	37.20
CEA52-66	CEA52-66	66	39.60	40.80
CEA52-70	CEA52-70	70	42.00	43.20
CEA52-72	CEA52-72	72	43.20	44.40
CEA52-84	CEA52-84	84	50.40	51.60
CEA52-90	CEA52-90	90	54.00	55.20
CEA52-96	CEA52-96	96	57.60	58.80
CEA52-100	CEA52-100	100	60.00	61.20
CEA52-102	CEA52-102	102	61.20	62.40
CEA52-105	CEA52-105	105	63.00	64.20
CEA52-108	CEA52-108	108	64.80	66.00
CEA52-110	CEA52-110	110	66.00	67.20
CEA52-114	CEA52-114	114	68.40	69.60
CEA52-120	CEA52-120	120	72.00	73.20
CEA52-126	CEA52-126	126	75.60	76.80
CEA52-132	CEA52-132	132	79.20	80.40
CEA52-138	CEA52-138	138	82.80	84.00
CEA52-140	CEA52-140	140	84.00	85.20
CEA52-144	CEA52-144	144	86.40	87.60
CEA52-150	CEA52-150	150	90.00	91.20
CEA52-156	CEA52-156	156	93.60	94.80
CEA52-160	CEA52-160	160	96.00	97.20
CEA52-168	CEA52-168	168	100.80	102.00
CEA52-170	CEA52-170	170	102.00	103.20

Available on request:
 Other bore sizes;
 numbers of teeth;
 14-12° Pressure Angle;
 Quality Class DIN 5/AGMA12

For Couplings See Section MG.
For Shafts, Bearings and Collars See Section MI.

SPUR GEARS

MODULE	STYLE	BORE	FACE	MATERIAL	QUALITY	PRESSURE ANGLE
0.6	CLAMP HUB	8	3	STAINLESS STEEL DIN 1.4305	DIN 7/AGMA 10	20°

B

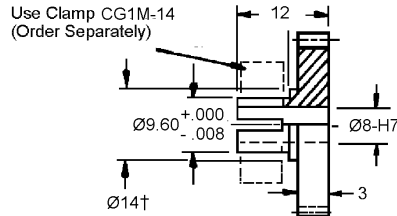
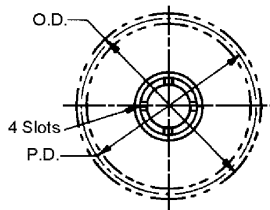

Available on request:
Other numbers of teeth;
14-12° Pressure Angle;
Quality Class DIN 5/AGMA12

†Teeth may runout on flange diameter.

STAINLESS STEEL STOCK NO.	NO. OF TEETH	PITCH DIA.	OUTSIDE DIA.
CES64-23	23†	13.80	15.00
CES64-24	24†	14.00	15.60
CES64-25	25†	15.00	16.20
CES64-28	28	16.80	18.00
CES64-30	30	18.00	19.20
CES64-32	32	19.20	20.40
CES64-36	36	21.60	22.80
CES64-40	40	24.00	25.20
CES64-42	42	25.20	26.40
CES64-45	45	27.00	28.20
CES64-48	48	28.80	30.00
CES64-50	50	30.00	31.20
CES64-54	54	32.40	33.60
CES64-60	60	36.00	37.20
CES64-70	70	42.00	42.20
CES64-72	72	43.20	44.40
CES64-75	75	45.00	46.20
CES64-78	78	46.80	48.00
CES64-80	80	48.00	49.20
CES64-84	84	50.40	51.60
CES64-88	88	52.80	54.00
CES64-90	90	54.00	55.20
CES64-96	96	57.60	58.80
CES64-100	100	60.00	61.20
CES64-108	108	64.80	66.00
CES64-112	112	67.20	68.40
CES64-120	120	72.00	73.20
CES64-128	128	76.80	78.00
CES64-132	132	79.20	80.40
CES64-144	144	86.40	87.60
CES64-150	150	90.00	91.20
CES64-162	162	97.20	98.40
CES64-168	168	100.80	102.00

For Couplings See Section MG.
For Shafts, Bearings and Collars See Section MI.

SPUR GEARS

MODULE	STYLE	BORE	FACE	MATERIAL	QUALITY	PRESSURE ANGLE
0.6	CLAMP HUB	8	5	STAINLESS STEEL DIN 1.4305 OR ALUMINUM DIN 3.1355 ANODIZED	DIN 7/AGMA 10	20°

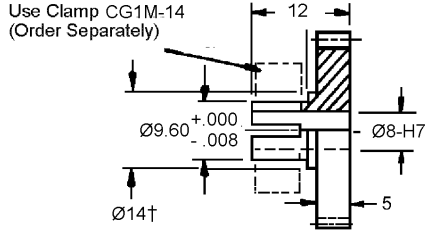
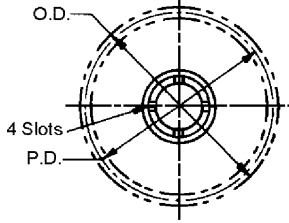

Available on request:
 Other bore sizes;
 numbers of teeth;
 14-12° Pressure Angle;
 Quality Class DIN 5/AGMA12

†Teeth may runout on flange diameter.

STAINLESS STEEL STOCK NO.	ALUMINUM STOCK NO.	NO. OF TEETH	PITCH DIA.	OUTSIDE DIA.
CES65-20	CEA65-20	20†	12.00	13.20
CES65-21	CEA65-21	21†	12.60	13.80
CES65-22	CEA65-22	22†	13.20	14.40
CES65-23	CEA65-23	23†	13.80	15.00
CES65-24	CEA65-24	24†	14.40	15.60
CES65-25	CEA65-25	25†	15.00	16.80
CES65-26	CEA65-26	26	15.60	17.40
CES65-27	CEA65-27	27	16.20	18.00
CES65-28	CEA65-28	28	16.80	18.60
CES65-29	CEA65-29	29	17.40	19.20
CES65-30	CEA65-30	30	18.00	20.40
CES65-32	CEA65-32	32	19.20	21.60
CES65-34	CEA65-34	34	20.40	22.50
CES65-35	CEA65-35	35	21.00	22.20
CES65-36	CEA65-36	36	21.60	22.80
CES65-38	CEA65-38	38	22.80	24.00
CES65-40	CEA65-40	40	24.00	25.20
CES65-42	CEA65-42	42	25.20	26.40
CES65-44	CEA65-44	44	26.40	27.40
CES65-45	CEA65-45	45	27.00	28.20
CES65-46	CEA65-46	46	27.60	28.80
CES65-47	CEA65-47	47	28.20	29.40
CES65-48	CEA65-48	48	28.80	30.00
CES65-50	CEA65-50	50	30.00	31.20
CES65-54	CEA65-54	54	32.40	33.60
CES65-55	CEA65-55	55	33.00	34.20
CES65-56	CEA65-56	56	33.60	34.80
CES65-60	CEA65-60	60	36.00	37.20
CES65-64	CEA65-64	64	38.40	39.60
CES65-66	CEA65-66	66	39.60	40.80
CES65-68	CEA65-68	68	40.80	42.00
CES65-70	CEA65-70	70	42.00	43.20
CES65-72	CEA65-72	72	43.20	44.40
CES65-75	CEA65-75	75	45.00	46.20
CES65-78	CEA65-78	78	46.80	48.00
CES65-80	CEA65-80	80	48.00	49.20
CES65-81	CEA65-81	81	48.60	49.80
CES65-84	CEA65-84	84	50.40	51.60
CES65-85	CEA65-85	85	51.00	52.20
CES65-88	CEA65-88	88	52.80	54.00
CES65-90	CEA65-90	90	54.00	55.20
CES65-91	CEA65-91	91	54.60	55.80
CES65-92	CEA65-92	92	55.20	56.40
CES65-93	CEA65-93	93	55.80	57.00
CES65-96	CEA65-96	96	57.60	58.80
CES65-100	CEA65-100	100	60.00	61.20
CES65-102	CEA65-102	102	61.20	62.40
CES65-104	CEA65-104	104	62.40	63.60
CES65-105	CEA65-105	105	63.00	64.20
CES65-108	CEA65-108	108	64.80	66.00
CES65-112	CEA65-112	112	67.20	68.40
CES65-114	CEA65-114	114	68.40	69.60
CES65-120	CEA65-120	120	72.00	73.20
CES65-126	CEA65-126	126	75.60	76.80
CES65-127	CEA65-127	127	76.20	77.40
CES65-128	CEA65-128	128	76.80	78.00
CES65-132	CEA65-132	132	79.20	80.40
CES65-136	CEA65-136	136	81.60	82.80
CES65-138	CEA65-138	138	82.80	84.00
CES65-144	CEA65-144	144	86.40	87.60
CES65-150	CEA65-150	150	90.00	91.20
CES65-152	CEA65-152	152	91.20	92.40
CES65-156	CEA65-156	156	93.60	94.80
CES65-162	CEA65-162	162	97.20	98.40
CES65-168	CEA65-168	168	100.80	102.00
CES65-171	CEA65-171	171	102.60	103.80
CES65-175	CEA65-175	175	105.00	106.20

For Couplings See Section MG.

For Shafts, Bearings and Collars See Section MI.

GEAR RACKS

MODULE	STYLE	MATERIAL	QUALITY	PRESSURE ANGLE
0.6	ROUND & RECTANGULAR	STAINLESS STEEL DIN 1.4005	DIN 7/AGMA 10	20°

B

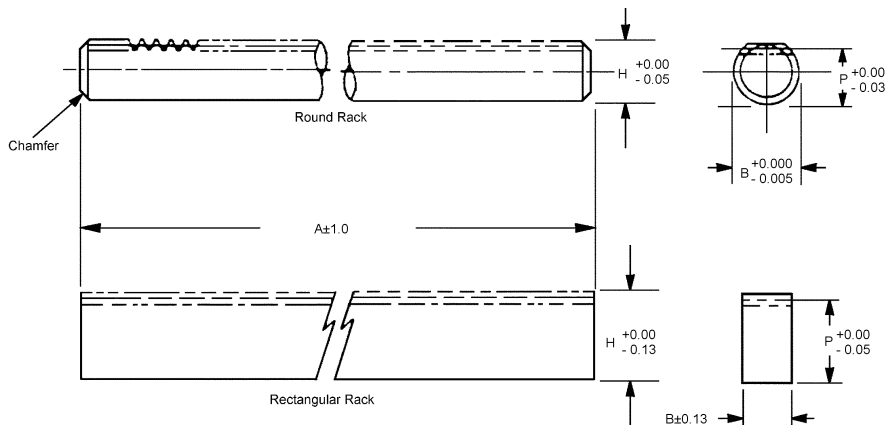

STOCK NO.	RACK STYLE	MOD.	P (Ref.)	B	A	H
R2M-5	ROUND	0.6	4.99	5.974	450	5.59
R3M-5	RECTANGULAR	0.6	11.59	5.84	450	12.19

Available on request: Special, modified and custom racks.

MODULE	STYLE	MATERIAL	QUALITY	PRESSURE ANGLE
0.6	RECTANGULAR	STAINLESS STEEL DIN 1.4005	DIN 7/AGMA 10	20°

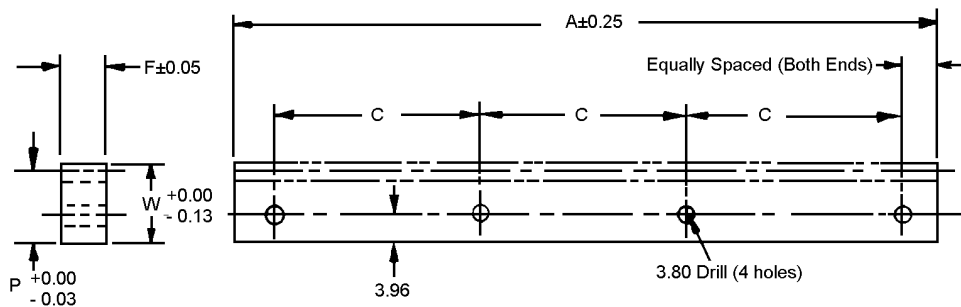

STOCK NO.	A	P (Ref.)	W	F	C
R4M-17	244.3	11.6	12.2	5.8	70.0

Available on request: special, modified and custom racks.

Quality Class AGMA12/DIN 5 available on request.

GEAR RACKS

MODULE	STYLE	MATERIAL	QUALITY	PRESSURE ANGLE
0.6	RECTANGULAR	STAINLESS STEEL DIN 1.4005	DIN 7/AGMA 10	20°

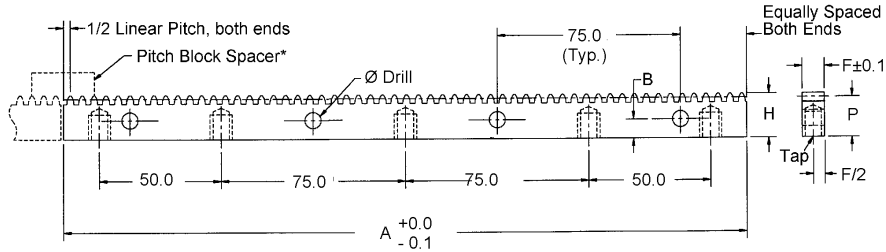

Spacer block is designed for butting to achieve continuous lengths.

RACKS	SPACER BLOCK								
STOCK NO.	STOCK NO.	LINEAR PITCH	A	P (REF.)	H +0.00 -0.13	F	B	Ø DRILL	TAP
R1M-5	R1M-5-SB	1.88	280.9	11.47	12.07	5.8	5.5	3.8	M4.0 X 0.7

Quality Class AGMA 12/Din 5 available on request. Custom racks available on request.

ANTI-BACKLASH GEARS

MODULE	STYLE	BORE	FACE	MATERIAL	QUALITY	PRESSURE ANGLE
0.6	PIN HUB	5	3	STAINLESS STEEL DIN 1.4305 OR ALUMINUM DIN 3.1355 ANODIZED	DIN 7/AGMA 10	20°

B

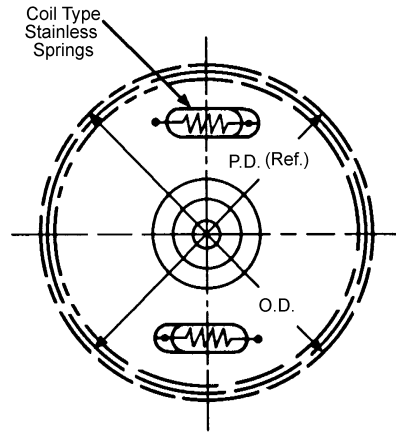
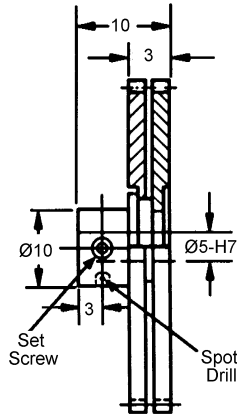

STAINLESS STEEL DIN 1.4305 STOCK NO.	ALUMINUM DIN 3.1355 STOCK NO.	NO. OF TEETH	PITCH DIA.	OUTSIDE DIA.
APEUM-65	APEVM-65	65	39.00	40.2
APEUM-70	APEVM-70	70	42.00	43.2
APEUM-72	APEVM-72	72	43.20	44.4
APEUM-75	APEVM-75	75	45.00	46.2
APEUM-80	APEVM-80	80	48.00	49.2
APEUM-84	APEVM-84	84	50.40	51.6
APEUM-85	APEVM-85	85	51.00	52.2
APEUM-90	APEVM-90	90	54.00	55.2
APEUM-95	APEVM-95	95	57.00	58.2
APEUM-96	APEVM-96	96	57.60	58.8
APEUM-100	APEVM-100	100	60.00	61.2
APEUM-105	APEVM-105	105	63.00	64.2
APEUM-110	APEVM-110	110	66.00	67.2
APEUM-115	APEVM-115	115	69.00	70.2
APEUM-120	APEVM-120	120	72.00	73.2
APEUM-125	APEVM-125	125	75.00	76.2
APEUM-130	APEVM-130	130	78.00	79.2
APEUM-132	APEVM-132	132	79.20	80.4
APEUM-140	APEVM-140	140	84.00	85.2
APEUM-144	APEVM-144	144	88.40	87.6
APEUM-150	APEVM-150	150	90.00	91.2

Available on request:
Other numbers of teeth;
Quality Class AGMA12 & 14 / DIN 5 & 3;
14-1/2° Pressure Angle

Hub Material: Stainless Steel DIN 1.4305

For Couplings See Section MG.
For Shafts, Bearings and Collars See Section MI.

ANTI-BACKLASH GEARS

MODULE	STYLE	BORE	FACE	MATERIAL	QUALITY	PRESSURE ANGLE
0.6	PIN HUB	8	3	STAINLESS STEEL DIN 1.4305 OR ALUMINUM DIN 3.1355 ANODIZED	DIN 7/AGMA 10	20°

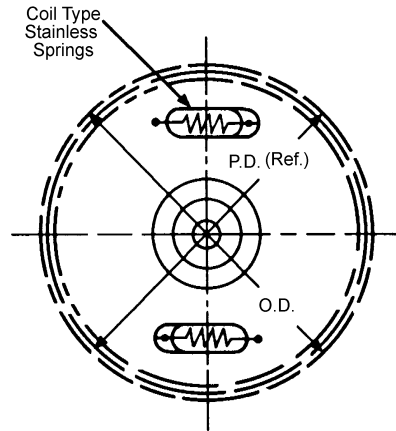
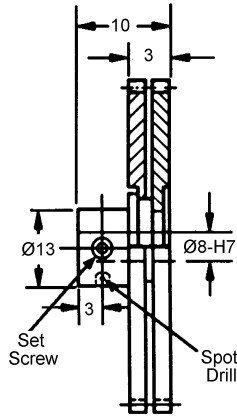

STAINLESS STEEL DIN 1.4305 STOCK NO.	ALUMINUM DIN 3.1355 STOCK NO.	NO. OF TEETH	PITCH DIA.	OUTSIDE DIA.
APEWM-65-X	APEXM-65-X	65	39.00	40.2
APEWM-70-X	APEXM-70-X	70	42.00	43.2
APEWM-72-X	APEXM-72-X	72	43.20	44.4
APEWM-75-X	APEXM-75-X	75	45.00	46.2
APEWM-80-X	APEXM-80-X	80	48.00	49.2
APEWM-84-X	APEXM-84-X	84	50.40	51.6
APEWM-85-X	APEXM-85-X	85	51.00	52.2
APEWM-90-X	APEXM-90-X	90	54.00	55.2
APEWM-95-X	APEXM-95-X	95	57.00	58.2
APEWM-96-X	APEXM-96-X	96	57.60	58.8
APEWM-100-X	APEXM-100-X	100	60.00	61.2
APEWM-105-X	APEXM-105-X	105	63.00	64.2
APEWM-110-X	APEXM-110-X	110	66.00	67.2
APEWM-115-X	APEXM-115-X	115	69.00	70.2
APEWM-120-X	APEXM-120-X	120	72.00	73.2
APEWM-125-X	APEXM-125-X	125	75.00	76.2
APEWM-130-X	APEXM-130-X	130	78.00	79.2
APEWM-132-X	APEXM-132-X	132	79.20	80.4
APEWM-140-X	APEXM-140-X	140	84.00	85.2
APEWM-144-X	APEXM-144-X	144	88.40	87.6
APEWM-150-X	APEXM-150-X	150	90.00	91.2

Available on request:
 Other numbers of teeth;
 Quality Class AGMA12 & 14 / DIN 5 & 3;
 14-1/2° Pressure Angle

Hub Material: Stainless Steel DIN 1.4305

For Couplings See Section MG.
For Shafts, Bearings and Collars See Section MI.

ANTI-BACKLASH GEARS

B

MODULE	STYLE	BORE	FACE	MATERIAL	QUALITY	PRESSURE ANGLE
0.6	PIN HUB	8	6	STAINLESS STEEL DIN 1.4305 OR ALUMINUM DIN 3.1355 ANODIZED	DIN 7/AGMA 10	20°

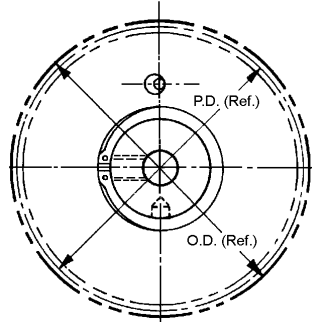
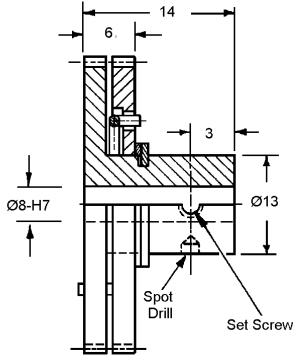

Available on request:
Other numbers of teeth;
Other Quality Classes;
14-1/2° Pressure Angle

Hub Material: Stainless Steel DIN 1.4305

STAINLESS STEEL DIN 1.4305 STOCK NO.	ALUMINUM DIN 3.1355 STOCK NO.	NO. OF TEETH	PITCH DIA.	OUTSIDE DIA.
APEBSM-28-X	APEDSM-28-X	28	16.80	18.00
APEBSM-32-X	APEDSM-32-X	32	19.20	20.40
APEBSM-36-X	APEDSM-36-X	36	21.60	22.80

MODULE	STYLE	BORE	FACE	MATERIAL	QUALITY	PRESSURE ANGLE
0.6	CLAMP HUB	5	3	STAINLESS STEEL DIN 1.4305 OR ALUMINUM DIN 3.1355 ANODIZED	DIN 7/AGMA 10	20°

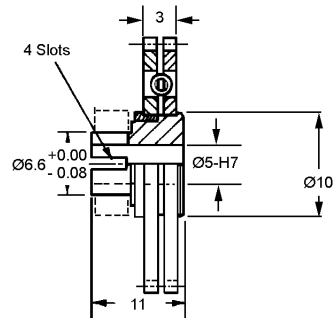

Available on request:
Other numbers of teeth;
Other Quality Classes;
14-1/2° Pressure Angle

Hub Material: Stainless Steel DIN 1.4305

STAINLESS STEEL DIN 1.4305 STOCK NO.	ALUMINUM DIN 3.1355 STOCK NO.	NO. OF TEETH	PITCH DIA.	OUTSIDE DIA.
ACEUM-65	ACEVM-65	65	39.00	40.2
ACEUM-70	ACEVM-70	70	42.00	43.2
ACEUM-72	ACEVM-72	72	43.20	44.4
ACEUM-75	ACEVM-75	75	45.00	46.2
ACEUM-80	ACEVM-80	80	48.00	49.2
ACEUM-84	ACEVM-84	84	50.40	51.6
ACEUM-85	ACEVM-85	85	51.00	52.2
ACEUM-90	ACEVM-90	90	54.00	55.2
ACEUM-95	ACEVM-95	95	57.00	58.2
ACEUM-96	ACEVM-96	96	57.60	58.8
ACEUM-100	ACEVM-100	100	60.00	61.2
ACEUM-105	ACEVM-105	105	63.00	64.2
ACEUM-110	ACEVM-110	110	66.00	67.2
ACEUM-115	ACEVM-115	115	69.00	70.2
ACEUM-120	ACEVM-120	120	72.00	73.2
ACEUM-125	ACEVM-125	125	75.00	76.2
ACEUM-130	ACEVM-130	130	78.00	79.2
ACEUM-132	ACEVM-132	132	79.20	80.4
ACEUM-140	ACEVM-140	140	84.00	85.2
ACEUM-144	ACEVM-144	144	88.40	87.6
ACEUM-150	ACEVM-150	150	90.00	91.2

ANTI-BACKLASH GEARS

MODULE	STYLE	BORE	FACE	MATERIAL	QUALITY	PRESSURE ANGLE
0.6	CLAMP HUB	8	3	STAINLESS STEEL DIN 1.4305 OR ALUMINUM DIN 3.1355 ANODIZED	DIN 7/AGMA 10	20°

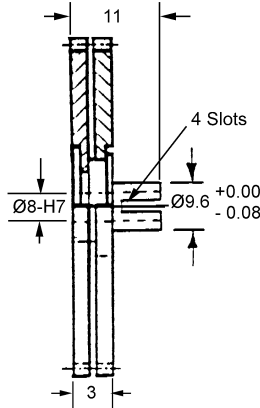

STAINLESS STEEL DIN 1.4305 STOCK NO.	ALUMINUM DIN 3.1355 STOCK NO.	NO. OF TEETH	PITCH DIA.	OUTSIDE DIA.
ACEWM-65-X	ACEXM-65-X	65	39.00	40.2
ACEWM-70-X	ACEXM-70-X	70	42.00	43.2
ACEWM-72-X	ACEXM-72-X	72	43.20	44.4
ACEWM-75-X	ACEXM-75-X	75	45.00	46.2
ACEWM-80-X	ACEXM-80-X	80	48.00	49.2
ACEWM-84-X	ACEXM-84-X	84	50.40	51.6
ACEWM-85-X	ACEXM-85-X	85	51.00	52.2
ACEWM-90-X	ACEXM-90-X	90	54.00	55.2
ACEWM-95-X	ACEXM-95-X	95	57.00	58.2
ACEWM-96-X	ACEXM-96-X	96	57.60	58.8
ACEWM-100-X	ACEXM-100-X	100	60.00	61.2
ACEWM-105-X	ACEXM-105-X	105	63.00	64.2
ACEWM-110-X	ACEXM-110-X	110	66.00	67.2
ACEWM-115-X	ACEXM-115-X	115	69.00	70.2
ACEWM-120-X	ACEXM-120-X	120	72.00	73.2
ACEWM-125-X	ACEXM-125-X	125	75.00	76.2
ACEWM-130-X	ACEXM-130-X	130	78.00	79.2
ACEWM-132-X	ACEXM-132-X	132	79.20	80.4
ACEWM-140-X	ACEXM-140-X	140	84.00	85.2
ACEWM-144-X	ACEXM-144-X	144	88.40	87.6
ACEWM-150-X	ACEXM-150-X	150	90.00	91.2

Available on request:
Other numbers of teeth;
Other Quality Classes;
14-1/2° Pressure Angle

Hub Material: Stainless Steel DIN 1.4305

**For Couplings See Section MG.
For Shafts, Bearings and Collars See Section MI.**

ANTI-BACKLASH GEARS

MODULE	STYLE	BORE	FACE	MATERIAL	QUALITY	PRESSURE ANGLE
0.6	CLAMP HUB	8	6	STAINLESS STEEL DIN 1.4305 OR ALUMINUM DIN 3.1355 ANODIZED	DIN 7/AGMA 10	20°

B

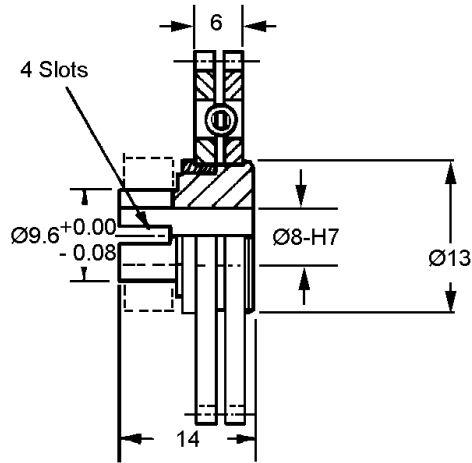

STAINLESS STEEL DIN 1.4305 STOCK NO.	ALUMINUM DIN 3.1355 STOCK NO.	NO. OF TEETH	PITCH DIA.	OUTSIDE DIA.
ACEBSM-28-X	ACEDSM-28-X	28	16.80	18.00
ACEBSM-32-X	ACEDSM-32-X	32	19.20	20.40
ACEBSM-36-X	ACEDSM-36-X	36	21.60	22.80

Available on request:
Other numbers of teeth;
Other Quality Classes;
14-1/2° Pressure Angle

Hub Material: Stainless Steel DIN 1.4305

For Couplings See Section MG.
For Shafts, Bearings and Collars See Section MI.

SPUR GEARS

MODULE	STYLE	BORE	FACE	MATERIAL	QUALITY	PRESSURE ANGLE
0.5	HUBLESS	10	3	STAINLESS STEEL DIN 1.4305 OR ALUMINUM DIN 3.1355 ANODIZED	DIN 7/AGMA 10	20°

B

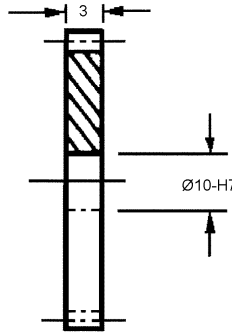
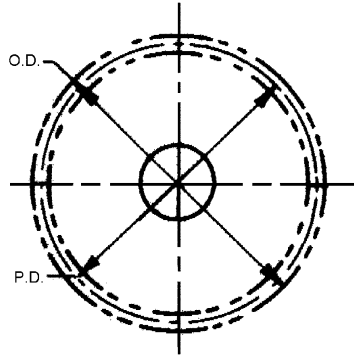

Available on request:
Other numbers of teeth;
Quality Class AGMA 12 & 14 / DIN 5 & 3;
14 - 1/2° pressure angle.



STAINLESS STEEL STOCK NO.	ALUMINUM STOCK NO.	NO. OF TEETH	PITCH DIA.	OUTSIDE DIA.
FFS103-30	FFA103-30	30	15.00	16.00
FFS103-32	FFA103-32	32	16.00	17.00
FFS103-40	FFA103-40	40	20.00	21.00
FFS103-42	FFA103-42	42	21.00	22.00
FFS103-44	FFA103-44	44	22.00	23.00
FFS103-48	FFA103-48	48	24.00	25.00
FFS103-50	FFA103-50	50	25.00	26.00
FFS103-54	FFA103-54	54	27.00	28.00
FFS103-60	FFA103-60	60	30.00	31.00
FFS103-64	FFA103-64	64	32.00	33.00
FFS103-65	FFA103-65	65	32.50	33.50
FFS103-70	FFA103-70	70	35.00	36.00
FFS103-72	FFA103-72	72	36.00	37.00
FFS103-75	FFA103-75	75	37.50	38.50
FFS103-80	FFA103-80	80	40.00	41.00
FFS103-84	FFA103-84	84	42.00	43.00
FFS103-85	FFA103-85	85	42.50	43.50
FFS103-90	FFA103-90	90	45.00	46.00
FFS103-96	FFA103-96	96	48.00	49.00
FFS103-100	FFA103-100	100	50.00	51.00
FFS103-105	FFA103-105	105	52.50	53.50
FFS103-108	FFA103-108	108	54.00	55.00
FFS103-110	FFA103-110	110	55.00	56.00
FFS103-114	FFA103-114	114	57.00	58.00
FFS103-120	FFA103-120	120	60.00	61.00
FFS103-125	FFA103-125	125	62.50	63.50
FFS103-130	FFA103-130	130	65.00	66.00
FFS103-132	FFA103-132	132	66.00	67.00
FFS103-135	FFA103-135	135	67.50	68.50
FFS103-138	FFA103-138	138	69.00	70.00
FFS103-140	FFA103-140	140	70.00	71.00
FFS103-144	FFA103-144	144	72.00	73.00
FFS103-150	FFA103-150	150	75.00	76.00
FFS103-156	FFA103-156	156	78.00	79.00
FFS103-160	FFA103-160	160	80.00	81.00
FFS103-168	FFA103-168	168	84.00	85.00
FFS103-170	FFA103-170	170	85.00	86.00
FFS103-180	FFA103-180	180	90.00	91.00
FFS103-186	FFA103-186	186	93.00	94.00
FFS103-190	FFA103-190	190	95.00	96.00
FFS103-192	FFA103-192	192	96.00	97.00

MODULE	STYLE	BORE	FACE	MATERIAL	QUALITY	PRESSURE ANGLE
0.5	HUBLESS	10	3	POLYURETHANE WITH LUBRICANT	DIN 7/AGMA 10	20°

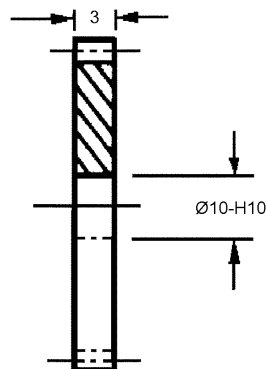
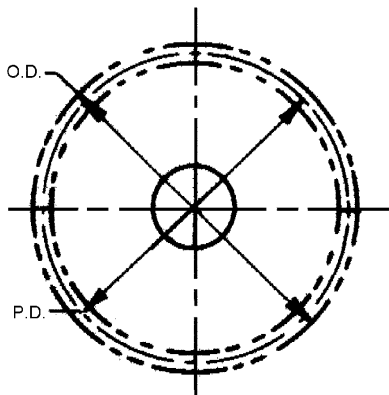

STOCK NO.	NO. OF TEETH	PITCH DIA.	OUTSIDE DIA.
FFU103-48	48	24.00	25.00
FFU103-60	60	30.00	31.00
FFU103-72	72	36.00	37.00
FFU103-84	84	42.00	43.00
FFU103-96	96	48.00	49.00
FFU103-108	108	54.00	55.00

Available on request:
Other numbers of teeth;
Quality Class AGMA 12 & 14 / DIN 5 & 3;
14 - 1/2° pressure angle.

SPUR GEARS

MODULE	STYLE	BORE	FACE	MATERIAL	QUALITY	PRESSURE ANGLE
0.5	HUBLESS	10	5	DELTRIN	DIN 8/AGMA 9	20°

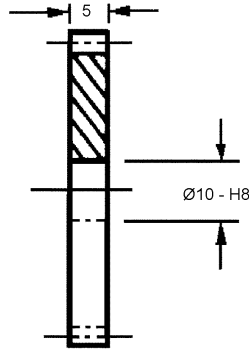
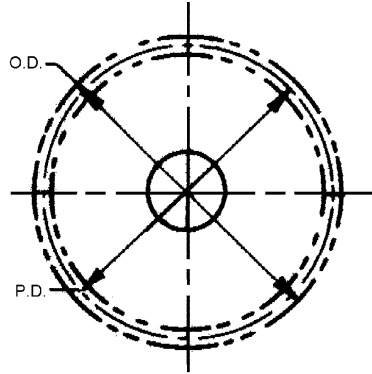

Available on request:
Other numbers of teeth;
14 - 1/2° pressure angle.

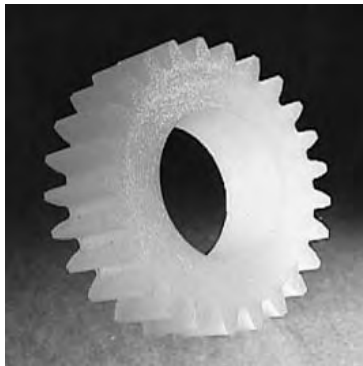

STOCK NO.	NO. OF TEETH	PITCH DIA.	OUTSIDE DIA.
FFD105-28	28	14.00	15.00
FFD105-29	29	14.50	15.50
FFD105-30	30	15.00	16.00
FFD105-32	32	16.00	17.00
FFD105-34	34	17.00	18.00
FFD105-36	36	18.00	19.00
FFD105-38	38	19.00	20.00
FFD105-40	40	20.00	21.00
FFD105-42	42	21.00	22.00
FFD105-44	44	22.00	23.00
FFD105-46	46	23.00	24.00
FFD105-48	48	24.00	25.00
FFD105-50	50	25.00	26.00
FFD105-55	55	27.50	28.50
FFD105-56	56	28.00	29.00
FFD105-60	60	30.00	31.00
FFD105-64	64	32.00	33.00
FFD105-68	68	34.00	35.00
FFD105-72	72	36.00	37.00
FFD105-75	75	37.50	38.50
FFD105-80	80	40.00	41.00
FFD105-84	84	42.00	43.00
FFD105-90	90	45.00	46.00
FFD105-92	92	46.00	47.00
FFD105-96	96	48.00	49.00
FFD105-100	100	50.00	51.00
FFD105-110	110	55.00	56.00
FFD105-120	120	60.00	61.00
FFD105-132	132	66.00	67.00
FFD105-138	138	69.00	70.00
FFD105-144	144	72.00	73.00
FFD105-156	156	78.00	79.00
FFD105-168	168	84.00	85.00
FFD105-180	180	90.00	91.00
FFD105-186	186	93.00	94.00

MODULE	STYLE	BORE	FACE	MATERIAL	QUALITY	PRESSURE ANGLE
0.5	HUBLESS	10	6	POLYMRETHANE	DIN 7/AGMA 10	20°

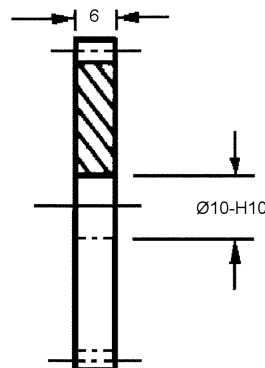
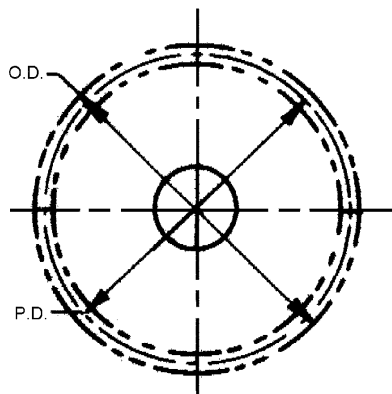

STOCK NO.	NO. OF TEETH	PITCH DIA.	OUTSIDE DIA.
FFU103-120	120	60.00	61.00
FFU103-144	144	72.00	73.00
FFU103-168	168	84.00	85.00
FFU103-192	192	96.00	97.00

Available on request:
Other numbers of teeth;
Quality Class AGMA 12 & 14 / DIN 5 & 3;
14 - 1/2° pressure angle.

SPUR GEARS

MODULE	STYLE	BORE	FACE	MATERIAL	QUALITY	PRESSURE ANGLE
0.5	PIN HUB	3	3	STAINLESS STEEL DIN 1.4305 OR ALUMINUM DIN 3.1355 ANODIZED	DIN 7/AGMA 10	20°

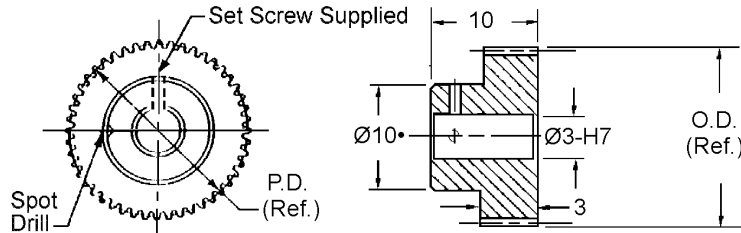

STAINLESS STEEL STOCK NO.	ALUMINUM STOCK NO.	NO. OF TEETH	PITCH DIA.	OUTSIDE DIA.
PFS80-18	PFA80-18	18•	9.00	10.00
PFS80-19	PFA80-19	19•	9.50	10.50
PFS80-20	PFA80-20	20•	10.00	11.00
PFS80-21	PFA80-21	21•	10.50	11.50
PFS80-22	PFA80-22	22•	11.00	12.00
PFS80-24	PFA80-24	24	12.00	13.00
PFS80-25	PFA80-25	25	12.50	13.50
PFS80-26	PFA80-26	26	13.00	14.00
PFS80-27	PFA80-27	27	13.50	14.50
PFS80-28	PFA80-28	28	14.00	15.00
PFS80-30	PFA80-30	30	15.00	16.00
PFS80-32	PFA80-32	32	16.00	17.00
PFS80-34	PFA80-34	34	17.00	18.00
PFS80-36	PFA80-36	36	18.00	19.00
PFS80-40	PFA80-40	40	20.00	21.00
PFS80-42	PFA80-42	42	21.00	22.00
PFS80-46	PFA80-46	46	23.00	24.00
PFS80-48	PFA80-48	48	24.00	25.00
PFS80-50	PFA80-50	50	25.00	26.00
PFS80-55	PFA80-55	55	27.50	28.50
PFS80-56	PFA80-56	56	28.00	29.00
PFS80-60	PFA80-60	60	30.00	31.00
PFS80-64	PFA80-64	64	32.00	33.00
PFS80-65	PFA80-65	65	32.50	33.50
PFS80-70	PFA80-70	70	35.00	36.00
PFS80-72	PFA80-72	72	36.00	37.00
PFS80-75	PFA80-75	75	37.50	38.50
PFS80-80	PFA80-80	80	40.00	41.00
PFS80-84	PFA80-84	84	42.00	43.00
PFS80-85	PFA80-85	85	42.50	43.50
PFS80-90	PFA80-90	90	45.00	46.00
PFS80-96	PFA80-96	96	48.00	49.00
PFS80-100	PFA80-100	100	50.00	51.00
PFS80-102	PFA80-102	102	51.00	52.00
PFS80-105	PFA80-105	105	52.50	53.50
PFS80-110	PFA80-110	110	55.00	56.00
PFS80-120	PFA80-120	120	60.00	61.00

Available on request:
Other numbers of teeth;
14 - 1/2° pressure angle;
Quality Class AGMA 12 and 14 / DIN 5 and 3

• For 14-22 teeth hub diameter equals 5.6

**For Couplings See Section MG.
For Shafts, Bearings and Collars See Section MI.**

SPUR GEARS

MODULE	STYLE	BORE	FACE	MATERIAL	QUALITY	PRESSURE ANGLE
0.5	PIN HUB	5	3	STAINLESS STEEL DIN 1.4305 OR ALUMINUM DIN 3.1355 ANODIZED	DIN 7/AGMA 10	20°

B

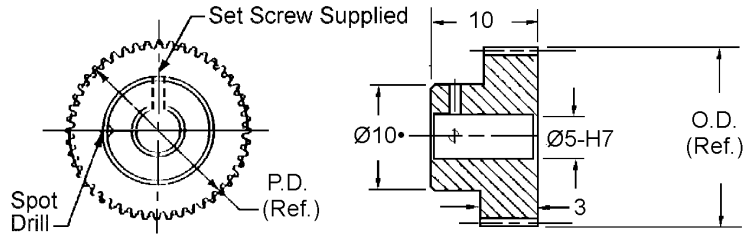

STAINLESS STEEL STOCK NO.	ALUMINUM STOCK NO.	NO. OF TEETH	PITCH DIA.	OUTSIDE DIA.
PFS82-20	PFA82-20	20•	10.00	11.00
PFS82-21	PFA82-21	21•	10.50	11.50
PFS82-22	PFA82-22	22•	11.00	12.00
PFS82-23	PFA82-23	23	11.50	12.50
PFS82-24	PFA82-24	24	12.00	13.00
PFS82-25	PFA82-25	25	12.50	13.50
PFS82-28	PFA82-28	28	14.00	15.00
PFS82-30	PFA82-30	30	15.00	16.00
PFS82-32	PFA82-32	32	16.00	17.00
PFS82-34	PFA82-34	34	17.00	18.00
PFS82-36	PFA82-36	36	18.00	19.00
PFS82-40	PFA82-40	40	20.00	21.00
PFS82-42	PFA82-42	42	21.00	22.00
PFS82-46	PFA82-46	46	23.00	24.00
PFS82-48	PFA82-48	48	24.00	25.00
PFS82-50	PFA82-50	50	25.00	26.00
PFS82-60	PFA82-60	60	30.00	31.00
PFS82-64	PFA82-64	64	32.00	33.00
PFS82-70	PFA82-70	70	35.00	36.00
PFS82-72	PFA82-72	72	36.00	37.00
PFS82-80	PFA82-80	80	40.00	41.00
PFS82-84	PFA82-84	84	42.00	43.00
PFS82-90	PFA82-90	90	45.00	46.00
PFS82-96	PFA82-96	96	48.00	49.00
PFS82-105	PFA82-105	105	52.50	53.50
PFS82-120	PFA82-120	120	60.00	61.00
PFS82-132	PFA82-132	132	66.00	67.00
PFS82-144	PFA82-144	144	72.00	73.00
PFS82-156	PFA82-156	156	78.00	79.00
PFS82-168	PFA82-168	168	84.00	85.00
PFS82-190	PFA82-190	190	95.00	96.00
PFS82-192	PFA82-192	192	96.00	97.00

Available on request:
Other numbers of teeth;
14 - 1/2° pressure angle;
Quality Class AGMA 12 and 14 / DIN 5 and 3

• For 20-22 teeth hub diameter equals 8.1

For Couplings See Section MG.
For Shafts, Bearings and Collars See Section MI.

SPUR GEARS

MODULE	STYLE	BORE	FACE	MATERIAL	QUALITY	PRESSURE ANGLE
0.5	PIN HUB	8	3	STAINLESS STEEL DIN 1.4305 OR ALUMINUM DIN 3.1355 (ANODIZED)	DIN 7/AGMA 10	20°

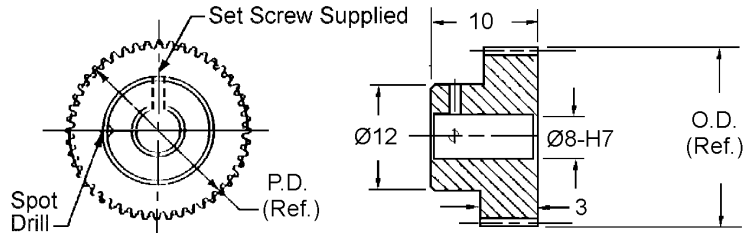

STAINLESS STEEL STOCK NO.	ALUMINUM STOCK NO.	NO. OF TEETH	PITCH DIA.	OUTSIDE DIA.
PFS94-28	PFA94-28	28	14.00	15.00
PFS94-30	PFA94-30	30	15.00	16.00
PFS94-32	PFA94-32	32	16.00	17.00
PFS94-35	PFA94-35	35	17.50	18.50
PFS94-36	PFA94-36	36	18.00	19.00
PFS94-40	PFA94-40	40	20.00	21.00
PFS94-42	PFA94-42	42	21.00	22.00
PFS94-44	PFA94-44	44	22.00	23.00
PFS94-45	PFA94-45	45	22.50	23.50
PFS94-46	PFA94-46	46	23.00	24.00
PFS94-48	PFA94-48	48	24.00	25.00
PFS94-50	PFA94-50	50	25.00	26.00
PFS94-54	PFA94-54	54	27.00	28.00
PFS94-55	PFA94-55	55	27.50	28.50
PFS94-56	PFA94-56	56	28.00	29.00
PFS94-60	PFA94-60	60	30.00	31.00
PFS94-64	PFA94-64	64	32.00	33.00
PFS94-65	PFA94-65	65	32.50	33.50
PFS94-70	PFA94-70	70	35.00	36.00
PFS94-72	PFA94-72	72	36.00	37.00
PFS94-75	PFA94-75	75	37.50	38.50
PFS94-78	PFA94-78	78	39.00	40.00
PFS94-80	PFA94-80	80	40.00	41.00
PFS94-84	PFA94-84	84	42.00	43.00
PFS94-85	PFA94-85	85	42.50	43.50
PFS94-90	PFA94-90	90	45.00	46.00
PFS94-96	PFA94-96	96	48.00	49.00
PFS94-100	PFA94-100	100	50.00	51.00
PFS94-105	PFA94-105	105	52.50	53.50
PFS94-108	PFA94-108	108	54.00	55.00
PFS94-110	PFA94-110	110	55.00	56.00
PFS94-120	PFA94-120	120	60.00	61.00
PFS94-126	PFA94-126	126	63.00	64.00
PFS94-132	PFA94-132	132	66.00	67.00
PFS94-140	PFA94-140	140	70.00	71.00
PFS94-144	PFA94-144	144	72.00	73.00
PFS94-145	PFA94-145	145	72.50	73.50
PFS94-150	PFA94-150	150	75.00	76.00
PFS94-156	PFA94-156	156	78.00	79.00
PFS94-160	PFA94-160	160	80.00	81.00
PFS94-168	PFA94-168	168	84.00	85.00
PFS94-180	PFA94-180	180	90.00	91.00
PFS94-192	PFA94-192	192	96.00	97.00

Available on request:
Other numbers of teeth;
14 - 1/2° pressure angle;
Quality Class AGMA 12 and 14 / DIN 5 and 3

For Couplings See Section MG.
For Shafts, Bearings and Collars See Section MI.

SPUR GEARS

MODULE	STYLE	BORE	FACE	MATERIAL	QUALITY	PRESSURE ANGLE
0.5	PIN HUB	8	5	STAINLESS STEEL DIN 1.4305 OR ALUMINUM DIN 3.1355 ANODIZED	DIN 7/AGMA 10	20°

B

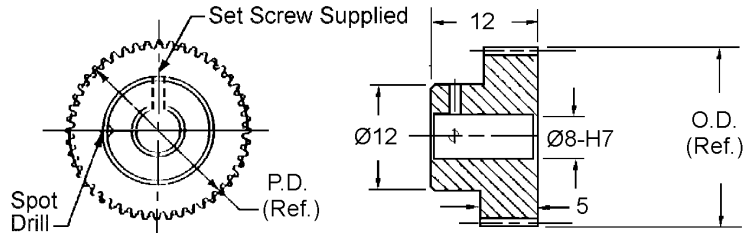

STAINLESS STEEL STOCK NO.	ALUMINUM STOCK NO.	NO. OF TEETH	PITCH DIA.	OUTSIDE DIA.
PFS95-27	PFA95-27	27	13.50	14.50
PFS95-28	PFA95-28	28	14.00	15.00
PFS95-29	PFA95-29	29	14.50	15.50
PFS95-30	PFA95-30	30	15.00	16.00
PFS95-32	PFA95-32	32	16.00	17.00
PFS95-34	PFA95-34	34	17.00	18.00
PFS95-36	PFA95-36	36	18.00	19.00
PFS95-40	PFA95-40	40	20.00	21.00
PFS95-42	PFA95-42	42	21.00	22.00
PFS95-45	PFA95-45	45	22.50	23.50
PFS95-48	PFA95-48	48	24.00	25.00
PFS95-50	PFA95-50	50	25.00	26.00
PFS95-55	PFA95-55	55	27.50	28.50
PFS95-56	PFA95-56	56	28.00	29.00
PFS95-60	PFA95-60	60	30.00	31.00
PFS95-64	PFA95-64	64	32.00	33.00
PFS95-65	PFA95-65	65	32.50	33.50
PFS95-70	PFA95-70	70	35.00	36.00
PFS95-72	PFA95-72	72	36.00	37.00
PFS95-75	PFA95-75	75	37.50	38.50
PFS95-80	PFA95-80	80	40.00	41.00
PFS95-84	PFA95-84	84	42.00	43.00
PFS95-85	PFA95-85	85	42.50	43.50
PFS95-90	PFA95-90	90	45.00	46.00
PFS95-95	PFA95-95	95	47.50	48.50
PFS95-96	PFA95-96	96	48.00	49.00
PFS95-100	PFA95-100	100	50.00	51.00
PFS95-105	PFA95-105	105	52.50	53.50
PFS95-108	PFA95-108	108	54.00	55.00
PFS95-110	PFA95-110	110	55.00	56.00
PFS95-120	PFA95-120	120	60.00	61.00
PFS95-128	PFA95-128	128	64.00	65.00
PFS95-168	PFA95-168	168	84.00	85.00
PFS95-192	PFA95-192	192	96.00	97.00
PFS95-198	PFA95-198	198	99.00	100.00

Available on request:
Other numbers of teeth;
14 - 1/2° pressure angle;
Quality Class AGMA 12 and 14 / DIN 5 and 3

For Couplings See Section MG.
For Shafts, Bearings and Collars See Section MI.

SPUR GEARS

MODULE	STYLE	BORE	FACE	MATERIAL	QUALITY	PRESSURE ANGLE
0.5	PIN HUB	5	5	DELRIN	DIN 8/AGMA 9	20°

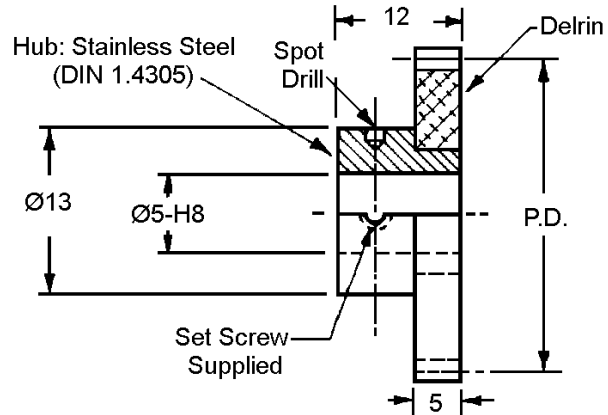

STOCK NO.	NO. OF TEETH	PITCH DIA.	OUTSIDE DIA.
PFD121X-28	28	14.00	15.00
PFD121X-29	29	14.50	15.50
PFD121X-30	30	15.00	16.00
PFD121X-32	32	16.00	17.00
PFD121X-34	34	17.00	18.00
PFD121X-36	36	18.00	19.00
PFD121X-38	38	19.00	20.00
PFD121X-40	40	20.00	21.00
PFD121X-42	42	21.00	22.00
PFD121X-44	44	22.00	23.00
PFD121X-46	46	23.00	24.00
PFD121X-48	48	24.00	25.00
PFD121X-50	50	25.00	26.00
PFD121X-55	55	27.50	28.50
PFD121X-56	56	28.00	29.00
PFD121X-60	60	30.00	31.00
PFD121X-64	64	32.00	33.00
PFD121X-68	68	34.00	35.00
PFD121X-72	72	36.00	37.00
PFD121X-75	75	37.50	38.50
PFD121X-80	80	40.00	41.00
PFD121X-84	84	42.00	43.00
PFD121X-90	90	45.00	46.00
PFD121X-92	92	46.00	47.00
PFD121X-96	96	48.00	49.00
PFD121X-100	100	50.00	51.00
PFD121X-110	110	55.00	56.00
PFD121X-120	120	60.00	61.00
PFD121X-132	132	66.00	67.00
PFD121X-138	138	69.00	70.00
PFD121X-144	144	72.00	73.00
PFD121X-156	156	78.00	79.00
PFD121X-168	168	84.00	85.00
PFD121X-180	180	90.00	91.00
PFD121X-186	186	93.00	94.00

Available on request:
Other numbers of teeth;
14 - 1/2° pressure angle

For Couplings See Section MG.
For Shafts, Bearings and Collars See Section MI.

SPUR GEARS

MODULE	STYLE	BORE	FACE	MATERIAL	QUALITY	PRESSURE ANGLE
0.5	PIN HUB	6	6	MOLDED DELRIN	DIN 12/AGMA 5	20°

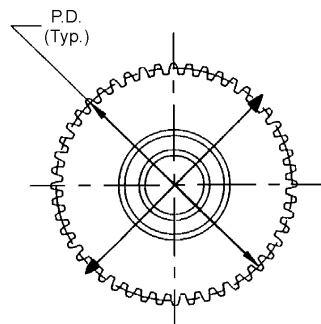
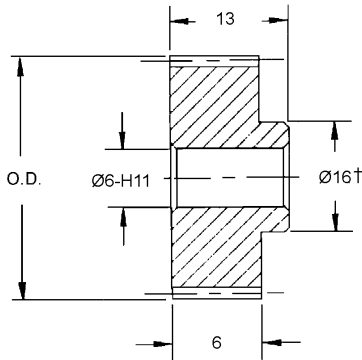

STOCK NO.	NO. OF TEETH	PITCH DIA.	OUTSIDE DIA.
PFD106M-28	28†	14.00	15.00
PFD106M-30	30†	15.00	16.00
PFD106M-36	36	18.00	19.00
PFD106M-40	40	20.00	21.00
PFD106M-42	42	21.00	22.00
PFD106M-48	48	24.00	25.00
PFD106M-50	50	25.00	26.00
PFD106M-60	60	30.00	31.00
PFD106M-70	70	35.00	36.00
PFD106M-72	72	36.00	37.00
PFD106M-80	80	40.00	41.00
PFD106M-84	84	42.00	43.00
PFD106M-90	90	45.00	46.00
PFD106M-96	96	48.00	49.00
PFD106M-100	100	50.00	51.00
PFD106M-108	108	54.00	55.00
PFD106M-120	120	60.00	61.00

Available on request:
Other bore sizes, numbers of teeth;
14-12° Pressure Angle

† Teeth runout on hub.

MODULE	STYLE	BORE	FACE	MATERIAL	QUALITY	PRESSURE ANGLE
0.5	PIN HUB	6	6	CAST POLYURETHANE GRAPHITE IMPREGNATED 70D DURO	DIN 9/AGMA 8	20°

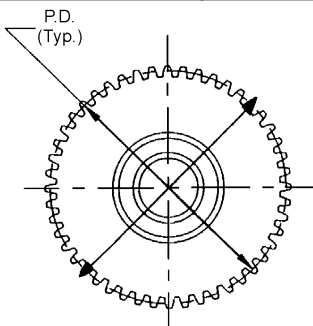
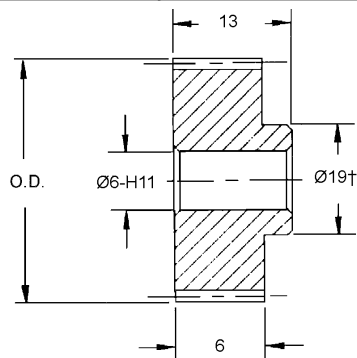

STOCK NO.	NO. OF TEETH	PITCH DIA.	OUTSIDE DIA.
PFU166-24	24†	12.00	13.00
PFU166-28	28†	14.00	15.00
PFU166-30	30†	15.00	16.00
PFU166-36	36	18.00	19.00
PFU166-42	42	21.00	22.00
PFU166-48	48	24.00	25.00
PFU166-60	60	30.00	31.00
PFU166-72	72	36.00	37.00
PFU166-84	84	42.00	43.00
PFU166-96	96	48.00	49.00

Available on request:
Other bore sizes, numbers of teeth;
14-12° Pressure Angle

† Teeth runout on hub.

SPUR GEARS

MODULE	STYLE	BORE	FACE	MATERIAL	QUALITY	PRESSURE ANGLE
0.5	PIN HUB	8	5	DELRIN	DIN 8/AGMA 9	20°

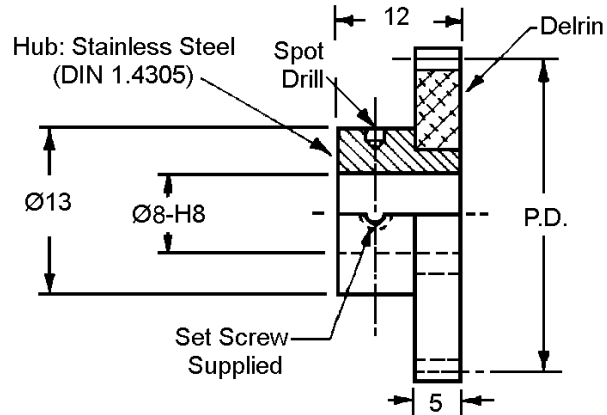

STOCK NO.	NO. OF TEETH	PITCH DIA.	OUTSIDE DIA.
PFD138X-28	28	14.00	15.00
PFD138X-29	29	14.50	15.50
PFD138X-30	30	15.00	16.00
PFD138X-32	32	16.00	17.00
PFD138X-34	34	17.00	18.00
PFD138X-36	36	18.00	19.00
PFD138X-38	38	19.00	20.00
PFD138X-40	40	20.00	21.00
PFD138X-42	42	21.00	22.00
PFD138X-44	44	22.00	23.00
PFD138X-46	46	23.00	24.00
PFD138X-48	48	24.00	25.00
PFD138X-50	50	25.00	26.00
PFD138X-55	55	27.50	28.50
PFD138X-56	56	28.00	29.00
PFD138X-60	60	30.00	31.00
PFD138X-64	64	32.00	33.00
PFD138X-68	68	34.00	35.00
PFD138X-72	72	36.00	37.00
PFD138X-75	75	37.50	38.50
PFD138X-80	80	40.00	41.00
PFD138X-84	84	42.00	43.00
PFD138X-90	90	45.00	46.00
PFD138X-92	92	46.00	47.00
PFD138X-96	96	48.00	49.00
PFD138X-100	100	50.00	51.00
PFD138X-110	110	55.00	56.00
PFD138X-120	120	60.00	61.00
PFD138X-132	132	66.00	67.00
PFD138X-138	138	69.00	70.00
PFD138X-144	144	72.00	73.00
PFD138X-156	156	78.00	79.00
PFD138X-168	168	84.00	85.00
PFD138X-180	180	90.00	91.00
PFD138X-186	186	93.00	94.00

Available on request:
Other numbers of teeth;
14 - 1/2° pressure angle

For Couplings See Section MG.
For Shafts, Bearings and Collars See Section MI.

SPUR GEARS

MODULE	STYLE	BORE	FACE	MATERIAL	QUALITY	PRESSURE ANGLE
0.5	PIN HUB	10	6	CAST POLYURETHANE GRAPHITE IMPREGNATED 70D DURO	DIN 9/AGMA 8	20°

B

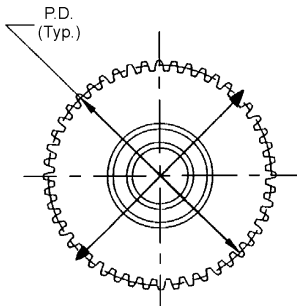
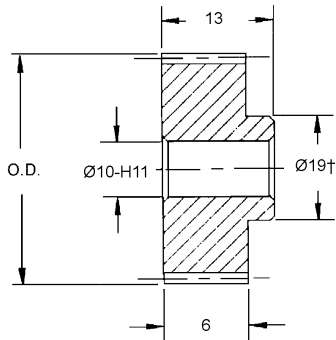

STOCK NO.	NO. OF TEETH	PITCH DIA.	OUTSIDE DIA.
PFU167-24	24†	12.00	13.00
PFU167-28	28†	14.00	15.00
PFU167-30	30†	15.00	16.00
PFU167-36	36	18.00	19.00
PFU167-42	42	21.00	22.00
PFU167-48	48	24.00	25.00
PFU167-60	60	30.00	31.00
PFU167-72	72	36.00	37.00
PFU167-84	84	42.00	43.00
PFU167-96	96	48.00	49.00

Available on request:
Other bore sizes, numbers of teeth;
14-12° Pressure Angle

† Teeth runout on hub.

For Couplings See Section MG.
For Shafts, Bearings and Collars See Section MI.

GEAR RACKS

MODULE	STYLE	MATERIAL	QUALITY	PRESSURE ANGLE
0.5	ROUND & RECTANGULAR	STAINLESS STEEL DIN 1.4005	DIN 7/AGMA 10	20°

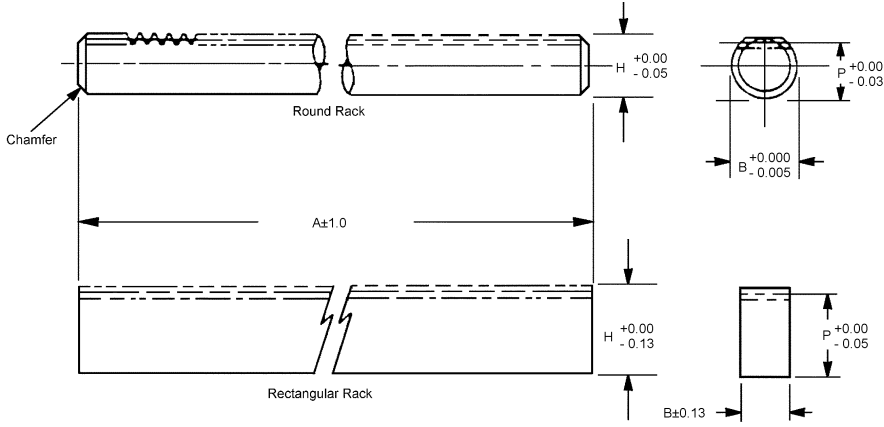

STOCK NO.	RACK STYLE	MOD.	P (Ref.)	B	A	H
R2M-6	ROUND	0.5	5.09	5.974	450	5.59
R3M-6	RECTANGULAR	0.5	11.69	5.84	450	12.19

Available on request: Special, modified and custom racks.

MODULE	STYLE	MATERIAL	QUALITY	PRESSURE ANGLE
0.5	RECTANGULAR	STAINLESS STEEL DIN 1.4005	DIN 7/AGMA 10	20°

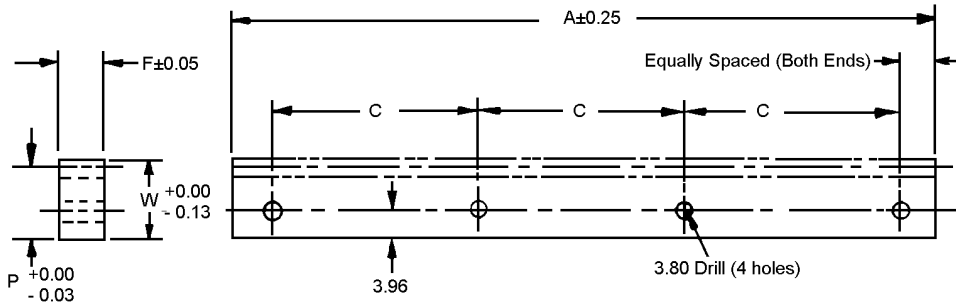

STOCK NO.	A	P (Ref.)	W	F	C
R4M-19	244.7	11.7	12.2	5.8	70.0

Available on request: special, modified and custom racks.

Quality Class AGMA12/DIN 5 available on request.

GEAR RACKS

MODULE	STYLE	MATERIAL	QUALITY	PRESSURE ANGLE
0.5	RECTANGULAR	STAINLESS STEEL DIN 1.4005	DIN 7/AGMA 10	20°

B

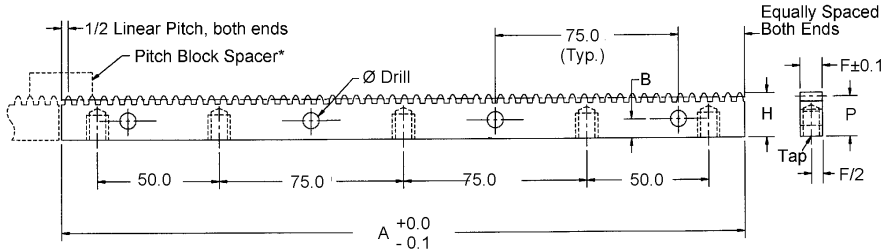

Spacer block is designed for butting to achieve continuous lengths.

RACKS	SPACER BLOCK								
STOCK NO.	STOCK NO.	LINEAR PITCH	A	P (REF.)	H +0.00 -0.13	F	B	Ø DRILL	TAP
R1M-6	R1M-6-SB	1.57	279.6	11.56	12.07	5.8	5.5	3.8	M4.0 X 0.7

Quality Class AGMA 12/Din 5 available on request. Custom racks available on request.

ANTI-BACKLASH GEARS

MODULE	STYLE	BORE	FACE	MATERIAL	QUALITY	PRESSURE ANGLE
0.5	PIN HUB	5	3	STAINLESS STEEL DIN 1.4305 OR ALUMINUM DIN 3.1355 ANODIZED	DIN 7/AGMA 10	20°

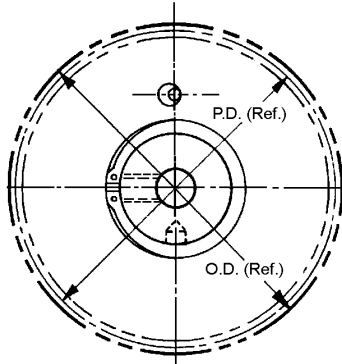
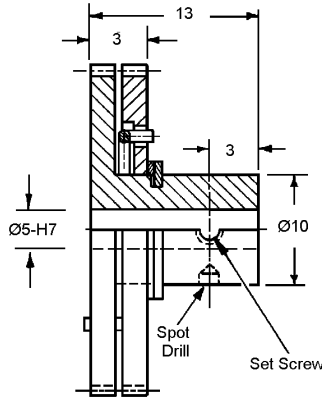

Available on request:
 Other numbers of teeth;
 Other Quality Classes;
 14-1/2° Pressure Angle

Hub Material: Stainless Steel DIN 1.4305

STAINLESS STEEL DIN 1.4305 STOCK NO.	ALUMINUM DIN 3.1355 STOCK NO.	NO. OF TEETH	PITCH DIA.	OUTSIDE DIA.
APFHSM-30	APFJSM-30	30	15.00	16.00
APFHSM-32	APFJSM-32	32	16.00	17.00
APFHSM-36	APFJSM-36	36	18.00	19.00
APFHSM-48	APFJSM-48	48	24.00	25.00

For Couplings See Section MG.
For Shafts, Bearings and Collars See Section MI.

ANTI-BACKLASH GEARS

MODULE	STYLE	BORE	FACE	MATERIAL	QUALITY	PRESSURE ANGLE
0.5	PIN HUB	5	3	STAINLESS STEEL DIN 1.4305 OR ALUMINUM DIN 3.1355 ANODIZED	DIN 7/AGMA 10	20°

B

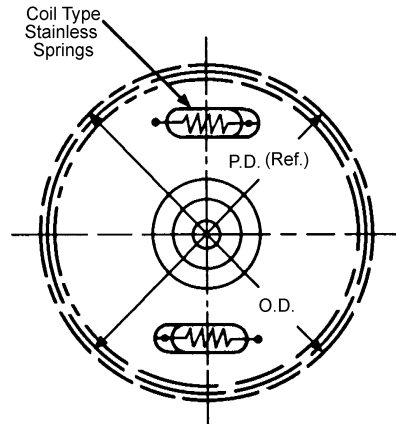
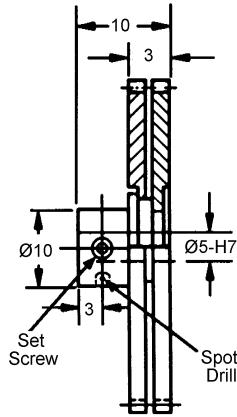

STAINLESS STEEL DIN 1.4305 STOCK NO.	ALUMINUM DIN 3.1355 STOCK NO.	NO. OF TEETH	PITCH DIA.	OUTSIDE DIA.
APFUM-65	APFVM-65	65	32.50	33.50
APFUM-70	APFVM-70	70	35.00	36.00
APFUM-72	APFVM-72	72	36.00	37.00
APFUM-75	APFVM-75	75	37.50	38.50
APFUM-80	APFVM-80	80	40.00	41.00
APFUM-84	APFVM-84	84	42.00	43.00
APFUM-85	APFVM-85	85	42.50	43.50
APFUM-90	APFVM-90	90	45.00	46.00
APFUM-95	APFVM-95	95	47.50	48.50
APFUM-96	APFVM-96	96	48.00	49.00
APFUM-100	APFVM-100	100	50.00	51.00
APFUM-106	APFVM-105	105	52.50	53.50
APFUM-110	APFVM-110	110	55.00	56.00
APFUM-115	APFVM-115	115	57.50	58.50
APFUM-120	APFVM-120	120	60.00	61.00
APFUM-125	APFVM-125	125	62.50	63.50
APFUM-130	APFVM-130	130	65.00	66.00
APFUM-132	APFVM-132	132	66.00	67.00
APFUM-140	APFVM-140	140	70.00	71.00
APFUM-144	APFVM-144	144	72.00	73.00
APFUM-150	APFVM-150	150	75.00	76.00

Available on request:
 Other numbers of teeth;
 Quality Class AGMA12 & 14 / DIN 5 & 3;
 14-1/2° Pressure Angle

Hub Material: Stainless Steel DIN 1.4305

**For Couplings See Section MG.
 For Shafts, Bearings and Collars See Section MI.**

ANTI-BACKLASH GEARS

MODULE	STYLE	BORE	FACE	MATERIAL	QUALITY	PRESSURE ANGLE
0.5	PIN HUB	8	3	STAINLESS STEEL DIN 1.4305 OR ALUMINUM DIN 3.1355 ANODIZED	DIN 7/AGMA 10	20°

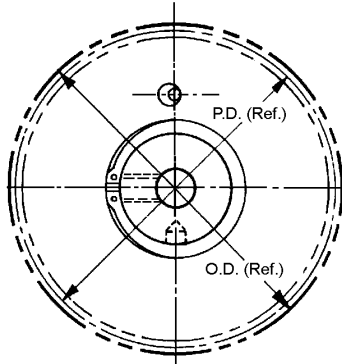
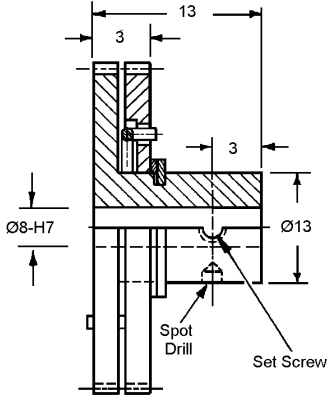

Available on request:
Other numbers of teeth;
Other Quality Classes;
14-1/2° Pressure Angle

Hub Material: Stainless Steel DIN 1.4305

STAINLESS STEEL DIN 1.4305 STOCK NO.	ALUMINUM DIN 3.1355 STOCK NO.	NO. OF TEETH	PITCH DIA.	OUTSIDE DIA.
APFKSM-32-X	APFLSM-32-X	32	16.00	17.00
APFKSM-36-X	APFLSM-36-X	36	18.00	19.00
APFKSM-48-X	APFLSM-48-X	48	24.00	25.00

MODULE	STYLE	BORE	FACE	MATERIAL	QUALITY	PRESSURE ANGLE
0.5	PIN HUB	8	6	STAINLESS STEEL DIN 1.4305 OR ALUMINUM DIN 3.1355 ANODIZED	DIN 7/AGMA 10	20°

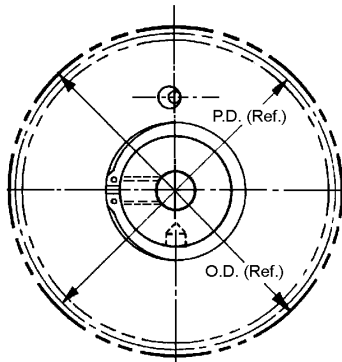
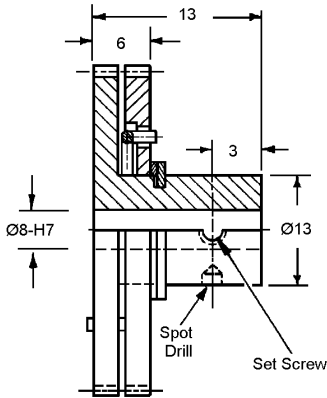

Available on request:
Other numbers of teeth;
Other Quality Classes;
14-1/2° Pressure Angle

Hub Material: Stainless Steel DIN 1.4305

STAINLESS STEEL DIN 1.4305 STOCK NO.	ALUMINUM DIN 3.1355 STOCK NO.	NO. OF TEETH	PITCH DIA.	OUTSIDE DIA.
APFBSM-36-X	APFDMSM-36-X	36	18.00	19.00
APFBSM-42-X	APFDMSM-42-X	42	21.00	22.00
APFBSM-48-X	APFDMSM-48-X	48	24.00	25.00

**For Couplings See Section MG.
For Shafts, Bearings and Collars See Section MI.**

ANTI-BACKLASH GEARS

MODULE	STYLE	BORE	FACE	MATERIAL	QUALITY	PRESSURE ANGLE
0.5	PIN HUB	8	3	STAINLESS STEEL DIN 1.4305 OR ALUMINUM DIN 3.1355 ANODIZED	DIN 7/AGMA 10	20°

B

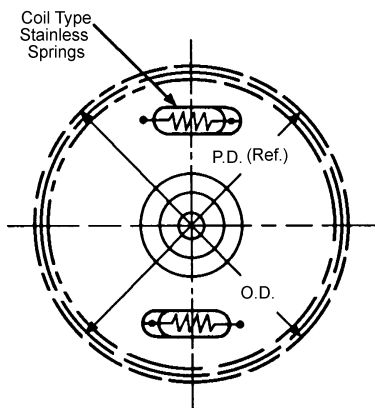
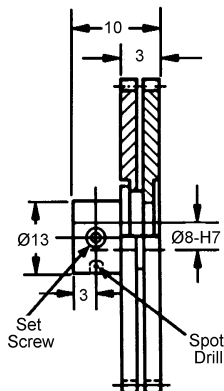

STAINLESS STEEL DIN 1.4305 STOCK NO.	ALUMINUM DIN 3.1355 STOCK NO.	NO. OF TEETH	PITCH DIA.	OUTSIDE DIA.
APFWM-65-X	APFXM-65-X	65	32.50	33.50
APFWM-70-X	APFXM-70-X	70	35.00	36.00
APFWM-72-X	APFXM-72-X	72	36.00	37.00
APFWM-75-X	APFXM-75-X	75	37.50	38.50
APFWM-80-X	APFXM-80-X	80	40.00	41.00
APFWM-84-X	APFXM-84-X	84	42.00	43.00
APFWM-85-X	APFXM-85-X	85	42.50	43.50
APFWM-90-X	APFXM-90-X	90	45.00	46.00
APFWM-95-X	APFXM-95-X	95	47.50	48.50
APFWM-96-X	APFXM-96-X	96	48.00	49.00
APFWM-100-X	APFXM-100-X	100	50.00	51.00
APFWM-105-X	APFXM-105-X	105	52.50	53.50
APFWM-110-X	APFXM-110-X	110	55.00	56.00
APFWM-115-X	APFXM-115-X	115	57.50	58.50
APFWM-120-X	APFXM-120-X	120	60.00	61.00
APFWM-125-X	APFXM-125-X	125	62.50	63.50
APFWM-130-X	APFXM-130-X	130	65.00	66.00
APFWM-132-X	APFXM-132-X	132	66.00	67.00
APFWM-140-X	APFXM-140-X	140	70.00	71.00
APFWM-144-X	APFXM-144-X	144	72.00	73.00
APFWM-150-X	APFXM-150-X	150	75.00	76.00

Available on request:
 Other numbers of teeth;
 Quality Class AGMA12 & 14 / DIN 5 & 3;
 14-1/2° Pressure Angle

Hub Material: Stainless Steel DIN 1.4305

**For Couplings See Section MG.
 For Shafts, Bearings and Collars See Section MI.**

ANTI-BACKLASH GEARS

MODULE	STYLE	BORE	FACE	MATERIAL	QUALITY	PRESSURE ANGLE
0.5	CLAMP HUB	5	3	STAINLESS STEEL DIN 1.4305 OR ALUMINUM DIN 3.1355 ANODIZED	DIN 7/AGMA 10	20°

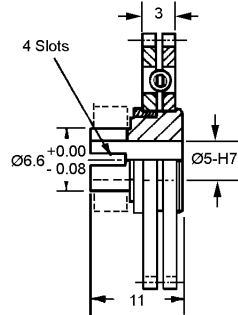

Available on request:
 Other numbers of teeth;
 Other Quality Classes;
 14-1/2° Pressure Angle

Hub Material: Stainless Steel DIN 1.4305

STAINLESS STEEL DIN 1.4305 STOCK NO.	ALUMINUM DIN 3.1355 STOCK NO.	NO. OF TEETH	PITCH DIA.	OUTSIDE DIA.
ACFUM-65	ACFVM-65	65	32.50	33.50
ACFUM-70	ACFVM-70	70	35.00	36.00
ACFUM-72	ACFVM-72	72	36.00	37.00
ACFUM-75	ACFVM-75	75	37.50	38.50
ACFUM-80	ACFVM-80	80	40.00	41.00
ACFUM-84	ACFVM-84	84	42.00	43.00
ACFUM-85	ACFVM-85	85	42.50	43.50
ACFUM-90	ACFVM-90	90	45.00	46.00
ACFUM-95	ACFVM-95	95	47.50	48.50
ACFUM-96	ACFVM-96	96	48.00	49.00
ACFUM-100	ACFVM-100	100	50.00	51.00
ACFUM-105	ACFVM-105	105	52.50	53.50
ACFUM-110	ACFVM-110	110	55.00	56.00
ACFUM-115	ACFVM-115	115	57.50	58.50
ACFUM-120	ACFVM-120	120	60.00	61.00
ACFUM-125	ACFVM-125	125	62.50	63.50
ACFUM-130	ACFVM-130	130	65.00	66.00
ACFUM-132	ACFVM-132	132	66.00	67.00
ACFUM-140	ACFVM-140	140	70.00	71.00
ACFUM-144	ACFVM-144	144	72.00	73.00
ACFUM-150	ACFVM-150	150	75.00	76.00

For Couplings See Section MG.
For Shafts, Bearings and Collars See Section MI.

ANTI-BACKLASH GEARS

B

MODULE	STYLE	BORE	FACE	MATERIAL	QUALITY	PRESSURE ANGLE
0.5	CLAMP HUB	5	3	STAINLESS STEEL DIN 1.4305 OR ALUMINUM DIN 3.1355 ANODIZED	DIN 7/AGMA 10	20°

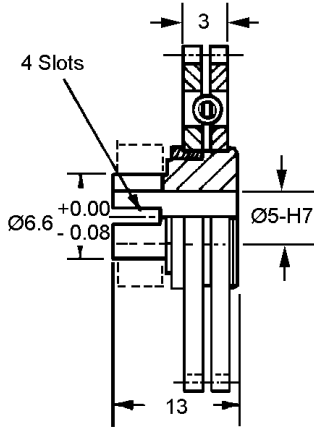

STAINLESS STEEL DIN 1.4305 STOCK NO.	ALUMINUM DIN 3.1355 STOCK NO.	NO. OF TEETH	PITCH DIA.	OUTSIDE DIA.
ACFHSM-30	ACFJSM-30	30	15.00	16.00
ACFHSM-32	ACFJSM-32	32	16.00	17.00
ACFHSM-36	ACFJSM-36	36	18.00	19.00
ACFHSM-48	ACFJSM-48	48	24.00	25.00

Available on request:
Other numbers of teeth;
Other Quality Classes;
14-1/2° Pressure Angle

Hub Material: Stainless Steel DIN 1.4305

MODULE	STYLE	BORE	FACE	MATERIAL	QUALITY	PRESSURE ANGLE
0.5	CLAMP HUB	8	3	STAINLESS STEEL DIN 1.4305 OR ALUMINUM DIN 3.1355 ANODIZED	DIN 7/AGMA 10	20°

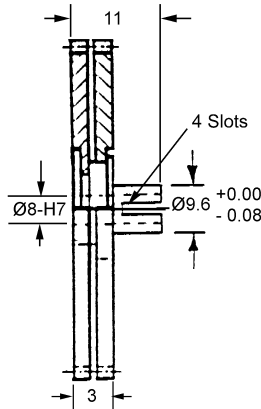

STAINLESS STEEL DIN 1.4305 STOCK NO.	ALUMINUM DIN 3.1355 STOCK NO.	NO. OF TEETH	PITCH DIA.	OUTSIDE DIA.
ACFWM-65-X	ACFXM-65-X	65	32.50	33.50
ACFWM-70-X	ACFXM-70-X	70	35.00	36.00
ACFWM-72-X	ACFXM-72-X	72	36.00	37.00
ACFWM-75-X	ACFXM-75-X	75	37.50	38.50
ACFWM-80-X	ACFXM-80-X	80	40.00	41.00
ACFWM-84-X	ACFXM-84-X	84	42.00	43.00
ACFWM-85-X	ACFXM-85-X	85	42.50	43.50
ACFWM-90-X	ACFXM-90-X	90	45.00	46.00
ACFWM-95-X	ACFXM-95-X	95	47.50	48.50
ACFWM-96-X	ACFXM-96-X	96	48.00	49.00
ACFWM-100-X	ACFXM-100-X	100	50.00	51.00
ACFWM-105-X	ACFXM-105-X	105	52.50	53.50
ACFWM-110-X	ACFXM-110-X	110	55.00	56.00
ACFWM-115-X	ACFXM-115-X	115	57.50	58.50
ACFWM-120-X	ACFXM-120-X	120	60.00	61.00
ACFWM-125-X	ACFXM-125-X	125	62.50	63.50
ACFWM-130-X	ACFXM-130-X	130	65.00	66.00
ACFWM-132-X	ACFXM-132-X	132	66.00	67.00
ACFWM-140-X	ACFXM-140-X	140	70.00	71.00
ACFWM-144-X	ACFXM-144-X	144	72.00	73.00
ACFWM-150-X	ACFXM-150-X	150	75.00	76.00

Available on request:
Other numbers of teeth;
Other Quality Classes;
14-1/2° Pressure Angle

Hub Material: Stainless Steel DIN 1.4305

ANTI-BACKLASH GEARS

MODULE	STYLE	BORE	FACE	MATERIAL	QUALITY	PRESSURE ANGLE
0.5	CLAMP HUB	8	3	STAINLESS STEEL DIN 1.4305 OR ALUMINUM DIN 3.1355 ANODIZED	DIN 7/AGMA 10	20°

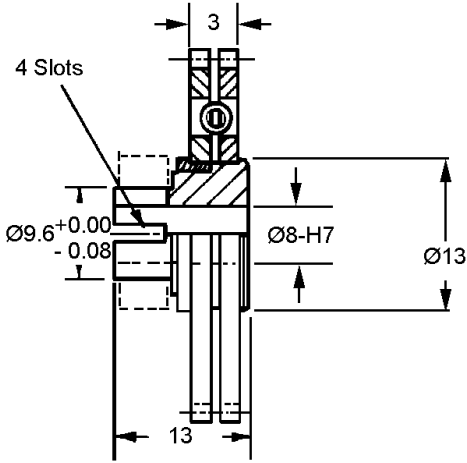

STAINLESS STEEL DIN 1.4305 STOCK NO.	ALUMINUM DIN 3.1355 STOCK NO.	NO. OF TEETH	PITCH DIA.	OUTSIDE DIA.
ACFKSM-32-X	ACFLSM-32-X	32	16.00	17.00
ACFKSM-36-X	ACFLSM-36-X	36	18.00	19.00
ACFKSM-48-X	ACFLSM-48-X	48	24.00	25.00

Available on request:
Other numbers of teeth;
Other Quality Classes;
14-1/2° Pressure Angle

Hub Material: Stainless Steel DIN 1.4305

MODULE	STYLE	BORE	FACE	MATERIAL	QUALITY	PRESSURE ANGLE
0.5	CLAMP HUB	8	6	STAINLESS STEEL DIN 1.4305 OR ALUMINUM DIN 3.1355 ANODIZED	DIN 7/AGMA 10	20°

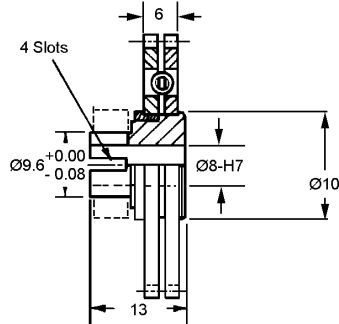

STAINLESS STEEL DIN 1.4305 STOCK NO.	ALUMINUM DIN 3.1355 STOCK NO.	NO. OF TEETH	PITCH DIA.	OUTSIDE DIA.
ACFBSM-36-X	ACFDSM-36-X	36	18.00	19.00
ACFBSM-42-X	ACFDSM-42-X	42	21.00	22.00
ACFBSM-48-X	ACFDSM-48-X	48	24.00	25.00

Available on request:
Other numbers of teeth;
Other Quality Classes;
14-1/2° Pressure Angle

Hub Material: Stainless Steel DIN 1.4305

For Couplings See Section MG.
For Shafts, Bearings and Collars See Section MI.

SPUR GEAR STOCK

MODULE	STYLE	MATERIAL	PRESSURE ANGLE
0.5	PINION WIRE	BRASS ALLOY	20°

B

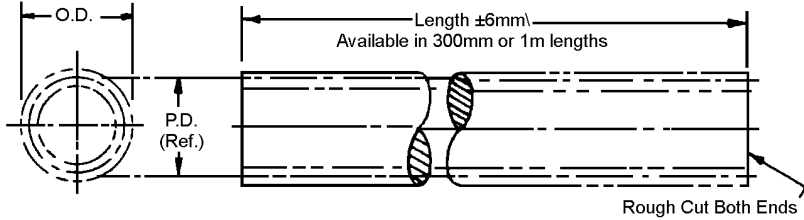

1 METER. LONG STOCK NO.	300mm LONG STOCK NO.	NO. OF TEETH	PITCH DIA.	OUTSIDE DIA.
PWPFB-8	PWPFB-8A	8	4.00	5.00
PWPFB-10	PWPFB-10A	10	5.00	6.00
PWPFB-12	PWPFB-12A	12	6.00	7.00
PWPFB-14	PWPFB-14A	14	7.00	8.00
PWPFB-15	PWPFB-15A	15	7.50	8.50
PWPFB-16	PWPFB-16A	16	8.00	9.00
PWPFB-18	PWPFB-18A	18	9.00	10.00
PWPFB-20	PWPFB-20A	20	10.00	11.00
PWPFB-24	PWPFB-24A	24	12.00	13.00

Available on request:
Other numbers of teeth;
14-1/2° Pressure Angle

Hub Material: Stainless Steel DIN 1.4305

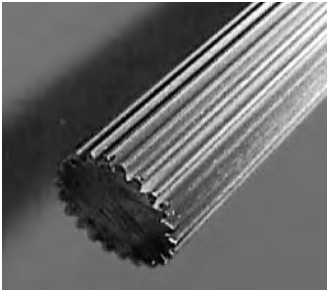

SPUR GEARS

MODULE	STYLE	BORE	FACE	MATERIAL	QUALITY	PRESSURE ANGLE
0.4	HUBLESS	10	3	STAINLESS STEEL DIN 1.4305 OR ALUMINUM DIN 3.1355 ANODIZED	DIN 7/AGMA 10	20°

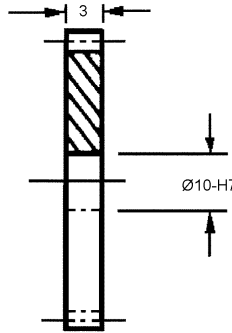
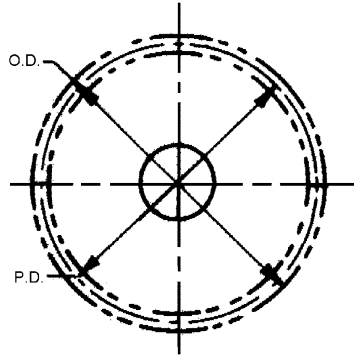

Available on request:
Other numbers of teeth;
Quality Class AGMA 12 & 14 / DIN 5 & 3;
14 - 1/2° pressure angle.

STAINLESS STEEL STOCK NO.	ALUMINUM STOCK NO.	NO. OF TEETH	PITCH DIA.	OUTSIDE DIA.
FGS103-38	FGA103-38	38	15.20	16.00
FGS103-40	FGA103-40	40	16.00	16.80
FGS103-48	FGA103-48	48	19.20	20.00
FGS103-50	FGA103-50	50	20.00	20.80
FGS103-64	FGA103-64	64	25.60	26.40
FGS103-66	FGA103-66	66	26.40	27.20
FGS103-70	FGA103-70	70	28.00	28.80
FGS103-72	FGA103-72	72	28.80	29.60
FGS103-75	FGA103-75	75	30.00	30.80
FGS103-80	FGA103-80	80	32.00	32.80
FGS103-84	FGA103-84	84	33.60	34.40
FGS103-90	FGA103-90	90	36.00	36.80
FGS103-96	FGA103-96	96	38.40	39.20
FGS103-100	FGA103-100	100	40.00	40.80
FGS103-110	FGA103-110	110	44.00	44.80
FGS103-120	FGA103-120	120	48.00	48.80
FGS103-128	FGA103-128	128	51.20	52.00
FGS103-130	FGA103-130	130	52.00	52.80
FGS103-140	FGA103-140	140	56.00	56.80
FGS103-144	FGA103-144	144	57.60	58.40
FGS103-150	FGA103-150	150	60.00	60.80
FGS103-155	FGA103-155	155	62.00	62.80
FGS103-160	FGA103-160	160	64.00	64.80
FGS103-165	FGA103-165	165	66.00	66.80
FGS103-170	FGA103-170	170	68.00	68.80
FGS103-176	FGA103-176	176	70.40	71.20
FGS103-180	FGA103-180	180	72.00	72.80
FGS103-190	FGA103-190	190	76.00	76.80
FGS103-192	FGA103-192	192	76.80	77.60
FGS103-224	FGA103-224	224	89.60	90.40
FGS103-256	FGA103-256	256	102.40	103.20
FGS103-264	FGA103-264	264	105.60	106.40

MODULE	STYLE	BORE	FACE	MATERIAL	QUALITY	PRESSURE ANGLE
0.4	HUBLESS	10	3	POLYURETHANE WITH LUBRICANT	DIN 9/AGMA 8	20°

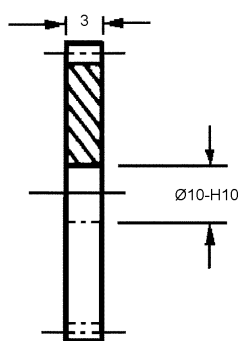
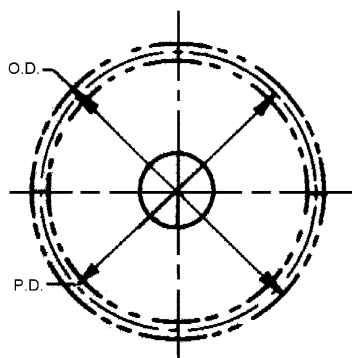

STOCK NO.	NO. OF TEETH	PITCH DIA.	OUTSIDE DIA.
FGU103-64	64	25.60	26.40
FGU103-80	80	32.00	32.80
FGU103-96	96	38.40	39.20
FGU103-112	112	44.80	45.60
FGU103-128	128	51.20	52.00
FGU103-144	144	57.60	58.40

Available on request:
Other numbers of teeth;
Quality Class AGMA 12 & 14 / DIN 5 & 3;
14 - 1/2° pressure angle.

For Couplings See Section MG.
For Shafts, Bearings and Collars See Section MI.

SPUR GEARS

B

MODULE	STYLE	BORE	FACE	MATERIAL	QUALITY	PRESSURE ANGLE
0.4	HUBLESS	10	5	DELTRIN	DIN 8/AGMA 9	20°

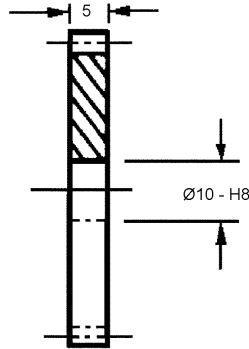
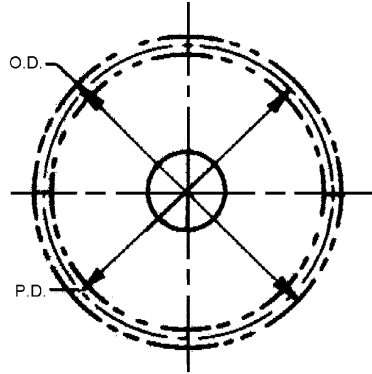

STOCK NO.	NO. OF TEETH	PITCH DIA.	OUTSIDE DIA.
FGD105-36	36	14.40	15.20
FGD105-37	37	14.80	15.60
FGD105-38	38	15.20	16.00
FGD105-40	40	16.00	16.80
FGD105-42	42	16.80	17.60
FGD105-44	44	17.60	18.40
FGD105-46	46	18.40	19.20
FGD105-48	48	19.20	20.00
FGD105-50	50	20.00	20.80
FGD105-56	56	22.40	23.20
FGD105-60	60	24.00	24.80
FGD105-64	64	25.60	26.40
FGD105-72	72	28.80	29.60
FGD105-74	74	29.60	30.40
FGD105-80	80	32.00	32.80
FGD105-84	84	33.60	34.40
FGD105-88	88	35.20	36.00
FGD105-90	90	36.00	36.80
FGD105-96	96	38.40	39.20
FGD105-100	100	40.00	40.80
FGD105-112	112	44.80	45.60
FGD105-120	120	48.00	48.80
FGD105-127	127	50.80	51.60
FGD105-128	128	51.20	52.00
FGD105-144	144	57.60	58.40
FGD105-152	152	60.80	61.60
FGD105-160	160	64.00	64.80
FGD105-168	168	67.20	68.00
FGD105-176	176	70.40	71.20
FGD105-184	184	73.60	74.40
FGD105-192	192	76.80	77.60
FGD105-224	224	89.60	90.40

Available on request:
Other numbers of teeth;
14 - 1/2° pressure angle.

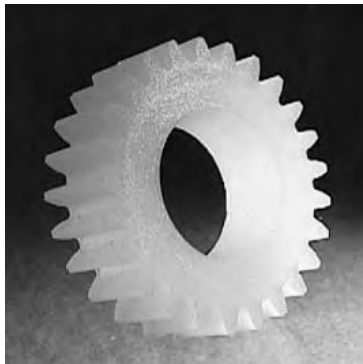

MODULE	STYLE	BORE	FACE	MATERIAL	QUALITY	PRESSURE ANGLE
0.4	HUBLESS	10	6	POLYURETHANE WITH LUBRICANT	DIN 9/AGMA 8	20°

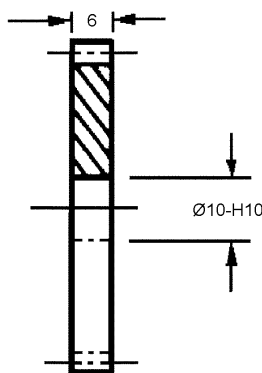
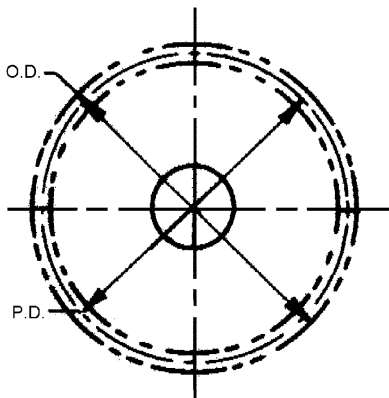

STOCK NO.	NO. OF TEETH	PITCH DIA.	OUTSIDE DIA.
FGU103-160	160	64.00	64.80
FGU103-192	192	76.80	77.60
FGU103-224	224	89.60	90.40
FGU 103-256	256	102.40	103.20

Available on request:
Other numbers of teeth;
Quality Class AGMA 12 & 14 / DIN 5 & 3;
14 - 1/2° pressure angle.

For Couplings See Section MG.
For Shafts, Bearings and Collars See Section MI.

SPUR GEARS

MODULE	STYLE	BORE	FACE	MATERIAL	QUALITY	PRESSURE ANGLE
0.4	PIN HUB	3	3	STAINLESS STEEL DIN 1.4305 OR ALUMINUM DIN 3.1355 ANODIZED	DIN 7/AGMA 10	20°

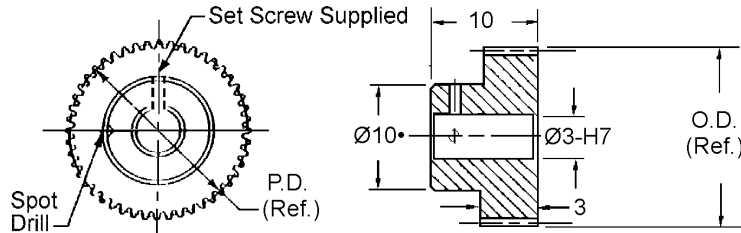

STAINLESS STEEL STOCK NO.	ALUMINUM STOCK NO.	NO. OF TEETH	PITCH DIA.	OUTSIDE DIA.
PGS80-20	PGA80-20	20•	8.00	8.80
PGS80-21	PGA80-21	21•	8.40	9.20
PGS80-22	PGA80-22	22•	8.80	9.60
PGS80-23	PGA80-23	23•	9.20	10.00
PGS80-24	PGA80-24	24•	9.60	10.40
PGS80-25	PGA80-25	25•	10.00	10.80
PGS80-26	PGA80-26	26•	10.40	11.20
PGS80-27	PGA80-27	27•	10.80	11.60
PGS80-28	PGA80-28	28	11.20	12.00
PGS80-29	PGA80-29	29	11.60	12.40
PGS80-30	PGA80-30	30	12.00	12.80
PGS80-32	PGA80-32	32	12.80	13.60
PGS80-34	PGA80-34	34	13.60	14.40
PGS80-36	PGA80-36	36	14.40	15.20
PGS80-38	PGA80-38	38	15.20	16.00
PGS80-40	PGA80-40	40	16.00	16.80
PGS80-42	PGA80-42	42	16.80	17.60
PGS80-44	PGA80-44	44	17.60	18.40
PGS80-46	PGA80-46	46	18.40	19.20
PGS80-48	PGA80-48	48	19.20	20.00
PGS80-50	PGA80-50	50	20.00	20.80
PGS80-55	PGA80-55	55	22.00	22.80
PGS80-56	PGA80-56	56	22.40	23.20
PGS80-60	PGA80-60	60	24.00	24.80
PGS80-64	PGA80-64	64	25.60	26.40
PGS80-65	PGA80-65	65	26.00	26.80
PGS80-70	PGA80-70	70	28.00	28.80
PGS80-72	PGA80-72	72	28.80	29.60
PGS80-75	PGA80-75	75	30.00	30.80
PGS80-80	PGA80-80	80	32.00	32.80
PGS80-84	PGA80-84	84	33.60	34.40
PGS80-85	PGA80-85	85	34.00	34.80
PGS80-88	PGA80-88	88	35.20	36.00
PGS80-90	PGA80-90	90	36.00	36.80
PGS80-92	PGA80-92	92	36.80	37.60
PGS80-95	PGA80-95	95	38.00	38.80
PGS80-96	PGA80-96	96	38.40	39.20
PGS80-104	PGA80-104	104	41.60	42.40
PGS80-105	PGA80-105	105	42.00	42.80
PGS80-112	PGA80-112	112	44.80	45.60
PGS80-120	PGA80-120	120	48.00	48.80
PGS80-121	PGA80-121	121	48.40	49.20
PGS80-127	PGA80-127	127	50.80	51.60
PGS80-128	PGA80-128	128	51.20	52.00

Available on request:
Other numbers of teeth;
14 - 1/2° pressure angle;
Quality Class AGMA 12 and 14 / DIN 5 and 3

• For 17-27 teeth hub diameter equals 5.7

**For Couplings See Section MG.
For Shafts, Bearings and Collars See Section MI.**

SPUR GEARS

MODULE	STYLE	BORE	FACE	MATERIAL	QUALITY	PRESSURE ANGLE
0.4	PIN HUB	5	3	STAINLESS STEEL DIN 1.4305 OR ALUMINUM DIN 3.1355 ANODIZED	DIN 7/AGMA 10	20°

B

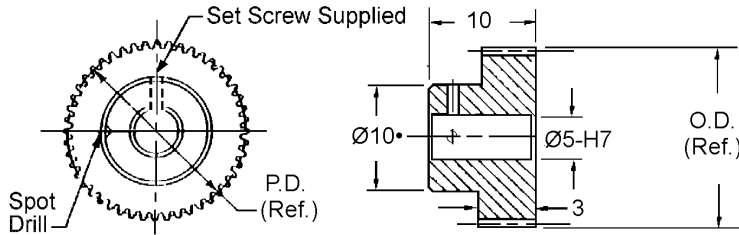

Available on request:
Other numbers of teeth;
14 - 1/2° pressure angle;
Quality Class AGMA 12 and 14 / DIN 5 and 3

• For 23-27 teeth hub diameter equals 8.1

STAINLESS STEEL STOCK NO.	ALUMINUM STOCK NO.	NO. OF TEETH	PITCH DIA.	OUTSIDE DIA.
PGS82-23	PGA82-23	23•	9.20	10.00
PGS82-24	PGA82-24	24•	9.60	10.40
PGS82-25	PGA82-25	25•	10.00	10.80
PGS82-26	PGA82-26	26•	10.40	11.20
PGS82-28	PGA82-28	28	11.20	12.00
PGS82-29	PGA82-29	29	11.60	12.40
PGS82-30	PGA82-30	30	12.00	12.80
PGS82-31	PGA82-31	31	12.40	13.20
PGS82-32	PGA82-32	32	12.80	13.60
PGS82-34	PGA82-34	34	13.60	14.40
PGS82-35	PGA82-35	35	14.00	14.80
PGS82-36	PGA82-36	36	14.40	15.20
PGS82-38	PGA82-38	38	15.20	16.00
PGS82-40	PGA82-40	40	16.00	16.80
PGS82-42	PGA82-42	42	16.80	17.60
PGS82-44	PGA82-44	44	17.60	18.40
PGS82-45	PGA82-45	45	18.00	18.80
PGS82-46	PGA82-46	46	18.40	19.20
PGS82-48	PGA82-48	48	19.20	20.00
PGS82-50	PGA82-50	50	20.00	20.80
PGS82-55	PGA82-55	55	22.00	22.80
PGS82-56	PGA82-56	56	22.40	23.20
PGS82-60	PGA82-60	60	24.00	24.80
PGS82-64	PGA82-64	64	25.60	26.40
PGS82-65	PGA82-65	65	26.00	26.80
PGS82-70	PGA82-70	70	28.00	28.80
PGS82-72	PGA82-72	72	28.80	29.60
PGS82-75	PGA82-75	75	30.00	30.80
PGS82-80	PGA82-80	80	32.00	32.80
PGS82-84	PGA82-84	84	33.60	34.40
PGS82-85	PGA82-85	85	34.00	34.80
PGS82-88	PGA82-88	88	35.20	36.00
PGS82-90	PGA82-90	90	36.00	36.80
PGS82-92	PGA82-92	92	36.80	37.60
PGS82-95	PGA82-95	95	38.00	38.80
PGS82-96	PGA82-96	96	38.40	39.20
PGS82-100	PGA82-100	100	40.00	40.80
PGS82-105	PGA82-105	105	42.00	42.80
PGS82-110	PGA82-110	110	44.00	44.80
PGS82-115	PGA82-115	115	46.00	46.80
PGS82-120	PGA82-120	120	48.00	48.80
PGS82-122	PGA82-122	122	48.80	49.60
PGS82-124	PGA82-124	124	49.60	50.40
PGS82-127	PGA82-127	127	50.80	51.60
PGS82-128	PGA82-128	128	51.20	52.00
PGS82-130	PGA82-130	130	52.00	52.80
PGS82-136	PGA82-136	136	54.40	55.20
PGS82-140	PGA82-140	140	56.00	56.80
PGS82-144	PGA82-144	144	57.60	58.40
PGS82-150	PGA82-150	150	60.00	60.80
PGS82-152	PGA82-152	152	60.80	61.60
PGS82-156	PGA82-156	156	62.40	63.20
PGS82-160	PGA82-160	160	64.00	64.80
PGS82-164	PGA82-164	164	65.60	66.40
PGS82-168	PGA82-168	168	67.20	68.00
PGS82-170	PGA82-170	170	68.00	68.80
PGS82-176	PGA82-176	176	70.40	71.20
PGS82-180	PGA82-180	180	72.00	72.80
PGS82-184	PGA82-184	184	73.60	74.40
PGS82-190	PGA82-190	190	76.00	76.80
PGS82-192	PGA82-192	192	76.80	77.60
PGS82-200	PGA82-200	200	80.00	80.80
PGS82-224	PGA82-224	224	89.60	90.40
PGS82-256	PGA82-256	256	102.40	103.20

For Couplings See Section MG.
For Shafts, Bearings and Collars See Section MI.

SPUR GEARS

MODULE	STYLE	BORE	FACE	MATERIAL	QUALITY	PRESSURE ANGLE
0.4	PIN HUB	5	5	STAINLESS STEEL DIN 1.4305 OR ALUMINUM DIN 3.1355 ANODIZED	DIN 7/AGMA 10	20°

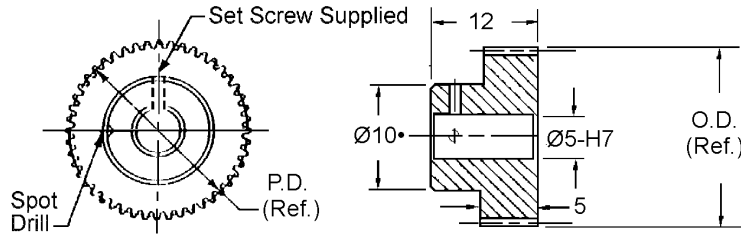

STAINLESS STEEL STOCK NO.	ALUMINUM STOCK NO.	NO. OF TEETH	PITCH DIA.	OUTSIDE DIA.
PGS83-24	PGA83-24	24•	9.60	10.40
PGS83-25	PGA83-25	25•	10.00	10.80
PGS83-26	PGA83-26	26•	10.40	11.20
PGS83-28	PGA83-28	28	11.20	12.00
PGS83-30	PGA83-30	30	12.00	12.80
PGS83-32	PGA83-32	32	12.80	13.60
PGS83-36	PGA83-36	36	14.40	15.20
PGS83-40	PGA83-40	40	16.00	16.80
PGS83-44	PGA83-44	44	17.60	18.40
PGS83-46	PGA83-46	46	18.40	19.20
PGS83-48	PGA83-48	48	19.20	20.00
PGS83-50	PGA83-50	50	20.00	20.80
PGS83-56	PGA83-56	56	22.40	23.20
PGS83-60	PGA83-60	60	24.00	24.80
PGS83-64	PGA83-64	64	25.60	26.40
PGS83-70	PGA83-70	70	28.00	28.80
PGS83-75	PGA83-75	75	30.00	30.80
PGS83-80	PGA83-80	80	32.00	32.80
PGS83-88	PGA83-88	88	35.20	36.00
PGS83-90	PGA83-90	90	36.00	36.80
PGS83-96	PGA83-96	96	38.40	39.20
PGS83-100	PGA83-100	100	40.00	40.80
PGS83-110	PGA83-110	110	44.00	44.80
PGS83-112	PGA83-112	112	44.80	45.60
PGS83-120	PGA83-120	120	48.00	48.80
PGS83-128	PGA83-128	128	51.20	52.00
PGS83-136	PGA83-136	136	54.40	55.20
PGS83-144	PGA83-144	144	57.60	58.40
PGS83-152	PGA83-152	152	60.80	61.60
PGS83-160	PGA83-160	160	64.00	64.80
PGS83-176	PGA83-176	176	70.40	71.20
PGS83-192	PGA83-192	192	76.80	77.60
PGS83-200	PGA83-200	200	80.00	80.80
PGS83-208	PGA83-208	208	83.20	84.00
PGS83-224	PGA83-224	224	89.60	90.40
PGS83-240	PGA83-240	240	96.00	96.80
PGS83-256	PGA83-256	256	102.40	103.20

Available on request:
Other numbers of teeth;
14 - 1/2° pressure angle;
Quality Class AGMA 12 and 14 / DIN 5 and 3

• For 24-27 teeth hub diameter equals 8.1

For Couplings See Section MG.
For Shafts, Bearings and Collars See Section MI.

SPUR GEARS

MODULE	STYLE	BORE	FACE	MATERIAL	QUALITY	PRESSURE ANGLE
0.4	PIN HUB	8	3	STAINLESS STEEL DIN 1.4305 OR ALUMINUM DIN 3.1355 ANODIZED	DIN 7/AGMA 10	20°

B

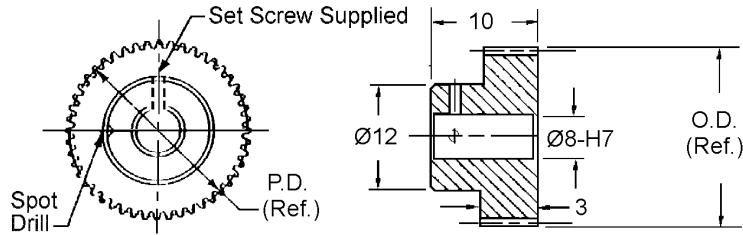

STAINLESS STEEL STOCK NO.	ALUMINUM STOCK NO.	NO. OF TEETH	PITCH DIA.	OUTSIDE DIA.
PGS94-34	PGA94-34	34	13.60	14.40
PGS94-35	PGA94-35	35	14.00	14.80
PGS94-36	PGA94-36	36	14.40	15.20
PGS94-40	PGA94-40	40	16.00	16.80
PGS94-42	PGA94-42	42	16.80	17.60
PGS94-44	PGA94-44	44	17.60	18.40
PGS94-45	PGA94-45	45	18.00	18.80
PGS94-46	PGA94-46	46	18.40	19.20
PGS94-48	PGA94-48	48	19.20	20.00
PGS94-50	PGA94-50	50	20.00	20.80
PGS94-54	PGA94-54	54	21.60	22.40
PGS94-55	PGA94-55	55	22.00	22.80
PGS94-56	PGA94-56	56	22.40	23.20
PGS94-60	PGA94-60	60	24.00	24.80
PGS94-64	PGA94-64	64	25.60	26.40
PGS94-70	PGA94-70	70	28.00	28.80
PGS94-72	PGA94-72	72	28.80	29.60
PGS94-75	PGA94-75	75	30.00	30.80
PGS94-80	PGA94-80	80	32.00	32.80
PGS94-84	PGA94-84	84	33.60	34.40
PGS94-85	PGA94-85	85	34.00	34.80
PGS94-86	PGA94-86	86	34.40	35.20
PGS94-90	PGA94-90	90	36.00	36.80
PGS94-95	PGA94-95	95	38.00	38.80
PGS94-100	PGA94-100	100	40.00	40.80
PGS94-105	PGA94-105	105	42.00	42.80
PGS94-110	PGA94-110	110	44.00	44.80
PGS94-112	PGA94-112	112	44.80	45.60
PGS94-120	PGA94-120	120	48.00	48.80
PGS94-124	PGA94-124	124	49.60	50.40
PGS94-128	PGA94-128	128	51.20	52.00
PGS94-130	PGA94-130	130	52.00	52.80
PGS94-140	PGA94-140	140	56.00	56.80
PGS94-144	PGA94-144	144	57.60	58.40
PGS94-150	PGA94-150	150	60.00	60.80
PGS94-160	PGA94-160	160	64.00	64.80
PGS94-168	PGA94-168	168	67.20	68.00
PGS94-170	PGA94-170	170	68.00	68.80
PGS94-176	PGA94-176	176	70.40	71.20
PGS94-180	PGA94-180	180	72.00	72.80
PGS94-184	PGA94-184	184	73.60	74.40
PGS94-190	PGA94-190	190	76.00	76.80
PGS94-192	PGA94-192	192	76.80	77.60
PGS94-200	PGA94-200	200	80.00	80.80
PGS94-208	PGA94-208	208	83.20	84.00
PGS94-216	PGA94-216	216	86.40	87.20
PGS94-224	PGA94-224	224	89.60	90.40
PGS94-232	PGA94-232	232	92.80	93.60
PGS94-240	PGA94-240	240	96.00	96.80
PGS94-248	PGA94-248	248	99.20	100.00
PGS94-256	PGA94-256	256	102.40	103.20

Available on request:
Other numbers of teeth;
14 - 1/2° pressure angle;
Quality Class AGMA 12 and 14 / DIN 5 and 3

For Couplings See Section MG.
For Shafts, Bearings and Collars See Section MI.

SPUR GEARS

MODULE	STYLE	BORE	FACE	MATERIAL	QUALITY	PRESSURE ANGLE
0.4	PIN HUB	5	5	DELRIN	DIN 8/AGMA 9	20°

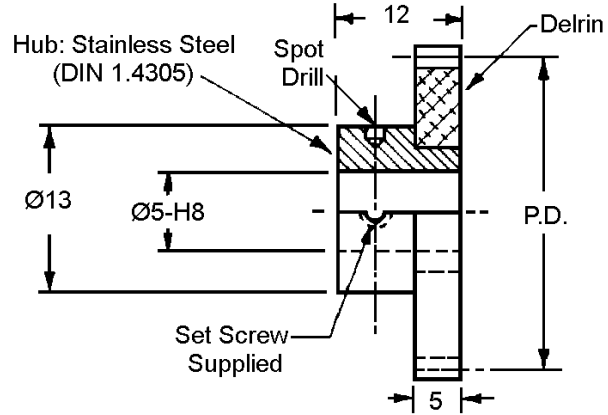

STOCK NO.	NO. OF TEETH	PITCH DIA.	OUTSIDE DIA.
PGD121X-36	36	14.40	15.20
PGD121X-37	37	14.80	15.60
PGD121X-38	38	15.20	16.00
PGD121X-40	40	16.00	16.80
PGD121X-42	42	16.80	17.60
PGD121X-44	44	17.60	18.40
PGD121X-46	46	18.40	19.20
PGD121X-48	48	19.20	20.00
PGD121X-50	50	20.00	20.80
PGD121X-56	56	22.40	23.20
PGD121X-60	60	24.00	24.80
PGD121X-64	64	25.60	26.40
PGD121X-72	72	28.80	29.60
PGD121X-74	74	29.60	30.40
PGD121X-80	80	32.00	32.80
PGD121X-84	84	33.60	34.40
PGD121X-88	88	35.20	36.00
PGD121X-90	90	36.00	36.80
PGD121X-96	96	38.40	39.20
PGD121X-100	100	40.00	40.80
PGD121X-112	112	44.80	45.60
PGD121X-120	120	48.00	48.80
PGD121X-127	127	50.80	51.60
PGD121X-128	128	51.20	52.00
PGD121X-144	144	57.60	58.40
PGD121X-152	152	60.80	61.60
PGD121X-160	160	64.00	64.80
PGD121X-168	168	67.20	68.00
PGD121X-176	176	70.40	71.20
PGD121X-184	184	73.60	74.40
PGD121X-192	192	76.80	77.60
PGD121X-224	224	89.60	90.40

Available on request:
Other numbers of teeth;
14 - 1/2° pressure angle

For Couplings See Section MG.
For Shafts, Bearings and Collars See Section MI.

SPUR GEARS

MODULE	STYLE	BORE	FACE	MATERIAL	QUALITY	PRESSURE ANGLE
0.4	PIN HUB	8	5	DELRIN	DIN 8/AGMA 9	20°

B

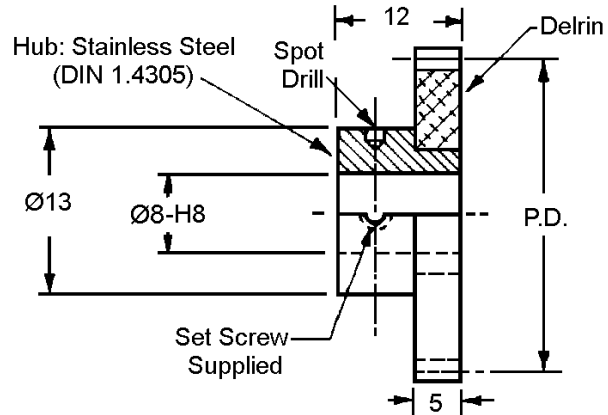

STOCK NO.	NO. OF TEETH	PITCH DIA.	OUTSIDE DIA.
PGD138X-36	36	14.40	15.20
PGD138X-37	37	14.80	15.60
PGD138X-38	38	15.20	16.00
PGD138X-40	40	16.00	16.80
PGD138X-42	42	16.80	17.60
PGD138X-44	44	17.60	18.40
PGD138X-46	46	18.40	19.20
PGD138X-48	48	19.20	20.00
PGD138X-50	50	20.00	20.80
PGD138X-56	56	22.40	23.20
PGD138X-60	60	24.00	24.80
PGD138X-64	64	25.60	26.40
PGD138X-72	72	28.80	29.60
PGD138X-74	74	29.60	30.40
PGD138X-80	80	32.00	32.80
PGD138X-84	84	33.60	34.40
PGD138X-88	88	35.20	36.00
PGD138X-90	90	36.00	36.80
PGD138X-96	96	38.40	39.20
PGD138X-100	100	40.00	40.80
PGD138X-112	112	44.80	45.60
PGD138X-120	120	48.00	48.80
PGD138X-127	127	50.80	51.60
PGD138X-128	128	51.20	52.00
PGD138X-144	144	57.60	58.40
PGD138X-152	152	60.80	61.60
PGD138X-160	160	64.00	64.80
PGD138X-168	168	67.20	68.00
PGD138X-176	176	70.40	71.20
PGD138X-184	184	73.60	74.40
PGD138X-192	192	76.80	77.60
PGD138X-224	224	89.60	90.40

Available on request:
Other numbers of teeth;
14 - 1/2° pressure angle

For Couplings See Section MG.
For Shafts, Bearings and Collars See Section MI.

SPUR GEARS

MODULE	STYLE	BORE	FACE	MATERIAL	QUALITY	PRESSURE ANGLE
0.4	CLAMP HUB	3	3	STAINLESS STEEL DIN 1.4305 OR ALUMINUM DIN 3.1355 ANODIZED	DIN 7/AGMA 10	20°

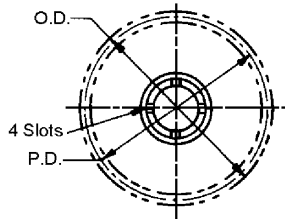

Use Clamp CG1M-3
(Order Separately)

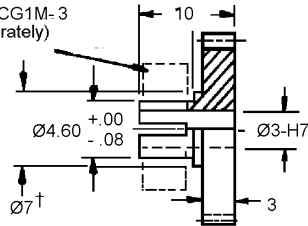

Available on request:
Other bore sizes;
numbers of teeth;
14-12° Pressure Angle;
Quality Class DIN 5/AGMA12

†Teeth may runout on flange diameter.

STAINLESS STEEL STOCK NO.	ALUMINUM STOCK NO.	NO. OF TEETH	PITCH DIA.	OUTSIDE DIA.
CGS50-18	CGA50-18	18†	7.20	8.00
CGS50-19	CGA50-19	19†	7.60	8.40
CGS50-20	CGA50-20	20	8.00	8.80
CGS50-21	CGA50-21	21	8.40	9.20
CGS50-22	CGA50-22	22	8.80	9.60
CGS50-23	CGA50-23	23	9.20	10.00
CGS50-24	CGA50-24	24	9.60	10.40
CGS50-25	CGA50-25	25	10.00	10.80
CGS50-26	CGA50-26	26	10.40	11.20
CGS50-27	CGA50-27	27	10.80	11.60
CGS50-28	CGA50-28	28	11.20	12.00
CGS50-29	CGA50-29	29	11.60	12.40
CGS50-30	CGA50-30	30	12.00	12.80
CGS50-32	CGA50-32	32	12.80	13.60
CGS50-34	CGA50-34	34	13.60	14.40
CGS50-36	CGA50-36	36	14.40	15.20
CGS50-38	CGA50-38	38	15.20	16.00
CGS50-40	CGA50-40	40	16.00	16.80
CGS50-42	CGA50-42	42	16.80	17.60
CGS50-44	CGA50-44	44	17.60	18.40
CGS50-46	CGA50-46	46	18.40	19.40
CGS50-48	CGA50-48	48	19.20	20.00
CGS50-50	CGA50-50	50	20.00	20.80
CGS50-55	CGA50-55	55	22.00	22.80
CGS50-56	CGA50-56	56	22.40	23.20
CGS50-60	CGA50-60	60	24.00	24.80
CGS50-64	CGA50-64	64	25.60	26.40
CGS50-72	CGA50-72	72	28.80	29.60
CGS50-80	CGA50-80	80	32.00	32.80
CGS50-88	CGA50-88	88	35.20	36.00
CGS50-96	CGA50-96	96	38.40	39.20
CGS50-104	CGA50-104	104	41.60	42.40
CGS50-112	CGA50-112	112	44.80	45.60
CGS50-120	CGA50-120	120	48.00	48.00

For Couplings See Section MG.
For Shafts, Bearings and Collars See Section MI.

SPUR GEARS

MODULE	STYLE	BORE	FACE	MATERIAL	QUALITY	PRESSURE ANGLE
0.4	CLAMP HUB	5	3	STAINLESS STEEL DIN 1.4305 OR ALUMINUM DIN 3.1355 ANODIZED	DIN 7/AGMA 10	20°

B

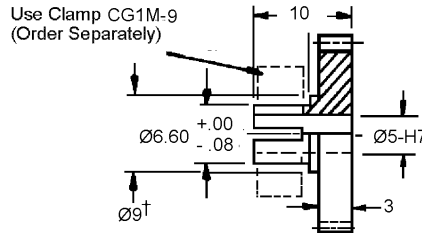
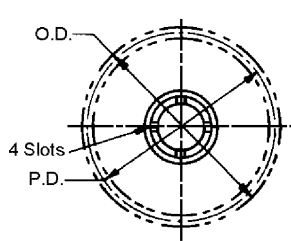

STAINLESS STEEL STOCK NO.	ALUMINUM STOCK NO.	NO. OF TEETH	PITCH DIA.	OUTSIDE DIA.
CGS52-24	CGA52-24	24†	9.60	10.40
CGS52-25	CGA52-25	25	10.00	10.80
CGS52-28	CGA52-28	28	11.20	12.00
CGS52-30	CGA52-30	30	12.00	12.80
CGS52-32	CGA52-32	32	12.80	13.60
CGS52-40	CGA52-40	40	16.00	16.80
CGS52-42	CGA52-42	42	16.80	17.60
CGS52-44	CGA52-44	44	17.60	18.40
CGS52-46	CGA52-46	46	18.40	19.20
CGS52-48	CGA52-48	48	19.20	20.00
CGS52-50	CGA52-50	50	20.00	20.80
CGS52-52	CGA52-52	52	20.80	21.60
CGS52-56	CGA52-56	56	22.40	23.20
CGS52-60	CGA52-60	60	24.00	24.80
CGS52-64	CGA52-64	64	25.60	26.40
CGS52-72	CGA52-72	72	28.80	29.60
CGS52-76	CGA52-76	76	30.40	31.20
CGS52-80	CGA52-80	80	32.00	32.80
CGS52-84	CGA52-84	84	33.60	34.40
CGS52-85	CGA52-85	85	34.00	34.80
CGS52-88	CGA52-88	88	35.20	36.00
CGS52-90	CGA52-90	90	36.00	36.80
CGS52-96	CGA52-96	96	38.40	39.20
CGS52-100	CGA52-100	100	40.00	40.80
CGS52-104	CGA52-104	104	41.60	42.40
CGS52-112	CGA52-112	112	44.80	45.60
CGS52-120	CGA52-120	120	48.00	48.80
CGS52-128	CGA52-128	128	51.20	52.00
CGS52-130	CGA52-130	130	52.00	52.80
CGS52-144	CGA52-144	144	57.20	58.40
CGS52-152	CGA52-152	152	60.80	61.60
CGS52-160	CGA52-160	160	64.00	64.80
CGS52-176	CGA52-176	176	70.40	71.20
CGS52-180	CGA52-180	180	72.00	72.80
CGS52-192	CGA52-192	192	76.80	77.60
CGS52-224	CGA52-224	224	89.60	90.40
CGS52-256	CGA52-256	256	102.40	103.20

Available on request:
Other bore sizes;
numbers of teeth;
14-12° Pressure Angle;
Quality Class DIN 5/AGMA12

†Teeth may runout on flange diameter.

**For Couplings See Section MG.
For Shafts, Bearings and Collars See Section MI.**

SPUR GEARS

MODULE	STYLE	BORE	FACE	MATERIAL	QUALITY	PRESSURE ANGLE
0.4	CLAMP HUB	8	3	STAINLESS STEEL DIN 1.4305 OR ALUMINUM DIN 3.1355 ANODIZED	DIN 7/AGMA 10	20°

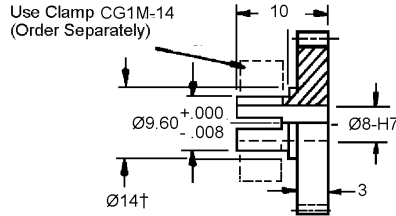
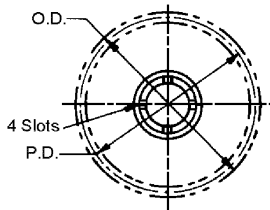

STAINLESS STEEL STOCK NO.	ALUMINUM STOCK NO.	NO. OF TEETH	PITCH DIA.	OUTSIDE DIA.
CGS64-30	CGA64-30	30†	12.00	12.80
CGS64-32	CGA64-32	32†	12.80	13.60
CGS64-35	CGA64-35	35†	14.00	14.80
CGS64-36	CGA64-36	36†	14.40	15.20
CGS64-40	CGA64-40	40	16.00	16.80
CGS64-45	CGA64-45	45	18.00	18.80
CGS64-48	CGA64-48	48	19.20	20.00
CGS64-50	CGA64-50	50	20.00	28.80
CGS64-60	CGA64-60	60	24.00	24.80
CGS64-64	CGA64-64	64	25.60	26.40
CGS64-70	CGA64-70	70	28.00	28.80
CGS64-72	CGA64-72	72	28.80	26.60
CGS64-75	CGA64-75	75	30.00	30.80
CGS64-80	CGA64-80	80	32.00	32.80
CGS64-84	CGA64-84	84	33.60	34.40
CGS64-88	CGA64-88	88	35.20	36.00
CGS64-90	CGA64-90	90	36.00	36.80
CGS64-96	CGA64-96	96	38.40	39.20
CGS64-112	CGA64-112	112	44.80	45.60
CGS64-120	CGA64-120	120	48.00	48.80
CGS64-125	CGA64-125	125	50.00	50.80
CGS64-128	CGA64-128	128	51.20	52.00
CGS64-130	CGA64-130	130	52.00	52.80
CGS64-140	CGA64-140	140	56.00	56.80
CGS64-144	CGA64-144	144	57.60	58.40
CGS64-160	CGA64-160	160	64.00	64.80
CGS64-176	CGA64-176	176	70.40	71.20
CGS64-180	CGA64-180	180	72.00	72.80
CGS64-192	CGA64-192	192	76.80	77.60
CGS64-224	CGA64-224	224	89.60	90.40
CGS64-256	CGA64-256	256	102.40	103.20

Available on request:
 Other bore sizes;
 numbers of teeth;
 14-12° Pressure Angle;
 Quality Class DIN 5/AGMA12

†Teeth may runout on flange diameter.

For Couplings See Section MG.
 For Shafts, Bearings and Collars See Section MI.

GEAR RACKS

MODULE	STYLE	MATERIAL	QUALITY	PRESSURE ANGLE
0.4	ROUND & RECTANGULAR	STAINLESS STEEL DIN 1.4005	DIN 7/AGMA 10	20°

B

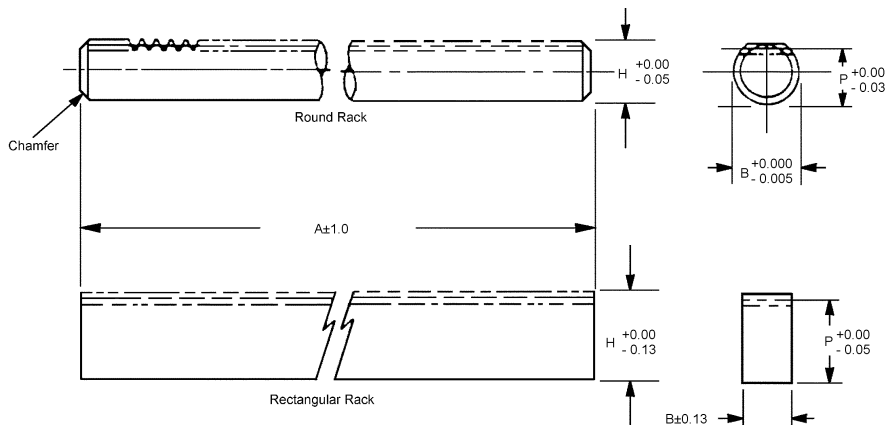

STOCK NO.	RACK STYLE	MOD.	P (Ref.)	B	A	H
R2M-7	ROUND	0.4	5.19	5.974	275	5.59
R3M-7	RECTANGULAR	0.4	11.79	5.84	275	12.19

Available on request: Special, modified and custom racks.

MODULE	STYLE	MATERIAL	QUALITY	PRESSURE ANGLE
0.4	RECTANGULAR	STAINLESS STEEL DIN 1.4005	DIN 7/AGMA 10	20°

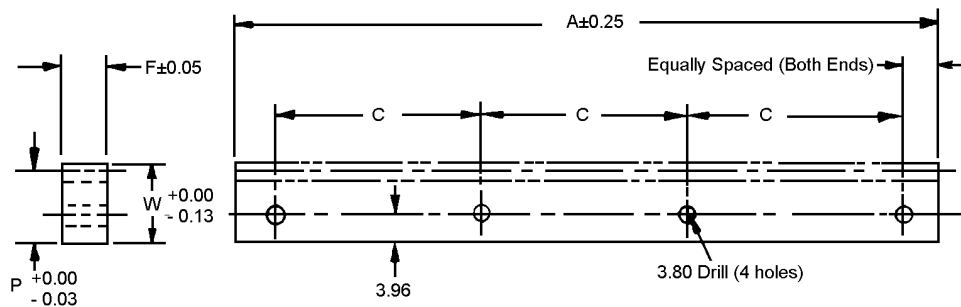

STOCK NO.	A	P (Ref.)	W	F	C
R4M-21	174.7	11.8	12.2	5.8	55.5

Available on request: special, modified and custom racks.

Quality Class AGMA12/DIN 5 available on request.

GEAR RACKS

MODULE	STYLE	MATERIAL	QUALITY	PRESSURE ANGLE
0.4	RECTANGULAR	STAINLESS STEEL DIN 1.4005	DIN 7/AGMA 10	20°

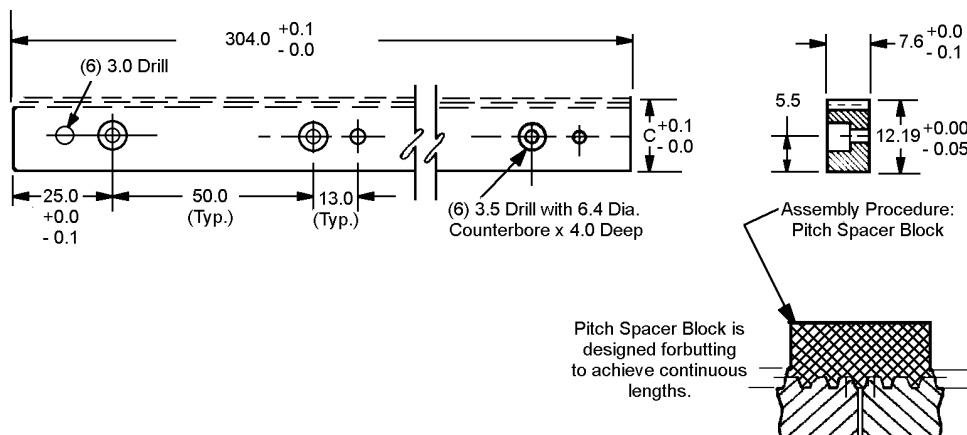

RACKS STOCK NO.	SPACER BLOCKS STOCK NO.	MODULE	LINEAR PITCH	C
R8M-2-G1	R8M-2-SB	0.4	1.26	11.79

Available on request: special, modified and custom racks.

Quality Class AGMA12/DIN 5 available on request.

Adjacent hole center ± 0.06
Accumulative hole centers ± 0.14

MODULE	STYLE	MATERIAL	QUALITY	PRESSURE ANGLE
0.4	RECTANGULAR	STAINLESS STEEL DIN 1.4005	DIN 7/AGMA 10	20°

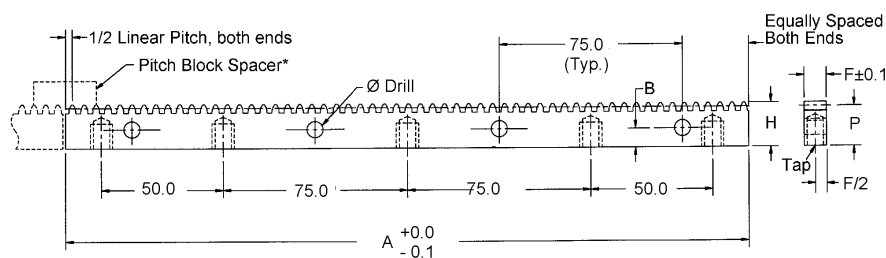

Spacer block is designed for butting to achieve continuous lengths.

RACKS STOCK NO.	SPACER BLOCK STOCK NO.	LINEAR PITCH	A	P (REF.)	H +0.00 -0.13	F	B	Ø DRILL	TAP
R1M-7	R1M-7-SB	1.26	280.2	11.66	12.07	5.8	5.5	3.8	M4.0 X 0.7

Quality Class AGMA 12/Din 5 available on request. Custom racks available on request.

ANTI-BACKLASH GEARS

MODULE	STYLE	BORE	FACE	MATERIAL	QUALITY	PRESSURE ANGLE
0.4	PIN HUB	5	3	STAINLESS STEEL DIN 1.4305 OR ALUMINUM DIN 3.1355 ANODIZED	DIN 7/AGMA 10	20°

B

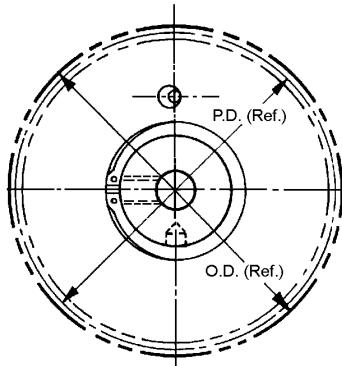
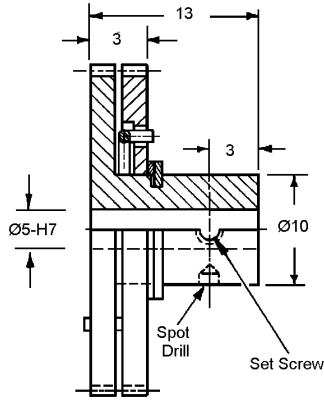

Available on request:
 Other numbers of teeth;
 Other Quality Classes;
 14-1/2° Pressure Angle

Hub Material: Stainless Steel DIN 1.4305

STAINLESS STEEL DIN 1.4305 STOCK NO.	ALUMINUM DIN 3.1355 STOCK NO.	NO. OF TEETH	PITCH DIA.	OUTSIDE DIA.
APGHSM-40	APGJSM-40	40	16.00	16.80
APGHSM-48	APGJSM-48	48	19.20	20.00
APGHSM-64	APGJSM-64	64	25.60	26.40

For Couplings See Section MG.
For Shafts, Bearings and Collars See Section MI.

ANTI-BACKLASH GEARS

MODULE	STYLE	BORE	FACE	MATERIAL	QUALITY	PRESSURE ANGLE
0.4	PIN HUB	5	3	STAINLESS STEEL DIN 1.4305 OR ALUMINUM DIN 3.1355 ANODIZED	DIN 7/AGMA 10	20°

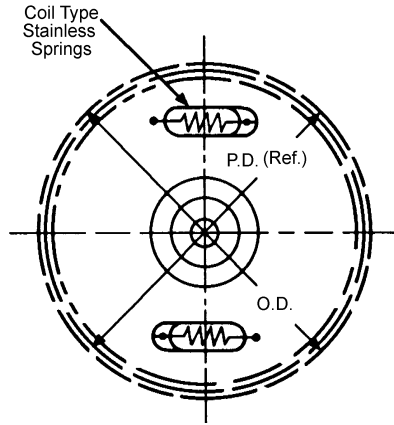
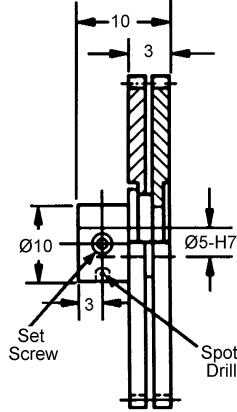

STAINLESS STEEL DIN 1.4305 STOCK NO.	ALUMINUM DIN 3.1355 STOCK NO.	NO. OF TEETH	PITCH DIA.	OUTSIDE DIA.
APGUM-85	APGVM-85	85	34.00	34.80
APGUM-90	APGVM-90	90	36.00	36.80
APGUM-95	APGVM-95	95	38.00	38.80
APGUM-96	APGVM-96	96	38.40	39.20
APGUM-100	APGVM-100	100	40.00	40.80
APGUM-105	APGVM-105	105	42.00	42.80
APGUM-108	APGVM-108	108	43.20	44.00
APGUM-110	APGVM-110	110	44.00	44.80
APGUM-115	APGVM-115	115	46.00	46.80
APGUM-120	APGVM-120	120	48.00	48.80
APGUM-125	APGVM-125	125	50.00	50.80
APGUM-128	APGVM-128	128	51.20	52.00
APGUM-130	APGVM-130	130	52.00	52.80
APGUM-140	APGVM-140	140	56.00	56.80
APGUM-150	APGVM-150	150	60.00	60.80
APGUM-160	APGVM-160	160	64.00	64.80
APGUM-170	APGVM-170	170	68.00	68.80
APGUM-176	APGVM-176	176	70.40	71.20
APGUM-180	APGVM-180	180	72.00	72.80
APGUM-190	APGVM-190	190	76.00	76.80
APGUM-192	APGVM-192	192	76.80	77.60
APGUM-200	APGVM-200	200	80.00	80.80

Available on request:
 Other numbers of teeth;
 Quality Class AGMA12 & 14 / DIN 5 & 3;
 14-1/2° Pressure Angle

Hub Material: Stainless Steel DIN 1.4305

**For Couplings See Section MG.
 For Shafts, Bearings and Collars See Section MI.**

ANTI-BACKLASH GEARS

MODULE	STYLE	BORE	FACE	MATERIAL	QUALITY	PRESSURE ANGLE
0.4	PIN HUB	5	3	STAINLESS STEEL DIN 1.4305 OR ALUMINUM DIN 3.1355 ANODIZED	DIN 7/AGMA 10	20°

B

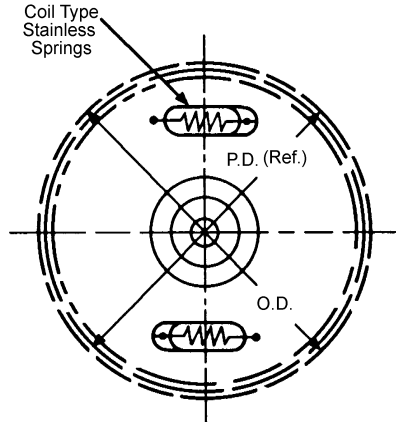
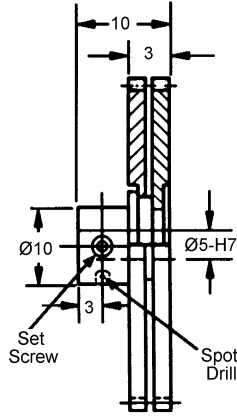

STAINLESS STEEL DIN 1.4305 STOCK NO.	ALUMINUM DIN 3.1355 STOCK NO.	NO. OF TEETH	PITCH DIA.	OUTSIDE DIA.
APGUM-85	APGVM-85	85	34.00	34.80
APGUM-90	APGVM-90	90	36.00	36.80
APGUM-95	APGVM-95	95	38.00	38.80
APGUM-96	APGVM-96	96	38.40	39.20
APGUM-100	APGVM-100	100	40.00	40.80
APGUM-105	APGVM-105	105	42.00	42.80
APGUM-108	APGVM-108	108	43.20	44.00
APGUM-110	APGVM-110	110	44.00	44.80
APGUM-115	APGVM-115	115	46.00	46.80
APGUM-120	APGVM-120	120	48.00	48.80
APGUM-125	APGVM-125	125	50.00	50.80
APGUM-128	APGVM-128	128	51.20	52.00
APGUM-130	APGVM-130	130	52.00	52.80
APGUM-140	APGVM-140	140	56.00	56.80
APGUM-150	APGVM-150	150	60.00	60.80
APGUM-160	APGVM-160	160	64.00	64.80
APGUM-170	APGVM-170	170	68.00	68.80
APGUM-176	APGVM-176	176	70.40	71.20
APGUM-180	APGVM-180	180	72.00	72.80
APGUM-190	APGVM-190	190	76.00	76.80
APGUM-192	APGVM-192	192	76.80	77.60
APGUM-200	APGVM-200	200	80.00	80.80

Available on request:
 Other numbers of teeth;
 Quality Class AGMA12 & 14 / DIN 5 & 3;
 14-1/2° Pressure Angle

Hub Material: Stainless Steel DIN 1.4305

For Couplings See Section MG.
For Shafts, Bearings and Collars See Section MI.

ANTI-BACKLASH GEARS

MODULE	STYLE	BORE	FACE	MATERIAL	QUALITY	PRESSURE ANGLE
0.4	PIN HUB	8	3	STAINLESS STEEL DIN 1.4305 OR ALUMINUM DIN 3.1355 ANODIZED	DIN 7/AGMA 10	20°

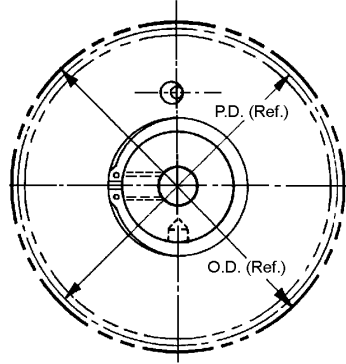
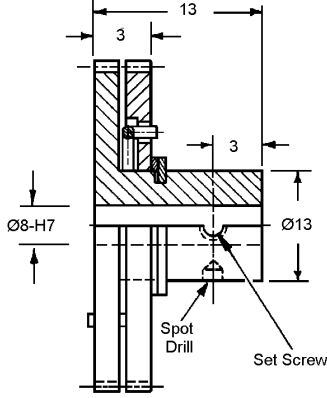

STAINLESS STEEL DIN 1.4305 STOCK NO.	ALUMINUM DIN 3.1355 STOCK NO.	NO. OF TEETH	PITCH DIA.	OUTSIDE DIA.
APGKSM-48-X	APGLSM-48-X	48	19.20	20.00
APGKSM-64-X	APGLSM-64-X	64	25.60	26.40

Available on request:
Other numbers of teeth;
Other Quality Classes;
14-1/2° Pressure Angle

Hub Material: Stainless Steel DIN 1.4305

MODULE	STYLE	BORE	FACE	MATERIAL	QUALITY	PRESSURE ANGLE
0.4	PIN HUB	8	3	STAINLESS STEEL DIN 1.4305 OR ALUMINUM DIN 3.1355 ANODIZED	DIN 7/AGMA 10	20°

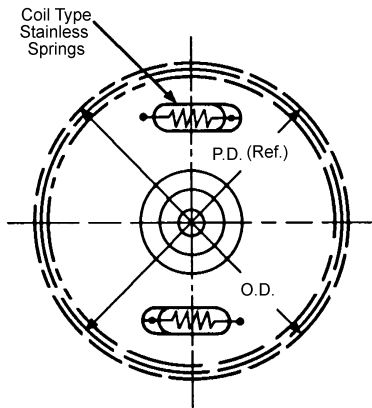
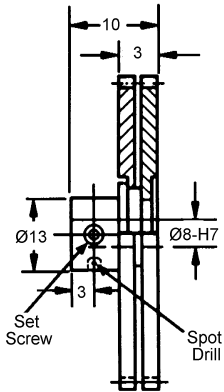

STAINLESS STEEL DIN 1.4305 STOCK NO.	ALUMINUM DIN 3.1355 STOCK NO.	NO. OF TEETH	PITCH DIA.	OUTSIDE DIA.
APGWM-85-X	APGXM-85-X	85	34.00	34.80
APGWM-90-X	APGXM-90-X	90	36.00	36.80
APGWM-95-X	APGXM-95-X	95	38.00	38.80
APGWM-96-X	APGXM-96-X	96	38.40	39.20
APGWM-100-X	APGXM-100-X	100	40.00	40.80
APGWM-105-X	APGXM-105-X	105	42.00	42.80
APGWM-108-X	APGXM-108-X	108	43.20	44.00
APGWM-110-X	APGXM-110-X	110	44.00	44.80
APGWM-115-X	APGXM-115-X	115	46.00	46.80
APGWM-120-X	APGXM-120-X	120	48.00	48.80
APGWM-125-X	APGXM-125-X	125	50.00	50.80
APGWM-128-X	APGXM-128-X	128	51.20	52.00
APGWM-130-X	APGXM-130-X	130	52.00	52.80
APGWM-140-X	APGXM-140-X	140	56.00	56.80
APGWM-150-X	APGXM-150-X	150	60.00	60.80
APGWM-160-X	APGXM-160-X	160	64.00	64.80
APGWM-170-X	APGXM-170-X	170	68.00	68.80
APGWM-176-X	APGXM-176-X	176	70.40	71.20
APGWM-180-X	APGXM-180-X	180	72.00	72.80
APGWM-190-X	APGXM-190-X	190	76.00	76.80
APGWM-192-X	APGXM-192-X	192	76.80	77.60
APGWM-200-X	APGXM-200-X	200	80.00	80.80

Available on request:
Other numbers of teeth;
Quality Class AGMA12 & 14 / DIN 5 & 3;
14-1/2° Pressure Angle

Hub Material: Stainless Steel DIN 1.4305



ANTI-BACKLASH GEARS

B

MODULE	STYLE	BORE	FACE	MATERIAL	QUALITY	PRESSURE ANGLE
0.4	CLAMP HUB	5	3	STAINLESS STEEL DIN 1.4305 OR ALUMINUM DIN 3.1355 ANODIZED	DIN 7/AGMA 10	20°

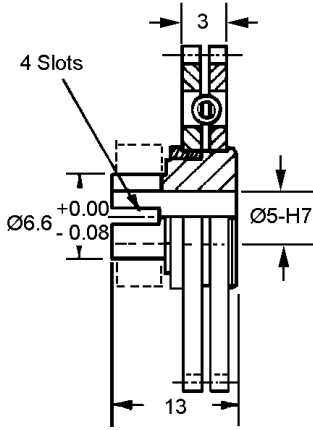

STAINLESS STEEL DIN 1.4305 STOCK NO.	ALUMINUM DIN 3.1355 STOCK NO.	NO. OF TEETH	PITCH DIA.	OUTSIDE DIA.
ACGHSM-40	ACGJSM-40	40	16.00	16.80
ACGHSM-48	ACGJSM-48	48	19.20	20.00
ACGHSM-64	ACGJSM-64	64	25.60	26.40

Available on request:
Other numbers of teeth;
Other Quality Classes;
14-1/2° Pressure Angle

Hub Material: Stainless Steel DIN 1.4305

MODULE	STYLE	BORE	FACE	MATERIAL	QUALITY	PRESSURE ANGLE
0.4	CLAMP HUB	5	3	STAINLESS STEEL DIN 1.4305 OR ALUMINUM DIN 3.1355 ANODIZED	DIN 7/AGMA 10	20°

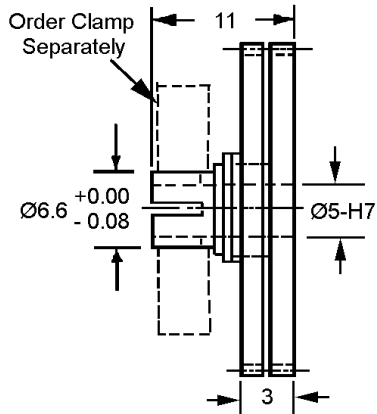

STAINLESS STEEL DIN 1.4305 STOCK NO.	ALUMINUM DIN 3.1355 STOCK NO.	NO. OF TEETH	PITCH DIA.	OUTSIDE DIA.
ACGUM-85	ACGVM-85	85	34.00	34.80
ACGUM-90	ACGVM-90	90	36.00	36.80
ACGUM-95	ACGVM-95	95	38.00	38.80
ACGUM-96	ACGVM-96	96	38.40	39.20
ACGUM-100	ACGVM-100	100	40.00	40.80
ACGUM-105	ACGVM-105	105	42.00	42.80
ACGUM-108	ACGVM-108	108	43.20	44.00
ACGUM-110	ACGVM-110	110	44.00	44.80
ACGUM-115	ACGVM-115	115	46.00	46.80
ACGUM-120	ACGVM-120	120	48.00	48.80
ACGUM-125	ACGVM-125	125	50.00	50.80
ACGUM-128	ACGVM-128	128	51.20	52.00
ACGUM-130	ACGVM-130	130	52.00	52.80
ACGUM-140	ACGVM-140	140	56.00	56.80
ACGUM-150	ACGVM-150	150	60.00	60.80
ACGUM-160	ACGVM-160	160	64.00	64.80
ACGUM-170	ACGVM-170	170	68.00	68.80
ACGUM-176	ACGVM-176	176	70.40	71.20
ACGUM-180	ACGVM-180	180	72.00	72.80
ACGUM-190	ACGVM-190	190	76.00	76.80
ACGUM-192	ACGVM-192	192	76.80	77.60
ACGUM-200	ACGVM-200	200	80.00	80.80

Available on request:
Other numbers of teeth;
Other Quality Classes;
14-1/2° Pressure Angle

Hub Material: Stainless Steel DIN 1.4305

For Couplings See Section MG.
For Shafts, Bearings and Collars See Section MI.

ANTI-BACKLASH GEARS

MODULE	STYLE	BORE	FACE	MATERIAL	QUALITY	PRESSURE ANGLE
0.4	CLAMP HUB	8	3	STAINLESS STEEL DIN 1.4305 OR ALUMINUM DIN 3.1355 ANODIZED	DIN 7/AGMA 10	20°

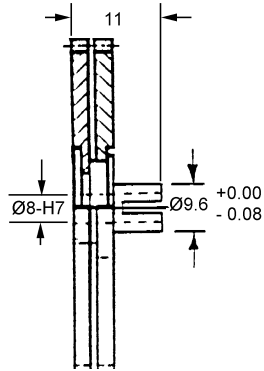

STAINLESS STEEL DIN 1.4305 STOCK NO.	ALUMINUM DIN 3.1355 STOCK NO.	NO. OF TEETH	PITCH DIA.	OUTSIDE DIA.
ACGKSM-48-X	ACGJSM-48	48	19.20	20.00
ACGKSM-64-X	ACGJSM-64	64	25.60	26.40

Available on request:
Other numbers of teeth;
Other Quality Classes;
14-1/2° Pressure Angle

Hub Material: Stainless Steel DIN 1.4305

MODULE	STYLE	BORE	FACE	MATERIAL	QUALITY	PRESSURE ANGLE
0.4	CLAMP HUB	8	3	STAINLESS STEEL DIN 1.4305 OR ALUMINUM DIN 3.1355 ANODIZED	DIN 7/AGMA 10	20°

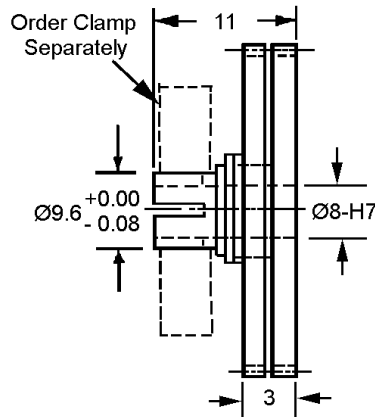

STAINLESS STEEL DIN 1.4305 STOCK NO.	ALUMINUM DIN 3.1355 STOCK NO.	NO. OF TEETH	PITCH DIA.	OUTSIDE DIA.
ACGWM-85-X	ACGXM-85-X	85	34.00	34.80
ACGWM-90-X	ACGXM-90-X	90	36.00	36.80
ACGWM-95-X	ACGXM-95-X	95	38.00	38.80
ACGWM-96-X	ACGXM-96-X	96	38.40	39.20
ACGWM-100-X	ACGXM-100-X	100	40.00	40.80
ACGWM-105-X	ACGXM-105-X	105	42.00	42.80
ACGWM-108-X	ACGXM-108-X	108	43.20	44.00
ACGWM-110-X	ACGXM-110-X	110	44.00	44.80
ACGWM-115-X	ACGXM-115-X	115	46.00	46.80
ACGWM-120-X	ACGXM-120-X	120	48.00	48.80
ACGWM-125-X	ACGXM-125-X	125	50.00	50.80
ACGWM-128-X	ACGXM-128-X	128	51.20	52.00
ACGWM-130-X	ACGXM-130-X	130	52.00	52.80
ACGWM-140-X	ACGXM-140-X	140	56.00	56.80
ACGWM-150-X	ACGXM-150-X	150	60.00	60.80
ACGWM-160-X	ACGXM-160-X	160	64.00	64.80
ACGWM-170-X	ACGXM-170-X	170	68.00	68.80
ACGWM-176-X	ACGXM-176-X	176	70.40	71.20
ACGWM-180-X	ACGXM-180-X	180	72.00	72.80
ACGWM-190-X	ACGXM-190-X	190	76.00	76.80
ACGWM-192-X	ACGXM-192-X	192	76.80	77.60
ACGWM-200-X	ACGXM-200-X	200	80.00	80.80

Available on request:
Other numbers of teeth;
Other Quality Classes;
14-1/2° Pressure Angle

Hub Material: Stainless Steel DIN 1.4305

SPUR GEAR STOCK

MODULE	STYLE	MATERIAL	PRESSURE ANGLE
0.4	PINION WIRE	BRASS ALLOY	20°

B

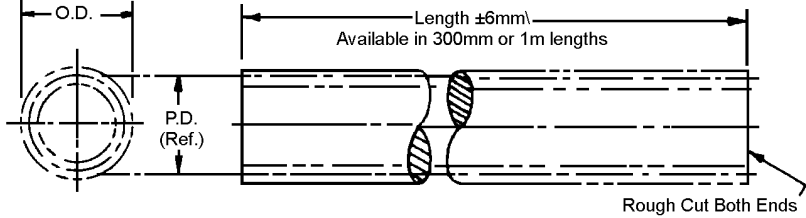

1 METER. LONG STOCK NO.	300mm LONG STOCK NO.	NO. OF TEETH	PITCH DIA.	OUTSIDE DIA.
PWPGGB-13	PWPGGB-13A	13	5.20	6.00
PWPGGB-16	PWPGGB-16A	16	6.40	7.20
PWPGGB-18	PWPGGB-18A	18	7.20	8.00

Available on request:
Other numbers of teeth;
14-1/2° Pressure Angle

Hub Material: Stainless Steel DIN 1.4305

SPUR GEARS

MODULE	STYLE	BORE	FACE	MATERIAL	QUALITY	PRESSURE ANGLE
0.3	HUBLESS	10	3	STAINLESS STEEL DIN 1.4305 OR ALUMINUM DIN 3.1355 ANODIZED	DIN 7/AGMA 10	20°

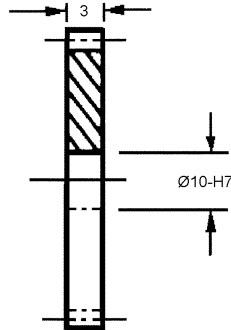
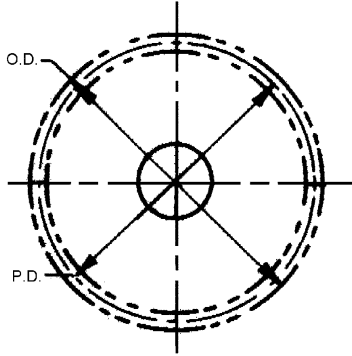

STAINLESS STEEL DIN 1.4305 STOCK NO.	ALUMINUM DIN 3.1355 ANODIZED STOCK NO.	NO. OF TEETH	PITCH DIA.	OUTSIDE DIA.
FHS103-72	FHA103-72	72	21.60	22.20
FHS103-80	FHA103-80	80	24.00	24.60
FHS103-81	FHA103-81	81	24.30	24.90
FHS103-90	FHA103-90	90	27.00	27.60
FHS103-96	FHA103-96	96	28.80	29.40
FHS103-99	FHA103-99	99	29.70	30.30
FHS103-100	FHA103-100	100	30.00	30.60
FHS103-108	FHA103-108	108	32.40	33.00
FHS103-115	FHA103-115	115	34.50	35.10
FHS103-130	FHA103-130	130	39.00	39.60
FHS103-135	FHA103-135	135	40.50	41.10
FHS103-140	FHA103-140	140	42.00	42.60
FHS103-144	FHA103-144	144	43.20	43.80
FHS103-150	FHA103-150	150	45.00	45.60
FHS103-160	FHA103-160	160	48.00	48.60
FHS103-180	FHA103-180	180	54.00	54.60
FHS103-192	FHA103-192	192	57.60	58.20
FHS103-200	FHA103-200	200	60.00	60.60
FHS103-216	FHA103-216	216	64.80	65.40
FHS103-288	FHA103-288	288	86.40	87.00

Available on request:
Other numbers of teeth;
Quality Class AGMA 12 & 14 / DIN 5 & 3;
14-1/2° Pressure Angle

MODULE	STYLE	BORE	FACE	MATERIAL	QUALITY	PRESSURE ANGLE
0.3	HUBLESS	10	6	POLYURETHANE	DIN 7/AGMA 10	20°

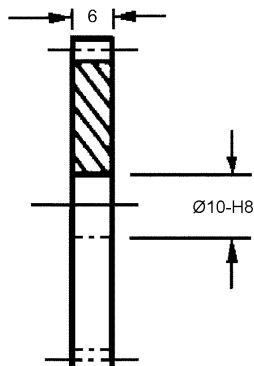
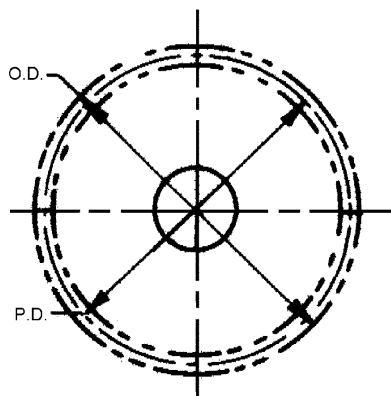

STOCK NO.	NO. OF TEETH	PITCH DIA.	OUTSIDE DIA.
FHU103-72	72	21.60	22.20
FHU103-96	96	28.80	29.40
FHU103-100	100	30.00	30.60
FHU103-108	108	32.40	33.00
FHU103-120	120	36.00	36.60
FHU103-125	125	37.50	38.10
FHU103-135	135	40.50	41.10
FHU103-140	140	32.00	42.60
FHU103-150	150	45.00	45.60

Available on request:
Other numbers of teeth;
Quality Class AGMA 12 & 14 / DIN 5 & 3;
14 - 1/2° pressure angle.

SPUR GEARS

MODULE	STYLE	BORE	FACE	MATERIAL	QUALITY	PRESSURE ANGLE
0.3	PIN HUB	3	3	STAINLESS STEEL DIN 1.4305 OR ALUMINUM DIN 3.1355 ANODIZED	DIN 7/AGMA 10	20°

B

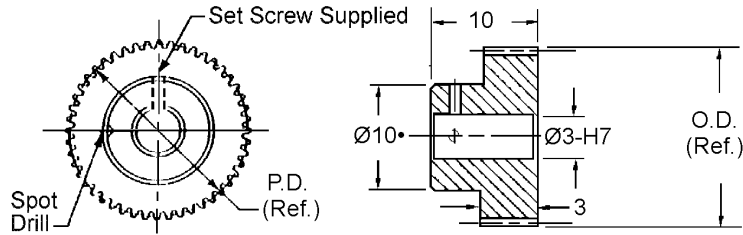

STAINLESS STEEL STOCK NO.	ALUMINUM STOCK NO.	NO. OF TEETH	PITCH DIA.	OUTSIDE DIA.
PHS80-26	PHA80-26	26•	7.80	8.40
PHS80-27	PHA80-27	27•	8.10	8.70
PHS80-28	PHA80-28	28•	8.40	9.00
PHS80-29	PHA80-29	29•	8.70	9.30
PHS80-30	PHA80-30	30•	9.00	9.60
PHS80-32	PHA80-32	32•	9.60	10.20
PHS80-34	PHA80-34	34•	10.20	10.80
PHS80-36	PHA80-36	36•	10.80	11.40
PHS80-38	PHA80-38	38	11.40	12.00
PHS80-40	PHA80-40	40	12.00	12.60
PHS80-42	PHA80-42	42	12.60	13.20
PHS80-44	PHA80-44	44	13.20	13.80
PHS80-45	PHA80-45	45	13.50	14.10
PHS80-46	PHA80-46	46	13.80	14.40
PHS80-48	PHA80-48	48	14.40	15.00
PHS80-50	PHA80-50	50	15.00	15.60
PHS80-54	PHA80-54	54	16.20	16.80
PHS80-56	PHA80-56	56	16.80	17.40
PHS80-60	PHA80-60	60	18.00	18.60
PHS80-64	PHA80-64	64	19.20	19.80
PHS80-70	PHA80-70	70	21.00	21.60
PHS80-72	PHA80-72	72	21.60	22.20
PHS80-75	PHA80-75	75	22.50	23.10
PHS80-80	PHA80-80	80	24.00	24.60
PHS80-84	PHA80-84	84	25.20	25.80
PHS80-85	PHA80-85	85	25.50	26.10
PHS80-90	PHA80-90	90	27.00	27.60
PHS80-92	PHA80-92	92	27.60	28.20
PHS80-96	PHA80-96	96	28.80	29.40
PHS80-100	PHA80-100	100	30.00	30.60
PHS80-110	PHA80-110	110	33.00	33.60
PHS80-117	PHA80-117	117	35.10	35.70
PHS80-120	PHA80-120	120	36.00	36.60
PHS80-130	PHA80-130	130	39.00	39.60
PHS80-144	PHA80-144	144	43.20	43.80

Available on request:
Other numbers of teeth;
14 - 1/2° pressure angle;
Quality Class AGMA 12 and 14 / DIN 5 and 3

• For 26-36 teeth hub diameter equals 5.4

For Couplings See Section MG.
For Shafts, Bearings and Collars See Section MI.

SPUR GEARS

MODULE	STYLE	BORE	FACE	MATERIAL	QUALITY	PRESSURE ANGLE
0.3	PIN HUB	5	3	STAINLESS STEEL DIN 1.4305 OR ALUMINUM DIN 3.1355 ANODIZED	DIN 7/AGMA 10	20°

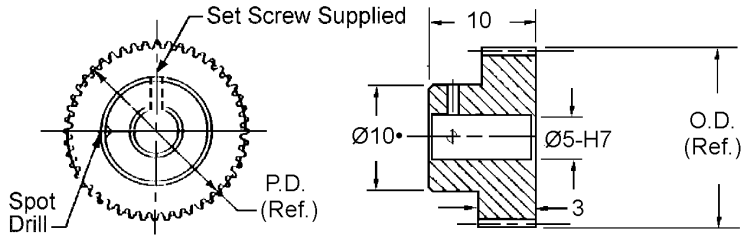

Available on request:
Other numbers of teeth;
14 - 1/2° pressure angle;
Quality Class AGMA 12 and 14 / DIN 5 and 3

• For 30-36 teeth hub diameter equals 8.1

STAINLESS STEEL STOCK NO.	ALUMINUM STOCK NO.	NO. OF TEETH	PITCH DIA.	OUTSIDE DIA.
PHS82-30	PHA82-30	30*	9.00	9.60
PHS82-32	PHA82-32	32*	9.60	10.20
PHS82-36	PHA82-36	36*	10.80	11.40
PHS82-38	PHA82-38	38	11.40	12.00
PHS82-40	PHA82-40	40	12.00	12.60
PHS82-42	PHA82-42	42	12.60	13.20
PHS82-44	PHA82-44	44	13.20	13.80
PHS82-45	PHA82-45	45	13.50	14.10
PHS82-46	PHA82-46	46	13.80	14.40
PHS82-48	PHA82-48	48	14.40	15.00
PHS82-50	PHA82-50	50	15.00	15.60
PHS82-54	PHA82-54	54	16.20	16.80
PHS82-55	PHA82-55	55	16.50	17.10
PHS82-56	PHA82-56	56	16.80	17.40
PHS82-60	PHA82-60	60	18.00	18.60
PHS82-64	PHA82-64	64	19.20	19.80
PHS82-70	PHA82-70	70	21.00	21.60
PHS82-72	PHA82-72	72	21.60	22.20
PHS82-75	PHA82-75	75	22.50	23.10
PHS82-80	PHA82-80	80	24.00	24.60
PHS82-81	PHA82-81	81	24.30	24.90
PHS82-90	PHA82-90	90	27.00	27.60
PHS82-96	PHA82-96	96	28.80	29.40
PHS82-99	PHA82-99	99	29.70	30.30
PHS82-100	PHA82-100	100	30.00	30.60
PHS82-108	PHA82-108	108	32.40	33.00
PHS82-110	PHA82-110	110	33.00	33.60
PHS82-120	PHA82-120	120	36.00	36.60
PHS82-126	PHA82-126	126	37.80	38.40
PHS82-130	PHA82-130	130	39.00	39.60
PHS82-140	PHA82-140	140	42.00	42.60
PHS82-144	PHA82-144	144	43.20	43.80
PHS82-150	PHA82-150	150	45.00	45.60
PHS82-153	PHA82-153	153	45.90	46.50
PHS82-162	PHA82-162	162	48.60	49.20
PHS82-168	PHA82-168	168	50.40	51.00
PHS82-170	PHA82-170	170	51.00	51.60
PHS82-180	PHA82-180	180	54.00	54.60
PHS82-198	PHA82-198	198	59.40	60.00
PHS82-200	PHA82-200	200	60.00	60.60
PHS82-216	PHA82-216	216	64.80	65.40

For Couplings See Section MG.
For Shafts, Bearings and Collars See Section MI.

SPUR GEARS

MODULE	STYLE	BORE	FACE	MATERIAL	QUALITY	PRESSURE ANGLE
0.3	PIN HUB	8	5	STAINLESS STEEL DIN 1.4305 OR ALUMINUM DIN 3.1355 ANODIZED	DIN 7/AGMA 10	20°

B

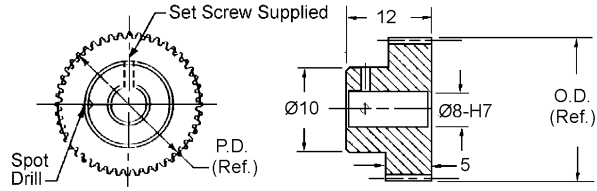

STAINLESS STEEL STOCK NO.	ALUMINUM STOCK NO.	NO. OF TEETH	PITCH DIA.	OUTSIDE DIA.
PHS95-44	PHA95-44	44	13.20	13.80
PHS95-45	PHA95-45	45	13.50	14.10
PHS95-46	PHA95-46	46	13.80	14.40
PHS95-48	PHA95-48	48	14.40	15.00
PHS95-50	PHA95-50	50	15.00	15.60
PHS95-54	PHA95-54	54	16.20	16.80
PHS95-55	PHA95-55	55	16.50	17.10
PHS95-60	PHA95-60	60	18.00	18.60
PHS95-63	PHA95-63	63	18.90	19.50
PHS95-64	PHA95-64	64	19.20	19.80
PHS95-65	PHA95-65	65	19.50	20.10
PHS95-70	PHA95-70	70	21.00	21.60
PHS95-72	PHA95-72	72	21.60	22.20
PHS95-80	PHA95-80	80	24.00	24.60
PHS95-90	PHA95-90	90	27.00	27.60
PHS95-96	PHA95-96	96	28.80	29.40
PHS95-100	PHA95-100	100	30.00	30.60
PHS95-105	PHA95-105	105	31.50	32.10
PHS95-110	PHA95-110	110	33.00	33.60
PHS95-120	PHA95-120	120	36.00	36.60
PHS95-126	PHA95-126	126	37.80	38.40
PHS95-130	PHA95-130	130	39.00	39.60
PHS95-136	PHA95-136	136	40.80	41.40
PHS95-140	PHA95-140	140	42.00	42.60
PHS95-150	PHA95-150	150	45.00	45.60
PHS95-160	PHA95-160	160	48.00	48.60
PHS95-170	PHA95-170	170	51.00	51.60
PHS95-180	PHA95-180	180	54.00	54.60

Available on request:
Other numbers of teeth;
14 - 1/2° pressure angle;
Quality Class AGMA 12 and 14 / DIN 5 and 3

For Couplings See Section MG.
For Shafts, Bearings and Collars See Section MI.

SPUR GEARS

MODULE	STYLE	BORE	FACE	MATERIAL	QUALITY	PRESSURE ANGLE
0.3	CLAMP HUB	3	3	STAINLESS STEEL DIN 1.4305 OR ALUMINUM DIN 3.1355 ANODIZED	DIN 7/AGMA 10	20°

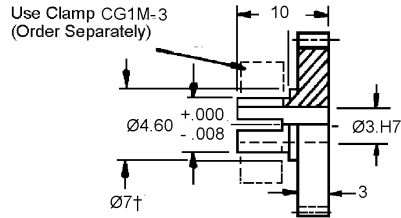
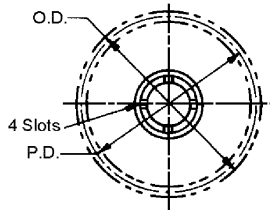

STAINLESS STEEL STOCK NO.	ALUMINUM STOCK NO.	NO. OF TEETH	PITCH DIA.	OUTSIDE DIA.
CHS50-22	CHA50-22	22†	6.60	7.20
CHS50-23	CHA50-23	23†	6.90	7.50
CHS50-25	CHA50-25	25†	7.50	8.10
CHS50-26	CHA50-26	26	7.80	8.40
CHS50-27	CHA50-27	27	8.10	8.70
CHS50-28	CHA50-28	28	8.40	9.00
CHS50-30	CHA50-30	30	9.00	9.60
CHS50-32	CHA50-32	32	9.60	10.20
CHS50-34	CHA50-34	34	10.20	10.80
CHS50-36	CHA50-36	36	10.80	11.40
CHS50-38	CHA50-38	38	11.40	12.00
CHS50-40	CHA50-40	40	12.00	12.60
CHS50-42	CHA50-42	42	12.60	13.20
CHS50-50	CHA50-50	50	15.00	15.60
CHS50-56	CHA50-56	56	16.80	17.40
CHS50-60	CHA50-60	60	18.00	18.60
CHS50-64	CHA50-64	64	19.20	19.80
CHS50-70	CHA50-70	70	21.00	21.60
CHS50-72	CHA50-72	72	21.60	22.20
CHS50-75	CHA50-75	75	22.50	23.10
CHS50-80	CHA50-80	80	24.00	24.60
CHS50-81	CHA50-81	81	24.30	24.90
CHS50-85	CHA50-85	85	25.50	26.10
CHS50-90	CHA50-90	90	27.00	27.80
CHS50-96	CHA50-96	96	28.80	29.40

Available on request:
 Other bore sizes;
 numbers of teeth;
 14-12° Pressure Angle;
 Quality Class DIN 5/AGMA12

†Teeth may runout on flange diameter.

**For Couplings See Section MG.
 For Shafts, Bearings and Collars See Section MI.**

SPUR GEARS

MODULE	STYLE	BORE	FACE	MATERIAL	QUALITY	PRESSURE ANGLE
0.3	CLAMP HUB	5	3	STAINLESS STEEL DIN 1.4305 OR ALUMINUM DIN 3.1355 ANODIZED	DIN 7/AGMA 10	20°

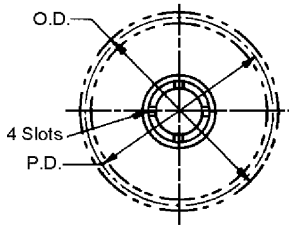

Use Clamp CG1M-9 (Order Separately)

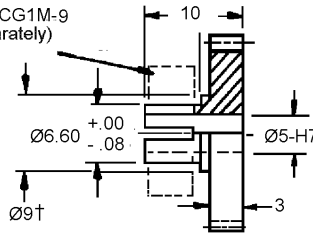

STAINLESS STEEL STOCK NO.	ALUMINUM STOCK NO.	NO. OF TEETH	PITCH DIA.	OUTSIDE DIA.
CHS52-30	CHA52-30	30†	9.00	9.60
CHS52-36	CHA52-36	36	10.80	11.40
CHS52-72	CHA52-72	72	21.60	22.20
CHS52-100	CHA52-100	100	30.00	30.60
CHS52-126	CHA52-126	126	37.80	38.40
CHS52-160	CHA52-160	160	48.00	48.60
CHS52-180	CHA52-180	180	54.00	54.60
CHS52-216	CHA52-216	216	64.80	65.40
CHS52-288	CHA52-288	288	86.40	87.00

Available on request:
Other bore sizes;
numbers of teeth;
14-12° Pressure Angle;
Quality Class DIN 5/AGMA12

†Teeth may runout on flange diameter.

MODULE	STYLE	BORE	FACE	MATERIAL	QUALITY	PRESSURE ANGLE
0.3	CLAMP HUB	8	3	STAINLESS STEEL DIN 1.4305 OR ALUMINUM DIN 3.1355 ANODIZED	DIN 7/AGMA 10	20°

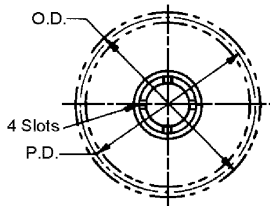

Use Clamp CG1M-14 (Order Separately)

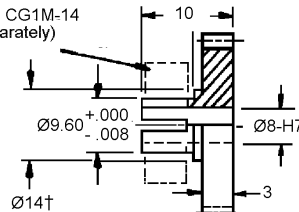

STAINLESS STEEL STOCK NO.	ALUMINUM STOCK NO.	NO. OF TEETH	PITCH DIA.	OUTSIDE DIA.
CHS64-45	CHA64-45	45†	13.50	14.10
CHS64-63	CHA64-63	63	18.90	19.50
CHS64-72	CHA64-72	72	21.60	22.20
CHS64-90	CHA64-90	90	27.70	27.60
CHS64-99	CHA64-99	99	29.70	30.30
CHS64-108	CHA64-108	108	32.40	33.00
CHS64-126	CHA64-126	126	37.80	38.40
CHS64-144	CHA64-144	144	43.20	43.80
CHS64-180	CHA64-180	180	54.00	54.60
CHS64-216	CHA64-216	216	64.80	65.40
CHS64-288	CHA64-288	288	86.40	87.00

Available on request:
Other bore sizes;
numbers of teeth;
14-12° Pressure Angle;
Quality Class DIN 5/AGMA12

†Teeth may runout on flange diameter.

**For Couplings See Section MG.
For Shafts, Bearings and Collars See Section MI.**

GEAR RACKS

MODULE	STYLE	MATERIAL	QUALITY	PRESSURE ANGLE
0.3	ROUND & RECTANGULAR	STAINLESS STEEL DIN 1.4005	DIN 7/AGMA 10	20°

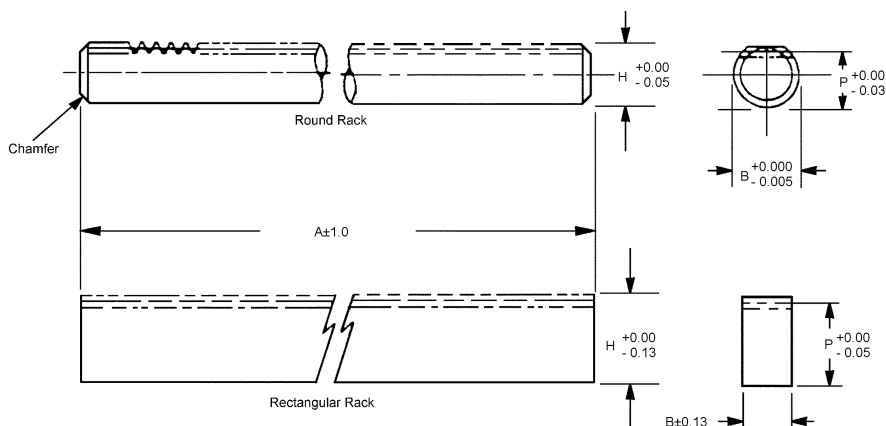

STOCK NO.	RACK STYLE	MOD.	P (Ref.)	B	A	H
R2M-8	ROUND	0.3	3.66	4.755	275	3.96
R3M-8	RECTANGULAR	0.3	8.72	4.24	275	9.02

Available on request: Special, modified and custom racks.

MODULE	STYLE	MATERIAL	QUALITY	PRESSURE ANGLE
0.3	RECTANGULAR	STAINLESS STEEL DIN 1.4005	DIN 7/AGMA 10	20°

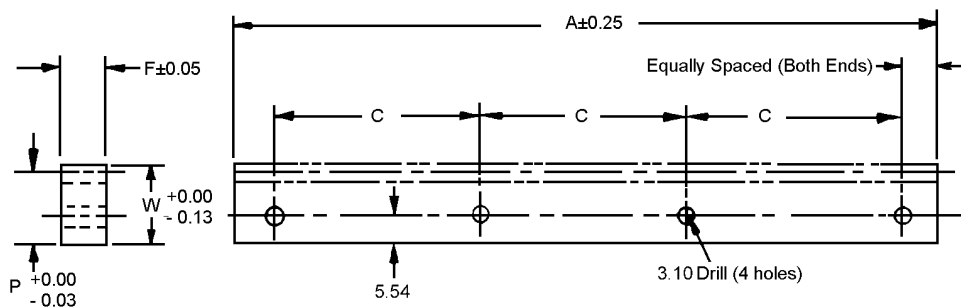

STOCK NO.	A	P (Ref.)	W	F	C
R4M-23	124.4	8.7	9.0	4.2	35.0

Available on request: special, modified and custom racks.

Quality Class AGMA12/DIN 5 available on request.

GEAR RACKS

MODULE	STYLE	MATERIAL	QUALITY	PRESSURE ANGLE
0.3	RECTANGULAR	STAINLESS STEEL DIN 1.4005	DIN 7/AGMA 10	20°

B

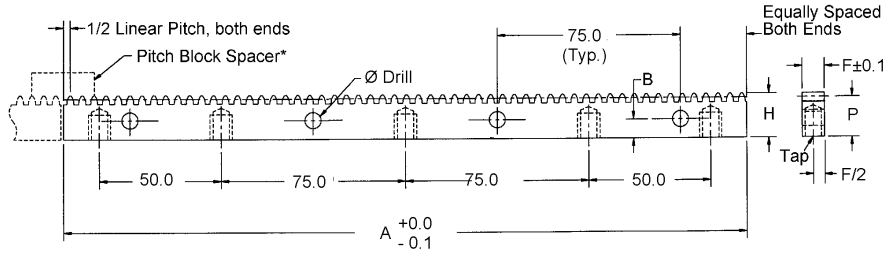

Spacer block is designed for butting to achieve continuous lengths.

RACKS	SPACER BLOCK								
STOCK NO.	STOCK NO.	LINEAR PITCH	A	P (REF.)	H +0.00 -0.13	F	B	Ø DRILL	TAP
R1M-8	R1M-8-SB	0.94	280.9	8.59	8.89	4.2	4.0	3.1	M3.0 X 0.5

Quality Class AGMA 12/Din 5 available on request. Custom racks available on request.

ANTI-BACKLASH GEARS

MODULE	STYLE	BORE	FACE	MATERIAL	QUALITY	PRESSURE ANGLE
0.3	PIN HUB	3	3	STAINLESS STEEL DIN 1.4305 OR ALUMINUM DIN 3.1355 ANODIZED	DIN 7/AGMA 10	20°

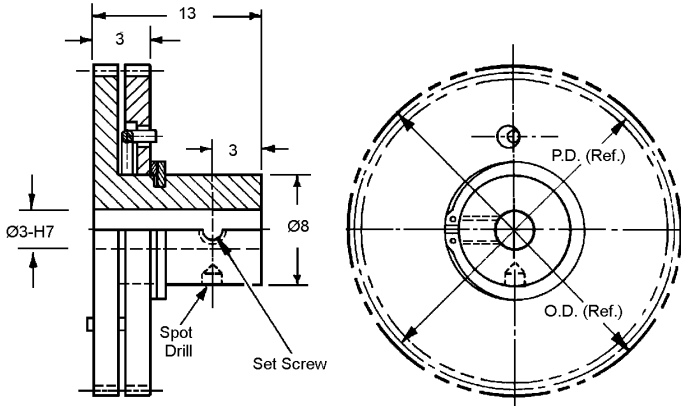

Available on request:
Other numbers of teeth;
Other Quality Classes;
14-1/2° Pressure Angle

Hub Material: Stainless Steel DIN 1.4305

STAINLESS STEEL DIN 1.4305 STOCK NO.	ALUMINUM DIN 3.1355 STOCK NO.	NO. OF TEETH	PITCH DIA.	OUTSIDE DIA.
APHFSM-44	APHGSM-44	44	13.20	13.80
APHFSM-56	APHGSM-56	56	16.80	17.40
APHFSM-72	APHGSM-72	72	21.60	22.20

MODULE	STYLE	BORE	FACE	MATERIAL	QUALITY	PRESSURE ANGLE
0.3	PIN HUB	5	3	STAINLESS STEEL DIN 1.4305 OR ALUMINUM DIN 3.1355 ANODIZED	DIN 7/AGMA 10	20°

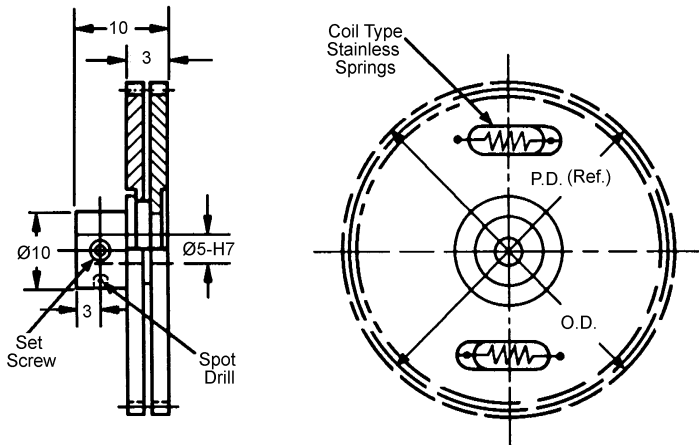

STAINLESS STEEL DIN 1.4305 STOCK NO.	ALUMINUM DIN 3.1355 STOCK NO.	NO. OF TEETH	PITCH DIA.	OUTSIDE DIA.
APHUM-130	APHVM-130	130	39.00	39.60
APHUM-135	APHVM-135	135	40.50	41.10
APHUM-140	APHVM-140	140	42.00	42.60
APHUM-144	APHVM-144	144	43.20	43.80
APHUM-145	APHVM-145	145	43.50	44.10
APHUM-150	APHVM-150	150	45.00	45.60
APHUM-160	APHVM-160	160	48.00	48.60
APHUM-170	APHVM-170	170	51.00	51.60
APHUM-180	APHVM-180	180	54.00	54.60
APHUM-190	APHVM-190	190	57.00	57.60
APHUM-192	APHVM-192	192	57.60	58.20
APHUM-200	APHVM-200	200	60.00	60.60
APHUM-210	APHVM-210	210	63.00	63.60
APHUM-220	APHVM-220	220	66.00	66.60
APHUM-230	APHVM-230	230	69.00	69.60
APHUM-240	APHVM-240	240	72.00	72.60
ACHUM-250	ACHVM-250	250	75.00	75.60

Available on request:
Other numbers of teeth;
Quality Class AGMA12 & 14 / DIN 5 & 3;
14-1/2° Pressure Angle

Hub Material: Stainless Steel DIN 1.4305



ANTI-BACKLASH GEARS

B

MODULE	STYLE	BORE	FACE	MATERIAL	QUALITY	PRESSURE ANGLE
0.3	PIN HUB	5	3	STAINLESS STEEL DIN 1.4305 OR ALUMINUM DIN 3.1355 ANODIZED	DIN 7/AGMA 10	20°

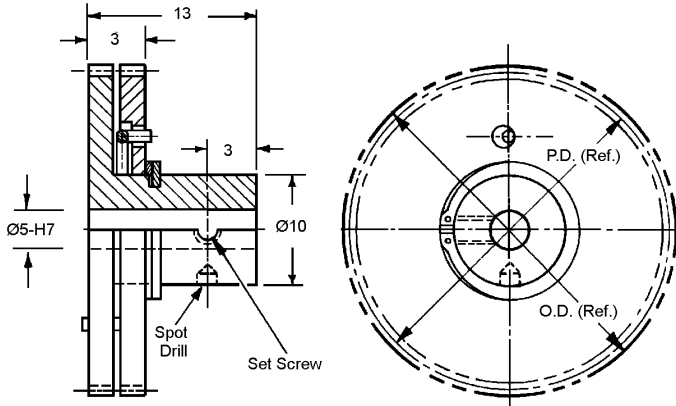

Available on request:
Other numbers of teeth;
Other Quality Classes;
14-1/2° Pressure Angle

Hub Material: Stainless Steel DIN 1.4305

STAINLESS STEEL DIN 1.4305 STOCK NO.	ALUMINUM DIN 3.1355 STOCK NO.	NO. OF TEETH	PITCH DIA.	OUTSIDE DIA.
APHHSM-44	APHJSM-44	44	13.20	13.80
APHHSM-56	APHJSM-56	56	16.80	17.40
APHHSM-72	APHJSM-72	72	21.60	22.20

MODULE	STYLE	BORE	FACE	MATERIAL	QUALITY	PRESSURE ANGLE
0.3	PIN HUB	8	3	STAINLESS STEEL DIN 1.4305 OR ALUMINUM DIN 3.1355 ANODIZED	DIN 7/AGMA 10	20°

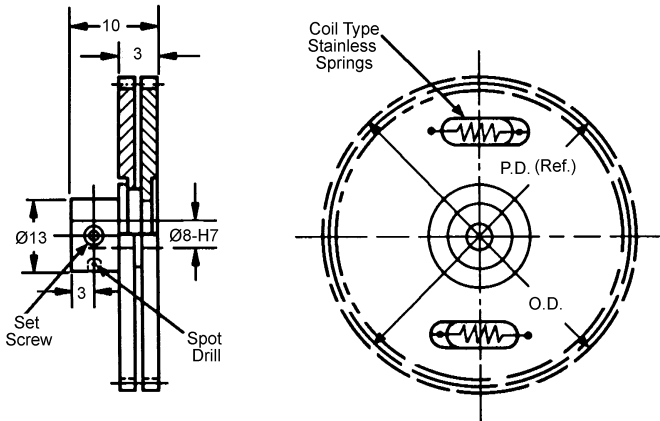

STAINLESS STEEL DIN 1.4305 STOCK NO.	ALUMINUM DIN 3.1355 STOCK NO.	NO. OF TEETH	PITCH DIA.	OUTSIDE DIA.
APHWM-130-X	APHXM-130-X	130	39.00	39.60
APHWM-135-X	APHXM-135-X	135	40.50	41.10
APHWM-140-X	APHXM-140-X	140	42.00	42.60
APHWM-144-X	APHXM-144-X	144	43.20	43.80
APHWM-145-X	APHXM-145-X	145	43.50	44.10
APHWM-150-X	APHXM-150-X	150	45.00	45.60
APHWM-160-X	APHXM-160-X	160	48.00	48.60
APHWM-170-X	APHXM-170-X	170	51.00	51.60
APHWM-180-X	APHXM-180-X	180	54.00	54.60
APHWM-190-X	APHXM-190-X	190	57.00	57.60
APHWM-192-X	APHXM-192-X	192	57.60	58.20
APHWM-200-X	APHXM-200-X	200	60.00	60.60
APHWM-210-X	APHXM-210-X	210	63.00	63.60
APHWM-220-X	APHXM-220-X	220	66.00	66.60
APHWM-230-X	APHXM-230-X	230	69.00	69.60
APHWM-240-X	APHXM-240-X	240	72.00	72.60
APHWM-250-X	APHXM-250-X	250	75.00	75.60

Available on request:
Other numbers of teeth;
Quality Class AGMA12 & 14 / DIN 5 & 3;
14-1/2° Pressure Angle

Hub Material: Stainless Steel DIN 1.4305



ANTI-BACKLASH GEARS

MODULE	STYLE	BORE	FACE	MATERIAL	QUALITY	PRESSURE ANGLE
0.3	CLAMP HUB	3	3	STAINLESS STEEL DIN 1.4305 OR ALUMINUM DIN 3.1355 ANODIZED	DIN 7/AGMA 10	20°

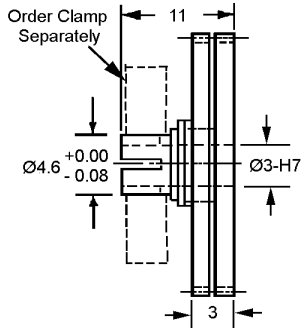

STAINLESS STEEL DIN 1.4305 STOCK NO.	ALUMINUM DIN 3.1355 STOCK NO.	NO. OF TEETH	PITCH DIA.	OUTSIDE DIA.
ACHFSM-44	ACHGSM-44	44	13.20	13.80
ACHFSM-56	ACHGSM-56	56	16.80	17.40
ACHFSM-72	ACHGSM-72	72	21.60	22.20

Available on request:
Other numbers of teeth;
Other Quality Classes;
14-1/2° Pressure Angle

Hub Material: Stainless Steel DIN 1.4305

MODULE	STYLE	BORE	FACE	MATERIAL	QUALITY	PRESSURE ANGLE
0.3	CLAMP HUB	5	3	STAINLESS STEEL DIN 1.4305 OR ALUMINUM DIN 3.1355 ANODIZED	DIN 7/AGMA 10	20°

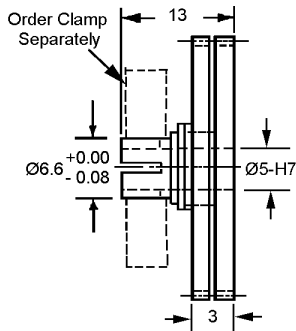

STAINLESS STEEL DIN 1.4305 STOCK NO.	ALUMINUM DIN 3.1355 STOCK NO.	NO. OF TEETH	PITCH DIA.	OUTSIDE DIA.
ACHHSM-44	ACHJSM-44	44	13.20	13.80
ACHHSM-56	ACHJSM-56	56	16.80	17.40
ACHHSM-72	ACHJSM-72	72	21.60	22.20

Available on request:
Other numbers of teeth;
Other Quality Classes;
14-1/2° Pressure Angle

Hub Material: Stainless Steel DIN 1.4305

For Couplings See Section MG.
For Shafts, Bearings and Collars See Section MI.

ANTI-BACKLASH GEARS

B

MODULE	STYLE	BORE	FACE	MATERIAL	QUALITY	PRESSURE ANGLE
0.3	CLAMP HUB	5	3	STAINLESS STEEL DIN 1.4305 OR ALUMINUM DIN 3.1355 ANODIZED	DIN 7/AGMA 10	20°

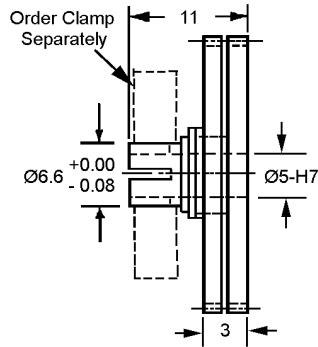

STAINLESS STEEL DIN 1.4305 STOCK NO.	ALUMINUM DIN 3.1355 STOCK NO.	NO. OF TEETH	PITCH DIA.	OUTSIDE DIA.
ACHUM-130	ACHVM-130	130	39.00	39.60
ACHUM-135	ACHVM-135	135	40.50	41.10
ACHUM-140	ACHVM-140	140	42.00	42.60
ACHUM-144	ACHVM-144	144	43.20	43.80
ACHUM-145	ACHVM-145	145	43.50	44.10
ACHUM-150	ACHVM-150	150	45.00	45.60
ACHUM-160	ACHVM-160	160	48.00	48.60
ACHUM-170	ACHVM-170	170	51.00	51.60
ACHUM-180	ACHVM-180	180	54.00	54.60
ACHUM-190	ACHVM-190	190	57.00	57.60
ACHUM-192	ACHVM-192	192	57.60	58.20
ACHUM-200	ACHVM-200	200	60.00	60.60
ACHUM-210	ACHVM-210	210	63.00	63.60
ACHUM-220	ACHVM-220	220	66.00	66.60
ACHUM-230	ACHVM-230	230	69.00	69.60
ACHUM-240	ACHVM-240	240	72.00	72.60
ACHUM-250	ACHVM-250	250	75.00	75.60

Available on request:
Other numbers of teeth;
Other Quality Classes;
14-1/2° Pressure Angle

Hub Material: Stainless Steel DIN 1.4305

MODULE	STYLE	BORE	FACE	MATERIAL	QUALITY	PRESSURE ANGLE
0.3	CLAMP HUB	8	3	STAINLESS STEEL DIN 1.4305 OR ALUMINUM DIN 3.1355 ANODIZED	DIN 7/AGMA 10	20°

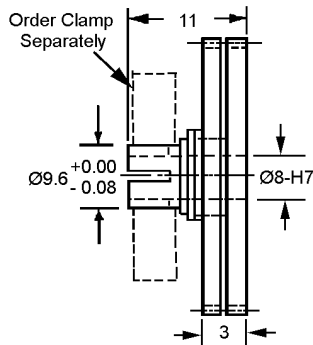

STAINLESS STEEL DIN 1.4305 STOCK NO.	ALUMINUM DIN 3.1355 STOCK NO.	NO. OF TEETH	PITCH DIA.	OUTSIDE DIA.
ACHWM-130-X	ACHXM-130-X	130	39.00	39.60
ACHWM-135-X	ACHXM-135-X	135	40.50	41.10
ACHWM-140-X	ACHXM-140-X	140	42.00	42.60
ACHWM-144-X	ACHXM-144-X	144	43.20	43.80
ACHWM-145-X	ACHXM-145-X	145	43.50	44.10
ACHWM-150-X	ACHXM-150-X	150	45.00	45.60
ACHWM-160-X	ACHXM-160-X	160	48.00	48.60
ACHWM-170-X	ACHXM-170-X	170	51.00	51.60
ACHWM-180-X	ACHXM-180-X	180	54.00	54.60
ACHWM-190-X	ACHXM-190-X	190	57.00	57.60
ACHWM-192-X	ACHXM-192-X	192	57.60	58.20
ACHWM-200-X	ACHXM-200-X	200	60.00	60.60
ACHWM-210-X	ACHXM-210-X	210	63.00	63.60
ACHWM-220-X	ACHXM-220-X	220	66.00	66.60
ACHWM-230-X	ACHXM-230-X	230	69.00	69.60
ACHWM-240-X	ACHXM-240-X	240	72.00	72.60
ACHWM-250-X	ACHXM-250-X	250	75.00	75.60

Available on request:
Other numbers of teeth;
Other Quality Classes;
14-1/2° Pressure Angle

Hub Material: Stainless Steel DIN 1.4305



SPUR GEARS

MODULE	STYLE	BORE	FACE	MATERIAL	QUALITY	PRESSURE ANGLE
0.25	HUBLESS	10	3	STAINLESS STEEL DIN 1.4305 OR ALUMINUM DIN 3.1355 ANODIZED	DIN 7/AGMA 10	20°

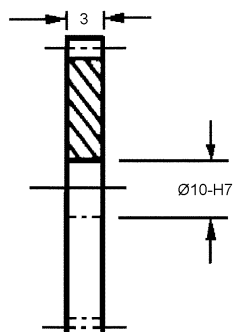
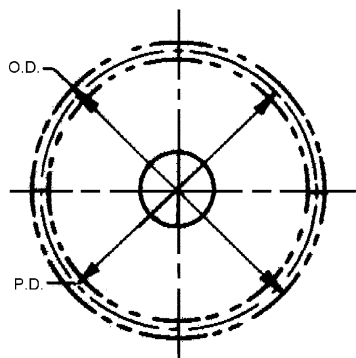

STAINLESS STEEL DIN 1.4305 STOCK NO.	ALUMINUM DIN 3.1355 ANODIZED STOCK NO.	NO. OF TEETH	PITCH DIA.	OUTSIDE DIA.
FJS103-96	FJA103-96	96	24.00	24.50
FJS103-100	FJA103-100	100	25.00	25.50
FJS103-105	FJA103-105	105	26.25	26.75
FJS103-108	FJA103-108	108	27.00	27.50
FJS103-110	FJA103-110	110	27.50	28.00
FJS103-120	FJA103-120	120	30.00	30.50
FJS103-125	FJA103-125	125	31.25	31.75
FJS103-132	FJA103-132	132	33.00	33.50
FJS103-140	FJA103-140	140	35.00	35.50
FJS103-144	FJA103-144	144	36.00	36.50
FJS103-150	FJA103-150	150	37.50	38.00
FJS103-160	FJA103-160	160	40.00	40.50
FJS103-180	FJA103-180	180	45.00	45.50
FJS103-190	FJA103-190	190	47.50	48.00
FJS103-192	FJA103-192	192	48.00	48.50

Available on request:
Other numbers of teeth;
Quality Class AGMA 12 & 14 / DIN 5 & 3;
14-1/2° Pressure Angle

For Couplings See Section MG.
For Shafts, Bearings and Collars See Section MI.

SPUR GEARS

MODULE	STYLE	BORE	FACE	MATERIAL	QUALITY	PRESSURE ANGLE
0.25	PIN HUB	5	3	STAINLESS STEEL DIN 1.4305 OR ALUMINUM DIN 3.1355 ANODIZED	DIN 7/AGMA 10	20°

B

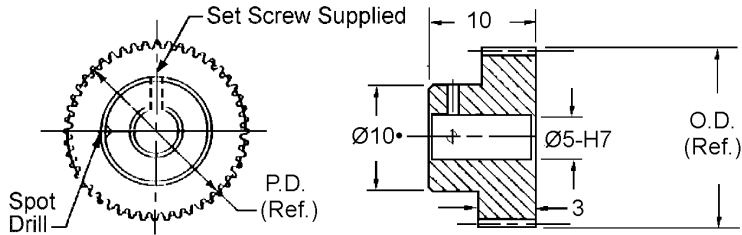

Available on request:
Other numbers of teeth;
14 - 1/2° pressure angle;
Quality Class AGMA 12 and 14 / DIN 5 and 3

• For 35-42 teeth hub diameter equals 8.0

STAINLESS STEEL STOCK NO.	ALUMINUM STOCK NO.	NO. OF TEETH	PITCH DIA.	OUTSIDE DIA.
PJS82-35	PJA82-35	35•	8.75	9.25
PJS82-36	PJA82-36	36•	9.00	9.50
PJS82-38	PJA82-38	38•	9.50	10.00
PJS82-40	PJA82-40	40•	10.00	10.50
PJS82-42	PJA82-42	42•	10.50	11.00
PJS82-44	PJA82-44	44	11.00	11.50
PJS82-45	PJA82-45	45	11.25	11.75
PJS82-48	PJA82-48	48	12.00	12.50
PJS82-50	PJA82-50	50	12.50	13.00
PJS82-52	PJA82-52	52	13.00	13.50
PJS82-54	PJA82-54	54	13.50	14.50
PJS82-60	PJA82-60	60	15.00	15.50
PJS82-64	PJA82-64	64	16.00	16.50
PJS82-66	PJA82-66	66	16.50	17.00
PJS82-70	PJA82-70	70	17.50	18.00
PJS82-72	PJA82-72	72	18.00	18.50
PJS82-75	PJA82-75	75	18.75	19.25
PJS82-77	PJA82-77	77	19.25	19.75
PJS82-80	PJA82-80	80	20.00	20.50
PJS82-85	PJA82-85	85	21.25	21.75
PJS82-90	PJA82-90	90	22.50	23.00
PJS82-95	PJA82-95	95	23.75	24.25
PJS82-96	PJA82-96	96	24.00	24.50
PJS82-100	PJA82-100	100	25.00	25.50
PJS82-105	PJA82-105	105	26.25	26.75
PJS82-110	PJA82-110	110	27.50	28.00
PJS82-120	PJA82-120	120	30.00	30.50
PJS82-130	PJA82-130	130	32.50	33.00
PJS82-140	PJA82-140	140	35.00	35.50
PJS82-160	PJA82-160	160	40.00	40.50
PJS82-180	PJA82-180	180	45.00	45.50
PJS82-192	PJA82-192	192	48.00	48.50

For Couplings See Section MG.
For Shafts, Bearings and Collars See Section MI.

SPUR GEARS

MODULE	STYLE	BORE	FACE	MATERIAL	QUALITY	PRESSURE ANGLE
0.25	CLAMP HUB	3	3	STAINLESS STEEL DIN 1.4305 OR ALUMINUM DIN 3.1355 ANODIZED	DIN 7/AGMA 10	20°

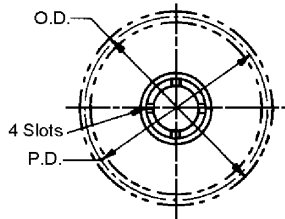

Use Clamp CG1M-3 (Order Separately)

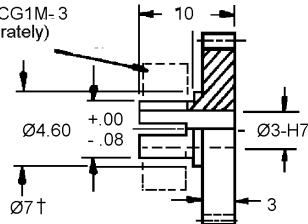

Available on request:
Other bore sizes;
numbers of teeth;
14-12° Pressure Angle;
Quality Class DIN 5/AGMA12

†Teeth may runout on flange diameter.

STAINLESS STEEL STOCK NO.	ALUMINUM STOCK NO.	NO. OF TEETH	PITCH DIA.	OUTSIDE DIA.
CJS50-26	CJA50-26	26†	6.50	7.00
CJS50-28	CJA50-28	28†	7.00	7.50
CJS50-30	CJA50-30	30	7.50	8.00
CJS50-32	CJA50-32	32	8.00	8.50
CJS50-33	CJA50-33	33	8.25	8.75
CJS50-34	CJA50-34	34	8.50	9.00
CJS50-35	CJA50-35	35	8.75	9.25
CJS50-36	CJA50-36	36	9.00	9.50
CJS50-38	CJA50-38	38	9.50	10.00
CJS50-40	CJA50-40	40	10.00	10.50
CJS50-42	CJA50-42	42	10.50	11.00
CJS50-44	CJA50-44	44	11.00	11.50
CJS50-48	CJA50-48	48	12.00	12.50
CJS50-50	CJA50-50	50	12.50	13.00
CJS50-52	CJA50-52	52	13.00	13.50
CJS50-54	CJA50-54	54	13.50	14.00
CJS50-56	CJA50-56	56	14.00	14.50
CJS50-58	CJA50-58	58	14.50	15.00
CJS50-60	CJA50-60	60	15.00	15.50
CJS50-64	CJA50-64	64	16.00	16.50
CJS50-70	CJA50-70	70	17.50	18.00
CJS50-72	CJA50-72	72	18.00	18.50
CJS50-76	CJA50-76	76	19.00	19.50
CJS50-78	CJA50-78	78	19.50	20.00
CJS50-80	CJA50-80	80	20.00	20.50
CJS50-84	CJA50-84	84	21.00	21.50
CJS50-90	CJA50-90	90	22.50	23.00
CJS50-95	CJA50-95	95	23.75	24.25
CJS50-96	CJA50-96	96	24.00	24.50
CJS50-100	CJA50-100	100	25.00	25.50
CJS50-105	CJA50-105	105	26.25	26.75
CJS50-108	CJA50-108	108	27.00	27.50
CJS50-110	CJA50-110	110	27.50	28.00
CJS50-115	CJA50-115	115	28.75	29.25
CJS50-120	CJA50-120	120	30.00	30.50
CJS50-127	CJA50-127	127	31.75	32.25
CJS50-132	CJA50-132	132	33.00	33.50
CJS50-144	CJA50-144	144	36.00	36.50
CJS50-168	CJA50-168	168	42.00	42.50
CJS50-180	CJA50-180	180	45.00	45.50

For Couplings See Section MG.
For Shafts, Bearings and Collars See Section MI.

GEAR RACKS

MODULE	STYLE	MATERIAL	QUALITY	PRESSURE ANGLE
0.25	ROUND & RECTANGULAR	STAINLESS STEEL DIN 1.4005	DIN 7/AGMA 10	20°

B

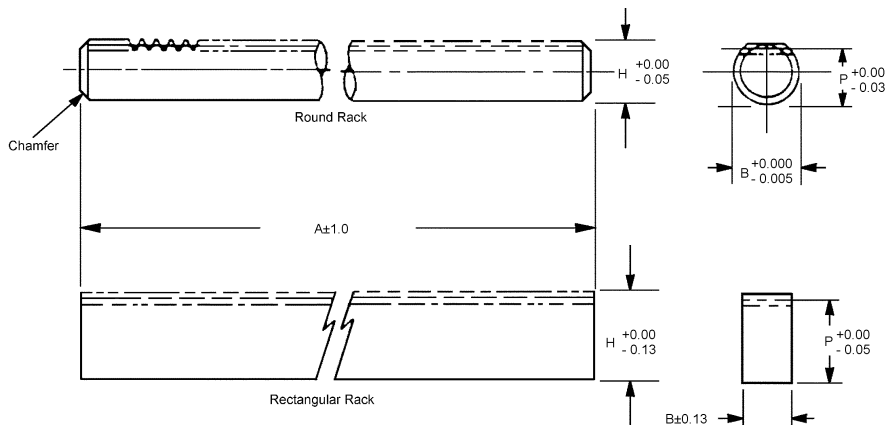

STOCK NO.	RACK STYLE	MOD.	P (Ref.)	B	A	H
R2M-9	ROUND	0.25	3.71	4.755	275	3.96
R3M-9	RECTANGULAR	0.25	8.77	4.24	275	9.02

Available on request: Special, modified and custom racks.

MODULE	STYLE	MATERIAL	QUALITY	PRESSURE ANGLE
0.25	RECTANGULAR	STAINLESS STEEL DIN 1.4005	DIN 7/AGMA 10	20°

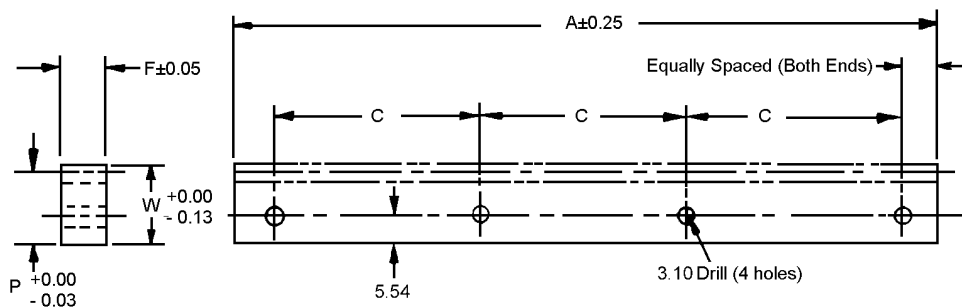

STOCK NO.	A	P (Ref.)	W	F	C
R4M-25	74.6	8.8	9.0	4.2	20.0

Available on request: special, modified and custom racks.

Quality Class AGMA12/DIN 5 available on request.

GEAR RACKS

MODULE	STYLE	MATERIAL	QUALITY	PRESSURE ANGLE
0.25	RECTANGULAR	STAINLESS STEEL DIN 1.4005	DIN 7/AGMA 10	20°

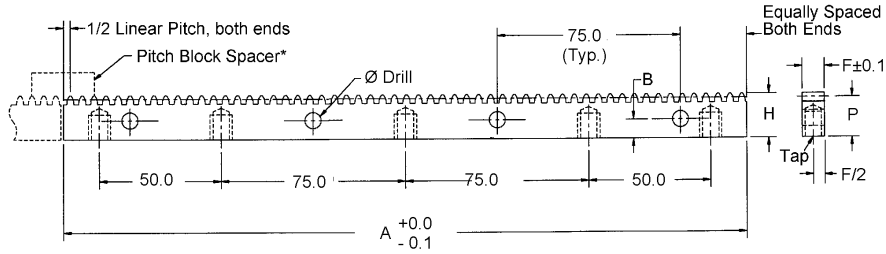

Spacer block is designed for butting to achieve continuous lengths.

RACKS	SPACER BLOCK								
STOCK NO.	STOCK NO.	LINEAR PITCH	A	P (REF.)	H +0.00 -0.13	F	B	Ø DRILL	TAP
R1M-9	R1M-9-SB	0.78	279.6	8.64	8.89	4.2	4.0	3.1	M3.0 X 0.5

Quality Class AGMA 12/Din 5 available on request. Custom racks available on request.

ANTI-BACKLASH GEARS

B

MODULE	STYLE	BORE	FACE	MATERIAL	QUALITY	PRESSURE ANGLE
0.25	PIN HUB	3	3	STAINLESS STEEL DIN 1.4305 OR ALUMINUM DIN 3.1355 ANODIZED	DIN 7/AGMA 10	20°

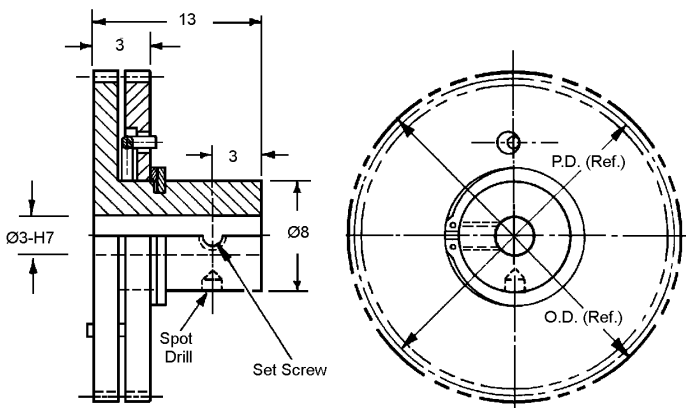

Available on request:
Other numbers of teeth;
Other Quality Classes;
14-1/2° Pressure Angle

Hub Material: Stainless Steel DIN 1.4305

STAINLESS STEEL DIN 1.4305 STOCK NO.	ALUMINUM DIN 3.1355 STOCK NO.	NO. OF TEETH	PITCH DIA.	OUTSIDE DIA.
APJFSM-60	APJGSM-60	60	15.00	15.50
APJFSM-72	APJGSM-72	72	18.00	18.50
APJFSM-96	APJGSM-96	96	24.00	24.50

MODULE	STYLE	BORE	FACE	MATERIAL	QUALITY	PRESSURE ANGLE
0.25	PIN HUB	5	3	STAINLESS STEEL DIN 1.4305 OR ALUMINUM DIN 3.1355 ANODIZED	DIN 7/AGMA 10	20°

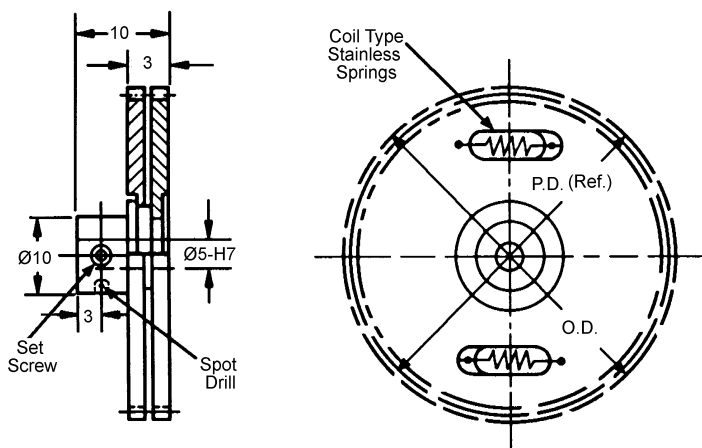

STAINLESS STEEL DIN 1.4305 STOCK NO.	ALUMINUM DIN 3.1355 STOCK NO.	NO. OF TEETH	PITCH DIA.	OUTSIDE DIA.
APJUM-100	APJVM-100	100	25.00	25.50
APJUM-105	APJVM-105	105	26.25	26.75
APJUM-108	APJVM-108	108	27.00	27.50
APJUM-110	APJVM-110	110	27.50	28.00
APJUM-115	APJVM-115	115	28.75	29.25
APJUM-120	APJVM-120	120	30.00	30.50
APJUM-125	APJVM-125	125	31.25	31.75
APJUM-130	APJVM-130	130	32.50	33.00
APJUM-140	APJVM-140	140	35.00	35.50
APJUM-144	APJVM-144	144	36.00	36.50
APJUM-150	APJVM-150	150	37.50	38.00
APJUM-160	APJVM-160	160	40.00	40.50
APJUM-170	APJVM-170	170	42.50	43.00
APJUM-180	APJVM-180	180	45.00	45.50
APJUM-190	APJVM-190	190	47.50	48.00
APJUM-200	APJVM-200	200	50.00	50.50
APJUM-210	APJVM-210	210	52.50	53.00
APJUM-216	APJVM-216	216	54.00	54.50
APJUM-220	APJVM-220	220	55.00	55.50
APJUM-225	APJVM-225	225	56.25	56.75
APJUM-230	APJVM-230	230	57.50	58.00
APJUM-240	APJVM-240	240	60.00	60.50
APJUM-250	APJVM-250	250	62.50	63.00
APJUM-260	APJVM-260	260	65.00	65.50
APJUM-270	APJVM-270	270	67.50	68.00
APJUM-275	APJVM-275	275	68.75	69.25
APJUM-280	APJVM-280	280	70.00	70.50
APJUM-285	APJVM-285	265	71.25	71.75
APJUM-290	APJVM-290	290	72.50	73.00
APJUM-300	APJVM-300	300	75.00	75.50

Available on request:
Other numbers of teeth;
Quality Class AGMA12 & 14 / DIN 5 & 3;
14-1/2° Pressure Angle

Hub Material: Stainless Steel DIN 1.4305

ANTI-BACKLASH GEARS

MODULE	STYLE	BORE	FACE	MATERIAL	QUALITY	PRESSURE ANGLE
0.25	PIN HUB	5	3	STAINLESS STEEL DIN 1.4305 OR ALUMINUM DIN 3.1355 ANODIZED	DIN 7/AGMA 10	20°

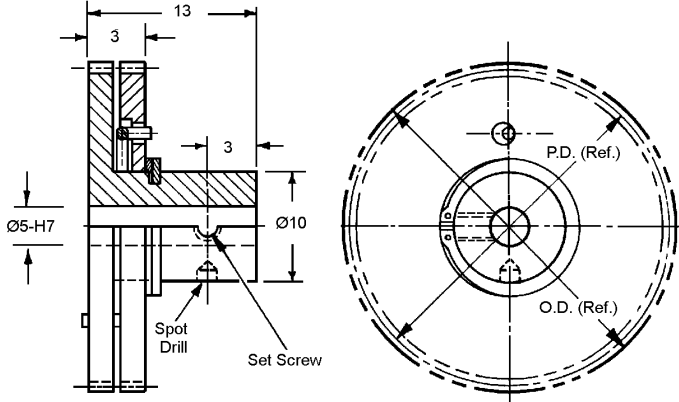

Available on request:
Other numbers of teeth;
Other Quality Classes;
14-1/2° Pressure Angle

Hub Material: Stainless Steel DIN 1.4305

STAINLESS STEEL DIN 1.4305 STOCK NO.	ALUMINUM DIN 3.1355 STOCK NO.	NO. OF TEETH	PITCH DIA.	OUTSIDE DIA.
APJHSM-60	APJJS-60	60	15.00	15.50
APJHSM-72	APJJS-72	72	18.00	18.50
APJHSM-96	APJJS-96	96	24.00	24.50

MODULE	STYLE	BORE	FACE	MATERIAL	QUALITY	PRESSURE ANGLE
0.25	PIN HUB	8	3	STAINLESS STEEL DIN 1.4305 OR ALUMINUM DIN 3.1355 ANODIZED	DIN 7/AGMA 10	20°

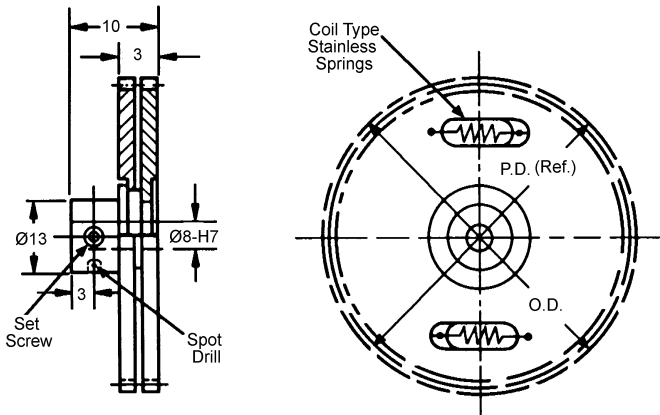

STAINLESS STEEL DIN 1.4305 STOCK NO.	ALUMINUM DIN 3.1355 STOCK NO.	NO. OF TEETH	PITCH DIA.	OUTSIDE DIA.
APJWM-100-X	APJXM-100-X	100	25.00	25.50
APJWM-105-X	APJXM-105-X	105	26.25	26.75
APJWM-108-X	APJXM-108-X	108	27.00	27.50
APJWM-110-X	APJXM-110-X	110	27.50	28.00
APJWM-115-X	APJXM-115-X	115	28.75	29.25
APJWM-120-X	APJXM-120-X	120	30.00	30.50
APJWM-125-X	APJXM-125-X	125	31.25	31.75
APJWM-130-X	APJXM-130-X	130	32.50	33.00
APJWM-140-X	APJXM-140-X	140	35.00	35.50
APJWM-144-X	APJXM-144-X	144	36.00	36.50
APJWM-150-X	APJXM-150-X	150	37.50	38.00
APJWM-160-X	APJXM-160-X	160	40.00	40.50
APJWM-170-X	APJXM-170-X	170	42.50	43.00
APJWM-180-X	APJXM-180-X	180	45.00	45.50
APJWM-190-X	APJXM-190-X	190	47.50	48.00
APJWM-200-X	APJXM-200-X	200	50.00	50.50
APJWM-210-X	APJXM-210-X	210	52.50	53.00
APJWM-216-X	APJXM-216-X	216	54.00	54.50
APJWM-220-X	APJXM-220-X	220	55.00	55.50
APJWM-225-X	APJXM-225-X	225	56.25	56.70
APJWM-230-X	APJXM-230-X	230	57.50	58.00
APJWM-240-X	APJXM-240-X	240	60.00	60.50
APJWM-250-X	APJXM-250-X	250	62.50	63.00
APJWM-260-X	APJXM-260-X	260	65.00	65.50
APJWM-270-X	APJXM-270-X	270	67.50	68.00
APJWM-275-X	APJXM-275-X	275	68.75	69.25
APJWM-280-X	APJXM-280-X	280	70.00	70.50
APJWM-285-X	APJXM-285-X	285	71.25	71.75
APJWM-290-X	APJXM-290-X	290	72.50	73.00
APJWM-300-X	APJXM-300-X	300	75.00	75.50

Available on request: Other numbers of teeth;
Quality Class AGMA12 & 14 / DIN 5 & 3; 14-1/2° Pressure Angle

Hub Material: Stainless Steel DIN 1.4305

ANTI-BACKLASH GEARS

B

MODULE	STYLE	BORE	FACE	MATERIAL	QUALITY	PRESSURE ANGLE
0.25	CLAMP HUB	3	3	STAINLESS STEEL DIN 1.4305 OR ALUMINUM DIN 3.1355 ANODIZED	DIN 7/AGMA 10	20°

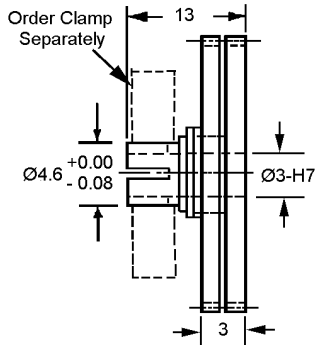

STAINLESS STEEL DIN 1.4305 STOCK NO.	ALUMINUM DIN 3.1355 STOCK NO.	NO. OF TEETH	PITCH DIA.	OUTSIDE DIA.
ACJFSM-60	ACJGSM-60	60	15.00	15.50
ACJFSM-72	ACJGSM-72	72	18.00	18.50
ACJFSM-96	ACJGSM-96	96	24.00	24.50

Available on request:
Other numbers of teeth;
Other Quality Classes;
14-1/2° Pressure Angle

Hub Material: Stainless Steel DIN 1.4305

MODULE	STYLE	BORE	FACE	MATERIAL	QUALITY	PRESSURE ANGLE
0.25	CLAMP HUB	5	3	STAINLESS STEEL DIN 1.4305 OR ALUMINUM DIN 3.1355 ANODIZED	DIN 7/AGMA 10	20°

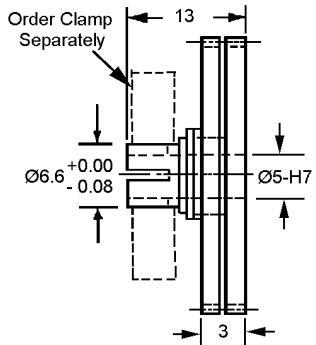

STAINLESS STEEL DIN 1.4305 STOCK NO.	ALUMINUM DIN 3.1355 STOCK NO.	NO. OF TEETH	PITCH DIA.	OUTSIDE DIA.
ACJHSM-60	ACJISM-60	60	15.00	15.50
ACJHSM-72	ACJISM-72	72	18.00	18.50
ACJHSM-96	ACJISM-96	96	24.00	24.50

Available on request:
Other numbers of teeth;
Other Quality Classes;
14-1/2° Pressure Angle

Hub Material: Stainless Steel DIN 1.4305

For Couplings See Section MG.
For Shafts, Bearings and Collars See Section MI.

ANTI-BACKLASH GEARS

MODULE	STYLE	BORE	FACE	MATERIAL	QUALITY	PRESSURE ANGLE
0.25	CLAMP HUB	5	3	STAINLESS STEEL DIN 1.4305 OR ALUMINUM DIN 3.1355 ANODIZED	DIN 7/AGMA 10	20°

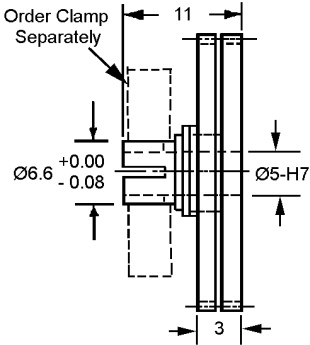

Available on request:
 Other numbers of teeth;
 Other Quality Classes;
 14-1/2° Pressure Angle

Hub Material: Stainless Steel DIN 1.4305

STAINLESS STEEL DIN 1.4305 STOCK NO.	ALUMINUM DIN 3.1355 STOCK NO.	NO. OF TEETH	PITCH DIA.	OUTSIDE DIA.
ACJUM-100	ACJVM-100	100	25.00	25.50
ACJUM-105	ACJVM-105	105	26.25	26.75
ACJUM-108	ACJVM-108	108	27.00	27.50
ACJUM-110	ACJVM-110	110	27.50	28.00
ACJUM-115	ACJVM-115	115	28.75	29.25
ACJUM-120	ACJVM-120	120	30.00	30.50
ACJUM-125	ACJVM-125	125	31.25	31.75
ACJUM-130	ACJVM-130	130	32.50	33.00
ACJUM-140	ACJVM-140	140	35.00	35.50
ACJUM-144	ACJVM-144	144	36.00	36.50
ACJUM-150	ACJVM-150	150	37.50	38.00
ACJUM-160	ACJVM-160	160	40.00	40.50
ACJUM-170	ACJVM-170	170	42.50	43.00
ACJUM-180	ACJVM-180	180	45.00	45.50
ACJUM-190	ACJVM-190	190	47.50	48.00
ACJUM-200	ACJVM-200	200	50.00	50.50
ACJUM-210	ACJVM-210	210	52.50	53.00
ACJUM-216	ACJVM-216	216	54.00	54.50
ACJUM-220	ACJVM-220	220	55.00	55.50
ACJUM-225	ACJVM-225	225	56.25	56.75
ACJUM-230	ACJVM-230	230	57.50	58.00
ACJUM-240	ACJVM-240	240	60.00	60.50
ACJUM-250	ACJVM-250	250	62.50	63.00
ACJUM-260	ACJVM-260	260	65.00	65.50
ACJUM-270	ACJVM-270	270	67.50	68.00
ACJUM-275	ACJVM-275	275	68.75	69.25
ACJUM-280	ACJVM-280	280	70.00	70.50
ACJUM-285	ACJVM-285	265	71.25	71.75
ACJUM-290	ACJVM-290	290	72.50	73.00
ACJUM-300	ACJVM-300	300	75.00	75.50

MODULE	STYLE	BORE	FACE	MATERIAL	QUALITY	PRESSURE ANGLE
0.25	CLAMP HUB	8	3	STAINLESS STEEL DIN 1.4305 OR ALUMINUM DIN 3.1355 ANODIZED	DIN 7/AGMA 10	20°

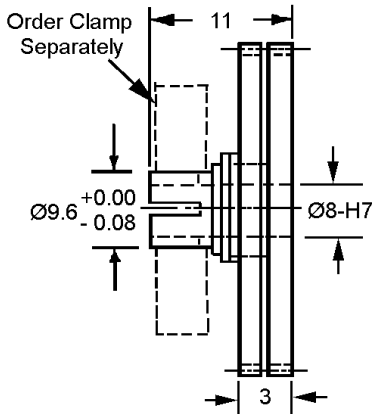

Available on request:
 Other numbers of teeth;
 Other Quality Classes;
 14-1/2° Pressure Angle

Hub Material: Stainless Steel DIN 1.4305



STAINLESS STEEL DIN 1.4305 STOCK NO.	ALUMINUM DIN 3.1355 STOCK NO.	NO. OF TEETH	PITCH DIA.	OUTSIDE DIA.
ACJWM-100-X	ACJXM-100-X	100	25.00	25.50
ACJWM-105-X	ACJXM-105-X	105	26.25	26.75
ACJWM-108-X	ACJXM-108-X	108	27.00	27.50
ACJWM-110-X	ACJXM-110-X	110	27.50	28.00
ACJWM-115-X	ACJXM-115-X	115	28.75	29.25
ACJWM-120-X	ACJXM-120-X	120	30.00	30.50
ACJWM-125-X	ACJXM-125-X	125	31.25	31.75
ACJWM-130-X	ACJXM-130-X	130	32.50	33.00
ACJWM-140-X	ACJXM-140-X	140	35.00	35.50
ACJWM-144-X	ACJXM-144-X	144	36.00	36.50
ACJWM-150-X	ACJXM-150-X	150	37.50	38.00
ACJWM-160-X	ACJXM-160-X	160	40.00	40.50
ACJWM-170-X	ACJXM-170-X	170	42.50	43.00
ACJWM-180-X	ACJXM-180-X	180	45.00	45.50
ACJWM-190-X	ACJXM-190-X	190	47.50	48.00
ACJWM-200-X	ACJXM-200-X	200	50.00	50.50
ACJWM-210-X	ACJXM-210-X	210	52.50	53.00
ACJWM-216-X	ACJXM-216-X	216	54.00	54.50
ACJWM-220-X	ACJXM-220-X	220	55.00	55.50
ACJWM-225-X	ACJXM-225-X	225	56.25	56.70
ACJWM-230-X	ACJXM-230-X	230	57.50	58.00
ACJWM-240-X	ACJXM-240-X	240	60.00	60.50
ACJWM-250-X	ACJXM-250-X	250	62.50	63.00
ACJWM-260-X	ACJXM-260-X	260	65.00	65.50
ACJWM-270-X	ACJXM-270-X	270	67.50	68.00
ACJWM-275-X	ACJXM-275-X	275	68.75	69.25
ACJWM-280-X	ACJXM-280-X	280	70.00	70.50
ACJWM-285-X	ACJXM-285-X	285	71.25	71.75
ACJWM-290-X	ACJXM-290-X	290	72.50	73.00
ACJWM-300-X	ACJXM-300-X	300	75.00	75.50

HELICAL GEARS

B

MODULE	STYLE	BORE	MATERIAL	QUALITY	PRES. ANGLE	HELIX ANGLE
1.5	R & L Hand PIN HUB	12	STAINLESS STEEL DIN 1.4305	DIN 8 AGMA 9	20°	45°

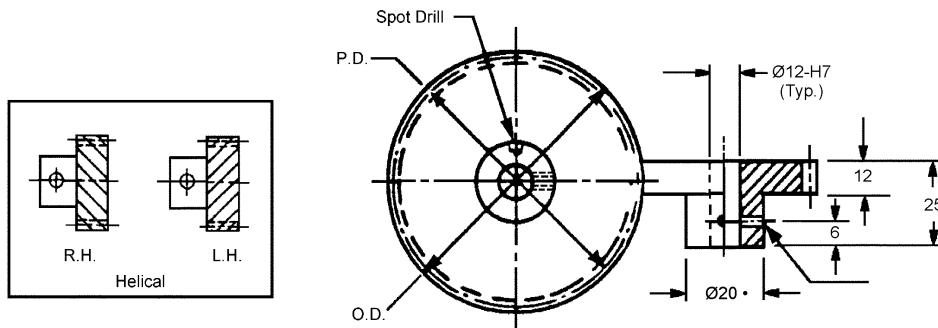

RIGHT HAND STOCK NO.	LEFT HAND STOCK NO.	NO. OF TEETH	P.D.	O.D.
HAS89-R12	HAS89-L12	12	25.46	28.46
HAS89-R16	HAS89-L16	16	33.94	36.94
HAS89-R20	HAS89-L20	20	42.43	45.43
HAS89-R24	HAS89-L24	24	50.91	53.91
HAS89-R32	HAS89-L32	32	67.88	70.88
HAS89-R40	HAS89-L40	40	84.85	87.85
HAS89-R48	HAS89-L48	48	101.82	104.82

Other numbers of teeth are available on request.
 • For 11 teeth hub diameter equals 19.6



MODULE	STYLE	BORE	MATERIAL	QUALITY	PRES. ANGLE	HELIX ANGLE
1.25	R & L Hand PIN HUB	10	STAINLESS STEEL DIN 1.4305	DIN 8 AGMA 9	20°	45°

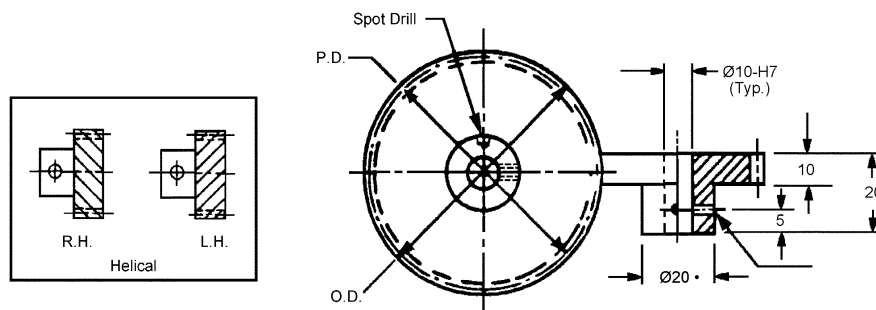

RIGHT HAND STOCK NO.	LEFT HAND STOCK NO.	NO. OF TEETH	P.D.	O.D.
HBS86-R11	HBS86-L11	11	19.44	21.94
HBS86-R15	HBS86-L15	15	26.52	29.02
HBS86-R20	HBS86-L20	20	35.36	37.86
HBS86-R25	HBS86-L25	25	44.19	46.69
HBS86-R30	HBS86-L30	30	53.03	55.53
HBS86-R40	HBS86-L40	40	70.71	73.21
HBS86-R50	HBS86-L50	50	88.39	90.89
HBS86-R60	HBS86-L60	60	106.07	108.57

Other numbers of teeth are available on request.
 • For 11 - 13 teeth hub diameter equals 16.3



HELICAL GEARS

MODULE	STYLE	BORE	MATERIAL	QUALITY	PRES. ANGLE	HELIX ANGLE
1.0	R & L Hand PIN HUB	8	STAINLESS STEEL DIN 1.4305	DIN 7 AGMA 10	20°	45°

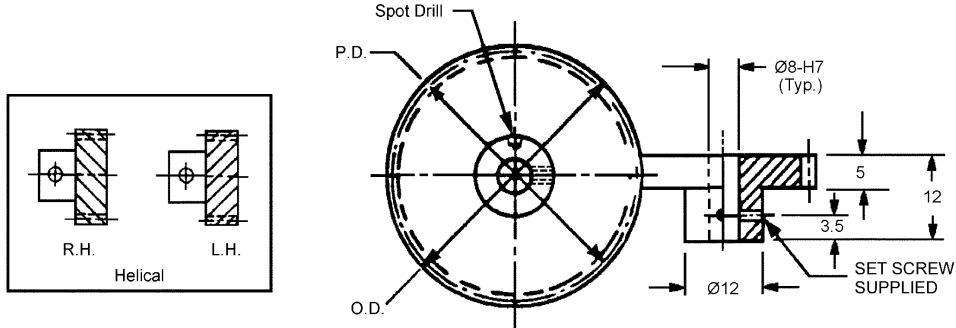

RIGHT HAND STOCK NO.	LEFT HAND STOCK NO.	NO. OF TEETH	P.D.	O.D.
HCS95-R12	HCS95-L12	12	16.94	18.97
HCS95-R18	HCS95-L18	18	25.45	27.45
HCS95-R24	HCS95-L24	24	33.94	35.94
HCS95-R30	HCS95-L30	30	42.42	44.42
HCS95-R36	HCS95-L36	36	50.91	52.91
HCS95-R48	HCS95-L48	48	67.88	69.88
HCS95-R60	HCS95-L60	60	84.85	86.85
HCS95-R72	HCS95-L72	72	101.82	103.82

Other numbers of teeth are available on request.



MODULE	STYLE	BORE	MATERIAL	QUALITY	PRES. ANGLE	HELIX ANGLE
1.0	R & L Hand PIN HUB	8	ALUMINUM DIN 3.1355	DIN 7 AGMA 10	20°	45°

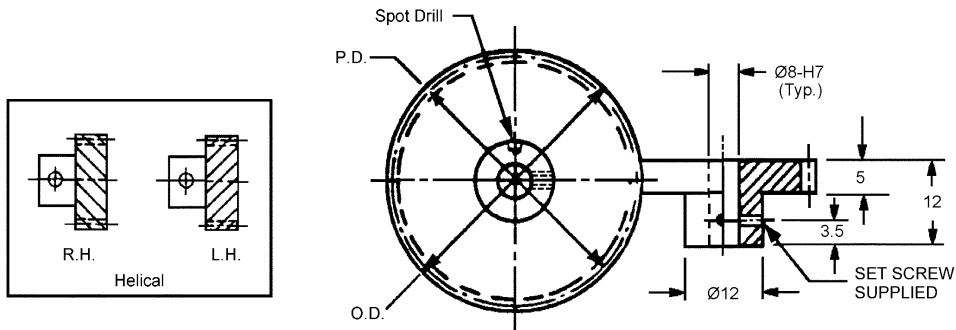

RIGHT HAND STOCK NO.	LEFT HAND STOCK NO.	NO. OF TEETH	P.D.	O.D.
HCA95-R12	HCA95-L12	12	16.94	18.97
HCA95-R18	HCA95-L18	18	25.45	27.45
HCA95-R24	HCA95-L24	24	33.94	35.94
HCA95-R30	HCA95-L30	30	42.42	44.42
HCA95-R36	HCA95-L36	36	50.91	52.91
HCA95-R48	HCA95-L48	48	67.88	69.88
HCA95-R60	HCA95-L60	60	84.85	86.85
HCA95-R72	HCA95-L72	72	101.82	103.82

Other numbers of teeth are available on request.



HELICAL GEARS

B

MODULE	STYLE	BORE	MATERIAL	QUALITY	PRES. ANGLE	HELIX ANGLE
0.8	R & L Hand PIN HUB	8	STAINLESS STEEL DIN 1.4305	DIN 7 AGMA 10	20°	45°

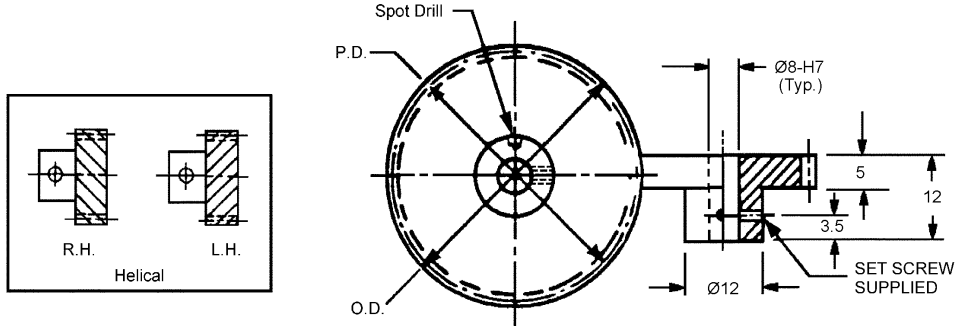

RIGHT HAND STOCK NO.	LEFT HAND STOCK NO.	NO. OF TEETH	P.D.	O.D.
HDS95-R16	HDS95-L16	16	18.10	19.70
HDS95-R24	HDS95-L24	24	27.15	28.75
HDS95-R32	HDS95-L32	32	36.20	37.80
HDS95-R40	HDS95-L40	40	45.25	46.85
HDS95-R48	HDS95-L48	48	54.30	55.90
HDS95-R64	HDS95-L64	64	72.40	74.00
HDS95-R80	HDS95-L80	80	90.50	92.10
HDS95-R96	HDS95-L96	96	108.61	110.21

Other numbers of teeth are available on request.



MODULE	STYLE	BORE	MATERIAL	QUALITY	PRES. ANGLE	HELIX ANGLE
0.8	R & L Hand PIN HUB	8	ALUMINUM DIN 3.1355	DIN 7 AGMA 10	20°	45°

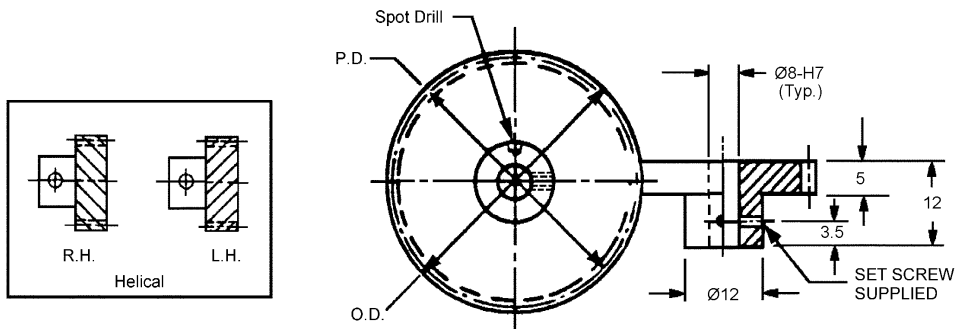

RIGHT HAND STOCK NO.	LEFT HAND STOCK NO.	NO. OF TEETH	P.D.	O.D.
HDA95-R16	HDA95-L16	16	18.10	19.70
HDA95-R24	HDA95-L24	24	27.15	28.75
HDA95-R32	HDA95-L32	32	36.20	37.80
HDA95-R40	HDA95-L40	40	45.25	46.85
HDA95-R48	HDA95-L48	48	54.30	55.90
HDA95-R64	HDA95-L64	64	72.40	74.00
HDA95-R80	HDA95-L80	80	90.50	92.10
HDA95-R96	HDA95-L96	96	108.61	110.21

Other numbers of teeth are available on request.



HELICAL GEARS

B

MODULE	STYLE	BORES	MATERIAL	QUALITY	PRES. ANGLE	HELIX ANGLE
0.5	RIGHT HAND PIN HUB	5	STAINLESS STEEL DIN 1.4305 OR ALUMINUM DIN 3.1555	DIN 7 AGMA 10	20°	45°

STAINLESS STEEL STOCK NO.	ALUMINUM STOCK NO.	NO. OF TEETH	P.D.	O.D.
HFS83-R20	HFA83-R20	20	14.14	15.14
HFS83-R24	HFA83-R24	24	16.97	17.97
HFS83-R25	HFA83-R25	25	17.68	18.68
HFS83-R30	HFA83-R30	30	21.21	22.21
HFS83-R35	HFA83-R35	35	24.75	25.75
HFS83-R36	HFA83-R36	36	25.46	26.46
HFS83-R40	HFA83-R40	40	28.28	29.28
HFS83-R45	HFA83-R45	45	31.82	32.82
HFS83-R48	HFA83-R48	48	33.94	34.94
HFS83-R50	HFA83-R50	50	35.36	36.36
HFS83-R60	HFA83-R60	60	42.43	43.43
HFS83-R70	HFA83-R70	70	49.50	50.50
HFS83-R72	HFA83-R72	72	50.91	51.91
HFS83-R80	HFA83-R80	80	56.57	57.57
HFS83-R90	HFA83-R90	90	63.64	64.64
HFS83-R96	HFA83-R96	96	67.88	68.88
HFS83-R100	HFA83-R100	100	70.71	71.71
HFS83-R120	HFA83-R120	120	84.85	85.85
HFS83-R144	HFA83-R144	144	101.82	102.82

Other numbers of teeth are available on request.
 • For 15 teeth hub diameter equals 9.3

MODULE	STYLE	BORES	MATERIAL	QUALITY	PRES. ANGLE	HELIX ANGLE
0.5	LEFT HAND PIN HUB	5	STAINLESS STEEL DIN 1.4305 OR ALUMINUM DIN 3.1555	DIN 7 AGMA 10	20°	45°

STAINLESS STEEL STOCK NO.	ALUMINUM STOCK NO.	NO. OF TEETH	P.D.	O.D.
HFS83-L20	HFA83-L20	20	14.14	15.14
HFS83-L24	HFA83-L24	24	16.97	17.97
HFS83-L25	HFA83-L25	25	17.68	18.68
HFS83-L30	HFA83-L30	30	21.21	22.21
HFS83-L35	HFA83-L35	35	24.75	25.75
HFS83-L36	HFA83-L36	36	25.46	26.46
HFS83-L40	HFA83-L40	40	28.28	29.28
HFS83-L45	HFA83-L45	45	31.82	32.82
HFS83-L48	HFA83-L48	48	33.94	34.94
HFS83-L50	HFA83-L50	50	35.36	36.36
HFS83-L60	HFA83-L60	60	42.43	43.43
HFS83-L70	HFA83-L70	70	49.50	50.50
HFS83-L72	HFA83-L72	72	50.91	51.91
HFS83-L80	HFA83-L80	80	56.57	57.57
HFS83-L90	HFA83-L90	90	63.64	64.64
HFS83-L96	HFA83-L96	96	67.88	68.88
HFS83-L100	HFA83-L100	100	70.71	71.71
HFS83-L120	HFA83-L120	120	84.85	85.85
HFS83-L144	HFA83-L144	144	101.82	102.82

Other numbers of teeth are available on request.
 • For 15 teeth hub diameter equals 9.3

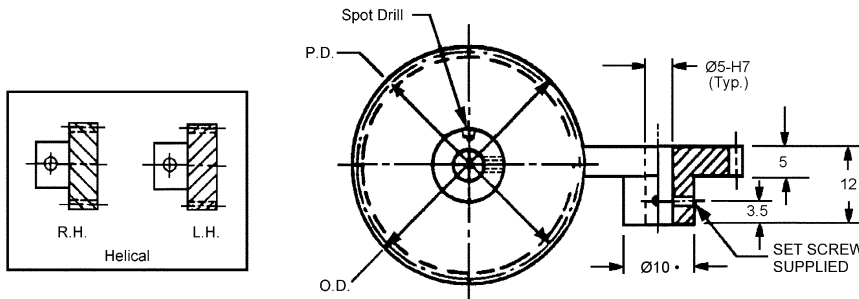

1-800-232-BERG (USA ONLY)

MB 144

WWW.WMBERG.COM

HELICAL GEARS

B

MODULE	STYLE	BORES	MATERIAL	QUALITY	PRES. ANGLE	HELIX ANGLE
0.5	RIGHT HAND PIN HUB	8	STAINLESS STEEL DIN 1.4305 OR ALUMINUM DIN 3.1555	DIN 7 AGMA 10	20°	45°

STAINLESS STEEL STOCK NO.	ALUMINUM STOCK NO.	NO. OF TEETH	P.D.	O.D.
HFS95-R20	HFA95-R20	20	14.14	15.14
HFS95-R24	HFA95-R24	24	16.97	17.97
HFS95-R25	HFA95-R25	25	17.68	18.68
HFS95-R30	HFA95-R30	30	21.21	22.21
HFS95-R35	HFA95-R35	35	24.75	25.75
HFS95-R36	HFA95-R36	36	25.46	26.46
HFS95-R40	HFA95-R40	40	28.28	29.28
HFS95-R45	HFA95-R45	45	31.82	32.82
HFS95-R48	HFA95-R48	48	33.94	34.94
HFS95-R50	HFA95-R50	50	35.36	36.36
HFS95-R60	HFA95-R60	60	42.43	43.43
HFS95-R70	HFA95-R70	70	49.50	50.50
HFS95-R72	HFA95-R72	72	50.91	51.91
HFS95-R80	HFA95-R80	80	56.57	57.57
HFS95-R90	HFA95-R90	90	63.64	64.64
HFS95-R96	HFA95-R96	96	67.88	68.88
HFS95-R100	HFA95-R100	100	70.71	71.71
HFS95-R120	HFA95-R120	120	84.85	85.85
HFS95-R144	HFA95-R144	144	101.82	102.82

Other numbers of teeth are available on request.

MODULE	STYLE	BORES	MATERIAL	QUALITY	PRES. ANGLE	HELIX ANGLE
0.5	LEFT HAND PIN HUB	8	STAINLESS STEEL DIN 1.4305 OR ALUMINUM DIN 3.1555	DIN 7 AGMA 10	20°	45°

STAINLESS STEEL STOCK NO.	ALUMINUM STOCK NO.	NO. OF TEETH	P.D.	O.D.
HFS95-L20	HFA95-L20	20	14.14	15.14
HFS95-L24	HFA95-L24	24	16.97	17.97
HFS95-L25	HFA95-L25	25	17.68	18.68
HFS95-L30	HFA95-L30	30	21.21	22.21
HFS95-L35	HFA95-L35	35	24.75	25.75
HFS95-L36	HFA95-L36	36	25.46	26.46
HFS95-L40	HFA95-L40	40	28.28	29.28
HFS95-L45	HFA95-L45	45	31.82	32.82
HFS95-L48	HFA95-L48	48	33.94	34.94
HFS95-L50	HFA95-L50	50	35.36	36.36
HFS95-L60	HFA95-L60	60	42.43	43.43
HFS95-L70	HFA95-L70	70	49.50	50.50
HFS95-L72	HFA95-L72	72	50.91	51.91
HFS95-L80	HFA95-L80	80	56.57	57.57
HFS95-L90	HFA95-L90	90	63.64	64.64
HFS95-L96	HFA95-L96	96	67.88	68.88
HFS95-L100	HFA95-L100	100	70.71	71.71
HFS95-L120	HFA95-L120	120	84.85	85.85
HFS95-L144	HFA95-L144	144	101.82	102.82

Other numbers of teeth are available on request.

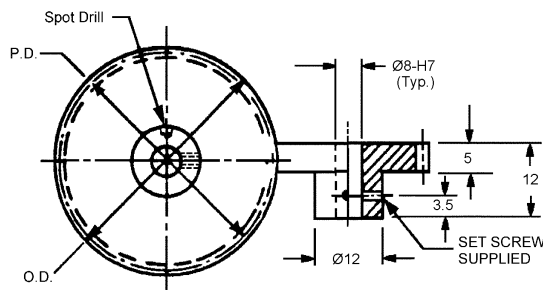
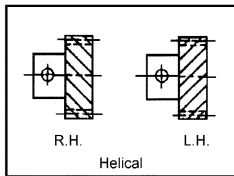

HELICAL GEARS

MODULE	STYLE	BORES	MATERIAL	QUALITY	PRES. ANGLE	HELIX ANGLE
0.4	RIGHT HAND PIN HUB	3	STAINLESS STEEL DIN 1.4305 OR ALUMINUM DIN 3.1555	DIN 7 AGMA 10	20°	45°

STAINLESS STEEL STOCK NO.	ALUMINUM STOCK NO.	NO. OF TEETH	P.D.	O.D.
HGS80-R20	HGA80-R20	20	11.31	12.11
HGS80-R25	HGA80-R25	25	14.14	14.94
HGS80-R30	HGA80-R30	30	16.97	17.77
HGS80-R32	HGA80-R32	32	18.10	18.90
HGS80-R35	HGA80-R35	35	19.80	20.60
HGS80-R40	HGA80-R40	40	22.63	23.43
HGS80-R45	HGA80-R45	45	54.46	26.26
HGS80-R48	HGA80-R48	48	27.15	27.95
HGS80-R50	HGA80-R50	50	28.28	29.08
HGS80-R60	HGA80-R60	60	33.94	34.74
HGS80-R64	HGA80-R64	64	36.20	37.00
HGS80-R70	HGA80-R70	70	39.60	40.40
HGS80-R80	HGA80-R80	80	45.25	46.05
HGS80-R90	HGA80-R90	90	50.91	51.71
HGS80-R96	HGA80-R96	96	54.31	55.11
HGS80-R100	HGA80-R100	100	56.57	57.37
HGS80-R128	HGA80-R128	128	72.41	73.21
HGS80-R160	HGA80-R160	160	90.51	91.31

Other numbers of teeth are available on request.
 • For 12 - 19 teeth hub diameter equals 5.7

MODULE	STYLE	BORES	MATERIAL	QUALITY	PRES. ANGLE	HELIX ANGLE
0.4	LEFT HAND PIN HUB	3	STAINLESS STEEL DIN 1.4305 OR ALUMINUM DIN 3.1555	DIN 7 AGMA 10	20°	45°

STAINLESS STEEL STOCK NO.	ALUMINUM STOCK NO.	NO. OF TEETH	P.D.	O.D.
HGS80-L20	HGA80-L20	20	11.31	12.11
HGS80-L25	HGA80-L25	25	14.14	14.94
HGS80-L30	HGA80-L30	30	16.97	17.77
HGS80-L32	HGA80-L32	32	18.10	18.90
HGS80-L35	HGA80-L35	35	19.80	20.60
HGS80-L40	HGA80-L40	40	22.63	23.43
HGS80-L45	HGA80-L45	45	54.46	26.26
HGS80-L48	HGA80-L48	48	27.15	27.95
HGS80-L50	HGA80-L50	50	28.28	29.08
HGS80-L60	HGA80-L60	60	33.94	34.74
HGS80-L64	HGA80-L64	64	36.20	37.00
HGS80-L70	HGA80-L70	70	39.60	40.40
HGS80-L80	HGA80-L80	80	45.25	46.05
HGS80-L90	HGA80-L90	90	50.91	51.71
HGS80-L96	HGA80-L96	96	54.31	55.11
HGS80-L100	HGA80-L100	100	56.57	57.37
HGS80-L128	HGA80-L128	128	72.41	73.21
HGS80-L160	HGA80-L160	160	90.51	91.31

Other numbers of teeth are available on request.
 • For 12 - 19 teeth hub diameter equals 5.7

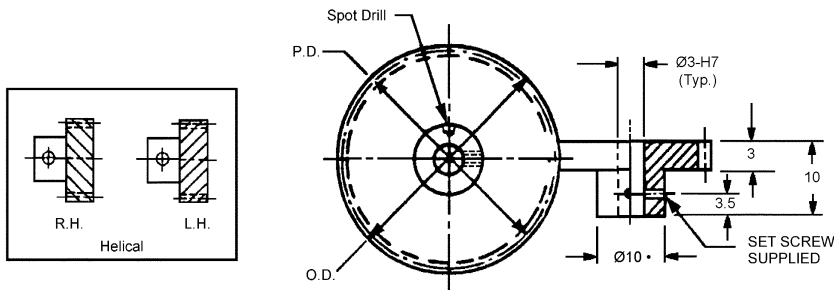

HELICAL GEARS

B

MODULE	STYLE	BORES	MATERIAL	QUALITY	PRES. ANGLE	HELIX ANGLE
0.4	RIGHT HAND PIN HUB	5	STAINLESS STEEL DIN 1.4305 OR ALUMINUM DIN 3.1555	DIN 7 AGMA 10	20°	45°

STAINLESS STEEL STOCK NO.	ALUMINUM STOCK NO.	NO. OF TEETH	P.D.	O.D.
HGS83-R20	HGA83-R20	20	11.31	12.11
HGS83-R25	HGA83-R25	25	14.14	14.94
HGS83-R30	HGA83-R30	30	16.97	17.77
HGS83-R32	HGA83-R32	32	18.10	18.90
HGS83-R35	HGA83-R35	35	19.80	20.60
HGS83-R40	HGA83-R40	40	22.63	23.43
HGS83-R45	HGA83-R45	45	25.46	26.26
HGS83-R48	HGA83-R48	48	27.15	27.95
HGS83-R50	HGA83-R50	50	28.28	29.08
HGS83-R60	HGA83-R60	60	33.94	34.74
HGS83-R64	HGA83-R64	64	36.20	37.00
HGS83-R70	HGA83-R70	70	39.60	40.40
HGS83-R80	HGA83-R80	80	45.25	46.05
HGS83-R90	HGA83-R90	90	50.91	51.71
HGS83-R96	HGA83-R96	96	54.31	55.11
HGS83-R100	HGA83-R100	100	56.57	57.37
HGS83-R128	HGA83-R128	128	72.41	73.21
HGS83-R160	HGA83-R160	160	90.51	91.31

Other numbers of teeth are available on request.
 • For 15 - 19 teeth hub diameter is 7.5

MODULE	STYLE	BORES	MATERIAL	QUALITY	PRES. ANGLE	HELIX ANGLE
0.4	LEFT HAND PIN HUB	5	STAINLESS STEEL DIN 1.4305 OR ALUMINUM DIN 3.1555	DIN 7 AGMA 10	20°	45°

STAINLESS STEEL STOCK NO.	ALUMINUM STOCK NO.	NO. OF TEETH	P.D.	O.D.
HGS83-L20	HGA83-L20	20	11.31	12.11
HGS83-L25	HGA83-L25	25	14.14	14.94
HGS83-L30	HGA83-L30	30	16.97	17.77
HGS83-L32	HGA83-L32	32	18.10	18.90
HGS83-L35	HGA83-L35	35	19.80	20.60
HGS83-L40	HGA83-L40	40	22.63	23.43
HGS83-L45	HGA83-L45	45	25.46	26.26
HGS83-L48	HGA83-L48	48	27.15	27.95
HGS83-L50	HGA83-L50	50	28.28	29.08
HGS83-L60	HGA83-L60	60	33.94	34.74
HGS83-L64	HGA83-L64	64	36.20	37.00
HGS83-L70	HGA83-L70	70	39.60	40.40
HGS83-L80	HGA83-L80	80	45.25	46.05
HGS83-L90	HGA83-L90	90	50.91	51.71
HGS83-L96	HGA83-L96	96	54.31	55.11
HGS83-L100	HGA83-L100	100	56.57	57.37
HGS83-L128	HGA83-L128	128	72.41	73.21
HGS83-L160	HGA83-L160	160	90.51	91.31

Other numbers of teeth are available on request.
 • For 15 - 19 teeth hub diameter is 7.5

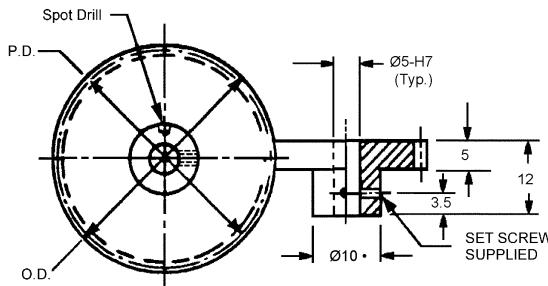
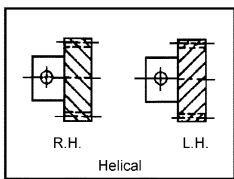

WORM GEARS

MODULE	STYLE	BORE	FACE	MATERIAL	QUALITY	TYPE
0.4	SINGLE, DOUBLE OR FOUR THREAD CLAMP HUB	5	5	464 BRASS ALLOY	DIN 7/AGMA 10	RIGHT HAND

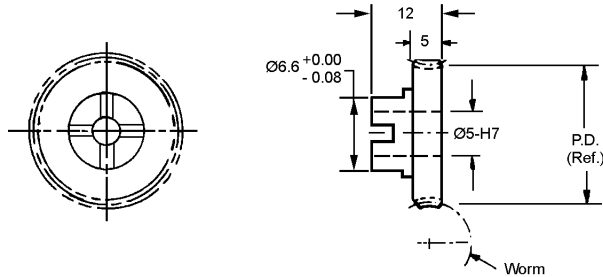

May be two piece construction. Hub diameter never exceeds O.D.
Other number of teeth AGMA 12 ir 14 / DIN 5 or 3 available on request.

SINGLE THREAD WORM	DOUBLE THREAD WORM	FOUR THREAD WORM	NO. OF TEETH	PITCH DIA.
Circular Pitch 1.257 Helix Angle 1° 44' Pressure Angle 14-1/2°	Circular Pitch 2.513 Helix Angle 3° 28' Pressure Angle 14-1/2°	Circular Pitch 5.027 Helix Angle 6° 54' Pressure Angle 14-1/2°		
STOCK NO.	STOCK NO.	STOCK NO.		
WGB83-S40C	WGB83-D40C	WGB83-F40C	40	16.00
WGB83-S50C	WGB83-D50C	WGB83-F50C	50	20.00
WGB83-S60C	WGB83-D60C	WGB83-F60C	60	24.00
WGB83-S70C	WGB83-D70C	WGB83-F70C	70	28.00
WGB83-S80C	WGB83-D80C	WGB83-F80C	80	32.00
WGB83-S90C	WGB83-D90C	WGB83-F90C	90	36.00
WGB83-S100C	WGB83-D100C	WGB83-F100C	100	40.00
WGB83-S110C	WGB83-D110C	WGB83-F110C	110	44.00
WGB83-S120C	WGB83-D120C	WGB83-F120C	120	48.00

$$\text{Ratio} = \frac{\# \text{ of Teeth}}{\text{Worm Threads}}$$

MODULE	STYLE	BORE	FACE	MATERIAL	QUALITY	TYPE
0.4	SINGLE, DOUBLE OR FOUR THREAD CLAMP HUB	8	5	464 BRASS ALLOY	DIN 7/AGMA 10	RIGHT HAND

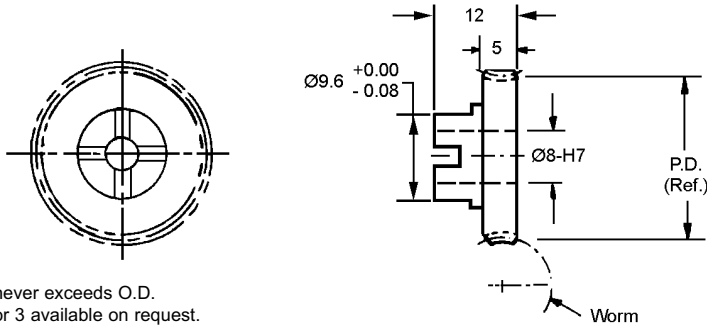

May be two piece construction. Hub diameter never exceeds O.D.
Other number of teeth AGMA 12 ir 14 / DIN 5 or 3 available on request.

SINGLE THREAD WORM	DOUBLE THREAD WORM	FOUR THREAD WORM	NO. OF TEETH	PITCH DIA.
Circular Pitch 1.257 Helix Angle 1° 44' Pressure Angle 14-1/2°	Circular Pitch 2.513 Helix Angle 3° 28' Pressure Angle 14-1/2°	Circular Pitch 5.027 Helix Angle 6° 54' Pressure Angle 14-1/2°		
STOCK NO.	STOCK NO.	STOCK NO.		
WGB95-S40C	WGB95-D40C	WGB95-F40C	40	16.00
WGB95-S50C	WGB95-D50C	WGB95-F50C	50	20.00
WGB95-S60C	WGB95-D60C	WGB95-F60C	60	24.00
WGB95-S70C	WGB95-D70C	WGB95-F70C	70	28.00
WGB95-S80C	WGB95-D80C	WGB95-F80C	80	32.00
WGB95-S90C	WGB95-D90C	WGB95-F90C	90	36.00
WGB95-S100C	WGB95-D100C	WGB95-F100C	100	40.00
WGB95-S110C	WGB95-D110C	WGB95-F110C	110	44.00
WGB95-S120C	WGB95-D120C	WGB95-F120C	120	48.00
WGB95-S180C	WGB95-D180C	WGB95-F180C	180	72.00

$$\text{Ratio} = \frac{\# \text{ of Teeth}}{\text{Worm Threads}}$$

ANTI-BACKLASH WORM GEARS

B

MODULE	STYLE	BORE	FACE	MATERIAL	QUALITY	TYPE
0.5	SINGLE THREAD PIN HUB	5	5	GEARS 464 BRASS ALLOY HUBS STAINLESS DIN 1.4305	DIN 7/AGMA 10	RIGHT HAND

STOCK NO.	NO. OF TEETH	PITCH DIA.
AWFB83-S40	40	20.00
AWFB83-S50	50	25.00
AWFB83-S60	60	30.00
AWFB83-S70	70	35.00
AWFB83-S80	80	40.00
AWFB83-S90	90	45.00
AWFB83-S100	100	50.00
AWFB83-S120	120	60.00
AWFB83-S180	180	90.00

$$\text{Ratio} = \frac{\# \text{ of Teeth}}{\text{Worm Threads}}$$

Circular Pitch 1.571
Helix Angle 3° 10'
Pressure Angle 14-1/2°

Runs with worm # WFS-5S

MODULE	STYLE	BORE	FACE	MATERIAL	QUALITY	TYPE
0.5	DOUBLE THREAD PIN HUB	5	5	GEARS 464 BRASS ALLOY HUBS STAINLESS DIN 1.4305	DIN 7/AGMA 10	RIGHT HAND

STOCK NO.	NO. OF TEETH	PITCH DIA.
AWFB83-D40	40	20.00
AWFB83-D50	50	25.00
AWFB83-D60	60	30.00
AWFB83-D70	70	35.00
AWFB83-D80	80	40.00
AWFB83-D90	90	45.00
AWFB83-D100	100	50.00
AWFB83-D120	120	60.00
AWFB83-D180	180	90.00

$$\text{Ratio} = \frac{\# \text{ of Teeth}}{\text{Worm Threads}}$$

Circular Pitch 3.142
Helix Angle 6° 20'
Pressure Angle 20°

Runs with worm # WFS-5D

MODULE	STYLE	BORE	FACE	MATERIAL	QUALITY	TYPE
0.5	FOUR THREAD PIN HUB	5	5	GEARS 464 BRASS ALLOY HUBS STAINLESS DIN 1.4305	DIN 7/AGMA 10	RIGHT HAND

STOCK NO.	NO. OF TEETH	PITCH DIA.
AWFB83-F40	40	20.00
AWFB83-F50	50	25.00
AWFB83-F60	60	30.00
AWFB83-F70	70	35.00
AWFB83-F80	80	40.00
AWFB83-F90	90	45.00
AWFB83-F100	100	50.00
AWFB83-F120	120	60.00
AWFB83-F180	180	90.00

$$\text{Ratio} = \frac{\# \text{ of Teeth}}{\text{Worm Threads}}$$

Circular Pitch 6.283
Helix Angle 12° 31'
Pressure Angle 25°

Runs with worm # WFS-5F

Scissor Spring
Or Coil Hub

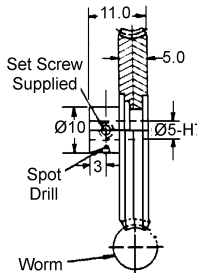
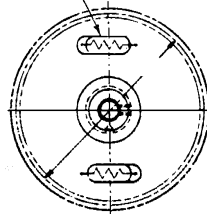

Other numbers of teeth are available on request.

**For Couplings See Section MG.
For Shafts, Bearings and Collars See Section MI.**

ANTI-BACKLASH WORM GEARS

MODULE	STYLE	BORE	FACE	MATERIAL	QUALITY	TYPE
0.5	SINGLE THREAD PIN HUB	8	5	GEARS 464 BRASS ALLOY HUBS STAINLESS DIN 1.4305	DIN 7/AGMA 10	RIGHT HAND

STOCK NO.	NO. OF TEETH	PITCH DIA.
AWFB95-S40	40	20.00
AWFB95-S50	50	25.00
AWFB95-S60	60	30.00
AWFB95-S70	70	35.00
AWFB95-S80	80	40.00
AWFB95-S90	90	45.00
AWFB95-S100	100	50.00
AWFB95-S120	120	60.00
AWFB95-S180	180	90.00

$$\text{Ratio} = \frac{\# \text{ of Teeth}}{\text{Worm Threads}}$$

Circular Pitch 1.571
Helix Angle 3° 10'
Pressure Angle 14-1/2°

Runs with worm # WFS-3S

MODULE	STYLE	BORE	FACE	MATERIAL	QUALITY	TYPE
0.5	DOUBLE THREAD PIN HUB	8	5	GEARS 464 BRASS ALLOY HUBS STAINLESS DIN 1.4305	DIN 7/AGMA 10	RIGHT HAND

STOCK NO.	NO. OF TEETH	PITCH DIA.
AWFB95-D40	40	20.00
AWFB95-D50	50	25.00
AWFB95-D60	60	30.00
AWFB95-D70	70	35.00
AWFB95-D80	80	40.00
AWFB95-D90	90	45.00
AWFB95-D100	100	50.00
AWFB95-D120	120	60.00
AWFB95-D180	180	90.00

$$\text{Ratio} = \frac{\# \text{ of Teeth}}{\text{Worm Threads}}$$

Circular Pitch 3.142
Helix Angle 6° 20'
Pressure Angle 20°

Runs with worm # WFS-3D

MODULE	STYLE	BORE	FACE	MATERIAL	QUALITY	TYPE
0.5	FOUR THREAD PIN HUB	8	5	GEARS 464 BRASS ALLOY HUBS STAINLESS DIN 1.4305	DIN 7/AGMA 10	RIGHT HAND

STOCK NO.	NO. OF TEETH	PITCH DIA.
AWFB95-F40	40	20.00
AWFB95-F50	50	25.00
AWFB95-F60	60	30.00
AWFB95-F70	70	35.00
AWFB95-F80	80	40.00
AWFB95-F90	90	45.00
AWFB95-F100	100	50.00
AWFB95-F120	120	60.00
AWFB95-F180	180	90.00

$$\text{Ratio} = \frac{\# \text{ of Teeth}}{\text{Worm Threads}}$$

Circular Pitch 6.283
Helix Angle 12° 31'
Pressure Angle 25°

Runs with worm # WFS-3F

Scissor Spring
Or Coil Hub

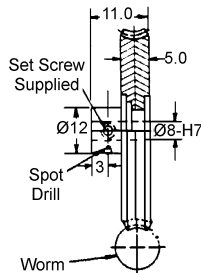
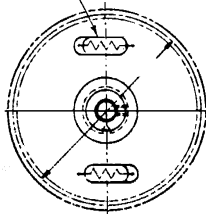

Other numbers of teeth are available on request.

ANTI-BACKLASH WORM GEARS

B

MODULE	STYLE	BORE	FACE	MATERIAL	QUALITY	TYPE
0.4	SINGLE THREAD PIN HUB	5	5	GEARS 464 BRASS ALLOY HUBS STAINLESS DIN 1.4305	DIN 7/AGMA 10	RIGHT HAND

STOCK NO.	NO. OF TEETH	PITCH DIA.
AWGB83-S50	50	20.00
AWGB83-S60	60	24.00
AWGB83-S70	70	28.00
AWGB83-S80	80	32.00
AWGB83-S90	90	36.00
AWGB83-S100	100	40.00
AWGB83-S110	110	44.00
AWGB83-S120	120	48.00
AWGB83-S180	180	72.00

$$\text{Ratio} = \frac{\# \text{ of Teeth}}{\text{Worm Threads}}$$

Circular Pitch 1.257
Helix Angle 1°44'
Pressure Angle 14-1/2°

Runs with worm # WGS-5S

MODULE	STYLE	BORE	FACE	MATERIAL	QUALITY	TYPE
0.4	DOUBLE THREAD PIN HUB	5	5	GEARS 464 BRASS ALLOY HUBS STAINLESS DIN 1.4305	DIN 7/AGMA 10	RIGHT HAND

STOCK NO.	NO. OF TEETH	PITCH DIA.
AWGB83-D50	50	20.00
AWGB83-D60	60	24.00
AWGB83-D70	70	28.00
AWGB83-D80	80	32.00
AWGB83-D90	90	36.00
AWGB83-D100	100	40.00
AWGB83-D110	110	44.00
AWGB83-D120	120	48.00
AWGB83-D180	180	72.00

$$\text{Ratio} = \frac{\# \text{ of Teeth}}{\text{Worm Threads}}$$

Circular Pitch 2.513
Helix Angle 3°28'
Pressure Angle 14-1/2°

Runs with worm # WGS-5D

MODULE	STYLE	BORE	FACE	MATERIAL	QUALITY	TYPE
0.4	FOUR THREAD PIN HUB	5	5	GEARS 464 BRASS ALLOY HUBS STAINLESS DIN 1.4305	DIN 7/AGMA 10	RIGHT HAND

STOCK NO.	NO. OF TEETH	PITCH DIA.
AWGB83-F50	50	20.00
AWGB83-F60	60	24.00
AWGB83-F70	70	28.00
AWGB83-F80	80	32.00
AWGB83-F90	90	36.00
AWGB83-F100	100	40.00
AWGB83-F110	110	44.00
AWGB83-F120	120	48.00
AWGB83-F180	180	72.00

$$\text{Ratio} = \frac{\# \text{ of Teeth}}{\text{Worm Threads}}$$

Circular Pitch 5.027
Helix Angle 6°54'
Pressure Angle 14-1/2°

Runs with worm # WGS-5F

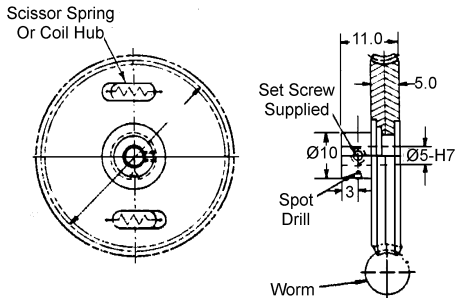

Other numbers of teeth are available on request.

ANTI-BACKLASH WORM GEARS

MODULE	STYLE	BORE	FACE	MATERIAL	QUALITY	TYPE
0.4	SINGLE THREAD PIN HUB	8	5	GEARS 464 BRASS ALLOY HUBS STAINLESS DIN 1.4305	DIN 7/AGMA 10	RIGHT HAND

STOCK NO.	NO. OF TEETH	PITCH DIA.
AWGB95-S50	50	20.00
AWGB95-S60	60	24.00
AWGB95-S70	70	28.00
AWGB95-S80	80	32.00
AWGB95-S90	90	36.00
AWGB95-S100	100	40.00
AWGB95-S110	110	44.00
AWGB95-S120	120	48.00
AWGB95-S180	180	72.00

$$\text{Ratio} = \frac{\# \text{ of Teeth}}{\text{Worm Threads}}$$

Circular Pitch 1.257
Helix Angle 1°44'
Pressure Angle 14-1/2°

Runs with worm # WGS-3S
WGS-5S
WGS-7S

MODULE	STYLE	BORE	FACE	MATERIAL	QUALITY	TYPE
0.4	DOUBLE THREAD PIN HUB	8	5	GEARS 464 BRASS ALLOY HUBS STAINLESS DIN 1.4305	DIN 7/AGMA 10	RIGHT HAND

STOCK NO.	NO. OF TEETH	PITCH DIA.
AWGB95-D50	50	20.00
AWGB95-D60	60	24.00
AWGB95-D70	70	28.00
AWGB95-D80	80	32.00
AWGB95-D90	90	36.00
AWGB95-D100	100	40.00
AWGB95-D110	110	44.00
AWGB95-D120	120	48.00
AWGB95-D180	180	72.00

$$\text{Ratio} = \frac{\# \text{ of Teeth}}{\text{Worm Threads}}$$

Circular Pitch 2.513
Helix Angle 3°28'
Pressure Angle 14-1/2°

Runs with worm # WGS-3D
WGS-5D
WGS-7D

MODULE	STYLE	BORE	FACE	MATERIAL	QUALITY	TYPE
0.4	FOUR THREAD PIN HUB	8	5	GEARS 464 BRASS ALLOY HUBS STAINLESS DIN 1.4305	DIN 7/AGMA 10	RIGHT HAND

STOCK NO.	NO. OF TEETH	PITCH DIA.
AWGB95-F50	50	20.00
AWGB95-F60	60	24.00
AWGB95-F70	70	28.00
AWGB95-F80	80	32.00
AWGB95-F90	90	36.00
AWGB95-F100	100	40.00
AWGB95-F110	110	44.00
AWGB95-F120	120	48.00
AWGB95-F180	180	72.00

$$\text{Ratio} = \frac{\# \text{ of Teeth}}{\text{Worm Threads}}$$

Circular Pitch 5.027
Helix Angle 6°54'
Pressure Angle 14-1/2°

Runs with worm # WFG-3D
WFG-5D
WFG-7D

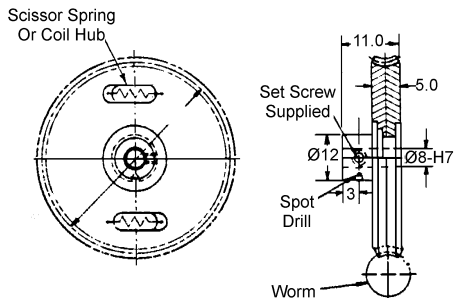

Other numbers of teeth are available on request.

For Couplings See Section MG.
For Shafts, Bearings and Collars See Section MI.

ANTI-BACKLASH WORM GEARS

B

MODULE	STYLE	BORE	FACE	MATERIAL	QUALITY	TYPE
0.5	SINGLE THREAD CLAMP STYLE	5	5	GEARS 464 BRASS ALLOY HUBS STAINLESS DIN 1.4305	DIN 7/AGMA 10	RIGHT HAND

STOCK NO.	NO. OF TEETH	PITCH DIA.
AWFB83-S40-C	40	20.00
AWFB83-S50-C	50	25.00
AWFB83-S60-C	60	30.00
AWFB83-S70-C	70	35.00
AWFB83-S80-C	80	40.00
AWFB83-S90-C	90	45.00
AWFB83-S100-C	100	50.00
AWFB83-S120-C	120	60.00
AWFB83-S180-C	180	90.00

$$\text{Ratio} = \frac{\# \text{ of Teeth}}{\text{Worm Threads}}$$

Circular Pitch 1.571
Helix Angle 3° 10'
Pressure Angle 14/1/2°

Runs with worm # WFS-5S

MODULE	STYLE	BORE	FACE	MATERIAL	QUALITY	TYPE
0.5	DOUBLE THREAD CLAMP STYLE	5	5	GEARS 464 BRASS ALLOY HUBS STAINLESS DIN 1.4305	DIN 7/AGMA 10	RIGHT HAND

STOCK NO.	NO. OF TEETH	PITCH DIA.
AWFB83-D40-C	40	20.00
AWFB83-D50-C	50	25.00
AWFB83-D60-C	60	30.00
AWFB83-D70-C	70	35.00
AWFB83-D80-C	80	40.00
AWFB83-D90-C	90	45.00
AWFB83-D100-C	100	50.00
AWFB83-D120-C	120	60.00
AWFB83-D180-C	180	90.00

$$\text{Ratio} = \frac{\# \text{ of Teeth}}{\text{Worm Threads}}$$

Circular Pitch 3.142
Helix Angle 6° 20'
Pressure Angle 20°

Runs with worm # WFS-5D

MODULE	STYLE	BORE	FACE	MATERIAL	QUALITY	TYPE
0.5	FOUR THREAD CLAMP STYLE	5	5	GEARS 464 BRASS ALLOY HUBS STAINLESS DIN 1.4305	DIN 7/AGMA 10	RIGHT HAND

STOCK NO.	NO. OF TEETH	PITCH DIA.
AWFB83-F40-C	40	20.00
AWFB83-F50-C	50	25.00
AWFB83-F60-C	60	30.00
AWFB83-F70-C	70	35.00
AWFB83-F80-C	80	40.00
AWFB83-F90-C	90	45.00
AWFB83-F100-C	100	50.00
AWFB83-F120-C	120	60.00
AWFB83-F180-C	180	90.00

$$\text{Ratio} = \frac{\# \text{ of Teeth}}{\text{Worm Threads}}$$

Circular Pitch 6.283
Helix Angle 12° 31'
Pressure Angle 25°

Runs with worm # WFS-5F

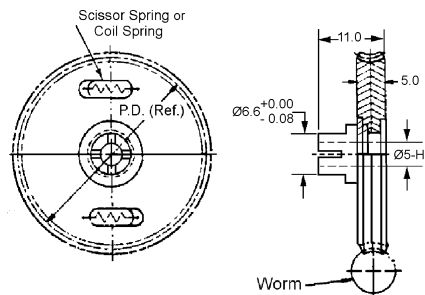

Other numbers of teeth are available on request.

ANTI-BACKLASH WORM GEARS

MODULE	STYLE	BORE	FACE	MATERIAL	QUALITY	TYPE
0.5	SINGLE THREAD CLAMP STYLE	8	5	GEARS 464 BRASS ALLOY HUBS STAINLESS DIN 1.4305	DIN 7/AGMA 10	RIGHT HAND

STOCK NO.	NO. OF TEETH	PITCH DIA.
AWFB95-S40-C	40	20.00
AWFB95-S50-C	50	25.00
AWFB95-S60-C	60	30.00
AWFB95-S70-C	70	35.00
AWFB95-S80-C	80	40.00
AWFB95-S90-C	90	45.00
AWFB95-S100-C	100	50.00
AWFB95-S120-C	120	60.00
AWFB95-S180-C	180	90.00

$$\text{Ratio} = \frac{\# \text{ of Teeth}}{\text{Worm Threads}}$$

Circular Pitch 1.571
Helix Angle 3° 10'
Pressure Angle 14/1/2°

Runs with worm # WFS-3S

MODULE	STYLE	BORE	FACE	MATERIAL	QUALITY	TYPE
0.5	DOUBLE THREAD CLAMP STYLE	8	5	GEARS 464 BRASS ALLOY HUBS STAINLESS DIN 1.4305	DIN 7/AGMA 10	RIGHT HAND

STOCK NO.	NO. OF TEETH	PITCH DIA.
AWFB95-D40-C	40	20.00
AWFB95-D50-C	50	25.00
AWFB95-D60-C	60	30.00
AWFB95-D70-C	70	35.00
AWFB95-D80-C	80	40.00
AWFB95-D90-C	90	45.00
AWFB95-D100-C	100	50.00
AWFB95-D120-C	120	60.00
AWFB95-D180-C	180	90.00

$$\text{Ratio} = \frac{\# \text{ of Teeth}}{\text{Worm Threads}}$$

Circular Pitch 3.142
Helix Angle 6° 20'
Pressure Angle 20°

Runs with worm # WFS-3D

MODULE	STYLE	BORE	FACE	MATERIAL	QUALITY	TYPE
0.5	FOUR THREAD CLAMP STYLE	8	5	GEARS 464 BRASS ALLOY HUBS STAINLESS DIN 1.4305	DIN 7/AGMA 10	RIGHT HAND

STOCK NO.	NO. OF TEETH	PITCH DIA.
AWFB95-F40-C	40	20.00
AWFB95-F50-C	50	25.00
AWFB95-F60-C	60	30.00
AWFB95-F70-C	70	35.00
AWFB95-F80-C	80	40.00
AWFB95-F90-C	90	45.00
AWFB95-F100-C	100	50.00
AWFB95-F120-C	120	60.00
AWFB95-F180-C	180	90.00

$$\text{Ratio} = \frac{\# \text{ of Teeth}}{\text{Worm Threads}}$$

Circular Pitch 6.283
Helix Angle 12° 31'
Pressure Angle 25°

Runs with worm # WFS-3F

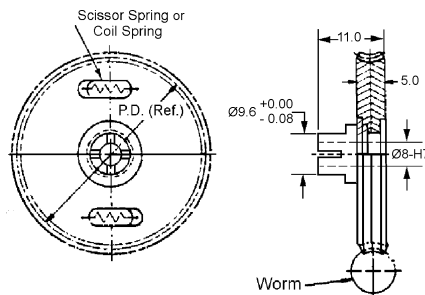

Other numbers of teeth are available on request.

For Couplings See Section MG.
For Shafts, Bearings and Collars See Section MI.

ANTI-BACKLASH WORM GEARS

B

MODULE	STYLE	BORE	FACE	MATERIAL	QUALITY	TYPE
0.4	SINGLE THREAD CLAMP STYLE	5	5	GEARS 464 BRASS ALLOY HUBS STAINLESS DIN 1.4305	DIN 7/AGMA 10	RIGHT HAND

STOCK NO.	NO. OF TEETH	PITCH DIA.
AWGB83-S50-C	50	20.00
AWGB83-S60-C	60	24.00
AWGB83-S70-C	70	28.00
AWGB83-S80-C	80	32.00
AWGB83-S90-C	90	36.00
AWGB83-S100-C	100	40.00
AWGB83-S110-C	110	44.00
AWGB83-S120-C	120	48.00
AWGB83-S180-C	180	72.00

$$\text{Ratio} = \frac{\text{\# of Teeth}}{\text{Worm Threads}}$$

Circular Pitch 1.257
Helix Angle 1° 44'
Pressure Angle 14/1/2°

Runs with worm # WGS-3S
WGS-5S
WGS-7S

MODULE	STYLE	BORE	FACE	MATERIAL	QUALITY	TYPE
0.4	DOUBLE THREAD CLAMP STYLE	5	5	GEARS 464 BRASS ALLOY HUBS STAINLESS DIN 1.4305	DIN 7/AGMA 10	RIGHT HAND

STOCK NO.	NO. OF TEETH	PITCH DIA.
AWGB83-D50-C	50	20.00
AWGB83-D60-C	60	24.00
AWGB83-D70-C	70	28.00
AWGB83-D80-C	80	32.00
AWGB83-D90-C	90	36.00
AWGB83-D100-C	100	40.00
AWGB83-D110-C	110	44.00
AWGB83-D120-C	120	48.00
AWGB83-D180-C	180	72.00

$$\text{Ratio} = \frac{\text{\# of Teeth}}{\text{Worm Threads}}$$

Circular Pitch 2.513
Helix Angle 3° 28'
Pressure Angle 14-1/2°

Runs with worm # WGS-3D
WGS-5D
WGS-7D

MODULE	STYLE	BORE	FACE	MATERIAL	QUALITY	TYPE
0.4	FOUR THREAD CLAMP STYLE	5	5	GEARS 464 BRASS ALLOY HUBS STAINLESS DIN 1.4305	DIN 7/AGMA 10	RIGHT HAND

STOCK NO.	NO. OF TEETH	PITCH DIA.
AWGB83-F50-C	50	20.00
AWGB83-F60-C	60	24.00
AWGB83-F70-C	70	28.00
AWGB83-F80-C	80	32.00
AWGB83-F90-C	90	36.00
AWGB83-F100-C	100	40.00
AWGB83-F110-C	110	44.00
AWGB83-F120-C	120	48.00
AWGB83-F180-C	180	72.00

$$\text{Ratio} = \frac{\text{\# of Teeth}}{\text{Worm Threads}}$$

Circular Pitch 5.027
Helix Angle 6° 54'
Pressure Angle 14-1/2°

Runs with worm # WGS-3F
WGS-5F
WGS-7F

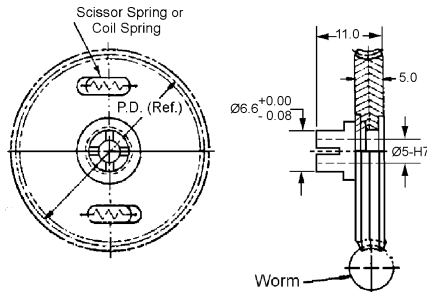

Other numbers of teeth are available on request.

**For Couplings See Section MG.
For Shafts, Bearings and Collars See Section MI.**

ANTI-BACKLASH WORM GEARS

MODULE	STYLE	BORE	FACE	MATERIAL	QUALITY	TYPE
0.4	SINGLE THREAD CLAMP STYLE	8	5	GEARS 464 BRASS ALLOY HUBS STAINLESS DIN 1.4305	DIN 7/AGMA 10	RIGHT HAND

STOCK NO.	NO. OF TEETH	PITCH DIA.
AWGB95-S50-C	50	20.00
AWGB95-S60-C	60	24.00
AWGB95-S70-C	70	28.00
AWGB95-S80-C	80	32.00
AWGB95-S90-C	90	36.00
AWGB95-S100-C	100	40.00
AWGB95-S110-C	110	44.00
AWGB95-S120-C	120	48.00
AWGB95-S180-C	180	72.00

$$\text{Ratio} = \frac{\# \text{ of Teeth}}{\text{Worm Threads}}$$

Circular Pitch 1.257
Helix Angle 1° 44'
Pressure Angle 14/1/2°

Runs with worm # WGS-3S
WGS-5S
WGS-7S

MODULE	STYLE	BORE	FACE	MATERIAL	QUALITY	TYPE
0.4	DOUBLE THREAD CLAMP STYLE	8	5	GEARS 464 BRASS ALLOY HUBS STAINLESS DIN 1.4305	DIN 7/AGMA 10	RIGHT HAND

STOCK NO.	NO. OF TEETH	PITCH DIA.
AWGB95-D50-C	50	20.00
AWGB95-D60-C	60	24.00
AWGB95-D70-C	70	28.00
AWGB95-D80-C	80	32.00
AWGB95-D90-C	90	36.00
AWGB95-D100-C	100	40.00
AWGB95-D110-C	110	44.00
AWGB95-D120-C	120	48.00
AWGB95-D180-C	180	72.00

$$\text{Ratio} = \frac{\# \text{ of Teeth}}{\text{Worm Threads}}$$

Circular Pitch 2.513
Helix Angle 3° 28'
Pressure Angle 14-1/2°

Runs with worm # WGS-3D
WGS-5D
WGS-7D

MODULE	STYLE	BORE	FACE	MATERIAL	QUALITY	TYPE
0.4	FOUR THREAD CLAMP STYLE	8	5	GEARS 464 BRASS ALLOY HUBS STAINLESS DIN 1.4305	DIN 7/AGMA 10	RIGHT HAND

STOCK NO.	NO. OF TEETH	PITCH DIA.
AWGB95-F50-C	50	20.00
AWGB95-F60-C	60	24.00
AWGB95-F70-C	70	28.00
AWGB95-F80-C	80	32.00
AWGB95-F90-C	90	36.00
AWGB95-F100-C	100	40.00
AWGB95-F110-C	110	44.00
AWGB95-F120-C	120	48.00
AWGB95-F180-C	180	72.00

$$\text{Ratio} = \frac{\# \text{ of Teeth}}{\text{Worm Threads}}$$

Circular Pitch 5.027
Helix Angle 6° 54'
Pressure Angle 14-1/2°

Runs with worm # WGS-3F
WGS-5F
WGS-7F

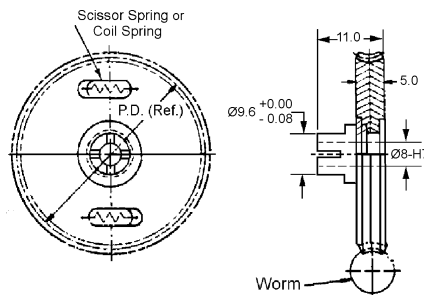

Other numbers of teeth are available on request.

For Couplings See Section MG.
For Shafts, Bearings and Collars See Section MI.

ASSEMBLIES

Table of Contents

GEARBOXES - WORM WHEEL AND HELICAL GEARS		
TECHNICAL DATA - SPEED REDUCERS	MC 2	
WORM & WORM WHEEL GEAR BOXES		
SHAFT SIZE - 3MM,4MM AND 6MM	MC3 - MC 4	
HELICAL GEAR BOXES	MC 5	
MINIATURE MITER GEARBOX	MC 6, MC 8, MC9	
BEVEL GEARBOX	MC 7, MC10	
SERVO GEARBOX		
SHAFT SIZE -3MM	MC 11	
SHAFT SIZE - 4MM	MC 12	
SHAFT SIZE - 6MM"	MC 13	
SPEED REDUCER		
SHAFT SIZE - 3MM	MC 14	
SHAFT SIZE - 6MM	MC 15	
PRECISION PLANETARY GEAR HEADS		
SHAFT SIZE -16MM, 20MM AND 24MM	MC 16	
INTERMITTENT MOTION ASSEMBLY		
SHAFT SIZE - 6MM	MC 17	
GENEVA MECHANISM		
SHAFT SIZE - 6MM AND 7MM	MC 18	
CAM FOLLOWERS	MC 19	
ROLLER BEARING CAM FOLLOWER	MC 20	
RATCHETS AND PAWLS	MC 21	

C

GEARBOXES - WORM WHEEL AND HELICAL GEARS

TECHNICAL INFORMATION PRECISION SPEED REDUCERS 3mm, 4mm and 6mm Shafts

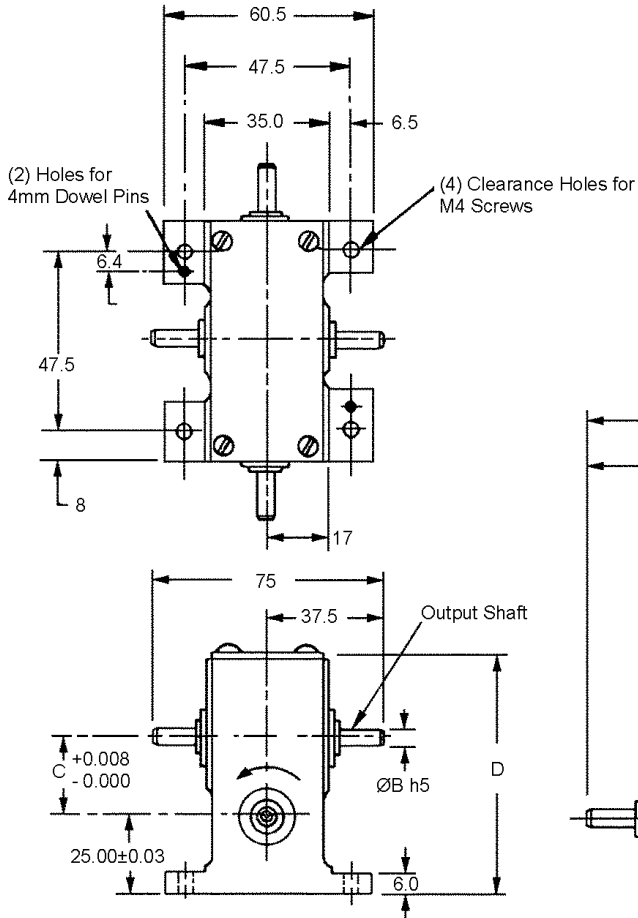

Materials

Housing	Cast Aluminum (Anodized)
Worm Wheel	Bronze
Worm	Stainless Steel
Helical Gear	Aluminum
Helical Pinion	Stainless Steel

Bearings	Stainless Steel or Bronze
Shafts	Stainless Steel
Lubrication	Grease
Housing Cover	Aluminum
All other parts	Stainless Steel

Backlash @ Output Shaft

Ball Bearing Unit	20 Minutes Max.
Bronze Bearing Unit	30 Minutes Max.

Maximum Output

3mm Shaft Series	- 177N·cm
4mm Shaft Series	- 247N·cm
6mm Shaft Series	- 353N·cm

Maximum Input Speed

2000 RPM

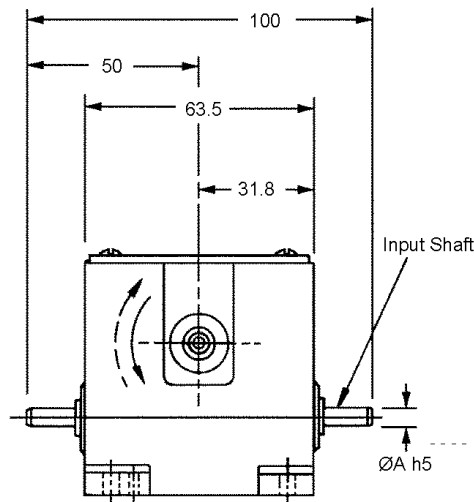

Worm and Wheel units can only be driven from input shaft and will only operate as a Speed Reducer.
Helical Gear units can be driven from input shaft as a Speed Reducer or from output shaft as a Speed Increaser.
Other ratios available on request.
Anti-Backlash unit available on request.



WORM & WHEEL GEAR BOXES

SHAFT SIZE	TYPE
ØA= 3MM ØB= 3MM	BALL BEARING OR BRONZE BEARING

BALL BEARINGS UNITS STOCK NO.	BRONZE BEARINGS UNITS STOCK NO.	UNIT TYPE	SHAFT SIZE		NOMINAL RATIO	C CENTER	D HEIGHT	MAXIMUM OUTPUT TORQUE (N•cm.)
			ØA	ØB				
WX64B2-1M	WX64P2-1M	WORM & WHEEL	3.00	3.00	15:1	18.263	59	79
WX64B2-2M	WX64P2-2M				20:1	22.233	66	112
WX64B2-3M	WX64P2-3M				25:1	26.200	75	135
WX64B2-4M	WX64P2-4M				30:1	30.170	82	169
WX64B2-5M	WX64P2-5M				30:1	18.263	59	101
WX64B2-6M	WX64P2-6M				40:1	22.233	66	135
WX64B2-7M	WX64P2-7M				50:1	26.200	75	169
WX64B2-8M	WX64P2-8M				60:1	30.170	72	203
WX64B2-9M	WX64P2-9M				60:1	18.263	59	101
WX64B2-10M	WX64P2-10M				80:1	22.233	66	135
WX64B2-11M	WX64P2-11M				100:1	26.200	75	169
WX64B2-12M	WX64P2-12M				120:1	30.170	82	203

C

SHAFT SIZE	TYPE
ØA= 4MM ØB= 4MM	BALL BEARING OR BRONZE BEARING

BALL BEARINGS UNITS STOCK NO.	BRONZE BEARINGS UNITS STOCK NO.	UNIT TYPE	SHAFT SIZE		NOMINAL RATIO	C CENTER	D HEIGHT	MAXIMUM OUTPUT TORQUE (N•cm.)
			ØA	ØB				
WX64B3-1M	WX64P3-1M	WORM & WHEEL	4.00	4.00	15:1	18.263	59	79
WX64B3-2M	WX64P3-2M				20:1	22.233	66	112
WX64B3-3M	WX64P3-3M				25:1	26.200	75	135
WX64B3-4M	WX64P3-4M				30:1	30.170	82	169
WX64B3-5M	WX64P3-5M				30:1	18.263	59	101
WX64B3-6M	WX64P3-6M				40:1	22.233	66	135
WX64B3-7M	WX64P3-7M				50:1	26.200	75	169
WX64B3-8M	WX64P3-8M				60:1	30.170	72	203
WX64B3-9M	WX64P3-9M				60:1	18.263	59	101
WX64B3-10M	WX64P3-10M				80:1	22.233	66	135
WX64B3-11M	WX64P3-11M				100:1	26.200	75	169
WX64B3-12M	WX64P3-12M				120:1	30.170	82	203

SHAFT SIZE	TYPE
ØA= 6MM ØB= 6MM	BALL BEARING OR BRONZE BEARING

BALL BEARINGS UNITS STOCK NO.	BRONZE BEARINGS UNITS STOCK NO.	UNIT TYPE	SHAFT SIZE		NOMINAL RATIO	C CENTER	D HEIGHT	MAXIMUM OUTPUT TORQUE (N•cm.)
			ØA	ØB				
WX64B4-1M	WX64P4-1M	WORM & WHEEL	6.00	6.00	15:1	18.263	59	79
WX64B4-2M	WX64P4-2M				20:1	22.233	66	112
WX64B4-3M	WX64P4-3M				25:1	26.200	75	135
WX64B4-4M	WX64P4-4M				30:1	30.170	82	169
WX64B4-5M	WX64P4-5M				30:1	18.263	59	101
WX64B4-6M	WX64P4-6M				40:1	22.233	66	135
WX64B4-7M	WX64P4-7M				50:1	26.200	75	169
WX64B4-8M	WX64P4-8M				60:1	30.170	72	203
WX64B4-9M	WX64P4-9M				60:1	18.263	59	101
WX64B4-10M	WX64P4-10M				80:1	22.233	66	135
WX64B4-11M	WX64P4-11M				100:1	26.200	75	169
WX64B4-12M	WX64P4-12M				120:1	30.170	82	203

WORM & WHEEL GEAR BOXES

SHAFT SIZE	TYPE
ØA= 3MM ØB= 3MM	BALL BEARING OR BRONZE BEARING

BALL BEARINGS UNITS STOCK NO.	BRONZE BEARINGS UNITS STOCK NO.	UNIT TYPE	SHAFT SIZE		NOMINAL RATIO	C CENTER	D HEIGHT	MAXIMUM OUTPUT TORQUE (N•cm.)
			ØA	ØB				
WX48B2-1M	WX48P2-1M	WORM & WHEEL	3.00	3.00	12.5:1	17.470	59	101
WX48B2-2M	WX48P2-2M				15:1	20.117	64	124
WX48B2-3M	WX48P2-3M				20:1	25.408	75	164
WX48B2-4M	WX48P2-4M				22.5:1	28.054	80	192
WX48B2-5M	WX48P2-5M				25:1	17.470	59	124
WX48B2-6M	WX48P2-6M				30:1	20.117	64	146
WX48B2-7M	WX48P2-7M				40:1	25.408	75	203
WX48B2-8M	WX48P2-8M				45:1	28.054	80	225
WX48B2-9M	WX48P2-9M				50:1	17.470	59	124
WX48B2-10M	WX48P2-10M				60:1	20.117	64	146
WX48B2-11M	WX48P2-11M				80:1	25.408	75	203
WX48B2-12M	WX48P2-12M				90:1	28.054	80	225

SHAFT SIZE	TYPE
ØA= 4MM ØB= 4MM	BALL BEARING OR BRONZE BEARING

BALL BEARINGS UNITS STOCK NO.	BRONZE BEARINGS UNITS STOCK NO.	UNIT TYPE	SHAFT SIZE		NOMINAL RATIO	C CENTER	D HEIGHT	MAXIMUM OUTPUT TORQUE (N•cm.)
			ØA	ØB				
WX48B3-1M	WX48P3-1M	WORM & WHEEL	4.00	4.00	12.5:1	17.470	59	101
WX48B3-2M	WX48P3-2M				15:1	20.117	64	124
WX48B3-3M	WX48P3-3M				20:1	25.408	75	164
WX48B3-4M	WX48P3-4M				22.5:1	28.054	80	192
WX48B3-5M	WX48P3-5M				25:1	17.470	59	124
WX48B3-6M	WX48P3-6M				30:1	20.117	64	146
WX48B3-7M	WX48P3-7M				40:1	25.408	75	203
WX48B3-8M	WX48P3-8M				45:1	28.054	80	225
WX48B3-9M	WX48P3-9M				50:1	17.470	59	124
WX48B3-10M	WX48P3-10M				60:1	20.117	64	146
WX48B3-11M	WX48P3-11M				80:1	25.408	75	203
WX48B3-12M	WX48P3-12M				90:1	28.054	80	225

SHAFT SIZE	TYPE
ØA= 6MM ØB= 6MM	BALL BEARING OR BRONZE BEARING

BALL BEARINGS UNITS STOCK NO.	BRONZE BEARINGS UNITS STOCK NO.	UNIT TYPE	SHAFT SIZE		NOMINAL RATIO	C CENTER	D HEIGHT	MAXIMUM OUTPUT TORQUE (N•cm.)
			ØA	ØB				
WX48B4-1M	WX48P4-1M	WORM & WHEEL	6.00	6.00	12.5:1	17.470	59	101
WX48B4-2M	WX48P4-2M				15:1	20.117	64	124
WX48B4-3M	WX48P4-3M				20:1	25.408	75	164
WX48B4-4M	WX48P4-4M				22.5:1	28.054	80	192
WX48B4-5M	WX48P4-5M				25:1	17.470	59	124
WX48B4-6M	WX48P4-6M				30:1	20.117	64	146
WX48B4-7M	WX48P4-7M				40:1	25.408	75	203
WX48B4-8M	WX48P4-8M				45:1	28.054	80	225
WX48B4-9M	WX48P4-9M				50:1	17.470	59	124
WX48B4-10M	WX48P4-10M				60:1	20.117	64	146
WX48B4-11M	WX48P4-11M				80:1	25.408	75	203
WX48B4-12M	WX48P4-12M				90:1	28.054	80	225

HELICAL GEAR BOXES

SHAFT SIZE				TYPE			
ØA= 3MM		ØB= 3MM		BALL BEARING OR BRONZE BEARING			

BALL BEARINGS UNITS STOCK NO.	BRONZE BEARINGS UNITS STOCK NO.	UNIT TYPE	SHAFT SIZE		NOMINAL RATIO	C CENTER	D HEIGHT	MAXIMUM OUTPUT TORQUE (N•cm)
			ØA	ØB				
HX64B2-1M	HX64P2-1M	HELICAL	3.00	3.00	1:1	11.232	45	34
HX64B2-2M	HX64P2-2M				2:1	16.845	56	
HX64B2-3M	HX64P2-3M				3:1	22.456	68	
HX64B2-4M	HX64P2-4M				4:1	28.070	79	

SHAFT SIZE				TYPE			
ØA= 4MM		ØB= 4MM		BALL BEARING OR BRONZE BEARING			

BALL BEARINGS UNITS STOCK NO.	BRONZE BEARINGS UNITS STOCK NO.	UNIT TYPE	SHAFT SIZE		NOMINAL RATIO	C CENTER	D HEIGHT	MAXIMUM OUTPUT TORQUE (N•cm)
			ØA	ØB				
HX64B3-1M	HX64P3-1M	HELICAL	4.00	4.00	1:1	11.232	45	51
HX64B3-2M	HX64P3-2M				2:1	16.845	56	
HX64B3-3M	HX64P3-3M				3:1	22.456	68	
HX64B3-4M	HX64P3-4M				4:1	28.070	79	

SHAFT SIZE				UNITS			
ØA= 4MM		ØB= 4MM		BALL BEARING OR BRONZE BEARING			

BALL BEARINGS UNITS STOCK NO.	BRONZE BEARINGS UNITS STOCK NO.	UNIT TYPE	SHAFT SIZE		NOMINAL RATIO	C CENTER	D HEIGHT	MAXIMUM OUTPUT TORQUE (N•cm.)
			ØA	ØB				
HX48B3-1M	HX48P3-1M	HELICAL	4.00	4.00	1:1	14.973	51	51
HX48B3-2M	HX48P3-2M				2:1	22.456	65	
HX48B3-3M	HX48P3-3M				3:1	29.939	55	

SHAFT SIZE				UNITS			
ØA= 6MM		ØB= 6MM		BALL BEARING OR BRONZE BEARING			

BALL BEARINGS UNITS STOCK NO.	BRONZE BEARINGS UNITS STOCK NO.	UNIT TYPE	SHAFT SIZE		NOMINAL RATIO	C CENTER	D HEIGHT	MAXIMUM OUTPUT TORQUE (N•cm.)
			ØA	ØB				
HX48B4-1M	HX48P4-1M	HELICAL	6.00	6.00	1:1	14.973	51	91
HX48B4-2M	HX48P4-2M				2:1	22.456	65	
HX48B4-3M	HX48P4-3M				3:1	29.939	55	

MINIATURE MITER GEARBOX

SHAFT SIZE	TYPE
4MM	BRONZE BEARING

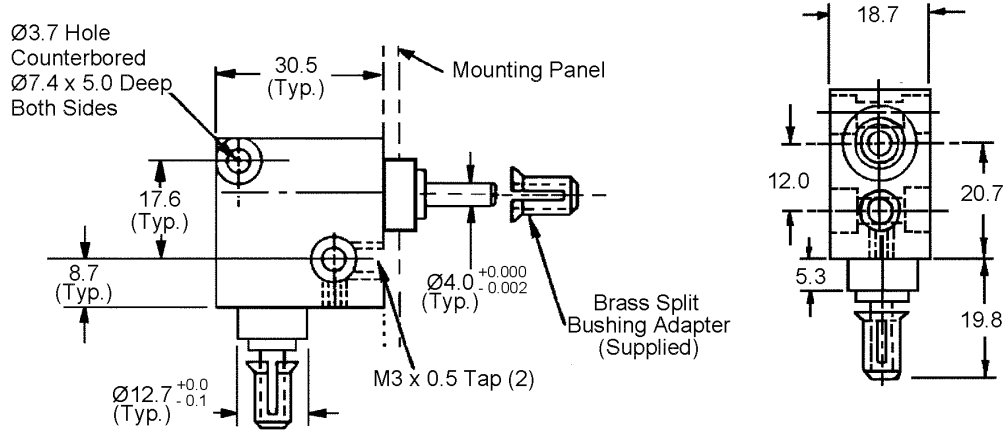

STOCK NO.	GEAR MATERIAL	OPERATING TORQUE
MX-14M	HARDENED STEEL	140N•cm

- Ground and hardened steel shafts
- Sintered bronze bearing system
- Gearbox and bearings lubricated for life
- 1000 RPM Maximum

BEVEL GEARBOX

SHAFT SIZE	RATIOS	TYPE
5MM	1:1 and 1:2	BRONZE BEARING

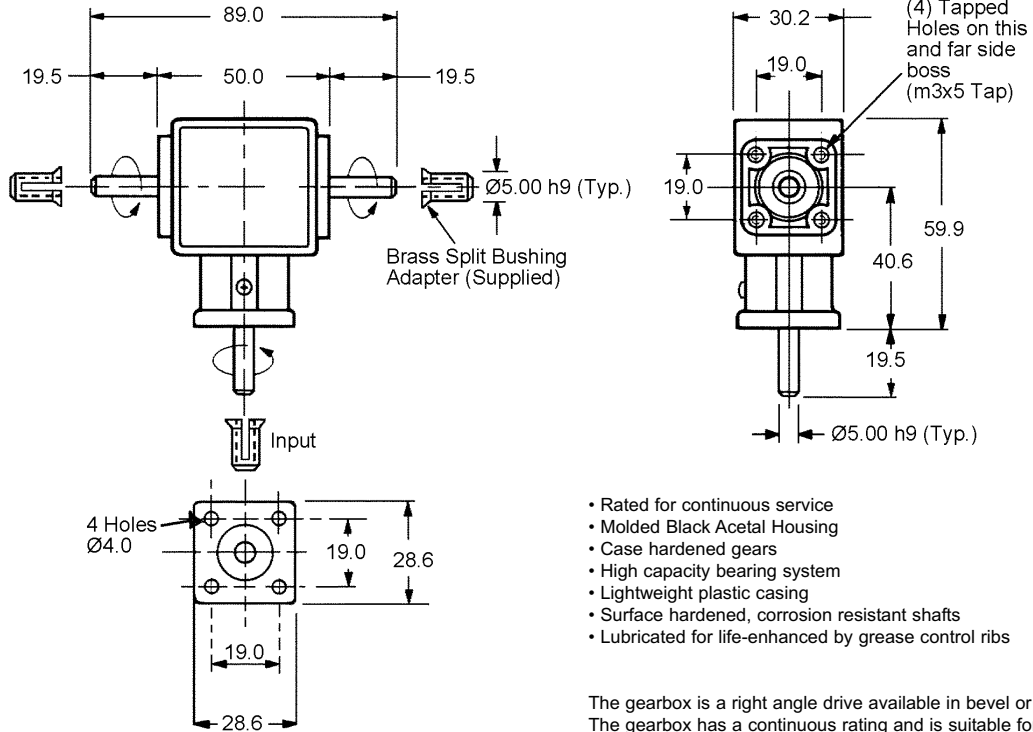

- Rated for continuous service
- Molded Black Acetal Housing
- Case hardened gears
- High capacity bearing system
- Lightweight plastic casing
- Surface hardened, corrosion resistant shafts
- Lubricated for life-enhanced by grease control ribs

The gearbox is a right angle drive available in bevel or miter gear versions. The gearbox has a continuous rating and is suitable for instrument and light duty drives. It is both economical and reliable.

STOCK NO.	RATIO	RPM MAX.	OPERATING TORQUE	BACKLASH MAX.
MX-16M	1:1	1500	30N•cm	2°
MX-17M	1:2	1500	65N•cm	2°

MITER GEARBOX

SHAFT SIZE	RATIO	TYPE
3MM	1:1	BALL BEARING OR BRONZE BEARING

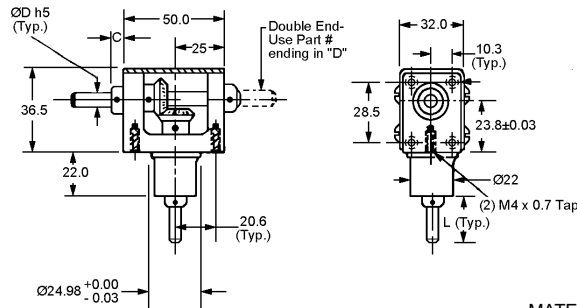

Consult Berg's Engineering Department for higher torque units.

ABEC 7 BALL BEARING	OIL-LESS BRONZE BEARING UNIT	SHAFT ØD	C	L	SHAFT END STYLE	R.P.M. (MAX.)	TORQUE (MAX.)
STOCK NO.	STOCK NO.						
MX-101	MX-101B	2.993	4.76	18.0	SINGLE	1000	140N•cm
MX-101-D	MX-101B-D				DOUBLE		

MATERIAL:
 Housing: Aluminum
 Shafts and Hardware: Stainless Steel
 Bearings: Stainless Steel or Bronze
 Gears: Stainless Steel and Aluminum
 Lubrication: MIL. Spec. Oil and Grease

SHAFT SIZE	RATIO	TYPE
4MM	1:1	BALL BEARING OR BRONZE BEARING

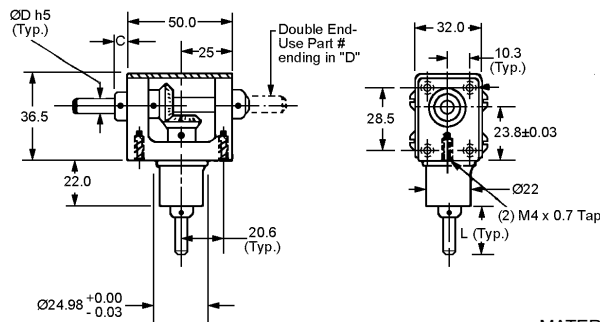

Consult Berg's Engineering Department for higher torque units.

ABEC 7 BALL BEARING	OIL-LESS BRONZE BEARING UNIT	SHAFT ØD	C	L	SHAFT END STYLE	R.P.M. (MAX.)	TORQUE (MAX.)
STOCK NO.	STOCK NO.						
MX-102	MX-102B	3.993	5.59	22.0	SINGLE	2000	210N•cm
MX-102-D	MX-102B-D				DOUBLE		

MATERIAL:
 Housing: Aluminum
 Shafts and Hardware: Stainless Steel
 Bearings: Stainless Steel or Bronze
 Gears: Stainless Steel and Aluminum
 Lubrication: MIL. Spec. Oil and Grease

SHAFT SIZE	RATIO	TYPE
6MM	1:1	BALL BEARING OR BRONZE BEARING

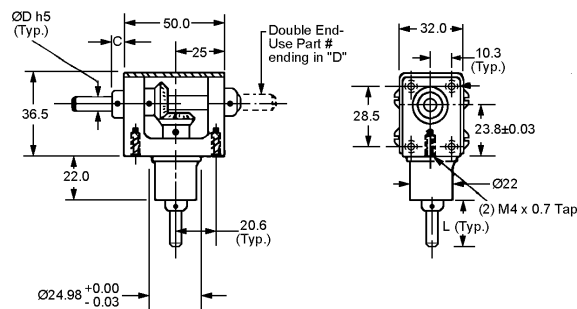

Consult Berg's Engineering Department for higher torque units.

ABEC 7 BALL BEARING	OIL-LESS BRONZE BEARING UNIT	SHAFT ØD	C	L	SHAFT END STYLE	R.P.M. (MAX.)	TORQUE (MAX.)
STOCK NO.	STOCK NO.						
MX-103	MX-103B	5.993	6.35	26.0	SINGLE	2500	350N•cm
MX-103-D	MX-103B-D				DOUBLE		

MATERIAL:
 Housing: Aluminum
 Shafts and Hardware: Stainless Steel
 Bearings: Stainless Steel or Bronze
 Gears: Stainless Steel and Aluminum
 Lubrication: MIL. Spec. Oil and Grease

MINIATURE MITER GEARBOX

SHAFT SIZE	RATIO	TYPE
3MM	1:1	BALL BEARING OR BRONZE BEARING

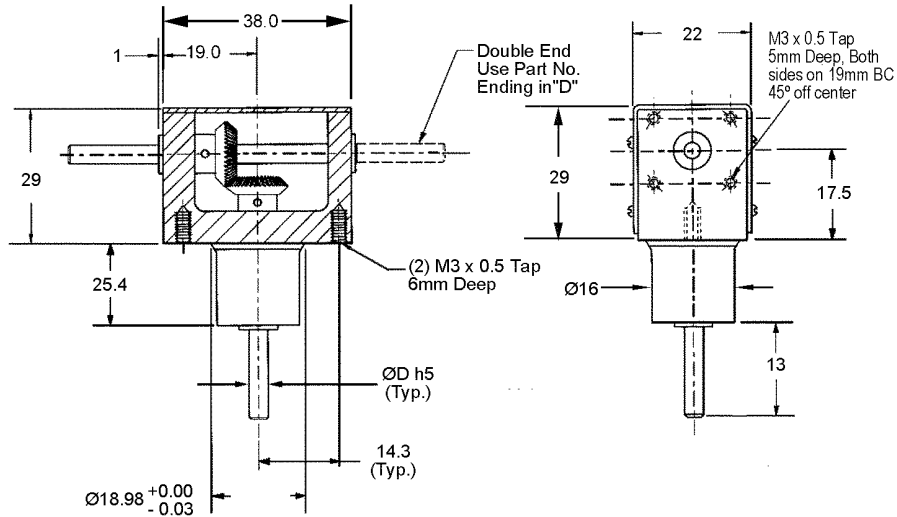

MATERIAL:
 Housing: Aluminum
Shafts and Hardware: Stainless Steel
Bearings: Stainless Steel or Bronze
Gears: Stainless Steel
Lubrication: Grease

ABEC 7 BALL BEARING	OIL-LESS BRONZE BEARING UNIT				
STOCK NO.	STOCK NO.	ϕD	SHAFT END STYLE	R.P.M. (MAX.)	TORQUE (MAX.)
MX-4M	MX-4BM	3.00	SINGLE	1000	70N*cm
MX-4M-D	MX-4BM-D		DOUBLE		

Consult Berg's Engineering Department for higher torque units.
 Anti-Backlash units available on request.



C

BEVEL GEARBOX

SHAFT SIZE	RATIO	TYPE
3MM	FROM 1:1 TO 1:3	BALL BEARING OR BRONZE BEARING

ABEC 7 BALL BEARING	OIL-LESS BRONZE BEARING UNIT	NOMINAL RATIO	ØD	B	C	E	F	G	H	A	RPM (MAX.)	STATIC TORQUE (MAX.)
STOCK NO.	STOCK NO.											
MX-5M MX-6M MX-7M	MX-5BM MX-6BM MX-7BM	1:1 1:2 1:3	3.00	70	48	41	48	21	37 43 49	25	1000	42N•cm

- Maximum backlash 10 minutes
- Units can be driven in either direction from any shaft

MATERIAL:
 Housing Aluminum
Shafts and Hardware Stainless Steel
Bearings Stainless Steel or Bronze
Gears Stainless Steel and Aluminum
Lubrication Grease

SHAFT SIZE	RATIO	TYPE
4MM	FROM 1:1 TO 1:3	BALL BEARING OR BRONZE BEARING

ABEC 7 BALL BEARING	OIL-LESS BRONZE BEARING UNIT	NOMINAL RATIO	ØD	B	C	E	F	G	H	A	RPM (MAX.)	STATIC TORQUE (MAX.)
STOCK NO.	STOCK NO.											
MX-8M MX-9M MX-10M	MX-8BM MX-9BM MX-10BM	1:1 1:2 1:3	4.00	70	48	41	48	21	37 43 49	25	2000	57N•cm

- Maximum backlash 10 minutes
- Units can be driven in either direction from any shaft

MATERIAL:
 Housing Aluminum
Shafts and Hardware Stainless Steel
Bearings Stainless Steel or Bronze
Gears Stainless Steel and Aluminum
Lubrication Grease

SHAFT SIZE	RATIO	TYPE
6MM	FROM 1:1 TO 1:3	BALL BEARING OR BRONZE BEARING

ABEC 7 BALL BEARING	OIL-LESS BRONZE BEARING UNIT	NOMINAL RATIO	ØD	B	C	E	F	G	H	A	RPM (MAX.)	STATIC TORQUE (MAX.)
STOCK NO.	STOCK NO.											
MX-11M MX-12M MX-13M	MX-11BM MX-12BM MX-13BM	1:1 1:2 1:3	6.00	89	67	51	57	24	51 59 65	38	2500	71N•cm

- Maximum backlash 10 minutes
- Units can be driven in either direction from any shaft

MATERIAL:
 Housing Aluminum
Shafts and Hardware Stainless Steel
Bearings Stainless Steel or Bronze
Gears Stainless Steel and Aluminum
Lubrication Grease

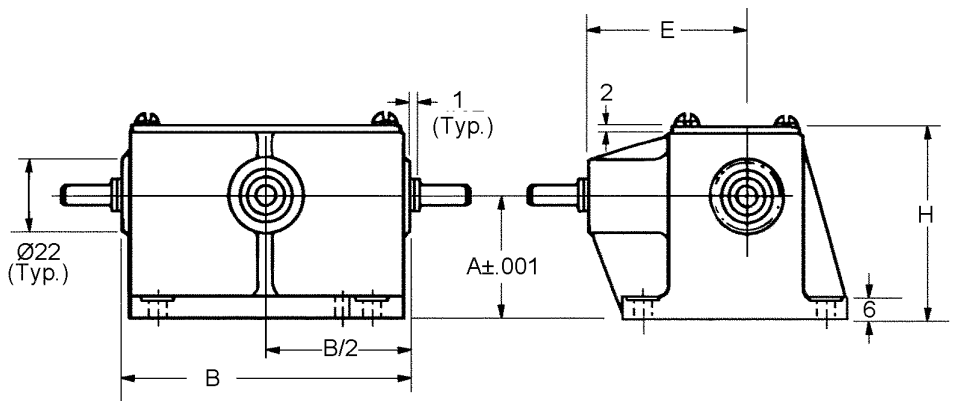
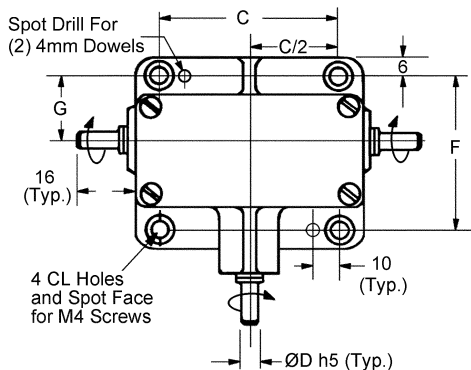

SERVO GEARBOX - PRECISION SPEED REDUCER

SHAFT SIZE	TYPE
3MM	BALL BEARING OR BRONZE BEARING

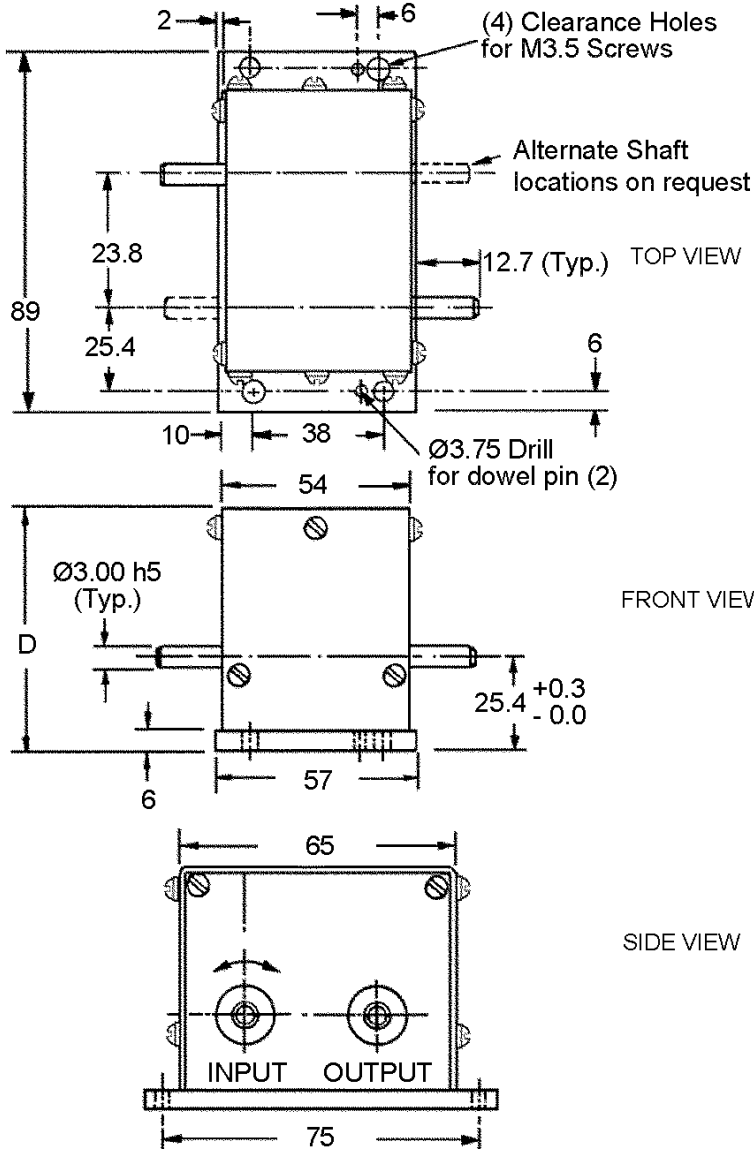

Special units available on request.
 Anti-Backlash gear - Output End
 Slip Clutch included - Input End
 Contact Berg's Engineering Department for recommendations for use as a Speed Increaser.

• See instructions below to order alternate shaft locations.

ABEC 7 BALL BEARINGS UNITS	BRONZE BEARINGS UNITS	NOMINAL RATIO	D HEIGHT	DIRECTION ROTATION
SX-B2-1M	SX-P2-1M	2:1	63.5	SAME
SX-B2-2M	SX-P2-2M	3:1		
SX-B2-3M	SX-P2-3M	4:1		
SX-B2-4M	SX-P2-4M	5:1		
SX-B2-5M	SX-P2-5M	6:1		
SX-B2-6M	SX-P2-6M	7:1		
SX-B2-7M	SX-P2-7M	8:1		
SX-B2-8M	SX-P2-8M	9:1		
SX-B2-9M	SX-P2-9M	10:1		
SX-B2-10M	SX-P2-10M	12:1		
SX-B2-11M	SX-P2-11M	15:1		
SX-B2-12M	SX-P2-12M	16:1		
SX-B2-13M	SX-P2-13M	20:1		
SX-B2-14M	SX-P2-14M	25:1		
SX-B2-15M	SX-P2-15M	30:1	67.0	OPPOSITE
SX-B2-16M	SX-P2-16M	32:1		
SX-B2-17M	SX-P2-17M	36:1		
SX-B2-18M	SX-P2-18M	40:1		
SX-B2-19M	SX-P2-19M	45:1		
SX-B2-20M	SX-P2-20M	48:1		
SX-B2-21M	SX-P2-21M	50:1		
SX-B2-22M	SX-P2-22M	60:1		
SX-B2-23M	SX-P2-23M	64:1		
SX-B2-24M	SX-P2-24M	75:1		
SX-B2-25M	SX-P2-25M	80:1		
SX-B2-26M	SX-P2-26M	100:1		
SX-B2-27M	SX-P2-27M	125:1		
SX-B2-28M	SX-P2-28M	72:1	84.0	SAME
SX-B2-29M	SX-P2-29M	90:1		
SX-B2-30M	SX-P2-30M	96:1		
SX-B2-31M	SX-P2-31M	128:1		
SX-B2-32M	SX-P2-32M	150:1		
SX-B2-33M	SX-P2-33M	180:1		
SX-B2-34M	SX-P2-34M	200:1		
SX-B2-35M	SX-P2-35M	250:1		
SX-B2-36M	SX-P2-36M	256:1		
SX-B2-37M	SX-P2-37M	300:1		
SX-B2-38M	SX-P2-38M	375:1		
SX-B2-39M	SX-P2-39M	400:1		
SX-B2-40M	SX-P2-40M	500:1		
SX-B2-41M	SX-P2-41M	625:1		

Alternate Shaft Locations

Add Style Letter to complete stock number, if different from that shown.

Style:

- = Opposite of as shown
- R = In and Out on R.H. side only
- L = In and Out on L.H. side only
- A = In and Out on all sides

Send drawing if other than listed above.

Materials

Housing and Cover Aluminum Anodized

Gears Stainless Steel and Aluminum

Shafts and Hardware Stainless Steel

Bearings Stainless Steel or Bronze

Lubrication Grease

Maximum Speed

5000 RPM

Maximum Output Torque

212N·cm



SERVO GEARBOXES

SHAFT SIZE	TYPE
4MM	BALL BEARING OR BRONZE BEARING

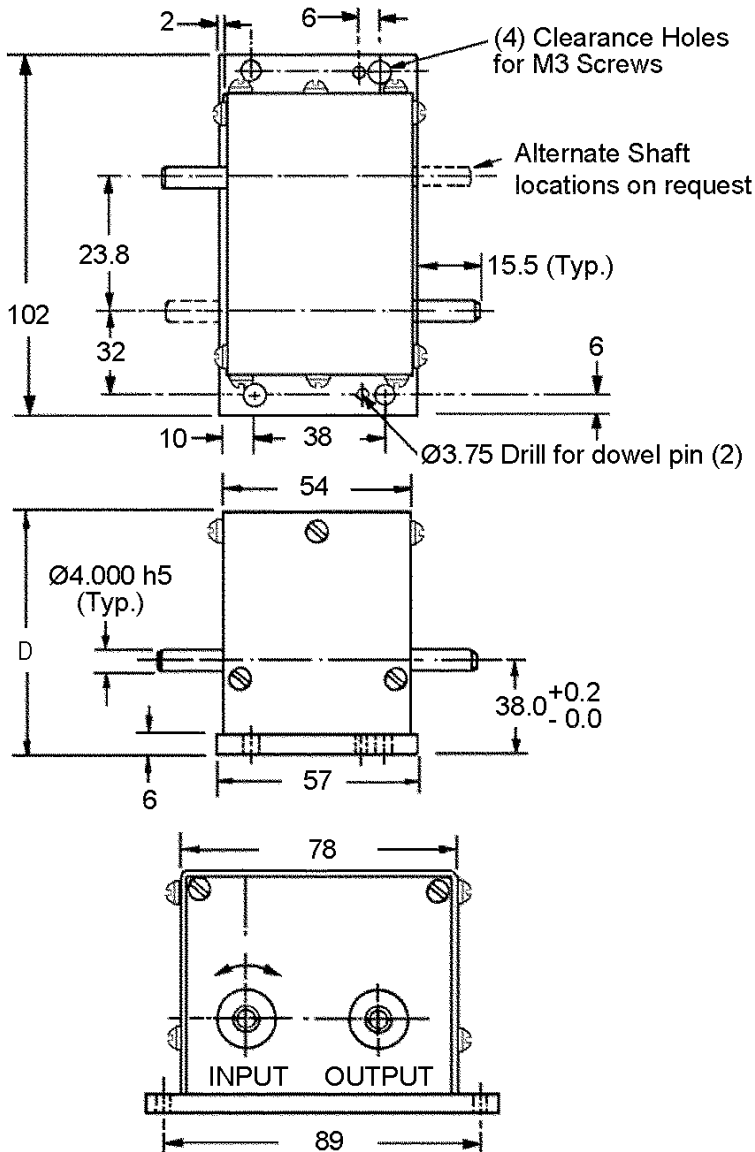

Special units available on request.

Anti-Backlash gear - Output End

Slip Clutch included - Input End

Contact Berg's Engineering Department for recommendations for use as a Speed Increaser.

• See instructions below to order alternate shaft locations.

ABEC 7 BALL BEARINGS UNITS	BRONZE BEARINGS UNITS	NOMINAL RATIO	D HEIGHT	DIRECTION ROTATION
STOCK NO.	STOCK NO.			
SX-B3-1M	SX-P3-1	2:1	86.0	SAME
SX-B3-2M	SX-P3-2	3:1		
SX-B3-3M	SX-P3-3	4:1		
SX-B3-4M	SX-P3-4	5:1		
SX-B3-5M	SX-P3-5	6:1		
SX-B3-6M	SX-P3-6	7:1		
SX-B3-7M	SX-P3-7	8:1		
SX-B3-8M	SX-P3-8	9:1		
SX-B3-9M	SX-P3-9	10:1		
SX-B3-10M	SX-P3-10	12:1		
SX-B3-11M	SX-P3-11	15:1		
SX-B3-12M	SX-P3-12	16:1		
SX-B3-13M	SX-P3-13	20:1		
SX-B3-14M	SX-P3-14	25:1		
SX-B3-15M	SX-P3-15	30:1	86.0	OPPOSITE
SX-B3-16M	SX-P3-16	32:1		
SX-B3-17M	SX-P3-17	36:1		
SX-B3-18M	SX-P3-18	40:1		
SX-B3-19M	SX-P3-19	45:1		
SX-B3-20M	SX-P3-20	48:1		
SX-B3-21M	SX-P3-21	50:1		
SX-B3-22M	SX-P3-22	60:1		
SX-B3-23M	SX-P3-23	64:1		
SX-B3-24M	SX-P3-24	75:1		
SX-B3-25M	SX-P3-25	80:1		
SX-B3-26M	SX-P3-26	100:1		
SX-B3-27M	SX-P3-27	125:1		
SX-B3-28M	SX-P3-28	72:1	109.0	SAME
SX-B3-29M	SX-P3-29	90:1		
SX-B3-30M	SX-P3-30	96:1		
SX-B3-31M	SX-P3-31	128:1		
SX-B3-32M	SX-P3-32	150:1		
SX-B3-33M	SX-P3-33	180:1		
SX-B3-34M	SX-P3-34	200:1		
SX-B3-35M	SX-P3-35	250:1		
SX-B3-36M	SX-P3-36	256:1		
SX-B3-37M	SX-P3-37	300:1		
SX-B3-38M	SX-P3-38	375:1		
SX-B3-39M	SX-P3-39	400:1		
SX-B3-40M	SX-P3-40	500:1		
SX-B3-41M	SX-P3-41	625:1		

Alternate Shaft Locations

Add **Style Letter** to complete stock number, if different from that shown.

Style:

- O** = Opposite of as shown
- R** = In and Out on R.H. side only
- L** = In and Out on L.H. side only
- A** = In and Out on all sides

Send drawing if other than listed above.

Backlash

At Output Shaft

Ball Bearing - 15 Minutes Max.

Bronze Bearing - 30 Minutes Max.

Materials

Housing and Cover Aluminum Anodized

Gears Stainless Steel and Aluminum

Shafts and Hardware Stainless Steel

Bearings Stainless Steel or Bronze

Lubrication Grease

Maximum Speed

5000 RPM

Maximum Output Torque

280N•cm



SERVO GEARBOXES

SHAFT SIZE	TYPE
6MM	BALL BEARING OR BRONZE BEARING

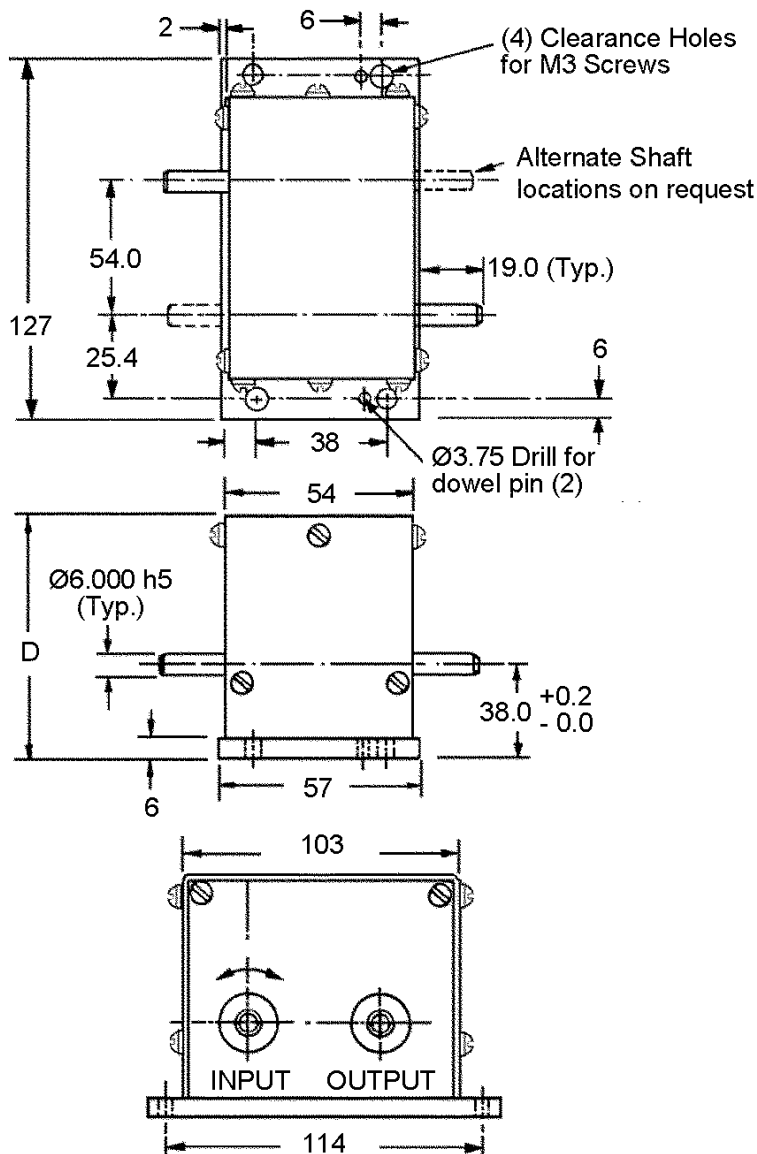

Special units available on request.

Anti-Backlash gear - Output End

Slip Clutch included - Input End

Contact Berg's Engineering Department for recommendations for use as a Speed Increaser.

• See instructions below to order alternate shaft locations.

ABEC 7 BALL BEARINGS UNITS	BRONZE BEARINGS UNITS	NOMINAL RATIO	D HEIGHT	DIRECTION ROTATION
SX-B4-1M	SX-P4-1M	2:1	83.5	SAME
SX-B4-2M	SX-P4-2M	3:1		
SX-B4-3M	SX-P4-3M	4:1		
SX-B4-4M	SX-P4-4M	5:1		
SX-B4-5M	SX-P4-5M	6:1		
SX-B4-6M	SX-P4-6M	7:1		
SX-B4-7M	SX-P4-7M	8:1		
SX-B4-8M	SX-P4-8M	9:1		
SX-B4-9M	SX-P4-9M	10:1		
SX-B4-10M	SX-P4-10M	12:1		
SX-B4-11M	SX-P4-11M	15:1		
SX-B4-12M	SX-P4-12M	16:1		
SX-B4-13M	SX-P4-13M	20:1		
SX-B4-14M	SX-P4-14M	25:1		
SX-B4-15M	SX-P4-15M	30:1	97.0	OPPOSITE
SX-B4-16M	SX-P4-16M	32:1		
SX-B4-17M	SX-P4-17M	36:1		
SX-B4-18M	SX-P4-18M	40:1		
SX-B4-19M	SX-P4-19M	45:1		
SX-B4-20M	SX-P4-20M	48:1		
SX-B4-21M	SX-P4-21M	50:1		
SX-B4-22M	SX-P4-22M	60:1		
SX-B4-23M	SX-P4-23M	64:1		
SX-B4-24M	SX-P4-24M	75:1		
SX-B4-25M	SX-P4-25M	80:1		
SX-B4-26M	SX-P4-26M	100:1		
SX-B4-27M	SX-P4-27M	125:1	122.5	SAME
SX-B4-28M	SX-P4-28M	72:1		
SX-B4-29M	SX-P4-29M	90:1		
SX-B4-30M	SX-P4-30M	96:1		
SX-B4-31M	SX-P4-31M	128:1		
SX-B4-32M	SX-P4-32M	150:1		
SX-B4-33M	SX-P4-33M	180:1		
SX-B4-34M	SX-P4-34M	200:1		
SX-B4-35M	SX-P4-35M	250:1		
SX-B4-36M	SX-P4-36M	256:1		
SX-B4-37M	SX-P4-37M	300:1		
SX-B4-38M	SX-P4-38M	375:1		
SX-B4-39M	SX-P4-39M	400:1		
SX-B4-40M	SX-P4-40M	500:1		
SX-B4-41M	SX-P4-41M	625:1		

Alternate Shaft Locations

Add **Style Letter** to complete stock number, if different from that shown.

Style:

- O** = Opposite of as shown
- R** = In and Out on R.H. side only
- L** = In and Out on L.H. side only
- A** = In and Out on all sides

Send drawing if other than listed above.

Backlash

At Output Shaft

Ball Bearing - 15 Minutes Max.

Bronze Bearing - 30 Minutes Max.

Materials

Housing and Cover Aluminum Anodized

Gears Stainless Steel and Aluminum

Shafts and Hardware Stainless Steel

Bearings Stainless Steel or Bronze

Lubrication Grease

Maximum Speed

5000 RPM

Maximum Output Torque

423N*cm



SPEED REDUCER

SHAFT	DIAMETER	BEARINGS	RATIOS
3MM	Ø27	ABEC -5	9:1 to 3600:1

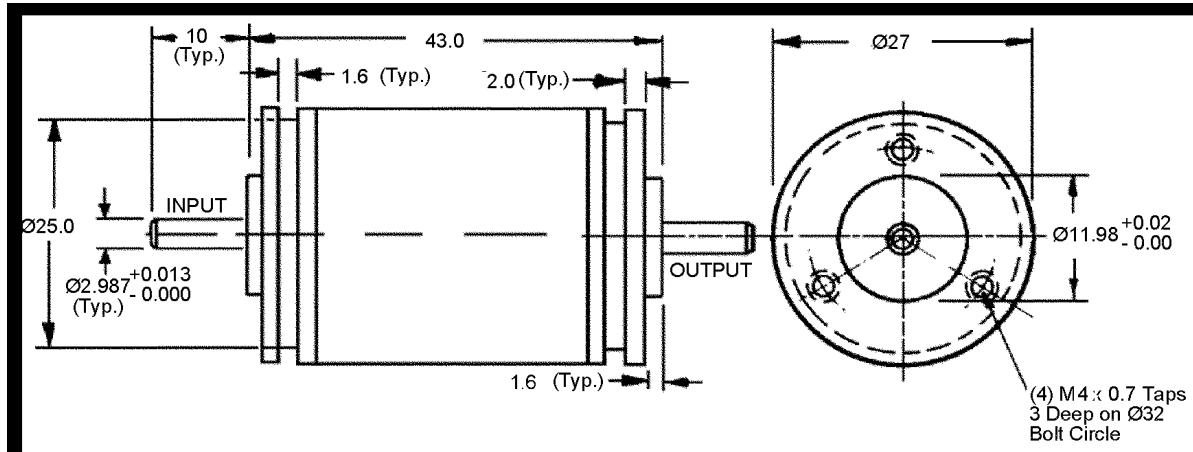

- Starting Torque (Max.) .004N·cm
- Rated Output Torque 46N·cm
- Maximum Backlash 0° 30'
- Moment of Inertia at Input Shaft 0.10mm
- Approximate Weight 220 gr.
- Ball Bearings On All Cluster Shafts



STOCK NO.	NOMINAL RATIO	NO. OF SHAFT ROTATION	GEAR CLUSTERS
RX11-1M	9:1	SAME	1
RX11-2M	10:1		
RX11-3M	12:1		
RX11-4M	15:1		
RX11-5M	20:1		
RX11-6M	25:1		
RX11-7M	30:1	OPPOSITE	2
RX11-8M	40:1	SAME	3
RX11-9M	50:1		
RX11-10M	60:1		
RX11-11M	80:1	OPPOSITE	4
RX11-12M	90:1		
RX11-13M	100:1		
RX11-14M	180:1		
RX11-15M	200:1	SAME	5
RX11-16M	300:1		
RX11-17M	360:1		
RX11-18M	400:1		
RX11-19M	500:1	OPPOSITE	6
RX11-20M	600:1		
RX11-21M	800:1		
RX11-22M	1000:1	SAME	5
RX11-23M	2000:1		
RX11-24M	3000:1		
RX11-25M	3600:1	SAME	5

SPEED REDUCER

SHAFT	DIAMETER	BEARINGS	RATIOS
6MM	44.5MM	ABEC -5	4.96:1 to 3000:1

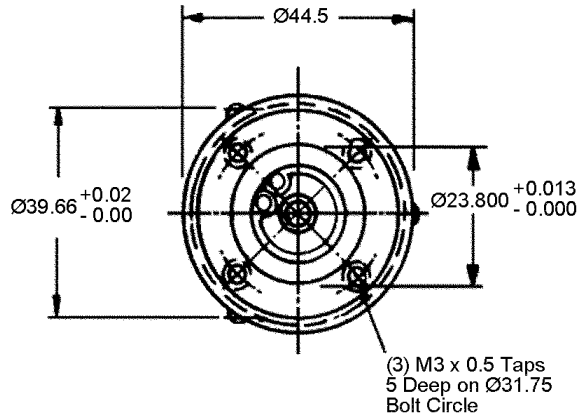
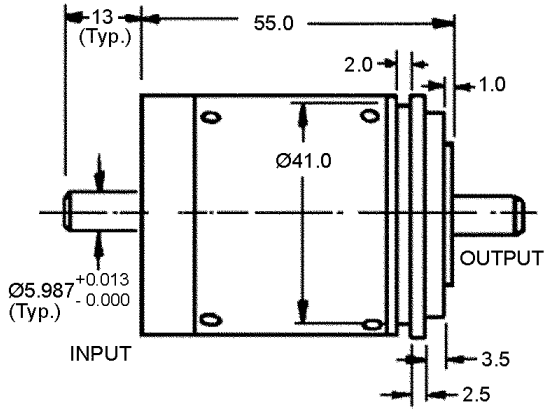

- Starting Torque (Max.) .02N.cm
- Rated Output Torque 88N.cm
- Maximum Backlash 0° 30'
- Shaft End Play (Max.) 2.5mm or .1mm
- Approximate Weight 85 gr.
- Ball Bearings On All Cluster Shafts



STOCK NO.	NOMINAL RATIO	NO. OF SHAFT ROTATION	GEAR CLUSTERS
RX18-1M	4.96:1	SAME	1
RX18-2M	6:1		
RX18-3M	9.93:1	OPPOSITE	2
RX18-4M	15.27:1		
RX18-5M	20:1	SAME	1
RX18-6M	30:1	OPPOSITE	2
RX18-7M	40:1		
RX18-8M	50.9:1		
RX18-9M	80:1		
RX18-10M	100:1	SAME	3
RX18-11M	124.8:1		
RX18-12M	150:1		
RX18-13M	200:1		
RX18-14M	248.16:1		
RX18-15M	300.3:1		
RX18-16M	400:1		
RX18-17M	500:1	OPPOSITE	4
RX18-18M	600:1		
RX18-19M	1000:1		
RX18-20M	1600:1	OPPOSITE	6
RX18-21M	1800:1		
RX18-22M	2000:1		
RX18-23M	2300:1		
RX18-24M	2500:1		
RX18-25M	3000:1	SAME	5

PRECISION PLANETARY GEAR HEADS

SHAFT SIZES			RATIOS		
16	20	24	3:1 TO 100:1		

NEMA PLANETARY GEARHEADS

STOCK NO.	RATIO	A	B	C	D	ØE	F	G	H	I	J	K	L	M	N	O	P	Q	R
GHPG60-3	3:1	60	5.0	70	50	16	25	2.5	13	80	5	26	78.2	3	16	18.0	5	1.0	22
GHPG60-5	5:1	60	5.0	70	50	16	25	2.5	13	80	5	26	78.2	3	16	18.0	5	1.0	22
GHPG60-8	8:1	60	5.0	70	50	16	25	2.5	13	80	5	26	78.2	3	16	18.0	5	1.0	22
GHPG60-10	10:1	60	5.0	70	50	16	25	2.5	13	80	5	26	78.2	3	16	18.0	5	1.0	22
GHPG60-15	15:1	60	5.0	70	50	16	25	2.5	13	80	5	26	78.2	3	16	18.0	5	1.0	22
GHPG60-20	20:1	60	5.0	70	50	16	25	2.5	13	80	5	26	78.2	3	16	18.0	5	1.0	22
GHPG60-30	30:1	60	5.0	70	50	16	25	2.5	13	80	5	26	78.2	3	16	18.0	5	1.0	22
GHPG60-50	50:1	60	5.0	70	50	16	25	2.5	13	80	5	26	78.2	3	16	18.0	5	1.0	22
GHPG60-100	100:1	60	5.0	70	50	16	25	2.5	13	80	5	26	78.2	3	16	18.0	5	1.0	22
GHPG90-3	3:1	90	6.5	100	80	20	40	2.5	12	116	7	34	95.3	5	28	22.5	6	1.0	36
GHPG90-5	5:1	90	6.5	100	80	20	40	2.5	12	116	7	34	95.3	5	28	22.5	6	1.0	36
GHPG90-8	8:1	90	6.5	100	80	20	40	2.5	12	116	7	34	95.3	5	28	22.5	6	1.0	36
GHPG90-10	10:1	90	6.5	100	80	20	40	2.5	12	116	7	34	95.3	5	28	22.5	6	1.0	36
GHPG90-15	15:1	90	6.5	100	80	20	40	2.5	12	116	7	34	95.3	5	28	22.5	6	1.0	36
GHPG90-20	20:1	90	6.5	100	80	20	40	2.5	12	116	7	34	95.3	5	28	22.5	6	1.0	36
GHPG90-30	30:1	90	6.5	100	80	20	40	2.5	12	116	7	34	95.3	5	28	22.5	6	1.0	36
GHPG90-50	50:1	90	6.5	100	80	20	40	2.5	12	116	7	34	95.3	5	28	22.5	6	1.0	36
GHPG90-100	100:1	90	6.5	100	80	20	40	2.5	12	116	7	34	95.3	5	28	22.5	6	1.0	36
GHPG115-3	3:1	115	8.5	130	110	24	50	3.0	14	145	8	40	117.5	7	32	27.0	8	1.5	40
GHPG115-5	5:1	115	8.5	130	110	24	50	3.0	14	145	8	40	117.5	7	32	27.0	8	1.5	40
GHPG115-8	8:1	115	8.5	130	110	24	50	3.0	14	145	8	40	117.5	7	32	27.0	8	1.5	40
GHPG115-10	10:1	115	8.5	130	110	24	50	3.0	14	145	8	40	117.5	7	32	27.0	8	1.5	40
GHPG115-15	15:1	115	8.5	130	110	24	50	3.0	14	145	8	40	117.5	7	32	27.0	8	1.5	40
GHPG115-20	20:1	115	8.5	130	110	24	50	3.0	14	145	8	40	117.5	7	32	27.0	8	1.5	40
GHPG115-30	30:1	115	8.5	130	110	24	50	3.0	14	145	8	40	117.5	7	32	27.0	8	1.5	40
GHPG115-50	50:1	115	8.5	130	110	24	50	3.0	14	145	8	40	117.5	7	32	27.0	8	1.5	40
GHPG115-100	100:1	115	8.5	130	110	24	50	3.0	14	145	8	40	117.5	7	32	27.0	8	1.5	40

PLANETARY GEAR HEADS PERFORMANCE SPECIFICATIONS

STOCK NO.	RATED OUTPUT TOR. Nm	PEAK OUTPUT TOR. Nm	RATED INPUT SP. RPM	*BACK LASH MIN.	AVE. EFF. %	MOM. OF IN. kg-m ²	TOR. STIFF. Nm/min	MAX. WEIGHT kg	RAD LOAD ⁽¹⁾ N	AXIAL LOAD N
60 Series	33.9	56.3	5000	10	90	4x10 ⁻⁶	5.7	1.4	1779.4	1079.4
90 Series	90.4	150.1	5000	10	90	2x10 ⁻⁵	9.0	3.2	2669.0	2669.0
115 Series	180.2	300.1	5000	10	90	5x10 ⁻⁵	15.0	7.3	4893.2	4893.2

* 5 minute backlash available on request

⁽¹⁾ Radial loads are at 25.4mm from the face of the gear head.

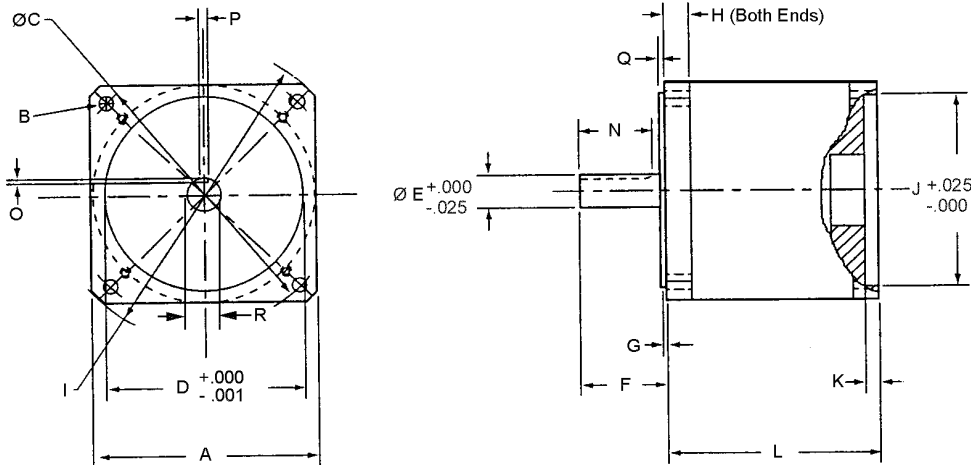

Materials:

- Housing - Anodized Aluminum
- Gears - Stainless Steel Q12 / DIN 7 Quality Class
- Shafts - Stainless Steel
- Bearings - Stainless Steel or Bronze
- Lubrication - Sny. Grease

INTERMITTENT MOTION ASSEMBLY

SHAFT	TYPE
6MM	BALL BEARING

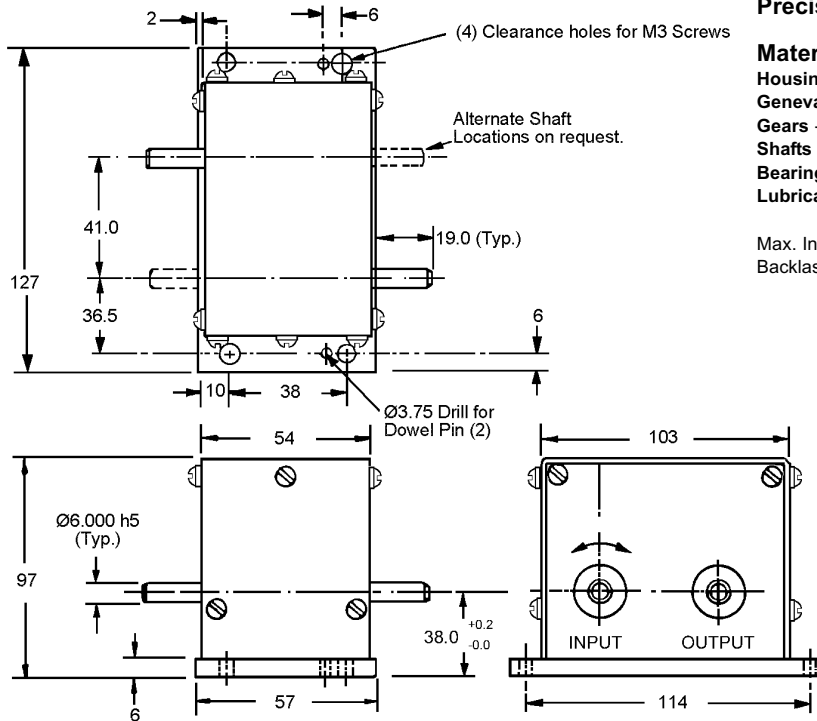

Precision Geneva Mechanism

Materials:

Housing and Cover - Anodized Aluminum

Geneva - Stainless Steel

Gears - Stainless Steel and Aluminum

Shafts and Hardware - Stainless Steel

Bearings - Stainless Steel - ABEC 7

Lubrication - Grease

Max. Input Speed - 300 RPM

Backlash at Output Shaft - 30 Minutes Max.

C

PRECISION BALL BEARING UNIT	ROTATION OF OUTPUT SHAFT PER EACH 360° REV. OF INPUT
STOCK NUMBER	
GX-1M	90 DEGREES
GX-2M	60 DEGREES
GX-3M	45 DEGREES
GX-4M	30 DEGREES
GX-5M	22.5 DEGREES
GX-6M	10 DEGREES

PRECISION BALL BEARING UNIT	ROTATION OF OUTPUT SHAFT PER EACH 180° REV. OF INPUT
STOCK NUMBER	
GX-7M	180 DEGREES
GX-8M	120 DEGREES
GX-9M	90 DEGREES
GX-10M	60 DEGREES
GX-11M	45 DEGREES
GX-12M	20 DEGREES



GENEVA MECHANISM

BORE	POINTS	MATERIAL
6 AND 7	4, 5, 6 AND 8	STAINLESS STEEL

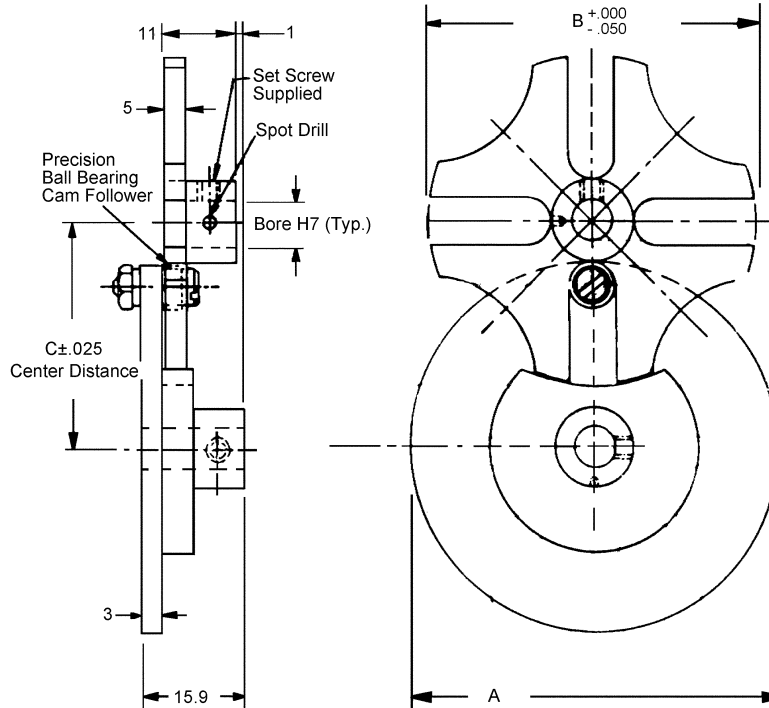

4 POINT DRIVE ILLUSTRATED

STOCK NO.	NO. ROLLERS ON DRIVER	RELATIVE ROTATION DRIVER TO DRIVEN		POINTS ON DRIVEN	MAX. TORQUE (N•cm)	MAX OPER. TORQUE (N•cm)	A	B	C	BORE
		360°	180°							
GM-1-M	ONE	360°	90°	4	50	25	57	50	35.11	7
GM-1A-M	TWO	180°								
GM-2-M	ONE	360°	72°	5	78	39	57	63	38.57	7
GM-2A-M	TWO	180°								
GM-3-M	ONE	360°	60°	6	124	62	64	88	50.72	7
GM-3A-M	TWO	180°								
GM-4-M	ONE	360°	45°	8	170	85	51	104	56.02	6
GM-4A-M	TWO	180°								

STOCK NO.	DESCRIPTION
JE-1-PH	REPLACEMENT CAM FOLLOWER

Other Bore sizes available on request.



CAM FOLLOWER

TYPE	MATERIAL	ABEC
BALL BEARING OR OIL-LESS BRONZE BEARING	303 STAINLESS STEEL	5

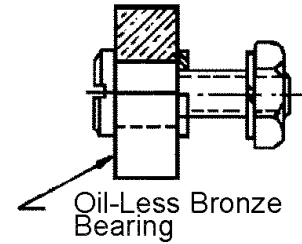
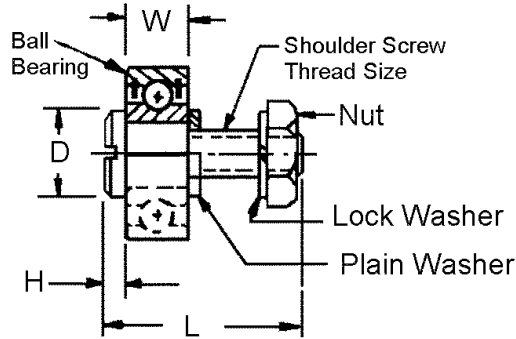
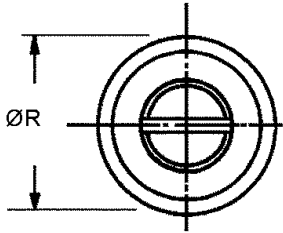

STOCK NO.	ØR	W	L	D	H	SCREW THREAD	BEARING
JEM-10	7.00	3.0	12.0	5	3	M3.0 X 0.5	BALL BEARING
JEM-11	9.00	4.0	11.0	6	3	M3.0 X 0.5	
JEM-12	11.00	5.0	13.0	8	4	M4.0 X 0.7	
JEM-13	13.00	4.0	14.0	8	4	M4.0 X 0.7	
JEM-14	16.00	5.0	13.0	8	4	M4.0 X 0.7	
JEM-15	19.00	6.0	17.0	10	5	M5.0 X 0.8	BRONZE BEARING
JEM-B-11	8.00	4.0	11.0	6	3	M3.0 X 0.5	
JEM-B-12	10.00	5.0	14.0	8	4	M4.0 X 0.7	
JEM-B-13	13.00	5.0	14.0	8	4	M4.0 X 0.7	
JEM-B-14	16.00	5.0	16.0	10	5	M5.0 X 0.8	

MATERIALS

Bearings - Stainless Steel or Bronze

Screw - Stainless Steel DIN 1.4005

Hardware - Stainless Steel



C

ROLLER BEARING CAM FOLLOWER

TYPE
HEAVY DUTY

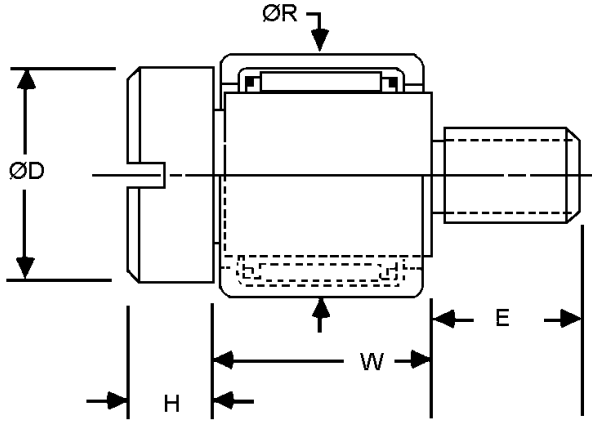

Materials:

Screw - Stainless Steel DIN 1.4005

Roller Cup - Case Hardened Steel

Needle Bearings - Hardened Steel

Bearing Cage - Low Carbon Steel

See the Bearings Section of this book for Bearings Specifications.

STOCK NO.	$\varnothing R$	W	$\varnothing D$	H	E	SCREW THREAD
JEM-R-1	8.00	8.00	6.0	2.7	4	M3 X 0.5
JEM-R-3	9.00	9.00	8.0	4.0	5	M4 X 0.7
JEM-R-4	10.00	9.00	8.5	5.0	6	M5 X 0.8
JEM-R-5	12.00	10.00	10.5	5.7	11	M6 X 1.0
JEM-R-6	14.00	10.00	12.5	6.7	12	M8 X 1.25
JEM-R-8	16.00	12.00	14.5	7.7	16	M10 X 1.50

- High Load
- Low Profile
- Low Friction

RATCHETS AND PAWLS

PITCH	STYLE	MATERIAL
16 to 48	RIGHT HAND OPERATION	STAINLESS STEEL

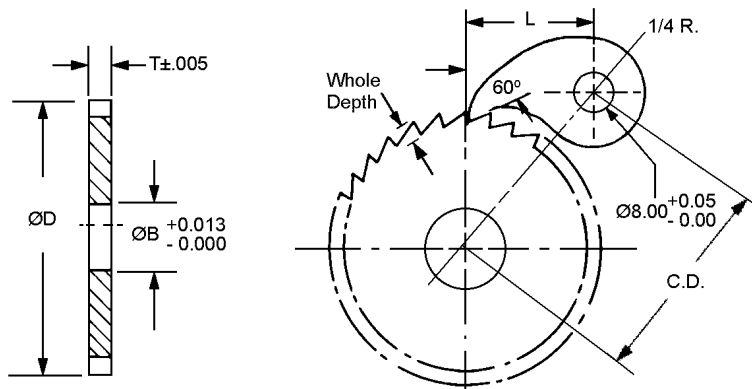

17-4 PH STAINLESS STEEL HARDENED RC 32-38			416 STAINLESS STEEL
STOCK PAWLS			MOUNTING SHOULDER SCREW (Order Separately)
STOCK NO.	T THICKNESS	L LENGTH	
RP-2M	6.2	19	PLM-28
RP-375M	9.4	33	PLM-30

- For Shoulder Screw Dimensions - See Index
- Ratchets Material - 303 Stainless Steel
- Last number in Stock No. indicate the total number of teeth. Special ratchets and pawls made to order, contact us.

RATCHET STOCK NO.	PITCH	OUTSIDE DIA.	BORE	T	C.D. +.06 -.00	WHOLE DEPTH	PAWL STOCK NO
R16S120-20	16	31.7	16	9.5	38.9	3.1	RP-375M
R16S120-24		38.1			40.6		
R16S120-32		50.8			44.5		
R16S120-48		76.2			53.3		
R16S120-56		88.9			58.4		
R16S120-65		101.6			63.5		
R24S106-24	24	25.4	10	6.4	28.2	1.8	RP-2M
R24S106-30		31.7			30.0		
R24S106-36		38.1			32.0		
R24S106-48		50.8			36.8		
R24S106-72		76.2			47.2		
R32S103-24	32	19.0	10	3.0	26.4	1.5	RP-2M
R32S103-32		25.4			28.2		
R32S103-40		31.7			30.0		
R32S103-48		38.1			32.0		
R32S103-64		50.8			36.8		
R32S103-96		76.2			47.2		
R48S103-36	48	19.0	10	3.0	26.2	0.9	RP-2M
R48S103-48		25.4			28.4		
R48S103-60		31.7			30.5		
R48S103-72		38.1			32.5		
R48S103-96		50.8			37.3		
R48S103-144		76.2			47.8		



C

LINEAR COMPONENTS

Table of Contents

ACME LEAD SCREWS, NUTS & FLANGES ME 2 - E 5

Technical Data	ME 2
Lead Screw, Nuts & Flanges	ME 3 - ME 4
Lubricating Spray	ME 5
Lubricating Grease	ME 5

HIGH PRECISION AND PRECISION LEAD SCREWS

Technical Data	ME 6 - ME 7
Anti-Backlash Lead Screw Assemblies	ME 8
Lead Screws	ME 9

LINEAR CLUTCH - LINEAR ACTUATORSME 10

LINEAR SLIDES

Technical Data Linear Slides	ME 11
Cross Roller Bearing Rail Set	ME 12
Cross Roller Bearing Double V Rail Sets	ME 13
Cross Roller Recirculating Bearings & Rail Sets	ME 14 - ME 15
Cross Roller Slide Assemblies, Long Travel	ME 16
Cross Roller Slide Assemblies, Low Profile	ME 17
Cross Roller Flange Based Slide Assemblies	ME 18
Cross Roller Slides	ME 19
Linear Ball Slides	ME 20
Cross Roller Lead Screw Driven Slide	ME 21 - ME 22
Rack Driven Ball Slides	ME 23
Rack Driven Ball Slide Pinions	ME 24

BEARINGS

Linear Rotary Bearings	ME 25
Linear Motion Adjustable Bearings	ME 26
Precision Linear "Gear Drive" Bearings	ME 27

LINEAR DRIVE GEAR RACKSME 28

THERMOPLASTIC ROD ENDSME 29 - ME 30

SELF-ALIGNING ROD ENDSME 31 - ME 32

LINEAR BEARINGS

Flanged Type	ME 33
Ball Bearings	ME 34 - ME 35, ME 37
Self-Aligning - Barrel Style	ME 36
No Lube	ME 38
Thermoplastic	ME 39
Thermoplastic Self-Aligning	ME 40

LINEAR PILLOW BLOCK ASSEMBLIESME 41

Linear Pillow Block	ME 42
With Shaft Wipers	ME 43

LINEAR BEARING BRACKETSME 44 - ME 45

SHAFT SUPPORTME 46

SHAFT HANGERSME 47

GROUND SHAFTINGME 48

Seals	ME 49
-------------	-------

ACME LEAD SCREWS, NUTS & FLANGE

TECHNICAL DATA - See Reference Section for more information.

ROLLED ACME SCREWS

Rolled thread acme screws offer the largest selection of size and pitch choices in the industry. Rolled thread screws are cost effective.



MATERIAL	THREAD CLASS	LEAD ACCURACY	SCREW DIAMETER	SCREW LENGTHS
4140 Alloy Steel	Centralizing 2C or Stub	±6.25µm/25mm up to 26mm	10mm to 26mm	Available up to 1825 mm
300 Stainless Steel	Centralizing 2C or Stub	±6.25µm/25mm up to 26mm	10mm to 26mm	Available up to 1825 mm

Special end configurations are available on request, call Berg TSR Group for special quotes. Materials used in these acme nuts have been selected for low friction, minimum wear, long life and clean operation.

BRONZE ACME & ISO NUT

Special high tensile bronze is selected for our smooth running, anti-wedging bronze nuts.



MATERIAL	BRONZE
TENSILE YIELD	344 Mpa
TENSILE ULTIMATE	448 Mpa
HARDNESS	RB75
DYNAMIC CO-EFFICIENT OF FRICTION	0.125 with Lubricant

PLASTIC ACME ISO NUTS

The high strength and inherent lubricity of this material can result in product life that can equal or exceed conventional nut materials.



TENSILE STRENGTH @ 21°C	55 Mpa
COMPRESSIVE STRENGTH @ 21°C	110 Mpa
PV LIMIT @ N•m / mm ² - min.	21
CO-EFFICIENT OF FRICTION	0.10

FLANGES FOR BRONZE & PLASTIC NUTS

Made of carbon steel alloy with black oxide finish.



LEAD SCREW SPECIFICATIONS	ALLOY	STAINLESS STEEL
MATERIAL	4140 Series	300 Series
MINIMUM HARDNESS	200 Brinell	170 Brinell
TENSILE ULTIMATE STRENGTH	655 Mpa	586 Mpa
FINISH	Black Oxide	Natural

ACME LEAD SCREWS

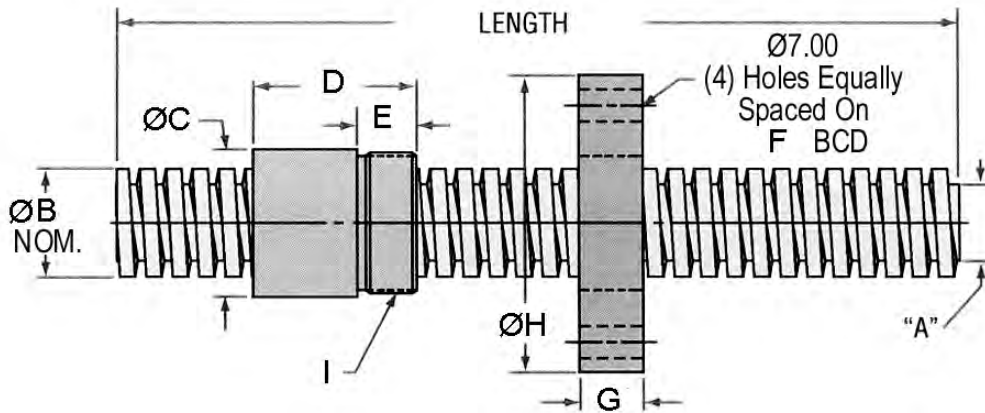

SERIES	ØB	ØC	D	E	F	G	ØH	I
TIM10	10.0	18.0	16.0	10.0	28.50	11.0	42.0	M15X1
TIM12	12.0	28.0	19.0	13.0	53.00	14.0	66.0	M25X1.5
TIM16	16.0	28.0	26.0	13.0	53.00	14.0	66.0	M25X1.5
TIM20	20.0	34.0	32.0	13.0	60.00	14.0	75.0	M30X1.5
TIM26	26.0	45.0	45.0	15.0	70.00	16.0	85.0	M40X1.5

To extend the life of these lead screws we recommend that you lubricate with either spray lubricant (Stock No. E-100) or grease (Stock No. PAG-1). See Page ME 5.

SIZE (O.D.)	FORM	LEAD	STARTS
10MM	ISO RIGHT HAND	3.000	2

LEAD SCREW STOCK NO.	LENGTH (MM)	MATERIAL	BACKLASH	"A" ROOT DIA.
TIM10SS3-100	100	300 Series STAINLESS STEEL	0.13	7.92
TIM10SS3-200	200			
TIM10SS3-250	250			
TIM10SS3-300	300			
TIM10SS3-900	900			
TIM10SS3-1825	1825			
TIM10AS3-100	100	4140 ALLOY STEEL	0.13	7.92
TIM10AS3-200	200			
TIM10AS3-250	250			
TIM10AS3-300	300			
TIM10AS3-900	900			
TIM10AS3-1825	1825			

NUT(S) / FLANGE - ARE TO BE ORDERED SEPARATELY

NUT STOCK NO.	O.D.	MATERIAL	EFFICIENCY	TORQUE* (N·m)	DYNAMIC LOAD (KN)	STATIC LOAD (KN)
TIM10B3-NT	10MM	BRONZE	44%	1.09	3447	11032
TIM10P3-NT		PLASTIC	53%	.843	1723	1723

FLANGE STOCK NO.	MATERIAL	FINISH
TIM1S-FL**	CARBON ALLOY STEEL	BLACK OXIDE

* TORQUE TO RAISE ONE (1) KN.

** STAINLESS STEEL FLANGES AVAILABLE ON REQUEST.

SIZE (O.D.)	FORM	LEAD	STARTS
12MM	ISO RIGHT HAND	3.000	1

LEAD SCREW STOCK NO.	LENGTH (MM)	MATERIAL	BACKLASH	"A" ROOT DIA.
TIM12SS3-100	100	300 Series STAINLESS STEEL	0.16	7.69
TIM12SS3-200	200			
TIM12SS3-250	250			
TIM12SS3-300	300			
TIM12SS3-900	900			
TIM12SS3-1825	1825			
TIM12AS3-100	100	4140 ALLOY STEEL	0.16	7.69
TIM12AS3-200	200			
TIM12AS3-250	250			
TIM12AS3-300	300			
TIM12AS3-900	900			
TIM12AS3-1825	1825			

NUT(S) / FLANGE - ARE TO BE ORDERED SEPARATELY

NUT STOCK NO.	O.D.	MATERIAL	EFFICIENCY	TORQUE* (N·m)	DYNAMIC LOAD (KN)	STATIC LOAD (KN)
TIM12B3-NT	12MM	BRONZE	33%	1.11	4963	15858
TIM12P3-NT		PLASTIC	55%	.860	2481	2481

FLANGE STOCK NO.	MATERIAL	FINISH
TIM2S-FL**	CARBON ALLOY STEEL	BLACK OXIDE

* TORQUE TO RAISE ONE (1) KN.

** STAINLESS STEEL FLANGES AVAILABLE ON REQUEST.

ACME LEAD SCREWS

SIZE (O.D.)	FORM	LEAD	STARTS
16MM	ISO RIGHT HAND	4.000	1

LEAD SCREW STOCK NO.	LENGTH (MM)	MATERIAL	BACKLASH	"A" ROOT DIA.
TIM16SS4-100	100	300 Series STAINLESS STEEL	0.24	10.90
TIM16SS4-200	200			
TIM16SS4-250	250			
TIM16SS4-300	300			
TIM16SS4-900	900			
TIM16SS4-1825	1825			
TIM16AS4-100	100	4140 ALLOY STEEL		
TIM16AS4-200	200			
TIM16AS4-250	250			
TIM16AS4-300	300			
TIM16AS4-900	900			
TIM16AS4-1825	1825			

NUT(S) / FLANGE - ARE TO BE ORDERED SEPARATELY

NUT STOCK NO.	O.D.	MATERIAL	EFFICIENCY	TORQUE* (N•m)	DYNAMIC LOAD (KN)	STATIC LOAD (KN)
TIM16B4-NT	16MM	BRONZE	41%	1.56	8825	28240
TIM16P4-NT		PLASTIC	53%	1.188	4412	4412

FLANGE STOCK NO.	MATERIAL	FINISH
TIM2S-FL**	CARBON ALLOY STEEL	BLACK OXIDE

* TORQUE TO RAISE ONE (1) KN.

** STAINLESS STEEL FLANGES AVAILABLE ON REQUEST.

SIZE (O.D.)	FORM	LEAD	STARTS
20MM	ISO RIGHT HAND	4.000	1

LEAD SCREW STOCK NO.	LENGTH (MM)	MATERIAL	BACKLASH	"A" ROOT DIA.
TIM20SS4-100	100	300 Series STAINLESS STEEL	0.24	14.90
TIM20SS4-200	200			
TIM20SS4-250	250			
TIM20SS4-300	300			
TIM20SS4-900	900			
TIM20SS4-1825	1825			
TIM20AS4-100	100	4140 ALLOY STEEL		
TIM20AS4-200	200			
TIM20AS4-250	250			
TIM20AS4-300	300			
TIM20AS4-900	900			
TIM20AS4-1825	1825			

NUT(S) / FLANGE - ARE TO BE ORDERED SEPARATELY

NUT STOCK NO.	O.D.	MATERIAL	EFFICIENCY	TORQUE* (N•m)	DYNAMIC LOAD (KN)	STATIC LOAD (KN)
TIM20B4-NT	20MM	BRONZE	35%	1.818	13790	44128
TIM20P4-NT		PLASTIC	47%	1.342	6895	6895

FLANGE STOCK NO.	MATERIAL	FINISH
TIM3S-FL**	CARBON ALLOY STEEL	BLACK OXIDE

* TORQUE TO RAISE ONE (1) KN.

** STAINLESS STEEL FLANGES AVAILABLE ON REQUEST.

SIZE (O.D.)	FORM	LEAD	STARTS
26MM	ISO RIGHT HAND	6.000	1

LEAD SCREW STOCK NO.	LENGTH (MM)	MATERIAL	BACKLASH	"A" ROOT DIA.
TIM26SS6-100	100	300 Series STAINLESS STEEL	0.30	17.84
TIM26SS6-200	200			
TIM26SS6-250	250			
TIM26SS6-300	300			
TIM26SS6-900	900			
TIM26SS6-1825	1825			
TIM26AS6-100	100	4140 ALLOY STEEL		
TIM26AS6-200	200			
TIM26AS6-250	250			
TIM26AS6-300	300			
TIM26AS6-900	900			
TIM26AS6-1825	1825			

NUT(S) / FLANGE - ARE TO BE ORDERED SEPARATELY

NUT STOCK NO.	O.D.	MATERIAL	EFFICIENCY	TORQUE* (N•m)	DYNAMIC LOAD (KN)	STATIC LOAD (KN)
TIM26B6-NT	26MM	BRONZE	39%	2.469	23304	74573
TIM26P6-NT		PLASTIC	51%	1.859	11652	11652

FLANGE STOCK NO.	MATERIAL	FINISH
TIM4S-FL**	CARBON ALLOY STEEL	BLACK OXIDE

* TORQUE TO RAISE ONE (1) KN.

** STAINLESS STEEL FLANGES AVAILABLE ON REQUEST.

LUBRICATION FOR ACME LEAD SCREWS & NUTS

Proper lubrication is the key to continued performance and reliability of acme screw assemblies.



340g Acme Screw (Spray) Lubricant = STOCK NO. E-100
453g Can of Acme Screw Grease = STOCK NO. PAG-1

SPECIFICATIONS:

NLGI Grade No.	2
Penetration (worked)	285
Dropping Point	287°C
Gelling Agent	Synthetic
Oil Viscosity	cst @ 40°C is 96 / cst @ 100°C is 11.3
Temperature Range	-9°C to 204°C

E

HIGH PRECISION & PRECISION LEAD SCREWS

TECHNICAL DATA Lead Screws and Components

Berg is a pioneer in the development of lead screws. Providing cost effective solutions to linear actuation problems. The close tolerance, free running nuts are ideal for miniature applications requiring rotary to linear or linear to rotary actuation.

For applications requiring precision positioning, Berg also manufactures Anti-Backlash Nuts. This device, consisting of only three components, utilizes the constant force of a compression spring to push two nut halves apart. This action eliminates any play (backlash) which exists between the internal thread of the nut and the external screw thread. To ensure accuracy and repeatability the nut can be fine tuned through the use of the many available spring constants, to meet any pre-load design requirements.

Lead Screw Specification	High Precision
Lead Error	±0.05mm/100mm
Repeatability	0.001mm.
Straightness	0.03mm/100mm
Backlash	0.08mm (zero when using Anti-Backlash nut)
Temperature Range	-45°C to +93°C

LEAD SCREW DIAMETER	HELITRONICS NUTLOAD CAPACITY* kg	HIGH HELIX NUTLOAD CAPACITY* kg
4	10	7
5	10	7
6	15	10
8	26	14
10	30	18
12	50	20
16	75	25
20	120	30
25	170	35

* Based on the shear value of nut.



Design Considerations

Critical Speed - The critical speed of a lead screw shaft is the maximum speed (rpm) before the screw will become dynamically unstable. This results when the forced frequency of the rotating screw corresponds to its natural frequency. It's value is dependent on the length of the screw, the diameter of the thread, and the support configuration. The critical speed value is governed by the following equation.

$$\text{Critical Screw Speed (N)} = K \times C \times 10^6 \times d/D^2$$

Where:

- K = End support factor
 - 0.36 one end fixed, other free (Figure 9.1)
 - 1.00 simple supports both ends (Figure 9.2)
 - 1.47 one end fixed, one simple (Figure 9.3)
 - 2.23 both ends fixed (Figure 9.4)
- C = Material factor
 - 4.5 for Stainless Steel screws
 - 1.6 for Aluminum screws
- d = Root diameter of the screw
- D = Distance between the nut and the support bearing

Load - In order to properly incorporate a lead screw into a design, load requirements must be taken into account. Maximum load values for the nuts are listed in the tables on the following pages. These numbers are based on the shear of the nuts and does not take shaft buckling into account (see Max. Column Load formula below). Wherever possible, nuts should be positioned so as to be put in tension, pulling the load. This eliminates the need for buckling considerations. Listed below are some helpful formulas to assist in proper lead screw selection.

$$\text{Max. Critical Column Load (F)} = K \times C \times 10^6 \times d^4/D^2$$

Where:

- K = End support factor
 - 0.25 one end fixed, other free (Figure 9.1)
 - 1.00 simple supports both ends (Figure 9.2)
 - 2.00 one end fixed, one simple (Figure 9.3)
 - 4.00 both ends fixed (Figure 9.4)
- C = Material factor
 - 13.4 for Stainless Steel screws
 - 4.8 for Aluminum screws
- d = Root diameter of the screw
- D = Distance between the nut and the support bearing

$$\text{Torque to Move a Load (T)} = F \times L/2 \times \xi \times E$$

Where:

- F = Load
- L = Lead
- E = Efficiency (consult Berg Engineering Department for efficiency values)



Figure 9.1



Figure 9.2



Figure 9.3



Figure 9.4

ANTI-BACKLASH LEAD SCREW ASSEMBLIES

SERIES	MATERIAL
HIGH PRECISION	NUT - ACETAL, SPRING - STEEL PLATED ZINC, SCREW - STAINLESS STEEL (400 SERIES)

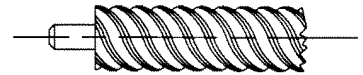
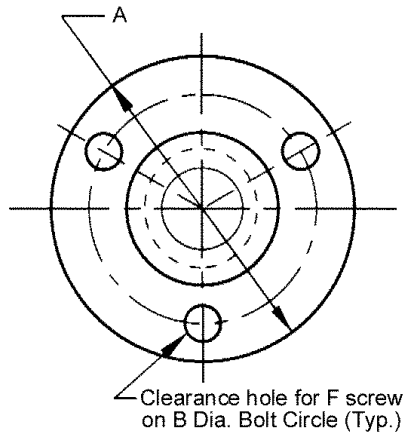
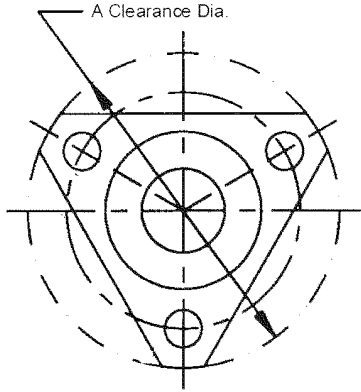
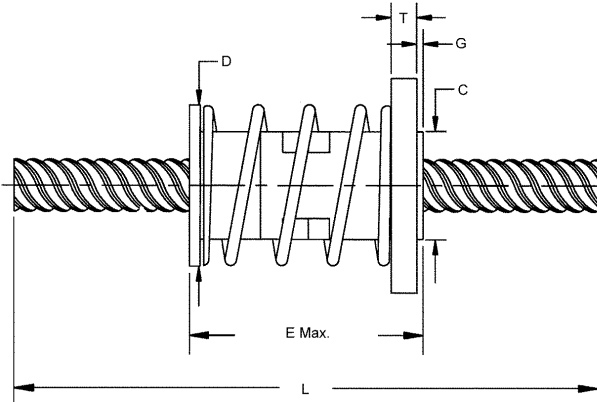

Special end configurations available on request.

Helitronic Thread

STOCK NO.	PITCH DIA.	LEAD	ØA	ØS	ØC	ØD	E	G	T	F	L
TTMS4ABS1-300	4	1									
TTMS6ABS2-300	6	2	25.5	19	11	15	29	1.5	5	M3	300
TTMS8ABS4-300	8	4									
TTMS10ABS2-500	10	2									
TTMS10ABS20-500	10	20	38	28.5	16	19	38	1.5	5	M3	500
TTMS12ABS5-500	12	5									
TTMS12ABS10-500	12	10									
TTMS16ABS4-1000	16	4									
TTMS16ABS10-1000	16	10	44.5	35	22.5	26	53	2	6.5	M4	1000
TTMS20ABS4-1000	20	4									
TTMS20ABS10-1000	20	10									
TTMS20ABS20-1000	20	20									
TTMS25ABS5-1000	25	5	55.5	45.50	30	40	63.5	2	6.5	M5	1000
TTMS25ABS10-1000	25	10									
TTMS25ABS20-1000	25	20									

Additional nuts, other lengths and materials are available, call for quotes.

PRECISION LEAD SCREWS

MATERIAL

**NUT - ACETAL SCREW - HIGH HELIX THREAD, ALUMINUM ANODIZED
HELITRONIC THREAD, STAINLESS STEEL (400 SERIES)**

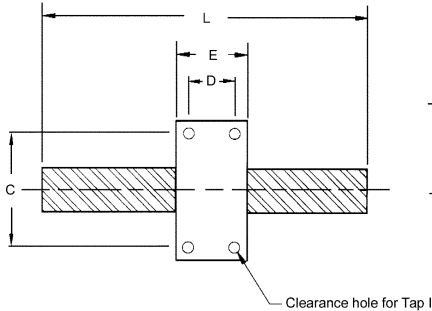

LEAD SCREW WITH SQUARE NUT

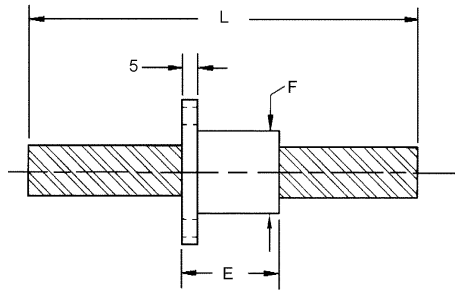
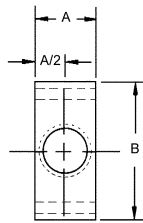

LEAD SCREW WITH ROUND NUT

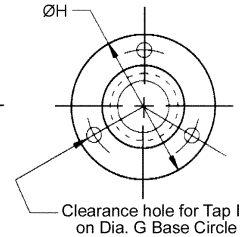

Rectangular Nut

HELITRONIC THREAD STOCK NO.	HELIX THREAD STOCK NO.	PITCH DIA.	LEAD	A	B	C	D	E	ØF	ØG ¹	ØH	I ¹	L
TTM4KS1-300	-	4	1										
-	HTM5KA10-300	5	10										
-	HTM5KA15-300	5	15	12.5	33	25	*	19	12	20	28	M3	300
TTM6KS2-300	-	6	2										
TTM8KS4-300	-	8	4										
TTM10KS2-500	-	10	2										
TTM10KS20-500	HTM10KA20-500	10	20	16	44.5	35	*	19	16	25	35	M4	500
-	HTM10KA30-500	10	30										
TTM12K-500	-	12	5										
TTM12KS10-500	-	12	10	19	50	40	15.5	25	20	30 ¹	40	M ¹	500
TTM16KS4-1000	-	16	4										
TTM16KS10-1000	-	16	10	25	50	40	15.5	25	25	35	45	M4	1000
TTM20K-1000	-	20	4										
TTM20KS10-1000	-	20	10										
TTM20KS20-1000	-	20	20	35	60	50	20	30	30	40	50	M5	1000
-	HTM20KA40-1000	20	40										
-	HTM20KA60-1000	20	60										
TTM25KS5-1000	-	25	5										
TTM25KS10-1000	-	25	10										
TTM25KS20-1000	-	25	20	35	60	50	20	30	35	45	55	M5	1000
-	HTM25KA50-1000	25	50										
-	HTM25KA75-1000	25	75										

NOTE:
Special lengths, ends or diameters and additional nuts available on request.

*These items are supplied with one mounting hole at E/2, on each side.

Round Nut

HELITRONIC THREAD STOCK NO.	HELIX THREAD STOCK NO.	PITCH DIA.	LEAD	A	B	C	D	E	ØF	ØG ¹	ØH	I ¹	L
TTM4LS1-300	-	4	1										
-	HTM5LA10-300	5	10										
-	HTM5LA15-300	5	15	12.5	33	25	*	19	12	20	28	M3	300
TTM6LS2-300	-	6	2										
TTM8LS4-300	-	8	4										
TTM10LS2-500	-	10	2										
TTM10LS20-500	HTM10LA20-500	10	20	16	44.5	35	*	19	16	25	35	M4	500
-	HTM10LA30-500	10	30										
TTM12K-500	-	12	5										
TTM12LS10-500	-	12	10	19	50	40	15.5	25	20	30 ¹	40	M4 ¹	500
TTM16LS4-1000	-	16	4										
TTM16LS10-1000	-	16	10	25	50	40	15.5	25	25	35	45	M4	1000
TTM20K-1000	-	20	4										
TTM20LS10-1000	-	20	10										
TTM20LS20-1000	-	20	20	35	60	50	20	30	30	40	50	M5	1000
-	HTM20LA40-1000	20	40										
-	HTM20LA60-1000	20	60										
TTM25LS5-1000	-	25	5										
TTM25LS10-1000	-	25	10										
TTM25LS20-1000	-	25	20	35	60	50	20	30	35	45	55	M5	1000
-	HTM25LA50-1000	25	50										
-	HTM25LA75-1000	25	75										

¹ These holes / bolt circles may be slotted to accept a range of sizes.

LINEAR CLUTCH - LINEAR ACTUATORS

SHAFT SIZE	STYLES	MATERIAL
8mm - 25mm	A & B	ALUMINUM HOUSING STEEL BALL BEARINGS AND SCREWS

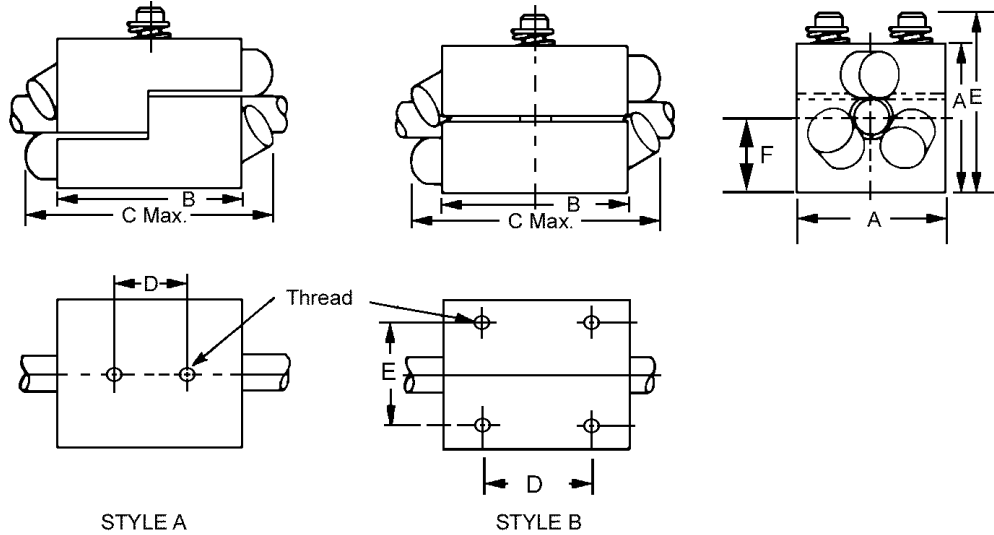

- Translates rotating motion into linear motion
- Built In Safety - Adjustable tension allows device to slip free when overloaded
- Infinite Travel - On threadless shafting
- Ends Backlash Problems - Free axial backlash less than 0.025mm
- No Lubrication - Shaft runs dry - Bearing factory lubricated
- Installs Fast, Two halves assemble around shaft
- Longer Life for shafts and actuators
- Greatly reduces maintenance
- Operates on standard Berg ground shafting (hard or soft)
- Efficiency .90 (approximately)



STOCK NO.	SHAFT DIA.	LEAD (mm)	THRUST RATING	A	B	C	D	E	F	THREAD	STYLE
LCAM-1	8 mm	1.3	22N	28.4	41.1	57.2	19.0	42.2	14.5	M3x0.5x6.3DP	A
LCAM-2		2.5									
LCAM-3		2.5	133N	38.1	50.8	71.4	25.4	48.5	19.3	M5x0.8x9.5DP	
LCAM-4		15.0									
LCAM-7	15.0										
LCAM-9	12 mm	25.0	266N	50.8	63.5	85.8	31.8	68.3	25.6	M6x1.0x12.7DP	
LCAM-10		2.50									
LCAM-11		10.0									
LCAM-12	16 mm	2.5	266N	50.8	63.5	85.8	31.8	68.3	25.6	M6x1.0x12.7DP	
LCAM-13		15.0									
LCAM-14		25.0									
LCAM-15		2.5									
LCAM-16	25 mm	5	444N	76.2	63.5	90.4	33	88.9	38.1	M6x1.0x12.7DP	B
LCAM-17		25									

LINEAR SLIDES

TECHNICAL DATA

W. M. Berg, Inc. manufactures a complete line of off the shelf linear ball slides and linear crossed roller slide bearings. Made to the highest quality standards, components must pass strict inspection requirements at each stage of manufacturing. These Quality Control steps ensure precise, uniform, linear movement with low friction and minimum side-play.

Available in inch or metric sizes, and in travel lengths ranging from 12mm to 600mm, slides have flat, parallel, and smooth mounting surfaces. Equipped with mounting holes, they are shipped ready to install, with no need for modifications or adjustments.

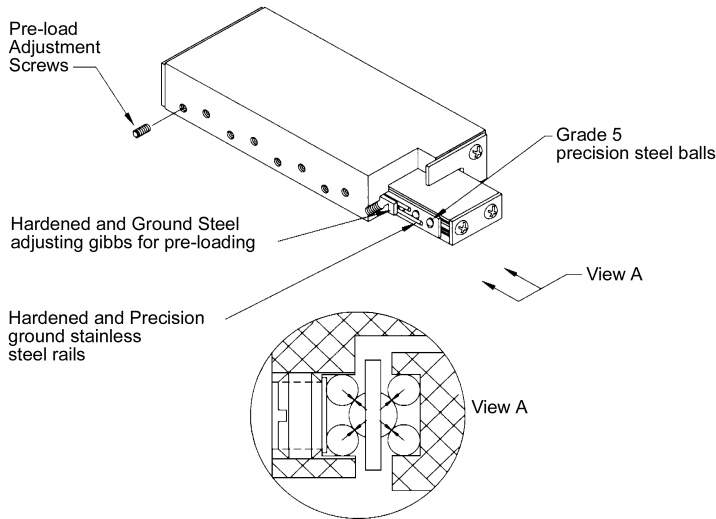

FIGURE 1

Linear Ball Slides

W. M. Berg Inc. Linear Ball Slides are designed to provide precise linear movement for **light to medium loads**. Their construction, as shown in Figure 1, consists of precision Grade 5 balls rolling along ground wire ways. Since the rolling contact surface is a point, the bearing ways are self cleaning, expelling matter which may deposit on their surfaces.

Linear Crossed Roller Slides

W. M. Berg Inc. Linear Crossed Roller Slides are designed to provide precise linear movement for medium to heavy loads. Their improved stiffness and rigidity mean long term reliability under the punishment of vibration and shock conditions. Their construction as shown in Figure 2 consists of precision rollers rolling along ground flat ways. Since the rolling contact surface is a line, they can support greater loads than the ball slides

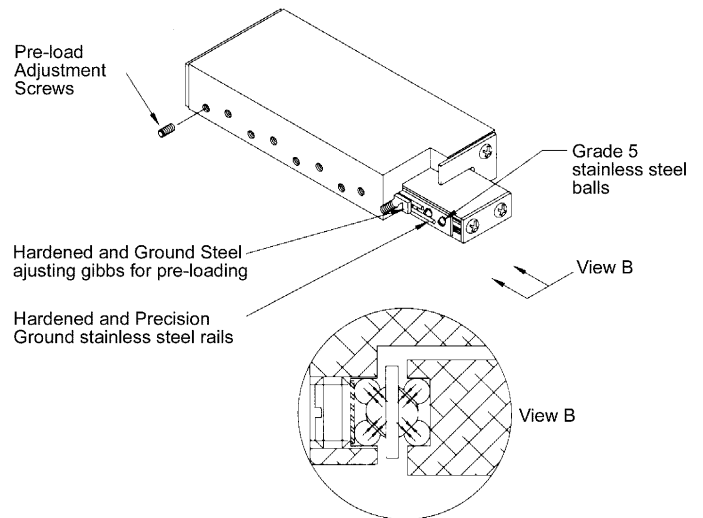

FIGURE 2

- Straightness of Travel = Precision Series - 0.0127mm/mm
* Ultra-precision Series - 0.0101mm/mm
- Repeatability of Travel = Precision Series - 0.254 mm
Ultra-precision Series - 0.00127 mm
- Life = 2.5×10^6 mm of Travel at Safe Load Capacity
= 2.5×10^6 mm of Travel at 1/2 Safe Load Capacity
Coefficient of Friction = .003

$$\text{Safe Load Capacity} = \frac{\text{Rated Load Capacity}}{\text{Safety Factor (SF)}}$$

* Inspection Report Available for This Accuracy



CROSS ROLLER BEARINGS RAIL SET

MATERIAL

RAILS & ROLLERS - HARDENED & GROUND TOOL STEEL • RETAINERS - BRASS

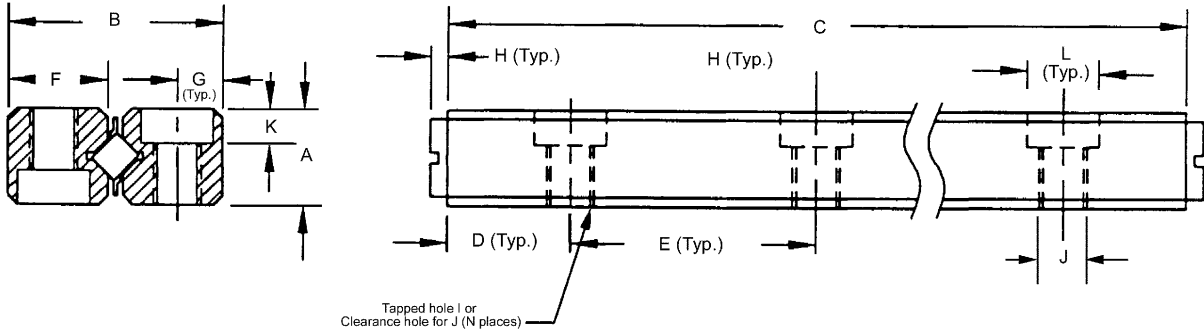

STOCK NO.	TRAVEL	A	B +0.00 -0.20	C	D	E	F	G	H	I	J	K	N	RATED CAPACITY (kg)
LR1-02M	23.9			50mm									2	105
LR1-03M	33.8			75mm									3	160
LR1-04M	33.8			100mm									4	210
LR1-05M	33.8			125mm									5	290
LR1-06M	53.8			150mm									6	315
LR1-07M	53.6	8.0	18.0	175mm	12.5	25.0	8.3	3.5	2.0	M4 x 0.7	3.3	3.1	7	395
LR1-08M	53.6			200mm									8	448
LR1-09M	83.6			225mm									9	474
LR1-10M	103.6			250mm									10	527
LR1-11M	103.6			275mm									11	579
LR1-12M	103.4			300mm									12	658
LR2-04M	44.2			100mm									2	325
LR2-06M	72.1			150mm									3	545
LR2-08M	100.3			200mm									4	650
LR2-10M	128.5			250mm									5	870
LR2-12M	156.5			300mm									6	980
LR2-14M	184.7			350mm									7	1200
LR2-16M	212.6			400mm									8	1300
LR2-18M	216.9			450mm									9	1525
LR2-20M	221.0	15.0	31.0	507mm	25.0	50.0	13.8	6.0	3.0	M6 x 1.0	5.2	5.5	10	1740
LR2-22M	225.0			550mm									11	1960
LR2-24M	229.1			600mm									12	2180
LR2-26M	412.8			650mm									13	1960
LR2-28M	440.9			700mm									14	2180
LR2-30M	486.9			750mm									15	2290
LR2-32M	497.1			800mm									16	2500
LR2-34M	525.0			850mm									17	2610
LR2-36M	577.1			900mm									18	2725

Part number represents two sets of parts shown in diagram.

ULTRA PRECISION CROSS ROLLER BEARINGS DOUBLE V RAIL SETS

TRAVEL	MATERIAL
23mm TO 53mm	RAILS & ROLLERS - HARDENED AND GROUND TOOL STEEL • RETAINERS - BRASS*

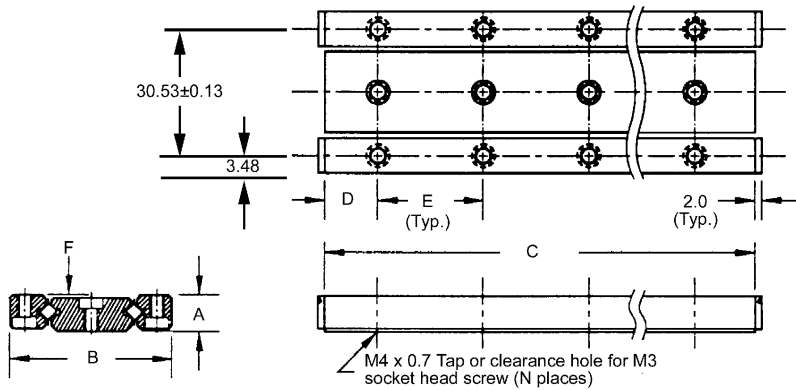

STOCK NO.	TRAVEL	A	B	C mm	D	E	F	N	RATED CAPACITY kg
LVL-01M	23.0			50.0				2	105
LVL-02M	33.0			75.0				3	180
LVL-03M	33.0	8.2	37.6	100.0	12.5	25.0	.15	4	210
LVL-04M	33.0			125.0				5	290
LVL-05M	53.0			150.0				6	315

* In some cases, may be plastic.

E

TRAVEL	MATERIAL
125mm TO 875mm	RAILS & ROLLERS - HARDENED AND GROUND TOOL STEEL • RETAINERS - BRASS*

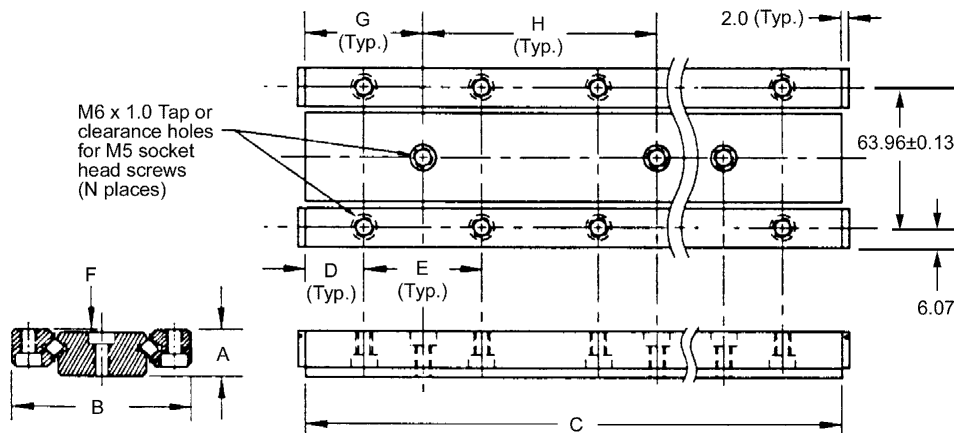

STOCK NO.	TRAVEL	A	B	C	D	E	F	G	H	N		RATED CAPACITY (kg)
										SIDE RAILS	CENTER RAILS	
LVH-05M	125.0			150.0				25.0	50.0	3	3	545
LVH-11M	275.0			300.0						6	3	980
LVH-15M	375.0	19.0	76.0	400.0	25.0	50.0	.2	50.0	100.0	8	4	1300
LVH-23M	575.0			600.0						12	6	1960
LVH-35M	875.0			900.0						18	9	2940

ULTRA PRECISION CROSS ROLLER "RECIRCULATING" BEARINGS & RAIL SETS

TRAVEL	MATERIAL
150mm TO 800mm	RAILS & ROLLERS - HARDENED AND GROUND TOOL STEEL

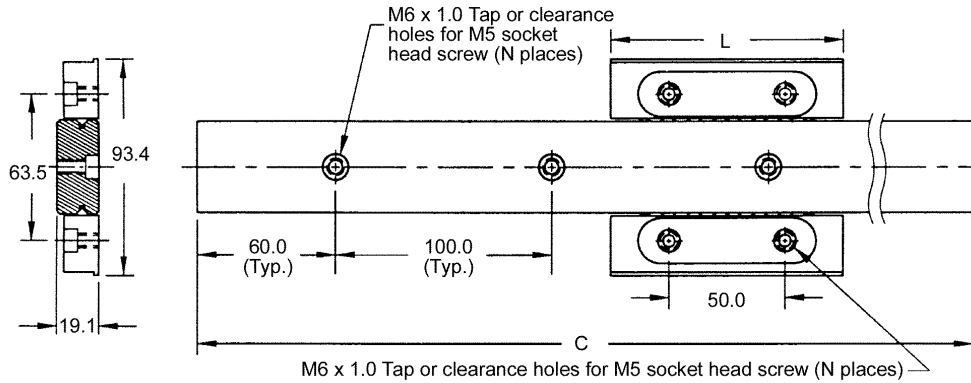

STOCK NO.	TRAVEL	C	L	N	RATED CAPACITY (kg)
DRWA-08M	200	320		3	435
DRWA-20M	500	620	100	6	
DRWA-32M	800	920		9	
DRWB-06M	150	320		3	870
DRWB-18M	450	620	148	6	
DRWB-30M	750	920		9	

ULTRA PRECISION CROSS ROLLER “RECIRCULATING” BEARINGS & RAIL SETS

TRAVEL	MATERIAL
150mm TO 800mm	RAILS & ROLLERS -HARDENED AND GROUND TOOL STEEL TOP CARRIAGE - 6061-T6 ALUMINUM, CLEAR ANODIZED

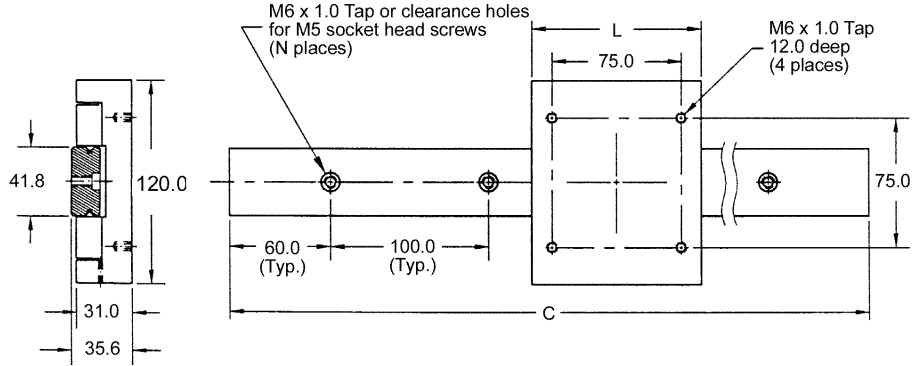

STOCK NO.	TRAVEL	C	L	N	RATED CAPACITY (kg)
RWSA-08M	200	320		3	435
RWSA-20M	500	620	100	6	
RWSA-32M	800	920		9	
RWSB-06M	150	320		3	870
RWSB-18M	450	620	148	6	
RWSB-30M	750	920		9	

E

ULTRA-PRECISION CROSS ROLLER SLIDE ASSEMBLIES, LONG TRAVEL

TRAVEL	MATERIAL
25mm TO 575mm	RAILS & ROLLERS - HARDENED AND GROUND TOOL STEEL TOP CARRIAGE 6061-T6 ALUMINUM, CLEAR ANODIZED OR G2 CLOSE GRAIN CAST IRON • RETAINERS - BRASS

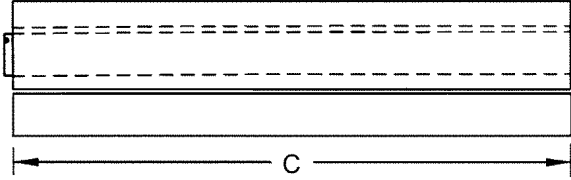
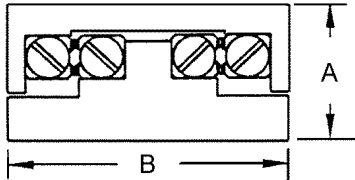

ALUMINUM STOCK NO.	CAST IRON STOCK NO.	TRAVEL	A	B	C	RATED CAPACITY (lbs.)
LWAA-01	LWSA-01	25			50.6	79
LWAA-02	LWSA-02	50			76.2	105
LWAA-03	LWSA-03	75			101.6	160
LWAA-04	LWSA-04	100			127.0	184
LWAA-05	LWSA-05	125			152.4	210
LWAA-06	LWSA-06	150	25.0	50.8	177.8	235
LWAA-07	LWSA-07	175			203.2	290
LWAA-08	LWSA-08	200			228.6	315
LWAA-09	LWSA-09	225			254.0	340
LWAA-10	LWSA-10	250			279.4	370
LWAA-11	LWSA-11	275			304.8	420
LWAB-02	LWSB-02	50			76.2	105
LWAB-03	LWSB-03	75			101.6	160
LWAB-04	LWSB-04	100			127.0	184
LWAB-05	LWSB-05	125			152.4	210
LWAB-06	LWSB-06	150			177.8	235
LWAB-07	LWSB-07	175	31.8	76.2	203.2	290
LWAB-08	LWSB-08	200			228.6	315
LWAB-09	LWSB-09	225			254.0	340
LWAB-10	LWSB-10	250			279.4	370
LWAB-11	LWSB-11	275			304.8	420
LWAC-03	LWSC-03	75			101.6	218
LWAC-05	LWSC-05	125			152.4	325
LWAC-07	LWSC-07	175			203.2	435
LWAC-09	LWSC-09	225			254.0	545
LWAC-11	LWSC-11	275			304.8	650
LWAC-13	LWSC-13	325			355.6	760
LWAC-15	LWSC-15	375	36.6	10.6	406.4	870
LWAC-17	LWSC-17	425			457.2	980
LWAC-19	LWSC-19	475			508.0	1090
LWAC-21	LWSC-21	525			558.8	1200
LWAC-23	LWSC-23	575			609.6	1300
LWAD-04	LWSD-04	120			152.4	325
LWAD-06	LWSD-06	170			203.2	435
LWAD-08	LWSD-08	220			254.0	545
LWAD-10	LWSD-10	270			304.8	650
LWAD-12	LWSD-12	320			355.6	760
LWAD-14	LWSD-14	375	50.8	152.4	406.4	870
LWAD-16	LWSD-16	425			457.2	980
LWAD-18	LWSD-18	475			508.0	1090
LWAD-20	LWSD-20	525			558.8	1200
LWAD-22	LWSD-22	575			609.6	1300



Mounting holes can be supplied at an additional cost, contact Customer Service.

Specify desired mounting holes and locations when ordering.

ULTRA-PRECISION CROSSED ROLLER SLIDE ASSEMBLIES, LOW PROFILE

TRAVEL	MATERIAL
25mm TO 125mm	RAILS & ROLLERS - HARDENED AND GROUND TOOL STEEL TOP & BASE - 6061-T6 ALUMINUM, CLEAR ANODIZED RETAINERS - PLASTIC

STOCK NO.	TRAVEL	A	B	C	D	E	I	J	N	RATED CAPACITY (kg)
LPA-01M	25			50.8					2	34
LPA-02M	50			76.2					3	34
LPA-03M	75	15.9	38	101.6	12.5	25.0	M4 x 0.7	M3	4	45
LPA-04M	100			127.0					5	45
LPA-05M	125			152.4					6	45

TRAVEL	MATERIAL
25mm TO 125mm	RAILS & ROLLERS - HARDENED AND GROUND TOOL STEEL TOP & BASE - 6061-T6 ALUMINUM, CLEAR ANODIZED RETAINERS - BRASS

STOCK NO.	TRAVEL	A	B	C	D	E	I	J	N	RATED CAPACITY (kg)
LPB-01M	25			50.8					2	34
LPB-02M	50			76.2					3	34
LPB-03M	75	15.9	51	101.6	12.5	25.0	M4 x 0.7	M3	4	34
LPB-04M	100			127.0					5	34
LPB-05M	125			152.4					6	34

TRAVEL	MATERIAL
150mm TO 900mm	RAILS & ROLLERS - HARDENED AND GROUND TOOL STEEL TOP & BASE - 6061-T6 ALUMINUM, CLEAR ANODIZED RETAINERS - PLASTIC

STOCK NO.	TRAVEL	A	B	C	D	E	I	J	N	RATED CAPACITY (kg)
LPC-06M	150			152.9	25.0	50.0			3	435
LPC-12M	300			305.3					3	870
LPC-24M	600	31.8	95	610.1	50.0	100.0	M6 x 1.0	M5	6	1850
LPC-36M	900			914.9					9	2725

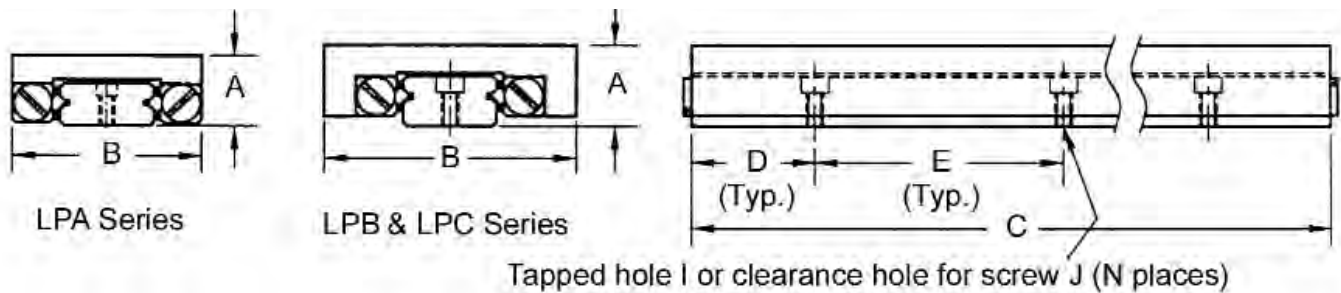

Mounting holes can be supplied at an additional cost, contact Customer Service.
Specify desired mounting holes and locations when ordering.

ULTRA-PRECISION CROSS ROLLER FLANGE BASED SLIDE ASSEMBLIES

TRAVEL	MATERIAL
150mm TO 500mm	RAILS & ROLLERS - HARDENED AND GROUND TOOL STEEL TOP CARRIAGE 6061-T6 ALUMINUM, CLEAR ANODIZED OR G2 CLOSE GRAIN CAST IRON • RETAINERS - BRASS

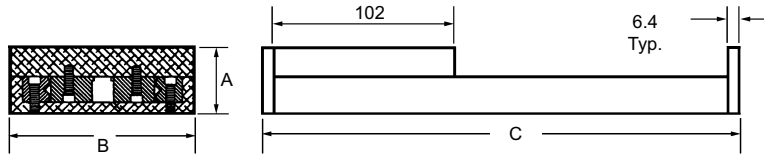

ALUMINUM STOCK NO.	CAST IRON STOCK NO.	TRAVEL	A	B	C	RATED CAPACITY (kg)
RWAA-06	RWAS-06	150			254	435
RWAA-08	RWAS-08	200			305	
RWAA-10	RWAS-10	250			356	
RWAA-12	RWAS-12	300			406	
RWAA-14	RWAS-14	350	36.6	102	457	
RWAA-16	RWAS-16	400			508	
RWAA-18	RWAS-18	450			559	
RWAA-20	RWAS-20	500			610	
RWBA-06	RWBS-06	150			254	
RWBA-08	RWBS-08	200			305	
RWBA-10	RWBS-10	250			356	
RWBA-12	RWBS-12	300			406	
RWBA-14	RWBS-14	350	50.8	152	457	
RWBA-16	RWBS-16	400			508	
RWBA-18	RWBS-18	450			559	
RWBA-20	RWBS-20	500			610	

Mounting holes can be supplied at an additional cost, contact Customer Service. specify desired mounting holes and locations when ordering.

CROSS ROLLER SLIDES

TRAVEL	MATERIAL
13.0mm TO 152.4mm	ALUMINUM BLACK ANODIZED

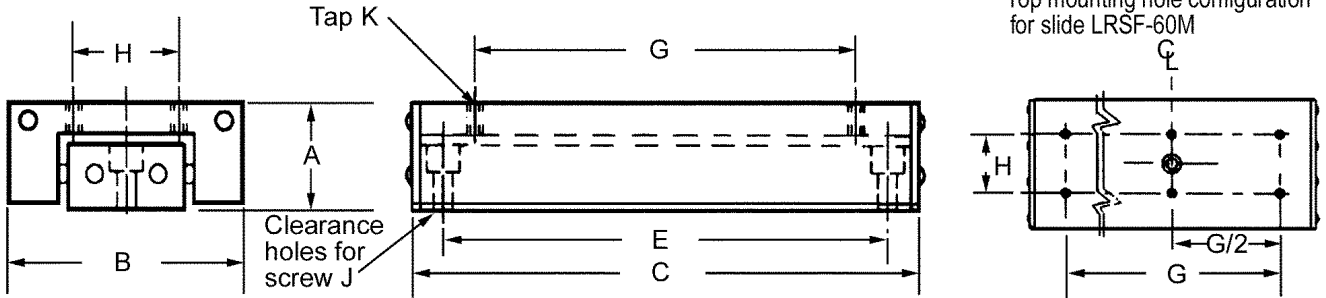

STOCK NUMBER	TRAVEL	A	B	C	E	G	H	J	RATED CAPACITY (kg)
LRSA-5M	13.0			26.9	19.0	16.0			15
LRSA-10M	25.5	8.0	14.0	52.3	35.0	41.5	5.5	M2.0 X 0.4	25
LRSA-20M	51.0			77.7	60.5	66.5			31
LRSB-5M	13.0			26.9	19.0	16.0			23
LRSB-10M	25.5	10.0	19.0	52.3	35.0	41.5	9.5	M3.0 X 0.5	36
LRSB-20M	51.0			77.7	60.5	66.5			45
LRSC-15M	38.1			65.0	54.0	57.0			61
LRSC-20M	50.8	13.5	27.0	90.4	79.5	82.5	11.0	M4.0 X 0.7	102
LRSC-30M	76.2			115.8	82.5	101.5			120
LRSD-10M	25.4			50.8	36.0	35.0			61
LRSD 20M	50.8	16.0	38.0	76.2	63.5	60.5	16.0	M4.0 X 0.7	82
LSRD 30M	76.2			101.6	89.0	85.5			82
LRSD-40M*	101.6			152.4	101.5	136.5			141
LRSE-10M	25.4			50.8	41.5	35.0			82
LRSE-20M	50.8			82.6	70.0	66.5			82
LRSE 30M	76.2	19.1	44.5	101.6	89.0	85.5	22.0	M4.0 X 0.7	109
LRSE-40M	101.6			152.4	101.5	139.5			141
LRSF-15M	38.1			66.5	47.5	41.5			150
LRSF-20M	50.8			101.5	85.5	76.0			190
LRSF-30M	76.2	25.5	66.5	127.0	111.0	101.6	32.0	M5.0 X 0.8	204
LRSF-40M	101.6			152.5	136.5	127.0			227
LRSF-60M*	152.4			228.5	178.0	152.4			320

Other sizes and load capacities available.

E

LINEAR BALL SLIDES

TRAVEL	MATERIAL
12.0mm TO 200mm	ALUMINUM BLACK ANODIZED

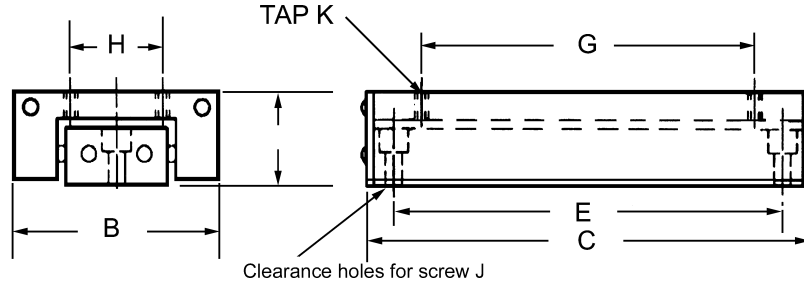

STOCK NUMBER	TRAVEL	A	B	C	E	G	H	J	K	RATED LOAD kg
LBSGM-12	12			20	10	10				1
LBSGM-25	25	6.0	9.5	32	20	20	4	M2 X 0.4*	M2 X 0.4	1
LBSGM-35	35			45	30	30				1
LBSKM-12	12			28	20	15				2
LBSKM-25	25			51	30	40				4
LBSKM-50	50	8.0	14.0	102	80	65	5	M2	M2 x 0.4	5
LBSKM-100	100			127	90	115				7
LBSKM-125	125			152	100	140				8
LBSEM-12	12			27	19	15				2
LBSEM-25	25			52	35	40				4
LBSEM-50	50	10.0	19.0	78	60	65	10	M3	M3 x 0.5	5
LBSEM-75	75			103	86	90				6
LBSEM-100	100			129	89	115				7
LBSEM-125	125			154	114	140				8
LBSFM-25	25			52	40	40				8
LBSFM-50	50			90	75	75				9
LBSFM-75	75	13.5	27.0	116	75	100				11
LBSFM-100	100			152	100	130	10	M4	M4 x 0.7	14
LBSFM-150	150			203	125	190				16
LBSFM-200	200			254	175	240				18
LBSHM-25	25			51	30	30				7
LBSHM-50	50			78	55	60				9
LBSHM-75	75			102	80	80				11
LBSHM-100	100	15.5	38.0	152	100	130	15	M4	M4 x 0.7	16
LBSHM-150	150			203	125	180				20
LBSHM-200	200			254	175	225				25
LBSAM-25	25			50	35	35				14
LBSAM-35	35			65	50	50				15
LBSAM-50	50	20.0	44.0	80	65	65	20	M5	M5 x 0.8	16
LBSAM-75	75			100	85	85				18
LBSBM-50	50			100	75	75				48
LBSBM-75	75	25.0	66.0	125	100	100	35	M5	M5 x 0.8	52
LBSBM-100	100			150	125	125				58

*Tapped hole in this series only.

ULTRA-PRECISION CROSS ROLLER LEAD SCREW DRIVEN SLIDE ASSEMBLIES

STYLE	TRAVEL	MATERIAL
KNOB	25mm TO 150mm	RAILS & ROLLERS - HARDENED AND GROUND TOOL STEEL TOP CARRIAGE 6061-T6 ALUMINUM, CLEAR ANODIZED OR G2 CLOSE GRAIN CAST IRON • RETAINERS BRASS

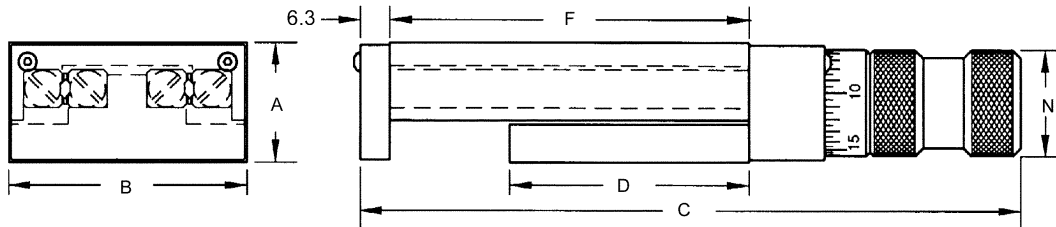

ALUMINUM STOCK NO.	CAST STOCK NO.	TRAVEL	A	B	C	D	F	RATED CAPACITY (kg)	N
LDA-01K	LDS-01K	25	25.0	50.8	140	50.8	76.2	105	22.2
LDA-02K	LDS-02K	25			165	76.2	101.6	160	
LDA-03K	LDS-03K	50			190	101.6	152.4	210	
LDA-04K	LDS-04K	25	31.7	76.2	175	76.2	101.6	160	27.7
LDA-05K	LDS-05K	25			200	101.6	127.0	235	
LDA-06K	LDS-06K	50			225	101.6	152.4	210	
LDA-07K	LDS-07K	25	36.5	101.6	225	127.0	152.4	290	
LDA-08K	LDS-08K	60			276	152.4	203.2	340	
LDA-09K	LDS-09K	50			327	203.2	254.0	475	
LDA-10K	LDS-10K	75			378	228.6	304.8	500	
LDA-11K	LDS-11K	50	50.8	152.4	269	152.4	203.2	545	34.9
LDA-12K	LDS-12K	100			390	203.2	304.8	650	
LDA-13K	LDS-13K	150			492	304.8	406.4	780	

Mounting holes can be supplied at an additional cost, contact Customer Service.

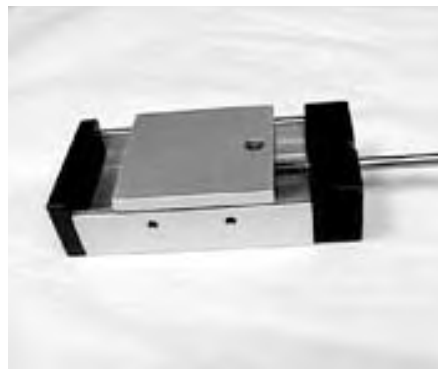

E

ULTRA-PRECISION CROSS ROLLER LEAD SCREW DRIVEN SLIDE ASSEMBLIES

STYLE	TRAVEL	MATERIAL
CRANK	25mm TO 150mm	RAILS & ROLLERS - HARDENED AND GROUND TOOL STEEL TOP CARRIAGE 6061-T6 ALUMINUM, CLEAR ANODIZED OR G2 CLOSE GRAIN CAST IRON • RETAINERS BRASS

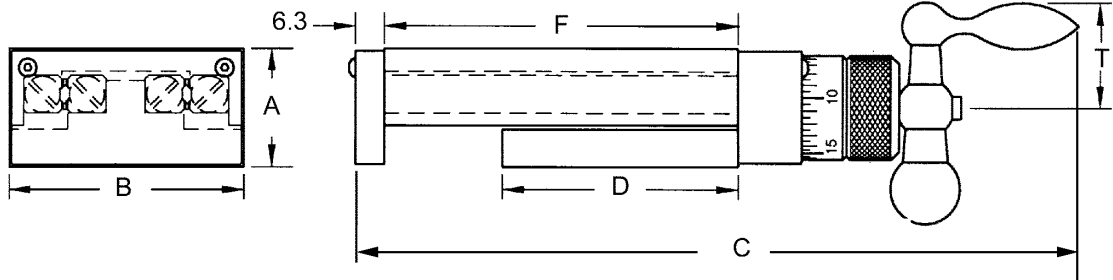

ALUMINUM STOCK NO.	CAST STOCK NO.	TRAVEL	A	B	C	D	F	T	RATED CAPACITY (kg)
LDA-01C	LDS-01C	25			155	50.8	76.2		105
LDA-02C	LDS-02C	25	25.0	50.8	180	76.2	101.6	25	160
LDA-03C	LDS-03C	50			206	101.6	152.4		210
LDA-04C	LDS-04C	25			184	76.2	101.6		160
LDA-05C	LDS-05C	25	31.7	76.2	210	101.6	127.0	25	235
LDA-06C	LDS-06C	50			235	101.6	152.4		210
LDA-07C	LDS-07C	25			235	127.0	152.4		290
LDA-08C	LDS-08C	60			285	152.4	203.2		340
LDA-09C	LDS-09C	50	36.5	101.6	337	203.2	254.0	25	475
LDA-10C	LDS-10C	75			387	228.6	304.8		500
LDA-11C	LDS-11C	50			313	152.4	203.2		545
LDA-12C	LDS-12C	100	50.8	152.4	414	203.2	304.8	38	650
LDA-13C	LDS-13C	150			515	304.8	406.4		780

Mounting holes can be supplied at an additional cost, contact Customer Service.

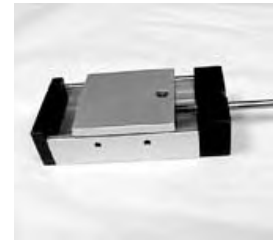

STYLE	TRAVEL	MATERIAL
SHAFT	25mm TO 150mm	RAILS & ROLLERS - HARDENED AND GROUND TOOL STEEL TOP CARRIAGE 6061-T6 ALUMINUM, CLEAR ANODIZED OR G2 CLOSE GRAIN CAST IRON • RETAINERS BRASS

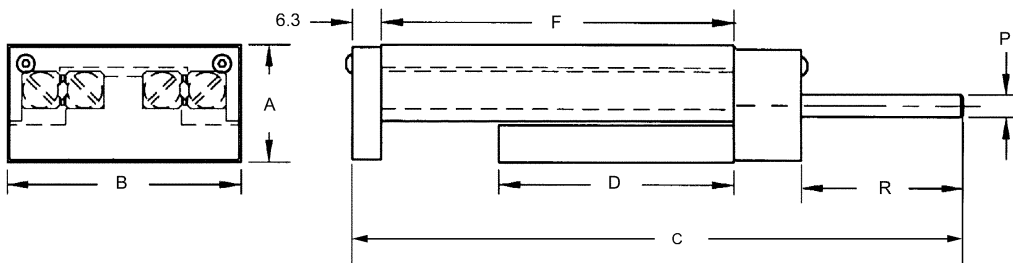

ALUMINUM STOCK NO.	CAST STOCK NO.	TRAVEL	A	B	C	D	F	P +0.005 +0.018	R	RATED CAPACITY (kg)
LDA-01SM	LDS-01SM	25			133	50.8	76.2			105
LDA-02SM	LDS-02SM	25	25.0	50.8	159	76.2	101.6	4.00	35	160
LDA-03SM	LDS-03SM	50			164	101.6	152.4			210
LDA-04SM	LDS-04SM	25			165	76.2	101.6			160
LDA-05SM	LDS-05SM	25	31.7	76.2	190	101.6	127.0	4.00	38	235
LDA-06SM	LDS-06SM	50			216	101.6	152.4			210
LDA-07SM	LDS-07SM	25			216	127.0	152.4			290
LDA-08SM	LDS-08SM	60			266	152.4	203.2			340
LDA-09SM	LDS-09SM	50	36.5	101.6	316	203.2	254.0	4.00	36	475
LDA-10SM	LDS-10SM	75			368	228.6	304.8			500
LDA-11SM	LDS-11SM	50			279	152.4	203.2			545
LDA-12SM	LDS-12SM	100	50.8	152.4	361	203.2	304.8	6.00	54	650
LDA-13SM	LDS-13SM	150			483	304.8	406.4			780

Mounting holes can be supplied at an additional cost, contact Customer Service.

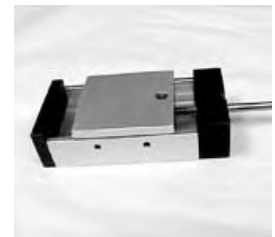

RACK DRIVEN BALL SLIDES

TRAVEL	MATERIAL	PRESSURE ANGLE
13mm TO 100mm	RACK - 416 STAINLESS STEEL BALL SLIDE - ANODIZED ALUMINUM	20°

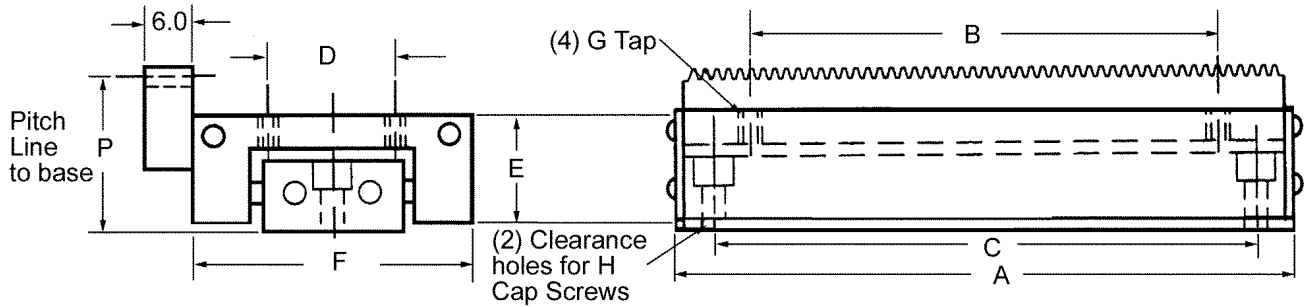

- Low starting and running friction
- Zero sideplay and wobble
- High accuracy and repeatability
- No lubrication required
- Heavy load carrying capacity
- Operates in any position
- Factory aligned and preloaded
- Easy replacement

STOCK NUMBER	MAX TRAVEL	MAX LOAD (kg)	A	B	C	D	E	F	G	H	P	MODULE
LRDB-5M	13	2.3	39.5	31.5	31.5							
LRDB-10M	25	4.5	65.0	57.0	57.0							
LRDB-15M	38	6.8	77.5	70.0	69.8	11.0	12.7	25.5	M3x0.5	M3	14.0	0.4
LRDB-20M	50	9.0	90.5	82.5	82.5							
LRDB-30M	75	13.6	116.0	108.0	108.0							
LRDD-10M	25	18.0	66.5	54.0	54.0							
LRDD-20M	50	27.0	101.6	76.2	85.5							
LRDD-30M	75	40.7	127.0	101.6	111.0	31.5	25.4	66.5	M4X0.7	M4	28.0	0.8
LRDD-40M	100	52.5	152.4	127.0	136.5							

Other sizes available on request.



E

RACK DRIVEN BALL SLIDE PINIONS

MODULE	MATERIAL	PRESSURE ANGLE
0.4 AND 0.8	STAINLESS STEEL 1.4305	20°

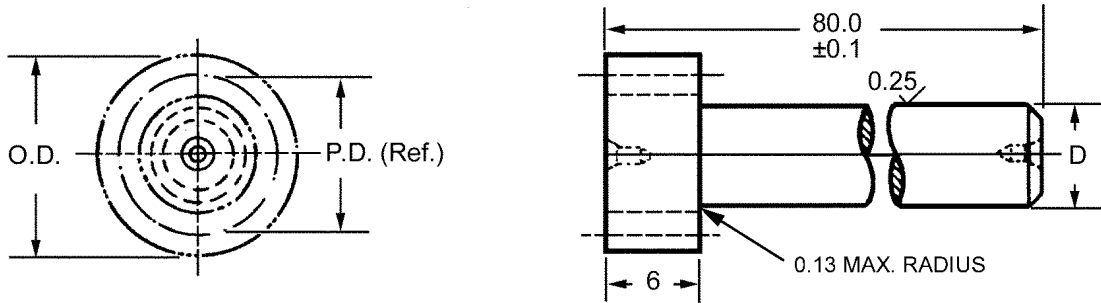

STOCK NUMBER	MODULE	NO. OF TEETH	P.D.	OD	D	USE FOR SLIDES
PSGS6M-20H	0.4	20	8.00	8.80	6.000	LRDB
PSDS6M-10H	0.8	10	8.00	9.60	6.000	LRDD

LINEAR-ROTARY BEARINGS PRE-LOADED, GENERAL PURPOSE

BORE	MAX. LINEAR TRAVEL	MATERIAL
16mm TO 50mm	25mm TO 150mm	HOUSING - STEEL DIN 1.0601 RETAINER - 16mm BORE-BRASS, 20-50mm BORE - ALUMINUM SEALS-NITRILE RUBBER

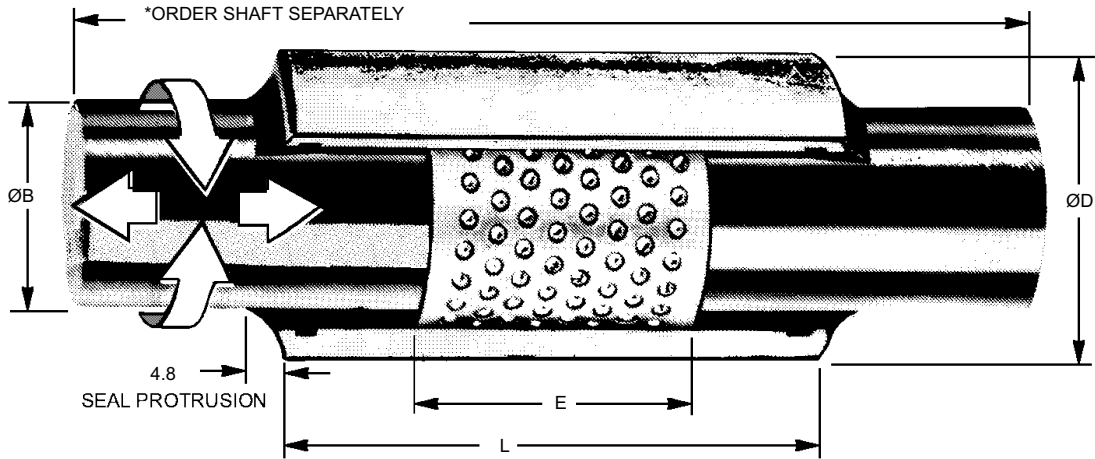

STOCK NO.	SHAFT DIA. (REF.)	OUTSIDE DIA. ØD	HOUSING DIA. FOR PROPER FIT	E	L -0.13	MAX LINEAR TRAVEL	RATED LOAD (kg)	SHAFT STOCK NO.
LRM-16M-1 LRM-16M-2	16.00	28.007	+0.012 27.995	16.0	45.00 55.00	25 50	137	LMS-16M-300
LRM-20M-1 LRM-20M-2	20.00	32.010	+0.015 31.995	21.0	50.00 60.00	25 50	195	LMS-20M-300
LRM-25M-1 LRM-25M-2 LRM-25M-3 LRM-25M-4	25.00	39.013	+0.018 38.995	25.0	55.00 65.00 80.00 95.00	25 50 75 100	243	LMS-25M-300
LRM-32M-1 LRM-32M-2 LRM-32M-3 LRM-32M-4 LRM-32M-5	32.00	46.013	+0.018 45.995	36.0	65.00 75.00 90.00 105.00 125.00	25 50 75 100 150	445	LMS-32M-300
LRM-40M-1 LRM-40M-2 LRM-40M-3 LRM-40M-4 LRM-40M-5	40.00	55.013	+0.018 54.995	43.0	70.00 85.00 95.00 110.00 135.00	25 50 75 100 150	548	LMS-40M-300
LRM-50M-1 LRM-50M-2 LRM-50M-3 LRM-50M-4 LRM-50M-5	50.00	70.013	+0.018 69.995	58.5	85.00 100.00 110.00 125.00 150.00	25 50 75 100 150	952	LMS-50M-300

- Seals can be hand removed to reduce friction
- Supporting combinations of linear and rotary motion bearings
- Temperature ranges -40°C to +120°C



LINEAR MOTION ADJUSTABLE BEARINGS

STYLE	MATERIAL
F, W, FS & WS	HOUSING - STAINLESS STEEL DIN 1.4305 or MILD STEEL, BLACK OXIDE FINISH BEARINGS, SPINDLES & BALL BEARINGS - STAINLESS STEEL DIN 1.4112

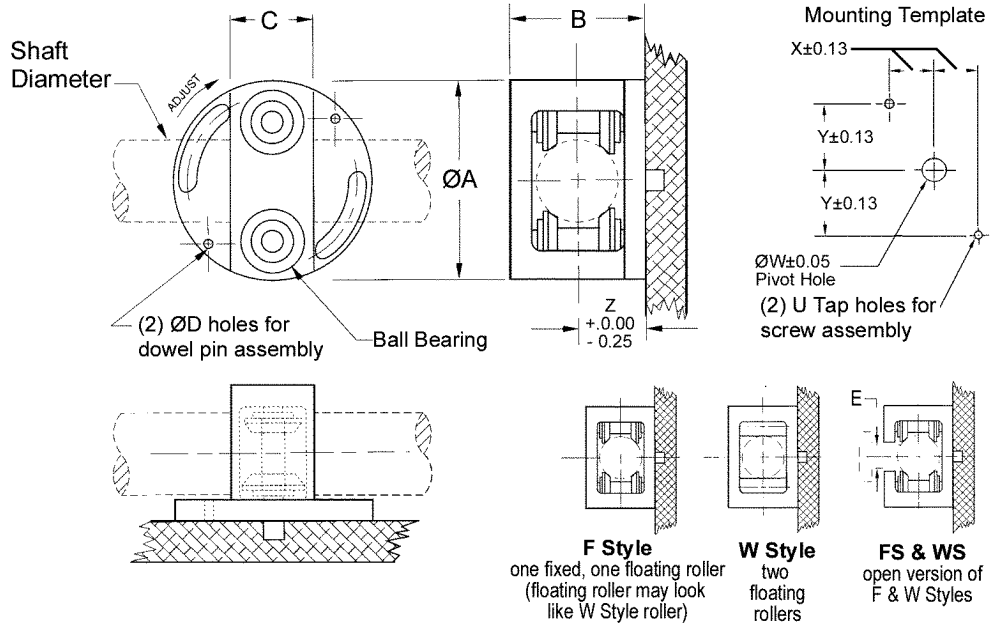

STAINLESS STEEL STOCK NO.	MILD STEEL STOCK NO.	SHAFT DIA. MIN. - MAX.	ØA	B	C	D	E	U	ØW	X	Y	Z	RATED LOAD (kg)
-	LMX-4-F	6.25-6.5MM	15.7	14.2	6	-	-	M3	3.2	6.9	6.9	7.1	10
-	LMX-4-W	6.25-6.5MM	15.7	14.2	6	-	-	M3	3.2	6.9	6.9	7.1	10
LMA-6-F	LMX-6-F	9.5-13MM	31.8	23.6	13	2.5	-	M4	6.4	7.9	9.4	1.5	41
LMA-6-W	LMX-6-W	9.5-13MM	31.8	23.6	13	2.5	-	M4	6.4	7.9	9.4	1.5	41
LMA-12-F	LMX-12-F	19-26MM	60.2	41.1	25	2.5	-	M4	6.4	16.9	19.7	20.2	209
LMA-12-W	LMX-12-W	19-26MM	60.2	41.1	25	2.5	-	M4	6.4	16.9	19.7	20.2	209
LMA-12-FS	LMX-12-FS	25-26MM	60.2	41.1	25	2.5	14	M4	6.4	16.9	19.7	20.2	209
LMA-12-WS	LMX-12-WS	25-26MM	60.2	41.1	25	2.5	14	M4	6.4	16.9	19.7	20.2	209
LMA-20-F	LMX-20-F	31-32MM	82.6	53.8	*	3.8	16	M4	9.6	21.8	26.1	25.6	340
LMA-20-W	LMX-20-W	31-32MM	82.6	53.8	*	3.8	16	M4	9.6	21.8	26.1	25.6	340
LMA-20-FS	LMX-20-FS	31-32MM	82.6	53.8	*	3.8	16	M4	9.6	21.8	26.1	25.6	340
LMA-20-WS	LMX-20-WS	31-32MM	82.6	53.8	*	3.8	16	M4	9.6	21.8	26.1	25.6	340
-	LMX-24-F	37-39MM	91.2	70	*	3.8	19	M6	9.6	25.4	25.1	35.1	568
-	LMX-24-W	37-39MM	91.2	70	*	3.8	19	M6	9.6	25.4	25.1	35.1	568
-	LMX-24-FS	37-39MM	91.2	70	*	3.8	19	M6	9.6	25.4	25.1	35.1	568
-	LMX-24-WS	37-39MM	91.2	70	*	3.8	19	M6	9.6	25.4	25.1	35.1	568
-	LMX-32-F	50-51MM	120.7	77.7	*	3.8	25	M6	12.8	28.3	47.0	38.5	1362
-	LMX-32-W	50-51MM	120.7	77.7	*	3.8	25	M6	12.8	28.3	47.0	38.5	1362
-	LMX-32-FS	50-51MM	120.7	77.7	*	3.8	25	M6	12.8	28.3	47.0	38.5	1362
-	LMX-32-WS	50-51MM	120.7	77.7	*	3.8	25	M6	12.8	28.3	47.0	38.5	1362

* 31 thru 51mm shaft units are round. C = A.



PRECISION LINEAR "GEAR DRIVE" BEARINGS

MATERIAL

STAINLESS STEEL DIN 1.4305 WITH DIN 1.4112 BALL BEARINGS

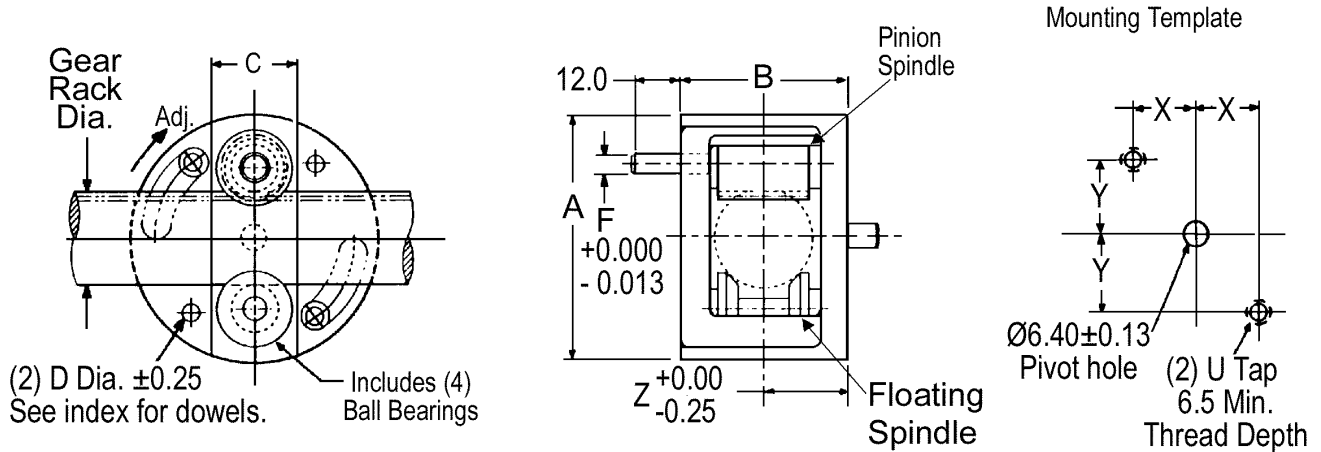

STOCK NO.	LINEAR DRIVE GEAR RACK STOCK NO.	$\text{Ø}A$ ± 0.5	B ± 0.5	C	$\text{Ø}D$	U	X ± 0.13	Y ± 0.13	Z	$\text{Ø}F$	GEAR DRIVE PINION DATA 0.4 MOD 20° PRESSURE ANGLE		
											NO. OF TEETH	PITCH DIA. (REF.)	TRAVEL PER (REV.)
LMA-G-6M	R11M-1	32	24	13	2.5	M3	8.03	9.4	11.51	3	20	8	25.2
LMA-G-12M	R11M-2	60	41	25.5	2.5	M4	16.87	19.71	20.22	6	40	16	50.3

- Power take off for encoders, feedback systems, etc.
- Power drive. Direct drive through stepper motors, etc.
- Mount with Dial and Vernier for simple, accurate positioning.
- Backlash adjustable by rotating housing against gear rack.
- Mounting screws and washers supplied.



E

LINEAR DRIVE GEAR RACKS

MODULE	MATERIAL	PRESSURE ANGLE
0.4	STAINLESS STEEL DIN 1.4005	20°

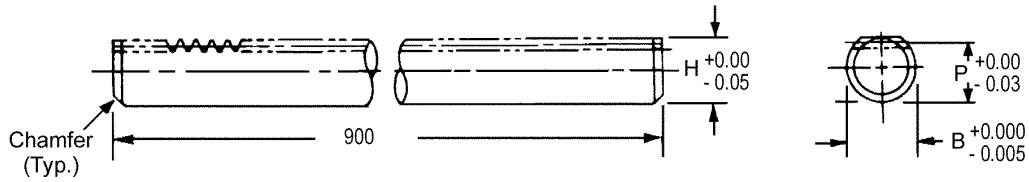

STOCK NO.	MOD	USE WITH DRIVE BEARING	P	B	H
R11M-1	0.4	LMA-G-6M	10.60	12.000	11.00
R11M-2	0.4	LMA-G-12M	22.60	25.000	23.00

- Use with linear "gear drive" bearings
- Can be butted for longer lengths.
- High Precision, High Performance



THERMOPLASTIC ROD ENDS

STYLE	MATERIAL
EXTERNAL THREAD	HOUSING - REINFORCED THERMOPLASTIC RACE - B15 BEARING

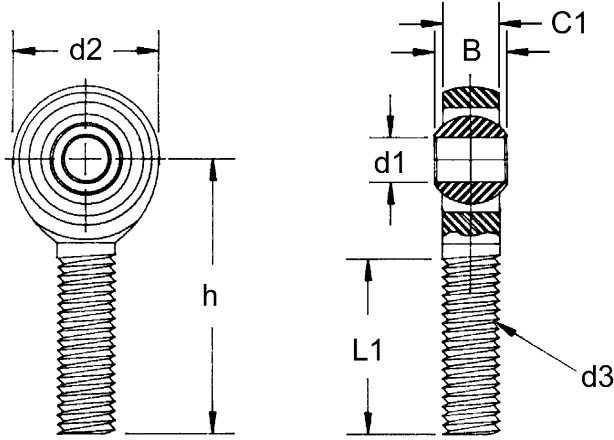

RIGHT THREAD STOCK NO.	LEFT THREAD STOCK NO.	d1 +.06 -.02	d2	d3	c1	B	h	L1 +1.6 -0.8
RKARM-05	RKALM-05	5	18	M5 x 0.8	6	8	33	19
RKARM-06	RKALM-06	6	20	M6 x 1.0	7	9	36	21
RKARM-08	RKALM-08	8	24	M8 x 1.25	9	12	42	25
RKARM-10	RKALM-10	10	30	M10 x 1.5	10.5	14	48	28
RKARM-12	RKALM-12	12	34	M12 x 1.75	12	16	54	32
RKARM-14	RKALM-14	14	38	M14 x 2.0	13.5	19	60	36
RKARM-16	RKALM-16	16	42	M16 x 2.0	15	21	66	37
RKARM-18	RKALM-18	18	46	M18 x 1.5	16.5	23	72	41
RKARM-20	RKALM-20	20	50	M20 x 1.5	18	25	78	45
RKARM-22	RKALM-22	22	56	M22 x 1.5	20	28	84	48

E

THERMOPLASTIC ROD ENDS

STYLE	MATERIAL
INTERNAL THREAD	HOUSING - REINFORCED THERMOPLASTIC RACE - B15 BEARING

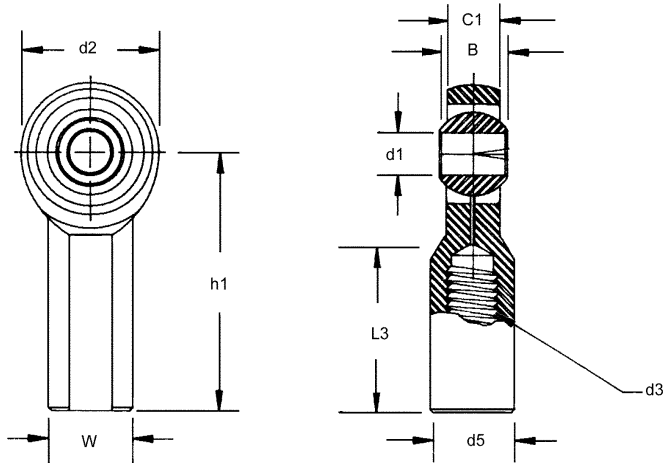

RIGHT THREAD STOCK NO.	LEFT THREAD STOCK NO.	d1 +.06 -.02	d2	d3	d5	c1	B	h1	L3 +1.6mm -.8mm	W
RKBRM-05	RKBLM-05	5	18	M5 x 0.8	12	6	8	27	10	SW09
RKBRM-06	RKBLM-06	6	20	M6 x 1.0	13	7	9	30	12	SW11
RKBRM-08	RKBLM-08	8	24	M8 x 1.25	16	9	12	36	16	SW14
RKBRM-10	RKBLM-10	10	30	M10 x 1.5	19	10.5	14	43	20	SW17
RKBRM-12	RKBLM-12	12	34	M12 x 1.75	22	12	16	50	22	SW19
RKBRM-14	RKBLM-14	14	38	M14 x 2.0	25	13.5	19	57	25	SW22
RKBRM-16	RKBLM-16	16	42	M16 x 2.0	27	15	21	64	28	SW22
RKBRM-18	RKBLM-18	18	46	M18 x 1.5	31	16.5	23	71	32	SW23
RKBRM-20	RKBLM-20	20	50	M20 x 1.5	34	18	25	77	33	SW30
RKBRM-22	RKBLM-22	22	56	M22 x 1.5	37	20	28	84	37	SW32

SELF-ALIGNING ROD ENDS

BORE	STYLE	MATERIAL
5mm TO 25mm	EXTERNAL THREAD	BODY AND RACE- LOW CARBON STEEL WITH PROTECTIVE COATING BALL - ALLOY STEEL, CHROME PLATED

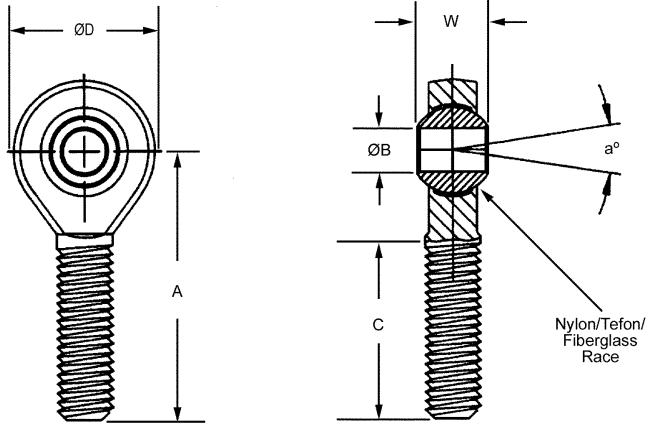

STOCK NUMBER	ØB +0.065 -0.012	W	A	ØD	C ±1.0	THREAD	a _p MISALIGN ANGLE	RADIAL STATIC LOAD CAP (kg)
REM-5	5	8	33	16	20	M5X0.8	7.5	527
REM-6	6	9	36	19	22	M6X1.0	6.5	744
REM-8	8	12	42	22.25	25	M8X1.25	7.5	1,386
REM-10	10	14	48	27	29	M10X1.5	8.0	1,789
REM-12	12	16	54	30	33	M12X1.75	8.0	1,886
REM-16	16	21	66	38	40	M16X2.0	8.5	3,286
REM-18	18	23	72	42	44	M18X1.5	9.5	4,212
REM-20	20	25	78	46	47	M20X1.5	9.0	5,196
REM-25	25	31	95	60	57	M24X2.0	10.0	10,650

E

SELF-ALIGNING ROD ENDS

BORE	STYLE	MATERIAL
5mm TO 25mm	INTERNAL THREAD	BODY AND RACE- LOW CARBON STEEL WITH PROTECTIVE COATING BALL - ALLOY STEEL, CHROME PLATED

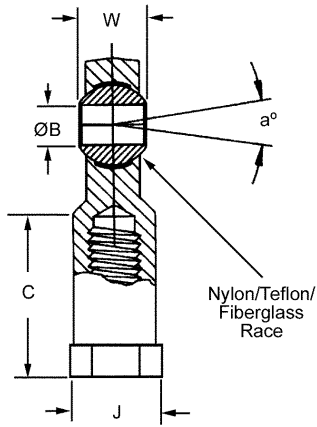
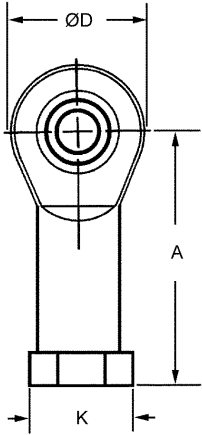

STOCK NUMBER	ØB +0.065 -0.012	W	A	ØD	C ±1.0	K	J	THREAD	a° MISALIGN ANGLE	RADIAL STATIC LOAD CAP (kg)
RIM-5	5	8	27	16	10	11	9	M5X0.8	7.5	723
RIM-6	6	9	30	19	12	13	11	M6X1.0	6.5	1125
RIM-8	8	12	36	22.5	16	16	14	M8X1.25	7.5	1,435
RIM-10	10	14	43	29	20	19	17	M10X1.5	8.0	1,789
RIM-12	12	16	50	35	22	22	19	M12X1.75	8.0	1,886
RIM-16	16	21	64	38	27	27	22	M16X2.0	8.5	3,286
RIM-18	18	23	71	42	32	31	27	M18X1.5	9.5	4,212
RIM-20	20	25	77	46	33	34	30	M20X1.5	9.0	5,196
RIM-25	25	31	95	60	42	42	36	M24X2.0	10.0	10,158

- High Radical and Trust Loads
- Long Cycle Life

FLANGED TYPE LINEAR BEARINGS

STYLE	MATERIAL
SQUARE OR ROUND FLANGE	HOUSING & BALLS - 52100 CHROME STEEL RETAINER - DELRIN

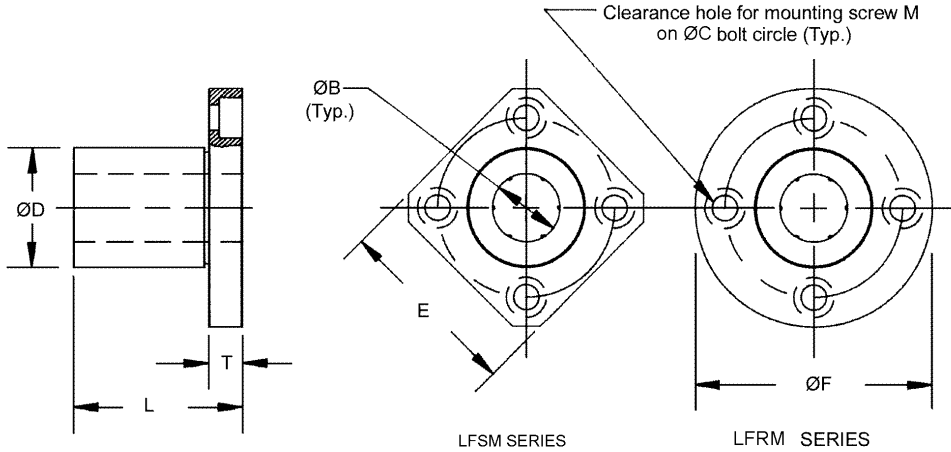

SQUARE FLANGE STOCK NO.	ROUND FLANGE STOCK NO.	WORKING BORE ØB	OUTSIDE DIA. ØC	L MAX.	T	ØF	E	ØC	M	LOAD RATING (kg)
LFSM-1	LFRM-1	6.000-0.009	12.000-0.011	19	5	28	22	20	M3	21
LFSM-2	LFRM-2	8.000-0.009	15.000-0.011	24	5	32	25	24	M3	28
LFSM-3	LFRM-3	10.000-0.009	19.000-0.013	29	6	40	30	29	M4	38
LFSM-4	LFRM-4	12.000-0.009	21.000-0.013	30	6	42	32	32	M4	42
LFSM-5	LFRM-5	13.000-0.009	23.000-0.013	32	6	43	34	33	M4	52
LFSM-6	LFRM-6	16.000-0.009	28.000-0.013	37	6	48	37	38	M4	79
LFSM-7	LFRM-7	20.000-0.010	32.000-0.019	42	8	54	42	43	M5	90
LFSM-8	LFRM-8	25.000-0.010	40.000-0.019	59	8	62	50	51	M5	100
LFSM-9	LFRM-9	30.000-0.010	45.000-0.019	64	10	74	58	69	M6	100

E

LINEAR BALL BEARINGS

SHAFT SIZE	MATERIAL
6mm TO 30mm	HOUSING AND BALLS - STAINLESS STEEL OR 52100 CHROME STEEL BALL RETAINER - PLASTIC

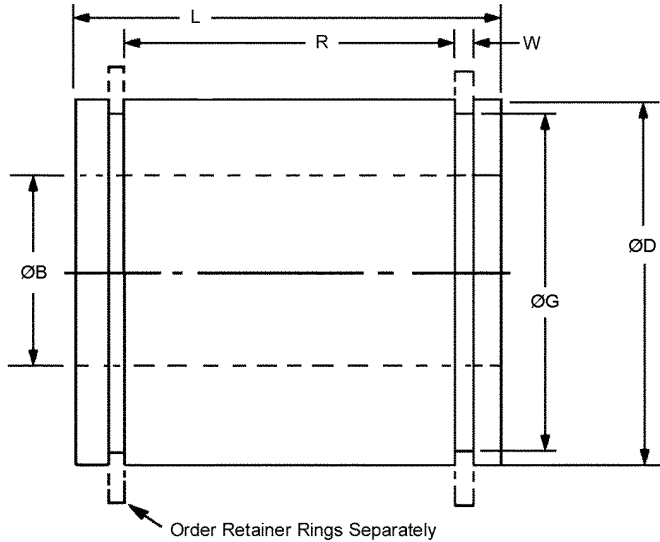

STAINLESS STEEL STOCK NO.	CHROME STEEL STOCK NO.	WORKING BORE ØB	OUTSIDE DIA. ØD	L ±0.3	R	W	ØG	RATED LOAD (kg)	RECOMMENDED FITS		SHAFT STOCK NO.	RETAINER RING STOCK NO.
									NORMAL ±0.013	PRESS ±0.013		
LMBM-1SS	LMBM-1	6.000-0.009	12-11um	19.0	11.3	1.1	11.5	21	12.000	11.975	S416-6M-900	Q2M-12
LMBM-2SS	LMBM-2	10.000-0.009	19-13um	29.0	19.4	1.3	18.0	38	19.000	18.975	S416-10M-900	Q2M-19
LMBM-3SS	LMBM-3	13.000-0.009	23-13um	32.0	20.4	1.3	22.0	52	23.000	22.975	S416-13M-900	Q2M-23
LMBM-4SS	LMBM-4	20.000-0.009	32-16um	42.0	27.3	1.6	30.5	90	32.000	31.975	S416-20M-900	Q2M-32
LMBM-5SS	LMBM-5	25.000-0.010	40-16um	59.0	37.3	1.8	38.0	100	40.000	39.975	S416-25M-900	Q2M-40
LMBM-6SS	LMBM-6	30.000-0.010	45-16um	64.0	40.8	1.8	43.0	160	45.000	44.975	S416-30M-900	Q2M-45

* Specify Length Required.

LINEAR BALL BEARINGS

STYLE	SHAFT SIZE	MATERIAL
ADJUSTABLE DIAMETER SERIES	13mm TO 30mm	HOUSING AND BALLS - CHROME STEEL BALL RETAINER - PLASTIC

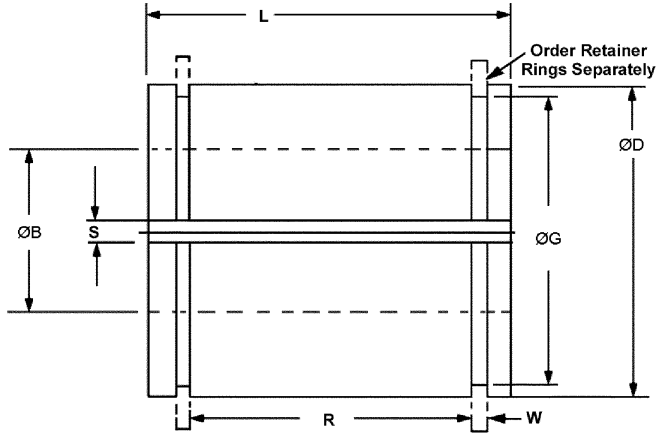

STOCK NO.	WORKING BORE (Before Adjust. ØB)	HOUSING BORE (Before Adj. ØD Ref.)	L	R ±0.3	W	ØG	RATED LOAD (kg)	MINIMUM SLOT WIDTHS	SHAFT STOCK NO.	RETAINER RING STOCK NO.
LMCM-3	13.000-0.009	23-13um	32.0	20.4	1.3	22.0	52	1.5	S416-13M-900	Q2M-23
LMCM-4	20.000-0.010	32-16um	42.0	27.3	1.6	30.5	90	1.5	S416-20M-900	Q2M-32
LMCM-5	25.000-0.010	40-16um	59.0	37.3	1.8	38.0	100	2.0	S416-25M-900	Q2M-40
LMCM-6	30.000-0.010	45-16um	64.0	40.8	1.8	43.0	160	2.5	S416-30M-900	Q2M-45

E

LINEAR BALL BEARINGS SELF-ALIGNING-BARREL STYLE

SHAFT SIZE	MATERIAL
6mm TO 30mm	HOUSING AND BALLS - CHROME STEEL BALL RETAINER - PLASTIC

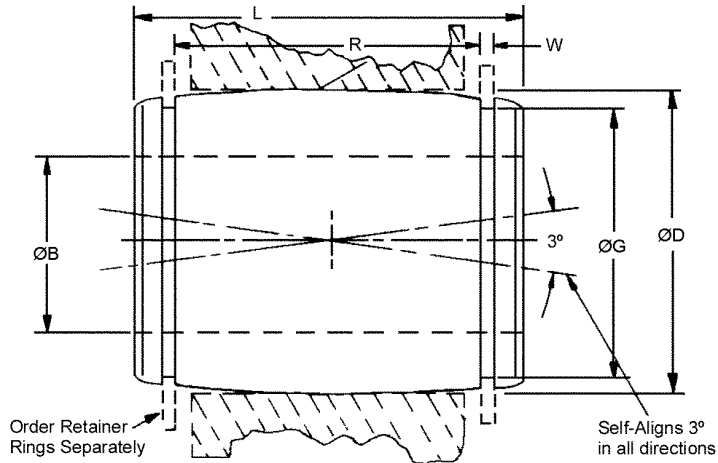

STOCK NO.	WORKING BORE ØB	HOUSING BORE ØD	L	R ±0.3	W	ØG	RATED LOAD (kg)	SHAFT STOCK NO.	RETAINER RING STOCK NO.
LMBM-1-B	6.000-0.009	12-11um	19.0	11.3	1.1	11.5	21	S416-6M-900	Q2M-12
LMBM-2-B	10.000-0.009	19-13um	29.0	19.4	1.3	18.0	38	S416-10M-900	Q2M-19
LMBM-3-B	13.000-0.009	23-13um	32.0	20.4	1.3	22.0	52	S416-13M-900	Q2M-23
LMBM-4-B	20.000-0.010	32-16um	42.0	27.3	1.6	30.5	90	S416-20M-900	Q2M-32
LMBM-5-B	25.000-0.010	40-16um	59.0	37.3	1.8	38.0	100	S416-25M-900	Q2M-40
LMBM-6-B	30.000-0.010	45-16um	64.0	40.8	1.8	43.0	160	S416-30M-900	Q2M-45

LINEAR BALL BEARINGS

STYLE	SHAFT SIZE	MATERIAL
OPEN SERIES	13mm TO 30mm	HOUSING AND BALLS - CHROME STEEL BALL RETAINER - PLASTIC

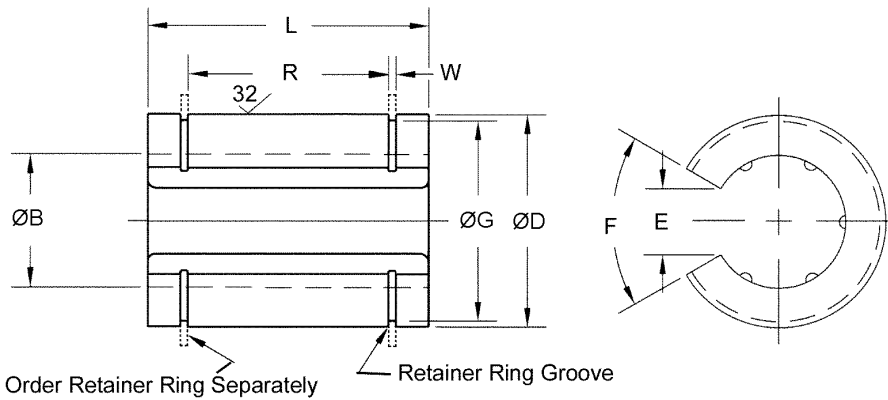

STOCK NO.	BORE (Before Adjust. ØB)	HOUSING BORE ØD (Ref.)	L	R ±0.3	W	ØG	RATED LOAD (kg)	MINIMUM SLOT		SHAFT STOCK NO.	RETAINER RING STOCK NO.
								WIDTH E	ANGLE F		
LMDM-3	13.000-0.009	23-13um	32.0	20.4	1.3	22.0	52	9	80°	S416-13M-900	Q5M-23
LMDM-4	20.000-0.010	32-16um	42.0	27.3	1.6	30.5	90	11	60°	S416-20M-900	Q5M-32
LMDM-5	25.000-0.010	40-16um	59.0	37.3	1.8	38.0	100	12	50°	S416-25M-900	Q5M-40
LMDM-6	30.000-0.010	45-16um	64.0	40.8	1.8	43.0	160	15	50°	S416-30M-900	Q5M-45

E

LINEAR "NO LUBE" BEARINGS

STYLE	SHAFT SIZE	MATERIAL
OPEN	6mm TO 30mm	MOLYBDENUM DISULFIDE FILLED NYLATRON

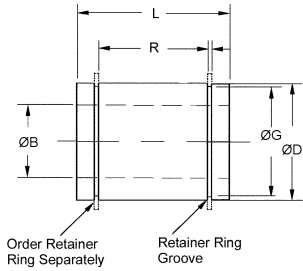

Open Style

STOCK NO.	WORKING BORE ØB	OUTSIDE DIA. ØD	L	R ±0.3	W	ØG	HARDENED SHAFT STOCK NO.	SOFT ST/ST SHAFT STOCK NO.	RETAINER RING STOCK NO.
LMNM-1-OPN	6.00+0.08	12.00/-0.08	19.0	11.3	1.1	11.5	S416-6M-900	S1-106	Q2M-12
LMNM-2-OPN	10.00+0.08	19.00/-0.08	29.0	19.4	1.3	18.0	S416-10M-900	S1-110	Q2M-19
LMNM-3-OPN	13.00+0.11	23.00/-0.11	32.0	20.4	1.3	22.0	S416-13M-900	S1-113	Q2M-23
LMNM-4-OPN	20.00+0.11	32.00/-0.11	42.0	27.3	1.6	30.5	S416-20M-900	S1-120	Q2M-32
LMNM-5-OPN	25.00+0.11	40.00/-0.15	59.0	37.3	1.8	38.0	S416-25M-900	S1-125	Q2M-40
LMNM-6-OPN	30.00+0.15	45.00/-0.15	64.0	40.8	1.8	43.0	S416-30M-900	S1-130	Q2M-45

STYLE	SHAFT SIZE	MATERIAL
CLOSED	6mm TO 30mm	MOLYBDENUM DISULFIDE FILLED NYLATRON

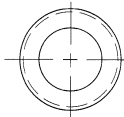
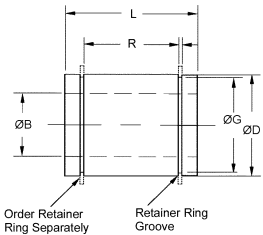

May be used with either hard or soft ground shafting

STOCK NO.	WORKING BORE ØB	OUTSIDE DIA. ØD	L	R ±0.3	W	ØG	HARDENED SHAFT STOCK NO.	SOFT ST/ST SHAFT STOCK NO.	RETAINER RING STOCK NO.
LMNM-1	6.00+0.08	12.00/-0.08	19.0	11.3	1.1	11.5	S416-6M-900	S1-106	Q2M-12
LMNM-2	10.00+0.08	19.00/-0.08	29.0	19.4	1.3	18.0	S416-10M-900	S1-110	Q2M-19
LMNM-3	13.00+0.11	23.00/-0.11	32.0	20.4	1.3	22.0	S416-13M-900	S1-113	Q2M-23
LMNM-4	20.00+0.11	32.00/-0.11	42.0	27.3	1.6	30.5	S416-20M-900	S1-120	Q2M-32
LMNM-5	25.00+0.11	40.00/-0.15	59.0	37.3	1.8	38.0	S416-25M-900	S1-125	Q2M-40
LMNM-6	30.00+0.15	45.00/-0.15	64.0	40.8	1.8	43.0	S416-30M-900	S1-130	Q2M-45

STYLE	SHAFT SIZE	MATERIAL
ADJUSTABLE	6mm TO 30mm	MOLYBDENUM DISULFIDE FILLED NYLATRON

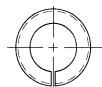
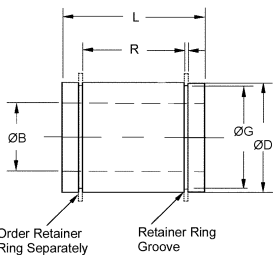

Adjustable Style

STOCK NO.	WORKING BORE ØB	OUTSIDE DIA. ØD	L	R ±0.3	W	ØG	HARDENED SHAFT STOCK NO.	SOFT ST/ST SHAFT STOCK NO.	RETAINER RING STOCK NO.
LMNM-1-ADJ	6.00+0.08	12.00/-0.08	19.0	11.3	1.1	11.5	S416-6M-900	S1-106	Q2M-12
LMNM-2-ADJ	10.00+0.08	19.00/-0.08	29.0	19.4	1.3	18.0	S416-10M-900	S1-110	Q2M-19
LMNM-3-ADJ	13.00+0.11	23.00/-0.11	32.0	20.4	1.3	22.0	S416-13M-900	S1-113	Q2M-23
LMNM-4-ADJ	20.00+0.11	32.00/-0.11	42.0	27.3	1.6	30.5	S416-20M-900	S1-120	Q2M-32
LMNM-5-ADJ	25.00+0.11	40.00/-0.15	59.0	37.3	1.8	38.0	S416-25M-900	S1-125	Q2M-40
LMNM-6-ADJ	30.00+0.15	45.00/-0.15	64.0	40.8	1.8	43.0	S416-30M-900	S1-130	Q2M-45

THERMOPLASTIC LINEAR BEARINGS

STYLE	SHAFT SIZE	MATERIAL
CLOSED	5mm TO 50mm	SHELL - ALUMINUM LINER - THERMOPLASTIC POLYMER

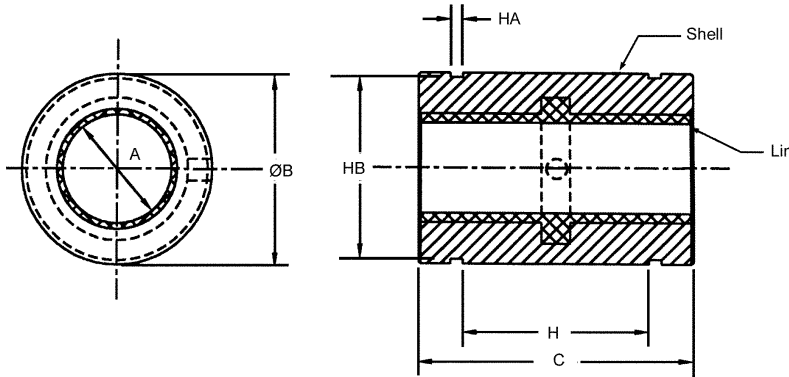

STOCK NO.	NOMINAL SIZE	ØA	ØB	C	H	HA	HB
LBUM-01-05	5	5.025/5.060	12	22	12	1.10	11.5
LBUM-01-08	8	8.032/8.070	16	25	14	1.10	15.2
LBUM-01-10	10	10.030/10.088	19	29	19	1.20	17.5
LBUM-01-12	12	12.030/12.088	22	32	20	1.20	20.5
LBUM-01-16	16	16.030/16.088	26	36	22	1.20	24.2
LBUM-01-20	20	20.030/20.091	32	45	28	1.50	29.6
LBUM-01-25	25	25.030/25.091	40	58	40	1.75	36.5
LBUM-01-30	30	30.040/30.110	47	68	48	1.75	43.5
LBUM-01-40	40	40.040/40.115	62	80	56	2.00	57.6
LBUM-01-50	50	50.050/50.130	75	100	72	2.50	70.5

E

STYLE	SHAFT SIZE	MATERIAL
OPEN	10mm TO 50mm	SHELL - ALUMINUM LINER - THERMOPLASTIC POLYMER

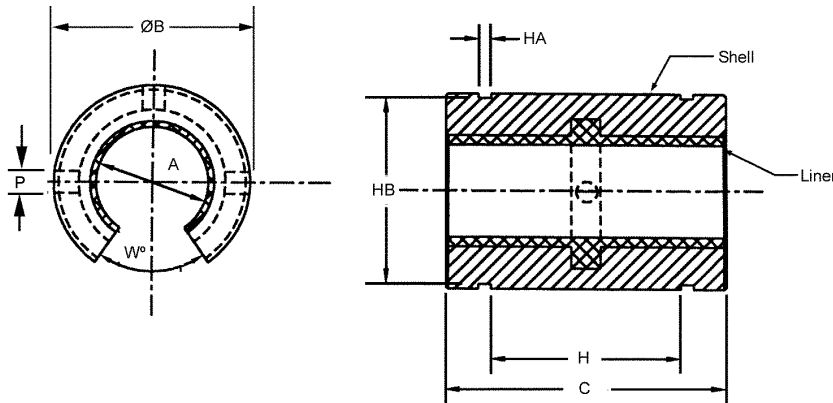

STOCK NO.	NOMINAL SIZE	ØA	ØB	C	W°	P +0.1
LBOUM-01-10	10	10.030/10.088	19	29	60	3
LBOUM-01-12	12	12.030/12.088	22	32	80	3
LBOUM-01-16	16	16.030/16.088	26	36	80	3
LBOUM-01-20	20	20.030/20.091	32	45	70	4
LBOUM-01-25	25	25.030/25.091	40	58	70	4
LBOUM-01-30	30	30.040/30.110	47	68	75	4
LBOUM-01-40	40	40.040/40.115	62	80	75	6
LBOUM-01-50	50	50.050/50.130	75	100	75	6

THERMOPLASTIC SELF ALIGNING LINEAR BEARINGS

STYLE	SHAFT SIZE	MATERIAL
CLOSED	10mm TO 50mm	SHELL - ALUMINUM LINER - THERMOPLASTIC POLYMER

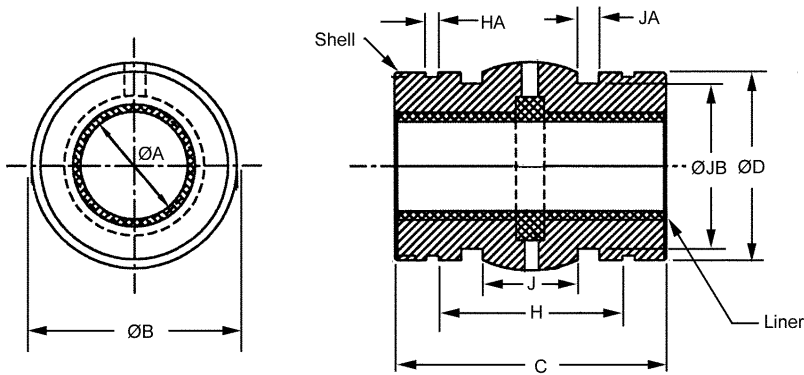

STOCK NO.	NOMINAL SIZE	ØA	ØB	C	H	HA	ØHB	D	ØJB	JA	J	R
LBUM-03-10	10	10.05/10.02	19	28.9	19.2	1.2	17.5	15.5	15.4	3	5	13
LBUM-03-12	12	12.05/12.02	22	31.9	20.2	1.2	20.5	21.5	18.4	3	6	18
LBUM-03-16	16	16.05/16.02	26	35.9	22.25	1.2	24.2	25.5	20.4	4	8	32
LBUM-03-20	20	20.06/20.02	32	44.8	28.3	1.5	29.6	31.5	26.4	4	10	50
LBUM-03-25	25	25.06/25.02	40	57.8	40.35	1.75	35.5	39.5	34.4	4	12.5	39
LBUM-03-30	30	30.07/30.03	47	67.8	48.4	1.75	43.5	46.0	41.4	4	15	57
LBUM-03-40	40	40.07/40.03	62	89.8	56.55	2.0	57.6	56.4	56.4	4	20	100
LBUM-03-60	50	50.09/50.04	75	99.8	72.65	2.5	70.5	69.4	69.4	4	25	157

Self-aligning bearings are fitted with O-Rings as standard.

STYLE	SHAFT SIZE	MATERIAL
OPEN	10mm TO 50mm	SHELL - ALUMINUM LINER - THERMOPLASTIC POLYMER

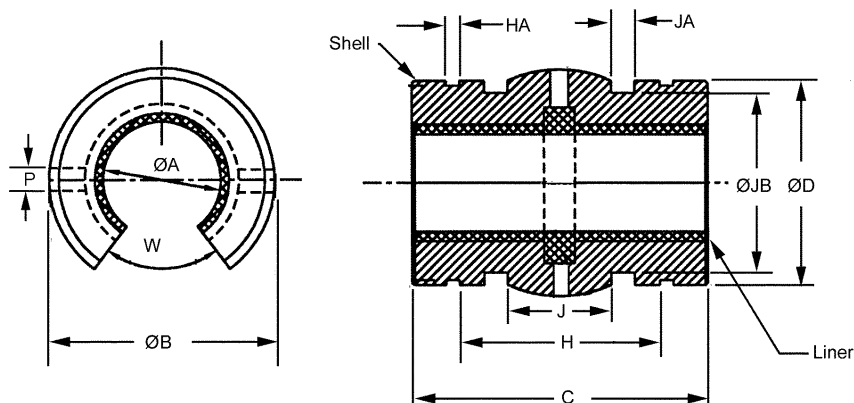

STOCK NO.	NOMINAL SIZE	ØA	ØB	D	J	JA	ØJB	ØHB	H	HA	C	R	W°	P +0.1
LBOUM-03-10	10	10.05/10.02	19	18.5	5	3	15.4	17.5	19.2	1.2	28.9	13	60	3
LBOUM-03-12	12	12.05/12.02	22	21.5	6	3	18.4	20.5	20.2	1.2	31.9	18	80	3
LBOUM-03-16	16	16.05/16.02	26	25.5	8	4	20.4	24.2	22.25	1.2	35.9	32	80	3
LBOUM-03-20	20	20.06/20.02	32	31.5	10	4	26.4	29.6	28.3	1.5	44.8	50	70	4
LBOUM-03-25	25	25.06/25.02	40	39.0	12.5	4	34.4	36.5	40.35	1.75	57.8	39	70	4
LBOUM-03-30	30	30.07/30.03	47	46.0	15	4	41.4	43.5	48.4	1.75	67.8	57	75	4
LBOUM-03-40	40	40.07/40.03	62	56.4	20	4	56.4	57.8	56.55	2.0	89.8	100	75	8
LBOUM-03-50	50	50.09/50.04	75	74.0	25	4	69.4	70.5	72.65	2.5	99.6	157	75	6

Self-aligning bearings are fitted with O-Rings as standard.

LINEAR PILLOW BLOCK ASSEMBLIES

STYLE	SHAFT SIZE	MATERIAL
CLOSED (SEE FIG. 1)	6mm TO 30mm	HOUSING - BLACK ANODIZED ALUMINUM, BEARING HOUSING & BALLS - CHROME STEEL, BALL RETAINER - PLASTIC, RETAINER RING - CARBON STEEL

STOCK NO.	SHAFT SIZE	D	E	F	G	H ±0.03	K	L	M	RATED LOAD (kg)	SHAFT STOCK NO.	MOUNTING SCREW STOCK NO.
LPAM-1	6	29	11	16.7	21	11.00	19	*	22.0	21	S416-6M-900	Y9-M3-A16
LPAM-2	10	32	20	19.8	24	12.50	29	*	25.5	38	S416-10M-900	Y9-M3-A20
LPAM-3	13	38	20	25.4	30	16.00	32	12.0	30.0	52	S416-13M-900	Y9-M3-A25
LPAM-4	20	48	27	36.5	42	22.00	42	19.0	40.0	90	S416-20M-900	Y9-M4-A30
LPAM-5	25	60	37	41.3	49	25.50	59	26.0	50.5	100	S416-25M-900	Y9-M5-A35
LPAM-6	30	70	41	52.4	64	33.00	64	30.0	60.0	160	S416-30M-900	Y9-M5-A45

STYLE	SHAFT SIZE	MATERIAL
OPEN (SEE FIG. 2)	13mm TO 30mm	HOUSING - BLACK ANODIZED ALUMINUM, BEARING HOUSING & BALLS - CHROME STEEL, BALL RETAINER - PLASTIC, RETAINER RING - CARBON STEEL

STOCK NO.	SHAFT SIZE	D	E	F	G	H ±0.03	K	L	M	N	RATED LOAD (kg)	MOUNTING SHAFT STOCK NO.	SCREW STOCK NO.
LPAM-13	13	38	20	25.4	30	16.00	32	12.0	30.0	11	52	S416-13M-900	Y9-M3-A25
LPAM-14	20	48	27	36.5	42	22.00	42	19.0	40.0	13	90	S416-20M-900	Y9-M4-A35
LPAM-15	25	60	37	41.3	49	25.50	59	26.0	50.0	15	100	S416-25M-900	Y9-M5-A35
LPAM-16	30	70	41	52.4	64	33.00	64	30.0	60.0	18	160	S416-30M-900	Y9-M5-A45

STYLE	SHAFT SIZE	MATERIAL
ADJUSTABLE (SEE FIG.3)	13mm TO 30mm	HOUSING - BLACK ANODIZED ALUMINUM, BEARING HOUSING & BALLS - CHROME STEEL, BALL RETAINER - PLASTIC, RETAINER RING - CARBON STEEL

STOCK NO.	SHAFT SIZE	D	E	F	G	H ±0.03	K	L	M	RATED LOAD (kg)	SHAFT STOCK NO.	MOUNTING SCREW STOCK NO.
LPAM-23	13	38	20	25.4	30	16.00	32	12.0	30.0	52	S416-13M-900	Y9-M3-A13
LPAM-24	20	48	27	36.5	42	22.00	42	19.0	40.0	90	S416-20M-900	Y9-M4-A16
LPAM-25	25	60	37	41.3	49	25.50	59	26.0	50.0	100	S416-25M-900	Y9-M5-A20
LPAM-26	30	70	41	52.4	64	33.00	64	30.1	60.0	160	S416-30M-900	Y9-M5-A25

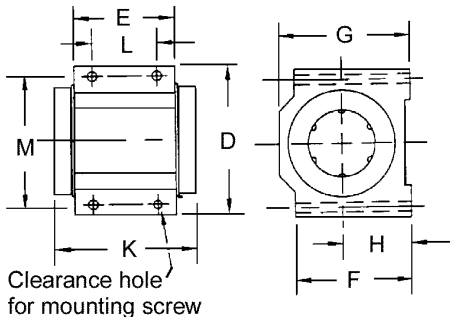

CLOSED STYLE
FIGURE 1

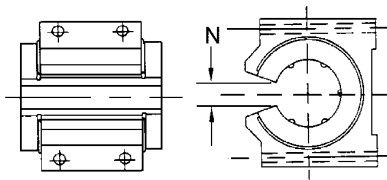

OPEN STYLE
FIGURE 2

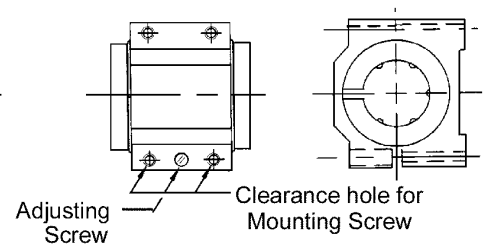

ADJUSTABLE STYLE
FIGURE 3

PILLOW BLOCK

STYLE	SHAFT SIZE	MATERIAL
CLOSED (SEE FIG. 1)	6mm TO 30mm	BLACK ANODIZED ALUMINUM

STOCK NO.	BORE ØB +0.013 -0.000	USE WITH LINEAR BEARING STOCK NO.	USE WITH RETAINER RING STOCK NO.	USE WITH MOUNTING SCREW STOCK NO.	SHAFT SIZE (REF.)	USE WITH SHAFT WIPER STOCK NO.	D	E	R	G	H ±0.03	L	M
LMFM-1	12.000	LMBM-1	Q2M-12	Y9-M3-A20	6	LMGM-R-5	29	23	16.7	21	11.00	14	22.0
LMFM-2	19.000	LMBM-2	Q2M-19	Y9-M3-A25	10	LMGM-R-6	32	43	19.8	24	12.50	34	25.5
LMFM-3	23.000	LMBM-3	Q2M-23	Y9-M3-A30	13	LMGM-R-1	38	46	25.4	30	16.00	37	30.0
LMFM-4	32.000	LMBM-4	Q2M-32	Y9-M4-A40	20	LMGM-R-2	48	56	36.5	42	22.00	46	40.0
LMFM-5	40.000	LMBM-5	Q2M-40	Y9-M5-A45	25	LMGM-R-3	60	69	41.3	49	25.50	55	50.0
LMFM-6	45.000	LMBM-6	Q2M-45	Y9-M5-A60	30	LMGM-R-4	70	74	52.4	64	33.00	60	60.0

STYLE	SHAFT SIZE	MATERIAL
OPEN (SEE FIG. 2)	13mm TO 30mm	BLACK ANODIZED ALUMINUM

STOCK NO.	BORE ØB +0.013 -0.000	USE WITH LINEAR BEARING STOCK NO.	USE WITH RETAINER RING STOCK NO.	USE WITH MOUNTING SCREW STOCK NO.	SHAFT SIZE (REF.)	USE WITH SHAFT WIPER STOCK NO.	D	E	R	G	H ±0.03	L	M	N
LMFM-13	23.000	LMDM-3	Q5M-23	Y9-M3-A30	13	LMGM-P-1	38	46	25.4	30	16.00	13	30.0	11
LMFM-14	32.000	LMDM-4	Q5M-32	Y9-M4-A40	20	LMGM-P-2	48	56	36.5	42	22.00	20	40.0	13
LMFM-15	40.000	LMDM-5	Q5M-40	Y9-M5-A45	25	LMGM-P-3	60	69	41.3	49	25.50	25	50.0	15
LMFM-16	45.000	LMDM-6	Q5M-45	Y9-M3-A60	30	LMGM-P-4	70	74	52.4	64	33.00	30	60.0	18

STYLE	SHAFT SIZE	MATERIAL
ADJUSTABLE (SEE FIG. 3)	13mm TO 30mm	BLACK ANODIZED ALUMINUM

STOCK NO.	BORE ØB +0.013 -0.000	USE WITH LINEAR BEARING STOCK NO.	USE WITH RETAINER RING STOCK NO.	USE WITH MOUNTING SCREW STOCK NO.	SHAFT SIZE (REF.)	USE WITH SHAFT WIPER STOCK NO.	D	E	R	G	H ±0.03	L	M
LMFM-23	23.000	LMCM-3	Q2M-23	Y9-M3-A30	13	LMGM-A-1	38	46	25.4	30	16.00	13	30.0
LMFM-24	32.000	LMCM-4	Q2M-32	Y9-M4-A40	20	LMGM-A-2	48	56	36.5	42	22.00	20	40.0
LMFM-25	40.000	LMCM-5	Q2M-40	Y9-M5-A45	25	LMGM-A-3	60	69	41.3	49	25.50	25	50.0
LMFM-26	45.000	LMCM-6	Q2M-45	Y9-M5-A60	30	LMGM-A-4	70	74	52.4	64	33.00	30	60.0

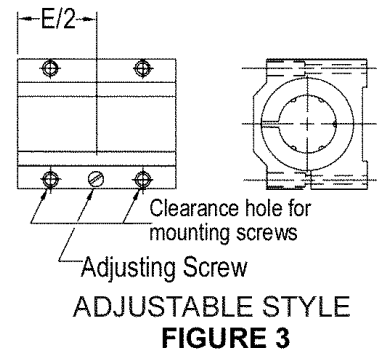
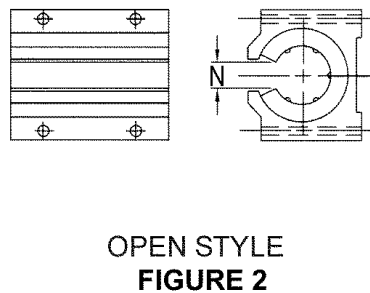
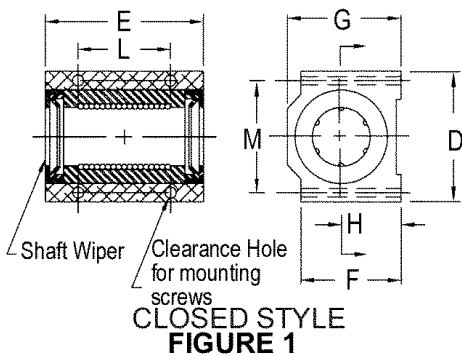

Linear Bearing, Retainer Ring, Mounting Screw and Shaft Wipers sold separately.

LINEAR PILLOW BLOCK ASSEMBLIES WITH WIPERS

STYLE	SHAFT SIZE	MATERIAL
CLOSED (SEE FIG. 1)	6mm TO 30mm	HOUSING - BLACK ANODIZED ALUMINUM, BEARING HOUSING & BALLS - CHROME STEEL, BALL RETAINER - PLASTIC, RETAINER RING - CARBON STEEL, WIPER- SYNTHETIC RUBBER

STOCK NO.	SHAFT SIZE	D	E	F	G	H ±0.03	L	M	RATED LOAD (kg)	SHAFT STOCK NO.	MOUNTING SCREW STOCK NO.	REPLACEMENT SHAFT WIPER STOCK NO.
LPWM-1A	6	29	23	16.7	21	11.00	14	22.0	21	S416-6M-900	Y9-M3-A20	LMGM-R-5
LPWM-2A	10	32	43	19.6	24	12.50	34	25.5	38	S416-10M-900	Y9-M3-A25	LMGM-R-6
LPWM-3A	13	38	46	25.4	30	16.00	37	30.0	52	S416-13M-900	Y9-M3-A30	LMGM-R-1
LPWM-4A	20	46	56	36.5	42	22.00	46	40.0	90	S416-20M-900	Y9-M4-A40	LMGM-R-2
LPWM-5A	25	60	69	41.3	49	25.50	55	50.0	100	S416-25M-900	Y9-M5-A45	LMGM-R-3
LPWM-6A	30	70	74	52.4	64	33.00	60	60.0	160	S416-30M-900	Y9-M5-A60	LMGM-R-4

STYLE	SHAFT SIZE	MATERIAL
OPEN (SEE FIG. 2)	13mm TO 30mm	HOUSING - BLACK ANODIZED ALUMINUM, BEARING HOUSING & BALLS - CHROME STEEL, BALL RETAINER - PLASTIC, RETAINER RING - CARBON STEEL, WIPER- SYNTHETIC RUBBER

STOCK NO.	SHAFT SIZE	D	E	F	G	H ±0.03	L	M	N	RATED LOAD (kg)	SHAFT STOCK NO.	MOUNTING SCREW STOCK NO.	REPLACEMENT SHAFT WIPER STOCK NO.
LPWM-13A	13	36	46	25.4	30	16.00	37	30.0	11	52	S416-13M-900	Y9-M3-A30	LMGM-P-1
LPWM-14A	20	46	56	36.5	42	22.00	46	40.0	13	90	S416-20M-900	Y9-M4-A40	LMGM-P-2
LPWM-15A	25	60	69	41.3	49	25.50	55	50.0	15	100	S416-25M-900	Y9-M5-A45	LMGM-P-3
LPWM-16A	30	70	74	52.4	64	33.00	60	60.0	16	160	S416-30M-900	Y9-M3-A60	LMGM-P-4

STYLE	SHAFT SIZE	MATERIAL
ADJUSTABLE (SEE FIG.3)	13mm TO 30mm	HOUSING - BLACK ANODIZED ALUMINUM, BEARING HOUSING & BALLS - CHROME STEEL, BALL RETAINER - PLASTIC, RETAINER RING - CARBON STEEL, WIPER- SYNTHETIC RUBBER

STOCK NO.	SHAFT SIZE	D	E	F	G	H ±0.03	L	M	RATED LOAD (kg)	SHAFT STOCK NO.	MOUNTING SCREW STOCK NO.	REPLACEMENT SHAFT WIPER STOCK NO.
LPWM-23A	13	36	46	25.4	30	16.00	37	30.0	52	S416-13M-900	Y9-M3-A30	LMGM-A-1
LPWM-24A	20	48	56	36.5	42	22.00	46	40.0	90	S416-20M-900	Y9-M4-A40	LMGM-A-2
LPWM-25A	25	60	69	41.3	49	25.50	55	50.0	100	S416-25M-900	Y9-M5-A45	LMGM-A-3
LPWM-26A	30	70	74	52.4	64	33.00	60	60.0	160	S416-30M-900	Y9-M5-A60	LMGM-A-4

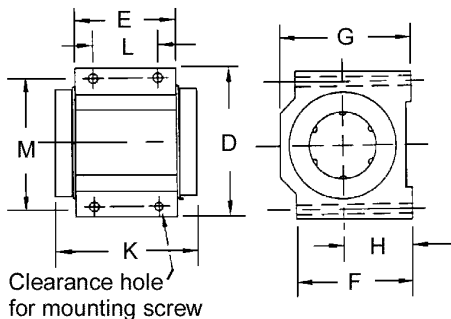

CLOSED STYLE
FIGURE 1

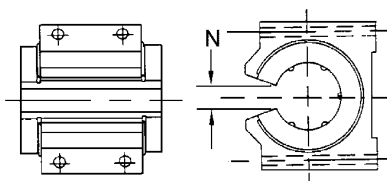

OPEN STYLE
FIGURE 2

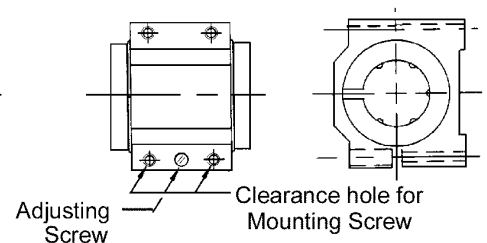

ADJUSTABLE STYLE
FIGURE 3

LINEAR BEARING BRACKETS

TYPE	FOR SHAFT SIZES	MATERIAL
CLOSED RETAINER RING DESIGN	6mm TO 30mm	6061T6 ALUMINUM BLACK ANODIZED

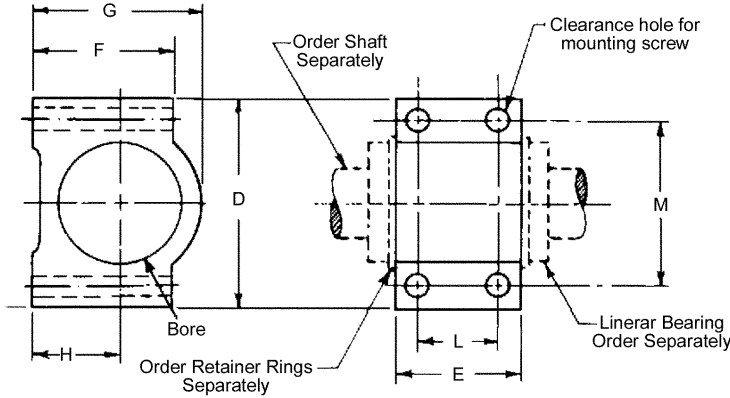

STOCK NO.	BORE ØB +0.013 -0.000	USE WITH LINEAR BEARING STOCK NO.	USE WITH RETAINER RING STOCK NO.	USE WITH MOUNTING SCREW STOCK NO.	SHAFT SIZE (Ref.)	D	E	F	G	H ±0.03	L	M
LMEM-1	12.000	LMBM-1	Q2M-12	Y9-M3-A20	6	29	11	16.7	21	11.00	*	22.0
LMEM-2	19.000	LMBM-2	Q2M-19	Y9-M3-A25	10	32	20	19.8	24	12.50	*	25.5
LMEM-3	23.000	LMBM-3	Q2M-23	Y9-M3-A30	13	38	20	25.4	30	16.00	12.0	30.0
LMEM-4	32.000	LMBM-4	Q2M-32	Y9-M4-A40	20	48	27	36.5	42	22.00	19.0	40.0
LMEM-5	40.000	LMBM-5	Q2M-40	Y9-M5-A45	25	60	37	41.3	49	25.50	26.0	50.0
LMEM-6	45.000	LMBM-6	Q2M-45	Y9-M5-A60	30	70	41	52.4	64	33.00	30.0	60.0

* 2 Mounting holes centered on length.

TYPE	FOR SHAFT SIZES	MATERIAL
OPEN RETAINER RING DESIGN	13mm TO 30mm	6061T6 ALUMINUM BLACK ANODIZED

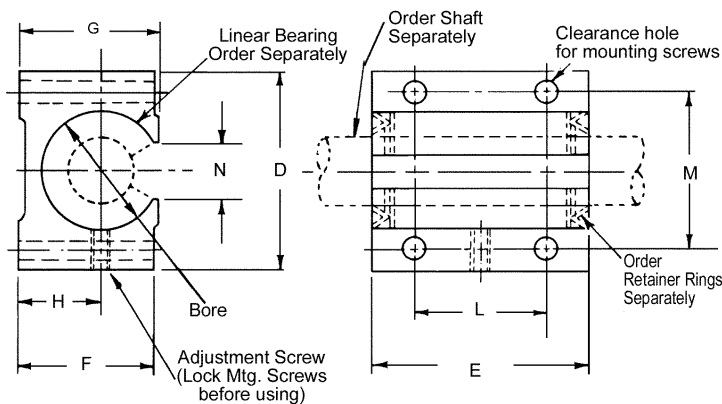

STOCK NO.	BORE ØB +0.013 -0.000	USE WITH LINEAR BEARING STOCK NO.	USE WITH RETAINER RING STOCK NO.	USE WITH MOUNTING SCREW STOCK NO.	SHAFT SIZE (Ref.)	D	E	F	G	H ±0.03	L	M	N
LMEM-13	23.000	LMDM-3	Q5M-23	Y9-M3-A30	13	38	20	25.4	30	16.00	12.0	30.0	11
LMEM-14	32.000	LMDM-4	Q5M-32	Y9-M4-A40	20	48	27	36.5	42	22.00	19.0	40.0	13
LMEM-15	40.000	LMDM-5	Q5M-40	Y9-M5-A45	25	60	37	41.3	49	25.50	26.0	50.0	15
LMEM-16	45.000	LMDM-6	Q5M-45	Y9-M5-A60	30	70	41	52.4	64	33.00	30.0	60.0	18

LINEAR BEARING BRACKETS

TYPE	FOR SHAFT SIZES	MATERIAL
ADJUSTABLE RETAINER RING DESIGN	13mm TO 30mm	6061T6 ALUMINUM BLACK ANODIZED

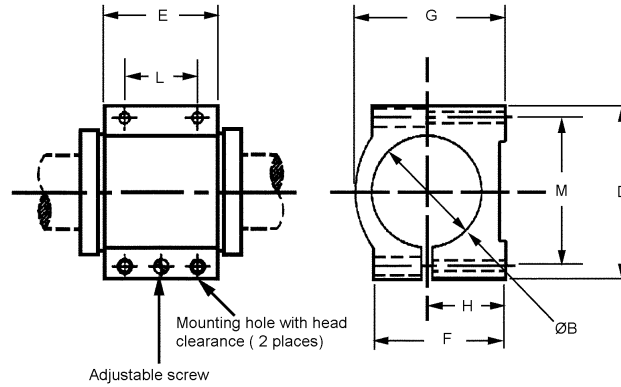

STOCK NO.	BORE ØB +0.013 -0.000	USE WITH LINEAR BEARING STOCK NO.	USE WITH RETAINER RING STOCK NO.	USE WITH MOUNTING SCREW STOCK NO.	SHAFT SIZE (Ref.)	D	E	F	G	H ±0.03	L	M
LMEM-23	23.000	LMCM-3	Q2M-23	Y9-M3-A30	13	38	20	25.4	30	16.00	12.0	30.0
LMEM-24	32.000	LMCM-4	Q2M-32	Y9-M4-A40	20	48	27	36.5	42	22.00	19.0	40.0
LMEM-25	40.000	LMCM-5	Q2M-40	Y9-M5-A45	25	60	37	41.3	49	25.50	26.0	50.0
LMEM-26	45.000	LMCM-6	Q2M-45	Y9-M5-A60	30	70	41	52.4	64	33.00	30.0	60.0

E

SHAFT SUPPORT

FOR SHAFT SIZES	MATERIAL	USE WITH
13mm TO 50mm	EXTRUDED ALUMINUM	LMD, LMA & LMX OPEN STYLE, LINEAR BEARINGS

EXAMPLES

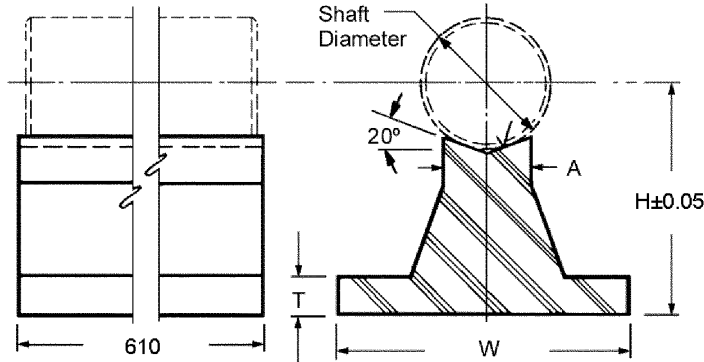
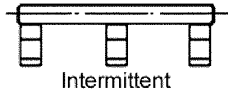
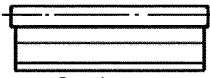

STOCK NO.	SHAFT DIA.	H	T	W	A
LMR-1	13	28.70	5	38	6
LMR-2	20	38.60	6	44	10
LMR-3	25	44.23	6	54	13
LMR-4	30	53.03	8	64	14
LMR-5	40	64.43	10	76	17
LMR-6	50	82.28	13	95	22

FOR SHAFT SIZES	MATERIAL
13mm TO 50mm	EXTRUDED ALUMINUM

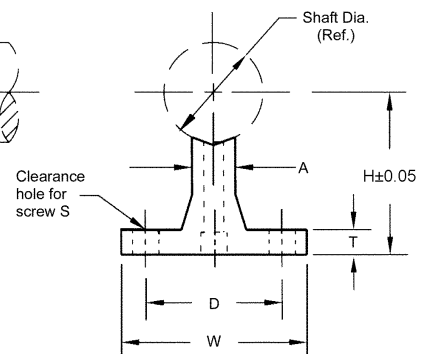
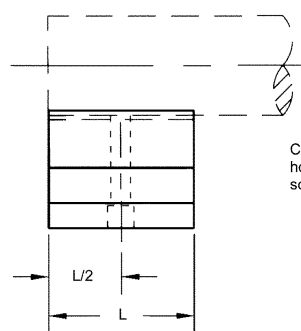
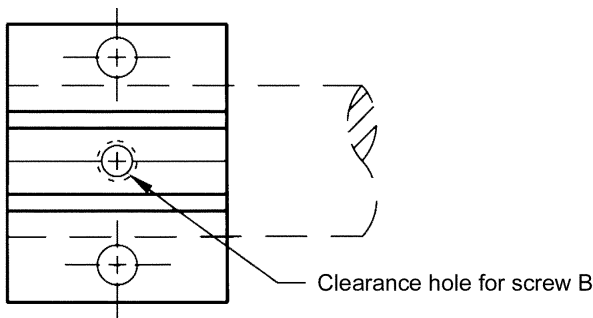

STOCK NO.	SHAFT DIA. (Ref.)	H	T	W	A	L	S	B	
								THREAD	LENGTH
LMR-1HM	13	28.70	5	38	6	102	M4	M4	20
LMR-2HM	20	38.60	6	44	10	152	M5	M5	30
LMR-3HM	25	44.23	6	54	13	152	M6	M8	35
LMR-4HM	30	53.03	8	64	14	152	M8	M10	40
LMR-5HM	40	64.43	10	76	17	203	M8	M12	40
LMR-6HM	50	82.28	13	95	22	203	M10	M14	60



SHAFT HANGERS

FOR SHAFT SIZES	MATERIAL
6mm TO 30mm	ALUMINUM M12.0 BLACK ANODIZED

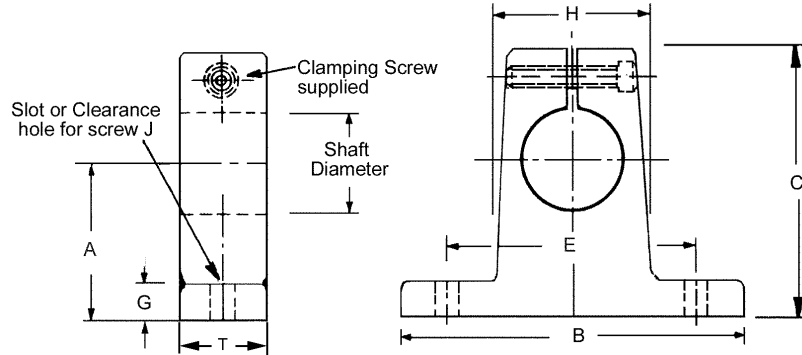

STOCK NO.	SHAFT DIA.	A	B	C	E	T	G	H	J
LMHM-1	6	15.00	29	29	22.0	10	5	16	M3
LMHM-2	10	17.00	32	33	24.0	13	5	16	M4
LMHM-3	13	19.00	38	37	29.0	16	6	19	M5
LMHM-5A	20	27.00	48	48	38.0	22	13	25	M6
LMHM-6	25	54.00	57	78	44.0	25	16	32	M6
LMHM-7A	30	60.00	64	86	51.0	32	19	35	M6

E

GROUND STOCK

FOR SHAFT SIZES	MATERIAL
6mm TO 30mm	303 STAINLESS STEEL

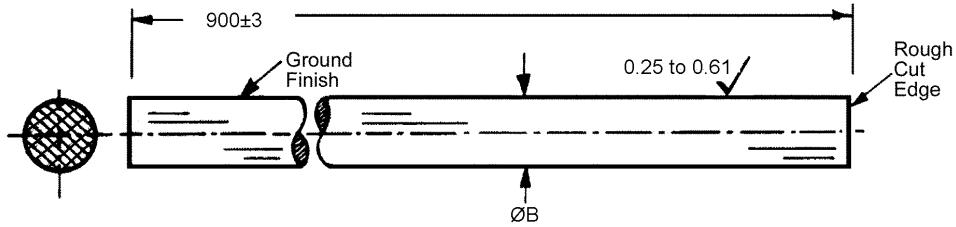

Modification on request
send drawings

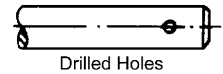
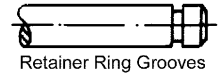

STOCK NO.	NOMINAL DIA.*	ØB	B TOL.
S1-106	6	5.992	+0.000
S1-136	6	6.000	-0.005
S1-110	10	9.992	
S1-143	10	10.000	
S1-112	12	11.991	
S1-146	12	12.000	
S1-113	13	12.993	
S1-114	14	13.993	+0.000
S1-116	16	15.974	-0.008
S1-147	16	16.000	
S1-120	20	19.992	
S1-125	25	24.993	
S1-148	25	25.000	
S1-130	30	29.992	

*Straightness: 10mm diameter and above .0101 mm/mm, 6mm diameter and below on best efforts basis.

SHAFT SEALS

STYLE	FOR SHAFT SIZES
REGULAR	6mm TO 30mm

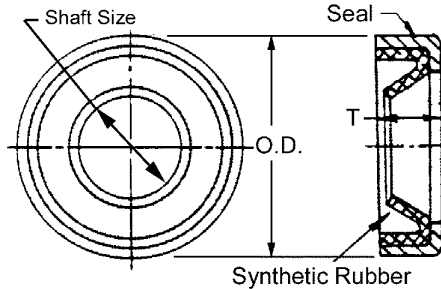

STOCK NO.	SHAFT SIZE	OUTSIDE DIA.	T
LMGM-R-5	6	12	2
LMGM-R-6	10	19	7
LMGM-R-1	13	23	7
LMGM-R-2	20	32	7
LMGM-R-3	25	40	5
LMGM-R-4	30	45	5

STYLE	FOR SHAFT SIZES
ADJUSTABLE	6mm TO 30mm

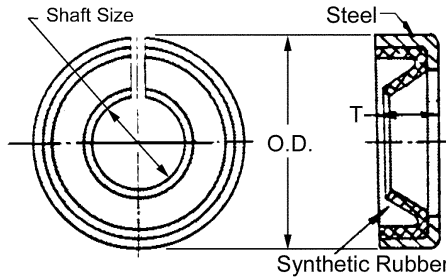

STOCK NO.	SHAFT SIZE	OUTSIDE DIA.	T
LMGM-A-5	6	12	2
LMGM-A-6	10	19	7
LMGM-A-1	13	23	7
LMGM-A-2	20	32	7
LMGM-A-3	25	40	5
LMGM-A-4	30	45	5

STYLE	FOR SHAFT SIZES
OPEN	6mm TO 30mm

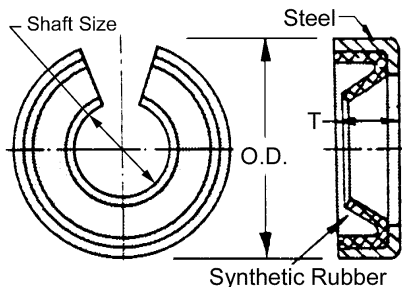

STOCK NO.	SHAFT SIZE	OUTSIDE DIA.	T
LMGM-P-5	6	12	2
LMGM-P-6	10	19	7
LMGM-P-1	13	23	7
LMGM-P-2	20	32	7
LMGM-P-3	25	40	5
LMGM-P-4	30	45	5



E

HARDWARE AND FASTENERS

Table of Contents

HARDWARE KIT	
Assorted Fastener Kits	MF2
PARTS BOXES	
Natural Wood	MF3
Plastic	MF3
SCREW HEAD TECHNICAL DATA	MF4
MACHINE SCREWS	
Stainless Steel, Flat, Cheese, Socket and Button	MF5-6
Long-Lok® and Nyloc® Flat, Cheese, Socket	MF7-9
INTEGRAL SEAL SCREWS	
Slotted Pan Head	MF10
SET SCREWS	
Slotted and Hex Head, Stainless Steel	MF11
Brass Soft Tip, Hex Socket	MF12
Silver Solder Tip, Slotted Head and Hex Socket	MF13
Soft Tip, Slotted Head and Hex Socket	MF14-15
SHOULDER SCREWS	
Stainless Steel, Slotted Head	MF16-17
Stainless Steel, Hex Socket Head	MF18-19
PRECISION CAPTIVE SCREWS	
Slotted, Hex Socket and Knurled Head, Stainless Steel	MF20
PRECISION JIG BUTTONS	
Stainless Steel	MF21
THUMB SCREWS	
Plastic Head, Knurled	MF22-23
Stainless Steel, Knurled	MF24-25
Stainless Steel, Knurled, Socket Head	MF26
THUMB NUTS	
Stainless Steel, Knurled	MF27
THREADED STUDS	
Stainless Steel, Double Ended	MF28-29
HEX NUTS	
Stainless Steel and Molded Nylon	MF30
WASHERS	
Nylon and Stainless Steel	MF31
LOCK WASHERS	
Stainless Steel, External and Internal Tooth	MF32
THRUST WASHERS	
Stainless Steel, Plastic, Bronze and Tool Steel	MF33
Belleville Washers	MF34
Curved Washers	MF34
THREAD INSERTS	
Stainless Steel, Free Running and Locking	MF35
PINS	
Taper, Stainless Steel	MF36
Roller or Spring Pins, Stainless Steel	MF37
Cotter Pins, Stainless Steel	MF38
DOWEL PINS	
Soft Pins, Stainless Steel	MF39-40
MISCELLANEOUS ITEMS	
Grease, Oil, Inspection Mirrors, Screw Drivers, Plastic Hammers, Scale, Hex Wrenches, Tweezers, Loupes, Cable Cutters Adhesives, Liquid Pin, Solvent, Lubricants	MF41-42
RETAINER RINGS	
External Lug Design, Stainless Steel, Copper Plated	MF43
External Snap On Design	MF44
External Power Grip Design	MF44
External Bowed Snap On Design	MF45
External, Carbon Steel and Stainless Steel	MF45
BEARING PRE-LOAD SPRINGS	MF46
SPACERS	
Inner and Outer Race Shim	MF47
Shaft Spacers	MF48
Assorted Inner Race Shaft Spacers Kit	MF48
BEARING SPACERS	MF49
BALLS	
Hardened Steel	MF50
SPRINGS	
Compression	MF51
Experimental	MF52
Extension	MF52
Torsion	MF53

HARDWARE KITS

TYPE
ASSORTED FASTENER

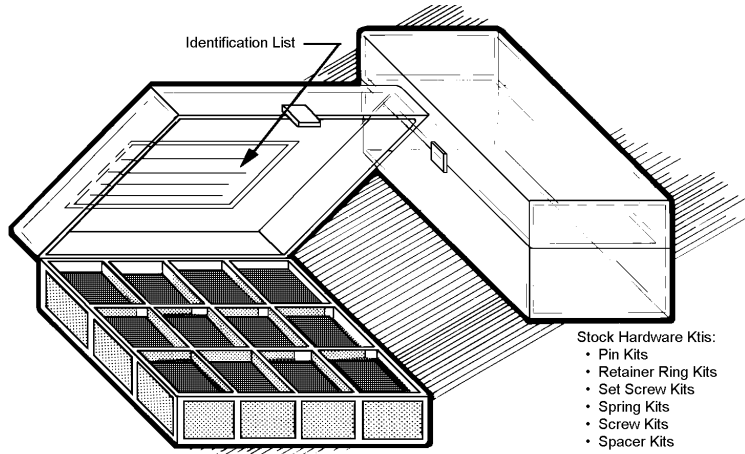

STOCK NO.	DESCRIPTION OF KIT CONTENTS
KIT-DMH	Dowel Pins - Hardware Stainless Steel, 2mm to 10mm Dia. - 5mm to 30mm Long
KIT-DMS	Dowel Pins - Soft Stainless Steel - 1mm to 6mm Dia. - 3mm to 24mm Long
KIT-QM	Retainer Rings - Internal and External Spring Steel for 3mm, 4mm and 6mm Shafts
KIT-SC2M	Set Screws - Stainless Steel - Cup Point - Socket Head - M2-M6
KIT-SC8M	Set Screws - Stainless Steel - Soft Tip - Socket Head - M2-M6
KIT SC10M	Set Screws - Stainless Steel - Brass Tip - Socket Head - M4-M10
KIT-SPR9	Compression Springs - Stainless Steel - 1.5mm to 18mm Dia. - Lengths up to 51mm
KIT-SPR10	Extension Springs - Stainless Steel - 1.6mm to 25mm Dia. - Lengths up to 51mm
KIT-Y5M	Hex Nuts, Washers & Lock Washers - Stainless Steel - M2-M8
KIT-Y9M	Socket Head Cap Screws - Stainless Steel - M2-M10

Available From Stock:
 Replacement Parts
 Special Kits

PARTS BOX

MATERIAL

SELECTED HARDWOOD - NATURAL VARNISH SEALER WITH SOFT FLOCK-LINING

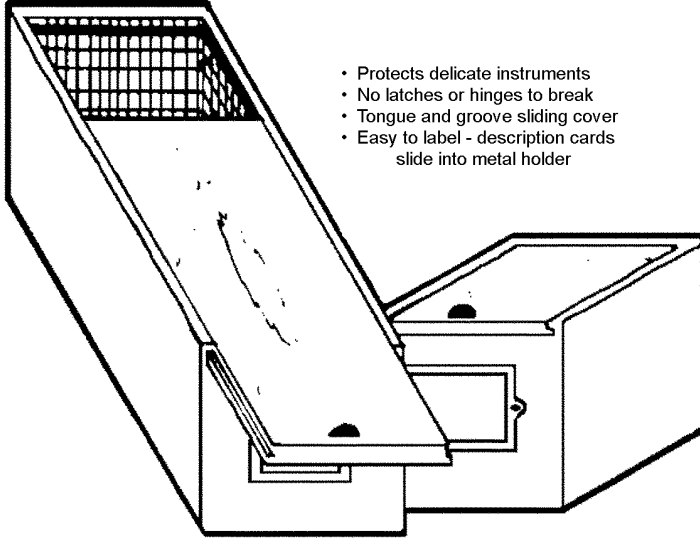

- Protects delicate instruments
- No latches or hinges to break
- Tongue and groove sliding cover
- Easy to label - description cards slide into metal holder

STOCK NO.	OUTSIDE DIMENSIONS HEIGHT x WIDTH x LENGTH	INSIDE DIMENSIONS HEIGHT x WIDTH x LENGTH
X-1	82 x 102 x 102	63 x 76 x 76
X-2	111 x 102 x 152	92 x 76 x 127
X-3	111 x 127 x 203	92 x 102 x 178
X-4	102 x 127 x 292	82 x 102 x 267
X-5	130 x 152 x 203	111 x 127 x 178
X-6	149 x 152 x 241	130 x 127 x 216
X-7	149 x 152 x 292	130 x 127 x 267
X-8	178 x 178 x 292	159 x 152 x 267

MATERIAL

PLASTIC

- Ideal storage boxes for small parts
 - Sectioned and non-sectioned boxes
- Other sizes available on request.

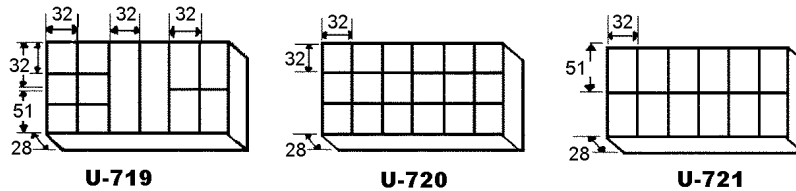
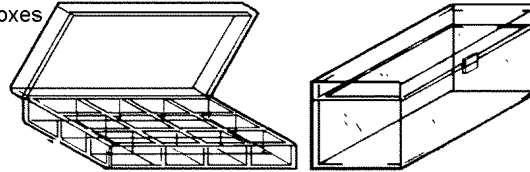

STOCK NO.	OUTSIDE DIMENSIONS HEIGHT x WIDTH x LENGTH	NO. OF COMPARTMENTS	MATERIAL
U-719	35 x 114 x 210	12	CLEAR STYRENE
U-720		18	
U-721		12	
U-722	102 x 140 x 254	1	TAN POLYPROPYLENE
U-723	27 x 114 x 213	1	

SCREW HEAD

Technical Data

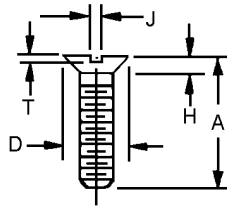

SCREW SIZE	#Y6-FLAT HEAD 92°			
	D	H MAX.	J	T MIN.
M 1.6	3.0	1.0	0.4	0.3
M 2.0	3.8	1.2	0.5	0.4
M 3.0	5.6	1.7	0.8	0.6
M 4.0	7.5	2.2	1.0	0.8
M 5.0	9.2	2.5	1.2	1.0
M 6.0	11.0	3.0	1.6	1.2
M 8.0	14.5	4.0	2.0	1.6
M 10.0	18.0	5.0	2.5	2.0

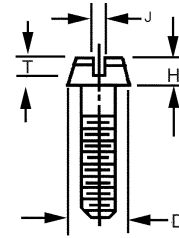

SCREW SIZE	#Y8-CHEESE HEAD			
	D	H MAX.	J	T MIN.
M 1.6	3.0	1.0	0.4	0.5
M 2.0	3.8	1.3	0.5	0.6
M 3.0	5.5	2.0	0.8	0.9
M 4.0	7.0	2.6	1.0	1.2
M 5.0	8.5	3.3	1.2	1.5
M 6.0	10.0	3.9	1.6	1.8
M 8.0	13.0	5.0	2.0	2.3
M 10.0	16.0	6.0	2.5	2.7

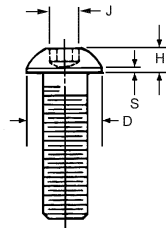

NOMINAL SIZE	#Y-19 BUTTON HEAD			
	D MAX.	H MAX.	S REF.	J NOM.
M3	5.50	1.60	0.38	2.00
M4	7.50	2.10	0.38	2.50
M5	9.50	2.70	0.50	3.00
M6	10.50	3.20	0.80	4.00
M8	14.00	4.30	0.80	5.00
M10	18.00	5.30	0.80	6.00

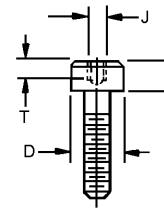

SCREW SIZE	#Y-9 CAP SOCKET HEAD			
	D	H MAX.	J ACROSS FLATS	T MIN.
M 1.6	3.0	1.6	1.5	0.7
M 2.0	3.8	2.0	1.5	1.0
M 3.0	5.5	3.0	2.5	1.3
M 4.0	6.0	4.0	3.0	2.0
M 5.0	8.5	5.0	4.0	2.5
M 8.0	13.0	8.0	6.0	4.0
M 10.0	16.0	10.0	8.0	5.0

MACHINE SCREWS

THREAD	STYLE	MATERIAL
M1.6 X 0.35	FLAT, CHEESE, SOCKET AND BUTTON	STAINLESS STEEL DIN 1.4300

STOCK NUMBERS				THREAD Tol=6g	LENGTH A
STYLES					
FLAT	CHEESE	SOCKET	BUTTON		
Y6-M1-A4	Y8-M1-A4	Y9-M1-A4	Y19-M1-A4	M1.6 x 0.35	4.0
Y6-M1-A5	Y8-M1-A5	Y9-M1-A5	Y19-M1-A5		5.0
Y6-M1-A6	Y8-M1-A6	Y9-M1-A6	Y19-M1-A6		6.0
Y6-M1-A8	Y8-M1-A8	Y9-M1-A8	Y19-M1-A8		8.0
Y6-M1-A10	Y8-M1-A10	Y9-M1-A10	Y19-M1-A10		10.0

THREAD	STYLE	MATERIAL
M2 X 0.4	FLAT, CHEESE, SOCKET AND BUTTON	STAINLESS STEEL DIN 1.4300

STOCK NUMBERS				THREAD Tol=6g	LENGTH A
STYLES					
FLAT	CHEESE	SOCKET	BUTTON		
Y6-M2-A3	Y8-M2-A3	Y9-M2-A3	Y19-M2-A3	M2 x 0.4	3.0
Y6-M2-A4	Y8-M2-A4	Y9-M2-A4	Y19-M2-A4		4.0
Y6-M2-A5	Y8-M2-A5	Y9-M2-A5	Y19-M2-A5		5.0
Y6-M2-A6	Y8-M2-A6	Y9-M2-A6	Y19-M2-A6		6.0
Y6-M2-A8	Y8-M2-A8	Y9-M2-A8	Y19-M2-A8		8.0
Y6-M2-A10	Y8-M2-A10	Y9-M2-A10	Y19-M2-A10		10.0
Y6-M2-A13	Y8-M2-A13	Y9-M2-A13	Y19-M2-A13		12.0
Y6-M2-A16	Y8-M2-A16	Y9-M2-A16	Y19-M2-A16		16.0
Y6-M2-A20	Y8-M2-A20	Y9-M2-A20	Y19-M2-A20		20.0

THREAD	STYLE	MATERIAL
M3 X 0.5	FLAT, CHEESE, SOCKET AND BUTTON	STAINLESS STEEL DIN 1.4300

STOCK NUMBERS				THREAD Tol=6g	LENGTH A
STYLES					
FLAT	CHEESE	SOCKET	BUTTON		
Y6-M3-A5	Y8-M3-A5	Y9-M3-A5	Y19-M3-A5	M3 x 0.5	5.0
Y6-M3-A6	Y8-M3-A6	Y9-M3-A6	Y19-M3-A6		6.0
Y6-M3-A8	Y8-M3-A8	Y9-M3-A8	Y19-M3-A8		8.0
Y6-M3-A10	Y8-M3-A10	Y9-M3-A10	Y19-M3-A10		10.0
Y6-M3-A13	Y8-M3-A13	Y9-M3-A13	Y19-M3-A13		12.0
Y6-M3-A16	Y8-M3-A16	Y9-M3-A16	Y19-M3-A16		16.0
Y6-M3-A20	Y8-M3-A20	Y9-M3-A20	Y19-M3-A20		20.0
Y6-M3-A25	Y8-M3-A25	Y9-M3-A25	Y19-M3-A25		25.0
Y6-M3-A30	Y8-M3-A30	Y9-M3-A30	Y19-M3-A30		30.0

THREAD	STYLE	MATERIAL
M4 X 0.7	FLAT, CHEESE, SOCKET AND BUTTON	STAINLESS STEEL DIN 1.4300

STOCK NUMBERS				THREAD Tol=6g	LENGTH A
STYLES					
FLAT	CHEESE	SOCKET	BUTTON		
Y6-M4-A6	Y8-M4-A6	Y9-M4-A6	Y19-M4-A6	M4 x 0.7	6.0
Y6-M4-A8	Y8-M4-A8	Y9-M4-A8	Y19-M4-A8		8.0
Y6-M4-A10	Y8-M4-A10	Y9-M4-A10	Y19-M4-A10		10.0
Y6-M4-A13	Y8-M4-A13	Y9-M4-A13	Y19-M4-A13		12.0
Y6-M4-A16	Y8-M4-A16	Y9-M4-A16	Y19-M4-A16		16.0
Y6-M4-A20	Y8-M4-A20	Y9-M4-A20	Y19-M4-A20		20.0
Y6-M4-A25	Y8-M4-A25	Y9-M4-A25	Y19-M4-A25		25.0
Y6-M4-A30	Y8-M4-A30	Y9-M4-A30	Y19-M4-A30		30.0
Y6-M4-A35	Y8-M4-A35	Y9-M4-A35	Y19-M4-A35		35.0
Y6-M4-A40	Y8-M4-A40	Y9-M4-A40	Y19-M4-A40		40.0

F

MACHINE SCREWS

THREAD	STYLE	MATERIAL
M5 X 0.8	FLAT, CHEESE, SOCKET AND BUTTON	STAINLESS STEEL DIN 1.4300

STOCK NUMBERS				THREAD Tol=6g	LENGTH A
STYLES					
FLAT	CHEESE	SOCKET	BUTTON		
Y6-M5-A4	Y8-M5-A4	Y9-M5-A4	Y19-M5-A4	M5 x 0.8	4.0
Y6-M5-A8	Y8-M5-A8	Y9-M5-A8	Y19-M5-A8		8.0
Y6-M5-A10	Y8-M5-A10	Y9-M5-A10	Y19-M5-A10		10.0
Y6-M5-A13	Y8-M5-A13	Y9-M5-A13	Y19-M5-A13		12.0
Y6-M5-A16	Y8-M5-A16	Y9-M5-A16	Y19-M5-A16		16.0
Y6-M5-A20	Y8-M5-A20	Y9-M5-A20	Y19-M5-A20		20.0
Y6-M5-A25	Y8-M5-A25	Y9-M5-A25	Y19-M5-A25		25.0
Y6-M5-A30	Y8-M5-A30	Y9-M5-A30	Y19-M5-A30		30.0
Y6-M5-A35	Y8-M5-A35	Y9-M5-A35	Y19-M5-A35		35.0
Y6-M5-A40	Y8-M5-A40	Y9-M5-A40	Y19-M5-A40		40.0
Y6-M5-A45	Y8-M5-A45	Y9-M5-A45	Y19-M5-A45		45.0
Y6-M5-A50	Y8-M5-A50	Y9-M5-A50	Y19-M5-A50		50.0

THREAD	STYLE	MATERIAL
M6 X 1.0	FLAT, CHEESE, SOCKET AND BUTTON	STAINLESS STEEL DIN 1.4300

STOCK NUMBERS				THREAD Tol=6g	LENGTH A
STYLES					
FLAT	CHEESE	SOCKET	BUTTON		
Y6-M6-A8	Y8-M6-A8	Y9-M6-A8	Y19-M6-A8	M6 x 1.0	8.0
Y6-M6-A10	Y8-M6-A10	Y9-M6-A10	Y19-M6-A10		10.0
Y6-M6-A12	Y8-M6-A12	Y9-M6-A12	Y19-M6-A12		12.0
Y6-M6-A16	Y8-M6-A16	Y9-M6-A16	Y19-M6-A16		16.0
Y6-M6-A20	Y8-M6-A20	Y9-M6-A20	Y19-M6-A20		20.0
Y6-M6-A25	Y8-M6-A25	Y9-M6-A25	Y19-M6-A25		25.0
Y6-M6-A30	Y8-M6-A30	Y9-M6-A30	Y19-M6-A30		30.0

THREAD	STYLE	MATERIAL
M8 X 1.25	FLAT, CHEESE, SOCKET AND BUTTON	STAINLESS STEEL DIN 1.4300

STOCK NUMBERS				THREAD Tol=6g	LENGTH A
STYLES					
FLAT	CHEESE	SOCKET	BUTTON		
Y6-M8-A10	Y8-M8-A10	Y9-M8-A10	Y19-M8-A10	M8 X 1.25	10.0
Y6-M8-A13	Y8-M8-A13	Y9-M8-A13	Y19-M8-A13		12.0
Y6-M8-A16	Y8-M8-A16	Y9-M8-A16	Y19-M8-A16		16.0
Y6-M8-A25	Y8-M8-A25	Y9-M8-A25	Y19-M8-A25		25.0
Y6-M8-A30	Y8-M8-A30	Y9-M8-A30	Y19-M8-A30		30.0
Y6-M8-A35	Y8-M8-A35	Y9-M8-A35	Y19-M8-A35		35.0
Y6-M8-A40	Y8-M8-A40	Y9-M8-A40	Y19-M8-A40		40.0
Y6-M8-A45	Y8-M8-A45	Y9-M8-A45	Y19-M8-A45		45.0

THREAD	STYLE	MATERIAL
M10 X 1.5	FLAT, CHEESE, SOCKET AND BUTTON	STAINLESS STEEL DIN 1.4300

STOCK NUMBERS				THREAD Tol=6g	LENGTH A
STYLES					
FLAT	CHEESE	SOCKET	BUTTON		
Y6-M10-A13	Y8-M10-A13	Y9-M10-A13	Y19-M10-A13	M10 X 1.5	12.0
Y6-M10-A16	Y8-M10-A16	Y9-M10-A16	Y19-M10-A16		16.0
Y6-M10-A20	Y8-M10-A20	Y9-M10-A20	Y19-M10-A20		20.0
Y6-M10-A25	Y8-M10-A25	Y9-M10-A25	Y19-M10-A25		25.0
Y6-M10-A30	Y8-M10-A30	Y9-M10-A30	Y19-M10-A30		30.0
Y6-M10-A35	Y8-M10-A35	Y9-M10-A35	Y19-M10-A35		35.0
Y6-M10-A40	Y8-M10-A40	Y9-M10-A40	Y19-M10-A40		40.0

LONG-LOK® AND NYLOC® MACHINE SCREWS

THREAD	STYLE	MATERIAL
M1.6 X 0.35	SELF LOCKING - VIBRATION PROOF FLAT, CHEESE, AND SOCKET	STAINLESS STEEL DIN 1.4300 WITH NYLON STRIP/PELLET

LONG-LOCK®		NYLOC®	THREAD TOL=6g	LENGTH A
FLAT STYLE STOCK NO.	CHEESE STYLE STOCK NO.	SOCKET STYLE* STOCK NO.		
Y6-M1-A4-L	Y8-M1-A4-L	Y9-M1-A4-N	M1.6 x 0.35	4.0
Y6-M1-A5-L	Y8-M1-A5-L	Y9-M1-A5-N		5.0
Y6-M1-A6-L	Y8-M1-A6-L	Y9-M1-A6-N		6.0
Y6-M1-A8-L	Y8-M1-A8-L	Y9-M1-A8-N		8.0
Y6-M1-A10-L	Y8-M1-A10-L	Y9-M1-A10-N		10.0

THREAD	STYLE	MATERIAL
M2 X 0.4	SELF LOCKING - VIBRATION PROOF FLAT, CHEESE, AND SOCKET	STAINLESS STEEL DIN 1.4300 WITH NYLON STRIP/PELLET

LONG-LOCK®		NYLOC®	THREAD TOL=6g	LENGTH A
FLAT STYLE STOCK NO.	CHEESE STYLE STOCK NO.	SOCKET STYLE* STOCK NO.		
Y6-M2-A3-L	Y8-M2-A3-L	Y9-M2-A3-N	M2 x 0.4	3.0
Y6-M2-A4-L	Y8-M2-A4-L	Y9-M2-A4-N		4.0
Y6-M2-A5-L	Y8-M2-A5-L	Y9-M2-A5-N		5.0
Y6-M2-A6-L	Y8-M2-A6-L	Y9-M2-A6-N		6.0
Y6-M2-A8-L	Y8-M2-A8-L	Y9-M2-A8-N		8.0
Y6-M2-A10-L	Y8-M2-A10-L	Y9-M2-A10-N		10.0
Y6-M2-A13-L	Y8-M2-A13-L	Y9-M2-A13-N		12.0
Y6-M2-A16-L	Y8-M2-A16-L	Y9-M2-A16-N		16.0
Y6-M2-A20-L	Y8-M2-A20-L	Y9-M2-A20-N		20.0

THREAD	STYLE	MATERIAL
M3 X 0.5	SELF LOCKING - VIBRATION PROOF FLAT, CHEESE, AND SOCKET	STAINLESS STEEL DIN 1.4300 WITH NYLON STRIP/PELLET

LONG-LOCK®		NYLOC®	THREAD TOL=6g	LENGTH A
FLAT STYLE STOCK NO.	CHEESE STYLE STOCK NO.	SOCKET STYLE* STOCK NO.		
Y6-M3-A5-L	Y8-M3-A5-L	Y9-M3-A5-N	M3 x 0.5	5.0
Y6-M3-A6-L	Y8-M3-A6-L	Y9-M3-A6-N		6.0
Y6-M3-A8-L	Y8-M3-A8-L	Y9-M3-A8-N		8.0
Y6-M3-A10-L	Y8-M3-A10-L	Y9-M3-A10-N		10.0
Y6-M3-A13-L	Y8-M3-A13-L	Y9-M3-A13-N		12.0
Y6-M3-A16-L	Y8-M3-A16-L	Y9-M3-A16-N		16.0
Y6-M3-A20-L	Y8-M3-A20-L	Y9-M3-A20-N		20.0
Y6-M3-A25-L	Y8-M3-A25-L	Y9-M3-A25-N		25.0
Y6-M3-A30-L	Y8-M3-A30-L	Y9-M3-A30-N		30.0

*Y9 Series Socket Cap screws are available only with Nyloc® insert.
Long-Lok® registered Long Lok Corporation. Nyloc® registered Nyloc Corporation.

F

LONG-LOK® AND NYLOC® MACHINE SCREWS

THREAD	STYLE	MATERIAL
M4 X 0.7	SELF LOCKING - VIBRATION PROOF FLAT, CHEESE, AND SOCKET	STAINLESS STEEL DIN 1.4300 WITH NYLON STRIP/PELLET

LONG-LOCK®		NYLOC®	THREAD TOL=6g	LENGTH A
FLAT STYLE STOCK NO.	CHEESE STYLE STOCK NO.	SOCKET STYLE* STOCK NO.		
Y6-M4-A6-L	Y8-M4-A6-L	Y9-M4-A6-N	M4 X 0.7	6.0
Y6-M4-A8-L	Y8-M4-A8-L	Y9-M4-A8-N		8.0
Y6-M4-A10-L	Y8-M4-A10-L	Y9-M4-A10-N		10.0
Y6-M4-A13-L	Y8-M4-A13-L	Y9-M4-A13-N		12.0
Y6-M4-A16-L	Y8-M4-A16-L	Y9-M4-A16-N		16.0
Y6-M4-A20-L	Y8-M4-A20-L	Y9-M4-A20-N		20.0
Y6-M4-A25-L	Y8-M4-A25-L	Y9-M4-A25-N		25.0
Y6-M4-A30-L	Y8-M4-A30-L	Y9-M4-A30-N		30.0
Y6-M4-A35-L	Y8-M4-A35-L	Y9-M4-A35-N		35.0
Y6-M4-A40-L	Y8-M4-A40-L	Y9-M4-A40-N		40.0

THREAD	STYLE	MATERIAL
M5 X 0.8	SELF LOCKING - VIBRATION PROOF FLAT, CHEESE, AND SOCKET	STAINLESS STEEL DIN 1.4300 WITH NYLON STRIP/PELLET

LONG-LOCK®		NYLOC®	THREAD TOL=6g	LENGTH A
FLAT STYLE STOCK NO.	CHEESE STYLE STOCK NO.	SOCKET STYLE* STOCK NO.		
Y6-M5-A8-L	Y8-M5-A8-L	Y9-M5-A8-N	M5 X 0.8	8.0
Y6-M5-A10-L	Y8-M5-A10-L	Y9-M5-A10-N		10.0
Y6-M5-A13-L	Y8-M5-A13-L	Y9-M5-A13-N		12.0
Y6-M5-A16-L	Y8-M5-A16-L	Y9-M5-A16-N		16.0
Y6-M5-A20-L	Y8-M5-A20-L	Y9-M5-A20-N		20.0
Y6-M5-A25-L	Y8-M5-A25-L	Y9-M5-A25-N		25.0
Y6-M5-A30-L	Y8-M5-A30-L	Y9-M5-A30-N		30.0
Y6-M5-A35-L	Y8-M5-A35-L	Y9-M5-A35-N		35.0
Y6-M5-A40-L	Y8-M5-A40-L	Y9-M5-A40-N		40.0
Y6-M5-A50-L	Y8-M5-A50-L	Y9-M5-A50-N		50.0

THREAD	STYLE	MATERIAL
M6 X 1.0	SELF LOCKING - VIBRATION PROOF FLAT, CHEESE, AND SOCKET	STAINLESS STEEL DIN 1.4300 WITH NYLON STRIP/PELLET

LONG-LOCK®		NYLOC®	THREAD TOL=6g	LENGTH A
FLAT STYLE STOCK NO.	CHEESE STYLE STOCK NO.	SOCKET STYLE* STOCK NO.		
Y6-M6-A8-L	Y8-M6-A8-L	Y9-M6-A8-N	M6 X 1.0	8.0
Y6-M6-A10-L	Y8-M6-A10-L	Y9-M6-A10-N		10.0
Y6-M6-A12-L	Y8-M6-A12-L	Y9-M6-A12-N		12.0
Y6-M6-A16-L	Y8-M6-A16-L	Y9-M6-A16-N		16.0
Y6-M6-A20-L	Y8-M6-A20-L	Y9-M6-A20-N		20.0
Y6-M6-A25-L	Y8-M6-A25-L	Y9-M6-A25-N		25.0
Y6-M6-A30-L	Y8-M6-A30-L	Y9-M6-A30-N		30.0

*Y9 Series Socket Cap screws are available only with Nyloc® insert.
Long-Lok® registered Long Lok Corporation. Nyloc® registered Nyloc Corporation.

LONG-LOK® AND NYLOC® MACHINE SCREWS

THREAD	STYLE	MATERIAL
M8 X 1.25	SELF LOCKING - VIBRATION PROOF FLAT, CHEESE, AND SOCKET	STAINLESS STEEL DIN 1.4300 WITH NYLON STRIP/PELLET

LONG-LOCK®		NYLOC®		THREAD TOL=6g	LENGTH A
FLAT STYLE STOCK NO.	CHEESE STYLE STOCK NO.	SOCKET STYLE* STOCK NO.			
Y6-M8-A10-L	Y8-M8-A10-L	Y9-M8-A10-N		M8 x 1.25	10.0
Y6-M8-A13-L	Y8-M8-A13-L	Y9-M8-A13-N			12.0
Y6-M8-A16-L	Y8-M8-A16-L	Y9-M8-A16-N			16.0
Y6-M8-A20-L	Y8-M8-A20-L	Y9-M8-A20-N			20.0
Y6-M8-A25-L	Y8-M8-A25-L	Y9-M8-A25-N			25.0
Y6-M8-A30-L	Y8-M8-A30-L	Y9-M8-A30-N			30.0
Y6-M8-A35-L	Y8-M8-A35-L	Y9-M8-A35-N			35.0
Y6-M8-A40-L	Y8-M8-A40-L	Y9-M8-A40-N			40.0
Y6-M8-A45-L	Y8-M8-A45-L	Y9-M8-A45-N			45.0

THREAD	STYLE	MATERIAL
M10 X 1.5	SELF LOCKING - VIBRATION PROOF FLAT, CHEESE, AND SOCKET	STAINLESS STEEL DIN 1.4300 WITH NYLON STRIP/PELLET

LONG-LOCK®		NYLOC®		THREAD TOL=6g	LENGTH A
FLAT STYLE STOCK NO.	CHEESE STYLE STOCK NO.	SOCKET STYLE* STOCK NO.			
Y6-M10-A13-L	Y8-M10-A13-L	Y9-M10-A13-N		M10 x 1.5	12.0
Y6-M10-A16-L	Y8-M10-A16-L	Y9-M10-A16-N			16.0
Y6-M10-A20-L	Y8-M10-A20-L	Y9-M10-A20-N			20.0
Y6-M10-A25-L	Y8-M10-A25-L	Y9-M10-A25-N			25.0
Y6-M10-A30-L	Y8-M10-A30-L	Y9-M10-A30-N			30.0
Y6-M10-A35-L	Y8-M10-A35-L	Y9-M10-A35-N			35.0
Y6-M10-A40-L	Y8-M10-A40-L	Y9-M10-A40-N			40.0

*Y9 Series Socket Cap screws are available only with Nyloc® insert.
Long-Lok® registered Long Lok Corporation. Nyloc® registered Nyloc Corporation.

F

INTEGRAL SEAL SCREWS

THREAD	STYLE	MATERIAL
M2 x 0.4	SLOTTED PAN HEAD	STAINLESS STEEL DIN 1.4300 SCREW WITH SILICONE O RING

STOCK NO.	THREAD SIZE	LENGTH	A	B	CLEARANCE HOLE	
					MIN.	MAX.
Y18-M2-A4	M2 x 0.4	4.00	1.37	4.24	2.31	2.41
Y18-M2-A8		8.00				
Y18-M2-A12		12.00				

THREAD	STYLE	MATERIAL
M3 x 0.5	SLOTTED PAN HEAD	STAINLESS STEEL DIN 1.4300 SCREW WITH SILICONE O RING

STOCK NO.	THREAD SIZE	LENGTH	A	B	CLEARANCE HOLE	
					MIN.	MAX.
Y18-M3-A6	M3 x 0.5	6.00	1.91	6.22	3.56	3.66
Y18-M3-A12		12.00				
Y18-M3-A20		20.00				

THREAD	STYLE	MATERIAL
M4 x 0.7	SLOTTED PAN HEAD	STAINLESS STEEL DIN 1.4300 SCREW WITH SILICONE O RING

STOCK NO.	THREAD SIZE	LENGTH	A	B	CLEARANCE HOLE	
					MIN.	MAX.
Y18-M4-A6	M4 x 0.7	6.00	2.44	8.18	4.39	4.55
Y18-M4-A12		12.00				
Y18-M4-A20		20.00				

THREAD	STYLE	MATERIAL
M6 x 1.0	SLOTTED PAN HEAD	STAINLESS STEEL DIN 1.4300 SCREW WITH SILICONE O RING

STOCK NO.	THREAD SIZE	LENGTH	A	B	CLEARANCE HOLE	
					MIN.	MAX.
Y18-M6-A12	M6 x 1.0	12.00	3.73	12.50	6.73	6.83
Y18-M6-A20		20.00				
Y18-M6-A25		25.00				

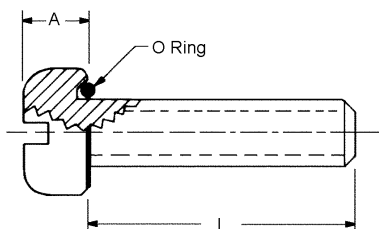
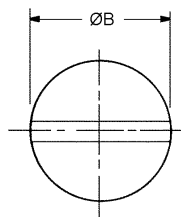

- Reusable
- Clearance holes recommended for maximum sealing
- Maximum temperature range -106°C to +260°C
- Pressure range - up to 4124 N/CM²

SET SCREWS

THREAD	STYLE	MATERIAL
M1.6 X 0.35 TO M10 X 1.5	SLOTTED HEAD AND HEX SOCKET	STAINLESS STEEL

SLOTTED HEAD STAINLESS STEEL	HEX SOCKET HEAD STAINLESS STEEL	THREAD	L
STOCK NO.	STOCK NO.		
SC1M-1	SC2M-1	M1.6 x 0.35	3.0
SC1M-2	SC2M-2		4.0
SC1M-3	SC2M-3		5.0
SC1M-4	SC2M-4	M2 x 0.4	3.0
SC1M-5	SC2M-5		4.0
SC1M-6	SC2M-6		5.0
SC1M-7	SC2M-7		6.0
SC1M-8	SC2M-8	M3 x 0.5	3.0
SC1M-9	SC2M-9		4.0
SC1M-10	SC2M-10		5.0
SC1M-11	SC2M-11		6.0
SC1M-12	SC2M-12	M4 x 0.7	4.0
SC1M-13	SC2M-13		6.0
SC1M-14	SC2M-14		10.0
SC1M-15	SC2M-15		14.0
SC1M-16	SC2M-16	M5 x 0.8	6.0
SC1M-17	SC2M-17		10.0
SC1M-18	SC2M-18		14.0
SC1M-19	SC2M-19		20.0
SC1M-20	SC2M-20	M6 x 1.0	6.0
SC1M-21	SC2M-21		10.0
SC1M-22	SC2M-22		16.0
SC1M-23	SC2M-23		25.0
SC1M-28	SC2M-28	M8 x 1.25	10.0
SC1M-29	SC2M-29		16.0
SC1M-30	SC2M-30		25.0
SC1M-24	SC2M-24	M10 x 1.5	12.0
SC1M-25	SC2M-25		20.0
SC1M-26	SC2M-26		30.0

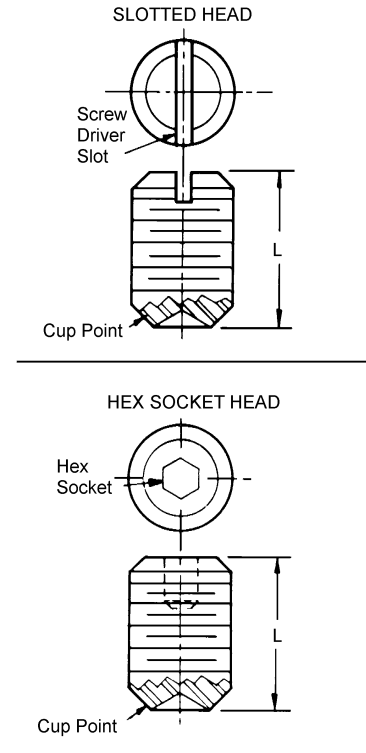

See Index for Allen Socket Head Keys.

These parts are sold in packages of 10.

F

SET SCREWS

THREAD	STYLE	MATERIAL
M3 X 0.5 TO M10 X 1.5	BRASS SOFT TIP HEX SOCKET	STAINLESS STEEL DIN 1.4300 AND HEAT TREATED ALLOY STEEL

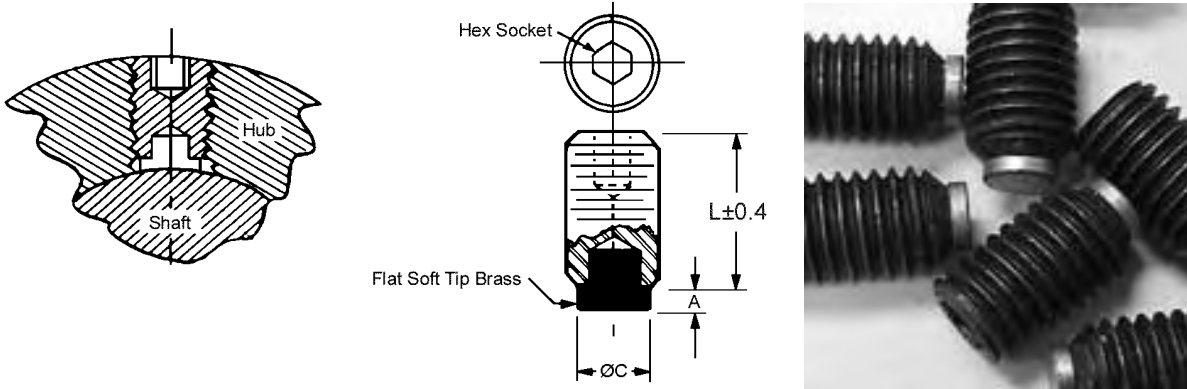

STOCK NO.	THREAD	L	C	A	MATERIAL	
SC10M-3	M3 x 0.5	3.0	1.6	.8	STAINLESS STEEL DIN 1.4300	
SC10M-4		6.0				
SC10M-5		9.0				
SC10M-6	M4 x 0.7	4.0	2.4	1.2		
SC10M-7		6.0				
SC10M-8		10.0				
SC10M-9	M5 x 0.8	6.0	2.4	1.2		
SC10M-10		10.0				
SC10M-11		16.0				
SC10M-12	M6 x 1.0	6.0	3.2	1.6		ALLOY STEEL
SC10M-14		10.0				
SC10M-15		25.0				
SC10M-16	M8 x 1.25	6.0	3.2	1.6		
SC10M-17		10.0				
SC10M-18		16.0				
SC10M-19		25.0				
SC10M-20	M10 x 1.5	10.0	4.8	2.4	BLACK OXIDE FINISH	
SC10M-21		16.0				
SC10M-22		25.0				

- Non marring
- Self locking
- Also used as position adjustment screw
- Screws may be used over and over
- Conforms to shaft surface for positive grip

Length is exclusive of brass tip.

SET SCREWS

THREAD	STYLE	MATERIAL
M2 X 0.4 TO M10 X 1.5	SILVER SOLDER TIP SLOTTED HEAD AND HEX SOCKET	STAINLESS STEEL DIN 1.4300

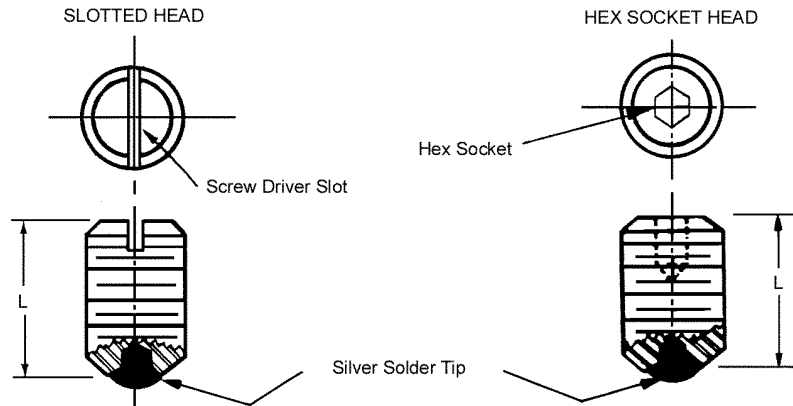

SLOTTED HEAD STOCK NO.	HEX SOCKET HEAD STOCK NO.	THREAD	L
SC5M-4	SC6M-4	M2 x 0.4	3.0
SC5M-5	SC6M-5		4.0
SC5M-6	SC6M-6		5.0
SC5M-7	SC6M-7		6.0
SC5M-8	SC6M-8	M3 x 0.5	3.0
SC5M-9	SC6M-9		4.0
SC5M-10	SC6M-10		5.0
SC5M-11	SC6M-11		6.0
SC5M-12	SC6M-12	M4 x 0.7	4.0
-	SC6M-13		6.0
-	SC6M-14		10.0
-	SC6M-15		14.0
SC5M-16	SC6M-16	M5 x 0.8	6.0
SC5M-17	SC6M-17		10.0
SC5M-18	SC6M-18		14.0
SC5M-19	SC6M-19		20.0
SC5M-20	SC6M-20	M6 x 1.0	6.0
SC5M-21	SC6M-21		10.0
SC5M-22	SC6M-22		16.0
SC5M-23	SC6M-23		25.0
SC5M-28	SC6M-28	M8 x 1.25	10.0
SC5M-29	SC6M-29		16.0
SC5M-30	SC6M-30		25.0
SC5M-24	SC6M-24	M10 x 1.5	12.0
SC5M-25	SC6M-25		20.0
SC5M-26	SC6M-26		30.0

- Also used as position adjustment screw
- Conforms to shaft surface for positive grip
- Non marring
- Self locking

Special sizes are available on request.

Length is exclusive of silver tip.

F

SET SCREWS

THREAD	STYLE	MATERIAL
M2 X 0.4 TO M10 X 1.5	SOFT TIP SLOTTED HEAD	STAINLESS STEEL DIN 1.4300 WITH NYLON TIP

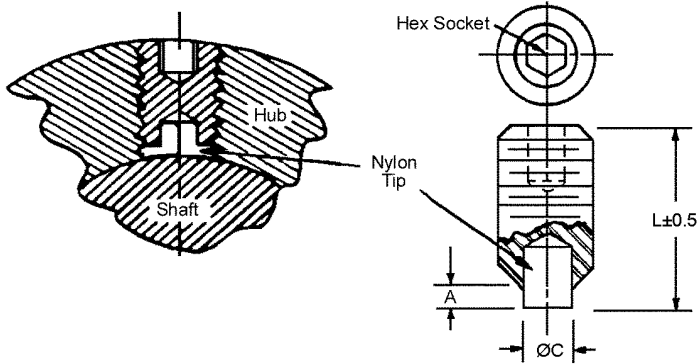

STOCK NO.	THREAD	L	C	A
SC8M-1	M2 X 0.4	3.8	.8	.8
SC8M-2		4.8		
SC8M-3		5.8		
SC8M-4		6.8		
SC8M-5	M3 X 0.5	3.8	1.6	.8
SC8M-6		4.8		
SC8M-7		5.8		
SC8M-8		6.8		
SC8M-9	M4 x 0.7	5.2	2.4	1.2
SC8M-10		7.2		
SC8M-11		11.2		
SC8M-12		15.2		
SC8M-13	M5 x 0.8	7.2	2.4	1.2
SC8M-14		11.2		
SC8M-15		15.2		
SC8M-16		21.2		
SC8M-17	M6 x 1.0	7.6	3.2	1.6
SC8M-18		11.6		
SC8M-19		17.6		
SC8M-20		26.6		
SC8M-24	M8 x 1.25	8.4	4.8	2.4
SC8M-25		12.4		
SC8M-26		18.4		
SC8M-27		27.4		
SC8M-21	M10 x 1.5	14.4	6.5	3.5
SC8M-22		22.4		
SC8M-23		32.4		

- Self locking
- Extra holding power from full face control
- Will not mar or damage shaft
- Nylon "soft tip" conforms to shape of shaft

SET SCREWS

THREAD	STYLE	MATERIAL
M3 X 0.5 TO M6 X 1.0	SOFT TIP SLOTTED HEAD	STAINLESS STEEL DIN 1.4300 WITH NYLON TIP

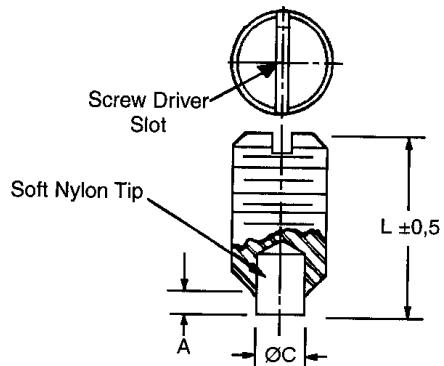

STOCK NO.	THREAD	L	C	A
SC7M-1	M3 x 0.5	4.8	1.6	.8
SC7M-2	M4 x 0.7	7.2	2.4	1.2
SC7M-3	M5 x 0.8	11.2	2.4	1.2
SC7M-4	M6 x 1.0	7.6	3.2	1.6
SC7M-6		20.6		

- Self locking
- Non marring
- Also used as position adjustment screw
- Screw may be used over and over
- Conforms to shaft surface for positive grip

SHOULDER SCREWS

THREAD	STYLE	MATERIAL
M3 X 0.5	SLOTTED HEAD	STAINLESS STEEL DIN 1.4005 AND STAINLESS STEEL DIN 1.4305

DIN 1.4005 STOCK NO.	DIN 1.4305 STOCK NO.	THREAD	Ød	L	ØD	H	E
PLM-1	PLM-1-3	M3 x 0.5	3.987 (4)	4.01	6	3	4
PLM-2	PLM-2-3			5.01			
PLM-3	PLM-3-3			6.01			
PLM-4	PLM-4-3			8.01			
PLM-5	PLM-5-3			10.01			

THREAD	STYLE	MATERIAL
M4 X 0.7	SLOTTED HEAD	STAINLESS STEEL DIN 1.4005 AND STAINLESS STEEL DIN 1.4305

DIN 1.4005 STOCK NO.	DIN 1.4305 STOCK NO.	THREAD	Ød	L	ØD	H	E
PLM-6	PLM-6-3	M4 x 0.7	4.987 (5)	4.01	8	4	5
PLM-7	PLM-7-3			5.01			
PLM-8	PLM-8-3			6.01			
PLM-9	PLM-9-3			8.01			
PLM-10	PLM-10-3			10.01			
PLM-11	PLM-11-3			12.01			
PLM-12	PLM-12-3			14.01			
PLM-13	PLM-13-3			16.01			
PLM-14	PLM-14-3			20.01			
PLM-15	PLM-15-3			25.01			
PLM-16	PLM-16-3			30.01			

THREAD	STYLE	MATERIAL
M5 X 0.8	SLOTTED HEAD	STAINLESS STEEL DIN 1.4005 AND STAINLESS STEEL DIN 1.4305

DIN 1.4005 STOCK NO.	DIN 1.4305 STOCK NO.	THREAD	Ød	L	ØD	H	E
PLM-17	PLM-17-3	M5 x 0.8	5.987 (6)	4.01	10	5	6
PLM-18	PLM-18-3			5.01			
PLM-19	PLM-19-3			6.01			
PLM-20	PLM-20-3			8.01			
PLM-21	PLM-21-3			10.01			
PLM-22	PLM-22-3			12.01			
PLM-23	PLM-23-3			14.01			
PLM-24	PLM-24-3			16.01			
PLM-25	PLM-25-3			20.01			
PLM-26	PLM-26-3			25.01			
PLM-27	PLM-27-3			30.01			

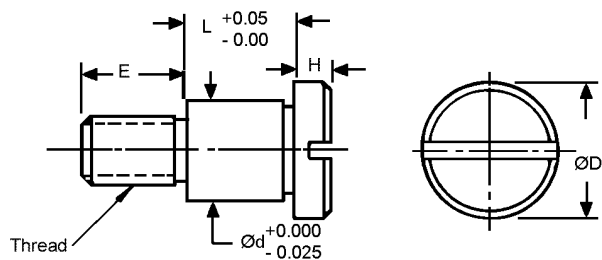

SHOULDER SCREWS

THREAD	STYLE	MATERIAL
M6 X 1.0	SLOTTED HEAD	STAINLESS STEEL DIN 1.4005 AND STAINLESS STEEL DIN 1.4305

DIN 1.4005 STOCK NO.	DIN 1.4305 STOCK NO.	THREAD	Ød	L	ØD	H	E
PLM-28	PLM-28-3	M6 x 1.0	7.987 (8)	6.01	12	6	11
PLM-29	PLM-29-3			8.01			
PLM-30	PLM-30-3			10.01			
PLM-31	PLM-31-3			12.01			
PLM-32	PLM-32-3			16.01			
PLM-33	PLM-33-3			20.01			

THREAD	STYLE	MATERIAL
M6 X 1.0	SLOTTED HEAD	STAINLESS STEEL DIN 1.4005 AND STAINLESS STEEL DIN 1.4305

DIN 1.4005 STOCK NO.	DIN 1.4305 STOCK NO.	THREAD	Ød	L	ØD	H	E
PLM-34	PLM-34-3	M6 x 1.0	9.987 (10)	8.01	12	6	11
PLM-35	PLM-35-3			10.01			
PLM-36	PLM-36-3			12.01			
PLM-37	PLM-37-3			16.01			
				16.01			

THREAD	STYLE	MATERIAL
M8 X 1.25	SLOTTED HEAD	STAINLESS STEEL DIN 1.4005 AND STAINLESS STEEL DIN 1.4305

DIN 1.4005 STOCK NO.	DIN 1.4305 STOCK NO.	THREAD	Ød	L	ØD	H	E
PLM-38	PLM-38-3	M8 x 1.25	9.987 (10)	8.01	14	7	12
PLM-39	PLM-39-3			10.01			
PLM-40	PLM-40-3			12.01			
PLM-41	PLM-41-3			16.01			
				16.01			

THREAD	STYLE	MATERIAL
M10 X 1.5	SLOTTED HEAD	STAINLESS STEEL DIN 1.4005 AND STAINLESS STEEL DIN 1.4305

DIN 1.4005 STOCK NO.	DIN 1.4305 STOCK NO.	THREAD	Ød	L	ØD	H	E
PLM-42	PLM-42-3	M10 x 1.5	11.987 (12)	12.01	20	8	16
PLM-43	PLM-43-3			16.01			
PLM-44	PLM-44-3			20.01			
PLM-45	PLM-45-3			25.01			
				25.01			

Drawing on previous page.

F

SHOULDER SCREWS

THREAD	STYLE	MATERIAL
M3 X 0.5	HEX SOCKET HEAD	STAINLESS STEEL DIN 1.4005 AND STAINLESS STEEL DIN 1.4305

DIN 1.4005 STOCK NO.	DIN 1.4305 STOCK NO.	THREAD	Ød	L	ØD	H	E	S
PZM-1	PZM-1-3	M3 x 0.5	3.987 (4)	4.01	6	3	4	2
PZM-2	PZM-2-3			5.01				
PZM-3	PZM-3-3			6.01				
PZM-4	PZM-4-3			8.01				
PZM-5	PZM-5-3			10.01				

THREAD	STYLE	MATERIAL
M4 X 0.7	HEX SOCKET HEAD	STAINLESS STEEL DIN 1.4005 AND STAINLESS STEEL DIN 1.4305

DIN 1.4005 STOCK NO.	DIN 1.4305 STOCK NO.	THREAD	Ød	L	ØD	H	E	S
PZM-6	PZM-6-3	M4 x 0.7	4.987 (5)	4.01	8	4	5	2.5
PZM-7	PZM-7-3			5.01				
PZM-8	PZM-8-3			6.01				
PZM-9	PZM-9-3			8.01				
PZM-10	PZM-10-3			10.01				
PZM-11	PZM-11-3			12.01				
PZM-12	PZM-12-3			14.01				
PZM-13	PZM-13-3			16.01				
PZM-14	PZM-14-3			20.01				
PZM-15	PZM-15-3			25.01				
PZM-16	PZM-16-3			30.01				

THREAD	STYLE	MATERIAL
M5 X 0.8	HEX SOCKET HEAD	STAINLESS STEEL DIN 1.4005 AND STAINLESS STEEL DIN 1.4305

DIN 1.4005 STOCK NO.	DIN 1.4305 STOCK NO.	THREAD	Ød	L	ØD	H	E	S
PZM-17	PZM-17-3	M5 x 0.8	5.987 (6)	4.01	10	5	6	3
PZM-18	PZM-18-3			5.01				
PZM-19	PZM-19-3			6.01				
PZM-20	PZM-20-3			8.01				
PZM-21	PZM-21-3			10.01				
PZM-22	PZM-22-3			12.01				
PZM-23	PZM-23-3			14.01				
PZM-24	PZM-24-3			16.01				
PZM-25	PZM-25-3			20.01				
PZM-26	PZM-26-3			25.01				
PZM-27	PZM-27-3			30.01				

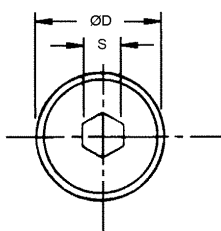
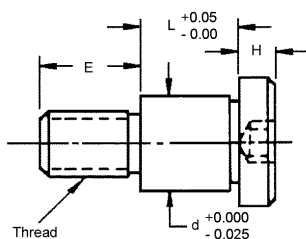

See index for hex wrenches.

SHOULDER SCREWS

THREAD	STYLE	MATERIAL
M6 X 1.0	HEX SOCKET HEAD	STAINLESS STEEL DIN 1.4005 AND STAINLESS STEEL DIN 1.4305

DIN 1.4005 STOCK NO.	DIN 1.4305 STOCK NO.	THREAD	Ød	L	ØD	H	E	S
PZM-28 PZM-29 PZM-30 PZM-32 PZM-33	PZM-28-3 PZM-29-3 PZM-31-3 PZM-32-3 PZM-33-3	M6 x 1.0	7.987 (8)	6.01 8.01 12.01 16.01 20.01	12	6	11	4

THREAD	STYLE	MATERIAL
M6 X 1.0	HEX SOCKET HEAD	STAINLESS STEEL DIN 1.4005 AND STAINLESS STEEL DIN 1.4305

DIN 1.4005 STOCK NO.	DIN 1.4305 STOCK NO.	THREAD	Ød	L	ØD	H	E	S
PZM-34 PZM-35 PZM-36 PZM-37	PZM-34-3 PZM-35-3 PZM-36-3 PZM-37-3	M6 x 1.0	9.987 (10)	8.01 10.01 12.01 16.01	12	6	11	4

THREAD	STYLE	MATERIAL
M8 X 1.25	HEX SOCKET HEAD	STAINLESS STEEL DIN 1.4005 AND STAINLESS STEEL DIN 1.4305

DIN 1.4005 STOCK NO.	DIN 1.4305 STOCK NO.	THREAD	Ød	L	ØD	H	E	S
PZM-38 PZM-39 PZM-40 PZM-41	PZM-38-3 PZM-39-3 PZM-40-3 PZM-41-3	M8 x 1.25	9.987 (10)	8.01 10.01 12.01 16.01	14	7	12	5

THREAD	STYLE	MATERIAL
M10 X 1.5	HEX SOCKET HEAD	STAINLESS STEEL DIN 1.4005 AND STAINLESS STEEL DIN 1.4305

DIN 1.4005 STOCK NO.	DIN 1.4305 STOCK NO.	THREAD	Ød	L	ØD	H	E	S
PZM-42 PZM-43 PZM-44 PZM-45	PZM-42-3 PZM-43-3 PZM-44-3 PZM-45-3	M10 x1.5	11.987 (12)	12.01 16.01 20.01 25.01	20	8	16	6

See index for hex wrenches.

Drawing on previous page.

F

PRECISION CAPTIVE SCREWS

THREAD	STYLE	MATERIAL
M3 x 0.5 to M5 x 0.8	SLOTTED HEAD	DIN 1.4305 STAINLESS STEEL

SLOTTED HEAD STOCK NO.	L	M	H	ØE	ØD	THREAD TOL=6g
Z12M-1	6.75	4.5	2.0	2.14	5.2	M3 x 0.5
Z12M-2	8.25	4.5	2.0	2.14	5.2	M3 x 0.5
Z12M-3	9.75	6.0	2.8	2.89	7.0	M4 x 0.7
Z12M-4	11.75	6.0	2.8	2.89	7.0	M4 x 0.7
Z12M-5	12.75	6.0	2.8	2.89	7.0	M4 x 0.7
Z12M-6	13.25	7.5	3.5	3.77	9.0	M5 x 0.8
Z12M-7	14.25	7.5	3.5	3.77	9.0	M5 x 0.8

Specials Upon request.

THREAD	STYLE	MATERIAL
M3 x 0.5 to M5 x 0.8	HEX SOCKET HEAD	DIN 1.4305 STAINLESS STEEL

HEX SOCKET STOCK NO.	L	M	H	ØE	ØD	THREAD TOL=6g
Z12M-1-H	6.75	4.5	2.0	2.14	5.2	M3 x 0.5
Z12M-2-H	8.25	4.5	2.0	2.14	5.2	M3 x 0.5
Z12M-3-H	9.75	6.0	2.8	2.89	7.0	M4 x 0.7
Z12M-4-H	11.75	6.0	2.8	2.89	7.0	M4 x 0.7
Z12M-5-H	12.75	6.0	2.8	2.89	7.0	M4 x 0.7
Z12M-6-H	13.25	7.5	3.5	3.77	9.0	M5 x 0.8
Z12M-7-H	14.25	7.5	3.5	3.77	9.0	M5 x 0.8

Specials Upon request.

See index for hex wrenches.

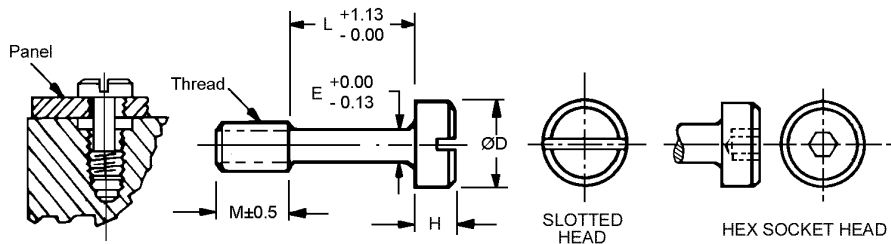

PRECISION JIG BUTTONS

MATERIAL
STAINLESS STEEL DIN 1.4300

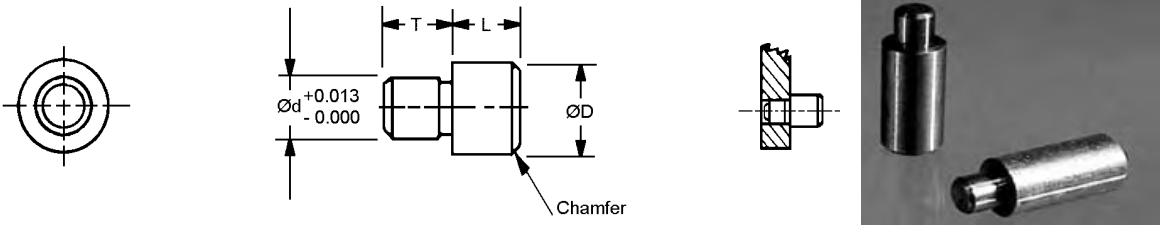

STOCK NO.	L	T	ØD	Ød
PMM-1	6	6	10	5.000
PMM-2	10	6	10	5.000
PMM-3	12	6	10	5.000
PMM-4	6	8	12	6.000
PMM-5	10	8	12	6.000
PMM-6	12	8	12	8.000
PMM-7	19	8	12	8.000
PMM-8	25	8	12	8.000

F

THUMB SCREWS

THREAD	STYLE	MATERIAL
M3 X 0.5	PLASTIC HEAD, KNURLED	STAINLESS STEEL WITH BLACK PLASTIC HEAD

STOCK NO.	THREAD TOL=6g	ØA	B	ØC	L
PQCM-1	M3 X 0.5	9.6	4.4	8.3	5
PQCM-2					8
PQCM-3					12
PQCM-4					20
PQCM-5					25

THREAD	STYLE	MATERIAL
M4 X 0.7	PLASTIC HEAD, KNURLED	STAINLESS STEEL WITH BLACK PLASTIC HEAD

STOCK NO.	THREAD TOL=6g	ØA	B	ØC	L
PQCM-6	M4 X 0.7	13.0	5.5	9.8	6
PQCM-7					10
PQCM-8					12
PQCM-9					20
PQCM-10					25

THREAD	STYLE	MATERIAL
M5 X 0.8	PLASTIC HEAD, KNURLED	STAINLESS STEEL WITH BLACK PLASTIC HEAD

STOCK NO.	THREAD TOL=6g	ØA	B	ØC	L
PQCM-11	M5 X 0.8	16.0	6.5	11.5	8
PQCM-12					10
PQCM-13					12
PQCM-14					20
PQCM-15					25

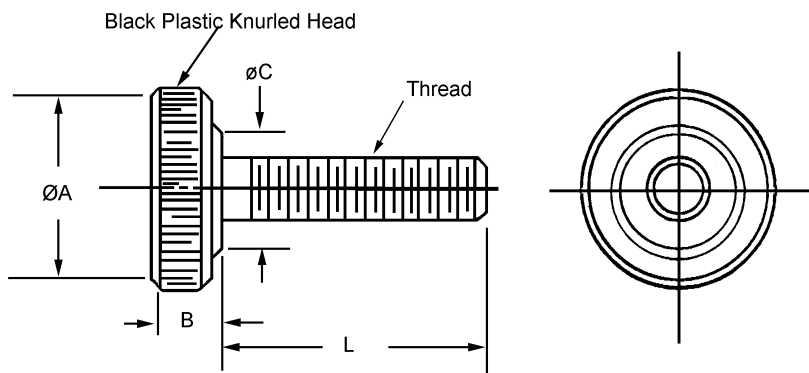

Other sizes, special lengths and non-stainless screws available on request.

THUMB SCREWS

THREAD	STYLE	MATERIAL
M6 X 1.0	PLASTIC HEAD, KNURLED	STAINLESS STEEL DIN 1.4005 WITH BLACK PLASTIC HEAD

STOCK NO.	THREAD	ØA	B	ØC	L
PQCM-16	M6 X 1.0	19.0	7.6	13.0	10
PQCM-17					12
PQCM-18					16
PQCM-18					20
PQCM-20					25

THREAD	STYLE	MATERIAL
M8 X 1.25	PLASTIC HEAD, KNURLED	STAINLESS STEEL 1.4005 WITH BLACK PLASTIC HEAD

STOCK NO.	THREAD	ØA	B	ØC	L
PQCM-21	M8 X 1.25	26.0	9.8	16.0	10
PQCM-22					12
PQCM-23					16
PQCM-24					20
PQCM-25					25

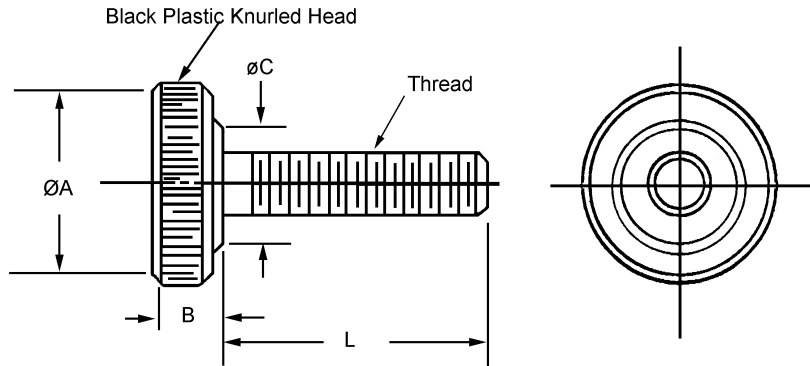

Other sizes, special lengths and non-stainless screws available on request.



F

THUMB SCREWS

THREAD	STYLE	MATERIAL
M3 X 0.5	STRAIGHT KNURLED	STAINLESS STEEL DIN 1.4005 AND STAINLESS STEEL DIN 1.4305

DIN 1.4005 STOCK NO.	DIN 1.4305 STOCK NO.	THREAD	ØD	L	F	E
PQM-1	PQM-1-3	M3 X 0.5	7	12	8	3
PQM-2	PQM-2-3			25	11	12
PQM-3	PQM-3-3			32	16	12

THREAD	STYLE	MATERIAL
M3 X 0.5	STRAIGHT KNURLED	STAINLESS STEEL DIN 1.4005 AND STAINLESS STEEL DIN 1.4305

DIN 1.4005 STOCK NO.	DIN 1.4305 STOCK NO.	THREAD	ØD	L	F	E
PQM-4	PQM-4-3	M3 X 0.5	10	12	8	3
PQM-5	PQM-5-3			16	11	3

THREAD	STYLE	MATERIAL
M4 X 0.7	STRAIGHT KNURLED	STAINLESS STEEL DIN 1.4005 AND STAINLESS STEEL DIN 1.4305

DIN 1.4005 STOCK NO.	DIN 1.4305 STOCK NO.	THREAD	ØD	L	F	E
PQM-11	PQM-11-3	M4 X 0.7	7	25	11	12
PQM-12	PQM-12-3			32	16	12
PQM-13	PQM-13-3			38	24	12

THREAD	STYLE	MATERIAL
M4 X 0.7	STRAIGHT KNURLED	STAINLESS STEEL DIN 1.4005 AND STAINLESS STEEL DIN 1.4305

DIN 1.4005 STOCK NO.	DIN 1.4305 STOCK NO.	THREAD	ØD	L	F	E
PQM-14	PQM-14-3	M4 X 0.7	10	12	8	3
PQM-15	PQM-15-3			16	10	3

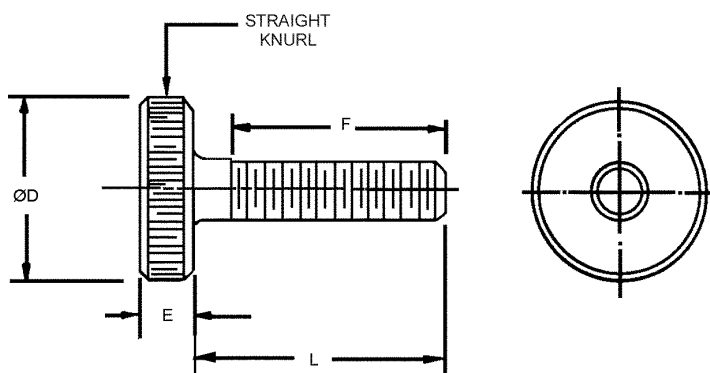

THUMB SCREWS

THREAD	STYLE	MATERIAL
M5 X 0.8	STRAIGHT KNURLED	STAINLESS STEEL DIN 1.4005 AND STAINLESS STEEL DIN 1.4305

DIN 1.4005 STOCK NO.	DIN 1.4305 STOCK NO.	THREAD	ØD	L	F	E
PQM-16	PQM-16-3	M5 X 0.8	10	18	11	5
PQM-17	PQM-17-3			25	16	
PQM-18	PQM-18-3			30	20	
PQM-19	PQM-19-3			36	25	

THREAD	STYLE	MATERIAL
M5 X 0.8	STRAIGHT KNURLED	STAINLESS STEEL DIN 1.4005 AND STAINLESS STEEL DIN 1.4305

DIN 1.4005 STOCK NO.	DIN 1.4305 STOCK NO.	THREAD	ØD	L	F	E
PQM-20	PQM-20-3	M5 X 0.8	12	25	16	5
PQM-21	PQM-21-3			36	20	
PQM-22	PQM-22-3			25	25	
PQM-23	PQM-23-3			42	32	

THREAD	STYLE	MATERIAL
M5 X 0.8	STRAIGHT KNURLED	STAINLESS STEEL DIN 1.4005 AND STAINLESS STEEL DIN 1.4305

DIN 1.4005 STOCK NO.	DIN 1.4305 STOCK NO.	THREAD	ØD	L	F	E
PQM-24	PQM-24-3	M5 X 0.8	19	25	16	5
PQM-25	PQM-25-3			30	20	
PQM-26	PQM-26-3			36	25	
PQM-27	PQM-27-3			42	32	

THREAD	STYLE	MATERIAL
M6 X 1.0	STRAIGHT KNURLED	STAINLESS STEEL DIN 1.4005 AND STAINLESS STEEL DIN 1.4305

DIN 1.4005 STOCK NO.	DIN 1.4305 STOCK NO.	THREAD	ØD	L	F	E
PQM-28	PQM-28-3	M6 X 1.0	19.0	25.0	16	5
PQM-29	PQM-29-3			30.0	20	
PQM-30	PQM-30-3			36.5	25	
PQM-31	PQM-31-3			42.5	32	

THREAD	STYLE	MATERIAL
M6 X 1.0	STRAIGHT KNURLED	STAINLESS STEEL DIN 1.4005 AND STAINLESS STEEL DIN 1.4305

DIN 1.4005 STOCK NO.	DIN 1.4305 STOCK NO.	THREAD	ØD	L	F	E
PQM-32	PQM-32-3	M6 X 1.0	25.5	25.0	16	5
PQM-33	PQM-33-3			30.0	20	
PQM-34	PQM-34-3			36.5	25	
PQM-35	PQM-35-3			42.0	32	

Drawing on previous page.

THUMB SCREWS

THREAD	STYLE	MATERIAL
M3 X 0.5	KNURLED SOCKET HEAD	STAINLESS STEEL DIN 1.4305

STOCK NO.	THREAD	A	ØC	B	E	F (MIN.)
PQHM-1 PQHM-2	M3 X 0.5	12 19	6	11 16	2	2
PQHM-3 PQHM-4	M3 X 0.5	12 19	8	11 16	2	2
PQHM-5 PQHM-6	M3 X 0.5	10 12	10	8 11	3	3

THREAD	STYLE	MATERIAL
M4 X 0.7	KNURLED SOCKET HEAD	STAINLESS STEEL DIN 1.4305

STOCK NO.	THREAD	A	ØC	B	E	F (MIN.)
PQHM-15 PQHM-16 PQHM-17	M4 X 0.7	12 19 25	6	11 16 20	2	2
PQHM-18 PQHM-19 PQHM-20	M4 X 0.7	19 10 25	8	11 16 20	2	2
PQHM-21 PQHM-22	M4 X 0.7	10 12	10	8 12	3	3

THREAD	STYLE	MATERIAL
M5 X 0.8	KNURLED SOCKET HEAD	STAINLESS STEEL DIN 1.4305

STOCK NO.	THREAD	A	ØC	B	E	F (MIN.)
PQHM-23 PQHM-24 PQHM-25 PQHM-26	M5 X 0.8	12 19 25 32	8	11 16 20 25	2	2
PQHM-27 PQHM-28 PQHM-27 PQHM-29	M5 X 0.8	10 25 10 32	10	11 16 20 25	3	3

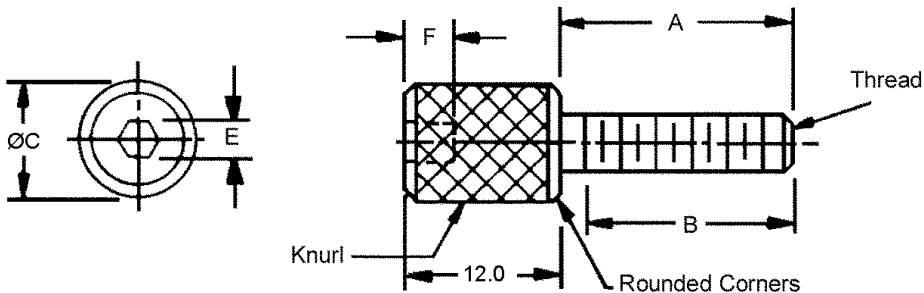

THUMB NUTS

THREAD	STYLE	MATERIAL
M3 X 0.5	KNURLED	STAINLESS STEEL DIN 1.4305

STOCK NO.	THREAD	ØA	B	ØC	D	COUNTERBORE	
						DIA.	DEEP
PD1M-1	M3 X 0.5	12.0	6.0	3.0	6.0	-	-
PD1M-2		12.0			3.2	6.0	
PD1M-3		19.0			-	-	
PD1M-4		19.0			3.2	6.0	

THREAD	STYLE	MATERIAL
M4 X 0.7	KNURLED	STAINLESS STEEL DIN 1.4305

STOCK NO.	THREAD	ØA	B	ØC	D	COUNTERBORE	
						DIA.	DEEP
PD1M-9	M4 X 0.7	12.0	8.0	3.0	6.0	-	-
PD1M-10		12.0			4.2	6.0	
PD1M-11		19.0			-	-	
PD1M-12		19.0			4.2	6.0	

THREAD	STYLE	MATERIAL
M5 X 0.8	KNURLED	STAINLESS STEEL DIN 1.4305

STOCK NO.	THREAD	ØA	B	ØC	D	COUNTERBORE	
						DIA.	DEEP
PD1M-13	M5 X 0.8	12.0	10.0	5.0	6.0	-	-
PD1M-14		12.0			5.3	7.5	
PD1M-15		25.5			-	-	
PD1M-16		25.5			5.3	7.5	

THREAD	STYLE	MATERIAL
M6 X 1.0	KNURLED	STAINLESS STEEL DIN 1.4305

STOCK NO.	THREAD	ØA	B	ØC	D	COUNTERBORE	
						DIA.	DEEP
PD1M-17	M6 X 1.0	19.0	12.5	6.5	6.0	-	-
PD1M-18		19.0			6.4	9.0	
PD1M-19		25.5			-	-	
PD1M-20		25.5			6.4	9.0	
PD1M-21		25.5			6.4	15.0	

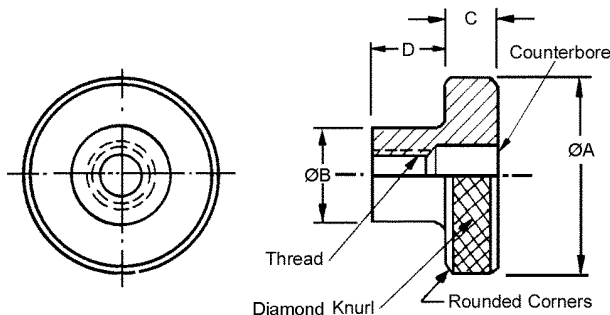

F

THREADED STUDS

THREAD	STYLE	MATERIAL
M3.5 X 0.6	DOUBLE ENDED	STAINLESS STEEL DIN 1.4305

STOCK NO.	L	THREAD SIZE BOTH ENDS	D	d
PVM-1	25.5	M3.5 X 0.6	6.0	12.0
PVM-2	32.0			15.0
PVM-3	38.0			19.0
PVM-4	44.5			19.0
PVM-5	50.0			19.0

THREAD	STYLE	MATERIAL
M4 X 0.7	DOUBLE ENDED	STAINLESS STEEL DIN 1.4305

STOCK NO.	L	THREAD SIZE BOTH ENDS	D	d
PVM-6	25.5	M4 X 0.7	6.0	12.0
PVM-7	32.0			15.0
PVM-8	38.0			19.0
PVM-9	44.5			19.0
PVM-10	50.0			19.0

THREAD	STYLE	MATERIAL
M5 X 0.8	DOUBLE ENDED	STAINLESS STEEL DIN 1.4305

STOCK NO.	L	THREAD SIZE BOTH ENDS	D	d
PVM-11	25.5	M5 X 0.8	6.0	12.0
PVM-12	32.0			15.0
PVM-13	38.0			19.0
PVM-14	44.5			19.0
PVM-15	50.0			19.0

THREAD	STYLE	MATERIAL
M6 X 1.0	DOUBLE ENDED	STAINLESS STEEL DIN 1.4305

STOCK NO.	L	THREAD SIZE BOTH ENDS	D	d
PVM-16	37.0	M6 X 1.0	7.0	15.0
PVM-17	38.0			15.0
PVM-18	44.5			19.0
PVM-19	50.0			19.0
PVM-20	63.5			19.0
PVM-21	76.0			25.0

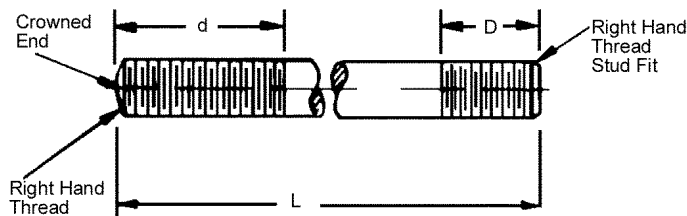

THREADED STUDS

THREAD	STYLE	MATERIAL
M8 X 1.25	DOUBLE ENDED	STAINLESS STEEL DIN 1.4305

STOCK NO.	L	THREAD SIZE BOTH ENDS	D	d
PVM-22	38.0	M8 X 1.25	8.0	15.0
PVM-23	50.0			25.5
PVM-24	63.5			32.0
PVM-25	76.0			35.0
PVM-26	88.0			38.0
PVM-27	100.0			38.0

THREAD	STYLE	MATERIAL
M10 X 1.5	DOUBLE ENDED	STAINLESS STEEL DIN 1.4305

STOCK NO.	L	THREAD SIZE BOTH ENDS	D	d
PVM-28	42.0	M10 X 1.5	8.0	19.0
PVM-29	50.0			25.4
PVM-30	63.5			32.0
PVM-31	76.0			35.0
PVM-32	89.0			38.0
PVM-33	102.0			38.0

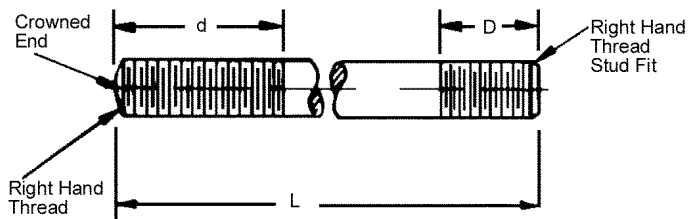

F

HEX NUTS

MATERIAL

STAINLESS STEEL DIN 1.4305

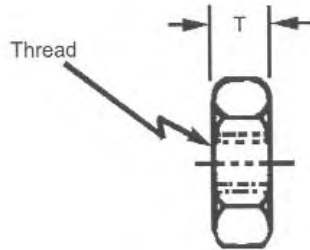
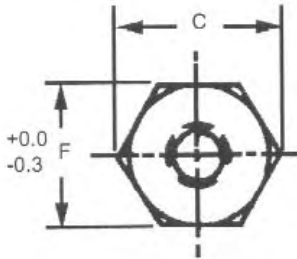

STOCK NO.	THREAD SIZE	T (MAX.)	C (Ref.)	F
Y5-M1	M1.6 X 0.35	1.3	3.5	3.2
Y5-M2	M2 X 0.4	1.6	4.4	4.0
Y5-M3	M3 X 0.5	2.4	6.0	5.5
Y5-M4	M4 X 0.7	3.2	7.7	7.0
Y5-M5	M5 X 0.8	4.0	8.8	8.0
Y5-M6	M6 X 1.0	5.0	11.1	10.0
Y5-M8	M8 X 1.25	6.5	14.4	13.0
Y5-M10	M10 X 1.5	8.0	18.9	17.0

MATERIAL

MOLDED NYLON

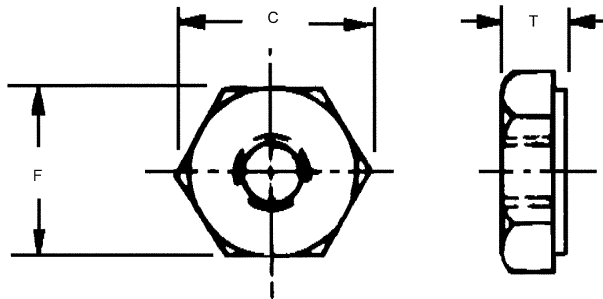

STOCK NO.	THREAD SIZE	T	C (Ref.)	F
Z5-N-M2	M2 X 0.4	1.2	3.9	3.9
Z5-N-M3	M3 X 0.5	2.2	5.4	5.4
Z5-N-M4	M4 X 0.7	3.0	6.9	6.9
Z5-N-M5	M5 X 0.8	4.3	7.9	7.9
Z5-N-M6	M6 X 1.0	5.4	9.9	9.9
Z5-N-M8	M8 X 1.25	6.4	12.9	12.9
Z5-N-M10	M10 X 1.5	9.8	14.8	16.9

WASHERS

SCREW SIZE	TYPE	MATERIAL
M2 TO M10	PLAIN	MOLDED NYLON

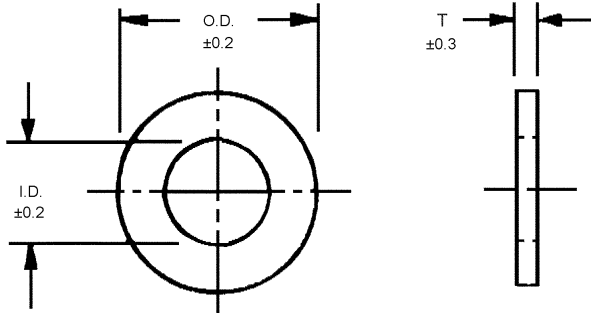

STOCK NO.	SCREW SIZE	O.D.	I.D.	T
Z4-N-M2	M2	5.0	2.2	0.8
Z4-N-M3	M3	8.0	3.2	0.8
Z4-N-M4	M4	9.0	4.3	0.8
Z4-N-M5	M5	11.0	5.3	1.0
Z4-N-M6	M6	12.0	6.4	1.5
Z4-N-M8	M8	18.0	8.4	2.0
Z4-N-M10	M10	20.0	10.5	2.5

SOLD IN PACKAGES OF 10.

SCREW SIZE	TYPE	MATERIAL
M2 TO M10	SPLIT LOCK	STAINLESS STEEL DIN 1.4300

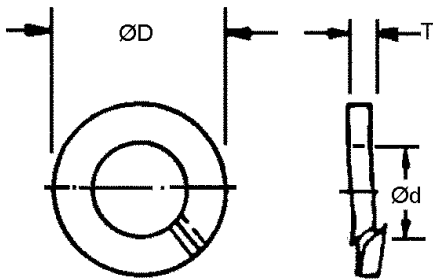

STOCK NO.	THREAD	ØD	Ød	TOL	T	TOL
Z3-M2	M2	4.4	2.1	+0.3	0.5	±0.1
Z3-M3	M3	6.2	3.1	+0.3	0.8	±0.1
Z3-M4	M4	7.6	4.1	+0.3	0.9	±0.1
Z3-M5	M5	9.2	5.1	+0.3	1.2	±0.1
Z3-M6	M6	11.8	6.1	+0.4	1.6	±0.1
Z3-M8	M8	14.8	8.1	+0.4	2.0	±0.1
Z3-M10	M10	18.1	10.2	+0.5	2.2	±0.15

SOLD IN PACKAGES OF 10.

SCREW SIZE	TYPE	MATERIAL
M2 TO M10	PLAIN	STAINLESS STEEL DIN 1.4300

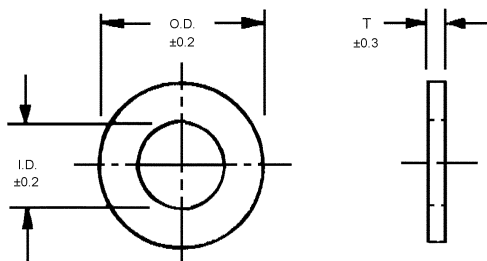

STOCK NO.	THREAD	ØD	Ød	TOL	T	TOL
Z4-M2	M2	5	2.2	+0.14	0.30	±0.05
Z4-M3	M3	5	3.2	+0.18	0.50	±0.05
Z4-M4	M4	9	4.3	+0.18	0.8	±0.1
Z4-M5	M5	10	5.3	+0.18	1.0	±0.1
Z4-M6	M6	12.5	6.4	+0.22	1.6	±0.2
Z4-M8	M8	17	8.4	+0.22	1.6	±0.2
Z4-M10	M10	21	10.5	+0.22	2.0	±0.2

SOLD IN PACKAGES OF 10.

LOCK WASHERS

SCREW SIZE	STYLE	MATERIAL
M2 TO M10	EXTERNAL TOOTH	STAINLESS STEEL DIN 1.4006

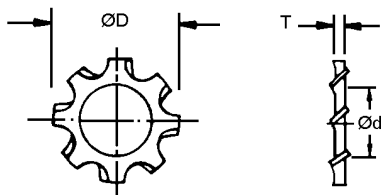

STOCK NO.	THREAD	ØD	Ød	TOL	T	TOL
Z1-M2	M2	4.4	2.1	+0.3	0.5	±0.1
Z1-M3	M3	6.2	3.1	+0.3	0.8	±0.1
Z1-M4	M4	7.6	4.1	+0.3	0.9	±0.1
Z1-M5	M5	9.2	5.1	+0.3	1.2	±0.1
Z1-M6	M6	11.8	6.1	+0.4	1.6	±0.1
Z1-M8	M8	14.8	8.1	+0.4	2.0	±0.1
Z1-M10	M10	18.1	10.2	+0.5	2.2	±0.15

SCREW SIZE	STYLE	MATERIAL
M2 TO M10	INTERNAL TOOTH	STAINLESS STEEL DIN 1.4006

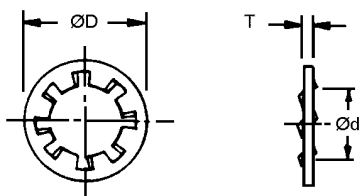

STOCK NO.	SCREW SIZE	ØD h14	Ød h13	T
Z2-M2	M2	4.5	2.2	0.3
Z2-M3	M3	6.0	3.2	0.4
Z2-M4	M4	8.0	4.3	0.5
Z2-M5	M5	10.0	5.3	0.6
Z2-M6	M6	11.0	6.4	0.7
Z2-M8	M8	15.0	8.4	0.8
Z2-M10	M10	18.0	10.5	0.9



THRUST WASHERS

SHAFT SIZE	TYPE	MATERIAL
5 TO 25	HARDENED GROUND	STAINLESS STEEL DIN 1.4006 OR CARBON STEEL

STAINLESS STEEL STOCK NO.	CARBON STEEL STOCK NO.	INSIDE DIA. +0.30 -0.00	OUTSIDE DIA. +0.00 -0.31	T ±0.05	SHAFT SIZE
CD1M-2-SS	CD1M-2	5.00	12.00	1.30	5
CD1M-3-SS	CD1M-3	6.00	14.00	1.30	6
CD1M-4-SS	CD1M-4	7.00	17.00	1.30	7
CD1M-5-SS	CD1M-5	8.00	16.00	1.30	8
CD1M-6-SS	CD1M-6	10.00	21.00	1.60	10
CD1M-7-SS	CD1M-7	12.00	24.00	1.60	12
CD1M-8-SS	CD1M-8	16.00	28.00	2.40	16
CD1M-9-SS	CD1M-9	19.00	32.00	2.40	19
CD1M-10-SS	CD1M-10	25.00	41.00	3.18	25

SHAFT SIZE	TYPE	MATERIAL
3 TO 25	PLASTIC	NYLON AND TEFLON

NYLON STOCK NO.	TEFLON® STOCK NO.	I.D. +0.13 -0.00	O.D. +0.00 -0.13	T ±0.05	SHAFT SIZE
CD7M-1	CD8M-1	3.00	9	2.5	3
CD7M-2	CD8M-2	4.00	12	2.5	4
CD7M-3	CD8M-3	5.00	13	2.5	5
CD7M-4	CD8M-4	6.00	15	2.5	6
CD7M-5	CD8M-5	8.00	19	2.5	8
CD7M-6	CD8M-6	10.00	24	2.5	10
CD7M-7	CD8M-7	12.00	30	2.5	12
CD7M-8	CD8M-8	20.00	40	2.5	20
CD7M-9	CD8M-9	25.00	40	2.5	25

SHAFT SIZE	TYPE	MATERIAL
3 TO 11	LUBRICATING	BRONZE OIL-IMPREGNATED

STOCK NO.	I.D. +0.1 -0.0	O.D. +0.00 -0.1	T ±0.05	SHAFT SIZE
CD3M-1	3.1	8.9	1.5	3
CD3M-2	4.1	11.9	1.5	4
CD3M-3	6.1	14.9	1.5	6
CD3M-4	8.1	18.9	2.2	8
CD3M-5	10.1	23.9	3.0	10
CD3M-6	11.1	28.9	4.7	11

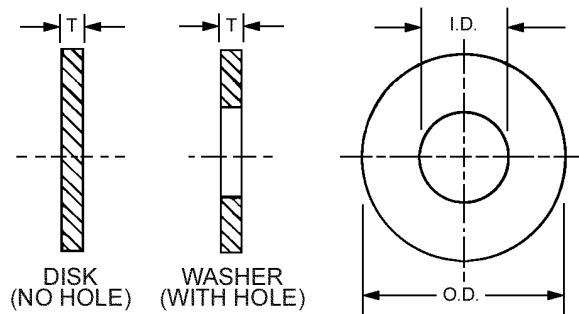

F

WASHERS

STYLE	SHAFT SIZE	OUTSIDE DIAMETER	MATERIALS
BELLEVILLE	4 TO 12	8 TO 25	1095 CARBON STEEL

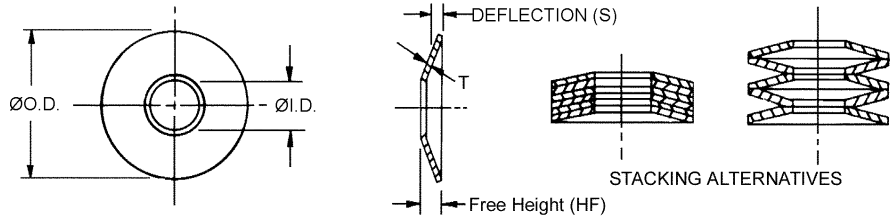

STOCK NO.	ØO.D.	ØI.D.	T	HF (Ref.)	SPRING LOAD (N) AT S=0.25HF
STM-1	8	4.2	0.2	0.45	21
STM-2			0.3	0.55	52
STM-3			0.4	0.6	78
STM-4	10	5.2	0.25	0.55	30
STM-5			0.4	0.7	88
STM-6			0.5	0.75	122
STM-7	12.5	6.2	0.35	0.8	84
STM-8			0.50	0.85	120
STM-9			0.7	1.0	239
STM-10	16	8.2	0.4	0.9	84
STM-11			0.6	1.05	172
STM-12			0.9	1.25	363
STM-13	20	10.2	0.5	1.15	141
STM-14			0.8	1.35	304
STM-15			1.1	1.55	548
STM-16	25	12.2	0.7	1.6	331
STM-17			0.9	1.6	367
STM-18			1.5	2.05	1040



Sold in packages of 10.

STYLE	SHAFT SIZE	OUTSIDE DIAMETER	MATERIALS
CURVED	3 TO 10	6 TO 18	1095 CARBON STEEL

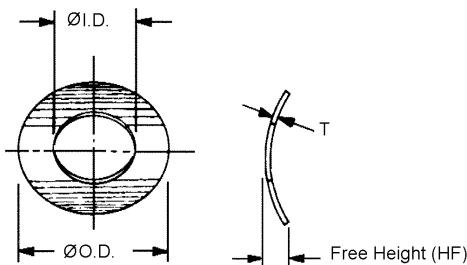

STOCK NO.	ØI.D. (H14)	ØO.D. (js16)	HF (MIN.)	T
SUM-1	3.2	6.0	0.65	0.4
SUM-2	4.3	8.0	0.8	0.5
SUM-3	5.3	10.0	0.9	0.5
SUM-4	6.4	11.0	1.1	0.5
SUM-5	8.4	15.0	1.7	0.5
SUM-6	10.5	18.0	2.0	0.8



I.D. Based in long axis providing free fit on normal screw.

Sold in packages of 10.

THREAD INSERTS

THREAD SIZE	TYPE	MATERIAL
M3 X 0.5 TO M8 X 1.25	SELF TAPING	STAINLESS STEEL DIN 1.4305

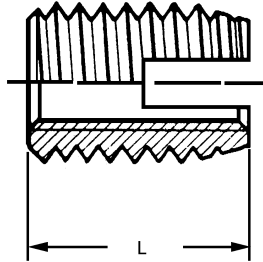
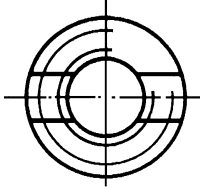

LOCKING			INSTALLATION DATA			
STOCK NUMBER	THREAD SIZE	LENGTH L ±0.3	RETAINING HOLE DIAMETER		MIN. HOLE DEPTH	INSTAL. TOOL PART NO.
			SOFT PLASTICS HARD WOOD	ALUMINUM HARD BRITTLE PLASTICS		
Y23-M3-4	M3 x 0.5	6	4.5 To 4.6	4.6 To 4.7	8	Y15-PM3
Y23-M4-5	M4 x 0.7	8	5.8 To 5.9	6.0 To 6.1	10	Y15-PM4
Y23-M5-8	M5 x 0.8	10	7.1 To 7.2	7.3 To 7.5	13	Y15-PM5
Y23-M6-10	M6 x 1.0	14	8.1 To 8.2	8.3 To 8.5	15	Y15-PM6
Y23-M8-12	M8 x 1.25	15	10.6 To 10.8	10.9 To 11.2	18	Y15-PM8

- Increase holding power
- Positive locking power
- Eliminates stripping, seizing and corrosion
- Long life without thread wear
- Save space, weight and material
- No more lock nuts

F

PINS

TYPE	MATERIALS
TAPER	STAINLESS STEEL DIN 1.4305

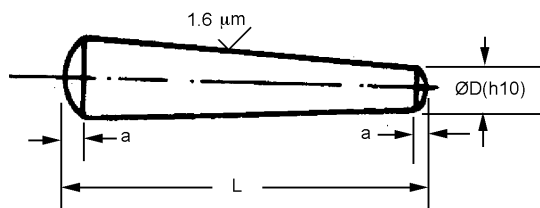

STOCK NO.	ØO.D.	L	a	Ref. SHAFT SIZE
CP3M-1	1.00	8.00	0.12	3.00
CP3M-2		10.00		TO
CP3M-3		12.00		4.00
CP3M-4	1.50	10.00	0.20	5.00
CP3M-5		12.00		
CP3M-6		14.00		
CP3M-7		16.00		
CP3M-8	20.00			
CP3M-9	2.00	12.00	0.25	6.00
CP3M-10		14.00		
CP3M-11		16.00		
CP3M-13		20.00		
CP3M-14	3.00	14.00	0.40	10.00
CP3M-16		20.00		
CP3M-17		25.00		
CP3M-18	4.00	16.00	0.50	12.00
CP3M-19		20.00		
CP3M-20		25.00		
CP3M-21		30.00		

Sold in packages of 10.

Taper 1:50

PINS

TYPE	MATERIALS
ROLL OR SPRING	STAINLESS STEEL DIN 1.4300

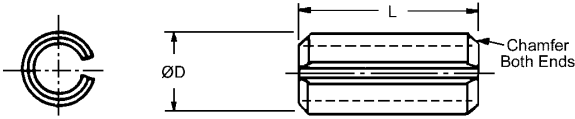

STOCK NO.	O.D. MIN.	L	DRILL SIZE	REF. SHAFT DIA.
CP5M-1	1.7	6	1.5	4.00 TO 5.00
CP5M-2		8		
CP5M-3		10		
CP5M-4		12		
CP5M-5		14		
CP5M-6		16		
CP5M-7	2.3	10	2.0	6.00
CP5M-8		12		
CP5M-9		14		
CP5M-10		16		
CP5M-11		18		
CP5M-12	3.3	10	3.0	8.00 TO 10.00
CP5M-13		12		
CP5M-14		14		
CP5M-15		16		
CP5M-16		18		
CP5M-17		20		



Sold in packages of 10.

TYPE	MATERIALS
ROLL OR SPRING STANDARD DUTY	STAINLESS STEEL DIN 1.4300

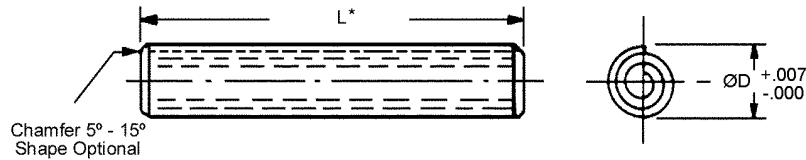

STOCK NO.	ØD	L*	DRILL SIZE	(Ref.) SHAFT
CP6M-6	1.0	4	1.0	3.00
CP6M-7		6		
CP6M-8		8		
CP6M-9		10		
CP6M-10		14		
CP6M-18	1.5	6	1.5	3.00 AND 4.00
CP6M-19		10		
CP6M-24	2.0	4	2.0	5.00 AND 6.00
CP6M-25		10		
CP6M-26		14		
CP6M-27		20		
CP6M-31	2.5	6	2.5	7.00
CP6M-32		12		
CP6M-33		18		
CP6M-38	3.0	12	3.0	8.00 THROUGH 10.00
CP6M-39		20		
CP6M-40		30		
CP6M-43	4.0	8	4.0	11.00 AND 12.00
CP6M-44		12		
CP6M-45		20		
CP6M-46		30		
CP6M-47		40		
CP6M-48*		50		



*Length tolerance of plus 0.5 for all lengths through 10mm
Plus 1.0 for all lengths over 10mm through 50mm.

Sold in packages of 10.

PINS

TYPE	MATERIALS
COTTER	STAINLESS STEEL DIN 1.4310

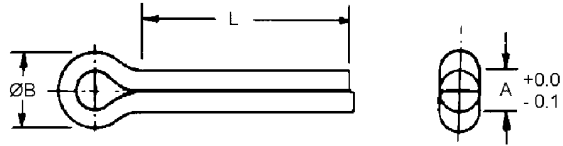

STOCK NO.	A	ØB MIN.	L	HOLE SIZE
CP1-31	0.8	2	10	1.2
CP1-32			13	
CP1-1			19	
CP1-34			25	
CP1-2	1.2	2	25	1.6
CP1-35	1.5	3	10	2.0
CP1-36			13	
CP1-37			19	
CP1-3			25	
CP1-9			38	
CP1-4	1.9	4	32	2.4
CP1-10	2.3	5	13	2.8
CP1-11			19	
CP1-12			25	
CP1-5			38	
CP1-14	3.0	6	13	3.6
CP1-15			19	
CP1-16			25	
CP1-17			38	
CP1-7			51	
CP1-19	3.8	6	19	4.4
CP1-20			25	
CP1-21			38	
CP1-22			51	
CP1-23	4.5	10	25	5.2
CP1-24			38	
CP1-25			51	
CP1-26			64	
CP1-27	5.7	13	38	6.8
CP1-28			51	
CP1-29			64	

SOLD IN PACKAGES OF 10.

PINS

TYPE	DIAMETER SIZE	MATERIALS
DOWEL SOFT PINS	1 TO 12	STAINLESS STEEL DIN 1.4305 ROCKWELL B75-95

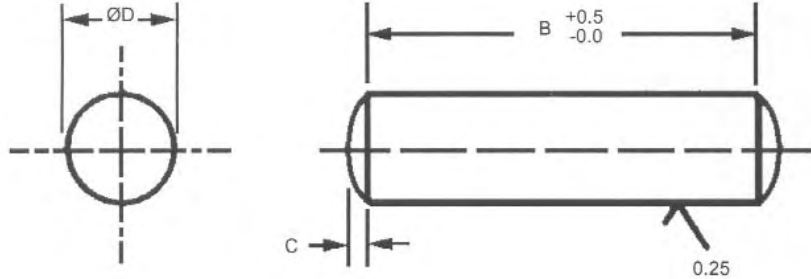

B	$\text{ØD}=1^{+0.009}_{+0.002}$	$\text{ØD}=1.5^{+0.009}_{+0.002}$	$\text{ØD}=2^{+0.009}_{+0.002}$	$\text{ØD}=2.5^{+0.009}_{+0.002}$
	C=0.15	C=0.23	C=0.30	C=0.40
	STOCK NO.	STOCK NO.	STOCK NO.	STOCK NO.
3	D10M-1	-	-	-
4	D10M-2	D15M-2	D20M-2	D25M-2
5	D10M-3	D15M-3	D20M-3	D25M-3
6	D10M-4	D15M-4	D20M-4	D25M-4
8	D10M-5	D15M-5	D20M-5	D25M-5
10	D10M-6	D15M-6	D20M-6	D25M-6
12	D10M-7	D15M-7	D20M-7	D25M-7
14	D10M-8	D15M-8	D20M-8	D25M-8
16	D10M-9	D15M-9	D20M-9	D25M-9
18	D10M-10	D15M-10	D20M-10	D25M-10
20	D10M-11	D15M-11	D20M-11	D25M-11
24	D10M-12	D15M-12	D20M-12	D25M-12
B	$\text{ØD}=3^{+0.012}_{+0.004}$	$\text{ØD}=4^{+0.012}_{+0.004}$	$\text{ØD}=5^{+0.012}_{+0.004}$	$\text{ØD}=6^{+0.015}_{+0.006}$
	C=0.45	C=0.63	C=0.75	C=0.90
	STOCK NO.	STOCK NO.	STOCK NO.	STOCK NO.
4	D30M-1	-	-	-
5	D30M-2	D40M-2	D50M-2	-
6	D30M-3	D40M-3	D50M-3	D60M-3
8	D30M-4	D40M-4	D50M-4	D60M-4
10	D30M-5	D40M-5	D50M-5	D60M-5
12	D30M-6	D40M-6	D50M-6	D60M-6
14	D30M-7	D40M-7	D50M-7	D60M-7
16	D30M-8	D40M-8	D50M-8	D60M-8
18	D30M-9	D40M-9	D50M-9	D60M-9
20	D30M-10	D40M-10	D50M-10	D60M-10
24	D30M-11	D40M-11	D50M-11	D60M-11
28	D30M-12	D40M-12	D50M-12	D60M-12
B	$\text{ØD}=8^{+0.015}_{+0.006}$	$\text{ØD}=10^{+0.015}_{+0.006}$	$\text{ØD}=12^{+0.018}_{+0.007}$	
	C=1.20	C=1.50	C=1.80	
	STOCK NO.	STOCK NO.	STOCK NO.	
12	D80M-1			
14	D80M-2	D100M-2	-	
16	D80M-3	D100M-3	-	
18	D80M-4	D100M-4	D120M-4	
20	D80M-5	D100M-5	D120M-5	
24	D80M-6	D100M-6	D120M-6	
28	D80M-7	D100M-7	D120M-7	
32	D80M-8	D100M-8	D120M-8	
36	-	D100M-9	D120M-9	
40	-	D100M-10	D120M-10	
50	-	-	D120M-11	

SOLD IN PACKAGES OF 10.

PINS

TYPE	DIAMETER SIZE	MATERIALS
HARDENED DOWEL	2 TO 10	STAINLESS STEEL DIN 1.4005 ROCKWELL B36-42

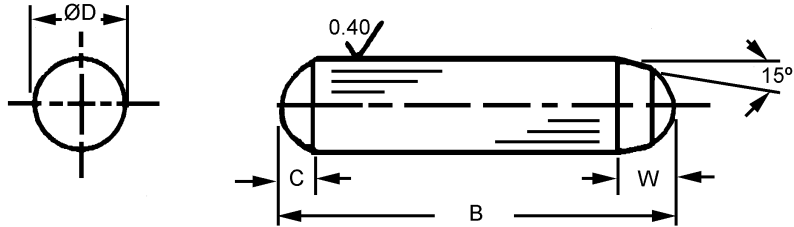

B	ØD = 2.009 - .007	ØD = 2.509 - .007	ØD = 3.012 - .007	ØD = 4.012 - .008
	W = 0.78 C = 0.30	W = 0.95 C = 0.40	W = 1.10 C = 0.45	W = 1.40 C = 0.60
	STOCK NO.	STOCK NO.	STOCK NO.	STOCK NO.
5	D40-1	D41-1	-	-
6	D40-2	D41-2	D42-2	-
8	D40-3	D41-3	D42-3	-
10	D40-4	D41-4	D42-4	D43-4
12	D40-5	D41-5	D42-5	D43-5
14	D40-6	D41-6	D42-6	D43-6
16	D40-7	D41-7	D42-7	D43-7
20	D40-8	D41-8	D42-8	D43-8
24	D40-9	D41-9	D42-9	D43-9
B	ØD = 5.012 - .008	ØD = 6.015 - .009	ØD = 8.015 - .009	ØD = 10.018 - .011
	W = 1.70 C = 0.75	W = 2.10 C = 0.90	W = 2.50 C = 1.20	W = 3.00 C = 1.50
	STOCK NO.	STOCK NO.	STOCK NO.	STOCK NO.
10	D44-4	-	-	-
12	D44-5	D45-5	-	-
16	D44-7	D45-7	D46-7	-
20	D44-8	D45-8	D46-8	D47-8
24	D44-9	D45-9	D46-9	D47-9
30	D44-10	D45-10	D46-10	D47-10
40	-	D45-11	D46-11	D47-11

SOLD IN PACKAGES OF 10.

MISCELLANEOUS ITEMS

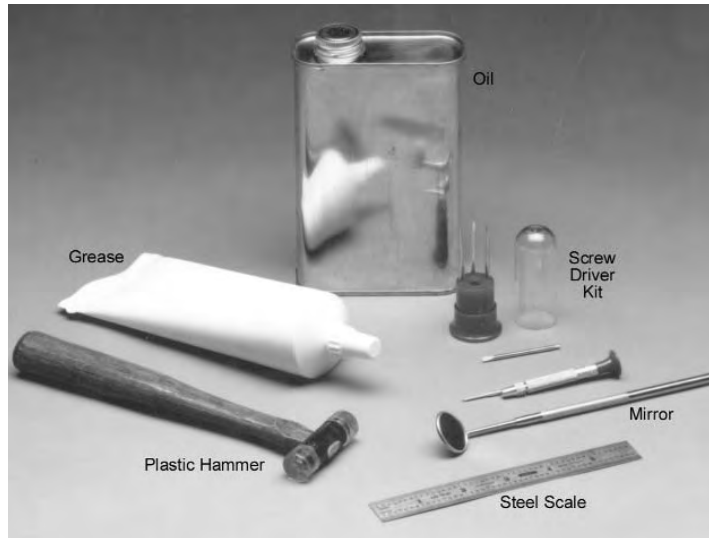

STOCK NO.	ITEM	DESCRIPTION
TR-8 TR-34	GREASE	INSTRUMENT (-54°C TO +121°C) RECOMMENDED FOR GEAR MESHES & BALL BEARINGS. (-73°C TO +121°C) RECOMMENDED FOR GEAR MESHES & BALL BEARINGS
TR-9	OIL	(-54°C TO +121°C) RECOMMENDED FOR ALL PRECISION APPLICATIONS
TR-18 TR-19	INSP MIRROR	19mm DIAMETER MIRROR WITH HANDLE 19mm DIAMETER MAGNIFYING MIRROR WITH HANDLE
TR-20	INSTR. SCREW DRIVERS	SET OF ASSTD. SMALL PRECISION INSTR. SCREW DRIVER IN A PLASTIC CASE WITH COVER
TR-21	PLASTIC HAMMER	HAMMER IS STYLED TO PREVENT MARKING FACES OF WORKING SURFACE
TR-22	STEEL SCALE	6" STAINLESS STEEL 1/32 & 1/64 GRAD'S WITH DECIMAL CHART (INCH SCALE ONLY)

F

MISCELLANEOUS ITEMS



STOCK NO.	ITEM	DESCRIPTION
TR-35	HEX WRENCHES	PLASTIC CASE WITH 8 KEYS (1.3 TO 4.0)
TR-23	TWEEZERS	STAINLESS STEEL FOR INSTR. PARTS HANDLING
TR-36	LOUPE	2.5 IPOWER
TL-1	CABLE CUTTERS	CUTTER FOR UP TO Ø1.2 CABLE
TL-2	CABLE CUTTERS	CUTTER FOR UP TO Ø4.0 CABLE
CE-1	ADHESIVE	30cc BOTTLE USE WHEN METAL IS ONE OR BOTH OF THE BONDED PARTS
CE-3		30cc BOTTLE USE WHEN PLASTIC, RUBBER, CERAMIC OR GLASS IS TO BE BONDED
CE-24		3cc CONTAINER
CE-6	LIQUID PIN	50 cc BOTTLE
CE-7		250 cc BOTTLE
CE-28	SOLVENT	350cc CLEANER-SOLVENT SPRAY CAN
CE-10	LUBRICANT 12 OZ. CAN	SILICONE LUBRICANT & RELEASE AGENT NON TOXIC, NON FLAMMABLE & FOOD GRADE
CE-12	LUBRICANT 12 OZ. CAN	DRY LUBRICANT & ANTI STICK AGENT SLICK ACTION, CONTAINS NO OIL, NO GREASE, & NO SILICONE
CE-14	LUBRICANT 16 OZ. CAN	RUST INHIBITING LUBRICANT & PENETRANT ACTION LUBE, DISPLACES WATER, CLEANS AND PROTECTS
CE-16		INSTANT CLEANER & DEGREASER FOR CONTACTS, SWITCHES ETC. MAYBE APPLIED TO EQUIPMENT WHILE IN OPERATION

RETAINER RINGS

TYPE	MATERIALS
EXTERNAL LUG DESIGN	SPRING STEEL

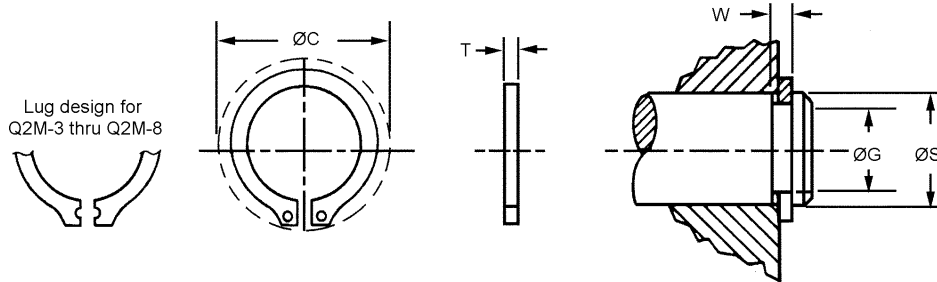

Lug design for Q2M-3 thru Q2M-8



Retainer Ring Pliers. Order separately.

STOCK NO.	ØG GROOVE DIA.	ØS SHAFT SIZE	GROOVE WIDTH W (H13)	T	ØC CLEARANCE DIAMETER	PLIERS STOCK NO.
Q2M-3	2.80 - 0.04	3.00	0.50	0.40	7.0	S11-12P
Q2M-4	3.80 - 0.04	4.00	0.50	0.40	8.6	S11-12P
Q2M-5	4.80 - 0.04	5.00	0.70	0.60	10.3	S11-18P
Q2M-6	5.70 - 0.04	6.00	0.80	0.70	11.7	S11-18P
Q2M-8	7.60 - 0.06	8.00	0.90	0.80	14.7	S11-25P
Q2M-10	9.60 - 0.11	10.00	1.10	1.00	17.0	S11-25P
Q2M-12	11.50 - 0.11	12.00	1.10	1.00	18.0	S11-25P



SOLD IN PACKAGES OF 10.

TYPE	MATERIALS
INTERNAL LUG DESIGN	SPRING STEEL

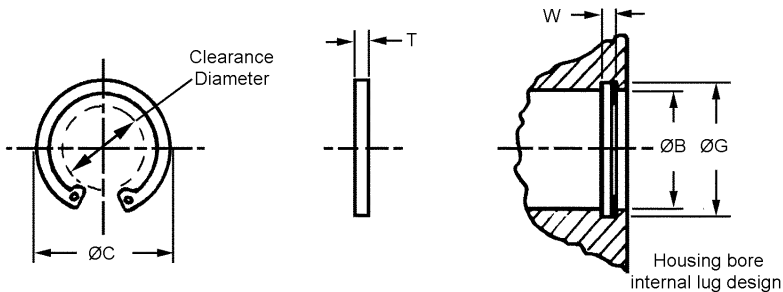

Retainer Ring Pliers. Order separately.

STOCK NO.	HOUSING BORE ØB	GROOVE DIA. ØG	RING THICKNESS T	PLIERS STOCK NO.	MAX. (ØC) CLEARANCE DIAMETER	GROOVE WIDTH W (MIN.)
Q4M-9	9.00	9.40 + 0.11	0.8	S13-37P	3.7	0.90
Q4M-10	10.00	10.40 + 0.11	1.0	S13-37P	3.3	1.10
Q4M-11	11.00	11.40 + 0.11	1.0	S13-37P	4.1	1.10
Q4M-13	13.00	13.60 + 0.11	1.0	S13-37P	5.4	1.10
Q4M-15	15.00	15.70 + 0.11	1.0	S13-37P	7.2	1.10
Q4M-16	16.00	16.80 + 0.11	1.0	S13-37P	8.0	1.10
Q4M-19	19.00	20.00 + 0.15	1.0	S13-37P	10.4	1.10
Q4M-22	22.00	23.00 + 0.15	1.0	S13-37P	13.2	1.10
Q4M-26	26.00	27.20 + 0.21	1.2	S13-37P	16.7	1.30

SOLD IN PACKAGES OF 10.



RETAINER RINGS

TYPE	MATERIALS
EXTERNAL SNAP ON DESIGN	SPRING STEEL

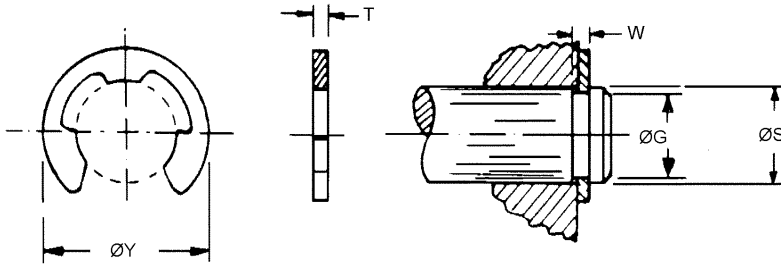

Retainer Ring Pliers. Order separately.

STOCK NO.	SHAFT SIZE ØS	GROOVE ØG (h11)	GROOVE WIDTH W (MIN)	T RING THICKNESS MAX.	O.D. RING Y MAX.	APPLICATOR TOOL NO.
Q1M-2	2	1.2	0.34	0.32	3.3	S10-6T
Q1M-3	3	1.9	0.54	0.52	4.8	S10-9T
Q1M-4	4	2.3	0.64	0.62	6.3	S10-12T
Q1M-5	5	3.2	0.64	0.62	7.3	S10-18T
Q1M-6	6	4.0	0.74	0.72	9.3	S10-18T
Q1M-8	8	5.0	0.74	0.72	11.3	S10-25T
Q1M-10	10	7.0	0.94	0.92	14.3	S10-31T
Q1M-11	11	8.0	1.05	1.03	16.3	S10-50T
Q1M-12	12	8.0	1.05	1.03	16.3	S10-50T
Q1M-16	16	12.0	1.35	1.33	23.4	S10-62T
Q1M-19	19	15.0	1.55	1.53	29.4	S10-75T



Sold in packages of 10.

TYPE	MATERIALS
EXTERNAL POWER GRIP DESIGN	SPRING STEEL

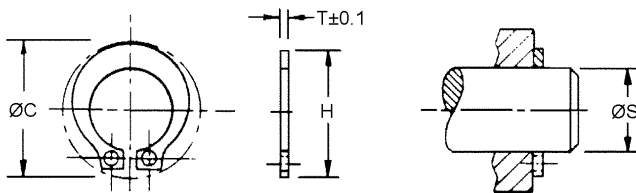

Retainer Ring Pliers. Order separately.

STOCK NO.	SHAFT SIZE ØS	T RING THICKNESS	CLEARANCE ØC	ASSEMBLY PLIER STOCK NO.
Q7M-2	2	0.6	6.4	S14-12P
Q7M-3	3	0.6	7.4	S14-12P
Q7M-4	4	0.6	9.1	S14-12P
Q7M-5	5	0.8	11.2	S14-25P
Q7M-6	6	1.0	12.7	S14-25P
Q7M-8	8	1.1	17.0	S14-37P
Q7M-10	10	1.2	19.3	S14-37P
Q7M-11	11	1.3	20.3	S14-87P
Q7M-14	14	1.5	25.1	S14-37P
Q7M-19	19	1.6	33.0	S14-37P

Sold in packages of 10.



RETAINER RINGS

TYPE	MATERIALS
EXTERNAL BOWED SNAP ON DESIGN	SPRING STEEL

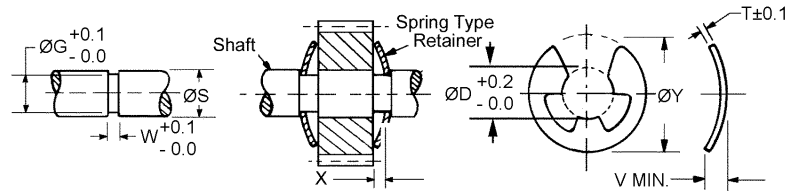

STOCK NO.	ØS SHAFT SIZE	FLAT ØY	T	V	X MAX. TAKE UP	FREE I.D. ØD	W	ØG
Q3M-3	3	5.8	0.3	0.6	0.3	2.3	0.6	2.4
Q3M-4	4	7.2	0.4	0.8	0.3	2.8	0.7	2.9
Q3M-8	8	12.7	0.6	1.3	0.6	6.1	1.2	6.3
Q3M-11	11	17.4	0.9	1.5	0.6	8.5	1.5	8.7
Q3M-16	16	23.9	1.1	2.0	0.9	12.1	2.0	12.3
Q3M-19	19	25.4	1.3	2.2	0.9	15.5	2.2	15.9
Q3M-25	25	38.1	1.3	2.2	0.9	20.8	2.2	21.2



Applicator tools are available on request.
Sold in packages of 10.

TYPE	MATERIALS
EXTERNAL DESIGN	CARBON STEEL PLATED

F

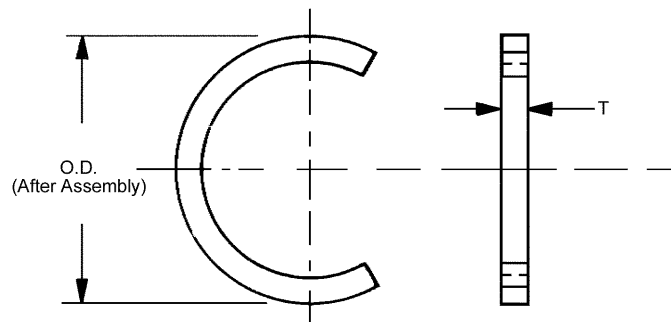

STOCK NO.	SHAFT SIZE	FREE O.D. (MAX.)	T	GROOVE DIMENSIONS	
				WIDTH (MIN.)	DIAMETER (MIN.)
Q5M-4	4	3.7	0.5	0.6	3.7
Q5M-8	8	7.4	0.8	0.9	7.5
Q5M-13	13	12.0	1.2	1.3	12.1
Q5M-16	16	15.0	1.4	1.6	15.2
Q5M-19	19	18.1	1.6	1.8	18.2
Q5M-23	23	21.8	1.2	1.3	22.0
Q5M-24	24	22.7	1.8	2.0	23.2
Q5M-32	32	130.2	1.5	1.6	30.5
Q5M-40	40	137.7	1.6	1.8	38.0
Q5M-45	45	142.7	1.6	1.8	43.0



Sold in packages of 10.

BEARING PRE-LOAD SPRINGS

TYPE	MATERIALS
FOR OUTER RACE BALL BEARIN PRE-LOAD	STAINLESS STEEL DIN 1.4300

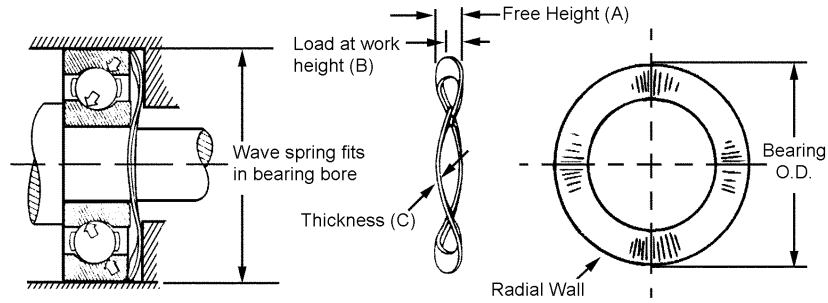

STOCK NO.	BEARING O.D. (Ref.)	A	B	C	FORCE TO DEFLECT TO B	RADIAL WALL
SVM-1	16	2.3	1.6	0.25	45N	1.98
SVM-2	19	3.0		0.25	50N	
SVM-3	22	2.8	1.6	0.30	60N	2.39
SVM-4	24	3.6		0.30	70N	

Sold in packages of 10.



SPACERS

TYPE	SHAFT SIZE	MATERIALS
INNER RACE SHIM	3 TO 10	BRASS

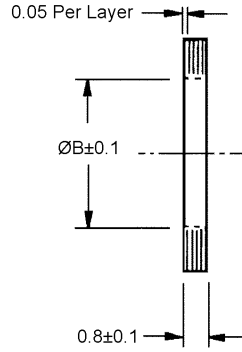
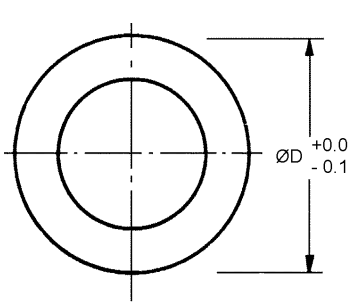

STOCK NO.	SHAFT SIZE	ØD	ØB
SS8-1M	3	5.9	3.2
SS8-2M	5	9.5	5.2
SS8-3M	6	12.7	6.2
SS8-4M	10	15.9	10.2

Sold in packages of 10.

The inner race spacer fits on shaft and pre-loads inner race of ball bearing.



TYPE	SHAFT SIZE	MATERIALS
OUTER RACE SHIM	8.0 TO 11.0	BRASS

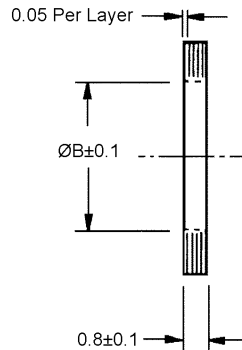
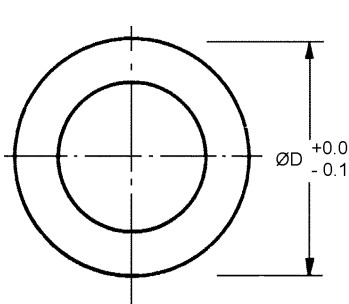

STOCK NO.	D	B
SS7-1M	10.0	7.9
SS7-2M	13.0	9.5
SS7-3M	16.0	11.1

Sold in packages of 10.

The outer race spacer fits in housing and pre-loads outer race of ball bearing.



F

SHAFT SPACERS

TYPE	SHAFT SIZE	MATERIALS
INNER RACE	3.00 TO 10.00	STAINLESS STEEL DIN 1.4310

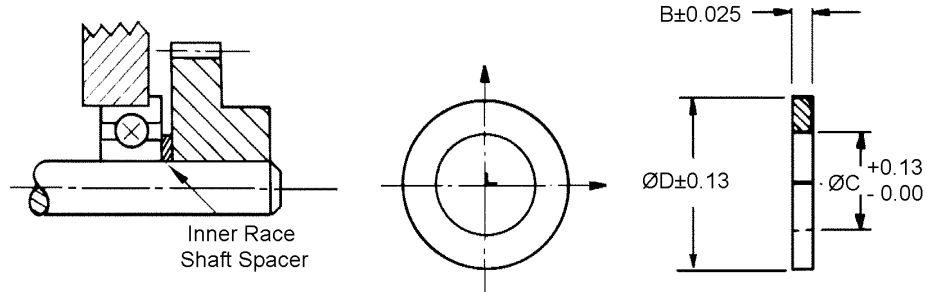

STOCK NO.	SHAFT SIZE OR BEARING I.D.	$\varnothing C$	$\varnothing D$	B
SS1-117 SS1-118	3.00	3.05	3.73	0.10 0.15
SS1-101 SS1-102 SS1-103 SS1-104	4.00	4.05	5.30	0.10 0.15 0.25 0.40
SS1-121 SS1-122 SS1-123 SS1-124	5.00	5.05	5.93	0.10 0.15 0.25 0.40
SS1-105 SS1-106 SS1-107 SS1-108	6.00	6.05	7.90	0.10 0.15 0.25 0.40
SS1-109 SS1-110 SS1-111 SS1-112	8.00	8.05	10.20	0.10 0.15 0.25 0.40
SS1-113 SS1-114 SS1-115 SS1-116	10.00	10.05	12.30	0.10 0.15 0.25 0.40



Sold in packages of 10.

Also available

STOCK NUMBER	DESCRIPTION
KIT-SS1M	STAINLESS STEEL SHAFT SPACERS, INNER RACE, 3mm THRU 10mm SHAFT SIZE (300 PIECES)

BEARING SPACERS

TYPE	SHAFT SIZE	MATERIALS
OUTER RACE	7.00 TO 19.00	STAINLESS STEEL DIN 1.4300

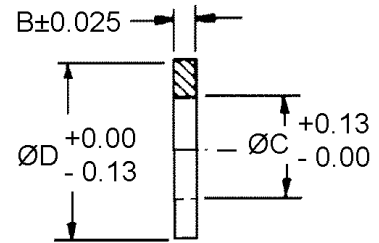
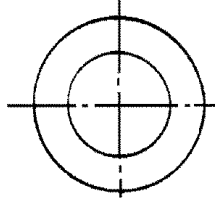
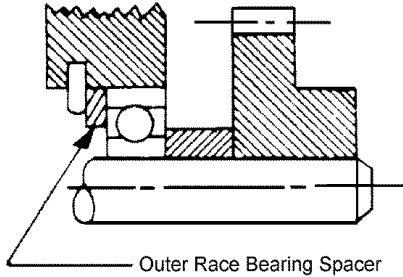

STOCK NO.	BEARING OUTSIDE DIA. (ØD)	ØC	B
SS3-113 SS3-114	7.00	6.25	0.15 0.25
SS3-115 SS3-116	8.00	6.75	0.15 0.25
SS3-101 SS3-102 SS3-103	9.00	7.85	0.15 0.25 0.40
SS3-117 SS3-118	10.00	8.25	0.15 0.25
SS3-119 SS3-120	11.00	10.00	0.15 0.25
SS3-104 SS3-105 SS3-106	13.00	11.15	0.15 0.25 0.40
SS3-121 SS3-122	15.00	13.00	0.15 0.25
SS3-107 SS3-108 SS3-109	16.00	13.85	0.15 0.25 0.40
SS3-110 SS3-111 SS3-112	19.00	16.65	0.15 0.25 0.40

F

BALLS

TYPE	DIAMETER	MATERIALS
HARDENED STEEL	2 TO 11	STAINLESS STEEL DIN 1.4112 OR CHROME STEEL DIN 1.3505

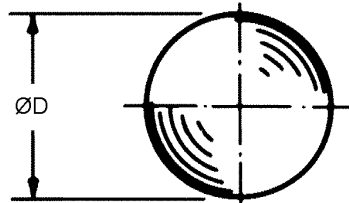

Sold in packages of 10.

$\varnothing D$	STAINLESS STEEL DIN 1.4112	CHROME STEEL DIN 1.3505
	$\pm.0012$	$\pm.0006$
	HARDNESS C55-60	HARDNESS C62-66
	STOCK NUMBER	STOCK NUMBER
2	PT4M-2	PT5M-2
3	PT4M-3	PT5M-3
4	PT4M-4	PT5M-4
5	PT4M-5	PT5M-5
6	PT4M-6	PT5M-6
7	PT4M-7	PT5M-7
8	PT4M-8	PT5M-8
9	PT4M-9	PT5M-9
10	PT4M-10	PT5M-10
11	PT4M-11	PT5M-11

SPRINGS

TYPE	STYLE	MATERIALS
COMPRESSION	RIGHT HAND - OPEN WOUND ENDS SQUARED	STAINLESS STEEL DIN 1.4305

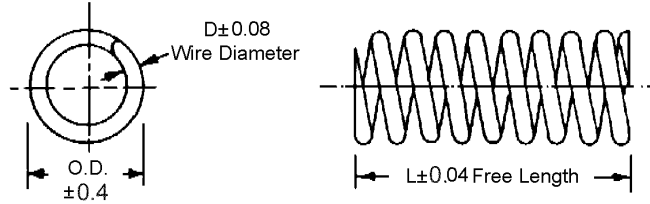

STOCK NO.	ØO.D.	ØD	L	COILS	K ±10%	
SPR1-1	1.45	0.18	9.5	18	276.5	
SPR9-1		0.20	6.3	13	771.7	
SPR9-2		0.20	12.7	24	364.0	
SPR9-3	2.24	0.25	6.3	9	728.0	
SPR1-2		0.25	12.7	17	334.3	
SPR9-5		0.30	9.5	14	946.7	
SPR9-6		0.30	19.0	24	465.5	
SPR9-7	3.05	0.41	6.3	7	2549.7	
SPR9-8		0.41	12.7	13	1209.2	
SPR9-9		0.46	9.5	10	2609.2	
SPR1-3		0.46	15.9	16	1543.5	
SPR9-10		0.46	19.0	19	1239.0	
SPR9-11		0.51	9.5	11	4037.2	
SPR9-12		0.51	19.0	20	1923.2	
SPR9-13		0.56	12.7	14	4532.5	
SPR9-14		0.56	25.4	27	2142.0	
SPR9-15		4.57	0.46	12.7	8	976.5
SPR9-16			0.46	25.4	14	465.5
SPR9-17			0.51	12.7	8	1414.0
SPR9-18			0.51	25.7	15	670.2
SPR1-4			0.56	12.7	8	2068.5
SPR9-20	0.56		25.4	16	946.7	
SPR9-21	0.61		12.7	9	2754.5	
SPR9-22	0.56		25.4	17	1610.7	
SPR9-23	0.66		12.7	9	3906.7	
SPR9-24	0.66		25.4	17	1778.0	
SPR9-25	0.74		19.0	14	3760.7	
SPR9-26	0.74		38.1	26	1806.0	
SPR9-27	0.81		19.0	14	6020.0	
SPR9-28	0.81		38.1	27	2740.5	
SPR9-29	6.10	0.66	12.7	6	3045.0	
SPR1-5		0.66	15.9	8	1849.7	
SPR9-30		0.66	25.4	12	1078.0	
SPR9-31		0.89	12.7	8	7070.0	
SPR9-32		0.89	25.4	14	3263.7	
SPR9-33		0.97	19.0	10	6720.0	
SPR9-34		0.97	38.1	20	3118.5	
SPR9-35		1.02	25.4	14	5684.0	
SPR9-36		1.02	50.8	27	2724.7	
SPR1-6	7.62	0.81	15.9	6	903.0	
SPR1-7	9.14	1.07	22.2	8	3717.0	
SPR1-8	10.67	1.14	25.4	7	2915.5	
SPR1-9	12.19	1.40	31.7	8	3935.7	
SPR1-10	15.24	1.60	38.1	8	3498.2	
SPR1-11	18.29	1.83	50.8	9	2915.5	

K = Average Spring Rate N/m.

Specials on request.

Sold in packages of 10.

SPRINGS

TYPE	LENGTHS	MATERIALS
COMPRESSION	38 TO 63	STAINLESS STEEL DIN 1.4305

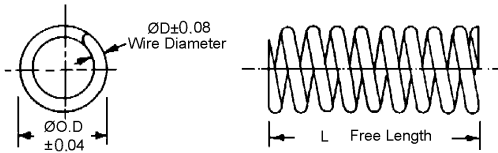

STOCK NO.	ØO.D.	ØD	L	APPROX. NO. COILS
SPR7-1	2.36	0.41	38.1	32
SPR7-2	3.18	0.46	50.8	37
SPR7-7	3.56	0.41	25.4	17
SPR7-8	4.37	0.46	31.7	19
SPR7-3	4.75	0.58	63.5	37
SPR7-4	6.35	0.64	76.2	29
SPR7-9	6.35	0.58	38.1	22
SPR7-10	8.33	0.64	44.4	19
SPR7-11	9.91	0.81	50.8	16
SPR7-12	11.89	1.02	57.1	12
SPR7-13	15.47	1.19	63.5	15

- Cut your own length
- Ends can be ground or looped

Special springs available on request (send drawing).

Sold in packages of 10.

TYPE	LENGTHS	MATERIALS
EXTENSION - FULL TWIST LOOPS CLOSE WOUND	6 TO 127	SPRING TEMPERED STAINLESS STEEL

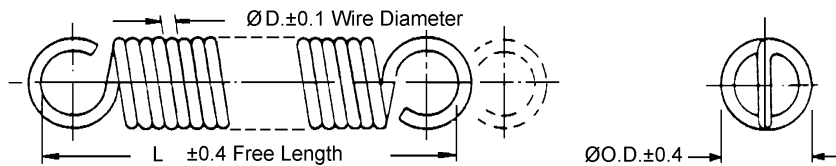

K = Spring rate in N/m

Sold in packages of 10.

STOCK NO.	ØO.D.	ØD	L	K ±10%	
SPR10-1	1.6	0.2	6.4	297	
SPR2-1		0.2	9.5	157	
SPR10-2		0.2	12.7	105	
SPR10-3	2.4	0.3	9.5	175	
SPR2-2		0.3	12.7	297	
SPR10-4		0.3	19.1	52	
SPR2-3	3.1	0.5	25.4	472	
SPR10-5	3.1	0.4	19.1	437	
SPR10-6		0.4	31.8	192	
SPR10-7		0.5	19.1	1207	
SPR10-8		0.5	31.8	647	
SPR2-4	4.6	0.7	31.8	735	
SPR10-9	4.6	0.6	19.1	630	
SPR10-10		0.6	31.8	297	
SPR10-11		0.7	19.1	1540	
SPR10-13		0.8	19.1	3953	
SPR10-4		0.8	31.8	1907	
SPR2-5		6.1	0.8	31.8	612
SPR10-15		6.1	0.7	19.1	822
SPR10-16	0.7		31.8	297	
SPR10-17	0.7		19.1	1435	
SPR10-18	0.7		31.8	560	
SPR10-19	0.8		19.1	2012	
SPR10-20	0.8		31.8	770	
SPR10-21	0.9		19.1	3220	
SPR10-22	0.9		31.8	1295	
SPR2-6	9.1	1.4	50.8	2660	
SPR10-27	9.1	0.8	25.4	472	
SPR10-28		0.8	31.8	210	
SPR10-29		0.9	25.4	1155	
SPR10-30		0.9	38.1	490	
SPR10-31		1.1	31.8	1977	
SPR10-32		1.1	50.8	910	
SPR10-33	1.4	31.8	5635		
SPR10-35	12.7	0.9	31.8	402	
SPR10-36		0.9	50.8	140	
SPR2-7		1.4	63.5	735	
SPR2-8	16.5	1.4	76.2	280	
SPR2-9	19.1	1.6	101.6	245	
SPR2-10	21.6	1.9	38.1	367	
SPR2-11	25.4	1.9	127.0	210	

SPRINGS

TYPE	LENGTHS	MATERIALS
TORSION LEFT HAND WOUND	12 TO 50	STAINLESS STEEL

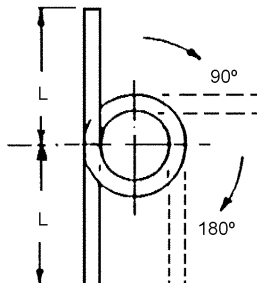
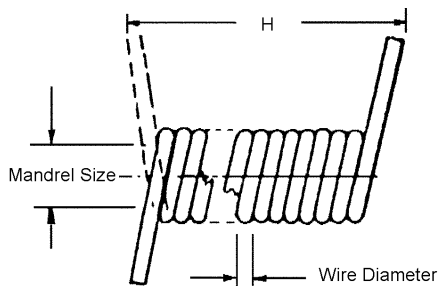

STOCK NUMBER	WIRE DIA.	OUTSIDE DIA.	L	MANDREL SIZE (MAX.)	H	TORQUE N*cm @ 180°
SPR3-1	0.3	4.2	12.7	2.8	1.5	0.5
SPR3-2	0.4	4.7	19.1	2.8	1.9	1.1
SPR3-3	0.5	5.5	19.1	3.6	2.8	1.6
SPR3-4	0.5	6.3	25.4	4.0	3.2	2.5
SPR3-5	0.6	7.7	25.4	5.2	3.8	4.2
SPR3-6	0.8	10.0	25.4	6.3	4.6	7.1
SPR3-7	0.9	11.4	31.8	7.1	3.1	11.3
SPR3-8	1.0	13.2	50.8	8.7	6.2	15.5
SPR3-9	1.2	15.6	50.8	10.3	7.4	28.3

Special springs on request, send sketch.

Right hand wound on request.

Sold in packages of 10.

F

COUPLINGS AND CLUTCHES

Table of Contents

COUPLINGS

Six Beam Flexible	.MG 2 - MG 7
Three Beam Flexible	.MG 8 - MG 11
Single Beam Flexible	.MG 12 - 13
Reli-A-Flex®	.MG 14 - MG 17
Flex-Thane Coupling	.MG 18
Absorbathane Flexible	.MG 19
Neo-Flex	.MG 20 - MG 21
Sleeve	.MG 22
Spider	.MG 23 - MG 24
Multi-Jaw	.MG 25
Bellows	.MG 26
Oldham	.MG 27 - MG 28
Universal Lateral	.MG 29 - MG 30
Wafer Spring	.MG 31 - MG 32

UNIVERSAL JOINTS .MG 33 - MG 34

TELESCOPIC UNIVERSAL JOINTS .MG 35

SHAFT ADAPTERS

Clamp Style	.MG 36
-------------	--------

SEE THE INCH SECTION FOR THE FOLLOWING

Metric Male / Inch Male - Plain	.G 61 - G 62
Inch Femal / Metric Male - Clamp Hub	.G 63 - G 64
Inch Male / Metric Female - Clamp Hub	.G 65
Inch Female / Metric Male - Pin Hub	.G 66 - G 68
Inch Male / Metric Female - Pin Hub	.G 69 - G 71

SHAFT EXTENSIONS (CLAMP HUB) .MG 37

SLIP COUPLINGS .MG 38 - MG 40

OVERRUNING COUPLING .MG 41

INLINE COUPLING SLIP CLUTCH .MG 42

SLIP CLUTCH .MG 43 - MG 46

MINIATURE SLIP CLUTCH .MG 47

SLIP CLUTCHES AND COUPLINGS .MG 48

ROLLER CLUTCHES .MG 49

SIX BEAM FLEXIBLE COUPLING

BORES	STYLE	MATERIAL
2MM TO 30MM	SET SCREW	ANODIZED ALUMINUM

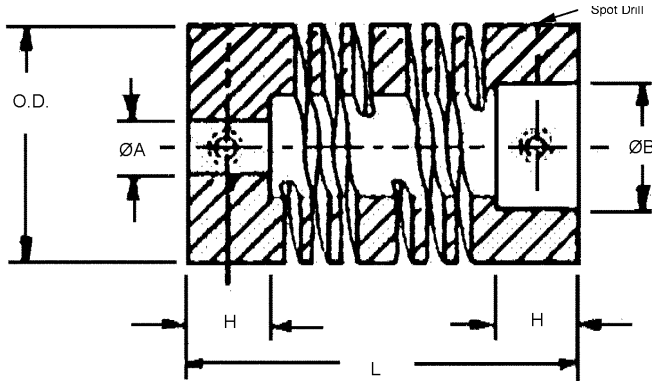

STOCK NO.	ØA +0.05 -0.00	ØB +0.05 -0.00	ØO.D.	L	H	ANGLE OFF SET	PARALLEL OFF SET	MAX. WORKING TORQUE (N*cm)
CO36A-1M	2.00	3.00	9.5	19.6	6.0	5°	0.1	55
CO36A-2M	3.00	3.00						
CO36A-3M	3.00	4.00						
CO36A-4M	4.00	4.00						
CO38A-1M	3.00	3.00	12.7	25.4	6.9	5°	0.2	110
CO38A-2M	3.00	5.00						
CO38A-3M	5.00	5.00						
CO38A-4M	6.00	6.00						
CO40A-1M	5.00	6.00	19.1	28.0	6.4	7°	0.3	280
CO40A-2M	6.00	6.00						
CO40A-3M	6.00	10.00						
CO40A-4M	10.00	10.00						
CO42A-1M	6.00	6.00	25.4	38.7	11.7	7°	0.4	490
CO42A-2M	8.00	8.00						
CO42A-3M	10.00	10.00						
CO42A-4M	13.00	13.00						
CO44A-1M	6.00	10.00	31.7	57.2	16.0	7°	0.5	680
CO44A-2M	10.00	10.00						
CO44A-3M	13.00	13.00						
CO44A-4M	16.00	16.00						
CO50A-1M	10.00	12.00	38.1	66.7	18.0	7°	0.6	900
CO50A-2M	12.00	12.00						
CO50A-3M	16.00	16.00						
CO52A-1M	14.00	14.00	44.5	76.2	20.0	7°	0.8	1000
CO52A-2M	16.00	16.00						
CO52A-3M	20.00	20.00						
CO54A-1M	20.00	20.00	57.2	130.0	32.0	7°	0.9	2200
CO54A-2M	25.00	25.00						
CO54A-3M	30.00	30.00						

Operating temperature -40° C to 120°C

Advantages

- One Piece construction, no mechanical joints
- No Backlash
- Constant velocity
- Torsionally rigid
- High Flexibility
- Small and lightweight
- High or low speeds
- Not temperature sensitive
- No lubrication
- Unaffected by climactic conditions
- Reversible

Applications

Encoders • Stepper Motors • Precision Ball Screws • Machine Tools • Robotics • Scientific Equipment
 • Measuring Instruments • Computers • Servo Systems • Optical Telescopes • Defense Systems
 • Medical Equipment • Appliances • Pumps • Valves • Fans

Central relief diameter may be smaller than bore in some cases.

SIX BEAM FLEXIBLE COUPLING

BORES	STYLE	MATERIAL
2MM TO 30MM	SET SCREW	STAINLESS STEEL DIN 1.4305

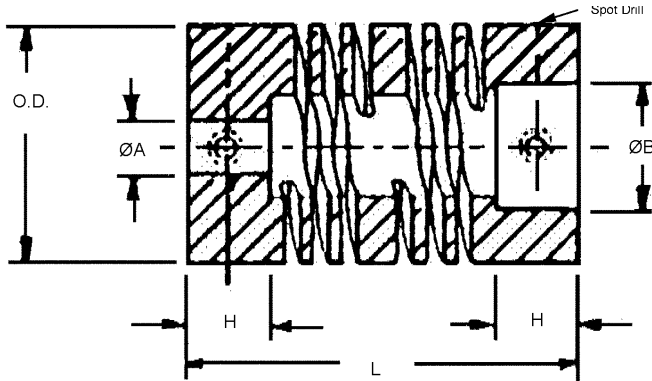

STOCK NO.	ØA +.05 -.00	ØB +.05 -.00	ØO.D.	L	H	ANGLE OFF SET	PARALLEL OFF SET	MAX. WORKING TORQUE (N*cm)
CO36S-1M	2.00	3.00						
CO36S-2M	3.00	3.00						
CO36S-3M	3.00	4.00	9.5	19.6	6.0	5°	0.1	85
CO36S-4M	4.00	4.00						
CO38S-1M	3.00	3.00						
CO38S-2M	3.00	5.00	12.7	25.4	6.9	5°	0.2	150
CO38S-3M	5.00	5.00						
CO38S-4M	6.00	6.00						
CO40S-1M	5.00	6.00						
CO40S-2M	6.00	6.00	19.1	28.0	6.4	7°	0.3	400
CO40S-3M	6.00	10.00						
CO40S-4M	10.00	10.00						
CO42S-1M	6.00	6.00						
CO42S-2M	8.00	8.00	25.4	38.7	11.7	7°	0.4	900
CO42S-3M	10.00	10.00						
CO42S-4M	13.00	13.00						
CO44S-1M	6.00	10.00						
CO44S-2M	10.00	10.00	31.7	57.2	16.0	7°	0.5	1000
CO44S-3M	13.00	13.00						
CO44S-4M	16.00	16.00						
CO50S-1M	10.00	12.00						
CO50S-2M	12.00	12.00	38.1	66.7	18.0	7°	0.6	1500
CO50S-3M	16.00	16.00						
CO52S-1M	14.00	14.00						
CO52S-2M	16.00	16.00	44.5	76.2	20.0	7°	0.8	1900
CO52S-3M	20.00	20.00						
CO54S-1M	20.00	20.00						
CO54S-2M	25.00	25.00	57.2	130.0	32.0	7°	0.9	4100
CO54S-3M	30.00	30.00						

Operating temperature -40° C to 120°C

Advantages

- One Piece construction. no mechanical joints
- No Backlash
- Constant velocity
- Torsionally rigid
- High Flexibility
- Small and lightweight
- High or low speeds
- Not temperature sensitive
- No lubrication
- Unaffected by climactic conditions
- Reversible

Applications

- Encoders • Stepper Motors • Precision Ball Screws • Machine Tools • Robotics • Scientific Equipment
 • Measuring Instruments • Computers • Servo Systems • Optical Telescopes • Defense Systems
 • Medical Equipment • Appliances • Pumps • Valves • Fans

Central relief diameter may be smaller than bore in some cases.



SIX BEAM FLEXIBLE COUPLING

BORES	STYLE	MATERIAL
2MM TO 30MM	SET SCREW	DELRIN

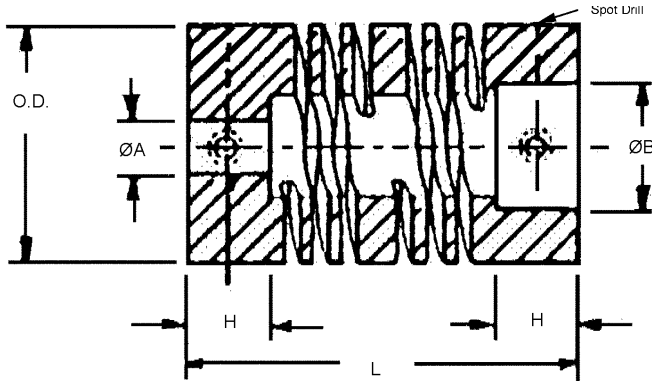

STOCK NO.	ØA +.05 -.00	ØB +.05 -.00	ØO.D.	L	H	ANGLE OFF SET	PARALLEL OFF SET	MAX. WORKING TORQUE (N*cm)
CO38D-1M CO38D-2M CO38D-3M CO38D-4M	3.00 3.00 5.00 6.00	3.00 5.00 5.00 6.00	12.7	25.4	6.9	5°	0.2	25
CO40D-1M CO40D-2M CO40D-3M CO40D-4M	5.00 6.00 6.00 10.00	6.00 6.00 10.00 10.00	19.1	28.0	6.4	7°	0.3	80
CO42D-1M CO42D-2M CO42D-3M CO42D-4M	6.00 8.00 10.00 13.00	6.00 8.00 10.00 13.00	25.4	38.7	11.7	7°	0.4	150
CO44D-1M CO44D-2M CO44D-3M CO44D-4M	6.00 10.00 13.00 16.00	10.00 10.00 13.00 16.00	31.7	57.2	16.0	7°	0.5	230
CO50D-1M CO50D-2M CO50D-3M	10.00 12.00 16.00	12.00 12.00 16.00	38.1	66.7	18.0	7°	0.6	275
CO52D-1M CO52D-2M CO52D-3M	14.00 16.00 20.00	14.00 16.00 20.00	44.5	76.2	20.0	7°	0.8	325
CO54D-1M CO54D-2M CO54D-3M	20.00 25.00 30.00	20.00 25.00 30.00	57.2	130.0	32.0	7°	0.9	380

Operating temperature -20° C to 60°C

Advantages

- One Piece construction. no mechanical joints
- No Backlash
- Constant velocity
- Torsionally rigid
- High Flexibility

• Small and lightweight

- High or low speeds
- Not temperature sensitive
- No lubrication
- Unaffected by climactic conditions
- Reversible

Applications

Encoders • Stepper Motors • Precision Ball Screws • Machine Tools • Robotics • Scientific Equipment
 • Measuring Instruments • Computers • Servo Systems • Optical Telescopes • Defense Systems
 • Medical Equipment • Appliances • Pumps • Valves • Fans

NOTE: Maximum angular offset of 10°.

Central relief diameter may be smaller than bore in some cases.

SIX BEAM FLEXIBLE COUPLING

BORES	STYLE	MATERIAL
2MM TO 30MM	CLAMP	ANODIZED ALUMINUM

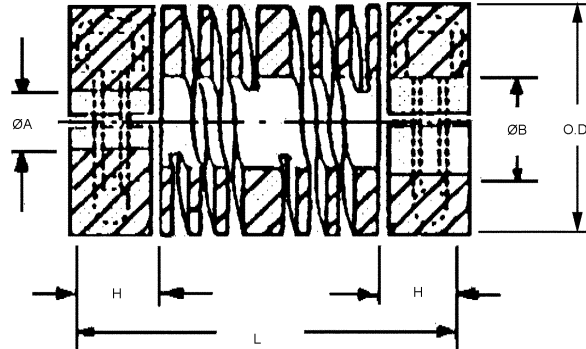

STOCK NO.	ØA +0.05 -0.00	ØB +0.05 -0.00	ØO.D.	L	H	ANGLE OFF SET	PARALLEL OFF SET	MAX. WORKING TORQUE (N*cm)
CO37A-1M	2.00	3.00	9.5	19.6	6.0	5°	0.1	55
CO37A-2M	3.00	3.00						
CO37A-3M	3.00	4.00						
CO37A-4M	4.00	4.00						
CO39A-1M	3.00	3.00	12.7	25.4	6.9	5°	0.2	110
CO39A-2M	3.00	5.00						
CO39A-3M	5.00	5.00						
CO39A-4M	6.00	6.00						
CO41A-1M	5.00	6.00	19.1	28.0	6.4	7°	0.3	280
CO41A-2M	6.00	6.00						
CO41A-3M	6.00	10.00						
CO41A-4M	10.00	10.00						
CO43A-1M	6.00	6.00	25.4	38.7	11.7	7°	0.4	490
CO43A-2M	8.00	8.00						
CO43A-3M	10.00	10.00						
CO43A-4M	13.00	13.00						
CO45A-1M	6.00	10.00	31.7	57.2	16.0	7°	0.5	680
CO45A-2M	10.00	10.00						
CO45A-3M	13.00	13.00						
CO45A-4M	16.00	16.00						
CO51A-1M	10.00	12.00	38.1	66.7	18.0	7°	0.6	900
CO51A-2M	12.00	12.00						
CO51A-3M	16.00	16.00						
CO51A-1M	14.00	14.00	44.5	76.2	20.0	7°	0.8	1000
CO51A-2M	16.00	16.00						
CO51A-3M	20.00	20.00						
CO55A-1M	20.00	20.00	57.2	130.0	32.0	7°	0.9	2200
CO55A-2M	25.00	25.00						
CO55A-3M	30.00	30.00						

Operating temperature -40° C to 120°C

Advantages

- One Piece construction, no mechanical joints
- No Backlash
- Constant velocity
- Torsionally rigid
- High Flexibility
- Small and lightweight
- High or low speeds
- Not temperature sensitive
- No lubrication
- Unaffected by climactic conditions
- Reversible

Applications

Encoders • Stepper Motors • Precision Ball Screws • Machine Tools • Robotics • Scientific Equipment
 • Measuring Instruments • Computers • Servo Systems • Optical Telescopes • Defense Systems
 • Medical Equipment • Appliances • Pumps • Valves • Fans

Central relief diameter may be smaller than bore in some cases.

SIX BEAM FLEXIBLE COUPLING

BORES	STYLE	MATERIAL
2MM TO 30MM	CLAMP	STAINLESS STEEL DIN 1.4305

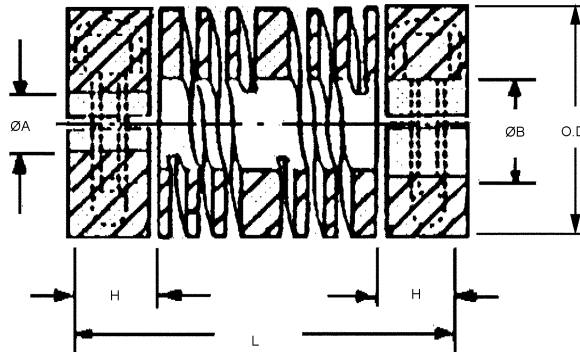

STOCK NO.	ØA +.05 -.00	ØB +.05 -.00	ØO.D.	L	H	ANGLE OFF SET	PARALLEL OFF SET	MAX. WORKING TORQUE (N*cm)
CO37S-1M	2.00	3.00						
CO37S-2M	3.00	3.00						
CO37S-3M	3.00	4.00	9.5	19.6	6.0	5°	0.1	85
CO37S-4M	4.00	4.00						
CO39S-1M	3.00	3.00						
CO39S-2M	3.00	5.00	12.7	25.4	6.9	5°	0.2	150
CO39S-3M	5.00	5.00						
CO39S-4M	6.00	6.00						
CO41S-1M	5.00	6.00						
CO41S-2M	6.00	6.00	19.1	28.0	6.4	7°	0.3	400
CO41S-3M	6.00	10.00						
CO41S-4M	10.00	10.00						
CO43S-1M	6.00	6.00						
CO43S-2M	8.00	8.00	25.4	38.7	11.7	7°	0.4	900
CO43S-3M	10.00	10.00						
CO43S-4M	13.00	13.00						
CO45S-1M	6.00	10.00						
CO45S-2M	10.00	10.00	31.7	57.2	16.0	7°	0.5	1000
CO45S-3M	13.00	13.00						
CO45S-4M	16.00	16.00						
CO51S-1M	10.00	12.00						
CO51S-2M	12.00	12.00	38.1	66.7	18.0	7°	0.6	1500
CO51S-3M	16.00	16.00						
CO53S-1M	14.00	14.00						
CO53S-2M	16.00	16.00	44.5	76.2	20.0	7°	0.8	1900
CO53S-3M	20.00	20.00						
CO55S-1M	20.00	20.00						
CO55S-2M	25.00	25.00	57.2	130.0	32.0	7°	0.9	4100
CO55S-3M	30.00	30.00						

Operating temperature -40° C to 120°C

Advantages

- One Piece construction. no mechanical joints
- No Backlash
- Constant velocity
- Torsionally rigid
- High Flexibility
- Small and lightweight
- High or low speeds
- Not temperature sensitive
- No lubrication
- Unaffected by climactic conditions
- Reversible

Applications

Encoders • Stepper Motors • Precision Ball Screws • Machine Tools • Robotics • Scientific Equipment
 • Measuring Instruments • Computers • Servo Systems • Optical Telescopes • Defense Systems
 • Medical Equipment • Appliances • Pumps • Valves • Fans

Central relief diameter may be smaller than bore in some cases.

SIX BEAM FLEXIBLE COUPLING

BORES	STYLE	MATERIAL
3MM TO 30MM	CLAMP	DELRIN

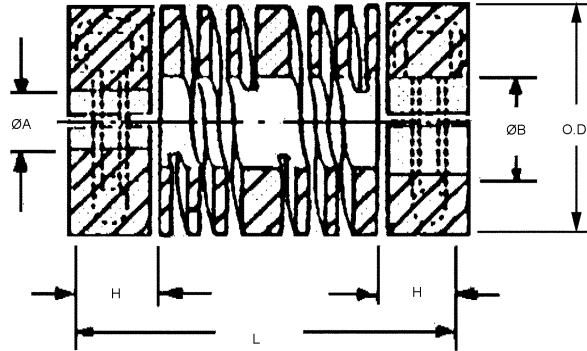

STOCK NO.	ØA +.05 -.00	ØB +.05 -.00	ØO.D.	L	H	ANGLE OFF SET	PARALLEL OFF SET	MAX. WORKING TORQUE (N*cm)
CO39D-1M CO39D-2M CO39D-3M CO39D-4M	3.00 3.00 5.00 6.00	3.00 5.00 5.00 6.00	12.7	25.4	6.9	5°	0.2	25
CO41D-1M CO41D-2M CO41D-3M CO41D-4M	5.00 6.00 6.00 10.00	6.00 6.00 10.00 10.00	19.1	28.0	6.4	7°	0.3	80
CO43D-1M CO43D-2M CO43D-3M CO43D-4M	6.00 8.00 10.00 13.00	6.00 8.00 10.00 13.00	25.4	38.7	11.7	7°	0.4	150
CO45D-1M CO45D-2M CO45D-3M CO45D-4M	6.00 10.00 13.00 16.00	10.00 10.00 13.00 16.00	31.7	57.2	16.0	7°	0.5	230
CO51D-1M CO51D-2M CO51D-3M	10.00 12.00 16.00	12.00 12.00 16.00	38.1	66.7	18.0	7°	0.6	275
CO53D-1M CO53D-2M CO53D-3M	14.00 16.00 20.00	14.00 16.00 20.00	44.5	76.2	20.0	7°	0.8	325
CO55D-1M CO55D-2M CO55D-3M	20.00 25.00 30.00	20.00 25.00 30.00	57.2	130.0	32.0	7°	0.9	380

Operating temperature -20° C to 60°C

Advantages

- One Piece construction. no mechanical joints
- No Backlash
- Constant velocity
- Torsionally rigid
- High Flexibility
- Small and lightweight
- High or low speeds
- Not temperature sensitive
- No lubrication
- Unaffected by climactic conditions
- Reversible

Applications

Encoders • Stepper Motors • Precision Ball Screws • Machine Tools • Robotics • Scientific Equipment
 • Measuring Instruments • Computers • Servo Systems • Optical Telescopes • Defense Systems
 • Medical Equipment • Appliances • Pumps • Valves • Fans

NOTE: Maximum angular offset of 10°.

Central relief diameter may be smaller than bore in some cases.

THREE BEAM FLEXIBLE COUPLING

BORE	STYLE	MATERIAL
3MM TO 12MM	SET SCREW	ALUMINUM ANODIZED

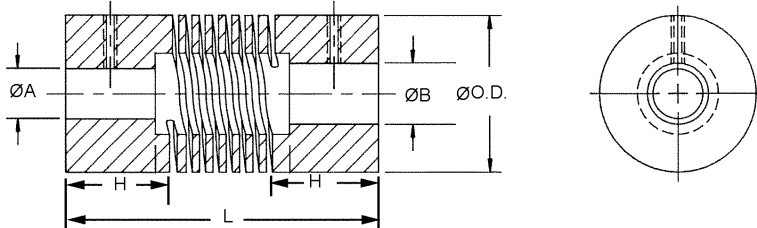

- Couplings can be supplied with a keyway
- Non-standard bore sizes available
- Operating temperature -40°C to 120°C

STOCK NO.	ØA +0.05 -0.00	ØB +0.05 -0.00	ØO.D.	L	H	ALLOWABLE MISALIGNMENT		
						MAX TOR. N•cm	ANGLE OFF SET	PARA OFF SET
CO71A-1M	3.00	3.00	9.5	14.2	2.8	40	5°	0.10
CO73A-1M	3.00	3.00	12.7	19.0	5.3	90	5°	0.13
CO73A-2M	4.00	4.00						
CO73A-3M	4.00	5.00						
CO73A-4M	5.00	5.00						
CO75A-1M	3.00	3.00	16.0	20.3	6.1	145	5°	0.13
CO75A-2M	3.00	4.00						
CO75A-3M	4.00	4.00						
CO75A-4M	4.00	5.00						
CO75A-5M	5.00	5.00						
CO77A-1M	4.00	4.00	19.0	22.9	7.1	245	5°	0.13
CO77A-2M	4.00	5.00						
CO77A-3M	5.00	5.00						
CO77A-4M	5.00	6.00						
CO77A-5M	6.00	6.00						
CO79A-1M	6.00	6.00	25.4	31.8	8.4	390	5°	0.13
CO79A-2M	6.00	8.00						
CO79A-3M	8.00	8.00						
CO79A-4M	8.00	10.00						
CO79A-5M	10.00	10.00						
CO81A-1M	10.00	10.00	31.8	44.5	11.2	590	5°	0.13
CO81A-2M	10.00	12.00						
CO81A-3M	12.00	12.00						

Central relief diameter may be smaller than bore in some cases.

THREE BEAM FLEXIBLE COUPLING

BORE	STYLE	MATERIAL
3MM TO 12MM	SET SCREW	STAINLESS STEEL DIN 1.4305

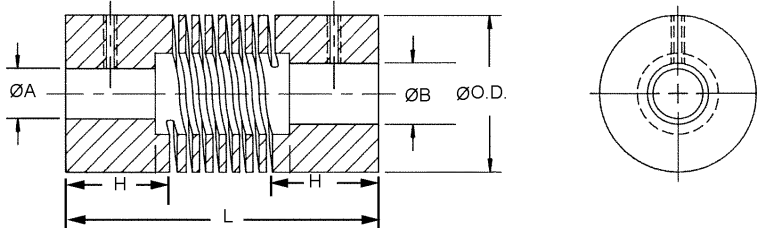

- Couplings can be supplied with a keyway
- Non-standard bore sizes available
- **Operating temperature -40° C to 120°C**

STOCK NO.	ØA +0.05 -0.00	ØB +0.05 -0.00	ØO.D.	L	H	ALLOWABLE MISALIGNMENT		
						MAX TOR. N•cm	ANGLE OFF SET	PARA OFF SET
CO71S-1M	3.00	3.00	9.5	14.2	2.8	40	5°	0.10
CO73S-1M	3.00	3.00	12.7	19.0	5.3	90	5°	0.13
CO73S-2M	4.00	4.00						
CO73S-3M	4.00	5.00						
CO73S-4M	5.00	5.00						
CO75S-1M	3.00	3.00	16.0	20.3	6.1	150	5°	0.13
CO75S-2M	3.00	4.00						
CO75S-3M	4.00	4.00						
CO75S-4M	4.00	5.00						
CO75S-5M	5.00	5.00						
CO77S-1M	4.00	4.00	19.0	22.9	7.1	250	5°	0.13
CO77S-2M	4.00	5.00						
CO77S-3M	5.00	5.00						
CO77S-4M	5.00	6.00						
CO77S-5M	6.00	6.00						
CO79S-1M	6.00	6.00	25.4	31.8	8.4	550	5°	0.13
CO79S-2M	6.00	8.00						
CO79S-3M	8.00	8.00						
CO79S-4M	8.00	10.00						
CO79S-5M	10.00	10.00						
CO81S-1M	10.00	10.00	31.8	44.5	11.2	950	5°	0.13
CO81S-2M	10.00	12.00						
CO81S-3M	12.00	12.00						

Central relief diameter may be smaller than bore in some cases.

G

THREE BEAM FLEXIBLE COUPLING

BORE	STYLE	MATERIAL
3MM TO 12MM	CLAMP	ALUMINUM ANODIZED

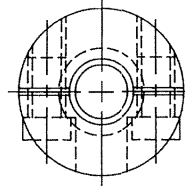
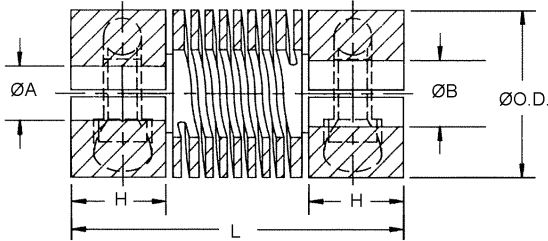

- Couplings can be supplied with a keyway
- Non-standard bore sizes available
- Operating temperature -40°C to 120°C

STOCK NO.	ØA +0.05 -0.00	ØB +0.05 -0.00	ØO.D.	L	H	ALLOWABLE MISALIGNMENT		
						MAX TOR. N·cm	ANGLE OFF SET	PARA OFF SET
CO72A-1M CO72A-2M CO72A-3M CO72A-4M	3.00 4.00 4.00 5.00	3.00 4.00 5.00 5.00	12.7	19.0	5.3	90	5°	0.13
CO74A-1M CO74A-2M CO74A-3M CO74A-4M CO74A-5M	3.00 3.00 4.00 4.00 5.00	3.00 4.00 4.00 5.00 5.00	16.0	20.3	6.1	145	5°	0.13
CO76A-1M CO76A-2M CO76A-3M CO76A-4M CO76A-5M	4.00 4.00 5.00 5.00 6.00	4.00 5.00 5.00 6.00 6.00	19.0	22.9	7.1	245	5°	0.13
CO78A-1M CO78A-2M CO78A-3M CO78A-4M CO78A-5M	6.00 6.00 8.00 8.00 10.00	6.00 8.00 8.00 10.00 10.00	25.4	31.8	8.4	390	5°	0.13
CO80A-1M CO80A-2M CO80A-3M	10.00 10.00 12.00	10.00 12.00 12.00	31.8	44.5	11.2	590	5°	0.13

Central relief diameter may be smaller than bore in some cases.

THREE BEAM FLEXIBLE COUPLING

BORE	STYLE	MATERIAL
3MM TO 12MM	CLAMP HUB	STAINLESS STEEL 1.4305

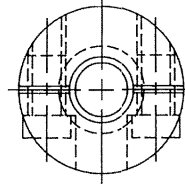
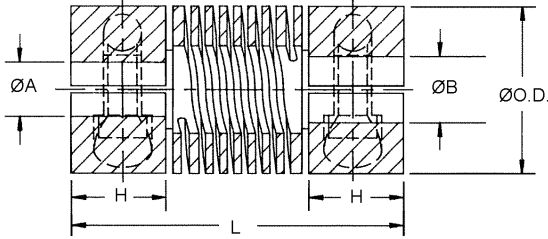

- Couplings can be supplied with a keyway
- Non-standard bore sizes available
- All couplings contain an integral relief chamber
- **Operating temperature -40° C to 140°C**

STOCK NO.	ØA +0.05 -0.00	ØB +0.05 -0.00	ØO.D.	L	H	ALLOWABLE MISALIGNMENT		
						MAX TOR. N•cm	ANGLE OFF SET	PARA OFF SET
CO72S-1M CO72S-2M CO72S-3M CO72S-4M	3.00 4.00 4.00 5.00	3.00 4.00 5.00 5.00	12.7	19.0	5.3	90	5°	0.13
CO74S-1M CO74S-2M CO74S-3M CO74S-4M CO74S-5M	3.00 3.00 4.00 4.00 5.00	3.00 4.00 4.00 5.00 5.00	16.0	20.3	6.1	150	5°	0.13
CO76S-1M CO76S-2M CO76S-3M CO76S-4M CO76S-5M	4.00 4.00 5.00 5.00 6.00	4.00 5.00 5.00 6.00 6.00	19.0	22.9	7.1	250	5°	0.13
CO78S-1M CO78S-2M CO78S-3M CO78S-4M CO78S-5M	6.00 6.00 8.00 8.00 10.00	6.00 8.00 8.00 10.00 10.00	25.4	31.8	8.4	550	5°	0.13
CO80S-1M CO80S-2M CO80S-3M	10.00 10.00 12.00	10.00 12.00 12.00	31.8	44.5	11.2	950	5°	0.13

Central relief diameter may be smaller than bore in some cases.



SINGLE BEAM FLEXIBLE COUPLING

BORES	STYLE	MATERIAL
3MM TO 25MM	SET SCREW	ALUMINUM ANODIZED

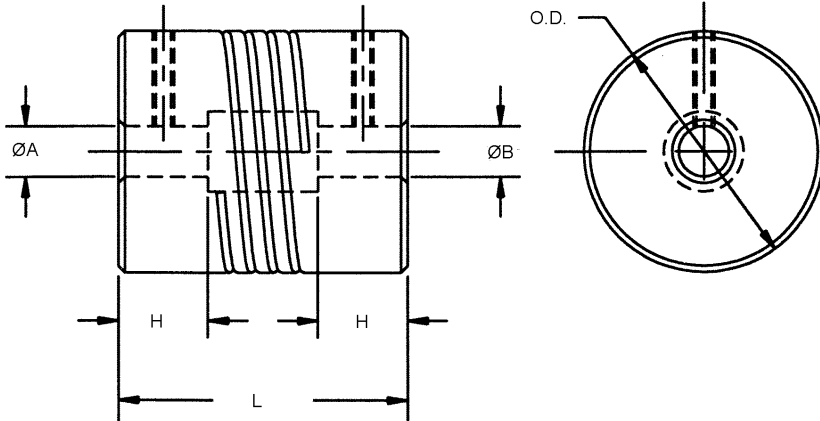

STOCK NO.	ØA +0.05 -0.00	ØB +0.05 -0.00	ØO.D.	L	H	MAX. WORKING TORQUE (N*cm)	ANGULAR OFFSET	PARALLEL OFFSET
COS71A-1M	3.00	3.00	9.5	14.2	2.8	15	5°	0.13
COS73A-1M	3.00	3.00	12.7	19.0	5.3	45	5°	0.25
COS73A-2M	4.00	4.00						
COS73A-3M	4.00	4.00						
COS73A-4M	5.00	5.00						
COS75A-1M	3.00	3.00	16.0	20.3	6.1	65	5°	0.25
COS75A-2M	3.00	3.00						
COS75A-3M	4.00	4.00						
COS75A-4M	4.00	4.00						
COS75A-5M	5.00	5.00						
COS77A-1M	4.00	4.00	19.1	22.9	7.1	115	5°	0.25
COS77A-2M	4.00	4.00						
COS77A-3M	5.00	5.00						
COS77A-4M	5.00	5.00						
COS77A-5M	6.00	6.00						
COS79A-1M	6.00	6.00	25.5	31.8	8.4	165	5°	0.25
COS79A-2M	6.00	8.00						
COS79A-3M	8.00	8.00						
COS79A-4M	8.00	10.00						
COS79A-5M	10.00	10.00						
COS81A-1M	10.00	10.00	31.8	44.5	11.2	345	5°	0.25
COS81A-2M	10.00	12.00						
COS81A-3M	12.00	12.00						
COS83A-1M	12.00	12.00	38.0	67.0	18.0	500	5°	0.25
COS83A-2M	16.00	16.00						
COS83A-3M	19.00	19.00						
COS85A-1M	12.00	12.00	44.5	76.2	20.0	675	5°	0.25
COS85A-2M	16.00	16.00						
COS85A-3M	19.00	19.00						
COS87A-1M	19.00	19.00	57.0	130.3	32.0	1100	5°	0.25
COS87A-2M	22.00	22.00						
COS87A-3M	25.00	25.00						

Central relief diameter may be smaller than bore in some cases.

SINGLE BEAM FLEXIBLE COUPLING

BORE	STYLE	MATERIAL
3MM TO 25MM	CLAMP	ALUMINUM ANODIZED

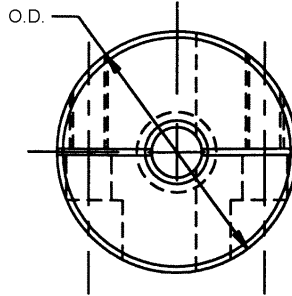
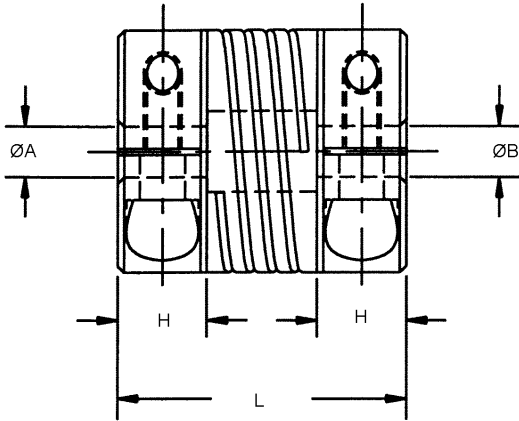

STOCK NO.	$\varnothing A$ +0.05	$\varnothing B$ +0.05	$\varnothing O.D.$	L	H	MAX. WORKING TORQUE (N*cm)	ANGULAR OFFSET	PARALLEL OFFSET
COS72A-1M	3.00	3.00	12.7	19.0	5.3	45	5°	0.25
COS72A-2M	4.00	4.00						
COS72A-3M	4.00	4.00						
COS72A-4M	5.00	5.00						
COS74A-1M	3.00	3.00	16.0	20.3	6.1	68	5°	0.25
COS74A-2M	3.00	3.00						
COS74A-3M	4.00	4.00						
COS74A-4M	4.00	4.00						
COS74A-5M	5.00	5.00						
COS76A-1M	4.00	4.00	19.1	22.9	7.1	118	5°	0.25
COS76A-2M	4.00	4.00						
COS76A-3M	5.00	5.00						
COS76A-4M	5.00	5.00						
COS76A-5M	6.00	6.00						
COS78A-1M	6.00	6.00	25.5	31.8	8.4	170	5°	0.25
COS78A-2M	6.00	8.00						
COS78A-3M	8.00	8.00						
COS78A-4M	8.00	10.00						
COS78A-5M	10.00	10.00						
COS80A-1M	10.00	10.00	31.8	44.5	11.2	350	5°	0.25
COS80A-2M	10.00	12.00						
COS80A-3M	12.00	12.00						
COS82A-1M	12.00	12.00	38.0	67.0	18.0	508	5°	0.25
COS82A-2M	16.00	16.00						
COS82A-3M	19.00	19.00						
COS84A-1M	12.00	12.00	44.5	76.2	20.0	678	5°	0.25
COS84A-2M	16.00	16.00						
COS84A-3M	19.00	19.00						
COS86A-1M	19.00	19.00	57.0	130.3	32.0	1130	5°	0.25
COS86A-2M	22.00	22.00						
COS86A-3M	25.00	25.00						

Central relief diameter may be smaller than bore in some cases.

RELI-A-FLEX COUPLINGS

BORES	STYLE	MATERIAL
3MM TO 12MM	CLAMP, SHORT	ALUMINUM 7075 ALOCROM FINISH

STOCK NO.	L	ØD	ØB1 +.05 - .00	ØB2 +.05 - .00	E	SOCKET SCREW SIZE	ØH
RCSA13C-1M	13	16.80	3.0	3.0	5.0	M1.6	14.5
RCSA13C-2M	13	16.80	3.0	4.0	5.0	M1.6	14.5
RCSA13C-3M	13	16.80	4.0	4.0	5.0	M1.6	14.5
RCSA13C-4M	13	16.80	4.0	5.0	5.0	M1.6	14.5
RCSA13C-5M	13	16.80	5.0	5.0	5.0	M1.6	14.5
RCSA13C-6M	13	16.80	5.0	6.0	5.0	M1.6	14.5
RCSA13C-7M	13	16.80	6.0	6.0	5.0	M1.6	14.5
RCSA16C-1M	16	19.75	3.0	3.0	5.90	M2	18.0
RCSA16C-2M	16	19.75	3.0	4.0	5.90	M2	18.0
RCSA16C-3M	16	19.75	4.0	4.0	5.90	M2	18.0
RCSA16C-4M	16	19.75	4.0	5.0	5.90	M2	18.0
RCSA16C-5M	16	19.75	5.0	5.0	5.90	M2	18.0
RCSA16C-6M	16	19.75	5.0	6.0	5.90	M2	18.0
RCSA16C-7M	16	19.75	6.0	6.0	5.90	M2	18.0
RCSA16C-8M	16	19.75	6.0	8.0	5.90	M2	18.0
RCSA16C-9M	16	19.75	8.0	8.0	5.90	M2	18.0
RCSA20C-1M	20	21.50	4.0	4.0	6.60	M3	21.8
RCSA20C-2M	20	21.50	4.0	5.0	6.60	M3	21.8
RCSA20C-3M	20	21.50	5.0	5.0	6.60	M3	21.8
RCSA20C-4M	20	21.50	5.0	6.0	6.60	M3	21.8
RCSA20C-5M	20	21.50	6.0	6.0	6.60	M3	21.8
RCSA20C-6M	20	21.50	6.0	8.0	6.60	M3	21.8
RCSA20C-7M	20	21.50	8.0	8.0	6.60	M3	21.8
RCSA20C-8M	20	21.50	8.0	10.0	6.60	M3	21.8
RCSA20C-9M	20	21.50	10.0	10.0	6.60	M3	21.8
RCSA25C-1M	25	25.80	5.0	5.0	7.60	M3	26.9
RCSA25C-2M	25	25.80	5.0	6.0	7.60	M3	26.9
RCSA25C-3M	25	25.80	6.0	6.0	7.60	M3	26.9
RCSA25C-4M	25	25.80	6.0	8.0	7.60	M3	26.9
RCSA25C-5M	25	25.80	8.0	8.0	7.60	M3	26.9
RCSA25C-6M	25	25.80	8.0	10.0	7.60	M3	26.9
RCSA25C-7M	25	25.80	10.0	10.0	7.60	M3	26.9
RCSA25C-8M	25	25.80	10.0	12.0	7.60	M3	26.9
RCSA25C-9M	25	25.80	12.0	12.0	7.60	M3	26.9

TECHNICAL FEATURES

- Zero backlash, reliable one-piece construction
- Unique design maximizes torsional stiffness without including high bearing loads
- Minimal velocity and positional fluctuations
- Over 50,000,000 test cycles at test load and 80% offset without failure
- Maintenance free
- Recommended temperature range -80°C to +80°C

TECHNICAL SPECIFICATIONS

SIZE	TORSIONAL STIFFNESS mNm/arcmin	RADIAL COMPLIANCE microns/N	MISALIGNMENT			MAX. INERTIA g.cm ²	MAX. MASS g	TYPICAL TORQUE CAPACITY			MAX. SPEED RPM
			PARALLEL MM	ANGULAR DEG.	AXIAL MM			REVERSING Nm	NONREV. Nm	PEAK Nm	
13C	13.09	29.2	0.08	2.5	±0.30	1.0	4.4	0.35	0.45	0.50	12000
16C	20.36	28.9	0.10	2.5	±0.40	2.9	8.6	0.55	0.85	1.25	10000
20C	33.45	23.4	0.12	3.0	±0.50	7.9	14.9	0.95	1.45	2.45	7500
25C	52.94	20.0	0.16	3.0	±0.70	23.0	27.5	1.55	2.35	3.90	5000

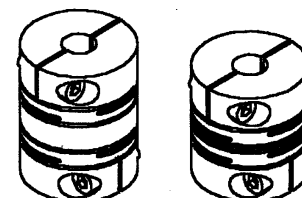
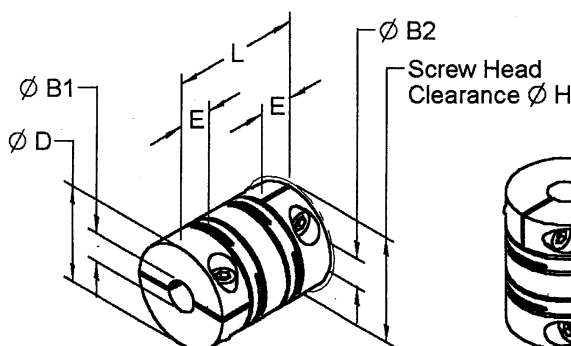

1-800-232-BERG (USA ONLY)

MG 14

WWW.WMBERG.COM

RELI-A-FLEX COUPLINGS

BORES	STYLE	MATERIAL
3MM TO 12MM	CLAMP, LONG	ALUMINUM 7075 ALOCROM FINISH

STOCK NO.	L	ØD	ØB1 +.05 -.00	ØB2 +.05 -.00	E	SOCKET SCREW SIZE	ØH
RCLA13C-1M	13	20.0	3.0	3.0	5.0	M1.6	14.5
RCLA13C-2M	13	20.0	3.0	4.0	5.0	M1.6	14.5
RCLA13C-3M	13	20.0	4.0	4.0	5.0	M1.6	14.5
RCLA13C-4M	13	20.0	4.0	5.0	5.0	M1.6	14.5
RCLA13C-5M	13	20.0	5.0	5.0	5.0	M1.6	14.5
RCLA13C-6M	13	20.0	5.0	6.0	5.0	M1.6	14.5
RCLA13C-7M	13	20.0	6.0	6.0	5.0	M1.6	14.5
RCLA16C-1M	16	23.5	3.0	3.0	5.90	M2	18.0
RCLA16C-2M	16	23.5	3.0	4.0	5.90	M2	18.0
RCLA16C-3M	16	23.5	4.0	4.0	5.90	M2	18.0
RCLA16C-4M	16	23.5	4.0	5.0	5.90	M2	18.0
RCLA16C-5M	16	23.5	5.0	5.0	5.90	M2	18.0
RCLA16C-6M	16	23.5	5.0	6.0	5.90	M2	18.0
RCLA16C-7M	16	23.5	6.0	6.0	5.90	M2	18.0
RCLA16C-8M	16	23.5	6.0	8.0	5.90	M2	18.0
RCLA16C-9M	16	23.5	8.0	8.0	5.90	M2	18.0
RCLA20C-1M	20	26.0	4.0	4.0	6.60	M3	21.8
RCLA20C-2M	20	26.0	4.0	5.0	6.60	M3	21.8
RCLA20C-3M	20	26.0	5.0	5.0	6.60	M3	21.8
RCLA20C-4M	20	26.0	5.0	6.0	6.60	M3	21.8
RCLA20C-5M	20	26.0	6.0	6.0	6.60	M3	21.8
RCLA20C-6M	20	26.0	6.0	8.0	6.60	M3	21.8
RCLA20C-7M	20	26.0	8.0	8.0	6.60	M3	21.8
RCLA20C-8M	20	26.0	8.0	10.0	6.60	M3	21.8
RCLA20C-9M	20	26.0	10.0	10.0	6.60	M3	21.8
RCLA25C-1M	25	34.0	5.0	5.0	7.60	M3	26.9
RCLA25C-2M	25	34.0	5.0	6.0	7.60	M3	26.9
RCLA25C-3M	25	34.0	6.0	6.0	7.60	M3	26.9
RCLA25C-4M	25	34.0	6.0	8.0	7.60	M3	26.9
RCLA25C-5M	25	34.0	8.0	8.0	7.60	M3	26.9
RCLA25C-6M	25	34.0	8.0	10.0	7.60	M3	26.9
RCLA25C-7M	25	34.0	10.0	10.0	7.60	M3	26.9
RCLA25C-8M	25	34.0	10.0	12.0	7.60	M3	26.9
RCLA25C-9M	25	34.0	12.0	12.0	7.60	M3	26.9

TECHNICAL FEATURES

- Zero backlash, reliable one-piece construction
- Unique design maximizes torsional stiffness without including high bearing loads
- Minimal velocity and positional fluctuations
- Over 50,000,000 test cycles at test load and 80% offset without failure
- Maintenance free
- Recommended temperature range -80°C to +80°C

TECHNICAL SPECIFICATIONS

SIZE	TORSIONAL STIFFNESS mNm/arcmin	RADIAL COMPLIANCE microns/N	MISALIGNMENT			MAX. INERTIA g.cm ²	MAX. MASS g	TYPICAL TORQUE CAPACITY			MAX. SPEED RPM
			PARALLEL MM	ANGULAR DEG.	AXIAL MM			REVERSING Nm	NONREV. Nm	PEAK Nm	
13C	15.56	64.3	0.15	2.5	±0.30	1.2	5.5	0.35	0.45	0.50	12000
16C	24.43	65.1	0.20	2.5	±0.40	3.3	10.6	0.55	0.85	1.25	10000
20C	40.43	62.0	0.25	3.0	±0.50	9.0	18.7	0.95	1.45	2.45	7500
25C	66.03	82.2	0.40	3.0	±0.70	31.0	3805	1.55	2.35	3.90	5000

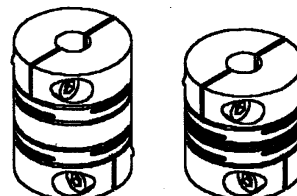
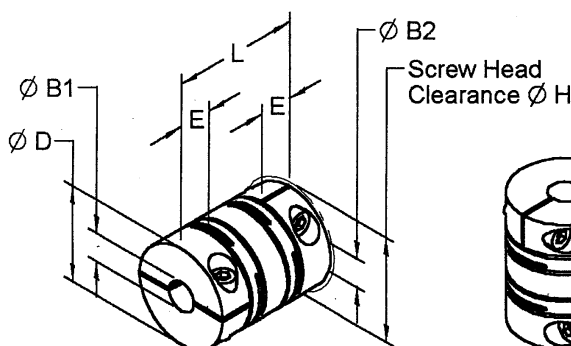

RELI-A-FLEX COUPLINGS

BORES		STYLE				MATERIAL	
1.5MM TO 12MM		SET SCREW, SHORT				ALUMINUM 7075 ALOCROM FINISH	

STOCK NO.	L	ØD	ØB1 +.05 -.00	ØB2 +.05 -.00	E	SET SCREW SIZE
RCSA6-1M	6	9.35	1.5	1.5	2.80	M1.2 (SLOT SET SCREW)
RCSA6-2M	6	9.35	1.5	2.0	2.80	M1.2 (SLOT SET SCREW)
RCSA6-3M	6	9.35	2.0	2.0	2.80	M1.2 (SLOT SET SCREW)
RCSA6-4M	6	9.35	2.0	3.0	2.80	M1.2 (SLOT SET SCREW)
RCSA6-5M	6	9.35	3.0	3.0	2.80	M1.2 (SLOT SET SCREW)
RCSA8-1M	8	11.70	2.0	2.0	3.20	M1.6
RCSA8-2M	8	11.70	2.0	3.0	3.20	M1.6
RCSA8-3M	8	11.70	3.0	3.0	3.20	M1.6
RCSA8-4M	8	11.70	3.0	4.0	3.20	M1.6
RCSA8-5M	8	11.70	4.0	4.0	3.20	M1.6
RCSA10-1M	10	13.65	3.0	3.0	4.00	M2
RCSA10-2M	10	13.65	3.0	4.0	4.00	M2
RCSA10-3M	10	13.65	4.0	4.0	4.00	M2
RCSA10-4M	10	13.65	4.0	5.0	4.00	M2
RCSA10-5M	10	13.65	5.0	5.0	4.00	M2
RCSA13-1M	13	16.80	3.0	3.0	5.00	M2.5
RCSA13-2M	13	16.80	3.0	4.0	5.00	M2.5
RCSA13-3M	13	16.80	4.0	4.0	5.00	M2.5
RCSA13-4M	13	16.80	4.0	5.0	5.00	M2.5
RCSA13-5M	13	16.80	5.0	5.0	5.00	M2.5
RCSA13-6M	13	16.80	5.0	6.0	5.00	M2.5
RCSA13-7M	13	16.80	6.0	6.0	5.00	M2.5
RCSA16-1M	16	19.75	3.0	3.0	5.90	M3
RCSA16-2M	16	19.75	3.0	4.0	5.90	M3
RCSA16-3M	16	19.75	4.0	4.0	5.90	M3
RCSA16-4M	16	19.75	4.0	5.0	5.90	M3
RCSA16-5M	16	19.75	5.0	5.0	5.90	M3
RCSA16-6M	16	19.75	5.0	6.0	5.90	M3
RCSA16-7M	16	19.75	6.0	6.0	5.90	M3
RCSA16-8M	16	19.75	6.0	8.0	5.90	M3
RCSA16-9M	16	19.75	8.0	8.0	5.90	M3
RCSA20-1M	20	21.50	4.0	4.0	6.60	M4
RCSA20-2M	20	21.50	4.0	5.0	6.60	M4
RCSA20-3M	20	21.50	5.0	5.0	6.60	M4
RCSA20-4M	20	21.50	5.0	6.0	6.60	M4
RCSA20-5M	20	21.50	6.0	6.0	6.60	M4
RCSA20-6M	20	21.50	6.0	8.0	6.60	M4
RCSA20-7M	20	21.50	8.0	8.0	6.60	M4
RCSA20-8M	20	21.50	8.0	10.0	6.60	M4
RCSA20-9M	20	21.50	10.0	10.0	6.60	M4
RCSA25-1M	25	25.80	5.0	5.0	7.60	M5
RCSA25-2M	25	25.80	5.0	6.0	7.60	M5
RCSA25-3M	25	25.80	6.0	6.0	7.60	M5
RCSA25-4M	25	25.80	6.0	8.0	7.60	M5
RCSA25-5M	25	25.80	8.0	8.0	7.60	M5
RCSA25-6M	25	25.80	8.0	10.0	7.60	M5
RCSA25-7M	25	25.80	10.0	10.0	7.60	M5
RCSA25-8M	25	25.80	10.0	12.0	7.60	M5
RCSA25-9M	25	25.80	12.0	12.0	7.60	M5

TECHNICAL FEATURES

- Zero backlash, reliable one-piece construction
- Unique design maximizes torsional stiffness without including high bearing loads
- Minimal velocity and positional fluctuations
- Over 50,000,000 test cycles at test load and 80% offset without failure
- Maintenance free
- Recommended temperature range -80°C to +80°C

TECHNICAL SPECIFICATIONS

SIZE	TORSIONAL STIFFNESS mNm/arcmin	RADIAL COMPLIANCE microns/N	MISALIGNMENT			MAX. INERTIA g.cm ²	MAX. MASS g	TYPICAL TORQUE CAPACITY			MAX. SPEED RPM
			PARALLEL MM	ANGULAR DEG.	AXIAL MM			REVERSING Nm	NONREV. Nm	PEAK Nm	
6	1.22	21.0	0.020	1.7	±0.06	0.03	0.65	0.10	0.15	0.25	7000
8	2.53	35.0	0.050	2.0	±0.10	0.11	1.30	0.20	0.30	0.50	40000
10	4.89	28.0	0.060	2.0	±0.17	0.33	2.30	0.30	0.45	0.75	35000

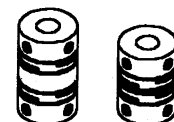
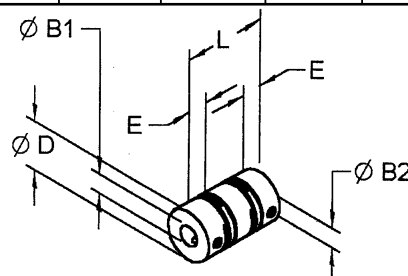

RELI-A-FLEX COUPLINGS

BORES	STYLE	MATERIAL
1.5MM TO 12MM	SET SCREW, LONG	ALUMINUM 7075 ALOCROM FINISH

STOCK NO.	L	ØD	ØB1 +.05 -.00	ØB2 +.05 -.00	E	SET SCREW SIZE
RCLA6-1M	6	12.5	1.5	1.5	2.80	M1.2 (SLOT SET SCREW)
RCLA6-2M	6	12.5	1.5	2.0	2.80	M1.2 (SLOT SET SCREW)
RCLA6-3M	6	12.5	2.0	2.0	2.80	M1.2 (SLOT SET SCREW)
RCLA6-4M	6	12.5	2.0	3.0	2.80	M1.2 (SLOT SET SCREW)
RCLA6-5M	6	12.5	3.0	3.0	2.80	M1.2 (SLOT SET SCREW)
RCLA8-1M	8	14.5	2.0	2.0	3.20	M1.6
RCLA8-2M	8	14.5	2.0	3.0	3.20	M1.6
RCLA8-3M	8	14.5	3.0	3.0	3.20	M1.6
RCLA8-4M	8	14.5	3.0	4.0	3.20	M1.6
RCLA8-5M	8	14.5	4.0	4.0	3.20	M1.6
RCLA10-1M	10	17.0	3.0	3.0	4.00	M2
RCLA10-2M	10	17.0	3.0	4.0	4.00	M2
RCLA10-3M	10	17.0	4.0	4.0	4.00	M2
RCLA10-4M	10	17.0	4.0	5.0	4.00	M2
RCLA10-5M	10	17.0	5.0	5.0	4.00	M2
RCLA13-1M	13	20.0	3.0	3.0	5.00	M2.5
RCLA13-2M	13	20.0	3.0	4.0	5.00	M2.5
RCLA13-3M	13	20.0	4.0	4.0	5.00	M2.5
RCLA13-4M	13	20.0	4.0	5.0	5.00	M2.5
RCLA13-5M	13	20.0	5.0	5.0	5.00	M2.5
RCLA13-6M	13	20.0	5.0	6.0	5.00	M2.5
RCLA13-7M	13	20.0	6.0	6.0	5.00	M2.5
RCLA16-1M	16	23.50	3.0	3.0	5.90	M3
RCLA16-2M	16	23.50	3.0	4.0	5.90	M3
RCLA16-3M	16	23.50	4.0	4.0	5.90	M3
RCLA16-4M	16	23.50	4.0	5.0	5.90	M3
RCLA16-5M	16	23.50	5.0	5.0	5.90	M3
RCLA16-6M	16	23.50	5.0	6.0	5.90	M3
RCLA16-7M	16	23.50	6.0	6.0	5.90	M3
RCLA16-8M	16	23.50	6.0	8.0	5.90	M3
RCLA16-9M	16	23.50	8.0	8.0	5.90	M3
RCLA20-1M	20	26.0	4.0	4.0	6.60	M4
RCLA20-2M	20	26.0	4.0	5.0	6.60	M4
RCLA20-3M	20	26.0	5.0	5.0	6.60	M4
RCLA20-4M	20	26.0	5.0	6.0	6.60	M4
RCLA20-5M	20	26.0	6.0	6.0	6.60	M4
RCLA20-6M	20	26.0	6.0	8.0	6.60	M4
RCLA20-7M	20	26.0	8.0	8.0	6.60	M4
RCLA20-8M	20	26.0	8.0	10.0	6.60	M4
RCLA20-9M	20	26.0	10.0	10.0	6.60	M4
RCLA25-1M	25	34.0	5.0	5.0	7.60	M5
RCLA25-2M	25	34.0	5.0	6.0	7.60	M5
RCLA25-3M	25	34.0	6.0	6.0	7.60	M5
RCLA25-4M	25	34.0	6.0	8.0	7.60	M5
RCLA25-5M	25	34.0	8.0	8.0	7.60	M5
RCLA25-6M	25	34.0	8.0	10.0	7.60	M5
RCLA25-7M	25	34.0	10.0	10.0	7.60	M5
RCLA25-8M	25	34.0	10.0	12.0	7.60	M5
RCLA25-9M	25	34.0	12.0	12.0	7.60	M5

TECHNICAL FEATURES

- Zero backlash, reliable one-piece construction
- Unique design maximizes torsional stiffness without including high bearing loads
- Minimal velocity and positional fluctuations
- Over 50,000,000 test cycles at test load and 80% offset without failure
- Maintenance free
- Recommended temperature range -80°C to +80°C



TECHNICAL SPECIFICATIONS

SIZE	TORSIONAL STIFFNESS mNm/arcmin	RADIAL COMPLIANCE microns/N	MISALIGNMENT			MAX. INERTIA g.cm ²	MAX. MASS g	TYPICAL TORQUE CAPACITY			MAX. SPEED RPM
			PARALLEL MM	ANGULAR DEG.	AXIAL MM			REVERSING Nm	NONREV. Nm	PEAK Nm	
6	1.25	79.0	0.040	1.7	±0.05	0.05	0.95	0.10	0.15	0.25	7000
8	2.53	102.0	0.100	2.0	±0.15	0.15	1.70	0.20	0.30	0.50	40000
10	4.89	83.0	0.120	2.0	±0.43	0.43	3.00	0.30	0.45	0.75	35000

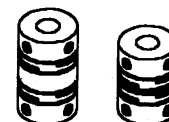
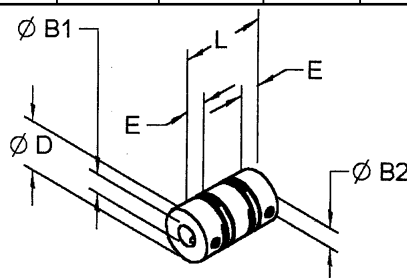

FLEX-THANE COUPLINGS

BORES	NO. OF PINS	MATERIAL
3MM TO 13MM	8 TO 12	POLYURETHANE PINS ALUMINUM DIN 3.1355 HUBS

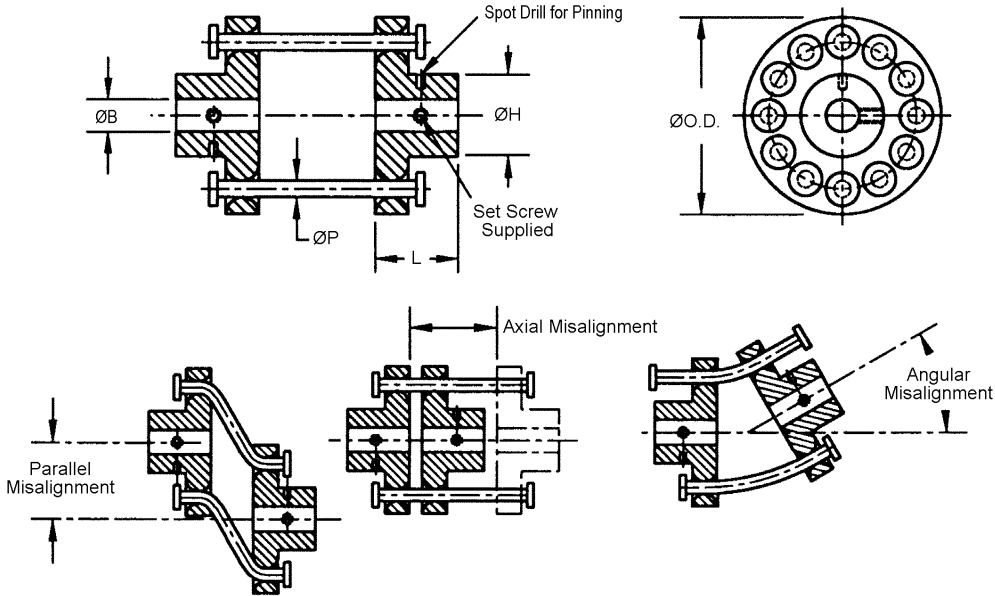

STOCK NO.	ØB +0.05	ØP	ØH	L	ØO.D.	NO. OF PINS	MAX WORKING TORQUE (N•CM)	MAX PARALLEL MISALIGN	MAX AXIAL MISALIGN	MAX ANGULAR MISALIGN
CC5M-10-L	3.00	1.6	8.0	8.0	17.5	8	280	1.6	3.6	10°
CC5M-19-L	5.00	3.2	9.5	8.7	25.5	8	390	3.2	4.8	
CC5M-28-L	7.00	3.2	12.7	11.0	32.0	10	560	6.4	6.4	
CC5M-32-L	8.00	4.8	12.7	11.0	38.0	10	680	5.6	7.9	
CC5M-35-L	10.00	6.4	19.0	19.0	50.0	12	1130	4.0	9.5	
CC5M-37-L	13.00	7.9	25.5	22.0	63.5	12	2260	3.2	12.7	
CC5M-10-A	3.00	1.6	8.0	8.0	17.5	8	280	12.7	11.0	30°
CC5M-19-A	5.00	3.2	9.5	8.7	25.5	8	390	16.0	16.0	
CC5M-28-A	7.00	3.2	12.7	11.0	32.0	10	560	19.0	22.0	
CC5M-32-A	8.00	4.8	12.7	11.0	38.0	10	680	22.0	28.5	
CC5M-35-A	10.00	6.4	19.0	19.0	51.0	12	1130	22.5	35.0	
CC5M-37-A	13.00	7.9	25.5	22.0	63.5	12	2260	32.0	51.0	

ABSORBATHANE FLEXIBLE COUPLINGS

BORE	STYLE	MATERIAL
5.00 TO 10.00	EXTERNAL HUB	BLACK POLYURETHANE PLATED MILD STEEL HUBS

STOCK NO.	BORES ØB1 and ØB2 +0.05	ØA	C	ØD	MAX. WORKING TORQUE (N•cm)	MAX. PARALLEL MISALIGN	MAX. ANGULAR MISALIGN
CC3M-18	5.00	28.5	28.5	17.5	30	2.4	10°
CC3M-19	6.00						
CC3M-20	8.00						
CC3M-21	10.00						

BORE	STYLE	MATERIAL
6.00 TO 13.00	INTERNAL HUB	BLACK POLYURETHANE PLATED MILD STEEL HUBS

STOCK NO.	BORES ØB1 and ØB2 +0.05	ØA	C	ØD	MAX. WORKING TORQUE (N•cm)	MAX. PARALLEL MISALIGN	MAX. ANGULAR MISALIGN
CC3M-22	6.00	47.5	44.5	25.5	135	3.2	15°
CC3M-23	8.00						
CC3M-24	10.00						
CC3M-25	11.00						
CC3M-26	13.00						

BORE	STYLE	MATERIAL
10.00 TO 16.00	INTERNAL HUB	BLACK POLYURETHANE PLATED MILD STEEL HUBS

STOCK NO.	BORES ØB1 and ØB2 +0.05	ØA	C	ØD	MAX. WORKING TORQUE (N•cm)	MAX. PARALLEL MISALIGN	MAX. ANGULAR MISALIGN
CC3M-27	10.00	54.0	54.0	32.0	315	4.7	15°
CC3M-28	11.00						
CC3M-29	13.00						
CC3M-30	14.00						
CC3M-31	16.00						

BORE	STYLE	MATERIAL
13.00 TO 16.00	INTERNAL HUB	BLACK POLYURETHANE PLATED MILD STEEL HUBS

STOCK NO.	BORES ØB1 and ØB2 +0.05	ØA	C	ØD	MAX. WORKING TORQUE (N•cm)	MAX. PARALLEL MISALIGN	MAX. ANGULAR MISALIGN
CC3M-32	13.00	54.0	60.5	32.0	450	3.2	15°
CC3M-33	14.00						
CC3M-34	16.00						

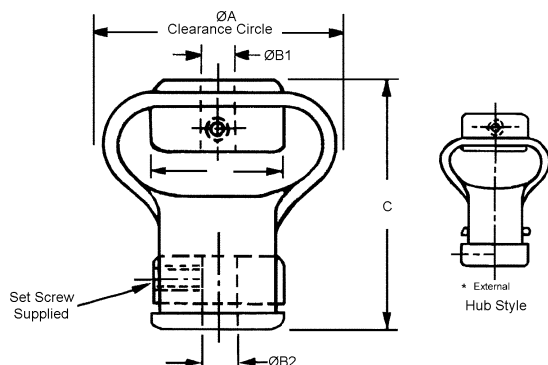

Available on request:
Other bore sizes
or bore combinations.

- Absorbs end play
- Quiet running
- Maintenance free (No moving parts)
- 3600 R.P.M. Maximum



NEO-FLEX COUPLINGS

BORE	STYLE	MATERIAL
3MM TO 10MM	PIN HUB	STAINLESS STEEL DIN 1.4305 HUBS MOLDED NEOPRENE BODY

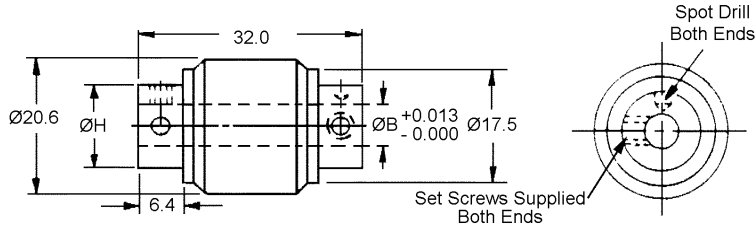

- Isolates torsional vibrations
- Insulates between shafts
- 1° angular misalignment (Max.)
- 0.13 Shaft misalignment (Max.)
- Maximum working torque of 105 N•cm

STOCK NO.	ØB	ØH	ØC
CO14M-1	2.995	7.9	4.6
CO14M-2	3.995	8.7	5.6
CO14M-3	4.995	9.7	6.6
CO14M-4	5.995	12.3	7.6
CO14M-5	7.995	12.8	9.6
CO14M-6	9.995	16.4	11.6

(Special bore sizes and mixed bore combinations available on request.)

BORE	STYLE	MATERIAL
5MM TO 13MM	PIN HUB	STAINLESS STEEL DIN 1.4305 HUBS POLYURETHANE CENTER

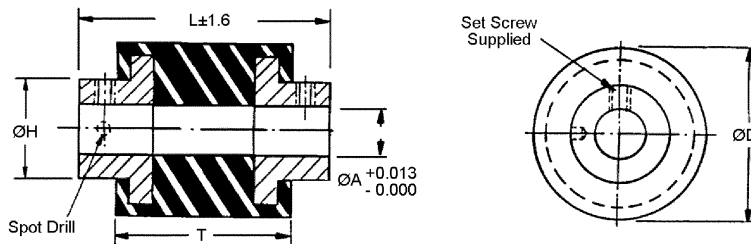

STOCK NO.	ØA	H	ØD	L	T
CC1-3M	4.995	9.5	23.8	31.8	19.1
CC1-14M	5.995	15.9	28.6	39.7	23.8
CC1-15M	7.995	15.9	28.6	39.7	23.8
CC1-16M	9.995	15.9	28.6	39.7	23.8
CC1-8M	12.995	25.4	41.3	57.2	35.0

Combination bores are available on request.

NEO-FLEX COUPLINGS

BORE	STYLE	MATERIAL
3MM TO 10MM	CLAMP HUB	STAINLESS STEEL DIN 1.4305 HUBS MOLDED NEOPRENE BODY

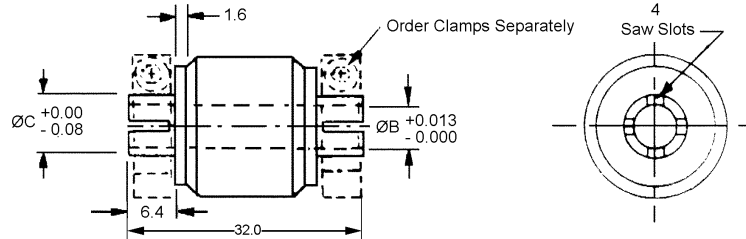

- Isolates torsional vibrations
- Insulates between shafts
- 1° angular misalignment (Max.)
- 0.13 Shaft misalignment (Max.)
- Maximum working torque of 105 N•cm

STOCK NO.	$\varnothing B$	$\varnothing H$	$\varnothing C$	CLAMP STOCK NO.
CO15M-1	2.995	7.9	4.6	CG1M-4
CO15M-2	3.995	8.7	5.6	CG1M-5
CO15M-3	4.995	9.7	6.6	CG1M-8
CO15M-4	5.995	12.3	7.6	CG1M-11
CO15M-5	7.995	12.8	9.6	CG1M-14
CO15M-6	9.995	16.4	11.6	CG1M-16

(Special bore sizes and mixed bore combinations available on request.)

BORE	STYLE	MATERIAL
5MM TO 13MM	CLAMP HUB	STAINLESS STEEL DIN 1.4305 HUBS POLYURETHANE CENTER

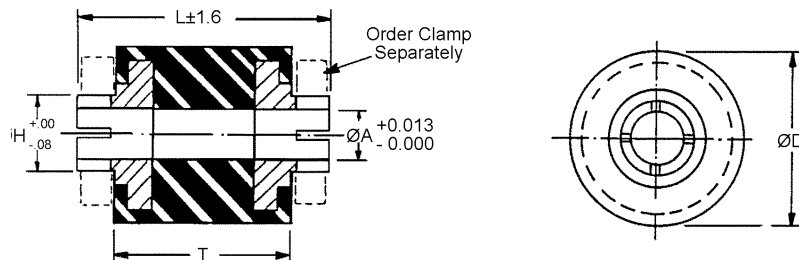

STOCK NO.	$\varnothing A$	H	$\varnothing D$	L	T
CC1-3M	4.995	6.6	23.8	31.8	19.1
CC1-14M	5.995	7.6	28.6	39.7	23.8
CC1-15M	7.995	9.6	28.6	39.7	23.8
CC1-16M	9.995	11.6	28.6	39.7	23.8
CC1-8M	12.995	14.6	41.3	57.2	35.0

Combination bores are available on request.

SLEEVE COUPLINGS

BORE	STYLE	MATERIAL
3MM TO 25MM	SET SCREW	STAINLESS STEEL DIN 1.4305

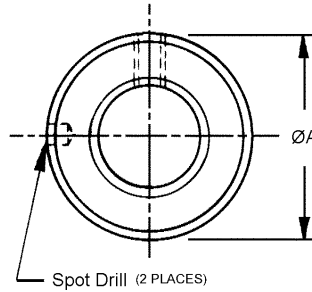
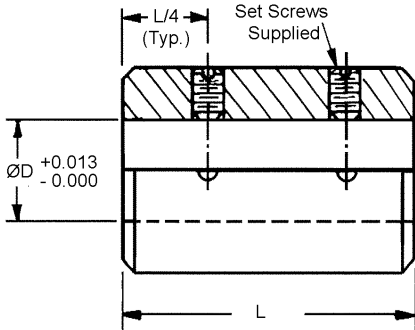

STOCK NO.	SHAFT SIZE	$\varnothing D$	L	$\varnothing A$
CTM-1	3	2.995	11	9
CTM-2	4	3.995	13	9
CTM-3	6	5.995	15	13
CTM-4	8	7.995	15	13
CTM-5	9	8.995	19	19
CTM-6	9	8.995	25	19
CTM-7	12	11.995	25	25
CTM-8	12	11.995	38	25
CTM-9	16	15.995	50	32
CTM-10	19	18.995	50	38
CTM-11	25	24.995	76	50
CTM-12	3-4	2.995 3.995	11	9
CTM-13	3-5	2.995 4.995	13	9
CTM-14	3-6	2.995 5.995	14	13
CTM-15	4-6	3.995 5.995	14	13
CTM-16	5-6	4.995 5.995	14	13
CTM-17	6-8	5.995 7.995	14	14
CTM-18	6-9	5.995 8.995	19	19
CTM-19	8-9	7.995 8.995	19	19
CTM-20	9-12	8.995 11.995	25	25

Modified or specials are available on request.

SPIDER COUPLINGS

BORES	DESCRIPTION	MATERIAL
3MM TO 12MM	SOFT 80 DURO SPIDER	ALUMINUM HUBS POLYURETHANE SPIDER

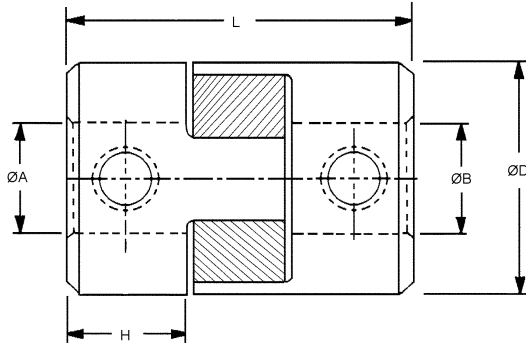

SOFT 80 DURO SPIDER STOCK NO.	ØA H10	ØB H10	ØD	H	L	MAX. WORKING TORQUE (N*cm) 80 DURO	MAX. PARALLEL MISALIGN.	MAX. ANGULAR MISALIGN.
CO46M-1A CO46M-2A	3.00 5.00	3.00 5.00	10.0	5.0	15.0	30	0.8	1°
CO47M-1A CO47M-2A CO47M-3A	3.00 5.00 7.00	3.00 5.00 7.00	14.0	7.0	22.0	140	1.2	
CO48M-1A CO48M-2A CO48M-3A	7.00 8.00 10.00	7.00 8.00 10.00	20.0	10.0	30.0	360	1.6	
CO49M-1A CO49M-2A CO49M-3A	8.00 10.00 12.00	8.00 10.00 12.00	30.0	11.0	35.0	800	2.0	

- Backlash free coupling for feedback devices, stepper motors and positioning devices.
- Torsional rigidity
- Contoured and machined components for quick assembly and minimum wear over extended use. Components assembled with pre-load.
- Bearing protection from parallel and angular misalignment
- Allowance for axial shaft float
- Small size, low WR², electrical isolation and light weight aluminum hubs.

Other bore sizes and combinations are available on request.
Clamp style couplings are available on request.

SPIDER COUPLINGS

BORE	DESCRIPTION	MATERIAL
3MM TO 12MM	RIGID 98 DURO SPIDER	ALUMINUM HUBS POLYURETHANE SPIDER

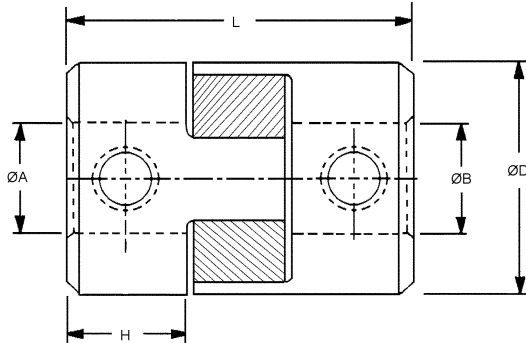

RIGID 98 DURO SPIDER STOCK NO.	ØA H10	ØB H10	ØD	H	L	MAX. WORKING TORQUE (N*cm) 98 DURO	MAX. PARALLEL MISALIGN.	MAX. ANGULAR MISALIGN.
CO46M-1B CO46M-2B	3.00 5.00	3.00 5.00	10.0	5.0	15.0	100	0.8	1°
CO47M-1B CO47M-2B CO47M-3B	3.00 5.00 7.00	3.00 5.00 7.00	14.0	7.0	22.0	400	1.2	
CO48M-1B CO48M-2B CO48M-3B	7.00 8.00 10.00	7.00 8.00 10.00	20.0	10.0	30.0	1000	1.6	
CO49M-1B CO49M-2B CO49M-3B	8.00 10.00 12.00	8.00 10.00 12.00	30.0	11.0	35.0	2500	2.0	

- Backlash free coupling for feedback devices, stepper motors and positioning devices.
- Torsional rigidity
- Contoured and machined components for quick assembly and minimum wear over extended use. Components assembled with pre-load.
- Bearing protection from parallel and angular misalignment
- Allowance for axial shaft float
- Small size, low WR², electrical isolation and light weight aluminum hubs.

Other bore sizes and combinations are available on request.
Clamp style couplings are available on request.

MULTI-JAW COUPLINGS

BORE	MATERIAL
3MM TO 13MM	STAINLESS STEEL DIN 1.4305

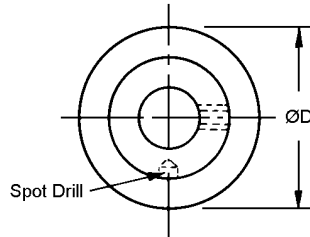
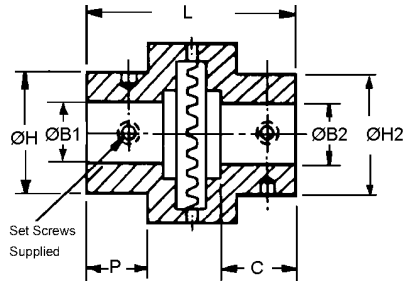

STOCK NO.	ØB1 +0.013 -0.000	ØB2 +0.013 -0.000	H1	H2	L	C	P	ØD	NO. OF TEETH	MAX. TORQUE
CM3M-1	2.995	2.995	8.0	8.0						
CM3M-2	2.995	3.995	8.0	9.0						
CM3M-3	3.995	3.995	9.0	9.0						
CM3M-4	3.995	4.995	9.0	10.0						
CM3M-5	3.995	5.995	9.0	13.0	20.0	6.0	6.0	14	32	200 N•cm
CM3M-6	4.995	4.995	10.0	10.0						
CM3M-7	4.995	5.995	10.0	13.0						
CM3M-8	5.995	5.995	13.0	13.0						
CM1M-1	2.995	3.995	8.0	9.0						
CM1M-2	3.995	3.995	9.0	9.0						
CM1M-3	3.995	4.995	9.0	10.0						
CM1M-4	3.995	5.995	9.0	13.0						
CM1M-5	4.995	4.995	10.0	10.0	22.0	6.0	7.0	19	48	350 N•cm
CM1M-6	4.995	5.995	10.0	13.0						
CM1M-7	5.995	5.995	13.0	13.0						
CM1M-8	7.995	7.995	13.0	13.0						
CM1M-9	9.995	9.995	18.0	18.0	32.0	11.0	8.0			
CM1M-10	12.995	12.995	24.0	24.0	38.0	14.0	11.0	25	64	640 N•cm

1.3 Disengagement and assembly clearance.

Other bore to bore combinations can be assembled to order from stock.

BORE	MATERIAL
5MM TO 13MM	STAINLESS STEEL DIN 1.0718 HEAVY DUTY

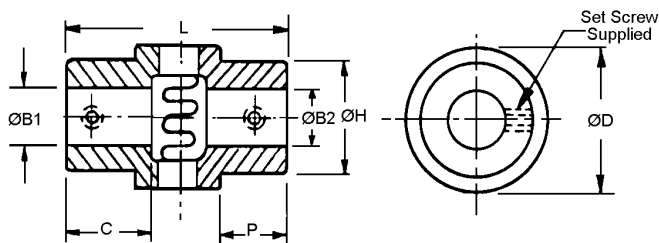

STOCK NO.	ØB1 +0.05 -0.00	ØB2 +0.05 -0.00	ØD	L	C	ØH	P	NO. OF TEETH	MAX. TORQUE (N•cm)
CM2M-1	5.00	5.00	13	28	13	11.0	11	10	280
CM2M-2	6.00	6.00	13	28	13	11.0	11	10	280
CM2M-3	8.00	8.00	19	38	16	17.0	13	10	460
CM2M-4	10.00	10.00	19	38	16	17.0	13	10	460
CM2M-5	13.00	13.00	25	51	22	23.0	19	12	780

7.1 Disengagement & Assembly Clearance

BELLOWS COUPLINGS

BORE	STYLE	MATERIAL
3MM TO 10MM	PIN HUB	STAINLESS STEEL DIN 1.4305

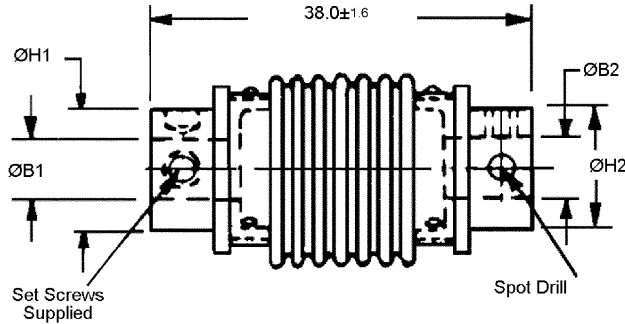

STOCK NO.	ØB1 H6	ØB2 H6	ØH1	ØH2
CO5M-1	2.995	2.995	8	8
CO5M-2	2.995	3.995	8	9
CO5M-3	2.995	4.995	8	10
CO5M-4	2.995	5.995	8	13
CO5M-5	3.995	3.995	9	9
CO5M-6	3.995	4.995	8	10
CO5M-7	3.995	5.995	8	13
CO5M-8	4.995	4.995	10	10
CO5M-9	4.995	5.995	10	11
CO5M-10	5.995	6.995	11	13
CO5M-11	5.995	5.995	11	11
CO5M-12	7.995	7.995	13	13
CO5M-13	9.995	9.995	15	15

- Eliminates end play
- Zero backlash
- Provides uniform angular velocity
- Absorbs vibration, noise and shock

Other bore sizes available.

BORE	STYLE	MATERIAL
3MM TO 10MM	CLAMP HUB	STAINLESS STEEL DIN 1.4305

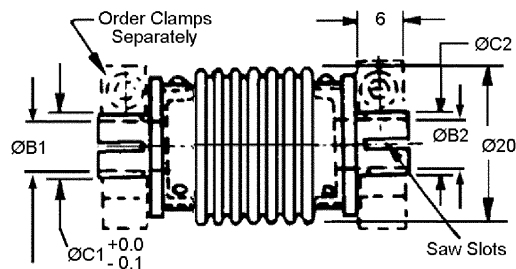

STOCK NO.	ØB1 H6	ØB2 H6	ØC1	ØC2
CO5M-1C	2.995	2.995	4.6	4.6
CO5M-2C	2.995	3.995	4.6	5.6
CO5M-3C	2.995	4.995	4.6	6.6
CO5M-4C	2.995	5.995	4.6	7.6
CO5M-5C	3.995	3.995	5.6	5.6
CO5M-6C	3.995	4.995	5.6	6.6
CO5M-7C	3.995	5.995	5.6	7.6
CO5M-8C	4.995	4.995	6.6	6.6
CO5M-9C	4.995	5.995	6.6	7.6
CO5M-10C	5.995	6.995	7.6	8.6
CO5M-11C	5.995	5.995	7.6	7.6
CO5M-12C	7.995	7.995	9.6	9.6
CO5M-13C	9.995	9.995	11.6	11.6

- Eliminates end play
- Zero backlash
- Provides uniform angular velocity
- Absorbs vibration, noise and shock

Other bore sizes available.

OLDHAM COUPLINGS

BORE	STYLE	MATERIAL
4MM TO 13MM	PIN HUB	STAINLESS STEEL DIN 1.4305 HUBS CENTER BLOCK: U = POLYURETHANE B = BRONZE OR N = NYLON

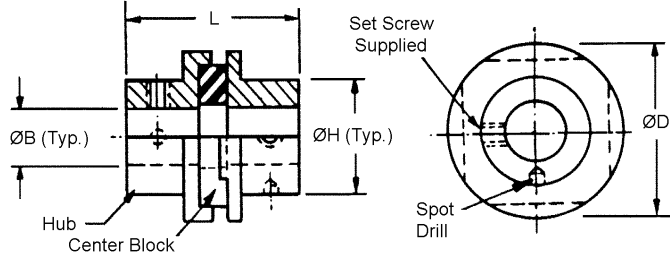

- Shaft to shaft misalignment 0.3 maximum
- Angular misalignment 1° maximum
- Maximum backlash 10 minutes

STOCK NO.	ØB +0.013 - 0.000	ØD	ØH	L	MAX. TORQUE N•cm.
CO3-4M-U CO3-4M-B CO3-4M-N	3.995	15.9	7.9	16.7	U = 50 B = 250 N = 75
CO3-5M-U CO3-5M-B CO3-5M-N	4.995	15.9	9.5	18.3	
CO3-6M-U CO3-6M-B CO3-6M-N	5.995	15.9	12.7	19.8	
CO3-8M-U CO3-8M-B CO3-8M-N	7.995	15.9	12.7	19.8	U = 250 N = 360
CO3-10M-U CO3-10M-N	9.995	34.9	19.1	39.7	
CO3-13M-U CO3-13M-B CO3-13M-N	12.995	38.1	25.4	46.0	U = 300 B = 1225 N = 430

BORES	STYLE	MATERIAL
2MM TO 16MM	PIN HUB	ALUMINUM HUBS DELRIN INSERTS

STOCK NO.	ØA +0.03	ØB +0.03	E	ØO.D.	L	MAX. WORKING TORQUE (N•cm)	MAX. PARALLEL MISALIGNMENT	MAX. ANGULAR MISALIGNMENT
CO30-B	SOLID	SOLID	-					
CO30M-1*	2.00	2.00						
CO30M-2*	3.00	3.00	3.8	6.3	12.7	10	.7	
CO31-B	SOLID	SOLID	-					
CO31M-1*	3.00	3.00						
CO31M-2*	4.00	4.00	3.8	9.5	12.7	20	.9	
CO32-B	SOLID	SOLID	-					
CO32M-1	3.00	3.00						
CO32M-2	4.00	4.00	4.3	12.7	15.9	49	1.2	
CO32M-3	6.00	6.00						
CO33-B	SOLID	SOLID	-					
CO33M-1	4.00	4.00						
CO33M-2	5.00	5.00	6.3	19.1	22.0	169	2.0	1/2°
CO33M-3	6.00	6.00						
CO33M-4	8.00	8.00						
CO34-B	SOLID	SOLID	-					
CO34M-1	6.00	6.00						
CO34M-2	8.00	8.00	8.6	25.4	28.4	395	2.5	
CO34M-3	10.00	10.00						
CO60-B	SOLID	SOLID	-					
CO60M-1	8.00	8.00						
CO60M-2	10.00	10.00	13.0	33.3	48.0	904	3.3	
CO60M-3	12.00	12.00						
CO35-B	SOLID	SOLID	-					
CO35M-1	10.00	10.00						
CO35M-2	12.00	12.00	16.7	41.3	50.8	2250	4.0	
CO35M-3	14.00	14.00						
CO35M-4	16.00	16.00						

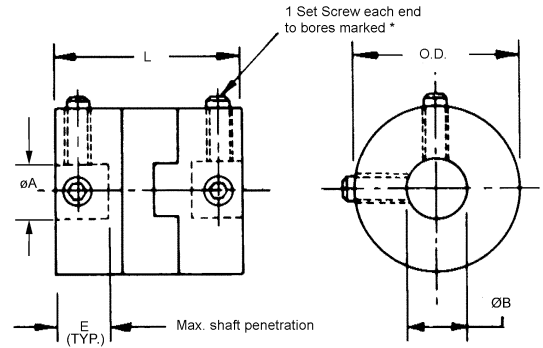

NOTE: Hubs are interchangeable within the same series. Special combinations will be assembled to order. Set screws are omitted from blanks. One (1) set screw supplied to bores marked (*), two (2) set screws supplied otherwise.

- Simple construction
- No backlash
- Corrosion resistant
- Reduces vibration
- Electrical Isolation
- No lubrication required

OLDHAM COUPLINGS

BORE	STYLE	MATERIAL
4MM TO 6MM	CLAMP HUB	STAINLESS STEEL DIN 1.4305 HUBS CENTER BLOCK: U = POLYURETHANE B = BRONZE AND N = NYLON

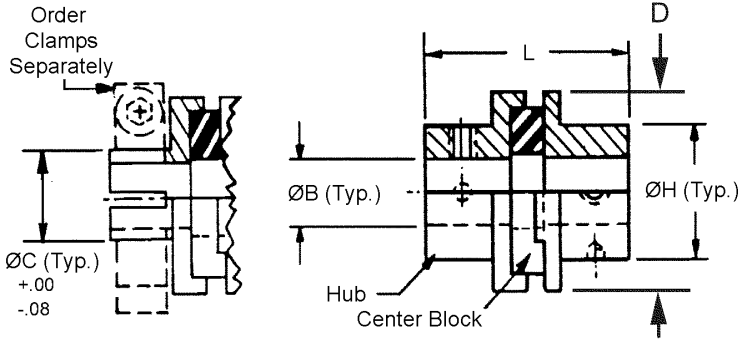

STOCK NO.	ØB +0.013 - 0.000	ØD	ØC	L	MAX. TORQUE N*cm.
CO6-4M-U CO6-4M-B CO6-4M-N	3.995	15.9	5.6	21.4	U = 50 B = 250 N = 75
CO6-5M-U CO6-5M-B CO6-5M-N	4.995	15.9	6.6		
CO6-6M-U CO6-6M-B CO6-6M-N	5.995	15.9	7.6		

- Shaft to shaft misalignment 0.3 maximum
- Angular misalignment 1° maximum
- Maximum backlash 10 minutes

BORE	STYLE	MATERIAL
4MM TO 16MM	CLAMP HUB	ALUMINUM HUBS DELTRIN CENTER BLOCK

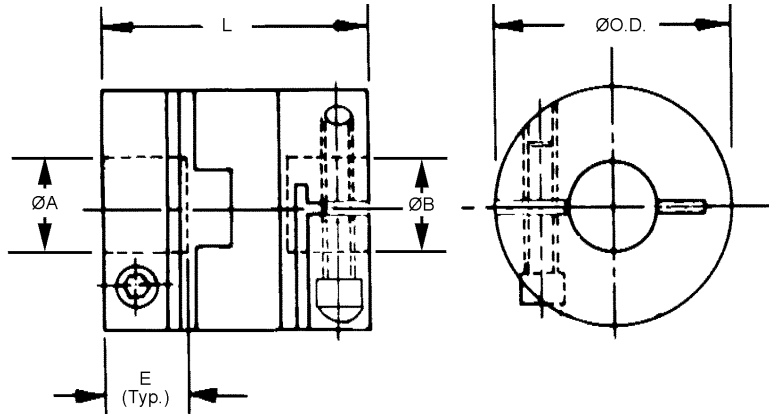

STOCK NO.	ØA +0.03	ØB +0.03	E	ØO.D.	L	MAX. WORKING TORQUE (N*cm)	MAX. PARALLEL MISALIGNMENT	MAX. ANGULAR MISALIGNMENT
CO33M-1C CO33M-4C	4.00 8.00	4.00 8.00	6.3	19.1	22.0	169	2.0	1/2°
CO34M-1C CO34M-2C CO34M-3C	6.00 8.00 10.00	6.00 8.00 10.00	8.6	25.4	28.4	395	2.5	
CO60M-1C CO60M-2C CO60M-3C	8.00 10.00 12.00	8.00 10.00 12.00	13.0	33.3	48.0	904	3.3	
CO35M-1C CO35M-2C CO35M-3C CO35M-4C	10.00 12.00 14.00 16.00	10.00 12.00 14.00 16.00	16.7	41.3	50.8	2250	4.0	



- Simple construction
- No backlash
- Corrosion resistant
- Reduces vibration
- Electrical Isolation
- No lubrication required

UNIVERSAL LATERAL COUPLINGS

BORE	STYLE	MATERIAL
3MM TO 16MM	PIN HUB	DELTRIN OUTER RING BRASS OR ALUMINUM HUBS

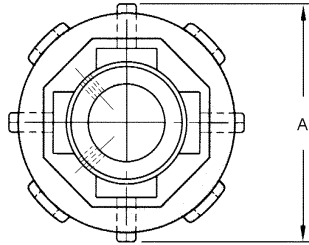
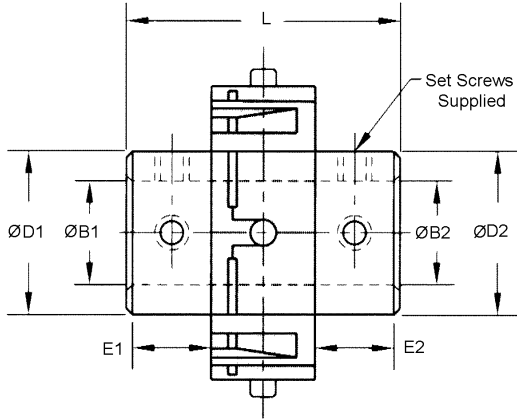

STOCK NO.	ØB1 +0.03	ØB2 +0.03	ØD1	ØD2	E1	E2	L	A	MAX WORKING TORQUE (N•cm)	MAX PARALLEL MISALIGN.	MAX - ANGULAR MISALIGN.	HUB MATERIAL
CO26M-1	3.00	3.00	8.9	8.9	4.0	4.0	14.2	18	27	1.3	10°	BRASS
CO26M-2	4.00	4.00										
CO26M-3	5.00	5.00										
CO26M-4	4.00	6.00	8.9	11.1	4.0	6.5	16.7					
CO26M-5	6.00	6.00						11.1	11.1			
CO23M-1	3.00	6.00	12.7	12.7	4.8	4.8	19.1	27.2	169			
CO23M-2	4.00	4.00										
CO23M-3	4.00	6.00										
CO23M-4	6.00	6.00	12.7	15.1	4.8	7.9	22.3					
CO23M-5	8.00	8.00										
CO23M-6	6.00	10.00	15.1	15.1	7.9	7.9	25.4	86				
CO23M-7	8.00	8.00										
CO23M-8	10.00	10.00										
CO25XM-1	6.00	6.00	17.6	17.6	7.6	7.6	25.2	33.7	248			
CO25XM-2	6.00	10.00										
CO25XM-3	8.00	8.00	17.6	20.1	7.6	10.2	28.0					
CO25XM-4	10.00	12.00										
CO25XM-5	12.00	12.00						20.1	20.1	10.2	10.2	30.7
CO25M-1	6.00	6.00	22.1	22.1	7.6	7.6	28.4	41.4	429			
CO25M-2	7.00	7.00										
CO25M-3	8.00	8.00										
CO25M-4	10.00	10.00										
CO25M-5	16.00	16.00								24.2	24.2	12.5

- Zero backlash
- Offers simultaneous lateral & angular misalignment
- Corrosion resistant
- No lubrication required
- Resonance damping
- Low inertia
- Shafts can pass through for easy installation
- Maximum operating temperature 60°C
- Misalignment
 - Angular 10° maximum
 - Lateral .050 maximum



UNIVERSAL LATERAL COUPLINGS

BORES	STYLE	MATERIAL
3.18MM TO 12MM	CLAMP	DELTRIN OUTER RING BRASS OR ALUMINUM HUBS

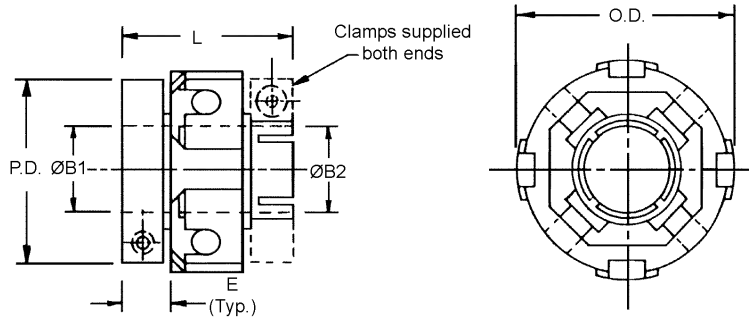

STOCK NO.	ØB1 +0.03 -0.00	ØB2 +0.03 -0.00	ØD	E	L	MAXIMUM WORKING TORQUE (N*cm)	O.D.	HUB MATERIAL
CO27-3 CO27M-1 CO27-6	3.18 6.00 6.35	6.35 6.00 6.35	19.1	6.5	19.1	27	19.1	TARNISH RESISTANT BRASS
CO28M-1 CO28M-2 CO28M-3 CO28M-4	5.00 6.00 6.00 7.00	5.00 6.00 8.00 7.00	27.2	7.9	25.4	169	27.9	
CO29XM-1 CO29XM-2 CO29XM-3 CO29XM-4	6.00 6.00 8.00 10.00	6.00 8.00 10.00 10.00	20.1	10.2	30.7	248	33.7	
CO29M-1 CO29M-2 CO29M-3 CO29M-4 CO29M-5 CO29M-6	6.00 6.00 8.00 10.00 11.00 12.00	6.00 12.00 8.00 12.00 11.00 12.00	24.2	12.5	38.1	429	41.4	

- Low inertia
- Resonance damping
- Electrically insulated
- Zero backlash
- Offers simultaneous lateral & angular misalignment
- Corrosion resistant
- No lubrication required
- Shafts can pass through for easy installation
- Maximum operating temperature 60°C
- Misalignment
 - Angular 10° maximum
 - Lateral .050 maximum

*Clamp hub is integral to hub on CO29 series.

Compatible with 2mm or 5/64" key.

Additional sizes and bore combinations available on request.

WAFER SPRING COUPLINGS

BORES	STYLE	MATERIAL
3MM TO 12MM	PIN HUB	HUBS AND CENTER BLOCK: ALUMINUM LEAVES:BERYLLIUM COPPER

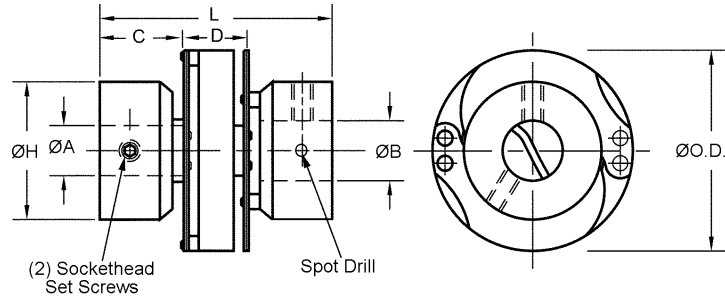

STOCK NO.	$\varnothing A$ +0.03	$\varnothing B$ +0.03	L	$\varnothing H$	C	$\varnothing O.D.$	MAX. WORKING OUTSIDE DIA.	MAX. TORQUE (N•cm)	MAX. PARALLEL MISALIGNMENT	MAX. ANGULAR MISALIGNMENT	MOMENT OF INERTIA (Kgm ²)
CO20M-1P	3.00	3.00								8°	.365
CO20M-2P	3.00	4.00									
CO20M-3P	3.00	5.00									
CO20M-4P	3.00	6.00									
CO20M-5P	4.00	4.00									
CO20M-6P	4.00	5.00									
CO20M-7P	4.00	6.00	22.3	14.2	7.5	7.1	19.1	115	0.4		
CO20M-8P	5.00	5.00									
CO20M-9P	5.00	6.00									
CO20M-10P	6.00	6.00									
CO20M-11P	6.00	7.00								1.223	
CO20M-12P	6.00	8.00									
CO20M-13P	7.00	7.00	30.7	19.1	11.1	8.4	25.4	160	0.5		
CO20M-14P	7.00	8.00									
CO20M-15P	8.00	8.00									
CO20M-16P	6.00	10.00								11.523	
CO20M-17P	6.00	12.00									
CO20M-18P	8.00	10.00									
CO20M-19P	8.00	12.00	46.2	25.4	16.7	12.7	38.1	310	0.7		
CO20M-20P	10.00	10.00									
CO20M-21P	10.00	12.00									
CO20M-22P	12.00	10.00									

G

WAFER SPRING COUPLINGS

BORES	STYLE	MATERIAL
3MM TO 12MM	CLAMP HUB	HUBS AND CENTER BLOCK: ALUMINUM LEAVES:BERYLLIUM COPPER

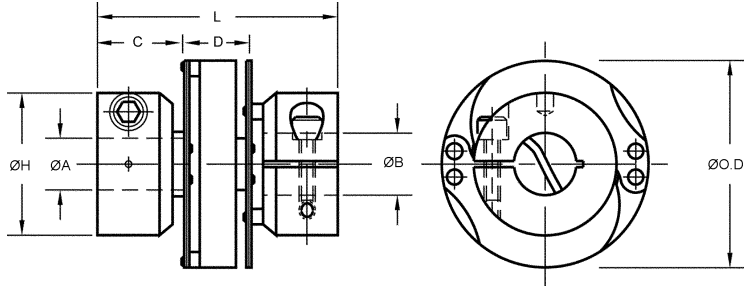

STOCK NO.	ØA +0.03	ØB +0.03	L	ØH	C	ØO.D.	MAX. WORKING OUTSIDE DIA.	MAX. TORQUE (N·cm)	MAX. PARALLEL MISALIGNMENT	ANGULAR MISALIGNMENT	MOMENT OF INERTIA (Kg ^m ²)
CO20M-1	3.00	3.00								8°	.365
CO20M-2	3.00	4.00									
CO20M-3	3.00	5.00									
CO20M-4	3.00	6.00									
CO20M-5	4.00	4.00									
CO20M-6	4.00	5.00									
CO20M-7	4.00	6.00	23.9	14.3	7.5	7.1	19.1	115	0.4		
CO20M-8	5.00	5.00									
CO20M-9	5.00	6.00									
CO20M-10	6.00	6.00									
CO20M-11	6.00	7.00								1.223	
CO20M-12	6.00	8.00									
CO20M-13	7.00	7.00	30.7	19.1	11.1	8.4	25.4	160	0.5		
CO20M-14	7.00	8.00									
CO20M-15	8.00	8.00									
CO20M-16	6.00	10.00								11.523	
CO20M-17	6.00	12.00									
CO20M-18	8.00	10.00									
CO20M-19	8.00	12.00	46.2	25.4	16.7	12.7	38.1	310	0.7		
CO20M-20	10.00	10.00									
CO20M-21	10.00	12.00									
CO20M-22	12.00	10.00									

UNIVERSAL JOINTS

BORE	STYLE	MATERIAL
3MM TO 13MM	PIN	STAINLESS STEEL DIN 1.4305

STOCK NO.	ØB +0.013	ØH	L	A BORE LENGTH	MAX. WORKING TORQUE (N•cm)	MAX. ANGULAR MISALIGNMENT (N•cm)	FIG.
UJM-1	2.995	8.0	38.0	11.0	339		2
UJM-2	4.995	9.5	38.0	11.0	339		2
UJM-3	5.995	12.5	38.0	11.0	339	30°@ 500 RPM	1
UJM-4	7.995	12.5	38.0	11.0	339	10°@ 1000 RPM	1
UJM-5	9.995	19.0	66.5	23.5	904		1
UJM-6	12.995	25.5	85.5	29.5	2994		1

- Maximum parallel misalignment 0:0
- Ideal operating angle 10° at 1000 RPM
- Lubrication required at all times

Special bore and bore-to-bore connections available on request.

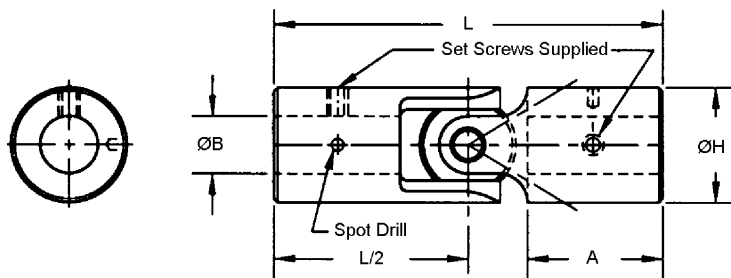

FIGURE 1 PIN STYLE

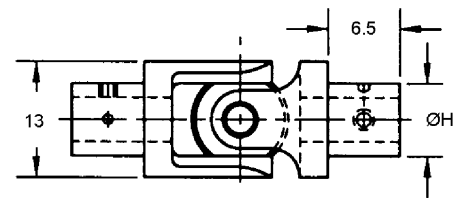

FIGURE 2 PIN STYLE

BORE	STYLE	MATERIAL
3MM TO 6MM	CLAMP	STAINLESS STEEL DIN 1.4305

STOCK NO.	ØB +0.013	ØH	L	CLAMP BORE LENGTH	CLAMP STOCK NO.	MAX. TORQUE (N•cm)	MAX. ANGULAR MISALIGNMENT
UJM-10	2.995	4.6	35.0	10.0	CG1M-4	339	30°@ 500 RPM
UJM-11	4.995	6.6			CG1M-10		10°@ 1000 RPM
UJM-12	5.995	7.6			CG1M-11		

- Maximum operating angle 30° at 500 RPM
- Ideal operating angle 10° at 1000 RPM
- Lubrication required at all times

Special bore and bore-to-bore connections available on request.

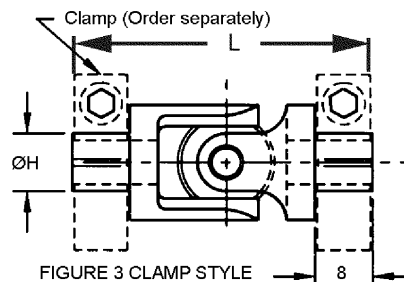

FIGURE 3 CLAMP STYLE

G

UNIVERSAL JOINTS

BORES	STYLE	MATERIAL
3MM TO 10MM	SINGLE AND DOUBLE JOINT	DELRIN BODY BRASS HUB ENDS AND SPIDER

SINGLE JOINT STOCK NUMBER	DOUBLE JOINT STOCK NUMBER	ØB1 +0.03	ØB2 +0.03	L	ØA	C	D	M
UJS-1M	UJD-1M	* 3.00	* 3.00	27.2	6.3	7.11	8.1	35.3
UJS-2M UJS-3M UJS-4M	UJD-2M UJD-3M UJD-4M	* 3.00 4.00 5.00	* 3.00 4.00 5.00	37.6	9.5	11.1	13.2	50.8
UJS-5M	UJD-5M	6.00	6.00	46.2	12.7	14.3	15.9	62.1
UJS-6M UJS-7M UJS-8M	UJD-6M UJD-7M UJD-8M	6.00 8.00 10.00	6.00 8.00 10.00	67.6	15.9	17.5	22.2	89.8

Reference Data:

SINGLE JOINT STOCK NUMBER	DOUBLE JOINT STOCK NUMBER	MAX. WORKING TORQUE (N-cm)		MAX. PARALLEL MISALIGNMENT		MAX. ANGULAR MISALIGNMENT	
		SINGLE JOINT	DOUBLE JOINT	SINGLE JOINT	DOUBLE JOINT	SINGLE JOINT	DOUBLE JOINT
UJS-1M	UJD-1M	11	8	0	5.6	45°	90°
UJS-2M UJS-3M UJS-4M	UJD-2M UJD-3M UJD-4M	39	16		9.1		
UJS-5M	UJD-5M	107	59		10.9		
UJS-6M UJS-7M UJS-8M	UJD-6M UJD-7M UJD-8M	169	129		15.5		

* 3.00mm bore couplings are supplied with one set screw each end.

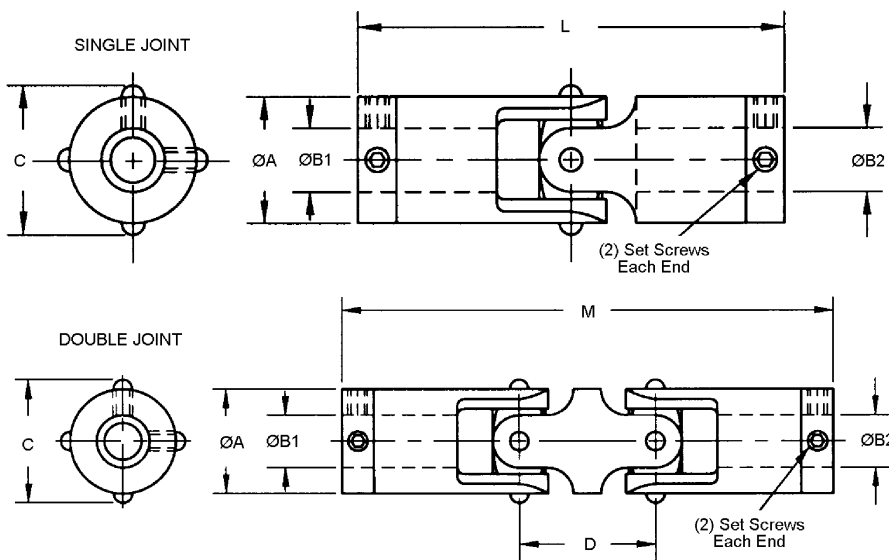

- Needs no lubrication
- Can be submersed in water
- Resists corrosion and chemical attack
- Electrically isolates input from output
- Zero backlash
- Lightweight
- Shock absorbent
- Non contaminant
- Temperature Range -40° F to +185° F



TELESCOPIC UNIVERSAL JOINTS

BORE	MATERIAL
3MM TO 10MM	DELRIN BODY BRASS ENDS, SPIDER AND TELESCOPIC SECTIONS

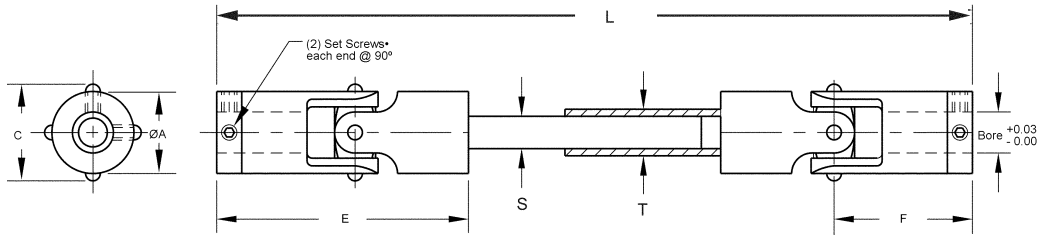

STOCK NUMBER	BORES	ØA	C	L		E	F	MAXIMUM TORQUE N*cm		S SQ.	T SQ.
				MAX	MIN			BREAK	WORKING		
				UJT-1M	3.00						
UJT-2M	4.00										
UJT-3M	5.00										
UJT-4M	6.00	12.7	13.8	186	139	40.9	23.1	451	107	4.8	6.4
UJT-5M	10.00	15.9	17.2	260	198	60.3	33.8	677	169	6.4	8.0

Minimum length can be reduced by cutting equal lengths off both telescope halves.

- Temperature Range -40° C to +85° C
- Needs no lubrication
- Can be submersed in water
- Resists corrosion
- Electrically isolates input from output
- Minimum Backlash

- Lightweight
- Non contaminant (e.g. food, textiles and paper handling)
- Non-magnetic
- Resists chemical attack
- Shock absorbent



G

SHAFT ADAPTERS

BORE	STYLE	MATERIAL
3MM TO 10MM	CLAMP	STAINLESS STEEL DIN 1.4305

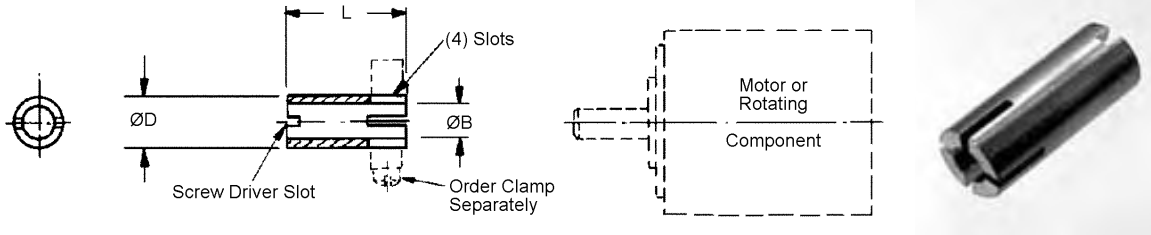

STOCK NUMBER	ØB +0.03	ØD -0.03	L
SAM-10	3.00	4.00	11
SAM-11	3.00	5.00	10
SAM-12	3.00	6.00	11
SAM-13	4.00		
SAM-14	5.00		
SAM-15	5.00	8.00	11
SAM-16	6.00		
SAM-18	6.00	10.00	13
SAM-19	8.00		
SAM-20	6.00	12.00	13
SAM-21	8.00		
SAM-22	10.00		

Modifications and specials are available upon request.

NOW AVAILABLE FROM W.M. BERG

INCH TO METRIC ADAPTORS

SEE PAGES G57 THROUGH G67 IN THE INCH SECTION OF THIS CATALOG

SHAFT EXTENSIONS

SHAFT SIZES	STYLE	MATERIAL
4MM TO 10MM	CLAMP HUB	STAINLESS STEEL DIN 1.4305

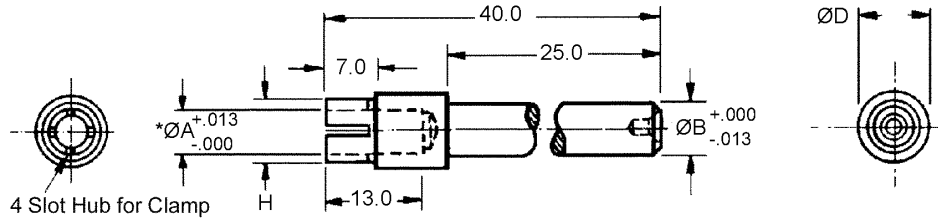

STOCK NUMBER	ØA (FEMALE END)	ØB (MALE END)	ØD	ØH	CLAMP (ORDER SEPARATELY)
PE3M-1	3.996	3.995	7.0	5.6	
PE3M-2	3.996	4.995	7.0	5.6	CG1M-5
PE3M-3	3.996	5.995	8.0	5.6	
PE3M-4	4.996	3.995	8.0	6.6	
PE3M-5	4.996	4.995	8.0	6.6	CG1M-10
PE3M-6	4.996	5.995	8.0	6.6	
PE3M-7	5.996	3.995	10.0	7.6	
PE3M-8	5.996	4.995	10.0	7.6	CG1M-11
PE3M-9	5.996	5.995	10.0	7.6	
PE3M-10	5.996	9.995	10.0	7.6	
PE3M-11	9.996	5.995	13.0	11.6	
PE3M-12	9.996	9.995	13.0	11.6	CG1M-16

Modifications and specials are available upon request.

SLIP COUPLINGS

BORE	TORQUE	MATERIAL
6MM AND 8MM	ADJUSTABLE 2.4 N.cm TO 132.4 N.cm	HOUSING, ADJUSTER RING AND ADAPTERS - ALUMINUM WITH ALOCROM FINISH, HUBS AND PLATES - HEAT TREATED STEEL, BEARING - SINTERED BRONZE

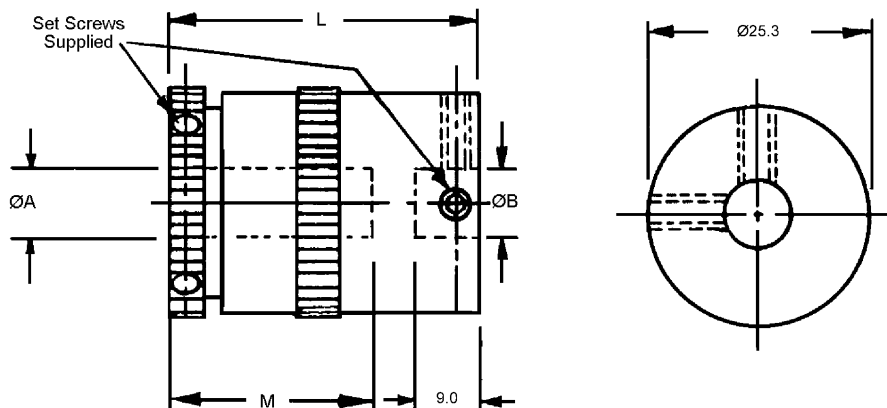

STOCK NO.	ØA BORE +0.03	ØB BORE +0.03	L	M	ADJUSTABLE TORQUE RANGE N•cm		WEIGHT
					MIN.	MAX.	
JJ-25M	6.00	6.00	36.0	25.0	2.4	53.0	50g
JJ-26M	8.00	8.00					
JJ-27M	6.00	6.00	42.5	31.0	7.8	132.4	61g
JJ-28M	8.00	8.00					

- Bi-directional
- Maximum operating Temperature 80°C
- Maximum backlash 2°

OLDHAM SLIP COUPLINGS

BORE	TORQUE	MATERIAL
6MM AND 8MM	ADJUSTABLE 2.4 N.cm TO 132.4 N.cm	HOUSING, ADJUSTER RING AND ADAPTERS - ALUMINUM WITH ALOCROM FINISH, HUBS AND PLATES - HEAT TREATED STEEL, BEARING - SINTERED BRONZE

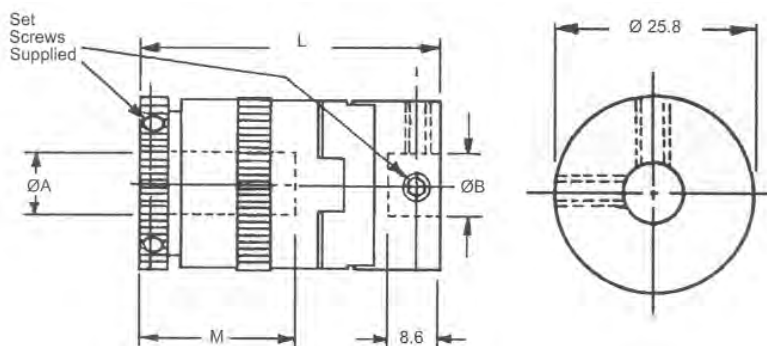

STOCK NO.	ØA BORE +0.03	ØB BORE +0.03	L	M	ADJUSTABLE TORQUE RANGE N•cm		WEIGHT
					MIN.	MAX.	
JJ-29M	6.00	6.00	46.5	25.0	2.4	53.0	57g
JJ-30M	8.00	8.00					
JJ-31M	6.00	6.00	53.4	31.0	7.8	132.4	68g
JJ-32M	8.00	8.00					

- Bi-directional
- Maximum operating Temperature 80°C
- Maximum backlash 2°

SLIP COUPLINGS

BORE	MATERIAL
3MM AND 19MM	STAINLESS STEEL DIN 1.4305

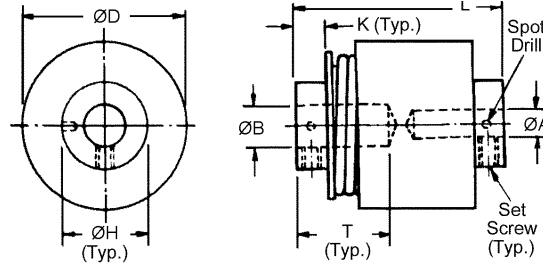

- Shaft to shaft misalignment to 0.3 max.
- Angular misalignment 3° maximum

STOCK NUMBER	BORE		L ±0.5	ØD ±0.5	ØH ±0.5	K ±0.5	T	TORQUE BI-DIRECTION N•cm
	+0.015 -0.000 ØA	ØB						
JJM-1	3.000	3.000	22.6	12.7	9.4	4.3	10.9	3.5 ± 0.5
JJM-2	3.000	4.000						
JJM-3	4.000	4.000						
JJM-4	4.000	4.000	28.2	19.1	12.7	4.8	12.7	8.5 ± 0.8
JJM-5	4.000	6.000						
JJM-6	6.000	6.000						
JJM-7	4.000	4.000	32.0	25.4	12.7	4.8	14.0	14.1 ± 1.4
JJM-8	4.000	6.000						
JJM-9	6.000	6.000						
JJM-10	6.000	6.000	36.3	31.8	15.7	6.4	15.7	33.9 ± 3.5
JJM-11	6.000	10.000						
JJM-12	10.000	10.000						
JJM-13	8.000	8.000	40.4	38.1	19.1	6.4	18.5	62.2 ± 6.4
JJM-14	10.000	10.000						
JJM-15	10.000	10.000	46.7	47.5	22.1	7.1	21.6	84.7 ± 8.5
JJM-16	10.000	12.000						
JJM-17	12.000	12.000						
JJM-18	10.000	10.000	57.2	57.2	38.1	9.7	25.4	169.5±16.9
JJM-19	10.000	12.000						
JJM-20	12.000	12.000						
JJM-21	12.000	16.000						
JJM-22	16.000	16.000						
JJM-23	16.000	19.000						
JJM-24	19.000	19.000						

Available On Request: Torque Limits Calibrated To 5%
Torques From 0.35 N•cm To 340 N•cm

G

SLIP COUPLINGS

BORE	TORQUE	MATERIAL
4MM TO 6MM	ADJUSTABLE 0 N.cm TO 35.5 N.cm	STAINLESS STEEL HOUSING

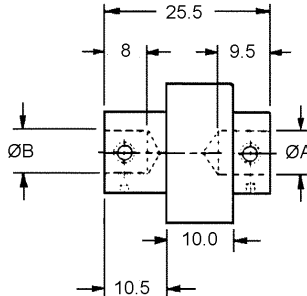
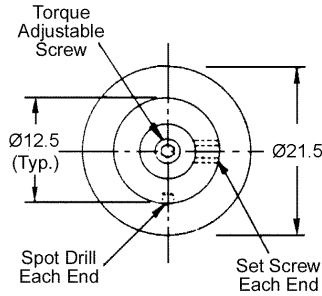

- Bi-directional
- No lubrication required
- Rulon clutch faces for smooth operation and long life at high speeds
- Consistent breakaway torques and performance at slip speeds up to 1200 R.P.M.
- Slip torque is set and may be adjusted

STOCK NUMBER	ØA BORE +0.013	ØB BORE +0.013	ADJUSTABLE TORQUE RANGE
JKM-1	4.000	4.000	0 To 35.5 N•cm
JKM-2	4.000	5.000	
JKM-3	4.000	6.000	
JKM-4	5.000	5.000	
JKM-5	5.000	6.000	
JKM-6	6.000	5.000	
JKM-7	6.000	6.000	

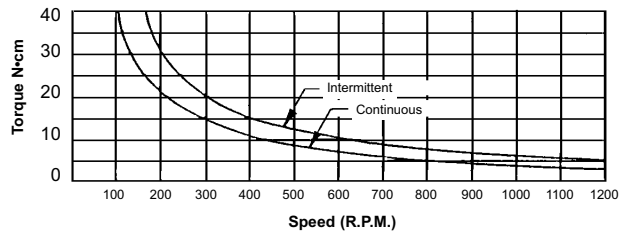

Note: Clutch capacity can be determined by use of the chart. The curves are based on a predetermined maximum temperature rise in the clutch when operated in an ambient temperature of 20°C. The intermittent curve applies to applications where the slipping period is 10 minutes or less and the cooling period is equal or greater.

Torque settings are maintained within plus or minus 20% over the full speed range. Stability is improved for constant speed applications.

OVERRUNNING COUPLING

BORE	STYLE	MATERIAL
4MM TO 13MM	CLOCKWISE SPRING WRAPPED - ONE DIRECTIONAL	STAINLESS STEEL DIN 1.4005 HUB DELTRIN CENTER

STOCK NO.	+0.015 ØA	+0.015 ØB	MAX DRIVE TORQUE	MAX DRAG TORQUE	C	ØD	ØE	F	H
JBM-R-1	3.995	3.995	113 N•cm	1.1 N•cm	25.0	19.0	14.0	5.4	12
JBM-R-2	3.995	4.995							
JBM-R-3	3.995	5.995							
JBM-R-4	4.995	4.995							
JBM-R-5	4.995	5.995							
JBM-R-6	5.995	5.995							
JBM-R-7	7.995	7.995	904 N•cm	2.8 N•cm	2.8	35.0	25.0	8.4	18.5
JBM-R-8	7.995	9.995							
JBM-R-9	7.995	12.995							
JBM-R-10	9.995	9.995							
JBM-R-11	9.995	12.995							
JBM-R-12	12.995	12.995							

Locking R.H. Hub, L.H. Hub drives clockwise.

BORE	STYLE	MATERIAL
4MM TO 13MM	COUNTER-CLOCKWISE SPRING WRAPPED - ONE DIRECTIONAL	STAINLESS STEEL DIN 1.4005 HUB DELTRIN CENTER

STOCK NO.	+0.015 ØA	+0.015 ØB	MAX DRIVE TORQUE	MAX DRAG TORQUE	C	ØD	ØE	F	H
JBM-L-1	3.995	3.995	113 N•cm	1.1 N•cm	25.0	19.0	14.0	5.4	12
JBM-L-2	3.995	4.995							
JBM-L-3	3.995	5.995							
JBM-L-4	4.995	4.995							
JBM-L-5	4.995	5.995							
JBM-L-6	5.995	5.995							
JBM-L-7	7.995	7.995	904 N•cm	2.8 N•cm	2.8	35.0	25.0	8.4	18.5
JBM-L-8	7.995	9.995							
JBM-L-9	7.995	12.995							
JBM-L-10	9.995	9.995							
JBM-L-11	9.995	12.995							
JBM-L-12	12.995	12.995							

Locking R.H. Hub, L.H. Hub drives counter-clockwise.

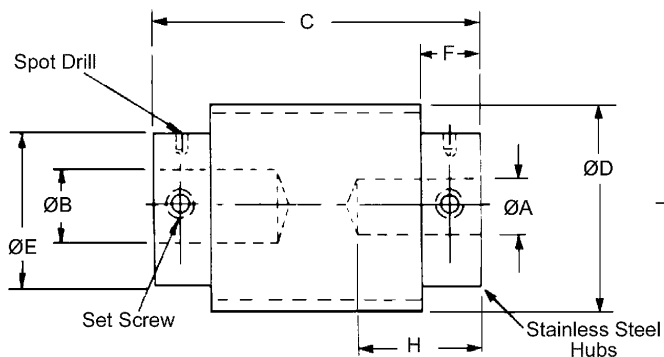

Drive load in one direction.
Clutch rotates freely in opposite direction

Note: Backlash is less than 1° (degree) in driving direction.

INLINE COUPLING SLIP CLUTCH

BORE	STYLE	TORQUE	MATERIAL
4MM TO 6MM	PIN HUB	ADJUSTABLE 0 N.cm TO 17 N.cm	STAINLESS STEEL DIN 1.4305

STOCK NO.	ØB1* +0.013	ØB2 +0.013	ØH	ADJUSTABLE SLIP TORQUE
CO16M-1	3.995	3.995	8	0 TO 17 N*cm
CO16M-2	4.995	4.995	10	
CO16M-3	5.995	5.995	13	
CO16M-4	3.995	4.995	10	
CO16M-5	3.995	5.995	13	
CO16M-6	4.995	5.995	13	

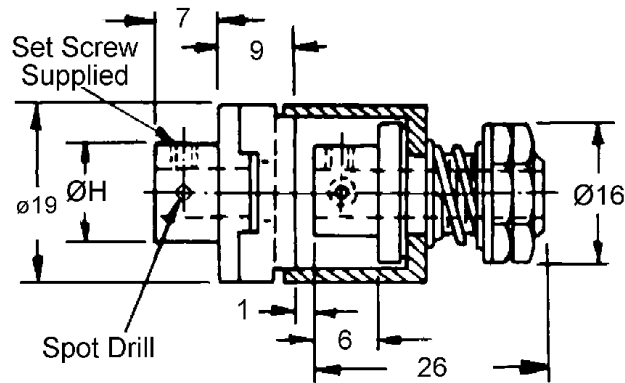

PIN HUB

BORE	STYLE	TORQUE	MATERIAL
4MM TO 6MM	CLAMP HUB	ADJUSTABLE 0 N.cm TO 17 N.cm	STAINLESS STEEL DIN 1.4305

STOCK NO.	ØB1* +0.013	ØB2 +0.013	ØC	ADJUSTABLE SLIP TORQUE
CO17M-1	3.995	3.995	5	0 TO 17 N*cm
CO17M-2	4.995	4.995	7	
CO17M-3	5.995	5.995	8	
CO17M-4	3.995	4.995	7	
CO17M-5	3.995	5.995	8	
CO17M-6	4.995	5.995	8	

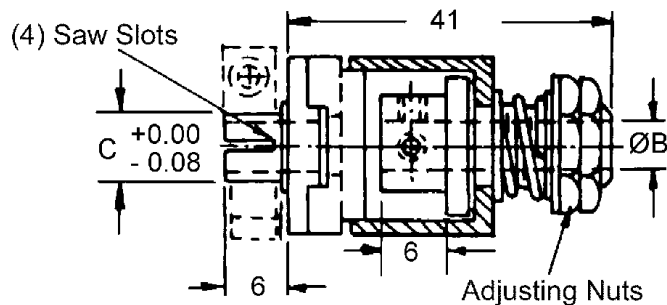

CLAMP HUB

*Bore size on adjustable end.
Other bore combinations on request.
For 35 N*cm units, add -35 to stock number.

SLIP CLUTCH

BORE	STYLE	TORQUE	MATERIAL
4MM TO 6MM	PIN HUB	ADJUSTABLE 0 N.cm TO 35 N.cm	STAINLESS STEEL DIN 1.4305

STOCK NO.	BORE SIZE	ØH	ØD	ADJUSTABLE SLIP TORQUE
JCM-10	3.995	8	15	0 TO 7 N•cm
JCM-11	4.995	10		
JCM-12	5.995	13		
JCM-10-50	3.995	8	15	7 TO 35 N•cm
JCM-11-50	4.995	10		
JCM-12-50	5.995	13		
JAM-1	3.995	8	25	7 TO 35 N•cm
JAM-2	4.995	10		
JAM-3	5.995	13		
JCM-1	3.995	8	25	0 TO 7 N•cm
JCM-2	4.995	10		
JCM-3	5.995	13		
JCM-1-50	3.995	8	25	7 TO 35 N•cm
JCM-2-50	4.995	10		
JCM-3-50	5.995	13		

BORE	STYLE	TORQUE	MATERIAL
4MM TO 6MM	CLAMP HUB	ADJUSTABLE 0 N.cm TO 35 N.cm	STAINLESS STEEL DIN 1.4305

STOCK NO.	BORE SIZE	ØC	ØD	ADJUSTABLE SLIP TORQUE
JAM-1C	3.995	8	25	7 TO 35 N•cm
JAM-2C	4.995	10		
JAM-3C	5.995	13		
JCM-1C	3.995	8	25	0 TO 7 N•cm
JCM-2C	4.995	10		
JCM-3C	5.995	13		
JCM-1-50C	3.995	8	25	7 TO 35 N•cm
JCM-2-50C	4.995	10		
JCM-3-50C	5.995	13		

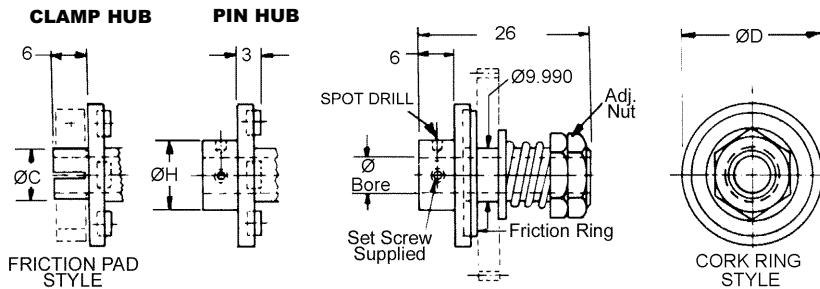

Order gears and clamps separately.

SLIP CLUTCH

BORE	STYLE	TORQUE	MATERIAL
4MM TO 6MM	CLAMP HUB	ADJUSTABLE 0 N.cm TO 70 N.cm	STAINLESS STEEL DIN 1.4305*

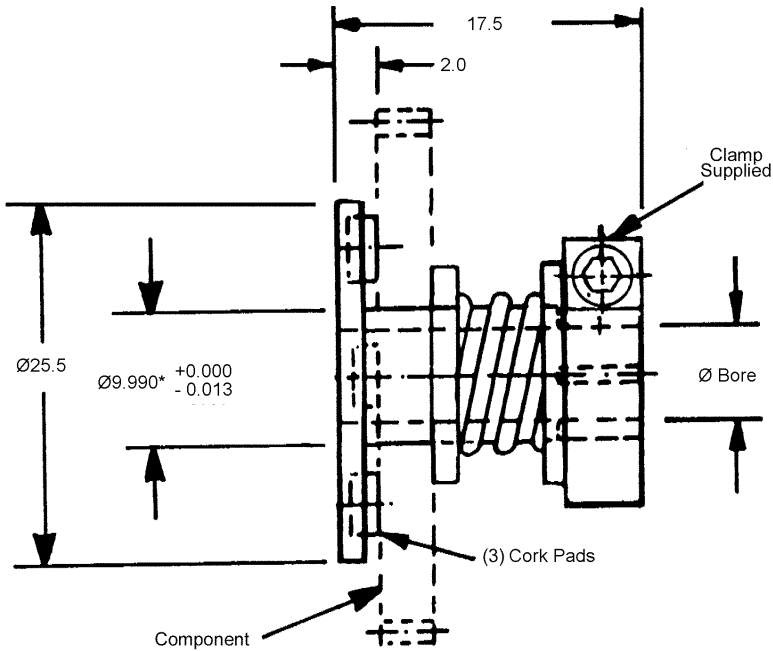

- Use with gears, sprockets, pulleys, ratchets, cams, or other components with 10mm bores.

STOCK NO.	BORE	COMPONENT THICKNESS (IN.)	ADJUSTABLE SLIP TORQUE (IN.)
JCM-7	3.995	1.5 THROUGH 3.0	1.5, 0-10 N•cm 3.0, 3-20 N•cm
JCM-8	4.995		
JC-M9	5.995		
JC-7M-50	3.995	1.5 THROUGH 3.0	1.5, 10-35 N•cm 3.0, 18-70 N•cm
JC-8M-50	4.995		
JC-9M-50	5.995		

* Adjustable by varying spring force

SLIP CLUTCHES

BORE	TORQUE	MATERIAL
6MM OR 8MM	ADJUSTABLE 2.5 N.cm TO 132 N.cm	HOUSING, ADJUSTOR RING & ADAPTERS-ALUMINUM HUB & PLAES-STEEL, BEARING-SINTERED BRONZE

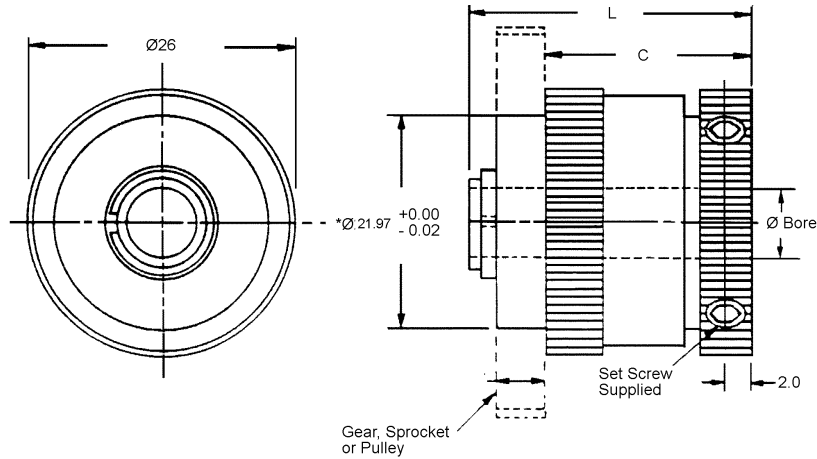

STOCK NO.	Ø BORE +0.03	L	C	ADJUSTABLE TORQUE RANGE		WEIGHT
				MIN.	MAX.	
JH-11M	6.00			2.5	53.5	37g
JH-12M	8.00	26.4	20.0	N• cm.	N• cm	
JH-13M	6.00			7.8	132.0	48g
JH-14M	8.00	32.4	25.6	N• cm	N• cm	

- Maximum operating temperature 80°C
- Maximum backlash 2°
- Bi-directional
- Fine-knurled torque adjustment rings

SLIP CLUTCH

BORE	STYLE	MATERIAL
3MM TO 12MM	1 AND 2	STAINLESS STEEL BRONZE BEARINGS

STOCK NO.	ØB BORE +0.02 - 0.00	TORQUE BI-DIRECTIONAL	ØK DIA. -0.02	L	A	C	STYLE	ØD	T THREAD (DEPTH)	ØB.C.	F	ØQ (MAX.)	E	ØH
JH-1M	3.00	6.4 N•cm ± 0.7	10.00	26.7	18.3	4.6	1	16	M1.2 X 2.5 X 2.0Dp.	12	2.0	11.4	0.8	10
JH-2M	4.00	14.1 N•cm ± 1.4	12.00	31.5	21.6	5.3	1	25	M1.2 X 2.5 X 2.0Dp.	16	2.4	17.3	1.0	13
JH-2AM	6.00	14.1 N•cm ± 1.4	12.00	31.5	21.6	5.3	1	25	M1.2 X 2.5 X 2.0Dp.	16	2.4	17.3	1.0	13
JH-3M	6.00	33.9 N•cm ± 3.5	12.00	35.3	23.9	5.8	1	35	M2.0 X 0.4 X 2.5Dp.	25	3.3	17.3	1.0	13
JH-4M	6.00	56.5 N•cm ± 5.7	12.00	35.3	23.9	5.8	2	35	M2.0 X 0.4 X 2.5Dp.	25	3.3	17.3	1.0	16
JH-5M	6.00	84.7 N•cm ± 8.5	12.00	42.4	30.5	6.4	1	48	M2.0 X 0.4 X 2.5Dp.	20	3.3	17.3	1.0	16
JH-5AM	8.00	84.7 N•cm ± 8.5	12.00	42.4	30.5	6.4	1	48	M2.0 X 0.4 X 2.5Dp.	20	3.3	17.3	1.0	25
JH-6M	10.00	105.9 N•cm ± 10.6	20.00	47.8	34.0	7.4	1	48	M2.0 X 0.4 X 2.5Dp.	30	3.3	18.8	1.0	25
JH-6AM	12.00	105.9 N•cm ± 10.6	20.00	47.8	34.0	7.4	1	48	M2.0 X 0.4 X 2.5Dp.	30	3.3	18.8	1.0	25
JH-7M	6.00	169.5 N•cm ± 17.0	20.00	47.8	34.0	7.4	2	57	M3.0 X 0.5 X 4.0Dp.	30	3.3	18.8	1.0	25
JH-8M	8.00													
JH-9M	10.001													
JH-10M	12.00													
JH-7M-X	6.00	226 N•cm ± 23.0	20.00	47.8	34.0	7.4	2	57	M3.0 X 0.5 X 4.0Dp.	30	3.3	18.8	1.0	25
JH-8M-X	8.00													
JH-9M-X	10.001													
JH-10M-X	12.00													

- Torque limits calibrated to 5% on request.
- Torques from 0.35 N.cm to 339 N.cm are available on request.

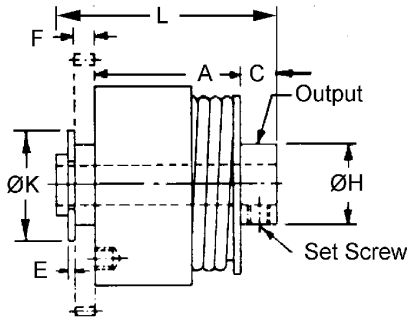
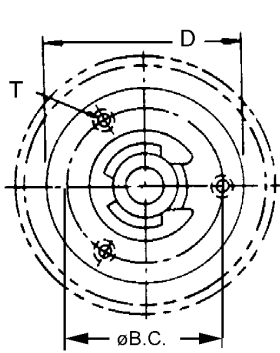

STYLE 2

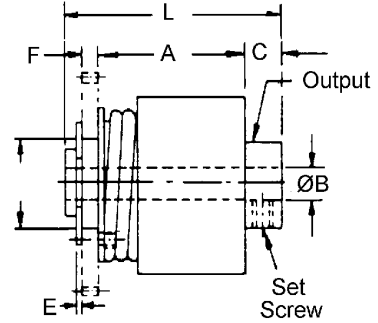

STYLE 1

MINIATURE SLIP CLUTCH

BORE	STYLE	TORQUE	MATERIAL
4MM TO 5MM	CLAMP HUB	ADJUSTABLE 0 N.cm TO 35.5 N.cm	ANODIZED ALUMINUM

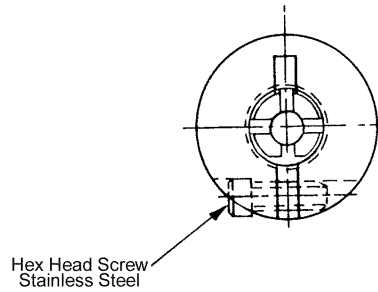
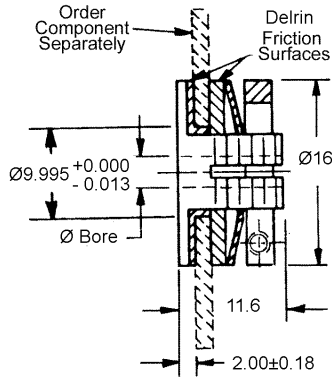

STOCK NO.	\varnothing BORE +0.005	COMPONENT THICKNESS
JAM-4	3.995	1.5 THROUGH 3.0
JAM-5	4.995	

- Use with gears, sprockets, pulleys, ratchets, cams, or other components with 10mm bores.

Special bore sizes available on request.

* Adjustable by varying spring force

SLIP CLUTCHES AND COUPLINGS

BORE	STYLE	TORQUE	MATERIAL
3MM TO 12MM	OPEN OR CLOSED	ADJUSTABLE 3.4 N.cm TO 280 N.cm	HOUSING, ADJUSTER RING AND ADAPTERS - ALUMINUM; ALOCROM FINISH, HUBS; PLATES - HEAT TREATED STEEL; BEARING - SINTERED BRONZE

SLIP CLUTCH STOCK NO.	SLIP COUPLING STOCK NO.	ØB +0.03	ØA	C	ØD	E	ØG	ADJUSTABLE TORQUE RANGE	STYLE
JCL-1M JCL-2M JCL-3M	JCO-1M JCO-2M JCO-3M	3 4 6	25	33	10	6	18	3.4 TO 113 N*cm	CLOSED
JCL-4M JCL-5M JCL-6M	JCO-4M JCO-5M JCO-6M	6 8 12	38	64	25	10	30	5.6 TO 280 N*cm	OPEN

**SLIP COUPLING
JCO SERIES - CLOSED**

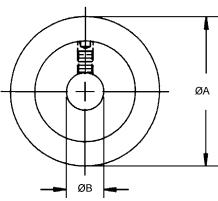

**SLIP CLUTCH
JCL SERIES - CLOSED**

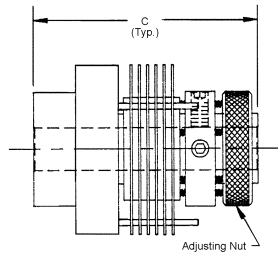
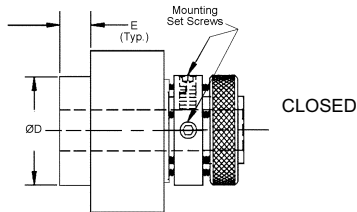
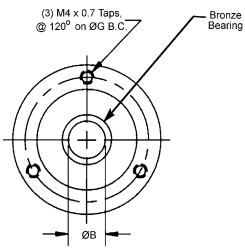

ROLLER CLUTCHES

BORE	STYLE	MATERIAL
4MM TO 20MM	DRAWN CUP DESIGN ONE DIRECTIONAL DRIVE	ROLLER CUP - CASE HARDENED STEEL; NEEDLE BEARINGS - HARDENED CHROME STEEL DIN 1.3505; SPRINGS - STAINLESS STEEL*; CAGE - NYLON 66 (or Equiv.)

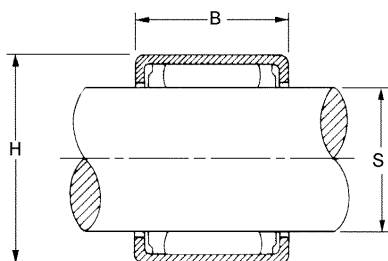

- Ideal For Indexing, Backstopping Or Overrunning Operations
- Free Rolling One Way, Drives In Opposite Direction
- Light Weight, Low Profile
- High Indexing, Frequency
- Temp. Range, Grease - 45°C to + 70°C
- Minimum Backlash

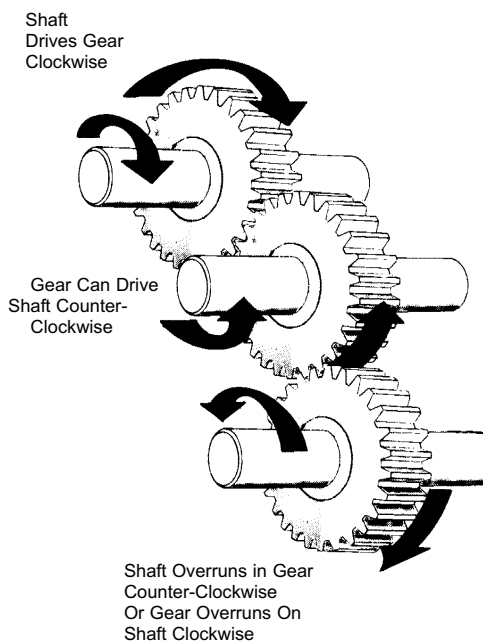

STOCK NO.	BORE ØS	ØH CLUTCH O.D.	B + .000 - .008	MAX TORQ N•cm	HOUSING DIAMETER N7 STEEL R7 ALUM.	OVERRUN SPEED (MAX) (RPM)
NRC-4M*	4	8.000	6.00	0.34	8.000	17000
NRC-6M	6	10.000	12.00	1.76	10.000	23060
NRC-8M	8	12.000	12.00	3.15	12.000	17000
NRC-10M	10	14.000	12.00	5.30	14.000	14000
NRC-12M	12	18.000	16.00	12.20	18.000	11000
NRC-20M	20	26.000	16.00	28.50	26.000	7000

* HARDENED SHAFTING STOCK LENGTH 300mm OTHER LENGTHS ON REQUEST	
SHAFTING STOCK NO.	SHAFT DIAMETER h6
LMS-6M	6.000
LMS-8M	8.000
LMS-12M	12.000
LMS-20M	20.000

- * Order Shaft Separately.
- Maximum operating temperature +70°C due to plastic spring design.



VIBRATION DAMPING COMPONENTS

Table of Contents

MULTI-AXIS ISOLATOR	MH 2
BUSHINGS	MH 3
ISOLATION RINGS/PADS	MH 4
HEMISPHERES	MH 5

MULTI-AXIS ISOLATOR

MATERIAL

SORBOTHANE AND COPPER

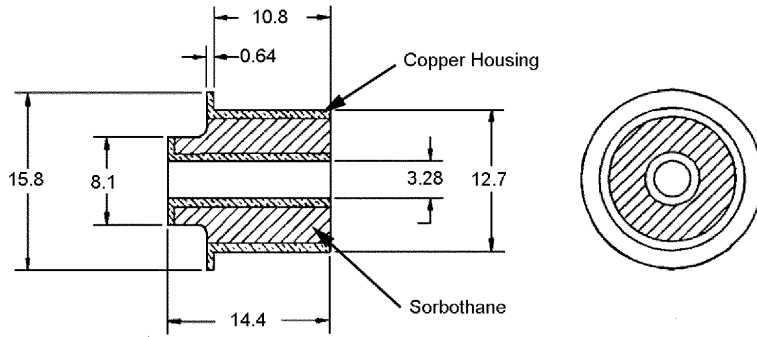

Ideal for applications involving drive units, the Sorbothane is encapsulated in a copper housing. The isolator provides attenuation of vibration and shock in any direction. Simply use pins to locate your unit inside the copper housing.

STOCK NO.
SMAI-1

BUSHINGS

MATERIAL

SORBOTHANE

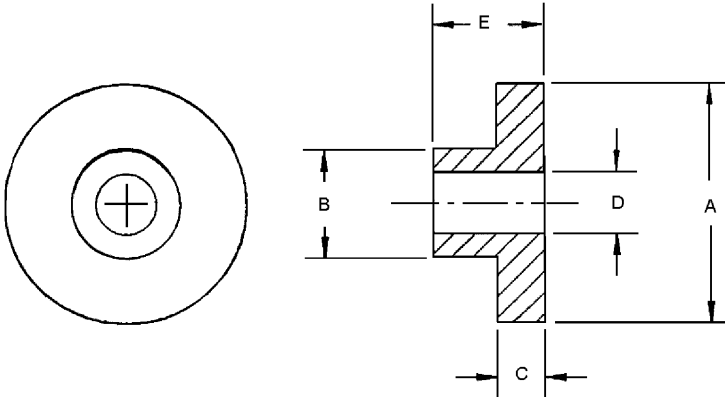

STOCK NO.	A	B	C	D	E	LOAD PER BUSHING (N) 70 DUROMETER
SB-1	19.0	12.7	3.8	6.4	5.6	35.6 - 93.4
SB-2	25.4	11.7	4.8	7.2	7.9	89.0 - 186.8
SB-3	25.4	-	4.8	11.4	4.8	35.6 - 48.9
SB-4	25.4	11.4	4.8	6.4	15.2	124.6 - 195.7

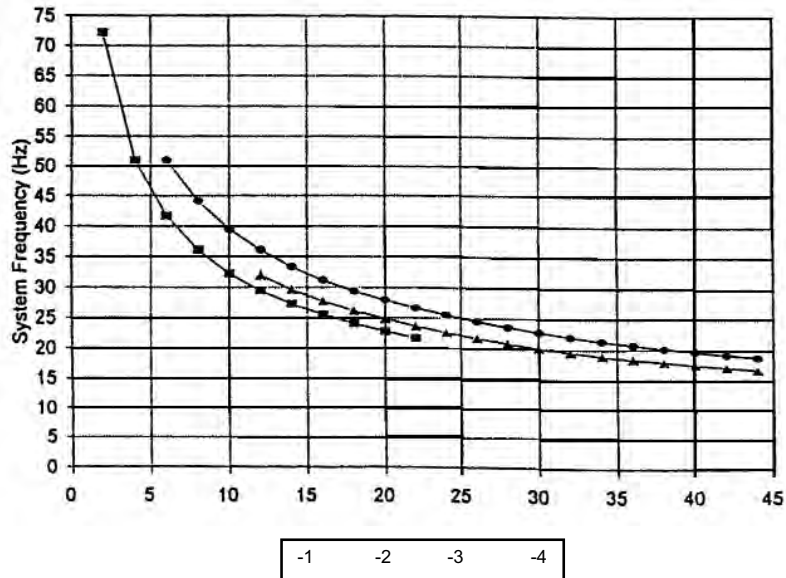

Sorbothane bushings isolate vibration and absorb shock for delicate electronics and other light weight applications. Using two bushings together, you can create a floating bolt which isolates your unit from any metal to metal contact. To achieve this floating bolt, use two pieces of stock numbers SB-1 or SB-2 respectively and one piece each of part numbers SB-3 and SB-4 together. Different durometers allow for different spring rates. Load ratings assume a 10% torsional deflection of the bushing material.

H

ISOLATION RINGS

MATERIAL
SORBOTHANE

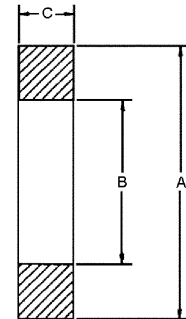
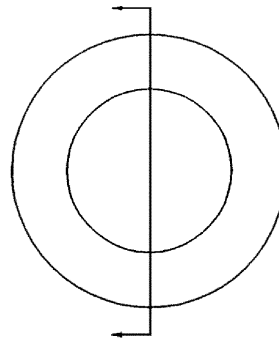
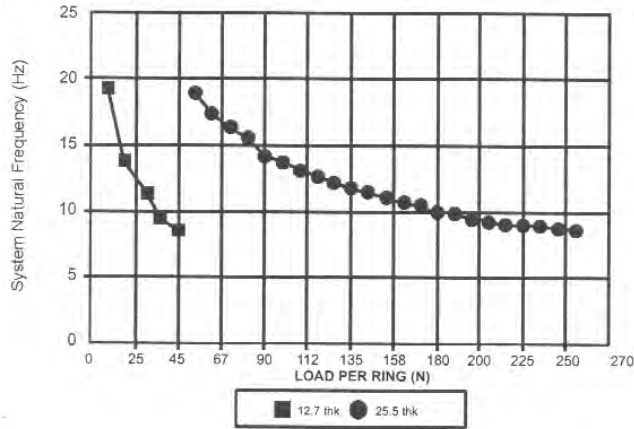

STOCK NO.	A	B	C	LOAD PER RING (N) 70 DUROMETER
SIR-1	127	78.7	12.7	20 - 29
SIR-2	127	78.7	25.5	119 - 245

ISOLATION PADS

MATERIAL
SORBOTHANE

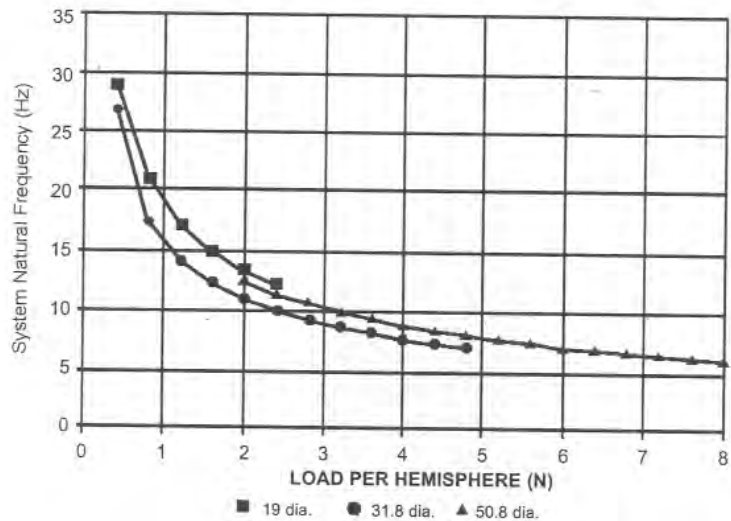
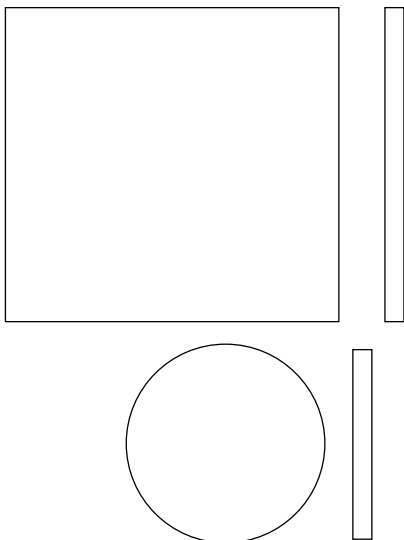

STOCK NO.	DESCRIPTION	LOAD PER PAD (N) 70 DUROMETER SHORE SCALE 00
SIP-1	101.6 X 101.6 X 12.7	1280-2000
SIP-2	127 X 127 X 6.4	2400-4800
SIP-3	127 X 127 X 12.7	3000-4800
SIP-4	63.5 X 63.5 X 12.7	1440-1920
SIP-5	57.2 X 6.4	160-240

A wide range of loads can be isolated by choosing the correct thickness, durometer and varying the number of pads. The pads are designed to offer isolation for all types of static and dynamic systems. Higher disturbing frequencies and lower temperatures are parameters that indicate the need for a lower durometer pad. Ideal for applications with heavier loads.

HEMISPHERES

MATERIAL

SORBOTHANE

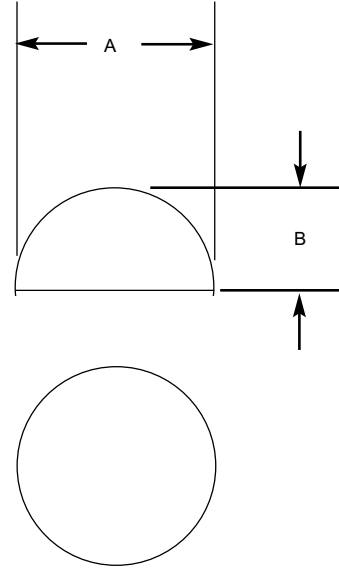
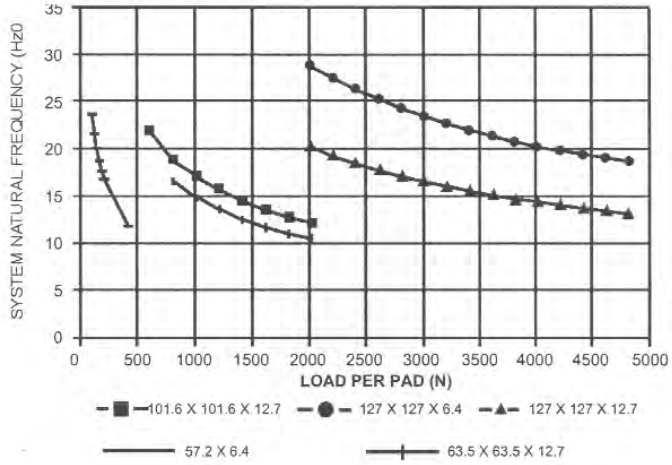

STOCK NO.		A	B	LOAD PER HEMISPHERE (N) 70 DUROMETER SHORE SCALE 00
Backing				
Without Adhesive	With Adhesive			
SH-1	SH-1-A	19.0	9.5	2 - 2.5
SH-2	SH-2-A	31.8	15.8	3 - 5
SH-3	SH-3-A	50.8	25.5	5 - 8.5
SH-4	SH-4-A	50.8	25.5	6 - 8.5

Sorbothane Hemisphere mounts provide a quick cost effective method of isolating bench equipment and small machinery. Simply place the hemisphere under the unit to be isolated with the curved surface up. Expect a 25 to 30% deflection when statically loaded.

H

BEARING, SHAFTS, CLAMPS, COLLARS & HUBS

Table of Contents

HUBS

Gear, Dial and Sprocket Assemblies - Tech Info. . . .	MI 2
Phase Adjustable Hub	MI 3
Quick-2-Lock® Hub	MI 4
Gear, Sprocket and Dial Hubs	MI 5 - MI 7
Dual Gear Hubs	MI 8

CLAMPS

Split Hub Clamps	MI 9 - MI 10
Shaft Clamp	MI 11
Clamps	MI 12
Threaded Shaft Clamp	MI 13
Squeeze Clamp	MI 14

COLLARS

Set Screw Collars	MI 15 - MI 16
-----------------------------	---------------

SHAFTS

Threaded Stock	MI 17
Case Hardened Ground Shafts	MI 18
Stainless Ground Shafts	MI 19, MI 21 - MI 27
Ground Shafting	MI 20

BEARINGS

Dyna-Speed Needle Roller Bearings	MI 27
Ball Bearings	MI 28 - MI 30
Oil-Less Bearings	MI 31 - MI 33
Te-F-Thane® Bearing	MI 34 - MI 35
Long-Life Bearings	MI 36
Thermoplastic Bearings - Reference Chart	MI 37
Thermoplastic Bearings	MI 38 - MI 40
Ceramic Bearings	MI 41 - MI 46
Spherical Bearings	MI 47
Spherical Pillow Block Bearings	MI 48
Thrust Bearings	MI 49
Roller Thrust Bearings	MI 50

GEAR, DIAL OR SPROCKET ASSEMBLIES

Technical Information

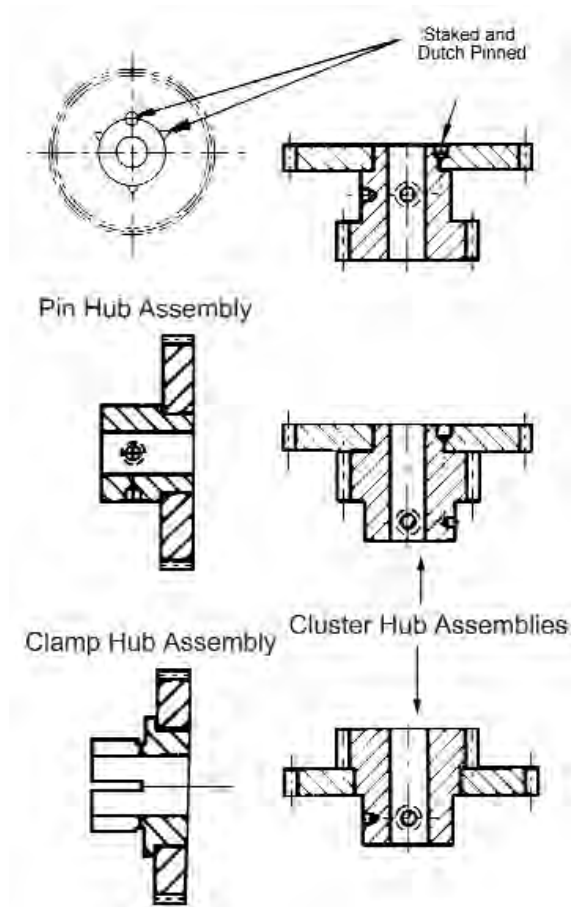

W.M. Berg has a wide selection of hub sizes and styles to select from. Our all stainless steel hubs are available in bore diameters ranging from 1.98mm to 31.75mm.

See the following pages for pin hub, clamp hubs and dual hubs, see index for cluster gears. W.M. Berg assembles hubless gears, sprockets or dials to hubs for a nominal assembly charge. Contact our Customer Service Department for more information.

PHASE ADJUSTABLE HUB

BORE	TYPE	MATERIAL
4MM TO 6MM	PIN HUB 360° ADJUSTABLE BI-DIRECTIONAL	STAINLESS STEEL DIN 1.4305

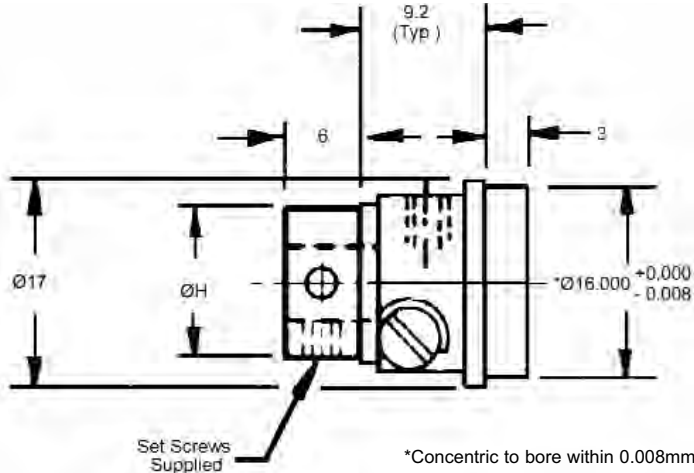

STOCK NO.	$\varnothing B$ BORE	$\varnothing H$	$\varnothing C$
PH6M-1	3.995	9.0	5.6
PH6M-2	4.995	10.0	6.6
PH6M-3	5.995	13.0	7.6

BORE	TYPE	MATERIAL
4MM TO 6MM	CLAMP HUB 360° ADJUSTABLE BI-DIRECTIONAL	STAINLESS STEEL DIN 1.4305

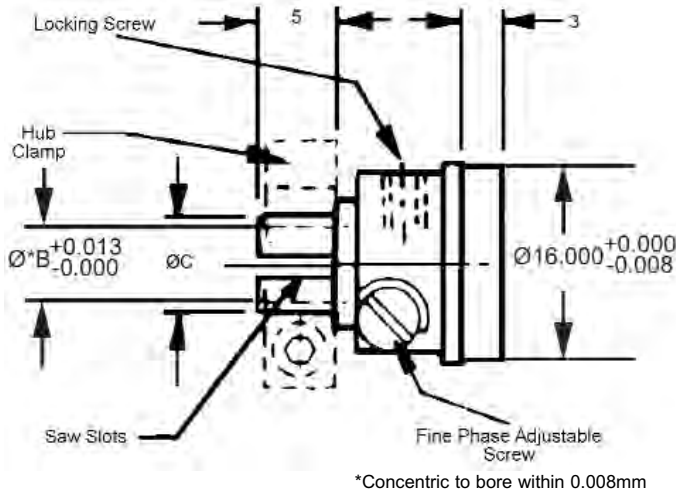

STOCK NO.	$\varnothing B$ BORE	$\varnothing C$	HUB CLAMP NO. (ORDER SEPARATELY)
CH6M-1	3.995	5.6	CG1M-5
CH6M-2	4.995	6.6	CG1M-8
CH6M-3	5.995	7.9	CG1M-11

QUICK-2-LOCK® HUBS

BORE	TYPE	MATERIAL
5MM TO 16MM	QUICK-2-LOCK®	TOOL STEEL

STOCK NO.	Ød	ØD	L1	L2	A	B	MAX. TRANSMISSIBLE		CONTACT PRESSURE		INSTALLATION TORQUE ON NUT N•m	APPROX. WT. gm.
							TORQUE N•m	THRUST kn	ON HUB N•cm2	ON SHAFT N•cm2		
QHM-5T	5	16.0	19.0	9.5	13	3	12	3.2	3565	4698	14.1	14
QHM-6T	6	16.0	19.0	9.5	13	3	16	3.4	3565	3915	14.1	14
QHM-8T	8	19.0	22.0	11.0	16	3	23	4.0	2547	2517	17.0	28
QHM-9T	9	19.0	22.0	11.0	16	3	28	4.1	2547	2237	17.0	28
QHM-10T	10	22.5	25.5	12.5	19	5	30	4.2	1857	2056	19.8	42
QHM-12T	12	22.5	25.5	12.5	19	5	38	4.3	1857	1713	19.8	42
QHM-14T	14	25.5	28.5	16.0	22	5	44	4.4	1238	1240	22.6	56
QHM-16T	16	25.5	28.5	16.0	22	5	50	4.5	1238	1087	22.6	56

- Quick and easy installation - just tighten the nut
- Positive release for removal or adjustment
- Eliminates expensive machining operations such as cutting of keyways, turning of snap ring grooves, splines, shoulders and threads for lock nuts, drilling and pinning
- Drastically relaxes shaft and hub tolerances, permitting the use of commercially finished shafting
- Smaller diameter shafts (and bearings) may be used, offering equal strength and stiffness because of the rigidizing effect of quick-2-lock and because of the elimination of keyways
- Infinite lateral and easy circumference positioning
- Quick and easy removal
- Excellent concentricity
- Greater shaft strength and stiffness
- Unaffected by vibration and torque reversal



Permissible tolerance on shaft bore: for 5mm. thru 16mm. - 0.04
for 17mm. thru 19mm. - 0.08

- The "torque on nut" column represents values which are necessary to obtain the maximum transmissible torque/thrust.

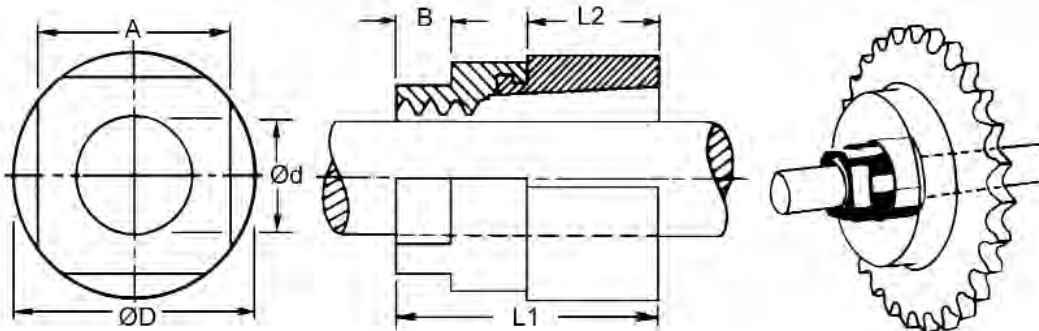

GEAR, SPROCKET AND DIAL HUBS

BORE	TYPE	MATERIAL
4MM TO 12MM	PIN HUB	STAINLESS STEEL DIN 1.4305

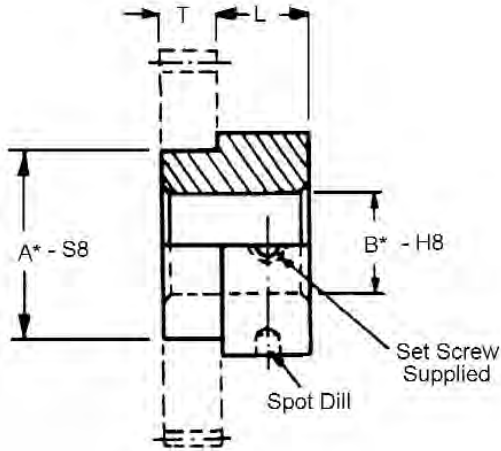

STOCK NO.	ØB	ØA	T	L	ØH
PH4M-1	4.00	10.00	1.6	6	13
PH4M-2			3.0		
PH4M-3			5.0		
PH4M-4			6.4		
PH4M-5			9.5		
PH4M-6	6.00	10.00	1.6	6	13
PH4M-7			3.0		
PH4M-8			5.0		
PH4M-9			6.4		
PH4M-10			9.5		
PH4M-11	7.00	10.00	1.6	6	13
PH4M-12			3.0		
PH4M-13			5.0		
PH4M-14			6.4		
PH4M-15			9.5		
PH4M-40	8.00	10.00	1.6	13	20
PH4M-41			3.0		
PH4M-42			5.0		
PH4M-43			6.4		
PH4M-44			9.5		
PH4M-16	10.00	16.00	1.6	13	20
PH4M-17			4.8		
PH4M-18			6.4		
PH4M-19			9.5		
PH4M-20			10.0		
PH4M-21	12.00	16.00	1.6	13	20
PH4M-22			4.8		
PH4M-23			6.4		
PH4M-24			9.5		
PH4M-25			10.0		

* Diameters A & B are concentric within 0.013mm.

- Fasten component to hub with epoxy cement or stake and dutch pin
- Assembly by Berg available.

GEAR, SPROCKET AND DIAL HUBS

BORE	TYPE	MATERIAL
3MM TO 8MM	PIN HUB	STAINLESS STEEL DIN 1.4305

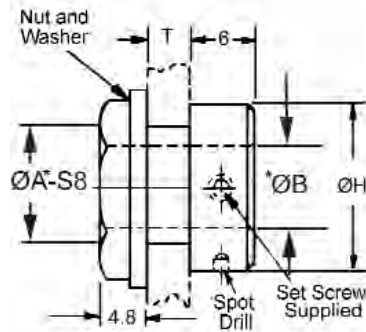

STOCK NO.	ØB-H8	T	ØH	A
PH4M-30 PH4M-31	3	1.6 3.0	12	10
PH4M-32 PH4M-33	4	1.6 3.0	12	10
PH4M-34 PH4M-35	6	1.6 3.0	12	10
PH4M-38 PH4M-39	8	1.6 3.0	15	12

* Concentric to bore within 0.013mm

BORE	TYPE	MATERIAL
3MM TO 8MM	CLAMP HUB	STAINLESS STEEL DIN 1.4305

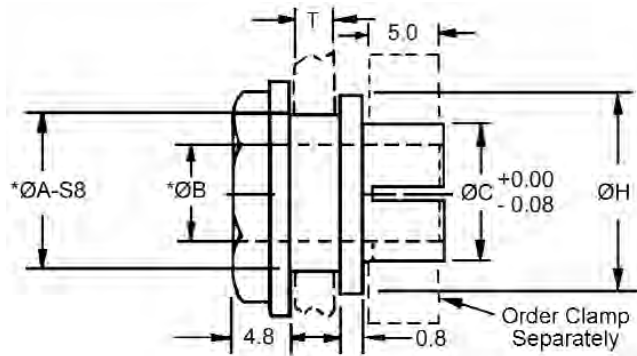

STOCK NO.	ØB-H8	T	ØH	ØC	CLAMP STOCK NO.	ØA
CH2M-30 CH2M-31	3	1.6 3.0	12	4.60	CG1M-3	10
CH2M-32 CH2M-33	4	1.6 3.0	12	5.60	CG1M-5	10
CH2M-34 CH2M-35	6	1.6 3.0	12	7.60	CG1M-11	10
CH2M-38 CH2M-39	8	1.6 3.0	15	9.60	CG1M-14	12

* Concentric to bore within 0.013mm

GEAR, SPROCKET AND DIAL HUBS

BORE	TYPE	MATERIAL
4MM TO 12MM	CLAMP HUB	STAINLESS STEEL DIN 1.4305

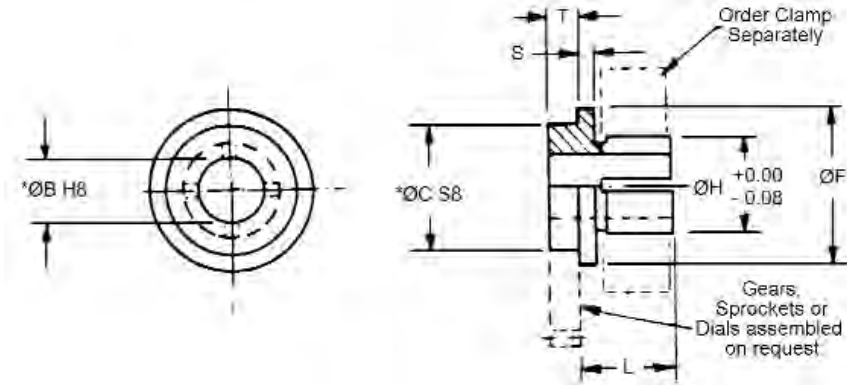

* Concentric within 0.008mm



STOCK NO.	ØB	ØC	T	L	ØH	ØF	S	CLAMP STOCK .NO.
CH2M-1	4	10	1.6	4.8	5.6	12	0.8	CG1M-5
CH2M-2			3.0					
CH2M-3			5.0					
CH2M-4			6.4					
CH2M-5			9.5					
CH2M-6	6	10	1.6	6.2	7.6	13	1.2	CG1M-11
CH2M-7			3.0					
CH2M-8			5.0					
CH2M-9			6.4					
CH2M-10			9.5					
CH2M-11	7	10	1.6	6.6	8.6	14	1.6	CG1M-12
CH2M-12			3.0					
CH2M-13			5.0					
CH2M-14			6.4					
CH2M-15			9.5					
CH2M-40	8	10	1.6	7.6	9.6	16	1.6	CG1M-14
CH2M-41			3.0					
CH2M-42			5.0					
CH2M-43			6.4					
CH2M-44			9.5					
CH2M-16	10	16	1.6	7.6	11.6	24	1.6	CG1M-16
CH2M-17			4.8					
CH2M-18			6.4					
CH2M-19			9.5					
CH2M-20			10.0					
CH2M-21	12	16	1.6	9.6	13.6	30	1.6	CG1M-18
CH2M-22			4.8					
CH2M-23			6.4					
CH2M-24			9.5					
CH2M-25			10.0					

DUAL GEAR HUBS

BORE	TYPE	MATERIAL
3MM TO 8MM	PIN HUB	STAINLESS STEEL DIN 1.4305

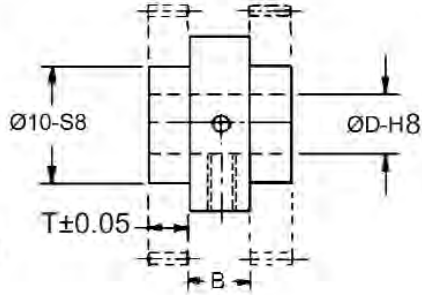
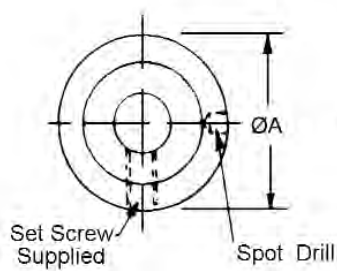

STOCK NO.	$\varnothing D$	T	$\varnothing A$	B
PH3M-1	3		11.0	
PH3M-2	5		11.0	
PH3M-3	6	3.00	12.7	6.5
PH3M-4	8		12.7	

- Assembly available
- Gears are triple staked and dutch pinned at assembly
- Components may also be assembled to hubs with epoxy cement
- Order gears separately

SPLIT HUB CLAMPS

BORE	TYPE	MATERIAL
4.60MM TO 13.60MM	COMPACT CLAMP DESIGN	STAINLESS STEEL DIN 1.4305 OR ALUMINUM ANODIZED DIN 3.1355

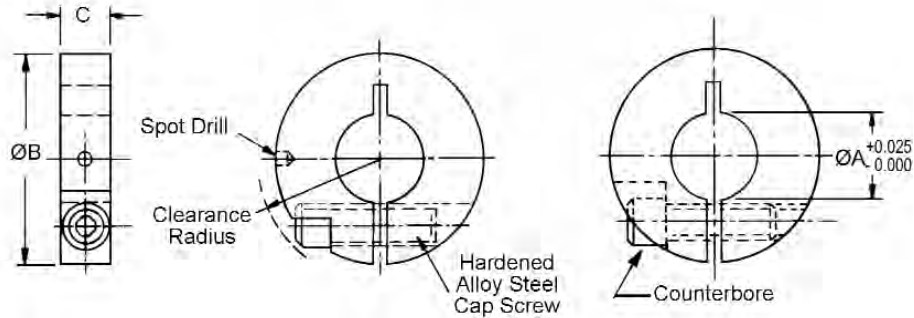

Note: Some sizes may be full or semi-counterbored or step cut at manufacturer's option.

STAINLESS STEEL DIN 1.4305	ALUMINUM ANODIZED DIN 3.1355	ØA	ØB	C	CLEAR RADIUS	SPLIT HUB I.D. (Ref.)
STOCK NO.	STOCK NO.					
CG1M-1	CG1M-1A	4.60	14.0	4.0	8.5	3
CG1M-2	CG1M-2A		16.0	4.0	8.5	
CG1M-3	CG1M-3A		16.0	5.0	8.5	
CG1M-4	CG1M-4A		16.0	6.5	10.0	
CG1M-5	—		5.60	16.0	4.0	
CG1M-7	CG1M-7A	6.60	16.0	4.0	8.5	5
CG1M-8	CG1M-8A		16.0	5.0	8.5	
CG1M-9	CG1M-9A		22.0	5.0	12.5	
CG1M-10	CG1M-10A		22.0	6.0	13.0	
CG1M-11	—	7.60	22.0	5.0	12.5	6
CG1M-12	—	8.60	22.0	5.0	12.5	7
CG1M-13	CG1M-13A		22.0	6.0	13.0	
CG1M-14	CG1M-14A	9.60	28.5	6.5	16.0	8
CG1M-15	CG1M-15A		28.5	8.0	16.0	
CG1M-16	CG1M-16A	11.60	28.5	6.5	16.0	10
CG1M-17	CG1M-17A		32.0	8.0	16.0	
CG1M-18	CG1M-18A	13.60	32.0	8.0	16.0	12

Special clamps are available on request.

SPLIT HUB CLAMPS

SHAFT SIZE	MATERIAL
3MM TO 12MM	STAINLESS STEEL AND MILD STEEL

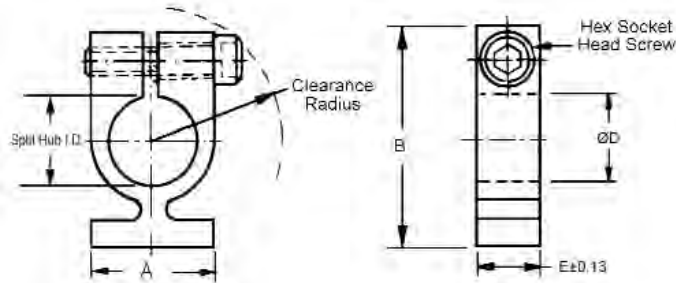

STOCK NO.	MATERIAL	D	A	B	CLEAR. RADIUS	E	FINISH	SHAFT SIZE
CG3M-1	DIN 1.4005 S.S.	4.60	7.9	17.5	11.1	6.35	BLACK PASS.	3.00
CG3M-2	DIN 1.4305 S.S.					6.35	CLEAR PASS.	
CG3M-3	MILD STEEL					3.56	CAD. PLATE	
CG3M-4	DIN 1.4005 S.S.	6.60	9.6	20.6	13.1	6.35	BLACK PASS.	5.00
CG3M-5	DIN 1.4305 S.S.					6.35	CLEAR PASS.	
CG3M-6	MILD STEEL					3.56	CAD. PLATE	
CG3M-7	DIN 1.4005 S.S.	8.60	11.1	20.6	14.3	6.35	BLACK PASS.	7.00
CG3M-8	DIN 1.4305 S.S.					6.35	CLEAR PASS.	
CG3M-9	MILD STEEL					3.56	CAD. PLATE	
CG3M-10	DIN 1.4005 S.S.	11.60	15.9	26.2	17.1	6.35	CLEAR PASS.	10.00
CG3M-11	MILD STEEL					6.35	CAD. PLATE	
CG3M-12	MILD STEEL					3.56	CAD. PLATE	
CG3M-13	DIN 1.4005 S.S.	13.60	15.9	26.2	17.1	6.35	CLEAR PASS.	12.00
CG3M-14	MILD STEEL					6.35	CAD. PLATE	
CG3M-15	MILD STEEL					3.56	CAD. PLATE	

SHAFT SIZE	TYPE	MATERIAL
3MM TO 7MM	BALANCED CLAMP	STAINLESS STEEL AND MILD STEEL

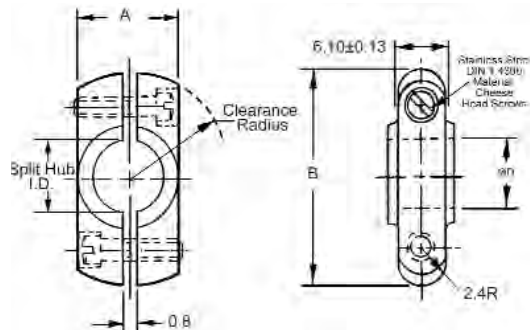

STOCK NO.	ØD	A	B	TYPE CLEAR. RADIUS	SPLIT HUB OF BALANCE	INSIDE DIA. (REF.)
CG2M-1	4.60	7.9	17.4	9.5	DYNAMICALLY BALANCED	3.00
CG2M-2	6.60	9.5	18.85	10.3		5.00
CG2M-3	8.60	11.1	20.6	11.9		7.00
CG2M-4	4.60	7.9	17.4	9.5	AS CAST	3.00
CG2M-5	6.60	9.5	18.85	10.3		5.00
CG2M-6	8.60	11.1	20.6	11.9		7.00

SHAFT CLAMP

SHAFT SIZE	MATERIAL
3MM TO 6MM	STAINLESS STEEL DIN 1.4005

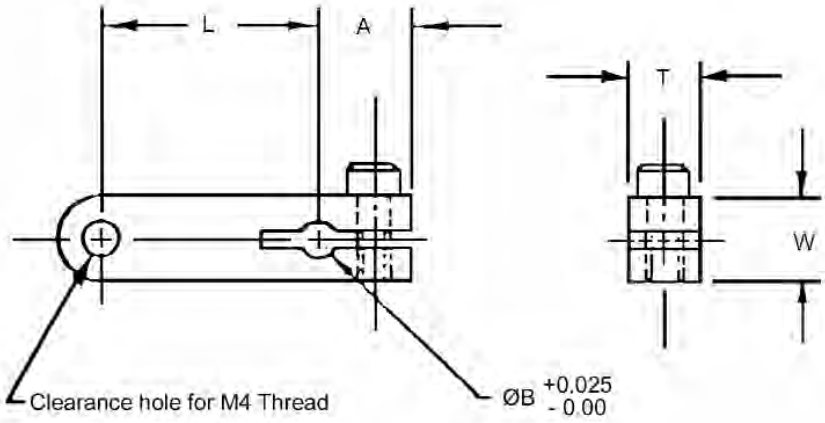

STOCK NO.	A	ØB	L	T	W
CG7M-1	6.4	3.00	15.9	4.8	6.4
CG7M-2	6.4	4.00	15.9	4.8	6.4
CG7M-3	6.4	5.00	15.9	4.8	7.9
CG7M-4	6.7	6.00	15.9	4.8	7.9



CLAMPS

BORE	TYPE	MATERIAL
3MM TO 26MM	ONE AND TWO PIECE STYLES	COLD ROLLED STEEL OR STAINLESS STEEL

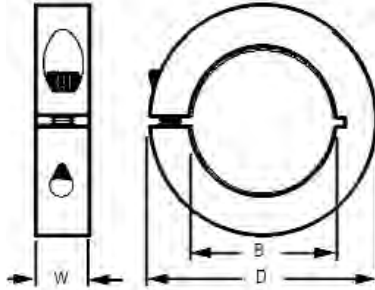

One Piece Style

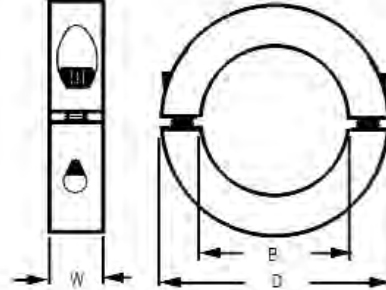

Two Piece Style

STOCK NUMBER				BORE (B)	O.D (D)	WIDTH (W)	FORGED CLAMP SCREW	REC. MAX SCREW TOR. N•m
COLD ROLLED STEEL		STAINLESS STEEL						
ONE-PIECE STYLE	TWO-PIECE STYLE	ONE-PIECE STYLE	TWO-PIECE STYLE					
CG8M-3	CG8SM-3	CG8M-3SS	CG8SM-3SS	3	16	9	M3x8	2.1
CG8M-4	CG8SM-4	CG8M-4SS	CG8SM-4SS	4	16	9	M3x8	2.1
CG8M-5	CG8SM-5	CG8M-5SS	CG8SM-5SS	5	16	9	M3x8	2.1
CG8M-6	CG8SM-6	CG8M-6SS	CG8SM-6SS	6	16	9	M3x8	2.1
CG8M-7	CG8SM-7	CG8M-7SS	CG8SM-7SS	7	18	9	M3x8	2.1
CG8M-8	CG8SM-8	CG8M-8SS	CG8SM-8SS	8	18	9	M3x8	2.1
CG8M-9	CG8SM-9	CG8M-9SS	CG8SM-9SS	9	24	9	M3x10	2.1
CG8M-10	CG8SM-10	CG8M-10SS	CG8SM-10SS	10	24	9	M3x10	2.1
CG8M-11	CG8SM-11	CG8M-11SS	CG8SM-11SS	11	28	11	M4x12	4.6
CG8M-12	CG8SM-12	CG8M-12SS	CG8SM-12SS	12	28	11	M4x12	4.6
CG8M-13	CG8SM-13	CG8M-13SS	CG8SM-13SS	13	30	11	M4x14	4.6
CG8M-14	CG8SM-14	CG8M-14SS	CG8SM-14SS	14	30	11	M4x14	4.6
CG8M-15	CG8SM-15	CG8M-15SS	CG8SM-15SS	15	34	13	M5x16	9.5
CG8M-16	CG8SM-16	CG8M-16SS	CG8SM-16SS	16	34	13	M5x16	9.5
CG8M-17	CG8SM-17	CG8M-17SS	CG8SM-17SS	17	36	13	M5x16	9.5
CG8M-18	CG8SM-18	CG8M-18SS	CG8SM-18SS	18	36	13	M5x16	9.5
CG8M-19	CG8SM-19	CG8M-19SS	CG8SM-19SS	19	40	15	M6x16	16
CG8M-20	CG8SM-20	CG8M-20SS	CG8SM-20SS	20	40	15	M6x16	16
CG8M-21	CG8SM-21	CG8M-21SS	CG8SM-21SS	21	42	15	M6x16	16
CG8M-22	CG8SM-22	CG8M-22SS	CG8SM-22SS	22	42	15	M6x16	16
CG8M-23	CG8SM-23	CG8M-23SS	CG8SM-23SS	23	45	15	M6x16	16
CG8M-24	CG8SM-24	CG8M-24SS	CG8SM-24SS	24	45	15	M6x16	16
CG8M-25	CG8SM-25	CG8M-25SS	CG8SM-25SS	25	45	15	M6x16	16
CG8M-26	CG8SM-26	CG8M-26SS	CG8SM-26SS	26	48	15	M6x16	16

THREADED SHAFT CLAMP

THREAD SIZE	MATERIAL
M8 X 1.25 TO M20 X 2.50	STEEL DIN 1.0718

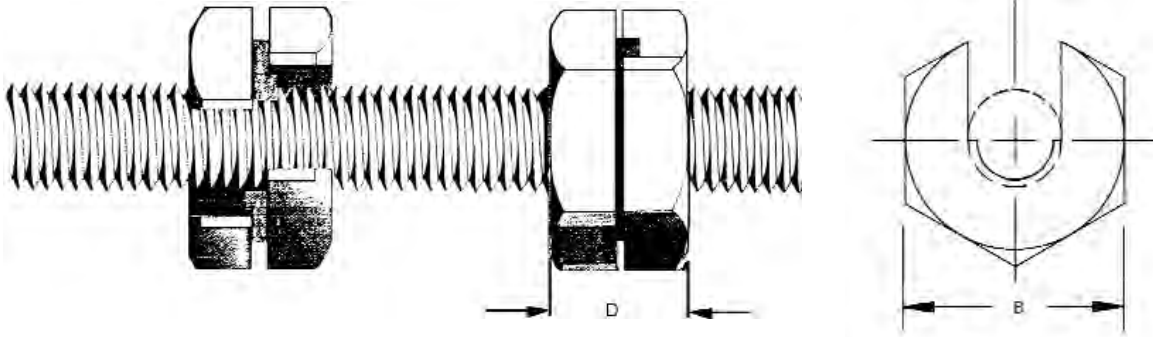

STOCK NO.	THREAD	B	D (APPROX)	REC.* LOAD (kg)
TSC-8M	M8 X 1.25	19	9	295
TSC-10M	M10 X 1.50	22	12	900
TSC-12M	M12 X 1.75	28	15	1815
TSC-16M	M16 X 2.00	33	15	2265
TSC-20M	M20 X 2.50	41	20	3625

* Or as limited by rod.



SQUEEZE CLAMP

SHAFT SIZE	MATERIAL
3MM TO 12MM	NUT - STAINLESS STEEL DIN 1.4005 BUSHING - SINTERED BRONZE

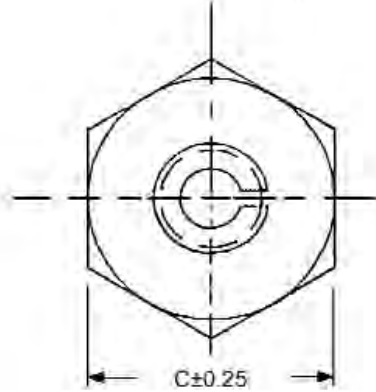
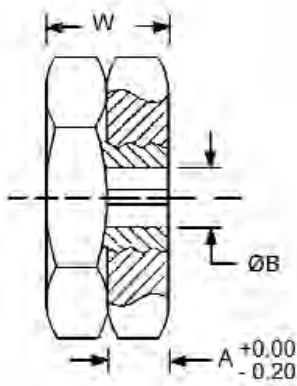

STOCK NO.	BORE ØB	A	WIDTH W	REF. D	C	SPLIT HUB I.D. (REF.)
SCL-3M-1 SCL-3M-2	4.6	2.4 3.2	4.8 6.4	18.1	15.8	3
SCL-4M-1 SCL-4M-2	5.6	2.4 3.2	4.8 6.4	18.1	15.8	4
SCL-5M-1 SCL-5M-2	6.6	2.4 3.2	4.8 6.4	18.1	15.8	5
SCL-6M-1 SCL-6M-2	7.6	2.4 3.2	4.8 6.4	18.1	15.8	6
SCL-7M-1 SCL-7M-2	8.6	2.4 3.2	4.8 6.4	23.8	20.8	7
SCL-8M-1 SCL-8M-2	9.6	2.4 3.2	4.8 6.4	23.8	20.8	8
SCL-9M	10.6	3.2	6.4	27.2	23.8	9
SCL-10M	11.6	3.2	6.4	27.2	23.8	10
SCL-11M	12.6	3.2	6.4	27.2	23.8	11
SCL-12M	13.6	4.0	8.0	27.2	23.8	12

- High clamping force
- Clamp directly to shafting or over a split hub
- Dynamically balance
- Higher holding torques
- Smaller outline
- Low moment of inertia
- Eliminates costly machining of keyways
- Eliminates the marking of shafts with set screws

1. The Squeeze Clamp consists of an externally threaded & slotted bushing with two internally threaded nuts. By tightening one nut against the other, the bushing is squeezed onto a clamp hub or shaft thereby retaining the part on the shaft.
2. The dynamically balanced Squeeze Clamp is dimensionally smaller in comparison with conventional clamps, but has a higher holding torque due to its unique shaft holding mechanism.
3. Shaft size 3mm to 12 mm can be accommodated.

- Material:
- Nut - Stainless Steel
 - Bushing - Bronze

SET SCREW COLLARS

BORE SIZE	MATERIAL
3MM TO 19MM PRECISION BORE	STAINLESS STEEL DIN 1.4305 WITH INTEGRAL BEARING SHIM SPACER

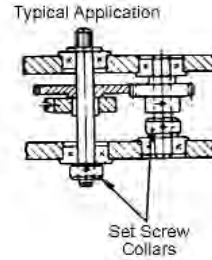
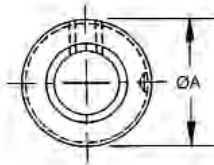
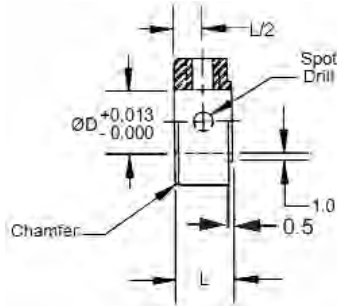

STOCK NUMBER	SHAFT SIZE	ØD	L	ØA
CSM-1	3	3.003	4	8
CSM-2	4	4.003	5	10
CSM-3	5	5.003	5	12
CSM-4	6	6.003	6	12
CSM-5	7	7.003	6	16
CSM-6	8	8.003	6	16
CSM-7	10	10.003	10	19
CSM-8	12	12.003	10	19
CSM-9	16	16.003	12	32
CSM-10	19	19.003	14	38

- No shim spacers required
- Used to pre-load bearing

BORE SIZE	MATERIAL
3MM TO 32MM COMMERCIAL BORE	COLD ROLLED STEEL ZINC PLATED

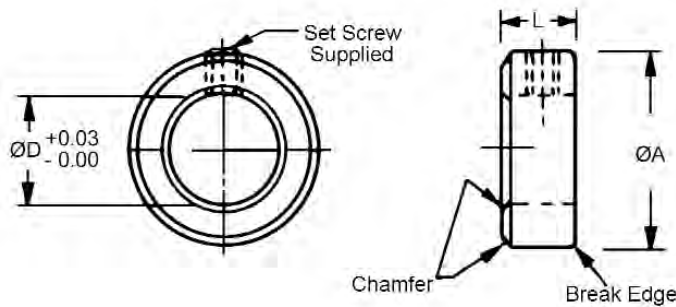

STOCK NO.	ØD	ØA	L
CSM-19	3.01	10	6
CSM-20	4.01	10	6
CSM-21	6.01	12	8
CSM-22	8.01	16	8
CSM-23	10.01	16	10
CSM-24	12.01	19	10
CSM-25	16.01	29	12
CSM-26	19.01	32	12
CSM-27	25.01	38	16
CSM-28	32.01	44	18

SET SCREW COLLARS

BORE SIZE	MATERIAL
3MM TO 12MM PRECISION BORE	STAINLESS STEEL DIN 1.4305

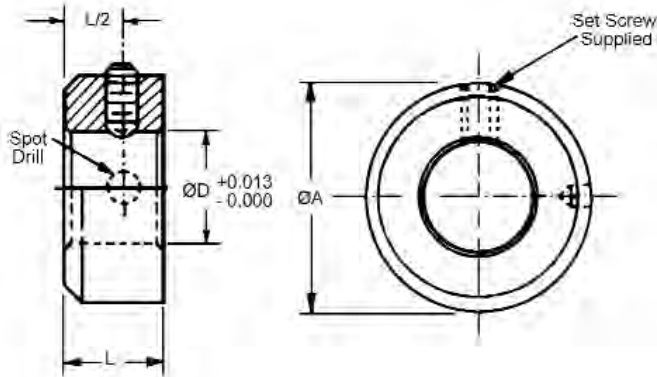

STOCK NUMBER	SHAFT SIZE	ØD	L	ØA
CSM-11	3	3.003	4	8
CSM-12	4	4.003	5	10
CSM-13	5	5.003	5	12
CSM-14	6	6.003	6	12
CSM-15	7	7.003	6	16
CSM-16	8	8.003	6	16
CSM-17	10	10.003	10	19
CSM-18	12	12.003	10	19

BORE SIZE	MATERIAL
3MM TO 12MM COMMERCIAL BORE SCREW TYPE	STAINLESS STEEL DIN 1.4305 OR ALUMINUM ANODIZED DIN 3.1355

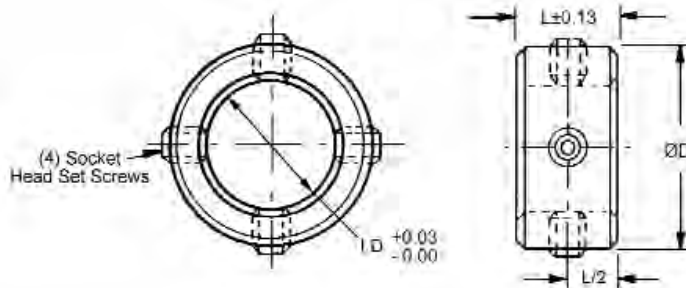

STAINLESS DIN 1.4305	ALUMINUM DIN 3.1355	I.D.	ØD	L	SPLIT HUB I.D. (Ref.)
STOCK NO.	STOCK NO.				
CSM-29	CSM-29A	4.60	6.4	9.53	3.00
CSM-30	CSM-30A	6.60	6.4	12.70	5.00
CSM-31	CSM-31A	8.60	6.4	12.70	7.00
CSM-32	CSM-32A	11.60	7.9	19.05	10.00
CSM-33	CSM-33A	13.60	7.9	19.05	12.00

THREADED STOCK

THREAD	MATERIAL
M4 X 0.70 MM TO M30 X 3.50 MM	STAINLESS STEEL DIN 1.4305

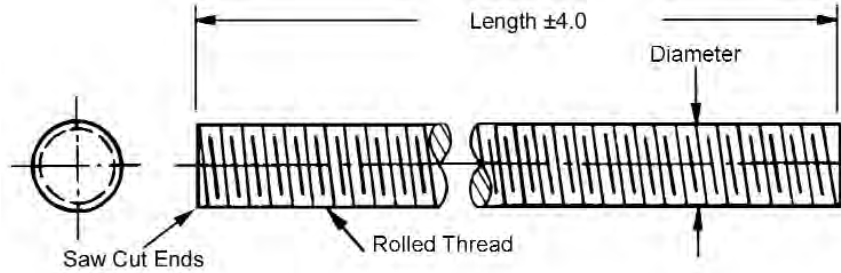

Special sizes and lengths are available on request. See index for threaded studs.

STOCK NO.	NOMINAL THREAD SIZE	PITCH	LENGTH
T1M-1	M4 x 0.70	0.70	250 mm
T1M-2	M5 x 0.80	0.80	250 mm
T1M-3	M6 x 1.00	1.00	500 mm
T1M-4	M8 x 1.25	1.25	500 mm
T1M-5	M10 x 1.50	1.50	500 mm
T1M-6	M12 x 1.75	1.75	500 mm
T1M-7	M14 x 2.00	2.00	500 mm
T1M-8	M16 x 2.00	2.00	1000 mm
T1M-9	M18 x 2.50	2.50	1000 mm
T1M-10	M20 x 2.50	2.50	1000 mm
T1M-11	M22 x 2.50	2.50	1000 mm
T1M-12	M24 x 3.00	3.00	1000 mm
T1M-13	M27 x 3.00	3.00	1000 mm
T1M-14	M30 x 3.50	3.50	1000 mm

Straightness: .0254 mm/mm

CASE HARDENED GROUND SHAFTS

DIAMETER	MATERIAL
6MM TO 50MM	STAINLESS STEEL DIN 1.4005 HARDENED OR STEEL DIN 1.0601 HARDENED

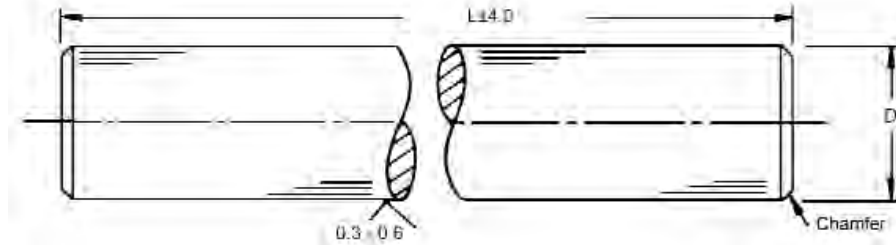

STOCK NOS.		NOM. DIA.	D	L
ST/ST DIN 1.4005	STEEL DIN 1.0601			
S416-6M-900	-	6	5.987/6.000	900
-	LMS-8M-300 LMS-8M-900	8	7.991/8.000	300 900
S416-10M-900	-	10	9.992/10.000	900
-	LMS-12M-300 LMS-12M-900	12	11.989/11.999	300 900
S416-13M-900	-	13	12.989/13.000	900
-	LMS-16M-300 LMS-16M-900	16	15.989/15.999	300 900
-	LMS-20M-300 LMS-20M-900	20	19.987/20.000	300 900
S416-20M-900	-	20	19.987/20.000	900
-	LMS-25M-300 LMS-25M-900	25	24.989/25.000	300 900
S416-25M-900	-	25	24.989/25.000	900
-	LMS-30M-300 LMS-30M-900	30	29.987/30.000	300 900
S416-30M-900	-	30	29.987/30.000	900
-	LMS-40M-300 LMS-40M-900	40	39.987/40.000	300 900
-	LMS-50M-300 LMS-50M-900	50	49.985/50.000	300 900

Straightness:

6MM - Best Efforts Basis

8MM To 50MM - Within 0.08 - 0.17 mm/Meter

• Shafting available in other lengths.

Specify by similar stock number and length required.

Example: LMS-25M-1000 (25mm Diameter, 1000mm long).

STAINLESS GROUND SHAFTS

DIAMETER	MATERIAL
3MM TO 30MM	STAINLESS STEEL DIN 1.4305

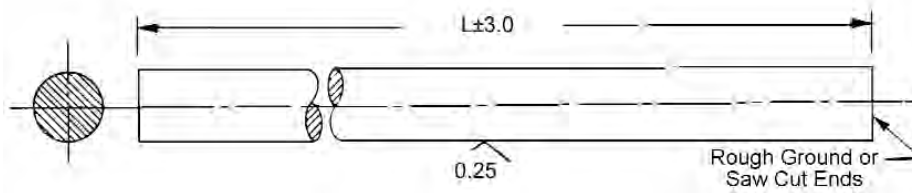

STOCK NO.	FRACT. DIA. REF.	ACTUAL DIA.	DIAMETER TOL.	L
S1-103	3	2.992	+0.000 -0.005	600
S1-131		3.000		600
S1-132		3.003		300
S1-133		3.003		600
S1-104	4	3.992		600
S1-134		3.999		600
S1-105	5	4.991		900
S1-135		5.000		600
S1-106	6	5.992		900
S1-136		6.000		900
S1-137	7	6.992		900
S1-138		6.992		600
S1-139		7.000		900
S1-140		7.000		600
S1-108	8	7.993		900
S1-141		8.000		600
S1-109	9	8.992	900	
S1-110	10	9.992	900	
S1-142		10.000	400	
S1-143		10.000	900	
S1-144	12	11.991	400	
S1-112		11.991	900	
S1-145		12.000	400	
S1-146		12.000	900	
S1-149	13	12.993	400	
S1-113		12.993	900	
S1-114	14	13.993	900	
S1-116	16	15.974	900	
S1-147		16.000	900	
S1-120	20	19.992	900	
S1-125	25	24.993	900	
S1-148		25.000	900	
S1-130	30	29.992	900	

*Straightness: 10 mm diameter and above .0101 mm/mm. 6mm diameter and below on best efforts basis.

GROUND SHAFTS

DIAMETER	MATERIAL
3MM TO 32MM	CARBON STEEL DIN 1.0718 SURFACE FINISH

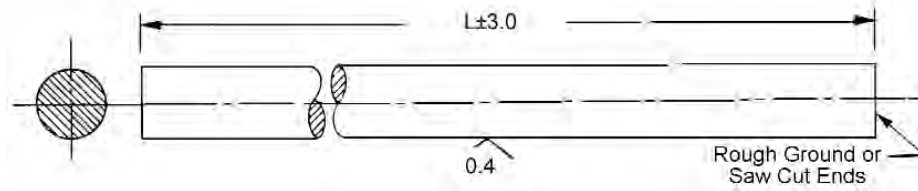

STOCK NO.	FRACT. DIA. REF.	ACTUAL DIA.	DIAMETER TOL.	L
S20M-1	3	2.993		900
S20M-2	4	3.993	+0.000	
S20M-3	6	5.993	-0.005	
S20M-4	8	7.993		
S20M-5	10	9.993		
S20M-6	12	11.993		900
S20M-7	16	15.993	+0.000	
S20M-8	19	18.993	-0.010	
S20M-9	25	24.993		
S20M-10	32	31.993		

STAINLESS GROUND SHAFTS

DIAMETER	MATERIAL
3MM AND 4MM	STAINLESS STEEL DIN 1.4305

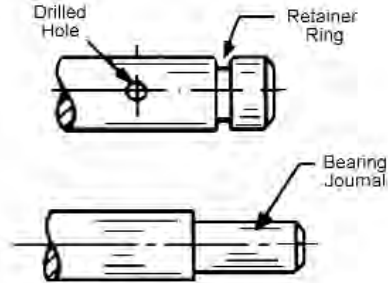
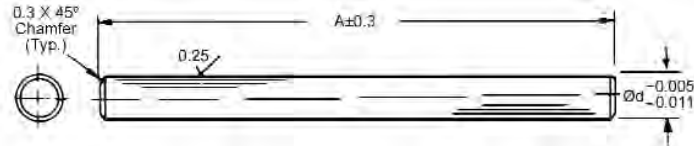

TYPICAL MODIFICATIONS

- Precision ground finish
- Straightness within .0076 mm/mm
- Send sketch for quotation on modifications

Available on request:

- Retainer ring grooves
- Special shaft lengths
- Journals
- Drilled holes
- Milled flats

STOCK NO. Ød = 3	STOCK NO. Ød = 4	A
S3M-20	S4M-20	20.0
S3M-25	S4M-25	25.0
S3M-30	S4M-30	30.0
S3M-35	S4M-35	35.0
S3M-40	S4M-40	40.0
S3M-45	S4M-45	45.0
S3M-50	S4M-50	50.0
S3M-55	S4M-55	55.0
S3M-60	S4M-60	60.0
S3M-65	S4M-65	65.0
S3M-70	S4M-70	70.0
S3M-75	S4M-75	75.0
S3M-80	S4M-80	80.0
S3M-85	S4M-85	85.0
S3M-90	S4M-90	90.0
S3M-95	S4M-95	95.0
S3M-100	S4M-100	100.0
S3M-105	S4M-105	105.0
S3M-110	S4M-110	110.0
S3M-115	S4M-115	115.0
S3M-120	S4M-120	120.0
S3M-125	S4M-125	125.0
S3M-130	S4M-130	130.0
S3M-135	S4M-135	135.0
S3M-140	S4M-140	140.0
S3M-145	S4M-145	145.0
S3M-150	S4M-150	150.0
S3M-155	S4M-155	155.0
S3M-160	S4M-160	160.0
S3M-165	S4M-165	165.0
S3M-170	S4M-170	170.0
S3M-175	S4M-175	175.0
S3M-180	S4M-180	180.0
S3M-185	S4M-185	185.0
S3M-190	S4M-190	190.0
S3M-195	S4M-195	195.0
S3M-200	S4M-200	200.0
S3M-210	S4M-210	210.0
S3M-220	S4M-220	220.0
S3M-230	S4M-230	230.0
S3M-240	S4M-240	240.0
S3M-250	S4M-250	250.0
S3M-260	S4M-260	260.0
S3M-270	S4M-270	270.0
S3M-280	S4M-280	280.0
S3M-290	S4M-290	290.0
S3M-300	S4M-300	300.0
S3M-310	S4M-310	310.0
S3M-320	S4M-320	320.0
S3M-330	S4M-330	330.0
S3M-340	S4M-340	340.0
S3M-350	S4M-350	350.0
S3M-360	S4M-360	360.0
S3M-370	S4M-370	370.0
S3M-380	S4M-380	380.0
S3M-390	S4M-390	390.0
S3M-400	S4M-400	400.0
S3M-420	S4M-420	420.0
S3M-440	S4M-440	440.0
S3M-460	S4M-460	460.0
S3M-480	S4M-480	480.0
S3M-500	S4M-500	500.0
S3M-520	S4M-520	520.0
S3M-540	S4M-540	540.0
S3M-560	S4M-560	560.0
S3M-580	S4M-580	580.0
S3M-600	S4M-600	600.0

STAINLESS GROUND SHAFTS

DIAMETER	MATERIAL
5MM	STAINLESS STEEL DIN 1.4305

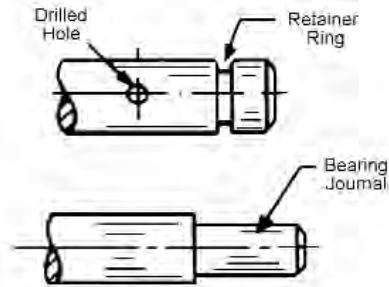
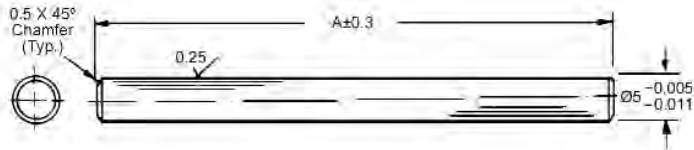

TYPICAL MODIFICATIONS

- Precision ground finish
- Straight within .0076mm/mm
- Send sketch for quotation on modifications

Available on request:

- Retainer ring grooves
- Special shaft lengths
- Journals
- Drilled holes
- Milled flats

STOCK NO.	A
S5M-20	20.0
S5M-25	25.0
S5M-30	30.0
S5M-35	35.0
S5M-40	40.0
S5M-45	45.0
S5M-50	50.0
S5M-55	55.0
S5M-60	60.0
S5M-65	65.0
S5M-70	70.0
S5M-75	75.0
S5M-80	80.0
S5M-85	85.0
S5M-90	90.0
S5M-95	95.0
S5M-100	100.0
S5M-105	105.0
S5M-110	110.0
S5M-115	115.0
S5M-120	120.0
S5M-125	125.0
S5M-130	130.0
S5M-135	135.0
S5M-140	140.0
S5M-145	145.0
S5M-150	150.0
S5M-155	155.0
S5M-160	160.0
S5M-165	165.0
S5M-170	170.0
S5M-175	175.0
S5M-180	180.0
S5M-185	185.0
S5M-190	190.0
S5M-195	195.0
S5M-200	200.0
S5M-210	210.0
S5M-220	220.0
S5M-230	230.0
S5M-240	240.0
S5M-250	250.0
S5M-260	260.0
S5M-270	270.0
S5M-280	280.0
S5M-290	290.0
S5M-300	300.0
S5M-310	310.0
S5M-320	320.0
S5M-330	330.0
S5M-340	340.0
S5M-350	350.0
S5M-360	360.0
S5M-370	370.0
S5M-380	380.0
S5M-390	390.0
S5M-400	400.0
S5M-420	420.0
S5M-440	440.0
S5M-460	460.0
S5M-480	480.0
S5M-500	500.0
S5M-520	520.0
S5M-540	540.0
S5M-560	560.0
S5M-580	580.0
S5M-600	600.0

STAINLESS GROUND SHAFTS

DIAMETER	MATERIAL
6MM	STAINLESS STEEL DIN 1.4305

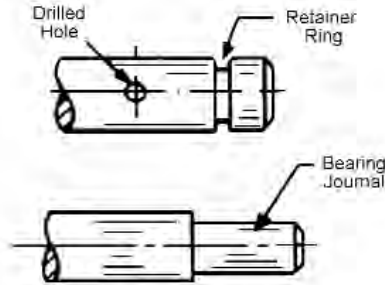
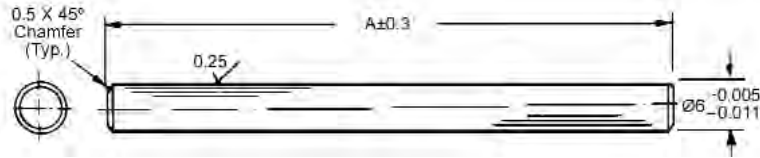

TYPICAL MODIFICATIONS

- Precision ground finish
- Straightness within .0076 mm/mm
- Send sketch for quotation on modifications

Available on request:

- Retainer ring grooves
- Special shaft lengths
- Journals
- Drilled holes
- Milled flats

STOCK NO.	A
S6M-20	20.0
S6M-25	25.0
S6M-30	30.0
S6M-35	35.0
S6M-40	40.0
S6M-45	45.0
S6M-50	50.0
S6M-55	55.0
S6M-60	60.0
S6M-65	65.0
S6M-70	70.0
S6M-75	75.0
S6M-80	80.0
S6M-85	85.0
S6M-90	90.0
S6M-95	95.0
S6M-100	100.0
S6M-105	105.0
S6M-110	110.0
S6M-115	115.0
S6M-120	120.0
S6M-125	125.0
S6M-130	130.0
S6M-135	135.0
S6M-140	140.0
S6M-145	145.0
S6M-150	150.0
S6M-155	155.0
S6M-160	160.0
S6M-165	165.0
S6M-170	170.0
S6M-175	175.0
S6M-180	180.0
S6M-185	185.0
S6M-190	190.0
S6M-195	195.0
S6M-200	200.0
S6M-210	210.0
S6M-220	220.0
S6M-230	230.0
S6M-240	240.0
S6M-250	250.0
S6M-260	260.0
S6M-270	270.0
S6M-280	280.0
S6M-290	290.0
S6M-300	300.0
S6M-310	310.0
S6M-320	320.0
S6M-330	330.0
S6M-340	340.0
S6M-350	350.0
S6M-360	360.0
S6M-370	370.0
S6M-380	380.0
S6M-390	390.0
S6M-400	400.0
S6M-420	420.0
S6M-440	440.0
S6M-460	460.0
S6M-480	480.0
S6M-500	500.0
S6M-525	525.0
S6M-550	550.0
S6M-575	575.0
S6M-600	600.0

STAINLESS GROUND SHAFTS

DIAMETER	MATERIAL
7MM AND 8MM	STAINLESS STEEL DIN 1.4305

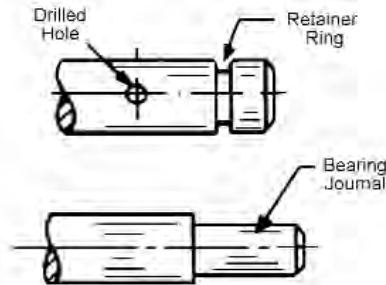
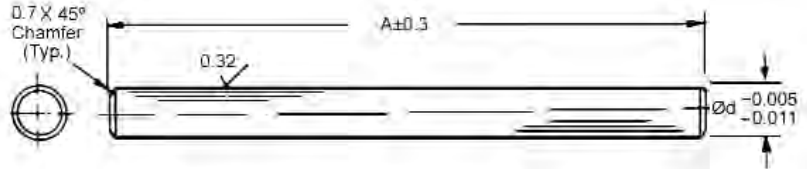

TYPICAL MODIFICATIONS

- Precision ground finish
- Straight within .0101mm/mm
- Send sketch for quotation on modifications

Available on request:

- Retainer ring grooves
- Special shaft lengths
- Journals
- Drilled holes
- Milled flats

STOCK NO. Ød = 7	STOCK NO. Ød = 8	A
S7M-35	S8M-35	35.0
S7M-40	S8M-40	40.0
S7M-45	S8M-45	45.0
S7M-50	S8M-50	50.0
S7M-55	S8M-55	55.0
S7M-60	S8M-60	60.0
S7M-65	S8M-65	65.0
S7M-70	S8M-70	70.0
S7M-75	S8M-75	75.0
S7M-80	S8M-80	80.0
S7M-85	S8M-85	85.0
S7M-90	S8M-90	90.0
S7M-95	S8M-95	95.0
S7M-100	S8M-100	100.0
S7M-105	S8M-105	105.0
S7M-110	S8M-110	110.0
S7M-115	S8M-115	115.0
S7M-120	S8M-120	120.0
S7M-125	S8M-125	125.0
S7M-130	S8M-130	130.0
S7M-135	S8M-135	135.0
S7M-140	S8M-140	140.0
S7M-145	S8M-145	145.0
S7M-150	S8M-150	150.0
S7M-155	S8M-155	155.0
S7M-160	S8M-160	160.0
S7M-165	S8M-165	165.0
S7M-170	S8M-170	170.0
S7M-175	S8M-175	175.0
S7M-180	S8M-180	180.0
S7M-185	S8M-185	185.0
S7M-190	S8M-190	190.0
S7M-195	S8M-195	195.0
S7M-200	S8M-200	200.0
S7M-210	S8M-210	210.0
S7M-220	S8M-220	220.0
S7M-230	S8M-230	230.0
S7M-240	S8M-240	240.0
S7M-250	S8M-250	250.0
S7M-260	S8M-260	260.0
S7M-270	S8M-270	270.0
S7M-280	S8M-280	280.0
S7M-290	S8M-290	290.0
S7M-300	S8M-300	300.0
S7M-310	S8M-310	310.0
S7M-320	S8M-320	320.0
S7M-330	S8M-330	330.0
S7M-340	S8M-340	340.0
S7M-350	S8M-350	350.0
S7M-360	S8M-360	360.0
S7M-370	S8M-370	370.0
S7M-380	S8M-380	380.0
S7M-390	S8M-390	390.0
S7M-400	S8M-400	400.0
S7M-425	S8M-425	425.0
S7M-450	S8M-450	450.0
S7M-475	S8M-475	475.0
S7M-500	S8M-500	500.0
S7M-550	S8M-550	550.0
S7M-600	S8M-600	600.0

STAINLESS GROUND SHAFTS

DIAMETER	MATERIAL
10MM	STAINLESS STEEL DIN 1.4305

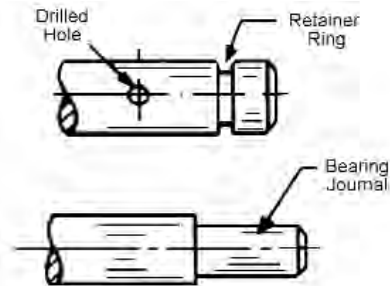
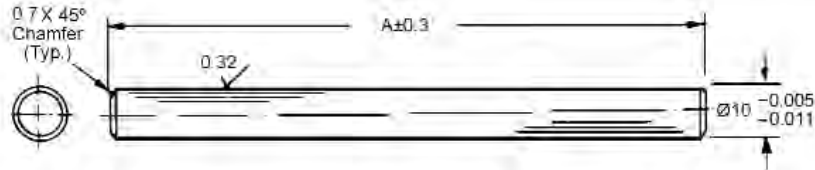

TYPICAL MODIFICATIONS

- Precision ground finish
- Straight within .0101mm/mm
- Send sketch for quotation on modifications

Available on request:

- Retainer ring grooves
- Special shaft lengths
- Journals
- Drilled holes
- Milled flats

STOCK NO.	A
S10M-55	55.0
S10M-60	60.0
S10M-65	65.0
S10M-70	70.0
S10M-75	75.0
S10M-80	80.0
S10M-85	85.0
S10M-90	90.0
S10M-95	95.0
S10M-100	100.0
S10M-105	105.0
S10M-110	110.0
S10M-115	115.0
S10M-120	120.0
S10M-125	125.0
S10M-130	130.0
S10M-135	135.0
S10M-140	140.0
S10M-145	145.0
S10M-150	150.0
S10M-155	155.0
S10M-160	160.0
S10M-165	165.0
S10M-170	170.0
S10M-175	175.0
S10M-180	180.0
S10M-185	185.0
S10M-190	190.0
S10M-195	195.0
S10M-200	200.0
S10M-210	210.0
S10M-220	220.0
S10M-230	230.0
S10M-240	240.0
S10M-250	250.0
S10M-260	260.0
S10M-270	270.0
S10M-280	280.0
S10M-290	290.0
S10M-300	300.0
S10M-310	310.0
S10M-320	320.0
S10M-330	330.0
S10M-340	340.0
S10M-350	350.0
S10M-360	360.0
S10M-370	370.0
S10M-380	380.0
S10M-390	390.0
S10M-400	400.0
S10M-420	420.0
S10M-440	440.0
S10M-460	460.0
S10M-480	480.0
S10M-500	500.0
S10M-600	600.0
S10M-700	700.0
S10M-800	800.0
S10M-900	900.0

STAINLESS GROUND SHAFTS

DIAMETER	MATERIAL
12MM	STAINLESS STEEL DIN 1.4305

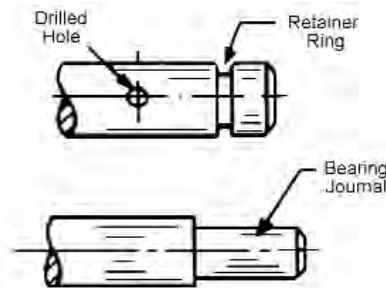
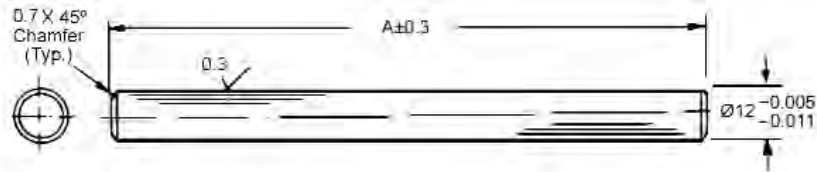

TYPICAL MODIFICATIONS

- Precision ground finish
- Straight within .0101mm/mm
- Send sketch for quotation on modifications

Available on request:

- Retainer ring grooves
- Special shaft lengths
- Journals
- Drilled holes
- Milled flats

STOCK NO.	A
S12M-60	60.0
S12M-65	65.0
S12M-70	70.0
S12M-75	75.0
S12M-80	80.0
S12M-85	85.0
S12M-90	90.0
S12M-95	95.0
S12M-100	100.0
S12M-105	105.0
S12M-110	110.0
S12M-115	115.0
S12M-120	120.0
S12M-125	125.0
S12M-130	130.0
S12M-135	135.0
S12M-140	140.0
S12M-145	145.0
S12M-150	150.0
S12M-155	155.0
S12M-160	160.0
S12M-165	165.0
S12M-170	170.0
S12M-175	175.0
S12M-180	180.0
S12M-185	185.0
S12M-190	190.0
S12M-195	195.0
S12M-200	200.0
S12M-220	220.0
S12M-230	230.0
S12M-240	240.0
S12M-250	250.0
S12M-260	260.0
S12M-270	270.0
S12M-280	280.0
S12M-290	290.0
S12M-300	300.0
S12M-310	310.0
S12M-320	320.0
S12M-330	330.0
S12M-340	340.0
S12M-350	350.0
S12M-360	360.0
S12M-370	370.0
S12M-380	380.0
S12M-390	390.0
S12M-400	400.0
S12M-420	420.0
S12M-440	440.0
S12M-460	460.0
S12M-480	480.0
S12M-500	500.0
S12M-600	600.0
S12M-700	700.0
S12M-800	800.0

DYNA-SPEED NEEDLE ROLLER BEARING

TYPE	MATERIAL
DRAWN CUP DESIGN FOR 3MM TO 25MM HARDENED SHAFTS	ROLLER CUP - CASE HARDENED STEEL NEEDLE ROLLERS - HARDENED STEEL DIN 1.3505 BEARING CAGE - LOW CARBON STEEL

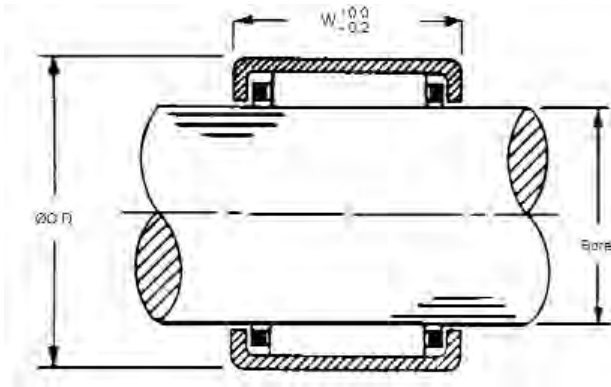

STOCK NO.	BORE	BRG. O.D.	HOUSING BORE DIA.	BRG W	MAX.* SPEED RPM	LOAD CAPACITIES	
						DYNAMIC (N)	STATIC (N)
NRB-3	3	6.5	6.481-6.496	6.0	48.000	1230	840
NRB-4	4	8.0	7.981-7.996	8.0	43.000	1740	1270
NRB-5	5	9.0	8.981-8.996	9.0	39.000	2400	1990
NRB-6	6	10.0	9.981-9.996	9.0	37.000	2850	2600
NRB-7	7	11.0	10.997-10.995	9.0	33.000	3100	2950
NRB-8	8	12.0	11.977-11.995	10.0	29.000	3800	3950
NRB-9	9	13.0	12.977-12.995	10.0	27.000	4250	4650
NRB-10	10	14.0	13.977-13.995	10.0	24.000	4400	5100
NRB-12	12	16.0	15.977-15.995	10.0	21.000	4950	6200
NRB-13	13	19.0	18.972-18.993	12.0	19.000	6800	7900
NRB-14	14	20.0	19.972-19.993	12.0	18.000	7100	8500
NRB-15	15	21.0	20.972-20.993	12.0	16.000	7900	9400
NRB-16	16	22.0	21.972-21.993	12.0	16.000	7600	9700
NRB-17	17	23.0	22.972-22.993	12.0	15.000	7900	10300
NRB-18	18	24.0	23.972-23.993	12.0	14.000	8100	10900
NRB-20	20	26.0	25.972-25.993	12.0	13.000	8600	12100
NRB-22	22	28.0	27.972-27.993	12.0	12.000	9100	13400
NRB-25	25	32.0	31.967-31.992	12.0	10.000	11000	15200

* Represents speed values of bearing submerged in Oil.

- Extremely high speed
- High load capacity
- Low profile, Light weight
- Caged needle bearings offer up to 3 times the speed of uncaged designs
- Extremely low rolling friction
- High lubrication capacity
- Low sensitivity to misalignment

Mounting Tolerances:

Housing: N7
Shaft: h6

BALL BEARINGS

BORE SIZE	TYPE	MATERIAL
3MM TO 10MM	PLAIN PRECISION ABEC-7	STAINLESS STEEL DIN 1.4112

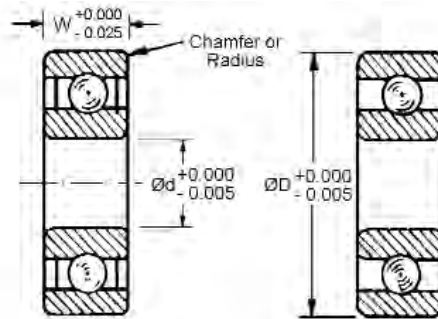
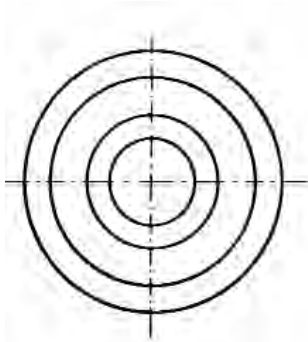

**Shielded
and Lubricated with Grease

* Unshielded
and Lubricated with Oil



STOCK NO.	Ød	ØD	W	SHIELD DATA	DYNAMIC LOAD (N)	STATIC LOAD (N)
B1-50	3.000	7.000	2.000	*	206	108
B1-50-S			3.000	**		
B1-51	3.000	8.000	3.000	*	333	196
B1-51-S			4.000	**		
B1-52	3.000	10.000	4.000	*	383	216
B1-52-S			4.000	**		
B1-104-7	4.000	9.000	2.500	*	353	196
B1-104-S-7				4.000		
B1-53	5.000	11.000	3.000	*	392	216
B1-53-S				5.000		
B1-54	5.000	13.000	4.000	*	451	284
B1-54-S				4.000		
B1-55	5.000	16.000	5.000	*	1480	746
B1-55-S				5.000		
B1-106-7	6.000	13.000	3.500	*	579	353
B1-106-S-7				5.000		
B1-56	6.000	15.000	5.000	*	628	402
B1-56-S				5.000		
B1-57	6.000	19.000	6.000	*	1890	991
B1-57-S				6.000		
B1-108-7	8.000	16.000	4.000	*	951	628
B1-108-S-7				6.000		
B1-110-7	10.000	19.000	5.000	*	1020	696
B1-110-S-7				7.000		

BALL BEARINGS

BORE SIZE	TYPE	MATERIAL
3MM TO 10MM	SINGLE ROW - FLANGED PRECISION ABEC-7	STAINLESS STEEL DIN 1.4112

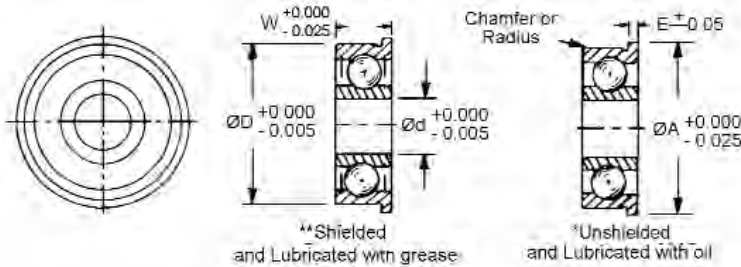

STOCK NO.	Ød	ØD	W	A	SHIELD & LUBE DATA	E	DYNAMIC LOADS (N) CAPACITY	STATIC LOADS (N) CAPACITY
B2-50 B2-50-S	3.000	7.000	2.000 3.000	8.100	* **	0.50 0.80	206	108
B2-51 B2-51-S		8.000	3.000 4.000	9.500	* **	0.70 0.90	333	196
B2-52 B2-52-S		10.000	4.000 4.000	11.500	* **	1.00 1.00	383	216
B2-104-7 B2-104-S7	4.000	9.000	2.500 4.000	10.300	* **	0.60 1.00	353	196
B2-53 B2-53-S	5.000	11.000	3.000 5.000	12.500	* **	0.80 1.00	392	216
B2-54 B2-54-S		13.000	4.000 4.000	15.000	* **	1.00 1.00	451	284
B2-55 B2-55-S		16.000	5.000 5.000	18.000	* **	1.00 1.00	1480	746
B2-106-7 B2-106-S7	6.000	13.000	3.500 5.000	15.000	* **	1.00 1.10	579	353
B2-56 B2-56-S		15.000	5.000 5.000	17.000	* **	1.20 1.20	628	402
B2-57 B2-57-S	8.000	19.000	6.000 6.000	22.000	* **	1.50 1.50	1890	991
B2-108-7 B2-108-S7		16.000	4.000 6.000	18.000	* **	1.00 1.30	951	628
B2-58 B2-58-S		10.000	19.000	5.000 5.000	21.000	* **	1.50 1.50	1020

BALL BEARINGS

BORE SIZE	TYPE	MATERIAL
3MM TO 10MM	ABEC 1	STAINLESS STEEL DIN 1.3505

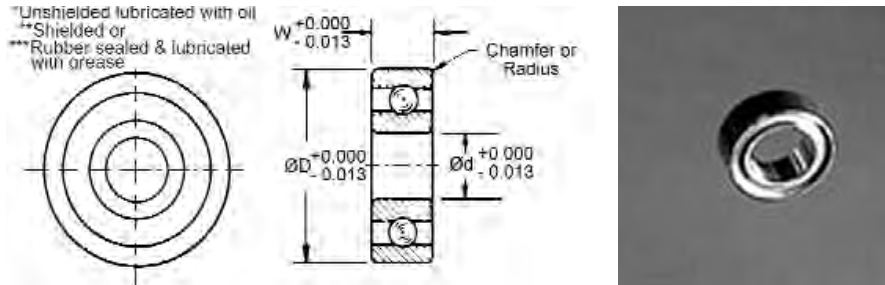

STOCK NO.	Ød	ØD	W	SHIELD AND LUBE DATA	DYNAMIC LOAD (N) CAPACITY	STATIC LOAD (N) CAPACITY
B11M-1 B11M-2 B11M-3	3.000	10.000	4.00	* ** ***	382	216
B11M-4 B11M-5 B11M-6	5.000	16.000	5.00	* ** ***	1480	746
B11M-7 B11M-8 B11M-9	6.000	19.000	6.00	* ** ***	1890	991
B11M-10 B11M-11 B11M-12	10.000	19.000	5.00	* ** ***	1020	696

BORE SIZE	TYPE	MATERIAL
3MM TO 10MM	FLANGED ABEC-1	STAINLESS STEEL DIN 1.3505

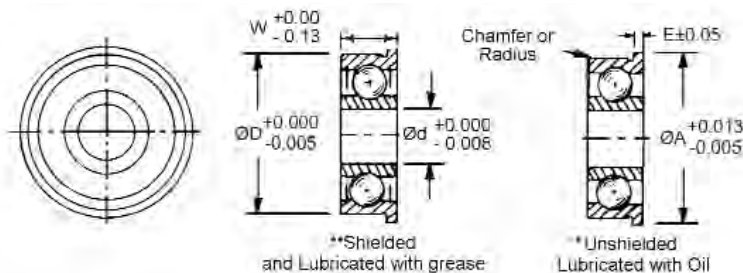

STOCK NO.	Ød	ØD	W	ØA	SHIELD AND LUBE DATA	E	DYNAMIC LOAD (N) CAPACITY	STATIC LOAD (N) CAPACITY
B13-103 B13-103-S	3.000	10.000	4.0	11.50	* **	1.00	383	216
B13-105 B13-105-S	5.000	16.000	5.0	18.00	* **	1.00	1480	749
B13-106 B13-106-S	6.000	19.000	6.0	22.00	* **	1.50	1890	991
B13-110 B13-110-S	10.000	19.000	5.0 7.0	21.00	* **	1.00 1.50	1020	696

“OIL-LESS” BEARINGS

BORE SIZE	TYPE	MATERIAL
3MM TO 12MM	PLAIN ULTRA PRECISION	SINTERED BRONZE

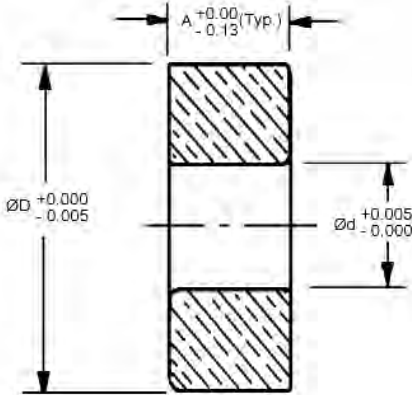

STOCK NO.	SHAFT SIZE	Ød	ØD	A
B3M-1	3	3.000	6.000	2.50
B3M-2	3	3.000	8.000	3.00
B3M-3	3	3.000	10.000	4.00
B3M-4	4	4.000	8.000	4.00
B3M-5	5	5.000	12.000	4.00
B3M-6	5	5.000	13.000	5.00
B3M-7	5	5.000	10.000	5.00
B3M-8	6	6.000	16.000	5.00
B3M-9	6	6.000	10.000	5.00
B3M-10	8	8.000	16.000	6.00
B3M-11	10	10.000	19.000	7.00
B3M-12	12	12.000	20.000	8.00



BORE SIZE	TYPE	MATERIAL
3MM TO 12MM	FLANGED ULTRA PRECISION	SINTERED BRONZE

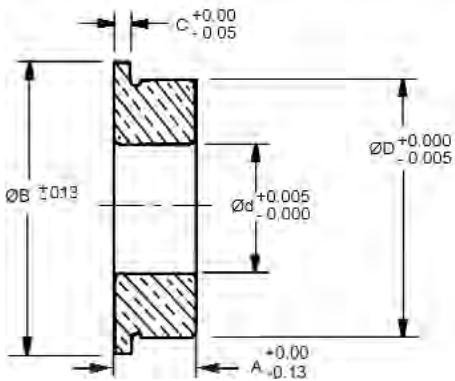

STOCK NO.	SHAFT SIZE	Ød	ØD	A	ØB	C
B4M-1	3	3.000	6.000	2.50	8.00	0.50
B4M-2	3	3.000	8.000	3.00	10.00	0.50
B4M-3	3	3.000	10.000	4.00	12.00	1.00
B4M-4	4	4.000	8.000	4.00	10.00	1.00
B4M-5	5	5.000	12.000	4.00	14.00	1.00
B4M-6	5	5.000	13.000	5.00	14.00	1.00
B4M-7	5	5.000	10.000	5.00	12.00	1.00
B4M-8	6	6.000	16.000	5.00	18.00	1.00
B4M-9	6	6.000	10.000	5.00	12.00	1.00
B4M-10	8	8.000	16.000	6.00	18.00	1.00
B4M-11	10	10.000	19.000	7.00	21.00	1.50
B4M-12	12	12.000	20.000	8.00	22.00	1.50



“OIL-LESS” BEARINGS

SHAFT SIZE	TYPE	MATERIAL
3MM TO 10MM	PLAIN	SINTERED BRONZE

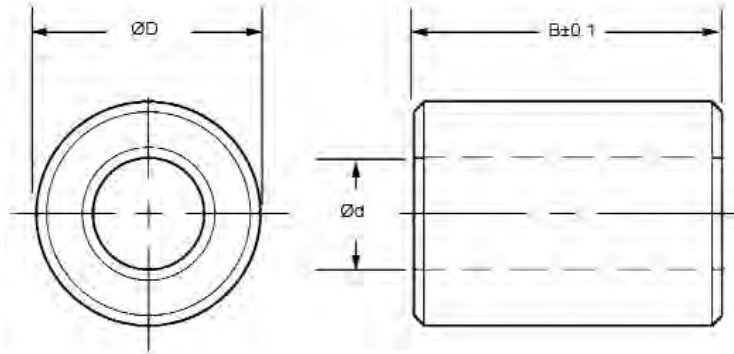

STOCK NO.	SHAFT SIZE	Ød +.02	ØD -.03	B
B6M-1	3	3.01	6.04	4
B6M-2				6
B6M-3				10
B6M-4	4	4.01	8.04	4
B6M-5				10
B6M-6	5	5.01	8.04	5
B6M-7				8
B6M-8				12
B6M-9				16
B6M-10	6	6.01	10.04	6
B6M-11				10
B6M-12				12
B6M-13	8	8.01	12.05	8
B6M-14				12
B6M-15				16
B6M-16	10	10.01	13.05	10
B6M-17				16
B6M-18				20

OIL-LESS BEARINGS

SHAFT SIZE	TYPE	MATERIAL
3MM TO 10MM	FLANGED	SINTERED BRONZE

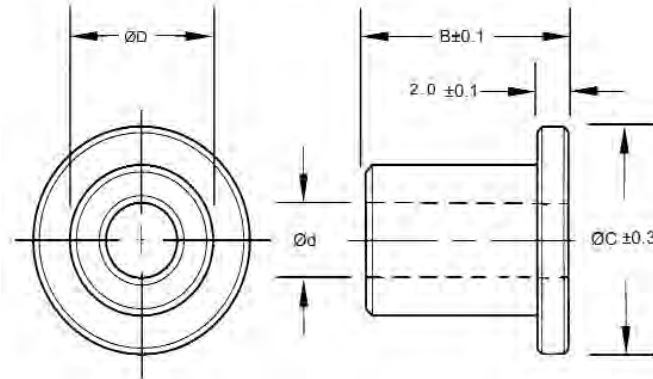

STOCK NO.	SHAFT SIZE	$\varnothing d$ +0.02	$\varnothing D$ -0.03	B	$\varnothing C$
B7M-1 B7M-2 B7M-3	3	3.01	6.04	4 6 10	9
B7M-4 B7M-5	4	4.01	8.04	4 10	11
B7M-6 B7M-7 B7M-8 B7M-9	5	5.01	8.04	5 8 12 16	11
B7M-10 B7M-11 B7M-12	6	6.01	10.04	6 10 12	13
B7M-13 B7M-14 B7M-15	8	8.01	12.05	8 12 16	14
B7M-16 B7M-17 B7M-18	10	10.01	13.05	10 16 20	16

Te-F-Thane[®] BEARINGS

SHAFT SIZE	TYPE	MATERIAL
3MM TO 12MM	PLAIN	TEFLON

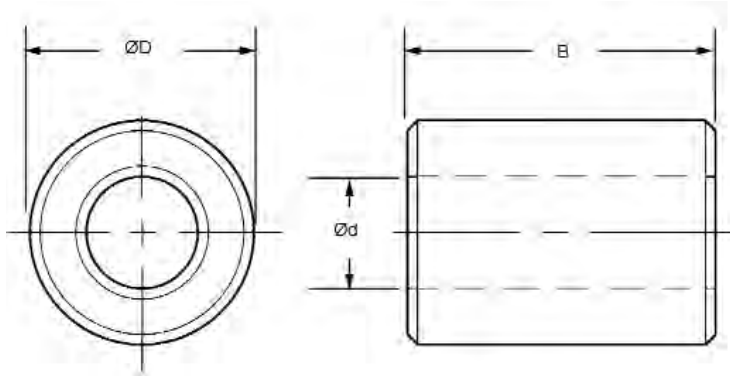

STOCK NO.	SHAFT SIZE	$\varnothing d$ +.13	$\varnothing D$ -.008	B ± 0.13
B8M-1 B8M-2 B8M-3	3	3.02	6.04	4 6 10
B8M-4 B8M-5 B8M-6	5	5.02	8.04	4 8 12
B8M-7 B8M-8 B8M-9 B8M-10	6	6.02	10.04	6 10 12 16
B8M-11 B8M-12 B8M-13	8	8.02	12.05	8 12 16
B8M-14 B8M-15 B8M-16 B8M-17	10	10.02	13.05	8 10 16 20
B8M-18 B8M-19 B8M-20 B8M-21	12	12.02	16.05	10 12 20 25

- Long life
- Smooth operation
- No lubrication required
- Minimal breakaway torque resistance

Te-F-Thane[®] BEARINGS

SHAFT SIZE	TYPE	MATERIAL
3MM TO 12MM	FLANGED	TEFLON

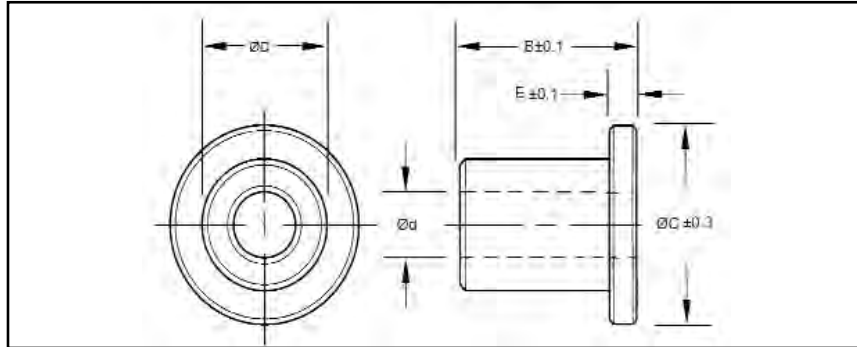

STOCK NO.	SHAFT SIZE	Ød +0.13	ØD -0.08	B ± 0.13	ØC	E
B9M-1 B9M-2 B9M-3	3	3.02	6.04	4 6 10	8	1.2
B9M-4 B9M-5 B9M-6	5	5.02	8.04	4 8 12	10	1.2
B9M-7 B9M-8 B9M-9 B9M-10	6	6.02	10.04	6 10 12 16	12	1.2
B9M-11 B9M-12 B9M-13	8	8.02	12.05	8 12 16	16	1.5
B9M-14 B9M-15 B9M-16 B9M-17	10	10.02	13.05	8 10 16 20	16	1.5
B9M-18 B9M-19 B9M-20 B9M-21	12	12.02	16.05	10 12 20 25	19.0	1.5

- Long life
- Smooth operation
- No lubrication required
- Minimal breakaway torque resistance

LONG-LIFE® BEARINGS

SHAFT SIZE	TYPE	MATERIAL
3MM TO 25MM	DRY PFTE-LEAD LUBRICATING	STEEL BACKED POROUS BRONZE

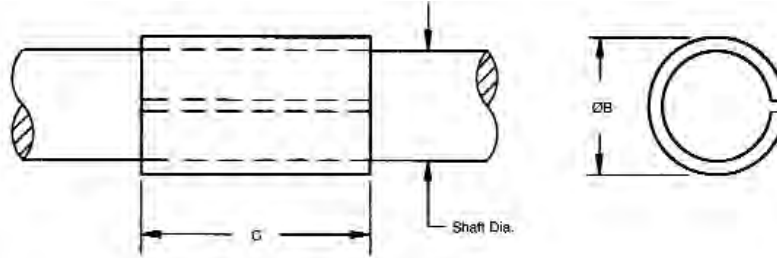

- Lasts up to 10 times longer than oil impregnated porous bronze bearings
- High loads
- Runs cool - excellent heat dissipation
- Extremely low coefficient of friction
- Operates in extreme temperatures
- Reduce costs - lower maintenance - eliminate hardened shafting and expensive shaft preparations
- Excellent for rotating sliding or oscillating motion and both thrust and radial loads
- In fully lubricated environments provides protection during dry starts and from lubrication system failure

Max. Cont. Load = 1.7 PV's ($\frac{N}{mm^2} \times \frac{M}{sec}$) Unlubricated
 70 PV's ($\frac{N}{mm^2} \times \frac{M}{sec}$) Lubricated

Max. Cont. Speed = 5 M/sec Unlubricated
 10 M/sec Lubricated

Temp. Range = -200°C to +280°C

Compressive Strength = 310 N/mm²

STOCK NO.	NORMAL SHAFT SIZE	ACTUAL SHAFT SIZE	NOMINAL O.D. ØB	HOUSING BORE	C	SHAFT STOCK NO.
DU14M-1 DU14M-2	3	3.000/2.994	4.5	4.508/4.500	3 6	S1-131
DU14M-3 DU14M-4 DU14M-5	5	4.991/4.979	7	7.016/7.001	5 8 10	S1-105
DU14M-6 DU14M-7	6	5.992/5.980	8	8.017/8.002	6 10	S1-106
DU14M-8 DU14M-9	8	7.993/7.978	10	10.021/10.006	8 12	S1-108
DU14M-10 DU14M-11 DU14M-12	10	9.992/9.977	12	12.023/12.005	8 12 20	S1-110
DU14M-13 DU14M-14 DU14M-15	12	11.991/11.973	14	14.025/14.007	8 12 25	S1-112
DU14M-16 DU14M-17 DU14M-18	16	15.984/15.966	18	18.018/18.00	12 15 25	S1-116
DU14M-19 DU14M-20 DU14M-21	20	19.992/19.971	23	23.033/23.012	15 20 30	S1-120
DU14M-22 DU14M-23 DU14M-24	25	24.993/24.972	28	28.034/28.013	15 25 50	S1-125

THERMOPLASTIC BEARING

Reference Chart

The B15/16 Series is a thick-walled light-duty bearing used in many types of machinery to dampen vibration and shock loads. They are dimensionally interchangeable with most sintered metal bearings, and can be retro-fitted without changing the housing bore or shaft. Typically they're used in agricultural and exercise equipment and machinery such as woodworking, packaging, and welding equipment.

The B17/18 Series is available for situations where even the excellent abrasion resistance of the B19/20 Series is insufficient. It's superior characteristics are especially well suited for high performance requirements. Applications include, for example, pneumatic cylinders, lifting equipment, fitness machinery, industrial brakes, clutches and automotive components in general.

The B19/20 Series was initially designed for applications in chemical processing equipment. This material is a unique combination of exotic materials best suited for high load, temperature and speed applications. It is resistant to virtually any substance except for concentrated sulfuric acids. At present, this material is unique and unequalled. Applications include chemical mountings and pumps, oven manufacture, semi-conductors, film developing equipment, equipment for industrial-sized kitchens, etc.

DATA	B15/16 SERIES	B17/18 SERIES	B19/20 SERIES
MAX. LOAD (KG/CM ²)	161	662	1529
TEMP. RANGE FOR CONTINUOUS OPERATION	-40°f to 135°f 200°f	-40°f to 135°f 210°f	-149°f to 250°f 315°f
MAX. PV (NO LUB.)	208	594	2122
SPEEDS (MPM)			
OSCILLATING (CONTINUOUS)	59	119	178
OSCILLATING (SHORT TERM)	119	180	238
ROTATIONAL (CONTINUOUS)	59	90	90
ROTATIONAL (SHORT TERM)	119	149	209
LINEAR (CONTINUOUS)	178	297	297
LINEAR (SHORT TERM)	297	359	356
COEFFICIENT OF FRICTION. DYNAMIC STEEL. DRY.	.18-.30	.08-.15	.11-.17
MAINTENANCE FREE	YES	YES	YES
DRY OPERATION	YES	YES	YES
COMPRESSIVE STRENGTH (KG/CM ²)	183	662	1529
SPACE REQUIREMENTS	MEDIUM WALL THICKNESS	THIN WALLED	THIN WALLED
DENSITY (KG/CM ³)	.0010	.0012	.0012
MODULUS OF ELASTICITY (KG/CM ²)	17.331	56.071	67.285
H ₂ O ABSORPTION @50% HUM. & 23° C (%)	1.6	.65	.10

THERMOPLASTIC BEARINGS

BORE SIZE	SHAFT SIZE	TYPE
1MM TO 12MM	1MM TO 12MM	SLEEVE AND FLANGED

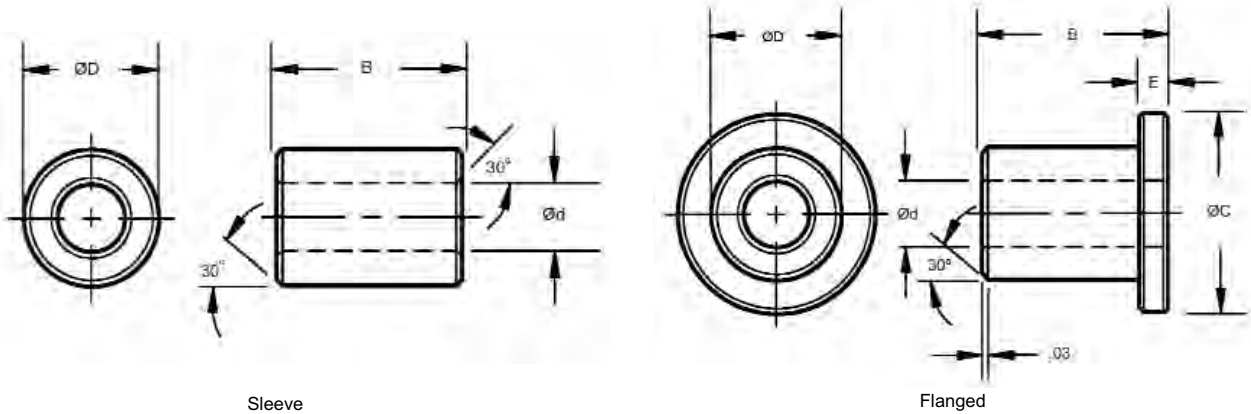

SLEEVE STOCK NO.	FLANGED STOCK NO.	NOMINAL SIZES					I.D. AFTER PRESS FIT		HOUSING BORE		SHAFT SIZE	
		Ød	ØD	ØC	B	E	MAX.	MIN.	MAX.	MIN.	MAX.	MIN.
B15M-1	B16M-1	1	3	5	2	1	1.080	1.020	3.080	3.000	1.000	0.975
B15M-2	B16M-2	1.5	4	6	2	1	1.580	1.520	4.012	4.000	1.500	1.475
B15M-3	B16M-3	2	5	8	3	1.5	2.080	2.020	5.012	5.000	2.000	1.975
B15M-4	B16M-4	3	6	9	4	1.5	3.080	3.020	6.012	6.000	3.000	2.975
B15M-5	B16M-5	4	8	12	6	2	4.105	4.030	8.015	8.000	4.000	3.970
B15M-6	B16M-6	5	9	13	5	2	5.105	5.030	9.015	9.000	5.000	4.970
B15M-7	B16M-7	5	9	13	8	2	5.105	5.030	9.015	9.000	5.000	4.970
B15M-8	B16M-8	6	10	14	4	2	6.105	6.030	10.015	10.000	6.000	5.970
B15M-9	B16M-9	6	10	14	6	2	6.105	6.030	10.015	10.000	6.000	5.970
B15M-11	B16M-11	6	12	14	6	3	6.105	6.030	12.018	12.000	6.000	5.970
B15M-12	B16M-12	6	12	14	10	3	6.105	6.030	12.018	12.000	6.000	5.970
B15M-13	B16M-13	8	11	13	8	2	8.130	8.040	11.018	11.000	8.000	7.964
B15M-14	B16M-14	8	12	16	6	2	8.130	8.040	12.018	12.000	8.000	7.964
B15M-15	B16M-15	8	12	16	8	2	8.130	8.040	12.018	12.000	8.000	7.964
B15M-16	B16M-16	8	12	16	12	2	8.130	8.040	12.018	12.000	8.000	7.964
B15M-17	B16M-17	8	14	18	6	3	8.130	8.040	14.018	14.000	8.000	7.964
B15M-18	B16M-18	8	14	18	10	3	8.130	8.040	14.018	14.000	8.000	7.964
B15M-19	B16M-19	10	16	20	6	3	10.130	10.040	16.018	16.000	10.000	9.964
B15M-20	B16M-20	10	16	22	10	3	10.130	10.040	16.018	16.000	10.000	9.964
B15M-21	B16M-21	10	16	22	16	3	10.130	10.040	16.018	16.000	10.000	9.964
B15M-22	B16M-22	12	18	24	8	3	12.160	12.050	18.018	18.000	12.000	11.957
B15M-23	B16M-23	12	18	22	10	3	12.160	12.050	18.018	18.000	12.000	11.957
B15M-24	B16M-24	12	18	22	15	3	12.160	12.050	18.018	18.000	12.000	11.957
B15M-25	B16M-25	12	18	22	20	3	12.160	12.050	18.018	18.000	12.000	11.957



THERMOPLASTIC BEARINGS

BORE SIZE	SHAFT SIZE	TYPE
3MM TO 12MM	3MM TO 14MM	SLEEVE AND FLANGED

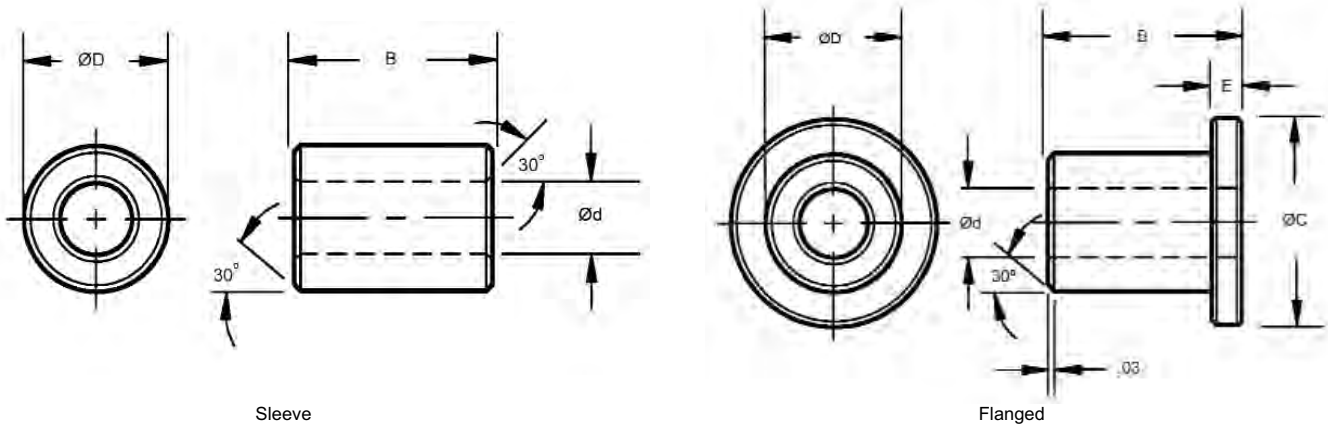

SLEEVE STOCK NO.	FLANGED STOCK NO.	NOMINAL SIZES					I.D. AFTER PRESS FIT		HOUSING BORE		SHAFT SIZE	
		ød	ØD	ØC	B	E (+0/-140)	MAX.	MIN.	MAX.	MIN.	MAX.	MIN.
B17M-1	B18M-1	3	4.5	7.5	3	0.75	3.054	3.014	4.512	4.500	3.000	2.975
B17M-2	B18M-2	3	4.5	7.5	5	0.75	3.054	3.014	4.512	4.500	3.000	2.975
B17M-3	B18M-3	4	5.5	9.5	4	0.75	4.068	4.020	5.512	5.500	4.000	3.970
B17M-4	B18M-4	4	5.5	9.5	6	0.75	4.068	4.020	5.512	5.500	4.000	3.970
B17M-5	B18M-5	5	7	11	5	1	5.068	5.020	7.015	7.000	5.000	4.970
B17M-6	B18M-6	6	8	12	6	1	6.068	6.020	8.015	8.000	6.000	5.970
B17M-7	B18M-7	6	8	12	8	1	6.068	6.020	8.015	8.000	6.000	5.970
B17M-8	B18M-8	6	8	12	10	1	6.068	6.020	8.015	8.000	6.000	5.970
B17M-9	B18M-9	7	9	15	12	1	7.083	7.025	9.015	9.000	7.000	6.964
B17M-10	B18M-10	8	10	15	5.5	1	8.083	8.025	10.015	10.000	8.000	7.964
B17M-11	B18M-11	8	10	15	7.5	1	8.083	8.025	10.015	10.000	8.000	7.964
B17M-12	B18M-12	8	10	15	10	1	8.083	8.025	10.015	10.000	8.000	7.964
B17M-13	B18M-13	10	12	18	6	1	10.083	10.025	12.018	12.000	10.000	9.964
B17M-14	B18M-14	10	12	18	9	1	10.083	10.025	12.018	12.000	10.000	9.964
B17M-15	B18M-15	10	12	18	10	1	10.083	10.025	12.018	12.000	10.000	9.964
B17M-16	B18M-16	10	12	18	12	1	10.083	10.025	12.018	12.000	10.000	9.964
B17M-17	B18M-17	10	12	18	15	1	10.083	10.025	12.018	12.000	10.000	9.964
B17M-18	B18M-18	10	12	18	17	1	10.083	10.025	12.018	12.000	12.000	9.964
B17M-19	B18M-19	12	14	20	10	1	12.102	12.032	14.018	14.000	12.000	11.957
B17M-20	B18M-20	12	14	20	11	1	12.102	12.032	14.018	14.000	12.000	11.957



THERMOPLASTIC BEARINGS

BORE SIZE	SHAFT SIZE	TYPE
4MM TO 14MM	4MM TO 12MM	SLEEVE AND FLANGED

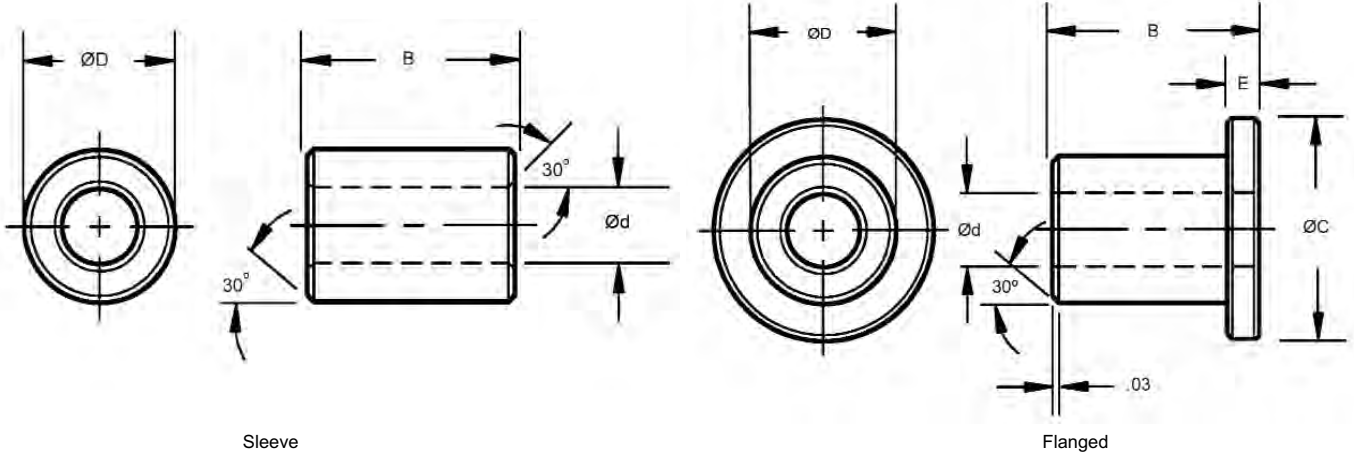

SLEEVE STOCK NO.	FLANGED STOCK NO.	NOMINAL SIZES					I.D. AFTER PRESS FIT		HOUSING BORE		SHAFT SIZE	
		ød	ØD	ØC	B	E (+0/- .140)	MAX.	MIN.	MAX.	MIN.	MAX.	MIN.
B19M-1	B20M-1	4	5.5	9.5	4	0.75	4.058	4.010	5.512	5.500	4.000	3.970
B19M-2	B20M-2	5	7	11	5	1	5.058	5.010	7.015	7.000	5.000	4.970
B19M-3	B20M-3	6	8	12	8	1	6.058	6.010	8.015	8.000	6.000	5.970
B19M-4	B20M-4	8	10	15	*	1	8.071	8.013	10.015	10.000	8.000	7.964
B19M-5	B20M-5	10	12	18	6	1	10.071	10.013	12.018	12.000	10.000	9.964
B19M-6	B20M-6	10	12	18	*	1	10.071	10.013	12.018	12.000	10.000	9.964
B19M-7	B20M-7	12	14	20	*	1	12.086	12.016	14.018	14.000	12.000	11.957
B19M-8	B20M-8	14	16	22	12	1	12.086	12.016	16.018	16.000	12.000	11.957

* Nominal Size for Sleeve version is 10, for Flanged version is 9.



CERAMIC BEARINGS

BORE SIZE	MAX. SHAFT DIAMETER	TYPE
5MM TO 50MM	5MM TO 50MM h6 or h7	STYLE L

STOCK NO.	WORKING BORE		OUTSIDE DIA h7 Tol.	LENGTH		RETAINING RING		MAX. SHAFT DIA (h6 or h7)	HOUSING BORE DIA H7
	Tolerance -,000			C	D	W			
	A	+	B						
L5	5	.038-.065	12	22	12	1.1	5	12	
L8	8	.038-.065	16	25	14	1.1	8	16	
L12	12	.038-.065	22	32	20	1.3	12	22	
L16	16	.038-.065	26	36	22	1.3	16	26	
L20	20	.047-.074	32	45	28	1.6	20	32	
L25	25	.047-.074	40	58	40	1.85	25	40	
L30	30	.047-.074	47	68	48	1.85	30	47	
L40	40	.049-.089	62	80	56	2.15	40	62	
L50	50	.049-.089	75	100	72	2.65	50	75	

BORE SIZE	MAX. SHAFT DIAMETER	TYPE
5MM TO 50MM	5MM TO 50MM h6 or h7	STYLE LA

STOCK NO.	WORKING BORE		OUTSIDE DIA h7 Tol.	LENGTH		RETAINING RING		MAX. SHAFT DIA (h6 or h7)	HOUSING BORE DIA H7	ADJ. SLOT WIDTH G
	Tolerance -,000			C	D	W				
	A	+	B							
LA5	5	.038-.065	12	22	12	1.1	5	12	2	
LA8	8	.038-.065	16	25	14	1.1	8	16	2	
LA12	12	.038-.065	22	32	20	1.3	12	22	2.5	
LA16	16	.038-.065	26	36	22	1.3	16	26	3	
LA20	20	.047-.074	32	45	28	1.6	20	32	3.5	
LA25	25	.047-.074	40	58	40	1.85	25	40	4.5	
LA30	30	.047-.074	47	68	48	1.85	30	47	5	
LA40	40	.049-.089	62	80	56	2.15	40	62	7	
LA50	50	.049-.089	75	100	72	2.65	50	75	8	

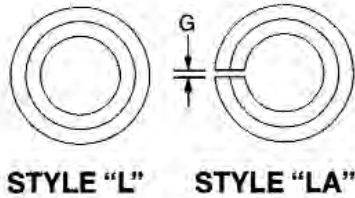
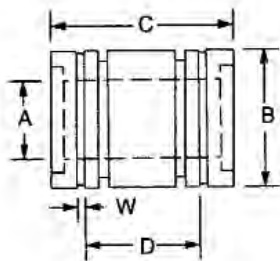

	CERAMIC SERIES
Maximum PV (continuous)	1.4N/mm ² m/s
Maximum P-(static)	34,4 N/mm ²
Maximum V (no load)	unlimited
Shaft Hardness (minimum)	RC 35-63
Shaft Finish (RMS)	8-16
Coefficient of Friction	.04-.08
Temp. Limits-typical range	-130° to +200°C

Recommended Shafting: Hardness RC 58-63 ^{.42}√.

CERAMIC BEARINGS

BORE SIZE	MAX. SHAFT DIAMETER	TYPE
12MM TO 50MM	12MM TO 50MM h6 or h7	STYLE LX

STOCK NO.	WORKING BORE		OUTSIDE DIA h7 Tol.	LENGTH	RETAINING RING		MAX. SHAFT DIA (h6 or h7)	HOUSING BORE DIA H7	OPEN SLOT WIDTH E	OPEN SLOT ANGLE F
	Tolerance -.000									
	A	+	B	C	D	W				
LX12	12	.038-.065	22	32	20	1.3	12	22	7.6	78
LX16	16	.038-.065	26	36	22	1.3	16	26	10.8	78
LX20	20	.047-.074	32	45	28	1.6	20	32	10.8	60
LX25	25	.047-.074	40	58	40	1.85	25	40	13.2	60
LX30	30	.047-.074	47	68	48	1.85	30	47	14.2	50
LX40	40	.049-.089	62	80	56	2.15	40	62	18.7	50
LX50	50	.049-.089	75	100	72	2.65	50	75	23.6	50

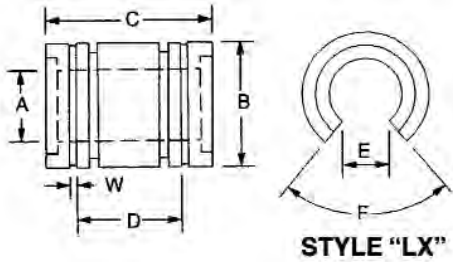

	CERAMIC SERIES
Maximum PV (continuous)	1.4N/mm ² m/s
Maximum P-(static)	34,4 N/mm ²
Maximum V (no load)	unlimited
Shaft Hardness (minimum)	RC 35-63
Shaft Finish (RMS)	8-16
Coefficient of Friction	.04-.08
Temp. Limits-typical range	-130° to +200°C

Recommended Shafting: Hardness RC 58-63 ⁴²√.

CERAMIC BEARINGS

BORE SIZE	MAX. SHAFT DIAMETER	TYPE
5MM TO 50MM	5MM TO 50MM h6 or h7	STYLE L SELF ALIGNING

STOCK NO.	WORKING BORE	OUTSIDE DIA h7 Tol.	LENGTH	RETAINING RING		MAX. SHAFT DIA (h6 or h7)	HOUSING BORE DIA H7
	Tolerance -.000			D	W		
	A	+	B			C	
L-5SA	5 .038-.065	12	22	12	1.1	5	12
L-8SA	8 .038-.065	16	25	14	1.1	8	16
L-12SA	12 .038-.065	22	32	20	1.3	12	22
L-16SA	16 .038-.065	26	36	22	1.3	16	26
L-20SA	20 .047-.074	32	45	28	1.6	20	32
L-25SA	25 .047-.074	40	58	40	1.85	25	40
L-30SA	30 .047-.074	47	68	48	1.85	30	47
L-40SA	40 .049-.089	62	80	56	2.15	40	62
L-50SA	50 .049-.089	75	100	72	2.65	50	75

BORE SIZE	MAX. SHAFT DIAMETER	TYPE
5MM TO 50MM	5MM TO 50MM h6 or h7	STYLE LA SELF ALIGNING

STOCK NO.	WORKING BORE	OUTSIDE DIA h7 Tol.	LENGTH	RETAINING RING		MAX. SHAFT DIA (h6 or h7)	HOUSING BORE DIA H7	A
	Tolerance -.000			D	W			
	A	+	B			C	D	W
LA-5SA	5 .038-.065	12	22	12	1.1	5	12	2
LA-8SA	8 .038-.065	16	25	14	1.1	8	16	2
LA-12SA	12 .038-.065	22	32	20	1.3	12	22	2.5
LA-16SA	16 .038-.065	26	36	22	1.3	16	26	3
LA-20SA	20 .047-.074	32	45	28	1.6	20	32	3.5
LA-25SA	25 .047-.074	40	58	40	1.85	25	40	4.5
LA-30SA	30 .047-.074	47	68	48	1.85	30	47	5
LA-40SA	40 .049-.089	62	80	56	2.15	40	62	7
LA-50SA	50 .049-.089	75	100	72	2.65	50	75	8

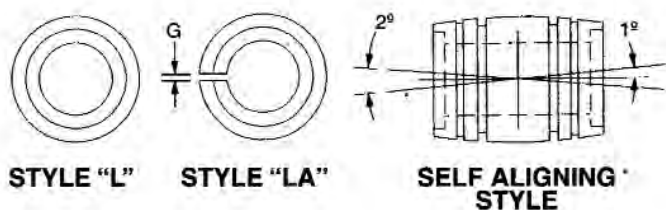

	CERAMIC SERIES
Maximum PV (continuous)	1.4N/mm ² m/s
Maximum P-(static)	34.4 N/mm ²
Maximum V (no load)	unlimited
Shaft Hardness (minimum)	RC 35-63
Shaft Finish (RMS)	8-16
Coefficient of Friction	.04-.08
Temp. Limits-typical range	-130° to +200°C

Recommended Shafting: Hardness RC 58-63 ^{.42}√.

CERAMIC BEARINGS

BORE SIZE	MAX. SHAFT DIAMETER	TYPE
12MM TO 50MM	12MM TO 50MM h6 or h7	STYLE LX SELF ALIGNING

STOCK NO.	WORKING BORE		OUTSIDE DIA h7 Tol.	LENGTH		RETAINING RING		MAX. SHAFT DIA (h6 or h7)	HOUSING BORE DIA H7	OPEN SLOT WIDTH E	OPEN SLOT ANGLE F
	A	Tolerance		B	C	D	W				
LX-12SA	12	.038-.065	22	32	20	1.3	12	22	22	7.6	78
LX-16SA	16	.038-.065	26	36	22	1.3	16	26	26	10.8	78
LX-20SA	20	.047-.074	32	45	28	1.6	20	32	32	10.8	60
LX-25SA	25	.047-.074	40	58	40	1.85	25	40	40	13.2	60
LX-30SA	30	.047-.074	47	68	48	1.85	30	47	47	14.2	50
LX-40SA	40	.049-.089	62	80	56	2.15	40	62	62	18.7	50
LX-50SA	50	.049-.089	75	100	72	2.65	50	75	75	23.6	50

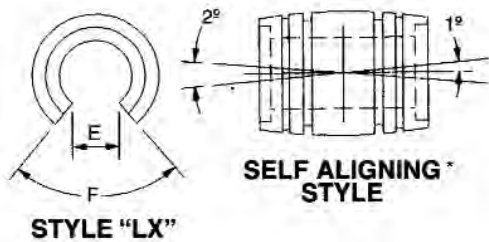

	CERAMIC SERIES
Maximum PV (continuous)	1.4N/mm ² m/s
Maximum P-(static)	34,4 N/mm ²
Maximum V (no load)	unlimited
Shaft Hardness (minimum)	RC 35-63
Shaft Finish (RMS)	8-16
Coefficient of Friction	.04-.08
Temp. Limits-typical range	-130° to +200°C

Recommended Shafting: Hardness RC 58-63 ⁴²√.

CERAMIC BEARINGS

BORE SIZE	STYLE	TYPE
5MM TO 50MM	ROUND FLANGE	PIN HUB

STOCK NO.	WORKING BORE		OUTSIDE DIA h7 Tol.	LENGTH		ROUND FLANGE (KBF)		BOLT HOLE			Dp
	A	Tolerance						B	C	D	
			B	C	D	W	X				
L5KBF	5	0.038-0.065	12	22	28	5	3.5	6	3.1	20	
L8KBF	8	0.038-0.065	16	25	32	5	3.5	6	3.1	24	
L12KBF	12	0.038-0.065	22	32	42	6	4.5	7.5	4.1	32	
L16KBF	16	0.038-0.065	26	36	46	6	4.5	7.5	4.1	36	
L20KBF	20	0.047-0.074	32	45	54	8	5.5	9	5.1	43	
L25KBF	25	0.047-0.074	40	58	62	8	5.5	9	5.1	51	
L30KBF	30	0.047-0.074	47	68	76	10	6.6	11	6.1	62	
L40KBF	40	0.049-0.089	62	80	98	13	9	14	8.1	80	
L50KBF	50	0.049-0.089	75	100	112	13	9	14	8.1	94	

BORE SIZE	STYLE	TYPE
5MM TO 50MM	SQUARE FLANGE	PIN HUB

STOCK NO.	WORKING BORE		OUTSIDE DIA h7 Tol.	LENGTH		SQUARE FLANGE (KBK)		BOLT HOLE			Dp
	A	Tolerance						B	C	K	
			B	C	K	X	Y				
L5KBK	5	0.038-0.065	12	22	22	3.5	6	3.1	20		
L8KBK	8	0.038-0.065	16	25	25	3.5	6	3.1	24		
L12KBK	12	0.038-0.065	22	32	32	4.5	7.5	4.1	32		
L16KBK	16	0.038-0.065	26	36	35	4.5	7.5	4.1	36		
L20KBK	20	0.047-0.074	32	45	42	5.5	9	5.1	43		
L25KBK	25	0.047-0.074	40	58	50	5.5	9	5.1	51		
L30KBK	30	0.047-0.074	47	68	60	6.6	11	6.1	62		
L40KBK	40	0.049-0.089	62	80	75	9	14	8.1	80		
L50KBK	50	0.049-0.089	75	100	88	9	14	8.1	94		

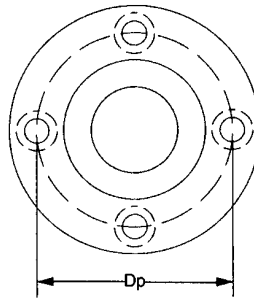
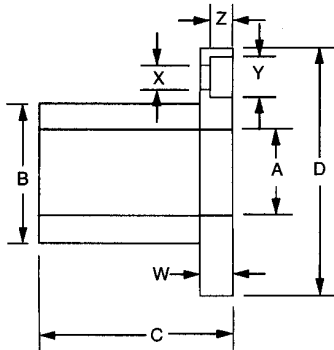

KBF STYLE

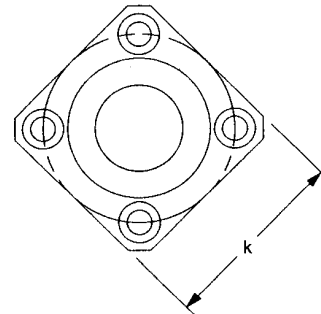

KBK STYLE

	CERAMIC SERIES
Maximum PV (continuous)	1.4N/mm ² m/s
Maximum P-(static)	34,4 N/mm ²
Maximum V (no load)	unlimited
Shaft Hardness (minimum)	RC 35-63
Shaft Finish (RMS)	8-16
Coefficient of Friction	.04-.08
Temp. Limits-typical range	-130° to +200°C

CERAMIC BEARINGS

BORE SIZE	STYLE	TYPE
5MM TO 50MM	ROUND FLANGE	PIN HUB SELF LUBRICATING

STOCK NO.	WORKING BORE		OUTSIDE DIA h7 Tol.	LENGTH	ROUND FLANGE (KBF)		BOLT HOLE			Dp
	A	Tolerance			D	W	X	Y	Z	
			B	C						
L5KBFSL	5	0.038-0.065	12	22	28	5	3.5	6	3.1	20
L8KBFSL	8	0.038-0.065	16	25	32	5	3.5	6	3.1	24
L12KBFSL	12	0.038-0.065	22	32	42	6	4.5	7.5	4.1	32
L16KBFSL	16	0.038-0.065	26	36	46	6	4.5	7.5	4.1	36
L20KBFSL	20	0.047-0.074	32	45	54	8	5.5	9	5.1	43
L25KBFSL	25	0.047-0.074	40	58	62	8	5.5	9	5.1	51
L30KBFSL	30	0.047-0.074	47	68	76	10	6.6	11	6.1	62
L40KBFSL	40	0.049-0.089	62	80	98	13	9	14	8.1	80
L50KBFSL	50	0.049-0.089	75	100	112	13	9	14	8.1	94

BORE SIZE	STYLE	TYPE
5MM TO 50MM	SQUARE FLANGE	PIN HUB SELF LUBRICATING

STOCK NO.	WORKING BORE		OUTSIDE DIA h7 Tol.	LENGTH	SQUARE FLANGE (KBK)	BOLT HOLE			Dp
	A	Tolerance				X	Y	Z	
			B	C	K				
L5KBKSL	5	0.038-0.065	12	22	22	3.5	6	3.1	20
L8KBKSL	8	0.038-0.065	16	25	25	3.5	6	3.1	24
L12KBKSL	12	0.038-0.065	22	32	32	4.5	7.5	4.1	32
L16KBKSL	16	0.038-0.065	26	36	35	4.5	7.5	4.1	36
L20KBKSL	20	0.047-0.074	32	45	42	5.5	9	5.1	43
L25KBKSL	25	0.047-0.074	40	58	50	5.5	9	5.1	51
L30KBKSL	30	0.047-0.074	47	68	60	6.6	11	6.1	62
L40KBKSL	40	0.049-0.089	62	80	75	9	14	8.1	80
L50KBKSL	50	0.049-0.089	75	100	88	9	14	8.1	94

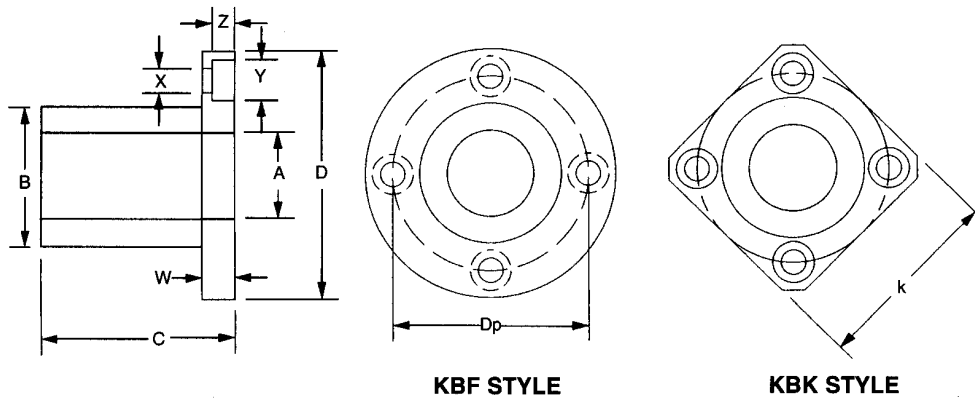

	SELF LUBRICATING SERIES	CERAMIC SERIES
Maximum PV (continuous)	0.26 N/mm ² M/S	1.4N/mm ² m/s
Maximum P-(static)	5.2 N/mm ²	34.4 N/mm ²
Maximum V (no load)	2 m/s	unlimited
Shaft Hardness (minimum)	RB 25	RC 35-63
Shaft Finish (RMS)	8-16	8-16
Coefficient of Friction	.10-.18	.04-.08
Temp. Limits-typical range	-240°C to +190°C	-130° to +200°C

SPHERICAL BEARINGS

BORE SIZE	TYPE	MATERIAL
5MM TO 25MM	SELF LUBRICATING	REINFORCED THERMOPLASTIC HOUSING, BALL B15/16 BEARING THERMOPLASTIC

- High radial and thrust load
- Long life cycle

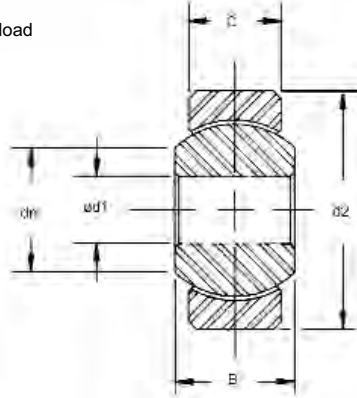

STOCK NO.	$\varnothing d1$	$d2$	B	C	dn
SKGLM-05	5	13	8	6	7.7
SKGLM-06	6	16	9	6.5	8.9
SKGLM-08	8	19	12	9	10.3
SKGLM-10	10	22	14	10.5	12.9
SKGLM-12	12	26	16	12	15.4
SKGLM-14	14	28	19	13.5	16.8
SKGLM-16	16	32	21	15	19.3
SKGLM-18	18	35	23	16.5	21.8
SKGLM-20	20	40	25	18	24.3
SKGLM-22	22	42	28	20	25.8
SKGLM-25	25	47	31	22	29.5

SPHERICAL PILLOW BLOCK BEARINGS

BORE SIZE	MATERIAL
5MM TO 25MM	HOUSING - REINFORCED THERMOPLASTIC BALL - B15/16 BEARING THERMOPLASTIC

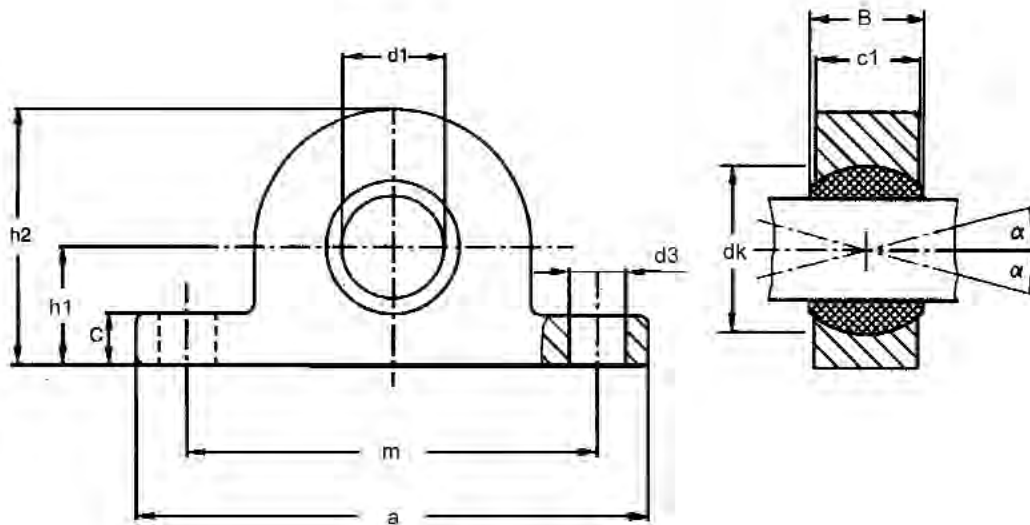

STOCK NO.	d1	B	c1	dk	h1	m	d3	a	c	h2
PSJAM-05	5	8	6	11.1	7	25	4.5	36	3	14
PSJAM-06	6	9	7	12.7	10	33	4.5	44	4	20
PSJAM-08	8	12	9	15.8	10	33	4.5	44	4	20
PSJAM-10	10	14	10.5	19.0	14	35	5.5	60	6	28
PSJAM-12	12	16	12	22.2	14	35	5.5	60	6	28
PSJAM-14	14	19	13.5	25.4	18	60	6.5	80	6	36
PSJAM-16	16	21	15	28.5	18	60	6.5	80	6	36
PSJAM-18	18	23	16.5	31.7	22	68	8.5	88	9	44
PSJAM-20	20	25	18	34.9	22	68	8.5	88	9	44
PSJAM-22	22	28	20	38.1	24	74	8.5	97	9	48
PSJAM-25	25	31	22	42.8	27	86	8.5	110	10	54

THRUST BEARINGS

BORE SIZE	MATERIAL
5MM TO 25MM	STAINLESS STEEL

STOCK NO.	ØB +0.13 -0.00	ØA +0.00 -0.13	ØC	L ±0.05	T	NO. OF BALLS	LOAD RATING AT 15 RPM
B5M-2-SS	5.00	12.00	8.7	1.30	4.98	7	323 N
B5M-3-SS	6.00	14.00	10.3	1.30	4.98	8	371 N
B5M-4-SS	7.00	17.00	11.9	1.30	4.98	9	418 N
B5M-5-SS	8.00	16.00	11.9	1.30	4.98	6	418 N
B5M-6-SS	10.00	21.00	15.1	1.60	6.38	6	467 N
B5M-7-SS	12.00	24.00	18.3	1.60	6.38	8	618 N
B5M-8-SS	16.00	28.00	22.2	2.40	8.80	6	755 N
B5M-9-SS	19.00	32.00	25.4	2.40	8.80	8	1002 N
B5M-10-SS	25.00	41.00	33.3	3.18	11.12	10	1544 N

BORE SIZE	MATERIAL
5MM TO 25MM	CARBON STEEL

STOCK NO.	ØB +0.13 -0.00	ØA +0.00 -0.13	ØC	L ±0.05	T	NO. OF BALLS	LOAD RATING AT 15 RPM
B5M-2	5.00	12.00	8.7	1.30	4.98	7	461 N
B5M-3	6.00	14.00	10.3	1.30	4.98	8	530 N
B5M-4	7.00	17.00	11.9	1.30	4.98	9	598 N
B5M-5	8.00	16.00	11.9	1.30	4.98	6	598 N
B5M-6	10.00	21.00	15.1	1.60	6.38	6	667 N
B5M-7	12.00	24.00	18.3	1.60	6.38	8	883 N
B5M-8	16.00	28.00	22.2	2.40	8.80	6	1079 N
B5M-9	19.00	32.00	25.4	2.40	8.80	8	1432 N
B5M-10	25.00	41.00	33.3	3.18	11.12	10	2207 N

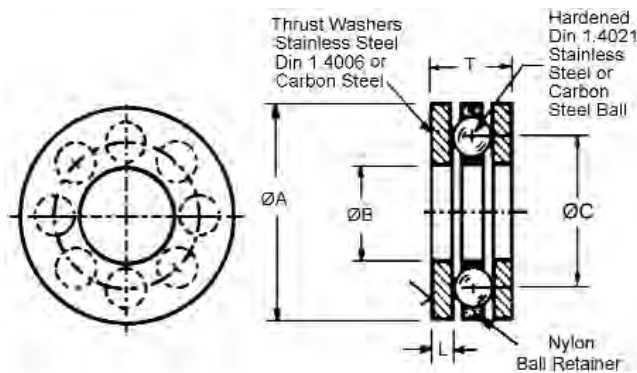

ROLLER THRUST BEARINGS

BORE SIZE	MATERIAL
4MM TO 25MM	ROLLERS 52100 CHROME STEEL CAGE CARBON STEEL, WASHERS 1074 STEEL

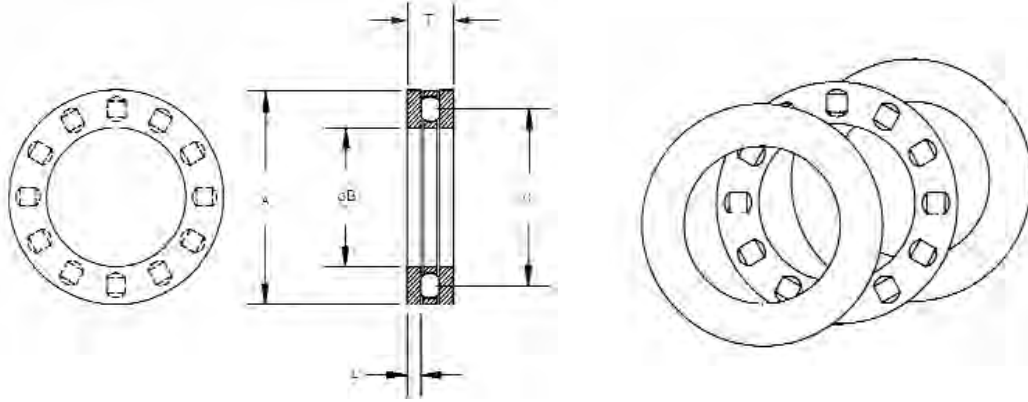

PART NO.	DIMENSIONS ØB	A Tol. E10	T Tol. a12	L +0.000 -0.075	C	LOAD RATINGS		SPEED RATING rpm
						DYN. N	STAT. N	
BR5M-1	4	14	4.0	1.00	9.0	4450	8000	18000
BR5M-2*	5	15	4.0	1.00	10.0	4750	9200	17000
BR5M-3*	6	19	7.5	2.75	12.5	6800	15500	16000
BR5M-4*	8	21	7.5	2.75	14.5	7800	19400	15000
BR5M-5	10	24	7.5	2.75	17.5	9200	25500	14000
BR5M-6	12	26	7.5	2.75	19.5	9900	29000	13000
BR5M-7	15	28	7.5	2.75	22.0	11300	36000	11000
BR5M-8	17	30	7.5	2.75	24.0	11900	39500	10000
BR5M-9	20	35	7.5	2.75	28.0	13100	46500	8500
BR5M-10	25	42	8.0	3.00	35.0	14700	58000	7000

*These part numbers contain a plastic cage and limit operating temp. to 120° Cont. 150° intermittently.

