

**SIEMENS**

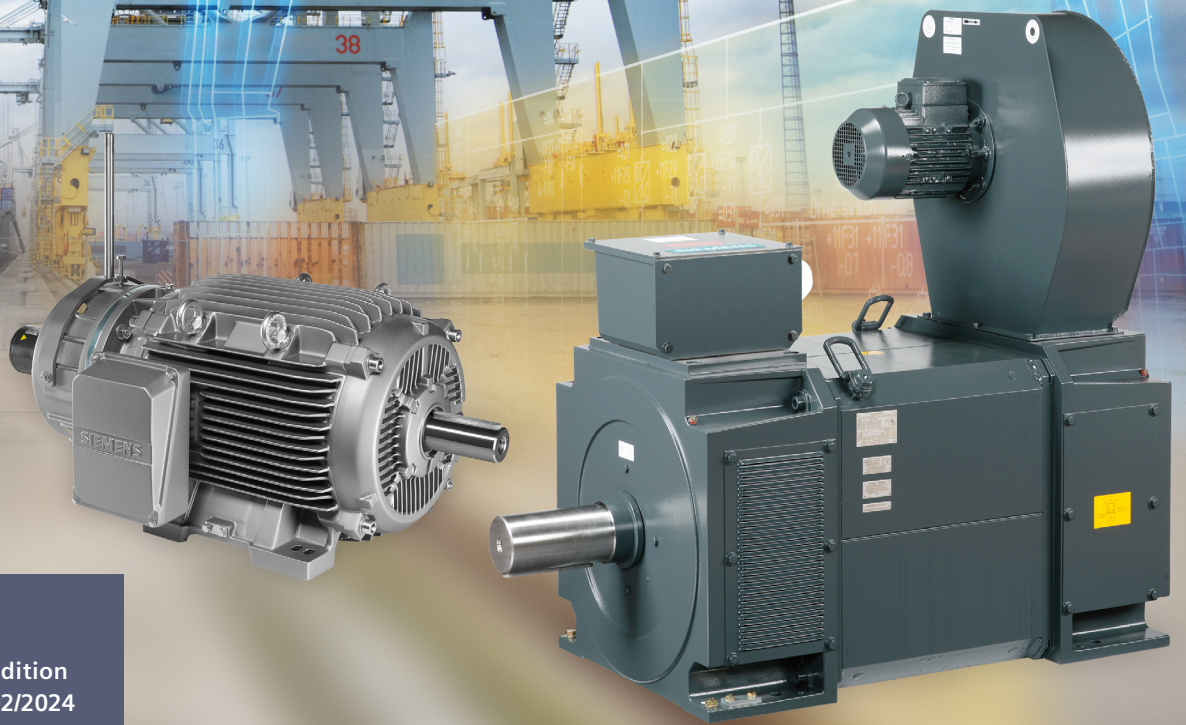

Catalog  
CR 81t

Edition  
02/2024

**MOTORS**





# **SIMOTICS Motors for Cranes**

**SIMOTICS DP – Crane duty motors**

**SIMOTICS M – Main motors**

[siemens.com/drives](https://www.siemens.com/drives)

## Related catalogs

<p><b>Cranes</b> Drive and Control Components for Cranes</p> <p>E86060-K1301-A101-A3-7600</p>	<p>CR 1</p> 
<p><b>SIMOTICS GP, SD, XP, DP</b> <b>Low-Voltage Motors</b> Type series 1FP1, 1LE1, 1LE5, 1MB1, 1MB5, 1PC1 Frame sizes 63 to 450 Power range 0.09 to 1000 kW PDF (E86060-K5581-A111-B3-7600)</p>	<p>D 81.1</p> 
<p><b>SINAMICS S120</b> Chassis Format Converter Units Cabinet Modules</p> <p><b>SINAMICS S150</b> Converter Cabinet Units E86060-K5521-A131-A6-7600</p>	<p>D 21.3</p> 
<p><b>Motion Control Drives</b> SINAMICS S120 and SIMOTICS</p> <p>E86060-K5521-A141-A1-7600</p>	<p>D 21.4</p> 
<p><b>Industry Mall</b> Information and Ordering Platform on the Internet:</p> <p><a href="http://www.siemens.com/industrymall">www.siemens.com/industrymall</a></p>	

The Siemens Businesses **Large Drives Applications** and **Low Voltage Motors** have been transferred to **Innomotics**. The brand change from Siemens to Innomotics is ongoing.

Siemens' or Innomotics' legal information, trademarks or logos contained in product related documents **do not necessarily represent the actual branding** used for the products. Any technical product information remains valid **independently of the brand**.

**Orders** received as of **August 1, 2024**, will be confirmed exclusively with the product mark "**Innomotics**" regarding the concerned products and services.

Independent of the order date, all ordered products or services with **delivery** dates from **April 1, 2025**, will be delivered with the product mark "Innomotics".

**INNOMOTICS**

A Siemens Business



# SIMOTICS Motors for Cranes

## Motors

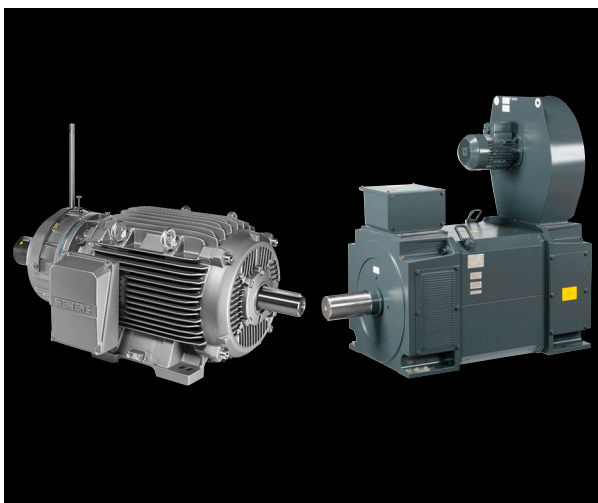

### Catalog CR 81 · 02/2024

Supersedes:  
Catalog CR 81 · 2021  
Catalog CR 1 · 2015, chapter 7

© Siemens AG 2024

This catalog covers the SIMOTICS DP motor range especially designed for use in cranes applications.

For proper selection and configuration, in addition to the specifications within this document, also refer to:

- Chapter 1 of Catalog D 81.1 for SIMOTICS DP cranes motors

Potential deviations/contradictions between this Catalog and Catalogs D 81.1 may be specific to the cranes motors. In this case, observe the specifications mentioned in this document, or contact your Siemens Partner to avoid any errors in selection and configuration.



The products and systems described in this catalog are manufactured/distributed under application of a certified quality management system in accordance with DIN EN ISO 9001 (04-31-1267 Certified Registration No. DE-000357 QM). The certificate is recognized by all IQNet countries.

**Introduction**  
Orientation  
General technical specifications

**1**

**SIMOTICS DP – Crane duty motors**

**2**

**SIMOTICS M – Main motors**

**3**

**Appendix**

**4**

# Digital Enterprise

## The building blocks that ensure everything works together perfectly in the digital enterprise

Digitalization is already changing all areas of life and existing business models. It is placing greater pressure on industry while at the same time creating new business opportunities. Today, thanks to scalable solutions from Siemens, companies can already become a digital enterprise and ensure their competitiveness.



### Industry faces tremendous challenges



#### Reduce time-to-market

Today manufacturers have to bring products to market at an ever-increasing pace despite the growing complexity of these products. In the past, a major manufacturer would push aside a small one, but now it is a fast manufacturer that overtakes a slow one.



#### Boost flexibility

Consumers want customized products, but at a price they would pay for a mass-produced item. That only works if production is more flexible than ever before.



#### Improve quality

To ensure a high level of quality while meeting legal requirements, companies have to establish closed quality loops and enable the traceability of products.

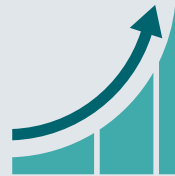

#### Boost efficiency

Today the product itself needs to be sustainable and environmentally friendly, while energy efficiency in production has become a competitive advantage.



#### Increase security

Increasing networking escalates the threat to production facilities of cyberattacks. Today more than ever, companies need suitable security measures.

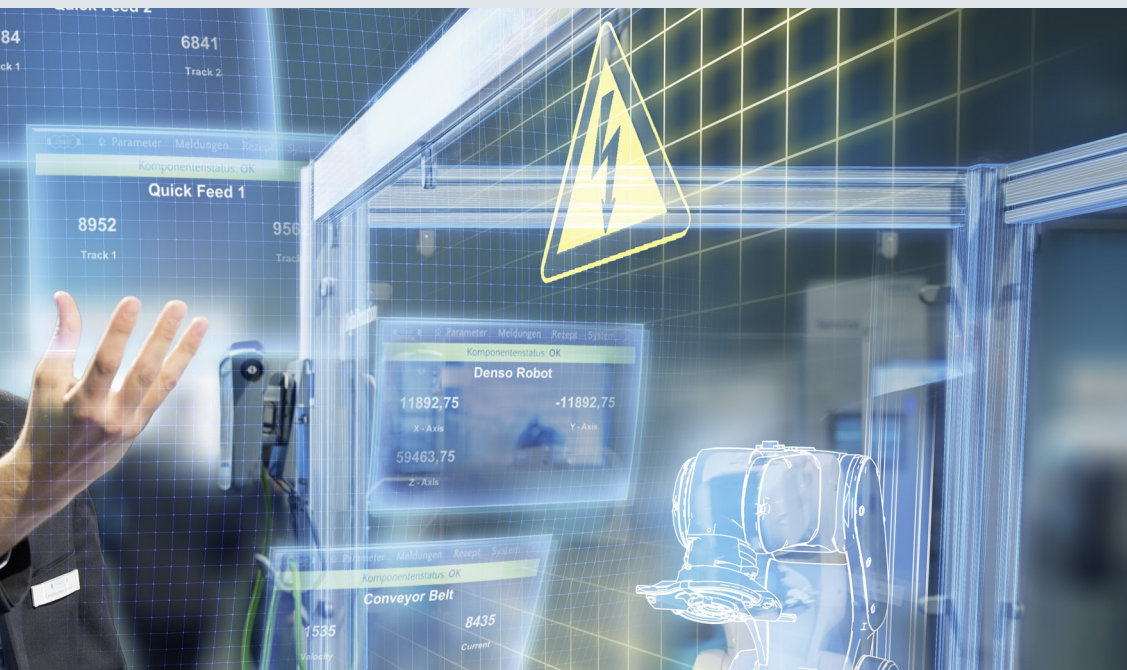

## The digital enterprise has already become a reality

To fully benefit from all the advantages of digitalization, companies first have to achieve complete consistency of their data. Fully digitally integrated business processes, including those of suppliers, can help to create a digital representation of the entire value chain. This requires

- the integration of industrial software and automation,
- expansion of the communication networks,
- security in automation,
- and the use of business-specific industrial services.

## MindSphere

### The cloud-based open IoT operating system from Siemens

With MindSphere, Siemens offers a cost-effective and scalable cloud platform as a service (PaaS) for the development of applications. The platform, designed as an open operating system for the Internet of Things, makes it possible to improve the efficiency of plants by collecting and analyzing large volumes of production data.

### Totally Integrated Automation (TIA) Where digitalization becomes reality

Totally Integrated Automation (TIA) ensures the seamless transition from the virtual to the real world. It already encompasses all the necessary conditions for transforming the benefits of digitalization into true added value. The data that will form the digital twin for actual production is generated from a common base.

### Digital Plant

Learn more about the digital enterprise for the process industry  
[www.siemens.com/digitalplant](http://www.siemens.com/digitalplant)

### Digital Enterprise Suite

Learn more about the digital enterprise for the discrete industry  
[www.siemens.com/digital-enterprise-suite](http://www.siemens.com/digital-enterprise-suite)

# Integrated Drive Systems

Faster on the market and in the black with Integrated Drive Systems

Integrated Drive Systems are Siemens' trendsetting answer to the high degree of complexity that characterizes drive and automation technology today. The world's only true one-stop solution for entire drive systems is characterized in particular by its threefold integration: Horizontal, vertical, and lifecycle integration ensure that every drive system component fits seamlessly into the whole system, into any automation environment, and even into the entire lifecycle of a plant.

The outcome is an optimal workflow – from engineering all the way to service that entails more productivity, increased efficiency, and better availability. That's how Integrated Drive Systems reduce time to market and time to profit.

## Horizontal integration

**Integrated drive portfolio:** The core elements of a fully integrated drive portfolio are frequency converters, motors, couplings, and gear units. At Siemens, they're all available from a single source. Perfectly integrated, perfectly interacting. For all power and performance classes. As standard solutions or fully customized. No other player in the market can offer a comparable portfolio. Moreover, all Siemens drive components are perfectly matched, so they are optimally interacting.



You can boost the availability of your application or plant to up to

**99%\***

\*e.g., conveyor application

## Vertical integration

Thanks to **vertical integration**, the complete drive train is seamlessly integrated in the entire automation environment – an important prerequisite for production with maximum value added. Integrated Drive Systems are part of Totally Integrated Automation (TIA), which means that they are perfectly embedded into the system architecture of the entire industrial production process. This enables optimal processes through maximum communication and control.

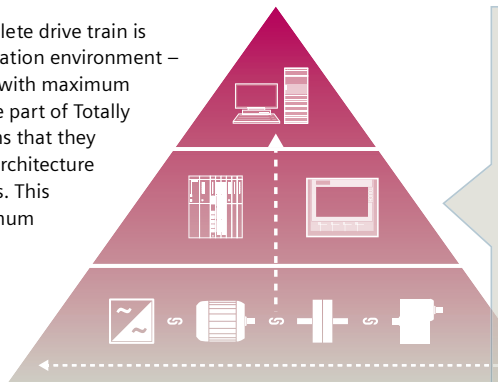

With TIA Portal you can cut your engineering time by up to

**30%**

## Lifecycle integration

**Lifecycle integration** adds the factor of time: Software and service are available for the entire lifecycle of an Integrated Drive System. That way, important optimization potential for maximum productivity, increased efficiency, and highest availability can be leveraged throughout the system's lifecycle – from planning, design, and engineering to operation, maintenance, and all the way even to modernization.

With Integrated Drive Systems, assets become important success factors. They ensure shorter time to market, maximum productivity and efficiency in operation, and shorter time to profit.

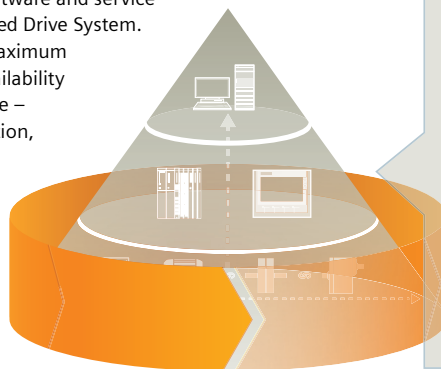

With Integrated Drive Systems you can reduce your maintenance costs by up to

**15%**



## Introduction

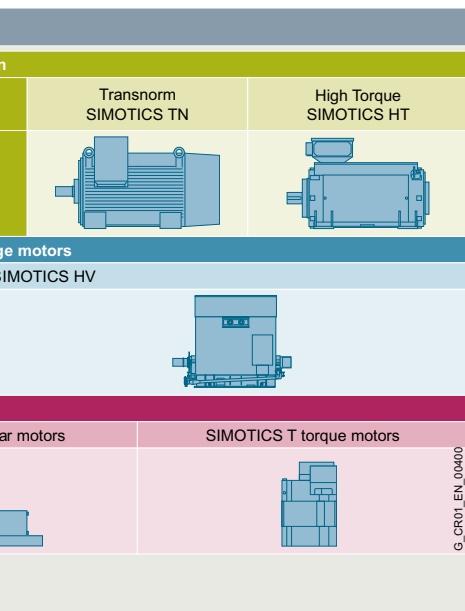

1/2

Orientation

1/6

General technical specifications

# Introduction

## Orientation

Innovative drive technology for all industries, applications and power classes

### Overview

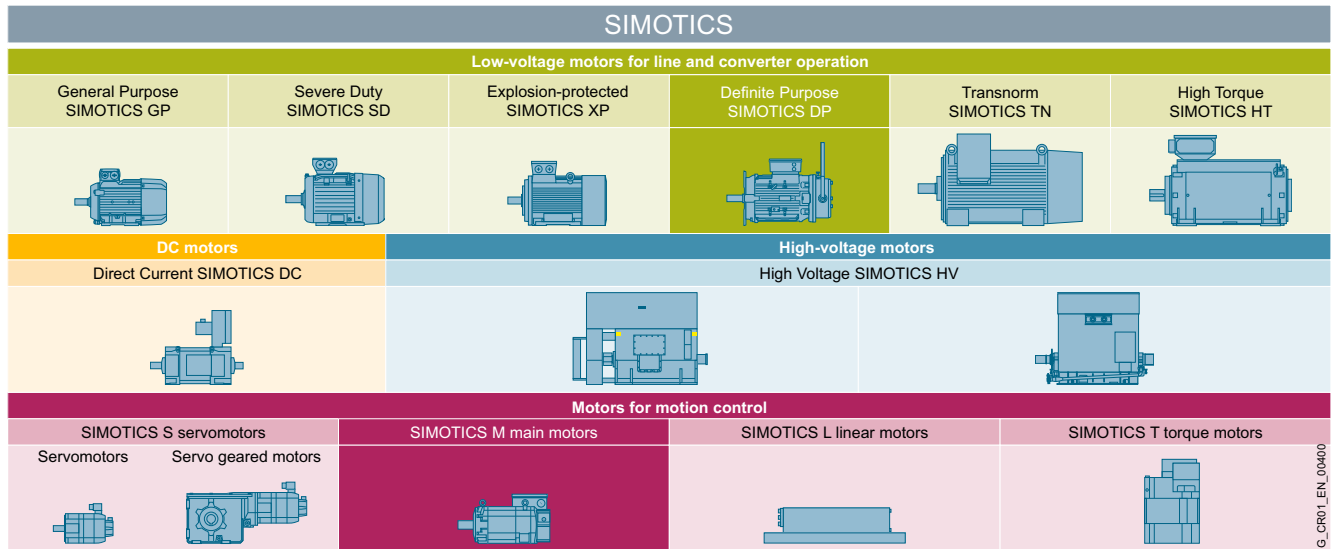

G-CR01-EN\_04/00

### SIMOTICS motors

With SIMOTICS, Siemens has the most comprehensive portfolio of electric motors worldwide. From energy-efficient, low-voltage motors through servomotors with high dynamic performance up to well-proven DC motors and powerful high-voltage motors. Innovative drive technology for all industries, applications and power classes.

Outstanding performance, quality, efficiency, and compactness.

The SIMOTICS motor portfolio:

- SIMOTICS Low-Voltage Motors for line and converter operation:  
For standard applications with low to high motor power ratings
- SIMOTICS Motion Control motors:  
For highly dynamic and extremely precise applications in mechanical engineering
- SIMOTICS DC motors:  
For DC applications
- SIMOTICS High-Voltage Motors:  
For line and converter operation in standard applications with high to very high motor power ratings.

### SIMOTICS Low-Voltage Motors for line and converter operation

SIMOTICS Low-Voltage Motors are the right choice for solving drive tasks efficiently and reliably. In contrast to Motion Control motors, which are additionally characterized by very high dynamic response and precision, the more favorably priced low-voltage motors are predestined for continuous or periodic, as well as powerful motions with fixed or variable speed, such as in pumps, fans, compressors, conveyor belts, lifts, hoisting and traversing gear, winders, mixers, kneaders and centrifuges.

SIMOTICS Low-Voltage Motors are characterized by very high reliability, ruggedness, and efficiency in operation.

They are available in diverse series and versions, which means that the appropriate motor can always be found for any application in an industrial or commercial environment, as well as in building management systems, shipbuilding and infrastructure.

SIMOTICS Low-Voltage Motors comply with the most important relevant standards and guidelines and are available in IEC, NEMA, and APAC versions. They can be used all over the world, and have a global, long-term spare parts service. For these reasons, they provide a sustainable basis for export-oriented, globally operating companies to enable them to conduct their international business efficiently.

**Overview** (continued)

**SIMOTICS GP – General Purpose** motors are the most economical solution for use under standard environmental conditions. Typically, these motors have an aluminum housing and are characterized by their low weight. SIMOTICS GP motors are available in the power range from 0.09 to 45 kW.

Available motor variants:

- Induction motors, optimized for line operation
  - in efficiency classes IE4, IE3, IE2, IE1
  - as a standards-compliant version or compact version with increased power (IE3, IE2, IE1)
  - as a 2-, 4-, 6-, 8-pole version
  - as pole-changing motors
  - as an APAC version for use in the ASEAN Pacific region (IE3, IE2)
  - as a NEMA version for use in the NAFTA area
    - electrically (mechanically acc. to IEC): Eagle Line
    - electrically and mechanically
  - can optionally be run on a converter
- Motors optimized for operation on frequency converters
  - as a SIMOTICS GP – VSD10 line induction motor
  - as a SIMOTICS GP – VSD4000 line synchronous reluctance motor for particularly efficient operation in conjunction with SINAMICS converters.
- Different types of construction, voltage versions, and a wide variety of options/add-ons for precise adaptation of the motors to application and customer-specific requirements.

**SIMOTICS SD – Severe Duty** motors have a rugged cast-iron housing, which means that they are also suitable for use in harsh to very harsh environments. With a wide power range from 0.09 to 1000 kW, SIMOTICS SD motors are the basis for machine and plant builders and owners who require a universal motor for flexible requirements and conditions of use.

Available motor variants:

- Induction motors, optimized for line operation
  - in efficiency classes IE4, IE3, IE2, IE1
  - standards-compliant version or compact version with increased power (IE3, IE2, IE1)
  - as a 2-, 4-, 6-, 8-pole version
  - as an APAC version for use in the ASEAN Pacific region (IE3, IE2)
  - as a NEMA version for use in the NAFTA area
    - electrically (mechanically acc. to IEC): Eagle Line
    - electrically and mechanically
  - can optionally be run on a converter
- Motors optimized for operation on frequency converters
  - as a SIMOTICS SD – VSD10 line induction motor
  - as a SIMOTICS SD – VSD4000 line synchronous reluctance motor for particularly efficient operation in conjunction with SINAMICS converters.
- Basic Line and particularly rugged Performance Line
- Different types of construction, voltage versions, and a very wide variety of options/add-ons for precise adaptation of the motors to application and customer-specific requirements.

**SIMOTICS – next generation** is the next innovation step in low-voltage motors.

In particular, these motors offer the following advantages for customers:

- More efficiency in the engineering process due to the Digital Twin Concept.
- Further increase in availability due to the Smart Motor Concept.

**SIMOTICS XP – Explosion Proof** motors are designed for use in hazardous environments. For all conditions of use and hazard zones, e.g. in explosive gas atmospheres of the chemical/petrochemical sector or in explosive dust atmospheres in the mining or food and beverage sectors, there are suitable motor versions in aluminum and cast iron that ensure maximum safety and satisfy the relevant standards and regulations.

SIMOTICS XP motors are available in the power range from 0.09 to 460 kW.

Available motor variants:

- Motors for use in Zones 1, 2, 21 and 22
- Induction motors optimized for line operation
  - in efficiency classes IE3, IE2, IE1
  - as a 2-, 4-, 6-, 8-pole version
  - as a NEMA version for use in the NAFTA area
- For motors suitable for line and converter operation
- Basic Line and particularly rugged Performance Line in a cast-iron housing
- Different types of construction, voltage versions, and a wide variety of options/add-ons for precise adaptation of the motors to application and customer-specific requirements.

**SIMOTICS DP – Definite Purpose** motors are low-voltage motors for application-specific, customized and industry-specific use.

They have the required respective industry-specific properties and certificates.

SIMOTICS DP motors:

- Marine motors for use on ships
- Steel plant motors for use in the steel industry
- Roller table motors for roller table applications in the steel industry

**SIMOTICS TN – Transnorm** motors are low-voltage motors for line and converter operation in a cast-iron housing with higher power ratings up to 5000 kW from shaft height 315. In non-standard (Transnorm) motors, the assignment of the power rating and shaft extensions to frame size is not standardized.

**SIMOTICS HT – High Torque** motors are permanent-magnet synchronous motors and are used in applications that require extremely powerful drives without gear units, even at low speeds.

# Introduction

## Orientation

1

### Innovative drive technology for all industries, applications and power classes

#### Overview (continued)

##### SIMOTICS low-voltage motors for cranes

Within its SIMOTICS motor family, Siemens offers a series of low-voltage motors that are ideally suited to use in crane applications:

- In industrial cranes and harbor cranes
- In indoor and the outdoor areas

The motors are perfectly suited to use with a converter which enables the typical load profiles in crane applications to be implemented efficiently and reliably.











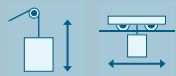



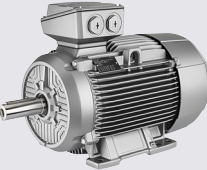

Different motor series can be selected depending on the environment of use and the application:

- SIMOTICS SD cast-iron motors for use in industrial cranes in indoor areas
- SIMOTICS DP cranes motors have been specially designed for use in harbor cranes and in outdoor areas.

This catalog contains the selection and ordering data of the SIMOTICS DP – Crane duty motors (Chapter 2).











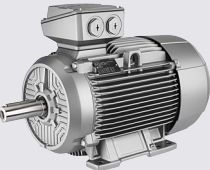

The selection and ordering data of the SIMOTICS SD cast-iron motors which are often used for applications other than crane applications can be found in Catalog D 81.1.

#### Overview of motors in crane application

Motor type	Industry	Industry			Harbor	
		Indoor	Indoor – heavy	Outdoor	Machine house	Outdoor
<b>SIMOTICS DP – Definite Purpose</b> 	1PC1341	-	-		 	
	1PC1361	-	-			
<b>SIMOTICS SD – Severe Duty</b> 	1LE15 1LE16 1LE5	 	  With order codes for elevated temperature and dust	-		-
<b>SIMOTICS M – Main motors</b> 	1PH8			-		-

- Not preferred version

**Overview** (continued)

	Motor type	IP class	Type of cooling	Frame size	Power range	Torque range	No. of poles	Nom. speed range	Application
					kW	Nm			
<b>SIMOTICS DP – Definite Purpose</b>  	1PC1341	IP55	self	132S ... 280M	5.5 ... 132	50 ... 1066	4	1500	
		IP55	self	132S ... 280M	9 ... 90	41 ... 1089	6	1000	
		IP55	forced	315L	117 ... 214	1425 ... 2605	6	1000	
		IP55	forced	315L	101 ... 179	1657 ... 2923	8	750	
	1PC1361	IP55	non	132S ... 280M	2 ... 47	28 ... 675	4	1500	
IP55		non	132S ... 280M	1.1 ... 32	24 ... 694	6	1000		
<b>SIMOTICS SD – Severe Duty</b>  	1LE15	IP55	self	100 ... 450	1.75 ... 1000	15 ... 8100	4, 6, 8	750 ... 1800	  
	1LE16								
	1LE5								
<b>SIMOTICS M – Main motors</b>  	1PH8	IP23, IP55	forced	355	230 ... 1340	3661 ... 12415	6	600 ... 1350	  

Symbol	Explanation	Symbol	Explanation
--------	-------------	--------	-------------



**Hoist**



**Trolley**



**Gantry**



**Boom**



**Hoisting gear and trolley**

<sup>1)</sup> Referring to a duty cycle of S3-25 % or S2-60 min.

## Introduction

### General technical specifications

1

#### Overview

Siemens is since many years the leading manufacturer of crane motors. This overview covers the current range of three-phase motors specifically for use in cranes (for SIMOTICS SD see catalog D 81.1).

The range of crane motors is aimed at crane manufacturers, system integrators, and crane operators. To make it easier to select motors, they are listed by speed and output (continuous and intermittent duty). The tables indicate the rated motor torques and the maximum permissible torques.

The asynchronous motors with the DURIGNIT 2000 winding insulation are suitable for use on the SINAMICS S120 drive system.

The requirements of the motors vary depending on the application conditions:

- Industry cranes which are used in production halls are usually not directly exposed to climatic influences. The motors do not necessarily need high degrees of protection or special paint.
- Cranes located in seaports are often exposed to harsh environment like saltwater, dust, high humidity and rain, which means that special measures must be taken to protect the motors against corrosion as well as the ingress of dust and water.
- Cranes in steel works are often subject to very high ambient temperatures. The electrical and mechanical design must take this into account. Please contact your local sales partner.

#### Application

Siemens crane motors are particularly suitable for crane operations under difficult conditions. These robust motors

- offer a high degree of protection and are particularly suitable for harsh operating conditions
- offer torque reserves that can handle high peak loads
- are specially optimized for high-inertia drives with high torque

The compact SIMOTICS DP asynchronous cranes motors with cast-iron housing are particularly rugged and are, therefore, the first choice in crane applications.

#### Configuration

##### Motor dimensioning

When motors are dimensioned for crane drives (high-inertia drives), two criteria must be taken into account:

- The required maximum torque (starting torque)
- The rated output (thermal motor capacity)

Since the hoist motors in particular operate in a large field weakening range during converter operation, you must check – alongside the usual design criteria such as thermal load (rms torque) and maximum acceleration torque – whether the motor can still generate the required maximum torque in the field weakening range. A torque-speed diagram can be created to check this.

When checking the torque, check whether the motor can generate the required maximum torque (e.g. for acceleration). The maximum permissible torque is higher than the rated torque and is often specified as a multiple of the rated torque. An adequate safety margin from the stalling torque must be maintained.

When the output is dimensioned, the rated motor output is adjusted in accordance with the effective power requirements of the motion. The rated motor output depends on the motor temperature which, in turn, is influenced by the operating mode and the thermal behavior of the motor. The rating data of a motor differs for the various operating modes in accordance with EN 60034-1. The data is usually specified for one or more of the following operating modes:

- S9-non-periodic variation in load and speed
- Short-time duty S2
- Intermittent duty S3

Intermittent duties S4 and S5 vary to such an extent that accurate data can only be provided when certain additional conditions have been clearly defined.

The operating modes are defined in accordance with EN 60034-1.

Symbols used in formulae:

$P$	Load/specified motor output
$P_V$	Power loss of the motor
$\vartheta_e$	Final temperature, steady-state temperature
$\vartheta_{max}$	Max. winding temperature in respective operating mode
$\vartheta_{mean}$	Mean winding temperature
$t_e$	Operating time
$t_p$	Idle time
$t_S$	Duty cycle duration
$T_L$	Thermal time constant of the motor (running)
$T_{St}$	Thermal time constant of the motor (stationary)

### Configuration (continued)

#### S9: Duty with non-periodic variation in load and speed

##### Definition

Operation with a constant load state, the duration of which is sufficient to attain thermal equilibrium.

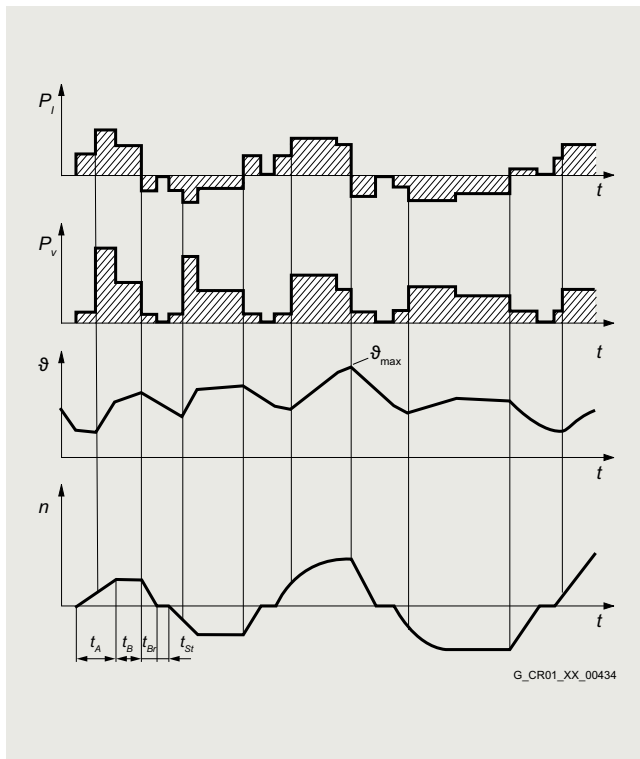

#### Short-time duty (S2)

##### Definition

Operation with a constant load state that, however, does not last long enough to attain thermal equilibrium, followed by idle time that lasts until the machine temperature differs from the coolant temperature by no more than 2 K.

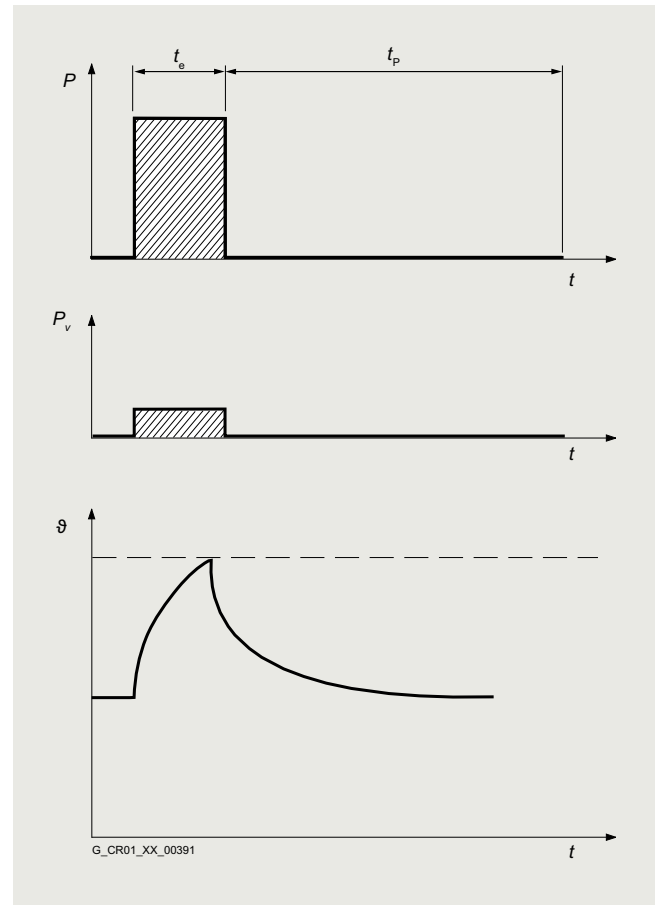

## Introduction

### General technical specifications

1

#### Configuration (continued)

##### **Intermittent duty without the effect of the start-up process (S3)**

###### Definition

Operation that involves a sequence of similar duty cycles, each with a constant-load period and idle time, whereby the starting current does not have a noticeable effect on the temperature rise (the duty cycle duration is generally short enough to ensure that thermal equilibrium is not attained).

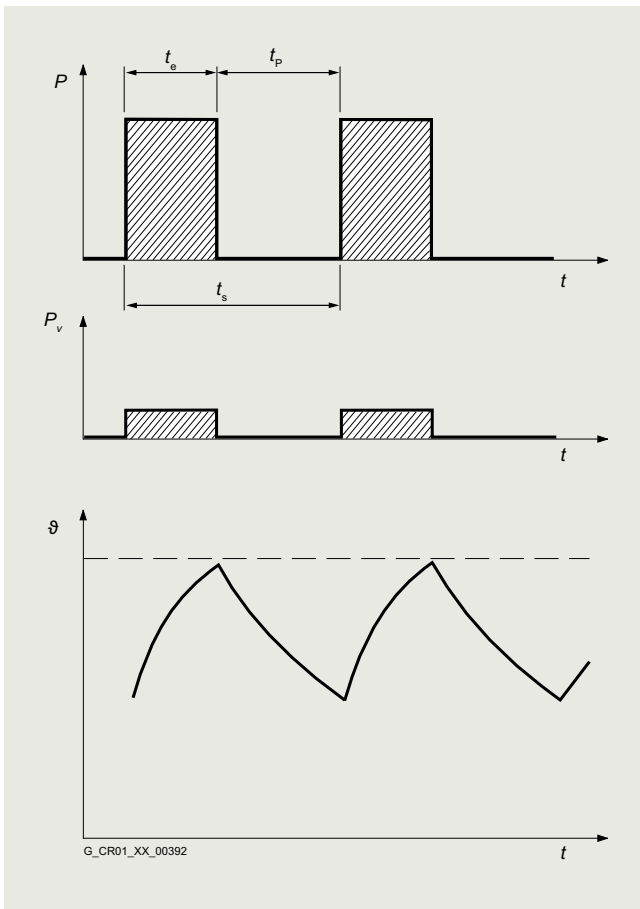

##### **Continuous duty with intermittent load (S6)**

###### Definition

This is a mode of operation that comprises a sequence of similar duty cycles, each of which consists of a constant load time followed by a no-load time.

There are no periods where the motor is not running - i.e. there are no off periods.

When specifying the increased power on the rating plate, duty type S3 and S6 must be supplemented by the on time and/or the cycle duration. If the duty cycle is not specified, then according to VDE 10 min. apply. Operation with alternating load times of 5 minutes and no-current off periods of 10 minutes that consecutively follow one another is e.g. designated as duty type S3: 5 min/15 min. However, this data can also be replaced by the relative on time and the cycle duration: Duty type S3: 33 %, 15 min. Recommended values of the relative on time are 15, 25, 40 and 60 %.

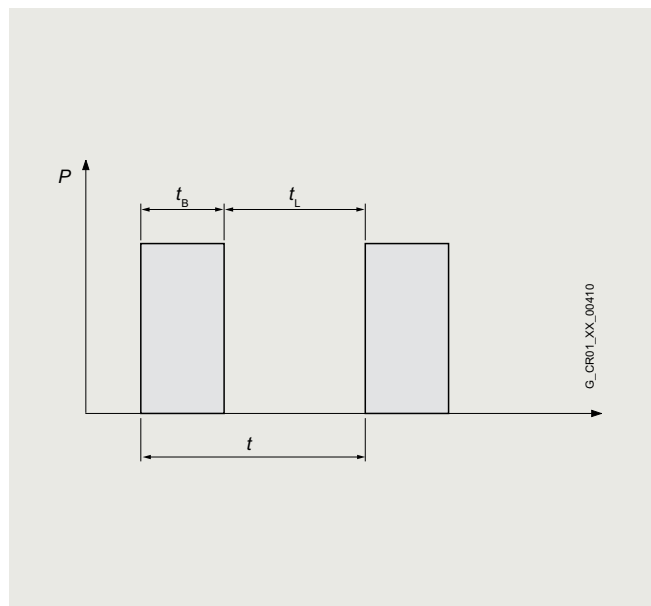



**Configuration** (continued)**Calculating the rms value, ON duration**

Actual duty can also be converted to a thermally equivalent S3 mode by means of "rms value calculation", which means that the S3 motor tables can be used again.

Please be aware, that the values for S3-duty are based on a cycle time of 10 min. Details for calculation see EN 13135.

A torque diagram (duty cycle diagram) must be available when the calculation is performed (see diagrams below).

The value (assumed to be constant throughout the operating time) that would generate the same temperature rise as the actual torque is defined as the rms torque. The ON duration is the sum of operating times with respect to the total duty cycle duration.

The torque that occurs must not exceed any reduced limits imposed by the drive technology of the stalling torque. If the required highest torque differs from the lowest torque by more than a factor of 2 (not considering the no-load condition), the mean current must be used for calculating, please inquire

If the individual traveling duty cycles are not the same (e.g. due to different loads or distances), all the different traveling cycles must be included in the rms value and ON duration calculation until they repeat themselves.

Differences in thermal behavior when the motor is running and when it is at a standstill are already taken into account with respect to the ON durations in the S3 tables. For this reason,  $M_{rms}$  must be calculated with respect to the operating time  $t_e$  and not to the duty cycle duration  $t_s$ .

To ensure that the rms value can be defined with sufficient accuracy, however, the operating phases during which the motor is not cooled as efficiently must be taken into account (e.g. during correction runs at low speeds and with naturally cooled motors).

Effects such as these can only be taken into account by the motor manufacturer.

The operating conditions for hoist and traversing gears also vary enormously:

- The external moment of inertia with respect to the motor moment of inertia is usually greater in traversing gears than in hoist gears; in other words, the acceleration and braking work are more relevant for traversing gears than for hoists even when the number of duty cycles performed and the ON duration are the same.
- The steady-state torque (load torque) with respect to the rated motor torque is usually greater in hoists than in traversing gears (traveling resistance).
- The torque diagram for traversing gears does not take the direction of travel into account (without wind forces). The effect of the payload is minimal with high traversing gear weights; i.e. with handling cranes, it is repeated after each travel movement (after the second travel movement at the latest).
- The torque diagram for hoists is largely dependent on the load. The motor torques when the same load is hoisted and lowered are different (efficiency) and, in the case of handling cranes, a traveling duty cycle with a load is usually followed by a traveling duty cycle with empty load tackle (collective loading; see also FEM, Section I, Calculation Principles for Cranes); i.e. the cycle required for calculating the rms value is repeated after the fourth travel movement at the earliest.

$$M_{rms} = \sqrt{\frac{\sum M^2 \times t}{t_e}}$$

$$\text{ON duration} = \frac{t_e \times 100}{t_s} \%$$

ED	ON time
$M_{rms}$	rms torque
$M_1, M_2, M_3$	Torques in travel diagram
$t_1, t_2, t_3$	Operating times of torques $M_1, M_2, M_3$
$t_p$	Idle time
$t_e$	Operating time of motor = $t_1 + t_2 + t_3$
$t_s$	Duty cycle duration = $t_e + t_p$

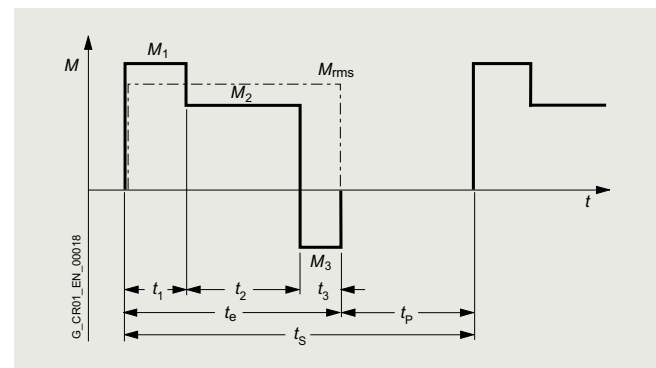

Torque diagram

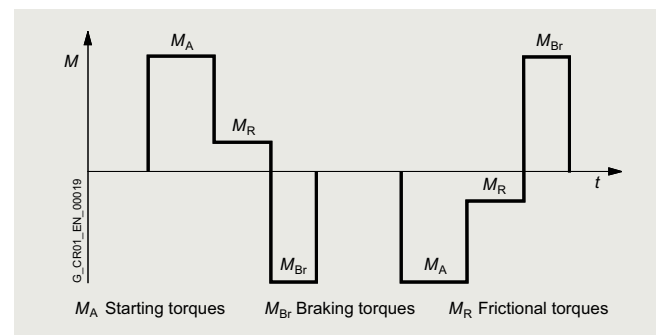

Typical torque diagram for a gantry across one conveying cycle

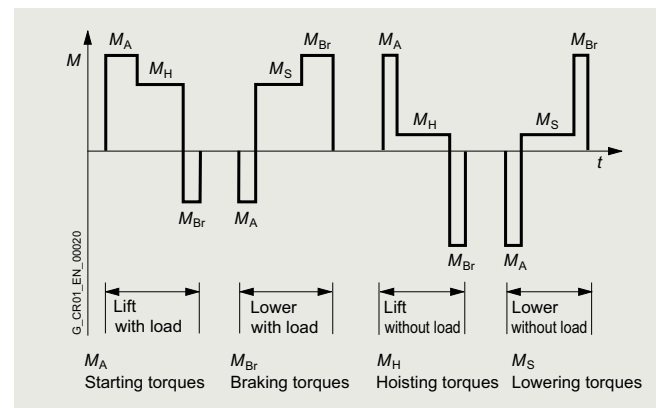

Typical torque diagram for hoist across one conveying cycle

## Introduction

### General technical specifications

1

#### Technical specifications

##### **Standards and specifications**

The motors comply with the appropriate standards and regulations, especially those listed in the table below.

Title	IEC	DIN/EN
General specifications for rotating electrical machines	IEC 60034-1 IEC 60085	EN 60034-1
General-purpose three-phase induction motors having standard dimensions and outputs	IEC 60072 mounting dimensions only	EN 50347
Terminal designations and direction of rotation for rotating electrical machines	IEC 60034-8	EN 60034-8
Designation for types of construction, installation and terminal box position	IEC 60034-7	EN 60034-7
Entry to terminal box	–	DIN 42925
Built-in thermal protection	IEC 60034-11	EN 60034-11
Noise limit values for rotating electrical machines	IEC 60034-9	EN 60034-9
IEC standard voltages	IEC 60038	IEC 60038
Cooling methods for rotating electrical machines	IEC 60034-6	EN 60034-6
Mechanical vibrations for rotating electrical machines	IEC 60034-14	EN 60034-14
Vibration limits	–	ISO 10816
Degrees of protection of rotating electrical machines	IEC 60034-5	EN 60034-5

##### **Testing, quality assurance, acceptance inspection**

In series production, each motor is subjected to a routine test.











As part of quality assurance measures, the motors are subjected to in-process inspections.

Type test or routine test certificates can be issued optionally, [see chapter 2 and 3, options tables](#).

**Technical specifications** (continued)**Types of construction according to EN 60034-7/IEC 60034-7**

Hoisting gear motors are primarily used in types of construction IM B3, IM B5, IM V1, and IM B35, although they can be supplied in other types of construction (please inquire).

The individual sections provide information about the listed available types of construction of the various motor series.

										
<b>EN 60034-7 Code I</b>	IM B3	IM B35	IM B5	IM V1	IM V5	IM V6	IM B6	IM B7	IM B8	IM V3
<b>EN 60034-7 Code II</b>	IM 1001	IM 2001	IM 3001	IM 3011	IM 1011	IM 1031	IM 1051	IM 1061	IM 1071	IM 3031

**Insulation**

The insulation system protects the winding against aggressive gases, vapors, dust, oil and increased air humidity. It can withstand the vibration stresses and ambient conditions that normally occur in hoisting operations.

Temperature classes

In EN 60034-1, the winding insulation (incl. impregnating material) is classified into temperature classes which are assigned specific overtemperatures.

The motor output specifications are uniformly based on a coolant temperature of 40 °C at an installation altitude of 1000 m above sea level for all insulation classes. The various sections provide information about the permissible outputs under other ambient conditions.

Temperature limit in K according to temperature class

Temperature class	B	F	H
Temperature limit	80 K	105 K	125 K

**Mechanical balance quality**Dynamic balancing

All rotors in hoisting gear motors are dynamically balanced with an inserted half featherkey. This corresponds to vibration severity grade A (normal). EN 60034-14 specifies the factory acceptance vibration test procedures and vibration limits for electrical machines. "Half-key balancing" (half featherkey = code H) is specified here based on ISO 8821.

Full-key balanced machines can also be shipped as special versions (please inquire).

Note for 1PC1341/1PC1361 three-phase squirrel-cage motors:

Low-vibration version B can be supplied to fulfill stricter requirements on smooth running. For converter-fed operation with frequencies greater than 60 Hz, special balancing is required for compliance with the specified limit values (plain text: maximum supply frequency/speed).

Vibration severity

The vibration severity is the r.m.s. value of the vibration velocity (frequency range from 10 Hz to 1000 Hz).

A motor balanced in accordance with the relevant standard, however, may vibrate more strongly at the operating site.

This can be caused by the following factors:

- Unsuitable foundation
- Interference from the driven machine
- Components with a natural frequency that is almost identical to the frequency of the residual unbalance of the motor.

In cases such as these, each element in the system – not just the motor itself – needs to be checked.

## Introduction

### General technical specifications

1

#### Technical specifications (continued)

The table below shows the limit values of electrical machines in accordance with EN 60034-14 Nov. 2004.

Limits (rms values) of max. vibration variables of vibration displacement $s$ , vibration velocity $v$ and acceleration $a$ for the shaft height $H$										
Vibration severity grade	Machine installation	Shaft height $H$ in mm								
		$56 < H \leq 132$			$132 < H \leq 280$			$H > 280$		
		$s_{rms}$ $\mu\text{mm}$	$v_{rms}$ $\text{mm/s}$	$a_{rms}$ $\text{mm/s}^2$	$s_{rms}$ $\mu\text{mm}$	$v_{rms}$ $\text{mm/s}$	$a_{rms}$ $\text{mm/s}^2$	$s_{rms}$ $\mu\text{mm}$	$v_{rms}$ $\text{mm/s}$	$a_{rms}$ $\text{mm/s}^2$
A	Free suspension	25	1.6	2.5	35	2.2	3.5	45	2.8	4.4
	Rigid clamping	21	1.3	2.0	29	1.8	2.8	37	2.3	3.6
B	Free suspension	11	0.7	1.1	18	1.1	1.7	29	1.8	2.8
	Rigid clamping	–	–	–	14	0.9	1.4	24	1.5	2.4

The balancing type is stamped on the face of the DE <sup>1)</sup> shaft extension:

- F = Balancing with full featherkey
- H = Balancing with half featherkey
- N = Balancing without featherkey

#### Bearings

All motors are equipped with rolling-contact bearings.

Motors equipped with cylindrical roller bearings are shipped with a rotor shipping brace to prevent brinelling in the DE <sup>1)</sup> bearings during transportation and storage.

#### Shaft extensions

The motors have cylindrical shaft extensions and are always supplied with a featherkey inserted in the shaft. Dimensions according IEC 60072.

#### Coupling

The standard versions of hoisting gear motors are designed for coupling output. Pinion, chain, and belt outputs generate greater cantilever forces and bearing loads, which must be taken into account.

#### Motor protection

Hoisting gear motors are operated with a higher load factor in intermittent duty. If there is excessive power consumption, an undervoltage in the supply, an excessive ON duration, or excessive coolant temperatures or if the heat is not being dissipated adequately (speed of naturally cooled machines is too low), this can cause the temperature in the windings to rise and the motors to overheat. Direct and indirect measures can be taken to protect the motors from overheating. An adequate monitoring concept should take into account all the relevant factors and must be properly implemented.

The resistance of the PTC thermistor detectors integrated in the windings increases significantly if the response temperature is exceeded. A tripping unit (Catalog LV1) detects this increase and uses a contact to intervene in the open-loop control. An additional detector loop for emitting a warning signal just below the shutdown temperature can also be used in process-critical cranes applications to allow working cycles that have already been started to be brought to an end.

It is recommended that Pt 1000 temperature sensors be installed in converter-fed drives. This sensor is embedded in the winding head of the motor in the same manner as a PTC thermistor. The data is evaluated directly in the converter. Warning and shutdown response limits can be set. Since only one sensor can be evaluated in the converter, this motor protection method is only suitable in single-motor drives; PTC thermistors are recommended for drives with more than one motor (e.g. gantry and trolley motor gears).

<sup>1)</sup> DE is the motor's drive end with shaft. NDE is the motor's non-drive end.

## SIMOTICS DP – Crane duty motors

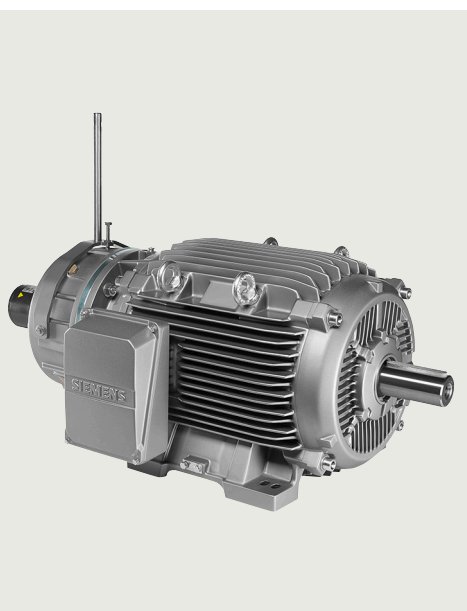

2/2	<b>1PC1361, 1PC1341</b>
2/10	<b>SIMOTICS DP – 1PC1341: Self-/Forced-ventilated (IC411/IC416)</b>
2/20	<b>SIMOTICS DP – 1PC1341: Forced-ventilated (IC416)</b>
2/24	<b>SIMOTICS DP – 1PC1361: Non-ventilated</b>
2/35	<b>Supplements to article numbers and special versions</b> <u>Cast-iron series 1PC1341 and 1PC1361</u>
2/35	Voltages
2/36	Types of construction
2/37	Motor protection
2/38	Terminal box position
2/39	Options
2/44	<b>Dimensional drawings</b>

**SIMOTICS DP – Crane duty motors**

1PC1361, 1PC1341

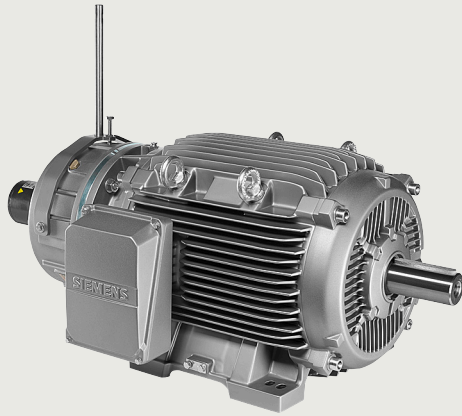
**Overview**

Three-phase asynchronous motor 1PC1361 with fitted seawater protected electromagnetic brake

SIMOTICS DP crane duty motors with seawater protected brakes provide a compact solution for crane travelling applications. The DC-operated brake is designed as a holding brake, but is also capable of emergency shutdown braking operations at maximum motor speed. In the case of power failure, the brake is applied automatically by its spring force and brings the drive to a standstill.

**Product range**

The product range includes shaft heights 132 S to 315 L in rating 8.3 kW to 191 kW power range for 4-pole motors, in the 4.1 to 310 kW power range for 6-pole motors, or in the 146 to 259 kW power range for 8-pole motors for duty type S3 – 25 % in each case.

As the table below shows, more than one type of brake can be fitted to a motor; this flexibility allows the user to tailor the drive unit – comprising the motor and brake – to the exact requirements of the crane.

The motors can also be ordered without a brake. The same article numbers apply, but the article number supplements for the brake are excluded.

SIEMENS								H CE	
Made in Czech. Rep.									
3-Mot. 1CV2222B		1PC1361BB204AB6			UC 1603/173978201				
IEC/EN 60034 225M IMB3 IP55				Brake:					
350kg		Th.Cl. 155(F)		-20°C ≤ TAMB ≤ 40°C				KFB63	
Bearing		400V AC 50/60Hz 1.25A						Th.Cl. 155(F) 630Nm	
DE 6313-ZC3									
NE 6313-ZC3									
INVERTER DUTY ONLY VPWM				SINAMICS G120					
V	Hz	A	kW	cosφ	1/min	EFF	IE - CL		
400 Δ	50	52	27	0.81	1485		S3 – 60%		
400 Δ	50	66	36	0.85	1478		S3 – 40%		
400 Δ	50	80	45	0.87	1475		S3 – 25%		

Example of rating plate

G\_CR01\_XX\_00435

Motor shaft height	Brake type							
	KFB 10 100 Nm	KFB 16 160 Nm	KFB 25 250 Nm	KFB 30 300 Nm	KFB 40 400 Nm	KFB 63 630 Nm	KFB 100 1000 Nm	KFB 160 1600 Nm
<b>132</b>	✓	–	–	–	–	–	–	–
<b>160</b>	✓	✓	–	–	–	–	–	–
<b>180</b>	✓	✓	✓	✓	✓	–	–	–
<b>200</b>	–	✓	✓	✓	✓	–	–	–
<b>225</b>	–	–	✓	✓	✓	✓	–	–
<b>250</b>	–	–	✓	✓	✓	✓	✓	✓ <sup>1)</sup>
<b>280</b>	–	–	–	–	✓	✓	✓	✓

<sup>1)</sup> Only for motor 1PC1361.

## Technical specifications

### Electrical design

#### Operating voltage

The crane motors are available for the following rated voltages:

- 400 V 3 AC, 50 Hz
- 500 V 3 AC, 50 Hz
- 690 V 3 AC, 50 Hz

Other main voltage version, like 460 V 60 Hz are available by option.

#### Connected in delta for dispatch – Order code **M02**

The terminal board of the motor is connected in delta for dispatch.

The catalog data apply for operation with Siemens SINAMICS S converters. The catalog data apply approximately for the following general conditions:

- The converter can provide the rated voltage as listed in the catalog
- Permissible voltage peaks for reinforced insulation system (Advanced):  
 $\hat{U}_{LL} = 1600 \text{ V}$ ,  $\hat{U}_{LE} = 1400 \text{ V}$ ,  $t_s > 0.1 \mu\text{s}$
- Permissible voltage peaks for special insulation system (Premium):  
 $\hat{U}_{LL} = 2200 \text{ V}$ ,  $\hat{U}_{LE} = 1500 \text{ V}$ ,  $t_s > 0.1 \mu\text{s}$

Operation with third party converters requires an insulation coordination. Please refer to IEC 60034-18-41.

Further information is available in DT Configurator ([www.siemens.com/dt-configurator](http://www.siemens.com/dt-configurator)).

#### Motor protection

The following protective equipment can be installed (see "Article number supplements and special versions"):

- 3 PTC thermistors for tripping
- 3 PTC thermistors for tripping and 3 PTC thermistors for alarm
- 1 KTY 84-130/PT1000 temperature sensor for evaluation in the converter

#### Standstill heating

The motors can be fitted with a standstill heater with nominal supply voltage of 230 V AC (Option **Q02**) or 115 V AC (**Q03**).

The heat outputs are as follows:

Motor shaft height	Heat output W
<b>132 ... 160</b>	50
<b>180 ... 200</b>	55
<b>225 ... 250</b>	92
<b>280 ... 315</b>	109

#### Noises

The noises of the motors are in accordance with the noise limit values for rotating electrical machines specified in IEC 600034-9.

#### Insulation

The motors can be operated with line voltages up to 690 V 3 AC with SINAMICS S converters, (uncontrolled and controlled in-feed) when maintaining the permissible peak voltages specified above. Depending on the selected motor connection voltage, a suitable insulation system is used for converter operation.

- 400 V up to 460 V motor voltage "Advanced" insulation system is used
- Motor supply voltages above, a "Premium" insulation system is used.

For converter operation on SINAMICS S120 with the power ratings specified in the catalog, the motors can be utilized corresponding to thermal class 155 (F) (service factor 1.0).

In the case of a fault when connected to an IT supply system (ground fault), the insulation is excessively stressed. In this case, the process should be terminated as quickly as possible ( $t < 2 \text{ h}$ ), and the fault resolved. Siemens does not recommend operation on TN supply systems with transition-point grounding, for systems with a rated voltage below 500 V and strictly recommends IT supply for systems with a rated voltage above 500 V. Application notes are available through your local sales contact.

#### Mechanical design

Motors 1PC1361 and 1PC1341 are made of cast iron. The brake itself does not have a separate terminal box; all the brake connections, whether coil, microswitch or heater, are taken to the motor terminal box. The DE flange (**L18**) and the bolt-on feet (**L17**, only for SH 180–315) can be supplied in spheroidal graphite cast iron by option.

#### Types of construction

The motors are available in types of construction IM B3, IM B35, IM V5, IM B5 and IM V1. Other types of construction are available on request.

The position of the condensate drain holes is determined by the type of construction and (for flange mounted motors) by the position of the terminal box. To assure that the condensate drain hole is always on the lowest point of the motor, a proper clarification of the mounting in the application has to be done. If motors are mounted deviating from vertical or horizontal position (slope more than 15° against horizontal or vertical line) Siemens recommends to send a request.

#### Degree of protection

The degree of protection of the standard motor models is IP55. IP56 is also available as an option **H22**.

#### Mounted equipment

Sensing equipment such as the POG 10 incremental encoder (made by Baumer Hübner) can be mounted on the motors. The brakes themselves can be supplied with an emergency manual release mechanism.

Additional following encoders can be mounted (only for 1PC1341):

- HOG 10 D
- HOG 10 D with centrifugal switch FSL (on request)

Based on the SIMOTICS SD 1LE15 series, following options are already included in the standard design of crane duty motors:

- Special finish system "sea air resistant" C4 (**S03**)
- Internal finish; Machined laminated rotor core, shaft, inner diameter of cast-iron housing primed with rust inhibitor
- Non-rusting screws externally (**H07**)
- T-drain plugs (**H03**)
- Silicone seal for terminal box cover
- Cast resin inside flange enshield for 1PC13[4,6]1-...-[G,H,L,M].. (mounting IM V\*)
- Rating plate, stainless steel (**M11**)
- External fan for SH 315 (**F79**)
- Insulated bearing NDE side in SH 280/315

#### Bearing system

A measuring nipple for SPM shock pulse measurement can be mounted to check bearing vibration. The motors have an M8 tapped hole for each bearing plate and a measuring nipple with a protective cap. If a second tapped hole is provided, it is fitted with a sealing plug.

Order code **Q01**

## SIMOTICS DP – Crane duty motors

### 1PC1361, 1PC1341

#### Technical specifications (continued)

##### Terminal box and feet and flange

Standard position of the terminal box on DE-side.  
Following variations are possible:

- Terminal box on top can be ordered with the digit "4" on position 16 of the article number code.
- Terminal box on right-hand side (viewed from DE) can be selected with the digit "5" on position 16 of the article number code.
- Terminal box on left-hand side (viewed from DE) can be selected with the digit "6" on position 16 of the article number code.
- Feet made of spheroidal graphite iron (GGG) material instead of lamellar graphite iron (GG) can be ordered with options **L17** + **H01**.

For foot-mounted motors, and motors with feet and flange, cast feet are standard. Material: GG-20 valid for frame sizes 132 - 315.

Screwed-on feet can be ordered with option **H01**. Feet in GGG can be ordered with option codes **H01** + **L17**.

The position of the condensate drain holes will always on the lowest point, depending on the ordered mounting code and terminal box position.

Terminals for motor-integrated sensors and actors like space heater, temperature sensors and brakes will be connected to terminals in the terminal box.

If the motor is ordered with option **R01**, the position of terminal box is fixed and it cannot be rotated afterwards.

Some flanges made of spheroidal graphite iron (GGG) material instead of GG-20 can be ordered with option **L18**.

Resin sealing between motor and terminal box is optionally available (**R01**).

Rotation terminal box with option **R01** is not possible. Resin sealing for motors according UL not available.

Terminal box 1PC13. Cranes – standard						
Frame size	Terminal box type	Maximum dimensions W × H × L mm	Size of thread bolt	Supply conductor cross- section (one phase) mm <sup>2</sup>	Cable entry – standard	Cable entry – max.
132	TB1J01	165 × 119 × 190	M4	6	2 × M32 × 1.5	M50 × 1.5
160	TB1J01	165 × 119 × 190	M5	16	2 × M40 × 1.5	M50 × 1.5
180	TB1K01	197 × 123 × 266	M6	25	2 × M50 × 1.5	M63 × 1.5
200	TB1L01	197 × 123 × 266	M8	35	2 × M50 × 1.5	M63 × 1.5
225	TB1L01	197 × 123 × 266	M8	35	2 × M50 × 1.5	M63 × 1.5
250	TB1N01	233 × 167 × 319	M10	120	2 × M63 × 1.5	M75 × 1.5
280						
315	TB1Q01	299 × 214 × 374	M12	185	2 × M63 × 1.5	M75 × 1.5

Terminal box 1PC13. Cranes – Option <b>R50</b> (larger terminal box)						
Frame size	Terminal box type	Maximum dimensions W × H × L mm	Size of thread bolt	Supply conductor cross- section (one phase) mm <sup>2</sup>	Cable entry – standard	Cable entry – max.
132	TB1K01	197 × 123 × 266	M5	16	2 × M32 × 1.5	M63 × 1.5
160	TB1K01	197 × 123 × 266	M5	16	2 × M40 × 1.5	M63 × 1.5
180	TB1K01	197 × 123 × 266	M8	35	2 × M50 × 1.5	M63 × 1.5
200	TB1N01	233 × 167 × 319	M10	120	2 × M63 × 1.5	M63 × 1.5
225	TB1N01	233 × 167 × 319	M10	120	2 × M63 × 1.5	M63 × 1.5
250	TB1Q01	299 × 214 × 374	M12	185	2 × M63 × 1.5	M75 × 1.5
280						
315	TB1R01	330 × 278 × 470	M16	240	2 × M63 × 1.5	M90 × 1.5

##### Auxiliary terminal designation

Temperature sensor	Terminal designation
3 PTC thermistors for alarm	1TP1-1TP2
3 PTC thermistors for tripping	2TP1-2TP2
Bimetallic (NC contact) for tripping	2TB1-2TB2
Standstill heater (motor)	1HE1-1HE2
Brake coil DC	BD1-BD2
Brake coil AC	BA1-BA2
Standstill heater (brake)	HE1-HE2
Microswitch brake opened	S11-S13
Microswitch brake air gap monitoring	S21-S23

##### Bearing

Motor shaft height	DE bearing	NDE bearing
<b>132</b>	6208 2ZC3	6208 2ZC3
<b>160</b>	6209 2ZC3	6209 2ZC3
<b>180</b>	6210 C3	6210 C3
<b>200</b>	6212 C3	6212 C3
<b>225</b>	6213 ZC3	6213 ZC3
<b>250</b>	6215 ZC3	6215 ZC3
<b>280</b>	6317 C3	6317 C3
<b>315</b>	6319 C3	6319 C3

##### Shaft extension

Standard brake motors are designed with a cylindrical shaft extension.

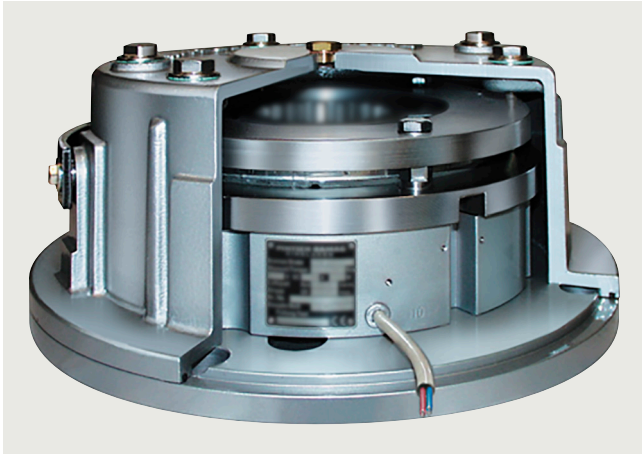

**Design**

The electromagnetic double-disc spring-set brake KFB, see picture "KFB spring-set brake with manual lever", is intended to operate solely as a holding brake for this application. With the exception of emergency braking, it may only be operated as a dynamically loaded operational brake if it is appropriately dimensioned or after consultation with Siemens.

To ensure an optimized design regarding water- and dustprotection, combination with hollow shaft encoders or motors in IC411 should be avoided. Preferred solution for brake motors are motors in IC410, if encoders needed, flange encoders like POG10 should be used.

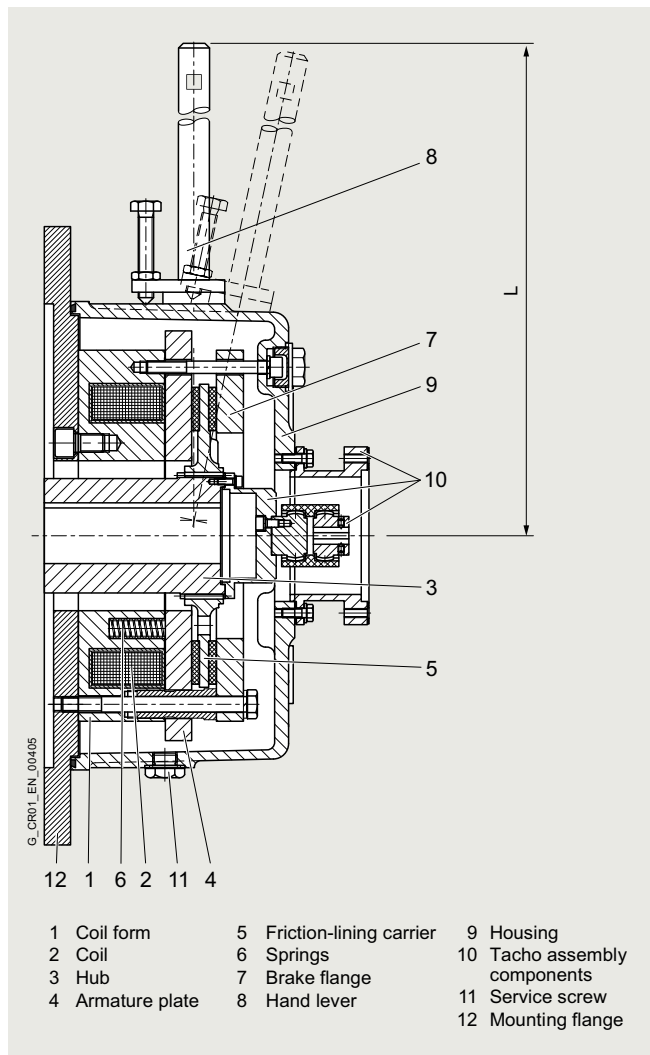
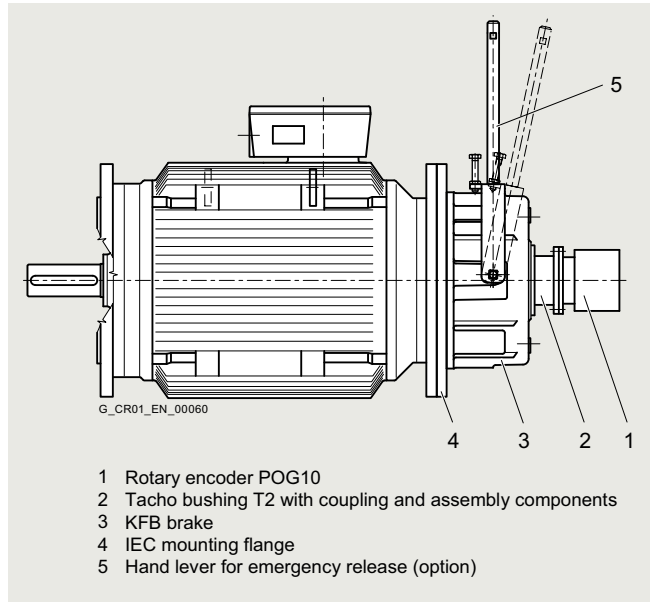

KFB spring-set brake with manual lever

## SIMOTICS DP – Crane duty motors

### 1PC1361, 1PC1341

#### Design (continued)

##### Protective element

The brakes should be switched on DC side i.e. between the rectifier and coil (see circuit diagram below). This ensures a significantly shorter closing time than switching on AC end. A protective element (varistor + spark quenching) must be fitted in parallel to each brake coil. This protects the brake coil against excessively high de-energization voltages on the one hand, and the contactor contacts on the other. These protective elements must be installed close to the brake coils where possible, e.g. in the motor terminal box or in a distribution board on the sub-frames in the case of traversing gear. Protective elements PE-400/150/5 are directly available from the manufacturer under Article No. 008099300249.

For an easy installable system providing a supervision of the brake for wearing of the lining, brake function, including brake voltage control, we recommend to use a Pintsch Bubbenzer brake control unit BCU2001 (single brakes) or BCMS-4 (up to 4 brakes controlled with one unit).

##### Technical specifications

Protective element	
Connection voltage, max. (coil voltage)	400 V DC
Max. coil current	5 A
Max. energy absorption of one trip	150 J
Max. continuous output (average) of energy absorption	5 W
Trip peak at max. coil current	< 450 V
Ambient temperature	-40 ... +50 °C
Permissible cross section of connecting lead	0.2 ... 2.5 mm <sup>2</sup>
Weight, approx.	0.2 kg
Degree of protection	IP20

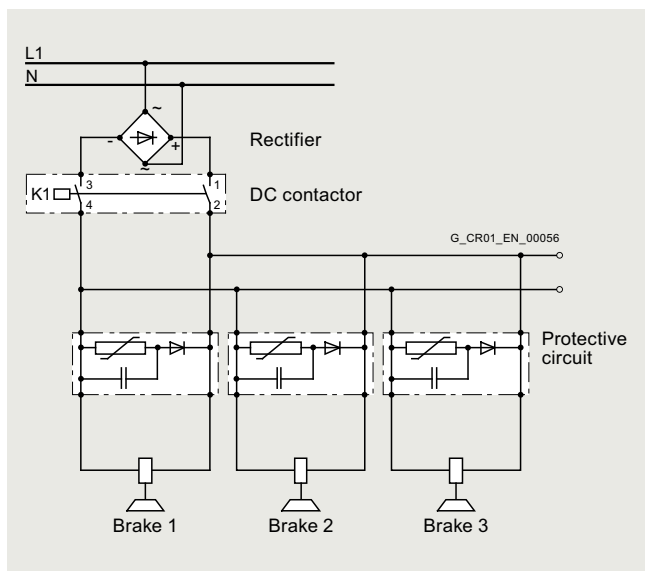

##### Special versions

###### Emergency release with hand lever, option F50

In addition to brake release at zero current via 2 emergency release screws, it is also possible to release the brake by means of a hand lever permanently mounted on the brake housing. The lever is lockable.

###### Microswitch for "brake released" monitoring, option F26

The brake can be fitted with a microswitch for monitoring the "brake released" state. The contact is rated for:

- < 30 V DC, 5.0 A
- < 125 V DC, 0.5 A
- < 250 V AC, 5.0 A

###### Microswitch for air gap monitoring/wear, option F51

A second microswitch can be fitted to monitor the "maximum air gap" function. Tripping of this contact indicates that full braking power is no longer available and the air gap must be adjusted immediately. The contact load rating is identical to that of the "brake released" microswitch.

###### Standstill heater, option F27

The installation of a heater can prevent the formation of condensate, e.g. caused by fluctuations in temperature and air humidity, inside the brake. This heater must not be switched on when the motor is operating. The heater is designed for a supply voltage of 230 V AC and a heat output of 40 W.

###### Encoder mounting, option F28/F29

An encoder POG 10 DN 1024 I mounted on the brake can be order with combination of options **F28+G07** (or that **G10** = POG 10 DN 1024 I +FSL).

If an encoder is to be fitted later by customer, the brake can be prepared for encoder mounting. This is possible with option **F29**. Mounting components are included.

It is also possible to retrofit an encoder by replacing the brake housing (the parts required, such as new housing, coupling, etc., can be ordered directly from the manufacturer) using the brake serial number as a reference).

###### Brake control unit BCU

A brake control unit (BCU) can also be used to supply and monitor the brake on single drives. For technical specifications, price, etc., please contact the manufacturer directly.

###### Brake supply

The nominal voltage of brake is 207 V DC and has to be ordered by option **F16**.

Additional following brake supply is optional available:

- 230 V AC 50/60 Hz with bridge rectifier in terminal box (**F11**)
- 400 V AC 50/60 Hz with half-wave rectifier in terminal box (**F12**)

###### Note:

It must, however, be noted that the closing time for the brake can be a factor of 10 longer than the values specified in the tables (see section "Technical specifications") if it is switched on AC-side only.

---

## Configuration

The following dimensioning parameters must be taken into account when a brake is selected:

### ***Braking torque***

The brake torque must comply with the requirements of the application. Calculation of required torque has to be performed as per actual standards, e.g. EN13135. Relevant deratings caused e.g. due to high motor speeds have to be considered.

### ***Braking energy on emergency trip***

The energetic capacity of the brake must comply with the requirements of the application. Calculation of required energy capacity has to be performed as per actual standards, e.g. EN13135. Relevant deratings e.g. due to high ambient temperature have to be considered.

# SIMOTICS DP – Crane duty motors

1PC1361, 1PC1341

## Configuration (continued)

### Configuration Braking energy and energy capability

The brake must be capable of absorbing the heat produced by the occasional emergency braking operation. The maximum permissible energy capability  $Q$  is shown in the diagram below as a function of the number of switching operations.

The permissible energy capability  $Q$  for a single emergency trip can be found in the table in section "Technical specifications".

2

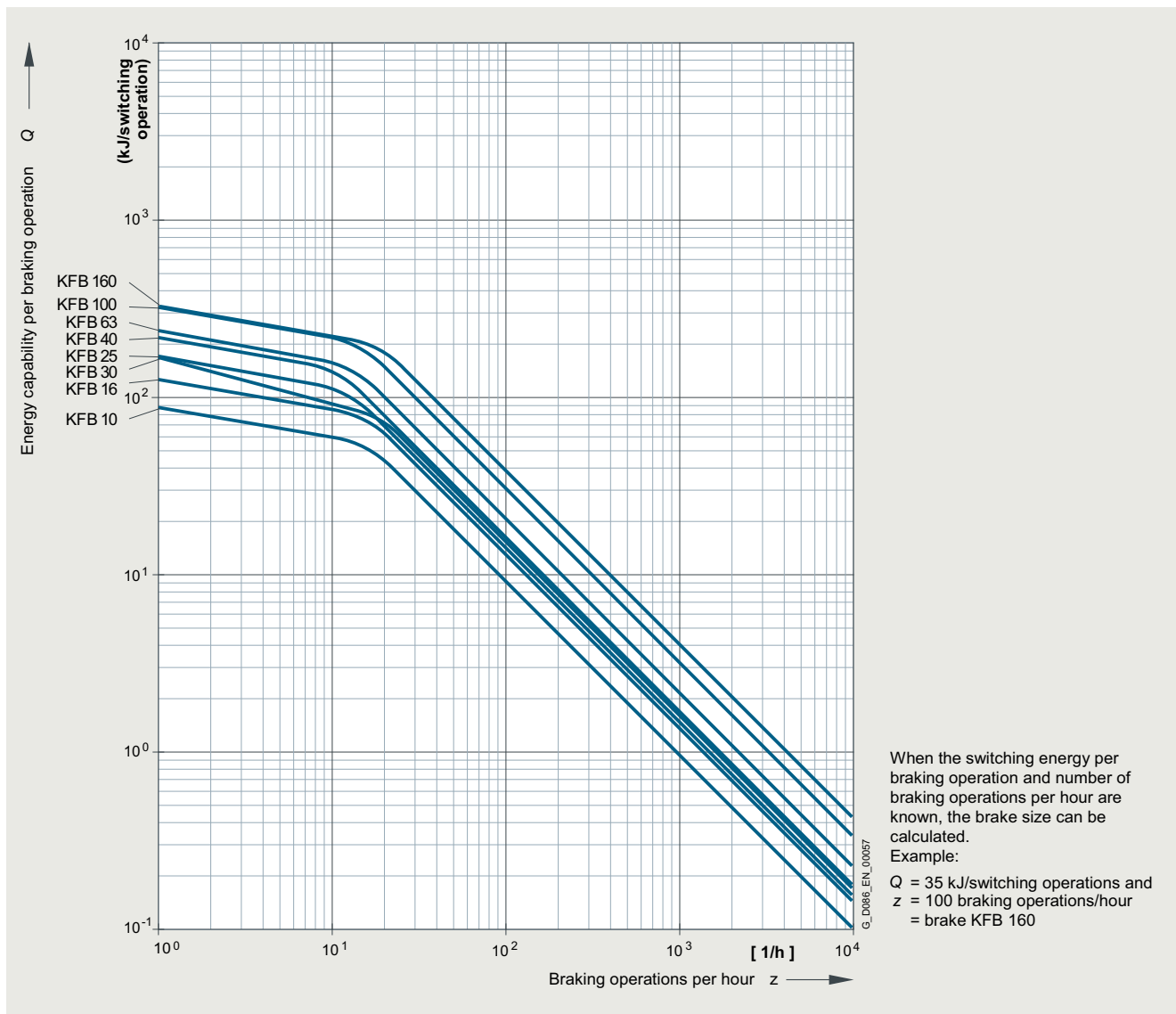

Energy capability  $Q$ , braking speed  $n = 1500 \text{ rpm}$

**Technical specifications**

		KFB spring-set brakes							
		Type							
		KFB 10	KFB 16	KFB 25	KFB 30	KFB 40	KFB 63	KFB 100	KFB 160
Rated brake torque acc. to VDE 0580	Nm	100	160	250	300	400	630	1000	1600
Permissible speed $n$	rpm	6000	6000	6000	6000	5500	4700	4000	3600
Rated voltage $U_{\text{rated}}^{1)}$	V DC	207	207	207	207	207	207	207	207
Rated output $P_{\text{rated}}$	W	100	118	160	154	188	206	316	340
Rated current $I_{\text{rated}}$	A	0.48	0.57	0.77	0.74	0.91	1	1.53	1.64
Moment of inertia $J$	kgm <sup>2</sup>	0.0017	0.0037	0.0048	0.0055	0.0068	0.017	0.036	0.05
Weight, approx.	kg	19	28	42	50	55	74	106	168
Energy capability $Q$									
• at $n = 1500 \text{ rpm}/z = 1$	kJ	88	126	169	167	216	235	321	331
• at $n = 1500 \text{ rpm}/z = 100$	kJ	8	11.7	12.6	13.8	14.5	18.4	27.1	34.8
Closing time $t_1^{2)}$	ms	55	75	80	85	90	120	135	195
Release time $t_2^{2)}$	ms	128	173	239	245	251	342	375	498

$Q$  Energy capability per braking operation  
[kJ per switching operation]

$n$  Speed [rpm]

$z$  Braking operations per hour [1/h]

$t_1$  Closing time: Time from power OFF until 90 % of rated braking torque is reached

$t_2$  Release time: Time from power ON until 10 % of rated braking torque is reached

$t$  Measured at 20 °C

The normal version of the brake is supplied for a coil voltage of 207 V DC. Voltages of 110 V DC and 180 V DC are also available at no extra cost (please state in plain text in the order). Other coil voltages on request.

<sup>1)</sup> Rated voltage according to DIN IEC 38 with tolerances of +6 % and -10 % according to DIN VDE 0580.

<sup>2)</sup> Switching time terms defined according to DIN VDE 0580, Closing time  $t_2$  = Connection time  $t_1$ , Release time  $t_2$  = Disconnection time  $t_2$

**SIMOTICS DP – Crane duty motors**

SIMOTICS DP – 1PC1341: Self-/Forced-ventilated (IC411/IC416)

**Selection and ordering data**

Frame-size	Rated speed	Rated output	Rated torque	Rated current			Power factor	Break-down torque	Moment of inertia	<b>1PC13</b> 400 VΔ, 50 Hz 500 VΔ, 50 Hz 690 VΔ, 50 Hz	Weight, approx. (without brake)
				$I_{rated}$ 400 V	$I_{rated}$ 500 V	$I_{rated}$ 690 V					
FS	$n_{rated}$ rpm	$P_{rated}$ kW	$M_{rated}$ Nm	$I_{rated}$ A	$I_{rated}$ A	$I_{rated}$ A	cos φ	Nm	$J$ kgm <sup>2</sup>	Article No.	kg
<b>4-pole, 1500 rpm</b>											
<b>Intermittent duty S3 – 15 %</b>											
<b>132 S</b>	1438	8.6	57	17.6	14.1	10.2	0.85	101	0.022	<b>1PC1341-1CB09-0</b>	61
<b>132 M</b>	1428	12.5	84	25	20	14.5	0.87	147	0.028	<b>1PC1341-1CB29-0</b>	75
<b>160 M</b>	1445	18.3	121	36	29	21	0.86	213	0.055	<b>1PC1341-1DB29-0</b>	96
<b>160 L</b>	1450	25.8	170	49.5	39.5	28.5	0.85	301	0.071	<b>1PC1341-1DB49-0</b>	104
<b>180 M</b>	1430	32.6	218	60	48	35	0.88	411	0.12	<b>1PC1341-1EB29-0</b>	160
<b>180 L</b>	1432	38.8	259	72	58	41.5	0.87	501	0.13	<b>1PC1341-1EB49-0</b>	170
<b>180 L</b>	1428	52.9	354	100	80	58	0.85	647	0.16	<b>1PC1341-1EB69-0</b>	185
<b>200 L</b>	1442	51.6	342	96	77	56	0.88	605	0.2	<b>1PC1341-2AB59-0</b>	230
<b>200 L</b>	1442	61.6	408	113	90	66	0.87	720	0.25	<b>1PC1341-2AB69-0</b>	240
<b>200 L</b>	1448	81.3	290	151	121	88	0.84	1044	0.28	<b>1PC1341-2AB79-0</b>	260
<b>225 S</b>	1445	66	436	122	97	71	0.89	690	0.42	<b>1PC1341-2BB09-0</b>	280
<b>225 M</b>	1445	81	535	148	118	86	0.89	900	0.46	<b>1PC1341-2BB29-0</b>	305
<b>225 M</b>	1450	99	652	190	152	110	0.84	960	0.47	<b>1PC1341-2BB69-0</b>	320
<b>250 M</b>	1460	99	648	187	149	108	0.85	1060	0.75	<b>1PC1341-2CB29-0</b>	385
<b>250 M</b>	1460	135	883	250	200	146	0.85	1350	0.85	<b>1PC1341-2CB69-0</b>	440
<b>250 M</b>	1470	162	1052	300	240	174	0.85	1960	1.2	<b>1PC1341-2CB79-0</b>	480
<b>280 S</b>	1470	135	877	240	193	140	0.88	1440	1.3	<b>1PC1341-2DB09-0</b>	550
<b>280 M</b>	1470	162	1052	290	230	167	0.88	1790	1.4	<b>1PC1341-2DB29-0</b>	570
<b>280 M</b>	1470	198	1286	350	280	205	0.88	2120	1.7	<b>1PC1341-2DB69-0</b>	680
<b>280 M</b>	1465	237	1545	425	340	245	0.88	2380	1.8	<b>1PC1341-2DB79-0</b>	750

## Type of construction

IMB3, IM1001 horizontal foot mounted  
 IMB5, IM3001 horizontal flange mounted  
 IMV1, IM3011 vertical flange mounted

Further types of construction, code numbers, order codes and descriptions, see page 2/36.

## Motor protection

Without winding protection  
 3 x PTC for tripping, 2 terminals  
 6 x PTC for tripping and warning, 4 terminals  
 1 x KTY84, 2 terminals  
 2 x KTY84, 4 terminals  
 3 x Pt100, 6 terminals  
 1 x Pt1000, 2 terminals  
 2 x Pt1000, 4 terminals

Further motor protection, code numbers, order codes and descriptions, see page 2/37.

## Terminal box position

Terminal box at top  
 Terminal box at right side  
 Terminal box at top left side

Further terminal box positions, code numbers, order codes and descriptions, see page 2/38.

## Winding

400 VΔ, 50 Hz  
 460 VΔ, 50 Hz  
 500 VΔ, 50 Hz  
 690 VΔ, 50 Hz

Further voltages, code numbers, order codes and descriptions, see page 2/35.

## Order code

M4B  
 M4C  
 M4D  
 M4F

For inertia mass and weight of brakes, see technical specifications for KFB spring-set brake for SIMOTICS DP 1PC134, 1PC136.

For ordering example, see Page 2/23.

## SIMOTICS DP – Crane duty motors

### SIMOTICS DP – 1PC1341: Self-/Forced-ventilated (IC411/IC416)

#### Selection and ordering data

Frame-size	Rated speed	Rated output	Rated torque	Rated current			Power factor	Break-down torque	Moment of inertia	<b>1PC13</b> 400 VΔ, 50 Hz 500 VΔ, 50 Hz 690 VΔ, 50 Hz	Weight, approx. (without brake)
				$I_{rated}$ 400 V	$I_{rated}$ 500 V	$I_{rated}$ 690 V					
FS	$n_{rated}$	$P_{rated}$	$M_{rated}$	$I_{rated}$	$I_{rated}$	$I_{rated}$	cos φ		$J$	Article No.	kg
	rpm	kW	Nm	A	A	A		Nm	kgm <sup>2</sup>		
<b>4-pole, 1500 rpm</b>											
<b>Intermittent duty S3 – 25 %</b>											
<b>132 S</b>	1440	8.3	55	17	13.6	9.9	0.85	101	0.022	<b>1PC1341-1CB09-0</b> ■■■■	61
<b>132 M</b>	1435	11.3	75	22.5	18	13	0.86	147	0.028	<b>1PC1341-1CB29-0</b> ■■■■	75
<b>160 M</b>	1450	16	105	31.5	25	18.2	0.85	213	0.055	<b>1PC1341-1DB29-0</b> ■■■■	96
<b>160 L</b>	1460	21.8	143	42	33.6	24.5	0.84	301	0.071	<b>1PC1341-1DB49-0</b> ■■■■	104
<b>180 M</b>	1440	26.9	178	50	40	29	0.87	411	0.12	<b>1PC1341-1EB29-0</b> ■■■■	160
<b>180 L</b>	1445	32	211	60	48	35	0.86	501	0.13	<b>1PC1341-1EB49-0</b> ■■■■	170
<b>180 L</b>	1440	43.6	289	83	66	48	0.84	647	0.16	<b>1PC1341-1EB69-0</b> ■■■■	185
<b>200 L</b>	1450	44.5	293	82	66	47.5	0.87	605	0.2	<b>1PC1341-2AB59-0</b> ■■■■	230
<b>200 L</b>	1450	54.8	361	101	81	59	0.86	720	0.25	<b>1PC1341-2AB69-0</b> ■■■■	240
<b>200 L</b>	1458	66.7	290	126	101	73	0.83	1044	0.28	<b>1PC1341-2AB79-0</b> ■■■■	260
<b>225 S</b>	1455	53	348	95	76	55	0.89	690	0.42	<b>1PC1341-2BB09-0</b> ■■■■	280
<b>225 M</b>	1460	65	425	116	93	67	0.89	900	0.46	<b>1PC1341-2BB29-0</b> ■■■■	305
<b>225 M</b>	1465	79	515	146	117	85	0.85	960	0.47	<b>1PC1341-2BB69-0</b> ■■■■	320
<b>250 M</b>	1470	79	513	146	117	85	0.85	1060	0.75	<b>1PC1341-2CB29-0</b> ■■■■	385
<b>250 M</b>	1470	108	702	196	157	114	0.86	1350	0.85	<b>1PC1341-2CB69-0</b> ■■■■	440
<b>250 M</b>	1475	130	842	235	189	137	0.85	1960	1.2	<b>1PC1341-2CB79-0</b> ■■■■	480
<b>280 S</b>	1475	108	699	190	152	110	0.88	1440	1.3	<b>1PC1341-2DB09-0</b> ■■■■	550
<b>280 M</b>	1478	130	840	230	183	132	0.88	1790	1.4	<b>1PC1341-2DB29-0</b> ■■■■	570
<b>280 M</b>	1478	159	1027	280	225	162	0.88	2120	1.7	<b>1PC1341-2DB69-0</b> ■■■■	680
<b>280 M</b>	1475	191	1237	335	265	193	0.89	2380	1.8	<b>1PC1341-2DB79-0</b> ■■■■	750

#### Type of construction

IMB3, IM1001 horizontal foot mounted  
 IMB5, IM3001 horizontal flange mounted  
 IMV1, IM3011 vertical flange mounted

Further types of construction, code numbers, order codes and descriptions, see page 2/36.

#### Motor protection

Without winding protection  
 3 x PTC for tripping, 2 terminals  
 6 x PTC for tripping and warning, 4 terminals  
 1 x KTY84, 2 terminals  
 2 x KTY84, 4 terminals  
 3 x Pt100, 6 terminals  
 1 x Pt1000, 2 terminals  
 2 x Pt1000, 4 terminals

Further motor protection, code numbers, order codes and descriptions, see page 2/37.

#### Terminal box position

Terminal box at top  
 Terminal box at right side  
 Terminal box at top left side

Further terminal box positions, code numbers, order codes and descriptions, see page 2/38.

#### Winding

400 VΔ, 50 Hz  
 460 VΔ, 50 Hz  
 500 VΔ, 50 Hz  
 690 VΔ, 50 Hz

Further voltages, code numbers, order codes and descriptions, see page 2/35.

#### Order code

M4B  
 M4C  
 M4D  
 M4F

For inertia mass and weight of brakes, see technical specifications for KFB spring-set brake for SIMOTICS DP 1PC134, 1PC136.

For ordering example, see Page 2/23.

**SIMOTICS DP – Crane duty motors**

SIMOTICS DP – 1PC1341: Self-/Forced-ventilated (IC411/IC416)

**Selection and ordering data**

Frame-size	Rated speed	Rated output	Rated torque	Rated current			Power factor	Break-down torque	Moment of inertia	<b>1PC13</b> 400 VΔ, 50 Hz 500 VΔ, 50 Hz 690 VΔ, 50 Hz	Weight, approx. (without brake)
FS	$n_{rated}$	$P_{rated}$	$M_{rated}$	$I_{rated}$ 400 V	$I_{rated}$ 500 V	$I_{rated}$ 690 V	cos φ		$J$	Article No.	kg
	rpm	kW	Nm	A	A	A		Nm	kgm <sup>2</sup>		
<b>4-pole, 1500 rpm</b>											
<b>Intermittent duty S3 – 40 %</b>											
<b>132 S</b>	1445	7.5	50	15.5	12.4	9	0.84	101	0.022	<b>1PC1341-1CB09-0</b> ■■■■	61
<b>132 M</b>	1440	10	66	19.9	15.9	11.5	0.85	147	0.028	<b>1PC1341-1CB29-0</b> ■■■■	75
<b>160 M</b>	1460	13.7	90	27	21.5	15.6	0.84	213	0.055	<b>1PC1341-1DB29-0</b> ■■■■	96
<b>160 L</b>	1465	18.7	122	36	29	21	0.83	301	0.071	<b>1PC1341-1DB49-0</b> ■■■■	104
<b>180 M</b>	1450	23.1	152	43.5	35	25	0.86	411	0.12	<b>1PC1341-1EB29-0</b> ■■■■	160
<b>180 L</b>	1455	27.5	180	52	41.5	30	0.85	501	0.13	<b>1PC1341-1EB49-0</b> ■■■■	170
<b>180 L</b>	1450	37.4	246	72	58	41.5	0.83	647	0.16	<b>1PC1341-1EB69-0</b> ■■■■	185
<b>200 L</b>	1460	37.9	248	71	57	41	0.85	605	0.2	<b>1PC1341-2AB59-0</b> ■■■■	230
<b>200 L</b>	1458	46.8	307	87	70	50	0.85	720	0.25	<b>1PC1341-2AB69-0</b> ■■■■	240
<b>200 L</b>	1465	56.9	290	109	87	63	0.81	1044	0.28	<b>1PC1341-2AB79-0</b> ■■■■	260
<b>225 S</b>	1465	46	300	82	65	47.5	0.89	690	0.42	<b>1PC1341-2BB09-0</b> ■■■■	280
<b>225 M</b>	1465	56	365	100	80	58	0.88	900	0.46	<b>1PC1341-2BB29-0</b> ■■■■	305
<b>225 M</b>	1470	68	442	125	100	72	0.85	960	0.47	<b>1PC1341-2BB69-0</b> ■■■■	320
<b>250 M</b>	1475	68	440	125	100	72	0.85	1060	0.75	<b>1PC1341-2CB29-0</b> ■■■■	385
<b>250 M</b>	1475	93	602	167	134	97	0.86	1350	0.85	<b>1PC1341-2CB69-0</b> ■■■■	440
<b>250 M</b>	1478	112	724	205	164	119	0.84	1960	1.2	<b>1PC1341-2CB79-0</b> ■■■■	480
<b>280 S</b>	1480	93	600	163	130	94	0.88	1440	1.3	<b>1PC1341-2DB09-0</b> ■■■■	550
<b>280 M</b>	1480	112	723	198	158	115	0.87	1790	1.4	<b>1PC1341-2DB29-0</b> ■■■■	570
<b>280 M</b>	1480	137	884	240	191	138	0.88	2120	1.7	<b>1PC1341-2DB69-0</b> ■■■■	680
<b>280 M</b>	1478	165	1066	285	230	166	0.89	2380	1.8	<b>1PC1341-2DB79-0</b> ■■■■	750

## Type of construction

IMB3, IM1001 horizontal foot mounted  
 IMB5, IM3001 horizontal flange mounted  
 IMV1, IM3011 vertical flange mounted

Further types of construction, code numbers, order codes and descriptions, see page 2/36.

## Motor protection

Without winding protection  
 3 x PTC for tripping, 2 terminals  
 6 x PTC for tripping and warning, 4 terminals  
 1 x KTY84, 2 terminals  
 2 x KTY84, 4 terminals  
 3 x Pt100, 6 terminals  
 1 x Pt1000, 2 terminals  
 2 x Pt1000, 4 terminals

Further motor protection, code numbers, order codes and descriptions, see page 2/37.

## Terminal box position

Terminal box at top  
 Terminal box at right side  
 Terminal box at top left side

Further terminal box positions, code numbers, order codes and descriptions, see page 2/38.

## Winding

400 VΔ, 50 Hz  
 460 VΔ, 50 Hz  
 500 VΔ, 50 Hz  
 690 VΔ, 50 Hz

Further voltages, code numbers, order codes and descriptions, see page 2/35.

## Order code

M4B  
 M4C  
 M4D  
 M4F

For inertia mass and weight of brakes, see technical specifications for KFB spring-set brake for SIMOTICS DP 1PC134, 1PC136.

For ordering example, see Page 2/23.



## SIMOTICS DP – Crane duty motors

### SIMOTICS DP – 1PC1341: Self-/Forced-ventilated (IC411/IC416)

#### Selection and ordering data

Frame-size	Rated speed	Rated output	Rated torque	Rated current			Power factor	Break-down torque	Moment of inertia	<b>1PC13</b> 400 VΔ, 50 Hz 500 VΔ, 50 Hz 690 VΔ, 50 Hz	Weight, approx. (without brake)
				$I_{rated}$ 400 V	$I_{rated}$ 500 V	$I_{rated}$ 690 V					
FS	$n_{rated}$ rpm	$P_{rated}$ kW	$M_{rated}$ Nm	$I_{rated}$ A	$I_{rated}$ A	$I_{rated}$ A	cos φ	Nm	$J$ kgm <sup>2</sup>	Article No.	kg
<b>4-pole, 1500 rpm</b>											
<b>Intermittent duty S3 – 60 %</b>											
<b>132 S</b>	1455	6.5	43	13.5	10.8	7.8	0.83	101	0.022	<b>1PC1341-1CB09-0</b> ■■■■	61
<b>132 M</b>	1450	8.8	58	17.5	14	10.1	0.84	147	0.028	<b>1PC1341-1CB29-0</b> ■■■■	75
<b>160 M</b>	1465	12.3	80	24.5	19.6	14.1	0.83	213	0.055	<b>1PC1341-1DB29-0</b> ■■■■	96
<b>160 L</b>	1470	16.8	109	32.5	26	18.8	0.82	301	0.071	<b>1PC1341-1DB49-0</b> ■■■■	104
<b>180 M</b>	1458	20.6	135	38.5	31	22.5	0.85	411	0.12	<b>1PC1341-1EB29-0</b> ■■■■	160
<b>180 L</b>	1460	24.6	161	46.5	37	27	0.85	501	0.13	<b>1PC1341-1EB49-0</b> ■■■■	170
<b>180 L</b>	1455	33.5	220	64	51	37	0.82	647	0.16	<b>1PC1341-1EB69-0</b> ■■■■	185
<b>200 L</b>	1465	33.7	220	63	50	36.5	0.84	605	0.2	<b>1PC1341-2AB59-0</b> ■■■■	230
<b>200 L</b>	1462	41.6	272	77	62	44.5	0.85	720	0.25	<b>1PC1341-2AB69-0</b> ■■■■	240
<b>200 L</b>	1470	50.6	290	98	78	57	0.79	1044	0.28	<b>1PC1341-2AB79-0</b> ■■■■	260
<b>225 S</b>	1470	40	260	71	57	41.5	0.88	690	0.42	<b>1PC1341-2BB09-0</b> ■■■■	280
<b>225 M</b>	1470	49	318	87	70	50	0.88	900	0.46	<b>1PC1341-2BB29-0</b> ■■■■	305
<b>225 M</b>	1475	60	388	111	89	64	0.84	960	0.47	<b>1PC1341-2BB69-0</b> ■■■■	320
<b>250 M</b>	1478	60	388	109	88	63	0.85	1060	0.75	<b>1PC1341-2CB29-0</b> ■■■■	385
<b>250 M</b>	1478	82	530	147	118	85	0.86	1350	0.85	<b>1PC1341-2CB69-0</b> ■■■■	440
<b>250 M</b>	1482	99	638	181	144	105	0.84	1960	1.2	<b>1PC1341-2CB79-0</b> ■■■■	480
<b>280 S</b>	1482	82	528	143	114	83	0.88	1440	1.3	<b>1PC1341-2DB09-0</b> ■■■■	550
<b>280 M</b>	1482	99	638	176	141	102	0.86	1790	1.4	<b>1PC1341-2DB29-0</b> ■■■■	570
<b>280 M</b>	1482	121	780	210	170	123	0.87	2120	1.7	<b>1PC1341-2DB69-0</b> ■■■■	680
<b>280 M</b>	1480	145	936	250	200	146	0.88	2380	1.8	<b>1PC1341-2DB79-0</b> ■■■■	750

#### Type of construction

IMB3, IM1001 horizontal foot mounted  
 IMB5, IM3001 horizontal flange mounted  
 IMV1, IM3011 vertical flange mounted

Further types of construction, code numbers, order codes and descriptions, see page 2/36.

#### Motor protection

Without winding protection  
 3 x PTC for tripping, 2 terminals  
 6 x PTC for tripping and warning, 4 terminals  
 1 x KTY84, 2 terminals  
 2 x KTY84, 4 terminals  
 3 x Pt100, 6 terminals  
 1 x Pt1000, 2 terminals  
 2 x Pt1000, 4 terminals

Further motor protection, code numbers, order codes and descriptions, see page 2/37.

#### Terminal box position

Terminal box at top  
 Terminal box at right side  
 Terminal box at top left side

Further terminal box positions, code numbers, order codes and descriptions, see page 2/38.

#### Winding

400 VΔ, 50 Hz  
 460 VΔ, 50 Hz  
 500 VΔ, 50 Hz  
 690 VΔ, 50 Hz

Further voltages, code numbers, order codes and descriptions, see page 2/35.

#### Order code

M4B  
 M4C  
 M4D  
 M4F

For inertia mass and weight of brakes, see technical specifications for KFB spring-set brake for SIMOTICS DP 1PC134, 1PC136.

For ordering example, see Page 2/23.

**SIMOTICS DP – Crane duty motors**

SIMOTICS DP – 1PC1341: Self-/Forced-ventilated (IC411/IC416)

**Selection and ordering data**

Frame-size	Rated speed	Rated output	Rated torque	Rated current			Power factor	Efficiency	Break-down torque	Moment of inertia	<b>1PC13</b> 400 VA, 50 Hz 500 VA, 50 Hz 690 VA, 50 Hz	Weight, approx. (without brake)
				$I_{rated}$ 400 V	$I_{rated}$ 500 V	$I_{rated}$ 690 V						
FS	$n_{rated}$ rpm	$P_{rated}$ kW	$M_{rated}$ Nm	$I_{rated}$ A	$I_{rated}$ A	$I_{rated}$ A	$\cos \varphi$	$\eta$		$J$ kgm <sup>2</sup>	Article No.	kg
<b>4-pole, 1500 rpm</b>												
<b>Intermittent duty S9: Duty with non-periodic variation in load and speed</b>												
<b>132 S</b>	1465	5.5	36	11.3	9.1	6.6	0.80	87.7	101	0.022	<b>1PC1341-1CB09-0</b>	61
<b>132 M</b>	1460	7.5	49	14.9	11.9	8.6	0.82	88.7	147	0.028	<b>1PC1341-1CB29-0</b>	75
<b>160 M</b>	1470	11.0	71	21.5	17.2	12.5	0.82	89.8	213	0.055	<b>1PC1341-1DB29-0</b>	96
<b>160 L</b>	1475	15.0	97	29.5	23.5	17.1	0.81	90.6	301	0.071	<b>1PC1341-1DB49-0</b>	104
<b>180 M</b>	1465	18.5	121	35.0	28.0	20.0	0.84	91.2	411	0.12	<b>1PC1341-1EB29-0</b>	160
<b>180 L</b>	1465	22.0	143	41.5	33.0	24.0	0.84	91.6	501	0.13	<b>1PC1341-1EB49-0</b>	170
<b>180 L</b>	1465	30.0	196	58.0	46.5	33.5	0.81	92.3	647	0.16	<b>1PC1341-1EB69-0</b>	185
<b>200 L</b>	1470	30.0	195	56.0	44.5	32.5	0.84	92.3	605	0.2	<b>1PC1341-2AB59-0</b>	230
<b>200 L</b>	1470	37.0	240	69.0	55.0	40.0	0.84	92.7	720	0.25	<b>1PC1341-2AB69-0</b>	240
<b>200 L</b>	1472	45.0	290	89.0	72.0	52.0	0.78	93.1	1044	0.28	<b>1PC1341-2AB79-0</b>	260
<b>225 S</b>	1470	37.0	240	65.0	52.0	38.0	0.88	92.7	690	0.42	<b>1PC1341-2BB09-0</b>	280
<b>225 M</b>	1475	45.0	291	80.0	64.0	46.5	0.87	93.1	900	0.46	<b>1PC1341-2BB29-0</b>	305
<b>225 M</b>	1475	55.0	356	101.0	81.0	59.0	0.84	93.5	960	0.47	<b>1PC1341-2BB69-0</b>	320
<b>250 M</b>	1480	55.0	355	100.0	80.0	58.0	0.85	93.5	1060	0.75	<b>1PC1341-2CB29-0</b>	385
<b>250 M</b>	1480	75.0	484	134.0	107.0	78.0	0.86	94.0	1350	0.85	<b>1PC1341-2CB69-0</b>	440
<b>250 M</b>	1485	90.0	579	166.0	133.0	96.0	0.83	94.2	1960	1.2	<b>1PC1341-2CB79-0</b>	480
<b>280 S</b>	1485	75.0	482	132.0	106.0	77.0	0.87	94.0	1440	1.3	<b>1PC1341-2DB09-0</b>	550
<b>280 M</b>	1486	90.0	578	159.0	127.0	92.0	0.87	94.2	1790	1.4	<b>1PC1341-2DB29-0</b>	570
<b>280 M</b>	1485	110.0	707	193.0	154.0	112.0	0.87	94.5	2120	1.7	<b>1PC1341-2DB69-0</b>	680
<b>280 M</b>	1482	132.0	851	230.0	183.0	133.0	0.88	94.7	2380	1.8	<b>1PC1341-2DB79-0</b>	750

## Type of construction

IMB3, IM1001 horizontal foot mounted  
 IMB5, IM3001 horizontal flange mounted  
 IMV1, IM3011 vertical flange mounted

Further types of construction, code numbers, order codes and descriptions, see page 2/36.

## Motor protection

Without winding protection  
 3 x PTC for tripping, 2 terminals  
 6 x PTC for tripping and warning, 4 terminals  
 1 x KTY84, 2 terminals  
 2 x KTY84, 4 terminals  
 3 x Pt100, 6 terminals  
 1 x Pt1000, 2 terminals  
 2 x Pt1000, 4 terminals

Further motor protection, code numbers, order codes and descriptions, see page 2/37.

## Terminal box position

Terminal box at top  
 Terminal box at right side  
 Terminal box at top left side

Further terminal box positions, code numbers, order codes and descriptions, see page 2/38.

## Winding

400 VA, 50 Hz  
 460 VA, 50 Hz  
 500 VA, 50 Hz  
 690 VA, 50 Hz

Further voltages, code numbers, order codes and descriptions, see page 2/35.

## Order code

M4B  
 M4C  
 M4D  
 M4F

For inertia mass and weight of brakes, see technical specifications for KFB spring-set brake for SIMOTICS DP 1PC134, 1PC136.

For ordering example, see Page 2/23.

## SIMOTICS DP – Crane duty motors

### SIMOTICS DP – 1PC1341: Self-/Forced-ventilated (IC411/IC416)

#### Selection and ordering data

Frame-size	Rated speed	Rated output	Rated torque	Rated current			Power factor	Break-down torque	Moment of inertia	<b>1PC13</b> 400 VΔ, 50 Hz 500 VΔ, 50 Hz 690 VΔ, 50 Hz	Weight, approx. (without brake)
				$I_{rated}$ 400 V	$I_{rated}$ 500 V	$I_{rated}$ 690 V					
FS	$n_{rated}$	$P_{rated}$	$M_{rated}$	$I_{rated}$	$I_{rated}$	$I_{rated}$	$\cos \varphi$		$J$	Article No.	kg
	rpm	kW	Nm	A	A	A		Nm	kgm <sup>2</sup>		
<b>6-pole, 1000 rpm</b>											
<b>Intermittent duty S3 – 15 %</b>											
<b>132 S</b>	955	4.1	29.5	9.4	7.5	5.4	0.75	74	0.024	<b>1PC1341-1CC09-0</b> ■■■■	56
<b>132 M</b>	958	5.1	39.5	11.5	9.2	6.7	0.78	91	0.029	<b>1PC1341-1CC29-0</b> ■■■■	61
<b>132 M</b>	955	7.9	79	17.9	14.3	10.5	0.78	140	0.037	<b>1PC1341-1CC39-0</b> ■■■■	70
<b>160 M</b>	970	9.1	90	20.5	16.4	11.9	0.75	161	0.075	<b>1PC1341-1DC29-0</b> ■■■■	106
<b>160 L</b>	962	13.4	133	28	22.5	16.2	0.77	237	0.098	<b>1PC1341-1DC49-0</b> ■■■■	122
<b>180 L</b>	950	25.8	259	51	41	29.5	0.82	455	0.17	<b>1PC1341-1EC49-0</b> ■■■■	155
<b>180 L</b>	950	29.8	300	60	48	35	0.82	525	0.19	<b>1PC1341-1EC69-0</b> ■■■■	165
<b>180 L</b>	948	39.7	400	82	66	47.5	0.8	710	0.25	<b>1PC1341-1EC79-0</b> ■■■■	185
<b>200 L</b>	962	26.7	265	52	41.5	30	0.83	470	0.25	<b>1PC1341-2AC49-0</b> ■■■■	200
<b>200 L</b>	965	31.7	314	61	49	35.5	0.84	559	0.3	<b>1PC1341-2AC59-0</b> ■■■■	220
<b>200 L</b>	960	45	295	91	73	53	0.8	797	0.38	<b>1PC1341-2AC69-0</b> ■■■■	240
<b>200 L</b>	958	55.3	360	107	87	62	0.8	972	0.43	<b>1PC1341-2AC79-0</b> ■■■■	264
<b>225 M</b>	955	54	540	107	85	62	0.84	780	0.58	<b>1PC1341-2BC29-0</b> ■■■■	300
<b>225 M</b>	960	66	657	127	101	73	0.85	1040	0.67	<b>1PC1341-2BC69-0</b> ■■■■	325
<b>225 M</b>	965	81	802	155	124	90	0.85	1310	0.79	<b>1PC1341-2BC79-0</b> ■■■■	395
<b>250 M</b>	965	66	653	131	105	76	0.83	900	0.86	<b>1PC1341-2CC29-0</b> ■■■■	370
<b>250 M</b>	965	81	802	153	123	89	0.86	1170	1.0	<b>1PC1341-2CC69-0</b> ■■■■	410
<b>250 M</b>	970	99	975	187	149	108	0.86	1590	1.2	<b>1PC1341-2CC79-0</b> ■■■■	480
<b>280 S</b>	970	81	797	158	126	91	0.84	1130	1.1	<b>1PC1341-2DC09-0</b> ■■■■	460
<b>280 M</b>	970	99	975	190	152	110	0.85	1380	1.4	<b>1PC1341-2DC29-0</b> ■■■■	510
<b>280 M</b>	970	135	1329	250	200	145	0.86	2100	1.8	<b>1PC1341-2DC69-0</b> ■■■■	570
<b>280 M</b>	975	162	1587	315	250	181	0.84	2870	1.9	<b>1PC1341-2DC79-0</b> ■■■■	630

#### Type of construction

IMB3, IM1001 horizontal foot mounted  
 IMB5, IM3001 horizontal flange mounted  
 IMV1, IM3011 vertical flange mounted

Further types of construction, code numbers, order codes and descriptions, see page 2/36.

#### Motor protection

Without winding protection  
 3 x PTC for tripping, 2 terminals  
 6 x PTC for tripping and warning, 4 terminals  
 1 x KTY84, 2 terminals  
 2 x KTY84, 4 terminals  
 3 x Pt100, 6 terminals  
 1 x Pt1000, 2 terminals  
 2 x Pt1000, 4 terminals

Further motor protection, code numbers, order codes and descriptions, see page 2/37.

#### Terminal box position

Terminal box at top  
 Terminal box at right side  
 Terminal box at top left side

Further terminal box positions, code numbers, order codes and descriptions, see page 2/38.

#### Winding

400 VΔ, 50 Hz  
 460 VΔ, 50 Hz  
 500 VΔ, 50 Hz  
 690 VΔ, 50 Hz

Further voltages, code numbers, order codes and descriptions, see page 2/35.

#### Order code

M4B  
 M4C  
 M4D  
 M4F

For inertia mass and weight of brakes, see technical specifications for KFB spring-set brake for SIMOTICS DP 1PC134, 1PC136.

For ordering example, see Page 2/23.

## SIMOTICS DP – Crane duty motors

SIMOTICS DP – 1PC1341: Self-/Forced-ventilated (IC411/IC416)

### Selection and ordering data

Frame-size	Rated speed	Rated output	Rated torque	Rated current			Power factor	Break-down torque	Moment of inertia	<b>1PC13</b> 400 VΔ, 50 Hz 500 VΔ, 50 Hz 690 VΔ, 50 Hz	Weight, approx. (without brake)
				$I_{rated}$ 400 V	$I_{rated}$ 500 V	$I_{rated}$ 690 V					
FS	$n_{rated}$ rpm	$P_{rated}$ kW	$M_{rated}$ Nm	$I_{rated}$ A	$I_{rated}$ A	$I_{rated}$ A	$\cos \varphi$		$J$ kgm <sup>2</sup>	Article No.	kg
<b>6-pole, 1000 rpm</b>											
<b>Intermittent duty S3 – 25 %</b>											
<b>132 S</b>	955	4.1	29.5	9.4	7.5	5.4	0.75	74	0.024	<b>1PC1341-1CC09-0</b>	56
<b>132 M</b>	958	5.1	39.5	11.5	9.2	6.7	0.78	91	0.029	<b>1PC1341-1CC29-0</b>	61
<b>132 M</b>	955	7.9	79	17.9	14.3	10.5	0.78	140	0.037	<b>1PC1341-1CC39-0</b>	70
<b>160 M</b>	970	9.1	90	20.5	16.4	11.9	0.75	161	0.075	<b>1PC1341-1DC29-0</b>	106
<b>160 L</b>	962	13.4	133	28	22.5	16.2	0.77	237	0.098	<b>1PC1341-1DC49-0</b>	122
<b>180 L</b>	955	22.2	220	45	36	26	0.81	455	0.17	<b>1PC1341-1EC49-0</b>	155
<b>180 L</b>	955	27.4	274	56	45	32.5	0.81	525	0.19	<b>1PC1341-1EC69-0</b>	165
<b>180 L</b>	958	32.6	325	67	54	38.5	0.79	710	0.225	<b>1PC1341-1EC79-0</b>	185
<b>200 L</b>	962	26.7	265	52	41.5	30	0.83	470	0.25	<b>1PC1341-2AC49-0</b>	200
<b>200 L</b>	965	31.7	314	61	49	35.5	0.84	559	0.3	<b>1PC1341-2AC59-0</b>	220
<b>200 L</b>	960	44.5	295	90	72	52	0.8	797	0.38	<b>1PC1341-2AC69-0</b>	240
<b>200 L</b>	958	52.6	360	106	85	61	0.80	972	0.43	<b>1PC1341-2AC79-0</b>	264
<b>225 M</b>	970	43	423	82	66	48	0.84	780	0.58	<b>1PC1341-2BC29-0</b>	300
<b>225 M</b>	970	53	522	99	80	58	0.85	1040	0.67	<b>1PC1341-2BC69-0</b>	325
<b>225 M</b>	970	65	640	122	97	71	0.85	1310	0.79	<b>1PC1341-2BC79-0</b>	395
<b>250 M</b>	975	53	519	101	81	59	0.84	900	0.86	<b>1PC1341-2CC29-0</b>	370
<b>250 M</b>	975	65	637	120	96	70	0.86	1170	1.0	<b>1PC1341-2CC69-0</b>	410
<b>250 M</b>	975	79	774	147	118	85	0.85	1590	1.2	<b>1PC1341-2CC79-0</b>	480
<b>280 S</b>	978	65	635	122	98	71	0.85	1130	1.1	<b>1PC1341-2DC09-0</b>	460
<b>280 M</b>	978	79	771	146	117	84	0.86	1380	1.4	<b>1PC1341-2DC29-0</b>	510
<b>280 M</b>	978	108	1055	197	158	114	0.86	2100	1.8	<b>1PC1341-2DC69-0</b>	570
<b>280 M</b>	980	130	1267	250	200	145	0.82	2870	1.9	<b>1PC1341-2DC79-0</b>	630

#### Type of construction

IMB3, IM1001 horizontal foot mounted  
IMB5, IM3001 horizontal flange mounted  
IMV1, IM3011 vertical flange mounted

Further types of construction, code numbers, order codes and descriptions, see page 2/36.

#### Motor protection

Without winding protection  
3 x PTC for tripping, 2 terminals  
6 x PTC for tripping and warning, 4 terminals  
1 x KTY84, 2 terminals  
2 x KTY84, 4 terminals  
3 x Pt100, 6 terminals  
1 x Pt1000, 2 terminals  
2 x Pt1000, 4 terminals

Further motor protection, code numbers, order codes and descriptions, see page 2/37.

#### Terminal box position

Terminal box at top  
Terminal box at right side  
Terminal box at top left side

Further terminal box positions, code numbers, order codes and descriptions, see page 2/38.

#### Winding

400 VΔ, 50 Hz  
460 VΔ, 50 Hz  
500 VΔ, 50 Hz  
690 VΔ, 50 Hz

Further voltages, code numbers, order codes and descriptions, see page 2/35.

#### Order code

M4B  
M4C  
M4D  
M4F

For inertia mass and weight of brakes, see technical specifications for KFB spring-set brake for SIMOTICS DP 1PC134, 1PC136.

For ordering example, see Page 2/23.

## SIMOTICS DP – Crane duty motors

### SIMOTICS DP – 1PC1341: Self-/Forced-ventilated (IC411/IC416)

#### Selection and ordering data

Frame-size	Rated speed	Rated output	Rated torque	Rated current			Power factor	Break-down torque	Moment of inertia	<b>1PC13</b> 400 VΔ, 50 Hz 500 VΔ, 50 Hz 690 VΔ, 50 Hz	Weight, approx. (without brake)
				$I_{rated}$ 400 V	$I_{rated}$ 500 V	$I_{rated}$ 690 V					
FS	$n_{rated}$ rpm	$P_{rated}$ kW	$M_{rated}$ Nm	$I_{rated}$ A	$I_{rated}$ A	$I_{rated}$ A	$\cos \varphi$	Nm	$J$ kgm <sup>2</sup>	Article No.	kg
<b>6-pole, 1000 rpm</b>											
<b>Intermittent duty S3 – 40 %</b>											
<b>132 S</b>	955	4.1	29.5	9.4	7.5	5.4	0.75	74	0.024	<b>1PC1341-1CC09-0</b> ■■■■	56
<b>132 M</b>	958	5.1	39.5	11.5	9.2	6.7	0.78	91	0.029	<b>1PC1341-1CC29-0</b> ■■■■	61
<b>132 M</b>	960	7	70	15.7	12.6	9.1	0.77	140	0.037	<b>1PC1341-1CC39-0</b> ■■■■	70
<b>160 M</b>	970	9.1	90	20.5	16.4	11.9	0.75	161	0.075	<b>1PC1341-1DC29-0</b> ■■■■	106
<b>160 L</b>	962	13.4	133	28	22.5	16.2	0.77	237	0.098	<b>1PC1341-1DC49-0</b> ■■■■	122
<b>180 L</b>	965	19	188	38.5	31	22	0.8	455	0.17	<b>1PC1341-1EC49-0</b> ■■■■	155
<b>180 L</b>	965	23.4	232	47.5	38	27.5	0.8	525	0.19	<b>1PC1341-1EC69-0</b> ■■■■	165
<b>180 L</b>	965	27.8	275	57	45.5	33	0.78	710	0.25	<b>1PC1341-1EC79-0</b> ■■■■	185
<b>200 L</b>	968	23.4	231	45.5	36.5	26.5	0.82	470	0.25	<b>1PC1341-2AC49-0</b> ■■■■	200
<b>200 L</b>	970	27.8	274	54	43	31.5	0.83	559	0.3	<b>1PC1341-2AC59-0</b> ■■■■	220
<b>200 L</b>	965	37.9	295	76	61	44	0.79	797	0.38	<b>1PC1341-2AC69-0</b> ■■■■	240
<b>200 L</b>	965	44.9	360	90	72	52	0.79	972	0.43	<b>1PC1341-2AC79-0</b> ■■■■	264
<b>225 M</b>	975	37	362	70	56	40.5	0.84	780	0.58	<b>1PC1341-2BC29-0</b> ■■■■	300
<b>225 M</b>	975	46	451	87	69	50	0.84	1040	0.67	<b>1PC1341-2BC69-0</b> ■■■■	325
<b>225 M</b>	975	56	548	106	85	62	0.83	1310	0.79	<b>1PC1341-2BC79-0</b> ■■■■	395
<b>250 M</b>	978	46	449	88	70	51	0.83	900	0.86	<b>1PC1341-2CC29-0</b> ■■■■	370
<b>250 M</b>	978	56	547	104	83	60	0.85	1170	1.0	<b>1PC1341-2CC69-0</b> ■■■■	410
<b>250 M</b>	980	68	663	126	100	73	0.85	1590	1.2	<b>1PC1341-2CC79-0</b> ■■■■	480
<b>280 S</b>	980	56	546	104	83	60	0.85	1130	1.1	<b>1PC1341-2DC09-0</b> ■■■■	460
<b>280 M</b>	980	68	663	124	99	72	0.86	1380	1.4	<b>1PC1341-2DC29-0</b> ■■■■	510
<b>280 M</b>	982	93	904	168	134	97	0.86	2100	1.8	<b>1PC1341-2DC69-0</b> ■■■■	570
<b>280 M</b>	982	112	1089	215	170	123	0.82	2870	1.9	<b>1PC1341-2DC79-0</b> ■■■■	630
Type of construction											
IMB3, IM1001 horizontal foot mounted											A
IMB5, IM3001 horizontal flange mounted											F
IMV1, IM3011 vertical flange mounted											G
Further types of construction, code numbers, order codes and descriptions, see page 2/36.											
Motor protection											
Without winding protection											A
3 x PTC for tripping, 2 terminals											B
6 x PTC for tripping and warning, 4 terminals											C
1 x KTY84, 2 terminals											F
2 x KTY84, 4 terminals											G
3 x Pt100, 6 terminals											H
1 x Pt1000, 2 terminals											K
2 x Pt1000, 4 terminals											L
Further motor protection, code numbers, order codes and descriptions, see page 2/37.											
Terminal box position											
Terminal box at top											4
Terminal box at right side											5
Terminal box at top left side											6
Further terminal box positions, code numbers, order codes and descriptions, see page 2/38.											
Winding											Order code
400 VΔ, 50 Hz											M4B
460 VΔ, 50 Hz											M4C
500 VΔ, 50 Hz											M4D
690 VΔ, 50 Hz											M4F
Further voltages, code numbers, order codes and descriptions, see page 2/35.											

For inertia mass and weight of brakes, see technical specifications for KFB spring-set brake for SIMOTICS DP 1PC134, 1PC136.

For ordering example, see Page 2/23.

**SIMOTICS DP – Crane duty motors**

SIMOTICS DP – 1PC1341: Self-/Forced-ventilated (IC411/IC416)

**Selection and ordering data**

Frame-size	Rated speed	Rated output	Rated torque	Rated current			Power factor	Break-down torque	Moment of inertia	<b>1PC13</b> 400 VΔ, 50 Hz 500 VΔ, 50 Hz 690 VΔ, 50 Hz	Weight, approx. (without brake)
				$I_{rated}$ 400 V	$I_{rated}$ 500 V	$I_{rated}$ 690 V					
FS	$n_{rated}$ rpm	$P_{rated}$ kW	$M_{rated}$ Nm	$I_{rated}$ A	$I_{rated}$ A	$I_{rated}$ A	cos φ	Nm	$J$ kgm <sup>2</sup>	Article No.	kg
<b>6-pole, 1000 rpm</b>											
<b>Intermittent duty S3 – 60 %</b>											
<b>132 S</b>	958	3.9	29.5	8.9	7.1	5.2	0.74	74	0.024	<b>1PC1341-1CC09-0</b> ■■■■	56
<b>132 M</b>	962	4.7	39.5	10.7	8.6	6.2	0.77	91	0.029	<b>1PC1341-1CC29-0</b> ■■■■	61
<b>132 M</b>	965	6.2	61	14	11.2	8.1	0.75	140	0.037	<b>1PC1341-1CC39-0</b> ■■■■	70
<b>160 M</b>	972	8.4	83	18.7	15	10.8	0.75	161	0.075	<b>1PC1341-1DC29-0</b> ■■■■	106
<b>160 L</b>	968	12.3	121	26.5	21	15.3	0.76	237	0.098	<b>1PC1341-1DC49-0</b> ■■■■	122
<b>180 L</b>	970	16.9	166	34.5	27.5	19.9	0.79	455	0.17	<b>1PC1341-1EC49-0</b> ■■■■	155
<b>180 L</b>	970	20.8	205	42.5	34	24.5	0.78	525	0.19	<b>1PC1341-1EC69-0</b> ■■■■	165
<b>180 L</b>	970	24.7	243	52	41.5	30	0.75	710	0.25	<b>1PC1341-1EC79-0</b> ■■■■	185
<b>200 L</b>	972	20.8	204	40.5	32.5	23	0.82	470	0.25	<b>1PC1341-2AC49-0</b> ■■■■	200
<b>200 L</b>	972	24.7	243	48	38.5	28	0.83	559	0.3	<b>1PC1341-2AC59-0</b> ■■■■	220
<b>200 L</b>	970	33.7	295	68	54	39.5	0.78	797	0.38	<b>1PC1341-2AC69-0</b> ■■■■	240
<b>200 L</b>	970	39.9	360	81	65	47	0.78	972	0.43	<b>1PC1341-2AC79-0</b> ■■■■	264
<b>225 M</b>	975	33	323	63	50	36.5	0.83	780	0.58	<b>1PC1341-2BC29-0</b> ■■■■	300
<b>225 M</b>	975	40	392	77	61	44.5	0.82	1040	0.67	<b>1PC1341-2BC69-0</b> ■■■■	325
<b>225 M</b>	978	49	478	94	75	54	0.82	1310	0.79	<b>1PC1341-2BC79-0</b> ■■■■	395
<b>250 M</b>	980	40	390	76	61	44	0.83	900	0.86	<b>1PC1341-2CC29-0</b> ■■■■	370
<b>250 M</b>	980	49	477	91	73	53	0.84	1170	1.0	<b>1PC1341-2CC69-0</b> ■■■■	410
<b>250 M</b>	982	60	583	111	89	65	0.84	1590	1.2	<b>1PC1341-2CC79-0</b> ■■■■	480
<b>280 S</b>	982	49	476	90	72	52	0.85	1130	1.1	<b>1PC1341-2DC09-0</b> ■■■■	460
<b>280 M</b>	982	60	583	110	88	64	0.85	1380	1.4	<b>1PC1341-2DC29-0</b> ■■■■	510
<b>280 M</b>	985	82	795	149	119	86	0.85	2100	1.8	<b>1PC1341-2DC69-0</b> ■■■■	570
<b>280 M</b>	985	99	960	188	150	109	0.81	2870	1.9	<b>1PC1341-2DC79-0</b> ■■■■	630
Type of construction											
IMB3, IM1001 horizontal foot mounted											A
IMB5, IM3001 horizontal flange mounted											F
IMV1, IM3011 vertical flange mounted											G
Further types of construction, code numbers, order codes and descriptions, see page 2/36.											
Motor protection											
Without winding protection											A
3 x PTC for tripping, 2 terminals											B
6 x PTC for tripping and warning, 4 terminals											C
1 x KTY84, 2 terminals											F
2 x KTY84, 4 terminals											G
3 x Pt100, 6 terminals											H
1 x Pt1000, 2 terminals											K
2 x Pt1000, 4 terminals											L
Further motor protection, code numbers, order codes and descriptions, see page 2/37.											
Terminal box position											
Terminal box at top											4
Terminal box at right side											5
Terminal box at top left side											6
Further terminal box positions, code numbers, order codes and descriptions, see page 2/38.											
Winding											Order code
400 VΔ, 50 Hz											M4B
460 VΔ, 50 Hz											M4C
500 VΔ, 50 Hz											M4D
690 VΔ, 50 Hz											M4F
Further voltages, code numbers, order codes and descriptions, see page 2/35.											

For inertia mass and weight of brakes, see technical specifications for KFB spring-set brake for SIMOTICS DP 1PC134, 1PC136.

For ordering example, see Page 2/23.

## SIMOTICS DP – Crane duty motors

### SIMOTICS DP – 1PC1341: Self-/Forced-ventilated (IC411/IC416)

#### Selection and ordering data

Frame-size	Rated speed	Rated output	Rated torque	Rated current			Power factor	Efficiency	Break-down torque	Moment of inertia	<b>1PC13</b> 400 VΔ, 50 Hz 500 VΔ, 50 Hz 690 VΔ, 50 Hz	Weight, approx. (without brake)
FS	$n_{rated}$	$P_{rated}$	$M_{rated}$	$I_{rated}$ 400 V	$I_{rated}$ 500 V	$I_{rated}$ 690 V	$\cos \varphi$	$\eta$		$J$	Article No.	kg
	rpm	kW	Nm	A	A	A		%	Nm	kgm <sup>2</sup>		
<b>6-pole, 1000 rpm</b>												
<b>Intermittent duty S9: Duty with non-periodic variation in load and speed</b>												
<b>132 S</b>	970	3.0	29.5	7.2	5.8	4.2	0.72	83.3	74	0.024	<b>1PC1341-1CC09-0</b> ■■■■	56
<b>132 M</b>	970	4.0	39.5	9.1	7.3	5.3	0.75	84.6	91	0.029	<b>1PC1341-1CC29-0</b> ■■■■	61
<b>132 M</b>	972	5.5	54	12.5	10.0	7.2	0.74	86.0	140	0.037	<b>1PC1341-1CC39-0</b> ■■■■	70
<b>160 M</b>	975	7.5	73	16.8	13.4	9.7	0.74	87.2	161	0.075	<b>1PC1341-1DC29-0</b> ■■■■	106
<b>160 L</b>	975	11.0	108	23.5	18.8	13.6	0.76	88.7	237	0.098	<b>1PC1341-1DC49-0</b> ■■■■	122
<b>180 L</b>	975	15.0	147	31.0	25.0	17.9	0.78	89.7	455	0.17	<b>1PC1341-1EC49-0</b> ■■■■	155
<b>180 L</b>	975	18.5	181	38.5	30.5	22.0	0.77	90.4	525	0.19	<b>1PC1341-1EC69-0</b> ■■■■	165
<b>180 L</b>	975	22.0	215	47.0	38.0	27.5	0.74	90.9	710	0.25	<b>1PC1341-1EC79-0</b> ■■■■	185
<b>200 L</b>	978	18.5	181	36.0	29.0	21.0	0.82	90.4	470	0.25	<b>1PC1341-2AC49-0</b> ■■■■	200
<b>200 L</b>	978	22.0	215	42.5	34.0	24.5	0.82	90.9	559	0.3	<b>1PC1341-2AC59-0</b> ■■■■	220
<b>200 L</b>	975	30.0	295	61.0	49.0	35.5	0.77	91.7	797	0.38	<b>1PC1341-2AC69-0</b> ■■■■	240
<b>200 L</b>	975	37.0	360	75.0	60.0	43.5	0.77	92.2	972	0.43	<b>1PC1341-2AC79-0</b> ■■■■	264
<b>225 M</b>	980	30.0	292	57.0	45.5	33.0	0.83	91.7	780	0.58	<b>1PC1341-2BC29-0</b> ■■■■	300
<b>225 M</b>	978	37.0	361	70.0	56.0	40.5	0.83	92.2	1040	0.67	<b>1PC1341-2BC69-0</b> ■■■■	325
<b>225 M</b>	978	45.0	439	87.0	69.0	50.0	0.81	92.7	1310	0.79	<b>1PC1341-2BC79-0</b> ■■■■	395
<b>250 M</b>	982	37.0	360	70.0	56.0	40.5	0.83	92.2	900	0.86	<b>1PC1341-2CC29-0</b> ■■■■	370
<b>250 M</b>	985	45.0	436	83.0	67.0	48.5	0.84	92.7	1170	1.0	<b>1PC1341-2CC69-0</b> ■■■■	410
<b>250 M</b>	985	55.0	533	102.0	81.0	59.0	0.84	93.1	1590	1.2	<b>1PC1341-2CC79-0</b> ■■■■	480
<b>280 S</b>	985	45.0	436	83.0	67.0	48.5	0.84	92.7	1130	1.1	<b>1PC1341-2DC09-0</b> ■■■■	460
<b>280 M</b>	985	55.0	533	99.0	79.0	57.0	0.86	93.1	1380	1.4	<b>1PC1341-2DC29-0</b> ■■■■	510
<b>280 M</b>	986	75.0	726	136.0	109.0	79.0	0.85	93.7	2100	1.8	<b>1PC1341-2DC69-0</b> ■■■■	570
<b>280 M</b>	988	90.0	870	171.0	136.0	99.0	0.81	94.0	2870	1.9	<b>1PC1341-2DC79-0</b> ■■■■	630
<b>Type of construction</b>												
IMB3, IM1001 horizontal foot mounted												A
IMB5, IM3001 horizontal flange mounted												F
IMV1, IM3011 vertical flange mounted												G
Further types of construction, code numbers, order codes and descriptions, see page 2/36.												
<b>Motor protection</b>												
Without winding protection												A
3 x PTC for tripping, 2 terminals												B
6 x PTC for tripping and warning, 4 terminals												C
1 x KTY84, 2 terminals												F
2 x KTY84, 4 terminals												G
3 x Pt100, 6 terminals												H
1 x Pt1000, 2 terminals												K
2 x Pt1000, 4 terminals												L
Further motor protection, code numbers, order codes and descriptions, see page 2/37.												
<b>Terminal box position</b>												
Terminal box at top												4
Terminal box at right side												5
Terminal box at top left side												6
Further terminal box positions, code numbers, order codes and descriptions, see page 2/38.												
<b>Winding</b>												
400 VΔ, 50 Hz												M4B
460 VΔ, 50 Hz												M4C
500 VΔ, 50 Hz												M4D
690 VΔ, 50 Hz												M4F
Further voltages, code numbers, order codes and descriptions, see page 2/35.												

For inertia mass and weight of brakes, see technical specifications for KFB spring-set brake for SIMOTICS DP 1PC134, 1PC136.

For ordering example, see Page 2/23.

## SIMOTICS DP – Crane duty motors

SIMOTICS DP – 1PC1341: Forced-ventilated (IC416)

## Selection and ordering data

Frame-size	Rated speed	Rated output	Rated torque	Rated current			Power factor	Efficiency	Break-down torque	Moment of inertia	<b>1PC13</b> 400 VΔ, 50 Hz 500 VΔ, 50 Hz 690 VΔ, 50 Hz	Weight, approx. (without brake)
				$I_{rated}$ 400 V	$I_{rated}$ 500 V	$I_{rated}$ 690 V						
FS	$n_{rated}$ rpm	$P_{rated}$ kW	$M_{rated}$ Nm	$I_{rated}$ A	$I_{rated}$ A	$I_{rated}$ A	$\cos \varphi$	$\eta$		$J$ kgm <sup>2</sup>	Article No.	kg
<b>6-pole, 1000 rpm</b>												
<b>Intermittent duty S3 – 15 %</b>												
<b>315 L</b>	978	198	1933	355	285	355	0.87	–	3160	3.6	<b>1PC1341-3AC49-0</b> ■■■■	985
<b>315 L</b>	978	239	2334	430	345	430	0.87	–	4220	4.0	<b>1PC1341-3AC59-0</b> ■■■■	1035
<b>315 L</b>	978	209	2041	375	300	375	0.87	–	5450	4.6	<b>1PC1341-3AC69-0</b> ■■■■	1205
<b>315 L</b>	980	363	3537	650	520	650	0.87	–	6190	5.6	<b>1PC1341-3AC79-0</b> ■■■■	1460
<b>Intermittent duty S3 – 25 %</b>												
<b>315 L</b>	982	169	1643	300	240	175	0.87	–	3160	3.6	<b>1PC1341-3AC49-0</b> ■■■■	985
<b>315 L</b>	982	204	1984	365	290	210	0.87	–	4220	4.0	<b>1PC1341-3AC59-0</b> ■■■■	1035
<b>315 L</b>	982	248	2412	440	350	255	0.87	–	5450	4.6	<b>1PC1341-3AC69-0</b> ■■■■	1205
<b>315 L</b>	985	310	3005	550	440	320	0.87	–	6190	5.6	<b>1PC1341-3AC79-0</b> ■■■■	1460
<b>Intermittent duty S3 – 40 %</b>												
<b>315 L</b>	985	147	1425	265	210	153	0.86	–	3160	3.6	<b>1PC1341-3AC49-0</b> ■■■■	985
<b>315 L</b>	985	177	1716	315	255	183	0.86	–	4220	4.0	<b>1PC1341-3AC59-0</b> ■■■■	1035
<b>315 L</b>	985	215	2084	385	305	220	0.86	–	5450	4.6	<b>1PC1341-3AC69-0</b> ■■■■	1205
<b>315 L</b>	986	269	2605	480	385	280	0.86	–	6190	5.6	<b>1PC1341-3AC79-0</b> ■■■■	1460
<b>Intermittent duty S3 – 60 %</b>												
<b>315 L</b>	986	131	1269	235	187	136	0.86	–	3160	3.6	<b>1PC1341-3AC49-0</b> ■■■■	985
<b>315 L</b>	986	158	1530	280	225	163	0.86	–	4220	4.0	<b>1PC1341-3AC59-0</b> ■■■■	1035
<b>315 L</b>	986	191	1850	340	270	197	0.86	–	5450	4.6	<b>1PC1341-3AC69-0</b> ■■■■	1205
<b>315 L</b>	988	239	2310	425	340	245	0.86	–	6190	5.6	<b>1PC1341-3AC79-0</b> ■■■■	1460
<b>Intermittent duty S9: Duty with non-periodic variation in load and speed</b>												
<b>315 L</b>	988	117.0	1131	210.0	–	–	0.86	94.4	3160	3.6	<b>1PC1341-3AC49-0</b> ■■■■	985
<b>315 L</b>	988	141.0	1363	255.0	–	–	0.85	94.7	4220	4.0	<b>1PC1341-3AC59-0</b> ■■■■	1035
<b>315 L</b>	988	171.0	1653	300.0	–	–	0.86	95.0	5450	4.6	<b>1PC1341-3AC69-0</b> ■■■■	1205
<b>315 L</b>	990	214.0	2064	390.0	–	–	0.83	95.0	6190	5.6	<b>1PC1341-3AC79-0</b> ■■■■	1460
Type of construction												
IMB3, IM1001 horizontal foot mounted											A F G	
IMB5, IM3001 horizontal flange mounted												
IMV1, IM3011 vertical flange mounted												
Further types of construction, code numbers, order codes and descriptions, see page 2/36.												
Motor protection												
Without winding protection											A B C F G H K L	
3 x PTC for tripping, 2 terminals												
6 x PTC for tripping and warning, 4 terminals												
1 x KTY84, 2 terminals												
2 x KTY84, 4 terminals												
3 x Pt100, 6 terminals												
1 x Pt1000, 2 terminals												
2 x Pt1000, 4 terminals												
Further motor protection, code numbers, order codes and descriptions, see page 2/37.												
Terminal box position												
Terminal box at top											4 5 6	
Terminal box at right side												
Terminal box at top left side												
Further terminal box positions, code numbers, order codes and descriptions, see page 2/38.												
Winding												
400 VΔ, 50 Hz											Order code	M4B
460 VΔ, 50 Hz												M4C
500 VΔ, 50 Hz												M4D
690 VΔ, 50 Hz												M4F
Further voltages, code numbers, order codes and descriptions, see page 2/35.												

For inertia mass and weight of brakes, see technical specifications for KFB spring-set brake for SIMOTICS DP 1PC134, 1PC136.

For ordering example, see Page 2/23.



## SIMOTICS DP – Crane duty motors

### SIMOTICS DP – 1PC1341: Forced-ventilated (IC416)

#### Selection and ordering data

Frame-size	Rated speed	Rated output	Rated torque	Rated current			Power factor	Efficiency	Break-down torque	Moment of inertia	<b>1PC13</b> 400 VΔ, 50 Hz 500 VΔ, 50 Hz 690 VΔ, 50 Hz	Weight, approx. (without brake)
				$I_{rated}$ 400 V	$I_{rated}$ 500 V	$I_{rated}$ 690 V						
FS	$n_{rated}$ rpm	$P_{rated}$ kW	$M_{rated}$ Nm	$I_{rated}$ A	$I_{rated}$ A	$I_{rated}$ A	$\cos \varphi$	$\eta$ %		$J$ kgm <sup>2</sup>	Article No.	kg
<b>8-pole, 750 rpm</b>												
<b>Intermittent duty S3 – 15 %</b>												
<b>315 L</b>	728	171	2243	325	260	189	0.84	–	3400	3.1	<b>1PC1341-3AD49-0</b> ■■■■	905
<b>315 L</b>	725	209	2753	395	315	230	0.84	–	4610	3.9	<b>1PC1341-3AD59-0</b> ■■■■	1025
<b>315 L</b>	728	251	3292	490	395	285	0.81	–	5360	4.5	<b>1PC1341-3AD69-0</b> ■■■■	1115
<b>315 L</b>	728	304	3988	570	455	330	0.84	–	5790	5.6	<b>1PC1341-3AD79-0</b> ■■■■	1460
<b>Intermittent duty S3 – 25 %</b>												
<b>315 L</b>	730	146	1910	280	225	162	0.82	–	3400	3.1	<b>1PC1341-3AD49-0</b> ■■■■	905
<b>315 L</b>	728	178	2335	340	270	196	0.83	–	4610	3.9	<b>1PC1341-3AD59-0</b> ■■■■	1025
<b>315 L</b>	732	215	2805	415	335	240	0.81	–	5360	4.5	<b>1PC1341-3AD69-0</b> ■■■■	1115
<b>315 L</b>	732	259	3379	480	385	280	0.84	–	5790	5.6	<b>1PC1341-3AD79-0</b> ■■■■	1460
<b>Intermittent duty S3 – 40 %</b>												
<b>315 L</b>	732	127	1657	240	193	140	0.82	–	3400	3.1	<b>1PC1341-3AD49-0</b> ■■■■	905
<b>315 L</b>	732	155	2022	295	235	171	0.82	–	4610	3.9	<b>1PC1341-3AD59-0</b> ■■■■	1025
<b>315 L</b>	735	186	2417	360	290	210	0.8	–	5360	4.5	<b>1PC1341-3AD69-0</b> ■■■■	1115
<b>315 L</b>	735	225	2923	420	335	245	0.83	–	5790	5.6	<b>1PC1341-3AD79-0</b> ■■■■	1460
<b>Intermittent duty S3 – 60 %</b>												
<b>315 L</b>	736	113	1466	215	172	125	0.81	–	3400	3.1	<b>1PC1341-3AD49-0</b> ■■■■	905
<b>315 L</b>	735	139	1806	265	215	154	0.81	–	4610	3.9	<b>1PC1341-3AD59-0</b> ■■■■	1025
<b>315 L</b>	736	166	2154	325	260	188	0.79	–	5360	4.5	<b>1PC1341-3AD69-0</b> ■■■■	1115
<b>315 L</b>	740	202	2607	385	305	220	0.81	–	5790	5.6	<b>1PC1341-3AD79-0</b> ■■■■	1460
<b>Intermittent duty S9: Duty with non-periodic variation in load and speed</b>												
<b>315 L</b>	736	101.0	1310	189.0	–	–	0.86	92.1	3400	3.1	<b>1PC1341-3AD49-0</b> ■■■■	905
<b>315 L</b>	738	123.0	1592	230.0	–	–	0.85	92.5	4610	3.9	<b>1PC1341-3AD59-0</b> ■■■■	1025
<b>315 L</b>	738	148.0	1915	280.0	–	–	0.86	92.8	5360	4.5	<b>1PC1341-3AD69-0</b> ■■■■	1115
<b>315 L</b>	738	179.0	2316	335.0	–	–	0.83	93.0	5790	5.6	<b>1PC1341-3AD79-0</b> ■■■■	1460
Type of construction												
IMB3, IM1001 horizontal foot mounted											A F G	
IMB5, IM3001 horizontal flange mounted												
IMV1, IM3011 vertical flange mounted												
Further types of construction, code numbers, order codes and descriptions, see page 2/36.												
Motor protection												
Without winding protection											A B C F G H K L	
3 x PTC for tripping, 2 terminals												
6 x PTC for tripping and warning, 4 terminals												
1 x KTY84, 2 terminals												
2 x KTY84, 4 terminals												
3 x Pt100, 6 terminals												
1 x Pt1000, 2 terminals												
2 x Pt1000, 4 terminals												
Further motor protection, code numbers, order codes and descriptions, see page 2/37.												
Terminal box position												
Terminal box at top											4 5 6	
Terminal box at right side												
Terminal box at top left side												
Further terminal box positions, code numbers, order codes and descriptions, see page 2/38.												
Winding												
400 VΔ, 50 Hz											Order code	M4B
460 VΔ, 50 Hz												M4C
500 VΔ, 50 Hz												M4D
690 VΔ, 50 Hz												M4F
Further voltages, code numbers, order codes and descriptions, see page 2/35.												

For inertia mass and weight of brakes, see technical specifications for KFB spring-set brake for SIMOTICS DP 1PC134, 1PC136.

For ordering example, see Page 2/23.

**SIMOTICS DP – Crane duty motors**

SIMOTICS DP – 1PC1341: Forced-ventilated (IC416)

**Selection and ordering data****Product range shaft height 315, 69 Hz and 87 Hz**

Frame-size FS	Number of poles –	Fre- quency Hz	Intermittent duty S9: Duty with non- periodic variation in load and speed		Intermittent duty S3 – 60		Intermittent duty S3 – 40		Intermittent duty S3 – 25		Article No.
			Rated output kW	Rated current $I_{rated}$ 400 V A	Rated output kW	Rated current $I_{rated}$ 400 V A	Rated output kW	Rated current $I_{rated}$ 400 V A	Rated output kW	Rated current $I_{rated}$ 400 V A	
<b>Product range shaft height 315, 69 Hz and 87 Hz</b>											
<b>315L</b>	6	69	150	268	168	298	189	335	218	388	<b>1PC1341-3AC49-0 + M3L</b>
<b>315L</b>	6	69	180	316	202	353	227	396	261	455	<b>1PC1341-3AC59-0 + M3L</b>
<b>315L</b>	6	69	219	388	245	424	276	477	318	554	<b>1PC1341-3AC69-0 + M3L</b>
<b>315L</b>	6	69	274	476	307	535	345	598	397	695	<b>1PC1341-3AC79-0 + M3L</b>
<b>315L</b>	8	69	129	239	144	266	162	300	187	351	<b>1PC1341-3AD49-0 + M3L</b>
<b>315L</b>	8	69	157	280	176	315	198	357	228	418	<b>1PC1341-3AD59-0 + M3L</b>
<b>315L</b>	8	69	189	336	212	378	238	427	274	502	<b>1PC1341-3AD69-0 + M3L</b>
<b>315L</b>	8	69	229	408	256	455	288	512	332	600	<b>1PC1341-3AD79-0 + M3L</b>
<b>315L</b>	6	87	181	318	203	355	228	397	262	461	<b>1PC1341-3AC49-0 + M3A</b>
<b>315L</b>	6	87	219	380	245	420	276	469	318	548	<b>1PC1341-3AC59-0 + M3A</b>
<b>315L</b>	6	87	265	454	297	509	334	572	384	665	<b>1PC1341-3AC69-0 + M3A</b>
<b>315L</b>	6	87	332	580	372	648	418	728	481	848	<b>1PC1341-3AC79-0 + M3A</b>
<b>315L</b>	8	87	156	280	175	315	196	351	226	412	<b>1PC1341-3AD49-0 + M3A</b>
<b>315L</b>	8	87	191	340	214	383	241	434	277	508	<b>1PC1341-3AD59-0 + M3A</b>
<b>315L</b>	8	87	229	410	256	460	288	522	332	609	<b>1PC1341-3AD69-0 + M3A</b>
<b>315L</b>	8	87	277	478	310	538	349	610	402	712	<b>1PC1341-3AD79-0 + M3A</b>

## SIMOTICS DP – Crane duty motors

### SIMOTICS DP – 1PC1341: Forced-ventilated (IC416)

#### Options

##### Ordering example 1

Force-ventilated trolley motor with brake and encoder in IM B5  
1PC1341-2AC69-0FL5-Z M4D+F28+F33+G07+F70+L18+Q02

Selection criteria	Requirement	Structure of the Article No.
Motor type	Crane duty motor with fan (IC411/IC416), degree of protection IP55, cast iron design	1PC1341-■■■■■-■■■■■
Motor frame size/No. of poles/Speed	Motor in framesize 200, 6-pole version, 30 kW S9 (50 Hz-rating)	1PC1341-2AC6■-■■■■■
Voltage and frequency	Voltage: 500 V, 50 Hz	1PC1341-2AC69-0■■■■■ M4D
Motor protection	IM B5 with flange FF350 (A400)	1PC1341-2AC69-0F■■■ M4D
Type of construction	2 × Pt1000 resistance thermometers (4 terminals)	1PC1341-2AC69-0FL■ M4D
Terminal box position	Terminal box on right hand side	1PC1341-2AC69-0FL5 M4D
Options	Mounting of the brake KFB 30, 300 Nm	1PC1341-2AC69-0FL5-Z M4D+F33
Options	Mounting of POG 10 DN 1024 I rotary pulse encoder	1PC1341-2AC69-0FL5-Z M4D+F33+G07
Options	Mounting of rotary pulse encoder POG 10 on the brake	1PC1341-2AC69-0FL5-Z M4D+F28+F33+G07
Options	Mounting of external fan (IC416)	1PC1341-2AC69-0FL5-Z M4D+F28+F33+G07+F70
Options	End shield DE made of GGG40 for mounting in IM B5	1PC1341-2AC69-0FL5-Z M4D+F28+F33+G07+F70+L18
Options	Anti-condensation heating for 230 V AC (2 terminals)	1PC1341-2AC69-0FL5-Z M4D+F28+F33+G07+F70+L18+Q02

##### Ordering example 2

Forced ventilated hoist motor in IM B3  
1PC1341-3AC59-0AL5-Z M3N+G10+L06+Q02

Selection criteria	Requirement	Structure of the Article No.
Motor type	Crane duty motor with fan (IC411/IC416), degree of protection IP55, cast iron design	1PC1341-■■■■■-■■■■■
Motor frame size/No. of poles/Speed	Motor in framesize 315, 6-pole version, 141 kW, S9-non-periodic variation in load and speed (69 Hz-rating)	1PC1341-3AC59-■■■■■
Voltage and frequency	Voltage: 500 VΔ, 69 Hz	1PC1341-3AC59-0■■■■■ M3N
Motor protection	IM B3	1PC1341-3AC59-0A■■■ M3N
Type of construction	2 Pt1000 resistance thermometers (4 terminals)	1PC1341-3AC59-0AL■ M3N
Terminal box position	Terminal box on right hand side	1PC1341-3AC59-0AL5 M3N
Options	Mounting of rotary pulse encoder POG10DN1024I + FSL	1PC1341-3AC59-0AL5-Z M3N+G10
Options	Standard shaft made of stainless steel	1PC1341-3AC59-0AL5-Z M3N+G10+L06
Options	Anti-condensation heating for 230 V AC (2 terminals)	1PC1341-3AC59-0AL5-Z M3N+G10+L06+Q02

## SIMOTICS DP – Crane duty motors

## SIMOTICS DP – 1PC1361: Non-ventilated

## Selection and ordering data

Frame-size	Rated speed	Rated output	Rated torque	Rated current			Power factor	Break-down torque	Moment of inertia	<b>1PC13</b> 400 VA, 50 Hz 500 VA, 50 Hz 690 VA, 50 Hz	Weight, approx. (without brake)
				$I_{rated}$ 400 V	$I_{rated}$ 500 V	$I_{rated}$ 690 V					
FS	$n_{rated}$ rpm	$P_{rated}$ kW	$M_{rated}$ Nm	$I_{rated}$ A	$I_{rated}$ A	$I_{rated}$ A	$\cos \varphi$	Nm	$J$ kgm <sup>2</sup>	Article No.	kg
<b>4-pole, 1500 rpm</b>											
<b>Intermittent duty S3 – 15 % or S2 – 30 min.</b>											
<b>132S</b>	1460	6.6	43	13.5	10.8	7.8	0.82	100	0.027	<b>1PC1361-1CB09-0</b> ■■■■	61
<b>132M</b>	1450	9	59	17.9	14.3	10.4	0.83	147	0.034	<b>1PC1361-1CB29-0</b> ■■■■	75
<b>160M</b>	1460	13.2	86	26	21	15	0.83	213	0.065	<b>1PC1361-1DB29-0</b> ■■■■	96
<b>160L</b>	1470	18	117	35	28	20.5	0.83	300	0.083	<b>1PC1361-1DB49-0</b> ■■■■	104
<b>180M</b>	1455	22.2	146	42	33.5	24.5	0.85	411	0.120	<b>1PC1361-1EB29-0</b> ■■■■	160
<b>180L</b>	1455	26.4	173	49.5	39.5	28.5	0.85	500	0.130	<b>1PC1361-1EB49-0</b> ■■■■	170
<b>180L</b>	1450	36	237	69	55	40	0.83	646	0.159	<b>1PC1361-1EB69-0</b> ■■■■	185
<b>200L</b>	1460	36	235	67	54	38.5	0.85	605	0.200	<b>1PC1361-2AB59-0</b> ■■■■	230
<b>200L</b>	1460	44	288	81	65	47.0	0.85	720	0.246	<b>1PC1361-2AB69-0</b> ■■■■	240
<b>200L</b>	1475	54	350	104	83	60	0.8	1051	0.275	<b>1PC1361-2AB79-0</b> ■■■■	260
<b>225S</b>	1465	44	287	79	63	45.5	0.88	680	0.420	<b>1PC1361-2BB09-0</b> ■■■■	280
<b>225M</b>	1465	54	352	96	77	56	0.88	890	0.460	<b>1PC1361-2BB29-0</b> ■■■■	305
<b>225M</b>	1470	66	429	122	98	71	0.84	940	0.470	<b>1PC1361-2BB69-0</b> ■■■■	320
<b>250M</b>	1475	66	427	121	96	70	0.85	1060	0.750	<b>1PC1361-2CB29-0</b> ■■■■	385
<b>250M</b>	1478	90	581	162	129	94	0.86	1340	0.850	<b>1PC1361-2CB69-0</b> ■■■■	440
<b>250M</b>	1480	108	697	196	157	113	0.85	1950	1.200	<b>1PC1361-2CB79-0</b> ■■■■	480
<b>280S</b>	1480	90	581	157	126	91	0.88	1430	1.300	<b>1PC1361-2DB09-0</b> ■■■■	550
<b>280M</b>	1482	108	696	192	154	111	0.86	1770	1.400	<b>1PC1361-2DB29-0</b> ■■■■	570
<b>280M</b>	1482	132	851	230	185	134	0.87	2090	1.700	<b>1PC1361-2DB69-0</b> ■■■■	680
<b>280M</b>	1478	158	1021	275	220	160	0.88	2250	1.800	<b>1PC1361-2DB79-0</b> ■■■■	750
<b>4-pole, 1500 rpm</b>											
<b>Data for cooling with wind ~ 10 m/s IC418</b>											
<b>Intermittent duty S3 – 15 %</b>											
<b>160 M</b>	1445	18.3	121	36	29	21	0.86	213	0.055	<b>1PC1361-1DB29-0</b> ■■■■	96
<b>160 L</b>	1450	25.8	170	49.5	39.5	28.5	0.85	301	0.071	<b>1PC1361-1DB49-0</b> ■■■■	104
<b>180 M</b>	1430	32.6	218	60	48	35	0.88	411	0.120	<b>1PC1361-1EB29-0</b> ■■■■	160
<b>180 L</b>	1432	38.8	259	72	58	41.5	0.87	501	0.130	<b>1PC1361-1EB49-0</b> ■■■■	170
<b>180 L</b>	1428	52.9	354	100	80	58	0.85	647	0.160	<b>1PC1361-1EB69-0</b> ■■■■	185
<b>200 L</b>	1442	51.6	342	96	77	56	0.88	605	0.200	<b>1PC1361-2AB59-0</b> ■■■■	230
<b>200 L</b>	1442	61.6	408	113	90	66	0.87	720	0.250	<b>1PC1361-2AB69-0</b> ■■■■	240
<b>200 L</b>	1448	81.3	536	151	121	88	0.84	1044	0.280	<b>1PC1361-2AB79-0</b> ■■■■	260
Type of construction											
IMB3, IM1001 horizontal foot mounted											A F G
IMB5, IM3001 horizontal flange mounted											
IMV1, IM3011 vertical flange mounted											
Further types of construction, code numbers, order codes and descriptions, see page 2/36.											
Motor protection											
Without winding protection											A B C F G H K L
3 x PTC for tripping, 2 terminals											
6 x PTC for tripping and warning, 4 terminals											
1 x KTY84, 2 terminals											
2 x KTY84, 4 terminals											
3 x Pt100, 6 terminals											
1 x Pt1000, 2 terminals											
2 x Pt1000, 4 terminals											
Further motor protection, code numbers, order codes and descriptions, see page 2/37.											
Terminal box position											
Terminal box at top											4 5 6
Terminal box at right side											
Terminal box at top left side											
Further terminal box positions, code numbers, order codes and descriptions, see page 2/38.											
Winding											
400 VA, 50 Hz											Order code M4B M4C M4D M4F
460 VA, 50 Hz											
500 VA, 50 Hz											
690 VA, 50 Hz											
Further voltages, code numbers, order codes and descriptions, see page 2/35.											

For inertia mass and weight of brakes, see technical specifications for KFB spring-set brake for SIMOTICS DP 1PC134, 1PC136.

For ordering example, see Page 2/34.

**SIMOTICS DP – Crane duty motors**  
SIMOTICS DP – 1PC1361: Non-ventilated

**Selection and ordering data**

Frame-size	Rated speed	Rated output	Rated torque	Rated current			Power factor	Break-down torque	Moment of inertia	<b>1PC13</b> 400 VΔ, 50 Hz 500 VΔ, 50 Hz 690 VΔ, 50 Hz	Weight, approx. (without brake)
				$I_{rated}$ 400 V	$I_{rated}$ 500 V	$I_{rated}$ 690 V					
FS	$n_{rated}$ rpm	$P_{rated}$ kW	$M_{rated}$ Nm	$I_{rated}$ A	$I_{rated}$ A	$I_{rated}$ A	cos φ	Nm	J kgm <sup>2</sup>	Article No.	kg
<b>4-pole, 1500 rpm</b>											
<b>Intermittent duty S3 – 25 % or S2 – 60 min.</b>											
<b>132S</b>	1465	5.5	36	11.3	9	6.6	0.8	100	0.027	<b>1PC1361-1CB09-0</b> ■■■■	61
<b>132M</b>	1460	7.5	49	14.9	11.9	8.6	0.82	147	0.034	<b>1PC1361-1CB29-0</b> ■■■■	75
<b>160M</b>	1470	11	71	21.5	17.2	12.5	0.82	213	0.065	<b>1PC1361-1DB29-0</b> ■■■■	96
<b>160L</b>	1475	15	97	29.5	23.5	17.1	0.81	300	0.083	<b>1PC1361-1DB49-0</b> ■■■■	104
<b>180M</b>	1465	18.5	121	35	28	20	0.84	411	0.120	<b>1PC1361-1EB29-0</b> ■■■■	160
<b>180L</b>	1465	22	143	41.5	33	24	0.84	500	0.130	<b>1PC1361-1EB49-0</b> ■■■■	170
<b>180L</b>	1465	30	196	58	46.5	33.5	0.81	646	0.159	<b>1PC1361-1EB69-0</b> ■■■■	185
<b>200L</b>	1470	30	195	56	49	32.5	0.84	605	0.200	<b>1PC1361-2AB59-0</b> ■■■■	230
<b>200L</b>	1470	37	240	69	55	40	0.84	720	0.246	<b>1PC1361-2AB69-0</b> ■■■■	240
<b>200L</b>	1472	45	292	89	71	52	0.78	1051	0.275	<b>1PC1361-2AB79-0</b> ■■■■	260
<b>225S</b>	1470	37	240	66	52	38	0.88	680	0.420	<b>1PC1361-2BB09-0</b> ■■■■	280
<b>225M</b>	1475	45	291	80	64	46.5	0.87	890	0.460	<b>1PC1361-2BB29-0</b> ■■■■	305
<b>225M</b>	1475	55	356	101	81	59	0.84	940	0.470	<b>1PC1361-2BB69-0</b> ■■■■	320
<b>250M</b>	1480	55	355	100	80	58	0.85	1060	0.750	<b>1PC1361-2CB29-0</b> ■■■■	385
<b>250M</b>	1480	75	484	134	107	78	0.86	1340	0.850	<b>1PC1361-2CB69-0</b> ■■■■	440
<b>250M</b>	1482	90	580	164	131	95	0.84	1950	1.200	<b>1PC1361-2CB79-0</b> ■■■■	480
<b>280S</b>	1485	75	482	132	105	76	0.87	1430	1.300	<b>1PC1361-2DB09-0</b> ■■■■	550
<b>280M</b>	1485	90	579	161	129	93	0.85	1770	1.400	<b>1PC1361-2DB29-0</b> ■■■■	570
<b>280M</b>	1485	110	707	194	155	113	0.86	2090	1.700	<b>1PC1361-2DB69-0</b> ■■■■	680
<b>280M</b>	1482	132	851	230	185	134	0.87	2250	1.800	<b>1PC1361-2DB79-0</b> ■■■■	750

<b>4-pole, 1500 rpm</b>											
<b>Data for cooling with wind ~ 10 m/s IC418</b>											
<b>Intermittent duty S3 – 25 %</b>											
<b>160 M</b>	1450	16	105	31.5	25	18.2	0.85	213	0.055	<b>1PC1361-1DB29-0</b> ■■■■	96
<b>160 L</b>	1460	21.8	143	42	33.6	24.5	0.84	301	0.071	<b>1PC1361-1DB49-0</b> ■■■■	104
<b>180 M</b>	1440	26.9	178	50	40	29	0.87	411	0.120	<b>1PC1361-1EB29-0</b> ■■■■	160
<b>180 L</b>	1445	32	211	60	48	35	0.86	501	0.130	<b>1PC1361-1EB49-0</b> ■■■■	170
<b>180 L</b>	1440	43.6	289	83	66	48	0.84	647	0.160	<b>1PC1361-1EB69-0</b> ■■■■	185
<b>200 L</b>	1450	44.5	293	82	66	47.5	0.87	605	0.200	<b>1PC1361-2AB59-0</b> ■■■■	230
<b>200 L</b>	1450	54.8	361	101	81	59	0.86	720	0.250	<b>1PC1361-2AB69-0</b> ■■■■	240
<b>200 L</b>	1458	66.7	437	126	101	73	0.83	1044	0.280	<b>1PC1361-2AB79-0</b> ■■■■	260

Type of construction	IMB3, IM1001 horizontal foot mounted IMB5, IM3001 horizontal flange mounted IMV1, IM3011 vertical flange mounted Further types of construction, code numbers, order codes and descriptions, see page 2/36.	A F G
Motor protection	Without winding protection 3 x PTC for tripping, 2 terminals 6 x PTC for tripping and warning, 4 terminals 1 x KTY84, 2 terminals 2 x KTY84, 4 terminals 3 x Pt100, 6 terminals 1 x Pt1000, 2 terminals 2 x Pt1000, 4 terminals Further motor protection, code numbers, order codes and descriptions, see page 2/37.	A B C F G H K L
Terminal box position	Terminal box at top Terminal box at right side Terminal box at top left side Further terminal box positions, code numbers, order codes and descriptions, see page 2/38.	4 5 6
Winding	400 VΔ, 50 Hz 460 VΔ, 50 Hz 500 VΔ, 50 Hz 690 VΔ, 50 Hz Further voltages, code numbers, order codes and descriptions, see page 2/35.	Order code M4B M4C M4D M4F

For inertia mass and weight of brakes, see technical specifications for KFB spring-set brake for SIMOTICS DP 1PC134, 1PC136.

For ordering example, see Page 2/34.



## SIMOTICS DP – Crane duty motors

## SIMOTICS DP – 1PC1361: Non-ventilated

## Selection and ordering data

Frame-size	Rated speed	Rated output	Rated torque	Rated current			Power factor	Break-down torque	Moment of inertia	<b>1PC13</b> 400 VA, 50 Hz 500 VA, 50 Hz 690 VA, 50 Hz	Weight, approx. (without brake)
				$I_{rated}$ 400 V	$I_{rated}$ 500 V	$I_{rated}$ 690 V					
FS	$n_{rated}$ rpm	$P_{rated}$ kW	$M_{rated}$ Nm	$I_{rated}$ A	$I_{rated}$ A	$I_{rated}$ A	$\cos \varphi$	Nm	$J$ kgm <sup>2</sup>	Article No.	kg
<b>4-pole, 1500 rpm</b>											
<b>Intermittent duty S3 – 40 %</b>											
<b>132S</b>	1475	4.4	28	9.7	7.8	5.6	0.75	100	0.027	<b>1PC1361-1CB09-0</b> ■■■■	61
<b>132M</b>	1470	6	39	12.4	9.9	7.2	0.79	147	0.034	<b>1PC1361-1CB29-0</b> ■■■■	75
<b>160M</b>	1475	8.8	57	18.2	14.6	10.5	0.79	213	0.065	<b>1PC1361-1DB29-0</b> ■■■■	96
<b>160L</b>	1480	12	77	25	20	14.5	0.76	300	0.083	<b>1PC1361-1DB49-0</b> ■■■■	104
<b>180M</b>	1470	14.8	96	29	23	16.8	0.81	411	0.120	<b>1PC1361-1EB29-0</b> ■■■■	160
<b>180L</b>	1475	17.6	114	34	27	19.7	0.81	500	0.130	<b>1PC1361-1EB49-0</b> ■■■■	170
<b>180L</b>	1470	24	156	48	38.5	28	0.78	646	0.159	<b>1PC1361-1EB69-0</b> ■■■■	185
<b>200L</b>	1475	24	155	46	37	26.5	0.82	605	0.200	<b>1PC1361-2AB59-0</b> ■■■■	230
<b>200L</b>	1475	29	188	56	45	32.5	0.8	720	0.246	<b>1PC1361-2AB69-0</b> ■■■■	240
<b>200L</b>	1480	36	232	77	62	44.5	0.72	1051	0.275	<b>1PC1361-2AB79-0</b> ■■■■	260
<b>225S</b>	1478	29	187	52	41.5	30	0.86	680	0.420	<b>1PC1361-2BB09-0</b> ■■■■	280
<b>225M</b>	1478	36	233	65	52	37.5	0.86	890	0.460	<b>1PC1361-2BB29-0</b> ■■■■	305
<b>225M</b>	1482	44	284	82	66	47.5	0.82	940	0.470	<b>1PC1361-2BB69-0</b> ■■■■	320
<b>250M</b>	1485	44	283	81	65	47	0.83	1060	0.750	<b>1PC1361-2CB29-0</b> ■■■■	385
<b>250M</b>	1485	60	386	108	86	63	0.85	1340	0.850	<b>1PC1361-2CB69-0</b> ■■■■	440
<b>250M</b>	1488	72	462	134	107	78	0.82	1950	1.200	<b>1PC1361-2CB79-0</b> ■■■■	480
<b>280S</b>	1488	60	385	107	86	62	0.85	1430	1.300	<b>1PC1361-2DB09-0</b> ■■■■	550
<b>280M</b>	1488	72	462	133	107	77	0.82	1770	1.400	<b>1PC1361-2DB29-0</b> ■■■■	570
<b>280M</b>	1488	88	565	161	129	93	0.83	2090	1.700	<b>1PC1361-2DB69-0</b> ■■■■	680
<b>280M</b>	1485	105	675	190	152	110	0.84	2250	1.800	<b>1PC1361-2DB79-0</b> ■■■■	750

<b>4-pole, 1500 rpm</b>											
<b>Data for cooling with wind ~ 10 m/s IC418</b>											
<b>Intermittent duty S3 – 40 %</b>											
<b>160 M</b>	1460	13.7	90	27	21.5	15.6	0.84	213	0.055	<b>1PC1361-1DB29-0</b> ■■■■	96
<b>160 L</b>	1465	18.7	122	36	29	21	0.83	301	0.071	<b>1PC1361-1DB49-0</b> ■■■■	104
<b>180 M</b>	1450	23.1	152	43.5	35	25	0.86	411	0.120	<b>1PC1361-1EB29-0</b> ■■■■	160
<b>180 L</b>	1455	27.5	180	52	41.5	30	0.85	501	0.130	<b>1PC1361-1EB49-0</b> ■■■■	170
<b>180 L</b>	1450	37.4	246	72	58	41.5	0.83	647	0.160	<b>1PC1361-1EB69-0</b> ■■■■	185
<b>200 L</b>	1460	37.9	248	71	57	41	0.85	605	0.200	<b>1PC1361-2AB59-0</b> ■■■■	230
<b>200 L</b>	1458	46.8	307	87	70	50	0.85	720	0.250	<b>1PC1361-2AB69-0</b> ■■■■	240
<b>200 L</b>	1465	56.9	371	109	87	63	0.81	1044	0.280	<b>1PC1361-2AB79-0</b> ■■■■	260

## Type of construction

IMB3, IM1001 horizontal foot mounted  
 IMB5, IM3001 horizontal flange mounted  
 IMV1, IM3011 vertical flange mounted

Further types of construction, code numbers, order codes and descriptions, see page 2/36.

## Motor protection

Without winding protection  
 3 x PTC for tripping, 2 terminals  
 6 x PTC for tripping and warning, 4 terminals  
 1 x KTY84, 2 terminals  
 2 x KTY84, 4 terminals  
 3 x Pt100, 6 terminals  
 1 x Pt1000, 2 terminals  
 2 x Pt1000, 4 terminals

Further motor protection, code numbers, order codes and descriptions, see page 2/37.

## Terminal box position

Terminal box at top  
 Terminal box at right side  
 Terminal box at top left side

Further terminal box positions, code numbers, order codes and descriptions, see page 2/38.

## Winding

400 VA, 50 Hz  
 460 VA, 50 Hz  
 500 VA, 50 Hz  
 690 VA, 50 Hz

Further voltages, code numbers, order codes and descriptions, see page 2/35.

A  
F  
GA  
B  
C  
F  
G  
H  
K  
L4  
5  
6

## Order code

M4B  
M4C  
M4D  
M4F

For inertia mass and weight of brakes, see technical specifications for KFB spring-set brake for SIMOTICS DP 1PC134, 1PC136.

For ordering example, see Page 2/34.

## SIMOTICS DP – Crane duty motors

### SIMOTICS DP – 1PC1361: Non-ventilated

#### Selection and ordering data

Frame-size	Rated speed	Rated output	Rated torque	Rated current			Power factor	Break-down torque	Moment of inertia	<b>1PC13</b> 400 VΔ, 50 Hz 500 VΔ, 50 Hz 690 VΔ, 50 Hz	Weight, approx. (without brake)
				$I_{rated}$ 400 V	$I_{rated}$ 500 V	$I_{rated}$ 690 V					
FS	$n_{rated}$ rpm	$P_{rated}$ kW	$M_{rated}$ Nm	$I_{rated}$ A	$I_{rated}$ A	$I_{rated}$ A	cos φ	Nm	J kgm <sup>2</sup>	Article No.	kg
<b>4-pole, 1500 rpm</b>											
<b>Intermittent duty S3 – 60 %</b>											
<b>132S</b>	1480	3.3	21	8.2	6.6	4.8	0.68	100	0.027	<b>1PC1361-1CB09-0</b> ■■■■	61
<b>132M</b>	1475	4.5	29	10.2	8.2	5.9	0.72	147	0.034	<b>1PC1361-1CB29-0</b> ■■■■	75
<b>160M</b>	1482	6.6	43	14.7	11.8	8.5	0.73	213	0.065	<b>1PC1361-1DB29-0</b> ■■■■	96
<b>160L</b>	1485	9	58	21.5	17.2	12.5	0.68	300	0.083	<b>1PC1361-1DB49-0</b> ■■■■	104
<b>180M</b>	1480	11.1	72	23.5	18.8	13.6	0.74	411	0.120	<b>1PC1361-1EB29-0</b> ■■■■	160
<b>180L</b>	1480	13.2	85	27.5	22	15.9	0.75	500	0.130	<b>1PC1361-1EB49-0</b> ■■■■	170
<b>180L</b>	1478	18	116	39.5	31.5	23	0.71	646	0.159	<b>1PC1361-1EB69-0</b> ■■■■	185
<b>200L</b>	1482	18	116	37	29.5	21.5	0.76	605	0.200	<b>1PC1361-2AB59-0</b> ■■■■	230
<b>200L</b>	1482	22	142	45.5	36.5	26.5	0.75	720	0.246	<b>1PC1361-2AB69-0</b> ■■■■	240
<b>200L</b>	1485	27	174	66	41.5	38	0.64	1051	0.275	<b>1PC1361-2AB79-0</b> ■■■■	260
<b>225S</b>	1485	22	141	41	32.5	23.5	0.83	680	0.420	<b>1PC1361-2BB09-0</b> ■■■■	280
<b>225M</b>	1485	27	174	51	40.5	29.5	0.82	890	0.460	<b>1PC1361-2BB29-0</b> ■■■■	305
<b>225M</b>	1486	33	212	65	52	37.5	0.78	940	0.470	<b>1PC1361-2BB69-0</b> ■■■■	320
<b>250M</b>	1490	33	211	64	51	37	0.79	1060	0.750	<b>1PC1361-2CB29-0</b> ■■■■	385
<b>250M</b>	1490	45	288	85	68	49	0.81	1340	0.850	<b>1PC1361-2CB69-0</b> ■■■■	440
<b>250M</b>	1491	54	346	106	85	61	0.78	1950	1.200	<b>1PC1361-2CB79-0</b> ■■■■	480
<b>280S</b>	1491	45	288	86	69	49.5	0.8	1430	1.300	<b>1PC1361-2DB09-0</b> ■■■■	550
<b>280M</b>	1491	54	346	109	87	63	0.75	1770	1.400	<b>1PC1361-2DB29-0</b> ■■■■	570
<b>280M</b>	1491	66	423	128	103	74	0.78	2090	1.700	<b>1PC1361-2DB69-0</b> ■■■■	680
<b>280M</b>	1490	79	506	153	123	89	0.78	2250	1.800	<b>1PC1361-2DB79-0</b> ■■■■	750
<b>4-pole, 1500 rpm</b>											
<b>Data for cooling with wind ~ 10 m/s IC418</b>											
<b>Intermittent duty S3 – 60 %</b>											
<b>160 M</b>	1465	12.3	80	24.5	19.6	14.1	0.83	213	0.055	<b>1PC1361-1DB29-0</b> ■■■■	96
<b>160 L</b>	1470	16.8	109	32.5	26	18.8	0.82	301	0.071	<b>1PC1361-1DB49-0</b> ■■■■	104
<b>180 M</b>	1458	20.6	135	38.5	31	22.5	0.85	411	0.120	<b>1PC1361-1EB29-0</b> ■■■■	160
<b>180 L</b>	1460	24.6	161	46.5	37	27	0.85	501	0.130	<b>1PC1361-1EB49-0</b> ■■■■	170
<b>180 L</b>	1455	33.5	220	64	51	37	0.82	647	0.160	<b>1PC1361-1EB69-0</b> ■■■■	185
<b>200 L</b>	1465	33.7	220	63	50	36.5	0.84	605	0.200	<b>1PC1361-2AB59-0</b> ■■■■	230
<b>200 L</b>	1462	41.6	272	77	62	44.5	0.85	720	0.250	<b>1PC1361-2AB69-0</b> ■■■■	240
<b>200 L</b>	1470	50.6	329	98	78	57	0.79	1044	0.280	<b>1PC1361-2AB79-0</b> ■■■■	260
Type of construction											
IMB3, IM1001 horizontal foot mounted											A F G
IMB5, IM3001 horizontal flange mounted											
IMV1, IM3011 vertical flange mounted											
Further types of construction, code numbers, order codes and descriptions, see page 2/36.											
Motor protection											
Without winding protection											A B C F G H K L
3 x PTC for tripping, 2 terminals											
6 x PTC for tripping and warning, 4 terminals											
1 x KTY84, 2 terminals											
2 x KTY84, 4 terminals											
3 x Pt100, 6 terminals											
1 x Pt1000, 2 terminals											
2 x Pt1000, 4 terminals											
Further motor protection, code numbers, order codes and descriptions, see page 2/37.											
Terminal box position											
Terminal box at top											4 5 6
Terminal box at right side											
Terminal box at top left side											
Further terminal box positions, code numbers, order codes and descriptions, see page 2/38.											
Winding											
400 VΔ, 50 Hz											Order code M4B M4C M4D M4F
460 VΔ, 50 Hz											
500 VΔ, 50 Hz											
690 VΔ, 50 Hz											
Further voltages, code numbers, order codes and descriptions, see page 2/35.											

For inertia mass and weight of brakes, see technical specifications for KFB spring-set brake for SIMOTICS DP 1PC134, 1PC136.

For ordering example, see Page 2/34.

# SIMOTICS DP – Crane duty motors

## SIMOTICS DP – 1PC1361: Non-ventilated

### Selection and ordering data

Frame-size	Rated speed	Rated output	Rated torque	Rated current			Power factor	Efficiency	Break-down torque	Moment of inertia	<b>1PC13</b> 400 VΔ, 50 Hz 500 VΔ, 50 Hz 690 VΔ, 50 Hz	Weight, approx. (without brake)
FS	$n_{rated}$	$P_{rated}$	$M_{rated}$	$I_{rated}$ 400 V	$I_{rated}$ 500 V	$I_{rated}$ 690 V	$\cos \varphi$	$\eta$		$J$	Article No.	kg
	rpm	kW	Nm	A	A	A	%	%	Nm	kgm <sup>2</sup>		

#### 4-pole, 1500 rpm

#### Intermittent duty S9: Duty with non-periodic variation in load and speed

<b>132S</b>	1488	2.0	13	6.7	5.4	3.9	0.51	83.9	100	0.027	<b>1PC1361-1CB09-0</b> ■■■■	61
<b>132M</b>	1485	2.8	18	8.1	6.6	4.7	0.57	85.3	147	0.034	<b>1PC1361-1CB29-0</b> ■■■■	75
<b>160M</b>	1490	4.1	26	11.7	9.4	6.8	0.58	86.7	213	0.065	<b>1PC1361-1DB29-0</b> ■■■■	96
<b>160L</b>	1490	5.6	36	17.3	13.9	10.0	0.53	87.7	300	0.083	<b>1PC1361-1DB49-0</b> ■■■■	104
<b>180M</b>	1488	6.9	44	18.4	15.0	10.9	0.60	88.4	411	0.120	<b>1PC1361-1EB29-0</b> ■■■■	160
<b>180L</b>	1488	8.2	53	22.0	17.4	12.8	0.61	88.9	500	0.130	<b>1PC1361-1EB49-0</b> ■■■■	170
<b>180L</b>	1485	11.2	72	32.0	25.5	18.6	0.56	89.8	646	0.159	<b>1PC1361-1EB69-0</b> ■■■■	185
<b>200L</b>	1490	11.2	72	28.0	23.0	16.2	0.63	89.8	605	0.200	<b>1PC1361-2AB59-0</b> ■■■■	230
<b>200L</b>	1488	13.8	89	35.5	29.0	20.5	0.61	90.4	720	0.246	<b>1PC1361-2AB69-0</b> ■■■■	240
<b>200L</b>	1492	16.8	108	56.0	40.0	28.5	0.48	90.9	1051	0.275	<b>1PC1361-2AB79-0</b> ■■■■	260
<b>225S</b>	1490	13.8	88	30.0	24.0	17.3	0.72	92.7	680	0.420	<b>1PC1361-2BB09-0</b> ■■■■	280
<b>225M</b>	1491	16.8	108	37.0	30.0	21.5	0.70	93.1	890	0.460	<b>1PC1361-2BB29-0</b> ■■■■	305
<b>225M</b>	1492	20.0	128	47.5	38.0	27.5	0.65	93.5	940	0.470	<b>1PC1361-2BB69-0</b> ■■■■	320
<b>250M</b>	1494	20.0	128	46.0	37.0	26.5	0.67	93.5	1060	0.750	<b>1PC1361-2CB29-0</b> ■■■■	385
<b>250M</b>	1493	28.0	179	66.0	53.0	38.5	0.65	94.0	1340	0.850	<b>1PC1361-2CB69-0</b> ■■■■	440
<b>250M</b>	1494	34.0	217	84.0	67.0	48.5	0.62	94.2	1950	1.200	<b>1PC1361-2CB79-0</b> ■■■■	480
<b>280S</b>	1494	28.0	179	64.0	51.0	37.0	0.67	94.0	1430	1.300	<b>1PC1361-2DB09-0</b> ■■■■	550
<b>280M</b>	1495	34.0	217	80.0	64.0	46.5	0.65	94.2	1770	1.400	<b>1PC1361-2DB29-0</b> ■■■■	570
<b>280M</b>	1495	41.0	262	99.0	80.0	58.0	0.63	94.5	2090	1.700	<b>1PC1361-2DB69-0</b> ■■■■	680
<b>280M</b>	1494	47.0	300	112.0	90.0	65.0	0.64	94.7	2250	1.800	<b>1PC1361-2DB79-0</b> ■■■■	750

#### 4-pole, 1500 rpm

#### Data for cooling with wind ~ 10 m/s IC418

#### Intermittent duty S9: Duty with non-periodic variation in load and speed

<b>160 M</b>	1470	11.0	71	21.5	17.2	12.5	0.82	89.8	213	0.065	<b>1PC1361-1DB29-0</b> ■■■■	96
<b>160 L</b>	1475	15.0	97	29.5	23.5	17.1	0.81	90.6	300	0.083	<b>1PC1361-1DB49-0</b> ■■■■	104
<b>180 M</b>	1465	18.5	121	35.0	28.0	20.0	0.84	91.2	411	0.12	<b>1PC1361-1EB29-0</b> ■■■■	160
<b>180 L</b>	1465	22.0	143	41.5	33.0	24.0	0.84	91.6	500	0.13	<b>1PC1361-1EB49-0</b> ■■■■	170
<b>180 L</b>	1465	30.0	196	58.0	46.5	33.5	0.81	92.3	646	0.159	<b>1PC1361-1EB69-0</b> ■■■■	185
<b>200 L</b>	1470	30.0	195	56.0	44.5	32.5	0.84	92.3	605	0.2	<b>1PC1361-2AB59-0</b> ■■■■	230
<b>200 L</b>	1470	37.0	240	69.0	55.0	40.0	0.84	92.7	720	0.246	<b>1PC1361-2AB69-0</b> ■■■■	240
<b>200 L</b>	1472	45.0	292	89.0	72.0	52.0	0.78	93.1	1051	0.275	<b>1PC1361-2AB79-0</b> ■■■■	260

#### Type of construction

IMB3, IM1001 horizontal foot mounted  
 IMB5, IM3001 horizontal flange mounted  
 IMV1, IM3011 vertical flange mounted

Further types of construction, code numbers, order codes and descriptions, see page 2/36.

#### Motor protection

Without winding protection  
 3 x PTC for tripping, 2 terminals  
 6 x PTC for tripping and warning, 4 terminals  
 1 x KTY84, 2 terminals  
 2 x KTY84, 4 terminals  
 3 x Pt100, 6 terminals  
 1 x Pt1000, 2 terminals  
 2 x Pt1000, 4 terminals

Further motor protection, code numbers, order codes and descriptions, see page 2/37.

#### Terminal box position

Terminal box at top  
 Terminal box at right side  
 Terminal box at top left side

Further terminal box positions, code numbers, order codes and descriptions, see page 2/38.

#### Winding

400 VΔ, 50 Hz  
 460 VΔ, 50 Hz  
 500 VΔ, 50 Hz  
 690 VΔ, 50 Hz

Further voltages, code numbers, order codes and descriptions, see page 2/35.

A  
F  
G  
  
A  
B  
C  
F  
G  
H  
K  
L  
  
4  
5  
6

#### Order code

M4B  
 M4C  
 M4D  
 M4F

For inertia mass and weight of brakes, see technical specifications for KFB spring-set brake for SIMOTICS DP 1PC134, 1PC136.

For ordering example, see Page 2/34.



## SIMOTICS DP – Crane duty motors

### SIMOTICS DP – 1PC1361: Non-ventilated

#### Selection and ordering data

Frame-size	Rated speed	Rated output	Rated torque	Rated current			Power factor	Break-down torque	Moment of inertia	<b>1PC13</b> 400 VΔ, 50 Hz 500 VΔ, 50 Hz 690 VΔ, 50 Hz	Weight, approx. (without brake)
				$I_{rated}$ 400 V	$I_{rated}$ 500 V	$I_{rated}$ 690 V					
FS	$n_{rated}$	$P_{rated}$	$M_{rated}$	$I_{rated}$	$I_{rated}$	$I_{rated}$	cos φ		$J$	Article No.	kg
	rpm	kW	Nm	A	A	A		Nm	kgm <sup>2</sup>		
<b>6-pole, 1000 rpm</b>											
<b>Intermittent duty S3 – 15 % or S2 – 30 min.</b>											
<b>132S</b>	960	3.6	36	8.3	6.6	4.8	0.74	72	0.024	<b>1PC1361-1CC09-0</b> ■■■■	56
<b>132M</b>	965	4.8	48	10.9	8.7	6.3	0.76	90	0.029	<b>1PC1361-1CC29-0</b> ■■■■	61
<b>132M</b>	965	6.6	65	14.9	11.9	8.6	0.76	140	0.037	<b>1PC1361-1CC39-0</b> ■■■■	70
<b>160M</b>	972	9	88	20	16	11.6	0.75	160	0.075	<b>1PC1361-1DC29-0</b> ■■■■	106
<b>160L</b>	965	13.2	131	28	22.5	16.2	0.77	237	0.098	<b>1PC1361-1DC49-0</b> ■■■■	122
<b>180L</b>	968	18	178	36.5	29	21	0.8	455	0.170	<b>1PC1361-1EC49-0</b> ■■■■	155
<b>180L</b>	968	22	217	45	36	26	0.79	525	0.206	<b>1PC1361-1EC69-0</b> ■■■■	165
<b>180L</b>	968	26	256	54	43	31.5	0.77	710	0.247	<b>1PC1361-1EC79-0</b> ■■■■	185
<b>200L</b>	970	22	217	43	34.5	25	0.82	470	0.250	<b>1PC1361-2AC49-0</b> ■■■■	200
<b>200L</b>	970	26	256	51	41	29.5	0.83	559	0.300	<b>1PC1361-2AC59-0</b> ■■■■	220
<b>200L</b>	970	36	354	72	58	41.5	0.78	794	0.381	<b>1PC1361-2AC69-0</b> ■■■■	240
<b>200L</b>	968	44	434	88	70	51	0.78	977	0.434	<b>1PC1361-2AC79-0</b> ■■■■	264
<b>225M</b>	975	36	353	68	54	39.5	0.84	770	0.580	<b>1PC1361-2BC29-0</b> ■■■■	300
<b>225M</b>	975	44	431	84	67	48.5	0.83	1030	0.670	<b>1PC1361-2BC69-0</b> ■■■■	325
<b>225M</b>	975	54	529	104	84	61	0.82	1290	0.790	<b>1PC1361-2BC79-0</b> ■■■■	395
<b>250M</b>	978	44	430	83	67	48.5	0.83	890	0.860	<b>1PC1361-2CC29-0</b> ■■■■	370
<b>250M</b>	978	54	527	100	80	58	0.85	1150	1.000	<b>1PC1361-2CC69-0</b> ■■■■	410
<b>250M</b>	980	66	643	123	98	71	0.84	1590	1.200	<b>1PC1361-2CC79-0</b> ■■■■	480
<b>280S</b>	982	54	525	101	81	58	0.84	1120	1.100	<b>1PC1361-2DC09-0</b> ■■■■	460
<b>280M</b>	982	66	642	121	97	70	0.85	1380	1.400	<b>1PC1361-2DC29-0</b> ■■■■	510
<b>280M</b>	982	90	875	164	131	95	0.85	2090	1.800	<b>1PC1361-2DC69-0</b> ■■■■	570
<b>280M</b>	985	108	1047	205	162	118	0.82	2670	1.900	<b>1PC1361-2DC79-0</b> ■■■■	630
Type of construction											
IMB3, IM1001 horizontal foot mounted											A
IMB5, IM3001 horizontal flange mounted											F
IMV1, IM3011 vertical flange mounted											G
Further types of construction, code numbers, order codes and descriptions, see page 2/36.											
Motor protection											
Without winding protection											A
3 x PTC for tripping, 2 terminals											B
6 x PTC for tripping and warning, 4 terminals											C
1 x KTY84, 2 terminals											F
2 x KTY84, 4 terminals											G
3 x Pt100, 6 terminals											H
1 x Pt1000, 2 terminals											K
2 x Pt1000, 4 terminals											L
Further motor protection, code numbers, order codes and descriptions, see page 2/37.											
Terminal box position											
Terminal box at top											4
Terminal box at right side											5
Terminal box at top left side											6
Further terminal box positions, code numbers, order codes and descriptions, see page 2/38.											
Winding											Order code
400 VΔ, 50 Hz											M4B
460 VΔ, 50 Hz											M4C
500 VΔ, 50 Hz											M4D
690 VΔ, 50 Hz											M4F
Further voltages, code numbers, order codes and descriptions, see page 2/35.											

For inertia mass and weight of brakes, see technical specifications for KFB spring-set brake for SIMOTICS DP 1PC134, 1PC136.

For ordering example, see Page 2/34.

**SIMOTICS DP – Crane duty motors**

## SIMOTICS DP – 1PC1361: Non-ventilated

**Selection and ordering data**

Frame-size	Rated speed	Rated output	Rated torque	Rated current			Power factor	Break-down torque	Moment of inertia	<b>1PC13</b> 400 VΔ, 50 Hz 500 VΔ, 50 Hz 690 VΔ, 50 Hz	Weight, approx. (without brake)
FS	$n_{rated}$	$P_{rated}$	$M_{rated}$	$I_{rated}$ 400 V	$I_{rated}$ 500 V	$I_{rated}$ 690 V	cos φ		$J$	Article No.	kg
	rpm	kW	Nm	A	A	A		Nm	kgm <sup>2</sup>		
<b>6-pole, 1000 rpm</b>											
<b>Intermittent duty S3 – 25 % or S2 – 60 min.</b>											
<b>132S</b>	970	3	29	7.2	5.8	4.2	0.72	72	0.024	<b>1PC1361-1CC09-0</b> ■■■■	56
<b>132M</b>	970	4	39	9.1	7.3	5.3	0.75	90	0.029	<b>1PC1361-1CC29-0</b> ■■■■	61
<b>132M</b>	972	5.5	54	12.5	10	7.2	0.74	140	0.037	<b>1PC1361-1CC39-0</b> ■■■■	70
<b>160M</b>	975	7.5	73	16.8	13.4	9.7	0.74	160	0.075	<b>1PC1361-1DC29-0</b> ■■■■	106
<b>160L</b>	975	11	108	23.5	18.8	13.6	0.76	237	0.098	<b>1PC1361-1DC49-0</b> ■■■■	122
<b>180L</b>	975	15	147	31	24.5	17.9	0.78	455	0.170	<b>1PC1361-1EC49-0</b> ■■■■	155
<b>180L</b>	975	18.5	181	38.5	31	22	0.77	525	0.206	<b>1PC1361-1EC69-0</b> ■■■■	165
<b>180L</b>	975	22	215	47	37.5	27	0.74	710	0.247	<b>1PC1361-1EC79-0</b> ■■■■	185
<b>200L</b>	978	18.5	181	36	29	21	0.82	470	0.250	<b>1PC1361-2AC49-0</b> ■■■■	200
<b>200L</b>	978	22	215	42.5	34	24.5	0.82	559	0.300	<b>1PC1361-2AC59-0</b> ■■■■	220
<b>200L</b>	975	30	294	61	49	35.5	0.77	794	0.381	<b>1PC1361-2AC69-0</b> ■■■■	240
<b>200L</b>	975	37	362	75	60	43.5	0.77	977	0.434	<b>1PC1361-2AC79-0</b> ■■■■	264
<b>225M</b>	978	30	293	58	46	33.5	0.82	770	0.580	<b>1PC1361-2BC29-0</b> ■■■■	300
<b>225M</b>	978	37	361	71	57	41	0.82	1030	0.670	<b>1PC1361-2BC69-0</b> ■■■■	325
<b>225M</b>	978	45	439	88	71	51	0.8	1290	0.790	<b>1PC1361-2BC79-0</b> ■■■■	395
<b>250M</b>	982	37	360	70	56	40.5	0.82	890	0.860	<b>1PC1361-2CC29-0</b> ■■■■	370
<b>250M</b>	982	45	438	83	67	48.5	0.84	1150	1.000	<b>1PC1361-2CC69-0</b> ■■■■	410
<b>250M</b>	985	55	533	102	81	59	0.84	1590	1.200	<b>1PC1361-2CC79-0</b> ■■■■	480
<b>280S</b>	985	45	436	83	66	48	0.84	1120	1.100	<b>1PC1361-2DC09-0</b> ■■■■	460
<b>280M</b>	985	55	533	100	80	58	0.85	1380	1.400	<b>1PC1361-2DC29-0</b> ■■■■	510
<b>280M</b>	986	75	726	136	109	79	0.85	2090	1.800	<b>1PC1361-2DC69-0</b> ■■■■	570
<b>280M</b>	988	90	870	170	136	99	0.81	2670	1.900	<b>1PC1361-2DC79-0</b> ■■■■	630
Type of construction											
IMB3, IM1001 horizontal foot mounted											A
IMB5, IM3001 horizontal flange mounted											F
IMV1, IM3011 vertical flange mounted											G
Further types of construction, code numbers, order codes and descriptions, see page 2/36.											
Motor protection											
Without winding protection											A
3 x PTC for tripping, 2 terminals											B
6 x PTC for tripping and warning, 4 terminals											C
1 x KTY84, 2 terminals											F
2 x KTY84, 4 terminals											G
3 x Pt100, 6 terminals											H
1 x Pt1000, 2 terminals											K
2 x Pt1000, 4 terminals											L
Further motor protection, code numbers, order codes and descriptions, see page 2/37.											
Terminal box position											
Terminal box at top											4
Terminal box at right side											5
Terminal box at top left side											6
Further terminal box positions, code numbers, order codes and descriptions, see page 2/38.											
Winding											Order code
400 VΔ, 50 Hz											M4B
460 VΔ, 50 Hz											M4C
500 VΔ, 50 Hz											M4D
690 VΔ, 50 Hz											M4F
Further voltages, code numbers, order codes and descriptions, see page 2/35.											

For inertia mass and weight of brakes, see technical specifications for KFB spring-set brake for SIMOTICS DP 1PC134, 1PC136.

For ordering example, see Page 2/34.

## SIMOTICS DP – Crane duty motors

### SIMOTICS DP – 1PC1361: Non-ventilated

#### Selection and ordering data

Frame-size	Rated speed	Rated output	Rated torque	Rated current			Power factor	Break-down torque	Moment of inertia	<b>1PC13</b> 400 VΔ, 50 Hz 500 VΔ, 50 Hz 690 VΔ, 50 Hz	Weight, approx. (without brake)
				$I_{rated}$ 400 V	$I_{rated}$ 500 V	$I_{rated}$ 690 V					
FS	$n_{rated}$	$P_{rated}$	$M_{rated}$	$I_{rated}$	$I_{rated}$	$I_{rated}$	cos φ		$J$	Article No.	kg
	rpm	kW	Nm	A	A	A		Nm	kgm <sup>2</sup>		
<b>6-pole, 1000 rpm</b>											
<b>Intermittent duty S3 – 40 %</b>											
<b>132S</b>	975	2.4	24	6.3	5	3.7	0.63	72	0.024	<b>1PC1361-1CC09-0</b> ■■■■	56
<b>132M</b>	978	3.2	31	8.2	6.6	4.8	0.67	90	0.029	<b>1PC1361-1CC29-0</b> ■■■■	61
<b>132M</b>	978	4.4	43	10.9	8.7	6.3	0.67	140	0.037	<b>1PC1361-1CC39-0</b> ■■■■	70
<b>160M</b>	985	6	58	14	11.2	8.1	0.7	160	0.075	<b>1PC1361-1DC29-0</b> ■■■■	106
<b>160L</b>	982	8.8	86	19.5	15.6	11.3	0.72	237	0.098	<b>1PC1361-1DC49-0</b> ■■■■	122
<b>180L</b>	980	12	117	26	21	15	0.73	455	0.170	<b>1PC1361-1EC49-0</b> ■■■■	155
<b>180L</b>	980	14.8	144	32.5	26	18.8	0.72	525	0.206	<b>1PC1361-1EC69-0</b> ■■■■	165
<b>180L</b>	980	17.6	172	40.5	32.5	23.5	0.69	710	0.247	<b>1PC1361-1EC79-0</b> ■■■■	185
<b>200L</b>	982	14.8	144	29.5	23.5	17.1	0.78	470	0.250	<b>1PC1361-2AC49-0</b> ■■■■	200
<b>200L</b>	982	17.6	171	35	28	20.5	0.79	559	0.300	<b>1PC1361-2AC59-0</b> ■■■■	220
<b>200L</b>	980	24	234	50	40	29	0.74	794	0.381	<b>1PC1361-2AC69-0</b> ■■■■	240
<b>200L</b>	980	29	283	63	50	36.5	0.72	977	0.434	<b>1PC1361-2AC79-0</b> ■■■■	264
<b>225M</b>	985	24	233	46	37	26.5	0.81	770	0.580	<b>1PC1361-2BC29-0</b> ■■■■	300
<b>225M</b>	985	29	281	56	45	32.5	0.8	1030	0.670	<b>1PC1361-2BC69-0</b> ■■■■	325
<b>225M</b>	982	36	350	72	57	41.5	0.78	1290	0.790	<b>1PC1361-2BC79-0</b> ■■■■	395
<b>250M</b>	986	29	281	56	44.5	32.5	0.8	890	0.860	<b>1PC1361-2CC29-0</b> ■■■■	370
<b>250M</b>	986	36	349	68	54	39.5	0.82	1150	1.000	<b>1PC1361-2CC69-0</b> ■■■■	410
<b>250M</b>	988	44	425	84	67	48.5	0.81	1590	1.200	<b>1PC1361-2CC79-0</b> ■■■■	480
<b>280S</b>	988	36	348	68	55	39.5	0.81	1120	1.100	<b>1PC1361-2DC09-0</b> ■■■■	460
<b>280M</b>	988	44	425	81	65	47	0.83	1380	1.400	<b>1PC1361-2DC29-0</b> ■■■■	510
<b>280M</b>	990	60	579	112	89	65	0.82	2090	1.800	<b>1PC1361-2DC69-0</b> ■■■■	570
<b>280M</b>	990	72	694	142	114	83	0.77	2670	1.900	<b>1PC1361-2DC79-0</b> ■■■■	630

#### Type of construction

IMB3, IM1001 horizontal foot mounted  
 IMB5, IM3001 horizontal flange mounted  
 IMV1, IM3011 vertical flange mounted

Further types of construction, code numbers, order codes and descriptions, see page 2/36.

#### Motor protection

Without winding protection  
 3 x PTC for tripping, 2 terminals  
 6 x PTC for tripping and warning, 4 terminals  
 1 x KTY84, 2 terminals  
 2 x KTY84, 4 terminals  
 3 x Pt100, 6 terminals  
 1 x Pt1000, 2 terminals  
 2 x Pt1000, 4 terminals

Further motor protection, code numbers, order codes and descriptions, see page 2/37.

#### Terminal box position

Terminal box at top  
 Terminal box at right side  
 Terminal box at top left side

Further terminal box positions, code numbers, order codes and descriptions, see page 2/38.

#### Winding

400 VΔ, 50 Hz  
 460 VΔ, 50 Hz  
 500 VΔ, 50 Hz  
 690 VΔ, 50 Hz

Further voltages, code numbers, order codes and descriptions, see page 2/35.

#### Order code

M4B  
 M4C  
 M4D  
 M4F

For inertia mass and weight of brakes, see technical specifications for KFB spring-set brake for SIMOTICS DP 1PC134, 1PC136.

For ordering example, see Page 2/34.

**SIMOTICS DP – Crane duty motors**

SIMOTICS DP – 1PC1361: Non-ventilated

**Selection and ordering data**

Frame-size	Rated speed	Rated output	Rated torque	Rated current			Power factor	Break-down torque	Moment of inertia	<b>1PC13</b> 400 VΔ, 50 Hz 500 VΔ, 50 Hz 690 VΔ, 50 Hz	Weight, approx. (without brake)
				$I_{rated}$ 400 V	$I_{rated}$ 500 V	$I_{rated}$ 690 V					
FS	$n_{rated}$ rpm	$P_{rated}$ kW	$M_{rated}$ Nm	$I_{rated}$ A	$I_{rated}$ A	$I_{rated}$ A	cos φ	Nm	$J$ kgm <sup>2</sup>	Article No.	kg
<b>6-pole, 1000 rpm</b>											
<b>Intermittent duty S3 – 60 %</b>											
<b>132S</b>	982	1.8	18	5.6	4.5	3.2	0.53	72	0.024	<b>1PC1361-1CC09-0</b> ■■■■	56
<b>132M</b>	985	2.4	23	7.1	5.7	4.1	0.58	90	0.029	<b>1PC1361-1CC29-0</b> ■■■■	61
<b>132M</b>	985	3.3	32	9.4	7.5	5.4	0.58	140	0.037	<b>1PC1361-1CC39-0</b> ■■■■	70
<b>160M</b>	988	4.5	43	11.8	9.4	6.8	0.64	160	0.075	<b>1PC1361-1DC29-0</b> ■■■■	106
<b>160L</b>	990	6.6	64	16	12.8	9.2	0.66	237	0.098	<b>1PC1361-1DC49-0</b> ■■■■	122
<b>180L</b>	985	9	87	22	17.6	12.7	0.65	455	0.170	<b>1PC1361-1EC49-0</b> ■■■■	155
<b>180L</b>	985	11.1	108	27.5	22	15.9	0.64	525	0.206	<b>1PC1361-1EC69-0</b> ■■■■	165
<b>180L</b>	985	13.2	128	34.5	27.5	19.9	0.6	710	0.247	<b>1PC1361-1EC79-0</b> ■■■■	185
<b>200L</b>	988	11.1	107	24	19.2	13.9	0.72	470	0.250	<b>1PC1361-2AC49-0</b> ■■■■	200
<b>200L</b>	985	13.2	128	28.5	23	16.5	0.74	559	0.300	<b>1PC1361-2AC59-0</b> ■■■■	220
<b>200L</b>	985	18	175	40.5	32.5	23.5	0.68	794	0.381	<b>1PC1361-2AC69-0</b> ■■■■	240
<b>200L</b>	985	22	213	53	42.5	30.5	0.64	977	0.434	<b>1PC1361-2AC79-0</b> ■■■■	264
<b>225M</b>	988	18	174	36.5	29.5	21.5	0.76	770	0.580	<b>1PC1361-2BC29-0</b> ■■■■	300
<b>225M</b>	988	22	213	45.5	36.5	26.5	0.75	1030	0.670	<b>1PC1361-2BC69-0</b> ■■■■	325
<b>225M</b>	988	27	261	58	46.5	33.5	0.72	1290	0.790	<b>1PC1361-2BC79-0</b> ■■■■	395
<b>250M</b>	990	22	212	45	36	26	0.75	890	0.860	<b>1PC1361-2CC29-0</b> ■■■■	370
<b>250M</b>	990	27	260	53	42.5	31	0.78	1150	1.000	<b>1PC1361-2CC69-0</b> ■■■■	410
<b>250M</b>	991	33	318	67	53	38.5	0.76	1590	1.200	<b>1PC1361-2CC79-0</b> ■■■■	480
<b>280S</b>	992	27	260	54	43.5	31.5	0.76	1120	1.100	<b>1PC1361-2DC09-0</b> ■■■■	460
<b>280M</b>	992	33	318	64	52	37.5	0.78	1380	1.400	<b>1PC1361-2DC29-0</b> ■■■■	510
<b>280M</b>	992	45	433	90	72	52	0.76	2090	1.800	<b>1PC1361-2DC69-0</b> ■■■■	570
<b>280M</b>	993	54	519	117	94	68	0.7	2670	1.900	<b>1PC1361-2DC79-0</b> ■■■■	630

## Type of construction

IMB3, IM1001 horizontal foot mounted  
 IMB5, IM3001 horizontal flange mounted  
 IMV1, IM3011 vertical flange mounted

Further types of construction, code numbers, order codes and descriptions, see page 2/36.

## Motor protection

Without winding protection  
 3 x PTC for tripping, 2 terminals  
 6 x PTC for tripping and warning, 4 terminals  
 1 x KTY84, 2 terminals  
 2 x KTY84, 4 terminals  
 3 x Pt100, 6 terminals  
 1 x Pt1000, 2 terminals  
 2 x Pt1000, 4 terminals

Further motor protection, code numbers, order codes and descriptions, see page 2/37.

## Terminal box position

Terminal box at top  
 Terminal box at right side  
 Terminal box at top left side

Further terminal box positions, code numbers, order codes and descriptions, see page 2/38.

## Winding

400 VΔ, 50 Hz  
 460 VΔ, 50 Hz  
 500 VΔ, 50 Hz  
 690 VΔ, 50 Hz

Further voltages, code numbers, order codes and descriptions, see page 2/35.

## Order code

M4B  
 M4C  
 M4D  
 M4F

For inertia mass and weight of brakes, see technical specifications for KFB spring-set brake for SIMOTICS DP 1PC134, 1PC136.

For ordering example, see Page 2/34.

# SIMOTICS DP – Crane duty motors

## SIMOTICS DP – 1PC1361: Non-ventilated

### Selection and ordering data

Frame-size	Rated speed	Rated output	Rated torque	Rated current			Power factor	Efficiency	Break-down torque	Moment of inertia	<b>1PC13</b> 400 VΔ, 50 Hz 500 VΔ, 50 Hz 690 VΔ, 50 Hz	Weight, approx. (without brake)
FS	$n_{rated}$	$P_{rated}$	$M_{rated}$	$I_{rated}$ 400 V	$I_{rated}$ 500 V	$I_{rated}$ 690 V	$\cos \varphi$	$\eta$		$J$	Article No.	kg
	rpm	kW	Nm	A	A	A		%	Nm	kgm <sup>2</sup>		
<b>6-pole, 1000 rpm</b>												
<b>Intermittent duty S9: Duty with non-periodic variation in load and speed</b>												
<b>132S</b>	990	1.1	11	5.1	4.2	3.0	0.39	78.1	72	0.024	<b>1PC1361-1CC09-0</b> ■■■■	56
<b>132M</b>	990	1.5	14	6.3	5.0	3.7	0.43	79.8	90	0.029	<b>1PC1361-1CC29-0</b> ■■■■	61
<b>132M</b>	990	2.0	19	8.3	6.6	4.8	0.43	81.3	140	0.037	<b>1PC1361-1CC39-0</b> ■■■■	70
<b>160M</b>	992	2.8	27	9.9	7.9	5.8	0.49	83.0	160	0.075	<b>1PC1361-1DC29-0</b> ■■■■	106
<b>160L</b>	992	4.1	39	13.0	11.0	7.5	0.51	84.7	237	0.098	<b>1PC1361-1DC49-0</b> ■■■■	122
<b>180L</b>	990	5.6	54	18.2	15.0	10.5	0.50	86.1	455	0.170	<b>1PC1361-1EC49-0</b> ■■■■	155
<b>180L</b>	990	6.9	67	23.0	18.7	13.3	0.49	86.9	525	0.206	<b>1PC1361-1EC69-0</b> ■■■■	165
<b>180L</b>	990	8.2	79	29.5	24.5	17.0	0.44	87.6	710	0.247	<b>1PC1361-1EC79-0</b> ■■■■	185
<b>200L</b>	992	6.9	66	18.9	15.8	11.0	0.58	86.9	470	0.250	<b>1PC1361-2AC49-0</b> ■■■■	200
<b>200L</b>	992	8.2	79	22.0	18.0	12.8	0.60	87.6	559	0.300	<b>1PC1361-2AC59-0</b> ■■■■	220
<b>200L</b>	992	11.2	108	31.5	27.0	18.3	0.54	88.7	794	0.381	<b>1PC1361-2AC69-0</b> ■■■■	240
<b>200L</b>	990	13.8	133	44.0	35.0	24.5	0.49	89.4	977	0.434	<b>1PC1361-2AC79-0</b> ■■■■	264
<b>225M</b>	993	11.2	108	28.0	22.5	16.2	0.63	91.7	770	0.580	<b>1PC1361-2BC29-0</b> ■■■■	300
<b>225M</b>	993	13.8	133	35.0	28.0	20.0	0.62	92.2	1030	0.670	<b>1PC1361-2BC69-0</b> ■■■■	325
<b>225M</b>	993	16.8	162	46.0	36.5	26.5	0.57	92.7	1290	0.790	<b>1PC1361-2BC79-0</b> ■■■■	395
<b>250M</b>	994	13.8	133	35.0	28.0	20.0	0.62	92.2	890	0.860	<b>1PC1361-2CC29-0</b> ■■■■	370
<b>250M</b>	994	16.8	161	40.0	32.0	23.5	0.65	92.7	1150	1.000	<b>1PC1361-2CC69-0</b> ■■■■	410
<b>250M</b>	995	20.0	192	50.0	40.0	29.0	0.62	93.1	1590	1.200	<b>1PC1361-2CC79-0</b> ■■■■	480
<b>280S</b>	995	16.8	161	42.0	34.0	24.5	0.62	92.7	1120	1.100	<b>1PC1361-2DC09-0</b> ■■■■	460
<b>280M</b>	995	20.0	192	49.0	39.5	28.5	0.63	93.1	1380	1.400	<b>1PC1361-2DC29-0</b> ■■■■	510
<b>280M</b>	995	28.0	269	70.0	56.0	40.5	0.62	93.7	2090	1.800	<b>1PC1361-2DC69-0</b> ■■■■	570
<b>280M</b>	995	32.0	307	89.0	71.0	52.0	0.55	94.0	2670	1.900	<b>1PC1361-2DC79-0</b> ■■■■	630
Type of construction												
IMB3, IM1001 horizontal foot mounted												A
IMB5, IM3001 horizontal flange mounted												F
IMV1, IM3011 vertical flange mounted												G
Further types of construction, code numbers, order codes and descriptions, see page 2/36.												
Motor protection												
Without winding protection												A
3 x PTC for tripping, 2 terminals												B
6 x PTC for tripping and warning, 4 terminals												C
1 x KTY84, 2 terminals												F
2 x KTY84, 4 terminals												G
3 x Pt100, 6 terminals												H
1 x Pt1000, 2 terminals												K
2 x Pt1000, 4 terminals												L
Further motor protection, code numbers, order codes and descriptions, see page 2/37.												
Terminal box position												
Terminal box at top												4
Terminal box at right side												5
Terminal box at top left side												6
Further terminal box positions, code numbers, order codes and descriptions, see page 2/38.												
Winding												Order code
400 VΔ, 50 Hz												M4B
460 VΔ, 50 Hz												M4C
500 VΔ, 50 Hz												M4D
690 VΔ, 50 Hz												M4F
Further voltages, code numbers, order codes and descriptions, see page 2/35.												

For inertia mass and weight of brakes, see technical specifications for KFB spring-set brake for SIMOTICS DP 1PC134, 1PC136.

For ordering example, see Page 2/34.

**SIMOTICS DP – Crane duty motors**

SIMOTICS DP – 1PC1361: Non-ventilated

**Options****Ordering example**

Non-ventilated gantry motor with brake and encoder in IM V1  
 1PC1361-1EB29-0GB4-Z M4B+F28+G07+F31+H08+Q02+R10

Selection criteria	Requirement	Structure of the Article No.
Motor type	Crane duty motor without fan (IC410), degree of protection IP55, cast iron design	<b>1PC1361-■■■■■-■■■■■</b>
Motor frame size/No. of poles/Speed	Motor in framesize 180, 4-pole version, 18.5 kW, S3-25 % (50 Hz-rating)	<b>1PC1361-1EB2■-■■■■■</b>
Voltage and frequency	Voltage: 400 VΔ, 50 Hz	<b>1PC1361-1EB29-0■■■■ M4B</b>
Motor protection	3 PTC thermistors for disconnection (2 terminals)	<b>1PC1361-1EB29-0G■■■ M4B</b>
Type of construction	IM V1 without canopy, flange: FF300 (A350)	<b>1PC1361-1EB29-0GB■ M4B</b>
Terminal box position	Terminal box at top	<b>1PC1361-1EB29-0GB4 M4B</b>
Options	Mounting of the brake KFB 16, 160 Nm	<b>1PC1361-1EB29-0GB4-Z M4B+F31</b>
Options	Mounting of POG 10 DN 1024 I rotary pulse encoder	<b>1PC1361-1EB29-0GB4-Z M4B+G07+F31</b>
Options	Mounting of rotary pulse encoder POG 10 to the brake	<b>1PC1361-1EB29-0GB4-Z M4B+F28+G07+F31</b>
Options	Terminal box on NDE	<b>1PC1361-1EB29-0GB4-Z M4B+F28+G07+F31+H08</b>
Options	Terminal box rotated by 90°, entry from DE (drive end)	<b>1PC1361-1EB29-0GB4-Z M4B+F28+G07+F31+H08+R10</b>
Options	Anti-condensation heating for 230 V (2 terminals)	<b>1PC1361-1EB29-0GB4-Z M4B+F28+G07+F31+H08+Q02+R10</b>

2

## SIMOTICS DP – Crane duty motors

Supplements to article numbers and special versions

### Voltages · Cast-iron series 1PC1341 and 1PC1361

#### Selection and ordering data

Voltages	Article No. supplements		Frame size								Motor version	
	Voltage code 12th and 13th position of the Article No.	Additional identification code with order code and plain text if required	132	160	180	200	225	250	280	315		
			<b>1PC1341</b>								TEFC (IC411)	1PC1341
			<b>1PC13 61</b>								TENV (IC410)	1PC1361
	<b>1PC13 . . . . .</b>	<b>- ■ - ■ . . .</b>										
		Order code										

#### Voltage at 50 Hz and 50 Hz power

400 VΔ	9 0	M4B	□	□	□	□	□	□	□	□	□
460 VΔ	9 0	M4C	✓	✓	✓	✓	✓	✓	✓	✓	✓
480 VΔ	9 0	M4L	✓	✓	✓	✓	✓	✓	✓	✓	✓
500 VΔ	9 0	M4D	□	□	□	□	□	□	□	□	✓
690 VΔ	9 0	M4F	✓	✓	✓	✓	✓	✓	✓	✓	✓

#### Voltage at 60 Hz and 60 Hz power

400 VΔ	9 0	M1N	✓	✓	✓	✓	✓	✓	✓	✓	✓
460 VΔ	9 0	M1F	✓	✓	✓	✓	✓	✓	✓	✓	✓
480 VΔ	9 0	M1L	✓	✓	✓	✓	✓	✓	✓	✓	✓
500 VΔ	9 0	M1P	✓	✓	✓	✓	✓	✓	✓	✓	✓
690 VΔ	9 0	M1Q	✓	✓	✓	✓	✓	✓	✓	✓	✓

#### Voltage at 69 Hz and 69 Hz power

400 VΔ	9 0	M3L	-	-	-	-	-	-	-	-	✓
460 VΔ	9 0	M3M	-	-	-	-	-	-	-	-	✓
500 VΔ	9 0	M3N	-	-	-	-	-	-	-	-	✓
690 VΔ	9 0	M3P	-	-	-	-	-	-	-	-	✓

#### Voltage at 87 Hz and 87 Hz power

400 VΔ	9 0	M3A	-	-	-	-	-	-	-	-	✓
460 VΔ	9 0	M3H	-	-	-	-	-	-	-	-	✓
500 VΔ	9 0	M3J	-	-	-	-	-	-	-	-	✓
690 VΔ	9 0	M3K	-	-	-	-	-	-	-	-	✓

#### Non-standard voltage and/or frequencies

Non-standard winding Reinforced insulation system (Advanced) <sup>1)</sup>	9 0	M1Y • and customer specifications	✓	✓	✓	✓	✓	✓	✓	✓	✓
Non-standard winding Special insulation system (Premium) <sup>2)</sup>	9 0	M2Y • and customer specifications	✓	✓	✓	✓	✓	✓	✓	✓	✓

- Standard version
- ✓ With additional charge
- Not possible

<sup>1)</sup> Plain text must be specified in the order: Voltage between 200 V and 460 V, frequency, circuit, for 60 Hz additionally required rated power in kW.







<sup>2)</sup> Plain text must be specified in the order: Converter-proof for voltages with special insulation up to 690 V.

## SIMOTICS DP – Crane duty motors

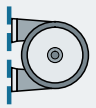
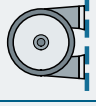
Supplements to article numbers and special versions

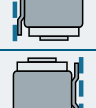
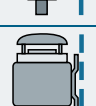
### Types of construction · Cast-iron series 1PC1341 and 1PC1361

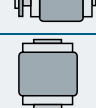
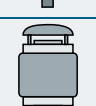
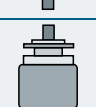
#### Selection and ordering data

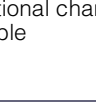
Types of construction	Article No. supplements	Frame size	Motor version								
			132	160	180	200	225	250	280	315	
	Type of construction letter 14th position of the Article No.	For types of construction with order code(s) Article No. With additional identification code <b>-Z</b> Order code									
		<b>1PC1341</b>	TEFC (IC411) 1PC1341								
		<b>1PC1361</b>	TENV (IC410) 1PC1361								
<b>1PC13</b> . . . . . ■ . .											
<b>Without flange</b>											
IM B3		<b>A</b>	-	□	□	□	□	□	□	□	
IM B6		<b>T</b>	-	□	□	□	□	□	□	□	
IM B7		<b>U</b>	-	□	□	□	□	□	□	□	
IM B8		<b>V</b>	-	□	□	□	□	□	□	□	
IM V6		<b>D</b>	-	□	□	□	□	□	□	□	
IM V5 without protective cover		<b>C</b>	-	□	□	□	□	□	□	□	
IM V5 with protective cover		<b>C</b>	<b>H00</b>	✓	✓	✓	✓	✓	✓	✓	TEFC (IC411) All except 1PC1361
<b>With flange</b>											
	acc. to EN 50347		FF265	FF300	FF300	FF350	FF400	FF500	FF500	FF600	
	acc. to DIN 42948		A 300	A 350	A 350	A 400	A 450	A 550	A 550	A 660	
IM B5		<b>F</b>	-	✓	✓	✓	✓	✓	✓	✓	-
IM V1 without protective cover		<b>G</b>	-	✓	✓	✓	✓	✓	✓	✓	✓
IM V1 with protective cover		<b>G</b>	<b>H00</b>	✓	✓	✓	✓	✓	✓	✓	TEFC (IC411) All except 1PC1361
IM V3		<b>H</b>	-	✓	✓	✓	✓	✓	✓	✓	-
IM B35		<b>J</b>	-	✓	✓	✓	✓	✓	✓	✓	✓

- Standard version
- ✓ With additional charge
- Not possible



## SIMOTICS DP – Crane duty motors

Supplements to article numbers and special versions

### Motor protection · Cast-iron series 1PC1341 and 1PC1361

#### Selection and ordering data

Motor protection	Article No. supplements		Frame size								Motor version	
	Motor protection code 15th position of the Article No.	Additional identification code with order code and plain text if required	132	160	180	200	225	250	280	315		
			<b>1PC1341</b>								TEFC (IC411)	1PC1341
			<b>1PC1361</b>								TENV (IC410)	1PC1361
<b>1PC13 . . . . .</b>	<b>■</b>	Order code										

#### Motor protection (winding protection)

Without (Standard)	<b>A</b>	–	<input type="checkbox"/>	<input type="checkbox"/>	<input type="checkbox"/>	<input type="checkbox"/>	<input type="checkbox"/>	<input type="checkbox"/>	<input type="checkbox"/>	<input type="checkbox"/>	<input type="checkbox"/>
3 PTC thermistors – for tripping (2 terminals) <sup>1)</sup>	<b>B</b>	–	<input checked="" type="checkbox"/>	<input checked="" type="checkbox"/>	<input checked="" type="checkbox"/>	<input checked="" type="checkbox"/>	<input checked="" type="checkbox"/>	<input checked="" type="checkbox"/>	<input checked="" type="checkbox"/>	<input checked="" type="checkbox"/>	<input checked="" type="checkbox"/>
6 PTC thermistors – for alarm and tripping (4 terminals) <sup>1)</sup>	<b>C</b>	–	<input checked="" type="checkbox"/>	<input checked="" type="checkbox"/>	<input checked="" type="checkbox"/>	<input checked="" type="checkbox"/>	<input checked="" type="checkbox"/>	<input checked="" type="checkbox"/>	<input checked="" type="checkbox"/>	<input checked="" type="checkbox"/>	<input checked="" type="checkbox"/>
1 KTY84-130 temperature sensor (2 terminals)	<b>F</b>	–	<input type="checkbox"/>	<input type="checkbox"/>	<input type="checkbox"/>	<input type="checkbox"/>	<input type="checkbox"/>	<input type="checkbox"/>	<input type="checkbox"/>	<input type="checkbox"/>	<input type="checkbox"/>
2 KTY84-130 temperature sensor (4 terminals)	<b>G</b>	–	<input checked="" type="checkbox"/>	<input checked="" type="checkbox"/>	<input checked="" type="checkbox"/>	<input checked="" type="checkbox"/>	<input checked="" type="checkbox"/>	<input checked="" type="checkbox"/>	<input checked="" type="checkbox"/>	<input checked="" type="checkbox"/>	<input checked="" type="checkbox"/>
3 Pt100 resistance thermometers – 2-wire circuit (6 terminals) <sup>2)</sup>	<b>H</b>	–	<input checked="" type="checkbox"/>	<input checked="" type="checkbox"/>	<input checked="" type="checkbox"/>	<input checked="" type="checkbox"/>	<input checked="" type="checkbox"/>	<input checked="" type="checkbox"/>	<input checked="" type="checkbox"/>	<input checked="" type="checkbox"/>	<input checked="" type="checkbox"/>
1 Pt1000 resistance thermometer (2 terminals)	<b>K</b>	–	<input checked="" type="checkbox"/>	<input checked="" type="checkbox"/>	<input checked="" type="checkbox"/>	<input checked="" type="checkbox"/>	<input checked="" type="checkbox"/>	<input checked="" type="checkbox"/>	<input checked="" type="checkbox"/>	<input checked="" type="checkbox"/>	<input checked="" type="checkbox"/>
2 Pt1000 resistance thermometer (4 terminals)	<b>L</b>	–	<input checked="" type="checkbox"/>	<input checked="" type="checkbox"/>	<input checked="" type="checkbox"/>	<input checked="" type="checkbox"/>	<input checked="" type="checkbox"/>	<input checked="" type="checkbox"/>	<input checked="" type="checkbox"/>	<input checked="" type="checkbox"/>	<input checked="" type="checkbox"/>
1 Pt100 resistance thermometer – 2-wire circuit (2 terminals)	<b>P</b>	–	<input checked="" type="checkbox"/>	<input checked="" type="checkbox"/>	<input checked="" type="checkbox"/>	<input checked="" type="checkbox"/>	<input checked="" type="checkbox"/>	<input checked="" type="checkbox"/>	<input checked="" type="checkbox"/>	<input checked="" type="checkbox"/>	<input checked="" type="checkbox"/>
3 Pt100 resistance thermometers – 3-wire circuit (9 terminals)	<b>Q</b>	–	<input checked="" type="checkbox"/>	<input checked="" type="checkbox"/>	<input checked="" type="checkbox"/>	<input checked="" type="checkbox"/>	<input checked="" type="checkbox"/>	<input checked="" type="checkbox"/>	<input checked="" type="checkbox"/>	<input checked="" type="checkbox"/>	<input checked="" type="checkbox"/>
6 Pt100 resistance thermometers – 3-wire circuit (18 terminals)	<b>R</b>	–	<input checked="" type="checkbox"/>	<input checked="" type="checkbox"/>	<input checked="" type="checkbox"/>	<input checked="" type="checkbox"/>	<input checked="" type="checkbox"/>	<input checked="" type="checkbox"/>	<input checked="" type="checkbox"/>	<input checked="" type="checkbox"/>	<input checked="" type="checkbox"/>
3 bimetal sensors (NC contact) for tripping (2 terminals) <sup>2)</sup>	<b>Z</b>	<b>Q3A</b>	<input checked="" type="checkbox"/>	<input checked="" type="checkbox"/>	<input checked="" type="checkbox"/>	<input checked="" type="checkbox"/>	<input checked="" type="checkbox"/>	<input checked="" type="checkbox"/>	<input checked="" type="checkbox"/>	<input checked="" type="checkbox"/>	<input checked="" type="checkbox"/>

- Standard version
- With additional charge
- Not possible

#### Note:

Options are available specifically for bearing protection – For order codes and descriptions, see from Page 2/39.

<sup>1)</sup> Evaluation with appropriate tripping unit (see Catalog IC 10) is recommended.

<sup>2)</sup> Not available for option code **D31/D40**.

## SIMOTICS DP – Crane duty motors

Supplements to article numbers and special versions

### Terminal box position · Cast-iron series 1PC1341 and 1PC1361

#### Selection and ordering data

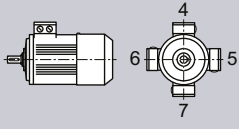
Terminal box position 	Article No. supplements Terminal box position code 16th position of the Article No.	Additional identification code with order code and plain text if required	Frame size								Motor version
			132	160	180	200	225	250	280	315	
			<b>1PC1341</b>								TEFC (IC411) 1PC1341
			<b>1PC1361</b>								TENV (IC410) 1PC1361
	<b>1PC13...-.....</b>	Order code									

Terminal box position										
Terminal box top <sup>1)</sup>	<b>4</b>	-	<input type="checkbox"/>	<input type="checkbox"/>	<input type="checkbox"/>	<input type="checkbox"/>	<input type="checkbox"/>	<input type="checkbox"/>	<input type="checkbox"/>	<input type="checkbox"/>
Terminal box on RHS <sup>1)</sup>	<b>5</b>	-	<input checked="" type="checkbox"/>	<input checked="" type="checkbox"/>	<input checked="" type="checkbox"/>	<input checked="" type="checkbox"/>	<input checked="" type="checkbox"/>	<input checked="" type="checkbox"/>	<input checked="" type="checkbox"/>	<input checked="" type="checkbox"/>
Terminal box on LHS <sup>1)</sup>	<b>6</b>	-	<input checked="" type="checkbox"/>	<input checked="" type="checkbox"/>	<input checked="" type="checkbox"/>	<input checked="" type="checkbox"/>	<input checked="" type="checkbox"/>	<input checked="" type="checkbox"/>	<input checked="" type="checkbox"/>	<input checked="" type="checkbox"/>

- Standard version
- With additional charge

<sup>1)</sup> For types of construction with feet and flange-mounted with feet, cast feet are standard. Screwed-on feet are available with order code **H01**.

## SIMOTICS DP – Crane duty motors

Supplements to article numbers and special versions

### Optionen · Cast-iron series 1PC1341 and 1PC1361

#### Selection and ordering data

Special versions	Additional identification code <b>-Z</b> with order code and plain text if required	Frame size								Motor version	
		132	160	180	200	225	250	280	315	TEFV (IC411)	1PC1341
		<b>1PC1341</b>									
		<b>1PC1361</b>									
<b>1PC1341-.....-Z</b>	Order code										
<b>1PC1361-.....-Z</b>											
<b>Motor protection</b>											
1 temperature sensor KTY84-130 (2 terminals)	<b>Q23</b>	✓	✓	✓	✓	✓	✓	✓	✓		
1 Pt1000 (2 terminals)	<b>Q35</b>	✓	✓	✓	✓	✓	✓	✓	✓		
2 Pt1000 resistance thermometers (4 terminals)	<b>Q36</b>	✓	✓	✓	✓	✓	✓	✓	✓		
<b>Motor connection and terminal box</b>											
Terminal box on NDE <sup>8)</sup>	<b>H08</b>	✓	✓	✓	✓	✓	✓	✓	✓		
Ground of cable bushing (inside terminal box) sealed with resin <sup>2)</sup>	<b>R01</b>	✓	✓	✓	✓	✓	✓	✓	✓		
Rotation of the terminal box through 90°, entry from DE	<b>R10</b>	○	○	✓	✓	✓	✓	✓	✓		
Rotation of the connection box through 90°, entry from NDE	<b>R11</b>	○	○	✓	✓	✓	✓	✓	✓		
Rotation of the terminal box through 180°	<b>R12</b>	○	○	✓	✓	✓	✓	✓	✓		
Larger terminal box	<b>R50</b>	✓	✓	✓	✓	✓	✓	✓	✓		
Terminal box without cable entry holes	<b>R51</b>	–	–	○	○	○	○	○	○		
Cast-iron auxiliary terminal box (small) <sup>11)</sup>	<b>R62</b>	✓	✓	✓	✓	✓	✓	✓	✓		
Non-standard cable entry hole thread (NPT or G thread)	<b>Y61 •</b> and customer specifications	–	–	✓	✓	✓	✓	✓	✓		
Special cable entry plate	<b>Y73 •</b> and customer specifications	O. R.	O. R.	O. R.	O. R.	O. R.	O. R.	O. R.	O. R.		
<b>Windings and insulation</b>											
Temperature class 155 (F), utilized acc. to 155 (F), coolant temperature 45 °C, derating approx. 4 %	<b>N05</b>	✓	✓	✓	✓	✓	✓	✓	✓		
Temperature class 155 (F), utilized acc. to 155 (F), coolant temperature 50 °C, derating approx. 8 %	<b>N06</b>	✓	✓	✓	✓	✓	✓	✓	✓		
Temperature class 155 (F), utilized acc. to 155 (F), coolant temperature 55 °C, derating approx. 13 %	<b>N07</b>	✓	✓	✓	✓	✓	✓	✓	✓		
Temperature class 155 (F), utilized acc. to 155 (F), coolant temperature 60 °C, derating approx. 18 % <sup>2)</sup>	<b>N08</b>	✓	✓	✓	✓	✓	✓	✓	✓		
Temperature class 180 (H) at rated power and max. CT 60 °C <sup>12)</sup>	<b>N11</b>	✓	✓	✓	✓	✓	✓	✓	✓		
Temperature class 180 (H)	<b>Y75 •</b> spec. power, CT ...°C or IA ... m above sea level)	✓	✓	✓	✓	✓	✓	✓	✓		

**SIMOTICS DP – Crane duty motors**

Supplements to article numbers and special versions

**Optionen · Cast-iron series 1PC1341 and 1PC1361**

Special versions	Additional identification code <b>-Z</b> with order code and plain text if required	Frame size								Motor version	
		132	160	180	200	225	250	280	315		
		<b>1PC1341</b>								TEFV (IC411)	1PC1341
		<b>1PC1361</b>								TENV (IC410)	1PC1361
<b>1PC1341-.....-Z</b>											
<b>1PC1361-.....-Z</b>	Order code										

**Colors and paint finish**

Special finish sea air resistant		□	□	□	□	□	□	□	□
Special paint for use offshore	<b>S04</b>	✓	✓	✓	✓	✓	✓	✓	✓
Finish in other standard RAL colors: RAL 1002, 1013, 1015, 1019, 2003, 2004, 3000, 3007, 5007, 5009, 5010, 5012, 5015, 5017, 5018, 5019, 6011, 6019, 6021, 7000, 7001, 7004, 7011, 7016, 7022, 7031, 7032, 7033, 7035, 9001, 9002, 9005 (see Catalog D 81.1 Section 1 "Introduction")	<b>Y53 •</b> and standard paint finish RAL ...	✓	✓	✓	✓	✓	✓	✓	✓
Finish in special RAL colors: For RAL colors, see "Special finish in special RAL colors" (see Catalog D 81.1 Section 1 "Introduction")	<b>Y56 •</b> and special paint finish RAL ...	✓	✓	✓	✓	✓	✓	✓	✓

**Modular technology – Basic versions <sup>6)</sup>**

Brake prepared for mounting of encoder POG10 (T2) (encoder socket T2 with coupling and mounting components)	<b>F28</b>	✓	✓	✓	✓	✓	✓	✓	–	
Brake prepared for mounting of encoder POG10 (T1) (without coupling and mounting components)	<b>F29</b>	✓	✓	✓	✓	✓	✓	✓	–	
Mounting of holding brake KFB 10 100 Nm <sup>3)</sup>	<b>F30</b>	✓	✓	✓	–	–	–	–	–	
Mounting of holding brake KFB 16 160 Nm <sup>3)</sup>	<b>F31</b>	–	✓	✓	✓	–	–	–	–	
Mounting of holding brake KFB 25 250 Nm <sup>3)</sup>	<b>F32</b>	–	–	✓	✓	✓	✓	–	–	
Mounting of holding brake KFB 30 300 Nm <sup>3)</sup>	<b>F33</b>	–	–	✓	✓	✓	✓	–	–	
Mounting of holding brake KFB 40 400 Nm <sup>3)</sup>	<b>F34</b>	–	–	✓	✓	✓	✓	✓	–	
Mounting of holding brake KFB 63 630 Nm <sup>3)</sup>	<b>F35</b>	–	–	–	–	✓	✓	✓	–	
Mounting of holding brake KFB 100 1000 Nm <sup>3)</sup>	<b>F36</b>	–	–	–	–	–	✓	✓	–	
Mounting of holding brake KFB 160 1600 Nm <sup>3)</sup>	<b>F37</b>	–	–	–	–	–	✓	✓	–	Not available for 1PC1341 FS250
Mounting of separately driven fan	<b>F70</b>	✓	✓	✓	✓	–	–	–	–	Only for: 1PC1341
Mounting of separately driven fan acc. IEC 60721-3-3 class 3K9/3K10	<b>F79</b>	–	–	–	–	✓	✓	✓	□	Only for: 1PC1341

**Modular technology – Additional versions**

Brake supply voltage 230 V AC, 50/60 Hz	<b>F11</b>	✓	✓	✓	✓	✓	✓	✓	–	
Brake supply voltage 400 V AC, 50/60 Hz	<b>F12</b>	✓	✓	✓	✓	✓	✓	✓	–	
Brake supply voltage 207 V DC	<b>F16</b>	✓	✓	✓	✓	✓	✓	✓	–	
Brake Microswitch on/off (Brake ventilated)	<b>F26</b>	✓	✓	✓	✓	✓	✓	✓	–	
Anti-condensation heating for Brake 230 V AC	<b>F27</b>	✓	✓	✓	✓	✓	✓	✓	–	
Mechanical manual brake release with lever	<b>F50</b>	✓	✓	✓	✓	✓	✓	✓	–	
Brake Microswitch for air gap supervision	<b>F51</b>	✓	✓	✓	✓	✓	✓	✓	–	

For legends and footnotes, see Page 2/42.

## SIMOTICS DP – Crane duty motors

Supplements to article numbers and special versions

### Optionen · Cast-iron series 1PC1341 and 1PC1361

Special versions	Additional identification code <b>-Z</b> with order code and plain text if required	Frame size								Motor version		
		<b>132</b>	<b>160</b>	<b>180</b>	<b>200</b>	<b>225</b>	<b>250</b>	<b>280</b>	<b>315</b>			
		<b>1PC1341</b>								TEFV (IC411)	1PC1341	
											TENV (IC410)	1PC1361
<b>1PC1341-.....-Z</b>												
<b>1PC1361-.....-Z</b>	Order code											
<b>Special technology</b>												
Mounting of POG 10 DN 1024 I + FSL rotary pulse encoder (only in combination with separately driven fan or brake)	<b>G10</b>	–	–	✓	✓	✓	✓	✓	✓	✓	Only for 1PC1361 or 1PC1341 in combination with external fan (IC416)	
Mounting of POG 10 DN 1024 I rotary pulse encoder	<b>G07</b>	✓	✓	✓	✓	✓	✓	✓	✓	✓	Only for 1PC1361 or 1PC1341 in combination with external fan (IC416)	
Mounting of HOG 10 DN 1024 I rotary pulse encoder, terminal box moisture protection	<b>G15</b>	✓	✓	✓	✓	✓	✓	✓	✓	✓	Only for 1PC1341 except IC416 versions	
Mounting of HOG 10 DN 1024 I rotary pulse encoder, terminal box dust protection	<b>G16</b>	✓	✓	✓	✓	✓	✓	✓	✓	✓	Only for 1PC1341 except IC416 versions	
Mounting of rotary pulse encoder HOG 10 DN 1024 I + FSL (integrated centrifugal switch, speed ... rpm), terminal box moisture protection	<b>Y74 •</b> and spec. speed ... rpm	–	–	✓	✓	✓	✓	✓	✓	✓	Only for 1PC1341 except IC416 versions	
Mounting of rotary pulse encoder HOG 10 DN 1024 I + FSL (integrated centrifugal switch, speed ... rpm), terminal box dust protection	<b>Y76 •</b> and spec. speed ... rpm	–	–	✓	✓	✓	✓	✓	✓	✓	Only for 1PC1341 except IC416 versions	
<b>Mechanical design and degrees of protection</b>												
Protective cover	<b>H00</b>	✓	✓	✓	✓	✓	✓	✓	✓	✓		
Screwed-on (instead of cast) feet	<b>H01</b>	✓	✓	✓	✓	✓	✓	✓	✓	✓		
Condensation drainage holes		□	□	□	□	□	□	□	□	□		
Condensation drainage sealing plug		□	□	□	□	□	□	□	□	□		
Rust-resistant screws (externally)		□	□	□	□	□	□	□	□	□		
IP56 degree of protection	<b>H22</b>	✓	✓	✓	✓	✓	✓	✓	✓	✓		
Drive-end seal for flange-mounting motors, oil-tight to 0.1 bar <sup>4) 10)</sup>	<b>H23</b>	✓	✓	✓	✓	✓	✓	✓	✓	✓		
<b>Coolant temperature and installation altitude</b>												
Coolant temperature –40 to +40 °C <sup>5)</sup>	<b>D03</b>	✓	✓	✓	✓	✓	✓	✓	✓	✓		
Coolant temperature –30 to +40 °C <sup>5)</sup>	<b>D04</b>	✓	✓	✓	✓	✓	✓	✓	✓	✓		
<b>Bearings and lubrication</b>												
Bolt-on feet material spheroidal graphite iron, only possible in combination with H01	<b>L17</b>	–	–	✓	✓	✓	✓	✓	✓	✓		
End shield material IMB5 on DE in spheroidal graphite iron <sup>6)</sup>	<b>L18</b>	–	✓	✓	✓	✓	✓	✓	✓	✓		
Regreasing device with M10 × 1 grease nipple according to DIN 71412-A	<b>L19</b>	–	–	✓	✓	✓	✓	○	○	○		
Regreasing device <sup>1)</sup>	<b>L23</b>	✓	✓	✓	✓	✓	✓	□	□	□		

## SIMOTICS DP – Crane duty motors

Supplements to article numbers and special versions

### Optionen · Cast-iron series 1PC1341 and 1PC1361

Special versions	Additional identification code <b>-Z</b> with order code and plain text if required	Frame size								Motor version	
		132	160	180	200	225	250	280	315		
		<b>1PC1341</b>								TEFV (IC411)	1PC1341
		<b>1PC1361</b>								TENV (IC410)	1PC1361
<b>1PC1341-.....-Z</b>											
<b>1PC1361-.....-Z</b>	Order code										

#### Bearings and lubrication (continued)

Special bearing for DE and NDE, bearing size 63	<b>L25</b>	✓	✓	✓	✓	✓	✓	□	□	
Bearing insulation DE	<b>L50</b>	–	–	–	–	✓	✓	✓	✓	
Bearing insulation NDE	<b>L51</b>	–	–	–	–	✓	✓	□	□	
Measuring nipple for SPM shock pulse-measurement for bearing inspection	<b>Q01</b>	✓	✓	✓	✓	✓	✓	✓	✓	

#### Shaft and rotor

Standard shaft made of stainless steel	<b>L06</b>	✓	✓	✓	✓	✓	✓	✓	✓	
--	------------	---	---	---	---	---	---	---	---	--

#### Heating and ventilation

Sheet metal fan cover	<b>F74</b>	✓	✓	✓	✓	✓	✓	✓	□	Only for: 1PC1341
Metal external fan <sup>9)</sup>	<b>F76</b>	✓	✓	✓	✓	✓	✓	✓	✓	Only for: 1PC1341
Anti-condensation heating for 230 V (2 terminals)	<b>Q02</b>	✓	✓	✓	✓	✓	✓	✓	✓	
Anti-condensation heating for 115 V (2 terminals)	<b>Q03</b>	✓	✓	✓	✓	✓	✓	✓	✓	

#### Rating plate and extra rating plates

Rating plate, stainless steel		□	□	□	□	□	□	□	□	
Extra rating plate with identification codes	<b>Y82 •</b> and customer specifications	✓	✓	✓	✓	✓	✓	✓	✓	

#### Packaging, safety notes, documentation and test certificates

Acceptance test certificate 3,1 in accordance with EN 102044 <sup>7)</sup>	<b>B02</b>	✓	✓	✓	✓	✓	✓	✓	✓	
Document – Order dimensional drawing	<b>B61</b>	✓	✓	✓	✓	✓	✓	✓	✓	
Design according to UL with "Recognition Mark" <sup>13)</sup>	<b>D31</b>	✓	✓	✓	✓	✓	✓	✓	✓	
Canadian regulations (CSA) <sup>13)</sup>	<b>D40</b>	✓	✓	✓	✓	✓	✓	✓	✓	
TR CU product safety certificate EAC for the Eurasian customs union	<b>D47</b>	✓	✓	✓	✓	✓	✓	✓	✓	
Connected in delta for dispatch	<b>M02</b>	✓	✓	✓	✓	✓	✓	✓	✓	

- Standard version
- Without additional charge
- ✓ With additional charge
- Not possible

<sup>1)</sup> Up to frame size 160 not possible when brake is mounted.

<sup>2)</sup> Cannot be used for motors in UL version (order code D31).

<sup>3)</sup> For order codes F11, F12 and F16, the brake supply voltage must be specified or ordered.

<sup>4)</sup> Not possible for type of construction IM V3.

<sup>5)</sup> In connection with mountings, the respective technical data must be observed, please inquire before ordering.

<sup>6)</sup> Special bearing for DE required, bearing size 63

<sup>7)</sup> The delivery time for the factory test certificate may differ from the delivery time for the motor.

<sup>8)</sup> With H08, feet dimensions C and CA differ from EN 50347! Further information is available in DT Configurator ([www.siemens.com/dt-configurator](http://www.siemens.com/dt-configurator)).

<sup>9)</sup> Not possible in combination with order codes F70 or F79.

<sup>10)</sup> Not possible in combination with order codes Q72 and Q78.

<sup>11)</sup> Order code R62 is only possible in combination with R50.

<sup>12)</sup> Not possible for nominal voltage > 460V (Insul. sys. premium).

<sup>13)</sup> Not available in combination with **R01**. Not available in combination with 1PC13(4; 6)1-...-(G; H; L; M).. (mounting IM V\*).

**More information****Replacement motors and repair parts**

- Commitment to provide replacement motors and repair parts following delivery of the motor:
  - For up to 3 years after delivery of the original motor, in the event of total motor failure, Siemens will supply a comparable replacement motor with regard to the mounting dimensions and functions (the type series may vary).
  - If a replacement motor is supplied within the 3-year period, this does not mean that the warranty restarts.
  - Replacement motors delivered after the active production of the machine series are also identified as spare motors on the rating plate.
  - Spare parts are offered only for these spare motors on request; repair and replacement are not possible.
  - After a period of 3 years (after the delivery of the original motor), it is only possible to repair these motors (depending on the availability of the spare parts required).
  - For up to 5 years after the delivery of the original motor, spare parts will be available and for a further 5 years, Siemens will provide information about spare parts and will supply documents when required.
- When repair parts are ordered, the following details must be provided:
  - Designation and part number
  - Article No. and factory number of the motor.

Example for ordering a fan cover 1LE1003,  
frame size 112 M, 4-pole:

**Fan cover No. 7.40,  
1LE1003-1BB23-4AA4-Z, part No. E1001/5236197\_01\_001**

- For bearing types, see Catalog Section 1 "Introduction".
- Repair parts for 1MJ6, 1MJ7, 1MJ8, 1MJ1, 1ME8, 1ML8 motors are available on request.
- For standard components, a commitment to supply repaired parts does not apply.
- Support hotline  
In Germany  
Phone +49 (180) 5050448

You will find telephone numbers for other countries on our Internet site:

[www.siemens.com/automation/service&support](http://www.siemens.com/automation/service&support)

## SIMOTICS DP – Crane duty motors

### Dimensional drawings

#### Notes on the dimensions

##### Overview

- Dimensional designations according to EN 50347 and IEC 60072.
- Fits  
The shaft extensions specified in the dimension tables (DIN 748) and centering spigot diameters (EN 50347) are machined with the following fits:

Dimension designation	ISO fit	DIN ISO 286-2
D, DA	to 30	j6
	over 30 to 50	k6
	over 50	m6
N	to 250	j6
	over 250	h6
F, FA		h9
S	flange (FF)	H17

The drilled holes of couplings and belt pulleys should have an ISO fit of at least H7.

Dimension K: nominal dimension according IEC 60072-1, negative deviation of tolerance H17 possible

- Dimensional tolerances  
For the following dimensions, the admissible deviations are given below:

Dimension designation	Dimension	Admissible deviation
H	to 250	- 0.5
	over 250	- 1.0
E, EA		- 0.5

Keyways and feather keyways (dimensions GA, GC, F, and FA) are made in compliance with DIN 6885 Part 1.

- All dimensions are specified in mm.

#### Dimension sheet generator (within the DT Configurator)

##### Overview

A dimensional drawing can be created in the "Drive Technology Configurator" (DT Configurator) for every configurable motor. A dimensional drawing can be requested for every other motor.

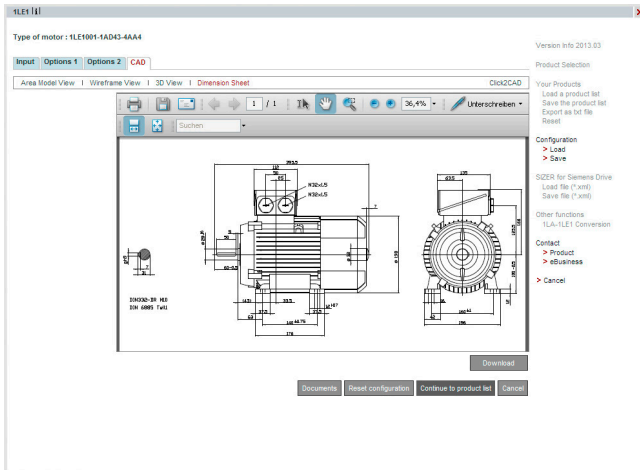

When a complete Article No. is entered with or without order codes, a dimensional drawing can be called up under the "Documentation" tab.

These dimensional drawings can be presented in different views and sections and printed.

The corresponding dimension sheets can be exported, saved and processed further in DXF format (interchange/import format for CAD systems) or as bitmap graphics.

Online access in the Siemens Industry Mall

The DT Configurator is integrated into the Siemens Industry Mall and can be used on the Internet without installation.

German: [www.siemens.de/dt-konfigurator](http://www.siemens.de/dt-konfigurator)  
English: [www.siemens.com/dt-configurator](http://www.siemens.com/dt-configurator)



**Dimensional drawings**

**1PC1361, type of construction IM B3**

With POG10 pulse encoder

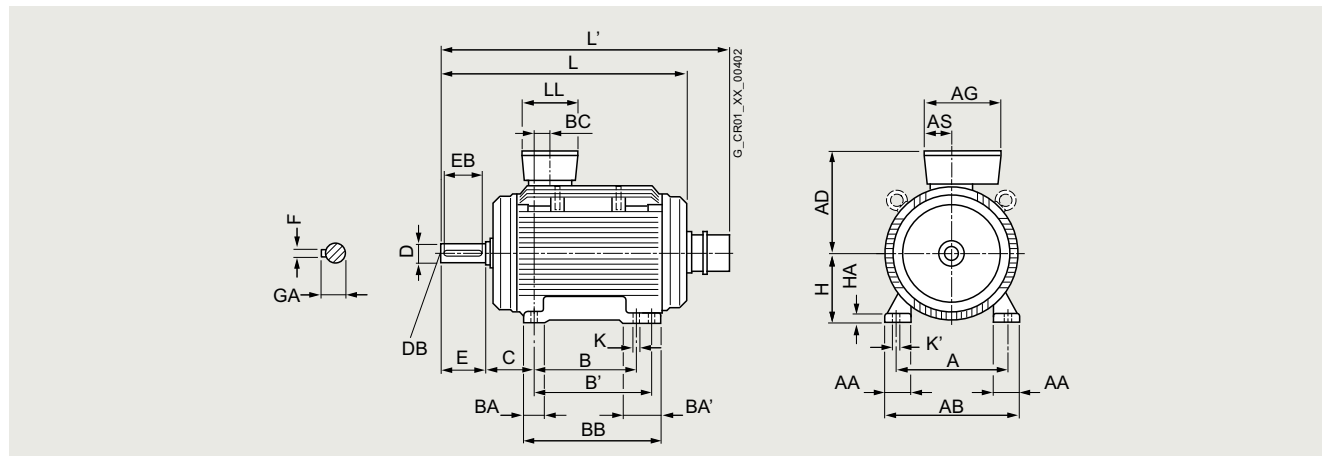

With brake and with POG10 pulse encoder

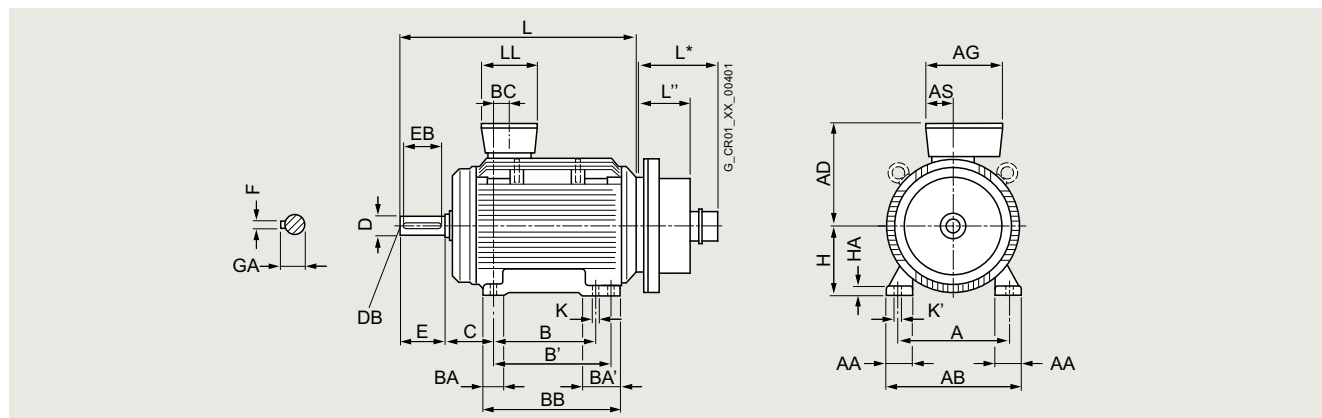

		Dimensions in mm																			
Frame size	Motor type	A	AA	AB	AD	AG	AS	B	B'	BA	BA'	BB	BC	C	H	HA	L	L'	K	K'	LL
132 S	1CB0, 1CC0	216	53	256	240	190	91	140	×	41	41	180	26.5	89	132	15	384	568	12	16	165
132 M	1CB2, 1CC2 1CC3							178			79	218									
160 M	1DB2, 1DC2	254	60	300	265	190	91	210	×	49	49	256	47	108	160	18	512	707	15	19	165
160 L	1DB4, 1DC4							254			93	300									
180 M	1EB2	279	65	339	292	265	112	241	279	85	120	328	34	121	180	20	562	741	15	19	197
180 L	1EC4																562	741			
180 L	1EB4, 1EB6, 1EC6, 1EC7																592	771			
200 L	2AB5, 2AC4, 2AC5,	318	70	378	315	265	112	305	×	104	104	355	31	133	200	25	617	799	19	25	197
	2AB6, 2AC6, 2AB7, 2AC7																642	824			

# SIMOTICS DP – Crane duty motors

## Dimensional drawings

### Dimensional drawings (continued)

#### 1PC1361, type of construction IM B5

With POG10 pulse encoder

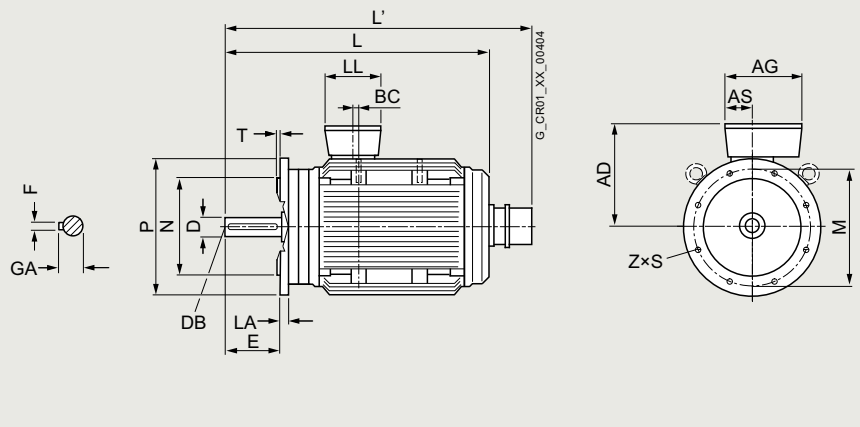

#### Brake mounting - L" (mm)

FS 132		FS 160	
KFB 10	156	KFB 10	162
		KFB 16	149
FS 180		FS 200	
KFB10	178	KFB16	173
KFB16	165	KFB25	197
KFB25	189	KFB30	207
KFB30	199	KFB40	207
KFB40	199		

With brake and with POG10 pulse encoder

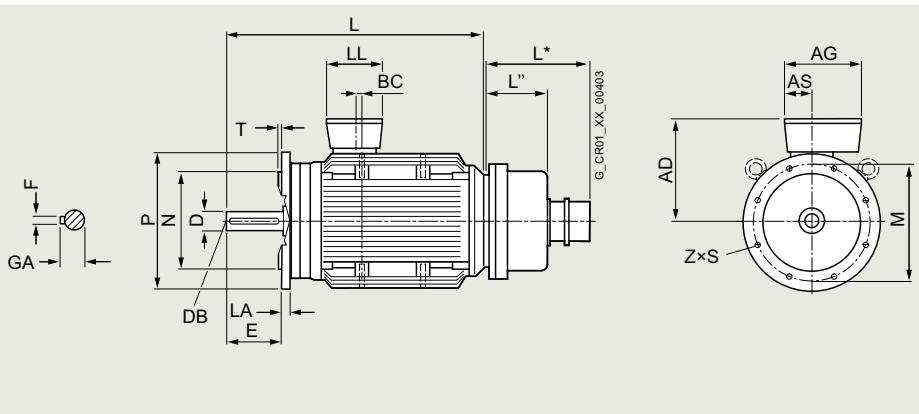

#### Brake mounting + POG10 - L\* (mm)

FS 132		FS 160	
KFB10+	307	KFB10+	329
POG10		POG10	
		KFB16+	315
		POG10	
FS 180		FS 200	
KFB10+	329	KFB16+	323
POG10		POG10	
KFB16+	315	KFB25+	348
POG10		POG10	
KFB25+	340	KFB30+	367
POG10		POG10	
KFB30+	359	KFB40+	348
POG10		POG10	
KFB40+	340		
POG10			

Frame size	Motor type	Dimensions in mm												
		D	DB	E	EB	F	GA	LA	M	N	P	S	T	Z
132 S	1CB0, 1CC0	38	M12	80	70	10	41	12	265	230	300	14.5	4	4
132 M	1CB2, 1CC2 1CC3													
160 M	1DB2, 1DC2	42	M16	110	90	12	45	13	300	250	350	18.5	5	4
160 L	1DB4, 1DC4													
180 M	1EB2	48	M16	110	100	14	51.5	13	300	250	350	18.5	5	4
180 L	1EC4													
180 L	1EB4, 1EB6, 1EC6, 1EC7													
200 L	2AB5, 2AC4, 2AC5, 2AB6, 2AC6, 2AB7, 2AC7	55	M20	110	100	16	59	15	350	300	400	18.5	5	4

**Dimensional drawings** (continued)

**1PC1361, type of construction IM B3**

With POG10 pulse encoder

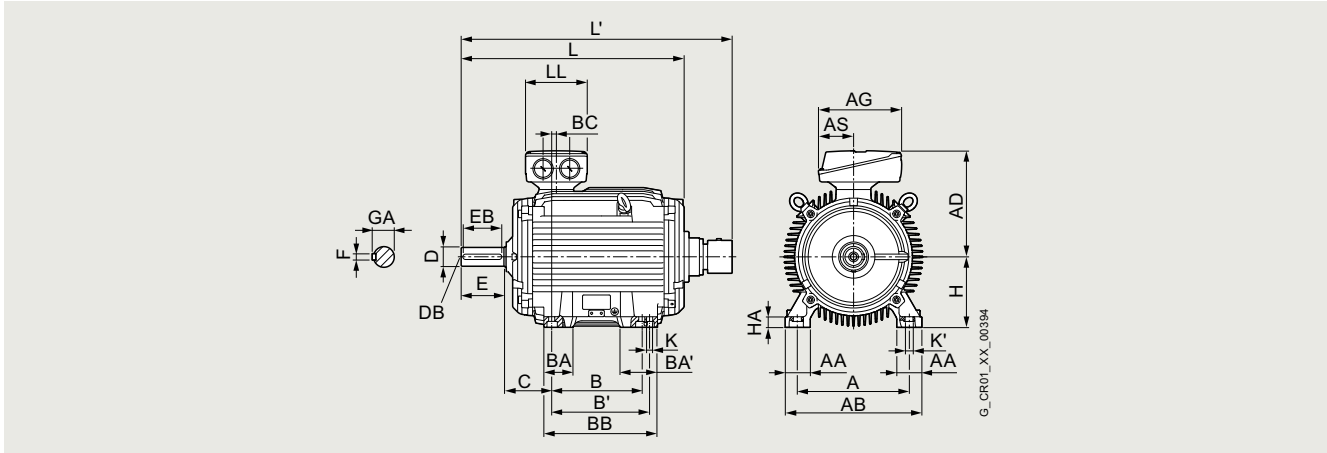

With brake and with POG10 pulse encoder

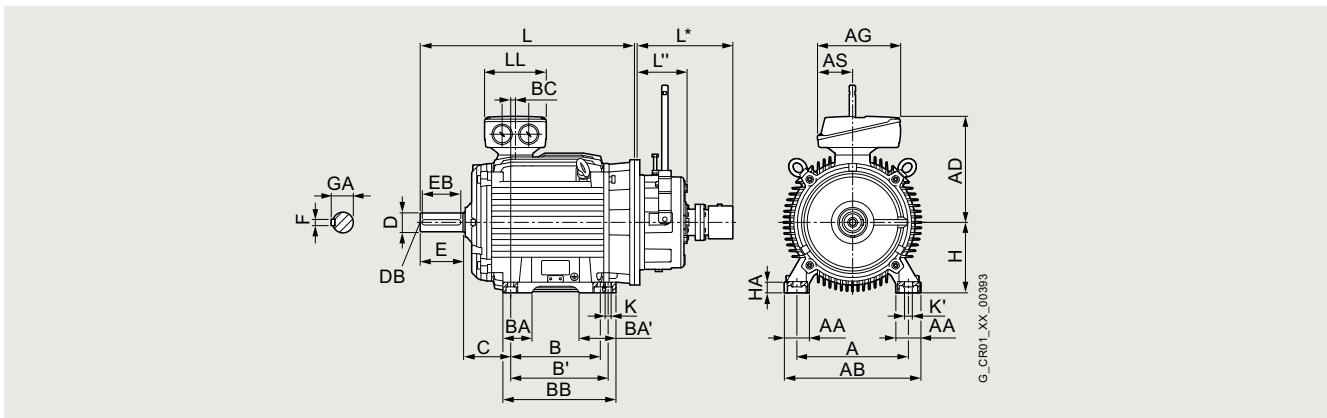

Frame size	Motor type	Dimensions in mm																				
		A	AA	AB	AD	AG	AS	B	B'	BA	BA'	BB	BC	C	H	HA	L	L'	K	K'	LL	
225 S	2BB0	4	356	80	436	338	266	112	286*	311	92	117	361	15	149	225	34	650	802	19	25	197
225 M	2BB2, 2BC2	4, 6	356	80	436	338	266	112	286	311 <sup>1)</sup>	92	117	361	15	149	225	34	710	862	19	25	197
	2BB6, 2BC6	4, 6	356	80	436	338	266	112	286	311 <sup>1)</sup>	92	117	361	15	149	225	34	710	862	19	25	197
	2BC7	6	356	80	436	338	266	112	286	311 <sup>1)</sup>	92	117	361	15	149	225	34	790	942	19	25	197
250 M	2CB2, 2CC2	4, 6	406	100	490	410	319	140	349	–	102	102	409	24	168	250	40	743	896	24	30	233
	2CB6	4	406	100	490	410	319	140	349	–	102	102	409	24	168	250	40	813	966	24	30	233
	2CC6	6	406	100	490	410	319	140	349	–	102	102	409	24	168	250	40	743	896	24	30	233
	2CB7, 2CC7	4	406	100	490	410	319	140	349	–	102	102	409	24	168	250	40	813	966	24	30	233
280 S	2DB0, 2DC0	4, 6	457	100	540	433	319	140	368*	419	101	152	479	20	190	280	40	806	956	24	30	233
280 M	2DB2, 2DC2	4, 6	457	100	540	433	319	140	368	419 <sup>1)</sup>	101	152	479	20	190	280	40	806	956	24	30	233
	2DB6	4	457	100	540	433	319	140	368	419 <sup>1)</sup>	101	152	479	20	190	280	40	916	1066	24	30	233
	2DC6	6	457	100	540	433	319	140	368	419 <sup>1)</sup>	101	152	479	20	190	280	40	806	956	24	30	233
	2DB7, 2DC7	4, 6	457	100	540	433	319	140	368	419 <sup>1)</sup>	101	152	479	20	190	280	40	916	1066	24	30	233

<sup>1)</sup> This dimension is assigned in DIN EN 50347 to the frame size listed.

# SIMOTICS DP – Crane duty motors

## Dimensional drawings

### Dimensional drawings (continued)

#### 1PC1361, type of construction IM B5<sup>1)</sup>

With POG10 pulse encoder

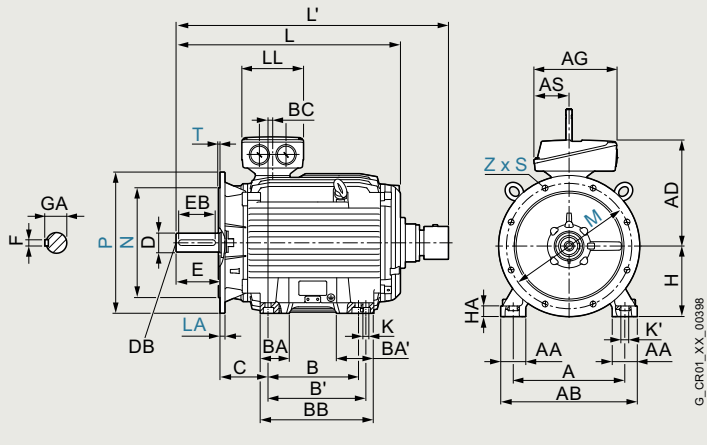

#### Brake mounting - L" (mm)

	FS225	FS250
KFB25	168.5	KFB25 180.5
KFB30	168.5	KFB30 180.5
KFB40	168.5	KFB40 180.5
KFB63	168.5	KFB63 180.5
<b>FS280</b>		KFB100 180.5
KFB40	188.5	KFB160 180.5
KFB63	188.5	
KFB100	188.5	
KFB160	188.5	

With brake and with POG10 pulse encoder

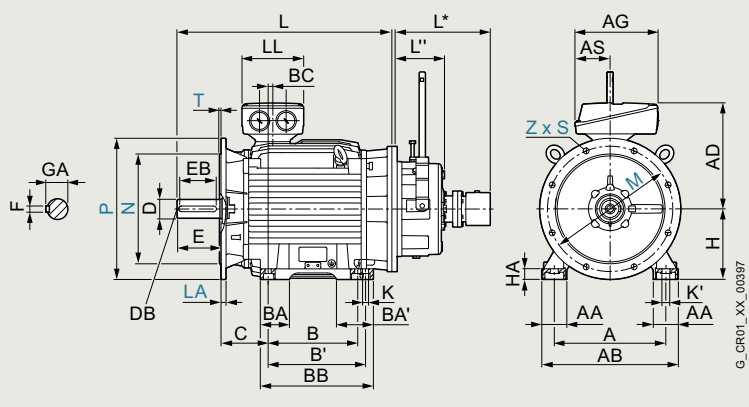

#### Brake mounting + POG10 - L\* (mm)

	FS225	FS250
KFB25+ POG10	314	KFB25+ POG10 346
KFB30+ POG10	314	KFB30+ POG10 346
KFB40+ POG10	314	KFB40+ POG10 346
KFB63+ POG10	314	KFB63+ POG10 346
<b>FS280</b>		KFB100 346 +POG10
KFB40+ POG10	350	KFB160 346 +POG10
KFB63+ POG10	350	
KFB100 +POG10	350	
KFB160 +POG10	350	

Frame size	Motor type	Dimensions in mm													
		D	DB	E	EB	F	GA	LA	M	N	P	S	T	Z	
225 S	2BB0	4	60	M20	140	125	18	64	16	400	350	450	18.5	5	8
225 M	2BB2, 2BC2	4, 6	60	M20	140	125	18	64	16	400	350	450	18.5	5	8
	2BB6, 2BC6	4, 6	60	M20	140	125	18	64	16	400	350	450	18.5	5	8
	2BC7	6	60	M20	140	125	18	64	16	400	350	450	18.5	5	8
250 M	2CB2, 2CC2	4, 6	65	M20	140	125	18	69	16	400	350	450	18.5	5	8
	2CB6	4	65	M20	140	125	18	69	16	400	350	450	18.5	5	8
	2CC6	6	65	M20	140	125	18	69	16	400	350	450	18.5	5	8
	2CB7, 2CC7	4	65	M20	140	125	18	69	16	400	350	450	18.5	5	8
280 S	2DB0, 2DC0	4, 6	75	M20	140	125	20	79.5	18	500	450	550	22	6	8
280 M	2DB2, 2DC2	4, 6	75	M20	140	125	20	79.5	18	500	450	550	22	6	8
	2DB6	4	75	M20	140	125	20	79.5	18	500	450	550	22	6	8
	2DC6	6	75	M20	140	125	20	79.5	18	500	450	550	22	6	8
	2DB7, 2DC7	4, 6	75	M20	140	125	20	79.5	18	500	450	550	22	6	8

<sup>1)</sup> Motor drawing shows motor in IM B35. IM B5-motor comes without feet.

**Dimensional drawings**

**1PC1341, type of construction IM B3**

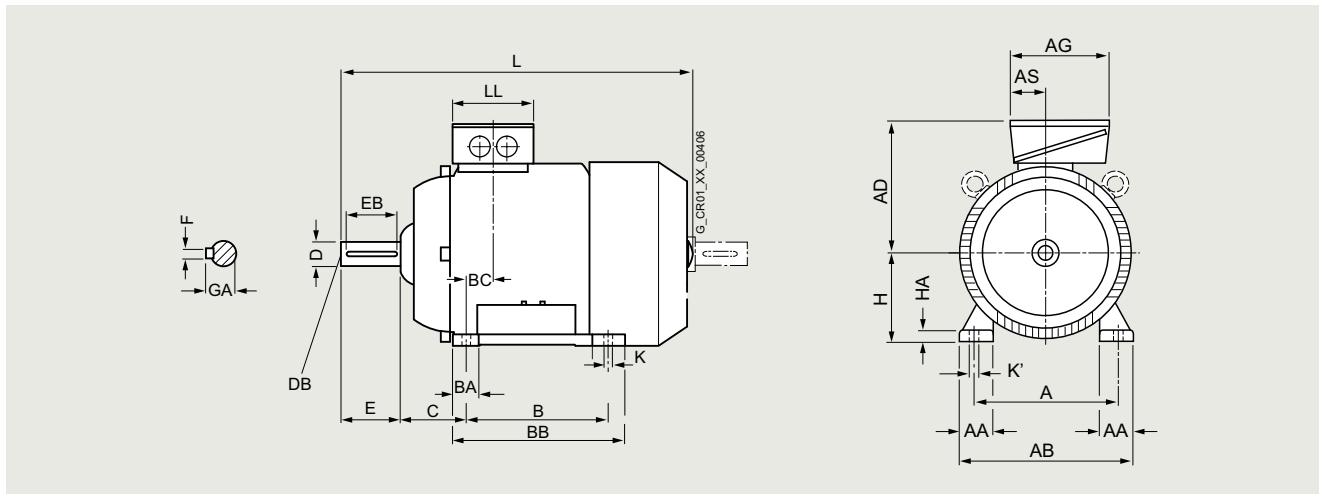

**1PC1341, type of construction IM B5**

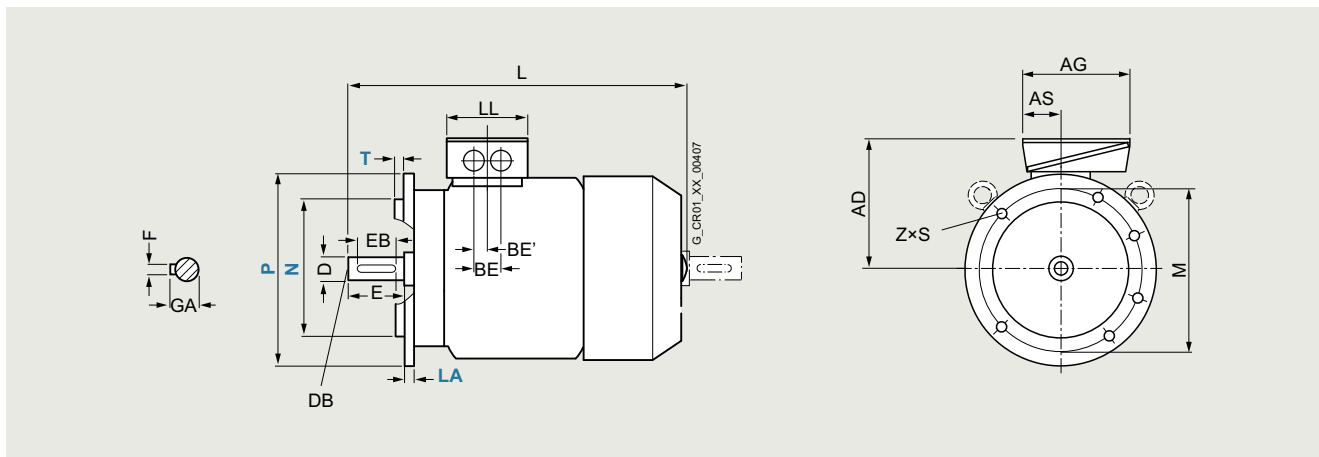

Frame size	Motor type	Dimensions in mm																
		A	AA	AB	AD	AG	AS	B	BA	BB	BC	C	H	HA	L	K	K'	LL
132 S	1CB0, 1CC0	216	53	256	240	190	91	140	41	180	26.5	89	132	15	466.5	12	16	165
132 M	1CB2, 1CC2 1CC3							178		218								
160 M	1DB2, 1DC2	254	60	300	265	190	91	210	49	256	47	108	160	18	606.0	15	19	165
160 L	1DB4, 1DC4							254		300								
180 M	1EB2	279	65	339	292	265	112	241	85	328	34	121	180	20	668.0	15	19	197
180 L	1EC4														668.0			
180 L	1EB4, 1EB6, 1EC6, 1EC7														698.0			
200 L	2AB5, 2AC4, 2AC5,	318	70	378	315	265	112	305	104	355	31	133	200	25	721.0	19	25	197
	2AB6, 2AC6, 2AB7, 2AC7														746.0			

# SIMOTICS DP – Crane duty motors

## Dimensional drawings

### Dimensional drawings (continued)

#### 1PC1341, type of construction IM B35

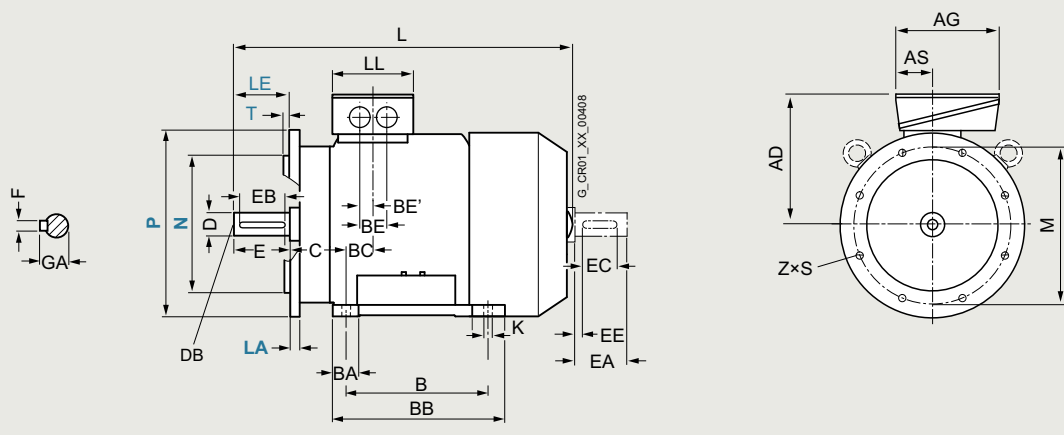

2

Frame size	Motor type	Dimensions in mm													
		D	DB	E	EB	F	GA	LA	M	N	P	S	T	Z	
132 S	1CB0, 1CC0	38	M12	80	70	10	41	12	265	230	300	14.5	4	4	
132 M	1CB2, 1CC2 1CC3														
160 M	1DB2, 1DC2	42	M16	110	90	12	45	13	300	250	350	18.5	5	4	
160 L	1DB4, 1DC4														
180 M	1EB2	48	M16	110	100	14	51.5	13	300	250	350	18.5	5	4	
180 L	1EC4														
180 L	1EB4, 1EB6, 1EC6, 1EC7														
200 L	2AB5, 2AC4, 2AC5, 2AB6, 2AC6, 2AB7, 2AC7	55	M20	110	100	16	59	15	350	300	400	18.5	5	4	

**Dimensional drawings** (continued)

**1PC1341, type of construction IM B3**

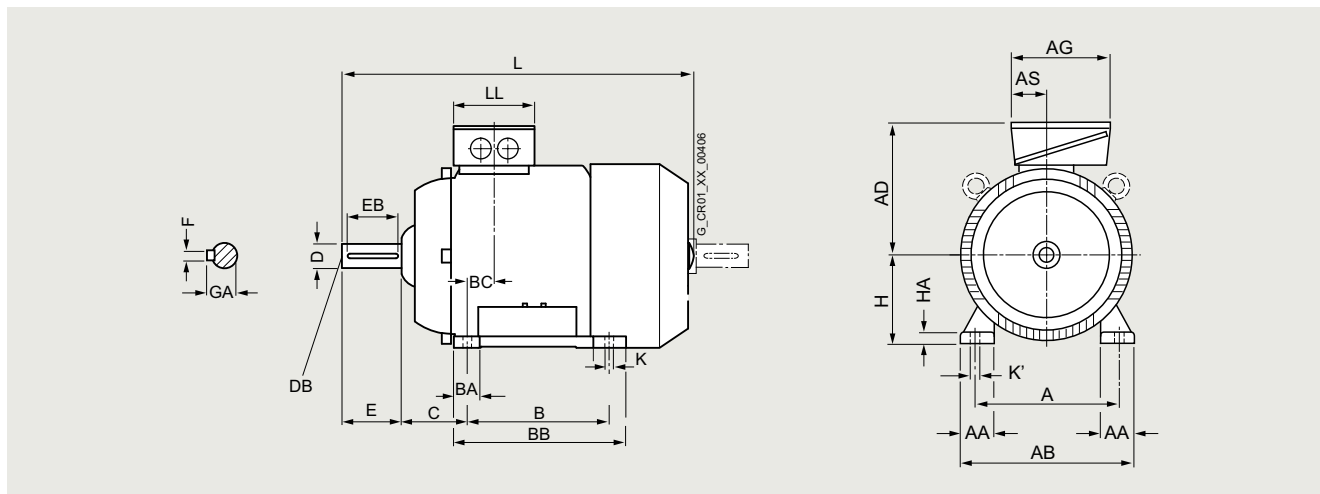

**1PC1341, type of construction IM B5**

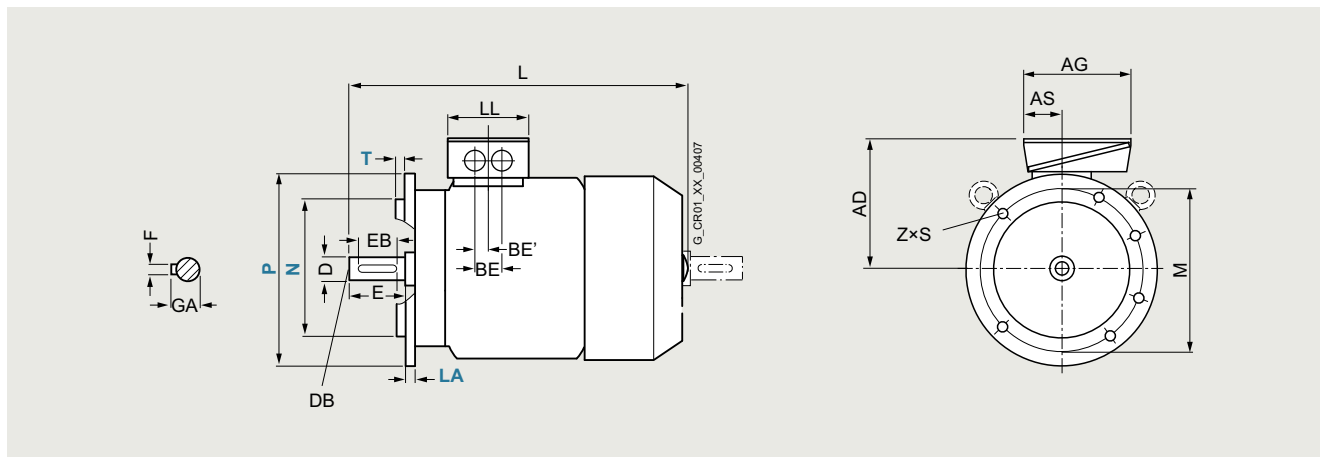

Frame size	Motor type	Dimensions in mm																	
		A	AA	AB	AD	AG	AS	B	BA	BB	BC	C	H	HA	L	K	K'	LL	
225 S	2BB0	4	356	80	436	338	266	112	286*	92	361	15	149	225	34	788.0	19	25	197
225 M	2BB2, 2BC2	4, 6	356	80	436	338	266	112	286	92	361	15	149	225	34	848.0	19	25	197
	2BB6, 2BC6	4, 6	356	80	436	338	266	112	286	92	361	15	149	225	34	848.0	19	25	197
	2BC7	6	356	80	436	338	266	112	286	92	361	15	149	225	34	928.0	19	25	197
250 M	2CB2, 2CC2	4, 6	406	100	490	410	319	140	349	102	409	24	168	250	40	887.0	24	30	233
	2CB6	4	406	100	490	410	319	140	349	102	409	24	168	250	40	957.0	24	30	233
	2CC6	6	406	100	490	410	319	140	349	102	409	24	168	250	40	887.0	24	30	233
	2CB7, 2CC7	4	406	100	490	410	319	140	349	102	409	24	168	250	40	957.0	24	30	233
280 S	2DB0, 2DC0	4, 6	457	100	540	433	319	140	368*	101	479	20	190	280	40	960.0	24	30	233
280 M	2DB2, 2DC2	4, 6	457	100	540	433	319	140	368	101	479	20	190	280	40	960.0	24	30	233
	2DB6	4	457	100	540	433	319	140	368	101	479	20	190	280	40	1070.0	24	30	233
	2DC6	6	457	100	540	433	319	140	368	101	479	20	190	280	40	960.0	24	30	233
	2DB7, 2DC7	4, 6	457	100	540	433	319	140	368	101	479	20	190	280	40	1070.0	24	30	233

# SIMOTICS DP – Crane duty motors

## Dimensional drawings

### Dimensional drawings (continued)

#### 1PC1341, type of construction IM B35

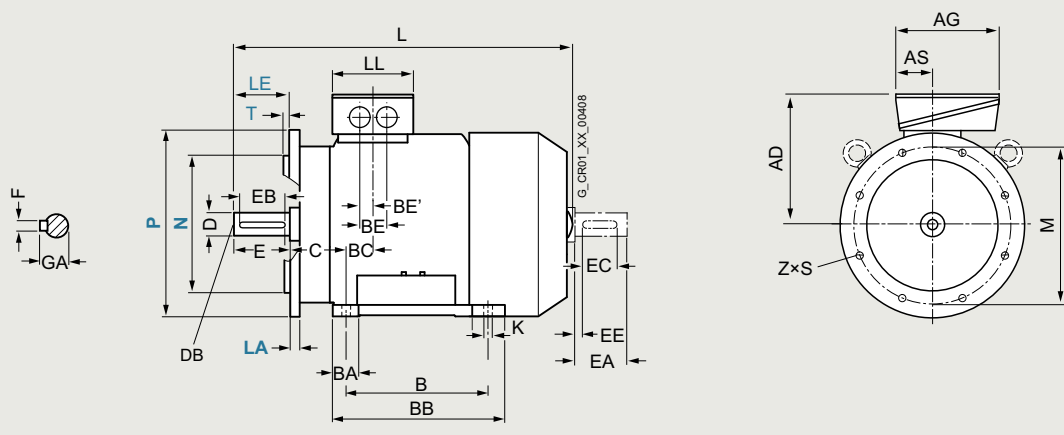

2

Frame size	Motor type	Dimensions in mm													
		D	DB	E	EB	F	GA	LA	M	N	P	S	T	Z	
225 S	2BB0	4	60	M20	140	125	18	64	16	400	350	450	18.5	5	8
225 M	2BB2, 2BC2	4, 6	60	M20	140	125	18	64	16	400	350	450	18.5	5	8
	2BB6, 2BC6	4, 6	60	M20	140	125	18	64	16	400	350	450	18.5	5	8
	2BC7	6	60	M20	140	125	18	64	16	400	350	450	18.5	5	8
250 M	2CB2, 2CC2	4, 6	65	M20	140	125	18	69	16	400	350	450	18.5	5	8
	2CB6	4	65	M20	140	125	18	69	16	400	350	450	18.5	5	8
	2CC6	6	65	M20	140	125	18	69	16	400	350	450	18.5	5	8
	2CB7, 2CC7	4	65	M20	140	125	18	69	16	400	350	450	18.5	5	8
280 S	2DB0, 2DC0	4, 6	75	M20	140	125	20	79.5	18	500	450	550	22	6	8
280 M	2DB2, 2DC2	4, 6	75	M20	140	125	20	79.5	18	500	450	550	22	6	8
	2DB6	4	75	M20	140	125	20	79.5	18	500	450	550	22	6	8
	2DC6	6	75	M20	140	125	20	79.5	18	500	450	550	22	6	8
	2DB7, 2DC7	4, 6	75	M20	140	125	20	79.5	18	500	450	550	22	6	8



**Dimensional drawings** (continued)

**1PC1341 shaft height 315, type of construction IM B3**

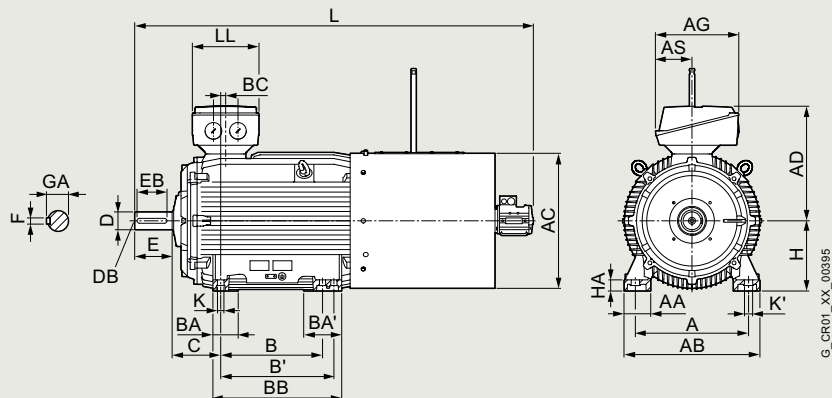

2

Frame size	Motor type	Dimensions in mm																		
		A	AA	AB	AC	AD	AD'	AF	AG	AS	B <sup>1)</sup>	B'	BA	BA'	BB	BC	BE	BE'	C	
315	3AC4, 3AD4	6, 8	508	120	610	623	515	515	404	374	164	457	508 <sup>1)</sup>	113	170	578	22	110	55	216
	3AC5, 3AD5	6, 8	508	120	610	623	515	515	404	374	164	457	508 <sup>1)</sup>	176	227	578	22	110	55	216
	3AC6	6	508	120	610	623	515	515	404	374	164	457	508 <sup>1)</sup>	176	227	648	22	110	55	216
	3AD6	8	508	120	610	623	515	515	404	374	164	457	508 <sup>1)</sup>	176	227	578	22	110	55	216
	3AC7, 3AD7	6, 8	508	120	610	623	515	515	404	374	164	457	508 <sup>1)</sup>	176	227	648	22	110	55	216

<sup>1)</sup> This dimension is assigned in DIN EN 50347 to the frame size listed

<sup>2)</sup> Additional information: not a standard dimension acc. to DIN EN 50347

# SIMOTICS DP – Crane duty motors

## Dimensional drawings

### Dimensional drawings (continued)

#### 1PC1341 shaft height 315, type of construction IM B5

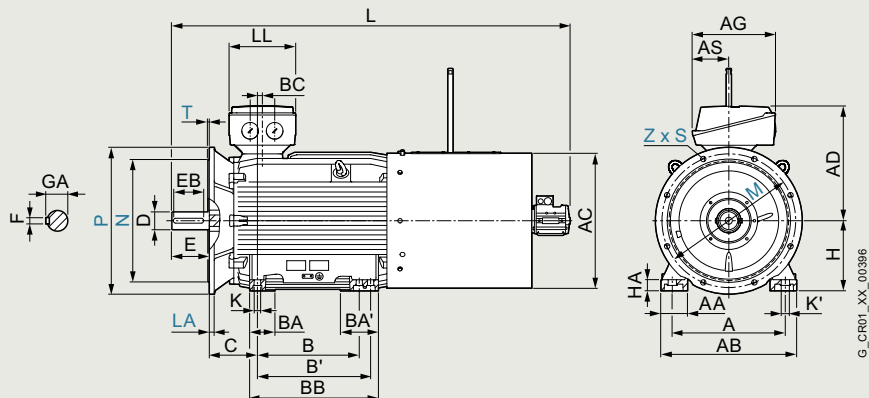

2

Frame size	Motor type	Dimensions in mm																						
		H	HA	Y <sup>2)</sup>	HH	K	K'	L	LL	D	DB	E	EB	ED	F	GA	LA	M	N	P	S	T	Z	
315	3AC4, 3AD4	6, 8	315	50	181	238	28	35	1521	299	80	M20	170	140	25	22	85	22	600	550	660	22	6	8
	3AC5, 3AD5	6, 8	315	50	181	238	28	35	1521	299	80	M20	170	140	25	22	85	22	600	550	660	22	6	8
	3AC6	6	315	50	146	238	28	35	1676	299	80	M20	170	140	25	22	85	22	600	550	660	22	6	8
	3AD6	8	315	50	181	238	28	35	1521	299	80	M20	170	140	25	22	85	22	600	550	660	22	6	8
	3AC7, 3AD7	6, 8	315	50	146	238	28	35	1676	299	80	M20	170	140	25	22	85	22	600	550	660	22	6	8

## SIMOTICS M – Main motors



3/2

3/4

3/24

3/28

3/29

3/31

**1PH8 for SINAMICS S120 for cranes**

Degree of protection IP23

Degree of protection IP55

Article No. supplements

Options

Dimensional drawings

**SIMOTICS M – Main motors**

1PH8 for SINAMICS S120 for cranes

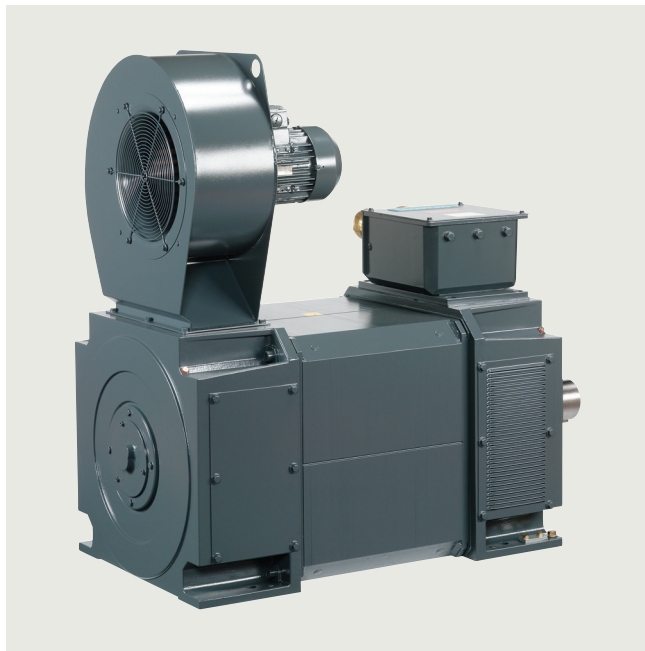
**Overview**

1PH8 three-phase motor, shaft height 355

The innovations in the field of modern crane installations place higher and higher demands on compact asynchronous motors.

The compact asynchronous motor 1PH8 of shaft height 355 covers the increased performance requirements, e.g. for intermittent duty S3-40 % with up to 1.97 MW.

This motor serie is a converter solution which has been developed for use in conjunction with the SINAMICS S120 drive system. The 1PH8 asynchronous motors have the following features:

- Forced ventilated asynchronous motors with squirrel-cage rotor with IP55 degree of protection. The motors are ventilated as standard by a radial, externally mounted fan unit. With the "enhanced corrosion protection" option, the motors can also be installed outdoors.
- Forced ventilated asynchronous motors with squirrel-cage rotor with IP23 degree of protection. These motors are also ventilated as standard by a radial, externally mounted fan unit. These motors are particularly suitable for installation in power houses.

**Benefits**

- High power density with small motor dimensions
- Wide speed control ranges
- Speed down to zero without reducing the torque (constant torque characteristic)
- High rotational accuracy, even at the lowest speeds
- Fitted as standard with regreasing unit and insulated NDE bearing
- Optimized for converter-fed operation on SINAMICS
- Large selection of options

**Technical specifications**

<b>Insulation of the stator winding according to EN 60034-1 (IEC 60034-1)</b>	Utilization to temperature class 155 (F) for a coolant temperature of up to 40 °C
<b>Cooling in accordance with EN 60034-6 (IEC 60034-6)</b>	Radial fan NDE top mounted (intake from NDE)
<b>Temperature monitoring</b>	Temperature sensor in the stator winding, additional as spare
<b>Motor supply voltage</b> (for technical specifications, see the ventilation data and sound pressure level)	400 V 3 AC, 50/60 Hz 480 V 3 AC, 60 Hz
<b>Type of construction according to EN 60034-7 (IEC 60034-7)</b>	IM B3
<b>Degree of protection according to EN 60034-5 (IEC 60034-5)</b>	IP23 or IP55
<b>Shaft extension on the drive end according to DIN 748-3 (IEC 60072-1)</b>	Feather key full or half-key balancing
<b>Shaft and flange accuracy according to (IEC 60072-1)<sup>1)</sup></b>	Tolerance N (normal) Tolerance R (reduced)
<b>Vibration severity according to Siemens/ EN 60034-14 (IEC 60034-14)</b>	Level A (normal) Level R/A (reduced)
<b>Sound pressure level according to DIN EN ISO 1680</b> Tolerance +3 dB	Sound pressure level 85 dB(A)
<b>Maximum speeds</b>	2800 rpm
<b>External encoder systems</b>	Incremental encoder HTL 1024 S/R POG 10 (Baumer-Hübner) Incremental encoder HTL 1024 S/R HOG 28 (Baumer-Hübner)
<b>Connection</b>	Terminal box NDE right or DE top
<b>Paint finish</b>	Standard paint finish, anthracite, RAL 7016
<b>Options</b>	Refer to Options and Selection and ordering data

S/R = signals/revolution

**Notes:**

The rated motor data is specified in the selection and ordering data for a nominal pulse frequency of 2.5 kHz.

<sup>1)</sup> Rotational accuracy of shaft extension, concentricity of spigot and shaft and perpendicularity of mounting face of flange to shaft.

### Technical specifications

#### Ventilation data and sound pressure level

Motor version <b>Forced ventilation</b> (see 8th and 11th positions in the Article No.)	Fan motor:			Direction of air-flow	Sound pressure level $L_{pA}$ (1 m) Motor + external fan, rated load, tolerance +3 dB, nominal pulse frequency 2.5 kHz	Volume of air min.  m <sup>3</sup> /s
	Current consumption at					
	400 V/50 Hz (± 10 %)	400 V/60 Hz (± 10 %)	460 V/60 Hz (± 10 %)			
	A	A	A		dB	
<b>1PH8 motors, shaft height 355</b>						
<b>1PH835.-7..1</b> (asynchronous version, external fan with noise level of 85 dB(A), IP55 degree of protection)	8.2	7.9	7.9	NDE → DE DE → NDE	85	1
<b>1PH835.-7..4</b> (asynchronous version, external fan with noise level of 85 dB(A), IP23 degree of protection)	8.2	13.2 <sup>1)</sup>	10.9 <sup>2)</sup>	NDE → DE DE → NDE	85	1.3

#### Important note:

For 1PH8/SH 355/IP23/85 dB(A) motors, a special fan motor must be ordered using option **R60/R61** for operating the external fan on a supply voltage of 60 Hz (see Selection and ordering data/Article No. supplements).

#### Terminal box, max. connectable conductor cross sections

Terminal box type (see selection and ordering data for details)	Cable entry (power)	Cable entry (external signals)	Outer cable diameter, max. <sup>3)</sup>	Number of main terminals	Cross section, max. per terminal	Current, max. per terminal <sup>4)</sup>
<b>1PH8 motors, shaft height 355</b>						
<b>1XB7712-P01<sup>5)</sup></b>	3 × M63 × 1.5	1 × M20 × 1.5 <sup>6)</sup> 1 × M25 × 1.5 <sup>7)</sup>	53	Phases: 3 × 4 M16 Grounding: 4 × M16	3 × 95	450
<b>1XB7712-P03<sup>5)</sup></b>	4 × M75 × 1.5	1 × M20 × 1.5 <sup>6)</sup> 1 × M25 × 1.5 <sup>7)</sup>	68	Phases: 3 × 4 M16 Grounding: 4 × M16	4 × 185	1150
<b>1XB7820-P00</b>	Not drilled	1 × M20 × 1.5 <sup>6)</sup> 1 × M25 × 1.5 <sup>7)</sup>	–	Phases: 2 × 3 × 4 M16 Grounding: 8 × M16	8 × 240	2100

<sup>1)</sup> Special fan for operation at 460 V/60 Hz (± 10 %), option: **R60** (see Selection and ordering data/Article No. supplements).

<sup>2)</sup> Special fan for operation at 400 V/60 Hz (± 10 %), option: **R61** (see Selection and ordering data/Article No. supplements).

<sup>3)</sup> Dependent on the design of the metric cable gland.

<sup>4)</sup> Current carrying capacity based on IEC 60364-5-52, routing type C.

<sup>5)</sup> For terminal box type 1XB7712-P..., depending on the standard, other cable entries (power) can be ordered using P options (see Selection and ordering data/Article No. supplements).

<sup>6)</sup> Mounted on left side of terminal box (viewed towards cable entries).

<sup>7)</sup> Mounted on right side of terminal box (viewed toward cable entries).

# SIMOTICS M – Main motors

## 1PH8 for SINAMICS S120 for cranes

Degree of protection IP23

### Selection and ordering data

#### SIMOTICS M-1PH8 asynchronous motors, shaft height 355, type of construction IM B3

Rated speed $n_{rated}$	Rated frequency $f_{rated}$	Rated output $P_{rated}$	Rated torque $M_{rated}$	Rated current $I_{rated}$	Max. torque $M_{max}^1$	Max. current $I_{max}^1$	Maximum speed at constant output (field weakening) $n_2^2$	Maximum torque $M_{max}^1$ at				Moment of inertia $J$	1PH8 asynchronous motor Shaft height 355	Weight, approx.	Terminal box
								1000 rpm	1500 rpm	2000 rpm	2500 rpm			kg	Type
rpm	Hz	kW	Nm	A	Nm	A	rpm	Nm	Nm	Nm	Nm	kgm <sup>2</sup>	Article No.	kg	Type
<b>1PH8 35. asynchronous motors, IP23 degree of protection, noise level 85 dB(A), operating speed 600 rpm</b>															
<b>Supply voltage 480 V 3 AC for SINAMICS S120 converters, Active Line Module, Vector Control</b>															
<b>Intermittent duty S3 – 40 %</b>															
600	30,4	545	8675	755 (at 500 V)	12640	1310	1100	4840	2260	1320	870	14,74	1PH8 350-7 B4 0 - ■■■■ 0	2235	1XB7712-P03
	30,5	610	9709	850 (at 500 V)	12500	1280	1100	4810	2260	1320	870	14,74	1PH8 351-7 B4 0 - ■■■■ 0	2235	1XB7712-P03
	30,5	735	11699	1010 (at 500 V)	15040	1490	1000	5770	2700	1570	1040	17,40	1PH8 352-7 B4 0 - ■■■■ 0	2560	1XB7712-P03
	30,5	865	13768	1175 (at 500 V)	17050	1630	1000	6550	3070	1790	1180	20,66	1PH8 354-7 B4 0 - ■■■■ 0	2889	1XB7712-P03
	30,5	1015	16155	1360 (at 500 V)	20690	1950	900	7930	3710	2160	1420	24,22	1PH8 356-7 B4 0 - ■■■■ 0	3256	1XB7712-P03
	30,5	1145	18225	1535 (at 500 V)	23650	2200	900	9070	4240	2470	1630	27,79	1PH8 358-7 B4 0 - ■■■■ 0	3629	1XB7712-P03
<b>Intermittent duty S3 – 60 %</b>															
600	30,4	455	7242	640 (at 500 V)	12640	1310	1100	4840	2260	1320	870	14,74	1PH8 350-7 B4 0 - ■■■■ 0	2235	1XB7712-P03
	30,5	510	8118	720 (at 500 V)	12500	1280	1100	4810	2260	1320	870	14,74	1PH8 351-7 B4 0 - ■■■■ 0	2235	1XB7712-P03
	30,5	615	9789	855 (at 500 V)	15040	1490	1000	5770	2700	1570	1040	17,40	1PH8 352-7 B4 0 - ■■■■ 0	2560	1XB7712-P03
	30,5	725	11540	990 (at 500 V)	17050	1630	1000	6550	3070	1790	1180	20,66	1PH8 354-7 B4 0 - ■■■■ 0	2889	1XB7712-P03
	30,5	850	13529	1145 (at 500 V)	20690	1950	900	7930	3710	2160	1420	24,22	1PH8 356-7 B4 0 - ■■■■ 0	3256	1XB7712-P03
	30,5	960	15280	1295 (at 500 V)	23650	2200	900	9070	4240	2470	1630	27,79	1PH8 358-7 B4 0 - ■■■■ 0	3629	1XB7712-P03
<b>Intermittent duty S3 - 100 % (S1)</b>															
600	30,4	370	5889	530 (at 500 V)	12640	1310	1100	4840	2260	1320	870	14,74	1PH8 350-7 B4 0 - ■■■■ 0	2235	1XB7712-P03
	30,5	415	6605	590 (at 500 V)	12500	1280	1100	4810	2260	1320	870	14,74	1PH8 351-7 B4 0 - ■■■■ 0	2235	1XB7712-P03
	30,5	500	7958	700 (at 500 V)	15040	1490	1000	5770	2700	1570	1040	17,40	1PH8 352-7 B4 0 - ■■■■ 0	2560	1XB7712-P03
	30,5	590	9391	810 (at 500 V)	17050	1630	1000	6550	3070	1790	1180	20,66	1PH8 354-7 B4 0 - ■■■■ 0	2889	1XB7712-P03
	30,5	690	10983	940 (at 500 V)	20690	1950	900	7930	3710	2160	1420	24,22	1PH8 356-7 B4 0 - ■■■■ 0	3256	1XB7712-P03
	30,5	780	12415	1060 (at 500 V)	23650	2200	900	9070	4240	2470	1630	27,79	1PH8 358-7 B4 0 - ■■■■ 0	3629	1XB7712-P03

For versions, see Article No. supplements and options.

For more operating characteristics and engineering data, please contact your local Siemens representative. Compliance with the rated pulse frequencies is essential; the rated motor data is valid for 2.5 kHz.

<sup>1)</sup> Maximum torque/current that is briefly available for dynamic operations (e.g. accelerating). Please refer to the planning documents for the values for thyristor or diode infeeds (e.g. Basic Line Module).

<sup>2)</sup>  $n_2$ : Max. permissible thermal speed at constant output or speed, which is at the voltage limit when  $P = P_{rated}$ .

**Selection and ordering data**

**SIMOTICS M-1PH8 asynchronous motors, shaft height 355, type of construction IM B3**

Rated speed $n_{rated}$	Rated frequency $f_{rated}$	Rated output $P_{rated}$	Rated torque $M_{rated}$	Rated current $I_{rated}$	Max. torque $M_{max}^1$	Max. current $I_{max}^1$	Maximum speed at constant output (field weakening) <sup>2)</sup> $n_2$	Maximum torque $M_{max}^1$ at				Moment of inertia $J$	1PH8 asynchronous motor Shaft height 355	Weight, Terminal	
								1000 rpm	1500 rpm	2000 rpm	2500 rpm			approx. box	
rpm	Hz	kW	Nm	A	Nm	A	rpm	Nm	Nm	Nm	Nm	kgm <sup>2</sup>	Article No.	kg	Type

**1PH8 35. asynchronous motors, IP23 degree of protection, noise level 85 dB(A), operating speed 600 rpm**  
Supply voltage 690 V 3 AC for SINAMICS S120 converters, Active Line Module, Vector Control

**Intermittent duty S3 – 40 %**

<b>600</b>	30,5	545	8675	545 (at 690 V)	12620	950	1100	4830	2250	1310	860	14,74	1PH8 350-7 H4 0 - ■■■■ 0	2235	1XB7712-P01
	30,5	610	9709	620 (at 690 V)	12490	930	1100	4810	2250	1310	870	14,74	1PH8 351-7 H4 0 - ■■■■ 0	2235	1XB7712-P01
	30,5	735	11699	740 (at 690 V)	14450	1040	1000	5570	2610	1530	1010	17,40	1PH8 352-7 H4 0 - ■■■■ 0	2560	1XB7712-P03
	30,5	865	13768	855 (at 690 V)	17320	1200	1000	6650	3110	1810	1190	20,66	1PH8 354-7 H4 0 - ■■■■ 0	2889	1XB7712-P03
	30,5	1015	16155	980 (at 690 V)	20800	1420	900	7980	3730	2170	1430	24,22	1PH8 356-7 H4 0 - ■■■■ 0	3256	1XB7712-P03
	30,4	1145	18225	1110 (at 690 V)	24270	1630	900	9320	4360	2540	1670	27,79	1PH8 358-7 H4 0 - ■■■■ 0	3629	1XB7712-P03

**Intermittent duty S3 – 60 %**

<b>600</b>	30,5	455	7242	460 (at 690 V)	12620	950	1100	4830	2250	1310	860	14,74	1PH8 350-7 H4 0 - ■■■■ 0	2235	1XB7712-P01
	30,5	510	8118	525 (at 690 V)	12490	930	1100	4810	2250	1310	870	14,74	1PH8 351-7 H4 0 - ■■■■ 0	2235	1XB7712-P01
	30,5	615	9789	625 (at 690 V)	14450	1040	1000	5570	2610	1530	1010	17,40	1PH8 352-7 H4 0 - ■■■■ 0	2560	1XB7712-P03
	30,5	725	11540	720 (at 690 V)	17320	1200	1000	6650	3110	1810	1190	20,66	1PH8 354-7 H4 0 - ■■■■ 0	2889	1XB7712-P03
	30,5	850	13529	830 (at 690 V)	20800	1420	900	7980	3730	2170	1430	24,22	1PH8 356-7 H4 0 - ■■■■ 0	3256	1XB7712-P03
	30,4	960	15280	940 (at 690 V)	24270	1630	900	9320	4360	2540	1670	27,79	1PH8 358-7 H4 0 - ■■■■ 0	3629	1XB7712-P03

**Intermittent duty S3 - 100 % (S1)**

<b>600</b>	30,5	370	5889	380 (at 690 V)	12620	950	1100	4830	2250	1310	860	14,74	1PH8 350-7 H4 0 - ■■■■ 0	2235	1XB7712-P01
	30,5	415	6605	430 (at 690 V)	12490	930	1100	4810	2250	1310	870	14,74	1PH8 351-7 H4 0 - ■■■■ 0	2235	1XB7712-P01
	30,5	500	7958	510 (at 690 V)	14450	1040	1000	5570	2610	1530	1010	17,40	1PH8 352-7 H4 0 - ■■■■ 0	2560	1XB7712-P03
	30,5	590	9391	590 (at 690 V)	17320	1200	1000	6650	3110	1810	1190	20,66	1PH8 354-7 H4 0 - ■■■■ 0	2889	1XB7712-P03
	30,5	690	10983	680 (at 690 V)	20800	1420	900	7980	3730	2170	1430	24,22	1PH8 356-7 H4 0 - ■■■■ 0	3256	1XB7712-P03
	30,4	780	12415	770 (at 690 V)	24270	1630	900	9320	4360	2540	1670	27,79	1PH8 358-7 H4 0 - ■■■■ 0	3629	1XB7712-P03

For versions, see Article No. supplements and options.

For more operating characteristics and engineering data, please contact your local Siemens representative. Compliance with the rated pulse frequencies is essential; the rated motor data is valid for 2.5 kHz.

<sup>1)</sup> Maximum torque/current that is briefly available for dynamic operations (e.g. accelerating). Please refer to the planning documents for the values for thyristor or diode infeeds (e.g. Basic Line Module).

<sup>2)</sup>  $n_2$ : Max. permissible thermal speed at constant output or speed, which is at the voltage limit when  $P = P_{rated}$ .



# SIMOTICS M – Main motors

## 1PH8 for SINAMICS S120 for cranes

Degree of protection IP23

### Selection and ordering data

#### SIMOTICS M-1PH8 asynchronous motors, shaft height 355, type of construction IM B3

Rated speed $n_{rated}$	Rated frequency $f_{rated}$	Rated output $P_{rated}$	Rated torque $M_{rated}$	Rated current $I_{rated}$	Max. torque $M_{max}^1$	Max. current $I_{max}^1$	Maximum speed at constant output (field weakening) <sup>2)</sup> $n_2$	Maximum torque $M_{max}^1$ at				Moment of inertia $J$	1PH8 asynchronous motor Shaft height 355	Weight, approx.	Terminal box
								1000 rpm	1500 rpm	2000 rpm	2500 rpm				
rpm	Hz	kW	Nm	A	Nm	A	rpm	Nm	Nm	Nm	Nm	kgm <sup>2</sup>	Article No.	kg	Type

1PH8 35. asynchronous motors, IP23 degree of protection, noise level 85 dB(A), operating speed 800 rpm  
Supply voltage 480 V 3 AC for SINAMICS S120 converters, Active Line Module, Vector Control

#### Intermittent duty S3 – 40 %

800	40,4	705	8416	975 (at 500 V)	12910	1850	1400	8430	3890	2250	1470	14,74	1PH8 350-7 Q4 0 - ■ ■ ■ ■ 0	2235	1XB7712-P03
	40,5	780	9311	1080 (at 500 V)	12830	1810	1400	8390	3880	2250	1470	14,74	1PH8 351-7 Q4 0 - ■ ■ ■ ■ 0	2235	1XB7712-P03
	40,5	925	11042	1255 (at 500 V)	15280	2050	1300	9990	4610	2660	1740	17,40	1PH8 352-7 Q4 0 - ■ ■ ■ ■ 0	2560	1XB7712-P03
	40,4	1105	13191	1500 (at 500 V)	19170	2480	1300	12520	5770	3330	2170	20,66	1PH8 354-7 Q4 0 - ■ ■ ■ ■ 0	2889	1XB7712-P03
	40,4	1265	15101	1700 (at 500 V)	22380	2830	1200	14610	6730	3890	2540	24,22	1PH8 356-7 Q4 0 - ■ ■ ■ ■ 0	3256	1XB7820-P00
	40,5	1410	16832	1885 (at 500 V)	23090	2860	1200	15090	6980	4030	2640	27,79	1PH8 358-7 Q4 0 - ■ ■ ■ ■ 0	3629	1XB7820-P00

#### Intermittent duty S3 – 60 %

800	40,4	590	7043	825 (at 500 V)	12910	1850	1400	8430	3890	2250	1470	14,74	1PH8 350-7 Q4 0 - ■ ■ ■ ■ 0	2235	1XB7712-P03
	40,5	650	7759	915 (at 500 V)	12830	1810	1400	8390	3880	2250	1470	14,74	1PH8 351-7 Q4 0 - ■ ■ ■ ■ 0	2235	1XB7712-P03
	40,5	775	9252	1060 (at 500 V)	15280	2050	1300	9990	4610	2660	1740	17,40	1PH8 352-7 Q4 0 - ■ ■ ■ ■ 0	2560	1XB7712-P03
	40,4	925	11042	1265 (at 500 V)	19170	2480	1300	12520	5770	3330	2170	20,66	1PH8 354-7 Q4 0 - ■ ■ ■ ■ 0	2889	1XB7712-P03
	40,4	1060	12654	1435 (at 500 V)	22380	2830	1200	14610	6730	3890	2540	24,22	1PH8 356-7 Q4 0 - ■ ■ ■ ■ 0	3256	1XB7820-P00
	40,5	1180	14086	1590 (at 500 V)	23090	2860	1200	15090	6980	4030	2640	27,79	1PH8 358-7 Q4 0 - ■ ■ ■ ■ 0	3629	1XB7820-P00

#### Intermittent duty S3 - 100 % (S1)

800	40,4	480	5730	680 (at 500 V)	12910	1850	1400	8430	3890	2250	1470	14,74	1PH8 350-7 Q4 0 - ■ ■ ■ ■ 0	2235	1XB7712-P03
	40,5	530	6327	750 (at 500 V)	12830	1810	1400	8390	3880	2250	1470	14,74	1PH8 351-7 Q4 0 - ■ ■ ■ ■ 0	2235	1XB7712-P03
	40,5	630	7521	870 (at 500 V)	15280	2050	1300	9990	4610	2660	1740	17,40	1PH8 352-7 Q4 0 - ■ ■ ■ ■ 0	2560	1XB7712-P03
	40,4	750	8953	1040 (at 500 V)	19170	2480	1300	12520	5770	3330	2170	20,66	1PH8 354-7 Q4 0 - ■ ■ ■ ■ 0	2889	1XB7712-P03
	40,4	860	10266	1180 (at 500 V)	22380	2830	1200	14610	6730	3890	2540	24,22	1PH8 356-7 Q4 0 - ■ ■ ■ ■ 0	3256	1XB7820-P00
	40,5	960	11460	1300 (at 500 V)	23090	2860	1200	15090	6980	4030	2640	27,79	1PH8 358-7 Q4 0 - ■ ■ ■ ■ 0	3629	1XB7820-P00

For versions, see Article No. supplements and options.

For more operating characteristics and engineering data, please contact your local Siemens representative. Compliance with the rated pulse frequencies is essential; the rated motor data is valid for 2.5 kHz.

<sup>1)</sup> Maximum torque/current that is briefly available for dynamic operations (e.g. accelerating). Please refer to the planning documents for the values for thyristor or diode infeeds (e.g. Basic Line Module).

<sup>2)</sup>  $n_2$ : Max. permissible thermal speed at constant output or speed, which is at the voltage limit when  $P = P_{rated}$ .



### Selection and ordering data

#### SIMOTICS M-1PH8 asynchronous motors, shaft height 355, type of construction IM B3

Rated speed $n_{rated}$	Rated frequency $f_{rated}$	Rated output $P_{rated}$	Rated torque $M_{rated}$	Rated current $I_{rated}$	Max. torque $M_{max}^1$	Max. current $I_{max}^1$	Maximum speed at constant output (field weakening) <sup>2)</sup> $n_2$	Maximum torque $M_{max}^1$ at				Moment of inertia $J$	1PH8 asynchronous motor Shaft height 355	Weight, approx.	Terminal box
								1000 rpm	1500 rpm	2000 rpm	2500 rpm				
rpm	Hz	kW	Nm	A	Nm	A	rpm	Nm	Nm	Nm	Nm	kgm <sup>2</sup>	Article No.	kg	Type
<b>1PH8 35. asynchronous motors, IP23 degree of protection, noise level 85 dB(A), operating speed 800 rpm</b>															
<b>Supply voltage 690 V 3 AC for SINAMICS S120 converters, Active Line Module, Vector Control</b>															
<b>Intermittent duty S3 – 40 %</b>															
800	40,5	705	8416	705 (at 690 V)	12600	1330	1400	8240	3810	2200	1440	14,74	1PH8 350-7 K4 0 - ■ ■ ■ ■ 0	2235	1XB7712-P03
	40,5	780	9311	780 (at 690 V)	12530	1300	1400	8200	3800	2200	1440	14,74	1PH8 351-7 K4 0 - ■ ■ ■ ■ 0	2235	1XB7712-P03
	40,4	925	11042	920 (at 690 V)	15760	1520	1300	10300	4750	2740	1790	17,40	1PH8 352-7 K4 0 - ■ ■ ■ ■ 0	2560	1XB7712-P03
	40,5	1105	13191	1070 (at 690 V)	18080	1710	1300	11820	5460	3160	2060	20,66	1PH8 354-7 K4 0 - ■ ■ ■ ■ 0	2889	1XB7712-P03
	40,4	1265	15101	1215 (at 690 V)	21500	1990	1200	14040	6470	3730	2440	24,22	1PH8 356-7 K4 0 - ■ ■ ■ ■ 0	3256	1XB7712-P03
	40,4	1410	16832	1360 (at 690 V)	23550	2110	1200	15410	7130	4120	2700	27,79	1PH8 358-7 K4 0 - ■ ■ ■ ■ 0	3629	1XB7712-P03
<b>Intermittent duty S3 – 60 %</b>															
800	40,5	590	7043	595 (at 690 V)	12600	1330	1400	8240	3810	2200	1440	14,74	1PH8 350-7 K4 0 - ■ ■ ■ ■ 0	2235	1XB7712-P03
	40,5	650	7759	660 (at 690 V)	12530	1300	1400	8200	3800	2200	1440	14,74	1PH8 351-7 K4 0 - ■ ■ ■ ■ 0	2235	1XB7712-P03
	40,4	775	9252	780 (at 690 V)	15760	1520	1300	10300	4750	2740	1790	17,40	1PH8 352-7 K4 0 - ■ ■ ■ ■ 0	2560	1XB7712-P03
	40,5	925	11042	905 (at 690 V)	18080	1710	1300	11820	5460	3160	2060	20,66	1PH8 354-7 K4 0 - ■ ■ ■ ■ 0	2889	1XB7712-P03
	40,4	1060	12654	1025 (at 690 V)	21500	1990	1200	14040	6470	3730	2440	24,22	1PH8 356-7 K4 0 - ■ ■ ■ ■ 0	3256	1XB7712-P03
	40,4	1180	14086	1150 (at 690 V)	23550	2110	1200	15410	7130	4120	2700	27,79	1PH8 358-7 K4 0 - ■ ■ ■ ■ 0	3629	1XB7712-P03
<b>Intermittent duty S3 - 100 % (S1)</b>															
800	40,5	480	5730	490 (at 690 V)	12600	1330	1400	8240	3810	2200	1440	14,74	1PH8 350-7 K4 0 - ■ ■ ■ ■ 0	2235	1XB7712-P03
	40,5	530	6327	540 (at 690 V)	12530	1300	1400	8200	3800	2200	1440	14,74	1PH8 351-7 K4 0 - ■ ■ ■ ■ 0	2235	1XB7712-P03
	40,4	630	7521	640 (at 690 V)	15760	1520	1300	10300	4750	2740	1790	17,40	1PH8 352-7 K4 0 - ■ ■ ■ ■ 0	2560	1XB7712-P03
	40,5	750	8953	740 (at 690 V)	18080	1710	1300	11820	5460	3160	2060	20,66	1PH8 354-7 K4 0 - ■ ■ ■ ■ 0	2889	1XB7712-P03
	40,4	860	10266	840 (at 690 V)	21500	1990	1200	14040	6470	3730	2440	24,22	1PH8 356-7 K4 0 - ■ ■ ■ ■ 0	3256	1XB7712-P03
	40,4	960	11460	940 (at 690 V)	23550	2110	1200	15410	7130	4120	2700	27,79	1PH8 358-7 K4 0 - ■ ■ ■ ■ 0	3629	1XB7712-P03

For versions, see Article No. supplements and options.

For more operating characteristics and engineering data, please contact your local Siemens representative. Compliance with the rated pulse frequencies is essential; the rated motor data is valid for 2.5 kHz.

<sup>1)</sup> Maximum torque/current that is briefly available for dynamic operations (e.g. accelerating). Please refer to the planning documents for the values for thyristor or diode infeeds (e.g. Basic Line Module).

<sup>2)</sup>  $n_2$ : Max. permissible thermal speed at constant output or speed, which is at the voltage limit when  $P = P_{rated}$ .

**SIMOTICS M – Main motors**

1PH8 for SINAMICS S120 for cranes

**Degree of protection IP23****Selection and ordering data****SIMOTICS M-1PH8 asynchronous motors, shaft height 355, type of construction IM B3**

Rated speed $n_{rated}$	Rated frequency $f_{rated}$	Rated output $P_{rated}$	Rated torque $M_{rated}$	Rated current $I_{rated}$	Max. torque $M_{max}^1$	Max. current $I_{max}^1$	Maximum speed at constant output (field weakening) <sup>2)</sup> $n_2$	Maximum torque $M_{max}^1$ at				Moment of inertia $J$	<b>1PH8 asynchronous motor Shaft height 355</b>	Weight, approx.	Terminal box
								1500 rpm	2000 rpm	2500 rpm	2800 rpm				
rpm	Hz	kW	Nm	A	Nm	A	rpm	Nm	Nm	Nm	Nm	kgm <sup>2</sup>	Article No.	kg	Type

**1PH8 35. asynchronous motors, IP23 degree of protection, noise level 85 dB(A), operating speed 1000 rpm  
Supply voltage 480 V 3 AC for SINAMICS S120 converters, Active Line Module, Vector Control**

**Intermittent duty S3 – 40 %**

<b>1000</b>	50,4	880	8404	1205 (at 500 V)	13470	2490	1500	6160	3540	2300	1850	14,74	<b>1PH8 350-7 C4 0 - ■ ■ ■ ■ 0</b>	2235	1XB7712-P03
	50,5	985	9407	1355 (at 500 V)	13380	2470	1500	6140	3540	2300	1850	14,74	<b>1PH8 351-7 C4 0 - ■ ■ ■ ■ 0</b>	2235	1XB7712-P03
	50,5	1145	10935	1565 (at 500 V)	14980	2540	1400	6870	3950	2570	2070	17,40	<b>1PH8 352-7 C4 0 - ■ ■ ■ ■ 0</b>	2560	1XB7712-P03
	50,5	1325	12654	1770 (at 500 V)	17230	2790	1300	7910	4550	2970	2390	20,66	<b>1PH8 354-7 C4 0 - ■ ■ ■ ■ 0</b>	2889	1XB7820-P00
	50,4	1530	14612	2025 (at 500 V)	21370	3380	1200	9810	5640	3670	2960	24,22	<b>1PH8 356-7 C4 0 - ■ ■ ■ ■ 0</b>	3256	1XB7820-P00
	50,4	1765	16856	2445 (at 480 V)	27150	4400	1200	12430	7140	4650	3730	27,79	<b>1PH8 358-7 C4 0 - ■ ■ ■ ■ 0</b>	3629	1XB7820-P00

**Intermittent duty S3 – 60 %**

<b>1000</b>	50,4	740	7067	1020 (at 500 V)	13470	2490	1500	6160	3540	2300	1850	14,74	<b>1PH8 350-7 C4 0 - ■ ■ ■ ■ 0</b>	2235	1XB7712-P03
	50,5	825	7879	1145 (at 500 V)	13380	2470	1500	6140	3540	2300	1850	14,74	<b>1PH8 351-7 C4 0 - ■ ■ ■ ■ 0</b>	2235	1XB7712-P03
	50,5	960	9168	1320 (at 500 V)	14980	2540	1400	6870	3950	2570	2070	17,40	<b>1PH8 352-7 C4 0 - ■ ■ ■ ■ 0</b>	2560	1XB7712-P03
	50,5	1105	10553	1495 (at 500 V)	17230	2790	1300	7910	4550	2970	2390	20,66	<b>1PH8 354-7 C4 0 - ■ ■ ■ ■ 0</b>	2889	1XB7820-P00
	50,4	1280	12224	1710 (at 500 V)	21370	3380	1200	9810	5640	3670	2960	24,22	<b>1PH8 356-7 C4 0 - ■ ■ ■ ■ 0</b>	3256	1XB7820-P00
	50,4	1475	14086	2070 (at 480 V)	27150	4400	1200	12430	7140	4650	3730	27,79	<b>1PH8 358-7 C4 0 - ■ ■ ■ ■ 0</b>	3629	1XB7820-P00

**Intermittent duty S3 - 100 % (S1)**

<b>1000</b>	50,4	600	5730	840 (at 500 V)	13470	2490	1500	6160	3540	2300	1850	14,74	<b>1PH8 350-7 C4 0 - ■ ■ ■ ■ 0</b>	2235	1XB7712-P03
	50,5	670	6399	940 (at 500 V)	13380	2470	1500	6140	3540	2300	1850	14,74	<b>1PH8 351-7 C4 0 - ■ ■ ■ ■ 0</b>	2235	1XB7712-P03
	50,5	780	7449	1080 (at 500 V)	14980	2540	1400	6870	3950	2570	2070	17,40	<b>1PH8 352-7 C4 0 - ■ ■ ■ ■ 0</b>	2560	1XB7712-P03
	50,5	900	8595	1220 (at 500 V)	17230	2790	1300	7910	4550	2970	2390	20,66	<b>1PH8 354-7 C4 0 - ■ ■ ■ ■ 0</b>	2889	1XB7820-P00
	50,4	1040	9932	1400 (at 500 V)	21370	3380	1200	9810	5640	3670	2960	24,22	<b>1PH8 356-7 C4 0 - ■ ■ ■ ■ 0</b>	3256	1XB7820-P00
	50,4	1200	11460	1700 (at 480 V)	27150	4400	1200	12430	7140	4650	3730	27,79	<b>1PH8 358-7 C4 0 - ■ ■ ■ ■ 0</b>	3629	1XB7820-P00

For versions, see Article No. supplements and options.

For more operating characteristics and engineering data, please contact your local Siemens representative. Compliance with the rated pulse frequencies is essential; the rated motor data is valid for 2.5 kHz.

<sup>1)</sup> Maximum torque/current that is briefly available for dynamic operations (e.g. accelerating). Please refer to the planning documents for the values for thyristor or diode infeeds (e.g. Basic Line Module).

<sup>2)</sup>  $n_2$ : Max. permissible thermal speed at constant output or speed, which is at the voltage limit when  $P = P_{rated}$ .

**Selection and ordering data**

**SIMOTICS M-1PH8 asynchronous motors, shaft height 355, type of construction IM B3**

Rated speed $n_{rated}$	Rated frequency $f_{rated}$	Rated output $P_{rated}$	Rated torque $M_{rated}$	Rated current $I_{rated}$	Max. torque $M_{max}^1$	Max. current $I_{max}^1$	Maximum speed at constant output (field weakening) <sup>2)</sup> $n_2$	Maximum torque $M_{max}^1$ at				Moment of inertia $J$	<b>1PH8 asynchronous motor</b> <b>Shaft height 355</b>	Weight, approx.	Terminal box
								1500 rpm	2000 rpm	2500 rpm	2800 rpm				
rpm	Hz	kW	Nm	A	Nm	A	rpm	Nm	Nm	Nm	Nm	kgm <sup>2</sup>	Article No.	kg	Type

**1PH8 35. asynchronous motors, IP23 degree of protection, noise level 85 dB(A), operating speed 1000 rpm**  
**Supply voltage 690 V 3 AC for SINAMICS S120 converters, Active Line Module, Vector Control**

**Intermittent duty S3 – 40 %**

<b>1000</b>	50,5	880	8404	875 (at 690 V)	13570	1810	1500	6200	3550	2310	1850	14,74	<b>1PH8 350-7 U4 0 - ■ ■ ■ ■ 0</b>	2235	1XB7712-P03
	50,5	985	9407	980 (at 690 V)	13480	1800	1500	6180	3550	2310	1860	14,74	<b>1PH8 351-7 U4 0 - ■ ■ ■ ■ 0</b>	2235	1XB7712-P03
	50,5	1145	10935	1130 (at 690 V)	15390	1870	1400	7050	4050	2640	2120	17,40	<b>1PH8 352-7 U4 0 - ■ ■ ■ ■ 0</b>	2560	1XB7712-P03
	50,4	1325	12654	1285 (at 690 V)	18240	2110	1300	8360	4810	3130	2520	20,66	<b>1PH8 354-7 U4 0 - ■ ■ ■ ■ 0</b>	2889	1XB7712-P03
	50,5	1530	14612	1480 (at 690 V)	20940	2420	1200	9590	5510	3580	2880	24,22	<b>1PH8 356-7 U4 0 - ■ ■ ■ ■ 0</b>	3256	1XB7712-P03
	50,4	1765	16856	1680 (at 690 V)	24680	2770	1200	11330	6530	4250	3420	27,79	<b>1PH8 358-7 U4 0 - ■ ■ ■ ■ 0</b>	3629	1XB7820-P00

**Intermittent duty S3 – 60 %**

<b>1000</b>	50,5	740	7067	740 (at 690 V)	13570	1810	1500	6200	3550	2310	1850	14,74	<b>1PH8 350-7 U4 0 - ■ ■ ■ ■ 0</b>	2235	1XB7712-P03
	50,5	825	7879	830 (at 690 V)	13480	1800	1500	6180	3550	2310	1860	14,74	<b>1PH8 351-7 U4 0 - ■ ■ ■ ■ 0</b>	2235	1XB7712-P03
	50,5	960	9168	955 (at 690 V)	15390	1870	1400	7050	4050	2640	2120	17,40	<b>1PH8 352-7 U4 0 - ■ ■ ■ ■ 0</b>	2560	1XB7712-P03
	50,4	1105	10553	1085 (at 690 V)	18240	2110	1300	8360	4810	3130	2520	20,66	<b>1PH8 354-7 U4 0 - ■ ■ ■ ■ 0</b>	2889	1XB7712-P03
	50,5	1280	12224	1250 (at 690 V)	20940	2420	1200	9590	5510	3580	2880	24,22	<b>1PH8 356-7 U4 0 - ■ ■ ■ ■ 0</b>	3256	1XB7712-P03
	50,4	1475	14086	1415 (at 690 V)	24680	2770	1200	11330	6530	4250	3420	27,79	<b>1PH8 358-7 U4 0 - ■ ■ ■ ■ 0</b>	3629	1XB7820-P00

**Intermittent duty S3 - 100 % (S1)**

<b>1000</b>	50,5	600	5730	610 (at 690 V)	13570	1810	1500	6200	3550	2310	1850	14,74	<b>1PH8 350-7 U4 0 - ■ ■ ■ ■ 0</b>	2235	1XB7712-P03
	50,5	670	6399	680 (at 690 V)	13480	1800	1500	6180	3550	2310	1860	14,74	<b>1PH8 351-7 U4 0 - ■ ■ ■ ■ 0</b>	2235	1XB7712-P03
	50,5	780	7449	780 (at 690 V)	15390	1870	1400	7050	4050	2640	2120	17,40	<b>1PH8 352-7 U4 0 - ■ ■ ■ ■ 0</b>	2560	1XB7712-P03
	50,4	900	8595	890 (at 690 V)	18240	2110	1300	8360	4810	3130	2520	20,66	<b>1PH8 354-7 U4 0 - ■ ■ ■ ■ 0</b>	2889	1XB7712-P03
	50,5	1040	9932	1020 (at 690 V)	20940	2420	1200	9590	5510	3580	2880	24,22	<b>1PH8 356-7 U4 0 - ■ ■ ■ ■ 0</b>	3256	1XB7712-P03
	50,4	1200	11460	1160 (at 690 V)	24680	2770	1200	11330	6530	4250	3420	27,79	<b>1PH8 358-7 U4 0 - ■ ■ ■ ■ 0</b>	3629	1XB7820-P00

For versions, see Article No. supplements and options.

For more operating characteristics and engineering data, please contact your local Siemens representative. Compliance with the rated pulse frequencies is essential; the rated motor data is valid for 2.5 kHz.

<sup>1)</sup> Maximum torque/current that is briefly available for dynamic operations (e.g. accelerating). Please refer to the planning documents for the values for thyristor or diode infeeds (e.g. Basic Line Module).

<sup>2)</sup>  $n_2$ : Max. permissible thermal speed at constant output or speed, which is at the voltage limit when  $P = P_{rated}$ .



# SIMOTICS M – Main motors

## 1PH8 for SINAMICS S120 for cranes

Degree of protection IP23

### Selection and ordering data

#### SIMOTICS M-1PH8 asynchronous motors, shaft height 355, type of construction IM B3

Rated speed $n_{rated}$	Rated frequency $f_{rated}$	Rated output $P_{rated}$	Rated torque $M_{rated}$	Rated current $I_{rated}$	Max. torque $M_{max}^1$	Max. current $I_{max}^1$	Maximum speed at constant output (field weakening) <sup>2)</sup> $n_2$	Maximum torque $M_{max}^1$ at				Moment of inertia $J$	1PH8 asynchronous motor Shaft height 355	Weight, approx.	Terminal box
								1500 rpm	2000 rpm	2500 rpm	2800 rpm				
rpm	Hz	kW	Nm	A	Nm	A	rpm	Nm	Nm	Nm	Nm	kgm <sup>2</sup>	Article No.	kg	Type

1PH8 35. asynchronous motors, IP23 degree of protection, noise level 85 dB(A), operating speed 1350 rpm  
Supply voltage 480 V 3 AC for SINAMICS S120 converters, Active Line Module, Vector Control

#### Intermittent duty S3 – 40 %

1350	68,0	985	6968	1340 (at 500 V)	9990	2450	1700	8150	4670	3030	2430	14,74	1PH8 350-7 D4 0 - ■■■■ 0	2235	1XB7712-P03
	68,1	1105	7817	1520 (at 500 V)	9950	2400	1700	8120	4660	3030	2430	14,74	1PH8 351-7 D4 0 - ■■■■ 0	2235	1XB7712-P03
	68,0	1340	9479	1800 (at 500 V)	13910	3310	1700	11350	6500	4220	3390	17,40	1PH8 352-7 D4 0 - ■■■■ 0	2560	1XB7820-P00
	68,0	1530	10823	2045 (at 500 V)	14180	3160	1400	11570	6640	4320	3470	20,66	1PH8 354-7 D4 0 - ■■■■ 0	2889	1XB7820-P00
	67,9	1765	12486	2325 (at 500 V)	19150	4130	1400	15630	8960	5820	4680	24,22	1PH8 356-7 D4 0 - ■■■■ 0	3256	1XB7820-P00
	67,9	1970	13936	2585 (at 500 V)	21870	4620	1400	17840	10250	6660	5350	27,79	1PH8 358-7 D4 0 - ■■■■ 0	3629	1XB7820-P00

#### Intermittent duty S3 – 60 %

1350	68,0	825	5836	1130 (at 500 V)	9990	2450	1700	8150	4670	3030	2430	14,74	1PH8 350-7 D4 0 - ■■■■ 0	2235	1XB7712-P03
	68,1	925	6544	1280 (at 500 V)	9950	2400	1700	8120	4660	3030	2430	14,74	1PH8 351-7 D4 0 - ■■■■ 0	2235	1XB7712-P03
	68,0	1120	7923	1520 (at 500 V)	13910	3310	1700	11350	6500	4220	3390	17,40	1PH8 352-7 D4 0 - ■■■■ 0	2560	1XB7820-P00
	68,0	1280	9055	1720 (at 500 V)	14180	3160	1400	11570	6640	4320	3470	20,66	1PH8 354-7 D4 0 - ■■■■ 0	2889	1XB7820-P00
	67,9	1475	10434	1960 (at 500 V)	19150	4130	1400	15630	8960	5820	4680	24,22	1PH8 356-7 D4 0 - ■■■■ 0	3256	1XB7820-P00
	67,9	1650	11672	2180 (at 500 V)	21870	4620	1400	17840	10250	6660	5350	27,79	1PH8 358-7 D4 0 - ■■■■ 0	3629	1XB7820-P00

#### Intermittent duty S3 - 100 % (S1)

1350	68,0	670	4740	920 (at 500 V)	9990	2450	1700	8150	4670	3030	2430	14,74	1PH8 350-7 D4 0 - ■■■■ 0	2235	1XB7712-P03
	68,1	750	5306	1040 (at 500 V)	9950	2400	1700	8120	4660	3030	2430	14,74	1PH8 351-7 D4 0 - ■■■■ 0	2235	1XB7712-P03
	68,0	910	6437	1240 (at 500 V)	13910	3310	1700	11350	6500	4220	3390	17,40	1PH8 352-7 D4 0 - ■■■■ 0	2560	1XB7820-P00
	68,0	1040	7357	1400 (at 500 V)	14180	3160	1400	11570	6640	4320	3470	20,66	1PH8 354-7 D4 0 - ■■■■ 0	2889	1XB7820-P00
	67,9	1200	8489	1600 (at 500 V)	19150	4130	1400	15630	8960	5820	4680	24,22	1PH8 356-7 D4 0 - ■■■■ 0	3256	1XB7820-P00
	67,9	1340	9479	1780 (at 500 V)	21870	4620	1400	17840	10250	6660	5350	27,79	1PH8 358-7 D4 0 - ■■■■ 0	3629	1XB7820-P00

For versions, see Article No. supplements and options.

For more operating characteristics and engineering data, please contact your local Siemens representative. Compliance with the rated pulse frequencies is essential; the rated motor data is valid for 2.5 kHz.

<sup>1)</sup> Maximum torque/current that is briefly available for dynamic operations (e.g. accelerating). Please refer to the planning documents for the values for thyristor or diode infeeds (e.g. Basic Line Module).

<sup>2)</sup>  $n_2$ : Max. permissible thermal speed at constant output or speed, which is at the voltage limit when  $P = P_{rated}$ .

### Selection and ordering data

#### SIMOTICS M-1PH8 asynchronous motors, shaft height 355, type of construction IM B3

Rated speed $n_{rated}$	Rated frequency $f_{rated}$	Rated output $P_{rated}$	Rated torque $M_{rated}$	Rated current $I_{rated}$	Max. torque $M_{max}^1$	Max. current $I_{max}^1$	Maximum speed at constant output (field weakening) <sup>2)</sup> $n_2$	Maximum torque $M_{max}^1$ at				Moment of inertia $J$	1PH8 asynchronous motor Shaft height 355	Weight, approx.	Terminal box
								1500 rpm	2000 rpm	2500 rpm	2800 rpm				
rpm	Hz	kW	Nm	A	Nm	A	rpm	Nm	Nm	Nm	Nm	kgm <sup>2</sup>	Article No.	kg	Type

1PH8 35. asynchronous motors, IP23 degree of protection, noise level 85 dB(A), operating speed 1350 rpm  
Supply voltage 690 V 3 AC for SINAMICS S120 converters, Active Line Module, Vector Control

#### Intermittent duty S3 – 40 %

1350	68,1	985	6968	975 (at 690 V)	10260	1810	1700	8360	4790	3100	2490	14,74	1PH8 350-7 V 4 0 - ■ ■ ■ ■ 0	2235	1XB7712-P03
	68,1	1105	7817	1095 (at 690 V)	10230	1840	1700	8340	4780	3100	2490	14,74	1PH8 351-7 V 4 0 - ■ ■ ■ ■ 0	2235	1XB7712-P03
	68,0	1340	9479	1315 (at 690 V)	12720	2310	1700	10400	6000	3920	3150	17,40	1PH8 352-7 V 4 0 - ■ ■ ■ ■ 0	2560	1XB7712-P03
	68,1	1530	10823	1495 (at 690 V)	13890	2270	1400	11330	6490	4220	3390	20,66	1PH8 354-7 V 4 0 - ■ ■ ■ ■ 0	2889	1XB7712-P03
	67,9	1765	12486	1685 (at 690 V)	19270	3010	1400	15730	9020	5870	4710	24,22	1PH8 356-7 V 4 0 - ■ ■ ■ ■ 0	3256	1XB7820-P00
	68,0	1970	13936	1865 (at 690 V)	20360	3120	1400	16620	9540	6200	4990	27,79	1PH8 358-7 V 4 0 - ■ ■ ■ ■ 0	3629	1XB7820-P00

#### Intermittent duty S3 – 60 %

1350	68,1	825	5836	820 (at 690 V)	10260	1810	1700	8360	4790	3100	2490	14,74	1PH8 350-7 V 4 0 - ■ ■ ■ ■ 0	2235	1XB7712-P03
	68,1	925	6544	920 (at 690 V)	10230	1840	1700	8340	4780	3100	2490	14,74	1PH8 351-7 V 4 0 - ■ ■ ■ ■ 0	2235	1XB7712-P03
	68,0	1120	7923	1105 (at 690 V)	12720	2310	1700	10400	6000	3920	3150	17,40	1PH8 352-7 V 4 0 - ■ ■ ■ ■ 0	2560	1XB7712-P03
	68,1	1280	9055	1255 (at 690 V)	13890	2270	1400	11330	6490	4220	3390	20,66	1PH8 354-7 V 4 0 - ■ ■ ■ ■ 0	2889	1XB7712-P03
	67,9	1475	10434	1420 (at 690 V)	19270	3010	1400	15730	9020	5870	4710	24,22	1PH8 356-7 V 4 0 - ■ ■ ■ ■ 0	3256	1XB7820-P00
	68,0	1650	11672	1570 (at 690 V)	20360	3120	1400	16620	9540	6200	4990	27,79	1PH8 358-7 V 4 0 - ■ ■ ■ ■ 0	3629	1XB7820-P00

#### Intermittent duty S3 - 100 % (S1)

1350	68,1	670	4740	670 (at 690 V)	10260	1810	1700	8360	4790	3100	2490	14,74	1PH8 350-7 V 4 0 - ■ ■ ■ ■ 0	2235	1XB7712-P03
	68,1	750	5306	750 (at 690 V)	10230	1840	1700	8340	4780	3100	2490	14,74	1PH8 351-7 V 4 0 - ■ ■ ■ ■ 0	2235	1XB7712-P03
	68,0	910	6437	900 (at 690 V)	12720	2310	1700	10400	6000	3920	3150	17,40	1PH8 352-7 V 4 0 - ■ ■ ■ ■ 0	2560	1XB7712-P03
	68,1	1040	7357	1020 (at 690 V)	13890	2270	1400	11330	6490	4220	3390	20,66	1PH8 354-7 V 4 0 - ■ ■ ■ ■ 0	2889	1XB7712-P03
	67,9	1200	8489	1160 (at 690 V)	19270	3010	1400	15730	9020	5870	4710	24,22	1PH8 356-7 V 4 0 - ■ ■ ■ ■ 0	3256	1XB7820-P00
	68,0	1340	9479	1280 (at 690 V)	20360	3120	1400	16620	9540	6200	4990	27,79	1PH8 358-7 V 4 0 - ■ ■ ■ ■ 0	3629	1XB7820-P00

For versions, see Article No. supplements and options.

For more operating characteristics and engineering data, please contact your local Siemens representative. Compliance with the rated pulse frequencies is essential; the rated motor data is valid for 2.5 kHz.

<sup>1)</sup> Maximum torque/current that is briefly available for dynamic operations (e.g. accelerating). Please refer to the planning documents for the values for thyristor or diode infeeds (e.g. Basic Line Module).

<sup>2)</sup>  $n_2$ : Max. permissible thermal speed at constant output or speed, which is at the voltage limit when  $P = P_{rated}$ .

# SIMOTICS M – Main motors

## 1PH8 for SINAMICS S120 for cranes

Degree of protection IP23

### Selection and ordering data

#### SIMOTICS M-1PH8 asynchronous motors, shaft height 355, type of construction IM B3

Rated speed $n_{rated}$	Rated frequency $f_{rated}$	Rated output $P_{rated}$	Rated torque $M_{rated}$	Rated current $I_{rated}$	Max. torque $M_{max}^1$	Max. current $I_{max}^1$	Maximum speed at constant output (field weakening) <sup>2)</sup> $n_2$	Maximum torque $M_{max}^1$ at				Moment of inertia $J$	1PH8 asynchronous motor Shaft height 355	Weight, Terminal approx. box	
								1000 rpm	1500 rpm	2000 rpm	2500 rpm			kg	Type
rpm	Hz	kW	Nm	A	Nm	A	rpm	Nm	Nm	Nm	Nm	kgm <sup>2</sup>	Article No.	kg	Type
<b>1PH8 35. asynchronous motors, IP55 degree of protection, noise level 85 dB(A), operating speed 600 rpm</b>															
<b>Supply voltage 480 V 3 AC for SINAMICS S120 converters, Active Line Module, Vector Control</b>															
<b>Intermittent duty S3 – 40 %</b>															
<b>600</b>	30,3	340	5412	475 (at 500 V)	12120	1260	1400	4710	2220	1310	860	14,74	1PH8 350-7 B1 0 - ■■■■ 0	2235	1XB7712-P01
	30,3	405	6446	555 (at 500 V)	14570	1440	1400	5640	2660	1560	1030	17,40	1PH8 352-7 B1 0 - ■■■■ 0	2560	1XB7712-P01
	30,3	480	7640	655 (at 500 V)	16670	1590	1400	6450	3030	1780	1170	20,66	1PH8 354-7 B1 0 - ■■■■ 0	2889	1XB7712-P03
	30,3	560	8913	755 (at 500 V)	20320	1920	1400	7840	3680	2150	1420	24,22	1PH8 356-7 B1 0 - ■■■■ 0	3256	1XB7712-P03
	30,2	630	10028	850 (at 500 V)	23390	2180	1400	8990	4210	2460	1620	27,79	1PH8 358-7 B1 0 - ■■■■ 0	3629	1XB7712-P03
<b>Intermittent duty S3 – 60 %</b>															
<b>600</b>	30,3	285	4536	410 (at 500 V)	12120	1260	1400	4710	2220	1310	860	14,74	1PH8 350-7 B1 0 - ■■■■ 0	2235	1XB7712-P01
	30,3	340	5412	480 (at 500 V)	14570	1440	1400	5640	2660	1560	1030	17,40	1PH8 352-7 B1 0 - ■■■■ 0	2560	1XB7712-P01
	30,3	400	6367	565 (at 500 V)	16670	1590	1400	6450	3030	1780	1170	20,66	1PH8 354-7 B1 0 - ■■■■ 0	2889	1XB7712-P03
	30,3	465	7401	650 (at 500 V)	20320	1920	1400	7840	3680	2150	1420	24,22	1PH8 356-7 B1 0 - ■■■■ 0	3256	1XB7712-P03
	30,2	530	8436	735 (at 500 V)	23390	2180	1400	8990	4210	2460	1620	27,79	1PH8 358-7 B1 0 - ■■■■ 0	3629	1XB7712-P03
<b>Intermittent duty S3 - 100 % (S1)</b>															
<b>600</b>	30,3	230	3661	350 (at 500 V)	12120	1260	1400	4710	2220	1310	860	14,74	1PH8 350-7 B1 0 - ■■■■ 0	2235	1XB7712-P01
	30,3	275	4377	410 (at 500 V)	14570	1440	1400	5640	2660	1560	1030	17,40	1PH8 352-7 B1 0 - ■■■■ 0	2560	1XB7712-P01
	30,3	325	5173	475 (at 500 V)	16670	1590	1400	6450	3030	1780	1170	20,66	1PH8 354-7 B1 0 - ■■■■ 0	2889	1XB7712-P03
	30,3	380	6048	550 (at 500 V)	20320	1920	1400	7840	3680	2150	1420	24,22	1PH8 356-7 B1 0 - ■■■■ 0	3256	1XB7712-P03
	30,2	430	6844	620 (at 500 V)	23390	2180	1400	8990	4210	2460	1620	27,79	1PH8 358-7 B1 0 - ■■■■ 0	3629	1XB7712-P03

For versions, see Article No. supplements and options.

For more operating characteristics and engineering data, please contact your local Siemens representative. Compliance with the rated pulse frequencies is essential; the rated motor data is valid for 2.5 kHz.

<sup>1)</sup> Maximum torque/current that is briefly available for dynamic operations (e.g. accelerating). Please refer to the planning documents for the values for thyristor or diode infeeds (e.g. Basic Line Module).

<sup>2)</sup>  $n_2$ : Max. permissible thermal speed at constant output or speed, which is at the voltage limit when  $P = P_{rated}$ .

### Selection and ordering data

#### SIMOTICS M-1PH8 asynchronous motors, shaft height 355, type of construction IM B3

Rated speed $n_{rated}$	Rated frequency $f_{rated}$	Rated output $P_{rated}$	Rated torque $M_{rated}$	Rated current $I_{rated}$	Max. torque $M_{max}^{1)}$	Max. current $I_{max}^{1)}$	Maximum speed at constant output (field weakening) <sup>2) <math>n_2</math></sup>	Maximum torque $M_{max}^{1)}$ at				Moment of inertia $J$	1PH8 asynchronous motor Shaft height 355	Weight, Terminal approx. box	
								1000 rpm	1500 rpm	2000 rpm	2500 rpm			kg	Type
rpm	Hz	kW	Nm	A	Nm	A	rpm	Nm	Nm	Nm	Nm	kgm <sup>2</sup>	Article No.	kg	Type
<b>1PH8 35. asynchronous motors, IP55 degree of protection, noise level 85 dB(A), operating speed 600 rpm</b>															
<b>Supply voltage 690 V 3 AC for SINAMICS S120 converters, Active Line Module, Vector Control</b>															
<b>Intermittent duty S3 – 40 %</b>															
600	30,3	340	5412	345 (at 690 V)	12090	910	1400	4690	2210	1300	860	14,74	1PH8 350-7 H1 0 - ■■■■ 0	2235	1XB7712-P01
	30,3	405	6446	405 (at 690 V)	13880	1000	1400	5390	2550	1500	990	17,40	1PH8 352-7 H1 0 - ■■■■ 0	2560	1XB7712-P01
	30,3	480	7640	475 (at 690 V)	16940	1170	1400	6550	3080	1810	1190	20,66	1PH8 354-7 H1 0 - ■■■■ 0	2889	1XB7712-P01
	30,3	560	8913	550 (at 690 V)	20480	1400	1400	7890	3700	2160	1430	24,22	1PH8 356-7 H1 0 - ■■■■ 0	3256	1XB7712-P01
	30,2	630	10028	620 (at 690 V)	24230	1630	1400	9310	4350	2540	1670	27,79	1PH8 358-7 H1 0 - ■■■■ 0	3629	1XB7712-P03
<b>Intermittent duty S3 – 60 %</b>															
600	30,3	285	4536	300 (at 690 V)	12090	910	1400	4690	2210	1300	860	14,74	1PH8 350-7 H1 0 - ■■■■ 0	2235	1XB7712-P01
	30,3	340	5412	350 (at 690 V)	13880	1000	1400	5390	2550	1500	990	17,40	1PH8 352-7 H1 0 - ■■■■ 0	2560	1XB7712-P01
	30,3	400	6367	410 (at 690 V)	16940	1170	1400	6550	3080	1810	1190	20,66	1PH8 354-7 H1 0 - ■■■■ 0	2889	1XB7712-P01
	30,3	465	7401	470 (at 690 V)	20480	1400	1400	7890	3700	2160	1430	24,22	1PH8 356-7 H1 0 - ■■■■ 0	3256	1XB7712-P01
	30,2	530	8436	535 (at 690 V)	24230	1630	1400	9310	4350	2540	1670	27,79	1PH8 358-7 H1 0 - ■■■■ 0	3629	1XB7712-P03
<b>Intermittent duty S3 - 100 % (S1)</b>															
600	30,3	230	3661	255 (at 690 V)	12090	910	1400	4690	2210	1300	860	14,74	1PH8 350-7 H1 0 - ■■■■ 0	2235	1XB7712-P01
	30,3	275	4377	295 (at 690 V)	13880	1000	1400	5390	2550	1500	990	17,40	1PH8 352-7 H1 0 - ■■■■ 0	2560	1XB7712-P01
	30,3	325	5173	345 (at 690 V)	16940	1170	1400	6550	3080	1810	1190	20,66	1PH8 354-7 H1 0 - ■■■■ 0	2889	1XB7712-P01
	30,3	380	6048	400 (at 690 V)	20480	1400	1400	7890	3700	2160	1430	24,22	1PH8 356-7 H1 0 - ■■■■ 0	3256	1XB7712-P01
	30,2	430	6844	455 (at 690 V)	24230	1630	1400	9310	4350	2540	1670	27,79	1PH8 358-7 H1 0 - ■■■■ 0	3629	1XB7712-P03

For versions, see Article No. supplements and options.

For more operating characteristics and engineering data, please contact your local Siemens representative. Compliance with the rated pulse frequencies is essential; the rated motor data is valid for 2.5 kHz.

<sup>1)</sup> Maximum torque/current that is briefly available for dynamic operations (e.g. accelerating). Please refer to the planning documents for the values for thyristor or diode infeeds (e.g. Basic Line Module).

<sup>2)</sup>  $n_2$ : Max. permissible thermal speed at constant output or speed, which is at the voltage limit when  $P = P_{rated}$ .

# SIMOTICS M – Main motors

## 1PH8 for SINAMICS S120 for cranes

Degree of protection IP23

### Selection and ordering data

#### SIMOTICS M-1PH8 asynchronous motors, shaft height 355, type of construction IM B3

Rated speed $n_{rated}$	Rated frequency $f_{rated}$	Rated output $P_{rated}$	Rated torque $M_{rated}$	Rated current $I_{rated}$	Max. torque $M_{max}^1$	Max. current $I_{max}^1$	Maximum speed at constant output (field weakening) <sup>2)</sup> $n_2$	Maximum torque $M_{max}^1$ at				Moment of inertia $J$	1PH8 asynchronous motor Shaft height 355	Weight, approx.	Terminal box
								1000 rpm	1500 rpm	2000 rpm	2500 rpm				
rpm	Hz	kW	Nm	A	Nm	A	rpm	Nm	Nm	Nm	Nm	kgm <sup>2</sup>	Article No.	kg	Type

1PH8 35. asynchronous motors, IP55 degree of protection, noise level 85 dB(A), operating speed 800 rpm  
Supply voltage 480 V 3 AC for SINAMICS S120 converters, Active Line Module, Vector Control

#### Intermittent duty S3 – 40 %

800	40,3	440	5253	615 (at 500 V)	12500	1790	1400	8210	3830	2230	1460	14,74	1PH8 350-7 Q1 0 - ■■■■ 0	2235	1XB7712-P03
	40,3	530	6327	730 (at 500 V)	14870	1990	1400	9750	4540	2640	1730	17,40	1PH8 352-7 Q1 0 - ■■■■ 0	2560	1XB7712-P03
	40,3	615	7342	845 (at 500 V)	19960	2580	1400	12960	5910	3390	2200	20,66	1PH8 354-7 Q1 0 - ■■■■ 0	2889	1XB7712-P03
	40,2	720	8595	985 (at 500 V)	22050	2790	1400	14420	6670	3860	2520	24,22	1PH8 356-7 Q1 0 - ■■■■ 0	3256	1XB7712-P03
	40,3	830	9908	1105 (at 500 V)	22770	2820	1400	14930	6930	4020	2640	27,79	1PH8 358-7 Q1 0 - ■■■■ 0	3629	1XB7712-P03

#### Intermittent duty S3 – 60 %

800	40,3	370	4417	530 (at 500 V)	12500	1790	1400	8210	3830	2230	1460	14,74	1PH8 350-7 Q1 0 - ■■■■ 0	2235	1XB7712-P03
	40,3	445	5312	630 (at 500 V)	14870	1990	1400	9750	4540	2640	1730	17,40	1PH8 352-7 Q1 0 - ■■■■ 0	2560	1XB7712-P03
	40,3	515	6148	730 (at 500 V)	19960	2580	1400	12960	5910	3390	2200	20,66	1PH8 354-7 Q1 0 - ■■■■ 0	2889	1XB7712-P03
	40,2	605	7222	850 (at 500 V)	22050	2790	1400	14420	6670	3860	2520	24,22	1PH8 356-7 Q1 0 - ■■■■ 0	3256	1XB7712-P03
	40,3	695	8297	945 (at 500 V)	22770	2820	1400	14930	6930	4020	2640	27,79	1PH8 358-7 Q1 0 - ■■■■ 0	3629	1XB7712-P03

#### Intermittent duty S3 - 100 % (S1)

800	40,3	300	3581	450 (at 500 V)	12500	1790	1400	8210	3830	2230	1460	14,74	1PH8 350-7 Q1 0 - ■■■■ 0	2235	1XB7712-P03
	40,3	360	4298	530 (at 500 V)	14870	1990	1400	9750	4540	2640	1730	17,40	1PH8 352-7 Q1 0 - ■■■■ 0	2560	1XB7712-P03
	40,3	420	5014	620 (at 500 V)	19960	2580	1400	12960	5910	3390	2200	20,66	1PH8 354-7 Q1 0 - ■■■■ 0	2889	1XB7712-P03
	40,2	490	5849	720 (at 500 V)	22050	2790	1400	14420	6670	3860	2520	24,22	1PH8 356-7 Q1 0 - ■■■■ 0	3256	1XB7712-P03
	40,3	565	6745	790 (at 500 V)	22770	2820	1400	14930	6930	4020	2640	27,79	1PH8 358-7 Q1 0 - ■■■■ 0	3629	1XB7712-P03

For versions, see Article No. supplements and options.

For more operating characteristics and engineering data, please contact your local Siemens representative. Compliance with the rated pulse frequencies is essential; the rated motor data is valid for 2.5 kHz.

<sup>1)</sup> Maximum torque/current that is briefly available for dynamic operations (e.g. accelerating). Please refer to the planning documents for the values for thyristor or diode infeeds (e.g. Basic Line Module).

<sup>2)</sup>  $n_2$ : Max. permissible thermal speed at constant output or speed, which is at the voltage limit when  $P = P_{rated}$ .



**Selection and ordering data**

**SIMOTICS M-1PH8 asynchronous motors, shaft height 355, type of construction IM B3**

Rated speed $n_{rated}$	Rated frequency $f_{rated}$	Rated output $P_{rated}$	Rated torque $M_{rated}$	Rated current $I_{rated}$	Max. torque $M_{max}^1$	Max. current $I_{max}^1$	Maximum speed at constant output (field weakening) <sup>2)</sup> $n_2$	Maximum torque $M_{max}^1$ at				Moment of inertia $J$	1PH8 asynchronous motor Shaft height 355	Article No.	Weight, approx. kg	Terminal box Type
								1000 rpm	1500 rpm	2000 rpm	2500 rpm					
rpm	Hz	kW	Nm	A	Nm	A	rpm	Nm	Nm	Nm	Nm	kgm <sup>2</sup>		kg	Type	

**1PH8 35. asynchronous motors, IP55 degree of protection, noise level 85 dB(A), operating speed 800 rpm**  
Supply voltage 690 V 3 AC for SINAMICS S120 converters, Active Line Module, Vector Control

**Intermittent duty S3 – 40 %**

<b>800</b>	40,3	440	5253	440 (at 690 V)	12180	1290	1400	8010	3740	2180	1430	14,74	1PH8 350-7 K1 0 - ■ ■ ■ ■ 0	2235	1XB7712-P01
	40,3	530	6327	530 (at 690 V)	15360	1480	1400	10070	4670	2710	1780	17,40	1PH8 352-7 K1 0 - ■ ■ ■ ■ 0	2560	1XB7712-P01
	40,3	615	7342	610 (at 690 V)	17590	1660	1400	11560	5390	3140	2060	20,66	1PH8 354-7 K1 0 - ■ ■ ■ ■ 0	2889	1XB7712-P03
	40,3	720	8595	705 (at 690 V)	20960	1940	1400	13760	6400	3720	2440	24,22	1PH8 356-7 K1 0 - ■ ■ ■ ■ 0	3256	1XB7712-P03
	40,3	830	9908	805 (at 690 V)	23360	2090	1400	15290	7080	4100	2680	27,79	1PH8 358-7 K1 0 - ■ ■ ■ ■ 0	3629	1XB7712-P03

**Intermittent duty S3 – 60 %**

<b>800</b>	40,3	370	4417	380 (at 690 V)	12180	1290	1400	8010	3740	2180	1430	14,74	1PH8 350-7 K1 0 - ■ ■ ■ ■ 0	2235	1XB7712-P01
	40,3	445	5312	460 (at 690 V)	15360	1480	1400	10070	4670	2710	1780	17,40	1PH8 352-7 K1 0 - ■ ■ ■ ■ 0	2560	1XB7712-P01
	40,3	515	6148	525 (at 690 V)	17590	1660	1400	11560	5390	3140	2060	20,66	1PH8 354-7 K1 0 - ■ ■ ■ ■ 0	2889	1XB7712-P03
	40,3	605	7222	605 (at 690 V)	20960	1940	1400	13760	6400	3720	2440	24,22	1PH8 356-7 K1 0 - ■ ■ ■ ■ 0	3256	1XB7712-P03
	40,3	695	8297	690 (at 690 V)	23360	2090	1400	15290	7080	4100	2680	27,79	1PH8 358-7 K1 0 - ■ ■ ■ ■ 0	3629	1XB7712-P03

**Intermittent duty S3 - 100 % (S1)**

<b>800</b>	40,3	300	3581	320 (at 690 V)	12180	1290	1400	8010	3740	2180	1430	14,74	1PH8 350-7 K1 0 - ■ ■ ■ ■ 0	2235	1XB7712-P01
	40,3	360	4298	390 (at 690 V)	15360	1480	1400	10070	4670	2710	1780	17,40	1PH8 352-7 K1 0 - ■ ■ ■ ■ 0	2560	1XB7712-P01
	40,3	420	5014	440 (at 690 V)	17590	1660	1400	11560	5390	3140	2060	20,66	1PH8 354-7 K1 0 - ■ ■ ■ ■ 0	2889	1XB7712-P03
	40,3	490	5849	510 (at 690 V)	20960	1940	1400	13760	6400	3720	2440	24,22	1PH8 356-7 K1 0 - ■ ■ ■ ■ 0	3256	1XB7712-P03
	40,3	565	6745	580 (at 690 V)	23360	2090	1400	15290	7080	4100	2680	27,79	1PH8 358-7 K1 0 - ■ ■ ■ ■ 0	3629	1XB7712-P03

For versions, see Article No. supplements and options.

For more operating characteristics and engineering data, please contact your local Siemens representative. Compliance with the rated pulse frequencies is essential; the rated motor data is valid for 2.5 kHz.

<sup>1)</sup> Maximum torque/current that is briefly available for dynamic operations (e.g. accelerating). Please refer to the planning documents for the values for thyristor or diode infeeds (e.g. Basic Line Module).

<sup>2)</sup>  $n_2$ : Max. permissible thermal speed at constant output or speed, which is at the voltage limit when  $P = P_{rated}$ .



**SIMOTICS M – Main motors**

1PH8 for SINAMICS S120 for cranes

**Degree of protection IP23****Selection and ordering data****SIMOTICS M-1PH8 asynchronous motors, shaft height 355, type of construction IM B3**

Rated speed $n_{rated}$	Rated frequency $f_{rated}$	Rated output $P_{rated}$	Rated torque $M_{rated}$	Rated current $I_{rated}$	Max. torque $M_{max}^1$	Max. current $I_{max}^1$	Maximum speed at constant output (field weakening) <sup>2)</sup> $n_2$	Maximum torque $M_{max}^1$ at				Moment of inertia $J$	<b>1PH8 asynchronous motor Shaft height 355</b>	Weight, approx.	Terminal box
								1500 rpm	2000 rpm	2500 rpm	2800 rpm				
rpm	Hz	kW	Nm	A	Nm	A	rpm	Nm	Nm	Nm	Nm	kgm <sup>2</sup>	Article No.	kg	Type
<b>1PH8 35. asynchronous motors, IP55 degree of protection, noise level 85 dB(A), operating speed 1000 rpm Supply voltage 480 V 3 AC for SINAMICS S120 converters, Active Line Module, Vector Control</b>															
<b>Intermittent duty S3 – 40 %</b>															
<b>1000</b>	50,3	530	5062	735 (at 500 V)	13150	2430	1500	6070	3510	2290	1850	14,74	<b>1PH8 350-7 C1 0 - ■ ■ ■ ■ 0</b>	2235	1XB7712-P03
	50,3	630	6017	860 (at 500 V)	14700	2490	1500	6780	3910	2550	2060	17,40	<b>1PH8 352-7 C1 0 - ■ ■ ■ ■ 0</b>	2560	1XB7712-P03
	50,3	740	7067	1005 (at 500 V)	16970	2750	1500	7830	4530	2960	2380	20,66	<b>1PH8 354-7 C1 0 - ■ ■ ■ ■ 0</b>	2889	1XB7712-P03
	50,3	855	8165	1145 (at 500 V)	21120	3340	1600	9730	5610	3660	2950	24,22	<b>1PH8 356-7 C1 0 - ■ ■ ■ ■ 0</b>	3256	1XB7712-P03
	50,2	985	9407	1415 (at 480 V)	26910	4360	1600	12360	7120	4640	3730	27,79	<b>1PH8 358-7 C1 0 - ■ ■ ■ ■ 0</b>	3629	1XB7712-P03
<b>Intermittent duty S3 – 60 %</b>															
<b>1000</b>	50,3	445	4250	635 (at 500 V)	13150	2430	1500	6070	3510	2290	1850	14,74	<b>1PH8 350-7 C1 0 - ■ ■ ■ ■ 0</b>	2235	1XB7712-P03
	50,3	530	5062	735 (at 500 V)	14700	2490	1500	6780	3910	2550	2060	17,40	<b>1PH8 352-7 C1 0 - ■ ■ ■ ■ 0</b>	2560	1XB7712-P03
	50,3	620	5921	860 (at 500 V)	16970	2750	1500	7830	4530	2960	2380	20,66	<b>1PH8 354-7 C1 0 - ■ ■ ■ ■ 0</b>	2889	1XB7712-P03
	50,3	715	6828	985 (at 500 V)	21120	3340	1600	9730	5610	3660	2950	24,22	<b>1PH8 356-7 C1 0 - ■ ■ ■ ■ 0</b>	3256	1XB7712-P03
	50,2	825	7879	1225 (at 480 V)	26910	4360	1600	12360	7120	4640	3730	27,79	<b>1PH8 358-7 C1 0 - ■ ■ ■ ■ 0</b>	3629	1XB7712-P03
<b>Intermittent duty S3 - 100 % (S1)</b>															
<b>1000</b>	50,3	360	3438	540 (at 500 V)	13150	2430	1500	6070	3510	2290	1850	14,74	<b>1PH8 350-7 C1 0 - ■ ■ ■ ■ 0</b>	2235	1XB7712-P03
	50,3	430	4107	620 (at 500 V)	14700	2490	1500	6780	3910	2550	2060	17,40	<b>1PH8 352-7 C1 0 - ■ ■ ■ ■ 0</b>	2560	1XB7712-P03
	50,3	505	4823	720 (at 500 V)	16970	2750	1500	7830	4530	2960	2380	20,66	<b>1PH8 354-7 C1 0 - ■ ■ ■ ■ 0</b>	2889	1XB7712-P03
	50,3	580	5539	830 (at 500 V)	21120	3340	1600	9730	5610	3660	2950	24,22	<b>1PH8 356-7 C1 0 - ■ ■ ■ ■ 0</b>	3256	1XB7712-P03
	50,2	670	6399	1040 (at 480 V)	26910	4360	1600	12360	7120	4640	3730	27,79	<b>1PH8 358-7 C1 0 - ■ ■ ■ ■ 0</b>	3629	1XB7712-P03

For versions, see Article No. supplements and options.

For more operating characteristics and engineering data, please contact your local Siemens representative. Compliance with the rated pulse frequencies is essential; the rated motor data is valid for 2.5 kHz.

<sup>1)</sup> Maximum torque/current that is briefly available for dynamic operations (e.g. accelerating). Please refer to the planning documents for the values for thyristor or diode infeeds (e.g. Basic Line Module).

<sup>2)</sup>  $n_2$ : Max. permissible thermal speed at constant output or speed, which is at the voltage limit when  $P = P_{rated}$ .

**Selection and ordering data**

**SIMOTICS M-1PH8 asynchronous motors, shaft height 355, type of construction IM B3**

Rated speed $n_{rated}$	Rated frequency $f_{rated}$	Rated output $P_{rated}$	Rated torque $M_{rated}$	Rated current $I_{rated}$	Max. torque $M_{max}^1$	Max. current $I_{max}^1$	Maximum speed at constant output (field weakening) <sup>2)</sup> $n_2$	Maximum torque $M_{max}^1$ at				Moment of inertia $J$	<b>1PH8 asynchronous motor</b> <b>Shaft height 355</b>	Weight, approx.	Terminal box
								1500 rpm	2000 rpm	2500 rpm	2800 rpm				
rpm	Hz	kW	Nm	A	Nm	A	rpm	Nm	Nm	Nm	Nm	kgm <sup>2</sup>	Article No.	kg	Type
<b>1PH8 35. asynchronous motors, IP55 degree of protection, noise level 85 dB(A), operating speed 1000 rpm</b>															
<b>Supply voltage 690 V 3 AC for SINAMICS S120 converters, Active Line Module, Vector Control</b>															
<b>Intermittent duty S3 – 40 %</b>															
<b>1000</b>	50,3	530	5062	535 (at 690 V)	13240	1770	1500	6110	3530	2310	1860	14,74	<b>1PH8 350-7 U1 0 - ■■■■ 0</b>	2235	1XB7712-P01
	50,3	630	6017	625 (at 690 V)	15110	1840	1500	6960	4010	2620	2110	17,40	<b>1PH8 352-7 U1 0 - ■■■■ 0</b>	2560	1XB7712-P01
	50,3	740	7067	730 (at 690 V)	18280	2110	1500	8430	4860	3180	2560	20,66	<b>1PH8 354-7 U1 0 - ■■■■ 0</b>	2889	1XB7712-P03
	50,3	855	8165	835 (at 690 V)	20510	2370	1600	9450	5450	3560	2860	24,22	<b>1PH8 356-7 U1 0 - ■■■■ 0</b>	3256	1XB7712-P03
	50,2	985	9407	955 (at 690 V)	24570	2760	1600	11310	6520	4250	3420	27,79	<b>1PH8 358-7 U1 0 - ■■■■ 0</b>	3629	1XB7712-P03
<b>Intermittent duty S3 – 60 %</b>															
<b>1000</b>	50,3	445	4250	465 (at 690 V)	13240	1770	1500	6110	3530	2310	1860	14,74	<b>1PH8 350-7 U1 0 - ■■■■ 0</b>	2235	1XB7712-P01
	50,3	530	5062	540 (at 690 V)	15110	1840	1500	6960	4010	2620	2110	17,40	<b>1PH8 352-7 U1 0 - ■■■■ 0</b>	2560	1XB7712-P01
	50,3	620	5921	630 (at 690 V)	18280	2110	1500	8430	4860	3180	2560	20,66	<b>1PH8 354-7 U1 0 - ■■■■ 0</b>	2889	1XB7712-P03
	50,3	715	6828	715 (at 690 V)	20510	2370	1600	9450	5450	3560	2860	24,22	<b>1PH8 356-7 U1 0 - ■■■■ 0</b>	3256	1XB7712-P03
	50,2	825	7879	820 (at 690 V)	24570	2760	1600	11310	6520	4250	3420	27,79	<b>1PH8 358-7 U1 0 - ■■■■ 0</b>	3629	1XB7712-P03
<b>Intermittent duty S3 - 100 % (S1)</b>															
<b>1000</b>	50,3	360	3438	395 (at 690 V)	13240	1770	1500	6110	3530	2310	1860	14,74	<b>1PH8 350-7 U1 0 - ■■■■ 0</b>	2235	1XB7712-P01
	50,3	430	4107	455 (at 690 V)	15110	1840	1500	6960	4010	2620	2110	17,40	<b>1PH8 352-7 U1 0 - ■■■■ 0</b>	2560	1XB7712-P01
	50,3	505	4823	530 (at 690 V)	18280	2110	1500	8430	4860	3180	2560	20,66	<b>1PH8 354-7 U1 0 - ■■■■ 0</b>	2889	1XB7712-P03
	50,3	580	5539	600 (at 690 V)	20510	2370	1600	9450	5450	3560	2860	24,22	<b>1PH8 356-7 U1 0 - ■■■■ 0</b>	3256	1XB7712-P03
	50,2	670	6399	690 (at 690 V)	24570	2760	1600	11310	6520	4250	3420	27,79	<b>1PH8 358-7 U1 0 - ■■■■ 0</b>	3629	1XB7712-P03

For versions, see Article No. supplements and options.

For more operating characteristics and engineering data, please contact your local Siemens representative. Compliance with the rated pulse frequencies is essential; the rated motor data is valid for 2.5 kHz.

<sup>1)</sup> Maximum torque/current that is briefly available for dynamic operations (e.g. accelerating). Please refer to the planning documents for the values for thyristor or diode infeeds (e.g. Basic Line Module).

<sup>2)</sup>  $n_2$ : Max. permissible thermal speed at constant output or speed, which is at the voltage limit when  $P = P_{rated}$ .



**SIMOTICS M – Main motors**

1PH8 for SINAMICS S120 for cranes

Degree of protection IP23

**Selection and ordering data****SIMOTICS M-1PH8 asynchronous motors, shaft height 355, type of construction IM B3**

Rated speed $n_{rated}$	Rated frequency $f_{rated}$	Rated output $P_{rated}$	Rated torque $M_{rated}$	Rated current $I_{rated}$	Max. torque $M_{max}^1$	Max. current $I_{max}^1$	Maximum speed at constant output (field weakening) <sup>2)</sup> $n_2$	Maximum torque $M_{max}^1$ at				Moment of inertia $J$	1PH8 asynchronous motor Shaft height 355	Weight, approx.	Terminal box
								1500 rpm	2000 rpm	2500 rpm	2800 rpm				
rpm	Hz	kW	Nm	A	Nm	A	rpm	Nm	Nm	Nm	Nm	kgm <sup>2</sup>	Article No.	kg	Type
<b>1PH8 35. asynchronous motors, IP55 degree of protection, noise level 85 dB(A), operating speed 1350 rpm Supply voltage 480 V 3 AC for SINAMICS S120 converters, Active Line Module, Vector Control</b>															
<b>Intermittent duty S3 – 40 %</b>															
1350	67,8	560	3961	760 (at 500 V)	9840	2410	1800	8040	4620	3010	2420	14,74	1PH8 350-7 D1 0 - ■■■■ 0	2235	1XB7712-P03
	67,7	675	4775	925 (at 500 V)	13690	3260	1800	11180	6430	4190	3370	17,40	1PH8 352-7 D1 0 - ■■■■ 0	2560	1XB7712-P03
	67,8	810	5730	1075 (at 500 V)	14050	3130	1700	11480	6620	4310	3470	20,66	1PH8 354-7 D1 0 - ■■■■ 0	2889	1XB7712-P03
	67,7	925	6544	1250 (at 500 V)	18980	4090	1700	15500	8910	5800	4660	24,22	1PH8 356-7 D1 0 - ■■■■ 0	3256	1XB7712-P03
	67,7	1075	7605	1445 (at 500 V)	21720	4590	1700	17740	10220	6660	5360	27,79	1PH8 358-7 D1 0 - ■■■■ 0	3629	1XB7712-P03
<b>Intermittent duty S3 – 60 %</b>															
1350	67,8	465	3289	650 (at 500 V)	9840	2410	1800	8040	4620	3010	2420	14,74	1PH8 350-7 D1 0 - ■■■■ 0	2235	1XB7712-P03
	67,7	565	3997	795 (at 500 V)	13690	3260	1800	11180	6430	4190	3370	17,40	1PH8 352-7 D1 0 - ■■■■ 0	2560	1XB7712-P03
	67,8	675	4775	915 (at 500 V)	14050	3130	1700	11480	6620	4310	3470	20,66	1PH8 354-7 D1 0 - ■■■■ 0	2889	1XB7712-P03
	67,7	775	5482	1070 (at 500 V)	18980	4090	1700	15500	8910	5800	4660	24,22	1PH8 356-7 D1 0 - ■■■■ 0	3256	1XB7712-P03
	67,7	900	6367	1240 (at 500 V)	21720	4590	1700	17740	10220	6660	5360	27,79	1PH8 358-7 D1 0 - ■■■■ 0	3629	1XB7712-P03
<b>Intermittent duty S3 - 100 % (S1)</b>															
1350	67,8	380	2688	540 (at 500 V)	9840	2410	1800	8040	4620	3010	2420	14,74	1PH8 350-7 D1 0 - ■■■■ 0	2235	1XB7712-P03
	67,7	460	3254	670 (at 500 V)	13690	3260	1800	11180	6430	4190	3370	17,40	1PH8 352-7 D1 0 - ■■■■ 0	2560	1XB7712-P03
	67,8	550	3891	760 (at 500 V)	14050	3130	1700	11480	6620	4310	3470	20,66	1PH8 354-7 D1 0 - ■■■■ 0	2889	1XB7712-P03
	67,7	630	4457	900 (at 500 V)	18980	4090	1700	15500	8910	5800	4660	24,22	1PH8 356-7 D1 0 - ■■■■ 0	3256	1XB7712-P03
	67,7	730	5164	1040 (at 500 V)	21720	4590	1700	17740	10220	6660	5360	27,79	1PH8 358-7 D1 0 - ■■■■ 0	3629	1XB7712-P03

For versions, see Article No. supplements and options.

For more operating characteristics and engineering data, please contact your local Siemens representative. Compliance with the rated pulse frequencies is essential; the rated motor data is valid for 2.5 kHz.

<sup>1)</sup> Maximum torque/current that is briefly available for dynamic operations (e.g. accelerating). Please refer to the planning documents for the values for thyristor or diode infeeds (e.g. Basic Line Module).

<sup>2)</sup>  $n_2$ : Max. permissible thermal speed at constant output or speed, which is at the voltage limit when  $P = P_{rated}$ .

**Selection and ordering data**

**SIMOTICS M-1PH8 asynchronous motors, shaft height 355, type of construction IM B3**

Rated speed $n_{rated}$	Rated frequency $f_{rated}$	Rated output $P_{rated}$	Rated torque $M_{rated}$	Rated current $I_{rated}$	Max. torque $M_{max}^1$	Max. current $I_{max}^1$	Maximum speed at constant output (field weakening) <sup>2)</sup> $n_2$	Maximum torque $M_{max}^1$ at				Moment of inertia $J$	1PH8 asynchronous motor Shaft height 355	Weight, approx.	Terminal box
								1500 rpm	2000 rpm	2500 rpm	2800 rpm				
rpm	Hz	kW	Nm	A	Nm	A	rpm	Nm	Nm	Nm	Nm	kgm <sup>2</sup>	Article No.	kg	Type
<b>1PH8 35. asynchronous motors, IP55 degree of protection, noise level 85 dB(A), operating speed 1350 rpm</b>															
<b>Supply voltage 690 V 3 AC for SINAMICS S120 converters, Active Line Module, Vector Control</b>															
<b>Intermittent duty S3 – 40 %</b>															
1350	67,8	560	3961	550 (at 690 V)	10200	1800	1800	8320	4780	3110	2500	14,74	1PH8 350-7 V 1 0 - ■ ■ ■ ■ 0	2235	1XB7712-P01
	67,8	675	4775	660 (at 690 V)	12290	2230	1800	10040	5780	3760	3030	17,40	1PH8 352-7 V 1 0 - ■ ■ ■ ■ 0	2560	1XB7712-P03
	67,8	810	5730	780 (at 690 V)	13660	2230	1700	11160	6420	4180	3360	20,66	1PH8 354-7 V 1 0 - ■ ■ ■ ■ 0	2889	1XB7712-P03
	67,7	925	6544	900 (at 690 V)	19140	2990	1700	15630	8980	5840	4700	24,22	1PH8 356-7 V 1 0 - ■ ■ ■ ■ 0	3256	1XB7712-P03
	67,7	1075	7605	1040 (at 690 V)	20270	3110	1700	16550	9510	6190	4970	27,79	1PH8 358-7 V 1 0 - ■ ■ ■ ■ 0	3629	1XB7712-P03
<b>Intermittent duty S3 – 60 %</b>															
1350	67,8	465	3289	475 (at 690 V)	10200	1800	1800	8320	4780	3110	2500	14,74	1PH8 350-7 V 1 0 - ■ ■ ■ ■ 0	2235	1XB7712-P01
	67,8	565	3997	565 (at 690 V)	12290	2230	1800	10040	5780	3760	3030	17,40	1PH8 352-7 V 1 0 - ■ ■ ■ ■ 0	2560	1XB7712-P03
	67,8	675	4775	665 (at 690 V)	13660	2230	1700	11160	6420	4180	3360	20,66	1PH8 354-7 V 1 0 - ■ ■ ■ ■ 0	2889	1XB7712-P03
	67,7	775	5482	775 (at 690 V)	19140	2990	1700	15630	8980	5840	4700	24,22	1PH8 356-7 V 1 0 - ■ ■ ■ ■ 0	3256	1XB7712-P03
	67,7	900	6367	890 (at 690 V)	20270	3110	1700	16550	9510	6190	4970	27,79	1PH8 358-7 V 1 0 - ■ ■ ■ ■ 0	3629	1XB7712-P03
<b>Intermittent duty S3 - 100 % (S1)</b>															
1350	67,8	380	2688	395 (at 690 V)	10200	1800	1800	8320	4780	3110	2500	14,74	1PH8 350-7 V 1 0 - ■ ■ ■ ■ 0	2235	1XB7712-P01
	67,8	460	3254	470 (at 690 V)	12290	2230	1800	10040	5780	3760	3030	17,40	1PH8 352-7 V 1 0 - ■ ■ ■ ■ 0	2560	1XB7712-P03
	67,8	550	3891	550 (at 690 V)	13660	2230	1700	11160	6420	4180	3360	20,66	1PH8 354-7 V 1 0 - ■ ■ ■ ■ 0	2889	1XB7712-P03
	67,7	630	4457	650 (at 690 V)	19140	2990	1700	15630	8980	5840	4700	24,22	1PH8 356-7 V 1 0 - ■ ■ ■ ■ 0	3256	1XB7712-P03
	67,7	730	5164	740 (at 690 V)	20270	3110	1700	16550	9510	6190	4970	27,79	1PH8 358-7 V 1 0 - ■ ■ ■ ■ 0	3629	1XB7712-P03

For versions, see Article No. supplements and options.

For more operating characteristics and engineering data, please contact your local Siemens representative. Compliance with the rated pulse frequencies is essential; the rated motor data is valid for 2.5 kHz.

<sup>1)</sup> Maximum torque/current that is briefly available for dynamic operations (e.g. accelerating). Please refer to the planning documents for the values for thyristor or diode infeeds (e.g. Basic Line Module).

<sup>2)</sup>  $n_2$ : Max. permissible thermal speed at constant output or speed, which is at the voltage limit when  $P = P_{rated}$ .



**SIMOTICS M – Main motors**

1PH8 for SINAMICS S120 for cranes

Degree of protection IP23

**Selection and ordering data****SIMOTICS M-1PH8 asynchronous motors, shaft height 355, type of construction IM B3**

Rated speed	Rated output	Rated torque	Rated current	Rated voltage	Rated frequency	Operating speed during field weakening, max. <sup>1)</sup>	Max. speed <sup>2)</sup>	Max. torque <sup>3)</sup>	Max. current <sup>4)</sup>	<b>1PH8 asynchronous motor</b> Forced ventilation, IP23 degree of protection
$n_{rated}$	$P_{rated}$	$M_{rated}$	$I_{rated}$	$U_{rated}$	$f_{rated}$	$n_2$	$n_{max}$	$M_{max}$ at $n_{rated}$	$I_{max}$	
rpm	kW	Nm	A	V	Hz	rpm	rpm	Nm	A	
<b>Supply voltage 480 V 3 AC, Active Line Module, Vector Control</b>										
<b>600</b>	370	5889	530	500	30.4	1100	2800	12640	1310	<b>1PH8350-7 B40</b> ■■■■
	415	6605	590	500	30.5	1100	2800	12500	1280	<b>1PH8351-7 B40</b> ■■■■
	500	7958	700	500	30.5	1000	2800	15040	1490	<b>1PH8352-7 B40</b> ■■■■
	590	9391	810	500	30.5	1000	2800	17050	1630	<b>1PH8354-7 B40</b> ■■■■
	690	10983	940	500	30.5	900	2800	20690	1950	<b>1PH8356-7 B40</b> ■■■■
	780	12415	1060	500	30.5	900	2800	23650	2200	<b>1PH8358-7 B40</b> ■■■■
<b>800</b>	480	5730	680	500	40.4	1400	2800	12910	1850	<b>1PH8350-7 Q40</b> ■■■■
	530	6327	750	500	40.5	1400	2800	12830	1810	<b>1PH8351-7 Q40</b> ■■■■
	630	7521	870	500	40.5	1300	2800	15280	2050	<b>1PH8352-7 Q40</b> ■■■■
	750	8953	1040	500	40.4	1300	2800	19170	2480	<b>1PH8354-7 Q40</b> ■■■■
	860	10266	1180	500	40.4	1200	2800	22380	2830	<b>1PH8356-7 Q40</b> ■■■■
	960	11460	1300	500	40.5	1200	2800	23090	2860	<b>1PH8358-7 Q40</b> ■■■■
<b>1000</b>	600	5730	840	500	50.4	1500	2800	13470	2490	<b>1PH8350-7 C40</b> ■■■■
	670	6399	940	500	50.5	1500	2800	13380	2470	<b>1PH8351-7 C40</b> ■■■■
	780	7449	1080	500	50.5	1400	2800	14980	2540	<b>1PH8352-7 C40</b> ■■■■
	900	8595	1220	500	50.5	1300	2800	17230	2790	<b>1PH8354-7 C40</b> ■■■■
	1040	9932	1400	500	50.4	1200	2800	21370	3380	<b>1PH8356-7 C40</b> ■■■■
	1200	11460	1700	480	50.4	1200	2800	27150	4400	<b>1PH8358-7 C40</b> ■■■■
<b>1350</b>	670	4740	920	500	68	1700	2800	9990	2450	<b>1PH8350-7 D40</b> ■■■■
	750	5306	1040	500	68.1	1700	2800	9950	2400	<b>1PH8351-7 D40</b> ■■■■
	910	6437	1240	500	68	1700	2800	13910	3310	<b>1PH8352-7 D40</b> ■■■■
	1040	7357	1400	500	68	1400	2800	14180	3160	<b>1PH8354-7 D40</b> ■■■■
	1200	8489	1600	500	67.9	1400	2800	19150	4130	<b>1PH8356-7 D40</b> ■■■■
	1340	9479	1780	500	67.9	1400	2800	21870	4620	<b>1PH8358-7 D40</b> ■■■■

For versions, see  
Article No. supplements and  
options.

Overload factors for intermittent duty (S3) for  
1PH835.-7..40-....

Operating mode	S3-40 %	S3-60 %
Overload factor	1.47	1.23

### Selection and ordering data

Motor type (repeated)	Max. torque <sup>3)</sup>					Power factor	Magnetizing current	Efficiency	Moment of inertia	Weight, approx.	Terminal box					
	$M_{\max}$ at											$\cos \varphi$	$I_{\mu}$	$\eta$	$J$	Type
	1000 rpm	1500 rpm	2000 rpm	2500 rpm	2800 rpm											
<b>Supply voltage 480 V 3 AC, Active Line Module, Vector Control</b>																
1PH8350-7.B4-...	4840	2260	1320	870	580	0.85	194	0.946	14.74	2235	1XB7712-P01					
1PH8351-7.B4-...	4810	2260	1320	870	580	0.85	194	0.946	14.74	2235	1XB7712-P01					
1PH8352-7.B4-...	5770	2700	1570	1040	700	0.86	223	0.949	17.4	2560	1XB7712-P03					
1PH8354-7.B4-...	6550	3070	1790	1180	800	0.88	236	0.949	20.66	2889	1XB7712-P03					
1PH8356-7.B4-...	7930	3710	2160	1420	1000	0.88	285	0.952	24.22	3256	1XB7712-P03					
1PH8358-7.B4-...	9070	4240	2470	1630	1150	0.89	316	0.954	27.79	3629	1XB7712-P03					
1PH8350-7.Q4-...	8430	3890	2250	1470	1100	0.85	235	0.957	14.74	2235	1XB7712-P03					
1PH8351-7.Q4-...	8390	3880	2250	1470	1100	0.85	235	0.957	14.74	2235	1XB7712-P03					
1PH8352-7.Q4-...	9990	4610	2660	1740	1300	0.86	267	0.959	17.4	2560	1XB7712-P03					
1PH8354-7.Q4-...	12520	5770	3330	2170	1600	0.87	334	0.962	20.66	2889	1XB7712-P03					
1PH8356-7.Q4-...	14610	6730	3890	2540	1900	0.88	380	0.963	24.22	3256	1XB7820-P00					
1PH8358-7.Q4-...	15090	6980	4030	2640	1950	0.89	359	0.963	27.79	3629	1XB7820-P00					
1PH8350-7.C4...	13470	6160	3540	2300	1850	0.85	294	0.962	14.74	2235	1XB7712-P03					
1PH8351-7.C4...	13380	6140	3540	2300	1850	0.85	294	0.962	14.74	2235	1XB7712-P03					
1PH8352-7.C4...	14980	6870	3950	2570	2070	0.87	302	0.963	17.4	2560	1XB7712-P03					
1PH8354-7.C4...	17230	7910	4550	2970	2390	0.88	328	0.965	20.66	2889	1XB7820-P00					
1PH8356-7.C4...	21370	9810	5640	3670	2960	0.88	410	0.967	24.22	3256	1XB7820-P00					
1PH8358-7.C4...	27150	12430	7140	4650	3730	0.88	567	0.969	27.79	3629	1XB7820-P00					
1PH8350-7.D4...	9990	8150	4670	3030	2430	0.86	235	0.965	14.74	2235	1XB7712-P03					
1PH8351-7.D4...	9950	8120	4660	3030	2430	0.86	235	0.965	14.74	2235	1XB7712-P03					
1PH8352-7.D4...	13910	11350	6500	4220	3390	0.87	338	0.969	17.4	2560	1XB7820-P00					
1PH8354-7.D4...	14180	11570	6640	4320	3470	0.88	314	0.969	20.66	2889	1XB7820-P00					
1PH8356-7.D4...	19150	15630	8960	5820	4680	0.88	433	0.972	24.22	3256	1XB7820-P00					
1PH8358-7.D4...	21870	17840	10250	6660	5350	0.89	489	0.973	27.79	3629	1XB7820-P00					

<sup>1)</sup>  $n_2$ : Max. permissible thermal speed at constant output or speed, which is at the voltage limit when  $P = P_{\text{rated}}$ .

<sup>2)</sup>  $n_{\max}$ : Maximum speed that must not be exceeded.

<sup>3)</sup> Maximum torque which is briefly available for dynamic operations (e.g. when accelerating).

<sup>4)</sup> Maximum current which is briefly available for dynamic operations (e.g. when accelerating).

**SIMOTICS M – Main motors**

1PH8 for SINAMICS S120 for cranes

**Degree of protection IP23****Selection and ordering data**

Rated speed	Rated output	Rated torque	Rated current	Rated voltage	Rated frequency	Operating speed during field weakening, max. <sup>1)</sup>	Max. speed <sup>2)</sup>	Max. torque <sup>3)</sup>	Max. current <sup>4)</sup>	<b>1PH8 asynchronous motor</b> Forced ventilation, IP23 degree of protection
$n_{rated}$	$P_{rated}$	$M_{rated}$	$I_{rated}$	$U_{rated}$	$f_{rated}$	$n_2$	$n_{max}$	$M_{max}$ at $n_{rated}$	$I_{max}$	
rpm	kW	Nm	A	V	Hz	rpm	rpm	Nm	A	
<b>Supply voltage 690 V 3 AC, Active Line Module, Vector Control</b>										
<b>600</b>	370	5889	380	690	30.5	1100	2800	12620	950	1PH8350-7 H40-■■■■■
	415	6605	430	690	30.5	1100	2800	12490	930	1PH8351-7 H40-■■■■■
	500	7958	510	690	30.5	1000	2800	14450	1040	1PH8352-7 H40-■■■■■
	590	9391	590	690	30.5	1000	2800	17320	1200	1PH8354-7 H40-■■■■■
	690	10983	680	690	30.5	900	2800	20800	1420	1PH8356-7 H40-■■■■■
	780	12415	770	690	30.4	900	2800	24270	1630	1PH8358-7 H40-■■■■■
<b>800</b>	480	5730	490	690	40.5	1400	2800	12600	1330	1PH8350-7 K40-■■■■■
	530	6327	540	690	40.5	1400	2800	12530	1300	1PH8351-7 K40-■■■■■
	630	7521	640	690	40.4	1300	2800	15760	1520	1PH8352-7 K40-■■■■■
	750	8953	740	690	40.5	1300	2800	18080	1710	1PH8354-7 K40-■■■■■
	860	10266	840	690	40.4	1200	2800	21500	1990	1PH8356-7 K40-■■■■■
	960	11460	940	690	40.4	1200	2800	23550	2110	1PH8358-7 K40-■■■■■
<b>1000</b>	600	5730	610	690	50.5	1500	2800	13570	1810	1PH8350-7 U40-■■■■■
	670	6399	680	690	50.5	1500	2800	13480	1800	1PH8351-7 U40-■■■■■
	780	7449	780	690	50.5	1400	2800	15390	1870	1PH8352-7 U40-■■■■■
	900	8595	890	690	50.4	1300	2800	18240	2110	1PH8354-7 U40-■■■■■
	1040	9932	1020	690	50.5	1200	2800	20940	2420	1PH8356-7 U40-■■■■■
	1200	11460	1160	690	50.4	1200	2800	24680	2770	1PH8358-7 U40-■■■■■
<b>1350</b>	670	4740	670	690	68.1	1700	2800	10260	1810	1PH8350-7 V40-■■■■■
	750	5306	750	690	68.1	1700	2800	10230	1840	1PH8351-7 V40-■■■■■
	910	6437	910	690	68	1700	2800	12720	2310	1PH8352-7 V40-■■■■■
	1040	7357	1040	690	68.1	1400	2800	13890	2270	1PH8354-7 V40-■■■■■
	1200	8489	1200	690	67.9	1400	2800	19270	3010	1PH8356-7 V40-■■■■■
	1340	9479	1340	690	68	1400	2800	20360	3120	1PH8358-7 V40-■■■■■

For versions, see  
Article No. supplements and  
options.

Overload factors for intermittent duty (S3) for  
1PH835-7..40-....

Operating mode	S3-40 %	S3-60 %
Overload factor	1.47	1.23



### Selection and ordering data

Motor type (repeated)	Max. torque <sup>3)</sup>					Power factor $\cos \varphi$	Magnetizing current $I_{\mu}$ A	Efficiency $\eta$	Moment of inertia $J$ kgm <sup>2</sup>	Weight, approx. kg	Terminal box Type
	$M_{\max}$ at										
	1000 rpm	1500 rpm	2000 rpm	2500 rpm	2800 rpm						
<b>Supply voltage 690 V 3 AC, Active Line Module, Vector Control</b>											
1PH8350-7.H4...	4830	2250	1310	860	580	0.85	139	0.947	14.74	2235	1XB7712-P01
1PH8351-7.H4...	4810	2250	1310	870	580	0.85	139	0.947	14.74	2235	1XB7712-P01
1PH8352-7.H4...	5570	2610	1530	1010	700	0.87	149	0.946	17.4	2560	1XB7712-P03
1PH8354-7.H4...	6650	3110	1810	1190	800	0.88	176	0.95	20.66	2889	1XB7712-P03
1PH8356-7.H4...	7980	3730	2170	1430	1000	0.88	209	0.953	24.22	3256	1XB7712-P03
1PH8358-7.H4...	9320	4360	2540	1670	1160	0.88	245	0.955	27.79	3629	1XB7712-P03
1PH8350-7.K4...	8240	3810	2200	1440	1120	0.86	162	0.956	14.74	2235	1XB7712-P03
1PH8351-7.K4...	8200	3800	2200	1440	1120	0.86	162	0.956	14.74	2235	1XB7712-P03
1PH8352-7.K4...	10300	4750	2740	1790	1320	0.86	207	0.959	17.4	2560	1XB7712-P03
1PH8354-7.K4...	11820	5460	3160	2060	1500	0.88	215	0.96	20.66	2889	1XB7712-P03
1PH8356-7.K4...	14040	6470	3730	2440	1850	0.88	249	0.962	24.22	3256	1XB7820-P00
1PH8358-7.K4...	15410	7130	4120	2700	2000	0.89	272	0.964	27.79	3629	1XB7820-P00
1PH8350-7.U4...	13570	6200	3550	2310	1850	0.85	216	0.962	14.74	2235	1XB7712-P03
1PH8351-7.U4...	13480	6180	3550	2310	1860	0.85	216	0.962	14.74	2235	1XB7712-P03
1PH8352-7.U4...	15390	7050	4050	2640	2120	0.86	232	0.964	17.4	2560	1XB7712-P03
1PH8354-7.U4...	18240	8360	4810	3130	2520	0.87	269	0.966	20.66	2889	1XB7712-P03
1PH8356-7.U4...	20940	9590	5510	3580	2880	0.88	283	0.967	24.22	3256	1XB7712-P03
1PH8358-7.U4...	24680	11330	6530	4250	3420	0.88	339	0.968	27.79	3629	1XB7820-P00
1PH8350-7.V4...	10260	8360	4790	3100	2490	0.86	178	0.966	14.74	2235	1XB7712-P03
1PH8351-7.V4...	10230	8340	4780	3100	2490	0.86	178	0.966	14.74	2235	1XB7712-P03
1PH8352-7.V4...	12720	10400	6000	3920	3150	0.87	208	0.967	17.4	2560	1XB7712-P03
1PH8354-7.V4...	13890	11330	6490	4220	3390	0.88	219	0.968	20.66	2889	1XB7712-P03
1PH8356-7.V4...	19270	15730	9020	5870	4710	0.88	317	0.972	24.22	3256	1XB7820-P00
1PH8358-7.V4...	20360	16620	9540	6200	4990	0.89	322	0.972	27.79	3629	1XB7820-P00

<sup>1)</sup>  $n_2$ : Max. permissible thermal speed at constant output or speed, which is at the voltage limit when  $P = P_{\text{rated}}$ .

<sup>2)</sup>  $n_{\max}$ : Maximum speed that must not be exceeded.

<sup>3)</sup> Maximum torque which is briefly available for dynamic operations (e.g. when accelerating).

<sup>4)</sup> Maximum current which is briefly available for dynamic operations (e.g. when accelerating).

**SIMOTICS M – Main motors**

1PH8 for SINAMICS S120 for cranes

Degree of protection IP55

**Selection and ordering data****SIMOTICS M-1PH8 asynchronous motors, shaft height 355, type of construction IM B3**

Rated speed	Rated output	Rated torque	Rated current	Rated voltage	Rated frequency	Operating speed during field weakening, max. <sup>1)</sup>	Max. speed <sup>2)</sup>	Max. torque <sup>3)</sup>	Max. current <sup>4)</sup>	<b>1PH8 asynchronous motor</b> Forced ventilation, IP55 degree of protection
$n_{rated}$	$P_{rated}$	$M_{rated}$	$I_{rated}$	$U_{rated}$	$f_{rated}$	$n_2$	$n_{max}$	$M_{max}$ at $n_{rated}$	$I_{max}$	
rpm	kW	Nm	A	V	Hz	rpm	rpm	Nm	A	
<b>Supply voltage 480 V 3 AC, Active Line Module, Vector Control</b>										
<b>600</b>	230	3661	350	500	30.3	1400	2800	12120	1260	<b>1PH8350-7 B10</b> ■■■■
	275	4377	410	500	30.3	1400	2800	14570	1440	<b>1PH8352-7 B10</b> ■■■■
	325	5173	475	500	30.3	1400	2800	16670	1590	<b>1PH8354-7 B10</b> ■■■■
	380	6048	550	500	30.3	1400	2800	20320	1920	<b>1PH8356-7 B10</b> ■■■■
	430	6844	620	500	30.2	1400	2800	23390	2180	<b>1PH8358-7 B10</b> ■■■■
<b>800</b>	300	3581	450	500	40.3	1400	2800	12500	1790	<b>1PH8350-7 Q10</b> ■■■■
	360	4298	530	500	40.3	1400	2800	14870	1990	<b>1PH8352-7 Q10</b> ■■■■
	420	5014	620	500	40.3	1400	2800	19960	2580	<b>1PH8354-7 Q10</b> ■■■■
	490	5849	720	500	40.2	1400	2800	22050	2790	<b>1PH8356-7 Q10</b> ■■■■
	565	6745	790	500	40.3	1400	2800	22770	2820	<b>1PH8358-7 Q10</b> ■■■■
<b>1000</b>	360	3438	540	500	50.3	1500	2800	13150	2430	<b>1PH8350-7 C10</b> ■■■■
	430	4107	620	500	50.3	1500	2800	14700	2490	<b>1PH8352-7 C10</b> ■■■■
	505	4823	720	500	50.3	1500	2800	16970	2750	<b>1PH8354-7 C10</b> ■■■■
	580	5539	830	500	50.3	1600	2800	21120	3340	<b>1PH8356-7 C10</b> ■■■■
	670	6399	1040	480	50.2	1600	2800	26910	4360	<b>1PH8358-7 C10</b> ■■■■
<b>1350</b>	380	2688	540	500	67.8	1800	2800	9840	2410	<b>1PH8350-7 D10</b> ■■■■
	460	3254	670	500	67.7	1800	2800	13690	3260	<b>1PH8352-7 D10</b> ■■■■
	550	3891	760	500	67.8	1700	2800	14050	3130	<b>1PH8354-7 D10</b> ■■■■
	630	4457	900	500	67.7	1700	2800	18980	4090	<b>1PH8356-7 D10</b> ■■■■
	730	5164	1040	500	67.7	1700	2800	21720	4590	<b>1PH8358-7 D10</b> ■■■■

For versions, see  
Article No. supplements and  
options.

Overload factors for intermittent duty (S3) for  
1PH835-7..10-....

Operating mode	S3-40 %	S3-60 %
Overload factor	1.47	1.23

### Selection and ordering data

Motor type (repeated)	Max. torque <sup>3)</sup>					Power factor	Magnetizing current	Efficiency	Moment of inertia	Weight, approx.	Terminal box					
	$M_{\max}$ at											$\cos \varphi$	$I_{\mu}$	$\eta$	$J$	Type
	1000 rpm	1500 rpm	2000 rpm	2500 rpm	2800 rpm											
<b>Supply voltage 480 V 3 AC, Active Line Module, Vector Control</b>																
1PH8350-7.B1...	4710	2220	1310	860	580	0.79	194	0.959	14.74	2235	1XB7712-P01					
1PH8352-7.B1...	5640	2660	1560	1030	700	0.8	223	0.961	17.4	2560	1XB7712-P01					
1PH8354-7.B1...	6450	3030	1780	1170	800	0.82	236	0.962	20.66	2889	1XB7712-P03					
1PH8356-7.B1...	7840	3680	2150	1420	980	0.82	285	0.964	24.22	3256	1XB7712-P03					
1PH8358-7.B1...	8990	4210	2460	1620	1100	0.82	316	0.965	27.79	3629	1XB7820-P00					
1PH8350-7.Q1...	8210	3830	2230	1460	1050	0.8	235	0.964	14.74	2235	1XB7712-P03					
1PH8352-7.Q1...	9750	4540	2640	1730	1250	0.81	267	0.966	17.40	2560	1XB7712-P03					
1PH8354-7.Q1...	12960	5910	3390	2200	1690	0.8	334	0.967	20.66	2889	1XB7820-P00					
1PH8356-7.Q1...	14420	6670	3860	2520	1850	0.81	380	0.968	24.22	3256	1XB7820-P00					
1PH8358-7.Q1...	14930	6930	4020	2640	1890	0.84	359	0.969	27.79	3629	1XB7820-P00					
1PH8350-7.C1...	13150	6070	3510	2290	1850	0.79	294	0.967	14.74	2235	1XB7712-P03					
1PH8352-7.C1...	14700	6780	3910	2550	2060	0.82	302	0.969	17.40	2560	1XB7820-P00					
1PH8354-7.C1...	16970	7830	4530	2960	2380	0.83	328	0.97	20.66	2889	1XB7820-P00					
1PH8356-7.C1...	21120	9730	5610	3660	2950	0.82	410	0.971	24.22	3256	1XB7820-P00					
1PH8358-7.C1...	26910	12360	7120	4640	3730	0.8	567	0.971	27.79	3629	1XB7820-P00					
1PH8350-7.D1...	9840	8040	4620	3010	2420	0.83	235	0.97	14.74	2235	1XB7712-P03					
1PH8352-7.D1...	13690	11180	6430	4190	3370	0.81	338	0.97	17.4	2560	1XB7820-P00					
1PH8354-7.D1...	14050	11480	6620	4310	3470	0.85	314	0.972	20.66	2889	1XB7820-P00					
1PH8356-7.D1...	18980	15500	8910	5800	4660	0.83	433	0.972	24.22	3256	1XB7820-P00					
1PH8358-7.D1...	21720	17740	10220	6660	5360	0.83	489	0.972	27.79	3629	1XB7820-P00					

<sup>1)</sup>  $n_2$ : Max. permissible thermal speed at constant output or speed, which is at the voltage limit when  $P = P_{\text{rated}}$ .

<sup>2)</sup>  $n_{\max}$ : Maximum speed that must not be exceeded.

<sup>3)</sup> Maximum torque which is briefly available for dynamic operations (e.g. when accelerating).

<sup>4)</sup> Maximum current which is briefly available for dynamic operations (e.g. when accelerating).

**SIMOTICS M – Main motors**

1PH8 for SINAMICS S120 for cranes

Degree of protection IP55

**Selection and ordering data**

Rated speed	Rated output	Rated torque	Rated current	Rated voltage	Rated frequency	Operating speed during field weakening, max. <sup>1)</sup>	Max. speed <sup>2)</sup>	Max. torque <sup>3)</sup>	Max. current <sup>4)</sup>	<b>1PH8 asynchronous motor</b> Forced ventilation, IP55 degree of protection  Article No.
$n_{rated}$	$P_{rated}$	$M_{rated}$	$I_{rated}$	$U_{rated}$	$f_{rated}$	$n_2$	$n_{max}$	$M_{max}$ at $n_{rated}$	$I_{max}$	
rpm	kW	Nm	A	V	Hz	rpm	rpm	Nm	A	
<b>Supply voltage 690 V 3 AC, Active Line Module, Vector Control</b>										
<b>600</b>	230	3661	255	690	30.3	1400	2800	12090	910	<b>1PH8350-7 H10</b> ■■■■
	275	4377	295	690	30.3	1400	2800	13880	1000	<b>1PH8352-7 H10</b> ■■■■
	325	5173	345	690	30.3	1400	2800	16940	1170	<b>1PH8354-7 H10</b> ■■■■
	380	6048	400	690	30.3	1400	2800	20480	1400	<b>1PH8356-7 H10</b> ■■■■
	430	6844	455	690	30.2	1400	2800	24230	1630	<b>1PH8358-7 H10</b> ■■■■
<b>800</b>	300	3581	320	690	40.3	1400	2800	12180	1290	<b>1PH8350-7 K10</b> ■■■■
	360	4298	390	690	40.3	1400	2800	15360	1480	<b>1PH8352-7 K10</b> ■■■■
	420	5014	440	690	40.3	1400	2800	17590	1660	<b>1PH8354-7 K10</b> ■■■■
	490	5849	510	690	40.3	1400	2800	20960	1940	<b>1PH8356-7 K10</b> ■■■■
	565	6745	580	690	40.3	1400	2800	23360	2090	<b>1PH8358-7 K10</b> ■■■■
<b>1000</b>	360	3438	395	690	50.3	1500	2800	13240	1770	<b>1PH8350-7 U10</b> ■■■■
	430	4107	455	690	50.3	1500	2800	15110	1840	<b>1PH8352-7 U10</b> ■■■■
	505	4823	530	690	50.3	1500	2800	18280	2110	<b>1PH8354-7 U10</b> ■■■■
	580	5539	600	690	50.3	1600	2800	20510	2370	<b>1PH8356-7 U10</b> ■■■■
	670	6399	690	690	50.2	1600	2800	24570	2760	<b>1PH8358-7 U10</b> ■■■■
<b>1350</b>	380	2688	395	690	67.8	1800	2800	10200	1800	<b>1PH8350-7 V10</b> ■■■■
	460	3254	470	690	67.8	1800	2800	12290	2230	<b>1PH8352-7 V10</b> ■■■■
	550	3891	550	690	67.8	1700	2800	13660	2230	<b>1PH8354-7 V10</b> ■■■■
	630	4457	650	690	67.7	1700	2800	19140	2990	<b>1PH8356-7 V10</b> ■■■■
	730	5164	740	690	67.7	1700	2800	20270	3110	<b>1PH8358-7 V10</b> ■■■■

For versions, see  
Article No. supplements and  
options.

Overload factors for intermittent duty (S3) for  
1PH835-7..10-....

Operating mode	S3-40 %	S3-60 %
Overload factor	1.47	1.23

## SIMOTICS M – Main motors

### 1PH8 for SINAMICS S120 for cranes

Degree of protection IP55

#### Selection and ordering data

Motor type (repeated)	Max. torque <sup>3)</sup>					Power factor	Magnetizing current	Efficiency	Moment of inertia	Weight, approx.	Terminal box					
	$M_{\max}$ at											$\cos \varphi$	$I_{\mu}$	$\eta$	$J$	Type
	1000 rpm	1500 rpm	2000 rpm	2500 rpm	2800 rpm											
<b>Supply voltage 690 V 3 AC, Active Line Module, Vector Control</b>																
1PH8350-7.H1...	4690	2210	1300	860	580	0.79	139	0.959	14.74	2235	1XB7712-P01					
1PH8352-7.H1...	5390	2550	1500	990	680	0.81	149	0.96	17.4	2560	1XB7712-P01					
1PH8354-7.H1...	6550	3080	1810	1190	820	0.82	176	0.962	20.66	2889	1XB7712-P01					
1PH8356-7.H1...	7890	3700	2160	1430	1000	0.82	209	0.964	24.22	3256	1XB7712-P01					
1PH8358-7.H1...	9310	4350	2540	1670	1160	0.81	242	0.965	27.79	3629	1XB7712-P03					
1PH8350-7.K1...	8010	3740	2180	1430	1000	0.8	162	0.965	14.74	2235	1XB7712-P01					
1PH8352-7.K1...	10070	4670	2710	1780	1290	0.8	207	0.966	17.40	2560	1XB7712-P01					
1PH8354-7.K1...	11560	5390	3140	2060	1490	0.82	215	0.969	20.66	2889	1XB7712-P03					
1PH8356-7.K1...	13760	6400	3720	2440	1800	0.83	249	0.969	24.22	3256	1XB7712-P03					
1PH8358-7.K1...	15290	7080	4100	2680	2010	0.84	272	0.969	27.79	3629	1XB7712-P03					
1PH8350-7.U1...	13240	6110	3530	2310	1860	0.78	216	0.967	14.74	2235	1XB7712-P01					
1PH8357-7.U1...	15110	6960	4010	2620	2110	0.81	232	0.968	17.40	2560	1XB7712-P01					
1PH8354-7.U1...	18280	8430	4860	3180	2560	0.82	269	0.97	20.66	2889	1XB7712-P03					
1PH8356-7.U1...	20510	9450	5450	3560	2860	0.83	283	0.971	24.22	3256	1XB7712-P03					
1PH8358-7.U1...	24570	11310	6520	4250	3420	0.83	339	0.971	27.79	3629	1XB7820-P00					
1PH8350-7.V1...	10200	8320	4780	3110	2500	0.83	178	0.97	14.74	2235	1XB7712-P01					
1PH8352-7.V1...	12290	10040	5780	3760	3030	0.84	208	0.971	17.4	2560	1XB7712-P03					
1PH8354-7.V1...	13660	11160	6420	4180	3360	0.86	219	0.972	20.66	2889	1XB7712-P03					
1PH8356-7.V1...	19140	15630	8980	5840	4700	0.83	317	0.972	24.22	3256	1XB7712-P03					
1PH8358-7.V1...	20270	16550	9510	6190	4970	0.85	322	0.973	27.79	3629	1XB7712-P03					

<sup>1)</sup>  $n_2$ : Max. permissible thermal speed at constant output or speed, which is at the voltage limit when  $P = P_{\text{rated}}$ .

<sup>2)</sup>  $n_{\max}$ : Maximum speed that must not be exceeded.

<sup>3)</sup> Maximum torque which is briefly available for dynamic operations (e.g. when accelerating).

<sup>4)</sup> Maximum current which is briefly available for dynamic operations (e.g. when accelerating).

# SIMOTICS M – Main motors

## 1PH8 for SINAMICS S120 for cranes

### Article No. supplements

#### Selection and ordering data

Position of the Article No.	1	2	3	4	5	6	7	8	9	10	11	12	13	14	15	16				
<b>Shaft height 355</b>	1	P	H	8	3	5	.	-	7	.	.	.	-	.	.	.	-	Z		
<b>Overall length<sup>1)</sup></b>	.																			
<b>Asynchronous variant</b>																				
Forced ventilation with noise value 85 dB									7											
<b>Encoder systems for motors without DRIVE-CLiQ interface</b>																				
Without encoder									A											
<b>Prepared for encoder mounting systems<sup>2)</sup></b>																				
Incremental encoder 22-bit with commutation position (encoder IC22DQ)									D											
Absolute value encoder ENDAT 2048 S/R (encoder AM2048S/R)									E											
Absolute value encoder 22 BIT singleturn + 12 BIT multeturn (encoder AM22DQ)									F											
Incremental encoder HTL 1024 S/R HOG 28 (Huebner) pre assembly (without encoder)	Order code required: <b>H75</b>								G											
Incremental encoder HTL 1024 S/R (encoder IC1024 S/R)									H											
Incremental encoder HTL 2048 S/R									J											
Incremental encoder HTL 1024 S/R POG 10 (Huebner)	Order code required: <b>H56</b>								K											
Incremental encoder HTL 1024 S/R with solid shaft	Order code required: <b>G80</b>								K											
Incremental encoder POG 10 supplied by customer																				
Incremental encoder sin/cos 1VPP with C and D truck (encoder IC2048 S/R)									M											
Mounting prepared for MHGE 200									X											
Mounting prepared for MAGG 200									Y											
<b>Rated speed</b> (winding version)	.																			
<b>Cooling</b>																				
<b>Degree of protection</b>																				
Forced ventilation	IP55																	1		
Forced ventilation	IP23 (open-circuit cooling)																	4		
<b>Type</b>																				
IM B3																	0			
<b>Shaft extension (DE)</b>																				
<b>Balancing</b>																				
Featherkey groove	Full-key																	0		
Featherkey	Full-key																	1		
Featherkey	Half-key																	2		
<b>Bearings</b>																				
<b>Vibration magnitude acc. to</b>																				
<b>Shaft and flange accuracy<sup>3)</sup></b>																				
Standard	A								N									A		
Standard	R/A								R									B		
increased cantilever forces	A								N									E		
increased cantilever forces	R/A								R									F		
<b>Cable connection</b> (view of DE)																				
<u>Terminal box</u>	<u>Cable infeed</u>								<u>External fan NDE with air inlet from NDE</u> <u>Air-flow direction NDE</u>											
NDE right	Bottom								Top									U		
									Left									U	-	Z
									Right									V	-	Z
NDE left	Bottom								Top									V	-	Z
									Right									W	-	Z
									Left									W	-	Z
NDE top	Right								Right									W	-	Z
									Left									X	-	Z
									Top <sup>5)</sup>									X	-	Z
DE top <sup>4)</sup>	Right								Left									X	-	Z
									Right									X	-	Z
<b>Temperature monitoring</b>																				
Temperature sensor PT1000 in the stator winding																	2			
<b>Special versions</b> Order No. supplement "-Z" with order code and plain text if required, see options.																				
																	-	Z		

<sup>1)</sup> Not selectable. Determined by the choice of rated power.

<sup>2)</sup> For more information on incremental encoders, visit [www.baumerhuebner.com](http://www.baumerhuebner.com)

<sup>3)</sup> For definition, see 1PH8 Configuration Manual.

<sup>4)</sup> Signal connection for 1PH835 NDE at bearing shield.

<sup>5)</sup> Only possible for assignments with terminal box 1XB7712-P..

**Options**

Order code	Description
<b>A08</b>	Air flow monitoring 24 V DC
<b>A12</b>	Thermistors for alarm
<b>A31</b>	Motor temperature monitoring through switch
<b>A60</b>	Motor protection through 3 × Pt100
<b>A72</b>	Bearing temperature monitoring with Pt100
<b>G00</b>	External fan NDE left (possible if 15th position of Article No. is U, W or X)
<b>G02</b>	External fan NDE right (possible if 15th position of Article No. is V, W or X)
<b>G14</b>	With air filter
<b>G80</b>	Mounting of a supplied POG 10 incremental encoder (possible if 9th position of Article No. is K)
<b>H56</b>	Mounting of a POG 10 DN 1024 incremental encoder (HTL 1024 S/R; possible if 9th position of Article No. is K)
<b>H75</b>	Mounting of a supplied HOG 28 incremental encoder (possible if 9th position of Article No. is G)
<b>K12</b>	Additional PTC thermistor chain for alarm and tripping
<b>K16</b>	Second shaft extension 120 mm × 210 mm (d × l; possible if 9th position of Article No. = "A" or "G")
<b>K45</b>	230 V standstill heating
<b>K46</b>	110 V standstill heating
<b>K83</b>	Terminal box rotated through +90° (possible if 15th position of Article No. is V or W)
<b>K84</b>	Terminal box rotated through -90° (possible if 15th position of Article No. is U or W)
<b>K85</b>	Terminal box rotated through +180°
<b>L00</b>	Terminal box 1XB7820 (cable entry plate undrilled) instead of terminal box 1XB7712
<b>L12</b>	Condensation water drain hole provided unsealed
<b>L29</b>	Enhanced corrosion protection (possible if 11th position of Article No. is 1)
<b>L50</b>	Adapter base for mounting a fan
<b>P00</b>	Cable entry plate undrilled (with terminal box 1XB7712 only)
<b>P01</b>	Cable entry plate 3 × M63 × 1.5 (only with terminal box 1XB7712)
<b>P02</b>	Cable entry plate 3 × M75 × 1.5 (only with terminal box 1XB7712)
<b>P03</b>	Cable entry plate 4 × M75 × 1.5 (only with terminal box 1XB7712)
<b>P04</b>	Cable entry plate 4 × M63 × 1.5 (only with terminal box 1XB7712)
<b>P12</b>	Cable entry plate 6 × M63 × 1.5 + 2 × M20 (only with terminal box 1XB7820)
<b>P13</b>	Cable entry plate 7 × M50 × 1.5 + 2 × M20 + 1 × M25 (only with terminal box 1XB7820)
<b>P14</b>	Cable entry plate 6 × M63 × 1.5 + 1 × M20 + 1 × M25 (only with terminal box 1XB7820)
<b>P15</b>	Cable entry plate 9 × M63 × 1.5 + 1 × M20 + 1 × M25 (only with terminal box 1XB7820)
<b>P16</b>	Cable entry plate 12 × M63 × 1.5 + 1 × M20 + 1 × M25 (only with terminal box 1XB7820)
<b>Q00</b>	Increased number of ground terminals in the terminal box (12 × M6 for 1XB771, 24 × M6 for 1XB7820)
<b>Q14</b>	Air filter for harsh environment
<b>R60</b>	Special fan for operation at 460 V / 60 Hz (±10 %)
<b>R61</b>	Special fan for operation at 400 V / 60 Hz (±10 %)
<b>Y80</b>	Additional rating plate with deviating rating plate data
<b>Y82</b>	Additional rating plate with customer specifications
<b>Y84</b>	Customer-specific information on rating plate (maximum 30 characters) <sup>1)</sup>
<b>Colors</b>	
–	Standard paint is anthracite RAL 7016
<b>X01</b>	Standard finish in RAL 9005 (black)
<b>K24</b>	Primer
<b>K23</b>	Special paint finish worldwide (anthracite RAL 7016)
<b>K23+X..</b>	Special paint finish worldwide in another color X.. (on request)

Order No. supplement "-Z" with order code and plain text, if required.

<sup>1)</sup> Specify plain text when ordering.

**SIMOTICS M – Main motors**

1PH8 for SINAMICS S120 for cranes

**Options****Options** continued**Ordering example**

Selection criteria	Requirement	Structure of the Article No.
Motor type	Asynchronous motor, shaft height 355, IP55 degree of protection, type of construction IM B3, noise level 85 dB(A), operating speed 800 rpm, Supply voltage 690 V 3 AC Intermittent duty S3-60 % Rated output 445 kW Rated torque 5312 Nm, Rated current 460 A, Terminal box type 1XB7712-P01	<b>1PH8352-7</b> ■ <b>K10</b> -■ <b>■</b> ■ <b>■</b> ■
Encoder systems	Incremental encoder HTL 1024 S/R POG 10 (Baumer-Hübner)	<b>1PH8352-7</b> ■ <b>KK10</b> -■ <b>■</b> ■ <b>■</b> ■
Shaft extension (DE)/balancing	Featherkey + full-key balancing	<b>1PH8352-7</b> ■ <b>KK10-1</b> ■ <b>■</b> ■ <b>■</b> ■
Bearings	Standard (A/N)	<b>1PH8352-7</b> ■ <b>KK10-1</b> ■ <b>A</b> ■ <b>■</b> ■
Terminal box	DE top, cable entry right	<b>1PH8352-7</b> ■ <b>KK10-1</b> ■ <b>AX</b> ■ <b>■</b> ■
Temperature monitoring	Temperature sensor PT1000 in the stator winding	<b>1PH8352-7</b> ■ <b>KK10-1</b> ■ <b>AX2</b> ■ <b>■</b> ■
Special version	Mounting of a supplied pulse encoder with POG 10 mounting flange	<b>1PH8352-7</b> ■ <b>KK10-1</b> ■ <b>AX2-Z</b> <b>G80</b>
	230 V standstill heating	<b>1PH8352-7</b> ■ <b>KK10-1</b> ■ <b>AX2-Z</b> <b>G80+K45</b>
	Cable entry plate 4 × M75 × 1.5	<b>1PH8352-7</b> ■ <b>KK10-1</b> ■ <b>AX2-Z</b> <b>G80+K45+P03</b>
<b>Complete ordering information for required version of motor</b>		<b>1PH8352-7</b> ■ <b>KK10-1</b> ■ <b>AX2-Z</b> <b>G80+K45+P03</b>



**Dimensional drawings**

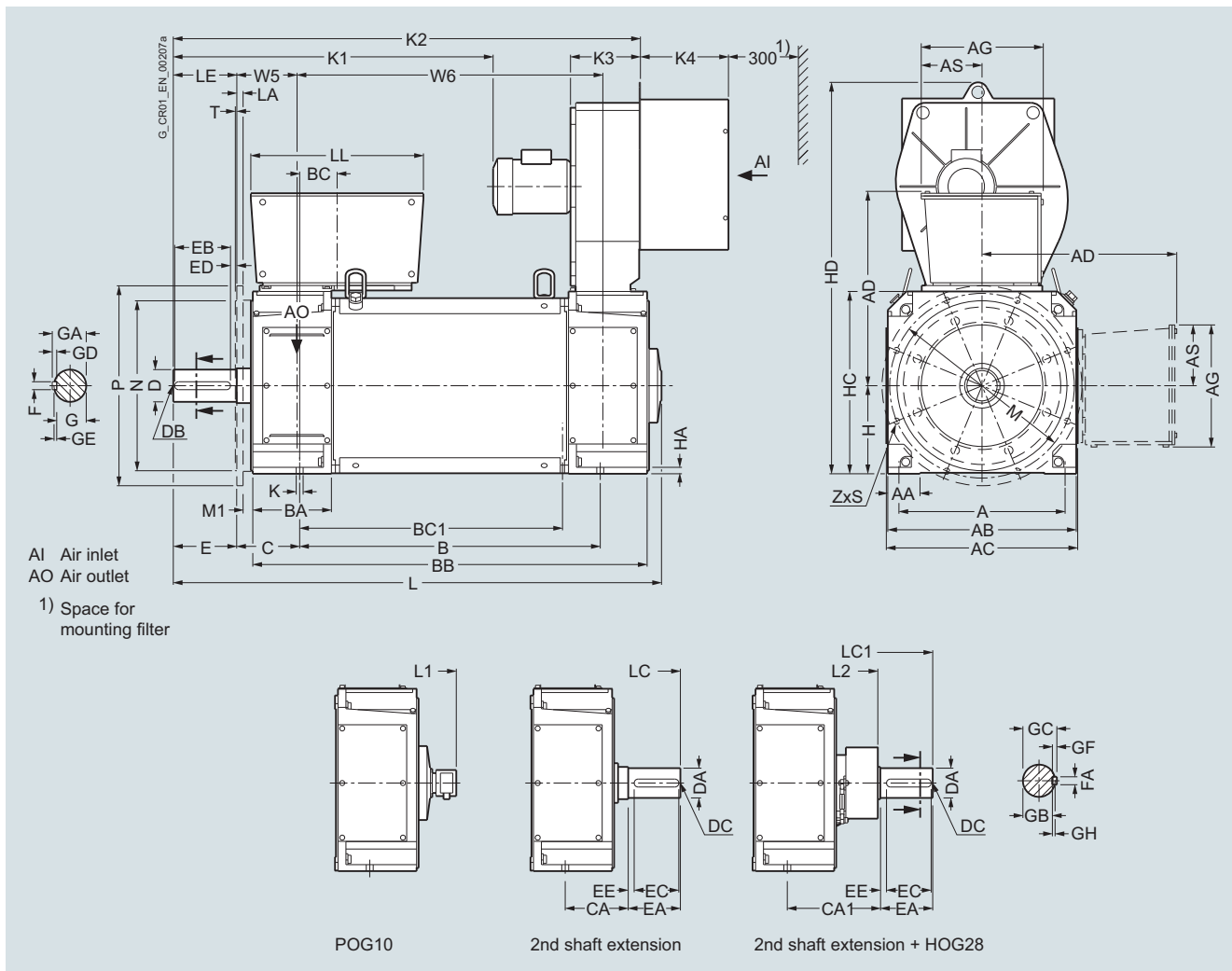

**SIMOTICS M – Main motors**

1PH8 for SINAMICS S120 for cranes

**Dimensional drawings****Dimensional drawings**

Shaft height	Dimensions to IEC																					
1PH8...	A	AA	AB	AC	B	BA	BB	C	CA	CA1	W5	W6	D	DA	DB	DC	E	EA	EB	EC	ED	EE
350/351	670	130	760	781	772	317	1150	254	254	375	243	795	Ø130	Ø120	M24	M24	250	210	220	180	25	25
352	670	130	760	781	862	317	1240	254	254	375	243	885	Ø130	Ø120	M24	M24	250	210	220	180	25	25
354	670	130	760	781	972	317	1350	254	254	375	243	995	Ø130	Ø120	M24	M24	250	210	220	180	25	25
356	670	130	760	781	1092	317	1470	254	254	375	243	1115	Ø130	Ø120	M24	M24	250	210	220	180	25	25
358	670	130	760	781	1212	317	1590	254	254	375	243	1235	Ø130	Ø120	M24	M24	250	210	220	180	25	25

Shaft height	Dimensions to IEC																			
1PH8...	F	FA	G	GA	GB	GC	GD	GE	GF	GH	H	HA	HC	K	L	L1	L2	LC	LC1	
350/351	32	32	119	137	114	127	18	11	18	11	355	26	735	Ø28	1523	1625	1644	1740	1861	
352	32	32	119	137	114	127	18	11	18	11	355	26	735	Ø28	1613	1715	1734	1830	1951	
354	32	32	119	137	114	127	18	11	18	11	355	26	735	Ø28	1723	1825	1844	1940	2061	
356	32	32	119	137	114	127	18	11	18	11	355	26	735	Ø28	1843	1945	1964	2060	2181	
358	32	32	119	137	114	127	18	11	18	11	355	26	735	Ø28	1963	2065	2084	2180	2301	

Shaft height	Terminal box						Fan					Flange									
1PH8...	AD	AG	DE	BC	BC1	LL	K1	K2	K3	K4	HD	LA	LE	M	M1	N	P	S	T	Z	
	<b>1 XB7 820</b>						<b>85 dB (A)</b>														
350/351	784	492	245	151	861	696	844	1438	282	355	1578	25	250	Ø740	40	Ø680	Ø800	Ø24	6	8	
352	784	492	245	151	951	696	934	1528	282	355	1578	25	250	Ø740	40	Ø680	Ø800	Ø24	6	8	
354	784	492	245	151	1061	696	1044	1638	282	355	1578	25	250	Ø740	40	Ø680	Ø800	Ø24	6	8	
356	784	492	245	151	1181	696	1164	1758	282	355	1578	25	250	Ø740	40	Ø680	Ø800	Ø24	6	8	
358	784	492	245	151	1301	696	1284	1878	282	355	1578	25	250	Ø740	40	Ø680	Ø800	Ø24	6	8	
	<b>1 XB7 712</b>						<b>R60/R61 fan 60 Hz</b>														
350/351	640	377	201	-12	784	370	802	1438	282	355	1578										
352	640	377	201	-12	874	370	892	1528	282	355	1578										
354	640	377	201	-12	984	370	1002	1638	282	355	1578										
356	640	377	201	-12	1104	370	1122	1758	282	355	1578										
358	640	377	201	-12	1224	370	1242	1878	282	355	1578										

3

## Appendix

### Service Programs and Agreements



<b>4/2</b>	<b>Industry Services</b>
<b>4/3</b>	Industry Services – Portfolio overview
<b>4/4</b>	<b>Online Support</b>
<b>4/5</b>	<b>Partner</b>
<b>4/6</b>	<b>Metal surcharges</b>
<b>4/9</b>	<b>Conditions of sale and delivery</b>

## Appendix

### Industry Services

#### Overview

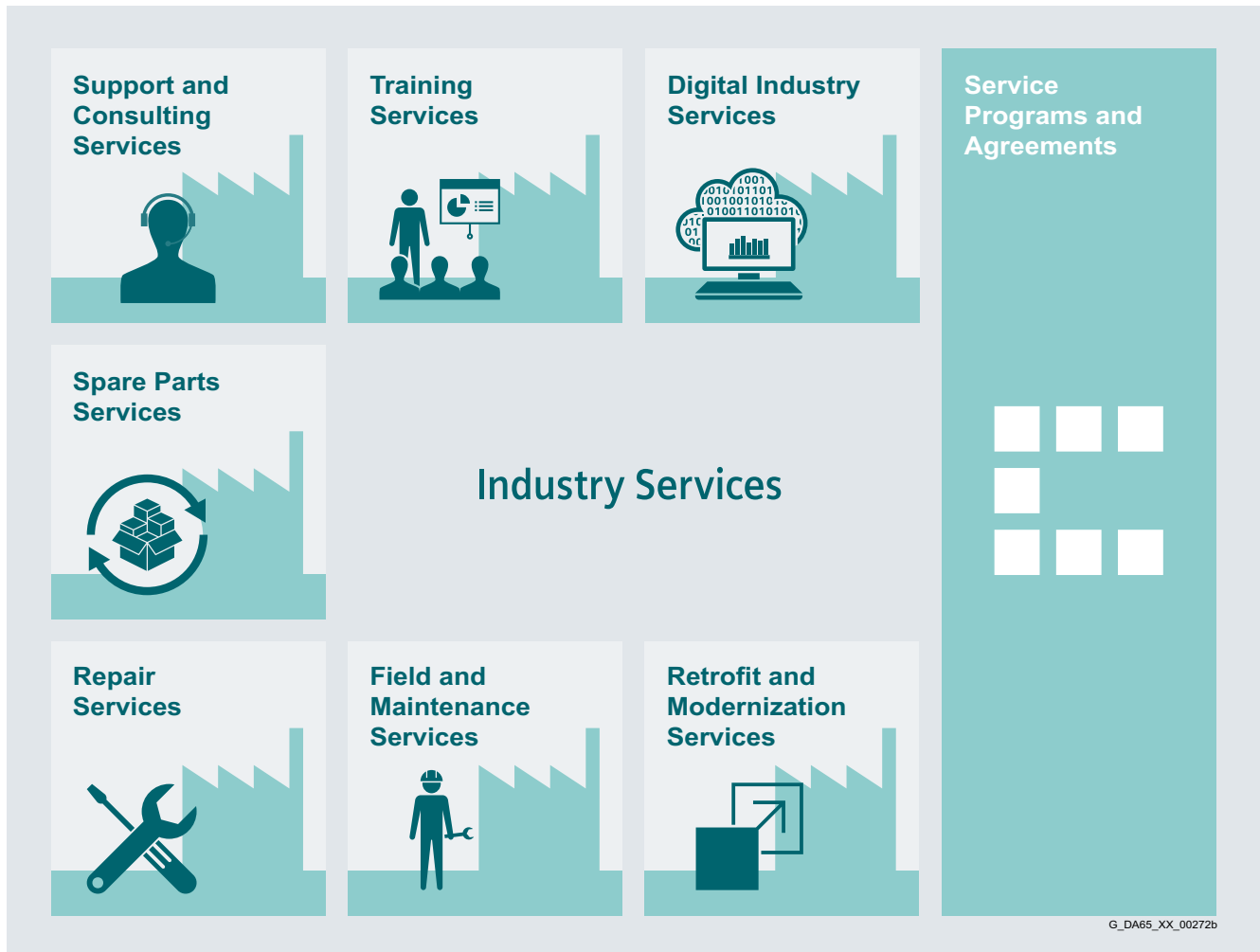

4

#### **Keep your business running and shaping your digital future – with Industry Services**

Optimizing the productivity of your equipment and operations can be a challenge, especially with constantly changing market conditions. Working with our service experts makes it easier. We understand your industry's unique processes and provide the services needed so that you can better achieve your business goals.

You can count on us to maximize your uptime and minimize your downtime, increasing your operations' productivity and reliability. When your operations have to be changed quickly to meet a new demand or business opportunity, our services give you the flexibility to adapt. Of course, we take care that your production is protected against cyber threats. We assist in keeping your operations as energy and resource efficient as possible and reducing your total cost of ownership. As a trendsetter, we ensure that you can capitalize on the opportunities of digitalization and by applying data analytics to enhance decision making: You can be sure that your plant reaches its full potential and retains this over the longer lifespan.

You can rely on our highly dedicated team of engineers, technicians and specialists to deliver the services you need – safely, professionally and in compliance with all regulations. We are there for you, where you need us, when you need us.

[www.siemens.com/industryservices](http://www.siemens.com/industryservices)

#### Overview



Digital Industry Services

#### Digital Industry Services

Digital Industry Services make your industrial processes transparent to gain improvements in productivity, asset availability, and energy efficiency.

Production data is generated, filtered and translated with intelligent analytics to enhance decision-making.

This is done whilst taking data security into consideration and with continuous protection against cyber-attack threats.

<https://www.siemens.com/global/en/home/products/services/industry/digital-services.html>

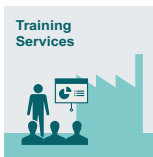

Training Services

#### Training Services

From the basics and advanced to specialist skills, SITRAIN courses provide expertise right from the manufacturer – and encompass the entire spectrum of Siemens products and systems for the industry.

Worldwide, SITRAIN courses are available wherever you need a training course in more than 170 locations in over 60 countries.

<https://support.industry.siemens.com/cs/ww/en/sc/2226>

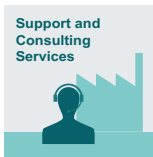

Support and Consulting Services

#### Support and Consulting Services

**Industry Online Support** site for comprehensive information, application examples, FAQs and support requests.

**Technical and Engineering Support** for advice and answers for all inquiries about functionality, handling, and fault clearance. The Service Card as prepaid support for value added services such as Priority Call Back or Extended Support offers the clear advantage of quick and easy purchasing.

**Information & Consulting Services**, e.g. SIMATIC System Audit; clarity about the state and service capability of your automation system or Lifecycle Information Services; transparency on the lifecycle of the products in your plants.

<https://support.industry.siemens.com/cs/ww/en/sc/2235>



Spare Parts Services

#### Spare Parts

Spare Parts Services are available worldwide for smooth and fast supply of spare parts – and thus optimal plant availability. Genuine spare parts are available for up to ten years. Logistic experts take care of procurement, transport, custom clearance, storage and order management.

Reliable logistics processes ensure that components reach their destination as needed.

Since not all spare parts can be kept in stock at all times, Siemens offers a preventive measure for spare parts provisioning on the customer's premises with optimized **Spare Parts Packages** for individual products, custom-assembled drive components and entire integrated drive trains – including risk consulting.

**Asset Optimization Services** help you design a strategy for parts supply where your investment and carrying costs are reduced and the risk of obsolescence is avoided.

<https://support.industry.siemens.com/cs/ww/en/sc/2110>



Repair Services

#### Repair Services

Repair Services are offered on-site and in regional repair centers for fast restoration of faulty devices' functionality.

Also available are extended repair services, which include additional diagnostic and repair measures, as well as emergency services.

<https://support.industry.siemens.com/cs/ww/en/sc/2154>



Field and Maintenance Services

#### Field and Maintenance Services

Siemens specialists are available globally to provide expert field and maintenance services, including commissioning, functional testing, preventive maintenance and fault clearance.

All services can be included in customized service agreements with defined reaction times or fixed maintenance intervals.

<https://support.industry.siemens.com/cs/ww/en/sc/2265>



Retrofit and Modernization Services

#### Retrofit and Modernization Services

Provide a cost-effective solution for the expansion of entire plants, optimization of systems or upgrading existing products to the latest technology and software, e.g. migration services for automation systems.

Service experts support projects from planning through commissioning and, if desired over the entire extended lifespan, e.g. Retrofit for Integrated Drive Systems for an extended lifetime of your machines and plants.

<https://support.industry.siemens.com/cs/ww/en/sc/2286>



Service Programs and Agreements

#### Service Programs and Agreements

A technical Service Program or Agreement enables you to easily bundle a wide range of services into a single annual or multi-year agreement.

You pick the services you need to match your unique requirements or fill gaps in your organization's maintenance capabilities.

Programs and agreements can be customized as KPI-based and/or performance-based contracts.

<https://support.industry.siemens.com/cs/ww/en/sc/2275>

# Appendix Industry Services

## Online Support

### Overview

Online Support – fast, intuitive, whenever you want, wherever you need

**Web**

support.industry.siemens.com

**App**

SIEMENS

GET IT ON Google Play | Learn on the App Store | Herunterladen von Microsoft

Scan the QR code for information on our Online Support app.

- FAQ / Application examples**  
Information about industrial products, programming and configuration as well as application examples
- Technical information**  
Videos, documentation, manuals, updates, product notes, compatibility tool, certificates, planning data such as dimensional drawings, product data, 3D models
- Forum**  
Exchange information and experience with other users and experts

## Online Support for Siemens Industry Products

Siemens Industry and Online Support with some 1.7 million visitors per month is one of the most popular web services provided by Siemens. It is the central access point for comprehensive technical know-how about products, systems and services for automation and drives applications as well as for process industries.

In connection with the challenges and opportunities related to digitalization you can look forward to continued support with innovative offerings.

**Partner at Siemens**

At your service locally, around the globe for consulting, sales, training, service, support, spare parts on the entire portfolio of Siemens.

Your partner can be found in our Personal Contacts Database at: [www.siemens.com/automation-contact](http://www.siemens.com/automation-contact)

You start by selecting

- the required competence,
- products and branches,
- a country and a city

or by a

location search or free text search.

## Appendix

### Industry Services

#### Metal surcharges

#### Explanation of the raw material/metal surcharges<sup>1)</sup>

##### Surcharge calculation

To compensate for variations in the price of the raw materials silver, copper, aluminum, lead, gold, dysprosium<sup>2)</sup> and/or neodym<sup>2)</sup>, surcharges are calculated on a daily basis using the so-called metal factor for products containing these raw materials. A surcharge for the respective raw material is calculated as a supplement to the price of a product if the basic official price of the raw material in question is exceeded.

The surcharges are calculated in accordance with the following criteria:

- Basic official price of the raw material  
Basic official price from the day prior to receipt of the order or prior to release order (daily price) for<sup>3)</sup>
  - Silver (sales price, processed)
  - Gold (sales price, processed)
 and for<sup>4)</sup>
  - Copper (lower DEL notation + 1 %)
  - Aluminum (aluminum in cables)
  - Lead (lead in cables)
- Metal factor of the products  
Certain products are displayed with a metal factor. The metal factor determines the official price (for those raw materials concerned) as of which the metal surcharges are applied and the calculation method used (weight or percentage method). An exact explanation is given below.

##### Structure of the metal factor

The metal factor consists of several digits; the first digit indicates whether the percentage method of calculation refers to the list price or a possible discounted price (customer net price) (L = list price / N = customer net price).

The remaining digits indicate the method of calculation used for the respective raw material. If no surcharge is added for a raw material, a "-" is used.

1st digit	List or customer net price using the percentage method
2nd digit	for silver (AG)
3rd digit	for copper (CU)
4th digit	for aluminum (AL)
5th digit	for lead (PB)
6th digit	for gold (AU)
7th digit	for dysprosium (Dy) <sup>2)</sup>
8th digit	for neodym (Nd) <sup>2)</sup>

##### Weight method

The weight method uses the basic official price, the daily price and the raw material weight. In order to calculate the surcharge, the basic official price must be subtracted from the daily price. The difference is then multiplied by the raw material weight.

The basic official price can be found in the table below using the number (1 to 9) of the respective digit of the metal factor. The raw material weight can be found in the respective product descriptions.

##### Percentage method

Use of the percentage method is indicated by the letters A-Z at the respective digit of the metal factor.

The surcharge is increased - dependent on the deviation of the daily price compared with the basic official price - using the percentage method in "steps" and consequently offers surcharges that remain constant within the framework of this "step range". A higher percentage rate is charged for each new step. The respective percentage level can be found in the table below.

##### Metal factor examples

###### LEA-----

Basis for % surcharge: List price

Silver Basis 150 €, Step 50 €, 0.5 %

Copper Basis 150 €, Step 50 €, 0.1 %

No surcharge for aluminum

No surcharge for lead

No surcharge for gold

No surcharge for dysprosium

No surcharge for neodym

###### N-A6-----

Basis for % surcharge: Customer net price

No surcharge for silver

Copper Basis 150 €, Step 50 €, 0.1 %

Aluminum acc. to weight, basic offic. price 225 €

No surcharge for lead

No surcharge for gold

No surcharge for dysprosium

No surcharge for neodym

###### --3-----

No basis necessary

No surcharge for silver

Copper acc. to weight, basic official price 150 €

No surcharge for aluminum

No surcharge for lead

No surcharge for gold

No surcharge for dysprosium

No surcharge for neodym

<sup>1)</sup> Refer to the separate explanation on the next page regarding the raw materials dysprosium and neodym (= rare earths).

<sup>2)</sup> For a different method of calculation, refer to the separate explanation for these raw materials on the next page.

<sup>3)</sup> Source: Umicore, Hanau ([www.metalsmanagement.umicore.com](http://www.metalsmanagement.umicore.com)).

<sup>4)</sup> Source: Schutzvereinigung DEL-Notiz e.V. ([www.del-notiz.org](http://www.del-notiz.org)).



**Explanation of the raw material/metal surcharges for dysprosium and neodym (rare earths)****Surcharge calculation**

To compensate for variations in the price of the raw materials silver<sup>1)</sup>, copper<sup>1)</sup>, aluminum<sup>1)</sup>, lead<sup>1)</sup>, gold<sup>1)</sup>, dysprosium and/or neodym, surcharges are calculated on a daily basis using the so-called metal factor for products containing these raw materials. The surcharge for dysprosium and neodym is calculated as a supplement to the price of a product if the basic official price of the raw material in question is exceeded.

The surcharge is calculated in accordance with the following criteria:

- Basic official price of the raw material<sup>2)</sup>  
Three-month basic average price (see below) in the period before the quarter in which the order was received or the release order took place (= average official price) for  
- dysprosium (Dy metal, 99 % min. FOB China; USD/kg)  
- neodym (Nd metal, 99 % min. FOB China; USD/kg)
- Metal factor of the products  
Certain products are displayed with a metal factor. The metal factor indicates (for those raw materials concerned) the basic official price as of which the surcharges for dysprosium and neodym are calculated using the weight method. An exact explanation of the metal factor is given below.

**Three-month average price**

The prices of rare earths vary according to the foreign currency, and there is no freely accessible stock exchange listing. This makes it more difficult for all parties involved to monitor changes in price. In order to avoid continuous adjustment of the surcharges, but to still ensure fair, transparent pricing, an average price is calculated over a three-month period using the average monthly foreign exchange rate from USD to EUR (source: European Central Bank). Since not all facts are immediately available at the start of each month, a one-month buffer is allowed before the new average price applies.

Examples of calculation of the average official price:

Period for calculation of the average price:	Period during which the order/release order is effected and the average price applies:
Sep 2012 - Nov 2012	Q1 in 2013 (Jan - Mar)
Dec 2012 - Feb 2013	Q2 in 2013 (Apr - Jun)
Mar 2013 - May 2013	Q3 in 2013 (Jul - Sep)
Jun 2013 - Aug 2013	Q4 in 2013 (Oct - Dec)

**Structure of the metal factor**

The metal factor consists of several digits; the first digit is not relevant to the calculation of dysprosium and neodym.

The remaining digits indicate the method of calculation used for the respective raw material. If no surcharge is added for a raw material, a "-" is used.

1st digit	List or customer net price using the percentage method
2nd digit	for silver (AG) <sup>1)</sup>
3rd digit	for copper (CU) <sup>1)</sup>
4th digit	for aluminum (AL) <sup>1)</sup>
5th digit	for lead (PB) <sup>1)</sup>
6th digit	for gold (AU) <sup>1)</sup>
7th digit	for dysprosium (Dy)
8th digit	for neodym (Nd)

**Weight method**

The weight method uses the basic official price, the average price and the raw material weight. In order to calculate the surcharge, the basic official price must be subtracted from the average price. The difference is then multiplied by the raw material weight.

The basic official price can be found in the table below using the number (1 to 9) of the respective digit of the metal factor. Your Sales contact can inform you of the raw material weight.

**Metal factor examples**

-----71	No basis necessary
↑	No surcharge for silver
↑	No surcharge for copper
↑	No surcharge for aluminum
↑	No surcharge for lead
↑	No surcharge for gold
↑	Dysprosium acc. to weight, basic official price 300 €
↑	Neodym acc. to weight, basic official price 50 €

<sup>1)</sup> For a different method of calculation, refer to the separate explanation for these raw materials on the previous page.

<sup>2)</sup> Source: Asian Metal Ltd ([www.asianmetal.com](http://www.asianmetal.com))

## Appendix

### Industry Services

#### Metal surcharges

##### Values of the metal factor

Percentage method	Basic official price in €	Step range in €	% surcharge 1st step	% surcharge 2nd step	% surcharge 3rd step	% surcharge 4th step	% surcharge per additional step	
			Price in €	Price in €	Price in €	Price in €		
			150.01 - 200.00	200.01 - 250.00	250.01 - 300.00	300.01 - 350.00		
A	150	50	0.1	0.2	0.3	0.4	0.1	
B	150	50	0.2	0.4	0.6	0.8	0.2	
C	150	50	0.3	0.6	0.9	1.2	0.3	
D	150	50	0.4	0.8	1.2	1.6	0.4	
E	150	50	0.5	1.0	1.5	2.0	0.5	
F	150	50	0.6	1.2	1.8	2.4	0.6	
G	150	50	1.0	2.0	3.0	4.0	1.0	
H	150	50	1.2	2.4	3.6	4.8	1.2	
I	150	50	1.6	3.2	4.8	6.4	1.6	
J	150	50	1.8	3.6	5.4	7.2	1.8	
			175.01 - 225.00	225.01 - 275.00	275.01 - 325.00	325.01 - 375.00		
O	175	50	0.1	0.2	0.3	0.4	0.1	
P	175	50	0.2	0.4	0.6	0.8	0.2	
R	175	50	0.5	1.0	1.5	2.0	0.5	
			225.01 - 275.00	275.01 - 325.00	325.01 - 375.00	375.01 - 425.00		
S	225	50	0.2	0.4	0.6	0.8	0.2	
U	225	50	1.0	2.0	3.0	4.0	1.0	
V	225	50	1.0	1.5	2.0	3.0	1.0	
W	225	50	1.2	2.5	3.5	4.5	1.0	
			150.01 - 175.00	175.01 - 200.00	200.01 - 225.00	225.01 - 250.00		
Y	150	25	0.3	0.6	0.9	1.2	0.3	
			400.01 - 425.00	425.01 - 450.00	450.01 - 475.00	475.01 - 500.00		
Z	400	25	0.1	0.2	0.3	0.4	0.1	
<b>Price basis (1st digit)</b>								
L	Calculation based on the list price							
N	Calculation based on the customer net price (discounted list price)							
<b>Weight method</b>	<b>Basic official price in €</b>							
1	50	Calculation based on raw material weight						
2	100							
3	150							
4	175							
5	200							
6	225							
7	300							
8	400							
9	555							
<b>Miscellaneous</b>								
-	No metal surcharge							

### 1. General Provisions

By using this catalog you can purchase products (hardware, software and services) described therein from Siemens Aktiengesellschaft subject to the following Terms and Conditions of Sale and Delivery (hereinafter referred to as "T&C"). Please note that the scope, the quality and the conditions for supplies and services, including software products, by any Siemens entity having a registered office outside Germany, shall be subject exclusively to the General Terms and Conditions of the respective Siemens entity. The following T&C apply exclusively for orders placed with Siemens Aktiengesellschaft, Germany.

#### 1.1 For customers with a seat or registered office in European Union

For customers with a seat or registered office in European Union, the following terms and conditions apply subordinate to T&C:

- for products, which include specific terms and conditions in the description text, these specific terms and conditions shall apply and subordinate thereto,
- for stand-alone software products and software products forming a part of a product or project, the "General License Conditions for Software Products for Automation and Drives for Customers with a Seat or registered Office in Germany"<sup>1)</sup> and/or
- for consulting services the "Allgemeine Geschäftsbedingungen für Beratungsleistungen der Division DF – Deutschland" (available only in German) and/or
- for other services, the „Supplementary Terms and Conditions for Services ("BL")"<sup>1)</sup> and/or
- for other supplies the "General Conditions for the Supply of Products and Services of the Electrical and Electronics Industry"<sup>1)</sup>.

In case such supplies should contain Open Source Software, the conditions of which shall prevail over the "General Conditions for the Supply of Products and Services of the Electrical and Electronics Industry"<sup>1)</sup>, a notice will be contained in the scope of delivery in which the applicable conditions for Open Source Software are specified. This shall apply mutatis mutandis for notices referring to other third party software components.

#### 1.2 For customers with a seat or registered office outside European Union

For customers with a seat or registered office outside European Union, the following terms and conditions apply subordinate to T&C:

- for products, which include specific terms and conditions in the description text, these specific terms and conditions shall apply and subordinate thereto,
- for consulting services the "Standard Terms and Conditions for Consulting Services of the Division DF for Customers with a Seat or Registered Office Outside of Germany"<sup>1)</sup> and/or
- for other services the "International Terms & Conditions for Services"<sup>1)</sup> supplemented by "Software Licensing Conditions"<sup>1)</sup> and/or
- for other supplies of hard- and software the "International Terms & Conditions for Products"<sup>1)</sup> supplemented by "Software Licensing Conditions"<sup>1)</sup>

#### 1.3 For customers with master or framework agreement

To the extent our supplies and/or services offered are covered by an existing master or framework agreement, the terms and conditions of that agreement shall apply instead of T&C.

### 2. Prices

The prices are in € (Euro) ex point of delivery, exclusive of packaging.

The sales tax (value added tax) is not included in the prices. It shall be charged separately at the respective rate according to the applicable statutory legal regulations.

Prices are subject to change without prior notice. We will charge the prices valid at the time of delivery.

To compensate for variations in the price of raw materials (e.g. silver, copper, aluminum, lead, gold, dysprosium and neodym), surcharges are calculated on a daily basis using the so-called metal factor for products containing these raw materials.

A surcharge for the respective raw material is calculated as a supplement to the price of a product if the basic official price of the raw material in question is exceeded.

The metal factor of a product indicates the basic official price (for those raw materials concerned) as of which the surcharges on the price of the product are applied, and with what method of calculation.

You will find a detailed explanation of the metal factor on the page headed "Metal surcharges".

To calculate the surcharge (except in the cases of dysprosium and neodym), the official price from the day prior to that on which the order was received or the release order was effected is used.

To calculate the surcharge applicable to dysprosium and neodym ("rare earths"), the corresponding three-month basic average price in the quarter prior to that in which the order was received or the release order was effected is used with a one-month buffer (details on the calculation can be found in the explanation of the metal factor).

### 3. Additional Terms and Conditions

The dimensions are in mm. In Germany, according to the German law on units in measuring technology, data in inches apply only to devices for export.

Illustrations are not binding.

Insofar as there are no remarks on the individual pages of this catalog – especially with regard to data, dimensions and weights given – these are subject to change without prior notice.

<sup>1)</sup> The text of the Terms and Conditions of Siemens AG can be downloaded at [https://mall.industry.siemens.com/legal/ww/en/terms\\_of\\_trade\\_en.pdf](https://mall.industry.siemens.com/legal/ww/en/terms_of_trade_en.pdf)

## Appendix

### Conditions of sale and delivery

#### 4. Export Regulations

We shall not be obligated to fulfill any agreement if such fulfillment is prevented by any impediments arising out of national or international foreign trade or customs requirements or any embargoes and/or other sanctions.

Export may be subject to license. We shall indicate in the delivery details whether licenses are required under German, European and US export lists.

Our products are controlled by the U.S. Government (when labeled with "ECCN" unequal "N") and authorized for export only to the country of ultimate destination for use by the ultimate consignee or end-user(s) herein identified. They may not be resold, transferred, or otherwise disposed of, to any other country or to any person other than the authorized ultimate consignee or end-user(s), either in their original form or after being incorporated into other items, without first obtaining approval from the U.S. Government or as otherwise authorized by U.S. law and regulations. Products labeled with "AL" unequal "N" are subject to European / national export authorization.

The export indications can be viewed in advance in the description of the respective goods on the Industry Mall, our online catalog system. Only the export labels "AL" and "ECCN" indicated on order confirmations, delivery notes and invoices are authoritative.

Products without label, with label "AL:N" / "ECCN:N", or label "AL:9X9999" / "ECCN: 9X9999" may require authorization from responsible authorities depending on the final end-use, or the destination.

If you transfer goods (hardware and/or software and/or technology as well as corresponding documentation, regardless of the mode of provision) delivered by us or works and services (including all kinds of technical support) performed by us to a third party worldwide, you shall comply with all applicable national and international (re-)export control regulations. In any event of such transfer of goods, works and services you shall comply with the (re-) export control regulations of the Federal Republic of Germany, of the European Union and of the United States of America.

Prior to any transfer of goods, works and services provided by us to a third party you shall in particular check and guarantee by appropriate measures that

- there will be no infringement of an embargo imposed by the European Union, by the United States of America and/ or by the United Nations by such transfer, by brokering of contracts concerning those goods, works and services or by provision of other economic resources in connection with those goods, works and services, also considering the limitations of domestic business and prohibitions of by-passing those embargoes;
- such goods, works and services are not intended for use in connection with armaments, nuclear technology or weapons, if and to the extent such use is subject to prohibition or authorization, unless required authorization is provided;
- the regulations of all applicable Sanctioned Party Lists of the European Union and the United States of America concerning the trading with entities, persons and organizations listed therein are considered.

If required to enable authorities or us to conduct export control checks, you, upon request by us, shall promptly provide us with all information pertaining to the particular end customer, the particular destination and the particular intended use of goods, works and services provided by us, as well as any export control restrictions existing.

You acknowledge that under the EU embargo regulations against Iran, Syria and Russia respectively the sale of certain listed goods and related services is subject to authorization by the competent export control authorities of the European Union. If (i) the goods or services ordered by you are destined for Iran, Syria or Russia, and (ii) the contract for our supplies and/or services is subject to prior authorization of the competent export control authorities of the European Union, the contract between you and us shall come into force in this respect only upon granting of such authorization.

The products listed in this catalog may be subject to European/German and/or US export regulations. Any export requiring approval is therefore subject to authorization by the relevant authorities.

Errors excepted and subject to change without prior notice.

## Selection and ordering at Siemens Industry Mall, Catalog CA 01, downloading and ordering catalogs

### Easy product selection and ordering: Industry Mall and Interactive Catalog CA 01

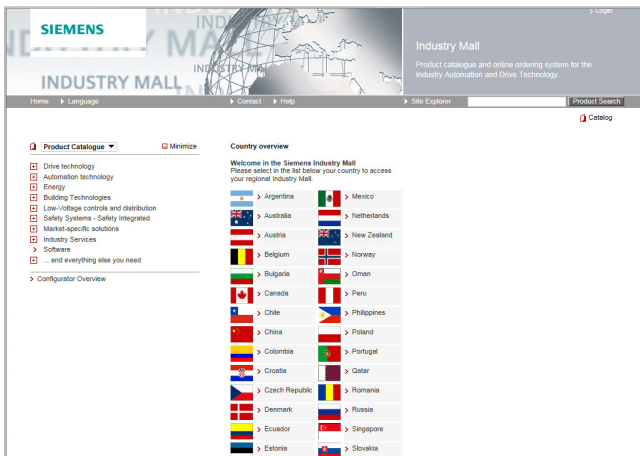

#### Industry Mall

The Industry Mall is a Siemens AG Internet ordering platform. It provides you with online access to a comprehensive product spectrum that is presented in an informative, well-organized way.

Powerful search functions help you select the required products, while configurators enable you to configure complex product and system components quickly and easily. CAx data are also available for you to use.

Data transfer allows the entire procedure, from selection through ordering to tracking and tracing, to be carried out online. Availability checks, individual customer discounting, and quotation preparation are also possible.

[www.siemens.com/industrymall](http://www.siemens.com/industrymall)



#### Interactive Catalog CA 01 – Products for automation and drives

The Interactive Catalog CA 01 combined with the Siemens Industry Mall unites the benefits of offline and online media in one application – the performance of an offline catalog with the availability of a wide range of up-to-date information on the Internet.

Select products and assemble orders using the CA 01, determine the availability of the selected products, and track and trace them via the Industry Mall.

Information and download:

[www.siemens.com/automation/ca01](http://www.siemens.com/automation/ca01)

### Downloading catalogs

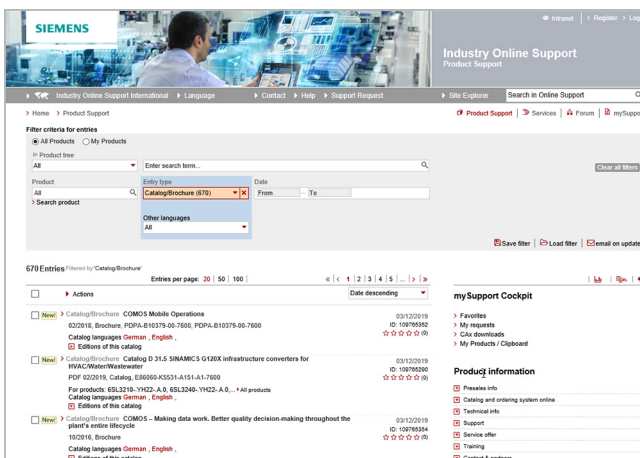

#### Siemens Industry Online Support

You can download catalogs and brochures in PDF format from Siemens Industry Online Support without having to register.

The filter box makes it possible to perform targeted searches.

[www.siemens.com/industry-catalogs](http://www.siemens.com/industry-catalogs)

### Ordering printed catalogs



Please contact your local Siemens branch if you are interested in ordering printed catalogs.

Addresses can be found at

[www.siemens.com/automation-contact](http://www.siemens.com/automation-contact)

## Get more information

Siemens Motors:

[www.siemens.com/motors](http://www.siemens.com/motors)

Local partners worldwide:

[www.siemens.com/automation-contact](http://www.siemens.com/automation-contact)

Published by

Siemens AG

Digital Industries

Motion Control

P.O. Box 31 80

91050 Erlangen, Germany

For the U.S. published by

Siemens Industry Inc.

5300 Triangle Parkway

Norcross, GA30092

United States

PDF (E86060-K1381-A101-A4-7600)

V6.MKKATA.CRT.102

KG 1119 96 EN

Produced in Germany

© Siemens 2023

## Cybersecurity information

Siemens provides products and solutions with industrial cybersecurity functions that support the secure operation of plants, systems, machines and networks.

In order to protect plants, systems, machines and networks against cyber threats, it is necessary to implement – and continuously maintain – a holistic, state-of-the-art industrial cybersecurity concept. Siemens' products and solutions constitute one element of such a concept.

Customers are responsible for preventing unauthorized access to their plants, systems, machines and networks. Such systems, machines and components should only be connected to an enterprise network or the internet if and to the extent such a connection is necessary and only when appropriate security measures (e.g. firewalls and/or network segmentation) are in place.

For additional information on industrial cybersecurity measures that may be implemented, please visit

[www.siemens.com/cybersecurity-industry](http://www.siemens.com/cybersecurity-industry)

Siemens' products and solutions undergo continuous development to make them more secure. Siemens strongly recommends that product updates are applied as soon as they are available and that the latest product versions are used. Use of product versions that are no longer supported, and failure to apply the latest updates may increase customer's exposure to cyber threats.

To stay informed about product updates, subscribe to the Siemens Industrial Cybersecurity RSS Feed under

<https://www.siemens.com/cert>

Subject to changes and errors. The information given in this document only contains general descriptions and/or performance features which may not always specifically reflect those described, or which may undergo modification in the course of further development of the products. The requested performance features are binding only when they are expressly agreed upon in the concluded contract.

All product designations may be trademarks or product names of Siemens AG or other companies whose use by third parties for their own purposes could violate the rights of the owners.

