

**SECO  
HIGH FEED  
MILLING**

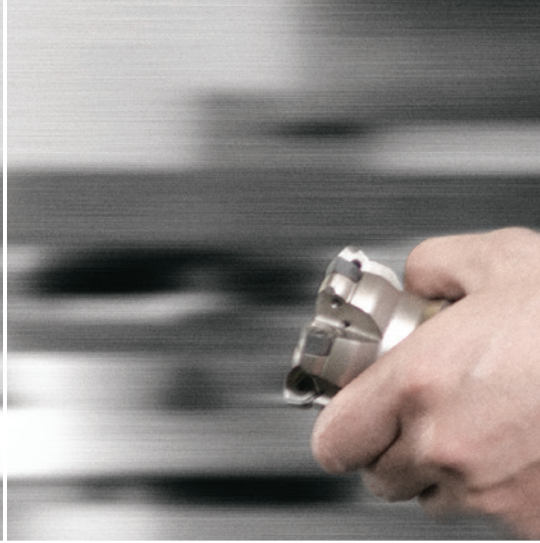

**REMOVE MORE METAL.  
MAKE MORE PARTS.**

High feed milling is an extremely versatile metal cutting method that can be used in a multitude of operations and industries. The following provides some top-level recommendations on where high feed milling can find its greatest potential.



#### INDUSTRY SEGMENTS

- Mold & die
- Aerospace
- General engineering
- Medical engineering
- Power generation
- Oil & gas



**EVERYTHING YOU  
NEED FOR HFM.**



**MAXIMIZE  
YOUR  
BUSINESS.**

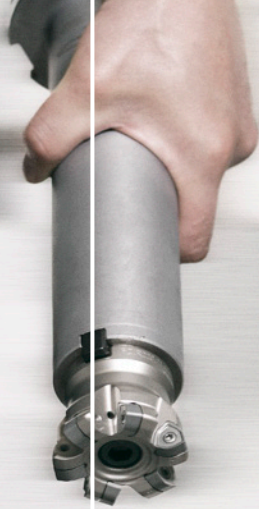

# HIGH FEED MILLING

High feed milling is a roughing method developed to achieve higher metal removal rates that increase productivity and decrease machining time for each workpiece. The process combines a shallow depth of cut with a large cutting radius or small lead angle to ensure that the cutting forces are directed towards the machine spindle in the axial direction. Axially directed cutting forces result in greater tool stability, which allows for greatly increased feed rates - sometimes up to 10 times the normal rate.

Even though high feed milling is primarily a roughing method, with our tools it is possible to achieve near net shapes. This allows you to skip the semi-finishing step and go directly from roughing to the final finishing operations which saves a tremendous amount of time and effort and increases efficiency.

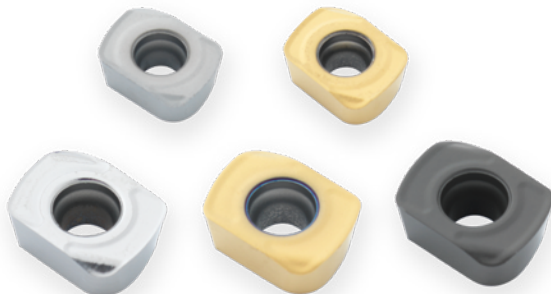

## HIGH FEED MILLING

Intro .....	2-3
Choose the right tool .....	4-5
Product highlights .....	6-12
Jabro® JHF980 .....	13-14
Jabro® JHF181 .....	15
Niagara Cutter™ SN200R, SN400R & SN500R.....	16
Niagara Cutter™ MZN410R & MZN510R.....	17
Minimaster® Plus.....	18-23
High Feed 2.....	24-27

High Feed 4.....	28-29
High Feed 6.....	30
R220.21 - 218.19 .....	31-34
R220.01-ON09 - ONMU.....	35
R220.01-21 - SCET.....	36
Choosing the right insert ...	37-38
Insert selection .....	39-41

<b>CUTTING DATA</b> .....	42-70
Milling technical info .....	71

Product	Product Family	APMX	Range	Material suitability	Machine suitability		Ramping capability	Plunging suitability
	<b>JHF980</b> - 2-, 3-, 4- and 5-flute versions - True high feed design - Universal workpiece materials - Projection length 1.5, 3, 5, 7 x DCX	9%*DCX	0.040" - 0.472" 1 mm - 12 mm	P M K S H	✓	=	✓	✓
	<b>JHF181</b> - 3-, 4- and 5-flute versions - Torical high feed design - Hard milling and ISO-S - Projection length 2, 4, 5, 7 DCX - Selection with ICC	5.5%*DCX	0.078" - 0.630" 2 mm - 16 mm	P K S H	✓	=	✓	✗
	<b>Niagara Cutter™ MZ series</b> - 4- and 5-flute versions - 1/8" - 5/8" diameters - AlTiN coating - Open flute cavity	5.5%*DCX	1/8" - 5/8"	P K S H	✓	=	✓	✗
	<b>Niagara Cutter™ SN series</b> - 2-, 4- and 5-flute versions - 1/16"-1/2" diameter range - 3xD, 5xD and 7xD - Deep pockets and long reach - AlTiN coating	9%*DCX	1/16"-1/2"	P M K S H	✓	=	✓	✓
	<b>Minimaster® Plus</b> - 3-flute versions with ICC - High productivity in all materials - For medium to long overhangs - Excellent chip control	6%*DCX	0.393" - 0.625" 10 mm - 16 mm	P M K S H	✓	=	✓	✓

Product	Product Family	APMX	Range	Material suitability	Machine suitability		Ramping capability	Plunging suitability
	<b>R17/220.21-LP, HF2 LP05/LP06</b> - Versatility - Economical in small dimensions - Close pitch for optimization - High performance in M & S materials - 2-edge positive insert	LP05, .025" 0.65 mm  LP06, 0.030" 0.8 mm	0.500" - 0.750" 12 mm - 20 mm (LP05)  0.625" - 1.500" 16 mm - 40 mm (LP06)	P M K N S H	✓	≈	✓	✓
	<b>R217/220.21-L006, HF4</b> - 4-edge double-sided insert - Close pitch for optimization - Good suitability in most materials - Peak performance in P, K & H materials	0.035" 0.9 mm	1.00" - 2.50" 20 mm - 60 mm	P M K S H	✓	≈	≈	=
	<b>R217/220.21-R160</b> - 3-edge positive insert - Strong insert - High performance in M, H & S materials	0.070" 1.8 mm	1.250" - 4.00" 32 mm - 100 mm	P M K N S H	≠	✓	✓	✓
	<b>R217/220.21-R160C</b> - 3-edge positive insert - Strong insert - High performance in M, H & S materials - For face milling applications	2.5 mm	88 mm - 208 mm	P M K N S H	≠	✓	≠	✓
	<b>R217/220.21-R230 HF6</b> - 6-edge negative insert - Very strong insert - High performance in P & K materials - Close pitch for optimization	0.070" 1.8 mm	2.00" - 4.00" 50 mm - 160 mm	P M K S H	≠	✓	≈	=
	<b>R217/220.21-SC12</b> - 4-edge positive insert - Very strong insert - Optimized for strong horizontal machines - Big depth of cut	0.078" 2 mm	2.00" - 4.00" 50 mm - 160 mm	P M K S H	≠	✓	≈	✓
	<b>R217/220.21-ON09</b> - Economical solution with 16 cutting edges - Optimized for P & K materials - Dedicated for face milling operations	0.094" 2.4 mm	3.00" - 6.00" 80 mm - 160 mm	P K	≠	✓	≠	≠



High speed machine with low power/torque



Strong stable machine with rigid connection

- ✓ Recommended
- = Alternative
- ≈ Possible
- ≠ Not recommended

# JABRO® JHF980 & JHF181

Jabro® HFM is the high feed machining range of solid carbide end mills. The range consists of two geometries; the **JHF181** and the **JHF980** cutters. Both tools have the typical high feed front end geometry resulting in chip thinning. Due to this chip thinning effect relative high feed rates can be applied as compensation factor for the small average chip thickness.

High feed machining is the first choice for applications with large overhangs, 3D contouring for Mold & Die applications and machining in unstable conditions.

#### YOUR SECO BENEFIT:

- Unsurpassed metal removal rates
- Exceptional tool life
- High productivity
- Application versatility
- Through-tool coolant



FEED YOUR  
HUNGER FOR  
FASTER  
METAL  
REMOVAL

**1 - 16 MM = JABRO® SOLID END MILLS, A TOOL RANGE PERFECT FOR SMALL WORKPIECES AND SMALL CAVITIES**

**JHF980** The JHF980 is positioned for machining steels, cast iron, stainless steels and super alloys (ISO-P, ISO-K, ISO-M & ISO-S)

**JHF181** The JHF181 is positioned for machining hardened steels, cast iron, and normal to difficult tool steels (ISO-H, ISO-K & ISO-P)



# JHF980

The **JHF980** solid carbide end mills are a top choice in high feed machining applications and now even more so with new 4- and 5-flute cutter options. Engineered for high metal removal rates in face, slot and select plunge milling applications, this tool takes advantage of the latest design and grinding developments to incorporate an increased number of flutes. This doubles the feed rate capability compared to the previous Jabro® versions. And, when applied at the same table feed rates as the prior tools, these new high feed cutters deliver increased tool life results.

## PRODUCT OVERVIEW:

- Solid carbide high feed tools excel in face, slot and plunge milling
- High feed capabilities yield significant productivity gains
- Reduced production costs when processing deep and shallow pockets
- Longer tool life than previous cutters when applied at the same table feed rates
- Low radial forces minimize vibration and machine wear
- Wide application area covered, from steel to exotic materials

## RANGE OVERVIEW:

- 2-flute end mill diameters from 1.5 - 12 mm
- 3-flute end mill diameters from 8 - 12 mm
- 4-flute end mill diameters from 2 - 6 mm
- 5-flute end mill diameters from 8 - 12 mm
- 1.5xD, 3xD, 5xD and 7xD length versions available



**“HIGH FEED MILLING IS A MILLING METHOD THAT PERMITS UP TO THREE TIMES FASTER MACHINING THAN CONVENTIONAL METHODS.”**

# JHF181

Meet the **JHF181**, the latest addition to the Jabro® HFM family of solid carbide end mills. Because it can take small depths of cut at high table feeds, the JHF181 is an excellent choice for any high feed milling strategy, especially when it involves machining ISO-H and S materials via helical interpolation, ramping or Z-level roughing.

Our new HXT coating adds a hard top layer to the JHF181, resulting in advanced thermal protection and high wear resistance. The special edge preparation that occurs prior to coating helps reduce edge chipping. As such, JHF181 provides up to 30% more tool life than other comparable solid carbide end mills when processing ISO-H materials.

## PRODUCT OVERVIEW:

- Developed for high feed milling strategies in ISO-H and S materials
- Performs advanced machining methods such as helical interpolation
- Reliable end mill with extreme productivity potential
- Rigid tapered neck design reduces tool deflection
- Flute design and rear tooth angle support effective chip removal
- Exclusive HXT coating contributes to high wear resistance

## RANGE OVERVIEW:

- Available in 3-, 4- or 5-flute options
- Cutting diameters from 2 - 16 mm
- Length options range from 2xD to 7xD
- Through tool coolant capability (6 - 12 mm diameters)



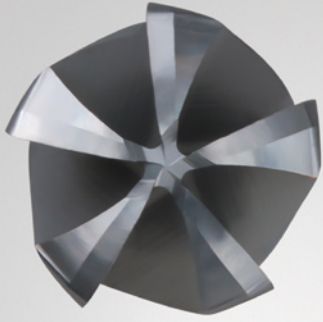

# NIAGARA CUTTER™

## SN200R, 400R, 500R

Niagara Cutter's **SN200R**, **SN400R** and **SN500R** series of end mills completes the family of high feed tools by offering a complete range of 2-, 4- and 5-flute versions to cover a broad range of applications and materials. Available in 3, 5 and 7 times diameter of reach, these end mills also feature a defined radius ( $r_p$ ) which helps direct radial cutting pressure axially up into the tool holder and spindle. These features allow for increased metal removal rates in deep pockets and long reach applications.

These end mills also feature an AlTiN coating that offers high heat resistance and superior abrasion resistance to maximize tool life.

**PUSHING  
THE LIMITS.**

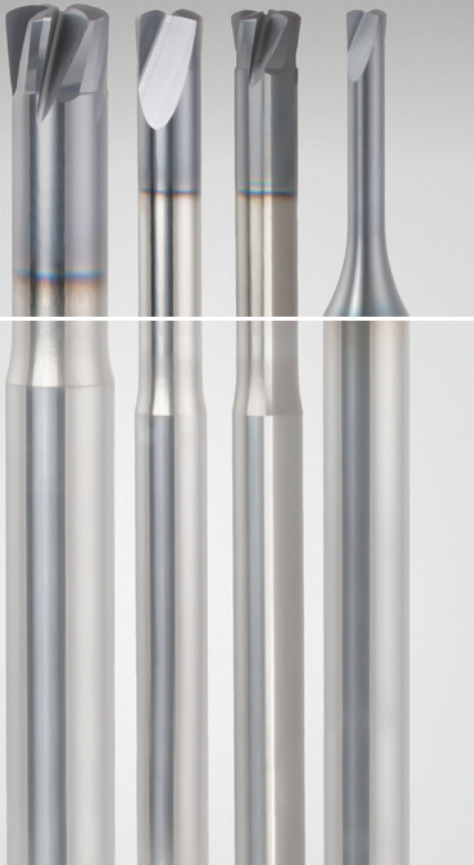

### PRODUCT OVERVIEW:

- 2-, 4- and 5-flute end mill diameters from 1/16" - 1/2"
- 3xD, 5xD and 7xD length versions available
- Solid carbide high feed tools excel in face, slot and plunge milling
- High feed capabilities yield significant productivity gains
- Reduced production costs when processing deep and shallow pockets
- Longer tool life than previous cutters when applied at the same table feed rates
- Low radial forces minimize vibration and machine wear
- Wide application area covered, from steel to exotic materials

### YOUR NIAGARA CUTTER BENEFIT:

- Multiple flutes
- Long tool overhang
- Axial directed cutting forces
- High heat and abrasion resistant
- Reduced cycle time, higher metal removal rates
- Deep cavity milling
- Provides smoother cutting in long reach applications
- Long and predictable tool life

### RANGE OVERVIEW:

- **SN200R** (2-flutes) high feed series, 3, 5 and 7 x diameter of reach, diameters range from (0.063" - 0.500"), cylindrical shank, defined radius ( $r_p$ )
- **SN400R** (4-flutes) high feed series, 3, 5 and 7 x diameter of reach, diameters range from (0.125" - 0.500"), cylindrical shank, defined radius ( $r_p$ )
- **SN500R** (5-flutes) high feed series, 3 x diameter of reach, diameters range from (0.375" - 0.500"), cylindrical shank, defined radius ( $r_p$ )





PRECISE,  
FAST &  
VERSATILE

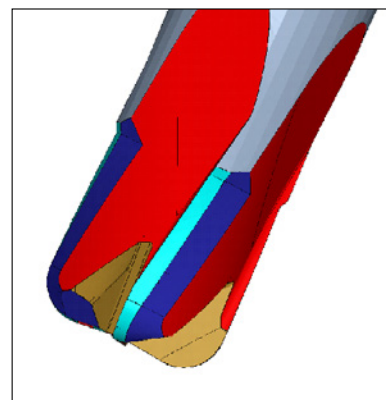

#### YOUR NIAGARA CUTTER BENEFIT:

- Solid carbide
- End tooth design gives improved surface quality
- Open flute cavity and relief length gives improved chip evacuation
- Full form radius for more stability
- Edge preparation increases tool life

#### RANGE OVERVIEW:

- 4- and 5- Flute High Feed
- 1/8" - 5/8" diameters
- Hardened steels and nickel based superalloys such as Inconel
- Edge preparation for increased cutting edge strength
- 2° back-taper with reduced neck diameter for workpiece clearance
- High wear resistant AlTiN coating
- Strong end tooth design

## NIAGARA CUTTER™ MZN410R & MZN510R

The Niagara Cutter **MZN410R** and **MZN510R** are designed to maximize productivity in hardened steels and superalloys. These end mills feature optimized substrate, geometry and coating to offer superior performance and process reliability.

The MZN410R and MZN510R are effective in hardened steels, cast irons and nickel based super alloys. A typical application for these end mills is when machining hardened tool steels used in mold & die components.

REACHING A  
HIGHER LEVEL

# MINIMASTER® PLUS

The choice between a solid end mill and a **Minimaster Plus** end mill depends on the application. Minimaster Plus offers more flexibility in long reach applications. There are a variety of shank versions to provide an optimized tool setup for flexibility. It should be possible to always find a good combination for any application. The insert is good for all types of materials such as steel, cast iron, stainless steel, superalloys and hardened steels. The Minimaster Plus high feed cutters are flexible tools, which can also be used for pocketing and plunging applications. They are specially designed for maximum metal removal rates under unfavorable conditions.

## RANGE OVERVIEW:

- Diameter ranges from 0.375" - 0.625" (10 - 16 mm)
- 3-flute internal through coolant channels
- Carbide shanks for long reach applications
- Shanks with internal taper provide a radial run-out of < 15  $\mu\text{m}$  and axial run-out of < 25  $\mu\text{m}$

## YOUR SECO BENEFIT:

- Increased productivity and precision
- Coolant delivered at cutting edge
- Excellent performance in all workpiece materials
- Improved and consistent insert life

## INTERFACE PRECISION WILL SAVE YOU TIME

It is now no longer necessary to measure the setting length when using Minimaster. And due to the interface precision, the insert can be changed at the machine saving you time and increasing productivity!



**MORE TEETH  
PER TOOL**

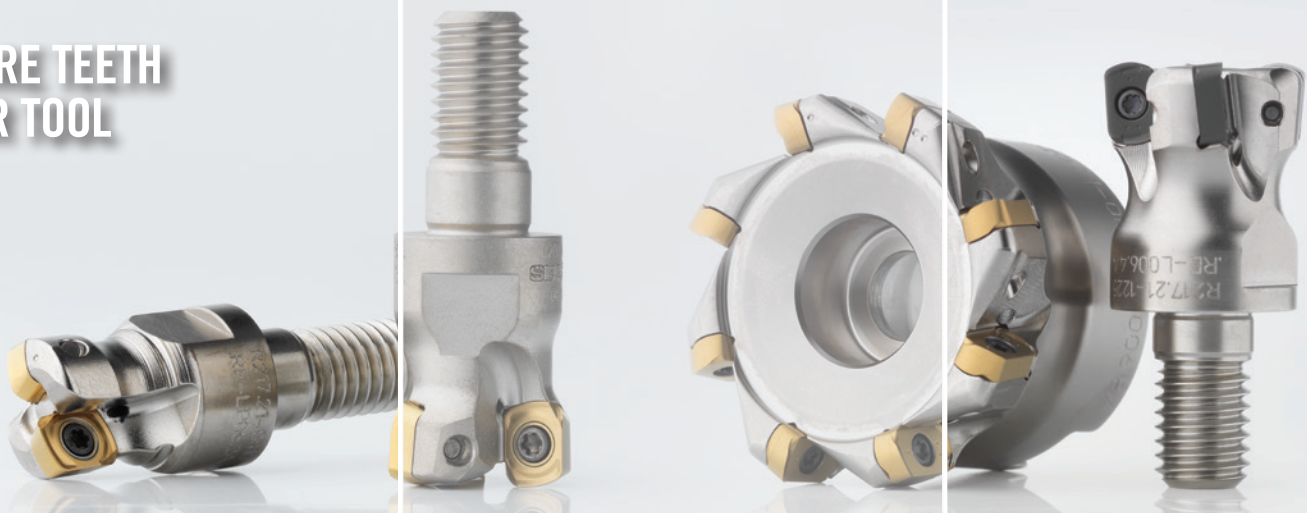

## HIGH FEED 2 & 4

The **High Feed 2** and **4 (HF2 and HF4)** provide a high feed method of machining in a parallel style of insert. The advantage to a parallel style insert is when we encounter enclosed areas with straight walls. There is minimal risk for vibrations with a tool designed in this way. The HF2 comes in two insert sizes and is single sided. The HF4 offers four cutting edges which provides an economical solution while still offering a robust way to machine fast.

Both systems include Combimaster, cylindrical shank and shell end types that incorporate close-pitch and normal pitch designs, together with new inserts - **LP05**, **LP06** and **LO06** - that allow for more teeth/insert pockets per cutter diameter. With more teeth, higher feeds are achieved through the additional insert which excels in high velocity, high speed cutting of hard and tough-to-machine materials - especially when using smaller machines with high-rpm/low torque spindles.

### RANGE OVERVIEW:

- **HF2 (LP05 & LP06)** - Best suited toward applications requiring ramping and helical interpolation are needed
- Ideal in stainless steel and high temp alloys
- LP05 insert for 0.500" - 0.750" cutter bodies
- LP06 insert for 0.625" - 1.500" cutter bodies
- E, ME, M, MD, and D insert geometries

### RANGE OVERVIEW:

- **HF4 (LO06)** - Economical solution for processes that do not require ramping or helical interpolation
- Ideal in steel and cast iron
- Double-sided LO06 inserts for 0.750" - 2.500" cutter bodies
- ME, M, MD and D insert geometries

### YOUR SECO BENEFIT:

- Insert indexability with small diameter cutters for economical performance, especially in long reach applications
- Optimized number of inserts per cutting diameter for higher speeds and feeds
- Smoother, stable cutting for higher productivity
- Efficient chip evacuation

### PRODUCT OVERVIEW:

- **LP05 & LP06** - Inserts feature two cutting edges
- Ideal in sticky materials stainless steels, titanium and superalloys
- First choice for applications requiring a higher ramping angle



### PRODUCT OVERVIEW:

- **LO06** - Double sided inserts provide four cutting edges for cost effective machining
- Efficient performance in the most common workpiece materials, such as steels, cast irons, and die steels



PREPARE FOR  
SOMETHING  
AMAZING

## HIGH FEED 6

The **High Feed 6 (HF6)** range offers an economical double-sided insert with 6 cutting edges and can handle up to 0.070" (1.8 mm) axial depth of cut for incomparable material removal and low operating costs. The cutter performs equally well in all types of high feed applications, and can perform face milling and plunging operations. The HF6 handles all kinds of materials including steels, stainless steels, cast irons, and high temp alloys.

The pocket design of the HF6 ensures precise and stable mounting to the cutter bodies. The inserts mount at a low lead angle to direct the machining forces up into the spindle rather than radially against the side of the tool. As such, the tool experiences less vibration and can provide long, predictable performance with very high feed rates.

**In comparative testing, the HF6 proved more cost effective and reliable over competitive designs, as well as led the way in productivity and tool life. In one test, the HF6 provided 186% more productivity and 200% more tool life-how's that for amazing.**

### PRODUCT OVERVIEW:

- Cutter Diameters range from 2.00" to 4.00"
- Double sided insert with 6 cutting edges, three cutting geometries ME, M and MD
- Available in normal and close-pitch cutter versions
- V-shaped cutting edge ensures optimal positioning
- Inserts mount to cutter bodies at low lead angles
- Effective in face milling, slotting, contouring, plunging and helical interpolation

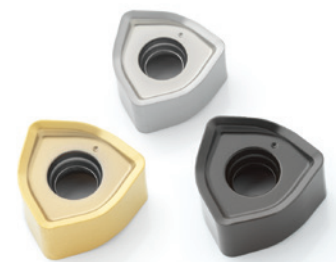

### YOUR SECO BENEFIT:

- Excellent cutting behavior
- Highly stable performance
- Long, predictable tool life
- Increased material removal
- Lower cost per part
- Unsurpassed productivity
- Application versatility



JHF980 - Solid carbide end mill - cylindrical - high feed geometry



Tolerances:  
 DMM = h5  
 DC = 0,02/-0,04 mm  
 r<sub>el</sub> = +/-0,05 mm  
 α° = collision angle

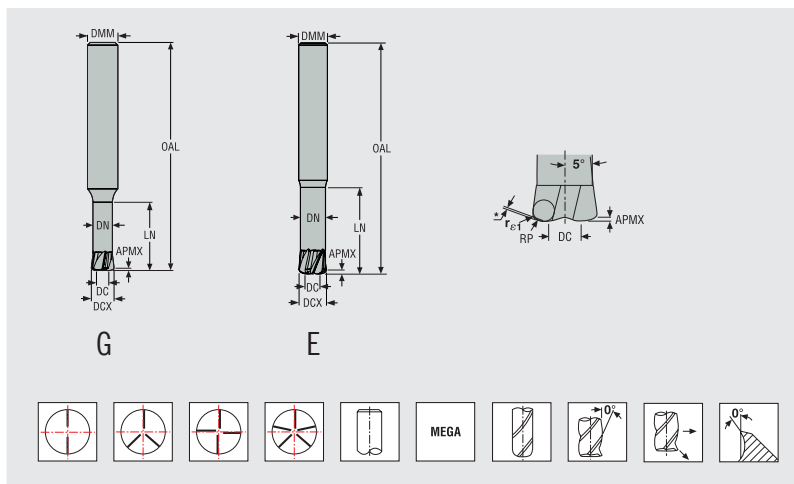

EDP	DESCRIPTION	LENGTH INDEX	TOOL SHAPE	DIMENSIONS IN MM								RE	RP	UTCN	CA	NA	ZNP	Cylindrical
				DCX	DC	DMM	APMX	OAL	LN	DN								
Metric																		
33646	980K080Z3-MEGA	1	E	8	4	8.0	0.4	70.0	12.0	3.0	0.6	0.935	0.198	-	-	3	■	
53531	JHF980080E1H.0Z5-MEGA	1	E	8	4	8.0	0.4	70.0	12.0	7.0	0.6	0.935	0.198	-	-	5	■	
33647	980K100Z3-MEGA	1	E	10	5	10.0	0.45	80.0	15.0	3.8	0.8	1.176	0.232	-	-	3	■	
53533	JHF980100E1H.0Z5-MEGA	1	E	10	5	10.0	0.45	80.0	15.0	8.8	0.8	1.176	0.232	-	-	5	■	
33648	980K120Z3-MEGA	1	E	12	6	12.0	0.5	80.0	18.0	4.6	1.0	1.417	0.266	-	-	3	■	
53535	JHF980120E1H.0Z5-MEGA	1	E	12	6	12.0	0.5	80.0	18.0	10.6	1.0	1.417	0.265	-	-	5	■	
33643	980010-MEGA	2	G	1	0.5	6.0	0.07	40.0	3.0	0.7	0.07	0.127	0.028	19.5	-	2	■	
24561	980015-MEGA	2	G	1.5	0.75	6.0	0.1	40.0	4.5	1.2	0.1	0.183	0.043	14.0	-	2	■	
24564	980020-MEGA	2	G	2	1	6.0	0.15	40.0	6.0	1.7	0.15	0.269	0.055	11.0	-	2	■	
24567	980030-MEGA	2	G	3	1.5	6.0	0.2	50.0	9.0	2.6	0.2	0.366	0.085	7.0	-	2	■	
53537	JHF980030G2H.0Z4-MEGA	2	G	3	1.5	6.0	0.2	50.0	9.0	2.6	0.2	0.366	0.085	7.12	-	4	■	
24570	980040-MEGA	2	G	4	2	6.0	0.25	60.0	12.0	3.5	0.3	0.503	0.107	4.0	-	2	■	
53538	JHF980040G2H.0Z4-MEGA	2	G	4	2	6.0	0.25	60.0	12.0	3.5	0.3	0.503	0.107	4.0	-	4	■	
24573	980050-MEGA	2	G	5	2.5	6.0	0.3	60.0	15.0	4.4	0.4	0.641	0.128	2.0	-	2	■	
53539	JHF980050G2H.0Z4-MEGA	2	G	5	2.5	6.0	0.3	60.0	15.0	4.4	0.4	0.641	0.128	1.77	-	4	■	
24580	980060-MEGA	2	G	6	3	8.0	0.35	60.0	18.0	5.2	0.5	0.778	0.15	3.0	-	2	■	
53540	JHF980060G2H.0Z4-MEGA	2	G	6	3	8.0	0.35	60.0	18.0	5.2	0.5	0.778	0.15	2.86	-	4	■	
24584	980080-MEGA	2	E	8	4	8.0	0.4	70.0	24.0	7.0	0.6	0.935	0.198	-	-	2	■	
53541	JHF980080E2H.0Z5-MEGA	2	E	8	4	8.0	0.4	70.0	24.0	7.0	0.6	0.935	0.198	-	-	5	■	
24589	980100-MEGA	2	E	10	5	10.0	0.45	80.0	30.0	8.8	0.8	1.176	0.232	-	-	2	■	
24590	980100Z3-MEGA	2	E	10	5	10.0	0.45	80.0	30.0	8.8	0.8	1.176	0.232	-	-	3	■	
53546	JHF980100E2H.0Z5-MEGA	2	E	10	5	10.0	0.45	80.0	30.0	8.8	0.8	1.176	0.232	-	-	5	■	
24593	980120-MEGA	2	E	12	6	12.0	0.5	80.0	36.0	10.6	1.0	1.417	0.266	-	-	2	■	
24594	980120Z3-MEGA	2	E	12	6	12.0	0.5	80.0	36.0	10.6	1.0	1.417	0.266	-	-	3	■	
53548	JHF980120E2H.0Z5-MEGA	2	E	12	6	12.0	0.5	80.0	36.0	10.6	1.0	1.417	0.265	-	-	5	■	
33644	980ML010-MEGA	3	G	1	0.5	6.0	0.07	40.0	5.0	0.7	0.07	0.127	0.028	15.5	-	2	■	
24562	980ML015-MEGA	3	G	1.5	0.75	6.0	0.1	40.0	7.5	1.2	0.1	0.183	0.043	10.5	-	2	■	
24565	980ML020-MEGA	3	G	2	1	6.0	0.15	40.0	10.0	1.7	0.15	0.269	0.055	8.0	-	2	■	
53549	JHF980020G3H.0Z4-MEGA	3	G	2	1	6.0	0.15	40.0	10.0	1.7	0.15	0.269	0.055	8.46	-	4	■	
24568	980ML030-MEGA	3	G	3	1.5	6.0	0.2	50.0	15.0	2.6	0.2	0.366	0.085	5.0	-	2	■	
53551	JHF980030G3H.0Z4-MEGA	3	G	3	1.5	6.0	0.2	50.0	15.0	2.6	0.2	0.366	0.085	4.79	-	4	■	
24571	980ML040-MEGA	3	G	4	2	6.0	0.25	70.0	20.0	3.5	0.3	0.503	0.107	2.5	-	2	■	
53553	JHF980040G3H.0Z4-MEGA	3	G	4	2	6.0	0.25	70.0	20.0	3.5	0.3	0.503	0.107	2.59	-	4	■	
24574	980ML050-MEGA	3	G	5	2.5	6.0	0.3	80.0	25.0	4.4	0.4	0.641	0.128	1.5	-	2	■	
53556	JHF980050G3H.0Z4-MEGA	3	G	5	2.5	6.0	0.3	80.0	25.0	4.4	0.4	0.641	0.128	1.12	-	4	■	
24581	980ML060-MEGA	3	G	6	3	8.0	0.35	80.0	30.0	5.2	0.5	0.778	0.15	2.0	-	2	■	
53558	JHF980060G3H.0Z4-MEGA	3	G	6	3	8.0	0.35	80.0	30.0	5.2	0.5	0.778	0.15	1.8	-	4	■	

\* UTCN=uncut-thickness

■ Stock standard. Subject to change refer to current price-and stock-list. For Cutting Data see page(s) 42-43

JHF980 - Solid carbide end mill - cylindrical - high feed geometry

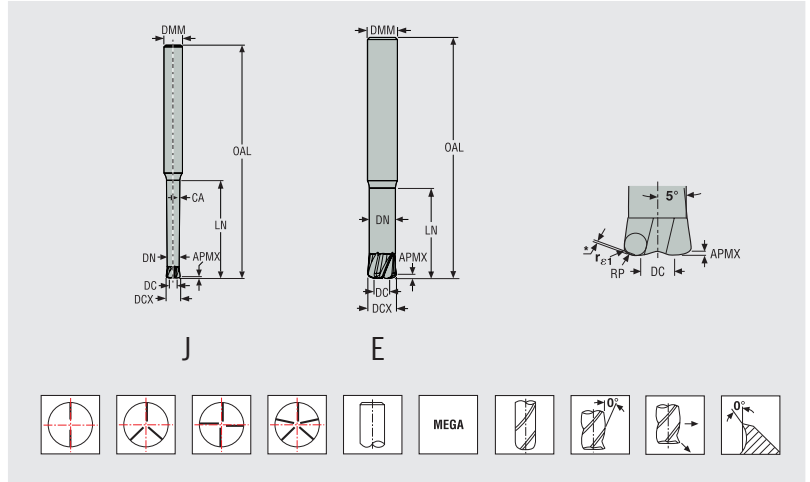

Tolerances:  
 DMM = h5  
 DC = 0,02/-0,04 mm  
 r<sub>c</sub> = +/-0,05 mm  
 α<sub>c</sub> = collision angle

EDP	DESCRIPTION	LENGTH INDEX	TOOL SHAPE	DIMENSIONS IN MM											RE	RP	UTCN	CA	NA	ZNP	Cylindrical
				DCX	DC	DMM	APMX	OAL	LN	DN											
Metric																					
24587	980ML080-MEGA	3	E	8	4	8.0	0.4	80.0	40.0	7.0	0.6	0.935	0.198	-	-	2	■				
53559	JHF980080E3H.OZ5-MEGA	3	E	8	4	8.0	0.4	80.0	40.0	7.0	0.6	0.935	0.198	-	-	5	■				
24591	980ML100-MEGA	3	E	10	5	10.0	0.45	90.0	50.0	8.8	0.8	1.176	0.232	-	-	2	■				
53565	JHF980100E3H.OZ5-MEGA	3	E	10	5	10.0	0.45	90.0	50.0	8.8	0.8	1.176	0.232	-	-	5	■				
24595	980ML120-MEGA	3	E	12	6	12.0	0.5	110.0	60.0	10.6	1.0	1.417	0.266	-	-	2	■				
53569	JHF980120E3H.OZ5-MEGA	3	E	12	6	12.0	0.5	110.0	60.0	10.6	1.0	1.417	0.265	-	-	5	■				
33645	980TL010-MEGA	4	J	1	0.5	6.0	0.07	40.0	7.0	0.7	0.07	0.127	0.028	13.0	0.5	2	■				
24563	980TL015-MEGA	4	J	1.5	0.75	6.0	0.1	40.0	10.5	1.2	0.1	0.183	0.043	8.5	0.5	2	■				
24566	980TL020-MEGA	4	J	2	1	6.0	0.15	50.0	14.0	1.7	0.15	0.269	0.055	6.5	0.5	2	■				
24569	980TL030-MEGA	4	J	3	1.5	6.0	0.2	60.0	21.0	2.6	0.2	0.366	0.085	3.5	0.5	2	■				
53570	JHF980030J4H.OZ4-MEGA	4	J	3	1.5	6.0	0.2	60.0	21.0	2.6	0.2	0.366	0.085	3.63	0.5	4	■				
24572	980TL040-MEGA	4	J	4	2	6.0	0.25	80.0	28.0	3.5	0.3	0.503	0.107	2.0	0.5	2	■				
53571	JHF980040J4H.OZ4-MEGA	4	J	4	2	6.0	0.25	80.0	28.0	3.5	0.3	0.503	0.107	1.93	0.5	4	■				
24575	980TL050-MEGA	4	J	5	2.5	6.0	0.3	90.0	35.0	4.4	0.4	0.641	0.128	1.0	0.5	2	■				
53573	JHF980050J4H.OZ4-MEGA	4	J	5	2.5	6.0	0.3	90.0	35.0	4.4	0.4	0.641	0.128	0.82	0.5	4	■				
24583	980TL060-MEGA	4	J	6	3	8.0	0.35	100.0	42.0	5.2	0.5	0.778	0.15	1.5	0.5	2	■				
	JHF980060J4H.OZ4-MEGA	4	J	6	3	8.0	0.35	100.0	42.0	5.2	0.5	0.778	0.15	1.33	0.5	4	■				
24588	980TL080-MEGA	4	E	8	4	8.0	0.4	100.0	56.0	7.0	0.6	0.935	0.198	-	0.5	2	■				
53578	JHF980080E4H.OZ5-MEGA	4	E	8	4	8.0	0.4	100.0	56.0	7.0	0.6	0.935	0.198	-	0.5	5	■				
24592	980TL100-MEGA	4	E	10	5	10.0	0.45	110.0	70.0	8.8	0.8	1.176	0.232	-	0.5	2	■				
53581	JHF980100E4H.OZ5-MEGA	4	E	10	5	10.0	0.45	110.0	70.0	8.8	0.8	1.176	0.232	-	0.5	5	■				
24596	980TL120-MEGA	4	E	12	6	12.0	0.5	130.0	84.0	10.6	1.0	1.417	0.266	-	0.5	2	■				
53582	JHF980120E4H.OZ5-MEGA	4	E	12	6	12.0	0.5	130.0	84.0	10.6	1.0	1.417	0.265	-	0.5	5	■				

\* UTCN=uncut-thickness

■ Stock standard. Subject to change refer to current price-and stock-list. For Cutting Data see page(s) 42-43

JHF181 - Solid carbide end mill - cylindrical - high feed hard materials - corner radius - CEDC 3,4,5

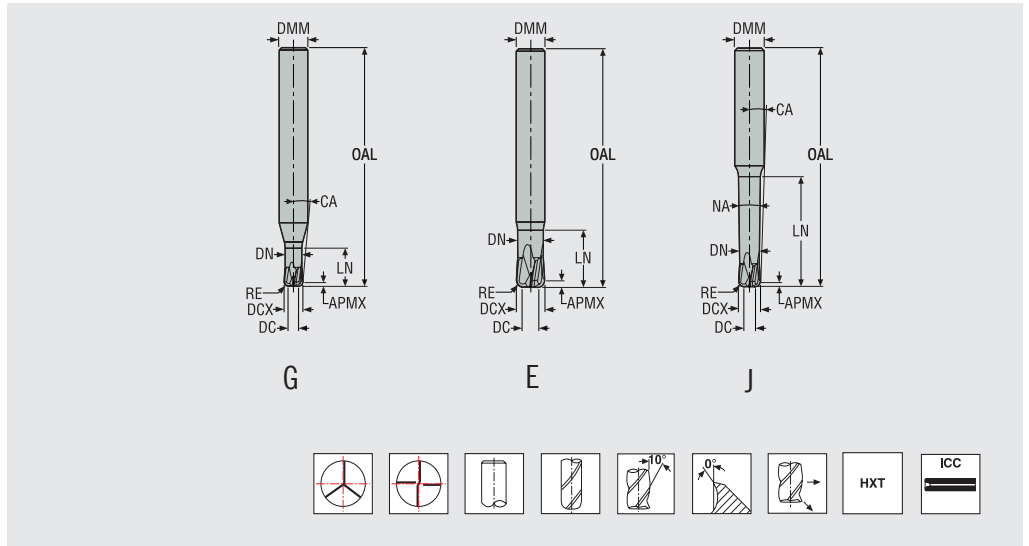

Tolerances:  
DMM = -0,02-0,04  
Radius = +/-0,01

EDP	DESCRIPTION	LENGTH INDEX	TOOL SHAPE	DIMENSIONS IN MM											CEDC	ICC	Cylindrical
				DCX	DC	DMM	APMX	OAL	LN	DN	CA	NA	RE				
Metric																	
11115	JHF181020G1R050.0Z4-HXT	1	G	2.0	1.0	6.0	0.5	50.0	4.0	1.8	10.0	15.0	0.5	4		■	
11116	JHF181030G1R075.0Z4-HXT	1	G	3.0	1.5	6.0	0.75	50.0	6.0	2.7	7.5	15.0	0.75	4		■	
11119	JHF181040G1R100.0Z4-HXT	1	G	4.0	2.0	6.0	1.0	50.0	8.0	3.6	5.0	15.0	1.0	4		■	
11120	JHF181060E1R150.0Z4-HXT	1	E	6.0	3.0	6.0	1.5	50.0	12.0	5.4	-	-	1.5	4		■	
11121	JHF181080E1R200.0Z4-HXT	1	E	8.0	4.0	8.0	2.0	55.0	16.0	7.3	-	-	2.0	4		■	
11122	JHF181100E1R200.0Z4-HXT	1	E	10.0	6.0	10.0	2.0	65.0	20.0	9.2	-	-	2.0	4		■	
11124	JHF181100E1R200.0Z5-HXT	1	E	10.0	6.0	10.0	2.0	65.0	20.0	9.2	-	-	2.0	5		■	
11126	JHF181120E1R300.0Z4-HXT	1	E	12.0	6.0	12.0	3.0	75.0	24.0	11.0	-	-	3.0	4		■	
11128	JHF181120E1R300.0Z5-HXT	1	E	12.0	6.0	12.0	3.0	75.0	24.0	11.0	-	-	3.0	5		■	
11130	JHF181160E1R300.0Z4-HXT	1	E	16.0	10.0	16.0	3.0	80.0	32.0	14.8	-	-	3.0	4		■	
11132	JHF181020G2R050.0Z4-HXT	2	G	2.0	1.0	6.0	0.5	50.0	8.0	1.8	7.5	15.0	0.5	4		■	
11134	JHF181030G2R075.0Z4-HXT	2	G	3.0	1.5	6.0	0.75	50.0	12.0	2.7	5.0	15.0	0.75	4		■	
11136	JHF181040G2R100.0Z4-HXT	2	G	4.0	2.0	6.0	1.0	50.0	16.0	3.6	3.0	15.0	1.0	4		■	
46933	JHF181060E2R150.0Z4A-HXT	2	E	6.0	3.0	6.0	1.5	65.0	24.0	5.4	-	-	1.5	4	■	■	
46932	JHF181060E2R150.0Z4-HXT	2	E	6.0	3.0	6.0	1.5	65.0	24.0	5.4	-	-	1.5	4		■	
46935	JHF181080E2R200.0Z4A-HXT	2	E	8.0	4.0	8.0	2.0	70.0	32.0	7.3	-	-	2.0	4	■	■	
46934	JHF181080E2R200.0Z4-HXT	2	E	8.0	4.0	8.0	2.0	70.0	32.0	7.3	-	-	2.0	4		■	
46938	JHF181100E2R200.0Z4A-HXT	2	E	10.0	6.0	10.0	2.0	85.0	40.0	9.2	-	-	2.0	4	■	■	
46940	JHF181120E2R300.0Z4A-HXT	2	E	12.0	6.0	12.0	3.0	100.0	48.0	11.0	-	-	3.0	4	■	■	
46939	JHF181120E2R300.0Z4-HXT	2	E	12.0	6.0	12.0	3.0	100.0	48.0	11.0	-	-	3.0	4		■	
46941	JHF181020J3R050.0Z4-HXT	3	J	2.0	1.0	6.0	0.5	50.0	10.0	1.8	6.8	0.9	0.5	4		■	
46942	JHF181030J3R075.0Z4-HXT	3	J	3.0	1.5	6.0	0.75	50.0	15.0	2.7	4.4	0.9	0.75	4		■	
46944	JHF181040J3R100.0Z4-HXT	3	J	4.0	2.0	6.0	1.0	60.0	20.0	3.6	2.6	0.9	1.0	4		■	
46946	JHF181060J3R150.0Z4A-HXT	3	J	6.0	3.0	8.0	1.5	65.0	30.0	5.4	1.9	0.9	1.5	4	■	■	
46945	JHF181060J3R150.0Z4-HXT	3	J	6.0	3.0	8.0	1.5	65.0	30.0	5.4	1.9	0.9	1.5	4		■	
46948	JHF181080J3R200.0Z4A-HXT	3	J	8.0	4.0	10.0	2.0	85.0	40.0	7.3	1.5	0.9	2.0	4	■	■	
46947	JHF181080J3R200.0Z4-HXT	3	J	8.0	4.0	10.0	2.0	85.0	40.0	7.3	1.5	0.9	2.0	4		■	
46952	JHF181100J3R200.0Z4A-HXT	3	J	10.0	6.0	12.0	2.0	100.0	50.0	9.2	1.2	0.9	2.0	4	■	■	
46951	JHF181100J3R200.0Z4-HXT	3	J	10.0	6.0	12.0	2.0	100.0	50.0	9.2	1.2	0.9	2.0	4		■	
46953	JHF181020J4R050.0Z3-HXT	4	J	2.0	1.0	6.0	0.5	50.0	14.0	1.8	5.6	0.9	0.5	3		■	
46954	JHF181030J4R075.0Z3-HXT	4	J	3.0	1.5	6.0	0.75	60.0	21.0	2.7	3.4	0.9	0.75	3		■	
46955	JHF181040J4R100.0Z3-HXT	4	J	4.0	2.0	6.0	1.0	65.0	28.0	3.6	2.0	0.9	1.0	3		■	
46956	JHF181060J4R150.0Z3-HXT	4	J	6.0	3.0	8.0	1.5	80.0	42.0	5.4	1.4	0.9	1.5	3		■	
46961	JHF181080J4R200.0Z3-HXT	4	J	8.0	4.0	10.0	2.0	100.0	56.0	7.3	1.1	0.9	2.0	3		■	
46962	JHF181100J4R200.0Z3-HXT	4	J	10.0	6.0	12.0	2.0	125.0	70.0	9.2	0.9	0.9	2.0	3		■	

■ Stock standard. Subject to change refer to current price- and stock-list, For Cutting Data see page(s) 44

## SN200R, SN400R, SN500R

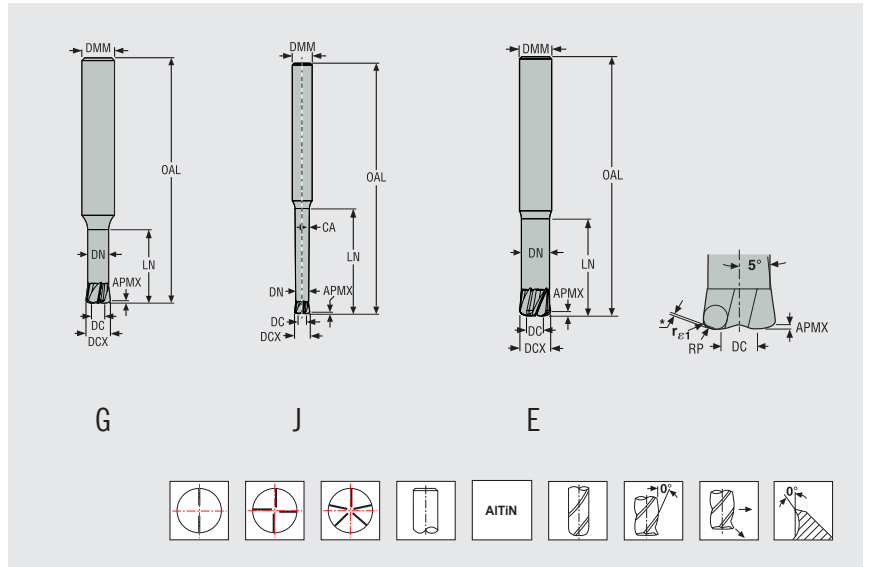

EDP	DESCRIPTION	TOOL SHAPE	DIMENSIONS IN INCH										FLUTES	COATING
			METRIC CROSS	FLUTE DIA (DCX)	SHANK DIA (DMM)	LOC (APMX)	OAL	RADIUS (RP)*	NECK DIA (DN)	REACH LENGTH (LN)	SHANK LENGTH			
Inch														
N13984	SN200R-0.063-G1-H007.0-Z2	G	1.5	1/16	1/4	0.004	2	0.0074	0.055	0.188	1.813	2	AITIN	
N13985	SN200R-0.063-G2-H007.0-Z2	G	1.5	1/16	1/4	0.004	2	0.0074	0.055	0.313	1.688	2	AITIN	
N13986	SN200R-0.063-J3-H007.0-Z2	J	1.5	1/16	1/4	0.004	2	0.0074	0.055	0.438	1.563	2	AITIN	
N13987	SN200R-0.094-G1-H011.0-Z2	G	2.0	3/32	1/4	0.006	2	0.0111	0.082	0.281	1.719	2	AITIN	
N13988	SN200R-0.094-G2-H011.0-Z2	G	2.0	3/32	1/4	0.006	2	0.0111	0.082	0.469	1.531	2	AITIN	
N13989	SN200R-0.094-J3-H011.0-Z2	J	2.0	3/32	1/4	0.006	2-1/2	0.0111	0.082	0.656	1.844	2	AITIN	
N13992	SN200R-0.125-G1-H015.0-Z2	G	3.0	1/8	1/4	0.008	2	0.0148	0.109	0.375	1.625	2	AITIN	
N13993	SN200R-0.125-G2-H015.0-Z2	G	3.0	1/8	1/4	0.008	2-1/2	0.0148	0.109	0.625	1.875	2	AITIN	
N13994	SN200R-0.125-J3-H015.0-Z2	J	3.0	1/8	1/4	0.008	2-1/2	0.0148	0.109	0.875	1.625	2	AITIN	
N13995	SN400R-0.125-G1-H015.0-Z4	G	3.0	1/8	1/4	0.008	2	0.0148	0.109	0.375	1.625	4	AITIN	
N13996	SN400R-0.125-G2-H015.0-Z4	G	3.0	1/8	1/4	0.008	2-1/2	0.0148	0.109	0.625	1.875	4	AITIN	
N13997	SN200R-0.156-G1-H020.0-Z2	G	4.0	5/32	1/4	0.010	2	0.0200	0.136	0.469	1.531	2	AITIN	
N13998	SN200R-0.156-G2-H020.0-Z2	G	4.0	5/32	1/4	0.010	2-1/2	0.0200	0.136	0.781	1.719	2	AITIN	
N13999	SN200R-0.156-J3-H020.0-Z2	J	4.0	5/32	1/4	0.010	2-1/2	0.0200	0.136	1.094	1.406	2	AITIN	
N14002	SN400R-0.156-G1-H020.0-Z4	G	4.0	5/32	1/4	0.010	2	0.0200	0.136	0.469	1.531	4	AITIN	
N14003	SN400R-0.156-G2-H020.0-Z4	G	4.0	5/32	1/4	0.010	2-1/2	0.0200	0.136	0.781	1.719	4	AITIN	
N14004	SN200R-0.188-G1-H023.0-Z2	G	5.0	3/16	1/4	0.012	2	0.0230	0.166	0.562	1.438	2	AITIN	
N14005	SN200R-0.188-G2-H023.0-Z2	G	5.0	3/16	1/4	0.012	2-1/2	0.0230	0.166	0.937	1.563	2	AITIN	
N14006	SN200R-0.188-J3-H023.0-Z2	J	5.0	3/16	1/4	0.012	3	0.0230	0.166	1.313	1.688	2	AITIN	
N14007	SN400R-0.188-G1-H023.0-Z4	G	5.0	3/16	1/4	0.012	2	0.0230	0.166	0.562	1.438	4	AITIN	
N14008	SN400R-0.188-G2-H023.0-Z4	G	5.0	3/16	1/4	0.012	2-1/2	0.0230	0.166	0.937	1.563	4	AITIN	
N14009	SN200R-0.250-E1-H032.0-Z2	E	6.0	1/4	1/4	0.014	2-1/2	0.0322	0.218	0.750	1.750	2	AITIN	
N14012	SN200R-0.250-E2-H032.0-Z2	E	6.0	1/4	1/4	0.014	3	0.0322	0.218	1.250	1.750	2	AITIN	
N14013	SN200R-0.250-J3-H032.0-Z2	J	6.0	1/4	1/4	0.014	3-1/2	0.0322	0.218	1.750	1.750	2	AITIN	
N14014	SN400R-0.250-E1-H032.0-Z4	E	6.0	1/4	1/4	0.014	2-1/2	0.0322	0.218	0.750	1.750	4	AITIN	
N14015	SN400R-0.250-E2-H032.0-Z4	E	6.0	1/4	1/4	0.014	3	0.0322	0.218	1.250	1.750	4	AITIN	
N14016	SN200R-0.313-G1-H037.0-Z2	G	8.0	5/16	3/8	0.016	2-1/2	0.0373	0.273	0.938	1.563	2	AITIN	
N14017	SN200R-0.313-G2-H037.0-Z2	G	8.0	5/16	3/8	0.016	3-1/2	0.0373	0.273	1.563	1.938	2	AITIN	
N14018	SN200R-0.313-J3-H037.0-Z2	J	8.0	5/16	3/8	0.016	4	0.0373	0.273	2.188	1.813	2	AITIN	
N14019	SN400R-0.313-G1-H037.0-Z4	G	8.0	5/16	3/8	0.016	2-1/2	0.0373	0.273	0.938	1.563	4	AITIN	
N14022	SN400R-0.313-G2-H037.0-Z4	G	8.0	5/16	3/8	0.016	3-1/2	0.0373	0.273	1.563	1.938	4	AITIN	
N14023	SN200R-0.375-E1-H043.0-Z2	E	10.0	3/8	3/8	0.018	3	0.0432	0.329	1.125	1.875	2	AITIN	
N14024	SN200R-0.375-E2-H043.0-Z2	E	10.0	3/8	3/8	0.018	3-1/2	0.0432	0.329	1.875	1.625	2	AITIN	
N14025	SN200R-0.375-J3-H043.0-Z2	J	10.0	3/8	3/8	0.018	4-1/2	0.0432	0.329	2.625	1.875	2	AITIN	
N14026	SN400R-0.375-E1-H043.0-Z4	E	10.0	3/8	3/8	0.018	3	0.0432	0.329	1.125	1.875	4	AITIN	
N14027	SN500R-0.375-E1-H043.0-Z5	E	10.0	3/8	3/8	0.018	3	0.0432	0.329	1.125	1.875	5	AITIN	
N14028	SN400R-0.375-E2-H043.0-Z4	E	10.0	3/8	3/8	0.018	3-1/2	0.0432	0.329	1.875	1.625	4	AITIN	
N14029	SN200R-0.500-E1-H061.0-Z2	E	12.0	1/2	1/2	0.020	3-1/2	0.0614	0.444	1.500	2.000	2	AITIN	
N14032	SN200R-0.500-E2-H061.0-Z2	E	12.0	1/2	1/2	0.020	4-1/2	0.0614	0.444	2.500	2.000	2	AITIN	
N14033	SN200R-0.500-J3-H061.0-Z2	J	12.0	1/2	1/2	0.020	6	0.0614	0.444	3.500	2.500	2	AITIN	
N14034	SN400R-0.500-E1-H061.0-Z4	E	12.0	1/2	1/2	0.020	3-1/2	0.0614	0.444	1.500	2.000	4	AITIN	
N14035	SN500R-0.500-E1-H061.0-Z5	E	12.0	1/2	1/2	0.020	3-1/2	0.0614	0.444	1.500	2.000	5	AITIN	
N14036	SN400R-0.500-E2-H061.0-Z4	E	12.0	1/2	1/2	0.020	4-1/2	0.0614	0.444	2.500	2.000	4	AITIN	

For Cutting Data see page(s) 45-49

RP\* = Programmable radius



## MZN410R & MZN510R

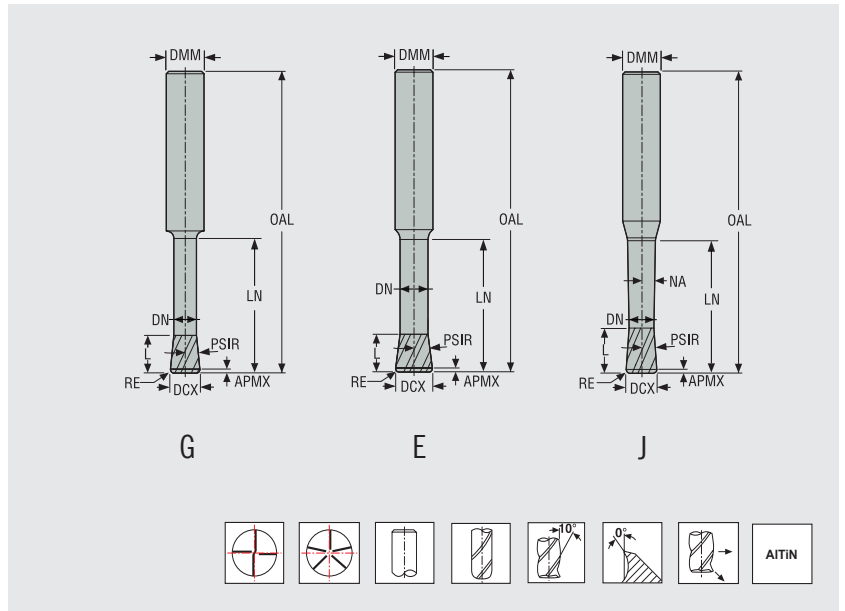

EDP	DESCRIPTION	TOOL SHAPE	DIMENSIONS IN INCH							NO. OF FLUTES	COATING
			FLUTE DIA (DCX)	SHANK DIA (DMM)	OAL	RADIUS (RE)	NECK DIA (DN)	L	REACH LENGTH (LN)		
Inch											
N00305	MZN410R-0.125-J1-R030.0-Z4	J	1/8	1/4	2-1/2	0.030	0.112	0.1250	0.375	4	AITIN
N00001	MZN410R-0.125-J2-R030.0-Z4	J	1/8	1/4	2-1/2	0.030	0.112	0.1250	0.625	4	AITIN
N00002	MZN410R-0.188-J1-R050.0-Z4	J	3/16	1/4	2-1/2	0.050	0.172	0.1875	0.562	4	AITIN
N00003	MZN410R-0.188-J2-R050.0-Z4	J	3/16	1/4	2-1/2	0.050	0.172	0.2500	0.937	4	AITIN
N00004	MZN410R-0.250-E1-R060.0-Z4	E	1/4	1/4	2-1/2	0.060	0.230	0.3125	0.750	4	AITIN
N00005	MZN410R-0.250-E2-R060.0-Z4	E	1/4	1/4	2-1/2	0.060	0.230	0.3125	1.250	4	AITIN
N00006	MZN410R-0.313-G1-R080.0-Z4	G	5/16	3/8	3	0.080	0.290	0.3750	0.750	4	AITIN
N00007	MZN410R-0.313-G2-R080.0-Z4	G	5/16	3/8	3	0.080	0.290	0.3125	1.250	4	AITIN
N00008	MZN410R-0.375-E1-R080.0-Z4	E	3/8	3/8	3	0.080	0.348	0.3750	1.125	4	AITIN
N00009	MZN510R-0.375-E2-R080.0-Z5	E	3/8	3/8	3	0.080	0.348	0.3750	1.125	5	AITIN
N00010	MZN410R-0.375-E3-R080.0-Z4	E	3/8	3/8	3	0.080	0.348	0.3750	1.875	4	AITIN
N00011	MZN410R-0.500-E1-R120.0-Z4	E	1/2	1/2	4	0.120	0.468	0.5000	1.500	4	AITIN
N00012	MZN510R-0.500-E2-R120.0-Z5	E	1/2	1/2	4	0.120	0.468	0.5000	1.500	5	AITIN
N00013	MZN510R-0.625-E1-R120.0-Z5	E	5/8	5/8	4	0.120	0.584	0.6250	1.875	5	AITIN

For Cutting Data see page(s) 50

## MP10 Shanks

Steel and solid carbide shanks

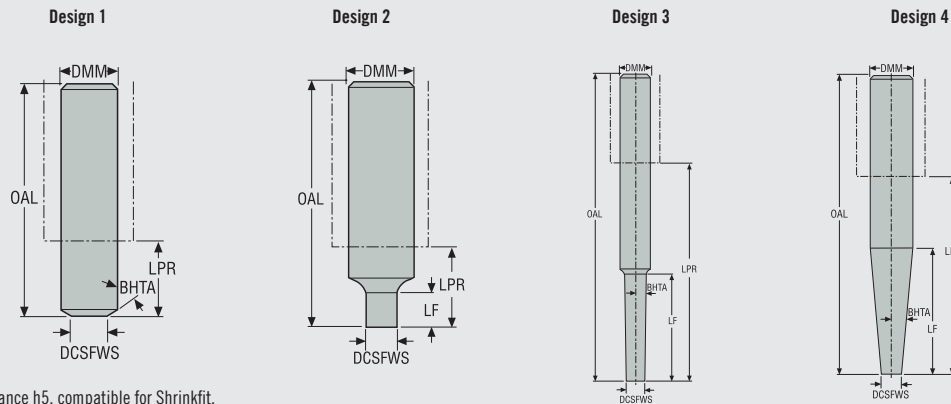

- Cylindrical shank DMM with tolerance h5, compatible for Shrinkfit.
- Max RPM 80000 r/min

EDP	DESCRIPTION	CONNECTING SIZE	DIMENSIONS IN IN/MM							Design		LB/KG
			DCSFWS	DMM	OAL	LPR	LF	BHTA				
	Inch											
44989	MP10 -0372.1-0.39.00	MP10	0.370	0.375	2.1	0.59	0.39	-	2	✓	0.2	
44988	-0622.6-0.00.60	MP10	0.374	0.625	2.7	0.79	-	60	1	✓	0.2	
44990	-0622.8-0.59.00	MP10	0.370	0.625	2.9	0.98	0.59	-	2	✓	0.2	
44992	-0624.6-1.37.01	MP10	0.374	0.625	4.6	2.76	1.38	1	3	✓	0.4	
44993	-0626.2-2.36.01	MP10	0.374	0.625	6.2	4.33	2.36	1	3	✓	0.4	
44994	-0753.9-1.80.03	MP10	0.374	0.750	4.0	1.97	1.80	3	3	✓	0.4	
44995	-0755.5-3.40.03	MP10	0.374	0.750	5.5	3.54	3.40	3	4	✓	0.7	
44996	-0755.5-3.54.05	MP10	0.374	0.750	5.5	3.54	2.15	5	4	✓	0.7	
18061	MP10 -0504.8-2.36.00-E	MP10	0.370	0.500	4.9	3.15	2.36	-	2	✓	0.4	
18065	-0626.6-3.93.01-E	MP10	0.374	0.625	6.7	4.80	3.94	1	3	✓	0.9	
18081	-0626.6-4.80.03-E	MP10	0.374	0.625	6.7	4.80	2.40	3	4	✓	0.9	
	Metric											
51271	MP10 -10055-010.00	MP10	9.8	10	55	15	10	-	2	✓	0.2	
51268	-16068-000.60	MP10	9.5	16	68	20	-	60	1	✓	0.2	
51281	-16073-015.00	MP10	9.8	16	73	25	15	-	2	✓	0.2	
51291	-16118-035.01	MP10	9.5	16	118	70	35	1	3	✓	0.4	
51293	-16158-060.01	MP10	9.5	16	158	110	60	1	3	✓	0.4	
51294	-20100-045.03	MP10	9.5	20	100	50	45	3	3	✓	0.4	
51295	-20140-085.03	MP10	9.5	20	140	90	85	3	3	✓	0.7	
51296	-20140-090.05	MP10	9.5	20	140	90	60	5	4	✓	0.7	
45092	MP10 -12095-030.00-E	MP10	9.8	12	95	50	30	-	2	✓	0.4	
69296	-12105-040.00-E	MP10	9.8	12	105	60	40	-	2	✓	0.4	
69297	-12125-060.00-E	MP10	9.8	12	125	80	60	-	2	✓	0.4	
69300	-16120-050.01-E	MP10	9.5	16	120	72	50	1	3	✓	0.7	
69301	-16150-080.01-E	MP10	9.5	16	150	102	80	1	3	✓	0.7	
69302	-16170-100.01-E	MP10	9.5	16	170	122	100	1	3	✓	0.9	
69303	-16140-092.03-E	MP10	9.5	16	140	92	62	3	4	✓	0.9	
69304	-16170-122.03-E	MP10	9.5	16	170	122	62	3	4	✓	0.9	

...-E = Solid carbide shank

Spare Parts, not included. Must be ordered separately.

Inserts	Key	Replacement blade	Torque key
MP10	MP1016	MP00-10M	MP00-10.110

Torque value 97 in/lbs.  
Blades are included with the torque key.

## MP10 Highfeed

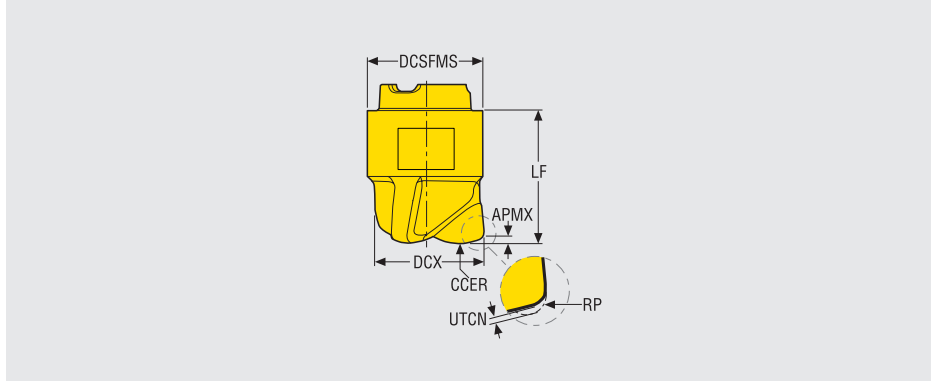

• For Cutting Data see page(s) 51

Z3



DESCRIPTION	PMX	DIMENSIONS IN IN/MM						ZNP		Coated	
		DCX	CCER	RP	DCSFMS	LF	UTCN			Grades (EDP)	
										MP3000	
<b>Inch</b>											
MP10 -00.375-.28-HFZ3-MD08	0.024	0.375	0.244	0.044	0.370	0.433	0.013	3	✓	<a href="#">76116</a>	
<b>Metric</b>											
MP10 -1000.6HFZ3-MD08	0.6	10	6.2	1.13	9.6	11	0.32	3	✓	<a href="#">76118</a>	

UTCN = Uncut thickness, deviation between programmed corner radii ( $r_p$ ) and generated machined profile.

## MP12 Shanks

## Steel and solid carbide shanks

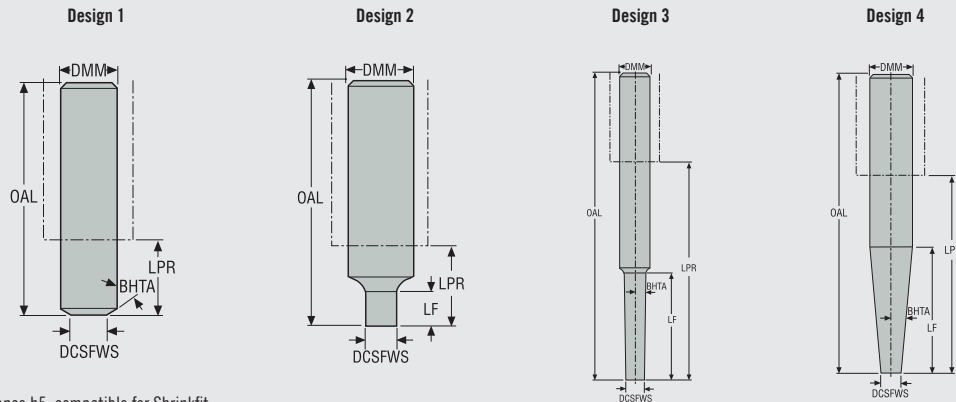

- Cylindrical shank DMM with tolerance h5, compatible for Shrinkfit.
- Max RPM 72700 r/min

EDP	DESCRIPTION	Connecting size	DIMENSIONS IN IN/MM							Design		LB/KG
			DCSFWS	DMM	OAL	LPR	LF	BHTA				
<b>Inch</b>												
44998	MP12 -0502.3-0.47.00	MP12	0.453	0.500	2.3	0.59	0.47	-	2	✓	0.2	
44997	-0622.6-0.00.60	MP12	0.453	0.625	2.7	0.79	-	60	1	✓	0.2	
44999	-0623.0-0.70.00	MP12	0.453	0.625	3.1	1.18	0.71	-	2	✓	0.2	
45005	-0626.0-1.65.01	MP12	0.453	0.625	6.0	4.13	1.65	1	3	✓	0.4	
45007	-0754.3-2.20.03	MP12	0.453	0.750	4.4	2.36	2.20	3	3	✓	0.4	
45008	-0755.9-3.93.03	MP12	0.453	0.750	5.9	3.94	2.83	3	3	✓	0.7	
45009	-0756.1-4.13.05	MP12	0.453	0.750	6.1	4.13	1.70	5	4	✓	0.7	
45006	-0756.7-2.83.01	MP12	0.453	0.750	6.7	4.72	2.83	1	4	✓	0.7	
<b>Metric</b>												
51321	MP12 -12060-012.00	MP12	11.5	12	60	15	12	-	2	✓	0.2	
51320	-16068-000.60	MP12	11.5	16	68	20	-	60	1	✓	0.2	
51322	-16078-018.00	MP12	11.5	16	78	30	18	-	2	✓	0.2	
51331	-16153-042.01	MP12	11.5	16	153	105	42	1	3	✓	0.4	
51335	-20170-072.01	MP12	11.5	20	170	120	72	1	3	✓	0.7	
51336	-20110-055.03	MP12	11.5	20	110	60	55	3	3	✓	0.4	
51337	-20150-100.03	MP12	11.5	20	150	100	81.1	3	4	✓	0.7	
51338	-20155-105.05	MP12	11.5	20	155	105	48.6	5	4	✓	0.9	
69305	MP12 -16107-036.00-E	MP12	11.5	16	107	59	36	-	2	✓	0.7	
69308	-16120-048.00-E	MP12	11.5	16	120	72	48	-	2	✓	0.7	
69309	-16150-072.00-E	MP12	11.5	16	150	102	72	-	2	✓	0.7	
69310	-16120-060.01-E	MP12	11.5	16	120	72	60	1	3	✓	0.7	
69311	-16150-096.01-E	MP12	11.5	16	150	102	96	1	3	✓	0.9	
69312	-16175-120.01-E	MP12	11.5	16	175	127	120	1	3	✓	0.9	
69313	-16155-107.03-E	MP12	11.5	16	155	107	42.9	3	4	✓	0.9	
69314	-16180-132.03-E	MP12	11.5	16	180	132	42.9	3	4	✓	1.1	

...-E = Solid carbide shank

Spare Parts, not included. Must be ordered separately.

Inserts	Torque key	Replacement blade	Key
MP12	MP00-12.150	MP00-12M	MP1016

Torque value 133 in/lbs.  
Blades are included with the torque key.



## MP12 Highfeed

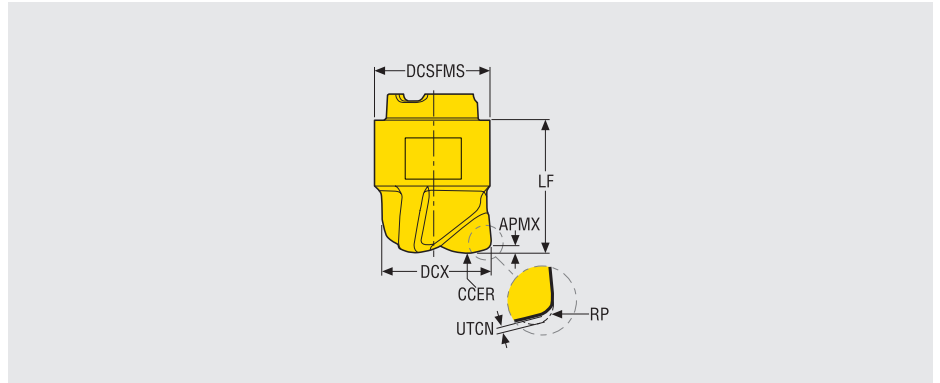

• For Cutting Data see page(s) 52

Z3



DESCRIPTION	APMX	DIMENSIONS IN IN/MM						ZNP		Coated	
		DCX	CCER	RP	DCSFMS	LF	UTCN			Grades (EDP)	
										MP3000	F40M
<b>Inch</b>											
MP12 -00.500-.31-HFZ3-MD10	0.028	0.500	0.295	0.065	0.453	0.512	0.013	3	✓	76122	-
<b>Metric</b>											
MP12 -1200.7HFZ3-MD10	0.7	12	7.5	1.66	11.5	13	0.33	3	✓	76120	-

\* Effective number of flutes  
 UTCN = Uncut thickness, deviation between programmed corner radii ( $r_p$ ) and generated machined profile.

## MP16 Shanks

## Steel and solid carbide shanks

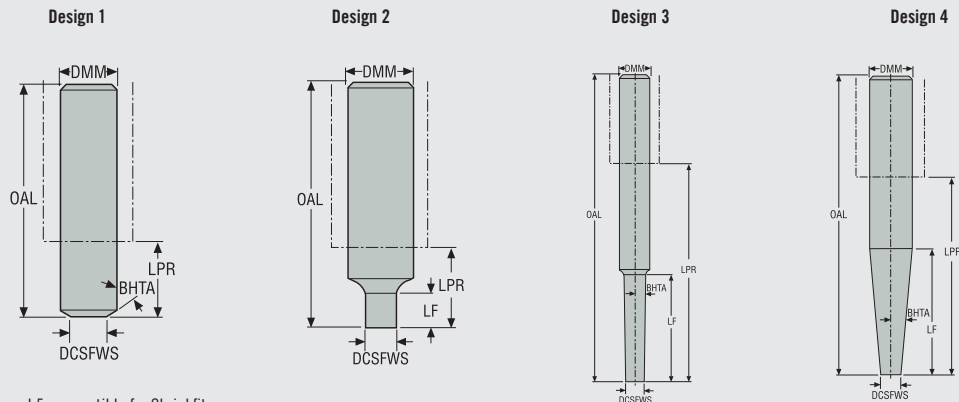

- Cylindrical shank DMM with tolerance h5, compatible for Shrinkfit.
- Max RPM 63600 r/min

EDP	DESCRIPTION	Connecting size	DIMENSIONS IN IN/MM							Design		LB/KG
			DCSFWS	DMM	OAL	LPR	LF	BHTA				
Inch												
45011	MP16 -0622.6-0.63.00	MP16	0.598	0.625	2.7	0.79	0.63	-	2	✓	0.2	
45010	MP16 -0752.7-0.00.60	MP16	0.598	0.750	2.8	0.79	-	60	1	✓	1.5	
45012	MP16 -0753.5-0.94.00	MP16	0.598	0.750	3.6	1.57	0.94	-	2	✓	0.4	
45014	MP16 -0757.5-2.20.01	MP16	0.598	0.750	7.5	5.51	2.20	1	3	✓	0.9	
45015	MP16 -0757.7-3.74.01	MP16	0.598	0.750	7.7	5.71	3.74	1	3	✓	0.9	
45016	MP16 -1005.3-3.00.03	MP16	0.598	1.000	5.4	3.15	3.00	3	3	✓	0.9	
45017	MP16 -1007.1-4.92.03	MP16	0.598	1.000	7.2	4.92	3.83	3	4	✓	1.3	
45019	MP16 -1007.1-4.92.05	MP16	0.598	1.000	7.2	4.92	2.30	5	4	✓	0.4	
Metric												
18126	MP16 -0627.0-3.77.00-E	MP16	0.598	0.625	7.1	5.20	3.78	-	2	✓	1.1	
18135	MP16 -0757.9-5.90.01-E	MP16	0.598	0.750	7.9	5.91	4.34	1	4	✓	1.5	
18148	MP16 -0758.2-6.29.03-E	MP16	0.598	0.750	8.3	6.30	1.45	3	4	✓	1.8	
51345	MP16 -16068-016.00	MP16	15.2	16	68	20	16	-	2	✓	0.2	
51344	MP16 -20070-000.60	MP16	15.2	20	70	20	-	60	1	✓	0.4	
51346	MP16 -20090-024.00	MP16	15.2	20	90	40	24	-	2	✓	0.4	
51348	MP16 -20190-056.01	MP16	15.2	20	190	140	56	1	3	✓	0.9	
51349	MP16 -20195-095.01	MP16	15.2	20	195	145	95	1	3	✓	0.9	
51350	MP16 -25136-075.03	MP16	15.2	25	136	80	75	3	3	✓	0.9	
51351	MP16 -25181-125.03	MP16	15.2	25	181	125	93.5	3	4	✓	1.3	
51354	MP16 -25181-125.05	MP16	15.2	25	181	125	56	5	4	✓	1.3	
69315	MP16 -16126-048.00-E	MP16	15.2	16	126	78	48	-	2	✓	0.9	
69316	MP16 -16140-064.00-E	MP16	15.2	16	140	92	64	-	2	✓	0.9	
69317	MP16 -16180-096.00-E	MP16	15.2	16	180	132	96	-	2	✓	1.1	
69319	MP16 -20135-080.01-E	MP16	15.2	20	135	85	80	1	3	✓	1.1	
69320	MP16 -20180-128.01-E	MP16	15.2	20	180	130	128	1	3	✓	1.5	
69325	MP16 -20200-150.01-E	MP16	15.2	20	200	150	137.5	1	4	✓	1.8	
69326	MP16 -20180-130.03-E	MP16	15.2	20	180	130	45.8	3	4	✓	1.8	
69327	MP16 -20210-160.03-E	MP16	15.2	20	210	160	45.8	3	4	✓	2.0	

...-E = Solid carbide shank

Spare Parts, not included. Must be ordered separately.

Inserts	Torque key	Replacement blade	Key
MP16	MP00-16.190	MP00-16M	MP1016

Torque value 168 in/lbs.  
Blades are included with the torque key.

## MP16 Highfeed

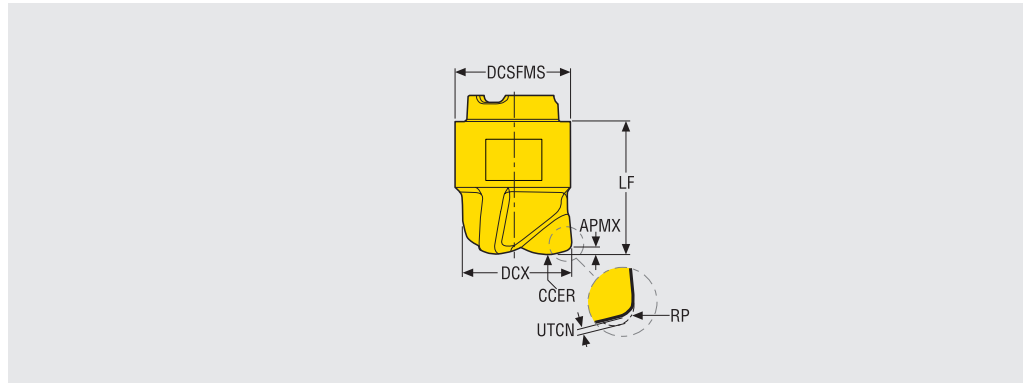

• For Cutting Data see page(s) 53

Z3



DESCRIPTION	APMX	DIMENSIONS IN IN/MM							ZNP		Coated	
		DCX	CCER	RP	DCSFMS	LF	UTCN	Grades (EDP)				
								MP3000			F40M	
Inch												
MP16 -00.625-.39-HFZ3-MD12	0.035	0.625	0.307	0.070	0.606	0.748	0.018	3	✓	<a href="#">76125</a>	-	
Metric												
MP16 -1600.9HFZ3-MD12	0.9	16	7.8	1.79	15.4	19	0.46	3	✓	<a href="#">76127</a>	-	

\* Effective number of flutes  
 UTCN = Uncut thickness, deviation between programmed corner radii ( $r_p$ ) and generated machined profile.

R217/220.21

High feed cutters - LP05

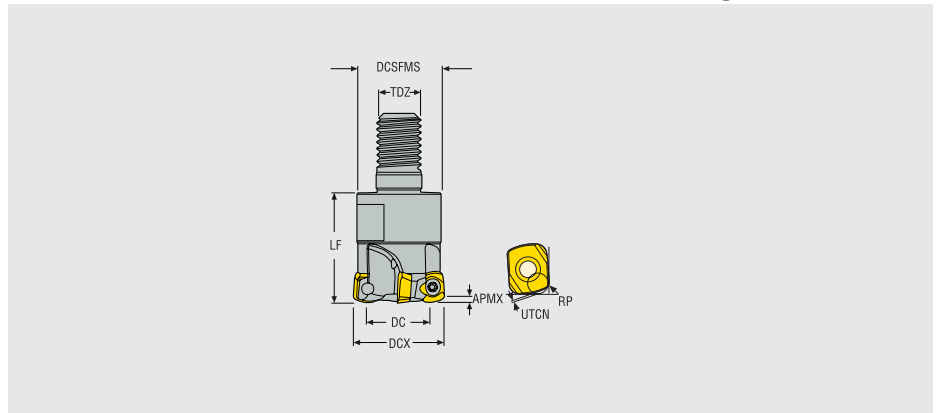

- For cutting data recommendations, see page(s) 54-55
- For insert selections, see page 39
- For complete insert program and helical interpolation, see MN Milling

EDP	DESCRIPTION	TYPE OF MOUNTING	DIMENSIONS IN IN/MM								RMPX		LB/KG		INSERT
			APMX	DCX	DC	DCSFMS	TDZ	LF	UTCN	RP					
Inch															
84138	R217.21 -00.500-06RE-LP05-2A	Combimaster*	0.026	0.500	0.240	0.433	M6	0.709	0.013	0.059	3.9	2	0.22	45000	LP.05
14008	R217.21 -00.500-08RE-LP05-2A	Combimaster*	0.026	0.500	0.240	0.531	M8	0.787	0.013	0.059	3.9	2	0.22	45000	LP.05
84139	R217.21 -00.625-08RE-LP05-3A	Combimaster*	0.026	0.625	0.362	0.531	M8	0.787	0.013	0.059	3.0	3	0.22	39000	LP.05
84140	R217.21 -00.750-10RE-LP05-4A	Combimaster*	0.026	0.750	0.488	0.728	M10	0.906	0.013	0.059	1.9	4	0.22	35000	LP.05
Metric															
14000	R217.21 -0612.RE-LP05.2A	Combimaster	0.65	12.0	5.4	11.0	M6	18.0	0.32	1.5	3.9	2	0.1	45000	LP.05
14003	R217.21 -0812.RE-LP05.2A	Combimaster	0.65	12.0	5.4	13.5	M8	20.0	0.32	1.5	3.9	2	0.1	45000	LP.05
84131	R217.21 -0614.RE-LP05.2A	Combimaster	0.65	14.0	7.4	11.0	M6	18.0	0.32	1.5	3.5	2	0.1	42000	LP.05
14005	R217.21 -0814.RE-LP05.2A	Combimaster	0.65	14.0	7.4	13.5	M8	20.0	0.32	1.5	3.5	2	0.1	42000	LP.05
84132	R217.21 -0816.RE-LP05.3A	Combimaster	0.65	16.0	9.4	13.5	M8	20.0	0.32	1.5	3.0	3	0.1	39000	LP.05
84133	R217.21 -1020.RE-LP05.4A	Combimaster	0.65	20.0	13.4	18.5	M10	23.0	0.32	1.5	1.9	4	0.1	35000	LP.05

UTCN = Uncut thickness, deviation between programmed corner radii (RP) and generated machined profile. Ramping angle = RMPX

For Combimaster shanks and dimensions, see MN Milling

Spare Parts, not included. Must be ordered separately.

For cutter	Key (T-handle)	Insert screw	Insert key
Dia 12	DOUBLE-T	C02005-T06P	H4B-T06P
Dia 14-20	DOUBLE-T	C02053-T06P	H4B-T06P

Torque value 4.4 in/lbs, Torque keys, see MN Milling

R217.21

High feed cutters - LP05

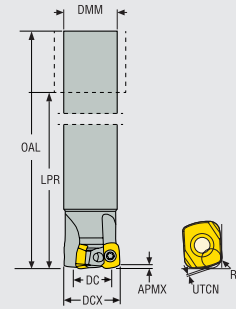

- For cutting data recommendations, see page(s) 54-55
- For insert selections, see page 39
- For complete insert program and helical interpolation, see MN Milling

EDP	DESCRIPTION	TYPE OF MOUNTING	DIMENSIONS IN IN/MM									RMPX	Flute Count	LB/KG	RPM	INSERT
			APMX	DCX	DC	DMM	OAL	LPR	UTCN	RP						
Inch																
84141	R217.21 -00.500-0-LP05-2A	Cylindrical	0.026	0.500	0.242	0.500	5.000	3.228	0.013	0.059	3.9	2	0.4	45000	LP.05	
84142	R217.21 -00.625-0-LP05-2A	Cylindrical	0.026	0.625	0.362	0.625	6.000	4.157	0.013	0.059	3.0	2	0.4	39000	LP.05	
84143	R217.21 -00.750-0-LP05-3A	Cylindrical	0.026	0.750	0.488	0.750	6.500	4.338	0.013	0.059	1.9	3	0.7	35000	LP.05	
Metric																
14006	R217.21 -1012.0-LP05.2A	Cylindrical	0.65	12.0	5.4	10.0	100.0	60.0	0.32	1.5	3.9	2	0.1	45000	LP.05	
84134	R217.21 -1214.0-LP05.2A	Cylindrical	0.65	14.0	7.4	12.0	120.0	75.0	0.32	1.5	3.5	2	0.1	42000	LP.05	
84135	R217.21 -1416.0-LP05.2A	Cylindrical	0.65	16.0	9.4	14.0	150.0	105.0	0.32	1.5	3.0	2	0.2	39000	LP.05	
84136	R217.21 -1618.0-LP05.3A	Cylindrical	0.65	18.0	11.4	16.0	160.0	112.0	0.32	1.5	2.2	3	0.3	37000	LP.05	
84137	R217.21 -1820.0-LP05.3A	Cylindrical	0.65	20.0	13.4	18.0	160.0	112.0	0.32	1.5	1.9	3	0.3	35000	LP.05	

UTCN = Uncut thickness, deviation between programmed corner radii (RP) and generated machined profile. Ramping angle = RMPX

**Spare Parts**, not included. Must be ordered separately.

For cutter	Key (T-handle)	Insert screw	Insert key
R217.21-...	DOUBLE-T	C02053-T06P	H4B-T06P

Torque value 4.4 in/lbs, Torque keys, see MN Milling



R217.21

High feed cutters - LP06

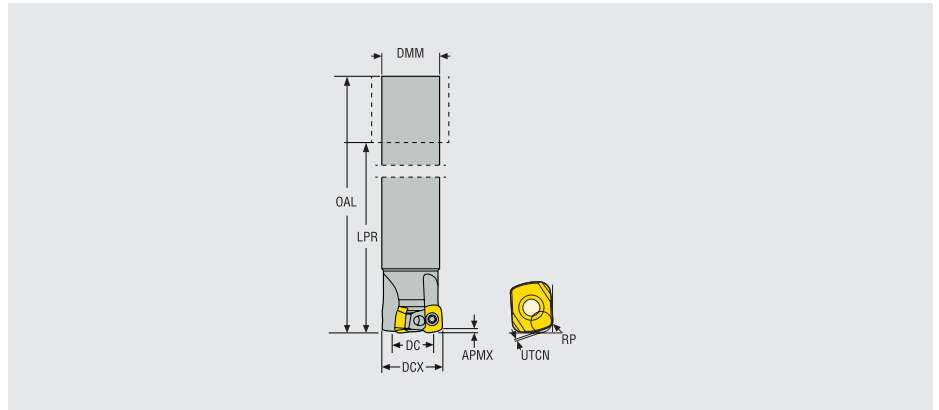

- For cutting data recommendations, see page(s) 56-57
- For insert selections, see page 39
- For complete insert program and helical interpolation, see MN Milling

EDP	DESCRIPTION	TYPE OF MOUNTING	DIMENSIONS IN IN/MM									RMPX	RPM	LB/KG	LIFE	INSERT
			APMX	DCX	DC	DMM	OAL	LPR	UTCN	RP						
<b>Inch</b>																
71017	R217.21 -00.625-0-LP06-2A	Cylindrical	0.030	0.625	0.290	0.625	6.000	4.000	0.018	0.071	5.0	2	0.44	39000	LP.06	
71018	R217.21 -00.750-0-LP06-2A	Cylindrical	0.030	0.750	0.498	0.750	6.500	4.400	0.018	0.071	3.0	2	0.66	35000	LP.06	
71019	R217.21 -01.00-0-LP06-3A	Cylindrical	0.030	1.000	0.660	1.000	7.000	4.800	0.018	0.071	2.0	3	1.54	30000	LP.06	
71020	R217.21 -01.25-0-LP06-4A	Cylindrical	0.030	1.250	0.659	1.250	8.000	5.500	0.018	0.071	1.5	4	2.20	27000	LP.06	
<b>Metric</b>																
70984	R217.21 -1416.0-LP06.2A	Cylindrical	0.8	16.0	7.5	14.0	150.0	102.0	0.45	1.8	5.0	2	0.4	39000	LP.06	
70986	R217.21 -1618.0-LP06.2A	Cylindrical	0.8	18.0	9.5	16.0	160.0	112.0	0.45	1.8	3.5	2	0.4	37000	LP.06	
70989	R217.21 -1820.0-LP06.2A	Cylindrical	0.8	20.0	11.6	18.0	160.0	110.0	0.45	1.8	3.0	2	0.4	35000	LP.06	
70991	R217.21 -2525.0-LP06.3A	Cylindrical	0.8	25.0	16.5	25.0	180.0	124.0	0.45	1.8	2.0	3	0.4	30000	LP.06	
70993	R217.21 -2527.0-LP06.3A	Cylindrical	0.8	27.0	18.5	25.0	250.0	194.0	0.45	1.8	1.5	3	0.4	30000	LP.06	
70995	R217.21 -3232.0-LP06.4A	Cylindrical	0.8	32.0	23.5	32.0	200.0	140.0	0.45	1.8	1.5	4	0.4	27000	LP.06	
70998	R217.21 -3235.0-LP06.4A	Cylindrical	0.8	35.0	26.5	32.0	250.0	190.0	0.45	1.8	1.2	4	0.4	26000	LP.06	

UTCN = Uncut thickness, deviation between programmed corner radii (RP) and generated machined profile. Ramping angle = RMPX

**Spare Parts, not included. Must be ordered separately.**

For cutter	Key (T-handle)	Insert screw	Insert key
Dia 16-20	DOUBLE-T	C02555-T08P	H4B-T08P
Dia 25-35	DOUBLE-T	C02506-T08P	H4B-T08P

Torque value 10.6 in/lbs, Torque keys, see MN Milling

## R217/220.21-LP06

## High feed cutters - LP06



- For cutting data recommendations, see page(s) 56-57
- For insert selections, see page 39
- For complete insert program and helical interpolation, see MN Milling

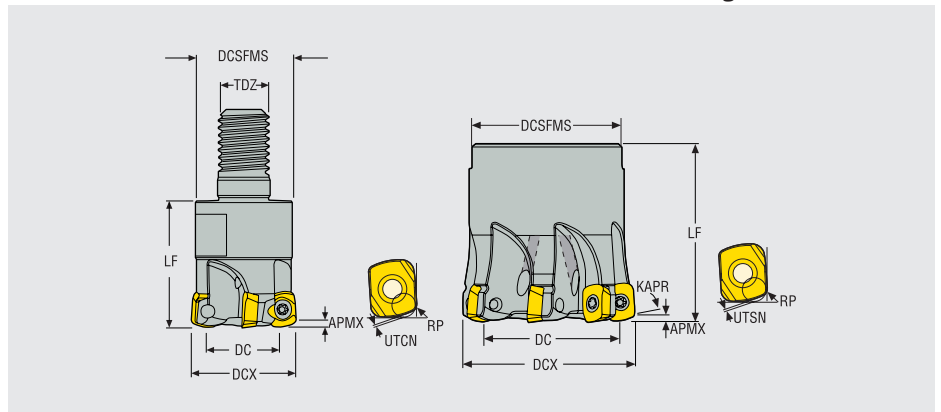

EDP	DESCRIPTION	TYPE OF MOUNTING	DIMENSIONS IN IN/MM									RMPX		LB/KG		INSERT
			APMX	DCX	DC	DCSFMS	TDZ	LF	UTCN	RP						
Inch																
71011	R217.21 -00.625-08RE-LP06-2A	Combimaster	0.031	0.625	0.294	0.531	M8	0.787	0.018	0.071	5.0	2	0.04	39000	LP.06	
71012	R217.21 -00.750-10RE-LP06-3A	Combimaster	0.031	0.750	0.494	0.728	M1	1.124	0.018	0.071	3.0	3	0.11	35000	LP.06	
71013	R217.21 -01.00-12RE-LP06-3A	Combimaster	0.031	1.000	0.660	0.955	M12	1.181	0.018	0.071	2.0	3	0.44	30000	LP.06	
71014	R217.21 -01.00-12RE-LP06-4A	Combimaster	0.031	1.000	0.660	0.955	M12	1.181	0.018	0.071	2.0	4	0.22	30000	LP.06	
71016	R217.21 -01.25-16RE-LP06-5A	Combimaster	0.031	1.250	0.994	1.181	M16	1.378	0.018	0.071	1.2	5	0.44	27000	LP.06	
05938	R217.21 -01.50-20RE-LP06-7A	Combimaster	0.031	1.500	1.181	1.438	M2	1.575	0.018	0.071	0.9	7	0.66	24000	LP.06	
86606	R220.21 -01.50-LP06-6A	Arbor	0.031	1.500	1.165	1.260	-	1.500	0.018	0.071	0.9	6	0.44	25000	LP.06	
Metric																
70967	R217.21 -0816.RE-LP06.2A	Combimaster	0.8	16.0	7.5	13.5	M8	20.0	0.45	1.8	5.0	2	0.3	39000	LP.06	
70970	R217.21 -1020.RE-LP06.2A	Combimaster	0.8	20.0	11.5	18.5	M10	28.0	0.45	1.8	3.0	2	0.3	35000	LP.06	
70971	R217.21 -1020.RE-LP06.3A	Combimaster	0.8	20.0	11.5	18.5	M10	28.0	0.45	1.8	3.0	3	0.4	35000	LP.06	
70973	R217.21 -1225.RE-LP06.3A	Combimaster	0.8	25.0	16.5	23.0	M12	30.0	0.45	1.8	2.0	3	0.3	30000	LP.06	
70976	R217.21 -1225.RE-LP06.4A	Combimaster	0.8	25.0	16.5	23.0	M12	30.0	0.45	1.8	2.0	4	0.4	30000	LP.06	
70978	R217.21 -1632.RE-LP06.5A	Combimaster	0.8	32.0	23.5	30.0	M16	35.0	0.45	1.8	1.5	5	0.2	27000	LP.06	
70982	R217.21 -1635.RE-LP06.5A	Combimaster	0.8	35.0	26.5	30.0	M16	35.0	0.45	1.8	1.5	5	0.3	26000	LP.06	
06251	R217.21 -2040.RE-LP06.7A	Combimaster	0.8	40.0	31.5	36.5	M20	40.0	0.45	1.8	0.9	7	0.4	24000	LP.06	
71003	R220.21 -0035-LP06.6A	Arbor	0.8	35.0	26.5	32.0	-	35.0	0.45	1.8	1.29	6	0.4	26000	LP.06	
86605	R220.21 -0040-LP06.6A	Arbor	0.8	40.0	31.5	32.0	-	40.0	0.45	1.8	0.9	6	0.2	24000	LP.06	

For Combimaster shanks and dimensions, see MN Milling. UTCN = Uncut thickness, deviation between programmed corner radii (RP) and generated machined profile. Ramping angle = RMPX.

### Mounting Dimensions

FOR CUTTER	DIMENSIONS IN INCH		
	DCB	KWW	C
R220.21-1.50	0.500	0.258	0.157
R220.21-0035 - 0040	16.00	8.400	5.600

Spare Parts, not included. Must be ordered separately.

For cutter	Key (T-handle)	Insert screw	Insert key	Arbor screw
R217.21-16-20	DOUBLE-T	C02555-T08P	H4B-T08P	-
R217.21-25-35	DOUBLE-T	C02506-T08P	H4B-T08P	-
R220.21-35	DOUBLE-T	C02506-T08P	H4B-T08P	220.17-689
R217.21-40	DOUBLE-T	C02506-T08P	H4B-T08P	-
R220.21-40	DOUBLE-T	C02506-T08P	H4B-T08P	220.17-689

Torque value 10.6 in/lbs, Torque keys, see MN Milling Torque keys, see MN Milling

R217.21

High feed cutters - L006

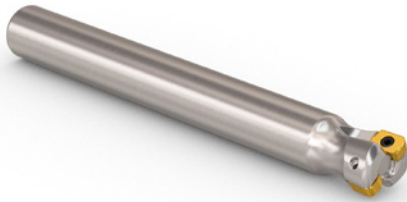

- For cutting data recommendations, see page(s) 58-59
- For insert selections, see page 39
- For complete insert program and helical interpolation, see MN Milling

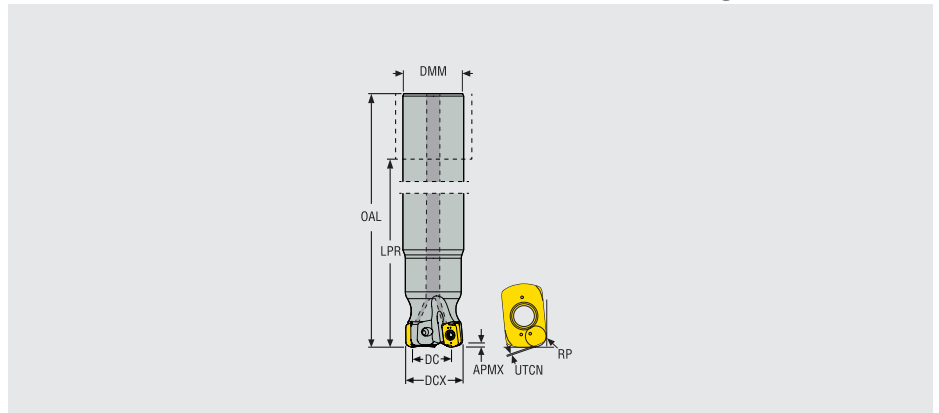

EDP	DESCRIPTION	TYPE OF MOUNTING	DIMENSIONS IN IN/MM										RMPX		LB/KG		INSERT	
			APMX	DCX	DC	DMM	OAL	LPR	UTCN	RP								
Inch																		
16121	R217.21 -01.00-0-L006-3A	Cylindrical	0.035	1.000	0.736	1.000	7.000	4.882	0.015	0.071	0.8	3	1.5	30000	LOH.06			
16199	R217.21 -01.25-0-L006-4A	Cylindrical	0.035	1.250	0.984	1.250	8.000	5.512	0.015	0.071	0.5	4	2.6	27000	LOH.06			
Metric																		
14023	R217.21 -1820.0-L006.2A	Cylindrical	0.9	20.0	13.3	18.0	160.0	110.0	0.38	1.8	1.0	2	0.3	35000	LO..06			
82268	R217.21 -2525.0-L006.3A	Cylindrical	0.9	25.0	18.3	25.0	180.0	124.0	0.38	1.8	0.8	3	0.7	30000	LO..06			
82269	R217.21 -2527.0-L006.3A	Cylindrical	0.9	27.0	20.3	25.0	200.0	140.0	0.38	1.8	0.7	3	0.7	29000	LO..06			
82273	R217.21 -3232.0-L006.4A	Cylindrical	0.9	32.0	25.3	32.0	200.0	140.0	0.38	1.8	0.5	4	1.2	27000	LO..06			

UTCN = Uncut thickness, deviation between programmed corner radii (RP) and generated machined profile. Ramping angle = RMPX

**Spare Parts**, not included. Must be ordered separately.

For cutter	Key (T-handle)	Insert screw	Insert key
R217.21-20			
R217.21-25-32	DOUBLE-T	C02508-T08P	H4B-T08P
	DOUBLE-T	C02508-T08P	H4B-T08P

Torque value 10.6 in/lbs,

R217/220.21-L006

High feed cutters - L006



- For cutting data recommendations, see page(s) 58-59
- For insert selections, see page 39
- For complete insert program and helical interpolation, see MN Milling

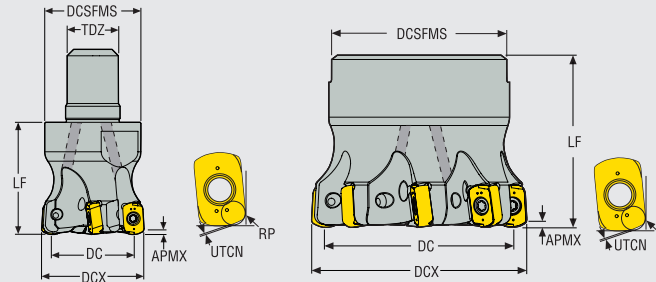

EDP	DESCRIPTION	TYPE OF MOUNTING	DIMENSIONS IN IN/MM									RMPX	⊘	LB/KG	⏱	Insert
			APMX	DCX	DC	DCSFMS	TDZ	LF	UTCN	RP						
Inch																
09955	R217.21 -01.00-12RE-L006-3A	Combimaster	0.035	1.000	0.736	0.906	M12	0.035	0.015	0.071	0.7	3	0.2	30000	LOH.06	
16119	R217.21 -01.00-12RE-L006-4A	Combimaster	0.035	1.000	0.736	0.906	M12	0.035	0.015	0.071	0.7	4	0.2	30000	LOH.06	
14025	R217.21 -01.25-16RE-L006-4A	Combimaster	0.035	1.250	0.984	1.181	M16	0.035	0.015	0.071	0.5	4	0.4	27000	LOH.06	
16154	R217.21 -01.25-16RE-L006-5A	Combimaster	0.035	1.250	0.984	1.181	M16	0.035	0.015	0.071	0.5	5	0.4	27000	LOH.06	
14026	R217.21 -01.50-16RE-L006-5A	Combimaster	0.035	1.500	1.236	1.181	M16	0.035	0.015	0.071	0.4	5	0.4	18000	LOH.06	
52990	R217.21 -01.50-20RE-L006-6A	Combimaster	0.035	1.500	1.299	1.437	M20	0.035	0.015	0.071	0.4	6	0.7	18000	LOH.06	
16203	R220.21 -01.50-L006-6A	Arbor	0.035	1.500	1.236	1.260	-	0.035	0.015	0.071	0.4	6	0.4	18000	LOH.06	
14028	R217.21 -02.00-L006-8A	Arbor	0.035	2.000	1.736	1.654	-	0.035	0.015	0.071	0.3	8	0.9	16000	LOH.06	
14031	R217.21 -02.50-L006-9A	Arbor	0.035	2.500	2.236	1.850	-	0.035	0.015	0.071	0.25	9	1.1	15000	LOH.06	
Metric																
09976	R217.21 -1020.RE-L006.2A	Combimaster	0.9	20.0	13.3	18.5	M10	28.0	0.38	1.8	1.0	2	0.1	35000	LO.06	
09978	R217.21 -1225.RE-L006.3A	Combimaster	0.9	25.0	18.3	23.0	M12	30.0	0.38	1.8	0.8	3	0.1	30000	LO.06	
82263	R217.21 -1225.RE-L006.4A	Combimaster	0.9	25.0	18.3	23.0	M12	30.0	0.38	1.8	0.8	4	0.1	30000	LO.06	
01350	R217.21 -1632.RE-L006.4A	Combimaster	0.9	32.0	25.3	30.0	M16	35.0	0.38	1.8	0.5	4	0.2	27000	LO.06	
82270	R217.21 -1632.RE-L006.5A	Combimaster	0.9	32.0	25.3	30.0	M16	35.0	0.38	1.8	0.5	5	0.2	27000	LO.06	
82271	R217.21 -1635.RE-L006.5A	Combimaster	0.9	35.0	28.3	30.0	M16	35.0	0.38	1.8	0.5	5	0.2	26000	LO.06	
82277	R217.21 -1640.RE-L006.5A	Combimaster	0.9	40.0	33.3	30.0	M16	35.0	0.38	1.8	0.4	5	0.2	18000	LO.06	
05735	R217.21 -2040.RE-L006.6A	Combimaster	0.9	40.0	33.0	36.5	M20	40.0	0.38	1.8	0.4	6	0.4	18000	LO.06	
14040	R220.21 -0035-L006.6A	Arbor	0.9	35.0	28.3	32.0	-	35.0	0.38	1.8	0.5	6	0.2	24500	LO.06	
01332	R220.21 -0040-L006.7A	Arbor	0.9	40.0	33.3	35.0	-	40.0	0.38	1.8	0.4	7	0.2	18000	LO.06	
82276	R217.21 -0042-L006.7A	Arbor	0.9	42.0	35.3	35.0	-	40.0	0.38	1.8	0.4	7	0.2	18000	LO.06	
01336	R220.21 -0050-L006.8A	Arbor	0.9	50.0	43.3	42.0	-	40.0	0.38	1.8	0.3	8	0.3	16000	LO.06	
14038	R217.21 -0052-L006.8A	Arbor	0.9	52.0	45.3	42.0	-	40.0	0.38	1.8	0.3	8	0.4	16000	LO.06	
14039	R220.21 -0063-L006.9A	Arbor	0.9	63.0	56.3	47.0	-	40.0	0.38	1.8	0.25	9	0.5	15000	LO.06	

For Combimaster shanks and dimensions, see MN Milling. UTCN = Uncut thickness, deviation between programmed corner radii (RP) and generated machined profile. Ramping angle = RPMX.

## Mounting Dimensions

FOR CUTTER	DIMENSIONS IN INCH		
	DCB	KWW	C
R220.21-01.50	0.50	0.26	0.16
R220.21-02.50	0.75	0.32	0.19
R220.21-0035 - 0042	16.0	8.40	5.60
R220.21-0050 - 0063	22.0	10.4	6.40

Spare Parts, not included. Must be ordered separately.

For cutter	Key (T-handle)	Insert screw	Insert key	Arbor screw
R217.21-...	DOUBLE-T	C02508-T08P	H4B-T08P	
R217.21-1225-4A	DOUBLE-T	C02508-T08P	H4B-T08P	
R217.21-1632.5A	DOUBLE-T	C02508-T08P	H4B-T08P	
R217.21-1635	DOUBLE-T	C02508-T08P	H4B-T08P	
R220.21-Dia 35	DOUBLE-T	C02508-T08P	H4B-T08P	MC6S8X25
R220.21-Dia 40-42	DOUBLE-T	C02508-T08P	H4B-T08P	220.17-689
R220.21-Dia 50-63	DOUBLE-T	C02508-T08P	H4B-T08P	220.17-692

Torque value 10.6 in/lbs, Torque keys, see MN Milling

## R220.21-R230

## High feed cutters

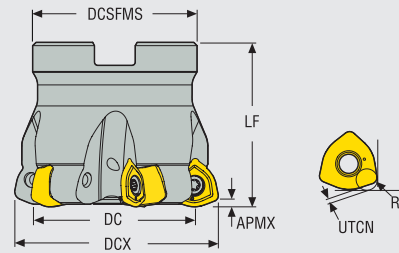

- For cutting data recommendations, see page(s) 60-61
- For insert selections, see page 40
- For complete insert program, see MN Milling

EDP	DESCRIPTION	TYPE OF MOUNTING	DIMENSIONS IN IN/MM								RMPX		LB/KG		Insert
			APMX	DCX	DC	DCSFMS	LF	UTCN	RP						
<b>Inch</b>															
84973	R220.21 -02.00-R230.4A	Arbor	0.071	2.00	1.42	1.654	1.575	0.033	0.131	0.9	4	0.66	12100	218.21-230..	
84972	R220.21 -02.00-R230.5A	Arbor	0.071	2.00	1.42	1.654	1.575	0.033	0.131	0.9	5	0.66	12100	218.21-230..	
84974	R220.21 -02.50-R230.5A	Arbor	0.071	2.50	1.92	1.850	1.575	0.035	0.131	0.6	5	1.10	9600	218.21-230..	
84975	R220.21 -02.50-R230.6A	Arbor	0.071	2.50	1.92	1.850	1.575	0.035	0.131	0.6	6	1.10	9600	218.21-230..	
84976	R220.21 -03.00-R230.5A	Arbor	0.071	3.00	2.43	2.441	1.969	0.034	0.131	0.5	5	1.98	9800	218.21-230..	
84977	R220.21 -03.00-R230.6A	Arbor	0.071	3.00	2.43	2.441	1.969	0.034	0.131	0.5	6	2.20	9800	218.21-230..	
13820	R220.21 -03.50-R230.8A	Arbor	0.071	3.50	2.93	3.031	1.969	0.034	0.131	0.4	8	3.09	9100	218.21-230..	
11114	R220.21 -04.00-R230.7A	Arbor	0.071	4.00	3.43	3.543	1.969	0.035	0.130	0.3	7	3.97	8500	218.21-230..	
84978	R220.21 -04.00-R230.9A	Arbor	0.071	4.00	3.43	3.543	1.969	0.035	0.130	0.3	9	3.97	8500	218.21-230..	
<b>Metric</b>															
82293	R220.21 -0050-R230.4A	Arbor	1.8	50.0	35.6	42.0	40.0	0.83	3.32	0.9	4	0.3	12100	218.21-230..	
82292	R220.21 -0050-R230.5A	Arbor	1.8	50.0	35.6	42.0	40.0	0.83	3.32	0.9	5	0.3	12100	218.21-230..	
82294	R220.21 -0052-R230.5A	Arbor	1.8	52.0	37.6	42.0	40.0	0.83	3.32	0.9	5	0.3	11900	218.21-230..	
82295	R220.21 -0063-R230.5A	Arbor	1.8	63.0	48.3	50.0	50.0	0.83	3.32	0.6	5	0.6	10800	218.21-230..	
82296	R220.21 -0063-R230.6A	Arbor	1.8	63.0	48.3	50.0	50.0	0.83	3.32	0.6	6	0.6	10800	218.21-230..	
82299	R220.21 -0066-R230.6A	Arbor	1.8	66.0	51.3	62.0	50.0	0.83	3.32	0.6	6	0.8	10600	218.21-230..	
82301	R220.21 -0080-R230.6A	Arbor	1.8	80.0	65.6	62.0	50.0	0.87	3.32	0.4	6	1.0	9600	218.21-230..	
82306	R220.21 -0080-R230.7A	Arbor	1.8	80.0	65.6	62.0	50.0	0.87	3.32	0.4	7	1.0	9600	218.21-230..	
82307	R220.21 -0084-R230.8A	Arbor	1.8	84.0	69.6	77.0	50.0	0.87	3.32	0.4	8	1.3	9400	218.21-230..	
13817	R220.21 -0100-R230.7A	Arbor	1.8	100.0	85.6	77.0	50.0	0.89	3.3	0.3	7	1.5	8600	218.21-230..	
82308	R220.21 -0100-R230.9A	Arbor	1.8	100.0	85.6	77.0	50.0	0.89	3.32	0.3	9	1.6	8600	218.21-230..	
82309	R220.21 -0125-R230.9A	Arbor	1.8	125.0	110.2	90.0	63.0	0.88	3.32	0.2	9	2.8	7700	218.21-230..	
82317	R220.21 -8160-R230.10A	Arbor	1.8	160.0	145.2	90.0	63.0	0.89	3.32	0.1	10	4.1	6800	218.21-230..	

UTCN = Uncut thickness, deviation between programmed corner radii (RP) and generated machined profile. RMPX = Ramping angle

### Mounting Dimensions

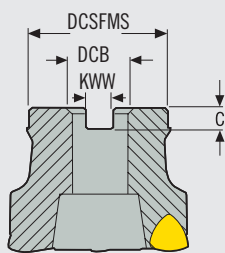

#### FOR CUTTER

#### DIMENSIONS IN INCH

	DCB	KWW	C
R220.21-01.50	0.50	0.26	0.16
R220.21-03.00	1.00	0.38	0.22
R220.21-03.50	1.25	0.51	0.29
R220.21-04.00	1.50	0.63	0.38
R220.21-0050 - 0052	22.0	10.4	6.40
R220.21-0063 - 0080	27.0	12.4	7.00
R220.21-0084 - 0100	32.0	14.4	8.00
R220.21-0125 - 8160	40.0	16.4	9.00

Spare Parts, not included. Must be ordered separately.

For cutter	Key (T-handle)	Insert screw	Insert key	Arbor screw
R220.21-0050	DOUBLE-T	C04011-T15P	H6B-T15P	220.17-692
R220.21-0063-0066	DOUBLE-T	C04011-T15P	H6B-T15P	MC6S12X35
R220.21-0080	DOUBLE-T	C04011-T15P	H6B-T15PL	MC6S12X35
R220.21-0084-0100	DOUBLE-T	C04011-T15P	H6B-T15PL	MLC6S16X35
R220.21-0125	DOUBLE-T	C04011-T15P	H6B-T15PL	MLC6S20X40
R220.21-8160	DOUBLE-T	C04011-T15P	H6B-T15PL	

Torque value 44.3 in/lbs, For dimension of mounting and torque key see MN Milling



R217.21

High feed cutters

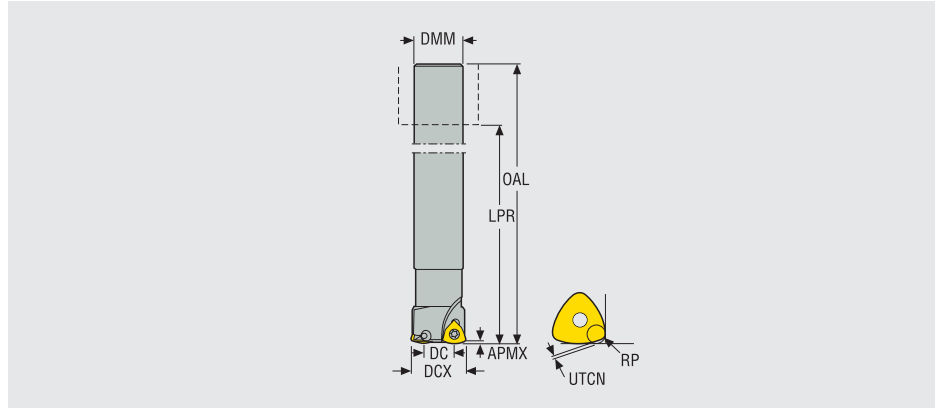

- For cutting data recommendations, see page(s) 62-67
- For insert selections, see page 40
- For complete insert program, see MN Milling

EDP	DESCRIPTION	TYPE OF MOUNTING	DIMENSIONS IN IN/MM										RMPX	LB/KG	Insert	
			APMX	DCX	DC	DMM	OAL	LPR	UTCN	RP						
<b>Inch</b>																
30661	R217.21 -00.750-0-R100-2A	Cylindrical	0.029	0.750	0.410	0.750	6.500	4.531	0.018	0.058	5.7	2	1.10	32600	218.19-100	
30662	R217.21 -01.00-0-R100-3A	Cylindrical	0.029	1.000	0.660	1.000	7.000	4.795	0.018	0.058	3.48	3	1.32	29100	218.19-100	
30180	R217.21 -01.25-0-R125-3A	Cylindrical	0.039	1.250	0.823	1.250	7.500	5.138	0.024	0.069	3.67	3	2.43	19700	218.19-125	
29647	R217.21 -00.750-0-R100-2HA	Cylindrical	0.043	0.750	0.357	0.750	6.500	4.000	0.024	0.071	4.32	2	1.10	32600	218.19-100	
30179	R217.21 -01.00-0-R125-2HA	Cylindrical	0.059	1.000	0.502	1.000	7.039	4.500	0.031	0.086	4.25	2	1.54	29100	218.19-125	
30181	R217.21 -01.25-0-R160-2HA	Cylindrical	0.080	1.250	0.583	1.250	7.500	5.220	0.041	0.121	3.76	2	2.65	19700	218.19-160	
30183	R217.21 -01.50-0-R160-3HA	Cylindrical	0.080	1.500	0.591	1.500	8.000	5.310	0.041	0.120	2.18	3	3.75	17600	218.19-160	
<b>Metric</b>																
45766	R217.21 -1820.0-R100.2A	Cylindrical	0.74	20.0	11.4	18.0	160.0	110.0	0.45	1.47	5.7	2	0.3	32600	218.19-100	
39120	R217.21 -2025.0-R100.2A	Cylindrical	0.74	25.0	16.46	20.0	170.0	120.0	0.45	1.47	3.48	2	0.4	29100	218.19-100	
39121	R217.21 -2525.0-R100.3A	Cylindrical	0.74	25.0	16.46	25.0	170.0	114.0	0.45	1.47	3.48	3	0.6	29100	218.19-100	
39122	R217.21 -2532.0-R125.2A	Cylindrical	1.0	32.0	21.16	25.0	195.0	140.0	0.61	1.74	3.67	2	0.8	19700	218.19-125	
39125	R217.21 -3232.0-R125.3A	Cylindrical	1.0	32.0	21.16	32.0	195.0	135.0	0.61	1.74	3.67	3	1.1	19700	218.19-125	

UTCN = Uncut thickness, deviation between programmed corner radii (RP) and generated machined profile. Ramping angle = RMPX

**Spare Parts**, not included. Must be ordered separately.

For cutter	Key (T-handle)	Insert screw	Insert key
R217.21-R080	DOUBLE-T	C02205-T07P	H4B-T07P
R217.21-R100	DOUBLE-T	C02506-T08P	H4B-T08P
R217.21-R125	DOUBLE-T	C03007-T09P	H4B-T09P

Torque value, for insert 218.19-080 8.0 in/lbs, 218.19-100 10.6 in/lbs, 218.19-125 17.7 in/lbs, 218.19-160 26.6 in/lbs, Torque keys, see MN Milling

R217.21

High feed cutters

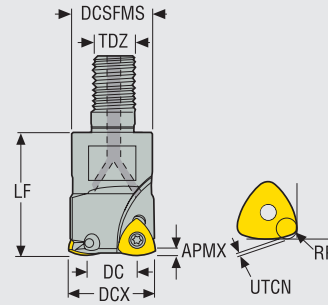

- For cutting data recommendations, see page(s) 62-67
- For insert selections, see page 40
- For complete insert program, see MN Milling

EDP	DESCRIPTION	TYPE OF MOUNTING	DIMENSIONS IN IN/MM										RMPX	Insert		
			APMX	DCX	DC	DCSFMS	TDZ	LF	UTCN	RP						
Inch																
07331	R217.21 -00.750-10RE-R100-2A	Combimaster	0.028	0.750	0.414	0.728	M10	1.100	0.017	0.058	5.71	2	0.44	32600	218.19-100	
07332	R217.21 -01.00-12RE-R100-3A	Combimaster	0.028	1.000	0.663	0.906	M12	1.400	0.018	0.058	3.48	3	0.44	29100	218.19-100	
07334	R217.21 -01.25-16RE-R125-3A	Combimaster	0.039	1.250	0.823	1.181	M16	1.600	0.024	0.069	3.67	3	0.66	19700	218.19-125	
12506	R217.21 -01.50-16RE-R125-4A	Combimaster	0.059	1.500	1.002	1.181	M16	1.600	0.031	0.086	2.47	4	0.66	17600	218.19-125	
05927	R217.21 -01.50-20RE-R125-4A	Combimaster	0.059	1.500	0.984	1.437	M20	1.600	0.024	0.069	2.47	4	0.66	17600	218.19-125	
29648	R217.21 -00.750-10RE-R100-2HA	Combimaster	0.043	0.750	0.357	0.728	M10	1.100	0.024	0.071	4.32	2	0.44	32600	218.19-100	
29644	R217.21 -01.00-12RE-R125-2HA	Combimaster	0.059	1.000	0.502	0.906	M12	1.400	0.031	0.086	4.25	2	0.44	29100	218.19-125	
29645	R217.21 -01.25-16RE-R160-2HA	Combimaster	0.079	1.250	0.543	1.181	M16	1.600	0.041	0.121	3.76	2	0.66	19700	218.19-160	
29646	R217.21 -01.50-16RE-R160-3HA	Combimaster	0.079	1.498	0.791	1.181	M16	1.600	0.041	0.121	2.18	3	0.88	17600	218.19-160	
05835	R217.21 -01.50-20RE-R160-3HA	Combimaster	0.079	1.500	0.906	1.437	M20	1.600	0.038	0.113	2.18	3	0.66	14500	218.19-160	
Metric																
03281	R217.21 -1020.RE-R100.2A	Combimaster	0.7	20.0	11.45	18.5	M10	28.0	0.45	1.47	5.71	2	0.1	32600	218.19-100	
29345	R217.21 -1020.RE-R100.2HA	Combimaster	1.0	20.0	10.44	18.5	M10	28.0	0.55	1.7	4.32	2	0.1	32600	218.19-100	
03286	R217.21 -1225.RE-R100.3A	Combimaster	0.7	25.0	16.46	23.0	M12	35.0	0.45	1.47	3.48	3	0.1	29100	218.19-100	
23098	R217.21 -1225.RE-R125.2HA	Combimaster	1.5	25.0	12.36	23.0	M12	35.0	0.8	2.18	4.25	2	0.1	29100	218.19-125	
03288	R217.21 -1632.RE-R125.2A	Combimaster	1.0	32.0	21.16	30.0	M16	40.0	0.61	1.74	3.67	2	0.2	19700	218.19-125	
03295	R217.21 -1632.RE-R125.3A	Combimaster	1.0	32.0	21.21	30.0	M16	40.0	0.61	1.74	3.7	3	0.3	19700	218.19-125	
29346	R217.21 -1632.RE-R160.2HA	Combimaster	1.8	32.0	16.09	30.0	M16	40.0	0.97	2.87	3.76	2	0.2	16200	218.19-160	
03298	R217.21 -1635.RE-R125.3A	Combimaster	1.0	35.0	24.16	30.0	M16	40.0	0.61	1.74	3.1	3	0.2	18800	218.19-125	
03307	R217.21 -1640.RE-R125.4A	Combimaster	1.0	40.0	29.25	30.0	M16	40.0	0.61	1.74	2.47	4	0.3	17600	218.19-125	
29347	R217.21 -1640.RE-R160.3HA	Combimaster	1.8	40.0	23.99	30.0	M16	40.0	0.97	2.87	2.18	3	0.2	14500	218.19-160	
06250	R217.21 -2040.RE-R125.4A	Combimaster	1.0	40.0	29.25	36.5	M20	40.0	0.61	1.74	2.47	4	0.3	17600	218.19-125	
06282	R217.21 -2040.RE-R160.3HA	Combimaster	1.8	40.0	23.99	36.5	M20	40.0	0.97	2.87	2.18	3	0.3	14500	218.19-160	

UTCN = Uncut thickness, deviation between programmed corner radii (RP) and generated machined profile. Ramping angle = RPMX.

For Combimaster shanks and dimensions, see MN Milling

Spare Parts, not included. Must be ordered separately.

For cutter	Key (T-handle)	Insert screw	Insert key
R217.21-R080	DOUBLE-T	C02205-T07P	H4B-T07P
R217.21-R100	DOUBLE-T	C02506-T08P	H4B-T08P
R217.21-R125	DOUBLE-T	C03007-T09P	H4B-T09P
R217.21-R160	DOUBLE-T	C03510-T15P	H6B-T15P

Torque value, for insert 218.19-080 8.0 in/lbs, 218.19-100 10.6 in/lbs, 218.19-125 17.7 in/lbs, 218.19-160 26.6 in/lbs, Torque keys, see MN Milling

## R220.21

## High feed cutters

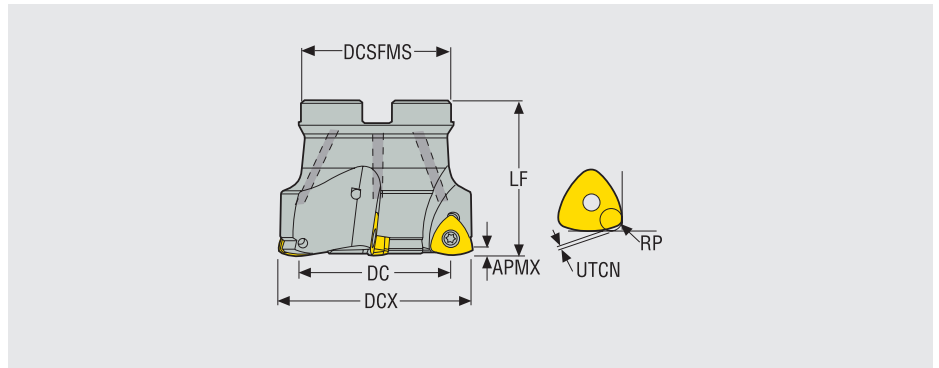

- For cutting data recommendations, see page(s) 62-67
- For insert selections, see page 40
- For complete insert program, see MN Milling

EDP	DESCRIPTION	TYPE OF MOUNTING	DIMENSIONS IN IN/MM								RMPX	Insert	LB/KG	Insert	
			APMX	DCX	DC	DCSFMS	LF	UTCN	RP	Insert					
Inch															
07338	R220.21 -01.50-R125-4A	Arbor	0.060	1.500	1.002	1.378	1.600	0.032	0.087	2.47	4	0.66	17600	218.19-125	
07339	R220.21 -02.00-R160-3A	Arbor	0.079	2.000	1.346	1.850	1.600	0.041	0.119	1.47	3	1.10	12900	218.19-160	
07340	R220.21 -02.00-R160-4A	Arbor	0.079	2.000	1.346	1.850	1.600	0.041	0.119	1.47	4	1.10	12900	218.19-160	
07341	R220.21 -02.50-R160-4A	Arbor	0.079	2.500	1.843	1.850	2.000	0.041	0.119	1.0	4	1.54	11500	218.19-160	
07342	R220.21 -02.50-R160-5A	Arbor	0.079	2.500	1.843	1.850	2.000	0.041	0.119	1.0	5	1.54	11500	218.19-160	
04973	R220.21 -03.00-R160-6A	Arbor	0.098	3.000	2.280	2.441	2.000	0.047	0.138	0.73	6	2.20	10200	218.19-160	
09496	R220.21 -03.50-R160-8A	Arbor	0.098	3.500	2.846	3.030	2.000	0.047	0.138	0.60	8	3.50	10200	218.19-160	
04975	R220.21 -04.00-R160-7A	Arbor	0.098	4.000	3.286	3.543	2.000	0.047	0.138	0.54	7	4.63	9100	218.19-160	
Metric															
03300	R220.21 -0040-R125.4A	Arbor	1.0	40.0	29.2	35.0	40.0	0.61	1.75	2.47	4	0.2	17600	218.19-125	
03301	R220.21 -0042-R125.4A	Arbor	1.0	42.0	31.2	35.0	40.0	0.61	1.75	2.28	4	0.2	17200	218.19-125	
03302	R220.21 -0050-R160.3A	Arbor	1.8	50.0	34.17	47.0	40.0	0.97	2.85	1.47	3	0.3	12900	218.19-160	
03303	R220.21 -0050-R160.4A	Arbor	1.8	50.0	34.17	47.0	40.0	0.97	2.85	1.47	4	0.3	12900	218.19-160	
05100	R220.21 -0052-R160.4A	Arbor	1.8	52.0	36.19	47.0	40.0	0.97	2.85	1.38	4	0.4	12700	218.19-160	
03304	R220.21 -0063-R160.4A	Arbor	1.8	63.0	47.2	50.0	50.0	0.97	2.85	1.0	4	0.5	11500	218.19-160	
03305	R220.21 -0063-R160.5A	Arbor	1.8	63.0	47.2	50.0	50.0	0.97	2.85	1.0	5	0.6	11500	218.19-160	
05097	R220.21 -0066-R160.5A	Arbor	1.8	66.0	50.21	50.0	50.0	0.97	2.85	0.95	5	0.6	11200	218.19-160	
17569	R220.21 -0080-R160.6A	Arbor	1.8	80.0	64.15	62.0	50.0	0.97	2.85	0.73	6	1.0	10200	218.19-160	
44932	R220.21 -0084-R160.6A	Arbor	1.8	84.0	68.00	62.0	50.0	0.97	2.85	0.60	6	1.4	10000	218.19-160	
17556	R220.21 -0100-R160.7A	Arbor	1.8	100.0	84.13	77.0	50.0	0.97	2.85	0.54	7	1.6	9700	218.19-160	

UTCN = Uncut thickness, deviation between programmed corner radii (RP) and generated machined profile. Ramping angle = RMPX

### Mounting Dimensions

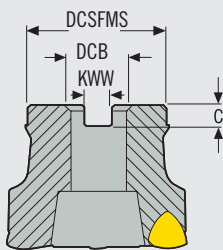

#### FOR CUTTER

#### DIMENSIONS IN INCH

	DCB	KWW	C
R220.21-01.50	0.50	0.26	0.16
R220.21-02.00 / 02.50	0.75	0.32	0.19
R220.21-03.00	1.00	0.38	0.22
R220.21-03.50	1.25	0.51	0.29
R220.21-04.00	1.50	0.63	0.38
R220.21-0040 - 0042	16.0	8.40	5.60
R220.21-0050 - 0052	22.0	10.4	6.40
R220.21-0063 - 0080	27.0	12.4	7.00
R220.21-0084 - 0100	32.0	14.4	8.00

Spare Parts, not included. Must be ordered separately.

For cutter	Key (T-handle)	Insert screw	Insert key	Arbor screw
R220.21-0040-0042	DOUBLE-T	C03007-T09P	H4B-T09P	220.17-689
R220.21-0050-0052	DOUBLE-T	C03510-T15P	H6B-T15P	220.17-692
R220.21-0063	DOUBLE-T	C03510-T15P	H6B-T15P	MC6S12X35
R220.21-0066-0080	DOUBLE-T	C03510-T15P	H6B-T15P	MC6S12X35
R220.21-0066-0080	DOUBLE-T	C03510-T15P	H6B-T15PL	MC6S12X35
R220.21-0100	DOUBLE-T	C03510-T15P	H6B-T15PL	220.17-694

Torque value, for insert 218.19-125 17.7 in/lbs, 218.19-160 26.6 in/lbs, Torque keys, see MN Milling

## R220.21C

## High feed cutters

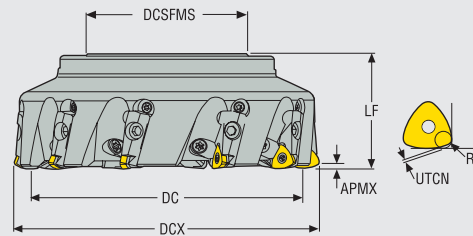

- For cutting data recommendations, see page(s) 62-67
- For insert selections, see page 40
- For complete insert program, see MN Milling

EDP	DESCRIPTION	TYPE OF MOUNTING	DIMENSIONS IN MM										RMPX	⌀	LB/KG		Insert
			APMX	DCX	DC	DCSFMS	DCB	LF	UTCN	RP							
<b>Metric</b>																	
18653	R220.21 -0088-R160.5C	Arbor	2.5	88.0	70.0	62.0	27.0	50.0	1.21	3.53	-	5	1.5	7200	218.19-160..		
18673	R220.21 -0108-R160.6C	Arbor	2.5	108.0	90.0	77.0	32.0	50.0	1.21	3.53	-	6	2.3	6500	218.19-160..		
18678	R220.21 -0133-R160.8C	Arbor	2.5	133.0	115.0	90.0	40.0	63.0	1.21	3.53	-	8	3.7	5900	218.19-160..		
18679	R220.21 -8168-R160.10C	Arbor	2.5	168.0	150.0	90.0	40.0	63.0	1.21	3.53	-	10	5.8	5200	218.19-160..		
22450	R220.21 -8208-R160.12C	Arbor	2.5	208.0	190.0	90.0	60.0	63.0	1.21	3.53	-	12	8.7	4700	218.19-160..		

UTCN = Uncut thickness, deviation between programmed corner radii (RP) and generated machined profile.

## Mounting Dimensions

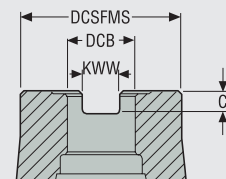

### FOR CUTTER

### DIMENSIONS IN MM

	DCB	KWW	C
R220.21-0088	27	12.4	7
R220.21-0108	32	14.4	8
R220.21-0133 -0168	40	16.4	9
R220.21-0208	60	25.7	14

Spare Parts, not included. Must be ordered separately.

For cutter	Wedge screw	Setting gauge	Key (T-handle)	Insert wedge	Insert screw	Insert key	Cassette screw	Cassette	Arbor screw
R220.21-0088	LD8020-T25P	AU1114T-T15P	DOUBLE-T	334.5-640M	C03508-T15P	H6B-T15PL	FS96018	218.19-160ZR	MC6S12X35
R220.21-0108	LD8020-T25P	AU1114T-T15P	DOUBLE-T	334.5-640M	C03508-T15P	H6B-T15PL	FS96018	218.19-160ZR	220.17-694
R220.21-0133-8208	LD8020-T25P	AU1114T-T15P	DOUBLE-T	334.5-640M	C03508-T15P	H6B-T15PL	FS96018	218.19-160ZR	

Torque value 44.3 in/lbs, Torque keys, see MN Milling

## R220.21-ON09

High feed cutters

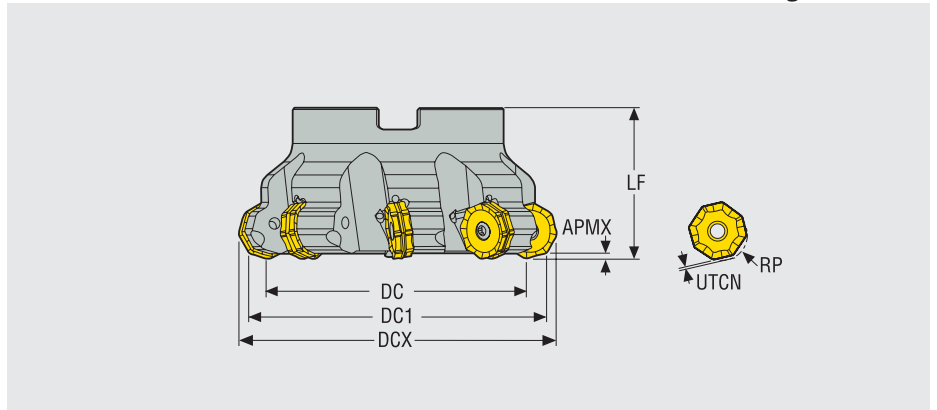

- For cutting data recommendations, see page(s) 68
- For insert selections, see page 41
- For complete insert program, see MN Milling

EDP	DESCRIPTION	TYPE OF MOUNTING	DIMENSIONS IN IN/MM										LB/KG	Insert
			APMX	DCX	DC	DC1	DCSFMS	LF	UTCN	RP				
<b>Inch</b>														
79006	R220.21 -03.00-ON09-6A	Arbor	0.094	3.389	2.423	3.000	2.441	1.969	0.033	0.405	6	2.0	4400	ON..09
79007	R217.21 -04.00-ON09-7A	Arbor	0.094	4.389	3.423	4.000	3.031	1.969	0.033	0.405	7	3.3	3900	ON..09
79008	R217.21 -05.00-ON09-8A	Arbor	0.094	5.389	4.423	5.000	3.543	2.480	0.033	0.405	8	7.1	3500	ON..09
79009	R217.21 -06.00-ON09-10	Arbor	0.094	6.389	5.423	6.000	4.331	2.480	0.033	0.405	10	7.7	3200	ON..09
<b>Metric</b>														
79002	R220.21 -0080-ON09-6A	Arbor	2.4	89.9	65.35	80.0	62.0	50.0	0.85	10.28	6	1.0	4400	ON..09
79003	R217.21 -0100-ON09-7A	Arbor	2.4	109.9	85.35	100.0	77.0	50.0	0.85	10.28	7	1.5	3900	ON..09
79004	R217.21 -0125-ON09-8A	Arbor	2.4	134.9	110.35	125.0	90.0	63.0	0.85	10.28	8	2.9	3500	ON..09
79005	R217.21 -8160-ON09-10	Arbor	2.4	169.9	145.35	66.7	90.0	63.0	0.85	10.28	10	4.1	3100	ON..09

UTCN = Uncut thickness, deviation between programmed corner radii (RP) and generated machined profile. Ramping angle = RPMX

## Mounting Dimensions

FOR CUTTER	DIMENSIONS IN INCH		
	DCB	KWW	C
R220.21-03.00	1.00	0.38	0.22
R220.21-04.00 - 05.00	1.50	0.63	0.38
R220.21-06.00	2.00	0.76	0.44
R220.21-0080	27.0	12.4	7.00
R220.21-0100	32.0	14.4	8.00
R220.21-0125 - 8160	40.0	16.4	9.00

Spare Parts, not included. Must be ordered separately.

For cutter	Key (T-handle)	Insert screw	Insert key	Arbor screw
R220.21-0080	DOUBLE-T	C05013-T20P	H6B-T20P	MC6S12X35
R220.21-0100-8160	DOUBLE-T	C05013-T20P	H6B-T20PL	
R220.21-0100-8160	DOUBLE-T	C05013-T20P	H6B-T20P	

Torque value 44.3 in/lbs, Torque keys, see MN Milling. Torque keys, see MN Milling



## R220.21SC

## High feed cutters

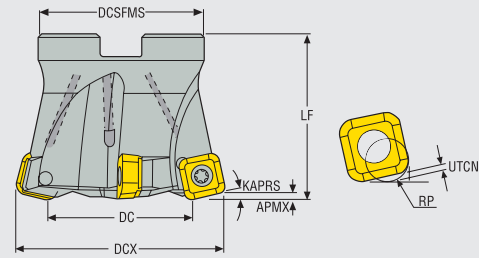

- For cutting data recommendations, see page(s) 69-70
- For insert selections, see page 41
- For complete insert program, see MN Milling

EDP	DESCRIPTION	TYPE OF MOUNTING	DIMENSIONS IN IN/MM								RMPX		LB/KG		Insert
			APMX	DCX	DC	DCSFMS	LF	UTCN	RP						
Inch															
34518	R220.21 -02.00-SC12-4A	Arbor	0.08	2.00	1.25	1.75	1.60	0.04	0.17	2.3	4	0.9	10700	SC..12	
34519	R220.21 -02.50-SC12-4A	Arbor	0.08	2.50	1.75	1.75	2.00	0.04	0.17	0.9	4	1.3	9600	SC..12	
34520	R220.21 -03.00-SC12-5A	Arbor	0.08	3.00	2.25	2.25	2.00	0.04	0.17	0.8	5	2.0	8500	SC..12	
34521	R220.21 -04.00-SC12-5A	Arbor	0.08	4.00	3.25	3.50	2.00	0.04	0.17	0.75	5	3.5	7600	SC..12	
Metric															
36192	R220.21 -0050-SC12.4A	Arbor	2.0	50.0	31.0	42.0	40.0	1.1	4.4	2.3	4	0.3	10700	SCET120630T	
33567	R220.21 -0052-SC12.4A	Arbor	2.0	52.0	33.0	42.0	40.0	1.1	4.4	2.2	4	0.3	10500	SCET120630T	
33568	R220.21 -0063-SC12.4A	Arbor	2.0	63.0	44.0	50.0	50.0	1.1	4.4	0.9	4	0.6	9600	SCET120630T	
44779	R220.21 -0063-SC12.5A	Arbor	2.0	63.0	44.0	50.0	50.0	1.1	4.4	0.9	5	0.6	9600	SCET120630T	
33569	R220.21 -0066-SC12.4A	Arbor	2.0	66.0	47.0	60.0	50.0	1.1	4.4	0.85	4	0.6	9400	SCET120630T	
33570	R220.21 -0080-SC12.5A	Arbor	2.0	80.0	61.0	62.0	50.0	1.1	4.4	0.8	5	1.0	8500	SCET120630T	
44898	R220.21 -0080-SC12.6A	Arbor	2.0	80.0	61.0	62.0	50.0	1.1	4.4	0.8	6	1.0	8500	SCET120630T	
36194	R220.21 -0084-SC12.5A	Arbor	2.0	84.0	65.0	77.0	55.0	1.1	4.4	0.8	5	1.2	8300	SCET120630T	
33571	R220.21 -0100-SC12.5A	Arbor	2.0	100.0	81.0	77.0	50.0	1.1	4.4	0.75	5	1.3	7600	SCET120630T	
44899	R220.21 -0100-SC12.7A	Arbor	2.0	100.0	81.0	77.0	50.0	1.1	4.4	0.75	7	1.5	7600	SCET120630T	
33572	R220.21 -0125-SC12.6A	Arbor	2.0	125.0	106.0	90.0	63.0	1.1	4.4	0.7	6	2.4	6800	SCET120630T	
33575	R220.21 -8160-SC12.7	Arbor	2.0	160.0	141.0	90.0	63.0	1.1	4.4	-	7	3.8	6000	SCET120630T	

UTCN = Uncut thickness, deviation between programmed corner radii (RP) and generated machined profile. Ramping angle = RPMX

## Mounting Dimensions

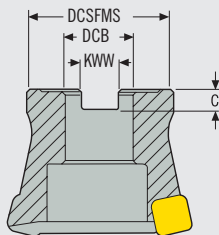

### FOR CUTTER

### DIMENSIONS IN INCH

	DCB	KWW	C
<b>SCET</b>			
R220.21-02.00 - 02.50	0.75	0.32	0.19
R220.21-03.00	1.00	0.38	0.22
R220.21-04.00	1.50	0.63	0.38
R220.21-0050 - 0052	22.0	10.4	6.4
R220.21-0063 - 0080	27.0	12.4	7.0
R220.21-0084 - 0100	32.0	14.4	8.0
R220.21-0125 - 8160	40.0	16.4	9.0

Spare Parts, not included. Must be ordered separately.

For cutter	Key (T-handle)	Insert screw	Insert key	Arbor screw
R220.21-0050-0052	DOUBLE-T	C45011-T20P	H6B-T20P	
R220.21-0063-0080	DOUBLE-T	C45011-T20P	H6B-T20P	MC6S12X35
R220.21-0084	DOUBLE-T	C45011-T20P	H6B-T20PL	MC6S16X40
R220.21-0100	DOUBLE-T	C45011-T20P	H6B-T20PL	MLC6S16X35
R220.21-0125-8160	DOUBLE-T	C45011-T20P	H6B-T20PL	

Torque value 44.3 in/lbs, Torque keys, see MN Milling

# CHOOSING THE RIGHT INSERT

## 218.19 TRIGON INSERTS

- Large overhangs and/or unstable conditions
- Small cutting depths (maximum 0.070") and/or long tool lengths
- Modern, small-to-medium-size CNC machines with high rpms and high feeds
- Can also be used for less powerful machines

## SCET 120630T SQUARE INSERTS WITH STRONG CORNER RADII

- Large, powerful machines
- Horizontal milling
- Stable conditions
- Larger depths of cut (maximum 0.078")

## LPXX TWO-EDGED POSITIVE INSERTS

- Modern design with 2-edged positive insert that achieves low cutting forces
- Small-to-medium-size machines with low torque spindles
- Max cutting depth LP06 = 0.031" and LP05 = 0.026"
- Very good solution for plunge milling as well

## LO06 DOUBLE-SIDED NEGATIVE-EDGED INSERTS

- Modern design with double-sided negative insert with 4 cutting edges that achieves low cutting forces
- Small-to-medium-size machines with low torque spindles
- Max cutting depth LO06 = 0.035"
- Plunge milling possible

## HF6 218.21 DOUBLE-SIDED NEGATIVE-EDGED INSERTS

- Double-sided negative insert, 6 cutting edges with raised edges for positive cutting rake angle in position
- From medium-size machines with medium to high torque spindles
- Max cutting depth 218.21 = 0.070"
- Plunge milling possible

## ON09 DOUBLE-SIDED 16-EDGED INSERTS

- Economical choice for face milling applications in steel and cast iron
- Uses the same insert types as R220.48-ON09 family



## HIGH FEED MILLING - GRADE SELECTION GUIDELINES

Product	Basic Choice	Optimization	Troubleshooting
<b>P</b>	MP2500	MP1500/MP3000	F40M/T350M
<b>M</b>	T350M	MS2500/MS2050	F40M/MM4500
<b>K</b>	MK2050	MK1500/MP1500	MP2500
<b>N</b>	H25		F40M/MM4500
<b>S</b> 1-3	F40M	MS2500	F350M/MM4500
<b>S</b> 11-13	F40M/MS2050	MS2500	T350M/MM4500
<b>H</b>	MH1000		MP3000/F25M

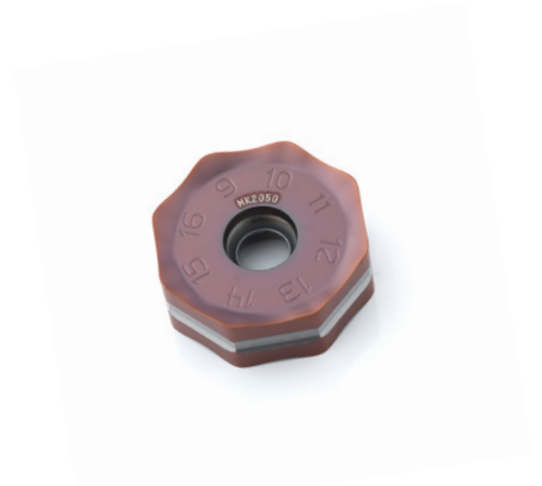

NOTE: Some grades might not be available for all high feed families. Refer to pg 4-5 for additional tool selection information

## HIGH FEED MILLING - PVD-COATED INSERTS

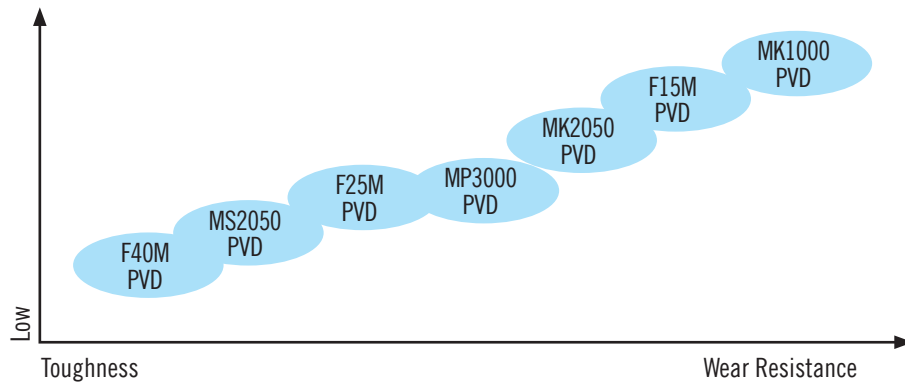

## HIGH FEED MILLING - CVD-COATED INSERTS

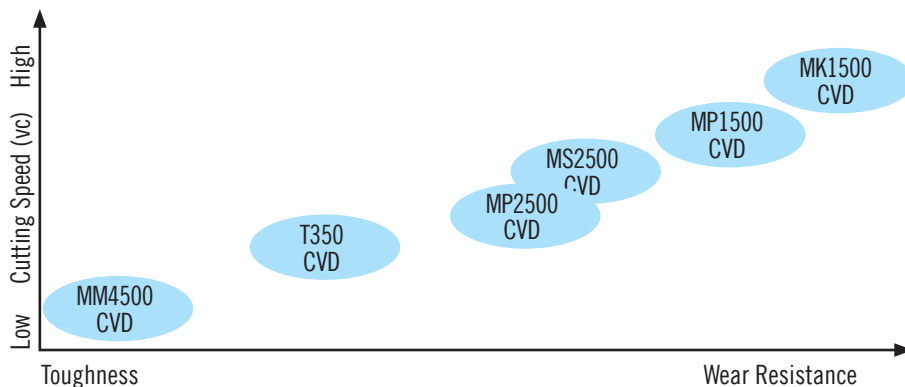

## LP.05/06

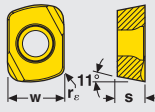

Size	DIMENSIONS IN INCH	
	W	s
05T2	0.200	0.100
0603	0.250	0.125

E05/ME04/ME05/M05/M06



MD05/MD07/D06



DESCRIPTION	$r_e$	Cutting rate	Grades (EDP)								
			Coated								Uncoated
			MP2500	MP3000	MH1000	MM4500	MS2050	MS2500	T350M	F40M	
LPHT 05T210TR-ME04	0.039	16°	-	-	-	84130	84127	-	84129	84128	-
LPKT 05T210TR-M05	0.039	11°	84124	84125	-	-	13822	13823	-	84126	-
LPKW 05T210TR-MD05	0.039	0°	84123	13821	-	-	-	-	-	-	-
LPHT 060310ER-E05	0.039	16°	-	-	-	70901	-	-	-	70892	70887
060310TR-ME05	0.039	16°	-	70871	-	70879	92065	-	-	70873	-
060310TR-M06	0.039	11°	70864	70866	-	-	90227	70855	70859	70867	-
LPHW 060310TR-D06	0.039	0°	-	70840	70837	-	-	-	-	-	-
060310TR-MD07	0.039	0°	70846	-	-	-	-	70844	-	-	-

## LOH.06

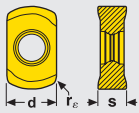

Size	DIMENSIONS IN INCH	
	d	s
LOHT 06	0.250	0.141
LOHT 06 MD	0.250	0.140
LOHW 06	0.250	0.136

D07



M07



MD07



ME06



DESCRIPTION	$r_e$	CUTTING RATE	GRADES (EDP)									
			COATED									
			MP1500	MP2500	MP3000	MH1000	MM4500	MM2050	MS2050	MS2500	T350M	F40M
LOHT 060310TR-M07	0.039	20.0°	-	82255	82245	-	-	-	82253	44207	82254	82246
060310TR-MD07	0.039	7.0°	14018	14014	14019	-	-	14017	-	-	-	-
060310TR-ME06	0.039	27.0°	-	-	-	-	82258	-	14020	82247	82257	82248
LOHW 060310TR-D07	0.039	0.0°	82244	-	82582	82243	-	-	-	-	-	-



## 218.21 - INSERTS

DESCRIPTION	RE	GAN	GRADES (EDP)																
			COATED																
			MP1500	MP2500	MP3000	MH1000	MM4500	MK1500	MK2050	MS2050	MS2500	T350M	F40M						
218.21 -230TR-06-ME13	1.6	21.0°					46462			13736	13737	82289	82290						
218.21 -230TR-06-M15	1.6	17.0°		82286	82287					13733	82283	82284	82288						
218.21 -230TR-06-MD17	1.6	7.0°	82281	82282	13730					13731		82280							

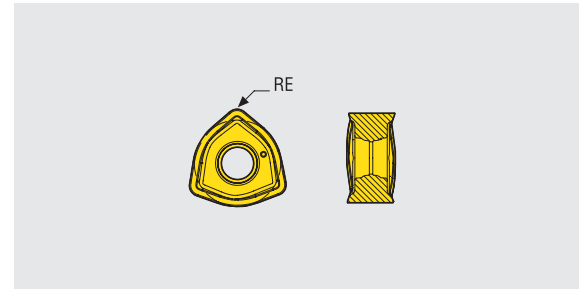

## 218.19

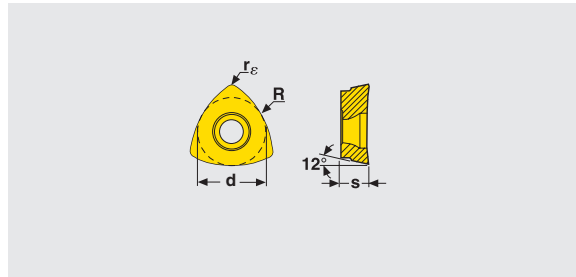

Size	DIMENSIONS IN INCH	
	d	s
100	0.278	0.109
125	0.350	0.156
160	0.440	0.187
200	0.500	0.217
250	0.651	0.250

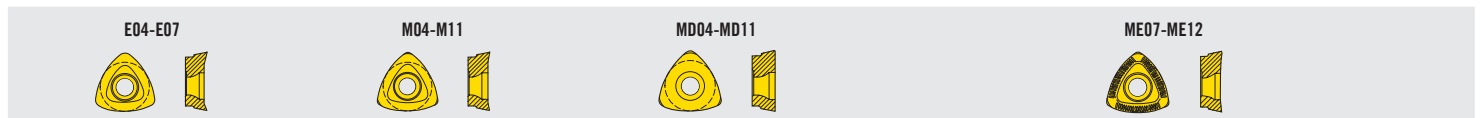

DESCRIPTION	R	r <sub>c</sub>	CUTTING RAKE	GRADES (EDP)														Uncoated H25		
				COATED																
				MP1500	MP2500	MP3000	MH1000	MM4500	MK2050	MS2050	MS2500	T25M	T350M	F15M	F25M	F30M	F40M			
218.19 -100-E06	.394	.031	20°	-	-	-	-	-	-	-	-	-	-	-	-	-	-	-	-	16290
-125-T3-E06	.492	.031	20°	-	-	-	-	-	-	-	-	-	-	-	-	-	-	-	-	16292
-160-04-E07	.630	.047	20°	-	-	-	-	-	-	-	-	-	-	-	-	-	-	-	-	16294
218.19 -125T-T3-ME07	.492	.031	20°	-	-	-	-	-	-	-	-	-	-	-	-	-	-	-	-	23602
-160T-04-ME08	.630	.047	20°	-	-	-	-	-	-	-	-	-	-	-	-	-	-	-	-	23905
-200T-05-ME10	.787	.024	20°	-	-	-	-	-	-	-	-	-	-	-	-	-	-	-	-	23906
-250T-06-ME12	.984	.047	20°	-	-	-	-	-	-	-	-	-	69559	-	-	-	-	-	-	-
218.19 -100T-M06	.394	.031	7°	-	31635	44570	-	65273	-	90224	43151	-	16971	-	79713	79714	23601	-	-	-
-125T-T3-M07	.492	.031	10°	-	31636	44571	-	65274	-	90225	43150	69526	16972	-	79719	79720	69524	-	-	-
-160T-04-M08	.630	.047	10°	-	31637	44574	-	65275	-	90226	43149	69544	17688	-	79736	79737	23605	-	-	-
-160T-04-M11	.630	.047	15°	18248	81950	-	-	-	-	-	-	81952	-	-	-	-	-	-	-	-
-200T-05-M10	.787	.024	10°	-	-	-	-	-	-	-	-	-	-	-	79722	-	23607	-	-	-
218.19 -100T-MD08	.394	.031	0°	35208	35115	-	29619	-	09425	-	43152	-	-	16269	12507	-	-	-	-	-
-125T-T3-MD08	.492	.031	0°	-	-	44572	-	-	-	-	-	-	-	-	-	-	79718	-	-	-
-125T-T3-MD10	.492	.031	0°	35211	35116	-	30651	-	09420	-	43156	-	23837	16282	16897	-	-	-	-	-
-160T-04-MD09	.630	.047	0°	-	-	44575	-	-	-	-	-	-	-	-	-	-	79739	-	-	-
-160T-04-MD11	.630	.047	0°	35215	35117	-	65262	-	84397	-	43148	-	24178	16285	16898	-	-	-	-	-

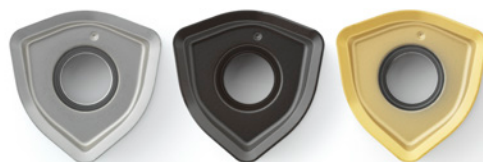



## ON..05/09

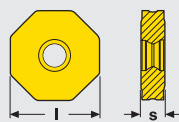

Size	DIMENSIONS IN INCH	
	l	s
ON..05	0.472	0.157
ON..09	0.866	0.228

MD16/MD17



ME10-13/M10-15



ZZTN4-M10/M14



DESCRIPTION	B	Cutting rake	GRADES (EDP)										Cermet
			COATED										
			MP1500	MP2500	MP3000	MM4500	MK1500	MK2050	MS2050	MS2500	T350M	F40M	
ONMU 090520ANTN-MD16	0.018	0°	55060	52539	-	-	52537	-	-	-	55416	-	-
090520ANTN-MD17	0.083	0°	55066	52545	-	-	52542	-	-	-	-	-	-
090520ANTN-ME12	0.018	20°	65474	65476	65478	65477	65464	-	90218	81172	65482	65480	-
090520ANTN-ME13	0.083	20°	62489	62490	62491	65488	62486	78951	90220	81174	62492	62485	-
090520ANTN-M12	0.018	20°	65458	65459	-	65460	65455	78957	-	84851	65463	65462	-
090520ANTN-M13	0.083	20°	55054	52532	52533	65505	52529	78956	-	81173	55420	52534	09977
090520ANTN-M14	0.018	15°	55020	52524	52526	-	52517	78955	-	-	55414	52528	-
090520ANTN-M15	0.083	15°	55019	52512	52515	-	45389	78954	-	-	55415	52516	-

\* ONEU wiper inserts have 4 right hand and 4 left hand cutting edges.

## SC..12

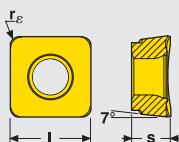

Size	DIMENSIONS IN INCH	
	l	s
SC..1206	0.500	0.250

M11/M14/MD15/MD16



ME10



DESCRIPTION	r <sub>c</sub>	Cutting rake	GRADES (EDP)										Uncoated
			COATED										
			MP1500	MP2500	MP3000	MK1500	MK2050	MS2050	MS2500	T25M	T350M	F40M	
SCET 120612T-ME10	0.047	22°	-	-	-	-	-	14214	-	-	-	24022	-
120612T-M11	0.047	14°	35253	31679	-	31392	-	14212	-	-	03997	91827	-
120612T-M14	0.047	15°	-	31680	-	31393	-	14213	-	17057	03979	04903	43724
120612T-MD15	0.047	15°	35254	-	44668	-	-	-	-	-	23955	-	-
120630T-M14	0.118*	15°	-	35118	59218	-	09408	14215	43905	-	23956	57376	-
120630T-MD16	0.118*	15°	42331	42333	-	-	-	-	42345	-	42340	42336	-
SCEX 120660T-M14	0.236*	15°	-	-	-	-	-	-	-	-	23957	-	-
SCMT 120612T-M14	0.047	15°	-	-	-	-	-	-	-	-	16991	07514	-

\* When using inserts with corner radii > 0.118" the cutter body must be modified.



## Cutting data - JHF980 Slotting

SMG		APMX / DC1	$f_z$											$v_c$
			1	1.5	2	3	4	5	6	8	10	12		
P1	E/M/A	0.080	0.090	0.11	0.13	0.15	0.18	0.20	0.22	0.26	0.30	0.36	325 (395 - 315)	
P2	E/M/A	0.080	0.090	0.11	0.13	0.16	0.18	0.20	0.22	0.26	0.30	0.36	320 (385 - 305)	
P3	E/M/A	0.080	0.085	0.10	0.12	0.15	0.17	0.19	0.20	0.24	0.30	0.36	275 (330 - 265)	
P4	E/M/A	0.080	0.085	0.10	0.12	0.15	0.17	0.19	0.20	0.24	0.30	0.36	240 (290 - 230)	
P5	E/M/A	0.080	0.080	0.10	0.12	0.14	0.16	0.18	0.20	0.24	0.30	0.36	230 (275 - 220)	
P6	E/M/A	0.080	0.080	0.10	0.12	0.14	0.16	0.18	0.20	0.24	0.30	0.36	260 (310 - 250)	
P7	E/M/A	0.080	0.080	0.10	0.12	0.14	0.16	0.18	0.20	0.24	0.30	0.36	245 (295 - 235)	
P8	E/M/A	0.080	0.085	0.10	0.12	0.15	0.17	0.19	0.20	0.24	0.30	0.36	230 (275 - 220)	
P11	E/M/A	0.080	0.080	0.10	0.12	0.14	0.16	0.18	0.20	0.24	0.30	0.36	235 (285 - 230)	
M1	E/M/A	0.065	0.060	0.075	0.085	0.10	0.12	0.13	0.15	0.20	0.26	0.30	125 (155 - 120)	
M2	E/M/A	0.065	0.060	0.075	0.085	0.10	0.12	0.13	0.15	0.20	0.26	0.30	100 (125 - 95)	
M3	E/M/A	0.065	0.060	0.075	0.085	0.10	0.12	0.13	0.15	0.20	0.26	0.30	95 (120 - 90)	
M4	E/M/A	0.048	0.060	0.075	0.090	0.11	0.12	0.14	0.15	0.20	0.26	0.30	75 (95 - 65)	
M5	E/M/A	0.048	0.060	0.075	0.090	0.11	0.12	0.14	0.15	0.20	0.26	0.30	60 (75 - 55)	
K1	E/M/A	0.080	0.080	0.10	0.12	0.14	0.16	0.18	0.20	0.24	0.30	0.36	180 (220 - 165)	
K2	E/M/A	0.080	0.080	0.10	0.12	0.14	0.16	0.18	0.20	0.24	0.30	0.36	155 (190 - 145)	
K3	E/M/A	0.080	0.080	0.10	0.12	0.14	0.16	0.18	0.20	0.24	0.30	0.36	130 (165 - 120)	
K4	E/M/A	0.080	0.080	0.10	0.12	0.14	0.16	0.18	0.20	0.24	0.30	0.36	125 (155 - 115)	
K5	E/M/A	0.080	0.080	0.10	0.12	0.14	0.16	0.18	0.20	0.24	0.30	0.36	130 (165 - 110)	
K6	E/M/A	0.080	0.080	0.10	0.12	0.14	0.16	0.18	0.20	0.24	0.30	0.36	190 (245 - 165)	
K7	E/M/A	0.080	0.080	0.10	0.12	0.14	0.16	0.18	0.20	0.24	0.30	0.36	165 (215 - 140)	
S1	E	0.040	0.038	0.046	0.055	0.065	0.075	0.090	0.11	0.14	0.18	0.22	50 (65 - 44)	
S2	E	0.040	0.038	0.046	0.055	0.065	0.075	0.090	0.11	0.14	0.18	0.22	41 (55 - 35)	
S3	E	0.040	0.038	0.046	0.055	0.065	0.075	0.090	0.11	0.14	0.18	0.22	31 (44 - 22)	
S11	E	0.040	0.055	0.065	0.075	0.090	0.11	0.12	0.13	0.15	0.18	0.22	150 (185 - 140)	
S12	E	0.040	0.055	0.065	0.075	0.090	0.11	0.12	0.13	0.15	0.18	0.22	115 (140 - 110)	
S13	E	0.034	0.050	0.065	0.075	0.090	0.10	0.11	0.13	0.15	0.18	0.22	90 (110 - 85)	
H5	M/A/D	0.065	0.060	0.075	0.085	0.10	0.12	0.13	0.15	0.20	0.26	0.30	95 (120 - 90)	
H8	M/A/D	0.055	0.055	0.065	0.075	0.090	0.11	0.13	0.15	0.20	0.26	0.30	100 (125 - 90)	
H21	M/A/D	0.055	0.055	0.065	0.075	0.090	0.11	0.13	0.15	0.20	0.26	0.30	100 (125 - 90)	
H31	M/A/D	0.065	0.060	0.075	0.085	0.10	0.12	0.13	0.15	0.20	0.26	0.30	70 (90 - 65)	

SMG = Seco material group

Coolant = A=air D=dry E=emulsion M=mist spray

$v_c$  = m/min

$f_z$  = mm

APMX (mm)/DC (mm)= factor

All cutting data are target values

## Cutting data - JHF980 Side milling $a_e/DC = 0,3$

SMG		APMX / DC1	$f_z$											$v_c$
			1.0	1.5	2	3	4	5	6	8	10	12		
P1	E/M/A	0.080	0.10	0.15	0.20	0.30	0.40	0.46	0.50	0.55	0.65	0.70	415 (500 - 400)	
P2	E/M/A	0.080	0.10	0.15	0.20	0.30	0.40	0.46	0.50	0.60	0.65	0.70	405 (485 - 390)	
P3	E/M/A	0.080	0.10	0.15	0.20	0.30	0.40	0.44	0.48	0.55	0.60	0.65	355 (425 - 340)	
P4	E/M/A	0.080	0.10	0.15	0.20	0.30	0.38	0.42	0.46	0.55	0.60	0.65	310 (375 - 300)	
P5	E/M/A	0.080	0.10	0.15	0.20	0.30	0.38	0.42	0.46	0.50	0.60	0.65	300 (360 - 285)	
P6	E/M/A	0.080	0.10	0.15	0.20	0.30	0.38	0.42	0.46	0.50	0.60	0.60	335 (405 - 325)	
P7	E/M/A	0.080	0.10	0.15	0.20	0.30	0.38	0.42	0.46	0.50	0.60	0.60	315 (380 - 305)	
P8	E/M/A	0.080	0.10	0.15	0.20	0.30	0.40	0.44	0.48	0.55	0.60	0.65	300 (360 - 285)	
P11	E/M/A	0.080	0.10	0.15	0.20	0.30	0.38	0.42	0.46	0.50	0.60	0.60	305 (370 - 295)	
M1	E/M/A	0.065	0.085	0.13	0.17	0.24	0.28	0.30	0.32	0.38	0.42	0.46	170 (205 - 160)	
M2	E/M/A	0.065	0.085	0.13	0.17	0.22	0.24	0.28	0.30	0.34	0.38	0.42	140 (170 - 135)	
M3	E/M/A	0.065	0.085	0.13	0.17	0.24	0.28	0.30	0.32	0.38	0.42	0.46	130 (160 - 120)	
M4	E/M/A	0.065	0.085	0.13	0.17	0.20	0.24	0.26	0.28	0.34	0.36	0.40	100 (125 - 90)	
M5	E/M/A	0.065	0.085	0.13	0.17	0.20	0.24	0.26	0.28	0.34	0.36	0.40	85 (105 - 75)	
K1	E/M/A	0.080	0.10	0.15	0.20	0.30	0.38	0.42	0.46	0.50	0.60	0.65	230 (285 - 215)	
K2	E/M/A	0.080	0.10	0.15	0.20	0.30	0.34	0.38	0.42	0.48	0.55	0.55	205 (255 - 190)	
K3	E/M/A	0.080	0.10	0.15	0.20	0.30	0.34	0.38	0.42	0.48	0.55	0.55	175 (215 - 160)	
K4	E/M/A	0.080	0.10	0.15	0.20	0.30	0.34	0.38	0.42	0.48	0.55	0.55	165 (205 - 155)	
K5	E/M/A	0.080	0.10	0.15	0.20	0.30	0.38	0.42	0.46	0.50	0.60	0.65	165 (215 - 145)	
K6	E/M/A	0.080	0.10	0.15	0.20	0.30	0.40	0.46	0.50	0.60	0.65	0.70	240 (315 - 210)	
K7	E/M/A	0.080	0.10	0.15	0.20	0.30	0.38	0.42	0.46	0.50	0.60	0.65	210 (275 - 185)	
H5	M/A/D	0.065	0.085	0.13	0.17	0.24	0.28	0.30	0.32	0.38	0.42	0.46	130 (165 - 120)	
H8	M/A/D	0.065	0.085	0.13	0.15	0.18	0.20	0.22	0.26	0.28	0.32	0.34	140 (170 - 125)	
H21	M/A/D	0.065	0.085	0.13	0.15	0.18	0.20	0.22	0.26	0.28	0.32	0.34	140 (170 - 125)	
H31	M/A/D	0.065	0.085	0.13	0.17	0.24	0.28	0.30	0.32	0.38	0.42	0.46	95 (120 - 90)	

SMG = Seco material group  
 Coolant = A=air D=dry E=emulsion M=mist spray  
 $v_c$  = m/min  
 $f_z$  = mm  
 APMX (mm)/DC (mm)= factor  
 $a_e$  (mm)/DC (mm)= factor  
 All cutting data are target values

## Cutting data - JHF980 Side milling $a_e/DC1 = 0,3$

SMG		APMX / DC	$f_z$			$v_c$
			4	5	6	
P1	E/M/A	0.080	0.55	0.65	0.70	410 (495 - 395)
P2	E/M/A	0.080	0.60	0.65	0.70	400 (485 - 385)
P3	E/M/A	0.080	0.55	0.60	0.65	350 (425 - 340)
P4	E/M/A	0.080	0.55	0.60	0.65	310 (370 - 300)
P5	E/M/A	0.080	0.50	0.60	0.65	295 (355 - 285)
P6	E/M/A	0.080	0.50	0.60	0.60	330 (400 - 320)
P7	E/M/A	0.080	0.50	0.60	0.60	315 (375 - 300)
P8	E/M/A	0.080	0.55	0.60	0.65	295 (355 - 285)
P11	E/M/A	0.080	0.50	0.60	0.60	305 (365 - 295)
M1	E/M/A	0.065	0.38	0.42	0.46	170 (205 - 160)
M2	E/M/A	0.065	0.34	0.38	0.42	140 (170 - 130)
M3	E/M/A	0.065	0.38	0.42	0.46	130 (160 - 115)
M4	E/M/A	0.065	0.34	0.36	0.40	100 (125 - 90)
M5	E/M/A	0.065	0.34	0.36	0.40	80 (105 - 75)
K1	E/M/A	0.080	0.50	0.60	0.65	230 (285 - 215)
K2	E/M/A	0.080	0.48	0.55	0.55	205 (250 - 190)
K3	E/M/A	0.080	0.48	0.55	0.55	170 (215 - 160)
K4	E/M/A	0.080	0.48	0.55	0.55	165 (205 - 150)
K5	E/M/A	0.080	0.50	0.60	0.65	165 (215 - 140)
K6	E/M/A	0.080	0.60	0.65	0.70	240 (310 - 205)
K7	E/M/A	0.080	0.50	0.60	0.65	210 (275 - 180)
H5	M/A/D	0.065	0.38	0.42	0.46	130 (160 - 120)
H8	M/A/D	0.065	0.28	0.32	0.34	135 (170 - 125)
H21	M/A/D	0.065	0.28	0.32	0.34	135 (170 - 125)
H31	M/A/D	0.065	0.38	0.42	0.46	95 (120 - 90)

SMG = Seco material group  
 Coolant = A=air D=dry E=emulsion M=mist spray  
 $v_c$  = m/min  
 $f_z$  = mm  
 APMX (mm)/DC (mm)= factor  
 $a_e$  (mm)/DC (mm)= factor  
 All cutting data are target values

Plunging data is available on page 341 of the Solid Milling Navigator 2016

## Cutting data - JHF180 Slotting CEDC 3, 4, 5

SMG		APMX / DCX	f <sub>z</sub>								v <sub>c</sub>
			2	3	4	6	8	10	12		
P6	E/M/A	0.024	0.048	0.065	0.090	0.13	0.18	0.20	0.20	270 (240 - 300)	
P7	E/M/A	0.024	0.048	0.065	0.090	0.13	0.18	0.20	0.20	255 (225 - 285)	
P8	E/M/A	0.024	0.050	0.065	0.090	0.13	0.18	0.20	0.22	240 (215 - 270)	
P11	E/M/A	0.024	0.048	0.065	0.090	0.13	0.18	0.20	0.20	250 (220 - 275)	
K1	E/M/A	0.024	0.055	0.070	0.090	0.13	0.18	0.22	0.24	190 (160 - 215)	
K2	E/M/A	0.024	0.055	0.070	0.090	0.13	0.18	0.20	0.22	165 (140 - 185)	
K3	E/M/A	0.024	0.055	0.070	0.090	0.13	0.18	0.20	0.22	140 (120 - 155)	
K4	E/M/A	0.024	0.055	0.070	0.090	0.13	0.18	0.20	0.22	130 (115 - 150)	
K5	E/M/A	0.024	0.050	0.060	0.070	0.090	0.11	0.14	0.17	135 (110 - 160)	
K6	E/M/A	0.024	0.050	0.060	0.070	0.090	0.11	0.14	0.17	200 (160 - 240)	
K7	E/M/A	0.024	0.050	0.060	0.070	0.090	0.11	0.14	0.17	175 (140 - 205)	
H3	M/A/D	0.017	0.060	0.075	0.085	0.11	0.13	0.16	0.20	75 (50 - 95)	
H5	M/A/D	0.028	0.065	0.080	0.090	0.13	0.18	0.22	0.26	135 (105 - 160)	
H7	M/A/D	0.015	0.065	0.080	0.095	0.11	0.13	0.16	0.20	75 (50 - 95)	
H8	M/A/D	0.024	0.055	0.070	0.090	0.13	0.18	0.22	0.24	135 (110 - 160)	
H21	M/A/D	0.024	0.055	0.070	0.090	0.13	0.18	0.22	0.24	135 (110 - 160)	
H31	M/A/D	0.024	0.050	0.065	0.090	0.13	0.18	0.20	0.20	100 (80 - 120)	

## Cutting data - JHF181 Side roughing a<sub>e</sub>/DC = 0,3

SMG		APMX / DC1	f <sub>z</sub>												v <sub>c</sub>
			2	3	4	6	7	8	9	10	11	12	13	16	
P6	E/M/A	0.050	0.20	0.24	0.28	0.34	0.36	0.38	0.38	0.40	0.40	0.40	0.40	0.40	355 (315 - 395)
P7	E/M/A	0.050	0.20	0.24	0.28	0.34	0.36	0.38	0.38	0.40	0.40	0.40	0.40	0.40	335 (295 - 370)
P8	E/M/A	0.050	0.20	0.26	0.30	0.36	0.38	0.40	0.40	0.42	0.42	0.42	0.44	310 (275 - 345)	
P11	E/M/A	0.050	0.20	0.24	0.28	0.34	0.36	0.38	0.38	0.40	0.40	0.40	0.40	0.40	325 (290 - 360)
K1	E/M/A	0.050	0.20	0.24	0.28	0.34	0.36	0.38	0.40	0.40	0.40	0.42	0.42	245 (210 - 280)	
K2	E/M/A	0.050	0.18	0.22	0.26	0.32	0.34	0.34	0.36	0.36	0.36	0.38	0.38	215 (185 - 245)	
K3	E/M/A	0.050	0.18	0.22	0.26	0.32	0.34	0.34	0.36	0.36	0.36	0.38	0.38	180 (155 - 210)	
K4	E/M/A	0.050	0.18	0.22	0.26	0.32	0.34	0.34	0.36	0.36	0.36	0.38	0.38	175 (150 - 200)	
K5	E/M/A	0.050	0.17	0.22	0.26	0.32	0.34	0.34	0.36	0.36	0.36	0.38	0.38	165 (135 - 200)	
K6	E/M/A	0.050	0.17	0.24	0.28	0.34	0.36	0.38	0.40	0.40	0.40	0.42	0.42	240 (195 - 290)	
K7	E/M/A	0.050	0.17	0.22	0.26	0.32	0.34	0.34	0.36	0.36	0.36	0.38	0.38	210 (170 - 255)	
H3	M/A/D	0.034	0.16	0.20	0.22	0.28	0.30	0.30	0.32	0.32	0.32	0.34	0.34	95 (65 - 120)	
H5	M/A/D	0.055	0.24	0.30	0.36	0.42	0.46	0.48	0.50	0.50	0.50	0.50	0.50	165 (135 - 200)	
H7	M/A/D	0.030	0.17	0.20	0.24	0.30	0.32	0.32	0.34	0.34	0.34	0.36	0.36	95 (65 - 120)	
H8	M/A/D	0.050	0.20	0.24	0.28	0.34	0.36	0.38	0.40	0.40	0.40	0.42	0.42	175 (140 - 210)	
H21	M/A/D	0.050	0.20	0.24	0.28	0.34	0.36	0.38	0.40	0.40	0.40	0.42	0.42	175 (140 - 210)	
H31	M/A/D	0.050	0.17	0.22	0.24	0.30	0.32	0.34	0.34	0.34	0.36	0.36	0.36	135 (110 - 165)	

SMG = Seco material group

Coolant = A=air D=dry E=emulsion M=mist spray

v<sub>c</sub> = m/min

f<sub>z</sub> = mm

APMX (mm)/DC (mm)= factor

a<sub>e</sub> (mm)/DC (mm)= factor

All cutting data are target values



## Cutting data - SN200R, SN400R, SN500R Slot Milling

ISO GROUP	SMG	a <sub>e</sub> (Max)	V <sub>c</sub> (sf / min)	SLOT MILLING											
				Zn = 4										Zn = 5	
				1/8	5/32	3/16	1/4	5/16	3/8	1/2	3/8	1/2			
P	M/A/D 1 - 2	1.00 x DCX	984	n [rev/min]	30079	24062	20052	15039	12031	10026	7520	10026	7520		
				fz [in]	0.0041	0.0052	0.0062	0.0083	0.0103	0.0124	0.0165	0.0124	0.0165		
			820	1148	vf [in/min]	496	496	496	496	496	496	496	620	620	
		1.00 x DCX	738	n [rev/min]	22559	18047	15039	11280	9024	7520	5640	7520	5640		
				fz [in]	0.0038	0.0047	0.0056	0.0075	0.0094	0.0113	0.0150	0.0113	0.0150		
			656	820	vf [in/min]	338	338	338	338	338	338	338	423	423	
	1.00 x DCX	574	n [rev/min]	17546	14036	11697	8773	7018	5849	4386	5849	4386			
			fz [in]	0.0034	0.0042	0.0051	0.0068	0.0084	0.0101	0.0135	0.0101	0.0135			
		492	656	vf [in/min]	237	237	237	237	237	237	237	296	296		
	H	M/A/D 7a	1.00 x DCX	312	n [rev/min]	9525	7620	6350	4762	3810	3175	2381	3175	2381	
					fz [in]	0.0030	0.0038	0.0045	0.0060	0.0075	0.0090	0.0120	0.0090	0.0120	
				262	361	vf [in/min]	114	114	114	114	114	114	143	143	
1.00 x DCX			410	n [rev/min]	12533	10026	8355	6266	5013	4178	3133	4178	3133		
				fz [in]	0.0030	0.0038	0.0045	0.0060	0.0075	0.0090	0.0120	0.0090	0.0120		
			361	459	vf [in/min]	150	150	150	150	150	150	188	188		
M		E/M/A 8 - 9	1.00 x DCX	312	n [rev/min]	9525	7620	6350	4762	3810	3175	2381	3175	2381	
					fz [in]	0.0030	0.0038	0.0045	0.0060	0.0075	0.0090	0.0120	0.0090	0.0120	
				262	361	vf [in/min]	114	114	114	114	114	114	143	143	
		1.00 x DCX	574	n [rev/min]	17546	14036	11697	8773	7018	5849	4386	5849	4386		
				fz [in]	0.0038	0.0047	0.0056	0.0075	0.0094	0.0113	0.0150	0.0113	0.0150		
			492	656	vf [in/min]	263	263	263	263	263	263	263	329	329	
K	E/M/A 12 - 13	1.00 x DCX	410	n [rev/min]	12533	10026	8355	6266	5013	4178	3133	4178	3133		
				fz [in]	0.0034	0.0042	0.0051	0.0068	0.0084	0.0101	0.0135	0.0101	0.0135		
			328	492	vf [in/min]	169	169	169	169	169	169	211	211		
	1.00 x DCX	164	n [rev/min]	5013	4010	3342	2507	2005	1671	1253	1671	1253			
			fz [in]	0.0023	0.0028	0.0034	0.0045	0.0056	0.0068	0.0090	0.0068	0.0090			
		131	197	vf [in/min]	45	45	45	45	45	45	56	56			
S	E 19	1.00 x DCX	164	n [rev/min]	5013	4010	3342	2507	2005	1671	1253	1671	1253		
				fz [in]	0.0023	0.0028	0.0034	0.0045	0.0056	0.0068	0.0090	0.0068	0.0090		
			131	197	vf [in/min]	45	45	45	45	45	45	56	56		
		1.00 x DCX	98	n [rev/min]	3008	2406	2005	1504	1203	1003	752	1003	752		
				fz [in]	0.0023	0.0028	0.0034	0.0045	0.0056	0.0068	0.0090	0.0068	0.0090		
			66	131	vf [in/min]	27	27	27	27	27	27	34	34		
	1.00 x DCX	377	n [rev/min]	11530	9224	7687	5765	4612	3843	2883	3843	2883			
			fz [in]	0.0023	0.0028	0.0034	0.0045	0.0056	0.0068	0.0090	0.0068	0.0090			
		328	427	vf [in/min]	104	104	104	104	104	104	130	130			
	1.00 x DCX	377	n [rev/min]	11530	9224	7687	5765	4612	3843	2883	3843	2883			
			fz [in]	0.0023	0.0028	0.0034	0.0045	0.0056	0.0068	0.0090	0.0068	0.0090			
		328	427	vf [in/min]	104	104	104	104	104	104	130	130			

\*E = Emulsion M = Mist spray A = Air \*\*Reduce APMX 20% and Feed per tooth 15% when using 5 x D version

\*\*Reduce APMX 40% and Feed per tooth 30% when using 7 x D version \*\*\*pd: plunge depth

ap = APMX



## Cutting data -SN200R, SN400R, SN500R Side Milling

ISO GROUP	SMG	ae (Max)	vc (sf / min)		SIDE MILLING										
					Zn = 2										
					1/16	3/32	1/8	5/32	3/16	1/4	5/16	3/8	1/2		
P	M/A/D 1 - 2	0.30 x DCX	984	1148	n [rev/min]	60157	40105	30079	24062	20052	15039	12031	10026	7520	
					fz [in]	0.0034	0.0052	0.0069	0.0086	0.0103	0.0138	0.0172	0.0206	0.0275	
			vf [in/min]	414	414	414	414	414	414	414	414	414			
	M/A/D 3 - 4	0.30 x DCX	738	820	820	APMX max**	0.0040	0.0060	0.0080	0.0100	0.0120	0.0140	0.0160	0.0180	0.0200
						n [rev/min]	45118	30079	22559	18047	15039	11280	9024	7520	5640
			fz [in]	0.0031	0.0047	0.0063	0.0078	0.0094	0.0125	0.0156	0.0188	0.0250			
	M/A/D 5 - 6	0.30 x DCX	574	492	656	vf [in/min]	282	282	282	282	282	282	282	282	282
						APMX max**	0.0040	0.0060	0.0080	0.0100	0.0120	0.0140	0.0160	0.0180	0.0200
			n [rev/min]	35092	23395	17546	14036	11697	8773	7018	5849	4386			
H	M/A/D 7a	0.30 x DCX	312	361	n [rev/min]	19050	12700	9525	7620	6350	4762	3810	3175	2381	
					fz [in]	0.0025	0.0038	0.0050	0.0063	0.0075	0.0100	0.0125	0.0150	0.0200	
			vf [in/min]	95	95	95	95	95	95	95	95	95			
M	E/M/A 8 - 9	0.30 x DCX	410	459	n [rev/min]	25066	16710	12533	10026	8355	6266	5013	4178	3133	
					fz [in]	0.0025	0.0038	0.0050	0.0063	0.0075	0.0100	0.0125	0.0150	0.0200	
			vf [in/min]	125	125	125	125	125	125	125	125	125			
	E/M/A 10 - 11	0.30 x DCX	459	262	361	APMX max**	0.0032	0.0048	0.0064	0.0080	0.0096	0.0112	0.0128	0.0144	0.0160
						n [rev/min]	28073	18716	14037	11229	9358	7018	5615	4679	3509
			fz [in]	0.0025	0.0038	0.0050	0.0063	0.0075	0.0100	0.0125	0.0150	0.0200			
K	E/M/A 12 - 13	0.30 x DCX	574	492	656	vf [in/min]	175	175	175	175	175	175	175	175	
						APMX max**	0.0040	0.0060	0.0080	0.0100	0.0120	0.0140	0.0160	0.0180	0.0200
			n [rev/min]	35092	23395	17546	14036	11697	8773	7018	5849	4386			
	E/M/A 14 - 15	0.30 x DCX	410	328	492	n [rev/min]	25066	16710	12533	10026	8355	6266	5013	4178	3133
						fz [in]	0.0019	0.0028	0.0038	0.0047	0.0056	0.0075	0.0094	0.0113	0.0150
			vf [in/min]	94	94	94	94	94	94	94	94	94			
S	E 19	0.30 x DCX	164	131	197	n [rev/min]	10026	6684	5013	4010	3342	2507	2005	1671	1253
						fz [in]	0.0015	0.0023	0.0030	0.0038	0.0045	0.0060	0.0075	0.0090	0.0120
			vf [in/min]	30	30	30	30	30	30	30	30	30			
	E 20	0.30 x DCX	164	131	197	APMX max**	0.0020	0.0030	0.0040	0.0050	0.0060	0.0070	0.0080	0.0090	0.0100
						n [rev/min]	10026	6684	5013	4010	3342	2507	2005	1671	1253
			fz [in]	0.0015	0.0023	0.0030	0.0038	0.0045	0.0060	0.0075	0.0090	0.0120			
	E 21	0.30 x DCX	98	66	131	vf [in/min]	30	30	30	30	30	30	30	30	30
						APMX max**	0.0020	0.0030	0.0040	0.0050	0.0060	0.0070	0.0080	0.0090	0.0100
			n [rev/min]	6016	4010	3008	2406	2005	1504	1203	1003	752			
	E 22	0.30 x DCX	377	328	427	fz [in]	0.0015	0.0023	0.0030	0.0038	0.0045	0.0060	0.0075	0.0090	0.0120
						vf [in/min]	18	18	18	18	18	18	18	18	18
			APMX max**	0.0020	0.0030	0.0040	0.0050	0.0060	0.0070	0.0080	0.0090	0.0100			
			377	427	n [rev/min]	23060	15374	11530	9224	7687	5765	4612	3843	2883	
					fz [in]	0.0022	0.0033	0.0044	0.0055	0.0066	0.0088	0.0109	0.0131	0.0175	
			vf [in/min]	101	101	101	101	101	101	101	101	101			
					APMX max**	0.0020	0.0030	0.0040	0.0050	0.0060	0.0070	0.0080	0.0090	0.0100	

\*E = Emulsion M = Mist spray A = Air \*\*Reduce APMX 20% and Feed per tooth 15% when using 5 x D version

\*\*Reduce APMX 40% and Feed per tooth 30% when using 7 x D version \*\*\*pd: plunge depth

ap = APMX

## Cutting data -SN200R, SN400R, SN500R Side Milling

ISO GROUP	SMG	a <sub>e</sub> (Max)	v <sub>c</sub> (sf / min)	SIDE MILLING												
				Zn = 4								Zn = 5				
				1/8	5/32	3/16	1/4	5/16	3/8	1/2	3/8	1/2				
P	M/A/D 1 - 2	0.30 x DCX	984	n [rev/min]	30079	24062	20052	15039	12031	10026	7520	10026	7520			
				fz [in]	0.0069	0.0086	0.0103	0.0138	0.0172	0.0206	0.0275	0.0206	0.0275			
			820	1148	vf [in/min]	827	827	827	827	827	827	827	1034	1034		
	APMX max**	0.0080			0.0100	0.0120	0.0140	0.0160	0.0180	0.0200	0.0180	0.0200				
	M/A/D 3 - 4	0.30 x DCX	738	n [rev/min]	22559	18047	15039	11280	9024	7520	5640	7520	5640			
				fz [in]	0.0063	0.0078	0.0094	0.0125	0.0156	0.0188	0.0250	0.0188	0.0250			
			656	820	vf [in/min]	564	564	564	564	564	564	564	705	705		
	APMX max**	0.0080			0.0100	0.0120	0.0140	0.0160	0.0180	0.0200	0.0180	0.0200				
	M/A/D 5 - 6	0.30 x DCX	574	n [rev/min]	17546	14036	11697	8773	7018	5849	4386	5849	4386			
fz [in]				0.0056	0.0070	0.0084	0.0113	0.0141	0.0169	0.0225	0.0169	0.0225				
492			656	vf [in/min]	395	395	395	395	395	395	395	493	493			
	APMX max**	0.0080		0.0100	0.0120	0.0140	0.0160	0.0180	0.0200	0.0180	0.0200					
H	M/A/D 7a	0.30 x DCX	312	n [rev/min]	9525	7620	6350	4762	3810	3175	2381	3175	2381			
				fz [in]	0.0050	0.0063	0.0075	0.0100	0.0125	0.0150	0.0200	0.0150	0.0200			
			262	361	vf [in/min]	190	190	190	190	190	190	190	238	238		
					APMX max**	0.0064	0.0080	0.0096	0.0012	0.0128	0.0144	0.0160	0.0144	0.0160		
			M	E/M/A 8 - 9	0.30 x DCX	410	n [rev/min]	12533	10026	8355	6266	5013	4178	3133	4178	3133
							fz [in]	0.0050	0.0063	0.0075	0.0100	0.0125	0.0150	0.0200	0.0150	0.0200
361	459	vf [in/min]				251	251	251	251	251	251	251	313	313		
		APMX max**		0.0064	0.0080	0.0096	0.0012	0.0128	0.0144	0.0160	0.0144	0.0160				
E/M/A 10 - 11	0.30 x DCX	459		n [rev/min]	14037	11229	9358	7018	5615	4679	3509	4679	3509			
				fz [in]	0.0050	0.0063	0.0075	0.0100	0.0125	0.0150	0.0200	0.0150	0.0200			
		262	361	vf [in/min]	281	281	281	281	281	281	281	351	351			
APMX max**	0.0064			0.0080	0.0096	0.0012	0.0128	0.0144	0.0160	0.0144	0.0160					
K	E/M/A 12 - 13	0.30 x DCX	574	n [rev/min]	17546	14036	11697	8773	7018	5849	4386	5849	4386			
				fz [in]	0.0050	0.0063	0.0075	0.0100	0.0125	0.0150	0.0200	0.0150	0.0200			
			492	656	vf [in/min]	351	351	351	351	351	351	351	439	439		
	APMX max**	0.0080			0.0100	0.0120	0.0140	0.0160	0.0180	0.0200	0.0180	0.0200				
	E/M/A 14 - 15	0.30 x DCX	410	n [rev/min]	12533	10026	8355	6266	5013	4178	3133	4178	3133			
				fz [in]	0.0038	0.0047	0.0056	0.0075	0.0094	0.0113	0.0150	0.0113	0.0150			
328			492	vf [in/min]	188	188	188	188	188	188	188	235	235			
	APMX max**	0.0080		0.0100	0.0120	0.0140	0.0160	0.0180	0.0200	0.0180	0.0200					
S	E 19	0.30 x DCX	164	n [rev/min]	5013	4010	3342	2507	2005	1671	1253	1671	1253			
				fz [in]	0.0030	0.0038	0.0045	0.0060	0.0075	0.0090	0.0120	0.0090	0.0120			
			131	197	vf [in/min]	60	60	60	60	60	60	60	75	75		
					APMX max**	0.0040	0.0050	0.0060	0.0070	0.0080	0.0090	0.0100	0.0090	0.0100		
	E 20	0.30 x DCX	164	n [rev/min]	5013	4010	3342	2507	2005	1671	1253	1671	1253			
				fz [in]	0.0030	0.0038	0.0045	0.0060	0.0075	0.0090	0.0120	0.0090	0.0120			
			131	197	vf [in/min]	60	60	60	60	60	60	60	75	75		
					APMX max**	0.0040	0.0050	0.0060	0.0070	0.0080	0.0090	0.0100	0.0090	0.0100		
	E 21	0.30 x DCX	98	n [rev/min]	3008	2406	2005	1504	1203	1003	752	1003	752			
				fz [in]	0.0030	0.0038	0.0045	0.0060	0.0075	0.0090	0.0120	0.0090	0.0120			
			66	131	vf [in/min]	36	36	36	36	36	36	36	45	45		
					APMX max**	0.0040	0.0050	0.0060	0.0070	0.0080	0.0090	0.0100	0.0090	0.0100		
E 22	0.30 x DCX	377	n [rev/min]	11530	9224	7687	5765	4612	3843	2883	3843	2883				
			fz [in]	0.0044	0.0055	0.0066	0.0088	0.0109	0.0131	0.0175	0.0131	0.0175				
		328	427	vf [in/min]	202	202	202	202	202	202	202	252	252			
				APMX max**	0.0040	0.0050	0.0060	0.0070	0.0080	0.0090	0.0100	0.0090	0.0100			

\*E = Emulsion M = Mist spray A = Air \*\*Reduce APMX 20% and Feed per tooth 15% when using 5 x D version

\*\*Reduce APMX 40% and Feed per tooth 30% when using 7 x D version \*\*\*pd: plunge depth

ap = APMX

## Cutting data -SN200R, SN400R, SN500R Plunge Milling

ISO GROUP	SMG	a <sub>e</sub> (Max)	v <sub>c</sub> (sf / min)	PLUNGE MILLING									
				Zn = 2									
				1/16	3/32	1/8	5/32	3/16	1/4	5/16	3/8	1/2	
P	M/A/D 1 - 2	0.30 x DCX	699	n [rev/min]	42712	28475	21356	17084	14237	10678	8542	7119	5339
				fz [in]	0.0006	0.0009	0.0013	0.0016	0.0019	0.0025	0.0031	0.0038	0.0050
			576	822	vf [in/min]	53	53	53	53	53	53	53	53
	APMX=pd***	0.1250			0.1875	0.2500	0.3125	0.3750	0.5000	0.6250	0.7500	1.0000	
	M/A/D 3 - 4	0.30 x DCX	518	n [rev/min]	31683	21122	15841	12673	10561	7921	6337	5280	3960
				fz [in]	0.0006	0.0009	0.0013	0.0016	0.0019	0.0025	0.0031	0.0038	0.0050
			459	577	vf [in/min]	40	40	40	40	40	40	40	40
	APMX=pd***	0.1250			0.1875	0.2500	0.3125	0.3750	0.5000	0.6250	0.7500	1.0000	
	M/A/D 5 - 6	0.30 x DCX	410	n [rev/min]	25066	16710	12533	10026	8355	6266	5013	4178	3133
fz [in]				0.0006	0.0009	0.0013	0.0016	0.0019	0.0025	0.0031	0.0038	0.0050	
361			459	vf [in/min]	31	31	31	31	31	31	31	31	31
	APMX=pd***	0.1250		0.1875	0.2500	0.3125	0.3750	0.5000	0.6250	0.7500	1.0000		
H	M/A/D 7a	0.30 x DCX	213	n [rev/min]	13034	8689	6517	5213	4345	3259	2607	2172	1629
				fz [in]	0.0004	0.0007	0.0009	0.0011	0.0013	0.0018	0.0022	0.0026	0.0035
			180	246	vf [in/min]	11	11	11	11	11	11	11	11
APMX=pd***	0.1250	0.1875			0.2500	0.3125	0.3750	0.5000	0.6250	0.7500	1.0000		
M	E/M/A 8 - 9	0.30 x DCX	289	n [rev/min]	17646	11764	8823	7058	5882	4412	3529	2941	2206
				fz [in]	0.0004	0.0007	0.0009	0.0011	0.0013	0.0018	0.0022	0.0026	0.0035
			246	331	vf [in/min]	15	15	15	15	15	15	15	15
	APMX=pd***	0.1250			0.1875	0.2500	0.3125	0.3750	0.5000	0.6250	0.7500	1.0000	
	E/M/A 10 - 11	0.30 x DCX	246	n [rev/min]	15039	10026	7520	6016	5013	3760	3008	2507	1880
				fz [in]	0.0004	0.0007	0.0009	0.0011	0.0013	0.0018	0.0022	0.0026	0.0035
180			246	vf [in/min]	13	13	13	13	13	13	13	13	13
	APMX=pd***	0.1250		0.1875	0.2500	0.3125	0.3750	0.5000	0.6250	0.7500	1.0000		
K	E/M/A 12 - 13	0.30 x DCX	410	n [rev/min]	25066	16710	12533	10026	8355	6266	5013	4178	3133
				fz [in]	0.0004	0.0007	0.0009	0.0011	0.0013	0.0018	0.0022	0.0026	0.0035
			361	459	vf [in/min]	22	22	22	22	22	22	22	22
	APMX=pd***	0.1250			0.1875	0.2500	0.3125	0.3750	0.5000	0.6250	0.7500	1.0000	
	E/M/A 14 - 15	0.30 x DCX	295	n [rev/min]	18047	12031	9024	7219	6016	4512	3609	3008	2256
				fz [in]	0.0004	0.0006	0.0008	0.0009	0.0011	0.0015	0.0019	0.0023	0.0030
230			361	vf [in/min]	14	14	14	14	14	14	14	14	14
	APMX=pd***	0.1250		0.1875	0.2500	0.3125	0.3750	0.5000	0.6250	0.7500	1.0000		
S	E 19	0.30 x DCX	115	n [rev/min]	7018	4679	3509	2807	2339	1755	1404	1170	877
				fz [in]	0.0004	0.0006	0.0008	0.0009	0.0011	0.0015	0.0019	0.0023	0.0030
			98	131	vf [in/min]	5	5	5	5	5	5	5	5
	APMX=pd***	0.1250			0.1875	0.2500	0.3125	0.3750	0.5000	0.6250	0.7500	1.0000	
	E 20	0.30 x DCX	115	n [rev/min]	7018	4679	3509	2807	2339	1755	1404	1170	877
				fz [in]	0.0004	0.0006	0.0008	0.0009	0.0011	0.0015	0.0019	0.0023	0.0030
			98	131	vf [in/min]	5	5	5	5	5	5	5	5
	APMX=pd***	0.1250			0.1875	0.2500	0.3125	0.3750	0.5000	0.6250	0.7500	1.0000	
	E 21	0.30 x DCX	75	n [rev/min]	4612	3075	2306	1845	1537	1153	922	769	577
				fz [in]	0.0004	0.0006	0.0008	0.0009	0.0011	0.0015	0.0019	0.0023	0.0030
			49	102	vf [in/min]	3	3	3	3	3	3	3	3
	APMX=pd***	0.1250			0.1875	0.2500	0.3125	0.3750	0.5000	0.6250	0.7500	1.0000	
E 22	0.30 x DCX	262	n [rev/min]	16042	10695	8021	6417	5347	4010	3208	2674	2005	
			fz [in]	0.0004	0.0007	0.0009	0.0011	0.0013	0.0018	0.0022	0.0026	0.0035	
		230	295	vf [in/min]	14	14	14	14	14	14	14	14	14
APMX=pd***	0.1250			0.1875	0.2500	0.3125	0.3750	0.5000	0.6250	0.7500	1.0000		

\*E = Emulsion M = Mist spray A = Air \*\*Reduce APMX 20% and Feed per tooth 15% when using 5 x D version

\*\*Reduce APMX 40% and Feed per tooth 30% when using 7 x D version \*\*\*pd: plunge depth

ap - APMX

## Cutting data - MZN410R/MZN510R Slotting

ISO GROUP	SMG	a <sub>e</sub> (Max)	v <sub>c</sub> (sf / min)	SLOTTING										
				Zn = 4								Zn = 5		
				1/8	3/16	1/4	5/16	3/8	1/2	5/8	1/2	5/8		
P	E/M/A 5 - 6	1.00 x DCX	740	n [rev/min]	22614	15076	11967	9046	7538	5654	4523	5654	4523	
				fz [in]	0.0031	0.0047	0.0059	0.0078	0.0094	0.0125	0.0156	0.0125	0.0156	
			690	790	vf [in/min]	283	283	283	283	283	283	283	353	353
					APMX max	0.0059	0.0079	0.0098	0.0138	0.0157	0.0177	0.0197	0.0217	0.0217
H	M/A/D 7a	1.00 x DCX	440	n [rev/min]	13446	8964	7115	5379	4482	3362	2689	3362	2689	
				fz [in]	0.0031	0.0047	0.0059	0.0078	0.0094	0.0125	0.0156	0.0125	0.0156	
			390	490	vf [in/min]	168	168	168	168	168	168	168	210	210
					APMX max	0.0059	0.0079	0.0098	0.0138	0.0157	0.0177	0.0197	0.0217	0.0217
	M/A/D 7b	1.00 x DCX	230	n [rev/min]	7029	4686	3719	2812	2343	1757	1406	1757	1406	
				fz [in]	0.0025	0.0038	0.0047	0.0063	0.0075	0.0100	0.0125	0.0100	0.0125	
			200	260	vf [in/min]	70	70	70	70	70	70	70	88	88
					APMX max	0.0030	0.0039	0.0049	0.0069	0.0079	0.0089	0.0098	0.0108	0.0108
K	E/M/A 12 - 13	1.00 x DCX	570	n [rev/min]	17419	11610	9220	6970	5810	4350	3480	4350	3480	
				fz [in]	0.0030	0.0045	0.0057	0.0075	0.0090	0.0120	0.0150	0.0120	0.0150	
			490	660	vf [in/min]	209	209	209	209	209	209	209	261	261
					APMX max	0.0059	0.0079	0.0098	0.0138	0.0157	0.0177	0.0197	0.0217	0.0217
	E/M/A 14 - 15	1.00 x DCX	410	n [rev/min]	12530	8353	6630	5012	4177	3132	2506	3132	2506	
				fz [in]	0.0023	0.0034	0.0043	0.0056	0.0068	0.0090	0.0113	0.0090	0.0113	
			330	490	vf [in/min]	113	113	113	113	113	113	113	141	141
					APMX max	0.0059	0.0079	0.0098	0.0138	0.0157	0.0177	0.0197	0.0217	0.0217
S	E 21	1.00 x DCX	100	n [rev/min]	3056	2037	1617	1222	1019	764	611	764	611	
				fz [in]	0.0017	0.0026	0.0033	0.0042	0.0051	0.0070	0.0087	0.0070	0.0087	
			90	110	vf [in/min]	21	21	21	21	21	21	21	27	27
					APMX max	0.0038	0.0050	0.0070	0.0077	0.0100	0.0150	0.0150	0.0150	0.0150

## Cutting data - MZN410R/MZN510R Side Milling - Roughing

ISO GROUP	SMG	a <sub>e</sub> (Max)	v <sub>c</sub> (sf / min)n	SIDE MILLING - ROUGHING										
				Zn = 4								Zn = 5		
				1/8	3/16	1/4	5/16	3/8	1/2	5/8	1/2	5/8		
P	E/M/A 5 - 6	0.30 x DCX	740	n [rev/min]	22614	15076	11967	9046	7538	5654	4523	5654	4523	
				fz [in]	0.0050	0.0075	0.0094	0.0125	0.0150	0.0200	0.0250	0.0200	0.0250	
			690	790	vf [in/min]	452	452	452	452	452	452	452	565	565
					APMX max	0.0047	0.0063	0.0079	0.0110	0.0126	0.0142	0.0157	0.0173	0.0173
H	M/A/D 7a	0.30 x DCX	480	n [rev/min]	14669	9779	7762	5868	4890	3667	2934	3667	2934	
				fz [in]	0.0050	0.0075	0.0094	0.0125	0.0150	0.0200	0.0250	0.0200	0.0250	
			430	520	vf [in/min]	293	293	293	293	293	293	293	367	367
					APMX max	0.0047	0.0063	0.0079	0.0110	0.0126	0.0142	0.0157	0.0173	0.0173
	M/A/D 7b	0.30 x DCX	260	n [rev/min]	7946	5297	4205	3178	2649	1986	1589	1986	1589	
				fz [in]	0.0038	0.0056	0.0071	0.0094	0.0113	0.0150	0.0188	0.0150	0.0188	
			230	300	vf [in/min]	119	119	119	119	119	119	119	149	149
					APMX max	0.0047	0.0063	0.0079	0.0110	0.0126	0.0142	0.0157	0.0173	0.0173
K	E/M/A 12 - 13	0.30 x DCX	570	n [rev/min]	17419	11613	9218	6968	5806	4355	3484	4355	3484	
				fz [in]	0.0050	0.0075	0.0094	0.0125	0.0150	0.0200	0.0250	0.0200	0.0250	
			490	660	vf [in/min]	348	348	348	348	348	348	348	435	435
					APMX max	0.0059	0.0079	0.0098	0.0138	0.0157	0.0177	0.0197	0.0217	0.0217
	E/M/A 14 - 15	0.30 x DCX	410	n [rev/min]	12530	8353	6630	5012	4177	3132	2506	3132	2506	
				fz [in]	0.0038	0.0056	0.0071	0.0094	0.0113	0.0150	0.0188	0.0150	0.0188	
			330	490	vf [in/min]	188	188	188	188	188	188	188	235	235
					APMX max	0.0059	0.0079	0.0098	0.0138	0.0157	0.0177	0.0197	0.0217	0.0217
S	E 21	0.30 x DCX	100	n [rev/min]	3056	2037	1617	1222	1019	764	611	764	611	
				fz [in]	0.0026	0.0039	0.0049	0.0065	0.0078	0.0105	0.0130	0.0105	0.0130	
			90	110	vf [in/min]	32	32	32	32	32	32	32	40	40
					APMX max	0.0038	0.0050	0.0070	0.0077	0.0100	0.0150	0.0150	0.0150	0.0150

## MP10 Highfeed milling - Insert selection

SMG		Recommended APMX**	f <sub>z</sub>			
			100%	70%	30%	20%
P1	MP10-1000.6HFZ3-MD08 MP3000	0.010	0.032	0.032	0.036	0.048
P2	MP10-1000.6HFZ3-MD08 MP3000	0.010	0.032	0.032	0.036	0.048
P3	MP10-1000.6HFZ3-MD08 MP3000	0.010	0.030	0.030	0.034	0.044
P4	MP10-1000.6HFZ3-MD08 MP3000	0.010	0.030	0.030	0.034	0.044
P5	MP10-1000.6HFZ3-MD08 MP3000	0.010	0.030	0.030	0.034	0.044
P6	MP10-1000.6HFZ3-MD08 MP3000	0.010	0.028	0.028	0.032	0.040
P7	MP10-1000.6HFZ3-MD08 MP3000	0.010	0.028	0.028	0.032	0.040
P8	MP10-1000.6HFZ3-MD08 MP3000	0.010	0.030	0.030	0.034	0.044
P11	MP10-1000.6HFZ3-MD08 MP3000	0.010	0.028	0.028	0.032	0.040
M1	MP10-1000.6HFZ3-MD08 MP3000	0.010	0.032	0.032	0.036	0.048
M2	MP10-1000.6HFZ3-MD08 MP3000	0.010	0.030	0.030	0.034	0.044
M3	MP10-1000.6HFZ3-MD08 MP3000	0.0085	0.026	0.026	0.028	0.036
M4	MP10-1000.6HFZ3-MD08 MP3000	0.0085	0.022	0.022	0.024	0.030
M5	MP10-1000.6HFZ3-MD08 MP3000	0.0085	0.022	0.022	0.024	0.030
K1	MP10-1000.6HFZ3-MD08 MP3000	0.010	0.032	0.032	0.036	0.048
K2	MP10-1000.6HFZ3-MD08 MP3000	0.010	0.030	0.030	0.034	0.044
K3	MP10-1000.6HFZ3-MD08 MP3000	0.010	0.030	0.030	0.034	0.044
K4	MP10-1000.6HFZ3-MD08 MP3000	0.010	0.030	0.030	0.034	0.044
K5	MP10-1000.6HFZ3-MD08 MP3000	0.010	0.026	0.026	0.030	0.036
K6	MP10-1000.6HFZ3-MD08 MP3000	0.010	0.030	0.030	0.034	0.044
K7	MP10-1000.6HFZ3-MD08 MP3000	0.010	0.026	0.026	0.030	0.036
N1	MP10-1000.6HFZ3-MD08 MP3000	0.010	0.040	0.040	0.048	0.080
N2	MP10-1000.6HFZ3-MD08 MP3000	0.010	0.040	0.040	0.048	0.080
N3	MP10-1000.6HFZ3-MD08 MP3000	0.010	0.040	0.040	0.048	0.080
N11	MP10-1000.6HFZ3-MD08 MP3000	0.010	0.040	0.040	0.048	0.080
S1	MP10-1000.6HFZ3-MD08 MP3000	0.0085	0.022	0.022	0.024	0.030
S2	MP10-1000.6HFZ3-MD08 MP3000	0.0085	0.022	0.022	0.024	0.030
S3	MP10-1000.6HFZ3-MD08 MP3000	0.0085	0.020	0.020	0.022	0.028
S11	MP10-1000.6HFZ3-MD08 MP3000	0.0085	0.026	0.026	0.028	0.036
S12	MP10-1000.6HFZ3-MD08 MP3000	0.0085	0.026	0.026	0.028	0.036
S13	MP10-1000.6HFZ3-MD08 MP3000	0.0085	0.022	0.022	0.024	0.030
H5	MP10-1000.6HFZ3-MD08 MP3000	0.0085	0.022	0.022	0.024	0.030
H8	MP10-1000.6HFZ3-MD08 MP3000	0.0085	0.016	0.016	0.018	0.022
H11	MP10-1000.6HFZ3-MD08 MP3000	0.0085	0.022	0.022	0.024	0.030
H12	MP10-1000.6HFZ3-MD08 MP3000	0.0085	0.022	0.022	0.024	0.030
H21	MP10-1000.6HFZ3-MD08 MP3000	0.0085	0.016	0.016	0.018	0.022

## MP10 Highfeed milling - Cutting data v<sub>c</sub> = (sf/min)

SMG	MP3000			
	100%	70%	30%	20%
P1	790	950	1150	1200
P2	760	930	1125	1175
P3	670	810	980	1025
P4	590	710	860	900
P5	570	690	820	870
P6	640	780	920	980
P7	600	730	870	920
P8	560	680	820	860
P11	590	710	840	900
M1	570	700	840	880
M2	475	580	680	730
M3	380	455	540	580
M4	295	355	415	440
M5	245	295	345	370
K1	610	740	890	930
K2	540	660	780	830
K3	460	560	660	700
K4	435	530	630	670
K5	265	320	385	410
K6	385	470	550	590
K7	340	410	495	520
N1	2275	2775	3300	3350
N2	1825	2225	2675	2700
N3	1225	1500	1775	1800
N11	1400	1700	2025	2075
S1	135	165	195	205
S2	110	135	155	165
S3	95	115	135	145
S11	190	230	275	290
S12	110	135	160	165
S13	90	105	125	135
H5	115	140	165	180
H8	120	145	175	185
H11	150	180	210	225
H12	225	270	320	340
H21	120	145	175	185

\*\* For optimum tool life SMG = Seco Material Group f<sub>z</sub> = in/tooth v<sub>c</sub> = sf/min APMX = inch a<sub>p</sub>/D<sub>c</sub> = % All cutting data are start values

## MP12 Highfeed milling - Insert selection

SMG		Recommended APMX**	f <sub>z</sub>			
			100%	70%	30%	20%
P1	MP12-1200.7HFZ3-MD10 MP3000	0.012	0.040	0.040	0.044	0.060
P2	MP12-1200.7HFZ3-MD10 MP3000	0.012	0.040	0.040	0.048	0.060
P3	MP12-1200.7HFZ3-MD10 MP3000	0.012	0.038	0.038	0.044	0.055
P4	MP12-1200.7HFZ3-MD10 MP3000	0.012	0.038	0.038	0.044	0.055
P5	MP12-1200.7HFZ3-MD10 MP3000	0.012	0.036	0.036	0.040	0.050
P6	MP12-1200.7HFZ3-MD10 MP3000	0.012	0.036	0.036	0.040	0.050
P7	MP12-1200.7HFZ3-MD10 MP3000	0.012	0.036	0.036	0.040	0.050
P8	MP12-1200.7HFZ3-MD10 MP3000	0.012	0.038	0.038	0.044	0.055
P11	MP12-1200.7HFZ3-MD10 MP3000	0.012	0.036	0.036	0.040	0.050
M1	MP12-1200.7HFZ3-MD10 MP3000	0.012	0.040	0.040	0.048	0.060
M2	MP12-1200.7HFZ3-MD10 MP3000	0.012	0.036	0.036	0.040	0.050
M3	MP12-1200.7HFZ3-MD10 MP3000	0.010	0.032	0.032	0.036	0.044
M4	MP12-1200.7HFZ3-MD10 MP3000	0.010	0.028	0.028	0.032	0.038
M5	MP12-1200.7HFZ3-MD10 MP3000	0.010	0.028	0.028	0.032	0.038
K1	MP12-1200.7HFZ3-MD10 MP3000	0.012	0.040	0.040	0.048	0.060
K2	MP12-1200.7HFZ3-MD10 MP3000	0.012	0.036	0.036	0.040	0.050
K3	MP12-1200.7HFZ3-MD10 MP3000	0.012	0.036	0.036	0.040	0.050
K4	MP12-1200.7HFZ3-MD10 MP3000	0.012	0.036	0.036	0.040	0.050
K5	MP12-1200.7HFZ3-MD10 MP3000	0.012	0.032	0.032	0.038	0.048
K6	MP12-1200.7HFZ3-MD10 MP3000	0.012	0.036	0.036	0.040	0.050
K7	MP12-1200.7HFZ3-MD10 MP3000	0.012	0.032	0.032	0.038	0.048
N1	MP12-1200.7HFZ3-MD10 MP3000	0.012	0.050	0.050	0.060	0.095
N2	MP12-1200.7HFZ3-MD10 MP3000	0.012	0.050	0.050	0.060	0.095
N3	MP12-1200.7HFZ3-MD10 MP3000	0.012	0.050	0.050	0.060	0.095
N11	MP12-1200.7HFZ3-MD10 MP3000	0.012	0.050	0.050	0.060	0.095
S1	MP12-1200.7HFZ3-MD10 MP3000	0.010	0.028	0.028	0.032	0.038
S2	MP12-1200.7HFZ3-MD10 MP3000	0.010	0.028	0.028	0.032	0.038
S3	MP12-1200.7HFZ3-MD10 MP3000	0.010	0.026	0.026	0.030	0.036
S11	MP12-1200.7HFZ3-MD10 MP3000	0.010	0.032	0.032	0.036	0.044
S12	MP12-1200.7HFZ3-MD10 MP3000	0.010	0.032	0.032	0.036	0.044
S13	MP12-1200.7HFZ3-MD10 MP3000	0.010	0.028	0.028	0.032	0.038
H5	MP12-1200.7HFZ3-MD10 MP3000	0.010	0.028	0.028	0.030	0.038
H8	MP12-1200.7HFZ3-MD10 MP3000	0.010	0.020	0.020	0.024	0.028
H11	MP12-1200.7HFZ3-MD10 MP3000	0.010	0.028	0.028	0.030	0.038
H12	MP12-1200.7HFZ3-MD10 MP3000	0.010	0.028	0.028	0.030	0.038
H21	MP12-1200.7HFZ3-MD10 MP3000	0.010	0.020	0.020	0.024	0.028

## MP12 Highfeed milling - Cutting data v<sub>c</sub> = (sf/min)

SMG	MP3000			
	100%	70%	30%	20%
P1	740	900	1075	1125
P2	720	880	1050	1100
P3	630	770	920	970
P4	560	670	810	850
P5	540	650	780	810
P6	600	730	880	910
P7	570	690	830	860
P8	530	640	780	810
P11	550	670	810	840
M1	540	660	780	830
M2	450	550	650	680
M3	360	430	520	550
M4	275	335	395	420
M5	230	280	330	350
K1	570	700	830	880
K2	510	620	740	770
K3	430	520	620	650
K4	410	500	600	620
K5	250	300	365	390
K6	365	440	520	550
K7	320	385	465	495
N1	2125	2575	3100	3150
N2	1725	2075	2500	2550
N3	1150	1400	1675	1700
N11	1300	1600	1900	1925
S1	130	155	185	195
S2	105	125	150	160
S3	90	110	130	140
S11	180	220	260	275
S12	105	125	150	155
S13	85	100	120	125
H5	110	135	160	170
H8	120	140	170	180
H11	140	170	200	215
H12	215	260	305	325
H21	120	140	170	180



## MP16 Highfeed milling - Insert selection

SMG		Recommended APMX**	f <sub>z</sub>			
			100%	70%	30%	20%
P1	MP16-1600.9HFZ3-MD12 MP3000	0.015	0.044	0.044	0.048	0.060
P2	MP16-1600.9HFZ3-MD12 MP3000	0.015	0.044	0.044	0.048	0.065
P3	MP16-1600.9HFZ3-MD12 MP3000	0.015	0.040	0.040	0.048	0.060
P4	MP16-1600.9HFZ3-MD12 MP3000	0.015	0.040	0.040	0.044	0.055
P5	MP16-1600.9HFZ3-MD12 MP3000	0.015	0.040	0.040	0.044	0.055
P6	MP16-1600.9HFZ3-MD12 MP3000	0.015	0.040	0.040	0.044	0.055
P7	MP16-1600.9HFZ3-MD12 MP3000	0.015	0.040	0.040	0.044	0.055
P8	MP16-1600.9HFZ3-MD12 MP3000	0.015	0.040	0.040	0.048	0.060
P11	MP16-1600.9HFZ3-MD12 MP3000	0.015	0.040	0.040	0.044	0.055
M1	MP16-1600.9HFZ3-MD12 MP3000	0.015	0.044	0.044	0.048	0.065
M2	MP16-1600.9HFZ3-MD12 MP3000	0.015	0.040	0.040	0.044	0.055
M3	MP16-1600.9HFZ3-MD12 MP3000	0.013	0.034	0.034	0.038	0.048
M4	MP16-1600.9HFZ3-MD12 MP3000	0.013	0.030	0.030	0.034	0.040
M5	MP16-1600.9HFZ3-MD12 MP3000	0.013	0.030	0.030	0.034	0.040
K1	MP16-1600.9HFZ3-MD12 MP3000	0.015	0.044	0.044	0.048	0.065
K2	MP16-1600.9HFZ3-MD12 MP3000	0.015	0.040	0.040	0.044	0.055
K3	MP16-1600.9HFZ3-MD12 MP3000	0.015	0.040	0.040	0.044	0.055
K4	MP16-1600.9HFZ3-MD12 MP3000	0.015	0.040	0.040	0.044	0.055
K5	MP16-1600.9HFZ3-MD12 MP3000	0.015	0.036	0.036	0.040	0.048
K6	MP16-1600.9HFZ3-MD12 MP3000	0.015	0.040	0.040	0.044	0.055
K7	MP16-1600.9HFZ3-MD12 MP3000	0.015	0.036	0.036	0.040	0.048
N1	MP16-1600.9HFZ3-MD12 MP3000	0.015	0.055	0.055	0.065	0.085
N2	MP16-1600.9HFZ3-MD12 MP3000	0.015	0.055	0.055	0.065	0.085
N3	MP16-1600.9HFZ3-MD12 MP3000	0.015	0.055	0.055	0.065	0.085
N11	MP16-1600.9HFZ3-MD12 MP3000	0.015	0.055	0.055	0.065	0.085
S1	MP16-1600.9HFZ3-MD12 MP3000	0.013	0.030	0.030	0.034	0.040
S2	MP16-1600.9HFZ3-MD12 MP3000	0.013	0.030	0.030	0.034	0.040
S3	MP16-1600.9HFZ3-MD12 MP3000	0.013	0.028	0.028	0.032	0.038
S11	MP16-1600.9HFZ3-MD12 MP3000	0.013	0.034	0.034	0.038	0.048
S12	MP16-1600.9HFZ3-MD12 MP3000	0.013	0.034	0.034	0.038	0.048
S13	MP16-1600.9HFZ3-MD12 MP3000	0.013	0.030	0.030	0.034	0.040
H5	MP16-1600.9HFZ3-MD12 MP3000	0.013	0.030	0.030	0.032	0.040
H7	MP16-1600.9HFZ3-MD12 MP3000	-	-	-	-	-
H11	MP16-1600.9HFZ3-MD12 MP3000	0.013	0.030	0.030	0.032	0.040
H12	MP16-1600.9HFZ3-MD12 MP3000	0.013	0.030	0.030	0.032	0.040
H21	MP16-1600.9HFZ3-MD12 MP3000	0.013	0.022	0.022	0.024	0.030

## MP16 Highfeed milling - Cutting data v<sub>c</sub> = (sf/min)

SMG	MP3000			
	100%	70%	30%	20%
P1	690	830	1025	1075
P2	680	810	970	1050
P3	600	720	850	920
P4	530	630	750	810
P5	500	600	740	770
P6	560	680	830	870
P7	530	640	780	820
P8	500	600	720	770
P11	520	620	760	790
M1	510	610	730	780
M2	420	500	610	640
M3	340	405	485	510
M4	265	315	375	395
M5	220	260	310	330
K1	540	640	770	830
K2	475	570	700	730
K3	405	485	590	620
K4	385	460	560	590
K5	235	280	340	360
K6	340	405	495	520
K7	300	360	435	460
N1	2000	2375	2875	3000
N2	1600	1925	2325	2425
N3	1075	1275	1550	1625
N11	1225	1475	1775	1850
S1	125	145	175	185
S2	100	120	140	150
S3	85	105	125	130
S11	170	205	245	255
S12	100	120	140	145
S13	80	95	115	120
H5	105	125	150	160
H8	110	135	155	170
H11	130	160	190	200
H12	200	240	285	305
H21	110	135	155	170

\*\* For optimum tool life SMG = Seco Material Group f<sub>z</sub> = in/tooth v<sub>c</sub> = sf/min APMX = inch a<sub>p</sub>/D<sub>c</sub> = % All cutting data are start values

## R217/220.21-LP05 - Insert selection

SMG		Recommended APMX**	f <sub>z</sub>		
			100%	70%	30%
P1	LPHT05T210TR-ME04 T350M	0.016	0.013	0.013	0.013
P2	LPHT05T210TR-ME04 T350M	0.016	0.013	0.013	0.014
P3	LPHT05T210TR-ME04 T350M	0.016	0.012	0.012	0.013
P4	LPKT05T210TR-M05 MP2500	0.016	0.015	0.015	0.016
P5	LPKT05T210TR-M05 MP2500	0.016	0.014	0.014	0.016
P6	LPKT05T210TR-M05 MP2500	0.016	0.014	0.014	0.016
P7	LPKT05T210TR-M05 MP2500	0.016	0.014	0.014	0.016
P8	LPKW05T210TR-MD05 MP2500	0.016	0.015	0.015	0.017
P11	LPKT05T210TR-M05 MP2500	0.016	0.014	0.014	0.016
M1	LPKT05T210TR-M05 F40M	0.016	0.016	0.016	0.017
M2	LPKT05T210TR-M05 F40M	0.016	0.014	0.014	0.016
M3	LPKT05T210TR-M05 F40M	0.013	0.013	0.013	0.014
M4	LPKT05T210TR-M05 F40M	0.0095	0.013	0.013	0.014
M5	LPKT05T210TR-M05 F40M	0.0095	0.013	0.013	0.014
K1	LPKW05T210TR-MD05 MP2500	0.016	0.016	0.016	0.017
K2	LPKW05T210TR-MD05 MP2500	0.016	0.014	0.014	0.016
K3	LPKW05T210TR-MD05 MP2500	0.016	0.014	0.014	0.016
K4	LPKW05T210TR-MD05 MP2500	0.016	0.014	0.014	0.016
K5	LPKW05T210TR-MD05 MP2500	0.016	0.013	0.013	0.014
K6	LPKW05T210TR-MD05 MP2500	0.016	0.014	0.014	0.016
K7	LPKW05T210TR-MD05 MP2500	0.016	0.013	0.013	0.014
N1	LPHT05T210TR-ME04 F40M	0.016	0.016	0.016	0.017
N2	LPHT05T210TR-ME04 F40M	0.016	0.016	0.016	0.017
N3	LPHT05T210TR-ME04 F40M	0.016	0.016	0.016	0.017
N11	LPHT05T210TR-ME04 F40M	0.016	0.016	0.016	0.017
S1	LPHT05T210TR-ME04 F40M	0.0095	0.010	0.010	0.012
S2	LPHT05T210TR-ME04 F40M	0.0095	0.010	0.010	0.012
S3	LPKT05T210TR-M05 F40M	0.0095	0.012	0.012	0.013
S11	LPHT05T210TR-ME04 MS2050	0.011	0.011	0.011	0.012
S12	LPHT05T210TR-ME04 MS2050	0.011	0.011	0.011	0.012
S13	LPHT05T210TR-ME04 MS2050	0.0095	0.010	0.010	0.012
H5	LPHW05T210TR-MD05 MH1000	0.013	0.011	0.011	0.012
H8	LPHW05T210TR-MD05 MH1000	0.011	0.0085	0.0085	0.010
H11	LPKT05T210TR-M05 F40M	0.013	0.011	0.011	0.012
H12	LPKT05T210TR-M05 F40M	0.013	0.011	0.011	0.012
H21	LPHW05T210TR-MD05 MH1000	0.011	0.0085	0.0085	0.010

\*\* For optimum tool life

SMG = Seco Material Group

f<sub>z</sub> = in/tooth

v<sub>c</sub> = sf/min

a<sub>e</sub>/DC = %

All cutting data are start values.

## R217/220.21-LP05 - Cutting data $v_c =$ (sf/min)

SMG	MP2500			MP3000			T350M			F40M			MM4500			MP3000		
	100%	70%	30%	100%	70%	30%	100%	70%	30%	100%	70%	30%	100%	70%	30%	100%	70%	30%
P1	1275	1475	1775	1200	1400	1675	1200	1400	1675	960	1125	1325	840	980	1175	1300	1525	1825
P2	1225	1425	1725	1175	1350	1625	1175	1350	1600	930	1100	1300	820	960	1125	1275	1475	1750
P3	1075	1250	1500	1025	1175	1425	1025	1175	1400	810	950	1125	720	830	990	1100	1300	1525
P4	940	1100	1325	890	1050	1250	890	1050	1250	710	830	1000	630	740	880	970	1125	1350
P5	910	1075	1275	860	1000	1200	850	1000	1200	690	810	960	600	700	840	930	1075	1300
P6	1025	1200	1425	970	1125	1350	960	1125	1350	780	900	1075	680	790	940	1050	1225	1450
P7	970	1125	1350	910	1075	1275	900	1050	1275	730	850	1025	640	740	890	980	1150	1375
P8	900	1050	1250	850	1000	1200	850	1000	1175	680	800	950	600	700	830	930	1075	1275
P11	940	1100	1300	890	1025	1225	880	1025	1225	710	830	990	620	720	860	950	1125	1325
M1	890	1025	1250	870	1025	1225	900	1050	1250	750	880	1050	700	820	970	950	1100	1300
M2	730	860	1025	720	840	1000	730	860	1025	620	730	860	580	670	800	770	900	1075
M3	580	680	800	570	670	790	590	680	810	495	570	680	460	530	630	620	720	850
M4	445	510	610	435	500	600	450	520	610	375	435	520	350	405	475	475	550	640
M5	370	425	510	365	420	500	375	430	510	315	360	430	295	340	395	395	455	530
K1	980	1150	1350	920	1075	1300	920	1075	1275	740	860	1025	-	-	-	1000	1175	1400
K2	870	1000	1200	820	960	1150	810	950	1125	660	760	910	-	-	-	880	1025	1225
K3	730	850	1025	690	810	960	690	800	960	550	650	770	-	-	-	740	870	1050
K4	700	820	970	660	770	920	650	760	910	530	620	740	-	-	-	710	830	990
K5	420	490	590	400	465	560	400	470	550	320	370	445	-	-	-	435	510	600
K6	620	720	860	580	680	810	580	670	810	465	540	650	-	-	-	630	730	880
K7	540	630	760	510	600	720	510	600	700	410	475	570	-	-	-	560	650	770
N1	3675	4275	5125	3475	4050	4875	-	-	-	2775	3250	3900	-	-	-	3750	4375	5225
N2	2950	3450	4150	2800	3275	3925	-	-	-	2250	2625	3150	-	-	-	3025	3525	4225
N3	1975	2300	2775	1875	2175	2625	-	-	-	1500	1750	2100	-	-	-	2025	2350	2825
N11	2250	2625	3150	2125	2500	3000	-	-	-	1700	2000	2400	-	-	-	2300	2675	3225
S1	215	250	295	205	235	280	210	240	285	175	205	240	110	125	145	220	255	300
S2	175	200	240	165	190	225	170	195	230	140	165	195	85	100	115	180	205	240
S3	155	175	210	145	165	195	145	170	200	125	145	170	75	90	100	155	180	210
S11	305	350	420	285	330	400	295	340	405	245	285	345	150	175	210	310	360	430
S12	175	205	245	165	190	230	170	195	235	145	165	200	115	135	160	180	210	245
S13	140	160	190	130	150	180	135	155	185	115	130	155	95	105	125	145	165	195
H5	180	210	250	175	205	240	185	215	255	150	175	205	-	-	-	190	220	260
H8	190	220	255	185	215	250	195	225	265	155	180	215	-	-	-	195	230	265
H11	230	265	315	220	260	310	235	275	325	190	220	265	-	-	-	240	280	330
H12	345	400	475	335	390	465	355	415	490	285	335	395	-	-	-	365	420	500
H21	190	220	255	185	215	250	195	225	265	155	180	215	-	-	-	195	230	265

## R217/220.21-LP05 - Cutting data $v_c =$ (sf/min)

SMG	MS2500			MH1000		
	100%	70%	30%	100%	70%	30%
P1	1375	1600	1925	1275	1500	1800
P2	1350	1575	1875	1250	1450	1750
P3	1175	1375	1625	1075	1275	1525
P4	1025	1200	1425	960	1125	1325
P5	990	1150	1375	920	1075	1275
P6	1125	1300	1550	1050	1200	1450
P7	1050	1225	1475	980	1150	1375
P8	980	1150	1375	910	1075	1275
P11	1025	1200	1425	950	1100	1325
M1	960	1125	1350	-	-	-
M2	800	930	1100	-	-	-
M3	630	740	870	-	-	-
M4	480	560	660	-	-	-
M5	400	465	550	-	-	-
K1	1075	1250	1475	990	1150	1375
K2	940	1100	1300	880	1025	1225
K3	800	930	1100	740	870	1025
K4	760	890	1050	710	830	990
K5	460	540	640	425	500	600
K6	670	780	930	620	730	870
K7	590	690	820	550	640	770
S1	235	270	325	-	-	-
S2	190	220	260	-	-	-
S3	165	195	225	-	-	-
S11	330	385	460	-	-	-
S12	190	220	265	-	-	-
S13	150	175	210	-	-	-
H5	195	225	270	200	230	275
H8	205	235	275	210	245	285
H11	245	285	340	255	295	350
H12	375	435	520	385	445	530
H21	205	235	275	210	245	285

## R217/220.21-LP06 - Insert selection

SMG		Recommended APMX**	f <sub>z</sub>		
			100%	70%	30%
P1	LPHT060310TR-M06 T350M	0.019	0.019	0.019	0.022
P2	LPHT060310TR-M06 T350M	0.019	0.020	0.020	0.022
P3	LPHT060310TR-M06 T350M	0.019	0.018	0.018	0.020
P4	LPHT060310TR-M06 MP2500	0.019	0.018	0.018	0.020
P5	LPHT060310TR-M06 MP2500	0.019	0.017	0.017	0.020
P6	LPHT060310TR-M06 MP2500	0.019	0.017	0.017	0.019
P7	LPHW060310TR-MD07 MP2500	0.019	0.020	0.020	0.022
P8	LPHW060310TR-MD07 MP2500	0.019	0.022	0.022	0.024
P11	LPHW060310TR-MD07 MP2500	0.019	0.020	0.020	0.022
M1	LPHT060310TR-ME05 F40M	0.019	0.017	0.017	0.018
M2	LPHT060310TR-ME05 F40M	0.019	0.015	0.015	0.017
M3	LPHT060310TR-ME05 F40M	0.015	0.013	0.013	0.014
M4	LPHT060310TR-M06 F40M	0.011	0.017	0.017	0.018
M5	LPHT060310TR-M06 F40M	0.011	0.017	0.017	0.018
K1	LPHW060310TR-D06 MP3000	0.019	0.020	0.020	0.022
K2	LPHW060310TR-D06 MP3000	0.019	0.017	0.017	0.020
K3	LPHW060310TR-D06 MP3000	0.019	0.017	0.017	0.020
K4	LPHW060310TR-D06 MP3000	0.019	0.017	0.017	0.020
K5	LPHW060310TR-D06 MP3000	0.019	0.016	0.016	0.017
K6	LPHW060310TR-D06 MP3000	0.019	0.017	0.017	0.020
K7	LPHW060310TR-D06 MP3000	0.019	0.016	0.016	0.017
N1	LPHT060310ER-E05 H25	0.019	0.020	0.020	0.024
N2	LPHT060310ER-E05 H25	0.019	0.020	0.020	0.024
N3	LPHT060310ER-E05 H25	0.019	0.020	0.020	0.024
N11	LPHT060310ER-E05 H25	0.019	0.020	0.020	0.024
S1	LPHT060310TR-M06 MS2500	0.011	0.017	0.017	0.018
S2	LPHT060310TR-M06 MS2500	0.011	0.017	0.017	0.018
S3	LPHT060310TR-M06 MS2500	0.011	0.015	0.015	0.017
S11	LPHT060310TR-M06 MS2050	0.013	0.017	0.017	0.019
S12	LPHT060310TR-M06 MS2050	0.013	0.017	0.017	0.019
S13	LPHT060310TR-M06 MS2050	0.011	0.017	0.017	0.018
H5	LPHW060310TR-D06 MH1000	0.015	0.013	0.013	0.015
H8	LPHW060310TR-D06 MH1000	0.013	0.011	0.011	0.012
H11	LPHW060310TR-D06 MH1000	0.015	0.013	0.013	0.015
H12	LPHW060310TR-D06 MH1000	0.015	0.013	0.013	0.015
H21	LPHW060310TR-D06 MH1000	0.013	0.011	0.011	0.012

\*\* For optimum tool life

SMG = Seco Material Group

f<sub>z</sub> = in/tooth

v<sub>c</sub> = sf/min

APMX = inch

a<sub>p</sub>/DC = %

All cutting data are start values

# CUTTING DATA - HIGH FEED MILLING CUTTERS



## R217/220.21-LP06 - Cutting data $v_c =$ (sf/min)

SMG	MP2500			MP3000			T350M			F40M			MM4500			MS2050		
	100%	70%	30%	100%	70%	30%	100%	70%	30%	100%	70%	30%	100%	70%	30%	100%	70%	30%
P1	1150	1300	1550	1100	1225	1475	1000	1125	1350	870	990	1175	760	860	1025	860	970	980
P2	1100	1250	1500	1050	1200	1425	970	1100	1325	840	950	1150	730	830	1000	850	960	960
P3	970	1100	1325	920	1050	1250	850	960	1150	740	840	1000	640	720	880	710	800	780
P4	860	970	1175	810	920	1100	750	850	1025	650	740	890	570	640	770	630	710	690
P5	820	930	1125	770	880	1050	710	810	970	620	700	850	540	620	740	600	680	660
P6	930	1050	1275	880	1000	1200	810	920	1100	700	800	960	610	690	830	660	750	720
P7	870	990	1200	830	940	1125	760	860	1050	660	750	900	570	650	790	620	700	680
P8	820	930	1125	770	880	1050	710	810	970	620	700	850	540	610	740	600	680	660
P11	850	960	1150	800	910	1100	740	840	1000	640	730	880	560	630	770	610	680	660
M1	800	910	1100	780	890	1075	740	840	1025	680	770	920	630	710	860	740	840	840
M2	660	750	900	650	730	880	610	700	840	560	630	760	520	590	700	580	660	640
M3	530	600	720	520	590	700	495	560	670	450	510	610	415	470	560	390	445	410
M4	405	460	550	400	450	540	380	425	510	345	390	465	320	360	430	270	310	280
M5	340	380	455	335	375	450	315	355	425	285	325	385	265	300	355	225	255	230
K1	880	1000	1200	830	940	1125	760	870	1050	670	750	910	-	-	-	860	970	970
K2	780	880	1050	730	830	1000	680	770	920	590	670	800	-	-	-	720	820	800
K3	660	740	900	620	710	850	570	650	780	495	560	680	-	-	-	610	690	670
K4	630	710	860	590	670	810	550	620	750	475	540	650	-	-	-	580	660	640
K5	385	435	520	365	415	495	335	380	455	290	330	395	-	-	-	330	370	355
K6	550	630	750	520	590	710	480	550	660	420	475	570	-	-	-	520	580	570
K7	495	560	670	465	530	630	430	485	580	375	425	510	-	-	-	420	475	450
N1	3250	3700	4475	3075	3500	4250	-	-	-	2475	2800	3400	-	-	-	-	-	-
N2	2625	2975	3625	2500	2825	3425	-	-	-	2000	2250	2750	-	-	-	-	-	-
N3	1750	1975	2400	1650	1875	2275	-	-	-	1325	1500	1825	-	-	-	-	-	-
N11	2000	2275	2750	1900	2150	2600	-	-	-	1525	1725	2075	-	-	-	-	-	-
S1	195	225	265	185	210	250	175	200	240	160	180	215	100	110	130	190	200	240
S2	160	180	215	150	170	200	140	160	190	130	145	175	80	90	105	150	165	190
S3	140	160	190	130	150	175	125	140	170	115	130	155	70	80	95	135	145	170
S11	280	315	380	265	300	355	250	285	340	225	255	305	135	155	185	260	280	335
S12	160	180	220	150	170	205	145	165	195	130	150	175	105	120	140	200	215	260
S13	130	145	170	120	135	160	115	130	155	105	115	140	85	95	115	160	175	205
H5	165	185	220	160	180	215	155	180	210	135	155	185	-	-	-	-	-	-
H8	170	195	230	165	190	225	165	185	220	145	160	195	-	-	-	-	-	-
H11	210	235	280	205	230	275	200	225	270	175	195	235	-	-	-	-	-	-
H12	315	355	425	305	350	415	300	340	405	265	295	355	-	-	-	-	-	-
H21	170	195	230	165	190	225	165	185	220	145	160	195	-	-	-	-	-	-

## R217/220.21-LP06 - Cutting data $v_c =$ (sf/min)

SMG	MS2500			MH1000			H25		
	100%	70%	30%	100%	70%	30%	100%	70%	30%
P1	1250	1425	1700	1175	1325	1575	-	-	-
P2	1200	1375	1650	1125	1275	1525	-	-	-
P3	1050	1200	1450	990	1125	1350	-	-	-
P4	930	1050	1275	870	990	1175	-	-	-
P5	890	1000	1225	830	940	1125	-	-	-
P6	1000	1150	1375	940	1075	1275	-	-	-
P7	950	1075	1300	890	1000	1200	-	-	-
P8	890	1000	1225	830	940	1125	-	-	-
P11	930	1050	1275	860	980	1175	-	-	-
M1	870	980	1175	-	-	-	-	-	-
M2	710	810	970	-	-	-	-	-	-
M3	570	650	780	-	-	-	-	-	-
M4	440	495	590	-	-	-	-	-	-
M5	365	415	495	-	-	-	-	-	-
K1	960	1075	1300	890	1000	1225	-	-	-
K2	850	960	1150	790	890	1075	-	-	-
K3	720	810	980	670	760	910	-	-	-
K4	680	780	930	640	720	870	-	-	-
K5	420	475	570	390	445	530	-	-	-
K6	600	680	820	560	640	770	-	-	-
K7	540	610	730	500	570	680	-	-	-
N1	-	-	-	-	-	-	2525	2875	3450
N2	-	-	-	-	-	-	2050	2325	2800
N3	-	-	-	-	-	-	1350	1550	1850
N11	-	-	-	-	-	-	1550	1775	2125
S1	215	245	290	-	-	-	-	-	-
S2	175	195	235	-	-	-	-	-	-
S3	150	170	205	-	-	-	-	-	-
S11	305	345	410	-	-	-	-	-	-
S12	175	200	235	-	-	-	-	-	-
S13	140	155	185	-	-	-	-	-	-
H5	180	200	240	185	205	245	-	-	-
H8	185	210	250	190	215	260	-	-	-
H11	225	255	305	235	265	315	-	-	-
H12	340	385	460	350	400	475	-	-	-
H21	185	210	250	190	215	260	-	-	-

## R217/220.21-L006 - Insert selection

SMG		Recommended APMX**	f <sub>z</sub>		
			100%	70%	30%
P1	LOHT060310TR-ME06 T350M	0.022	0.015	0.015	0.016
P2	LOHT060310TR-ME06 T350M	0.022	0.015	0.015	0.017
P3	LOHT060310TR-ME06 T350M	0.022	0.014	0.014	0.016
P4	LOHT060310TR-M07 MP2500	0.022	0.017	0.017	0.018
P5	LOHT060310TR-M07 MP2500	0.022	0.016	0.016	0.017
P6	LOHT060310TR-M07 MP2500	0.022	0.016	0.016	0.017
P7	LOHT060310TR-M07 MP2500	0.022	0.016	0.016	0.017
P8	LOHT060310TR-MD07 MP2500	0.022	0.017	0.017	0.018
P11	LOHT060310TR-ME06 T350M	0.022	0.013	0.013	0.015
M1	LOHT060310TR-ME06 T350M	0.022	0.015	0.015	0.017
M2	LOHT060310TR-ME06 T350M	0.022	0.013	0.013	0.015
M3	LOHT060310TR-ME06 T350M	0.017	0.013	0.013	0.013
M4	LOHT060310TR-ME06 T350M	0.013	0.013	0.013	0.013
M5	LOHT060310TR-ME06 T350M	0.013	0.013	0.013	0.013
K1	LOHT060310TR-MD07 MK2050	0.022	0.017	0.017	0.019
K2	LOHT060310TR-MD07 MK2050	0.022	0.016	0.016	0.017
K3	LOHT060310TR-MD07 MK2050	0.022	0.016	0.016	0.017
K4	LOHW060310TR-D07 MP1500	0.022	0.016	0.016	0.017
K5	LOHW060310TR-D07 MP1500	0.022	0.014	0.014	0.016
K6	LOHT060310TR-MD07 MK2050	0.022	0.016	0.016	0.017
K7	LOHT060310TR-MD07 MK2050	0.022	0.014	0.014	0.016
S1	LOHT060310TR-ME06 MS2500	0.013	0.013	0.013	0.013
S2	LOHT060310TR-ME06 MS2500	0.013	0.013	0.013	0.013
S3	LOHT060310TR-M07 F40M	0.013	0.013	0.013	0.015
S11	LOHT060310TR-ME06 MS2050	0.015	0.013	0.013	0.014
S12	LOHT060310TR-ME06 MS2050	0.015	0.013	0.013	0.014
S13	LOHT060310TR-ME06 MS2050	0.013	0.013	0.013	0.013
H5	LOHW060310TR-D07 MH1000	0.017	0.013	0.013	0.013
H8	LOHW060310TR-D07 MH1000	0.015	0.010	0.010	0.011
H11	LOHT060310TR-M07 T350M	0.017	0.013	0.013	0.013
H12	LOHT060310TR-M07 T350M	0.017	0.013	0.013	0.013
H21	LOHW060310TR-D07 MH1000	0.015	0.010	0.010	0.011

\*\* For optimum tool life

SMG = Seco Material Group

f<sub>z</sub> = in/tooth

v<sub>c</sub> = sf/min

a<sub>p</sub>/DC = %

All cutting data are start values.



## R217/220.21-L006 - Cutting data $v_c =$ (sf/min)

SMG	MP1500			MP2500			MP3000			T350M			F40M			MM4500		
	100%	70%	30%	100%	70%	30%	100%	70%	30%	100%	70%	30%	100%	70%	30%	100%	70%	30%
P1	1075	1200	1475	1050	1175	1425	1000	1125	1350	1000	1125	1350	800	900	1075	700	790	950
P2	1050	1175	1425	1025	1150	1400	970	1100	1325	970	1100	1300	780	870	1050	680	770	920
P3	920	1025	1250	890	1000	1200	850	950	1150	850	950	1150	680	760	910	600	670	800
P4	810	900	1100	790	880	1075	740	830	1000	750	840	1025	600	670	810	530	590	720
P5	780	870	1050	760	850	1025	720	810	970	720	810	970	580	650	780	510	570	680
P6	870	980	1175	850	960	1150	810	910	1100	810	910	1100	650	720	870	570	640	770
P7	820	930	1125	800	900	1075	760	860	1025	760	860	1025	610	680	820	540	610	720
P8	770	860	1050	750	840	1025	710	800	960	710	800	960	570	640	770	500	560	680
P11	800	900	1075	780	880	1050	740	830	1000	740	830	1000	590	660	800	520	590	700
M1	-	-	-	740	830	1000	730	810	980	750	840	1000	630	700	850	590	660	790
M2	-	-	-	610	690	830	600	670	810	620	700	830	520	580	700	485	550	650
M3	-	-	-	490	550	660	480	540	650	490	550	670	415	465	560	385	435	520
M4	-	-	-	375	420	510	370	415	500	380	430	510	320	355	430	300	335	405
M5	-	-	-	315	350	425	310	345	415	320	355	430	265	300	360	250	280	335
K1	830	930	1125	810	910	1100	770	860	1050	770	860	1050	620	690	830	-	-	-
K2	740	830	1000	720	810	970	680	770	920	680	770	920	550	610	740	-	-	-
K3	630	700	840	610	680	820	580	650	780	580	650	780	460	520	620	-	-	-
K4	600	670	810	580	650	790	550	620	740	550	620	740	440	495	600	-	-	-
K5	365	410	490	355	400	480	335	380	455	335	375	455	270	300	360	-	-	-
K6	530	590	710	510	580	690	485	550	660	485	550	660	390	435	520	-	-	-
K7	465	520	630	455	510	610	430	485	580	425	480	580	345	385	465	-	-	-
S1	-	-	-	185	205	245	175	195	235	180	200	240	150	165	200	90	105	125
S2	-	-	-	150	165	200	140	155	190	145	160	195	120	135	160	75	85	100
S3	-	-	-	130	145	175	125	140	165	125	140	170	105	120	140	65	70	85
S11	-	-	-	255	285	350	240	270	330	250	280	335	210	235	285	130	145	175
S12	-	-	-	150	165	200	140	155	190	145	160	195	120	135	165	100	110	135
S13	-	-	-	120	130	160	110	125	150	115	130	155	95	110	130	80	90	105
H5	170	195	230	155	170	205	150	165	200	160	175	210	125	145	170	-	-	-
H8	180	200	240	160	180	215	155	175	210	165	185	220	135	150	180	-	-	-
H11	220	245	290	195	220	260	190	210	250	200	225	270	160	180	215	-	-	-
H12	330	370	440	295	330	390	285	320	380	305	340	410	245	275	325	-	-	-
H21	180	200	240	160	180	215	155	175	210	165	185	220	135	150	180	-	-	-

## R217/220.21-L006 - Cutting data $v_c =$ (sf/min)

SMG	MK2050			MS2050			MP3000			MH1000		
	100%	70%	30%	100%	70%	30%	100%	70%	30%	100%	70%	30%
P1	950	1075	1300	880	990	1000	1100	1225	1475	1000	1125	1350
P2	930	1050	1250	860	960	970	1075	1200	1450	980	1100	1325
P3	810	900	1100	730	820	810	930	1050	1250	850	950	1150
P4	710	800	960	640	720	700	820	920	1125	750	840	1025
P5	690	770	930	600	670	670	790	890	1075	720	810	980
P6	770	860	1050	670	760	750	890	1000	1200	810	910	1100
P7	730	820	980	630	710	710	840	940	1125	770	860	1025
P8	680	760	920	610	690	680	780	880	1050	720	800	970
P11	710	790	950	610	690	690	820	920	1100	740	840	1000
M1	-	-	-	750	840	850	800	900	1075	-	-	-
M2	-	-	-	580	660	650	660	740	890	-	-	-
M3	-	-	-	405	465	425	520	590	710	-	-	-
M4	-	-	-	270	315	275	405	455	550	-	-	-
M5	-	-	-	225	260	230	340	380	455	-	-	-
K1	1000	1125	1350	870	970	980	850	950	1150	770	870	1050
K2	890	1000	1200	720	820	810	750	840	1000	690	770	930
K3	750	840	1025	610	690	680	640	710	860	580	650	790
K4	720	800	970	580	660	650	610	680	820	550	620	750
K5	435	490	590	340	385	360	365	410	500	340	380	455
K6	630	710	850	510	580	570	540	600	720	490	550	660
K7	560	630	750	430	490	460	470	530	640	435	485	580
N1	-	-	-	-	-	-	-	-	-	-	-	-
N2	-	-	-	-	-	-	-	-	-	-	-	-
N3	-	-	-	-	-	-	-	-	-	-	-	-
N11	-	-	-	-	-	-	-	-	-	-	-	-
S1	-	-	-	195	205	245	190	215	255	-	-	-
S2	-	-	-	155	165	195	155	170	205	-	-	-
S3	-	-	-	135	145	170	135	150	180	-	-	-
S11	-	-	-	260	280	340	265	300	360	-	-	-
S12	-	-	-	200	215	260	155	170	205	-	-	-
S13	-	-	-	165	175	210	125	135	165	-	-	-
H5	-	-	-	-	-	-	160	180	220	160	180	215
H8	-	-	-	-	-	-	170	190	225	165	190	225
H11	-	-	-	-	-	-	205	230	280	205	230	270
H12	-	-	-	-	-	-	310	350	420	305	345	410
H21	-	-	-	-	-	-	170	190	225	165	190	225

## R217/220.21-R230 - Insert selection

SMG		APMX	f <sub>z</sub>		
			100%	70%	30%
P1	218.21-230TR-06-ME13 T350M	0.063	0.047	0.047	0.051
P2	218.21-230TR-06-ME13 T350M	0.063	0.047	0.047	0.051
P3	218.21-230TR-06-ME13 T350M	0.063	0.043	0.043	0.047
P4	218.21-230TR-06-M15 MP2500	0.063	0.051	0.051	0.055
P5	218.21-230TR-06-M15 MP2500	0.063	0.047	0.047	0.051
P6	218.21-230TR-06-M15 MP2500	0.063	0.047	0.047	0.051
P7	218.21-230TR-06-M15 MP2500	0.063	0.047	0.047	0.051
P8	218.21-230TR-06-M15 MP2500	0.063	0.051	0.051	0.055
P11	218.21-230TR-06-ME13 T350M	0.063	0.043	0.043	0.047
M1	218.21-230TR-06-ME13 T350M	0.063	0.047	0.047	0.051
M2	218.21-230TR-06-ME13 T350M	0.063	0.043	0.043	0.047
M3	218.21-230TR-06-ME13 T350M	0.051	0.033	0.033	0.037
M4	218.21-230TR-06-ME13 MM4500	0.035	0.035	0.035	0.037
M5	218.21-230TR-06-ME13 MM4500	0.035	0.035	0.035	0.037
K1	218.21-230TR-06-MD17 MK2050	0.063	0.067	0.067	0.071
K2	218.21-230TR-06-MD17 MK2050	0.063	0.059	0.059	0.063
K3	218.21-230TR-06-MD17 MK2050	0.063	0.059	0.059	0.063
K4	218.21-230TR-06-MD17 MK2050	0.063	0.059	0.059	0.063
K5	218.21-230TR-06-MD17 MK2050	0.063	0.055	0.055	0.059
K6	218.21-230TR-06-MD17 MK2050	0.063	0.059	0.059	0.063
K7	218.21-230TR-06-MD17 MK2050	0.063	0.055	0.055	0.059
S1	218.21-230TR-06-ME13 MS2500	0.035	0.035	0.035	0.037
S2	218.21-230TR-06-ME13 MS2500	0.035	0.035	0.035	0.037
S3	218.21-230TR-06-M15 F40M	0.035	0.035	0.035	0.039
S11	218.21-230TR-06-ME13 MS2050	0.043	0.035	0.035	0.039
S12	218.21-230TR-06-ME13 MS2050	0.043	0.035	0.035	0.039
S13	218.21-230TR-06-ME13 MS2050	0.035	0.035	0.035	0.037
H5	218.21-230TR-06-MD17 MP3000	0.039	0.037	0.037	0.043
H8	218.21-230TR-06-MD17 MP3000	0.035	0.031	0.031	0.033
H11	218.21-230TR-06-M15 T350M	0.039	0.031	0.031	0.033
H12	218.21-230TR-06-M15 T350M	0.039	0.031	0.031	0.033
H21	218.21-230TR-06-MD17 MP3000	0.035	0.031	0.031	0.033
H31	218.21-230TR-06-MD17 MP3000	-	-	-	-

SMG = Seco Material Group

f<sub>z</sub> = in/tooth

v<sub>c</sub> = sf/min

APMX = inch

a<sub>p</sub>/DC = %

All cutting data are start values

## R217/220.21-R230 - Cutting data $v_c =$ (sf/min)

SMG	MK2050			MS2050			MS2500		
	100%	70%	30%	100%	70%	30%	100%	70%	30%
P1	670	780	960	720	800	1025	910	1050	1300
P2	640	740	930	700	780	990	880	1025	1275
P3	560	650	820	630	710	870	780	910	1125
P4	510	590	720	560	620	770	690	800	980
P5	485	560	700	530	590	730	660	760	940
P6	540	630	780	600	670	820	740	860	1050
P7	510	600	740	560	630	780	700	810	990
P8	475	550	690	530	590	730	660	760	940
P11	500	580	720	550	610	760	680	790	970
M1	-	-	-	610	680	860	630	740	910
M2	-	-	-	520	580	720	530	610	750
M3	-	-	-	465	520	590	455	530	640
M4	-	-	-	360	400	430	360	410	500
M5	-	-	-	300	330	360	300	345	420
K1	690	800	1000	-	-	-	-	-	-
K2	630	730	900	-	-	-	-	-	-
K3	530	610	760	-	-	-	-	-	-
K4	510	590	730	-	-	-	-	-	-
K5	310	355	445	-	-	-	-	-	-
K6	445	520	640	-	-	-	-	-	-
K7	395	455	570	-	-	-	-	-	-
S1	-	-	-	115	125	170	175	200	245
S2	-	-	-	95	100	140	140	160	200
S3	-	-	-	90	95	125	125	145	175
S11	-	-	-	155	170	225	245	285	345
S12	-	-	-	120	130	175	140	165	200
S13	-	-	-	100	110	145	115	130	160
H5	-	-	-	-	-	-	-	-	-
H8	-	-	-	-	-	-	-	-	-
H11	-	-	-	-	-	-	-	-	-
H12	-	-	-	-	-	-	-	-	-
H21	-	-	-	-	-	-	-	-	-

## R217/220.21-R230 - Cutting data $v_c =$ (sf/min)

SMG	MP1500			MP2500			MP3000			T350M			F40M			MM4500		
	100%	70%	30%	100%	70%	30%	100%	70%	30%	100%	70%	30%	100%	70%	30%	100%	70%	30%
P1	770	890	1100	790	920	1100	650	750	920	690	800	970	600	690	840	510	590	730
P2	730	850	1075	750	870	1075	620	720	890	650	760	940	570	660	820	495	580	710
P3	650	750	930	660	770	950	540	630	780	580	670	830	500	580	720	440	510	630
P4	580	670	820	580	680	830	485	570	690	510	590	730	440	510	630	385	450	550
P5	550	640	800	570	660	820	465	540	670	495	580	710	430	500	620	370	430	530
P6	620	720	900	640	740	920	520	610	750	560	650	800	485	560	690	415	480	590
P7	590	680	850	600	700	860	495	570	710	530	610	750	455	530	650	390	455	560
P8	540	630	790	550	640	800	455	530	660	485	560	690	420	490	600	370	430	530
P11	570	660	820	590	680	840	480	560	690	510	590	730	445	520	640	380	440	540
M1	-	-	-	540	630	780	460	540	670	500	580	720	455	530	660	425	495	610
M2	-	-	-	460	530	660	390	450	560	425	495	610	390	450	560	355	410	510
M3	-	-	-	390	450	550	335	390	480	365	420	510	330	385	465	310	355	430
M4	-	-	-	310	360	435	270	310	380	290	335	405	265	305	370	240	275	340
M5	-	-	-	260	300	360	225	260	315	240	280	335	220	255	305	200	230	285
K1	580	680	840	590	690	850	490	570	710	-	-	-	450	520	650	500	580	720
K2	530	610	760	540	630	770	440	510	640	-	-	-	410	475	590	445	520	640
K3	445	520	640	455	530	650	375	435	540	-	-	-	345	405	495	380	440	540
K4	425	495	610	435	510	630	355	415	520	-	-	-	330	385	475	360	420	520
K5	260	300	375	265	310	380	215	250	315	-	-	-	200	235	290	220	255	315
K6	375	435	540	385	445	550	315	365	455	-	-	-	290	340	415	320	370	455
K7	330	385	475	340	395	490	280	325	400	-	-	-	260	300	370	285	330	405
S1	-	-	-	-	-	-	125	145	175	135	155	190	125	140	170	75	85	105
S2	-	-	-	-	-	-	100	115	140	110	125	150	100	115	140	60	70	85
S3	-	-	-	-	-	-	90	105	125	95	110	135	90	100	120	55	60	75
S11	-	-	-	-	-	-	170	200	245	190	220	265	175	200	245	105	120	145
S12	-	-	-	-	-	-	100	115	140	110	125	155	100	115	140	80	90	110
S13	-	-	-	-	-	-	80	95	115	90	100	120	80	90	110	65	75	90
H5	145	165	195	130	150	185	115	130	155	125	145	175	110	125	155	-	-	-
H8	150	175	215	140	160	195	120	135	170	135	155	185	115	135	160	-	-	-
H11	180	210	250	165	190	235	145	165	195	160	185	225	140	160	195	-	-	-
H12	425	490	590	425	490	600	355	410	490	370	425	520	325	370	455	-	-	-
H21	150	175	215	140	160	195	120	135	170	135	155	185	115	135	160	-	-	-

## R217.21-100 - Insert selection

SMG		Recommended APMX**	f <sub>z</sub>		
			100%	70%	30%
P1	218.19-100T-M06 T350M	0.017	0.022	0.022	0.026
P2	218.19-100T-M06 T350M	0.017	0.024	0.024	0.026
P3	218.19-100T-M06 T350M	0.017	0.022	0.022	0.024
P4	218.19-100T-MD08 MS2500	0.017	0.028	0.028	0.032
P5	218.19-100T-MD08 MS2500	0.017	0.028	0.028	0.032
P6	218.19-100T-MD08 MS2500	0.017	0.028	0.028	0.030
P7	218.19-100T-MD08 MS2500	0.017	0.028	0.028	0.030
P8	218.19-100T-MD08 MP2500	0.017	0.030	0.030	0.032
P11	218.19-100T-MD08 MS2500	0.017	0.028	0.028	0.030
M1	218.19-100T-M06 F40M	0.017	0.024	0.024	0.026
M2	218.19-100T-M06 F40M	0.017	0.022	0.022	0.024
M3	218.19-100T-M06 F40M	0.013	0.019	0.019	0.022
M4	218.19-100T-M06 F40M	0.010	0.019	0.019	0.022
M5	218.19-100T-M06 F40M	0.010	0.019	0.019	0.022
K1	218.19-100T-MD08 MK2050	0.017	0.032	0.032	0.034
K2	218.19-100T-MD08 MK2050	0.017	0.028	0.028	0.032
K3	218.19-100T-MD08 MK2050	0.017	0.028	0.028	0.032
K4	218.19-100T-MD08 MK2050	0.017	0.028	0.028	0.032
K5	218.19-100T-MD08 MK2050	0.017	0.026	0.026	0.028
K6	218.19-100T-MD08 MK2050	0.017	0.028	0.028	0.032
K7	218.19-100T-MD08 MK2050	0.017	0.026	0.026	0.028
N1	218.19-100-E06 H25	0.017	0.030	0.030	0.032
N2	218.19-100-E06 H25	0.017	0.030	0.030	0.032
N3	218.19-100-E06 H25	0.017	0.030	0.030	0.032
N11	218.19-100-E06 H25	0.017	0.030	0.030	0.032
S1	218.19-100T-M06 MS2500	0.010	0.019	0.019	0.022
S2	218.19-100T-M06 MS2500	0.010	0.019	0.019	0.022
S3	218.19-100T-M06 MS2500	0.010	0.017	0.017	0.020
S11	218.19-100T-M06 MS2050	0.012	0.020	0.020	0.022
S12	218.19-100T-M06 MS2050	0.012	0.020	0.020	0.022
S13	218.19-100T-M06 MS2050	0.010	0.019	0.019	0.022
H5	218.19-100T-MD08 MH1000	0.013	0.022	0.022	0.024
H8	218.19-100T-MD08 MH1000	0.012	0.017	0.017	0.019
H11	218.19-100T-MD08 MH1000	0.013	0.022	0.022	0.024
H12	218.19-100T-MD08 MH1000	0.013	0.022	0.022	0.024
H21	218.19-100T-MD08 MH1000	0.012	0.017	0.017	0.019

\*\* For optimum tool life

SMG = Seco Material Group

f<sub>z</sub> = in/tooth

v<sub>c</sub> = sf/min

APMX = inch

a<sub>p</sub>/DC = %

All cutting data are start values

# CUTTING DATA - HIGH FEED MILLING CUTTERS



## R217.21-100 - Cutting data $v_c =$ (sf/min)

SMG	MP1500			MP2500			MP3000			T350M			F15M			F25M		
	100%	70%	30%	100%	70%	30%	100%	70%	30%	100%	70%	30%	100%	70%	30%	100%	70%	30%
P1	1200	1375	1675	1050	1225	1475	1125	1300	1575	1025	1200	1450	960	1100	1350	990	1150	1375
P2	1150	1350	1625	1025	1175	1450	1100	1275	1525	1000	1175	1400	930	1075	1300	960	1125	1350
P3	1000	1175	1425	900	1050	1250	960	1125	1350	880	1025	1225	810	940	1150	850	980	1175
P4	890	1025	1250	790	910	1100	850	980	1175	780	900	1075	720	830	1000	740	860	1025
P5	860	1000	1200	770	890	1050	810	940	1125	740	860	1025	700	810	960	710	820	990
P6	970	1125	1350	860	1000	1200	910	1050	1275	830	970	1150	780	910	1075	800	930	1100
P7	920	1050	1275	810	940	1125	860	990	1200	790	910	1100	740	850	1025	750	870	1050
P8	850	980	1200	750	870	1050	810	940	1125	740	860	1025	680	790	960	710	820	990
P11	890	1025	1225	790	910	1100	830	960	1150	760	890	1075	720	830	990	730	850	1025
M1	-	-	-	740	860	1050	820	950	1150	780	900	1075	750	870	1050	780	900	1075
M2	-	-	-	620	710	850	670	780	940	640	740	890	630	730	870	640	740	890
M3	-	-	-	490	560	680	540	620	740	510	590	700	500	570	690	510	590	700
M4	-	-	-	380	435	520	415	480	560	395	455	540	385	440	530	395	455	540
M5	-	-	-	315	360	435	345	400	470	330	380	445	320	370	440	330	380	445
K1	920	1050	1300	810	940	1150	870	1000	1200	800	920	1125	740	850	1050	760	880	1075
K2	820	950	1125	730	840	1000	770	890	1075	710	820	980	660	770	910	670	780	940
K3	690	800	960	620	710	850	650	750	900	600	690	830	560	650	770	570	660	790
K4	660	770	920	590	680	810	620	720	860	570	660	790	530	620	740	540	630	760
K5	400	465	560	355	410	500	380	440	520	350	405	480	325	375	455	335	390	460
K6	580	680	810	520	600	720	550	630	760	500	580	700	470	550	650	480	560	670
K7	510	600	720	455	530	640	485	560	670	450	520	620	415	480	580	430	495	590
N1	-	-	-	3025	3500	4250	3250	3775	4500	-	-	-	2750	3200	3850	2850	3325	3975
N2	-	-	-	2450	2825	3425	2625	3050	3625	-	-	-	2225	2575	3125	2300	2675	3200
N3	-	-	-	1625	1900	2275	1750	2025	2425	-	-	-	1475	1725	2075	1550	1775	2125
N11	-	-	-	1875	2150	2625	2000	2325	2775	-	-	-	1700	1975	2375	1750	2050	2450
S1	-	-	-	185	210	255	195	225	265	185	210	250	180	205	245	185	210	250
S2	-	-	-	150	170	205	155	180	210	150	170	200	145	165	200	150	170	200
S3	-	-	-	130	150	180	135	160	190	130	150	180	125	145	175	130	150	180
S11	-	-	-	255	295	355	275	315	375	260	300	355	250	290	350	260	300	355
S12	-	-	-	150	170	205	160	180	215	150	175	205	145	165	200	150	175	205
S13	-	-	-	120	135	165	125	145	170	120	135	160	115	135	160	120	135	160
H5	190	220	260	150	175	210	165	190	230	165	190	225	150	175	210	155	180	215
H8	200	230	275	160	185	220	175	200	240	170	195	235	160	185	220	165	190	225
H11	240	275	330	195	225	270	210	245	290	210	240	285	195	225	270	200	230	275
H12	365	420	500	290	335	405	320	370	440	315	365	435	290	335	405	300	350	415
H21	200	230	275	160	185	220	175	200	240	170	195	235	160	185	220	165	190	225

## R217.21-100 - Cutting data $v_c =$ (sf/min)

SMG	F40M			MK2050			MS2050			MS2500			MH1000			H25		
	100%	70%	30%	100%	70%	30%	100%	70%	30%	100%	70%	30%	100%	70%	30%	100%	70%	30%
P1	900	1050	1250	1025	1200	1450	910	1025	1000	1300	1500	1800	1150	1350	1625	-	-	-
P2	880	1025	1225	1000	1175	1425	890	1000	980	1250	1450	1750	1125	1300	1575	-	-	-
P3	770	890	1075	880	1025	1250	740	840	800	1100	1275	1550	980	1150	1375	-	-	-
P4	680	780	940	780	900	1100	650	740	710	970	1125	1350	870	1000	1225	-	-	-
P5	650	750	900	750	870	1050	620	700	680	930	1075	1300	840	980	1175	-	-	-
P6	730	840	1000	850	980	1175	700	790	760	1050	1200	1450	940	1100	1300	-	-	-
P7	680	790	950	800	930	1100	660	740	720	990	1150	1375	890	1025	1225	-	-	-
P8	650	750	900	740	860	1050	620	700	680	930	1075	1300	830	960	1175	-	-	-
P11	670	770	930	780	900	1075	640	720	700	960	1100	1325	870	1000	1200	-	-	-
M1	710	820	990	-	-	-	770	870	860	900	1050	1250	-	-	-	-	-	-
M2	580	670	810	-	-	-	610	690	660	740	860	1025	-	-	-	-	-	-
M3	465	540	640	-	-	-	410	465	435	600	690	820	-	-	-	-	-	-
M4	360	410	485	-	-	-	275	315	290	460	530	620	-	-	-	-	-	-
M5	300	345	405	-	-	-	230	260	240	385	440	520	-	-	-	-	-	-
K1	690	800	970	1100	1250	1525	890	1000	990	1000	1150	1400	890	1025	1250	-	-	-
K2	610	710	850	980	1125	1350	750	850	820	880	1025	1225	800	930	1100	-	-	-
K3	520	600	720	830	960	1150	640	720	690	750	870	1050	680	780	930	-	-	-
K4	495	570	690	790	910	1100	610	690	660	710	830	990	650	750	890	-	-	-
K5	305	355	420	475	550	670	340	385	370	440	510	600	390	455	550	-	-	-
K6	435	510	610	690	800	960	540	600	580	630	730	880	570	660	790	-	-	-
K7	390	450	540	610	710	860	435	495	475	560	650	770	500	580	700	-	-	-
N1	2600	3000	3600	-	-	-	-	-	-	-	-	-	-	-	-	2700	3125	3725
N2	2100	2425	2900	-	-	-	-	-	-	-	-	-	-	-	-	2175	2525	3025
N3	1400	1625	1950	-	-	-	-	-	-	-	-	-	-	-	-	1450	1675	2000
N11	1600	1850	2225	-	-	-	-	-	-	-	-	-	-	-	-	1650	1925	2300
S1	165	190	225	-	-	-	195	215	250	225	260	305	-	-	-	-	-	-
S2	135	155	185	-	-	-	160	175	200	180	210	245	-	-	-	-	-	-
S3	120	135	160	-	-	-	140	155	180	160	180	215	-	-	-	-	-	-
S11	235	270	325	-	-	-	275	300	355	315	365	435	-	-	-	-	-	-
S12	135	155	185	-	-	-	210	230	275	185	210	250	-	-	-	-	-	-
S13	110	125	145	-	-	-	170	185	215	145	165	195	-	-	-	-	-	-
H5	140	165	195	-	-	-	-	-	-	185	215	255	185	210	255	-	-	-
H8	150	170	205	-	-	-	-	-	-	195	220	265	195	225	270	-	-	-
H11	180	210	250	-	-	-	-	-	-	235	270	325	235	270	325	-	-	-
H12	275	315	375	-	-	-	-	-	-	355	410	490	355	410	490	-	-	-
H21	150	170	205	-	-	-	-	-	-	195	220	265	195	225	270	-	-	-

## R217/220.21-125 - Insert selection

SMG		Recommended APMX**	f <sub>z</sub>		
			100%	70%	30%
P1	218.19-125T-T3-M07 T350M	0.024	0.026	0.026	0.028
P2	218.19-125T-T3-M07 T350M	0.024	0.026	0.026	0.028
P3	218.19-125T-T3-M07 T350M	0.024	0.024	0.024	0.026
P4	218.19-125T-T3-MD10 MS2500	0.024	0.034	0.034	0.038
P5	218.19-125T-T3-MD10 MS2500	0.024	0.034	0.034	0.036
P6	218.19-125T-T3-MD10 MS2500	0.024	0.032	0.032	0.036
P7	218.19-125T-T3-MD10 MS2500	0.024	0.032	0.032	0.036
P8	218.19-125T-T3-MD10 MP2500	0.024	0.034	0.034	0.038
P11	218.19-125T-T3-MD10 MS2500	0.024	0.032	0.032	0.036
M1	218.19-125T-T3-M07 F40M	0.024	0.026	0.026	0.028
M2	218.19-125T-T3-M07 F40M	0.024	0.024	0.024	0.026
M3	218.19-125T-T3-M07 F40M	0.019	0.020	0.020	0.022
M4	218.19-125T-T3-M07 F40M	0.014	0.022	0.022	0.024
M5	218.19-125T-T3-M07 F40M	0.014	0.022	0.022	0.024
K1	218.19-125T-T3-MD10 MK2050	0.024	0.036	0.036	0.040
K2	218.19-125T-T3-MD10 MK2050	0.024	0.034	0.034	0.036
K3	218.19-125T-T3-MD10 MK2050	0.024	0.034	0.034	0.036
K4	218.19-125T-T3-MD10 MK2050	0.024	0.034	0.034	0.036
K5	218.19-125T-T3-MD10 MK2050	0.024	0.030	0.030	0.032
K6	218.19-125T-T3-MD10 MK2050	0.024	0.034	0.034	0.036
K7	218.19-125T-T3-MD10 MK2050	0.024	0.030	0.030	0.032
N1	218.19-125-T3-E06 H25	0.024	0.028	0.028	0.030
N2	218.19-125-T3-E06 H25	0.024	0.028	0.028	0.030
N3	218.19-125-T3-E06 H25	0.024	0.028	0.028	0.030
N11	218.19-125-T3-E06 H25	0.024	0.028	0.028	0.030
S1	218.19-125T-T3-M07 MS2500	0.014	0.022	0.022	0.024
S2	218.19-125T-T3-M07 MS2500	0.014	0.022	0.022	0.024
S3	218.19-125T-T3-M07 MS2500	0.014	0.020	0.020	0.022
S11	218.19-125T-T3-M07 MS2050	0.017	0.022	0.022	0.024
S12	218.19-125T-T3-M07 MS2050	0.017	0.022	0.022	0.024
S13	218.19-125T-T3-M07 MS2050	0.014	0.022	0.022	0.024
H5	218.19-125T-T3-MD10 MH1000	0.019	0.026	0.026	0.028
H8	218.19-125T-T3-MD10 MH1000	0.017	0.020	0.020	0.022
H11	218.19-125T-T3-MD10 MH1000	0.019	0.026	0.026	0.028
H12	218.19-125T-T3-MD10 MH1000	0.019	0.026	0.026	0.028
H21	218.19-125T-T3-MD10 MH1000	0.017	0.020	0.020	0.022

\*\* For optimum tool life

SMG = Seco Material Group

f<sub>z</sub> = in/tooth

v<sub>c</sub> = sf/min

APMX = inch

a<sub>p</sub>/DC = %

All cutting data are start values

# CUTTING DATA - HIGH FEED MILLING CUTTERS



## R217/220.21-125 - Cutting data $v_c =$ (sf/min)

SMG	MP1500			MP2500			MP3000			T350M			F40M			MK2050		
	100%	70%	30%	100%	70%	30%	100%	70%	30%	100%	70%	30%	100%	70%	30%	100%	70%	30%
P1	1100	1250	1525	1125	1300	1575	1075	1225	1500	990	1125	1375	860	980	1200	960	1100	1325
P2	1075	1225	1475	1100	1275	1525	1050	1200	1450	960	1100	1325	840	960	1150	930	1075	1275
P3	930	1075	1275	970	1100	1350	920	1050	1275	840	970	1175	730	840	1025	810	930	1125
P4	820	940	1125	850	980	1175	810	920	1125	740	850	1025	650	740	890	720	820	990
P5	780	890	1100	820	930	1125	770	880	1075	710	810	980	620	710	850	680	780	950
P6	880	1000	1225	910	1050	1275	870	990	1200	800	910	1100	690	790	960	770	880	1075
P7	830	950	1150	860	990	1200	820	940	1125	750	860	1050	650	750	900	720	830	1000
P8	780	890	1075	820	930	1125	770	880	1075	710	810	980	620	710	850	680	780	940
P11	810	920	1125	840	960	1150	790	910	1100	730	840	1000	640	730	880	700	800	980
M1	-	-	-	800	910	1100	780	890	1075	740	850	1025	670	770	930	-	-	-
M2	-	-	-	660	750	910	640	740	890	610	700	840	560	640	770	-	-	-
M3	-	-	-	520	600	720	510	590	700	490	560	670	445	510	610	-	-	-
M4	-	-	-	405	460	550	400	450	540	375	430	510	345	390	465	-	-	-
M5	-	-	-	335	385	460	330	375	450	315	355	425	285	325	390	-	-	-
K1	850	970	1175	880	1000	1200	830	950	1150	760	870	1050	660	760	920	1000	1150	1375
K2	740	850	1050	770	880	1075	730	840	1025	670	770	930	590	670	810	880	1000	1225
K3	630	720	880	650	750	900	620	710	860	570	650	790	495	570	690	750	850	1050
K4	600	690	840	620	710	860	590	680	820	540	620	750	475	540	650	710	820	1000
K5	370	420	510	380	435	520	360	410	495	330	380	455	290	330	395	440	500	600
K6	530	600	740	550	630	760	520	600	720	480	550	660	415	475	580	630	720	880
K7	475	540	650	485	560	670	460	530	630	425	485	580	370	420	510	560	640	770
N1	-	-	-	3275	3750	4500	3100	3550	4275	-	-	-	2475	2850	3425	-	-	-
N2	-	-	-	2650	3025	3650	2500	2875	3450	-	-	-	2000	2300	2750	-	-	-
N3	-	-	-	1775	2025	2425	1675	1900	2300	-	-	-	1350	1525	1850	-	-	-
N11	-	-	-	2025	2300	2775	1900	2175	2625	-	-	-	1525	1750	2100	-	-	-
S1	-	-	-	195	225	270	185	210	250	175	200	240	160	180	220	-	-	-
S2	-	-	-	160	180	215	150	170	205	140	160	195	130	145	175	-	-	-
S3	-	-	-	140	160	190	130	150	180	125	140	170	115	130	155	-	-	-
S11	-	-	-	280	320	380	265	300	360	250	285	340	225	260	310	-	-	-
S12	-	-	-	160	185	220	150	175	210	145	165	195	130	150	180	-	-	-
S13	-	-	-	125	145	175	120	135	165	115	130	155	105	115	140	-	-	-
H5	175	200	240	165	190	225	160	185	220	160	180	215	135	155	185	-	-	-
H8	185	215	255	175	200	235	170	195	230	165	190	225	145	165	195	-	-	-
H11	220	250	305	210	240	285	205	235	280	200	230	275	175	200	240	-	-	-
H12	335	380	460	315	360	430	310	350	420	305	345	415	265	300	360	-	-	-
H21	185	215	255	175	200	235	170	195	230	165	190	225	145	165	195	-	-	-

## R217/220.21-125 - Cutting data $v_c =$ (sf/min)

SMG	MM4500			MS2050			MS2500			MH1000			H25		
	100%	70%	30%	100%	70%	30%	100%	70%	30%	100%	70%	30%	100%	70%	30%
P1	700	800	970	940	1050	1075	1250	1425	1725	1075	1225	1475	-	-	-
P2	680	780	940	920	1025	1050	1200	1375	1675	1050	1175	1425	-	-	-
P3	600	680	820	780	870	880	1050	1200	1450	910	1025	1250	-	-	-
P4	520	600	720	680	770	770	930	1075	1275	800	910	1100	-	-	-
P5	500	570	690	650	730	740	890	1025	1225	760	870	1075	-	-	-
P6	560	640	780	730	820	830	1000	1150	1375	860	980	1200	-	-	-
P7	530	610	730	690	780	780	940	1075	1300	810	920	1125	-	-	-
P8	500	570	690	650	730	740	890	1025	1225	760	870	1050	-	-	-
P11	520	590	710	670	750	760	920	1050	1275	780	900	1100	-	-	-
M1	580	670	810	800	900	920	860	990	1200	-	-	-	-	-	-
M2	480	550	660	640	720	720	710	810	980	-	-	-	-	-	-
M3	380	435	520	455	510	495	570	650	780	-	-	-	-	-	-
M4	295	335	400	315	355	335	440	500	600	-	-	-	-	-	-
M5	245	280	335	260	295	275	365	415	495	-	-	-	-	-	-
K1	-	-	-	920	1025	1050	950	1100	1325	820	940	1125	-	-	-
K2	-	-	-	790	890	890	840	970	1175	720	830	1000	-	-	-
K3	-	-	-	670	750	760	710	820	990	610	700	860	-	-	-
K4	-	-	-	640	720	720	680	780	940	580	670	820	-	-	-
K5	-	-	-	370	420	415	415	475	570	360	410	495	-	-	-
K6	-	-	-	560	630	640	600	690	830	510	590	720	-	-	-
K7	-	-	-	475	530	530	530	610	730	460	530	630	-	-	-
N1	-	-	-	-	-	-	-	-	-	-	-	-	2625	2975	3625
N2	-	-	-	-	-	-	-	-	-	-	-	-	2100	2400	2925
N3	-	-	-	-	-	-	-	-	-	-	-	-	1400	1600	1950
N11	-	-	-	-	-	-	-	-	-	-	-	-	1600	1850	2225
S1	90	105	125	180	195	235	215	245	290	-	-	-	-	-	-
S2	75	85	100	145	155	190	175	195	235	-	-	-	-	-	-
S3	65	75	85	130	140	170	150	175	205	-	-	-	-	-	-
S11	130	145	175	255	275	330	305	345	415	-	-	-	-	-	-
S12	100	110	135	195	210	255	175	200	240	-	-	-	-	-	-
S13	80	90	105	155	170	205	140	155	190	-	-	-	-	-	-
H5	-	-	-	-	-	-	180	205	245	170	195	235	-	-	-
H8	-	-	-	-	-	-	190	215	255	180	210	250	-	-	-
H11	-	-	-	-	-	-	225	260	310	215	245	295	-	-	-
H12	-	-	-	-	-	-	340	390	465	325	370	450	-	-	-
H21	-	-	-	-	-	-	190	215	255	180	210	250	-	-	-



## R217/220.21-160 - Insert selection

SMG		Recommended APMX**	f <sub>z</sub>		
			100%	70%	30%
P1	218.19-160T-04-M08 T350M	0.044	0.024	0.024	0.026
P2	218.19-160T-04-M08 T350M	0.044	0.024	0.024	0.026
P3	218.19-160T-04-M08 T350M	0.044	0.024	0.024	0.026
P4	218.19-160T-04-MD11 MS2500	0.044	0.032	0.032	0.034
P5	218.19-160T-04-MD11 MS2500	0.044	0.030	0.030	0.034
P6	218.19-160T-04-MD11 MS2500	0.044	0.030	0.030	0.034
P7	218.19-160T-04-MD11 MS2500	0.044	0.030	0.030	0.034
P8	218.19-160T-04-MD11 MP2500	0.044	0.032	0.032	0.034
P11	218.19-160T-04-MD11 MS2500	0.044	0.030	0.030	0.034
M1	218.19-160T-04-M08 F40M	0.044	0.024	0.024	0.026
M2	218.19-160T-04-M08 F40M	0.044	0.022	0.022	0.024
M3	218.19-160T-04-M08 F40M	0.034	0.020	0.020	0.022
M4	218.19-160T-04-M08 F40M	0.026	0.020	0.020	0.022
M5	218.19-160T-04-M08 F40M	0.026	0.020	0.020	0.022
K1	218.19-160T-04-MD11 MK2050	0.044	0.034	0.034	0.036
K2	218.19-160T-04-MD11 MK2050	0.044	0.030	0.030	0.034
K3	218.19-160T-04-MD11 MK2050	0.044	0.030	0.030	0.034
K4	218.19-160T-04-MD11 MK2050	0.044	0.030	0.030	0.034
K5	218.19-160T-04-MD11 MK2050	0.044	0.028	0.028	0.030
K6	218.19-160T-04-MD11 MK2050	0.044	0.030	0.030	0.034
K7	218.19-160T-04-MD11 MK2050	0.044	0.028	0.028	0.030
N1	218.19-160-04-E07 H25	0.044	0.028	0.028	0.030
N2	218.19-160-04-E07 H25	0.044	0.028	0.028	0.030
N3	218.19-160-04-E07 H25	0.044	0.028	0.028	0.030
N11	218.19-160-04-E07 H25	0.044	0.028	0.028	0.030
S1	218.19-160T-04-M08 MS2500	0.026	0.020	0.020	0.022
S2	218.19-160T-04-M08 MS2500	0.026	0.020	0.020	0.022
S3	218.19-160T-04-M08 MS2500	0.026	0.019	0.019	0.020
S11	218.19-160T-04-M08 MS2050	0.032	0.020	0.020	0.022
S12	218.19-160T-04-M08 MS2050	0.032	0.020	0.020	0.022
S13	218.19-160T-04-M08 MS2050	0.026	0.020	0.020	0.022
H5	218.19-160T-04-MD11 MH1000	0.034	0.024	0.024	0.026
H8	218.19-160T-04-MD11 MH1000	0.032	0.018	0.018	0.020
H11	218.19-160T-04-MD11 MH1000	0.034	0.024	0.024	0.026
H12	218.19-160T-04-MD11 MH1000	0.034	0.024	0.024	0.026
H21	218.19-160T-04-MD11 MH1000	0.032	0.018	0.018	0.020

\*\* For optimum tool life

SMG = Seco Material Group

f<sub>z</sub> = in/tooth

v<sub>c</sub> = sf/min

APMX = inch

a<sub>p</sub>/DC = %

All cutting data are start values

# CUTTING DATA - HIGH FEED MILLING CUTTERS



## R217/220.21-160 - Cutting data $v_c$ = (sf/min)

SMG	MP1500			MP2500			MP3000			T350M			F15M			F25M		
	100%	70%	30%	100%	70%	30%	100%	70%	30%	100%	70%	30%	100%	70%	30%	100%	70%	30%
P1	1075	1225	1525	950	1100	1350	1050	1225	1500	980	1125	1375	860	1000	1225	940	1075	1325
P2	1050	1200	1450	920	1075	1300	1025	1200	1425	950	1100	1300	840	970	1175	910	1050	1250
P3	910	1050	1275	810	930	1125	890	1025	1250	820	950	1150	730	850	1025	780	910	1100
P4	800	930	1150	710	820	1000	800	930	1100	740	850	1025	650	750	920	710	820	970
P5	780	900	1100	690	800	960	770	890	1075	700	810	990	630	730	880	670	780	940
P6	880	1025	1225	780	900	1075	860	990	1200	790	910	1100	710	820	980	760	870	1050
P7	830	960	1150	730	850	1025	810	940	1125	750	860	1050	670	770	930	710	830	1000
P8	770	890	1075	680	790	950	750	870	1050	690	800	970	620	710	860	660	760	920
P11	800	930	1125	710	820	990	790	910	1100	730	840	1025	650	750	900	690	800	970
M1	-	-	-	670	770	930	770	890	1075	730	850	1000	680	780	950	730	850	1000
M2	-	-	-	560	640	780	640	740	900	610	700	850	570	650	790	610	700	850
M3	-	-	-	445	510	630	510	590	710	485	560	670	455	520	640	485	560	670
M4	-	-	-	345	395	480	395	455	540	375	430	520	350	405	490	375	430	520
M5	-	-	-	290	330	400	330	380	455	315	360	430	295	335	405	315	360	430
K1	830	950	1150	730	840	1025	820	950	1125	750	870	1050	660	770	930	720	830	990
K2	740	860	1025	660	760	920	730	840	1025	670	770	940	600	690	830	640	740	900
K3	630	730	870	560	640	770	610	710	860	570	650	790	510	580	700	540	630	760
K4	600	690	830	530	610	740	590	680	820	540	620	760	480	560	670	520	600	720
K5	365	420	510	320	370	455	360	415	500	330	380	460	295	340	415	315	365	440
K6	530	610	740	465	540	650	520	600	720	475	550	670	425	490	590	455	530	640
K7	465	540	660	410	475	580	460	530	640	420	490	590	375	435	530	405	465	560
N1	-	-	-	2675	3100	3800	3000	3450	4250	-	-	-	2425	2800	3450	2625	3050	3750
N2	-	-	-	2175	2500	3050	2425	2800	3425	-	-	-	1975	2275	2775	2125	2450	3025
N3	-	-	-	1450	1675	2050	1600	1875	2275	-	-	-	1300	1525	1850	1425	1650	2025
N11	-	-	-	1650	1900	2325	1850	2125	2625	-	-	-	1500	1725	2125	1625	1875	2300
S1	-	-	-	170	195	235	185	210	255	175	200	240	165	190	230	175	200	240
S2	-	-	-	135	155	190	150	170	205	140	160	195	130	150	185	140	160	195
S3	-	-	-	120	135	165	130	150	180	125	140	170	115	135	160	125	140	170
S11	-	-	-	235	270	325	255	295	355	240	280	335	230	265	320	240	280	335
S12	-	-	-	135	155	190	145	170	205	140	160	195	135	155	185	140	160	195
S13	-	-	-	110	125	150	120	135	165	115	130	155	105	120	145	115	130	155
H5	175	200	240	140	160	195	155	180	215	155	180	215	140	160	195	150	170	205
H8	185	210	255	150	170	205	165	190	230	165	190	225	150	170	205	155	180	215
H11	220	255	305	175	205	245	200	230	275	195	225	270	175	205	245	190	215	260
H12	330	380	460	265	305	370	300	345	420	295	340	410	265	305	370	285	325	395
H21	185	210	255	150	170	205	165	190	230	165	190	225	150	170	205	155	180	215

## R217/220.21-160 - Cutting data $v_c$ = (sf/min)

SMG	F40M			MK2050			MS2050			MS2500			MH1000			H25		
	100%	70%	30%	100%	70%	30%	100%	70%	30%	100%	70%	30%	100%	70%	30%	100%	70%	30%
P1	850	980	1200	930	1075	1325	970	1100	1150	1225	1425	1725	1050	1200	1475	-	-	-
P2	830	960	1150	910	1050	1275	950	1050	1125	1200	1375	1650	1025	1175	1425	-	-	-
P3	710	820	1000	800	920	1100	810	910	960	1025	1175	1450	890	1025	1250	-	-	-
P4	640	740	880	700	810	990	710	800	850	920	1075	1275	780	900	1100	-	-	-
P5	610	710	860	680	790	950	680	760	790	880	1025	1225	760	880	1050	-	-	-
P6	690	800	960	770	880	1075	760	860	880	990	1150	1375	850	990	1200	-	-	-
P7	650	750	910	720	830	1000	720	810	830	930	1075	1300	810	930	1125	-	-	-
P8	600	690	840	670	770	930	680	770	810	860	1000	1200	750	860	1050	-	-	-
P11	630	730	880	700	810	980	700	790	810	910	1050	1275	780	900	1100	-	-	-
M1	670	770	920	-	-	-	830	930	990	850	990	1175	-	-	-	-	-	-
M2	550	640	770	-	-	-	660	750	770	710	820	990	-	-	-	-	-	-
M3	445	510	610	-	-	-	480	540	530	570	650	780	-	-	-	-	-	-
M4	340	390	470	-	-	-	335	380	365	435	500	600	-	-	-	-	-	-
M5	285	325	390	-	-	-	280	320	300	365	415	500	-	-	-	-	-	-
K1	660	760	900	980	1125	1375	950	1075	1150	940	1100	1300	800	930	1125	-	-	-
K2	580	670	810	880	1025	1225	820	920	950	840	970	1175	720	830	1000	-	-	-
K3	490	570	690	750	860	1050	700	780	810	710	820	990	610	710	850	-	-	-
K4	470	540	660	710	820	990	660	750	770	680	780	950	580	670	810	-	-	-
K5	285	330	400	430	500	610	390	440	440	410	475	580	355	410	500	-	-	-
K6	415	480	580	630	720	870	580	660	680	600	690	830	510	590	720	-	-	-
K7	365	425	510	550	640	780	500	560	570	530	610	740	455	520	640	-	-	-
N1	2400	2775	3400	-	-	-	-	-	-	-	-	-	-	-	-	2525	2925	3575
N2	1925	2225	2750	-	-	-	-	-	-	-	-	-	-	-	-	2050	2350	2875
N3	1300	1500	1825	-	-	-	-	-	-	-	-	-	-	-	-	1350	1575	1925
N11	1475	1700	2100	-	-	-	-	-	-	-	-	-	-	-	-	1550	1800	2200
S1	160	185	220	-	-	-	175	190	235	215	245	295	-	-	-	-	-	-
S2	130	145	175	-	-	-	140	155	190	170	195	235	-	-	-	-	-	-
S3	110	130	155	-	-	-	125	135	170	150	170	210	-	-	-	-	-	-
S11	220	255	305	-	-	-	230	250	315	295	340	410	-	-	-	-	-	-
S12	125	145	175	-	-	-	175	190	240	170	195	235	-	-	-	-	-	-
S13	105	120	140	-	-	-	150	165	200	140	160	190	-	-	-	-	-	-
H5	135	155	185	-	-	-	-	-	-	175	200	240	170	195	235	-	-	-
H8	145	165	195	-	-	-	-	-	-	185	215	255	180	205	250	-	-	-
H11	170	195	235	-	-	-	-	-	-	220	255	305	215	245	300	-	-	-
H12	260	295	355	-	-	-	-	-	-	335	385	465	325	370	450	-	-	-
H21	145	165	195	-	-	-	-	-	-	185	215	255	180	205	250	-	-	-

## R220.21-0N09 - Insert selection

SMG		Recommended APMX**	f <sub>z</sub>		
			100%	70%	30%
P1	ONMU090520ANTN-M12 MP2500	0.048	0.024	0.024	0.026
P2	ONMU090520ANTN-M12 MP2500	0.048	0.024	0.024	0.028
P3	ONMU090520ANTN-M12 MP2500	0.048	0.024	0.024	0.026
P4	ONMU090520ANTN-M12 MP2500	0.048	0.024	0.024	0.026
P5	ONMU090520ANTN-M12 MP2500	0.048	0.022	0.022	0.024
P6	ONMU090520ANTN-M12 MP2500	0.048	0.022	0.022	0.024
P7	ONMU090520ANTN-MD16 MP1500	0.048	0.028	0.028	0.030
P8	ONMU090520ANTN-MD16 MP1500	0.048	0.030	0.030	0.032
P11	ONMU090520ANTN-MD16 MP1500	0.048	0.028	0.028	0.030
K1	ONMU090520ANTN-M14 MK2050	0.048	0.030	0.030	0.032
K2	ONMU090520ANTN-M14 MK2050	0.048	0.026	0.026	0.028
K3	ONMU090520ANTN-M14 MK2050	0.048	0.026	0.026	0.028
K4	ONMU090520ANTN-M14 MK2050	0.048	0.026	0.026	0.028
K5	ONMU090520ANTN-M14 MK2050	0.048	0.024	0.024	0.026
K6	ONMU090520ANTN-MD16 MK1500	0.048	0.028	0.028	0.030
K7	ONMU090520ANTN-MD16 MK1500	0.048	0.026	0.026	0.028

\*\* For optimum tool life  
 SMG = Seco Material Group  
 f<sub>z</sub> = in/tooth  
 v<sub>c</sub> = sf/min  
 APMX = inch  
 a<sub>g</sub>/D<sub>c</sub> = %  
 All cutting data are start values

## R220.21-0N09 - Cutting data v<sub>c</sub> = (sf/min)

SMG	MP1500			MP2500			MK1500			MK2050		
	100%	70%	30%	100%	70%	30%	100%	70%	30%	100%	70%	30%
P1	1025	1125	1375	900	1000	1225	-	-	-	820	910	1100
P2	990	1100	1325	880	970	1175	-	-	-	780	860	1075
P3	850	940	1150	750	840	1025	-	-	-	680	760	930
P4	750	830	1025	660	740	900	-	-	-	620	680	820
P5	730	820	990	650	720	880	-	-	-	590	650	800
P6	820	920	1125	730	810	990	-	-	-	660	730	900
P7	780	860	1050	690	770	930	-	-	-	620	690	850
P8	720	790	970	630	700	860	-	-	-	570	640	790
P11	760	840	1025	670	740	910	-	-	-	610	670	820
K1	780	870	1050	690	770	920	890	980	1225	840	930	1150
K2	700	770	940	620	690	840	800	890	1100	760	840	1025
K3	590	650	800	520	580	710	680	750	930	640	710	880
K4	560	620	760	500	550	680	650	720	880	610	680	840
K5	345	385	465	305	340	410	395	440	540	375	415	510
K6	495	550	670	440	490	600	570	630	780	540	600	740
K7	440	490	600	390	435	530	510	560	690	480	530	650

## R220.21-SC12- Insert selection

SMG		Recommended APMX**	f <sub>z</sub>		
			100%	70%	30%
P1	SCET120630T-M14 T350M	0.040	0.038	0.038	0.044
P2	SCET120630T-M14 T350M	0.040	0.040	0.040	0.044
P3	SCET120630T-M14 T350M	0.040	0.038	0.038	0.040
P4	SCET120630T-MD16 MS2500	0.040	0.040	0.040	0.044
P5	SCET120630T-MD16 MS2500	0.040	0.040	0.040	0.044
P6	SCET120630T-MD16 MS2500	0.040	0.040	0.040	0.044
P7	SCET120630T-MD16 MS2500	0.040	0.040	0.040	0.044
P8	SCET120630T-MD16 MP2500	0.040	0.044	0.044	0.048
P11	SCET120630T-MD16 MS2500	0.040	0.040	0.040	0.044
M1	SCET120630T-M14 F40M	0.040	0.040	0.040	0.044
M2	SCET120630T-M14 F40M	0.040	0.036	0.036	0.040
M3	SCET120630T-M14 F40M	0.030	0.030	0.030	0.032
M4	SCET120630T-M14 F40M	0.024	0.026	0.026	0.028
M5	SCET120630T-M14 F40M	0.024	0.026	0.026	0.028
K1	SCET120630T-MD16 MP1500	0.040	0.044	0.044	0.048
K2	SCET120630T-MD16 MP1500	0.040	0.040	0.040	0.044
K3	SCET120630T-MD16 MP1500	0.040	0.040	0.040	0.044
K4	SCET120630T-MD16 MP1500	0.040	0.040	0.040	0.044
K5	SCET120630T-MD16 MP1500	0.040	0.036	0.036	0.040
K6	SCET120630T-MD16 MP1500	0.040	0.040	0.040	0.044
K7	SCET120630T-MD16 MP1500	0.040	0.036	0.036	0.040
S1	SCET120630T-M14 MS2500	0.024	0.026	0.026	0.028
S2	SCET120630T-M14 MS2500	0.024	0.026	0.026	0.028
S3	SCET120630T-M14 MS2500	0.024	0.024	0.024	0.026
S11	SCET120630T-M14 MS2500	0.028	0.030	0.030	0.032
S12	SCET120630T-M14 MS2500	0.028	0.030	0.030	0.032
S13	SCET120630T-M14 MS2500	0.024	0.026	0.026	0.028
H5	SCET120630T-MD16 MP1500	0.030	0.028	0.028	0.032
H8	SCET120630T-MD16 MP1500	0.028	0.022	0.022	0.024
H11	SCET120630T-MD16 MP1500	0.030	0.028	0.028	0.032
H12	SCET120630T-MD16 MP1500	0.030	0.028	0.028	0.032
H21	SCET120630T-MD16 MP1500	0.028	0.022	0.022	0.024

\*\* For optimum tool life

SMG = Seco Material Group

f<sub>z</sub> = in/tooth

v<sub>c</sub> = sf/min

APMX = inch

a<sub>p</sub>/DC = %

All cutting data are start values

## R220.21-SC12 - Cutting data $v_c = (sf/min)$

SMG	MP1500			MP2500			MP3000			T350M			F40M			MK2050		
	100%	70%	30%	100%	70%	30%	100%	70%	30%	100%	70%	30%	100%	70%	30%	100%	70%	30%
P1	980	1125	1375	870	1000	1225	860	990	1200	790	910	1100	690	790	960	900	1025	1250
P2	960	1100	1350	850	970	1200	830	950	1150	760	870	1075	660	760	930	860	980	1200
P3	820	940	1150	730	830	1025	720	830	1025	660	760	950	580	660	820	750	860	1075
P4	750	850	1050	660	760	930	650	740	910	590	680	830	520	590	720	670	770	940
P5	710	820	1000	630	720	890	620	710	860	570	650	800	495	560	690	640	730	900
P6	800	910	1125	710	810	1000	690	790	980	640	730	910	550	630	790	720	820	1025
P7	750	860	1050	670	760	940	650	750	930	600	690	860	520	600	740	680	780	970
P8	690	790	980	610	700	870	610	690	860	560	640	800	485	560	690	630	720	900
P11	730	840	1025	650	740	910	640	730	900	580	670	830	510	580	720	660	760	940
M1	-	-	-	610	700	860	620	710	870	590	670	820	530	610	750	-	-	-
M2	-	-	-	510	580	710	520	590	720	490	560	680	445	510	620	-	-	-
M3	-	-	-	405	460	570	415	470	580	390	445	550	355	405	500	-	-	-
M4	-	-	-	315	355	435	325	365	445	305	345	420	280	315	380	-	-	-
M5	-	-	-	265	295	365	270	305	370	255	285	350	230	260	320	-	-	-
K1	760	870	1075	670	770	950	650	750	920	600	690	850	520	600	740	930	1050	1300
K2	680	770	950	600	690	840	590	670	820	540	620	750	470	540	660	830	950	1150
K3	570	650	800	510	580	710	495	570	690	455	520	640	395	455	560	700	800	980
K4	550	620	770	485	550	680	475	540	660	435	500	610	380	435	530	670	770	940
K5	330	380	470	295	335	415	290	335	405	270	305	375	235	265	325	415	475	580
K6	480	550	680	425	490	600	415	475	580	385	440	540	335	380	465	590	680	830
K7	425	485	600	375	430	530	375	425	520	345	395	480	300	340	415	530	610	740
N1	-	-	-	2450	2800	3425	2375	2725	3375	-	-	-	1900	2175	2700	-	-	-
N2	-	-	-	1975	2275	2775	1925	2200	2725	-	-	-	1550	1750	2200	-	-	-
N3	-	-	-	1325	1525	1850	1275	1475	1825	-	-	-	1025	1175	1450	-	-	-
N11	-	-	-	1525	1725	2100	1475	1675	2075	-	-	-	1175	1350	1675	-	-	-
S1	-	-	-	155	175	210	150	170	205	145	160	195	130	145	180	-	-	-
S2	-	-	-	125	140	170	120	135	165	115	130	160	105	120	145	-	-	-
S3	-	-	-	110	125	150	105	120	145	100	115	140	90	105	125	-	-	-
S11	-	-	-	215	240	300	210	235	290	200	225	275	180	205	250	-	-	-
S12	-	-	-	125	140	170	120	135	165	115	130	160	105	120	145	-	-	-
S13	-	-	-	100	110	135	95	110	135	90	105	125	85	95	115	-	-	-
H5	160	180	220	130	145	180	130	150	180	130	145	180	110	125	155	-	-	-
H8	170	190	235	135	155	190	140	155	190	135	155	190	120	135	165	-	-	-
H11	205	230	285	165	185	230	165	190	230	165	185	225	140	160	195	-	-	-
H12	305	345	425	245	280	345	250	285	350	245	280	340	215	245	300	-	-	-
H21	170	190	235	135	155	190	140	155	190	135	155	190	120	135	165	-	-	-

## R220.21-SC12 - Cutting data $v_c = (sf/min)$

SMG	MS2500		
	100%	70%	30%
P1	990	1125	1375
P2	950	1100	1350
P3	830	950	1175
P4	740	850	1050
P5	710	810	1000
P6	800	910	1125
P7	750	860	1075
P8	700	800	1000
P11	730	840	1050
M1	680	780	960
M2	570	650	800
M3	455	520	640
M4	355	400	490
M5	295	335	410
K1	750	860	1050
K2	670	770	950
K3	570	650	800
K4	540	620	760
K5	335	385	470
K6	480	550	670
K7	430	490	600
S1	175	195	240
S2	140	160	195
S3	125	140	170
S11	240	275	335
S12	140	160	195
S13	115	125	155
H5	145	165	200
H8	155	175	215
H11	185	210	255
H12	280	315	385
H21	155	175	215

## HELICAL INTERPOLATION DATA

The milling cutter design and the clearance on the bottom side of the chosen insert determines the tool's suitability for helical interpolation ramping. Maximum and minimum hole diameters and maximum cutting depth per revolution recommendations for suitable tools are in the tables below.

**Note:** Please refer to product page(s) 24-36 for ramping information (RMPX)

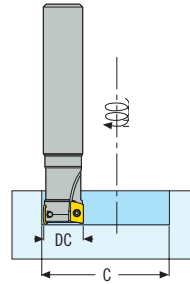

	Cutter dia ø DCX inch	C min ø	C max ø
<b>217.21-L006</b>	1.00	1.736	1.921
	1.25	2.234	2.421
	1.50	2.736	2.921
	2.00	3.736	3.921
	2.50	4.737	4.921
<b>217.21-LP05</b>	0.500	0.685	0.866
	0.625	1.000	1.181
	0.750	1.315	1.496
<b>217.21-LP06</b>	0.625	0.925	1.181
	0.750	1.240	1.496
	1.000	1.633	1.889
	1.250	2.185	2.440
	1.500	1.950	2.956

	Cutter dia ø DCX inch	C min ø	C max ø
<b>R217/220.21-218.19</b>	0.625	0.75	1.17
	0.750	0.88	1.42
	0.750H	0.88	1.42
	1.00	1.37	1.92
	1.00H	1.19	1.92
	1.25	1.69	2.42
	1.25H	1.46	2.42
	1.50	2.20	2.92
	1.50H	1.96	2.92
	2.00	3.01	3.92
	2.50	4.00	4.92
	3.00	5.02	5.92
	4.00	7.02	7.92

	Cutter dia ø DCX inch	C min ø	C max ø
<b>R217/220.21-218.21-230</b>	2.00	3.421	3.921
	2.50	4.421	4.921
	3.00	5.429	5.921
	3.50	6.433	6.921
	4.00	7.433	7.921

	Cutter dia ø DCX inch	C min ø	C max ø
<b>R217/220.21-SC12</b>	2.00	3.189	3.858
	2.50	4.213	4.882
	3.00	5.551	6.220
	4.00	7.126	7.795

## PLUNGING

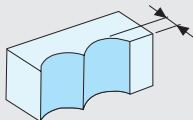

TYPE OF CUTTER	APMX MAX INCH
217/220.21-L006	.098
217/220.21-LP05	.137
217/220.21-LP06	.177
217/220.21	.276
217/220.21-R125	.354
217/220.21-R160	.433
R220.21-R230	.394

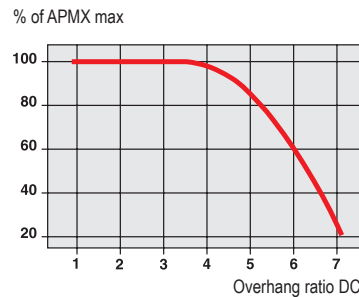
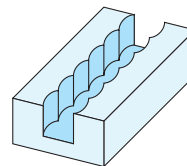
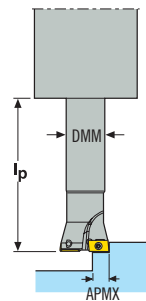

**NOTE:** The insert design and the insert clamping system determines the tool's suitability for plunging. Maximum cutting depth recommendations for suitable tools are in the tables below. Note that the definition of APMX is different for plunge milling. Use the cutting speeds and feed rates recommended for normal operations.

APMX max can normally be used if the overhang ratio is up to 4 but should be reduced at higher ratios as shown in the graph.

To create a flat bottom surface with axial feed direction, APMX max = wiper flat width B.



Follow Seco Tools on Twitter, Facebook, Blogger and YouTube. Stay up to date on new products and technology, special events, promotions and more.

**[SECOTOOLS.COM/US/FOLLOWSECO](http://SECOTOOLS.COM/US/FOLLOWSECO)**

**SECO TOOLS, LLC**  
NORTH AMERICAN HEADQUARTERS  
2805 Bellingham Drive  
Troy, MI 48083  
248-528-5200

**[SECOTOOLS.COM](http://SECOTOOLS.COM)**

Niagara Cutter™ is a Seco Tools company.

P-1612-5000 GT16-134  
Copyright © 2016 Seco Tools, LLC  
Printed in USA. All rights reserved.

To find an Authorized SECO  
Distributor near you, please refer  
to our Distributor Locator:

**[SECOLOCATOR.COM](http://SECOLOCATOR.COM)**

For technical assistance, call:  
**1-800-832-8326**

For customer service, call:  
**1-248-528-5220**