

CUTTERS & CUTTER WHEELS

SECTION

1

Cutter Wheels

Quick Release™
Tubing Cutters 

Tubing Cutters

Telescoping Tubing Cutters 

Tubing Cutters for Stainless Steel

Mini Tubing Cutters

Repair Kits

Deburring Tools

CSST Tubing Cutters 

Steel Pipe Cutters

Pipe Reamer

Soil Pipe Cutters

Pipe Descalers

Saw It®

Universal Pipe Cutters 

Hinged Cutters™

Rotary™ Cutters & Low
Clearance Rotary™ Cutters

CUTTERS & CUTTER WHEELS

BEST EVER!

✓ WHY REED? CUTTER WHEELS ARE BETTER...

All Reed cutter wheels are made from high shock-resistant tool steel, while competitive wheels are made from carbon steel or still lower quality tool steel. By using this higher quality raw material, Reed cutter wheels can be made thinner and can therefore cut pipe more easily and leave less burr. Also, because of their higher quality, certified material, only Reed wheels can be heat-treated for the perfect balance between hardness and toughness to make the wheels resist breakage and last longer.

Reed pioneered the development of wheels for plastic pipe and today has the widest variety and highest quality wheels for various types and wall thicknesses of plastic pipe and tubing.

Reed offers the largest cutter wheel line for all types of pipe, tubing and conduit. Reed wheels are the best value for use in Reed cutters, or in the cutters of any other manufacturer.

CUTTER WHEEL INTERCHANGEABILITY P. 6 - 9

DESIGNED FOR PERFORMANCE

Thickness of
Reed Wheels

Thickness of
All Other Wheels

NEW Reed 2-Pack Replacement Cutter Wheels

Item Code	Reed Catalog No.	Standard Pack*	Reed Cutter	Blade Exposure** inches	mm	Application
2-PACK REPLACEMENT WHEELS						
63655	2PK-OSS	2	TC1Q; TC1.6Q; TC2Q; T10; T15; T20	0.160	4.1	Stainless Steel
63660	2PK-O	2	TC1Q; TC1.6Q; TC2Q; T10; T15; T20; MC3; RT15T1; RT15T2; RT15T3; RTC1.1; RTC1.4	0.180	4.6	Copper; Aluminum; Brass; Steel Tubing
63665	2PK-30-40	2	TC3Q; TC4Q; TC5Q; TC6Q; TC8Q	0.250	6.4	Copper; Aluminum; Brass; Steel Tubing
63670	2PK-R2558	2	TC3Q; TC4Q; TC5Q; TC6Q; TC8Q	0.188	4.8	Muffler Systems Tubing
63671	2PK-30-40SS	2	TC3Q; TC4Q; TC5Q; TC6Q; TC8Q	0.160	4.1	Stainless Steel
64180	2PK-OP2	2	TC1Q; TC1.6Q; TC2Q; T10; T15; T20	0.275	7.0	ABS; PE; PEX; PP; PEX/AL/PEX
64184	2PK-1-2PVC	2	TC1Q; TC1.6Q; TC2Q; T10; T15; T20	0.160	4.1	Stainless Steel
64190	2PK-30-40P	2	TC3Q; TC4Q; TC5Q; TC6Q	0.343	8.7	ABS; PE; PP
64194	2PK-3-6PVC	2	TC3Q; TC4Q; TC5Q; TC6Q	0.377	9.6	3"-6" PVC; 4" Heavy Wall; CPVC
63662	2PK-75015	2	TC11; TC17	0.125	3.2	Copper; Aluminum; Brass; Steel Tubing
63663	2PK-75046	2	TC11; TC17	0.125	3.2	Copper; Aluminum; Brass; Steel; Stainless Steel
63690	2PK-73505	2	TC14	0.170	4.3	Copper; Aluminum; Brass; Steel Tubing
63691	2PK-73515	2	TC14	0.170	4.3	Stainless Steel Only
63661	2PK-32633	2	MC1	0.127	3.2	Copper; Aluminum; Brass; Steel Tubing
63666	2PK-345T	2	MC2	0.146	3.7	Copper; Aluminum; Brass
63659	2PK-OCSST-2	2	TC1.6ORGT; TC2Q; TC2ORGT	0.281	7.1	CSST Tubing
63612	2PK-2RBS	2	2-1; 2-1Q; 2-4WG; 2-3; 2-3Q; 2-4	0.300	7.6	Steel; Stainless Steel
63613	2PK-2RBHD	2	2-1; 2-1Q; 2-4WG; 2-3; 2-3Q; 2-4	0.296	7.5	HD for Steel; Stainless Steel
63634	2PK-ACWR	2	GENERAL - ATC12; ATC34; ATC100	0.125	3.2	Copper

Reed Replacement Cutter Wheels

Item Code	Reed Catalog No.	Standard Pack*	Reed Cutter	Blade Exposure**		Application
				inches	mm	
FOR TUBING CUTTERS – METAL						
03655	OSS	12	TC1Q; TC1.6Q; TC2Q; T10; T15; T20	0.160	4.1	Stainless Steel
03657	3T23	4	T23	0.125	3.2	Copper; Aluminum; Brass; Steel Tubing
03659	OCSST-2	12	TC1Q; TC2Q; TC2QRGT	0.281	7.1	CSST Tubing
03660	O	12	TC1Q; TC1.6Q; TC2Q; T10; T15; T20; MC3; RT15T1; RT15T2; RT15T3; RTC1.1; RTC1.4	0.180	4.6	Copper; Aluminum; Brass; Steel Tubing
03661	32633	12	MC1	0.127	3.2	Copper; Aluminum; Brass; Steel Tubing
03662	75015	12	TC11; TC17	0.125	3.2	Copper; Aluminum; Brass; Steel Tubing
03663	75046	12	TC11; TC17	0.125	3.2	Copper; Aluminum; Brass; Steel; Stainless Steel
03665	30-40	12	TC3Q; TC4Q; TC5Q; TC6Q; TC8Q	0.250	6.4	Copper; Aluminum; Brass; Steel Tubing
03666	345T	12	MC2	0.146	3.7	Copper; Aluminum; Brass
03668	R4546	6	MC2	0.161	4.1	Steel; Stainless Steel
03670	R2558	12	TC3Q; TC4Q; TC5Q; TC6Q; TC8Q	0.188	4.8	Muffler Systems Tubing
03671	30-40SS	12	TC3Q; TC4Q; TC5Q; TC6Q; TC8Q	0.250	6.4	Stainless Steel Tubing
03690	73505	12	TC14; TC166	0.170	4.3	Copper; Aluminum; Brass; Steel Tubing
03691	73515	12	TC14; TC166	0.170	4.3	Stainless Steel Only
FOR TUBING CUTTERS – PLASTIC						
04180	OP2	12	TC1Q; TC1.6Q; TC2Q; T10; T15; T20	0.275	7.0	ABS; PE; PEX; PP; PEX/AL/PEX
04181	2CON	4	TC2Q	0.180	4.6	2" PE Conduit
04184	1-2PVC	12	TC1Q; TC1.6Q; TC2Q; T10; T15; T20	0.280	7.1	PVC; CPVC; PVDS
04187	R10279	4	TC3Q; TC4Q; TC5Q; TC6Q	0.221	5.6	Thin Wall PVC
04188	R1740	4	MC2	0.148	3.7	Soft Flexible Plastic
04190	30-40P	12	TC3Q; TC4Q; TC5Q; TC6Q	0.343	8.7	ABS; PE; PP
04192	680PVC	4	TC6Q; TC8Q	0.575	14.6	PVC – Standard & Heavy Wall; CPVC
04194	3-6PVC	12	TC3Q; TC4Q; TC5Q; TC6Q	0.377	9.6	3"–6" PVC; 4" Heavy Wall; CPVC
04198	6QP	4	TC4Q; TC5Q; TC6Q; TC8Q	0.550	14.0	Thick Wall PE
04199	80P	4	TC6Q; TC8Q	0.750	19.1	ABS; PE; PP
FOR PIPE CUTTERS						
03504	HS4	4	3-1; 3-3; 3-4	0.383	9.7	Steel; Stainless Steel
03522	HI4	4	3-1; 3-3; 3-4	0.258	6.6	Cast Iron; Ductile Iron
03612	2RBS	12	2-1; 2-1Q; 2-4WG; 2-3; 2-3Q; 2-4; 5301PD	0.300	7.6	Steel; Stainless Steel
03613	2RBHD	12	2-1; 2-1Q; 2-4WG; 2-3; 2-3Q; 2-4; 5301PD	0.296	7.5	HD for Steel; Stainless Steel
03620	REU2	4	2-1; 2-3; 2-4; 2-4WG	0.295	7.5	Steel; Stainless Steel
03624	2RBCI	4	2-1; 2-1Q; 2-4WG; 2-3; 2-3Q; 2-4	0.172	4.4	Cast Iron
03532	R1032/S	6	5301PD	0.450	11.4	Steel; Stainless Steel; Schedule 80
FOR HINGED CUTTERS						
03502	HS21/2	4	H21/2	0.312	7.9	Steel; Stainless Steel
03504	HS4	4	H4	0.320	8.1	Steel; Stainless Steel
03505	HSI4	4	H4	0.275	7.0	Steel; Stainless Steel; Cast Iron; Ductile Iron
03506	HS6	4	H6	0.390	9.9	Steel; Stainless Steel
03507	HSI6-8	4	H6; H8	0.350	8.9	Steel; Stainless Steel; Cast Iron; Ductile Iron
03508	HS8-12	4	H8; H12	0.450	11.4	Steel; Stainless Steel
03510	HX21/2	4	H21/2	0.383	9.7	Steel; Stainless Steel; Schd 80
03512	HX4	4	H4	0.383	9.7	Steel; Stainless Steel; Schd 80
03514	HX6	4	H6	0.476	12.1	Steel; Stainless Steel; Schd 80
03516	HX8	4	H8; H12	0.567	14.4	Steel; Stainless Steel; Schd 80
03518	HXX8	4	H8; H12	0.682	17.3	Steel; Stainless Steel; Schd 100
03522	HI4	4	H4	0.258	6.6	Cast Iron; Ductile Iron
03524	HI6	4	H6; H8; H12	0.410	10.4	Cast Iron; Ductile Iron
03525	H6PSE5	4	H6; H8; H12	0.400	10.2	Steel; Cast Iron; Ductile Iron
03624	2RBCI	4	H21/2	0.172	4.4	Cast Iron; Ductile Iron
FOR ROTARY™ CUTTERS						
03530	RCS8-36	4	LCRC8; LCRC12; LCRC16; RC20; RC24; RC30; RC36	0.635	16.1	Steel; Stainless Steel
03531	RC58-36 7MM	4	LCRC8; LCRC12; LCRC16; RC20; RC24; RC30; RC36	0.512	13.0	Spiral Weld Pipe
03533	RCS8-36 6MM	4	LCRC8; LCRC12; LCRC16; RC20; RC24; RC30; RC36	0.394	10.0	Spiral Weld Pipe
03535	RCI8-30	4	LCRC8; LCRC12; LCRC16; RC20; RC24; RC30; RC36	0.500	12.7	Cast Iron; Ductile Iron (manual)
03545	RCDX	4	LCRC8; LCRC12; LCRC16; RC20; RC24; RC30; RC36	0.531	13.5	Heavy Cast Iron; Ductile Iron (PRC)
03550	RCX	4	LCRC8; LCRC12; LCRC16; RC20; RC24; RC30; RC36	0.800	20.3	Heavy Wall Steel; Stainless Steel

REQUIRES: ONE SET (8) OF THE RC8-30XR ROLLERS WHEN USING RCX WHEELS

* Cutter wheels sold to distributors in standard package quantities only.

** Blade Exposure determines wall thickness capacity of cutter wheel.

Cutter Wheel Conversions

Manufacturer Cutter No.	Manufacturer Wheel	Reed Catalog No.	Reed Item Code	Standard Pack*	Blade Exposure**		Application
					inches	mm	
RIDGID®							
50	M-50	R2558	03670	12	0.188	4.8	Muffler Systems Tubing
315	E-2990	R2990	03667	6	0.117	3.0	Copper; Aluminum; Brass; Steel Tubing
10; 15; 20	E-1240	OSS	03655	12	0.160	4.1	Stainless Steel
10; 15; 20	E-1240	O	03660	12	0.180	4.6	Steel
10; 15; 20	F-158	O	03660	12	0.180	4.6	Copper; Aluminum
101; 103; 104; 105; 150; 131P; 132P; 151P; 152P; 153P; 205P; 150L	E-1740	R1740	04188	4	0.148	3.7	Soft Flexible Plastic
101; 103; 104; 105; 118; 150; 150L; 131; 132; 151; 152; 153; 205	E-3469	345T	03666	12	0.146	3.7	Copper; Aluminum; Brass
105; 150; 150L; 131; 132; 151; 152; 153; 205	E-4546	R4546	03668	6	0.161	4.1	Steel; Stainless Steel
131P; 132P; 151P; 152P; 153P; 205P	E-2155	R2155	04185	6	0.295	7.5	PE; PP – Standard & Heavy Wall
131P; 132P; 151P; 152P; 153P; 205P	E-5272	R5272	04186	6	0.295	7.5	PVC; ABS – Standard Wall
134P; 136P; 154P; 156P	E-702	680PVC	04192	4	0.575	14.6	PVC – Standard & Heavy Wall; CPVC
134P; 136P; 154P; 156P	E-2157	6QP	04198	4	0.550	14.0	Thick Wall PE
134P; 154P; 136P; 156P	E-10279	R10279	04187	4	0.221	5.6	Thin Wall PVC
136P; 156P	E-2880	80P	04199	4	0.750	19.1	ABS; PE; PP
1A; 2A; 42A; 202; 360; 820; 364; 732; 300 power drive	E-1032S	R1032/S	03532	6	0.450	11.4	Steel; Stainless Steel; Schedule 80
1A; 2A; 42A; 202; 360; 820; 364; 732	F-514	2RBS	03612	12	0.300	7.6	Steel; Stainless Steel
1A; 2A; 42A; 202; 360; 820; 364; 732	F-3	2RBHD	03613	12	0.296	7.5	HD for Steel; Stainless Steel
1A; 2A; 42A; 202; 360; 820; 364; 733	F-3S	2RBHD	03613	12	0.296	7.5	HD for Steel; Stainless Steel
1A; 2A; 42A; 206; 360; 820; 364; 732	F-119	2RBCI	03624	4	0.172	4.4	Cast Iron
30; 40; 106; 108; 109; 133; 134; 136; 154; 156	E-2191	30-40	03665	12	0.250	6.4	Copper; Aluminum; Brass; Steel Tubing
30; 40; 106; 108; 109; 133; 134; 136; 154; 156	E-2558	30-40	03665	12	0.250	6.4	Copper; Aluminum; Brass; Steel Tubing
30; 40; 106; 108; 109; 133; 134; 154; 136; 156	E-2558	R2558	03670	12	0.188	4.8	Muffler Systems Tubing
30P; 40P; 106; 108; 109P; 133P; 134P; 136P; 154P; 156P	E-5299	3-6PVC	04194	12	0.377	9.6	3" -6" PVC; 4" Heavy Wall
30P; 40P; 106; 108; 109P; 133P; 134P; 154P; 136P; 156P	E-5299	30-40P	04190	12	0.343	8.7	ABS; PE; PP
30P; 40P; 133P; 134P; 136P; 154P; 156P	E-2156	30-40P	04190	12	0.343	8.7	ABS; PE; PP
3S; 4S; 44S; 466S; 466C; 466HWS; 468C; 468S; 468HWS; 472C; 472S; 472HWS; 764	F-229	3RG	03616	4	0.399	10.1	Steel; Stainless Steel
3S; 4S; 44S; 466S; 466C; 466HWS; 468C; 468S; 468HWS; 472C; 472S; 472HWS; 764	F-229S	3RG	03616	4	0.399	10.1	Steel; Stainless Steel
3S; 4S; 44S; 466S; 466C; 466HWS; 468C; 468S; 468HWS; 472C; 472S; 472HWS; 764	F-515	3RG	03616	4	0.399	10.1	Steel; Stainless Steel
42A; 202; 360; 820; 364; 732; 300 power drive	E-1032	R1032/S	03532	6	0.450	11.4	Steel; Stainless Steel; Schedule 80
466; 468; 472; 1224	E-1962	3RGCI	03617	4	0.285	7.2	Cast Iron; Ductile Iron
466C; 466S; 466HWS; 468C; 468S; 468HWS; 472C; 472S; 472HWS	E-3186	R3186	03526	4	0.680	17.3	Steel; Ductile Iron Heavy Wall
6S; 208; 209	F-367	R367	03639	6	0.480	12.2	Steel; Ductile Iron Heavy Wall
ARMSTRONG®							
1T; 2T; 2TA		2RBS	03612	12	0.300	7.6	Steel; Stainless Steel
1T; 2T; 2TA		2RBHD	03613	12	0.296	7.5	HD for Steel; Stainless Steel
4A		3RG	03616	4	0.399	10.1	Steel; Stainless Steel
4A		3RGCI	03617	4	0.285	7.2	Cast Iron; Ductile Iron
GASTITE®							
RT15T1; RT15T3; RT15T2; T15T1; T15T2		O	03660	12	0.180	4.6	Copper; Aluminum; Brass; Steel Tubing; CSST
GENERAL WIRE SPRING®							
ATC12; ATC34; ATC100	ATCW	ACWR	03634	12	0.125	3.2	Copper
IMPERIAL EASTMAN®							
127-F/FA/FB; TC1050; 227-FA	S32633	32633	03661	12	0.127	3.2	Copper; Aluminum; Brass
TC1000; TC1020; 374; 312-FC/FB; 274-FC/FB; 174-F	S75015	75015	03662	12	0.125	3.2	Copper; Aluminum; Brass; Steel Tubing
TC1000; TC1020; 374; 312-FC/FB; 274-FC/FB; 174-F	S75046	75046	03663	12	0.125	3.2	Copper; Aluminum; Brass; Steel; Stainless Steel

Cutter Wheel Conversions

Manufacturer Cutter No.	Manufacturer Wheel	Reed Catalog No.	Reed Item Code	Standard Pack*	Blade Exposure** inches	Blade Exposure** mm	Application
LENOX®							
21010-TC11/8; 21011-TC13/8; 21012-TC13/4	21017-TCW158C	O	03660	12	0.180	4.6	Copper; Aluminum; Brass; Steel Tubing
21010-TC11/8; 21012-TC13/4; 21011-TC13/8; 21013-TC25/8	21015-TCW158SS	OSS	03655	12	0.160	4.1	Brass; Stainless Steel
21013-TC25/8	21016-TCW158P	1-2PVC	04184	12	0.280	7.1	PVC; Plastic
STAHLWILLE®							
2" PIPE CUTTER		REU2	03620	4	0.295	7.5	Steel; Stainless Steel
SWAGELOK®							
MS-TC-308	MS-TCW-308	OSS	03655	12	0.160	4.1	Stainless Steel
VIRAX®							
2101 10; 2101 20; 2101 30		REU2	03620	4	0.295	7.5	Steel; Stainless Steel
WHEELER REX®							
95041	8050	HS4	03504	4	0.320	8.1	Steel; Stainless Steel
95041	8078	HS4	03504	4	0.320	8.1	Steel; Stainless Steel
95061	8052	HS6	03506	4	0.390	9.9	Steel; Stainless Steel
95081; 95121	8054	HS8-12	03508	4	0.450	11.4	Steel; Stainless Steel
	8002	HX21/2	03510	4	0.383	9.7	Steel; Stainless Steel; Schd 80
95041	8051	HI4	03522	4	0.258	6.6	Cast Iron; Ductile Iron
95061; 95081; 95121	8053	HI6	03524	4	0.410	10.4	Cast Iron; Ductile Iron
95061; 95081; 95121	8076	H6PSE5	03525	4	0.400	10.2	Steel; Cast Iron; Ductile Iron
	8839	RCS8-36	03530	4	0.635	16.1	Steel; Stainless Steel
6090; 7090; 6190; 6290; 6390; 6490; 6590; 6790; 6793; 6794; 6890	60324	RXM	03534	1	0.432	11	Steel Pipe
	8838	RCI8-30	03535	4	0.500	12.7	Cast Iron; Ductile Iron
9590	8001	2RBHD	03613	12	0.296	7.5	HD for Steel; Stainless Steel
	8004	3RG	03616	4	0.399	10.1	Steel; Stainless Steel
	8016	3RG	03616	4	0.399	10.1	Steel; Stainless Steel
	8006	R367	03639	6	0.480	12.2	Steel; Ductile Iron Heavy Wall
9290; 9291	8012	OSS	03655	12	0.160	4.1	Stainless Steel
9290; 9291	8015	O	03660	12	0.180	4.6	Copper; Aluminum; Brass; Steel Tubing
	8021	30-40	03665	12	0.250	6.4	Copper; Aluminum; Brass; Steel Tubing
9490	8025	30-40	03665	12	0.250	6.4	Copper; Aluminum; Brass; Steel Tubing
	8034	345T	03666	12	0.146	3.7	Copper; Aluminum; Brass
	8045	R4546	03668	6	0.161	4.1	Steel; Stainless Steel
90735; 90728; 90750	8071	73505	03690	12	0.170	4.3	Copper; Aluminum; Brass; Steel Tubing
	8065	OP2	04180	12	0.275	7	ABS; PE; PEX; PP; PEX/AL/PEX
	8036	30-40P	04190	12	0.343	8.7	ABS; PE; PP
	8037	3-6PVC	04194	12	0.377	9.6	3"-6" PVC; 4" Heavy Wall; CPVC

* Cutter wheels sold to distributors in standard package quantities only.

** Blade Exposure determines wall thickness capacity of cutter wheel.



PIPE TOOLS & VISES
SINCE 1896

**Reed has the widest variety of high-quality wheels
for more cutters and more brands than any other manufacturer!**



Replacement wheels for every pipe and every pipe cutter

Be on the **CUTTING** edge with Reed!

DESIGNED FOR PERFORMANCE

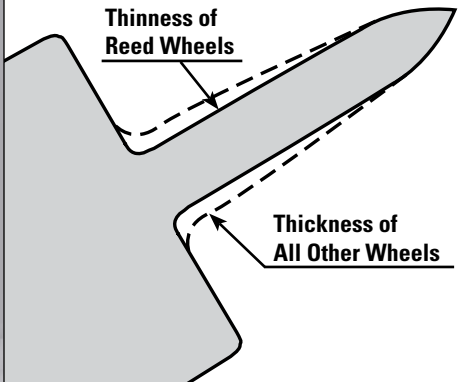

Optimally thin tool profile cuts pipe easily, leaves less burr and lasts longer!

Reed offers the largest cutter wheel line for all types of pipe, tubing and conduit.

The most popular types of genuine Reed cutter wheels (P. 6) are also sold in convenient, two-pack display bags for quick and easy showroom purchases.



Front

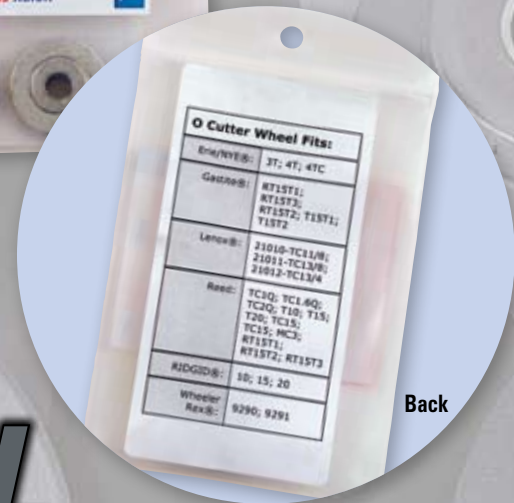

Back

Your distributorship can become a **CUTTER WHEEL HEADQUARTERS™**



Distributors participating in Cutter Wheel Annual Contracts are eligible for this durable, metal display case that makes choosing the right wheel easy. Additional showroom support includes our large counter mat with handy wheel conversion charts. Wheel conversions are also available at www.reedmfgco.com. Contact your Reed Rep or Regional Manager for program details.

www.reedmfgco.com



PIPE TOOLS & VISES
SINCE 1898

Quick Release™ Tubing Cutters

Best tracking, easiest cutting tubing cutters available. Cut copper, aluminum, light wall steel, and stainless steel tubing. With alternate wheels it will cut a wide variety of plastic pipe and tubing. Three new cutters feature the **R2558** wheel for muffler systems tubing. **TC10**, **TC1.6Q** and **TC20** sliding bars are die-cast zinc aluminum for greater strength. Each of these three also features a built-in reamer and **spare cutter wheel in the knob**. Xtra Value – just change the wheel to cut a wide variety of tubing.

Catalog No.	Item Code	O.D. Capacity		Length		Weight		Wheel
		Actual Inches	Actual Ø mm	in	mm	lbs	kg	
TC1Q*	03410	1/8 - 1 5/16	3 - 33	6	152	0.6	0.3	0
TC1.6Q*	03416	1/4 - 1 5/8	6 - 42	6.5	165	0.8	0.4	0
TC2Q*	03420	1/4 - 2 5/8	6 - 63	8	203	1.2	0.5	0
TC3Q	03430	3/8 - 3 1/2	10 - 90	11	279	2.5	1.1	30 - 40
★ TC3Q2558	03439	3/8 - 3 1/2	10 - 90	11	279	2.5	1.1	R2558
TC4Q	03440	1 7/8 - 4 1/2	48 - 114	12	305	2.8	1.3	30 - 40
★ TC5Q2558	03459	2 1/2 - 5	63 - 125	13	330	3.0	1.4	R2558
TC6Q	03460	4 - 6 5/8	102 - 168	15	381	3.9	1.8	30 - 40
★ TC6Q2558	03469	4 - 6 5/8	102 - 168	15	381	3.9	1.8	R2558

★ **NEW**

*Spare "0" Cutter Wheel in Knob.

CUTTER WHEELS ON P. 6 - 7

QUICK RELEASE™ CUTTERS FOR PLASTIC ON P. 54



✓ WHY REED?

Quick Release™ cutter is a Reed invention and still the industry standard! First used by Reed, the ball detent wheel pin makes cutter wheel change easy. No other cutter on the market tracks or cuts as well!

Tubing Cutters

Popular copper tubing cutters are long-lasting due to quality construction and have a large grip knob for comfort during use. A reamer is built inside grip knob for convenience and safety. Wide rollers yield a square cut while thin cutter wheel profile ensures a quick, clean cut. When structures, equipment, or ditch walls get in the way, the three wheel **T23** requires only 3" clearance and a 150° cutting radius. Large capacity (2" nominal) means the T23 gets the job done when mini cutters are too small. Includes large knob with built-in reamer for comfort and convenience, plus large reamer in body for larger tubing clean-up.

Catalog No.	Item Code	O.D. Capacity		Weight		Cutter Wheel**		
		Actual Inches	Actual Ø mm	lbs	kg	Copper	Plastic	
T10	03483	1/8 - 1	3 - 25	0.9	0.4	0	OP2	1 - 2PVC
T15	03485	3/16 - 1 1/4	4 - 32	1.3	0.6	0	OP2	1 - 2PVC
T20*	03487	5/8 - 2 1/8	15 - 54	1.5	0.7	0	OP2	1 - 2PVC
T23*	03496	3/4 - 2 1/8	19 - 54	1.4	0.6	3T23	-	-

*EXCLUSIVE

**Ships with wheel for copper. To cut plastic pipe, order recommended cutter wheel separately.

*AWWA Approved for Tapping Contest.

CUTTER WHEELS ON P. 6 - 7

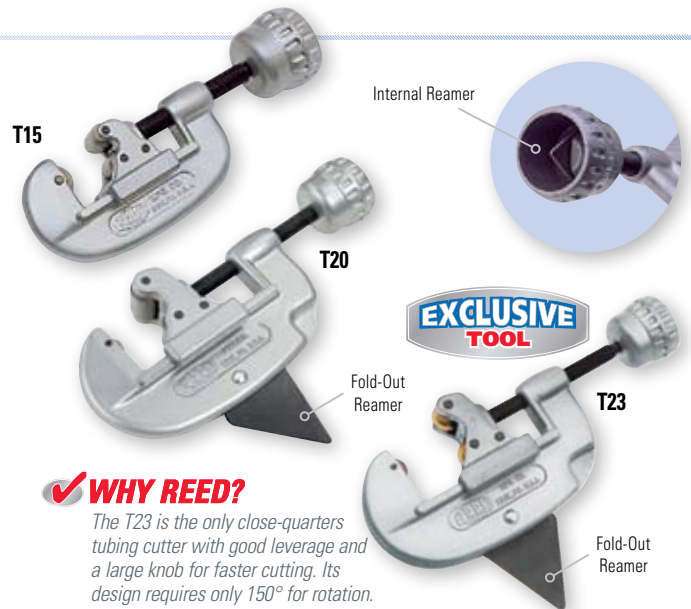

✓ WHY REED?

The T23 is the only close-quarters tubing cutter with good leverage and a large knob for faster cutting. Its design requires only 150° for rotation.

Telescoping Tubing Cutters

Telescoping Tubing Cutters are a good choice for tight spaces as their feed screw keeps them a consistent size throughout the cut. **TC11** tubing cutter with strong, aluminum alloy body and nickel-chrome finish, makes a clean, square cut. Cutters have easy action, enclosed feed screw, fold-out reamer, grooved rollers, and spare cutting wheel. **TC14** and **TC166** move smoothly and offer a pencil reamer. TC14 features a spare cutter wheel.

Catalog No.	Item Code	O.D. Capacity		Weight		Cutter Wheel**	Heavy-Duty Wheel
		Actual Inches	Actual Ø mm	lbs	kg		
TC11	03480	1/8 - 1 1/8	3 - 28	0.7	0.3	75015	75046
TC14*	03475	1/4 - 1 3/8	6 - 35	1.1	0.5	73505	73515
★ TC166	03485	1/4 - 1 5/8	6 - 42	1.2	0.5	73505	73515

★ **NEW**

*Replacement deburring blade available (Item Code #03473 or #94437 for 10 pack).

**Ships with regular wheel. Order heavy-duty wheels separately.

CUTTER WHEELS ON P. 6 - 7



1

T15SS



✓ WHY REED?
Only Reed offers such a wide variety of professional-quality cutters with wheels for stainless installed. No more early replacement of the first wheel!

TC11SS

Fold-Out Reamer

Spare Cutter Wheel Storage



MC3

MC2GRIP



MC2



MC1

✓ WHY REED?

MC1 features smallest cutting radius in the industry and finer screw thread for easier tightening. MC2 is heavy-duty – the strongest mini cutter available. MC2GRIP also includes a larger, high-torque feed. Larger, deeply knurled knob allows easier tightening.

Repair cutters on-site for less lost time!



RPR Kit

1-2 PARTS

3-4-6 PARTS

XTRA VALUE!

DEB3



DEB0



Tubing Cutters for Stainless Steel

Reed tubing cutters are equipped with special wheels for stainless steel. Reed wheels for stainless tubing use specialized steel for toughness and heat dissipation, resulting in long wheel life. **T10SS, T15SS, and T20SS** offer a large knob for firm grip and easy turning, along with an internal reamer in the knob. **TC11SS** telescoping cutter includes a fold-out reamer and spare wheel for stainless tubing.

Catalog No.	Item Code	Capacity		Cutter Wheel	Weight	
		Actual in	Actual mm		lbs	kg
T10SS	03476	1/8 - 1	3 - 25	OSS	0.9	0.4
T15SS	03477	3/16 - 1 1/4	4 - 32	OSS	1.4	0.6
T20SS	03479	5/8 - 2 1/8	15 - 54	OSS	1.5	0.7
TC11SS*	03481	1/8 - 1 1/8	3 - 28	75046*	0.7	0.3

*Includes spare cutter wheel.

CUTTER WHEELS ON P. 6 - 7

Mini Tubing Cutters

For use in extremely tight places, these tubing cutters require minimal swing around the tubing. Mini cutters can be used on copper, steel, stainless steel, and aluminum tubing. **MC2GRIP** has rounded corners and edges of the body for a more comfortable grip when rotating the cutter around tubing. **MC3SL** contains a self-feeding cutter wheel. After tightening the feed screw, the tool cuts faster by providing a more consistent cutting force on the wheel.

Catalog No.	Item Code	O.D. Capacity		Weight		Cutter Wheel	Cutter Swing Inches
		Actual Inches	Actual Ø mm	lbs	kg		
MC1	03470	1/8 - 5/8	3 - 15	0.2	0.1	32633	1 1/4
MC2	03490	1/8 - 15/16	3 - 24	0.3	0.1	345T	1 11/16
MC2GRIP	03493	1/8 - 15/16	3 - 24	0.4	0.2	345T	1 11/16
MC3	03495	1/8 - 1 1/8	3 - 28	0.4	0.2	0	1 7/8
MC3SL	03341	1/8 - 1 1/8	3 - 28	0.4	0.2	0	1 7/8

CUTTER WHEELS ON P. 6 - 7

Repair Kits for Tubing Cutters

RPR Kit contains the parts, except body, for all Reed TCQ and TCQP sizes 1 through 6. It also contains blades for ratchet and scissor shears. It is a great choice for distributor counter repairs or maintenance departments. Simple field repairs can be handled with **1-2 Parts** and **3-4-6 Parts** kits which are plastic bags containing the most popular parts for Quick Release™ Cutters. Common spare parts for T10, T15, and T20 cutters are contained in **T10-T15-T20 Parts** kit.

Catalog No.	Item Code	Weight	
		lbs	kg
1-2 Parts	03009	2.2 oz	0.1
3-4-6 Parts	03010	3.3 oz	0.1
RPR Kit	03011	5.5 lbs	2.5
T10-T15-T20 Parts	03014	3.0 oz	0.1

Deburring Tools

These feature a long-lasting, hardened tool steel deburring blade. **DEB0** eliminates internal burrs in copper tubing. It has an aluminum handle and handy pocket clip. **DEB3** deburrs aluminum, copper, and steel tubing. It has a plastic body and three spare blades stored in its handle, giving this tool extra value.

Catalog No.	Item Code	Nominal Pipe Capacity	Weight	
			lbs	kg
DEB0	04434	unlimited	0.1	0.05
DEB3*	04437	unlimited	0.1	0.05

*Reamer replacement blade #94437 fits DEB3, TC1.6Q, and TC14.

DEBURRING TOOLS FOR PLASTIC ON P. 61

CSST Tubing Cutters †

Reed offers CSST (corrugated stainless steel tubing) Tubing Cutters in different models for cuts with the outer plastic wrapper jacket on or off. They fit 1/4" up to 2 1/2" CSST flexible gas piping. For cuts with the jacket off, Reed recommends the **RT15T1** and the **RT15T2** which feature a special nylon roller design allowing square and central cuts for optimal flaring in various CSST systems. The **TC1.6QCSST** is a great option for cutting CSST tubing up to 1 5/8" with the jacket on. For cuts of 1 1/4" up to 2 1/2" with the jacket either off or on, Reed recommends the **TC2QRGT**.

Catalog No.	Item Code	Capacity	Weight		Roller	Jacket
			lbs	kg		
RT15T1	03497	3/8" & 1/2"	1.3	0.6	RT15T1R	Off
RT15T2	03498	3/4" & 1"	1.3	0.6	RT15T2R	Off
★ TC1.6QCSST	03418	1/4" - 1 5/8"	0.8	0.4	CORRUGATED	On
★ NEW TC2QRGT	03426	1/4" - 2 1/2"	1.2	0.5	RGT2QLR	Off or On

† Reed's tested cutters are suitable for Gastite®, Parker Parflex®, WARDFLEX®, TracPipe®, and Pro-Flex® systems.

ACCESSORIES

ROLLERS

Item Code	Roller	Description
93628	TC16QR	Regular Roller for TC1.6Q/TC1.6QCSST
93438	RT15T1R	Corrugated Rollers for 1/2" and 3/8" CSST tubing
93439	RT15T2R	Corrugated Rollers for 3/4" and 1" CSST tubing
93444	RGT2QSR	Small Roller for TC2QRGT
93446	RGT2QLR	Large Roller for TC2QRGT

CSST CUTTER WHEELS

Catalog No.	Item Code	Blade Exposure		Fits
		in	mm	
0	03660	0.180	4.6	RT15T1, RT15T2
OCSST-2	03659	0.281	7.1	TC1.6QCSST, TC2QRGT

CUTTER WHEELS ON P. 6-7

XTRA VALUE!

EXCLUSIVE FEATURES

Change the rollers and cutter wheel to use as a regular tubing cutter.



✓ WHY REED?

Reed works with pipe and tube manufacturers to constantly improve piping solutions.



Left Photo - Top Row, L to R - Mike Pruzinsky, Pat Reinke, Bill Stevens, Debbie Sulecki, Steve Angermeier
Seated L to R - Joyce Carr, Todd Gilpatrick, LaVerna Ritchie



Above Photo - Top Row, L to R - Gene Lachman, Minnie Confer, Tom Fess, Marnie Caldwell
Seated L to R - Julie Machinski, Patty Soderberg, Rich Stummer



Left Photo - Top Row, L to R - Carrie Applequist, Sophia Liuxuelian, Matt Harvey, Michael Balliett
Seated L to R - Brian Gunderson, Wan-Xin Werstler, Tim Donohue

From our family to yours...

Reed Associates have produced fine tools for professional trades around the world since 1896. Reed engineers developed many of the most innovative and effective tools in the industry – such as the Quick Release™ Tubing Cutter, the Hinged Cutter™, the Rotary™ Cutter, and the Universal Pipe Cutter. Many of these tools have been copied by others, but through continuous improvements and everyday dedication to quality workmanship, Reed products remain the finest in the world.

The goals of each Reed Associate are to ship 98% of orders within three working days, to provide immediate, informed responses to customer inquiries and to produce 100% error-free work. Reed works diligently to cultivate relationships with dependable distributors to reach the end-user market. Selling through traditional, local distributors is the best avenue to strengthen ties with Reed tool users. The strong links in the customer service chain – from product development and manufacturing, through order processing and inquiry fulfillment, to distribution – make Reed a leader in customer satisfaction. Reed identifies the best people to provide the best quality tools which results in the best service available.

**Best Service + Best Quality +
Best People = The Lowest Total Cost**

**QUALITY
& Service**
that Last a Lifetime

Steel Pipe Cutters

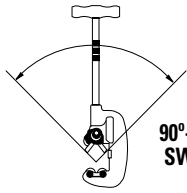

✓ WHY REED?

Guide bars are exclusive to Reed and the best way to get a square cut on stainless steel and corroded pipe. Guide bars also reduce wheel breakage.

90°- 140° SWING

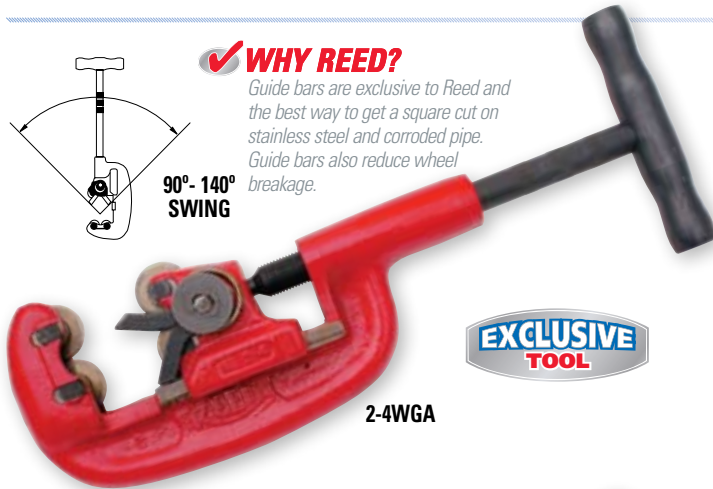

2-4WGA



4-Wheel With Guides – Spring-tensioned guide bars of **2-4WGA** provide square alignment for 4-wheel cutters. The short handle allows for close-quarter work. Thinnest wheels of highest quality tool steel make cutting easier and faster. Sharper wheels allow shorter handles for work in smaller spaces.

Standard – Strong malleable iron frames and wide rollers ensure square cuts. Thinnest wheels of highest quality tool steel make cutting easier and faster. Sharper wheels allow shorter handles for work in smaller spaces. The **2-1** cutter leaves no burr, which is great for threading jobs; the **2-3** with three wheels means more cutting surface and less handle swing.

Catalog No.	Item Code	Pipe Capacity		Length		Weight		Wheel*
		Inches-Nom.	Actual OD Ø mm	in	mm	lbs	kg	
4-WHEEL WITH GUIDES								
2-4WGA*	03338	1/2 - 2	21 - 63	14.3	362	7.2	3.3	2RBS
STANDARD 1-WHEEL								
2-1	03320	1/8 - 2	10 - 63	15.8	400	6.9	3.1	2RBS
STANDARD 3-WHEEL								
2-3	03305	1/8 - 2	10 - 63	15.8	400	6.8	3.1	2RBS
STANDARD 4-WHEEL								
2-4	03335	1/2 - 2	21 - 63	14.3	362	6.8	3.1	2RBS

*EXCLUSIVE

*2RBS wheels available for cast iron. 2RBHD heavy-duty wheels available for steel and stainless steel. CUTTER WHEELS ON P. 6 - 7

Replacement Wheel Pins available for Ridgid® cutters: 1-A, 2-A, 42-A, 202, 2000A. Order Reed pin R34780 #93320 5/pk. to replace Ridgid® pin No. 34780 (Old #F-9).

✓ WHY REED?

With rollers on the side away from the operator and the cutter wheel closer, Reed Steel Pipe Cutters are the easiest to line up with the cut-off mark. Wheel change is quick as the ring on the top of the wheel pin makes it convenient to find and center the pin through the second hole.

2-1



2-3

Convert 2-1 and 2-3 back and forth simply by changing wheels and rollers.

2-4



Pipe Reamer

Pipe Reamers are used to deburr steel pipe before threading. Cone is made from tool steel and hardened for maximum life. Unique cutting edge makes this spiral reamer self-feeding and easy to start and operate.

Catalog No.	Item Code	Pipe Capacity		Weight	
		Inches-Nom.	Actual ID Ø mm	lbs	kg
2-71	06060	1/8 - 2	3 - 50	6.7	3.0

✓ WHY REED?

This Reed invention has two pawls for faster action and for work in tight places – requires half the handle swing space of competitive reamers.

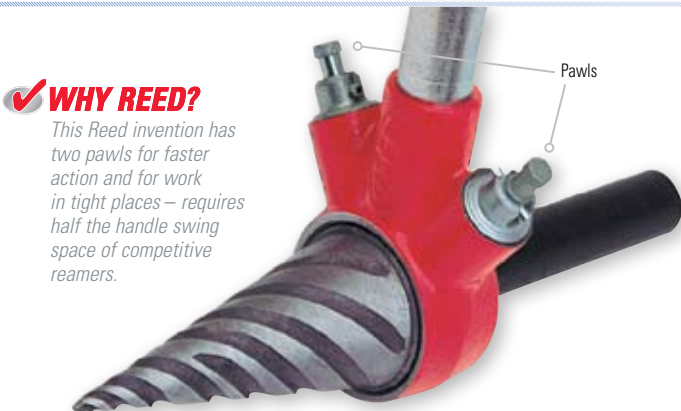

Ridgid® is a registered trademark of Ridgid, Inc. and is not associated with Reed Manufacturing Company.

Soil Pipe Cutters

The fastest way to cut cast iron soil pipe, clay pipe, and small diameter concrete pipe is with a chain pipe cutter. Great for gray water applications! Reed has improved the original manufacturer's design by providing stronger jaws and more durable adjusting screws which are interchangeable with the original tools. Reed soil pipe cutters are available in a single stroke **SC59** model and a ratcheting **SC49** model for close quarter work. Multiple use 1/2" ratchet wrench ships with SC49 models. No-Hub® Roller Kit is standard on all models.

FOR CUTTING DUCTILE IRON PIPE, REED RECOMMENDS HINGED CUTTERS™ ON P. 18 AND LOW CLEARANCE ROTARY™ CUTTERS ON P. 19

RATCHET

Catalog No.	Item Code	Pipe Capacity**		Length		Weight	
		Inches-Nom.	Actual Ø mm	in	mm	lbs	kg
SC49-6*	08049	1 1/2 - 6	160	26	660	17.6	8.0
SC49-8*	08050	1 1/2 - 8	212	26	660	19.4	8.8
SC49-10*	08051	1 1/2 - 10	268	26	660	21.2	9.6
SC49-12*	08052	1 1/2 - 12	317	26	660	23.0	10.5
SC49-15*	08053	1 1/2 - 15	403	26	660	24.8	11.3

SINGLE STROKE

SC59-6	08059	1 1/2 - 6	160	43	1,092	23.8	10.8
SC59-8	08060	1 1/2 - 8	212	43	1,092	25.6	11.6
SC59-10	08061	1 1/2 - 10	268	43	1,092	27.4	12.5
SC59-12	08062	1 1/2 - 12	317	43	1,092	29.2	13.3
SC59-15	08063	1 1/2 - 15	403	43	1,092	31.0	14.1

*Ratchet Wrench (#40208) included with all SC49 cutters.

**Maximum Pipe Capacities (determined by maximum pressure applied):

- Extra heavy cast iron soil pipe 2-4" (62-125 mm)
- Service weight cast iron soil pipe 2-8" (62-212 mm)
- Concrete pipe 4-6" (125-160 mm)
- No-Hub® cast iron soil pipe 1 1/2"-8" (38-212 mm)
- Clay pipe 2-15" (62-403 mm)

Extension chains available to increase capacity of smaller cutters.

NOTE: Jaw sets and cutter chains are interchangeable with Wheeler-Rex® models. Pressure Screw Assembly available offering heavy-duty parts for current and prior Reed models, along with Wheeler-Rex® 490. Order #98046 for Reed SC49 models and Wheeler-Rex® 490 series; use #98047 for Reed SC59 models.

ACCESSORIES

Catalog No.	Item Code	Description
SCEXT	40336	10" Extension Chain with 8 pitches at 1.25" per pitch
TW516	02298	5/16" Torque Wrench
TW38	02300	3/8" Torque Wrench

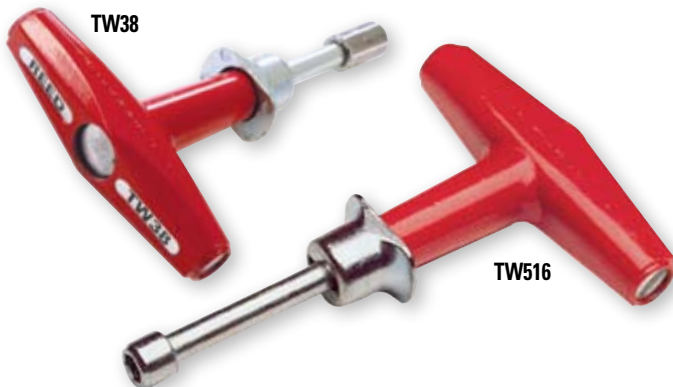

TORQUE WRENCHES FOR CAST IRON SOIL PIPE ON P. 68



TRAINING AVAILABLE

Captured Screw

✓ WHY REED?

First introduced by Reed, the captured screw makes the SC49 close-quarter soil pipe cutters both easy to use and less costly. The screw does not have to be manipulated into place which reduces screw and cutter breakage.



www.reedmfgco.com

For the latest information on **NEW REED** Tools!

Pipe Descalers

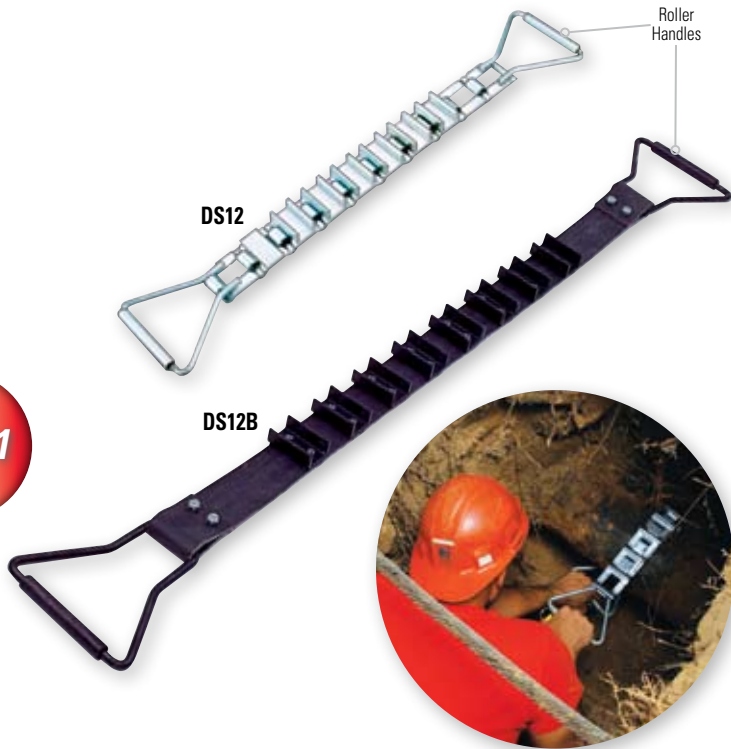

Reed pipe descalers feature wide, tough scrapers that remove scale, dirt, and corrosion cleanly and quickly from the pipe surface to allow more effective cutting, joining, gasket/valve seating, or other operations. Descalers are faster and more effective than chisels, chains or files and need only 2" of clearance around the pipe. Use descalers to clean pipe before cutting or water tapping or drilling. Roller handles allow smoother movement in use. **DS12** and **DS36** chain descalers are made entirely of steel that is zinc-plated for corrosion resistance and toughness. The scrapers are welded on for long life and can be sharpened. Also, Reed produces a heavy-duty power transmission belting pipe descaler, **DS12B**. Its handles and scrapers are blackened for good rust protection. Belt descaler benefits include lighter weight than all-metal descalers or chains, longer length to ease back strain during use, and high-profile scrapers that don't clog with dirt as readily. Reed also offers replacement belts with scrapers attached; simply bolt the new belt onto the handles.

Catalog No.	Item Code	Type	Pipe Capacity		Length		Weight	
			Inches-Nom.	mm	in	mm	lbs	kg
DS12	08000	Steel Chain	3 - 12	70 - 300	32	810	5.7	2.6
DS36	08006	Steel Chain	3 - 36	70 - 910	44	1110	8.2	3.7
DS12B	08008	Belt	3 - 12	70 - 300	50	1257	4.2	1.9

REPLACEMENT BELT

Catalog No.	Item Code	Description	Length		Weight	
			in	mm	lbs	kg
DS12BRB	98008	Replacement belt fits REED DS12B or Wheeler-Rex® 1300	45	1143	3.0	1.4

Saw It® Pneumatic Saw



Saw It® provides pneumatic power and reciprocating motion to blades. Saw improvements allow the tool to turn and work more freely, along with starting easier and running smoother. Reed offers blades to cut plastic, steel, stainless steel, and C900 PVC pipe.* **Saw It®** needs a 6" clearance beyond the pipe to accommodate blade movement. Cuts up to 20" (500 mm) diameter pipe with a single setup. The **Saw It®** must have a means to hold it in place. The recommended **Saw It® Vise** (sold separately) fits 4" - 12" diameter pipe (up to 24" with chain extensions), and provides stability and safety for the cut. Pneumatic saws are less likely to ignite materials than gas-powered saws and even some electrical-powered saws. However, the **Saw It®** is not recommended for gas lines.

Catalog No.	Item Code	Diameter Capacity*		Maximum Power	Air Consumption	Speed	Weight	
		In - Nom.	mm Nom.				Strokes/Min.	lbs
SAWIT	07600	up to 24" max.	up to 610 max.	1.5 HP; 1100 watts	50 cfm @ 90 psi 1.4 cu. m/min. @ 6.2 BAR	300	17.0	7.7
SAWITVISE	04600	4" - 12"	102 - 305	—	—	—	14.0	6.4

*Capacity is dependent on blade and chain extensions.
NOTE: **Saw It®**, **Saw It® Vise**, and **Blades** are all sold separately.
PORTABLE POWER HACK SAW BLADES ON P. 74

ACCESSORIES

CHAIN EXTENSIONS

Item Code	Description
40628	6" diameter increment plus pin
40629	12" diameter increment plus pin



In Use on Plastic

Great for work on process piping!



Process Piping Application

✓ WHY REED?

This saw is safer and cuts straighter than a gas-powered chop saw. The **Saw It® Vise** allows the saw to pivot straight into the pipe, giving the operator better control over the cut. Used together, this saw is **EASY** to handle.

Universal Pipe Cutters (6"-48" or 150-1300 mm)

These lightweight, easy-to-use Universal Pipe Cutters (UPC) are available to cut 6" - 48" (150-1300 mm) outside diameter ductile iron, cast iron, clay, concrete, **steel**, PVC, or PE pipe. The cutters are pneumatic powered. The lower cost **UPC616A** uses the same motor as the others, but does not need connecting frames. The UPC616 is shipped in a steel toolbox with a three-gallon, formed-steel water tank. The **UPC636A** and **UPC648A** come in a steel toolbox with a seven-gallon, stainless steel water tank and cart.

PNEUMATIC

Catalog No.	Item Code	Pipe Diameter		Net Weight*	
		Inches-Nom.	O.D. mm	lbs	kg
UPC616A	07512	6 - 16	150 - 450	89	40.5
UPC636A	07510	6 - 36	150 - 1000	131	59.5
UPC648A	07511	6 - 48	150 - 1300	138	62.7

*NET WEIGHT includes all components that may be part of any given tool item code, but does not include packing materials.

MUST ORDER REQUIRED BLADES SEPARATELY.

BLADE SELECTION CHART

Catalog No.	Item Code	Description	Pipe Diameter	Pipe Material
UPCARB4	97510	4" BLADES cut up to $^{23}/_{32}$ " (18.3 mm) wall thickness	6" (150 mm)	PVC
UPBEVEL	97512	Available by special order. Minimum order applies.		PVC
UPCARB6	97514	6" BLADES cut up to $^{123}/_{32}$ " (43.7 mm) wall thickness	8" - 48" (200-1300 mm)	PVC
★UPCSTEELA	97519	4" BLADES cut up to $^{23}/_{32}$ " (18.3 mm) wall thickness	6" - 8" (150-200 mm)	Steel, PE
★UPCSTEEL6	97520	6" BLADES cut up to $^{123}/_{32}$ " (43.7 mm) wall thickness	8" - 48" (200-1300 mm)	Steel, PE
UPDIA6C	97524	6" BLADES cut up to $^{123}/_{32}$ " (43.7 mm) wall thickness	8" - 48" (200-1300 mm)	Cast Iron, Pit Cast, Ductile Iron Clay, Concrete
UPDIA4C	97528	4" BLADES cut up to $^{23}/_{32}$ " (18.3 mm) wall thickness	6" (150 mm)	Cast Iron, Pit Cast, Ductile Iron Clay, Concrete

★ **NEW**
PIPE DESCALERS ON P. 16

UPC POWER REQUIREMENTS

Pneumatic

Horsepower = 1.7 H.P.
Maximum R.P.M. = 3675
Air Consumption = 50 cu. ft./min. (1.4 cu. m/min.)
Pressure = 90 P.S.I. Maximum (6 BAR)
Shut-Off = $^{3}/_{4}$ " Ball Valve
Air Supply Fittings = $^{3}/_{4}$ " Dixon "Air King" Coupling

ACCESSORIES

Accessory	Item Code
Air-Line Oil	97583
Arbor Locknut	97543
Arbor Wrench	97590
Chain Hooks	97546
Diamond Blade Sharpening Stone	97595
Filter for the FRL	40139
Hex Key Set	40156
Motor Grease, 2 oz.	97588
Release Pins	97545
Water Tank Hose System	97581
Wedges	97589

SERVICE

UPC motor reconditioning/refurbishing is available. Complete UPC cutters can also be reconditioned/refurbished.

BEFORE shipping items, contact Reed by phone, fax, or email for a return authorization number.

All items should arrive freight prepaid at the Reed factory. Quotes, including any labor charges, will be issued upon inspection of the unit.



Blades for Steel Pipe NOW AVAILABLE!



TRAINING AVAILABLE

✓ WHY REED?

The Reed UPC is lightweight; cuts fast; requires only 12" (300 mm) clearance around the pipe; provides a square cut virtually every time; and can be operated underwater. It is by far the safest, easiest and fastest power cutter to setup, operate and maintain, which nets a low operating cost.



UPC636A

Hinged Cutters™ (1"-12" or 32-356 mm)

Four wheels cut steel, stainless steel, cast and ductile iron with only 90° to 110° handle swing. Only 4" (125 mm) clearance required around pipe. Strong guide fingers ensure perfect wheel alignment for square cuts. A closed 360° frame forces all energy into cutting the pipe for maximum efficiency. There is no shower of sparks in this cold cut. This is the only hinged cutter that tracks every time and the only one recommended for ductile iron, steel, and stainless steel to Schedule 100. This tool is a Reed invention.

✓ WHY REED?

Hinged Cutters™ are a Reed invention! They are lighter, track better for square cuts, and require less clearance, yet provide better torque so the cut is made faster and with less effort. Can be used anywhere – in the ditch, underwater, in explosive atmospheres (cold cut), in noise-free zones, over head, in racks of pipes, etc.

Catalog No.	Item Code	Pipe Capacity		Length		Weight	
		Inches-Nom.	Actual Ø mm	in	mm	lbs	kg
H21/2S*	03110	1 - 2 1/2	32 - 76	17	419	7.2	3.3
H21/2I*	03112	1 - 2 1/2	32 - 76	17	419	7.2	3.3
H21/2X*	03114	1 - 2 1/2	32 - 76	17	419	7.2	3.3
H4S	03120	2 - 4	60 - 125	22	559	12.8	5.8
H4I	03122	2 - 4	60 - 125	22	559	12.8	5.8
H4X	03124	2 - 4	60 - 125	22	559	12.8	5.8
H6S	03130	4 - 6	114 - 182	28	711	19.4	8.8
H6I	03132	4 - 6	114 - 182	28	711	19.4	8.8
H6X	03134	4 - 6	114 - 182	28	711	19.4	8.8
H8S	03140	6 - 8	168 - 240	32	813	24.4	11.1
H8I	03142	6 - 8	168 - 240	32	813	24.4	11.1
H8X	03144	6 - 8	168 - 240	32	813	24.4	11.1
H8XX	03146	6 - 8	168 - 240	32	813	24.4	11.1
H12S	03150	8 - 12	219 - 356	34	864	34.9	15.9
H12I	03152	8 - 12	219 - 356	34	864	34.9	15.9
H12X	03154	8 - 12	219 - 356	34	864	34.9	15.9
H12XX	03156	8 - 12	219 - 356	34	864	34.9	15.9

*EXCLUSIVE

NOTE: S= includes cutter wheels for steel; I= includes cutter wheels for cast and ductile iron; X= includes cutter wheels for schedule 80 steel; XX= for schedule 100 steel.

Wheels for same size cutters are interchangeable. Recommend only Reed cutter wheels be used with these Hinged Cutters™. Reed wheels are made from high shock-resistant tool steel on computerized (CNC) machines and then precisely heat-treated. This allows for a thinner profile yet stronger blade, so they:

- Cut easier and faster, especially stainless steel and ductile pipe
- Last much longer
- Allow for shorter cutter handle for work in tight spaces
- Provide the best value

CUTTER WHEELS ON P. 7
PIPE DESCALERS ON P. 16

Replacement Wheel Pins for Ridgid® cutters: 3S, 4S, 6S, 44S, 466, 468, 472. Order Reed pin R34790 #93322 5/pk. to replace Ridgid® pin No. 34790 (Old #F-14).

Ridgid® is a registered trademark of Ridgid, Inc. and is not associated with Reed Manufacturing Company.



www.reedmfgco.com

For the latest information on **NEW REED Tools!**



TRAINING AVAILABLE

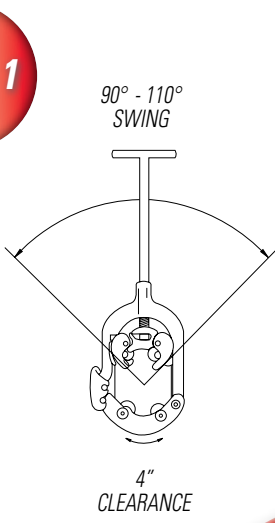

EXCLUSIVE SIZE

Rotary™ Cutters & Low Clearance Rotary™ Cutters (6"-36" or 159-915 mm)

Cold cut large diameter steel, most stainless steel, ductile, and cast iron pipe in close quarters. The low profile design of the LCRC models needs only 4" clearance for up to 16" pipe diameter; only 8" clearance for the RC20 and RC24; and just 11.8" clearance for the RC30 and RC36 large diameter pipe cutters. Each cutter is supplied with a slip-on handle that is used to turn the cutter around the pipe in one direction. The handle is also used to tighten the cutter every 1/2 revolution.

Best manual cutters for ductile iron. With good leverage from long handle, pipe snaps off squarely before wheel penetrates halfway through pipe. Cutters have heavy-duty frames.

All sizes use the same cutter wheels: either RCS8-36 for steel and RC18-30 for ductile and cast iron. RCX wheels cut up to 25/32" wall thickness for steel pipe.



WHY REED?

Rotary™ cutters are a Reed invention! Reed Rotary™ cutters cut pipe safely, easily, quickly, and at a low cost. Provides a square cut and can be used anywhere – in the ditch, underwater, in explosive atmospheres (cold cut), in noise-free zones, over head, in racks of pipes, etc. Reed Rotary™ cutters last for decades.

Catalog No.	Item Code	Pipe Capacity			Length		Weight	
		Steel**	Cast Iron & Ductile	Actual Ø mm	in	mm	lbs	kg
		Inches-Nom.	Inches-Nom.					
LCRC8S*	03309	6 - 8		159 - 246	58	1473	41	18.6
LCRC8I*	03308		6 - 8	159 - 246	58	1473	41	18.6
LCRC12S*	03313	10 - 14		266 - 358	61	1549	50	22.7
LCRC12I*	03312		10 - 12	266 - 358	61	1549	50	22.7
LCRC16S*	03317	16 - 18		368 - 462	66	1664	60	27.3
LCRC16I*	03316		14 - 16	368 - 462	66	1664	60	27.3
RC20S*	03240	20 - 22		476 - 572	106	2680	89	40.5
RC20I*	03242		18 - 20	476 - 572	106	2680	89	40.5
RC24S*	03250	24 - 26		584 - 660	111	2807	107	48.6
RC24I*	03252		22 - 24	584 - 660	111	2807	107	48.6
RC30S*†	03260	28 - 34		698 - 864	96	2438	283	128.6
RC30I*†	03262		30	698 - 864	96	2438	283	128.6
RC36S*†	03264	32 - 36		813 - 915	96	2438	295	134.1

*EXCLUSIVE

† Conversion Kits Available Below

**For heavy wall steel and stainless steel, order RCX cutter wheels (03550) and eight RC8-30XR rollers (93222).

NOTE: S= includes cutter wheels for steel; I= for cast and ductile iron. Wheels for same size cutters are interchangeable. Recommend only Reed cutter wheels be used with these cutters. Reed wheels are made from high shock-resistant tool steel on computerized (CNC) machines and then precisely heat-treated. This allows for a thinner profile yet stronger blade, so they:

- Cut easier and faster, especially stainless steel and ductile pipe
- Last much longer
- Provide the best value

CUTTER WHEELS ON P. 7

PIPE DESCALERS ON P. 16

CONVERSION KITS

Catalog No.	Item Code	Converts
RC30CONV	03267	RC36 to RC30
RC36CONV	03268	RC30 to RC36

NEW

LCRC ACCESSORY

To improve use in awkward locations, Reed now offers an angled handle option that allows the user to turn the LCRC cutter from the side of a ditch, using one's body weight, rather than having to turn the cutter from on top.

Catalog No.	Item Code	Converts
BAHANDLE	93177	Angled Handle option for use with LCRC (Low Clearance Rotary Cutters)

★ **NEW**

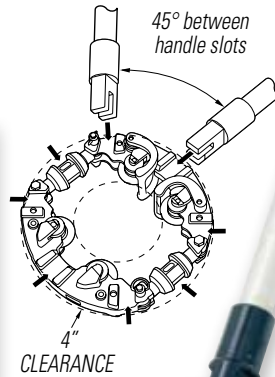

EXCLUSIVE TOOL

TRAINING AVAILABLE

CLEARANCES

Cat. No.	in	mm
RC20	8.0	204
RC24	8.0	204
RC30	11.8	300
RC36	11.8	300



Handle Extension
Affixes to main handle for additional leverage. Included with RC20/RC24 models.

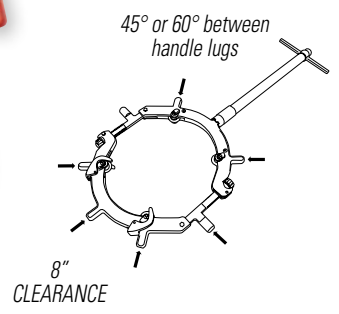

1



CNC Horizontal Mill



CNC technology is widely used for milling and machining components in Reed's product line.

CNC Vertical Mill



CNC Lathe



CNC Surface Grinder

REED *Manufacturing Technology*

Leading-edge processes and state-of-the-art equipment infused with old world craftsmanship have been and remain the standard at Reed Manufacturing for over 110 years. The results of this century of commitment are unparalleled professional trade products offering quite possibly the world's best quality, service and value. Products made to exacting specifications, products made to last for a lifetime, and products with a full lifetime warranty.

