

## CITY OF SPOKANE



### NOTICE

#### REGARDING CITY COUNCIL MEETINGS

Notice is hereby given that City Council has resumed in-person meetings (effective Monday, March 14, 2022). City Council's standing committee meetings, Briefing Sessions, Legislative Sessions and study sessions are held in City Council Chambers – Lower Level of City Hall, 808 W. Spokane Falls Blvd.

City Council Members, City staff, presenters and members of the public will still have the option to participate virtually via WebEx during all meetings, with the exception of Executive Sessions which are closed to the public. Call in information for the June 27, 2022, meetings is below. All meetings will continue to be streamed live on Channel 5 and online at <https://my.spokanecity.org/citycable5/live> and <https://www.facebook.com/spokanecitycouncil>.

#### **WebEx call in information for the week of June 27, 2022:**

1:15 p.m. Committee Meeting: 1-408-418-9388; access code: 2491 952 4023; password: 0320

3:30 p.m. Briefing Session: 1-408-418-9388; access code: 2485 018 9050; password: 0320

6:00 p.m. Legislative Session: 1-408-418-9388; access code: 2490 370 7923; password: 0320

Thursday Study Session: 1-408-418-9388; access code: 2480 676 7327; password: 0320

#### **To participate in public comment (including Open Forum):**

Testimony sign up is open from 5:00-6:00 p.m. on Monday, June 27, 2022. You must sign up by 6:00 p.m. to be called on to testify. Sign up forms will be available outside of Council Chambers for in-person attendees.

Those wishing to give testimony virtually can sign up between 5:00-6:00 p.m. at <https://forms.gle/Vd7n381x3seaL1NW6>. (If you are unable to access the form by clicking the hyperlink, please copy and paste the link address into your browser window.) Instructions for participation are provided on the form when you sign up.

The Open Forum is a limited public forum; all matters discussed in the open forum shall relate to the affairs of the City and items of interest not relating to the Current or Advance Agendas, pending hearing items, or initiatives or referenda in a pending election. Individuals speaking during the open forum shall address their comments to the Council President and shall not use profanity, engage in obscene speech, or make personal comment or verbal insults about any individual.

**CITY COUNCIL MEETINGS  
RULES – PUBLIC DECORUM**

**Strict adherence to the following rules of decorum by the public will be observed and adhered to during City Council meetings, including open forum, public comment period on legislative items, and Council deliberations:**

- 1. No Clapping!**
- 2. No Cheering!**
- 3. No Booing!**
- 4. No public outbursts!**
- 5. Three-minute time limit for comments made during open forum and public testimony on legislative items!**

**In addition, please silence your cell phones when entering the Council Chambers!**

Further, keep the following City Council Rules in mind:

**Rule 2.2 OPEN FORUM**

- A. At the 6:00 p.m. legislative session, after the conclusion of the legislative agenda, the Council shall hold an open forum unless a majority of Council Members vote otherwise. The open forum will not extend past 9:30 p.m. unless extended by a supermajority of the Council.
- B. Members of the public can sign up for open forum in the hour preceding the legislative session via the virtual testimony form linked in the meeting packet or in person outside Council Chambers. The order of the speakers be determined at the discretion of the chair. Each speaker shall be limited to no more than three minutes unless a majority of the Council Members in attendance vote on an alternate time limit.
- C. No action, other than a statement of Council Members' intent to address the matter in the future, points of order, or points of information will be taken by Council Members during an open forum.
- D. The open forum is a limited public forum and all matters discussed in the open forum shall relate to the affairs of the City. No person shall be permitted to speak in open forum regarding items on that week's current agenda or the next week's advanced agenda, pending hearing items, or initiatives or referenda in a pending election. Individuals speaking during open forum shall address their comments to the Council President and shall not use profanity, engage in obscene speech, or make personal comment or verbal insults about any individual.

**Rule 2.7 SERVICE ANIMALS AT CITY COUNCIL MEETINGS**

- A. For purposes of these Rules, only dogs that are individually trained to do work or perform tasks for a person with a disability are recognized as service animals. Dogs or other animals whose sole function is to provide comfort or emotional support do not qualify as service animals under these Rules. Service animals are permitted to accompany people with disabilities in City Council meetings, as well as all areas where members of the public are allowed to go.
- B. Service animals must, at all times while present in a City Council meeting, be harnessed, leashed, or tethered, unless these devices interfere with the service animal's work or the individual's disability prevents using these devices, in which case, the individual must maintain control of the animal through voice, signal, or other effective controls.

**Rule 2.15 PARTICIPATION OF MEMBERS OF THE PUBLIC IN COUNCIL MEETINGS**

- A. Members of the public may address the Council regarding the following items during the Council's legislative session: the consent agenda as a whole, first and final readings of regular and special budget ordinances, emergency ordinances, special consideration items, hearing items, and other items before the City Council requiring Council action, except those that are adjudicatory or solely administrative in nature. This rule shall not limit the public's right to speak on issues that are not part of the current or advanced agendas during open forum.
- B. No member of the public may speak without first being recognized for that purpose by the chair. Except for named parties to an adjudicative hearing, a person may be required to sign a sign-up sheet and provide their city of residence as a condition of recognition. Council Members must be recognized by the chair for the purpose of obtaining the floor.
- C. Each person speaking in a public Council meeting shall verbally identify themselves by name, city of residence, and, if appropriate, representative capacity.
- D. Each speaker shall follow all written and verbal instructions so that verbal remarks are electronically recorded, and documents submitted for the record are identified and marked by the Clerk.

- E. In order that evidence and expressions of opinion be included in the record and that decorum befitting a deliberative process be maintained, no modes of expression not provided by these rules, including but not limited to demonstrations, banners, signs, applause, profanity, vulgar language, or personal insults will be permitted.
- F. A speaker asserting a statement of fact may be asked to document and identify the sources of the factual datum being asserted.
- G. When addressing the Council, members of the public shall direct all remarks to the Council President, shall refrain from remarks directed personally to any Council Member or any other individual, and shall confine remarks to the matters that are specifically before the Council at that time.
- H. Members of City Council staff may participate in public comment, including open forum, providing they are in compliance with the City of Spokane Code of Ethics and they do the following:
  - 1. Announce at the beginning of their testimony that they are there in their personal capacity or their capacity as a member of a relevant board, commission, committee or community group;
  - 2. Protect confidential information, including, but not limited to, confidential financial information and attorney-client communications;
  - 3. Do not use, or be perceived to use, City funds, including giving testimony during paid work time, or City property, including using a City-issued computer or cell phone, in giving testimony.
- I. When any person, including members of the public, City staff, and others, are addressing the Council, Council Members shall observe the same decorum and process, as the rules require among the members *inter se*. That is, a Council Member shall not engage the person addressing the Council in colloquy but shall speak only when granted the floor by the Council President. All persons and/or Council Members shall not interrupt one another. The duty of mutual respect set forth in Rule 1.2 and the rules governing debate set forth in *Robert's Rules of Order, newly revised*, shall extend to all speakers before the City Council. The City Council's Director of Policy and Government Relations and/or City Attorney shall, with the assistance of Council staff, assist the Council President to ensure that all individuals desiring to speak shall be identified, appropriately recognized, and provided the opportunity to speak.

**Rule 2.16 PUBLIC TESTIMONY REGARDING LEGISLATIVE AGENDA ITEMS – TIME LIMITS**

- A. The City Council shall take public testimony on all matters included on its legislative agenda as described at Rule 2.15(A), with those exceptions stated in Rule 2.16(B). Public testimony shall be limited to the final Council action, except that public testimony shall be allowed at the first reading of ordinances. Public testimony shall be limited to three (3) minutes per speaker unless the time limit is adjusted by a majority vote of the Council. The chair may allow additional time if the speaker is asked to respond to questions from the Council. Public testimony and consideration of an item may be extended to a subsequent meeting by a majority vote of the Council.
- B. No public testimony shall be taken on amendments to consent or legislative agenda items, or solely procedural, parliamentary, or administrative matters of the Council.
- C. Public testimony will be taken on consent and legislative items that are moved to Council's regular briefing session or study session unless a majority of Council votes otherwise during the meeting in which the items are moved.
- D. For legislative or hearing items that may affect an identifiable individual, association, or group, the following procedure may be implemented at the discretion of the Council President:
  - 1. Following an assessment by the chair of factors such as complexity of the issue(s), the apparent number of people indicating a desire to testify, representation by designated spokespersons, etc., the chair shall, in the absence of objection by the majority of the Council present, impose the following procedural time limitations for taking public testimony regarding legislative matters:
    - a. There shall be up to fifteen (15) minutes for staff, board, or commission presentation of background information, if any.
    - b. The designated representative of the proponents of the issue shall speak first and may include within their presentation the testimony of expert witnesses, visual displays, and any other reasonable methods of presenting the case. Up to thirty (30) minutes may be granted for the proponent's presentation. If there be more than one designated representative, they shall allocate the allotted time between or among themselves.
    - c. Following the presentation of the proponents of the issue, three (3) minutes shall be granted for any other person not associated with the designated representative of the proponents who wishes to speak on behalf of the proponent's position.
    - d. The designated representative, if any, of the opponents of the issue shall speak following the

presentation of the testimony of expert witnesses, visual displays, and any other reasonable methods of presenting the case. The designated representative(s) of the opponents shall have the same amount of time which was allotted to the proponents.

- e. Following the presentation by the opponents of the issue, three (3) minutes shall be granted for any other person not associated with the designated representative of the opponents who wishes to speak on behalf of the opponents' position.
  - f. Up to ten (10) minutes of rebuttal time may be granted to the designated representative for each side, the proponents speaking first, the opponents speaking second.
2. In the event the party or parties representing one side of an issue has a designated representative and the other side does not, the chair shall publicly ask the unrepresented side if they wish to designate one or more persons to utilize the time allotted for the designated representative. If no such designation is made, each person wishing to speak on behalf of the unrepresented side shall be granted three (3) minutes to present their position, and no additional compensating time shall be allowed due to the fact that the side has no designated representative.
  3. In the event there appears to be more than two groups wishing to advocate their distinct positions on a specific issue, the chair may grant the same procedural and time allowances to each group or groups, as stated previously.
  4. In the event that the side for which individuals wish to speak is not identified, those wishing to give testimony shall be granted three (3) minutes to present their position after all sides have made their initial presentations and before each side's rebuttal period.
- E. The time taken for staff or Council Member questions and responses thereto shall be in addition to the time allotted for any individual or designated representative's testimony.
- F. Testimony may also be submitted by mail to City Council Office, Spokane City Hall, 808 W. Spokane Falls Blvd., Spokane, WA, 99201, by email to all Council Members, or via the Contact form on the Council's website.<sup>1</sup>

---

<sup>1</sup> <https://my.spokanecity.org/citycouncil/members/>

# THE CITY OF SPOKANE



## ADVANCE COUNCIL AGENDA

MEETING OF MONDAY, JUNE 27, 2022

### **MISSION STATEMENT**

**TO DELIVER EFFICIENT AND EFFECTIVE SERVICES  
THAT FACILITATE ECONOMIC OPPORTUNITY  
AND ENHANCE QUALITY OF LIFE.**

**MAYOR NADINE WOODWARD**

**COUNCIL PRESIDENT BREEAN BEGGS**

**COUNCIL MEMBER JONATHAN BINGLE**

**COUNCIL MEMBER LORI KINNEAR**

**COUNCIL MEMBER BETSY WILKERSON**

**COUNCIL MEMBER MICHAEL CATHCART**

**COUNCIL MEMBER KAREN STRATTON**

**COUNCIL MEMBER ZACK ZAPPONE**

**CITY COUNCIL CHAMBERS  
CITY HALL**

**808 W. SPOKANE FALLS BLVD.  
SPOKANE, WA 99201**

## **LAND ACKNOWLEDGEMENT**

We acknowledge that we are on the unceded land of the Spokane people. And that these lands were once the major trading center for the Spokanes as they shared this place and welcomed other area tribes through their relations, history, trade, and ceremony. We also want to acknowledge that the land holds the spirit of the place, through its knowledge, culture, and all the original peoples Since Time Immemorial.

As we take a moment to consider the impacts of colonization may we also acknowledge the strengths and resiliency of the Spokanes and their relatives. As we work together making decisions that benefit all, may we do so as one heart, one mind, and one spirit.

We are grateful to be on the shared lands of the Spokane people and ask for the support of their ancestors and all relations. We ask that you recognize these injustices that forever changed the lives of the Spokane people and all their relatives.

We agree to work together to stop all acts of continued injustices towards Native Americans and all our relatives. It is time for reconciliation. We must act upon the truths and take actions that will create restorative justice for all people.

Adopted by Spokane City Council on the 22nd day of March, 2021  
*via Resolution 2021-0019*

## BRIEFING AND LEGISLATIVE SESSIONS

The Briefing Session is open to the public, but will be a workshop meeting. Discussion will be limited to Council Members and appropriate Staff and Counsel. Pursuant to Council Rule 2.16.C, public testimony will be taken on consent and legislative items that are moved to Council's regular Briefing Session unless a majority of Council votes otherwise during the meeting in which the items are moved. The Legislative Session is also open to the public and public comment will be taken on Legislative Session items, except those that are adjudicatory or solely administrative in nature. Following the conclusion of the Legislative Agenda, an Open Forum will be held unless a majority of Council Members vote otherwise. Please see additional Open Forum information that appears at the end of the City Council agenda.

SPOKANE CITY COUNCIL BRIEFING SESSIONS (BEGINNING AT 3:30 P.M. EACH MONDAY) AND LEGISLATIVE SESSIONS (BEGINNING AT 6:00 P.M. EACH MONDAY) ARE BROADCAST LIVE ON CITY CABLE CHANNEL FIVE AND STREAMED LIVE ON THE CHANNEL FIVE WEBSITE. THE SESSIONS ARE REPLAYED ON CHANNEL FIVE ON THURSDAYS AT 6:00 P.M. AND FRIDAYS AT 10:00 A.M.

### ADDRESSING THE COUNCIL

- No member of the public may speak without first being recognized for that purpose by the Chair. Except for named parties to an adjudicative hearing, a person may be required to sign a sign-up sheet and provide their city of residence as a condition of recognition. Council Members must be recognized by the chair for the purpose of obtaining the floor.
- Each person speaking at the public microphone shall verbally identify themselves by name, city of residency and, if appropriate, representative capacity.
- Each speaker shall follow all written and verbal instructions so that verbal remarks are electronically recorded, and documents submitted for the record are identified and marked by the Clerk. (If you are submitting letters or documents to the Council Members, please provide a minimum of ten copies via the City Clerk. The City Clerk is responsible for officially filing and distributing your submittal.)
- In order that evidence and expressions of opinion be included in the record and that decorum befitting a deliberative process be maintained, no modes of expression including but not limited to demonstrations, banners, signs, applause, profanity, vulgar language, or personal insults will be permitted.
- A speaker asserting a statement of fact may be asked to document and identify the source of the factual datum being asserted.
- When addressing the Council, members of the public shall direct all remarks to the Council President, shall refrain from remarks directed personally to any Council Member or any other individual, and shall continue to the matters that are specifically before the Council at that time.
- Members of the City Council staff may participate in public comment, including open forum, providing they are in compliance with the City of Spokane Code of Ethics and they follow the steps outlined in the City Council Rules of Procedure.

**SPEAKING TIME LIMITS:** Unless the time limit is adjusted by a majority vote of the Council, each person addressing the Council shall be limited to a three-minute speaking time. The chair may allow additional time if the speaker is asked to respond to questions from the Council. Public testimony and consideration of an item may be extended to a subsequent meeting by a majority vote of the Council. Note: No public testimony shall be taken on amendments to consent or legislative agenda items, or solely procedural, parliamentary, or administrative matters of the Council.

**CITY COUNCIL AGENDA:** The City Council Advance and Current Agendas may be obtained prior to Council Meetings by accessing the City website at <https://my.spokanecity.org>.

# **BRIEFING SESSION**

(3:30 p.m.)

(Council Chambers Lower Level of City Hall)  
(No Public Testimony Taken)

**ROLL CALL OF COUNCIL**

**INTERVIEWS OF NOMINEES TO BOARDS AND COMMISSIONS**

**COUNCIL OR STAFF REPORTS OF MATTERS OF INTEREST**

**ADVANCE AGENDA REVIEW (Staff or Council Member briefings and discussion)**

**APPROVAL BY MOTION OF THE ADVANCE AGENDA**

**CURRENT AGENDA REVIEW (Presentation of any new background information and discussion of any adjustments)**

---

# **EXECUTIVE SESSION**

(Closed Session of Council)

(Executive Session may be held or reconvened during the 6:00 p.m. Legislative Session)

---

# **LEGISLATIVE SESSION**

(6:00 P.M.)

(Council Reconvenes in Council Chamber)

**PLEDGE OF ALLEGIANCE**

**WORDS OF INSPIRATION AND SPECIAL INTRODUCTIONS**

**ROLL CALL OF COUNCIL**

**COUNCIL AND COMMITTEE REPORTS**

(Committee Reports for City Council Standing Committees and other Boards and Commissions)

**PROCLAMATIONS AND SALUTATIONS**

**REPORTS FROM NEIGHBORHOOD COUNCILS AND/OR OTHER CITY-SPONSORED  
COMMUNITY ORGANIZATIONS**

**ANNOUNCEMENTS**

(Announcements regarding Changes to the City Council Agenda)



# NO BOARDS AND COMMISSIONS APPOINTMENTS

## ADMINISTRATIVE REPORT

### CONSENT AGENDA

REPORTS, CONTRACTS AND CLAIMS

RECOMMENDATION

- |   |   |                                      |
|---|---|--------------------------------------|
| <p>1. Purchase of Liebert branded Uninterruptible Power Supply (UPS) replacement at the Combined Communications Building utilizing State Contract Agreement No. 05114—\$129,846.64 (incl. tax). (Council Sponsor: Council Member Kinnear)<br/><b>David Stockdill</b></p>  | <p>Approve</p>                            | <p>OPR 2022-0462</p>                 |
| <p>2. Contract with Concourse Financial Group, Inc. (Birmingham, AL), parent company for Time Value Investment (TVI), for non-discretionary investment services from March 1, 2022 through February 28, 2025—annual flat rate fee of \$65,000. (Deferred from March 21, 2022, Agenda) (Council Sponsor: Council Member Stratton)<br/><b>Tonya Wallace</b></p> | <p>Approve</p>                            | <p>OPR 2022-0127</p>                 |
| <p>3. Acceptance of additional Consolidated Homeless Grant funds from the Washington State Office of Family and Adult Homelessness and approval to sub-award funds to sub-recipients—increase of \$358,467 Revenue. Total Grant Amount: \$9,969,518. (Council Sponsor: Council Member Cathcart)<br/><b>Jenn Cerecedes</b></p>                                 | <p>Approve &amp; Authorize Agreements</p> | <p>OPR 2021-0532</p>                 |
| <p>4. Low Bid of (<u>to be determined at bid opening to be held on June 21, 2022</u>) (<u>City, ST</u>) for Cochran Basin Stormwater Treatment Facility - Downriver Disc Golf Course—\$____. An administrative reserve of \$____, which is 10% of the contract price, will be set aside. (Council Sponsor: Council Member Kinnear)<br/><b>Dan Buller</b></p>  | <p>Approve</p>                            | <p>OPR 2022-0463<br/>ENG 2018058</p> |
| <p>5. Contract with Spokane Emergency Physicians (Spokane) to provide medical advisory services to the Fire Department from May 1, 2022 through April 30, 2027—\$498,403.19. (Council Sponsors: Council President Beggs and Council Member Kinnear)<br/><b>Brian Schaeffer</b></p>  | <p>Approve</p>                            | <p>OPR 2022-0464<br/>RFP 5607-22</p> |
| <p>6. Consultant Agreement with Alliant Insurance Services (Spokane) for employee benefits broker and consultant services from July 1, 2022 through</p>   | <p>Approve</p>                            | <p>OPR 2022-0465<br/>RFP 5652-22</p> |

June 30, 2025—\$405,000 (or \$135,000 annually) (excluding tax, if applicable). (Council Sponsor: Council Member Wilkerson)

**Johnnie Perkins**

- |    |  |                              |               |
|----|--|------------------------------|---------------|
| 7. | Report of the Mayor of pending:  | Approve & Authorize Payments |               |
| a. | Claims and payments of previously approved obligations, including those of Parks and Library, through _____, 2022, total \$_____, with Parks and Library claims approved by their respective boards. Warrants excluding Parks and Library total \$_____. |                              | CPR 2022-0002 |
| b. | Claims and payments of previously approved obligations, including those of Parks and Library, through _____, 2022, total \$_____, with Parks and Library claims approved by their respective boards. Warrants excluding Parks and Library total \$_____. |                              | CPR 2022-0002 |
| c. | Payroll claims of previously approved obligations through_____, 2022: \$_____.   |                              | CPR 2022-0003 |
| 8. | City Council Meeting Minutes: _____, 2022.   | Approve All                  | CPR 2022-0013 |

The following items (Nos. 9-17) were deferred from the June 20, 2022, Advance Agenda, and were briefed on June 13, 2022:

Request motion to accept revised version of the following (OPR 2022-0412):

- |     |   |         |                               |
|-----|---|---------|-------------------------------|
| 9.  | Contract with Volt Management Corporation (Orange, CA) for technical resources in support of the Project Management Office, Community Housing and Human Services, and the Innovation and Technology Services Division from May 1, 2022 through April 30, 2024—\$350,000 per year, not including tax. (Deferred from June 6, 2022, Agenda)(Council Sponsor: Council Member Cathcart) | Approve | OPR 2022-0412                 |
| 10. | Value Blanket with Airgas Specialty Products Inc. (Lawrenceville, GA) for the purchase of anhydrous ammonia at the Waste to Energy Facility from July 1, 2022 through June 30, 2025—not to exceed \$880,000 annually (\$2,640,000 for 3-year term) (plus tax). (Council Sponsor: Council Member Kinnear)  | Approve | OPR 2022-0440<br>ITB #5634-22 |
| 11. | Purchase of Cubicles for the Spokane Police Department Gardner Building utilizing Herman Miller   | Approve | OPR 2022-0441                 |

**OMNIA cooperative contract #2020000622—\$65,070.44 (incl. tax) (Council Sponsor: Council Member Cathcart)**

- |   |                        |  |
|---|------------------------|--|
| <b>12. Purchase of Dell Server utilizing NASPO contract—\$594,798.72 (incl. tax). (Relates to Consent Agenda Item No. 17) (Council Sponsor: Council Member Cathcart)</b>  | <b>Approve</b>         | <b>OPR 2022-0442</b>                     |
| <br>  |                        |  |
| <b>13. Low Bids of:</b>   | <b>Approve<br/>All</b> |  |
| <b>a. Bacon Concrete, Inc. (Spokane) for Cycle 9 Traffic Calming Projects—\$498,305.25. An administrative reserve of \$49,830.53, which is 10% of the contract price, will be set aside. (Various Neighborhoods) (Council Sponsors: Council President Beggs and Council Member Kinnear)</b> |                        | <b>OPR 2022-0443<br/>ENG 2019088</b>     |
| <b>b. Halme Construction, Inc. (Spokane) for Washington Basin Stormwater - Knox Avenue Project—\$1,999,122.75. An administrative reserve of \$199,912.78, which is 10% of the contract price, will be set aside. (Emerson/Garfield) (Council Sponsor: Council Member Kinnear)</b>           |                        | <b>OPR 2022-0444<br/>ENG 2017178</b>     |
| <br>  |                        |  |
| <b>14. One-year Value Blanket Renewal with Camtek for cameras, other security hardware and video management software—\$295,000. (Council Sponsor: Council Member Cathcart)</b>  | <b>Approve</b>         | <b>OPR 2019-0073</b>                     |
| <br>  |                        |  |
| <b>15. Contract Renewal No. 1 of 2 with Frank Gurney, Inc. (Spokane Valley, WA) for needed on-call guardrail repair services—not to exceed \$125,000. (Council Sponsor: Council Member Kinnear)</b>   | <b>Approve</b>         | <b>OPR 2021-0302<br/>PW ITB #5407-21</b> |
| <br>  |                        |  |
| <b>16. One-year Contract Extension with Superior LLC (Lake Mary, FL) for continued joint administration of the False Alarm Program from July 1, 2022 through July 30, 2023—Estimated revenue \$380,000/year. (Council Sponsor: Council Member Kinnear)</b>                                  | <b>Approve</b>         | <b>OPR 2011-0535</b>                     |
| <br>  |                        |  |
| <b>17. First Amendment to Master Services and Purchasing Agreement with Axon Enterprise, Inc. to add on additional products and services—\$7,614,420.75. (Relates to Consent Agenda Item No. 12) (Council Sponsor: Council Member Cathcart).</b>  | <b>Approve</b>         | <b>OPR 2019-1095</b>                     |

# LEGISLATIVE AGENDA

## SPECIAL BUDGET ORDINANCES

(Require Five Affirmative, Recorded Roll Call Votes)

Ordinances amending Ordinance No. C36161 passed by the City Council December 13, 2021, and entitled, "An Ordinance adopting the Annual Budget of the City of Spokane for 2022, making appropriations to the various funds of the City of Spokane government for the fiscal year ending December 31, 2022, and providing it shall take effect immediately upon passage," and declaring an emergency and appropriating funds in:

- ORD C36193** Forfeitures & Contributions Fund
- 1) Increase appropriations by \$175,000.
    - A) Of the increased appropriations; \$40,000 of the increase is to be used as confidential funds used for controlled purchases of illegal substances.
    - B) \$125,000 shall be used to fund a request for proposal to non-profit entities that provide at-risk youth services that will support prevention of drug use and drug crimes using peer support and leadership from individuals who have successfully exited criminal justice involvement.
    - C) \$10,000 for training.
  - 2) The increased appropriation is funded from unappropriated reserves in the Forfeitures & Contributions Fund.

(This action arises from the need to continue and expand the use of confidential funds.) (Deferred from June 6, 2022, Agenda) (Council Sponsors: Council Members Cathcart and Bingle)

**Michael McNab**

- ORD C36231** Forfeitures & Contributions Fund
- 1) Increase appropriations by \$95,000.
    - A) Of the increased appropriation; \$95,000 of the increase is to be used for the procurement of used vehicles \$95,000.
    - B) The increased appropriation is funded from unappropriated reserves in the Forfeitures & Contributions Fund

(This action arises from the need to procure additional undercover vehicles.) (Council Sponsors: Council Members Cathcart and Bingle)

**Michael McNab**

The following items were deferred from the June 20, 2022, Advance Agenda, and were briefed on June 13, 2022:

- ORD C36227** Public Safety Personnel and Crime Reduction Fund
- 1) Add two Parking Enforcement Specialist I positions (from 0 to 2) and increase the associated appropriation for salary and benefits by approximately \$69,225.

(This action arises from the need to create an abandoned vehicle unit.)  
(Council Sponsors: Council Members Cathcart and Stratton)

- ORD C36228      **Public Safety Personnel and Crime Reduction Fund**
  - 1) Increase the appropriation by \$668,000.
  - A) Of the increased appropriation, approximately \$256,000 is provided solely for wages and benefits for fire academy recruit school instructors.
  - B) Of the increased appropriation, \$412,000 is provided solely for equipment needs related to the fire academy recruit school.

(This action arises from the need to run an additional fire recruiting academy beginning in 2022.) (Council Sponsors: Council Members Cathcart and Kinnear)

- ORD C36229      **General Fund**
  - 1) Decrease the appropriation for a Public Defender I position in the Office of Public Defender by \$27,000.
  - 2) Increase the appropriation for legal services by \$27,000.
  - 3) There is no change to the overall appropriation level in the General Fund.

(This action arises from the need transfer budget authority from personnel to non-personnel expenses to provide expert witness legal services) (Council Sponsors: Council Members Cathcart and Kinnear)

## **NO EMERGENCY ORDINANCES**

## **RESOLUTIONS & FINAL READING ORDINANCES**

(Require Four Affirmative, Recorded Roll Call Votes)

- RES 2022-0026      **Updating methodology for the distribution of investment earnings in Spokane Investment Pool to participating funds not restricted by bond covenants, grant terms, contractual terms, or establishing ordinances. (Deferred from March 21, 2022, Agenda) (Council Sponsors: Council Members Wilkerson and Cathcart)**  
**Tonya Wallace**

The following items (RES 2022-0055 and RES 2022-0056) were deferred from the June 20, 2022, Advance Agenda, and were briefed on June 13, 2022:

- RES 2022-0055      **Recognizing the US 195 / I-90 Transportation Study (“The Study”) as a declaration of the City’s desired future transportation conditions within the US 195 corridor from I-90 to Hatch Road. (Council Sponsors: Council President Beggs and Council Member Kinnear)**
- RES 2022-0056      **(To be considered under Hearings Item H1.)**

- ORD C36224 (To be considered under Hearings Item H2.)
- ORD C36225 (To be considered under Hearings Item H3.)
- ORD C36226 (To be considered under Hearings Item H4.)

## FIRST READING ORDINANCES

ORD C36230 Amending Ordinance C-21606 that vacated Mallon Avenue from the west line of Section 16, Township 25 North, Range 43 E.W.M. to the west line of Hogan Street and of Perry Street from the south line of Mallon Avenue to the northerly boundary line of the right of way of the Union Pacific Railroad Co., City and County of Spokane, Washington. (Releases easements at request of the property owners, Iron Bridge development.) (Council Sponsor: Council Member Cathcart)  
**Eldon Brown**

The following item was deferred from the June 20, 2022, Advance Agenda, and was briefed on June 13, 2022:

ORD C36223 Relating to parking municipal codes amending SMC sections 16A.04.100, 16A.05.060, 16A.05.460, 16A.06.010; repealing SMC sections 16A.06.030, 16A.06.040, 16A.06.050; and adding new section 16A.06.080, 16A.06.090 to chapter 16A.06 of the Spokane Municipal Code and setting an effective date. (Council Sponsors: Council Members Stratton and Kinnear)

### FURTHER ACTION DEFERRED

---

## SPECIAL CONSIDERATIONS

### RECOMMENDATION

S1.	Lease Agreement with Lawrence B. Stone Properties #4320, LLC (Spokane) for the use of the building at 4320 E.Trent Avenue as a shelter space from August 1, 2022 through July 31, 2027, with option for one five-year renewal—\$145,770 for 2022. Total for all years combined: \$1,867,256. (Council Sponsors: Council Members Cathcart and Bingle) <b>Jenn Cerecedes</b>	Approve	OPR 2022-0469
-----	---	---------	---------------

# HEARINGS

## RECOMMENDATION

The following item was deferred from the June 20, 2022, Advance Agenda, and was briefed on June 13, 2022:

- |  |  |                      |
|--|--|----------------------|
| <p>H1. Hearing on Resolution 2022-0056 adopting the 2023-2028 Six-Year Comprehensive Street Program. (Various neighborhoods)(Council Sponsors: Council President Beggs and Council Member Kinnear)</p> | <p>Adopt<br/>Upon Roll<br/>Call Vote</p> | <p>RES 2022-0056</p> |
|--|--|----------------------|

The following items (ORD C36224 thru ORD C36226) were briefed as First Reading Ordinances on June 13, 2022:

- |   |   |                   |
|---|---|-------------------|
| <p>H2. <u>Request motion to accept substitute version of the following ordinance (Ordinance C36224):</u><br/>Final Reading Ordinance C36224 relating to short plat notification amending Spokane Municipal Code (SMC) Sections 17G.060.100, 17G.060T.003, 17G.060.130, and 17G.080.040. (Council Sponsors: Council Members Wilkerson and Zappone)<br/><b>Amanda Beck</b></p>  | <p>Pass Upon<br/>Roll Call<br/>Vote</p> | <p>ORD C36224</p> |
| <p>H3. <u>Request motion to accept substitute version of the following ordinance (Ordinance C36225):</u><br/>Final Reading Ordinance C36225 relating to lot size transitions, accessory structures, and accessory dwelling units amending Spokane Municipal Code (SMC) Sections 17C.110.200, 17C.110.225, 17C.300.100, 17C.300.110, 17C.300.120, 17C.300.130, 17C.300.140. (Council Sponsors: Council Members Wilkerson and Zappone)<br/><b>Amanda Beck</b></p> | <p>Pass Upon<br/>Roll Call<br/>Vote</p> | <p>ORD C36225</p> |
| <p>H4. Final Reading Ordinance C36226 relating to permit fees for short plats amending Spokane Municipal Code (SMC) Sections 8.02.064 and 8.02.066. (Council Sponsors: Council Members Cathcart and Wilkerson)<br/><b>Amanda Beck</b></p>   | <p>Pass Upon<br/>Roll Call<br/>Vote</p> | <p>ORD C36226</p> |

---

**Motion to Approve Advance Agenda for June 27, 2022**  
(per Council Rule 2.1.2)

---

## OPEN FORUM

At each meeting after the conclusion of the legislative agenda, the Council shall hold an open public comment period until 9:30 p.m., which may be extended by motion. Each speaker is limited to no more than three minutes. In order to participate in Open Forum, you must sign up by 6:00 p.m. A sign-up

form will be available on the day of the meeting from 5:00-6:00 p.m. outside of Council Chambers for in-person attendees. Those wishing to comment virtually can sign up between 5:00-6:00 p.m. at <https://forms.gle/Vd7n381x3seaL1NW6>. (If you are unable to access the form by clicking the hyperlink, please copy and paste the link address into your browser window.) Instructions for virtual participation are provided on the form when you sign up. The Open Forum is a limited public forum; all matters discussed in the open forum shall relate to the affairs of the City and items of interest not relating to the Current or Advance Agendas, pending hearing items, or initiatives or referenda in a pending election. Individuals speaking during the open forum shall address their comments to the Council President and shall not use profanity, engage in obscene speech, or make personal comment or verbal insults about any individual.

## **ADJOURNMENT**

The June 27, 2022, Regular Legislative Session of the City Council will be held and is adjourned to July 11, 2022.

**NOTE:** There is no meeting scheduled for Monday, July 4, 2022, as this day is designated for the observation of the Independence Day holiday. A regularly scheduled City Council meeting will not be held on Tuesday, July 5, 2022.

---

## **NOTES**



**Agenda Sheet for City Council Meeting of:**

06/27/2022

<b>Date Rec'd</b>	6/13/2022
<b>Clerk's File #</b>	OPR 2022-0462
<b>Renews #</b>	
<b>Cross Ref #</b>	
<b>Project #</b>	
<b>Bid #</b>	
<b>Requisition #</b>	2023 CIP

<b>Submitting Dept</b>	FIRE
<b>Contact Name/Phone</b>	DAVID STOCKDILL 625-7080
<b>Contact E-Mail</b>	DSTOCKDILL@SPOKANECITY.ORG
<b>Agenda Item Type</b>	Purchase w/o Contract
<b>Agenda Item Name</b>	1640 - CCB UPS REPLACEMENT

**Agenda Wording**

Purchase approval of a Liebert branded UPS replacement at the Spokane Combined Communications Building. Total price of \$129,846.64 does not include engineering review and installation.

**Summary (Background)**

The UPS at Combined Communications (CCB), 1620 N. Rebecca St., has exceeded its service life. It is the single remaining UPS from the original, dual-redundant system installed at CCB commissioning in 2002. The 24/7/365, critical nature of this facility necessitates UPS replacement as soon as possible. Current equipment lead time is 6-7 months. The UPS provides temporary backup power until the dual-redundant, automated generator systems come online in the event of commercial power interruption.

Lease? NO Grant related? NO Public Works? YES

**Fiscal Impact**

Expense \$ 129,846.64

Select \$

Select \$

Select \$

**Budget Account**

# 1620-35351-94000-56203-99999

#

#

#

**Approvals**

**Dept Head** SCHAEFFER, BRIAN

**Division Director** SCHAEFFER, BRIAN

**Finance** SCHMITT, KEVIN

**Legal** ODLE, MARI

**For the Mayor** ORMSBY, MICHAEL

**Additional Approvals**

**Purchasing**

**Council Notifications**

**Study Session\Other** PSCHC 6/6/2022

**Council Sponsor** Councilmember Kinnear

**Distribution List**

fireaccounting@spokanecity.org

dstockdill@spokanecity.org

tprince@spokanecity.org

jatwood@spokanefire.org

## Committee Agenda Sheet

### [PUBLIC SAFETY AND COMMUNITY HEALTH]

<b>Submitting Department</b>	Fire
<b>Contact Name &amp; Phone</b>	Brian Schaeffer 435-7001
<b>Contact Email</b>	bschaeffer@spokanecity.org
<b>Council Sponsor(s)</b>	CM Kinnear
<b>Select Agenda Item Type</b>	<input checked="" type="checkbox"/> Consent <input type="checkbox"/> Discussion    Time Requested:
<b>Agenda Item Name</b>	Combined Communications (CCB) Uninterruptible Power Supply (UPS) replacement
<b>Summary (Background)</b>	<p>The UPS at Combined Communications (CCB), 1620 N. Rebecca St., has exceeded its service life. It is the single remaining UPS from the original, dual-redundant system installed at CCB commissioning in 2002. The 24/7/365, critical nature of this facility necessitates UPS replacement as soon as possible.</p> <ul style="list-style-type: none"> <li>• UPS replacement is scheduled as a 2023 Capital project. This project requires advance approval due to the long production lead time – currently 6-7 months.</li> <li>• Project Timeline: <ul style="list-style-type: none"> <li>○ Spring 2022 – Order UPS equipment.</li> <li>○ Summer 2022 – Site engineering review (REET funds in the amount of \$50,000 have been previously approved for 2022 budget. Actual engineering costs TBD).</li> <li>○ December 2022/January 2023 – UPS equipment delivered.</li> <li>○ January/February 2023 UPS installation (cost TBD).</li> </ul> </li> <li>• Project Cost: <ul style="list-style-type: none"> <li>○ The attached quote for \$129,846.64 is for the Liebert branded UPS system hardware (control system, batteries and associated cabinets) and includes WSST. This quote does not include costs for engineering review and installation.</li> <li>○ Pricing is pre-negotiated via State Contract Agreement #05114.</li> </ul> </li> <li>• Additional information: <ul style="list-style-type: none"> <li>○ The UPS provides temporary backup power until the dual-redundant, automated generator systems come online in the event of commercial power interruption.</li> <li>○ UPS replacement is part of an ongoing project to ensure critical backup power and control systems are robust and up to date.</li> <li>○ The new system is more energy efficient than the legacy unit and is internally redundant such that only one UPS needs to be purchased to replace the dual-redundant, legacy units.</li> </ul> </li> </ul>

<b>Proposed Council Action &amp; Date:</b>	Approval to order and purchase critically needed, Liebert-brand, UPS equipment from Consolidated Electrical Equipment (CED). Order to be placed as soon as possible to avoid/minimize potential price increase.
<b>Fiscal Impact:</b> Total Cost: Approved in current year budget? <input type="checkbox"/> Yes <input checked="" type="checkbox"/> No <input type="checkbox"/> N/A  Funding Source <input checked="" type="checkbox"/> One-time <input type="checkbox"/> Recurring Specify funding source: REET  Expense Occurrence <input checked="" type="checkbox"/> One-time <input type="checkbox"/> Recurring  Other budget impacts: (revenue generating, match requirements, etc.) Equipment purchase and installation costs are a 2023 Capital project.	
<b>Operations Impacts</b>	
What impacts would the proposal have on historically excluded communities?  This proposal is neutral regarding historically excluded communities.	
How will data be collected, analyzed, and reported concerning the effect of the program/policy by racial, ethnic, gender identity, national origin, income level, disability, sexual orientation, or other existing disparities?  Since this proposal is for the repair of a facility, any data collection will focus on the quality of the work performed and won't involve disparities.	
How will data be collected regarding the effectiveness of this program, policy or product to ensure it is the right solution?  Reliable backup power and control systems will ensure uninterrupted operation at the CCB. Reduced service calls for system failures will be an indicator that this project was effective.	
Describe how this proposal aligns with current City Policies, including the Comprehensive Plan, Sustainability Action Plan, Capital Improvement Program, Neighborhood Master Plans, Council Resolutions, and others?  Quoted pricing is based on State Contract Agreement #05114 which complies with City of Spokane purchasing guidelines and procedures. This project is aligned with City Budget/Capital Plan for maintaining City Facilities and Utilities including Comprehensive Plan goals and/or policies: CFU1: Adequate Public Facilities and Services, CFU2: Concurrency, CFU4: Service Provision, CFU5: Environmental Concerns, CFU6: Multiple Objectives.	

CED  
 3333 E MAIN AVE.  
 SPOKANE WA 99202  
 TEL: 509 535-8891 FAX: 509 535-3745

CONTACT: MARK PUKSTA

QUOTE FOR: CITY OF SPOKANE  
 ACCT #: GT-79605 CITY OF SPOKANE

PURCHASING DEPT  
 808 W SPOKANE FALLS  
 SPOKANE, WA 99201  
 TEL: (509) 625-6400

QUOTATION		PAGE 001 OF 001	
QUOTE #	DATE	REV #	REV DATE
1082412	04/27/22	006	06/10/22
QUOTE EXPIRES		PREPARED BY	
07/06/2022		MP	
SLS		INSL	
0832		0014	
FOB		FREIGHT	
SHIPPING POINT		PREPAID	

CUS PO #:
JOB NAME: UPS SYSTEM

LN	QTY	MFR	CATALOG #	DESCRIPTION	PRICE	UOM	EXT AMT
01	1	LIEB	47SA080GBC00UAW	LBRT EXM 208V UPS	37,765.05	E	37,765.05
02	4	LIEB	605370G2	FLOOR ANCHOR KIT SEISMIC	821.93	E	3,287.72
03	1	LIEB	607949G1	FLOOR ANCHOR KIT 300MM	661.95	E	661.95
04	1	LIEB	CTD	CERTIFIED FACTORY TR	147.23	E	147.23
05	1	LIEB	1STDESTINATION		3,411.68	E	3,411.68
06	1	LIEB	47MBH33CC0R1TGB	LBRT EXM 208V MBC BDC	7,737.26	E	7,737.26
07	1	LIEB	47BPHWX93L10265	LBRT EXM 208V BATTERY 1	19,836.95	E	19,836.95
08	1	LIEB	47BPHWX93L20265	LBRT EXM 208V BATTERY 2	19,836.95	E	19,836.95
09	1	LIEB	47BPHWX93L30265	LBRT EXM 208V BATTERY 3	19,836.95	E	19,836.95
10	1	LIEB	SUEXM60-100P7	S/UPLUS7X24 EXM60-100KVA	4,119.14	E	4,119.14
11	1	LIEB	MUEXM208-60PF1	PMSVC EXM208 60LVA 1PM8X5	2,126.16	E	2,126.16
12	1	LIEB	MPEXM10-2001PF	PMSV 10-200 EXM PERIPH 1PM8X5	358.32	E	358.32
13	1	LIEB	LOT PRICE	FREIGHT INCLUDED	0.00	E	.00
14	*	QUOTE VAILD FOR 30 DAYS					
15	*	PER STAT CONTRACT AGREEMENT 05114					

MDSE: 119,125.36  
 TAX: 10,721.28  
 TOTAL: 129,846.64

PLEASE NOTE: THIS IS NOT AN OFFER TO CONTRACT, BUT MERELY A QUOTATION OF CURRENT PRICES FOR YOUR CONVENIENCE AND INFORMATION. ORDERS BASED ON THIS QUOTATION ARE SUBJECT TO YOUR ACCEPTANCE OF THE TERMS AND CONDITIONS LOCATED AT SALES.OUR-TERMS.COM, WHICH WE MAY CHANGE FROM TIME TO TIME WITHOUT PRIOR NOTICE. WE MAKE NO REPRESENTATION WITH RESPECT TO COMPLIANCE WITH JOB SPECIFICATIONS.

**Agenda Sheet for City Council Meeting of:**

02/28/2022

<b>Date Rec'd</b>	2/15/2022
<b>Clerk's File #</b>	OPR 2022-0127
<b>Renews #</b>	
<b>Cross Ref #</b>	
<b>Project #</b>	
<b>Bid #</b>	A&E MRSC ROSTER
<b>Requisition #</b>	CR 23343

<b>Submitting Dept</b>	FINANCE, TREASURY & ADMIN
<b>Contact Name/Phone</b>	TONYA WALLACE 625-6845
<b>Contact E-Mail</b>	TWALLACE@SPOKANECITY.ORG
<b>Agenda Item Type</b>	Contract Item
<b>Agenda Item Name</b>	FINANCE - NON DISCRETIONARY INVESTMENT SERVICES

**Agenda Wording**

The contract will be for non-discretionary investment services at an annual flat rate fee of \$65,000 for the first 3 years. TVI is the only firm listed on the MRSC Roster offering the listed Investment Advisory services.

**Summary (Background)**

Concourse Financial Group, parent company for Time Value Investment or TVI, will assist the City with its primary investment pool. TVI will support updating the City's investment policy incorporating industries best practices including the priorities safety liquidity and yield. Specifically, TVI/Concourse Financial Group will assist the City in determining the appropriate risk parameters, maturity constraints and diversification to meet City's objectives.

Lease? NO Grant related? NO Public Works? NO

**Fiscal Impact**

Expense \$ 65,000.00

Select \$

Select \$

Select \$

**Budget Account**

# 0410-30400-14230-54202

#

#

#

**Approvals****Dept Head** WALLACE, TONYA**Division Director** WALLACE, TONYA**Finance** INGIOSI, PAUL**Legal** ODLE, MARI**For the Mayor** ORMSBY, MICHAEL**Additional Approvals****Purchasing** PRINCE, THEA**Council Notifications****Study Session\Other** Urban Experience -  
2/14/22**Council Sponsor** CP Karen Stratton**Distribution List**

twallace@spokanecity.org

ddaniels@spokanecity.org

mmurray@spokanecity.org

## Committee Agenda Sheet

### Urban Development

<b>Submitting Department</b>	Finance
<b>Contact Name &amp; Phone</b>	Tonya Wallace 625-6845
<b>Contact Email</b>	<a href="mailto:twallace@spokanecity.org">twallace@spokanecity.org</a>
<b>Council Sponsor(s)</b>	Karen Stratton
<b>Select Agenda Item Type</b>	<input checked="" type="checkbox"/> Consent <input type="checkbox"/> Discussion      Time Requested: _____
<b>Agenda Item Name</b>	True Value Investment Advisory Services Agreement
<b>Summary (Background)</b>	<p>Concourse Financial Group, parent company for Time Value Investment or TVI, will assist the City with its primary investment pool. TVI will support updating the City's investment policy incorporating industries best practices including the priorities safety liquidity and yield. Specifically, TVI/Concourse Financial Group will assist the City in determining the appropriate risk parameters, maturity constraints and diversification to meet City's objectives.</p> <p>TVI will work closely with the City and offers the following primary services:</p> <ul style="list-style-type: none"> <li>• Continuous oversight of the investment portfolio.</li> <li>• Assistance with 3<sup>rd</sup> party DVP safekeeping setup (if necessary).</li> <li>• Investment purchase and sale recommendations for maturities and as need or opportunity arises.</li> <li>• Best pricing execution on securities transactions. Multiple bids acquired whenever available.</li> <li>• Regularly scheduled phone/Zoom meetings to discuss the portfolio (in person meetings as availability allows).</li> <li>• Ensure portfolio remains in compliance with all state and city policies and regulations.</li> <li>• Investment policy review and updating as appropriate.</li> <li>• Monthly portfolio reporting (see "sample platinum" attached).</li> <li>• GASB year-end reporting.</li> <li>• Access to ongoing CPE educational opportunities and classes.</li> <li>• Monthly market update newsletter and quarterly economic reports.</li> </ul> <p>The contract will be for non-discretionary investment services at an annual flat rate fee of \$65,000 for the first 3 years. TVI is the only firm listed on the MRSC Roster offering the listed Investment Advisory services.</p>
<b>Proposed Council Action &amp; Date:</b>	Approve contract with Concourse Financial Group for Investment Advisory Services on Feb. 28

**Fiscal Impact:**

Total Cost: \$65,000 Per year

Approved in current year budget?  Yes  No  N/A

Funding Source  One-time  Recurring

Specify funding source:

Expense Occurrence  One-time  Recurring

Other budget impacts: (revenue generating, match requirements, etc.)

**Operations Impacts**

What impacts would the proposal have on historically excluded communities?

N/A

How will data be collected, analyzed, and reported concerning the effect of the program/policy by racial, ethnic, gender identity, national origin, income level, disability, sexual orientation, or other existing disparities?

N/A

How will data be collected regarding the effectiveness of this program, policy or product to ensure it is the right solution?

Staff capacity will be measured and redirected to other Treasury priorities.

Describe how this proposal aligns with current City Policies, including the Comprehensive Plan, Sustainability Action Plan, Capital Improvement Program, Neighborhood Master Plans, Council Resolutions, and others?

This contract helps to ensure that staff is compliant with all Investment and Treasury policies.



**City of Spokane**  
**PERSONAL SERVICES AGREEMENT**  
Title: **INVESTMENT ADVISORS**

This Agreement is made and entered into by and between the **CITY OF SPOKANE** as (“City”), a Washington municipal corporation, and **CONCOURSE FINANCIAL GROUP, INC.**, whose address is 2801 Highway 280 South, Birmingham Alabama 35223, as (“Company”), individually hereafter referenced as a “party”, and together as the “parties”.

*WHEREAS, the purpose of this Contract is to provide Investment Advisor Services to the City of Spokane; and*

*WHEREAS, Company was selected from the MRSC A&E Roster.*

*NOW, THEREFORE, in consideration of the terms, conditions, covenants and performance of the Scope of Work contained herein, the City and Company mutually agree as follows:*

**1. SCOPE OF SERVICES.**

Company shall provide Investment Advisor Services in accordance with its Non-Discretionary Investment Advisory Services Agreement attached hereto as Exhibit B. In the event of a conflict or discrepancy in the Agreement documents, this City Contract controls.

**2. TERM OF AGREEMENT.**

The term of this Agreement begins on March 1, 2022, and shall run through February 28, 2025, unless amended by written agreement or terminated earlier under the provisions. This Agreement may be renewed by agreement of the parties not to exceed two (2) additional one (1) year contract periods.

**3. COMPENSATION / PAYMENT.**

Total compensation for Company’s services under this Agreement shall not exceed **SIXTY FIVE THOUSAND AND NO/100 DOLLARS (\$65,000.00)**, including tax if applicable, unless modified by a written amendment to this Agreement. This is the maximum amount to be paid under this Agreement for the work described in Section 3 above, and shall not be exceeded without the prior written authorization of the City in the form of an executed amendment to this Agreement.

Company shall submit its applications for payment to City of Spokane Finance Department, Fourth Floor, City Hall, 808 West Spokane Falls Boulevard, Spokane, Washington 99201-3317. Spokane, Washington 99201. Payment will be made within thirty (30) days after receipt of the Company’s application except as provided by state law. If the City objects to all or any portion of



the invoice, it shall notify the Company and pay that portion of the invoice not in dispute. In that event, the parties shall immediately make every effort to settle the disputed amount.

#### **4. TAXES, FEES AND LICENSES.**

- A. Company shall pay and maintain in current status, all necessary licenses, fees, assessments, permit charges, etc. necessary to conduct the work included under this Agreement. It is Company's sole responsibility to monitor and determine changes or the enactment of any subsequent requirements for said fees, assessments, or changes and to immediately comply.
- B. The cost of any permits, licenses, fees, etc. arising as a result of the projects included in this Agreement shall be included in the project budgets.

#### **5. CITY OF SPOKANE BUSINESS LICENSE.**

Section 8.01.070 of the Spokane Municipal Code states that no person may engage in business with the City without first having obtained a valid annual business registration. Company shall be responsible for contacting the State of Washington Business License Services at [www.dor.wa.gov](http://www.dor.wa.gov) or 360-705-6741 to obtain a business registration. If Company does not believe it is required to obtain a business registration, it may contact the City's Taxes and Licenses Division at (509) 625-6070 to request an exemption status determination.

#### **6. SOCIAL EQUITY REQUIREMENTS / NON-DISCRIMINATION.**

No individual shall be excluded from participation in, denied the benefit of, subjected to discrimination under, or denied employment in the administration of or in connection with this Agreement because of age, sex, race, color, religion, creed, marital status, familial status, sexual orientation including gender expression or gender identity, national origin, honorably discharged veteran or military status, the presence of any sensory, mental or physical disability, or use of a service animal by a person with disabilities. Company agrees to comply with, and to require that all subcontractors comply with, federal, state and local nondiscrimination laws, including but not limited to: the Civil Rights Act of 1964, the Rehabilitation Act of 1973, the Age Discrimination in Employment Act, and the American's With Disabilities Act, to the extent those laws are applicable.

#### **7. INDEMNIFICATION.**

Company shall defend, indemnify, and hold the City and its officers and employees harmless from all claims, demands, or suits at law or equity asserted by third parties for bodily injury (including death) and/or property damage which arise from Company's negligence or willful misconduct under this Agreement, including attorneys' fees and litigation costs; provided that nothing herein shall require a Company to indemnify the City against and hold harmless the City from claims, demands or suits based solely upon the negligence of the City, its agents, officers, and employees. If a claim or suit is caused by or results from the concurrent negligence of Company's agents or employees and the City, its agents, officers and employees, this indemnity provision shall be valid and enforceable to the extent of the negligence of Company, its agents or employees. Company specifically assumes liability and agrees to defend, indemnify, and hold the City harmless for actions brought by Company's own employees against the City and, solely for the purpose of this indemnification and defense, Company specifically waives any immunity under the Washington State industrial insurance law, or Title 51 RCW. Company recognizes that this waiver was specifically entered into pursuant to the provisions of RCW 4.24.115 and was the subject of mutual negotiation. The indemnity and agreement to defend and hold the City harmless provided for in this section shall survive any termination or expiration of this agreement.

## **8. INSURANCE.**

During the period of the Agreement, Company shall maintain in force at its own expense, each insurance noted below with companies or through sources approved by the State Insurance Commissioner pursuant to Title 48 RCW:

A. **Worker's Compensation Insurance** in compliance with RCW 51.12.020, which requires subject employers to provide workers' compensation coverage for all their subject workers and Employer's Liability Insurance in the amount of \$1,000,000;

B. **General Liability Insurance** on an occurrence basis, with a combined single limit of not less than \$1,000,000 each occurrence for bodily injury and property damage. It shall include contractual liability coverage for the indemnity provided under this agreement. It shall provide that the City, its officers and employees are additional insureds but only with respect to Company's services to be provided under this Agreement;

i. Acceptable **supplementary Umbrella insurance** coverage combined with Company's General Liability insurance policy must be a minimum of \$1,000,000, in order to meet the insurance coverage limits required in this Agreement; and

C. **Automobile Liability Insurance** with a combined single limit, or the equivalent of not less than \$1,000,000 each accident for bodily injury and property damage, including coverage for owned, hired and non-owned vehicles.

There shall be no cancellation, material change, reduction of limits or intent not to renew the insurance coverage(s) without thirty (30) days written notice from Company or its insurer(s) to the City. As evidence of the insurance coverage(s) required by this Agreement, Company shall furnish acceptable Certificates Of Insurance (COI) to the City at the time it returns this signed Agreement. The certificate shall specify the City of Spokane as "Additional Insured" specifically for Company's services under this Agreement, as well as all of the parties who are additional insureds, and include applicable policy endorsements, the thirty (30) day cancellation clause, and the deduction or retention level. Company shall be financially responsible for all pertinent deductibles, self-insured retentions, and/or self-insurance.

## **9. DEBARMENT AND SUSPENSION.**

Company has provided its certification that it is in compliance with and shall not contract with individuals or organizations which are debarred, suspended, or otherwise excluded from or ineligible from participation in Federal Assistance Programs under Executive Order 12549 and "Debarment and Suspension", codified at 29 CFR part 98.

## **10. AUDIT.**

Company and its sub-Company shall maintain for a minimum of three (3) years following final payment all records related to its performance of the Agreement. Company and its sub-consultants shall provide access to authorized City representatives, at reasonable times and in a reasonable manner to inspect and copy any such record. In the event of conflict between this provision and related auditing provisions required under federal law applicable to the Agreement, the federal law shall prevail.

## **11. ASSIGNMENT AND SUBCONTRACTING.**

Company shall not assign or subcontract its obligations under this Agreement without the City's written consent, which may be granted or withheld in the City's sole discretion. Any subcontract made by Company shall incorporate by reference this Agreement, except as otherwise provided.

Company shall ensure that all subcontractor comply with the obligations and requirements of the subcontract. The City's consent to any assignment or subcontract does not release Company from liability or any obligation within this Agreement, whether before or after City consent, assignment or subcontract.

## **12. TERMINATION.**

Either party may terminate this Agreement, with or without cause, by ten (10) days written notice to the other party. In the event of such termination, the City shall pay Company for all work previously authorized and performed prior to the termination date.

## **13. STANDARD OF PERFORMANCE.**

The standard of performance applicable to Company's services will be the degree of skill and diligence normally employed by professional Companies performing the same or similar services at the time the services under this Agreement are performed.

## **14. OWNERSHIP AND USE OF RECORDS AND DOCUMENTS.**

Original documents, drawings, designs, reports, or any other records developed or created under this Agreement shall belong to and become the property of the City. All records submitted by the City to Company shall be safeguarded by Company. Company shall make such data, documents and files available to the City upon the City's request. If the City's use of Company's records or data is not related to this project, it shall be without liability or legal exposure to Company.

Under Washington State Law (reference RCW Chapter 42.56, the *Public Records Act* [PRA]) all materials received or created by the City of Spokane are **public records** and are available to the public for viewing via the City Clerk's Records (online) or a valid Public Records Request (PRR).

## **15. ANTI KICK-BACK.**

No officer or employee of the City of Spokane, having the power or duty to perform an official act or action related to this Agreement shall have or acquire any interest in the Agreement, or have solicited, accepted or granted a present or future gift, favor, service or other thing of value from or to any person involved in this Agreement.

## **16. MISCELLANEOUS PROVISIONS.**

- A. **Amendments/Modifications:** This Agreement may be modified by the City in writing when necessary, and no modification or Amendment of this Agreement shall be effective unless signed by an authorized representative of each of the parties hereto.
- B. Company, at no expense to the City, shall comply with all laws of the United States and Washington, the Charter and ordinances of the City of Spokane; and rules, regulations, orders and directives of their administrative agencies and officers. Without limiting the generality of this paragraph, Company shall comply with the requirements of this Section.
- C. This Agreement shall be construed and interpreted under the laws of Washington. The venue of any action brought shall be in a court of competent jurisdiction, located in Spokane County, Washington.
- D. **Captions:** The titles of sections or subsections are for convenience only and do not define or limit the contents.
- E. **Severability:** If any term or provision is determined by a court of competent jurisdiction to be invalid or unenforceable, the remainder of this Agreement shall not be affected, and each term and provision shall be valid and enforceable to the fullest extent permitted by law.

- F. **Waiver:** No covenant, term or condition or the breach shall be deemed waived, except by written consent of the party against whom the waiver is claimed, and any waiver of the breach of any covenant, term or condition shall not be deemed a waiver of any preceding or succeeding breach of the same or any other covenant, term of condition. Neither the acceptance by the City of any performance by Company after the time the same shall have become due nor payment to Company for any portion of the Work shall constitute a waiver by the City of the breach or default of any covenant, term or condition unless otherwise expressly agreed to by the City in writing.
- G. **Entire Agreement:** This document along with any exhibits and all attachments, and subsequently issued addenda, comprises the entire agreement between the City and Company. If conflict occurs between Agreement documents and applicable laws, codes, ordinances or regulations, the most stringent or legally binding requirement shall govern and be considered a part of this Agreement to afford the City the maximum benefits.
- H. **No personal liability:** No officer, agent or authorized employee of the City shall be personally responsible for any liability arising under this Agreement, whether expressed or implied, nor for any statement or representation made or in any connection with this Agreement.

IN WITNESS WHEREOF, in consideration of the terms, conditions and covenants contained, or attached and incorporated and made a part, the parties have executed this Agreement by having legally-binding representatives affix their signatures below.

**CONCOURSE FINANCIAL GROUP, INC.**

**CITY OF SPOKANE**

By \_\_\_\_\_  
Signature                      Date

By \_\_\_\_\_  
Signature                      Date

\_\_\_\_\_  
Type or Print Name

\_\_\_\_\_  
Type or Print Name

\_\_\_\_\_  
Title

\_\_\_\_\_  
Title

Attest:

Approved as to form:

\_\_\_\_\_  
City Clerk

\_\_\_\_\_  
Assistant City Attorney

**Attachments that are part of this Agreement:**  
 Exhibit A – Certificate Regarding Debarment  
 Exhibit B - Non-Discretionary Investment Advisory Services Agreement  
 22-039

**EXHIBIT A**

**CERTIFICATION REGARDING DEBARMENT, SUSPENSION,  
INELIGIBILITY AND VOLUNTARY EXCLUSION**

1. The undersigned (i.e., signatory for the Subrecipient / Company / Consultant) certifies, to the best of its knowledge and belief, that it and its principals:
  - a. Are not presently debarred, suspended, proposed for debarment, declared ineligible, or voluntarily excluded from covered transactions by any federal department or agency;
  - b. Have not within a three-year period preceding this contract been convicted or had a civil judgment rendered against them for commission of fraud or a criminal offense in connection with obtaining, attempting to obtain, or performing a public (federal, state, or local) transaction or contract under a public transaction; violation of federal or state antitrust statutes or commission of embezzlement, theft, forgery, bribery, falsification or destruction of records, making false statements, tax evasion, receiving stolen property, making false claims, or obstruction of justice;
  - c. Are not presently indicted or otherwise criminally or civilly charged by a government entity (federal, state, or local) with commission of any of the offenses enumerated in paragraph (1)(b) of this certification; and,
  - d. Have not within a three-year period preceding this contract had one or more public transactions (federal, state, or local) terminated for cause or default.

2. The undersigned agrees by signing this contract that it shall not knowingly enter into any lower tier covered transaction with a person who is debarred, suspended, declared ineligible, or voluntarily excluded from participation in this covered transaction.

3. The undersigned further agrees by signing this contract that it will include the following clause, without modification, in all lower tier covered transactions and in all solicitations for lower tier covered transactions:

Certification Regarding Debarment, Suspension, Ineligibility and Voluntary Exclusion – Lower Tier Covered Transactions

1. The lower tier Company certified, by signing this contract that neither it nor its principals is presently debarred, suspended, proposed for debarment, declared ineligible, or voluntarily excluded from participation in this transaction by any federal department or agency.
2. Where the lower tier Company is unable to certify to any of the statements in this contract, such Company shall attach an explanation to this contract.

4. I understand that a false statement of this certification may be grounds for termination of the contract.

<hr/> Name of Subrecipient / Company / Consultant (Type or Print)	<hr/> Program Title (Type or Print)
<hr/> Name of Certifying Official (Type or Print)	<hr/> Signature
<hr/> Title of Certifying Official (Type or Print)	<hr/> Date (Type or Print)

**EXHIBIT B**



## Investment Advisors

### Non-Discretionary Investment Advisory Services Agreement

---

**THIS NON-DISCRETIONARY INVESTMENT ADVISORY SERVICES AGREEMENT** (“Agreement”) is between Concourse Financial Group, Inc., an Alabama corporation doing investment advisory business as Investment Advisors (“Advisor”), and City of Spokane (“Client”). The non-discretionary advisory services (“Non-Discretionary Investment Advisory Services”) provided by Advisor under this Agreement shall be furnished by the investment advisor representative of Advisor named in the “Signatures” section of this Agreement (“Representative”), unless Client and Advisor agree otherwise.

Advisor is registered with the Securities and Exchange Commission as an investment advisor, and is registered or exempt from registration under all applicable state laws regarding investment advisor registration. Advisor provides investment advisor services for its clients. Client wishes to retain Advisor to provide Client with Non-Discretionary Investment Advisory Services under the terms set forth below:

**Section 1 – Non-Discretionary Investment Advisory Services.** Based upon information furnished to Advisor by Client, Advisor shall provide Client with such Non-Discretionary Investment Advisory Services as may be agreed upon by Advisor and Client and further detailed in Schedule A. The foregoing notwithstanding, Advisor shall not, and shall not be required to, take any action or render any advice with respect to legal action or proceedings (including bankruptcy proceedings) with respect to securities.

**Section 2 – Client Information.** Client agrees to consult with Advisor and to provide Advisor with all information relevant to the Non-Discretionary Investment Advisory Services to be provided by Advisor. Client understands that Advisor shall depend on the accuracy, timeliness and completeness of such information in providing the Non-Discretionary Investment Advisory Services. Client represents and agrees that the information provided by Client will be, to the best of Client’s knowledge, substantially accurate and complete.

**Section 3 – Risk of Investment.** Client recognizes that there is no assurance as to the accuracy or timeliness of the Non-Discretionary Investment Advisory Services provided hereunder, and that any market losses resulting from such services are a risk assumed by Client. Client further acknowledges that the past performance of Advisor is not a guarantee of future results, which may prove to be better or worse than past results. Advisor has not and does not promise, represent or guarantee that Advisor’s services will result in a profit to Client, will yield a stated level of returns or will result in achievement of Client’s financial or investment objectives. Advisor may rely on information furnished to it which it reasonably believes to be accurate and reliable. Advisor shall have no liability for Client’s failure to inform

Advisor in a timely manner of any material change in Client's financial circumstances, investment or financial needs or objectives, or risk tolerance.

**Section 4 – Fees.** Client shall pay Advisor a Non-Discretionary Investment Advisory Services Fee for the provision of the Non-Discretionary Investment Advisory Services in accordance with fee table listed in Schedule A. The Non-Discretionary Investment Advisory Services Fee shall be a flat fee agreed upon at contract commencement. The Non-Discretionary Investment Advisory Services Fee shall be paid to the order of Concourse Financial Group, Inc.

**Section 5 – Ongoing Review.** Except as otherwise explicitly set forth in Schedule A, Advisor makes no commitment to initiate a review or update of any Non-Discretionary Investment Advisory Services previously provided hereunder, or to monitor Client's progress toward achieving Client's financial objectives.

**Section 6 – No Legal, Tax or Accounting Advice.** Nothing in this Agreement shall require Advisor or Representative to provide legal, tax or accounting advice. Client is responsible for consulting, and is encouraged to consult legal, tax and accounting advisors of Client's choosing.

**Section 7 – Relationship of the Parties.** Client acknowledges that Advisor is a registered investment advisory firm and Representative is an investment advisory representative of Advisor. As such, Representative shall receive, and other individuals affiliated with Advisor may receive, a portion of the compensation paid by Client to Advisor under this Agreement.

**Section 8 – Confidentiality; Disclosure to Advisors.** The information about Client in Advisor's possession or control that arises pursuant to the terms of this Agreement shall be treated as confidential, as set forth in Advisor's privacy policy (a copy of which has been provided to Client). Notwithstanding the foregoing, Client hereby grants Advisor and Representative the authority to discuss, disclose and communicate any or all information received from Client or related to this Agreement to such third-party service providers as Client may designate.

**Section 9 – Term and Termination.** Notwithstanding Section 11 below, the term of this Agreement shall commence on the date last signed below by a party to this Agreement, and shall remain effective until either party elects to terminate it. This Agreement may be terminated by Client upon thirty (30) days' written notice to Advisor in accordance with Section 13 below. The Advisor may terminate the agreement with ninety (90) days' written notice to the Client.

**Section 10 – Effective Date; Amendment and Assignment.** This Agreement shall not become effective unless approved in writing by an authorized signatory of Advisor. No modification or amendment to this Agreement shall be effective unless made in writing and signed by Client and Advisor. This Agreement may not be assigned by either party without the written consent of the other party.

**Section 11 – Applicable Law; Interpretation.** This Agreement shall be interpreted and construed in accordance with the laws of the state in which Client executed this Agreement (without giving effect to such state's conflict of laws principles) and in a manner consistent with the securities laws, including



Investment Advisors Act of 1940 and the rules and regulations thereunder. The headings in this Agreement are for convenience of reference only, and shall not be considered in the interpretation hereof. This Agreement (including all Schedules and attachments hereto) constitutes the complete agreement of the parties with respect to the subject matter hereof.

**Section 12 – Arbitration. (a) THIS AGREEMENT CONTAINS A DISPUTE ARBITRATION CLAUSE. BY SIGNING AN ARBITRATION AGREEMENT THE PARTIES AGREE AS FOLLOWS:**

**(b) Arbitration Disclosure**

- 1. ALL PARTIES TO THIS AGREEMENT ARE GIVING UP THE RIGHT TO SUE EACH OTHER IN COURT, INCLUDING THE RIGHT TO A TRIAL BY JURY, EXCEPT AS PROVIDED BY THE RULES OF THE ARBITRATION FORUM IN WHICH A CLAIM IS FILED.**
- 2. ARBITRATION AWARDS ARE GENERALLY FINAL AND BINDING; A PARTY’S ABILITY TO HAVE A COURT REVERSE OR MODIFY AN ARBITRATION AWARD IS VERY LIMITED.**
- 3. THE ABILITY OF THE PARTIES TO OBTAIN DOCUMENTS, WITNESS STATEMENTS AND OTHER DISCOVERY IS GENERALLY MORE LIMITED IN ARBITRATION THAN IN COURT PROCEEDINGS.**
- 4. THE ARBITRATORS DO NOT HAVE TO EXPLAIN THE REASON(S) FOR THEIR AWARD UNLESS, IN AN ELIGIBLE CASE, A JOINT REQUEST FOR AN EXPLAINED DECISION HAS BEEN SUBMITTED BY ALL PARTIES TO THE PANEL AT LEAST 20 DAYS PRIOR TO THE FIRST SCHEDULED HEARING DATE.**
- 5. THE PANEL OF ARBITRATORS MAY INCLUDE A MINORITY OF ARBITRATORS WHO WERE OR ARE AFFILIATED WITH THE SECURITIES INDUSTRY.**
- 6. THE RULES OF SOME ARBITRATION FORUMS MAY IMPOSE TIME LIMITS FOR BRINGING A CLAIM IN ARBITRATION. IN SOME CASES, A CLAIM THAT IS INELIGIBLE FOR ARBITRATION MAY BE BROUGHT IN COURT.**
- 7. THE RULES OF THE ARBITRATION FORUM IN WHICH THE CLAIM IS FILED, AND ANY AMENDMENTS THERETO, SHALL BE INCORPORATED INTO THIS AGREEMENT.**

**(c) Arbitration Agreement**

ANY CONTROVERSY BETWEEN CLIENT, ADVISOR AND REPRESENTATIVE ARISING OUT OF ANY BUSINESS CONDUCTED BY OR BETWEEN THE PARTIES OR THIS AGREEMENT SHALL BE SUBMITTED TO ARBITRATION CONDUCTED BEFORE THE NATIONAL ASSOCIATION OF SECURITIES DEALERS, INC., AND IN ACCORDANCE WITH ITS RULES. IF FINRA ARBITRATION IS NOT AVAILABLE AND ENFORCEABLE FOR ANY REASON, THE ARBITRATION SHALL BE

CONDUCTED UNDER THE COMMERCIAL ARBITRATION RULES OF THE AMERICAN ARBITRATION ASSOCIATION (OR, IF SUCH RULES DO NOT EXIST, PURSUANT TO SUCH SUCCESSOR OR SIMILAR RULES AS ADVISOR SHALL STIPULATE). ARBITRATION MUST BE COMMENCED BY SERVICE UPON THE OTHER PARTY OF A WRITTEN DEMAND FOR ARBITRATION OR A WRITTEN NOTICE OF INTENTION TO ARBITRATE.

NO PERSON SHALL BRING A PUTATIVE OR CERTIFIED CLASS ACTION TO ARBITRATION, NOR SEEK TO ENFORCE ANY PREDISPUTE ARBITRATION AGREEMENT AGAINST ANY PERSON WHO HAS INITIATED IN COURT A PUTATIVE CLASS ACTION, OR WHO IS A MEMBER OF A PUTATIVE CLASS ACTION; OR WHO IS A MEMBER OF A PUTATIVE CLASS ACTION WHO HAS NOT OPTED OUT OF THE CLASS WITH RESPECT TO ANY CLAIMS ENCOMPASSED BY THE PUTATIVE CLASS ACTION UNTIL: (i) THE CLASS CERTIFICATION IS DENIED; (ii) THE CLASS ACTION IS DECERTIFIED; OR (iii) THE CUSTOMER IS EXCLUDED FROM THE CLASS BY THE COURT. SUCH FORBEARANCE TO ENFORCE AN AGREEMENT TO ARBITRATE SHALL NOT CONSTITUTE A WAIVER OF ANY RIGHTS UNDER THIS AGREEMENT EXCEPT TO THE EXTENT STATED HEREIN.

THE TERMS OF THIS SECTION 12 REGARDING ARBITRATION SHALL SURVIVE THE TERMINATION OF THIS AGREEMENT.

**Section 13 – Address for Notices.** All notices under this Agreement (including, without limitation, notices of termination under Section 10) shall be deemed properly given if delivered by hand, faxed, mailed by U.S. mail (first class, certified or registered), or delivered to a nationally-recognized express delivery service, and addressed to a party at the address set forth in the “Signatures” section of this Agreement (or to such other address as such party may provide by written notice as described herein).

**Section 14 – Municipal Advisor Exemption.** Client acknowledges that Advisor is *not* acting as a “municipal advisor” as that term is defined in Section 15B of the Securities Exchange Act and the rules promulgated thereunder (the “Municipal Advisor Rules”). Client further acknowledges that Advisor is acting under an exemption from registration as a municipal advisor for SEC-registered investment advisors.

**Section 15 – Receipt of Information and Agreement.** Client acknowledges that Client has received (1) a copy of Advisor’s Form ADV Part 2A; (2) Form ADV Part 2B; and (3) a copy of this Agreement, as signed by Client and Representative. Client has read and understands this Agreement. Client has had the opportunity to review this Agreement with advisors of Client’s choosing, and has either done so or has decided not to have this Agreement reviewed. **Client agrees that disputes under this Agreement shall be resolved by binding arbitration, as provided in Section 12 entitled, “Arbitration”.**

#### SIGNATURES ON FOLLOWING PAGE

IN WITNESS WHEREOF, the parties hereto have executed this Agreement as of the day and year first above written.

\_\_\_\_\_  
Client Name

**CONCOURSE FINANCIAL GROUP, INC.**  
2801 Highway 280 South, Birmingham AL 35223

\_\_\_\_\_  
By

\_\_\_\_\_  
By

\_\_\_\_\_  
Name

\_\_\_\_\_  
Name

\_\_\_\_\_  
Title

\_\_\_\_\_  
Title

\_\_\_\_\_  
Date

\_\_\_\_\_  
Date

\_\_\_\_\_  
Client Address (Street or P.O. Box, City, State, Zip Code)

\_\_\_\_\_  
Investment Advisor Representative Signature

\_\_\_\_\_  
Rep Number

\_\_\_\_\_  
Investment Advisor Representative Address (Street or P.O. Box, City, State, Zip Code)

## SCHEDULE A

### A. Scope of Services

Advisor will provide the following non-discretionary advisory services to Client:

1. **Review of investment policy.**

Concourse Financial Group will assist the public entity in either updating or creating an investment policy incorporating industries best practices including the priorities safety liquidity and yield. Specifically, TVI/Concourse Financial Group will assist the client in determining the appropriate risk parameters, maturity constraints and diversification to meet the client's objectives.

2. **Establishment of investment strategy and corresponding benchmarks.**

Concourse Financial Group will work closely with the public entity to develop investment strategies that fall within the risk parameters of the investment policy and the client's objectives. A benchmark will be established as an appropriate gauge of the portfolio's performance.

3. **Analysis of weighted average maturity and duration measures.**

Through current economic, market and yield curve analysis, Concourse Financial Group will advise the client regarding the appropriate weighted average maturity for the portfolio. The preferred effective duration measures will also be determined in an effort to manage the volatility of the portfolio's market value in a changing interest rate environment.

4. **Identify securities for purchase that comply with Client's investment policy.**

Concourse Financial Group has broad visibility of the typical legal securities that are currently available and will select those securities that comply with the entity's investment policy. These will be recommended to the client when appropriate.

5. **At the Client's direction, purchase securities on behalf of Client.**

With the client's approval, Concourse Financial Group will purchase securities on the client's behalf. After the client has approved the purchase of the recommended security, Concourse Financial Group will purchase the security and provide a confirmation to the client. Concourse Financial Group will monitor the delivery of the security to the client's US Bank Safekeeping account.

6. **Provide professional bond reporting.**

TVI/CFG is able to provide proprietary “Platinum” bond reporting to our investment advisory clientele. This reporting tracks important portfolio metrics like yield-to-maturity, duration, and asset allocation. PLEASE NOTE: Unless custodial services are provided by US Bank Safekeeping, which our reporting is linked directly to, portfolio reporting will be on a best-efforts basis.

**B. Fee Table**

Advisor will charge a flat fee as described below:

**\$65,000 per year (flat fee), billed quarterly in arrears**

**This amount will not increase for at least three years, after which time TVI/CFG may reevaluate and modify fees with permission of the client.**



**Agenda Sheet for City Council Meeting of:**

06/27/2022

<b>Date Rec'd</b>	6/10/2022
<b>Clerk's File #</b>	OPR 2021-0532
<b>Renews #</b>	
<b>Cross Ref #</b>	
<b>Project #</b>	
<b>Bid #</b>	
<b>Requisition #</b>	

<b>Submitting Dept</b>	NEIGHBORHOOD, HOUSING & HUMAN SERVICES
<b>Contact Name/Phone</b>	JENN CERCEDES 6055
<b>Contact E-Mail</b>	JCERCEDES@SPOKANECITY.ORG
<b>Agenda Item Type</b>	Contract Item
<b>Agenda Item Name</b>	1680 - CONSOLIDATED HOMELESS GRANT AMENDMENT

**Agenda Wording**

CHHS is requesting approval to accept additional Consolidated Homeless Grant funds from the Washington State Office of Family and Adult Homelessness and approval to sub-award funds in accordance with the CHHS 5-year RFP (OPR 2019-0336 & 2019-0649).

**Summary (Background)**

On July 12, 2021, the Office of Family and Adult Homelessness (OFAH) released a grant agreements to CHHS Department for the Consolidated Homeless Grant (CHG) for the period of July 1, 2021, through June 30, 2022. Amendment amount: \$358,467 Total Grant Amount: \$9,969,518.

Lease? NO Grant related? YES Public Works? NO

**Fiscal Impact**

Revenue \$ 358,467.00

Select \$

Select \$

Select \$

**Budget Account**

# 1540-95571-99999-33442-72007

#

#

#

**Approvals**

**Dept Head** CERCEDES, JENNIFER

**Division Director** FINCH, ERIC

**Finance** MURRAY, MICHELLE

**Legal** PICCOLO, MIKE

**For the Mayor** ORMSBY, MICHAEL

**Council Notifications**

**Study Session\Other** Public Safety 6/6

**Council Sponsor** Council Member Cathcart

**Distribution List**

chhsgrants@spokanecity.org

chhsaccounting@spokanecity.org

jcerecedes@spokanecity.org

kclifton@spokanecity.org

**GRANTS, CONTRACTS & PURCHASING** MURRAY, MICHELLE

efinch@spokanecity.org

## Committee Agenda Sheet [COMMITTEE]

<b>Submitting Department</b>	CHHS
<b>Contact Name &amp; Phone</b>	Jenn Cerecedes 509.625.6055
<b>Contact Email</b>	<a href="mailto:jcerecedes@spokanecity.org">jcerecedes@spokanecity.org</a>
<b>Council Sponsor(s)</b>	
<b>Select Agenda Item Type</b>	<input checked="" type="checkbox"/> Consent <input type="checkbox"/> Discussion    Time Requested:
<b>Agenda Item Name</b>	Dept. Commerce CHG Amendment Acceptance
<b>Summary (Background)</b>	Department of Commerce as amended our current Consolidated Homeless Grant (CHG) with an additional \$358,467. The amendment is effective 2/1/22 and ends 6/30/23. We plan to allocate this additional funding to existing sub-recipients once we have consent to receive these additional funds.
<b>Proposed Council Action &amp; Date:</b>	Please approve the receipt of these additional funds
<b>Fiscal Impact:</b>	
Total Cost:	
Approved in current year budget? <input type="checkbox"/> Yes <input type="checkbox"/> No <input checked="" type="checkbox"/> N/A	
Funding Source <input checked="" type="checkbox"/> One-time <input type="checkbox"/> Recurring	
Specify funding source: This is a one-time amendment to a recurring grant	
Expense Occurrence <input type="checkbox"/> One-time <input type="checkbox"/> Recurring	
Other budget impacts: (revenue generating, match requirements, etc.)	
<b>Operations Impacts</b>	
What impacts would the proposal have on historically excluded communities? These funds go to support homeless services	
How will data be collected, analyzed, and reported concerning the effect of the program/policy by racial, ethnic, gender identity, national origin, income level, disability, sexual orientation, or other existing disparities?	

How will data be collected regarding the effectiveness of this program, policy or product to ensure it is the right solution?

We utilize CMIS data to report outcomes

Describe how this proposal aligns with current City Policies, including the Comprehensive Plan, Sustainability Action Plan, Capital Improvement Program, Neighborhood Master Plans, Council Resolutions, and others?

This aligns with the 5-year strategy to end homelessness



**Amendment**

**Contract Number: 22-46108-30**

**Amendment Number:A**

**Washington State Department of Commerce  
Community Services and Housing Division  
Housing Assistance Unit  
Consolidated Homeless Grant (CHG)**

<b>1. Contractor</b> City of Spokane Community, Housing, and Human Services Department 808 W. Spokane Falls Blvd. Spokane, WA		<b>2. Contractor Doing Business As (optional)</b>	
<b>3. Contractor Representative</b> Biviano, Devin Program Professional – Homelessness dbiviano@spokanecity.org		<b>4. COMMERCE Representative</b> Esmeralda Zavala Montalvo PO Box 42525 Grant Manager 1011 Plum St SE esmeralda.zavala- Olympia, WA 98504-2525 montalvo@commerce.wa.gov	
<b>5. Original Contract Amount (and any previous amendments)</b> \$9,611,051	<b>6. Amendment Amount</b> \$358,467	<b>7. New Contract Amount</b> \$9,969,518	
<b>8. Amendment Funding Source</b> Federal: State: X Other: N/A:		<b>9. Amendment Start Date</b> February 1, 2022	<b>10. Amendment End Date</b> June 30, 2023
<b>11. Federal Funds (as applicable):</b> N/A	<b>Federal Agency:</b> N/A	<b>CFDA Number:</b> N/A	
<b>12. Amendment Purpose:</b> Adds CHG standard funding.			

COMMERCE, defined as the Department of Commerce, and the Contractor, as defined above, acknowledge and accept the terms of this Contract As Amended and attachments and have executed this Contract Amendment on the date below to start as of the date and year referenced above. The rights and obligations of both parties to this Contract As Amended are governed by this Contract Amendment and the following other documents incorporated by reference: CHG Guidelines (as they may be revised from time to time), and Contract Terms and Conditions including Attachment “A” – Scope of Work, Attachment “B” – Budget. A copy of this Contract Amendment shall be attached to and made a part of the original Contract between COMMERCE and the Contractor. Any reference in the original Contract to the “Contract” shall mean the “Contract as Amended”.

<p><b>FOR GRANTEE</b></p>  <p>_____</p> <p>Nadine Woodward, Mayor</p>  <p>_____</p> <p>Date</p>	<p><b>FOR COMMERCE</b></p>  <p>_____</p> <p>Diane Klontz, Assistant Director Community Services and Housing Division</p>  <p>_____</p> <p>Date</p>  <p><b>APPROVED AS TO FORM ONLY</b></p> <p>_____</p> <p>Sandra Adix Assistant Attorney General</p> <p>_____</p> <p>3/20/2014 Date</p>
---	--

**Amendment**

This Contract is **amended** as follows:

**Attachment B**

**Budget**

<b>Budget Categories</b>	<b>Current Contract Amount (and any previous amendments and revisions)</b>	<b>Amendment A</b>	<b>New Total</b>
<b>CHG Standard</b>			
Admin	\$208,922	\$53,770	\$262,692
Rent/Fac Support Lease	\$486,252	\$125,464	\$611,716
Other Rent/Fac Support Lease and Housing Costs	\$71,601	\$17,923	\$89,524
Operations	\$626,038	\$161,310	\$787,348
<b>PSH CHF</b>			
PSH CHF Rent/Fac Support Lease	\$236,500		\$236,500
PSH CHF Other Rent/Fac Support Lease and Housing Costs	\$10,000		\$10,000
PSH CHF Operations	\$122,400		\$122,400
<b>HEN SFY 2022 (July 2021-June 2022)</b>			
HEN Admin 2022	\$221,985		\$221,985
HEN Rent/Fac Support and Housing Costs 2022	\$1,852,858		\$1,852,858
HEN Operations 2022	\$1,849,826		\$1,849,826
<b>HEN SFY 2023 (July 2022-June 2023)</b>			
HEN Admin 2023	\$221,985		\$221,985
HEN Rent/Fac Support and Housing Costs 2023	\$1,852,858		\$1,852,858
HEN Operations 2023	\$1,849,826		\$1,849,826
<b>Hotel Leasing and Rapid Re-Housing</b>			
Admin for Hotel Leasing/RRH			
Hotel Leasing/RRH/Operations			
<b>Total</b>	<b>\$9,611,051</b>	<b>\$358,467</b>	<b>\$9,969,518</b>

ALL OTHER TERMS AND CONDITIONS OF THIS CONTRACT REMAIN IN FULL FORCE AND EFFECT.

**Agenda Sheet for City Council Meeting of:**

06/27/2022

<b>Date Rec'd</b>	6/6/2022
<b>Clerk's File #</b>	OPR 2022-0463
<b>Renews #</b>	
<b>Cross Ref #</b>	
<b>Project #</b>	2018058
<b>Bid #</b>	
<b>Requisition #</b>	

<b>Submitting Dept</b>	ENGINEERING SERVICES
<b>Contact Name/Phone</b>	DAN BULLER 625-6391
<b>Contact E-Mail</b>	DBULLER@SPOKANECITY.ORG
<b>Agenda Item Type</b>	Contract Item
<b>Agenda Item Name</b>	0370 - LOW BID AWARD - COCHRAN BASIN (2018058) - TO BE DETERMINED

**Agenda Wording**

Low Bid of (to be determined at bid opening to be held on June 21, 2022) (City, ST) for Cochran Basin Stormwater Treatment Facility - Downriver Disc Golf Course - \$\_. An administrative reserve of \$\_, which is 10% of the contract price, will be set a

**Summary (Background)**

On June 21, 2022 bids were opened for the above project. The low bid was from (to be determined at bid opening) in the amount of \$\_, which is \$\_ or \_% (above/below) the Engineer's Estimate of \$4,111,111.00; \_\_\_\_\_ other bids were received as follows: (to be determined). All information will be provided prior to the 6/20 council meeting.

Lease? NO Grant related? NO Public Works? YES

**Fiscal Impact**

Expense \$ 0

Expense \$ 0

Select \$

Select \$

**Budget Account**

# 4250-98817-94310-56501-14427

# 4250-98817-94310-56501-14400

#

#

**Approvals****Dept Head** TWOHIG, KYLE**Division Director** TWOHIG, KYLE**Finance** ORLOB, KIMBERLY**Legal** ODLE, MARI**For the Mayor** ORMSBY, MICHAEL**Additional Approvals****Purchasing****Council Notifications****Study Session\Other** PIES 5/23**Council Sponsor** Kinnear**Distribution List**

eraea@spokanecity.org

publicworksaccounting@spokanecity.org

kgoodman@spokanecity.org

jgraff@spokanecity.org

ddaniels@spokanecity.org

pyoung@spokanecity.org

# Committee Agenda Sheet

## PIES

<b>Submitting Department</b>	Public Works, Engineering
<b>Contact Name &amp; Phone</b>	Dan Buller 625-6391
<b>Contact Email</b>	<a href="mailto:dbuller@spokanecity.org">dbuller@spokanecity.org</a>
<b>Council Sponsor(s)</b>	Lori Kinnear/Breean Beggs
<b>Select Agenda Item Type</b>	X Consent <input type="checkbox"/> Discussion    Time Requested: _____
<b>Agenda Item Name</b>	Cochran Basin Stormwater Projects
<b>Summary (Background)</b>	<ul style="list-style-type: none"> <li>• This briefing paper is an update to the briefing paper submitted for the June 2021 PIES meeting.</li> <li>• The Cochran storm drainage basin covers approximately 5,300 acres in NE Spokane, generally bounded on the west by Alberta St., on the north by Francis Ave. on the east by Market St. and on the south by Montgomery St.</li> <li>• Stormwater from this basin currently flows untreated to the Spokane River at the northwest end of the TJ Meenach Br. For several years the City has been seeking and has now acquired funding necessary to address this issue.</li> <li>• Engineering Services has formulated the series of projects shown on the attached exhibit which began last year and will continue this year and into 2023. Those projects are described as follows.             <ul style="list-style-type: none"> <li>○ The largest proposed treatment swale area is at the disc golf course west of downriver golf course. Following swale construction, the disc golf course will be restored and upgraded.</li> <li>○ A second treatment swale area is south of the existing parking lot at the NW end of the TJ-Meenach bridge. That parking lot, which serves river rafters, will be expanded and upgraded. These two swales will be packaged into a single project to be bid in late May/early June of this year.</li> <li>○ To get the stormwater to the disc golf course treatment area, a pump station will be constructed at the SE corner of TJ Meenach &amp; NW Blvd. That project, which will also reconstruct the north portion of TJ Meenach, will bid in July of this year.</li> <li>○ Water from that pump station will be piped to the proposed swales at the disc golf course via Cleveland Ave (via a project already under construction). and across Downriver golf course (via a project completed in 2021) and also to the proposed swales at the NW end of the TJ Meenach Bridge via a new pipe in TJ Meenach Dr.</li> <li>○ TJ Meenach Dr. will also be reconstructed from the bridge to Northwest Blvd. That project will include various utility work including replacement of the existing water main, installation of new/replacement stormwater mains, and installation of 2<sup>nd</sup> 60" diameter siphon beneath TJ Meenach which is one of the biggest utility pipes in the city. The connection of that proposed secondary siphon to the existing 60" sewer main will be constructed in a separate project to be bid later this summer and constructed in summer 2023.</li> </ul> </li> <li>• Impacts to the project vary by project.</li> </ul>

	<ul style="list-style-type: none"> <li>• The treatment swale construction at the disc golf will impact traffic minimally but will result in disc golf course closure for the duration of construction.</li> <li>• The treatment swale construction at the NW end of the TJ Meenach bridge will impact traffic minimally but will result in closure of that parking lot and associated river access for the duration of construction.</li> <li>• The pump station construction will be mostly but not entirely out of TJ Meenach and is planned to largely coincide with TJ Meenach construction. If construction does extend beyond the TJ Meenach construction window, TJ Meenach will remain open to one lane each direction.</li> <li>• The project with the biggest public impact will be the TJ Meenach reconstruction and utility project which will require full closure of this important road. We will coordinate closely with the community college and structure the work in such a way that overall closure time is minimized.</li> </ul> <p>These projects are largely funded with multiple state grants and loans which have various overlapping deadlines which the project timing indicated on the attached exhibit is designed to satisfy.</p>
<b>Proposed Council Action &amp; Date:</b>	None at this time. Following bid opening, we will bring a construction contract to Council for approval.
<p><b>Fiscal Impact:</b>  Total Cost:  Approved in current year budget?      X Yes <input type="checkbox"/> No    <input type="checkbox"/> N/A</p> <p>Funding Source            X One-time <input type="checkbox"/> Recurring  Specify funding source: project funds (generally street or utility funds)</p> <p>Expense Occurrence    X One-time <input type="checkbox"/> Recurring</p> <p>Other budget impacts: (revenue generating, match requirements, etc.)</p>	
<b>Operations Impacts</b>	
<p>What impacts would the proposal have on historically excluded communities?</p> <p>Public Works services and projects are designed to serve all citizens and businesses. We strive to offer a consistent level of service to all, to distribute public investment throughout the community, and to respond to gaps in services identified in various City plans. We recognize the need to maintain affordability and predictability for utility customers. And we are committed to delivering work that is both financially and environmentally responsible. This item supports the operations of Public Works.</p>	
<p>How will data be collected, analyzed, and reported concerning the effect of the program/policy by racial, ethnic, gender identity, national origin, income level, disability, sexual orientation, or other existing disparities?</p> <p>N/A – This contract supports multiple public works projects and should not impact racial, gender identity, national origin, income level, disability, sexual orientation or other existing disparity factors.</p>	
<p>How will data be collected regarding the effectiveness of this program, policy or product to ensure it is the right solution?</p>	

Public Works follows the City's established procurement and public works bidding regulations and policies to bring items forward, and then uses contract management best practices to ensure desired outcomes and regulatory compliance.

Describe how this proposal aligns with current City Policies, including the Comprehensive Plan, Sustainability Action Plan, Capital Improvement Program, Neighborhood Master Plans, Council Resolutions, and others?

The projects which will use this on-call contract are consistent with our adopted six year programs as well as the annual budget and strategic initiative to advance street maintenance activities.

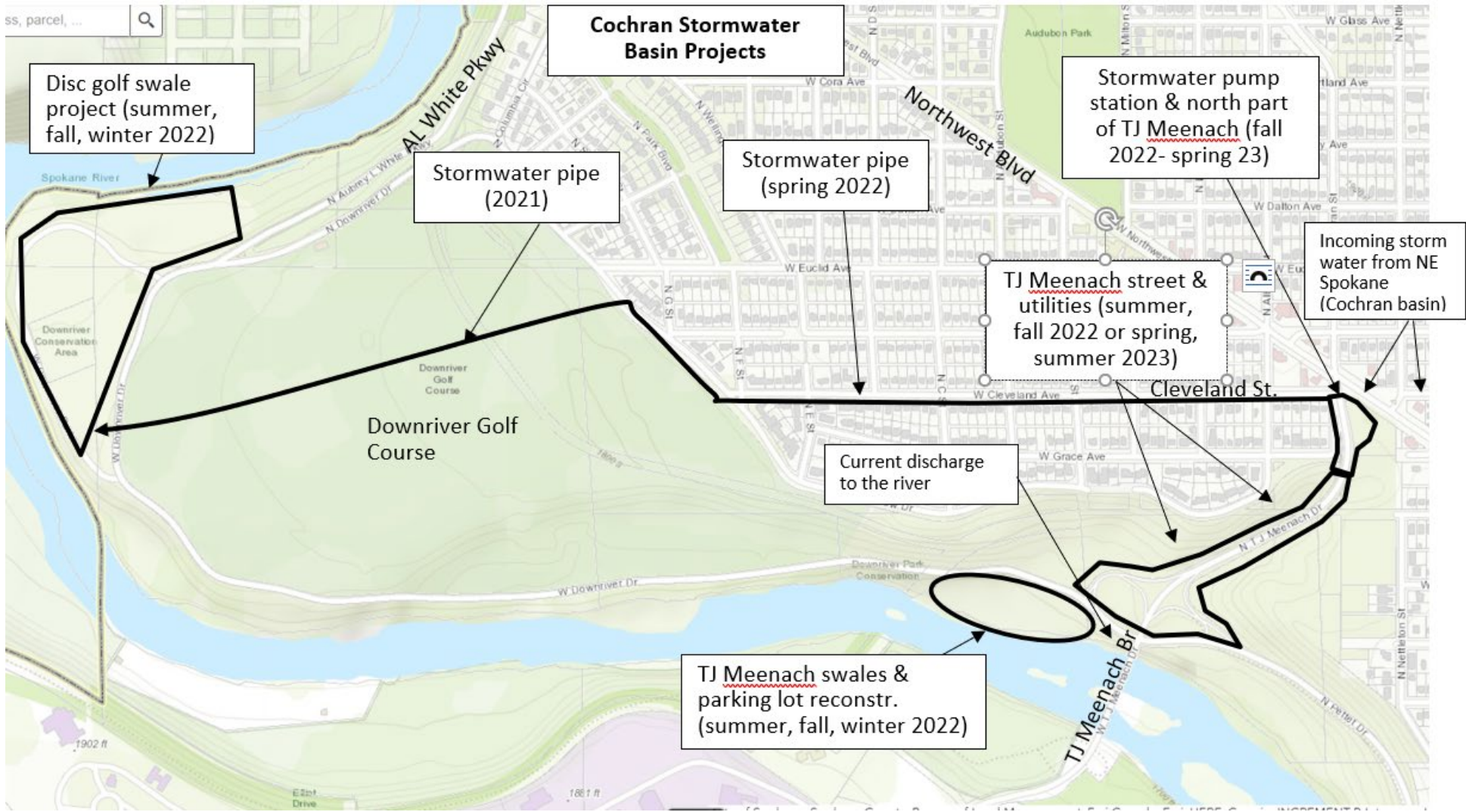

**Agenda Sheet for City Council Meeting of:**

06/27/2022

<b>Date Rec'd</b>	6/15/2022
<b>Clerk's File #</b>	OPR 2022-0464
<b>Renews #</b>	
<b>Cross Ref #</b>	
<b>Project #</b>	
<b>Bid #</b>	RFP 5607-22
<b>Requisition #</b>	

<b>Submitting Dept</b>	FIRE
<b>Contact Name/Phone</b>	BRIAN SCHAEFFER 625-7001
<b>Contact E-Mail</b>	BSCHAEFFER@SPOKANEFIRE.ORG
<b>Agenda Item Type</b>	Contract Item
<b>Agenda Item Name</b>	1970 FIRE DEPARTMENT MEDICAL ADVISOR

**Agenda Wording**

Contract with SPOKANE EMERGENCY PHYSICIANS to provide medical advisory services to the Fire Department. The term of this contract is May 1, 2022 to April 30, 2027 for a total cast of \$498,403.19 over five years.

**Summary (Background)**

The Spokane Fire Department's Emergency Medical Services program has contracted for the services of a physician since 1980. The Medical Advisor assists the Department in assuring adequate programs for the certification and recertification of the Department's paramedics, emergency medical technicians, CPR instructors and CPR instructor trainers.

Lease? NO Grant related? NO Public Works? NO

**Fiscal Impact**

Expense \$ 498,403.19

Select \$

Select \$

Select \$

**Budget Account**

# 1970-35121-22200-54201-99999

#

#

#

**Approvals****Dept Head** SCHAEFFER, BRIAN**Division Director** SCHAEFFER, BRIAN**Finance** SCHMITT, KEVIN**Legal** ODLE, MARI**For the Mayor** ORMSBY, MICHAEL**Council Notifications****Study Session\Other** PSCHC 5/2/2022**Council Sponsor** CP Beggs, CM Kinnear**Distribution List**

fireaccounting@spokanecity.org

bschaeffer@spokanefire.org

**Additional Approvals****Purchasing** PRINCE, THEA





**City of Spokane Fire Department**

**PERSONAL SERVICE CONTRACT**

Title: **EMERGENCY MEDICAL SERVICES  
SUPERVISORY PHYSICIAN**

This Agreement is made and entered into by and between the **CITY OF SPOKANE FIRE DEPARTMENT** as (“City”), a Washington municipal corporation, and **SPOKANE EMERGENCY PHYSICIANS**, whose address is 9 East Ninth Avenue, Suite 12, Spokane, Washington 99202 as (“Physicians”), individually hereafter referenced as a “party”, and together as the “parties”.

The parties agree as follows:

**1. PERFORMANCE.**

The Physicians shall provide Emergency Medical Services Supervisory Physician Services, in accordance with RFP No. 5607-22 issued by the City, and Physician’s Response to RFP, which is attached as Attachment B. In the event of a conflict between Physicians’ Response and this City Contract, the terms of this contract will control.

**2. TERM OF AGREEMENT.**

The term of this Agreement begins on May 1, 2022, and shall run through April 30, 2027, unless amended by written agreement or terminated earlier under the provisions.

**4. COMPENSATION / PAYMENT.**

Total compensation for Physicians’ services under this Agreement shall not exceed **FOUR HUNDRED NINETY-EIGHT THOUSAND FOUR HUNDRED THREE AND 19/100 DOLLARS (\$498,403.19)**, and applicable sales tax, payable at \$7,945.00 per month with an annual 2% CLI increase and \$450.00 Annual National Association of EMS Physicians Membership Dues, unless modified by a written amendment to this Agreement. Monthly payments are due by the 5<sup>th</sup> day of each month.

The Physicians shall submit its applications for payment to Spokane Fire Department, Administration Office, 44 West Riverside Avenue, Spokane, Washington, 99201. **Payment will be made via direct deposit/ACH** within thirty (30) days after receipt of the Physicians’ application except as provided by state law. If the City objects to all or any portion of the invoice, it shall notify the Physicians and reserves the right to only pay that portion of the invoice not in dispute. In that event, the parties shall immediately make every effort to settle the disputed amount.

**5. TAXES, FEES AND LICENSES.**

- A. Physicians shall pay and maintain in current status, all necessary licenses, fees, assessments, permit charges, etc. necessary to conduct the work included under this Agreement. It is the Physicians’ sole responsibility to monitor and determine

changes or the enactment of any subsequent requirements for said fees, assessments, or changes and to immediately comply.

- B. The cost of any permits, licenses, fees, etc. arising as a result of the projects included in this Agreement shall be included in the project budgets.

#### **6. CITY OF SPOKANE BUSINESS LICENSE.**

Section 8.01.070 of the Spokane Municipal Code states that no person may engage in business with the City without first having obtained a valid annual business registration. The Physicians shall be responsible for contacting the State of Washington Business License Services at [www.dor.wa.gov](http://www.dor.wa.gov) or 360-705-6741 to obtain a business registration. If the Physicians does not believe it is required to obtain a business registration, it may contact the City's Taxes and Licenses Division at (509) 625-6070 to request an exemption status determination.

#### **7. SOCIAL EQUITY REQUIREMENTS / NON-DISCRIMINATION.**

No individual shall be excluded from participation in, denied the benefit of, subjected to discrimination under, or denied employment in the administration of or in connection with this Agreement because of age, sex, race, color, religion, creed, marital status, familial status, sexual orientation including gender expression or gender identity, national origin, honorably discharged veteran or military status, the presence of any sensory, mental or physical disability, or use of a service animal by a person with disabilities. The Physicians agrees to comply with, and to require that all subcontractors comply with, federal, state and local nondiscrimination laws, including but not limited to: the Civil Rights Act of 1964, the Rehabilitation Act of 1973, the Age Discrimination in Employment Act, and the American's With Disabilities Act, to the extent those laws are applicable.

#### **8. INDEMNIFICATION.**

The Physicians shall defend, indemnify, and hold the City and its officers and employees harmless from all claims, demands, or suits at law or equity asserted by third parties for bodily injury (including death) and/or property damage which arise from the Physicians' negligence or willful misconduct under this Agreement, including attorneys' fees and litigation costs; provided that nothing herein shall require a Physicians to indemnify the City against and hold harmless the City from claims, demands or suits based solely upon the negligence of the City, its agents, officers, and employees. If a claim or suit is caused by or results from the concurrent negligence of the Physicians' agents or employees and the City, its agents, officers and employees, this indemnity provision shall be valid and enforceable to the extent of the negligence of the Physicians, its agents or employees. The Physicians specifically assumes liability and agrees to defend, indemnify, and hold the City harmless for actions brought by the Physicians' own employees against the City and, solely for the purpose of this indemnification and defense, the Physicians specifically waives any immunity under the Washington State industrial insurance law, or Title 51 RCW. The Physicians recognizes that this waiver was specifically entered into pursuant to the provisions of RCW 4.24.115 and was the subject of mutual negotiation. The indemnity and agreement to defend and hold the City harmless provided for in this section shall survive any termination or expiration of this agreement.

#### **9. INSURANCE.**

During the period of the Agreement, the Physicians shall maintain in force at its own expense, each insurance noted below with companies or through sources approved by the State Insurance Commissioner pursuant to Title 48 RCW:

- A. **Worker's Compensation Insurance** in compliance with RCW 51.12.020, which requires subject employers to provide workers' compensation coverage for all their subject workers and Employer's Liability Insurance in the amount of \$1,000,000;
- B. **General Liability Insurance** on an occurrence basis, with a combined single limit of not less than \$1,000,000 each occurrence for bodily injury and property damage. It shall include contractual liability coverage for the indemnity provided under this Agreement. It shall provide that the City, its officers and employees are additional insureds but only with respect to the Physicians' services to be provided under this Agreement;
  - i. Acceptable **supplementary Umbrella insurance** coverage combined with Physicians' General Liability insurance policy must be a minimum of \$500,000, in order to meet the insurance coverage limits required in this Agreement; and
- C. **Automobile Liability Insurance** with a combined single limit, or the equivalent of not less than \$1,000,000 each accident for bodily injury and property damage, including coverage for owned, hired and non-owned vehicles.

There shall be no cancellation, material change, reduction of limits or intent not to renew the insurance coverage(s) without forty-five (45) days written notice from the Physicians or its insurer(s) to the City. As evidence of the insurance coverage(s) required by this Agreement, the Physicians shall furnish acceptable Certificates of Insurance (COI) to the City at the time it returns this signed Agreement. The certificate shall specify the City of Spokane as "Additional Insured" specifically for Physicians' services under this Agreement, as well as all of the parties who are additional insureds, and include applicable policy endorsements, the forty-five (45) day cancellation clause, and the deduction or retention level. The Physicians shall be financially responsible for all pertinent deductibles, self-insured retentions, and/or self-insurance.

#### **9. DEBARMENT AND SUSPENSION.**

The Physicians has provided its certification that it is in compliance with and shall not contract with individuals or organizations which are debarred, suspended, or otherwise excluded from or ineligible from participation in Federal Assistance Programs under Executive Order 12549 and "Debarment and Suspension", codified at 29 CFR part 98.

#### **10. AUDIT.**

The Physicians and its sub-contractor shall maintain for a minimum of three (3) years following final payment all records related to its performance of the Agreement. The Physicians and its sub-contractors shall provide access to authorized City representatives, at reasonable times and in a reasonable manner to inspect and copy any such record. In the event of conflict between this provision and related auditing provisions required under federal law applicable to the Agreement, the federal law shall prevail.

#### **11. ASSIGNMENT AND SUBCONTRACTING.**

The Physicians shall not assign or subcontract its obligations under this Agreement without the City's written consent, which may be granted or withheld in the City's sole discretion. Any subcontract made by the Physicians shall incorporate by reference this Agreement, except as otherwise provided. The Physicians shall ensure that all subcontractors comply with the obligations and requirements of the subcontract. The City's consent to any assignment or

subcontract does not release the Physicians from liability or any obligation within this Agreement, whether before or after City consent, assignment or subcontract.

## **12. TERMINATION.**

Either party may terminate this Agreement, with or without cause, by ten (10) days written notice to the other party. In the event of such termination, the City shall pay the Physicians for all work previously authorized and performed prior to the termination date.

## **13. STANDARD OF PERFORMANCE.**

The standard of performance applicable to Physicians' services will be the degree of skill and diligence normally employed by professional Physicians performing the same or similar services at the time the services under this Agreement are performed.

## **14. OWNERSHIP AND USE OF RECORDS AND DOCUMENTS.**

Original documents, drawings, designs, reports, or any other records developed or created under this Agreement shall belong to and become the property of the City. All records submitted by the City to the Physicians shall be safeguarded by the Physicians. The Physicians shall make such data, documents and files available to the City upon the City's request. If the City's use of the Physicians' records or data is not related to this project, it shall be without liability or legal exposure to the Physicians.

Under Washington State Law (reference RCW Chapter 42.56, the *Public Records Act* [PRA]) all materials received or created by the City of Spokane are **public records** and are available to the public for viewing via the City Clerk's Records (online) or a valid Public Records Request (PRR).

## **15. ANTI KICK-BACK.**

No officer or employee of the City of Spokane, having the power or duty to perform an official act or action related to this Agreement shall have or acquire any interest in the Agreement, or have solicited, accepted or granted a present or future gift, favor, service or other thing of value from or to any person involved in this Agreement.

## **16. MISCELLANEOUS PROVISIONS.**

- A. **Amendments/Modifications:** This Agreement may be modified by the City in writing when necessary, and no modification or Amendment of this Agreement shall be effective unless signed by an authorized representative of each of the parties hereto.
- B. The Physicians, at no expense to the City, shall comply with all laws of the United States and Washington, the Charter and ordinances of the City of Spokane; and rules, regulations, orders and directives of their administrative agencies and officers. Without limiting the generality of this paragraph, the Physicians shall comply with the requirements of this Section.
- C. This Agreement shall be construed and interpreted under the laws of Washington. The venue of any action brought shall be in a court of competent jurisdiction, located in Spokane County, Washington.
- D. **Captions:** The titles of sections or subsections are for convenience only and do not define or limit the contents.
- E. **Severability:** If any term or provision is determined by a court of competent jurisdiction to be invalid or unenforceable, the remainder of this Agreement shall not be affected, and each term and provision shall be valid and enforceable to the fullest extent permitted by law.

- F. **Waiver:** No covenant, term or condition or the breach shall be deemed waived, except by written consent of the party against whom the waiver is claimed, and any waiver of the breach of any covenant, term or condition shall not be deemed a waiver of any preceding or succeeding breach of the same or any other covenant, term of condition. Neither the acceptance by the City of any performance by the Physicians after the time the same shall have become due nor payment to the Physicians for any portion of the Work shall constitute a waiver by the City of the breach or default of any covenant, term or condition unless otherwise expressly agreed to by the City in writing.
- G. **Entire Agreement:** This document along with any exhibits and all attachments, and subsequently issued addenda, comprises the entire agreement between the City and the Physicians. If conflict occurs between Agreement documents and applicable laws, codes, ordinances or regulations, the most stringent or legally binding requirement shall govern and be considered a part of this Agreement to afford the City the maximum benefits.
- H. **No personal liability:** No officer, agent or authorized employee of the City shall be personally responsible for any liability arising under this Agreement, whether expressed or implied, nor for any statement or representation made or in any connection with this Agreement.

IN WITNESS WHEREOF, in consideration of the terms, conditions and covenants contained, or attached and incorporated and made a part, the parties have executed this Agreement by having legally-binding representatives affix their signatures below.

**SPOKANE EMERGENCY PHYSICIANS**

**CITY OF SPOKANE FIRE DEPARTMENT**

By \_\_\_\_\_  
Signature                      Date

By \_\_\_\_\_  
Signature                      Date

\_\_\_\_\_  
Type or Print Name

\_\_\_\_\_  
Type or Print Name

\_\_\_\_\_  
Title

\_\_\_\_\_  
Title

Attest:

Approved as to form:

\_\_\_\_\_  
City Clerk

\_\_\_\_\_  
Assistant City Attorney

**Attachments that are part of this Agreement:**

- Exhibit A – Certificate Regarding Debarment
- Exhibit B – Response to RFP

**EXHIBIT A**

**CERTIFICATION REGARDING DEBARMENT, SUSPENSION,  
INELIGIBILITY AND VOLUNTARY EXCLUSION**

1. The undersigned (i.e., signatory for the Subrecipient / Contractor / Consultant) certifies, to the best of its knowledge and belief, that it and its principals:
  - a. Are not presently debarred, suspended, proposed for debarment, declared ineligible, or voluntarily excluded from covered transactions by any federal department or agency;
  - b. Have not within a three-year period preceding this contract been convicted or had a civil judgment rendered against them for commission of fraud or a criminal offense in connection with obtaining, attempting to obtain, or performing a public (federal, state, or local) transaction or contract under a public transaction; violation of federal or state antitrust statutes or commission of embezzlement, theft, forgery, bribery, falsification or destruction of records, making false statements, tax evasion, receiving stolen property, making false claims, or obstruction of justice;
  - c. Are not presently indicted or otherwise criminally or civilly charged by a government entity (federal, state, or local) with commission of any of the offenses enumerated in paragraph (1)(b) of this certification; and,
  - d. Have not within a three-year period preceding this contract had one or more public transactions (federal, state, or local) terminated for cause or default.

2. The undersigned agrees by signing this contract that it shall not knowingly enter into any lower tier covered transaction with a person who is debarred, suspended, declared ineligible, or voluntarily excluded from participation in this covered transaction.

3. The undersigned further agrees by signing this contract that it will include the following clause, without modification, in all lower tier covered transactions and in all solicitations for lower tier covered transactions:

Certification Regarding Debarment, Suspension, Ineligibility and Voluntary Exclusion – Lower Tier Covered Transactions

1. The lower tier contractor certified, by signing this contract that neither it nor its principals is presently debarred, suspended, proposed for debarment, declared ineligible, or voluntarily excluded from participation in this transaction by any federal department or agency.
2. Where the lower tier contractor is unable to certify to any of the statements in this contract, such contractor shall attach an explanation to this contract.

4. I understand that a false statement of this certification may be grounds for termination of the contract.

<hr/> Name of Subrecipient / Contractor / Consultant (Type or Print)	<hr/> Program Title (Type or Print)
<hr/> Name of Certifying Official (Type or Print)	<hr/> Signature
<hr/> Title of Certifying Official (Type or Print)	<hr/> Date (Type or Print)

## EXHIBIT B

## Committee Agenda Sheet

### [Public Safety and Community Health]

<b>Submitting Department</b>	Spokane Fire Department-EMS Division
<b>Contact Name &amp; Phone</b>	Michael Lopez 509.625.7092
<b>Contact Email</b>	<a href="mailto:mlopez@spokanecity.org">mlopez@spokanecity.org</a>
<b>Council Sponsor(s)</b>	Council President Beggs & Council Member Kinnear
<b>Select Agenda Item Type</b>	<input checked="" type="checkbox"/> Consent <input type="checkbox"/> Discussion    Time Requested:
<b>Agenda Item Name</b>	Fire Department EMS Supervising Physician Contract
<b>Summary (Background)</b>	<p><u>Executive Summary:</u></p> <p>This is a five-year contract that replaces the current five-year contract for an EMS Supervising Physician for the Spokane Fire Department. The Fire Department worked with City Purchasing to develop and advertise a Request for Proposals (RFP #5607-22) to solicit responses from individuals interested in filling this role. There was one response to the RFP that was developed and advertised by the City Purchasing Department in March and April of 2022. The respondent was Dr. Joel Edminster, a practicing Emergency Department Physician at Providence Sacred Heart Medical Center. The RCW and WAC of the State of Washington authorizes a single physician in each county (County Medical Program Director or MPD) who is responsible for adopting protocols, practice, and education standards and recommending certification, recertification, and disciplinary actions impacting certified EMS professionals. For large EMS agencies, the statute and rule permit the MPD to appoint EMS supervising physicians who are delegated many of these responsibilities (MPD-Delegate Supervising Physician). The Spokane Fire Department, due to the number of certified EMS professionals, has an MPD-Delegate Supervising Physician to provide more in-depth clinical supervision of our personnel. The expectations of the Fire Department's Supervising Physician include provision of monthly EMS education, clinical Continuous Quality Improvement, review and input into MPD-approved patient care protocols, responsibility for oversight of Scheduled Medications in accordance with the standards of the Federal Food and Drug Administration, periodic field supervision/observation of Fire Department personnel and other duties that assure quality care is provided to the citizens. The cost incurred by the Fire Department is \$95,340.00, annually with a 2% cost of living adjustment applied in subsequent years of the contract. Additionally, to remain aware of and consistent with current, evidence-based EMS treatment strategies to assure our personnel provide contemporary care, the proposal includes the cost of membership with the National Association of EMS Physicians (NAEMSP). This membership allows the physician to engage with other EMS Physicians throughout the United States. The annual cost of this membership is \$450.00. Therefore, the total cost of the first year of this contract is \$95,790.00. Subsequent years will reflect the 2% COLA adjustment. It is important to note that the SFD Supervising Physician provides the same services to the Spokane Valley Fire Department so that we have an integrated approach in providing EMS services in the more densely populated areas of the County. The Spokane Valley Fire Department contributes 40% of the annual cost</p>



and pays the City to offset the costs for the Supervising Physician and Integrated Medical Services Manager (who supports the Supervising Physician) through the Integrated Medical Services Contract between the City and the Spokane Valley Fire Department.

**Proposed Council Action & Date:**

**Fiscal Impact:**

Total Cost:  
Approved in current year budget?       Yes    No    N/A

Funding Source       One-time    Recurring  
Specify funding source: General Fund

Expense Occurrence       One-time    Recurring

Other budget impacts: (revenue generating, match requirements, etc.) The Spokane Valley Fire Department contributes 40% of the annual cost and pays the City to offset the costs for the Supervising Physician and Integrated Medical Services Manager (who supports the Supervising Physician) through the Integrated Medical Services Contract between the City and the Spokane Valley Fire Department.

**Operations Impacts**

What impacts would the proposal have on historically excluded communities?  
Within WA State, there is a focused effort to address health equity. As such, rules are being developed to require 2 hours of health equity training every four years for all health care professions. This requirement applies to certified EMS professionals. The Spokane Fire Department’s Supervising Physician will play an integral role in implementing this training for Fire Department personnel. This will heighten awareness among all EMS providers to the importance of providing emergency health care with distinct focus on the importance of health equity. The Spokane Fire Department will incorporate this training in its Washington State Department of Health-approved Ongoing Education and Training Program (OTEP).

How will data be collected, analyzed, and reported concerning the effect of the program/policy by racial, ethnic, gender identity, national origin, income level, disability, sexual orientation, or other existing disparities? The Spokane Fire Department has a WA State Department-approved Continuous Quality Improvement Program (CQIP) in place. While the CQIP addresses several high-acuity conditions, reporting incorporates gender, race, age and disability and the new state mandated health equity initiative will most likely include other equity related data.

How will data be collected regarding the effectiveness of this program, policy, or product to ensure it is the right solution? The Spokane Fire Department already tracks quality of care through its State-approved CQIP program. Additionally, the Fire Department tracks and verifies successful completion of assigned education for Paramedics and EMT's as well as evaluates compliance with Clinical Key Performance Indicators for conditions like Cardiac Arrest, Stroke, Heart Attack and Multi-System Trauma. The findings of these efforts drive future educational sessions that are conducted by the Fire Department's Supervising Physician. Once such example is the quality improvement activities surrounding stroke care. There are verified instances when opportunities for improvement drove focused education and there was a noticeable improvement in care as evidenced by the ongoing KPI measurement program. The Supervising Physician is the lead in this effort.

Describe how this proposal aligns with current City Policies, including the Comprehensive Plan, Sustainability Action Plan, Capital Improvement Program, Neighborhood Master Plans, Council Resolutions, and others?

The existence of an MPD-delegate Supervising Physician assures that the quality of care delivered to citizens of Spokane meets or exceeds industry standards through education, protocol development, quality assurance and real-time feedback. This also assures that the Spokane Fire Department's personnel have direct clinical oversight by a licensed, practicing Emergency Department physician. This reduces the risk associated with provision of Emergency Medical Services (Risk Management, Safety, etc.).

## Bid Response Summary

**Bid Number** RFP 5607-22  
**Bid Title** Emergency Medical Services Supervisory Physician  
**Due Date** Monday, April 18, 2022 1:00:00 PM [(UTC-08:00) Pacific Time (US & Canada)]  
**Bid Status** Closed to Bidding  
**Company** Spokane Emergency Physicians, P.S. / Joel Edminster MD  
**Submitted By** joel.edminster@gmail.com joel.edminster@gmail.com - Monday, April 18, 2022 9:05:39 AM [(UTC-08:00) Pacific Time (US & Canada)]  
 joel.edminster@gmail.com

### Comments

### Question Responses

Group	Reference Number	Question	Response
PROPOSER ACKNOWLEDGMENTS:			
	1	Proposer Acknowledges receipt of Addenda by entering quantity of Addenda here (enter 0 if none have been issued):	0
	2	Proposer agrees and acknowledges that Request for Proposal document(s) and all related information has been read and understood.	AGREED AND ACKNOWLEDGED
	3	Proposer agrees and acknowledges compliance with Terms and Conditions in Informal Request for Proposal document(s). If answer is "AGREED WITH EXCEPTION IDENTIFIED", include requested exception in proposal submittal on separate page and title as "Exception to Terms and Conditions". The City will consider and determine if exception will be accepted.	AGREED AND ACKNOWLEDGED
	4	Proposer acknowledges and agrees with Paragraph 4.4 Award/Rejection of Proposal/Contract.	AGREED AND ACKNOWLEDGED
	5	Proposer agrees and acknowledges that proprietary information must be included in Proposal submittal on separate page(s) and clearly identified as "Proprietary". See "Proprietary Information/Public Disclosure" Paragraph for public record requirements.	AGREED AND ACKNOWLEDGED
	6	Proposer has included Cover Letter with Proposal combined into one document per Section 3 "Proposal Content" instructions.	YES
	7	Provide the name, phone number and email address for point of contact person regarding this Proposal.	Joel Edminster jedminster@sepspokane.com (509) 435-7099

8	Provide the name, phone number, and email address for the person in your Firm that would potentially sign a contract through the DocuSign process used by the City.	Joel Edminster jedminster@sepspokane.com (509) 435-7099
DOCUMENTS TO UPLOAD:		
1	Upload Request for Proposal Response (your Firm's Proposal). Combine documents as needed. Only one document can be uploaded in this line item.	EdminsterRFP2022.doc
2	Upload Addenda documents if applicable and if not combined with uploaded Proposal response. Combine documents as needed. Only one document can be uploaded in this line item.	
3	Upload any other information required or desired. Combine documents as needed. Only one document can be uploaded in this line item.	
4	Upload any other information required or desired. Combine documents as needed. Only one document can be uploaded in this line item.	

Spokane Emergency Physicians PS  
9 E. 9<sup>th</sup> Ave # 12  
Spokane, WA 99202

April 15, 2022  
City Of Spokane - Purchasing  
4th Floor City Hall  
808 W. Spokane Falls Blvd.  
Spokane WA 99201-3316

Re: RFP 5607-22, Emergency Medical Services Supervising Physician

To Whom It May Concern:

The enclosed application will provide you with strong evidence of my qualification for the position of EMS Supervising Physician for Spokane City Fire. Since my initial assignment as medical director for the City of Spokane Fire Department in 2014 I have been dedicated to the duties assigned to me in that role. I have every intention to continue that same course with re-appointment as the medical advisor. We have had the opportunity to demonstrate excellence in a number of arenas; from collaboration with neighboring EMS agencies in training and implementation of advanced resuscitation techniques, continuing education for EMS healthcare delivery, and direct involvement with community crises. Since my last reappointment in 2017 we have been faced with challenges, not the least of which was the COVID-19 Pandemic. I was involved with the development of a county-wide EMS operating procedure to address our response to that threat as a fire agency which included the organization of drive-through vaccination clinics, remote testing sites, and support and guidelines for EMS providers in the field. I continue to be engaged in the development of county EMS protocols and am an active participant with the County EMS Trauma Council and QI Committee. Since my last re-appointment I have been elected as an EMS representative for the Statewide Disaster Medical Advisory Committee and work closely with the Department of Health during healthcare crisis. I remain active with Spokane Emergency Physicians (Fed. ID# 72-1530221/UBI 602224367), at Sacred Heart Medical Center and we value our partnership with Spokane City Fire. I look forward to the opportunity to continue serve the citizens of Spokane County by assisting in the delivery of excellent EMS care through Spokane City Fire Department.

Sincerely,

Dr. Joel D. Edminster  
[jedminster@spokanecity.org](mailto:jedminster@spokanecity.org)  
(509) 435-7099

## Joel D. Edminster, MD, FACEP

2012 S. Molter Rd.  
Liberty Lake, WA 99019  
joel.edminster@gmail.com  
(509) 435-7099

### EMPLOYER

---

2008-Present *Providence Sacred Heart Medical Center & Providence Sacred Heart Children's Hospital*

- 694-bed nonprofit, Catholic hospital, sponsored by the Sisters of Providence
- Serving the region from the Cascades to Eastern Montana, Southern BC to Northern Oregon
- Tertiary Care Center with Level II Trauma Designation
- JAHCO Certified Primary Stroke Center
- Academic Institution affiliated with UW & WSU Schools of Medicine

2008 - Present *Spokane Emergency Physicians*

- Independent, Democratic Group employing 40 fulltime and part time physicians
- Providing Staff for both Pediatric & Adult Emergency Departments
- Providing academic opportunities for multiple residency programs statewide and Students from Elson S. Floyd & UW Schools of Medicine
- Elected to Executive Committee consecutive terms 2010-2014 and 2020 to current

### EDUCATION

---

2005-2008 *MetroHealth Medical Center/Cleveland Clinic Foundation Emergency Medicine Residency Program - Cleveland, Ohio*

- MetroHealth Medical Center ED treats > 90,000 patients annually
  - Level 1 Trauma Center with Pediatric Commitment
  - Level 1 Burn Center
  - JCAHO Primary Stroke Center
- Cleveland Clinic Foundation ED treats > 65, 000 patients
  - Rated #1 13 straight years for cardiac care, *US News & World Report*

- JCAHO Primary Stroke Center

2001-2005 *Case Western Reserve University- School of Medicine*  
Cleveland, OH

- Doctor of Medicine

1996-2001 *Carroll College - Helena, MT*

- Bachelor of Arts – Graduation with Honors – *Cum Laude*
  - Biology & Psychology

## EMS EXPERIENCE

---

2016 – Present **Medical Director**  
**Spokane County Fire Dist#9**

- BLS & ALS Agency
- Serving the Citizens of the City of Spokane, Mead & Colbert
- Administrative responsibilities including quality assurance measures and EMS education.

2014 – Present **Medical Director**  
**Spokane City Fire Department**

- BLS & ALS Agency
- Serving the Citizens of the City of Spokane
- Administrative responsibilities including quality assurance measures and EMS education.

2014-Present **Medical Director**  
**Spokane Valley Fire Department**

- BLS & ALS Agency
- Serving the Citizens of Spokane Valley & Liberty Lake
- Administrative responsibilities including quality assurance measures and EMS education.

2012 - 2017 **Medical Director**  
**INHS HTN Paramedic Program**

- 1,508 hour, three-quarter time program leads to certification as a Paramedic in the State of Washington and the National Registry of EMTs.
- U.S. Department of Transportation, National Highway Traffic Safety Administration 2009 Paramedic Curriculum

- CoAEMSP Accredited

2010 - 2014

### Medical Director

#### Deer Park Ambulance

- BLS, ILS, & ALS Agency
- Non-profit, private agency serving approximately 600 square miles in Spokane & Stevens County
- Administrative responsibilities including quality assurance measures and EMS education.

2010 - 2014

### Medical Director

#### Spokane County Fire District #4

- Established in 1945, the district to serves over 330 square miles of North Spokane County
- 170 member volunteer Firefighters, 25 plus Part-Time Paid Firefighters, 13 career staff/officers
- Administrative responsibilities including quality assurance measures and EMS education.

2007-2008

### Flight Physician

- Primary physician on the nationally recognized critical care transport service LifeFlight with 3,500 flights annually.
- Flights include inter-hospital transport of critically ill patients and trauma scene transport for adult and pediatric patients.
- Flight team consists of physician, critical care nurse, and 2 pilots on Sikorsky S-76 rotor wing aircraft.

## ACADEMIC WORK EXPERIENCE

---

2008 - Present

### Resident & Medical Student Clinical Instructor

- J. Floyd School of Medicine, WSU – Medical Students
- UW School of Medicine – Medical Students
- Sacred Heart Transitional Year Residency
- Internal Medicine Residency of Spokane (UW Affiliate)
- Family Medicine Residency of Spokane (UW affiliate)

2007-2008

### Chief Resident

- Administrative responsibilities including participation in the Resident Steering Committee, scheduling, quality assurance measures and conflict resolution.



- Resident education responsibilities including regular didactic sessions, organization of resident lectures and literature review for, and the management of the resident website.

## RESEARCH & PUBLICATIONS

---

- Evaluation of Physiologic Alterations During Prehospital Paramedic –Performed Rapid Sequence Intubation
  - Prehospital Emergency Care.
  - May-June 2018;22(3):300-311
- EMS & Schools for Cardiac Arrest Survival - 2013
  - 2-day Program with video didactic & hands-on training in bystander CPR & AED use
  - Pairing Local EMS agencies with public schools for CPR training
- *ABCD Score in TIA* –validation study of a published TIA “score” in an effort to determine its utility as a decision making tool in the ED setting
  - Presented at Midwest ACEP 2006
  - Presented at International Stroke conference – San Francisco 2007
- *Ohio Burden of Stroke Study* – State wide, CDC funded study involving pre-hospital stroke education for rural EMS departments in an effort to improve run times and improve time to definitive therapy.

## CERTIFICATIONS

---

- Fellow of the American College of Emergency Physicians
- Board Certified in Emergency Medicine (ABEM)
- Washington State Medical License
- Certified in Ultrasound for FAST, renal, gallbladder, aorta and 1<sup>st</sup> trimester OB

## PROFESSIONAL MEMBERSHIPS

---

- Diplomat American Board of Emergency Medicine
- American College of Emergency Physicians (ACEP)
- National Association of EMS Physicians (NAEMSP)
- Spokane County EMS Council
- Spokane County EMS QI/QA Committee
- Washington State Disaster Medical Advisory Committee
- Spokane Disaster Clinical Advisory Committee
- Spokane County EMS Podcast - Host

**Insurance**



1301 Second Avenue, Suite 2700  
 PO Box 91220  
 Seattle, WA 98111  
 (206) 343-7300  
 (800) 962-1399  
 F (206) 343-7100

**ALTERNATIVE RATED INSURED ENDORSEMENT**

As of the endorsement effective date, Joel David Edminster, MD shown below is an **insured** under this Policy on an individual limits basis, while acting within the course and scope of his or her duties to the **named insured**. This endorsement shall not serve to increase the Limits of Insurance as stated on the Declarations of this Policy. The Limits of Insurance shown below apply separately to each such additional insured as stated below.

<u>NAME:</u>	<u>REFERENCE NUMBER:</u>	<u>RETROACTIVE DATE:</u>	<u>LIMITS OF INSURANCE - COVERAGE A</u>	
Joel David Edminster, MD	242002	7/1/2008	Subject to Section VIII. Limits of Liability	
			Each Medical Incident	\$2,000,000
			Aggregate	\$6,000,000

Policy provisions are amended as follows:

1. When coverage terminates under this Endorsement, Joel David Edminster, MD retains the right to report **claims** arising out of **direct patient treatment**, or a **medical incident**, rendered by that particular **insured** on or after the **retroactive date** shown above and prior to the date of termination of coverage under this Endorsement until the Policy is cancelled or FTE position 1 is removed from this policy, whichever occurs first.
2. This policy has one or more **insureds** assigned to one or more FTE positions. Joel David Edminster, MD is assigned to FTE position 1 in this Policy.
3. SECTION IX. 3. of the policy, "Waiver of Premium In Specified Circumstances For Extended Reporting Endorsement For **Additional Named Insureds**", is deleted.

<b>Named Insured's Name &amp; Address:</b>  Spokane Emergency Physicians PS 9 E 9th Ave #212 Spokane, WA 99202	<b>Policy Number</b>	300003266
	<b>Effective Date &amp; Expiration Date</b>	01/01/22 - 01/01/23
	<b>Endorsement Effective Date</b>	January 1, 2022
	<b>Authorized Signature:</b>	

This endorsement is subject to the declarations, conditions, exclusions and all other terms of the policy indicated above which are not inconsistent with this endorsement and forms a part of that policy when signed by an authorized representative of the company.

END316-PI.080116

11/17/21

9093041

010951



State of Washington  
Department of Labor and Industries  
PO Box 44140  
Olympia WA 98504-4140

THIS IS  
NOT A  
BILL

12-08-21

Policyholder  
**SPOKANE EMERGENCY PHYSICIANS**  
9 EAST 9TH AVE STE 212  
SPOKANE WA 99204

Effective Date:		Experience Factor:	
<b>January 1, 2022</b>		<b>0.9731</b>	
Experience Period:			
<b>July 1, 2017 - June 30, 2020</b>			
WA Unified Business Identifier (UBI):			
<b>602 224 367</b>			
L&I Account ID:		PAC Number:	
<b>041,711-00</b>		<b>16148034</b>	
Account Manager:			
<b>STEPHANIE HORNBAC</b>			
<b>(360)902-6134</b>			

**What went into calculating your 2022 workers' comp rates?**

1. Change in L&I average 'base' rate: 3.1% average rate increase for 2022; rates specific to your industry can be found on our website at [lni.wa.gov](http://lni.wa.gov)
2. Changes in industry costs: Changes in claim costs compared to premiums collected for your industry ('risk class') in which some or all of your employees worked.
3. Your Experience Factor: Based on the medical, wage replacement and disability benefit costs for worker claims on your account, during the experience period listed above.
4. A claim-free discount: You don't have a claim-free discount. Learn how to earn a discount at [www.Lni.wa.gov/ClaimFreeDiscount](http://www.Lni.wa.gov/ClaimFreeDiscount).

Pay your premiums online: [www.Lni.wa.gov/QuarterlyReports](http://www.Lni.wa.gov/QuarterlyReports)  
Need help understanding this notice? Call your account manager at the phone number shown above.

Have a payroll service?  
Send them a copy of this notice.

Your Rate Information	Class Code	Class Code Description	Accident Fund (AF)	Medical Aid Fund (MA)	Stay at Work Program	Supp. Pension Fund (SP)	Hourly* Employer Contribution	+ Hourly* Employee Withholding	= Your Total Hourly* Rate [(1+2+3)x4+5]
		6109-00	Physician/Surgeon NOC-All Oper	0.1532	0.0715	0.0026	0.1564	\$0.26335	\$0.11425

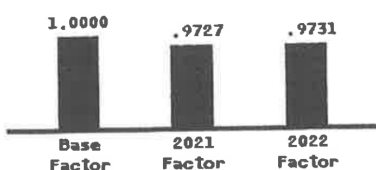

This is the employer's contribution to workers' comp coverage.  
Withhold this amount from employee pay for each hour\* they work. It is their contribution to workers' comp coverage.  
On the Quarterly Report, the employer will multiply this number by the number of hours\* worked to calculate premiums.

What's an experience factor?  
See back for an explanation.



SPOKEME-02

DPIKE

### CERTIFICATE OF LIABILITY INSURANCE

DATE (MM/DD/YYYY)  
4/18/2022

THIS CERTIFICATE IS ISSUED AS A MATTER OF INFORMATION ONLY AND CONFERS NO RIGHTS UPON THE CERTIFICATE HOLDER. THIS CERTIFICATE DOES NOT AFFIRMATIVELY OR NEGATIVELY AMEND, EXTEND OR ALTER THE COVERAGE AFFORDED BY THE POLICIES BELOW. THIS CERTIFICATE OF INSURANCE DOES NOT CONSTITUTE A CONTRACT BETWEEN THE ISSUING INSURER(S), AUTHORIZED REPRESENTATIVE OR PRODUCER, AND THE CERTIFICATE HOLDER.

**IMPORTANT:** If the certificate holder is an ADDITIONAL INSURED, the policy(ies) must have ADDITIONAL INSURED provisions or be endorsed. If SUBROGATION IS WAIVED, subject to the terms and conditions of the policy, certain policies may require an endorsement. A statement on this certificate does not confer rights to the certificate holder in lieu of such endorsement(s).

<b>PRODUCER</b> Alliant Insurance Services, Inc. 818 W Riverside Ave Ste 800 Spokane, WA 99201	<b>CONTACT NAME:</b> PHONE (A/C, No, Ext): (509) 325-3024      FAX (A/C, No): (509) 325-1803 E-MAIL: ADDRESS:	
	<b>INSURER(S) AFFORDING COVERAGE</b> NAIC # INSURER A : <b>Ohio Security Insurance Company</b> <b>24082</b> INSURER B : INSURER C : INSURER D : INSURER E : INSURER F :	
<b>INSURED</b>  Spokane Emergency Physicians PS 9 East 9th, Ste 212 Spokane, WA 99202		

**COVERAGES**      **CERTIFICATE NUMBER:**      **REVISION NUMBER:**

THIS IS TO CERTIFY THAT THE POLICIES OF INSURANCE LISTED BELOW HAVE BEEN ISSUED TO THE INSURED NAMED ABOVE FOR THE POLICY PERIOD INDICATED. NOTWITHSTANDING ANY REQUIREMENT, TERM OR CONDITION OF ANY CONTRACT OR OTHER DOCUMENT WITH RESPECT TO WHICH THIS CERTIFICATE MAY BE ISSUED OR MAY PERTAIN, THE INSURANCE AFFORDED BY THE POLICIES DESCRIBED HEREIN IS SUBJECT TO ALL THE TERMS, EXCLUSIONS AND CONDITIONS OF SUCH POLICIES. LIMITS SHOWN MAY HAVE BEEN REDUCED BY PAID CLAIMS.

INSR LTR	TYPE OF INSURANCE	ADL SUBR INSD WVD	POLICY NUMBER	POLICY EFF (MM/DD/YYYY)	POLICY EXP (MM/DD/YYYY)	LIMITS
A	<input checked="" type="checkbox"/> COMMERCIAL GENERAL LIABILITY <input type="checkbox"/> CLAIMS-MADE <input checked="" type="checkbox"/> OCCUR  GEN'L AGGREGATE LIMIT APPLIES PER: <input type="checkbox"/> POLICY <input type="checkbox"/> PRO-JECT <input type="checkbox"/> LOC OTHER:	X	BLS64685446	4/14/2022	4/14/2023	EACH OCCURRENCE \$ <b>1,000,000</b> DAMAGE TO RENTED PREMISES (Ea occurrence) \$ <b>300,000</b> MED EXP (Any one person) \$ <b>5,000</b> PERSONAL & ADV INJURY \$ <b>1,000,000</b> GENERAL AGGREGATE \$ <b>2,000,000</b> PRODUCTS - COMPIOP AGG \$ <b>2,000,000</b> \$
A	<b>AUTOMOBILE LIABILITY</b> <input type="checkbox"/> ANY AUTO OWNED AUTOS ONLY <input type="checkbox"/> SCHEDULED AUTOS <input checked="" type="checkbox"/> HIRED AUTOS ONLY <input checked="" type="checkbox"/> NON-OWNED AUTOS ONLY		BLS64685446	4/14/2022	4/14/2023	COMBINED SINGLE LIMIT (Ea accident) \$ <b>1,000,000</b> BODILY INJURY (Per person) \$ BODILY INJURY (Per accident) \$ PROPERTY DAMAGE (Per accident) \$ \$
	<input type="checkbox"/> UMBRELLA LIAB <input type="checkbox"/> OCCUR <input type="checkbox"/> EXCESS LIAB <input type="checkbox"/> CLAIMS-MADE DED    RETENTION \$					EACH OCCURRENCE \$ AGGREGATE \$ \$
	<b>WORKERS COMPENSATION AND EMPLOYERS' LIABILITY</b> ANY PROPRIETOR/PARTNER/EXECUTIVE OFFICER/MEMBER EXCLUDED? (Mandatory in NH)    Y/N    N/A If yes, describe under DESCRIPTION OF OPERATIONS below					PER STATUTE    OTH-ER E.L. EACH ACCIDENT \$ E.L. DISEASE - EA EMPLOYEE \$ E.L. DISEASE - POLICY LIMIT \$

DESCRIPTION OF OPERATIONS / LOCATIONS / VEHICLES (ACORD 101, Additional Remarks Schedule, may be attached if more space is required)  
The City of Spokane is an Additional Insured under General Liability as respects services provided by the Named Insured

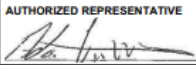
<b>CERTIFICATE HOLDER</b>  City of Spokane 808 W Spokane Falls Blvd Spokane, WA 99201	<b>CANCELLATION</b>  SHOULD ANY OF THE ABOVE DESCRIBED POLICIES BE CANCELLED BEFORE THE EXPIRATION DATE THEREOF, NOTICE WILL BE DELIVERED IN ACCORDANCE WITH THE POLICY PROVISIONS.  AUTHORIZED REPRESENTATIVE 
---	--

**AUTOMOBILE POLICY DECLARATIONS**

**NAMED INSURED:**  
ANGELA EDMINSTER  
JOEL D EDMINSTER  
2012 S MOLTER RD  
LIBERTY LAKE WA 99019-8725

**POLICY PERIOD FROM:** JAN. 31 2022  
**TO:** JULY 31 2022

at 12:01 A.M. standard time at  
the address of the insured as  
stated herein.

**AGENT:**  
OSPREY AGENCY INC  
PO BOX 866  
VERADALE WA 99037-0866

**AGENT TELEPHONE:**  
(800) 214-1044

RATED DRIVERS			
ANGELA EDMINSTER, JOEL D EDMINSTER			
<b>2018 GMC</b>	SIERRA K1500 SLT	4 DOOR PICK-UP	ID# 3GTU2NEC3JG530374
LOSS PAYEE	GM FINANCIAL		
<b>2021 GMC</b>	YUKON AT4	4 DOOR	ID# 1GKS2CKD8MR326042
LOSS PAYEE	ACAR LEASING		

Insurance is afforded only for the coverages for which limits of liability or premium charges are indicated.

COVERAGES	2018 GMC LIMITS	PREMIUMS	2021 GMC LIMITS	PREMIUMS
<b>COMBINED SINGLE LIMIT:</b>				
BODILY INJURY & PROPERTY DAMAGE LIABILITY	\$500,000 Each Occurrence	\$ 145.00	\$500,000 Each Occurrence	\$ 145.00
<b>PERSONAL INJURY PROTECTION</b>		REJECTED		REJECTED
<b>UNDERINSURED MOTORISTS:</b>				
BODILY INJURY	\$500,000 Each Person	77.70	\$500,000 Each Person	77.70
PROPERTY DAMAGE	\$500,000 Each Accident	17.50	\$500,000 Each Accident	18.20
DEDUCTIBLE:	\$50,000 Each Accident SEE YOUR POLICY		\$60,000 Each Accident SEE YOUR POLICY	
<b>COMPREHENSIVE</b>	Actual Cash Value Less \$250 Deductible	75.80	Actual Cash Value Less \$250 Deductible	71.30
<b>COLLISION</b>	Actual Cash Value Less \$500 Deductible	164.00	Actual Cash Value Less \$500 Deductible	166.00
<b>ADDITIONAL COVERAGES:</b>				
LOSS OF USE	\$50 Per Day/\$1000 Max	19.60	\$50 Per Day/\$1000 Max	24.10
AUTO LOAN/LEASE				7.10
ROADSIDE ASSIST		4.00		2.80
ORIGINAL PARTS REPLACEMENT ENDORSEMENT		24.00		23.70
<b>ENHANCED COVERAGE LEVEL</b>		24.60		24.40
<b>TOTAL \$</b>		552.20	<b>TOTAL \$</b>	560.30

-CONTINUED-

## References

James Nania MD  
Spokane County EMS Medical Director  
1618. N Rebecca  
Spokane, WA 99217  
(509) 625-7122

Ryan Pursley MD  
Spokane Emergency Physicians – President  
9 E. 9<sup>th</sup> Ave # 12  
Spokane, WA 99202  
(509) 496-9272

Greg Cover MD  
American Medical Response - Medical Director  
915 W Sharp Ave  
Spokane, WA 99201  
(509) 994 -2088

**Cost Proposal:**

-\$7,945/month with an annual 2% CLI due on the 5<sup>th</sup> day of each month

-Annual National Association of EMS Physicians Membership Dues – \$450.00

**Exception to Terms and Conditions:**

18(c) – “Automobile Liability Insurance with a combined single limit, or equivalent of not less than **\$500,000.00** each accident for bodily injury and property damage, including coverage for owned, hired and non-owned vehicles” has been the requirement for prior contractual agreements for the position of Emergency Medical Services Supervising Physician. We request that the requirement remain unchanged with regard to automobile liability insurance coverage.



CITY OF SPOKANE - PURCHASING  
 808 W. Spokane Falls Blvd.  
 Spokane, Washington 99201-3316  
 (509) 625-6400

# REQUEST FOR PROPOSALS

<p><b>RFP NUMBER: 5607-22</b>  <b>RFP TITLE: EMERGENCY MEDICAL SERVICES SUPERVISING PHYSICIAN</b></p> <p><b>RFP COORDINATOR: Thea Prince, City of Spokane Purchasing Department</b></p> <p><b>QUESTION DEADLINE: March 28, 2022 at 3:00 pm</b></p>	<p><b>PROPOSAL DUE DATE: April 18, 2022</b></p> <p><b><u>TIME: 1:00 pm</u></b></p> <p><b><u>Proposal Submittal:</u></b>  <b>All Proposals shall be submitted electronically through the ProcureWare online procurement system portal:</b>  <a href="https://spokane.procureware.com">https://spokane.procureware.com</a>  <b>before the due date and time.</b></p>
--	--

## TABLE OF CONTENTS

1. GENERAL INFORMATION .....	2
1.1 COMMUNICATION.....	2
1.2 BACKGROUND AND PURPOSE: .....	2
1.3 MINIMUM QUALIFICATIONS: .....	2
1.4 CONTRACT PERIOD .....	2
1.5 ADDENDA: .....	2
1.6 TERMS AND CONDITIONS: .....	2
1.7 ESTIMATED SCHEDULE OF PROCUREMENT ACTIVITIES.....	3
1.8 DEFINITIONS .....	3
2. SCOPE OF SERVICES .....	3
3. PROPOSAL CONTENTS .....	3
3.1 PREPARATION OF PROPOSAL:.....	4
1 COVER LETTER: .....	<b>Error! Bookmark not defined.</b> 4
2 EXPERIENCE/QUALIFICATIONS .....	4
3 EDUCATION.....	4
4 INSURANCE COVERATE .....	5
5 REFERENCES.....	5
6 COST PROPOSAL.....	5
4. SUBMISSION AND EVALUATION.....	5
4.1 SUBMISSION OF PROPOSALS: .....	5
4.2 EVALUATION PROCEDURE .....	6
4.3 EVALUATION SCORING.....	6
4.4 AWARD/REJECTION OF PROPOSAL/CONTENT.....	6
5. RFP ATTACHMENTS.....	6



## **1. GENERAL INFORMATION**

### **1.1 COMMUNICATION**

All communication between the Proposer and the City shall be with the RFP Coordinator and submitted through the 'Clarifications' tab in the City of Spokane's online procurement system portal: <https://spokane.procureware.com>. Any communication directed to other parties is prohibited.

### **1.2 BACKGROUND AND PURPOSE**

The City of Spokane, through its Fire Department (hereinafter "City") is initiating this Request for Proposals (RFP) to solicit Proposals from Individuals interested in providing EMERGENCY MEDICAL SERVICES SUPERVISING PHYSICIAN services as authorized in RCW 18.71 and WAC 246-976-920.

### **1.3 MINIMUM QUALIFICATIONS**

The EMS Supervising Physician shall be:

- A physician or group of physicians licensed to practice in City of Spokane, Washington;
- Current Board Certified as an Emergency Physician or physicians;
- Currently practicing as an Emergency Department Physician in Spokane, WA;
- Familiar with the design and operation of Fire-Based EMS systems;
- Experienced in pre-hospital emergency care of acutely ill or injured patients;
- Knowledgeable about local multi-casualty and disaster plans;
- Knowledgeable with emergency medical communications and integration of pre-hospital medical transport systems;
- Knowledgeable about laws and regulations affecting Spokane, the EMS and Trauma East Region, and Washington State EMS Rules, Regulations and Operations

### **1.4 CONTRACT PERIOD**

Any contract resulting from this RFP will be for five (5) years and tentatively scheduled to begin on or about June 1, 2022 and to end on May 31, 2027.

### **1.5 ADDENDA**

It is the responsibility of Proposers to check the City of Spokane's online procurement system <https://spokane.procureware.com> for Addenda or other additional information that may be posted regarding this Request for Proposals.

### **1.6 TERMS AND CONDITIONS**

Terms and Conditions applicable to this RFP are included herein by reference and attached to this RFP as Attachment 1.

## 1.7 ESTIMATED SCHEDULE OF PROCUREMENT ACTIVITIES

Question and answer period	March 2, 2022 – March 28, 2022
Proposals due	April 18, 2022
Evaluation, Negotiation and Contract Award	April 19, 2022 – May 31, 2022
Begin contract work	June 1, 2022

The City reserves the right to revise the above schedule.

## 1.8 DEFINITIONS

Definitions for the purposes of this RFP include:

**City** – The City of Spokane, a Washington State municipal corporation, the agency issuing this RFP.

**Firm or Consultant or Individual** – Individual or company whose Proposal has been accepted by the City and is awarded a fully executed, written contract.

**Proposal** – A formal offer submitted in response to this solicitation.

**Proposer** - Individual or Firm submitting a Proposal in order to attain a contract with the City.

**Request for Proposals (RFP)** – Formal procurement document in which a service or need is identified but no specific method to achieve it has been chosen. The purpose of an RFP is to permit the consultant community to suggest various approaches to meet the City’s needs at a given price.

## 2. SCOPE OF SERVICES

The City of Spokane Fire Department (SFD) provides a tiered response to emergency medical incidents with both basic level and paramedic level first response. The SFD also provides Emergency Medical Dispatch (EMD) services through its Fire Dispatch Center. The Spokane Fire Department is recognized as being heavily involved in the Health Community and a regional leader throughout the State in pre-hospital medicine.

The duties of the EMS Supervising Physician shall include but not be limited to the following:

- Establish and monitor compliance with field performance guidelines for EMS personnel.
- Establish and monitor compliance with training guidelines, which meet or exceed the minimum standards set forth in the Washington State Health EMS certification regulations.
- Develop, implement, and revise protocols, if appropriate, governing pre-hospital care and medical aspects of patient treatment and dispatch
- Participate in an effective system audit and the Spokane Fire Department’s WA State Department of Health-approved quality improvement program.
- Assist with review of EMS communication protocols and emergency medical dispatch training;

- Oversee certification and recertification of basic and advanced life support providers;
- Consult for HAZ MAT (Hazardous Materials) Team medical issues;
- Attend the following meetings and other meetings, as needed,
  - 1) Spokane County EMS Council,
  - 2) Relevant East Region EMS and Trauma Council meetings
  - 3) Relevant State Department of Health meetings
  - 3) Spokane Fire Department staff meetings
- Review future planning of EMS and Community Paramedicine to be provided by the department;
- Be available to the Fire Chief or his designee for consultation on EMS issues, and if called, respond to major incidents and unusual occurrences; and
- Provide such other related services as may be agreed from time to time.
- Function as the primary liaison between the EMS administration and the local medical community, ascertaining and being responsive to the needs of each.
- Take or recommend appropriate remedial or corrective measures for EMS personnel, in conjunction with local EMS administration, which may include, but are not limited to, counseling, retraining, testing, probation, and/or field preceptorship.

### **3. PROPOSAL CONTENTS**

#### **3.1 PREPARATION OF PROPOSAL**

The responses to this Request for Statement of Professional Qualifications will consist of six (6) specific information subject areas which must be completed uploaded in the appropriate spot in the ProcureWare system.

#### **1. COVER LETTER**

The Proposal packet will include a cover letter at the beginning. The cover letter shall provide a summary of the information presented in the RFP; include the name, title, address, telephone and email address of the respondent/respondents to this RFP.

#### **2. EXPERIENCE/QUALIFICATIONS**

Provide a statement of experience relevant to the Supervising Physician's Scope of Work, clinical experience, and qualifications for the individual or group of individuals.

#### **3. EDUCATION**

Provide all applicable information pertaining to education and training that qualifies

respondent/respondents for this position.

#### **4. INSURANCE COVERAGE:**

Provide a copy of the individual or group's insurance policies or an insurance binder for the required insurance coverages in called out in #18 of the Attached Terms & Conditions Document.

#### **5. REFERENCES:**

Provide three (3) professional references. Provide the name, contact person, telephone number, and complete address.

#### **6. COST PROPOSAL**

The Cost Proposal shall identify all costs to be charged including any expenses necessary to accomplish the tasks and to produce the deliverables under the contract. Submit as a fully detailed budget with a total cost. Firms are required to collect and pay Washington state sales tax, if applicable. Do not include Washington state sales tax in Proposal.

### **4. PROPOSAL SUBMISSION AND EVALUATION**

#### **4.1 SUBMISSION OF PROPOSALS**

Proposals shall be submitted with most favorable terms that can be proposed. There will be no best and final offer procedure. Proposals shall be submitted electronically through the City of Spokane's online procurement system portal: <https://spokane.procureware.com> before the due date and time. **Hard paper, e-mailed or faxed copies will not be accepted. Late Proposals shall not be accepted.** Proposers must register if they have not done so previously and follow the steps below to enter and submit the electronic Proposal:

1. Click on "Bids" located on the left hand column.
2. Find the applicable project and click the "Project Number".
3. Click on the "Response" tab.
4. In the "Questions" tab, **answer questions and** upload required documents into the bid portal by clicking on "Browse" for each item. Note that only one document can be uploaded per question line item so combine if necessary.
5. Click on the "Pricing" tab and enter pricing as requested. A "Comment" field is available if needed. If there are no lines in the "Pricing" Tab, skip tab. Cost shall be included in Proposal document submitted.
6. Once the Questions have been entered, the yellow "Question Response" information message will change from incomplete to complete. Then the "Submit" button will become available.
7. Click the "Submit Bid" button and review the terms and conditions, pop-up window that appears. If you agree to the terms and conditions, click the "I Accept and Submit this Bid" button.
8. If you want to remove your Proposal, click the red "Withdraw Bid" button in the "Response" tab for the applicable Proposal.

## 4.2 EVALUATION PROCEDURE

Responsive Proposals will be evaluated in accordance with the requirements stated in this solicitation and any addenda issued. The City, at its sole discretion, may elect to select the top-scoring Firms as finalists for an oral presentation and evaluation. The RFP Coordinator may contact the Firm for clarification of any portion of the Firm's Proposal.

## 4.3 EVALUATION SCORING

The Proposal will be evaluated as follows:

<b>TECHNICAL PROPOSAL – 24%</b> Adequacy and completeness of the statement with regard to the information specified. i.e., compliance with terms, conditions and other provisions contained in the RFP	24 Points Available	24
<b>MANAGEMENT PROPOSAL - 24%</b> Qualifications, experience and education of respondent	24 Points Available	24
Professional ability to satisfactorily perform the required services as described in the Scope of Work section of this document. – 24%	24 Points Available	24
<b>REFERENCES – 24%</b>	24 Points Available	24
<b>COST PROPOSAL – 4%</b>	4 Points Available	4
<b>GRAND TOTAL FOR WRITTEN PROPOSAL</b>		<b>100 POINTS</b>

## 4.4 AWARD/REJECTION OF PROPOSAL/CONTRACT

This RFP does not obligate the City to award a contract. Any contract awarded as a result of this procurement is contingent upon the availability of funding.

The City of Spokane reserves the option of awarding this contract in any manner most advantageous for the City and without further discussion of submitted Proposal. Failure to comply with any part of the RFP may result in rejection of Proposal as non-responsive. The City also reserves the right, at its sole discretion, to waive minor irregularities, reject any and all Proposals received without penalty and to not issue a contract from this RFP. More than one contract may be awarded. Contract negotiations may incorporate some or all of the Proposal.

Award of contract, when and if made, will be to the proposer whose Proposal is the most favorable to the City including consideration the evaluation criteria. Interlocal agreements accessing other agency contracts where applicable may be considered as a Proposal.

## 6. RFP ATTACHMENTS

Attached to this RFP and incorporated herein by reference are the following background documents:

1. Terms & Conditions Document



**Agenda Sheet for City Council Meeting of:**  
06/27/2022

<b>Date Rec'd</b>	6/15/2022
<b>Clerk's File #</b>	OPR 2022-0465
<b>Renews #</b>	
<b>Cross Ref #</b>	OPR 2017-0420
<b>Project #</b>	
<b>Bid #</b>	RFP 5652-22
<b>Requisition #</b>	TBD

<b>Submitting Dept</b>	HUMAN RESOURCES
<b>Contact Name/Phone</b>	JOHNNIE PERKINS X6502
<b>Contact E-Mail</b>	JPERKINS@SPOKANECITY.ORG
<b>Agenda Item Type</b>	Contract Item
<b>Agenda Item Name</b>	0620 MASTER CONTRACT WITH ALLIANT INSURANCE SERVICES FOR EMPLOYEE BENEFITS

**Agenda Wording**

On May 9, 2022, RFP #5652-22; Employee Benefits Broker/Consultant Services was sent to 41 prospective Firms. Three (3) responses were received. The response from Alliant Insurance Services was determined to best meet the needs of the City.

**Summary (Background)**

The current provider for these services is Alliant Insurance Services & their contract expires July 1, 2022. The initial contract term will be for three (3) years beginning July 1, 2022 through June 30, 2025. There will be an option to renew the Contract, based on performance, for two (2) one (1) year renewal options. This totals, the potential of, five (5) years.

Lease? NO Grant related? NO Public Works? NO

**Fiscal Impact**

Expense	\$ 95,000.00 annually
Expense	\$ \$20,000.00 annually
Expense	\$ \$20,000.00 annually
Select	\$

**Budget Account**

#	5830-78710-17310-54201-99999
#	6200-85020-17210-54620-99999
#	6300-85030-17210-54620-99999
#	

**Approvals**

<b>Dept Head</b>	PICCOLO, MIKE
<b>Division Director</b>	PICCOLO, MIKE
<b>Finance</b>	MURRAY, MICHELLE
<b>Legal</b>	PICCOLO, MIKE
<b>For the Mayor</b>	ORMSBY, MICHAEL

**Council Notifications**

<b>Study Session\Other</b>	06/27/22 Finance Committee
<b>Council Sponsor</b>	CM Wilkerson

**Additional Approvals**

<b>Purchasing</b>	

**Distribution List**

	tcollins@spokanecity.org
	shenry@spokanecity.org
	jlargent@spokanecity.org
	kbustos@spokanecity.org
	mpiccolo@spokanecity.org
	paul.belles@alliant.com

## Committee Agenda Sheet

### FINANCE COMMITTEE

<b>Submitting Department</b>	Human Resources - Employee Benefits
<b>Contact Name &amp; Phone</b>	Johnnie Perkins, City Administrator
<b>Contact Email</b>	<a href="mailto:jperkins@spokanecity.org">jperkins@spokanecity.org</a>
<b>Council Sponsor(s)</b>	CM Wilkerson
<b>Select Agenda Item Type</b>	<input checked="" type="checkbox"/> Consent <input type="checkbox"/> Discussion    Time Requested: _____
<b>Agenda Item Name</b>	Employee Benefits Broker/Consultant Services Master Contract: Alliant Insurance Services
<b>Summary (Background)</b>	<p>On May 9, 2022, RFP #5652-22; Employee Benefits Broker/Consultant Services was sent to 41 prospective Firms. Three (3) responses were received. The response from Alliant Insurance Services was determined to best meet the needs of the City. The current provider for these services is Alliant Insurance Services, their contract expires July 1, 2022.</p> <p>On May 16, 2022, three (3) sealed proposals were received to provide the City of Spokane with professional Broker/Consultant services. These services include, but are not limited to the following:</p> <ul style="list-style-type: none"> <li>• Provide services for medical, dental, life and disability insurance</li> <li>• Assist the City in establishing risk retention strategies including setting rates for our self-insured medical and dental plans</li> <li>• Negotiate our fixed costs, including stop-loss, with our Third Party Administrators</li> <li>• Evaluate our claims data and model impacts to various plan design changes while managing the potential change to the health care spend, always ensuring the high quality of health care does not suffer</li> <li>• Continually keep us updated on state and federal mandates which keeps us in compliance with the law</li> </ul> <p>The initial contract term will be for three (3) years beginning July 1, 2022 through June 30, 2025. There will be an option to renew the Contract, based on performance, for two (2) one (1) year renewal options. This totals, the potential of, five (5) years.</p>
<b>Proposed Council Action &amp; Date:</b>	Approval of Master Contract with Alliant Insurance Services.
<p><b>Fiscal Impact:</b>  <u>Total Cost: \$135,000 per year for 3 years (\$95k City portion/\$40k LEOFF portion) w/ two (2) optional one (1) year renewal options @ \$145,000 per year (\$102k City portion/\$43k LEOFF portion)</u></p> <p>Approved in current year budget?    <input checked="" type="checkbox"/> Yes    <input type="checkbox"/> No    <input type="checkbox"/> N/A</p> <p>Funding Source                    <input type="checkbox"/> One-time    <input checked="" type="checkbox"/> Recurring</p> <p>Specify funding source:</p>	

Expense Occurrence     One-time     Recurring

Other budget impacts: (revenue generating, match requirements, etc.)

**Operations Impacts**

What impacts would the proposal have on historically excluded communities?

N/A

How will data be collected, analyzed, and reported concerning the effect of the program/policy by racial, ethnic, gender identity, national origin, income level, disability, sexual orientation, or other existing disparities?

N/A

How will data be collected regarding the effectiveness of this program, policy or product to ensure it is the right solution?

The Firm will provide annual Stewardship Reports. Additionally, the City communicates with the Firm, nearly weekly, throughout the year.

Describe how this proposal aligns with current City Policies, including the Comprehensive Plan, Sustainability Action Plan, Capital Improvement Program, Neighborhood Master Plans, Council Resolutions, and others?

*These services provide protection to the City by ensuring we stay in compliance with State and Federal laws and/or mitigates risk to the City that could be experienced through fines and/or penalties.*





**City of Spokane**  
**CONSULTANT AGREEMENT**  
**Title: EMPLOYEE BENEFITS  
BROKER/CONSULTANT SERVICES**

This Consultant Agreement is made and entered into by and between the **CITY OF SPOKANE** as ("City"), a Washington municipal corporation, and **ALLIANT INSURANCE SERVICES**, whose address is 818 West Riverside Avenue, Spokane, Washington 99201 as ("Consultant"), individually hereafter referenced as a "party", and together as the "parties".

*WHEREAS, the purpose of this Agreement is to provide Employee Benefits Broker/Consultant Services and*

*WHEREAS, the Consultant was selected from Request for Proposals No. 5652-22.*

*NOW, THEREFORE, in consideration of the terms, conditions, covenants and performance of the Scope of Work contained herein, the City and Consultant mutually agree as follows:*

**1. TERM OF AGREEMENT.**

The term of this Agreement begins on July 1, 2022, and ends on June 30, 2025, unless amended by written agreement or terminated earlier under the provisions. This Agreement may be renewed for two (2) one-year renewal options upon mutual agreement of the parties.

**2. TIME OF BEGINNING AND COMPLETION.**

The Consultant shall begin the work outlined in the "Scope of Work" ("Work") on the beginning date, above. The City will acknowledge in writing when the Work is complete. Time limits established under this Agreement shall not be extended because of delays for which the Consultant is responsible, but may be extended by the City, in writing, for the City's convenience or conditions beyond the Consultant's control.

**3. SCOPE OF WORK.**

The General Scope of Work for this Agreement is described in the City's Request for Proposal, and in Consultant's Response which is attached as Exhibit B and made a part of this Agreement. In the event of a conflict or discrepancy in the contract documents, this City Agreement controls.

The Work is subject to City review and approval. The Consultant shall confer with the City periodically, and prepare and present information and materials (e.g. detailed outline of completed Work) requested by the City to determine the adequacy of the Work or Consultant's progress.

#### **4. COMPENSATION.**

Total compensation for Consultant's services under this Agreement shall not exceed **FOUR HUNDRED FIVE THOUSAND AND NO/100 DOLLARS (\$405,000.00)**, excluding tax, if applicable, unless modified by a written amendment to this Agreement. This is the maximum amount to be paid under this Agreement for the work described in Section 3 above, and shall not be exceeded without the prior written authorization of the City in the form of an executed amendment to this Agreement.

#### **5. PAYMENT.**

The Consultant shall submit its applications for payment to City of Spokane Human Resources Department, Fourth Floor, City Hall, 808 West Spokane Falls Boulevard, Spokane, Washington 99201. **Payment will be made via direct deposit/ACH** within thirty (30) days after receipt of the Consultant's application except as provided by state law. If the City objects to all or any portion of the invoice, it shall notify the Consultant and pay that portion of the invoice not in dispute. In that event, the parties shall immediately make every effort to settle the disputed amount.

#### **6. TAXES, FEES AND LICENSES.**

- A. Consultant shall pay and maintain in current status, all necessary licenses, fees, assessments, permit charges, etc. necessary to conduct the work included under this Agreement. It is the Consultant's sole responsibility to monitor and determine changes or the enactment of any subsequent requirements for said fees, assessments, or changes and to immediately comply.
- B. Where required by state statute, ordinance or regulation, Consultant shall pay and maintain in current status all taxes necessary for performance. Consultant shall not charge the City for federal excise taxes. The City will furnish Consultant an exemption certificate where appropriate.
- C. The Director of Finance and Administrative Services may withhold payment pending satisfactory resolution of unpaid taxes and fees due the City.
- D. The cost of any permits, licenses, fees, etc. arising as a result of the projects included in this Agreement shall be included in the project budgets.

#### **7. CITY OF SPOKANE BUSINESS LICENSE.**

Section 8.01.070 of the Spokane Municipal Code states that no person may engage in business with the City without first having obtained a valid annual business registration. The Consultant shall be responsible for contacting the State of Washington Business License Services at [www.dor.wa.gov](http://www.dor.wa.gov) or 360-705-6741 to obtain a business registration. If the Contractor does not believe it is required to obtain a business registration, it may contact the City's Taxes and Licenses Division at (509) 625-6070 to request an exemption status determination.

#### **8. SOCIAL EQUITY REQUIREMENTS.**

No individual shall be excluded from participation in, denied the benefit of, subjected to discrimination under, or denied employment in the administration of or in connection with this Agreement because of age, sex, race, color, religion, creed, marital status, familial status, sexual orientation including gender expression or gender identity, national origin, honorably discharged veteran or military status, the presence of any sensory, mental or physical disability, or use of a service animal by a person with disabilities. Consultant agrees to comply with, and to require that all subcontractors comply with, Section 504 of the Rehabilitation Act of 1973 and the Americans with Disabilities Act, as applicable to the Consultant. Consultant shall seek inclusion of woman and minority business for subcontracting. A woman or minority business is one that self-identifies to be at least 51% owned by a woman and/or minority. Such firms do not have to be certified by the State of Washington.

#### **9. INDEMNIFICATION.**

The Consultant shall indemnify, and hold the City and its officers and employees harmless from all claims, demands, or suits at law or equity asserted by third parties for bodily injury (including death) and/or property damage to the extent caused by the Consultant's negligence or willful misconduct under this Agreement, including attorneys' fees and litigation costs; provided that nothing herein shall require a Consultant to indemnify the City against and hold harmless the City from claims, demands or suits based solely upon the negligence of the City, its agents, officers, and employees. If a claim or suit is caused by or results from the concurrent negligence of the Consultant's agents or employees and the City, its agents, officers and employees, this indemnity provision shall be valid and enforceable to the extent of the negligence of the Consultant, its agents or employees. The Consultant specifically assumes liability and agrees to defend, indemnify, and hold the City harmless for actions brought by the Consultant's own employees against the City and, solely for the purpose of this indemnification and defense, the Consultant specifically waives any immunity under the Washington State industrial insurance law, or Title 51 RCW. The Consultant recognizes that this waiver was specifically entered into pursuant to the provisions of RCW 4.24.115 and was the subject of mutual negotiation. The indemnity and agreement to defend and hold the City harmless provided for in this section shall survive any termination or expiration of this agreement.

## **10. INSURANCE.**

During the period of the Agreement, the Consultant shall maintain in force at its own expense, each insurance noted below with companies or through sources approved by the State Insurance Commissioner pursuant to RCW Title 48;

A. Worker's Compensation Insurance in compliance with RCW 51.12.020, which requires subject employers to provide workers' compensation coverage for all their subject workers and Employer's Liability Insurance in the amount of \$1,000,000;

B. General Liability Insurance on an occurrence basis, with a combined single limit of not less than \$1,000,000 each occurrence for bodily injury and property damage. It shall include contractual liability coverage for the indemnity provided under this agreement. It shall provide that the City, its officers and employees are additional insureds but only with respect to the Consultant's services to be provided under this Agreement; and

C. Automobile Liability Insurance with a combined single limit, or the equivalent of not less than \$1,000,000 each accident for bodily injury and property damage, including coverage for owned, hired and non-owned vehicles.

D. Professional Liability Insurance with a combined single limit of not less than \$1,000,000 each claim, incident or occurrence. This is to cover damages caused by the error, omission, or negligent acts related to the professional services to be provided under this Agreement. The coverage must remain in effect for at least two (2) years after the Agreement is completed.

There shall be no cancellation, material change, reduction of limits or intent not to renew the insurance coverage(s) without forty-five (45) days written notice from the Consultant or its insurer(s) to the City. As evidence of the insurance coverage(s) required by this Agreement, the Consultant shall furnish acceptable Certificates Of Insurance (COI) to the City at the time it returns this signed Agreement. The certificate shall specify the City of Spokane as "Additional Insured" specifically for Consultant's services under this Agreement, as well as all of the parties who are additional insureds, and include applicable policy endorsements, the -forty-five (45) day cancellation clause, and the deduction or retention level. The Consultant shall be financially responsible for all pertinent deductibles, self-insured retentions, and/or self-insurance.

## **11. DEBARMENT AND SUSPENSION.**

The Consultant has provided its certification that it is in compliance with and shall not contract with individuals or organizations which are debarred, suspended, or otherwise excluded from or ineligible from participation in Federal Assistance Programs under Executive Order 12549 and "Debarment and Suspension", codified at 29 CFR part 98.

## **12. AUDIT.**

Upon request, the Consultant shall permit the City and any other governmental agency ("Agency") involved in the funding of the Work to inspect and audit all pertinent books and records. This includes work of the Consultant, any subconsultant, or any other person or entity that performed connected or related Work. Such books and records shall be made available upon reasonable notice of a request by the City, including up to three (3) years after final payment or release of withheld amounts. Such inspection and audit shall occur in Spokane County, Washington, or other reasonable locations mutually agreed to by the parties. The Consultant shall permit the City to copy such books and records at its own expense. The Consultant shall ensure that inspection, audit and copying rights of the City is a condition of any subcontract, agreement or other arrangement under which any other persons or entity may perform Work under this Agreement.

## **13. INDEPENDENT CONSULTANT.**

- A. The Consultant is an independent Consultant. This Agreement does not intend the Consultant to act as a City employee. The City has neither direct nor immediate control over the Consultant nor the right to control the manner or means by which the Consultant works. Neither the Consultant nor any Consultant employee shall be an employee of the City. This Agreement prohibits the Consultant to act as an agent or legal representative of the City. The Consultant is not granted express or implied rights or authority to assume or create any obligation or responsibility for or in the name of the City, or to bind the City. The City is not liable for or obligated to pay sick leave, vacation pay, or any other benefit of employment, nor to pay social security or other tax that may arise from employment. The Consultant shall pay all income and other taxes as due. The Consultant may perform work for other parties; the City is not the exclusive user of the services that the Consultant provides.
- B. If the City needs the Consultant to Work on City premises and/or with City equipment, the City may provide the necessary premises and equipment. Such premises and equipment are exclusively for the Work and not to be used for any other purpose.
- C. If the Consultant works on the City premises using City equipment, the Consultant remains an independent Consultant and not a City employee. The Consultant will notify the City Project Manager if s/he or any other Workers are within ninety (90) days of a consecutive 36-month placement on City property. If the City determines using City premises or equipment is unnecessary to complete the Work, the Consultant will be required to work from its own office space or in the field. The City may negotiate a reduction in Consultant fees or charge a rental fee based on the actual costs to the City, for City premises or equipment.

## **14. KEY PERSONS.**

The Consultant shall not transfer or reassign any individual designated in this Agreement as essential to the Work, nor shall those key persons, or employees of Consultant identified as to be involved in the Project Work be replaced, removed or withdrawn from the Work without the express written consent of the City, which shall not be unreasonably withheld. If any such individual leaves the Consultant's employment, the Consultant shall present to the City one or more individuals with greater or equal qualifications as a replacement, subject to the City's approval, which shall not be unreasonably withheld. The City's approval does not release the Consultant from its obligations under this Agreement.

## **15. ASSIGNMENT AND SUBCONTRACTING.**

The Consultant shall not assign or subcontract its obligations under this Agreement without the City's written consent, which may be granted or withheld in the City's sole discretion. Any subcontract made by the Consultant shall incorporate by reference this Agreement, except as otherwise provided. The Consultant shall require that all subconsultants comply with the obligations and requirements of the subcontract. The City's consent to any assignment or subcontract does not release the consultant from liability or any obligation within this Agreement, whether before or after City consent, assignment or subcontract.

#### **16. CITY ETHICS CODE.**

- A. Consultant shall promptly notify the City in writing of any person expected to be a Consultant Worker (including any Consultant employee, subconsultant, principal, or owner) and was a former City officer or employee within the past twelve (12) months.
- B. Consultant shall ensure compliance with the City Ethics Code by any Consultant Worker when the Work or matter related to the Work is performed by a Consultant Worker who has been a City officer or employee within the past two (2) years.
- C. Consultant shall not directly or indirectly offer anything of value (such as retainers, loans, entertainment, favors, gifts, tickets, trips, favors, bonuses, donations, special discounts, work or meals) to any City employee, volunteer or official that is intended, or may appear to a reasonable person to be intended, to obtain or give special consideration to the Consultant. Promotional items worth less than \$25 may be distributed by the Consultant to a City employee if the Consultant uses the items as routine and standard promotional materials. Any violation of this provision may cause termination of this Agreement. Nothing in this Agreement prohibits donations to campaigns for election to City office, so long as the donation is disclosed as required by the election campaign disclosure laws of the City and of the State.

#### **17. NO CONFLICT OF INTEREST.**

Consultant confirms that the Consultant or workers have no business interest or a close family relationship with any City officer or employee who was or will be involved in the consultant selection, negotiation, drafting, signing, administration or evaluation of the Consultant's work. As used in this Section, the term Consultant includes any worker of the Consultant who was, is, or will be, involved in negotiation, drafting, signing, administration or performance of the Agreement. The term "close family relationship" refers to: spouse or domestic partner, any dependent parent, parent-in-law, child, son-in-law, daughter-in-law; or any parent, parent in-law, sibling, uncle, aunt, cousin, niece or nephew residing in the household of a City officer or employee described above.

#### **18. ERRORS AND OMISSIONS, CORRECTIONS.**

Consultant is responsible for professional quality, technical accuracy, and the coordination of all designs, drawings, specifications, and other services furnished by or on the behalf of the Consultant under this Agreement in the delivery of a final work product. The standard of care applicable to Consultant's services will be the degree of skill and diligence normally employed by professional engineers or Consultants performing the same or similar services at the time said services are performed. The Final Work Product is defined as a stamped, signed work product. Consultant, without additional compensation, shall correct or revise errors or mistakes in designs, drawings, specifications, and/or other consultant services immediately upon notification by the City. The obligation provided for in this Section regarding acts or omissions resulting from this Agreement survives Agreement termination or expiration.

#### **19. INTELLECTUAL PROPERTY RIGHTS.**

- A. Copyrights. The Consultant shall retain the copyright (including the right of reuse) to all materials and documents prepared by the Consultant for the Work, whether or not the Work is completed. The Consultant grants to the City a non-exclusive, irrevocable, unlimited, royalty-free license to use copy and distribute every document and all the materials

prepared by the Consultant for the City under this Agreement. If requested by the City, a copy of all drawings, prints, plans, field notes, reports, documents, files, input materials, output materials, the media upon which they are located (including cards, tapes, discs, and other storage facilities), software program or packages (including source code or codes, object codes, upgrades, revisions, modifications, and any related materials) and/or any other related documents or materials developed solely for and paid for by the City to perform the Work, shall be promptly delivered to the City.

- B. Patents: The Consultant assigns to the City all rights in any invention, improvement, or discovery, with all related information, including but not limited to designs, specifications, data, patent rights and findings developed with the performance of the Agreement or any subcontract. Notwithstanding the above, the Consultant does not convey to the City, nor does the City obtain, any right to any document or material utilized by the Consultant created or produced separate from the Agreement or was pre-existing material (not already owned by the City), provided that the Consultant has identified in writing such material as pre-existing prior to commencement of the Work. If pre-existing materials are incorporated in the work, the Consultant grants the City an irrevocable, non-exclusive right and/or license to use, execute, reproduce, display and transfer the pre-existing material, but only as an inseparable part of the work.
- C. The City may make and retain copies of such documents for its information and reference with their use on the project. The Consultant does not represent or warrant that such documents are suitable for reuse by the City or others, on extensions of the project or on any other project, and the City releases the Consultant from liability for any unauthorized reuse of such documents.

## **20. CONFIDENTIALITY.**

Notwithstanding anything to the contrary, City will maintain the confidentiality of Consultant's materials and information only to the extent that is legally allowed in the State of Washington. City is bound by the State Public Records Act, RCW Ch. 42.56. That law presumptively makes all records in the possession of the City public records which are freely available upon request by anyone. In the event that City gets a valid public records request for Consultant's materials or information and the City determines there are exemptions only the Consultant can assert, City will endeavor to give Consultant notice. Consultant will be required to go to Court to get an injunction preventing the release of the requested records. In the event that Consultant does not get a timely injunction preventing the release of the records, the City will comply with the Public Records Act and release the records.

## **21. DISPUTES.**

Any dispute or misunderstanding that may arise under this Agreement, concerning the Consultant's performance, shall first be through negotiations, if possible, between the Consultant's Project Manager and the City's Project Manager. It shall be referred to the Director and the Consultant's senior executive(s). If such officials do not agree upon a decision within a reasonable period of time, either party may decline or discontinue such discussions and may then pursue the legal means to resolve such disputes, including but not limited to mediation, arbitration and/or alternative dispute resolution processes. Nothing in this dispute process shall mitigate the rights of the City to terminate the Agreement. Notwithstanding all of the above, if the City believes in good faith that some portion of the Work has not been completed satisfactorily, the City may require the Consultant to correct such work prior to the City payment. The City will provide to the Consultant an explanation of the concern and the remedy that the City expects. The City may withhold from any payment otherwise due, an amount that the City in good faith finds to be under dispute, or if the Consultant provides no sufficient remedy, the City may retain the amount equal to the cost to the City for otherwise correcting or remedying the work not properly completed. Waiver of any of these rights is not deemed a future waiver of any such right or remedy available at law, contract or equity.

## **22. TERMINATION.**

- A. For Cause: The City or Consultant may terminate the Agreement if the other party is in material breach of this Agreement, and such breach has not been corrected to the other party's reasonable satisfaction in a timely manner. Notice of termination under this Section shall be given by the party terminating this Agreement to the other, not fewer than thirty (30) business days prior to the effective date of termination.
- B. For Reasons Beyond Control of Parties: Either party may terminate this Agreement without recourse by the other where performance is rendered impossible or impracticable for reasons beyond such party's reasonable control, such as, but not limited to, an act of nature, war or warlike operation, civil commotion, riot, labor dispute including strike, walkout or lockout, except labor disputes involving the Consultant's own employees, sabotage, or superior governmental regulation or control. Notice of termination under this Section shall be given by the party terminating this Agreement to the other, not fewer than thirty (30) business days prior to the effective date of termination.
- C. For Convenience: Either party may terminate this Agreement without cause, upon thirty (30) days written notice to the other party.
- D. Actions upon Termination: if termination occurs not the fault of the Consultant, the Consultant shall be paid for the services properly performed prior to the actual termination date, with any reimbursable expenses then due, but such compensation shall not exceed the maximum compensation to be paid under the Agreement. The Consultant agrees this payment shall fully and adequately compensate the Consultant and all subconsultants for all profits, costs, expenses, losses, liabilities, damages, taxes and charges of any kind (whether foreseen or unforeseen) attributable to the termination of this Agreement.
- E. Upon termination, the Consultant shall provide the City with the most current design documents, contract documents, writings and other products the Consultant has produced to termination, along with copies of all project-related correspondence and similar items. The City shall have the same rights to use these materials as if termination had not occurred; provided however, that the City shall indemnify and hold the Consultant harmless from any claims, losses, or damages to the extent caused by modifications made by the City to the Consultant's work product.

## **23. EXPANSION FOR NEW WORK.**

This Agreement scope may be expanded for new work. Any expansion for New Work (work not specified within the original Scope of Work Section of this Agreement, and/or not specified in the original RFP as intended work for the Agreement) must comply with all the following limitations and requirements: (a) the New Work is not reasonable to solicit separately; (b) the New Work is for reasonable purpose; (c) the New Work was not reasonably known either the City or Consultant at time of contract or else was mentioned as a possibility in the solicitation (such as future phases of work, or a change in law); (d) the New Work is not significant enough to be reasonably regarded as an independent body of work; (e) the New Work would not have attracted a different field of competition; and (f) the change does not vary the essential identified or main purposes of the Agreement. The City may make exceptions for immaterial changes, emergency or sole source conditions, or other situations required in City opinion. Certain changes are not New Work subject to these limitations, such as additional phases of Work anticipated at the time of solicitation, time extensions, Work Orders issued on an On-Call contract, and similar. New Work must be mutually agreed and issued by the City through written Addenda. New Work performed before an authorizing Amendment may not be eligible for payment.

## **24. MISCELLANEOUS PROVISIONS.**

- A. Amendments: No modification of this Agreement shall be effective unless in writing and signed by an authorized representative of each of the parties hereto.

- B. Binding Agreement: This Agreement shall not be binding until signed by both parties. The provisions, covenants and conditions in this Agreement shall bind the parties, their legal heirs, representatives, successors and assigns.
- C. Americans with Disabilities Act (ADA): Specific attention by the designer is required in association with the Americans with Disabilities Act (ADA) 42 U.S.C. 12101-12213 and 47 U.S.C. 225 and 611, its requirements, regulations, standards and guidelines, which were updated in 2010 and are effective and mandatory for all State and local government facilities and places of public accommodation for construction projects including alteration of existing facilities, as of March 15, 2012. The City advises that the requirements for accessibility under the ADA, may contain provisions that differ substantively from accessibility provisions in applicable State and City codes, and if the provisions of the ADA impose a greater or equal protection for the rights of individuals with disabilities or individuals associated with them than the adopted local codes, the ADA prevail unless approval for an exception is obtained by a formal documented process. Where local codes provide exceptions from accessibility requirements that differ from the ADA Standards; such exceptions may not be permitted for publicly owned facilities subject to Title II requirements unless the same exception exists in the Title II regulations. It is the responsibility of the designer to determine the code provisions.
- D. The Consultant, at no expense to the City, shall comply with all laws of the United States and Washington, the Charter and ordinances of the City of Spokane; and rules, regulations, orders and directives of their administrative agencies and officers. Without limiting the generality of this paragraph, the Consultant shall comply with the requirements of this Section.
- E. This Agreement shall be construed and interpreted under the laws of Washington. The venue of any action brought shall be in the Superior Court of Spokane County.
- F. Remedies Cumulative: Rights under this Agreement are cumulative and nonexclusive of any other remedy of law or in equity.
- G. Captions: The titles of sections or subsections are for convenience only and do not define or limit the contents.
- H. Severability: If any term or provision is determined by a court of competent jurisdiction to be invalid or unenforceable, the remainder of this Agreement shall not be affected, and each term and provision shall be valid and enforceable to the fullest extent permitted by law.
- I. Waiver: No covenant, term or condition or the breach shall be deemed waived, except by written consent of the party against whom the waiver is claimed, and any waiver of the breach of any covenant, term or condition shall not be deemed a waiver of any preceding or succeeding breach of the same or any other covenant, term of condition. Neither the acceptance by the City of any performance by the Consultant after the time the same shall have become due nor payment to the Consultant for any portion of the Work shall constitute a waiver by the City of the breach or default of any covenant, term or condition unless otherwise expressly agreed to by the City in writing.
- J. Additional Provisions: This Agreement may be modified by additional terms and conditions ("Special Conditions") which shall be attached to this Agreement as an Exhibit. The parties agree that the Special Conditions shall supplement the terms and conditions of the Agreement, and in the event of ambiguity or conflict with the terms and conditions of the Agreement, these Special Conditions shall govern.
- K. Entire Agreement: This document along with any exhibits and all attachments, and subsequently issued addenda, comprises the entire agreement between the City and the Consultant. If conflict occurs between contract documents and applicable laws, codes, ordinances or regulations, the most stringent or legally binding requirement shall govern and be considered a part of this contract to afford the City the maximum benefits.
- L. Negotiated Agreement: The parties acknowledge this is a negotiated agreement, that they have had this Agreement reviewed by their respective legal counsel, and that the terms and conditions of this Agreement are not to be construed against any party on the basis of such party's draftsmanship.



M. No personal liability: No officer, agent or authorized employee of the City shall be personally responsible for any liability arising under this Agreement, whether expressed or implied, nor for any statement or representation made or in any connection with this Agreement.

IN WITNESS WHEREOF, in consideration of the terms, conditions and covenants contained, or attached and incorporated and made a part, the parties have executed this Agreement by having legally-binding representatives affix their signatures below.

**ALLIANT INSURANCE SERVICES**

**CITY OF SPOKANE**

By \_\_\_\_\_  
Signature Date

By \_\_\_\_\_  
Signature Date

\_\_\_\_\_  
Type or Print Name

\_\_\_\_\_  
Type or Print Name

\_\_\_\_\_  
Title

\_\_\_\_\_  
Title

Attest:

Approved as to form:

\_\_\_\_\_  
City Clerk

\_\_\_\_\_  
Assistant City Attorney

**Attachments:**

- Exhibit A – Certificate Regarding Debarment
- Exhibit B – Consultant’s Response to RFP

**EXHIBIT A**

**CERTIFICATION REGARDING DEBARMENT, SUSPENSION,  
INELIGIBILITY AND VOLUNTARY EXCLUSION**

1. The undersigned (i.e., signatory for the Subrecipient / Contractor / Consultant) certifies, to the best of its knowledge and belief, that it and its principals:
  - a. Are not presently debarred, suspended, proposed for debarment, declared ineligible, or voluntarily excluded from covered transactions by any federal department or agency;
  - b. Have not within a three-year period preceding this contract been convicted or had a civil judgment rendered against them for commission of fraud or a criminal offense in connection with obtaining, attempting to obtain, or performing a public (federal, state, or local) transaction or contract under a public transaction; violation of federal or state antitrust statutes or commission of embezzlement, theft, forgery, bribery, falsification or destruction of records, making false statements, tax evasion, receiving stolen property, making false claims, or obstruction of justice;
  - c. Are not presently indicted or otherwise criminally or civilly charged by a government entity (federal, state, or local) with commission of any of the offenses enumerated in paragraph (1)(b) of this certification; and,
  - d. Have not within a three-year period preceding this contract had one or more public transactions (federal, state, or local) terminated for cause or default.
  
2. The undersigned agrees by signing this contract that it shall not knowingly enter into any lower tier covered transaction with a person who is debarred, suspended, declared ineligible, or voluntarily excluded from participation in this covered transaction.
  
3. The undersigned further agrees by signing this contract that it will include the following clause, without modification, in all lower tier covered transactions and in all solicitations for lower tier covered transactions:
 

Certification Regarding Debarment, Suspension, Ineligibility and Voluntary Exclusion – Lower Tier Covered Transactions

  1. The lower tier contractor certified, by signing this contract that neither it nor its principals is presently debarred, suspended, proposed for debarment, declared ineligible, or voluntarily excluded from participation in this transaction by any federal department or agency.
  
  2. Where the lower tier contractor is unable to certify to any of the statements in this contract, such contractor shall attach an explanation to this contract.
  
4. I understand that a false statement of this certification may be grounds for termination of the contract.

<hr/> Name of Subrecipient / Contractor / Consultant (Type or Print)	<hr/> Program Title (Type or Print)
<hr/> Name of Certifying Official (Type or Print)	<hr/> Signature
<hr/> Title of Certifying Official (Type or Print)	<hr/> Date (Type or Print)

**EXHIBIT B**

**Agenda Sheet for City Council Meeting of:**

06/06/2022

<b>Date Rec'd</b>	5/24/2022
<b>Clerk's File #</b>	OPR 2022-0412
<b>Renews #</b>	
<b>Cross Ref #</b>	
<b>Project #</b>	
<b>Bid #</b>	RFP 5435-21
<b>Requisition #</b>	MASTER

<b>Submitting Dept</b>	INNOVATION & TECHNOLOGY SERVICES
<b>Contact Name/Phone</b>	MICHAEL SLOON 625-6468
<b>Contact E-Mail</b>	MSLOON@SPOKANECITY.ORG
<b>Agenda Item Type</b>	Contract Item
<b>Agenda Item Name</b>	5300 VOLT - TECHNICAL SERVICES FOR PMO, CHHS & ITSD PROJECTS

**Agenda Wording**

Contract with Volt Management Corp. for technical services in support of PMO, CHHS and ITSD projects. Requesting \$350,000 per year, not including tax. Term is May 1, 2022 - April 30, 2024.

**Summary (Background)**

The PMO, CHHS and ITSD currently manages several projects that occasionally require augmentation to City resources. Specific contracting needs will be in the areas of Project Management, Business Analysis, Software Development and Infrastructure support. Volt was a successful bidder under RFP 5435-21 to be contracted for various PMO and ITSD projects. The 2022 annual contract amount is \$350,000.

Lease? NO Grant related? NO Public Works? NO

**Fiscal Impact**

Expense \$ 350,000.00

Select \$

Select \$

Select \$

**Budget Account**

# Various Accounts

#

#

#

**Approvals****Dept Head** SLOON, MICHAEL**Division Director** FINCH, ERIC**Finance** MURRAY, MICHELLE**Legal** ODLE, MARI**For the Mayor** ORMSBY, MICHAEL**Additional Approvals****Purchasing** WAHL, CONNIE**Council Notifications****Study Session\Other** 5/23/22 PIES Committee**Council Sponsor** CM Michael Cathcart**Distribution List**

Accounting - ywang@spokanecity.org

Contract Accounting - ddaniels@spokanecity.org

Legal - modle@spokanecity.org

Purchasing - cwahl@spokanecity.org

IT - itadmin@spokanecity.org

Tax &amp; Licenses

Beau Burnett - BBurnett@volt.com

## Committee Agenda Sheet

### PIES Committee

<b>Submitting Department</b>	Innovation and Technology Services Division
<b>Contact Name &amp; Phone</b>	Michael Sloon, 625-6468
<b>Contact Email</b>	<a href="mailto:msloon@spokanecity.org">msloon@spokanecity.org</a>
<b>Council Sponsor(s)</b>	Michael Cathcart
<b>Select Agenda Item Type</b>	<input checked="" type="checkbox"/> Consent <input type="checkbox"/> Discussion    Time Requested: 5/23/2022
<b>Agenda Item Name</b>	Contract for Technical Services for PMO, CHHS and ITSD Projects
<b>Summary (Background)</b>	The PMO, CHHS and ITSD currently manages several projects that occasionally require augmentation to City resources. Specific contracting needs will be in the areas of Project Management, Business Analysis, Software Development and Infrastructure support. Volt Management, was a successful bidder under RFP 5435-21 to be contracted for various PMO and ITSD projects. Term is May 1, 2022 – April 30, 2024.
<b>Proposed Council Action &amp; Date:</b>	Pass Council on June 6 <sup>th</sup> , 2022
<b>Fiscal Impact:</b>	
Total Cost: \$350,000 per year	
Approved in current year budget? <input type="checkbox"/> Yes <input checked="" type="checkbox"/> No <input type="checkbox"/> N/A	
Funding Source <input type="checkbox"/> One-time <input checked="" type="checkbox"/> Recurring	
Specify funding source: Various	
Expense Occurrence <input type="checkbox"/> One-time <input checked="" type="checkbox"/> Recurring	
Other budget impacts:	
<b>Operations Impacts</b>	
What impacts would the proposal have on historically excluded communities?	
Not applicable – annual software maintenance	
How will data be collected, analyzed, and reported concerning the effect of the program/policy by racial, ethnic, gender identity, national origin, income level, disability, sexual orientation, or other existing disparities?	
Not applicable – annual software maintenance	
How will data be collected regarding the effectiveness of this program, policy or product to ensure it is the right solution?	
Not applicable – annual software maintenance	
Describe how this proposal aligns with current City Policies, including the Comprehensive Plan, Sustainability Action Plan, Capital Improvement Program, Neighborhood Master Plans, Council Resolutions, and others?	
This service aligns with the Sustainable Resources strategic initiative based on sound financial objectives, and quality customer service in support of PMO, CHHS and ITSD projects.	



**City of Spokane**  
**MASTER CONTRACT**  
Title: **TECHNICAL RESOURCES**

THIS MASTER CONTRACT is between the **CITY OF SPOKANE**, a Washington State municipal corporation, as ("City"), and **VOLT WORKFORCE SOLUTIONS, a division of VOLT MANAGEMENT, CORP.**, whose address is 2401 N. Glassell St., Orange, California 92865, as ("Company"), individually hereafter referenced as a "party", and together as the "parties".

The parties agree as follows:

1. **PERFORMANCE.** The Company will provide Technical Resources for the Project Management Office, CHHS, and Innovation and Technology Services Division in accordance with RFP 5435-21, and Company's Response to RFP, attached as Exhibit B. In the event of a discrepancy between the documents this City Contract controls. City shall supervise, direct and control the day-to-day work and/or tasks performed and to be performed by Technical Resources while assigned to City in accordance with City's rules, policies and procedures and furnish a safe and appropriate work environment, provide appropriate safety and hazardous materials training, and all tools and other materials, including protective devices, wearing apparel, instruments and/or other materials, required for Technical Resources to perform their duties in compliance with all local, state and federal employment, safety, health and environmental laws and regulations. City shall not request, require or permit Technical Resources to (i) operate any motorized vehicle or equipment or (ii) handle or be entrusted with (a) unattended premises, cash, checks, credit cards, merchandise, negotiable instruments, or other valuables or (b) sensitive financial information, protected health information or personally identifiable information regulated by law, without Company's express prior written approval.

**Background Screening.** Company at its sole expense will pre-screen contingent employees before placing them on assignment at the City for the following items: Social Security Number Trace, Criminal – County felonies and misdemeanors – 7 years off trace, Sanctions – OFAC (global terrorist watch list), 5 panel drug screen via oral swab.

2. **CONTRACT TERMS.** The Contract shall begin May 1, 2022, and run through April 30, 2024, unless amended by written agreement or terminated earlier under the provisions. This Contract may be renewed by agreement of the parties not to exceed three (3) additional one (1) year contract periods.

3. **COMPENSATION.** Total annual compensation for Company's services under this Agreement shall not exceed **THREE HUNDRED FIFTY THOUSAND AND NO/100 DOLLARS (\$350,000.00)**, plus any applicable tax for everything furnished and done under this Contract.

This is the maximum amount to be paid under this Contract for the work described in Section 3 above, and shall not be exceeded without the prior written authorization of the City in the form of an executed amendment to this Contract. Notwithstanding anything to the contrary, Company shall have the right to pass through rate increases associated with its staffing services in placing Technical Resources arising out of or resulting from increased costs associated with direct or indirect employer's contribution, legal or statutory changes, economic factors that influence actual costs, or any other conditions that increase Company's operational costs. Such rate increases shall become effective upon providing reasonable notice to City and shall not require further notice nor amendment. Furthermore, sick leave hours taken by an eligible Technical Resource will be invoiced to City at the applicable straight time bill rate.

4. PAYMENT. The Company shall send its application for payment to Innovation and Technology Services Division, Administration Office, Seventh Floor, City Hall, 808 West Spokane Falls Boulevard, Spokane, Washington 99201. **Payment will be made via direct deposit/ACH** within thirty (30) days after receipt of the Contractor's application except as provided by state law. The bill rates of Technical Resources shall be determined on a case by case basis and as mutually agreed to by the parties under the Work Authorization Template, attached as Exhibit C.

5. COMPLIANCE WITH LAWS. Each party shall comply with all applicable federal, state, and local laws and regulations.

6. ASSIGNMENTS. This Contract is binding on the parties and their heirs, successors, and assigns. Neither party may assign, transfer or subcontract its interest, in whole or in part, without the other party's prior written consent.

7. AMENDMENTS. This Contract may be amended at any time by mutual written agreement.

8. ANTI-KICKBACK. No officer or employee of the City of Spokane, having the power or duty to perform an official act or action related to this Contract shall have or acquire any interest in the Contract, or have solicited, accepted or granted a present or future gift, favor, service or other thing of value from or to any person involved in this Contract.

9. TERMINATION. Either party may terminate this Contract by thirty (30) days written notice to the other party. In the event of such termination, the City shall pay the Company for all work previously authorized and performed prior to the termination date.

10. INSURANCE. During the term of the Agreement, the Company shall maintain in force at its own expense, the following insurance coverages:

A. Worker's Compensation Insurance in compliance with RCW 51.12.020, which requires subject employers to provide workers' compensation coverage for all their subject workers; and

B. General Liability Insurance on an occurrence basis, with a combined single limit of not less than \$2,000,000 each occurrence for bodily injury and property damage, \$4,000,000 general aggregate. It shall include contractual liability coverage for the indemnity provided under this contract. It shall provide that the City, its officers and employees are additional insureds, but only with respect to the Contractor's services to be provided under this contract;

- i. Acceptable supplementary Umbrella insurance coverage, combined with the Company's General Liability insurance policy must be a *minimum* of \$1,000,000, in order to meet the insurance coverages required under this Contract;
- C. Automobile Liability Insurance with a combined single limit, or the equivalent of not less than \$3,000,000 each accident for bodily injury and property damage, including coverage for owned, hired and non-owned vehicles.

There shall be no cancellation, material change, reduction of limits or intent not to renew the insurance coverage(s) without the Company endeavoring to provide sixty (60) days written notice from the Company or its insurer(s) to the City. As evidence of the insurance coverage(s) required by this Agreement, the Company shall furnish acceptable Certificates of Insurance (COI) to the City at the time it returns this signed Agreement. **The certificate shall specify the City of Spokane as "Additional Insured"** specifically for Company's services under this Agreement, as well as all of the parties who are additional insureds, and include applicable policy endorsements. The Company shall be financially responsible for all pertinent deductibles, self-insured retentions, and/or self-insurance.

11. INDEMNIFICATION. The Company shall defend, indemnify, and hold the City and its officers and employees harmless from all claims, demands, or suits at law or equity asserted by third parties for bodily injury (including death) and/or property damage which arise from the Company's negligence or willful misconduct under this Agreement, including attorneys' fees and litigation costs; provided that nothing herein shall require a Company to indemnify the City against and hold harmless the City from claims, demands or suits based solely upon the willful misconduct or negligence of the City, its agents, officers, and employees, or City's failure to carry out its obligations under this Agreement or applicable law. If a claim or suit is caused by or results from the concurrent negligence of the Company's agents or employees and the City, its agents, officers and employees, this indemnity provision shall be valid and enforceable to the extent of the negligence of the Company, its agents or employees. The Company specifically assumes liability and agrees to defend, indemnify, and hold the City harmless for actions brought by the Company's own employees against the City and, solely for the purpose of this indemnification and defense, the Company specifically waives any immunity under the Washington State industrial insurance law, or Title 51 RCW. The Company recognizes that this waiver was specifically entered into pursuant to the provisions of RCW 4.24.115 and was the subject of mutual negotiation. The indemnity and agreement to defend and hold the City harmless provided for in this section shall survive any termination or expiration of this agreement. Notwithstanding the foregoing, in no event shall either party be liable for any indirect, incidental, consequential, exemplary, special, punitive or lost profit damages of any kind or nature arising out of or related to this Agreement and/or the staffing services rendered hereunder regardless of the form of action (whether in contract, tort, negligence, strict liability, or otherwise) and regardless of how characterized, even if such party has been advised of the possibility of such damages.

12. DEBARMENT AND SUSPENSION. The Company has provided its certification that it is in compliance with and shall not contract with individuals or organizations which are debarred, suspended, or otherwise excluded from or ineligible from participation in Federal Assistance Programs under Executive Order 12549 and "Debarment and Suspension", codified at 29 CFR part 98.

13. SEVERABILITY. In the event any provision of this Contract should become invalid, the rest of the Contract shall remain in full force and effect.



14. STANDARD OF PERFORMANCE. The silence or omission in the Contract regarding any detail required for the proper performance of the work, means that the Company shall perform the best general practice.

15. NONDISCRIMINATION. No individual shall be excluded from participation in, denied the benefit of, subjected to discrimination under, or denied employment in the administration of or in connection with this Contract because of age, sex, race, color, religion, creed, marital status, familial status, sexual orientation including gender expression or gender identity, national origin, honorably discharged veteran or military status, the presence of any sensory, mental or physical disability, or use of a service animal by a person with disabilities. The Company agrees to comply with, and to require that all subcontractors comply with, Section 504 of the Rehabilitation Act of 1973 and the Americans with Disabilities Act, as applicable to the Company.

16. BUSINESS REGISTRATION REQUIREMENT. Section 8.01.070 of the Spokane Municipal Code states that no person may engage in business with the City without first having obtained a valid annual business registration. The Company shall be responsible for contacting the State of Washington Business License Services at [www.dor.wa.gov](http://www.dor.wa.gov) or 360-705-6741 to obtain a business registration. If the Company does not believe it is required to obtain a business registration, it may contact the City's Taxes and Licenses Division at (509) 625-6070 to request an exemption status determination.

17. AUDIT / RECORDS. The Company and its subcontractors shall maintain for a minimum of three (3) years following final payment all records related to its performance of the Contract. The Company and its subcontractors shall provide access to authorized City representatives, at reasonable times and in a reasonable manner to inspect and copy any such record. In the event of conflict between this provision and related auditing provisions required under federal law applicable to the Contract, the federal law shall prevail.

18. CONFIDENTIALITY/PUBLIC RECORDS. Notwithstanding anything to the contrary, City will maintain the confidentiality of Company's materials and information only to the extent that is legally allowed in the State of Washington. City is bound by the State Public Records Act, RCW Ch. 42.56. That law presumptively makes all records in the possession of the City public records which are freely available upon request by anyone. In the event that City gets a valid public records request for Company's materials or information and the City determines there are exemptions only the Company can assert, City will endeavor to give Company notice. Company, at its own expense, will be required to go to Court to get an injunction preventing the release of the requested records. In the event that Company does not get a timely injunction preventing the release of the records, the City will comply with the Public Records Act and release the records.

19. DISPUTES. This Contract shall be performed under the laws of the State of Washington. Any dispute or controversy arising out of or related to this Contract shall be settled by binding arbitration in accordance with the Rules of the American Arbitration Association in the State of Washington. Judgment upon any award may be entered in any court having jurisdiction. Should the foregoing arbitration agreement be unenforceable for any reason, Company and City hereby waive their respective right(s) to trial by jury of any cause of action, claim, counterclaim or cross complaint in any action, proceeding, and/or hearing. Any litigation to enforce this Contract or any of its provisions shall be brought in Spokane County, Washington.

**Volt Workforce Solutions,  
a division of Volt Management Corp.**

**CITY OF SPOKANE**

By \_\_\_\_\_  
Signature                      Date

By \_\_\_\_\_  
Signature                      Date

William B. Burnett  
\_\_\_\_\_  
Type or Print Name

\_\_\_\_\_  
Type or Print Name

SVP, Chief Contracts Officer  
\_\_\_\_\_  
Title

\_\_\_\_\_  
Title

Attest:  
  
\_\_\_\_\_  
City Clerk

Approved as to form:  
  
\_\_\_\_\_  
Assistant City Attorney

- Attachments that are part of this Agreement:**  
Exhibit A – Certificate Regarding Debarment  
Exhibit B – Company’s Response to RFP  
Exhibit C – Work Authorization Email Template

**EXHIBIT A  
CERTIFICATION REGARDING DEBARMENT, SUSPENSION,  
INELIGIBILITY AND VOLUNTARY EXCLUSION**

1. The undersigned (i.e., signatory for the Subrecipient / Contractor / Consultant) certifies, to the best of its knowledge and belief, that it and its principals:
  - a. Are not presently debarred, suspended, proposed for debarment, declared ineligible, or voluntarily excluded from covered transactions by any federal department or agency;
  - b. Have not within a three-year period preceding this contract been convicted or had a civil judgment rendered against them for commission of fraud or a criminal offense in connection with obtaining, attempting to obtain, or performing a public (federal, state, or local) transaction or contract under a public transaction; violation of federal or state antitrust statutes or commission of embezzlement, theft, forgery, bribery, falsification or destruction of records, making false statements, tax evasion, receiving stolen property, making false claims, or obstruction of justice;
  - c. Are not presently indicted or otherwise criminally or civilly charged by a government entity (federal, state, or local) with commission of any of the offenses enumerated in paragraph (1)(b) of this certification; and,
  - d. Have not within a three-year period preceding this contract had one or more public transactions (federal, state, or local) terminated for cause or default.
  
2. The undersigned agrees by signing this contract that it shall not knowingly enter into any lower tier covered transaction with a person who is debarred, suspended, declared ineligible, or voluntarily excluded from participation in this covered transaction.
  
3. The undersigned further agrees by signing this contract that it will include the following clause, without modification, in all lower tier covered transactions and in all solicitations for lower tier covered transactions:
 

Certification Regarding Debarment, Suspension, Ineligibility and Voluntary Exclusion – Lower Tier Covered Transactions

  1. The lower tier contractor certified, by signing this contract that neither it nor its principals is presently debarred, suspended, proposed for debarment, declared ineligible, or voluntarily excluded from participation in this transaction by any federal department or agency.
  2. Where the lower tier contractor is unable to certify to any of the statements in this contract, such contractor shall attach an explanation to this contract.
  
4. I understand that a false statement of this certification may be grounds for termination of the contract.

<hr style="border: none; border-top: 1px solid black; margin-bottom: 5px;"/> Name of Subrecipient / Contractor / Consultant (Type or Print)	<hr style="border: none; border-top: 1px solid black; margin-bottom: 5px;"/> Program Title (Type or Print)
<hr style="border: none; border-top: 1px solid black; margin-bottom: 5px;"/> Name of Certifying Official (Type or Print)	<hr style="border: none; border-top: 1px solid black; margin-bottom: 5px;"/> Signature
<hr style="border: none; border-top: 1px solid black; margin-bottom: 5px;"/> Title of Certifying Official (Type or Print)	<hr style="border: none; border-top: 1px solid black; margin-bottom: 5px;"/> Date (Type or Print)

**EXHIBIT B**

## EXHIBIT C

### Work Authorization Email Template

Job Title:

Job Description:

Start Date and Anticipated End Date:

Named Resource:

Report to:

Straight Time Bill Rate:

Overtime Bill Rate:



**City of Spokane**  
**MASTER CONTRACT**  
Title: **TECHNICAL RESOURCES**

THIS MASTER CONTRACT is between the **CITY OF SPOKANE**, a Washington State municipal corporation, as ("City"), and **VOLT MANAGEMENT, CORP.**, whose address is 2401 N. Glassell St., Orange, California 92865, as ("Company"), individually hereafter referenced as a "party", and together as the "parties".

The parties agree as follows:

1. **PERFORMANCE**. The Company will provide Technical Resources for the Project Management Office, CHHS, and Innovation and Technology Services Division in accordance with RFP 5435-21, and Company's Response to RFP, attached as Exhibit B. In the event of a discrepancy between the documents this City Contract controls.
2. **CONTRACT TERMS**. The Contract shall begin May 1, 2022, and run through April 30, 2024, unless amended by written agreement or terminated earlier under the provisions. This Contract may be renewed by agreement of the parties not to exceed three (3) additional one (1) year contract periods.
3. **COMPENSATION**. Total annual compensation for Company's services under this Agreement shall not exceed **THREE HUNDRED FIFTY THOUSAND AND NO/100 DOLLARS (\$350,000.00)**, plus any applicable tax for everything furnished and done under this Contract. This is the maximum amount to be paid under this Contract for the work described in Section 3 above, and shall not be exceeded without the prior written authorization of the City in the form of an executed amendment to this Contract.
4. **PAYMENT**. The Company shall send its application for payment to Innovation and Technology Services Division, Administration Office, Seventh Floor, City Hall, 808 West Spokane Falls Boulevard, Spokane, Washington 99201. **Payment will be made via direct deposit/ACH** within thirty (30) days after receipt of the Contractor's application except as provided by state law.
5. **COMPLIANCE WITH LAWS**. Each party shall comply with all applicable federal, state, and local laws and regulations.
6. **ASSIGNMENTS**. This Contract is binding on the parties and their heirs, successors, and assigns. Neither party may assign, transfer or subcontract its interest, in whole or in part, without the other party's prior written consent.

7. AMENDMENTS. This Contract may be amended at any time by mutual written agreement.

8. ANTI-KICKBACK. No officer or employee of the City of Spokane, having the power or duty to perform an official act or action related to this Contract shall have or acquire any interest in the Contract, or have solicited, accepted or granted a present or future gift, favor, service or other thing of value from or to any person involved in this Contract.

9. TERMINATION. Either party may terminate this Contract by thirty (30) days written notice to the other party. In the event of such termination, the City shall pay the Company for all work previously authorized and performed prior to the termination date.

10. INSURANCE. During the term of the Agreement, the Company shall maintain in force at its own expense, the following insurance coverages:

- A. Worker's Compensation Insurance in compliance with RCW 51.12.020, which requires subject employers to provide workers' compensation coverage for all their subject workers; and
- B. General Liability Insurance on an occurrence basis, with a combined single limit of not less than \$1,000,000 each occurrence for bodily injury and property damage. It shall include contractual liability coverage for the indemnity provided under this contract. It shall provide that the City, its officers and employees are additional insureds, but only with respect to the Contractor's services to be provided under this contract;
  - i. Acceptable supplementary Umbrella insurance coverage, combined with the Company's General Liability insurance policy must be a *minimum* of \$1,000,000, in order to meet the insurance coverages required under this Contract;
- C. Automobile Liability Insurance with a combined single limit, or the equivalent of not less than \$1,000,000 each accident for bodily injury and property damage, including coverage for owned, hired and non-owned vehicles.

There shall be no cancellation, material change, reduction of limits or intent not to renew the insurance coverage(s) without sixty (60) days written notice from the Company or its insurer(s) to the City. As evidence of the insurance coverage(s) required by this Agreement, the Company shall furnish acceptable Certificates of Insurance (COI) to the City at the time it returns this signed Agreement. **The certificate shall specify the City of Spokane as "Additional Insured"** specifically for Company's services under this Agreement, as well as all of the parties who are additional insureds, and include applicable policy endorsements, the sixty (60) day cancellation clause, and the deduction or retention level. The Company shall be financially responsible for all pertinent deductibles, self-insured retentions, and/or self-insurance.

11. INDEMNIFICATION. The Company shall defend, indemnify, and hold the City and its officers and employees harmless from all claims, demands, or suits at law or equity asserted by third parties for bodily injury (including death) and/or property damage which arise from the Company's negligence or willful misconduct under this Agreement, including attorneys' fees and litigation costs; provided that nothing herein shall require a Company to indemnify the City against and hold harmless the City from claims, demands or suits based solely upon the negligence of the City, its agents, officers, and employees. If a claim or suit is caused by or results from the

concurrent negligence of the Company's agents or employees and the City, its agents, officers and employees, this indemnity provision shall be valid and enforceable to the extent of the negligence of the Company, its agents or employees. The Company specifically assumes liability and agrees to defend, indemnify, and hold the City harmless for actions brought by the Company's own employees against the City and, solely for the purpose of this indemnification and defense, the Company specifically waives any immunity under the Washington State industrial insurance law, or Title 51 RCW. The Company recognizes that this waiver was specifically entered into pursuant to the provisions of RCW 4.24.115 and was the subject of mutual negotiation. The indemnity and agreement to defend and hold the City harmless provided for in this section shall survive any termination or expiration of this agreement.

12. DEBARMENT AND SUSPENSION. The Company has provided its certification that it is in compliance with and shall not contract with individuals or organizations which are debarred, suspended, or otherwise excluded from or ineligible from participation in Federal Assistance Programs under Executive Order 12549 and "Debarment and Suspension", codified at 29 CFR part 98.

13. SEVERABILITY. In the event any provision of this Contract should become invalid, the rest of the Contract shall remain in full force and effect.

14. STANDARD OF PERFORMANCE. The silence or omission in the Contract regarding any detail required for the proper performance of the work, means that the Company shall perform the best general practice.

15. NONDISCRIMINATION. No individual shall be excluded from participation in, denied the benefit of, subjected to discrimination under, or denied employment in the administration of or in connection with this Contract because of age, sex, race, color, religion, creed, marital status, familial status, sexual orientation including gender expression or gender identity, national origin, honorably discharged veteran or military status, the presence of any sensory, mental or physical disability, or use of a service animal by a person with disabilities. The Company agrees to comply with, and to require that all subcontractors comply with, Section 504 of the Rehabilitation Act of 1973 and the Americans with Disabilities Act, as applicable to the Company.

16. BUSINESS REGISTRATION REQUIREMENT. Section 8.01.070 of the Spokane Municipal Code states that no person may engage in business with the City without first having obtained a valid annual business registration. The Company shall be responsible for contacting the State of Washington Business License Services at [www.dor.wa.gov](http://www.dor.wa.gov) or 360-705-6741 to obtain a business registration. If the Company does not believe it is required to obtain a business registration, it may contact the City's Taxes and Licenses Division at (509) 625-6070 to request an exemption status determination.

17. AUDIT / RECORDS. The Company and its subcontractors shall maintain for a minimum of three (3) years following final payment all records related to its performance of the Contract. The Company and its subcontractors shall provide access to authorized City representatives, at reasonable times and in a reasonable manner to inspect and copy any such record. In the event of conflict between this provision and related auditing provisions required under federal law applicable to the Contract, the federal law shall prevail.

18. CONFIDENTIALITY/PUBLIC RECORDS. Notwithstanding anything to the contrary, City will maintain the confidentiality of Company's materials and information only to the extent that is



legally allowed in the State of Washington. City is bound by the State Public Records Act, RCW Ch. 42.56. That law presumptively makes all records in the possession of the City public records which are freely available upon request by anyone. In the event that City gets a valid public records request for Company's materials or information and the City determines there are exemptions only the Company can assert, City will endeavor to give Company notice. Company, at its own expense, will be required to go to Court to get an injunction preventing the release of the requested records. In the event that Company does not get a timely injunction preventing the release of the records, the City will comply with the Public Records Act and release the records.

19. DISPUTES. This Contract shall be performed under the laws of the State of Washington. Any litigation to enforce this Contract or any of its provisions shall be brought in Spokane County, Washington.

**VOLT GROUP, INC.**

**CITY OF SPOKANE**

By \_\_\_\_\_  
Signature                      Date

By \_\_\_\_\_  
Signature                      Date

\_\_\_\_\_  
Type or Print Name

\_\_\_\_\_  
Type or Print Name

\_\_\_\_\_  
Title

\_\_\_\_\_  
Title

Attest:

Approved as to form:

\_\_\_\_\_  
City Clerk

\_\_\_\_\_  
Assistant City Attorney

**Attachments that are part of this Agreement:**

Exhibit A – Certificate Regarding Debarment

Exhibit B – Company's Response to RFP

22-052

**EXHIBIT A  
CERTIFICATION REGARDING DEBARMENT, SUSPENSION,  
INELIGIBILITY AND VOLUNTARY EXCLUSION**

1. The undersigned (i.e., signatory for the Subrecipient / Contractor / Consultant) certifies, to the best of its knowledge and belief, that it and its principals:
  - a. Are not presently debarred, suspended, proposed for debarment, declared ineligible, or voluntarily excluded from covered transactions by any federal department or agency;
  - b. Have not within a three-year period preceding this contract been convicted or had a civil judgment rendered against them for commission of fraud or a criminal offense in connection with obtaining, attempting to obtain, or performing a public (federal, state, or local) transaction or contract under a public transaction; violation of federal or state antitrust statutes or commission of embezzlement, theft, forgery, bribery, falsification or destruction of records, making false statements, tax evasion, receiving stolen property, making false claims, or obstruction of justice;
  - c. Are not presently indicted or otherwise criminally or civilly charged by a government entity (federal, state, or local) with commission of any of the offenses enumerated in paragraph (1)(b) of this certification; and,
  - d. Have not within a three-year period preceding this contract had one or more public transactions (federal, state, or local) terminated for cause or default.
  
2. The undersigned agrees by signing this contract that it shall not knowingly enter into any lower tier covered transaction with a person who is debarred, suspended, declared ineligible, or voluntarily excluded from participation in this covered transaction.
  
3. The undersigned further agrees by signing this contract that it will include the following clause, without modification, in all lower tier covered transactions and in all solicitations for lower tier covered transactions:
 

Certification Regarding Debarment, Suspension, Ineligibility and Voluntary Exclusion – Lower Tier Covered Transactions

  1. The lower tier contractor certified, by signing this contract that neither it nor its principals is presently debarred, suspended, proposed for debarment, declared ineligible, or voluntarily excluded from participation in this transaction by any federal department or agency.
  
  2. Where the lower tier contractor is unable to certify to any of the statements in this contract, such contractor shall attach an explanation to this contract.
  
4. I understand that a false statement of this certification may be grounds for termination of the contract.

<hr/> Name of Subrecipient / Contractor / Consultant (Type or Print)	<hr/> Program Title (Type or Print)
<hr/> Name of Certifying Official (Type or Print)	<hr/> Signature
<hr/> Title of Certifying Official (Type or Print)	<hr/> Date (Type or Print)

**EXHIBIT B**



# CITY OF SPOKANE

## Volt's Proposal Response to RFP 5435-21

May 17, 2021

FOR MORE INFORMATION, PLEASE CONTACT:



**Jakob Pakenbush**  
*Senior Business Development Manager*  
[JPackebush@Volt.com](mailto:JPackebush@Volt.com)  
(509) 954-2229

Volt Workforce Solutions, a division of Volt Management Corp.

This proposal includes data that shall not be disclosed outside of City of Spokane and shall not be duplicated, used or disclosed – in whole or in part – for any purpose other than to evaluate this proposal. If, however, a contract is awarded to the offeror as a result of, or in connection with, the submission of this data, City of Spokane shall have the right to duplicate, use or disclose the data to the extent provided in the resulting contract. This restriction does not limit City of Spokane's right to use the information contained in this document if it is obtained from another source without restriction. All data contained herein is subject to this restriction. Please note that all offerings contained in this proposal are valid for sixty (60) days after the date of submission.

# Table of Contents

---

Volt’s Letter of Submittal.....	1
Technical Proposal .....	3
A) Demonstration of Understanding.....	3
B) Describe process for City to request project employees, etc.....	8
C) Job Descriptions.....	11
D) Non-Compete Agreement.....	12
Management Proposal.....	13
A) Volt's Experience.....	13
B) Current Contracts.....	16
C) Contract Termination for Default.....	18
D) Cost Proposal.....	18

## ATTACHMENTS

Sample Resumes. ....	Attachments A01-A19
Job Descriptions.....	Attachment B

## Volt's Letter of Submittal

---

May 17<sup>th</sup> 2021

**Volt Workforce Solutions**  
2401 N. Glassell Street, Orange, CA 92865  
w 509-818-3934 | c 509-954-2229  
[JPackebush@Volt.com](mailto:JPackebush@Volt.com)

**Connie Wahl,**  
City of Spokane Purchasing Department  
808 W. Spokane Falls Blvd.  
Spokane, WA 99201-3316

*A. The Legal entity with which the contract will be written is:*

Volt Management Corp.  
2401 N. Glassell St.  
Orange, CA 92865  
Tel. 714.921.8800

Authorized representative:

Beau Burnett  
(714) 921-5597  
[BBurnett@volt.com](mailto:BBurnett@volt.com)

Volt's contact:

Jakob Pakebush  
W (509) 818-3934  
C (509) 954-2229  
[JPackebush@Volt.com](mailto:JPackebush@Volt.com)

*B. Legal status of the Firm (sole proprietorship, partnership, corporation, etc.) and location of the facility from which the Firm would operate.*

Volt Workforce Solutions, a division of Volt Management Corp., is the largest business unit of Volt Information Sciences, Inc. a publicly owned company whose shares are traded on the New York Stock Exchange (NYSE) American as VOLT.

*C. Identification of any current or former employees from the participating Agencies employed by or on the Firm's governing board as of the date of the Proposal or during the previous twelve (12) months*

**Volt and the City of Spokane**

Volt currently has temporary associates on assignment at the City of Spokane, WA. During the 12 months prior to the date of this submission (05.17.2021), none of Volt's governing board or management have worked for the City of Spokane.

**Volt's Executive Leadership**

Linda Perneau, *President and Chief Executive Officer*

Herb Mueller, *Senior Vice President and Chief Financial Officer*

Nancy Avedissian, *Senior Vice President, Chief Legal Officer and Corporate Secretary*

Lori Schultz, *Chief Global Solutions Officer*

Chris Kelly, *Senior Vice President, Strategic Solutions*

Lauren Griffin, *Senior Vice President, Specialty Solutions Group*

Lenny Naujokas, *Chief Accounting Officer and Controller*

Signature of Authorized Representative,



William (Beau) Burnett,  
Vice President, VWS and Chief Contracts Officer  
[BBurnett@volt.com](mailto:BBurnett@volt.com)  
Volt Workforce Solutions  
2401 N. Glassell,  
Orange, CA 92865

**Following is Volt’s Proposal Response to the City of Spokane’s RFP for Technical Resources for the Innovation and Technology Services Division and PMO Office (RFP 5435-21)**

## Technical Proposal

---

A) Provide a brief general description of how your Firm accomplishes the service of planning and providing project employees to best meet customer needs on projects.

Volt will work with the City of Spokane to establish customized recruiting processes and strategies developed around both the hard and soft skill requirements of each assignment to be filled. We do not utilize benched resources, but rather qualify each individual need, understanding the technical and soft skill requirements, then use our world class recruiting team and methodologies to find the talent you need—aligned to your project needs.

Matching the right person to the right position with the right company requires detailed knowledge of industry trends, client business objectives, and the precise skills that define best-in-field talent. Recognized experts in their communities who actively participate in social networks, Volt’s recruiters have such knowledge. Our recruiters put themselves in the jobseeker’s shoes and discuss skill requirements, industry trends, and common experiences.

Each recruiter remains attuned to emerging trends that may impact demand for specific skills and focuses on interacting with individuals who continually demonstrate expertise in these areas. Such an approach increases the recruiter’s likelihood of identifying active and passive candidates well suited for a position, engaging their strengths, and piquing their interests.

### Sourcing and Recruiting Methodology

Our recruiting process is built on a proven, repeatable framework with the flexibility to design unique recruiting plans for each client. Volt’s recruiters dedicated to sourcing for our client’s required skill sets and local market(s) leverage their specialized expertise and partner with

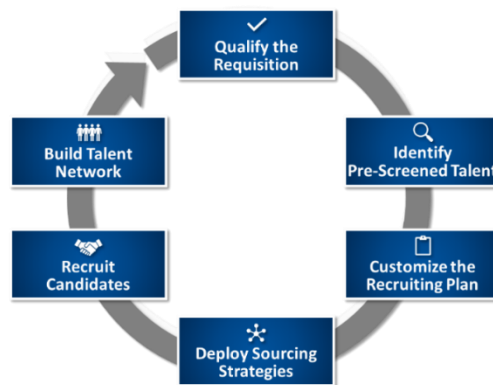



clients to create customized recruiting plans that allow us to rapidly and reliably deliver the best-fit, qualified candidates for open requisitions.

## Sourcing Channels

Volt’s recruiting plans focus on the sources that are most applicable to each client and their specific positions. These multi-faceted plans incorporate online and community-based recruiting resources and include ideas for targeted campaigns.

Traditional Sourcing	Web-Based Networking	Targeted Recruiting
<ul style="list-style-type: none"> <li>Referrals</li> <li>Job fairs</li> <li>Open houses</li> <li>Print advertising</li> <li>Colleges and schools</li> </ul>	<ul style="list-style-type: none"> <li>jobs.volt.com</li> <li>Career sites/job boards</li> <li>Community boards</li> <li>Blogs and user groups</li> <li>Social networking</li> <li>Digital ads</li> </ul>	<ul style="list-style-type: none"> <li>Volt’s military program</li> <li>Strategic search</li> <li>Hiring sessions</li> <li>Skill-specific</li> <li>Networking</li> <li>Campaigns</li> </ul>

## Technology-driven Recruiting Network

### Our Jobs Get Noticed!

Volt’s commitment to technology is evident through partnerships with industry-leading technology platforms which streamline the recruiting and onboarding process and ensure a premium candidate experience.



## Screening, Interviewing, and Verifying

Every candidate we present to a client meets the criteria of the position to be filled and is a good cultural match. Volt achieves this by having each candidate undergo our stringent screening and interviewing processes to ensure they are a good fit for the company.

Volt works closely with clients to assess each position and thoroughly understand the skill sets and experience needed to conduct laser-focused searches that produce candidates with the requisite skill sets. Recruiters advise candidates of the client’s company culture

and philosophy and conduct in-depth interviews that help the recruiter ascertain whether the candidates are a good match. These measures ensure the placements of candidates who will remain with the client long-term, mitigating turnover.

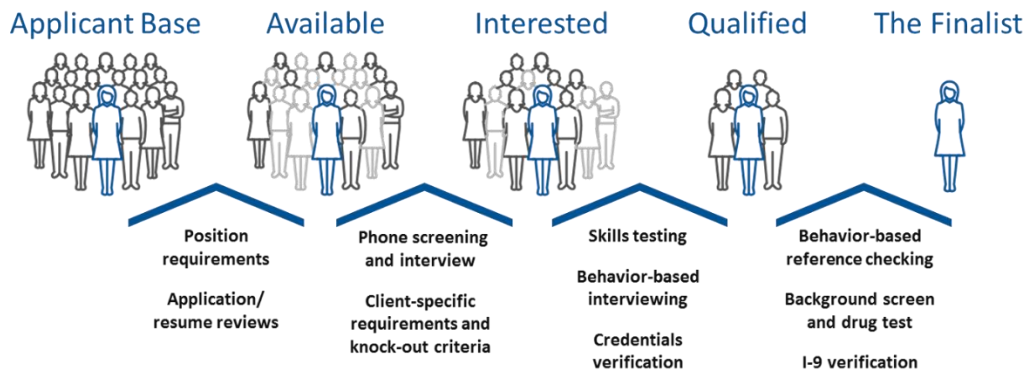

Proven screening and selection methods ensure that Volt’s clients receive well-rounded employees who possess the vital skills crucial to specific job duties. Each client’s industry, work environment and company culture shape the screening, testing and interviewing procedures that we create for each account. This consultative methodology ensures that we continually meet the expectations and requirements unique to each client. The core of our streamlined screening practices represents more than six decades of best practices and intense scrutiny, using Six Sigma tools, to ensure efficiency at every stage.

### Recruiting Innovation

Volt continues to embrace and deploy emerging technologies that create value for our clients, enabling them to adapt with speed and agility to global market forces. We continually evaluate our recruiting strategies to keep pace with the latest labor market trends and challenges. Our leaders drive our strategic and innovative use of various technologies to ensure we quickly connect the right candidates with our clients. Included among our recent technology innovations is the integration of chat capabilities into our sourcing and screening process, an innovation that significantly increases candidate engagement.

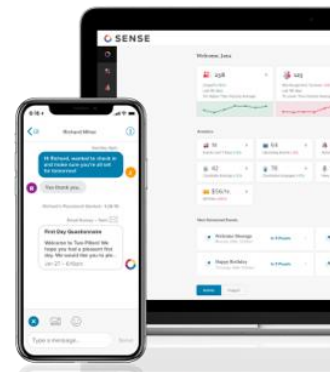

As part of this drive to innovate, we have recently implemented the use of **Sense technology** that allows Volt to interact and engage with candidates during every step of the recruiting and onboarding process.

Volt utilizes **Sense's Chatbot** (known as "Reva") functionality to screen new web responses for specific skills using texting conversations within 60 minutes of a candidate applying. All questions and candidate responses are saved to the candidate's record in our applicant tracking system (ATS). This assists our recruiters in quickly narrowing down the pool of qualified candidates, resulting in increased fulfillment rates and decreased time to fill. Additionally, Reva improves the candidate experience by responding to everyone who applied for a position in a timely manner.

We use targeted personalized messages after every stage of the hiring process to communicate directly with our candidates. By doing so we turn passive candidates into active employees and provide them a better relationship with their employer. This relationship will keep employees engaged during the five phases of their employment: Candidacy, Pre-Deployment, Onboarding, On-Assignment, and Redeployment. Sense also provides Volt a means by which to engage candidates in a way that is comfortable to them—through their mobile devices. This method of communication, texting and easy to use mobile access, allows candidates the opportunity to give feedback and feel connected every step of the way. Sense allows us to keep in regular contact with our candidates, once hired, to gauge their experience on:

- Day 1
- Day 7
- Day 14
- Day 30
- Every 30 days thereafter

By utilizing texting and mobile access, we give our candidates the opportunity to provide feedback and feel connected every step of the way. Volt uses Sense technology to help us keep our candidates actively engaged, fostering retention, and maintaining candidate care at the core of our business.

## **Able**

Volt uses Able, a state-of-the-art onboarding automation platform that is fully integrated with our ATS, to deliver a 100% mobile-enabled experience to our candidates, including delivering documents for signature from any device while maintaining compliance.

Able demonstrates our commitment to providing expert workforce solutions, speeding up the hiring and onboarding process while maintaining an unparalleled experience for our candidates and clients.

The benefits of Able include:

- Driving candidate quality
- Auditability
- Allowing recruiters to focus on enhancing the candidate experience
- Reducing time-to-fill

## Employee Relations Program

In today's tight labor market, managing the candidate experience is crucial to successfully identifying and retaining top talent. Starting with the initial conversation, through the interview process, offer, onboarding and continuing throughout the assignment, Volt ensures continuous communication with our candidates and employees. We understand that well-cared for and satisfied employees result in higher productivity and lower turnover rates.

We take the time to understand our candidates' work preference and align them with the right assignment. We offer guidance and preparation during the interview process, provide a realistic job preview which allows for a clear understanding of the client's environment, and respond quickly with feedback. Once the candidate is selected, we maintain clear communication during onboarding and greet the candidate on their first day of assignment. Volt strives to connect with every employee on assignment at least once a month, preferably in person, or by phone or email depending on the field employee's job. We interact with each Volt employee throughout the duration of their assignment, building a foundation of positive interactions and support between Volt and our employees.

## Volt's Project Team for the City of Spokane

The internal team that will support your needs includes:

- **Jakob Packebush** *Business Manger*
- **Allisen Moser** *Lead Recruiter*
- **Taylor Carr** *Recruiter*
- **Aimee Zehrung** *Recruiter*
- **Lauryn Giem** *Program Manager*
- **Emily Jannings-Thomas** *Program Coordinator*

Depending on your volume requirements or specialty needs, our team has access to Volt's Recruitment Delivery Centers and the possibility of escalating our reach via Volt's network of local branches across the West Coast, our approved suppliers, and our remote recruiting resources.

**B) Describe process for City to request project employees for specific projects and general response time for Firm to provide plan and employee resources to best support the City's needs. Describe how Firm will respond proactively to issues and project scope changes. Include any required involvement by City staff.**

## **Requisition Process**

The process by which the City of Spokane will request project employees needs to be straight forward and simple. We suggest a two-step approach:

1. Fill out a Requisition Request (this will be a Word document template we will provide) that supplies the basic information: City of Spokane contact, job title, estimated length of the project, skills & experience needed, timeline for start date, potential for project extension or conversion to city employee, remote vs. onsite, work hours, on call expectations, etc. This requisition should take no longer than five minutes to complete.
2. 20-minute discussion between your Volt recruiter and the hiring manager to dive deeper into the role. This will give us the opportunity to learn more about the project, the team, the goals for the first 30/60/90 days, technical skill assessments, interview process, soft skills, etc.

Our local Volt team can guide you through this process and we make it very easy to request project help. By getting it right up front, we avoid having to spend cycles with your employees and let them focus on their jobs, while we work behind the scenes to find the right candidates for you to choose from.

Below is a more detailed look at the process, which we will customize as necessary for the City of Spokane.

## Requisition Management Process

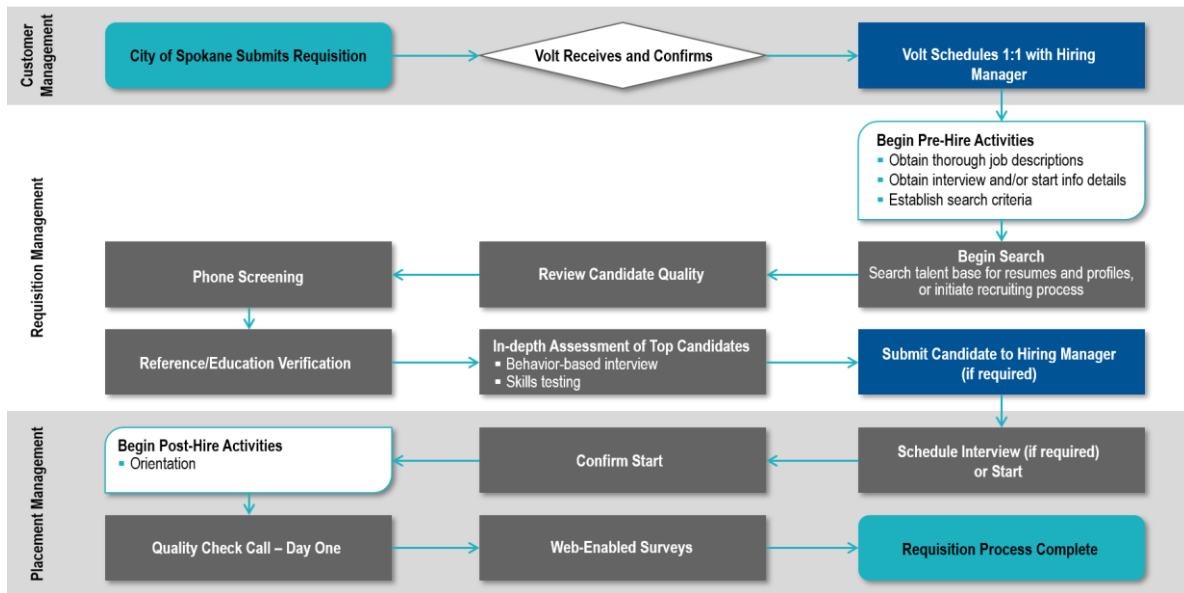

Our requisition process is tailored to meet our client requirements and incorporates, at minimum, the following steps:

- Receive requisition
- Review the City of Spokane’s requirements
- Contact hiring manager for clarification of requirements or additional information, if necessary
- Initiate candidate search in our talent database to match requisition with readily available talent
- If a match is not found in the internal talent base, engage other recruiting resources:
  - Recruiting Technology: jobs.volt.com, social networking, career sites, specialty boards
  - Community: job advisory boards, colleges and schools, job fairs, open-house events, hiring sessions
  - Targeted Campaigns: redeployment, email blasts, advertisements, recruitment branding, text and phone message broadcasts
- Source through other local resources, including associate vendors, as necessary
- Conduct initial screening:
  - Resume review
  - Initial phone screening
  - Skills testing
- Identify best match to client requirements and company culture
- Conduct candidate screening:

- Behavior-based interviewing
- Behavior-based reference checking
- Submit candidate information for client review, if required
- Schedule interview(s) as required by client or hiring manager
- Offer assignment to selected candidate
- Candidate accepts assignment
- Conduct employee screening:
  - Verification of qualifications
  - I-9 verification
- Employee completes onboarding process
- Employee assigned
- Requisition complete

The City of Spokane will benefit from our consultative approach to thoroughly understand your position, skills, and business culture requirements. This in-depth profile of the “ideal candidate” will allow us to proactively source the best talent and the most qualified employees to meet the requirements of the Scope of Services.

### **Time to Fill**

For all roles listed in this RFP, Volt’s average time to present screened, qualified candidates is 1-5 business days. We have 25+ years of experience in this market recruiting Information Technology and Project Management roles and are well equipped with a large network and a strong, talented local team.

Typical timeline from request to someone starting is normally 3-5 weeks, which includes recruitment time, interviews, onboarding, etc.

### **Proactive Response to Problem Resolution**

The City of Spokane can be confident in the services Volt provides, knowing that we will work with the City of Spokane to ensure any problems with a candidate we provide are immediately addressed.

We are local, with a team of 8 that takes pride in being actively involved with all of our field employees throughout their assignments. We have a very structured Employee Relations programs set up to stay connected with our people, identifying issues or roadblocks before they become issues for our clients.

When Volt is informed of a problem, a service alert is initiated to rapidly escalate the issue, if necessary. For minor problems, local staff will work with the City of Spokane to rectify the situation. For more serious matters, Volt’s executive leadership will become involved in the resolution process, and all service alerts will be shared with account

managers to ensure that all issues are tracked, and solutions are monitored. Additional steps could include:

- Counsel the employee
- Retrain the employee, if necessary
- Replace the employee, if requested

Any performance issue and resulting action taken are noted in the employee's file, and local management will follow up with the client to ensure that the solution is satisfactory.

Volt employs a wide range of tools and procedures to track our employees' performance providing several venues to monitor our employees while on assignment and reinforce our role as the employer of record. These methods are tailored to our clients' requirements and specific work environment and could include in-person evaluations, phone calls and written and electronic surveys.

If the City of Spokane believes that it would be in your best interest for a contingent employee to be replaced, Volt will remove the employee immediately and begin the replacement process. For IT, engineering, technical, professional positions, if Volt is notified of unsatisfactory performance within 16 hours, you will not be invoiced for that employee's time.

C) Provide a list of existing job descriptions for various services outlined in section 2 "Scope of Services".

We provide a list of appropriate job descriptions as Attachment B). These descriptions have been compiled from past client engagements and represent our prior experience with recruiting for such positions—as such, they are general and require refinement with the input of the City of Spokane's hiring managers to qualify each opportunity according to its own unique engagement. Please treat these descriptions as confidential and proprietary,

The following Job Descriptions are included:

- Business Analyst
- Database Administrator
- IT Support Specialist
- Project Assistance
- Software Developer
- Data Analyst
- GIS Analyst
- Network Administrator
- Project Manager
- System Administrator



D) Include a copy of your Firm’s “Non-Compete Agreement” that would come into play should the City want to hire a Firm resource into a full time City position. In addition, please provide all Firm policy information that speaks to the process and costs associated with converting a Firm resource to a City full time position.

### Volt’s Non-Solicitation Policy

As an organization committed to ethical practices and upholding the standards of the American Staffing Association (ASA) to which we belong, Volt never recruits from our existing customers. Additionally, we honor existing relationships that contingent employees have with their employers in the IT/technical/engineering disciplines.

Volt’s standard master services agreement states that neither our client nor a third party may solicit or employ any Volt employee for a period of ninety (90) days following completion of the employee's assignment, except for normal conversion.

### Conversion to the City of Spokane’s Payroll

Except as provided for in the below Conversion Fee schedule, The City of Spokane agrees that it will neither solicit Field Employees for direct employment at/with the City of Spokane nor directly employ any Field Employee for a period of one-hundred and eighty (90) days following termination of the Field Employee's assignment by Volt with the City of Spokane.

We welcome the conversion of Volt contractors to City of Spokane full time employees. For any Volt employees the City of Spokane wishes to convert to its payroll, the below conversion fee schedule will apply.

CITY OF SPOKANE CONVERSION FEE SCHEDULE	
Field Employee Hours on Assignment	Fee as a Percentage of Annual Salary
1 – 160 hours	20%
161 – 320 hours	17%
321 – 480 hours	15%
481 – 640 hours	12%
641 – 800 hours	7%
801 – 1040 hours	5%
1041+ hours	No Fee

# Management Proposal

---

A) Indicate the experience the Firm, staff and any sub-consultants have relevant to the scope of services. Provide name, title, brief description of duties, responsibilities, qualifications, and years of pertinent experience. Resumes may be included limited to 2 pages per person. The Firm shall commit that staff identified in its Proposal will actually perform the assigned work. Any staff substitution must have the prior approval of the City.

## Volt's Experience

We have been an active partner with the City of Spokane since 2018 and currently have two consultants working with you who have proven very successful.

Volt has had an office in Spokane since 1994 and our recruiters are deeply ingrained in the local Spokane Information Technology space.

- 20+ years in E. Washington market
- 300+ Information Technology consultants placed in the past 4 years
- Actively working with 30+ clients across multiple vertical markets – banking, utilities, technology, government, manufacturing, healthcare, and non-profits
- Five-time Supplier of the Year award from a local client (we will gladly provide references, upon request)

In the Spokane area we currently have 29 active clients and 228 consultants on assignment.

To provide a better idea of how well aligned we are to respond to the City's needs, as communicated in the Scope of Services section, we offer a current snapshot of our Volt consultants currently working in the Spokane region and how they line up to the roles you identified in Section 2, Scope of Services:

Job Title / Service	Volt Consultants currently on assignment
Project Manager	37
Project Assistance	34
Business Analyst	6
Software Developer	21
Network Administrator/Engineer	19
Database Administrator	2
Data Analyst	3
GIS Analyst	8

Systems Administrator/Engineer	11
IT Support Specialist	35

As noted above, for your consideration, we have provided sample resumes as Attachments A01-A19. We are pleased to present the candidates below in response to this RFP, with the understanding that we would also want to know more about the exact project needs in order to perform a targeted search to identify the best resource options for the City of Spokane. Following are the candidates whose resumes we have provided for you.

### Project Manager Candidates

Resource Name	Years of Pertinent Experience	Brief description of duties, responsibilities & qualifications
Brianna Buchman	10	10+ yrs. managing large scale, enterprise projects from initiation through closing. PMP certified.
Vicki Stewart	30	30+ yrs. managing large scale, enterprise projects from initiation through closing. PMP and CSM certified.

### Project Assistance Candidates

Resource Name	Years of Pertinent Experience	Brief description of duties, responsibilities & qualifications
Simone Vernego	7	7 years of professional experience, 4 specifically supporting projects in a variety of ways.
Cole Tanner	7	7+ years in Project Coordinator role, assisting PM's or running small projects. BA in International Business

### Business Analyst Candidates

Resource Name	Years of Pertinent Experience	Brief description of duties, responsibilities & qualifications
Carlos Barbour	6	6 years of direct experience with large organizations, BA degree
Nina Ozaki	10+	10+ years of direct experience, government experience, BA degree, Scrum certified

### Software Developer Candidates

Resource Name	Years of Pertinent Experience	Brief description of duties, responsibilities & qualifications
Derek Drysdale	11	10+ years of relevant experience as a full stack developer, BA degree
Tyler Latimer	3	3+ years of experience, BA degree and very skilled in front-end technologies

### Network Administrator Candidates

Resource Name	Years of Pertinent Experience	Brief description of duties, responsibilities & qualifications
David Parkins	8+	8+ years of relevant experience, 5 of them in large, enterprise environments, CCNA certification
Matthew Collinson	20	20 years' experience, predominantly in enterprise environments, BAS degree

### Database Administrator Candidates

Resource Name	Years of Pertinent Experience	Brief description of duties, responsibilities & qualifications
Launa Sallai	18+	Experienced SQL DBA with enterprise experience, multiple certifications

### Data Analyst Candidates

Resource Name	Years of Pertinent Experience	Brief description of duties, responsibilities & qualifications
Elijah Orlando	6	6 years of relevant, enterprise experience with Fortune 500 firms
Jacob Bowen	2	New degree from EWU – Data Analytics, well versed in Cloud, Toolkits, BA degree

### GIS Analyst Candidates

Resource Name	Years of Pertinent Experience	Brief description of duties, responsibilities & qualifications
Andrea Perez	6	6 years of relevant experience with large, enterprise companies, has government experience, BA degree, GIS certificate
Christopher Pieroni	4	4 years direct experience, including with government entities, BA degree

## Systems Administrator Candidates

Resource Name	Years of Pertinent Experience	Brief description of duties, responsibilities & qualifications
Daniel Haider	5	5 years of relevant experience, AA degree
Vasily Bunakov	11	10+ years of relevant experience, including government, BAS degree

## IT Support Specialist Candidates

Resource Name	Years of Pertinent Experience	Brief description of duties, responsibilities & qualifications
Amanda Ashling	17	17 years of IT Support experience, very well-rounded technology exposure, BS degree
Tom Olson	9	9 years of relevant experience – 5+ years at enterprise level, AAS degree

B) Include a list of contracts the Firm has had during the last three (3) years that relate to the Firm’s ability to perform the services needed under this RFP. Provide contract period, contact names, phone numbers and e-mail addresses. Identify three (3) specific references from this list and briefly describe the work accomplished. Do not include City staff as references. The Firm grants permission to the City to contact the list provided.

## List of Current Contracts

Client	Performance Period	Job Title	Description
Public Utility	2010 to present	Project Manager Project Assistance	Since 2018, we have recruited and placed 33 Project Managers and 37 Project Coordinators/Project Admins for this client.
Energy Consulting Firm	2017 to present	Software Developer	In the past 3 years, we have recruited and placed 12 Software Developers with this client.
Regional Bank, Public	2005 to present	IT Support Specialist	In the past 3 years, we have recruited and placed 15+ Technical Support Specialists with this client
Central WA PUD	2018 to present	Project Manager	In the past 3 years, we have recruited and placed 7 Project Managers with the client
Technology, Application Delivery Company	2019 to present	System Administrator	In the past 6 months, we have recruited and placed 3 System Engineers with this client

<b>Public Utility</b>	2010 to present	Business Analyst	Since 2018, we have recruited and placed 4 Business/Data Analysts with this client
<b>Technology Consulting Firm</b>	2005 to present	IT Support Specialist	In the past 4 months, we have recruited and placed 20+ IT Support Specialists
<b>Reginal Bank, Private</b>	2020 to present	Project Manager Project Coordinator	In the past 3 months, we have placed one Project Manager and one Project Coordinator
<b>Public Utility</b>	2010 to present	Network Administrator	Since 2018, we have recruited and placed 30+ Network Administrator/Engineers with this client
<b>Medical Company</b>	2006 to present	Network Administrator	In the past 3 years, we have recruited and placed 4 Network Administrators/Engineers with this client
<b>Hospital</b>	2017 to present	IT Support Specialist	In the past 3 years, we have recruited and placed 9 IT Support Specialists with this client

## References

As a courtesy to our clients, we would ask that you allow us to facilitate contact with our references.

### Avista Corporation

Forrest Toop, Corporate Category Manager

509-495-8757

[Forrest.toop@avistacorp.com](mailto:Forrest.toop@avistacorp.com)

**Services Provided:** Avista is a 10+ year client of Volt and we provide a wide array of recruitment services to them in the following areas: Information Technology, Engineering, Accounting, etc. Forrest Toop is our Supply Chain Category Manager and can speak to our specific, measured performance as we are graded annually as a supplier. In fact, we have been awarded Supplier of the Year at Avista for the past five years.

### Engie North America

Ken Mathis, Senior Manager, Technology

425-319-3648

[Ken.mathis@engie.com](mailto:Ken.mathis@engie.com)

**Services Provided:** We have worked with Engie since 2005, supplying them with a variety of IT consultants including Software Engineer, System Engineer, IS Support Technicians

and QA/Performance Engineers. Most recently, we partnered with them on a large domain migration project that Ken was responsible for. We were able to quickly help staff his team and the project was a success.

**Labcorp**

Sarah Rosman, IT Manager  
 509-638-7992  
[rosmans@labcorp.com](mailto:rosmans@labcorp.com)

**Services Provided:** We have partners with PAML/Labcorp since 2006, helping them with a variety of roles including Network Engineers, Helpdesk Technicians, Software Developers and Project Coordinators.

C) If the Firm has had a contract terminated for default in the last five (5) years, describe the incident. Termination for default is defined as notice to stop performance due to the Firm’s non-performance or poor performance and if the issue of performance was either (a) not litigated due to inaction on the part of the Proposer, or (b) litigated and such litigation determined that the Proposer was in default. Provide other party’s name, address, phone number and email address. If no such termination for default has been experienced by the Firm in the past five (5) years, so indicate.

At the date of this submission (05/17/2021), to the best of our knowledge, Volt has not defaulted on a contract in the last five years.

The Cost Proposal shall identify all costs to be charged including any expenses necessary to accomplish the tasks and to produce the deliverables under the contract. Submit as a fully detailed budget with a total cost. Firms are required to collect and pay Washington state sales tax, if applicable. Do not include Washington state sales tax in Proposal.

**COST PROPOSAL**

We charge on a time and materials basis. Below is our bill rate table for all the roles identified:

Job Title	Low	Mid	High
<b>Project Manager</b>	\$50.00	\$70.00	\$90.00
<b>Project Assistance</b>	\$35.00	\$45.00	\$55.00
<b>Business Analyst</b>	\$50.00	\$70.00	\$90.00
<b>Software Developer</b>	\$50.00	\$70.00	\$90.00
<b>Network Administrator/Engineer</b>	\$50.00	\$70.00	\$90.00

<b>Database Administrator</b>	\$55.00	\$72.50	\$95.00
<b>Data Analyst</b>	\$55.00	\$70.00	\$90.00
<b>GIS Analyst</b>	\$45.00	\$62.50	\$75.00
<b>Systems Administrator/Engineer</b>	\$45.00	\$65.00	\$85.00
<b>IT Support Specialist</b>	\$30.00	\$40.00	\$50.00

In order to provide for the City of Spokane’s requisitions, Volt can utilize an onsite/hybrid approach if required. Such an approach would revolve around Volt both working onsite with the City of Spokane to deliver candidates to you and utilizing our expertise in remote recruiting to fill your requisitions as they occur, while using Able to onboard the selected candidates remotely.

During the Covid-19 pandemic, we have successfully deployed such an approach to recruit and onboard numerous candidates for our clients.

### Pricing Notes

The following notes apply to Volt’s pricing:

- Volt’s rates are valid for 45 days from the date of our proposal
- Our quoted rates are based on Volt’s standard terms and conditions and weekly invoices with payment terms of Net 30 days from date of invoice
- Our medical plan offerings are fully compliant with Affordable Care Act (ACA) requirements and Volt’s markups include costs related to the employer contribution for ACA medical benefits
- State specific sexual harassment training included
- State specific sick leave included
- Additional services that are not listed may be added if desired, with modifications to the proposed pricing, as applicable



## Attachments A01-A19: Resumes

---

# Carlos Barbour

---

## SUMMARY

---

### **Professional Experience:**

Over 6 years' experience as a Senior Business Analyst.

Over 10 years' experience acting as a liaison between all levels of a corporation.

Over 11 years Advance knowledge of Word, Excel, PowerPoint, and a working knowledge of Microsoft Project.

Strong knowledge of Cognos. Working knowledge of Tableau, SAS, SQL

### **Bachelor of Arts degree in Business Administration**

---

## PROFESSIONAL EXPERIENCE

---

### **Premera Blue Cross Blue Shield**

**07/2013 – 02/2019 Business Analyst**

**Mountlake Terrace, WA**

- Translated ambiguous business needs into solid business and functional requirements for small to large projects.
- Acted as a liaison among stakeholders to validate requirements and meet business needs.
- Gathered, analyzed and documented business and functional requirements from clients and business users.
- Investigated and researched system problems & worked collaboratively to identify and provide business and/or technical solutions.
- Assessed problems, interpreted and clarified customer needs, and created solutions.
- Communicated technical information to non-technical customers.
- Research possible software solutions to increase work efficiency.
- Lean leadership
- Used Cognos, Tableau, SAS, and SQL to provide quantitative analysis to Executive level management.

### **The Spokesman-Review**

**04/2001 – 07/2013**

**District Manager**

**Spokane, WA**

- Mentored support staff and supervisors.
- Gathered required data and prepared related reports.

**Social Media Marketing Strategist**

**Spokane, WA**

- Engaged client/customers using proven analytic techniques which provided quantitative data towards analyzing marketing objective.
- Defined key performance indicators, analytics, and reporting methods to gauge success.
- Additionally, I kept all duties formerly as a Marketing Research and Database Manager.

**Marketing Research and Database Manager**

**Spokane, WA**

- Used research data to make strategic and product decisions.
- Distilled research obtained from Cognos, Tableau, and SQL to provide quantitative analysis to Executive level management.
- Define key performance indicators, analytics, and reporting methods to gauge success.
- Function as an escalation point for internal and external customers.
- Estimate costs and time requirements of projects.
- Develop user documentation for new software releases.
- Managed projects as lead project manager for large complex company wide system implementation.
- Provided in person, over the phone, or email support to resolve technical issues.
- Additionally, I kept all duties formerly as Marketing Administrator.

**Marketing Administrator**

**Spokane, WA**

- Recruited and trained supervisors and managers.
- Performed professional IT business analysis functions.
- Performed as an assistant project manager. Managed small and complex system implementations.
- Analyzed IT requirements for new implementations.
- Developed, delivered and maintained, both standard and customized training programs.
- Provided in person, over the phone, or email support to resolve technical issues.
- Learned Point-of-Sale system for new retail location.
- Assessed problems, interpreted and clarified customer needs, and created solutions.

**EDUCATION**

**Eastern Washington University (NCWWU accredited, 1919) 2011**

Bachelor of Arts, Business Administration, Focus Marketing

**Spokane Community College (NCWWU accredited)**

09/95-06/97, 09/07-06/09

Associated Arts of Science, and Associate Arts degree.

**Shadle Park High School 1994**

Diploma

# Nina Ozaki

## SUMMARY

Nina Ozaki is an accomplished Business Analyst who has demonstrated proficiency in technical writing, technical training, process mapping, and navigating ambiguity. Additionally, she has liaised between business partners and technical teams, skillfully building and maintaining business relationships that were reliant on the success of each project.

Nina’s work has spanned across different industries in both private and public sectors, including tech, telecom, retail and e-commerce, demonstrating her ability to shift between environments and cultures.

Her scope of work has traversed into learning and change enablement, and she has a proven success in assisting clients with the adoption of new systems. In addition to her analytical skills, she has a conceptual understanding of Agile processes and can shift between different methodologies.

## AREAS OF EXPERTISE

- Technical writing
- Training
- Business & systems analysis
- Change management
- Business process optimization
- Requirements definition
- System testing

## INDUSTRIES

- Tech
- Telecom
- Food & Beverage
- Retail/E-commerce
- Nonprofit
- Healthcare

## PROFESSIONAL EXPERIENCE

**Volt Workforce Solutions, Business Analyst** | 2019 to present

**Independent Contractor – Business Analyst | Generalist** | Seattle, WA | 2017 - 2019

**Slalom – Consultant** | Seattle, WA | 2011–2017

## PROJECTS

**Business Analyst – Grant County PUD (Volt) | 10/2019 to present**

Business analyst and co-project manager for AssetWorks FleetFocus, FuelFocus, and KeyValet fleet management software implementation for Grant County. This has been primarily a project rescue role through April 2021.

I restarted the project in the discovery phase with contract reviews and renewals, business process development, aligning business requirements to OOB capabilities, and negotiating vendor project structure and commitment to ensure the project would be driven to completion.

The first phase of the project launched in December 2020 with shop operations stabilizing within one week. The second phase involves fuel and motor pool capabilities is on target for go-live in May 2021.

**Business Analyst – Seattle Department of Transportation (SDOT) | 11/2018 – Present**

Technical writing scoped around business procedures and training curriculum for the implementation of Accela, the new permitting system which will support SDOT's Street Use division.

Highlights

- Liaised with business leaders and end users to document business procedures that will guide staff through the new system, which will issue over 30 types of permits impacting the public right-of-way.
- Created training materials.
- Delivered training and support for 100+ end users to enable them to effectively and efficiently serve the public using the new system.
- Managing enhancement requests from the business for future releases.

**Business Analyst - REI | 3/2018 – 11/2018**

RFP management, business requirements and business process optimization for a Supply Planning automation solution for REI's Co-op Brands.

Highlights

- Produced the RFP, vendor scoring approach and process, and planned and hosted the vendor demo sessions to enable the Business and IT in their strategic vendor down-selection process
- Supply Planning requirements solicitation and optimization for the new solution
- Interim PM throughout the Discovery phase

**Business Analyst – Starbucks | 6/2017 – 10/2017**

Customer experience mapping, business process engineering and user acceptance testing for the launch of the Starbucks credit card through the Loyalty program.

Highlights

- Partnered with program leadership, Marketing and Global Digital Products teams to build out customer experience maps to drive strategic planning and identify gaps in the product and portfolio
- Engineered a new process for tracking source code from first click to better target and measure marketing efforts, and ultimately determine bounty assignment within the partnership
- UAT for multiple products within the program, including drafting UAT plans, test scenarios and test cases

**Business Analyst – F5 Networks | 2/2016 – 12/2016**

Assessed the impact of 50+ peripheral applications and co-managed the scope of 38 of these for F5 Networks Chart of Accounts and Oracle eBS reimplementation project, a multi-million dollar enterprise upgrade, representing the largest financial and people investment in the company.

Highlights

- Built the approach and scope for each application, including hosting 36 internal stakeholder discovery interviews and workshops
- Strategized around system and data dependencies, and sequencing of applications for Integration and UAT test execution, including hosting scenario workshops for each application
- Extensive liaising and people management across cross-functional teams of an estimated 80 stakeholders
- Change Enablement across all application teams and the Business owners
- Production and stabilization support of all applications

**Business Analyst – Starbucks | 8/2015 – 11/2015**

Conducted an analysis of systems, tools, people and processes for the restructuring of a digital ordering platform, including key capabilities, such as product catalog, menu and order management. The objective was to enable this major Seattle retailer to streamline its digital space and allow business stakeholders across various channels, such as mobile, web and retail stores, to leverage the same product data in order to enable consistent product offerings to the end customers.

#### Highlights

- Built the recommended approach and scope for internal stakeholder interviews, which resulted in conducting over 40 interviews
- Documented as-is business processes and system architecture within the digital space in parallel with stakeholder interviews
- Coordinated with digital strategist to develop To-Be user stories by identifying pain points collected from interviews and used as input into a capability assessment and heat map output
- Partnered with other related project teams within the digital space to understand objectives and identify overlap where project inputs could be leveraged as part of digital ordering platform outputs
- Achieved sign-off by reviewing deliverables and findings with key stakeholders and refining the To-Be scope and approach as appropriate

#### ***Business Analyst – Premera | 5/2015 – 8/2015***

Owned multiple segments of a dental benefit integration project, including project planning, discovery and requirements consolidation, process engineering, data mapping and light project management, and ensured deliverables were on track for testing and implementation.

#### Highlights

- Produced the Business Requirements Document for the Provider Information data extract for the integration of dental providers into the existing Medicare Advantage medical network
- Produced the Business Requirements Document for the reconciliation of dental Provider Information between the source and destination systems of record
- Created workflows/process engineering for the related work streams which resulted from the newly embedded dental benefits
- Defined and coordinated electronic transmission requirements for the extracts with the third-party vendor
- Light Project Management, including monitoring testing, planning for Go-Live, stabilization and Production Support, and liaising between the cross-functional teams

#### ***Business Analyst – Rainier Scholars | 2/2015 – 5/2015***

Consulted in systems selection for various facets of Rainier Scholars' program and its internal operations. Additionally, designed the organization's website overhaul process and provided guidance throughout the planning phase of the project.

#### Highlights

- Assessed the current and target state of the organization's intranet and website by meeting with key stakeholders to understand the goals and needs of the program and the challenges within
- Collected business requirements for the program and internal operations by creating a survey and meeting with stakeholders
- Researched knowledge/content management systems and learning management systems per organizational needs and created a systems comparison matrix to facilitate in decision making
- Initiated a design package, including project charter, business requirements and site map, to deliver to the web development team for the design phase of the website overhaul project
- Developed and RFP template and provided guidance in the proposal process for web design vendor selection

#### ***Business Analyst – Microsoft | 11/2014 – 12/2014***

Development and ownership of training and support materials, including job-aids, FAQ's and user guides for the latest version of Microsoft Retail Store Portal for all US, Puerto Rico and Canada stores.

#### Highlights

- In alignment with senior leadership, designed and developed job aids and user guides for the Microsoft Retail Store Headquarters team, which are used for guidance, training and support of the new Store Portal 2.0 SharePoint site at corporate headquarters
- Upon request by the project team, assisted in Tier 3 support for launch of Store Portal 2.0
- Documented and validated Retail Help Desk processes to align with the new Store Portal site

### ***Business Analyst – Microsoft | 1/2014 – 11/2014***

Restructured Microsoft's IT application portfolio leveraging the newly implemented data repository tool, as well as increased user adoption of the tool. The outcome was a decrease in redundancies, which allowed IT to shut down servers and increase savings. Adoption of the tool prevented further redundancies and created data transparency across all organizations within the company as well as strengthen planning. Worked closely with executive level decision makers down to data owners to establish governance around the new tool and implement change management.

#### Highlights

- In coordination with project leadership and stakeholders, conducted a high-level diagnostic report of the current data repository tool capabilities in alignment to client defined requirements and recommended cost cutting initiatives. This was achieved by reviewing and analyzing the organization's data owners' needs, the established processes and communication channels.
- Tracked data requests made by the organization within IT as well as the business, and ran reports to monitor the completion of data within the application portfolio as well as the data quality
- Facilitated regular meetings with data stakeholders and managers, and tracked progress towards current data cleanup initiatives and reported out to a broad audience weekly
- Followed-up on system improvement requests and worked with business owners to prioritize system change efforts

### ***Business Analyst – Amazon | 4/2013 – 1/2014***

Time Management and Accruals Systems design and implementation for Amazon. Scope of work included business requirements gathering and modification, and development and ownership of system training tools and change management, including job-aids, FAQ's, quick reference guides, user guides and communications. Rolled out to an estimated 50,000 employees in the North America Fulfillment Centers, as well as an estimated 6,000 employees in the Customer Service centers.

#### Highlights

- Ownership of post-launch stabilization of system and process implementation as well as change management support and communications for 17 of 44 distribution centers
- Parallel Test Lead in the audit of employee's payroll import results against the production set of payroll results that were calculated using legacy time systems for the North America Customer Service location and fulfillment centers with an estimated 6,000 employees
- System Testing, accruals and User Acceptance Test (UAT) support, including writing and executing test scripts and defect resolution
- Created wiki pages for UAT, Accruals and Parallel testing guidance for vendors to reference throughout the South Africa, UK, Costa Rica, Czech Republic and Poland implementations
- Conducted post-deployment assessment of the U.S. implementation including acceptance of new HR policies and processes in alignment to the new time and attendance system

***Additional projects available upon request.***

## **EDUCATION, AFFILIATIONS AND CERTIFICATIONS**

### **Seattle Pacific University**

Bachelor of Arts, Business Administration and Merchandising | 2004

### **Network Design and Administration – Graduate Certification**

Seattle Central College | 2010

### **Scrum Alliance**

Certified ScrumMaster | 2015



## PHILANTHROPY

### ***Technical Instructor – King County Library Systems | 2011-2012***

Taught introductory computer classes to adult learners for a county-wide library system, including Internet and Microsoft Office classes. Curriculum was prepared and distributed to each class and instruction was conducted in an ad-hoc style to meet all personal requests and learning styles.

#### Highlights

- Effectively communicated complex technical information in a simplified and conducive manner to a wide variety of personalities and learning styles
- Developed technical curriculum that was simplified for beginners to understand and easily follow while obtaining effective results

### ***Technical Instructor – HandsOn Network | 2010***

Taught introductory computer classes and tutored adult learners for a nonprofit that assists exonerated individuals in learning basic technical skills to help them become more competitive in the job market.

#### Highlights

- Adapted curriculum to each learning style and unique personality
- Articulated technical information in a simplified and conducive manner
- Delivered resumes and skillsets that enabled the students to be competitive in the job market

# Elijah Andre-Orlando

*Data centric analyst/developer with a passion for building solutions.*

## Skills

SQL  
Python, R  
Power BI, Tableau  
Snowflake

Root-Cause Analysis  
Data Modeling  
Swift Learner  
Validation

Data Mining  
Data Analytics  
Strong Communication  
Research & Self-Learning

## Experience

### WotC (contract)

### Data Analyst

Apr 2020 – Feb 2021

- Managed a weekly report on mass sales data and provided snapshots for management
- Used Python to establish automated data processing for distributor and mass sales data
- Ensured weekly reports updated in line with business needs
- **Distributor Sales Report Automation** (July 2020 – Dec 2020)
  - Engineered Python scripts to pull, aggregate, and process historical and weekly data
  - Set up process for easily integrating data into Snowflake DB
  - Rebuilt and enhanced original report using Tableau
- **Mass POS Data Automation** (Apr 2020 – Feb 2021)
  - Established possible automation processes for mass point-of-sale data
  - Helped map UPCs to internal SKUs
  - Built proof of concept for identifying which SKU a UPC relates to
  - Designed Python scripts to process incoming mass data into a coherent data set

### Intel (contract)

### Senior Project Analyst

Oct 2018 – Apr 2020

- Engineered decision driving indicators for reporting with SQL, Power BI, and Excel
- Helped onboard other analysts by interviewing and performing introductory training.
- Advised on technologies and data model changes would best serve customers' reporting needs
- Outlined missing and dirty data required for reporting needs
- Cleansed usable data for proof of concept prototyping
- **Best-Known Configuration Kit Analytics** (Oct 2018 – April 2019)
  - Engineered a script to compare product configurations to each other with R, Python, and Power Query for different use cases.
  - Cut prototype reporting time in half by utilizing R, Power BI, and DAX for parsing, transformation, and dashboard creation.
  - Establish comprehensive kit to kit comparison reporting across multiple groupings
  - Identified and created dashboards to review inconsistent data
  - Created metrics for Kit throughput and build frequency
- **Sysdebug Daily Dashboard** (Dec 2019 – Current)
  - Based on requirements and constraints of other technologies, worked with the customer to determine Excel as the best option for their reporting needs
  - Built VBA and pivot-table layout allowing dynamic filter synchronization across visuals
  - Designed querying and document for easier updates and maintenance as business needs shift

<b>Ingredion</b>	<b>Data Analyst</b>	<b>May 2016 – Sep 2018</b>
------------------	---------------------	----------------------------

- Developed data validation and organization, report creation and validation, database, data mining, project prioritization, and programming skills.
- Engineered 2 Access applications data models, reporting and data entry UIs, and data management code into production in 18 months.
- Developed, maintained, and reformatted operations data and reporting for better data gathering and reporting.
- Worked with Excel, MS Access databases, and VBA.
- **SAP Migration Project** (Dec 2017 – Aug 2018)
  - Successfully migrated two SAP and supported migrating four SAP modules leveraging SQL, SSMS, and Excel for ETL
  - Bridged key communication gaps between customers and project leads
  - Helped identify solutions for required business processes
  - Identified key business solutions by collaborating with customers on data transform and business requirements
  - Explained functionality driving data to support customers making business decisions
  - Supported training and easing the business into new ERP system processes

### *Education*

<b>University of Phoenix</b>	<b>IT coursework</b>	<b>2016 – 2017</b>
------------------------------	----------------------	--------------------

- All coursework focused on team collaboration and asynchronous communication
- Developed basic web development skills with JS, JQuery, HTML, and CSS
- Built foundational program visualization skills

<b>Linn-Benton Comm. College</b>	<b>Accounting coursework</b>	<b>2015 – 2016</b>
----------------------------------	------------------------------	--------------------

- Cultivate business knowledge through coursework
- Refined accounting and documentation process through coursework

### *References*

Kenny Fortson	Director, Design Economics	(408)-458-6012
Gavin Verhey	Sr. Product Designer	(206)-713-5265
Jessica Nazario	Sysdebug Lead	(971)-570-5975
David Gatti	Controller	(503)-508-4656

## Jacob V. Bowen

### Objective

I am seeking an entry-level Data Scientist position in an organization that can best utilize my extensive knowledge of advanced statistical techniques and machine learning to provide exceptional business intelligence.

### Professional Experience

#### CPR Cell Phone Repair, Woodinville, WA

May-Sept 2016

##### Repair Technician

- Performed routine inspection, testing, and repair of smart phones and other mobile devices.
- Accurately documented repairs and parts information on repair tracking documents / work orders and in point of sale computer tracking system.
- Performed high quality repairs and refurbishment of electronic devices: phones/tablets/laptops/GPSs/ etc.
- Monitored parts inventories and inform management of status.
- Dismantled old electronic devices for OEM parts.
- Provided exceptional customer service while interacting with customers, as needed.
- Managed store design and maintained cleanliness.

#### Traxx Indoor Raceway, Mukilteo, WA

Jan-Apr 2016

##### Crew Chief

- Ensured that all track personnel perform their assigned duties safely, effectively and professionally
- Ensured that the daily attendance log is completed by all staff members
- Coordinated with Assistant and General Managers regarding disciplinary and operational issues
- Prepared track and karts prior to opening
- Instructed new customers on proper kart usage, race flag usage, and racing safety- Maintained an orderly and speedy flow of racers through the track(s)
- Supervised ongoing races and enforce race policies and procedures
- Responded to emergency situations as they arise
- Ensured that the pit and track areas remain clean and safe
- Performed specific facility cleaning and maintenance duties as assigned by management
- Performed closing duties to secure the pit and track and prepare for the following day's operation

#### Angel of the Winds Arena, Everett, WA

Feb 2012 – June 2015

##### Arena Facility Supervisor

- Managed arrangements for personnel, equipment, and material availability.
- Developed strong relationships with facility user groups.
- Maintained public relations and patron satisfaction.
- Provided customer service and dispute resolution, as needed.
- Synchronized in-house programs and independent hockey and figure skating associations.
- Coordinated repair and preventative maintenance issues to Arena Manager.
- Assisted in scheduling use of the arena.
- Upheld policies and rules to ensure safety of all guests.
- Performed staff duties as needed, including collecting fees, rental payments, and pro-shop sales.
- Sustained a complete knowledge of fees, programs, schedules, and rental information for customers.

### Education

#### Eastern Washington University, Cheney, WA

- Bachelor of Science – Data Analytics with a minor in Computer Science, June 2020
- GPA: 3.75 Major, 3.5 Minor, 3.1 Cumulative

### Awards

- Dean's List last 5 quarters
- 4.0 Senior Capstone

### Skills

- Experience with data science toolkits: Pandas, NumPy, Matplotlib, Seaborn, Tensorflow, etc.
- Strong technical and analytical abilities, a knack for driving impact and growth

- Competent understanding of statistical programming languages such as R, Python, and SAS.
- Competent understanding of Cloud (AWS, Azure, etc.)
- Excellent verbal and written communication skills
- Excellent understanding of Microsoft Suite (Outlook, Word, Excel, PowerPoint, Access)
- Ability to deliver complex analysis in easily digestible and interactive formats using Dashboard Programs (Microsoft PowerBI, Tableau)

## **Certifications**

- Microsoft Professional Program: Data Science
- Google Analytics IQ Certification

## **Notable Projects**

- Database/Dashboard development of Spokane Homeless Resource Directory
  - Used internally by Spokane City Government's Community, Housing and Human Services Department
- Management Survey Design alongside Spokane City Government's Community, Housing and Human Services Department concerning Homelessness
- Economic Research Analysis/Dashboard development concerning COVID-19 impact vs the other Influenza pandemics of the 20th and 21st centuries

## **Volunteer Work/Extra-Curriculars**

- Rouge Park Rescue (May 2009)
- Youth Hockey Coach, Everett, WA (March 2014-August 2014)
- Adult Hockey Program Instructor, Everett, WA (November 2013-February 2015)
- College Hockey Goalie, Eastern Washington University (2016-2020)

# Launa Sallai – Sr. Database Administrator

Hayden, ID 83835

---

## **SUMMARY:**

A Microsoft SQL Server Database Administrator (DBA) with a Computer Technology Diploma and 18+ years of professional experience with increasing responsibilities and successful record of achievements in Database Administration. Although my focus has been Database and some history of Legal, I am seeking a challenging, responsible and rewarding career.

## **PROFESSIONAL EXPERIENCE:**

**Nov 2007 – May 2020**

**Expedia Group – Seattle Washington**

**Senior Database Administrator**

- ◆ Monitor and provide support for Microsoft's internal services business applications.
  - ◆ Project based implement and support new and existing business applications into LAB, PPE and Production.
  - ◆ SQLServer installation and server configuration
  - ◆ Configuration of AAG(Always On Availability Groups, DAG set up
- 
- ◆ Successfully planned, implemented and support our Sheepdog process (snapshots of XIO Storage LUNs) to bring production backups from Production, fully scrubbed of PII and PCI data, to the LAB for Testers and Developers.
  - ◆ Fully support many Customers in Production, LAB and Pre-Production environments.
  - ◆ Planned, organized many migrations of SQL Server 2008 to 2016. LAB thru Production.

**Nov 2005 – Nov 2007**

**Microsoft Corporation – Issaquah Washington (Contract)**

**Database Administrator**

- ◆ Monitor and provide support for Microsoft's internal services business applications (Application Owner).
- ◆ Project based implement and support new and existing business applications into UAT (staging) and production.
- ◆ Administer SQL Server 2000 & 2005 environments. Working with Analysis Services and Full-Text Indexing.
- ◆ Administer and write custom queries for SQL Server
- ◆ Automate Application-monitoring systems.
- ◆ Document current processes and jobs running on the backend SQL Server.
- ◆ Document Troubleshooting guides for application/servers.

**Aug 2005 – Dec 2005**

**Atlas Solutions – Seattle Washington**

**Database Administrator**

- ◆ Maintain the MS SQL Server database environments used by AtlasDMT
- ◆ Optimizing and tuning database systems to maximize their performance and operation.
- ◆ Implement new databases and updates existing database systems.
- ◆ Partners with the software development team to ensure systems make maximum use of the existing database infrastructure.
- ◆ Define and improve the overall release process for database systems.
- ◆ Investigate and resolve issues that may originate in the database systems.
- ◆ Provide on-call support for database systems.

# Launa Sallai – Sr. Database Administrator

Hayden, ID 83835

---

**Feb 2005 – Aug 2005**

**Microsoft Corporation – Redmond Washington (Contract)**

**Database Administrator**

- ◆ Responsible for the day-to-day administration and maintenance of 6 SQL Server 2000, Windows 2003 Enterprise Servers.
- ◆ Responsible for performance monitoring of the servers and stored procedure optimization.
- ◆ Creating, setup and monitoring of automated performance monitoring tools for stored procedures.

**Nov 03 – Nov 04**     **Microsoft Corporation – Redmond Washington**  
*Database Administrator (Microsoft SQL Server platform)*

**Jun 03 – Oct 03**     **Northwest Administrators – Seattle Washington**  
*Database Administrator (Microsoft SQL Server platform)*

**Jan 03 – Mar 03**     **Iron Mountain - Renton, Washington (Contract)**  
*Database Administrator (Microsoft SQL Server platform)*

**Sept 99 – Jan 03**     **CORBIS - Bellevue, Washington**  
*Database Administrator (Microsoft SQL Server platform)*

**May 97 - May 99**     **NTI NEWSPAPER TECHNOLOGIES INC. - Calgary, Alberta**  
*Database Administrator (Microsoft SQL Server platform)*

**1996**     **NOVA RESEARCH & TECHNOLOGY CENTER - Calgary, Alberta**  
May - December     *Network & Desktop Analyst (Contract)*

**1995**     **NOWSCO WELL SERVICES - Calgary, Alberta**  
May - September     *Backup & Systems Analyst (Contract)*

## **EDUCATION:**

**Cloud - AWS Certified Solutions Architect – Associate**

Issued August 2, 2017

**MICROSOFT SQL SERVER 2000**

Redmond, Washington

**SOUTHERN ALBERTA INSTITUTE OF TECHNOLOGY**

Calgary, Alberta

Computer Technology Diploma Program, **Focus:** Information Systems - GPA: 3.23

**P.B.S.C. COMPUTER TRAINING CENTRES**

Calgary, Alberta

Windows '95 courses (Levels I & II)

**THE CAREER COLLEGE**

Calgary, Alberta

# Launa Sallai – Sr. Database Administrator

Hayden, ID 83835

---

Legal Assistant Diploma (WordPerfect 5.1 & MS-DOS courses)

## **SKILLS:**

### ***Database Administration:***

Database backup and restore strategies, performance tuning, Replication, SQL Job and Alert configuration, Security and permissions, Log Shipping, Data Transformation Services (DTS) packages, Distributed databases, SQL Mail/Database Mail, SQL Profiler, Index Tuning Wizard, Microsoft Analysis Services (OLAP) and Transact SQL (TSQL), MDW (Management Data Warehouse), Mirroring, AlwaysOn Availability Groups (AAG)

### ***Databases:***

Microsoft SQL 6.5, 7.0 and 2000-2016, Cassandra/DSE, PostgreSQL

### ***Operating Systems:***

Windows Server 2008 -2016, NT, XP, MS-DOS; Novell 3.11, Linux

### ***Tools:***

Microsoft Office 9x\2013, Visual Source Safe, Microsoft Word, Crystal Reports, MS FrontPage, ODBC, IIS, JIRA, PowerShell, SCOM, ServiceNow

### ***Programming Languages:***

Transact-SQL, PowerShell, HTML, vi editor

### ***Hardware:***

Build Production servers and configure for performance and redundancy, Storage Area Networks (SAN) systems including XtremIO, VMAX, and VNX technologies.

### ***Other:***

Team player, responsible, good customer interaction, troubleshooting and problem solving, production implementation process, production and end-user support, administering servers and basic network setup, disk administration. I attack each and every new problem or issue with optimism and energy. If the answer is not readily available, there is always a way to find one!

## **PERSONAL:**

***Key Attributes:*** Quick study, motivated, very dedicated, hardworking, multitasker, strong problem-solving abilities, creative, work well as a team, adaptable, leader and influencer

***Interests:*** Computers, reading, my personal web site, scrap booking, cooking, helping people, movies

***Activities:*** Walking, swimming, biking, cooking

**REFERENCES:** Available upon request



# ANDREA PEREZ

(951) 741-7275 | amperez2018@gmail.com | linkedin.com/andreaperez96

---

Multidisciplinary professional with 5+ years of experience in geospatial technologies application managing data collection and analysis, team collaboration, independent research, and organizational management. Record of success completing projects with overlapping deadlines in a timely manner, supporting organization missions, driving continuous task improvement, and meeting top levels of performance.

## STRENGTHS

- Interpersonal Communication
- Attention-to-detail
- Multi-tasking

## SKILLS & CERTIFICATIONS

- ESRI Suite: ArcGIS 10.x (Pro, Desktop, Catalog, Toolbox, Online), Collector, Survey 123
  - CARTO, Fusion, R-Studio, SQL, XLSTAT, SAP, ArcFM, PlanGrid
  - Microsoft Office Suite, Adobe Creative Suite, Google Suite, Analytics, Hootsuite
  - Red Card Qualifications: Faller A (FALA), Helicopter Crew Member Trainee (T-HECM), Firefighter 2 (FFT2)
  - Basic Life Services Certificate: CPR, AED, and Basic First Aid
  - Read, write, speak, and understand the Spanish Language (Fluent Native Speaker)
- 

## EXPERIENCE

### **GIS Research Project Specialist - Sewer lateral inspection project (SLIP)** **02/2019 - Present**

*Southern California Gas Company, San Bernardino, CA*

- Analyze databases (ArcGIS, SAP, ArcFM) and records to determine main gas line installation methods.
- Interpret city planning records (i.e. as-built plans, completion drawing sketches).
- Map and package work orders for field inspection to investigate possible sewer main intrusions.
- Project management for San Bernardino SLIP research team.
- Conduct quality assurance and quality control to verify research for final review.
- Provide additional training to research team members: guidance for solutions in work orders, research workflow updates, and interpretation of city planning records.
- Contributed to video and quality control department projects to meet SLIP team deadlines.
- Organize work tasks and deliver project presentations.
- Knowledge of gas company procedures, common terminology, installation methods, and GIS modeling.
- Representative for the San Bernardino SLIP Team for monthly meetings.

### **Teacher, Geospatial Information Systems** **04/2019 - 02/2020**

*Ignite Leadership Academy, Riverside, CA*

- Mentored and taught coding skill foundations to 15 female middle school students from urban areas.
- Developed curriculum for class: robotics, sustainability, and ESRI ArcOnline Programs.
- Spearheaded presentation on the application of GIS in wildland fire.

### **Wildland Firefighter, Sawyer Class A** **05/2018 - 05/2019**

*Stanislaus National Forest, Sonora, CA*

- Performed fire management operations within Type 2 hand crew on fuel projects crew, initial attack assignments, and headed fuel break construction under stressful and adverse conditions.
- Facilitated map briefings for the crew: basics of cartography, how to read and interpret map features, and how to predict fire behavior based on topography.
- Took weather readings using a portable weather kit to investigate weather patterns to determine fire line construction. Proficient in radio usage and terminology, weather kits, and kestrels.

### **GIS Analyst** **08/2017 - 05/2018**

*Murdered and Missing Indigenous Women (MMIW)*

- Independently researched cases of MMIW, built a database, and appropriately visualized incidents on maps.
- Produced high-quality cartographic products and presented to diverse audiences in a digestible manner.
- Awarded the Archbishop Oscar Romero Award, 2018 Recipient (Student Leadership Award) in recognition of outstanding commitment to social justice through efforts to alleviate poverty and oppression.

**Environmental Health & Safety Coordinator****08/2014 - 05/2018***USF Environmental Safety Office, San Francisco, CA*

- Managed 30+ employees, task delegation, schedule and projects with overlapping deadlines.
- Conducted environmental compliance reviews, data entry, collection for 10,000+ chemicals, biological, and hazardous waste, annual chemical inventories, and filed proper documentation to ensure compliance with state and federal regulations (i.e. Hazardous Waste Manifests, Material Safety Data Sheets).
- Planned USF Earth Day Festival 2015 and 2016: contacted 50+ vendors/organizations, 1,000+ attendees.
- Designed (Adobe Creative Suite) and instituted educational materials in an effort to promote waste diversion.
- Executed environmental outreach and education for 6,000+ people, generated 94% waste diversion.

**EDUCATION****Bachelor of Science, Environmental Science****08/2018***University of San Francisco, San Francisco, CA***Geospatial Technologies Certificate****05/2018***Geospatial Analysis Lab, University of San Francisco, San Francisco, CA*

- Reconstructed Battles et al. Model for the Air Resources Board of California, used to predict vegetation cover in the state to determine fuel types and predict fire behavior. Manipulated the model using the Monte Carlo method to shorten the run-time need to process data and replicate accuracy achieved by the original model.

# Christopher T. Pieroni

---

## CAREER OBJECTIVE

Future employment in environmentally related field such as city/county planning, GIS services, or land use consulting. Highly motivated college graduate with professional work experience with local governments and non-profit organizations. Ability to adapt to change, quick learner and excels in team settings.

## SUMMARY OF QUALIFICATIONS

- Professional post-college experience with local government agencies and departments
- Three years experience in sustainable development via academic coursework
- Skilled in environmental planning and site master planning through research-based projects
- Highly familiar with GIS utility mapping, complex legal documents, development regulations, and construction design processes
- Excels with Word processing, Adobe InDesign, Microsoft PPT, Sketch-up, and GIS software applications
- Outstanding written and verbal communication skills, and refined public speaking abilities
- Strong team-management skills, well organized and high ethical standards

## PROFESSIONAL EXPERIENCE

### City of Cheney, Public Works Department

#### Planning & Community Development Intern

[Sept. 2018 - Present]

- Seasonal, full-time employment with the City of Cheney
- Daily experience with ArcGIS desktop, Arc Catalog and GPS processes for utility mapping purposes
- Created a 45+ page *Water Irrigation Report* for the Parks & Recreation department irrigation systems
- Fundamental understanding of construction designs and site review plans
- Developed strong customer relations and an ability to work in a fast-paced environment

### Whatcom Land Trust

#### Conservation Intern

[June 2017 - June 2018]

- 400+ volunteer hours with non-profit conservation organization in Whatcom County
- Assisted the Conservation Director with multiple local and state grant applications through Washington State's Recreation and Conservation Office (RCO)
- Professional experience with ArcGIS software for various projects/presentations
- Hands-on stewardship experience regarding habitat restoration and ecosystem stabilization under the Stewardship Director
- Ability to work independently and accurately, displayed creative problem-solving skills

### Western Washington University

#### Intramural Coordinator

[Jan. 2018 - June 2018]

- Displayed effective leadership capabilities as a full-time student
- Coordinated schedules, meetings and events for all employees within the department
- Organized new hire interview processes and conducted employee promotions
- Highly organized and able to adapt to change

#### Assistant Intramural Coordinator

[June 2017 - January 2018]

- Demonstrated effective communication skills with co-workers and patrons alike
- Conveyed strong leadership qualities and aspirations
- Developed exceptional customer relations and customer service skills

#### Sport Supervisor

[Sept. 2016 - June 2017]

- Interacted professionally with peers, superiors, and patrons while developing strong interpersonal skills
- Demonstrated an ability to work in team settings and high-quality time management skills
- Flexible, high ethical standards and an ability to work in a fast-paced environment

## EDUCATION

- **Western Washington University, Bellingham, WA**

Bachelor of Arts: Environmental Studies

Concentration: Urban Planning and Sustainable Development

[Spring 2018]

# AMANDA ASHLING

509-688-7244



[ARAshling@protonmail.com](mailto:ARAshling@protonmail.com)

[www.linkedin.com/in/amanda-ashling](http://www.linkedin.com/in/amanda-ashling)

## IT EDUCATION/SUPPORT | IT/NETWORK SPECIALIST | PROJECT COORDINATOR

Highly experienced and trained IT professional with a lifelong passion in providing IT and network administration, end user and systems support. Troubleshoot, diagnose and resolve software/hardware and network issues. Train end users on current and new/emerging technology devices and software.

- Actively seeking an IT service and support role where deep technology knowledge, Windows desktop and server support experience and installation and maintenance of hardware and software in an enterprise environment are valued.

### PROVEN STRENGTHS

Diagnose/Resolve IT Issues  
End User Training  
Windows Enterprise Platform  
Network Design/Security  
Clear/Concise Communicator  
Problem Resolution Strategist

### TECHNOLOGY SKILLS

<b>Systems:</b>	MS Windows Operating Systems 3.x to Win 10, OS X (Mountain Lion to Catalina), Linux, iOS, Android, Windows Server 2008, 2012, Exchange Server
<b>Software:</b>	MS Office & Office 365 (OSx & Windows), BootCamp, AirWatch, ServiceDesk, IGT, Agilysys, Shift4, Citrix, UC700, VSphere/VMware, SimpleHelp, Windows Remote Desktop
<b>Browser:</b>	Edge, Internet Explorer, Chrome, Mozilla Firefox, Safari
<b>Cloud Drives:</b>	iCloud, Google Drive, OneDrive, DropBox, NAS Cloud
<b>Email:</b>	Outlook, Mozilla Thunderbird, Apple Mail, MS Outlook for Mac, Exchange
<b>Languages:</b>	Visual Basic
<b>Applications:</b>	Windows PowerShell, Active Directory, Group Policy, Hyper-V, VMware, VSphere, MS Exchange
<b>Networking:</b>	WireShark, PacketSniffer, MS Network Monitor, Google Extension

### EDUCATION / CERTIFICATIONS

**B.S. Information Technology** | Western Governors University (WGU) – *Anticipated 2022*

**A.A.S. Computer Networking Technology** | Iowa Central Community College, Fort Dodge, IA – 2016

President's Honor Roll, National Honor Society

CompTIA A+ Certification – 2017

Level 4 CJIS Certification – 2019

Class 3 Security Clearance and Gaming License – 2019

### PROFESSIONAL EXPERIENCE

**IT SUPPORT SPECIALIST** | Volt Workforce Solutions, Spokane Valley, WA | September 2020 to Present

Configure and deploy 50 Windows 10 laptops for an enterprise environment. Configure 15 Windows 10 Kiosk desktops. Coordinate and collaborate with others, both within and outside the IT department, for deployment. Troubleshoot any issues that arise. Organization and cable management.

**DESKTOP SUPPORT TECHNICIAN** | Northern Quest Resort & Casino, Airway Heights, WA | January 2018 to January 2020

Ensure the helpdesk phone is always answered. Immediately resolve issues that affect business or the guest experience for 8 remote venues and over 2 dozen local venues. Create and administer user accounts for most programs used site wide (over 150 programs).

**TECHNOLOGY ENGINEER AND EDUCATOR/Owner** | Hierophant Solutions, Spokane, WA | 2003 to Present

Troubleshoot, diagnose and resolve network issues and hardware/software issues for clients onsite. Build customized computers and install/configure needed software. IT Consultant for individual/business IT requirements.

- Train users on various technology devices including iPhone/smartphones, laptop/desktop systems, printers and software; remote into user's systems using remote desktop software.
- Complete upgrades from previous Windows to Windows 10; assemble Ethernet cables needed for hardware connectivity; walk users through configuration issues to resolve certain IT issues.
- Streamline business productivity by setting up entire systems, backup/update performed in the background.

# Thomas R. Olson

22855 E Country Vista Dr #366 | Liberty Lake, WA 99019 | 509.768.2232 | olson.thomasr@gmail.com

## Career Objective

A challenging and rewarding position utilizing my experience in IT and strong, solution-oriented troubleshooting skills to provide customers with consistent and reliable work environments.

## Summary of Qualifications

- Eight+ years of hands-on experience between being a one-man IT department for an expanding small business, to being an IT Site Lead for a global pharmaceutical research company.
- IT background obtained from on-the-job experience and a degree in Network Administration and Design
- Life-long learner dedicated to researching tough problems to find the most effective, timely solutions
- Career focus on delivery of personalized IT support services and network administration

## Professional Profile

- Extensive experience providing technical assistance with Windows Operating Systems and Servers
- Consistently utilized strong interpersonal skills to build quality customer relations while troubleshooting various issues
- Facilitated new employee system set-up, to include hardware and software installation, and configuration of desktop components and network profiles
- Utilized effective oral and written communication to relay relevant IT-related information, to many different levels of staff, in a tactful and timely manner
- Assisted with management with updating IT procedures to keep up with evolving technologies
- Regularly provided guidance on the creation, distribution, and implementation of new network policies and procedure to improve overall IT infrastructure
- Comfortable in roles responsible for the prioritization of workload and oversight of quality of work
- Familiarity setting-up virtual machines as well as managing remote user connections and devices

## Technical Competencies

- **MS Windows Administration:** Microsoft Windows XP/7/10 and Server 2003/2012R2/Sequel
- **Unix Administration:** Ubuntu, Fedora Linux, CentOS Linux, Red Hat Linux, Kali Linux
- **System Hardware:** Dell & HP PC's, Cisco Routers (1941 series) & Switches (2960 series), Lenovo laptops and associated docks/cables/adapters
- **Software & Services:** Active Directory Services, DNS, DHCP, DFS, MS Office, MS Exchange, AVG Anti-Virus software, PowerShell, NMAP, Python, Mitel phone systems
- **Virtualization:** Citrix, Hyper-V, VMware Workstation & vSphere

## Education

**Network Design and Administration, A.A.S | Spokane Community College | 2018**  
3.9 GPA, with Honors

## Professional Experience

### Delivery Services/Windows 10 Tech | Avista/VOLT | Spokane, WA | 2019 – Present

Contracted for multimillion-dollar, company-wide IT/IS projects for this regional utility. Managed computer hardware, software and server network system upgrade projects at 60 sites across a 4-state region. Updated over 800 pieces of software to SCCM, and rolled out Windows 10 OS throughout the utility network, impacting over 2,000 users, and 3,200 PC devices. I had also been selected to be part of the Vulnerability Management team. The VMS team is tasked with finding and patching vulnerabilities, then testing patches, before deploying in the Avista network environment.

- Technologies used and supported include: Windows 10, IOS, Office 365, Active Directory, SCCM, ProxyPro, Skype for Business, InTune, vSphere, OneDrive, ticketing systems (Tracker), computer imaging (PXE), Cisco AnyConnect (VPN), RSA.
- Additional responsibilities included: Responsible for imaging of all devices: desktops, laptops, tablets, handhelds, and devices for mobile workforce. Also, printers, scanners, cell phones, cameras & all related peripherals. Application installation/configuration (manual installs of complex applications such as Adobe Suite, AutoCAD, Quickbooks). Deploying new workstations (PC, monitors, phone, hardware, etc.). Troubleshooting/Root cause analysis on deployment issues as they arise. Configuring and Deploying printers in an enterprise environment. Recovery of assets, hardware and software, using NMAP, SCCM, AD, and PowerShell. Providing support to our remote locations and users.

### IT Site Lead | Evidera/PPD | Bethesda, MD | 2018 – 2109

As the IT Site Lead, for the Bethesda office of a global research consulting group, I was part of a four-person global IT team. My main responsibilities consisted of Tier I and II HelpDesk support services. I provided hands-on desktop support to users on-site in the Bethesda office, and remote support for office staff at other Evidera/PPD offices and home-based employees.

- Technologies used and supported include: Windows 10, Office 365, Active Directory, SCCM, OneDrive, ticketing systems (Cherwell), computer imaging (PXE), mobile device management (Intune), conferencing technologies (GoToMeeting, WebEx), Skype for Business, desktop statistical software such as STATA, SAS and R.
- Additional IT Site Lead responsibilities included: Laptop imaging and configuration, hardware and mobile device inventory, telephony support, software installation, printer maintenance (local/network), meeting and video conferencing support, various team projects (hardware refresh, cell phone migration, company-wide software upgrades, etc.), adherence to global IT standard operating procedures and service level agreements.

### IT Specialist/Facilities/AP Specialist | Empowering Inc. Services | Spokane, WA | 2010 – 2016

As the IT Specialist for an expanding child welfare agency, I served as a one-man IT Department handling a wide array of responsibilities ranging from Tier I Helpdesk support services to Tier II Network and System Administration. During my time in this role, the agency grew from around 30 to 150 employees, which required the ability to multi-task and prioritize user issues to ensure mission critical needs were met in a timely fashion.

- Additional IT Specialist responsibilities included: working with Microsoft Windows Services including, but not limited to: DNS, DHCP, and DFS; addressing staff's network connectivity problems; creating documentation on network configuration, network mapping, circuit identification and processes; conducting trainings on network access and general use; participating in strategic planning exercises to develop and implement new technology or equipment to improve the agency's IT infrastructure; and consistently interfacing with various internal and external business associates in a professional manner.
- Additional facilities management responsibilities included: office set-up and equipment installation for employees; addressing building concerns with property management; managing external contractors; and ensuring building safety and security.

**Laborer | Laborers Local #238 | Spokane, WA | 2008 – 2010**

As a member of Laborers Local #238 Union, I led hydro-demolition and concrete crews comprised of 4-10 laborers. Responsibilities included: conducting safety meetings to familiarize staff with OSHA regulations; project workload management; coordinating equipment operators; and general managerial duties.

**Lead Man | Septagon Construction | Sedalia, MO | 2006 – 2008**

I served as the Lead Man on a concrete crew for a medium-sized company specializing in commercial, industrial, and institutional construction. In this role, I cultivated strong leadership skills through the oversight and direct management of the concrete crews. Additional responsibilities included: worksite layout design; site safety enforcement; inspection scheduling; foundation installation, flatwork, and finish work.

---

**References**

Gladly Upon Request



# DAVID PARKINS

16621 E Indiana Ave. Apt. E-306  
Spokane Valley, WA. 99216  
Phone: 509.951.0633 Email: [dparkins@gmail.com](mailto:dparkins@gmail.com)

## SUMMARY

Successfully complete project goals and objectives in a timely manner, while honoring business best practices and effectively communicating between stakeholders and technology personnel. Desire to face challenging problems and provide expertise in network engineering, administration, implementation, analysis, documentation and troubleshooting.

## EXPERIENCE

### Network Engineer

Volt Workforce Solutions / Katera Inc. – Spokane, WA  
March 2019 to December 2019

- Responsible for large-scale cross laminated timber industrial and corporate network
- Provided support and management to achieve a stable and reliable network environment for server infrastructure, workstations, switches and wireless and other supporting devices
- Duties primarily involve configuration, installation, problem resolution, and proactive monitoring of network switching and routing equipment to maintain optimized network communications
- Collaborated with Systems personnel to provide seamless application delivery to end users
- Support and troubleshooting of various peripheral and infrastructure
- Worked with various vendors and stakeholders to analyze complex situations
- Created network and rack elevation diagrams and detailed switchport maps for documentation
- Worked in a fast-paced and dynamic environment with limited supervision

### Network Engineer

Volt Workforce Solutions / Nuvodia – Spokane, WA  
October 2018 to December 2018

- Resolve ticket issues for various clients across the country
- Resolve various Cisco VoIP issues, CCM, CUC - create / change, extensions, voice mailboxes, install / config new phones, Music on Hold changes, minor scripting changes
- Research and solve cryptic syslog messages from various Cisco devices
- Upgraded client remote wireless site to Cisco FlexConnect to enable access to specific WLAN
- Gather and document network information as needed by clients
- Gather, sort, collate call detail records (CDR) as needed by clients
- Troubleshoot wireless network issues
- Worked with remote technicians and capable clients to resolve issues when needed

### Network Administrator II

Numerica Credit Union - Spokane Valley, WA  
February 2014 to February 2018

- Assisted in managing data, VoIP, VPN, and wireless network for HQ and 21 remote branch locations consisting of over 400 employees
- Upgrade, configure, replace Cisco and other networking equipment during branch builds and remodels
- Worked on many projects including:
- Upgrading multi-homed branches to facilitate fail-over redundancy and reliability utilizing iBGP
- Redesign and implementation of enterprise site-based IP scheme to introduce a multi-VLAN environment
- Provision network resources for outside vendors for a business web portal being created which would allow businesses to conduct transactions in a web-based format
- Implemented network monitoring solutions using PRTG, Cacti alongside Cisco NetFlow to monitor bandwidth and data traffic to proactively resolve issues including system crashes, network slowdowns, and connectivity problems
- Participated in team project migrating branch wireless central switching to FlexConnect local switching and fortifying existing wireless infrastructure
- Implemented strong AAA authentication on routers, switches and network appliances using Microsoft RADIUS



- Maintain Barracuda Load Balancers, SPAM filters and web filters
- Created detailed network documentation and diagrams using Microsoft Visio and migrated critical network documentation into central and collaborative SharePoint documents
- Setup and managed NetBrain, a network design, documentation, troubleshooting, and collaboration tool
- Provided secondary technical assistance for user connectivity issues, as well as VoIP and other network related issues
- Provide Tier 2 Helpdesk and rotating On-Call support
- Managed physical cabling and wiring closets

### **District Technology Specialist**

Medical Lake School District 326 - Medical Lake, WA

June 1999 to August 2013

- Scaled district network from 4 servers, various switches and hubs to over 65 Cisco switches, 48 access points, 40 IP cameras, 85 networked printers, 268 VoIP phones, and approximately 12 Novell, Windows and Linux servers
- Provided management, administration, configuration, implementation, maintenance, analysis, troubleshooting, optimization, and documentation of voice and data networks.
- Provided network services, connectivity, and support for 2,100 students, 250 faculty and staff with over 1,100 workstations and laptops
- Achieved greater utilization of resources and consolidation of multiple servers leveraging Cisco UCS and VMware vSphere 4.1 virtualization
- Optimized unmanaged district network with Cisco managed switches enabling gigabit speeds
- Implemented the use of VLANs and routing through layer 3 switching to leverage the district's infrastructure
- Replaced PBX with Cisco VoIP system
- Installation and maintenance of Cisco wireless network and controller system
- Coordinated with district staff, construction team, and various vendors during high school, middle school and elementary school renovations as well as construction of a new elementary school on Fairchild Air Force base
- Initiated and managed migration from Novell GroupWise to Google Gmail services
- Installed, configured, and managed Linux Request Tracker ticketing system to track issues and provide improved customer service
- Configure, upgrade, troubleshoot, manage, maintain and optimize district print, file, and application servers (both virtual and physical)
- Maintain current and accurate documentation
- Worked with administration and staff to analyze and introduce new services and support as requested
- Supervise and instruct technical support staff of four people
- Manage backup services for critical district and faculty data
- Manage Schools and Libraries Universal Service Fund Program (E-RATE) providing annual reimbursement to the district

## **SKILLS & Proficiencies**

### **Protocols:**

TCP/IP, VoIP, DNS, DHCP, HTTP(s), SSH, OSPF, EIGRP, NFS, SNMP, SMTP, FTP  
Basic knowledge MPLS, BGP, Cisco Call Manager

### **Cisco IOS:**

Cisco 1900 - 4500 switches and 2800 - 2900 series routers

### **Network documentation:**

Microsoft Visio, Excel, Word, NetBrain

### **Network monitoring solutions:**

PRTG, Solarwinds Orion, syslog server, Cacti network performance monitoring, Cisco NetFlow, SNMP, NetBrain network automation software

### **Network management:**

Barracuda Load Balancers, Barracuda Spam Filter, Barracuda Web Filter, Wireshark network traffic analyzer, Arpwatch ARP monitoring tool, Bluecoat Packetshaper 3500 traffic shaper

### **Wireless:**

Cisco, Meraki, Aruba

### **Voice:**

Cisco and Polycom VoIP phones

### **Programming:**

Python, Visual Basic

### **Operating system:**

Microsoft Windows Server up to 2012, Windows OS up to 10  
Microsoft GPO, Active Directory, Exchange  
CentOS Linux 7

### **Applications:**

Word, Excel, Visio, Outlook & OneNote

### **Other:**

Steelcase "RoomWizard" Meeting Room Scheduling System

### **Completed the following independent courses:**

- . Configuring and Administering Microsoft SharePoint 2010
- . Core Solutions of Microsoft Exchange Server 2013
- . Optimizing Converged Cisco Networks
- . Building Cisco Multilayer Switched Networks
- . Novell GroupWise 6.5 Administration
- . Novell Network Management
- . Custom ZENworks 4.0 for Desktops
- . Cisco Secure Pix Firewall Advanced
- . Interconnecting Cisco network Devices

## **EDUCATION**

### **Community Colleges of Spokane**

Associate of Science – AS, Network and System Administration / Administrator, 1997 – 1999

### **Certification:**

Cisco CCNA certification, current - 2022

### **Completed instructional courses:**

Configuring and Administering Microsoft SharePoint 2010  
Core Solutions of Microsoft Exchange Server 2013  
Optimizing Converged Cisco Networks  
Building Cisco Multilayer Switched Networks  
Novell GroupWise 6.5 Administration  
Novell Network Management  
Custom ZENworks 4.0 for Desktops  
Cisco Secure Pix Firewall Advanced  
Interconnecting Cisco network Devices

# MATTHEW COLLINSON

## SUMMARY

Network Engineering professional with over 19 years of progressive experience, including more than 9 years in healthcare as a Network/Systems Analyst and 4 years serving proudly in the United States Air Force. A diverse background of managing, maintaining, troubleshooting, and supporting healthcare and pharmaceutical systems as well as wireless, Cisco VoIP, and networking infrastructure.

## PROFESSIONAL EXPERIENCE

**JAN 2018 – CURRENT**

**NETWORK ENGINEER, INLAND NORTHWEST HEALTH SERVICES**

**APR 2017 – JAN 2018**

**NETWORK/SYSTEMS ADMINISRATOR, SPOKANE FEDERAL CREDIT UNION**

**MAR 2015 – APR 2017**

**NETWORK ADMINISTRATOR, HOLLISTERSTIER LABS**

**JAN 2013 – NOV 2014**

**NETWORK/SYSTEMS ANALYST, COLUMBIA MEDICAL ASSOCIATES**

**DEC 2006 – JAN 2013**

**SYSTEMS ANALYST, INLAND NORTHWEST HEALTH SERVICES**

**SEP 2005 – DEC 2006**

**SR PC TECHNICIAN, GENERAL DYNAMICS**

**SEP 2001 – SEP 2005**

**NETWORK ADMINISTRATOR, UNITED STATES AIR FORCE**

## EDUCATION

**DEC 2019**

**BAS INFORMATION SYSTEMS AND TECHNOLOGY**

SPOKANE FALLS COMMUNITY COLLEGE

**SEP 2018**

**AS NETWORK DESIGN AND ADMINISTRATION**

SPOKANE COMMUNITY COLLEGE

## HIGH-LEVEL SKILLS

- CISCO ASA/FIREWALL CLI
- CISCO SWITCH/ROUTE
- CISCO CUCM/UNITY
- JUNIPER SWITCH/ROUTE
- FORTIGATE FIREWALL
- IPSEC VPN
- DATACENTER HARDWARE

# BRIANNA BUCHMANN

---

## Summary

Brianna Buchmann is a Senior Project Manager, managing projects and staff augmentation engagements.

As a Senior Project Manager, Brianna ensures the successful delivery of a broad range of complex Information Technology projects. Additionally, she assists with project team management, resource management, and vendor/consultant management. Brianna joined Entisys360 in 2006 and has held the roles of Engagement Manager and Client Relationship Manager. In these roles, she was the single point of contact for all support requests, engagements, and projects at Entisys360, along with managing client relationships. Her organizational skills, time management, and business relationships both internally and externally are a fundamental contribution to the success of Entisys360.

Brianna started her career in IT over 20 years ago, working in the web hosting industry, eventually working her way into a management role in the tech world. She is passionate about every aspect of her career, and continuously strives to improve her skills, and the Project Management Office at Entisys360. Brianna possesses excellent communication skills and is committed to meeting, if not exceeding, customer expectations.

Throughout her career at Entisys360, Brianna has managed many projects from multiple industries including:

- Government
- Legal
- Financial
- Healthcare
- Pharmaceutical
- Software
- Property Management
- Education
- Entertainment

## Professional Experience

The following are a small subset of client engagements demonstrating a knowledge and solid understanding of complex business solutions.

### ***Infrastructure Upgrade - Financial***

Managed a project for a large financial company in San Francisco. A 5-year Infrastructure Upgrade project which merged their entire Information Technology infrastructure into a single unified organization. The ultimate goal was for all accounting, HR, line of business and back-end applications to be standardized across all business sites and managed as a cohesive unit by a single geographically dispersed team of administrators and merging ADs of separate organizations into a single forest with a single domain. The Entisys360 team was able to accomplish this, and in doing so, greatly simplified management and reduced overall complexity by assisting with Analysis, Design, and Implementation of unifying the Active Directory domains, email systems, and storage, virtualization, and DR infrastructures. This offered the company and team a platform for rolling into the next phase of unification which focused on business applications and practices, desktops, and remote access, including further consolidation of domains and computing infrastructures.

# BRIANNA BUCHMANN

---

## ***Wireless LAN Design, Configuration and Implementation – Pharmaceutical***

Large multi-vendor project involving the build of a new warehouse in order to consolidate multiple other warehouses and manufacturing facilities spanning over ~2 years. Design, configuration, and implementation of the Wireless LAN to be used by office and warehouse workers. Three phase approach was used to ensure seamless coverage throughout the warehouse for all handheld and mobile devices. Entisys360 provided a WLAN infrastructure upgrade and migration of existing WLAN infrastructure, developed a WLAN solution for the new warehouse, and provided post RF validation.

## ***Citrix XenDesktop Rebuild – Educational USD***

Project Manager for education system deploying a new XenDesktop/XenApp 7.15 environment as well as migrating existing workloads for a USD in Southern California. The ultimate goal was to replace their existing legacy XenApp 6.5 Farm. Additionally, the Entisys360 team began the foundation of a new Windows Server 2016 deployment for migration of applications in order to account for current 2008 end of support as it was not a long term support strategy.

## ***VDI Secure Workstation / HP Thin Client Deployment and Support – Entertainment***

Managed a 2-in-1 project, working with the client on both Citrix and HP. Entisys360 assisted with the migration of existing workloads from existing hardware to new Nutanix platform, while building a foundation for virtual desktops (Windows 7 and Windows 10). Began foundation of a Secure Desktop deployment utilizing Citrix XenDesktop 7.13 common infrastructure components.

Additionally, Entisys360 assisted with the deployment of HP Thin Clients in their environment, along with post project support.

## ***VMware Horizon 7 Pilot Implementation & Validation – Financial***

Project Manager for a large financial corporation located in Silicon Valley. 6 Month engagement working with existing VMware View environment, with desktops provisioned using and application layers deployed through Unidesk, as well as utilizing App-V application virtualization and XenApp application publishing. The end goal was to completely upgrade the client's Virtual Desktop Infrastructure by deploying and configuring a new Pilot Horizon 7 Virtual Desktop Infrastructure. The Pilot infrastructure was designed to support eventually just over 500 users. The following components were used to house, manage, or support this deployment: VMware vSphere cluster with vCenter and ESXi hosts, Horizon View Management Infrastructure, Unidesk Management Infrastructure. Testing and validation was also addressed at the end of the deployment and configuration, as well as documentation and post project support.

## ***Citrix Expansion & Relocation Implementation, New Citrix Environment – Healthcare***

Assisted a large healthcare company in the facilitation of a datacenter move from one location to another. The project contained elements of AllScripts Expansion, Web Interface Load Balancing, AllScripts Build, Migration Planning, NetScaler AG on SDX, and Decommissioning the old Citrix Environment.

With the success of the expansion and relocation project, we were quickly engaged on the next project deploying a new Citrix environment. The Entisys360 team focused on our customer's current and future needs of the deployment, ensuring compatibility with any existing solutions which could

# BRIANNA BUCHMANN

---

not be replaced. A “greenfield” approach was taken, all while considering what was being leveraged at that time and addressing any current issues within the environment.

## ***Office 365 Evaluate, Plan and Build POC plus Implementation – Restaurant***

A large restaurant chain had a requirement to migrate from Exchange to Office 365. In preparation, our team reviewed the existing Exchange and Active Directory environment prior to planning the migration to the Office 365 tenant. The initial focus was to be on email and no other Office 365 workloads. At the conclusion of the POC, we had a solid plan to migrate to Office 365. During the migration, there were a number of other services involved, and a handful of changes which were necessary to take place due to unexpected behaviors. Throughout the project we were able to identify and mitigate risks, lay out a full project plan, tracking high priorities to low priorities daily and weekly, and ultimately implemented the migration successfully.

## **Technology Skills**

- Citrix (XenDesktop, XenApp, XenMobile, ADC/NetScaler – SCOM/MAS, Includes HealthChecks, Discovery and Design, Implementations, Rebuilds, Upgrades, Migrations)
- VMware (ESX, View, Horizon, vSphere)
- Cisco UCS, UCM
- NetApp and other storage projects
- MS Exchange, Exchange Online, O365, AD, SQL, Windows Servers (2008, 2010, 2012, 2016)
- Wireless (Antennas, APs, etc.)
- HP blades, thin clients
- Disaster Recovery

## **Certifications**

- Project Management Professional (PMP)®



# VICKI STEWART , PMP , CSM , SSGB , CF , PMI-ACP

[www.linkedin.com/in/vickistewartpm](http://www.linkedin.com/in/vickistewartpm)

## *SUMMARY*

PMI PMP and ACP certified with extensive experience in management, project management, leadership, change management and process improvement. Passion for creating and leading departments that help organizations identify, prioritize, initiate, manage and track critical projects. Successful in deploying and managing various project and program groups – from deploying complex telecommunications sites across North America; to network enablement projects in HIPAA and Sarbanes-Oxley environments; to developing sustainable business processes. Strong track record of collaboration and creating effective partnerships across organizational lines. Analytical and process-oriented experience working at both the strategic and tactical levels of an initiative. Known for listening, being trustworthy and a supportive leader of people.

## AREAS OF EXPERTISE

- Project Management
- Project Management Office
- Collaborative Leadership
- Change Management
- Process Improvement
- Management
- Team Building
- Business Quality Assurance
- Creativity

## PROFESSIONAL EXPERIENCE

### **AVISTA UTILITIES** - Spokane, Washington 2018 – Current

- **Project Manager** – Responsible for IT Network projects. Working as a team member within the IT PMO, I am responsible to manage, track and secure funding for IT Network projects.

### **CLEARWATER PAPER** - Spokane, Washington 2015 – 2018

- **Project Manager** – Collaborating with Senior Management, Business Owners and Stakeholders at all levels of the organization to define project scope and deliverables that support the implementation of projects throughout the Enterprise. Led major Overall Equipment Effectiveness (OEE) initiative for all US based mills and plants.

### **PATHOLOGY ASSOCIATES MEDICAL LABORATORY** - Spokane, Washington 2005 – 2015

- **Senior Project Manager** – Responsible for major project initiatives that simplify and standardize laboratory operations through the reduction of dated applications and systems; along with the implementation of versatile product suites including development of custom applications and interfaces. These projects included physician office interfaces; major laboratory system implementation and retirement; as well as ICD-10 rollout.

VICKI STEWART , PMP , CSM , SSGB , CF , PMI-ACP

N. 4923 Idaho Road

Newman Lake, WA 99025

509.270.0035

[www.linkedin.com/in/vickistewartpm](http://www.linkedin.com/in/vickistewartpm)

[vbehar@comcast.net](mailto:vbehar@comcast.net)

- **Enterprise Manager, Project Management Office (Interim)** – Responsible for all aspects of IT and Integration projects including coordinating the planning, organizing, and integrating of all tasks associated with the installation and implementation of laboratory hardware and software solutions, interfaces, and other services. The PMO is also responsible for internal IT infrastructure projects and other enterprise IT projects.

**DATAPRO SOLUTIONS** – Spokane, Washington

2004- 2005

- **Program and Project Manager** – Led the deployment and services department. Developed, coached, and assigned project resources for prioritized projects. The team included team leads, engineers, technicians and support personnel who worked on implementation and support of numerous and wide-ranging projects throughout the Northwest. Responsible for managing the North American support contract for Weyerhaeuser Corporation.

**QUALXSERV** - Tewksbury, Massachusetts

1981 – 2004

- **Senior Project Manager** – Maintained customer account satisfaction. Project Management responsibilities for assigned customer base (Hughes Satellite Systems, Ford Motor Company, General Motors, Smith-Barney, Western Union, etc.) Reconciled and recovered \$67K within six weeks for State Farm Insurance. Reconciled and recovered \$20K in modem stock for Motorola.
- **Deployment Manager** – Managed all deployment and 3-tier service incidents for customers and wide-ranging projects, nationally and internationally.
- **Office Development Manager** – Responsible for budgetary control, implementation and recommendation for in-house office automation tools as well as managing the centralized document-processing department.
- **Systems Administrator** – System administration and management of five WANG VS systems for a centralized word processing department.

## VOLUNTEER EXPERIENCE

**Inland NW PMI Chapter**

2008-2016

- **Past VP of Membership** – Created and implemented policy and procedures for the business unit; provided input to the Chapter's strategic plan; initiated a 5% per year growth plan for Chapter membership.
- **Past VP of Education** – Established a sustainable virtual PMP preparation course with a 97% success pass rate. The course is one of the main revenue resources for the Chapter and increases membership at a minimum of 10% per year. Held the first Professional Development Day subsidized solely by the Chapter, thus allowing the Chapter to maintain all profits.
- **Past President** – Managed and directed all offices including Education, Marketing, Finance, Administration, Membership and Programs.

**VICKI STEWART, PMP, CSM, SSGB, CF, PMI-ACP**

N. 4923 Idaho Road



Newman Lake, WA 99025

---

509.270.0035

[www.linkedin.com/in/vickistewartpm](http://www.linkedin.com/in/vickistewartpm)

[vbehar@comcast.net](mailto:vbehar@comcast.net)

## **EDUCATION – TRAINING**

**Eastern Washington University, 1992**

Bachelor of Arts Degree – Business/MIS

## **Certifications**

PMP Certification - December, 2007

Change Facilitator Certification – June, 2010

PMI-ACP Certification – May, 2018

Certified Scrum Master – June, 2012

Six Sigma Green Belt – September, 2013

## **REFERENCES**

References are available and will be furnished upon request

# COLE TANNER

## **Objective:**

Having lived in Spokane most of my life, I am looking for opportunities that will enrich our community. With professional experience in Project Management and Marketing, I am hoping to find a position that will nurture learning and growth with a positive work environment.

## **Work Experience:**

### **2017-Present: Engie Impact, Spokane, WA:**

#### ***Project Coordinator:***

- Monitor daily metrics and clearly speak to numbers and resources.
  - Tools used to pull metrics are pivots, vlookups, and ad hoc reports.
- Key grasp of soft skills to informally lead team and deescalate client concerns.
- Manage 85 client's open and close work across 3 industries.
- Lead calls and make presentations to introduce services, best practices, and expectations to prepare clients for a successful implementation.
- Delegate and assign work across the team that will complement individual strengths to maximize productivity.
- Perform random quality audits to determine if additional training is needed.
- Run reports for clients to show progress and action items needed from them.

### **2015-2017: DeVries MPS, Spokane, WA:**

#### ***Project Manager***

***DeVries is an Atlas Van Lines Company specializing in long haul transportation and installation.***

- Provided clients with strategic planning for corporate installation projects and large scale relocations.
- Ability to read blueprints to determine installation phases.
- Performed project cost and labor forecasting. Determine resources needed for the project by calculating delivery schedule, time frame for project, and personnel needed.
- Drafted job proposals.
- Performed quality checks and client visits to ensure clients satisfaction.
- Implemented tracking system to manage equipment usage and requirements.

### **2012-2015: North By Northwest Productions, Spokane, WA:**

#### ***Post Production Editor / Colorist***

***NxNW is a full-service digital studio focusing on video production***

- In house Colorist work can be viewed in the television series "Z-Nation" (Season 1), "Washington Grown" (Seasons 1-3), the film "West of Redemption," and various ad campaigns.
- Strong understanding of video editing software, as well as current industry trends and practices.
- Maintain composure in a high pressure environment that includes constant critique and feedback.
- Ability to transfer clients vision into a consistent product.
- Basic knowledge of front end coding to assist interactive departments with video projects.

## **Programs Proficient In:**

Excel (If & formulas, Vlookups, Concatenates), Outlook, Powerpoint, Peachtree, AviTrack, DaVinci, Final Cut, PhotoShop, Adobe, DocuSign.

## **Education:**

2012: Western Washington University: Bachelor of Arts in International Business

2019: Lean Six Sigma: Yellow Belt

# Simone Vernengo

Currently working as a **Market Analytics Specialist** at **Engie Impact USA**, worked as a **Business Consultant** for the major Italian consulting firm for over 3 years gaining **international experience** in **project management** and **strategical advisory assignments**. Masters degree of economics with a focus on sustainability. **Recently moved to Coeur d'Alene, able to work in US (green card).**

## Working Experience

- ◆ Oct 2020 – Today      Job Title: Market Analytics Specialist  
Employer: Engie Impact USA      📍 Spokane (USA)
- Resolving** unusual cost, consumption patterns and discrepancies **determining huge savings opportunities**. Monitoring all costs and consumption reporting. **Analyzing daily utility bills using a firm understanding of client industry**, weather related usage patterns, market related changes and an internal audit process.
- ◆ Oct 2017 – Feb 2020      Job Title: Business Consultant  
Employer: B.I.P. and SESAR Deployment Manager      📍 Brussels (Belgium)
- Supported with **project management, strategical and operational advices** the major **European Union (EU) Aviation Organization** for the implementation of the IR 716/2014 in the framework of the Single European Sky initiative as regulated by the European Commission. **Lead a team of 2 people** in daily activities to be performed.
- Coordinated over 100 Stakeholders** (airlines, airports, militaries, etc.) to distribute **almost 10 billion € EU funding** for the modernization and synchronization of the European Airspace. **Set up dedicated monitoring tools** and **planned the initiatives** to accommodate the huge increase in air traffic expected in Europe over the next years thus bringing benefits to both passengers and environment. **Collected data** coming from a **huge number of Stakeholders**, **created and maintained the main database**. **Addressed Stakeholders comments** tackling any possible issue, **handled multiple time-sensitive demands accurately**.
- Produced a wide number of presentations for the major EU delegations** in the aviation business **to measure progress and witness deployment in action**. Drafted specific reports, analyzed the cost and benefits of a wide range of initiatives. **Produced slides and other material for weekly meeting with the Top Management** to plan the work and always keep track of the upcoming deadlines.
- ◆ Jan 2017 – Oct 2017      Job Title: Business Analyst  
Employer: B.I.P.      📍 Rome (Italy)
- Supported the evolution, revision, optimization and re-engineering of business processes for primary Italian companies in the **Public Administration, ICT and Transportation field**.
- ◆ Jun 2015 – Dec 2016      Job Title: Event Coordinator  
Employer: G.V.S.T. Group      📍 Rome (Italy)
- Coordinated the organization of large international events (both in Europe and USA)** from 500 to more than 1000 participants **supervising specific areas and planning** some of the activities to be done by the participants. **Managed the warehouse, established relationship with suppliers and relevant Stakeholder**.

## Studies

- ◆ Oct 2014 – Jul 2016      📄 Masters of Economics  
*Università degli Studi Roma Tre*  
Master's Degree in Environment and Development Economics with a final grade of 110/110 with Honors (4.0 GPA)
- ◆ Oct 2011 – Oct 2014      📄 Bachelor of Economics  
*Università degli Studi Roma Tre*

## Volunteering

-  Save The Children Italy
-  WWF Young Italy

## Personal Info

### Address

1009 E Mullan Ave, CdA

### Phone

208-763-8844

### Email

[simonevernengo@gmail.com](mailto:simonevernengo@gmail.com)

### LinkedIn

<https://bit.ly/2OSfx67>

## Skills

Project Management  
Strategic Planning  
Business Process Improvement  
Environmental Strategies  
Cross-cultural Communication  
Strong Organization

## Software

### Microsoft Power Point

Excellent

### Microsoft Excel

Excellent

### Microsoft Word

Excellent

### Microsoft Project

Good

### Visual Basic

Beginner

## Languages

### Italian

Mother tongue

### English

Highly proficient

### Spanish

Basic knowledge

### French

Basic knowledge

## Clubs

Soccer  
Cooking  
Photography

# Derek Drysdale

## Full-Stack Software Engineer

### About

Innovative and detailed-oriented software engineer who enjoys writing clean, well-structured code. Experienced in all areas of the full software development life cycle including, requirements gathering, design, development, testing, and support. Productive in both team-based and self-managed projects. Extremely passionate about delivering well-tested and easy to maintain code. Enjoys learning new technologies and frameworks, and has proven to come up to speed quickly and competently.

### Experience

#### Software Engineer

October 2018 - Present

Avista Utilities, Spokane, WA

- Responsible for the design, development, and deployment of internal ASP.NET Core microservices and Vue/TypeScript web applications.
- Ensures code is well-tested utilizing xUnit, Moq, and Jest testing frameworks.
- Maintains and creates all related Azure DevOps build and deploy pipelines.
- Utilizes Entity Framework and SQL to develop and maintain required databases.
- Mentors junior developers
- Refactors existing legacy applications making them more extensible and maintainable.

#### Software Engineer | CAD Library Manager

November 2010 - July 2017

AMX - Harman International, Cheney, WA

- Designed, developed, and maintained a full-stack MVVM application in C# to track and check all PCB designs, produce all fabrication and assembly deliverables, and archive all required design files. This resulted in improved accuracy and much quicker product release times.
- Developed RESTful WCF service API to provide MySQL CRUD functionality.
- Updated existing internal C# and Visual Basic applications to utilize object-oriented design principles.
- Developed web application in React to enhance and simplify the site-wide internal part request process.
- Managed parts library and all aspects of part development program for Cheney site.

#### Team Leader - Cryptologic Linguist

U.S. Army, El Paso, TX

- Supervised the interception, transcription, and reporting of Russian voice transmissions, supporting a 5000 member organization.
- Provided language and mission-specific training to subordinates.
- Top Secret clearance.

### Education

#### Bachelors of Science, Software Development

Western Governors University - Expected completion 04/2021

#### Nanodegree, React

Udacity - 2018

### Certifications

- CompTIA Project+
- CompTIA A+
- Axelos ITIL Foundation
- CIW User Interface Designer
- CIW Site Development Associate

### Contact

 32326 N Elk Chattaroy Rd  
Chattaroy, WA 99003

 509.795.6750

 [derek.drysdale@icloud.com](mailto:derek.drysdale@icloud.com)

 [linkedin.com/in/derek-drysdale](https://www.linkedin.com/in/derek-drysdale)

### Key Skills

#### Back End

- .NET Core, C#
- Microservice Architecture
- Swagger, OpenAPI
- REST
- Postman
- Hangfire

#### Front End

- React, JSX, Redux
- Vue, Vuetify, Vuex, Nuxt
- JavaScript (ES5, ES6, ES7)
- TypeScript
- HTML5, CSS3, Bootstrap
- NPM, WebPack, Babel, Sass
- UI/UX

#### DevOps

- Azure DevOps
- Build/Deploy Pipelines
- GIT, GitHub Actions

#### Database

- Entity Framework, SQL Server
- Oracle, PostgreSQL, MongoDB

#### Miscellaneous

- Test Driven Development
- SOLID/OOD Principles
- Layered, Clean Architecture
- WPF, MVVM
- Agile/SCRUM Methodologies
- Remote Development
- Project Management
- Disciplined
- Organized

# Tyler Latimer

---

## Professional Experience:

**Potlatch No. 1 Financial Credit Union** – Programmer    Lewiston, ID | *May 2019-Current*

- Analyze business processes and suggest/develop more efficient solutions
- Support the core software and develop additional modules and features
- Implement software processes and project cycles, maintain documentation
- Utilize PowerOn, HTML, CSS, JavaScript, Batch, and other languages

**Lewis-Clark State College** – IT Support Technician    Lewiston, ID | *April 2018 – May 2019*

- Write scripts to automate program installs and upgrades, including macOS
- Provide general IT and Helpdesk support
- Update/Reimage classrooms and labs to prepare for the upcoming year

## Project Experience:

**Member Letters**

July 2019 to Current

- Oversee conversion of letters between systems and vendor changes
- Develop modules to gather various data for letters through iterations
- Coordinate with three vendors for templates, processes, and data needs
- Test data to ensure proper selection and variable use

**Banking Application** - <https://github.com/trlatimer/bankingApplication>

June 2019

- Developed using C#, MySQL, and AWS RDS
- Base banking application that has potential to be expanded upon
- Provides solution for basic banking needs such as transactions and accounts

**Inventory App** - <https://github.com/trlatimer/InventoryApp>

Jan. 2019

- Visual C# Program designed for managing products and associated parts
- Utilizes local data structures and data elements in Visual C# for displays
- Created as a final project for my Software I course at WGU

## Education:

**Western Governor's University** – Software Development, B.S

*February 2018 to June 2019*

**Lewis-Clark State College** – Business Management, B.A.S

*August 2013 to May 2017*

## Certifications:

**Microsoft** - Microsoft Technology Associate

*December 2017*

**CompTIA** – A+, Network+, Project+

*January 2018*

**CIW** – Site Development Associate, Advanced HTML5 and CSS3 Specialist, UI Designer    2018

**Oracle** – Oracle Database SQL Certified Associate

*June 2019*

## Technical Skills:

Languages: HTML, CSS, Javascript, Python, C++, C#, PHP, MySQL, Bash, PowerOn

Frameworks/Libraries: Bootstrap, jQuery, Flask, SQLAlchemy, NodeJS, .NET

# Daniel Haider

2415 N Cherry, Apt 33  
Spokane Valley, WA 99216

(509) 981-0926  
dhaider999@gmail.com

## SYSTEM ADMINISTRATOR

Methodical and goal oriented System Admin with hands on experience with diagnosing and repairing many different types of hardware and software. Familiar with almost every type of OS on the market and has worked on them from installation all the way through to daily maintenance. Great communication skills are a high priority when helping end users with issues.

## SKILLS

### Technical

- Monitored, Maintained and fixed virtual windows servers
- Performed vulnerability patching on both Windows and Linux servers
- Monitored status of website interfaces and networking devices
- Taught end users how to identify issues with their local machines and peripherals
- Troubleshoot enduser's software and hardware remotely and in person
- repaired enterprise and home office printers and copiers
- Worked tickets in SCSM
- Performed installations and Maintenance of the following operating systems:
  - Windows 7
  - Windows 8.1
  - Windows 10
  - Windows Server 2008
  - Windows Server 2012
  - Windows Server 2016
  - Mac OS
  - CentOS
  - Ubuntu
- Repaired many physical pieces of hardware such as keyboards, printers, and networking devices
- Worked on Linux servers and have learned how to use the CLI for many different types of duties
- Built full scale network for case study that encompassed many network domains and various types of hardware
- Know how to use the OSI model to help when troubleshooting

### Customer Service

- Able to work with many customers at one time giving each one timely and courteous service
- Successfully calmed down and helped irate customers over the phone and in person
- Routinely worked with many different types of equipment to get projects done for customers on time and Budget
- Practiced patience when helping new customers
- Planned out jobs for customer projects, then work with said customer to make sure the job went smoothly
- Handled customer calls and imputed user information into ticketing system

## EDUCATION

Spokane Community College  
AA in Network Design/ Administration  
Spokane, WA

Fall 2012

# Daniel Haider

2415 N Cherry, Apt 33  
Spokane Valley, WA 99216

(509) 981-0926  
dhaider999@gmail.com

## EXPERIENCE

Associate The UPS Store Airway heights, WA	2008-2012
IT Consultant Witte Sound Solutions Spokane, WA	2011-2012
Tech Support Specialist I Banner Bank Spokane, WA	2013-2016
Network Operation Technician Imprezzio Spokane, WA	2016-2019
TOC Operations Technician Umpqua Bank Spokane, WA	2019-Present

# Vasily A. Bunakov

[vasiliy.bunakov@gmail.com](mailto:vasiliy.bunakov@gmail.com)

<https://tritecta.com>

## TECHNICAL SKILLS

- Systems administration: linux/windows server maintenance, LDAP, AuthN/Z management, apache, nginx, IIS, SSL, security, hypervisors (vmware, xen, virtualbox, hyper-v), wireshark, HIPAA/FERPA/DOE/DOD data, consulting, documentation, GIT, splunk, greylog, HPC, databases.
- Network administration: Dell, HP, Netgear, Cisco switches, VLANS, DHCP, DNS, pfsense firewalls, VPN's, servers, storage, network troubleshooting, designing networks, SNMP, IPTABLES.
- Enterprise open source solutions: CentOS, Ubuntu, HTML5 RDP, freenas, nas4free, pfsense, ZFS, FreeIPA, GIT, kubernetes, docker.
- Programming/scripting: bash, power shell, C/C++, PHP, Perl and Python.
- Management: led budget constraint projects, architect/design solutions, consulting, coached/mentored projects/colleagues..
- 10+ Year of IT experience: higher education, small/big business, research, HPC and consulting (TriTecta).

## EXPERIENCE

### **System Engineer Contractor      Engie Impact      2020 - Present**

- Designing, maintaining Windows servers, networks, hypervisors, DHCP, DNS, firewalls, UPS, switches, database, servers.
- Consulting and Architecting solutions, mentor fellow colleagues,
- Designing and documenting system solutions and configuring hardware, network, services, servers, storage, programming (e.g python, bash), devops, etc...

### **IT Contractor & Owner      TriTecTa LLC      2020 - Present**

- Specializing in IT consulting for business from hardware/software setup and maintenance (desktops/laptops/servers/point-of-sale systems, network access points/routers/switches, Windows/Mac/Linux, enterprise ERP/CMS, web sites, search engine optimization, virtualization, and custom needs).
- Specializing in Cyber Security (Compliance:HIPAA, PCI, SOC, SSL and custom needs).

### **Linux System Engineer      2barrels      2019 - 2020**

- Designing, implementing, re-building, and maintaining Linux and Windows servers, networks, hypervisors, DHCP, DNS, firewalls, UPS, switches, servers.
- Configuring hardware, network, services, servers, storage, AWS, programming (e.g python, bash), devops, etc.
- Consulting, Cyber Security, Architecting, Implementing, documenting and maintaining system solutions.

### **System Administrator      Washington State University      2010 – 2019**

- Consulted, Architected, Implemented IT solution for the Volian College Engineering Architect.
- Configured, managed, and troubleshooted software/hardware.
- Designed and documented system solutions for colleagues, faculty, staff and students.
- Maintained and managed server integrity, availability, and performance.
- Scripting, programming and devops.
- Designed, implemented and maintained the next generation of Linux servers for College of Engineering.
- Provided IT support to manage servers, desktops, authN/Z

## EDUCATION

### **BAS Cybersecurity      Spokane Falls Community College      2019 - 2021**

- Completed March 2021

### **Course Work      Washington State University      2009 – 2014**

- 120 Credits of Electrical Engineering, Computer Science, and general electives

### **AA Degree      Big Bend Community College      2006 – 2008**

- Associate Degree of Arts and Sciences



## Attachment B: Job Descriptions

---

### **Title: Business Analyst**

The Business Systems Analyst works with complex information systems and develops or modifies existing systems through analysis of business and user needs.

- Expertise in systems required to review capacity, limitation, delivery and results
- Responsible for analyzing and documenting findings, making recommendations, and revising system logic difficulties
- Supports systems design, implementation and testing.
- Responsible for creating detailed specifications from which software programs will be written
- May be required to perform cost/benefit/risk analysis
- Facilitate focused, effective meetings with clear agendas and thorough meeting minutes
- Define and develop, with guidance, detailed business requirements while identifying, tracking and resolving business systems issues
- Assess, research, analyze and document sponsor/stakeholder needs in accordance with Project Life Cycle utilizing reporting tools, requirements gathering methodologies, process models, data models and prototypes
- Recommend business solutions that satisfy sponsor/stakeholder needs continually exploring and assessing options for value-add for clients
- Works with internal leadership to identify tasks and scheduling
- May work closely with or delegate assignments to other members of the immediate workgroup.
- May complete end user documentation and prepare training material
- Develop and execute test plans to ensure quality
- Facilitate small group meetings and one-on-one interviews

### **Knowledge and Experience:**

- Bachelors degree in Computer Science, Computer Engineering or related field; relevant experience considered
- 3-6 years; experience as a business systems analyst
- Advanced verbal and written communication skills
- Advanced facilitation and presentation skills
- Advanced ability to resolve minor conflicts/issues using different tactics for prior to escalation
- Advanced knowledge of cost/benefit analysis, risk assessment and quantification methodologies
- Demonstrated ability in the following methods: interviewing, data modeling, business process modeling, business object modeling and user interface

- Strong Interpersonal skills and ability to work well within a team
- Creative thinker with problem solving skills
- Ability to drive results and mentor and provide constructive feedback
- Analytical and detailed oriented
- Ability to work independently
- Organized with strong time management

## **Title: Data Analyst**

The successful candidate will turn data into information and insights that will help support business decisions. They will work closely with the data team to interpret data, analyze results using statistical techniques and provide ongoing reports.

- Develop and implement databases, data collection systems, data analytics and other strategies that optimize statistical efficiency and quality.
- Acquire data from primary or secondary data sources and maintain databases/data systems.
- Identify, analyze, and interpret trends or patterns in complex data sets.
- Filter and “clean” data by reviewing computer reports, printouts, and performance indicators to locate and correct code problems.
- Work with management to prioritize business and information needs.
- Locate and define new process improvement opportunities.
- Develop end to end reporting solutions for complex processes.
- Gather business requirements, design and build automated reporting solutions in Tableau.
- Analyze, inspect and create reports against various data sources in Hadoop, SQL.
- Present the report findings to line of business reps to drive actions.
- Provide deep analysis on internal data sets and recommend/build aggregates, dashboards and scorecards to be used for reporting at detail and management level.
- Provide Tableau reporting expertise and knowledge to implement decision-based reporting solutions.
- Enhance and maintain existing production Tableau dashboards.
- Responsible for incoming reporting requests and liaise between the reporting groups to accomplish monthly release cycles.

### **Knowledge & Experience:**

- 5+ years of experience as a data analyst or data scientist
- 3+ years of experience with querying in Hadoop, e.g. Spark, Hive
- 3+ years of experience with a programming language, e.g. Python, Scala
- 3+ years of experience in developing and optimizing Tableau data sources, dashboards and stories
- Technical proficiency with SQL and relational databases
- Ability to understand API Specs, identify relevant API calls, extract/transform data and implement SQL friendly data structures
- Excellent analytical and problem solving skills
- Strong communication and presentation skills
- Demonstrated ability working with multiple teams to complete critical achievements under pressure with tight deadlines
- Experience with Jupyter Notebook, Airflow preferred

- Strong understanding of large-scale content management systems and data modeling strongly preferred

## **Title: Database Administrator**

DBA will be an integral part of the team and should have complete focus on tracking and resolving database related incidents and requests within SLAs, reviewing service-related reports (e.g.: database backups, maintenance, monitoring) on a daily basis to ensure service-related issues are identified and resolved.

- Assists in planning, implementing, and maintaining a production MSSQL database server environment
- Supports a robust security program by following best practices related to the database server environment
- Responds to database-oriented Engineering helpdesk requests
- Maintains automation scripts written in PowerShell
- Maintains system performance by performing system monitoring and analysis, and performance tuning
- Troubleshooting system hardware, software, networks and operating and system management systems
- Designing and running system load/stress testing; escalating application problems to vendors
- Performs system upgrades in collaboration with operation staff and external service providers as needed
- Ready to work in shift, if required
- Other duties may be assigned, as required

### **Knowledge and Experience:**

- BS in Computer Science or equivalent education
- 1-2 years' of MSSQL database administration experience
- Minimum of 2 Years of T-SQL programming experience
- Minimum 2 years of development experience using SQL Server Integration Services (SSIS) and SQL Server Reporting Services (SSRS)
- 2 years of experience importing and exporting data from non-SQL data-sources such as Excel, and delimited flat files
- Experience supporting large databases with heavy online and batch activities
- Good knowledge of High Availability (HA), Always On and Disaster Recovery (DR) options for MSSQL Server
- Experience troubleshooting and resolving database integrity issues, performance issues, security issues
- Experience with data modeling and design
- Experience with backups, restores and database recovery models

- Experience in Performance Tuning and Optimization (PTO), using native monitoring and troubleshooting tools like Idera
- Excellent analytical, problem solving, oral and written communication skills
- Great team player and a self-starter
- A basic understanding of Storage Area Network concepts and technologies.

## **Title: GIS Analyst**

The Geographic Information Systems (GIS) Analyst will have the responsibility of analyzing data, creating client-facing content, and presenting it in a compelling way. They will interpret client needs, find the information that addresses those needs, and present the data in the best format possible. This is a great opportunity for an analytically minded individual willing to learn multiple tools and technologies.

- Create captivating visualizations, integrating JLL’s proprietary research data for the purposes of business development, external distribution, and client requests
- Produce interactive maps, reports, and presentations that bring research content and real estate data to life
- Assist on projects from initial debrief to finished product with significant self-direction and limited oversight
- Respond to internal stakeholder and external client requests for data and information
- Desire to develop communication and presentation skills necessary for client facing interactions
- Develop and share best practice standards for the region and the Americas Research Group

### **Knowledge & Experience:**

- 1 – 3 years of related GIS experience, real estate knowledge a plus
- BS/BA in geography, GIS, urban planning, economics, or relevant experience
- Working knowledge of the Esri platform: ArcMap/ArcGIS Pro, ArcGIS Online, and ArcGIS Applications
- Comfort with analysis and visualization tools (such as Excel, PowerPoint, Tableau) and Adobe Creative Suite
- Strong written and oral communication skills and the ability to work independently and collaboratively
- Experience managing workload, ability to multi-task, succeed under pressure and effectively manage time

## **Title: IT Support Specialist**

Provides support services to internal and/or external users for software, applications, hardware, and telecommunications related issues. Troubleshoot core bank applications, Microsoft applications, hardware errors, and Operating System. Collect information, open tickets, perform triage, and resolve or escalate issues related to new hardware/software requests, network, application software and telecommunications to the appropriate staff.

- Assist and support users with the use of core banking applications, standard software, Windows, MS Office and other business solutions. Answer, evaluate, and prioritize incoming telephone, voicemail, email, and Self-Service site requests for assistance.
- Maintain the Technical Support Software (ServiceNow) by identifying trends and accurately capturing details to enable the Problem Management function to improve IT processes and systems through accurate reporting.
- Create and update documentation on established Technical Support procedures and processes, problem resolution steps, and escalation procedures. Make recommendations to management on updates and changes needed
- Identify and troubleshoot hardware, software, operating system, mobility, and telecommunication issues.
- Responsible for installing, configuring, troubleshooting, and resolving incidents with respect to networking and desktop environments, including LANs, WANs, remote access, and VPNs.
- Perform diagnostic techniques to identify problems, investigate causes, and recommend solutions to correct common failures utilizing remote access tools.
- Responsible for performing installations and configuring computers/laptops using standard processes and tools.
- Partner in a 24X5 global support team. May be required to be on-call during specific times/projects. Escalates complex problems to higher level of expertise within the organization.

### **Knowledge & Experience:**

- High school diploma or GED or the equivalent in vocational training. College degree in information technology preferred.
- Previous practical experience in a personal computer network environment. One year of IT related Help Desk experience required.
- A+ certification required. MCDST (Microsoft Certified Desktop Support Technician) certification preferred.



- Knowledge of TCP/IP Protocols and PC knowledge, including hardware and software configuration, directory tree structure, Windows Messaging services, Active Directory, and Internet Explorer.
- Good working knowledge of Windows Operating Systems, Microsoft Office software package, Active Directory, and system management tools. Proficient in MS Office Suite, Enterprise Networks, banking computer system, and print device troubleshooting in a networked environment.
- Possess outstanding customer service skills and the ability to communicate highly technical information to both technical and non-technical staff.
- Good research, analytical, problem solving, and troubleshooting skills. Ability to manage time efficiently and work under stressful conditions.
- Good working understanding of computer hardware architecture concepts and technology related terminology. Ability to effectively log tickets in call tracking software.

## **Title: Network Administrator**

Responsible for the overall integration of the enterprise-wide network, including reliability, planning, design, installation, maintenance, management, and coordination of the company networks. Participates in the development of strategy for information systems and the design infrastructure necessary to support that strategy. Advises on selection of technological purchases with regard to network infrastructure, data storage, data access, and applications support. Ensures continued uninterrupted service through identification and problem resolution.

- Under general supervision, design, recommend, administer, and/or maintain wide area network
- Remain current on border routing protocols, make recommendations, and troubleshoot issues
- Under general supervision, design, recommend, administer, and/or maintain remote access systems, protected network access, firewalls, wireless, and associated access controls
- Monitor, install, and configure all network systems
- Proactively discover ways to improve performance of assigned systems
- Remain current on new infrastructure technology and champion initiatives to evaluate and recommend improvements
- Document network systems and keep documentation up to date
- Retire and remove legacy systems as they are no longer relevant
- Under general supervision, design, recommend, administer, and/or maintain servers, including web filtering appliances, intrusion detection appliances, network optimization and aggregation appliances, firewalls, backup systems, server racks, and switching technologies
- Help design, recommend, administer, and/or maintain network storage infrastructures and replication infrastructure
- Monitor and report the status of assigned hardware systems and recommend changes
- Proactively look for ways to improve performance of assigned systems
- Maintain hardware device firmware and software
- Proactively monitor company hardware infrastructure and respond to alerts

### **Requirements:**

- A four-year degree in computer science, MIS or related field, or five years of directly relevant work experience and/or training
- Experience with Palo Alto firewalls
- Proficient knowledge and experience with the following technologies:

- IP routing and virtualization in a Wide Area Network – MPLS, VRF, IPSEC
- BGP, OSPF, EIGRP, Ethernet, and TDM configuration and operation
- Cisco Enterprise and Industrial routing and switching platforms, modules, and configuration
- WAN performance, optimization, configuration, and assurance techniques
- Back-office network management and authentication systems
- Wireless LAN configuration, operation, and maintenance
- IP subnetting
- IP protocols
- Configuration and operation of LAN switching technology – VLANs, Trunking, FHRP's
- Proficient knowledge of network security best practices with hands on experience configuring Access Control Lists, TACACS+, SNMP, AAA, SSH
- Ability to interact with a diverse user base in a competent and professional manner required
- Performs most tasks and projects independently (without close supervision or guidance)
- Performs project management duties on some key initiatives
- Excellent analytical, problem solving, and organizational skills required
- Project and time management skills required
- Presentation and training skills required
- Provide after-hours support in an on-call rotation, including nights and weekends

## **Title: Project Coordinator/Assistance**

The Project Coordinator will be assisting the Project Manager with project plans and supporting documentation, while ensuring that assigned projects meet strategic business objectives for clients. Additional duties include:

- Adhere to established PMO standards and take direction from PMO Team on project management best practices and approach
- Interacting and coordinating with different departments and team members, driving communication and collaboration.
- Assisting the Project Team leaders with the following:
  - Project Management Plan
  - Resource Management
  - Meetings (prep, notes, action items)
  - Business Requirements
  - Communication Plans
  - Work Breakdown Structures
  - Project Budgets and Forecasts

### **Knowledge and Experience:**

- BS in Computer Science, Engineering, or a related field; or equivalent experience
- 1+ years directly related experience
- Superior communication skills (verbal and written)
- Good understanding of the project lifecycle
- Proficient with all the Microsoft Office products, particularly Excel, SharePoint, and Teams
- Demonstrated ability to track and drive issues
- Good soft skills and an ability to deal with ambiguity
- Financial forecasting and budgeting background is a plus
- The person in this roll will need to have outstanding customer service and communication skills.
- Preferred experience with MS Project and Azure DevOps

## **Title: Project Manager**

Project Manager drives development of project plans and supporting documentation, while ensuring that assigned projects meet strategic business objectives for clients. The Project Manager works closely with business users to evaluate, recommend, and implement technical and process solutions to enhance business value of operations and assists in the decision-making process by providing complete, current, reliable, and objective information.

Essential duties and responsibilities include, but are not limited to, the following:

- Effectively identify, prioritize, and translate business goals/objectives into information technology strategies/solutions
- Work with vendor project teams and internal core team to ensure deliverables and timelines are being met
- Interact with business partners through process modeling to understand, identify, and define project scope, cost, and resource estimates
- Adhere to established PMO standards and take direction from PMO Team Members on project management best practices and approach
- Development of project charter and governance plan development
- Monitor project resources, set priorities, and clarify tasks and assignments
- Development of the Project Management Plan
- Develop the project resource plan and facilitate onboarding of project resources
- Facilitate a formal project kick-off meeting
- Development of business requirements in partnership with the business and vendor teams
- Develop work breakdown structure and schedule with critical path identified  
Create and maintain the Integrated Project Plan (IPP). The IPP will be updated and published every two weeks, at a minimum, and shared with the core team, vendor teams, PMO, and essential stakeholders
- Plan and lead project core team meetings, project manager meetings, steering committee meetings, and other project related meetings
- Tracking and aging of project action items and key decisions
- Management of project budget, actuals, cash flows, and forecast
- Bi-weekly project status reports
- Active risk and issue management: identify, manage, and as appropriate, escalate project issues and risks to the appropriate person
- Prepare and distribute meeting agendas and meeting minutes
- Provide Project specific guidance and recommendations throughout the duration of the Project
- Plan for and manage a project go-live readiness assessment and cut-over process.

- Manage effective transition from project to operations.
- Lead Project closeout and facilitate a lessons-learned workshop in partnership with the PMO.

**Requirements:**

- BS in Computer Science, Engineering, or a related field; or equivalent experience
- 5-7 years directly related experience
- Superior communication skills (verbal and written)
- Good understanding of the project lifecycle
- Proficient with all the Microsoft Office products, particularly Excel, SharePoint, and Teams
- Demonstrated ability to track and drive issues
- Good soft skills and an ability to deal with ambiguity
- Financial forecasting and budgeting background is a plus
- PMP highly desired
- PMP, Scrum Master, Agile-PMP, or equivalent Agile certification highly desired
- The person in this roll will need to have outstanding customer service and communication skills.
- Preferred experience with MS Project and Azure DevOps
- Experience managing all phases (Initiation, Planning, Execution, and Closure) large, enterprise level ERP or cloud projects
- Contracts / legal / vendor management experience
- Strong technology / network/ security systems background preferred

## **Title: Software Developer**

Primary responsibilities include consulting with end users and stakeholders, developing web-based applications and conducting technical analysis of systems and applications in order to implement, configure and test commercial-off-the-shelf applications. Additional responsibilities include the investigation and remedy of problems with existing systems and applications.

- Collaborate with peers on software design, maintenance, troubleshooting, and new feature implementation
- Provide accurate story and project estimations
- Perform peer code reviews
- Contribute ideas to continually improve the team's productivity and code quality
- Guide and mentor less experienced developers while remaining a productive coder wherever necessary
- Creating database schemas that represent and support business processes
- Analyze system architecture and structure requirements
- Implementing Unit tests

### **Qualifications & Requirements:**

- Full stack development experience in a Windows environment using object-oriented programming
- Strong understanding of Agile/Scrum methodology
- Front-end: experience with Angular 1.3+, CSS, JavaScript, Vue
- Back-end: experience with .NET, C#, SQL Server, Web Services (REST, ODATA, Vue)
- Experience architecting large software systems and enterprise integrations
- Solid grasp and fluent in common design patterns
- Tools: TFS, git, Visual Studio and VS Code

### **Preferred Skills & Competencies:**

- SharePoint 365
- Familiarity with continuous integration
- Front-end: Sass, TypeScript, ES2017
- Back-end: Oracle
- Cloud: AWS, Azure
- Other: Experience with CI/CD, UI/UX design skills
- Strong frontend dev with familiarity to .NET backend and strong .NET dev with some hands-on front-end development skills

## **Title: Systems Administrator**

Ideal candidate will be a motivated generalist who also works to resolve user tickets and is excited to be involved in nearly every aspect of technology. Above all else, we seek someone who is driven, friendly, and technical, and has a willingness to contribute in a meaningful way to support the needs of the company.

- Monitor systems and networks for issues or potential issues and be proactive in recommending appropriate resolutions
- Perform workstation imaging, inventory and asset management, and software installation and upgrades
- Support end users directly, with consistent follow through and issue resolution
- Perform routine maintenance and patching of systems
- Script and automate software installations and other changes
- Install, upgrade, and configure workstations, servers, network appliances, etc.
- Follow, maintain, and develop comprehensive written documentation
- Ensure company data and systems are secure and protected

### **Knowledge & Experience:**

- B.S. in Computer Science, Information Science, IT/IS or similar, or 4 years' experience as a mid-career system admin or equivalent role
- In-depth knowledge of Active Directory, Group Policy, and backup and replica processes and best practices
- Proficient in Office 365, Windows 10, and Windows Server (2012R2/2016/2019), and in scripting Windows batch and/or PowerShell
- Familiar with switching and routing basics such as DHCP, DNS, VLANs, firewalls, VPNs, WLANs, iSCSI, etc.
- Experience managing virtual server environments with shared storage, such as VMWare vSphere or Hyper-V
- Proactive and relentless approach to troubleshooting
- Effective, professional, and courteous communicator

### **Preferred Qualifications:**

- Certifications in MCSA/MCSE/CCNA/JNCP, or similar.
- Familiar with Autodesk products such as Autocad/Civil 3d, Infracore, and with Veeam Backup & Replication
- Experience with Hyper-V/Failover Cluster management, HPE Nimble/TrueNAS storage, Kace K2000 Systems Imaging/Kace K1000 Systems Management,



SNMP/Syslog (PRTG), Juniper, Meraki, SSO/MFA (Duo), Linux (CentOS), and/or  
DirectAccess/Always-On VPN



### License Information:

[New search](#) [Back to results](#)

**Entity name:** VOLT MANAGEMENT CORP.

**Business name:** VOLT MANAGEMENT CORP

**Entity type:** [Profit Corporation](#)

**UBI #:** 601-516-248

**Business ID:** 001

**Location ID:** 0023

**Location:** Active

**Location address:** 1420 N MULLAN RD  
STE 110  
SPOKANE VALLEY WA 99206-4333

**Mailing address:** TAX DEPT  
PO BOX 13500  
ORANGE CA 92857-8500

**Excise tax and reseller permit status:** [Click here](#)

**Secretary of State status:** [Click here](#)

### Endorsements

Endorsements held at this location	License #	Count	Details	Status	Expiration date	First issuance date
<a href="#">Spokane General Business - Non-Resident</a>	T12033544BUS			Active	Dec-31-2022	Oct-15-2012
<a href="#">Spokane Valley General Business</a>				Active	Dec-31-2022	May-05-2016



## Governing People May include governing people not registered with Secretary of State

Governing people	Title
AVEDISSIAN, NANCY	
HOWELL, DIANE	
MUELLER, HERB	
NAUJOKAS, LEONARD	
PERNEAU, LINDA	

## Registered Trade Names

Registered trade names	Status	First issued
VOLT SERVICES GROUP	Active	Jul-14-1994
VOLT WORKFORCE SOLUTIONS	Active	Jun-06-2007

[View Additional Locations](#)

The Business Lookup information is updated nightly. Search date and time: 2/17/2022 8:40:25 AM

[Contact us](#)

How are we doing?

[Take our survey!](#)

Don't see what you expected?

[Check if your browser is supported](#)





# CERTIFICATE OF LIABILITY INSURANCE

OPR 2017-0876

DATE (MM/DD/YYYY)  
12/09/2021

THIS CERTIFICATE IS ISSUED AS A MATTER OF INFORMATION ONLY AND CONFERS NO RIGHTS UPON THE CERTIFICATE HOLDER. THIS CERTIFICATE DOES NOT AFFIRMATIVELY OR NEGATIVELY AMEND, EXTEND OR ALTER THE COVERAGE AFFORDED BY THE POLICIES BELOW. THIS CERTIFICATE OF INSURANCE DOES NOT CONSTITUTE A CONTRACT BETWEEN THE ISSUING INSURER(S), AUTHORIZED REPRESENTATIVE OR PRODUCER, AND THE CERTIFICATE HOLDER.

IMPORTANT: If the certificate holder is an ADDITIONAL INSURED, the policy(ies) must have ADDITIONAL INSURED provisions or be endorsed. If SUBROGATION IS WAIVED, subject to the terms and conditions of the policy, certain policies may require an endorsement. A statement on this certificate does not confer rights to the certificate holder in lieu of such endorsement(s).

**PRODUCER**  
Willis Towers Watson Northeast, Inc.  
c/o 26 Century Blvd  
P.O. Box 305191  
Nashville, TN 372305191 USA

**CONTACT NAME:** Willis Towers Watson Certificate Center  
**PHONE (A/C, No, Ext):** 1-877-945-7378 **FAX (A/C, No):** 1-888-467-2378  
**E-MAIL ADDRESS:** certificates@willis.com

RECEIVED  
DEC 16 2021

**INSURER(S) AFFORDING COVERAGE**  
**INSURER A:** Columbia Casualty Company **NAIC #** 31127

**INSURED**  
Volt Workforce Solutions, a division of Volt Management Corp.  
2401 N. Glassell St  
Orange, CA 92865

CITY CLERK'S OFFICE

**INSURER B:**  
**INSURER C:**  
**INSURER D:**  
**INSURER E:**  
**INSURER F:**

**COVERAGES** **CERTIFICATE NUMBER: W23049019** **REVISION NUMBER:**

THIS IS TO CERTIFY THAT THE POLICIES OF INSURANCE LISTED BELOW HAVE BEEN ISSUED TO THE INSURED NAMED ABOVE FOR THE POLICY PERIOD INDICATED. NOTWITHSTANDING ANY REQUIREMENT, TERM OR CONDITION OF ANY CONTRACT OR OTHER DOCUMENT WITH RESPECT TO WHICH THIS CERTIFICATE MAY BE ISSUED OR MAY PERTAIN, THE INSURANCE AFFORDED BY THE POLICIES DESCRIBED HEREIN IS SUBJECT TO ALL THE TERMS, EXCLUSIONS AND CONDITIONS OF SUCH POLICIES. LIMITS SHOWN MAY HAVE BEEN REDUCED BY PAID CLAIMS.

INSR LTR	TYPE OF INSURANCE	ADDL SUBR INSD WVD	POLICY NUMBER	POLICY EFF (MM/DD/YYYY)	POLICY EXP (MM/DD/YYYY)	LIMITS	
	<b>COMMERCIAL GENERAL LIABILITY</b> <input type="checkbox"/> CLAIMS-MADE <input type="checkbox"/> OCCUR  GEN'L AGGREGATE LIMIT APPLIES PER: <input type="checkbox"/> POLICY <input type="checkbox"/> PRO-JECT <input type="checkbox"/> LOC OTHER:					EACH OCCURRENCE	\$
						DAMAGE TO RENTED PREMISES (Ea occurrence)	\$
						MED EXP (Any one person)	\$
						PERSONAL & ADV INJURY	\$
						GENERAL AGGREGATE	\$
						PRODUCTS - COMP/OP AGG	\$
							\$
	<b>AUTOMOBILE LIABILITY</b> <input type="checkbox"/> ANY AUTO <input type="checkbox"/> OWNED AUTOS ONLY <input type="checkbox"/> SCHEDULED AUTOS <input type="checkbox"/> NON-OWNED AUTOS ONLY <input type="checkbox"/> HIRED AUTOS ONLY					COMBINED SINGLE LIMIT (Ea accident)	\$
						BODILY INJURY (Per person)	\$
						BODILY INJURY (Per accident)	\$
						PROPERTY DAMAGE (Per accident)	\$
							\$
	<b>UMBRELLA LIAB</b> <input type="checkbox"/> OCCUR <b>EXCESS LIAB</b> <input type="checkbox"/> CLAIMS-MADE  DED <input type="checkbox"/> RETENTIONS					EACH OCCURRENCE	\$
						AGGREGATE	\$
							\$
	<b>WORKERS COMPENSATION AND EMPLOYERS' LIABILITY</b> ANY PROPRIETOR/PARTNER/EXECUTIVE OFFICER/MEMBER EXCLUDED? <input type="checkbox"/> Y/N <input checked="" type="checkbox"/> N/A (Mandatory in NH) If yes, describe under DESCRIPTION OF OPERATIONS below					PER STATUTE	OTH-ER
						E.L. EACH ACCIDENT	\$
						E.L. DISEASE - EA EMPLOYEE	\$
						E.L. DISEASE - POLICY LIMIT	\$
<b>A</b>	<b>Professional Liability</b>		652057576	12/08/2021	12/08/2022	Limit	\$1,000,000
						Retention	\$1,000,000

DESCRIPTION OF OPERATIONS / LOCATIONS / VEHICLES (ACORD 101, Additional Remarks Schedule, may be attached if more space is required)  
Re: Agreement City OPR Number 2017-0876 EVIDENCE OF INSURANCE.

<b>CERTIFICATE HOLDER</b>  City of Spokane Attn.: Shelley McCarrey 808 W. Spokane Falls Blvd. Spokane, WA 99201	<b>CANCELLATION</b>  SHOULD ANY OF THE ABOVE DESCRIBED POLICIES BE CANCELLED BEFORE THE EXPIRATION DATE THEREOF, NOTICE WILL BE DELIVERED IN ACCORDANCE WITH THE POLICY PROVISIONS.  AUTHORIZED REPRESENTATIVE  
---	--

© 1988-2016 ACORD CORPORATION. All rights reserved.



**Agenda Sheet for City Council Meeting of:**  
06/20/2022

<b>Date Rec'd</b>	6/6/2022
<b>Clerk's File #</b>	OPR 2022-0440
<b>Renews #</b>	
<b>Cross Ref #</b>	
<b>Project #</b>	
<b>Bid #</b>	ITB 5634-22
<b>Requisition #</b>	VALUE BLANKET

<b>Submitting Dept</b>	SOLID WASTE DISPOSAL
<b>Contact Name/Phone</b>	DAVID PAINE 625-6878
<b>Contact E-Mail</b>	DPAINE@SPOKANECITY.ORG
<b>Agenda Item Type</b>	Purchase w/o Contract
<b>Agenda Item Name</b>	4490 VALUE BLANKET FOR THE PURCHASE OF ANHYDROUS AMMONIA AT THE WTE

**Agenda Wording**

Value blanket with Airgas Specialty Products, Inc. (Lawrenceville, GA), for the purchase of anhydrous ammonia at the WTE from Jul. 1, 2022 thru Jun. 30, 2025 and a cost not to exceed \$880,000.00 annually (\$2,640,000.00 for 3-yr term) plus tax.

**Summary (Background)**

Anhydrous Ammonia is used for emissions control at the WTE. It is required to maintain compliance with the Air Operating permit emission limits. On May 2, 2022 bids for ITB 5634-22 for the purchase of Anhydrous Ammonia were received and Airgas Specialty Products, Inc. was the only respondent. The pricing will be at \$1.10/lb with an approximate annual usage of 800,000 lbs.

Lease? NO Grant related? NO Public Works? NO

**Fiscal Impact**

Expense	\$ 880,000 (2022-2023)
Expense	\$ 880,000 (2023-2024)
Expense	\$ 880,000 (2024-2055)
Select	\$

**Budget Account**

#	4490-44100-37148-53203
#	4490-44100-37148-53203
#	4490-44100-37148-53203
#	

**Approvals**

<b>Dept Head</b>	AVERYT, CHRIS
<b>Division Director</b>	FEIST, MARLENE
<b>Finance</b>	ALBIN-MOORE, ANGELA
<b>Legal</b>	ODLE, MARI
<b>For the Mayor</b>	ORMSBY, MICHAEL

**Council Notifications**

<b>Study Session\Other</b>	6/6/22 PSCH
<b>Council Sponsor</b>	CM Kinnear

**Additional Approvals**

<b>Distribution List</b>	mdorgan@spokanecity.org
	jsalstrom@spokanecity.org
	tprince@spokanecity.org
<b>Purchasing</b>	PRINCE, THEA
	rrinderle@spokanecity.org

## Committee Agenda Sheet

### Public Safety and Community Health Committee

<b>Submitting Department</b>	Solid Waste Disposal
<b>Contact Name &amp; Phone</b>	David Paine, 625-6878
<b>Contact Email</b>	<a href="mailto:dpaine@spokanecity.org">dpaine@spokanecity.org</a>
<b>Council Sponsor(s)</b>	CM Lori Kinnear
<b>Select Agenda Item Type</b>	<input checked="" type="checkbox"/> Consent <input type="checkbox"/> Discussion    Time Requested: _____
<b>Agenda Item Name</b>	Value blanket for the purchase of anhydrous ammonia at the WTE.
<b>Summary (Background)</b>	<p>Anhydrous Ammonia is used for emissions control at the Waste to Energy Facility. It is required to maintain compliance with the Air Operating permit emission limits.</p> <p>On May 2, 2022 bids for ITB 5634-22 for the purchase of Anhydrous Ammonia were received and Airgas Specialty Products, Inc. of Lawrenceville, GA, was the only respondent. The initial term of the value blanket will be for a three (3) year period beginning July 1, 2022 and spanning thru June 30, 2025 with the option of two (2) additional one-year renewals. The pricing will be at \$1.10/lb, so with an approximate annual usage of 800,000 lbs, the cost should not exceed \$880,000.00 each year or \$2,640,000.00 for the three year total, plus taxes.</p>
<b>Proposed Council Action &amp; Date:</b>	Committee's consent to proceed on 6/6/22.
<p><b>Fiscal Impact:</b> \$880,000.00  Total Cost: <u>\$2,640,000.00</u></p> <p>Approved in current year budget?    <input checked="" type="checkbox"/> Yes    <input type="checkbox"/> No    <input type="checkbox"/> N/A</p> <p>Funding Source    <input type="checkbox"/> One-time    <input checked="" type="checkbox"/> Recurring  Specify funding source: 2022 SWD Budget</p> <p>Expense Occurrence    <input type="checkbox"/> One-time    <input checked="" type="checkbox"/> Recurring</p> <p>Other budget impacts: (revenue generating, match requirements, etc.)</p>	

**Operations Impacts**

What impacts would the proposal have on historically excluded communities?

N/A

How will data be collected, analyzed, and reported concerning the effect of the program/policy by racial, ethnic, gender identity, national origin, income level, disability, sexual orientation, or other existing disparities?

N/A

How will data be collected regarding the effectiveness of this program, policy or product to ensure it is the right solution?

The use of anhydrous ammonia as part of the WTE's emission control process is evident in the reading seen in the continuous emission monitoring system and annual stack testing.

Describe how this proposal aligns with current City Policies, including the Comprehensive Plan, Sustainability Action Plan, Capital Improvement Program, Neighborhood Master Plans, Council Resolutions, and others?

Maintaining our emissions at or below the permitted and allowable levels supports the SAP while providing a necessary service to the citizens and our communities.



**Agenda Sheet for City Council Meeting of:**  
06/20/2022

<b>Date Rec'd</b>	6/7/2022
<b>Clerk's File #</b>	OPR 2022-0441
<b>Renews #</b>	
<b>Cross Ref #</b>	
<b>Project #</b>	
<b>Bid #</b>	
<b>Requisition #</b>	

<b>Submitting Dept</b>	POLICE
<b>Contact Name/Phone</b>	MIKE MCNAB 835-4514
<b>Contact E-Mail</b>	MMCNAB@SPOKANEPOLICE.ORG
<b>Agenda Item Type</b>	Purchase w/o Contract
<b>Agenda Item Name</b>	0680 CUBICLE PURCHASE FOR SPD GARDNER BUILDING

**Agenda Wording**

Seeking approval to purchase Cubicles for the SPD Gardner Building utilizing Herman Miller OMNIA cooperative contract #2020000622.

**Summary (Background)**

On April 25th, 2022 City Council approved special budget ordinance C36192 authorizing the procurement of office furniture using federal forfeiture funds. Due to increasing costs of materials, the estimate for purchasing cubicle panels has reached a total cost of \$65,070.44 (Incl. tax) requiring council approval for the purchase.

Lease? NO Grant related? NO Public Works? NO

**Fiscal Impact**

Expense \$ \$65,070.44

Select \$

Select \$

Select \$

**Budget Account**

# 1560-17100-21250-53505-99999

#

#

#

**Approvals**

**Dept Head** LUNDGREN, JUSTIN

**Division Director** MEIDL, CRAIG

**Finance** SCHMITT, KEVIN

**Legal** ODLE, MARI

**For the Mayor** ORMSBY, MICHAEL

**Council Notifications**

**Study Session\Other** 04/25/2022

**Council Sponsor** CM Cathcart

**Distribution List**

spdfinance@spokanepolice.org

mmncab@spokanepolice.org

**Additional Approvals**

**Purchasing**



## Committee Agenda Sheet

### Public Safety & Community Health

<b>Submitting Department</b>	Spokane Police Department
<b>Contact Name &amp; Phone</b>	Major Mike McNab 835-4514
<b>Contact Email</b>	mmcnab@spokanepolice.org
<b>Council Sponsor(s)</b>	Councilman Cathcart
<b>Select Agenda Item Type</b>	<input checked="" type="checkbox"/> Consent <input type="checkbox"/> Discussion    Time Requested: 0
<b>Agenda Item Name</b>	Approval to Purchase Cubicles for SPD Gardner Building
<b>Summary (Background)</b>	On April 25 <sup>th</sup> , 2022 City Council approved special budget ordinance C36192 authorizing the procurement of office furniture using federal forfeiture funds. Due to increasing costs of materials, the estimate for purchasing cubicle panels has reached a total cost of \$65,070.44 (Incl. tax) requiring council approval for the purchase.
<b>Proposed Council Action &amp; Date:</b>	Approval on June 20 <sup>th</sup> , 2022
<b>Fiscal Impact:</b>	Total Cost: \$65,070.44
Approved in current year budget?	<input checked="" type="checkbox"/> Yes <input type="checkbox"/> No <input type="checkbox"/> N/A
Funding Source	<input checked="" type="checkbox"/> One-time <input type="checkbox"/> Recurring
Specify funding source: Federal funds received for one-time costs related to law enforcement and criminal justice legislation	
Expense Occurrence	<input checked="" type="checkbox"/> One-time <input type="checkbox"/> Recurring
Other budget impacts: (revenue generating, match requirements, etc.)	
<b>Operations Impacts</b>	
What impacts would the proposal have on historically excluded communities?	
<b>None</b>	
How will data be collected, analyzed, and reported concerning the effect of the program/policy by racial, ethnic, gender identity, national origin, income level, disability, sexual orientation, or other existing disparities?	
<b>There will be no data collected for these purchases</b>	
How will data be collected regarding the effectiveness of this program, policy or product to ensure it is the right solution?	
<b>N/A</b>	
Describe how this proposal aligns with current City Policies, including the Comprehensive Plan, Sustainability Action Plan, Capital Improvement Program, Neighborhood Master Plans, Council Resolutions, and others?	
<b>The furniture and equipment purchased with increased budget allocation aligns with multiple goals from the Police Department's 2022- 2023 Strategic Plan Including:</b>	

- **Ensure the wellness and health of our employees, emotionally and physically.**
- **Maintain a progressive approach to best practices revolving around training, equipment, programs and service to the community and our employees.**

**The use of federal forfeiture funds for these purposes aligns with federal law and U.S. Department of Justice guidelines as permissible use for the “expansion of law enforcement activity”.**



Contract Design Associates

Spokane Showroom  
402 East Sprague Ave.  
Spokane, WA 99202

(509)624-4220 P  
(509)623-1777 F

www.cdainteriors.com

Missoula Showroom  
1330 West Broadway  
Missoula, MT 59802

(406)926-3313 P&F

# PROPOSAL

**PROPOSAL #: 49312**

DATE: 05/11/22

PROJECT #: 9-135

**PROPOSAL FOR: 1746**

CITY OF SPOKANE  
ATTN: ACCOUNTS PAYABLE  
808 SPOKANE FALLS BLVD  
SPOKANE WA 99201

**INSTALL AT:**

SPOKANE POLICE DEPARTMENT  
1427 W GARDNER  
SPOKANE WA 99201

CUSTOMER P.O.	PAYMENT TERMS	QUOTE VALID	SALESPERSON
	NET 10 DAYS	07/01/22	DEFELICE, CHLOE

#	QTY	PRODUCT	DESCRIPTION	SELL	EXTENDED
1	2	A8125.6724J	HERMAN MILLER OMNIA CONTRACT #2020000622 +Panel,Tack Ac-Bar,Thin Baser Npwr W/Rcp/Com Lc 67H 24W HF +inner tone light HF +inner tone light 8T +crossing-Pr Cat 1 19 +crossing shale 8T +crossing-Pr Cat 1 19 +crossing shale	257.64	515.28
2	2	A8125.6736J	+Panel,Tack Ac-Bar,Thin Baser Npwr W/Rcp/Com Lc 67H 36W HF +inner tone light HF +inner tone light 8T +crossing-Pr Cat 1 19 +crossing shale 8T +crossing-Pr Cat 1 19 +crossing shale	311.51	623.02
3	2	A8125.6742J	+Panel,Tack Ac-Bar,Thin Baser Npwr W/Rcp/Com Lc 67H 42W HF +inner tone light HF +inner tone light 8T +crossing-Pr Cat 1 19 +crossing shale 8T +crossing-Pr Cat 1 19 +crossing shale	325.19	650.38
4	2	A8125.6748J	+Panel,Tack Ac-Bar,Thin Baser Npwr W/Rcp/Com Lc 67H 48W HF +inner tone light HF +inner tone light 8T +crossing-Pr Cat 1 19 +crossing shale 8T +crossing-Pr Cat 1 19 +crossing shale	344.00	688.00



Contract Design Associates

Spokane Showroom  
402 East Sprague Ave.  
Spokane, WA 99202

(509)624-4220 P  
(509)623-1777 F

www.cdainteriors.com

Missoula Showroom  
1330 West Broadway  
Missoula, MT 59802

(406)926-3313 P&F

# PROPOSAL

**PROPOSAL #: 49312**

DATE: 05/11/22

PROJECT #: 9-135

**PROPOSAL FOR: 1746**

CITY OF SPOKANE  
ATTN: ACCOUNTS PAYABLE  
808 SPOKANE FALLS BLVD  
SPOKANE WA 99201

**INSTALL AT:**

SPOKANE POLICE DEPARTMENT  
1427 W GARDNER  
SPOKANE WA 99201

CUSTOMER P.O.	PAYMENT TERMS	QUOTE VALID	SALESPERSON
	NET 10 DAYS	07/01/22	DEFELICE, CHLOE

#	QTY	PRODUCT	DESCRIPTION	SELL	EXTENDED
5	2	A8220.67H	+Conn,2-Way 90 Deg,Thin Base Hard 67H	62.70	125.40
		HF	+inner tone light		
		HF	+inner tone light		
6	2	A8271.67H	+Fin End,Thin Base 67H	23.09	46.18
		HF	+inner tone light		
		HF	+inner tone light		
7	2	AO210.62	+Wall Start 62H	30.50	61.00
		HF	+inner tone light		
8	1	AO212.	+Wall Filler Strip, 4/Pkg	70.11	70.11
9	6	AO215.62	+Draw Rod 62H	10.83	64.98
10	3	A8125.6724J	+Panel,Tack Ac-Bar,Thin Baser Npwr W/Rcp/Com Lc 67H 24W	257.64	772.92
		HF	+inner tone light		
		HF	+inner tone light		
		8T	+crossing-Pr Cat 1		
		19	+crossing shale		
		8T	+crossing-Pr Cat 1		
		19	+crossing shale		
11	3	A8125.6730J	+Panel,Tack Ac-Bar,Thin Baser Npwr W/Rcp/Com Lc 67H 30W	278.45	835.35
		HF	+inner tone light		
		HF	+inner tone light		
		8T	+crossing-Pr Cat 1		
		19	+crossing shale		
		8T	+crossing-Pr Cat 1		
		19	+crossing shale		
12	9	A8125.6736J	+Panel,Tack Ac-Bar,Thin Baser Npwr W/Rcp/Com Lc 67H 36W	311.51	2,803.59
		HF	+inner tone light		
		HF	+inner tone light		
		8T	+crossing-Pr Cat 1		

CONTINUED...



Contract Design Associates

Spokane Showroom  
402 East Sprague Ave.  
Spokane, WA 99202

(509)624-4220 P  
(509)623-1777 F

www.cdainteriors.com

Missoula Showroom  
1330 West Broadway  
Missoula, MT 59802

(406)926-3313 P&F

# PROPOSAL

**PROPOSAL #: 49312**

DATE: 05/11/22

PROJECT #: 9-135

**PROPOSAL FOR: 1746**

CITY OF SPOKANE  
ATTN: ACCOUNTS PAYABLE  
808 SPOKANE FALLS BLVD  
SPOKANE WA 99201

**INSTALL AT:**

SPOKANE POLICE DEPARTMENT  
1427 W GARDNER  
SPOKANE WA 99201

CUSTOMER P.O.	PAYMENT TERMS	QUOTE VALID	SALESPERSON
	NET 10 DAYS	07/01/22	DEFELICE, CHLOE

#	QTY	PRODUCT	DESCRIPTION	SELL	EXTENDED
13	3	A8220.67H 19 8T 19 HF HF	+crossing shale +crossing-Pr Cat 1 +crossing shale +Conn,2-Way 90 Deg,Thin Base Hard 67H +inner tone light +inner tone light	62.70	188.10
14	3	A8271.67H HF HF	+Fin End,Thin Base 67H +inner tone light +inner tone light	23.09	69.27
15	3	AO210.62 HF	+Wall Start 62H +inner tone light	30.50	91.50
16	12	AO215.62	+Draw Rod 62H	10.83	129.96
17	12	A8125.6724J HF HF	+Panel,Tack Ac-Bar,Thin Baser Npwr W/Rcp/Com Lc 67H 24W +inner tone light +inner tone light	257.64	3,091.68
18	6	A8125.6730J 8T 19 8T 19 HF HF	+crossing-Pr Cat 1 +crossing shale +crossing-Pr Cat 1 +crossing shale +Panel,Tack Ac-Bar,Thin Baser Npwr W/Rcp/Com Lc 67H 30W +inner tone light +inner tone light	278.45	1,670.70
19	22	A8125.6736J 8T 19 8T 19 HF	+crossing-Pr Cat 1 +crossing shale +crossing-Pr Cat 1 +crossing shale +Panel,Tack Ac-Bar,Thin Baser Npwr W/Rcp/Com Lc 67H 36W +inner tone light	311.51	6,853.22

CONTINUED...



Contract Design Associates

Spokane Showroom  
402 East Sprague Ave.  
Spokane, WA 99202

(509)624-4220 P  
(509)623-1777 F

www.cdainteriors.com

Missoula Showroom  
1330 West Broadway  
Missoula, MT 59802

(406)926-3313 P&F

# PROPOSAL

**PROPOSAL #: 49312**

DATE: 05/11/22

PROJECT #: 9-135

**PROPOSAL FOR: 1746**

CITY OF SPOKANE  
ATTN: ACCOUNTS PAYABLE  
808 SPOKANE FALLS BLVD  
SPOKANE WA 99201

**INSTALL AT:**

SPOKANE POLICE DEPARTMENT  
1427 W GARDNER  
SPOKANE WA 99201

CUSTOMER P.O.	PAYMENT TERMS	QUOTE VALID	SALESPERSON
	NET 10 DAYS	07/01/22	DEFELICE, CHLOE

#	QTY	PRODUCT	DESCRIPTION	SELL	EXTENDED
20	12	A8125.6742J	HF +inner tone light 8T +crossing-Pr Cat 1 19 +crossing shale 8T +crossing-Pr Cat 1 19 +crossing shale +Panel,Tack Ac-Bar,Thin Baser Npwr W/Rcp/Com Lc 67H 42W	325.19	3,902.28
21	13	A8220.67H	HF +inner tone light HF +inner tone light 8T +crossing-Pr Cat 1 19 +crossing shale 8T +crossing-Pr Cat 1 19 +crossing shale +Conn,2-Way 90 Deg,Thin Base Hard 67H	62.70	815.10
22	3	A8230.67H	HF +inner tone light HF +inner tone light +Conn,3-Way 90 Deg,Thin Base Hard 67H	102.32	306.96
23	2	A8240.67H	HF +inner tone light HF +inner tone light +Conn,4-Way 90 Deg,Thin Base 67H	131.39	262.78
24	12	A8271.67H	HF +inner tone light HF +inner tone light +Fin End,Thin Base 67H	23.09	277.08
25	5	AO210.62	HF +inner tone light HF +inner tone light +Wall Start 62H	30.50	152.50
26	2	AO212.	HF +inner tone light +Wall Filler Strip, 4/Pkg	70.11	140.22
27	40	AO215.62	+Draw Rod 62H	10.83	433.20



Contract Design Associates

Spokane Showroom  
402 East Sprague Ave.  
Spokane, WA 99202

(509)624-4220 P  
(509)623-1777 F

www.cdainteriors.com

Missoula Showroom  
1330 West Broadway  
Missoula, MT 59802

(406)926-3313 P&F

# PROPOSAL

**PROPOSAL #: 49312**

DATE: 05/11/22

PROJECT #: 9-135

**PROPOSAL FOR: 1746**

CITY OF SPOKANE  
ATTN: ACCOUNTS PAYABLE  
808 SPOKANE FALLS BLVD  
SPOKANE WA 99201

**INSTALL AT:**

SPOKANE POLICE DEPARTMENT  
1427 W GARDNER  
SPOKANE WA 99201

CUSTOMER P.O.	PAYMENT TERMS	QUOTE VALID	SALESPERSON
	NET 10 DAYS	07/01/22	DEFELICE, CHLOE

#	QTY	PRODUCT	DESCRIPTION	SELL	EXTENDED
28	15	A8125.6724J	+Panel,Tack Ac-Bar,Thin Baser Npwr W/Rcp/Com Lc 67H 24W HF +inner tone light HF +inner tone light 8T +crossing-Pr Cat 1 19 +crossing shale 8T +crossing-Pr Cat 1 19 +crossing shale	257.64	3,864.60
29	6	A8125.6730J	+Panel,Tack Ac-Bar,Thin Baser Npwr W/Rcp/Com Lc 67H 30W HF +inner tone light HF +inner tone light 8T +crossing-Pr Cat 1 19 +crossing shale 8T +crossing-Pr Cat 1 19 +crossing shale	278.45	1,670.70
30	12	A8125.6736J	+Panel,Tack Ac-Bar,Thin Baser Npwr W/Rcp/Com Lc 67H 36W HF +inner tone light HF +inner tone light 8T +crossing-Pr Cat 1 19 +crossing shale 8T +crossing-Pr Cat 1 19 +crossing shale	311.51	3,738.12
31	2	A8125.6748J	+Panel,Tack Ac-Bar,Thin Baser Npwr W/Rcp/Com Lc 67H 48W HF +inner tone light HF +inner tone light 8T +crossing-Pr Cat 1 19 +crossing shale 8T +crossing-Pr Cat 1 19 +crossing shale	344.00	688.00



Contract Design Associates

Spokane Showroom  
402 East Sprague Ave.  
Spokane, WA 99202

(509)624-4220 P  
(509)623-1777 F

www.cdainteriors.com

Missoula Showroom  
1330 West Broadway  
Missoula, MT 59802

(406)926-3313 P&F

# PROPOSAL

PROPOSAL #: 49312

DATE: 05/11/22

PROJECT #: 9-135

**PROPOSAL FOR:** 1746

CITY OF SPOKANE  
ATTN: ACCOUNTS PAYABLE  
808 SPOKANE FALLS BLVD  
SPOKANE WA 99201

**INSTALL AT:**

SPOKANE POLICE DEPARTMENT  
1427 W GARDNER  
SPOKANE WA 99201

CUSTOMER P.O.	PAYMENT TERMS	QUOTE VALID	SALESPERSON
	NET 10 DAYS	07/01/22	DEFELICE, CHLOE

#	QTY	PRODUCT	DESCRIPTION	SELL	EXTENDED
32	21	AO215.62	+Draw Rod 62H	10.83	227.43
33	8	A8125.6724J	+Panel,Tack Ac-Bar,Thin Baser Npwr W/Rcp/Com Lc 67H 24W HF +inner tone light HF +inner tone light 8T +crossing-Pr Cat 1 19 +crossing shale 8T +crossing-Pr Cat 1 19 +crossing shale	257.64	2,061.12
34	4	A8125.6730J	+Panel,Tack Ac-Bar,Thin Baser Npwr W/Rcp/Com Lc 67H 30W HF +inner tone light HF +inner tone light 8T +crossing-Pr Cat 1 19 +crossing shale 8T +crossing-Pr Cat 1 19 +crossing shale	278.45	1,113.80
35	16	A8125.6736J	+Panel,Tack Ac-Bar,Thin Baser Npwr W/Rcp/Com Lc 67H 36W HF +inner tone light HF +inner tone light 8T +crossing-Pr Cat 1 19 +crossing shale 8T +crossing-Pr Cat 1 19 +crossing shale	311.51	4,984.16
36	12	A8125.6742J	+Panel,Tack Ac-Bar,Thin Baser Npwr W/Rcp/Com Lc 67H 42W HF +inner tone light HF +inner tone light 8T +crossing-Pr Cat 1 19 +crossing shale 8T +crossing-Pr Cat 1	325.19	3,902.28

CONTINUED...





Contract Design Associates

Spokane Showroom  
402 East Sprague Ave.  
Spokane, WA 99202

(509)624-4220 P  
(509)623-1777 F

www.cdainteriors.com

Missoula Showroom  
1330 West Broadway  
Missoula, MT 59802

(406)926-3313 P&F

# PROPOSAL

**PROPOSAL #: 49312**

DATE: 05/11/22

PROJECT #: 9-135

**PROPOSAL FOR: 1746**

CITY OF SPOKANE  
ATTN: ACCOUNTS PAYABLE  
808 SPOKANE FALLS BLVD  
SPOKANE WA 99201

**INSTALL AT:**

SPOKANE POLICE DEPARTMENT  
1427 W GARDNER  
SPOKANE WA 99201

CUSTOMER P.O.	PAYMENT TERMS	QUOTE VALID	SALESPERSON
	NET 10 DAYS	07/01/22	DEFELICE, CHLOE

#	QTY	PRODUCT	DESCRIPTION	SELL	EXTENDED
37	12	19 A8125.6748J HF HF 8T 19 8T 19	+crossing shale +Panel, Tack Ac-Bar, Thin Baser Npwr W/Rcp/Com Lc 67H 48W +inner tone light +inner tone light +crossing-Pr Cat 1 +crossing shale +crossing-Pr Cat 1 +crossing shale	344.00	4,128.00
38	8	A8220.67H HF HF	+Conn, 2-Way 90 Deg, Thin Base Hard 67H +inner tone light +inner tone light	62.70	501.60
39	4	A8230.67H HF HF	+Conn, 3-Way 90 Deg, Thin Base Hard 67H +inner tone light +inner tone light	102.32	409.28
40	2	A8240.67H HF HF	+Conn, 4-Way 90 Deg, Thin Base 67H +inner tone light +inner tone light	131.39	262.78
41	12	A8271.67H HF HF	+Fin End, Thin Base 67H +inner tone light +inner tone light	23.09	277.08
42	28	AO215.62	+Draw Rod 62H	10.83	303.24
43	2	1B2JK7- 226	+Lock Plug and Key, Chrome UM Series +key number 226	3.40	6.80
44	2	LTPL-04220 HF	@Tu File Top, Lam Top/TP Edge 42W 20D @inner tone light	117.34	234.68
45	2	LW400.4238 SS HF KA	+Storage Case, W-Pull 42W 38H +smooth paint on smooth steel +inner tone light +keyed alike	609.61	1,219.22



Contract Design Associates

Spokane Showroom  
402 East Sprague Ave.  
Spokane, WA 99202

(509)624-4220 P  
(509)623-1777 F

www.cdainteriors.com

Missoula Showroom  
1330 West Broadway  
Missoula, MT 59802

(406)926-3313 P&F

# PROPOSAL

**PROPOSAL #: 49312**

DATE: 05/11/22

PROJECT #: 9-135

**PROPOSAL FOR: 1746**

CITY OF SPOKANE  
ATTN: ACCOUNTS PAYABLE  
808 SPOKANE FALLS BLVD  
SPOKANE WA 99201

**INSTALL AT:**

SPOKANE POLICE DEPARTMENT  
1427 W GARDNER  
SPOKANE WA 99201

CUSTOMER P.O.	PAYMENT TERMS	QUOTE VALID	SALESPERSON
	NET 10 DAYS	07/01/22	DEFELICE, CHLOE

#	QTY	PRODUCT	DESCRIPTION	SELL	EXTENDED
46	1		Delivery Installation Services	4,464.00	4,464.00
<p><b><u>General Terms and Conditions of Sale</u></b></p> <p>*Upon approval of the Proposal, the order shall be deemed accepted and non-cancellable.            *Title to the property listed on these pages shall remain with Contract Design Associates, Inc. (CDA) until Buyer pays the obligation in full. Buyer agrees not to sell, encumber, or remove the same property from the county in which it was delivered prior to full payment, without the written approval of CDA.            *All invoices from CDA carry net 10-day terms. CDA reserves the right to assess and Buyer agrees to pay interest charges at 1.5% per month (18% per annum) on all unpaid balances past 30 days.</p> <p><b>Payments made by credit card for materials or services in excess of \$3000 per order will incur a 3% processing fee.</b></p> <p>*CDA reserves the right to make partial deliveries and to invoice accordingly and Buyer agrees to pay invoices for partial shipments.            *After Buyer's acceptance of this proposal, should Buyer not be able to accept delivery of the goods covered under this contract within 10 business days of arrival at CDA warehouse or a designated receiving location, CDA shall invoice for goods as well as storage and handling costs, and Buyer agrees to pay such charges. Installation charges will be withheld until completed.</p> <p><b>COMPLETE TERMS AND CONDITIONS AVAILABLE UPON REQUEST</b></p>					

**DEPOSIT REQUIRED: 0.00**

SUBTOTAL 59,697.65

SALES TAX 5,372.79

**TOTAL 65,070.44**

THANK YOU FOR YOUR BUSINESS!!!  
By acceptance of this proposal, I acknowledge and agree with the seller's standard terms and conditions.

ACCEPTED BY \_\_\_\_\_ DATE ACCEPTED \_\_\_\_\_

**Agenda Sheet for City Council Meeting of:**

06/20/2022

<b>Date Rec'd</b>	6/8/2022
<b>Clerk's File #</b>	OPR 2022-0442
<b>Renews #</b>	
<b>Cross Ref #</b>	
<b>Project #</b>	
<b>Bid #</b>	
<b>Requisition #</b>	PO 201694

<b>Submitting Dept</b>	POLICE
<b>Contact Name/Phone</b>	SHAWNA ERNST 625-4106
<b>Contact E-Mail</b>	SERNST@SPOKANEPOLICE.ORG
<b>Agenda Item Type</b>	Purchase w/o Contract
<b>Agenda Item Name</b>	0680 PURCHASE OF DELL SERVER

**Agenda Wording**

SEEKING APPROVAL TO PURCHASE DELL SERVER UTILIZING NASPO CONTRACT.

**Summary (Background)**

The Spokane Police Department is currently using antiquated technology for managing digital forensic evidence and for field reporting, and police records management. This program will overhaul the current technology stack for the department (in concert with regional partner agencies).

Lease? NO Grant related? NO Public Works? NO

**Fiscal Impact**

Expense \$ 594,798.72

Select \$

Select \$

Select \$

**Budget Account**

# 5902-79115-94000-56409-68404

#

#

#

**Approvals****Dept Head** OLSEN, ERIC**Division Director** OLSEN, ERIC**Finance** SCHMITT, KEVIN**Legal** ODLE, MARI**For the Mayor** ORMSBY, MICHAEL**Additional Approvals****Purchasing****Council Notifications****Study Session\Other** PSCHC 05/02/2022**Council Sponsor** CM CATHCART**Distribution List**

SPDFINANCE@SPOKANEPOLICE.ORG

SERNST@SPOKANEPOLICE.ORG

EOLSEN@SPOKANEPOLICE.ORG

## Committee Agenda Sheet

### Public Safety and Community Health Committee

<b>Submitting Department</b>	Spokane Police Department
<b>Contact Name &amp; Phone</b>	Shawna Ernst 509-625-4106
<b>Contact Email</b>	<a href="mailto:sernst@spokanepolice.org">sernst@spokanepolice.org</a>
<b>Council Sponsor(s)</b>	CM Cathcart
<b>Select Agenda Item Type</b>	<input checked="" type="checkbox"/> Consent <input type="checkbox"/> Discussion    Time Requested:
<b>Agenda Item Name</b>	Police Digital Evidence Storage, Records Management, and Axon and Dell Contracts
<b>Summary (Background)</b>	<p>The Spokane Police Department is currently using antiquated technology for managing digital forensic evidence and for field reporting, and police records management. This program will overhaul the current technology stack for the department (in concert with regional partner agencies).</p> <p>The program will include the following system improvements:</p> <ol style="list-style-type: none"> <li>1.) <b>Working Storage:</b> Provide secure on-premise short-term working storage for digital forensic evidence ensuring that investigations has timely access to forensic extracts to perform investigative analyses (Dell contract).</li> <li>2.) <b>Long-term Storage:</b> Provide secure, cloud-based, unlimited long-term storage for all digital evidence and body camera video ensuring that it meets Washington State retention requirements and can easily be shared with Prosecution and Courts to reduce the time required for case processing (Axon contract).</li> <li>3.) <b>Axon Records:</b> Work with our regional partner agencies (Spokane County Sheriff's Office, Spokane Valley Police, SREC 911, Liberty Lake Police, Airway Heights Police, Spokane International Airport Police, Kalispel Tribal Police, and Eastern Washington University Police) to migrate to a modern, cloud-based Field Reporting and Records Management System (Axon Records) which will accomplish the following: <ol style="list-style-type: none"> <li>a. Reduce system downtime</li> <li>b. Eliminate information silos</li> <li>c. Improve ability to conduct investigations</li> <li>d. Improve ability to enter data into the system and create reports/analyses for stakeholders</li> <li>e. Decrease the time it takes to write reports and the time it takes to disseminate case information to prosecution</li> </ol> </li> <li>4.) <b>Body-Worn Cameras and TASERs:</b> Provide regular hardware upgrades to the Department's body worn camera program and TASER program (Axon contract).</li> </ol>

- 5.) **Citizen Evidence:** Provide a method of obtaining photos and video evidence directly from Citizens (Axon contract).
- 6.) **VR Training:** Increase training for officers using Virtual Reality simulation. Situations available in VR training include:
  - a. Empathy Library: Ten modules focused on interacting with community members of various backgrounds (one example includes interacting with an individual on the Autism spectrum).
  - b. Tactical Library: Modules focused on analytical and de-escalation skills.
  - c. Officer Preparedness: Modules focused on proficiency with the TASER device.
  - d. Officer Coping: Modules focused on providing officers with tools and techniques to cope with the psychological impact of public safety work.
- 7.) **Disaster Recovery:** Improve our cybersecurity posture and strengthen our ability to continue operations during a natural or man-made disaster.

There are many other improvements to our overall system by adopting the Officer Safety Plan 7+ program.

The Spokane Police Department will utilize existing 2022 funding from SIP program carryovers and criminal justice assistance funds to accept both contracts.

- 1.) **Dell:** The Dell contract (secure, on-premises file storage for digital forensic evidence) will be funded with carryover SIP funding that has already been allocated to storage needs. Cost will not exceed the \$600,000 budgeted amount.
- 2.) **Axon OSP 7+ Premium:** The Department will amend our existing Axon contract. The new OSP 7+ Premium contract is valued at \$894,235 in 2022 (our 2022 budget has \$897,294 available). Future year costs (2023 – 2029) are \$965,070.19 annually with two one-time expenses due upon project implementation (Sub-project A and Sub-project B).
  - a. **Sub-project A (\$27,795.00):** Migrate from IA Pro and BlueTeam for Use of Force Incidents to Axon Standards so that body camera video is directly available to the reviewer (time-savings). This sub-project is currently unscheduled with no funding source identified.
  - b. **Sub-project B (\$516,115.00):** Implement Axon Records for the department and law enforcement partner agencies. This sub-project will begin in 2022, with payment due upon successful implementation (target date – January 2025). At that time, this expense will be cost-shared across the consortium.

--	--

**Proposed Council Action & Date:** Approval of both Dell and Axon Contracts – June 2022 (for a contract start date of July 1, 2022)

**Fiscal Impact:**

Total Cost: \$1,494,235

Approved in current year budget?       Yes    No    N/A

Funding Source       One-time    Recurring

Specify funding source: SIP Carryover funding for the Dell contract, Criminal Justice Assistance Fund for Axon contract for 2022

Expense Occurrence       One-time    Recurring

Dell expense is a one-time expense, Axon contract is a recurring expense

Other budget impacts: (revenue generating, match requirements, etc.)

**Operations Impacts**

What impacts would the proposal have on historically excluded communities?

- 1.) **Working Storage:** N/A
- 2.) **Long-term Storage:** N/A
- 3.) **Axon Records:** Moving to the Axon Records system will enable the department and regional partner agencies to better collect demographic information for use in analyses/reporting. The department will be able to more easily extract key data to develop a public-facing dashboard that increases transparency.
- 4.) **Body-Worn Cameras and TASERs:** N/A
- 5.) **Citizen Evidence:** Axon Citizen allows citizens to easily provide photos/videos to law enforcement. If a victim/witness does not feel comfortable with personally interacting with officers/report-takers, this system provides them an alternative way to ensure their evidence is available for investigations.
- 6.) **VR Training:** Axon’s VR training has an empathy section with ten modules (and growing) focused on improving interactions with people from all walks of life, including those from historically excluded communities.
- 7.) **Disaster Recovery:** Persons from historically excluded communities are often the most-impacted during natural disasters. Improving the department’s ability to continue operations during and after a disaster will directly benefit those communities as they seek emergency services.

How will data be collected, analyzed, and reported concerning the effect of the program/policy by racial, ethnic, gender identity, national origin, income level, disability, sexual orientation, or other existing disparities?

Upon completion of this program (specifically the Axon Records project), the department will be able to develop a public-facing dashboard including information on crime in the community and cross-reference crime data with socio-economic and demographic data to help identify disparities in where crime occurs.

How will data be collected regarding the effectiveness of this program, policy or product to ensure it is the right solution?

Spokane Police Department staff, along with staff from our regional partners have spent over two years discussing potential solutions for our technology issues. We have seen multiple demos of Axon's product line, and have the benefit of a long-standing partnership with Axon for our body-worn camera and TASER programs.

By bundling our Records system into the Axon ecosystem – we will be able to house all digital evidence and reports in a single repository, which will streamline operations from the time the report is written through closure of appeals. There is no other system that would provide that integration natively.

Describe how this proposal aligns with current City Policies, including the Comprehensive Plan, Sustainability Action Plan, Capital Improvement Program, Neighborhood Master Plans, Council Resolutions, and others?

This program aligns with the following strategic plan objectives:

- 1.) Innovative Infrastructure: This program will be the first on-premise/cloud hybrid at the City of Spokane and will serve as a model for other Information Technology initiatives.
- 2.) Safe and Healthy: This program will reduce the time officers spend writing field reports, reduce the time the Prosecutor's office spends assembling information and evidence for court, and will increase departmental transparency.
- 3.) Sustainable Resources: This program will reduce our overall dependence on physical assets (server clusters, network connections to County) in favor of utilizing cloud-based resources. The long-term cost-savings from using Axon's unlimited storage are immeasurable.



## A quote for your consideration

Based on your business needs, we put the following quote together to help with your purchase decision. Below is a detailed summary of the quote we've created to help you with your purchase decision.

To proceed with this quote, you may respond to this email, order online through your [Premier page](#), or, if you do not have Premier, use this [Quote to Order](#).

<b>Quote No.</b>	<b>3000118739165.1</b>	Sales Rep	Charles Anglin
<b>Total</b>	<b>\$594,798.72</b>	Phone	(800) 456-3355, 6180469
Customer #	64030	Email	Charles_Anglin@Dell.com
Quoted On	Apr. 29, 2022	<b>Billing To</b>	IT DEPT AP
Expires by	May. 29, 2022		CITY OF SPOKANE
Contract Name	Standard governing terms in Supplier's quote		999 USE CN
Contract Code	C000000006563		808 W SPOKANE FALLS BLVD
Solution ID	16021298.1		SPOKANE, WA 99201-3333

### Message from your Sales Rep

Please contact your Dell sales representative if you have any questions or when you're ready to place an order. Thank you for shopping with Dell!

Regards,  
Charles Anglin

### Shipping Group

Shipping To	Shipping Method	Install At
ACCOUNTS PAYABL CITY OF SPOKANE 808 W SPOKANE FALLS BLVD MIS DEPT 7TH FL SPOKANE, WA 99201-3333 (509) 456-3853	Standard Delivery Free Cost	ACCOUNTS PAYABL CITY OF SPOKANE 808 W SPOKANE FALLS BLVD MIS DEPT 7TH FL SPOKANE, WA 99201-3333 (509) 456-3853

### Solution Name:

City Of Spokane Forensics 1.5PB 8 x  
A300 SED With RWD

Product	Unit Price	Quantity	Subtotal
PowerScale Chassis - AMER	\$2,412.62	2	\$4,825.24
Data IQ - AMER	\$0.01	1	\$0.01
Backend Network Switches - AMER	\$23,308.93	2	\$46,617.86



<b>PowerScale Accessories - AMER</b>	<b>\$807.60</b>	<b>1</b>	<b>\$807.60</b>
<b>PowerScale A300 - AMER</b>	<b>\$59,908.73</b>	<b>8</b>	<b>\$479,269.84</b>
<b>Superna SEL Eyeglass DR Manager Enterprise VAPP</b>	<b>\$398.89</b>	<b>8</b>	<b>\$3,191.12</b>
<b>Superna SEL Maint Eyeglass DR Manager Ent 3YR</b>	<b>\$433.71</b>	<b>8</b>	<b>\$3,469.68</b>
<b>Superna SEL Eyeglass Cluster Addon Install Service</b>	<b>\$3,062.19</b>	<b>1</b>	<b>\$3,062.19</b>
<b>Superna SEL Ransomware Defender Agent Lic</b>	<b>\$1,678.28</b>	<b>1</b>	<b>\$1,678.28</b>
<b>Superna SEL Ransomware Defender Feature Lic</b>	<b>\$1,259.57</b>	<b>1</b>	<b>\$1,259.57</b>
<b>Superna SEL Ransomware Defender Agent 3YR</b>	<b>\$1,505.52</b>	<b>1</b>	<b>\$1,505.52</b>
			<hr/>
	<b>Subtotal:</b>		<b>\$545,686.91</b>
	<b>Shipping:</b>		<b>\$0.00</b>
	<b>Environmental Fee:</b>		<b>\$0.00</b>
	<b>Non-Taxable Amount:</b>		<b>\$0.01</b>
	<b>Taxable Amount:</b>		<b>\$545,686.90</b>
	<b>Estimated Tax:</b>		<b>\$49,111.81</b>
			<hr/>
	<b>Total:</b>		<b>\$594,798.72</b>

## Shipping Group Details

### Shipping To

ACCOUNTS PAYABL  
CITY OF SPOKANE  
808 W SPOKANE FALLS BLVD  
MIS DEPT 7TH FL  
SPOKANE, WA 99201-3333  
(509) 456-3853

### Shipping Method

Standard Delivery Free Cost

### Install At

ACCOUNTS PAYABL  
CITY OF SPOKANE  
808 W SPOKANE FALLS BLVD  
MIS DEPT 7TH FL  
SPOKANE, WA 99201-3333  
(509) 456-3853

### Solution Name:

City Of Spokane Forensics 1.5PB 8 x  
A300 SED Wlth RWD

	Quantity	Subtotal
<b>PowerScale Chassis - AMER</b>		
Estimated delivery if purchased today:		
May. 25, 2022		
Contract # C000000006563		
	<b>2</b>	<b>\$2,412.62</b>
		<b>\$4,825.24</b>

Description	SKU	Unit Price	Quantity	Subtotal
Base Chassis - Normal A-Series	210-BBFS	-	2	-
Dell Hardware Limited Warranty	854-0800	-	2	-
ProSupport Mission Critical 4-Hour 7x24 Onsite Service with Emergency Dispatch 1 Year	854-0810	-	2	-
ProSupport Mission Critical 4-Hour 7x24 Onsite Service with Emergency Dispatch 2 Years Extended	854-0812	-	2	-
ProSupport Mission Critical 7x24 Technical Support and Assistance 3 Years	854-0819	-	2	-
Dell Limited Hardware Warranty Extended Year(s)	975-3461	-	2	-
Thank you choosing Dell ProSupport. For tech support, visit //www.dell.com/support or call 1-800- 945-3355	989-3439	-	2	-

	Quantity	Subtotal
<b>Data IQ - AMER</b>		
Estimated delivery if purchased today:		
May. 18, 2022		
Contract # C000000006563		
	<b>1</b>	<b>\$0.01</b>
		<b>\$0.01</b>

Description	SKU	Unit Price	Quantity	Subtotal
DatalQ Perpetual Base	210-AVMU	-	1	-
ProSupport Mission Critical-DatalQ Instance Software Support Contract 3 Years	835-9427	-	1	-
Thank you for Your Order	929-3709	-	1	-
Thank you for Your Order	935-6720	-	1	-
DatalQ Dell Base Lic=IF	142-BBDM	-	1	-
ProSupport Mission Critical-DatalQ Instance Software Support- Maintenance 3 Years	835-9407	-	1	-

	Quantity	Subtotal
<b>Backend Network Switches - AMER</b>		
Estimated delivery if purchased today:		
May. 12, 2022		
Contract # C000000006563		
	<b>2</b>	<b>\$23,308.93</b>
		<b>\$46,617.86</b>

Description	SKU	Unit Price	Quantity	Subtotal
S5232F Dell Networking Switch	210-BCVB	-	2	-

S5232 Series User Guide	343-BBSQ	-	2	-
Dell Switch Field Installation Kit for S4148F, S5232, Z9100	750-ACVZ	-	2	-
OS10 Enterprise Software, S5232F	528-CSYU	-	2	-
Dell Hardware Limited Warranty Initial Year	870-3564	-	2	-
ProSupport Mission Critical 4-Hour 7x24 Onsite Service with Emergency Dispatch 1 Year	870-3579	-	2	-
ProSupport Mission Critical 4-Hour 7x24 Onsite Service with Emergency Dispatch 2 Years Extended	870-3581	-	2	-
ProSupport Mission Critical 7x24 Technical Support and Assistance 3 Years	870-3588	-	2	-
Dell Limited Hardware Warranty Extended Year(s)	975-3461	-	2	-
Thank you choosing Dell ProSupport. For tech support, visit //www.dell.com/support or call 1-800- 945-3355	989-3439	-	2	-

			<b>Quantity</b>	<b>Subtotal</b>
<b>PowerScale Accessories - AMER</b>		<b>\$807.60</b>	<b>1</b>	<b>\$807.60</b>
Estimated delivery if purchased today: May. 25, 2022 Contract # C000000006563				

Description	SKU	Unit Price	Quantity	Subtotal
Accessories Label BASE	210-AXGY	-	1	-
Thank you for Your Order	929-3709	-	1	-
Thank you for Your Order	935-6720	-	1	-
PWCRD KIT for Normal Chassis	450-AJHP	-	4	-
100G to 25G Breakout (4)SFP28 to (1)Q28 DAC 3M	470-AFFZ	-	4	-
			<b>Quantity</b>	<b>Subtotal</b>

<b>PowerScale A300 - AMER</b>		<b>\$59,908.73</b>	<b>8</b>	<b>\$479,269.84</b>
Estimated delivery if purchased today: May. 25, 2022 Contract # C000000006563				

Description	SKU	Unit Price	Quantity	Subtotal
A300 - L3 - SED 240TB (15x16TB)/800GB SSD	210-AZUD	-	8	-
2x25GbE (SFP28) Back-end W/O OPTICS	590-TFHE	-	8	-
2x25GbE (SFP28) W/O OPTICS	590-TFBK	-	8	-
OneFS Base License A3 12TB+ Tier 3 L3=ID	149-BBGL	-	8	-
OneFS Encrytion Key A3 12TB+ Tier 3 L3=ID	149-BBGY	-	8	-
SnapShotIQ Base License A3 Tier 3 L3 =ID	151-BBHJ	-	8	-
SmartPools Base License A3 Tier 3 L3 =ID	151-BBHN	-	8	-
SynclQ Base License A3 Tier 3 L3 =ID	151-BBIM	-	8	-
SmartConnect Base License A3 Tier 3 L3 =ID	151-BBJE	-	8	-
Enterprise Advanced Bundle A3 Tier 3 L3 =ID	151-BBJL	-	8	-
SmartQuotas Base License A3 Tier 3 L3 =ID	151-BBJS	-	8	-
HDFS for OneFS (\$0.00)	151-BBEH	-	8	-
Dell Hardware Limited Warranty	853-8872	-	8	-
ProSupport Mission Critical 4-Hour 7x24 Onsite Service with Emergency Dispatch 1 Year	853-8882	-	8	-
ProSupport Mission Critical 4-Hour 7x24 Onsite Service with Emergency Dispatch 2 Years Extended	853-8884	-	8	-

ProSupport Mission Critical 7x24 Technical Support and Assistance 3 Years	853-8891	-	8	-
Dell Limited Hardware Warranty Extended Year(s)	975-3461	-	8	-
Thank you choosing Dell ProSupport. For tech support, visit //www.dell.com/support or call 1-800- 945-3355	989-3439	-	8	-
3 Years ProSupport Mission Critical OneFS Enc-Key Mgt Base 12TB Plus Software Support-Maint	854-7408	-	8	-
3 Years ProSupport Mission Critical Enterprise Advanced Bundle Base Software Support-Maint	854-6861	-	8	-
3 Years ProSupport Mission Critical HDFS for OneFS Software Support-Maint	849-5190	-	8	-
None	825-6815	-	8	-
None	825-6815	-	8	-
None	825-6815	-	8	-
ProDeploy Plus No Charge Training 300	812-4005	-	8	-
ProDeploy Plus for PowerScale Node	829-3033	-	8	-
Transceivers/Optic/SFP+/SR/10GbE/2 GEN6	407-BCIU	-	8	-
OneFS Capacity A3 Tier 3 L3=CB	149-BBGI	-	1920	-
SynclQ Capacity License A3 Tier 3 L3=CB	151-BBHI	-	1920	-
SnapShotIQ Capacity License A3 Tier 3 L3=CB	151-BBIY	-	1920	-
SmartQuotas Capacity License A3 Tier 3 L3=CB	151-BBJM	-	1920	-
SmartPools Capacity License A3 Tier 3 L3=CB	151-BBJN	-	1920	-
SmartConnect Capacity License A3 Tier 3 L3=CB	151-BBJP	-	1920	-
Enterprise Advanced Bundle Capacity A3 Tier 3 L3=CB	151-BBJY	-	1920	-
3 Years ProSupport Mission Critical OneFS Capacity Software Support-Maint	854-6079	-	1920	-
3 Years ProSupport Mission Critical Enterprise Advanced Bundle Capacity Software Support-Maint	854-7356	-	1920	-
ProSupport Mission Critical 4-Hour 7x24 Onsite Capacity Addon 3 Years	854-3439	-	1920	-
None	825-6815	-	8	-
None	825-6815	-	8	-

			<b>Quantity</b>	<b>Subtotal</b>
<b>Superna SEL Eyeglass DR Manager Enterprise VAPP</b>		<b>\$398.89</b>	<b>8</b>	<b>\$3,191.12</b>

Estimated delivery if purchased today:  
May. 31, 2022  
Contract # C000000006563

Description	SKU	Unit Price	Quantity	Subtotal
Superna SEL Eyeglass DR Manager Enterprise VAPP	AA977295	-	8	-
			<b>Quantity</b>	<b>Subtotal</b>

<b>Superna SEL Maint Eyeglass DR Manager Ent 3YR</b>		<b>\$433.71</b>	<b>8</b>	<b>\$3,469.68</b>
--	--	-----------------	----------	-------------------

Estimated delivery if purchased today:  
May. 10, 2022  
Contract # C000000006563

Description	SKU	Unit Price	Quantity	Subtotal
Superna SEL Maint Eyeglass DR Manager Ent 3YR	AA977297	-	8	-
			<b>Quantity</b>	<b>Subtotal</b>

**Superna SEL Eyeglass Cluster Addon Install Service****\$3,062.19 1 \$3,062.19**

Estimated delivery if purchased today:  
 May. 10, 2022  
 Contract # C000000006563

Description	SKU	Unit Price	Quantity	Subtotal
Superna SEL Eyeglass Cluster Addon Install Service	AB109744	-	1	-
			<b>Quantity</b>	<b>Subtotal</b>

**Superna SEL Ransomware Defender Agent Lic****\$1,678.28 1 \$1,678.28**

Estimated delivery if purchased today:  
 May. 10, 2022  
 Contract # C000000006563

Description	SKU	Unit Price	Quantity	Subtotal
Superna SEL Ransomware Defender Agent Lic	AB109722	-	1	-
			<b>Quantity</b>	<b>Subtotal</b>

**Superna SEL Ransomware Defender Feature Lic****\$1,259.57 1 \$1,259.57**

Estimated delivery if purchased today:  
 May. 10, 2022  
 Contract # C000000006563

Description	SKU	Unit Price	Quantity	Subtotal
Superna SEL Ransomware Defender Feature Lic	AB109721	-	1	-
			<b>Quantity</b>	<b>Subtotal</b>

**Superna SEL Ransomware Defender Agent 3YR****\$1,505.52 1 \$1,505.52**

Estimated delivery if purchased today:  
 May. 10, 2022  
 Contract # C000000006563

Description	SKU	Unit Price	Quantity	Subtotal
Superna SEL Ransomware Defender Agent 3YR	AB109724	-	1	-

<b>Subtotal:</b>	<b>\$545,686.91</b>
<b>Shipping:</b>	<b>\$0.00</b>
<b>Environmental Fee:</b>	<b>\$0.00</b>
<b>Estimated Tax:</b>	<b>\$49,111.81</b>
<b>Total:</b>	<b>\$594,798.72</b>

# Important Notes

---

## Terms of Sale

This Quote will, if Customer issues a purchase order for the quoted items that is accepted by Supplier, constitute a contract between the entity issuing this Quote ("Supplier") and the entity to whom this Quote was issued ("Customer"). Unless otherwise stated herein, pricing is valid for thirty days from the date of this Quote. All product, pricing and other information is based on the latest information available and is subject to change. Supplier reserves the right to cancel this Quote and Customer purchase orders arising from pricing errors. Taxes and/or freight charges listed on this Quote are only estimates. The final amounts shall be stated on the relevant invoice. Additional freight charges will be applied if Customer requests expedited shipping. Please indicate any tax exemption status on your purchase order and send your tax exemption certificate to [Tax\\_Department@dell.com](mailto:Tax_Department@dell.com) or [ARSalesTax@emc.com](mailto:ARSalesTax@emc.com), as applicable.

**Governing Terms:** This Quote is subject to: (a) a separate written agreement between Customer or Customer's affiliate and Supplier or a Supplier's affiliate to the extent that it expressly applies to the products and/or services in this Quote or, to the extent there is no such agreement, to the applicable set of Dell's Terms of Sale (available at [www.dell.com/terms](http://www.dell.com/terms) or [www.dell.com/oemterms](http://www.dell.com/oemterms)), or for cloud/as-a-Service offerings, the applicable cloud terms of service (identified on the Offer Specific Terms referenced below); and (b) the terms referenced herein (collectively, the "Governing Terms"). Different Governing Terms may apply to different products and services on this Quote. The Governing Terms apply to the exclusion of all terms and conditions incorporated in or referred to in any documentation submitted by Customer to Supplier.

**Supplier Software Licenses and Services Descriptions:** Customer's use of any Supplier software is subject to the license terms accompanying the software, or in the absence of accompanying terms, the applicable terms posted on [www.Dell.com/eula](http://www.Dell.com/eula). Descriptions and terms for Supplier-branded standard services are stated at [www.dell.com/servicecontracts/global](http://www.dell.com/servicecontracts/global) or for certain infrastructure products at [www.dellemc.com/en-us/customer-services/product-warranty-and-service-descriptions.htm](http://www.dellemc.com/en-us/customer-services/product-warranty-and-service-descriptions.htm).

**Offer-Specific, Third Party and Program Specific Terms:** Customer's use of third-party software is subject to the license terms that accompany the software. Certain Supplier-branded and third-party products and services listed on this Quote are subject to additional, specific terms stated on [www.dell.com/offeringsspecificterms](http://www.dell.com/offeringsspecificterms) ("Offer Specific Terms").

**In case of Resale only:** Should Customer procure any products or services for resale, whether on standalone basis or as part of a solution, Customer shall include the applicable software license terms, services terms, and/or offer-specific terms in a written agreement with the end-user and provide written evidence of doing so upon receipt of request from Supplier.

**In case of Financing only:** If Customer intends to enter into a financing arrangement ("Financing Agreement") for the products and/or services on this Quote with Dell Financial Services LLC or other funding source pre-approved by Supplier ("FS"), Customer may issue its purchase order to Supplier or to FS. If issued to FS, Supplier will fulfill and invoice FS upon confirmation that: (a) FS intends to enter into a Financing Agreement with Customer for this order; and (b) FS agrees to procure these items from Supplier. Notwithstanding the Financing Agreement, Customer's use (and Customer's resale of and the end-user's use) of these items in the order is subject to the applicable governing agreement between Customer and Supplier, except that title shall transfer from Supplier to FS instead of to Customer. If FS notifies Supplier after shipment that Customer is no longer pursuing a Financing Agreement for these items, or if Customer fails to enter into such Financing Agreement within 120 days after shipment by Supplier, Customer shall promptly pay the Supplier invoice amounts directly to Supplier.

Customer represents that this transaction does not involve: (a) use of U.S. Government funds; (b) use by or resale to the U.S. Government; or (c) maintenance and support of the product(s) listed in this document within classified spaces. Customer further represents that this transaction does not require Supplier's compliance with any statute, regulation or information technology standard applicable to a U.S. Government procurement.

For certain products shipped to end users in California, a State Environmental Fee will be applied to Customer's invoice. Supplier encourages customers to dispose of electronic equipment properly.

Electronically linked terms and descriptions are available in hard copy upon request.

**^Dell Business Credit (DBC):** Offered to business customers by WebBank, Member FDIC, who determines qualifications for and terms of credit. Taxes, shipping and other charges are extra and vary. Minimum monthly payments are the greater of \$15 or 3% of the new balance shown on the monthly billing statement. Dell and the Dell logo are trademarks of Dell Inc.

**Agenda Sheet for City Council Meeting of:**

06/20/2022

<b>Date Rec'd</b>	6/6/2022
<b>Clerk's File #</b>	OPR 2022-0443
<b>Renews #</b>	
<b>Cross Ref #</b>	
<b>Project #</b>	2019088
<b>Bid #</b>	
<b>Requisition #</b>	

<b>Submitting Dept</b>	ENGINEERING SERVICES
<b>Contact Name/Phone</b>	DAN BULLER 625-6391
<b>Contact E-Mail</b>	DBULLER@SPOKANECITY.ORG
<b>Agenda Item Type</b>	Contract Item
<b>Agenda Item Name</b>	0370 - LOW BID AWARD - TRAFFIC CALMING (2019088) – BACON CONCRETE

**Agenda Wording**

Low Bid of Bacon Concrete (Spokane) for Cycle 9 Traffic Calming - \$498,305.25. An administrative reserve of \$49,830.53, which is 10% of the contract price, will be set aside. (Various Neighborhood Councils)

**Summary (Background)**

On June 13, 2022 bids were opened for the above project. The low bid was from Bacon Concrete, Inc. in the amount of \$498,305.25, which is \$52,645.75 or 9.56% below the Engineer's Estimate of \$550,951.00; two other bids were received as follows: LaRiviere, Inc. - \$573,911.00 and Wm. Winkler Company - \$594,333.80.

Lease? NO Grant related? NO Public Works? YES

**Fiscal Impact**

Select **\$84,375.87**

Select **\$463,759.91**

Select **\$**

Select **\$**

**Budget Account**

# 1380 24106 95300 56501 21011

# 1380 24103 95300 56501 21011

#

#

**Approvals**

**Dept Head** TWOHIG, KYLE

**Division Director** FEIST, MARLENE

**Finance** ORLOB, KIMBERLY

**Legal** ODLE, MARI

**For the Mayor** ORMSBY, MICHAEL

**Council Notifications**

**Study Session\Other** PIES 5/23

**Council Sponsor** Beggs/Kinnear

**Distribution List**

eraea@spokanecity.org

publicworksaccounting@spokanecity.org

kgoodman@spokanecity.org

jgraff@spokanecity.org

ddaniels@spokanecity.org

pyoung@spokanecity.org

greg@baconconcrete.com

**Additional Approvals****Purchasing**

# Committee Agenda Sheet

## PIES

<b>Submitting Department</b>	Public Works, Engineering
<b>Contact Name &amp; Phone</b>	Dan Buller 625-6391
<b>Contact Email</b>	<a href="mailto:dbuller@spokanecity.org">dbuller@spokanecity.org</a>
<b>Council Sponsor(s)</b>	Lori Kinnear
<b>Select Agenda Item Type</b>	X Consent <input type="checkbox"/> Discussion    Time Requested: _____
<b>Agenda Item Name</b>	Traffic Calming (Cycle 9)
<b>Summary (Background)</b>	<ul style="list-style-type: none"> <li>This is the annual neighborhood traffic calming project funded by red light camera funds</li> <li>Projects are in districts 2 and 3 only. District 1 funds are being held for use on landscaping type improvements around NSC.</li> <li>Project components can be seen in the attached exhibits.</li> <li>Work is planned this summer.</li> <li>This project is locally funded.</li> </ul>
<b>Proposed Council Action &amp; Date:</b>	None at this time. Following bid opening, we will bring a pipe purchase contract to Council for approval.
<b>Fiscal Impact:</b>	
Total Cost:	
Approved in current year budget?      X Yes <input type="checkbox"/> No <input type="checkbox"/> N/A	
Funding Source      X One-time <input type="checkbox"/> Recurring	
Specify funding source: project funds (generally street or utility funds)	
Expense Occurrence    X One-time <input type="checkbox"/> Recurring	
Other budget impacts: (revenue generating, match requirements, etc.)	
<b>Operations Impacts</b>	
What impacts would the proposal have on historically excluded communities?	
Public Works services and projects are designed to serve all citizens and businesses. We strive to offer a consistent level of service to all, to distribute public investment throughout the community, and to respond to gaps in services identified in various City plans. We recognize the need to maintain affordability and predictability for utility customers. And we are committed to delivering work that is both financially and environmentally responsible. This item supports the operations of Public Works.	
How will data be collected, analyzed, and reported concerning the effect of the program/policy by racial, ethnic, gender identity, national origin, income level, disability, sexual orientation, or other existing disparities?	
N/A – This contract supports multiple public works projects and should not impact racial, gender identity, national origin, income level, disability, sexual orientation or other existing disparity factors.	
How will data be collected regarding the effectiveness of this program, policy or product to ensure it is the right solution?	



Public Works follows the City's established procurement and public works bidding regulations and policies to bring items forward, and then uses contract management best practices to ensure desired outcomes and regulatory compliance.

Describe how this proposal aligns with current City Policies, including the Comprehensive Plan, Sustainability Action Plan, Capital Improvement Program, Neighborhood Master Plans, Council Resolutions, and others?

The projects which will use this on-call contract are consistent with our adopted six year programs as well as the annual budget and strategic initiative to advance street maintenance activities.



**City of Spokane**  
**PUBLIC WORKS CONTRACT**  
Title: **CYCLE 9 TRAFFIC CALMING PROJECTS**

This Contract is made and entered into by and between the **CITY OF SPOKANE** as (“City”), a Washington municipal corporation, and **BACON CONCRETE, INC.**, whose address is 16510 North Brannon Lane, Spokane, Washington, 99208 as (“Contractor”), individually hereafter referenced as a “party”, and together as the “parties”.

The parties agree as follows:

1. **PERFORMANCE.** The Contractor will do all work, furnish all labor, materials, tools, construction equipment, transportation, supplies, supervision, organization and other items of work and costs necessary for the proper execution and completion of the work described in the Special Provisions entitled **CYCLE 9 TRAFFIC CALMING PROJECTS.**
2. **CONTRACT DOCUMENTS.** The contract documents are this Contract, the Contractor’s completed bid proposal form, the Washington State Department of Transportation’s Standard Specifications for Road, Bridge and Municipal Construction 2022, City of Spokane Special Provisions, contract plans, standard plans, addenda, various certifications and affidavits, supplemental agreements, change orders and subsurface boring logs (if any). These contract documents are on file in the Engineering Services Department and are incorporated into this Contract by reference as if they were set forth at length. In the event of a conflict, or to resolve an ambiguity or dispute, the order of precedence defined in the City of Spokane Special Provisions section 1-04.2 shall apply.
3. **TIME OF PERFORMANCE.** The time of performance of the Contract shall be in accordance with the contract documents.
4. **LIQUIDATED DAMAGES.** Liquidated damages shall be in accordance with the contract documents.
5. **TERMINATION.** Either party may terminate this Contract in accordance with the contract documents.
6. **COMPENSATION.** This is a unit price contract, and upon full and complete performance by the Contractor, the City will pay only the amounts set forth in Schedule A-1 for the actual quantities furnished for each bid item.
7. **TAXES.** Bid items in Schedule A-1 shall include sales tax

8. PAYMENT. The Contractor will send its applications for payment to the Engineering Services Department – Construction Management, 998 E North Foothills Drive Spokane, WA 99207-2735 (from 1225 East Marietta Avenue Spokane, WA 99207. All invoices should include the City Clerk File No. “OPR XXXX-XXXX” and an approved L & I Intent to Pay Prevailing Wage number. The final invoice should include an approved Affidavit of Wages Paid number. Payment will not be made without this documentation included on the invoice. **Payment will be made via direct deposit/ACH** within thirty (30) days after receipt of the Company’s application except as provided by state law. Five percent (5%) of the Contract price may be retained by the City, in accord with RCW 60.28 for a minimum of forty five (45) days after final acceptance, as a trust fund for the protection and payment of: the claims of any person arising under the Contract; and the State with respect to taxes imposed pursuant to Titles 50, 51 and 82 RCW which may be due from the Contractor.

9. INDEMNIFICATION. The Contractor shall defend, indemnify, and hold the City and its officers and employees harmless from all claims, demands, or suits at law or equity asserted by third parties for bodily injury (including death) and/or property damage which arise from the Contractor’s negligence or willful misconduct under this Agreement, including attorneys’ fees and litigation costs; provided that nothing herein shall require a Contractor to indemnify the City against and hold harmless the City from claims, demands or suits based solely upon the negligence of the City, its agents, officers, and employees. If a claim or suit is caused by or results from the concurrent negligence of the Contractor’s agents or employees and the City, its agents, officers and employees, this indemnity provision shall be valid and enforceable to the extent of the negligence of the Contractor, its agents or employees. The Contractor specifically assumes liability and agrees to defend, indemnify, and hold the City harmless for actions brought by the Contractor’s own employees against the City and, solely for the purpose of this indemnification and defense, the Contractor specifically waives any immunity under the Washington State industrial insurance law, or Title 51 RCW. The Contractor recognizes that this waiver was specifically entered into pursuant to the provisions of RCW 4.24.115 and was the subject of mutual negotiation. The indemnity and agreement to defend and hold the City harmless provided for in this section shall survive any termination or expiration of this agreement.

10. BONDS. The Contractor may not commence work until it obtains all insurance, permits and bonds required by the contract documents and applicable law. This includes the execution of a performance bond and a payment bond on the forms attached, each equal to one hundred percent (100%) of the contract price, and written by a corporate surety company licensed to do business in Washington State.

11. INSURANCE. The Contractor represents that it and its employees, agents and subcontractors, in connection with the Contract, are protected against the risk of loss by the insurance coverages required in the contract documents. The policies shall be issued by companies that meet with the approval of the City Risk Manager. The policies shall not be canceled without at least minimum required written notice to the City as Additional Insured.

12. CONTRACTOR’S WARRANTY. The Contractor’s warranty for all work, labor and materials shall be in accordance with the contract documents.

13. WAGES. The Contractor and all subcontractors will submit a "Statement of Intent to Pay Prevailing Wages" certified by the industrial statistician of the Department of Labor and Industries, prior to any payments. The "Statement of Intent to Pay Prevailing Wages" shall include: (1) the Contractor’s registration number; and (2) the prevailing wages under RCW 39.12.020 and the number of workers in each classification. Each voucher claim submitted by the Contractor for

payment on a project estimate shall state that the prevailing wages have been paid in accordance with the "Statement(s) of Intent to Pay Prevailing Wages" on file with the City. Prior to the payment of funds held under RCW 60.28, the Contractor and subcontractors must submit an "Affidavit of Wages Paid" certified by the industrial statistician.

14. STATEMENT OF INTENT TO PAY PREVAILING WAGES TO BE POSTED. The Contractor and each subcontractor required to pay the prevailing rate of wages shall post in a location readily visible at the job site: (1) a copy of a "Statement of Intent to Pay Prevailing Wages" approved by the industrial statistician of the State Department of Labor and Industries; and (2) the address and telephone number of the industrial statistician of the Department of Labor and Industries where a complaint or inquiry concerning prevailing wages may be made.

15. PUBLIC WORKS REQUIREMENTS. The Contractor and each subcontractor are required to fulfill the Department of Labor and Industries Public Works and Prevailing Wage Training Requirement under RCW 39.04.350. The contractor must verify responsibility criteria for each first tier subcontractor, and a subcontractor of any tier that hires other subcontractors must verify the responsibility criteria listed in RCW 39.04.350(1) for each of its subcontractors. Verification shall include that each subcontractor, at the time of subcontract execution, meets the responsibility criteria. This verification requirement, as well as responsibility criteria, must be included in every public works contract and subcontract of every tier.

16. SUBCONTRACTOR RESPONSIBILITY.

A. The Contractor shall include the language of this section in each of its first tier subcontracts, and shall require each of its subcontractors to include the same language of this section in each of their subcontracts, adjusting only as necessary the terms used for the contracting parties. Upon request of the City, the Contractor shall promptly provide documentation to the City demonstrating that the subcontractor meets the subcontractor responsibility criteria below. The requirements of this section apply to all subcontractors regardless of tier.

B. At the time of subcontract execution, the Contractor shall verify that each of its first tier subcontractors meets the following bidder responsibility criteria:

1. Have a current certificate of registration in compliance with chapter 18.27 RCW, which must have been in effect at the time of subcontract bid submittal;
2. Have a current Washington Unified Business Identifier (UBI) number;
3. If applicable, have:
  - a. Have Industrial Insurance (workers' compensation) coverage for the subcontractor's employees working in Washington, as required in Title 51 RCW;
  - b. A Washington Employment Security Department number, as required in Title 50 RCW;
  - c. A Washington Department of Revenue state excise tax registration number, as required in Title 82 RCW;
  - d. An electrical contractor license, if required by Chapter 19.28 RCW;

- e. An elevator contractor license, if required by Chapter 70.87 RCW.
- 4. Not be disqualified from bidding on any public works contract under RCW 39.06.010 or 39.12.065 (3).

C. On Public Works construction projects, as defined in RCW 39.04.010, with an estimated cost of six hundred thousand dollars (\$600,000) or more, at least fifteen (15) percent of the labor hours on each project shall be performed by apprentices enrolled in a State-approved apprenticeship program; and for each contract in the project fifteen (15) percent of the labor hours for each craft that has an available state-approved apprenticeship program for Spokane County and utilizes more than one hundred sixty (160) hours in each contract shall be performed by apprentices enrolled in a state-approved apprenticeship program.

- 1. Subcontracting Requirements. The utilization percentages for apprenticeship labor for Public Works construction contracts shall also apply to all subcontracts of one hundred thousand dollars (\$100,000) or more within those contracts, and at least fifteen percent (15%) of the labor hours for each such subcontract shall be performed by apprentices in a state-approved apprenticeship program. For each craft that has an available apprenticeship program for Spokane county and performs more than one hundred sixty (160) hours on each project, fifteen (15) percent of the labor hours shall be performed by apprentices enrolled in a State-approved apprenticeship program
- 2. Each subcontractor which this chapter applies is required to execute a form, provided by the city, acknowledging that the requirements of Article X 07.06 SMC are applicable to the labor hours for the project.

17. NONDISCRIMINATION. No individual shall be excluded from participation in, denied the benefit of, subjected to discrimination under, or denied employment in the administration of or in connection with this Contract because of age, sex, race, color, religion, creed, marital status, familial status, sexual orientation including gender expression or gender identity, national origin, honorably discharged veteran or military status, the presence of any sensory, mental or physical disability, or use of a service animal by a person with disabilities. The Contractor agrees to comply with, and to require that all subcontractors comply with, Section 504 of the Rehabilitation Act of 1973 and the Americans with Disabilities Act, as applicable to the Contractor.

18. EXECUTIVE ORDER 11246.

- A. The Contractor will not discriminate against any employee or applicant for employment because of race, color, religion, sex or national origin. The Contractor will take affirmative action to insure that applicants are employed, and that employees are treated during employment, without regard to their race, color, religion, sex or national origin. Such action shall include but not be limited to the following: employment upgrading, demotion or transfer; recruitment or recruitment advertising; layoff or termination; rates of pay or other forms of compensation; and selection for training, including apprenticeship. The Contractor agrees to post in conspicuous places, available to employees and applicants for employment, notices to be provided by the contracting officer setting forth the provisions of this nondiscrimination clause.
- B. The Contractor will, in all solicitations or advertisements for employees placed by or on behalf of the Contractor, state that all qualified applicants will receive consideration for employment without regard to race, color, religion, sex or national origin.

- C. The Contractor will send each labor union, or representative of workers with which it has a collective bargaining contract or other contract or understanding, a notice, to be provided by the agency contracting officer, advising the labor union or workers' representative of the Contractor's commitments under Section 202 of Executive Order No. 11246 of September 24, 1965, and shall post copies of the notice in conspicuous places available to employees and applicants for employment.
- D. The Contractor will comply with all provisions of Executive Order No. 11246 of September 24, 1965, and of the rules, regulations, and relevant orders of the Secretary of Labor.
- E. The Contractor will furnish all information and reports required by Executive Order No. 11246 of September 24, 1965, and by the rules, regulations and orders of the Secretary of Labor, or pursuant thereto, and will permit access to its books, records, and accounts by the contracting agency and the Secretary of Labor for purposes of investigation to ascertain compliance with such rules, regulations and orders.
- F. In the event of the Contractor's noncompliance with the nondiscrimination clauses of this Contract or with any of such rules, regulations or orders, this Contract may be canceled, terminated or suspended in whole or in part, and the Contractor may be declared ineligible for further government contracts in accordance with procedures authorized in Executive Order No. 11246 of September 24, 1965, and such other sanctions may be imposed and remedies invoked as provided in Executive Order No. 11246 of September 24, 1965, or by rule, regulation, or order of the Secretary of Labor, or as otherwise provided by law.
- G. The Contractor will include the provisions of paragraphs A through G in every subcontract or purchase order unless exempted by rules, regulations or orders of the Secretary of Labor issued pursuant to Section 204 of Executive Order No. 11246 of September 24, 1965, so that such provisions will be binding upon each subcontractor or vendor. The Contractor will take such action with respect to any subcontract or purchase order as may be directed by the Secretary of Labor as a means of enforcing such provisions including sanctions for noncompliance: PROVIDED, HOWEVER, that in the event the Contractor becomes involved in, or is threatened with, litigation with a subcontractor or vendor as the result of such direction, the Contractor may request the United States to enter into such litigation to protect the interests of the United States.

19. DEBARMENT AND SUSPENSION. The Contractor has provided its certification that it is in compliance with and shall not contract with individuals or organizations which are debarred, suspended, or otherwise excluded from or ineligible from participation in Federal Assistance Programs under Executive Order 12549 and "Debarment and Suspension", codified at 29 CFR part 98.

20. ASSIGNMENTS. The Contractor may not assign, transfer or sublet any part of the work under this Contract, or assign any monies due, without the written approval of the City, except as may be required by law. In the event of assignment of accounts or monies due under this Contract, the Contractor specifically agrees to give immediate written notice to the City Administrator, no later than five (5) business days after the assignment.

21. ANTI-KICKBACK. No officer or employee of the City of Spokane, having the power or duty to perform an official act or action related to this Contract shall have or acquire any interest in the Contract, or have solicited, accepted or granted a present or future gift, favor, service or other thing of value from or to any person involved in the Contract.

22. COMPLIANCE WITH LAWS. Each party shall comply with all applicable federal, state, and local laws and regulations that are incorporated herein by reference.

23. DISPUTES. This Contract shall be performed under the laws of the State of Washington. Any litigation to enforce this Contract or any of its provisions shall be brought in Spokane County, Washington.
24. SEVERABILITY. In the event any provision of this Contract should become invalid, the rest of the Contract shall remain in full force and effect.
25. AUDIT / RECORDS. The Contractor and its subcontractors shall maintain for a minimum of three (3) years following final payment all records related to its performance of the Contract. The Contractor and its subcontractors shall provide access to authorized City representatives, at reasonable times and in a reasonable manner to inspect and copy any such record. In the event of conflict between this provision and related auditing provisions required under federal law applicable to the Contract, the federal law shall prevail.
26. BUSINESS REGISTRATION REQUIREMENT. Section 8.01.070 of the Spokane Municipal Code states that no person may engage in business with the City without first having obtained a valid annual business registration. The Contractor shall be responsible for contacting the State of Washington Business License Services at [www.dor.wa.gov](http://www.dor.wa.gov) or 360-705-6741 to obtain a business registration. If the Contractor does not believe it is required to obtain a business registration, it may contact the City's Taxes and Licenses Division at (509) 625-6070 to request an exemption status determination.
27. CONSTRUAL. The Contractor acknowledges receipt of a copy of the contract documents and agrees to comply with them. The silence or omission in the contract documents concerning any detail required for the proper execution and completion of the work means that only the best general practice is to prevail and that only material and workmanship of the best quality are to be used. This Contract shall be construed neither in favor of nor against either party.
28. MODIFICATIONS. The City may modify this Contract and order changes in the work whenever necessary or advisable. The Contractor will accept modifications when ordered in writing by the Director of Engineering Services, and the Contract time and compensation will be adjusted accordingly.
29. INTEGRATION. This Contract, including any and all exhibits and schedules referred to herein or therein set forth the entire Agreement and understanding between the parties pertaining to the subject matter and merges all prior agreements, negotiations and discussions between them on the same subject matter.
30. FORCE MAJEURE. Neither party shall be liable to the other for any failure or delay in performing its obligations hereunder, or for any loss or damage resulting therefrom, due to: (1) acts of God or public enemy, acts of government, riots, terrorism, fires, floods, strikes, lock outs, epidemics, act or failure to act by the other party, or unusually severe weather affecting City, Contractor or its subcontractors, or (2) causes beyond their reasonable control and which are not foreseeable (each a "Force Majeure Event"). In the event of any such Force Majeure Event, the date of delivery or performance shall be extended for a period equal to the time lost by reason of the delay.
31. CLEAN AIR ACT. Contractor must comply with all applicable standards, orders or regulations issued pursuant to the Clean Air Act (42 USC 7401-7671q) and the Federal Water Pollution Control Act as amended (33 USC 1251-1387). Violations will be reported.

32. USE OF PROJECT MANAGEMENT SOFTWARE. The Contractor shall transmit all submittal documentation for proposed project materials by uploading it to the City's web based construction management software. A City representative will be available to assist in learning this process.

**BACON CONCRETE, INC.**

**CITY OF SPOKANE**

By \_\_\_\_\_  
Signature                      Date

By \_\_\_\_\_  
Signature                      Date

\_\_\_\_\_  
Type or Print Name

\_\_\_\_\_  
Type or Print Name

\_\_\_\_\_  
Title

\_\_\_\_\_  
Title

Attest:

Approved as to form:

\_\_\_\_\_  
City Clerk

\_\_\_\_\_  
Assistant City Attorney

**Attachments that are part of this Contract:**  
Payment Bond  
Performance Bond  
Exhibit A – Certification Regarding Debarment  
Schedule A-1



**PAYMENT BOND**

We, **BACON CONCRETE, INC.**, as principal, and \_\_\_\_\_, as surety, are held and firmly bound to the City of Spokane, Washington, in the sum of **FOUR HUNDRED NINETY-EIGHT THOUSAND THREE HUNDRED FIVE AND 25/100 DOLLARS (\$498,305.25)**, for the payment of which, we bind ourselves and our legal representatives and successors, jointly and severally by this document.

The principal has entered into a contract with the City of Spokane, Washington, to do all work and furnish all materials for the **CYCLE 9 TRAFFIC CALMING PROJECTS**. If the principal shall:

- A. pay all laborers, mechanics, subcontractors, material suppliers and all person(s) who shall supply such person or subcontractors; and pay all taxes and contributions, increases and penalties as authorized by law; and
- B. comply with all applicable federal, state and local laws and regulations;

then this obligation shall be null and void; otherwise it shall remain in full force and effect.

The Surety for value received agrees that no change, extension of time, alteration or addition to the terms of the Contract, the specifications accompanying the Contract, or to the work to be performed under the Contract shall in any way affect its obligation on this bond, except as provided herein, and waives notice of any change, extension of time, alteration or addition to the terms of the Contract or the work performed. The Surety agrees that modifications and changes to the terms and conditions of the Contract that increase the total amount to be paid the Principal shall automatically increase the obligation of the Surety on this bond and notice to Surety is not required for such increased obligation... Any judgment obtained against the City, which relates to or is covered by the contract or this bond, shall be conclusive against the principal and the surety, as to the amount of damages, and their liability, if reasonable notice of the suit has been given.

SIGNED AND SEALED on \_\_\_\_\_.

**BACON CONCRETE, INC.,**  
AS PRINCIPAL

By: \_\_\_\_\_  
Title: \_\_\_\_\_

\_\_\_\_\_,  
AS SURETY

By: \_\_\_\_\_  
Its Attorney in Fact

A valid POWER OF ATTORNEY  
for the Surety's agent must  
accompany this bond.

STATE OF WASHINGTON        )  
  ) ss.  
County of \_\_\_\_\_)

I certify that I know or have satisfactory evidence that \_\_\_\_\_  
\_\_\_\_\_ signed this document; on oath stated that he/she was  
authorized to sign the document and acknowledged it as the agent or representative of the  
named surety company which is authorized to do business in the State of Washington, for  
the uses and purposes therein mentioned.

DATED: \_\_\_\_\_

\_\_\_\_\_  
Signature of Notary Public

My appointment expires \_\_\_\_\_

Approved as to form:

\_\_\_\_\_  
Assistant City Attorney

**PERFORMANCE BOND**

We, **BACON CONCRETE, INC.**, as principal, and \_\_\_\_\_, as Surety, are held and firmly bound to the City of Spokane, Washington, in the sum of **FOUR HUNDRED NINETY-EIGHT THOUSAND THREE HUNDRED FIVE AND 25/100 DOLLARS (\$498,305.25)**, for the payment of which, we bind ourselves and our legal representatives and successors, jointly and severally by this document.

The principal has entered into a Contract with the City of Spokane, Washington, to do all the work and furnish all materials for the **CYCLE 9 TRAFFIC CALMING PROJECTS**. If the principal shall:

- A. promptly and faithfully perform the Contract, and any contractual guaranty and indemnify and hold harmless the City from all loss, damage or claim which may result from any act or omission of the principal, its agents, employees, or subcontractors; and
- B. comply with all applicable federal, state and local laws and regulations;

then this obligation shall be null and void; otherwise it shall remain in full force and effect.

The Surety for value received agrees that no change, extension of time, alteration or addition to the terms of the Contract, the specifications accompanying the Contract, or to the work to be performed under the Contract shall in any way affect its obligation on this bond, except as provided herein, and waives notice of any change, extension of time, alteration or addition to the terms of the Contract or the work performed. The Surety agrees that modifications and changes to the terms and conditions of the Contract that increase the total amount to be paid the Principal shall automatically increase the obligation of the Surety on this bond and notice to Surety is not required for such increased obligation. Any judgment obtained against the City, which relates to or is covered by the Contract or this bond, shall be conclusive against the principal and the Surety, not only as to the amount of damages, but also as to their liability, if reasonable notice of the suit has been given.

SIGNED AND SEALED on \_\_\_\_\_

**BACON CONCRETE, INC.,**  
AS PRINCIPAL

By: \_\_\_\_\_  
Title: \_\_\_\_\_

\_\_\_\_\_,  
AS SURETY

By: \_\_\_\_\_  
Its Attorney in Fact

A valid POWER OF ATTORNEY  
for the Surety's agent must  
accompany this bond.

STATE OF WASHINGTON            )  
  ) ss.  
County of \_\_\_\_\_            )

I certify that I know or have satisfactory evidence that \_\_\_\_\_  
\_\_\_\_\_ signed this document; on oath stated that  
he/she was authorized to sign the document and acknowledged it as the agent or representative of  
the named Surety Company which is authorized to do business in the State of Washington, for the  
uses and purposes mentioned in this document.

DATED on \_\_\_\_\_.

\_\_\_\_\_  
Signature of Notary

My appointment expires \_\_\_\_\_

Approved as to form:

\_\_\_\_\_  
Assistant City Attorney

**EXHIBIT A**

**CERTIFICATION REGARDING DEBARMENT, SUSPENSION,  
INELIGIBILITY AND VOLUNTARY EXCLUSION**

1. The undersigned (i.e., signatory for the Subrecipient / Contractor / Consultant) certifies, to the best of its knowledge and belief, that it and its principals:
  - a. Are not presently debarred, suspended, proposed for debarment, declared ineligible, or voluntarily excluded from covered transactions by any federal department or agency;
  - b. Have not within a three-year period preceding this contract been convicted or had a civil judgment rendered against them for commission of fraud or a criminal offense in connection with obtaining, attempting to obtain, or performing a public (federal, state, or local) transaction or contract under a public transaction; violation of federal or state antitrust statutes or commission of embezzlement, theft, forgery, bribery, falsification or destruction of records, making false statements, tax evasion, receiving stolen property, making false claims, or obstruction of justice;
  - c. Are not presently indicted or otherwise criminally or civilly charged by a government entity (federal, state, or local) with commission of any of the offenses enumerated in paragraph (1)(b) of this certification; and,
  - d. Have not within a three-year period preceding this contract had one or more public transactions (federal, state, or local) terminated for cause or default.
  
2. The undersigned agrees by signing this contract that it shall not knowingly enter into any lower tier covered transaction with a person who is debarred, suspended, declared ineligible, or voluntarily excluded from participation in this covered transaction.
  
3. The undersigned further agrees by signing this contract that it will include the following clause, without modification, in all lower tier covered transactions and in all solicitations for lower tier covered transactions:

Certification Regarding Debarment, Suspension, Ineligibility and Voluntary Exclusion – Lower Tier Covered Transactions

1. The lower tier contractor certifies, by signing this contract that neither it nor its principals is presently debarred, suspended, proposed for debarment, declared ineligible, or voluntarily excluded from participation in this transaction by any federal department or agency.
  
  2. Where the lower tier contractor is unable to certify to any of the statements in this contract, such contractor shall attach an explanation to this contract.
4. I understand that a false statement of this certification may be grounds for termination of the contract.

<hr/> Name of Subrecipient / Contractor / Consultant (Type or Print)	<hr/> Program Title (Type or Print)
<hr/> Name of Certifying Official (Type or Print)	<hr/> Signature
<hr/> Title of Certifying Official (Type or Print)	<hr/> Date (Type or Print)

**SCHEDULE A-1**  
***Tax Classification: Sales tax shall be included in unit prices***

<b>ITEM NO.</b>	<b>ITEM DESCRIPTION</b>	<b>ESTIMATED QUANTITIES</b>	<b>UNIT PRICE</b>	<b>TOTAL</b>
1	ADA FEATURES SURVEYING	1.00 LS	\$ 3,400.00	\$ 3,400.00
2	REIMBURSEMENT OF THIRD PARTY DAMAGE	1.00 EST	\$ 1.00	\$ 1.00
3	SPCC PLAN	1.00 LS	\$ 1,000.00	\$ 1,000.00
4	POTHOLING	6.00 EA	\$ 700.00	\$ 4,200.00
5	PUBLIC LIAISON REPRESENTATIVE	1.00 LS	\$ 20,000.00	\$ 20,000.00
6	MOBILIZATION	1.00 LS	\$ 50,000.00	\$ 50,000.00
7	PROJECT TEMPORARY TRAFFIC CONTROL	1.00 LS	\$ 50,000.00	\$ 50,000.00
8	SEQUENTIAL ARROW SIGNS	80.00 HR	\$ 9.00	\$ 720.00
9	CLEARING AND GRUBBING	1.00 LS	\$ 8,000.00	\$ 8,000.00
10	TREE ROOT TREATMENT	2.00 EA	\$ 1,000.00	\$ 2,000.00
11	TREE PROTECTION ZONE	4.00 EA	\$ 350.00	\$ 1,400.00
12	TREE PRUNING	4.00 EA	\$ 350.00	\$ 1,400.00

13	REMOVE EXISTING CURB	440.00 LF	\$	14.00	\$	6,160.00
14	REMOVE EXISTING CURB AND GUTTER	10.00 LF	\$	20.00	\$	200.00
15	REMOVE CEMENT CONCRETE SIDEWALK AND DRIVEWAY	285.00 SY	\$	20.00	\$	5,700.00
16	REMOVE MANHOLE, CATCH BASIN, OR DRYWELL	1.00 EA	\$	980.00	\$	980.00
17	SAWCUTTING CURB	16.00 EA	\$	50.00	\$	800.00
18	SAWCUTTING RIGID PAVEMENT	730.00 LFI	\$	2.00	\$	1,460.00
19	SAWCUTTING FLEXIBLE PAVEMENT	4,310.00 LFI	\$	1.10	\$	4,741.00
20	ABANDON EXISTING MANHOLE, CATCH BASIN OR DRYWELL	1.00 EA	\$	920.00	\$	920.00
21	REMOVE UNSUITABLE FOUNDATION MATERIAL	5.00 CY	\$	30.00	\$	150.00
22	REPLACE UNSUITABLE FOUNDATION MATERIAL	5.00 CY	\$	30.00	\$	150.00
23	CONTROLLED DENSITY FILL	10.00 CY	\$	150.00	\$	1,500.00
24	CSTC FOR SIDEWALK AND DRIVEWAYS	24.00 CY	\$	110.00	\$	2,640.00
25	HMA FOR PAVEMENT REPAIR CL. 1/2 IN. MEDIUM TRAFFIC, 4 INCH THICK	82.00 SY	\$	94.00	\$	7,708.00
26	HMA FOR PAVEMENT REPAIR CL. 1/2 IN. HEAVY TRAFFIC, 6 INCH THICK	218.00 SY	\$	119.00	\$	25,942.00
27	PAVEMENT REPAIR EXCAVATION INCL. HAUL	300.00 SY	\$	42.00	\$	12,600.00

28	STORM SEWER PIPE 8 IN. DIA.	2.00 LF	\$	225.00	\$	450.00
29	MANHOLE - 48 IN.	1.00 EA	\$	4,200.00	\$	4,200.00
30	CATCH BASIN TYPE 3	2.00 EA	\$	3,800.00	\$	7,600.00
31	CLEANING EXISTING DRAINAGE STRUCTURE	8.00 EA	\$	580.00	\$	4,640.00
32	TRENCH SAFETY SYSTEM	1.00 LS	\$	600.00	\$	600.00
33	CATCH BASIN DI SEWER PIPE 8 IN. DIA.	60.00 LF	\$	130.00	\$	7,800.00
34	CONNECT 8 IN. DIA. SEWER PIPE TO EXISTING SEWER PIPE	2.00 EA	\$	900.00	\$	1,800.00
35	PLUGGING EXISTING PIPE	3.00 EA	\$	600.00	\$	1,800.00
36	ESC LEAD	1.00 LS	\$	1,100.00	\$	1,100.00
37	INLET PROTECTION	1.00 EA	\$	200.00	\$	200.00
38	TOPSOIL TYPE A, 2 INCH THICK	199.00 SY	\$	11.00	\$	2,189.00
39	HYDROSEEDING	5.00 SY	\$	120.00	\$	600.00
40	SOD INSTALLATION	194.00 SY	\$	20.00	\$	3,880.00
41	CONSTRUCT BIO-INFILTRATION SWALE	134.00 SY	\$	32.00	\$	4,288.00



42	CURB DROP INLET	1.00 EA	\$	180.00	\$	180.00
43	2 IN. PVC IRRIGATION SLEEVE	6.00 LF	\$	25.00	\$	150.00
44	REMOVE AND REPLACE EXISTING SPRINKLER HEADS AND LINES	1.00 LS	\$	6,000.00	\$	6,000.00
45	CEMENT CONCRETE CURB	580.00 LF	\$	42.00	\$	24,360.00
46	CEMENT CONCRETE CURB AND GUTTER	10.00 LF	\$	80.00	\$	800.00
47	CLASSIFICATION AND PROTECTION OF SURVEY MONUMENTS	1.00 LS	\$	6,500.00	\$	6,500.00
48	REFERENCE AND REESTABLISH SURVEY MONUMENT	1.00 EA	\$	700.00	\$	700.00
49	CEMENT CONCRETE SIDEWALK	450.00 SY	\$	72.00	\$	32,400.00
50	RAMP DETECTABLE WARNING	128.00 SF	\$	34.00	\$	4,352.00
51	PEDESTRIAN HYBRID BEACON SYSTEM, INDIAN TRAIL & LOWELL	1.00 LS	\$	100,390.00	\$	100,390.00
52	COMMUNICATION CABLES AND INTERFACES	1.00 LS	\$	1,507.00	\$	1,507.00
53	VIDEO & DATA TRANSMISSION AND DISTRIBUTION SYSTEM	1.00 LS	\$	7,000.00	\$	7,000.00
54	DIRECTIONAL BORING	150.00 LF	\$	86.00	\$	12,900.00
55	SIGNING, PERMANENT - CONTRACTOR MANUFACTURED SIGNS - DIST. 2	1.00 LS	\$	4,800.00	\$	4,800.00
56	SIGNING, PERMANENT - CONTRACTOR MANUFACTURED SIGNS - DIST. 3	1.00 LS	\$	25,000.00	\$	25,000.00

57	REMOVAL OF EXISTING PAVEMENT MARKINGS	340.00 SF	\$	7.15	\$	2,431.00
58	PAVEMENT MARKING - DURABLE HEAT APPLIED	1,025.00 SF	\$	9.45	\$	9,686.25
59	REINFORCED DOWELED CURB	62.00 LF	\$	40.00	\$	2,480.00
60	TRAFFIC ISLAND CONCRETE	14.00 SY	\$	125.00	\$	1,750.00
<b>Schedule A-1 Subtotal</b>					\$	<u>498,305.25</u>

**City Of Spokane**  
**Engineering Services Department**  
**\*\*\*Bid Tabulation\*\*\***

**Project Number**      **2019088**

**Project Description**      Cycle 9 - Traffic Calming

**Original Date**

6/13/2022 1:00:00 PM

<b>Project Number: 2019088</b>			<b>Engineer's Estimate</b>		BACON CONCRETE INC (Submitted)		LARIVIERE INC (Submitted)		WM WINKLER COMPANY (Submitted)	
<b>Item No</b>	<b>Bid Item Description</b>	<b>Est Qty</b>	<b>Unit Price</b>	<b>Amount</b>	<b>Unit Price</b>	<b>Amount</b>	<b>Unit Price</b>	<b>Amount</b>	<b>Unit Price</b>	<b>Amount</b>

**Tax Classification**

Sales tax shall be included in unit prices

1	ADA FEATURES SURVEYING	1 LS	5,000.00	5,000.00	3,400.00	\$3,400.00	2,207.00	\$2,207.00	2,000.00	\$2,000.00
2	REIMBURSEMENT OF THIRD PARTY DAMAGE	1 EST	1.00	1.00	1.00	\$1.00	1.00	\$1.00	1.00	\$1.00
3	SPCC PLAN	1 LS	1,200.00	1,200.00	1,000.00	\$1,000.00	387.00	\$387.00	735.50	\$735.50
4	POTHOLING	6 EA	900.00	5,400.00	700.00	\$4,200.00	431.00	\$2,586.00	1,070.00	\$6,420.00
5	PUBLIC LIAISON REPRESENTATIVE	1 LS	10,000.00	10,000.00	20,000.00	\$20,000.00	3,038.00	\$3,038.00	3,664.00	\$3,664.00
6	MOBILIZATION	1 LS	92,000.00	92,000.00	50,000.00	\$50,000.00	61,045.00	\$61,045.00	63,574.00	\$63,574.00
7	PROJECT TEMPORARY TRAFFIC CONTROL	1 LS	60,000.00	60,000.00	50,000.00	\$50,000.00	30,746.00	\$30,746.00	98,775.00	\$98,775.00
8	SEQUENTIAL ARROW SIGNS	80 HR	16.00	1,280.00	9.00	\$720.00	9.50	\$760.00	18.80	\$1,504.00
9	CLEARING AND GRUBBING	1 LS	12,000.00	12,000.00	8,000.00	\$8,000.00	20,562.00	\$20,562.00	6,012.00	\$6,012.00
10	TREE ROOT TREATMENT	2 EA	800.00	1,600.00	1,000.00	\$2,000.00	1,048.00	\$2,096.00	810.00	\$1,620.00
11	TREE PROTECTION ZONE	4 EA	300.00	1,200.00	350.00	\$1,400.00	384.00	\$1,536.00	297.00	\$1,188.00
12	TREE PRUNING	4 EA	650.00	2,600.00	350.00	\$1,400.00	384.00	\$1,536.00	297.00	\$1,188.00
13	REMOVE EXISTING CURB	440 LF	11.00	4,840.00	14.00	\$6,160.00	9.50	\$4,180.00	25.70	\$11,308.00
14	REMOVE EXISTING CURB AND GUTTER	10 LF	18.00	180.00	20.00	\$200.00	11.00	\$110.00	83.40	\$834.00
15	REMOVE CEMENT CONCRETE SIDEWALK AND DRIVEWAY	285 SY	16.00	4,560.00	20.00	\$5,700.00	15.00	\$4,275.00	30.80	\$8,778.00
16	REMOVE MANHOLE, CATCH BASIN, OR DRYWELL	1 EA	1,000.00	1,000.00	980.00	\$980.00	690.00	\$690.00	1,296.00	\$1,296.00
17	SAWCUTTING CURB	16 EA	35.00	560.00	50.00	\$800.00	56.00	\$896.00	37.80	\$604.80
18	SAWCUTTING RIGID PAVEMENT	730 LFI	2.00	1,460.00	2.00	\$1,460.00	3.00	\$2,190.00	1.20	\$876.00
19	SAWCUTTING FLEXIBLE PAVEMENT	4310 LFI	1.00	4,310.00	1.10	\$4,741.00	0.50	\$2,155.00	0.35	\$1,508.50

**City Of Spokane**  
**Engineering Services Department**  
**\*\*\*Bid Tabulation\*\*\***

<i>Project Number: 2019088</i>			<i>Engineer's Estimate</i>		BACON CONCRETE INC (Submitted)		LARIVIERE INC (Submitted)		WM WINKLER COMPANY (Submitted)	
<i>Item No</i>	<i>Bid Item Description</i>	<i>Est Qty</i>	<i>Unit Price</i>	<i>Amount</i>	<i>Unit Price</i>	<i>Amount</i>	<i>Unit Price</i>	<i>Amount</i>	<i>Unit Price</i>	<i>Amount</i>
20	ABANDON EXISTING MANHOLE, CATCH BASIN OR DRYWELL	1 EA	500.00	500.00	920.00	\$920.00	628.00	\$628.00	881.00	\$881.00
21	REMOVE UNSUITABLE FOUNDATION MATERIAL	5 CY	60.00	300.00	30.00	\$150.00	50.00	\$250.00	237.50	\$1,187.50
22	REPLACE UNSUITABLE FOUNDATION MATERIAL	5 CY	75.00	375.00	30.00	\$150.00	39.00	\$195.00	284.50	\$1,422.50
23	CONTROLLED DENSITY FILL	10 CY	200.00	2,000.00	150.00	\$1,500.00	196.00	\$1,960.00	314.00	\$3,140.00
24	CSTC FOR SIDEWALK AND DRIVEWAYS	24 CY	130.00	3,120.00	110.00	\$2,640.00	188.00	\$4,512.00	301.50	\$7,236.00
25	HMA FOR PAVEMENT REPAIR CL. 1/2 IN. MEDIUM TRAFFIC, 4 INCH THICK	82 SY	42.00	3,444.00	94.00	\$7,708.00	97.00	\$7,954.00	155.50	\$12,751.00
26	HMA FOR PAVEMENT REPAIR CL. 1/2 IN. HEAVY TRAFFIC, 6 INCH THICK	218 SY	70.00	15,260.00	119.00	\$25,942.00	133.00	\$28,994.00	143.00	\$31,174.00
27	PAVEMENT REPAIR EXCAVATION INCL. HAUL	300 SY	35.00	10,500.00	42.00	\$12,600.00	46.00	\$13,800.00	26.40	\$7,920.00
28	STORM SEWER PIPE 8 IN. DIA.	2 LF	120.00	240.00	225.00	\$450.00	473.00	\$946.00	1,919.00	\$3,838.00
29	MANHOLE - 48 IN.	1 EA	4,500.00	4,500.00	4,200.00	\$4,200.00	4,778.00	\$4,778.00	5,206.00	\$5,206.00
30	CATCH BASIN TYPE 3	2 EA	3,800.00	7,600.00	3,800.00	\$7,600.00	4,732.00	\$9,464.00	3,206.00	\$6,412.00
31	CLEANING EXISTING DRAINAGE STRUCTURE	8 EA	700.00	5,600.00	580.00	\$4,640.00	559.00	\$4,472.00	369.50	\$2,956.00
32	TRENCH SAFETY SYSTEM	1 LS	5,000.00	5,000.00	600.00	\$600.00	873.00	\$873.00	632.50	\$632.50
33	CATCH BASIN DI SEWER PIPE 8 IN. DIA.	60 LF	130.00	7,800.00	130.00	\$7,800.00	126.00	\$7,560.00	111.00	\$6,660.00
34	CONNECT 8 IN. DIA. SEWER PIPE TO EXISTING SEWER PIPE	2 EA	1,200.00	2,400.00	900.00	\$1,800.00	527.00	\$1,054.00	1,166.00	\$2,332.00
35	PLUGGING EXISTING PIPE	3 EA	1,000.00	3,000.00	600.00	\$1,800.00	341.00	\$1,023.00	444.50	\$1,333.50
36	ESC LEAD	1 LS	2,000.00	2,000.00	1,100.00	\$1,100.00	738.00	\$738.00	630.50	\$630.50
37	INLET PROTECTION	1 EA	115.00	115.00	200.00	\$200.00	164.00	\$164.00	272.00	\$272.00
38	TOPSOIL TYPE A, 2 INCH THICK	199 SY	10.00	1,990.00	11.00	\$2,189.00	36.00	\$7,164.00	4.00	\$796.00
39	HYDROSEEDING	5 SY	3.00	15.00	120.00	\$600.00	70.00	\$350.00	140.50	\$702.50
40	SOD INSTALLATION	194 SY	26.00	5,044.00	20.00	\$3,880.00	47.00	\$9,118.00	12.50	\$2,425.00

**City Of Spokane**  
**Engineering Services Department**  
**\*\*\*Bid Tabulation\*\*\***

<i>Project Number: 2019088</i>			<i>Engineer's Estimate</i>		BACON CONCRETE INC (Submitted)		LARIVIERE INC (Submitted)		WM WINKLER COMPANY (Submitted)	
<i>Item No</i>	<i>Bid Item Description</i>	<i>Est Qty</i>	<i>Unit Price</i>	<i>Amount</i>	<i>Unit Price</i>	<i>Amount</i>	<i>Unit Price</i>	<i>Amount</i>	<i>Unit Price</i>	<i>Amount</i>
41	CONSTRUCT BIO- INFILTRATION SWALE	134 SY	12.00	1,608.00	32.00	\$4,288.00	25.00	\$3,350.00	20.80	\$2,787.20
42	CURB DROP INLET	1 EA	700.00	700.00	180.00	\$180.00	394.00	\$394.00	468.00	\$468.00
43	2 IN. PVC IRRIGATION SLEEVE	6 LF	18.00	108.00	25.00	\$150.00	23.00	\$138.00	50.00	\$300.00
44	REMOVE AND REPLACE EXISTING SPRINKLER HEADS AND LINES	1 LS	10,000.00	10,000.00	6,000.00	\$6,000.00	16,490.00	\$16,490.00	5,500.00	\$5,500.00
45	CEMENT CONCRETE CURB	580 LF	37.00	21,460.00	42.00	\$24,360.00	71.00	\$41,180.00	80.50	\$46,690.00
46	CEMENT CONCRETE CURB AND GUTTER	10 LF	60.00	600.00	80.00	\$800.00	114.00	\$1,140.00	125.50	\$1,255.00
47	CLASSIFICATION AND PROTECTION OF SURVEY MONUMENTS	1 LS	7,500.00	7,500.00	6,500.00	\$6,500.00	8,385.00	\$8,385.00	6,480.00	\$6,480.00
48	REFERENCE AND REESTABLISH SURVEY MONUMENT	1 EA	1,000.00	1,000.00	700.00	\$700.00	908.00	\$908.00	702.00	\$702.00
49	CEMENT CONCRETE SIDEWALK	450 SY	58.00	26,100.00	72.00	\$32,400.00	106.00	\$47,700.00	125.00	\$56,250.00
50	RAMP DETECTABLE WARNING	128 SF	31.00	3,968.00	34.00	\$4,352.00	39.00	\$4,992.00	26.00	\$3,328.00
51	PEDESTRIAN HYBRID BEACON SYSTEM, INDIAN TRAIL & LOWELL	1 LS	115,000.00	115,000.00	100,390.00	\$100,390.00	122,813.00	\$122,813.00	95,296.00	\$95,296.00
52	COMMUNICATION CABLES AND INTERFACES	1 LS	2,000.00	2,000.00	1,507.00	\$1,507.00	265.00	\$265.00	205.50	\$205.50
53	VIDEO & DATA TRANSMISSION AND DISTRIBUTION SYSTEM	1 LS	6,000.00	6,000.00	7,000.00	\$7,000.00	7,477.00	\$7,477.00	5,802.00	\$5,802.00
54	DIRECTIONAL BORING	150 LF	130.00	19,500.00	86.00	\$12,900.00	125.00	\$18,750.00	97.30	\$14,595.00
55	SIGNING, PERMANENT - CONTRACTOR MANUFACTURED SIGNS - DIST. 2	1 LS	5,000.00	5,000.00	4,800.00	\$4,800.00	5,870.00	\$5,870.00	4,536.00	\$4,536.00
56	SIGNING, PERMANENT - CONTRACTOR MANUFACTURED SIGNS - DIST. 3	1 LS	19,000.00	19,000.00	25,000.00	\$25,000.00	24,597.00	\$24,597.00	19,008.00	\$19,008.00
57	REMOVAL OF EXISTING PAVEMENT MARKINGS	340 SF	4.50	1,530.00	7.15	\$2,431.00	7.00	\$2,380.00	5.40	\$1,836.00

**City Of Spokane**  
**Engineering Services Department**  
**\*\*\*Bid Tabulation\*\*\***

<i>Project Number: 2019088</i>			<i>Engineer's Estimate</i>		BACON CONCRETE INC (Submitted)		LARIVIERE INC (Submitted)		WM WINKLER COMPANY (Submitted)	
<i>Item No</i>	<i>Bid Item Description</i>	<i>Est Qty</i>	<i>Unit Price</i>	<i>Amount</i>	<i>Unit Price</i>	<i>Amount</i>	<i>Unit Price</i>	<i>Amount</i>	<i>Unit Price</i>	<i>Amount</i>
58	PAVEMENT MARKING - DURABLE HEAT APPLIED	1025 SF	15.00	15,375.00	9.45	\$9,686.25	15.00	\$15,375.00	11.30	\$11,582.50
59	REINFORCED DOWELED CURB	62 LF	49.00	3,038.00	40.00	\$2,480.00	53.00	\$3,286.00	60.90	\$3,775.80
60	TRAFFIC ISLAND CONCRETE	14 SY	105.00	1,470.00	125.00	\$1,750.00	102.00	\$1,428.00	153.00	\$2,142.00
<b>Bid Total</b>				<b>\$550,951.00</b>	<b>\$498,305.25</b>		<b>\$573,911.00</b>		<b>\$594,333.80</b>	

**SCHEDULE SUMMARY**

	<i>Sched 1</i>	<i>Sched 2</i>	<i>Sched 3</i>	<i>Sched 4</i>	<i>Sched 5</i>	<i>Sched 6</i>	<i>Total</i>
ENGINEER'S ESTIMATE	550,951.00	0.00	0.00	0.00	0.00	0.00	550,951.00
BACON CONCRETE INC (Submitted)	498,305.25	0.00	0.00	0.00	0.00	0.00	498,305.25
LARIVIERE INC (Submitted)	573,911.00	0.00	0.00	0.00	0.00	0.00	573,911.00
WM WINKLER COMPANY (Submitted)	594,333.80	0.00	0.00	0.00	0.00	0.00	594,333.80

**Low Bid Contractor:** BACON CONCRETE INC

	<i>Contractor's Bid</i>	<i>Engineer's Estimate</i>	<i>% Variance</i>
<i>Schedule 01</i>	498,305.25	550,951.00	9.56 % Under Estimate
<i>Schedule 03</i>	0.00	0.00	% Under Estimate
<b>Bid Totals</b>	<u>498,305.25</u>	<u>550,951.00</u>	<u>9.56 % Under Estimate</u>

### DISTRICT 2 PROJECTS

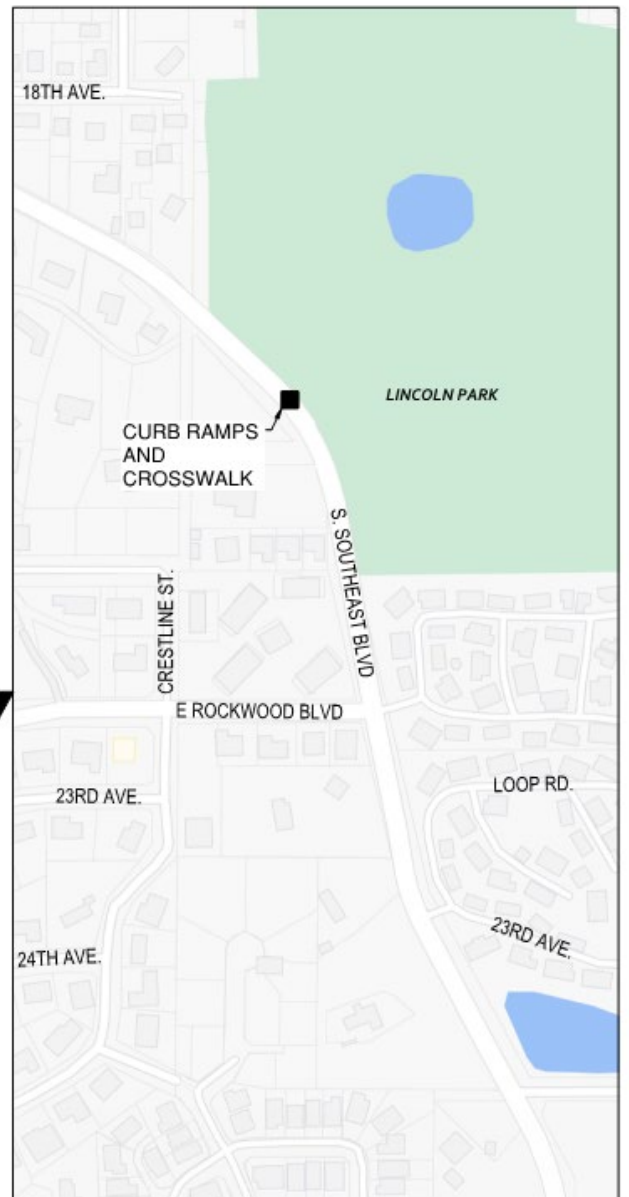
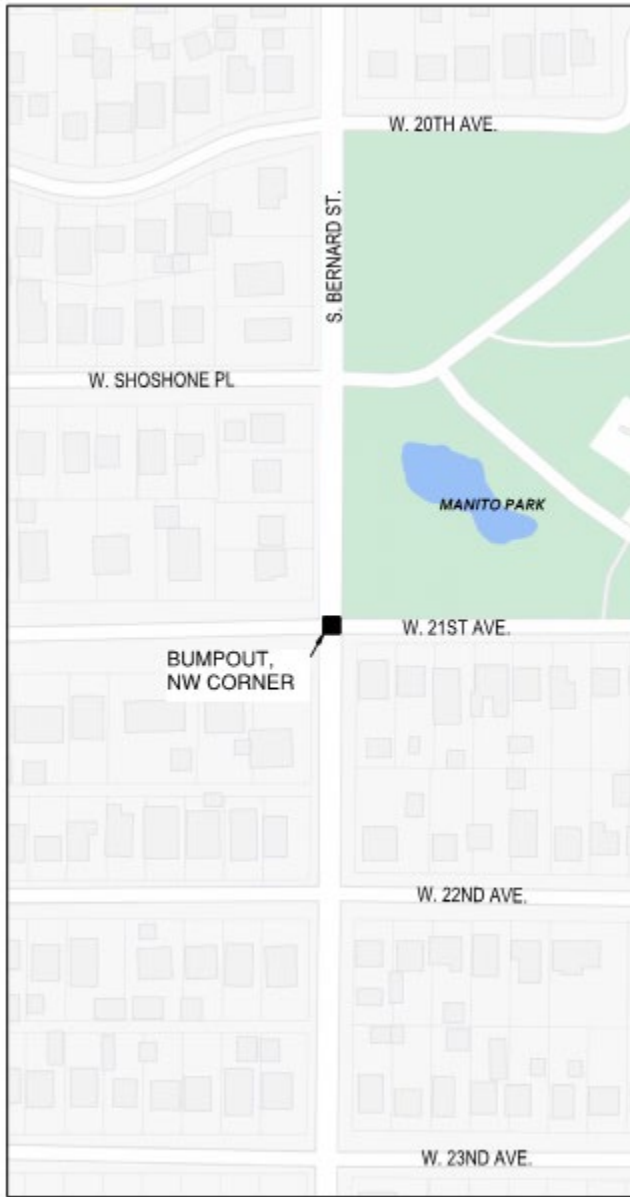

# DISTRICT 3 PROJECTS

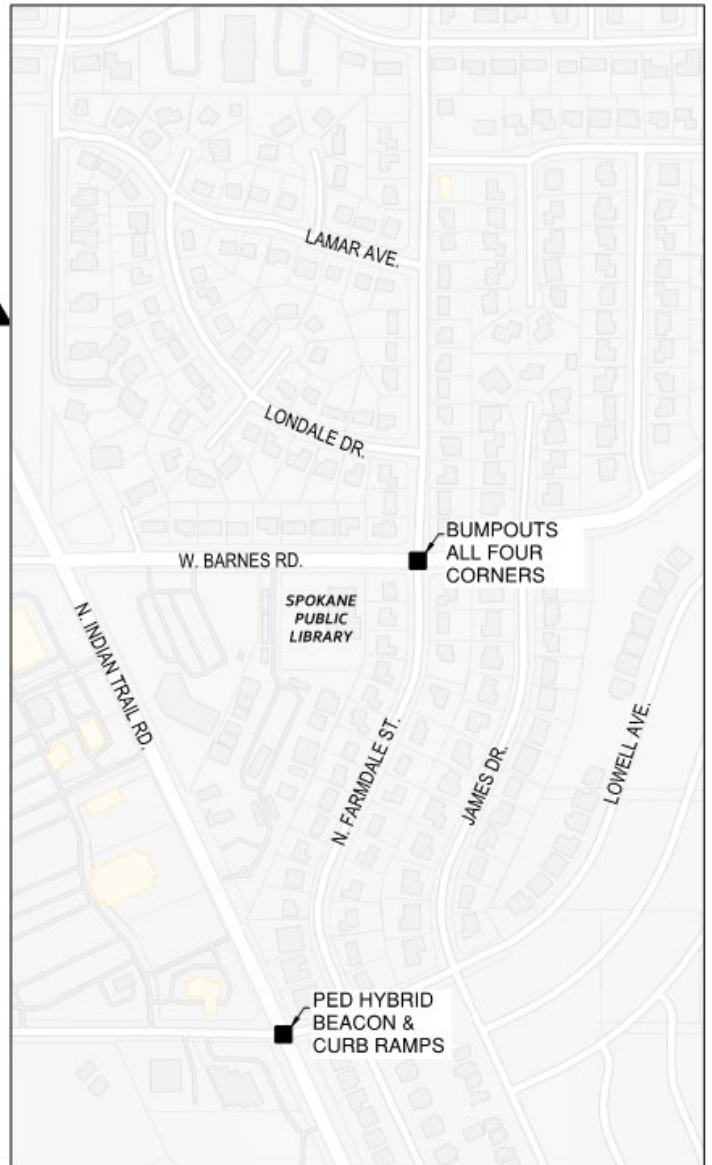





**Agenda Sheet for City Council Meeting of:**  
06/20/2022

<b>Date Rec'd</b>	6/6/2022
<b>Clerk's File #</b>	OPR 2022-0444
<b>Renews #</b>	
<b>Cross Ref #</b>	
<b>Project #</b>	2017178
<b>Bid #</b>	
<b>Requisition #</b>	

<b>Submitting Dept</b>	ENGINEERING SERVICES
<b>Contact Name/Phone</b>	DAN BULLER 625-6391
<b>Contact E-Mail</b>	DBULLER@SPOKANECITY.ORG
<b>Agenda Item Type</b>	Contract Item
<b>Agenda Item Name</b>	0370 - LOW BID AWARD - WA BASIN STORMWATER (2017178) - HALME

**Agenda Wording**

Low Bid of Halme Construction, Inc. (Spokane) for Washington Basin Stormwater - Knox Avenue - \$1,999,122.75. An administrative reserve of \$199,912.78, which is 10% of the contract price, will be set aside. (Emerson/Garfield)

**Summary (Background)**

On June 13, 2022, bids were opened for the above project. The low bid was from Halme Construction Inc. in the amount of \$1,999,122.75, which is \$259,122.75 or 15.9% above the Engineer's Estimate of \$1,740,000.00; two other bids were received as follows: Inland Infrastructure LLC - \$2,030,649.00 and DW Excavating Inc., - \$2,160,146.00.

Lease? NO Grant related? NO Public Works? YES

**Fiscal Impact**

Expense	<b>\$1,999,122.75</b>
Select	\$
Select	\$
Select	\$

**Budget Account**

#	4250-98817-94310-56501-14357
#	
#	
#	

**Approvals**

<b>Dept Head</b>	TWOHIG, KYLE
<b>Division Director</b>	TWOHIG, KYLE
<b>Finance</b>	ORLOB, KIMBERLY
<b>Legal</b>	ODLE, MARI
<b>For the Mayor</b>	ORMSBY, MICHAEL

**Council Notifications**

<b>Study Session\Other</b>	Public Safety 6/6
<b>Council Sponsor</b>	Kinnear

**Distribution List**

eraea@spokanecity.org
publicworksaccounting@spokanecity.org
kgoodman@spokanecity.org
jgraff@spokanecity.org
ddaniels@spokanecity.org
pyoung@spokanecity.org
Scott Halme: scotth@halmeconstruction.com

## Committee Agenda Sheet

### Public Health & Safety

<b>Submitting Department</b>	Public Works, Engineering
<b>Contact Name &amp; Phone</b>	Dan Buller 625-6391
<b>Contact Email</b>	<a href="mailto:dbuller@spokanecity.org">dbuller@spokanecity.org</a>
<b>Council Sponsor(s)</b>	Lori Kinnear/Breean Beggs
<b>Select Agenda Item Type</b>	X Consent <input type="checkbox"/> Discussion    Time Requested: _____
<b>Agenda Item Name</b>	Washington Basin Stormwater Treatment
<b>Summary (Background)</b>	<ul style="list-style-type: none"> <li>• This project collects and treats approximately stormwater from approximately 150 acres of land bounded roughly by Buckeye Ave. on the north, Northwest Blvd on the west, Wall St. on the east and Indiana St. on the south (see attached exhibit).</li> <li>• That stormwater is currently routed without treatment to the Spokane River.</li> <li>• The proposed project installs a packaged treatment system and drywells in a one block stretch of Knox Ave. between Wall St. and Howard St.</li> <li>• The project will also replace the water main and repaved curb to curb that one block.</li> <li>• Work is planned this summer. Because of the depth of excavation required, this one block will be closed to for the duration of the project.</li> <li>• This project is mostly paid with a DOE grant.</li> </ul>
<b>Proposed Council Action &amp; Date:</b>	None at this time. Following bid opening, we will bring a pipe purchase contract to Council for approval.
<b>Fiscal Impact:</b> Total Cost: Approved in current year budget?      X Yes <input type="checkbox"/> No <input type="checkbox"/> N/A  Funding Source      X One-time <input type="checkbox"/> Recurring Specify funding source: project funds (generally street or utility funds)  Expense Occurrence      X One-time <input type="checkbox"/> Recurring  Other budget impacts: (revenue generating, match requirements, etc.)	
<b>Operations Impacts</b>	
What impacts would the proposal have on historically excluded communities?  <p>Public Works services and projects are designed to serve all citizens and businesses. We strive to offer a consistent level of service to all, to distribute public investment throughout the community, and to respond to gaps in services identified in various City plans. We recognize the need to maintain affordability and predictability for utility customers. And we are committed to delivering work that is both financially and environmentally responsible. This item supports the operations of Public Works.</p>	
How will data be collected, analyzed, and reported concerning the effect of the program/policy by racial, ethnic, gender identity, national origin, income level, disability, sexual orientation, or other existing disparities?	

N/A – This contract supports multiple public works projects and should not impact racial, gender identity, national origin, income level, disability, sexual orientation or other existing disparity factors.

How will data be collected regarding the effectiveness of this program, policy or product to ensure it is the right solution?

Public Works follows the City's established procurement and public works bidding regulations and policies to bring items forward, and then uses contract management best practices to ensure desired outcomes and regulatory compliance.

Describe how this proposal aligns with current City Policies, including the Comprehensive Plan, Sustainability Action Plan, Capital Improvement Program, Neighborhood Master Plans, Council Resolutions, and others?

The projects which will use this on-call contract are consistent with our adopted six year programs as well as the annual budget and strategic initiative to advance street maintenance activities.



**City of Spokane**

**PUBLIC WORKS CONTRACT**

**Title: STORMWATER FOR WASHINGTON BASIN  
KNOX AVE. – WALL ST. TO HOWARD ST.**

This Contract is made and entered into by and between the **CITY OF SPOKANE** as (“City”), a Washington municipal corporation, and **HALME CONSTRUCTION, INC.**, whose address is 8727 West Highway 2, #100, Spokane, Washington 99208 as (“Contractor”), individually hereafter referenced as a “party”, and together as the “parties”.

The parties agree as follows:

1. **PERFORMANCE.** The Contractor will do all work, furnish all labor, materials, tools, construction equipment, transportation, supplies, supervision, organization and other items of work and costs necessary for the proper execution and completion of the work described in the Special Provisions entitled **STORMWATER FOR WASHINGTON BASIN KNOX AVE. – WALL ST. TO HOWARD ST.**
2. **CONTRACT DOCUMENTS.** The contract documents are this Contract, the Contractor’s completed bid proposal form, the Washington State Department of Transportation’s Standard Specifications for Road, Bridge and Municipal Construction 2022, City of Spokane Special Provisions, contract provisions, contract plans, , standard plans, addenda, various certifications and affidavits, supplemental agreements, change orders and subsurface boring logs (if any). These contract documents are on file in the Engineering Services Department and are incorporated into this Contract by reference as if they were set forth at length. In the event of a conflict, or to resolve an ambiguity or dispute, the order of precedence defined in the City of Spokane Special Provisions section 1-04.2 shall apply.
3. **TIME OF PERFORMANCE.** The time of performance of the Contract shall be in accordance with the contract documents.
4. **LIQUIDATED DAMAGES.** Liquidated damages shall be in accordance with the contract documents.
5. **TERMINATION.** Either party may terminate this Contract in accordance with the contract documents.
6. **COMPENSATION.** This is a unit price contract, and upon full and complete performance by the Contractor, the City will pay only the amount set forth in Schedules A-1 and A-3 for the actual quantities furnished for each bid item.

7. TAXES. Bid items in Schedule A-1 will include sales tax. Bid items in Schedule A-3 shall not include sales tax.

8. PAYMENT. The Contractor will send its applications for payment to the Engineering Services Department, 998 E North Foothills Drive Spokane, WA 99207-2735. All invoices should include the City Clerk's File No. "OPR XXXX-XXXX" and an approved L & I Intent to Pay Prevailing Wage number. The final invoice should include an approved Affidavit of Wages Paid number. Payment will not be made without this documentation included on the invoice. **Payment will be made via direct deposit/ACH** within thirty (30) days after receipt of the Company's application except as provided by state law. Five percent (5%) of the Contract price may be retained by the City, in accord with RCW 60.28 for a minimum of forty five (45) days after final acceptance, as a trust fund for the protection and payment of: the claims of any person arising under the Contract; and the State with respect to taxes imposed pursuant to Titles 50, 51 and 82 RCW which may be due from the Contractor.

9. INDEMNIFICATION. The Contractor shall defend, indemnify, and hold the City and its officers and employees harmless from all claims, demands, or suits at law or equity asserted by third parties for bodily injury (including death) and/or property damage which arise from the Contractor's negligence or willful misconduct under this Agreement, including attorneys' fees and litigation costs; provided that nothing herein shall require a Contractor to indemnify the City against and hold harmless the City from claims, demands or suits based solely upon the negligence of the City, its agents, officers, and employees. If a claim or suit is caused by or results from the concurrent negligence of the Contractor's agents or employees and the City, its agents, officers and employees, this indemnity provision shall be valid and enforceable to the extent of the negligence of the Contractor, its agents or employees. The Contractor specifically assumes liability and agrees to defend, indemnify, and hold the City harmless for actions brought by the Contractor's own employees against the City and, solely for the purpose of this indemnification and defense, the Contractor specifically waives any immunity under the Washington State industrial insurance law, or Title 51 RCW. The Contractor recognizes that this waiver was specifically entered into pursuant to the provisions of RCW 4.24.115 and was the subject of mutual negotiation. The indemnity and agreement to defend and hold the City harmless provided for in this section shall survive any termination or expiration of this agreement.

10. BONDS. The Contractor may not commence work until it obtains all insurance, permits and bonds required by the contract documents and applicable law. This includes the execution of a performance bond and a payment bond on the forms attached, each equal to one hundred percent (100%) of the contract price, and written by a corporate surety company licensed to do business in Washington State.

11. INSURANCE. The Contractor represents that it and its employees, agents and subcontractors, in connection with the Contract, are protected against the risk of loss by the insurance coverages required in the contract documents. The policies shall be issued by companies that meet with the approval of the City Risk Manager. The policies shall not be canceled without at least minimum required written notice to the City as Additional Insured.

12. CONTRACTOR'S WARRANTY. The Contractor's warranty for all work, labor and materials shall be in accordance with the contract documents.

13. WAGES. The Contractor and all subcontractors will submit a "Statement of Intent to Pay Prevailing Wages" certified by the industrial statistician of the Department of Labor and Industries,

prior to any payments. The "Statement of Intent to Pay Prevailing Wages" shall include: (1) the Contractor's registration number; and (2) the prevailing wages under RCW 39.12.020 and the number of workers in each classification. Each voucher claim submitted by the Contractor for payment on a project estimate shall state that the prevailing wages have been paid in accordance with the "Statement(s) of Intent to Pay Prevailing Wages" on file with the City. Prior to the payment of funds held under RCW 60.28, the Contractor and subcontractors must submit an "Affidavit of Wages Paid" certified by the industrial statistician.

14. STATEMENT OF INTENT TO PAY PREVAILING WAGES TO BE POSTED. The Contractor and each subcontractor required to pay the prevailing rate of wages shall post in a location readily visible at the job site: (1) a copy of a "Statement of Intent to Pay Prevailing Wages" approved by the industrial statistician of the State Department of Labor and Industries; and (2) the address and telephone number of the industrial statistician of the Department of Labor and Industries where a complaint or inquiry concerning prevailing wages may be made.

15. PUBLIC WORKS REQUIREMENTS. The Contractor and each subcontractor are required to fulfill the Department of Labor and Industries Public Works and Prevailing Wage Training Requirement under RCW 39.04.350. The contractor must verify responsibility criteria for each first tier subcontractor, and a subcontractor of any tier that hires other subcontractors must verify the responsibility criteria listed in RCW 39.04.350(1) for each of its subcontractors. Verification shall include that each subcontractor, at the time of subcontract execution, meets the responsibility criteria. This verification requirement, as well as responsibility criteria, must be included in every public works contract and subcontract of every tier.

16. SUBCONTRACTOR RESPONSIBILITY.

A. The Contractor shall include the language of this section in each of its first tier subcontracts, and shall require each of its subcontractors to include the same language of this section in each of their subcontracts, adjusting only as necessary the terms used for the contracting parties. Upon request of the City, the Contractor shall promptly provide documentation to the City demonstrating that the subcontractor meets the subcontractor responsibility criteria below. The requirements of this section apply to all subcontractors regardless of tier.

B. At the time of subcontract execution, the Contractor shall verify that each of its first tier subcontractors meets the following bidder responsibility criteria:

1. Have a current certificate of registration in compliance with chapter 18.27 RCW, which must have been in effect at the time of subcontract bid submittal;
2. Have a current Washington Unified Business Identifier (UBI) number;
3. If applicable, have:
  - a. Have Industrial Insurance (workers' compensation) coverage for the subcontractor's employees working in Washington, as required in Title 51 RCW;
  - b. A Washington Employment Security Department number, as required in Title 50 RCW;
  - c. A Washington Department of Revenue state excise tax registration

- number, as required in Title 82 RCW;
  - d. An electrical contractor license, if required by Chapter 19.28 RCW;
  - e. An elevator contractor license, if required by Chapter 70.87 RCW.
4. Not be disqualified from bidding on any public works contract under RCW 39.06.010 or 39.12.065 (3).

C. On Public Works construction projects, as defined in RCW 39.04.010, with an estimated cost of six hundred thousand dollars (\$600,000) or more, at least fifteen (15) percent of the labor hours on each project shall be performed by apprentices enrolled in a State-approved apprenticeship program; and for each contract in the project fifteen (15) percent of the labor hours for each craft that has an available state-approved apprenticeship program for Spokane County and utilizes more than one hundred sixty (160) hours in each contract shall be performed by apprentices enrolled in a state-approved apprenticeship program.

1. Subcontracting Requirements. The utilization percentages for apprenticeship labor for Public Works construction contracts shall also apply to all subcontracts of one hundred thousand dollars (\$100,000) or more within those contracts, and at least fifteen percent (15%) of the labor hours for each such subcontract shall be performed by apprentices in a state-approved apprenticeship program. For each craft that has an available apprenticeship program for Spokane county and performs more than one hundred sixty (160) hours on each project, fifteen (15) percent of the labor hours shall be performed by apprentices enrolled in a State-approved apprenticeship program
2. Each subcontractor which this chapter applies is required to execute a form, provided by the city, acknowledging that the requirements of Article X 07.06 SMC are applicable to the labor hours for the project.

17. **NONDISCRIMINATION.** No individual shall be excluded from participation in, denied the benefit of, subjected to discrimination under, or denied employment in the administration of or in connection with this Contract because of age, sex, race, color, religion, creed, marital status, familial status, sexual orientation including gender expression or gender identity, national origin, honorably discharged veteran or military status, the presence of any sensory, mental or physical disability, or use of a service animal by a person with disabilities. The Contractor agrees to comply with, and to require that all subcontractors comply with, Section 504 of the Rehabilitation Act of 1973 and the Americans with Disabilities Act, as applicable to the Contractor.

18. EXECUTIVE ORDER 11246.

- A. The Contractor will not discriminate against any employee or applicant for employment because of race, color, religion, sex or national origin. The Contractor will take affirmative action to insure that applicants are employed, and that employees are treated during employment, without regard to their race, color, religion, sex or national origin. Such action shall include but not be limited to the following: employment upgrading, demotion or transfer; recruitment or recruitment advertising; layoff or termination; rates of pay or other forms of compensation; and selection for training, including apprenticeship. The Contractor agrees to post in conspicuous places, available to employees and applicants for employment, notices to be provided by the contracting officer setting forth the provisions of this nondiscrimination clause.
- B. The Contractor will, in all solicitations or advertisements for employees placed by or on behalf of the Contractor, state that all qualified applicants will receive consideration for

- employment without regard to race, color, religion, sex or national origin.
- C. The Contractor will send each labor union, or representative of workers with which it has a collective bargaining contract or other contract or understanding, a notice, to be provided by the agency contracting officer, advising the labor union or workers' representative of the Contractor's commitments under Section 202 of Executive Order No. 11246 of September 24, 1965, and shall post copies of the notice in conspicuous places available to employees and applicants for employment.
  - D. The Contractor will comply with all provisions of Executive Order No. 11246 of September 24, 1965, and of the rules, regulations, and relevant orders of the Secretary of Labor.
  - E. The Contractor will furnish all information and reports required by Executive Order No. 11246 of September 24, 1965, and by the rules, regulations and orders of the Secretary of Labor, or pursuant thereto, and will permit access to its books, records, and accounts by the contracting agency and the Secretary of Labor for purposes of investigation to ascertain compliance with such rules, regulations and orders.
  - F. In the event of the Contractor's noncompliance with the nondiscrimination clauses of this Contract or with any of such rules, regulations or orders, this Contract may be canceled, terminated or suspended in whole or in part, and the Contractor may be declared ineligible for further government contracts in accordance with procedures authorized in Executive Order No. 11246 of September 24, 1965, and such other sanctions may be imposed and remedies invoked as provided in Executive Order No. 11246 of September 24, 1965, or by rule, regulation, or order of the Secretary of Labor, or as otherwise provided by law.
  - G. The Contractor will include the provisions of paragraphs A through G in every subcontract or purchase order unless exempted by rules, regulations or orders of the Secretary of Labor issued pursuant to Section 204 of Executive Order No. 11246 of September 24, 1965, so that such provisions will be binding upon each subcontractor or vendor. The Contractor will take such action with respect to any subcontract or purchase order as may be directed by the Secretary of Labor as a means of enforcing such provisions including sanctions for noncompliance: PROVIDED, HOWEVER, that in the event the Contractor becomes involved in, or is threatened with, litigation with a subcontractor or vendor as the result of such direction, the Contractor may request the United States to enter into such litigation to protect the interests of the United States.

19. DEBARMENT AND SUSPENSION. The Contractor has provided its certification that it is in compliance with and shall not contract with individuals or organizations which are debarred, suspended, or otherwise excluded from or ineligible from participation in Federal Assistance Programs under Executive Order 12549 and "Debarment and Suspension", codified at 29 CFR part 98.

20. ASSIGNMENTS. The Contractor may not assign, transfer or sublet any part of the work under this Contract, or assign any monies due, without the written approval of the City, except as may be required by law. In the event of assignment of accounts or monies due under this Contract, the Contractor specifically agrees to give immediate written notice to the City Administrator, no later than five (5) business days after the assignment.

21. ANTI-KICKBACK. No officer or employee of the City of Spokane, having the power or duty to perform an official act or action related to this Contract shall have or acquire any interest in the Contract, or have solicited, accepted or granted a present or future gift, favor, service or other thing of value from or to any person involved in the Contract. Contractor will comply with the Copeland "Anti-Kickback" Act (40 USC 3145), as supplemented by Department of Labor Regulations (29 CFR Part 3, "Contractors and Subcontractors on Public Building or Public Work Financed in Whole or in Part by Loans or Grants from the United States").



22. COMPLIANCE WITH LAWS. Each party shall comply with all applicable federal, state, and local laws and regulations that are incorporated herein by reference.
23. DISPUTES. This Contract shall be performed under the laws of the State of Washington. Any litigation to enforce this Contract or any of its provisions shall be brought in Spokane County, Washington.
24. SEVERABILITY. In the event any provision of this Contract should become invalid, the rest of the Contract shall remain in full force and effect.
25. AUDIT / RECORDS. The Contractor and its subcontractors shall maintain for a minimum of three (3) years following final payment all records related to its performance of the Contract. The Contractor and its subcontractors shall provide access to authorized City representatives, at reasonable times and in a reasonable manner to inspect and copy any such record. In the event of conflict between this provision and related auditing provisions required under federal law applicable to the Contract, the federal law shall prevail.
26. BUSINESS REGISTRATION REQUIREMENT. Section 8.01.070 of the Spokane Municipal Code states that no person may engage in business with the City without first having obtained a valid annual business registration. The Contractor shall be responsible for contacting the State of Washington Business License Services at [www.dor.wa.gov](http://www.dor.wa.gov) or 360-705-6741 to obtain a business registration. If the Contractor does not believe it is required to obtain a business registration, it may contact the City's Taxes and Licenses Division at (509) 625-6070 to request an exemption status determination.
27. CONSTRUAL. The Contractor acknowledges receipt of a copy of the contract documents and agrees to comply with them. The silence or omission in the contract documents concerning any detail required for the proper execution and completion of the work means that only the best general practice is to prevail and that only material and workmanship of the best quality are to be used. This Contract shall be construed neither in favor of nor against either party.
28. MODIFICATIONS. The City may modify this Contract and order changes in the work whenever necessary or advisable. The Contractor will accept modifications when ordered in writing by the Director of Engineering Services, and the Contract time and compensation will be adjusted accordingly.
29. INTEGRATION. This Contract, including any and all exhibits and schedules referred to herein or therein set forth the entire Agreement and understanding between the parties pertaining to the subject matter and merges all prior agreements, negotiations and discussions between them on the same subject matter.
30. OFF SITE PREFABRICATED ITEMS. In accordance with RCW 39.04.370, the Contractor shall submit certain information about off-site, prefabricated, nonstandard, project specific items produced under the terms of the Contract and produced outside Washington as a part of the "Affidavit of Wages Paid" form filed with the State Department of Labor and Industries.
31. FORCE MAJEURE. Neither party shall be liable to the other for any failure or delay in performing its obligations hereunder, or for any loss or damage resulting therefrom, due to: (1) acts of God or public enemy, acts of government, riots, terrorism, fires, floods, strikes, lock outs, epidemics, act or failure to act by the other party, or unusually severe weather affecting City, Contractor or its subcontractors, or (2) causes beyond their reasonable control and which are not

foreseeable (each a "Force Majeure Event"). In the event of any such Force Majeure Event, the date of delivery or performance shall be extended for a period equal to the time lost by reason of the delay.

32. CLEAN AIR ACT.

Contractor must comply with all applicable standards, orders or regulations issued pursuant to the Clean Air Act (42 USC 7401-7671q) and the Federal Water Pollution Control Act as amended (33 USC 1251-1387). Violations will be reported.

33. USE OF PROJECT MANAGEMENT SOFTWARE. The Contractor shall transmit all submittal documentation for proposed project materials by uploading it to the City's web based construction management software. A City representative will be available to assist in learning this process.

**HALME CONSTRUCTION, INC.**

**CITY OF SPOKANE**

By \_\_\_\_\_  
Signature                      Date

By \_\_\_\_\_  
Signature                      Date

\_\_\_\_\_  
Type or Print Name

\_\_\_\_\_  
Type or Print Name

\_\_\_\_\_  
Title

\_\_\_\_\_  
Title

Attest:

Approved as to form:

\_\_\_\_\_  
City Clerk

\_\_\_\_\_  
Assistant City Attorney

**Attachments that are part of this Contract:**

- Payment Bond
- Performance Bond
- Certification Regarding Debarment
- Schedules A-1 and A-3

**PAYMENT BOND**

We, **HALME CONSTRUCTION, INC.**, as principal, and \_\_\_\_\_,  
as surety, are held and firmly bound to the City of Spokane, Washington, in the sum of **ONE MILLION  
NINE HUNDRED NINETY-NINE THOUSAND ONE HUNDRED TWENTY-TWO AND 75/100 DOL-  
LARS (\$1,999,122.75)** for the payment of which, we bind ourselves and our legal representatives  
and successors, jointly and severally by this document.

The principal has entered into a contract with the City of Spokane, Washington, to do all work  
and furnish all materials for the **STORMWATER FOR WASHINGTON BASIN KNOX AVE. –  
WALL ST. TO HOWARD ST.** If the principal shall:

- A. pay all laborers, mechanics, subcontractors, material suppliers and all person(s) who shall  
supply such person or subcontractors; and pay all taxes and contributions, increases and  
penalties as authorized by law; and
- B. comply with all applicable federal, state and local laws and regulations;

then this obligation shall be null and void; otherwise it shall remain in full force and effect.

The Surety for value received agrees that no change, extension of time, alteration or addition  
to the terms of the Contract, the specifications accompanying the Contract, or to the work to be  
performed under the Contract shall in any way affect its obligation on this bond, except as provided  
herein, and waives notice of any change, extension of time, alteration or addition to the terms of the  
Contract or the work performed. The Surety agrees that modifications and changes to the terms and  
conditions of the Contract that increase the total amount to be paid the Principal shall automatically  
increase the obligation of the Surety on this bond and notice to Surety is not required for such in-  
creased obligation. Any judgment obtained against the City, which relates to or is covered by the  
contract or this bond, shall be conclusive against the principal and the surety, as to the amount of  
damages, and their liability, if reasonable notice of the suit has been given.

SIGNED AND SEALED on \_\_\_\_\_.

**HALME CONSTRUCTION, INC.,**

AS PRINCIPAL

By: \_\_\_\_\_  
Title: \_\_\_\_\_

\_\_\_\_\_,  
AS SURETY

By: \_\_\_\_\_  
Its Attorney in Fact

A valid POWER OF ATTORNEY  
for the Surety's agent must  
accompany this bond.

STATE OF WASHINGTON     )  
   ) ss.  
County of \_\_\_\_\_)

I certify that I know or have satisfactory evidence that \_\_\_\_\_ signed this document; on oath stated that he/she was authorized to sign the document and acknowledged it as the agent or representative of the named surety company which is authorized to do business in the State of Washington, for the uses and purposes therein mentioned.

DATED: \_\_\_\_\_

\_\_\_\_\_  
Signature of Notary Public

My appointment expires \_\_\_\_\_

**PERFORMANCE BOND**

We, **HALME CONSTRUCTION, INC.**, as principal, and \_\_\_\_\_, as Surety, are held and firmly bound to the City of Spokane, Washington, in the sum of **ONE MILLION NINE HUNDRED NINETY-NINE THOUSAND ONE HUNDRED TWENTY-TWO AND 75/100 DOLLARS (\$1,999,122.75)** for the payment of which, we bind ourselves and our legal representatives and successors, jointly and severally by this document.

The principal has entered into a Contract with the City of Spokane, Washington, to do all the work and furnish all materials for the **STORMWATER FOR WASHINGTON BASIN KNOX AVE. – WALL ST. TO HOWARD ST.** If the principal shall:

- A. promptly and faithfully perform the Contract, and any contractual guaranty and indemnify and hold harmless the City from all loss, damage or claim which may result from any act or omission of the principal, its agents, employees, or subcontractors; and
- B. comply with all applicable federal, state and local laws and regulations;

then this obligation shall be null and void; otherwise it shall remain in full force and effect.

The Surety for value received agrees that no change, extension of time, alteration or addition to the terms of the Contract, the specifications accompanying the Contract, or to the work to be performed under the Contract shall in any way affect its obligation on this bond, except as provided herein, and waives notice of any change, extension of time, alteration or addition to the terms of the Contract or the work performed. The Surety agrees that modifications and changes to the terms and conditions of the Contract that increase the total amount to be paid the Principal shall automatically increase the obligation of the Surety on this bond and notice to Surety is not required for such increased obligation. Any judgment obtained against the City, which relates to or is covered by the Contract or this bond, shall be conclusive against the principal and the Surety, not only as to the amount of damages, but also as to their liability, if reasonable notice of the suit has been given.

SIGNED AND SEALED on \_\_\_\_\_

**HALME CONSTRUCTION, INC.,**

AS PRINCIPAL

By: \_\_\_\_\_

Title: \_\_\_\_\_

\_\_\_\_\_,  
AS SURETY

By: \_\_\_\_\_

Its Attorney in Fact

A valid POWER OF ATTORNEY  
for the Surety's agent must  
accompany this bond.

STATE OF WASHINGTON            )  
  ) ss.  
County of \_\_\_\_\_            )

I certify that I know or have satisfactory evidence that \_\_\_\_\_  
\_\_\_\_\_ signed this document; on oath stated that  
he/she was authorized to sign the document and acknowledged it as the agent or representative of  
the named Surety Company which is authorized to do business in the State of Washington, for the  
uses and purposes mentioned in this document.

DATED on \_\_\_\_\_.

\_\_\_\_\_  
Signature of Notary

My appointment expires \_\_\_\_\_

**CERTIFICATION REGARDING DEBARMENT, SUSPENSION,  
INELIGIBILITY AND VOLUNTARY EXCLUSION**

1. The undersigned (i.e., signatory for the Subrecipient / Contractor / Consultant) certifies, to the best of its knowledge and belief, that it and its principals:
  - a. Are not presently debarred, suspended, proposed for debarment, declared ineligible, or voluntarily excluded from covered transactions by any federal department or agency;
  - b. Have not within a three-year period preceding this contract been convicted or had a civil judgment rendered against them for commission of fraud or a criminal offense in connection with obtaining, attempting to obtain, or performing a public (federal, state, or local) transaction or contract under a public transaction; violation of federal or state antitrust statutes or commission of embezzlement, theft, forgery, bribery, falsification or destruction of records, making false statements, tax evasion, receiving stolen property, making false claims, or obstruction of justice;
  - c. Are not presently indicted or otherwise criminally or civilly charged by a government entity (federal, state, or local) with commission of any of the offenses enumerated in paragraph (1)(b) of this certification; and,
  - d. Have not within a three-year period preceding this contract had one or more public transactions (federal, state, or local) terminated for cause or default.
2. The undersigned agrees by signing this contract that it shall not knowingly enter into any lower tier covered transaction with a person who is debarred, suspended, declared ineligible, or voluntarily excluded from participation in this covered transaction.
3. The undersigned further agrees by signing this contract that it will include the following clause, without modification, in all lower tier covered transactions and in all solicitations for lower tier covered transactions:

Certification Regarding Debarment, Suspension, Ineligibility and Voluntary Exclusion – Lower Tier Covered Transactions

1. The lower tier contractor certified, by signing this contract that neither it nor its principals is presently debarred, suspended, proposed for debarment, declared ineligible, or voluntarily excluded from participation in this transaction by any federal department or agency.
  2. Where the lower tier contractor is unable to certify to any of the statements in this contract, such contractor shall attach an explanation to this contract.
4. I understand that a false statement of this certification may be grounds for termination of the contract.

<hr/> Name of Subrecipient / Contractor / Consultant (Type or Print)	<hr/> Program Title (Type or Print)
<hr/> Name of Certifying Official (Type or Print)	<hr/> Signature
<hr/> Title of Certifying Official (Type or Print)	<hr/> Date (Type or Print)

**SCHEDULE A-1**  
*Tax Classification: Sales tax shall be included in unit prices*

<b>ITEM NO.</b>	<b>ITEM DESCRIPTION</b>	<b>ESTIMATED QUANTITIES</b>	<b>UNIT PRICE</b>	<b>TOTAL</b>
1	ADA FEATURES SURVEYING	1.00 LS	\$ 5,000.00	\$ 5,000.00
2	Apprentice Utilization	1.00 LS	\$ 4,500.00	\$ 4,500.00
3	REIMBURSEMENT OF THIRD PARTY DAMAGE	1.00 EST	\$ 1.00	\$ 1.00
4	SPCC PLAN	1.00 LS	\$ 600.00	\$ 600.00
5	POTHOLING	10.00 EA	\$ 700.00	\$ 7,000.00
6	PUBLIC LIAISON REPRESENTATIVE	1.00 LS	\$ 4,000.00	\$ 4,000.00
7	MOBILIZATION	1.00 LS	\$ 167,000.00	\$ 167,000.00
8	PROJECT TEMPORARY TRAFFIC CONTROL	1.00 LS	\$ 45,000.00	\$ 45,000.00
9	SPECIAL SIGNS	35.00 SF	\$ 23.00	\$ 805.00
10	TYPE III BARRICADE	24.00 EA	\$ 67.00	\$ 1,608.00
11	TREE ROOT TREATMENT	5.00 EA	\$ 850.00	\$ 4,250.00
12	TREE PROTECTION ZONE	14.00 EA	\$ 330.00	\$ 4,620.00



13	REMOVE TREE, CLASS II	2.00 EA	\$	1,100.00	\$	2,200.00
14	TREE PRUNING	14.00 EA	\$	310.00	\$	4,340.00
15	REMOVAL OF STRUCTURE AND OBSTRUCTION	1.00 LS	\$	10,000.00	\$	10,000.00
16	REMOVE EXISTING CURB	642.00 LF	\$	8.00	\$	5,136.00
17	REMOVE CEMENT CONCRETE SIDEWALK AND DRIVEWAY	310.00 SY	\$	13.00	\$	4,030.00
18	REMOVE MANHOLE, CATCH BASIN, OR DRYWELL	4.00 EA	\$	1,100.00	\$	4,400.00
19	REMOVE EXISTING > 12 IN. TO < 30 IN. DIA. PIPE	362.00 LF	\$	28.00	\$	10,136.00
20	REMOVE EXISTING ≥ 30 IN. TO ≤ 42 IN. DIA. PIPE	27.00 LF	\$	29.00	\$	783.00
21	SAWCUTTING CURB	16.00 EA	\$	30.00	\$	480.00
22	SAWCUTTING RIGID PAVEMENT	572.00 LFI	\$	1.00	\$	572.00
23	SAWCUTTING FLEXIBLE PAVEMENT	1,735.00 LFI	\$	0.25	\$	433.75
24	ROADWAY EXCAVATION INCL. HAUL	455.00 CY	\$	41.00	\$	18,655.00
25	PRE & POST CONSTRUCTION CONDITION SURVEY	1.00 LS	\$	10,000.00	\$	10,000.00
26	PREPARATION OF UNTREATED ROADWAY	1,939.00 SY	\$	3.00	\$	5,817.00
27	SHORING	1.00 LS	\$	40,000.00	\$	40,000.00

28	CRUSHED SURFACING TOP COURSE	181.00 CY	\$	70.00	\$	12,670.00
29	CRUSHED SURFACING BASE COURSE	68.00 CY	\$	56.00	\$	3,808.00
30	CSTC FOR SIDEWALK AND DRIVEWAYS	21.00 CY	\$	216.00	\$	4,536.00
31	HMA CL. 1/2 IN. MEDIUM TRAFFIC, 3 INCH THICK	1,377.00 SY	\$	27.00	\$	37,179.00
32	HMA CL. 1/2 IN. MEDIUM TRAFFIC, 5 INCH THICK	482.00 SY	\$	47.00	\$	22,654.00
33	HMA FOR PAVEMENT REPAIR CL. 1/2 IN. MEDIUM TRAFFIC, 5 INCH THICK	80.00 SY	\$	84.00	\$	6,720.00
34	PAVEMENT REPAIR EXCAVATION INCL. HAUL	80.00 SY	\$	30.00	\$	2,400.00
35	JOB MIX COMPLIANCE PRICE ADJUSTMENT	1.00 EST	\$	(1.00)	\$	(1.00)
36	COMPACTION PRICE ADJUSTMENT	1,825.00 EST	\$	1.00	\$	1,825.00
37	PRECAST UTILITY VAULT 5'x8'	1.00 EA	\$	16,600.00	\$	16,600.00
38	STORM SEWER PIPE 8 IN. DIA.	64.00 LF	\$	186.00	\$	11,904.00
39	STORM SEWER PIPE 36 IN. DIA.	16.00 LF	\$	723.00	\$	11,568.00
40	MODULAR WETLAND SYSTEM	3.00 LS	\$	361,300.00	\$	1,083,900.00
41	CATCH BASIN TYPE 3	4.00 EA	\$	3,580.00	\$	14,320.00
42	DRYWELL TYPE 2	3.00 EA	\$	11,800.00	\$	35,400.00

43	RETROFIT SURFACE INLET CB WITH FRAME & VANED GRATE	3.00 EA	\$	1,200.00	\$	3,600.00
44	MH OR DW FRAME AND COVER (STANDARD)	2.00 EA	\$	760.00	\$	1,520.00
45	MH OR DW FRAME AND COVER (LOCKABLE)	2.00 EA	\$	835.00	\$	1,670.00
46	CONNECT 8 IN. DIA. PIPE TO EXISTING CB, DW, OR MH	3.00 EA	\$	812.00	\$	2,436.00
47	CONNECT 36 IN. DIA. SEWER PIPE TO EXISTING SEWER PIPE	2.00 EA	\$	6,000.00	\$	12,000.00
48	ADJUST EXISTING VALVE BOX, MON, OR CO IN ASPHALT	1.00 EA	\$	270.00	\$	270.00
49	TRENCH SAFETY SYSTEM	1.00 LS	\$	2,800.00	\$	2,800.00
50	CATCH BASIN SEWER PIPE 8 IN. DIA.	128.00 LF	\$	110.00	\$	14,080.00
51	PLUGGING EXISTING PIPE	5.00 EA	\$	270.00	\$	1,350.00
52	TEMPORARY ADJACENT UTILITY SUPPORT	1.00 LS	\$	8,300.00	\$	8,300.00
53	CLEANING EXISTING SANITARY SEWERS	1.00 EA	\$	1,700.00	\$	1,700.00
54	ESC LEAD	1.00 LS	\$	500.00	\$	500.00
55	INLET PROTECTION	4.00 EA	\$	300.00	\$	1,200.00
56	STREET CLEANING	120.00 HR	\$	142.00	\$	17,040.00
57	SOD INSTALLATION	290.00 SY	\$	17.00	\$	4,930.00

58	2 INCH CALIPER DECIDUOUS TREE	3.00 EA	\$	700.00	\$	2,100.00
59	RECONSTRUCT BLOCK WALL	1.00 SF	\$	730.00	\$	730.00
60	REMOVE AND REPLACE EXISTING SPRINKLER HEADS AND LINES	1.00 LS	\$	5,600.00	\$	5,600.00
61	CEMENT CONCRETE CURB	596.00 LF	\$	40.00	\$	23,840.00
62	CEMENT CONCRETE CURB AND GUTTER	167.00 LF	\$	70.00	\$	11,690.00
63	CEMENT CONCRETE DRIVEWAY	26.00 SY	\$	100.00	\$	2,600.00
64	CEMENT CONCRETE DRIVEWAY TRANSITION	8.00 SY	\$	130.00	\$	1,040.00
65	TEMPORARY CONSTRUCTION FENCING	1.00 LS	\$	3,400.00	\$	3,400.00
66	CLASSIFICATION AND PROTECTION OF SURVEY MONUMENTS	1.00 LS	\$	4,500.00	\$	4,500.00
67	CEMENT CONCRETE SIDEWALK	287.00 SY	\$	150.00	\$	43,050.00
68	RAMP DETECTABLE WARNING	96.00 SF	\$	34.00	\$	3,264.00
69	SIGNING, PERMANENT - CONTRACTOR MANUFACTURED SIGNS	1.00 LS	\$	2,600.00	\$	2,600.00
70	PAVEMENT MARKING - DURABLE HEAT APPLIED	80.00 SF	\$	18.00	\$	1,440.00
<b>Schedule A-1 Subtotal</b>					\$	<u>1,806,099.75</u>

**SCHEDULE A-3**

***Tax Classification: Sales tax shall NOT be included in unit prices***

<b>ITEM NO.</b>	<b>ITEM DESCRIPTION</b>	<b>ESTIMATED QUANTITIES</b>	<b>UNIT PRICE</b>	<b>TOTAL</b>
71	POTHOLING	7.00 EA	\$ 700.00	\$ 4,900.00
72	CONNECT 21 IN. DIA. PIPE TO EXISTING CB, DW, OR MH	2.00 EA	\$ 6,000.00	\$ 12,000.00
73	TRENCH SAFETY SYSTEM	1.00 LS	\$ 2,500.00	\$ 2,500.00
74	RECONNECT SIDE SEWER	7.00 LF	\$ 350.00	\$ 2,450.00
75	SIDE SEWER CLEANING AND VIDEO INSPECTION	7.00 EA	\$ 1,200.00	\$ 8,400.00
76	TEMPORARY ADJACENT UTILITY SUPPORT	1.00 LS	\$ 8,340.00	\$ 8,340.00
77	DI PIPE FOR WATER MAIN 6 IN. DIA.	462.00 LF	\$ 82.00	\$ 37,884.00
78	DI PIPE FOR WATER MAIN 12 IN. DIA.	62.00 LF	\$ 198.00	\$ 12,276.00
79	INSTALL JOINT RESTRAINT ON EXISTING 10 IN. DIA. WM	3.00 EA	\$ 1,060.00	\$ 3,180.00
80	GATE VALVE 6 IN.	3.00 EA	\$ 1,305.00	\$ 3,915.00
81	GATE VALVE 12 IN.	1.00 EA	\$ 4,000.00	\$ 4,000.00
82	HYDRANT ASSEMBLY	1.00 EA	\$ 7,700.00	\$ 7,700.00
83	SANITARY SEWER PIPE 21 IN. DIA.	362.00 LF	\$ 150.00	\$ 54,300.00

84	BYPASS SEWER PUMPING	1.00 LS	\$	14,000.00	\$	14,000.00
<hr/>						
85	SIDE SEWER PIPE 4 IN. TO 6 IN. DIA.	83.00 LF	\$	206.00	\$	17,098.00
<hr/>						
86	SIDE SEWER PERMIT	2.00 EA	\$	40.00	\$	80.00
<hr/>						
<b>Schedule A-3 Subtotal</b>					\$	<u>193,023.00</u>
<hr/>						
<b>Summary of Bid Items</b>				<b>Bid Total</b>		\$ <u>1,999,122.75</u>

**City Of Spokane**  
**Engineering Services Department**  
**\*\*\*Bid Tabulation\*\*\***

**Project Number**      2017178

**Project Description**      Stormwater for Washington Basin -  
 Montgomery Ave and Knox Ave

**Original Date**

6/14/2022 5:00:00 PM

<b>Project Number: 2017178</b>			<b>Engineer's Estimate</b>		HALME CONSTRUCTION INC (Submitted)		INLAND INFRASTRUCTURE LLC (Submitted)		DW EXCAVATING INC (Submitted)	
<b>Item No</b>	<b>Bid Item Description</b>	<b>Est Qty</b>	<b>Unit Price</b>	<b>Amount</b>	<b>Unit Price</b>	<b>Amount</b>	<b>Unit Price</b>	<b>Amount</b>	<b>Unit Price</b>	<b>Amount</b>

**Tax Classification**

Sales tax shall be included in unit prices

1	ADA FEATURES SURVEYING	1 LS	6,000.00	6,000.00	5,000.00	\$5,000.00	4,550.00	\$4,550.00	3,300.00	\$3,300.00
2	Apprentice Utilization	1 LS	2,000.00	2,000.00	4,500.00	\$4,500.00	7,500.00	\$7,500.00	72.00	\$72.00
3	REIMBURSEMENT OF THIRD PARTY DAMAGE	1 EST	1.00	1.00	1.00	\$1.00	1.00	\$1.00	1.00	\$1.00
4	SPCC PLAN	1 LS	1,500.00	1,500.00	600.00	\$600.00	5,000.00	\$5,000.00	700.00	\$700.00
5	POTHOLING	10 EA	500.00	5,000.00	700.00	\$7,000.00	1,000.00	\$10,000.00	575.00	\$5,750.00
6	PUBLIC LIAISON REPRESENTATIVE	1 LS	10,000.00	10,000.00	4,000.00	\$4,000.00	7,550.00	\$7,550.00	4,300.00	\$4,300.00
7	MOBILIZATION	1 LS	115,537.50	115,537.50	167,000.00	\$167,000.00	197,000.00	\$197,000.00	21,500.00	\$21,500.00
8	PROJECT TEMPORARY TRAFFIC CONTROL	1 LS	50,000.00	50,000.00	45,000.00	\$45,000.00	30,000.00	\$30,000.00	19,800.00	\$19,800.00
9	SPECIAL SIGNS	35 SF	40.00	1,400.00	23.00	\$805.00	28.00	\$980.00	33.00	\$1,155.00
10	TYPE III BARRICADE	24 EA	100.00	2,400.00	67.00	\$1,608.00	110.00	\$2,640.00	200.00	\$4,800.00
11	TREE ROOT TREATMENT	5 EA	800.00	4,000.00	850.00	\$4,250.00	850.00	\$4,250.00	1,000.00	\$5,000.00
12	TREE PROTECTION ZONE	14 EA	400.00	5,600.00	330.00	\$4,620.00	300.00	\$4,200.00	350.00	\$4,900.00
13	REMOVE TREE, CLASS II	2 EA	1,000.00	2,000.00	1,100.00	\$2,200.00	4,750.00	\$9,500.00	5,600.00	\$11,200.00
14	TREE PRUNING	14 EA	350.00	4,900.00	310.00	\$4,340.00	300.00	\$4,200.00	370.00	\$5,180.00
15	REMOVAL OF STRUCTURE AND OBSTRUCTION	1 LS	5,000.00	5,000.00	10,000.00	\$10,000.00	3,000.00	\$3,000.00	7,200.00	\$7,200.00
16	REMOVE EXISTING CURB	642 LF	8.00	5,136.00	8.00	\$5,136.00	11.50	\$7,383.00	9.00	\$5,778.00
17	REMOVE CEMENT CONCRETE SIDEWALK AND DRIVEWAY	310 SY	20.00	6,200.00	13.00	\$4,030.00	25.00	\$7,750.00	15.00	\$4,650.00
18	REMOVE MANHOLE, CATCH BASIN, OR DRYWELL	4 EA	1,500.00	6,000.00	1,100.00	\$4,400.00	1,100.00	\$4,400.00	1,200.00	\$4,800.00
19	REMOVE EXISTING > 12 IN. TO < 30 IN. DIA. PIPE	362 LF	15.00	5,430.00	28.00	\$10,136.00	11.00	\$3,982.00	12.00	\$4,344.00

**City Of Spokane**  
**Engineering Services Department**  
**\*\*\*Bid Tabulation\*\*\***

<i>Project Number: 2017178</i>			<i>Engineer's Estimate</i>		HALME CONSTRUCTION INC (Submitted)		INLAND INFRASTRUCTURE LLC (Submitted)		DW EXCAVATING INC (Submitted)	
<i>Item No</i>	<i>Bid Item Description</i>	<i>Est Qty</i>	<i>Unit Price</i>	<i>Amount</i>	<i>Unit Price</i>	<i>Amount</i>	<i>Unit Price</i>	<i>Amount</i>	<i>Unit Price</i>	<i>Amount</i>
20	REMOVE EXISTING ≥ 30 IN. TO ≤ 42 IN. DIA. PIPE	27 LF	50.00	1,350.00	29.00	\$783.00	32.00	\$864.00	12.00	\$324.00
21	SAWCUTTING CURB	16 EA	50.00	800.00	30.00	\$480.00	22.50	\$360.00	33.00	\$528.00
22	SAWCUTTING RIGID PAVEMENT	572 LFI	1.00	572.00	1.00	\$572.00	1.00	\$572.00	0.50	\$286.00
23	SAWCUTTING FLEXIBLE PAVEMENT	1735 LFI	0.50	867.50	0.25	\$433.75	1.00	\$1,735.00	1.00	\$1,735.00
24	ROADWAY EXCAVATION INCL. HAUL	455 CY	30.00	13,650.00	41.00	\$18,655.00	50.00	\$22,750.00	43.00	\$19,565.00
25	PRE & POST CONSTRUCTION CONDITION SURVEY	1 LS	30,000.00	30,000.00	10,000.00	\$10,000.00	7,250.00	\$7,250.00	1,500.00	\$1,500.00
26	PREPARATION OF UNTREATED ROADWAY	1939 SY	2.00	3,878.00	3.00	\$5,817.00	3.00	\$5,817.00	4.00	\$7,756.00
27	SHORING	1 LS	10,000.00	10,000.00	40,000.00	\$40,000.00	95,500.00	\$95,500.00	75,000.00	\$75,000.00
28	CRUSHED SURFACING TOP COURSE	181 CY	60.00	10,860.00	70.00	\$12,670.00	110.00	\$19,910.00	64.00	\$11,584.00
29	CRUSHED SURFACING BASE COURSE	68 CY	60.00	4,080.00	56.00	\$3,808.00	95.00	\$6,460.00	64.00	\$4,352.00
30	CSTC FOR SIDEWALK AND DRIVEWAYS	21 CY	120.00	2,520.00	216.00	\$4,536.00	210.00	\$4,410.00	242.00	\$5,082.00
31	HMA CL. 1/2 IN. MEDIUM TRAFFIC, 3 INCH THICK	1377 SY	16.00	22,032.00	27.00	\$37,179.00	24.00	\$33,048.00	28.00	\$38,556.00
32	HMA CL. 1/2 IN. MEDIUM TRAFFIC, 5 INCH THICK	482 SY	30.00	14,460.00	47.00	\$22,654.00	54.00	\$26,028.00	63.00	\$30,366.00
33	HMA FOR PAVEMENT REPAIR CL. 1/2 IN. MEDIUM TRAFFIC, 5 INCH THICK	80 SY	70.00	5,600.00	84.00	\$6,720.00	80.00	\$6,400.00	95.00	\$7,600.00
34	PAVEMENT REPAIR EXCAVATION INCL. HAUL	80 SY	40.00	3,200.00	30.00	\$2,400.00	40.00	\$3,200.00	25.00	\$2,000.00
35	JOB MIX COMPLIANCE PRICE ADJUSTMENT	1 EST	(1.00)	(1.00)	(1.00)	(\$1.00)	(1.00)	(\$1.00)	(1.00)	(\$1.00)
36	COMPACTION PRICE ADJUSTMENT	1825 EST	1.00	1,825.00	1.00	\$1,825.00	1.00	\$1,825.00	1.00	\$1,825.00
37	PRECAST UTILITY VAULT 5'x8'	1 EA	13,000.00	13,000.00	16,600.00	\$16,600.00	28,000.00	\$28,000.00	24,000.00	\$24,000.00
38	STORM SEWER PIPE 8 IN. DIA.	64 LF	150.00	9,600.00	186.00	\$11,904.00	125.00	\$8,000.00	100.00	\$6,400.00
39	STORM SEWER PIPE 36 IN. DIA.	16 LF	250.00	4,000.00	723.00	\$11,568.00	590.00	\$9,440.00	700.00	\$11,200.00



**City Of Spokane**  
**Engineering Services Department**  
**\*\*\*Bid Tabulation\*\*\***

<i>Project Number: 2017178</i>			<i>Engineer's Estimate</i>		HALME CONSTRUCTION INC (Submitted)		INLAND INFRASTRUCTURE LLC (Submitted)		DW EXCAVATING INC (Submitted)	
<i>Item No</i>	<i>Bid Item Description</i>	<i>Est Qty</i>	<i>Unit Price</i>	<i>Amount</i>	<i>Unit Price</i>	<i>Amount</i>	<i>Unit Price</i>	<i>Amount</i>	<i>Unit Price</i>	<i>Amount</i>
40	MODULAR WETLAND SYSTEM	3 LS	300,000.00	900,000.00	361,300.00	\$1,083,900.00	325,000.00	\$975,000.00	447,000.00	\$1,341,000.00
41	CATCH BASIN TYPE 3	4 EA	3,500.00	14,000.00	3,580.00	\$14,320.00	3,200.00	\$12,800.00	4,000.00	\$16,000.00
42	DRYWELL TYPE 2	3 EA	10,000.00	30,000.00	11,800.00	\$35,400.00	16,500.00	\$49,500.00	20,500.00	\$61,500.00
43	RETROFIT SURFACE INLET CB WITH FRAME & VANED GRATE	3 EA	1,000.00	3,000.00	1,200.00	\$3,600.00	950.00	\$2,850.00	1,800.00	\$5,400.00
44	MH OR DW FRAME AND COVER (STANDARD)	2 EA	700.00	1,400.00	760.00	\$1,520.00	500.00	\$1,000.00	1,200.00	\$2,400.00
45	MH OR DW FRAME AND COVER (LOCKABLE)	2 EA	700.00	1,400.00	835.00	\$1,670.00	560.00	\$1,120.00	1,200.00	\$2,400.00
46	CONNECT 8 IN. DIA. PIPE TO EXISTING CB, DW, OR MH	3 EA	500.00	1,500.00	812.00	\$2,436.00	850.00	\$2,550.00	500.00	\$1,500.00
47	CONNECT 36 IN. DIA. SEWER PIPE TO EXISTING SEWER PIPE	2 EA	1,500.00	3,000.00	6,000.00	\$12,000.00	3,200.00	\$6,400.00	4,000.00	\$8,000.00
48	ADJUST EXISTING VALVE BOX, MON, OR CO IN ASPHALT	1 EA	800.00	800.00	270.00	\$270.00	560.00	\$560.00	1,300.00	\$1,300.00
49	TRENCH SAFETY SYSTEM	1 LS	24,000.00	24,000.00	2,800.00	\$2,800.00	20,500.00	\$20,500.00	700.00	\$700.00
50	CATCH BASIN SEWER PIPE 8 IN. DIA.	128 LF	70.00	8,960.00	110.00	\$14,080.00	60.00	\$7,680.00	82.00	\$10,496.00
51	PLUGGING EXISTING PIPE	5 EA	400.00	2,000.00	270.00	\$1,350.00	175.00	\$875.00	410.00	\$2,050.00
52	TEMPORARY ADJACENT UTILITY SUPPORT	1 LS	1,200.00	1,200.00	8,300.00	\$8,300.00	3,500.00	\$3,500.00	3,600.00	\$3,600.00
53	CLEANING EXISTING SANITARY SEWERS	1 EA	600.00	600.00	1,700.00	\$1,700.00	715.00	\$715.00	900.00	\$900.00
54	ESC LEAD	1 LS	1,000.00	1,000.00	500.00	\$500.00	13,500.00	\$13,500.00	2,400.00	\$2,400.00
55	INLET PROTECTION	4 EA	90.00	360.00	300.00	\$1,200.00	75.00	\$300.00	100.00	\$400.00
56	STREET CLEANING	120 HR	200.00	24,000.00	142.00	\$17,040.00	300.00	\$36,000.00	370.00	\$44,400.00
57	SOD INSTALLATION	290 SY	20.00	5,800.00	17.00	\$4,930.00	34.00	\$9,860.00	27.00	\$7,830.00
58	2 INCH CALIPER DECIDUOUS TREE	3 EA	600.00	1,800.00	700.00	\$2,100.00	400.00	\$1,200.00	660.00	\$1,980.00
59	RECONSTRUCT BLOCK WALL	1 SF	2,000.00	2,000.00	730.00	\$730.00	500.00	\$500.00	160.00	\$160.00
60	REMOVE AND REPLACE EXISTING SPRINKLER HEADS AND LINES	1 LS	7,000.00	7,000.00	5,600.00	\$5,600.00	2,850.00	\$2,850.00	3,300.00	\$3,300.00

**City Of Spokane**  
**Engineering Services Department**  
**\*\*\*Bid Tabulation\*\*\***

<i>Project Number: 2017178</i>			<i>Engineer's Estimate</i>		HALME CONSTRUCTION INC (Submitted)		INLAND INFRASTRUCTURE LLC (Submitted)		DW EXCAVATING INC (Submitted)	
<i>Item No</i>	<i>Bid Item Description</i>	<i>Est Qty</i>	<i>Unit Price</i>	<i>Amount</i>	<i>Unit Price</i>	<i>Amount</i>	<i>Unit Price</i>	<i>Amount</i>	<i>Unit Price</i>	<i>Amount</i>
61	CEMENT CONCRETE CURB	596 LF	45.00	26,820.00	40.00	\$23,840.00	38.00	\$22,648.00	51.00	\$30,396.00
62	CEMENT CONCRETE CURB AND GUTTER	167 LF	50.00	8,350.00	70.00	\$11,690.00	58.00	\$9,686.00	79.00	\$13,193.00
63	CEMENT CONCRETE DRIVEWAY	26 SY	75.00	1,950.00	100.00	\$2,600.00	105.00	\$2,730.00	92.00	\$2,392.00
64	CEMENT CONCRETE DRIVEWAY TRANSITION	8 SY	75.00	600.00	130.00	\$1,040.00	135.00	\$1,080.00	129.00	\$1,032.00
65	TEMPORARY CONSTRUCTION FENCING	1 LS	2,000.00	2,000.00	3,400.00	\$3,400.00	3,500.00	\$3,500.00	2,600.00	\$2,600.00
66	CLASSIFICATION AND PROTECTION OF SURVEY MONUMENTS	1 LS	6,000.00	6,000.00	4,500.00	\$4,500.00	4,550.00	\$4,550.00	5,300.00	\$5,300.00
67	CEMENT CONCRETE SIDEWALK	287 SY	50.00	14,350.00	150.00	\$43,050.00	140.00	\$40,180.00	147.00	\$42,189.00
68	RAMP DETECTABLE WARNING	96 SF	22.00	2,112.00	34.00	\$3,264.00	35.00	\$3,360.00	40.00	\$3,840.00
69	SIGNING, PERMANENT - CONTRACTOR MANUFACTURED SIGNS	1 LS	7,000.00	7,000.00	2,600.00	\$2,600.00	4,000.00	\$4,000.00	9,900.00	\$9,900.00
70	PAVEMENT MARKING - DURABLE HEAT APPLIED	80 SF	15.00	1,200.00	18.00	\$1,440.00	13.50	\$1,080.00	13.00	\$1,040.00

**Tax Classification**

**Schedule 01**

Sales tax shall NOT be included in unit prices

71	POTHOLING	7 EA	500.00	3,500.00	700.00	\$4,900.00	575.00	\$4,025.00	580.00	\$4,060.00
72	CONNECT 21 IN. DIA. PIPE TO EXISTING CB, DW, OR MH	2 EA	1,500.00	3,000.00	6,000.00	\$12,000.00	1,550.00	\$3,100.00	2,200.00	\$4,400.00
73	TRENCH SAFETY SYSTEM	1 LS	16,000.00	16,000.00	2,500.00	\$2,500.00	17,000.00	\$17,000.00	700.00	\$700.00
74	RECONNECT SIDE SEWER	7 LF	500.00	3,500.00	350.00	\$2,450.00	675.00	\$4,725.00	112.00	\$784.00
75	SIDE SEWER CLEANING AND VIDEO INSPECTION	7 EA	500.00	3,500.00	1,200.00	\$8,400.00	715.00	\$5,005.00	990.00	\$6,930.00
76	TEMPORARY ADJACENT UTILITY SUPPORT	1 LS	2,400.00	2,400.00	8,340.00	\$8,340.00	3,500.00	\$3,500.00	1,400.00	\$1,400.00
77	DI PIPE FOR WATER MAIN 6 IN. DIA.	462 LF	150.00	69,300.00	82.00	\$37,884.00	73.00	\$33,726.00	67.00	\$30,954.00
78	DI PIPE FOR WATER MAIN 12 IN. DIA.	62 LF	225.00	13,950.00	198.00	\$12,276.00	230.00	\$14,260.00	200.00	\$12,400.00
79	INSTALL JOINT RESTRAINT ON EXISTING 10 IN. DIA. WM	3 EA	1,200.00	3,600.00	1,060.00	\$3,180.00	1,325.00	\$3,975.00	570.00	\$1,710.00

**City Of Spokane**  
**Engineering Services Department**  
**\*\*\*Bid Tabulation\*\*\***

<i>Project Number: 2017178</i>			<i>Engineer's Estimate</i>		HALME CONSTRUCTION INC (Submitted)		INLAND INFRASTRUCTURE LLC (Submitted)		DW EXCAVATING INC (Submitted)	
<i>Item No</i>	<i>Bid Item Description</i>	<i>Est Qty</i>	<i>Unit Price</i>	<i>Amount</i>	<i>Unit Price</i>	<i>Amount</i>	<i>Unit Price</i>	<i>Amount</i>	<i>Unit Price</i>	<i>Amount</i>
80	GATE VALVE 6 IN.	3 EA	2,000.00	6,000.00	1,305.00	\$3,915.00	1,550.00	\$4,650.00	1,700.00	\$5,100.00
81	GATE VALVE 12 IN.	1 EA	2,500.00	2,500.00	4,000.00	\$4,000.00	4,275.00	\$4,275.00	5,000.00	\$5,000.00
82	HYDRANT ASSEMBLY	1 EA	6,000.00	6,000.00	7,700.00	\$7,700.00	8,000.00	\$8,000.00	9,300.00	\$9,300.00
83	SANITARY SEWER PIPE 21 IN. DIA.	362 LF	160.00	57,920.00	150.00	\$54,300.00	145.00	\$52,490.00	200.00	\$72,400.00
84	BYPASS SEWER PUMPING	1 LS	50,000.00	50,000.00	14,000.00	\$14,000.00	28,500.00	\$28,500.00	5,100.00	\$5,100.00
85	SIDE SEWER PIPE 4 IN. TO 6 IN. DIA.	83 LF	50.00	4,150.00	206.00	\$17,098.00	70.00	\$5,810.00	74.00	\$6,142.00
86	SIDE SEWER PERMIT	2 EA	40.00	80.00	40.00	\$80.00	40.00	\$80.00	40.00	\$80.00
<b>Bid Total</b>			<b>\$1,740,000.00</b>		<b>\$1,999,122.75</b>		<b>\$2,030,649.00</b>		<b>\$2,160,146.00</b>	

**SCHEDULE SUMMARY**

	<i>Sched 1</i>	<i>Sched 2</i>	<i>Sched 3</i>	<i>Sched 4</i>	<i>Sched 5</i>	<i>Sched 6</i>	<i>Total</i>
ENGINEER'S ESTIMATE	1,494,600.00	0.00	245,400.00	0.00	0.00	0.00	1,740,000.00
HALME CONSTRUCTION INC (Submitted)	1,806,099.75	0.00	193,023.00	0.00	0.00	0.00	1,999,122.75
INLAND INFRASTRUCTURE LLC (Submitted)	1,837,528.00	0.00	193,121.00	0.00	0.00	0.00	2,030,649.00
DW EXCAVATING INC (Submitted)	1,993,686.00	0.00	166,460.00	0.00	0.00	0.00	2,160,146.00

**Low Bid Contractor: HALME CONSTRUCTION INC**

	<i>Contractor's Bid</i>	<i>Engineer's Estimate</i>	<i>% Variance</i>
<b>Schedule 01</b>	1,806,099.75	1,494,600.00	20.84 % Over Estimate
<b>Schedule 03</b>	210,395.07	245,400.00	14.26 % Under Estimate
<b>Bid Totals</b>	2,016,494.82	1,740,000.00	15.89 % Over Estimate

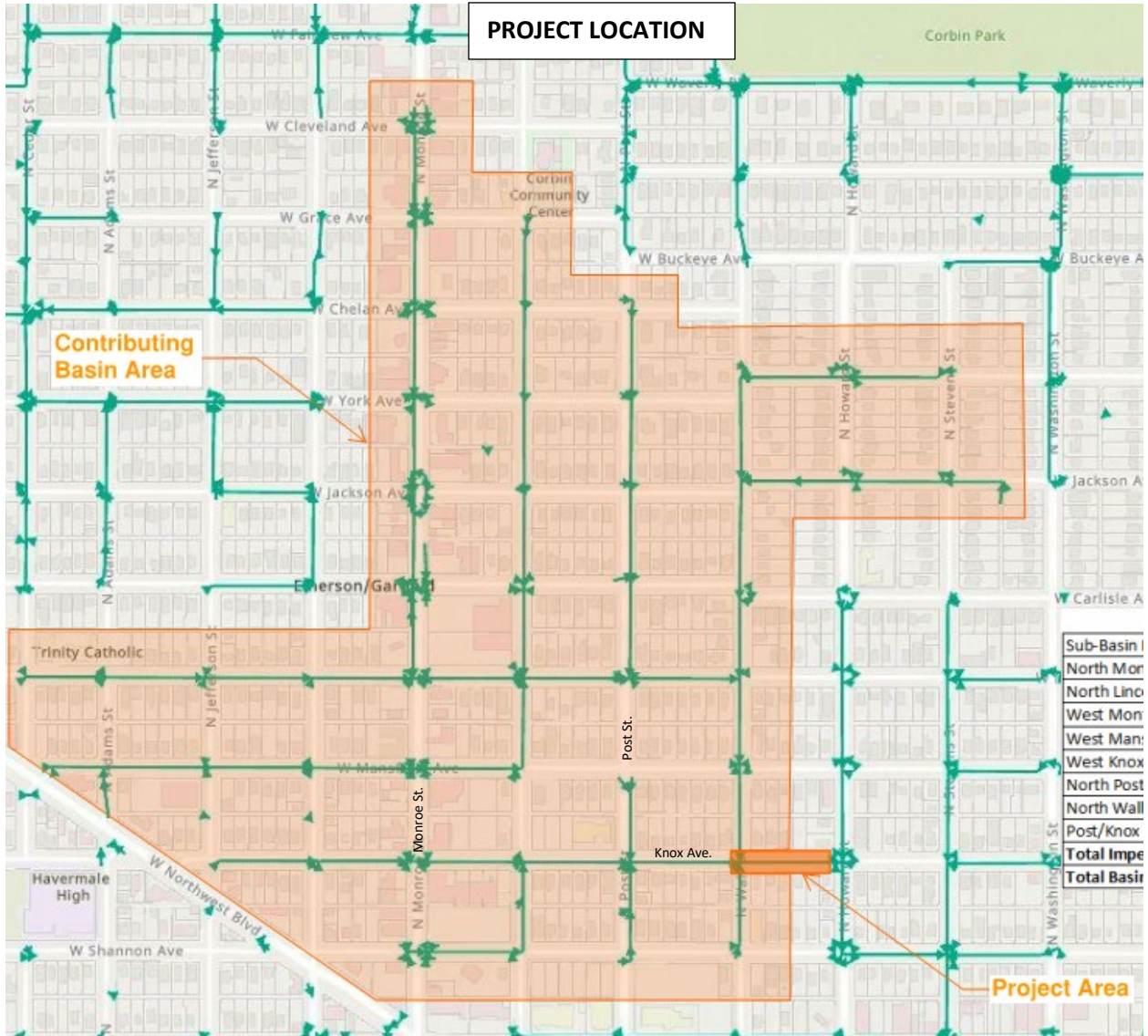



**Agenda Sheet for City Council Meeting of:**  
06/20/2022

<b>Date Rec'd</b>	6/7/2022
<b>Clerk's File #</b>	OPR 2019-0073
<b>Renews #</b>	
<b>Cross Ref #</b>	
<b>Project #</b>	
<b>Bid #</b>	
<b>Requisition #</b>	VALUE BLANKET

<b>Submitting Dept</b>	FACILITIES MANAGEMENT
<b>Contact Name/Phone</b>	DAVE STEELE 6064
<b>Contact E-Mail</b>	DSTEELE@SPOKANECITY.ORG
<b>Agenda Item Type</b>	Contract Item
<b>Agenda Item Name</b>	5900 CITY WIDE VALUE BLANKET FOR SECURITY CAMERAS RENEWAL

**Agenda Wording**

Request to approve one (1) year renewal of Camtek Value Blanket for cameras, other security hardware and video management software.

**Summary (Background)**

The City's long-term contract with Camtek OPR 2019-0073 for the provision of replacement security cameras has (2) two, one-year renewals. With the contract having expired, and replacements an ongoing process, Staff is requesting authorization of a one-year renewal to allow for the continuation of replacement of aging camera systems by various departments at various locations and facilities

Lease? NO Grant related? NO Public Works? NO

**Fiscal Impact**

Expense	\$ \$295,000.00
Select	\$
Select	\$
Select	\$

**Budget Account**

#	various
#	
#	
#	

**Approvals**

<b>Dept Head</b>	TEAL, JEFFREY
<b>Division Director</b>	INGIOSI, PAUL
<b>Finance</b>	BUSTOS, KIM
<b>Legal</b>	ODLE, MARI
<b>For the Mayor</b>	ORMSBY, MICHAEL

**Council Notifications**

<b>Study Session\Other</b>	6/6/22 PSCHC
<b>Council Sponsor</b>	CM Cathcart

**Additional Approvals**

<b>Purchasing</b>	laga@spokanecity.org
	kbustos@spokanecity.org
	lorie@camtekinc.com
	facilitiesdepartment@spokanecity.org

## Committee Agenda Sheet

### Public Safety Committee

<b>Submitting Department</b>	Facilities
<b>Contact Name &amp; Phone</b>	Dave Steele x-6064
<b>Contact Email</b>	Dsteele@spokanecity.org
<b>Council Sponsor(s)</b>	Councilman Cathcart
<b>Select Agenda Item Type</b>	<input checked="" type="checkbox"/> Consent <input type="checkbox"/> Discussion    Time Requested:
<b>Agenda Item Name</b>	CITY WIDE VALUE BLANKET FOR SECURITY CAMERAS RENEWAL
<b>Summary (Background)</b>	The City's long-term contract with Camtek OPR 2019-0073 for the provision of replacement security cameras has (2) two, one-year renewals. With the contract having expired, and replacements an ongoing process, Staff is requesting authorization of a one-year renewal to allow for the continuation of replacement of aging camera systems by various departments at various locations and facilities.
<b>Proposed Council Action &amp; Date:</b>	6/27/2022 Council Approval of Value Blanket Agreement
<b>Fiscal Impact:</b>	Renewal of contract, NTE \$295,000 annual expense
Approved in current year budget?	<input type="checkbox"/> Yes <input type="checkbox"/> No <input checked="" type="checkbox"/> N/A
Funding Source	<input type="checkbox"/> One-time <input checked="" type="checkbox"/> Recurring
Specify funding source:	Individual Departments are responsible for funding their camera replacements.
Expense Occurrence	<input type="checkbox"/> One-time <input checked="" type="checkbox"/> Recurring
Other budget impacts: (revenue generating, match requirements, etc.)	Revenue Generating
<b>Operations Impacts</b>	
What impacts would the proposal have on historically excluded communities?	NA
How will data be collected, analyzed, and reported concerning the effect of the program/policy by racial, ethnic, gender identity, national origin, income level, disability, sexual orientation, or other existing disparities?	NA

How will data be collected regarding the effectiveness of this program, policy or product to ensure it is the right solution?

NA

Describe how this proposal aligns with current City Policies, including the Comprehensive Plan, Sustainability Action Plan, Capital Improvement Program, Neighborhood Master Plans, Council Resolutions, and others?

# CAMTEK

Integrated Security Systems

Inc.

## Camera Catalog 2022 Prepared for the City of Spokane

### Contact Information

# CAMTEK

Integrated Security Systems Inc.

#### Lorie Stephenson

3815 East Everett Avenue  
Spokane, Washington 99217

[www.camtekinc.com](http://www.camtekinc.com)

509.443.2609

[lorie@camteckinc.com](mailto:lorie@camteckinc.com)

[dustin@camtekinc.com](mailto:dustin@camtekinc.com)



#### David Steele

City of Spokane Real Estate Manager

808 W. Spokane Falls Blvd  
Spokane, Washington 99201

509.625.6064



## How to use this Catalog

1. The Department requesting cameras will submit a facilities request through the Help Desk at: <http://cosmssp.spokanecity.org/>
2. The City of Spokane's Real Estate Manager will contact Camtek to request a site consultation. Contact information for the site requester will be forwarded to Camtek for scheduling.
3. Camtek will contact the Department requester and schedule a site survey.
4. Once the site survey is completed a proposal will be generated and sent to the Facilities Manager and then forwarded on to the Department requester for review.

## Supplemental Information

Camtek is pleased to offer the City of Spokane Security Cameras and Video Management Software in a catalog format. Camtek has provided as part of the IRFP part numbers and pricing for video equipment, software and accessories. Initial catalog pricing was valid from **January 1, 2019 – June 1, 2020**. Starting June 1 of 2020 The City of Spokane was provided with annual updated pricing and model numbers for all camera types to make sure we are providing the latest in technology from multiple manufacturers.

The reason June was selected as a catalog date was because ISC West (the largest converged security industry trade show in the U.S.) is held in April and all of the new technology will be readily available and in stock with manufacturers by June 1. Camtek will work with the Real Estate Manager for the City of Spokane to include in the catalog the latest technology, value and detail to formulate the best possible catalog for the City of Spokane.

**All pricing quoted in the catalog will be guaranteed by Camtek for the term of the catalog, i.e. January 1, 2021 - June 1, 2022 to enable management to plan strategically year to year.**

In the event of an unforeseen issue such as a natural disaster, production delay or part shortage which would impact manufacturing, such as the tsunami in Japan which affected both Sony and Samsung cameras and delayed production for 3 - 4 months. Camtek would notify the Real Estate Manager immediately and work with the manufacturers to address the issue and resolve the situation. It is Camtek's goal to provide the best camera for the best application at the best price.

**City of Spokane - Camera Catalog Pricing**  
**Pricing Reflects the Camera Only Price and Does Not Include any**  
**Installation, Termination, Network Certification or Wiring Infrastructure**

SPECIFIED PART NO	ITEM DESCRIPTION OR PRE-APPROVED SUBSTITUTE	MATERIAL COST	QUANTITY	EXTENSION
<b>Axis Pricing</b>				
01273-001	2N Helios IP Video Intercom Verso (with camera)	1368.95	1	1,368.95
01289-001	Frame Cover for IP Verso Brushed Stainless	89.69	1	89.69
	<a href="https://www.2n.cz/en_GB/documents/22902/87735/ip_verso_leaflet_a4_en_lq.pdf/48ce218b-2b36-4e92-ba44-cd6c31a513c5/searchTitle-Product+Leaflet+%28EN%29+-+2N%C2%AE+IP+Verso">https://www.2n.cz/en_GB/documents/22902/87735/ip_verso_leaflet_a4_en_lq.pdf/48ce218b-2b36-4e92-ba44-cd6c31a513c5/searchTitle-Product+Leaflet+%28EN%29+-+2N%C2%AE+IP+Verso</a>			
Q3518-LVE	Exterior Camera PoE Only	1598.03	1	1,598.03
	<a href="https://www.axis.com/en-us/products/axis-q3518-lve">https://www.axis.com/en-us/products/axis-q3518-lve</a>			
M3058-PLVE	360 Degree Camera 12MP	1006.01	1	1,006.01
	<a href="https://www.axis.com/en-us/search/result">https://www.axis.com/en-us/search/result</a>			
P3248-LVE MK	Outdoor Dome Camera Varifocal Lens 1080P IR	1289.13	1	1,289.13
	<a href="https://www.axis.com/en-us/products/axis-p3228-lve">https://www.axis.com/en-us/products/axis-p3228-lve</a>			
Q6075-E	Exterior PTZ Camera	3635.13	1	3,635.13
	<a href="https://www.axis.com/en-us/products/axis-q6055-e">https://www.axis.com/en-us/products/axis-q6055-e</a>			
291	1U Video Server Rack	4678.41	1	4,678.41
Q7436	Encoder Blade 6 Channel	1406.43	1	1,406.43
T91H61	Wall Mount Gooseneck	205.28	1	205.28
T94M01D	Pendant Cap	69.15	1	69.15
T91E61	Wall Mount Gooseneck	45.75	1	45.75
T94K01D	Pendant Cap	45.75	1	45.75
T91A64	Corner Bracket	92.67	1	92.67
T91G61	Wall Mount Gooseneck	233.43	1	233.43
T94A01D	Pendant Cap	71.86	1	71.86
<b>Hanwha Pricing</b>				
PNF-9010R	360 Degree 12MP Camera	1126.08	1	1,126.08
	<a href="https://www.hanwhasecurity.com/media/attachment/file/p/n/pnf-9010r_rv_rvm_datasheet_170815.pdf">https://www.hanwhasecurity.com/media/attachment/file/p/n/pnf-9010r_rv_rvm_datasheet_170815.pdf</a>			
XND-6080V	Indoor Fixed Camera 2MP	668.61	1	668.61
	<a href="http://www.securitydynamics.co.uk/media/assets/datasheets/XND-6080V%20Datasheet.pdf">http://www.securitydynamics.co.uk/media/assets/datasheets/XND-6080V%20Datasheet.pdf</a>			
XNV-6080R	Outdoor Fixed Camera 2MP IR	809.37	1	809.37
	<a href="https://www.hanwhasecurity.com/media/attachment/file/x/n/xnv-6080r_specifications.pdf">https://www.hanwhasecurity.com/media/attachment/file/x/n/xnv-6080r_specifications.pdf</a>			
PNV-9080R	Outdoor 4K Dome	1126.08	1	1,126.08
	<a href="https://www.hanwhasecurity.com/wp-content/uploads/attachments/p/n/pnv-9080r_datasheet_pt.pdf">https://www.hanwhasecurity.com/wp-content/uploads/attachments/p/n/pnv-9080r_datasheet_pt.pdf</a>			
XNP-6320H	Exterior PTZ Camera	3061.53	1	3,061.53
	<a href="https://www.hanwhasecurity.com/product/xnp-6320h/">https://www.hanwhasecurity.com/product/xnp-6320h/</a>			
SBP-300HM6	Cap for PNV	34.49	1	34.49
SPB-300WM	Wall Mount for Cap	55.60	1	55.60
SPB-300WM1	Wall Mount PTZ	55.60	1	55.60
SBP-329HM	Outdoor Cap for PNM-9080 Series	52.79	1	52.79
SBP-300NB	Mounting Plate for SBP-300WM, SBP-300WM1, SBP-300KM	211.20	1	211.20
PNM-9085RQZ	Outdoor IR MultiSensor Camera (4) 5 MP Cameras 1 Housing	2674.44	1	2,674.44

**City of Spokane - Camera Catalog Pricing**  
**Pricing Reflects the Camera Only Price and Does Not Include any**  
**Installation, Termination, Network Certification or Wiring Infrastructure**

SPECIFIED PART NO	ITEM DESCRIPTION OR PRE-APPROVED SUBSTITUTE	MATERIAL COST	QUANTITY	EXTENSION
	<a href="https://www.hanwhasecurity.com/products/security-cameras/network-cameras/multi-sensor-multi-directional/pnm-9081vq.html">https://www.hanwhasecurity.com/products/security-cameras/network-cameras/multi-sensor-multi-directional/pnm-9081vq.html</a>		1	
PNM-9084RQZ	Outdoor IR MultiSensor Camera (4) 2 MP Cameras 1 Housing	2027.44	1	2,027.44
	<a href="https://www.hanwhasecurity.com/wp-content/uploads/dlm_uploads/2020/12/DataSheet_PNM-9084RQZ1_220323_EN.pdf">https://www.hanwhasecurity.com/wp-content/uploads/dlm_uploads/2020/12/DataSheet_PNM-9084RQZ1_220323_EN.pdf</a>		1	
	<b>Open Eye Pricing</b>		1	
OE-C7084-AWR	Indoor/Outdoor 4 MP IP Dome	410.83	1	410.83
	<a href="https://www.openeye.net/products/cameras/oe-c7084-awr">https://www.openeye.net/products/cameras/oe-c7084-awr</a>			
OE-C3012T8	Indoor/Outdoor 8 MP IP Dome 4K	510.39	1	510.39
	<a href="https://www.openeye.net/products/cameras/oe-c7088-awr">https://www.openeye.net/products/cameras/oe-c7088-awr</a>			
OE-C8213	Exterior PTZ Camera 3MP IP 30X PTZ	2058.62	1	2,058.62
	<a href="https://www.openeye.net/products/cameras/oe-c8103">https://www.openeye.net/products/cameras/oe-c8103</a>			
OE-C97512	360 Degree 12 MP IP Camera	910.80	1	910.80
	<a href="https://www.openeye.net/products/cameras/oe-c97512">https://www.openeye.net/products/cameras/oe-c97512</a>			
OE-C3011D4	Indoor 3 MP IP Camera	313.05	1	313.05
	<a href="https://www.openeye.net/products/cameras/oe-c6413-awr">https://www.openeye.net/products/cameras/oe-c6413-awr</a>			
OE-CA79PM	Pendant Mount Adapter	25.12	1	25.12
OE-CA97CMS	Short Arm Corner Mount Kit	127.65	1	127.65
	<b>PoE Midspans and Misc Items</b>			
PD3501G/AC	PowerDsine Single Port High POE Midspan	106.26	1	106.26
PD9501G/AC/B	PowerDsine Single Port High PoE+ Midspan	138.35	1	138.35
5G460-5Y	Leviton Igiamax 5E Patch Cord	4.47	1	4.47
ALTV244175UL	Altronix UL Listed Power Supply	157.31	1	157.31
PCS615-MD-B	Self amplified 8" loud speaker - Surface	386.40	1	386.40
PSA802-MD	Self amplified 8" loud speaker - Flush	380.88	1	380.88
3.5mm	25ft 3.5mm audio cable, plenum rated	31.74	1	31.74
N-Tron 305FX-N-ST	Hardened Network Switch Fiber Connection	723.12	1	723.12
N-Tron 105TX	Hardened Network Switch Cat5e Connection	168.29	1	168.29
	<b>ONSSI Video Management Software and License</b>			
OC-ENT-1C	ONSSI Ocularis Enterprise Camera License	200.93	1	200.93
OC-ENT-B	ONSSI Base License	979.80	1	979.80
SC-OC-ENT-B-2Y	ONSSI Base StayCurrent 2 Year	310.50	1	310.50
SC-OC-ENT-1C-2Y	ONSSI Ocularis Camera StayCURRENT 2 Years	60.72	1	60.72
	<b>Sony Pricing</b>			
	<b>Wireless Equipment</b>			
NSM5	5GHZ Nanostation, 802.11, MIMO, airmax, PoE	181.06	1	181.06
Rocket M5	5GHZ airmax base station with omni antenna	386.39	1	386.39
	<b>Custom Video Mounts</b>			
Custom	New Standard Corner Mount (Replaces WM20G, ACA2 and Connection Access Box)	625.31	1	625.31
Custom	4K Single Mount - (1 Camera)	207.00	1	207.00
Custom	Bucket Truck/Lift Rental for Camera Installation	1242.00	1	1,242.00
Custom	Reach Fork for installation of camera poles	2001.00	1	2,001.00

**City of Spokane - Camera Catalog Pricing**  
**Pricing Reflects the Camera Only Price and Does Not Include any**  
**Installation, Termination, Network Certification or Wiring Infrastructure**

SPECIFIED PART NO	ITEM DESCRIPTION OR PRE-APPROVED SUBSTITUTE	MATERIAL COST	QUANTITY	EXTENSION
Custom	building color) per camera	138.00	1	138.00
Custom	Camera Pole to SPS Specifications - 1" Base Plate	1058.46	1	1,058.46



CERTIFICATE OF LIABILITY INSURANCE

DATE (MM/DD/YYYY) 10/6/2021

THIS CERTIFICATE IS ISSUED AS A MATTER OF INFORMATION ONLY AND CONFERS NO RIGHTS UPON THE CERTIFICATE HOLDER. THIS CERTIFICATE DOES NOT AFFIRMATIVELY OR NEGATIVELY AMEND, EXTEND OR ALTER THE COVERAGE AFFORDED BY THE POLICIES BELOW.

IMPORTANT: If the certificate holder is an ADDITIONAL INSURED, the policy(ies) must have ADDITIONAL INSURED provisions or be endorsed. If SUBROGATION IS WAIVED, subject to the terms and conditions of the policy, certain policies may require an endorsement.

PRODUCER: Alliant Insurance Services, Inc. 818 W Riverside Ave Ste 800 Spokane, WA 99201. CONTACT NAME: Michelle K. DeMoss, CIC, AINS, CLCS, CRIS, CCIP. PHONE: (509) 343-9239. FAX: (509) 325-1803. E-MAIL ADDRESS: Michelle.DeMoss@alliant.com. INSURER(S) AFFORDING COVERAGE: INSURER A: Crum & Forster Specialty Insurance Company 44520. INSURER B: Employers Mutual Casualty Company 21415. INSURER C: Scottsdale Insurance Company 41297. INSURED: Camtek, Inc. P.O. Box 6520 Spokane, WA 99217-0908.

COVERAGES CERTIFICATE NUMBER: REVISION NUMBER:

THIS IS TO CERTIFY THAT THE POLICIES OF INSURANCE LISTED BELOW HAVE BEEN ISSUED TO THE INSURED NAMED ABOVE FOR THE POLICY PERIOD INDICATED. NOTWITHSTANDING ANY REQUIREMENT, TERM OR CONDITION OF ANY CONTRACT OR OTHER DOCUMENT WITH RESPECT TO WHICH THIS CERTIFICATE MAY BE ISSUED OR MAY PERTAIN, THE INSURANCE AFFORDED BY THE POLICIES DESCRIBED HEREIN IS SUBJECT TO ALL THE TERMS, EXCLUSIONS AND CONDITIONS OF SUCH POLICIES. LIMITS SHOWN MAY HAVE BEEN REDUCED BY PAID CLAIMS.

Table with columns: INSR LTR, TYPE OF INSURANCE, ADDL INSD, SUBR WVD, POLICY NUMBER, POLICY EFF (MM/DD/YYYY), POLICY EXP (MM/DD/YYYY), LIMITS. Rows include Commercial General Liability, Automobile Liability, Umbrella Liab, Workers Compensation and Employers' Liability, Equipment Floater, and Professional Liab.

DESCRIPTION OF OPERATIONS / LOCATIONS / VEHICLES (ACORD 101, Additional Remarks Schedule, may be attached if more space is required) RE: Master Contract

City of Spokane, its officers and employees are named as Additional Insured for ongoing and completed operations per the policy forms. Waiver of subrogation applies per the policy forms

CERTIFICATE HOLDER: City of Spokane, 808 W Spokane Falls Blvd, Spokane, WA 99201. CANCELLATION: SHOULD ANY OF THE ABOVE DESCRIBED POLICIES BE CANCELLED BEFORE THE EXPIRATION DATE THEREOF, NOTICE WILL BE DELIVERED IN ACCORDANCE WITH THE POLICY PROVISIONS. AUTHORIZED REPRESENTATIVE: [Signature]

**THIS ENDORSEMENT CHANGES THE POLICY. PLEASE READ IT CAREFULLY.**

**ADDITIONAL INSURED – OWNERS, LESSEES OR  
CONTRACTORS – AUTOMATIC STATUS WHEN  
REQUIRED IN CONSTRUCTION AGREEMENT WITH YOU**

This endorsement modifies insurance provided under the following:

COMMERCIAL GENERAL LIABILITY COVERAGE PART

**A. Section II – Who Is An Insured** is amended to include as an additional insured any person or organization for whom you are performing operations when you and such person or organization have agreed in writing in a contract or agreement that such person or organization be added as an additional insured on your policy. Such person or organization is an additional insured only with respect to liability for "bodily injury", "property damage" or "personal and advertising injury" caused, in whole or in part, by:

1. Your acts or omissions; or
2. The acts or omissions of those acting on your behalf;

in the performance of your ongoing operations for the additional insured.

However, the insurance afforded to such additional insured:

1. Only applies to the extent permitted by law; and
2. Will not be broader than that which you are required by the contract or agreement to provide for such additional insured.

A person's or organization's status as an additional insured under this endorsement ends when your operations for that additional insured are completed.

**B.** With respect to the insurance afforded to these additional insureds, the following additional exclusions apply:

This insurance does not apply to:

1. "Bodily injury", "property damage" or "personal and advertising injury" arising out of the rendering of, or the failure to render, any professional architectural, engineering or surveying services, including:
  - a. The preparing, approving, or failing to prepare or approve, maps, shop drawings, opinions, reports, surveys, field orders, change orders or drawings and specifications; or
  - b. Supervisory, inspection, architectural or engineering activities.

This exclusion applies even if the claims against any insured allege negligence or other wrongdoing in the supervision, hiring, employment, training or monitoring of others by that insured, if the "occurrence" which caused the "bodily injury" or "property damage", or the offense which caused the "personal and advertising injury", involved the rendering of or the failure to render any professional architectural, engineering or surveying services.

2. "Bodily injury" or "property damage" occurring after:

- a. All work, including materials, parts or equipment furnished in connection with such work, on the project (other than service, maintenance or repairs) to be performed by or on behalf of the additional insured(s) at the location of the covered operations has been completed; or
- b. That portion of "your work" out of which the injury or damage arises has been put to its intended use by any person or organization other than another contractor or subcontractor engaged in performing operations for a principal as a part of the same project.

C. With respect to the insurance afforded to these additional insureds, the following is added to **Section III – Limits Of Insurance:**

The most we will pay on behalf of the additional insured is the amount of insurance:

1. Required by the contract or agreement you have entered into with the additional insured; or
2. Available under the applicable Limits of Insurance shown in the Declarations;

whichever is less.

This endorsement shall not increase the applicable Limits of Insurance shown in the Declarations.

**THIS ENDORSEMENT CHANGES THE POLICY. PLEASE READ IT CAREFULLY.**

**ADDITIONAL INSURED – OWNERS, LESSEES OR CONTRACTORS – COMPLETED OPERATIONS**

This endorsement modifies insurance provided under the following:

COMMERCIAL GENERAL LIABILITY COVERAGE PART  
PRODUCTS/COMPLETED OPERATIONS LIABILITY COVERAGE PART

**SCHEDULE**

Name Of Additional Insured Person(s) Or Organization(s)	Location And Description Of Completed Operations
Any person or organization you have agreed in a written contract to add as an additional insured on your policy provided the written contract is executed prior to the "bodily injury", "property damage" or "personal and advertising injury".	Premises covered under this policy when required by written contract executed prior to the "bodily injury", "property damage" or "personal and advertising injury".
Information required to complete this Schedule, if not shown above, will be shown in the Declarations.	

**A. Section II – Who Is An Insured** is amended to include as an additional insured the person(s) or organization(s) shown in the Schedule, but only with respect to liability for "bodily injury" or "property damage" caused, in whole or in part, by "your work" at the location designated and described in the Schedule of this endorsement performed for that additional insured and included in the "products-completed operations hazard".

However:

1. The insurance afforded to such additional insured only applies to the extent permitted by law; and
2. If coverage provided to the additional insured is required by a contract or agreement, the insurance afforded to such additional insured will not be broader than that which you are required by the contract or agreement to provide for such additional insured.

**B.** With respect to the insurance afforded to these additional insureds, the following is added to **Section III – Limits Of Insurance:**

If coverage provided to the additional insured is required by a contract or agreement, the most we will pay on behalf of the additional insured is the amount of insurance:

1. Required by the contract or agreement; or
  2. Available under the applicable Limits of Insurance shown in the Declarations;
- whichever is less.

This endorsement shall not increase the applicable Limits of Insurance shown in the Declarations.



## WAIVER OF TRANSFER OF RIGHTS OF RECOVERY AGAINST OTHERS TO US

This endorsement modifies insurance provided under the following:

COMMERCIAL GENERAL LIABILITY COVERAGE PART  
PRODUCTS/COMPLETED OPERATIONS LIABILITY COVERAGE PART

### SCHEDULE

**Name Of Person Or Organization:**

A person or organization you have agreed in a written contract to waive any right of recovery against provided the written contract is executed prior to the injury or damage.

Information required to complete this Schedule, if not shown above, will be shown in the Declarations.

The following is added to Paragraph 8. **Transfer Of Rights Of Recovery Against Others To Us** of Section IV – Conditions:

We waive any right of recovery we may have against the person or organization shown in the Schedule above because of payments we make for injury or damage arising out of your ongoing operations or "your work" done under a contract with that person or organization and included in the "products-completed operations hazard". This waiver applies only to the person or organization shown in the Schedule above.



**Agenda Sheet for City Council Meeting of:**  
06/20/2022

<b>Date Rec'd</b>	5/23/2022
<b>Clerk's File #</b>	OPR 2021-0302
<b>Renews #</b>	
<b>Cross Ref #</b>	
<b>Project #</b>	
<b>Bid #</b>	PW ITB 5407-21
<b>Requisition #</b>	

<b>Submitting Dept</b>	STREETS
<b>Contact Name/Phone</b>	CLINT HARRIS 625-7744
<b>Contact E-Mail</b>	CEHARRIS@SPOKANECITY.ORG
<b>Agenda Item Type</b>	Contract Item
<b>Agenda Item Name</b>	1100-STREET DEPARTMENT ON CALL GUARDRAIL REPAIR

**Agenda Wording**

The Street Department would like to renew an on-call service contract for needed guardrail repair services at a cost not to exceed \$125,000.00.

**Summary (Background)**

This contract was awarded, via bid, to Frank Gurney Inc in 2021 and is the first renewal. This contract provides a more timely and efficient means of procuring guardrail repairs. Funding for this is available in the Street Depart Budget.

Lease? NO Grant related? NO Public Works? NO

**Fiscal Impact**

Expense \$ 125,000.00

Select \$

Select \$

Select \$

**Budget Account**

# 1100-21700-42300-54801-99999

#

#

#

**Approvals**

**Dept Head** HARRIS, CLINT E.

**Division Director** FEIST, MARLENE

**Finance** ORLOB, KIMBERLY

**Legal** ODLE, MARI

**For the Mayor** ORMSBY, MICHAEL

**Additional Approvals**

**Purchasing** WAHL, CONNIE

**Council Notifications**

**Study Session\Other** PIES 5/23/2022

**Council Sponsor** Lori Kinnear

**Distribution List**

ceharris@spokanecity.org

jwthomas@spokanecity.org

jklapp@spokanecity.org

tbrazington@spokanecity.org

ccafaro@spokanecity.org

fgurney@comcast.net

jdykes@spokanecity.org



**City of Spokane**  
**CONTRACT RENEWAL #1 of 2**  
**Title: On-Call Guardrail Services – PW ITB 5407-02**

This Contract Renewal is made and entered into by and between the **City of Spokane** as (“City”), a Washington municipal corporation, and **FRANK GURNEY, INC.**, whose address is PO Box 11557, Parkwater Station, Spokane Valley, WA 99211 as (“Contractor”), individually hereafter referenced as a “party”, and together as the “parties”.

*WHEREAS, the parties entered into a Contract wherein the Contractor agreed to provide on-call guardrail services for the City of Spokane; and*

*WHEREAS, the original Contract needs to be formally renewed by this written Contract Renewal document; and*

*-- NOW, THEREFORE, in consideration of these terms, the parties mutually agree as follows:*

**1. CONTRACT DOCUMENTS.**

The original Contract, dated May 13, 2021, any previous amendments, renewals and / or extensions / thereto, are incorporated by reference into this document as though written in full and shall remain in full force and effect except as provided herein.

**2. EFFECTIVE DATE.**

This Contract Renewal shall become effective on April 1, 2022 and shall end March 31, 2023.

**3. COMPENSATION.**

The City shall pay an estimated maximum annual cost not to exceed **ONE HUNDRED TWENTY-FIVE THOUSAND AND 00/100 (\$125,000.00)** for everything furnished and done under this Contract Renewal. This is the maximum amount to be paid under this Renewal, and shall not be exceeded without the prior written authorization of the City, memorialized with the same formality as the original Contract and this Renewal document.

**4. DEBARMENT AND SUSPENSION.**

The Contractor has provided its certification that it is in compliance with and shall not contract with individuals or organizations which are debarred, suspended, or otherwise excluded from or ineligible from participation in Federal Assistance Programs under Executive Order 12549 and “Debarment and Suspension”, codified at 29 CFR part 98.

IN WITNESS WHEREOF, in consideration of the terms, conditions and covenants contained, or attached and incorporated and made a part, the parties have executed this Contract Renewal by having legally-binding representatives affix their signatures below.

**FRANK GURNEY, INC**

**CITY OF SPOKANE**

By \_\_\_\_\_  
Signature Date

By \_\_\_\_\_  
Signature Date

\_\_\_\_\_  
Type or Print Name

\_\_\_\_\_  
Type or Print Name

\_\_\_\_\_  
Title

\_\_\_\_\_  
Title

Attest:

Approved as to form:

\_\_\_\_\_  
City Clerk

\_\_\_\_\_  
Assistant City Attorney

**Attachments that are part of this Agreement:**

Contract Renewal - Scope of Work document  
Certificate of Debarment

U2022-034

**ATTACHMENT A**

**CERTIFICATION REGARDING DEBARMENT, SUSPENSION,  
INELIGIBILITY AND VOLUNTARY EXCLUSION**

1. The undersigned (i.e., signatory for the Subrecipient / Contractor / Consultant) certifies, to the best of its knowledge and belief, that it and its principals:
  - a. Are not presently debarred, suspended, proposed for debarment, declared ineligible, or voluntarily excluded from covered transactions by any federal department or agency;
  - b. Have not within a three-year period preceding this contract been convicted or had a civil judgment rendered against them for commission of fraud or a criminal offense in connection with obtaining, attempting to obtain, or performing a public (federal, state, or local) transaction or contract under a public transaction; violation of federal or state antitrust statutes or commission of embezzlement, theft, forgery, bribery, falsification or destruction of records, making false statements, tax evasion, receiving stolen property, making false claims, or obstruction of justice;
  - c. Are not presently indicted or otherwise criminally or civilly charged by a government entity (federal, state, or local) with commission of any of the offenses enumerated in paragraph (1)(b) of this certification; and,
  - d. Have not within a three-year period preceding this contract had one or more public transactions (federal, state, or local) terminated for cause or default.
  
2. The undersigned agrees by signing this contract that it shall not knowingly enter into any lower tier covered transaction with a person who is debarred, suspended, declared ineligible, or voluntarily excluded from participation in this covered transaction.
  
3. The undersigned further agrees by signing this contract that it will include the following clause, without modification, in all lower tier covered transactions and in all solicitations for lower tier covered transactions:

Certification Regarding Debarment, Suspension, Ineligibility and Voluntary Exclusion – Lower Tier Covered Transactions

1. The lower tier contractor certified, by signing this contract that neither it nor its principals is presently debarred, suspended, proposed for debarment, declared ineligible, or voluntarily excluded from participation in this transaction by any federal department or agency.
  
  2. Where the lower tier contractor is unable to certify to any of the statements in this contract, such contractor shall attach an explanation to this contract.
4. I understand that a false statement of this certification may be grounds for termination of the contract.

<hr/> Name of Subrecipient / Contractor / Consultant (Type or Print)	<hr/> Program Title (Type or Print)
<hr/> Name of Certifying Official (Type or Print)	<hr/> Signature
<hr/> Title of Certifying Official (Type or Print)	<hr/> Date (Type or Print)

## Committee Agenda Sheet

### [Public Infrastructure, Environment ,and Sustainability]

<b>Submitting Department</b>	Streets
<b>Contact Name &amp; Phone</b>	Jared Thomas
<b>Contact Email</b>	<a href="mailto:jwthomas@spokanecity.org">jwthomas@spokanecity.org</a>
<b>Council Sponsor(s)</b>	Lori Kinnear
<b>Select Agenda Item Type</b>	X Consent <input type="checkbox"/> Discussion    Time Requested: _____
<b>Agenda Item Name</b>	1100- Streets On Call Guardrail Repair Contract Renewal
<b>Summary (Background)</b>	The Street Department is requesting the renewal of on-call guardrail repair services with Frank Gurney Inc at an amount no to exceed \$125k. This contract was put out for bid in 2021 and this will be the first of three potential extensions.
<b>Proposed Council Action &amp; Date:</b>	Council Approval of Contract Renewal at PIES meeting on 5/23/22
<b>Fiscal Impact:</b> \$125,000.00 Total Cost: <u>\$125,000.00</u> Approved in current year budget?    X Yes <input type="checkbox"/> No <input type="checkbox"/> N/A  Funding Source        X One-time <input type="checkbox"/> Recurring Specify funding source:  Expense Occurrence    X One-time <input type="checkbox"/> Recurring  Other budget impacts: (revenue generating, match requirements, etc.)	
<b>Operations Impacts</b>	
What impacts would the proposal have on historically excluded communities? N/A	
How will data be collected, analyzed, and reported concerning the effect of the program/policy by racial, ethnic, gender identity, national origin, income level, disability, sexual orientation, or other existing disparities? N/A	
How will data be collected regarding the effectiveness of this program, policy or product to ensure it is the right solution? N/A	
Describe how this proposal aligns with current City Policies, including the Comprehensive Plan, Sustainability Action Plan, Capital Improvement Program, Neighborhood Master Plans, Council Resolutions, and others? N/A	



**Agenda Sheet for City Council Meeting of:**  
06/20/2022

<b>Date Rec'd</b>	6/7/2022
<b>Clerk's File #</b>	OPR 2011-0535
<b>Renews #</b>	
<b>Cross Ref #</b>	
<b>Project #</b>	
<b>Bid #</b>	
<b>Requisition #</b>	

<b>Submitting Dept</b>	POLICE
<b>Contact Name/Phone</b>	DAN WATERS 625-4031
<b>Contact E-Mail</b>	DWATERS@SPOKANEPOLICE.ORG
<b>Agenda Item Type</b>	Contract Item
<b>Agenda Item Name</b>	0680 - FALSE ALARM PROGRAM EXTENSION

**Agenda Wording**

One year contract extension with Superior LLC for continued joint administration of the False Alarm Program. Estimated revenue from the program is \$380,000/year. Extension term is July 1, 2022 through July 30, 2023.

**Summary (Background)**

The Police Department responds to over 7,000 alarm calls annually. Approximately, 98% of these alarms are false, resulting in the commitment of over 8,000 hours in Police Department resources to those alarms. This program will identify false alarm problems and hold alarm companies and their customers accountable through annual registration, education, and an assessment of cost recovery fees to reimburse the expense of responding to false alarms.

Lease? NO Grant related? NO Public Works? NO

**Fiscal Impact**

Revenue \$ 380,000

Select \$

Select \$

Select \$

**Budget Account**

# 0680-11150-21250-34210-68148

#

#

#

**Approvals**

<b>Dept Head</b>	MEIDL, CRAIG
<b>Division Director</b>	MEIDL, CRAIG
<b>Finance</b>	SCHMITT, KEVIN
<b>Legal</b>	ODLE, MARI
<b>For the Mayor</b>	ORMSBY, MICHAEL
<b>Additional Approvals</b>	
<b>Purchasing</b>	

**Council Notifications**

<b>Study Session\Other</b>	PSCHC Meeting 06/06/2022
<b>Council Sponsor</b>	Councilmember Kinnear
<b>Distribution List</b>	SPDFINANCE@SPOKANECITY.ORG
	jgoldman@spokanepolice.org
	jean.schommer@centralsquare.com
	dwaters



**City of Spokane**  
**CONTRACT EXTENSION  
WITH COST**  
Title: **ADMINISTRATION OF THE CITY'S  
FALSE ALARM PROGRAM**

This Contract Extension including additional compensation is made and entered into by and between the **City of Spokane** as ("City"), a Washington municipal corporation, and **SUPERION, LLC**, whose address is 1000 Business Center Drive, Lake Mary, Florida 32746 as ("Company"), individually hereafter referenced as a "party", and together as the "parties".

*WHEREAS, the parties entered into a Contract wherein AOT Public Safety Corporation agreed to provide for the City a system and Program for the monitoring of False Alarms; and*

*WHEREAS, the Contract with AOT Public Safety Corporation has been assigned to Superion, LLC; and*

*WHEREAS, the original contract including Extensions has run its Term, but additional time is required, and thus the original Contract currently in place needs to be formally extended by this written document for one (1) additional year.*

*-- NOW, THEREFORE, in consideration of these terms, the parties mutually agree as follows:*

**1. CONTRACT DOCUMENTS.**

The Contract, dated May 23, 2011 and May 27, 2011, any previous amendments, addendums and / or extensions / renewals thereto, are incorporated by reference into this document as though written in full and shall remain in full force and effect except as provided herein.

**2. EFFECTIVE DATE.**

This Contract Extension shall become effective on July 1, 2022.

**3. EXTENSION.**

The contract documents are hereby extended and shall run through June 30, 2023.



**4. COMPENSATION.**

The City shall receive an estimated annual revenue after compensation of the Program of **THREE HUNDRED EIGHTY THOUSAND AND NO/100 DOLLARS (\$380,000.00)** for everything furnished and done under this Contract Extension.

**5. DEBARMENT AND SUSPENSION.**

The Contractor has provided its certification that it is in compliance with and shall not contract with individuals or organizations which are debarred, suspended, or otherwise excluded from or ineligible from participation in Federal Assistance Programs under Executive Order 12549 and "Debarment and Suspension", codified at 29 CFR part 98.

IN WITNESS WHEREOF, in consideration of the terms, conditions and covenants contained, or attached and incorporated and made a part, the parties have executed this Contract Extension by having legally-binding representatives affix their signatures below.

**SUPERION, LLC**

**CITY OF SPOKANE**

By \_\_\_\_\_  
Signature                      Date

By \_\_\_\_\_  
Signature                      Date

\_\_\_\_\_  
Type or Print Name

\_\_\_\_\_  
Type or Print Name

\_\_\_\_\_  
Title

\_\_\_\_\_  
Title

Attest:

Approved as to form:

\_\_\_\_\_  
City Clerk

\_\_\_\_\_  
Assistant City Attorney

**ATTACHMENT A  
CERTIFICATION REGARDING DEBARMENT, SUSPENSION,  
INELIGIBILITY AND VOLUNTARY EXCLUSION**

1. The undersigned (i.e., signatory for the Subrecipient / Contractor / Consultant) certifies, to the best of its knowledge and belief, that it and its principals:
  - a. Are not presently debarred, suspended, proposed for debarment, declared ineligible, or voluntarily excluded from covered transactions by any federal department or agency;
  - b. Have not within a three-year period preceding this contract been convicted or had a civil judgment rendered against them for commission of fraud or a criminal offense in connection with obtaining, attempting to obtain, or performing a public (federal, state, or local) transaction or contract under a public transaction; violation of federal or state antitrust statutes or commission of embezzlement, theft, forgery, bribery, falsification or destruction of records, making false statements, tax evasion, receiving stolen property, making false claims, or obstruction of justice;
  - c. Are not presently indicted or otherwise criminally or civilly charged by a government entity (federal, state, or local) with commission of any of the offenses enumerated in paragraph (1)(b) of this certification; and,
  - d. Have not within a three-year period preceding this contract had one or more public transactions (federal, state, or local) terminated for cause or default.
  
2. The undersigned agrees by signing this contract that it shall not knowingly enter into any lower tier covered transaction with a person who is debarred, suspended, declared ineligible, or voluntarily excluded from participation in this covered transaction.
  
3. The undersigned further agrees by signing this contract that it will include the following clause, without modification, in all lower tier covered transactions and in all solicitations for lower tier covered transactions:

Certification Regarding Debarment, Suspension, Ineligibility and Voluntary Exclusion – Lower Tier Covered Transactions

1. The lower tier contractor certified, by signing this contract that neither it nor its principals is presently debarred, suspended, proposed for debarment, declared ineligible, or voluntarily excluded from participation in this transaction by any federal department or agency.
  
2. Where the lower tier contractor is unable to certify to any of the statements in this contract, such contractor shall attach an explanation to this contract.

4. I understand that a false statement of this certification may be grounds for termination of the contract.

<hr style="border: none; border-top: 1px solid black; margin-bottom: 5px;"/> Name of Subrecipient / Contractor / Consultant (Type or Print)	<hr style="border: none; border-top: 1px solid black; margin-bottom: 5px;"/> Program Title (Type or Print)
<hr style="border: none; border-top: 1px solid black; margin-bottom: 5px;"/> Name of Certifying Official (Type or Print)	<hr style="border: none; border-top: 1px solid black; margin-bottom: 5px;"/> Signature
<hr style="border: none; border-top: 1px solid black; margin-bottom: 5px;"/> Title of Certifying Official (Type or Print)	<hr style="border: none; border-top: 1px solid black; margin-bottom: 5px;"/> Date (Type or Print)

**Briefing Paper/Agenda**  
**PSCH Committee Meeting & Spokane City Council Agenda**  
**May/June 2022**

<b>Division &amp; Department:</b>	Spokane Police Department
<b>Subject:</b>	OPR 2011-0525 – SPD FARP Program
<b>Date:</b>	5/3/22
<b>Contact (email) :</b>	Lt. Dan Waters and Jody Goldman
<b>City Council Sponsor:</b>	CW Kinnear
<b>Executive Sponsor:</b>	
<b>Committee(s) Impacted:</b>	Public Safety
<b>Type of Agenda item:</b>	<input checked="" type="checkbox"/> Consent <input type="checkbox"/> Discussion <input type="checkbox"/> Strategic Initiative
<b>Alignment:</b> (link agenda item to guiding document – i.e., Master Plan, Budget , Comp Plan, Policy, Charter, Strategic Plan)	
<b>Strategic Initiative:</b>	
<b>Deadline:</b>	06/30/2022
<b>Outcome:</b> (deliverables, delivery duties, milestones to meet)	<p><b>Action</b>            SPD FARP additional contract extension from July 1, 2022 through June 30, 2023. The current vendor Superior LLC whom owns 100% of assets of PSC including all rights in the Crywolf software system has agreed to a 1-year contract extension with accepting the same terms and conditions for this 1-year contract extension period.</p> <p><b>Funding</b>            This is revenue to the general fund of approximately yearly \$380k.</p>
<b>Background/History:</b> The current contract extension to Superior LLC and the City of Spokane will expire on June 30, 2022. SPD approved and received an additional 1-year contract extension by Spokane City Legal.	
<b>Executive Summary:</b> <b>Subject</b> Contract extension with Superior LLC for the administration of the False Alarm Program. The estimated revenue that impacts the general fund is approximately \$380,000 for the 1-year term from July 1, 2022 through June 30, 2023. <b>Impact History</b> The False Alarm Program has substantial revenue impacts on the general fund. The Police Department responds to over 7,000 alarm calls annually. Approximately, 98% of these alarms are false, resulting in the commitment of over 8,000 hours in Police Department resources to those alarms. This program will identify false alarm problems and hold alarm companies and their customers accountable through annual registration, education, and an assessment of cost recovery fees to reimburse the expense of responding to false alarms.	
<b>Budget Impact:</b> Approved in current year budget? <input checked="" type="checkbox"/> Yes <input type="checkbox"/> No <input type="checkbox"/> N/A	

Annual/Reoccurring expenditure?  Yes  No  N/A

If new, specify funding source: Federal Funding – Department of Justice

Other budget impacts: (revenue generating, match requirements, etc.)

Operations Impact:

Consistent with current operations/policy?  Yes  No  N/A

Requires change in current operations/policy?  Yes  No  N/A

Specify changes required:

Known challenges/barriers:

**Agenda Sheet for City Council Meeting of:**

06/20/2022

<b>Date Rec'd</b>	6/8/2022
<b>Clerk's File #</b>	OPR 2019-1095
<b>Renews #</b>	
<b>Cross Ref #</b>	
<b>Project #</b>	
<b>Bid #</b>	
<b>Requisition #</b>	CR 23694

<b>Submitting Dept</b>	POLICE
<b>Contact Name/Phone</b>	SHAWNA ERNST 625-4106
<b>Contact E-Mail</b>	SERNST@SPOKANEPOLICE.ORG
<b>Agenda Item Type</b>	Contract Item
<b>Agenda Item Name</b>	0680 AXON CONTRACT AMENDMENT

**Agenda Wording**

Approval to amend current contract with Axon and add on additional products and services.

**Summary (Background)**

The Spokane Police Department is currently using antiquated technology for managing digital forensic evidence and for field reporting, and police records management. This program will overhaul the current technology stack for the department (in concert with regional partner agencies).

Lease? NO Grant related? NO Public Works? NO

**Fiscal Impact**

Expense \$ 7,614,420.75

Select \$

Select \$

Select \$

**Budget Account**

# 1910-11470-21140-54820-99999

#

#

#

**Approvals**

<b>Dept Head</b>	OLSEN, ERIC
<b>Division Director</b>	OLSEN, ERIC
<b>Finance</b>	SCHMITT, KEVIN
<b>Legal</b>	ODLE, MARI
<b>For the Mayor</b>	ORMSBY, MICHAEL

**Council Notifications**

<b>Study Session\Other</b>	PSCHC 5/2/2022
<b>Council Sponsor</b>	CM Cathcart
<b>Distribution List</b>	spdfinance@spokanepolice.org
	sernst@spokanepolice.org
	eolsen@spokanepolice.org

**Additional Approvals****Purchasing**

## Committee Agenda Sheet

### Public Safety and Community Health Committee

<b>Submitting Department</b>	Spokane Police Department
<b>Contact Name &amp; Phone</b>	Shawna Ernst 509-625-4106
<b>Contact Email</b>	<a href="mailto:sernst@spokanepolice.org">sernst@spokanepolice.org</a>
<b>Council Sponsor(s)</b>	CM Cathcart
<b>Select Agenda Item Type</b>	<input checked="" type="checkbox"/> Consent <input type="checkbox"/> Discussion    Time Requested:
<b>Agenda Item Name</b>	Police Digital Evidence Storage, Records Management, and Axon and Dell Contracts
<b>Summary (Background)</b>	<p>The Spokane Police Department is currently using antiquated technology for managing digital forensic evidence and for field reporting, and police records management. This program will overhaul the current technology stack for the department (in concert with regional partner agencies).</p> <p>The program will include the following system improvements:</p> <ol style="list-style-type: none"> <li>1.) <b>Working Storage:</b> Provide secure on-premise short-term working storage for digital forensic evidence ensuring that Investigations has timely access to forensic extracts to perform investigative analyses (Dell contract).</li> <li>2.) <b>Long-term Storage:</b> Provide secure, cloud-based, unlimited long-term storage for all digital evidence and body camera video ensuring that it meets Washington State retention requirements and can easily be shared with Prosecution and Courts to reduce the time required for case processing (Axon contract).</li> <li>3.) <b>Axon Records:</b> Work with our regional partner agencies (Spokane County Sheriff's Office, Spokane Valley Police, SREC 911, Liberty Lake Police, Airway Heights Police, Spokane International Airport Police, Kalispel Tribal Police, and Eastern Washington University Police) to migrate to a modern, cloud-based Field Reporting and Records Management System (Axon Records) which will accomplish the following: <ol style="list-style-type: none"> <li>a. Reduce system downtime</li> <li>b. Eliminate information silos</li> <li>c. Improve ability to conduct investigations</li> <li>d. Improve ability to enter data into the system and create reports/analyses for stakeholders</li> <li>e. Decrease the time it takes to write reports and the time it takes to disseminate case information to prosecution</li> </ol> </li> <li>4.) <b>Body-Worn Cameras and TASERs:</b> Provide regular hardware upgrades to the Department's body worn camera program and TASER program (Axon contract).</li> </ol>

- 5.) **Citizen Evidence:** Provide a method of obtaining photos and video evidence directly from Citizens (Axon contract).
- 6.) **VR Training:** Increase training for officers using Virtual Reality simulation. Situations available in VR training include:
  - a. Empathy Library: Ten modules focused on interacting with community members of various backgrounds (one example includes interacting with an individual on the Autism spectrum).
  - b. Tactical Library: Modules focused on analytical and de-escalation skills.
  - c. Officer Preparedness: Modules focused on proficiency with the TASER device.
  - d. Officer Coping: Modules focused on providing officers with tools and techniques to cope with the psychological impact of public safety work.
- 7.) **Disaster Recovery:** Improve our cybersecurity posture and strengthen our ability to continue operations during a natural or man-made disaster.

There are many other improvements to our overall system by adopting the Officer Safety Plan 7+ program.

The Spokane Police Department will utilize existing 2022 funding from SIP program carryovers and criminal justice assistance funds to accept both contracts.

- 1.) **Dell:** The Dell contract (secure, on-premises file storage for digital forensic evidence) will be funded with carryover SIP funding that has already been allocated to storage needs. Cost will not exceed the \$600,000 budgeted amount.
- 2.) **Axon OSP 7+ Premium:** The Department will amend our existing Axon contract. The new OSP 7+ Premium contract is valued at \$894,235 in 2022 (our 2022 budget has \$897,294 available). Future year costs (2023 – 2029) are \$965,070.19 annually with two one-time expenses due upon project implementation (Sub-project A and Sub-project B).
  - a. **Sub-project A (\$27,795.00):** Migrate from IA Pro and BlueTeam for Use of Force Incidents to Axon Standards so that body camera video is directly available to the reviewer (time-savings). This sub-project is currently unscheduled with no funding source identified.
  - b. **Sub-project B (\$516,115.00):** Implement Axon Records for the department and law enforcement partner agencies. This sub-project will begin in 2022, with payment due upon successful implementation (target date – January 2025). At that time, this expense will be cost-shared across the consortium.

--	--

**Proposed Council Action & Date:** Approval of both Dell and Axon Contracts – June 2022 (for a contract start date of July 1, 2022)

**Fiscal Impact:**  
 Total Cost: \$1,494,235  
 Approved in current year budget?       Yes    No    N/A  
  
 Funding Source                     One-time    Recurring  
 Specify funding source: SIP Carryover funding for the Dell contract, Criminal Justice Assistance Fund for Axon contract for 2022  
  
 Expense Occurrence     One-time     Recurring  
 Dell expense is a one-time expense, Axon contract is a recurring expense  
  
 Other budget impacts: (revenue generating, match requirements, etc.)

**Operations Impacts**

What impacts would the proposal have on historically excluded communities?

- 1.) **Working Storage:** N/A
- 2.) **Long-term Storage:** N/A
- 3.) **Axon Records:** Moving to the Axon Records system will enable the department and regional partner agencies to better collect demographic information for use in analyses/reporting. The department will be able to more easily extract key data to develop a public-facing dashboard that increases transparency.
- 4.) **Body-Worn Cameras and TASERs:** N/A
- 5.) **Citizen Evidence:** Axon Citizen allows citizens to easily provide photos/videos to law enforcement. If a victim/witness does not feel comfortable with personally interacting with officers/report-takers, this system provides them an alternative way to ensure their evidence is available for investigations.
- 6.) **VR Training:** Axon’s VR training has an empathy section with ten modules (and growing) focused on improving interactions with people from all walks of life, including those from historically excluded communities.
- 7.) **Disaster Recovery:** Persons from historically excluded communities are often the most-impacted during natural disasters. Improving the department’s ability to continue operations during and after a disaster will directly benefit those communities as they seek emergency services.



How will data be collected, analyzed, and reported concerning the effect of the program/policy by racial, ethnic, gender identity, national origin, income level, disability, sexual orientation, or other existing disparities?

Upon completion of this program (specifically the Axon Records project), the department will be able to develop a public-facing dashboard including information on crime in the community and cross-reference crime data with socio-economic and demographic data to help identify disparities in where crime occurs.

How will data be collected regarding the effectiveness of this program, policy or product to ensure it is the right solution?

Spokane Police Department staff, along with staff from our regional partners have spent over two years discussing potential solutions for our technology issues. We have seen multiple demos of Axon's product line, and have the benefit of a long-standing partnership with Axon for our body-worn camera and TASER programs.

By bundling our Records system into the Axon ecosystem – we will be able to house all digital evidence and reports in a single repository, which will streamline operations from the time the report is written through closure of appeals. There is no other system that would provide that integration natively.

Describe how this proposal aligns with current City Policies, including the Comprehensive Plan, Sustainability Action Plan, Capital Improvement Program, Neighborhood Master Plans, Council Resolutions, and others?

This program aligns with the following strategic plan objectives:

- 1.) Innovative Infrastructure: This program will be the first on-premise/cloud hybrid at the City of Spokane and will serve as a model for other Information Technology initiatives.
- 2.) Safe and Healthy: This program will reduce the time officers spend writing field reports, reduce the time the Prosecutor's office spends assembling information and evidence for court, and will increase departmental transparency.
- 3.) Sustainable Resources: This program will reduce our overall dependence on physical assets (server clusters, network connections to County) in favor of utilizing cloud-based resources. The long-term cost-savings from using Axon's unlimited storage are immeasurable.

	2021	2022	2023	2024	2025	2026	2027	2028	2029
Digital Forensics & Video Evidence	Mixed Solution: External Drives, Cloud Storage, Axon Storage, and ITSD Datacenter	Implement Dell Working Storage Implement Axon Long-Term Storage					Dell Working Storage Hardware Refresh		
Body Camera Program	Current Axon Contract			Body-Worn Camera Hardware Refresh #1			Body-Worn Camera Hardware Refresh #2		Body-Worn Camera Hardware Refresh #3
TASER Program	Current Axon Contract			TASER Hardware Refresh					
CAD	Tyler New World Law CAD Infor EnRoute Fire CAD	ILA and Governance Development SREC 911 RFP for Consultant	SREC 911 RFP for Combined Fire/Law CAD System	CAD System Configuration	CAD System Go-Live	Realized Infor Fire CAD Savings: \$128,000 annually City Portion: \$67,000	Realized Infor Fire CAD Savings: \$128,000 annually City Portion: \$67,000	Realized Infor Fire CAD Savings: \$128,000 annually City Portion: \$67,000	Realized Infor Fire CAD Savings: \$128,000 annually City Portion: \$67,000
Records Management System	Tyler New World Records Management System County IT LE Docs System	ILA and Governance Development Police and Criminal Justice Business Process Analysis	Axon Records System Configuration	Axon Records System Configuration	Axon Records System Go-Live Milestone Payment: \$516,000 City Portion: \$310,000	Realized Tyler New World CAD/RMS Savings: \$1,529,000 annually City Portion: \$309,000	Realized Tyler New World CAD/RMS Savings: \$1,529,000 annually City Portion: \$309,000	Realized Tyler New World CAD/RMS Savings: \$1,529,000 annually City Portion: \$309,000	Realized Tyler New World CAD/RMS Savings: \$1,529,000 annually City Portion: \$309,000
Public-Facing Data Dashboard	None			Data Dashboard Development	Data Dashboard Internal/External Launch				
Use of Force Reporting	IA Pro/BlueTeam		Axon Standards System Configuration	Axon Standards System Go-Live Milestone Payment: \$28,000	Realized IA Pro/BlueTeam Cost Savings: \$4,000 annually	Realized IA Pro/BlueTeam Cost Savings: \$4,000 annually	Realized IA Pro/BlueTeam Cost Savings: \$4,000 annually	Realized IA Pro/BlueTeam Cost Savings: \$4,000 annually	Realized IA Pro/BlueTeam Cost Savings: \$4,000 annually
VR Training	None	VR Training for Academy Staff	VR Training for Officers Go-Live						
Total Costs (City Only)	\$1,010,000 annually to City of Spokane*	\$1,010,000 annual expenses, \$315,000 new Axon Contract, \$600,000 Dell Contract, \$1,925,000 TOTAL	\$380,000 annual expenses, \$965,000 new Axon Contract, \$1,345,000 TOTAL	\$380,000 annual expenses, \$965,000 new Axon Contract, \$28,000 Axon Standards, \$1,373,000 TOTAL	\$376,000 annual expenses, \$965,000 new Axon Contract, \$310,000 Axon Records, \$1,651,000 TOTAL	\$965,000 new Axon Contract, \$965,000 TOTAL	\$965,000 new Axon Contract, \$200,000 Dell Refresh, \$1,165,000 TOTAL	\$965,000 new Axon Contract, \$965,000 TOTAL	\$965,000 new Axon Contract, \$965,000 TOTAL

Current State

Dell Contract/Project

Axon Contract/Program

CAD Project

Cost Outside of Contract

Realized Cost Savings

Annual Costs

\*Current annualized costs include: Tyler New World CAD & Records Management (with annualized hardware expense), Infor EnRoute Fire CAD (with annualized hardware expense), Digital Forensics storage, IA Pro/BlueTeam, and the current Axon Contract.

# Police Evidence and Records Management Program



This FIRST AMENDMENT TO MASTER SERVICES AND PURCHASING AGREEMENT (“**First Amendment**”) dated April 04, 2022 (“**First Amendment Effective Date**”) to the Agreement dated December 30, 2019 (“**Agreement**”), as amended, between AXON ENTERPRISE, INC., a Delaware corporation, *aka* TASER International Inc., (“**Axon**”) and Spokane Police Department, (“**Agency**”) is entered by such parties to amend the Agreement as set forth in this First Amendment. Axon and Company may also be referred to in this First Amendment individually as “Party” or collectively as “Parties.” To the extent this First Amendment contains terms and conditions that differ from those contained in the Agreement, this First Amendment shall control. The Parties agree that a concept or principle covered in this First Amendment shall apply and be incorporated into all other provisions of the Agreement in which the concept or principle is also applicable, notwithstanding the absence of any specific cross-reference thereto. All capitalized and defined terms referenced, but not defined, in this First Amendment shall have the meanings assigned to them in the Agreement.

NOW, THEREFORE, in consideration of the mutual covenants and agreements contained in this First Amendment and the Agreement, the Parties hereby agree as follows:

1. Section 1, first sentence of “Term,” in the Agreement is hereby replaced with the following:
  - a. **Term.** The term of this Agreement shall commence on the Effective Date and continues for ten (10) years unless terminated pursuant to this Agreement (“Term”).
2. Section 4, first sentence of “Payment” in the Agreement is hereby replaced with the following:
  - a. Agency may purchase additional products and services on the Quote at the pricing on the Quote for up to 90 months from the Effective Date for 50 additional officers, in order to account for Agency’s projected growth.
3. Section 17.3, first sentence of “By Agency” in the Agreement is hereby replaced with:
  - a. The Agency entered into this Agreement through NASPO cooperative contract OK-MA-145-015 ending 07/30/2022.
4. Add and incorporate Attachment A – Quote: Q-373588-44679.937JH.
5. The attached documents are hereby incorporated into the Agreement:
  - a. Attachment B - Axon Respond Appendix
  - b. Attachment C - Add-on Services Appendix
  - c. Attachment D - Axon Auto-Transcribe Appendix
  - d. Attachment E - Axon Virtual Reality Content Terms of Use Appendix
  - e. Attachment F - Axon Channel Services Appendix
6. Except as set forth in this First Amendment, the terms and provisions of the Agreement shall remain in full force and effect.
7. The signatories to this First Amendment represent and warrant that they have full rights, power and authority to enter into and bind his or her, as the case may be, respective Party to the obligations set forth in this First Amendment without further consent or approval of any kind.



---

IN WITNESS WHEREOF, each Party, by and through its respective representative, has duly executed and delivered this First Amendment as of the First Amendment Effective Date.

**AXON:**

AXON ENTERPRISE, INC., a Delaware corporation

By: \_\_\_\_\_

Name: \_\_\_\_\_

Title: \_\_\_\_\_

**Agency:**

SPOKANE POLICE DEPARTMENT- WA

By: \_\_\_\_\_

Name: \_\_\_\_\_

Title: \_\_\_\_\_

**Attachment A – Axon Quote**  
**See next page**

# Attachment A



**Axon Enterprise, Inc.**  
 17800 N 85th St.  
 Scottsdale, Arizona 85255  
 United States  
 VAT: 86-0741227  
 Domestic: (800) 978-2737  
 International: +1.800.978.2737

Q-373588-44679.937JH

Issued: 04/28/2022



Quote Expiration:

Estimated Contract Start Date: 07/15/2022

Account Number: 446518

Payment Terms: N30

Delivery Method: Fedex - Ground

SHIP TO	BILL TO
Business;Delivery;Invoice-1100 W Mallon Ave 1100 W Mallon Ave Spokane, WA 99260-2043 USA	Spokane Police Dept. - WA 1100 W Mallon Ave Spokane, WA 99260-2043 USA Email:

SALES REPRESENTATIVE	PRIMARY CONTACT
Chris Neubeck Phone: +1 6027080074 Email: cneubeck@axon.com Fax: (480) 658-0629	Phone: Email: Fax:

## Quote Summary

Program Length	90 Months
<b>TOTAL COST</b>	<b>\$7,009,792.65</b>
<b>ESTIMATED TOTAL W/ TAX</b>	<b>\$7,614,420.75</b>

## Discount Summary

Average Savings Per Year	\$350,014.31
<b>TOTAL SAVINGS</b>	<b>\$2,625,107.33</b>

## Payment Summary

Date	Subtotal	Tax	Total
Jun 2022	\$290,081.62	\$24,937.64	\$315,019.26
2022	\$25,500.00	\$2,295.00	\$27,795.00
Aug 2022	\$0.10	\$0.06	\$0.16
Jan 2023	\$888,672.99	\$76,397.20	\$965,070.19
Jan 2024	\$888,672.99	\$76,397.20	\$965,070.19
Jan 2025	\$1,362,172.99	\$119,012.20	\$1,481,185.19
Jan 2026	\$888,672.99	\$76,397.20	\$965,070.19
Jan 2027	\$888,672.99	\$76,397.20	\$965,070.19
Jan 2028	\$888,672.99	\$76,397.20	\$965,070.19
Jan 2029	\$888,672.99	\$76,397.20	\$965,070.19
<b>Total</b>	<b>\$7,009,792.65</b>	<b>\$604,628.10</b>	<b>\$7,614,420.75</b>

Quote Unbundled Price:	\$9,635,423.60
Quote List Price:	\$7,984,251.20
Quote Subtotal:	\$7,009,792.65

## Pricing

*All deliverables are detailed in Delivery Schedules section lower in proposal*

Item	Description	Qty	Term	Unbundled	List Price	Net Price	Subtotal	Tax	Total
<b>Program</b>									
2022T7CertVR10Yr	2022 Taser 7 Cert Bundle W/ VR 10 Year	20	90	\$117.07	\$79.28	\$79.28	\$142,703.99	\$12,843.35	\$155,547.34
2022OSP7+Premium10Year	2022 - OFFICER SAFETY PLAN 7 PLUS Premium 10 Year	275	90	\$319.04	\$254.72	\$229.27	\$5,674,400.81	\$484,442.85	\$6,158,843.66
2022T7CertVR10Yr	2022 Taser 7 Cert Bundle W/ VR 10 Year	48	90	\$77.25	\$79.28	\$60.83	\$262,767.85	\$23,649.10	\$286,416.95
<b>A la Carte Hardware</b>									
AB3C	AB3 Camera Bundle	284			\$699.00	\$0.00	\$0.00	\$0.00	\$0.00
AB3MBD	AB3 Multi Bay Dock Bundle	35			\$1,495.00	\$0.00	\$0.00	\$0.00	\$0.00
<b>A la Carte Software</b>									
73891	RECORDS LICENSE, NON-SWORN	120	60		\$29.00	\$0.00	\$0.00	\$0.00	\$0.00
73890	RECORDS LICENSE, NON-OSP	25	60		\$29.00	\$29.00	\$43,500.00	\$3,915.00	\$47,415.00
ProLicense	Pro License Bundle	120	90		\$39.00	\$39.90	\$430,920.00	\$38,782.80	\$469,702.80
<b>A la Carte Services</b>									
85157	Consortium - Records Milestone Payment	1	60		\$500.00	\$7,166.67	\$430,000.00	\$38,700.00	\$468,700.00
85144	AXON STARTER	1			\$2,750.00	\$2,750.00	\$2,750.00	\$247.50	\$2,997.50
85144	AXON STARTER	1			\$2,750.00	\$2,750.00	\$2,750.00	\$247.50	\$2,997.50
73897	STANDARDS SERVICE, PREMIUM	1			\$20,000.00	\$20,000.00	\$20,000.00	\$1,800.00	\$21,800.00
<b>A la Carte Warranties</b>									
80374	EXT WARRANTY, TASER 7 BATTERY PACK	387	90		\$0.44	\$0.00	\$0.00	\$0.00	\$0.00
80395	EXT WARRANTY, TASER 7 HANDLE	333	90		\$6.58	\$0.00	\$0.00	\$0.00	\$0.00
80396	EXT WARRANTY, TASER 7 SIX BAY DOCK	4	90		\$6.58	\$0.00	\$0.00	\$0.00	\$0.00
<b>Total</b>							<b>\$7,009,792.65</b>	<b>\$604,628.10</b>	<b>\$7,614,420.75</b>

# Delivery Schedule

## Hardware

Bundle	Item	Description	QTY	Estimated Delivery Date
2022 - OFFICER SAFETY PLAN 7 PLUS Premium 10 Year	20188	VR CONTROLLER KIT PELICAN CASE	4	06/15/2022
2022 - OFFICER SAFETY PLAN 7 PLUS Premium 10 Year	20296	SAMSUNG S7+ TABLET FOR VR SIMULATOR	4	06/15/2022
2022 - OFFICER SAFETY PLAN 7 PLUS Premium 10 Year	20297	SAMSUNG S7+ TABLET CASE FOR VR SIMULATOR	4	06/15/2022
2022 - OFFICER SAFETY PLAN 7 PLUS Premium 10 Year	20298	VR-ENABLED GLOCK 19 CONTROLLER	4	06/15/2022
2022 - OFFICER SAFETY PLAN 7 PLUS Premium 10 Year	20378	HTC FOCUS 3 VR HEADSET	11	06/15/2022
2022 - OFFICER SAFETY PLAN 7 PLUS Premium 10 Year	22196	TASER 7 VR CARTRIDGE, STANDOFF (3.5-DEGREE)	8	06/15/2022
2022 - OFFICER SAFETY PLAN 7 PLUS Premium 10 Year	22197	TASER 7 VR CARTRIDGE, CLOSE-QUARTERS (12-DEGREE)	8	06/15/2022
2022 - OFFICER SAFETY PLAN 7 PLUS Premium 10 Year	71044	BATTERY, SIGNAL SIDEARM, CR2430 SINGLE PACK	550	06/15/2022
2022 - OFFICER SAFETY PLAN 7 PLUS Premium 10 Year	75015	SIGNAL SIDEARM KIT	275	06/15/2022
2022 Taser 7 Cert Bundle W/ VR 10 Year	20008	TASER 7 HANDLE, YLW, HIGH VISIBILITY (GREEN LASER), CLASS 3R	20	06/15/2022
2022 Taser 7 Cert Bundle W/ VR 10 Year	20018	TASER 7 BATTERY PACK, TACTICAL	24	06/15/2022
2022 Taser 7 Cert Bundle W/ VR 10 Year	20160	TASER 7 HOLSTER - SAFARILAND, RH+CART CARRIER	20	06/15/2022
2022 Taser 7 Cert Bundle W/ VR 10 Year	20188	VR CONTROLLER KIT PELICAN CASE	1	06/15/2022
2022 Taser 7 Cert Bundle W/ VR 10 Year	20188	VR CONTROLLER KIT PELICAN CASE	1	06/15/2022
2022 Taser 7 Cert Bundle W/ VR 10 Year	20296	SAMSUNG S7+ TABLET FOR VR SIMULATOR	1	06/15/2022
2022 Taser 7 Cert Bundle W/ VR 10 Year	20296	SAMSUNG S7+ TABLET FOR VR SIMULATOR	1	06/15/2022
2022 Taser 7 Cert Bundle W/ VR 10 Year	20297	SAMSUNG S7+ TABLET CASE FOR VR SIMULATOR	1	06/15/2022
2022 Taser 7 Cert Bundle W/ VR 10 Year	20297	SAMSUNG S7+ TABLET CASE FOR VR SIMULATOR	1	06/15/2022
2022 Taser 7 Cert Bundle W/ VR 10 Year	20298	VR-ENABLED GLOCK 19 CONTROLLER	1	06/15/2022
2022 Taser 7 Cert Bundle W/ VR 10 Year	20298	VR-ENABLED GLOCK 19 CONTROLLER	1	06/15/2022
2022 Taser 7 Cert Bundle W/ VR 10 Year	20378	HTC FOCUS 3 VR HEADSET	1	06/15/2022
2022 Taser 7 Cert Bundle W/ VR 10 Year	20378	HTC FOCUS 3 VR HEADSET	2	06/15/2022
2022 Taser 7 Cert Bundle W/ VR 10 Year	22175	TASER 7 LIVE CARTRIDGE, STANDOFF (3.5-DEGREE) NS	60	06/15/2022
2022 Taser 7 Cert Bundle W/ VR 10 Year	22175	TASER 7 LIVE CARTRIDGE, STANDOFF (3.5-DEGREE) NS	40	06/15/2022
2022 Taser 7 Cert Bundle W/ VR 10 Year	22176	TASER 7 LIVE CARTRIDGE, CLOSE QUARTERS (12-DEGREE) NS	60	06/15/2022
2022 Taser 7 Cert Bundle W/ VR 10 Year	22176	TASER 7 LIVE CARTRIDGE, CLOSE QUARTERS (12-DEGREE) NS	40	06/15/2022
2022 Taser 7 Cert Bundle W/ VR 10 Year	22177	TASER 7 HOOK-AND-LOOP TRN (HALT) CARTRIDGE, STANDOFF NS	40	06/15/2022
2022 Taser 7 Cert Bundle W/ VR 10 Year	22178	TASER 7 HOOK-AND-LOOP TRN (HALT) CARTRIDGE, CLOSE QUART NS	40	06/15/2022
2022 Taser 7 Cert Bundle W/ VR 10 Year	22179	TASER 7 INERT CARTRIDGE, STANDOFF (3.5-DEGREE) NS	20	06/15/2022
2022 Taser 7 Cert Bundle W/ VR 10 Year	22181	TASER 7 INERT CARTRIDGE, CLOSE QUARTERS (12-DEGREE) NS	20	06/15/2022
2022 Taser 7 Cert Bundle W/ VR 10 Year	22196	TASER 7 VR CARTRIDGE, STANDOFF (3.5-DEGREE)	2	06/15/2022
2022 Taser 7 Cert Bundle W/ VR 10 Year	22196	TASER 7 VR CARTRIDGE, STANDOFF (3.5-DEGREE)	2	06/15/2022
2022 Taser 7 Cert Bundle W/ VR 10 Year	22197	TASER 7 VR CARTRIDGE, CLOSE-QUARTERS (12-DEGREE)	2	06/15/2022
2022 Taser 7 Cert Bundle W/ VR 10 Year	22197	TASER 7 VR CARTRIDGE, CLOSE-QUARTERS (12-DEGREE)	2	06/15/2022
2022 Taser 7 Cert Bundle W/ VR 10 Year	70033	WALL MOUNT BRACKET, ASSY, EVIDENCE.COM DOCK	1	06/15/2022
2022 Taser 7 Cert Bundle W/ VR 10 Year	71019	NORTH AMER POWER CORD FOR AB3 8-BAY, AB2 1-BAY / 6-BAY DOCK	1	06/15/2022
2022 Taser 7 Cert Bundle W/ VR 10 Year	74200	TASER 7 6-BAY DOCK AND CORE	1	06/15/2022
2022 Taser 7 Cert Bundle W/ VR 10 Year	80087	TASER 7 TARGET, CONDUCTIVE, PROFESSIONAL (RUGGEDIZED)	1	06/15/2022
2022 Taser 7 Cert Bundle W/ VR 10 Year	80090	TARGET FRAME, PROFESSIONAL, 27.5 IN. X 75 IN., TASER 7	1	06/15/2022
AB3 Camera Bundle	11534	USB-C to USB-A CABLE FOR AB3 OR FLEX 2	313	06/15/2022
AB3 Camera Bundle	73202	AXON BODY 3 - NA10 - US - BLK - RAPIDLOCK	284	06/15/2022
AB3 Camera Bundle	74028	WING CLIP MOUNT, AXON RAPIDLOCK	313	06/15/2022
AB3 Multi Bay Dock Bundle	71019	NORTH AMER POWER CORD FOR AB3 8-BAY, AB2 1-BAY / 6-BAY DOCK	35	08/15/2022



## Hardware

Bundle	Item	Description	QTY	Estimated Delivery Date
AB3 Multi Bay Dock Bundle	74210	AXON BODY 3 - 8 BAY DOCK	35	08/15/2022
2022 - OFFICER SAFETY PLAN 7 PLUS Premium 10 Year	22175	TASER 7 LIVE CARTRIDGE, STANDOFF (3.5-DEGREE) NS	550	12/15/2022
2022 - OFFICER SAFETY PLAN 7 PLUS Premium 10 Year	22176	TASER 7 LIVE CARTRIDGE, CLOSE QUARTERS (12-DEGREE) NS	550	12/15/2022
2022 Taser 7 Cert Bundle W/ VR 10 Year	22175	TASER 7 LIVE CARTRIDGE, STANDOFF (3.5-DEGREE) NS	96	12/15/2022
2022 Taser 7 Cert Bundle W/ VR 10 Year	22176	TASER 7 LIVE CARTRIDGE, CLOSE QUARTERS (12-DEGREE) NS	96	12/15/2022
2022 Taser 7 Cert Bundle W/ VR 10 Year	22175	TASER 7 LIVE CARTRIDGE, STANDOFF (3.5-DEGREE) NS	40	06/15/2023
2022 Taser 7 Cert Bundle W/ VR 10 Year	22176	TASER 7 LIVE CARTRIDGE, CLOSE QUARTERS (12-DEGREE) NS	40	06/15/2023
2022 - OFFICER SAFETY PLAN 7 PLUS Premium 10 Year	22175	TASER 7 LIVE CARTRIDGE, STANDOFF (3.5-DEGREE) NS	550	12/15/2023
2022 - OFFICER SAFETY PLAN 7 PLUS Premium 10 Year	22176	TASER 7 LIVE CARTRIDGE, CLOSE QUARTERS (12-DEGREE) NS	550	12/15/2023
2022 Taser 7 Cert Bundle W/ VR 10 Year	22175	TASER 7 LIVE CARTRIDGE, STANDOFF (3.5-DEGREE) NS	96	12/15/2023
2022 Taser 7 Cert Bundle W/ VR 10 Year	22176	TASER 7 LIVE CARTRIDGE, CLOSE QUARTERS (12-DEGREE) NS	96	12/15/2023
2022 Taser 7 Cert Bundle W/ VR 10 Year	22175	TASER 7 LIVE CARTRIDGE, STANDOFF (3.5-DEGREE) NS	40	06/15/2024
2022 Taser 7 Cert Bundle W/ VR 10 Year	22176	TASER 7 LIVE CARTRIDGE, CLOSE QUARTERS (12-DEGREE) NS	40	06/15/2024
2022 - OFFICER SAFETY PLAN 7 PLUS Premium 10 Year	100210	VIRTUAL REALITY TABLET REFRESH ONE	4	12/15/2024
2022 - OFFICER SAFETY PLAN 7 PLUS Premium 10 Year	20242	TASER CERTIFICATION PROGRAM YEAR 6-10 HARDWARE	275	12/15/2024
2022 - OFFICER SAFETY PLAN 7 PLUS Premium 10 Year	20373	VIRTUAL REALITY HEADSET REFRESH ONE	11	12/15/2024
2022 - OFFICER SAFETY PLAN 7 PLUS Premium 10 Year	73309	AXON CAMERA REFRESH ONE	284	12/15/2024
2022 - OFFICER SAFETY PLAN 7 PLUS Premium 10 Year	73689	MULTI-BAY BWC DOCK 1ST REFRESH	35	12/15/2024
2022 Taser 7 Cert Bundle W/ VR 10 Year	100210	VIRTUAL REALITY TABLET REFRESH ONE	1	12/15/2024
2022 Taser 7 Cert Bundle W/ VR 10 Year	100210	VIRTUAL REALITY TABLET REFRESH ONE	1	12/15/2024
2022 Taser 7 Cert Bundle W/ VR 10 Year	20242	TASER CERTIFICATION PROGRAM YEAR 6-10 HARDWARE	20	12/15/2024
2022 Taser 7 Cert Bundle W/ VR 10 Year	20242	TASER CERTIFICATION PROGRAM YEAR 6-10 HARDWARE	48	12/15/2024
2022 Taser 7 Cert Bundle W/ VR 10 Year	20373	VIRTUAL REALITY HEADSET REFRESH ONE	1	12/15/2024
2022 Taser 7 Cert Bundle W/ VR 10 Year	20373	VIRTUAL REALITY HEADSET REFRESH ONE	2	12/15/2024
2022 - OFFICER SAFETY PLAN 7 PLUS Premium 10 Year	100211	VIRTUAL REALITY TABLET REFRESH TWO	4	06/15/2027
2022 - OFFICER SAFETY PLAN 7 PLUS Premium 10 Year	20374	VIRTUAL REALITY HEADSET REFRESH TWO	11	06/15/2027
2022 - OFFICER SAFETY PLAN 7 PLUS Premium 10 Year	73310	AXON CAMERA REFRESH TWO	284	06/15/2027
2022 - OFFICER SAFETY PLAN 7 PLUS Premium 10 Year	73688	MULTI-BAY BWC DOCK 2ND REFRESH	35	06/15/2027
2022 Taser 7 Cert Bundle W/ VR 10 Year	100211	VIRTUAL REALITY TABLET REFRESH TWO	1	06/15/2027
2022 Taser 7 Cert Bundle W/ VR 10 Year	100211	VIRTUAL REALITY TABLET REFRESH TWO	1	06/15/2027
2022 Taser 7 Cert Bundle W/ VR 10 Year	20374	VIRTUAL REALITY HEADSET REFRESH TWO	1	06/15/2027
2022 Taser 7 Cert Bundle W/ VR 10 Year	20374	VIRTUAL REALITY HEADSET REFRESH TWO	2	06/15/2027
2022 - OFFICER SAFETY PLAN 7 PLUS Premium 10 Year	100212	VIRTUAL REALITY TABLET REFRESH THREE	4	12/15/2029
2022 - OFFICER SAFETY PLAN 7 PLUS Premium 10 Year	20375	VIRTUAL REALITY HEADSET REFRESH THREE	11	12/15/2029
2022 - OFFICER SAFETY PLAN 7 PLUS Premium 10 Year	73345	AXON CAMERA REFRESH THREE	284	12/15/2029
2022 - OFFICER SAFETY PLAN 7 PLUS Premium 10 Year	73347	MULTI-BAY BWC DOCK 3RD REFRESH	35	12/15/2029
2022 Taser 7 Cert Bundle W/ VR 10 Year	100212	VIRTUAL REALITY TABLET REFRESH THREE	1	12/15/2029
2022 Taser 7 Cert Bundle W/ VR 10 Year	100212	VIRTUAL REALITY TABLET REFRESH THREE	1	12/15/2029
2022 Taser 7 Cert Bundle W/ VR 10 Year	20375	VIRTUAL REALITY HEADSET REFRESH THREE	1	12/15/2029
2022 Taser 7 Cert Bundle W/ VR 10 Year	20375	VIRTUAL REALITY HEADSET REFRESH THREE	2	12/15/2029

## Software

Bundle	Item	Description	QTY	Estimated Start Date	Estimated End Date
2022 - OFFICER SAFETY PLAN 7 PLUS Premium 10 Year	100165	UNLIMITED 3RD-PARTY STORAGE	275	07/15/2022	01/14/2030
2022 - OFFICER SAFETY PLAN 7 PLUS Premium 10 Year	20248	TASER 7 EVIDENCE.COM LICENSE	275	07/15/2022	01/14/2030
2022 - OFFICER SAFETY PLAN 7 PLUS Premium 10 Year	20248	TASER 7 EVIDENCE.COM LICENSE	2	07/15/2022	01/14/2030

## Software

Bundle	Item	Description	QTY	Estimated Start Date	Estimated End Date
2022 - OFFICER SAFETY PLAN 7 PLUS Premium 10 Year	20370	FULL VR TASER 7 ADD-ON USER ACCESS	275	07/15/2022	01/14/2030
2022 - OFFICER SAFETY PLAN 7 PLUS Premium 10 Year	73478	REDACTION ASSISTANT USER LICENSE	275	07/15/2022	01/14/2030
2022 - OFFICER SAFETY PLAN 7 PLUS Premium 10 Year	73618	CITIZEN FOR COMMUNITIES USER LICENSE	275	07/15/2022	01/14/2030
2022 - OFFICER SAFETY PLAN 7 PLUS Premium 10 Year	73680	RESPOND DEVICE PLUS LICENSE	275	07/15/2022	01/14/2030
2022 - OFFICER SAFETY PLAN 7 PLUS Premium 10 Year	73681	AXON RECORDS FULL	275	07/15/2022	01/14/2030
2022 - OFFICER SAFETY PLAN 7 PLUS Premium 10 Year	73682	AUTO TAGGING LICENSE	275	07/15/2022	01/14/2030
2022 - OFFICER SAFETY PLAN 7 PLUS Premium 10 Year	73686	UNLIMITED BWC + CAPTURE STORAGE	275	07/15/2022	01/14/2030
2022 - OFFICER SAFETY PLAN 7 PLUS Premium 10 Year	73687	EVIDENCE.COM VIEWER LICENSE	2	07/15/2022	01/14/2030
2022 - OFFICER SAFETY PLAN 7 PLUS Premium 10 Year	73739	PERFORMANCE LICENSE	275	07/15/2022	01/14/2030
2022 - OFFICER SAFETY PLAN 7 PLUS Premium 10 Year	73746	PROFESSIONAL EVIDENCE.COM LICENSE	275	07/15/2022	01/14/2030
2022 - OFFICER SAFETY PLAN 7 PLUS Premium 10 Year	85760	Auto-Transcribe Unlimited Service	275	07/15/2022	01/14/2030
2022 Taser 7 Cert Bundle W/ VR 10 Year	20248	TASER 7 EVIDENCE.COM LICENSE	20	07/15/2022	01/14/2030
2022 Taser 7 Cert Bundle W/ VR 10 Year	20248	TASER 7 EVIDENCE.COM LICENSE	1	07/15/2022	01/14/2030
2022 Taser 7 Cert Bundle W/ VR 10 Year	20248	TASER 7 EVIDENCE.COM LICENSE	48	07/15/2022	01/14/2030
2022 Taser 7 Cert Bundle W/ VR 10 Year	20248	TASER 7 EVIDENCE.COM LICENSE	1	07/15/2022	01/14/2030
2022 Taser 7 Cert Bundle W/ VR 10 Year	20370	FULL VR TASER 7 ADD-ON USER ACCESS	20	07/15/2022	01/14/2030
2022 Taser 7 Cert Bundle W/ VR 10 Year	20370	FULL VR TASER 7 ADD-ON USER ACCESS	48	07/15/2022	01/14/2030
Pro License Bundle	73683	10 GB EVIDENCE.COM A-LA-CART STORAGE-	360	07/15/2022	01/14/2030
Pro License Bundle	73746	PROFESSIONAL EVIDENCE.COM LICENSE	120	07/15/2022	01/14/2030
A la Carte	73890	RECORDS LICENSE, NON-OSP	25	01/15/2025	01/14/2030
A la Carte	73891	RECORDS LICENSE, NON-SWORN	120	01/15/2025	01/14/2030

## Services

Bundle	Item	Description	QTY
2022 - OFFICER SAFETY PLAN 7 PLUS Premium 10 Year	11642	THIRD-PARTY VIDEO SUPPORT LICENSE	275
2022 - OFFICER SAFETY PLAN 7 PLUS Premium 10 Year	20119	TASER 7 MASTER INSTRUCTOR SCHOOL VOUCHER	1
2022 - OFFICER SAFETY PLAN 7 PLUS Premium 10 Year	20119	TASER 7 MASTER INSTRUCTOR SCHOOL VOUCHER	1
2022 - OFFICER SAFETY PLAN 7 PLUS Premium 10 Year	20120	TASER 7 INSTRUCTOR COURSE VOUCHER	3
2022 - OFFICER SAFETY PLAN 7 PLUS Premium 10 Year	20120	TASER 7 INSTRUCTOR COURSE VOUCHER	3
2022 - OFFICER SAFETY PLAN 7 PLUS Premium 10 Year	79999	AUTO TAGGING / PERFORMANCE IMPLEMENTATION SERVICE	1
2022 - OFFICER SAFETY PLAN 7 PLUS Premium 10 Year	80190	Evidence.com Channel Services	1
2022 - OFFICER SAFETY PLAN 7 PLUS Premium 10 Year	80223	INACTIVE CHANNEL ACCESS LICENSE	1
A la Carte	73897	STANDARDS SERVICE, PREMIUM	1
A la Carte	85144	AXON STARTER	1
A la Carte	85144	AXON STARTER	1
A la Carte	85157	Consortium - Records Milestone Payment	1

## Warranties

Bundle	Item	Description	QTY	Estimated Start Date	Estimated End Date
2022 - OFFICER SAFETY PLAN 7 PLUS Premium 10 Year	100198	AXON VR CONTROLLER KIT - WARRANTY	4	07/15/2022	01/14/2030
2022 - OFFICER SAFETY PLAN 7 PLUS Premium 10 Year	80464	EXT WARRANTY, CAMERA (TAP)	275	07/15/2022	01/14/2030
2022 - OFFICER SAFETY PLAN 7 PLUS Premium 10 Year	80464	EXT WARRANTY, CAMERA (TAP)	9	07/15/2022	01/14/2030
2022 - OFFICER SAFETY PLAN 7 PLUS Premium 10 Year	80465	EXT WARRANTY, MULTI-BAY DOCK (TAP)	35	07/15/2022	01/14/2030
2022 Taser 7 Cert Bundle W/ VR 10 Year	100198	AXON VR CONTROLLER KIT - WARRANTY	1	07/15/2022	01/14/2030

## Warranties

Bundle	Item	Description	QTY	Estimated Start Date	Estimated End Date
2022 Taser 7 Cert Bundle W/ VR 10 Year	100198	AXON VR CONTROLLER KIT - WARRANTY	1	07/15/2022	01/14/2030
A la Carte	80374	EXT WARRANTY, TASER 7 BATTERY PACK	387	07/15/2022	01/14/2030
A la Carte	80395	EXT WARRANTY, TASER 7 HANDLE	333	07/15/2022	01/14/2030
A la Carte	80396	EXT WARRANTY, TASER 7 SIX BAY DOCK	4	07/15/2022	01/14/2030
2022 Taser 7 Cert Bundle W/ VR 10 Year	80374	EXT WARRANTY, TASER 7 BATTERY PACK	24	06/15/2023	01/14/2030
2022 Taser 7 Cert Bundle W/ VR 10 Year	80395	EXT WARRANTY, TASER 7 HANDLE	20	06/15/2023	01/14/2030
2022 Taser 7 Cert Bundle W/ VR 10 Year	80396	EXT WARRANTY, TASER 7 SIX BAY DOCK	1	06/15/2023	01/14/2030

## Payment Details

<b>Jul 2021</b>						
<b>Invoice Plan</b>	<b>Item</b>	<b>Description</b>	<b>Qty</b>	<b>Subtotal</b>	<b>Tax</b>	<b>Total</b>
Invoice Upon Fulfillment	80374	EXT WARRANTY, TASER 7 BATTERY PACK	387	\$0.00	\$0.00	\$0.00
Invoice Upon Fulfillment	80395	EXT WARRANTY, TASER 7 HANDLE	333	\$0.00	\$0.00	\$0.00
Invoice Upon Fulfillment	80396	EXT WARRANTY, TASER 7 SIX BAY DOCK	4	\$0.00	\$0.00	\$0.00
<b>Total</b>				<b>\$0.00</b>	<b>\$0.00</b>	<b>\$0.00</b>

<b>Jun 2022</b>						
<b>Invoice Plan</b>	<b>Item</b>	<b>Description</b>	<b>Qty</b>	<b>Subtotal</b>	<b>Tax</b>	<b>Total</b>
Year 3 - T7Cert (48)	2022T7CertVR10Yr	2022 Taser 7 Cert Bundle W/ VR 10 Year	48	\$11,707.32	\$1,053.67	\$12,760.99
Invoice Upon Fulfillment	AB3C	AB3 Camera Bundle	284	\$0.00	\$0.00	\$0.00
Year 3 - OSP7+P	2022OSP7+Premium10Year	2022 - OFFICER SAFETY PLAN 7 PLUS Premium 10 Year	275	\$252,817.08	\$21,583.82	\$274,400.90
Year 3 - Axon	ProLicense	Pro License Bundle	120	\$19,199.18	\$1,727.93	\$20,927.11
Year 3 - T7Cert (20)	2022T7CertVR10Yr	2022 Taser 7 Cert Bundle W/ VR 10 Year	20	\$6,358.04	\$572.22	\$6,930.26
<b>Total</b>				<b>\$290,081.62</b>	<b>\$24,937.64</b>	<b>\$315,019.26</b>

<b>Jul 2022</b>						
<b>Invoice Plan</b>	<b>Item</b>	<b>Description</b>	<b>Qty</b>	<b>Subtotal</b>	<b>Tax</b>	<b>Total</b>
Invoice Upon Fulfillment	73897	STANDARDS SERVICE, PREMIUM	1	\$20,000.00	\$1,800.00	\$21,800.00
Invoice Upon Fulfillment	85144	AXON STARTER	1	\$2,750.00	\$247.50	\$2,997.50
Invoice Upon Fulfillment	85144	AXON STARTER	1	\$2,750.00	\$247.50	\$2,997.50
<b>Total</b>				<b>\$25,500.00</b>	<b>\$2,295.00</b>	<b>\$27,795.00</b>

<b>Aug 2022</b>						
<b>Invoice Plan</b>	<b>Item</b>	<b>Description</b>	<b>Qty</b>	<b>Subtotal</b>	<b>Tax</b>	<b>Total</b>
Invoice Upon Fulfillment	AB3MBD	AB3 Multi Bay Dock Bundle	35	\$0.10	\$0.06	\$0.16
<b>Total</b>				<b>\$0.10</b>	<b>\$0.06</b>	<b>\$0.16</b>

<b>Jan 2023</b>						
<b>Invoice Plan</b>	<b>Item</b>	<b>Description</b>	<b>Qty</b>	<b>Subtotal</b>	<b>Tax</b>	<b>Total</b>
Year 4 - T7Cert (48)	2022T7CertVR10Yr	2022 Taser 7 Cert Bundle W/ VR 10 Year	48	\$35,865.80	\$3,227.91	\$39,093.71
Year 4 - OSP7+P	2022OSP7+Premium10Year	2022 - OFFICER SAFETY PLAN 7 PLUS Premium 10 Year	275	\$774,511.96	\$66,122.73	\$840,634.69
Year 4 - Axon	ProLicense	Pro License Bundle	120	\$58,817.26	\$5,293.55	\$64,110.81
Year 4 - T7Cert (20)	2022T7CertVR10Yr	2022 Taser 7 Cert Bundle W/ VR 10 Year	20	\$19,477.97	\$1,753.01	\$21,230.98
<b>Total</b>				<b>\$888,672.99</b>	<b>\$76,397.20</b>	<b>\$965,070.19</b>

<b>Jan 2024</b>						
<b>Invoice Plan</b>	<b>Item</b>	<b>Description</b>	<b>Qty</b>	<b>Subtotal</b>	<b>Tax</b>	<b>Total</b>
Year 5 - T7Cert (48)	2022T7CertVR10Yr	2022 Taser 7 Cert Bundle W/ VR 10 Year	48	\$35,865.80	\$3,227.91	\$39,093.71
Year 5 - OSP7+P	2022OSP7+Premium10Year	2022 - OFFICER SAFETY PLAN 7 PLUS Premium 10 Year	275	\$774,511.96	\$66,122.73	\$840,634.69
Year 5 - Axon	ProLicense	Pro License Bundle	120	\$58,817.26	\$5,293.55	\$64,110.81
Year 5 - T7Cert (20)	2022T7CertVR10Yr	2022 Taser 7 Cert Bundle W/ VR 10 Year	20	\$19,477.97	\$1,753.01	\$21,230.98

<b>Jan 2024</b>						
<b>Invoice Plan</b>	<b>Item</b>	<b>Description</b>	<b>Qty</b>	<b>Subtotal</b>	<b>Tax</b>	<b>Total</b>
<b>Total</b>				<b>\$888,672.99</b>	<b>\$76,397.20</b>	<b>\$965,070.19</b>

<b>Jan 2025</b>						
<b>Invoice Plan</b>	<b>Item</b>	<b>Description</b>	<b>Qty</b>	<b>Subtotal</b>	<b>Tax</b>	<b>Total</b>
Year 6 - T7Cert (48)	2022T7CertVR10Yr	2022 Taser 7 Cert Bundle W/ VR 10 Year	48	\$35,865.80	\$3,227.91	\$39,093.71
Invoice Upon Fulfillment	73890	RECORDS LICENSE, NON-OSP	25	\$43,500.00	\$3,915.00	\$47,415.00
Invoice Upon Fulfillment	73891	RECORDS LICENSE, NON-SWORN	120	\$0.00	\$0.00	\$0.00
Invoice Upon Fulfillment	85157	Consortium - Records Milestone Payment	1	\$430,000.00	\$38,700.00	\$468,700.00
Year 6 - OSP7+P	2022OSP7+Premium10Year	2022 - OFFICER SAFETY PLAN 7 PLUS Premium 10 Year	275	\$774,511.96	\$66,122.73	\$840,634.69
Year 6 - Axon	ProLicense	Pro License Bundle	120	\$58,817.26	\$5,293.55	\$64,110.81
Year 6 - T7Cert (20)	2022T7CertVR10Yr	2022 Taser 7 Cert Bundle W/ VR 10 Year	20	\$19,477.97	\$1,753.01	\$21,230.98
<b>Total</b>				<b>\$1,362,172.99</b>	<b>\$119,012.20</b>	<b>\$1,481,185.19</b>

<b>Jan 2026</b>						
<b>Invoice Plan</b>	<b>Item</b>	<b>Description</b>	<b>Qty</b>	<b>Subtotal</b>	<b>Tax</b>	<b>Total</b>
Year 7 - T7Cert (48)	2022T7CertVR10Yr	2022 Taser 7 Cert Bundle W/ VR 10 Year	48	\$35,865.80	\$3,227.91	\$39,093.71
Year 7 - OSP7+P	2022OSP7+Premium10Year	2022 - OFFICER SAFETY PLAN 7 PLUS Premium 10 Year	275	\$774,511.96	\$66,122.73	\$840,634.69
Year 7 - Axon	ProLicense	Pro License Bundle	120	\$58,817.26	\$5,293.55	\$64,110.81
Year 7 - T7Cert (20)	2022T7CertVR10Yr	2022 Taser 7 Cert Bundle W/ VR 10 Year	20	\$19,477.97	\$1,753.01	\$21,230.98
<b>Total</b>				<b>\$888,672.99</b>	<b>\$76,397.20</b>	<b>\$965,070.19</b>

<b>Jan 2027</b>						
<b>Invoice Plan</b>	<b>Item</b>	<b>Description</b>	<b>Qty</b>	<b>Subtotal</b>	<b>Tax</b>	<b>Total</b>
Year 8 - T7Cert (48)	2022T7CertVR10Yr	2022 Taser 7 Cert Bundle W/ VR 10 Year	48	\$35,865.80	\$3,227.91	\$39,093.71
Year 8 - OSP7+P	2022OSP7+Premium10Year	2022 - OFFICER SAFETY PLAN 7 PLUS Premium 10 Year	275	\$774,511.96	\$66,122.73	\$840,634.69
Year 8 - Axon	ProLicense	Pro License Bundle	120	\$58,817.26	\$5,293.55	\$64,110.81
Year 8 - T7Cert (20)	2022T7CertVR10Yr	2022 Taser 7 Cert Bundle W/ VR 10 Year	20	\$19,477.97	\$1,753.01	\$21,230.98
<b>Total</b>				<b>\$888,672.99</b>	<b>\$76,397.20</b>	<b>\$965,070.19</b>

<b>Jan 2028</b>						
<b>Invoice Plan</b>	<b>Item</b>	<b>Description</b>	<b>Qty</b>	<b>Subtotal</b>	<b>Tax</b>	<b>Total</b>
Year 9 - T7Cert (48)	2022T7CertVR10Yr	2022 Taser 7 Cert Bundle W/ VR 10 Year	48	\$35,865.80	\$3,227.91	\$39,093.71
Year 9 - OSP7+P	2022OSP7+Premium10Year	2022 - OFFICER SAFETY PLAN 7 PLUS Premium 10 Year	275	\$774,511.96	\$66,122.73	\$840,634.69
Year 9 - Axon	ProLicense	Pro License Bundle	120	\$58,817.26	\$5,293.55	\$64,110.81
Year 9 - T7Cert (20)	2022T7CertVR10Yr	2022 Taser 7 Cert Bundle W/ VR 10 Year	20	\$19,477.97	\$1,753.01	\$21,230.98
<b>Total</b>				<b>\$888,672.99</b>	<b>\$76,397.20</b>	<b>\$965,070.19</b>

<b>Jan 2029</b>						
<b>Invoice Plan</b>	<b>Item</b>	<b>Description</b>	<b>Qty</b>	<b>Subtotal</b>	<b>Tax</b>	<b>Total</b>
Year 10 - T7Cert (48)	2022T7CertVR10Yr	2022 Taser 7 Cert Bundle W/ VR 10 Year	48	\$35,865.80	\$3,227.91	\$39,093.71
Year 10 - OSP7+P	2022OSP7+Premium10Year	2022 - OFFICER SAFETY PLAN 7 PLUS Premium 10 Year	275	\$774,511.96	\$66,122.73	\$840,634.69
Year 10 - Axon	ProLicense	Pro License Bundle	120	\$58,817.26	\$5,293.55	\$64,110.81
Year 10 - T7Cert (20)	2022T7CertVR10Yr	2022 Taser 7 Cert Bundle W/ VR 10 Year	20	\$19,477.97	\$1,753.01	\$21,230.98

**Jan 2029**

<b>Invoice Plan</b>	<b>Item</b>	<b>Description</b>	<b>Qty</b>	<b>Subtotal</b>	<b>Tax</b>	<b>Total</b>
<b>Total</b>				<b>\$888,672.99</b>	<b>\$76,397.20</b>	<b>\$965,070.19</b>

**Tax is estimated based on rates applicable at date of quote and subject to change at time of invoicing. If a tax exemption certificate should be applied, please submit prior to invoicing.**

## Standard Terms and Conditions

### Axon Enterprise Inc. Sales Terms and Conditions

#### Axon Master Services and Purchasing Agreement:

This Quote is limited to and conditional upon your acceptance of the provisions set forth herein and Axon's Master Services and Purchasing Agreement (posted at [www.axon.com/legal/sales-terms-and-conditions](http://www.axon.com/legal/sales-terms-and-conditions)), as well as the attached Statement of Work (SOW) for Axon Fleet and/or Axon Interview Room purchase, if applicable. In the event you and Axon have entered into a prior agreement to govern all future purchases, that agreement shall govern to the extent it includes the products and services being purchased and does not conflict with the Axon Customer Experience Improvement Program Appendix as described below.

#### ACEIP:

The Axon Customer Experience Improvement Program Appendix, which includes the sharing of de-identified segments of Agency Content with Axon to develop new products and improve your product experience (posted at [www.axon.com/legal/sales-terms-and-conditions](http://www.axon.com/legal/sales-terms-and-conditions)), is incorporated herein by reference. By signing below, you agree to the terms of the Axon Customer Experience Improvement Program.

#### Acceptance of Terms:

Any purchase order issued in response to this Quote is subject solely to the above referenced terms and conditions. By signing below, you represent that you are lawfully able to enter into contracts. If you are signing on behalf of an entity (including but not limited to the company, municipality, or government agency for whom you work), you represent to Axon that you have legal authority to bind that entity. If you do not have this authority, please do not sign this Quote.

## Exceptions to Standard Terms and Conditions

**Axon Records Subscription Term**. For the purposes of invoicing and payment, the Axon Records subscription begins upon Go-Live

Prior to Go-Live, as further defined in the SOW for Axon Records and/or Standards, Agency may terminate if Agency determines there is a material default with Axon Records and/or Standards and does not meet any requirements in the SOW. In the event Agency terminates under this Section, any payment obligations related to the integration of Axon Records and/or Standards will be cancelled.

Agency has existing contract #00025500 (originated via Q-226160) and is amending that contract upon the new license start date (7/15/2022) of this quote. All references to pricing and duration of the contract will be updated to reflect this quote.

The parties agree that Axon is granting a refund of \$248,415.13 to refund paid, but undelivered services. This discount is based on a ship date range of 6/15/2022-6/30/2022, resulting in a 7/15/2022 license date. Any change in this date and resulting license start date will result in modification of this discount value which may result in additional fees due to or from Axon.

## Exceptions to Standard Terms and Conditions

For the purposes of invoicing and payment, Axon Standards and Axon Records subscription begins upon Go-Live.

Spokane PD is entitled to the next iteration of CEW in 2025 at no additional cost.



Signature

Date Signed

4/28/2022



## ATTENTION

This order may qualify for freight shipping, please fill out the following information.

Who is the receiving contact and what is the contact phone number for this shipment?	
What are the receiving hours of operation?	
Is a loading dock available for this incoming shipment? If yes, are you able to unload pallets from the trailer or will the driver need to assist with unload?	
Do you have a forklift and/or pallet jack to transport pallets into your facility?	
Are there any delivery restrictions (no 53' trailers, no box trucks, etc.)?	



## Attachment B - Axon Respond Appendix

This Axon Respond Appendix applies to both Axon Respond and Axon Respond Plus, if either is included on the Quote.

1. **Axon Respond Subscription Term.** If Agency purchases Axon Respond as part of a bundled offering, the Axon Respond subscription begins on the later of the (1) start date of that bundled offering, or (2) date Axon provisions Axon Respond to Agency. If Agency purchases Axon Respond as a standalone, the Axon Respond subscription begins the later of the (1) date Axon provisions Axon Respond to Agency, or (2) first day of the month following the Effective Date. The Axon Respond subscription term will end upon the completion of the Axon Evidence Subscription associated with Axon Respond.
2. **Scope of Axon Respond.** The scope of Axon Respond is to assist Agency with real-time situational awareness during critical incidents to improve officer safety, effectiveness, and awareness. In the event Agency uses Axon Respond outside this scope, Axon may initiate good-faith discussions with Agency on upgrading Agency's Axon Respond to better meet Agency's needs.
3. **Axon Body 3 LTE Requirements.** Axon Respond is only available and usable with an LTE enabled body-worn camera. Axon is not liable if Agency utilizes the LTE device outside of the coverage area or if the LTE carrier is unavailable. LTE coverage is only available in the United States, including any U.S. territories. Axon may utilize a carrier of Axon's choice to provide LTE service. Axon may change LTE carriers during the Term without Agency's consent.
4. **Axon Fleet 3 LTE Requirements.** Axon Respond is only available and usable with a Fleet 3 system configured with LTE modem and service. Agency is responsible for providing LTE service for the modem. Coverage and availability of LTE service is subject to Agency's LTE carrier.
5. **Axon Respond Service Limitations.** Agency acknowledges that LTE service is made available only within the operating range of the networks. Service may be temporarily refused, interrupted, or limited because of: (a) facilities limitations; (b) transmission limitations caused by atmospheric, terrain, other natural or artificial conditions adversely affecting transmission, weak batteries, system overcapacity, movement outside a service area or gaps in coverage in a service area and other causes reasonably outside of the carrier's control such as intentional or negligent acts of third parties that damage or impair the network or disrupt service; or (c) equipment modifications, upgrades, relocations, repairs, and other similar activities necessary for the proper or improved operation of service.
  - 5.1. With regard to Axon Body 3, Partner networks are made available as-is and the carrier makes no warranties or representations as to the availability or quality of roaming service provided by carrier partners, and the carrier will not be liable in any capacity for any errors, outages, or failures of carrier partner networks. Agency expressly understands and agrees that it has no contractual relationship whatsoever with the underlying wireless service provider or its affiliates or contractors and Agency is not a third-party beneficiary of any agreement between Axon and the underlying carrier.
6. **Termination.** Upon termination of this Agreement, or if Agency stops paying for Axon Respond or bundles that include Axon Respond, Axon will end Axon Respond services, including any Axon-provided LTE service.



---

## Attachment C - Add-on Services Appendix

This Appendix applies if Axon Citizen for Communities, Axon Redaction Assistant, and/or Axon Performance are included on the Quote.

1. **Subscription Term**. If Agency purchases Axon Citizen for Communities, Axon Redaction Assistant, or Axon Performance as part of OSP 7, the subscription begins on the later of the (1) start date of the OSP 7 Term, or (2) date Axon provisions Axon Citizen for Communities, Axon Redaction Assistant, or Axon Performance to Agency.
  - 1.1. If Agency purchases Axon Citizen for Communities, Axon Redaction Assistant, or Axon Performance as a standalone, the subscription begins the later of the (1) date Axon provisions Axon Citizen for Communities, Axon Redaction Assistant, or Axon Performance to Agency, or (2) first day of the month following the Effective Date.
  - 1.2. The subscription term will end upon the completion of the Axon Evidence Subscription associated with the add-on.
2. **Axon Citizen Storage**. For Axon Citizen, Agency may store an unlimited amount of data submitted through the public portal ("**Portal Content**"), within Agency's Axon Evidence instance. The post-termination provisions outlined in the Axon Cloud Services Terms of Use Appendix also apply to Portal Content.
3. **Performance Auto-Tagging Data**. In order to provide some features of Axon Performance to Agency, Axon will need to store call for service data from Agency's CAD or RMS.



---

## Attachment D - Axon Auto-Transcribe Appendix

This Appendix applies if Axon Auto-Transcribe is included on the Quote.

1. **Subscription Term.** If Agency purchases Axon Auto-Transcribe as part of a bundle or Axon Cloud Services subscription, the subscription begins on the later of the (1) start date of the bundle or Axon Cloud Services license term, or (2) date Axon provisions Axon Auto-Transcribe to Agency. If Agency purchases Axon Auto-Transcribe minutes as a standalone, the subscription begins on the date Axon provisions Axon Auto-Transcribe to Agency.
  - 1.1. If Agency cancels Auto-Transcribe services, any amounts owed by the Parties will be based on the amount of time passed under the annual subscription, rather than on the number of minutes used, regardless of usage.
2. **Auto-Transcribe A-La-Carte Minutes.** Upon Axon granting Agency a set number of minutes, Agency may utilize Axon Auto-Transcribe, subject to the number of minutes allowed on the Quote. Agency will not have the ability to roll over unused minutes to future Auto-Transcribe terms. Axon may charge Agency additional fees for exceeding the number of purchased minutes. Axon Auto-Transcribe minutes expire one year after being provisioned to Agency by Axon.
3. **Axon Unlimited Transcribe.** Upon Axon granting Agency an Unlimited Transcribe subscription to Axon Auto-Transcribe, Agency may utilize Axon Auto-Transcribe with no limit on the number of minutes. Unlimited Transcribe includes automatic transcription of all Axon BWC and Axon Capture footage. With regard to Axon Interview Room, Axon Fleet, Axon Citizen, or third-party transcription, transcription must be requested on demand. Notwithstanding the foregoing, Axon may limit usage after 5,000 minutes per user per month for multiple months in a row. Axon will not bill for overages.
4. **Warranty.** Axon disclaims all warranties, express or implied, for Axon Auto-Transcribe.



---

## Attachment E - Axon Virtual Reality Content Terms of Use Appendix

If Virtual Reality is included on the Quote, this Appendix applies.

1. **Term.** The Quote will detail the products and license duration, as applicable, of the goods, services, and software, and contents thereof, provided by Axon to Agency related to virtual reality (collectively, "Virtual Reality Media").
2. **Headsets.** Agency may purchase additional virtual reality headsets from Axon. In the event Agency decides to purchase additional virtual reality headsets for use with Virtual Reality Media, Agency must purchase those headsets from Axon.
3. **License Restrictions.** All licenses will immediately terminate if Agency does not comply with any term of this Agreement. If Agency utilizes more users than stated in this Agreement, Agency must purchase additional Virtual Reality Media licenses from Axon. Agency may not use Virtual Reality Media for any purpose other than as expressly permitted by this Agreement. Agency may not:
  - 3.1. modify, tamper with, repair, or otherwise create derivative works of Virtual Reality Media;
  - 3.2. reverse engineer, disassemble, or decompile Virtual Reality Media or apply any process to derive the source code of Virtual Reality Media, or allow others to do the same;
  - 3.3. copy Virtual Reality Media in whole or part, except as expressly permitted in this Agreement;
  - 3.4. use trade secret information contained in Virtual Reality Media;
  - 3.5. resell, rent, loan or sublicense Virtual Reality Media;
  - 3.6. access Virtual Reality Media to build a competitive device or service or copy any features, functions, or graphics of Virtual Reality Media; or
  - 3.7. remove, alter, or obscure any confidentiality or proprietary rights notices (including copyright and trademark notices) of Axon or Axon's licensors on or within Virtual Reality Media or any copies of Virtual Reality Media.
4. **Privacy.** Agency's use of the Virtual Reality Media is subject to the Axon Virtual Reality Privacy Policy, a current version of which is available at <https://www.axon.com/legal/axon-virtual-reality-privacy-policy>.
5. **Termination.** Axon may terminate Agency's license immediately for Agency's failure to comply with any of the terms in this Agreement.



---

## Attachment F - Axon Channel Services Appendix

This Appendix applies if Agency purchases Axon Channel Service, as set forth on the Quote.

1. Definitions.
  - 1.1. “**Axon Digital Evidence Management System**” means Axon Evidence or Axon Commander, as specified in the attached Channel Services Statement of Work.
  - 1.2. “**Active Channel**” means a third-party system that is continuously communicating with an Axon Digital Evidence Management System.
  - 1.3. “**Inactive Channel**” means a third-party system that will have a one-time communication to an Axon Digital Evidence Management System.
2. **Scope.** Agency currently has a third-party system or data repository from which Agency desires to share data with Axon Digital Evidence Management. Axon will facilitate the transfer of Agency’s third-party data into an Axon Digital Evidence Management System or the transfer of Agency data out of an Axon Digital Evidence Management System as defined in the Channel Services Statement of Work (“**Channel Services SOW**”). Channel Services will not delete any Agency Content. Agency is responsible for verifying all necessary data is migrated correctly and retained per Agency policy.
3. **Purpose and Use.** Agency is responsible for verifying Agency has the right to share data from and provide access to third-party system as it relates to the Services described in this Appendix and the Channel Services SOW. For Active Channels, Agency is responsible for any changes to a third-party system that may affect the functionality of the channel service. Any additional work required for the continuation of the Service may require additional fees. An Axon Field Engineer may require access to Agency’s network and systems to perform the Services described in the Channel Services SOW. Agency is responsible for facilitating this access per all laws and policies applicable to Agency.
4. **Project Management.** Axon will assign a Project Manager to work closely with Agency’s project manager and project team members and will be responsible for completing the tasks required to meet all contract deliverables on time and budget.
5. **Warranty.** Axon warrants that it will perform the Channel Services in a good and workmanlike manner.
6. **Monitoring.** Axon may monitor Agency’s use of Channel Services to ensure quality, improve Axon devices and services, prepare invoices based on the total amount of data migrated, and verify compliance with this Agreement. Agency agrees not to interfere with such monitoring or obscure from Axon Agency’s use of channel services.
7. **Agency’s Responsibilities.** Axon’s successful performance of the Channel Services requires Agency:
  - 7.1. Make available its relevant systems for assessment by Axon (including making these systems available to Axon via remote access);
  - 7.2. Provide access to the building facilities and where Axon is to perform the Channel Services, subject to safety and security restrictions imposed by the Agency (including providing security passes or other necessary documentation to Axon representatives performing the Channel Services permitting them to enter and exit Agency premises with laptop personal computers and any other materials needed to perform the Channel Services);
  - 7.3. Provide all necessary infrastructure and software information (TCP/IP addresses, node names, and network configuration) for Axon to provide the Channel Services;
  - 7.4. Ensure all appropriate data backups are performed;
  - 7.5. Provide Axon with remote access to the Agency’s network and third-party systems when required for Axon to perform the Channel Services;
  - 7.6. Notify Axon of any network or machine maintenance that may impact the performance of the Channel Services; and
  - 7.7. Ensure the reasonable availability by phone or email of knowledgeable staff, personnel, system administrators, and operators to provide timely, accurate, complete, and up-to-date documentation and information to Axon (these contacts are to provide background information and clarification of information required to perform the Channel Services).



**Agenda Sheet for City Council Meeting of:**  
04/25/2022

<b>Date Rec'd</b>	4/13/2022
<b>Clerk's File #</b>	ORD C36193
<b>Renews #</b>	
<b>Cross Ref #</b>	
<b>Project #</b>	
<b>Bid #</b>	
<b>Requisition #</b>	

<b>Submitting Dept</b>	POLICE
<b>Contact Name/Phone</b>	MIKE MCNAB 835-4514
<b>Contact E-Mail</b>	MMCNAB@SPOKANEPOLICE.ORG
<b>Agenda Item Type</b>	Special Budget Ordinance
<b>Agenda Item Name</b>	1560 - STATE FORFEITURES CI FUNDS SBO

**Agenda Wording**

Special Budget Ordinance to increase appropriations by \$40,000 of State forfeiture funds to be used as confidential funds.

**Summary (Background)**

The department is requesting a \$40,000 increase in confidential funds in order to keep up with the influx of fentanyl and methamphetamines in our community. SPD accomplishes drug enforcement by targeting those distributing illegal substances through controlled purchases. This increase would align SPD's budget authority with the current demand to use these funds for enforcement.

Lease? NO Grant related? NO Public Works? NO

**Fiscal Impact**

Expense	\$ 40,000
Select	\$
Select	\$
Select	\$

**Budget Account**

# 1560-17200-21250-54922-99999
#
#
#

**Approvals**

<b>Dept Head</b>	HAMMOND, JENNIFER
<b>Division Director</b>	
<b>Finance</b>	SCHMITT, KEVIN
<b>Legal</b>	PICCOLO, MIKE
<b>For the Mayor</b>	ORMSBY, MICHAEL

**Council Notifications**

<b>Study Session\Other</b>	PSCHC Meeting 04/11/2022
<b>Council Sponsor</b>	CATHCART/BINGLE

**Distribution List**

spdfinance
MMCNAB

**Additional Approvals**

<b>Purchasing</b>	
<b>MANAGEMENT &amp; BUDGET</b>	INGIOSI, PAUL



## Committee Agenda Sheet

### Public Safety & Community Health

<b>Submitting Department</b>	Spokane Police Department
<b>Contact Name &amp; Phone</b>	Major Mike McNab 835-4514
<b>Contact Email</b>	mmc nab@spokanepolice.org
<b>Council Sponsor(s)</b>	Councilman Cathcart, Councilman Bingle
<b>Select Agenda Item Type</b>	<input type="checkbox"/> Consent <input checked="" type="checkbox"/> Discussion    Time Requested: 5 minutes
<b>Agenda Item Name</b>	SBO to access state drug forfeiture funding
<b>Summary (Background)</b>	<p>In the 2022 budget, the police department was allocated \$150,500 from the state drug forfeiture account for legal services, confidential funds and undercover vehicles. The current balance of state drug forfeiture funds after 2022 allocations is \$575,431.</p> <p>The department is requesting a \$40,000 increase in confidential funds in order to keep up with the influx of fentanyl and methamphetamines in our community. SPD accomplishes drug enforcement by targeting those distributing illegal substances through controlled purchases. Starting in 2020, confidential fund budgets were reduced between \$20,000 and \$25,000. SPD has run out of spending authority every year since. This has impacted on-going drug investigations and resulted in SPD having to cover overages with funding intended for other purposes. This increase would align SPD's budget authority with the current demand to use these funds for enforcement.</p>
<b>Proposed Council Action &amp; Date:</b>	Approval on April 25, 2022
<b>Fiscal Impact:</b> Total Cost: \$40,000 Approved in current year budget? <input type="checkbox"/> Yes <input checked="" type="checkbox"/> No <input type="checkbox"/> N/A  Funding Source <input checked="" type="checkbox"/> One-time <input type="checkbox"/> Recurring Specify funding source: State forfeiture/seizure funds  Expense Occurrence <input checked="" type="checkbox"/> One-time <input type="checkbox"/> Recurring  Other budget impacts: (revenue generating, match requirements, etc.)	
<b>Operations Impacts</b>	
What impacts would the proposal have on historically excluded communities?  <b>Targeting those distributing dangerous substances serves all populations in our community suffering from substance abuse. It further serves our entire community by reducing the violence and property crimes associated with illicit drug trade.</b>	
How will data be collected, analyzed, and reported concerning the effect of the program/policy by racial, ethnic, gender identity, national origin, income level, disability, sexual orientation, or other existing disparities?  <b>The Police Department keeps detailed records for the use of confidential funds. Instances of confidential fund use are further documented in police reporting which captures race and gender should this data be needed for a focused analysis.</b>	

How will data be collected regarding the effectiveness of this program, policy or product to ensure it is the right solution?

**This is a well-established police practice that has proven to be effective in drug enforcement by building criminal cases against those distributing illicit substances.**

Describe how this proposal aligns with current City Policies, including the Comprehensive Plan, Sustainability Action Plan, Capital Improvement Program, Neighborhood Master Plans, Council Resolutions, and others?

**Increasing the confidential fund allocation will ensure the police department can continue combating the influx of fentanyl and methamphetamine in our community without disruption. This increase in funding aligns with the goal from the Police Department's 2022- 2023 Strategic Plan to help create a safer, healthier, and more supportive environment for all residents and visitors.**

**The use of state drug forfeiture funds for these purposes aligns with RCW 69.50.505 where the funds are used exclusively for the expansion and improvement of controlled substances related law enforcement activity.**

ORDINANCE NO C36193

An ordinance amending Ordinance No. C-36161, passed by the City Council December 13, 2021, and entitled, "An ordinance adopting the Annual Budget of the City of Spokane for 2022, making appropriations to the various funds of the City of Spokane government for the fiscal year ending December 31, 2022, and providing it shall take effect immediately upon passage," and declaring an emergency.

WHEREAS, subsequent to the adoption of the 2022 budget Ordinance No. C-36161, as above entitled, and which passed the City Council December 13, 2021, it is necessary to make changes in the appropriations of the Forfeitures & Contributions fund, which changes could not have been anticipated or known at the time of making such budget ordinance; and

WHEREAS, this ordinance has been on file in the City Clerk's Office for five days; - Now, Therefore, The City of Spokane does ordain:

Section 1. That in the budget of the Forfeitures & Contributions Fund, and the budget annexed thereto with reference to the Fund, the following changes be made:

- 1) Increase appropriations by \$40,000
  - A) Of the increased appropriations; \$40,000 of the increase is to be used as confidential funds used for controlled purchases of illegal substances
  - B) The increased appropriation is funded from unappropriated reserves in the Forfeitures & Contributions Fund

Section 2. It is, therefore, by the City Council declared that an urgency and emergency exists for making the changes set forth herein, such urgency and emergency arising from the need to continue and expand the use of confidential funds, and because of such need, an urgency and emergency exists for the passage of this ordinance, and also, because the same makes an appropriation, it shall take effect and be in force immediately upon its passage.

Passed the City Council \_\_\_\_\_

\_\_\_\_\_

Council President

Attest: \_\_\_\_\_

City Clerk

Approved as to form: \_\_\_\_\_

Assistant City Attorney

\_\_\_\_\_

Mayor

\_\_\_\_\_

Date

\_\_\_\_\_

Effective Date



**Agenda Sheet for City Council Meeting of:**  
06/27/2022

<b>Date Rec'd</b>	5/25/2022
<b>Clerk's File #</b>	ORD C36231
<b>Renews #</b>	
<b>Cross Ref #</b>	
<b>Project #</b>	
<b>Bid #</b>	
<b>Requisition #</b>	

<b>Submitting Dept</b>	POLICE
<b>Contact Name/Phone</b>	MIKE MCNAB 835-4514
<b>Contact E-Mail</b>	MMCNAB@SPOKANEPOLICE.ORG
<b>Agenda Item Type</b>	Special Budget Ordinance
<b>Agenda Item Name</b>	1560 - STATE FORFEITURES UC VEHICLES SBO

**Agenda Wording**

Special Budget Ordinance that will increase appropriations by \$95,000 to be used for the replacement and purchase of undercover vehicles used in police investigations.

**Summary (Background)**

The police department was allocated \$150,500 out of its state drug forfeiture account in the 2022 budget for legal services, confidential funds, and undercover vehicles. The current balance of state drug forfeiture funds after 2022 allocations is \$575,431. The police department was allocated \$25,000 out of this account for the purchase of undercover vehicles. SPD recently lost two of these vehicles due to collisions.

Lease? NO	Grant related? NO	Public Works? NO
<b>Fiscal Impact</b>		<b>Budget Account</b>
Expense \$ 95,000		# 1560-17200-94000-56404-68074
Select \$		#
Select \$		#
Select \$		#

<b>Approvals</b>		<b>Council Notifications</b>	
<b>Dept Head</b>	MEIDL, CRAIG	<b>Study Session\Other</b>	PSCHC Meeting 04/11/2022
<b>Division Director</b>	MEIDL, CRAIG	<b>Council Sponsor</b>	CATHCART/BINGLE
<b>Finance</b>	SCHMITT, KEVIN	<b>Distribution List</b>	
<b>Legal</b>	PICCOLO, MIKE	mmcnab@spokanepolice.org	
<b>For the Mayor</b>	ORMSBY, MICHAEL	spdfinance@spokanecity.org	
<b>Additional Approvals</b>			
<b>Purchasing</b>			
<b>MANAGEMENT &amp; BUDGET</b>	STRATTON, JESSICA		

## Committee Agenda Sheet

### Public Safety & Community Health

<b>Submitting Department</b>	Spokane Police Department																																																																																				
<b>Contact Name &amp; Phone</b>	Major Mike McNab 835-4514																																																																																				
<b>Contact Email</b>	mmcncab@spokanepolice.org																																																																																				
<b>Council Sponsor(s)</b>	Councilman Cathcart, Councilman Bingle																																																																																				
<b>Select Agenda Item Type</b>	<input type="checkbox"/> Consent <input checked="" type="checkbox"/> Discussion    Time Requested: 5 minutes																																																																																				
<b>Agenda Item Name</b>	UC vehicle purchase & SBO to access state drug forfeiture funding																																																																																				
<b>Summary (Background)</b>	<p>The police department was allocated \$150,500 out a its state drug forfeiture account in the 2022 budget for legal services, confidential funds, and undercover vehicles. The current balance of state drug forfeiture funds after 2022 allocations is \$575,431. The police department was allocated \$25,000 out of this account for the purchase of undercover vehicles. SPD recently lost two of these vehicles due to collisions. Additionally, used vehicle prices have risen such that \$25,000 is no longer a sufficient amount to purchase a reliable used vehicle including the commissioning cost. SPD is asking for an increase of \$95,000 out of the state drug forfeiture funds to replace the two totaled vehicles and purchase a third vehicle as part of its annual rotation.</p> <p>The City Fleet Department provided the following study of used vehicle values. Because of the investment in commissioning and the infrequent replacement schedule (budgeted one car per year). Fleet recommends we purchase vehicles with no more than 36,000 miles. Depending on the commissioning necessary, vehicles would have a high-end cost off \$40,000 each.</p> <table border="1" style="width: 100%; border-collapse: collapse;"> <thead> <tr> <th>YEAR</th> <th>MAKE</th> <th>MODEL</th> <th>MILEAGE</th> <th>COST</th> <th>DEALERSHIP</th> </tr> </thead> <tbody> <tr><td>2018</td><td>SUBARU</td><td>CROSSTREK PREMIUM</td><td>35993</td><td>\$ 26,810.00</td><td>LHM</td></tr> <tr><td>2019</td><td>JEEP</td><td>CHEROKEE LATITUDE</td><td>36085</td><td>\$ 29,000.00</td><td>LHM</td></tr> <tr><td>2020</td><td>NISSAN</td><td>ROGUE S</td><td>33140</td><td>\$ 29,500.00</td><td>LHM</td></tr> <tr><td>2016</td><td>SUBARU</td><td>CROSSTREK LIMITED</td><td>31881</td><td>\$ 29,500.00</td><td>LHM</td></tr> <tr><td>2019</td><td>SUBARU</td><td>ASCENT PREMIUM</td><td>22437</td><td>\$ 35,865.00</td><td>LHM</td></tr> <tr><td>2019</td><td>JEEP</td><td>LAREDO</td><td>34422</td><td>\$ 36,000.00</td><td>LHM</td></tr> <tr><td>2019</td><td>SUBARU</td><td>ASCENT LIMITED</td><td>23316</td><td>\$ 42,500.00</td><td>LHM</td></tr> <tr><td>2019</td><td>SUBARU</td><td>CROSSTREK PREMIUM</td><td>32920</td><td>\$ 28,595.00</td><td>AUTONATION</td></tr> <tr><td>2019</td><td>SUBARU</td><td>OUTBACK LIMITED</td><td>21351</td><td>\$ 34,998.00</td><td>AUTONATION</td></tr> <tr><td>2019</td><td>JEEP</td><td>CHEROKEE LATITUDE</td><td>35284</td><td>\$ 28,998.00</td><td>AUTONATION</td></tr> <tr><td>2019</td><td>SUBARU</td><td>FORESTER LIMITED</td><td>25900</td><td>\$ 35,998.00</td><td>DAVE SMITH</td></tr> <tr><td>2018</td><td>JEEP</td><td>CHEROKEE LIMITED</td><td>28365</td><td>\$ 42,998.00</td><td>DAVE SMITH</td></tr> <tr><td>2017</td><td>NISSAN</td><td>ROGUE SV</td><td>31181</td><td>\$ 20,998.00</td><td>DAVE SMITH</td></tr> </tbody> </table>	YEAR	MAKE	MODEL	MILEAGE	COST	DEALERSHIP	2018	SUBARU	CROSSTREK PREMIUM	35993	\$ 26,810.00	LHM	2019	JEEP	CHEROKEE LATITUDE	36085	\$ 29,000.00	LHM	2020	NISSAN	ROGUE S	33140	\$ 29,500.00	LHM	2016	SUBARU	CROSSTREK LIMITED	31881	\$ 29,500.00	LHM	2019	SUBARU	ASCENT PREMIUM	22437	\$ 35,865.00	LHM	2019	JEEP	LAREDO	34422	\$ 36,000.00	LHM	2019	SUBARU	ASCENT LIMITED	23316	\$ 42,500.00	LHM	2019	SUBARU	CROSSTREK PREMIUM	32920	\$ 28,595.00	AUTONATION	2019	SUBARU	OUTBACK LIMITED	21351	\$ 34,998.00	AUTONATION	2019	JEEP	CHEROKEE LATITUDE	35284	\$ 28,998.00	AUTONATION	2019	SUBARU	FORESTER LIMITED	25900	\$ 35,998.00	DAVE SMITH	2018	JEEP	CHEROKEE LIMITED	28365	\$ 42,998.00	DAVE SMITH	2017	NISSAN	ROGUE SV	31181	\$ 20,998.00	DAVE SMITH
YEAR	MAKE	MODEL	MILEAGE	COST	DEALERSHIP																																																																																
2018	SUBARU	CROSSTREK PREMIUM	35993	\$ 26,810.00	LHM																																																																																
2019	JEEP	CHEROKEE LATITUDE	36085	\$ 29,000.00	LHM																																																																																
2020	NISSAN	ROGUE S	33140	\$ 29,500.00	LHM																																																																																
2016	SUBARU	CROSSTREK LIMITED	31881	\$ 29,500.00	LHM																																																																																
2019	SUBARU	ASCENT PREMIUM	22437	\$ 35,865.00	LHM																																																																																
2019	JEEP	LAREDO	34422	\$ 36,000.00	LHM																																																																																
2019	SUBARU	ASCENT LIMITED	23316	\$ 42,500.00	LHM																																																																																
2019	SUBARU	CROSSTREK PREMIUM	32920	\$ 28,595.00	AUTONATION																																																																																
2019	SUBARU	OUTBACK LIMITED	21351	\$ 34,998.00	AUTONATION																																																																																
2019	JEEP	CHEROKEE LATITUDE	35284	\$ 28,998.00	AUTONATION																																																																																
2019	SUBARU	FORESTER LIMITED	25900	\$ 35,998.00	DAVE SMITH																																																																																
2018	JEEP	CHEROKEE LIMITED	28365	\$ 42,998.00	DAVE SMITH																																																																																
2017	NISSAN	ROGUE SV	31181	\$ 20,998.00	DAVE SMITH																																																																																
<b>Proposed Council Action &amp; Date:</b>	Approval on June 06, 2022																																																																																				
<b>Fiscal Impact:</b>	Total Cost: \$95,000																																																																																				
Approved in current year budget?	<input type="checkbox"/> Yes <input checked="" type="checkbox"/> No <input type="checkbox"/> N/A																																																																																				

Funding Source       One-time       Recurring

Specify funding source: State forfeiture funds

Expense Occurrence       One-time       Recurring

Other budget impacts: (revenue generating, match requirements, etc.)

**Operations Impacts**

What impacts would the proposal have on historically excluded communities?

**None**

How will data be collected, analyzed, and reported concerning the effect of the program/policy by racial, ethnic, gender identity, national origin, income level, disability, sexual orientation, or other existing disparities?

**There will be no data collected for these purchases related to the listed demographics.**

How will data be collected regarding the effectiveness of this program, policy or product to ensure it is the right solution?

**N/A**

Describe how this proposal aligns with current City Policies, including the Comprehensive Plan, Sustainability Action Plan, Capital Improvement Program, Neighborhood Master Plans, Council Resolutions, and others?

**Providing our drug enforcement investigators with reliable used vehicles aligns with multiple goals from the Police Department's 2022- 2023 Strategic Plan Including:**

- **Combat crime by using innovative policing practices and technology.**
- **Ensure the wellness and health of our employees, emotionally and physically.**
- **Maintain a progressive approach to best practices revolving around training, equipment, programs and service to the community and our employees.**

**The use of state drug forfeiture funds for these purposes aligns with RCW 69.50.505 where the funds are used exclusively for the expansion and improvement of controlled substances related law enforcement activity.**

ORDINANCE NO C36231

An ordinance amending Ordinance No. C-36161, passed by the City Council December 13, 2021, and entitled, "An ordinance adopting the Annual Budget of the City of Spokane for 2022, making appropriations to the various funds of the City of Spokane government for the fiscal year ending December 31, 2022, and providing it shall take effect immediately upon passage," and declaring an emergency.

WHEREAS, subsequent to the adoption of the 2022 budget Ordinance No. C-36161, as above entitled, and which passed the City Council December 13, 2021, it is necessary to make changes in the appropriations of the Forfeitures & Contributions fund, which changes could not have been anticipated or known at the time of making such budget ordinance; and

WHEREAS, this ordinance has been on file in the City Clerk's Office for five days; - Now, Therefore, The City of Spokane does ordain:

Section 1. That in the budget of the Forfeitures & Contributions Fund, and the budget annexed thereto with reference to the Fund, the following changes be made:

- 1) Increase appropriations by \$95,000
  - A) Of the increased appropriation; \$95,000 of the increase is to be used for the procurement of used vehicles \$95,000.
  - B) The increased appropriation is funded from unappropriated reserves in the Forfeitures & Contributions Fund

Section 2. It is, therefore, by the City Council declared that an urgency and emergency exists for making the changes set forth herein, such urgency and emergency arising from the need to procure additional undercover vehicles, and because of such need, an urgency and emergency exists for the passage of this ordinance, and also, because the same makes an appropriation, it shall take effect and be in force immediately upon its passage.

Passed the City Council \_\_\_\_\_

\_\_\_\_\_  
Council President

Attest: \_\_\_\_\_

City Clerk

Approved as to form: \_\_\_\_\_

Assistant City Attorney

\_\_\_\_\_  
Mayor

\_\_\_\_\_  
Date

\_\_\_\_\_  
Effective Date

**Agenda Sheet for City Council Meeting of:**

06/20/2022

<b>Date Rec'd</b>	6/8/2022
<b>Clerk's File #</b>	ORD C36227
<b>Renews #</b>	
<b>Cross Ref #</b>	
<b>Project #</b>	
<b>Bid #</b>	
<b>Requisition #</b>	

<b>Submitting Dept</b>	POLICE
<b>Contact Name/Phone</b>	JUSTIN LUNDGREN 625-4115
<b>Contact E-Mail</b>	JCLUNDGREN@SPOKANEPOLICE.ORG
<b>Agenda Item Type</b>	Special Budget Ordinance
<b>Agenda Item Name</b>	1625 - ABANDONED VEHICLE UNIT SBO

**Agenda Wording**

Addition of 2 new Parking Enforcement Specialist positions employed by the Spokane Police Department for the creation of an Abandoned Vehicle Unit.

**Summary (Background)**

The City's current response to removing abandoned vehicles is not nearly sufficient to address the growing problem that impacts the quality of life in City neighborhoods. Neighborhood Resource Officers respond to some abandoned vehicle reports but have other duties and responsibilities which do not allow them to dedicate sufficient time to address the problem.

Lease? NO Grant related? NO Public Works? NO

**Fiscal Impact**

Expense \$ 69,225

Select \$

Select \$

Select \$

**Budget Account**

# 1625-11410-21250-04340

#

#

#

**Approvals****Dept Head** LUNDGREN, JUSTIN**Division Director** LUNDGREN, JUSTIN**Finance** SCHMITT, KEVIN**Legal** MURAMATSU, MARY**For the Mayor** ORMSBY, MICHAEL**Council Notifications****Study Session\Other** PSCHC Meeting  
06/06/2022**Council Sponsor** CM Cathcart/Stratton**Distribution List**

SPDFINANCE@SPOKANECITY.ORG

jclundgren@spokanepolice.org

budget@spokanecity.org

**Additional Approvals****Purchasing****MANAGEMENT & BUDGET** INGIOSI, PAUL



## Committee Agenda Sheet

### Public Safety & Community Health Committee

<b>Submitting Department</b>	Police
<b>Contact Name &amp; Phone</b>	AC Justin Lundgren, 625-4115
<b>Contact Email</b>	jclundgren@spokanepolice.org
<b>Council Sponsor(s)</b>	CM Stratton and CM Cathcart
<b>Select Agenda Item Type</b>	<input type="checkbox"/> Consent <input checked="" type="checkbox"/> Discussion    Time Requested: <u>10 minutes</u>
<b>Agenda Item Name</b>	SBO – Abandoned Vehicle Unit
<b>Summary (Background)</b>	<p><u>Background</u></p> <p>The City’s current response to removing abandoned vehicles is not nearly sufficient to address the growing problem that impacts the quality of life in City neighborhoods. Neighborhood Resource Officers respond to some abandoned vehicle reports but have other duties and responsibilities which do not allow them to dedicate sufficient time to address the problem.</p> <p><u>Summary</u></p> <p>An Abandoned Vehicle Unit (AVU) consisting of two (2) Parking Enforcement Specialist positions employed by the police department will have sole responsibility for abandoned vehicles and RVs throughout the North and South precinct areas and respond citywide.</p> <p>As employees of the police department, the individuals will receive a limited commission to enforce Spokane Municipal parking ordinances, tow vehicles, and receive access to information systems limited to law enforcement agencies. As such, the AVU employees will be able to quickly and safely bring community complaints to resolution.</p> <p>The AVU will not assume other parking-related functions that currently reside with Parking Enforcement, such as expired meter enforcement or the collection of parking meter funds.</p> <p>The estimated cost of the program through the rest of the current year is approximately \$69,000. The initial proposed funding source for these positions is the Public Safety Personnel and Crime Reduction Fund. It is anticipated the Parking System Fund will assume the cost of the program once the meter upgrade project is completed.</p>
<b>Proposed Council Action &amp; Date:</b>	SBO – June 20, 2022
<p><b>Fiscal Impact:</b>  Total Cost: \$69,225  Approved in current year budget?    <input type="checkbox"/> Yes    <input checked="" type="checkbox"/> No    <input type="checkbox"/> N/A</p> <p>Funding Source    <input type="checkbox"/> One-time    <input checked="" type="checkbox"/> Recurring  Specify funding source: Initial funding from Public Safety Personnel and Crime Reduction Fund; eventually funding will come from the Parking System Fund.</p> <p>Expense Occurrence    <input type="checkbox"/> One-time    <input checked="" type="checkbox"/> Recurring</p>	

Other budget impacts: (revenue generating, match requirements, etc.)

**Operations Impacts**

What impacts would the proposal have on historically excluded communities?

n/a

How will data be collected, analyzed, and reported concerning the effect of the program/policy by racial, ethnic, gender identity, national origin, income level, disability, sexual orientation, or other existing disparities?

n/a

How will data be collected regarding the effectiveness of this program, policy or product to ensure it is the right solution?

n/a

Describe how this proposal aligns with current City Policies, including the Comprehensive Plan, Sustainability Action Plan, Capital Improvement Program, Neighborhood Master Plans, Council Resolutions, and others?

n/a

ORDINANCE NO C36227

An ordinance amending Ordinance No. C-36161, passed by the City Council December 13, 2021, and entitled, "An ordinance adopting the Annual Budget of the City of Spokane for 2022, making appropriations to the various funds of the City of Spokane government for the fiscal year ending December 31, 2022, and providing it shall take effect immediately upon passage," and declaring an emergency.

WHEREAS, subsequent to the adoption of the 2022 budget Ordinance No. C-36161, as above entitled, and which passed the City Council December 13, 2021, it is necessary to make changes in the appropriations of the Public Safety Personnel and Crime Reduction Fund, which changes could not have been anticipated or known at the time of making such budget ordinance; and

WHEREAS, this ordinance has been on file in the City Clerk's Office for five days; - Now, Therefore,

The City of Spokane does ordain:

Section 1. That in the budget of the Public Safety Personnel and Crime Reduction Fund, and the budget annexed thereto with reference to the Public Safety Personnel and Crime Reduction Fund, the following changes be made:

- 1) Add two Parking Enforcement Specialist I positions (from 0 to 2) and increase the associated appropriation for salary and benefits by approximately \$69,225.

Section 2. It is, therefore, by the City Council declared that an urgency and emergency exists for making the changes set forth herein, such urgency and emergency arising from the need to create an abandoned vehicle unit, and because of such need, an urgency and emergency exists for the passage of this ordinance, and also, because the same makes an appropriation, it shall take effect and be in force immediately upon its passage.

Passed the City Council \_\_\_\_\_

\_\_\_\_\_  
Council President

Attest: \_\_\_\_\_  
City Clerk

Approved as to form: \_\_\_\_\_  
Assistant City Attorney

\_\_\_\_\_  
Mayor

\_\_\_\_\_  
Date

\_\_\_\_\_  
Effective Date



**Agenda Sheet for City Council Meeting of:**  
06/20/2022

<b>Date Rec'd</b>	6/8/2022
<b>Clerk's File #</b>	ORD C36228
<b>Renews #</b>	
<b>Cross Ref #</b>	
<b>Project #</b>	
<b>Bid #</b>	
<b>Requisition #</b>	

<b>Submitting Dept</b>	FIRE
<b>Contact Name/Phone</b>	BRIAN SCHAEFFER 625-7001
<b>Contact E-Mail</b>	BSCHAEFFER@SPOKANECITY.ORG
<b>Agenda Item Type</b>	Special Budget Ordinance
<b>Agenda Item Name</b>	1625 - ADDITIONAL FIRE ACADEMY SBO

**Agenda Wording**

Special budget ordinance to provide an additional \$668,00 to the Fire Department to allow an additional recruit academy of up to 25 firefighters. Funds will cover necessary PPE as well as backfill for instructor time.

**Summary (Background)**

The Spokane Fire Department (SFD) relies on fire recruit academies to fill vacant entry-level firefighter positions. However, since 2020, SFD has been unable to plan and run regular recruit classes due to the uncertainty surrounding the passage of the public safety property tax levy in 2019 and the subsequent COVID-19 global pandemic.

Lease? NO Grant related? NO Public Works? NO

**Fiscal Impact**

Expense	\$ 668,000
Select	\$
Select	\$
Select	\$

**Budget Account**

# 1625-35170-22450-VARIOUS-43021
#
#
#

**Approvals**

<b>Dept Head</b>	SCHAEFFER, BRIAN
<b>Division Director</b>	SCHAEFFER, BRIAN
<b>Finance</b>	SCHMITT, KEVIN
<b>Legal</b>	PICCOLO, MIKE
<b>For the Mayor</b>	ORMSBY, MICHAEL
<b>Additional Approvals</b>	
<b>Purchasing</b>	
<b>MANAGEMENT &amp; BUDGET</b>	INGIOSI, PAUL

**Council Notifications**

<b>Study Session\Other</b>	PSCHC Meeting 06/06/2022
<b>Council Sponsor</b>	CM Cathcart / CM Kinnear
<b>Distribution List</b>	
	bschaeffer@spokanecity.org
	fireaccounting@spokanecity.org
	kschmitt
	rstrickland
	budget@spokanecity.org

## Committee Agenda Sheet

### Public Safety & Community Health Committee

<b>Submitting Department</b>	Fire Department
<b>Contact Name &amp; Phone</b>	Brian Schaeffer, 509-625-7001
<b>Contact Email</b>	Bschaeffe@spokanecity.org
<b>Council Sponsor(s)</b>	Council Member Cathcart
<b>Select Agenda Item Type</b>	<input type="checkbox"/> Consent <input checked="" type="checkbox"/> Discussion    Time Requested: <u>10 minutes</u>
<b>Agenda Item Name</b>	SBO – Additional Fire Academy
<b>Summary (Background)</b>	<p><u>Background</u></p> <p>The Spokane Fire Department (SFD) relies on fire recruit academies to fill vacant entry-level firefighter positions. However, since 2020, SFD has been unable to plan and run regular recruit classes due to the uncertainty surrounding the passage of the public safety property tax levy in 2019 and the subsequent COVID-19 global pandemic.</p> <p>The 2022 budget provided approximately \$500,000 for a fire recruit academy class of up to 32 firefighters who recently graduated on June 4.</p> <p><u>Summary</u></p> <p>Despite the initial investment in one recruit academy for 2022, SFD continues to experience unprecedented vacancies in uniformed positions and increased uniform-overtime costs above historical levels. As a result, a need exists for an additional recruit academy of up to 25 firefighters beginning in 2022 at the cost of approximately \$668,000.</p> <p>The recommended funding source is unappropriated reserves from the Public Safety Personnel and Crime Reduction Fund. The unappropriated reserves in the fund at the beginning of 2022 were approximately \$3.8 million. Alternative funding sources to be considered include General Fund unappropriated reserves or additional American Rescue Plan Act funds.</p>
<b>Proposed Council Action &amp; Date:</b>	SBO – June 20, 2022
<p><b>Fiscal Impact:</b></p> <p>Total Cost: \$668,000</p> <p>Approved in current year budget?    <input type="checkbox"/> Yes    <input type="checkbox"/> No    <input checked="" type="checkbox"/> N/A</p> <p>Funding Source    <input checked="" type="checkbox"/> One-time    <input type="checkbox"/> Recurring</p> <p>Specify funding source: Various funds</p> <p>Expense Occurrence    <input checked="" type="checkbox"/> One-time    <input type="checkbox"/> Recurring</p> <p>Other budget impacts: (revenue generating, match requirements, etc.)</p>	
<b>Operations Impacts</b>	
<p>What impacts would the proposal have on historically excluded communities?</p> <p>The Spokane Fire Department (SFD) serves a compelling number of vulnerable and excluded communities such as people on Medicare or Medicaid, the elderly, those with psychiatric or</p>	

psychological problems, lower socioeconomic status, minority race or nationality, or sexual orientation. The SFD's vision is to cultivate a culture and legacy of pride through teamwork, inclusion, respect, and professionalism; rooted in our community and service. Every member of the organization is bound together by our mission and a passionate commitment to saving lives.

How will data be collected, analyzed, and reported concerning the effect of the program/policy by racial, ethnic, gender identity, national origin, income level, disability, sexual orientation, or other existing disparities?

Customer data is collected in compliance with National Fire Incident Reporting System (NFIRS) and National Emergency Medical Services Information System (NEMIS). Healthcare clinical outcome measures are reported as de-identified data to Washington State through the key performance indicator program and the quality improvement program (WAC 246-976-910). Fire Department performance measures are reported annually in compliance with RCW 52.33.030.

How will data be collected regarding the effectiveness of this program, policy or product to ensure it is the right solution?

Performance measures as outlined in RCW 52.33.030 are built for real-time monitoring and improvement on the City's PowerBI platform. The tool allows leaders to identify and evaluate changes, trends, and opportunities as the community changes.

Describe how this proposal aligns with current City Policies, including the Comprehensive Plan, Sustainability Action Plan, Capital Improvement Program, Neighborhood Master Plans, Council Resolutions, and others?

Effectively staffing and deploying fire department resources affects community outcomes in three critical areas: firefighter injury and death, civilian injury and death, property loss, and environmental impact. If fire department resources (both mobile and personnel) are deployed to match the risk levels inherent to Spokane's hazards, it is expected that outcomes in all three areas will likely be positive. Likewise, failure to match fire department resources deployed to the level of the risk events to which firefighters respond will likely result in negative community outcomes. Those expected outcomes and community expectations are outlined in the Comprehensive Plan, Council Resolutions and Expectations, CIP, and Sustainability Plans.

ORDINANCE NO C36228

An ordinance amending Ordinance No. C-36161, passed by the City Council December 13, 2021, and entitled, "An ordinance adopting the Annual Budget of the City of Spokane for 2022, making appropriations to the various funds of the City of Spokane government for the fiscal year ending December 31, 2022, and providing it shall take effect immediately upon passage," and declaring an emergency.

WHEREAS, subsequent to the adoption of the 2022 budget Ordinance No. C-36161, as above entitled, and which passed the City Council December 13, 2021, it is necessary to make changes in the appropriations of the Public Safety Personnel and Crime Reduction Fund, which changes could not have been anticipated or known at the time of making such budget ordinance; and

WHEREAS, this ordinance has been on file in the City Clerk's Office for five days; - Now, Therefore,

The City of Spokane does ordain:

Section 1. That in the budget of the Public Safety Personnel and Crime Reduction Fund, and the budget annexed thereto with reference to the Public Safety Personnel and Crime Reduction Fund, the following changes be made:

- 1) Increase the appropriation by \$668,000.
  - A) Of the increased appropriation, approximately \$256,000 is provided solely for wages and benefits for fire academy recruit school instructors.
  - B) Of the increased appropriation, \$412,000 is provided solely for equipment needs related to the fire academy recruit school.

Section 2. It is, therefore, by the City Council declared that an urgency and emergency exists for making the changes set forth herein, such urgency and emergency arising from the need to run an additional fire recruiting academy beginning in 2022, and because of such need, an urgency and emergency exists for the passage of this ordinance, and also, because the same makes an appropriation, it shall take effect and be in force immediately upon its passage.

Passed the City Council \_\_\_\_\_

\_\_\_\_\_  
Council President

Attest: \_\_\_\_\_  
City Clerk

Approved as to form: \_\_\_\_\_  
Assistant City Attorney

\_\_\_\_\_  
Mayor

\_\_\_\_\_  
Date

\_\_\_\_\_  
Effective Date

**Agenda Sheet for City Council Meeting of:**

06/20/2022

<b>Date Rec'd</b>	6/8/2022
<b>Clerk's File #</b>	ORD C36229
<b>Renews #</b>	
<b>Cross Ref #</b>	
<b>Project #</b>	
<b>Bid #</b>	
<b>Requisition #</b>	

<b>Submitting Dept</b>	FINANCE, TREASURY & ADMIN
<b>Contact Name/Phone</b>	PAUL INGIOSI 509-625-6061
<b>Contact E-Mail</b>	PINGIOSI@SPOKANECITY.ORG
<b>Agenda Item Type</b>	Special Budget Ordinance
<b>Agenda Item Name</b>	0410 - PUBLIC DEFENDER PERSONNEL SAVINGS SBO

**Agenda Wording**

An ordinance transferring budgeted personnel expenses to non-personnel expenses.

**Summary (Background)**

City code permits intrafund budget transfers of budgeted personnel expenses to non-personnel expenses only when approved by an ordinance passed by the vote of one more than the majority of all members of the City Council (SMC 07.09.010(A)(4)). Due to an internal promotion in the Office of Public Defender, there are available budgeted personnel expenses the department would like to transfer to the legal services expense type to pay for an expert witness and provide budget capacity for the year.

Lease? NO Grant related? NO Public Works? NO

**Fiscal Impact**

Expense \$ (27,000)

Expense \$ 27,000

Select \$

Select \$

**Budget Account**

# 0700-14100-15930-00950-99999

# 0700-14100-15930-54105-99999

#

#

**Approvals****Dept Head** MURRAY, MICHELLE**Division Director** INGIOSI, PAUL**Finance** MURRAY, MICHELLE**Legal** PICCOLO, MIKE**For the Mayor** ORMSBY, MICHAEL**Additional Approvals****Purchasing****MANAGEMENT & BUDGET** INGIOSI, PAUL**Council Notifications****Study Session\Other** Public Safety Committee - 6/6/22**Council Sponsor** CM Cathcart / CM Kinnear**Distribution List**

nantush@spokanecity.org

rkokot@spokanecity.org

budget@spokanecity.org



## Committee Agenda Sheet

### Public Safety & Community Health Committee

<b>Submitting Department</b>	Finance
<b>Contact Name &amp; Phone</b>	Paul Ingiosi – 509-625-6061
<b>Contact Email</b>	pingiosi@spokanecity.org
<b>Council Sponsor(s)</b>	Council Member Cathcart
<b>Select Agenda Item Type</b>	<input type="checkbox"/> Consent <input checked="" type="checkbox"/> Discussion    Time Requested: <u>5 minutes</u>
<b>Agenda Item Name</b>	SBO – Salary Savings to Contractual Services
<b>Summary (Background)</b>	<p><u>Background</u> City code permits intrafund budget transfers of budgeted personnel expenses to non-personnel expenses only when approved by an ordinance passed by the vote of one more than the majority of all members of the City Council (SMC 07.09.010(A)(4)).</p> <p><u>Summary</u> In May 2022, a Public Defender II was promoted to the position of Public Defender. The vacant Public Defender II position was later downgraded to a Public Defender I position for hiring purposes per departmental position policy. The salary and benefit difference between the Public Defender II and Public Defender I position is approximately \$27,000.</p> <p>The department would like to transfer the \$27,000 in salary and benefit savings to the legal services expense type to fund the payment of an expert witness requested by a departmental attorney and provide budget capacity for additional expenses throughout the year.</p>
<b>Proposed Council Action &amp; Date:</b>	SBO – June 20, 2022
<b>Fiscal Impact:</b>	<p>Total Cost: \$27,000</p> <p>Approved in current year budget?    <input type="checkbox"/> Yes    <input checked="" type="checkbox"/> No    <input type="checkbox"/> N/A</p> <p>Funding Source    <input checked="" type="checkbox"/> One-time    <input type="checkbox"/> Recurring</p> <p>Specify funding source: Various funds</p> <p>Expense Occurrence    <input checked="" type="checkbox"/> One-time    <input type="checkbox"/> Recurring</p> <p>Other budget impacts: (revenue generating, match requirements, etc.)</p>
<b>Operations Impacts</b>	<p>What impacts would the proposal have on historically excluded communities?</p> <p>n/a</p>
How will data be collected, analyzed, and reported concerning the effect of the program/policy by	

racial, ethnic, gender identity, national origin, income level, disability, sexual orientation, or other existing disparities?

n/a

How will data be collected regarding the effectiveness of this program, policy or product to ensure it is the right solution?

n/a

Describe how this proposal aligns with current City Policies, including the Comprehensive Plan, Sustainability Action Plan, Capital Improvement Program, Neighborhood Master Plans, Council Resolutions, and others?

n/a

ORDINANCE NO C36229

An ordinance amending Ordinance No. C-36161, passed by the City Council December 13, 2021, and entitled, "An ordinance adopting the Annual Budget of the City of Spokane for 2022, making appropriations to the various funds of the City of Spokane government for the fiscal year ending December 31, 2022, and providing it shall take effect immediately upon passage," and declaring an emergency.

WHEREAS, subsequent to the adoption of the 2022 budget Ordinance No. C-36161, as above entitled, and which passed the City Council December 13, 2021, it is necessary to make changes in the appropriations of the General Fund, which changes could not have been anticipated or known at the time of making such budget ordinance; and

WHEREAS, this ordinance has been on file in the City Clerk's Office for five days; - Now, Therefore,

The City of Spokane does ordain:

Section 1. That in the budget of the General Fund, and the budget annexed thereto with reference to the General Fund, the following changes be made:

- 1) Decrease the appropriation for a Public Defender I position in the Office of Public Defender by \$27,000.
- 2) Increase the appropriation for legal services by \$27,000.
- 3) There is no change to the overall appropriation level in the General Fund.

Section 2. It is, therefore, by the City Council declared that an urgency and emergency exists for making the changes set forth herein, such urgency and emergency arising from the need transfer budget authority from personnel to non-personnel expenses to provide expert witness legal services, and because of such need, an urgency and emergency exists for the passage of this ordinance, and also, because the same makes an appropriation, it shall take effect and be in force immediately upon its passage.

Passed the City Council \_\_\_\_\_

\_\_\_\_\_  
Council President

Attest: \_\_\_\_\_  
City Clerk

Approved as to form: \_\_\_\_\_  
Assistant City Attorney

\_\_\_\_\_  
Mayor

\_\_\_\_\_  
Date

\_\_\_\_\_  
Effective Date

**Agenda Sheet for City Council Meeting of:**

03/14/2022

<b>Date Rec'd</b>	3/2/2022
<b>Clerk's File #</b>	RES 2022-0026
<b>Renews #</b>	
<b>Cross Ref #</b>	
<b>Project #</b>	
<b>Bid #</b>	
<b>Requisition #</b>	

<b>Submitting Dept</b>	FINANCE, TREASURY & ADMIN
<b>Contact Name/Phone</b>	TONYA WALLACE 6845
<b>Contact E-Mail</b>	TWALLACE@SPOKANECITY.ORG
<b>Agenda Item Type</b>	Resolutions
<b>Agenda Item Name</b>	0410 INVESTMENT ALLOCATION METHODOLOGY

**Agenda Wording**

Update methodology for the distribution of investment earnings in Spokane Investment Pool to participating funds not restricted by bond covenants, grant terms, contractual terms, or establishing ordinances.

**Summary (Background)**

Distributions of investment earnings will be based on a proportionate share of earnings for such funds that held an average book value of more than \$2,500,000 in the prior year. This update replaces the guaranteed minimum earnings allocation and streamlines administrative workload.

Lease? NO	Grant related? NO	Public Works? NO
<b>Fiscal Impact</b>		<b>Budget Account</b>
Select \$		#
Select \$		#
Select \$		#
Select \$		#

<b>Approvals</b>		<b>Council Notifications</b>	
<b>Dept Head</b>	MURRAY, MICHELLE	<b>Study Session\Other</b>	Finance 2/28/22
<b>Division Director</b>	WALLACE, TONYA	<b>Council Sponsor</b>	Betsy Wilkerson; Michael Cathcart
<b>Finance</b>	MURRAY, MICHELLE	<b>Distribution List</b>	
<b>Legal</b>	PICCOLO, MIKE	twallace@spokanecity.org	
<b>For the Mayor</b>	ORMSBY, MICHAEL	baweber@spokanecity.org	
<b>Additional Approvals</b>			
<b>Purchasing</b>			
<b>ACCOUNTING - LEASE</b>	MURRAY, MICHELLE		

## Committee Agenda Sheet Finance & Administration

<b>Submitting Department</b>	Finance, Treasury and Administration – Treasury Services
<b>Contact Name &amp; Phone</b>	Tonya Wallace 509-844-4456
<b>Contact Email</b>	<a href="mailto:twallace@spokanecity.org">twallace@spokanecity.org</a>
<b>Council Sponsor(s)</b>	Betsy Wilkerson
<b>Select Agenda Item Type</b>	<input checked="" type="checkbox"/> Consent <input type="checkbox"/> Discussion    Time Requested: _____
<b>Agenda Item Name</b>	Investment Allocation Methodology
<b>Summary (Background)</b>	<p>Update methodology for the distribution of investment earnings in Spokane Investment Pool to participating funds not restricted by bond covenants, grant terms, contractual terms, or establishing ordinances.</p> <p>Distributions of investment earnings will be based on a proportionate share of earnings for such funds that held an average book value of more than \$2,500,000 in the prior year. This update replaces the guaranteed minimum earnings allocation and streamlines administrative workload.</p>
<b>Proposed Council Action &amp; Date:</b>	Approve amendments to resolution ____ TBA
<p><b>Fiscal Impact:</b>            Total Cost: \$0            Approved in current year budget?    <input type="checkbox"/> Yes    <input type="checkbox"/> No    <input checked="" type="checkbox"/> N/A</p> <p>Funding Source    <input type="checkbox"/> One-time    <input type="checkbox"/> Recurring            Specify funding source:</p> <p>Expense Occurrence    <input type="checkbox"/> One-time    <input type="checkbox"/> Recurring</p> <p>Other budget impacts: City funds having held less than \$2.5M in average book value from the prior year would see a reduction of \$48,040 previously budgeted in their departments</p>	
<b>Operations Impacts: N/A</b>	
What impacts would the proposal have on historically excluded communities?  N/A	
How will data be collected, analyzed, and reported concerning the effect of the program/policy by racial, ethnic, gender identity, national origin, income level, disability, sexual orientation, or other existing disparities?  N/A	
How will data be collected regarding the effectiveness of this program, policy or product to ensure it is the right solution?	

N/A

Describe how this proposal aligns with current City Policies, including the Comprehensive Plan, Sustainability Action Plan, Capital Improvement Program, Neighborhood Master Plans, Council Resolutions, and others?

N/A

## RESOLUTION NO 2022-0026

### CONCERNING DISTRIBUTION OF INVESTMENT REVENUES OF MONEYS DEPOSITED IN THE SPOKANE INVESTMENT POOL

WHEREAS, The City of Spokane has provided for the establishment of various separate funds for the deposit of moneys in the conduct of its business; and

WHEREAS, RCW 35.39.030 provides for the authority of the City to invest any portion of its moneys deposited in inactive funds or in other funds in excess of current needs; and

WHEREAS, RCW 35.39.032 provides that no investments may be made without the approval of the City's legislative authority, expressed by ordinance, and this has been done; and

WHEREAS, RCW 35.39.034 provides that moneys from individual funds may, unless otherwise restricted by law, be commingled within one common investment portfolio for investment, and

WHEREAS City investment activity was aggregated citywide in the city's Spokane Investment Pool (SIP) effective September 30, 2007; and

WHEREAS, The SIP is managed by the City's Chief Financial Officer or his or her designee; and

WHEREAS, prior to the creation of the SIP, the City's investable funds outside of the General Fund were generally invested at the direction of the individual departments in the State of Washington's Local Government Investment Pool (LGIP) and/or other short term investments; and

WHEREAS, RCW 35.39.034 provides that the governing body of a city may determine by ordinance or resolution that, unless otherwise restricted by law, income derived from citywide investments may be apportioned to the General Fund subject to certain restrictions pertaining to moneys derived from various types of indebtedness or grant-related activity; and

WHEREAS, is the desire of the City Council to apportion a reasonable level of investment income to the originating funds consistent with investment practices followed prior to the creation of the SIP;

NOW, THEREFORE - - it is hereby resolved by the Spokane City Council:

1. That effective January 1, 2022, SIP Investment earnings shall be apportioned to participating funds monthly based on average invested balances.
2. The funds restricted by bond covenants, grant terms, contractual terms or establishing ordinances shall be allocated investment earnings at a rate equal to the full interest earned for a given month. Realized and Unrealized gains and losses, and amortization of Premium and Discount shall be apportioned to such funds on a basis not to exceed quarterly.
3. City funds otherwise not restricted by bond covenants, grant terms, contractual terms or establishing ordinances, and maintain an average book value greater than \$2,500,000 based on the previous year balances, shall receive a proportionate share of all monthly investment earnings based on average invested balance. The remaining investment earnings balance or deficit, if any, will be deposited into or withdrawn from the General Fund.

BE IT ALSO RESOLVED that a one-time allocation adjustment will be performed in the year 2022 to amend current practice and ensure consistency with this resolution.

ADOPTED by City Council on this \_\_\_\_\_ day of \_\_\_\_\_ 2022.

\_\_\_\_\_  
City Clerk

Approved as to form:

\_\_\_\_\_  
Assistant City Attorney





**Agenda Sheet for City Council Meeting of:**  
06/20/2022

<b>Date Rec'd</b>	6/1/2022
<b>Clerk's File #</b>	RES 2022-0055
<b>Renews #</b>	
<b>Cross Ref #</b>	
<b>Project #</b>	
<b>Bid #</b>	
<b>Requisition #</b>	

<b>Submitting Dept</b>	INTEGRATED CAPITAL MANAGEMENT
<b>Contact Name/Phone</b>	INGA NOTE 625-6391
<b>Contact E-Mail</b>	INOTE@SPOKANECITY.ORG
<b>Agenda Item Type</b>	Resolutions
<b>Agenda Item Name</b>	4250 – RESOLUTION US 195 TRANSPORTATION STUDY ADOPTION

**Agenda Wording**

A resolution recognizing the US 195 / I-90 Transportation Study as a declaration of the City's desired future transportation conditions within the US 195 corridor from I-90 to Hatch Road.

**Summary (Background)**

The results of the US 195 study were presented at the March 17, 2022, Council study session. The recommendation is to adopt by resolution endorsing the results of the transportation study as a first step in the implementation process.

Lease? NO Grant related? NO Public Works? NO

**Fiscal Impact**

Select	\$	#
Select	\$	#
Select	\$	#
Select	\$	#

**Budget Account**

**Approvals**

<b>Dept Head</b>	MILLER, KATHERINE E
<b>Division Director</b>	FEIST, MARLENE
<b>Finance</b>	ORLOB, KIMBERLY
<b>Legal</b>	RICHMAN, JAMES
<b>For the Mayor</b>	ORMSBY, MICHAEL

**Council Notifications**

<b>Study Session\Other</b>	PIES 5/23/22
<b>Council Sponsor</b>	Beggs/Kinnear

**Distribution List**

ddaniels@spokanecity.org
icmaccounting@spokanecity.org
eraea@spokanecity.org
inote@spokanecity.org
kemiller@spokanecity.org

**Additional Approvals**

<b>Purchasing</b>

## Committee Agenda Sheet

### Public Infrastructure, Environment & Sustainability Committee

<b>Submitting Department</b>	Public Works Division – Integrated Capital Management Department
<b>Contact Name &amp; Phone</b>	Inga Note, 625-6331
<b>Contact Email</b>	<a href="mailto:inote@spokanecity.org">inote@spokanecity.org</a> ;
<b>Council Sponsor(s)</b>	CM Beggs
<b>Select Agenda Item Type</b>	<input type="checkbox"/> Consent <input checked="" type="checkbox"/> Discussion    Time Requested: <u>5 minutes</u>
<b>Agenda Item Name</b>	US 195 Transportation Study adoption resolution
<b>Summary (Background)</b>	<p>On February 4<sup>th</sup>, 2019 Council approved \$50,000 to help pay for the Hwy 195 Study that Spokane Regional Transportation Council is managing. The study began in late 2019 with evaluation of existing conditions, initial community outreach and forecasting of development. The consultant developed a long list of improvement ideas and combined them into project packages for evaluation and review. The study was completed in late 2021 and shared with all the partner agencies. <a href="https://us195transportationstudy.com/">https://us195transportationstudy.com/</a></p> <p>City staff presented the US 195 study results at the 3/17/22 Council study session. Staff recommends adopting a resolution endorsing the results of the transportation study as a first step in the implementation process. This action will be followed by updates to both the Comprehensive Plan’s Facilities Plan to reflect the proposed projects as well as the Transportation Impact Fee Program to reflect the costs of the proposed projects.</p>
<b>Proposed Council Action &amp; Date:</b>	Adoption resolution in June 2022. n/a
<b>Fiscal Impact:</b>	
Total Cost: n/a	
Approved in current year budget? <input type="checkbox"/> Yes <input type="checkbox"/> No <input checked="" type="checkbox"/> N/A	
Funding Source <input type="checkbox"/> One-time <input type="checkbox"/> Recurring	
Specify funding source:	
Expense Occurrence <input type="checkbox"/> One-time <input type="checkbox"/> Recurring	
Other budget impacts: (revenue generating, match requirements, etc.)	
<b>Operations Impacts</b>	
What impacts would the proposal have on historically excluded communities?	
<p><i>Public Works services and projects are designed to serve all citizens and businesses. We strive to offer a consistent level of service to all, to distribute public investment throughout the community, and to respond to gaps in services identified in various City plans. We recognize the need to maintain affordability and predictability for utility customers. And we are committed to delivering work that is both financially and environmentally responsible. This item supports the operations of Public Works.</i></p>	
How will data be collected, analyzed, and reported concerning the effect of the program/policy by racial, ethnic, gender identity, national origin, income level, disability, sexual orientation, or other existing disparities?	

*Potential projects for transportation grant opportunities are dispersed throughout the City and should not impact racial, gender identity, national origin, income level, disability, sexual orientation or other existing disparity factors. Equity considerations are included in SRTC's evaluation and scoring process.*

How will data be collected regarding the effectiveness of this program, policy or product to ensure it is the right solution?

*Projects within the 6-year Streets program are evaluated for consistency with the City's Comprehensive Plan when they are initially added to the program.*

Describe how this proposal aligns with current City Policies, including the Comprehensive Plan, Sustainability Action Plan, Capital Improvement Program, Neighborhood Master Plans, Council Resolutions, and others?

*Potential projects submitted for application comply with goals and policies of Chapter 4 – Transportation of the City's Comprehensive Plan.*

**RESOLUTION NO. 2022-0055**

A RESOLUTION RECOGNIZING THE US 195 / I-90 TRANSPORTATION STUDY (“THE STUDY”) AS A DECLARATION OF THE CITY’S DESIRED FUTURE TRANSPORTATION CONDITIONS WITHIN THE US 195 CORRIDOR FROM I-90 TO HATCH ROAD.

**WHEREAS**, the Spokane Regional Transportation Council (SRTC) managed a study of this area to identify practical solutions for transportation concerns; and

**WHEREAS**, the City of Spokane, WSDOT and Spokane County contributed financially to the study and their staff participated throughout the process; and

**WHEREAS**, the final report documents the need for parallel arterial routes to US 195 along with a number of new bicycle and pedestrian projects including shared-use pathways; and

**WHEREAS**, City staff presented updates on the study at the Public Infrastructure, Environment, & Sustainability Committee on February 22, 2021, a council briefing session on September 2, 2021 and the Planning Commission Transportation Subcommittee on 10/5/21; and

**WHEREAS**, the Spokane Regional Transportation Council Board of Directors adopted the study at their December 9<sup>th</sup>, 2021 meeting; and

**WHEREAS**, the recommended projects will be incorporated into city capital facilities planning documents; and

**WHEREAS**, the recommended projects will go through SEPA at the time they are added to the City’s Comprehensive Plan; and

**NOW, THEREFORE BE IT FURTHER RESOLVED**, that the City Council of Spokane recognizes the US 195 / I-90 Transportation Study and that the appropriate timing of the identified transportation projects be reflected in the City’s Comprehensive Plan to build a healthy, active, safe and connected neighborhood for residents.

**PASSED** by the City Council on \_\_\_\_\_

\_\_\_\_\_  
Council President

Attest:

Approved as to form:

---

City Clerk

---

Assistant City Attorney

---

Mayor

---

Date

---

Effect

**Agenda Sheet for City Council Meeting of:**

06/27/2022

<b>Date Rec'd</b>	6/13/2022
<b>Clerk's File #</b>	ORD C36230
<b>Renews #</b>	
<b>Cross Ref #</b>	
<b>Project #</b>	
<b>Bid #</b>	
<b>Requisition #</b>	

<b>Submitting Dept</b>	DSC, CODE ENFORCEMENT & PARKING SERVICES
<b>Contact Name/Phone</b>	ELDON BROWN 6305
<b>Contact E-Mail</b>	EBROWN@SPOKANECITY.ORG
<b>Agenda Item Type</b>	First Reading Ordinance
<b>Agenda Item Name</b>	AMENDING ORDINANCE C-21606

**Agenda Wording**

Amending Ordinance C-21606 to release a portion of an easement

**Summary (Background)**

The property owners of the Iron Bridge development have requested that the City release easements that were originally established as part of Ordinance C-21606 so that the lots have a larger buildable footprint. We have checked with the easement holders and they are ok with the release.

Lease? NO Grant related? NO Public Works? NO

**Fiscal Impact**

Neutral \$

Select \$

Select \$

Select \$

**Budget Account**

#

#

#

#

**Approvals**

<b>Dept Head</b>	DUVALL, MEGAN
<b>Division Director</b>	MACDONALD, STEVEN
<b>Finance</b>	ORLOB, KIMBERLY
<b>Legal</b>	PICCOLO, MIKE
<b>For the Mayor</b>	ORMSBY, MICHAEL

**Council Notifications**

<b>Study Session\Other</b>	PIES - 4/25/22
<b>Council Sponsor</b>	CMs Cathcart

**Distribution List**

rthompson@spokanecity.org
edjohnson@spokanecity.org
kbecker@spokanecity.org
ebrown@spokanecity.org

**Additional Approvals****Purchasing**

## Committee Agenda Sheet

### Public Infrastructure, Environment, and Sustainability Committee

<b>Submitting Department</b>	Developer Services Center
<b>Contact Name &amp; Phone</b>	Eldon Brown
<b>Contact Email</b>	<a href="mailto:ebrown@spokanecity.org">ebrown@spokanecity.org</a>
<b>Council Sponsor(s)</b>	Michael Cathcart
<b>Select Agenda Item Type</b>	<input type="checkbox"/> Consent <input checked="" type="checkbox"/> Discussion     Time Requested: _____
<b>Agenda Item Name</b>	Amending Ordinance C-21606 to release an easement
<b>Summary (Background)</b>	<p>The property owners of the Iron Bridge development have requested that the City release easements that were originally established as part of Ordinance C-21606 so that the lots have a larger buildable footprint.</p> <p>We have checked with the easement holders and they are ok with releasing the portion shown on the attached map</p>
<b>Proposed Council Action &amp; Date:</b>	Precedes a new first reading of the amended ordinance
<b>Fiscal Impact:</b>	
Total Cost:	
Approved in current year budget? <input type="checkbox"/> Yes <input type="checkbox"/> No <input checked="" type="checkbox"/> N/A	
Funding Source <input type="checkbox"/> One-time <input type="checkbox"/> Recurring <input checked="" type="checkbox"/> N/A	
Specify funding source:	
Expense Occurrence <input type="checkbox"/> One-time <input type="checkbox"/> Recurring <input checked="" type="checkbox"/>	
Other budget impacts: (revenue generating, match requirements, etc.)	
<b>Operations Impacts</b>	
What impacts would the proposal have on historically excluded communities? NA	
How will data be collected, analyzed, and reported concerning the effect of the program/policy by racial, ethnic, gender identity, national origin, income level, disability, sexual orientation, or other existing disparities? NA	
How will data be collected regarding the effectiveness of this program, policy or product to ensure it is the right solution? NA	
Describe how this proposal aligns with current City Policies, including the Comprehensive Plan, Sustainability Action Plan, Capital Improvement Program, Neighborhood Master Plans, Council Resolutions, and others?	
Addressed in Section 17G.080.020 of the Spokane Municipal Code and Chapter 35.79 of RCW regarding street vacations.	

City of Spokane  
Development Services Center  
808 West Spokane Falls Blvd.  
Spokane, WA 99201-3343  
(509) 625-6300

## ORDINANCE NO. C36230

An ordinance amending Ordinance C-21606 that vacated Mallon Avenue from the west line of Section 16, Township 25 North, Range 43 E.W.M. to the west line of Hogan Street and of Perry Street from the south line of Mallon Avenue to the northerly boundary line of the right of way of the Union Pacific Railroad Co., City and County of Spokane, Washington,

The City of Spokane does ordain:

Section 1. That Mallon Avenue from the west line of Section 16, Township 25 North, Range 43 E.W.M. to the west line of Hogan Street and of Perry Street from the south line of Mallon Avenue to the northerly boundary line of the right of way of the Union Pacific Railroad Co., City and County of Spokane, Washington, be, and the same is hereby vacated, subject to the following conditions:

- (1) That ~~an~~ easements ~~are~~ is reserved ~~over and through Mallon Ave~~ for the reconstruction, repair and maintenance of existing public and private utilities and that no buildings or structures shall be erected on ~~the~~ said easements, other than trackage and appurtenances of Burlington Northern, Inc., unless approved by the City Engineer.
- ~~(2) That entry upon the vacated land may be had at any time for necessary reconstruction, repair and maintenance of the said existing utilities without compensation to the owners their successors or assigns for any interference with their operation and use of the vacated land.~~
- ~~(3) That in the event the use of the vacated Land by the owners, their successors or assigns shall interfere with or damage the operation of the existing utilities located therein, the owners, their successors or assigns shall restore said utilities to the satisfaction of the City of Spokane, or pay the cost of such restoration.~~
- ~~(4) That the owners, their successors or assigns shall be responsible for any claims or damage resulting from loss of access to the vacated streets.~~
- (5) That the owners shall erect and maintain an appropriate barrier across Mallon Avenue satisfactory to the City Traffic Engineer indicating to the motorists that Mallon Avenue west of Hogan Street is no longer a public right of way.
- (6) That in the event that a river drive or freeway is constructed to pass through the ~~area vacated or any part thereof,~~ vacated right of way of Mallon Ave sufficient



to accommodate-such a river drive or freeway shall revert to the City of Spokane for said street or highway purposes without compensation to the owners, their successors or assigns.

Section 2. This ordinance shall take effect and be in force thirty (30) days from and after its passage.

Passed the City Council \_\_\_\_\_

\_\_\_\_\_  
Council President

Attest: \_\_\_\_\_  
City Clerk

Approved as to Form:

\_\_\_\_\_  
Assistant City Attorney

\_\_\_\_\_  
Mayor

Date: \_\_\_\_\_

Effective Date: \_\_\_\_\_

# Easement - Ord C-21606



**Right-of-way Description:**  
Perry St. from the south line of  
Mallon St. to the north line of the Union Pacific RW  
(Part of UP RW now vacated)

**Legend**

 Easement Release

THIS IS NOT A LEGAL DOCUMENT.  
The information shown on this map is compiled  
from various sources and is subject to constant  
revision. Information shown on this map should  
not be used to determine the location of facilities  
in relationship to property lines, section lines,  
streets, etc.





**Agenda Sheet for City Council Meeting of:**  
06/20/2022

<b>Date Rec'd</b>	6/7/2022
<b>Clerk's File #</b>	ORD C36223
<b>Renews #</b>	
<b>Cross Ref #</b>	
<b>Project #</b>	
<b>Bid #</b>	
<b>Requisition #</b>	

<b>Submitting Dept</b>	DSC, CODE ENFORCEMENT & PARKING SERVICES
<b>Contact Name/Phone</b>	JESTEN RAY 625-6819
<b>Contact E-Mail</b>	JRAY@SPOKANECITY.ORG
<b>Agenda Item Type</b>	First Reading Ordinance
<b>Agenda Item Name</b>	PARKING SERVICES - ORDINANCE RELATED TO PARKING MUNICIPAL CODES, PERMITS AN

**Agenda Wording**

Parking Services proposes an ordinance to amend 4 sections of municipal code, repeal 3 and adds 2 sections. Parking Services is also updating related fees in the Fee Schedule. Effective Date would be August 1, 2022.

**Summary (Background)**

The City is moving to a new parking permit system which uses license plates and/or digital permits. The Spokane Municipal Code relating to Permits was revised in 2021; however, it needs modified to align with parking space reservation use and needs. This ordinance decreases duplicate permits by combining several and clarifies two permit related definitions.

Lease? NO Grant related? NO Public Works? NO

**Fiscal Impact**

Revenue \$ Varies  
 Select \$  
 Select \$  
 Select \$

**Budget Account**

# 1460  
 #  
 #  
 #

**Approvals**

<b>Dept Head</b>	DUVALL, MEGAN
<b>Division Director</b>	MACDONALD, STEVEN
<b>Finance</b>	ORLOB, KIMBERLY
<b>Legal</b>	PICCOLO, MIKE
<b>For the Mayor</b>	ORMSBY, MICHAEL

**Council Notifications**

<b>Study Session\Other</b>	Public Safety and Community Health 6.6.22
<b>Council Sponsor</b>	CM Stratton and Kinnear
<b>Distribution List</b>	smacdonald@spokanecity.org; tszambelan@spokanecity.org; mmuramatsu@spokanecity.org; kbecker@spokanecity.org; jray@spokanecity.org; lgarcia@spokanecity.org; mwilliams@spokanecity.org

**Additional Approvals**

<b>Purchasing</b>	

## ORDINANCE NO. C36223

AN ORDINANCE relating to parking municipal codes amending SMC sections 16A.04.100, 16A.05.060, 16A.05.460, 16A.06.010; repealing SMC sections 16A.06.030, 16A.06.040, 16A.06.050; and adding new section 16A.06.080, 16A.06.090 to chapter 16A.06 of the Spokane Municipal Code and setting an effective date.

WHEREAS, the City updated code related to parking permits in 2021, and;

WHEREAS, the City realized the code related to permit use needed to be modified, and;

WHEREAS, the Parking Advisory Committee reviewed and considered the proposed code changes in 2022;-- Now, Therefore,

The City of Spokane does ordain:

**Section 1.** That SMC section 16A.04.100 is amended to read as follows

### **Section 16A.04.100 Definitions**

**A. Alley.**

A public highway not designed for general travel and used primarily as a means of access to the rear of residences and business establishments. (RCW 46.04.020)

**B. Block Face.**

One side of a street, inclusive of the public right-of-way between two consecutive features intersecting that street. The features can be other streets or boundaries of standard geographic areas.

**C. City Street or Street.**

Every public highway, or part thereof located within the limits of cities and towns, except alleys. (RCW 46.04.120)

**D. Commercial Vehicle.**

Any vehicle the principal use of which is the transportation of commodities, merchandise, produce, freight, animals, or passengers for hire. (RCW 46.04.140)

**E. Congested District.**

The area established within the Paid Parking Zone bounded and identified on the [Paid Parking Zone Map](#).

F. Definitions Generally.

Words and phrases, wherever used in this subtitle shall have the meaning ascribed to them in this Chapter except where otherwise defined, and unless where used the context thereof shall clearly indicate to the contrary. (RCW 46.04.010)

G. Entertainment Parking District (EPD).

The area established within the Paid Parking Zone for the purpose of meeting the specific operational and parking needs of the entertainment venues contained within the EPD as bounded and identified on the [Paid Parking Zone Map](#).

H. Fire Lane.

An area on public or private property reserved for providing Fire Department access to structures, firefighting fixtures, or equipment.

I. Highway.

The entire width between the boundary lines of every way publicly maintained when any part thereof is open to the use of the public for purposes of vehicular travel. (RCW 46.04.197)

J. Non-passenger Vehicle (NPV).

Any vehicle which does not meet the definition of a passenger vehicle ([SMC 16A.04.100\(R\)](#)) which includes but is not limited to: any vehicle requiring a commercial safety fee, limousine, any vehicle with over a one ton (thirty-five hundred) rating, vehicle requiring a commercial driver's license (CDL) to operate, farm vehicle, motor home, trailer of any type, camper, watercraft, or snowmobile.

K. Paid Parking Zone.

Portions of streets which the parking of vehicles shall be controlled, regulated and inspected with the aid of devices, herein referred to as parking payment devices. The Paid Parking Zone is bounded and identified on the [Paid Parking Zone Map](#).

L. Park or Parking.

The standing of a vehicle, whether occupied or not, otherwise than temporarily for the purpose of and while actually engaged in loading or unloading property or passengers. (RCW 46.04.381)

M. Parking Holidays.

Except for metered spaces at Spokane International Airport and Felts Field as authorized by [SMC 12.03.0600](#) and [SMC 12.03.0602](#), or where otherwise indicated by signposting in the area or for individual spaces, parking spaces regulated by a parking payment device may be used without charge during all hours on: Sundays, New Year's Day, Martin Luther King, Jr.'s Birthday, President's Day – Third Monday in February, Memorial Day, Independence Day – July 4th, Labor Day, Indigenous Peoples' Day – Second Monday in October, Veteran's Day – November 11th, Thanksgiving Day, and Christmas Day. Where a foregoing holiday falls on a Sunday, the immediately following Monday is observed. On days designated in the foregoing, vehicles shall adhere to posted time limit regulations.

N. Parking Manager.

The Director of Development Services Center, Code Enforcement and Parking Services or their designee.

O. Parking Payment Device.

Any device used to accept payment for parking, such as parking meters, pay station kiosks, mobile devices, or other methods approved by the Parking Manager.

P. Parking Permit.

A privilege that allows its holder to access certain parking spaces and locations, which form includes, but is not limited to, a printed pass, decal, or electronic privilege associated with a specific vehicle license plate.

Q. Parking Space.

The area on or adjacent to the roadway in which to stop, stand, or park a vehicle that is controlled by a parking payment device designated by lines, curb paint, posted sign, meter decal, or other markings.

R. Passenger Vehicle.

Every motor vehicle, except motorcycles and motor-driven cycles, designed for carrying ten (10) passengers or less and used for the transportation of persons.

S. Public Right-of-Way

A right-of-way that is dedicated or deeded to the public for public use and under the control of a public agency.

T. Residential Parking Permit Definitions

For the purposes of [SMC 16A.06.070](#) only, the terms in this section have the following meanings:

1. "Downtown residential parking district" or "DRPD" means a portion of the street commonly used for vehicular parking where vehicles properly displaying a parking permit or other city-approved authorization are exempt from the payment required pursuant to [SMC 16A.05.280](#).
2. "Downtown residential parking district permit" or "DRPD permit" means a printed pass, decal, electronic privilege associated with a specific vehicle license plate, or other identification issued to an eligible person to be displayed in or on the vehicle, as directed by the City, that enables it to park in a downtown residential parking district.
3. "Resident" means any person residing in a household unit that is located within downtown residential parking district.
4. "Household Unit" means any self-contained house, apartment, condominium, town house, detached or attached accessory dwelling unit, or group home that contains living, sleeping and cooking quarters and is used by of any number of related persons or up to six unrelated individuals. Each unit of a multiple-unit residential dwelling is considered a separate household unit.

U. Retail Zone of the Congested District.

The area established within the Paid Parking Zone bounded and identified on the [Paid Parking Zone Map](#).

V. Roadway.

Portion of a highway improved, designed, or ordinarily used for vehicular travel, exclusive of the sidewalk or shoulder even though such sidewalk or shoulder is used by persons riding bicycles. In the event a highway includes two or more separated roadways, the term "roadway" shall refer to any such roadway separately but shall not refer to all such roadways collectively. (RCW 46.04.500)

W. Safety Zone.

The area or space officially set apart within a roadway for the exclusive use of pedestrians and which is protected or is marked or indicated by painted marks, signs, buttons, standards, or otherwise, so as to be plainly discernible. (RCW 46.04.510)

X. Stand or Standing.

The halting of a vehicle, whether occupied or not, otherwise than temporarily for the purpose of and while actually engaged in receiving or discharging passengers. (RCW 46.04.555)

Y. Stop or Stopping.

Any halting even momentarily of a vehicle, whether occupied or not, except when necessary to avoid conflict with other traffic or in compliance with the directions of a police officer or traffic control sign or signal. (RCW 46.04.566)

Z. Taxicab, Cab, or Taxi

A for-hire vehicle held out to the public as providing transportation for passengers and/or articles for compensation and:

1. where the route traveled or destination is controlled by the customer;
2. that carries signs or indicia of a "taxi," "taxicab," or "cab" and is equipped as described in [SMC 10.34A.090](#);
3. where the fare is based on an amount recorded and indicated on a taximeter or by a special contract rate; and
4. where the vehicle is dispatched by radio or cell phone, or the ride is obtained by the use of a street hail.

AA. Temporary No Parking Zone

A. A parking space where an approved temporary no parking zone has been established and designated by temporary sign(s), barricade(s), or other device approved by the Parking Manager.

B. A temporary no parking zone will only become valid and enforceable if the zone has been established with signage for at least 24 hours giving notice that a vehicle will be removed if illegally parked in the zone and where such vehicle is interfering with the proper and intended use of such zones.

~~((AA-))~~ BB. Vehicle.

A device capable of being moved upon a street or alley and in, upon, or by which any person or property is or may be transported or drawn upon a public highway. "Vehicle" excludes, except where specifically referenced:

1. A power wheelchair or device other than a bicycle moved by human or animal power or used exclusively upon stationary rails or tracks;



2. A bicycle and a motorized foot scooter;
3. An electric personal assistive mobility device and a motorized foot scooter;  
and,
4. A golf cart.

**Section 2.** That SMC section 16A.05.060 is amended to read as follows

**Section 16A.05.060 Commercial Loading Zones**

- A. No person shall stop, stand, or park a vehicle except an authorized ~~((and identified))~~ commercial vehicle as defined in 16A.04.100(D) or other noncommercial vehicles as authorized by the Parking Manager during the hours indicated on the signs marking the zones.
- B. No person shall stop, stand, or park an authorized commercial vehicle as defined in 16A.04.100(D) or other noncommercial vehicles ~~((and identified commercial vehicle))~~ as authorized by the Parking Manager in a signed commercial loading zone for any purpose or length of time other than ~~((for the))~~ active and expeditious loading and unloading ~~((of commodities))~~. In no case shall the stopping, standing, or parking exceed thirty minutes.

**Section 3.** That SMC section 16A.05.460 is amended to read as follows

**Section 16A.05.460 Temporary No Parking Zone**

~~((A. No person shall stop, stand, or park a vehicle in a parking space where an approved temporary no parking zone has been established as defined in 16A.04.100(AA), and designated by meter hood, temporary sign(s), barricade(s), or other device approved by the Parking Manager except for vehicles displaying a temporary no parking zone permit (SMC 16A.06.050)).~~

~~((B.))A temporary no parking zone will only become valid and enforceable if the zone has been established with signage for at least 24 hours giving notice that a vehicle will be removed if illegally parked in the zone and where such vehicle is interfering with the proper and intended use of such zones.~~

**Section 4.** That SMC section 16A.06.010 is amended to read as follows

**Section 16A.06.010 Permits - Generally**

A. Purpose.

A parking permit may be issued to allow a vehicle to legally park in violation of specific parking regulations. A parking permit may apply in a designated parking

district or zone, paid parking space, or elsewhere depending on the specifications of the permit.

B. Authority.

The Parking Manager is hereby authorized to administer a system for the issuance of parking permits and to collect fees therefor.

C. Application.

1. Application for any parking permit required by this Chapter shall be made to Parking Services on forms provided for such purpose.
2. All parking permit applications shall include, at minimum the following information:
  - a. The name, address, and other current contact information for the applicant;
  - b. The license plate number and make, model and year of the vehicle for which the parking permit is sought;
  - c. A statement signed and sworn by the applicant, under penalty of perjury, that all information submitted is complete, true and accurate to the best of their knowledge; and
  - d. A copy of the current vehicle registration.
3. The Parking Manager may deny a parking permit application based on a demonstrated history of improper use by the applicant during the previous 12 months.

D. Outstanding ~~((Citations))~~ Parking Fees and Fines.

1. Outstanding parking fees and fines ~~((citations))~~ must be resolved prior to the issuance of any parking permit type.

E. Fees.

Parking permits for authorized vehicles shall be issued, pending approval by the Parking Manager, by the City upon application therefore and the paying of the fee as established in the [City of Spokane Parking Fee Schedule \(SMC 08.02.083\(A\)\)](#).

F. Proper Display of Parking Permit.

Parking permits shall be properly displayed as directed by the City.

G. Maximum Number of Parking Permits Issued.

The parking manger may limit the number of any type or zone parking permit.

H. Prohibition.

1. The provisions of this Chapter do not supersede any other provisions of the Spokane Municipal Code with respect to general parking regulations.
2. It is unlawful to falsely represent oneself as eligible for a parking permit under this Chapter or to furnish any false information in, or in conjunction with, an application for a parking permit. It shall be unlawful to attempt or to reproduce or alter any parking permit issued by the City.
3. Parking permits may be transferred upon review and approval by the Parking Manager.
4. Parking permits may be revoked in the event Parking Services determines that the owner of the vehicle, or the vehicle itself, for which a parking permit has been issued no longer meets the eligibility requirements established by Parking Services. Upon no longer meeting the eligibility requirements, the holder of the parking permit shall surrender such parking permit to Parking Services.
5. Violation of parking permit use shall result in the permit being revoked, cancellation of the permit, forfeiture of any fees paid or deposit and may result in the forfeiture of future reservations if applicable.

**Section 5.** That SMC section 16A.06.030 entitled “Service Parking Permit” is repealed.

**Section 6.** That SMC section 16A.06.040 entitled “Entertainment Event Exemption Permit” is repealed.

**Section 7** That SMC section 16A.06.050 entitled “Temporary No Parking Zone Parking Permit” is repealed.

**Section 8** That there is adopted a new section 16A.06.080 to chapter 16A.06 of the Spokane Municipal Code to read as follows:

**Section 16A.06.080 Parking Space Reservation Permit**

A parking space reservation permit allows parking within a designated parking space. The parking permit may contain allowances and restrictions as deemed necessary by the Parking Manager.

**Section 9** That there is adopted a new section 16A.06.090 to chapter 16A.06 of the Spokane Municipal Code to read as follows:

**Section 16A.06.090 Temporary Parking Permit**

A temporary parking permit allows parking in any area designated by the parking permit. The parking permit may contain restrictions as deemed necessary by the Parking Manager.

**Section 10** Effective Date. This ordinance shall take effect and be in force on August 1, 2022.

Passed the City Council \_\_\_\_\_

\_\_\_\_\_

Council President

Attest: \_\_\_\_\_  
City Clerk

Approved as to form: \_\_\_\_\_  
Assistant City Attorney

\_\_\_\_\_

Mayor

\_\_\_\_\_

Date

\_\_\_\_\_

Effective Date

City of Spokane Parking Fee Schedule  
 FY 2021~~2~~

<b>On-Street Paid Parking Zone Rates</b>		
Minimum Hourly Rate	Maximum Hourly Rate	Current rates by zone can be found at <a href="https://my.spokanecity.org/parking/">https://my.spokanecity.org/parking/</a>
\$0.50	\$3.00	
<b>Removal of Parking Payment Device(s)</b>		
Fee charged a contractor for removal and reinstallation of a parking payment device to accommodate construction work		\$60.00 per single space meter \$120.00 per dual space meter \$500.00 per pay station
<b>Delinquent Violations</b>		
The additional penalty for failure to respond to a notice of traffic violation or parking infraction is \$25.00.		
<b>Towing and Impound</b>		
Towing, storage, and related fees and charges by registered disposers are prominently posted on the disposers' premises but are not directly regulated by the City. Some rates may be fixed by contract.		
<b>Junk Vehicle Affidavit</b>		
Junk vehicle affidavit (AKA hulk slip)		\$0.00
<b>Administrative Fees</b>		
Fee per vehicle added to the Scofflaw List		\$25.00
Immobilization		\$50.00
<b>Permits</b>		
Commercial Loading Zone Permit – Annual		\$100.00/vehicle
Commercial Loading Zone Permit – Single Day		\$15.00/vehicle
Downtown Residential Parking District Permit - Monthly		<del>\$25.00</del> \$50.00 per month/vehicle
Service Permit		Month—\$50.00 Quarter—\$150.00 Annual—\$600.00
Entertainment Event Exemption Permit		\$15.00 + Paid Parking Zone rate per hour, per space for each event
Temporary No Parking Zone		\$15 per day + cost of lost paid parking revenue per space per day
Temporary No Parking Zone Permit		\$8.00 per vehicle per day
Parking Space Reservation Permit		\$25.00 per permit + cost of lost paid parking revenue per space per day
Temporary Parking Permit		\$15 per day + cost of lost paid parking revenue
Special Loading Zone – Commercial		Day - \$15.00 Month—\$125.00 Quarter—\$350.00
Special Loading Zone—News Media		Annual—\$1,000.00 for 1 <sup>st</sup> permit; \$500.00 for each additional permit
Special Loading Zone—Charitable Nonprofit		Month—\$60.00, maximum 2 permits
<b>Motor Vehicle Violations</b>		
Violation	Spokane Municipal Code Reference	Initial Fine
Advertising or For Sale	16A.05.010	\$45.00

<b>Motor Vehicle Violations</b>		
<b>Violation</b>	<b>Spokane Municipal Code Reference</b>	<b>Initial Fine</b>
Alley – Loading – Active Loading / 30 Min Max	16A.05.020(A)	\$45.00
Alley – Loading – Restricting Free Passage	16A.05.020(B)	\$65.00
Angle Parking / Backed to Curb	16A.05.030	\$45.00
Bicycle Lane – No Stopping/Standing/Parking	16A.05.040	\$65.00
Bus Zone – Unauthorized Vehicle No Stopping/Standing/Parking	16A.05.050	\$45.00
Commercial Loading Zone – Unauthorized Vehicle No Stopping/Standing/Parking	16A.05.060(A)	\$45.00
Commercial Loading Zone – No Stopping/Standing/Parking Active Loading 30 Min Max	16A.05.060(B)	\$45.00
Crosswalk – Approach - No Standing/Parking Within 20'	16A.05.070	\$45.00
Crosswalk – On - No Stopping/Standing/Parking	16A.05.080	\$65.00
Disabled Parking – Over 4Hr Time Limit At Expired Meter	16A.05.090(A)(2)	\$30.00
Disabled Parking – Unauthorized Use Placard/Plate	16A.05.110(A)	\$450.00 (\$250.00 + \$200.00 State Assessed Fee)
Disabled Parking – Park In/Block/Make Inaccessible Access Aisle or Space	16A.05.110(B)	\$450.00 (\$250.00 + \$200.00 State Assessed Fee)
Disabled Parking – No Placard/Plate	16A.05.110(C)	\$450.00 (\$250.00 + \$200.00 State Assessed Fee)
Disabled Parking – Fail to Fully Display Placard/Plate	16A.05.110(D)	\$450.00 (\$250.00 + \$200.00 State Assessed Fee)
Divided Highway - No Stopping/Standing/Parking Between Roadways	16A.05.130	\$45.00
Double Parking - No Stopping/Standing/Parking	16A.05.140	\$65.00
Driveway or Alley Entrance - No Standing/Parking Within 5'	16A.05.150	\$45.00
Excavation or Obstruction - No Stopping/Standing/Parking	16A.05.160	\$45.00
Fire Hydrant - No Standing/Parking Within 15'	16A.05.170	\$65.00
Fire Lane - No Stopping/Standing/Parking	16A.05.180	\$65.00
Fire Station - No Standing/Parking Within 20' of Entrance/Opposite Side of Street Within 75' of Entrance	16A.05.190	\$45.00
Flashing Signal – Approach - No Standing/Parking Within 30'	16A.05.200	\$45.00
Intersection - No Stopping/Standing/Parking	16A.05.210	\$65.00
Junk Vehicle - No Parking	16A.05.220	\$45.00
Motorcycle or Scooter - No Stopping/Standing/Parking Except Motorcycle or Scooter	16A.05.230(A)	\$45.00
Motorcycle or Scooter – Must Park Within Stalls and Be Secured from Tipping	16A.05.230(B)	\$45.00
Obstructing Traffic - No Stopping/Standing/Parking	16A.05.240	\$65.00
Paid Parking Zone – Illegal Use of Parking Payment Device	16A.05.250	\$30.00

<b>Motor Vehicle Violations</b>		
<b>Violation</b>	<b>Spokane Municipal Code Reference</b>	<b>Initial Fine</b>
Paid Parking Zone – Obstruction of Paid Parking Device	16A.05.260	\$30.00
Paid Parking Zone – Parking Payment Device Indicates No Stopping/Standing/Parking	16A.05.270	\$30.00
Paid Parking Zone – Valid Payment Required	16A.05.280(A)(1)	\$30.00
Paid Parking Zone – Required Information Incorrect	16A.05.280(A)(2)	\$30.00
Paid Parking Zone – Payment Not Made Immediately	16A.05.280(A)(3)	\$30.00
Parallel Parking – Wheels Parallel and Within 12” of the Curb	16A.05.290(A)	\$45.00
Parallel Parking – No stopping/Standing/Parking Against Authorized Traffic Movement	16A.05.290(B)	\$45.00
Parking Stalls - No Stopping/Standing/Parking – Across Lines/Markings	16A.05.300	\$45.00
Parking Time Limited – Outside of Paid Parking Zone - No Stopping/Standing/Parking Beyond 72 Hrs	16A.05.310(A)	\$45.00
Parking Time Limited – Non-Passenger Vehicle Outside of Paid Parking Zone - No Stopping/Standing/Parking Beyond 24 Hrs Loading	16A.05.310(B)	\$45.00
Parking Time Limited – Paid Parking Zone - No Stopping/Standing/Parking Beyond 24 Hrs	16A.05.310(C)	\$45.00
Parking Time Limited – Posted Sign/Payment Device	16A.05.310(D)	\$45.00
Parking Time Limited – No Re-Parking on Same Block Face Where Time Limit is Greater Than 30 Minutes	16A.05.310(D)(1)	\$45.00
Pedestrian Buffer Strip - No Stopping/Standing/Parking	16A.05.320	\$45.00
Permit Zones - No Stopping/Standing/Parking – No Permit	16A.05.330(A)	\$45.00
Permit Zones - No Stopping/Standing/Parking – Permit Does Not Match Vehicle	16A.05.330(B)(1)	\$45.00
Permit Zones - No Stopping/Standing/Parking – Outside Zone	16A.05.330(B)(2)	\$45.00
Permit Zones - No Stopping/Standing/Parking – Beyond Time Limit	16A.05.330(B)(3)	\$45.00
Police Vehicles Only – Unauthorized Vehicle No Stopping/Standing/Parking	16A.05.340	\$65.00
Posted Signs - No Stopping/Standing/Parking – Signs Prohibit	16A.05.350(A)	\$45.00
Posted Signs - No Standing/Parking – Signs Prohibit	16A.05.350(B)	\$45.00
Posted Signs - No Parking – Signs Prohibit	16A.05.350(C)	\$45.00
Public Safety Hazard – No Stopping/Standing/Parking	16A.05.370	\$65.00
Railroad Tracks - On - No Stopping/Standing/Parking	16A.05.380	\$65.00
Railroad Tracks – Loading - No Parking Within 50’	16A.05.390	\$45.00
Reserve a Portion of the Highway – Unlawful	16A.05.400	\$45.00
Safety Zone - No Stopping/Standing/Parking	16A.05.410	\$65.00
Sidewalk – On or Over - No Stopping/Standing/Parking	16A.05.420	\$65.00
Spokane International Airport – No Standing/Parking	16A.05.430	\$45.00
Stop Sign – Approach - No Standing/Parking Within 30’	16A.05.440	\$45.00

<b>Motor Vehicle Violations</b>		
<b>Violation</b>	<b>Spokane Municipal Code Reference</b>	<b>Initial Fine</b>
Taxicab Zones – Unauthorized Vehicle No Stopping/Standing/Parking	16A.05.450	\$45.00
Temporary No Parking Zone - No Stopping/Standing/Parking	16A.05.460(A)	\$100.00
Traffic Control Signal – Approach - No Standing/Parking Within 30'	16A.05.470	\$45.00
Vehicle Repairs - No Standing/Parking	16A.05.480	\$45.00
Yield Sign – Approach - No Standing/Parking Within 30'	16A.05.490	\$45.00
Snow Removal – No Stopping/Standing/Parking After Notice	16A.61.564(A)	\$45.00
Street Needs – No Stopping/Standing/Parking After Notice	16A.61.564(B)	\$45.00
Moving Vehicle of Another – Unlawful	16A.61.570	\$45.00
Special Loading Zone – Exceeding Time Limit	16A.61.5703(B)	\$45.00
Special Loading Zone – EPD Exceeding Time Limit	16A.61.5703(C)	\$45.00
Special Loading Zone – Unauthorized Vehicle Parked in SLZ	16A.61.5703(E)	\$45.00
Ski Jogging – Unlawful	16A.61.663	\$45.00
Sidewalk Riding and Parking Regulated – Unauthorized Bicycle or Non-Motorized Vehicle Upon Sidewalk	16A.61.787(A)	\$45.00
Sidewalk Riding and Parking Regulated – Failure to Yield to Pedestrians	16A.61.787(B)	\$45.00
Sidewalk Riding and Parking Regulated – Speeding	16A.61.787(C)	\$45.00
Sidewalk Riding and Parking Regulated – Obstruction	16A.61.787(D)	\$45.00





**Agenda Sheet for City Council Meeting of:**  
06/27/2022

<b>Date Rec'd</b>	6/9/2022
<b>Clerk's File #</b>	OPR 2022-0469
<b>Renews #</b>	
<b>Cross Ref #</b>	
<b>Project #</b>	
<b>Bid #</b>	
<b>Requisition #</b>	

<b>Submitting Dept</b>	HOUSING & HUMAN SERVICES
<b>Contact Name/Phone</b>	JENN CERCEDES 625-6055
<b>Contact E-Mail</b>	JCERCEDES@SPOKANECITY.ORG
<b>Agenda Item Type</b>	Contract Item
<b>Agenda Item Name</b>	1680- TRENT SHELTER LEASE

**Agenda Wording**

The CHHS department issued an RFP for a proposed new shelter on Trent Ave. We recommend that council approve moving forward to lease the Trent facility.

**Summary (Background)**

The lease for the Trent shelter to be used as a shelter space. Funding is covered through current funds with more details to be provided. Lease costs: 2022 - \$145,770 2023 - \$361,806 2024 - \$373,529 2025 - \$384,806 2026 - \$397,268 2027 - \$204,077 Total for all years combined: \$1,867,256

Lease? YES Grant related? NO Public Works? NO

**Fiscal Impact**

Expense	\$ 145,770.00
Select	\$
Select	\$
Select	\$

**Budget Account**

#	1910-53010-95410-54501-99999
#	
#	
#	

**Approvals**

<b>Dept Head</b>	CORTRIGHT, CARLY
<b>Division Director</b>	CORTRIGHT, CARLY
<b>Finance</b>	MURRAY, MICHELLE
<b>Legal</b>	RICHMAN, JAMES
<b>For the Mayor</b>	ORMSBY, MICHAEL

**Council Notifications**

<b>Study Session\Other</b>	Public Safety 6/6/22
<b>Council Sponsor</b>	CM Cathcart & CM Bingle

**Additional Approvals**

<b>Purchasing</b>	dnorman@spokanecity.org
<b>ACCOUNTING - LEASE</b>	MURRAY, MICHELLE

**Distribution List**

efinch@spokanecity.org
jcerecedes@spokanecity.org
dnorman@spokanecity.org
haller@spokanecity.org

## Committee Agenda Sheet

### [PUBLIC SAFETY]

<b>Submitting Department</b>	CHHS
<b>Contact Name &amp; Phone</b>	Jenn Cerecedes/ <b>Eric Finch (Briefer)</b>
<b>Contact Email</b>	jcerecedes@spokanecity.org efinch@spokanecity.org
<b>Council Sponsor(s)</b>	CM Cathcart, CM Bingle
<b>Select Agenda Item Type</b>	<input type="checkbox"/> Consent <input checked="" type="checkbox"/> Discussion    Time Requested:
<b>Agenda Item Name</b>	Trent Shelter Operator Contract
<b>Summary (Background)</b>	<p>The CHHS department issued an RFP for an Operator and a Services Provider at the proposed new shelter on Trent Ave. The RFP committee included the following representatives:          CHHS Board Member          CoC Board Member          Chief Garry Neighborhood Council Member          SRHD Member          2x Non-responsive Service Providers</p> <p>We received 2 operator proposals and 3 services proposals. Initial pass/fail criteria evaluated by the City Procurement department and 2 service proposals were not accepted due to non-conformance.</p> <p>The remaining applications were evaluated, and the committee recommended that The Guardians be awarded the Operator contract.</p> <p>The committee did not recommend a services provider based on the single application remaining after the pass/fail test. This was based on the more limited scope of services proposed.</p> <p>We recommend that council approve moving into contracting with The Guardians Foundation as the Operator of the new Shelter Facility.</p> <p>We are evaluating three options to provide services that include extension of existing provider contracted services to include this location, a pay-for-service model that would be more open to the multiple different specialist service providers we have in the area, and a refined RFP that allows multiple specialty awards that can be done with one of the above more immediate options.</p> <p>The initial submitted budget is \$700K per year over our initial annual budget. During the contracting discussion, we will look at options to reduce this gap without any critical service/bed impact as well as other budget options to fund any remaining gap.</p> <p>More details on the site plan and operations model will be provided moving forward.</p>
<b>Proposed Council Action &amp; Date:</b>	June 13, 2022 first reading, June 20, 2022 approval vote

**Fiscal Impact:** \*Note: Contracting phase will adjust final budget amount and that will be updated once completed for review.

Total Cost: \$5,750,000 for 18 months (\$3,700,000 annualized) estimate based on initial submitted budget

Approved in current year budget?  Yes  No  N/A (\$700K over NOFO initial budget, have 2022,2023 funding to cover this gap)

Funding Source  One-time  Recurring

Specify funding source: This is a mix of Criminal Justice funds, General Fund, and ARPA

Expense Occurrence  One-time  Recurring (Some startup one-time costs, most recurring operational costs.)

Other budget impacts: (revenue generating, match requirements, etc.)

**Operations Impacts**

What impacts would the proposal have on historically excluded communities?

This is low barrier 24/7 space for all populations.

How will data be collected, analyzed, and reported concerning the effect of the program/policy by racial, ethnic, gender identity, national origin, income level, disability, sexual orientation, or other existing disparities?

This will use the required HMIS/CMIS system for reporting and tracking.

How will data be collected regarding the effectiveness of this program, policy or product to ensure it is the right solution?

This used the existing framework for HMIS/CMIS performance monitoring to assess ongoing performance.

Describe how this proposal aligns with current City Policies, including the Comprehensive Plan, Sustainability Action Plan, Capital Improvement Program, Neighborhood Master Plans, Council Resolutions, and others?

This is fully aligned with Mayor and Council priorities for supporting vulnerable populations and existing Federal, State and Local codes and ordinances.

**OFFICE/WAREHOUSE LEASE**  
(Single Tenant NNN)

THIS OFFICE/WAREHOUSE LEASE ("Lease") is made this \_\_\_\_ day of \_\_\_\_\_ 2022, (the "Effective Date") between **Lawrence B. Stone Properties #4320, LLC**, a Washington limited liability company ("Landlord"), and **The City of Spokane**, a public municipal corporation ("Tenant").

**LEASE OF PREMISES**

Landlord hereby leases to Tenant and Tenant hereby rents from Landlord, subject to the terms and provisions of this Lease, the premises as described in Exhibit A (the "Premises") and located in the building described in Item 1 below (the "Building"). References to the Building shall mean the whole of the building structure, parking areas, landscaping and other improvements, together with the underlying land.

**BASIC PROVISIONS**

1. **Building Address:** 4320 E. Trent Avenue, Spokane, WA, 99212
2. **Use of Premises:** Tenant will retain an operator or operators to operate a shelter on the Premises and in the Building for the protection of vulnerable and homeless individuals and families along with such accessory uses as Tenant determines are reasonably necessary (the "Shelter"). The shelter will have an estimated daily usage of 250 beds with surge capacity as needed. The shelter will operate as a nightly shelter with off-season emergency activation ability to respond to community or environmental needs (e.g., a safer air center, cooling center, or early/late inclement weather center). The shelter will operate 24 hours a day, 7 days a week and will also be open for day use for members of the community, providing basic amenities such as bathroom access, shower access, access to electricity for charging, and meals. The operator will provide wrap-around services to guests at the shelter. Additional services will include, but won't be limited to, coordinate entry access point, outreach services, transportation, temporary storage for personal belongings, case management, and referrals for homeless and precariously housed persons.
3. **Rentable Footprint Area of Premises:** Deemed to be 36,046 square feet, more or less ("Net Rentable Area"), as depicted in Exhibit A-1.
4. **Building Premises Percentage:** Deemed to be 100% of the building.
5. **Monthly Rental Installments:** \$26,100.00 ("Base Rent") + NNN
6. **Rent Adjustment:** As provided for in Exhibit C.
7. **Initial Term:** Five (5) years, with one (1) option to renew for five (5) years as per Exhibit D.
8. **Commencement Date:** August 1, 2022
9. **Security Deposit:** \$26,100.00 (payment of which is due upon execution of this Lease, along with the required insurance certificate per Section 8.02)

10. **Tenant's Address for Delivery of Notices:**

\_\_\_\_\_  
\_\_\_\_\_  
\_\_\_\_\_  
\_\_\_\_\_

**Tenant's Accounts Payable Contact:**

Name: \_\_\_\_\_  
Phone: \_\_\_\_\_  
Address: \_\_\_\_\_  
\_\_\_\_\_

**11. Landlord's Address for Payment of Rent and Delivery of Notices:**

Lawrence B. Stone Properties #4320, LLC  
P.O. Box 3949  
Spokane, WA 99220-3949

- 12. Attachments:**
- Exhibit A, Description of Premises
  - Exhibit A-1, Layout Drawing of Premises
  - Exhibit B, Improvements
  - Exhibit C, Adjustment of Base Rent
  - Exhibit D, Option to Extend
  - Exhibit E, Required Additional Insureds
  - Exhibit F, Signs
  - Exhibit G, Tenant's Option to Purchase the Premises

\*\*\*\*\*  
***REMAINDER OF PAGE INTENTIONALLY LEFT BLANK***

IN WITNESS WHEREOF, the parties have executed this Lease, consisting of the foregoing Basic Provisions, the General Provisions and attached Exhibits, as of the date first above written.

TENANT:  
CITY OF SPOKANE

LANDLORD:  
LAWRENCE B. STONE PROPERTIES #4320,  
LLC

By: \_\_\_\_\_

By: \_\_\_\_\_

Name: \_\_\_\_\_

Name: Lawrence B. Stone

Its: \_\_\_\_\_

Its: Managing Member

Date: \_\_\_\_\_

Date: \_\_\_\_\_

Attest:

\_\_\_\_\_  
Clerk

Approved as to form:

\_\_\_\_\_  
City Attorney

State of Washington )  
 ) ss.  
County of Spokane )

ON THIS, the \_\_\_\_\_ day of \_\_\_\_\_, 2022, I certify that I know of and have satisfactory evidence that Lawrence B. Stone is the person who appeared before me, and said person acknowledged that he signed this Lease, on oath stated that he was authorized to execute such Lease and acknowledged it as the Managing Member of Lawrence B. Stone Properties #4320, LLC to be the free and voluntary act of such party for the uses and purposes contained therein.

WITNESS my hand and official seal hereto affixed the day and year first above written.

\_\_\_\_\_  
NOTARY PUBLIC in and for said County and State,  
residing at \_\_\_\_\_  
My appointment expires: \_\_\_\_\_

State of \_\_\_\_\_ )  
 ) ss.  
County of \_\_\_\_\_ )

ON THIS, the \_\_\_\_ day of \_\_\_\_\_, 2022, I certify that I know of and have satisfactory evidence that \_\_\_\_\_ and \_\_\_\_\_, being the \_\_\_\_\_ and City Clerk, respectively, of the City of Spokane, are the persons who appeared before me, and said person acknowledged that he/she signed this Lease, on oath stated that he/she was authorized to execute such Lease and acknowledged it as the free and voluntary act of such party for the uses and purposes contained therein.

WITNESS my hand and official seal hereto affixed the day and year first above written.

\_\_\_\_\_  
NOTARY PUBLIC in and for said County and State,  
residing at \_\_\_\_\_  
My appointment expires: \_\_\_\_\_

**GENERAL PROVISIONS**

**TABLE OF CONTENTS**

	<u>Page No.</u>
1. PREMISES .....	1
2. TERM.....	1
3. RENT .....	1
4. USE OF PREMISES.....	2
5. UTILITIES AND SERVICES.....	6
6. MAINTENANCE AND REPAIR.....	6
7. TAXES; OTHER ASSESSMENTS .....	8
8. INSURANCE .....	8
9. ALTERATIONS .....	9
10. SIGNS .....	10
11. QUIET ENJOYMENT .....	10
12. ASSIGNMENT AND SUBLETTING .....	10
13. SUBORDINATION AND FINANCING.....	11
14. SURRENDER OF PREMISES.....	11
15. DESTRUCTION OF PREMISES .....	13
16. EMINENT DOMAIN .....	13
17. DEFAULT.....	14
18. INDEMNITY .....	16
19. EXECUTIVE ORDER NO. 13224; THE PATRIOT ACT.....	17
20. ADDITIONAL PROVISIONS.....	17
EXHIBIT A: DESCRIPTION OF PREMISES	
EXHIBIT A-1: LAYOUT DRAWING OF PREMISES	
EXHIBIT B: IMPROVEMENTS	
EXHIBIT C: ADJUSTMENT OF BASE RENT	
EXHIBIT D: OPTION TO EXTEND	
EXHIBIT E: REQUIRED ADDITIONAL INSUREDS	
EXHIBIT F: SIGNS	
EXHIBIT G: TENANT’S OPTION TO PURCHASE THE PREMISES	



## GENERAL PROVISIONS

### 1. PREMISES

- 1.01 **"AS-IS"**. The Premises consist of the land and Building as shown in Exhibit A. Subject to the warranties in Sections 1.02 and 6.10 herein below, Tenant accepts the Premises "as is" and, except as described in Exhibit B, Landlord shall have no responsibility to construct or pay for any improvements.
- 1.02 **Delivery**. If Landlord, for any reason whatsoever, cannot deliver possession of the Premises to Tenant at the Commencement Date, this Lease shall not be void or voidable nor shall Landlord be liable to Tenant for any loss or damage resulting therefrom, but in that event there shall be a proportionate reduction of rent covering the periods between the commencement of said term and the time when Landlord delivers possession; provided however, notwithstanding the foregoing, in the event that Landlord fails to deliver possession of the Premises to Tenant within thirty (30) days of the Commencement Date of this Lease, then Tenant may at its option terminate this Lease by providing written notice of termination to Landlord. No delay in delivery of possession shall operate to extend the term hereof. Upon commencement of Lease, Landlord to provide Premises in good working order including, but not limited to; electrical, mechanical, HVAC and plumbing.

### 2. TERM

- 2.01. **Initial Term**. The Initial Term shall commence on the Commencement Date specified in Item 8 of the Basic Provisions.
- 2.02. **Option to Extend**. If an option to extend this Lease is indicated in Item 7 of the Basic Provisions, such option to extend shall be on the terms set forth in Exhibit D. As used elsewhere in this Lease "Term" shall include both the Initial Term and, if applicable, any Extension Term.

### 3. RENT

- 3.01. **Rent**. Tenant shall pay Landlord, without deduction or off-set, the Base Rent as shown in Item 5 of the Basic Provisions in equal monthly installments on the first day of each calendar month, in advance, commencing on the Commencement Date. Rent for any period less than a full calendar month shall be pro-rated calculated on a thirty (30) day month. The Base Rent shall be escalated as provided for in Exhibit C. In addition to the Base Rent, all amounts to be paid by Tenant pursuant to this Lease, including Additional Rent Expenses, shall be considered "additional rent" and included in all references to "rent".
- 3.02. **Security Deposit**.
- (a) The Security Deposit shall be held by Landlord as security for Tenant's performance of its obligations under this Lease. If Tenant defaults beyond any applicable notice and cure period Landlord may use all or any portion of the Security Deposit: (i) for the payment of rent or any other sum in default; (ii) for the payment of any reasonable and necessary amount which Landlord may spend by reason of Tenant's default, or (iii) as compensation for other loss or damage suffered by Landlord by reason of Tenant's default. If any portion of the Security Deposit is so used Tenant shall, within ten (10) days after Landlord's written demand, deposit cash with Landlord in an amount sufficient to restore the Security Deposit to its original amount. Tenant shall not be entitled to interest on such Security Deposit.
  - (b) If Tenant fully performs its obligations under this Lease the Security Deposit shall be returned within thirty (30) days after Tenant vacates the Premises following the expiration or earlier termination of this Lease, less any amounts required to reimburse Landlord for reasonable and necessary sums expended to place the Premises in the condition required under Section 14.

- (c) If Landlord sells or conveys the Premises Landlord shall transfer the Security Deposit to the successor in interest and, the successor in interest shall assume all of Landlord's obligations under this Lease, Landlord shall be released by Tenant from all liability for the return of the Security Deposit.

3.03 **Additional Rent Expenses.**

- (a) Tenant shall pay Landlord, as "Additional Rent," commencing on the Lease Commencement Date The following Triple Net ("NNN") expenses, billed on a monthly basis:
- Real Property Taxes - Annual property taxes for the Premises in accordance with Section 7.01.
  - Building Insurance Expenses - Annual building insurance expenses except in the case Tenant self-insures.
  - Maintenance as described in Section 6 and any other maintenance not covered elsewhere in this Lease.
  - Management Fee - Tenant shall pay Landlord, as additional rent for the management of the Premises a Management Fee ("Mgmt. Fee") equal to two- and one-half percent (2.5%) of the then Base Rent, and all sums paid or payable by Tenant as Additional Rent, billed on a monthly basis.

Tenant shall notify Landlord in writing within five (5) days of noticing any defect, hazard and/or needed repair.

3.04 **Late Charges.**

- (a) Tenant acknowledges that late payment or nonpayment of rent will cause Landlord to incur costs of undetermined amounts. Accordingly, if any monthly installment of the Base Rent or any other sum payable by Tenant under this Lease is not received by Landlord within ten (10) days after its due date, Tenant shall pay a late charge equal to the greater of 10% of such overdue payment or \$250.00. Sums (including rent) payable by Tenant pursuant to this Lease which are past due for thirty (30) or more days shall bear interest from the due date at the rate of 18% per annum.
- (b) Landlord's acceptance of a late charge or interest on overdue amounts shall not constitute a waiver of Tenant's default nor prevent Landlord from exercising any other rights or remedies. No payment by Tenant of an amount less than due shall be deemed as other than a partial payment on account of the most recent amounts due, nor shall any endorsement or statement on any check or letter accompanying any payment be deemed to create an accord and satisfaction.

3.05. **Place of Payment.** Until otherwise directed by Landlord Tenant shall deliver all notices and pay all Base Rent and other amounts due under this Lease to Landlord's address as set forth in Item 11 of the Basic Provisions.

3.06. **Net Lease.** The parties intend that this Lease shall be a net Lease, and that: (i) all rent payable by Tenant to Landlord shall be net of all costs and expenses relating to the Premises; and (ii) all such costs and expenses paid or incurred during the Term including, but not limited to, taxes, insurance, utilities, repairs and maintenance shall be paid by Tenant, unless otherwise provided for elsewhere in this Lease.

If Tenant request Landlord to provide any services, improvements or any other type of work, materials, labor or any other billable cost on Tenant's behalf, then Landlord shall invoice Tenant for same plus 20% should Landlord agree to perform on Tenant's behalf.

**4. USE OF PREMISES**

4.01. **Use.** Tenant shall use the Premises only for the purpose(s) set forth in Item 2 of the Basic Provisions. Any different use shall require the prior written consent of Landlord, which consent shall not be unreasonably withheld, delayed, or conditioned. Tenant's use shall be in full compliance with all applicable statutes, ordinances, laws, rules, regulations and restrictive covenants (collectively "Rules"), and in a manner which

does not result in a nuisance to or unnecessary disturbance to neighboring property owners or businesses, including interior or exterior noise which shall not exceed 80 decibels at any given time; provided, as long as Tenant and/or its operator uses the Premises as described in Item 2 of the Basic Provisions is in compliance with the Rules, the same shall not be considered a nuisance or unnecessary disturbance and shall not be considered a default or breach of Tenant's obligations under this Lease, Landlord hereby acknowledging that use of the Premises as described in Item 2 of the Basic Provisions in compliance with the Rules shall not be considered a nuisance or unnecessary disturbance under this Lease. Tenant shall regularly maintain the premises and surrounding area clean and free of debris, litter and abandoned or disabled vehicles. Tenant shall comply with all rules and regulations of the 2018 International Building Code and 2018 International Fire Code requirements currently adopted by Washington State and the Spokane Municipal Code, including any local amendments/requirements; provided, Landlord and Tenant acknowledge and agree Tenant will be availing itself of the exemption from such requirements pursuant to RCW 19.27.042 as codified locally in Spokane Municipal Code Section 17F.040.200. Tenant shall not maintain any item or do anything in or about the Premises which would cause the increase of insurance rates or make such insurance unobtainable.

(a) **No Outside Storage.** It shall be the Tenant's responsibility to not store any inventory, supplies, materials, chattel, or equipment outside on or about the Premises unless specifically enumerated in this Lease; provided, Tenant may use several containers for outdoor storage of such items. With written notice from Landlord, Tenant shall remove any offending items stored outside within forty-eight (48) hours of Tenant's receipt of Landlord's written notice. If Tenant fails to remove such offending items within the forty-eight (48) hours, Tenant shall be subject to a \$500.00 penalty and Tenant shall have an additional forty-eight (48) hours to remove such offending items. If Tenant again fails to remove such offending items, it shall constitute a default of this Lease and be subject to an additional \$500.00 penalty per week.

4.02. **Nuisance** Subject to Item 2 of the Basic Provisions and Section 4.01 herein above, Tenant shall not use the Premises in any manner that results in a nuisance or an unreasonable annoyance including, without limitation, the use of sound or light apparatus that can be heard or seen outside the Premises, or any other loud disturbances that could affect the neighboring property owners or businesses

4.03. **Electrical Requirements.** If Tenant installs electrical equipment which causes an overload on the electrical service to the Premises or the Building, Tenant shall, at Tenant's sole expense, make all changes necessary to comply with the requirements of insurers, the electrical utility company and any governmental authority having jurisdiction.

4.04. **Disposal of Refuse.** Tenant shall not dump, dispose, reduce or incinerate any trash, papers, refuse or garbage in or about the Premises. Tenant shall store trash and garbage within covered metal containers. Tenant shall be required to inspect the Primes and surrounding area on a daily basis for any refuse, trash, etc.

4.05. **Improvements by Tenant.** If Tenant is to construct and/or install improvements in the Premises, subject to Landlord's warranties in Section 6.10 below, Tenant's obligations as set forth in Sections 6, 8 and 18 shall commence from and after the date Tenant, or Tenant's employees, contractors or agents, take possession of the Premises.

4.06. **Suitability.**

(a) Tenant acknowledges that Landlord (including any agent of Landlord) has not made any representation or warranty with respect to the Premises or concerning its suitability for the uses intended by Tenant. Tenant agrees that Landlord has not agreed to undertake any modification, alteration or improvement of the Premises except as provided for in Exhibit B.

(b) Subject to the warranties in Sections 1.02 and 6.10 herein below, if Tenant has occupied the Premises during any period immediately preceding the Commencement Date, the continued possession of the Premises by Tenant as of the Commencement Date shall conclusively establish that the Premises were, at that time, in a satisfactory condition. If, immediately preceding the Commencement Date, Tenant has not occupied the Premises, Tenant taking possession of the Premises shall conclusively establish that the Premises were, at that time, in satisfactory condition unless, within thirty (30) days after the date of possession, Tenant provides Landlord a written notice specifying in reasonable detail items which are defective or in an unsatisfactory condition.

4.07. **Improvements.**

- (a) Landlord's Work. Prior to the Commencement Date, Landlord shall cause the work described in Section A of Exhibit B to this Lease to be completed to Tenant's reasonable satisfaction.
- (b) Improvements by Tenant specified in Section B of Exhibit B. Tenant may but shall not be obligated to complete the improvements and alterations identified in Section B of Exhibit B to this Lease at Tenant's expense, and with Landlord's prior consent, which shall not be unreasonably withheld, conditioned or delayed; provided, Tenant shall make all improvements as it elects to make in accordance with all laws, rules, regulations, and ordinances of governmental agencies, offices, and boards having jurisdiction, subject to the exemption referenced in Section 4.01 above.
- (c) Other Improvements. Tenant shall not make any improvements or alterations to the Premises other than those described in Exhibit B without the Landlord's prior consent, which consent shall not be unreasonably withheld, conditioned or delayed. After obtaining such consent, Tenant may make, at its own expense, those additional improvements or alterations to the Premises as Tenant desires. The foregoing notwithstanding, Tenant shall not be required to obtain the Landlord's consent for minor improvements or alterations, defined as improvements or alterations which cost \$10,000.00 or less and which do not involve structural modifications to the Building.

4.08. **Environmental Laws:**

- (a) During the Term of this Lease, Landlord and Tenant shall comply with all Environmental Laws and Environmental Permits (each as defined below) applicable to the operation or use of the Premises, will cause all other persons occupying or using the Premises to comply with all such Environmental Laws and Environmental Permits, will immediately pay or cause to be paid all costs and expenses incurred by reason of such compliance, and will obtain and renew all Environmental Permits required for operation or use of the Premises.
- (b) Neither Landlord nor Tenant shall generate, use, treat, store, handle, release or dispose of, or permit the generation, use, treatment, storage, handling, release or disposal of Hazardous Materials as defined below on the Premises, or the Building, or transport or permit the transportation of Hazardous Materials to or from the Premises or the Building except for quantities used or stored at the Premises and required in connection with the operation of Tenant's business from the Premises and the maintenance of the Premises, and then only in compliance with all applicable Environmental Laws and Environmental Permits. Tenant shall use best efforts to safely handle and dispose of any contraband belonging to or found on individuals seeking shelter on the Premises and the presence of the same on the Premises shall not be considered a breach or default under this Lease.
- (c) At any time and from time to time during the Term of this Lease, Landlord may perform, at Landlord's sole cost and expense, upon reasonable notice to Tenant, an environmental site assessment report concerning the Premises, prepared by an environmental consulting firm chosen by Landlord, to determine the presence or absence of Hazardous Materials caused or permitted by Tenant and the potential cost of any compliance, removal or remedial action in connection with any such Hazardous Materials on the Premises; provided, in no event will Tenant be responsible for the cost of any

compliance, removal or remedial action in connection with Hazardous Materials existing on or under the Premises as of the Commencement Date. Tenant shall grant and hereby grants to Landlord and its agents access to the Premises and specifically grants Landlord an irrevocable non-exclusive license to undertake such an assessment.

- (d) Landlord and Tenant will immediately advise the other party in writing of Landlord's or Tenant's knowledge of any of the following: (1) any pending or threatened Environmental Claim (as defined below) against Tenant or Landlord relating to the Premises or the Building; (2) any condition or occurrence on the Premises or the Building that (a) results in noncompliance of the Building or the Premises with any applicable Environmental Law, or (b) could reasonably be anticipated to form the basis of an Environmental Claim against Tenant or Landlord or the Premises; (3) any condition or occurrence on the Premises or any property adjoining the Premises that could reasonably be anticipated to cause the Premises to be subject to any restrictions on the ownership, occupancy, use or transferability of the Premises under any Environmental Law; and (4) the actual or anticipated taking of any removal or remedial action by Tenant in response to the actual or alleged presence of any Hazardous Material on the Premises or the Building. All such notices shall describe in reasonable detail the nature of the claim, investigation, condition, occurrence or removal or remedial action and Landlord's or Tenant's, respectively, response thereto. In addition, Landlord and Tenant will provide the other party with copies of all communications regarding the Premises with any governmental agency relating to Environmental Laws, all such communications with any person relating to Environmental Claims, and such detailed reports of any such Environmental Claim as may reasonably be requested by Landlord or Tenant.
- (e) "Hazardous Materials" means any hazardous or toxic substance, biohazard, material or waste which is or becomes: (i) regulated by any local, state or United States governmental agency; or (ii) defined as "hazardous material", "hazardous substance" or "hazardous waste" under any local, state or United States law, ordinance, regulation, rule, order or policy ("Environmental Laws"), including but not limited to: (i) petroleum or petroleum products, natural or synthetic gas, asbestos in any form that is or could become friable, urea formaldehyde foam insulation, and radon gas; and (ii) any substances defined as or included in the definition of "hazardous substances," "hazardous wastes," "hazardous materials," "extremely hazardous wastes," "restricted hazardous wastes," "toxic substances," "toxic pollutants," "contaminants" or "pollutants," or words of similar import, under any applicable Environmental Law; (b) "Environmental Law" means any federal, state or local statute, law, rule, regulation, ordinance, code, policy or rule of common law now or hereafter in effect and in each case as amended, and any judicial or administrative interpretation thereof, including any judicial or administrative order, consent decree or judgment, relating to the environment, health, safety or Hazardous Materials, including without limitation, the Comprehensive Environmental Response, Compensation, and Liability Act of 1980, 42 U.S.C. §§ 9601 et seq.; the Resource Conservation and Recovery Act, 42 U.S.C. §§ 6901 et seq.; the Hazardous Materials Transportation Act, 49 U.S.C. §§ 1801 et seq.; the Clean Water Act, 33 U.S.C. §§ 1251 et seq.; the Toxic Substances Control Act, 15 U.S.C. §§ 2601 et seq.; the Clean Air Act, 42 U.S.C. §§ 7401 et seq.; the Safe Drinking Water Act, 42 U.S.C. §§ 300f et seq.; the Atomic Energy Act, 42 U.S.C. §§ 2011 et seq.; the Federal Insecticide, Fungicide and Rodenticide Act, 7 U.S.C. §§ 136 et seq.; the Occupational Safety and Health Act, 29 U.S.C. §§ 651 et seq.; (c) "Environmental Claims" means any and all administrative, regulatory or judicial actions, suits, demands, demand letters, claims, liens, notices of non-compliance or violation, investigations, proceedings, consent orders or consent agreements relating in any way to any Environmental Law or any Environmental Permit, including without limitation (i) any and all environmental claims by governmental or regulatory authorities for enforcement, cleanup, removal, response, remedial or other actions or damages pursuant to any applicable Environmental Law and (ii) any and all environmental claims by any third party seeking damages, contribution, indemnification, cost recovery, compensation or injunctive relief resulting from Hazardous Materials or arising from alleged injury or threat of injury to health, safety or the environment; and (d) "Environmental Permits"

means all permits, approvals, identification numbers, licenses and other authorizations required under any applicable Environmental Law.

- (f) Landlord and Tenant agrees to indemnify, defend and hold harmless the other party, its Manager, affiliates and related parties from and against all obligations (including removal and remedial actions), losses, claims, suits, judgments, liabilities, penalties, damages (excluding consequential and punitive damages), costs and expenses (including reasonable attorneys' and consultants' fees and expenses) of any kind or nature whatsoever that may at any time be incurred by, imposed on or asserted against such indemnitees to the extent attributable to (a) the presence of Hazardous Materials on the Premises or the Building which is caused by the indemnifying party or a related party and (b) any Environmental Claim relating in any way to the indemnifying party's operation or use of the Building or the Premises (the "Hazardous Materials Indemnified Matters"). The provisions of this section shall survive the expiration or sooner termination of this Lease. The foregoing indemnification by Tenant only shall not apply to (i) any pre-existing Hazardous Materials located on or about the Premises; or (ii) any Hazardous Materials, or conditions arising therefrom, not caused by Tenant. The foregoing indemnification by Landlord shall not apply to any Hazardous Materials, or conditions arising therefrom which do not fall within Landlord's obligations under the expressed terms of this Lease.

## **5. UTILITIES AND SERVICES**

Tenant shall pay the cost for all utilities and services furnished to the Premises as required by Tenant including, but not limited to, electricity, natural gas, water, sewer, telephone service, refuse collection, internet access, security (alarm) system(s), if any, janitorial and maintenance services with respect to the exterior and interior of the Premises, including the parking lot, landscaping and sidewalks.

## **6. MAINTENANCE AND REPAIR**

- 6.01. **Generally.** Notwithstanding any other provision of this Lease, except for the repair of damage caused by a casualty event (e.g., fire, explosion, flood, earthquake, windstorm, terrorist attack, etc.), which shall be repaired by the Landlord unless the Landlord or Tenant elects to terminate this Lease as provided in Section 15 below, Tenant shall, at its sole expense, maintain the Premises in good condition and promptly make all repairs and replacements, whether structural or non-structural, necessary to keep the Premises in safe operating condition, including all utilities and other systems serving the Premises, but excluding the roof, foundation, and exterior walls, which the Landlord shall maintain in good condition and repair at the Landlord's expense. The Landlord shall also be responsible for the repair of any damage to the extent caused by the Landlord and its employees, agents and contractors. Tenant shall not damage any demising wall or disturb the structural integrity of the Premises and shall promptly repair or cause to be repaired, to Landlord's satisfaction, any damage or injury done to any such demising walls or structural elements caused by Tenant or its employees, agents, contractors, or invitees.
- 6.02. **HVAC System.** Tenant shall be responsible for keeping the currently installed heating and ventilation system ("HVAC System") operating and in good condition and repair; provided, Tenant may, at Tenant's sole cost and expense, replace the HVAC System with a comparable or superior HVAC System approved by the Landlord (which approval shall not be unreasonably withheld, conditioned or delayed). Prior to the Commencement Date, Tenant shall provide Landlord with a copy of an executed annual maintenance agreement covering the HVAC System with a heating and ventilation system maintenance provider reasonably acceptable to Landlord, and Tenant shall enter into such renewals as are necessary to cause such agreement (or a replacement agreement) to remain in effect for the Term of this Lease.
- 6.03. **Security System.** Tenant shall be responsible for keeping the currently installed security system, or such comparable or superior security system, as the Tenant may install with Landlord's approval (which approval shall not be unreasonably withheld, conditioned or delayed), operating and in good condition and repair,

and shall be responsible for paying to keep the system activated, in operation, and monitored during the Term of this Lease.

- 6.04 **Janitorial Services and Landscaping.** Tenant shall hire all necessary maintenance and janitorial personnel to keep the Premises clean and in good repair including landscaping and improvements on the Premises.
- 6.05 **Glass and Doors.** Tenant shall not damage any window(s) or doors on the Premises and shall promptly repair or replace or cause to be repaired or replaced, at Tenant's expense and to Landlord's reasonable satisfaction, any damaged or broken windows on the Premises during the Term of the Lease.
- 6.06 **Fire Sprinkler System.** Tenant shall be responsible for keeping any installed fire sprinkler system (or a comparable system) operating and in good condition.
- 6.07 **Parking Lot Maintenance and Snow Removal.** Tenant shall be responsible for all maintenance of the parking area, sidewalks and walkways and all snow and ice removal from the Premises, including removal of excess amounts of snow from the roof, and keeping gutters, downspouts and scuppers free and clear of any snow and ice that interferes with the normal drainage of water from the roof. Tenant shall also be responsible for the cost of seal coating, resurfacing and restriping of the parking lot which shall be completed in year spring of year three (3) of the Lease and year five (5) of the Lease.
- 6.08 **Condition of Premises.** At the end of the Term, Tenant shall return the Premises back to Landlord in as good a condition as they were at the beginning of the Lease Term, reasonable wear and tear excepted. Landlord has no obligation to make repairs, alterations, replacements or improvements to the Premises or the mechanical equipment serving the Premises, except as specifically provided for elsewhere in this Lease. Landlord shall not be required to make repairs, renewals, replacement, or perform any maintenance resulting from: (i) Tenant's negligence or intentional acts; (ii) Tenant's failure to observe any conditions or perform its obligations under this Lease; or (iii) alterations, additions or improvements made by Tenant.
- 6.09 **Failure to Repair.** If Tenant fails to make repairs and/or maintain the Premises in a manner reasonably satisfactory to Landlord, Landlord may, upon providing at least Tenant twenty (20) days' prior written notice unless additional time is reasonably needed in order to complete the repairs and/or maintenance, make such repairs or perform such maintenance on behalf of Tenant. In such event, such work shall be paid for by Tenant as additional rent and shall be due promptly upon Tenant's receipt of Landlord's invoice. Landlord's exercise of these rights shall not entitle Tenant to damages for inconvenience, or to any abatement of Base Rent or other amounts payable by Tenant under this Lease.
- 6.10 **Warranties.**
- (a) Landlord warrants that, as of the Commencement Date, the premises shall be in good working order, including but not limited to, HVAC, mechanical, plumbing, and electrical systems serving the Premises (the "Systems"), and that Landlord will fix any problems that arise with the Systems within thirty (30) days of the Commencement Date at no cost or expense to Tenant.
  - (b) If Landlord has obtained any warranties covering the Premises or any equipment therein which are to be repaired or replaced by Tenant, and a needed repair or replacement falls within the coverage of such warranty, Landlord shall either: (i) use reasonable efforts to cause such repairs or replacements to be made by the warranting party; or (ii) assign the warranty rights to Tenant.
- 6.11 **Americans with Disabilities Act and Related Laws.** Notwithstanding contained in this lease, Landlord and Tenant agree that responsibility for compliance with the Americans With Disabilities Act of 1990 and any related or similar local or state laws, rules, or regulations (the "ADA") shall be allocated as follows: (i)

Landlord shall be responsible for compliance with the provisions of Title III of the ADA for all Common Areas of the Building, including exterior and interior areas of the Building, unless such compliance is caused by Tenant's particular use of the Premises that is different than the customary use of the Building, (ii) Landlord shall be responsible for compliance with the provisions of Title III of the ADA for any construction, renovations, alterations and repairs made within the Premises if such construction, renovations, alterations or repairs are made by Landlord at Landlord's request and sole expense for the purpose of improving the Building generally, (iii) Tenant shall be responsible for compliance with the provisions of Title III of the ADA in connection with any construction, renovations, or improvement work within the Premises occurring after Landlord's delivery of the Premises to Tenant, and (iv) Tenant shall be responsible for compliance with the provisions of Title III of the ADA for Common Areas of the Building, whether interior or exterior, if necessitated or caused by Tenant's particular use of the Premises which is different than the customary use of the Building.

## **7. TAXES; OTHER ASSESSMENTS**

- 7.01. **Obligation to Pay Taxes.** Tenant shall pay all personal property taxes levied and assessed against Tenant's fixtures, equipment and other property on the Premises. In addition, Tenant shall pay Landlord, promptly upon demand, all ad valorem real property taxes and assessments levied and assessed against the Premises, including the land on which such Premises are situated. Taxes and assessments payable to Landlord shall be prorated for the first and last years of the Term.
- 7.02. **No Right to Contest.** Tenant shall not have the right to contest the amount or validity of all or any part of the real property taxes and assessments which Tenant is required to pay as determined by any governmental authority having jurisdiction in the state where the property is located. Tenant shall indemnify Landlord against any loss or liability incurred by reason of such unauthorized contest.
- 7.03. **New Taxes.** Tenant shall pay Landlord upon demand all taxes and other charges payable by Landlord to any government entity (other than net income, estate or inheritance taxes) whether or not now customarily paid or within the contemplation of the parties: (i) by reason of or measured by the Base Rent or additional rent payable by Tenant; (ii) allocable to or measured by the area or value of the Premises; (iii) allocable to or measured by the use and occupancy of the Premises by Tenant; or (iv) levied for services rendered by or on behalf of any public, quasi-public or governmental entity.

## **8. INSURANCE**

- 8.01. Tenant shall carry and maintain, at Tenant's sole expense, the following types and amounts of insurance, in the form as provided for elsewhere in this Section 8; provided, Tenant shall self-insure for the coverages required by this Section by providing Landlord with a letter from Tenant's risk manager describing Tenant's insurance coverages:
- (a) **Public Liability and Property Damage:** (i) bodily injury liability insurance with limits of at least \$5,000,000.00 per person and \$5,000,000.00 per occurrence insuring against liability of the insured(s) with respect to the Premises used by Tenant, its employees, agents, contractors, customers and invitees, or arising out of the maintenance, use and occupancy thereof; and (ii) property damage liability insurance with limits of at least \$5,000,000.00 per occurrence. All such bodily injury and property damage insurance shall insure the performance by Tenant of its indemnity obligations contained in this Lease as to liability for injury to or death of person and injury or damage to property, and shall name those persons and entities listed in Exhibit E as additional insureds.
  - (b) **Plate Glass.** Tenant shall be responsible for the maintenance, repair or replacement of any plate glass on the Premises but shall have the option to either insure the risk or to self-insure the same.
  - (c) **Premises Facilities Furnished and Installed by Tenant; Personal Property.** Insurance covering all items comprising Tenant's leasehold improvements, trade fixtures, equipment and personal



property on or upon the Premises in an amount not less than 90% of their full replacement cost, providing protection against any peril included within the classification "fire and extended coverage", together with insurance against sprinkler damage, vandalism and malicious mischief. Any policy proceeds shall be used for the repair or replacement of the property damaged or destroyed unless this Lease shall cease and terminate pursuant to the provisions of Section 15.

- 8.02. **Policy Form.** All insurance policies shall be issued by insurance companies with a general policyholder's rating of not less than A and a financial strength rating of A++ (or equivalent ratings if such are changed) as rated in the current "Best's Insurance Reports" and qualified to do business in the State of which the property is located. Certificates of such required insurance together with all required additional insured endorsements shall be delivered to Landlord within ten (10) days after the Commencement Date, and thereafter within thirty (30) days prior to the expiration of the term of each policy. Public liability and property damage policies shall contain a provision that Landlord shall be entitled to recover any loss under such policies. When any insurance policy expires or terminates, a like renewal or additional policy shall be purchased by Tenant and up-to-date certificates and endorsements shall be promptly delivered to Landlord as required above. All policies shall contain a provision that the insurer shall provide Landlord twenty (20) days' prior written notice of any cancellation, lapse or reduction in the amounts of insurance. All insurance policies required of Tenant shall be written as primary policies, not contributing with and not in excess of coverage which Landlord may carry.
- 8.03. **Failure of Tenant to Insure.** If Tenant fails to keep in force any of the insurance required in this Section 8, after providing Tenant with written notice and three (3) business days in which to cure such failure Landlord may, but shall not be required to, purchase and keep in force the same, and Tenant shall pay the full amount of Landlord's expense with respect thereto, such payment to be made within ten (10) days after Landlord's demand. Landlord's election to purchase such insurance on behalf of Tenant shall not constitute a curing of Tenant's default nor be an election of remedies otherwise available to Landlord.
- 8.04. **Waiver of Subrogation.** All required insurance shall include an endorsement denying to the insurer a right of subrogation against the other party to the extent rights have been waived by the insured prior to occurrence of an injury or loss. Notwithstanding any other provisions of this Lease Tenant waives all rights of recovery against Landlord for injury or loss due to hazards covered by insurance containing such endorsement, to the extent of the insurance proceeds paid or payable by reason of a covered injury or loss. The foregoing waiver: (i) shall apply to both the Premises and the entire Building; and (ii) shall not apply to losses in excess of available insurance coverage, losses excluded from available insurance coverage or losses for which insurance proceeds are not available for any reason.

## 9. **ALTERATIONS**

- 9.01. **Consent Required.** Except as provided for in Section B of Exhibit B, Tenant shall make no alterations, improvements or additions ("Improvements") in or about the Premises without Landlord's written approval, which consent shall not be unreasonably withheld, conditioned, or delayed. Improvements shall be performed at Tenant's expense in compliance with applicable statutes, ordinances, codes and regulations. Upon the expiration or early termination of this Lease, the Improvements shall remain with the Premises unless, at the time of Landlord's approval, Tenant is advised by Landlord that the Improvements are to be removed upon the expiration or early termination, in which event Tenant shall promptly remove the Improvements and restore the Premises to the same condition as existed prior to such Improvements.
- 9.02. **Tenant's Alterations.** Tenant shall promptly complete, at Tenant's sole expense, all alterations and/or repairs to the Premises required by: (i) any federal, state or local building, fire, life-safety or similar law, code or regulation adopted or amended after the Commencement Date; (ii) reason of any Tenant alterations to the Premises; or (iii) a change in Tenant's use of the Premises. Landlord shall be responsible for alterations and/or repairs to the Premises required by any federal, state or local building, fire, life-safety or similar law, code or regulation in effect prior to the Commencement Date.

- 9.03. **Trade Fixtures.** Trade fixtures, equipment and other personal property installed in the Premises by Tenant and not permanently affixed to the Premises shall remain Tenant's property, and provided that: (i) Tenant is not in default; and (ii) Tenant promptly repairs all damage resulting from the installation and/or removal, and fully restores the Premises, may be removed by Tenant at any time during the Term.
- 9.04. **Liens Prohibited.** Tenant shall pay all costs for the work done by or for it on the Premises and shall keep the Premises and the Building free and clear of all liens caused by Tenant, its employees, agents or contractors. Tenant shall indemnify, save and hold Landlord and the Building harmless against any liability, loss, damage, cost, attorneys' fees and all other expenses on account of any such prohibited lien.

## **10. SIGNS**

Tenant may only install exterior signs in accordance with the provisions of Exhibit F. After installation of any approved exterior sign(s) Tenant shall maintain same in good condition and repair. Upon the expiration or early termination of this Lease, Tenant shall repair all damage caused by the installation or removal. If Tenant fails to do so, Landlord shall have the right to perform such maintenance, repairs or replacement and Tenant shall pay Landlord all costs thereof within ten (10) days after Landlord's written demand.

## **11. QUIET ENJOYMENT**

Landlord intends that Tenant, upon paying the Base Rent and other amounts payable by Tenant under this Lease, and performing the covenants, terms and conditions of this Lease required of Tenant, will quietly have, hold and enjoy the Premises during the Term.

## **12. ASSIGNMENT AND SUBLETTING**

### **12.01. Restrictions.**

- (a) Tenant shall not transfer, assign, sublet or otherwise transfer this Lease (a "Transfer") without Landlord's prior written consent, which Landlord shall not unreasonably withhold, condition, or delay. Landlord may withhold consent if the proposed use of the Premises is different from the use permitted by Sub-Section 4.01 or if the use changes following such Transfer. Any Transfer without Landlord's prior written consent shall be null and void and, at the option of Landlord, constitute a default under this Lease.
- (b) Landlord may withhold such consent: (1) unless Tenant remains fully liable during the unexpired Term; (2) unless the creditworthiness of the proposed assignee or sub-tenant is at least equal to Tenant's creditworthiness as of the Effective Date; or (3) Landlord reasonably believes the assignment will: (i) cause a breach of any provision in any other agreement relating to the Premises; (ii) be in breach of any restrictions applicable to the Premises; (iii) involve the storage, use or disposal of any Hazardous Material; (iv) adversely affect the reputation or image of the Premises; or (v) require Landlord to perform alterations to the Premises or Building by reason of any applicable law, code or regulation.
- (c) Any assignment or subletting by Tenant of all or any portion of the Premises shall automatically operate to terminate all rights of Tenant with respect to this Lease, including any option to expand the Premises or to extend or renew the term of this Lease. Provided, providing shelter to vulnerable and homeless individuals and families shall not be considered a subletting of the Premises.

12.02. **Tenant's Obligations.** Tenant shall pay Landlord's attorney's fees and other costs incurred as a result of any Transfer. Landlord's consent to a Transfer shall not: (i) relieve Tenant of its obligations under this Lease, whether accruing before or after such Transfer; or (ii) constitute a waiver of the requirement to obtain Landlord's consent to subsequent Transfers. Each assignee shall assume in writing all obligations of Tenant under this Lease, and shall remain jointly and severally liable with Tenant for the full and timely performance of this Lease.

- 12.03. **Subsequent Modifications.** Assignment of this Lease by Tenant with Landlord's consent shall constitute the express agreement by Tenant those subsequent modifications of this Lease by Landlord and the assignee shall not: (i) require Tenant's prior consent or approval; or (ii) release or relieve Tenant from liability hereunder, provided that if such modifications increase the rent or other obligations of Tenant, Tenant's liability shall be limited to the terms of this Lease as the same existed on the date of assignment.
- 12.04. **Sublease Rent.** If Tenant subleases the Premises at a rent in excess of the then current Base Rent Landlord may refuse consent unless Tenant agrees that 75% of such excess rent to be paid by the sub-tenant shall be paid to Landlord. Rent includes rent or other consideration paid to Tenant directly or indirectly by any sub-tenant or any other amount received by Tenant from or in connection with any subletting.

### **13. SUBORDINATION AND FINANCING**

This Lease shall be subordinate to the lien of any mortgage, deed of trust or other encumbrance, together with any renewals, extensions or replacements now or hereafter placed, charged or enforced against Landlord's interest in the Building and the Premises; provided, however, that Tenant's rights under this Lease shall not be disrupted by such lien of mortgage. Upon Landlord's request Tenant agrees to execute and deliver such commercially reasonable documents as may be required to effectuate such subordination. If Tenant fails to execute and deliver such documents within ten (10) days after receipt, Tenant irrevocably appoints Landlord as Tenant's true and lawful attorney-in fact to execute and deliver in Tenant's own name such documents for and on behalf of Tenant in connection with such subordination.

### **14. SURRENDER OF PREMISES**

14.01. **Condition Upon Surrender.**

- (a) Upon the expiration or early termination of this Lease Tenant shall quit and surrender possession of the Premises to Landlord in as good order and condition as existed on the Commencement Date, or as hereafter may be improved by Landlord or Tenant, reasonable wear and tear excepted.
- (b) Prior to the expiration or early termination of this Lease Tenant shall, at its sole expense:
  - (i) repair all damage to Premises, including restrooms, caused by tenant operations and those individuals that used tenant's services over the term of the Lease;
  - (ii) remove from the Premises all debris, rubbish, furniture, equipment and trade fixtures, free standing cabinetwork, movable partitions and other articles of personal property owned by Tenant (exclusive of any items described in Sub-Section 14.04);
  - (iii) repair all damage resulting from the removal of items pursuant to Sub-Section (i) above;
  - (iv) repair and paint all area walls and trim damaged or that may be excessively dirty by Tenant in colors as selected by Landlord; and
  - (v) professionally clean all floors and carpets, or replace them if damage caused by Tenant's operations renders them uncleanable to the condition as existed on the Commencement Date, reasonable wear and tear excepted.

The actions in Sub-Section (b) above shall be taken by Tenant no earlier than thirty (30) days prior to the date of expiration or early termination of this Lease. Should Tenant not complete any of the items listed in Sub-Section (b) above, Landlord may contract the work to be completed. Upon contracting for such work as listed in Sub-Section (b), Landlord may require immediate payment from Tenant or may deduct the cost of the work, plus a 20% mark-up, from Tenant's Security Deposit refund.

Upon date of vacation, if Tenant does not properly discontinue service with all utility providers, then Tenant shall continue to be responsible for payment of all utility charges until said change is properly made.

14.02. **Consequential Damages.**

- (a) In addition to the remedies available at law or equity or under this Lease, Landlord shall be entitled to recover all damages as indicated elsewhere in this Sub-Section 14.02 from Tenant as a consequence of Tenant's failure, by the expiration or early termination of this Lease, to: (i) surrender the Premises; or (ii) restore the Premises to the condition required by Sub-Section 14.01 above.
- (b) Consequential Damages are recoverable if Tenant fails to take any of the actions indicated in Sub-Section (a) above, and Landlord shall be entitled to recover from Tenant an or all of the following: (i) holding over rent pursuant to Sub-Section 20.05; (ii) lost rental income resulting from Landlord's inability to timely deliver possession of the Premises to a new tenant; (iii) all costs and expenses incurred due to Landlord's inability to timely deliver possession of the Premises to a new tenant including holdover rent payable by such new tenant to its landlord, additional storage, moving and relocation expenses incurred by such new tenant, and the costs and expenses of any temporary premises for such new tenant; and (iv) commercially reasonable and necessary costs and expenses incurred by Landlord in restoring the Premises to the condition required by this Lease on an expedited basis including, without limitation, loan financing costs, interest, and overtime labor costs.

14.03. **Abandoned Property.** If Landlord re-enters the Premises as provided for in Section 17, any of Tenant's property not removed upon the expiration of this Lease (or within seventy-two (72) hours after termination by reason of Tenant's default) shall be considered abandoned, and Landlord may: (i) remove such property; (ii) dispose of such property in any manner; or (iii) store such property in a public warehouse or elsewhere for the account, and at the expense and risk of Tenant. If Tenant fails to pay the costs of storing such abandoned property after being stored for a period of thirty (30) days, Landlord may, without notice to Tenant, dispose of or sell such property at public or private sale in a manner and at such times and places as Landlord may deem proper, for the payment of such costs. Landlord shall apply the proceeds of such sale as follows: first, to the costs and expenses of such sale, including reasonable attorneys' fees; second, to the costs and charges for storing such property; third, to the payment of other sums of money which may then or thereafter be due from Tenant pursuant to this Lease; and fourth, the balance, if any, to Tenant. These provisions shall be without prejudice to Landlord to exercise any other rights over Tenant's property on the Premises as provided for elsewhere in this Lease or allowed by law.

14.04. **Permanent Property.** All fixtures, equipment, alterations, additions, improvements and/or appurtenances attached to or built into the Premises prior to or during the Term, whether by Landlord at its expense or at the expense of Tenant, shall remain part of the Premises and may not be removed by Tenant unless provided for elsewhere in this Lease, or otherwise directed by Landlord. Such fixtures, equipment, alterations, additions, improvements and/or appurtenances includes, but is not limited to: floor coverings, ceiling installation, drapes, paneling, vaults, plumbing systems, electrical systems, lighting systems, all fixtures, cabling and outlets for such systems, and all fixtures, cabling and outlets for telephone, radio and television.

14.05 **Tenant's Option to Terminate.** Tenant may terminate this Lease and vacate the Premises and surrender the same to Landlord if a hearing examiner or court of competent jurisdiction issues an order or judgment that the Premises may not be used for the purposes described in Item 2 of the Basic Provisions, or if, Tenant is otherwise prevented by law from using the building and/or premises for such purposes, and the same shall not be considered a default or breach of this Lease and all liability of Tenant hereunder shall cease but in either case, Tenant shall pay to Landlord a termination fee equal to eight (8) months of the current Base Rent as liquidated damages for the early termination of this Lease by Tenant. Tenant shall also have the right to terminate this lease at any time by giving written notice to Landlord of the intention of Tenant to do so at least sixty (60) days prior to the date of the proposed early termination of the Lease. In such an event, (i) the proposed early termination date shall operate as if that date were the time originally fixed for the termination of this Lease, and all provisions of this Lease that are to become effective on termination shall become operative or effective on that date, and (ii) Tenant shall pay to Landlord a termination fee

equal to eight (8) months of the current Base Rent as liquidated damages for the early termination of this Lease by Tenant.

### **15. DESTRUCTION OF PREMISES**

- 15.01. **Fully Tenantable.** If the Premises are damaged by any casualty (an "Occurrence"), but are not rendered untenable, in whole or in part, Landlord shall, at its expense repair such damage, and neither the Base Rent or other amounts payable by Tenant under this Lease shall be abated.
- 15.02. **Partially Untenantable.** If an Occurrence renders the Premises partially untenable Landlord shall, at its expense, repair such damage, and the Base Rent for the part of the Premises rendered untenable shall be abated on a pro-rata square foot basis as long as said part remains untenable. "Partially untenable" shall mean that Tenant is unable to use the Premises for the use as set forth in Item 2 of the Basic Provisions for a period of ten (10) or more consecutive days.
- 15.03. **Totally Untenantable.** If an Occurrence renders the Premises wholly untenable Landlord shall, at its own expense, repair such damage, and the Base Rent shall be abated. In such event Landlord and Tenant shall each have the right, upon written notice to the other party within thirty (30) days after the Occurrence, to terminate this Lease. All rights and obligations of the parties shall terminate as of the date of the Occurrence, except for Tenant's obligation to pay Base Rent or other amounts which were due and payable prior to the date of the Occurrence.
- 15.04. **Uninsured Casualty.**
- (a) If the Premises or Building are damaged by a casualty not covered by insurance and the cost of repairs exceeds \$50,000.00, Landlord may, upon written notice to Tenant within thirty (30) days after the Occurrence, terminate this Lease, in which event all rights and obligations of the parties shall terminate and end as of the date of the Occurrence, except for Tenant's obligation to pay any Base Rent or other amounts which were due and payable prior to the date of the Occurrence; provided in such an event, Tenant shall have the option, in Tenant's sole discretion, of completing the repairs at Tenant's expense in which case the Lease shall not terminate until the end of the Term including any extensions exercised by Tenant.
  - (b) Landlord shall have no obligation to repair the Premises and shall have the right to terminate this Lease if the Term (exclusive of unexercised options to renew the Term as of the date of the Occurrence) has less than two (2) years remaining from the date of the Occurrence to the date of expiration.
- 15.05. **Destruction of Building.** If 50% or more of the Building is damaged or destroyed, either party shall have the right, upon written notice to the other party within thirty (30) days after the Occurrence, to terminate this Lease, in which event all rights and obligations of the parties shall terminate as of the date of the Occurrence, except for Tenant's obligation to pay any Base Rent or other amounts which were due and payable prior to the date of the Occurrence.

### **16. EMINENT DOMAIN**

- 16.01. **Definition of Taking.** If the Premises are acquired or damaged by the exercise of the right of eminent domain or other activity by a public authority, whether or not such damage involves a physical taking of any portion of the Premises, this shall be considered a taking. If such taking renders the Premises no longer suitable for the purpose of the tenancy, this shall be considered a total taking. Any other taking shall be considered a partial taking.
- 16.02. **Total Taking.** In the case of a total taking this Lease shall terminate on the date the Premises are rendered unsuitable for the purposes of the tenancy and all compensation, whether fixed by agreement or judicial

award, shall belong to Landlord except those portions specifically allocated as compensation for Tenant's actual expenses incurred for moving Tenant's fixtures, equipment and inventory.

- 16.03. **Partial Taking.** In case of a partial taking: (i) Landlord shall, at its expense, repair the Premises in accordance with plans and specifications as approved by Tenant; (ii) all compensation paid by the condemning authority in connection with the taking shall be paid to Landlord and Tenant pursuant to Sub-Section 16.02; and (iii) the Base Rent shall be reduced proportionately on the basis which the then fair market value of that portion of the Premises taken bears to the total then fair market value of the Premises before the taking.

## **17. DEFAULT**

- 17.01. **Events of Default.** The occurrence of any of the following shall constitute a material default and breach of this Lease by Tenant:

- (a) Tenant vacating or abandoning the Premises any time after the Commencement Date and/or taking initial possession of the Premises unless this Lease is terminated early as provided in Section 14;
- (b) Failure of Tenant to pay any installment of rent within ten (10) days following its due date without the requirement of written notice of demand;
- (c) Failure of Tenant to pay any other sum payable under this Lease within thirty (30) days after receipt of written demand;
- (d) Default by Tenant in the performance of any of Tenant's covenants or obligations (excluding a default in the payment of rent or other monies due) which continues for thirty (30) days after written notice is delivered to Tenant by Landlord; provided, however, that if the nature of such default is such that same cannot reasonably be cured within such thirty (30) day period, such shall not constitute an event of default if Tenant commences performance within thirty (30) days of such notice and diligently pursues same to completion to the satisfaction of Landlord, but in any event, no more than sixty (60) days from notice; or
- (e) Filing by or against Tenant in any court, pursuant to any statute for: (i) a petition in bankruptcy or insolvency; (ii) reorganization or appointment of a receiver or trustee of all or a substantial portion of Tenant's property; (iii) an assignment for the benefit of creditors; or (iv) any execution or attachment issued against Tenant or all or a substantial portion of Tenant's property, and whereby all or any portion of the Premises or any improvements thereon shall be taken, occupied or attempted to be taken or occupied by someone other than Tenant, and such adjudication, appointment, assignment, execution or attachment is not set aside, discharged or bonded within thirty (30) days after the determination, issuance or filing of same.

- 17.02. **Landlord's Remedies.** In the event of Tenant's default under this Lease, Landlord shall have all rights and remedies allowed by law or equity including, but not limited to:

- (a) **Termination; Damages.** In addition to any other remedy available to Landlord at law or in equity, Landlord shall have the right to immediately terminate this Lease and/or Tenant's right to possession of the Premises by delivering written notice of termination. If Landlord so terminates this Lease and/or such possession, such termination shall constitute Landlord's right to recover from Tenant any damages equal to the sum of:
  - (i) The "worth" of any unpaid Rent due to Landlord as of the date of termination; plus
  - (ii) The "worth" of the amount by which the unpaid Rent which would have been earned after termination and until the time re-letting rent begins; plus
  - (iii) The "worth" of any balance of rent loss from the re-letting and until the time there is no rent loss suffered by the Landlord; plus

- (iv) Any other amount necessary to compensate Landlord for all detriment proximately caused by Tenant's failure to perform its obligations under this Lease or which would likely result from a default including, without limitation, Re-Letting Expenses; plus
- (v) Reasonable costs and attorneys' fees incurred by Landlord as the result of such material default if a suit is filed by Landlord to enforce any remedy; plus
- (vi) At Landlord's election, such other amounts in addition to or in lieu of the foregoing as may be permitted from time to time by applicable law in the state where the Premise are located.

As used in Sub-Sections (i), (ii) and (iii) above, the "worth" shall be computed by allowing interest for these Sub-Sections.

Termination of this Lease under this Sub-Section 17.02 shall not release or discharge Tenant from its obligations under this Lease but shall only constitute a termination of Tenant's right to possess and occupy the Premises.

**(b) Enforcement.**

(i) If Tenant defaults under this Lease Landlord may, without terminating this Lease, either recover Rent as it becomes due or re-let the Premises or any part thereof for such term, and at such rent and other terms and conditions as Landlord, in Landlord's sole discretion, may deem advisable, Landlord will retain the right to make commercially reasonable Alterations and repairs necessary to re-let Premises, the cost of which shall be chargeable to Tenant.

(ii) If Landlord elects to re-let the Premises, rents received from such re-letting shall be applied as follows: first, to reasonable attorneys' fees incurred by Landlord as a result of Tenant's default; second, to the costs of suit if action is filed to enforce Landlord's remedies; third, to payment of Tenant indebtedness other than Rent due under this Lease; fourth, to payment of commercially reasonable and necessary Re-Letting Expenses; fifth, to payment of commercially reasonable and necessary costs of Alterations and repairs to the Premises; and sixth, to payment of Rent due and unpaid. The remaining balance, if any, shall be held by Landlord and applied toward payment of future Rent as may become due and payable. Should that portion of rent received from re-letting during any month which is applied to the payment of Rent be less than the Rent owed by Tenant during that month, Tenant shall pay Landlord such deficiency. Tenant shall also pay, as soon as ascertained, commercially reasonable and necessary Re-Letting Expenses incurred by Landlord in re-letting or making Alterations and repairs to the Premises.

**(c) Non-Termination; Re-Entry.** Landlord may, without terminating this Lease: (i) re-enter and take possession of the Premises and all improvements; (ii) collect rents from any sub-tenants; and/or (iii) sublet all or any part of the Premises for the account of Tenant, upon terms and conditions as determined by Landlord. In the event of such subleasing: (a) Landlord may collect rent from such sublease and apply first towards expenses incurred by Landlord in dispossessing Tenant and subletting the Premises and, thereafter towards all Rent payable by Tenant under this Lease; and (b) Tenant shall be liable to Landlord for all Rent payable by Tenant under this Lease, less amounts received by Landlord from a sublease and after payment of Landlord's expenses.

**(d) No Termination.** Landlord's re-entry or taking possession of the Premises is not an election to terminate this Lease, unless Landlord delivers written notice of such election to Tenant. Notwithstanding a re-letting without termination Landlord may, after such re-letting but prior to cure of the default by Tenant to the satisfaction of Landlord, elect to terminate this Lease for such default.

**(e) Landlord's Lien.** Upon Tenant's default Landlord shall have the right to: (i) enter the Premises; (ii) change the door locks; (iii) exclude Tenant from the Premises; and (iv) take and retain possession of any property on the Premises owned by or in the possession of Tenant as security for Tenant's performance. Tenant hereby grants Landlord a lien under applicable state law on all of said property comprising the Premises and the Building, which lien shall secure the future performance by Tenant

of this Lease. No property subject to said lien shall be removed by Tenant from the Premises so long as Tenant is in default of any monetary obligations under this Lease. No Landlord's actions in connection with the enforcement of the rights as provided for in this Section 17 shall not constitute a trespass or conversion and Tenant shall indemnify and hold Landlord harmless from and against any such claim or demand.

(f) **Acceleration.** Should Tenant be in Default of this Lease for any reason up to and including non-payment of Rent and/or Additional Rent Expenses, Abandonment and/or Termination, acceleration of any and all Rent payments through the existing Term of this Lease shall be due and collectible immediately. Landlord is not required to mitigate expenses any further than required by law and as agreed to in Section 17.04. Application of this clause in no way terminates this Lease, Tenant's obligations under the Terms of this Lease, nor does it fully relieve Tenant of any other Remedies which may be available to Landlord under the current state laws.

(g) **Definitions.** As used in this Sub-Section 17.02:

- (i) "Alterations" means, and is limited to alterations that Landlord reasonably takes which mitigates Tenant's obligations pursuant to Sub-Section 17.02 above;
- (ii) "Re-Letting Expenses" means all expenses incurred by Landlord in re-letting the Premises including all repossession costs, brokerage commissions, attorneys' fees, remodeling and repair costs, costs for removing and storing Tenant's property, and tenant improvements and rent concessions granted to any new tenant, pro-rated over the affected term of the lease; and
- (iii) "Rent" means and includes the Base Rent, Additional Rent and all other sums required to be paid by Tenant pursuant to this Lease.

17.03. **Remedies Cumulative.** The rights, privileges, elections and remedies of Landlord set forth in this Lease or allowed by law or equity are cumulative and the enforcement by Landlord of a specific remedy shall not constitute an election of remedies and/or a waiver of other available remedies.

17.04. **Mitigation.** Landlord shall have the obligation to make reasonable efforts to mitigate the loss or damage occasioned by Tenant's default, provided that said obligation shall not: (a) relieve Tenant of the burden of proof as required in this Section 17; or (b) otherwise affect the rights and remedies available to Landlord in the event of Tenant's default, or otherwise allowed by law or equity. Notwithstanding any other provision of this Section 17, Landlord has no obligation to mitigate rental loss by re-letting the Premises so long as: (i) Landlord has other similar premises within the same Metropolitan Statistical Area vacant; (ii) a prospective tenant's use of the Premises would be undesirable in the reasonable judgment of Landlord; (iii) Landlord is required to incur expenses to remodel, alter or improve the Premises; or (iv) the result would be Landlord being in breach or default under any other contractual obligations of Landlord.

## **18. INDEMNITY**

18.01. **By Tenant.** Tenant shall indemnify and hold Landlord harmless against all actions, claims, damages or expenses of any kind, including attorneys' fees, which may be brought or made against Landlord, or which Landlord may pay or incur, by reason of Tenant's: (i) use and occupancy of the Premises; (ii) negligence; or (iii) failure to comply with its obligations as set forth in this Lease. This indemnity shall not, apply to claims or damages that are a direct result of the negligence or willful misconduct of Landlord or its agents, employees or contractors.

18.02. **By Landlord.** Landlord shall indemnify and hold Tenant harmless against all actions, claims, damages or expenses of any kind, including attorneys' fees, which may be brought or made against Tenant, or which Tenant may pay or incur, by reason of Landlord's negligence or failure to comply with its obligations as set forth in this Lease. This indemnity does not apply to claims or damages that are a direct result of the negligence or willful misconduct of Tenant or its agents, employees or contractors.



18.03. **Non-Liability of Landlord.** Notwithstanding any other provisions of this Lease Landlord shall have no liability for: (i) bodily or personal injury to any person(s) arising from or occurring on the Premises, unless caused by the negligence, intentional acts or omissions of Landlord or its employees, agents or contractors; (ii) damage to or loss, by theft or otherwise, of Tenant's property located on the Premises; or (iii) injuries or damage resulting from fire, explosion, sprinklers, falling plaster, steam, gas, electricity, water, rain, snow or leaks from pipes, appliances, plumbing, street or subsurface, except to the extent caused by the negligence, intentional acts or omissions of Landlord, its employees, agents or contractors. Tenant assumes the risk of property kept or stored on the Premises and shall hold Landlord harmless from any claims arising out of damage to same. Tenant shall give immediate notice to Landlord in case of fire or accidents on or in the Premises.

### **19. EXECUTIVE ORDER NO. 13224; THE PATRIOT ACT**

Tenant shall comply with all applicable orders, rules, regulations and recommendations promulgated under or in connection with: (i) Executive Order No. 13224, Blocking Property and Prohibiting Transactions with Persons Who Commit, Threaten to Commit, or Support Terrorism, effective September 24, 2001 ("Executive Order"); and (ii) the Patriot Act of 2001.

### **20. ADDITIONAL PROVISIONS**

20.01. **Landlord's Right of Entry.** Landlord shall and may enter the Premises during Tenant's normal business hours upon providing twenty-four (24) hour prior notice for the purposes of: (i) verifying the Premises' condition; (ii) making repairs or performing maintenance as allowed in Section 6.09 above; (iii) serving notice pursuant to this Lease; (iv) showing the Premises to prospective brokers, agents or buyers; or (v) showing the Premises to prospective tenants during the final twelve (12) months of the Term. If Landlord reasonably believes that an emergency exists requiring Landlord to enter the Premises, Landlord may do so without prior notice, but shall promptly notify Tenant after entry of the circumstances and the nature of actions taken upon entry.

20.02. **No Waiver.** The failure of Landlord or Tenant to seek redress for violations or to insist upon the strict performance of any covenant or condition of this Lease shall not be deemed a waiver of such violation or of any future violation. The waiver by Landlord or Tenant of any breach shall not be deemed a waiver of any past, present or future breach of the same or any other term, covenant or condition of this Lease.

20.03. **Notices.** Notices, approvals, consents, requests or elections given or made pursuant to this Lease shall be deemed delivered when in writing and deposited in the U.S. mail, postage prepaid, certified or registered mail, return receipt requested, or sent via a national overnight delivery service with delivery tracking services, and addressed to the party at the address set forth in Items 10 or 11 of the Basic Provisions.

20.04. **Limitation of Landlord's Liability.** Landlord's obligations under this Lease do not constitute personal obligations of Landlord or its successors or assigns. Tenant shall look solely to the real estate that is the subject of this Lease for satisfaction of any liability under this Lease. Landlord cannot be held responsible for any actions taken by Tenant or Tenant's guests while on Leased Premises.

20.05. **Holding Over.** If Tenant continues to occupy the Premises or any part thereof after the expiration or early termination of this Lease, such tenancy shall be month-to-month at a rent equal to 125% of the Base Rent in effect as of the last month of the Term of the expired or terminated Lease. Force majeure is not an excuse for holding over.

20.06. **Transfer of Landlord's Interest.** If Landlord sells or conveys the Premises, Landlord shall be relieved from all obligations and liabilities accruing thereafter, provided that funds in Landlord's possession at the time of transfer in which Tenant has an interest shall be delivered to Landlord's successor. This Lease shall not be affected by any such sale and Tenant agrees to attorn to the purchaser or assignee, provided all Landlord's obligations are assumed in writing by the transferee. Tenant may continue to send rent to

Landlord and otherwise treat Landlord as landlord until Tenant is provided with: (i) written notice of such sale or conveyance; (ii) the name and address of transferee; and (iii) a copy of the transferee's written acceptance of Landlord's obligations pursuant to this Lease.

- 20.07. **Notice of ADA Violations.** Within ten (10) days after receipt, Landlord and Tenant shall advise the other party in writing, and provide the other party with copies of any notices claiming or alleging violation of the Americans with Disabilities Act of 1990 ("ADA") relating to the Premises or the Building, or any claim made or threatened in writing regarding noncompliance with the ADA and relating to the Premises or the Building, or any governmental or regulatory actions or investigations instituted or threatened regarding noncompliance with the ADA and relating to the Premises or the Building.
- 20.08. **Succession.** This Lease shall be binding upon and shall inure to the benefit of the respective heirs, personal representatives, successors and assigns of the parties.
- 20.09. **Estoppel Certificate.**  
Within (10) days after written notice Tenant shall execute and deliver to Landlord a written statement: (i) certifying that this Lease is unmodified and in full force and effect (or, if modified, stating the nature of such modification and certifying that this modified Lease is in full force and effect), and the date to which rent and other charges are paid in advance; (ii) acknowledging that there are not, to Tenant's knowledge, any uncured defaults by Landlord, or specifying such defaults if they are claimed; and (iii) containing any other certifications, acknowledgments and representations as may be reasonably requested by Landlord or the party for whose benefit such estoppel certificate is requested.
- 20.10. **Warrant of Financial Statements.** Tenant, the officer(s) signing this Lease (if a corporate Tenant), and each guarantor of this Lease, if any, represent, warrant and certify to Landlord that all financial statements and information provided to Landlord are true, accurate and correct, and represent the financial condition of Tenant or the guarantor(s), as the case may be, as of the Effective Date.
- 20.11. **Severability.** If any provision of this Lease is determined by a court of competent jurisdiction to be invalid or unenforceable, the remainder of this Lease shall not be affected and each remaining provision of this Lease shall be valid and enforceable to the fullest extent permitted by law.
- 20.12. **Force Majeure.** Any prevention, delay or stoppage due to strikes, lockouts, labor disputes, court orders, acts of God, inability to obtain labor or materials or reasonable substitutes thereof, government restrictions, regulations or controls, hostile government action, civil commotion, war (declared or undeclared), acts of terrorism, fire or other causes beyond the reasonable control of the party obligated to perform, shall excuse the performance by such party for a period equal to any such prevention, delay or stoppage, except Tenant's obligations to pay rent and other charges pursuant to this Lease, which obligation shall not be affected by any such prevention, delay or stoppage.
- 20.13. **Recording; Disclosure.** Neither party shall record this Lease, it being agreed that Tenant's possession of the Premises is adequate notice of Tenant's leasehold interest.
- 20.14. **Periods of Time.** Unless otherwise specified, any period of time in this Lease shall: (i) mean Pacific Time; (ii) begin the day after the event starting the period; and (iii) expire at 5:00 p.m. of the last calendar day of the specified period of time, unless the last day is a Saturday, Sunday or legal holiday as defined in the applicable law of the State where the Premises are located, in which case the specified period of time shall expire the next day that is not a Saturday, Sunday or legal holiday.
- 20.15. **Waiver of Trial by Jury.** Tenant and Tenant's successors, sub-tenants and assignees shall, and do hereby waive, trial by jury in any action, proceeding or claim brought by or against Landlord on any matter arising out of or in any way connected with this Lease.

- 20.16. **Attorneys' Fees.** In any action or proceeding between the parties to enforce, interpret or construe the terms of this Lease, the prevailing party shall be entitled to recover reasonable attorneys' fees, expert witness fees and costs, and out-of-pocket costs arising out of or related to such action or proceeding.
- 20.17. **Entire Agreement.** This Lease, including the attached exhibits, contains the entire agreement between the parties as of the Effective Date, and its execution has not been induced by either party or any agent of either party, by representations, promises or undertakings not expressly contained herein. There are no collateral agreements, covenants, promises or undertakings whatsoever between the parties concerning the subject matter of this Lease which are not expressly contained herein, or in an amendment mutually executed by the parties and affixed hereto. No other prior or contemporaneous agreement or understanding shall have any legal effect whatsoever.

**EXHIBIT A**

DESCRIPTION OF PREMISES

THAT PORTION OF THE NORTHWEST QUARTER OF THE NORTHWEST QUARTER OF SECTION 14, TOWNSHIP 25 NORTH, RANGE 43 EAST, W.M., IN THE CITY OF SPOKANE, SPOKANE COUNTY, WASHINGTON, DESCRIBED AS FOLLOWS:

BEGINNING AT A POINT ON THE WEST LINE OF SAID SECTION 14, 572.7 FEET SOUTH OF THE NORTHWEST CORNER THEREOF; THENCE NORTH 72°34' EAST 308.31 FEET TO THE TRUE POINT OF BEGINNING;

THENCE NORTH ON A LINE PARALLEL WITH THE SAID WEST LINE OF SECTION 14, 297.63 FEET TO THE SOUTH RIGHT OF WAY LINE ON TRENT ROAD; THENCE NORTHEASTERLY ALONG SAID RIGHT OF WAY LINE AND THE SOUTH LINE OF THAT PARTICULAR TRACT CONVEYED TO THE CITY OF SPOKANE BY DEED RECORDED IN BOOK 519 OF DEEDS, PAGE 19, 277.14 FEET;

THENCE SOUTH PARALLEL WITH SAID WEST LINE OF SECTION 14, 359.05 FEET;

THENCE SOUTH 72°34' WEST 252.45 FEET TO THE TRUE POINT OF BEGINNING.

**EXHIBIT A-1**

**LAYOUT DRAWING OF PREMISES**

Commonly identified as the property located at 4320 E. Trent Avenue in Spokane, WA, APN 35142.0005, as illustrated on the following site plan:

**Note: All electronic transmissions of any drawings included with this Lease shall be depicted in color for proper clarity and identification.**

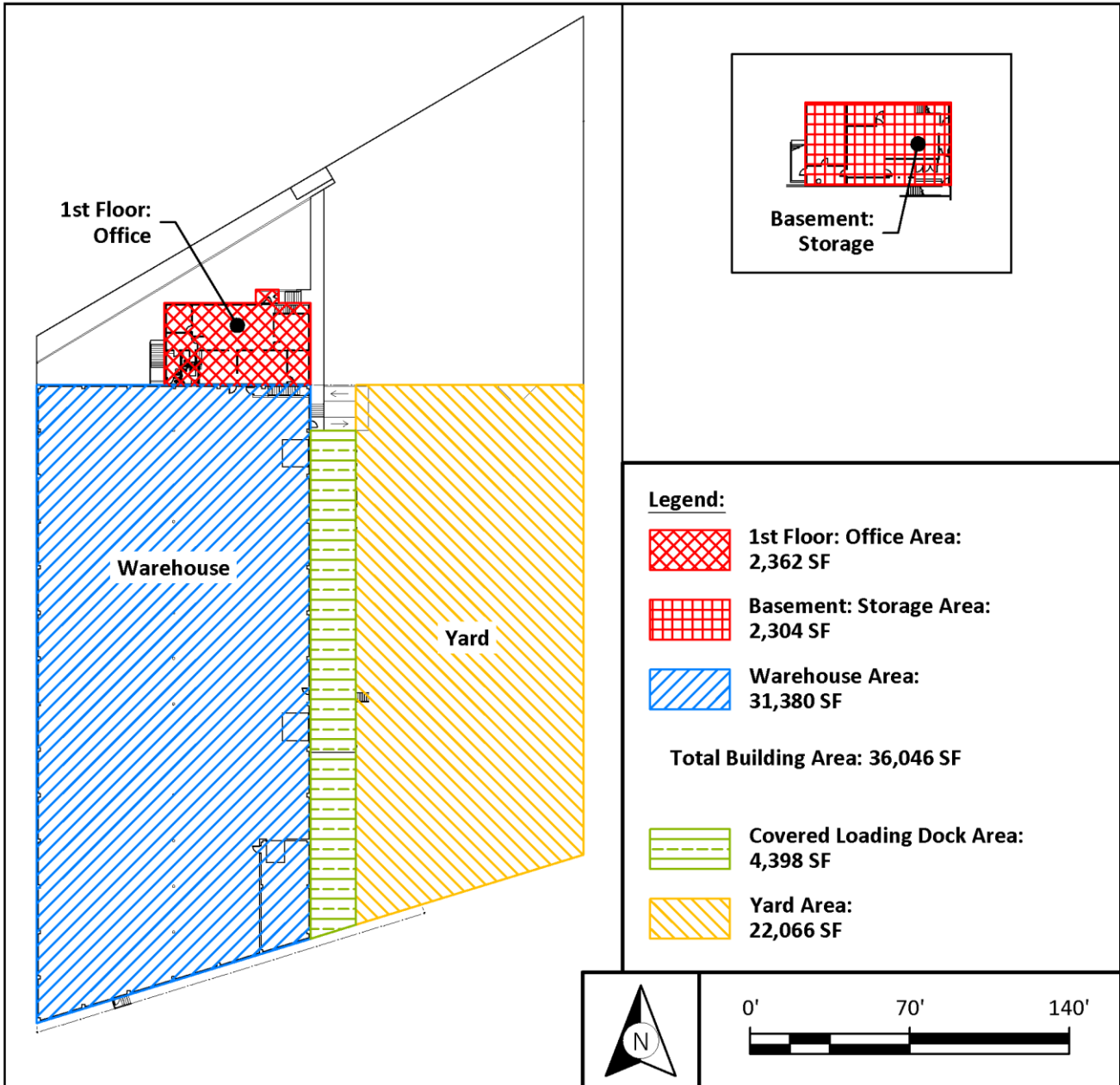

**EXHIBIT B**

IMPROVEMENTS

Landlord shall carry out, at its expense, the work (“Plans”) set forth in Section A below to municipal code per the described use. Any modifications or alterations to the Plans requested by Tenant resulting in any additional expenses or costs shall be paid by Tenant. Landlord shall have the right to require payment for such additional work prior to the performance of any such work. No modifications or alterations in the Plans shall be made without the prior written consent of Landlord which shall not be unreasonably withheld or delayed.

**A. DESCRIPTION OF LANDLORD'S WORK**

Following is the construction work to be carried out by Landlord at Landlord’s expense. The material specifications and layout shall be at Landlord's option subject to Tenant’s reasonable approval.

1. Insulate the warehouse walls with R-19 and ceiling with R-38. Install corrugated wall panels up to 8 feet tall to protect the insulation from damage.
2. Install additional exit lighting with battery packs and exit signage and exterior lighting.
3. Install suitable safety fencing to cargo loading area to prevent falls off loading dock.
4. Install heavy-duty laminate flooring to current top floor office space where current older carpeting exists.
5. Change egress door swing outward on southernmost pedestrian door on the east exterior wall.
6. Install panic bar hardware to the two egress doors on the east warehouse wall.
7. Install ADA ramp outside of the warehouse as identified in Exhibit A-1.
8. Install panic bar hardware on exit gate near ADA ramp including a knox box.
9. Install smoke and carbon monoxide detectors. (as per Fire and Code requirements)
10. Basement access to be made secured with no access allowed. (This should be keyed/restricted access, not fully “no access allowed”. Intent was to ensure that only site operators and staff can access for temporary, or storage uses as allowed by fire code. For the warehouse area, a chain link sectioned off with gated/key lock opening at head of the stairs is envisioned.
11. Install safety covers on all operational equipment.
12. Install locks on all electrical panels to restrict access.
13. Repair and improve exterior fencing.
14. Install exterior light along eastern exterior wall of office area to fully illuminate the walkway leading from the front parking lot to the gated access to the warehouse ADA ramp access point. Additional flood lights to be added to dock roof structure to increase the lighting in the ease yard area. This area lighting is poor during hours of darkness.
15. Install or facilitate install of temporary wall sections that allow the warehouse space to be divided into sections to improve use and separation of occupants.
16. Install a cementitious fence along the south and east property line, roughly 480 lineal feet.

**B. DESCRIPTION OF TENANT’S WORK**

Pursuant to Section 4.07(b) of the Lease, Tenant may but shall not be obligated to complete the following improvements and alterations:

1. Install an outside sewer connection to facilitate use of mobile/exterior shower or toilet facilities. Intention is to establish within three months of occupation if outside sewer connection can be made.
2. Install eight external stainless-steel sinks along north wall near hot water and sewer connection point. Diagram to be provided with intent to install within three months of occupation.
3. Install raised platform in northwest corner of warehouse with ADA capable ramp, sewer and water connections, additional tankless hot water capability and related requirements as defined in separate diagram to install 6-8 showers and 10-12 toilets. Location to facilitate use of existing water and sewer

connection points in vicinity of warehouse restroom wall with access to basement connection points. Intent is to complete this work by November 1, 2022.

4. Install additional kitchen capabilities to facilitate meal preparation and food storage on separate plan and diagram to be developed.
5. Establishment of power connections to facilitate location in fenced parking area of temporary semi-private shelter structures. These would conform to all applicable laws, codes, and ordinances and be fully removeable. Electrical connections would be required and separate diagram provided. Intent is to install these within six months to one year of occupation.
6. Install inside connections for water, sewer and exhaust to install 4-8 washers and dryers in the building in coordination with the interior restroom and shower facilities.
7. Furnishing and installing telephones and telephone system, music system, data cabling, internet service, security access cards or fobs for doors, and security devices as required by Tenant;
8. Furnishing and installing all fixtures and equipment necessary for Tenant's use and occupancy of the Premises;
9. Providing covered metal trash containers within the Premises; and
10. Any other work that may be required so that Tenant may properly and safely operate their business, with all such work to be approved by Landlord.

**EXHIBIT C**

ADJUSTMENT OF BASE RENT

Months 1-12: \$26,100.00 + NNN

Commencing on the first (1<sup>st</sup>) Anniversary of the Lease Commencement Date and continuing on the same date every year thereafter during the Initial Term (and any options to extend) the Base Rent due and payable to Landlord shall be adjusted for the next succeeding year. The adjusted Base Rent for each year shall be equal to the Base Rent paid during the immediately preceding twelve (12) month period (the Lease Year) increased by a percentage equal to the percentage increase in the CPI-U (The US Department of Labor's Consumer Price Index) for All Urban Consumers, West Region, All Items, or an annual increase of 3%; whichever is greater.



**EXHIBIT D**

**OPTION TO EXTEND**

- A. Tenant shall have the option to extend the term of this Lease for one (1) extension period, for a term of five (5) years commencing immediately following the expiration of the then current term, said extension to be upon all of the terms, conditions, covenants and provisions of this Lease except as provided below. If Tenant is granted more than one (1) extension term, the failure of Tenant to exercise the option for any extension period in the manner and within the time herein provided shall terminate the rights of Tenant with respect to that extension period and all subsequent extension periods, if any.
  
- B. Landlord agrees to the one (1), five (5) year option at the terms listed below:
  - 1. Base Rent shall increase over the Initial Term (and any options to extend) of this lease at the rate percentage of increase as noted in the CPI-U, based on the preceding 12-month period percentage increase, as defined in Exhibit C, or 3%, whichever is greater.
  
- C. If Landlord replaces the roof during the initial term of the Lease or during any option to extend the Lease, Tenant agrees if Tenant so chooses to exercise the Option to Extend that such cost shall be amortized over twenty-five (25) years and paid to Landlord as Additional Rent Expenses.
  
- D. Tenant's right to exercise the option to extend the term of this Lease shall be subject to the following conditions:
  - 1. The Lease shall be in full force and effect at the time the notice of Tenant's election to extend the term is delivered to Owner and on the last day of the then current term.
  - 2. Tenant shall not be in default under any provision of the Lease at the time Tenant delivers to Owner a notice of Tenant's election to extend the term or on the last day of the then current term.
  - 3. Tenant shall deliver to Owner a written notice irrevocably exercising the option to extend the term at least one hundred twenty (120) days before the last day of the then current term.

**EXHIBIT E**

REQUIRED ADDITIONAL INSUREDS

1. Lawrence B. Stone Properties #4320, LLC;
2. Lawrence B. Stone personally; and
3. Such other person(s) or entity(s) as shall, from time-to-time, be designated in writing by Landlord.

**EXHIBIT F**

SIGNS

The following provisions shall govern Tenant's installation of any exterior signage on the Building and/or the Premises:

1. All exterior signs shall be subject to Landlord's written consent, which shall not be unreasonably withheld, delayed or conditioned.
2. All governmental permits for Tenant's sign(s) shall be obtained by Tenant at Tenant's sole expense.
3. Installation of Tenant's sign(s) shall be in strict compliance with all building codes.
4. All building signs shall be constructed and installed at Tenant's expense.
5. All building-specific monument signs and associated Tenant panels will be constructed and installed at Landlord's expense.
6. All Building penetrations required for sign installation shall be neatly sealed in a watertight condition.
7. Tenant shall be fully responsible for the operations of Tenant's sign contractors, and shall indemnify and hold Landlord harmless from any acts or omissions of such sign contractors.
8. Tenant shall, upon the expiration or early termination of this Lease, remove Tenant's sign(s), repair all damage and restore the Premises and the Building to the condition that existed just prior to the initial installation of the sign(s).

## EXHIBIT G

### TENANT'S OPTION TO PURCHASE THE PREMISES

During the initial six (6) months of the Initial Term, Tenant shall have a non-assignable option to acquire the Premises (the "Purchase Option"). If Tenant desires to exercise the foregoing Purchase Option, Tenant must timely deliver written notice via certified mail, return receipt requested of Tenant's election to exercise the Purchase Option ("Tenant's Purchase Option Notice"), and within Tenant's Purchase Option Notice Tenant must provide reasonable evidence that it has readily available funds necessary to consummate such purchase.

Within fourteen (14) days from the date Landlord receives Tenant's Purchase Option Notice, the parties must agree upon the Qualified Appraiser who shall appraise the Premises. For purposes of this provision, a "Qualified Appraiser" shall mean and refer to an appraiser who (i) is unrelated to each of Landlord and Tenant and their respective Affiliates, (ii) is a member of the American Institute of Real Estate Appraisers and is employed by any of Colliers International, Cushman Wakefield, CBRE or JLL, and (iii) has no less than ten (10) years of full-time experience appraising commercial real estate that is comparable to the Premises. The cost of the appraisal provided by the Qualified Appraiser shall be split between Landlord and Tenant.

Upon receipt of the appraisal, the parties shall have fifteen (15) days to agree upon the purchase price for the Premises. Provided that the parties timely agree on the purchase price for the Premises, promptly thereafter Landlord shall deliver to Tenant a Commercial & Investment Real Estate Purchase & Sale Agreement on the standard Commercial Brokers Association form (the "Purchase Agreement"), which Purchase Agreement shall provide for the following:

1. The agreed-upon purchase price for the Premises;
2. Nonrefundable Earnest money in the amount of \$300,000.00 to be held by the closing agent;
3. Title company to be selected at Sellers discretion as the closing agent and title company for the transaction;
4. Closing to occur within thirty (30) days after mutual execution of the Purchase Agreement;
5. Seller to provide a bargain and sale deed;
6. Seller's exclusive remedy in the context of a buyer default to be the forfeiture of earnest money;
7. Buyer's remedies in the context of a seller default to be the recovery of its earnest money or specific enforcement; and
8. All closing costs to be apportioned according to local custom.



# SPOKANE WASHINGTON

## Homelessness Plan 2.0

*A plan to fundamentally shift how people transition out of homelessness through prevention and compassionate accountability*



# Vision statement

A **regional framework of community expectations for behavior that builds from successes** with youth, families, and veterans and prioritizes civility, prevention, efficient use of taxpayer resources, collaboration, outcomes, and universal accountability for behavior of the individuals, neighborhoods, and entities of a vibrant, clean, and safe community in a way that respects and values everyone.



# Opportunity statement

There is a universally shared belief **that sidewalks, alleyways, and other outdoor areas are not safe, healthy, or humane** for those struggling with mental health, substance abuse, or other conditions that require emergency interventions and a permanent housing solution to make homelessness rare, brief, and non-recurring by fostering shared responsibility among stakeholders.

*“Government entities are very capable, working hard and making progress in some areas, but, as in other cities, it is perceived that politics can and has gotten in the way of progress at times. Even though there are differing thought processes and approaches by different elected officials, it would be good if politics could be set aside more often to find some consensus and compromise on the critical issue of homelessness.”*

*Berry Consulting, Inc.*

*“This is not a partisan issue. It’s not a political issue. It’s a human issue.”*

*Christine Gregoire  
Challenge Seattle  
Former Governor*

*“Homelessness has been over-politicized in Spokane to the detriment of potential solutions.”*

*Hello for Good*

*“In light of the legal context for encampments in our region, there has been an increased emphasis on creating emergency shelter and focus on how that component of the system is addressing the community need. This has led to an emphasis on the funding of emergency shelter at previously unprecedented levels.”*

*Spokane City/County Continuum of Care*

*“Spokane has as seemingly impossible problem of accommodating ‘homeless’ people... There is a strong kickback, characterized by the term ‘NIMBY’ (Not in my Backyard) from citizens living near any known empty buildings.”*

*A Plan for a “Homeless”  
Facility for Spokane*



# Overarching strategy

Work collaboratively to build trust among regional partners, grow from areas of strength, and scale the solution based on successes to make best use of available resources.

- **Get individuals emergency housed as a transition strategy**
- **Meet people with individualized services**
- Coordinate supportive resources
- Know them by name and need
- Deploy case workers to meet people where they are physically and in life
- Deliver transparency and accountability to establish and maintain buy-in
- Create more housing inventory
- Expect compassionate accountability by demonstrating respect and that behavior matters

***“The greater Spokane community made solid strides in helping to make the experience of homelessness rare, brief, and non-recurring... We made progress toward reducing homelessness, particularly among certain portions of the population experiencing homelessness. Our community’s “Functional Zero” approach is making a huge difference. And, additional investment in new sheltering and bridge housing approaches will build on those successes into the next fiscal year and beyond.”***

*Spokane Regional Continuum of Care “Regional 5-Year Homeless Housing Plan Annual Report”  
November 2021*





# Here's where we go next

1. Identify a dependable shelter site for on-demand activation during emergent weather, disaster, and other needs
2. Identify new low-barrier shelter site to add space and better distribute services
3. Establish a plan for any tenant improvements that include potential for accommodating multiple populations before activating on-demand site
4. Seek proposals from operators of the on-demand location and encourage partnerships to accommodate multiple populations
5. **Develop transportation partnership and route for services connectivity**
6. Establish behavioral health resource connection to on-demand location
7. Coordinate with partners identified in the emergency activation plan
8. **Deploy public shelter dashboard for awareness of resources and capacity**
9. Identify and establish sustainable funding sources from public and private partnerships
10. **Launch a community fundraising effort to sustain operation of the regional system**
11. Raise awareness of need for additional volunteers
12. Evaluate potential navigators options
13. **Structure contracts to include expectation statements and deliver outcomes**
14. Open a dialogue with the court system about how to enhance therapeutic court options for greater accountability
15. Identify City responsibilities and those of the partners



New annual RFP in September for non-Federal or State funded shelters and services



# Plan for making this new shelter successful

1. Interim zoning ordinance to allow for use (Completed with Council May 16, 2022)
2. **Building lease, in progress (June 6, 2022, TI completion expected by end of July)**
3. **Operator and Services RFP recommendations (June 3, 2022, contracting in progress to complete June 17, 2022)**
  - a. **Wrap-around services, transportation, support and security complete review (June 17, 2022)**
  - b. Expanded specialty services part of new RFP process
4. **Completion of the site use plan with new selected operator (June 13, 2022)**
5. Impact mitigation plan and funding strategy (In progress, but not yet funded)
6. New ordinance revisions to help make progress on illegal camping that uses new shelter capacity as a positive tool to help on outreach and individual progression out of homelessness (In progress, late June 2022)
7. Coordinated outreach begins month prior to shelter opening to proactively identify and support individuals to transition to new facility (Late June 2022)
8. **Budget review to determine funding paths (Started May 2, 2022, completed after RFP contracting for known costs)**



# Lease



# Trent Shelter Lease 2022

- **Building Address:** 4320 E. Trent Avenue, Spokane, Washington 99212
- **Use of Premises:** Shelter operation for the protection of vulnerable and homeless individuals and families, providing wrap-around services with additional services provided; to include, but not limited to:
  - Coordinate entry access
  - Outreach services
  - Transportation
  - Temporary Storage for personal belongings
  - Case management
  - Referral services
  - Mental Health
  - Substance Abuse Counselors
  - Job Training Services
  - Education Outreach



# Trent Shelter Lease 2022

- **Bed capacity:** Minimum 150 to 250
- **Operation hours:** 24-Hours a day, 7 days a week
- **Monthly rental installments:** \$26,100.00 (base rent), security deposit of \$26,100.00 due upon execution of Lease, along with the required insurance certificate
- **Commencement Date/Term:** August 1, 2022/ Five (5) years, with one (1) option to renew for five (5) years

## **Costs:**

**Annual:** \$313K

**Term:** \$1.6M (with escalator)

**Private owner is investing over \$4M into the building**



# Exhibit B

## IMPROVEMENTS

Landlord shall carry out, **at its expense**, the work (“Plans”) set forth in Section A below to municipal code per the described use. Any modifications or alterations to the Plans requested by Tenant resulting in any additional expenses or costs shall be paid by Tenant...

### DESCRIPTION OF LANDLORD'S WORK

Following is the construction work to be carried out by Landlord. The material specifications and layout shall be at Landlord's option subject to Tenant's reasonable approval.

#### Schedule A-1

1. Insulate the warehouse walls with R-19 and ceiling with R-38. Install corrugated wall panels up to 8 feet tall to protect the insulation from damage.
2. Install additional exit lighting with battery packs and exit signage and exterior lighting.
3. Install suitable safety fencing to cargo loading area to prevent falls off loading dock.
4. Install heavy-duty laminate flooring to current top floor office space where current older carpeting exists.

The Schedule A-1 improvements shall be performed at Landlord's expense.

**COST: \$300K**



# Exhibit B

## IMPROVEMENTS

### Schedule A-2

1. Change egress door swing outward on southernmost pedestrian door on the east exterior wall.
2. Install panic bar hardware to the two egress doors on the east warehouse wall.
3. Install ADA ramp outside of the warehouse as identified in Exhibit A-1.
4. Install panic bar hardware on exit gate near ADA ramp including a knox box.
5. Install smoke and carbon monoxide detectors. (as per Fire and Code requirements).
6. Basement access to be made secured with no access allowed. (This should be keyed/restricted access, not fully “no access allowed”. Intent was to ensure that only site operators and staff can access for temporary, or storage uses as allowed by fire code. For the warehouse area, a chain link sectioned off with gated/key lock opening at head of the stairs is envisioned.
7. Install safety covers on all operational equipment.
8. Install locks on all electrical panels to restrict access.



# Exhibit B

## IMPROVEMENTS

### Schedule A-2 (cont.)

9. Repair and improve exterior fencing.
10. Install exterior light along eastern exterior wall of office area to fully illuminate the walkway leading from the front parking lot to the gated access to the warehouse ADA ramp access point. Additional flood lights to be added to dock roof structure to increase the lighting in the ease yard area. This area lighting is poor during hours of darkness.
11. Install or facilitate install of temporary wall sections that allow the warehouse space to be divided into sections to improve use and separation of occupants.
12. Install a cementitious fence along the south and east property line, roughly 480 lineal feet.

The Schedule A-2 improvements are specific to Tenant's need for the shelter. A one-time payment to the general contractor overseeing tenant improvements for \$250,000 shall be paid at Landlord's expense at no cost to Tenant.

**COST: \$250K**





# Exhibit C

## ADJUSTMENT OF BASE RENT

Commencing on the first (1<sup>st</sup>) Anniversary of the Lease Commencement Date and continuing on the same date every year thereafter during the Initial Term (and any options to extend) the Base Rent due and payable to Landlord shall be adjusted for the next succeeding year. The adjusted Base Rent for each year shall be equal to the Base Rent paid during the immediately preceding twelve (12) month period (the Lease Year) increased by a percentage equal to the percentage increase in the CPI-U (The US Department of Labor's Consumer Price Index) for All Urban Consumers, West Region, All Items, or an annual increase of 3%; whichever is greater.



# Exhibit D

## OPTION TO EXTEND

Tenant shall have the option to extend the term of this Lease for one (1) extension period, for a term of five (5) years commencing immediately following the expiration of the then current term, said extension to be upon all of the terms, conditions, covenants and provisions of this Lease except as provided below. If Tenant is granted more than one (1) extension term, the failure of Tenant to exercise the option for any extension period in the manner and within the time herein provided shall terminate the rights of Tenant with respect to that extension period and all subsequent extension periods, if any.



# Shelter Operator and Services



# Members

## Member Organizations

Transitions- Women's Hearth

CHHS Board

CoC Board and County Rep

Chief Garry Neighborhood Council

SRHD

VOA

# Overview of Process

- Pass Fail criteria evaluated by City of Spokane Procurement Department.
- May 24 kickoff meeting with review committee. Reviewed the process, scoring tool and expectations, sent scoring matrix and application materials.
- This was not a fully blind review. Redaction the names of the applicants still allowed identification of the proposers. All members were asked and indicated their review was unbiased and the partial redaction was not an issue.
- May 26 review meeting, collected scores, discussed applications, made recommendations.



# Pass-Fail Scoring

- Of the 5 applications received, 2 rejected for not meeting the pass/fail criteria.
- Fail
  - Jewels Helping Hands: Services application was for services **not** at the proposed location.
  - InMotion: Services Application only provided medical care, did not offer the full suite of services.
- Pass
  - The Guardians- Operator Application
  - The Salvation Army- Operator Application
  - The Salvation Army- Services Application



Reviewer	RFP Scoring		
	Guardians Operations	TSA Operations	TSA Services
Chief Gary Park Neighborhood	90	71	80
CHHS Board	88	53	51
VOA	61	51	48
CoC/County	54	73	41
SRHD	92	55	70
Transitions-Women's Hearth	93	77	57
	<b>478</b>	<b>380</b>	<b>347</b>

- The Guardians Operations application scored the highest in the operations category and they were **recommended** to be the operator of the new shelter
- The TSA Services Application was the only services application that made it past the pass/fail criteria but was **not** recommended to be awarded a contract.
- For Services it was recommended that we re-release an RFP or allow existing organizations to utilize the space for case management.



# Options for Filling Services Needs

Option 1 (**and initial next step**): Work with existing services provider contracts to co-locate onsite, could be contract expansions, or pay per service where we are billed for the time they actually spend with shelter guests.

- Can be activated as soon as shelter opens.

Option 2: Develop a pay per service model where select organizations can bill for hours spent with shelter guests.

- This has been recommended by several service providers as it allows more targeted and efficient delivery of services. Most service providers have not been able to meet the need for the breadth of different highly specialized services.
- Can be activated as soon as shelter opens.

Option 3: Release a new RFP for Services, changing scope to allow multiple selected service providers with specialty services (previous RFP was for all services)

- Health Care
- Mental Health
- Housing Search
- Substance Abuse
- Family Reunification
- Employment Support
- Process can happen in parallel with the above options



# New Shelter Financial Planning

TRENT LEASE COSTS	YEAR 1	YEAR 2	YEAR 3	YEAR 4	YEAR 5
	8/1/2022	8/1/2023	8/1/2024	8/1/2025	8/1/2026
<b>Annual Rent</b>	313,200	322,596	332,274	342,242	352,509
<b>Real Property Taxes</b>	22,845	23,987	25,187	26,446	27,768
<b>Building Insurance Expenses</b>	<b>CITY SELF INSURED</b>				
<b>Maintenance</b>					
<i>HVAC</i>	5,000	5,000	5,000	5,000	5,000
<i>Security System (Monitoring)</i>	1,500	1,500	1,500	1,500	1,500
<i>Janitorial</i>	<b>VENDOR PROVIDED</b>				
<i>Landscaping</i>	2,500	2,500	2,750	2,750	3,000
<i>Parking Lot Maintenance</i>	0	25,000	35,000	25,000	35,000
<b>Management Fee - 4%</b>	13,802	15,223	16,068	16,118	16,991
<b>Utilities and Services</b>					
<i>City</i>	12,000	12,000	12,000	12,000	12,000
<i>Avista</i>	90,000	92,500	95,000	95,000	97,500
<b>EST. ANNUAL COST</b>	<b>460,847</b>	<b>500,307</b>	<b>524,779</b>	<b>526,056</b>	<b>551,269</b>
<b>EST. MONTHLY COST</b>	<b>38,404</b>	<b>41,692</b>	<b>43,732</b>	<b>43,838</b>	<b>45,939</b>

- The estimated costs listed are specific to the Trent Shelter. Over \$4M will have been invested by private sector to facilitate City use in 2022
- 2022 funding covers current and new shelters and services (includes \$3.5M ARPA allocation)
- 2023 budget projected to cover existing and new shelters and services (includes \$3.5M ARPA allocation)
- From 2024 on there is a annual operating funding gap of over \$4M due to exhausting Criminal Justice fund and ARPA
- \$13+M State Commerce funding for region discussed specific to ROW camp assistance may come available over the next month
- The multitude of funding sources, emerging funding, and emerging projects worthy of a separate discussion session







# DISCUSSION





**Agenda Sheet for City Council Meeting of:**  
06/20/2022

<b>Date Rec'd</b>	6/6/2022
<b>Clerk's File #</b>	RES 2022-0056
<b>Renews #</b>	
<b>Cross Ref #</b>	
<b>Project #</b>	2022015
<b>Bid #</b>	
<b>Requisition #</b>	

<b>Submitting Dept</b>	INTEGRATED CAPITAL MANAGEMENT
<b>Contact Name/Phone</b>	KEVIN PICANCO 625-6088
<b>Contact E-Mail</b>	KPICANCO@SPOKANECITY.ORG
<b>Agenda Item Type</b>	Hearings
<b>Agenda Item Name</b>	4250 – RESOLUTION FOR THE 2023-2028 SIX-YEAR COMPREHENSIVE STREET PROGRAM

**Agenda Wording**

Hearing for the 2023-2028 Six-Year Comprehensive Street Program. (Various neighborhood councils)

**Summary (Background)**

RCW 35.77 provides that pursuant to a public hearing process, each City shall update its Six-Year Transportation Improvement Program annually prior to July 1st and file a copy of the adopted program with the Secretary of Transportation no later than July 31st of that same year. The Plan Commission held a workshop on April 13, 2022 and a public hearing in May. A hearing was held on May 11, 2022 which provided a recommendation of approval.

Lease? NO Grant related? NO Public Works? NO  
**Fiscal Impact** **Budget Account**

Select	\$	#
Select	\$	#
Select	\$	#
Select	\$	#

<b>Approvals</b>		<b>Council Notifications</b>	
<b>Dept Head</b>	MILLER, KATHERINE E	<b>Study Session\Other</b>	PIES 4/25/22
<b>Division Director</b>	FEIST, MARLENE	<b>Council Sponsor</b>	Beggs/Kinnear
<b>Finance</b>	ORLOB, KIMBERLY	<b>Distribution List</b>	
<b>Legal</b>	PICCOLO, MIKE	ddaniels@spokanecity.org	
<b>For the Mayor</b>	ORMSBY, MICHAEL	ddaniels@spokanecity.org	
<b>Additional Approvals</b>		eraea@spokanecity.org	
<b>Purchasing</b>		kpicanco@spokanecity.org	
		kemiller@spokanecity.org	
		mdavis@spokanecity.org	

**RESOLUTION 2022-0056**

**WHEREAS, pursuant to the requirements of RCW 35.77.010, Laws of the State of Washington, the City of Spokane has prepared a revised and extended Six-Year Comprehensive Street Program for the ensuing six years, 2022 through 2027; and**

**WHEREAS, the Spokane City Plan Commission, on May 12, 2022, following a public hearing, found the 2023-2028 Six-Year Comprehensive Street Program to be in full conformance with the City’s Comprehensive Plan; and**

**WHEREAS, the City of Spokane utilizes state and federal grants and low-interest loans as appropriate to supplement its financial resources and such anticipated funding is incorporated in the 2023-2028 Six-Year Comprehensive Street Program;**

**WHEREAS, pursuant to the above law, the City Council of the City of Spokane, being the legislative body of the City held a public hearing on the 2023-2028 Six Year Comprehensive Street Program at 6:00 pm., at City Hall in Spokane, Washington on the 20th day of June, 2022.**

**NOW, THEREFORE, BE IT RESOLVED by the City Council of the City of Spokane that the revised and extended 2023-2028 Six Year Comprehensive Street Program is hereby adopted; and,**

**BE IT FURTHER RESOLVED, that a copy of the revised and extended 2023-2028 Six Year Comprehensive Street Program, together with a copy of this resolution, be filed with the Secretary, Washington State Department of Transportation.**

**BE IT FURTHER RESOLVED, that City staff be authorized to apply for state and federal grants and low-interest loans in support of projects as identified in the 2023-2028 Six Year Comprehensive Street Program;**

**Adopted this 20th day of June, 2022**

\_\_\_\_\_

**Terri Pfister, City Clerk**

**Approved as to Form:**

\_\_\_\_\_

**Assistant City Attorney**

# **CITY PLAN COMMISSION FINDINGS OF FACT, CONCLUSIONS, AND RECOMMENDATIONS ON THE 2023-2028 SIX YEAR STREET PROGRAM**

**A Recommendation of the City Plan Commission certifying that the 2023-2028 Six Year Street Program is in conformance with the City of Spokane's Comprehensive Plan.**

## **FINDINGS OF FACT:**

**A. In May 2001, the City of Spokane adopted its Comprehensive Plan under the Growth Management Act (Chapter 36.70A RCW or "GMA").**

**B. The City's Comprehensive Plan is required to be consistent with the GMA.**

**C. The GMA requires that the City's annual Six Year Street Program shall be in conformance with the City's Comprehensive Plan.**

**D. The 2023-2028 Six Year Street Program identifies capital project activity which has implications on the growth of the community.**

**E. The City Plan Commission Transportation Subcommittee held a workshop on April 5, 2022 to review new projects for consistency with the goals and policies of the City's Comprehensive Plan, and made a recommendation to the Plan Commission to accept the new projects into the 2023-2028 Six Year Street Program.**

**F. The City Plan Commission held a workshop on April 13, 2022, and also held a public hearing on May 11, 2022, to obtain public comments on the 2023-2028 Six Year Street Program.**

**G. The City Council must receive a recommendation from the City Plan Commission to certify that the 2023-2028 Six Year Street Program is in conformance with the City's Comprehensive Plan in effect on the day of certification.**

***ACTION: Motion to accept the staff's Findings of Fact A through G.***

## **CONCLUSIONS:**

**A. The 2023-2028 Six Year Street Program has been prepared in full consideration of the City's Comprehensive Plan.**

**B. The 2023-2028 Six Year Street Program has been reviewed by the City Plan Commission and found to be in conformance with the goals and policies of the City's 2001 Comprehensive Plan, as well as the Arterial Street Plan.**

**C. The 2023-2028 Six Year Street Program has been reviewed by the City Plan Commission and found to be in conformance with the draft goals and policies of the City's update to the transportation chapter (chapter 4) of the 2001 Comprehensive Plan.**

***ACTION: Motion to accept conclusions A, B and C by staff as conclusions of the Plan Commission.***

**RECOMMENDATIONS:**

**A. The Spokane City Plan Commission agrees that the 2023-2028 Six Year Street Program is in full compliance with the existing Spokane Comprehensive Plan as required by RCW 36.70A and RCW 35.77.010 and recommends adoption by the Spokane City Council.**

**B. By a vote of 7 to 0, the Plan Commission recommends the approval of these amended documents by the City Council.**

  
Todd Beyreuther (May 18, 2022 18:54 PDT)

---

**Todd Beyreuther, President  
Spokane Plan Commission**

May 18, 2022

# PLAN\_COMMISSION\_RECOMMENDATION 2023-2028

Final Audit Report

2022-05-19

Created:	2022-05-18
By:	Jackie Churchill (jchurchill@spokanecity.org)
Status:	Signed
Transaction ID:	CBJCHBCAABAAVWzwg84nOsoduFMNZwbTxgyBwvVyMkuK

## "PLAN\_COMMISSION\_RECOMMENDATION 2023-2028" History

-  Document created by Jackie Churchill (jchurchill@spokanecity.org)  
2022-05-18 - 11:51:44 PM GMT- IP address: 198.1.39.252
-  Document emailed to Todd Beyreuther (tbeyreuther@spokanecity.org) for signature  
2022-05-18 - 11:52:13 PM GMT
-  Email viewed by Todd Beyreuther (tbeyreuther@spokanecity.org)  
2022-05-19 - 1:53:31 AM GMT- IP address: 172.226.2.159
-  Document e-signed by Todd Beyreuther (tbeyreuther@spokanecity.org)  
Signature Date: 2022-05-19 - 1:54:31 AM GMT - Time Source: server- IP address: 73.140.12.157
-  Agreement completed.  
2022-05-19 - 1:54:31 AM GMT



**Agenda Sheet for City Council Meeting of:**  
06/20/2022

<b>Date Rec'd</b>	6/6/2022
<b>Clerk's File #</b>	ORD C36224
<b>Renews #</b>	
<b>Cross Ref #</b>	
<b>Project #</b>	
<b>Bid #</b>	
<b>Requisition #</b>	

<b>Submitting Dept</b>	PLANNING & ECONOMIC DEVELOPMENT
<b>Contact Name/Phone</b>	AMANDA BECK 6414
<b>Contact E-Mail</b>	ABECK@SPOKANECITY.ORG
<b>Agenda Item Type</b>	First Reading Ordinance
<b>Agenda Item Name</b>	SHAPING SPOKANE HOUSING: SHORT PLAT NOTIFICATION

**Agenda Wording**

An Ordinance relating to short plat notification amending Spokane Municipal Code (SMC) Sections 17G.060.100, 17G.060T.003, 17G.060.130, and 17G.080.040.

**Summary (Background)**

Shaping Spokane Housing is a result of the Spokane Housing Action Plan, also guided by Mayor Woodward's July 26, 2021, Housing Emergency Proclamation, and the City Council's HAP Implementation Plan. These amendments propose changes to increase flexibility for accessory dwelling units; remove lot size transitions; and modify and streamline short plat notification. Changes to accessory dwelling unit are a grant deliverable for the \$100,000 grant the City received from WA Commerce to implement stra

Lease? NO Grant related? NO Public Works? NO

**Fiscal Impact**

Neutral	\$	#
Select	\$	#
Select	\$	#
Select	\$	#

**Budget Account**

**Approvals**

<b>Dept Head</b>	GARDNER, SPENCER
<b>Division Director</b>	MACDONALD, STEVEN
<b>Finance</b>	ORLOB, KIMBERLY
<b>Legal</b>	RICHMAN, JAMES
<b>For the Mayor</b>	ORMSBY, MICHAEL

**Council Notifications**

<b>Study Session\Other</b>	6/2 Study Session
<b>Council Sponsor</b>	CM Betsy Wilkerson and CM Zack Zappone

**Additional Approvals**

<b>Purchasing</b>	abeck@spokanecity.org
	tpalmquist@spokanecity.org
	jrichman@spokanecity.org
	smacdonald@spokanecity.org
	jchurchill@spokanecity.org

## ORDINANCE NO. C36224

An ORDINANCE relating to short plat notification amending Spokane Municipal Code (SMC) Sections 17G.060.100, 17G.060T.003, 17G.060.130, and 17G.080.040.

WHEREAS, RCW 36.70A.600 encourages the City to take a number of actions in order to increase its residential building capacity and authorized the City to adopt a housing action plan; and

WHEREAS, as authorized by RCW 36.70A.600(2), Council Resolution RES-2021-0062 adopted the City of Spokane Housing Action Plan as a guide for future housing planning, policy development, and regulatory and programmatic implementation measures that increase housing options that are affordable and accessible for people and families of all incomes in the City; including the Implementation Plan, included as Appendix A within the Housing Action Plan, which outlines several strategies and policies to remedy the current housing crisis; and

WHEREAS, the 2020 Housing Needs Assessment completed for the Housing Action Plan indicates several facts about the housing supply and need, particularly the need to accommodate for an estimated 6,000 additional housing units by 2037; and

WHEREAS, in adopting RES-2021-0062 the City Council outlined several code amendments and permit processes that the City should enact in support of the strategies and actions recommended in the Housing Action Plan and to encourage construction of more housing within Spokane; and

WHEREAS, on July 26, 2021, the Mayor of the City of Spokane proclaimed a housing emergency and directed the City to pursue actions to expand housing types, reduce overall development costs to increase development of affordable housing, and to streamline municipal procedures to support the development cycle; and

WHEREAS, the City was awarded a \$100,000 grant from the Department of Commerce through the Housing Action Plan and Implementation (HAPI) grant program to implement strategies from its adopted Housing Action Plan, and the scope of work includes revising accessory dwelling unit (ADU) standards in chapter 17C.300 SMC to allow for additional flexibility and expand the zones that permit ADUs; and

WHEREAS, the proposed actions are consistent with and supported by the Spokane Comprehensive Plan, as outlined in the Plan Commission Findings of Fact, Conclusions, and Recommendations (Exhibit A), and will implement actions specified in RCW 36.70A.600(1); and



WHEREAS, RCW 58.17.060(1) requires cities to adopt regulations and procedures for the summary approval of short plats and short subdivisions; and

WHEREAS, pursuant to WAC 197-11-800(6), most short plats and short subdivisions are categorically exempt from review under the State Environmental Policy Act (SEPA); and

WHEREAS, as outlined in RCW 36.70B.110 a notice of application is not required for project permits that are categorically exempt under chapter 43.21C RCW; and

WHEREAS, by virtue of the public process outlined in Exhibits A and B, interested agencies and the public have had extensive opportunities to participate throughout the process and all persons desiring to comment on the amendment were given a full and complete opportunity to be heard; and

WHEREAS, the City has complied with RCW 36.70A.370 in the adoption of this Ordinance, avoiding any unconstitutional taking of private property; and

WHEREAS, on March 24, 2022, the Washington State Department of Commerce and appropriate state agencies were given the required 60-day notice before adoption of proposed changes to the Unified Development Code pursuant to RCW 36.70A.106; and

WHEREAS, on April 1, 2022, a Notice of Intent to adopt and request for SEPA agency comments was issued for the draft code pertaining to ADUs, lot size transitions, and short plat notification. The comment period ended on April 15, 2022. The Spokane Tribe of Indians issued comment noting project actions may require case by case cultural surveys; and

WHEREAS, a State Environmental Protection Act (SEPA) Determination of Nonsignificance and Checklist were issued by Planning Services on April 25, 2022. The comment period ended on May 11, 2022. Two city department comments were received during the comment period; and

WHEREAS, prior to the Plan Commission public hearing, a legal notice of public hearing was published in the *Spokesman-Review* on April 27 and May 4, 2022 and the notice of the proposed amendment was distributed to the City's agency/interested party list and posted on the City's website at [www.ShapingSpokaneHousing.com](http://www.ShapingSpokaneHousing.com); and

WHEREAS, on May 11, 2022, the Spokane Plan Commission held a public hearing on the proposed amendment and heard testimony from the public, following which they voted to recommend the City Council adopt, with some modifications, the proposed amendments (see Exhibit A); and

WHEREAS, the City Council adopts the recitals set forth herein as its findings and conclusions in support of its adoption of this ordinance and further adopts the findings, conclusions, and recommendations from the Planning Services Staff Report (Exhibit B) and the City of Spokane Plan Commission (Exhibit A) for the same purposes; and

NOW, THEREFORE, the City of Spokane does ordain:

Section 1. That Section 17G.060.100 SMC is amended to read as follows:

**17G.060.100 Notice of Application**

Within fourteen days of the issuance of a determination of a complete application, a notice of application shall be provided for Type I, II and III project permit applications in accordance with this section (RCW 36.70B.110.2), except that notice of application is not required for short subdivision applications involving minor engineering review as defined in SMC 17G.080.040(C)(2). The notice of application shall follow the public notice requirements contained in SMC 17G.060.110 through 17G.060.120. The notice of application may be combined with the notice of public hearing, if a hearing has been scheduled by notice of application. The date, time, place and type of hearing, SEPA determination and SEPA appeal deadline (using the optional DNS process) are required to be added to the notice of application if this provision is used (RCW 36.70B.110(2)(f)).

Section 2. That Section 17G.060T.003 SMC is amended to read as follows:

**17G.060T.003 Table 17G.060-3 Type of Public Notice Required / Project Permit Review Process**

<b>TABLE 17G.060-3</b> <b>TYPE OF PUBLIC NOTICE REQUIRED / PROJECT PERMIT REVIEW PROCESS</b> (Click here to view PDF)						
Project Permit Type	Notice of Community Meeting	Notice of Application	Notice of Public Hearing	Review Official	City Council Review	Expiration of Permit [1]
<b>Building and Code Enforcement – Type I Application</b>						
Building Permit	No	No	No	Building Official	No	180 days
Grading Permit	No	No	No	Building Official	No	180 days
Demolition Permit	No	No [5]	No [2]	Building Official	No	180 days

Building Permit with SEPA	No	Posted / Legal	No	Building Official	No	180 days
Grading Permit with SEPA	No	Posted / Legal	No	Building Official	No	180 days
Demolition Permit with SEPA	No	Posted / Legal [5]	No	Building Official	No	180 days
<b>Planning Services – Type I Application</b>						
Floodplain with SEPA	Posted / Individual	Posted / Individual	No	Planning Director	No	180 days
<b>Planning Services – Type II Application</b>						
Binding Site Plan	No	Posted / Individual	No	Planning Director	No	5 years
Certificate of Compliance	No	Posted / Individual	No	Planning Director	No	None
Conditional Use Permit	No [3]	Posted / Individual	No	Planning Director	No	3 years
Plans-in-lieu	No	Posted / Individual	No	Planning Director	No	3 years
Shoreline SDP	No	Posted / Individual	No	Planning Director	No	Must Comply with WAC 173-27-90
Short Plat with SEPA	No	Posted / Individual	No	Planning Director	No	5 years
Short Plat with minor engineering review	<u>No</u>	<u>No</u>	<u>No</u>	<u>Planning Director</u>	<u>No</u>	<u>5 years</u>
Short Plat, with SEPA exemption and standard engineering review	<u>No</u>	<u>Individual</u>	<u>No</u>	<u>Planning Director</u>	<u>No</u>	<u>5 years</u>
<b>Planning Services – Type III Application (Hearing Required)</b>						
Certificate of Compliance	Posted / Individual	Posted / Individual	Posted / Individual	Hearing Examiner	No	None

Conditional Use Permit	Posted / Individual	Posted / Individual	Posted / Individual	Hearing Examiner	No	3 years
Floodplain Variance	Posted / Individual	Posted / Individual	Posted / Individual	Hearing Examiner	No	3 years
Long Plat	Posted / Individual	Posted / Individual	Newspaper / Posted / Individual	Hearing Examiner	No	5 years
Plans-in-lieu	Posted / Individual	Posted / Individual	Posted / Individual	Hearing Examiner	No	3 years
PUD	Posted / Individual	Posted / Individual	Posted / Individual	Hearing Examiner	Yes	5 years [4]
Rezone	Posted / Individual	Posted / Individual	Posted / Individual	Hearing Examiner	Yes	3 years
Shoreline CUP	Posted / Individual	Posted / Individual	Posted / Individual	Hearing Examiner	No	Must Comply with WAC 173-27-90
Shoreline Variance	Posted / Individual	Posted / Individual	Posted / Individual	Hearing Examiner	No	Must Comply with WAC 173-27-90
Skywalk	Posted / Individual	Posted / Individual	Posted / Individual	Hearing Examiner	Yes	2 years
Variance	Posted / Individual	Posted / Individual	Posted / Individual	Hearing Examiner	No	3 years

Notes:

[1] Approval expires after the specified time if no permit to develop the project is issued by the City of Spokane or building permit expires without completion of the improvements.

[2] Public Hearing is required if the structure is on the National Historic Register.

[3] Conditional Use Permits required under SMC 17C.110.110, Limited Use Standards for Religious Institutions and Schools, will complete posted/individual notification requirements for a Community Meeting.

[4] If a PUD is approved together with a preliminary plat, the expiration date for the PUD shall be the same as the expiration date of the preliminary plat.

[5] Applications for demolition permits for the demolition of an entire building or structure shall, in addition to any applicable requirements under chapter 43.21C RCW, be subject to a ten day review and comment period. This review and comment period shall run concurrently with any other applicable notice and comment period. Following receipt of such applications, copies shall be forwarded to the individual(s) designated pursuant to SMC 4.27.010(D) to receive written notice on behalf of the neighborhood council in which the building or structure is located, at the address for such neighborhood council designee(s) that is on file with the department. Any comments submitted to the department by the neighborhood council during this review and comment period shall be provided to the applicant prior to issuing the demolition permit.

Section 3. That Section 17G.060.130 SMC is amended to read as follows:

**17G.060.130 Public Comment Period**

- A. The public comment period for Type I, II, and III applications is fifteen days, except short subdivision applications with minor engineering review as provided in SMC 17G.080.040(C)(2) shall have no public comment period.
- B. The public comment period for a shoreline substantial development permit, shoreline conditional use, or shoreline variance shall be thirty days.
- C. The public comment period for a shoreline substantial development permit for limited utility extensions and bulkheads shall be twenty days (WAC 173-27-120).
- D. The longest public comment period shall prevail.

Section 4. That Section 17G.080.040 SMC is amended to read as follows:

**17G.080.040 Short Subdivisions**

- A. Predevelopment Meeting  
A predevelopment meeting is required if the proposal is located in the central business district, unless waived by the director, and is recommended for all other proposals prior to submittal of the application. The purpose of a predevelopment meeting is to acquaint the applicant with the applicable provisions of this chapter, minimum submission requirements and other plans or regulations, which may impact the proposal.
- B. Preliminary Short Plat Application and Map Requirements
  - 1. Applications for approval of a preliminary short subdivision shall be filed with the director. All applications shall be submitted on forms provided for such purpose by the department. The director may waive specific submittal requirements determined to be unnecessary for review of the application. The application shall include the following:
    - a. The general application.
    - b. The supplemental application.
    - c. The environmental checklist, if required under chapter 17E.050 SMC.
    - d. Title report no older than thirty days from issuance from the title company.
    - e. The filing fees as required under chapter 8.02 SMC.
    - f. The required number of documents, plans or maps drawn to a minimum scale of one inch equals one hundred feet, on a sheet

twenty-four by thirty-six inches, as set forth in the application checklist.

- g. A written narrative identifying consistency with the applicable policies, regulations and criteria for approval of the permit requested; and
- h. Additional application information which may be requested by the permitting department and may include, but is not limited to, the following: geotechnical studies, hydrologic studies, critical area studies, noise studies, air quality studies, visual analysis and transportation impact studies.
- i. One copy of the predevelopment conference notes (if applicable); and
- j. One copy of the notification district map.

2. Contents of Preliminary Short Plat Map

The preliminary short plat shall be prepared by a land surveyor and shall show the following:

- a. Plat name and the name of any subdivision to be replatted.
- b. The name, mailing address and phone number of the owner and the person with whom official contact should be made regarding the application.
- c. Surveyor's name, mailing address and phone number.
- d. Legal description.
- e. Section, township and range.
- f. Vicinity map.
- g. North arrow, scale and date.
- h. Datum plane.
- i. Acreage.
- j. Number of lots and proposed density.
- k. Zoning designation.
- l. The boundary lines of the proposed subdivision.
- m. City limits and section lines.
- n. Park or open space (if proposed).
- o. Existing topography at two-foot maximum interval.
- p. The boundaries and approximate dimensions of all blocks and lots, together with the numbers proposed to be assigned each lot and block, and the dimensions, square footage and acreage of all proposed lots and tracts.

- q. Proposed names of streets.
- r. The location and widths of streets, alleys, rights-of-way, easements (both public and private), turn around and emergency access, parks and open spaces.
- s. Conditions of adjacent property, platted or unplatted, and if platted, giving the name of the subdivision. If the proposed short plat is the subdivision of a portion of an existing plat, the approximate lines of the existing plat are to be shown along with any and all recorded covenants and easements.
- t. The names and address of the record owners and taxpayers of each parcel adjoining the subdivision.
- u. Indicate any street grades in excess of eight percent.
- v. The location and, where ascertainable, sizes of all permanent buildings, wells, wellhead protection areas, sewage disposal systems, water courses, bodies of water, flood zones, culverts, bridges, structures, overhead and underground utilities, railroad lines, and other features existing upon, over or under the land proposed to be subdivided, and identifying any which are to be retained or removed.
- w. Proposed one-foot strips for right-of-way conveyed to the City, in cases where a proposed public street or alley abuts unplatted land.
- x. If a body of water forms the boundary of the plat, the ordinary high water mark as defined in chapter 90.58 RCW.
- y. Critical areas as defined in chapters 17E.020, 17E.030, 17E.070 and 17G.030 SMC.
- z. Significant historic, cultural or archaeological resources; and
- aa. If the proposal is located in an irrigation district, the irrigation district name.

C. Review of Preliminary Short Plat

1. The application shall be reviewed in accordance with the procedures set forth in chapter 17G.060 SMC for a Type II application, except an application that meets the requirements for minor engineering review as provided in subsection (2) of this section shall be excluded from the public notice requirements contained in SMC 17G.060.110 through 17G.060.120 and public comment period under SMC 17G.060.130.

2. Minor Engineering Review.

A preliminary short plat application may qualify for a minor engineering review if it meets all of the following conditions:

- a. The application is categorically exempt from chapter 43.21C RCW (SEPA);
- b. There is direct water and sewer main lot frontage on an existing and improved public right-of-way;
- c. No extensions of public water, sewer, or other utility services will be needed;
- d. No public easements for water, sewer, or other utility service exists on the lot;
- e. The lot is not situated in a Special Drainage District as defined in SMC 17D.060.130; and
- f. Public utility mains do not exist on the lot.

D. Public Notice

All public notice of the application shall be given in accordance with the procedures set forth in chapter 17G.060 SMC for a Type II application, except a short plat that meets the requirements for minor engineering review as provided in subsection (C)(2) of this section shall not require a notice of application.

E. Preliminary Short Plat Approval Criteria

Prior to approval of a short plat application, the director shall find the application to be in the public use and interest, conform to applicable land use controls and the comprehensive plan of the City, and the approval criteria set forth in chapter 17G.060 SMC. The director has the authority to approve or disapprove a proposed preliminary short plat under the provisions of this chapter, subject to appeal as provided in chapters 17F.050 and 17G.060 SMC.

F. Final Short Plat Review Procedure

1. The subdivider shall submit to the director for review the following:
  - a. A final short plat, prepared by a registered land surveyor licensed in the state of Washington, consistent with the approved preliminary short plat.
  - b. A title report less than thirty days old confirming that the title of the lands as described and shown on said plat is in the name of the owners signing the certificate or instrument of dedication.
  - c. Covenants, conditions and restrictions, if applicable; and
  - d. Fees pursuant to chapter 8.02 SMC.
2. Within thirty days, unless the applicant has consented to a longer period of time, of receipt of a proposed final short plat, the director shall review the plat for conformance with all conditions of the preliminary short plat approval, the requirements of this chapter and that arrangements have been made to insure the construction of required improvements. If all such conditions are met, the director shall approve the final short plat and



authorize the recording of the plat. If all conditions are not met, the director shall provide the applicant in writing a statement of the necessary changes to bring the final short plat into conformance with the conditions.

- a. If the final short plat is required to be resubmitted, the subdivider is required to provide the following:
  - b. A cover letter addressing the corrections, additions or modifications required.
  - c. Title report no older than thirty days from issuance of a title company conforming that the title of the lands as described and shown on said plat is in the name of the owners signing the certificate or instrument of dedication; and
  - d. The required number of copies of the corrected final short plat map.
3. If the final short plat is approved, the surveyor causes the plat to be signed by the Spokane county treasurer and file of record with the Spokane county auditor. The surveyor is required to file the appropriate number of mylar and bond copies of the recorded short plat with the director.

#### G. Final Short Plat Map Requirements

The subdivider shall submit to the director a final short plat in the same form and with the same content as the preliminary short plat, as provided in subsections (B)(1) and (2) of this section, with the following exceptions or additional requirements:

1. A final short plat shall contain all the information required of the preliminary plat, except the following:
  - a. Show existing buildings.
  - b. Show existing utility lines and underground structures.
  - c. Show the topographical elevations; or
  - d. Contain the names and addresses of adjoining landowners.
2. The final short plat shall include the following:
  - a. Surveyor's certificate, stamp, date and signature, as follows:

The following land surveyor's certificate to be shown on each sheet of the plat: "I, \_\_\_\_\_ registered land surveyor, hereby certify the plat of \_\_\_\_\_, as shown hereon, is based upon actual field survey of the land described and that all angles, distances, and courses are correctly shown and that all non fronting lot corners are set as shown on the plat. Monuments and fronting lot corners shall be set upon completion of the utility and street improvements.

Signed \_\_\_\_\_(Seal)"
  - b. A certification by the city treasurer, as applicable:

i. "I hereby certify that the land described by this plat, as of the date of this certification, is not subject to any local improvement assessments. Examined and approved, this \_\_\_\_\_ day of \_\_\_\_\_, 20\_\_.

\_\_\_\_\_  
City of Spokane Treasurer"

ii. "I hereby certify that the land described by this plat, as of the date of this certificate, is not subject to any delinquent local improvement assessment. Future installments, if any, shall remain due and payable and it shall be the responsibility of the owners to initiate the segregation of the LID assessment. Examined and approved, this \_\_\_\_\_ day of \_\_\_\_\_, 20\_\_.

\_\_\_\_\_  
City of Spokane Treasurer"

iii. "A preliminary local improvement assessment exists against this property. It shall be the responsibility of the owner's to initiate the segregation of the LID assessment. After this assessment is finalized, it shall be due and payable. Examined and approved this \_\_\_\_\_ day of \_\_\_\_\_, 20\_\_.

\_\_\_\_\_  
City of Spokane Treasurer"

c. The certification by the planning director, as follows:

"This plat has been reviewed on this \_\_\_\_\_ day of \_\_\_\_\_, 20\_\_ and is found to be in full compliance with all the conditions of approval stipulated in the Hearing Examiner's/Planning Director's approval of the preliminary plat # - -PP/SP.

\_\_\_\_\_  
City of Spokane Planning Director"

d. The certification by the city engineer, as follows:

"Approved as to compliance with the survey data, the design of public works and provisions made for constructing the improvements and permanent control monuments this \_\_\_\_\_ day of \_\_\_\_\_, 20\_\_.

\_\_\_\_\_  
City of Spokane Engineer"

e. The certification by the Spokane county treasurer, as follows:

"I hereby certify that the land described in this plat, as of the date of this certification, is not subject to any outstanding fees or assessments. Examined and approved \_\_\_\_\_ day of \_\_\_\_\_, 20\_\_.

---

Spokane County Treasurer”

- f. The certification by the Spokane county auditor on each page of the final short plat including the time, date, book and page number of the recording of the final mylar.
- g. Signature of every owner certifying that:
  - i. the plat is made with the free consent and in accordance with the desires of the owners of the land;
  - ii. the owners are the owners of the property and the only parties having interest in the land and is not encumbered by any delinquent taxes or assessments;
  - iii. the owners adopt the plan of lots, blocks and streets shown;
  - iv. owner dedicates to the City and the City’s permittees the easements shown for utilities and cable television purposes;
  - v. owner dedicates to the City the streets, alleys and other public places, including slope and construction easements and waives all claims for damages against any governmental authority including, without limitation, the City which may be occasioned to the adjacent land by the establishment, construction, drainage and maintenance of any public way so dedicated; and
  - vi. owner conveys to the City as general City property the buffer strips adjoining unplatted property.
- h. The drawing shall:
  - i. be a legibly drawn, printed or reproduced permanent map;
  - ii. if more than one sheet is required, each sheet shall show sheet numbers for the total sheets;
  - iii. have margins that comply with the standards of the Spokane county auditor;
  - iv. show in dashed lines the existing plat being replatted, if applicable;
  - v. show monuments in accordance with SMC 17G.080.020(H)(1);
  - vi. include any other information required by the conditions of approval; and
  - vii. include any special statements of approval required from governmental agencies, including those pertaining to flood hazard areas, shorelines, critical areas and connections to adjacent state highways.

H. Filing.

Once the final plat has been reviewed, approved and signed by the applicable departments, the applicant shall file the final short plat with the county auditor within ten days of approval. No permits shall be issued for a proposed lot until the required conformed copies of the short plat have been submitted to the planning services department.

I. Redivision.

No land within the boundaries of a short subdivision may be further divided in any manner which will create additional lots within a period of five years except by subdivision in accordance with SMC 17G.080.050.

## ORDINANCE NO. C36224

An ORDINANCE relating to short plat notification amending Spokane Municipal Code (SMC) Sections 17G.060.100, 17G.060T.003, 17G.060.130, and 17G.080.040.

WHEREAS, RCW 36.70A.600 encourages the City to take a number of actions in order to increase its residential building capacity and authorized the City to adopt a housing action plan; and

WHEREAS, as authorized by RCW 36.70A.600(2), Council Resolution RES-2021-0062 adopted the City of Spokane Housing Action Plan as a guide for future housing planning, policy development, and regulatory and programmatic implementation measures that increase housing options that are affordable and accessible for people and families of all incomes in the City; including the Implementation Plan, included as Appendix A within the Housing Action Plan, which outlines several strategies and policies to remedy the current housing crisis; and

WHEREAS, the 2020 Housing Needs Assessment completed for the Housing Action Plan indicates several facts about the housing supply and need, particularly the need to accommodate for an estimated 6,000 additional housing units by 2037; and

WHEREAS, in adopting RES-2021-0062 the City Council outlined several code amendments and permit processes that the City should enact in support of the strategies and actions recommended in the Housing Action Plan and to encourage construction of more housing within Spokane; and

WHEREAS, on July 26, 2021, the Mayor of the City of Spokane proclaimed a housing emergency and directed the City to pursue actions to expand housing types, reduce overall development costs to increase development of affordable housing, and to streamline municipal procedures to support the development cycle; and

WHEREAS, the City was awarded a \$100,000 grant from the Department of Commerce through the Housing Action Plan and Implementation (HAPI) grant program to implement strategies from its adopted Housing Action Plan, and the scope of work includes revising accessory dwelling unit (ADU) standards in chapter 17C.300 SMC to allow for additional flexibility and expand the zones that permit ADUs; and

WHEREAS, the proposed actions are consistent with and supported by the Spokane Comprehensive Plan, as outlined in the Plan Commission Findings of Fact, Conclusions, and Recommendations (Exhibit A), and will implement actions specified in RCW 36.70A.600(1); and

WHEREAS, RCW 58.17.060(1) requires cities to adopt regulations and procedures for the summary approval of short plats and short subdivisions; and

WHEREAS, pursuant to WAC 197-11-800(6), most short plats and short subdivisions are categorically exempt from review under the State Environmental Policy Act (SEPA); and

WHEREAS, as outlined in RCW 36.70B.110 a notice of application is not required for project permits that are categorically exempt under chapter 43.21C RCW; and

WHEREAS, by virtue of the public process outlined in Exhibits A and B, interested agencies and the public have had extensive opportunities to participate throughout the process and all persons desiring to comment on the amendment were given a full and complete opportunity to be heard; and

WHEREAS, the City has complied with RCW 36.70A.370 in the adoption of this Ordinance, avoiding any unconstitutional taking of private property; and

WHEREAS, on March 24, 2022, the Washington State Department of Commerce and appropriate state agencies were given the required 60-day notice before adoption of proposed changes to the Unified Development Code pursuant to RCW 36.70A.106; and

WHEREAS, on April 1, 2022, a Notice of Intent to adopt and request for SEPA agency comments was issued for the draft code pertaining to ADUs, lot size transitions, and short plat notification. The comment period ended on April 15, 2022. The Spokane Tribe of Indians issued comment noting project actions may require case by case cultural surveys; and

WHEREAS, a State Environmental Protection Act (SEPA) Determination of Nonsignificance and Checklist were issued by Planning Services on April 25, 2022. The comment period ended on May 11, 2022. Two city department comments were received during the comment period; and

WHEREAS, prior to the Plan Commission public hearing, a legal notice of public hearing was published in the *Spokesman-Review* on April 27 and May 4, 2022 and the notice of the proposed amendment was distributed to the City's agency/interested party list and posted on the City's website at [www.ShapingSpokaneHousing.com](http://www.ShapingSpokaneHousing.com); and

WHEREAS, on May 11, 2022, the Spokane Plan Commission held a public hearing on the proposed amendment and heard testimony from the public, following which they voted to recommend the City Council adopt, with some modifications, the proposed amendments (see Exhibit A); and

WHEREAS, the City Council adopts the recitals set forth herein as its findings and conclusions in support of its adoption of this ordinance and further adopts the findings, conclusions, and recommendations from the Planning Services Staff Report (Exhibit B) and the City of Spokane Plan Commission (Exhibit A) for the same purposes; and

NOW, THEREFORE, the City of Spokane does ordain:

Section 1. That Section 17G.060.100 SMC is amended to read as follows:

**17G.060.100 Notice of Application**

Within fourteen days of the issuance of a determination of a complete application, a notice of application shall be provided for Type I, II and III project permit applications in accordance with this section (RCW 36.70B.110.2), except that notice of application is not required for short subdivision applications involving minor engineering review as defined in SMC 17G.080.040(C)(2). The notice of application shall follow the public notice requirements contained in SMC 17G.060.110 through 17G.060.120. The notice of application may be combined with the notice of public hearing, if a hearing has been scheduled by notice of application. The date, time, place and type of hearing, SEPA determination and SEPA appeal deadline (using the optional DNS process) are required to be added to the notice of application if this provision is used (RCW 36.70B.110(2)(f)).

Section 2. That Section 17G.060T.003 SMC is amended to read as follows:

**17G.060T.003 Table 17G.060-3 Type of Public Notice Required / Project Permit Review Process**

<b>TABLE 17G.060-3</b> <b>TYPE OF PUBLIC NOTICE REQUIRED / PROJECT PERMIT REVIEW PROCESS</b> (Click here to view PDF)						
Project Permit Type	Notice of Community Meeting	Notice of Application	Notice of Public Hearing	Review Official	City Council Review	Expiration of Permit [1]
<b>Building and Code Enforcement – Type I Application</b>						
Building Permit	No	No	No	Building Official	No	180 days
Grading Permit	No	No	No	Building Official	No	180 days
Demolition Permit	No	No [5]	No [2]	Building Official	No	180 days

Building Permit with SEPA	No	Posted / Legal	No	Building Official	No	180 days
Grading Permit with SEPA	No	Posted / Legal	No	Building Official	No	180 days
Demolition Permit with SEPA	No	Posted / Legal [5]	No	Building Official	No	180 days
<b>Planning Services – Type I Application</b>						
Floodplain with SEPA	Posted / Individual	Posted / Individual	No	Planning Director	No	180 days
<b>Planning Services – Type II Application</b>						
Binding Site Plan	No	Posted / Individual	No	Planning Director	No	5 years
Certificate of Compliance	No	Posted / Individual	No	Planning Director	No	None
Conditional Use Permit	No [3]	Posted / Individual	No	Planning Director	No	3 years
Plans-in-lieu	No	Posted / Individual	No	Planning Director	No	3 years
Shoreline SDP	No	Posted / Individual	No	Planning Director	No	Must Comply with WAC 173-27-90
Short Plat with SEPA	No	Posted / Individual	No	Planning Director	No	5 years
Short Plat with minor engineering review	<u>No</u>	<u>No</u>	<u>No</u>	<u>Planning Director</u>	<u>No</u>	<u>5 years</u>
Short Plat, with SEPA exemption and standard engineering review	<u>No</u>	<u>Individual</u>	<u>No</u>	<u>Planning Director</u>	<u>No</u>	<u>5 years</u>
<b>Planning Services – Type III Application (Hearing Required)</b>						
Certificate of Compliance	Posted / Individual	Posted / Individual	Posted / Individual	Hearing Examiner	No	None



Conditional Use Permit	Posted / Individual	Posted / Individual	Posted / Individual	Hearing Examiner	No	3 years
Floodplain Variance	Posted / Individual	Posted / Individual	Posted / Individual	Hearing Examiner	No	3 years
Long Plat	Posted / Individual	Posted / Individual	Newspaper / Posted / Individual	Hearing Examiner	No	5 years
Plans-in-lieu	Posted / Individual	Posted / Individual	Posted / Individual	Hearing Examiner	No	3 years
PUD	Posted / Individual	Posted / Individual	Posted / Individual	Hearing Examiner	Yes	5 years [4]
Rezone	Posted / Individual	Posted / Individual	Posted / Individual	Hearing Examiner	Yes	3 years
Shoreline CUP	Posted / Individual	Posted / Individual	Posted / Individual	Hearing Examiner	No	Must Comply with WAC 173-27-90
Shoreline Variance	Posted / Individual	Posted / Individual	Posted / Individual	Hearing Examiner	No	Must Comply with WAC 173-27-90
Skywalk	Posted / Individual	Posted / Individual	Posted / Individual	Hearing Examiner	Yes	2 years
Variance	Posted / Individual	Posted / Individual	Posted / Individual	Hearing Examiner	No	3 years

Notes:

[1] Approval expires after the specified time if no permit to develop the project is issued by the City of Spokane or building permit expires without completion of the improvements.

[2] Public Hearing is required if the structure is on the National Historic Register.

[3] Conditional Use Permits required under SMC 17C.110.110, Limited Use Standards for Religious Institutions and Schools, will complete posted/individual notification requirements for a Community Meeting.

[4] If a PUD is approved together with a preliminary plat, the expiration date for the PUD shall be the same as the expiration date of the preliminary plat.

[5] Applications for demolition permits for the demolition of an entire building or structure shall, in addition to any applicable requirements under chapter 43.21C RCW, be subject to a ten day review and comment period. This review and comment period shall run concurrently with any other applicable notice and comment period. Following receipt of such applications, copies shall be forwarded to the individual(s) designated pursuant to SMC 4.27.010(D) to receive written notice on behalf of the neighborhood council in which the building or structure is located, at the address for such neighborhood council designee(s) that is on file with the department. Any comments submitted to the department by the neighborhood council during this review and comment period shall be provided to the applicant prior to issuing the demolition permit.

Section 3. That Section 17G.060.130 SMC is amended to read as follows:

**17G.060.130 Public Comment Period**

- A. The public comment period for Type I, II, and III applications is fifteen days, except short subdivision applications with minor engineering review as provided in SMC 17G.080.040(C)(2) shall have no public comment period.
- B. The public comment period for a shoreline substantial development permit, shoreline conditional use, or shoreline variance shall be thirty days.
- C. The public comment period for a shoreline substantial development permit for limited utility extensions and bulkheads shall be twenty days (WAC 173-27-120).
- D. The longest public comment period shall prevail.

Section 4. That Section 17G.080.040 SMC is amended to read as follows:

**17G.080.040 Short Subdivisions**

- A. Predevelopment Meeting  
A predevelopment meeting is required if the proposal is located in the central business district, unless waived by the director, and is recommended for all other proposals prior to submittal of the application. The purpose of a predevelopment meeting is to acquaint the applicant with the applicable provisions of this chapter, minimum submission requirements and other plans or regulations, which may impact the proposal.
- B. Preliminary Short Plat Application and Map Requirements
  - 1. Applications for approval of a preliminary short subdivision shall be filed with the director. All applications shall be submitted on forms provided for such purpose by the department. The director may waive specific submittal requirements determined to be unnecessary for review of the application. The application shall include the following:
    - a. The general application.
    - b. The supplemental application.
    - c. The environmental checklist, if required under chapter 17E.050 SMC.
    - d. Title report no older than thirty days from issuance from the title company.
    - e. The filing fees as required under chapter 8.02 SMC.
    - f. The required number of documents, plans or maps drawn to a minimum scale of one inch equals one hundred feet, on a sheet

twenty-four by thirty-six inches, as set forth in the application checklist.

- g. A written narrative identifying consistency with the applicable policies, regulations and criteria for approval of the permit requested; and
- h. Additional application information which may be requested by the permitting department and may include, but is not limited to, the following: geotechnical studies, hydrologic studies, critical area studies, noise studies, air quality studies, visual analysis and transportation impact studies.
- i. One copy of the predevelopment conference notes (if applicable); and
- j. One copy of the notification district map.

2. Contents of Preliminary Short Plat Map

The preliminary short plat shall be prepared by a land surveyor and shall show the following:

- a. Plat name and the name of any subdivision to be replatted.
- b. The name, mailing address and phone number of the owner and the person with whom official contact should be made regarding the application.
- c. Surveyor's name, mailing address and phone number.
- d. Legal description.
- e. Section, township and range.
- f. Vicinity map.
- g. North arrow, scale and date.
- h. Datum plane.
- i. Acreage.
- j. Number of lots and proposed density.
- k. Zoning designation.
- l. The boundary lines of the proposed subdivision.
- m. City limits and section lines.
- n. Park or open space (if proposed).
- o. Existing topography at two-foot maximum interval.
- p. The boundaries and approximate dimensions of all blocks and lots, together with the numbers proposed to be assigned each lot and block, and the dimensions, square footage and acreage of all proposed lots and tracts.

- q. Proposed names of streets.
- r. The location and widths of streets, alleys, rights-of-way, easements (both public and private), turn around and emergency access, parks and open spaces.
- s. Conditions of adjacent property, platted or unplatted, and if platted, giving the name of the subdivision. If the proposed short plat is the subdivision of a portion of an existing plat, the approximate lines of the existing plat are to be shown along with any and all recorded covenants and easements.
- t. The names and address of the record owners and taxpayers of each parcel adjoining the subdivision.
- u. Indicate any street grades in excess of eight percent.
- v. The location and, where ascertainable, sizes of all permanent buildings, wells, wellhead protection areas, sewage disposal systems, water courses, bodies of water, flood zones, culverts, bridges, structures, overhead and underground utilities, railroad lines, and other features existing upon, over or under the land proposed to be subdivided, and identifying any which are to be retained or removed.
- w. Proposed one-foot strips for right-of-way conveyed to the City, in cases where a proposed public street or alley abuts unplatted land.
- x. If a body of water forms the boundary of the plat, the ordinary high water mark as defined in chapter 90.58 RCW.
- y. Critical areas as defined in chapters 17E.020, 17E.030, 17E.070 and 17G.030 SMC.
- z. Significant historic, cultural or archaeological resources; and
- aa. If the proposal is located in an irrigation district, the irrigation district name.

C. Review of Preliminary Short Plat

1. The application shall be reviewed in accordance with the procedures set forth in chapter 17G.060 SMC for a Type II application, except an application that meets the requirements for minor engineering review as provided in subsection (2) of this section shall be excluded from the public notice requirements contained in SMC 17G.060.110 through 17G.060.120 and public comment period under SMC 17G.060.130.

2. Minor Engineering Review.

A preliminary short plat application may qualify for a minor engineering review if it meets all of the following conditions:

- a. The application is categorically exempt from chapter 43.21C RCW (SEPA);
- b. There is direct water and sewer main lot frontage on an existing and improved public right-of-way;
- c. No extensions of public water, sewer, or other utility services will be needed;
- d. No public easements for water, sewer, or other utility service exists on the lot; and
- e. The lot is not situated in a Special Drainage District as defined in SMC 17D.060.130.

D. Public Notice

All public notice of the application shall be given in accordance with the procedures set forth in chapter 17G.060 SMC for a Type II application, except a short plat that meets the requirements for minor engineering review as provided in subsection (C)(2) of this section shall not require a notice of application.

E. Preliminary Short Plat Approval Criteria

Prior to approval of a short plat application, the director shall find the application to be in the public use and interest, conform to applicable land use controls and the comprehensive plan of the City, and the approval criteria set forth in chapter 17G.060 SMC. The director has the authority to approve or disapprove a proposed preliminary short plat under the provisions of this chapter, subject to appeal as provided in chapters 17F.050 and 17G.060 SMC.

F. Final Short Plat Review Procedure

1. The subdivider shall submit to the director for review the following:
  - a. A final short plat, prepared by a registered land surveyor licensed in the state of Washington, consistent with the approved preliminary short plat.
  - b. A title report less than thirty days old confirming that the title of the lands as described and shown on said plat is in the name of the owners signing the certificate or instrument of dedication.
  - c. Covenants, conditions and restrictions, if applicable; and
  - d. Fees pursuant to chapter 8.02 SMC.
2. Within thirty days, unless the applicant has consented to a longer period of time, of receipt of a proposed final short plat, the director shall review the plat for conformance with all conditions of the preliminary short plat approval, the requirements of this chapter and that arrangements have been made to insure the construction of required improvements. If all such conditions are met, the director shall approve the final short plat and authorize the recording of the plat. If all conditions are not met, the director

shall provide the applicant in writing a statement of the necessary changes to bring the final short plat into conformance with the conditions.

- a. If the final short plat is required to be resubmitted, the subdivider is required to provide the following:
  - b. A cover letter addressing the corrections, additions or modifications required.
  - c. Title report no older than thirty days from issuance of a title company conforming that the title of the lands as described and shown on said plat is in the name of the owners signing the certificate or instrument of dedication; and
  - d. The required number of copies of the corrected final short plat map.
3. If the final short plat is approved, the surveyor causes the plat to be signed by the Spokane county treasurer and file of record with the Spokane county auditor. The surveyor is required to file the appropriate number of mylar and bond copies of the recorded short plat with the director.

#### G. Final Short Plat Map Requirements

The subdivider shall submit to the director a final short plat in the same form and with the same content as the preliminary short plat, as provided in subsections (B)(1) and (2) of this section, with the following exceptions or additional requirements:

1. A final short plat shall contain all the information required of the preliminary plat, except the following:
  - a. Show existing buildings.
  - b. Show existing utility lines and underground structures.
  - c. Show the topographical elevations; or
  - d. Contain the names and addresses of adjoining landowners.
2. The final short plat shall include the following:
  - a. Surveyor's certificate, stamp, date and signature, as follows:

The following land surveyor's certificate to be shown on each sheet of the plat: "I, \_\_\_\_\_ registered land surveyor, hereby certify the plat of \_\_\_\_\_, as shown hereon, is based upon actual field survey of the land described and that all angles, distances, and courses are correctly shown and that all non fronting lot corners are set as shown on the plat. Monuments and fronting lot corners shall be set upon completion of the utility and street improvements.

Signed \_\_\_\_\_ (Seal)"
  - b. A certification by the city treasurer, as applicable:

i. "I hereby certify that the land described by this plat, as of the date of this certification, is not subject to any local improvement assessments. Examined and approved, this \_\_\_\_\_ day of \_\_\_\_\_, 20\_\_.

\_\_\_\_\_  
City of Spokane Treasurer"

ii. "I hereby certify that the land described by this plat, as of the date of this certificate, is not subject to any delinquent local improvement assessment. Future installments, if any, shall remain due and payable and it shall be the responsibility of the owners to initiate the segregation of the LID assessment. Examined and approved, this \_\_\_\_\_ day of \_\_\_\_\_, 20\_\_.

\_\_\_\_\_  
City of Spokane Treasurer"

iii. "A preliminary local improvement assessment exists against this property. It shall be the responsibility of the owner's to initiate the segregation of the LID assessment. After this assessment is finalized, it shall be due and payable. Examined and approved this \_\_\_\_\_ day of \_\_\_\_\_, 20\_\_.

\_\_\_\_\_  
City of Spokane Treasurer"

c. The certification by the planning director, as follows:

"This plat has been reviewed on this \_\_\_\_\_ day of \_\_\_\_\_, 20\_\_ and is found to be in full compliance with all the conditions of approval stipulated in the Hearing Examiner's/Planning Director's approval of the preliminary plat # - -PP/SP.

\_\_\_\_\_  
City of Spokane Planning Director"

d. The certification by the city engineer, as follows:

"Approved as to compliance with the survey data, the design of public works and provisions made for constructing the improvements and permanent control monuments this \_\_\_\_\_ day of \_\_\_\_\_, 20\_\_.

\_\_\_\_\_  
City of Spokane Engineer"

e. The certification by the Spokane county treasurer, as follows:

"I hereby certify that the land described in this plat, as of the date of this certification, is not subject to any outstanding fees or assessments. Examined and approved \_\_\_\_\_ day of \_\_\_\_\_, 20\_\_.

---

Spokane County Treasurer”

- f. The certification by the Spokane county auditor on each page of the final short plat including the time, date, book and page number of the recording of the final mylar.
- g. Signature of every owner certifying that:
  - i. the plat is made with the free consent and in accordance with the desires of the owners of the land;
  - ii. the owners are the owners of the property and the only parties having interest in the land and is not encumbered by any delinquent taxes or assessments;
  - iii. the owners adopt the plan of lots, blocks and streets shown;
  - iv. owner dedicates to the City and the City’s permittees the easements shown for utilities and cable television purposes;
  - v. owner dedicates to the City the streets, alleys and other public places, including slope and construction easements and waives all claims for damages against any governmental authority including, without limitation, the City which may be occasioned to the adjacent land by the establishment, construction, drainage and maintenance of any public way so dedicated; and
  - vi. owner conveys to the City as general City property the buffer strips adjoining unplatted property.
- h. The drawing shall:
  - i. be a legibly drawn, printed or reproduced permanent map;
  - ii. if more than one sheet is required, each sheet shall show sheet numbers for the total sheets;
  - iii. have margins that comply with the standards of the Spokane county auditor;
  - iv. show in dashed lines the existing plat being replatted, if applicable;
  - v. show monuments in accordance with SMC 17G.080.020(H)(1);
  - vi. include any other information required by the conditions of approval; and
  - vii. include any special statements of approval required from governmental agencies, including those pertaining to flood hazard areas, shorelines, critical areas and connections to adjacent state highways.



H. Filing.

Once the final plat has been reviewed, approved and signed by the applicable departments, the applicant shall file the final short plat with the county auditor within ten days of approval. No permits shall be issued for a proposed lot until the required conformed copies of the short plat have been submitted to the planning services department.

I. Redivision.

No land within the boundaries of a short subdivision may be further divided in any manner which will create additional lots within a period of five years except by subdivision in accordance with SMC 17G.080.050.

Passed the City Council \_\_\_\_\_

\_\_\_\_\_

Council President

Attest: \_\_\_\_\_

City Clerk

Approved as to form: \_\_\_\_\_

Assistant City Attorney

\_\_\_\_\_

Mayor

\_\_\_\_\_

Date

\_\_\_\_\_

Effective Date



**PLANNING & ECONOMIC DEVELOPMENT**  
808 W. SPOKANE FALLS BLVD.  
SPOKANE, WASHINGTON 99201-3329  
509.625.6500  
MY.SPOKANECITY.ORG

# Memo

To: Plan Commission Members  
From: Nathan Gwinn and Amanda Beck, Assistant Planner IIs  
Date: May 4, 2022  
Re: Changes to Draft Text for ADUs and Short Plat Notification Following 4/27 Workshop

Below is a summary of five changes to proposed draft text with new text highlighted, based on discussion at your workshop on April 27, 2022:

## 17C.300.110 Criteria

1. **17C.300.110(A)(2)** new text to read: “(a) The maximum detached ADU size is subject to building coverage per SMC 17C.300.130(B)(3) and floor area ratio per subsection (3) of this subsection (A); and (b) A detached ADU shall not exceed ((six hundred square feet)) seventy-five percent of the floor area of the principal structure, or eight hundred sixty-four square feet of floor area, whichever is greater.”

## 17C.300.130 Development Standards

2. **17C.300.130(A)(1)(e)** add language: “In the RTF, RMF, or RHD zone, constructing an attached or detached accessory dwelling unit on a site with any existing or new principal structure. All new structures and additions shall comply with all applicable building, fire, and engineering standards.”
3. **17C.300.130(A)(2)** to address question as to what regulates the number of individuals in a household, text refers back to RCW [35.21.682](#). Add language: “The total number of individuals that reside in both units may not exceed ((the number that is allowed for a household)) any lawful limits on occupant load per square foot or generally applicable health and safety provisions as established by applicable building or fire code, as provided in RCW 35.21.682.”

## 17G.080.040 Short Subdivisions

4. **17G.080.040(C)(2)(b)** – page A-32 – Add language to help clarify required proximity of improvements adjacent water/sewer mains that will result in new lots with standard service connections. “There is direct water and sewer main lot frontage on an existing and improved right-of-way;”
5. **17G.080.040(C)(2)(f)** strike the 2 lot limit per PC’s discussion.

See attached **EXHIBIT A** to staff report with text updated May 4, 2022.



# STAFF REPORT

PLANNING AND ECONOMIC DEVELOPMENT SERVICES DEPARTMENT

<b>To:</b>	City Plan Commission	
<b>Subject:</b>	Shaping Spokane Housing: Development Code Amendments for Accessory Dwelling Units, Lot Size Transition, and Short Plat Process	
<b>Staff Contact:</b>	Amanda Beck, AICP Assistant Planner II (509) 625-6414 <a href="mailto:abeck@spokanecity.org">abeck@spokanecity.org</a>	Nathan Gwinn, AICP Assistant Planner II (509) 625-6893 <a href="mailto:ngwinn@spokanecity.org">ngwinn@spokanecity.org</a>
<b>Report Date:</b>	May 4, 2022	
<b>Hearing Date:</b>	May 11, 2022	
<b>Recommendation:</b>	Approval	

## I. SUMMARY

These City-initiated text amendments are proposed to update the Spokane Municipal Code according to strategies outlined in the adopted Spokane Housing Action Plan and in order to implement some of the actions specified in subsection (1) or RCW 36.70A.600. Proposed draft code would revise several sections of Chapter 17C.110, Residential Zones; Chapter 17C.300, Accessory Dwelling Units; and Sections 17G.060.100, 17G.060T.003, 17G.060.130, and 17G.080.040. The proposed draft code has been developed by City staff, with assistance from the consultant firm MAKERS Architecture and Urban Design, to modify requirements for accessory dwelling units (ADUs), lot size transition, and the process for short subdivision in the city of Spokane.

## II. BACKGROUND

The 2021 Washington legislative session substantially amended the housing-related provisions of the Growth Management Act (GMA) through House Bill [HB 1220](#). Changes strengthened the GMA housing goal from “encourage the availability of affordable housing to all economic segments of the population” to “plan for and accommodate housing affordable to all economic segments of the population of this state.” The GMA housing goal still retains additional objectives to “promote a variety of residential densities and housing types, and encourage the preservation of existing housing stock.” The Washington Department of Commerce then oversaw the Increasing Urban Residential Building Capacity Grant program that was authorized with [E2SHB 1923](#). The City was awarded a grant to develop a housing action plan that analyzed and detailed how to meet the housing needs of our community, addressing the housing-related changes made by the Legislature.

The City’s Comprehensive Plan provides a vision of affordable housing that is safe, clean, healthy, and attainable for all residents. Approved in July 2021, the City adopted its [Housing Action Plan](#) (Res. 2021-0062) to guide implementation of policies within the Comprehensive Plan by identifying strategies to achieve our community’s housing needs and objectives. Spokane’s Housing Action Plan (HAP) identifies actions that the City and community partners can enact to encourage more housing options that create

more homes for more people. To implement the work of the HAP, City staff are completing several residential development code amendments. These proposed changes are also guided by Mayor Woodward's [July 26, 2021 Housing Emergency Proclamation](#) and the City Council's HAP [Implementation Plan](#).

Through Shaping Spokane Housing, the City will be evaluating a series of code amendments selected to align with items from the Housing Action Plan that were flagged for short- or mid-term starting timelines, with a focus on increasing housing units and the diversity of housing types. In addition, many of the amendments are proposed in order to implement/enact the actions specified in subsection (1) RCW 36.70A.600 in an effort to increase residential building capacity in Spokane. The code revisions are proposed to be run in two phases based upon the complexity of the group of proposals (internally referred to as "Phase 1 and 2"). The first phase proposes changes recommended for increasing housing supply, variety, and affordability and that would provide necessary updates for the second phase of code changes. Phase 1 will explore attached houses (townhouses), accessory dwellings, and smaller multifamily projects. Phase 2 code amendments would explore additional permitted housing types within the Residential Single Family and Residential Two-Family zoning districts, opportunities for increasing density, and permitting for a wider variety of housing types generally.

This staff reports reviews the proposed code revisions for Phase 1 of Shaping Spokane Housing. The code changes related to accessory dwelling units (ADUs), lot size transitions, and short plat notification specifically align with the below noted City Council implementation actions, as well as strategies from Mayor Woodward's emergency proclamation. Additionally, the City has proposed draft text which aligns with recommendations outlined in [RCW 36.70A.600](#).

- Housing Action Plan Strategy A1, "Explore and expand allowed housing types to encourage missing middle housing throughout Spokane's neighborhoods."
- Housing Action Plan Strategy A3, "Continue to streamline and simplify changes to the City's permit process, as necessary."
- Housing Action Plan Strategy A5, "Revise Accessory Dwelling Unit standards to allow for additional flexibility."
- City Council Implementation Plan Strategy I.6, III.2, and III.10
- Mayor's Emergency Proclamation Strategy 2.c, 2.g, and 2.h

Proposed phasing and code sections would promote development of housing types affordable to more households, help to streamline the review process, and realize increases in density where appropriate as indicated under the City's Comprehensive Plan. The proposed scope of work focuses on changing zoning and development regulations that would allow for more housing types available to a wider range of income levels in a wider set of zoning districts. This will continue to implement the City's goals in the Comprehensive Plan and be aligned with ongoing efforts to allow for denser development along existing infrastructure systems and near high performance transit lines operated by Spokane Transit Authority.

### III. PROCESS

#### DEVELOPMENT CODE AMENDMENT PROCEDURE

Article III Section 21, Amendments and Repeals, of the City of Spokane Charter provides for the ability of amendments of the Charter and Spokane Municipal Code through ordinances. Title 17 is known as the Unified Development Code (UDC) and is incorporated into the Spokane Municipal Code to implement the City's Comprehensive Plan, and by reference, the requirements of the Washington State Growth Management Act (GMA). Section [17G.025.010](#) establishes the procedure and decision criteria that the City

uses to review and amend the UDC. The City may approve amendments to the UDC if it is found that a proposed amendment is consistent with the provisions of the Comprehensive Plan, and bears a substantial relation to public health, safety, welfare, and protection of the environment.

## **ROLE OF THE CITY PLAN COMMISSION**

---

The proposed text amendments require a review process set forth in Section 17G.025.010(F) SMC. The Plan Commission is responsible for holding a public hearing and forwarding its findings, conclusions, and recommendations to the City Council. Utilizing the decision criteria in 17G.025 SMC, the Plan Commission may recommend approval, modification, or denial of the proposal.

The Plan Commission may incorporate the facts and findings of the staff report as the basis for its recommendation to the City Council or may modify the findings as necessary to support their final recommendation.

## **ROLE OF CITY COUNCIL**

---

The City Council will also conduct a review process considering the proposed text amendment, public comments and testimony, the staff report, and the Plan Commission's recommendation. The final decision to approve, modify, or deny the proposed amendment rests with the City Council. Proposals adopted by ordinance after public hearings are official amendments to the Spokane Municipal Code.

## **COMMUNITY ENGAGEMENT**

As a follow-up to the Housing Action Plan (HAP), engagement efforts for Shaping Spokane Housing have built upon the extensive community outreach conducted for the HAP. Engagement opportunities were undertaken throughout the draft code phase of this project. Emphasis has been placed on reaching development stakeholders, as well as the broader community. To ensure broad engagement efforts during a transitional time of limited in-person events, staff initiated a multi-faceted engagement plan that included in-person and virtual meetings, web content including a website and blog posts, regular email updates, and a social media presence. A summary of engagement and outreach activities can be found in **Exhibit C**.

Below is a list of the major outreach and engagement activities held for this phase of the Shaping Spokane Housing project:

- [“Next Steps for Housing Action Plan Implementation”](#) blog published on November 11, 2021
- Project webpage, [ShapingSpokaneHousing.com](#), was launched January 2022 and has been kept up to date with information about Plan Commission workshops, project progress, and public hearings
- Presentations at the Land Use Subcommittee on November 18, 2021; February 17, 2022; and April 21, 2022
- Vendor booth and poster activities at the Winter Market on December 15 and 22, 2021
- Presentation at Community Assembly on January 6, 2022
- Virtual open houses on January 25 and 27, 2022
- [Educational videos](#) shared in the City's Community Update e-newsletter, on official City social media channels, and available on project webpage
- [“Big Trends Squeezing Spokane's Housing Supply”](#) blog published March 10, 2022
- Community Update City newsletter addition of ADUs on March 8, lot size transition on March 15, and short plat application process on March 22, 2022
- Planning Services Director interviews of local developers took place in March and April, 2022

- Vendor booth and poster activities at the Spring Market on April 6, 13, 20, and 27, 2022
- Frequent Shaping Spokane Housing email updates sent to over 150 stakeholders

The planning team has provided updates on the proposed code changes to elected and appointed officials, as well as to staff from other City departments and interested agencies.

- City Council established Shaping Spokane Housing as part of the Plan Commission’s 2021-2022 work program
- City Council presentations on December 6 and 10, 2021
- Plan Commission workshop presentations related to accessory dwelling units, lot transition, and short plat processes on January 12, February 23, March 23, April 13, and April 27, 2022
- City Council study session presentations on February 10 and May 5, 2022
- Regular meetings with Development Services staff to review proposed code language and potential implementation considerations

## PUBLIC NOTIFICATION AND SEPA REVIEW

As outlined in Section 17G.025.010 SMC, notices of proposals to amend the UDC are distributed and interested parties should be made aware of such proposals during the Plan Commission review, including the SEPA checklist and determination. Similarly, a public notice published in the *Spokesman-Review* fourteen days prior to the Plan Commission public hearing is required.

This proposal was properly noticed pursuant to Section 17G.025.010(E). See **Exhibit B** for the SEPA Determination of Non-significance. Noted below are the public noticing activities:

- Notice of Intent to Adopt submitted to the Department of Commerce (March 24, 2022)
- Notice of Intent to Adopt pursuant to 17G.025.010 SMC, which included the SEPA Checklist, emailed to City departments, Local, County, Tribal, and State contacts (April 1, 2022)
- SEPA Determination of Non-significance (DNS) issued (April 25, 2022), the comment period ended on May 11, 2022
- Notice of Public Hearing for the Plan Commission was published in the *Spokesman-Review* on April 27 and May 4, 2022.

## COMMENTS RECEIVED

Written comments were provided to the Plan Commission prior to the public hearing at the February 23 and April 27, 2022 workshops. All public comments received by the planning department by 12:00 p.m. on May 4 are included in **Exhibit D**.

Notice of this proposal was sent to City departments and outside agencies for their review. Department and outside agency comments are included in this report as **Exhibit E**. Agency/City department comment was received regarding this application:

- Spokane Tribe of Indians
- City of Spokane Street Department
- City of Spokane Engineering Department

## IV. ANALYSIS

### PROPOSAL DESCRIPTION

Following adoption of the [Housing Action Plan](#) (Res. 2021-0062), the City has initiated a series of text amendments that enact Housing Action Plan strategies to encourage construction of more housing, and increase affordability and housing variety. These amendments are being adopted in order to implement the Legislature’s recommended actions outlined by [RCW 36.70A.600\(1\)](#) in order to increase residential building capacity.

This proposal will amend Spokane Municipal Code: Section 17C.110.200, Lot Size, and 17C.110.225 Accessory Structures; and Chapter 17C.300, Accessory Dwelling Units, specifically Sections 17C.300.100, 17C.300.110, 17C.300.120, 17C.300.130, and 17C.300.140.

Additional amendments are being made to short plat notification requirements revising Sections 17G.060.100, 17G.060T.003, 17G.060.130, and 17G.080.040; which are procedurally exempt from SEPA review per [WAC 197-11-800\(19\)](#).

### ACCESSORY DWELLING UNITS

Accessory dwelling units (ADU) are defined in SMC 17A.020.010 as “a separate additional living unit, including separate kitchen, sleeping, and bathroom facilities, attached or detached from the primary residential unit, on a single-family lot...” ADUs are also defined in [RCW 36.70A.696](#) as “a dwelling unit located on the same lot as a single-family housing unit, duplex, triplex, townhome, or other housing unit.”

Changes to chapter 17C.300 SMC respond to the suggestions in [RCW 36.70A.600\(1\)\(o\)](#) through (q), as well as Strategy A5 of the Housing Action Plan and the Mayor’s July 26, 2021, Proclamation Addressing the Housing Emergency. The changes proposed would:

- Remove the required minimum lot size of 5,000 square feet.
- Increase the maximum size for a detached ADU from 600 to 864 square feet, or 75 percent of the floor area of the principal structure, whichever is greater. The detached ADU would continue to be limited by building coverage and Floor Area Ratio (FAR) maximums.
- Allow internal ADUs to occupy the entire space of a basement or attic, even if this exceeds the 800 square feet maximum, but limit conversion or construction to two bedrooms.
- Incentivize construction of ADUs by increasing the site total FAR of 0.5 to 0.6 on lots smaller than 7,200 square feet with an ADU, and to 0.7 on lots smaller than 5,000 square feet with an ADU.
- Incentivize construction of ADUs by increasing the building coverage maximum of accessory structures from 15 percent to 20 percent on lots smaller than 5,500 square feet with an ADU.
- Increase the maximum wall height from 16 to 17 feet, and the maximum roof peak from 23 to 25 feet to allow for more diverse ADU designs as well as units built above existing garages.
- Relax parking requirements such that studio and one-bedroom units will not require an off-street parking space. Units with two or more bedrooms shall provide one additional off-street parking space for each bedroom above one unless they are exempt due to RCW 36.70A.698.
- Remove owner occupancy requirements, unless a short-term rental exists on the site, to encourage production of more units.
- Allow construction of an ADU on sites with a duplex or other principal structure in the RTF, RMF, and RHD zones. Currently ADUs are only allowed on sites with a house, attached house, or manufactured home.

## LOT SIZE TRANSITIONS

---

As outlined in [Section 17C.110.200\(C\)\(1\)](#), for parcels two acres or greater within areas zoned Residential Agricultural (RA) and Residential Single-Family (RSF), the current city code requires new subdivisions to provide a transitional lot size adjacent to existing parcels. The intent of transitioning lot sizes is to facilitate compatible development of buildings and maintaining consistency of the development pattern. Currently, the code requires an eighty-foot buffer along all parcel boundaries, in which a transitional lot size would be required. The transitional lot size is determined by averaging the existing lot sizes adjacent to the site, including lots across a public right-of-way. If the average lot size is greater than 7,200 square feet, then the transition lot size must be at least 7,200 square feet. If the existing average lot size is less than 7,200 square feet, then the transition lot size must be equal to the average or larger. The transition lot size requirement also applies to subdivisions created through the Planned Unit Development process outlined in Section 17G.070.030.

Following workshops with the Plan Commission, during which a range of possible code changes were presented, City staff have proposed to remove this requirement from the Spokane Municipal Code. The intent of the transitional lot size code provision has not been borne out by subdivisions created under the regulations. Instead, newly created lots frequently fulfill the requirements of 17C.110.200(C)(1) by meeting the minimum square footage requirement without having to address “consistent development” patterns such as lot depth or lot width. The focus on development pattern compatibility has resulted in larger lots and the construction of fewer housing units than would have otherwise been allowed under the minimum zoning requirements for parcels zoned RA or RSF.

Removing this regulation fits within the Housing Action Plan Strategy A3 recommendation to streamline and simplify permit processes. Additionally, this section of code is addressed in both the City Council’s Implementation Plan and the Mayor’s Proclamation. City Council Implementation Plan Strategy III.10 prompts action to, “seek prompt re-evaluation by the Plan Commission of SMC 17C.110.200.C and Table 17C. 110-3 to ensure that future transition standards are consistent with the City’s goal of increasing density by using smaller parcels while preserving other reasonable goals of these requirements.” Strategy 2.h of Mayor Woodward’s proclamation directs staff to create “additional flexibility or eliminate altogether the transitional lot requirements outlined in SMC 17C.110.200.”

The proposed changes would:

- Remove the lot size transition requirement from SMC 17C.110.200(C)(1); and
- Allow newly created lots that meet the dimensional standards of the underlying zoning district to be approved without being required to meet a larger square footage requirement.

## SHORT PLAT NOTIFICATION

---

This code amendment packet proposes changes to SMC 17G.060 and SMC 17G.080 to streamline and improve the short plat approval process, specifically the review and notification process. The proposal would designate three classes of short subdivisions in order to simplify the review and approval process. The changes follow guidance to adopt permit process improvements in RCW 36.70A.600(1) and Housing Action Plan Strategy A3.

The three classes are:

- Short plats with SEPA review
- Short plats with minor engineering review



- Short plats with standard engineering review

Short plats that are subject to SEPA would continue to require the existing methods of notice of application, including mailing to specified parties and site-posting the property.

To qualify for minor engineering review, the preliminary short plat would need to meet the following requirements:

- The preliminary plat has frontage on an existing, improved public right-of-way and does not propose to create new public right-of-way
- No extension of public utilities will be required as part of the preliminary plat
- There are no public easements on the property

Under this proposal, no changes to the treatment of neighborhood councils during the agency review period would occur. Neighborhood councils within 600 feet of a proposed short plat would continue to receive notice and be invited to submit comments during agency review as codified in [SMC 17G.060.090](#).

The proposal would also modify existing noticing requirements. Site posting would be eliminated for both minor and standard review short plats. For short plats that qualify for minor engineering review, the public comment period and mailing of public notice would also be eliminated. Neighborhood council notification and comments would continue during the agency review period.

The proposal would align with City review procedures and reduce the time required for administering the public notice for many short subdivisions, while continuing to require short plat agency and neighborhood council notification, for all short subdivisions, under the determination of a complete application stage.

Definitions and provisions for administrative, summary approval:

“Short” plats can be differentiated from “regular” or “long” plats by the **number** of lots created through the City’s approval process. [RCW 58.17.020](#) defines a short plat as the map or representation of a short subdivision. A short subdivision is the division or redivision of land into nine or fewer lots for the purpose of sale, lease, or transfer of ownership. That number, nine lots, is the maximum number of lots that the City Council and other local legislative authorities may authorize under the short subdivision process in urban growth areas. [RCW 58.17.060](#) provides that the City Council shall adopt regulations and procedures, and appoint administrative personnel for the summary approval of short plats and short subdivisions.

State Environmental Policy Act (SEPA):

[RCW 43.21C.110](#) provides statutory authority for rules to implement SEPA, anticipating the categorical exemption of government actions from SEPA which are not to be considered as potential major actions significantly affecting the quality of the environment. [WAC 197-11-800\(6\)](#) lists the categorical exemptions for land use decisions, stating short plats (except on land covered by water) are exempt from SEPA.

Local project review:

[RCW 36.70B.020](#) includes subdivisions as a type of project permit, which is a land-use permit required from the City for a project action and regulated by the State. Project permits are subject to standard time frames for determining whether an application is complete, for notification and public comments once the application is determined complete, and for making a decision and appeals. [RCW 36.70B.110\(5\)](#) provides that a notice of application shall not be required for SEPA-exempt projects unless a public comment period or a type of hearing is required. The City’s

Development Code implements the regulations in State law affecting short plats in SMC Title 17A, Administration, and Title 17G, Administration and Procedures. The City proposes to change the public comment requirements in SMC 17G.060.130 so that short subdivision applications with minor engineering review would have no public comment period, thereby eliminating the need for a notice of application for that classification of applications.

Growth Management Act (GMA):

As discussed above, the GMA suggests several actions for increasing residential building capacity. A number of suggestions relate to plats, and the City of Spokane has already implemented some of those actions. However, [RCW 36.70A.600\(1\)\(u\)](#) suggests other permit process improvements where it is demonstrated that the development regulation change will result in a more efficient permit process for customers. The Spokane Housing Action Plan echoes the provision by encouraging “a faster and more predictable permitting process for developers, particularly for housing that expands options and supports a broader range of household incomes” (p. 30). The City proposes changes to streamline and improve the short plat process to create two new classifications of short subdivisions that would reduce requirements for notice, thereby reducing cost or time for processing SEPA-exempt short plats in the city, including those that could make new sites available for increasing residential building capacity, and for development of a wide variety of housing types for all income levels.

## IMPLEMENTATION OF COMPREHENSIVE PLAN GOALS AND POLICIES

Section [17G.025.010](#) SMC establishes the review criteria for text amendments to the Unified Development Code. In order to approve a text amendment, City Council shall consider the findings and recommendations of the Plan Commission along with the approval criteria outlined in the Code. The applicable criteria are shown below in *bold and italic* with staff analysis following each criteria. Review of the Comprehensive Plan goals and policies indicates that the proposal meets the approval criteria for internal consistency set forth in SMC 17G.025.010(G). Excerpts of the applicable goals and policies, and their Comprehensive Plan discussion points, are contained in **Exhibit F**.

### **17G.025.010(G) APPROVAL CRITERIA**

**1. The proposed amendment is consistent with the applicable provisions of the comprehensive plan.**

***Land Use Goal LU 1 – Citywide Land Use.*** Offer a harmonious blend of opportunities for living, working, recreation, education, shopping, and cultural activities by protecting natural amenities, providing coordinated, efficient, and cost effective public facilities and utility services, carefully managing both residential and non-residential development and design, and proactively reinforcing downtown Spokane’s role as a vibrant urban center.

**Staff Analysis:** Within the Land Use chapter there are several values outlined which guide the goals and policies concerning land uses. This chapter highlights the importance of guaranteeing a variety of densities that support a mix of land uses and housing options in every neighborhood, as well as realizing the full potential of existing residential lots rather than encouraging sprawl. The proposed ADU code changes make it easier to construct an additional, accessory dwelling unit on a residential lot thereby efficiently using the City’s infrastructure for water, stormwater, and utilities. The changes also allow for the potential for more subtle increases in intensity, as an alternative to focused redevelopment. Removing the lot size transition requirement would allow for more lots to be platted, using land to its greater potential rather than forcing platting of larger lots. Allowing subdivisions to be built to the minimum lot size in the zone also reduces the amount of raw land

required to create a development, reducing the, need to develop on the City's fringe where larger parcels that might be able to more easily accommodate larger lots tend to be located.

**Land Use Policy LU 1.1 – Neighborhoods.** *Utilize the neighborhood concept as a unit of design for planning housing, transportation, services, and amenities.*

**Staff Analysis:** A variety of housing types are allowed, and encouraged, within the city's neighborhoods. The Comprehensive Plan notes that housing should span the range of single-family homes (attached and detached), duplexes, and multifamily units. This variety of types and densities better supports the other neighborhood land uses such as retail, office, and commercial. Increasing regulatory flexibility for ADUs provides the potential for additional households to support Neighborhood Centers, while also allowing city residents greater options for housing near amenities such as parks and open space, and public transit lines.

**Land Use Goal LU 3 – Efficient Land Use.** *Promote the efficient use of land by the use of incentives, density and mixed-use development in proximity to retail businesses, public services, places of work, and transportation systems.*

**Staff Analysis:** As a use that is accessory to the primary dwelling on a lot, accessory dwelling units gently and efficiently add housing to an existing block or neighborhood, which assists the city in achieving the mix of residential uses outlined in the Comprehensive Plan. Relaxing parking requirements for ADUs promotes efficient land use both from the perspective that less of a lot is being devoted to off-street car storage, and that it promotes the use of existing transit resources. The draft text thus aligns with the findings of the Legislature that siting ADUs near transit and public amenities can help to reduce greenhouse gas emissions by increasing walkability and shortening household commutes, and therefore should be incentivized by reducing parking requirements unless parking is already exempt under [RCW 36.70A.698](#). Removing the transitional lot requirements for new subdivisions, and instead relying on the minimum lot size of the zone, also allows for land to be used more efficiently. Rather than requiring more square footage to be dedicated to individual lots in the transition area, the land can be used for additional lots, an improved site circulation, or even shared open space that provides an amenity to the larger subdivision. Finally, the proposed changes to the current short plat process are an incentive for smaller divisions of land, shortening the review timeframe and thus costs for that type of infill development.

**Land Use Policy LU 3.6 – Compact Residential Patterns.** *Allow more compact and affordable housing in all neighborhoods, in accordance with design guidelines.*

**Staff Analysis:** The draft code revisions to the ADU chapter directly support the policy focus on both compact development and housing affordability. The Comprehensive Plan specifically notes that accessory dwelling units are a housing type that is more compact and affordable, including other missing middle housing types such as duplexes, triplexes, and townhouses. Additionally, removing the lot size transition requirement will allow new subdivisions to create lots within the Residential Agricultural (RA) and Residential Single-Family (RSF) zones that meet underlying requirements for lot depth, width, and square footage rather than requiring lots to average in size. The resulting smaller lots will inherently be more compact than the required larger lots of the current regulation, which in practice has meant the number of developable units is decreased to accommodate the transitional lots.

**Housing Goal H 1 – Housing Choice and Diversity.** *Provide opportunities for a variety of housing types that is safe and affordable for all income levels to meet the diverse housing needs of current and future residents.*

**Staff Analysis:** The values of the Housing chapter are grounded around maintaining affordable housing, developing a good mix of housing types, encouraging housing for low-income residents, and preserving existing housing. Proposed ADU code changes could encourage increased ADU construction, which can provide benefits such as additional income for homeowners, as well as housing options for senior residents who wish to age in place. During 2020 updates to the Growth Management Act, the Legislature noted that ADUs are often occupied by tenants who pay little to no rent, such as grandparents, adult children, family members with disabilities, and friends going through life transitions. Accessory dwelling units offer a housing type which can meet the needs of residents in various stages of life.

***Housing Policy H 1.11 – Access to Transportation.*** Encourage housing that provides easy access to public transit and other efficient modes of transportation.

**Staff Analysis:** As noted above, accessory dwelling units are a housing option that can meet the varied needs of residents in different income brackets, including the need to be in close proximity to public transit lines for lower income. ADUs are built within existing neighborhoods, which are largely already supported by public transit, with noted exceptions for developments further on the outskirts of city limits. Because Americans spend such a large portion of their income on housing and transportation, the proposed ADU code changes support a future development pattern which reduces household commutes, increases walkability, and reduces carbon footprints. Accessory dwelling units, as a housing type that may rely less on car ownership, will likely be a more affordable option for Spokane residents across their lifetime within the city.

***Housing Policy H 1.18 – Distribution of Housing Options.*** Promote a wide range of housing types and housing diversity to meet the needs of the diverse population and ensure that this housing is available throughout the community for people of all income levels and special needs.

**Staff Analysis:** As described above, accessory dwelling units add homes to an existing block or neighborhood in a manner that is potentially less impactful than site redevelopment, providing the opportunity for existing community residents to downsize or make additional housing available near existing transit access and services. As well, reducing the cost of processing short subdivisions may provide sites for new housing development for rental or fee-simple ownership in areas where there is existing additional capacity and demand for a variety of different housing types.

***Housing Policy H 1.20 – Accessory Dwelling Units.*** Allow one accessory dwelling unit as an ancillary use to single-family homes in all designated residential areas as an affordable housing option.

**Staff Analysis:** The proposed amendments provide greater flexibility for developing ADUs as an affordable housing option, increasing their feasibility. Meanwhile, provisions such as size, height, and building coverage limitation would provide physical compatibility of the ADU with surrounding structures.

***Capital Facilities and Utilities Policy CFU 4.1 – Compact Development.*** Promote compact areas of concentrated development in designated centers to facilitate economical and efficient provision of utilities, public facilities, and services.

**Staff Analysis:** The Growth Management Act provides very specific guidance as to the planning of capital facilities and utilities, clearly directing that growth should be focused in areas where existing capacity and facilities already exist, as well as the requirement for concurrency. Concurrency requires that utilities and services be provided at the time of development, so there is no drop in levels of service. The procedure for concurrency management (overseen by the City)

includes annual evaluation of adopted service levels and land use trends in order to anticipate demand for service and determine needed improvements. Infill and dense development where excess capacity is available is an efficient use of existing systems since compact systems are less expensive to build and maintain. Accessory dwelling units, which are located in existing neighborhoods with services, and incentivized short plats, which are often built as infill near existing facilities, support this policy.

**2. The proposed amendment bears a substantial relation to public health, safety, welfare, and protection of the environment.**

**Staff Analysis:** Responding to current housing affordability and vacancy challenges documented by statutes and adopted local plans, the proposed amendments closely follow the guidance in State law, the Housing Action Plan, and the Mayor’s July 26, 2021, Proclamation Addressing Housing Emergency. These amendments are coordinated and work together with additional changes identified in these documents for the City and its partners, and are essentially linked with those actions aimed at finding balance for the public welfare during a period of unprecedented low vacancy levels and climbing prices that threaten to worsen Spokane’s housing shortage. As stated above, these changes are consistent with the Comprehensive Plan and statutes protecting public health, safety, and the environment.

## V. CONCLUSION

Based on the facts and findings presented herein, staff concludes that the requested text amendments to the Unified Development Code satisfy the applicable criteria for approval as set forth in SMC Section 17G.025.010. To comply with RCW 36.70A.370 the proposed text amendments have been evaluated to ensure proposed changes do not result in unconstitutional takings of private property.

## VI. STAFF RECOMMENDATION

Following the close of public testimony and deliberation regarding conclusions with respect to the review criteria and decision criteria detailed in SMC 17G.025.010, Plan Commission will need to make a recommendation to City Council for approval or denial of the requested code amendments to the Unified Development Code.

Staff **recommends approval** of the requested accessory dwelling unit, lot size transition, and short plat processes amendments and recommends that the Plan Commission adopt the facts and findings of the staff report.

## VII. LIST OF EXHIBITS

- A. Proposed Draft Text
- B. SEPA Determination of Non-Significance
- C. Public Participation Summary
- D. Public Comments
- E. Department Comment
- F. Related Comprehensive Plan Goals and Policies

**DRAFT TEXT**

**Accessory Dwelling Unit (ADU), Lot Size Transition**

**Spokane Municipal Code Title 17C**

17C.110.200	Lot Size.....	A-2
17C.110.225	Accessory Structures.....	A-9
17C.300.100	General Regulations.....	A-15
17C.300.110	Criteria.....	A-15
17C.300.120	Application Procedures.....	A-16
17C.300.130	Development Standards.....	A-17
17C.300.140	ADU Expiration.....	A-24

Section \_\_\_. That SMC section 17C.110.200 is amended to read as follows:

**17C.110.200 Lot Size**

A. Purpose.

The standards of this section allow for development on lots, but do not legitimize lots that were divided in violation of [chapter 17G.080 SMC](#), Subdivisions. The required minimum lot size, lot depth, lot width and frontage requirements for new lots ensure that development will, in most cases, be able to comply with all site development standards. The standards also prevent the creation of very small lots that are difficult to develop at their full density potential. Finally, the standards also allow development on lots that were reduced by condemnation or required dedications for right-of-way.

B. Existing Lot Size.

1. Development is prohibited on lots that are not of sufficient area, dimension and frontage to meet minimum zoning requirements in the base zone. Except:
  - a. one single-family residence may be developed on a lot that was legally created under the provisions of chapter 58.17 RCW, Plats – Subdivisions – Dedications, or applicable platting statutes;
  - b. a PUD lot may be less than the minimum size of the base zone, if such lot is delineated on a PUD plan, which has been approved by the hearing examiner. All use and development standards of the zone wherein such lot is located, shall be complied with, unless modified through the PUD process by the hearing examiner. A PUD shall comply with the requirements of subsection (C) of this section.
2. No lot in any zone may be reduced so that the dimension, minimum lot area, frontage or area per dwelling unit is less than that required by this chapter, except as modified through the PUD process by the hearing examiner.
3. Lots Reduced by Condemnation or Required Dedication for Right-of-way. Development that meets the standards of this chapter is permitted on lots, or combinations of lots, that were legally created and met the minimum size requirements at the time of subdivision, but were reduced below one or more of those requirements solely because of condemnation or required dedication by a public agency for right-of-way.

C. Land Division.

1. All new lots created through subdivision must comply with the standards for the base zone listed in Table 17C.110-3.

~~((1. Transition Requirement:~~

~~For sites two acres or greater, transition lot sizes are required to be included as a buffer between existing platted land and new subdivision subject to the requirements of this section. The purpose of this section is to transition lot sizes between the proposed and existing residential developments in order to facilitate compatible development and a consistent development pattern. In the RA and RSF zones, the minimum lot size is subject to transitioning of lots sizes. Lots proposed within the initial eighty feet of the subject property are required to transition lot sizes based on averaging under the following formulas:~~

- ~~a. Transitioning is only required of properties adjacent to or across the right-of-way from existing residential development. “Existing residential development” in this section shall mean existing lots created through subdivision or short plat.~~
- ~~b. Lot size in the transition area is based on the average of the existing lot size in subdivisions adjacent to, or across the street from, the subject property. Lots greater than eleven thousand square feet are not counted in the averaging.~~
- ~~c. If the existing average lot size is greater than seven thousand two hundred square feet, then the lot size in the transition area can be no less than seven thousand two hundred square feet.~~
- ~~d. If the existing average lot size is less than seven thousand two hundred square feet, then the lot size in the transition area can be equal to or greater than the average.~~
- ~~e. If the subject site shares boundaries with more than one subdivision, the minimum lot size in the transition area shall be based on the average lot sizes along each boundary. When two boundaries meet, the lot size shall be based on the larger of the two boundaries. See example below; and~~



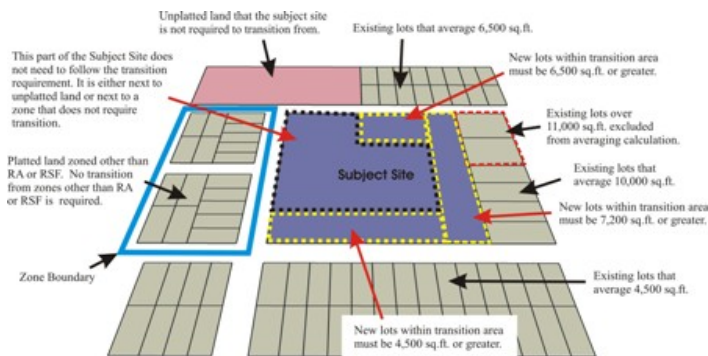

***[Note: Delete graphic above.]***

- ~~f. If the subject site shares a boundary with property zoned other than RA or RSF, then there are no transition requirements along that boundary.~~
- ~~g. After the first set of lots in the transition area, lot sizes may be developed to the minimum lot size of the base zone, i.e., four thousand three hundred fifty square feet in the RSF zone.)~~

- 2. Planned unit developments, combined with a subdivision, may reduce the minimum lot size, lot width, lot depth and frontage requirements in the RA and RSF zones pursuant to SMC 17G.070.030(C)(1) (~~except in the transition area required by subsection (C)(1) of this section~~).

D. Ownership of Multiple Lots.

Where more than one adjoining lot is in the same ownership, the ownership may be separated as follows:

- 1. If all requirements of this chapter will be met after the separation, including lot size, density and parking, the ownership may be separated through either a boundary line adjustment (BLA) or plat, as specified under [chapter 17G.080 SMC](#), Subdivisions.
- 2. If one or more of the lots does not meet the lot size standards in this section, the ownership may be separated along the original plat lot lines through a boundary line adjustment (BLA).

E. New Development on Standard Lots. New development on lots that comply with the lot size standards in this section are allowed subject to the development standards and density requirements of the base zone as required under Table 17C.110-3.

F. Lot Frontage. All residential lots shall front onto a public street and meet the minimum lot frontage requirements of Table 17C.110-3. Except, that frontage on

a public street is not required for lots created through alternative residential subdivision under SMC 17G.080.065, and lots approved in a planned unit development or a manufactured home park may have lots or spaces fronting onto private streets, subject to the decision criteria of [SMC 17H.010.090](#).

TABLE 17C.110-3 DEVELOPMENT STANDARDS [1]					
DENSITY STANDARDS					
	RA	RSF & RSF-C	RTF	RMF	RHD
Density - Maximum	4,350 (10 units/acre)	4,350 (10 units/acre)	2,100 (20 units/acre)	1,450 (30 units/acre)	--
Density - Minimum	11,000 (4 units/acre)	11,000 (4 units/acre)	4,350 (10 units/acre)	2,900 (15 units/acre)	2,900 (15 units/acre)
MINIMUM LOT DIMENSIONS LOTS TO BE DEVELOPED WITH:					
Multi-Dwelling Structures or Development					
	RA	RSF & RSF-C	RTF	RMF	RHD
Minimum Lot Area				2,900 sq. ft.	2,900 sq. ft.
Minimum Lot Width				25 ft.	25 ft.
Minimum Lot Depth				70 ft.	70 ft.
Minimum Front Lot Line				25 ft.	25 ft.
Compact Lot Standards [2]					
Minimum Lot Area [3]		3,000 sq. ft.			
Minimum Lot Width		36 ft.			
Minimum Lot Depth		80 ft.			
Minimum Front Lot Line		30 ft.			
Attached Houses as defined in SMC 17A.020.010					
Minimum Lot Area [3]	7,200 sq. ft.	4,350 sq. ft.	1,600 sq. ft.	1,450 sq. ft.	None

Minimum Lot Width	40 ft.	40 ft.	36 ft. or 16 ft. with alley parking and no street curb cut	Same	Same
Minimum Lot Depth	80 ft.	80 ft.	50 ft.	None	None
Minimum Front Lot Line	40 ft.	40 ft.	Same as lot width	Same as lot width	Same as lot Width
<b>Detached Houses</b>					
Minimum Lot Area [3]	7,200 sq. ft.	4,350 sq. ft.	1,800 sq. ft.	1,800 sq. ft.	None
Minimum Lot Width	40 ft.	40 ft.	36 ft.	25 ft.	25 ft.
Minimum Lot Depth	80 ft.	80 ft.	40 ft.	25 ft.	25 ft.
Minimum Front Lot Line	40 ft.	40 ft.	30 ft.	25 ft.	25 ft.
<b>Duplexes</b>					
Minimum Lot Area			4,200 sq. ft.	2,900 sq. ft.	None
Minimum Lot Width			25 ft.	25 ft.	25 ft.
Minimum Lot Depth			40 ft.	40 ft.	25 ft.
Minimum Front Lot Line			25 ft.	25 ft.	25 ft.
<b>PRIMARY STRUCTURE</b>					
<b>Maximum Building Coverage</b>					
	RA	RSF & RSF-C	RTF	RMF	RHD
Lots 5,000 sq. ft. or larger	40%	2,250 sq. ft. + 35% for portion of lot over 5,000 sq. ft.	2,250sq. ft. + 35% for portion of lot over 5,000 sq. ft.	50%	60%
Lots 3,000 - 4,999 sq. ft.	1,500 sq. ft. + 37.5% for portion of lot over 3,000 sq. ft.				
Lots less than 3,000 sq. ft.	50%				

Attached housing as defined in SMC 17A.020.010, lots any size	Same as above			Up to 70%	Up to 80%
<b>Building Height</b>					
Maximum Roof Height	35 ft. [5]	35 ft. [5]	35 ft. [5]	35 ft. [6]	35 ft. [6]
Maximum Wall Height	25 ft.	25 ft.	25 ft.	-- [6]	--
<b>Floor Area Ratio (FAR)</b>					
FAR	0.5	0.5 [4]	0.5 [4]	--	--
<b>Setbacks</b>					
Front Setback [7, 8]	15 ft.				
Side Lot Line Setback – Lot width more than 40 ft.	5 ft.				
Side Lot Line Setback – Lot width 40 ft. or less	3 ft.				
Street Side Lot Line Setback [7]	5 ft.				
Rear Setback [9, 10]	25 ft.	25 ft. [11]	15 ft.	10 ft.	10 ft.
<b>Required Outdoor Area</b>					
Required Outdoor Area for attached and detached houses. Minimum dimension (See SMC 17C.110.223)	250 sq. ft. 12 ft. x 12 ft.	250 sq. ft. 12 ft. x 12 ft.	250 sq. ft. 12 ft. x 12 ft.	200 sq. ft. 10 ft. x 10 ft.	48 sq. ft. 7 ft. x 7 ft.
<b>ACCESSORY STRUCTURES</b>					
	RA	RSF & RSF-C	RTF	RMF	RHD
Maximum Roof Height	30 ft.	20 ft.	20 ft.	35 ft.	35 ft.
Maximum Wall Height	30 ft.	15 ft.	15 ft.	35 ft.	35 ft.

Maximum Coverage [12]	20%	15%	15%	See Primary Structure	See Primary Structure
<u>Maximum Coverage with Accessory Dwelling Unit, Lots less than 5,500 sq. ft. [12]</u>		<u>20%</u>		<u>See Primary Structure</u>	<u>See Primary Structure</u>
Front Setback	20 ft.				
Side Lot Line Setback – Lot width 40 ft. or wider [13]	5 ft.				
Side Lot Line Setback – Lot width less than 40 ft. [13]	3 ft.				
Street Side Lot Line [14]	20 ft.				
Rear [13]	5 ft.				
Rear with Alley	0 ft.				

Notes:

-- No requirement

[1] Plan district, overlay zone, or development standards contained in SMC 17C.110.310 through 360 may supersede these standards.

[2] See SMC 17C.110.209, Compact Lot Standards.

[3] ~~((For developments two acres or greater, lots created through subdivision in the RA, RSF and the RSF-C zones are subject to the lot size transition requirements of SMC 17C.110.200(C)(1).)) [Deleted.]~~

[4] In the RSF-C and RTF zones, and sites in the RSF zone qualifying for compact lot development standards, described in SMC 17C.110.209, FAR may be increased to 0.65 for attached housing development only.

[5] No structure located in the rear yard may exceed twenty feet in height.

[6] Base zone height may be modified according to SMC 17C.110.215, Height.

[7] Attached garage or carport entrance on a street is required to be setback twenty feet from the property line.

[8] See SMC 17C.110.220(D)(1), setbacks regarding the use of front yard averaging.

[9] See SMC 17C.110.220(D)(2), setbacks regarding reduction in the rear yard setback.

[10] Attached garages may be built to five feet from the rear property line except, as specified in SMC 17C.110.225(C)(6)(b), but cannot contain any living space.

[11] In the RSF-C zone and sites in the RSF zone qualifying for compact lot development standards, described in SMC 17C.110.209, the rear setback is 15 feet.

[12] Maximum site coverage for accessory structures is counted as part of the maximum site coverage of the base zone. See SMC 17C.110.225(D).

[13] Setback for a detached accessory structure and a covered accessory structure may be reduced to zero feet with a signed waiver from the neighboring property owner, except, as specified in SMC 17C.110.225(C)(5)(b).

[14] The setback for a covered accessory structure may be reduced to five feet from the property line.

Section \_\_. That SMC section 17C.110.225 is amended to read as follows:

### **17C.110.225 Accessory Structures**

A. Purpose.

This section regulates structures that are incidental to primary buildings to prevent them from becoming the predominant element of the site. The standards provide for necessary access around structures, help maintain privacy to adjoining lots and maintain open front setbacks.

B. General Standards.

1. Accessory structures are allowed on a lot only in conjunction with a primary building, and may not exist on a lot prior to the construction of the primary structure, except as allowed by subsection (B)(2) of this section.

2. An accessory structure that becomes the only structure on a lot as the result of a land division may remain on the lot if the owner has submitted a financial guarantee to the City for the cost of demolition and removal of the structure. The financial guarantee will be used by the City if the owner has not removed the accessory structure if, within one year of final plat approval or boundary line adjustment (BLA), a primary structure has not been built and received final inspection. The financial guarantee must be accepted by the City prior to approval of the final plat or boundary line adjustment.
3. An accessory structure shall not contain a kitchen or space for living, sleeping, eating, or cooking unless it is approved as an accessory dwelling unit under chapter 17C.300 SMC.

C. Setbacks.

1. Mechanical Structures.  
Mechanical structures are items such as heat pumps, air conditioners, emergency generators, and water pumps.
  - a. Front Setback Standard.  
Mechanical structures are not allowed in required front building setbacks.
  - b. Side and Rear Setback Standard.  
Mechanical structures are allowed inside and rear building setbacks if the structure is no more than forty-eight inches high.
2. Vertical Structures.  
Vertical structures are items such as flagpoles, trellises and other garden structures, radio antennas, satellite receiving dishes and lampposts. Fences are addressed in SMC 17C.110.230. Sign standards are in chapter 17C.240 SMC, Signs.
  - a. Setback Standard.  
Vertical structures are allowed in required side and rear building setbacks if they are no larger than four feet in width, depth or diameter and no taller than seven feet. If they are larger or taller, they are not allowed in required building setbacks. Trellises and other gate features are allowed in front yard if they are no larger than four feet in width, depth or diameter and no taller than seven feet and do not conflict with the clear view triangle provisions under SMC 17C.110.230, Fences.
3. Uncovered Horizontal Structures.  
Uncovered horizontal structures are items such as decks, stairways, entry bridges, wheelchair ramps, swimming pools, hot tubs, tennis courts, and boat docks that are not covered or enclosed.

- a. Setback Standard.
  - i. Projection Allowed.

The following structures are allowed in required building setbacks, as follows:

    - A. Structures that are no more than two and one-half feet above the ground are allowed in side and rear building setbacks. Handrails required by the IBC/IRC are not included in the maximum height.
    - B. On lots that slope down from the street, vehicular or pedestrian entry bridges that are no more than two and one-half feet above the average sidewalk elevation are allowed in all building setbacks; and
    - C. Stairways and wheelchair ramps that lead to one entrance on the street-facing facade of a building are allowed in street setbacks.
4. Covered Accessory Structures.

Covered accessory structures are items such as greenhouses, storage buildings (not used to cover motor vehicles), sheds, covered decks, covered porches, gazebos, and covered recreational structures.

  - a. Setback Standard.

Covered accessory structures are not allowed in the required front ~~((and side))~~ building setbacks. Covered accessory structures are not allowed in the required side building setback without a signed waiver from the neighboring property owner.
5. Detached Accessory Structures.

Detached accessory structures are garages, carports, and other structures utilized to cover motorized vehicles.

  - a. Setback Standard.

A detached accessory structure is not allowed in the front building setback. A detached accessory structure is not allowed in the required side building setback without a signed waiver from the neighboring property owner. A detached accessory structure that has an entrance, which faces a street, is required to be setback twenty feet from the property line or from the back of the sidewalk, as stated in Table 17C.110-3.
  - b. Detached accessory structures may be built to the rear property line, unless parking in front of the structure is proposed, then the structure



is required to be built a minimum of eighteen feet from the edge of the alley tract, easement, or right-of-way.

6. Attached Accessory Structures.

Accessory structures are garages, carports or other structures utilized to cover motorized vehicles that are connected by a common wall to the primary structure.

a. Setback Standard.

An attached accessory structure is not allowed in the front building setback. An attached accessory structure that has an entrance which faces a street is required to be setback twenty feet from the property line as stated in Table 17C.110-3.

b. Attached accessory structures may be built to within five feet of the rear property line, unless parking in front of the structure is proposed, then the structure is required to be built a minimum of eighteen feet from the edge of the alley tract, easement or right-of-way.

D. Building Coverage.

1. Except as provided in subsection (2) of this subsection (D), ((The)) the combined building coverage of all detached accessory structures and covered accessory structures may not exceed fifteen percent of the total area of the site, and when combined with all other structures on-site shall not exceed the maximum building coverage of the base zone.

2. On lots smaller than five thousand five hundred square feet with an accessory dwelling unit, combined building coverage of all detached accessory structures and covered accessory structures may not exceed twenty percent of the total area of the site, and when combined with all other structures on-site shall not exceed the maximum building coverage of the base zone.

E. Building Height.

The building height of detached accessory structures and covered accessory structures is listed in Table 17C.110-3. Accessory structures, which contain an ADU over a garage, are subject to the height limitations in chapter 17C.300 SMC, Accessory Dwelling Units.

<b>TABLE 17C.110.225-1</b>	
<b>MAXIMUM HEIGHT – DETACHED ACCESSORY BUILDING [1]</b>	
Maximum Wall Height [2]	15 ft.
Maximum Roof Height [3]	20 ft.
<p>[1] Cannot include living area, nor any storage areas with a ceiling height of six-feet eight-inches or greater.</p> <p>[2] The height of the lowest point of the roof structure intersects with the outside plane of the wall.</p> <p>[3] The height of the ridge of the roof.</p> <p>See “Example A” below.</p>	

**Example A**

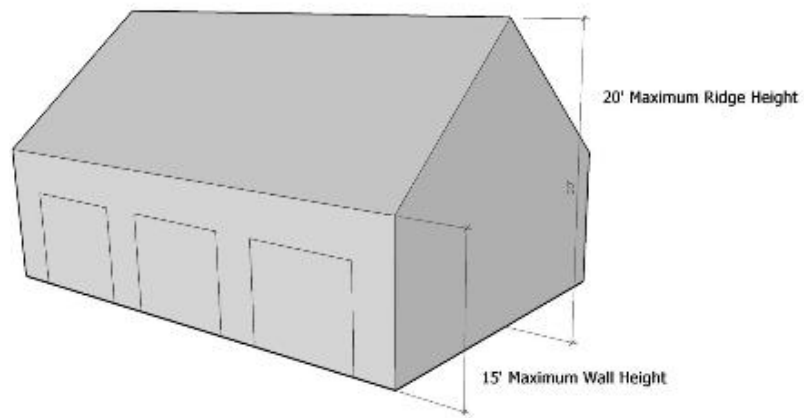

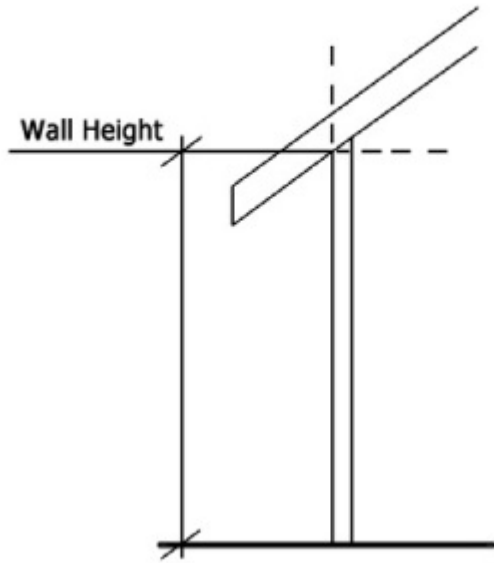

### 17C.300.100 General Regulations

- A. Where the Regulations Apply.  
Attached and detached accessory dwelling units are permitted in the RA through RHD zones, including planned unit developments, subject to the limitations of subsection (B) of this section.
- B. Limitation.
- ~~((1. One ADU is allowed per lot as an accessory use in conjunction with a detached single-family residence.~~
- ~~2. A detached ADU must either be combined with a garage or shall be the only detached structure in the rear yard setback area.~~
- ~~3. Detached))~~ One accessory dwelling ~~((units are))~~ unit is allowed per lot in the RA, RSF, RTF, RMF, and RHD zones subject to the development standards of the underlying zoning district.

Section   . That SMC 17C.300.110 is amended to read as follows:

### 17C.300.110 Criteria

~~((A. Minimum Lot Size.  
The minimum lot size for ADU is five thousand square feet.))~~

~~((B.))~~ A. ~~((ADU Minimum and))~~ Maximum Size.

1. Internal ADU.  
Before the establishment of an internal ADU the ~~((footprint))~~ floor area of the principal structure, excluding an attached garage, must be not less than eight hundred square feet.
- ~~a. The ((size)) internal ADU shall contain no more than two bedrooms and the floor area of the internal ADU must be ((not less than two hundred fifty square feet and)) not more than eight hundred square feet, excluding any related garage area.~~
- ~~b. The conversion of an existing interior basement or attic space of a principal structure into an ADU may exceed the maximum floor area for an internal ADU specified in subsection (1)(a) of this subsection.~~
2. Detached ADU.
- ~~a. The maximum detached ADU size is subject to building coverage per SMC 17C.300.130(B)(3) and floor area ratio per subsection (3) of this subsection (A); and~~

b. A detached ADU shall not exceed ~~((six hundred square feet))~~ seventy-five percent of the floor area of the principal structure, or eight hundred sixty-four square feet of floor area, whichever is greater.

3. FAR.

a. The ~~square footage floor area~~ of an ADU, excluding any garage, is counted as part of the floor area ratio (FAR). ~~((Internal ADUs may not exceed fifty percent of the total square footage of the principal structure's building footprint.))~~

b. To offer greater flexibility in integrating an ADU on smaller lots, the maximum allowable FAR may be increased to 0.6 on lots smaller than seven thousand two hundred square feet in area, with an ADU, and to 0.7 on lots smaller than five thousand square feet in area with an ADU.

~~((C.))~~ B. Occupancy for Short-Term Rentals.

~~((One))~~ Where a lot with an ADU also has a Short-Term Rental under chapter 17C.316 SMC, one of the dwelling units ~~((in the structure or))~~ on the lot shall be occupied by one or more owners of the property as the owner's permanent and principal residence. The owner-occupant must occupy the owner-occupied dwelling unit for more than six months of each calendar year. The owner-occupant may not receive rent for the owner-occupied dwelling unit. If a complaint that an owner has violated these requirements is filed, the owner shall:

1. submit evidence to the director showing good cause, such as a job dislocation, sabbatical leave, education or illness, for waiver of this requirement for up to one year absence from the property. Upon such showing the director may waive the requirement;
2. re-occupy the structure; or
3. remove the accessory dwelling unit.

Section   . That SMC 17C.300.120 is amended to read as follows:

**17C.300.120 Application Procedures**

A. Application.

Any property owner seeking to establish an ADU must obtain a building permit and a certificate of occupancy from the building services department.

B. Covenants.

~~((A))~~ Where a lot with an ADU also has a Short-Term Rental under chapter 17C.316 SMC, a covenant and deed restriction identifying the ADU and limitations of occupancy and ownership is required to be recorded and filed with

the Spokane county auditor's office. A copy of the recorded covenant must be provided to the City of Spokane planning and economic development services department prior to the issuance of a building permit or safety inspection.

Section \_\_. That SMC 17C.300.130 is amended to read as follows:

### **17C.300.130 Development Standards**

A. Development Standards – Requirements for All Accessory Dwelling Units.  
All accessory dwelling units must meet the following:

1. Creation.  
An accessory dwelling unit may only be created through the following methods:
  - a. Converting existing living area, attic, basement or garage.
  - b. Adding floor area.
  - c. Constructing a detached accessory dwelling unit on a site with an existing house, attached house or manufactured home ~~((;OF))~~.
  - d. Constructing a new house, attached house or manufactured home with an internal or detached accessory dwelling unit.
  - e. In the RTF, RMF, or RHD zone, constructing an attached or detached accessory dwelling unit on a site with any existing or new principal structure. All new structures and additions shall comply with all applicable building, fire, and engineering standards.
2. Number of Residents.  
The total number of individuals that reside in both units may not exceed ~~((the number that is allowed for a household))~~ any lawful limits on occupant load per square foot or generally applicable health and safety provisions as established by applicable building or fire code, as provided in RCW 35.21.682.
- ~~((3. Other Uses.  
An accessory dwelling unit is prohibited on a site with a home occupation.))~~
- ~~((4.))~~ 3. Location of Entrances for Internal ADUs.  
Only one entrance may be located on the facade of the ~~((house, attached house or manufactured home))~~ principal structure facing the street, unless the ~~((house, attached house or manufactured home))~~ principal structure contained additional entrances before the accessory dwelling unit was created. An exception to this regulation is entrances that do not have access from the ground such as entrances from balconies or decks.

~~((5-))~~ 4. Parking.

~~a. Studio and one-bedroom ADUs require no additional parking. One additional off-street parking space is required for the accessory dwelling unit with more than one bedroom, plus one per bedroom after two bedrooms. Existing required parking for the ~~((house, attached house or manufactured home))~~ principal structure must be maintained ~~((or replaced on-site)).~~~~

~~b. As an exception to subsection (a), no additional off-street parking space is required for the ADU within one-quarter-mile of stops for a bus or other transit mode providing actual fixed route service at intervals of no less frequently than fifteen minutes for at least five hours during the peak hours of operation on weekdays, defined as a major transit stop under RCW 36.70A.696.~~

~~((6. — Exterior Finish Materials.~~

~~The exterior finish material must be the same or visually match in type, size, and placement the exterior finish material of the house, attached house or manufactured home.))~~

~~7. — Roof Pitch.~~

~~The roof pitch must be the same as the predominant roof pitch of the house, attached house or manufactured home.~~

~~8. — Trim.~~

~~Trim must be the same in type, size and location as the trim used on the house, attached house or manufactured home.~~

~~9. — Windows.~~

~~Windows must match those in the house, attached house or manufactured home in proportion (relationship of width to height) and orientation (horizontal or vertical). This standard does not apply when it conflicts with building code regulations.))~~

B. Additional Development Standards for Detached ADUs.

1. Setbacks.

~~((The)) Except for conversion of existing accessory structures, the accessory dwelling unit must be ((at least)):~~

~~((a. — sixty feet from the front lot line; or~~

~~b. — six feet behind the house, attached house or manufactured home;))~~

~~((e.))~~ a. as specified for ~~((rear and side yard))~~ setbacks in Table 17C.110-3 for ~~((primary structures for attached ADUs and))~~ accessory structures ~~((for detached ADUs.))~~; and

b. in conformance with the forty-five degree setback plane:

i. The forty-five degree setback plane is measured at the maximum wall height listed in Table 17C.300-1, from the interior side lot line setback, or rear setback without an alley, as listed in Table 17C.110-3 for accessory structures. The setback plane does not apply on side or rear setbacks measured from alley or street lot lines.

ii. The setback plane increases at a forty-five degree angle away from the interior side and rear lot lines without an alley, up to the maximum roof height in Table 17C.300-1. See Figure 17C.300-A for examples.

iii. No portion of the accessory dwelling unit may project beyond the forty-five degree setback plane described in this subsection, except for the roof structure and minor extensions allowed by SMC 17C.110.220(C)(1).

iv. The setback may be reduced to zero feet with a signed waiver from the neighboring property owner. In that case, the forty-five degree setback plane would be measured from the maximum wall height and the property line.



**Figure 17C.300-A. Setback Plane [1]**

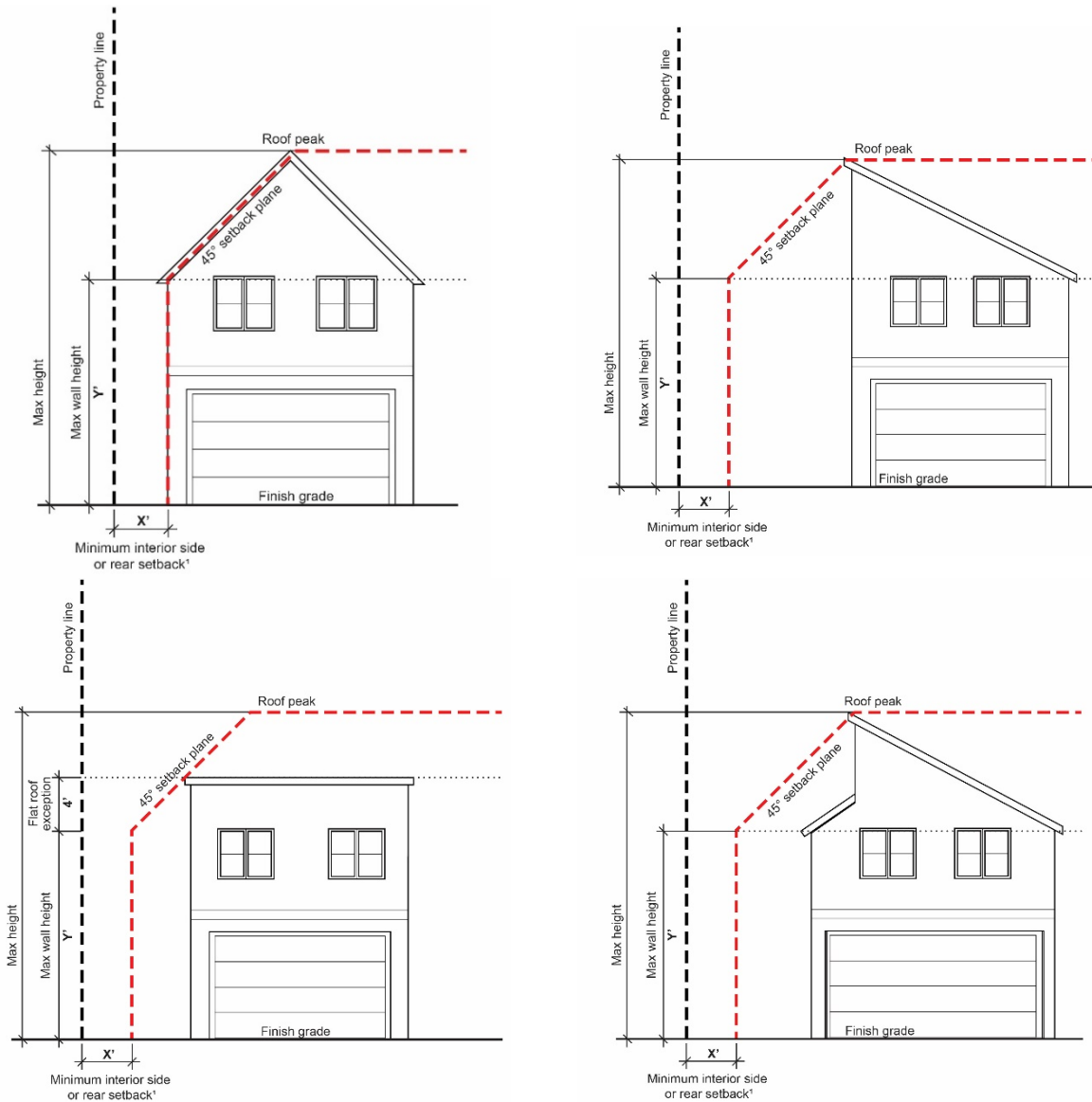

**[Note: Add the four graphics above.]**

**[1] The setback plane does not apply on side setbacks or rear setbacks measured from alley lot lines or street lot lines.**

2. Height.

The maximum height allowed for a detached accessory dwelling unit is shown in Table 17C.300-1. ~~A detached ADU over a detached accessory structure with flat or terraced roof forms with slopes of less than 3:12 that conform to the forty-five-degree setback plane in subsection (B)(1)(b) of this section may be granted a wall height exception up to four feet.~~

TABLE 17C.300-1 MAXIMUM ROOF AND WALL HEIGHT		
	Maximum Height – Detached Accessory Building Attached to an ADU or Detached ADU [1]	Maximum Height – Detached ADU Over a Detached Accessory Structure
Maximum Wall Height [2]	10 ft.	<del>((16))</del> <u>17</u> ft.
Maximum Roof Height [3]	20 ft.	<del>((23))</del> <u>25</u> ft.
<p>[1] Detached accessory structures cannot include living area, nor any storage areas with a ceiling height of six-feet eight-inches or greater.</p> <p>[2] The height of the lowest point of the roof structure intersects with the outside plane of the wall.</p> <p>[3] The height of the ridge of the roof. See “Figure <del>((A))</del> <u>17C.300-B</u>” below.</p>		

**Figure ((A)) 17C.300-B**

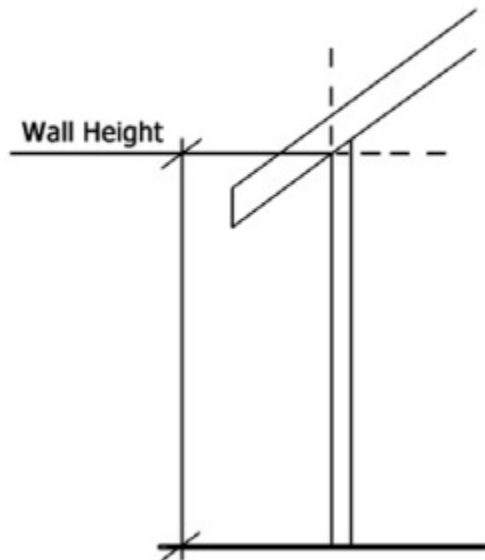
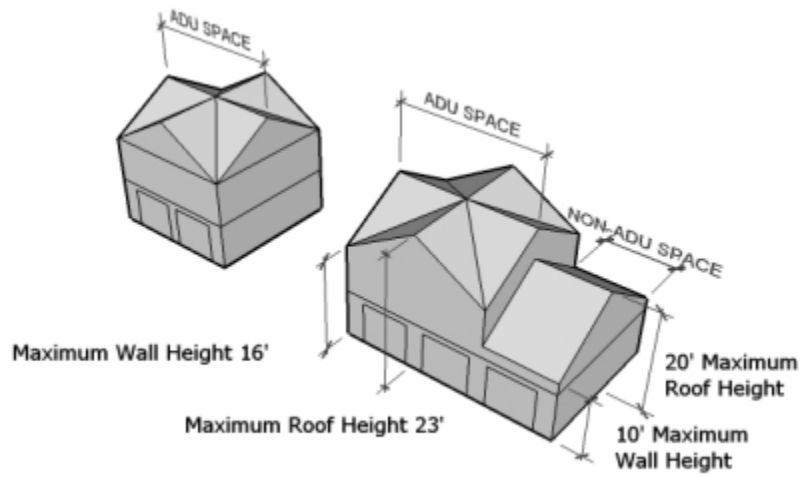

3. Bulk Limitation.

The building coverage for the detached accessory dwelling unit may not be larger than the building coverage of the ~~((house, attached house or manufactured home))~~ principal structure.

  - a. ~~((The))~~ On lots five thousand five hundred square feet or larger, the combined building coverage of all detached accessory structures may not exceed fifteen percent of the total area of the site.
  - b. On lots smaller than five thousand five hundred square feet, the combined building coverage of all detached accessory structures may not exceed twenty percent of the total area of the site.
4. Conversion of Existing Detached Accessory Structures.
  - a. In RA through RTF zones, conversion of an existing detached accessory structure that is in a front building setback required by [Table 17C.110-3](#) is not allowed. Conversion of an existing detached accessory structure that is in a rear or side building setback is allowed as provided by [SMC 17C.110.220](#), Setbacks, and [SMC 17C.110.225](#), Accessory Structures.
  - b. In RMF through RHD zones, conversion of an existing detached accessory structure that is in a front building setback required by [Table 17C.110-3](#) is not allowed. Conversion of an existing detached accessory structure that is in a rear or side building setback is allowed as provided by [SMC 17C.110.220](#), Setbacks, and [SMC 17C.110.225](#), Accessory Structures.
  - c. If the accessory dwelling unit is proposed for an existing detached accessory structure that meets any of the standards of subsections ~~((A)(6) through (9) and))~~ (B)(2) and (3) of this section, alterations that will move the structure out of conformance with the standards that are met are not allowed.
  - d. If the accessory dwelling unit is proposed as a conversion of an existing detached accessory structure or a portion of the building, and ~~((the existing detached accessory structure does not meet the standards of subsections (A)(6) through (9) of this section, the structure is exempt from those standards. If))~~ any floor area is added to the existing detached accessory structure to accommodate an ADU, then the entire structure must meet the ~~((standards of subsections (A)(6) through (9) of this section and the))~~ underlying zoning development standards.

- C. Utilities and Addressing.  
The ADU must utilize those municipal utilities and address established for the principal dwelling unit.
- D. Code Compliance.  
The ADU must meet all technical code standards of this title including building, electrical, fire, and plumbing code requirements and permits.

Section \_\_. That SMC 17C.300.140 is amended to read as follows:

### **17C.300.140 ADU Expiration**

- A. Transfer.  
~~((An))~~ In the case where a lot with an ADU also has a Short-Term Rental under chapter 17C.316 SMC, an ADU permit is not transferable to any other property or any other person except to the new owner of the subject property when the property will be owner occupied.
- B. Expiration.  
Approval of an ADU expires when the:
  - 1. accessory dwelling unit is altered and is thus no longer in conformance with the plans approved by the building services department; or
  - 2. property ceases to maintain the required off-street parking spaces for the accessory and principal dwelling units; or
  - 3. in the case where a lot with an ADU also has a Short-Term Rental under chapter 17C.316 SMC, legal titleholder of the property ceases to own and reside in either the principal or the accessory dwelling unit.

**DRAFT TEXT**  
**Short Plat Notification**  
**Spokane Municipal Code Title 17G Administration and Procedures**

17G.060.100 Notice of Application .....A-26  
17G.060T.003 Table 17G.060-3 Type of Public Notice Required / Project Permit  
Review Process .....A-26  
17G.060.130 Public Comment Period .....A-29  
17G.080.040 Short Subdivisions .....A-29

Section \_\_\_. That SMC section 17G.060.100 is amended to read as follows:

**17G.060.100 Notice of Application**

Within fourteen days of the issuance of a determination of a complete application, a notice of application shall be provided for Type I, II and III project permit applications in accordance with this section (RCW 36.70B.110.2), except that notice of application is not required for short subdivision applications involving minor engineering review as defined in SMC 17G.080.040(C)(2). The notice of application shall follow the public notice requirements contained in SMC 17G.060.110 through 17G.060.120. The notice of application may be combined with the notice of public hearing, if a hearing has been scheduled by notice of application. The date, time, place and type of hearing, SEPA determination and SEPA appeal deadline (using the optional DNS process) are required to be added to the notice of application if this provision is used (RCW 36.70B.110(2)(f)).

Section \_\_\_. That SMC section 17G.060T.003 is amended to read as follows:

**17G.060T.003 Table 17G.060-3 Type of Public Notice Required / Project Permit Review Process**

<b>TABLE 17G.060-3</b> <b>TYPE OF PUBLIC NOTICE REQUIRED / PROJECT PERMIT REVIEW PROCESS</b> (Click here to view PDF)						
Project Permit Type	Notice of Community Meeting	Notice of Application	Notice of Public Hearing	Review Official	City Council Review	Expiration of Permit [1]
<b>Building and Code Enforcement – Type I Application</b>						
Building Permit	No	No	No	Building Official	No	180 days
Grading Permit	No	No	No	Building Official	No	180 days
Demolition Permit	No	No [5]	No [2]	Building Official	No	180 days
Building Permit with SEPA	No	Posted / Legal	No	Building Official	No	180 days

Grading Permit with SEPA	No	Posted / Legal	No	Building Official	No	180 days
Demolition Permit with SEPA	No	Posted / Legal [5]	No	Building Official	No	180 days
<b>Planning Services – Type I Application</b>						
Floodplain with SEPA	Posted / Individual	Posted / Individual	No	Planning Director	No	180 days
<b>Planning Services – Type II Application</b>						
Binding Site Plan	No	Posted / Individual	No	Planning Director	No	5 years
Certificate of Compliance	No	Posted / Individual	No	Planning Director	No	None
Conditional Use Permit	No [3]	Posted / Individual	No	Planning Director	No	3 years
Plans-in-lieu	No	Posted / Individual	No	Planning Director	No	3 years
Shoreline SDP	No	Posted / Individual	No	Planning Director	No	Must Comply with WAC 173-27-90
Short Plat with SEPA	No	Posted / Individual	No	Planning Director	No	5 years
<u>Short Plat with minor engineering review</u>	<u>No</u>	<u>No</u>	<u>No</u>	<u>Planning Director</u>	<u>No</u>	<u>5 years</u>
<u>Short Plat with SEPA exemption and standard engineering review</u>	<u>No</u>	<u>Individual</u>	<u>No</u>	<u>Planning Director</u>	<u>No</u>	<u>5 years</u>
<b>Planning Services – Type III Application (Hearing Required)</b>						
Certificate of Compliance	Posted / Individual	Posted / Individual	Posted / Individual	Hearing Examiner	No	None
Conditional Use Permit	Posted / Individual	Posted / Individual	Posted / Individual	Hearing Examiner	No	3 years



Floodplain Variance	Posted / Individual	Posted / Individual	Posted / Individual	Hearing Examiner	No	3 years
Long Plat	Posted / Individual	Posted / Individual	Newspaper / Posted / Individual	Hearing Examiner	No	5 years
Plans-in-lieu	Posted / Individual	Posted / Individual	Posted / Individual	Hearing Examiner	No	3 years
PUD	Posted / Individual	Posted / Individual	Posted / Individual	Hearing Examiner	Yes	5 years [4]
Rezone	Posted / Individual	Posted / Individual	Posted / Individual	Hearing Examiner	Yes	3 years
Shoreline CUP	Posted / Individual	Posted / Individual	Posted / Individual	Hearing Examiner	No	Must Comply with WAC 173-27-90
Shoreline Variance	Posted / Individual	Posted / Individual	Posted / Individual	Hearing Examiner	No	Must Comply with WAC 173-27-90
Skywalk	Posted / Individual	Posted / Individual	Posted / Individual	Hearing Examiner	Yes	2 years
Variance	Posted / Individual	Posted / Individual	Posted / Individual	Hearing Examiner	No	3 years

Notes:

[1] Approval expires after the specified time if no permit to develop the project is issued by the City of Spokane or building permit expires without completion of the improvements.

[2] Public Hearing is required if the structure is on the National Historic Register.

[3] Conditional Use Permits required under SMC 17C.110.110, Limited Use Standards for Religious Institutions and Schools, will complete posted/individual notification requirements for a Community Meeting.

[4] If a PUD is approved together with a preliminary plat, the expiration date for the PUD shall be the same as the expiration date of the preliminary plat.

[5] Applications for demolition permits for the demolition of an entire building or structure shall, in addition to any applicable requirements under chapter 43.21C RCW, be subject to a ten day review and comment period. This review and comment period shall run concurrently with any other applicable notice and comment period. Following receipt of such applications, copies shall be forwarded to the individual(s) designated pursuant to SMC 4.27.010(D) to receive written notice on behalf of the neighborhood council in which the building or structure is located, at the address for such neighborhood council designee(s) that is on file with the department. Any comments submitted to the department by the neighborhood council during this review and comment period shall be provided to the applicant prior to issuing the demolition permit.

Section \_\_\_. That SMC section 17G.060.130 is amended to read as follows:

### **17G.060.130 Public Comment Period**

- A. The public comment period for Type I, II, and III applications is fifteen days, except short subdivision applications with minor engineering review as provided in SMC 17G.080.040(C)(2) shall have no public comment period.
- B. The public comment period for a shoreline substantial development permit, shoreline conditional use, or shoreline variance shall be thirty days.
- C. The public comment period for a shoreline substantial development permit for limited utility extensions and bulkheads shall be twenty days (WAC 173-27-120).
- D. The longest public comment period shall prevail.

Section \_\_\_. That SMC section 17G.080.040 is amended to read as follows:

### **17G.080.040 Short Subdivisions**

#### **A. Predevelopment Meeting**

A predevelopment meeting is required if the proposal is located in the central business district, unless waived by the director, and is recommended for all other proposals prior to submittal of the application. The purpose of a predevelopment meeting is to acquaint the applicant with the applicable provisions of this chapter, minimum submission requirements and other plans or regulations, which may impact the proposal.

#### **B. Preliminary Short Plat Application and Map Requirements**

- 1. Applications for approval of a preliminary short subdivision shall be filed with the director. All applications shall be submitted on forms provided for such purpose by the department. The director may waive specific submittal requirements determined to be unnecessary for review of the application. The application shall include the following:
  - a. The general application.
  - b. The supplemental application.
  - c. The environmental checklist, if required under chapter 17E.050 SMC.
  - d. Title report no older than thirty days from issuance from the title company.
  - e. The filing fees as required under chapter 8.02 SMC.
  - f. The required number of documents, plans or maps drawn to a minimum scale of one inch equals one hundred feet, on a sheet

twenty-four by thirty-six inches, as set forth in the application checklist.

- g. A written narrative identifying consistency with the applicable policies, regulations and criteria for approval of the permit requested; and
- h. Additional application information which may be requested by the permitting department and may include, but is not limited to, the following: geotechnical studies, hydrologic studies, critical area studies, noise studies, air quality studies, visual analysis and transportation impact studies.
- i. One copy of the predevelopment conference notes (if applicable); and
- j. One copy of the notification district map.

2. Contents of Preliminary Short Plat Map

The preliminary short plat shall be prepared by a land surveyor and shall show the following:

- a. Plat name and the name of any subdivision to be replatted.
- b. The name, mailing address and phone number of the owner and the person with whom official contact should be made regarding the application.
- c. Surveyor's name, mailing address and phone number.
- d. Legal description.
- e. Section, township and range.
- f. Vicinity map.
- g. North arrow, scale and date.
- h. Datum plane.
- i. Acreage.
- j. Number of lots and proposed density.
- k. Zoning designation.
- l. The boundary lines of the proposed subdivision.
- m. City limits and section lines.
- n. Park or open space (if proposed).
- o. Existing topography at two-foot maximum interval.
- p. The boundaries and approximate dimensions of all blocks and lots, together with the numbers proposed to be assigned each lot and block, and the dimensions, square footage and acreage of all proposed lots and tracts.
- q. Proposed names of streets.

- r. The location and widths of streets, alleys, rights-of-way, easements (both public and private), turn around and emergency access, parks and open spaces.
- s. Conditions of adjacent property, platted or unplatted, and if platted, giving the name of the subdivision. If the proposed short plat is the subdivision of a portion of an existing plat, the approximate lines of the existing plat are to be shown along with any and all recorded covenants and easements.
- t. The names and address of the record owners and taxpayers of each parcel adjoining the subdivision.
- u. Indicate any street grades in excess of eight percent.
- v. The location and, where ascertainable, sizes of all permanent buildings, wells, wellhead protection areas, sewage disposal systems, water courses, bodies of water, flood zones, culverts, bridges, structures, overhead and underground utilities, railroad lines, and other features existing upon, over or under the land proposed to be subdivided, and identifying any which are to be retained or removed.
- w. Proposed one-foot strips for right-of-way conveyed to the City, in cases where a proposed public street or alley abuts unplatted land.
- x. If a body of water forms the boundary of the plat, the ordinary high water mark as defined in chapter 90.58 RCW.
- y. Critical areas as defined in chapters 17E.020, 17E.030, 17E.070 and 17G.030 SMC.
- z. Significant historic, cultural or archaeological resources; and
- aa. If the proposal is located in an irrigation district, the irrigation district name.

C. Review of Preliminary Short Plat

1. The application shall be reviewed in accordance with the procedures set forth in chapter 17G.060 SMC for a Type II application, except an application that meets the requirements for minor engineering review as provided in subsection (2) of this section shall be excluded from the public notice requirements contained in SMC 17G.060.110 through 17G.060.120 and public comment period under SMC 17G.060.130.
2. Minor Engineering Review.  
A preliminary short plat application may qualify for a minor engineering review if it meets all of the following conditions:
  - a. The application is categorically exempt from chapter 43.21C RCW (SEPA);

- b. There is direct water and sewer main lot frontage on an existing and improved public right-of-way;
- c. No extensions of public water, sewer, or other utility services will be needed;
- d. No public easements for water, sewer, or other utility service exists on the lot; and
- e. The lot is not situated in a Special Drainage District as defined in SMC 17D.060.130.

D. Public Notice

All public notice of the application shall be given in accordance with the procedures set forth in chapter 17G.060 SMC for a Type II application, except a short plat that meets the requirements for minor engineering review as provided in subsection (C)(2) of this section shall not require a notice of application.

E. Preliminary Short Plat Approval Criteria

Prior to approval of a short plat application, the director shall find the application to be in the public use and interest, conform to applicable land use controls and the comprehensive plan of the City, and the approval criteria set forth in chapter 17G.060 SMC. The director has the authority to approve or disapprove a proposed preliminary short plat under the provisions of this chapter, subject to appeal as provided in chapters 17F.050 and 17G.060 SMC.

F. Final Short Plat Review Procedure

1. The subdivider shall submit to the director for review the following:
  - a. A final short plat, prepared by a registered land surveyor licensed in the state of Washington, consistent with the approved preliminary short plat.
  - b. A title report less than thirty days old confirming that the title of the lands as described and shown on said plat is in the name of the owners signing the certificate or instrument of dedication.
  - c. Covenants, conditions and restrictions, if applicable; and
  - d. Fees pursuant to chapter 8.02 SMC.
2. Within thirty days, unless the applicant has consented to a longer period of time, of receipt of a proposed final short plat, the director shall review the plat for conformance with all conditions of the preliminary short plat approval, the requirements of this chapter and that arrangements have been made to insure the construction of required improvements. If all such conditions are met, the director shall approve the final short plat and authorize the recording of the plat. If all conditions are not met, the director shall provide the applicant in writing a statement of the necessary changes to bring the final short plat into conformance with the conditions.

- a. If the final short plat is required to be resubmitted, the subdivider is required to provide the following:
  - b. A cover letter addressing the corrections, additions or modifications required.
  - c. Title report no older than thirty days from issuance of a title company conforming that the title of the lands as described and shown on said plat is in the name of the owners signing the certificate or instrument of dedication; and
  - d. The required number of copies of the corrected final short plat map.
3. If the final short plat is approved, the surveyor causes the plat to be signed by the Spokane county treasurer and file of record with the Spokane county auditor. The surveyor is required to file the appropriate number of mylar and bond copies of the recorded short plat with the director.

G. Final Short Plat Map Requirements

The subdivider shall submit to the director a final short plat in the same form and with the same content as the preliminary short plat, as provided in subsections (B)(1) and (2) of this section, with the following exceptions or additional requirements:

1. A final short plat shall contain all the information required of the preliminary plat, except the following:
  - a. Show existing buildings.
  - b. Show existing utility lines and underground structures.
  - c. Show the topographical elevations; or
  - d. Contain the names and addresses of adjoining landowners.
2. The final short plat shall include the following:
  - a. Surveyor's certificate, stamp, date and signature, as follows:

The following land surveyor's certificate to be shown on each sheet of the plat: "I, \_\_\_\_\_ registered land surveyor, hereby certify the plat of \_\_\_\_\_, as shown hereon, is based upon actual field survey of the land described and that all angles, distances, and courses are correctly shown and that all non fronting lot corners are set as shown on the plat. Monuments and fronting lot corners shall be set upon completion of the utility and street improvements.

Signed \_\_\_\_\_(Seal)"
  - b. A certification by the city treasurer, as applicable:
    - i. "I hereby certify that the land described by this plat, as of the date of this certification, is not subject to any local improvement assessments. Examined and approved, this \_\_\_\_\_ day of \_\_\_\_\_, 20\_\_.

\_\_\_\_\_  
City of Spokane Treasurer”

- ii. “I hereby certify that the land described by this plat, as of the date of this certificate, is not subject to any delinquent local improvement assessment. Future installments, if any, shall remain due and payable and it shall be the responsibility of the owners to initiate the segregation of the LID assessment. Examined and approved, this \_\_\_\_ day of \_\_\_\_\_, 20\_\_.

\_\_\_\_\_  
City of Spokane Treasurer”

- iii. “A preliminary local improvement assessment exists against this property. It shall be the responsibility of the owner’s to initiate the segregation of the LID assessment. After this assessment is finalized, it shall be due and payable. Examined and approved this \_\_\_\_ day of \_\_\_\_\_, 20\_\_.

\_\_\_\_\_  
City of Spokane Treasurer”

- c. The certification by the planning director, as follows:  
“This plat has been reviewed on this \_\_\_\_ day of \_\_\_\_\_, 20\_\_ and is found to be in full compliance with all the conditions of approval stipulated in the Hearing Examiner’s/Planning Director’s approval of the preliminary plat # - -PP/SP.

\_\_\_\_\_  
City of Spokane Planning Director”

- d. The certification by the city engineer, as follows:  
“Approved as to compliance with the survey data, the design of public works and provisions made for constructing the improvements and permanent control monuments this \_\_\_\_ day of \_\_\_\_\_, 20\_\_.

\_\_\_\_\_  
City of Spokane Engineer”

- e. The certification by the Spokane county treasurer, as follows:  
“I hereby certify that the land described in this plat, as of the date of this certification, is not subject to any outstanding fees or assessments. Examined and approved \_\_\_\_ day of \_\_\_\_\_, 20\_\_.

\_\_\_\_\_  
Spokane County Treasurer”

- f. The certification by the Spokane county auditor on each page of the final short plat including the time, date, book and page number of the recording of the final mylar.

- g. Signature of every owner certifying that:
  - i. the plat is made with the free consent and in accordance with the desires of the owners of the land;
  - ii. the owners are the owners of the property and the only parties having interest in the land and is not encumbered by any delinquent taxes or assessments;
  - iii. the owners adopt the plan of lots, blocks and streets shown;
  - iv. owner dedicates to the City and the City's permittees the easements shown for utilities and cable television purposes;
  - v. owner dedicates to the City the streets, alleys and other public places, including slope and construction easements and waives all claims for damages against any governmental authority including, without limitation, the City which may be occasioned to the adjacent land by the establishment, construction, drainage and maintenance of any public way so dedicated; and
  - vi. owner conveys to the City as general City property the buffer strips adjoining unplatted property.
- h. The drawing shall:
  - i. be a legibly drawn, printed or reproduced permanent map;
  - ii. if more than one sheet is required, each sheet shall show sheet numbers for the total sheets;
  - iii. have margins that comply with the standards of the Spokane county auditor;
  - iv. show in dashed lines the existing plat being replatted, if applicable;
  - v. show monuments in accordance with SMC 17G.080.020(H)(1);
  - vi. include any other information required by the conditions of approval; and
  - vii. include any special statements of approval required from governmental agencies, including those pertaining to flood hazard areas, shorelines, critical areas and connections to adjacent state highways.

#### H. Filing.

Once the final plat has been reviewed, approved and signed by the applicable departments, the applicant shall file the final short plat with the county auditor within ten days of approval. No permits shall be issued for a proposed lot until the required conformed copies of the short plat have been submitted to the planning services department.



I. Redivision.

No land within the boundaries of a short subdivision may be further divided in any manner which will create additional lots within a period of five years except by subdivision in accordance with SMC 17G.080.050.



## NONPROJECT DETERMINATION OF NONSIGNIFICANCE

**FILE NO(s):** Shaping Spokane Housing – Residential Development Code Revisions

**PROPONENT:** City of Spokane

### DESCRIPTION OF PROPOSAL:

Following adoption of the [Spokane Housing Action Plan](#) (Res. 2021-0062), the City has initiated a series of text amendments that enact Housing Action Plan strategies to encourage construction of more housing, and increase affordability and housing variety. These amendments are being adopted in order to implement the Legislature’s recommended actions outlined by [RCW 36.70A.600\(1\)](#) in order to increase residential building capacity. Per the provisions of RCW 43.21C.495 State Environmental Policy, this action is not subject to administrative or judicial appeals, as this action is taken expressly to implement provisions of RCW 36.70A.600 “Increasing residential building capacity.”

This proposal will amend Spokane Municipal Code (SMC): Section 17C.110.200, Lot Size, and 17C.110.225, Accessory Structures; and Chapter 17C.300, Accessory Dwelling Units, specifically Sections 17C.300.100, 17C.300.110, 17C.300.120, 17C.300.130, and 17C.300.140. Additional amendments are being made to short plat notification requirements revising Sections 17G.060.100, 17G.060T.003, 17G.060.130, and 17G.080.040; which are procedurally exempt from SEPA review per WAC 197-11-800(19). The exact amendments to the code are available online at the following address: [ShapingSpokaneHousing.com](#).

**LOCATION OF PROPOSAL, INCLUDING STREET ADDRESS, IF ANY:** This proposal has a City-wide impact

**LEAD AGENCY:** City of Spokane

### DETERMINATION:

The lead agency for this proposal has determined that it does not have a probable significant adverse impact on the environment. An Environmental Impact Statement (EIS) is not required under RCW [43.21C.030\(2\)\(c\)](#). This decision was made after review of a completed environmental checklist and other information on file with the lead agency. This information is available to the public upon request.

- There is no comment period for this DNS.
- This DNS is issued after using the optional DNS process in section 197-11-355 WAC. There is no further comment period on the DNS.
- This DNS is issued under 197-11-340(2); the lead agency will not act on this proposal for at least 14 days from the date of issuance (below). **Comments regarding this DNS must be submitted no later than 12:00 p.m. on May 11, 2022 if they are intended to alter the DNS.**



\*\*\*\*\*

**Responsible Official:** Spencer Gardner

**Position/Title:** Director, Planning Services

**Address:** 808 W. Spokane Falls Blvd., Spokane, WA 99201

**Phone:** 509-625-6097

**Date Issued:** April 25, 2022

**Signature:** \_\_\_\_\_  \_\_\_\_\_

\*\*\*\*\*

**APPEAL OF THIS DETERMINATION:**

Per the provisions of RCW 43.21C.495 State Environmental Policy, **this action is not subject to administrative or judicial appeals**, as this action is taken expressly to implement provisions of RCW 36.70A.600 "Increasing residential building capacity." RCW 43.21C.495 states that amendments to development regulations or comprehensive plans to implement certain portions of RCW 36.70A.600 may not be appealed.

<b>Date</b>	<b>Name/Event</b>
11/10/2021	Plan Commission workshop
11/11/2020	City Council study session
11/18/2021	Land Use Committee of the Community Assembly
12/8/2021	Plan Commission workshop
12/17 & 12/22/2021	Winter Market at Riverfront Park (approximately 120 visitors)
1/6/2022	Community Assembly
1/12/2022	Plan Commission workshop
1/18/2022	Lincoln Heights Neighborhood Council
1/25/2022	Virtual Open House #1 – 29 participants
1/26/2022	Plan Commission workshop
1/27/2022	Virtual Open House #2 – 35 participants
2/9/2022	Plan Commission workshop
2/10/2022	City Council study session
2/17/2022	Land Use Committee of the Community Assembly
2/23/2022	Plan Commission workshop
3/9/2022	Plan Commission workshop
3/23/2022	Plan Commission workshop
4/6, 4/13, 4/20, 4/27/2022	Spring Market at Riverfront Park (approximately 190 visitors)
4/12/2022	University District Development Committee
4/12/2022	West Hills Neighborhood Council
4/13/2022	Plan Commission workshop
4/21/2022	Land Use Committee of the Community Assembly
4/27/2022	Plan Commission workshop
5/05/2022	City Council study session
5/05/2022	Community Assembly

## Comment Log and Public Comments

### Substantive Public Comments Received - Updated 05/11/2022

	<b>Date</b>	<b>Name</b>	<b>Topic(s)</b>	<b>Page</b>
1	1/14/2022	Todd Sullivan	ADU size, ADU parking, Short-term rentals	3
2	1/20/2022	Ann Wick	ADU roof and material, ADU parking	5
3	1/20/2022	Hype Beast	Code & zoning changes for housing, Other	6
4	1/25/2022	Conor Muirhead	ADU size, ADU parking	11
5	1/27/2022	Vic Plese	Code changes for housing	13
6	1/28/2022	Sally Phillips	ADU parking	15
7	2/6/2022	Toni Sharkey	Code changes for housing, Duplexes	20
8	2/18/2022	Toni Sharkey	SEPA, Short-term rentals, Duplexes, Attached Homes	17
9	2/20/2022	Jim Frank	ADU size, ADU parking, ADU occupancy, Lot Size Transition	22
10	2/22/2022	Craig Hunt	Short-term rentals	26
11	2/27/2022	Jordan Brown	ADU occupancy	27
12	3/3/2022	Paul Knowles	ADUs, ADU occupancy	28
13	3/12/2022	Jeannie Robinson	ADUs, ADA accessibility	29
14	3/14/2022	Brad Harland	ADU occupancy	30
15	3/15/2022	Shari Mcevoy	ADUs, ADU occupancy	32
16	3/17/2022	Kate Bitz	Attached Homes, Duplexes	33
17	3/17/2022	Cheri Loveland	SEPA	34
18	3/22/2022	Zach Widmer	ADUs, Short-term rentals, ADU parking	35
19	3/24/2022	Diane Benson	Duplexes, Other	37
20	3/24/2022	Evelyn Popejoy	Short-term Rentals, Code changes for housing	38
21	4/6/2022	Barbara Morrissey	Code changes for housing	39
22	4/6/2022	Tracy Parks	Other	40
23	4/6/2022	John Schram	Short-term rentals, Duplexes, Attached Homes	42-46
24	4/9/2022	Brikjames	Code changes for housing	47
25	4/11/2022	Mary Winkes	ADU parking	49
26	4/14/2022	Phyllis Holmes	Short plat notification	50
27	4/14/2022	Nancy Sazama	Short plat notification, SEPA	52
28	4/15/2022	Robyn Hoffenberg	Short plat notification, SEPA	54
29	4/15/2022	Candace Smallfoot	Short plat notification, SEPA	57
30	4/15/2022	Kevin Stevens	Short plat notification, SEPA	60

## Comment Log and Public Comments

31	4/15/2022	Dick Thiel	Short plat notification, SEPA	64
32	4/16/2022	Karen Carlberg	Short plat notification, SEPA	65-68
33	4/18/2022	Mellisa Donaldson	Short plat notification, SEPA	69
34	4/20/2022	Carmela Conroy	ADU	72
35	4/21/2022	Ryan Hughes	ADU	74
36	4/21/2022	Will Maupin	General Phase 1 Code Topics	75
37	4/21/2022	Mariah McKay	ADU	77-81
38	4/22/2022	Liza Mattana	ADU, Attached Homes, Duplex	82
39	4/22/2022	Alice Galeotti	ADU	83
40	4/22/2022	Darin Watkins	General Phase 1 Code Topics	85
41	4/22/2022	Gene Brake	ADU, STR, Duplex	87
42	4/25/2022	Ben Stuckart (SLIHC)	ADU, Short plat notification, SEPA	89
43	4/26/2022	Carol Tomsic	Duplexes, Attached Homes, Short plat notification	90
44	4/28/2022	Gene Brake	General Phase 1 Code Topics	92
45	5/3/2022	Spokane Regional Continuum of Care	ADU, Short plat notification, SEPA	93
46	5/4/2022	Jim Frank	Lot Size Transition, Short Plat notification, ADU	94
47	5/4/2022	Darin Watkins	Lot Size Transition, Short Plat notification, ADU	99
Received after May 11 Plan Commission packet was posted on 5/4/2022				
48	5/10/2022	Carol Tomsic	Lot Size Transition	104
49	5/11/2022	Matt Side	Attached Homes, Duplexes, ADUs	105

## Beck, Amanda

---

**From:** Planning Services Development Code  
**Sent:** Friday, January 21, 2022 3:45 PM  
**To:** Todd Sullivan  
**Subject:** RE: ADU Comments from a Home Builder

Hi Todd,

Thank you for providing public comment concerning the proposed revisions to ADU regulations. This is now part of the public record for the project, and will be shared with the Plan Commission at the public hearing. We really appreciate your insightful and informed comments- in our research we've noticed that trend to increase the size for an ADU.

We are still exploring the range of code alternatives for accessory dwelling units. Plan Commission has another workshop to discuss this as well as duplexes, attached homes, and lot size transitions at their January 26<sup>th</sup> meeting that begins at 2:00 pm. If you're able or interested in attending, [the agenda](#) has the Webex login information. If not, it will be uploaded to the City's [Vimeo](#) soon after the meeting.

Thank you,  
Amanda

Amanda Beck, AICP | City of Spokane | Assistant Planner II  
509-625-6414 | *main* 509-625-6500 | [abeck@spokanecity.org](mailto:abeck@spokanecity.org) | [spokanecity.org](http://spokanecity.org)



---

**From:** Todd Sullivan <toddsull@live.com>  
**Sent:** Friday, January 14, 2022 9:19 AM  
**To:** Planning Services Development Code <erapsdc@spokanecity.org>  
**Subject:** ADU Comments from a Home Builder

**[CAUTION - EXTERNAL EMAIL - Verify Sender]**

As a home builder in the Spokane, Coeur d'Alene and Hayden region, we have been designing proposed ADU's in the Kootenai County for the last 2 years.

My recommendations that stem from my experience in Kootenai is as follows:

- Increase ADU size to 1,000. This provides an ADU with 2 bedrooms and 1 bathroom. Our typical ADU design will have on bedroom acting as an office.
- Require the ADU to match the primary home roof system. This will minimize chaotic design and integrate better with the property and neighborhood. If not, you will have shed roof ADU's as it's cheap to build and the result will be sheds in the backyard.
  - Drive around Coeur d'Alene and look at all the ADU's that are negatively impact the aesthetics of the neighborhood.
- Require 1 parking spot on the property. This is important as the ADU will likely become a rental or unit for family. Parking on-street creates havoc and congestion.
- Short term rentals are an issue. Coeur d'Alene has numerous ADU's for the AirBnB market. In the summer, it becomes hectic with parties, crowds, etc. The owners use the ADU's as additional revenue sources. An ADU

within walking distance to the lake can produce \$75,000 plus in revenue per year if properly managed. I don't have an opinion if that should be a factor, but it's important to understand.

If interested, I'm always available for comment and discussion.

Thanks,  
Todd Sullivan  
Sullivan Homes  
(208) 755-1017  
[todd@sullivanhomespnw.com](mailto:todd@sullivanhomespnw.com)

Sent from [Mail](#) for Windows



## Beck, Amanda

---

**From:** Planning Services Development Code  
**Sent:** Friday, January 21, 2022 3:19 PM  
**To:** ANN Wick  
**Subject:** RE: ADU housing

Hi Ann,

Thank you for providing public comment concerning the proposed revisions to ADU regulations. This is now part of the public record for the project, and will be shared with the Plan Commission for the public hearing once that is scheduled.

We are still exploring the range of code alternatives for accessory dwelling units. Plan Commission has another workshop to discuss this as well as duplexes, attached homes, and lot size transitions at their January 26<sup>th</sup> meeting that begins at 2:00 pm. If you're able or interested in attending, [the agenda](#) has the Webex login information. If not, it will be uploaded to the City's [Vimeo](#) soon after the meeting.

Thank you,  
 Amanda

**Amanda Beck, AICP** | City of Spokane | Assistant Planner II  
 509-625-6414 | *main* 509-625-6500 | [abeck@spokanecity.org](mailto:abeck@spokanecity.org) | [spokanecity.org](http://spokanecity.org)



---

**From:** ANN Wick <TWNANDCNTRY@msn.com>  
**Sent:** Thursday, January 20, 2022 10:07 PM  
**To:** Planning Services Development Code <erapsdc@spokanecity.org>  
**Subject:** ADU housing

**[CAUTION - EXTERNAL EMAIL - Verify Sender]**

I do not believe allowing different styles and different roof pitches would be a good idea for neighborhoods. It would definitely not allow for neighborhood continuity. In addition by not requiring parking the already overcrowded streets would be worse.

Ann Wick

Sent from [Mail](#) for Windows

## Beck, Amanda

---

**From:** Beck, Amanda  
**Sent:** Friday, January 21, 2022 3:41 PM  
**To:** tmbssoe@gmail.com  
**Subject:** Re: Shaping Spokane Housing Update

Good afternoon,

Thank you for providing public comment concerning the residential development code changes proposed under the Shaping Spokane Housing project. These comments have been added to the public record, and will be shared with the Plan Commission at public hearing.

The seven code changes under consideration are possible within the current Comprehensive Plan framework- they would not require amending things like density, land use categories, or the land use map. Some of your detailed suggestions would require code amendments in conjunction with changes to the Comprehensive Plan, which is the action the City will be taking in the second phase of changes. You are welcome and encouraged to reach out to your City Council Member to discuss these ideas as well, as they consider and collaborate with staff on setting the Plan Commission's work program each year.

We're still working through code alternatives with the Plan Commission. They will be further discussing accessory dwelling units, duplexes, attached homes, and lot size transitions at their January 26<sup>th</sup> meeting that starts at 2:00 pm. The [agenda](#) has the Webex login information if you are able or interested in attending, and the video will be posted to the City's [Vimeo](#) account soon after the workshop. Several of the other workshops with Plan Commission discussing these code amendments are available online now.

Thank you,  
 Amanda

**Amanda Beck, AICP** | City of Spokane | Assistant Planner II  
 509-625-6414 | *main* 509-625-6500 | [abeck@spokanecity.org](mailto:abeck@spokanecity.org) | [spokanecity.org](http://spokanecity.org)



**From:** Hype Beast <[tmbssoe@gmail.com](mailto:tmbssoe@gmail.com)>  
**Date:** January 20, 2022 at 6:25:58 PM PST  
**To:** "Davis, Kirstin" <[kdavis@spokanecity.org](mailto:kdavis@spokanecity.org)>  
**Subject:** Re: Shaping Spokane Housing Update

**[CAUTION - EXTERNAL EMAIL - Verify Sender]**  
 k.

Hello, I get and read all the e-mails that you send me. If the city really wants to help development the below items are great but that not your pinch point.

Your pinch point are as follows:

1. Stormwater systems, not being allow to count as open space, or to be used as the 44sf per unit area. People don't typical do stuff outside in bad or cold weather. So the rest of the time it should be an acceptable area to recreate in.

2. Update your Zoning in the City. High density zone should follow your center a corridor codes, but it really they don't on the south by target you have RSF they between apartments in the county and C2-DC that should RMF. Where there is a school you should have more RMF ground as that is a center by the cities definition. Down by Inland Empire that whole area should be a center and corridor as it is it's own community. Out by Geiger and Sunset Blvd the large area of RSF should be RMF as it is difficult ground between two commercial zones.
3. The City should contemplate extending Barnes road down to pine meadow road you have plans on file to do this. This would fix traffic problems in this area.
4. The area around Salk Middle school and the Indian trail shopping center should be a center and corridor just based on traffic alone.
5. Holy Cross Cemetery should be rezoned to RMF, as it is an adjacent to a large shopping area per the centers and corridor code.
6. Garlands RTF zone should be RMF so that, that area can better support local business by having more population.
7. STA, should only focus on major roads and have short wait times and not have a route every where with horrible wait and transit times. Please note that those bus destroy road are exempt from having the correct number of axials per law based on their vehicle weight.
8. The area east of Esmeralda Gold course should be RMF as it impacts no RSF

### Hype Beast

From: City of Spokane Planning <[kdavis@spokanecity.org](mailto:kdavis@spokanecity.org)>

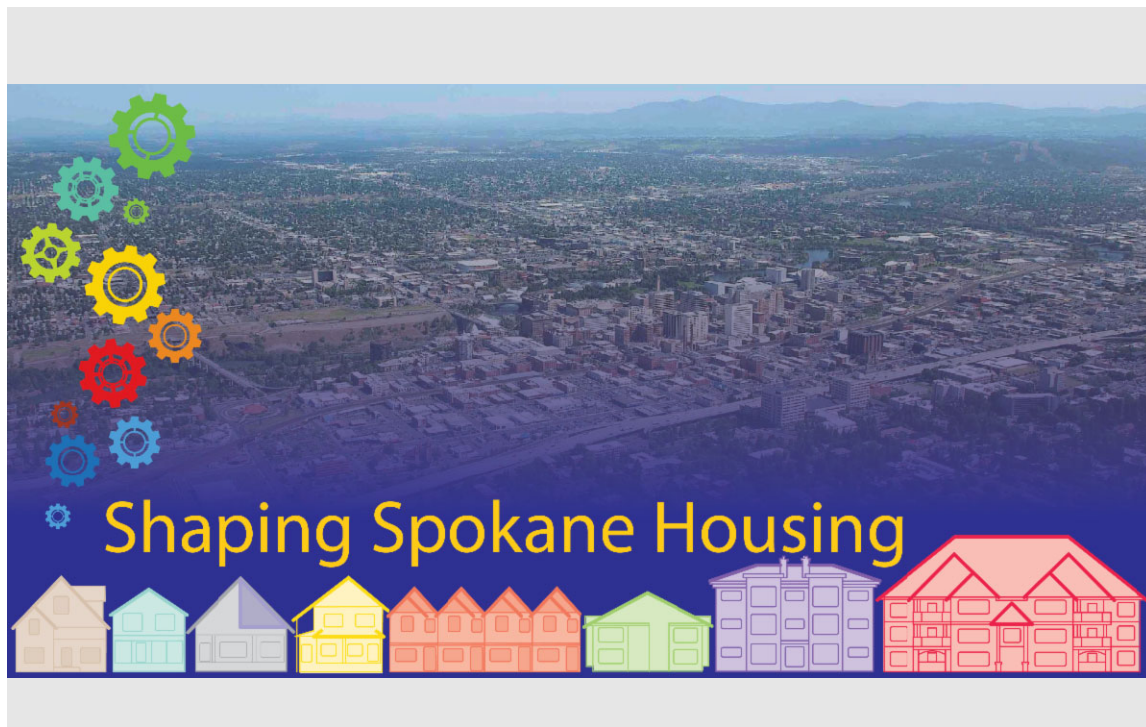

**Duplexes in Residential Single Family Zone**  
 Expand the permitted zoning districts and lot types, update design standards to integrate with neighborhood character.

Dear Community Member,

You are receiving this email because you have shown interest in the Housing Action Plan and requested information about housing topics. The 2021 [Housing Action Plan](#) provided several recommendations and the City planning department has organized them in phases for completion to address the housing crisis.



**Accessory Dwelling Units**

Increase flexibility of development and design standards for Accessory Dwelling Units (ADU).



**Attached Housing**

Encourage infill development, update development and design standards to integrate with neighborhood character.

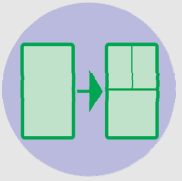

**Short Plat Application Process**

Reduce or streamline the notification and commenting requirements.



**Short Term Rentals**

Expand allowable zones to enable licensing compliance.



**Environmental Review Thresholds**

Adopt exemption levels as permitted in WAC 197-11-800 to streamline permitting processes, add standards for discovery of historic artifacts.

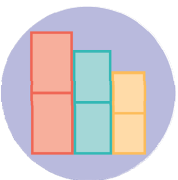

**Lot Size Transition Requirements**

Clarify development regulations, and provide additional flexibility for natural topography or critical areas.

### Learn More and Ask Questions at a Virtual Open House!

Two virtual public open houses have been scheduled to share information and gather input on the proposals. The City is offering two sessions online and by phone over the Webex meeting platform. Both open house sessions will feature the same content.

#### VIRTUAL OPEN HOUSE AGENDA

- **Introduction to Residential Development Code Amendment Process** (10 minutes)
- **Accessory Dwelling Units, Duplexes in More Areas, Attached Housing and Lot Size Transition** (10 minutes)
- **Q&A** (30 minutes)
- **Short Subdivisions, Short-Term Rentals, Environmental Review Thresholds** (10 minutes)
- **Q&A** (30 minutes)

**Tuesday, Jan. 25**  
12-1:30 p.m.  
Registration

**Thursday, Jan. 27**  
4-5:30 p.m.  
Registration

### We want your feedback!

You can **review a description of each proposal on the [project webpage](#)**, which will be updated as the draft revisions evolve.

- **Provide written comment in email to [DevelopmentCode@spokanecity.org](mailto:DevelopmentCode@spokanecity.org)**. This email list will be notified regarding additional opportunities for participation.
- **Sign up for email updates and announcements [here](#).**

### Plan Commission Workshops

Additionally, two City Plan Commission workshops have been scheduled to review possible revisions to the code. Public hearings have not been scheduled at this time. Please visit the [Plan Commission webpage](#) to view the Agendas, which contain packet material available for review and instructions for joining the virtual meetings:

- Wednesday, Jan. 12
- Topics: Short Subdivisions up to 9 Lots, Short-Term Rentals, and Environmental Review Thresholds (Minutes will be posted on the webpage soon.)
- Wednesday, Jan. 26 starting at 2:00 PM
- Topics: Accessory Dwelling Units, Duplexes, Attached Housing, and Lot Size Transition Requirements

You are receiving this email because you signed up via the [Spokane Housing Action Plan website](#), have been identified as an individual or stakeholder in the discussion, or expressed interest in receiving planning project updates from the City of Spokane. Please feel free to share this email with others who are interested in receiving [email announcements](#) about this project. To unsubscribe, please email [developmentcode@spokanecity.org](mailto:developmentcode@spokanecity.org).



[Unsubscribe ewhipple@whipplece.com](#)

[Update Profile](#) | [Constant Contact Data Notice](#)

Sent by kdavis@spokanecity.org powered by



## Beck, Amanda

---

**From:** Beck, Amanda  
**Sent:** Friday, January 28, 2022 10:59 AM  
**To:** Conor Muirhead  
**Subject:** Re: Comment on ADU changes

Hi Connor,

Thank you for providing public comment concerning the proposed revisions to ADU regulations. This is now part of the public record for the project, and will be shared with the Plan Commission at the public hearing. We really appreciate your comments- in our research we've noticed a trend to increase the size for an ADU.

It's not up on our [project webpage](#) just yet, but this week the Plan Commission heard from our consultant on proposals around ADU changes, one of them being to increase the detached ADU size from 600 to 800 square feet. We're also looking at allowing for a floor area ratio bonus that would hopefully help encourage ADU construction as well, in addition to relaxing parking requirements. The recording of the Plan Commission workshop should be uploaded soon, so check back in case you would like to watch it!

If you were able to attend the open house Thursday you might have seen/heard there are people on both sides of the issue concerning parking- some with concerns that it shouldn't be relaxed, and others who see parking requirements as discouraging ADU construction. Your comments on the matter are appreciated.

Thank you,  
 Amanda



**Amanda Beck, AICP** | City of Spokane | Assistant Planner II  
 509-625-6414 | main 509-625-6500 | [abeck@spokanecity.org](mailto:abeck@spokanecity.org) | [spokanecity.org](http://spokanecity.org)



*This email is subject to Washington State Public Records Act, Chapter 42.56 RCW, and may therefore be subject to public disclosure.*

-----Original Message-----

**From:** Conor Muirhead [muirheadc@gmail.com](mailto:muirheadc@gmail.com)  
**Sent:** Tuesday, January 25, 2022 10:47 PM  
**To:** Planning Services Development Code [erapsdc@spokanecity.org](mailto:erapsdc@spokanecity.org)  
**Subject:** Comment on ADU changes

[CAUTION - EXTERNAL EMAIL - Verify Sender]

Hi there,

I just wanted to take a minute to let you all know that I'm very happy you're considering changes around ADU codes, and wanted to emphasize a couple aspects that I hope you'll include in the changes.

Foremost, my hope is that you'll allow for something like a 2-unit ADU to be built in a backyard. At 600 sq. ft each, this could still be done reasonably well on a larger lot.

Second, I hope you'll increase the allowed square footage for detached ADUs, if I'm going through the effort to build a new structure, I'd like it to be large enough to be able to provide a good return on my investment.

Third, I hope that parking requirements will be eased, given that my area utilizes very little street parking, and having some cars on the street feels very reasonable.

Thanks for working on this project, I'm hopeful that we'll be able to make Spokane housing more accessible as a result.

Best,  
-Conor Muirhead



**Gwinn, Nathan**

---

**From:** Beck, Amanda  
**Sent:** Friday, January 28, 2022 12:40 PM  
**To:** Vic Plese; Gwinn, Nathan  
**Subject:** RE: Virtual open house - Code Amendments

Hi Vic,

Thank you for attending the Thursday open house for the residential code initiative concerning [Shaping Spokane Housing](#).

We recorded both open house sessions (2<sup>nd</sup> one will be up on our webpage soon), as well as several past presentations. If you're interested, I highly recommend viewing the Plan Commission workshop from January 12, where we discuss permit processes. The January 26 Plan Commission workshop discussing ADUs/duplexes/etc. from this week will be uploaded to the project page soon- definitely check them out if you have a chance.

If you would like to provide public comment on the project as a whole, or specific code amendments, we would welcome your comments. Please feel free to send those to either Nate or me. Similarly, please encourage other city residents or professionals you know to do the same!

Thank you,  
Amanda

Amanda Beck, AICP | City of Spokane | Assistant Planner II  
509-625-6414 | main 509-625-6500 | [abeck@spokanecity.org](mailto:abeck@spokanecity.org) | [spokanecity.org](http://spokanecity.org)



---

**From:** Vic Plese <Vic@plese.com>  
**Sent:** Thursday, January 27, 2022 5:21 PM  
**To:** Gwinn, Nathan <ngwinn@spokanecity.org>  
**Cc:** Beck, Amanda <abeck@spokanecity.org>  
**Subject:** Virtual open house - Code Amendments

**[CAUTION - EXTERNAL EMAIL - Verify Sender]**

Nathan & Amanda,

Thanks so much for your time working on this - we really need as many options as we can get with the housing shortage. I know I will have clients ask me about these changes so I wanted to have as much info as possible. I'm sorry I was multitasking during the meeting and I had people installing carpet in my office (UGGH) otherwise I would have had my video on. Hate to be rude I mainly wanted to listen. Let me know if I can help anytime if you need Realtor or developer input.

Have a great night...

Vic

**Vic Plese, SRES**

Selling Spokane for 33 years

Licensed in WA & ID

Managing Broker,

PLESE REALTY LLC

Family owned and operated since 1958

201 West Francis Ave

Spokane, WA 99205

e-mail [vic@plese.com](mailto:vic@plese.com)

[WWW.PLESE.COM](http://WWW.PLESE.COM)

**509-217-7889 cell**

**509-489-2323 office**

**509-466-4677 residence**

**509-489-3333 fax**

**888-450-2323 toll free**

**NEW HOMES \*\*\* EXISTING HOMES \*\*\* COMMERCIAL SALES  
LAND DEVELOPMENT \*\*\* LEASING \*\*\* NOTARY PUBLIC**

**From:** [Planning Services Development Code](#)  
**To:** [Sally Phillips](#)  
**Subject:** RE: Housing code changes - one more comment  
**Date:** Friday, January 28, 2022 12:33:00 PM  
**Attachments:** [image001.png](#)  
[image002.png](#)  
[image003.png](#)

---

Hi Sally,

Thank you for providing public comment on proposed revisions to residential code related to the project [Shaping Spokane Housing](#). This is now part of the public record for the project, and will be shared with the Plan Commission at the public hearing.

We're glad to hear that both presentations were useful! Except for the Plan Commission workshop that happened Wednesday this week, all of our past presentations are on the project webpage if you want to see us discuss items in more detail. Nate and I went into more detail with Plan Commission on January 12 about permit processes, and into more detail about ADUs/duplexes/etc. at their January 26 meeting. The video for the meeting on the 26<sup>th</sup> will be uploaded to the webpage soon, definitely check it out if you're interested.

As I'm sure you saw/heard at the open house on Thursday, there are people on both sides of the issue concerning parking- some with concerns that it shouldn't be relaxed, and others who see parking requirements as discouraging ADU construction. We're trying to balance not building to park cars, as you say, but also not creating parking issues- it's can be tricky to strike the correct balance. Your comments on the matter are appreciated.

Thank you,  
Amanda

**Amanda Beck, AICP** | City of Spokane | Assistant Planner II  
 509-625-6414 | main 509-625-6500 | [abeck@spokanecity.org](mailto:abeck@spokanecity.org) | [spokanecity.org](http://spokanecity.org)



---

**From:** Sally Phillips <phillips1948@comcast.net>  
**Sent:** Friday, January 28, 2022 10:44 AM  
**To:** Planning Services Development Code <erapsdc@spokanecity.org>  
**Subject:** Housing code changes - one more comment

**[CAUTION - EXTERNAL EMAIL - Verify Sender]**

**I attended your presentation yesterday on the proposed housing code changes.**

**Thanks for offering the presentation. I also received a briefer version at the Lincoln Heights Neighborhood Council meeting and found both helpful. It was particularly nice to have the slides with prompting questions for us attendees.**

**This is only one vote, but I would like you to know that I support reducing the parking requirement in developments. I am more interested in housing people than cars. I assume the plan where on-site parking is reduced is that people will park on the street. I am OK with that, but it would put more pressure on curbside parking. It seems like people feel very proprietary about curb space in front of their home, thinking (I believe erroneously) that it belongs to them. How you change that attitude, I don't know.**

**Again, nice job on the presentation.**

**Sally Phillips**

**Gwinn, Nathan**

---

**From:** Gwinn, Nathan  
**Sent:** Tuesday, February 22, 2022 4:59 PM  
**To:** 'Antonia DePasquale'  
**Subject:** RE: Housing Ordinance

Good afternoon Toni,

Thanks for your comments. I will combine this with the others and add to the record for the file.

Yes, the Council could ultimately choose to adopt all or part of the amendments. Yes, please send the link.

Nate

**Nathan Gwinn, AICP** | Assistant Planner | Planning & Development  
 509.625.6893 | [ngwinn@spokanecity.org](mailto:ngwinn@spokanecity.org) | [www.spokanecity.org](http://www.spokanecity.org)

Residential Development Code amendments project webpage: [my.spokanecity.org/projects/shaping-spokane-housing](http://my.spokanecity.org/projects/shaping-spokane-housing)

---

**From:** Antonia DePasquale <depasquale5@yahoo.com>  
**Sent:** Friday, February 18, 2022 8:56 PM  
**To:** Gwinn, Nathan <ngwinn@spokanecity.org>  
**Subject:** Re: Housing Ordinance

**[CAUTION - EXTERNAL EMAIL - Verify Sender]**

Good evening Nate, I was trying to be more supportive and open minded about the ordinance last night. The city of Spokane SEPA notifications are so transparent to the citizens, it is refreshing. In the valley notifications are the size of a piece of paper or found in the newspaper, so there are a lot of folks upset that there are so many apartments that happen so quick there.

Short term rentals folks hate them and they hate them with a passion, well 80% do, the 10-20% that are making a cash love them.

Is that piece of the ordinance to get a little more accountability, so we can do a moratorium or a reduction? At Friday Harbor (is where we are at right now ;- ) there's a moratorium on them and they have to give a pretty high percentage to the San Juan Island Land Trust.

So when Council votes, can they vote on certain pieces of the ordinance? Because there are some pieces that I do support, having more housing opportunities for home ownership. And the parking in back I like! Less curb cuts so we can add more trees & green, I like!

I printed this out a couple months back, you may want to change the language highlighted, it makes it seem like duplexes are only rentals.

Making sure that you're in the know about the legislation Andy Billig is working on about developing on undeveloped space? If not, I can send you a link? We could add 40,000 residents to our downtown if there were more developments: high rise condo, retail, apartments, townhomes penthouse OK too!

Nov. 10, and joint Study Session with City Council on Thursday, Nov. 11.

The Housing Action Plan identified potential first steps necessary to address housing affordability. Following any code revisions, **residents could see new types of housing in their neighborhoods**. For example, one recommendation that could be included is the introduction of small-scale duplex development in areas where single-family houses are more common. A duplex is a building that contains primary homes for two families living independently on a single lot. **Additional duplex development would give renters more housing options, increasing overall supply in the community.** However, in allowing additional duplex development as part of this first phase of code changes, design standards and neighborhood compatibility will be taken into consideration.

In many established neighborhoods, the City expects little physical change on any given block. But on a larger scale and in growing neighborhoods, **the ability for additional owners or developers to choose to build duplexes, accessory dwelling units, and attached housing is part of a coordinated strategy to provide greater relief and economic opportunity** to residents facing

Sent from my iPhone

On Feb 9, 2022, at 1:47 PM, Gwinn, Nathan <[ngwinn@spokanecity.org](mailto:ngwinn@spokanecity.org)> wrote:

Good afternoon Toni,

Thanks for your message. I will add it to the public record for the file.

To respond to the question you asked about encouraging ownership, yes, the proposals are designed to work to provide more options for all incomes and both homeownership and rental tenancies. For example, the attached housing (townhouse) proposals involve the possibility of separate fee-simple ownership. Allowing more than two attached houses with a common wall, and potentially smaller attached houses, could be introduced together with the changes to allow duplexes in additional locations, advancing more ownership options for that kind of housing in all neighborhoods.

I am also looking forward to the discussion at the Land Use Committee next week.

Nate

**Nathan Gwinn, AICP** | Assistant Planner | Planning & Development  
509.625.6893 | [ngwinn@spokanecity.org](mailto:ngwinn@spokanecity.org) | [www.spokanecity.org](http://www.spokanecity.org)

Residential Development Code amendments project webpage: [my.spokanecity.org/projects/shaping-spokane-housing](http://my.spokanecity.org/projects/shaping-spokane-housing)

---

**From:** Antonia DePasquale <[depasquale5@yahoo.com](mailto:depasquale5@yahoo.com)>

**Sent:** Sunday, February 6, 2022 2:43 PM

**To:** Gunderson, Dean <[dgunderson@spokanecity.org](mailto:dgunderson@spokanecity.org)>; Gwinn, Nathan <[ngwinn@spokanecity.org](mailto:ngwinn@spokanecity.org)>; Beggs, Breean <[bbeggs@spokanecity.org](mailto:bbeggs@spokanecity.org)>; Kinnear, Lori <[lkinnear@spokanecity.org](mailto:lkinnear@spokanecity.org)>; Greg Francis <[gfrancis1965@yahoo.com](mailto:gfrancis1965@yahoo.com)>; Robert Flowers <[mr\\_mouse@comcast.net](mailto:mr_mouse@comcast.net)>; Tanya Starkel <[tanya@avenuestonerealestate.com](mailto:tanya@avenuestonerealestate.com)>

**Subject:** Housing Ordinance

**[CAUTION - EXTERNAL EMAIL - Verify Sender]**

Good Afternoon Council Members, President and interested parties. I hope all had a nice weekend.

In meeting with RNC, members last week, I received a couple follow up e-mails. We have a few concerns about the new proposed housing and infill ordinance:

We all know we need housing, but home/condo/duplex Ownership (not just a rental market) is critical for any community to thrive and get ahead.



Nate, are there any pieces in the ordinance that encourage home ownership (not just rentals)? I also look forward to hearing about the Design Standards proposed at Land Use meeting next Thursday, thank you for coming.

Personally, I am not interested in an ordinance that makes a few rental market investors from Wall Street richer (see link) and I ask that my Council members and President look into this aspect as well, thank you.

<https://youtu.be/cOEZ2Csxxu8>

Thank you for listening,  
Toni Sharkey

Sent from my iPhone

**From:** [Gardner, Spencer](#)  
**To:** [Churchill, Jackie](#)  
**Cc:** [Black, Tirrell](#); [Gwinn, Nathan](#); [Beck, Amanda](#)  
**Subject:** FW: Comments of Housing Code Amendments  
**Date:** Tuesday, February 22, 2022 3:13:57 PM  
**Attachments:** [Transition and ADU Code Comments.docx](#)  
[Housing Comments Cover Letter.docx](#)

---

See below and attached for comments from Jim Frank.

Jackie: Can you make sure these are entered into the record for Plan Commission and distributed as appropriate?  
Thanks!

Spencer Gardner | Director | Planning Services  
Office 509-625-6097 | Mobile 509-723-7554 | [my.spokanecity.org](mailto:my.spokanecity.org)

-----Original Message-----

From: Jim Frank <[jfrank@greenstonehomes.com](mailto:jfrank@greenstonehomes.com)>  
Sent: Sunday, February 20, 2022 4:13 PM  
To: Gardner, Spencer <[sgardner@spokanecity.org](mailto:sgardner@spokanecity.org)>  
Cc: MacDonald, Steven <[smacdonald@spokanecity.org](mailto:smacdonald@spokanecity.org)>  
Subject: Comments of Housing Code Amendments

[CAUTION - EXTERNAL EMAIL - Verify Sender]

Spencer,

I have attached my comments to the two code sections being addressed by the Plan Commission on Wednesday along with a cover letter to the Commission. I would ask that this be made part of the record.

I know that you are just getting your feet on the ground and have not had the opportunity to dig into much of the housing issues yet. We are only going to get one chance to get the needed changes right. This will be incremental, but when a code review does arise we have to make sure we get it right. The options being presented to the Plan Commission regarding ADUs fall very short of what will be needed for this to be a viable housing option.

Thanks, Jim



February 20, 2022

Planning Commission  
City of Spokane

Re: Housing Code Amendments

Planning Commission Members:

The City of Spokane and the metropolitan region are facing a housing crisis. Housing issues have been raised and discussed in many forums over the past several years. Regrettably no action has been taken, so it is encouraging that some code changes are beginning to come forward. We must not lose sight of the inequality created by the rapidly rising home costs. Those that own a home have received windfall profits and significant wealth creation. Those that do not have become locked out of home ownership and struggle to pay rising rents. This is the price we pay for not allowing a wide range of homes sufficient to meet the needs of the people living in our community. This is sadly well documented in the recent NYT article on the Spokane housing market and the families it has impacted.

I have attached comments on the first two code changes being brought forward regarding the “transition” lot rule and the ADU standards. These are both very important, but only the beginning of the changes that are necessary. Economic and housing diversity is at the heart of what make strong and resilient neighborhoods.

The proposed ADU standards fall far short of what is necessary to encourage this as the significant housing option it can become. The important word here is “encourage”. Our housing development code must do more than permit a wide range of housing options, they must be “encouraged” by the development code so that investment is stimulated and an industry form around them.

Sincerely,

Jim Frank

## **Transition Lot Rules SMC 17C.110.200**

This code section is highly discriminatory, favoring wealthy families on large lots at the expense of middle and low income families. The impact of this code section can be devastating in the way it limits infill development. The Garden District PUD proposed to develop 60 small cottage homes on lots of about 3000 SF. As a result of this code section Greenstone was forced to develop 30 lots of about 7500 SF. The result is fewer very high-priced homes rather than twice as many modestly priced small homes.

No other jurisdiction in the region has a comparable provision. Because economic inequality leads to racial inequality, this code section is a likely violation of the Fair Housing Act.

Option 1, the complete deletion of this code section is the only acceptable option. The option to merely eliminate lots across a ROW is not acceptable. Rear lot line parcels are a significant problem, as they were in the Garden District case.

## **Accessory Dwelling Units (ADU)**

The proposed amendments to the ADU codes sections do not go nearly far enough to “encourage” the development of ADU units. Brent Todarian, the former Planning Director for the City of Vancouver BC, visited Spokane and reviewed Spokane’s ADU codes. He concluded that the rules were so restrictive they would prevent any significant ADU development. This is exactly what happened. He stated at a meeting with planning staff: “It is not sufficient to merely permit desired housing types, they must be encouraged by development regulations”. The code must provide enough flexibility that investment is encouraged and an industry is able to form around the product. Here are the changes that we feel are necessary:

1. There should be no ADU permit required and no permit notice recorded on title. An ADU should be treated as any other accessory building or garage located on a lot. It should require a building permit and compliance with building and development standards that are reviewed as part of the building permit approval. This eliminates the extra ADU fee.
2. An ADU should be allowed on any legal lot regardless of size. There should be no minimum lot size for an ADU. The ADU and the main residence should be required to meet the site coverage standard for the zone classification where the ADU is located. This means that the main residence and the ADU together will not exceed the site coverage in the underlying zone.
3. An ADU should be bound to the normal site development standards (site coverage, setbacks and building height) of the underlying zone. The special standards for ADUs should be eliminated.

4. There should be no maximum size for an ADU. There are no such standards for a single-family home on the lot. Compliance with the development standards of the zone should be sufficient to protect the neighborhood character. There is no justification for establishing separate ADU standard.
5. There should be no special parking standards applied to an ADU. The parking standards should be the same as those applied to the underlying zone. Why would a 1000SF home with a 700SF ADU have a different parking requirement than a 2500SF primary residence?
6. The occupancy requirement for an ADU should be deleted. We don't place occupancy requirements on SF homes and there is no justification for an occupancy requirement for an ADU. Such a requirement has a chilling impact on the development of ADUs and significant financing challenges.

## Beck, Amanda

---

**From:** Beck, Amanda  
**Sent:** Thursday, February 24, 2022 1:22 PM  
**To:** Craig Hunt  
**Subject:** RE: support for short term rentals

Hi Craig,

Thanks for your interest in the short-term rental code amendment and the [Shaping Spokane Housing](#) project. I will include your support for the short-term rental code change in the public comment record, which will be shared with Plan Commission at the public hearing.

Right now the draft code is in a sort of holding pattern, as we've heard a lot of push back from the public over concerns this is expanding a use that is negatively impacting the housing supply. So, we're trying to come up with some additional draft code options that might address these concerns, and the interaction of short-term rentals and accessory dwelling units. Once we have additional options we would take them back to Plan Commission for a workshop before the public hearing process.

Thank you,  
Amanda

**Amanda Beck, AICP** | City of Spokane | Assistant Planner II  
509-625-6414 | *main* 509-625-6500 | [abeck@spokanecity.org](mailto:abeck@spokanecity.org) | [spokanecity.org](http://spokanecity.org)



---

**From:** Craig Hunt <craigthunt@gmail.com>  
**Sent:** Tuesday, February 22, 2022 2:36 PM  
**To:** Beck, Amanda <abeck@spokanecity.org>  
**Subject:** support for short term rentals

**[CAUTION - EXTERNAL EMAIL - Verify Sender]**

Hi Amanda,

I'm wondering if you have any updates regarding the proposed allowance for short term rentals in "all" zones? I'm supportive of the proposed change to the code, which would allow short term rental in areas where residential use is already permitted.

Thanks for your time,  
Craig Hunt

**From:** [Planning Services Development Code](#)  
**To:** ["Jordan Brown"](#)  
**Cc:** [Beck, Amanda](#); [Andrie, Tate](#)  
**Subject:** RE: Support for modification  
**Date:** Wednesday, March 9, 2022 11:49:00 AM

---

Good morning,

Thank you for your comment. It will be added to the public record for the file and forwarded to the Plan Commission and Council when public hearings are scheduled, likely later this spring.

To follow the project, please stay tuned to the project webpage, where those events will be announced.

Nathan Gwinn, AICP | Assistant Planner | Planning & Development  
509.625.6893 | [ngwinn@spokanecity.org](mailto:ngwinn@spokanecity.org) | [www.spokanecity.org](http://www.spokanecity.org)

Residential Development Code amendments project webpage:  
<http://my.spokanecity.org/projects/shaping-spokane-housing>

-----Original Message-----

From: Jordan Brown <[jordan.brown.crna@gmail.com](mailto:jordan.brown.crna@gmail.com)>  
Sent: Sunday, February 27, 2022 12:34 PM  
To: Planning Services Development Code <[erapsdc@spokanecity.org](mailto:erapsdc@spokanecity.org)>  
Subject: Support for modification

[CAUTION - EXTERNAL EMAIL - Verify Sender]

I have been a resident for Spokane for nearly 8 years. In that time, I have seen the housing shortage get worse and the inability for individuals and families purchase homes due to bidding wars, increased prices, and low inventory.

I have been fortunate in that I have both a primary home and rental home. My rental is on a large double lot on the south hill. The home on it is small, and with the insane Costs to remodel, increasing the ability of the home to accommodate more people is not financially viable.

But a small ADU is. With the current owner/occupant restrictions, I cannot proceed this route even though I'd like to. Additionally, the seemingly random guidance for roof pitch/style/etc limits the ability and most likely increases cost of construction.

I appreciate the effort of the planning division in addressing these issues. Allow Spokane to grow in a way that is equitable for all.

Thank you,

Jordan Brown

**From:** [Planning Services Development Code](#)  
**To:** [Paul Knowles](#)  
**Cc:** [Beck, Amanda](#); [Andrie, Tate](#)  
**Subject:** RE: Proposed ADU Changes - Comments in Support  
**Date:** Wednesday, March 9, 2022 11:54:00 AM

---

Good afternoon Paul,

Thank you for your comment. It will be added to the public record for the file and forwarded to the Plan Commission and Council when public hearings are scheduled, likely later this spring.

To follow the project, please stay tuned to the project webpage, where those events will be announced.

**Nathan Gwinn, AICP** | Assistant Planner | Planning & Development  
509.625.6893 | [ngwinn@spokanecity.org](mailto:ngwinn@spokanecity.org) | [www.spokanecity.org](http://www.spokanecity.org)

Residential Development Code amendments project webpage: [my.spokanecity.org/projects/shaping-spokane-housing](http://my.spokanecity.org/projects/shaping-spokane-housing)

---

**From:** Paul Knowles <[knowlespa@gmail.com](mailto:knowlespa@gmail.com)>  
**Sent:** Thursday, March 3, 2022 9:49 PM  
**To:** Planning Services Development Code <[erapsdc@spokanecity.org](mailto:erapsdc@spokanecity.org)>  
**Subject:** Proposed ADU Changes - Comments in Support

**[CAUTION - EXTERNAL EMAIL - Verify Sender]**

Hi,

I just wanted to write a quick note to thank you for considering changes to the code related to ADUs. I believe the ownership requirement creates a barrier to more home owners like myself from investing in an ADU. Living in the Logan Neighborhood near Gonzaga, consider who the future buyer for this house will be. Given that many houses around us are rentals, I would guess that the future buyer will likely be an investor looking to rent to college kids. Given that assumption, it doesn't make sense for us to invest in an ADU unless the ownership requirement is removed - that ownership requirement would limit the pool of potential buyers and the highest and best use for this property - which is probably as a rental.

The other changes being considered for ADUs all seem reasonable and should result in an increase in ADUs being built within the City - providing much needed housing options while removing barriers that prevent homeowners like myself from being part of the housing solution!

Best Regards,  
Paul Knowles



**From:** [Planning Services Development Code](#)  
**To:** [Jeannie` Robinson](#)  
**Cc:** [Andrie. Tate](#)  
**Subject:** RE: Build more ADA units  
**Date:** Thursday, March 17, 2022 5:02:00 PM

---

Good afternoon Ms. Robinson:

Thank you for your comment. I will add it to the public record for the Plan Commission and City Council's review when public hearings are scheduled on the proposed amendments for accessory dwelling units.

Sincerely,

**Nathan Gwinn, AICP** | Assistant Planner | Planning & Development  
509.625.6893 | [ngwinn@spokanecity.org](mailto:ngwinn@spokanecity.org) | [www.spokanecity.org](http://www.spokanecity.org)

Residential Development Code amendments project webpage: [my.spokanecity.org/projects/shaping-spokane-housing](http://my.spokanecity.org/projects/shaping-spokane-housing)

---

**From:** Jeannie` Robinson <mrjeannro7@gmail.com>  
**Sent:** Saturday, March 12, 2022 12:08 PM  
**To:** Planning Services Development Code <erapsdc@spokanecity.org>  
**Subject:** Build more ADA units

**[CAUTION - EXTERNAL EMAIL - Verify Sender]**

Hello, I have many clients in need of ADA units on the ground floor. Please incorporate this type of unit in the different types of apartments that are being designed and built. Thank you,  
Jeannie Robinson

**From:** [Planning Services Development Code](#)  
**To:** [Brad Harland](#)  
**Cc:** [Andrie. Tate](#)  
**Subject:** RE: ADUs  
**Date:** Thursday, March 17, 2022 5:05:00 PM

---

Good afternoon Mr. Harland,

Thank you for your comment. I will include the message in the public record for the file and in the packet for review by the Plan Commission and City Council when public hearings are scheduled on the proposed amendments for accessory dwelling units.

Sincerely,

**Nathan Gwinn, AICP** | Assistant Planner | Planning & Development  
 509.625.6893 | [ngwinn@spokanecity.org](mailto:ngwinn@spokanecity.org) | [www.spokanecity.org](http://www.spokanecity.org)

Residential Development Code amendments project webpage: [my.spokanecity.org/projects/shaping-spokane-housing](http://my.spokanecity.org/projects/shaping-spokane-housing)

---

**From:** Brad Harland <bharland@nxnw.net>  
**Sent:** Monday, March 14, 2022 3:02 PM  
**To:** Planning Services Development Code <erapsdc@spokanecity.org>  
**Subject:** ADUs

**[CAUTION - EXTERNAL EMAIL - Verify Sender]**

Dear Planning Department

For ADU to really take off. You need to be able to address the CCRs that limit neighborhood under their control to Single Family Homes. Most of the neighborhoods built in the last 60 years will not allow ADUs. Therefore your rule change only affects the older neighborhoods.

I realize that will require a state law to override the CCRs. But I think Spokane needs to push for that.

Some of the law changes proposed at the state level (HB 1660) would allow two ADUs on any lot over 4,500sf. That is putting a triplex on these older small lots. That is a lot of density in a relatively small area. That law would also not have any requirement for the owner to live on site. I think that is a bad idea.

You need to be able to allow ADUs in the newer neighborhoods. That way the density is spread out through all neighborhoods.

I know there is also a push to get rid of the owner occupancy requirement for ADU. But I would maintain that requirement. Remember what happened to the lower South Hill when the large houses got cut up into fourplexes and they just became apartments. The neighborhood went downhill.

Without the owner occupancy requirement, a ADU just becomes a duplex. If you want to allow duplexes, zone it for a duplex.

Anyway those are my thoughts.

Brad Harland  
5126 S Lincoln Way, Spokane WA 99224

\_\_\_\_\_  
Brad Harland, CPA  
[bharland@nxnw.net](mailto:bharland@nxnw.net) / Cell 509 838-2924

**From:** [Planning Services Development Code](#)  
**To:** "Shari Mcevoy"  
**Cc:** [Andrie. Tate](#)  
**Subject:** RE: Adding zoning ADU options  
**Date:** Thursday, March 17, 2022 5:07:00 PM

---

Good afternoon Shari,

Thank you for your comment. I will include the message in the public record for the file and in the packet for review by the Plan Commission and City Council when public hearings are scheduled on the proposed amendments for accessory dwelling units.

Sincerely,

**Nathan Gwinn, AICP** | Assistant Planner | Planning & Development  
509.625.6893 | [ngwinn@spokanecity.org](mailto:ngwinn@spokanecity.org) | [www.spokanecity.org](http://www.spokanecity.org)

Residential Development Code amendments project webpage: [my.spokanecity.org/projects/shaping-spokane-housing](http://my.spokanecity.org/projects/shaping-spokane-housing)

-----Original Message-----

**From:** Shari Mcevoy <[smcevoy2222@gmail.com](mailto:smcevoy2222@gmail.com)>  
**Sent:** Tuesday, March 15, 2022 7:34 PM  
**To:** Planning Services Development Code <[erapsdc@spokanecity.org](mailto:erapsdc@spokanecity.org)>  
**Subject:** Adding zoning ADU options

[CAUTION - EXTERNAL EMAIL - Verify Sender]

Hello

I have 3 single family homes

I would like to add and ADU to each

I want you to please remove owner occupied restrictions.

I cannot add them with that restriction

Also

Do we have pre approved ADU plans for ease of permitting?

Sincerely

Shari real estate investor

Sent from my iPhone

**From:** [Planning Services Development Code](#)  
**To:** "Kate B."  
**Subject:** RE: General comment on attached housing & duplexes  
**Date:** Tuesday, March 22, 2022 10:54:00 AM

---

Hi Kate,

Thanks for your message. It will be added to the public record and provided to the Plan Commission and Council when hearings are scheduled on attached housing and duplexes.

Sincerely,  
Nate

**Nathan Gwinn, AICP** | Assistant Planner | Planning & Development  
509.625.6893 | [ngwinn@spokanecity.org](mailto:ngwinn@spokanecity.org) | [www.spokanecity.org](http://www.spokanecity.org)

Residential Development Code amendments project webpage: [my.spokanecity.org/projects/shaping-spokane-housing](http://my.spokanecity.org/projects/shaping-spokane-housing)

---

**From:** Kate B. <kate.a.bitz@gmail.com>  
**Sent:** Thursday, March 17, 2022 8:04 PM  
**To:** Planning Services Development Code <erapsdc@spokanecity.org>  
**Subject:** General comment on attached housing & duplexes

**[CAUTION - EXTERNAL EMAIL - Verify Sender]**

To whom it may concern,

It's so exciting to see progress on legalizing attached housing and duplexes in larger areas of the City. This is important for our city and I urge you to maximize this opportunity.

Thanks!

- Kate Bitz  
West Central Homeowner

**From:** [Planning Services Development Code](#)  
**To:** "cheri.loveland"  
**Cc:** [Beck, Amanda](#); [Andrie, Tate](#)  
**Subject:** RE: Environmental Review Changes  
**Date:** Thursday, March 17, 2022 5:21:00 PM

---

Good afternoon Ms. Loveland,

Thank you for your comment. I will include the message in the public record for the file and in the packet for review by the Plan Commission and City Council when public hearings are scheduled on the proposed amendments for the proposed SEPA changes. For information, the timing for that may differ from the consideration of the accessory dwelling unit and some of the other topics.

Sincerely,

**Nathan Gwinn, AICP** | Assistant Planner | Planning & Development  
 509.625.6893 | [ngwinn@spokanecity.org](mailto:ngwinn@spokanecity.org) | [www.spokanecity.org](http://www.spokanecity.org)

Residential Development Code amendments project webpage: [my.spokanecity.org/projects/shaping-spokane-housing](http://my.spokanecity.org/projects/shaping-spokane-housing)

---

**From:** cheri.loveland <cheriloveland@gmail.com>  
**Sent:** Thursday, March 17, 2022 4:30 PM  
**To:** Planning Services Development Code <erapsdc@spokanecity.org>  
**Subject:** Environmental Review Changes

**[CAUTION - EXTERNAL EMAIL - Verify Sender]**

Dear City of Spokane Planning Commission,

I would like to let my voice be heard in opposition to any changes in the current SEPA rules the city currently has implemented.

Those rules were decided with forethought and reason and should not be changed just because someone wants to streamline a process.

If the city is really thinking “green” you can’t increase the levels. It just doesn’t make sense.

Sincerely,  
 Cheri Loveland

**From:** [Gwinn, Nathan](#)  
**To:** [Zwidmer@gmail.com](mailto:Zwidmer@gmail.com)  
**Cc:** [Churchill, Jackie](#); [Beck, Amanda](#); [Gardner, Spencer](#)  
**Subject:** RE: ADU Code Public Comment  
**Date:** Tuesday, March 22, 2022 5:12:39 PM

---

Good afternoon Mr. Widmer,

I will add your comment to the public record for the file. This will be provided to the Plan Commission and City Council at the time of the public hearings for the code amendments for ADUs, likely later this spring.

Your contact information will be added to the project email and notified when hearings are scheduled. Or to follow the project, please stay tuned to the project webpage, where those events will be announced.

Sincerely,

Nate

**Nathan Gwinn, AICP** | Assistant Planner | Planning & Development  
[509.625.6893](tel:509.625.6893) | [ngwinn@spokanecity.org](mailto:ngwinn@spokanecity.org) | [www.spokanecity.org](http://www.spokanecity.org)

Residential Development Code amendments project webpage: [my.spokanecity.org/projects/shaping-spokane-housing](http://my.spokanecity.org/projects/shaping-spokane-housing)

---

**From:** Churchill, Jackie <[jchurchill@spokanecity.org](mailto:jchurchill@spokanecity.org)>  
**Sent:** Tuesday, March 22, 2022 4:17 PM  
**To:** Gwinn, Nathan <[ngwinn@spokanecity.org](mailto:ngwinn@spokanecity.org)>; Beck, Amanda <[abeck@spokanecity.org](mailto:abeck@spokanecity.org)>  
**Subject:** FW: ADU Code Public Comment

Hi Nate and Amanda,

The public comment below regarding ADU rules was sent to the Plan Commission email.

Thanks, Jackie

---

**From:** [zwidmer@gmail.com](mailto:zwidmer@gmail.com) <[zwidmer@gmail.com](mailto:zwidmer@gmail.com)>  
**Sent:** Tuesday, March 22, 2022 11:37 AM  
**To:** Plan Commission <[eraplanc@spokanecity.org](mailto:eraplanc@spokanecity.org)>  
**Cc:** Byrd, Giacobbe <[gbyrd@spokanecity.org](mailto:gbyrd@spokanecity.org)>; Kinnear, Lori <[lkinnear@spokanecity.org](mailto:lkinnear@spokanecity.org)>  
**Subject:** ADU Code Public Comment

**[CAUTION - EXTERNAL EMAIL - Verify Sender]**

I watched the meeting on ADU code development and have a few comments.

I'm no expert, but it does seem to me like ADU rules are really just punishing homeowners

with additional byzantine rules and costs that developers don't have to face just because homeowners have an existing structure. I don't like that developers get one set of rules and homeowners need to follow those rules, plus an additional set of rules because they have done the normal thing and purchased property with an existing house on it. It seems to me that if something is allowed for our neighborhood coding, it should be allowed, period.

Maybe I'm missing something, but I don't understand why structures that would be allowed by our overall code should be restricted just because of the basis that there is an existing structure on the property.

I do have two concerns:

1. I share Councilwoman Kinnear's perspective on what this could do considering existing market conditions. Specifically corporate capital being spent on properties affecting rates of rental vs home ownership and even rates of corporate landlords. Our community should take some steps to make sure that the benefits of our city flow reasonably to the residents of it.
2. Parking is and will always be an issue that we should attempt to mitigate, but adding additional legal requirements on top of already existing ones is not the place to address them. Once again, developers should not be given preferential treatment. If existing ones need to be adjusted, do so, but do not impose separate rules on owners and developers.

Thank you,  
Zach Widmer | District 3



**From:** [Planning Services Development Code](#)  
**To:** ["Diane Benson"](#)  
**Cc:** [Beck, Amanda](#)  
**Subject:** RE: Housing Action Plan  
**Date:** Monday, March 28, 2022 8:30:00 AM

---

Good morning Ms. Benson,

Thank you for your comment. I will add it to the public record for the files for the accessory dwelling unit and duplex topics. It will be provided to the Plan Commission and City Council when hearings are scheduled, probably later this spring. I will also add your name to the contact list for project information, and events will be announced on the project webpage.

Sincerely,

Nate

**Nathan Gwinn, AICP** | Assistant Planner | Planning & Development  
509.625.6893 | [ngwinn@spokanecity.org](mailto:ngwinn@spokanecity.org) | [www.spokanecity.org](http://www.spokanecity.org)

Residential Development Code amendments project webpage: [my.spokanecity.org/projects/shaping-spokane-housing](http://my.spokanecity.org/projects/shaping-spokane-housing)

---

**From:** Diane Benson <dcb1810@yahoo.com>  
**Sent:** Thursday, March 24, 2022 3:16 PM  
**To:** Planning Services Development Code <erapsdc@spokanecity.org>  
**Subject:** Housing Action Plan

**[CAUTION - EXTERNAL EMAIL - Verify Sender]**

Thanks so much for all of your hard work on the Housing Action Plan. I'm a home owner in Lower South Hill. I support the HAP and hope it is approved and implemented.

We need more affordable housing, especially condos, small houses, duplexes, etc. Not everyone wants a large house on a large lot, even if they can afford it.

My only concern about adding more apartments is irresponsible landlords. Here on South Hill, some of the apartment buildings are decrepit and strewn with trash. Please include consequences for landlords who don't keep their properties maintained.

Thanks,

Diane Benson

**From:** [Planning Services Development Code](#)  
**To:** [Evelyn Popejoy](#)  
**Cc:** [Beck, Amanda](#)  
**Subject:** RE: Changing Standards for Housing  
**Date:** Monday, March 28, 2022 8:25:00 AM

---

Good morning Ms. Popejoy,

Thank you for sending your comment. I will add it to the public record for the files for the accessory dwelling unit, short term rental, and duplex and attached housing topics. It will be provided to the Plan Commission and City Council when hearings are scheduled, probably later this spring. I will also add your name to the contact list for project information, and events will be announced on the project webpage.

Sincerely,

Nate

**Nathan Gwinn, AICP** | Assistant Planner | Planning & Development  
509.625.6893 | [ngwinn@spokanecity.org](mailto:ngwinn@spokanecity.org) | [www.spokanecity.org](http://www.spokanecity.org)

Residential Development Code amendments project webpage: [my.spokanecity.org/projects/shaping-spokane-housing](http://my.spokanecity.org/projects/shaping-spokane-housing)

-----Original Message-----

From: Evelyn Popejoy <evbunny@icloud.com>  
Sent: Thursday, March 24, 2022 1:11 PM  
To: Planning Services Development Code <erapsdc@spokanecity.org>  
Subject: Changing Standards for Housing

[CAUTION - EXTERNAL EMAIL - Verify Sender]

I think we should be very careful about changing all of our housing standards, especially without having input with each project. I think having a lot of tiny plots crammed into areas is not what our city needs. I particularly don't think that we need a lot of short term rentals, especially if they are not kept up to community standards. Is someone going to make sure these do not just turn into "dumps"? Evelyn Popejoy

**From:** [Planning Services Development Code](#)  
**To:** ["barbara morrissey"](#)  
**Cc:** [Gwinn, Nathan](#)  
**Subject:** RE: hillside development  
**Date:** Thursday, April 14, 2022 12:21:40 PM

---

Hi Barbara,

Thank you for providing public comment on proposed revisions to residential code related to the project Shaping Spokane Housing. Your email is now part of the public record for the project, and will be shared with the Plan Commission at the public hearing.

Thank you,  
Amanda

Amanda Beck, AICP | City of Spokane | Assistant Planner II  
509-625-6414 | main 509-625-6500 | [abeck@spokanecity.org](mailto:abeck@spokanecity.org) | [spokanecity.org](http://spokanecity.org)

-----Original Message-----

From: barbara morrissey <[taslin10@earthlink.net](mailto:taslin10@earthlink.net)>  
Sent: Wednesday, April 6, 2022 11:48 AM  
To: Planning Services Development Code <[erapsdc@spokanecity.org](mailto:erapsdc@spokanecity.org)>  
Subject: hillside development

[CAUTION - EXTERNAL EMAIL - Verify Sender]

lived in Peaceful valley for several years. On the south it is surrounded by steep spring undermined slopes with a history of landslides...most recently last year. on Clarke.

One of the old neighborhood plans recommended no development on the bluff between Clarke and Riverside....already several MULTIFAMILY buildings up there. This area should be reassessed for development (ie forbidden) Already a lot across from me is on a sliding hillside which could easily slide into an historic building downslope if it goes.

Sincerely,

Barbara Morrissey  
1647 west clarke ave  
509 456 5565  
[taslin10@earthlink.net](mailto:taslin10@earthlink.net)

**From:** [Planning Services Development Code](#)  
**To:** "Traci P"  
**Cc:** [Gwinn, Nathan](#)  
**Subject:** RE: small time landlord  
**Date:** Thursday, April 14, 2022 11:42:24 AM  
**Attachments:** [image001.png](#)  
[image002.png](#)  
[image003.png](#)

---

Hi Tracy,

Thank you for providing public comment concerning the residential development code changes proposed under the Shaping Spokane Housing project. These comments have been added to the public record, and will be shared with the Plan Commission at public hearing.

The City's [Rental Assistance Program for Landlords](#) did provide Covid-related assistance as much as funding could be spread out to small time landlords, and the monies have been disbursed. I believe the City is working on another application to request further Federal funds to support landlords, the caveat being federal funding has many strings (renter incomes within a certain range, unit rents set at a rate that is affordable, reporting and annual inspections, etc.) but we don't have additional funding at this time.

Through the [Shaping Spokane Housing](#) project we are encouraging missing middle housing types- duplexes and attached homes- in more of our residential zones with these code changes, and we're looking at doing more for missing middle housing types like tri- and four-plexes.

Thanks for your investment and time as a landlord in Spokane.

Thank you,  
Amanda

**Amanda Beck, AICP** | City of Spokane | Assistant Planner II  
 509-625-6414 | main 509-625-6500 | [abeck@spokanecity.org](mailto:abeck@spokanecity.org) | [spokanecity.org](http://spokanecity.org)



---

**From:** Traci P <tracip1961@gmail.com>  
**Sent:** Wednesday, April 6, 2022 10:28 AM  
**To:** Planning Services Development Code <erapsdc@spokanecity.org>  
**Subject:**

**[CAUTION - EXTERNAL EMAIL - Verify Sender]**

I have rental properties in Spokane. I have already sold one because of covid and people didn't have to pay rent. When the next one gets empty, I will do the same until all are gone.

My rentals are very reasonably priced and I have tons of applicants that apply when one becomes available. I did not increase my rents nor have I since everyone moved in. My promise to them.

My taxes have increased two fold since I've owned them. My insurance now is extremely high because our credit is no longer taken into consideration.

When I got into the rental business, things were more reasonable. Now you are pricing us out of our income. My main objective was to provide nice housing for a reasonable price. That is no longer true. This is my income, which with the increased expenses, has been diminished to next to nothing. Because of this, I am being forced to disolve my rentals so that I don't have to increase my rents. I know, I'm not the only landlord out there that is doing so.

You spend all this time and money trying to figure out how to house more people, when you have no incentive going to the landlord to keep their properties affordable or to even keep them as rentals. Personally, with the housing the way it is, I could probably get another \$500 a month for each property.

You give all kind of breaks to renters, but what about the landlords? We are suffering. The more properties we sell, the less rentals you will have. Thus you have to keep building. Wouldn't it be more cost effective to give us an incentive for keeping our properties available to rent? My rental house sold in 4 days at a very elevated cost.

There is no reason to hang onto them, if it no longer serves our interest.

That's what covid did to us. The renters got all the relief. We just took a huge hit, with higher taxes and insurance rates.

Between my houses, insurance and taxes, there was an increase of over \$1000 per year and that is for only 4 houses. That is ridiculous. I can't afford to keep them any longer. I would make much more money selling them and reinvesting in anything other than real estate.

It's only a matter of time, before there will only be rental places that are multi family dwellings. Houses will no longer be a dream. It's bad enough that the inventory of rental houses are going down. But home ownership is only going to be available to a select few, due to the increase in prices.

It's a double edged sword. I suggest you start with the landlords and see what they say. They are going to be essential for our housing future. Without landlords, where will Spokane be?

This coming from a small time landlord. The rental companies just keep jacking up the rents when their expenses go up.

Thank you for listening,

Tracy Parks  
L

**From:** [John Schram](#)  
**To:** [Planning Services Development Code](#)  
**Subject:** Re: attached housing feedback  
**Date:** Wednesday, April 6, 2022 12:21:03 PM

---

**[CAUTION - EXTERNAL EMAIL - Verify Sender]**

2<sup>nd</sup> attempt as my first email was rejected by the server

John

---

**From:** John Schram  
**Sent:** Wednesday, April 6, 2022 12:18 PM  
**To:** [developmentcode@spokanecity.org](mailto:developmentcode@spokanecity.org) <[developmentcode@spokanecity.org](mailto:developmentcode@spokanecity.org)>  
**Subject:** attached housing feedback

Please remove the proposed change to RA, RSF and RSF-C zoning to allow for additional attached housing units an already established neighborhoods. As one selects a neighborhood, let alone street to live on, there are many factors that are taken into consideration including what style and type of housing is predominant. This proposed change nullifies every existing homeowner's preference in that regard and degrades their experience.

If there is a desire for attached housing units and other non-single family standalone housing alternatives, have it an option for a new build community only.

John Schram

**From:** [John Schram](#)  
**To:** [Planning Services Development Code](#)  
**Subject:** Duplexes feedback  
**Date:** Wednesday, April 6, 2022 12:08:58 PM

---

**[CAUTION - EXTERNAL EMAIL - Verify Sender]**

Please remove the proposed change to RSF and RSF-C zoning to allow for duplexes in already established neighborhoods. As one selects a neighborhood let alone street to live on there are many factors that are taken into consideration including what style and type of housing is predominant. This proposed change nullifies every existing homeowners preference in that regard and degrades their experience.

If there is a desire for additional duplex and other non-single family housing alternatives, have it an option for a new build community only.

John Schram

**From:** [John Schram](#)  
**To:** [Planning Services Development Code](#)  
**Subject:** Short term rental reedback  
**Date:** Wednesday, April 6, 2022 11:34:12 AM

---

**[CAUTION - EXTERNAL EMAIL - Verify Sender]**

Please eliminate all short term rentals in Spokane County. This will immediately free up hundreds of rental units for those that wish to make/keep Spokane their permanent home. Let's employ basic economic principles to increase supply and keep housing in the affordability range. There is already adequate space in our existing hotel inventory for visitors.

John Schram



**From:** [Planning Services Development Code](#)  
**To:** "John Schram"  
**Cc:** [Gwinn, Nathan](#)  
**Subject:** RE: attached housing feedback  
**Date:** Thursday, April 14, 2022 12:08:50 PM  
**Attachments:** [image001.png](#)  
[image002.png](#)  
[image003.png](#)

---

Hi John,

Thank you for providing public comment on proposed revisions to residential code related to the project [Shaping Spokane Housing](#). This email and your other emails concerning short term rentals and duplexes are now part of the public record for the project, and will be shared with the Plan Commission at the public hearing.

I did want to highlight, we're looking at code changes around duplexes and attached houses, but attached houses are typically owner-occupied since they are single-family attached development. We're looking at both missing middle housing types.

None of those topics are scheduled for public hearing yet, but you will be able to see notice about public hearings on the project page and the [Plan Commission page](#) under Agenda.

Thank you,  
Amanda

**Amanda Beck, AICP** | City of Spokane | Assistant Planner II

509-625-6414 | main 509-625-6500 | [abeck@spokanecity.org](mailto:abeck@spokanecity.org) | [spokanecity.org](http://spokanecity.org)



---

**From:** John Schram <John@johnschram.com>  
**Sent:** Wednesday, April 6, 2022 12:21 PM  
**To:** Planning Services Development Code <erapsdc@spokanecity.org>  
**Subject:** Re: attached housing feedback

**[CAUTION - EXTERNAL EMAIL - Verify Sender]**

2<sup>nd</sup> attempt as my first email was rejected by the server  
John

---

**From:** John Schram  
**Sent:** Wednesday, April 6, 2022 12:18 PM  
**To:** [developmentcode@spokanecity.org](mailto:developmentcode@spokanecity.org) <[developmentcode@spokanecity.org](mailto:developmentcode@spokanecity.org)>  
**Subject:** attached housing feedback

Please remove the proposed change to RA, RSF and RSF-C zoning to allow for additional attached housing units in already established neighborhoods. As one selects a neighborhood, let alone street to live on, there are many factors that are taken into consideration including what style and type of housing is predominant. This proposed change nullifies every existing homeowner's preference in that regard and degrades their experience.

If there is a desire for attached housing units and other non-single family standalone housing alternatives, have it an option for a new build community only.

John Schram

**From:** [Beck, Amanda](#)  
**To:** "Brikjames"  
**Cc:** [Gwinn, Nathan](#)  
**Subject:** RE: Residential Development Code Amendments is an idiotic idea  
**Date:** Thursday, April 14, 2022 12:46:53 PM  
**Attachments:** [image001.png](#)  
[image002.png](#)  
[image003.png](#)

---

Hi Brikjames,

Thank you for providing public comment on proposed revisions to residential code related to the project [Shaping Spokane Housing](#). Your email is now part of the public record for the project, and will be shared with the Plan Commission at the public hearing.

We anticipate code changes to Accessory Dwelling Units, Short Plat Notification, and Lot Size Transitions will go to public hearing with Plan Commission on May 11<sup>th</sup>, if you wish to provide additional comment during the meeting we encourage you to attend in person or virtually. The other residential code topics are still being discussed and don't have a hearing date at this time. You can view the agenda once it's posted on the Plan Commission [page](#) under Agenda.

Thank you,  
Amanda

**Amanda Beck, AICP** | City of Spokane | Assistant Planner II

509-625-6414 | main 509-625-6500 | [abeck@spokanecity.org](mailto:abeck@spokanecity.org) | [spokanecity.org](http://spokanecity.org)



---

**From:** Brikjames <brikjames@aol.com>  
**Sent:** Saturday, April 9, 2022 5:33 PM  
**To:** Beck, Amanda <abeck@spokanecity.org>  
**Subject:** Residential Development Code Amendments is an idiotic idea

**[CAUTION - EXTERNAL EMAIL - Verify Sender]**

Hi,

I would like to say that there might be a couple ideas that are useful, but overall the plan is made be uneducated simple minded folk. This idea does not benefit the people of Spokane. It will create a poor city that lives off the money that we put into the government. This doesn't help the homeless that have no desire to work for a living and pay rent. If it does then that means even more money is coming out of my pocket to pay for them. Why would anyone want their house to be worth less? It is not our responsibility to facilitate people who want to move here. It is not our responsibility to change our city for anyone. They can either move into what is currently established or they can find somewhere else to live. I'm betting that you are all patting yourselves on the back for this simple-minded effort that does not take into account any of the possible ramifications from enacting it. If you did an organized effort in a single district then it might work. Trying to change the whole city all at once is asking for us to turn into a lesser known Seattle,

which has been an obvious failure as a city. Are you trying to bankrupt the people of this city?

**From:** [Planning Services Development Code](#)  
**To:** "mary"  
**Cc:** [Gwinn, Nathan](#)  
**Subject:** RE: Parking requirements for ADUs  
**Date:** Thursday, April 14, 2022 12:08:25 PM  
**Attachments:** [image001.png](#)  
[image002.png](#)  
[image003.png](#)

---

Hi Mary,

Thank you for providing public comment on proposed revisions to residential code related to the project [Shaping Spokane Housing](#). Your email concerning ADU parking is now part of the public record for the project, and will be shared with the Plan Commission at the public hearing.

There will be room for further public comment at the May 11<sup>th</sup> hearing if you wish to convey opinions from the Community Assembly folks, or want to encourage other residents to provide public comment.

Thank you,  
Amanda

**Amanda Beck, AICP** | City of Spokane | Assistant Planner II

509-625-6414 | main 509-625-6500 | [abeck@spokanecity.org](mailto:abeck@spokanecity.org) | [spokanecity.org](http://spokanecity.org)



---

**From:** mary <mmcsपो@yahoo.com>  
**Sent:** Monday, April 11, 2022 11:04 AM  
**To:** Planning Services Development Code <erapsdc@spokanecity.org>  
**Subject:** Parking requirements for ADUs

**[CAUTION - EXTERNAL EMAIL - Verify Sender]**

Please restore the parking requirement for 1 bedroom ADUs. There are already far too many cars parked on the city streets. The city has a serious, persistent problem with car burglaries and prowlings and adding more cars to target will just add to the already significant problem. I understand the need for more housing, but we need to be careful we are not creating a "Capitol Hill" here in Spokane. Let us learn from the mistakes that other cities have already made!

Thank you.

**From:** [Beck, Amanda](#)  
**To:** ["phyllisholmes@att.net"](mailto:phyllisholmes@att.net)  
**Cc:** [Gwinn, Nathan](#)  
**Subject:** RE: Changed to notifications  
**Date:** Thursday, April 14, 2022 1:13:25 PM  
**Attachments:** [image001.png](#)  
[image002.png](#)  
[image003.png](#)  
[image004.png](#)

---

Hi Phyllis,

Thank you for providing public comment on proposed revisions to residential code related to the project [Shaping Spokane Housing](#). Your email is now part of the public record for the project, and will be shared with the Plan Commission at the public hearing.

Our code will maintain notification for Neighborhood Councils. During the application completeness stage NCs as well as other City departments, local/state/federal agencies have a 14-day window to provide comments and require additional information. This is codified in [Section 17G.060.090](#). So, we are proposing some streamlining for notification on short plats (removing notice for 2-lots, keeping mailed notice for 3-9 lots) and think this strikes a sort of balance given that NCs are notified when a permit application is received.

Thank you for your service of Spokane.

Thank you,  
Amanda



**Amanda Beck, AICP** | City of Spokane | Assistant Planner II

509-625-6414 | main 509-625-6500 | [abeck@spokanecity.org](mailto:abeck@spokanecity.org) | [spokanecity.org](http://spokanecity.org)



*This email is subject to Washington State Public Records Act, Chapter 42.56 RCW, and may therefore be subject to public disclosure.*

-----Original Message-----

From: Phyllis Holmes [phyllisholmes@att.net](mailto:phyllisholmes@att.net)  
 Sent: Thursday, April 14, 2022 11:26 AM  
 To: Beck, Amanda [abeck@spokanecity.org](mailto:abeck@spokanecity.org)  
 Subject: Changed to notifications

[CAUTION - EXTERNAL EMAIL - Verify Sender]

I am reading proposed changes to notification procedures for short plats, etc. Is the intent to notify neighborhood councils? When Mayor Geraghty and I created neighborhood councils it was for the purpose of enhancing communication about impacts on those neighborhoods. I trust that intent is being maintained. Phyllis Holmes, former City Council member

Sent from my iPhone

**From:** [Beck, Amanda](#)  
**To:** "Nancy Sazama"  
**Cc:** [Gwinn, Nathan](#)  
**Subject:** RE: SEPA Changes  
**Date:** Thursday, April 14, 2022 1:12:35 PM  
**Attachments:** [image001.png](#)  
[image002.png](#)  
[image003.png](#)

---

Hi Nancy,

Thank you for providing public comment on proposed revisions to residential code related to the project [Shaping Spokane Housing](#). Your email is now part of the public record for the project, and will be shared with the Plan Commission at the public hearing.

The proposed changes to the SEPA categorical exemptions thresholds would remove notice on some projects, this is true, and we are trying to thread the needle on streamlining the development process to help construction of more housing while maintaining some notice to residents. SEPA is often a situation where if the number of units or square feet meets the threshold, but excavation or grading on site goes over threshold, then a project kicks back in for SEPA review since the intent there is to evaluate possible environmental impacts and enact mitigations.

There are other notification points during the permit application process though. During the application completeness stage neighborhood councils as well as other City departments, local/state/federal agencies have a 14-day window to provide comments and require additional information. This is codified in [Section 17G.060.090](#). Any Type II permit (site plan, conditional use permit, long or short plat) would have mailed notice and sometimes site postings (you can view that in [Table 17G.060T-3](#)). So, we are trying to balance a streamlined permit process, the urgent need for more housing, and notification to residents.

Thank you,  
Amanda

**Amanda Beck, AICP** | City of Spokane | Assistant Planner II

509-625-6414 | *main* 509-625-6500 | [abeck@spokanecity.org](mailto:abeck@spokanecity.org) | [spokanecity.org](http://spokanecity.org)



FIND US



LIKE US



FOLLOW US

---

**From:** Nancy Sazama <njsazz@gmail.com>  
**Sent:** Thursday, April 14, 2022 11:32 AM  
**To:** Beck, Amanda <abeck@spokanecity.org>  
**Subject:** SEPA Changes

**[CAUTION - EXTERNAL EMAIL - Verify Sender]**

I want to object to the changes the City is considering to SEPA. Why would the city not want their citizens to be in the loop regarding development? The City's priority is development. I can



understand why that is so, especially considering the lack of housing. Comment periods slow things down, making it more complicated to include public input. I get that. Developments with fewer than 30 houses can still be very impactful and citizens deserve to continue to be asked what they think. People who live in the area of a proposed development know that area better than anyone. They know the current problems and potential problems that may arise due to a development. Once the building is done it is often too late, or too expensive to correct issues that arise. Often the area neighborhood can give a heads up to potential issues. It is not just about stopping development but making sure development is done intelligently and with the good of all in mind.

A case in point is the continued development in Latah Valley. This issue has many sides, non easy to reconcile at this time. The inadequacy of infrastructure is critical to everyone's safety today and into the future.

I appreciate your willingness to hear our concerns.

Sincerely,  
Nancy J. Sazama

**From:** [Beck, Amanda](#)  
**To:** [rhoffenberg@aol.com](mailto:rhoffenberg@aol.com)  
**Subject:** RE: Comment on SEPA changes  
**Date:** Monday, April 18, 2022 12:54:00 PM  
**Attachments:** [image001.png](#)  
[image002.png](#)  
[image003.png](#)

---

Hi Robyn,

Thank you for providing public comment on proposed revisions to residential code related to the project [Shaping Spokane Housing](#). Your email is now part of the public record for the project, and will be shared with the Plan Commission at the public hearing.

Please be aware that proposed changes to short plat notification will be going to public hearing at the May 11th Plan Commission meeting. When the agenda is posted, you can find meeting information on the [Plan Commission webpage](#).

At the end of the 60-Day Agency and Public Comment period for the proposed SEPA code changes, which runs April 4 through June 6, the City will review and evaluate comments to determine if revisions to the proposed SEPA code changes are warranted before taking the draft code to public hearing. No public hearing is scheduled at this time.

Thank you,  
Amanda

**Amanda Beck, AICP** | City of Spokane | Assistant Planner II

509-625-6414 | main 509-625-6500 | [abeck@spokanecity.org](mailto:abeck@spokanecity.org) | [spokanecity.org](http://spokanecity.org)



---

**From:** rhoffenberg@aol.com <rhoffenberg@aol.com>  
**Sent:** Friday, April 15, 2022 6:07 AM  
**To:** Beck, Amanda <abeck@spokanecity.org>  
**Subject:** Comment on SEPA changes

**[CAUTION - EXTERNAL EMAIL - Verify Sender]**

Amanda Beck

This is not what the citizens and residences should be looking at. We have the right and, it's your responsibility to all of us, to do the right thing and not take away those rights to agree or disagree on what's going to happen in our neighbors (our homes).

The developers and local government are only looking at profit without looking at the whole picture. We have every right to know what's happening and you need to keep everyone informed. We, as a whole, will do whatever needs to be done to stop this.

Do the right thing.

Robyn Hoffenberg

-----Original Message-----

From: CALV <[contactcalv@gmail.com](mailto:contactcalv@gmail.com)>

To:

Sent: Thu, Apr 14, 2022 10:12 am

Subject: Keeping the Public in the Dark - City Changes Coming to Favor Developers Over Residents

Changes are coming for **SEPA** protections and Short Plat reviews unless we

## **Take Action and Comment!**

The **SEPA** (State Environmental Policy Act) process is really the only way for people in the neighborhood to comment on specific aspects of development like roads, wetlands, street issues and such. The SEPA process is also where other agencies like WSDOT, Fire, Schools, etc. have a chance to comment.

The City of Spokane's proposed SEPA changes are **detrimental and significant:**

- SEPA **would not be required** for 30 or less single-family home developments (currently SEPA is not required for 20 homes or less).

Losing SEPA review would eliminate our ability to comment about development in our neighborhoods on projects of 30 or less. **That is impactful.....**please share your concerns!

The City of Spokane is also proposing two types of changes to the review of short plats;

1. First, the City is proposing to remove the notice of application for short plats that create only **two** lots, similar to Type I applications.
2. Second, the City is considering removing the required posted sign, but continuing a mailed notice of application for short plats creating **three to nine** lots.

### **The proposed changes would include:**

- Amending the public notice to only require a mailed notice to properties within 400 feet.
- No notice in the newspaper; and
- Removing the site posting sign requirements.

**There is no mention of a requirement to notify the neighborhood council**

The 60-day agency and public comment period will run **60 days from April 4, 2022, through June 6, 2022, ending at 5:00 PM.**

**Submit comments to:**

Amanda Beck

[abeck@spokanecity.org](mailto:abeck@spokanecity.org), 509-625-6414

City of Spokane Planning Services, 6<sup>th</sup> Floor

808 W Spokane Falls Blvd.

Spokane, WA 99201



**From:** [Beck, Amanda](#)  
**To:** [Landry Smallfoot](#)  
**Subject:** RE: SEPA Changes  
**Date:** Monday, April 18, 2022 12:54:00 PM  
**Attachments:** [image001.png](#)  
[image002.png](#)  
[image003.png](#)

---

Hi Candace,

Thank you for providing public comment on proposed revisions to residential code related to the project [Shaping Spokane Housing](#). Your email is now part of the public record for the project, and will be shared with the Plan Commission at the public hearing.

Please be aware that proposed changes to short plat notification will be going to public hearing at the May 11th Plan Commission meeting. When the agenda is posted, you can find meeting information on the [Plan Commission webpage](#).

At the end of the 60-Day Agency and Public Comment period for the proposed SEPA code changes, which runs April 4 through June 6, the City will review and evaluate comments to determine if revisions to the proposed SEPA code changes are warranted before taking the draft code to public hearing. No public hearing is scheduled at this time.

Thank you,  
Amanda

**Amanda Beck, AICP** | City of Spokane | Assistant Planner II

509-625-6414 | main 509-625-6500 | [abeck@spokanecity.org](mailto:abeck@spokanecity.org) | [spokanecity.org](http://spokanecity.org)



---

**From:** Landry Smallfoot <cansmall2@comcast.net>  
**Sent:** Friday, April 15, 2022 12:40 PM  
**To:** Beck, Amanda <abeck@spokanecity.org>; Kevin <hawc929@comcast.net>;  
 parpolia@yahoo.com; tucbrown@gmail.com; contactcalv@gmail.com; Lobbch@comcast.net;  
 smith.dana5050@gmail.com; victoriapalmen68@gmail.com; jayrayfarmer@gmail.com;  
 amyndel@yahoo.com; Molly Marshall <molly.marshall475@gmail.com>  
**Subject:** SEPA Changes

**[CAUTION - EXTERNAL EMAIL - Verify Sender]**

Amanda,

For SEPA rqts., it is imperative that the neighborhoods and their councils be informed. We will live a neighborhood that the Lennar bros are proposing 183 homes. It is on a wetland and the whole neighborhood is impacted. Had we not

received notification from our neighborhood council and the posted signs of the meeting with the engineer, none of our voices would have been heard. There are very few neighbors that received the 400 ft notice (there are no neighbors that border that property except maybe 10) which is very restrictive to begin with. I am absolutely sick of the city allowing these developers to try to "sneak" into our neighborhoods.

It seems like developers want to put developments in our areas, but if they can "get away" with not providing improvements etc. that is the goal. Our neighborhood of Grandview Thorpe has developers all over the place and it is going to be very impactful and a disaster. Right now we cannot support any developments (two major ones Lennar and Toll).

If anything the SEPA notification needs to be increased and advertised all over the place! The city needs to quit "hoodwinking" city citizens and be there to support and listen to the concerns of huge developments that impact all of these neighborhoods safety and security!

Sincerely,

Candace Smallfoot

Changes are coming for **SEPA** protections and Short Plat reviews unless we

### **Take Action and Comment!**

The **SEPA** (State Environmental Policy Act) process is really the only way for people in the neighborhood to comment on specific aspects of development like roads, wetlands, street issues and such. The SEPA process is also where other agencies like WSDOT, Fire, Schools, etc. have a chance to comment.

The City of Spokane's proposed SEPA changes are **detrimental and significant:**

- SEPA **would not be required** for 30 or less single-family home developments (currently SEPA is not required for 20 homes or less).

Losing SEPA review would eliminate our ability to comment about development in our neighborhoods on projects of 30 or less. **That is impactful.....**please share your concerns!

The City of Spokane is also proposing two types of changes to the review of short plats;

1. First, the City is proposing to remove the notice of application for short plats

that create only **two** lots, similar to Type I applications.

1. Second, the City is considering removing the required posted sign, but continuing a mailed notice of application for short plats creating **three to nine** lots.

**The proposed changes would include:**

- Amending the public notice to only require a mailed notice to properties within 400 feet.
- No notice in the newspaper; and
- Removing the site posting sign requirements.

**There is no mention of a requirement to notify the neighborhood council**

The 60-day agency and public comment period will run **60 days from April 4, 2022, through June 6, 2022, ending at 5:00 PM.**

**Submit comments to:**

Amanda Beck

[abeck@spokanecity.org](mailto:abeck@spokanecity.org), 509-625-6414

City of Spokane Planning Services, 6<sup>th</sup> Floor

808 W Spokane Falls Blvd.

Spokane, WA 99201

**From:** [Beck, Amanda](#)  
**To:** [Kevin](#)  
**Subject:** RE: SEPA Changes  
**Date:** Monday, April 18, 2022 12:54:00 PM  
**Attachments:** [image001.png](#)  
[image002.png](#)  
[image003.png](#)

---

Hi Kevin,

Thank you for providing public comment on proposed revisions to residential code related to the project [Shaping Spokane Housing](#). Your email is now part of the public record for the project, and will be shared with the Plan Commission at the public hearing.

Please be aware that proposed changes to short plat notification will be going to public hearing at the May 11th Plan Commission meeting. When the agenda is posted, you can find meeting information on the [Plan Commission webpage](#).

At the end of the 60-Day Agency and Public Comment period for the proposed SEPA code changes, which runs April 4 through June 6, the City will review and evaluate comments to determine if revisions to the proposed SEPA code changes are warranted before taking the draft code to public hearing. No public hearing is scheduled at this time.

Thank you,  
Amanda

**Amanda Beck, AICP** | City of Spokane | Assistant Planner II

509-625-6414 | main 509-625-6500 | [abeck@spokanecity.org](mailto:abeck@spokanecity.org) | [spokanecity.org](http://spokanecity.org)



---

**From:** Kevin <hawc929@comcast.net>  
**Sent:** Friday, April 15, 2022 4:08 PM  
**To:** Beck, Amanda <abeck@spokanecity.org>  
**Subject:** Fwd: SEPA Changes

**[CAUTION - EXTERNAL EMAIL - Verify Sender]**

Amanda, I concur with the email from C. Smallfoot. I feel strongly the city is only about developing at all costs without any thought to those of us that have lived here and paid property taxes for years. As many others have stated on Next Door and other apps, between the horrible number of high priced home developments that will do absolutely nothing for homelessness, the increase in crime and nothing ever being done about it, it is time to look at moving out and let this city be taken over by crime and high priced homes!

To try and continue to sneak developments in on us is deplorable.



Kevin Stevens

Kevin V. Stevens, RN, MSN, MS, RD  
 Finish Line Performance Nutrition LLC  
 IRONMAN Certified Coach  
 Sports Nutrition Specialist ISSA  
[Hawc929@comcast.net](mailto:Hawc929@comcast.net)

Begin forwarded message:

**From:** Landry Smallfoot <[cansmall2@comcast.net](mailto:cansmall2@comcast.net)>  
**Date:** April 15, 2022 at 12:40:16 PM PDT  
**To:** [abeck@spokanecity.org](mailto:abeck@spokanecity.org), Kevin <[hawc929@comcast.net](mailto:hawc929@comcast.net)>, [parpolia@yahoo.com](mailto:parpolia@yahoo.com),  
[tucbrown@gmail.com](mailto:tucbrown@gmail.com), [contactcalv@gmail.com](mailto:contactcalv@gmail.com), [Lobbch@comcast.net](mailto:Lobbch@comcast.net),  
[smith.dana5050@gmail.com](mailto:smith.dana5050@gmail.com), [victoriapalmen68@gmail.com](mailto:victoriapalmen68@gmail.com), [jayrayfarmer@gmail.com](mailto:jayrayfarmer@gmail.com),  
[amyndel@yahoo.com](mailto:amyndel@yahoo.com), Molly Marshall <[molly.marshall475@gmail.com](mailto:molly.marshall475@gmail.com)>  
**Subject: SEPA Changes**

Amanda,

For SEPA rqts., it is imperative that the neighborhoods and their councils be informed. We will live a neighborhood that the Lennar bros are proposing 183 homes. It is on a wetland and the whole neighborhood is impacted. Had we not received notification from our neighborhood council and the posted signs of the meeting with the engineer, none of our voices would have been heard. There are very few neighbors that received the 400 ft notice (there are no neighbors that border that property except maybe 10) which is very restrictive to begin with. I am absolutely sick of the city allowing these developers to try to "sneak" into our neighborhoods.

It seems like developers want to put developments in our areas, but if they can "get away" with not providing improvements etc. that is the goal. Our neighborhood of Grandview Thorpe has developers all over the place and it is going to be very impactful and a disaster. Right now we cannot support any developments (two major ones Lennar and Toll).

If anything the SEPA notification needs to be increased and advertised all over the place! The city needs to quit "hoodwinking" city citizens and be there to support and listen to the concerns of huge developments that impact all of these neighborhoods safety and security!

Sincerely,

Candace Smallfoot

Changes are coming for **SEPA** protections and Short Plat reviews unless we

**Take Action and Comment!**

The **SEPA** (State Environmental Policy Act) process is really the only way for people in the neighborhood to comment on specific aspects of development like roads, wetlands, street issues and such. The SEPA process is also where other agencies like WSDOT, Fire, Schools, etc. have a chance to comment.

The City of Spokane's proposed SEPA changes are **detrimental and significant:**

- SEPA **would not be required** for 30 or less single-family home developments (currently SEPA is not required for 20 homes or less).

Losing SEPA review would eliminate our ability to comment about development in our neighborhoods on projects of 30 or less. **That is impactful.....please share your concerns!**

The City of Spokane is also proposing two types of changes to the review of short plats;

1. First, the City is proposing to remove the notice of application for short plats that create only **two** lots, similar to Type I applications.
1. Second, the City is considering removing the required posted sign, but continuing a mailed notice of application for short plats creating **three to nine** lots.

**The proposed changes would include:**

- Amending the public notice to only require a mailed notice to properties within 400 feet.
- No notice in the newspaper; and
- Removing the site posting sign requirements.

**There is no mention of a requirement to notify the neighborhood council**

The 60-day agency and public comment period will run **60 days from April 4, 2022, through June 6, 2022, ending at 5:00 PM.**

**Submit comments to:**

Amanda Beck

[abeck@spokanecity.org](mailto:abeck@spokanecity.org), 509-625-6414

City of Spokane Planning Services, 6<sup>th</sup> Floor

808 W Spokane Falls Blvd.

Spokane, WA 99201

**From:** [Beck, Amanda](#)  
**To:** [Dick Thiel](#)  
**Subject:** RE: SEPA Protections and short plat reviews  
**Date:** Monday, April 18, 2022 12:54:00 PM  
**Attachments:** [image001.png](#)  
[image002.png](#)  
[image003.png](#)

---

Hi Dick,

Thank you for providing public comment on proposed revisions to residential code related to the project [Shaping Spokane Housing](#). Your email is now part of the public record for the project, and will be shared with the Plan Commission at the public hearing.

Please be aware that proposed changes to short plat notification will be going to public hearing at the May 11th Plan Commission meeting. When the agenda is posted, you can find meeting information on the [Plan Commission webpage](#).

At the end of the 60-Day Agency and Public Comment period for the proposed SEPA code changes, which runs April 4 through June 6, the City will review and evaluate comments to determine if revisions to the proposed SEPA code changes are warranted before taking the draft code to public hearing. No public hearing is scheduled at this time.

Thank you,  
Amanda

**Amanda Beck, AICP** | City of Spokane | Assistant Planner II

509-625-6414 | main 509-625-6500 | [abeck@spokanecity.org](mailto:abeck@spokanecity.org) | [spokanecity.org](http://spokanecity.org)



---

**From:** Dick Thiel <dickthiel@comcast.net>  
**Sent:** Friday, April 15, 2022 10:33 AM  
**To:** Beck, Amanda <abeck@spokanecity.org>  
**Cc:** Patti Berg <catsmeow4814@yahoo.com>  
**Subject:** SEPA Protections and short plat reviews

**[CAUTION - EXTERNAL EMAIL - Verify Sender]**

Wrong, wrong, wrong. Do NOT do this. It will come back and bite you in the butt! Citizens and neighbors deserve to learn about proposed projects so they can comment, seek legitimate changes, and then live happily with the development. It appears you are being pressured by developers, and are hungry for development dollars. Don't do this. Listen to your neighbors (taxpayers) and don't foment the dissent that is sure to happen.

**From:** [Beck, Amanda](#)  
**To:** [Karen Carlberg](#)  
**Subject:** RE: Keeping the Public in the Dark - City Changes Coming to Favor Developers Over Residents  
**Date:** Monday, April 18, 2022 1:54:00 PM  
**Attachments:** [image005.png](#)  
[image006.png](#)  
[image007.png](#)  
[image008.png](#)  
[image009.png](#)  
[image010.png](#)

---

Hi Karen,

Due to the city's process to request comments during the determination of a complete application, NCS will maintain the opportunity to comment on applications. You are correct, this is not changing.

For some people I think the issue is timing. So that potential mitigations are reflected in a submitted application, SEPA is typically completed first followed by an application. Certainly if they run at the same time, any pertinent comments from the SEPA would be required to be reflected in an updated proposal for the application.

Hope that answers your question.

Thank you,  
Amanda

**Amanda Beck, AICP** | City of Spokane | Assistant Planner II  
 509-625-6414 | *main* 509-625-6500 | [abeck@spokanecity.org](mailto:abeck@spokanecity.org) | [spokanecity.org](http://spokanecity.org)



---

**From:** Karen Carlberg <karencarlberg@comcast.net>  
**Sent:** Monday, April 18, 2022 1:33 PM  
**To:** Beck, Amanda <abeck@spokanecity.org>  
**Subject:** Re: Keeping the Public in the Dark - City Changes Coming to Favor Developers Over Residents

**[CAUTION - EXTERNAL EMAIL - Verify Sender]**

Thanks Amanda. I'm interpreting this to say that there will be no change in opportunities for neighborhood council comment on projects. Right?

Karen

---

**From:** "Beck, Amanda" <[abeck@spokanecity.org](mailto:abeck@spokanecity.org)>  
**Date:** Monday, April 18, 2022 at 12:31 PM  
**To:** Karen Carlberg <[karencarlberg@comcast.net](mailto:karencarlberg@comcast.net)>  
**Subject:** RE: Keeping the Public in the Dark - City Changes Coming to Favor Developers Over

Residents

Hi Karen,

The CALV email is referencing two code changes that are a part of the [Shaping Spokane Housing](#) project. Sorry this is a bit long, hopefully it gives you plenty of information.

Proposed changes to short plat notification have been going through a series of workshops with Plan Commission. Draft text is available on the project webpage. The changes include removing notification for a short plat which creates two lots (e.g. the mother parcel and one other), and revise notification for short plats that create three to nine lots such that only a mailed noticed will be sent to property owners, tax payers, and residents within 400 feet of the subject site with no site posting. [This code change will be going to public hearing at the May 11<sup>th</sup> Plan Commission workshop.](#)

What that would look like: Neighborhood Councils would be solicited for comment during a fourteen day comment window when the city completes the determination of a complete application (outlined in [Section 17G.060.090](#)), regardless of number of lots. Taxpayers/property owners/residents would get a notice of application in the mail for short plats of three to nine lots, and could provide comment during that fifteen day window.

The second piece is proposed changes to our SEPA ordinance around the flexible threshold for categorical exemptions. The proposed draft is available on the project webpage. In line with recommendations from WA Commerce in [RCW 36.70A.600\(1\)\(r\)](#), the city has proposed to change the flexible thresholds as noted below, except to keep the fill/excavation at the current 500 cubic yard threshold. SEPA is often a situation where if the number of units or square feet meets the threshold, but excavation or grading on site goes over threshold, then a project kicks back in for SEPA review since the intent there is to evaluate possible environmental impacts and enact mitigations. [Revisions to this section of code require a 60-day Agency and Public Comment period, which began April 4 and runs through June 6- no public hearing is scheduled at this time.](#) At the end of the 60-Day Agency and Public Comment period the City will review and evaluate comments to determine if revisions to the proposed SEPA code changes are warranted before taking the draft code to public hearing.

<b>Construction Type</b>	<b>SMC 17E Flexible Threshold</b>	<b>197-11-800 WAC Max. Allowed by State</b>	<b>Proposed SMC 17E Flexible Threshold</b>
<b>Single-family residential</b>	20 units	30 units	<b>30 units</b>
<b>Multifamily residential</b>	20 units	60 units	<b>60 units</b>
<b>Agricultural structure</b>	20,000 SF	40,000 SF	<b>40,000 SF</b>
<b>Office, school, commercial, recreational, service, or storage buildings and related parking</b>	12,000 SF and 40 parking spaces	30,000 SF and 90 parking spaces	<b>30,000 SF and 90 parking spaces</b>
<b>Fill or excavation</b>	500 cubic yards	1,000 cubic yards	<b>500 cubic yards</b>

What that would look like: Projects under the threshold would not be required to do a SEPA review so there would be no SEPA notice or site posting, and projects over threshold would follow our current process of review and notification. Similar to above, NCs would be notified during the determination of a

complete application.

Let us know if you have questions. Thanks for reaching out.

Thank you,  
Amanda

**Amanda Beck, AICP** | City of Spokane | Assistant Planner II  
509-625-6414 | *main* 509-625-6500 | [abeck@spokanecity.org](mailto:abeck@spokanecity.org) | [spokanecity.org](http://spokanecity.org)



---

**From:** Karen Carlberg <[karencarlberg@comcast.net](mailto:karencarlberg@comcast.net)>  
**Sent:** Saturday, April 16, 2022 10:17 AM  
**To:** Beck, Amanda <[abeck@spokanecity.org](mailto:abeck@spokanecity.org)>  
**Cc:** [pfbundy0@gmail.com](mailto:pfbundy0@gmail.com); [karencarlberg@comcast.net](mailto:karencarlberg@comcast.net); [rkclapp@gmail.com](mailto:rkclapp@gmail.com);  
[dwrightemersonsr@gmail.com](mailto:dwrightemersonsr@gmail.com); [josettegates@gmail.com](mailto:josettegates@gmail.com); [mshkg@hotmail.com](mailto:mshkg@hotmail.com); [hagy\\_w@icloud.com](mailto:hagy_w@icloud.com);  
[kjhiker49@gmail.com](mailto:kjhiker49@gmail.com); [mensching65@gmail.com](mailto:mensching65@gmail.com); [jmotr56@msn.com](mailto:jmotr56@msn.com)  
**Subject:** FW: Keeping the Public in the Dark - City Changes Coming to Favor Developers Over Residents

**[CAUTION - EXTERNAL EMAIL - Verify Sender]**

Hi Amanda,

I received the email below, I assume so that I can distribute it to the West Hills neighborhood for comment. It is from the CALV group, which was formed to respond to all the proposals for new development in the Latah Valley and Grandview/Thorpe neighborhood. I responded to the email asking for more information and relevant websites. I got a response, but it wasn't very helpful.

My main concern is the comment below about possibly losing the possibility of neighborhood council opportunities to submit comments about projects in the neighborhood. I'm not seeing anything in the materials that suggests that.

Can you please clarify? What is the purpose of these proposed changes? And is there any change in neighborhood involvement in the review process for projects in the neighborhood?

Thanks for your help.

Karen Carlberg  
Chair, West Hills Neighborhood Council

---

**From:** CALV <[contactcalv@gmail.com](mailto:contactcalv@gmail.com)>  
**Date:** Thursday, April 14, 2022 at 10:11 AM

**To:** <undisclosed-recipients:>

**Subject:** Keeping the Public in the Dark - City Changes Coming to Favor Developers Over Residents

Changes are coming for **SEPA** protections and Short Plat reviews unless we

## **Take Action and Comment!**

The **SEPA** (State Environmental Policy Act) process is really the only way for people in the neighborhood to comment on specific aspects of development like roads, wetlands, street issues and such. The SEPA process is also where other agencies like WSDOT, Fire, Schools, etc. have a chance to comment.

The City of Spokane's proposed SEPA changes are **detrimental and significant:**

- SEPA **would not be required** for 30 or less single-family home developments (currently SEPA is not required for 20 homes or less).

Losing SEPA review would eliminate our ability to comment about development in our neighborhoods on projects of 30 or less. **That is impactful.....**please share your concerns!

The City of Spokane is also proposing two types of changes to the review of short plats;

1. First, the City is proposing to remove the notice of application for short plats that create only **two** lots, similar to Type I applications.
1. Second, the City is considering removing the required posted sign, but continuing a mailed notice of application for short plats creating **three to nine** lots.

### **The proposed changes would include:**

- Amending the public notice to only require a mailed notice to properties within 400 feet.
- No notice in the newspaper; and
- Removing the site posting sign requirements.

**There is no mention of a requirement to notify the neighborhood council**

The 60-day agency and public comment period will run **60 days from April 4, 2022, through June 6, 2022, ending at 5:00 PM.**

### **Submit comments to:**

Amanda Beck

[abeck@spokanecity.org](mailto:abeck@spokanecity.org), 509-625-6414

City of Spokane Planning Services, 6<sup>th</sup> Floor

808 W Spokane Falls Blvd.

Spokane, WA 99201





**From:** [Beck, Amanda](#)  
**To:** [mellisa donaldson](#)  
**Subject:** RE: Proposed changes to SEPA and short plats  
**Date:** Monday, April 18, 2022 1:12:00 PM  
**Attachments:** [image001.png](#)  
[image002.png](#)  
[image003.png](#)

---

Hi Mellisa,

Thank you for providing public comment on proposed revisions to residential code related to the project [Shaping Spokane Housing](#). Your email is now part of the public record for the project, and will be shared with the Plan Commission at the public hearing.

Please be aware that proposed changes to short plat notification will be going to public hearing at the May 11th Plan Commission meeting. When the agenda is posted, you can find meeting information on the [Plan Commission webpage](#).

At the end of the 60-Day Agency and Public Comment period for the proposed SEPA code changes, which runs April 4 through June 6, the City will review and evaluate comments to determine if revisions to the proposed SEPA code changes are warranted before taking the draft code to public hearing. No public hearing is scheduled at this time.

Thank you,  
Amanda

**Amanda Beck, AICP** | City of Spokane | Assistant Planner II

509-625-6414 | main 509-625-6500 | [abeck@spokanecity.org](mailto:abeck@spokanecity.org) | [spokanecity.org](http://spokanecity.org)



---

**From:** mellisa donaldson <mellisad2001@gmail.com>  
**Sent:** Monday, April 18, 2022 10:14 AM  
**To:** Beck, Amanda <abeck@spokanecity.org>  
**Cc:** Hadi hadi <Badrakhan@gmail.com>  
**Subject:** Proposed changes to SEPA and short plats

**[CAUTION - EXTERNAL EMAIL - Verify Sender]**

Dear Ms. Beck,

I am writing with concerns regarding the changes to following policy. I would like it to go on record that I am against these amendments. There continues to be a push for rapid growth in and around Spokane with little regard to detrimental effects to our community.

Tax payers and members of the community deserve a voice.

Thank you.

Sincerely,

Mellisa Donaldson

3111 W. Washington Rd, Spokane, WA 99224

714.357.4558

The **SEPA** (State Environmental Policy Act) process is really the only way for people in the neighborhood to comment on specific aspects of development like roads, wetlands, street issues and such. The SEPA process is also where other agencies like WSDOT, Fire, Schools, etc. have a chance to comment.

The City of Spokane's proposed SEPA changes are **detrimental and significant**:

- SEPA **would not be required** for 30 or less single-family home developments (currently SEPA is not required for 20 homes or less).

Losing SEPA review would eliminate our ability to comment about development in our neighborhoods on projects of 30 or less. **That is impactful.....**please share your concerns!

The City of Spokane is also proposing two types of changes to the review of short plats;

1. First, the City is proposing to remove the notice of application for short plats that create only **two** lots, similar to Type I applications.
2. Second, the City is considering removing the required posted sign, but continuing a mailed notice of application for short plats creating **three to nine** lots.

**The proposed changes would include:**

- Amending the public notice to only require a mailed notice to properties within 400 feet.
- No notice in the newspaper; and
- Removing the site posting sign requirements.

**There is no mention of a requirement to notify the neighborhood council**

The 60-day agency and public comment period will run **60 days from April 4, 2022, through June 6, 2022, ending at 5:00 PM.**

**Submit comments to:**

Amanda Beck

[abeck@spokanecity.org](mailto:abeck@spokanecity.org), 509-625-6414

City of Spokane Planning Services, 6<sup>th</sup> Floor

808 W Spokane Falls Blvd.  
Spokane, WA 99201



**From:** [Planning Services Development Code](#)  
**To:** [Carmela Conroy](#)  
**Subject:** RE: Appreciation for Draft ADU Revisions  
**Date:** Friday, April 22, 2022 9:17:00 AM

---

Good morning, Ms. Conroy:

Thanks for your message. I will add it to the public record for the file, and it will be shared with the Plan Commission at the public hearing, and with the City Council at its future, unscheduled public hearing. The Plan Commission's hearing is tentatively scheduled for May 11, 2022 at 4 pm. When the agenda for the May 11 hearing is posted, you can find meeting information on the [Plan Commission webpage](#).

**Nathan Gwinn, AICP** | Assistant Planner | Planning & Development  
 509.625.6893 | [ngwinn@spokanecity.org](mailto:ngwinn@spokanecity.org) | [www.spokanecity.org](http://www.spokanecity.org)

Residential Development Code amendments project webpage: [my.spokanecity.org/projects/shaping-spokane-housing](http://my.spokanecity.org/projects/shaping-spokane-housing)

---

**From:** Carmela Conroy <carmelaconroy@yahoo.com>  
**Sent:** Wednesday, April 20, 2022 10:29 PM  
**To:** Planning Services Development Code <erapsdc@spokanecity.org>  
**Subject:** Appreciation for Draft ADU Revisions

**[CAUTION - EXTERNAL EMAIL - Verify Sender]**

Dear Neighbors:

Thank you for sharing information via email about the draft revisions to the requirements for auxiliary dwelling units (ADUs). I have been considering converting over half of my basement into an ADU. I live in a single-family residential area. My house is on a bus line. I am approaching senior citizen hood, and would feel safer having someone living on the property with me.

Two particularly salient advantages of the revisions are greater flexibility in the size of the ADU, and in eliminating the need for offstreet parking. My basement is quite large, but unsuitable for any configuration other than a studio apartment. Having greater flexibility on size allows me to include storage space for a future tenant. This might be especially useful to a medical resident or academic assigned to Spokane for a year or two.

My garage and driveway allow for little to no expansion. My being on a bus line and within walking distance of the medical centers means some tenants might not need any parking at all. There's ample street parking if needed. Eliminating the off street parking requirement will significantly reduce the cost and speed with which I can put an ADU on the market.

I appreciate your taking the time to consider these comments.

Sincerely

Carmela Conroy

US Mobile: 571-276-4238

April 21, 2022

**RE: SMC 17C.300: ACCESSORY DWELLING UNITS – REVIEW AND SUGGESTED UPDATES**

Dear Spokane Planning, Ms. Murphy, Plan Commission, and Councilmembers:

Thank you for your work in implementing the city's Housing Action Plan, and for moving the needle forward on greater housing supply.

As you're well aware, there is a critical need to increase housing supply in Spokane. We are simply failing at producing the needed numbers that will result in 6,791 new units by 2037 (or 400+ units per year) per the City's 2020 Housing Needs Assessment. Unless bold changes are made, then we will continue to push would-be home-owners and renters, and community members to the margins.

Please consider moving quickly in adopting and codifying relaxed and flexible standards for Accessory Dwelling Units (ADUs) as a preliminary, 'low-hanging fruit', opportunity. I would encourage the Plan Commission and City Council to ratify polices suggested by in RCW 36.70A.600(1)(n),(o),(p),(q),and (x) regarding additional flexibility, and lessening restrictions, for accessory dwelling units.

The draft changes to "17C.300 SMC Accessory Dwelling Units" attempt to ratify some of these policies.

**Please consider the following suggestions / modifications to the proposed draft ADU updates:**

- 17C.300.100 (B)(2) – Multiple ADUs in all Residential Zones may be permitted through a Conditional Use Permit (CUP).
- 17C.300.100 (B)(2) – Development standards of the underlying district may be modified pursuant to the provisions of this section.
- 17C.300.110 (A)(1) – Reduce minimum size of principal structure to 500 square feet.
- 17C.300.110 (A)(1)(a) – Floor area of internal ADU not more than 50% the floor area of the principal structure, or 800 square feet, whichever is greater.
- 17C.300.110 (A)(2) – *Per WA House Bill 1660* - Floor area of detached ADU not more than 850 square feet for lots less than 4,500 square feet, and 1,350 square feet as the combined floor area for both attached and detached ADUs on lots greater than 4,500 square feet.
- 17C.300.110 (B) – *Per RCW 36.70A.600(1)(p)* - Remove owner-occupancy requirements, i.e. 'Draft Option SMC 110.C.1'

Thank you for your consideration and seeking to address dire need.

With Regards,



Ryan Hughes, AICP

210 W. 32<sup>nd</sup> Ave Spokane, WA, 99203

[Rhughes509@yahoo.com](mailto:Rhughes509@yahoo.com)

**From:** [Planning Services Development Code](#)  
**To:** "Will Maupin"  
**Subject:** RE: Shaping Spokane Housing Update Comments  
**Date:** Friday, April 22, 2022 9:37:00 AM

---

Hello Mr. Maupin,

Thanks for your comment. I will add it to the public record for the phase 1 topics, and it will be shared with the Plan Commission at the public hearing for the first 3 topics – accessory dwelling units, lot size transition, and short plats – and with the City Council at its future, unscheduled public hearing. The Plan Commission’s hearing is tentatively scheduled for May 11, 2022 at 4 pm.

When the agenda for the May 11 hearing is posted, you can find meeting information on the [Plan Commission webpage](#). We will continue to update the project webpage as public hearings are scheduled and new efforts are announced.

**Nathan Gwinn, AICP** | Assistant Planner | Planning & Development  
 509.625.6893 | [ngwinn@spokanecity.org](mailto:ngwinn@spokanecity.org) | [www.spokanecity.org](http://www.spokanecity.org)

Residential Development Code amendments project webpage: [my.spokanecity.org/projects/shaping-spokane-housing](http://my.spokanecity.org/projects/shaping-spokane-housing)

---

**From:** Will Maupin <willmaupin@gmail.com>  
**Sent:** Thursday, April 21, 2022 12:43 PM  
**To:** Planning Services Development Code <erapsdc@spokanecity.org>  
**Subject:** Shaping Spokane Housing Update Comments

**[CAUTION - EXTERNAL EMAIL - Verify Sender]**

Hello, thank you for updating me on the updates to the city's approach to the housing crisis. What I see from the city is an approach. It's nothing close to a solution.

According to a report on KXLY last night, the average home price in Spokane County increased by \$30k over the past month. ONE MONTH. A friend bought a house on the lower south hill in 2018 for \$220k. Zillow estimates it could go for \$428k today. If \$220k was his max budget today, there are two homes currently listed in Spokane he could afford. Two.

This is a crisis. People who have lived in Spokane for most of their lives, who grew up here, can't afford to live here anymore. I had to re-sign my apartment lease this spring, and my rent increased by 50%. There is an old, cheap motel on 3rd that has been converted to studio apartments leasing for \$1,200+. If you earn the median income for the county, those apartments would take more than 30% of your total income. Respectfully, you can't continue farting around with phase 1.

The longer the city fails to accept this, the worse it will get. Look at the fringes of the city limits now, where development regulations are more lax. What's being built there? Totally unsustainable, completely car-dependent developments that look like the "multifamily housing midsize apartment building" on the graphic in the update, and that's well outside of phase 1.

Those won't even solve the problem, and on top of the help they do provide, they exacerbate other problems like traffic (have you tried getting around the Southgate neighborhood anytime between 2 and 6 p.m. lately?) and climate change. They're a two steps forward, one step back situation.

It's time for big and active change. In the update I saw the word "encourage" once, and it was about townhouses. The city is exploding, cost of living is skyrocketing, and the only thing you're going to "encourage" is a few more townhouses? You're going to "allow" duplexes in more zones? Cool. Go further. Encourage them, too. And then go further than that.

Change the comprehensive plan.

Make owning a surface parking lot in the city center (which looks like swiss cheese from all of those) less appealing than developing it into high density housing. "Encourage" high density urban housing.

Apply the principles of Vancouverism to the Centers and Corridors plan, and expand the plan. Then "encourage" it. In recent years we've seen buildings demolished on the Ruby/Division couplet and be replaced with things like a Panda Express and a sprawling gas station. Encourage density in places like that to the point it would be financially stupid for a developer to build one story nonsense.

Expand where airbnbs are allowed? Ban them all together.

I know there is more red tape and more bureaucratic hurdles to this process than I could ever understand. So I appreciate the fact that this process is underway at all. But I'm frustrated. I grew up here, I've spent almost my entire adult life here, and I can barely afford to stay. I have a good job, and earn good money. Two years ago, before the pandemic hit and this all blew up, I could've bought a good house in a nice neighborhood. The homes I looked at then are being listed now for literally hundreds of thousands of dollars more than they were just two short years ago. Spokane used to lose so many of its best people to bigger, more vibrant cities. Now it's going to start losing those who stayed to places they can afford, like the Tri-Cities or somewhere awful.

Thank you for your work, and know it is appreciated. But please, we need to go so much further.

- Will Maupin



**From:** [Beck, Amanda](#)  
**To:** [Mariah McKay](#)  
**Cc:** [Gwinn, Nathan](#)  
**Subject:** RE: Shaping Spokane Housing Update  
**Date:** Wednesday, April 27, 2022 9:31:00 AM  
**Attachments:** [image005.png](#)  
[image006.png](#)  
[image007.png](#)  
[image008.png](#)  
[image009.png](#)  
[image010.png](#)  
[image011.png](#)  
[image001.png](#)

Hi Mariah,

Thank you for your comments concerning ADUs and owner occupancy. And, you're comments on how to improve communications for projects like this.

Your email is now part of the public record for the project, and will be shared with the Plan Commission at the public hearing. Please be aware that proposed changes to ADUs will be going to public hearing at the May 11th Plan Commission meeting. The agenda can be accessed from the [Plan Commission webpage](#).

You can search building permit records through [Accela Citizen Access](#). I would recommend the below search parameters. Since 2008 we've gotten approximately 175 ADUs that have been permitted.

<b>Record / Permit Number:</b> <input type="text"/>	<b>Record Type:</b> Residential Building New ▼
<b>Start Date:</b> <input type="text" value="01/01/2008"/>	<b>End Date:</b> <input type="text" value="04/27/2022"/>

Thank you,  
Amanda

**Amanda Beck, AICP** | City of Spokane | Assistant Planner II  
509-625-6414 | main 509-625-6500 | [abeck@spokanecity.org](mailto:abeck@spokanecity.org) | [spokanecity.org](http://spokanecity.org)



**From:** Davis, Kirstin <kdavis@spokanecity.org>  
**Sent:** Monday, April 25, 2022 11:25 AM  
**To:** Mariah McKay <ournaturalhomes@gmail.com>  
**Cc:** Gwinn, Nathan <ngwinn@spokanecity.org>; Beck, Amanda <abeck@spokanecity.org>; Black, Tirrell <tblack@spokanecity.org>  
**Subject:** RE: Shaping Spokane Housing Update

Mariah,

Thank you for your feedback. I am sharing it with our planning team and we will do what we can to make communications more relevant and address your specific ADU questions below.

Have a great day,

Kirstin



**Kirstin Davis** | Communications Manager | Public Works and Community & Economic Development  
 Desk 509.625.7773 | Mobile 509.481.7223 | [my.spokanecity.org](http://my.spokanecity.org)



**ADVISORY:** Please be advised the City of Spokane is required to comply with the Public Records Act (Chapter 42.56 RCW). As such, the information exchanged via email, including personal information, may ultimately be subject to disclosure as a public record.

---

**From:** Mariah McKay <[ournaturalhomes@gmail.com](mailto:ournaturalhomes@gmail.com)>  
**Sent:** Thursday, April 21, 2022 6:05 PM  
**To:** Davis, Kirstin <[kdavis@spokanecity.org](mailto:kdavis@spokanecity.org)>  
**Subject:** Re: Shaping Spokane Housing Update

**[CAUTION - EXTERNAL EMAIL - Verify Sender]**

Small business owners REALLY struggle to take the time to participate in public policy changes like these even though we are significantly impacted by them.

Instead of providing links to lengthy Zoom recordings and arcane procedural documents with way too much detail, it would be more helpful if city staff could contextualize and summarize what is actually going on now and ask us to briefly weigh in on that.

I understand the City is understaffed and that is impacting the level of service in planning and housing significantly. But if you are going to write and publish an email, please do so with making meaningful feedback from the end user more possible without deep diving on other websites.

That said, I support massive deregulation of the ADU housing type. Owners should not have to reside on their lots to be able to build an ADU. I also support City Issued Bonds to provide money for a loan fund that could be used to help underwrite loans for ADU development and pay for ADU ecosystem development barrier removal initiatives. In short, I would like to see this happen in our city:

<https://www.youtube.com/watch?v=569aqcdcN4A>

I would like the City to set ADU development goals, and then mobilize small-scale owners and developers to help meet those goals.

Where would one go to try and figure out how many ADUs have been built per year over the last several years?

And who would I talk to about eco-building materials like cob and aircrete meeting city code requirements?

Thanks,  
Mariah

--

**Mariah McKay** (pronouns: she/her)  
**Community Manager, Our Natural Homes**  
Mobile: 509-939-0015



Follow us on Facebook @ournaturalhomesllc  
*"Where coliving is all about community."*

On Wed, Apr 20, 2022 at 9:09 PM City of Spokane Planning <[kdavis@spokanecity.org](mailto:kdavis@spokanecity.org)> wrote:

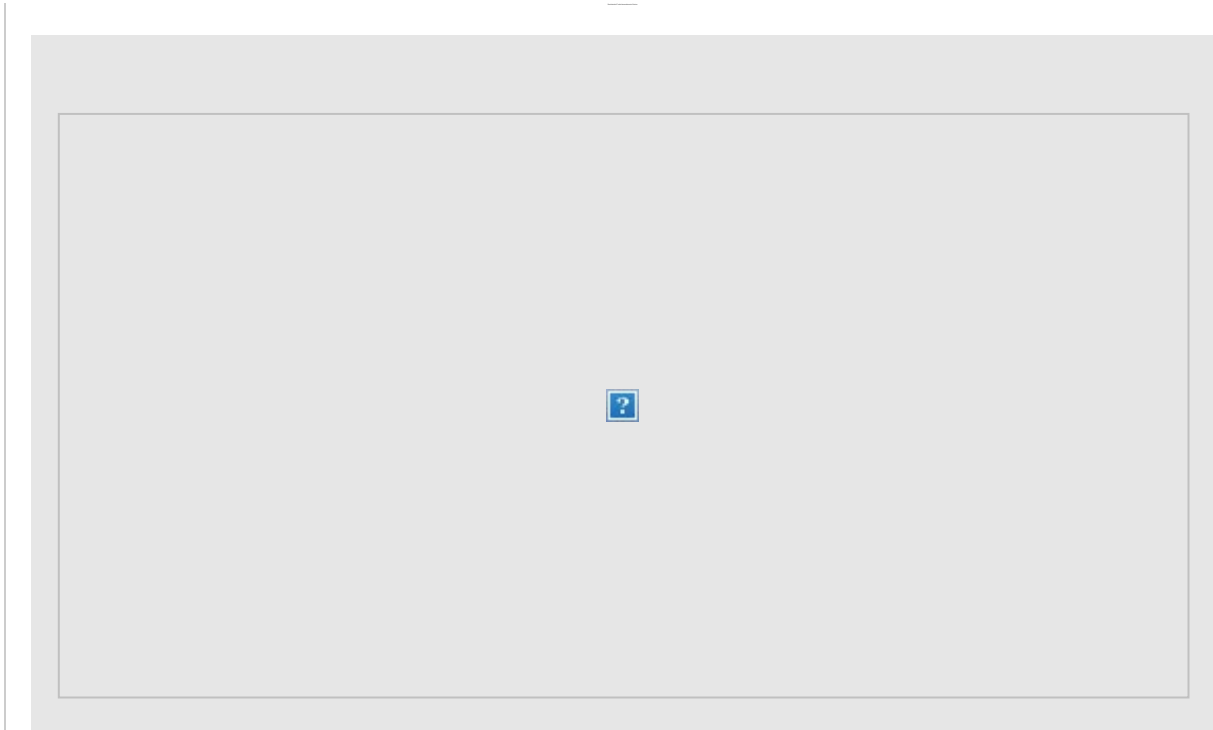

## Dear Community Member,

Thank you for your continued interest in addressing housing challenges in Spokane. You are receiving this email because you have shown interest in the Housing Action Plan and requested information about housing topics. The 2021 [Housing Action Plan](#) provided several recommendations and the City Plan Commission along with the Planning Services department have been discussing **seven initial proposed amendments** outlined on [ShapingSpokaneHousing.com](#).

## Plan Commission Meeting Recap

City Plan Commission workshops have been held to review and discuss proposed revisions to residential zoning codes including accessory dwelling units, various kinds of small-scale housing like duplexes and attached housing and lot size transition requirements. **The meeting held on April 13 reviewed draft code language related to the residential code language for accessory dwelling units and the short plat application process.** Get more information from the meeting [video](#) and view the discussion presentation at the [project webpage](#).



### Accessory Dwelling Units

Increase flexibility of development and design standards for Accessory Dwelling Units (ADU).



### Short Plat Application Process

Reduce or streamline the notification and commenting requirements.

## We want your feedback!

You can **review a description of each proposal on the [project webpage](#)**, which will be updated as the draft revisions evolve.

- **Provide written comment in email to [DevelopmentCode@spokanecity.org](mailto:DevelopmentCode@spokanecity.org).** This email list will be notified regarding additional opportunities for participation.
- **Sign up for email updates and announcements [here](#).**

## Coming Up

### Planning Services Staff at Riverfront Spring Market April 27 from 3-7 p.m.

You're invited to **ask questions and provide feedback** with City planners about the proposed Shaping Spokane Housing changes being considered right now. The **Spring Market is located in the Riverfront Pavilion** event space.

### Plan Commission Meeting on Wednesday, April 27 at 2 p.m.

The Commission will **revisit the City's residential zones**, including **provisions for additional attached housing (townhouses) and duplexes**, as well as **design standards for these and single-family residential development** types. The Commission will also **consider changes to the short plat application process** draft text.

### Attached Housing (Townhouses)

Encourage infill development, update development and

### Duplexes in Residential Single Family (RSF) Zone

Expand the permitted zoning districts and lot types, update



design standards to integrate with neighborhood character.



design standards to integrate with neighborhood character.

**Plan Commission Public Hearing on Wednesday, May 11 at 4 p.m.**

The Commission will **take testimony from the public on proposed changes** to development regulations for accessory dwelling units, lot size transition, and the short plat application process. The Commissions will also consider making a recommendation to the City Council on the proposed changes.

Please visit the [Plan Commission webpage](#) to view the agenda that contains packet materials available for review and instructions for joining the hybrid in-person/virtual meetings.

*You are receiving this email because you signed up via the [Spokane Housing Action Plan website](#), have been identified as an individual or stakeholder in the discussion, or expressed interest in receiving planning project updates from the City of Spokane. Please feel free to share this email with others who are interested in receiving [email announcements](#) about this project. To unsubscribe, please email [developmentcode@spokanecity.org](mailto:developmentcode@spokanecity.org).*



City of Spokane, Washington | 808 W Spokane Falls Blvd, Spokane, WA 99201

[Unsubscribe mariah@spokaneindependent.org](mailto:mariah@spokaneindependent.org)

[Update Profile](#) | [Constant Contact Data Notice](#)

Sent by [kdavis@spokanecity.org](mailto:kdavis@spokanecity.org) powered by



[Try email marketing for free today!](#)

**From:** [Planning Services Development Code](#)  
**To:** "Liza Mattana"  
**Subject:** RE: Manito Cannon Hill neighborhood & changing city code  
**Date:** Tuesday, April 26, 2022 2:11:00 PM

---

Good afternoon Ms. Mattana,

Thanks for your comment. I will add it to the public record for the phase 1 topics, and it will be shared with the Plan Commission at the public hearing for the first 3 topics – accessory dwelling units, lot size transition, and short plats – and with the City Council at its future, unscheduled public hearing. The Plan Commission’s hearing is scheduled for May 11, 2022 at 4 pm.

When the agenda for the May 11 hearing is posted, you can find meeting information on the [Plan Commission webpage](#). We will continue to update the project webpage as public hearings are scheduled and new efforts are announced, and I have added you to the contact list for notice of future opportunities.

Sincerely,

**Nathan Gwinn, AICP** | Assistant Planner | Planning & Development  
 509.625.6893 | [ngwinn@spokanecity.org](mailto:ngwinn@spokanecity.org) | [www.spokanecity.org](http://www.spokanecity.org)

Residential Development Code amendments project webpage: [my.spokanecity.org/projects/shaping-spokane-housing](http://my.spokanecity.org/projects/shaping-spokane-housing)

---

**From:** Liza Mattana <lizamattana@gmail.com>  
**Sent:** Friday, April 22, 2022 6:40 AM  
**To:** Planning Services Development Code <erapsdc@spokanecity.org>  
**Subject:** Manito Cannon Hill neighborhood & changing city code

**[CAUTION - EXTERNAL EMAIL - Verify Sender]**

Hi there,

I received a link from our neighborhood council meeting leaders. I wanted to say I'm all for the proposed changes to ours and other neighborhoods (like ADU, townhomes, duplexes in RSF zone) to promote density and lessen sprawl!

Please keep me posted if there are other opportunities to weigh in.

Thank you!  
 Liza Mattana  
 453 W 26th Ave, Spokane, WA 99203  
 South hill resident since 1982  
 LCHS alumni, class of 1992

**From:** [Alice Galeotti](#)  
**To:** [Planning Services Development Code](#)  
**Subject:** RE: Comment on ADU draft plan  
**Date:** Tuesday, April 26, 2022 2:46:23 PM

---

**[CAUTION - EXTERNAL EMAIL - Verify Sender]**

Nathan,

Thank you for your thorough and informative reply. Have a great rest of your week!

Alice Galeotti

On Apr 26, 2022, 2:25 PM -0700, Planning Services Development Code <erapsdc@spokanecity.org>, wrote:

Good afternoon Ms. Galeotti,

Thanks for your questions and comments. I will add your message to the public record for the ADU amendments, and it will be shared with the Plan Commission at the public hearing for the first 3 topics – accessory dwelling units, lot size transition, and short plats – and with the City Council at its future, unscheduled public hearing. The Plan Commission’s hearing is scheduled for May 11, 2022 at 4 pm.

The attached draft text proposes to remove that provision, showing additions in underlined text and deleted text struck through (page 16). A home occupation is described and regulated in sections [17C.340.100](#), [17C.340.110](#), and [17C.340.120](#) of the Spokane Municipal Code. In the March 23 workshop with the Plan Commission, the members discussed the changing nature of business practices, and some suggested this provision was no longer necessary in the ADU chapter. You may view the recording on the [project webpage](#) at the link below if you are interested.

When the agenda for the May 11 hearing is posted, you can find meeting information on the [Plan Commission webpage](#). We will continue to update the project webpage as public hearings are scheduled and new efforts are announced, and I have added you to the contact list for notice of future opportunities.

I hope this helps,

**Nathan Gwinn, AICP** | Assistant Planner | Planning & Development

509.625.6893 | [ngwinn@spokanecity.org](mailto:ngwinn@spokanecity.org) | [www.spokanecity.org](http://www.spokanecity.org)

Residential Development Code amendments project webpage: [my.spokanecity.org/projects/shaping-spokane-housing](https://my.spokanecity.org/projects/shaping-spokane-housing)

---

**From:** Alice Galeotti <agaleotti612@gmail.com>  
**Sent:** Friday, April 22, 2022 12:00 PM  
**To:** Planning Services Development Code <erapsdc@spokanecity.org>  
**Subject:** Comment on ADU draft plan

**[CAUTION - EXTERNAL EMAIL - Verify Sender]**

Good morning,

Regarding 17C.300.130 Development Standards, Sec A3, why is an ADU prohibited if the homeowner has a "home occupation"? And, what is the definition of home occupation? Does this mean I am prohibited from putting an ADU on my property if I work from a home office as a realtor, for example? Or have a business involving writing where I use my home office? This section is vague and frankly, seems unnecessary. Please explain.

Thank you,  
Alice Galeotti



**From:** [Planning Services Development Code](#)  
**To:** [DWatkins@spokanerealtor.com](mailto:DWatkins@spokanerealtor.com)  
**Subject:** RE: Comments for proposed code changes  
**Date:** Tuesday, April 26, 2022 2:45:00 PM

---

Good afternoon Darin,

Thanks for your comment. I will add it to the public record for the phase 1 topics, and it will be shared with the Plan Commission at the public hearing for the first 3 topics – accessory dwelling units, lot size transition, and short plats – and with the City Council at its future, unscheduled public hearing. The Plan Commission’s hearing is scheduled for May 11, 2022 at 4 pm.

When the agenda for the May 11 hearing is posted, you can find meeting information on the [Plan Commission webpage](#). We will continue to update the project webpage as public hearings are scheduled and new efforts are announced, and the City has you on its contact list for notice of future opportunities.

Sincerely,

**Nathan Gwinn, AICP** | Assistant Planner | Planning & Development  
 509.625.6893 | [ngwinn@spokanecity.org](mailto:ngwinn@spokanecity.org) | [www.spokanecity.org](http://www.spokanecity.org)

Residential Development Code amendments project webpage: [my.spokanecity.org/projects/shaping-spokane-housing](http://my.spokanecity.org/projects/shaping-spokane-housing)

---

**From:** Darin Watkins <[DWatkins@spokanerealtor.com](mailto:DWatkins@spokanerealtor.com)>  
**Sent:** Friday, April 22, 2022 1:19 PM  
**To:** Planning Services Development Code <[erapsdc@spokanecity.org](mailto:erapsdc@spokanecity.org)>  
**Subject:** Comments for proposed code changes

**[CAUTION - EXTERNAL EMAIL - Verify Sender]**

**A severe lack of housing in Spokane has become the greatest single challenge of our times.**

National averages show the City of Spokane should have 114,000 housing units. Instead, we have 89,000.

This leads to dramatically increased greenhouse gas emissions from commuters buying homes in neighboring communities, increases the gap in housing equity, and has been shown to be one of the key contributors to homelessness.

The proposed solutions are truly just a first step. And in many cases, simply update our current codes to match state requirements.

PLEASE support these changes. We MUST do what we can to solve our housing crisis.

**Darin Watkins**

Governmental Affairs Director

Spokane Association of REALTORS®

(509) 595-2012 (cell)

**From:** [Planning Services Development Code](#)  
**To:** [Gene Brake](#)  
**Subject:** RE: Shaping Spokane Housing  
**Date:** Tuesday, April 26, 2022 2:48:00 PM

---

Hi Gene,

Thanks for your comment. I will add it to the public record for all of the phase 1 topics, and it will be shared with the Plan Commission at the public hearing for the first 3 topics – accessory dwelling units, lot size transition, and short plats – and with the City Council at its future, unscheduled public hearing. The Plan Commission’s hearing is scheduled for May 11, 2022 at 4 pm.

When the agenda for the May 11 hearing is posted, you can find meeting information on the [Plan Commission webpage](#). We will continue to update the project webpage as public hearings are scheduled and new efforts are announced, and I have added the [genebrake.re@gmail.com](mailto:genebrake.re@gmail.com) address to the contact list for notice of future opportunities.

Sincerely,

**Nathan Gwinn, AICP** | Assistant Planner | Planning & Development  
 509.625.6893 | [ngwinn@spokanecity.org](mailto:ngwinn@spokanecity.org) | [www.spokanecity.org](http://www.spokanecity.org)

Residential Development Code amendments project webpage: [my.spokanecity.org/projects/shaping-spokane-housing](http://my.spokanecity.org/projects/shaping-spokane-housing)

---

**From:** Gene Brake <[genebrake.re@gmail.com](mailto:genebrake.re@gmail.com)>  
**Sent:** Friday, April 22, 2022 10:34 PM  
**To:** Planning Services Development Code <[erapsdc@spokanecity.org](mailto:erapsdc@spokanecity.org)>  
**Subject:** Shaping Spokane Housing

**[CAUTION - EXTERNAL EMAIL - Verify Sender]**

I do not support several parts of Phase 1 of the Housing Action Plan. I oppose and will actively work against any effort to expand Short Term Rentals, allow ADUs without the owner occupancy requirement and include duplexes in all Residential zones unless there are some limitations.

All three of these proposals will negatively impact housing availability, promote additional escalating home prices and negatively impact neighborhoods by encouraging out of area investors.

All of these will exacerbate the housing shortage and lead to net loss of affordable housing and more homeless neighbors.

Thank you,  
**Gene Brake**  
[www.genebrake.com](http://www.genebrake.com)

[www.corbinpark.net](http://www.corbinpark.net)

509-981-5555



601 W 1<sup>st</sup> Ave, Ste 1400  
Spokane, WA 99201

**"IMPORTANT NOTICE: Never trust wiring instructions sent via email. Always independently confirm wiring instructions in person or via a telephone call to a trusted and verified phone number. Never wire money without double-checking that the wiring instructions are correct."**



April 25, 2022

Spokane Planning Commission  
 808 Spokane Falls Blvd  
 Spokane WA 99201

Commission,

The Spokane Low Income Housing Consortium is a membership organization made up of over 25 organizations that design, build and support low income housing in Spokane. Our mission is to support all affordable housing and we know and unanimously support the phase one changes in Shaping Spokane!

We are writing this letter to support the changes to the Short Plat process (less notification), increasing the threshold for SEPA reviews on apartments to match the State and we believe that ADU's should be easier to produce.

I was the original sponsor of the neighborhood notification bill in 2014 and have a unique perspective on how a housing market has been stymied by folks who want to keep the status quo. Market rate apartments, house rentals and home ownership are all important to the system.

Studies and real world law changes clearly show that if you eliminate the owner occupancy requirement on ADU's, permits will go up. All three of these changes are designed to increase supply. Increasing supply in every way possible is necessary when rents and ownership have increased by over 50% in the last 24 months.

Housing is system and ownership and rental matter. These are just the first code changes in many. I urge you to pass these fast so we can get to other bigger changes.

Sincerely

A handwritten signature in blue ink that reads "Ben Stuckart".

Ben Stuckart, Executive Director  
 Spokane Low Income Housing Coalition

CC:

Steve McDonald, City of Spokane  
 Spencer Gardner, City of Spokane

**From:** [Beck, Amanda](#)  
**To:** [Carol Tomsic](#)  
**Cc:** [Gwinn, Nathan](#)  
**Subject:** RE: Comment on Residential Code Changes Plan Commission Meeting 4/27/22 at 2pm  
**Date:** Wednesday, April 27, 2022 9:38:00 AM  
**Attachments:** [image001.png](#)  
[image002.png](#)  
[image003.png](#)

---

Hi Carol,

Thank you for providing public comment on proposed revisions to residential code related to the project [Shaping Spokane Housing](#). Your email is now part of the public record for the project, and will be shared with the Plan Commission at the public hearing.

Please be aware that proposed changes to short plat notification will be going to public hearing at the May 11th Plan Commission meeting. You can find meeting information on the [Plan Commission webpage](#), which will be held as a hybrid in-person and virtual meeting.

Draft code for attached homes and duplexes are not currently scheduled for public hearing, but we will notify the email list once we have a date for those topics. Plan Commission will be further discussing design standards for all residential building types (detach and attached single-family as well as duplexes) at our meeting today, Wednesday 4/27.

Thank you,  
Amanda

**Amanda Beck, AICP** | City of Spokane | Assistant Planner II

509-625-6414 | main 509-625-6500 | [abeck@spokanecity.org](mailto:abeck@spokanecity.org) | [spokanecity.org](http://spokanecity.org)



---

**From:** Carol Tomsic <carol\_tomsic@yahoo.com>  
**Sent:** Tuesday, April 26, 2022 11:05 PM  
**To:** Gwinn, Nathan <ngwinn@spokanecity.org>; Beck, Amanda <abeck@spokanecity.org>; Plan Commission <eraplanc@spokanecity.org>; Kinnear, Lori <lkinnear@spokanecity.org>; Wilkerson, Betsy <bwilkerson@spokanecity.org>; Beggs, Breean <bbeggs@spokanecity.org>  
**Cc:** Marilyn <mdlloyd@comcast.net>; Mary Winkes - Manito/Cannon Hill <mmcspo@yahoo.com>; Cortright, Carly <ccortright@spokanecity.org>  
**Subject:** Comment on Residential Code Changes Plan Commission Meeting 4/27/22 at 2pm

**[CAUTION - EXTERNAL EMAIL - Verify Sender]**

Comment on Residential Code Changes Plan Commission Meeting 4/27/22 at 2 pm

**Duplexes in Residential Zones**

I support affordable housing. I raised my son in the Lincoln Heights neighborhood as a single-working mother. I was fortunate to buy a house before the housing prices skyrocketed. I want other families to experience the joy of home-ownership and raising a family in a walkable, bicycle-friendly neighborhood with a thriving center-core.

I also want our neighborhood to be a place where single people and empty nesters can afford to live and support our center-core.

I just ask that the city ensure developers construct housing in our neighborhood that is similar to a single-family home as to add to the quality of our established neighborhood and gently increase the density of residential zones, like stated in the info sheet.

I support smaller, more affordable duplexes in a single family neighborhood, so home-ownership remains viable in my neighborhood.

### **Attached Housing**

The Lincoln Heights neighborhood is dominated by single-family homes.

I would like to request the city notify residents of a proposed 4-unit attached house in a single-family zoning to allow public comments. It would ensure the new housing will be well-designed and add to the quality of the established neighborhood, as stated in the info sheet.

### **Short Plat Application Process**

I would like to request the city retain the notice of application for short plats that create only two lots, or for shot plats with only minor engineering review.

Our neighbors may be aware of any historic significance on the affected neighborhood lots, including historically walked across trails. I don't want our neighborhood to lose an opportunity to protect a feature on the lots during the short plat process.

Thank you!

Carol Tomsic  
resident

**From:** [Gene Brake](#)  
**To:** [Deasy, Annie](#)  
**Cc:** [Antonia DePasquale](#); [Barbara Biles](#); [Bill Heaton](#); [Black, Tirrell](#); [Charles Hansen](#); [Christopher Savage](#); [Chuck Milani](#); [Cliff Winger](#); [Comstock \(comstockneighborhoodcouncil@gmail.com\)](#); [Doug Tompkins](#); [Freibott, Kevin](#); [Byrd, Giacobbe](#); [Greg Francis](#); [Kosanke, Katie](#); [Kelly Cruz](#); [Laura Mincks](#); [McInnis, Bonnie](#); [Molly Marshall](#); [Nicola J Payette](#); [Pat Rooks](#); [Patricia Hansen](#); [Paul Kropp/Southgate](#); [Rachelle Bradley](#); [Robynn Sleep](#); [Teresa Kafentzis](#); [Terry Black](#); [Tiffany Picotte](#); [Timothy Diko](#); [Tom Powell-Emerson Garfield](#); [Gwinn, Nathan](#)  
**Subject:** Re: Presentation - Land Use Committee  
**Date:** Thursday, April 28, 2022 7:53:09 PM

---

**[CAUTION - EXTERNAL EMAIL - Verify Sender]**

Annie,

Thank you for sharing this. I'm disappointed planning has decided to move forward with a very developer friendly plan and yet most anti neighborhood plan possible in this first Phase. These plans do nothing to increase the number of low income units, yet will absolutely result in the loss of homes when developers and investors begin buying up single family homes. We all know this wont impact most of the South Hill but will decimate the Northside neighborhoods, especially Emerson Garfield.. Where are some of the most affordable homes at present in Spokane that would be Emerson Garfield, well you can kiss them goodbye.

As we see modest historic homes bulldozed we can at least sleep well knowing developers and investors made money. :( Families? Nah, they have to live with the progress. Shameful really.

Gene Brake  
 Housing Action Subcommittee member  
 Emerson Garfield Neighborhood Council - Treasurer  
 Corbin Park Homeowners Association - Vice President

On Thu, Apr 28, 2022 at 3:01 PM Deasy, Annie <[adeasy@spokanecity.org](mailto:adeasy@spokanecity.org)> wrote:

*Good afternoon Land Use Committee Representatives,*

Nathan Gwinn from Planning Services has requested that the attached presentation slides be shared with the committee.

Best,

Annie



Annie Deasy | City of Spokane | Community Programs Coordinator

Working Remotely, Off on Fridays | 509.625.6343 | mobile 509.504.3475 | [adeasy@spokanecity.org](mailto:adeasy@spokanecity.org) | [spokanecity.org](http://spokanecity.org)





May 3, 2022

Spokane Planning Commission  
 808 Spokane Falls Blvd  
 Spokane WA 99201

Commission,

The Spokane Regional Continuum of Care manages and distributes \$4.3 million annually of HUD's Homelessness service funds. Housing is the end goal of all the interventions funded by the CoC. Finding someone a stable place to call home is the purpose of the CoC's work. This means that our work is intricately connected to the state of Spokane's Housing Market.

We are writing this letter to support several changes that would help increase housing inventory. These include changes to the Short Plat process, increasing the threshold for SEPA reviews on apartments, and making ADU's easier to produce.

The CoC's chairperson was the original sponsor of the neighborhood notification bill in 2014 and has a unique perspective on how our housing market has been stymied by residents who want to maintain the status quo. Reducing notification requirements for Short Plats would be one step in the right direction to increasing housing availability. CoC programs can help fewer people the more market rate rents skyrocket. Increasing the threshold for SEPA reviews to match existing state requirements makes sense and would help to increase housing availability and reduce rental rates. Studies and real-world experience looking at changes to relevant laws clearly show that if the owner occupancy requirement for ADU's is eliminated, applications for permits will increase.

Increasing supply in every way possible is necessary as rents and housing prices have increased by over 50% in the last 24 months. These three changes will help to increase the supply of housing in our community which is desperately needed. These are just a few code changes that are needed to help address the current housing crisis. We urge you to pass these changes as soon as possible so we can focus on larger changes that are needed to address this crisis that impacts our entire community.

Sincerely,

The Spokane Regional Continuum of Care

CC:

Steve McDonald, City of Spokane  
 Spencer Gardner, City of Spokane



**From:** [Gardner, Spencer](#)  
**To:** [Beck, Amanda](#); [Churchill, Jackie](#); [Gwinn, Nathan](#)  
**Subject:** FW: Comments on Code Amendments  
**Date:** Wednesday, May 4, 2022 3:59:42 PM  
**Attachments:** [Building Site Coverage in RSF Limits ADU Development.pdf](#)

---

New comment for the public record. Another one to follow.

**Spencer Gardner** | Director | Planning Services  
Office 509-625-6097 | Mobile 509-723-7554 | [my.spokanecity.org](http://my.spokanecity.org)

---

**From:** Jim Frank <jfrank@greenstonehomes.com>  
**Sent:** Wednesday, May 4, 2022 1:01 PM  
**To:** Gardner, Spencer <sgardner@spokanecity.org>  
**Cc:** Ben Stuckart <benstuckart@gmail.com>; Michelle Pappas <michelle@futurewise.org>; Darin Watkins <dwatkins@spokanerealtor.com>  
**Subject:** Comments on Code Amendments

**[CAUTION - EXTERNAL EMAIL - Verify Sender]**

Spencer Gardner and Plan Commission:

I am very interested in the code amendments necessary to encourage infill development, having been involved in these efforts for more than 10 years.

I regrettably will not be able to testify in person as I have a hearing before the NPAC committee this afternoon at the same time as the Plan Commission public hearing.

These are complex matters and it is discouraging that so little time is being allowed between the finalization of the staff and Commission recommendations and the notice provided to the public. It is also discouraging that these changes are being made without any outreach to the architects, developers and contractors who will have to navigate the code and are familiar with the restrictions that are limiting infill development in the community.

In general I assume the purpose of the recommended changes is to significantly increase infill development in the community. In order for this to be achieved two things will be necessary: First, the regularity framework must be simple, clear and understandable to those looking to make infill investment. Lack of clarity and uncertainty will discourage investment more often than the actual code substance. Second, the code must “encourage” the investment you desire not merely “permit” the investment. These are very different. While I understand this is the beginning of a process and that change will be incremental, What is being proposed in these current changes fall short on both counts.

**I am fully supportive of the recommendation to do away with the lot transition rules.** This is long overdue. The worst part of the rules is not the substance (this will probably not impact more than about 10 units per year), but the message that it sends that “small homes on small lots” are a

problem that needs to be avoided and the code is here to protect you. This message is not only blatantly false, but enables structural inequality in housing policy.

The proposed changes around short plats, ADU development and attached housing fall very short of what is necessary.

**Short Plats:** The changes being proposed add to the complexity of the regulatory framework. The process for exempting 2 lot short plat from the public notice requirement is simply not worth the effort and complexity it entails. It is far more effective to simply make a short plat a Type I permit (rather than Type II). This avoids the public notice requirement and it significantly reduces the fees. If the short plat requires SEPA then a SEPA public notice maybe required, which is a separate and normal process. A Type I permits still has engineering review where required. What is being proposed is simply not worth the effort and will not benefit more than a small number of projects. RCW 58.17 allows jurisdictions to adopt a streamlined process for short plats. The danger of adopting what has been proposed is that it will close the door to the real and necessary changes that are required.

**ADU Development:** While some of the changes proposed for ADU development are beneficial (removal of the occupancy requirement), in total the regulation is overly complex and confusing. The biggest deterrent is building site coverage. The building site coverage in the Spokane SMC is by far the most restrictive in the region. In most instances common development of a home and garage will push up against the site development standards. This is illustrated in the attached exhibit. In nearly all cases there is no "excess building site coverage" available for ADU development. In realty you need a small house on a larger lot to have available site coverage for a 600-800SF ADU. While the new code amendments allow 15% to 20% site coverage for an ADU, that is very misleading. The total of the house, garage and ADU still have to meet to code site coverage which is very restrictive. You can see on the exhibit that a small 1500SF 3 bedroom house on a 5000 SF lot will have a site coverage of 39.6%. The total allowable site coverage on a 5000SF lot is 45%, insufficient for an ADU. For this to work the site coverage in table SMC 17C.110-3 needs to be amended to 55% as a minimum. That would be consistent with Spokane County and the City of Spokane Valley. The FAR standards add even more confusion. An FAR of .5 is ridiculously low for infill development which often requires two or three level development on small lots. It is far simpler to make the changes to FAR on Table SMC 17C.110-3 applicable to all development. Other jurisdictions have greatly simplified the process around ADU development. Spokane needs to do the same.

**Attached Housing:** There are lots of nice words about allowing more attached units without going through a PUD, however you are still required to meet all of the standards in Table SMC 17C.110-3. Attached housing is not possible without revision of the lot size, lot dimensional standards, site coverage, and FAR standards. These are not addressed in any way. It is misleading to say attached housing is being allowed without the required changes to the development standards necessary for such development to occur. For example, an interior townhome unit would like require a lot size as 1500 SF, lot width of 16 feet, site coverage of 80% and FAR of 1.0. The attached housing you see happening in Kendall Yards is possible only because we received a PUD approved that exempts us from nearly all of the development standards in Table 17C.110-3.

I am all in favor of incremental approach to code development, however when we undertake revision in a narrow area we need to address it in the best long term manner.

Thanks, Jim

# Building Site Coverage in RSF Limits ADU Development

Lot Size	House, SF	Garage, SF	ADU, SF	Total Building Coverage, SF	Building Coverage, %, w/ADU	Building Coverage%.W/O add
3000	1000	320	600	1920	64%	44.0%
4350	1300	400	600	2300	52.9%	39.1%
5000	1500	480	600	2580	51.6%	39.6%
			800	2780	55.6%	
6000	1750	625	600	2975	49.6%	39.6%
			800	3175	52.9%	
7000	2000	750	600	3350	47.9%	39.3%
			800	3550	50.7%	
						Spokane County Building Site Coverage
						Spokane Valley Building Site Coverage

Lot Size	Permitted Site Coverage
3000	1500.0
	50.0%
4350	2006.3
	46.1%
5000	2250.0
	45.0%
6000	2600
	43.3%
7000	2950.0
	42.1%
	55.0%%
	50% (8du/acre) and 60% (10du/acre)

**From:** [Gardner, Spencer](#)  
**To:** [Beck, Amanda](#); [Churchill, Jackie](#); [Gwinn, Nathan](#)  
**Subject:** FW: Comments on Code Amendments  
**Date:** Wednesday, May 4, 2022 4:00:17 PM  
**Attachments:** [Building Site Coverage in RSF Limits ADU Development.pdf](#)

---

Follow up comment.

**Spencer Gardner** | Director | Planning Services  
Office 509-625-6097 | Mobile 509-723-7554 | [my.spokanecity.org](http://my.spokanecity.org)

---

**From:** Darin Watkins <DWatkins@spokanerealtor.com>  
**Sent:** Wednesday, May 4, 2022 1:22 PM  
**To:** Jim Frank <jfrank@greenstonehomes.com>  
**Cc:** Gardner, Spencer <sgardner@spokanecity.org>; Ben Stuckart <benstuckart@gmail.com>; Michelle Pappas <michelle@futurewise.org>  
**Subject:** Re: Comments on Code Amendments

**[CAUTION - EXTERNAL EMAIL - Verify Sender]**

Jim, we could not be more in support of your position. In order to facilitate more housing, we need to keep these amendments and changes as simple as possible. Many of the changes are needed to stay within the guidelines of state law.

There are many new and very reasons to be talking about infill, ADU's and other needs. Underlying it all, is the tremendous need for housing that overrides so many of our conversations. We must do everything we can as quickly as we can to relieve the suffering for so many

**Darin Watkins**

Government Affairs Director  
Spokane Association of REALTORS®  
P:  [\(509\) 326-9222 ext. 203](tel:(509)326-9222)

On May 4, 2022, at 4:01 PM, Jim Frank <[jfrank@greenstonehomes.com](mailto:jfrank@greenstonehomes.com)> wrote:

Spencer Gardner and Plan Commission:

I am very interested in the code amendments necessary to encourage infill development, having been involved in these efforts for more than 10 years. I regrettably will not be able to testify in person as I have a hearing before the NPAC committee this afternoon at the same time as the Plan Commission public hearing.

These are complex matters and it is discouraging that so little time is being allowed between the finalization of the staff and Commission recommendations and the notice provided to the public. It is also discouraging that these changes are being made without any outreach to the architects, developers and contractors who will have to navigate the code and are familiar with the restrictions that are limiting infill development in the community.

In general I assume the purpose of the recommended changes is to significantly increase infill development in the community. In order for this to be achieved two things will be necessary: First, the regularity framework must be simple, clear and understandable to those looking to make infill investment. Lack of clarity and uncertainty will discourage investment more often than the actual code substance. Second, the code must “encourage” the investment you desire not merely “permit” the investment. These are very different. While I understand this is the beginning of a process and that change will be incremental, What is being proposed in these current changes fall short on both counts.

**I am fully supportive of the recommendation to do away with the lot transition rules.** This is long overdue. The worst part of the rules is not the substance (this will probably not impact more than about 10 units per year), but the message that it sends that “small homes on small lots” are a problem that needs to be avoided and the code is here to protect you. This message is not only blatantly false, but enables structural inequality in housing policy.

The proposed changes around short plats, ADU development and attached housing fall very short of what is necessary.

**Short Plats:** The changes being proposed add to the complexity of the regulatory framework. The process for exempting 2 lot short plat from the public notice requirement is simply not worth the effort and complexity it entails. It is far more effective to simply make a short plat a Type I permit (rather than Type II). this avoids the public notice requirement and it significantly reduces the fees. If the short plat requires SEPA then a SEPA public notice maybe required, which is a separate and normal process. A Type I permits still has engineering review where required. What is being proposed is simply not worth the effort and will not benefit more than a small number of projects. RCW 58.17 allows jurisdictions to adopt a streamlined process for short plats. The danger of adopting what has been proposed is that it will close the door to the real and necessary changes that are required.

**ADU Development:** While some of the changes proposed for ADU development are beneficial (removal of the occupancy requirement), in total the regulation is overly complex and confusing. The biggest deterrent is building site coverage. The building site coverage in the Spokane SMC is by far the most restrictive in the region. In most instances common development of a home and garage will push up against the site development standards. This is illustrated in the attached exhibit. In nearly all cases



these is no “excess building site coverage” available for ADU development. In realty you need a small house on a larger lot to have available site coverage for a 600-800SF ADU. While the new code amendments allow 15% to 20% site coverage for an ADU, that is very misleading. The total of the house, garage and ADU still have to meet to code site coverage which is very restrictive. You can see on the exhibit that a small 1500SF 3 bedroom house on a 5000 SF lot will have a site coverage of 39.6%. The total allowable site coverage on a 5000SF lot is 45%, insufficient for an ADU. For this to work the site coverage in table SMC 17C.110-3 needs to be amended to 55% as a minimum.

That would be consistent with Spokane County and the City of Spokane Valley. The FAR standards add even more confusion. An FAR of .5 is ridiculously low for infill development which often requires two or three level development on small lots. It is far simpler to make the changes to FAR on Table SMC 17C.110-3 applicable to all development. Other jurisdictions have greatly simplified the process around ADU development. Spokane needs to do the same.

**Attached Housing:** There are lots of nice words about allowing more attached units without going through a PUD, however you are still required to meet all of the standards in Table SMC 17C.110-3. Attached housing is not possible without revision of the lot size, lot dimensional standards, site coverage, and FAR standards. These are not addressed in any way. It is misleading to say attached housing is being allowed without the required changes to the development standards necessary for such development to occur. For example, an interior townhome unit would like require a lot size as 1500 SF, lot width of 16 feet, site coverage of 80% and FAR of 1.0. The attached housing you see happening in Kendall Yards is possible only because we received a PUD approved that exempts us from nearly all of the development standards in Table 17C.110-3.

I am all in favor of incremental approach to code development, however when we undertake revision in a narrow area we need to address it in the best long term manner.

Thanks, Jim

# Building Site Coverage in RSF Limits ADU Development

Lot Size	House, SF	Garage, SF	ADU, SF	Total Building Coverage, SF	Building Coverage, %, w/ADU	Building Coverage%.W/O add
3000	1000	320	600	1920	64%	44.0%
4350	1300	400	600	2300	52.9%	39.1%
5000	1500	480	600	2580	51.6%	39.6%
			800	2780	55.6%	
6000	1750	625	600	2975	49.6%	39.6%
			800	3175	52.9%	
7000	2000	750	600	3350	47.9%	39.3%
			800	3550	50.7%	
						Spokane County Building Site Coverage
						Spokane Valley Building Site Coverage

Lot Size	Permitted Site Coverage
3000	1500.0
	50.0%
4350	2006.3
	46.1%
5000	2250.0
	45.0%
6000	2600
	43.3%
7000	2950.0
	42.1%
	55.0%%
	50% (8du/acre) and 60% (10du/acre)

## Beck, Amanda

---

**From:** Beck, Amanda  
**Sent:** Wednesday, May 11, 2022 9:11 AM  
**To:** Carol Tomsic  
**Cc:** Gwinn, Nathan  
**Subject:** RE: Plan Commission Hearing 5/11/22 on Phase One Residential Development Code

Hi Carol,

Thank you for providing public comment on proposed revisions to short plat notifications that are a part of [Shaping Spokane Housing](#). Your email is now part of the public record for the project, and will be shared with the Plan Commission for tonight's public hearing.

In case you need it, you can find tonight's meeting information on the [Plan Commission webpage](#), which will be held as a hybrid in-person and virtual meeting. The public hearing starts at 4:00 pm.

Thank you,  
Amanda

Amanda Beck, AICP | City of Spokane | Assistant Planner II  
509-625-6414 | main 509-625-6500 | [abeck@spokanecity.org](mailto:abeck@spokanecity.org) | [spokanecity.org](http://spokanecity.org)



---

**From:** Carol Tomsic <carol\_tomsic@yahoo.com>  
**Sent:** Tuesday, May 10, 2022 11:13 PM  
**To:** Plan Commission <eraplanc@spokanecity.org>  
**Cc:** Gwinn, Nathan <ngwinn@spokanecity.org>; Beck, Amanda <abeck@spokanecity.org>; Marilyn <mdlloyd@comcast.net>; Mary Winkes - Manito/Cannon Hill <mmcsपो@yahoo.com>  
**Subject:** Plan Commission Hearing 5/11/22 on Phase One Residential Development Code

**[CAUTION - EXTERNAL EMAIL - Verify Sender]**

Comment on the proposed changes to the Short Plat Application Process

I request the city retain the notice of application for short plats that create only two lots, or for short plats with only minor engineering review.

Our neighborhood has lots that are undeveloped and forested.

The current short plat process notification allows our neighborhood to preserve any historic significance on proposed short plats, including historically walked across trails. A 400 foot notification, without any other notification to residents within the area, may result in a loss of an opportunity to protect a feature on lots during the short plat process.

And, the current short plat process prepares our residents for the proposed code amendments changes that may occur on a lot afterwards.

Thank you  
Carol Tomsic  
resident

## Beck, Amanda

---

**From:** Planning Services Development Code  
**Sent:** Wednesday, May 11, 2022 9:07 AM  
**To:** Matt Side  
**Cc:** Gwinn, Nathan  
**Subject:** RE: Public Comment Spokane City Plan Commission hearing scheduled for 4 p.m. May 11, 2022,

Hi Matt,

Thank you for providing public comment on proposed revisions to residential code related to the project [Shaping Spokane Housing](#). Your email is now part of the public record for the project, and will be shared with the Plan Commission for tonight's public hearing, and also the future hearing for the remaining code topics.

If you're interested, you can find tonight's meeting information on the [Plan Commission webpage](#), which will be held as a hybrid in-person and virtual meeting.

Draft code for attached homes and duplexes are not currently scheduled for public hearing, but we will notify the email list once we have a date for those topics.

Thank you,  
Amanda

Amanda Beck, AICP | City of Spokane | Assistant Planner II  
509-625-6414 | main 509-625-6500 | [abeck@spokanecity.org](mailto:abeck@spokanecity.org) | [spokanecity.org](http://spokanecity.org)



---

**From:** Matt Side <matt@evoreal.com>  
**Sent:** Tuesday, May 10, 2022 8:24 AM  
**To:** Planning Services Development Code <erapsdc@spokanecity.org>  
**Subject:** Public Comment Spokane City Plan Commission hearing scheduled for 4 p.m. May 11, 2022,

**[CAUTION - EXTERNAL EMAIL - Verify Sender]**

Hello My Name is Matt Side. I am a life long resident of Spokane. I am in favor of the proposed changes the Spokane City Plan Commission is considering when it comes to accessory dwelling units and lot size transition. One of the challenges that I think most of us are very aware of is a tight housing supply making it more and more difficult for home purchasers and tenants. I appreciate the Spokane City Council and the Spokane City Plan Commission reaching out to other communities that have gone before us in creating housing opportunity. As I write this comment I am sitting at my brothers apartment in Columbia City just south of Seattle. Ten years ago this was considered a very rough part of Seattle. However, as they have allowed mixed use and stacked flat development it has quickly become a desirable place to live. It is critical to our growth as a community to create neighborhood havens that encourage reinvestment into our local economy. Townhomes, stacked flats, and Accessory Dwelling Units with fewer restrictions in addition to investing in our smaller neighborhood commercial zones will open up housing accessibility and encourage people to stay in their communities and not always have to drive across town for the services they need. The state of Washington legislature was unable this last session to pass a missing middle housing bill which was intended to help solve so many of these issues. That inability to take action at the state level reinforces the need for the local governments to make adjustments

to zoning and building regulations that allow us to leverage the property we have inside the city instead of continuing to sprawl outward. Thank you for considering these changes to Spokane.

Matt Side

509-220-3961 Cell

509-747-1101 X 3 Office

509-271-0037 Fax

[matt@evoreal.com](mailto:matt@evoreal.com)



**Spokane Tribe of Indians  
Tribal Historic Preservation Officer**

P.O Box 100 Wellpinit WA 99040

April 5, 2022

**To:** Amanda Beck, Planner II

**RE: Shaping Spokane Housing Residential Development Code Amendments for  
Accessory Dwelling units, Lots Size Transition and Short Plats**

Ms. Beck,

Thank you for contacting the Tribe's Historic Preservation Office. We appreciate the opportunity to provide a cultural consult for your project. The intent of this process is to preserve and protect all cultural resources whenever protection is feasible.

As you know that the Spokane Tribe use of these area's was extensive in years prior to arrival of euro- Americans clearly the Spokane area was a great place of cultural and economic importance to our tribe an research and plan early.

**Recommendation: Case by Case review on each project and may require cultural surveys or monitoring.**

Should additional information become available or scope of work change our assessment may be revised.

Again, thank you for this opportunity to comment and consider this a positive action that will assist in protecting our shared heritage.

If questions arise, please contact me at (509) 258 – 4222.

Regards,

Randy Abrahamson  
Tribal Historic Preservation Officer (T.H.P.O.)



**STREET DEPARTMENT**  
901 N. NELSON ST.  
SPOKANE, WASHINGTON  
99202-3769  
509.232.8800  
FAX 509.232.8830

E-2

**DATE:** April 12<sup>th</sup>, 2022  
**TO:** Amanda Beck, Development Services  
**FROM:** Bobby Halbig, Street Department  
**SUBJECT:** Plan Review  
**PROJECT #:** Residential Dev Code Amendments

We have reviewed the amendments and have the following comment(s).

**General**

- 1 They need to evaluate the impact of smaller lot size on the ability to accommodate driveways, tree requirements and signing.
- 2 17C.300.130.A5.2(b) needs to say that no additional off street parking as long as on street parking is available on both sides of the street according to 17H.010.120.

Val Melvin, P.E.

Gerald Okihara, P.E.

Ken Knutson, P.E.

Marcus Eveland



**From:** [Studer, Duane](#)  
**To:** [Gardner, Spencer](#); [Beck, Amanda](#); [Nilsson, Mike](#)  
**Cc:** [Morris, Mike](#); [Hanson, Rich](#); [Saywers, John](#); [Brown, Eldon](#); [Gwinn, Nathan](#); [Black, Tirrell](#)  
**Subject:** RE: NonProject DNS For Shaping Spokane Housing - Residential Development Code Revisions (sewer comment)  
**Date:** Tuesday, May 3, 2022 4:26:59 PM  
**Attachments:** [image001.png](#)  
[image002.png](#)  
[image003.png](#)  
[image004.png](#)

---

Thanks All.

I just wanted to understand the change from quantitative to qualitative language. Perhaps adding “parcels with utility mains frontage” or “parcels with direct water and sewer main frontage” would be more clear.

Much Obligated,  
Duane.

---

**From:** Gardner, Spencer <[sgardner@spokanecity.org](mailto:sgardner@spokanecity.org)>  
**Sent:** Tuesday, May 3, 2022 9:35 AM  
**To:** Beck, Amanda <[abeck@spokanecity.org](mailto:abeck@spokanecity.org)>; Nilsson, Mike <[mnilsson@spokanecity.org](mailto:mnilsson@spokanecity.org)>; Studer, Duane <[dstuder@spokanecity.org](mailto:dstuder@spokanecity.org)>  
**Cc:** Morris, Mike <[mmorris@spokanecity.org](mailto:mmorris@spokanecity.org)>; Hanson, Rich <[rahanson@spokanecity.org](mailto:rahanson@spokanecity.org)>; Saywers, John <[jsaywers@spokanecity.org](mailto:jsaywers@spokanecity.org)>; Brown, Eldon <[ebrown@spokanecity.org](mailto:ebrown@spokanecity.org)>; Gwinn, Nathan <[ngwinn@spokanecity.org](mailto:ngwinn@spokanecity.org)>; Black, Tirrell <[tblack@spokanecity.org](mailto:tblack@spokanecity.org)>  
**Subject:** RE: NonProject DNS For Shaping Spokane Housing - Residential Development Code Revisions (sewer comment)

Hi all. I agree with the previous replies. Just wanted to reiterate that the “minor engineering review” category is ultimately just a method for charging different fees and imposing different noticing requirements. The process for engineering review will be unchanged.

**Spencer Gardner** | Director | Planning Services  
Office 509-625-6097 | Mobile 509-723-7554 | [my.spokanecity.org](http://my.spokanecity.org)

---

**From:** Beck, Amanda <[abeck@spokanecity.org](mailto:abeck@spokanecity.org)>  
**Sent:** Tuesday, May 3, 2022 8:35 AM  
**To:** Nilsson, Mike <[mnilsson@spokanecity.org](mailto:mnilsson@spokanecity.org)>; Studer, Duane <[dstuder@spokanecity.org](mailto:dstuder@spokanecity.org)>  
**Cc:** Morris, Mike <[mmorris@spokanecity.org](mailto:mmorris@spokanecity.org)>; Hanson, Rich <[rahanson@spokanecity.org](mailto:rahanson@spokanecity.org)>; Saywers, John <[jsaywers@spokanecity.org](mailto:jsaywers@spokanecity.org)>; Brown, Eldon <[ebrown@spokanecity.org](mailto:ebrown@spokanecity.org)>; Gardner, Spencer <[sgardner@spokanecity.org](mailto:sgardner@spokanecity.org)>; Gwinn, Nathan <[ngwinn@spokanecity.org](mailto:ngwinn@spokanecity.org)>; Black, Tirrell <[tblack@spokanecity.org](mailto:tblack@spokanecity.org)>  
**Subject:** RE: NonProject DNS For Shaping Spokane Housing - Residential Development Code Revisions (sewer comment)

Duane,

I attached the updated text (see Option 17G.2 on page 18-19), which Mike explained the logic behind. We drafted the new text to align with the internal review process for “easy” short plats that didn’t need to extend ROW/water/sewer/other utilities/easements versus those that require multiple reviews and require more staff time. So, we tried to create text that reflected actual processes.

Hope that addresses your questions, if not please let me know.

Thanks,  
Amanda

**Amanda Beck, AICP** | City of Spokane | Assistant Planner II

509-625-6414 | main 509-625-6500 | [abeck@spokanecity.org](mailto:abeck@spokanecity.org) | [spokanecity.org](http://spokanecity.org)



---

**From:** Nilsson, Mike <[mnilsson@spokanecity.org](mailto:mnilsson@spokanecity.org)>  
**Sent:** Tuesday, May 3, 2022 7:03 AM  
**To:** Studer, Duane <[dstuder@spokanecity.org](mailto:dstuder@spokanecity.org)>; Beck, Amanda <[abeck@spokanecity.org](mailto:abeck@spokanecity.org)>  
**Cc:** Morris, Mike <[mmorris@spokanecity.org](mailto:mmorris@spokanecity.org)>; Hanson, Rich <[rahanson@spokanecity.org](mailto:rahanson@spokanecity.org)>; Saywers, John <[jsaywers@spokanecity.org](mailto:jsaywers@spokanecity.org)>; Brown, Eldon <[ebrown@spokanecity.org](mailto:ebrown@spokanecity.org)>  
**Subject:** RE: NonProject DNS For Shaping Spokane Housing - Residential Development Code Revisions (sewer comment)

Eldon and I have been talking with Long Range Planning, the lots defined as requiring minor engineering review are those that have sewer/water mains currently adjacent to them (i.e., no main extensions required, utility easements proposed, etc.). The idea is for those parcels with standard service connections, the process can be streamlined from the engineering side. Everything else will follow our current review process.

Hope that helps clarify.

---

**From:** Studer, Duane <[dstuder@spokanecity.org](mailto:dstuder@spokanecity.org)>  
**Sent:** Monday, May 02, 2022 5:29 PM  
**To:** Beck, Amanda <[abeck@spokanecity.org](mailto:abeck@spokanecity.org)>; Nilsson, Mike <[mnilsson@spokanecity.org](mailto:mnilsson@spokanecity.org)>  
**Cc:** Morris, Mike <[mmorris@spokanecity.org](mailto:mmorris@spokanecity.org)>; Hanson, Rich <[rahanson@spokanecity.org](mailto:rahanson@spokanecity.org)>; Saywers, John <[jsaywers@spokanecity.org](mailto:jsaywers@spokanecity.org)>  
**Subject:** RE: NonProject DNS For Shaping Spokane Housing - Residential Development Code Revisions (sewer comment)

Amanda / Mike,

1. How does the “minor engineering review” in the proposed changes get quantified so that the level of effort and time to review for utilities is assessed?
2. Would there still be normal internal review time (e.g. for side sewers, water services, etc.)?

Duane.

pattern.

- Short Plat Notification
  - Notification and commenting requirements for short subdivisions would be streamlined to reduce the cost and time associated with short subdivisions.
    - For developments creating ~~only two lots~~ the requirement to send a notice of application, complete a site posting, and hold a public comment period would be removed.
    - For developments creating ~~three to nine lots~~ the requirement to send a notice of application and hold a public comment period would be retained, but the site posting requirement would be removed.

lots with minor engineering review,  
  
lots subject to standard engineering review or SEPA,

**From:** Churchill, Jackie <[jchurchill@spokanecity.org](mailto:jchurchill@spokanecity.org)>

**Sent:** Wednesday, April 27, 2022 8:56 AM

**Subject:** NonProject DNS For Shaping Spokane Housing - Residential Development Code Revisions

Good Morning,

Please find attached the NonProject Determination of NonSignificance and SEPA checklist for the following proposal:

**Proposal Name:** Shaping Spokane Housing – Residential Development Code Revisions

**Site Address:** Citywide

Please direct any questions or comments to Assistant Planner II, Amanda Beck at [abeck@spokanecity.org](mailto:abeck@spokanecity.org).

Thank you,



Jackie Churchill | Planning & Economic Development Services | Clerk III  
509.625.6986 | fax 509.625.6013 | [jchurchill@spokanecity.org](mailto:jchurchill@spokanecity.org)



**LAND USE GOAL LU 1 – CITYWIDE LAND USE.**

*Offer a harmonious blend of opportunities for living, working, recreation, education, shopping, and cultural activities by protecting natural amenities, providing coordinated, efficient, and cost effective public facilities and utility services, carefully managing both residential and non-residential development and design, and proactively reinforcing downtown Spokane’s role as a vibrant urban center.*

**Land Use Policy LU 1.1 – Neighborhoods.** *Utilize the neighborhood concept as a unit of design for planning housing, transportation, services, and amenities.*

Discussion: Neighborhoods generally should have identifiable physical boundaries, such as principal arterial streets or other major natural or built features. Ideally, they should have a geographical area of approximately one square mile and a population of around 3,000 to 8,000 people. Many neighborhoods have a Neighborhood Center that is designated on the Land Use Plan Map. The Neighborhood Center, containing a mix of uses, is the most intensive activity area of the neighborhood. It includes higher density housing mixed with neighborhood-serving retail uses, transit stops, office space, and public or semi-public activities, such as parks, government buildings, and schools.

A variety of compatible housing types are allowed in a neighborhood. The housing assortment should include higher density residences developed in the form of small scale apartments, townhouses, duplexes, and rental units that are accessory to single-family homes, as well as detached single-family homes.

A coordinated system of open space, nature space, parks, and trails should be furnished with a neighborhood park within walking distance or a short transit ride of all residences. A readily accessible elementary school should be available for neighborhood children. Neighborhood streets should be narrow and tree-lined with pedestrian buffer strips (planting strips) and sidewalks. They should be generally laid out in a grid pattern that allows easy access within the neighborhood. Alleys are used to provide access to garages and the rear part of lots. Pedestrian amenities like bus shelters, benches, and fountains should be available at transit stops.

**LAND USE GOAL LU 3 – EFFICIENT LAND USE.**

*Promote the efficient use of land by the use of incentives, density and mixed-use development in proximity to retail businesses, public services, places of work, and transportation systems.*

**Land Use Policy LU 3.6 – Compact Residential Patterns.** *Allow more compact and affordable housing in all neighborhoods, in accordance with design guidelines.*

Discussion: Compact and affordable housing includes such choices as townhouses, accessory dwelling units (granny flats), live-work housing, triplexes, zero-lot line, starter, small-lot, and row houses.

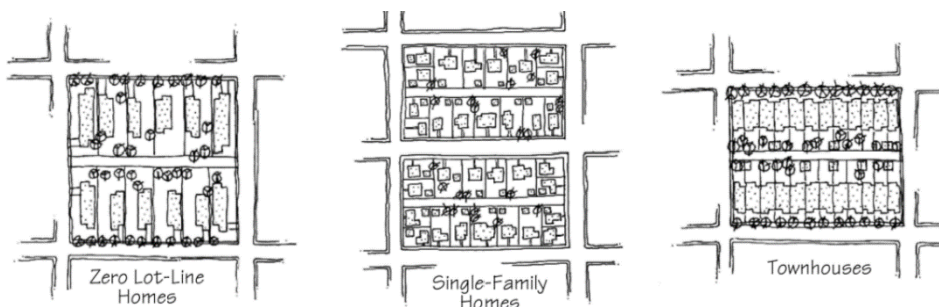

---

## HOUSING GOAL H 1 – HOUSING CHOICE AND DIVERSITY.

Provide opportunities for a variety of housing types that is safe and affordable for all income levels to meet the diverse housing needs of current and future residents.

**Housing Policy H 1.11 – Access to Transportation.** *Encourage housing that provides easy access to public transit and other efficient modes of transportation.*

Discussion: Transportation is the second largest expenditure after housing and can range from 10 to 25 percent of household expenditures. Examining where housing is located and the associated transportation costs may provide a more realistic evaluation of housing affordability in the future.

**Housing Policy H 1.18 – Distribution of Housing Options.** *Promote a wide range of housing types and housing diversity to meet the needs of the diverse population and ensure that this housing is available throughout the community for people of all income levels and special needs.*

Discussion: A variety of housing types should be available in each neighborhood. Diversity includes styles, types, size, and cost of housing. Many different housing forms can exist in an area and still exhibit an aesthetic continuity. Development of a diversity of housing must take into account the context of the area and should result in an improvement to the existing surrounding neighborhood.

**Housing Policy H 1.20 – Accessory Dwelling Units.** Allow one accessory dwelling unit as an ancillary use to single-family homes in all designated residential areas as an affordable housing option.

Discussion: Accessory dwelling units (ADUs) increase the amount and variety of available affordable housing. Increasing the variety of housing can help to satisfy changing family needs and the trend of smaller households. ADUs help provide an avenue for seniors, single parents, and families with grown children to remain in their homes and neighborhoods while obtaining extra income, security, companionship and services. Often ADUs allow a more efficient use of existing housing and infrastructure.

Accessory dwelling units should be built in a manner that does not adversely affect the neighborhood. They should be designed to be physically and visually compatible with surrounding structures.

---

## CAPITAL FACILITIES AND UTILITIES GOAL CFU 4 – SERVICE PROVISION

*Provide public services in a manner that facilitates efficient and effective delivery of services and meets current and future demand.*

**Capital Facilities and Utilities Policy CFU 4.1 – Compact Development.** *Promote compact areas of concentrated development in designated centers to facilitate economical and efficient provision of utilities, public facilities, and services.*

Discussion: Infill and dense development should be encouraged where excess capacity is available since compact systems are generally less expensive to build and maintain.

## Comment Log and Public Comments

### Substantive Public Comments Received After May 11 Plan Commission - Updated 06/06/2022

	<b>Date</b>	<b>Name</b>	<b>Topic(s)</b>	<b>Page</b>
1	5/12/2022	Joan Hunt	STR, Other	2
2	5/20/2022	Jim Haines	Attached homes, Duplexes	20
3	5/28/2022	Shari Mcevoy	ADUs	22
4	5/30/2022	Carol Tomsic	Short Plat notification	24

## Beck, Amanda

---

**From:** Beck, Amanda  
**Sent:** Thursday, May 12, 2022 12:29 PM  
**To:** Joan Hunt  
**Subject:** RE: Support for short term housing changes

Hi Joan,

Thank you for providing public comment in support of short-term rental code changes under the [Shaping Spokane Housing](#) project. These comments have been added to the public record, and will be included with the staff report to Plan Commission when a public hearing is scheduled.

You very thoughtfully lay out the complications of being a community landlord, and how the Covid pandemic impacted our housing market the past two years. We appreciate your perspective on this issue as we haven't heard as much on this topic from landlords.

Right now the draft code is in a sort of holding pattern, as we've heard a lot of push back from the public over concerns this is expanding a use that is negatively impacting the housing supply. The City is working to come up with additional draft code options that might address these concerns. Once we have additional options we would take them back to Plan Commission to workshop the language before the public hearing process. To help inform the workshop, we'll include comments received to date about short-term rentals to aid the Plan Commission in discussion on additional language.

Thanks for your investment and time as a landlord in Spokane.

Thank you,  
Amanda

Amanda Beck, AICP | City of Spokane | Assistant Planner II  
509-625-6414 | main 509-625-6500 | [abeck@spokanecity.org](mailto:abeck@spokanecity.org) | [spokanecity.org](http://spokanecity.org)



---

**From:** Joan Hunt <craigandjoanhunt@gmail.com>  
**Sent:** Thursday, May 12, 2022 9:39 AM  
**To:** Beck, Amanda <abeck@spokanecity.org>  
**Subject:** Support for short term housing changes

**[CAUTION - EXTERNAL EMAIL - Verify Sender]**

Hello, Amanda.

We are writing as property owners who are in support of allowing short term housing in areas of Spokane that are currently zoned commercial or carry other zoning designations where residential housing can occur or is currently occurring. Our property is one 8-unit, mid-century apartment building on the lower South Hill. We also co-own one short term condo unit in

a residential area. We do not fall into the category of a home-owner with a single room to rent, nor a "big corporate Airbnb" investment operator seeking to set up tens or hundreds of units in the downtown core. We are neither a solution to homelessness nor a threat to hotels.

Over the last years of the pandemic, property owners, particularly those of us who are small business owners and have a single apartment building with fewer than 10 units, have been hit very hard with the burden of supporting our citizens who are renters by keeping them housed and preventing more homelessness. The state's more than 20-month long rent moratorium, along with the post-pandemic RCW's governing how we may manage our property have left many of us with increased debt, damaged property, lost revenue, legal debt, and now, post-moratorium, the costs of repairing damaged units, or simply doing deferred maintenance on our property during a very high inflationary period. (This, of course, is one reason rents have gone up again...our cost of business has gone up as well.)

Allowing short term housing in a building such as ours that is currently zoned Commercial/RO, would have zero negative impact on our neighborhood, where the bulk of other buildings are also residential units (including one large SNAP apartment building across the street) and allow us to create even more positive impact. Unlike long-term rentals, short term housing allows us to better maintain our property, monitor the use and safety of our units, keep safety risks and damage to a minimum, and actually improve the surrounding neighborhood. We know what it takes to run our business and we feel we should have the ability to decide if short term units would help us, and how many we would need to incorporate in our building to gain that benefit.

Long term residential property management always has challenges, but became particularly difficult during the pandemic. 2 of 8 units in our building housed tenants who stopped paying rent, didn't apply for rent relief, damaged our property, and posed safety risks to others in the building and the construction workers employed on a building renovation next to our property. However, because of the prevailing state moratorium, we could not get an attorney to take our case in order to evict these tenants and even if we could have retained someone, we were told the timeline for the process would be very costly and take about 6 months if they were successful. (These were not frivolous cases; in one case, a gun was fired on two occasions on the property, and in the other, a worker was physically assaulted by our tenant, charges were pressed, and the police took the tenant to jail.) We lost other tenants in our building because of these 2 people, and when we finally were able to get the difficult tenants to vacate, we found thousands of dollars in damage in their units. (Including one broken brand new window; because of supply shortages, we had to wait 3 months just to receive the glass to repair it, which of course meant we had more lost revenue with an empty unit.) We were unable to recover any of the lost rent because the tenants moved, so we didn't qualify for any programs that were available for rent recovery. **This is just one story, but there are many like this from other owners as well.**

Short term housing can be a way for us to supplement our income to support our properties. I am not talking about drastically increasing our monthly personal income from this, I am speaking



about the need for income to simply maintain and pay our bills in order to hold on to our property. Yes, down the road we hope this increased income will become a retirement income, but still very modest by many standards. But what crime is in that - that is, to be responsible for one's own future by maintaining a small, high-quality business?

The State and City continually characterize the disease of homelessness as one that residential rental property owners somehow are responsible for curing, and now the City Council is apparently getting lots of input from those who advocate for the unhoused that changing short term rules will create even more problems, and that it shouldn't be allowed or at least should be heavily restricted or taxed even more. Selecting an arbitrary number of allowed short-term rental units in a building, or increasing fees to implement short term housing in the same, suggests that those making the rules have any idea of the economics of owning and managing a property. The intent of the State, and now our City Council, to lay the burden of homelessness at our feet is unconscionable. This problem has been around and growing since the financial crisis of 2008. Even though Spokane offers an incredible number of support options for homeless individuals, the fact that the City hasn't, even with all the non-profits, been able to come up with viable, LONG-TERM solutions to this issue, is no reason to turn to small property owners to take this burden from them. And it is farce to believe that the problem simply stems from a lack of housing. Restricting short term rentals, and increasing costs for property owners who choose this option is NOT the solution to this complex problem. Recognition is never given to the positive advantages that good quality, long and short-term housing provides in our area.

As small business owners with rental property, we create local jobs. We hire local, independant cleaners for cleaning our properties, and pay them more than twice the current minimum wage. We treat them with respect, we help them grow their businesses, (many are younger moms who want to create their own small businesses), and help them grow their hard and soft professional skills. We hire local companies to renovate and repair our property, we use a local professional property manager, and we hire a small painting company owned by a senior to do our painting (and all this at prevailing wages). We keep our property in excellent condition, it is safe, clean and monitored by us daily and we live nearby so we respond to any needs very quickly. We pay taxes, we give back to our community through charitable giving, and we spend our dollars locally with other small businesses in Spokane. We do our exterior property upkeep (lawn upkeep, snow removal, landscaping, cleaning up parking areas etc) ourselves and hire our high school aged niece and nephew to help us. We also co-own one short term condo rental unit in a residential area, and we do the same for that business. And in all this, we also pay our utility bills, our mortgages, our property taxes and for the short term rental, our city lodging and business taxes. Anyone who thinks that small business owners are lining their pockets with this work, has either never had the opportunity to talk with an owner or do this work themselves. I also challenge anyone to suggest that we tell grocery store owners, lawyers, retailers, restaurant owners or other small business owners that they have to be taxed more or limited in how they do their work because homeless persons need food, clothing and legal representation, and therefore these business owners must take on the weight of this problem.

The need for shorter term housing is real; traveling professionals doing contract work, entertainers who come to present the Best of Broadway series, families going through divorce needing housing, persons traveling to Spokane for medical care or visiting loved ones in the hospital, small groups or families traveling together, and travelers coming to spend money on tourism activities in our city are just some examples of people who want and need housing options. Hotels do not provide for the needs of every group. **And for what it may be worth, the taxes short term operators pay to the City are not insignificant.** It is not easy work, but it is satisfying to provide quality housing, to represent our city well, and improve our neighborhoods by our investment in them. We are not the terrible people we are often made out to be in news stories, nor are we mega landlords or absentee owners. (However, many local owners who were forced to sell their small rental properties during the pandemic, did indeed sell to cash investors from out of town...another sad loss created by the State, by legally binding property owners to subsidize non-paying tenants while offering no immediate balance of relief to owners, resulting in property owners who could not pay their bills being forced to sell.)

So often, property owners are cast as terrible "landlords" or "slum lords" while the homeless are cast as victims who have only come to their sad fate through no fault of their own; this is unfair to both groups, as both are diverse groups of individuals with varied needs and desires. This "good people, bad people" dynamic is simply an old trope that doesn't stand up and it is frustrating to read newspaper stories that represent such simplistic images. Of course it sells papers and makes the City look good to continue to engage in these myths (the latest story in [The Inlander](#) and quotes by Council President Beggs and Council Member Lori Kinnear are perfect examples). But the truth is that limiting short term housing, or increasing costs to those of us small owners who want to engage in it, is not a solution.

Obviously, we are in favor of expanding and modernizing the rules of short term housing. Please recognize that this method of housing is needed, it is a help to small business owners like we are, it supports investment in our local community, and it fills a need that does not exist in long term housing or hotels.

The changes brought into play by the pandemic have and will continue to shape the way people live, and it would benefit our community to recognize the larger narrative of how and why that is happening, in order to recognize the value and opportunity available in expanding short term housing options. This needs to happen concurrent with, but not as a threat to devising real, long term solutions to this problem of under housed people. We feel sure there is enough intelligence and imagination in our community to make this happen in the form of a win-win situation.

Thank you for your work on these changes; in our two conversations with individuals in the City Planning Department, we are encouraged by the level of thoughtful, intelligent work that has been done by your department to move this issue forward.

Respectfully,  
Joan and Craig Hunt  
Spokane

## Beck, Amanda

---

**From:** Joan Hunt <craigandjoanhunt@gmail.com>  
**Sent:** Thursday, May 12, 2022 12:44 PM  
**To:** Beck, Amanda  
**Subject:** Re: Support for short term housing changes

[CAUTION - EXTERNAL EMAIL - Verify Sender]

Thanks so much, Amanda.

I'm more than willing to contribute anything more if I can; I know this is challenging and efforts are being made to try to address many needs and concerns at once.

I have genuine concern that statements such as those made by Lori Kinnear and Breann Beggs in the recent Inlander article contribute to the public's perception that short term housing use is negatively impacting the local housing supply. Especially "affordable" housing, which is a topic that is in itself complex and I would venture to guess, most of the public does not understand in its true definition as outlined by HUD.

I am also very concerned that our leadership seems ill-informed as well, and I am writing to Council President Beggs and Members Kinnear and Wilkerson, who are in my district, in an effort to provide my perspective as a small business and rental property owner.

Thank you for your work; I appreciate it as well as your communication.

Sincerely,  
Joan

On Thu, May 12, 2022 at 12:29 PM Beck, Amanda <[abeck@spokanecity.org](mailto:abeck@spokanecity.org)> wrote:

Hi Joan,

Thank you for providing public comment in support of short-term rental code changes under the [Shaping Spokane Housing](#) project. These comments have been added to the public record, and will be included with the staff report to Plan Commission when a public hearing is scheduled.

You very thoughtfully lay out the complications of being a community landlord, and how the Covid pandemic impacted our housing market the past two years. We appreciate your perspective on this issue as we haven't heard as much on this topic from landlords.

Right now the draft code is in a sort of holding pattern, as we've heard a lot of push back from the public over concerns this is expanding a use that is negatively impacting the housing supply. The City is working to come up with additional draft code options that might address these concerns. Once we have additional options we would take them back to

Plan Commission to workshop the language before the public hearing process. To help inform the workshop, we'll include comments received to date about short-term rentals to aid the Plan Commission in discussion on additional language.

Thanks for your investment and time as a landlord in Spokane.

Thank you,

Amanda

**Amanda Beck, AICP** | City of Spokane | Assistant Planner II

509-625-6414 | *main* 509-625-6500 | [abeck@spokanecity.org](mailto:abeck@spokanecity.org) | [spokanecity.org](http://spokanecity.org)



---

**From:** Joan Hunt <[craigandjoanhunt@gmail.com](mailto:craigandjoanhunt@gmail.com)>  
**Sent:** Thursday, May 12, 2022 9:39 AM  
**To:** Beck, Amanda <[abeck@spokanecity.org](mailto:abeck@spokanecity.org)>  
**Subject:** Support for short term housing changes

**[CAUTION - EXTERNAL EMAIL - Verify Sender]**

Hello, Amanda.

We are writing as property owners who are in support of allowing short term housing in areas of Spokane that are currently zoned commercial or carry other zoning designations where residential housing can occur or is currently occurring. Our property is one 8-unit, mid-century apartment building on the lower South Hill. We also co-own one short term condo unit in a residential area. We do not fall into the category of a home-owner with a single room to rent, nor a "big corporate Airbnb" investment operator seeking to set up tens or hundreds of units in the downtown core. We are neither a solution to homelessness nor a threat to hotels.

Over the last years of the pandemic, property owners, particularly those of us who are small business owners and have a single apartment building with fewer than 10 units, have been hit very hard with the burden of supporting our citizens who are renters by keeping them housed and preventing more homelessness. The state's more than 20-month long rent moratorium, along with the post-pandemic RCW's governing how we may manage our property have left many of us with increased debt, damaged property, lost revenue, legal debt, and now, post-moratorium, the costs of repairing damaged units, or simply doing deferred maintenance on our property during a very high inflationary period. (This, of course, is one reason rents have gone up again...our cost of business has gone up as well.)

Allowing short term housing in a building such as ours that is currently zoned Commercial/RO, would have zero negative impact on our neighborhood, where the bulk of other buildings are also residential units (including one large SNAP apartment building across the street) and allow us to create even more positive impact. Unlike long-term rentals, short term housing allows us to better maintain our property, monitor the use and safety of our units, keep safety risks and damage to a minimum, and actually improve the surrounding neighborhood. We know what it takes to run our business and we feel we should have the ability to decide if short term units would help us, and how many we would need to incorporate in our building to gain that benefit.

Long term residential property management always has challenges, but became particularly difficult during the pandemic. 2 of 8 units in our building housed tenants who stopped paying rent, didn't apply for rent relief, damaged our property, and posed safety risks to others in the building and the construction workers employed on a building renovation next to our property. However, because of the prevailing state moratorium, we could not get an attorney to take our case in order to evict these tenants and even if we could have retained someone, we were told the timeline for the process would be very costly and take about 6 months if they were successful. (These were not frivolous cases; in one case, a gun was fired on two occasions on the property, and in the other, a worker was physically assaulted by our tenant, charges were pressed, and the police took the tenant to jail.) We lost other tenants in our building because of these 2 people, and when we finally were able to get the difficult tenants to vacate, we found thousands of dollars in damage in their units. (Including one broken brand new window; because of supply shortages, we had to wait 3 months just to receive the glass to repair it, which of course meant we had more lost revenue with an empty unit.) We were unable to recover any of the lost rent because the tenants moved, so we didn't qualify for any programs that were available for rent recovery. **This is just one story, but there are many like this from other owners as well.**

Short term housing can be a way for us to supplement our income to support our properties. I am not talking about drastically increasing our monthly personal income from this, I am speaking about the need for income to simply maintain and pay our bills in order to hold on to our property. Yes, down the road we hope this increased income will become a retirement income, but still very modest by many standards. But what crime is in that - that is, to be responsible for one's own future by maintaining a small, high-quality business?

The State and City continually characterize the disease of homelessness as one that residential rental property owners somehow are responsible for curing, and now the City Council is apparently getting lots of input from those who advocate for the unhoused that changing short term rules will create even more problems, and that it shouldn't be allowed or at least should be heavily restricted or taxed even more. Selecting an arbitrary number of allowed short-term rental units in a building, or increasing fees to implement short term housing in the same, suggests that those making the rules have any idea of the economics of owning and managing a property. The intent of the State, and now our City Council, to lay the burden of homelessness at our feet is unconscionable. This problem has been around and growing since the financial crisis of 2008. Even though Spokane offers an incredible number of support options for homeless individuals, the fact that the City hasn't, even with all the non-profits, been able to come up with viable, LONG-TERM solutions to this issue, is no reason to turn to small property owners to take this burden from them. And it is farce to believe that the problem simply stems from a lack of housing. Restricting short term rentals, and increasing costs for property owners who choose this option is NOT the solution to this complex problem. Recognition is never given to the positive advantages that good quality, long and short-term housing provides in our area.

As small business owners with rental property, we create local jobs. We hire local, independent cleaners for cleaning our properties, and pay them more than twice the current minimum wage. We treat them with respect, we help them grow their businesses, (many are younger moms who want to create their own small businesses), and help them grow their hard and soft professional skills. We hire local companies to renovate and repair our property, we use a local professional property manager, and we hire a small painting company owned by a senior to do our painting (and all this at prevailing wages). We keep our property in excellent condition, it is safe, clean and monitored by us daily and we live nearby so we respond to any needs very quickly. We pay taxes, we give back to our community through charitable giving, and we spend our dollars locally with other small businesses in Spokane. We do our exterior property upkeep (lawn upkeep, snow removal, landscaping, cleaning up parking areas etc) ourselves and hire our high school aged niece and nephew to help us. We also co-own one short term condo rental unit in a residential area, and we do the same for that business. And in all this, we also pay our utility bills, our mortgages, our property taxes and for the short term rental, our city lodging and business taxes. Anyone who thinks that small business owners are lining their pockets with this work, has either

never had the opportunity to talk with an owner or do this work themselves. I also challenge anyone to suggest that we tell grocery store owners, lawyers, retailers, restaurant owners or other small business owners that they have to be taxed more or limited in how they do their work because homeless persons need food, clothing and legal representation, and therefore these business owners must take on the weight of this problem.

The need for shorter term housing is real; traveling professionals doing contract work, entertainers who come to present the Best of Broadway series, families going through divorce needing housing, persons traveling to Spokane for medical care or visiting loved ones in the hospital, small groups or families traveling together, and travelers coming to spend money on tourism activities in our city are just some examples of people who want and need housing options. Hotels do not provide for the needs of every group. **And for what it may be worth, the taxes short term operators pay to the City are not insignificant.** It is not easy work, but it is satisfying to provide quality housing, to represent our city well, and improve our neighborhoods by our investment in them. We are not the terrible people we are often made out to be in news stories, nor are we mega landlords or absentee owners. (However, many local owners who were forced to sell their small rental properties during the pandemic, did indeed sell to cash investors from out of town...another sad loss created by the State, by legally binding property owners to subsidize non-paying tenants while offering no immediate balance of relief to owners, resulting in property owners who could not pay their bills being forced to sell.)

So often, property owners are cast as terrible "landlords" or "slum lords" while the homeless are cast as victims who have only come to their sad fate through no fault of their own; this is unfair to both groups, as both are diverse groups of individuals with varied needs and desires. This "good people, bad people" dynamic is simply an old trope that doesn't stand up and it is frustrating to read newspaper stories that represent such simplistic images. Of course it sells papers and makes the City look good to continue to engage in these myths (the latest story in [The Inlander](#) and quotes by Council President Beggs and Council Member Lori Kinnear are perfect examples). But the truth is that limiting short term housing, or increasing costs to those of us small owners who want to engage in it, is not a solution.

Obviously, we are in favor of expanding and modernizing the rules of short term housing. Please recognize that this method of housing is needed, it is a help to small business owners like we are, it supports investment in our local community, and it fills a need that does not exist in long term housing or hotels.



The changes brought into play by the pandemic have and will continue to shape the way people live, and it would benefit our community to recognize the larger narrative of how and why that is happening, in order to recognize the value and opportunity available in expanding short term housing options. This needs to happen concurrent with, but not as a threat to devising real, long term solutions to this problem of under housed people. We feel sure there is enough intelligence and imagination in our community to make this happen in the form of a win-win situation.

Thank you for your work on these changes; in our two conversations with individuals in the City Planning Department, we are encouraged by the level of thoughtful, intelligent work that has been done by your department to move this issue forward.

Respectfully,

Joan and Craig Hunt

Spokane

## Beck, Amanda

---

**From:** Joan Hunt <craigandjoanhunt@gmail.com>  
**Sent:** Friday, May 13, 2022 3:21 PM  
**To:** Beggs, Breean  
**Cc:** Kinnear, Lori; Wilkerson, Betsy; Beck, Amanda; Gardner, Spencer  
**Subject:** Re: Short Term Housing

[CAUTION - EXTERNAL EMAIL - Verify Sender]

Good Morning, President Beggs.

Thank you for your reply. I am in agreement that updating the short term rental policies is necessary and I appreciate that all voices will be considered and I look forward to a possible forum.

With regard to your statement about other people just like me who say they see larger impact to adjoining properties - I'm not exactly sure what you mean by "just like me" since I am a property owner and I'm guessing that those who may complain of negative impacts are **not** the owners/operators of short term housing? For my part I can, without a doubt, say that the quality of my experience as an owner, and the safety and quality of life in my building as it relates to those who live there have improved with the addition of shorter term guests. There hasn't been any increase in vehicle traffic or number of people in my building, but the quality of guests are professional, quiet, and there with a specific purpose. They are courteous, follow our house rules, and express appreciation for having pleasant accommodations that suit their needs.

The fact that there are many single-family unregistered/unlicensed properties is interesting; I agree it needs to be remedied. If they are operating in residential zones that already have a pathway for registration, then I believe they should be enforced and I hope that is one area that could potentially be addressed right away, even prior to code changes.

I would not have an issue registering if I were allowed to have a short term unit in my zone, and since I am currently doing a monthly rental, I treat it as I do the long-term leases. However, because of the structure of the platform, we do pay all applicable short-term housing taxes to the city. If those unregistered residences were paying comparable taxes, would those funds, along (with all the other revenue from short-term rentals) be available to put toward your affordable housing fund?

Thanks again for your reply; I know this is a mult-faceted issue and I hope the solutions can address the needs of all.

Joan

On Fri, May 13, 2022 at 7:51 AM Beggs, Breean <[bbeggs@spokanecity.org](mailto:bbeggs@spokanecity.org)> wrote:

Thanks so much Joan. We are attempting to gather all the feedback from as many stakeholders as possible to guide as as we do what is best for the entire City. Your well articulated perspective will be very helpful. Once we have an actual proposal on the table, we will also likely schedule some type of public engagement forum where we can hear from you and others in real time.

I do want to point out that the eviction moratorium imposed by the State expired last year and I don't see it coming back. The City Council also distributed tens of millions of dollars in rental assistance to landlords to mitigate some of the losses they experienced during that moratorium. I also don't see regulation of short term rentals as a solution for homeless individuals, because they need below market housing. I have heard many concerns from people just like you that short term rentals do pose larger impacts to adjoining properties than regular rentals; and, that the loss of market rate housing is making it more difficult for everyday families to find vacant rental housing.

Last I checked, there where almost 800 single family market rate residential units being diverted into short term rentals. Only a fraction of them where actually registered and licensed with the City. It seems appropriate to update our polices and enforcement and I look forward to your continued input.

Best,

Breean Beggs

---

**From:** Joan Hunt <[craigandjoanhunt@gmail.com](mailto:craigandjoanhunt@gmail.com)>

**Sent:** Thursday, May 12, 2022 3:54 PM

**To:** Beggs, Breean <[bbeggs@spokanecity.org](mailto:bbeggs@spokanecity.org)>; Kinnear, Lori <[lkinnear@spokanecity.org](mailto:lkinnear@spokanecity.org)>; Wilkerson, Betsy <[bwilkerson@spokanecity.org](mailto:bwilkerson@spokanecity.org)>

**Subject:** Short Term Housing

[CAUTION - EXTERNAL EMAIL - Verify Sender]

Council President Beggs, and Council Members Kinnear and Wilkerson,

I am writing in response to the current conversation about changes to the City Code governing short term rentals and specifically to points brought up in the May 5, 2022 article in The Inlander, "Spokane may consider tweaking its Airbnb policy - if it can figure out what the current one is"

My husband and I are property owners who are in support of allowing short term housing in areas of Spokane that are currently zoned commercial or carry other zoning designations where residential housing is currently occurring. Our property is one 8-unit, mid-century apartment building on the lower South Hill in a Commercial/RO zoning. We have been told by City Planning that based on our zone, we can enter into leases of 30 days, but no less, so we have 2 units in our building that we have furnished and offer for extended stays and advertise through Airbnb. We also co-own one condo unit (for the last 9 months), in a residential area northwest of Kendall Yards that is currently a licensed short-term rental advertised through Airbnb. We do not fall into the category of a home-owner with a single room to rent, nor a "big corporate Airbnb" investment operator seeking to set up tens or hundreds of units in the downtown core. **We do**

our best to set our rents at rates that allow us to maintain our property, pay our mortgage and taxes, pay the professionals we have to hire to do work for us, pay our professional property management company, and create some reserve for unexpected expenses, but the economics of that do not make it possible for us to charge 'affordable housing' rates as defined by the local housing authority. So we don't fall into a category of those who, if they set up a short term rental, would be denying affordable housing by doing so.

In the 4 years we've owned the property, we have taken less than \$6500 a year from the property for personal income. In that same time, we have had to make improvements and updates to the interiors of every unit in our building as well as do roof repair and chimney repairs, replace all windows, siding, railings, stairs and decking, and prune large trees. This was because when we purchased the property from my dad's estate, he and my mom had provided low rental rates (if not officially "affordable housing"), for so long, that they could not manage to keep up with the severe needs of the building, and the deterioration and resulting costs for repair and maintenance were overwhelming. The same tenants who my mom would provide birthday cards and Christmas cakes for, told us they did not report maintenance issues for fear that "our rent would be raised", which is pretty frustrating to hear, but reveals a bit of a not-uncommon mindset that we've encountered with tenants. Two of these tenants lived in the building for more than 20 years each and when we took on the building, we were dismayed at the amount of damage that existed from tenant neglect. We have done this work because we care about it, we believe we are good at it, we enjoy contributing to the neighborhood, and hope that one day it supplements our income. However, if we have an opportunity to make our lives smoother by having the option of diversifying our mix of rental options, and that allows us more income, we would like to take it.

We are also among small property owners who sustained financial losses during the more than 20-month rental moratorium. Specifically we had 2 tenants who stopped paying rent, would not apply for assistance, posed physical threats to others in the building and to workers next door to our building, and whom we could not evict because even with "just cause", no attorney would take our cases during the moratorium. Even if they had, we were told it would be very costly, and because of state laws, would take 6 months or more to go through the process of eviction. When one of these tenants finally went to jail for assaulting a construction worker next door to our building, he decided to flee town after he was released so we got our apartment back. Our cost to repair damage to the unit was \$4000, we had to wait 3 months for the glass to replace a broken window so lost time to re-rent the unit, and the tenant left owing \$2400 in unpaid rent that we could not recover. The other tenant whose "friends" visited her often, and for whom the police and paramedics were called 3 separate times for drug overdoses, and who twice fired a gun on our property, was finally convinced by our property manager to move. She left damages that cost \$3500 to repair and unpaid rent in the amount of \$2200. Because of this one tenant's

behaviour and our inability to evict her, we lost 2 other good tenants, two of whom we let out of their leases without penalty because we also feared for their safety and in good conscience could not expect them to stay when we no longer had the ability to do what was needed to provide a safe environment.

This backstory leads to why we are supportive of opening up other zoning areas to shorter-term units; our property is already being used for residential purposes, it has no negative impact on the neighborhood, we can provide a needed housing opportunity, we have more control over who is in our property, we have the freedom to immediately remove anyone who poses a danger, we have the ability to keep our units maintained by being in them more frequently and cleaning them regularly, the rent money is guaranteed prior to occupancy, we don't have the problem of squatters, and the additional income helps us keep up with rising costs for maintaining our property. With regard to costs, as an example, over the past 4 years our cost to renovate a unit has more than doubled. In 2018 we paid \$22,000 to update a 65 year-old 1 bedroom unit and today it will cost us \$48,000. The economics of keeping up a property, while paying usual costs such as professional management, mortgage, utilities, taxes, and maintenance simply do not allow us to charge the 'affordable housing' rates desired for our underhoused population. If we supplement our long-term rates with the shorter-term ones, it eases our burden and gives us a path toward a more stable business model.

President Beggs, in the Inlander article, you suggest charging additional fees of \$15 per night for short term rentals to fund affordable housing "since these units are taking away affordable housing". How do you know if these units would be priced as affordable housing by the owners if they were long-term housing versus short-term? I am aware of at least 7 studio studio units downtown currently rent for \$1000/month with \$50/month utility costs. And, if someone has to park a car, the rates are \$100/month in lots next to these buildings. If I'm correct, these costs are not consistent with affordable housing. So to assert that all units downtown are going to be affordable housing seems incorrect. Additionally, some of these units that I'm aware of are in very old buildings that have had to have extensive renovation or remodeling work to bring them to code in order for them to be habitable. Especially with inflation and supply chain issues, this is currently extremely costly work. Based on my experience as a business owner, I would guess it is not possible to charge lower rent on these units and be able to justify doing the necessary work to create this housing.

Unless the article is incorrect, it sounds like you may be thinking that needed changes will affect only two categories of persons; "big corporate Airbnb's" and "small-time homeowners renting out their rooms". I am neither of those entities, and my property is not in the downtown core. So to limit my ability to discern what works economically for me in my 8-unit building on the lower South Hill, by creating an ordinance limiting my ability to operate one unit as a short term unit because I already co-own another short term unit across town doesn't address my needs, and seems completely arbitrary; I am curious to know on what economic facts are you basing this suggestion.

Further, Council Member Kinnear, you are quoted as saying "We have almost 800 Airbnbs around"... "almost the same number of homeless in our city". Perhaps this quote is not contextualized correctly, but it sounds like you are saying that short-term housing is the reason 800 persons are unhoused in Spokane. If so, it's hard to believe that anyone who had looked into homelessness and its complexities, and anyone who had talked with rental property owners would be able to make such a correlation. And I personally feel it's a very misleading statement and a disservice to anyone reading this article who really cares about the issues and is looking for guidance about how to take a position on it.

It's also interesting that there is rarely a mention of the fact that beyond "tourism", short-term housing provides a service for a segment of the population for whom hotel stays or long term rentals don't work. Traveling professionals, health-care workers on contract, persons traveling to Spokane for extended health care, or to attend to or visit family members in the hospital for extended time, families who need intermediate housing while in the process of divorce, professionals coming to Spokane to perform in productions such as the Best of Broadway series or youth sports events all need and want options other than hotels. Additionally, those of us who have decided to offer short term housing through Airbnb pay taxes that benefit the region and state, collected and disbursed by Airbnb. From the Airbnb Site:

Airbnb [\*collects and pays\*](#) a number of taxes on your (the owner's) behalf, including:

- *The Washington Combined Sales Tax*
- *Special Host/Motel Tax*
- *Convention and Trade Center Tax*
- *Regional Transit Authority Tax*
- *Tourism Promotion Area Charges in the State of Washington*

*All locally imposed taxes on transient lodging will be collected on reservations in Washington. The Special Hotel/Motel Tax is typically 1-5% of the listing price including any cleaning fees for reservations 29 nights and shorter. Other local taxes vary and are only applicable in certain cities and counties.*

As small business owners who have long-term rentals as well as one short-term, we create local jobs. We hire local, independant cleaners for cleaning our properties, and pay them more than twice the current minimum wage. We treat them with respect, we help them grow their businesses, (many are younger moms who want to create their own small businesses), and help them grow their hard and soft professional skills. We hire local companies to renovate and repair our property, we use a local professional property manager, and we hire a small painting company owned by a senior to do our painting (and all this at prevailing wages). We keep our property in excellent condition, it is safe, clean and

monitored by us daily and we live nearby so we respond to any needs very quickly. We pay taxes, we give back to our community through charitable giving, and we spend our dollars locally with other small businesses in Spokane. We do our exterior property upkeep (lawn upkeep, snow removal, landscaping, cleaning up parking areas etc) ourselves and hire our high school aged niece and nephew to help us. We also pay our utility bills, our mortgages, our association dues and our property taxes. In our shorter term units, we provide a positive, high-quality, personal experience of Spokane hospitality which reflects well on our city. It is not necessarily always easy work, but it can be meaningful and satisfying.

Over the last 3 years, it seems like the intent of the State, and now our City Council, is to lay the burden of homelessness at our feet. In reality, this problem has been around and growing since the financial crisis of 2007-08, and the resulting fallouts from predatory lending activities have left long-lasting, complex and far-reaching problems that demand significant creativity, collaboration, and ongoing dedication to resolve for the long term. So expecting that private owners of residential rental property could suddenly have the power and responsibility to significantly impact this difficult issue is unfair and naive. Imagine trying to tell grocery store owners, restaurateurs, automobile sellers, lawyers, clothing retailers, or other small business owners who have something to offer the underhoused, that they have to be taxed more or limited in how they do their work because homeless persons need food, clothing, transportation, or legal representation, and therefore these business owners must take on the weight of solving this problem in the way that property owners, especially over the last 3 years, have been asked to.

Please consider the long-term breadth of impact your decision making will have on varied members of this community. The changes brought into play by the historic housing crisis, and then the pandemic, have and will continue to

shape the way people live, work, and engage in community, and we benefit by recognizing the larger narrative of how and why changes are happening, in order to recognize the value and opportunity available in expanding short term housing options. I believe this can happen concurrently with, but not as a threat to devising real, long term solutions to this problem of under housed people, and that it can happen via a win-win situation.

Thank you for your service to our community, and for your willingness to look at this meaningful issue.

Sincerely,

Joan Hunt



**From:** [Planning Services Development Code](#)  
**To:** [Yahoo Mail](#)  
**Subject:** RE: Shaping Spokane Housing  
**Date:** Monday, May 23, 2022 4:47:00 PM  
**Attachments:** [image001.png](#)  
[image002.png](#)  
[image003.png](#)

---

Hi Jim,

Thank you for providing public comment in support of attached homes and duplex code changes under the [Shaping Spokane Housing](#) project. These comments have been added to the public record, and will be included with the staff report to Plan Commission when a public hearing is scheduled. We appreciate your perspective on these topics as an architect.

City staff have workshopped draft code with Plan Commission (see the meetings for Dec-8, Jan-26, and Mar-9 on the above project webpage), but the Plan Commission would like further discussion on possible language changes. We're hoping to have them workshop with our Design Review Board, so we're currently trying to find a time when all of those commissioners can be in the same place, but it's looking like that could occur in July. To help inform the workshop, we'll include comments received to date about townhomes and duplexes to aid the Plan Commission in discussion.

It's not up on our project webpage just yet, but if you want to see past email updates from our Plan Commission workshops you can review them at these links:

May 19, 2022 - <https://conta.cc/3Ly9Q77>

May 6, 2022 - <https://conta.cc/3MVy7oB>

April 20, 2022 - <https://conta.cc/3K2ZOKz>

April 6, 2022 - <https://conta.cc/38akHX4>

March 16, 2022 - <https://conta.cc/3ly14eO>

January 13, 2022 - <https://conta.cc/38az9hQ>

Thank you,  
Amanda

**Amanda Beck, AICP** | City of Spokane | Assistant Planner II

509-625-6414 | main 509-625-6500 | [abeck@spokanecity.org](mailto:abeck@spokanecity.org) | [spokanecity.org](http://spokanecity.org)



---

**From:** Yahoo Mail <[hainesarch@yahoo.com](mailto:hainesarch@yahoo.com)>

**Sent:** Friday, May 20, 2022 10:51 AM

**To:** Planning Services Development Code <[erapsdc@spokanecity.org](mailto:erapsdc@spokanecity.org)>

**Subject:** Shaping Spokane Housing

**[CAUTION - EXTERNAL EMAIL - Verify Sender]**

I have the following thoughts that I believe can have a significant impact on our housing shortage :

1. Create more duplex lots , even changing some single family zones to two family .
2. A duplex or townhouse is much cheaper to construct than two single family houses .
3. Purchasers that may not be able to afford a single family residence can join with another purchaser to buy a duplex or townhouse .

Sincerely , Jim Haines , Haines Architectural Services

**From:** [Planning Services Development Code](#)  
**To:** [Shari Mcevoy](#)  
**Subject:** RE: ADU residential  
**Date:** Tuesday, May 31, 2022 2:09:00 PM  
**Attachments:** [image001.png](#)  
[image002.png](#)  
[image003.png](#)

---

Hi Shari,

Thank you for providing public comment in support of ADU code changes under the [Shaping Spokane Housing](#) project. These comments have been added to the public record, and will be shared with City Council once a public hearing is scheduled. I'm working to get these code changes to public hearing before City Council this week, and once we have the dates final an email will be sent to our interested parties list (which you are on).

Sorry I missed your call, you caught me at lunch, but I will respond to your other email about the specific property addresses. And, you are welcome to come to City Hall to discuss with our Current Planners details on each property- they're located on the 3<sup>rd</sup> Floor.

We have talked about doing pre-approved plans for ADUs, and as you note it could speed up the permitting processes. Because this is one of our aims, we're in talks with other city departments like Building and Fire so we can work through their needs to see how we can make this happen.

Thank you,  
Amanda

**Amanda Beck, AICP** | City of Spokane | Assistant Planner II

509-625-6414 | main 509-625-6500 | [abeck@spokanecity.org](mailto:abeck@spokanecity.org) | [spokanecity.org](http://spokanecity.org)



---

**From:** Shari Mcevoy <smcevoy2222@gmail.com>  
**Sent:** Saturday, May 28, 2022 8:48 PM  
**To:** Planning Services Development Code <erapsdc@spokanecity.org>  
**Subject:** ADU residential

**[CAUTION - EXTERNAL EMAIL - Verify Sender]**

Hello,

I am thrilled to see the proposed changes in ADU's. I agree w the proposals.

I have 3 SF homes that I rent out for my retirement income. They are all in R zones which I assume is residential and will qualify for all the changes. I will start with one and then build an ADU on all 3 which will double the occupancy available. We need good landlords like me and more affordable housing that I provide. Please approve the proposals soon.

My question is :

Do you have pre approved plans for detached ADU's, attached and all varieties to speed up the permitting process?

Do you have groups of contractors skilled in building ADU's to spokane's specifications that I could contact?

Thank you,

Sincerely,

Shari McEvoy

spokane, wa

**From:** [Carol Tomsic](#)  
**To:** [Beggs, Breean](#); [Kinnear, Lori](#); [Wilkerson, Betsy](#); [Stratton, Karen](#); [Cathcart, Michael](#); [Zappone, Zack](#); [Bingle, Jonathan](#); [Gardner, Spencer](#); [Beck, Amanda](#)  
**Cc:** [Marilyn](#); [ANDREW HOYE](#); [Mary Winkes](#); [Cortright, Carly](#); [Byrd, Giacobbe](#)  
**Subject:** A Comment on the Proposed Short Plat Code Amendment/Removal of Notifications  
**Date:** Monday, May 30, 2022 10:27:36 PM

---

**[CAUTION - EXTERNAL EMAIL - Verify Sender]**

The proposed removal of the notice of application for short plats that create only two lots and up to 9 lots, or for short plats with only minor engineering review does not support neighborhoods or carefully manage residential development, a goal, and a vision in our Comprehensive Plan (Land Use Chapter 3.2, 3.3).

The proposed removal of site-posting sign requirements, notices in the newspaper, and a mailed public notice just to properties within 400 feet, goes against a priority in our Housing Action Plan, “preserve housing affordability and quality to help people thrive where they live. This priority highlights the connections between housing affordability and quality to preserve and enhance existing housing throughout Spokane and support residents in every neighborhood.”

The removal of notification requirements to our residents in our development codes is not cited as a response strategy in the Addendum to Proclamation Addressing Housing Emergency. “A reduced fee for simple short plats in SMC 8.02.066 to \$250” is mentioned. A response strategy should not take away the quality to preserve and enhance existing housing in our neighborhoods. A reduced fee is an appropriate response strategy.

The continuation of public notice on short plat applications is necessary for our residents during the housing emergency proclamation. A notice of an application helps the neighborhood know about upcoming development in the area, as stated in the Residential Development Code Initiatives, Short Plat Application Process, Info Sheet.

Our neighborhoods will be affected by the upcoming proposed changes in land use.

The city intends to increase the number of lots to be regulated as short subdivision to a maximum of nine in any urban growth area. (RCW 36.70A.040 and chapter 36.70A). The RCW states the legislative authority of any city or town *may* by local ordinance increase the number of lots. The city is not required to align to the RCW.

The city intends to review the Comprehensive Plan Land Use Policies. A proposed review was not assigned in the 2021-2022 Comprehensive Plan Amendment process but will be considered under another program.

The Phase 1 code amendments, which includes the Short Plat Application Process, are necessary updates for the second phase of codes changes, which may require Comprehensive Plan changes, increase the number of homes per acre of land, and permit a wider variety of housing.

Neighborhood councils appreciate being part of the agency notification of land use applications and permits and make necessary comments. Neighborhood councils make every

effort possible to notify and keep our residents updated on the land use changes, but all residents directly affected still need be notified by the city.

The current short plat notification allows our neighborhood to preserve any historic significance on proposed short plats. A 400 foot notification, without any other notification to residents in the area, especially on lots that are undeveloped and forested, may result in a loss of an opportunity to protect a feature on parcels during the short plat process.

In addition, not all neighborhood councils meet monthly. Some neighborhood councils did not meet at all during the pandemic. Several neighborhood councils have struggled to maintain an executive board. Land use notifications are vital. Our residents traditionally rely on the city, and posted signs, for land use notifications.

And the city has already recognized the limited ability of a neighborhood council to reach out to every single resident in their neighborhood. The revised traffic calming program was updated to include a 'convening group' to reach out to the neighborhood for a broader response. Why would the city adopt a proposed process that would do just the opposite?

Please vote to keep the current notification process in the short plats.

Thank you!

Carol Tomsic  
resident

**CITY OF SPOKANE PLAN COMMISSION  
FINDINGS OF FACT, CONCLUSIONS, AND RECOMMENDATIONS  
REGARDING SHAPING SPOKANE HOUSING TEXT AMENDMENTS TO LOT SIZE  
TRANSITION, ACCESSORY DWELLING UNITS (ADUS), AND SHORT PLAT NOTIFICATION**

A recommendation of the City of Spokane Plan Commission to the City Council to approve amendments to the Spokane Municipal Code proposed by Shaping Spokane Housing text amendments. The proposal amends the Unified Development Code (UDC) Section 17C.110.200, Lot Size, and 17C.110.225 Accessory Structures; Chapter 17C.300, Accessory Dwelling Units, specifically Sections 17C.300.100, General Regulations, 17C.300.110, Criteria, 17C.300.120, Application Procedures, 17C.300.130, Development Standards, and 17C.300.140, ADU Expiration; and to short plat notification requirements in Sections 17G.060.100, Notice of Application, 17G.060T.003, Table 17G.060-3 Type of Public Notice Required / Project Permit Review Process, 17G.060.130, Public Comment Period, and 17G.080.040, Short Subdivisions.

**FINDINGS OF FACT:**

- A. The City of Spokane adopted a Comprehensive Plan in May of 2001 that complies with the requirements of the Growth Management Act (GMA) as set forth in RCW 36.70A, including a housing element meeting the requirements of RCW 36.70A.070(2).
- B. On July 26, 2021, Resolution 2021-0062 adopted the City of Spokane Housing Action Plan as a guide for future housing planning, policy development, and regulatory and programmatic implementation measures that increase housing options that are affordable and accessible for people and families of all incomes in the City; including the Implementation Plan included as Appendix A that outlines several strategies and policies to remedy the current housing crisis.
- C. In 2021, the Washington State Legislature appropriated \$5 million for cities planning under the GMA to adopt actions to increase residential building capacity and address housing affordability. Through the resulting Housing Action Plan and Implementation (HAPI) grant program, the Department of Commerce provided grants to support communities in implementing strategies from adopted housing action plans and recommendations contained within RCW 36.70A.600.
- D. The City of Spokane was awarded a \$100,000 grant from the Department of Commerce to implement strategies from its adopted Housing Action Plan. The scope of work includes revising accessory dwelling unit (ADU) standards in chapter 17C.300 SMC to allow for additional flexibility and expand the zones that permit ADUs.
- E. MAKERS Architecture and Urban Design, LLP, a consulting firm with expertise in community planning, design guidelines and regulations, was contracted to review existing development standards for opportunities to add flexibility and clarity to regulations. The consultant worked with city staff to develop a range of alternative standards and regulations which would allow for greater flexibility in the construction of housing, including ADUs.
- F. The proposed text amendments will implement and enact measures RCW 36.70A.600 encourages cities to take in order to increase residential building capacity.

- G. The amendments to short plat notification are procedurally exempt from SEPA review per WAC 197-11-800(19).
- H. Outreach and public communication began in November 2021, reaching approximately 375 residents, and included the following among others:
  - 1. Presentations at the Land Use Subcommittee on November 18, 2021; February 17, 2022; and April 21, 2022;
  - 2. In-person booth at the Riverfront Park Winter Market on December 15 and 22, 2021;
  - 3. Presentation at Community Assembly on January 6, 2022;
  - 4. Presentation at Lincoln Heights Neighborhood Council on January 18, 2022;
  - 5. Virtual open houses on January 25 and 27, 2022;
  - 6. Planning Services Director interviews with local developers in March and April, 2022;
  - 7. Presentations at University District Development Committee and the West Hills Neighborhood Council on April 12, 2022 and
  - 8. In-person booth at the Riverfront Park Spring Market on April 6, 13, 20, and 27, 2022.
- I. Public comment, as well as agency and department comments, received prior to the May 11, 2022, Plan Commission public hearing were included in the staff report as Exhibits D and E.
- J. On November 10, 2021; December 8, 2021; January 12, 2022; January 26, 2022; February 9, 2022; February 23, 2022; March 9, 2022; March 23, 2022; April 13, 2022; and April 27, 2022, the Spokane Plan Commission held workshops to discuss draft language, receive updates on public feedback as well as city department and agency comments, and review and evaluate with city staff alternatives to proposed text changes.
- K. On March 24, 2022, the Washington State Department of Commerce and appropriate state agencies were given the required 60-day notice before adoption of proposed changes to the Unified Development Code pursuant to RCW 36.70A.106.
- L. On April 1, 2022, a notice of intent to adopt and request for SEPA agency comments was issued for the draft code pertaining to ADUs, lot size transitions, and short plat notification. The comment period ended on April 15, 2022. The Spokane Tribe of Indians issued comment noting project actions may require case by case cultural surveys.
- M. A State Environmental Protection Act (SEPA) Determination of Nonsignificance and Checklist were issued by Planning Services on April 25, 2022. The comment period ended on May 11, 2022. Two city department comments were received during the comment period.
- N. A legal notice of public hearing was published in the *Spokesman-Review* on April 27 and May 4, 2022.



Findings of Fact, Conclusion, and Recommendation  
Shaping Spokane Housing Text Amendments to  
Lot Size Transition, Accessory Dwelling Units, and Short Plat Notification

- O. The proposed text amendments were drafted and reviewed pursuant to the process established under RCW 36.70A.370 to ensure that the proposed changes will not result in unconstitutional takings of private property.
- P. Amendments to Title 17 are subject to review and recommendation by the Plan Commission.
- Q. The Plan Commission held a public hearing on May 11, 2022 to obtain public comments on the proposed amendments.
- R. During deliberations held on May 11, 2022, the Plan Commission discussed a motion to modify the maximum detached accessory dwelling unit size, from the proposed 864 square feet or 75% of the house size, whichever is greater, to a maximum of 1,200 square feet or 75% of the house size, whichever is greater. The maximum detached accessory dwelling unit size was a topic that the Plan Commission workshopped with staff on several occasions, including the possibility of removing a maximum size altogether. Ultimately, the motion failed with three aye votes, three nay votes, and one Commissioner abstaining.
- S. During deliberations held on May 11, 2022, the Plan Commission voted to modify the proposed text concerning accessory dwelling units (ADUs), recommending removing the requirement to file a covenant and deed restriction on lots with an ADU when an owner would apply for a short-term rental application. The motion passed with six aye votes and one Commissioner abstaining.
- T. During deliberations held on May 11, 2022, the Plan Commission confirmed the preference for newly subdivided lots to be held to the standards and dimensional requirements of the underlying zoning district, rather than requiring larger lots, by removing the lot size transition requirement. The motion passed by a vote of six to zero.
- U. During deliberations held on May 11, 2022, the Plan Commission discussed the nexus of notice of applications and the neighborhood council system, as it relates to the proposed amendment to short plat notification. Plan Commission found that neighborhood councils are entitled to notice of certain land use development permit applications by virtue of SMC 17G.060.090(C) and that the proposed amendments will not detract from a neighborhood council's ability to comment on short plat applications. The motion to approve the proposed amendments to short plat notification passed with six ayes votes and one nay vote.
- V. Except as otherwise indicated in the above findings, the Spokane Plan Commission adopts the findings and analysis set forth in the staff report prepared for the proposal.
- W. The Spokane Plan Commission finds that the proposed text amendments meet the decision criteria established in SMC 17G.025.010(G).

## **CONCLUSIONS:**

Based upon the draft text amendments, staff report and analysis (which is hereby incorporated into these findings, conclusions, and recommendations), SEPA review, agency and public comments received, and public testimony presented, the Spokane Plan Commission makes the following conclusions with respect to the text amendments to lot size transition, accessory dwelling units (ADUs), and short plat notification:

1. The Plan Commission finds that the proposed amendments bear a substantial relation to the public health, safety, welfare, and protection of the environment pursuant to the requirements outlined in SMC 17G.025.010(G).
2. The proposed text amendments will implement and enact measures RCW 36.70A.600 encourages cities take in order to increase residential building capacity.
3. Interested agencies and the public have had extensive opportunities to participate throughout the process and persons desiring to comment were given an opportunity to comment.
4. SEPA review was completed for the proposal, and pursuant to SEPA, any adverse environmental impacts associated with the draft regulations will be mitigated by enforcement of the City's development regulations.
5. Plan Commission concludes that the intent of including neighborhood councils to the list of entities that receive notice of applications was to give neighborhood councils standing and the ability to advocate for their neighborhood residents. As entities with standing, neighborhood councils should assume the responsibility of proactively communicating with their residents about pertinent all-city or neighborhood-specific development applications.
6. The Plan Commission finds that the proposed amendments are consistent with the applicable provisions of the Comprehensive Plan, particularly the following adopted Shaping Spokane goals and policies:
  - a. Land Use Goal LU 1 – Citywide Land Use;
  - b. Land Use Policy LU 1.1 – Neighborhoods;
  - c. Land Use Goal LU 3 – Efficient Land Use;
  - d. Land Use Policy LU 3.6 – Compact Residential Patterns;
  - e. Housing Goal H 1 – Housing Choice and Diversity;
  - f. Housing Policy H 1.11 – Access to Transportation;
  - g. Housing Policy H 1.18 – Distribution of Housing Options;
  - h. Housing Policy H 1.20 – Accessory Dwelling Units; and
  - i. Capital Facilities and Utilities Policy CFU 4.1 – Compact Development.

**RECOMMENDATION:**

In the matter of the ordinances pertaining to lot size transition, accessory dwelling units (ADUs), and short plat notification, amending the Unified Development Code of the City of Spokane;

As based on the above listed findings and conclusions, the Spokane Plan Commission takes the following actions:

1. By a vote of six to zero, recommends to the Spokane City Council the **APPROVAL** of the proposed amendments to Section 17C.110.200, Lot Size, and 17C.110.225 Accessory Structures;
2. By a vote of six to one, recommends to the Spokane City Council the **APPROVAL WITH MODIFICATION** of the proposed amendments to Chapter 17C.300, Accessory Dwelling Units, as amended during the deliberations to include the following modification:

Strike 17C.300.120(B), Covenants, from the draft text for accessory dwelling units which requires that a covenant and deed restriction be recorded with the County Assessor for lots that contain an ADU and submit for a short-term rental application.

3. By a vote of six to one, recommends to the Spokane City Council the **APPROVAL** of the proposed amendments to Sections 17G.060.100, Notice of Application, 17G.060T.003, Table 17G.060-3 Type of Public Notice Required / Project Permit Review Process, 17G.060.130, Public Comment Period, and 17G.080.040, Short Subdivisions.
4. Authorizes the President to prepare and sign on the Commission's behalf a written decision setting forth the Plan Commission's findings, conclusions, and recommendations on the proposed amendments.



[Todd Beyreuther \(May 20, 2022 17:02 PDT\)](#)

---

**Todd Beyreuther, President**

**Spokane Plan Commission**

May 20, 2022

# 2022-05-19\_PC Findings and Conclusions\_ADUs Short Plats Lot Size

Final Audit Report

2022-05-21

Created:	2022-05-19
By:	Jackie Churchill (jchurchill@spokanecity.org)
Status:	Signed
Transaction ID:	CBJCHBCAABAAKQIyLhcEIWDG5Rz_iOjBettWnr9ZVP2h

## "2022-05-19\_PC Findings and Conclusions\_ADUs Short Plats Lot Size" History

-  Document created by Jackie Churchill (jchurchill@spokanecity.org)  
2022-05-19 - 11:44:26 PM GMT - IP address: 98.225.13.193
-  Document emailed to Todd Beyreuther (tbeyreuther@spokanecity.org) for signature  
2022-05-19 - 11:44:46 PM GMT
-  Email viewed by Todd Beyreuther (tbeyreuther@spokanecity.org)  
2022-05-20 - 11:59:32 PM GMT - IP address: 107.77.205.155
-  Document e-signed by Todd Beyreuther (tbeyreuther@spokanecity.org)  
Signature Date: 2022-05-21 - 0:02:28 AM GMT - Time Source: server- IP address: 107.77.205.155
-  Agreement completed.  
2022-05-21 - 0:02:28 AM GMT



**Agenda Sheet for City Council Meeting of:**  
06/20/2022

<b>Date Rec'd</b>	6/6/2022
<b>Clerk's File #</b>	ORD C36225
<b>Renews #</b>	
<b>Cross Ref #</b>	
<b>Project #</b>	
<b>Bid #</b>	
<b>Requisition #</b>	

<b>Submitting Dept</b>	PLANNING & ECONOMIC DEVELOPMENT
<b>Contact Name/Phone</b>	AMANDA BECK 6414
<b>Contact E-Mail</b>	ABECK@SPOKANECITY.ORG
<b>Agenda Item Type</b>	First Reading Ordinance
<b>Agenda Item Name</b>	SHAPING SPOKANE HOUSING: ACCESSORY DWELLING UNITS AND LOT SIZE TRANSITIONS

**Agenda Wording**

An Ordinance relating to lot size transitions, accessory structures, and accessory dwelling units amending Spokane Municipal Code (SMC) Sections 17C.110.200, 17C.110.225, 17C.300.100, 17C.300.110, 17C.300.120, 17C.300.130, 17C.300.140.

**Summary (Background)**

Shaping Spokane Housing is a result of the Spokane Housing Action Plan, also guided by Mayor Woodward's July 26, 2021, Housing Emergency Proclamation, and the City Council's HAP Implementation Plan. These amendments propose changes to increase flexibility for accessory dwelling units; remove lot size transitions; and modify and streamline short plat notification. Changes to accessory dwelling unit are a grant deliverable for the \$100,000 grant the City received from WA Commerce to implement stra

Lease? NO Grant related? NO Public Works? NO

**Fiscal Impact**

Neutral	\$	#
Select	\$	#
Select	\$	#
Select	\$	#

**Budget Account**

**Approvals**

<b>Dept Head</b>	GARDNER, SPENCER
<b>Division Director</b>	MACDONALD, STEVEN
<b>Finance</b>	ORLOB, KIMBERLY
<b>Legal</b>	RICHMAN, JAMES
<b>For the Mayor</b>	ORMSBY, MICHAEL

**Council Notifications**

<b>Study Session\Other</b>	6/2 Study Session
<b>Council Sponsor</b>	CM Betsy Wilkerson and CM Zack Zappone

**Additional Approvals**

<b>Purchasing</b>	abeck@spokanecity.org
	tpalmquist@spokanecity.org
	jrichman@spokanecity.org
	smacdonald@spokanecity.org
	jchurchill@spokanecity.org

## ORDINANCE NO. C36225

An ORDINANCE relating to lot size transitions, accessory structures, and accessory dwelling units amending Spokane Municipal Code (SMC) Sections 17C.110.200, 17C.110.225, 17C.300.100, 17C.300.110, 17C.300.120, 17C.300.130, 17C.300.140.

WHEREAS, RCW 36.70A.600 encourages the City to take a number of actions in order to increase its residential building capacity and authorized the City to adopt a housing action plan; and

WHEREAS, as authorized by RCW 36.70A.600(2), Council Resolution RES-2021-0062 adopted the City of Spokane Housing Action Plan as a guide for future housing planning, policy development, and regulatory and programmatic implementation measures that increase housing options that are affordable and accessible for people and families of all incomes in the City; including the Implementation Plan, included as Appendix A within the Housing Action Plan, which outlines several strategies and policies to remedy the current housing crisis; and

WHEREAS, the 2020 Housing Needs Assessment completed for the Housing Action Plan indicates several facts about the housing supply and need, particularly the need to accommodate for an estimated 6,000 additional housing units by 2037; and

WHEREAS, in adopting RES-2021-0062 the City Council outlined several code amendments and permit processes that the City should enact in support of the strategies and actions recommended in the Housing Action Plan and to encourage construction of more housing within Spokane; and

WHEREAS, on July 26, 2021, the Mayor of the City of Spokane proclaimed a housing emergency and directed the City to pursue actions to expand housing types, reduce overall development costs to increase development of affordable housing, and to streamline municipal procedures to support the development cycle; and

WHEREAS, the City was awarded a \$100,000 grant from the Department of Commerce through the Housing Action Plan and Implementation (HAPI) grant program to implement strategies from its adopted Housing Action Plan, and the scope of work includes revising accessory dwelling unit (ADU) standards in chapter 17C.300 SMC to allow for additional flexibility and expand the zones that permit ADUs; and

WHEREAS, the proposed actions are consistent with and supported by the Spokane Comprehensive Plan, as outlined in the Plan Commission Findings of Fact, Conclusions, and Recommendations (Exhibit A), and will implement actions specified in RCW 36.70A.600(1); and

WHEREAS, by virtue of the public process outlined in Exhibits A and B, interested agencies and the public have had extensive opportunities to participate throughout the process and all persons desiring to comment on the amendment were given a full and complete opportunity to be heard; and

WHEREAS, the City has complied with RCW 36.70A.370 in the adoption of this Ordinance, avoiding any unconstitutional taking of private property; and

WHEREAS, on March 24, 2022, the Washington State Department of Commerce and appropriate state agencies were given the required 60-day notice before adoption of proposed changes to the Unified Development Code pursuant to RCW 36.70A.106; and

WHEREAS, on April 1, 2022, a Notice of Intent to adopt and request for SEPA agency comments was issued for the draft code pertaining to ADUs, lot size transitions, and short plat notification. The comment period ended on April 15, 2022. The Spokane Tribe of Indians issued comment noting project actions may require case by case cultural surveys; and

WHEREAS, a State Environmental Protection Act (SEPA) Determination of Nonsignificance and Checklist were issued by Planning Services on April 25, 2022. The comment period ended on May 11, 2022. Two city department comments were received during the comment period; and

WHEREAS, prior to the Plan Commission public hearing, a legal notice of public hearing was published in the *Spokesman-Review* on April 27 and May 4, 2022 and the notice of the proposed amendment was distributed to the City's agency/interested party list and posted on the City's website at [www.ShapingSpokaneHousing.com](http://www.ShapingSpokaneHousing.com); and

WHEREAS, on May 11, 2022, the Spokane Plan Commission held a public hearing on the proposed amendment and heard testimony from the public, following which they voted to recommend the City Council adopt, with some modifications, the proposed amendments (see Exhibit A); and

WHEREAS, the City Council adopts the recitals set forth herein as its findings and conclusions in support of its adoption of this ordinance and further adopts the findings, conclusions, and recommendations from the Planning Services Staff Report (Exhibit B) and the City of Spokane Plan Commission (Exhibit A) for the same purposes; and

NOW, THEREFORE, the City of Spokane does ordain:

Section 1. That Section 17C.110.200 SMC is amended to read as follows:

**17C.110.200 Lot Size**

A. Purpose.

The standards of this section allow for development on lots, but do not legitimize lots that were divided in violation of [chapter 17G.080 SMC](#), Subdivisions. The required minimum lot size, lot depth, lot width and frontage requirements for new lots ensure that development will, in most cases, be able to comply with all site development standards. The standards also prevent the creation of very small lots that are difficult to develop at their full density potential. Finally, the standards also allow development on lots that were reduced by condemnation or required dedications for right-of-way.

B. Existing Lot Size.

1. Development is prohibited on lots that are not of sufficient area, dimension and frontage to meet minimum zoning requirements in the base zone. Except:
  - a. one single-family residence may be developed on a lot that was legally created under the provisions of chapter 58.17 RCW, Plats – Subdivisions – Dedications, or applicable platting statutes;
  - b. a PUD lot may be less than the minimum size of the base zone, if such lot is delineated on a PUD plan, which has been approved by the hearing examiner. All use and development standards of the zone wherein such lot is located, shall be complied with, unless modified through the PUD process by the hearing examiner. A PUD shall comply with the requirements of subsection (C) of this section.
2. No lot in any zone may be reduced so that the dimension, minimum lot area, frontage or area per dwelling unit is less than that required by this chapter, except as modified through the PUD process by the hearing examiner.
3. Lots Reduced by Condemnation or Required Dedication for Right-of-way. Development that meets the standards of this chapter is permitted on lots, or combinations of lots, that were legally created and met the minimum size requirements at the time of subdivision, but were reduced below one or more of those requirements solely because of condemnation or required dedication by a public agency for right-of-way.

C. Land Division.

1. All new lots created through subdivision must comply with the standards for the base zone listed in Table 17C.110-3.

~~((1.—Transition Requirement.~~



For sites two acres or greater, transition lot sizes are required to be included as a buffer between existing platted land and new subdivision subject to the requirements of this section. The purpose of this section is to transition lot sizes between the proposed and existing residential developments in order to facilitate compatible development and a consistent development pattern. In the RA and RSF zones, the minimum lot size is subject to transitioning of lots sizes. Lots proposed within the initial eighty feet of the subject property are required to transition lot sizes based on averaging under the following formulas:

- a. Transitioning is only required of properties adjacent to or across the right-of-way from existing residential development. “Existing residential development” in this section shall mean existing lots created through subdivision or short plat.
- b. Lot size in the transition area is based on the average of the existing lot size in subdivisions adjacent to, or across the street from, the subject property. Lots greater than eleven thousand square feet are not counted in the averaging.
- c. If the existing average lot size is greater than seven thousand two hundred square feet, then the lot size in the transition area can be no less than seven thousand two hundred square feet.
- d. If the existing average lot size is less than seven thousand two hundred square feet, then the lot size in the transition area can be equal to or greater than the average.
- e. If the subject site shares boundaries with more than one subdivision, the minimum lot size in the transition area shall be based on the average lot sizes along each boundary. When two boundaries meet, the lot size shall be based on the larger of the two boundaries. See example below; and

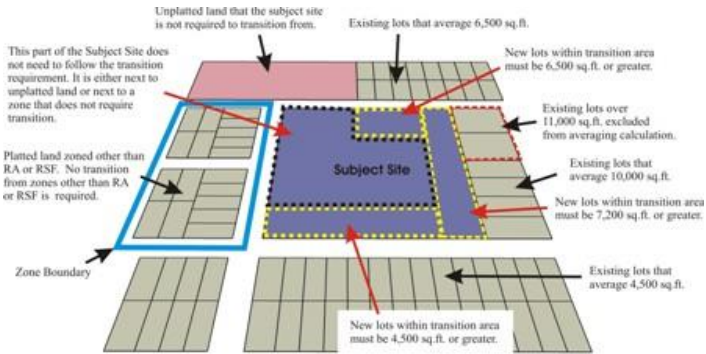

**[Note: Delete graphic above]**

- f. ~~If the subject site shares a boundary with property zoned other than RA or RSF, then there are no transition requirements along that boundary.~~
- g. ~~After the first set of lots in the transition area, lot sizes may be developed to the minimum lot size of the base zone, i.e., four thousand three hundred fifty square feet in the RSF zone.)~~
2. Planned unit developments, combined with a subdivision, may reduce the minimum lot size, lot width, lot depth and frontage requirements in the RA and RSF zones pursuant to SMC 17G.070.030(C)(1) (~~except in the transition area required by subsection (C)(1) of this section~~).
- D. Ownership of Multiple Lots.
- Where more than one adjoining lot is in the same ownership, the ownership may be separated as follows:
1. If all requirements of this chapter will be met after the separation, including lot size, density and parking, the ownership may be separated through either a boundary line adjustment (BLA) or plat, as specified under [chapter 17G.080 SMC](#), Subdivisions.
  2. If one or more of the lots does not meet the lot size standards in this section, the ownership may be separated along the original plat lot lines through a boundary line adjustment (BLA).
- E. New Development on Standard Lots. New development on lots that comply with the lot size standards in this section are allowed subject to the development standards and density requirements of the base zone as required under Table 17C.110-3.
- F. Lot Frontage. All residential lots shall front onto a public street and meet the minimum lot frontage requirements of Table 17C.110-3. Except, that frontage on a public street is not required for lots created through alternative residential subdivision under SMC 17G.080.065, and lots approved in a planned unit development or a manufactured home park may have lots or spaces fronting onto private streets, subject to the decision criteria of [SMC 17H.010.090](#).

TABLE 17C.110-3 DEVELOPMENT STANDARDS [1]					
DENSITY STANDARDS					
	RA	RSF & RSF-C	RTF	RMF	RHD
Density - Maximum	4,350 (10 units/acre)	4,350 (10 units/acre)	2,100 (20 units/acre)	1,450 (30 units/acre)	--
Density - Minimum	11,000 (4 units/acre)	11,000 (4 units/acre)	4,350 (10 units/acre)	2,900 (15 units/acre)	2,900 (15 units/acre)

MINIMUM LOT DIMENSIONS LOTS TO BE DEVELOPED WITH:					
Multi-Dwelling Structures or Development					
	RA	RSF & RSF-C	RTF	RMF	RHD
Minimum Lot Area				2,900 sq. ft.	2,900 sq. ft.
Minimum Lot Width				25 ft.	25 ft.
Minimum Lot Depth				70 ft.	70 ft.
Minimum Front Lot Line				25 ft.	25 ft.
Compact Lot Standards [2]					
Minimum Lot Area [3]		3,000 sq. ft.			
Minimum Lot Width		36 ft.			
Minimum Lot Depth		80 ft.			
Minimum Front Lot Line		30 ft.			
Attached Houses as defined in SMC 17A.020.010					
Minimum Lot Area [3]	7,200 sq. ft.	4,350 sq. ft.	1,600 sq. ft.	1,450 sq. ft.	None
Minimum Lot Width	40 ft.	40 ft.	36 ft. or 16 ft. with alley parking and no street curb cut	Same	Same
Minimum Lot Depth	80 ft.	80 ft.	50 ft.	None	None
Minimum Front Lot Line	40 ft.	40 ft.	Same as lot width	Same as lot width	Same as lot Width
Detached Houses					
Minimum Lot Area [3]	7,200 sq. ft.	4,350 sq. ft.	1,800 sq. ft.	1,800 sq. ft.	None
Minimum Lot Width	40 ft.	40 ft.	36 ft.	25 ft.	25 ft.
Minimum Lot Depth	80 ft.	80 ft.	40 ft.	25 ft.	25 ft.

Minimum Front Lot Line	40 ft.	40 ft.	30 ft.	25 ft.	25 ft.
<b>Duplexes</b>					
Minimum Lot Area			4,200 sq. ft.	2,900 sq. ft.	None
Minimum Lot Width			25 ft.	25 ft.	25 ft.
Minimum Lot Depth			40 ft.	40 ft.	25 ft.
Minimum Front Lot Line			25 ft.	25 ft.	25 ft.
<b>PRIMARY STRUCTURE</b>					
<b>Maximum Building Coverage</b>					
	RA	RSF & RSF-C	RTF	RMF	RHD
Lots 5,000 sq. ft. or larger	40%	2,250 sq. ft. + 35% for portion of lot over 5,000 sq. ft.	2,250sq. ft. + 35% for portion of lot over 5,000 sq. ft.	50%	60%
Lots 3,000 - 4,999 sq. ft.	1,500 sq. ft. + 37.5% for portion of lot over 3,000 sq. ft.				
Lots less than 3,000 sq. ft.	50%				
Attached housing as defined in SMC 17A.020.010, lots any size	Same as above			Up to 70%	Up to 80%
<b>Building Height</b>					
Maximum Roof Height	35 ft. [5]	35 ft. [5]	35 ft. [5]	35 ft. [6]	35 ft. [6]
Maximum Wall Height	25 ft.	25 ft.	25 ft.	-- [6]	--
<b>Floor Area Ratio (FAR)</b>					
FAR	0.5	0.5 [4]	0.5 [4]	--	--
<b>Setbacks</b>					
Front Setback [7, 8]	15 ft.				
Side Lot Line Setback – Lot	5 ft.				

width more than 40 ft.					
Side Lot Line Setback – Lot width 40 ft. or less	3 ft.				
Street Side Lot Line Setback [7]	5 ft.				
Rear Setback [9, 10]	25 ft.	25 ft. [11]	15 ft.	10 ft.	10 ft.
Required Outdoor Area					
Required Outdoor Area for attached and detached houses. Minimum dimension (See SMC 17C.110.223)	250 sq. ft. 12 ft. x 12 ft.	250 sq. ft. 12 ft. x 12 ft.	250 sq. ft. 12 ft. x 12 ft.	200 sq. ft. 10 ft. x 10 ft.	48 sq. ft. 7 ft. x 7 ft.
<b>ACCESSORY STRUCTURES</b>					
	RA	RSF & RSF-C	RTF	RMF	RHD
Maximum Roof Height	30 ft.	20 ft.	20 ft.	35 ft.	35 ft.
Maximum Wall Height	30 ft.	15 ft.	15 ft.	35 ft.	35 ft.
Maximum Coverage [12]	20%	15%	15%	See Primary Structure	See Primary Structure
<u>Maximum Coverage with Detached Accessory Dwelling Unit, Lots less than 5,500 sq. ft. [12]</u>	<u>20%</u>			<u>See Primary Structure</u>	<u>See Primary Structure</u>
Front Setback	20 ft.				
Side Lot Line Setback – Lot width 40 ft. or wider [13]	5 ft.				
Side Lot Line Setback – Lot	3 ft.				

width less than 40 ft. [13]	
Street Side Lot Line [14]	20 ft.
Rear [13]	5 ft.
Rear with Alley	0 ft.

Notes:

-- No requirement

[1] Plan district, overlay zone, or development standards contained in SMC 17C.110.310 through 360 may supersede these standards.

[2] See SMC 17C.110.209, Compact Lot Standards.

[3] ~~((For developments two acres or greater, lots created through subdivision in the RA, RSF and the RSF-C zones are subject to the lot size transition requirements of SMC 17C.110.200(C)(1).)) [Deleted.]~~

[4] In the RSF-C and RTF zones, and sites in the RSF zone qualifying for compact lot development standards, described in SMC 17C.110.209, FAR may be increased to 0.65 for attached housing development only.

[5] No structure located in the rear yard may exceed twenty feet in height.

[6] Base zone height may be modified according to SMC 17C.110.215, Height.

[7] Attached garage or carport entrance on a street is required to be setback twenty feet from the property line.

[8] See SMC 17C.110.220(D)(1), setbacks regarding the use of front yard averaging.

[9] See SMC 17C.110.220(D)(2), setbacks regarding reduction in the rear yard setback.

[10] Attached garages may be built to five feet from the rear property line except, as specified in SMC 17C.110.225(C)(6)(b), but cannot contain any living space.

[11] In the RSF-C zone and sites in the RSF zone qualifying for compact lot development standards, described in SMC 17C.110.209, the rear setback is 15 feet.

[12] Maximum site coverage for accessory structures is counted as part of the maximum site coverage of the base zone. See SMC 17C.110.225(D).

[13] Setback for a detached accessory structure and a covered accessory structure may be reduced to zero feet with a signed waiver from the neighboring property owner, except, as specified in SMC 17C.110.225(C)(5)(b).

[14] The setback for a covered accessory structure may be reduced to five feet from the property line.

Section 2. That SMC section 17C.110.225 is amended to read as follows:

**17C.110.225 Accessory Structures**

A. Purpose.

This section regulates structures that are incidental to primary buildings to prevent them from becoming the predominant element of the site. The standards provide for necessary access around structures, help maintain privacy to adjoining lots and maintain open front setbacks.

B. General Standards.

1. Accessory structures are allowed on a lot only in conjunction with a primary building, and may not exist on a lot prior to the construction of the primary structure, except as allowed by subsection (B)(2) of this section.
2. An accessory structure that becomes the only structure on a lot as the result of a land division may remain on the lot if the owner has submitted a financial guarantee to the City for the cost of demolition and removal of the structure. The financial guarantee will be used by the City if the owner has not removed the accessory structure if, within one year of final plat approval or boundary line adjustment (BLA), a primary structure has not been built and received final inspection. The financial guarantee must be accepted by the City prior to approval of the final plat or boundary line adjustment.
3. An accessory structure shall not contain a kitchen or space for living, sleeping, eating, or cooking unless it is approved as an accessory dwelling unit under [chapter 17C.300 SMC](#).

C. Setbacks.

1. Mechanical Structures.

Mechanical structures are items such as heat pumps, air conditioners, emergency generators, and water pumps.

a. Front Setback Standard.

Mechanical structures are not allowed in required front building setbacks.

b. Side and Rear Setback Standard.

Mechanical structures are allowed inside and rear building setbacks if the structure is no more than forty-eight inches high.

2. Vertical Structures.

Vertical structures are items such as flagpoles, trellises and other garden structures, radio antennas, satellite receiving dishes and lampposts. Fences are addressed in [SMC 17C.110.230](#). Sign standards are [in chapter 17C.240 SMC](#), Signs.

a. Setback Standard.

Vertical structures are allowed in required side and rear building setbacks if they are no larger than four feet in width, depth or diameter and no taller than seven feet. If they are larger or taller, they are not allowed in required building setbacks. Trellises and other gate features are allowed in front yard if they are no larger than four feet in width, depth or diameter and no taller than seven feet and do not conflict with the clear view triangle provisions under [SMC 17C.110.230](#), Fences.

3. Uncovered Horizontal Structures.

Uncovered horizontal structures are items such as decks, stairways, entry bridges, wheelchair ramps, swimming pools, hot tubs, tennis courts, and boat docks that are not covered or enclosed.

a. Setback Standard.

i. Projection Allowed.

The following structures are allowed in required building setbacks, as follows:

- A. Structures that are no more than two and one-half feet above the ground are allowed in side and rear building setbacks. Handrails required by the IBC/IRC are not included in the maximum height.
- B. On lots that slope down from the street, vehicular or pedestrian entry bridges that are no more than two and one-half feet above the average sidewalk elevation are allowed in all building setbacks; and
- C. Stairways and wheelchair ramps that lead to one entrance on the street-facing facade of a building are allowed in street setbacks.

4. Covered Accessory Structures.

Covered accessory structures are items such as greenhouses, storage buildings (not used to cover motor vehicles), sheds, covered decks, covered porches, gazebos, and covered recreational structures.

a. Setback Standard.

Covered accessory structures are not allowed in the required front ~~((and side))~~ building setbacks. Covered accessory structures are not allowed in the required side building setback without a signed waiver from the neighboring property owner.

5. Detached Accessory Structures.

Detached accessory structures are garages, carports, and other structures utilized to cover motorized vehicles.

a. Setback Standard.

A detached accessory structure is not allowed in the front building setback. A detached accessory structure is not allowed in the required side building setback without a signed waiver from the neighboring property owner. A detached accessory structure that has an entrance, which faces a street, is required to be setback twenty feet from the property line or from the back of the sidewalk, as stated in [Table 17C.110-3](#).



- b. Detached accessory structures may be built to the rear property line, unless parking in front of the structure is proposed, then the structure is required to be built a minimum of eighteen feet from the edge of the alley tract, easement, or right-of-way.

6. Attached Accessory Structures.

Accessory structures are garages, carports or other structures utilized to cover motorized vehicles that are connected by a common wall to the primary structure.

a. Setback Standard.

An attached accessory structure is not allowed in the front building setback. An attached accessory structure that has an entrance which faces a street is required to be setback twenty feet from the property line as stated in [Table 17C.110-3](#).

- b. Attached accessory structures may be built to within five feet of the rear property line, unless parking in front of the structure is proposed, then the structure is required to be built a minimum of eighteen feet from the edge of the alley tract, easement or right-of-way.

D. Building Coverage.

1. Except as provided in subsection (2) of this subsection (D), ((The)) the combined building coverage of all detached accessory structures and covered accessory structures may not exceed fifteen percent of the total area of the site, and when combined with all other structures on-site shall not exceed the maximum building coverage of the base zone.

2. On lots smaller than five thousand five hundred square feet with an accessory dwelling unit, combined building coverage of all detached accessory structures and covered accessory structures may not exceed twenty percent of the total area of the site, and when combined with all other structures on-site shall not exceed the maximum building coverage of the base zone.

E. Building Height.

The building height of detached accessory structures and covered accessory structures is listed in [Table 17C.110-3](#). Accessory structures, which contain an ADU over a garage, are subject to the height limitations in [chapter 17C.300 SMC](#), Accessory Dwelling Units.

<b>TABLE 17C.110.225-1 MAXIMUM HEIGHT – DETACHED ACCESSORY BUILDING [1]</b>	
Maximum Wall Height [2]	15 ft.
Maximum Roof Height [3]	20 ft.
<p>[1] Cannot include living area, nor any storage areas with a ceiling height of six-foot eight-inches or greater.</p> <p>[2] The height of the lowest point of the roof structure intersects with the outside plane of the wall.</p> <p>[3] The height of the ridge of the roof.</p> <p>See “Example A” below.</p>	

**Example A**

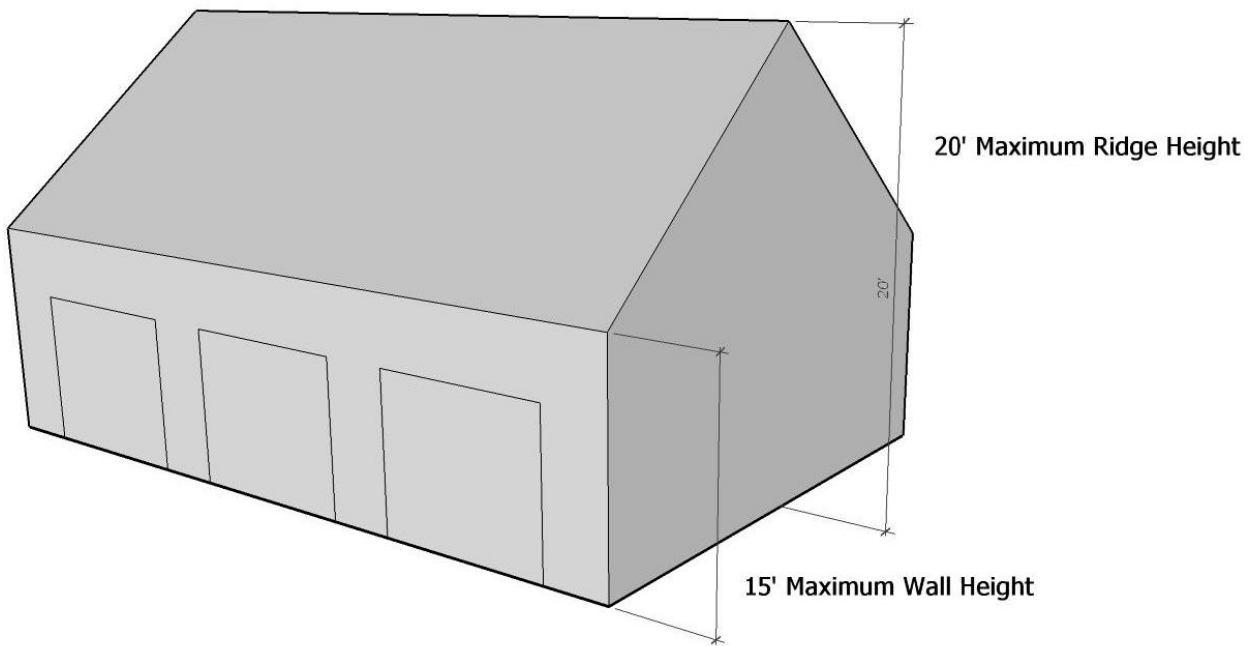

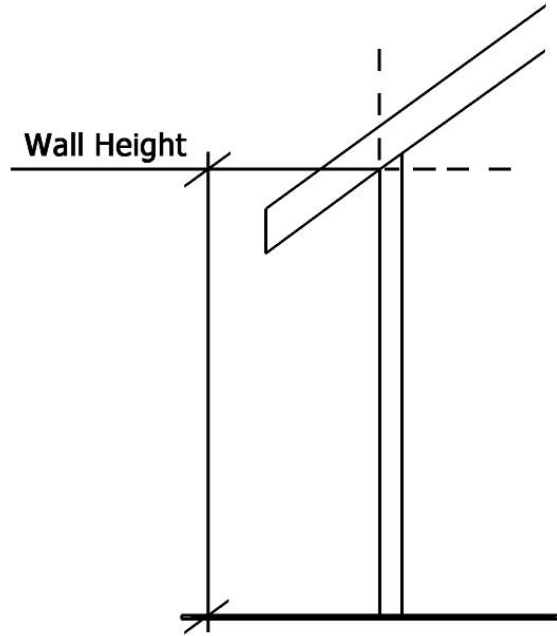

**[Note: Delete graphic above]**

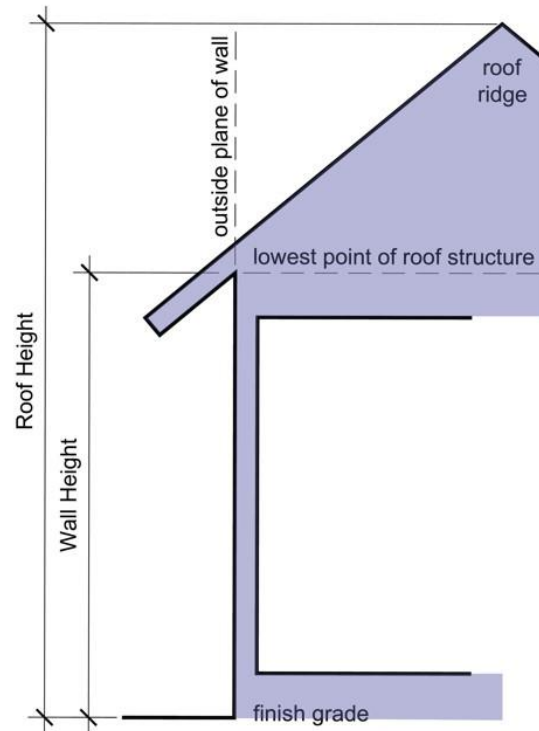

**[Note: New graphic added]**

Section 3. That SMC section 17C.300.100 is amended to read as follows:

### **17C.300.100 General Regulations**

A. Where the Regulations Apply.

Attached and detached accessory dwelling units are permitted in the RA through RHD zones, including planned unit developments, subject to the limitations of subsection (B) of this section.

B. Limitation.

~~((1. One ADU is allowed per lot as an accessory use in conjunction with a detached single-family residence.~~

~~2. A detached ADU must either be combined with a garage or shall be the only detached structure in the rear yard setback area.~~

~~3. Detached~~) One accessory dwelling ~~((units are))~~ unit is allowed per lot in the RA, RSF, RTF, RMF, and RHD zones subject to the development standards of the underlying zoning district.

Section 4. That SMC 17C.300.110 is amended to read as follows:

### **17C.300.110 Criteria**

~~((A. Minimum Lot Size.~~

~~The minimum lot size for ADU is five thousand square feet.))~~

~~((B.))~~ A. ~~((ADU Minimum and))~~ Maximum Size.

1. Internal ADU.

Before the establishment of an internal ADU the ~~((footprint))~~ floor area of the principal structure, excluding an attached garage, must be not less than eight hundred square feet.

a. The ((size)) internal ADU shall contain no more than two bedrooms and the floor area of the internal ADU must be ((not less than two hundred fifty square feet and)) not more than eight hundred square feet, excluding any related garage area.

b. The conversion of an existing interior basement or attic space of a principal structure into an ADU may exceed the maximum floor area for an internal ADU specified in subsection (1)(a) of this subsection.

2. Detached ADU.

a. The maximum detached ADU size is subject to building coverage per SMC 17C.300.130(B)(3) and floor area ratio per subsection (3) of this subsection (A); and

b. ~~\_\_\_\_\_~~ A detached ADU shall not exceed ~~((six hundred square feet))~~ seventy-five percent of the floor area of the principal structure, or eight hundred sixty-four square feet of floor area, whichever is greater.

3. FAR.

a. ~~\_\_\_\_\_~~ The ~~square footage~~ floor area of an ADU, excluding any garage, is counted as part of the floor area ratio (FAR). ~~((Internal ADUs may not exceed fifty percent of the total square footage of the principal structure's building footprint.))~~

b. ~~\_\_\_\_\_~~ To offer greater flexibility in integrating an ADU on smaller lots, the maximum allowable FAR may be increased to 0.6 on lots smaller than seven thousand two hundred square feet in area, with an ADU, and to 0.7 on lots smaller than five thousand square feet in area with an ADU.

~~((C.))~~ B. Occupancy for Short-Term Rentals.

~~((One))~~ Where a lot with an ADU also has a Short-Term Rental under chapter 17C.316 SMC, one of the dwelling units ((in the structure or)) on the lot shall be occupied by one or more owners of the property as the owner's permanent and principal residence. The owner-occupant must occupy the owner-occupied dwelling unit for more than six months of each calendar year. The owner-occupant may not receive rent for the owner-occupied dwelling unit. If a complaint that an owner has violated these requirements is filed, the owner shall:

1. submit evidence to the director showing good cause, such as a job dislocation, sabbatical leave, education or illness, for waiver of this requirement for up to one year absence from the property. Upon such showing the director may waive the requirement;
2. re-occupy the structure; or
3. remove the accessory dwelling unit.

Section 5. That SMC 17C.300.120 is amended to read as follows:

**17C.300.120 Application Procedures**

A. Application.

Any property owner seeking to establish an ADU must obtain a building permit and a certificate of occupancy from the building services department.

~~((B.))~~ ~~Covenants.~~

~~A covenant and deed restriction identifying the ADU and limitations of occupancy and ownership is required to be recorded and filed with the Spokane county~~

auditor's office. A copy of the recorded covenant must be provided to the City of Spokane planning and economic development services department prior to the issuance of a building permit or safety inspection.))

Section 6. That SMC 17C.300.130 is amended to read as follows:

### **17C.300.130 Development Standards**

#### **A. Development Standards – Requirements for All Accessory Dwelling Units.**

All accessory dwelling units must meet the following:

1. Creation.

An accessory dwelling unit may only be created through the following methods:

- a. Converting existing living area, attic, basement or garage.
- b. Adding floor area.
- c. Constructing a detached accessory dwelling unit on a site with an existing house, attached house or manufactured home ~~((;or))~~.
- d. Constructing a new house, attached house or manufactured home with an internal or detached accessory dwelling unit.
- e. In the RTF, RMF, or RHD zone, constructing an attached or detached accessory dwelling unit on a site with any existing or new principal structure. Any structure shall comply with all applicable building, fire, and engineering standards.

2. Number of Residents.

The total number of individuals that reside in both units may not exceed ~~((the number that is allowed for a household))~~ any lawful limits on occupant load per square foot or generally applicable health and safety provisions as established by applicable building or fire code, as provided in RCW 35.21.682.

~~((3. Other Uses.~~

~~An accessory dwelling unit is prohibited on a site with a home occupation.))~~

~~((4.))~~ 3. Location of Entrances for Internal ADUs.

Only one entrance may be located on the facade of the ~~((house, attached house or manufactured home))~~ principal structure facing the street, unless the ~~((house, attached house or manufactured home))~~ principal structure contained additional entrances before the accessory dwelling unit was created. An exception to this regulation is entrances that do not have access from the ground such as entrances from balconies or decks.

~~((5.))~~ 4. Parking.

a. Studio and one-bedroom ADUs require no additional parking. One additional off-street parking space is required for the accessory dwelling unit with more than one bedroom, plus one per bedroom after two bedrooms. Existing required parking for the ((house, attached house or manufactured home)) principal structure must be maintained ((or replaced on-site)).

b. As an exception to subsection (a), no additional off-street parking space is required for the ADU within one-quarter-mile of stops for a bus or other transit mode providing actual fixed route service at intervals of no less frequently than fifteen minutes for at least five hours during the peak hours of operation on weekdays, defined as a major transit stop under RCW 36.70A.696.

~~((6. Exterior Finish Materials.~~

~~The exterior finish material must be the same or visually match in type, size, and placement the exterior finish material of the house, attached house or manufactured home.))~~

~~7. Roof Pitch.~~

~~The roof pitch must be the same as the predominant roof pitch of the house, attached house or manufactured home.~~

~~8. Trim.~~

~~Trim must be the same in type, size and location as the trim used on the house, attached house or manufactured home.~~

~~9. Windows.~~

~~Windows must match those in the house, attached house or manufactured home in proportion (relationship of width to height) and orientation (horizontal or vertical). This standard does not apply when it conflicts with building code regulations.-))~~

B. Additional Development Standards for Detached ADUs.

1. Setbacks.

~~((The))~~ Except for conversion of existing accessory structures, the accessory dwelling unit must be ((at least)):

~~((a. sixty feet from the front lot line; or~~

~~b. six feet behind the house, attached house or manufactured home;))~~

~~((e.))~~ a. as specified for ((rear and side yard)) setbacks in [Table 17C.110-3](#) for ((primary structures for attached ADUs and)) accessory structures ((for detached ADUs.)); and

b. in conformance with the forty-five degree setback plane:

- i. The forty-five degree setback plane is measured at the maximum wall height listed in Table 17C.300-1, from the interior side lot line setback, or rear setback without an alley, as listed in Table 17C.110-3 for accessory structures. The setback plane does not apply on side or rear setbacks measured from alley or street lot lines.
- ii. The setback plane increases at a forty-five degree angle away from the interior side and rear lot lines without an alley, up to the maximum roof height in Table 17C.300-1. See Figure 17C.300-A for examples.
- iii. No portion of the accessory dwelling unit may project beyond the forty-five degree setback plane described in this subsection, except for the roof structure and minor extensions allowed by SMC 17C.110.220(C)(1).
- iv. The setback may be reduced to zero feet with a signed waiver from the neighboring property owner. In that case, the forty-five degree setback plane would be measured from the maximum wall height and the property line.



**Figure 17C.300-A. Setback Plane [1]**

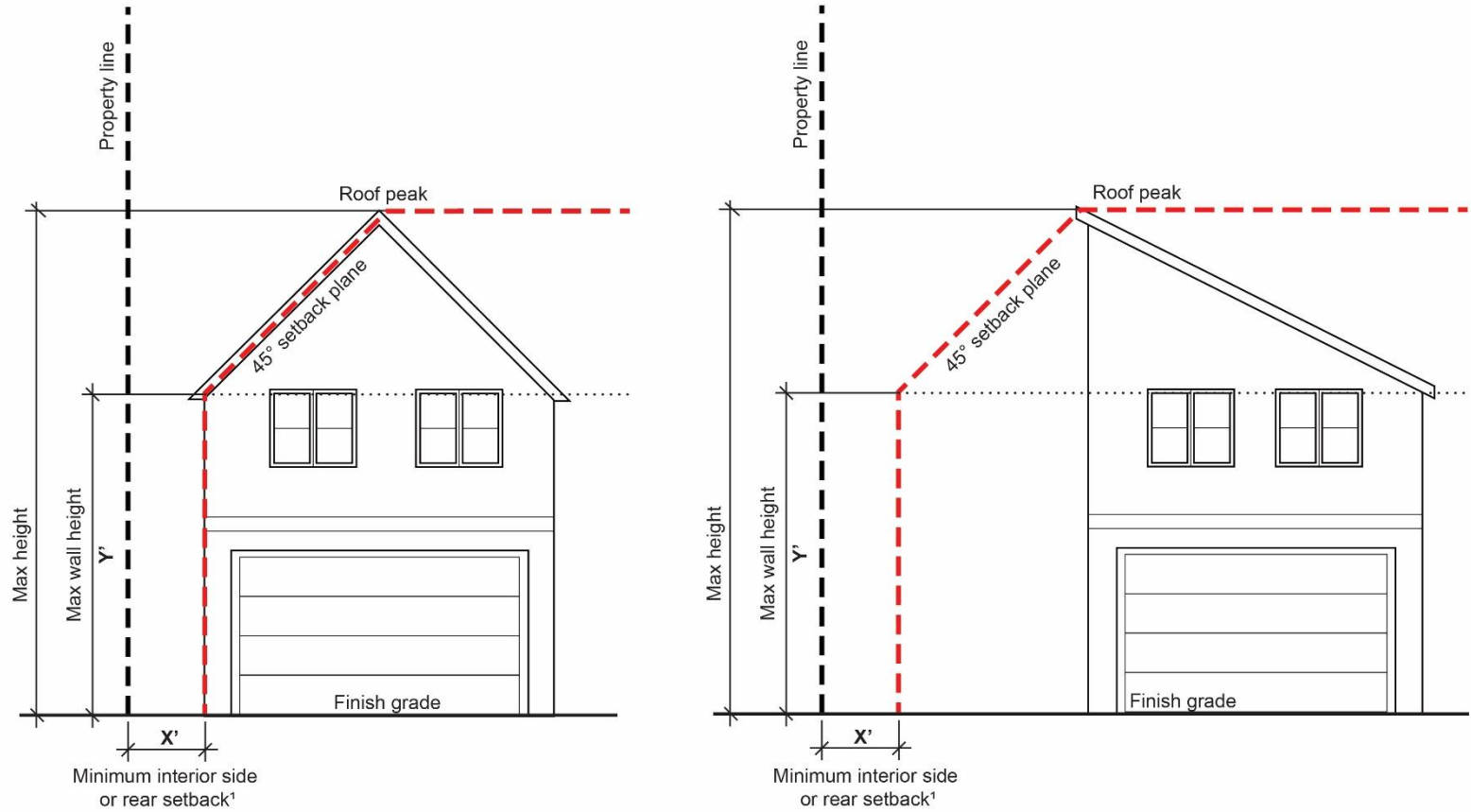

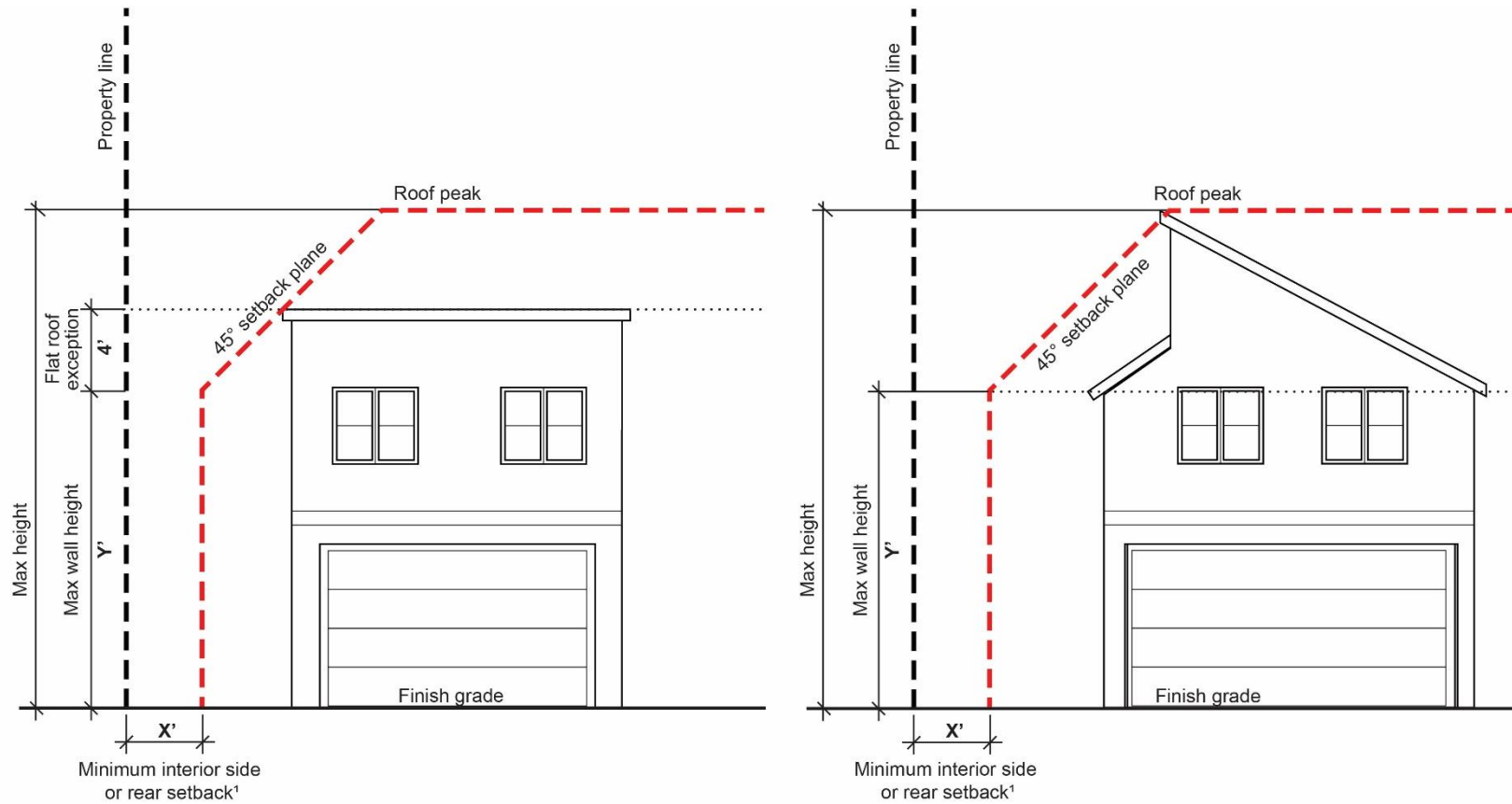

**[Note: New graphic added]**

2. Height.

The maximum height allowed for a detached accessory dwelling unit is shown in Table 17C.300-1. A detached ADU over a detached accessory structure with flat or terraced roof forms with slopes of less than 3:12 that conform to the forty-five-degree setback plane in subsection (B)(1)(b) of this section may be granted a wall height exception up to four feet.

<b>TABLE 17C.300-1            MAXIMUM ROOF AND WALL HEIGHT</b>		
	<b>Maximum Height –            Detached Accessory            Building Attached to an            ADU or Detached ADU            [1]</b>	<b>Maximum Height – Detached ADU            Over a Detached Accessory            Structure</b>
Maximum Wall Height [2]	10 ft.	<del>((16))</del> <u>17</u> ft.
Maximum Roof Height [3]	20 ft.	<del>((23))</del> <u>25</u> ft.
[1] Detached accessory structures cannot include living area, nor any storage areas with a ceiling height of six-feet eight-inches or greater. [2] The height of the lowest point of the roof structure intersects with the outside plane of the wall. [3] The height of the ridge of the roof. See “Figure <del>((A))</del> <u>17C.300-B</u> ” below.		

**Figure ((A)) 17C.300-B**

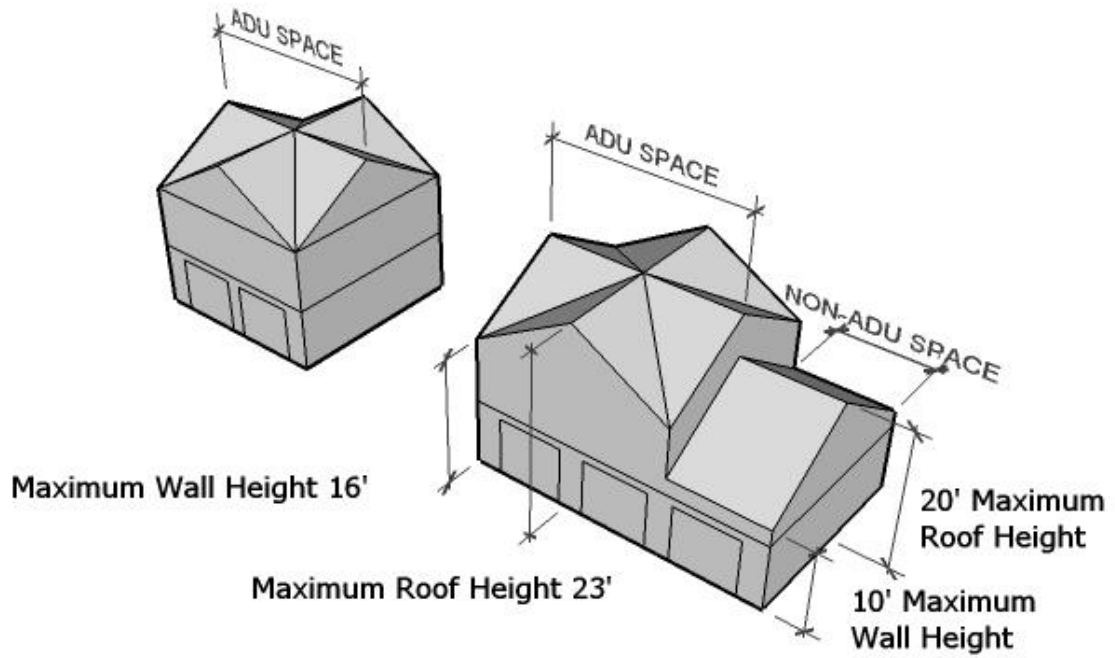

**[Note: Delete graphic above]**

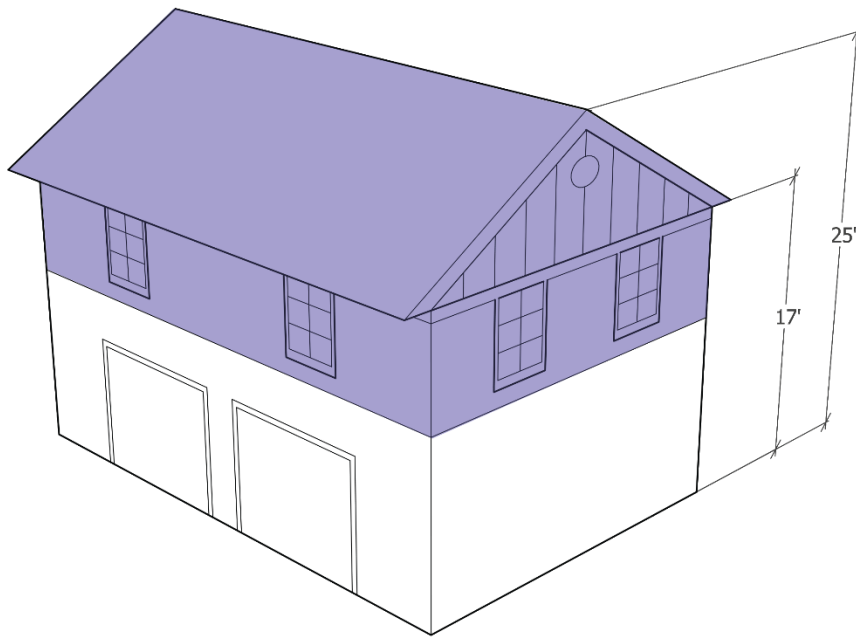
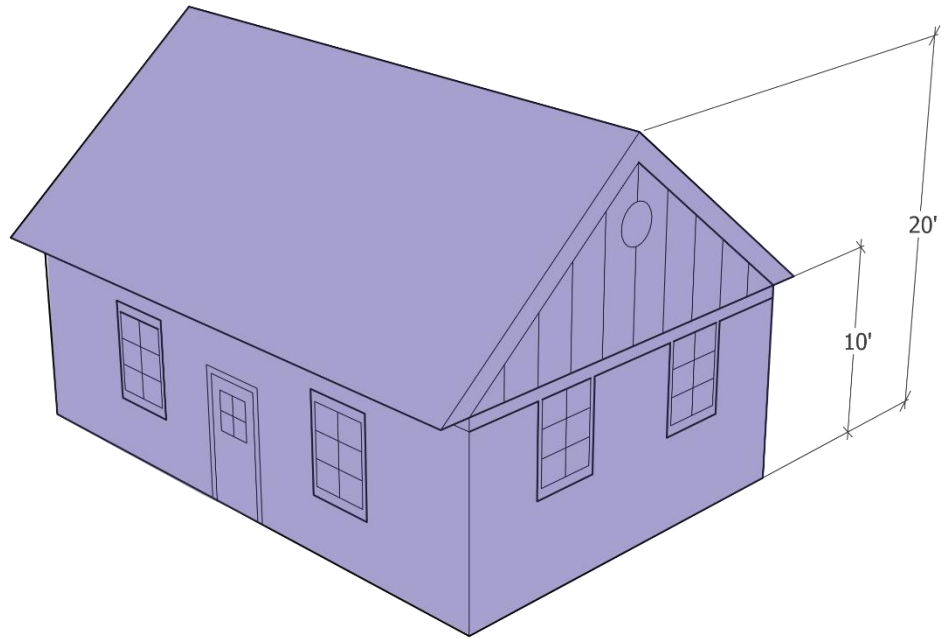

**[Note: New graphic added]**

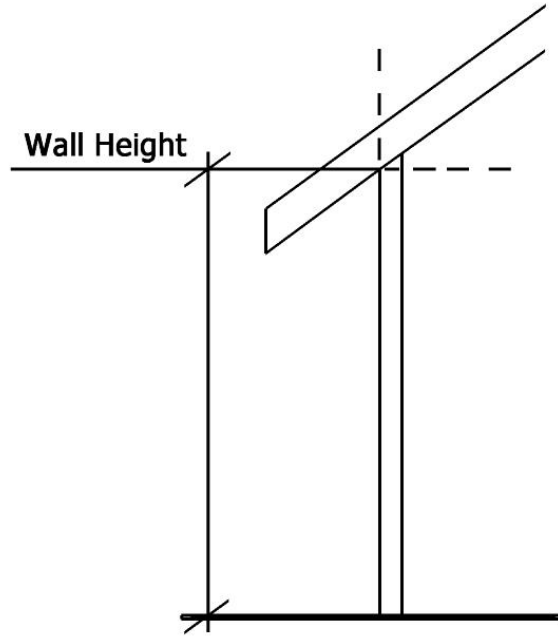

**[Note: Delete graphic above]**

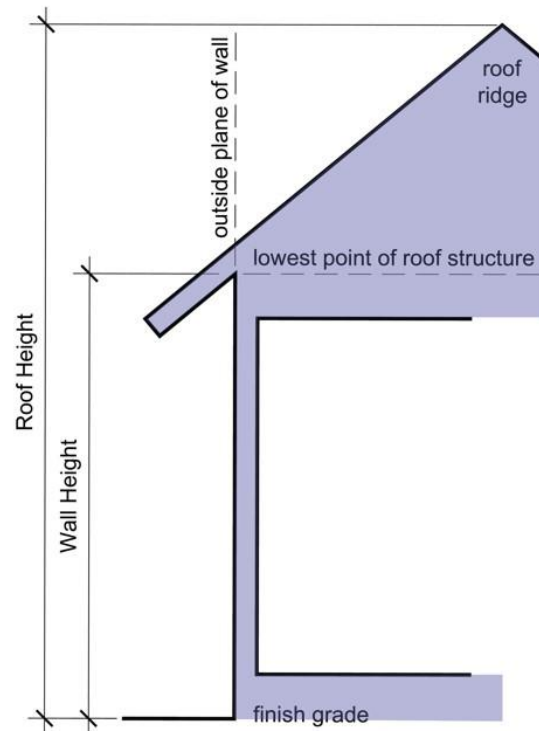

**[Note: New graphic added]**

3. Bulk Limitation.

The building coverage for the detached accessory dwelling unit may not be larger than the building coverage of the ~~((house, attached house or manufactured home))~~ principal structure.

a. ~~((The))~~ On lots five thousand five hundred square feet or larger, the combined building coverage of all detached accessory structures may not exceed fifteen percent of the total area of the site.

b. On lots smaller than five thousand five hundred square feet, the combined building coverage of all detached accessory structures may not exceed twenty percent of the total area of the site.

4. Conversion of Existing Detached Accessory Structures.

a. In RA through RTF zones, conversion of an existing detached accessory structure that is in a front building setback required by [Table 17C.110-3](#) is not allowed. Conversion of an existing detached accessory structure that is in a rear or side building setback is allowed as provided by [SMC 17C.110.220](#), Setbacks, and [SMC 17C.110.225](#), Accessory Structures.

b. In RMF through RHD zones, conversion of an existing detached accessory structure that is in a front building setback required by [Table 17C.110-3](#) is not allowed. Conversion of an existing detached accessory structure that is in a rear or side building setback is allowed as provided by [SMC 17C.110.220](#), Setbacks, and [SMC 17C.110.225](#), Accessory Structures.

c. If the accessory dwelling unit is proposed for an existing detached accessory structure that meets any of the standards of subsections ~~((A)(6) through (9) and))~~ (B)(2) and (3) of this section, alterations that will move the structure out of conformance with the standards that are met are not allowed.

d. If the accessory dwelling unit is proposed as a conversion of an existing detached accessory structure or a portion of the building, and ~~((the existing detached accessory structure does not meet the standards of subsections (A)(6) through (9) of this section, the structure is exempt from those standards. If))~~ any floor area is added to the existing detached accessory structure to accommodate an ADU, then the entire structure must meet the ~~((standards of subsections (A)(6) through (9) of this section and the))~~ underlying zoning development standards.

C. Utilities and Addressing.

The ADU must utilize those municipal utilities and address established for the principal dwelling unit.

D. Code Compliance.

The ADU must meet all technical code standards of this title including building, electrical, fire, and plumbing code requirements and permits.

Section 7. That SMC 17C.300.140 is amended to read as follows:

**17C.300.140 ADU Expiration**

A. Transfer.

~~((A))~~ In the case where a lot with an ADU also has a Short-Term Rental under chapter 17C.316 SMC, an ADU permit is not transferable to any other property or any other person except to the new owner of the subject property when the property will be owner occupied.

B. Expiration.

Approval of an ADU expires when the:

1. accessory dwelling unit is altered and is thus no longer in conformance with the plans approved by the building services department; or
2. property ceases to maintain the required off-street parking spaces for the accessory and principal dwelling units; or
3. in the case where a lot with an ADU also has a Short-Term Rental under chapter 17C.316 SMC, legal titleholder of the property ceases to own and reside in either the principal or the accessory dwelling unit.



## ORDINANCE NO. C36225

An ORDINANCE relating to lot size transitions, accessory structures, and accessory dwelling units amending Spokane Municipal Code (SMC) Sections 17C.110.200, 17C.110.225, 17C.300.100, 17C.300.110, 17C.300.120, 17C.300.130, 17C.300.140.

WHEREAS, RCW 36.70A.600 encourages the City to take a number of actions in order to increase its residential building capacity and authorized the City to adopt a housing action plan; and

WHEREAS, as authorized by RCW 36.70A.600(2), Council Resolution RES-2021-0062 adopted the City of Spokane Housing Action Plan as a guide for future housing planning, policy development, and regulatory and programmatic implementation measures that increase housing options that are affordable and accessible for people and families of all incomes in the City; including the Implementation Plan, included as Appendix A within the Housing Action Plan, which outlines several strategies and policies to remedy the current housing crisis; and

WHEREAS, the 2020 Housing Needs Assessment completed for the Housing Action Plan indicates several facts about the housing supply and need, particularly the need to accommodate for an estimated 6,000 additional housing units by 2037; and

WHEREAS, in adopting RES-2021-0062 the City Council outlined several code amendments and permit processes that the City should enact in support of the strategies and actions recommended in the Housing Action Plan and to encourage construction of more housing within Spokane; and

WHEREAS, on July 26, 2021, the Mayor of the City of Spokane proclaimed a housing emergency and directed the City to pursue actions to expand housing types, reduce overall development costs to increase development of affordable housing, and to streamline municipal procedures to support the development cycle; and

WHEREAS, the City was awarded a \$100,000 grant from the Department of Commerce through the Housing Action Plan and Implementation (HAPI) grant program to implement strategies from its adopted Housing Action Plan, and the scope of work includes revising accessory dwelling unit (ADU) standards in chapter 17C.300 SMC to allow for additional flexibility and expand the zones that permit ADUs; and

WHEREAS, the proposed actions are consistent with and supported by the Spokane Comprehensive Plan, as outlined in the Plan Commission Findings of Fact, Conclusions, and Recommendations (Exhibit A), and will implement actions specified in RCW 36.70A.600(1); and

WHEREAS, by virtue of the public process outlined in Exhibits A and B, interested agencies and the public have had extensive opportunities to participate throughout the process and all persons desiring to comment on the amendment were given a full and complete opportunity to be heard; and

WHEREAS, the City has complied with RCW 36.70A.370 in the adoption of this Ordinance, avoiding any unconstitutional taking of private property; and

WHEREAS, on March 24, 2022, the Washington State Department of Commerce and appropriate state agencies were given the required 60-day notice before adoption of proposed changes to the Unified Development Code pursuant to RCW 36.70A.106; and

WHEREAS, on April 1, 2022, a Notice of Intent to adopt and request for SEPA agency comments was issued for the draft code pertaining to ADUs, lot size transitions, and short plat notification. The comment period ended on April 15, 2022. The Spokane Tribe of Indians issued comment noting project actions may require case by case cultural surveys; and

WHEREAS, a State Environmental Protection Act (SEPA) Determination of Nonsignificance and Checklist were issued by Planning Services on April 25, 2022. The comment period ended on May 11, 2022. Two city department comments were received during the comment period; and

WHEREAS, prior to the Plan Commission public hearing, a legal notice of public hearing was published in the *Spokesman-Review* on April 27 and May 4, 2022 and the notice of the proposed amendment was distributed to the City's agency/interested party list and posted on the City's website at [www.ShapingSpokaneHousing.com](http://www.ShapingSpokaneHousing.com); and

WHEREAS, on May 11, 2022, the Spokane Plan Commission held a public hearing on the proposed amendment and heard testimony from the public, following which they voted to recommend the City Council adopt, with some modifications, the proposed amendments (see Exhibit A); and

WHEREAS, the City Council adopts the recitals set forth herein as its findings and conclusions in support of its adoption of this ordinance and further adopts the findings, conclusions, and recommendations from the Planning Services Staff Report (Exhibit B) and the City of Spokane Plan Commission (Exhibit A) for the same purposes; and

NOW, THEREFORE, the City of Spokane does ordain:

Section 1. That Section 17C.110.200 SMC is amended to read as follows:

**17C.110.200 Lot Size**

A. Purpose.

The standards of this section allow for development on lots, but do not legitimize lots that were divided in violation of [chapter 17G.080 SMC](#), Subdivisions. The required minimum lot size, lot depth, lot width and frontage requirements for new lots ensure that development will, in most cases, be able to comply with all site development standards. The standards also prevent the creation of very small lots that are difficult to develop at their full density potential. Finally, the standards also allow development on lots that were reduced by condemnation or required dedications for right-of-way.

B. Existing Lot Size.

1. Development is prohibited on lots that are not of sufficient area, dimension and frontage to meet minimum zoning requirements in the base zone. Except:
  - a. one single-family residence may be developed on a lot that was legally created under the provisions of chapter 58.17 RCW, Plats – Subdivisions – Dedications, or applicable platting statutes;
  - b. a PUD lot may be less than the minimum size of the base zone, if such lot is delineated on a PUD plan, which has been approved by the hearing examiner. All use and development standards of the zone wherein such lot is located, shall be complied with, unless modified through the PUD process by the hearing examiner. A PUD shall comply with the requirements of subsection (C) of this section.
2. No lot in any zone may be reduced so that the dimension, minimum lot area, frontage or area per dwelling unit is less than that required by this chapter, except as modified through the PUD process by the hearing examiner.
3. Lots Reduced by Condemnation or Required Dedication for Right-of-way. Development that meets the standards of this chapter is permitted on lots, or combinations of lots, that were legally created and met the minimum size requirements at the time of subdivision, but were reduced below one or more of those requirements solely because of condemnation or required dedication by a public agency for right-of-way.

C. Land Division.

1. All new lots created through subdivision must comply with the standards for the base zone listed in Table 17C.110-3.

~~((1.—Transition Requirement.~~

For sites two acres or greater, transition lot sizes are required to be included as a buffer between existing platted land and new subdivision subject to the requirements of this section. The purpose of this section is to transition lot sizes between the proposed and existing residential developments in order to facilitate compatible development and a consistent development pattern. In the RA and RSF zones, the minimum lot size is subject to transitioning of lots sizes. Lots proposed within the initial eighty feet of the subject property are required to transition lot sizes based on averaging under the following formulas:

- a. Transitioning is only required of properties adjacent to or across the right of way from existing residential development. "Existing residential development" in this section shall mean existing lots created through subdivision or short plat.
- b. Lot size in the transition area is based on the average of the existing lot size in subdivisions adjacent to, or across the street from, the subject property. Lots greater than eleven thousand square feet are not counted in the averaging.
- c. If the existing average lot size is greater than seven thousand two hundred square feet, then the lot size in the transition area can be no less than seven thousand two hundred square feet.
- d. If the existing average lot size is less than seven thousand two hundred square feet, then the lot size in the transition area can be equal to or greater than the average.
- e. If the subject site shares boundaries with more than one subdivision, the minimum lot size in the transition area shall be based on the average lot sizes along each boundary. When two boundaries meet, the lot size shall be based on the larger of the two boundaries. See example below; and

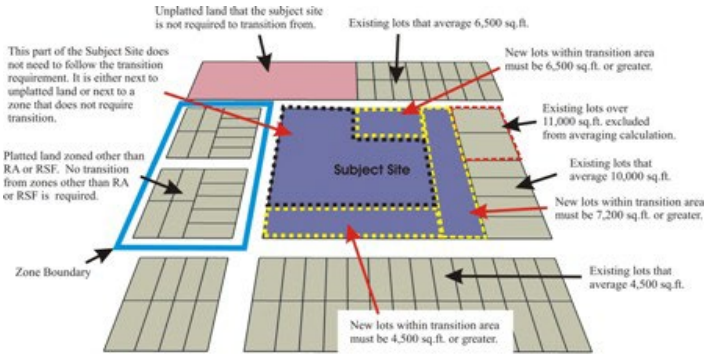

[Note: Delete graphic above]

- f. ~~If the subject site shares a boundary with property zoned other than RA or RSF, then there are no transition requirements along that boundary.~~
- g. ~~After the first set of lots in the transition area, lot sizes may be developed to the minimum lot size of the base zone, i.e., four thousand three hundred fifty square feet in the RSF zone.)~~
2. Planned unit developments, combined with a subdivision, may reduce the minimum lot size, lot width, lot depth and frontage requirements in the RA and RSF zones pursuant to SMC 17G.070.030(C)(1) (~~except in the transition area required by subsection (C)(1) of this section~~).
- D. Ownership of Multiple Lots.
- Where more than one adjoining lot is in the same ownership, the ownership may be separated as follows:
1. If all requirements of this chapter will be met after the separation, including lot size, density and parking, the ownership may be separated through either a boundary line adjustment (BLA) or plat, as specified under [chapter 17G.080 SMC](#), Subdivisions.
  2. If one or more of the lots does not meet the lot size standards in this section, the ownership may be separated along the original plat lot lines through a boundary line adjustment (BLA).
- E. New Development on Standard Lots. New development on lots that comply with the lot size standards in this section are allowed subject to the development standards and density requirements of the base zone as required under Table 17C.110-3.
- F. Lot Frontage. All residential lots shall front onto a public street and meet the minimum lot frontage requirements of Table 17C.110-3. Except, that frontage on a public street is not required for lots created through alternative residential subdivision under SMC 17G.080.065, and lots approved in a planned unit development or a manufactured home park may have lots or spaces fronting onto private streets, subject to the decision criteria of [SMC 17H.010.090](#).

TABLE 17C.110-3 DEVELOPMENT STANDARDS [1]					
DENSITY STANDARDS					
	RA	RSF & RSF-C	RTF	RMF	RHD
Density - Maximum	4,350 (10 units/acre)	4,350 (10 units/acre)	2,100 (20 units/acre)	1,450 (30 units/acre)	--
Density - Minimum	11,000 (4 units/acre)	11,000 (4 units/acre)	4,350 (10 units/acre)	2,900 (15 units/acre)	2,900 (15 units/acre)

MINIMUM LOT DIMENSIONS LOTS TO BE DEVELOPED WITH:					
Multi-Dwelling Structures or Development					
	RA	RSF & RSF-C	RTF	RMF	RHD
Minimum Lot Area				2,900 sq. ft.	2,900 sq. ft.
Minimum Lot Width				25 ft.	25 ft.
Minimum Lot Depth				70 ft.	70 ft.
Minimum Front Lot Line				25 ft.	25 ft.
Compact Lot Standards [2]					
Minimum Lot Area [3]		3,000 sq. ft.			
Minimum Lot Width		36 ft.			
Minimum Lot Depth		80 ft.			
Minimum Front Lot Line		30 ft.			
Attached Houses as defined in SMC 17A.020.010					
Minimum Lot Area [3]	7,200 sq. ft.	4,350 sq. ft.	1,600 sq. ft.	1,450 sq. ft.	None
Minimum Lot Width	40 ft.	40 ft.	36 ft. or 16 ft. with alley parking and no street curb cut	Same	Same
Minimum Lot Depth	80 ft.	80 ft.	50 ft.	None	None
Minimum Front Lot Line	40 ft.	40 ft.	Same as lot width	Same as lot width	Same as lot Width
Detached Houses					
Minimum Lot Area [3]	7,200 sq. ft.	4,350 sq. ft.	1,800 sq. ft.	1,800 sq. ft.	None
Minimum Lot Width	40 ft.	40 ft.	36 ft.	25 ft.	25 ft.
Minimum Lot Depth	80 ft.	80 ft.	40 ft.	25 ft.	25 ft.

Minimum Front Lot Line	40 ft.	40 ft.	30 ft.	25 ft.	25 ft.
<b>Duplexes</b>					
Minimum Lot Area			4,200 sq. ft.	2,900 sq. ft.	None
Minimum Lot Width			25 ft.	25 ft.	25 ft.
Minimum Lot Depth			40 ft.	40 ft.	25 ft.
Minimum Front Lot Line			25 ft.	25 ft.	25 ft.
<b>PRIMARY STRUCTURE</b>					
<b>Maximum Building Coverage</b>					
	RA	RSF & RSF-C	RTF	RMF	RHD
Lots 5,000 sq. ft. or larger	40%	2,250 sq. ft. + 35% for portion of lot over 5,000 sq. ft.	2,250sq. ft. + 35% for portion of lot over 5,000 sq. ft.	50%	60%
Lots 3,000 - 4,999 sq. ft.	1,500 sq. ft. + 37.5% for portion of lot over 3,000 sq. ft.				
Lots less than 3,000 sq. ft.	50%				
Attached housing as defined in SMC 17A.020.010, lots any size	Same as above			Up to 70%	Up to 80%
<b>Building Height</b>					
Maximum Roof Height	35 ft. [5]	35 ft. [5]	35 ft. [5]	35 ft. [6]	35 ft. [6]
Maximum Wall Height	25 ft.	25 ft.	25 ft.	-- [6]	--
<b>Floor Area Ratio (FAR)</b>					
FAR	0.5	0.5 [4]	0.5 [4]	--	--
<b>Setbacks</b>					
Front Setback [7, 8]	15 ft.				
Side Lot Line Setback – Lot	5 ft.				

width more than 40 ft.					
Side Lot Line Setback – Lot width 40 ft. or less	3 ft.				
Street Side Lot Line Setback [7]	5 ft.				
Rear Setback [9, 10]	25 ft.	25 ft. [11]	15 ft.	10 ft.	10 ft.
Required Outdoor Area					
Required Outdoor Area for attached and detached houses. Minimum dimension (See SMC 17C.110.223)	250 sq. ft. 12 ft. x 12 ft.	250 sq. ft. 12 ft. x 12 ft.	250 sq. ft. 12 ft. x 12 ft.	200 sq. ft. 10 ft. x 10 ft.	48 sq. ft. 7 ft. x 7 ft.
<b>ACCESSORY STRUCTURES</b>					
	RA	RSF & RSF-C	RTF	RMF	RHD
Maximum Roof Height	30 ft.	20 ft.	20 ft.	35 ft.	35 ft.
Maximum Wall Height	30 ft.	15 ft.	15 ft.	35 ft.	35 ft.
Maximum Coverage [12]	20%	15%	15%	See Primary Structure	See Primary Structure
Maximum Coverage with Accessory Dwelling Unit, Lots less than 5,500 sq. ft. [12]	<u>20%</u>			See Primary Structure	See Primary Structure
Front Setback	20 ft.				
Side Lot Line Setback – Lot width 40 ft. or wider [13]	5 ft.				
Side Lot Line Setback – Lot	3 ft.				



width less than 40 ft. [13]	
Street Side Lot Line [14]	20 ft.
Rear [13]	5 ft.
Rear with Alley	0 ft.

Notes:

- No requirement
- [1] Plan district, overlay zone, or development standards contained in SMC 17C.110.310 through 360 may supersede these standards.
- [2] See SMC 17C.110.209, Compact Lot Standards.
- [3] ~~((For developments two acres or greater, lots created through subdivision in the RA, RSF and the RSF-C zones are subject to the lot size transition requirements of SMC 17C.110.200(C)(1).)) [Deleted.]~~
- [4] In the RSF-C and RTF zones, and sites in the RSF zone qualifying for compact lot development standards, described in SMC 17C.110.209, FAR may be increased to 0.65 for attached housing development only.
- [5] No structure located in the rear yard may exceed twenty feet in height.
- [6] Base zone height may be modified according to SMC 17C.110.215, Height.
- [7] Attached garage or carport entrance on a street is required to be setback twenty feet from the property line.
- [8] See SMC 17C.110.220(D)(1), setbacks regarding the use of front yard averaging.
- [9] See SMC 17C.110.220(D)(2), setbacks regarding reduction in the rear yard setback.
- [10] Attached garages may be built to five feet from the rear property line except, as specified in SMC 17C.110.225(C)(6)(b), but cannot contain any living space.
- [11] In the RSF-C zone and sites in the RSF zone qualifying for compact lot development standards, described in SMC 17C.110.209, the rear setback is 15 feet.
- [12] Maximum site coverage for accessory structures is counted as part of the maximum site coverage of the base zone. See SMC 17C.110.225(D).
- [13] Setback for a detached accessory structure and a covered accessory structure may be reduced to zero feet with a signed waiver from the neighboring property owner, except, as specified in SMC 17C.110.225(C)(5)(b).
- [14] The setback for a covered accessory structure may be reduced to five feet from the property line.

Section 2. That SMC section 17C.110.225 is amended to read as follows:

**17C.110.225 Accessory Structures**

A. Purpose.

This section regulates structures that are incidental to primary buildings to prevent them from becoming the predominant element of the site. The standards provide for necessary access around structures, help maintain privacy to adjoining lots and maintain open front setbacks.

B. General Standards.

1. Accessory structures are allowed on a lot only in conjunction with a primary building, and may not exist on a lot prior to the construction of the primary structure, except as allowed by subsection (B)(2) of this section.
2. An accessory structure that becomes the only structure on a lot as the result of a land division may remain on the lot if the owner has submitted a financial guarantee to the City for the cost of demolition and removal of the structure. The financial guarantee will be used by the City if the owner has not removed the accessory structure if, within one year of final plat approval or boundary line adjustment (BLA), a primary structure has not been built and received final inspection. The financial guarantee must be accepted by the City prior to approval of the final plat or boundary line adjustment.
3. An accessory structure shall not contain a kitchen or space for living, sleeping, eating, or cooking unless it is approved as an accessory dwelling unit under [chapter 17C.300 SMC](#).

C. Setbacks.

1. Mechanical Structures.

Mechanical structures are items such as heat pumps, air conditioners, emergency generators, and water pumps.

a. Front Setback Standard.

Mechanical structures are not allowed in required front building setbacks.

b. Side and Rear Setback Standard.

Mechanical structures are allowed inside and rear building setbacks if the structure is no more than forty-eight inches high.

2. Vertical Structures.

Vertical structures are items such as flagpoles, trellises and other garden structures, radio antennas, satellite receiving dishes and lampposts. Fences are addressed in [SMC 17C.110.230](#). Sign standards are [in chapter 17C.240 SMC](#), Signs.

a. Setback Standard.

Vertical structures are allowed in required side and rear building setbacks if they are no larger than four feet in width, depth or diameter and no taller than seven feet. If they are larger or taller, they are not allowed in required building setbacks. Trellises and other gate features are allowed in front yard if they are no larger than four feet in width, depth or diameter and no taller than seven feet and do not conflict with the clear view triangle provisions under [SMC 17C.110.230](#), Fences.

3. Uncovered Horizontal Structures.

Uncovered horizontal structures are items such as decks, stairways, entry bridges, wheelchair ramps, swimming pools, hot tubs, tennis courts, and boat docks that are not covered or enclosed.

a. Setback Standard.

i. Projection Allowed.

The following structures are allowed in required building setbacks, as follows:

- A. Structures that are no more than two and one-half feet above the ground are allowed in side and rear building setbacks. Handrails required by the IBC/IRC are not included in the maximum height.
- B. On lots that slope down from the street, vehicular or pedestrian entry bridges that are no more than two and one-half feet above the average sidewalk elevation are allowed in all building setbacks; and
- C. Stairways and wheelchair ramps that lead to one entrance on the street-facing facade of a building are allowed in street setbacks.

4. Covered Accessory Structures.

Covered accessory structures are items such as greenhouses, storage buildings (not used to cover motor vehicles), sheds, covered decks, covered porches, gazebos, and covered recreational structures.

a. Setback Standard.

Covered accessory structures are not allowed in the required front ~~((and side))~~ building setbacks. Covered accessory structures are not allowed in the required side building setback without a signed waiver from the neighboring property owner.

5. Detached Accessory Structures.

Detached accessory structures are garages, carports, and other structures utilized to cover motorized vehicles.

a. Setback Standard.

A detached accessory structure is not allowed in the front building setback. A detached accessory structure is not allowed in the required side building setback without a signed waiver from the neighboring property owner. A detached accessory structure that has an entrance, which faces a street, is required to be setback twenty feet from the property line or from the back of the sidewalk, as stated in [Table 17C.110-3](#).

- b. Detached accessory structures may be built to the rear property line, unless parking in front of the structure is proposed, then the structure is required to be built a minimum of eighteen feet from the edge of the alley tract, easement, or right-of-way.

6. Attached Accessory Structures.

Accessory structures are garages, carports or other structures utilized to cover motorized vehicles that are connected by a common wall to the primary structure.

a. Setback Standard.

An attached accessory structure is not allowed in the front building setback. An attached accessory structure that has an entrance which faces a street is required to be setback twenty feet from the property line as stated in [Table 17C.110-3](#).

- b. Attached accessory structures may be built to within five feet of the rear property line, unless parking in front of the structure is proposed, then the structure is required to be built a minimum of eighteen feet from the edge of the alley tract, easement or right-of-way.

D. Building Coverage.

1. Except as provided in subsection (2) of this subsection (D), ((The)) the combined building coverage of all detached accessory structures and covered accessory structures may not exceed fifteen percent of the total area of the site, and when combined with all other structures on-site shall not exceed the maximum building coverage of the base zone.

2. On lots smaller than five thousand five hundred square feet with an accessory dwelling unit, combined building coverage of all detached accessory structures and covered accessory structures may not exceed twenty percent of the total area of the site, and when combined with all other structures on-site shall not exceed the maximum building coverage of the base zone.

E. Building Height.

The building height of detached accessory structures and covered accessory structures is listed in [Table 17C.110-3](#). Accessory structures, which contain an ADU over a garage, are subject to the height limitations in [chapter 17C.300 SMC](#), Accessory Dwelling Units.

<b>TABLE 17C.110.225-1</b>	
<b>MAXIMUM HEIGHT – DETACHED ACCESSORY BUILDING [1]</b>	
Maximum Wall Height [2]	15 ft.
Maximum Roof Height [3]	20 ft.
<p>[1] Cannot include living area, nor any storage areas with a ceiling height of six-foot eight-inches or greater.</p> <p>[2] The height of the lowest point of the roof structure intersects with the outside plane of the wall.</p> <p>[3] The height of the ridge of the roof.</p> <p>See “Example A” below.</p>	

**Example A**

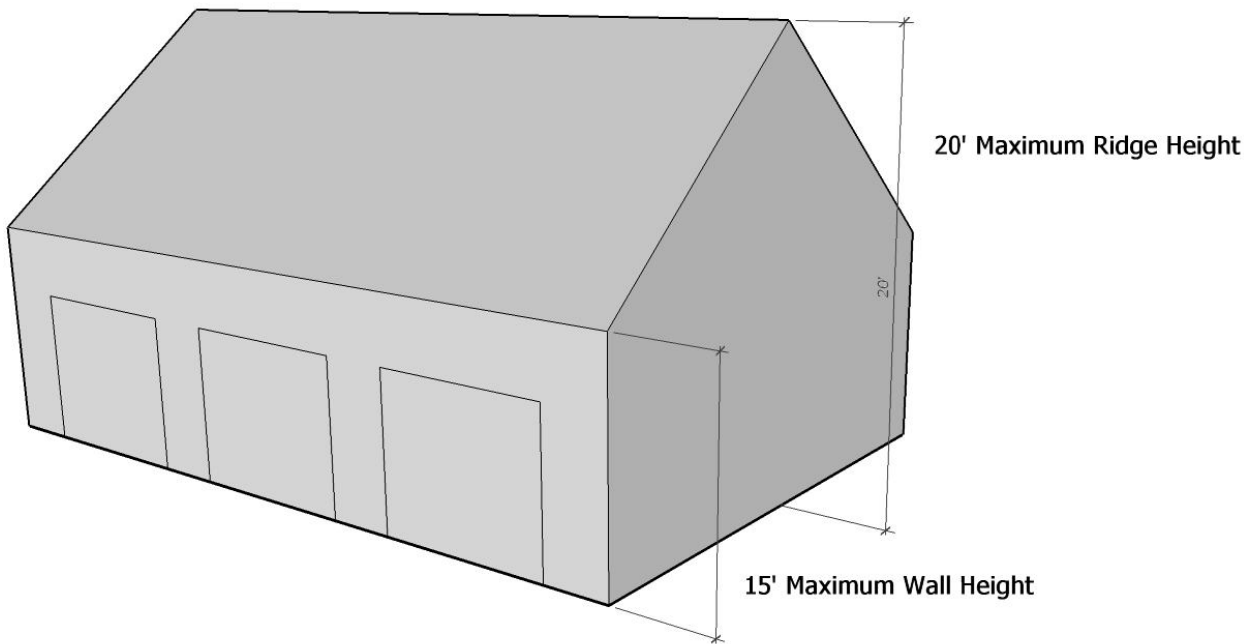

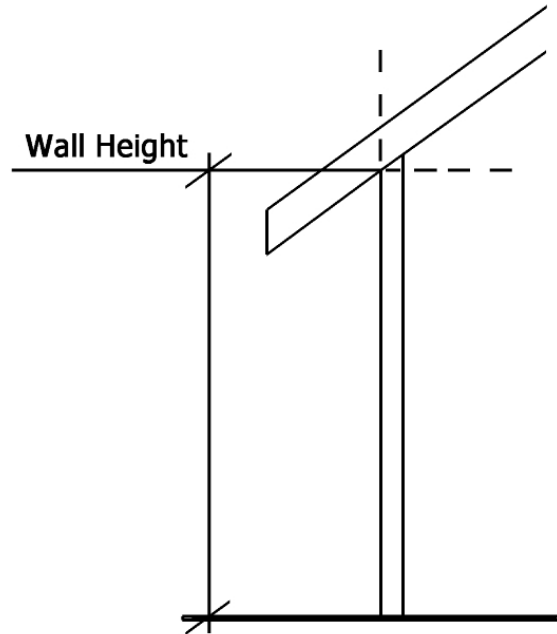

Section 3. That SMC section 17C.300.100 is amended to read as follows:

**17C.300.100 General Regulations**

A. Where the Regulations Apply.

Attached and detached accessory dwelling units are permitted in the RA through RHD zones, including planned unit developments, subject to the limitations of subsection (B) of this section.

B. Limitation.

- ~~((1. One ADU is allowed per lot as an accessory use in conjunction with a detached single family residence.~~
- ~~2. A detached ADU must either be combined with a garage or shall be the only detached structure in the rear yard setback area.~~
- 3. ~~Detached~~) One accessory dwelling ~~((units are))~~ unit is allowed per lot in the RA, RSF, RTF, RMF, and RHD zones subject to the development standards of the underlying zoning district.

Section 4. That SMC 17C.300.110 is amended to read as follows:

**17C.300.110 Criteria**

~~((A.))~~ Minimum Lot Size.

~~The minimum lot size for ADU is five thousand square feet.~~)

~~((B.))~~ A. ~~((ADU Minimum and))~~ Maximum Size.

1. Internal ADU.

Before the establishment of an internal ADU the ~~((footprint))~~ floor area of the principal structure, excluding an attached garage, must be not less than eight hundred square feet.

a. The ~~((size))~~ internal ADU shall contain no more than two bedrooms and the floor area of the internal ADU must be ~~((not less than two hundred fifty square feet and))~~ not more than eight hundred square feet, excluding any related garage area.

b. The conversion of an existing interior basement or attic space of a principal structure into an ADU may exceed the maximum floor area for an internal ADU specified in subsection (1)(a) of this subsection.

2. Detached ADU.

a. The maximum detached ADU size is subject to building coverage per SMC 17C.300.130(B)(3) and floor area ratio per subsection (3) of this subsection (A); and

b. A detached ADU shall not exceed ~~((six hundred square feet))~~ seventy-five percent of the floor area of the principal structure, or eight hundred sixty-four square feet of floor area, whichever is greater.

3. FAR.

a. The ~~square footage~~ floor area of an ADU, excluding any garage, is counted as part of the floor area ratio (FAR). ~~((Internal ADUs may not exceed fifty percent of the total square footage of the principal structure's building footprint.))~~

b. To offer greater flexibility in integrating an ADU on smaller lots, the maximum allowable FAR may be increased to 0.6 on lots smaller than seven thousand two hundred square feet in area, with an ADU, and to 0.7 on lots smaller than five thousand square feet in area with an ADU.

~~((C.))~~ B. Occupancy for Short-Term Rentals.

~~((One))~~ Where a lot with an ADU also has a Short-Term Rental under chapter 17C.316 SMC, one of the dwelling units ~~((in the structure or))~~ on the lot shall be occupied by one or more owners of the property as the owner's permanent and

principal residence. The owner-occupant must occupy the owner-occupied dwelling unit for more than six months of each calendar year. The owner-occupant may not receive rent for the owner-occupied dwelling unit. If a complaint that an owner has violated these requirements is filed, the owner shall:

1. submit evidence to the director showing good cause, such as a job dislocation, sabbatical leave, education or illness, for waiver of this requirement for up to one year absence from the property. Upon such showing the director may waive the requirement;
2. re-occupy the structure; or
3. remove the accessory dwelling unit.

Section 5. That SMC 17C.300.120 is amended to read as follows:

### **17C.300.120 Application Procedures**

A. Application.

Any property owner seeking to establish an ADU must obtain a building permit and a certificate of occupancy from the building services department.

~~((B. Covenants.~~

~~A covenant and deed restriction identifying the ADU and limitations of occupancy and ownership is required to be recorded and filed with the Spokane county auditor's office. A copy of the recorded covenant must be provided to the City of Spokane planning and economic development services department prior to the issuance of a building permit or safety inspection.))~~

Section 6. That SMC 17C.300.130 is amended to read as follows:

### **17C.300.130 Development Standards**

A. Development Standards – Requirements for All Accessory Dwelling Units.

All accessory dwelling units must meet the following:

1. Creation.

An accessory dwelling unit may only be created through the following methods:

- a. Converting existing living area, attic, basement or garage.
- b. Adding floor area.
- c. Constructing a detached accessory dwelling unit on a site with an existing house, attached house or manufactured home ~~((or)).~~



- d. Constructing a new house, attached house or manufactured home with an internal or detached accessory dwelling unit.
- e. In the RTF, RMF, or RHD zone, constructing an attached or detached accessory dwelling unit on a site with any existing or new principal structure. Any structure shall comply with all applicable building, fire, and engineering standards.

2. Number of Residents.

The total number of individuals that reside in both units may not exceed ~~((the number that is allowed for a household))~~ any lawful limits on occupant load per square foot or generally applicable health and safety provisions as established by applicable building or fire code, as provided in RCW 35.21.682.

~~((3. Other Uses.~~

~~An accessory dwelling unit is prohibited on a site with a home occupation.))~~

~~((4.))~~ 3. Location of Entrances for Internal ADUs.

Only one entrance may be located on the facade of the ~~((house, attached house or manufactured home))~~ principal structure facing the street, unless the ~~((house, attached house or manufactured home))~~ principal structure contained additional entrances before the accessory dwelling unit was created. An exception to this regulation is entrances that do not have access from the ground such as entrances from balconies or decks.

~~((5.))~~ 4. Parking.

a. Studio and one-bedroom ADUs require no additional parking. One additional off-street parking space is required for the accessory dwelling unit with more than one bedroom, plus one per bedroom after two bedrooms. Existing required parking for the ~~((house, attached house or manufactured home))~~ principal structure must be maintained ~~((or replaced on-site)).~~

b. As an exception to subsection (a), no additional off-street parking space is required for the ADU within one-quarter-mile of stops for a bus or other transit mode providing actual fixed route service at intervals of no less frequently than fifteen minutes for at least five hours during the peak hours of operation on weekdays, defined as a major transit stop under RCW 36.70A.696.

~~((6. Exterior Finish Materials.~~

~~The exterior finish material must be the same or visually match in type, size, and placement the exterior finish material of the house, attached house or manufactured home.))~~

~~7. Roof Pitch.~~

~~The roof pitch must be the same as the predominant roof pitch of the house, attached house or manufactured home.~~

~~8. Trim.~~

~~Trim must be the same in type, size and location as the trim used on the house, attached house or manufactured home.~~

~~9. Windows.~~

~~Windows must match those in the house, attached house or manufactured home in proportion (relationship of width to height) and orientation (horizontal or vertical). This standard does not apply when it conflicts with building code regulations.-))~~

B. Additional Development Standards for Detached ADUs.

1. Setbacks.

~~((The))~~ Except for conversion of existing accessory structures, the accessory dwelling unit must be ((at least)):

~~((a. sixty feet from the front lot line; or~~

~~b. six feet behind the house, attached house or manufactured home;))~~

~~((e.))~~ a. as specified for ((rear and side yard)) setbacks in [Table 17C.110-3](#) for ((primary structures for attached ADUs and)) accessory structures ((for detached ADUs.)); and

b. in conformance with the forty-five degree setback plane:

i. The forty-five degree setback plane is measured at the maximum wall height listed in Table 17C.300-1, from the interior side lot line setback, or rear setback without an alley, as listed in Table 17C.110-3 for accessory structures. The setback plane does not apply on side or rear setbacks measured from alley or street lot lines.

ii. The setback plane increases at a forty-five degree angle away from the interior side and rear lot lines without an alley, up to the maximum roof height in Table 17C.300-1. See Figure 17C.300-A for examples.

iii. No portion of the accessory dwelling unit may project beyond the forty-five degree setback plane described in this subsection, except for the roof structure and minor extensions allowed by SMC 17C.110.220(C)(1).

iv. The setback may be reduced to zero feet with a signed waiver from the neighboring property owner. In that case, the forty-five degree setback plane would be measured from the maximum wall height and the property line.

**Figure 17C.300-A. Setback Plane [1]**

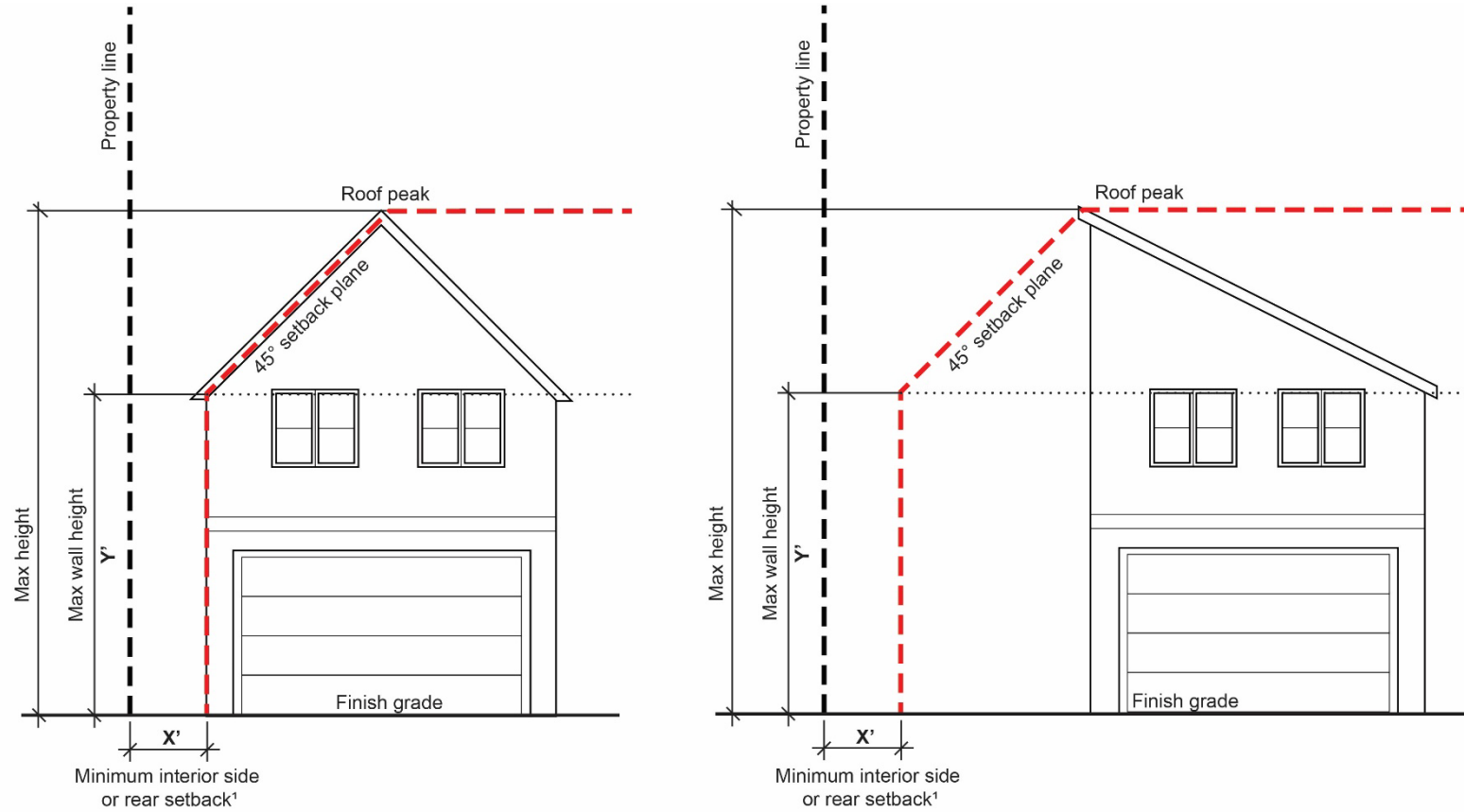

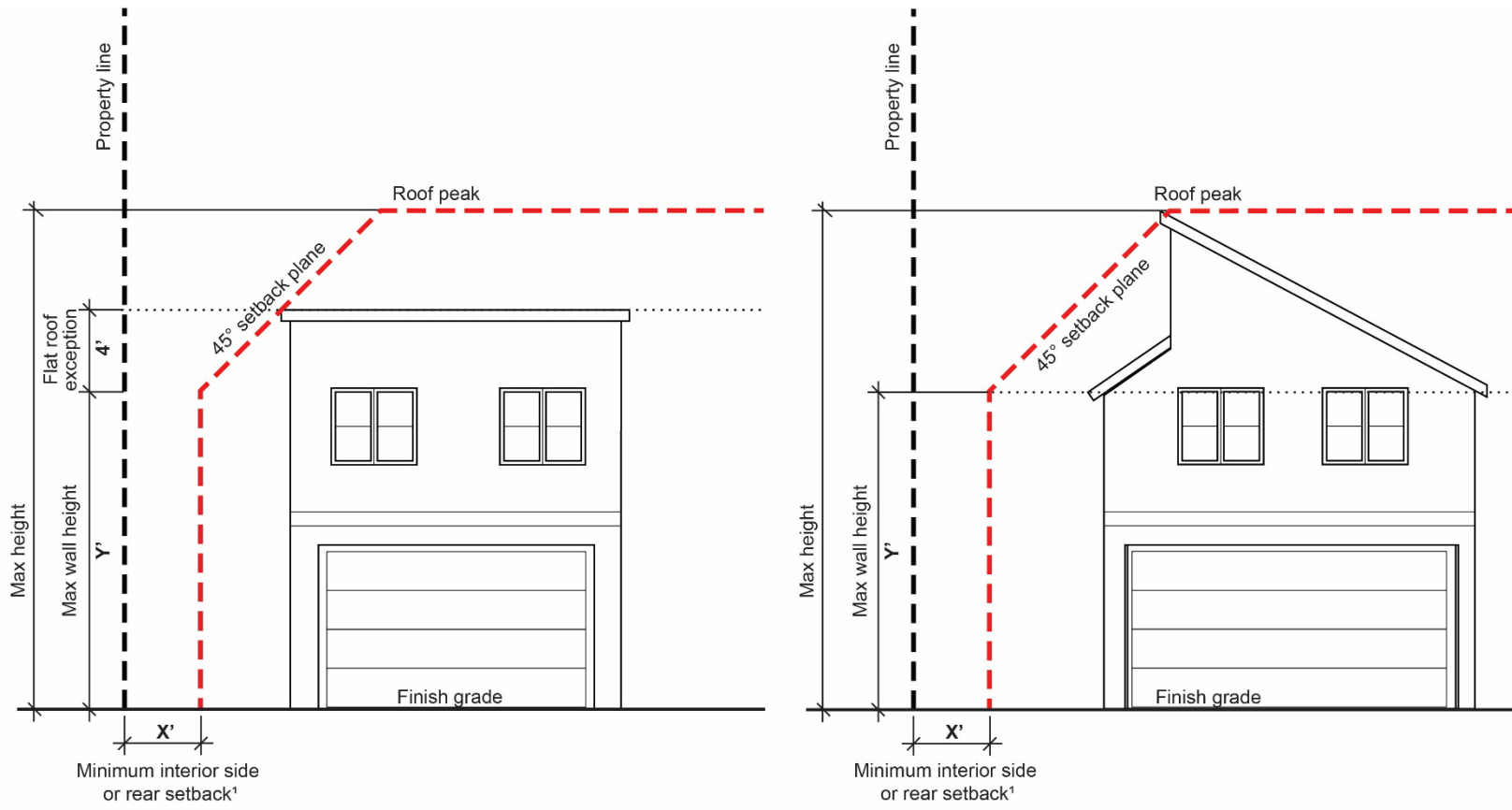

**[Note: New graphic added]**

2. Height.

The maximum height allowed for a detached accessory dwelling unit is shown in Table 17C.300-1. A detached ADU over a detached accessory structure with flat or terraced roof forms with slopes of less than 3:12 that conform to the forty-five-degree setback plane in subsection (B)(1)(b) of this section may be granted a wall height exception up to four feet.

<b>TABLE 17C.300-1            MAXIMUM ROOF AND WALL HEIGHT</b>		
	<b>Maximum Height –            Detached Accessory            Building Attached to an            ADU or Detached ADU            [1]</b>	<b>Maximum Height – Detached ADU            Over a Detached Accessory            Structure</b>
Maximum Wall Height [2]	10 ft.	<del>((16))</del> <u>17</u> ft.
Maximum Roof Height [3]	20 ft.	<del>((23))</del> <u>25</u> ft.
[1] Detached accessory structures cannot include living area, nor any storage areas with a ceiling height of six-feet eight-inches or greater. [2] The height of the lowest point of the roof structure intersects with the outside plane of the wall. [3] The height of the ridge of the roof. See “Figure <del>((A))</del> <u>17C.300-B</u> ” below.		

Figure ((A)) 17C.300-B

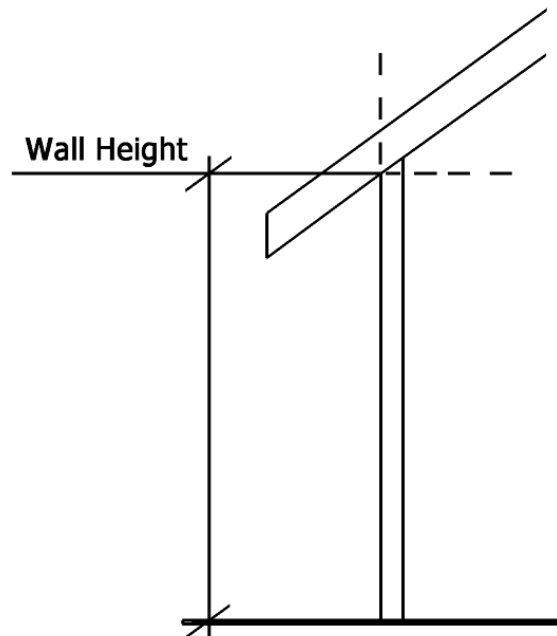
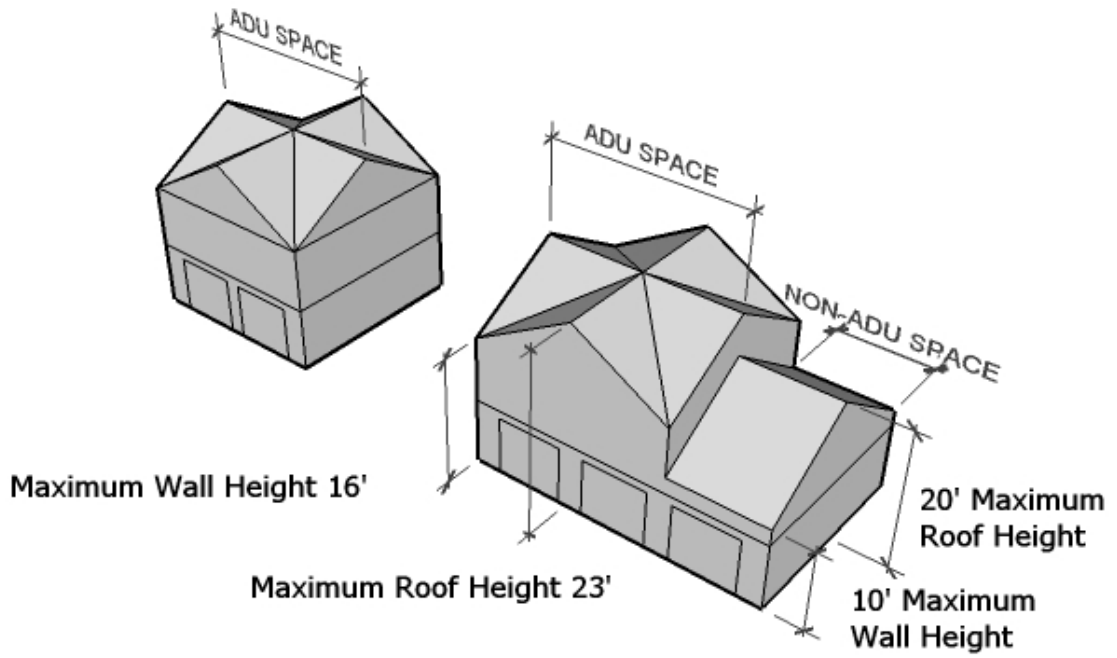

3. Bulk Limitation.

The building coverage for the detached accessory dwelling unit may not be larger than the building coverage of the ~~((house, attached house or manufactured home))~~ principal structure.

a. ~~((The))~~ On lots five thousand five hundred square feet or larger, the combined building coverage of all detached accessory structures may not exceed fifteen percent of the total area of the site.

b. On lots smaller than five thousand five hundred square feet, the combined building coverage of all detached accessory structures may not exceed twenty percent of the total area of the site.

4. Conversion of Existing Detached Accessory Structures.

a. In RA through RTF zones, conversion of an existing detached accessory structure that is in a front building setback required by [Table 17C.110-3](#) is not allowed. Conversion of an existing detached accessory structure that is in a rear or side building setback is allowed as provided by [SMC 17C.110.220](#), Setbacks, and [SMC 17C.110.225](#), Accessory Structures.

b. In RMF through RHD zones, conversion of an existing detached accessory structure that is in a front building setback required by [Table 17C.110-3](#) is not allowed. Conversion of an existing detached accessory structure that is in a rear or side building setback is allowed as provided by [SMC 17C.110.220](#), Setbacks, and [SMC 17C.110.225](#), Accessory Structures.

c. If the accessory dwelling unit is proposed for an existing detached accessory structure that meets any of the standards of subsections ~~((A)(6) through (9) and))~~ (B)(2) and (3) of this section, alterations that will move the structure out of conformance with the standards that are met are not allowed.

d. If the accessory dwelling unit is proposed as a conversion of an existing detached accessory structure or a portion of the building, and ~~((the existing detached accessory structure does not meet the standards of subsections (A)(6) through (9) of this section, the structure is exempt from those standards. If))~~ any floor area is added to the existing detached accessory structure to accommodate an ADU, then the entire structure must meet the ~~((standards of subsections (A)(6) through (9) of this section and the))~~ underlying zoning development standards.

C. Utilities and Addressing.

The ADU must utilize those municipal utilities and address established for the principal dwelling unit.

D. Code Compliance.

The ADU must meet all technical code standards of this title including building, electrical, fire, and plumbing code requirements and permits.

Section 7. That SMC 17C.300.140 is amended to read as follows:

**17C.300.140 ADU Expiration**

A. Transfer.

~~((A))~~ In the case where a lot with an ADU also has a Short-Term Rental under chapter 17C.316 SMC, an ADU permit is not transferable to any other property or any other person except to the new owner of the subject property when the property will be owner occupied.

B. Expiration.

Approval of an ADU expires when the:

1. accessory dwelling unit is altered and is thus no longer in conformance with the plans approved by the building services department; or
2. property ceases to maintain the required off-street parking spaces for the accessory and principal dwelling units; or
3. in the case where a lot with an ADU also has a Short-Term Rental under chapter 17C.316 SMC, legal titleholder of the property ceases to own and reside in either the principal or the accessory dwelling unit.

Passed the City Council \_\_\_\_\_

\_\_\_\_\_  
Council President

Attest: \_\_\_\_\_  
City Clerk

Approved as to form: \_\_\_\_\_  
Assistant City Attorney

\_\_\_\_\_  
Mayor

\_\_\_\_\_  
Date

\_\_\_\_\_  
Effective Date





# Memo

To: Plan Commission Members  
From: Nathan Gwinn and Amanda Beck, Assistant Planner IIs  
Date: May 4, 2022  
Re: Changes to Draft Text for ADUs and Short Plat Notification Following 4/27 Workshop

Below is a summary of five changes to proposed draft text with new text highlighted, based on discussion at your workshop on April 27, 2022:

## 17C.300.110 Criteria

1. **17C.300.110(A)(2)** new text to read: “(a) The maximum detached ADU size is subject to building coverage per SMC 17C.300.130(B)(3) and floor area ratio per subsection (3) of this subsection (A); and (b) A detached ADU shall not exceed ((six hundred square feet)) seventy-five percent of the floor area of the principal structure, or eight hundred sixty-four square feet of floor area, whichever is greater.”

## 17C.300.130 Development Standards

2. **17C.300.130(A)(1)(e)** add language: “In the RTF, RMF, or RHD zone, constructing an attached or detached accessory dwelling unit on a site with any existing or new principal structure. All new structures and additions shall comply with all applicable building, fire, and engineering standards.”
3. **17C.300.130(A)(2)** to address question as to what regulates the number of individuals in a household, text refers back to RCW [35.21.682](#). Add language: “The total number of individuals that reside in both units may not exceed ((the number that is allowed for a household)) any lawful limits on occupant load per square foot or generally applicable health and safety provisions as established by applicable building or fire code, as provided in RCW 35.21.682.”

## 17G.080.040 Short Subdivisions

4. **17G.080.040(C)(2)(b)** – page A-32 – Add language to help clarify required proximity of improvements adjacent water/sewer mains that will result in new lots with standard service connections. “There is direct water and sewer main lot frontage on an existing and improved right-of-way;”
5. **17G.080.040(C)(2)(f)** strike the 2 lot limit per PC’s discussion.

See attached **EXHIBIT A** to staff report with text updated May 4, 2022.



# STAFF REPORT

PLANNING AND ECONOMIC DEVELOPMENT SERVICES DEPARTMENT

<b>To:</b>	City Plan Commission	
<b>Subject:</b>	Shaping Spokane Housing: Development Code Amendments for Accessory Dwelling Units, Lot Size Transition, and Short Plat Process	
<b>Staff Contact:</b>	Amanda Beck, AICP Assistant Planner II (509) 625-6414 <a href="mailto:abeck@spokanecity.org">abeck@spokanecity.org</a>	Nathan Gwinn, AICP Assistant Planner II (509) 625-6893 <a href="mailto:ngwinn@spokanecity.org">ngwinn@spokanecity.org</a>
<b>Report Date:</b>	May 4, 2022	
<b>Hearing Date:</b>	May 11, 2022	
<b>Recommendation:</b>	Approval	

## I. SUMMARY

These City-initiated text amendments are proposed to update the Spokane Municipal Code according to strategies outlined in the adopted Spokane Housing Action Plan and in order to implement some of the actions specified in subsection (1) or RCW 36.70A.600. Proposed draft code would revise several sections of Chapter 17C.110, Residential Zones; Chapter 17C.300, Accessory Dwelling Units; and Sections 17G.060.100, 17G.060T.003, 17G.060.130, and 17G.080.040. The proposed draft code has been developed by City staff, with assistance from the consultant firm MAKERS Architecture and Urban Design, to modify requirements for accessory dwelling units (ADUs), lot size transition, and the process for short subdivision in the city of Spokane.

## II. BACKGROUND

The 2021 Washington legislative session substantially amended the housing-related provisions of the Growth Management Act (GMA) through House Bill [HB 1220](#). Changes strengthened the GMA housing goal from “encourage the availability of affordable housing to all economic segments of the population” to “plan for and accommodate housing affordable to all economic segments of the population of this state.” The GMA housing goal still retains additional objectives to “promote a variety of residential densities and housing types, and encourage the preservation of existing housing stock.” The Washington Department of Commerce then oversaw the Increasing Urban Residential Building Capacity Grant program that was authorized with [E2SHB 1923](#). The City was awarded a grant to develop a housing action plan that analyzed and detailed how to meet the housing needs of our community, addressing the housing-related changes made by the Legislature.

The City’s Comprehensive Plan provides a vision of affordable housing that is safe, clean, healthy, and attainable for all residents. Approved in July 2021, the City adopted its [Housing Action Plan](#) (Res. 2021-0062) to guide implementation of policies within the Comprehensive Plan by identifying strategies to achieve our community’s housing needs and objectives. Spokane’s Housing Action Plan (HAP) identifies actions that the City and community partners can enact to encourage more housing options that create

more homes for more people. To implement the work of the HAP, City staff are completing several residential development code amendments. These proposed changes are also guided by Mayor Woodward's [July 26, 2021 Housing Emergency Proclamation](#) and the City Council's HAP [Implementation Plan](#).

Through Shaping Spokane Housing, the City will be evaluating a series of code amendments selected to align with items from the Housing Action Plan that were flagged for short- or mid-term starting timelines, with a focus on increasing housing units and the diversity of housing types. In addition, many of the amendments are proposed in order to implement/enact the actions specified in subsection (1) RCW 36.70A.600 in an effort to increase residential building capacity in Spokane. The code revisions are proposed to be run in two phases based upon the complexity of the group of proposals (internally referred to as "Phase 1 and 2"). The first phase proposes changes recommended for increasing housing supply, variety, and affordability and that would provide necessary updates for the second phase of code changes. Phase 1 will explore attached houses (townhouses), accessory dwellings, and smaller multifamily projects. Phase 2 code amendments would explore additional permitted housing types within the Residential Single Family and Residential Two-Family zoning districts, opportunities for increasing density, and permitting for a wider variety of housing types generally.

This staff reports reviews the proposed code revisions for Phase 1 of Shaping Spokane Housing. The code changes related to accessory dwelling units (ADUs), lot size transitions, and short plat notification specifically align with the below noted City Council implementation actions, as well as strategies from Mayor Woodward's emergency proclamation. Additionally, the City has proposed draft text which aligns with recommendations outlined in [RCW 36.70A.600](#).

- Housing Action Plan Strategy A1, "Explore and expand allowed housing types to encourage missing middle housing throughout Spokane's neighborhoods."
- Housing Action Plan Strategy A3, "Continue to streamline and simplify changes to the City's permit process, as necessary."
- Housing Action Plan Strategy A5, "Revise Accessory Dwelling Unit standards to allow for additional flexibility."
- City Council Implementation Plan Strategy I.6, III.2, and III.10
- Mayor's Emergency Proclamation Strategy 2.c, 2.g, and 2.h

Proposed phasing and code sections would promote development of housing types affordable to more households, help to streamline the review process, and realize increases in density where appropriate as indicated under the City's Comprehensive Plan. The proposed scope of work focuses on changing zoning and development regulations that would allow for more housing types available to a wider range of income levels in a wider set of zoning districts. This will continue to implement the City's goals in the Comprehensive Plan and be aligned with ongoing efforts to allow for denser development along existing infrastructure systems and near high performance transit lines operated by Spokane Transit Authority.

### III. PROCESS

#### DEVELOPMENT CODE AMENDMENT PROCEDURE

Article III Section 21, Amendments and Repeals, of the City of Spokane Charter provides for the ability of amendments of the Charter and Spokane Municipal Code through ordinances. Title 17 is known as the Unified Development Code (UDC) and is incorporated into the Spokane Municipal Code to implement the City's Comprehensive Plan, and by reference, the requirements of the Washington State Growth Management Act (GMA). Section [17G.025.010](#) establishes the procedure and decision criteria that the City

uses to review and amend the UDC. The City may approve amendments to the UDC if it is found that a proposed amendment is consistent with the provisions of the Comprehensive Plan, and bears a substantial relation to public health, safety, welfare, and protection of the environment.

## **ROLE OF THE CITY PLAN COMMISSION**

---

The proposed text amendments require a review process set forth in Section 17G.025.010(F) SMC. The Plan Commission is responsible for holding a public hearing and forwarding its findings, conclusions, and recommendations to the City Council. Utilizing the decision criteria in 17G.025 SMC, the Plan Commission may recommend approval, modification, or denial of the proposal.

The Plan Commission may incorporate the facts and findings of the staff report as the basis for its recommendation to the City Council or may modify the findings as necessary to support their final recommendation.

## **ROLE OF CITY COUNCIL**

---

The City Council will also conduct a review process considering the proposed text amendment, public comments and testimony, the staff report, and the Plan Commission's recommendation. The final decision to approve, modify, or deny the proposed amendment rests with the City Council. Proposals adopted by ordinance after public hearings are official amendments to the Spokane Municipal Code.

## **COMMUNITY ENGAGEMENT**

As a follow-up to the Housing Action Plan (HAP), engagement efforts for Shaping Spokane Housing have built upon the extensive community outreach conducted for the HAP. Engagement opportunities were undertaken throughout the draft code phase of this project. Emphasis has been placed on reaching development stakeholders, as well as the broader community. To ensure broad engagement efforts during a transitional time of limited in-person events, staff initiated a multi-faceted engagement plan that included in-person and virtual meetings, web content including a website and blog posts, regular email updates, and a social media presence. A summary of engagement and outreach activities can be found in **Exhibit C**.

Below is a list of the major outreach and engagement activities held for this phase of the Shaping Spokane Housing project:

- [“Next Steps for Housing Action Plan Implementation”](#) blog published on November 11, 2021
- Project webpage, [ShapingSpokaneHousing.com](#), was launched January 2022 and has been kept up to date with information about Plan Commission workshops, project progress, and public hearings
- Presentations at the Land Use Subcommittee on November 18, 2021; February 17, 2022; and April 21, 2022
- Vendor booth and poster activities at the Winter Market on December 15 and 22, 2021
- Presentation at Community Assembly on January 6, 2022
- Virtual open houses on January 25 and 27, 2022
- [Educational videos](#) shared in the City's Community Update e-newsletter, on official City social media channels, and available on project webpage
- [“Big Trends Squeezing Spokane's Housing Supply”](#) blog published March 10, 2022
- Community Update City newsletter addition of ADUs on March 8, lot size transition on March 15, and short plat application process on March 22, 2022
- Planning Services Director interviews of local developers took place in March and April, 2022

- Vendor booth and poster activities at the Spring Market on April 6, 13, 20, and 27, 2022
- Frequent Shaping Spokane Housing email updates sent to over 150 stakeholders

The planning team has provided updates on the proposed code changes to elected and appointed officials, as well as to staff from other City departments and interested agencies.

- City Council established Shaping Spokane Housing as part of the Plan Commission's 2021-2022 work program
- City Council presentations on December 6 and 10, 2021
- Plan Commission workshop presentations related to accessory dwelling units, lot transition, and short plat processes on January 12, February 23, March 23, April 13, and April 27, 2022
- City Council study session presentations on February 10 and May 5, 2022
- Regular meetings with Development Services staff to review proposed code language and potential implementation considerations

## PUBLIC NOTIFICATION AND SEPA REVIEW

As outlined in Section 17G.025.010 SMC, notices of proposals to amend the UDC are distributed and interested parties should be made aware of such proposals during the Plan Commission review, including the SEPA checklist and determination. Similarly, a public notice published in the *Spokesman-Review* fourteen days prior to the Plan Commission public hearing is required.

This proposal was properly noticed pursuant to Section 17G.025.010(E). See **Exhibit B** for the SEPA Determination of Non-significance. Noted below are the public noticing activities:

- Notice of Intent to Adopt submitted to the Department of Commerce (March 24, 2022)
- Notice of Intent to Adopt pursuant to 17G.025.010 SMC, which included the SEPA Checklist, emailed to City departments, Local, County, Tribal, and State contacts (April 1, 2022)
- SEPA Determination of Non-significance (DNS) issued (April 25, 2022), the comment period ended on May 11, 2022
- Notice of Public Hearing for the Plan Commission was published in the *Spokesman-Review* on April 27 and May 4, 2022.

## COMMENTS RECEIVED

Written comments were provided to the Plan Commission prior to the public hearing at the February 23 and April 27, 2022 workshops. All public comments received by the planning department by 12:00 p.m. on May 4 are included in **Exhibit D**.

Notice of this proposal was sent to City departments and outside agencies for their review. Department and outside agency comments are included in this report as **Exhibit E**. Agency/City department comment was received regarding this application:

- Spokane Tribe of Indians
- City of Spokane Street Department
- City of Spokane Engineering Department

## IV. ANALYSIS

### PROPOSAL DESCRIPTION

Following adoption of the [Housing Action Plan](#) (Res. 2021-0062), the City has initiated a series of text amendments that enact Housing Action Plan strategies to encourage construction of more housing, and increase affordability and housing variety. These amendments are being adopted in order to implement the Legislature’s recommended actions outlined by [RCW 36.70A.600\(1\)](#) in order to increase residential building capacity.

This proposal will amend Spokane Municipal Code: Section 17C.110.200, Lot Size, and 17C.110.225 Accessory Structures; and Chapter 17C.300, Accessory Dwelling Units, specifically Sections 17C.300.100, 17C.300.110, 17C.300.120, 17C.300.130, and 17C.300.140.

Additional amendments are being made to short plat notification requirements revising Sections 17G.060.100, 17G.060T.003, 17G.060.130, and 17G.080.040; which are procedurally exempt from SEPA review per [WAC 197-11-800\(19\)](#).

### ACCESSORY DWELLING UNITS

Accessory dwelling units (ADU) are defined in SMC 17A.020.010 as “a separate additional living unit, including separate kitchen, sleeping, and bathroom facilities, attached or detached from the primary residential unit, on a single-family lot...” ADUs are also defined in [RCW 36.70A.696](#) as “a dwelling unit located on the same lot as a single-family housing unit, duplex, triplex, townhome, or other housing unit.”

Changes to chapter 17C.300 SMC respond to the suggestions in [RCW 36.70A.600\(1\)\(o\)](#) through (q), as well as Strategy A5 of the Housing Action Plan and the Mayor’s July 26, 2021, Proclamation Addressing the Housing Emergency. The changes proposed would:

- Remove the required minimum lot size of 5,000 square feet.
- Increase the maximum size for a detached ADU from 600 to 864 square feet, or 75 percent of the floor area of the principal structure, whichever is greater. The detached ADU would continue to be limited by building coverage and Floor Area Ratio (FAR) maximums.
- Allow internal ADUs to occupy the entire space of a basement or attic, even if this exceeds the 800 square feet maximum, but limit conversion or construction to two bedrooms.
- Incentivize construction of ADUs by increasing the site total FAR of 0.5 to 0.6 on lots smaller than 7,200 square feet with an ADU, and to 0.7 on lots smaller than 5,000 square feet with an ADU.
- Incentivize construction of ADUs by increasing the building coverage maximum of accessory structures from 15 percent to 20 percent on lots smaller than 5,500 square feet with an ADU.
- Increase the maximum wall height from 16 to 17 feet, and the maximum roof peak from 23 to 25 feet to allow for more diverse ADU designs as well as units built above existing garages.
- Relax parking requirements such that studio and one-bedroom units will not require an off-street parking space. Units with two or more bedrooms shall provide one additional off-street parking space for each bedroom above one unless they are exempt due to RCW 36.70A.698.
- Remove owner occupancy requirements, unless a short-term rental exists on the site, to encourage production of more units.
- Allow construction of an ADU on sites with a duplex or other principal structure in the RTF, RMF, and RHD zones. Currently ADUs are only allowed on sites with a house, attached house, or manufactured home.

## LOT SIZE TRANSITIONS

---

As outlined in [Section 17C.110.200\(C\)\(1\)](#), for parcels two acres or greater within areas zoned Residential Agricultural (RA) and Residential Single-Family (RSF), the current city code requires new subdivisions to provide a transitional lot size adjacent to existing parcels. The intent of transitioning lot sizes is to facilitate compatible development of buildings and maintaining consistency of the development pattern. Currently, the code requires an eighty-foot buffer along all parcel boundaries, in which a transitional lot size would be required. The transitional lot size is determined by averaging the existing lot sizes adjacent to the site, including lots across a public right-of-way. If the average lot size is greater than 7,200 square feet, then the transition lot size must be at least 7,200 square feet. If the existing average lot size is less than 7,200 square feet, then the transition lot size must be equal to the average or larger. The transition lot size requirement also applies to subdivisions created through the Planned Unit Development process outlined in Section 17G.070.030.

Following workshops with the Plan Commission, during which a range of possible code changes were presented, City staff have proposed to remove this requirement from the Spokane Municipal Code. The intent of the transitional lot size code provision has not been borne out by subdivisions created under the regulations. Instead, newly created lots frequently fulfill the requirements of 17C.110.200(C)(1) by meeting the minimum square footage requirement without having to address “consistent development” patterns such as lot depth or lot width. The focus on development pattern compatibility has resulted in larger lots and the construction of fewer housing units than would have otherwise been allowed under the minimum zoning requirements for parcels zoned RA or RSF.

Removing this regulation fits within the Housing Action Plan Strategy A3 recommendation to streamline and simplify permit processes. Additionally, this section of code is addressed in both the City Council’s Implementation Plan and the Mayor’s Proclamation. City Council Implementation Plan Strategy III.10 prompts action to, “seek prompt re-evaluation by the Plan Commission of SMC 17C.110.200.C and Table 17C. 110-3 to ensure that future transition standards are consistent with the City’s goal of increasing density by using smaller parcels while preserving other reasonable goals of these requirements.” Strategy 2.h of Mayor Woodward’s proclamation directs staff to create “additional flexibility or eliminate altogether the transitional lot requirements outlined in SMC 17C.110.200.”

The proposed changes would:

- Remove the lot size transition requirement from SMC 17C.110.200(C)(1); and
- Allow newly created lots that meet the dimensional standards of the underlying zoning district to be approved without being required to meet a larger square footage requirement.

## SHORT PLAT NOTIFICATION

---

This code amendment packet proposes changes to SMC 17G.060 and SMC 17G.080 to streamline and improve the short plat approval process, specifically the review and notification process. The proposal would designate three classes of short subdivisions in order to simplify the review and approval process. The changes follow guidance to adopt permit process improvements in RCW 36.70A.600(1) and Housing Action Plan Strategy A3.

The three classes are:

- Short plats with SEPA review
- Short plats with minor engineering review

- Short plats with standard engineering review

Short plats that are subject to SEPA would continue to require the existing methods of notice of application, including mailing to specified parties and site-posting the property.

To qualify for minor engineering review, the preliminary short plat would need to meet the following requirements:

- The preliminary plat has frontage on an existing, improved public right-of-way and does not propose to create new public right-of-way
- No extension of public utilities will be required as part of the preliminary plat
- There are no public easements on the property

Under this proposal, no changes to the treatment of neighborhood councils during the agency review period would occur. Neighborhood councils within 600 feet of a proposed short plat would continue to receive notice and be invited to submit comments during agency review as codified in [SMC 17G.060.090](#).

The proposal would also modify existing noticing requirements. Site posting would be eliminated for both minor and standard review short plats. For short plats that qualify for minor engineering review, the public comment period and mailing of public notice would also be eliminated. Neighborhood council notification and comments would continue during the agency review period.

The proposal would align with City review procedures and reduce the time required for administering the public notice for many short subdivisions, while continuing to require short plat agency and neighborhood council notification, for all short subdivisions, under the determination of a complete application stage.

Definitions and provisions for administrative, summary approval:

“Short” plats can be differentiated from “regular” or “long” plats by the **number** of lots created through the City’s approval process. [RCW 58.17.020](#) defines a short plat as the map or representation of a short subdivision. A short subdivision is the division or redivision of land into nine or fewer lots for the purpose of sale, lease, or transfer of ownership. That number, nine lots, is the maximum number of lots that the City Council and other local legislative authorities may authorize under the short subdivision process in urban growth areas. [RCW 58.17.060](#) provides that the City Council shall adopt regulations and procedures, and appoint administrative personnel for the summary approval of short plats and short subdivisions.

State Environmental Policy Act (SEPA):

[RCW 43.21C.110](#) provides statutory authority for rules to implement SEPA, anticipating the categorical exemption of government actions from SEPA which are not to be considered as potential major actions significantly affecting the quality of the environment. [WAC 197-11-800\(6\)](#) lists the categorical exemptions for land use decisions, stating short plats (except on land covered by water) are exempt from SEPA.

Local project review:

[RCW 36.70B.020](#) includes subdivisions as a type of project permit, which is a land-use permit required from the City for a project action and regulated by the State. Project permits are subject to standard time frames for determining whether an application is complete, for notification and public comments once the application is determined complete, and for making a decision and appeals. [RCW 36.70B.110\(5\)](#) provides that a notice of application shall not be required for SEPA-exempt projects unless a public comment period or a type of hearing is required. The City’s



Development Code implements the regulations in State law affecting short plats in SMC Title 17A, Administration, and Title 17G, Administration and Procedures. The City proposes to change the public comment requirements in SMC 17G.060.130 so that short subdivision applications with minor engineering review would have no public comment period, thereby eliminating the need for a notice of application for that classification of applications.

Growth Management Act (GMA):

As discussed above, the GMA suggests several actions for increasing residential building capacity. A number of suggestions relate to plats, and the City of Spokane has already implemented some of those actions. However, [RCW 36.70A.600\(1\)\(u\)](#) suggests other permit process improvements where it is demonstrated that the development regulation change will result in a more efficient permit process for customers. The Spokane Housing Action Plan echoes the provision by encouraging “a faster and more predictable permitting process for developers, particularly for housing that expands options and supports a broader range of household incomes” (p. 30). The City proposes changes to streamline and improve the short plat process to create two new classifications of short subdivisions that would reduce requirements for notice, thereby reducing cost or time for processing SEPA-exempt short plats in the city, including those that could make new sites available for increasing residential building capacity, and for development of a wide variety of housing types for all income levels.

## IMPLEMENTATION OF COMPREHENSIVE PLAN GOALS AND POLICIES

Section [17G.025.010](#) SMC establishes the review criteria for text amendments to the Unified Development Code. In order to approve a text amendment, City Council shall consider the findings and recommendations of the Plan Commission along with the approval criteria outlined in the Code. The applicable criteria are shown below in *bold and italic* with staff analysis following each criteria. Review of the Comprehensive Plan goals and policies indicates that the proposal meets the approval criteria for internal consistency set forth in SMC 17G.025.010(G). Excerpts of the applicable goals and policies, and their Comprehensive Plan discussion points, are contained in **Exhibit F**.

### **17G.025.010(G) APPROVAL CRITERIA**

**1. The proposed amendment is consistent with the applicable provisions of the comprehensive plan.**

***Land Use Goal LU 1 – Citywide Land Use.*** Offer a harmonious blend of opportunities for living, working, recreation, education, shopping, and cultural activities by protecting natural amenities, providing coordinated, efficient, and cost effective public facilities and utility services, carefully managing both residential and non-residential development and design, and proactively reinforcing downtown Spokane’s role as a vibrant urban center.

**Staff Analysis:** Within the Land Use chapter there are several values outlined which guide the goals and policies concerning land uses. This chapter highlights the importance of guaranteeing a variety of densities that support a mix of land uses and housing options in every neighborhood, as well as realizing the full potential of existing residential lots rather than encouraging sprawl. The proposed ADU code changes make it easier to construct an additional, accessory dwelling unit on a residential lot thereby efficiently using the City’s infrastructure for water, stormwater, and utilities. The changes also allow for the potential for more subtle increases in intensity, as an alternative to focused redevelopment. Removing the lot size transition requirement would allow for more lots to be platted, using land to its greater potential rather than forcing platting of larger lots. Allowing subdivisions to be built to the minimum lot size in the zone also reduces the amount of raw land

required to create a development, reducing the, need to develop on the City's fringe where larger parcels that might be able to more easily accommodate larger lots tend to be located.

**Land Use Policy LU 1.1 – Neighborhoods.** *Utilize the neighborhood concept as a unit of design for planning housing, transportation, services, and amenities.*

**Staff Analysis:** A variety of housing types are allowed, and encouraged, within the city's neighborhoods. The Comprehensive Plan notes that housing should span the range of single-family homes (attached and detached), duplexes, and multifamily units. This variety of types and densities better supports the other neighborhood land uses such as retail, office, and commercial. Increasing regulatory flexibility for ADUs provides the potential for additional households to support Neighborhood Centers, while also allowing city residents greater options for housing near amenities such as parks and open space, and public transit lines.

**Land Use Goal LU 3 – Efficient Land Use.** *Promote the efficient use of land by the use of incentives, density and mixed-use development in proximity to retail businesses, public services, places of work, and transportation systems.*

**Staff Analysis:** As a use that is accessory to the primary dwelling on a lot, accessory dwelling units gently and efficiently add housing to an existing block or neighborhood, which assists the city in achieving the mix of residential uses outlined in the Comprehensive Plan. Relaxing parking requirements for ADUs promotes efficient land use both from the perspective that less of a lot is being devoted to off-street car storage, and that it promotes the use of existing transit resources. The draft text thus aligns with the findings of the Legislature that siting ADUs near transit and public amenities can help to reduce greenhouse gas emissions by increasing walkability and shortening household commutes, and therefore should be incentivized by reducing parking requirements unless parking is already exempt under [RCW 36.70A.698](#). Removing the transitional lot requirements for new subdivisions, and instead relying on the minimum lot size of the zone, also allows for land to be used more efficiently. Rather than requiring more square footage to be dedicated to individual lots in the transition area, the land can be used for additional lots, an improved site circulation, or even shared open space that provides an amenity to the larger subdivision. Finally, the proposed changes to the current short plat process are an incentive for smaller divisions of land, shortening the review timeframe and thus costs for that type of infill development.

**Land Use Policy LU 3.6 – Compact Residential Patterns.** *Allow more compact and affordable housing in all neighborhoods, in accordance with design guidelines.*

**Staff Analysis:** The draft code revisions to the ADU chapter directly support the policy focus on both compact development and housing affordability. The Comprehensive Plan specifically notes that accessory dwelling units are a housing type that is more compact and affordable, including other missing middle housing types such as duplexes, triplexes, and townhouses. Additionally, removing the lot size transition requirement will allow new subdivisions to create lots within the Residential Agricultural (RA) and Residential Single-Family (RSF) zones that meet underlying requirements for lot depth, width, and square footage rather than requiring lots to average in size. The resulting smaller lots will inherently be more compact than the required larger lots of the current regulation, which in practice has meant the number of developable units is decreased to accommodate the transitional lots.

**Housing Goal H 1 – Housing Choice and Diversity.** *Provide opportunities for a variety of housing types that is safe and affordable for all income levels to meet the diverse housing needs of current and future residents.*

**Staff Analysis:** The values of the Housing chapter are grounded around maintaining affordable housing, developing a good mix of housing types, encouraging housing for low-income residents, and preserving existing housing. Proposed ADU code changes could encourage increased ADU construction, which can provide benefits such as additional income for homeowners, as well as housing options for senior residents who wish to age in place. During 2020 updates to the Growth Management Act, the Legislature noted that ADUs are often occupied by tenants who pay little to no rent, such as grandparents, adult children, family members with disabilities, and friends going through life transitions. Accessory dwelling units offer a housing type which can meet the needs of residents in various stages of life.

***Housing Policy H 1.11 – Access to Transportation.*** Encourage housing that provides easy access to public transit and other efficient modes of transportation.

**Staff Analysis:** As noted above, accessory dwelling units are a housing option that can meet the varied needs of residents in different income brackets, including the need to be in close proximity to public transit lines for lower income. ADUs are built within existing neighborhoods, which are largely already supported by public transit, with noted exceptions for developments further on the outskirts of city limits. Because Americans spend such a large portion of their income on housing and transportation, the proposed ADU code changes support a future development pattern which reduces household commutes, increases walkability, and reduces carbon footprints. Accessory dwelling units, as a housing type that may rely less on car ownership, will likely be a more affordable option for Spokane residents across their lifetime within the city.

***Housing Policy H 1.18 – Distribution of Housing Options.*** Promote a wide range of housing types and housing diversity to meet the needs of the diverse population and ensure that this housing is available throughout the community for people of all income levels and special needs.

**Staff Analysis:** As described above, accessory dwelling units add homes to an existing block or neighborhood in a manner that is potentially less impactful than site redevelopment, providing the opportunity for existing community residents to downsize or make additional housing available near existing transit access and services. As well, reducing the cost of processing short subdivisions may provide sites for new housing development for rental or fee-simple ownership in areas where there is existing additional capacity and demand for a variety of different housing types.

***Housing Policy H 1.20 – Accessory Dwelling Units.*** Allow one accessory dwelling unit as an ancillary use to single-family homes in all designated residential areas as an affordable housing option.

**Staff Analysis:** The proposed amendments provide greater flexibility for developing ADUs as an affordable housing option, increasing their feasibility. Meanwhile, provisions such as size, height, and building coverage limitation would provide physical compatibility of the ADU with surrounding structures.

***Capital Facilities and Utilities Policy CFU 4.1 – Compact Development.*** Promote compact areas of concentrated development in designated centers to facilitate economical and efficient provision of utilities, public facilities, and services.

**Staff Analysis:** The Growth Management Act provides very specific guidance as to the planning of capital facilities and utilities, clearly directing that growth should be focused in areas where existing capacity and facilities already exist, as well as the requirement for concurrency. Concurrency requires that utilities and services be provided at the time of development, so there is no drop in levels of service. The procedure for concurrency management (overseen by the City)

includes annual evaluation of adopted service levels and land use trends in order to anticipate demand for service and determine needed improvements. Infill and dense development where excess capacity is available is an efficient use of existing systems since compact systems are less expensive to build and maintain. Accessory dwelling units, which are located in existing neighborhoods with services, and incentivized short plats, which are often built as infill near existing facilities, support this policy.

**2. The proposed amendment bears a substantial relation to public health, safety, welfare, and protection of the environment.**

**Staff Analysis:** Responding to current housing affordability and vacancy challenges documented by statutes and adopted local plans, the proposed amendments closely follow the guidance in State law, the Housing Action Plan, and the Mayor’s July 26, 2021, Proclamation Addressing Housing Emergency. These amendments are coordinated and work together with additional changes identified in these documents for the City and its partners, and are essentially linked with those actions aimed at finding balance for the public welfare during a period of unprecedented low vacancy levels and climbing prices that threaten to worsen Spokane’s housing shortage. As stated above, these changes are consistent with the Comprehensive Plan and statutes protecting public health, safety, and the environment.

## V. CONCLUSION

Based on the facts and findings presented herein, staff concludes that the requested text amendments to the Unified Development Code satisfy the applicable criteria for approval as set forth in SMC Section 17G.025.010. To comply with RCW 36.70A.370 the proposed text amendments have been evaluated to ensure proposed changes do not result in unconstitutional takings of private property.

## VI. STAFF RECOMMENDATION

Following the close of public testimony and deliberation regarding conclusions with respect to the review criteria and decision criteria detailed in SMC 17G.025.010, Plan Commission will need to make a recommendation to City Council for approval or denial of the requested code amendments to the Unified Development Code.

Staff **recommends approval** of the requested accessory dwelling unit, lot size transition, and short plat processes amendments and recommends that the Plan Commission adopt the facts and findings of the staff report.

## VII. LIST OF EXHIBITS

- A. Proposed Draft Text
- B. SEPA Determination of Non-Significance
- C. Public Participation Summary
- D. Public Comments
- E. Department Comment
- F. Related Comprehensive Plan Goals and Policies

**DRAFT TEXT**

**Accessory Dwelling Unit (ADU), Lot Size Transition**

**Spokane Municipal Code Title 17C**

17C.110.200	Lot Size.....	A-2
17C.110.225	Accessory Structures.....	A-9
17C.300.100	General Regulations.....	A-15
17C.300.110	Criteria.....	A-15
17C.300.120	Application Procedures.....	A-16
17C.300.130	Development Standards.....	A-17
17C.300.140	ADU Expiration.....	A-24

Section \_\_\_. That SMC section 17C.110.200 is amended to read as follows:

**17C.110.200 Lot Size**

A. Purpose.

The standards of this section allow for development on lots, but do not legitimize lots that were divided in violation of [chapter 17G.080 SMC](#), Subdivisions. The required minimum lot size, lot depth, lot width and frontage requirements for new lots ensure that development will, in most cases, be able to comply with all site development standards. The standards also prevent the creation of very small lots that are difficult to develop at their full density potential. Finally, the standards also allow development on lots that were reduced by condemnation or required dedications for right-of-way.

B. Existing Lot Size.

1. Development is prohibited on lots that are not of sufficient area, dimension and frontage to meet minimum zoning requirements in the base zone. Except:
  - a. one single-family residence may be developed on a lot that was legally created under the provisions of chapter 58.17 RCW, Plats – Subdivisions – Dedications, or applicable platting statutes;
  - b. a PUD lot may be less than the minimum size of the base zone, if such lot is delineated on a PUD plan, which has been approved by the hearing examiner. All use and development standards of the zone wherein such lot is located, shall be complied with, unless modified through the PUD process by the hearing examiner. A PUD shall comply with the requirements of subsection (C) of this section.
2. No lot in any zone may be reduced so that the dimension, minimum lot area, frontage or area per dwelling unit is less than that required by this chapter, except as modified through the PUD process by the hearing examiner.
3. Lots Reduced by Condemnation or Required Dedication for Right-of-way. Development that meets the standards of this chapter is permitted on lots, or combinations of lots, that were legally created and met the minimum size requirements at the time of subdivision, but were reduced below one or more of those requirements solely because of condemnation or required dedication by a public agency for right-of-way.

C. Land Division.

1. All new lots created through subdivision must comply with the standards for the base zone listed in Table 17C.110-3.

~~((1. Transition Requirement:~~

~~For sites two acres or greater, transition lot sizes are required to be included as a buffer between existing platted land and new subdivision subject to the requirements of this section. The purpose of this section is to transition lot sizes between the proposed and existing residential developments in order to facilitate compatible development and a consistent development pattern. In the RA and RSF zones, the minimum lot size is subject to transitioning of lots sizes. Lots proposed within the initial eighty feet of the subject property are required to transition lot sizes based on averaging under the following formulas:~~

- ~~a. Transitioning is only required of properties adjacent to or across the right-of-way from existing residential development. “Existing residential development” in this section shall mean existing lots created through subdivision or short plat.~~
- ~~b. Lot size in the transition area is based on the average of the existing lot size in subdivisions adjacent to, or across the street from, the subject property. Lots greater than eleven thousand square feet are not counted in the averaging.~~
- ~~c. If the existing average lot size is greater than seven thousand two hundred square feet, then the lot size in the transition area can be no less than seven thousand two hundred square feet.~~
- ~~d. If the existing average lot size is less than seven thousand two hundred square feet, then the lot size in the transition area can be equal to or greater than the average.~~
- ~~e. If the subject site shares boundaries with more than one subdivision, the minimum lot size in the transition area shall be based on the average lot sizes along each boundary. When two boundaries meet, the lot size shall be based on the larger of the two boundaries. See example below; and~~

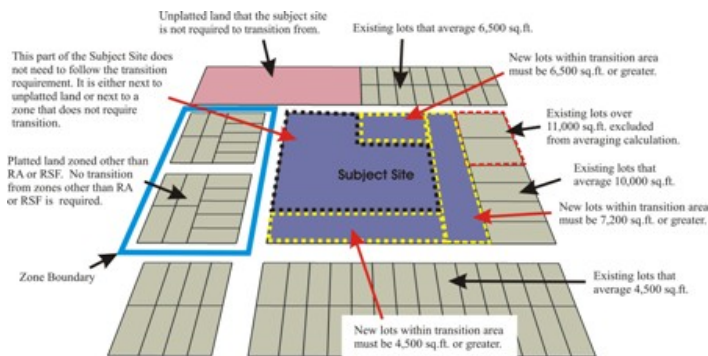

***[Note: Delete graphic above.]***

- ~~f. If the subject site shares a boundary with property zoned other than RA or RSF, then there are no transition requirements along that boundary.~~
- ~~g. After the first set of lots in the transition area, lot sizes may be developed to the minimum lot size of the base zone, i.e., four thousand three hundred fifty square feet in the RSF zone.)~~

2. Planned unit developments, combined with a subdivision, may reduce the minimum lot size, lot width, lot depth and frontage requirements in the RA and RSF zones pursuant to SMC 17G.070.030(C)(1) (~~except in the transition area required by subsection (C)(1) of this section~~).

D. Ownership of Multiple Lots.

Where more than one adjoining lot is in the same ownership, the ownership may be separated as follows:

1. If all requirements of this chapter will be met after the separation, including lot size, density and parking, the ownership may be separated through either a boundary line adjustment (BLA) or plat, as specified under [chapter 17G.080 SMC](#), Subdivisions.
2. If one or more of the lots does not meet the lot size standards in this section, the ownership may be separated along the original plat lot lines through a boundary line adjustment (BLA).

E. New Development on Standard Lots. New development on lots that comply with the lot size standards in this section are allowed subject to the development standards and density requirements of the base zone as required under Table 17C.110-3.

F. Lot Frontage. All residential lots shall front onto a public street and meet the minimum lot frontage requirements of Table 17C.110-3. Except, that frontage on



a public street is not required for lots created through alternative residential subdivision under SMC 17G.080.065, and lots approved in a planned unit development or a manufactured home park may have lots or spaces fronting onto private streets, subject to the decision criteria of [SMC 17H.010.090](#).

TABLE 17C.110-3 DEVELOPMENT STANDARDS [1]					
DENSITY STANDARDS					
	RA	RSF & RSF-C	RTF	RMF	RHD
Density - Maximum	4,350 (10 units/acre)	4,350 (10 units/acre)	2,100 (20 units/acre)	1,450 (30 units/acre)	--
Density - Minimum	11,000 (4 units/acre)	11,000 (4 units/acre)	4,350 (10 units/acre)	2,900 (15 units/acre)	2,900 (15 units/acre)
MINIMUM LOT DIMENSIONS LOTS TO BE DEVELOPED WITH:					
Multi-Dwelling Structures or Development					
	RA	RSF & RSF-C	RTF	RMF	RHD
Minimum Lot Area				2,900 sq. ft.	2,900 sq. ft.
Minimum Lot Width				25 ft.	25 ft.
Minimum Lot Depth				70 ft.	70 ft.
Minimum Front Lot Line				25 ft.	25 ft.
Compact Lot Standards [2]					
Minimum Lot Area [3]		3,000 sq. ft.			
Minimum Lot Width		36 ft.			
Minimum Lot Depth		80 ft.			
Minimum Front Lot Line		30 ft.			
Attached Houses as defined in SMC 17A.020.010					
Minimum Lot Area [3]	7,200 sq. ft.	4,350 sq. ft.	1,600 sq. ft.	1,450 sq. ft.	None

Minimum Lot Width	40 ft.	40 ft.	36 ft. or 16 ft. with alley parking and no street curb cut	Same	Same
Minimum Lot Depth	80 ft.	80 ft.	50 ft.	None	None
Minimum Front Lot Line	40 ft.	40 ft.	Same as lot width	Same as lot width	Same as lot Width
<b>Detached Houses</b>					
Minimum Lot Area [3]	7,200 sq. ft.	4,350 sq. ft.	1,800 sq. ft.	1,800 sq. ft.	None
Minimum Lot Width	40 ft.	40 ft.	36 ft.	25 ft.	25 ft.
Minimum Lot Depth	80 ft.	80 ft.	40 ft.	25 ft.	25 ft.
Minimum Front Lot Line	40 ft.	40 ft.	30 ft.	25 ft.	25 ft.
<b>Duplexes</b>					
Minimum Lot Area			4,200 sq. ft.	2,900 sq. ft.	None
Minimum Lot Width			25 ft.	25 ft.	25 ft.
Minimum Lot Depth			40 ft.	40 ft.	25 ft.
Minimum Front Lot Line			25 ft.	25 ft.	25 ft.
<b>PRIMARY STRUCTURE</b>					
<b>Maximum Building Coverage</b>					
	RA	RSF & RSF-C	RTF	RMF	RHD
Lots 5,000 sq. ft. or larger	40%	2,250 sq. ft. + 35% for portion of lot over 5,000 sq. ft.	2,250sq. ft. + 35% for portion of lot over 5,000 sq. ft.	50%	60%
Lots 3,000 - 4,999 sq. ft.	1,500 sq. ft. + 37.5% for portion of lot over 3,000 sq. ft.				
Lots less than 3,000 sq. ft.	50%				

Attached housing as defined in SMC 17A.020.010, lots any size	Same as above			Up to 70%	Up to 80%
<b>Building Height</b>					
Maximum Roof Height	35 ft. [5]	35 ft. [5]	35 ft. [5]	35 ft. [6]	35 ft. [6]
Maximum Wall Height	25 ft.	25 ft.	25 ft.	-- [6]	--
<b>Floor Area Ratio (FAR)</b>					
FAR	0.5	0.5 [4]	0.5 [4]	--	--
<b>Setbacks</b>					
Front Setback [7, 8]	15 ft.				
Side Lot Line Setback – Lot width more than 40 ft.	5 ft.				
Side Lot Line Setback – Lot width 40 ft. or less	3 ft.				
Street Side Lot Line Setback [7]	5 ft.				
Rear Setback [9, 10]	25 ft.	25 ft. [11]	15 ft.	10 ft.	10 ft.
<b>Required Outdoor Area</b>					
Required Outdoor Area for attached and detached houses. Minimum dimension (See SMC 17C.110.223)	250 sq. ft. 12 ft. x 12 ft.	250 sq. ft. 12 ft. x 12 ft.	250 sq. ft. 12 ft. x 12 ft.	200 sq. ft. 10 ft. x 10 ft.	48 sq. ft. 7 ft. x 7 ft.
<b>ACCESSORY STRUCTURES</b>					
	RA	RSF & RSF-C	RTF	RMF	RHD
Maximum Roof Height	30 ft.	20 ft.	20 ft.	35 ft.	35 ft.
Maximum Wall Height	30 ft.	15 ft.	15 ft.	35 ft.	35 ft.

Maximum Coverage [12]	20%	15%	15%	See Primary Structure	See Primary Structure
<u>Maximum Coverage with Accessory Dwelling Unit, Lots less than 5,500 sq. ft. [12]</u>		<u>20%</u>		<u>See Primary Structure</u>	<u>See Primary Structure</u>
Front Setback	20 ft.				
Side Lot Line Setback – Lot width 40 ft. or wider [13]	5 ft.				
Side Lot Line Setback – Lot width less than 40 ft. [13]	3 ft.				
Street Side Lot Line [14]	20 ft.				
Rear [13]	5 ft.				
Rear with Alley	0 ft.				

Notes:

-- No requirement

[1] Plan district, overlay zone, or development standards contained in SMC 17C.110.310 through 360 may supersede these standards.

[2] See SMC 17C.110.209, Compact Lot Standards.

[3] ~~((For developments two acres or greater, lots created through subdivision in the RA, RSF and the RSF-C zones are subject to the lot size transition requirements of SMC 17C.110.200(C)(1).)) [Deleted.]~~

[4] In the RSF-C and RTF zones, and sites in the RSF zone qualifying for compact lot development standards, described in SMC 17C.110.209, FAR may be increased to 0.65 for attached housing development only.

[5] No structure located in the rear yard may exceed twenty feet in height.

[6] Base zone height may be modified according to SMC 17C.110.215, Height.

[7] Attached garage or carport entrance on a street is required to be setback twenty feet from the property line.

[8] See SMC 17C.110.220(D)(1), setbacks regarding the use of front yard averaging.

[9] See SMC 17C.110.220(D)(2), setbacks regarding reduction in the rear yard setback.

[10] Attached garages may be built to five feet from the rear property line except, as specified in SMC 17C.110.225(C)(6)(b), but cannot contain any living space.

[11] In the RSF-C zone and sites in the RSF zone qualifying for compact lot development standards, described in SMC 17C.110.209, the rear setback is 15 feet.

[12] Maximum site coverage for accessory structures is counted as part of the maximum site coverage of the base zone. See SMC 17C.110.225(D).

[13] Setback for a detached accessory structure and a covered accessory structure may be reduced to zero feet with a signed waiver from the neighboring property owner, except, as specified in SMC 17C.110.225(C)(5)(b).

[14] The setback for a covered accessory structure may be reduced to five feet from the property line.

Section \_\_. That SMC section 17C.110.225 is amended to read as follows:

### **17C.110.225 Accessory Structures**

A. Purpose.

This section regulates structures that are incidental to primary buildings to prevent them from becoming the predominant element of the site. The standards provide for necessary access around structures, help maintain privacy to adjoining lots and maintain open front setbacks.

B. General Standards.

1. Accessory structures are allowed on a lot only in conjunction with a primary building, and may not exist on a lot prior to the construction of the primary structure, except as allowed by subsection (B)(2) of this section.

2. An accessory structure that becomes the only structure on a lot as the result of a land division may remain on the lot if the owner has submitted a financial guarantee to the City for the cost of demolition and removal of the structure. The financial guarantee will be used by the City if the owner has not removed the accessory structure if, within one year of final plat approval or boundary line adjustment (BLA), a primary structure has not been built and received final inspection. The financial guarantee must be accepted by the City prior to approval of the final plat or boundary line adjustment.
3. An accessory structure shall not contain a kitchen or space for living, sleeping, eating, or cooking unless it is approved as an accessory dwelling unit under chapter 17C.300 SMC.

C. Setbacks.

1. Mechanical Structures.  
Mechanical structures are items such as heat pumps, air conditioners, emergency generators, and water pumps.
  - a. Front Setback Standard.  
Mechanical structures are not allowed in required front building setbacks.
  - b. Side and Rear Setback Standard.  
Mechanical structures are allowed inside and rear building setbacks if the structure is no more than forty-eight inches high.
2. Vertical Structures.  
Vertical structures are items such as flagpoles, trellises and other garden structures, radio antennas, satellite receiving dishes and lampposts. Fences are addressed in SMC 17C.110.230. Sign standards are in chapter 17C.240 SMC, Signs.
  - a. Setback Standard.  
Vertical structures are allowed in required side and rear building setbacks if they are no larger than four feet in width, depth or diameter and no taller than seven feet. If they are larger or taller, they are not allowed in required building setbacks. Trellises and other gate features are allowed in front yard if they are no larger than four feet in width, depth or diameter and no taller than seven feet and do not conflict with the clear view triangle provisions under SMC 17C.110.230, Fences.
3. Uncovered Horizontal Structures.  
Uncovered horizontal structures are items such as decks, stairways, entry bridges, wheelchair ramps, swimming pools, hot tubs, tennis courts, and boat docks that are not covered or enclosed.

- a. Setback Standard.
  - i. Projection Allowed.

The following structures are allowed in required building setbacks, as follows:

    - A. Structures that are no more than two and one-half feet above the ground are allowed in side and rear building setbacks. Handrails required by the IBC/IRC are not included in the maximum height.
    - B. On lots that slope down from the street, vehicular or pedestrian entry bridges that are no more than two and one-half feet above the average sidewalk elevation are allowed in all building setbacks; and
    - C. Stairways and wheelchair ramps that lead to one entrance on the street-facing facade of a building are allowed in street setbacks.
4. Covered Accessory Structures.

Covered accessory structures are items such as greenhouses, storage buildings (not used to cover motor vehicles), sheds, covered decks, covered porches, gazebos, and covered recreational structures.

  - a. Setback Standard.

Covered accessory structures are not allowed in the required front ~~((and side))~~ building setbacks. Covered accessory structures are not allowed in the required side building setback without a signed waiver from the neighboring property owner.
5. Detached Accessory Structures.

Detached accessory structures are garages, carports, and other structures utilized to cover motorized vehicles.

  - a. Setback Standard.

A detached accessory structure is not allowed in the front building setback. A detached accessory structure is not allowed in the required side building setback without a signed waiver from the neighboring property owner. A detached accessory structure that has an entrance, which faces a street, is required to be setback twenty feet from the property line or from the back of the sidewalk, as stated in Table 17C.110-3.
  - b. Detached accessory structures may be built to the rear property line, unless parking in front of the structure is proposed, then the structure

is required to be built a minimum of eighteen feet from the edge of the alley tract, easement, or right-of-way.

6. Attached Accessory Structures.

Accessory structures are garages, carports or other structures utilized to cover motorized vehicles that are connected by a common wall to the primary structure.

a. Setback Standard.

An attached accessory structure is not allowed in the front building setback. An attached accessory structure that has an entrance which faces a street is required to be setback twenty feet from the property line as stated in Table 17C.110-3.

b. Attached accessory structures may be built to within five feet of the rear property line, unless parking in front of the structure is proposed, then the structure is required to be built a minimum of eighteen feet from the edge of the alley tract, easement or right-of-way.

D. Building Coverage.

1. Except as provided in subsection (2) of this subsection (D), ((The)) the combined building coverage of all detached accessory structures and covered accessory structures may not exceed fifteen percent of the total area of the site, and when combined with all other structures on-site shall not exceed the maximum building coverage of the base zone.

2. On lots smaller than five thousand five hundred square feet with an accessory dwelling unit, combined building coverage of all detached accessory structures and covered accessory structures may not exceed twenty percent of the total area of the site, and when combined with all other structures on-site shall not exceed the maximum building coverage of the base zone.

E. Building Height.

The building height of detached accessory structures and covered accessory structures is listed in Table 17C.110-3. Accessory structures, which contain an ADU over a garage, are subject to the height limitations in chapter 17C.300 SMC, Accessory Dwelling Units.



<b>TABLE 17C.110.225-1</b>	
<b>MAXIMUM HEIGHT – DETACHED ACCESSORY BUILDING [1]</b>	
Maximum Wall Height [2]	15 ft.
Maximum Roof Height [3]	20 ft.
<p>[1] Cannot include living area, nor any storage areas with a ceiling height of six-feet eight-inches or greater.</p> <p>[2] The height of the lowest point of the roof structure intersects with the outside plane of the wall.</p> <p>[3] The height of the ridge of the roof.</p> <p>See “Example A” below.</p>	

**Example A**

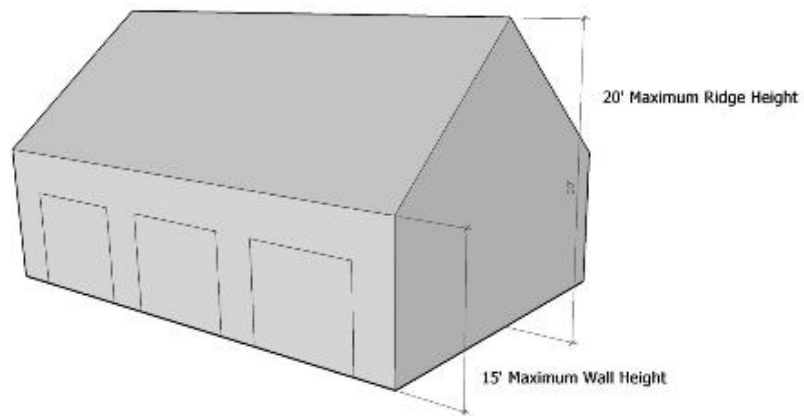

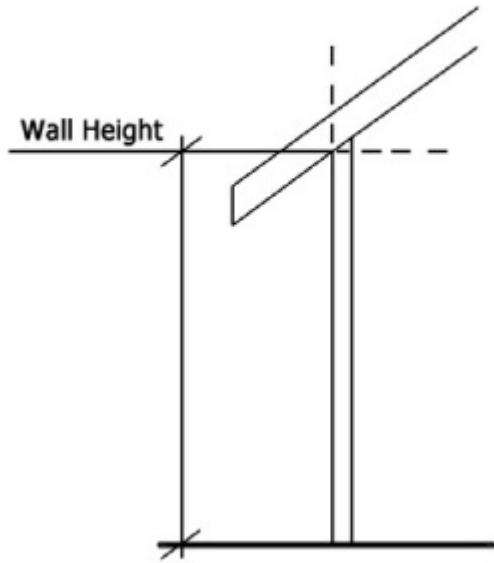

### 17C.300.100 General Regulations

- A. Where the Regulations Apply.  
Attached and detached accessory dwelling units are permitted in the RA through RHD zones, including planned unit developments, subject to the limitations of subsection (B) of this section.
- B. Limitation.
- ~~((1. One ADU is allowed per lot as an accessory use in conjunction with a detached single-family residence.~~
- ~~2. A detached ADU must either be combined with a garage or shall be the only detached structure in the rear yard setback area.~~
- ~~3. Detached))~~ One accessory dwelling ~~((units are))~~ unit is allowed per lot in the RA, RSF, RTF, RMF, and RHD zones subject to the development standards of the underlying zoning district.

Section   . That SMC 17C.300.110 is amended to read as follows:

### 17C.300.110 Criteria

~~((A. Minimum Lot Size.  
The minimum lot size for ADU is five thousand square feet.))~~  
~~((B.))~~ A. ~~((ADU Minimum and))~~ Maximum Size.

1. Internal ADU.  
Before the establishment of an internal ADU the ~~((footprint))~~ floor area of the principal structure, excluding an attached garage, must be not less than eight hundred square feet.
- a. The ((size)) internal ADU shall contain no more than two bedrooms and the floor area of the internal ADU must be ((not less than two hundred fifty square feet and)) not more than eight hundred square feet, excluding any related garage area.
- b. The conversion of an existing interior basement or attic space of a principal structure into an ADU may exceed the maximum floor area for an internal ADU specified in subsection (1)(a) of this subsection.
2. Detached ADU.  
a. The maximum detached ADU size is subject to building coverage per SMC 17C.300.130(B)(3) and floor area ratio per subsection (3) of this subsection (A); and

b. A detached ADU shall not exceed ~~((six hundred square feet))~~ seventy-five percent of the floor area of the principal structure, or eight hundred sixty-four square feet of floor area, whichever is greater.

3. FAR.

a. The ~~square footage floor area~~ of an ADU, excluding any garage, is counted as part of the floor area ratio (FAR). ~~((Internal ADUs may not exceed fifty percent of the total square footage of the principal structure's building footprint.))~~

b. To offer greater flexibility in integrating an ADU on smaller lots, the maximum allowable FAR may be increased to 0.6 on lots smaller than seven thousand two hundred square feet in area, with an ADU, and to 0.7 on lots smaller than five thousand square feet in area with an ADU.

~~((C.))~~ B. Occupancy for Short-Term Rentals.

~~((One))~~ Where a lot with an ADU also has a Short-Term Rental under chapter 17C.316 SMC, one of the dwelling units ~~((in the structure or))~~ on the lot shall be occupied by one or more owners of the property as the owner's permanent and principal residence. The owner-occupant must occupy the owner-occupied dwelling unit for more than six months of each calendar year. The owner-occupant may not receive rent for the owner-occupied dwelling unit. If a complaint that an owner has violated these requirements is filed, the owner shall:

1. submit evidence to the director showing good cause, such as a job dislocation, sabbatical leave, education or illness, for waiver of this requirement for up to one year absence from the property. Upon such showing the director may waive the requirement;
2. re-occupy the structure; or
3. remove the accessory dwelling unit.

Section   . That SMC 17C.300.120 is amended to read as follows:

**17C.300.120 Application Procedures**

A. Application.

Any property owner seeking to establish an ADU must obtain a building permit and a certificate of occupancy from the building services department.

B. Covenants.

~~((A))~~ Where a lot with an ADU also has a Short-Term Rental under chapter 17C.316 SMC, a covenant and deed restriction identifying the ADU and limitations of occupancy and ownership is required to be recorded and filed with

the Spokane county auditor's office. A copy of the recorded covenant must be provided to the City of Spokane planning and economic development services department prior to the issuance of a building permit or safety inspection.

Section \_\_. That SMC 17C.300.130 is amended to read as follows:

### **17C.300.130 Development Standards**

A. Development Standards – Requirements for All Accessory Dwelling Units.  
All accessory dwelling units must meet the following:

1. Creation.  
An accessory dwelling unit may only be created through the following methods:
  - a. Converting existing living area, attic, basement or garage.
  - b. Adding floor area.
  - c. Constructing a detached accessory dwelling unit on a site with an existing house, attached house or manufactured home ~~((;OF))~~.
  - d. Constructing a new house, attached house or manufactured home with an internal or detached accessory dwelling unit.
  - e. In the RTF, RMF, or RHD zone, constructing an attached or detached accessory dwelling unit on a site with any existing or new principal structure. All new structures and additions shall comply with all applicable building, fire, and engineering standards.
2. Number of Residents.  
The total number of individuals that reside in both units may not exceed ~~((the number that is allowed for a household))~~ any lawful limits on occupant load per square foot or generally applicable health and safety provisions as established by applicable building or fire code, as provided in RCW 35.21.682.
- ~~((3. Other Uses.  
An accessory dwelling unit is prohibited on a site with a home occupation.))~~
- ~~((4.))~~ 3. Location of Entrances for Internal ADUs.  
Only one entrance may be located on the facade of the ~~((house, attached house or manufactured home))~~ principal structure facing the street, unless the ~~((house, attached house or manufactured home))~~ principal structure contained additional entrances before the accessory dwelling unit was created. An exception to this regulation is entrances that do not have access from the ground such as entrances from balconies or decks.

~~((5-))~~ 4. Parking.

~~a. Studio and one-bedroom ADUs require no additional parking. One additional off-street parking space is required for the accessory dwelling unit with more than one bedroom, plus one per bedroom after two bedrooms. Existing required parking for the ((house, attached house or manufactured home)) principal structure must be maintained ((or replaced on-site)).~~

~~b. As an exception to subsection (a), no additional off-street parking space is required for the ADU within one-quarter-mile of stops for a bus or other transit mode providing actual fixed route service at intervals of no less frequently than fifteen minutes for at least five hours during the peak hours of operation on weekdays, defined as a major transit stop under RCW 36.70A.696.~~

~~((6. Exterior Finish Materials.~~

~~The exterior finish material must be the same or visually match in type, size, and placement the exterior finish material of the house, attached house or manufactured home.))~~

~~7. Roof Pitch.~~

~~The roof pitch must be the same as the predominant roof pitch of the house, attached house or manufactured home.~~

~~8. Trim.~~

~~Trim must be the same in type, size and location as the trim used on the house, attached house or manufactured home.~~

~~9. Windows.~~

~~Windows must match those in the house, attached house or manufactured home in proportion (relationship of width to height) and orientation (horizontal or vertical). This standard does not apply when it conflicts with building code regulations.))~~

B. Additional Development Standards for Detached ADUs.

1. Setbacks.

~~((The))~~ Except for conversion of existing accessory structures, the accessory dwelling unit must be ((at least)):

~~((a. sixty feet from the front lot line; or~~

~~b. six feet behind the house, attached house or manufactured home.))~~

~~((e.))~~ a. as specified for ~~((rear and side yard))~~ setbacks in Table 17C.110-3 for ~~((primary structures for attached ADUs and))~~ accessory structures ~~((for detached ADUs.))~~; and

b. in conformance with the forty-five degree setback plane:

i. The forty-five degree setback plane is measured at the maximum wall height listed in Table 17C.300-1, from the interior side lot line setback, or rear setback without an alley, as listed in Table 17C.110-3 for accessory structures. The setback plane does not apply on side or rear setbacks measured from alley or street lot lines.

ii. The setback plane increases at a forty-five degree angle away from the interior side and rear lot lines without an alley, up to the maximum roof height in Table 17C.300-1. See Figure 17C.300-A for examples.

iii. No portion of the accessory dwelling unit may project beyond the forty-five degree setback plane described in this subsection, except for the roof structure and minor extensions allowed by SMC 17C.110.220(C)(1).

iv. The setback may be reduced to zero feet with a signed waiver from the neighboring property owner. In that case, the forty-five degree setback plane would be measured from the maximum wall height and the property line.

**Figure 17C.300-A. Setback Plane [1]**

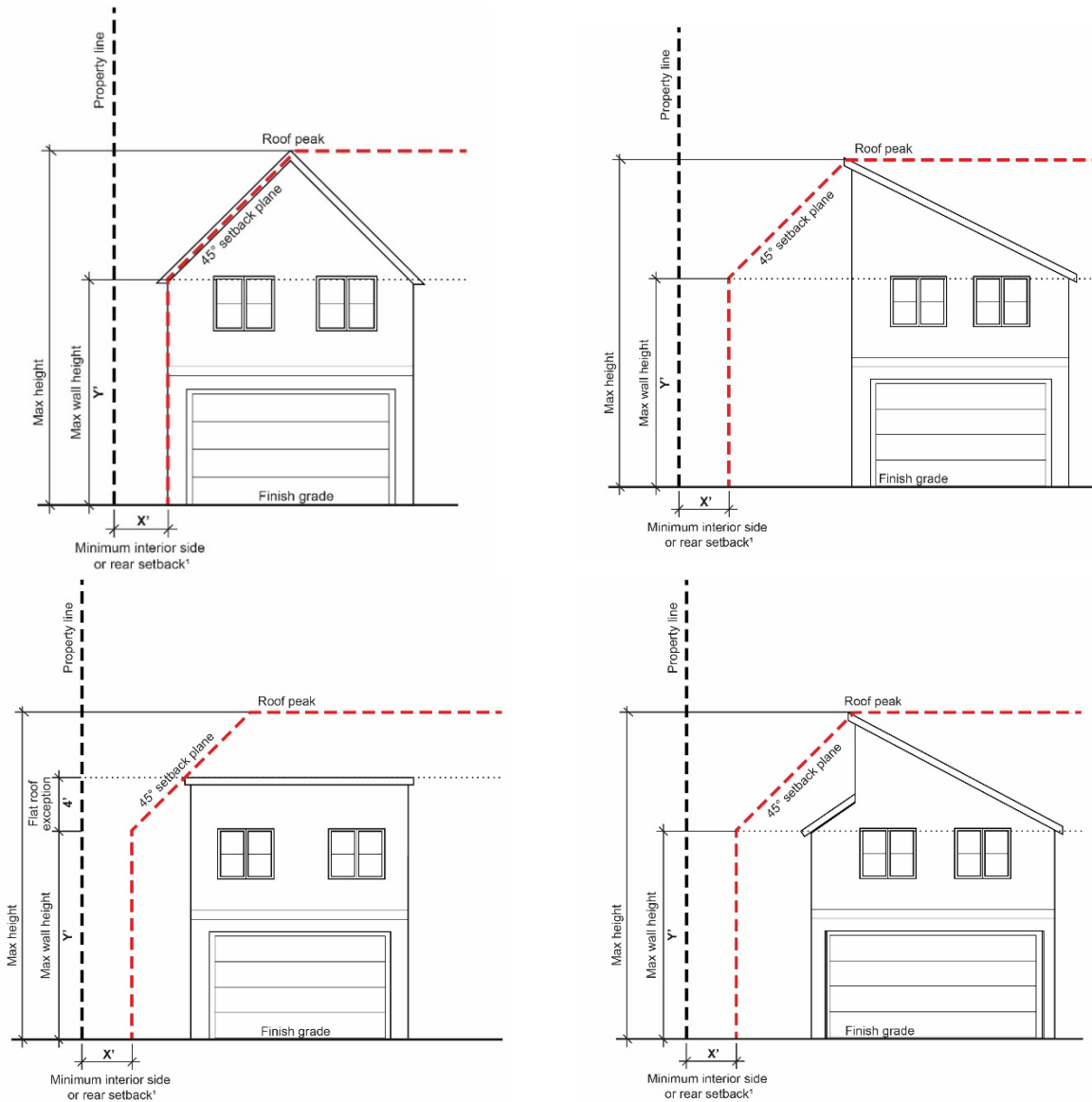

**[Note: Add the four graphics above.]**

**[1] The setback plane does not apply on side setbacks or rear setbacks measured from alley lot lines or street lot lines.**



2. Height.

The maximum height allowed for a detached accessory dwelling unit is shown in Table 17C.300-1. ~~A detached ADU over a detached accessory structure with flat or terraced roof forms with slopes of less than 3:12 that conform to the forty-five-degree setback plane in subsection (B)(1)(b) of this section may be granted a wall height exception up to four feet.~~

TABLE 17C.300-1 MAXIMUM ROOF AND WALL HEIGHT		
	Maximum Height – Detached Accessory Building Attached to an ADU or Detached ADU [1]	Maximum Height – Detached ADU Over a Detached Accessory Structure
Maximum Wall Height [2]	10 ft.	<del>((16))</del> <u>17</u> ft.
Maximum Roof Height [3]	20 ft.	<del>((23))</del> <u>25</u> ft.
<p>[1] Detached accessory structures cannot include living area, nor any storage areas with a ceiling height of six-feet eight-inches or greater.</p> <p>[2] The height of the lowest point of the roof structure intersects with the outside plane of the wall.</p> <p>[3] The height of the ridge of the roof. See “Figure <del>((A))</del> <u>17C.300-B</u>” below.</p>		

**Figure ((A)) 17C.300-B**

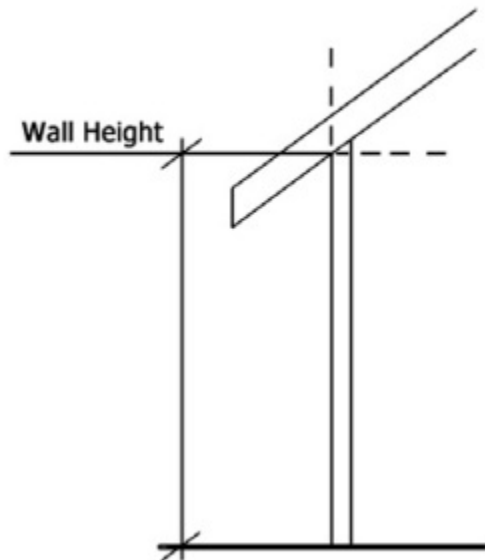
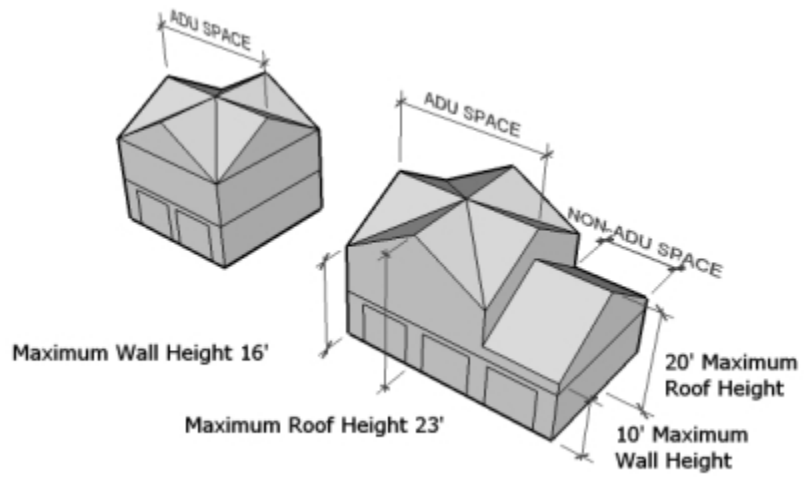

3. Bulk Limitation.

The building coverage for the detached accessory dwelling unit may not be larger than the building coverage of the ~~((house, attached house or manufactured home))~~ principal structure.

  - a. ~~((The))~~ On lots five thousand five hundred square feet or larger, the combined building coverage of all detached accessory structures may not exceed fifteen percent of the total area of the site.
  - b. On lots smaller than five thousand five hundred square feet, the combined building coverage of all detached accessory structures may not exceed twenty percent of the total area of the site.
4. Conversion of Existing Detached Accessory Structures.
  - a. In RA through RTF zones, conversion of an existing detached accessory structure that is in a front building setback required by [Table 17C.110-3](#) is not allowed. Conversion of an existing detached accessory structure that is in a rear or side building setback is allowed as provided by [SMC 17C.110.220](#), Setbacks, and [SMC 17C.110.225](#), Accessory Structures.
  - b. In RMF through RHD zones, conversion of an existing detached accessory structure that is in a front building setback required by [Table 17C.110-3](#) is not allowed. Conversion of an existing detached accessory structure that is in a rear or side building setback is allowed as provided by [SMC 17C.110.220](#), Setbacks, and [SMC 17C.110.225](#), Accessory Structures.
  - c. If the accessory dwelling unit is proposed for an existing detached accessory structure that meets any of the standards of subsections ~~((A)(6) through (9) and))~~ (B)(2) and (3) of this section, alterations that will move the structure out of conformance with the standards that are met are not allowed.
  - d. If the accessory dwelling unit is proposed as a conversion of an existing detached accessory structure or a portion of the building, and ~~((the existing detached accessory structure does not meet the standards of subsections (A)(6) through (9) of this section, the structure is exempt from those standards. If))~~ any floor area is added to the existing detached accessory structure to accommodate an ADU, then the entire structure must meet the ~~((standards of subsections (A)(6) through (9) of this section and the))~~ underlying zoning development standards.

- C. Utilities and Addressing.  
The ADU must utilize those municipal utilities and address established for the principal dwelling unit.
- D. Code Compliance.  
The ADU must meet all technical code standards of this title including building, electrical, fire, and plumbing code requirements and permits.

Section \_\_. That SMC 17C.300.140 is amended to read as follows:

### **17C.300.140 ADU Expiration**

- A. Transfer.  
~~((An))~~ In the case where a lot with an ADU also has a Short-Term Rental under chapter 17C.316 SMC, an ADU permit is not transferable to any other property or any other person except to the new owner of the subject property when the property will be owner occupied.
- B. Expiration.  
Approval of an ADU expires when the:
  - 1. accessory dwelling unit is altered and is thus no longer in conformance with the plans approved by the building services department; or
  - 2. property ceases to maintain the required off-street parking spaces for the accessory and principal dwelling units; or
  - 3. in the case where a lot with an ADU also has a Short-Term Rental under chapter 17C.316 SMC, legal titleholder of the property ceases to own and reside in either the principal or the accessory dwelling unit.

**DRAFT TEXT**  
**Short Plat Notification**  
**Spokane Municipal Code Title 17G Administration and Procedures**

17G.060.100 Notice of Application .....	A-26
17G.060T.003 Table 17G.060-3 Type of Public Notice Required / Project Permit Review Process .....	A-26
17G.060.130 Public Comment Period .....	A-29
17G.080.040 Short Subdivisions .....	A-29

Section \_\_. That SMC section 17G.060.100 is amended to read as follows:

**17G.060.100 Notice of Application**

Within fourteen days of the issuance of a determination of a complete application, a notice of application shall be provided for Type I, II and III project permit applications in accordance with this section (RCW 36.70B.110.2), except that notice of application is not required for short subdivision applications involving minor engineering review as defined in SMC 17G.080.040(C)(2). The notice of application shall follow the public notice requirements contained in SMC 17G.060.110 through 17G.060.120. The notice of application may be combined with the notice of public hearing, if a hearing has been scheduled by notice of application. The date, time, place and type of hearing, SEPA determination and SEPA appeal deadline (using the optional DNS process) are required to be added to the notice of application if this provision is used (RCW 36.70B.110(2)(f)).

Section \_\_. That SMC section 17G.060T.003 is amended to read as follows:

**17G.060T.003 Table 17G.060-3 Type of Public Notice Required / Project Permit Review Process**

<b>TABLE 17G.060-3</b> <b>TYPE OF PUBLIC NOTICE REQUIRED / PROJECT PERMIT REVIEW PROCESS</b> (Click here to view PDF)						
Project Permit Type	Notice of Community Meeting	Notice of Application	Notice of Public Hearing	Review Official	City Council Review	Expiration of Permit [1]
<b>Building and Code Enforcement – Type I Application</b>						
Building Permit	No	No	No	Building Official	No	180 days
Grading Permit	No	No	No	Building Official	No	180 days
Demolition Permit	No	No [5]	No [2]	Building Official	No	180 days
Building Permit with SEPA	No	Posted / Legal	No	Building Official	No	180 days

Grading Permit with SEPA	No	Posted / Legal	No	Building Official	No	180 days
Demolition Permit with SEPA	No	Posted / Legal [5]	No	Building Official	No	180 days
<b>Planning Services – Type I Application</b>						
Floodplain with SEPA	Posted / Individual	Posted / Individual	No	Planning Director	No	180 days
<b>Planning Services – Type II Application</b>						
Binding Site Plan	No	Posted / Individual	No	Planning Director	No	5 years
Certificate of Compliance	No	Posted / Individual	No	Planning Director	No	None
Conditional Use Permit	No [3]	Posted / Individual	No	Planning Director	No	3 years
Plans-in-lieu	No	Posted / Individual	No	Planning Director	No	3 years
Shoreline SDP	No	Posted / Individual	No	Planning Director	No	Must Comply with WAC 173-27-90
Short Plat with SEPA	No	Posted / Individual	No	Planning Director	No	5 years
<u>Short Plat with minor engineering review</u>	<u>No</u>	<u>No</u>	<u>No</u>	<u>Planning Director</u>	<u>No</u>	<u>5 years</u>
<u>Short Plat with SEPA exemption and standard engineering review</u>	<u>No</u>	<u>Individual</u>	<u>No</u>	<u>Planning Director</u>	<u>No</u>	<u>5 years</u>
<b>Planning Services – Type III Application (Hearing Required)</b>						
Certificate of Compliance	Posted / Individual	Posted / Individual	Posted / Individual	Hearing Examiner	No	None
Conditional Use Permit	Posted / Individual	Posted / Individual	Posted / Individual	Hearing Examiner	No	3 years

Floodplain Variance	Posted / Individual	Posted / Individual	Posted / Individual	Hearing Examiner	No	3 years
Long Plat	Posted / Individual	Posted / Individual	Newspaper / Posted / Individual	Hearing Examiner	No	5 years
Plans-in-lieu	Posted / Individual	Posted / Individual	Posted / Individual	Hearing Examiner	No	3 years
PUD	Posted / Individual	Posted / Individual	Posted / Individual	Hearing Examiner	Yes	5 years [4]
Rezone	Posted / Individual	Posted / Individual	Posted / Individual	Hearing Examiner	Yes	3 years
Shoreline CUP	Posted / Individual	Posted / Individual	Posted / Individual	Hearing Examiner	No	Must Comply with WAC 173-27-90
Shoreline Variance	Posted / Individual	Posted / Individual	Posted / Individual	Hearing Examiner	No	Must Comply with WAC 173-27-90
Skywalk	Posted / Individual	Posted / Individual	Posted / Individual	Hearing Examiner	Yes	2 years
Variance	Posted / Individual	Posted / Individual	Posted / Individual	Hearing Examiner	No	3 years

Notes:

[1] Approval expires after the specified time if no permit to develop the project is issued by the City of Spokane or building permit expires without completion of the improvements.

[2] Public Hearing is required if the structure is on the National Historic Register.

[3] Conditional Use Permits required under SMC 17C.110.110, Limited Use Standards for Religious Institutions and Schools, will complete posted/individual notification requirements for a Community Meeting.

[4] If a PUD is approved together with a preliminary plat, the expiration date for the PUD shall be the same as the expiration date of the preliminary plat.

[5] Applications for demolition permits for the demolition of an entire building or structure shall, in addition to any applicable requirements under chapter 43.21C RCW, be subject to a ten day review and comment period. This review and comment period shall run concurrently with any other applicable notice and comment period. Following receipt of such applications, copies shall be forwarded to the individual(s) designated pursuant to SMC 4.27.010(D) to receive written notice on behalf of the neighborhood council in which the building or structure is located, at the address for such neighborhood council designee(s) that is on file with the department. Any comments submitted to the department by the neighborhood council during this review and comment period shall be provided to the applicant prior to issuing the demolition permit.



Section \_\_\_. That SMC section 17G.060.130 is amended to read as follows:

### **17G.060.130 Public Comment Period**

- A. The public comment period for Type I, II, and III applications is fifteen days, except short subdivision applications with minor engineering review as provided in SMC 17G.080.040(C)(2) shall have no public comment period.
- B. The public comment period for a shoreline substantial development permit, shoreline conditional use, or shoreline variance shall be thirty days.
- C. The public comment period for a shoreline substantial development permit for limited utility extensions and bulkheads shall be twenty days (WAC 173-27-120).
- D. The longest public comment period shall prevail.

Section \_\_\_. That SMC section 17G.080.040 is amended to read as follows:

### **17G.080.040 Short Subdivisions**

#### **A. Predevelopment Meeting**

A predevelopment meeting is required if the proposal is located in the central business district, unless waived by the director, and is recommended for all other proposals prior to submittal of the application. The purpose of a predevelopment meeting is to acquaint the applicant with the applicable provisions of this chapter, minimum submission requirements and other plans or regulations, which may impact the proposal.

#### **B. Preliminary Short Plat Application and Map Requirements**

- 1. Applications for approval of a preliminary short subdivision shall be filed with the director. All applications shall be submitted on forms provided for such purpose by the department. The director may waive specific submittal requirements determined to be unnecessary for review of the application. The application shall include the following:
  - a. The general application.
  - b. The supplemental application.
  - c. The environmental checklist, if required under chapter 17E.050 SMC.
  - d. Title report no older than thirty days from issuance from the title company.
  - e. The filing fees as required under chapter 8.02 SMC.
  - f. The required number of documents, plans or maps drawn to a minimum scale of one inch equals one hundred feet, on a sheet

twenty-four by thirty-six inches, as set forth in the application checklist.

- g. A written narrative identifying consistency with the applicable policies, regulations and criteria for approval of the permit requested; and
- h. Additional application information which may be requested by the permitting department and may include, but is not limited to, the following: geotechnical studies, hydrologic studies, critical area studies, noise studies, air quality studies, visual analysis and transportation impact studies.
- i. One copy of the predevelopment conference notes (if applicable); and
- j. One copy of the notification district map.

2. Contents of Preliminary Short Plat Map

The preliminary short plat shall be prepared by a land surveyor and shall show the following:

- a. Plat name and the name of any subdivision to be replatted.
- b. The name, mailing address and phone number of the owner and the person with whom official contact should be made regarding the application.
- c. Surveyor's name, mailing address and phone number.
- d. Legal description.
- e. Section, township and range.
- f. Vicinity map.
- g. North arrow, scale and date.
- h. Datum plane.
- i. Acreage.
- j. Number of lots and proposed density.
- k. Zoning designation.
- l. The boundary lines of the proposed subdivision.
- m. City limits and section lines.
- n. Park or open space (if proposed).
- o. Existing topography at two-foot maximum interval.
- p. The boundaries and approximate dimensions of all blocks and lots, together with the numbers proposed to be assigned each lot and block, and the dimensions, square footage and acreage of all proposed lots and tracts.
- q. Proposed names of streets.

- r. The location and widths of streets, alleys, rights-of-way, easements (both public and private), turn around and emergency access, parks and open spaces.
- s. Conditions of adjacent property, platted or unplatted, and if platted, giving the name of the subdivision. If the proposed short plat is the subdivision of a portion of an existing plat, the approximate lines of the existing plat are to be shown along with any and all recorded covenants and easements.
- t. The names and address of the record owners and taxpayers of each parcel adjoining the subdivision.
- u. Indicate any street grades in excess of eight percent.
- v. The location and, where ascertainable, sizes of all permanent buildings, wells, wellhead protection areas, sewage disposal systems, water courses, bodies of water, flood zones, culverts, bridges, structures, overhead and underground utilities, railroad lines, and other features existing upon, over or under the land proposed to be subdivided, and identifying any which are to be retained or removed.
- w. Proposed one-foot strips for right-of-way conveyed to the City, in cases where a proposed public street or alley abuts unplatted land.
- x. If a body of water forms the boundary of the plat, the ordinary high water mark as defined in chapter 90.58 RCW.
- y. Critical areas as defined in chapters 17E.020, 17E.030, 17E.070 and 17G.030 SMC.
- z. Significant historic, cultural or archaeological resources; and
- aa. If the proposal is located in an irrigation district, the irrigation district name.

C. Review of Preliminary Short Plat

1. The application shall be reviewed in accordance with the procedures set forth in chapter 17G.060 SMC for a Type II application, except an application that meets the requirements for minor engineering review as provided in subsection (2) of this section shall be excluded from the public notice requirements contained in SMC 17G.060.110 through 17G.060.120 and public comment period under SMC 17G.060.130.
2. Minor Engineering Review.  
A preliminary short plat application may qualify for a minor engineering review if it meets all of the following conditions:
  - a. The application is categorically exempt from chapter 43.21C RCW (SEPA);

- b. There is direct water and sewer main lot frontage on an existing and improved public right-of-way;
- c. No extensions of public water, sewer, or other utility services will be needed;
- d. No public easements for water, sewer, or other utility service exists on the lot; and
- e. The lot is not situated in a Special Drainage District as defined in SMC 17D.060.130.

D. Public Notice

All public notice of the application shall be given in accordance with the procedures set forth in chapter 17G.060 SMC for a Type II application, except a short plat that meets the requirements for minor engineering review as provided in subsection (C)(2) of this section shall not require a notice of application.

E. Preliminary Short Plat Approval Criteria

Prior to approval of a short plat application, the director shall find the application to be in the public use and interest, conform to applicable land use controls and the comprehensive plan of the City, and the approval criteria set forth in chapter 17G.060 SMC. The director has the authority to approve or disapprove a proposed preliminary short plat under the provisions of this chapter, subject to appeal as provided in chapters 17F.050 and 17G.060 SMC.

F. Final Short Plat Review Procedure

1. The subdivider shall submit to the director for review the following:
  - a. A final short plat, prepared by a registered land surveyor licensed in the state of Washington, consistent with the approved preliminary short plat.
  - b. A title report less than thirty days old confirming that the title of the lands as described and shown on said plat is in the name of the owners signing the certificate or instrument of dedication.
  - c. Covenants, conditions and restrictions, if applicable; and
  - d. Fees pursuant to chapter 8.02 SMC.
2. Within thirty days, unless the applicant has consented to a longer period of time, of receipt of a proposed final short plat, the director shall review the plat for conformance with all conditions of the preliminary short plat approval, the requirements of this chapter and that arrangements have been made to insure the construction of required improvements. If all such conditions are met, the director shall approve the final short plat and authorize the recording of the plat. If all conditions are not met, the director shall provide the applicant in writing a statement of the necessary changes to bring the final short plat into conformance with the conditions.

- a. If the final short plat is required to be resubmitted, the subdivider is required to provide the following:
  - b. A cover letter addressing the corrections, additions or modifications required.
  - c. Title report no older than thirty days from issuance of a title company conforming that the title of the lands as described and shown on said plat is in the name of the owners signing the certificate or instrument of dedication; and
  - d. The required number of copies of the corrected final short plat map.
3. If the final short plat is approved, the surveyor causes the plat to be signed by the Spokane county treasurer and file of record with the Spokane county auditor. The surveyor is required to file the appropriate number of mylar and bond copies of the recorded short plat with the director.

G. Final Short Plat Map Requirements

The subdivider shall submit to the director a final short plat in the same form and with the same content as the preliminary short plat, as provided in subsections (B)(1) and (2) of this section, with the following exceptions or additional requirements:

1. A final short plat shall contain all the information required of the preliminary plat, except the following:
  - a. Show existing buildings.
  - b. Show existing utility lines and underground structures.
  - c. Show the topographical elevations; or
  - d. Contain the names and addresses of adjoining landowners.
2. The final short plat shall include the following:
  - a. Surveyor's certificate, stamp, date and signature, as follows:

The following land surveyor's certificate to be shown on each sheet of the plat: "I, \_\_\_\_\_ registered land surveyor, hereby certify the plat of \_\_\_\_\_, as shown hereon, is based upon actual field survey of the land described and that all angles, distances, and courses are correctly shown and that all non fronting lot corners are set as shown on the plat. Monuments and fronting lot corners shall be set upon completion of the utility and street improvements.

Signed \_\_\_\_\_(Seal)"
  - b. A certification by the city treasurer, as applicable:
    - i. "I hereby certify that the land described by this plat, as of the date of this certification, is not subject to any local improvement assessments. Examined and approved, this \_\_\_\_\_ day of \_\_\_\_\_, 20\_\_.

\_\_\_\_\_  
City of Spokane Treasurer”

- ii. “I hereby certify that the land described by this plat, as of the date of this certificate, is not subject to any delinquent local improvement assessment. Future installments, if any, shall remain due and payable and it shall be the responsibility of the owners to initiate the segregation of the LID assessment. Examined and approved, this \_\_\_\_ day of \_\_\_\_\_, 20\_\_.

\_\_\_\_\_  
City of Spokane Treasurer”

- iii. “A preliminary local improvement assessment exists against this property. It shall be the responsibility of the owner’s to initiate the segregation of the LID assessment. After this assessment is finalized, it shall be due and payable. Examined and approved this \_\_\_\_ day of \_\_\_\_\_, 20\_\_.

\_\_\_\_\_  
City of Spokane Treasurer”

- c. The certification by the planning director, as follows:  
“This plat has been reviewed on this \_\_\_\_ day of \_\_\_\_\_, 20\_\_ and is found to be in full compliance with all the conditions of approval stipulated in the Hearing Examiner’s/Planning Director’s approval of the preliminary plat # - -PP/SP.

\_\_\_\_\_  
City of Spokane Planning Director”

- d. The certification by the city engineer, as follows:  
“Approved as to compliance with the survey data, the design of public works and provisions made for constructing the improvements and permanent control monuments this \_\_\_\_ day of \_\_\_\_\_, 20\_\_.

\_\_\_\_\_  
City of Spokane Engineer”

- e. The certification by the Spokane county treasurer, as follows:  
“I hereby certify that the land described in this plat, as of the date of this certification, is not subject to any outstanding fees or assessments. Examined and approved \_\_\_\_ day of \_\_\_\_\_, 20\_\_.

\_\_\_\_\_  
Spokane County Treasurer”

- f. The certification by the Spokane county auditor on each page of the final short plat including the time, date, book and page number of the recording of the final mylar.

- g. Signature of every owner certifying that:
  - i. the plat is made with the free consent and in accordance with the desires of the owners of the land;
  - ii. the owners are the owners of the property and the only parties having interest in the land and is not encumbered by any delinquent taxes or assessments;
  - iii. the owners adopt the plan of lots, blocks and streets shown;
  - iv. owner dedicates to the City and the City's permittees the easements shown for utilities and cable television purposes;
  - v. owner dedicates to the City the streets, alleys and other public places, including slope and construction easements and waives all claims for damages against any governmental authority including, without limitation, the City which may be occasioned to the adjacent land by the establishment, construction, drainage and maintenance of any public way so dedicated; and
  - vi. owner conveys to the City as general City property the buffer strips adjoining unplatted property.
- h. The drawing shall:
  - i. be a legibly drawn, printed or reproduced permanent map;
  - ii. if more than one sheet is required, each sheet shall show sheet numbers for the total sheets;
  - iii. have margins that comply with the standards of the Spokane county auditor;
  - iv. show in dashed lines the existing plat being replatted, if applicable;
  - v. show monuments in accordance with SMC 17G.080.020(H)(1);
  - vi. include any other information required by the conditions of approval; and
  - vii. include any special statements of approval required from governmental agencies, including those pertaining to flood hazard areas, shorelines, critical areas and connections to adjacent state highways.

#### H. Filing.

Once the final plat has been reviewed, approved and signed by the applicable departments, the applicant shall file the final short plat with the county auditor within ten days of approval. No permits shall be issued for a proposed lot until the required conformed copies of the short plat have been submitted to the planning services department.

I. Redivision.

No land within the boundaries of a short subdivision may be further divided in any manner which will create additional lots within a period of five years except by subdivision in accordance with SMC 17G.080.050.





## NONPROJECT DETERMINATION OF NONSIGNIFICANCE

**FILE NO(s):** Shaping Spokane Housing – Residential Development Code Revisions

**PROPONENT:** City of Spokane

### DESCRIPTION OF PROPOSAL:

Following adoption of the [Spokane Housing Action Plan](#) (Res. 2021-0062), the City has initiated a series of text amendments that enact Housing Action Plan strategies to encourage construction of more housing, and increase affordability and housing variety. These amendments are being adopted in order to implement the Legislature’s recommended actions outlined by [RCW 36.70A.600\(1\)](#) in order to increase residential building capacity. Per the provisions of RCW 43.21C.495 State Environmental Policy, this action is not subject to administrative or judicial appeals, as this action is taken expressly to implement provisions of RCW 36.70A.600 “Increasing residential building capacity.”

This proposal will amend Spokane Municipal Code (SMC): Section 17C.110.200, Lot Size, and 17C.110.225, Accessory Structures; and Chapter 17C.300, Accessory Dwelling Units, specifically Sections 17C.300.100, 17C.300.110, 17C.300.120, 17C.300.130, and 17C.300.140. Additional amendments are being made to short plat notification requirements revising Sections 17G.060.100, 17G.060T.003, 17G.060.130, and 17G.080.040; which are procedurally exempt from SEPA review per WAC 197-11-800(19). The exact amendments to the code are available online at the following address: [ShapingSpokaneHousing.com](#).

**LOCATION OF PROPOSAL, INCLUDING STREET ADDRESS, IF ANY:** This proposal has a City-wide impact

**LEAD AGENCY:** City of Spokane

### DETERMINATION:

The lead agency for this proposal has determined that it does not have a probable significant adverse impact on the environment. An Environmental Impact Statement (EIS) is not required under RCW [43.21C.030\(2\)\(c\)](#). This decision was made after review of a completed environmental checklist and other information on file with the lead agency. This information is available to the public upon request.

- There is no comment period for this DNS.
- This DNS is issued after using the optional DNS process in section 197-11-355 WAC. There is no further comment period on the DNS.
- This DNS is issued under 197-11-340(2); the lead agency will not act on this proposal for at least 14 days from the date of issuance (below). **Comments regarding this DNS must be submitted no later than 12:00 p.m. on May 11, 2022 if they are intended to alter the DNS.**



\*\*\*\*\*

**Responsible Official:** Spencer Gardner

**Position/Title:** Director, Planning Services

**Address:** 808 W. Spokane Falls Blvd., Spokane, WA 99201

**Phone:** 509-625-6097

**Date Issued:** April 25, 2022

**Signature:** \_\_\_\_\_  \_\_\_\_\_

\*\*\*\*\*

**APPEAL OF THIS DETERMINATION:**

Per the provisions of RCW 43.21C.495 State Environmental Policy, **this action is not subject to administrative or judicial appeals**, as this action is taken expressly to implement provisions of RCW 36.70A.600 "Increasing residential building capacity." RCW 43.21C.495 states that amendments to development regulations or comprehensive plans to implement certain portions of RCW 36.70A.600 may not be appealed.

<b>Date</b>	<b>Name/Event</b>
11/10/2021	Plan Commission workshop
11/11/2020	City Council study session
11/18/2021	Land Use Committee of the Community Assembly
12/8/2021	Plan Commission workshop
12/17 & 12/22/2021	Winter Market at Riverfront Park (approximately 120 visitors)
1/6/2022	Community Assembly
1/12/2022	Plan Commission workshop
1/18/2022	Lincoln Heights Neighborhood Council
1/25/2022	Virtual Open House #1 – 29 participants
1/26/2022	Plan Commission workshop
1/27/2022	Virtual Open House #2 – 35 participants
2/9/2022	Plan Commission workshop
2/10/2022	City Council study session
2/17/2022	Land Use Committee of the Community Assembly
2/23/2022	Plan Commission workshop
3/9/2022	Plan Commission workshop
3/23/2022	Plan Commission workshop
4/6, 4/13, 4/20, 4/27/2022	Spring Market at Riverfront Park (approximately 190 visitors)
4/12/2022	University District Development Committee
4/12/2022	West Hills Neighborhood Council
4/13/2022	Plan Commission workshop
4/21/2022	Land Use Committee of the Community Assembly
4/27/2022	Plan Commission workshop
5/05/2022	City Council study session
5/05/2022	Community Assembly

## Comment Log and Public Comments

### Substantive Public Comments Received - Updated 05/11/2022

	<b>Date</b>	<b>Name</b>	<b>Topic(s)</b>	<b>Page</b>
1	1/14/2022	Todd Sullivan	ADU size, ADU parking, Short-term rentals	3
2	1/20/2022	Ann Wick	ADU roof and material, ADU parking	5
3	1/20/2022	Hype Beast	Code & zoning changes for housing, Other	6
4	1/25/2022	Conor Muirhead	ADU size, ADU parking	11
5	1/27/2022	Vic Plese	Code changes for housing	13
6	1/28/2022	Sally Phillips	ADU parking	15
7	2/6/2022	Toni Sharkey	Code changes for housing, Duplexes	20
8	2/18/2022	Toni Sharkey	SEPA, Short-term rentals, Duplexes, Attached Homes	17
9	2/20/2022	Jim Frank	ADU size, ADU parking, ADU occupancy, Lot Size Transition	22
10	2/22/2022	Craig Hunt	Short-term rentals	26
11	2/27/2022	Jordan Brown	ADU occupancy	27
12	3/3/2022	Paul Knowles	ADUs, ADU occupancy	28
13	3/12/2022	Jeannie Robinson	ADUs, ADA accessibility	29
14	3/14/2022	Brad Harland	ADU occupancy	30
15	3/15/2022	Shari Mcevoy	ADUs, ADU occupancy	32
16	3/17/2022	Kate Bitz	Attached Homes, Duplexes	33
17	3/17/2022	Cheri Loveland	SEPA	34
18	3/22/2022	Zach Widmer	ADUs, Short-term rentals, ADU parking	35
19	3/24/2022	Diane Benson	Duplexes, Other	37
20	3/24/2022	Evelyn Popejoy	Short-term Rentals, Code changes for housing	38
21	4/6/2022	Barbara Morrissey	Code changes for housing	39
22	4/6/2022	Tracy Parks	Other	40
23	4/6/2022	John Schram	Short-term rentals, Duplexes, Attached Homes	42-46
24	4/9/2022	Brikjames	Code changes for housing	47
25	4/11/2022	Mary Winkes	ADU parking	49
26	4/14/2022	Phyllis Holmes	Short plat notification	50
27	4/14/2022	Nancy Sazama	Short plat notification, SEPA	52
28	4/15/2022	Robyn Hoffenberg	Short plat notification, SEPA	54
29	4/15/2022	Candace Smallfoot	Short plat notification, SEPA	57
30	4/15/2022	Kevin Stevens	Short plat notification, SEPA	60

## Comment Log and Public Comments

31	4/15/2022	Dick Thiel	Short plat notification, SEPA	64
32	4/16/2022	Karen Carlberg	Short plat notification, SEPA	65-68
33	4/18/2022	Mellisa Donaldson	Short plat notification, SEPA	69
34	4/20/2022	Carmela Conroy	ADU	72
35	4/21/2022	Ryan Hughes	ADU	74
36	4/21/2022	Will Maupin	General Phase 1 Code Topics	75
37	4/21/2022	Mariah McKay	ADU	77-81
38	4/22/2022	Liza Mattana	ADU, Attached Homes, Duplex	82
39	4/22/2022	Alice Galeotti	ADU	83
40	4/22/2022	Darin Watkins	General Phase 1 Code Topics	85
41	4/22/2022	Gene Brake	ADU, STR, Duplex	87
42	4/25/2022	Ben Stuckart (SLIHC)	ADU, Short plat notification, SEPA	89
43	4/26/2022	Carol Tomsic	Duplexes, Attached Homes, Short plat notification	90
44	4/28/2022	Gene Brake	General Phase 1 Code Topics	92
45	5/3/2022	Spokane Regional Continuum of Care	ADU, Short plat notification, SEPA	93
46	5/4/2022	Jim Frank	Lot Size Transition, Short Plat notification, ADU	94
47	5/4/2022	Darin Watkins	Lot Size Transition, Short Plat notification, ADU	99
Received after May 11 Plan Commission packet was posted on 5/4/2022				
48	5/10/2022	Carol Tomsic	Lot Size Transition	104
49	5/11/2022	Matt Side	Attached Homes, Duplexes, ADUs	105

## Beck, Amanda

---

**From:** Planning Services Development Code  
**Sent:** Friday, January 21, 2022 3:45 PM  
**To:** Todd Sullivan  
**Subject:** RE: ADU Comments from a Home Builder

Hi Todd,

Thank you for providing public comment concerning the proposed revisions to ADU regulations. This is now part of the public record for the project, and will be shared with the Plan Commission at the public hearing. We really appreciate your insightful and informed comments- in our research we've noticed that trend to increase the size for an ADU.

We are still exploring the range of code alternatives for accessory dwelling units. Plan Commission has another workshop to discuss this as well as duplexes, attached homes, and lot size transitions at their January 26<sup>th</sup> meeting that begins at 2:00 pm. If you're able or interested in attending, [the agenda](#) has the Webex login information. If not, it will be uploaded to the City's [Vimeo](#) soon after the meeting.

Thank you,  
 Amanda

Amanda Beck, AICP | City of Spokane | Assistant Planner II  
 509-625-6414 | *main* 509-625-6500 | [abeck@spokanecity.org](mailto:abeck@spokanecity.org) | [spokanecity.org](http://spokanecity.org)



---

**From:** Todd Sullivan <toddsull@live.com>  
**Sent:** Friday, January 14, 2022 9:19 AM  
**To:** Planning Services Development Code <erapsdc@spokanecity.org>  
**Subject:** ADU Comments from a Home Builder

**[CAUTION - EXTERNAL EMAIL - Verify Sender]**

As a home builder in the Spokane, Coeur d'Alene and Hayden region, we have been designing proposed ADU's in the Kootenai County for the last 2 years.

My recommendations that stem from my experience in Kootenai is as follows:

- Increase ADU size to 1,000. This provides an ADU with 2 bedrooms and 1 bathroom. Our typical ADU design will have on bedroom acting as an office.
- Require the ADU to match the primary home roof system. This will minimize chaotic design and integrate better with the property and neighborhood. If not, you will have shed roof ADU's as it's cheap to build and the result will be sheds in the backyard.
  - Drive around Coeur d'Alene and look at all the ADU's that are negatively impact the aesthetics of the neighborhood.
- Require 1 parking spot on the property. This is important as the ADU will likely become a rental or unit for family. Parking on-street creates havoc and congestion.
- Short term rentals are an issue. Coeur d'Alene has numerous ADU's for the AirBnB market. In the summer, it becomes hectic with parties, crowds, etc. The owners use the ADU's as additional revenue sources. An ADU

within walking distance to the lake can produce \$75,000 plus in revenue per year if properly managed. I don't have an opinion if that should be a factor, but it's important to understand.

If interested, I'm always available for comment and discussion.

Thanks,  
Todd Sullivan  
Sullivan Homes  
(208) 755-1017  
[todd@sullivanhomespnw.com](mailto:todd@sullivanhomespnw.com)

Sent from [Mail](#) for Windows

## Beck, Amanda

---

**From:** Planning Services Development Code  
**Sent:** Friday, January 21, 2022 3:19 PM  
**To:** ANN Wick  
**Subject:** RE: ADU housing

Hi Ann,

Thank you for providing public comment concerning the proposed revisions to ADU regulations. This is now part of the public record for the project, and will be shared with the Plan Commission for the public hearing once that is scheduled.

We are still exploring the range of code alternatives for accessory dwelling units. Plan Commission has another workshop to discuss this as well as duplexes, attached homes, and lot size transitions at their January 26<sup>th</sup> meeting that begins at 2:00 pm. If you're able or interested in attending, [the agenda](#) has the Webex login information. If not, it will be uploaded to the City's [Vimeo](#) soon after the meeting.

Thank you,  
Amanda

**Amanda Beck, AICP** | City of Spokane | Assistant Planner II  
509-625-6414 | *main* 509-625-6500 | [abeck@spokanecity.org](mailto:abeck@spokanecity.org) | [spokanecity.org](http://spokanecity.org)



---

**From:** ANN Wick <TWNANDCNTRY@msn.com>  
**Sent:** Thursday, January 20, 2022 10:07 PM  
**To:** Planning Services Development Code <erapsdc@spokanecity.org>  
**Subject:** ADU housing

**[CAUTION - EXTERNAL EMAIL - Verify Sender]**

I do not believe allowing different styles and different roof pitches would be a good idea for neighborhoods. It would definitely not allow for neighborhood continuity. In addition by not requiring parking the already overcrowded streets would be worse.

Ann Wick

Sent from [Mail](#) for Windows



## Beck, Amanda

---

**From:** Beck, Amanda  
**Sent:** Friday, January 21, 2022 3:41 PM  
**To:** tmbssoe@gmail.com  
**Subject:** Re: Shaping Spokane Housing Update

Good afternoon,

Thank you for providing public comment concerning the residential development code changes proposed under the Shaping Spokane Housing project. These comments have been added to the public record, and will be shared with the Plan Commission at public hearing.

The seven code changes under consideration are possible within the current Comprehensive Plan framework- they would not require amending things like density, land use categories, or the land use map. Some of your detailed suggestions would require code amendments in conjunction with changes to the Comprehensive Plan, which is the action the City will be taking in the second phase of changes. You are welcome and encouraged to reach out to your City Council Member to discuss these ideas as well, as they consider and collaborate with staff on setting the Plan Commission's work program each year.

We're still working through code alternatives with the Plan Commission. They will be further discussing accessory dwelling units, duplexes, attached homes, and lot size transitions at their January 26<sup>th</sup> meeting that starts at 2:00 pm. The [agenda](#) has the Webex login information if you are able or interested in attending, and the video will be posted to the City's [Vimeo](#) account soon after the workshop. Several of the other workshops with Plan Commission discussing these code amendments are available online now.

Thank you,  
 Amanda

Amanda Beck, AICP | City of Spokane | Assistant Planner II  
 509-625-6414 | main 509-625-6500 | [abeck@spokanecity.org](mailto:abeck@spokanecity.org) | [spokanecity.org](http://spokanecity.org)



**From:** Hype Beast <[tmbssoe@gmail.com](mailto:tmbssoe@gmail.com)>  
**Date:** January 20, 2022 at 6:25:58 PM PST  
**To:** "Davis, Kirstin" <[kdavis@spokanecity.org](mailto:kdavis@spokanecity.org)>  
**Subject:** Re: Shaping Spokane Housing Update

**[CAUTION - EXTERNAL EMAIL - Verify Sender]**  
 k.

Hello, I get and read all the e-mails that you send me. If the city really wants to help development the below items are great but that not your pinch point.

Your pinch point are as follows:

1. Stormwater systems, not being allow to count as open space, or to be used as the 44sf per unit area. People don't typical do stuff outside in bad or cold weather. So the rest of the time it should be an acceptable area to recreate in.

2. Update your Zoning in the City. High density zone should follow your center a corridor codes, but it really they don't on the south by target you have RSF they between apartments in the county and C2-DC that should RMF. Where there is a school you should have more RMF ground as that is a center by the cities definition. Down by Inland Empire that whole area should be a center and corridor as it is it's own community. Out by Geiger and Sunset Blvd the large area of RSF should be RMF as it is difficult ground between two commercial zones.
3. The City should contemplate extending Barnes road down to pine meadow road you have plans on file to do this. This would fix traffic problems in this area.
4. The area around Salk Middle school and the Indian trail shopping center should be a center and corridor just based on traffic alone.
5. Holy Cross Cemetery should be rezoned to RMF, as it is an adjacent to a large shopping area per the centers and corridor code.
6. Garlands RTF zone should be RMF so that, that area can better support local business by having more population.
7. STA, should only focus on major roads and have short wait times and not have a route every where with horrible wait and transit times. Please note that those bus destroy road are exempt from having the correct number of axials per law based on their vehicle weight.
8. The area east of Esmeralda Gold course should be RMF as it impacts no RSF

### Hype Beast

From: City of Spokane Planning <[kdavis@spokanecity.org](mailto:kdavis@spokanecity.org)>



**Duplexes in Residential Single Family Zone**  
 Expand the permitted zoning districts and lot types, update design standards to integrate with neighborhood character.

Dear Community Member,

You are receiving this email because you have shown interest in the Housing Action Plan and requested information about housing topics. The 2021 [Housing Action Plan](#) provided several recommendations and the City planning department has organized them in phases for completion to address the housing crisis.



**Accessory Dwelling Units**

Increase flexibility of development and design standards for Accessory Dwelling Units (ADU).



**Attached Housing**

Encourage infill development, update development and design standards to integrate with neighborhood character.

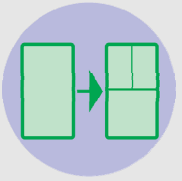

**Short Plat Application Process**

Reduce or streamline the notification and commenting requirements.



**Short Term Rentals**

Expand allowable zones to enable licensing compliance.



**Environmental Review Thresholds**

Adopt exemption levels as permitted in WAC 197-11-800 to streamline permitting processes, add standards for discovery of historic artifacts.

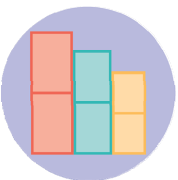

**Lot Size Transition Requirements**

Clarify development regulations, and provide additional flexibility for natural topography or critical areas.

### Learn More and Ask Questions at a Virtual Open House!

Two virtual public open houses have been scheduled to share information and gather input on the proposals. The City is offering two sessions online and by phone over the Webex meeting platform. Both open house sessions will feature the same content.

#### VIRTUAL OPEN HOUSE AGENDA

- **Introduction to Residential Development Code Amendment Process** (10 minutes)
- **Accessory Dwelling Units, Duplexes in More Areas, Attached Housing and Lot Size Transition** (10 minutes)
- **Q&A** (30 minutes)
- **Short Subdivisions, Short-Term Rentals, Environmental Review Thresholds** (10 minutes)
- **Q&A** (30 minutes)

**Tuesday, Jan. 25**  
12-1:30 p.m.  
Registration

**Thursday, Jan. 27**  
4-5:30 p.m.  
Registration

### We want your feedback!

You can **review a description of each proposal on the [project webpage](#)**, which will be updated as the draft revisions evolve.

- **Provide written comment in email to [DevelopmentCode@spokanecity.org](mailto:DevelopmentCode@spokanecity.org)**. This email list will be notified regarding additional opportunities for participation.
- **Sign up for email updates and announcements [here](#).**

### Plan Commission Workshops

Additionally, two City Plan Commission workshops have been scheduled to review possible revisions to the code. Public hearings have not been scheduled at this time. Please visit the [Plan Commission webpage](#) to view the Agendas, which contain packet material available for review and instructions for joining the virtual meetings:

- Wednesday, Jan. 12
- Topics: Short Subdivisions up to 9 Lots, Short-Term Rentals, and Environmental Review Thresholds (Minutes will be posted on the webpage soon.)
- Wednesday, Jan. 26 starting at 2:00 PM
- Topics: Accessory Dwelling Units, Duplexes, Attached Housing, and Lot Size Transition Requirements

You are receiving this email because you signed up via the [Spokane Housing Action Plan website](#), have been identified as an individual or stakeholder in the discussion, or expressed interest in receiving planning project updates from the City of Spokane. Please feel free to share this email with others who are interested in receiving [email announcements](#) about this project. To unsubscribe, please email [developmentcode@spokanecity.org](mailto:developmentcode@spokanecity.org).



[Unsubscribe ewhipple@whipplece.com](#)

[Update Profile](#) | [Constant Contact Data Notice](#)

Sent by kdavis@spokanecity.org powered by



## Beck, Amanda

---

**From:** Beck, Amanda  
**Sent:** Friday, January 28, 2022 10:59 AM  
**To:** Conor Muirhead  
**Subject:** Re: Comment on ADU changes

Hi Connor,

Thank you for providing public comment concerning the proposed revisions to ADU regulations. This is now part of the public record for the project, and will be shared with the Plan Commission at the public hearing. We really appreciate your comments- in our research we've noticed a trend to increase the size for an ADU.

It's not up on our [project webpage](#) just yet, but this week the Plan Commission heard from our consultant on proposals around ADU changes, one of them being to increase the detached ADU size from 600 to 800 square feet. We're also looking at allowing for a floor area ratio bonus that would hopefully help encourage ADU construction as well, in addition to relaxing parking requirements. The recording of the Plan Commission workshop should be uploaded soon, so check back in case you would like to watch it!

If you were able to attend the open house Thursday you might have seen/heard there are people on both sides of the issue concerning parking- some with concerns that it shouldn't be relaxed, and others who see parking requirements as discouraging ADU construction. Your comments on the matter are appreciated.

Thank you,  
 Amanda



**Amanda Beck, AICP** | City of Spokane | Assistant Planner II  
 509-625-6414 | main 509-625-6500 | [abeck@spokanecity.org](mailto:abeck@spokanecity.org) | [spokanecity.org](http://spokanecity.org)



*This email is subject to Washington State Public Records Act, Chapter 42.56 RCW, and may therefore be subject to public disclosure.*

-----Original Message-----

**From:** Conor Muirhead [muirheadc@gmail.com](mailto:muirheadc@gmail.com)  
**Sent:** Tuesday, January 25, 2022 10:47 PM  
**To:** Planning Services Development Code [erapsdc@spokanecity.org](mailto:erapsdc@spokanecity.org)  
**Subject:** Comment on ADU changes

[CAUTION - EXTERNAL EMAIL - Verify Sender]

Hi there,

I just wanted to take a minute to let you all know that I'm very happy you're considering changes around ADU codes, and wanted to emphasize a couple aspects that I hope you'll include in the changes.

Foremost, my hope is that you'll allow for something like a 2-unit ADU to be built in a backyard. At 600 sq. ft each, this could still be done reasonably well on a larger lot.

Second, I hope you'll increase the allowed square footage for detached ADUs, if I'm going through the effort to build a new structure, I'd like it to be large enough to be able to provide a good return on my investment.

Third, I hope that parking requirements will be eased, given that my area utilizes very little street parking, and having some cars on the street feels very reasonable.

Thanks for working on this project, I'm hopeful that we'll be able to make Spokane housing more accessible as a result.

Best,  
-Conor Muirhead

## Gwinn, Nathan

---

**From:** Beck, Amanda  
**Sent:** Friday, January 28, 2022 12:40 PM  
**To:** Vic Plese; Gwinn, Nathan  
**Subject:** RE: Virtual open house - Code Amendments

Hi Vic,

Thank you for attending the Thursday open house for the residential code initiative concerning [Shaping Spokane Housing](#).

We recorded both open house sessions (2<sup>nd</sup> one will be up on our webpage soon), as well as several past presentations. If you're interested, I highly recommend viewing the Plan Commission workshop from January 12, where we discuss permit processes. The January 26 Plan Commission workshop discussing ADUs/duplexes/etc. from this week will be uploaded to the project page soon- definitely check them out if you have a chance.

If you would like to provide public comment on the project as a whole, or specific code amendments, we would welcome your comments. Please feel free to send those to either Nate or me. Similarly, please encourage other city residents or professionals you know to do the same!

Thank you,  
 Amanda

**Amanda Beck, AICP** | City of Spokane | Assistant Planner II  
 509-625-6414 | main 509-625-6500 | [abeck@spokanecity.org](mailto:abeck@spokanecity.org) | [spokanecity.org](http://spokanecity.org)



---

**From:** Vic Plese <Vic@plese.com>  
**Sent:** Thursday, January 27, 2022 5:21 PM  
**To:** Gwinn, Nathan <ngwinn@spokanecity.org>  
**Cc:** Beck, Amanda <abeck@spokanecity.org>  
**Subject:** Virtual open house - Code Amendments

**[CAUTION - EXTERNAL EMAIL - Verify Sender]**

Nathan & Amanda,

Thanks so much for your time working on this - we really need as many options as we can get with the housing shortage. I know I will have clients ask me about these changes so I wanted to have as much info as possible. I'm sorry I was multitasking during the meeting and I had people installing carpet in my office (UGGH) otherwise I would have had my video on. Hate to be rude I mainly wanted to listen. Let me know if I can help anytime if you need Realtor or developer input.

Have a great night...

Vic



**Vic Plese, SRES**

Selling Spokane for 33 years

Licensed in WA & ID

Managing Broker,

PLESE REALTY LLC

Family owned and operated since 1958

201 West Francis Ave

Spokane, WA 99205

e-mail [vic@plese.com](mailto:vic@plese.com)

[WWW.PLESE.COM](http://WWW.PLESE.COM)

**509-217-7889 cell**

**509-489-2323 office**

**509-466-4677 residence**

**509-489-3333 fax**

**888-450-2323 toll free**

**NEW HOMES \*\*\* EXISTING HOMES \*\*\* COMMERCIAL SALES  
LAND DEVELOPMENT \*\*\* LEASING \*\*\* NOTARY PUBLIC**

**From:** [Planning Services Development Code](#)  
**To:** [Sally Phillips](#)  
**Subject:** RE: Housing code changes - one more comment  
**Date:** Friday, January 28, 2022 12:33:00 PM  
**Attachments:** [image001.png](#)  
[image002.png](#)  
[image003.png](#)

---

Hi Sally,

Thank you for providing public comment on proposed revisions to residential code related to the project [Shaping Spokane Housing](#). This is now part of the public record for the project, and will be shared with the Plan Commission at the public hearing.

We're glad to hear that both presentations were useful! Except for the Plan Commission workshop that happened Wednesday this week, all of our past presentations are on the project webpage if you want to see us discuss items in more detail. Nate and I went into more detail with Plan Commission on January 12 about permit processes, and into more detail about ADUs/duplexes/etc. at their January 26 meeting. The video for the meeting on the 26<sup>th</sup> will be uploaded to the webpage soon, definitely check it out if you're interested.

As I'm sure you saw/heard at the open house on Thursday, there are people on both sides of the issue concerning parking- some with concerns that it shouldn't be relaxed, and others who see parking requirements as discouraging ADU construction. We're trying to balance not building to park cars, as you say, but also not creating parking issues- it's can be tricky to strike the correct balance. Your comments on the matter are appreciated.

Thank you,  
Amanda

**Amanda Beck, AICP** | City of Spokane | Assistant Planner II  
 509-625-6414 | main 509-625-6500 | [abeck@spokanecity.org](mailto:abeck@spokanecity.org) | [spokanecity.org](http://spokanecity.org)



---

**From:** Sally Phillips <phillips1948@comcast.net>  
**Sent:** Friday, January 28, 2022 10:44 AM  
**To:** Planning Services Development Code <erapsdc@spokanecity.org>  
**Subject:** Housing code changes - one more comment

**[CAUTION - EXTERNAL EMAIL - Verify Sender]**

**I attended your presentation yesterday on the proposed housing code changes.**

**Thanks for offering the presentation. I also received a briefer version at the Lincoln Heights Neighborhood Council meeting and found both helpful. It was particularly nice to have the slides with prompting questions for us attendees.**

**This is only one vote, but I would like you to know that I support reducing the parking requirement in developments. I am more interested in housing people than cars. I assume the plan where on-site parking is reduced is that people will park on the street. I am OK with that, but it would put more pressure on curbside parking. It seems like people feel very proprietary about curb space in front of their home, thinking (I believe erroneously) that it belongs to them. How you change that attitude, I don't know.**

**Again, nice job on the presentation.**

**Sally Phillips**

**Gwinn, Nathan**

---

**From:** Gwinn, Nathan  
**Sent:** Tuesday, February 22, 2022 4:59 PM  
**To:** 'Antonia DePasquale'  
**Subject:** RE: Housing Ordinance

Good afternoon Toni,

Thanks for your comments. I will combine this with the others and add to the record for the file.

Yes, the Council could ultimately choose to adopt all or part of the amendments. Yes, please send the link.

Nate

**Nathan Gwinn, AICP** | Assistant Planner | Planning & Development  
 509.625.6893 | [ngwinn@spokanecity.org](mailto:ngwinn@spokanecity.org) | [www.spokanecity.org](http://www.spokanecity.org)

Residential Development Code amendments project webpage: [my.spokanecity.org/projects/shaping-spokane-housing](http://my.spokanecity.org/projects/shaping-spokane-housing)

---

**From:** Antonia DePasquale <depasquale5@yahoo.com>  
**Sent:** Friday, February 18, 2022 8:56 PM  
**To:** Gwinn, Nathan <ngwinn@spokanecity.org>  
**Subject:** Re: Housing Ordinance

**[CAUTION - EXTERNAL EMAIL - Verify Sender]**

Good evening Nate, I was trying to be more supportive and open minded about the ordinance last night. The city of Spokane SEPA notifications are so transparent to the citizens, it is refreshing. In the valley notifications are the size of a piece of paper or found in the newspaper, so there are a lot of folks upset that there are so many apartments that happen so quick there.

Short term rentals folks hate them and they hate them with a passion, well 80% do, the 10-20% that are making a cash love them.

Is that piece of the ordinance to get a little more accountability, so we can do a moratorium or a reduction? At Friday Harbor (is where we are at right now ;- ) there's a moratorium on them and they have to give a pretty high percentage to the San Juan Island Land Trust.

So when Council votes, can they vote on certain pieces of the ordinance? Because there are some pieces that I do support, having more housing opportunities for home ownership. And the parking in back I like! Less curb cuts so we can add more trees & green, I like!

I printed this out a couple months back, you may want to change the language highlighted, it makes it seem like duplexes are only rentals.

Making sure that you're in the know about the legislation Andy Billig is working on about developing on undeveloped space? If not, I can send you a link? We could add 40,000 residents to our downtown if there were more developments: high rise condo, retail, apartments, townhomes penthouse OK too!

Nov. 10, and joint Study Session with City Council on Thursday, Nov. 11.

The Housing Action Plan identified potential first steps necessary to address housing affordability. Following any code revisions, **residents could see new types of housing in their neighborhoods**. For example, one recommendation that could be included is the introduction of small-scale duplex development in areas where single-family houses are more common. A duplex is a building that contains primary homes for two families living independently on a single lot. **Additional duplex development would give renters more housing options, increasing overall supply in the community.** However, in allowing additional duplex development as part of this first phase of code changes, design standards and neighborhood compatibility will be taken into consideration.

In many established neighborhoods, the City expects little physical change on any given block. But on a larger scale and in growing neighborhoods, **the ability for additional owners or developers to choose to build duplexes, accessory dwelling units, and attached housing is part of a coordinated strategy to provide greater relief and economic opportunity** to residents facing

Sent from my iPhone

On Feb 9, 2022, at 1:47 PM, Gwinn, Nathan <[ngwinn@spokanecity.org](mailto:ngwinn@spokanecity.org)> wrote:

Good afternoon Toni,

Thanks for your message. I will add it to the public record for the file.

To respond to the question you asked about encouraging ownership, yes, the proposals are designed to work to provide more options for all incomes and both homeownership and rental tenancies. For example, the attached housing (townhouse) proposals involve the possibility of separate fee-simple ownership. Allowing more than two attached houses with a common wall, and potentially smaller attached houses, could be introduced together with the changes to allow duplexes in additional locations, advancing more ownership options for that kind of housing in all neighborhoods.

I am also looking forward to the discussion at the Land Use Committee next week.

Nate

**Nathan Gwinn, AICP** | Assistant Planner | Planning & Development  
509.625.6893 | [ngwinn@spokanecity.org](mailto:ngwinn@spokanecity.org) | [www.spokanecity.org](http://www.spokanecity.org)

Residential Development Code amendments project webpage: [my.spokanecity.org/projects/shaping-spokane-housing](http://my.spokanecity.org/projects/shaping-spokane-housing)

---

**From:** Antonia DePasquale <[depasquale5@yahoo.com](mailto:depasquale5@yahoo.com)>

**Sent:** Sunday, February 6, 2022 2:43 PM

**To:** Gunderson, Dean <[dgunderson@spokanecity.org](mailto:dgunderson@spokanecity.org)>; Gwinn, Nathan <[ngwinn@spokanecity.org](mailto:ngwinn@spokanecity.org)>; Beggs, Breean <[bbeggs@spokanecity.org](mailto:bbeggs@spokanecity.org)>; Kinnear, Lori <[lkinnear@spokanecity.org](mailto:lkinnear@spokanecity.org)>; Greg Francis <[gfrancis1965@yahoo.com](mailto:gfrancis1965@yahoo.com)>; Robert Flowers <[mr\\_mouse@comcast.net](mailto:mr_mouse@comcast.net)>; Tanya Starkel <[tanya@avenuestonerealestate.com](mailto:tanya@avenuestonerealestate.com)>

**Subject:** Housing Ordinance

**[CAUTION - EXTERNAL EMAIL - Verify Sender]**

Good Afternoon Council Members, President and interested parties. I hope all had a nice weekend.

In meeting with RNC, members last week, I received a couple follow up e-mails. We have a few concerns about the new proposed housing and infill ordinance:

We all know we need housing, but home/condo/duplex Ownership (not just a rental market) is critical for any community to thrive and get ahead.

Nate, are there any pieces in the ordinance that encourage home ownership (not just rentals)? I also look forward to hearing about the Design Standards proposed at Land Use meeting next Thursday, thank you for coming.

Personally, I am not interested in an ordinance that makes a few rental market investors from Wall Street richer (see link) and I ask that my Council members and President look into this aspect as well, thank you.

<https://youtu.be/cOEZ2Csxxu8>

Thank you for listening,  
Toni Sharkey

Sent from my iPhone



**From:** [Gardner, Spencer](#)  
**To:** [Churchill, Jackie](#)  
**Cc:** [Black, Tirrell](#); [Gwinn, Nathan](#); [Beck, Amanda](#)  
**Subject:** FW: Comments of Housing Code Amendments  
**Date:** Tuesday, February 22, 2022 3:13:57 PM  
**Attachments:** [Transition and ADU Code Comments.docx](#)  
[Housing Comments Cover Letter.docx](#)

---

See below and attached for comments from Jim Frank.

Jackie: Can you make sure these are entered into the record for Plan Commission and distributed as appropriate?  
Thanks!

Spencer Gardner | Director | Planning Services  
Office 509-625-6097 | Mobile 509-723-7554 | [my.spokanecity.org](mailto:my.spokanecity.org)

-----Original Message-----

From: Jim Frank <[jfrank@greenstonehomes.com](mailto:jfrank@greenstonehomes.com)>  
Sent: Sunday, February 20, 2022 4:13 PM  
To: Gardner, Spencer <[sgardner@spokanecity.org](mailto:sgardner@spokanecity.org)>  
Cc: MacDonald, Steven <[smacdonald@spokanecity.org](mailto:smacdonald@spokanecity.org)>  
Subject: Comments of Housing Code Amendments

[CAUTION - EXTERNAL EMAIL - Verify Sender]

Spencer,

I have attached my comments to the two code sections being addressed by the Plan Commission on Wednesday along with a cover letter to the Commission. I would ask that this be made part of the record.

I know that you are just getting your feet on the ground and have not had the opportunity to dig into much of the housing issues yet. We are only going to get one chance to get the needed changes right. This will be incremental, but when a code review does arise we have to make sure we get it right. The options being presented to the Plan Commission regarding ADUs fall very short of what will be needed for this to be a viable housing option.

Thanks, Jim



February 20, 2022

Planning Commission  
City of Spokane

Re: Housing Code Amendments

Planning Commission Members:

The City of Spokane and the metropolitan region are facing a housing crisis. Housing issues have been raised and discussed in many forums over the past several years. Regrettably no action has been taken, so it is encouraging that some code changes are beginning to come forward. We must not lose sight of the inequality created by the rapidly rising home costs. Those that own a home have received windfall profits and significant wealth creation. Those that do not have become locked out of home ownership and struggle to pay rising rents. This is the price we pay for not allowing a wide range of homes sufficient to meet the needs of the people living in our community. This is sadly well documented in the recent NYT article on the Spokane housing market and the families it has impacted.

I have attached comments on the first two code changes being brought forward regarding the “transition” lot rule and the ADU standards. These are both very important, but only the beginning of the changes that are necessary. Economic and housing diversity is at the heart of what make strong and resilient neighborhoods.

The proposed ADU standards fall far short of what is necessary to encourage this as the significant housing option it can become. The important word here is “encourage”. Our housing development code must do more than permit a wide range of housing options, they must be “encouraged” by the development code so that investment is stimulated and an industry form around them.

Sincerely,

Jim Frank

## **Transition Lot Rules SMC 17C.110.200**

This code section is highly discriminatory, favoring wealthy families on large lots at the expense of middle and low income families. The impact of this code section can be devastating in the way it limits infill development. The Garden District PUD proposed to develop 60 small cottage homes on lots of about 3000 SF. As a result of this code section Greenstone was forced to develop 30 lots of about 7500 SF. The result is fewer very high-priced homes rather than twice as many modestly priced small homes.

No other jurisdiction in the region has a comparable provision. Because economic inequality leads to racial inequality, this code section is a likely violation of the Fair Housing Act.

Option 1, the complete deletion of this code section is the only acceptable option. The option to merely eliminate lots across a ROW is not acceptable. Rear lot line parcels are a significant problem, as they were in the Garden District case.

## **Accessory Dwelling Units (ADU)**

The proposed amendments to the ADU codes sections do not go nearly far enough to “encourage” the development of ADU units. Brent Todarian, the former Planning Director for the City of Vancouver BC, visited Spokane and reviewed Spokane’s ADU codes. He concluded that the rules were so restrictive they would prevent any significant ADU development. This is exactly what happened. He stated at a meeting with planning staff: “It is not sufficient to merely permit desired housing types, they must be encouraged by development regulations”. The code must provide enough flexibility that investment is encouraged and an industry is able to form around the product. Here are the changes that we feel are necessary:

1. There should be no ADU permit required and no permit notice recorded on title. An ADU should be treated as any other accessory building or garage located on a lot. It should require a building permit and compliance with building and development standards that are reviewed as part of the building permit approval. This eliminates the extra ADU fee.
2. An ADU should be allowed on any legal lot regardless of size. There should be no minimum lot size for an ADU. The ADU and the main residence should be required to meet the site coverage standard for the zone classification where the ADU is located. This means that the main residence and the ADU together will not exceed the site coverage in the underlying zone.
3. An ADU should be bound to the normal site development standards (site coverage, setbacks and building height) of the underlying zone. The special standards for ADUs should be eliminated.

4. There should be no maximum size for an ADU. There are no such standards for a single-family home on the lot. Compliance with the development standards of the zone should be sufficient to protect the neighborhood character. There is no justification for establishing separate ADU standard.
5. There should be no special parking standards applied to an ADU. The parking standards should be the same as those applied to the underlying zone. Why would a 1000SF home with a 700SF ADU have a different parking requirement than a 2500SF primary residence?
6. The occupancy requirement for an ADU should be deleted. We don't place occupancy requirements on SF homes and there is no justification for an occupancy requirement for an ADU. Such a requirement has a chilling impact on the development of ADUs and significant financing challenges.

## Beck, Amanda

---

**From:** Beck, Amanda  
**Sent:** Thursday, February 24, 2022 1:22 PM  
**To:** Craig Hunt  
**Subject:** RE: support for short term rentals

Hi Craig,

Thanks for your interest in the short-term rental code amendment and the [Shaping Spokane Housing](#) project. I will include your support for the short-term rental code change in the public comment record, which will be shared with Plan Commission at the public hearing.

Right now the draft code is in a sort of holding pattern, as we've heard a lot of push back from the public over concerns this is expanding a use that is negatively impacting the housing supply. So, we're trying to come up with some additional draft code options that might address these concerns, and the interaction of short-term rentals and accessory dwelling units. Once we have additional options we would take them back to Plan Commission for a workshop before the public hearing process.

Thank you,  
 Amanda

**Amanda Beck, AICP** | City of Spokane | Assistant Planner II  
 509-625-6414 | *main* 509-625-6500 | [abeck@spokanecity.org](mailto:abeck@spokanecity.org) | [spokanecity.org](http://spokanecity.org)



---

**From:** Craig Hunt <craigthunt@gmail.com>  
**Sent:** Tuesday, February 22, 2022 2:36 PM  
**To:** Beck, Amanda <abeck@spokanecity.org>  
**Subject:** support for short term rentals

**[CAUTION - EXTERNAL EMAIL - Verify Sender]**

Hi Amanda,

I'm wondering if you have any updates regarding the proposed allowance for short term rentals in "all" zones? I'm supportive of the proposed change to the code, which would allow short term rental in areas where residential use is already permitted.

Thanks for your time,  
 Craig Hunt

**From:** [Planning Services Development Code](#)  
**To:** ["Jordan Brown"](#)  
**Cc:** [Beck, Amanda](#); [Andrie, Tate](#)  
**Subject:** RE: Support for modification  
**Date:** Wednesday, March 9, 2022 11:49:00 AM

---

Good morning,

Thank you for your comment. It will be added to the public record for the file and forwarded to the Plan Commission and Council when public hearings are scheduled, likely later this spring.

To follow the project, please stay tuned to the project webpage, where those events will be announced.

Nathan Gwinn, AICP | Assistant Planner | Planning & Development  
509.625.6893 | [ngwinn@spokanecity.org](mailto:ngwinn@spokanecity.org) | [www.spokanecity.org](http://www.spokanecity.org)

Residential Development Code amendments project webpage:  
<http://my.spokanecity.org/projects/shaping-spokane-housing>

-----Original Message-----

From: Jordan Brown <[jordan.brown.crna@gmail.com](mailto:jordan.brown.crna@gmail.com)>  
Sent: Sunday, February 27, 2022 12:34 PM  
To: Planning Services Development Code <[erapsdc@spokanecity.org](mailto:erapsdc@spokanecity.org)>  
Subject: Support for modification

[CAUTION - EXTERNAL EMAIL - Verify Sender]

I have been a resident for Spokane for nearly 8 years. In that time, I have seen the housing shortage get worse and the inability for individuals and families purchase homes due to bidding wars, increased prices, and low inventory.

I have been fortunate in that I have both a primary home and rental home. My rental is on a large double lot on the south hill. The home on it is small, and with the insane Costs to remodel, increasing the ability of the home to accommodate more people is not financially viable.

But a small ADU is. With the current owner/occupant restrictions, I cannot proceed this route even though I'd like to. Additionally, the seemingly random guidance for roof pitch/style/etc limits the ability and most likely increases cost of construction.

I appreciate the effort of the planning division in addressing these issues. Allow Spokane to grow in a way that is equitable for all.

Thank you,

Jordan Brown

**From:** [Planning Services Development Code](#)  
**To:** [Paul Knowles](#)  
**Cc:** [Beck, Amanda](#); [Andrie, Tate](#)  
**Subject:** RE: Proposed ADU Changes - Comments in Support  
**Date:** Wednesday, March 9, 2022 11:54:00 AM

---

Good afternoon Paul,

Thank you for your comment. It will be added to the public record for the file and forwarded to the Plan Commission and Council when public hearings are scheduled, likely later this spring.

To follow the project, please stay tuned to the project webpage, where those events will be announced.

**Nathan Gwinn, AICP** | Assistant Planner | Planning & Development  
509.625.6893 | [ngwinn@spokanecity.org](mailto:ngwinn@spokanecity.org) | [www.spokanecity.org](http://www.spokanecity.org)

Residential Development Code amendments project webpage: [my.spokanecity.org/projects/shaping-spokane-housing](http://my.spokanecity.org/projects/shaping-spokane-housing)

---

**From:** Paul Knowles <[knowlespa@gmail.com](mailto:knowlespa@gmail.com)>  
**Sent:** Thursday, March 3, 2022 9:49 PM  
**To:** Planning Services Development Code <[erapsdc@spokanecity.org](mailto:erapsdc@spokanecity.org)>  
**Subject:** Proposed ADU Changes - Comments in Support

**[CAUTION - EXTERNAL EMAIL - Verify Sender]**

Hi,

I just wanted to write a quick note to thank you for considering changes to the code related to ADUs. I believe the ownership requirement creates a barrier to more home owners like myself from investing in an ADU. Living in the Logan Neighborhood near Gonzaga, consider who the future buyer for this house will be. Given that many houses around us are rentals, I would guess that the future buyer will likely be an investor looking to rent to college kids. Given that assumption, it doesn't make sense for us to invest in an ADU unless the ownership requirement is removed - that ownership requirement would limit the pool of potential buyers and the highest and best use for this property - which is probably as a rental.

The other changes being considered for ADUs all seem reasonable and should result in an increase in ADUs being built within the City - providing much needed housing options while removing barriers that prevent homeowners like myself from being part of the housing solution!

Best Regards,  
Paul Knowles

**From:** [Planning Services Development Code](#)  
**To:** [Jeannie` Robinson](#)  
**Cc:** [Andrie. Tate](#)  
**Subject:** RE: Build more ADA units  
**Date:** Thursday, March 17, 2022 5:02:00 PM

---

Good afternoon Ms. Robinson:

Thank you for your comment. I will add it to the public record for the Plan Commission and City Council's review when public hearings are scheduled on the proposed amendments for accessory dwelling units.

Sincerely,

**Nathan Gwinn, AICP** | Assistant Planner | Planning & Development  
509.625.6893 | [ngwinn@spokanecity.org](mailto:ngwinn@spokanecity.org) | [www.spokanecity.org](http://www.spokanecity.org)

Residential Development Code amendments project webpage: [my.spokanecity.org/projects/shaping-spokane-housing](http://my.spokanecity.org/projects/shaping-spokane-housing)

---

**From:** Jeannie` Robinson <mrjeannro7@gmail.com>  
**Sent:** Saturday, March 12, 2022 12:08 PM  
**To:** Planning Services Development Code <erapsdc@spokanecity.org>  
**Subject:** Build more ADA units

**[CAUTION - EXTERNAL EMAIL - Verify Sender]**

Hello, I have many clients in need of ADA units on the ground floor. Please incorporate this type of unit in the different types of apartments that are being designed and built. Thank you,  
Jeannie Robinson



**From:** [Planning Services Development Code](#)  
**To:** [Brad Harland](#)  
**Cc:** [Andrie. Tate](#)  
**Subject:** RE: ADUs  
**Date:** Thursday, March 17, 2022 5:05:00 PM

---

Good afternoon Mr. Harland,

Thank you for your comment. I will include the message in the public record for the file and in the packet for review by the Plan Commission and City Council when public hearings are scheduled on the proposed amendments for accessory dwelling units.

Sincerely,

**Nathan Gwinn, AICP** | Assistant Planner | Planning & Development  
509.625.6893 | [ngwinn@spokanecity.org](mailto:ngwinn@spokanecity.org) | [www.spokanecity.org](http://www.spokanecity.org)

Residential Development Code amendments project webpage: [my.spokanecity.org/projects/shaping-spokane-housing](http://my.spokanecity.org/projects/shaping-spokane-housing)

---

**From:** Brad Harland <bharland@nxnw.net>  
**Sent:** Monday, March 14, 2022 3:02 PM  
**To:** Planning Services Development Code <erapsdc@spokanecity.org>  
**Subject:** ADUs

**[CAUTION - EXTERNAL EMAIL - Verify Sender]**

Dear Planning Department

For ADU to really take off. You need to be able to address the CCRs that limit neighborhood under their control to Single Family Homes. Most of the neighborhoods built in the last 60 years will not allow ADUs. Therefore your rule change only affects the older neighborhoods.

I realize that will require a state law to override the CCRs. But I think Spokane needs to push for that.

Some of the law changes proposed at the state level (HB 1660) would allow two ADUs on any lot over 4,500sf. That is putting a triplex on these older small lots. That is a lot of density in a relatively small area. That law would also not have any requirement for the owner to live on site. I think that is a bad idea.

You need to be able to allow ADUs in the newer neighborhoods. That way the density is spread out through all neighborhoods.

I know there is also a push to get rid of the owner occupancy requirement for ADU. But I would maintain that requirement. Remember what happened to the lower South Hill when the large houses got cut up into fourplexes and they just became apartments. The neighborhood went downhill.

Without the owner occupancy requirement, a ADU just becomes a duplex. If you want to allow duplexes, zone it for a duplex.

Anyway those are my thoughts.

Brad Harland  
5126 S Lincoln Way, Spokane WA 99224

\_\_\_\_\_  
Brad Harland, CPA  
[bharland@nxnw.net](mailto:bharland@nxnw.net) / Cell 509 838-2924

**From:** [Planning Services Development Code](#)  
**To:** "Shari Mcevoy"  
**Cc:** [Andrie. Tate](#)  
**Subject:** RE: Adding zoning ADU options  
**Date:** Thursday, March 17, 2022 5:07:00 PM

---

Good afternoon Shari,

Thank you for your comment. I will include the message in the public record for the file and in the packet for review by the Plan Commission and City Council when public hearings are scheduled on the proposed amendments for accessory dwelling units.

Sincerely,

**Nathan Gwinn, AICP** | Assistant Planner | Planning & Development  
509.625.6893 | [ngwinn@spokanecity.org](mailto:ngwinn@spokanecity.org) | [www.spokanecity.org](http://www.spokanecity.org)

Residential Development Code amendments project webpage: [my.spokanecity.org/projects/shaping-spokane-housing](http://my.spokanecity.org/projects/shaping-spokane-housing)

-----Original Message-----

**From:** Shari Mcevoy <[smcevoy2222@gmail.com](mailto:smcevoy2222@gmail.com)>  
**Sent:** Tuesday, March 15, 2022 7:34 PM  
**To:** Planning Services Development Code <[erapsdc@spokanecity.org](mailto:erapsdc@spokanecity.org)>  
**Subject:** Adding zoning ADU options

[CAUTION - EXTERNAL EMAIL - Verify Sender]

Hello

I have 3 single family homes

I would like to add and ADU to each

I want you to please remove owner occupied restrictions.

I cannot add them with that restriction

Also

Do we have pre approved ADU plans for ease of permitting?

Sincerely

Shari real estate investor

Sent from my iPhone

**From:** [Planning Services Development Code](#)  
**To:** "Kate B."  
**Subject:** RE: General comment on attached housing & duplexes  
**Date:** Tuesday, March 22, 2022 10:54:00 AM

---

Hi Kate,

Thanks for your message. It will be added to the public record and provided to the Plan Commission and Council when hearings are scheduled on attached housing and duplexes.

Sincerely,  
Nate

**Nathan Gwinn, AICP** | Assistant Planner | Planning & Development  
509.625.6893 | [ngwinn@spokanecity.org](mailto:ngwinn@spokanecity.org) | [www.spokanecity.org](http://www.spokanecity.org)

Residential Development Code amendments project webpage: [my.spokanecity.org/projects/shaping-spokane-housing](http://my.spokanecity.org/projects/shaping-spokane-housing)

---

**From:** Kate B. <kate.a.bitz@gmail.com>  
**Sent:** Thursday, March 17, 2022 8:04 PM  
**To:** Planning Services Development Code <erapsdc@spokanecity.org>  
**Subject:** General comment on attached housing & duplexes

**[CAUTION - EXTERNAL EMAIL - Verify Sender]**

To whom it may concern,

It's so exciting to see progress on legalizing attached housing and duplexes in larger areas of the City. This is important for our city and I urge you to maximize this opportunity.

Thanks!

- Kate Bitz  
West Central Homeowner

**From:** [Planning Services Development Code](#)  
**To:** "cheri.loveland"  
**Cc:** [Beck, Amanda](#); [Andrie, Tate](#)  
**Subject:** RE: Environmental Review Changes  
**Date:** Thursday, March 17, 2022 5:21:00 PM

---

Good afternoon Ms. Loveland,

Thank you for your comment. I will include the message in the public record for the file and in the packet for review by the Plan Commission and City Council when public hearings are scheduled on the proposed amendments for the proposed SEPA changes. For information, the timing for that may differ from the consideration of the accessory dwelling unit and some of the other topics.

Sincerely,

**Nathan Gwinn, AICP** | Assistant Planner | Planning & Development  
 509.625.6893 | [ngwinn@spokanecity.org](mailto:ngwinn@spokanecity.org) | [www.spokanecity.org](http://www.spokanecity.org)

Residential Development Code amendments project webpage: [my.spokanecity.org/projects/shaping-spokane-housing](http://my.spokanecity.org/projects/shaping-spokane-housing)

---

**From:** cheri.loveland <cheriloveland@gmail.com>  
**Sent:** Thursday, March 17, 2022 4:30 PM  
**To:** Planning Services Development Code <erapsdc@spokanecity.org>  
**Subject:** Environmental Review Changes

**[CAUTION - EXTERNAL EMAIL - Verify Sender]**

Dear City of Spokane Planning Commission,

I would like to let my voice be heard in opposition to any changes in the current SEPA rules the city currently has implemented.

Those rules were decided with forethought and reason and should not be changed just because someone wants to streamline a process.

If the city is really thinking “green” you can’t increase the levels. It just doesn’t make sense.

Sincerely,  
 Cheri Loveland

**From:** [Gwinn, Nathan](#)  
**To:** [Zwidmer@gmail.com](mailto:Zwidmer@gmail.com)  
**Cc:** [Churchill, Jackie](#); [Beck, Amanda](#); [Gardner, Spencer](#)  
**Subject:** RE: ADU Code Public Comment  
**Date:** Tuesday, March 22, 2022 5:12:39 PM

---

Good afternoon Mr. Widmer,

I will add your comment to the public record for the file. This will be provided to the Plan Commission and City Council at the time of the public hearings for the code amendments for ADUs, likely later this spring.

Your contact information will be added to the project email and notified when hearings are scheduled. Or to follow the project, please stay tuned to the project webpage, where those events will be announced.

Sincerely,

Nate

**Nathan Gwinn, AICP** | Assistant Planner | Planning & Development  
[509.625.6893](tel:509.625.6893) | [ngwinn@spokanecity.org](mailto:ngwinn@spokanecity.org) | [www.spokanecity.org](http://www.spokanecity.org)

Residential Development Code amendments project webpage: [my.spokanecity.org/projects/shaping-spokane-housing](http://my.spokanecity.org/projects/shaping-spokane-housing)

---

**From:** Churchill, Jackie <[jchurchill@spokanecity.org](mailto:jchurchill@spokanecity.org)>  
**Sent:** Tuesday, March 22, 2022 4:17 PM  
**To:** Gwinn, Nathan <[ngwinn@spokanecity.org](mailto:ngwinn@spokanecity.org)>; Beck, Amanda <[abeck@spokanecity.org](mailto:abeck@spokanecity.org)>  
**Subject:** FW: ADU Code Public Comment

Hi Nate and Amanda,

The public comment below regarding ADU rules was sent to the Plan Commission email.

Thanks, Jackie

---

**From:** [zwidmer@gmail.com](mailto:zwidmer@gmail.com) <[zwidmer@gmail.com](mailto:zwidmer@gmail.com)>  
**Sent:** Tuesday, March 22, 2022 11:37 AM  
**To:** Plan Commission <[eraplanc@spokanecity.org](mailto:eraplanc@spokanecity.org)>  
**Cc:** Byrd, Giacobbe <[gbyrd@spokanecity.org](mailto:gbyrd@spokanecity.org)>; Kinnear, Lori <[lkinnear@spokanecity.org](mailto:lkinnear@spokanecity.org)>  
**Subject:** ADU Code Public Comment

**[CAUTION - EXTERNAL EMAIL - Verify Sender]**

I watched the meeting on ADU code development and have a few comments.

I'm no expert, but it does seem to me like ADU rules are really just punishing homeowners

with additional byzantine rules and costs that developers don't have to face just because homeowners have an existing structure. I don't like that developers get one set of rules and homeowners need to follow those rules, plus an additional set of rules because they have done the normal thing and purchased property with an existing house on it. It seems to me that if something is allowed for our neighborhood coding, it should be allowed, period.

Maybe I'm missing something, but I don't understand why structures that would be allowed by our overall code should be restricted just because of the basis that there is an existing structure on the property.

I do have two concerns:

1. I share Councilwoman Kinnear's perspective on what this could do considering existing market conditions. Specifically corporate capital being spent on properties affecting rates of rental vs home ownership and even rates of corporate landlords. Our community should take some steps to make sure that the benefits of our city flow reasonably to the residents of it.
2. Parking is and will always be an issue that we should attempt to mitigate, but adding additional legal requirements on top of already existing ones is not the place to address them. Once again, developers should not be given preferential treatment. If existing ones need to be adjusted, do so, but do not impose separate rules on owners and developers.

Thank you,  
Zach Widmer | District 3

**From:** [Planning Services Development Code](#)  
**To:** ["Diane Benson"](#)  
**Cc:** [Beck, Amanda](#)  
**Subject:** RE: Housing Action Plan  
**Date:** Monday, March 28, 2022 8:30:00 AM

---

Good morning Ms. Benson,

Thank you for your comment. I will add it to the public record for the files for the accessory dwelling unit and duplex topics. It will be provided to the Plan Commission and City Council when hearings are scheduled, probably later this spring. I will also add your name to the contact list for project information, and events will be announced on the project webpage.

Sincerely,

Nate

**Nathan Gwinn, AICP** | Assistant Planner | Planning & Development  
509.625.6893 | [ngwinn@spokanecity.org](mailto:ngwinn@spokanecity.org) | [www.spokanecity.org](http://www.spokanecity.org)

Residential Development Code amendments project webpage: [my.spokanecity.org/projects/shaping-spokane-housing](http://my.spokanecity.org/projects/shaping-spokane-housing)

---

**From:** Diane Benson <dcb1810@yahoo.com>  
**Sent:** Thursday, March 24, 2022 3:16 PM  
**To:** Planning Services Development Code <erapsdc@spokanecity.org>  
**Subject:** Housing Action Plan

**[CAUTION - EXTERNAL EMAIL - Verify Sender]**

Thanks so much for all of your hard work on the Housing Action Plan. I'm a home owner in Lower South Hill. I support the HAP and hope it is approved and implemented.

We need more affordable housing, especially condos, small houses, duplexes, etc. Not everyone wants a large house on a large lot, even if they can afford it.

My only concern about adding more apartments is irresponsible landlords. Here on South Hill, some of the apartment buildings are decrepit and strewn with trash. Please include consequences for landlords who don't keep their properties maintained.

Thanks,

Diane Benson



**From:** [Planning Services Development Code](#)  
**To:** [Evelyn Popejoy](#)  
**Cc:** [Beck, Amanda](#)  
**Subject:** RE: Changing Standards for Housing  
**Date:** Monday, March 28, 2022 8:25:00 AM

---

Good morning Ms. Popejoy,

Thank you for sending your comment. I will add it to the public record for the files for the accessory dwelling unit, short term rental, and duplex and attached housing topics. It will be provided to the Plan Commission and City Council when hearings are scheduled, probably later this spring. I will also add your name to the contact list for project information, and events will be announced on the project webpage.

Sincerely,

Nate

**Nathan Gwinn, AICP** | Assistant Planner | Planning & Development  
509.625.6893 | [ngwinn@spokanecity.org](mailto:ngwinn@spokanecity.org) | [www.spokanecity.org](http://www.spokanecity.org)

Residential Development Code amendments project webpage: [my.spokanecity.org/projects/shaping-spokane-housing](http://my.spokanecity.org/projects/shaping-spokane-housing)

-----Original Message-----

From: Evelyn Popejoy <evbunny@icloud.com>  
Sent: Thursday, March 24, 2022 1:11 PM  
To: Planning Services Development Code <erapsdc@spokanecity.org>  
Subject: Changing Standards for Housing

[CAUTION - EXTERNAL EMAIL - Verify Sender]

I think we should be very careful about changing all of our housing standards, especially without having input with each project. I think having a lot of tiny plots crammed into areas is not what our city needs. I particularly don't think that we need a lot of short term rentals, especially if they are not kept up to community standards. Is someone going to make sure these do not just turn into "dumps"? Evelyn Popejoy

**From:** [Planning Services Development Code](#)  
**To:** ["barbara morrissey"](#)  
**Cc:** [Gwinn, Nathan](#)  
**Subject:** RE: hillside development  
**Date:** Thursday, April 14, 2022 12:21:40 PM

---

Hi Barbara,

Thank you for providing public comment on proposed revisions to residential code related to the project Shaping Spokane Housing. Your email is now part of the public record for the project, and will be shared with the Plan Commission at the public hearing.

Thank you,  
Amanda

Amanda Beck, AICP | City of Spokane | Assistant Planner II  
509-625-6414 | main 509-625-6500 | [abeck@spokanecity.org](mailto:abeck@spokanecity.org) | [spokanecity.org](http://spokanecity.org)

-----Original Message-----

From: barbara morrissey <[taslin10@earthlink.net](mailto:taslin10@earthlink.net)>  
Sent: Wednesday, April 6, 2022 11:48 AM  
To: Planning Services Development Code <[erapsdc@spokanecity.org](mailto:erapsdc@spokanecity.org)>  
Subject: hillside development

[CAUTION - EXTERNAL EMAIL - Verify Sender]

lived in Peaceful valley for several years. On the south it is surrounded by steep spring undermined slopes with a history of landslides...most recently last year. on Clarke.  
One of the old neighborhood plans recommended no development on the bluff between Clarke and Riverside....already several MULTIFAMILY buildings up there. This area should be reassessed for development (ie forbidden) Already a lot across from me is on a sliding hillside which could easily slide into an historic building downslope if it goes.

Sincerely,

Barbara Morrissey  
1647 west clarke ave  
509 456 5565  
[taslin10@earthlink.net](mailto:taslin10@earthlink.net)

**From:** [Planning Services Development Code](#)  
**To:** "Traci P"  
**Cc:** [Gwinn, Nathan](#)  
**Subject:** RE: small time landlord  
**Date:** Thursday, April 14, 2022 11:42:24 AM  
**Attachments:** [image001.png](#)  
[image002.png](#)  
[image003.png](#)

---

Hi Tracy,

Thank you for providing public comment concerning the residential development code changes proposed under the Shaping Spokane Housing project. These comments have been added to the public record, and will be shared with the Plan Commission at public hearing.

The City's [Rental Assistance Program for Landlords](#) did provide Covid-related assistance as much as funding could be spread out to small time landlords, and the monies have been disbursed. I believe the City is working on another application to request further Federal funds to support landlords, the caveat being federal funding has many strings (renter incomes within a certain range, unit rents set at a rate that is affordable, reporting and annual inspections, etc.) but we don't have additional funding at this time.

Through the [Shaping Spokane Housing](#) project we are encouraging missing middle housing types- duplexes and attached homes- in more of our residential zones with these code changes, and we're looking at doing more for missing middle housing types like tri- and four-plexes.

Thanks for your investment and time as a landlord in Spokane.

Thank you,  
Amanda

**Amanda Beck, AICP** | City of Spokane | Assistant Planner II  
 509-625-6414 | main 509-625-6500 | [abeck@spokanecity.org](mailto:abeck@spokanecity.org) | [spokanecity.org](http://spokanecity.org)



---

**From:** Traci P <tracip1961@gmail.com>  
**Sent:** Wednesday, April 6, 2022 10:28 AM  
**To:** Planning Services Development Code <erapsdc@spokanecity.org>  
**Subject:**

**[CAUTION - EXTERNAL EMAIL - Verify Sender]**

I have rental properties in Spokane. I have already sold one because of covid and people didn't have to pay rent. When the next one gets empty, I will do the same until all are gone.

My rentals are very reasonably priced and I have tons of applicants that apply when one becomes available. I did not increase my rents nor have I since everyone moved in. My promise to them.

My taxes have increased two fold since I've owned them. My insurance now is extremely high because our credit is no longer taken into consideration.

When I got into the rental business, things were more reasonable. Now you are pricing us out of our income. My main objective was to provide nice housing for a reasonable price. That is no longer true. This is my income, which with the increased expenses, has been diminished to next to nothing. Because of this, I am being forced to disolve my rentals so that I don't have to increase my rents. I know, I'm not the only landlord out there that is doing so.

You spend all this time and money trying to figure out how to house more people, when you have no incentive going to the landlord to keep their properties affordable or to even keep them as rentals. Personally, with the housing the way it is, I could probably get another \$500 a month for each property.

You give all kind of breaks to renters, but what about the landlords? We are suffering. The more properties we sell, the less rentals you will have. Thus you have to keep building. Wouldn't it be more cost effective to give us an incentive for keeping our properties available to rent? My rental house sold in 4 days at a very elevated cost.

There is no reason to hang onto them, if it no longer serves our interest.

That's what covid did to us. The renters got all the relief. We just took a huge hit, with higher taxes and insurance rates.

Between my houses, insurance and taxes, there was an increase of over \$1000 per year and that is for only 4 houses. That is ridiculous. I can't afford to keep them any longer. I would make much more money selling them and reinvesting in anything other than real estate.

It's only a matter of time, before there will only be rental places that are multi family dwellings. Houses will no longer be a dream. It's bad enough that the inventory of rental houses are going down. But home ownership is only going to be available to a select few, due to the increase in prices.

It's a double edged sword. I suggest you start with the landlords and see what they say. They are going to be essential for our housing future. Without landlords, where will Spokane be?

This coming from a small time landlord. The rental companies just keep jacking up the rents when their expenses go up.

Thank you for listening,

Tracy Parks  
L

**From:** [John Schram](#)  
**To:** [Planning Services Development Code](#)  
**Subject:** Re: attached housing feedback  
**Date:** Wednesday, April 6, 2022 12:21:03 PM

---

**[CAUTION - EXTERNAL EMAIL - Verify Sender]**

2<sup>nd</sup> attempt as my first email was rejected by the server

John

---

**From:** John Schram  
**Sent:** Wednesday, April 6, 2022 12:18 PM  
**To:** [developmentcode@spokanecity.org](mailto:developmentcode@spokanecity.org) <[developmentcode@spokanecity.org](mailto:developmentcode@spokanecity.org)>  
**Subject:** attached housing feedback

Please remove the proposed change to RA, RSF and RSF-C zoning to allow for additional attached housing units an already established neighborhoods. As one selects a neighborhood, let alone street to live on, there are many factors that are taken into consideration including what style and type of housing is predominant. This proposed change nullifies every existing homeowner's preference in that regard and degrades their experience.

If there is a desire for attached housing units and other non-single family standalone housing alternatives, have it an option for a new build community only.

John Schram

**From:** [John Schram](#)  
**To:** [Planning Services Development Code](#)  
**Subject:** Duplexes feedback  
**Date:** Wednesday, April 6, 2022 12:08:58 PM

---

**[CAUTION - EXTERNAL EMAIL - Verify Sender]**

Please remove the proposed change to RSF and RSF-C zoning to allow for duplexes an already established neighborhoods. As one selects a neighborhood let alone street to live on there are many factors that are taken into consideration including what style and type of housing is predominant. This proposed change nullifies every existing homeowners preference in that regard and degrades their experience.

If there is a desire for additional duplex and other non-single family housing alternatives, have it an option for a new build community only.

John Schram

**From:** [John Schram](#)  
**To:** [Planning Services Development Code](#)  
**Subject:** Short term rental reedback  
**Date:** Wednesday, April 6, 2022 11:34:12 AM

---

**[CAUTION - EXTERNAL EMAIL - Verify Sender]**

Please eliminate all short term rentals in Spokane County. This will immediately free up hundreds of rental units for those that wish to make/keep Spokane their permanent home. Let's employ basic economic principles to increase supply and keep housing in the affordability range. There is already adequate space in our existing hotel inventory for visitors.

John Schram

**From:** [Planning Services Development Code](#)  
**To:** "John Schram"  
**Cc:** [Gwinn, Nathan](#)  
**Subject:** RE: attached housing feedback  
**Date:** Thursday, April 14, 2022 12:08:50 PM  
**Attachments:** [image001.png](#)  
[image002.png](#)  
[image003.png](#)

---

Hi John,

Thank you for providing public comment on proposed revisions to residential code related to the project [Shaping Spokane Housing](#). This email and your other emails concerning short term rentals and duplexes are now part of the public record for the project, and will be shared with the Plan Commission at the public hearing.

I did want to highlight, we're looking at code changes around duplexes and attached houses, but attached houses are typically owner-occupied since they are single-family attached development. We're looking at both missing middle housing types.

None of those topics are scheduled for public hearing yet, but you will be able to see notice about public hearings on the project page and the [Plan Commission page](#) under Agenda.

Thank you,  
Amanda

**Amanda Beck, AICP** | City of Spokane | Assistant Planner II

509-625-6414 | main 509-625-6500 | [abeck@spokanecity.org](mailto:abeck@spokanecity.org) | [spokanecity.org](http://spokanecity.org)



---

**From:** John Schram <John@johnschram.com>  
**Sent:** Wednesday, April 6, 2022 12:21 PM  
**To:** Planning Services Development Code <erapsdc@spokanecity.org>  
**Subject:** Re: attached housing feedback

**[CAUTION - EXTERNAL EMAIL - Verify Sender]**

2<sup>nd</sup> attempt as my first email was rejected by the server  
John

---

**From:** John Schram  
**Sent:** Wednesday, April 6, 2022 12:18 PM  
**To:** [developmentcode@spokanecity.org](mailto:developmentcode@spokanecity.org) <[developmentcode@spokanecity.org](mailto:developmentcode@spokanecity.org)>  
**Subject:** attached housing feedback



Please remove the proposed change to RA, RSF and RSF-C zoning to allow for additional attached housing units in already established neighborhoods. As one selects a neighborhood, let alone street to live on, there are many factors that are taken into consideration including what style and type of housing is predominant. This proposed change nullifies every existing homeowner's preference in that regard and degrades their experience.

If there is a desire for attached housing units and other non-single family standalone housing alternatives, have it as an option for a new build community only.

John Schram

**From:** [Beck, Amanda](#)  
**To:** "Brikjames"  
**Cc:** [Gwinn, Nathan](#)  
**Subject:** RE: Residential Development Code Amendments is an idiotic idea  
**Date:** Thursday, April 14, 2022 12:46:53 PM  
**Attachments:** [image001.png](#)  
[image002.png](#)  
[image003.png](#)

---

Hi Brikjames,

Thank you for providing public comment on proposed revisions to residential code related to the project [Shaping Spokane Housing](#). Your email is now part of the public record for the project, and will be shared with the Plan Commission at the public hearing.

We anticipate code changes to Accessory Dwelling Units, Short Plat Notification, and Lot Size Transitions will go to public hearing with Plan Commission on May 11<sup>th</sup>, if you wish to provide additional comment during the meeting we encourage you to attend in person or virtually. The other residential code topics are still being discussed and don't have a hearing date at this time. You can view the agenda once it's posted on the Plan Commission [page](#) under Agenda.

Thank you,  
Amanda

**Amanda Beck, AICP** | City of Spokane | Assistant Planner II

509-625-6414 | main 509-625-6500 | [abeck@spokanecity.org](mailto:abeck@spokanecity.org) | [spokanecity.org](http://spokanecity.org)



---

**From:** Brikjames <brikjames@aol.com>  
**Sent:** Saturday, April 9, 2022 5:33 PM  
**To:** Beck, Amanda <abeck@spokanecity.org>  
**Subject:** Residential Development Code Amendments is an idiotic idea

**[CAUTION - EXTERNAL EMAIL - Verify Sender]**

Hi,

I would like to say that there might be a couple ideas that are useful, but overall the plan is made be uneducated simple minded folk. This idea does not benefit the people of Spokane. It will create a poor city that lives off the money that we put into the government. This doesn't help the homeless that have no desire to work for a living and pay rent. If it does then that means even more money is coming out of my pocket to pay for them. Why would anyone want their house to be worth less? It is not our responsibility to facilitate people who want to move here. It is not our responsibility to change our city for anyone. They can either move into what is currently established or they can find somewhere else to live. I'm betting that you are all patting yourselves on the back for this simple-minded effort that does not take into account any of the possible ramifications from enacting it. If you did an organized effort in a single district then it might work. Trying to change the whole city all at once is asking for us to turn into a lesser known Seattle,

which has been an obvious failure as a city. Are you trying to bankrupt the people of this city?

**From:** [Planning Services Development Code](#)  
**To:** "mary"  
**Cc:** [Gwinn, Nathan](#)  
**Subject:** RE: Parking requirements for ADUs  
**Date:** Thursday, April 14, 2022 12:08:25 PM  
**Attachments:** [image001.png](#)  
[image002.png](#)  
[image003.png](#)

---

Hi Mary,

Thank you for providing public comment on proposed revisions to residential code related to the project [Shaping Spokane Housing](#). Your email concerning ADU parking is now part of the public record for the project, and will be shared with the Plan Commission at the public hearing.

There will be room for further public comment at the May 11<sup>th</sup> hearing if you wish to convey opinions from the Community Assembly folks, or want to encourage other residents to provide public comment.

Thank you,  
Amanda

**Amanda Beck, AICP** | City of Spokane | Assistant Planner II

509-625-6414 | main 509-625-6500 | [abeck@spokanecity.org](mailto:abeck@spokanecity.org) | [spokanecity.org](http://spokanecity.org)



---

**From:** mary <mmcsपो@yahoo.com>  
**Sent:** Monday, April 11, 2022 11:04 AM  
**To:** Planning Services Development Code <erapsdc@spokanecity.org>  
**Subject:** Parking requirements for ADUs

**[CAUTION - EXTERNAL EMAIL - Verify Sender]**

Please restore the parking requirement for 1 bedroom ADUs. There are already far too many cars parked on the city streets. The city has a serious, persistent problem with car burglaries and prowlings and adding more cars to target will just add to the already significant problem. I understand the need for more housing, but we need to be careful we are not creating a "Capitol Hill" here in Spokane. Let us learn from the mistakes that other cities have already made!

Thank you.

**From:** [Beck, Amanda](#)  
**To:** ["phyllisholmes@att.net"](mailto:phyllisholmes@att.net)  
**Cc:** [Gwinn, Nathan](#)  
**Subject:** RE: Changed to notifications  
**Date:** Thursday, April 14, 2022 1:13:25 PM  
**Attachments:** [image001.png](#)  
[image002.png](#)  
[image003.png](#)  
[image004.png](#)

---

Hi Phyllis,

Thank you for providing public comment on proposed revisions to residential code related to the project [Shaping Spokane Housing](#). Your email is now part of the public record for the project, and will be shared with the Plan Commission at the public hearing.

Our code will maintain notification for Neighborhood Councils. During the application completeness stage NCs as well as other City departments, local/state/federal agencies have a 14-day window to provide comments and require additional information. This is codified in [Section 17G.060.090](#). So, we are proposing some streamlining for notification on short plats (removing notice for 2-lots, keeping mailed notice for 3-9 lots) and think this strikes a sort of balance given that NCs are notified when a permit application is received.

Thank you for your service of Spokane.

Thank you,  
Amanda



**Amanda Beck, AICP** | City of Spokane | Assistant Planner II

509-625-6414 | main 509-625-6500 | [abeck@spokanecity.org](mailto:abeck@spokanecity.org) | [spokanecity.org](http://spokanecity.org)



*This email is subject to Washington State Public Records Act, Chapter 42.56 RCW, and may therefore be subject to public disclosure.*

-----Original Message-----

**From:** Phyllis Holmes [phyllisholmes@att.net](mailto:phyllisholmes@att.net)  
**Sent:** Thursday, April 14, 2022 11:26 AM  
**To:** Beck, Amanda [abeck@spokanecity.org](mailto:abeck@spokanecity.org)  
**Subject:** Changed to notifications

[CAUTION - EXTERNAL EMAIL - Verify Sender]

I am reading proposed changes to notification procedures for short plats, etc. Is the intent to notify neighborhood councils? When Mayor Geraghty and I created neighborhood councils it was for the purpose of enhancing communication about impacts on those neighborhoods. I trust that intent is being maintained. Phyllis Holmes, former City Council member

Sent from my iPhone

**From:** [Beck, Amanda](#)  
**To:** "Nancy Sazama"  
**Cc:** [Gwinn, Nathan](#)  
**Subject:** RE: SEPA Changes  
**Date:** Thursday, April 14, 2022 1:12:35 PM  
**Attachments:** [image001.png](#)  
[image002.png](#)  
[image003.png](#)

---

Hi Nancy,

Thank you for providing public comment on proposed revisions to residential code related to the project [Shaping Spokane Housing](#). Your email is now part of the public record for the project, and will be shared with the Plan Commission at the public hearing.

The proposed changes to the SEPA categorical exemptions thresholds would remove notice on some projects, this is true, and we are trying to thread the needle on streamlining the development process to help construction of more housing while maintaining some notice to residents. SEPA is often a situation where if the number of units or square feet meets the threshold, but excavation or grading on site goes over threshold, then a project kicks back in for SEPA review since the intent there is to evaluate possible environmental impacts and enact mitigations.

There are other notification points during the permit application process though. During the application completeness stage neighborhood councils as well as other City departments, local/state/federal agencies have a 14-day window to provide comments and require additional information. This is codified in [Section 17G.060.090](#). Any Type II permit (site plan, conditional use permit, long or short plat) would have mailed notice and sometimes site postings (you can view that in [Table 17G.060T-3](#)). So, we are trying to balance a streamlined permit process, the urgent need for more housing, and notification to residents.

Thank you,  
Amanda

**Amanda Beck, AICP** | City of Spokane | Assistant Planner II

509-625-6414 | *main* 509-625-6500 | [abeck@spokanecity.org](mailto:abeck@spokanecity.org) | [spokanecity.org](http://spokanecity.org)



FIND US



LIKE US



FOLLOW US

---

**From:** Nancy Sazama <njsazz@gmail.com>  
**Sent:** Thursday, April 14, 2022 11:32 AM  
**To:** Beck, Amanda <abeck@spokanecity.org>  
**Subject:** SEPA Changes

**[CAUTION - EXTERNAL EMAIL - Verify Sender]**

I want to object to the changes the City is considering to SEPA. Why would the city not want their citizens to be in the loop regarding development? The City's priority is development. I can

understand why that is so, especially considering the lack of housing. Comment periods slow things down, making it more complicated to include public input. I get that. Developments with fewer than 30 houses can still be very impactful and citizens deserve to continue to be asked what they think. People who live in the area of a proposed development know that area better than anyone. They know the current problems and potential problems that may arise due to a development. Once the building is done it is often too late, or too expensive to correct issues that arise. Often the area neighborhood can give a heads up to potential issues. It is not just about stopping development but making sure development is done intelligently and with the good of all in mind.

A case in point is the continued development in Latah Valley. This issue has many sides, non easy to reconcile at this time. The inadequacy of infrastructure is critical to everyone's safety today and into the future.

I appreciate your willingness to hear our concerns.

Sincerely,  
Nancy J. Sazama



**From:** [Beck, Amanda](#)  
**To:** [rhoffenberg@aol.com](mailto:rhoffenberg@aol.com)  
**Subject:** RE: Comment on SEPA changes  
**Date:** Monday, April 18, 2022 12:54:00 PM  
**Attachments:** [image001.png](#)  
[image002.png](#)  
[image003.png](#)

---

Hi Robyn,

Thank you for providing public comment on proposed revisions to residential code related to the project [Shaping Spokane Housing](#). Your email is now part of the public record for the project, and will be shared with the Plan Commission at the public hearing.

Please be aware that proposed changes to short plat notification will be going to public hearing at the May 11th Plan Commission meeting. When the agenda is posted, you can find meeting information on the [Plan Commission webpage](#).

At the end of the 60-Day Agency and Public Comment period for the proposed SEPA code changes, which runs April 4 through June 6, the City will review and evaluate comments to determine if revisions to the proposed SEPA code changes are warranted before taking the draft code to public hearing. No public hearing is scheduled at this time.

Thank you,  
Amanda

**Amanda Beck, AICP** | City of Spokane | Assistant Planner II

509-625-6414 | main 509-625-6500 | [abeck@spokanecity.org](mailto:abeck@spokanecity.org) | [spokanecity.org](http://spokanecity.org)



---

**From:** rhoffenberg@aol.com <rhoffenberg@aol.com>  
**Sent:** Friday, April 15, 2022 6:07 AM  
**To:** Beck, Amanda <abeck@spokanecity.org>  
**Subject:** Comment on SEPA changes

**[CAUTION - EXTERNAL EMAIL - Verify Sender]**

Amanda Beck

This is not what the citizens and residences should be looking at. We have the right and, it's your responsibility to all of us, to do the right thing and not take away those rights to agree or disagree on what's going to happen in our neighbors (our homes).

The developers and local government are only looking at profit without looking at the whole picture. We have every right to know what's happening and you need to keep everyone informed. We, as a whole, will do whatever needs to be done to stop this.

Do the right thing.

Robyn Hoffenberg

-----Original Message-----

From: CALV <[contactcalv@gmail.com](mailto:contactcalv@gmail.com)>

To:

Sent: Thu, Apr 14, 2022 10:12 am

Subject: Keeping the Public in the Dark - City Changes Coming to Favor Developers Over Residents

Changes are coming for **SEPA** protections and Short Plat reviews unless we

## **Take Action and Comment!**

The **SEPA** (State Environmental Policy Act) process is really the only way for people in the neighborhood to comment on specific aspects of development like roads, wetlands, street issues and such. The SEPA process is also where other agencies like WSDOT, Fire, Schools, etc. have a chance to comment.

The City of Spokane's proposed SEPA changes are **detrimental and significant:**

- SEPA **would not be required** for 30 or less single-family home developments (currently SEPA is not required for 20 homes or less).

Losing SEPA review would eliminate our ability to comment about development in our neighborhoods on projects of 30 or less. **That is impactful.....**please share your concerns!

The City of Spokane is also proposing two types of changes to the review of short plats;

1. First, the City is proposing to remove the notice of application for short plats that create only **two** lots, similar to Type I applications.
2. Second, the City is considering removing the required posted sign, but continuing a mailed notice of application for short plats creating **three to nine** lots.

### **The proposed changes would include:**

- Amending the public notice to only require a mailed notice to properties within 400 feet.
- No notice in the newspaper; and
- Removing the site posting sign requirements.

**There is no mention of a requirement to notify the neighborhood council**

The 60-day agency and public comment period will run **60 days from April 4, 2022, through June 6, 2022, ending at 5:00 PM.**

**Submit comments to:**

Amanda Beck

[abeck@spokanecity.org](mailto:abeck@spokanecity.org), 509-625-6414

City of Spokane Planning Services, 6<sup>th</sup> Floor

808 W Spokane Falls Blvd.

Spokane, WA 99201



**From:** [Beck, Amanda](#)  
**To:** [Landry Smallfoot](#)  
**Subject:** RE: SEPA Changes  
**Date:** Monday, April 18, 2022 12:54:00 PM  
**Attachments:** [image001.png](#)  
[image002.png](#)  
[image003.png](#)

---

Hi Candace,

Thank you for providing public comment on proposed revisions to residential code related to the project [Shaping Spokane Housing](#). Your email is now part of the public record for the project, and will be shared with the Plan Commission at the public hearing.

Please be aware that proposed changes to short plat notification will be going to public hearing at the May 11th Plan Commission meeting. When the agenda is posted, you can find meeting information on the [Plan Commission webpage](#).

At the end of the 60-Day Agency and Public Comment period for the proposed SEPA code changes, which runs April 4 through June 6, the City will review and evaluate comments to determine if revisions to the proposed SEPA code changes are warranted before taking the draft code to public hearing. No public hearing is scheduled at this time.

Thank you,  
Amanda

**Amanda Beck, AICP** | City of Spokane | Assistant Planner II

509-625-6414 | main 509-625-6500 | [abeck@spokanecity.org](mailto:abeck@spokanecity.org) | [spokanecity.org](http://spokanecity.org)



---

**From:** Landry Smallfoot <cansmall2@comcast.net>  
**Sent:** Friday, April 15, 2022 12:40 PM  
**To:** Beck, Amanda <abeck@spokanecity.org>; Kevin <hawc929@comcast.net>;  
 parpolia@yahoo.com; tucbrown@gmail.com; contactcalv@gmail.com; Lobbch@comcast.net;  
 smith.dana5050@gmail.com; victoriapalmen68@gmail.com; jayrayfarmer@gmail.com;  
 amyndel@yahoo.com; Molly Marshall <molly.marshall475@gmail.com>  
**Subject:** SEPA Changes

**[CAUTION - EXTERNAL EMAIL - Verify Sender]**

Amanda,

For SEPA rqts., it is imperative that the neighborhoods and their councils be informed. We will live a neighborhood that the Lennar bros are proposing 183 homes. It is on a wetland and the whole neighborhood is impacted. Had we not

received notification from our neighborhood council and the posted signs of the meeting with the engineer, none of our voices would have been heard. There are very few neighbors that received the 400 ft notice (there are no neighbors that border that property except maybe 10) which is very restrictive to begin with. I am absolutely sick of the city allowing these developers to try to "sneak" into our neighborhoods.

It seems like developers want to put developments in our areas, but if they can "get away" with not providing improvements etc. that is the goal. Our neighborhood of Grandview Thorpe has developers all over the place and it is going to be very impactful and a disaster. Right now we cannot support any developments (two major ones Lennar and Toll).

If anything the SEPA notification needs to be increased and advertised all over the place! The city needs to quit "hoodwinking" city citizens and be there to support and listen to the concerns of huge developments that impact all of these neighborhoods safety and security!

Sincerely,

Candace Smallfoot

Changes are coming for **SEPA** protections and Short Plat reviews unless we

### **Take Action and Comment!**

The **SEPA** (State Environmental Policy Act) process is really the only way for people in the neighborhood to comment on specific aspects of development like roads, wetlands, street issues and such. The SEPA process is also where other agencies like WSDOT, Fire, Schools, etc. have a chance to comment.

The City of Spokane's proposed SEPA changes are **detrimental and significant:**

- SEPA **would not be required** for 30 or less single-family home developments (currently SEPA is not required for 20 homes or less).

Losing SEPA review would eliminate our ability to comment about development in our neighborhoods on projects of 30 or less. **That is impactful.....**please share your concerns!

The City of Spokane is also proposing two types of changes to the review of short plats;

1. First, the City is proposing to remove the notice of application for short plats

that create only **two** lots, similar to Type I applications.

1. Second, the City is considering removing the required posted sign, but continuing a mailed notice of application for short plats creating **three to nine** lots.

**The proposed changes would include:**

- Amending the public notice to only require a mailed notice to properties within 400 feet.
- No notice in the newspaper; and
- Removing the site posting sign requirements.

**There is no mention of a requirement to notify the neighborhood council**

The 60-day agency and public comment period will run **60 days from April 4, 2022, through June 6, 2022, ending at 5:00 PM.**

**Submit comments to:**

Amanda Beck

[abeck@spokanecity.org](mailto:abeck@spokanecity.org), 509-625-6414

City of Spokane Planning Services, 6<sup>th</sup> Floor

808 W Spokane Falls Blvd.

Spokane, WA 99201

**From:** [Beck, Amanda](#)  
**To:** [Kevin](#)  
**Subject:** RE: SEPA Changes  
**Date:** Monday, April 18, 2022 12:54:00 PM  
**Attachments:** [image001.png](#)  
[image002.png](#)  
[image003.png](#)

---

Hi Kevin,

Thank you for providing public comment on proposed revisions to residential code related to the project [Shaping Spokane Housing](#). Your email is now part of the public record for the project, and will be shared with the Plan Commission at the public hearing.

Please be aware that proposed changes to short plat notification will be going to public hearing at the May 11th Plan Commission meeting. When the agenda is posted, you can find meeting information on the [Plan Commission webpage](#).

At the end of the 60-Day Agency and Public Comment period for the proposed SEPA code changes, which runs April 4 through June 6, the City will review and evaluate comments to determine if revisions to the proposed SEPA code changes are warranted before taking the draft code to public hearing. No public hearing is scheduled at this time.

Thank you,  
Amanda

**Amanda Beck, AICP** | City of Spokane | Assistant Planner II

509-625-6414 | main 509-625-6500 | [abeck@spokanecity.org](mailto:abeck@spokanecity.org) | [spokanecity.org](http://spokanecity.org)



---

**From:** Kevin <hawc929@comcast.net>  
**Sent:** Friday, April 15, 2022 4:08 PM  
**To:** Beck, Amanda <abeck@spokanecity.org>  
**Subject:** Fwd: SEPA Changes

**[CAUTION - EXTERNAL EMAIL - Verify Sender]**

Amanda, I concur with the email from C. Smallfoot. I feel strongly the city is only about developing at all costs without any thought to those of us that have lived here and paid property taxes for years. As many others have stated on Next Door and other apps, between the horrible number of high priced home developments that will do absolutely nothing for homelessness, the increase in crime and nothing ever being done about it, it is time to look at moving out and let this city be taken over by crime and high priced homes!

To try and continue to sneak developments in on us is deplorable.

Kevin Stevens

Kevin V. Stevens, RN, MSN, MS, RD  
 Finish Line Performance Nutrition LLC  
 IRONMAN Certified Coach  
 Sports Nutrition Specialist ISSA  
[Hawc929@comcast.net](mailto:Hawc929@comcast.net)

Begin forwarded message:

**From:** Landry Smallfoot <[cansmall2@comcast.net](mailto:cansmall2@comcast.net)>  
**Date:** April 15, 2022 at 12:40:16 PM PDT  
**To:** [abeck@spokanecity.org](mailto:abeck@spokanecity.org), Kevin <[hawc929@comcast.net](mailto:hawc929@comcast.net)>, [parpolia@yahoo.com](mailto:parpolia@yahoo.com),  
[tucbrown@gmail.com](mailto:tucbrown@gmail.com), [contactcalv@gmail.com](mailto:contactcalv@gmail.com), [Lobbch@comcast.net](mailto:Lobbch@comcast.net),  
[smith.dana5050@gmail.com](mailto:smith.dana5050@gmail.com), [victoriapalmen68@gmail.com](mailto:victoriapalmen68@gmail.com), [jayrayfarmer@gmail.com](mailto:jayrayfarmer@gmail.com),  
[amyndel@yahoo.com](mailto:amyndel@yahoo.com), Molly Marshall <[molly.marshall475@gmail.com](mailto:molly.marshall475@gmail.com)>  
**Subject: SEPA Changes**

Amanda,

For SEPA rqts., it is imperative that the neighborhoods and their councils be informed. We will live a neighborhood that the Lennar bros are proposing 183 homes. It is on a wetland and the whole neighborhood is impacted. Had we not received notification from our neighborhood council and the posted signs of the meeting with the engineer, none of our voices would have been heard. There are very few neighbors that received the 400 ft notice (there are no neighbors that border that property except maybe 10) which is very restrictive to begin with. I am absolutely sick of the city allowing these developers to try to "sneak" into our neighborhoods.

It seems like developers want to put developments in our areas, but if they can "get away" with not providing improvements etc. that is the goal. Our neighborhood of Grandview Thorpe has developers all over the place and it is going to be very impactful and a disaster. Right now we cannot support any developments (two major ones Lennar and Toll).

If anything the SEPA notification needs to be increased and advertised all over the place! The city needs to quit "hoodwinking" city citizens and be there to support and listen to the concerns of huge developments that impact all of these neighborhoods safety and security!

Sincerely,



Candace Smallfoot

Changes are coming for **SEPA** protections and Short Plat reviews unless we

**Take Action and Comment!**

The **SEPA** (State Environmental Policy Act) process is really the only way for people in the neighborhood to comment on specific aspects of development like roads, wetlands, street issues and such. The SEPA process is also where other agencies like WSDOT, Fire, Schools, etc. have a chance to comment.

The City of Spokane's proposed SEPA changes are **detrimental and significant:**

- SEPA **would not be required** for 30 or less single-family home developments (currently SEPA is not required for 20 homes or less).

Losing SEPA review would eliminate our ability to comment about development in our neighborhoods on projects of 30 or less. **That is impactful.....please share your concerns!**

The City of Spokane is also proposing two types of changes to the review of short plats;

1. First, the City is proposing to remove the notice of application for short plats that create only **two** lots, similar to Type I applications.
1. Second, the City is considering removing the required posted sign, but continuing a mailed notice of application for short plats creating **three to nine** lots.

**The proposed changes would include:**

- Amending the public notice to only require a mailed notice to properties within 400 feet.
- No notice in the newspaper; and
- Removing the site posting sign requirements.

**There is no mention of a requirement to notify the neighborhood council**

The 60-day agency and public comment period will run **60 days from April 4, 2022, through June 6, 2022, ending at 5:00 PM.**

**Submit comments to:**

Amanda Beck

[abeck@spokanecity.org](mailto:abeck@spokanecity.org), 509-625-6414

City of Spokane Planning Services, 6<sup>th</sup> Floor

808 W Spokane Falls Blvd.

Spokane, WA 99201

**From:** [Beck, Amanda](#)  
**To:** [Dick Thiel](#)  
**Subject:** RE: SEPA Protections and short plat reviews  
**Date:** Monday, April 18, 2022 12:54:00 PM  
**Attachments:** [image001.png](#)  
[image002.png](#)  
[image003.png](#)

---

Hi Dick,

Thank you for providing public comment on proposed revisions to residential code related to the project [Shaping Spokane Housing](#). Your email is now part of the public record for the project, and will be shared with the Plan Commission at the public hearing.

Please be aware that proposed changes to short plat notification will be going to public hearing at the May 11th Plan Commission meeting. When the agenda is posted, you can find meeting information on the [Plan Commission webpage](#).

At the end of the 60-Day Agency and Public Comment period for the proposed SEPA code changes, which runs April 4 through June 6, the City will review and evaluate comments to determine if revisions to the proposed SEPA code changes are warranted before taking the draft code to public hearing. No public hearing is scheduled at this time.

Thank you,  
Amanda

**Amanda Beck, AICP** | City of Spokane | Assistant Planner II

509-625-6414 | main 509-625-6500 | [abeck@spokanecity.org](mailto:abeck@spokanecity.org) | [spokanecity.org](http://spokanecity.org)



---

**From:** Dick Thiel <dickthiel@comcast.net>  
**Sent:** Friday, April 15, 2022 10:33 AM  
**To:** Beck, Amanda <abeck@spokanecity.org>  
**Cc:** Patti Berg <catsmeow4814@yahoo.com>  
**Subject:** SEPA Protections and short plat reviews

**[CAUTION - EXTERNAL EMAIL - Verify Sender]**

Wrong, wrong, wrong. Do NOT do this. It will come back and bite you in the butt! Citizens and neighbors deserve to learn about proposed projects so they can comment, seek legitimate changes, and then live happily with the development. It appears you are being pressured by developers, and are hungry for development dollars. Don't do this. Listen to your neighbors (taxpayers) and don't foment the dissent that is sure to happen.

**From:** [Beck, Amanda](#)  
**To:** [Karen Carlberg](#)  
**Subject:** RE: Keeping the Public in the Dark - City Changes Coming to Favor Developers Over Residents  
**Date:** Monday, April 18, 2022 1:54:00 PM  
**Attachments:** [image005.png](#)  
[image006.png](#)  
[image007.png](#)  
[image008.png](#)  
[image009.png](#)  
[image010.png](#)

---

Hi Karen,

Due to the city's process to request comments during the determination of a complete application, NCS will maintain the opportunity to comment on applications. You are correct, this is not changing.

For some people I think the issue is timing. So that potential mitigations are reflected in a submitted application, SEPA is typically completed first followed by an application. Certainly if they run at the same time, any pertinent comments from the SEPA would be required to be reflected in an updated proposal for the application.

Hope that answers your question.

Thank you,  
Amanda

**Amanda Beck, AICP** | City of Spokane | Assistant Planner II  
 509-625-6414 | *main* 509-625-6500 | [abeck@spokanecity.org](mailto:abeck@spokanecity.org) | [spokanecity.org](http://spokanecity.org)



---

**From:** Karen Carlberg <karencarlberg@comcast.net>  
**Sent:** Monday, April 18, 2022 1:33 PM  
**To:** Beck, Amanda <abeck@spokanecity.org>  
**Subject:** Re: Keeping the Public in the Dark - City Changes Coming to Favor Developers Over Residents

**[CAUTION - EXTERNAL EMAIL - Verify Sender]**

Thanks Amanda. I'm interpreting this to say that there will be no change in opportunities for neighborhood council comment on projects. Right?

Karen

---

**From:** "Beck, Amanda" <[abeck@spokanecity.org](mailto:abeck@spokanecity.org)>  
**Date:** Monday, April 18, 2022 at 12:31 PM  
**To:** Karen Carlberg <[karencarlberg@comcast.net](mailto:karencarlberg@comcast.net)>  
**Subject:** RE: Keeping the Public in the Dark - City Changes Coming to Favor Developers Over

Residents

Hi Karen,

The CALV email is referencing two code changes that are a part of the [Shaping Spokane Housing](#) project. Sorry this is a bit long, hopefully it gives you plenty of information.

Proposed changes to short plat notification have been going through a series of workshops with Plan Commission. Draft text is available on the project webpage. The changes include removing notification for a short plat which creates two lots (e.g. the mother parcel and one other), and revise notification for short plats that create three to nine lots such that only a mailed noticed will be sent to property owners, tax payers, and residents within 400 feet of the subject site with no site posting. [This code change will be going to public hearing at the May 11<sup>th</sup> Plan Commission workshop.](#)

What that would look like: Neighborhood Councils would be solicited for comment during a fourteen day comment window when the city completes the determination of a complete application (outlined in [Section 17G.060.090](#)), regardless of number of lots. Taxpayers/property owners/residents would get a notice of application in the mail for short plats of three to nine lots, and could provide comment during that fifteen day window.

The second piece is proposed changes to our SEPA ordinance around the flexible threshold for categorical exemptions. The proposed draft is available on the project webpage. In line with recommendations from WA Commerce in [RCW 36.70A.600\(1\)\(r\)](#), the city has proposed to change the flexible thresholds as noted below, except to keep the fill/excavation at the current 500 cubic yard threshold. SEPA is often a situation where if the number of units or square feet meets the threshold, but excavation or grading on site goes over threshold, then a project kicks back in for SEPA review since the intent there is to evaluate possible environmental impacts and enact mitigations. [Revisions to this section of code require a 60-day Agency and Public Comment period, which began April 4 and runs through June 6- no public hearing is scheduled at this time.](#) At the end of the 60-Day Agency and Public Comment period the City will review and evaluate comments to determine if revisions to the proposed SEPA code changes are warranted before taking the draft code to public hearing.

<b>Construction Type</b>	<b>SMC 17E Flexible Threshold</b>	<b>197-11-800 WAC Max. Allowed by State</b>	<b>Proposed SMC 17E Flexible Threshold</b>
<b>Single-family residential</b>	20 units	30 units	<b>30 units</b>
<b>Multifamily residential</b>	20 units	60 units	<b>60 units</b>
<b>Agricultural structure</b>	20,000 SF	40,000 SF	<b>40,000 SF</b>
<b>Office, school, commercial, recreational, service, or storage buildings and related parking</b>	12,000 SF and 40 parking spaces	30,000 SF and 90 parking spaces	<b>30,000 SF and 90 parking spaces</b>
<b>Fill or excavation</b>	500 cubic yards	1,000 cubic yards	<b>500 cubic yards</b>

What that would look like: Projects under the threshold would not be required to do a SEPA review so there would be no SEPA notice or site posting, and projects over threshold would follow our current process of review and notification. Similar to above, NCs would be notified during the determination of a

complete application.

Let us know if you have questions. Thanks for reaching out.

Thank you,  
Amanda

**Amanda Beck, AICP** | City of Spokane | Assistant Planner II  
509-625-6414 | *main* 509-625-6500 | [abeck@spokanecity.org](mailto:abeck@spokanecity.org) | [spokanecity.org](http://spokanecity.org)



---

**From:** Karen Carlberg <[karencarlberg@comcast.net](mailto:karencarlberg@comcast.net)>  
**Sent:** Saturday, April 16, 2022 10:17 AM  
**To:** Beck, Amanda <[abeck@spokanecity.org](mailto:abeck@spokanecity.org)>  
**Cc:** [pfbundy0@gmail.com](mailto:pfbundy0@gmail.com); [karencarlberg@comcast.net](mailto:karencarlberg@comcast.net); [rkclapp@gmail.com](mailto:rkclapp@gmail.com);  
[dwrightemersonsr@gmail.com](mailto:dwrightemersonsr@gmail.com); [josettegates@gmail.com](mailto:josettegates@gmail.com); [mshkg@hotmail.com](mailto:mshkg@hotmail.com); [hagy\\_w@icloud.com](mailto:hagy_w@icloud.com);  
[kjhiker49@gmail.com](mailto:kjhiker49@gmail.com); [mensching65@gmail.com](mailto:mensching65@gmail.com); [jmotr56@msn.com](mailto:jmotr56@msn.com)  
**Subject:** FW: Keeping the Public in the Dark - City Changes Coming to Favor Developers Over Residents

**[CAUTION - EXTERNAL EMAIL - Verify Sender]**

Hi Amanda,

I received the email below, I assume so that I can distribute it to the West Hills neighborhood for comment. It is from the CALV group, which was formed to respond to all the proposals for new development in the Latah Valley and Grandview/Thorpe neighborhood. I responded to the email asking for more information and relevant websites. I got a response, but it wasn't very helpful.

My main concern is the comment below about possibly losing the possibility of neighborhood council opportunities to submit comments about projects in the neighborhood. I'm not seeing anything in the materials that suggests that.

Can you please clarify? What is the purpose of these proposed changes? And is there any change in neighborhood involvement in the review process for projects in the neighborhood?

Thanks for your help.

Karen Carlberg  
Chair, West Hills Neighborhood Council

---

**From:** CALV <[contactcalv@gmail.com](mailto:contactcalv@gmail.com)>  
**Date:** Thursday, April 14, 2022 at 10:11 AM

**To:** <undisclosed-recipients:;>

**Subject:** Keeping the Public in the Dark - City Changes Coming to Favor Developers Over Residents

Changes are coming for **SEPA** protections and Short Plat reviews unless we

## **Take Action and Comment!**

The **SEPA** (State Environmental Policy Act) process is really the only way for people in the neighborhood to comment on specific aspects of development like roads, wetlands, street issues and such. The SEPA process is also where other agencies like WSDOT, Fire, Schools, etc. have a chance to comment.

The City of Spokane's proposed SEPA changes are **detrimental and significant**:

- SEPA **would not be required** for 30 or less single-family home developments (currently SEPA is not required for 20 homes or less).

Losing SEPA review would eliminate our ability to comment about development in our neighborhoods on projects of 30 or less. **That is impactful**.....please share your concerns!

The City of Spokane is also proposing two types of changes to the review of short plats;

1. First, the City is proposing to remove the notice of application for short plats that create only **two** lots, similar to Type I applications.
1. Second, the City is considering removing the required posted sign, but continuing a mailed notice of application for short plats creating **three to nine** lots.

### **The proposed changes would include:**

- Amending the public notice to only require a mailed notice to properties within 400 feet.
- No notice in the newspaper; and
- Removing the site posting sign requirements.

**There is no mention of a requirement to notify the neighborhood council**

The 60-day agency and public comment period will run **60 days from April 4, 2022, through June 6, 2022, ending at 5:00 PM.**

### **Submit comments to:**

Amanda Beck

[abeck@spokanecity.org](mailto:abeck@spokanecity.org), 509-625-6414

City of Spokane Planning Services, 6<sup>th</sup> Floor

808 W Spokane Falls Blvd.

Spokane, WA 99201



**From:** [Beck, Amanda](#)  
**To:** [mellisa donaldson](#)  
**Subject:** RE: Proposed changes to SEPA and short plats  
**Date:** Monday, April 18, 2022 1:12:00 PM  
**Attachments:** [image001.png](#)  
[image002.png](#)  
[image003.png](#)

---

Hi Mellisa,

Thank you for providing public comment on proposed revisions to residential code related to the project [Shaping Spokane Housing](#). Your email is now part of the public record for the project, and will be shared with the Plan Commission at the public hearing.

Please be aware that proposed changes to short plat notification will be going to public hearing at the May 11th Plan Commission meeting. When the agenda is posted, you can find meeting information on the [Plan Commission webpage](#).

At the end of the 60-Day Agency and Public Comment period for the proposed SEPA code changes, which runs April 4 through June 6, the City will review and evaluate comments to determine if revisions to the proposed SEPA code changes are warranted before taking the draft code to public hearing. No public hearing is scheduled at this time.

Thank you,  
Amanda

**Amanda Beck, AICP** | City of Spokane | Assistant Planner II

509-625-6414 | main 509-625-6500 | [abeck@spokanecity.org](mailto:abeck@spokanecity.org) | [spokanecity.org](http://spokanecity.org)



---

**From:** mellisa donaldson <mellisad2001@gmail.com>  
**Sent:** Monday, April 18, 2022 10:14 AM  
**To:** Beck, Amanda <abeck@spokanecity.org>  
**Cc:** Hadi hadi <Badrakhan@gmail.com>  
**Subject:** Proposed changes to SEPA and short plats

**[CAUTION - EXTERNAL EMAIL - Verify Sender]**

Dear Ms. Beck,

I am writing with concerns regarding the changes to following policy. I would like it to go on record that I am against these amendments. There continues to be a push for rapid growth in and around Spokane with little regard to detrimental effects to our community.

Tax payers and members of the community deserve a voice.



Thank you.

Sincerely,

Mellisa Donaldson

3111 W. Washington Rd, Spokane, WA 99224

714.357.4558

The **SEPA** (State Environmental Policy Act) process is really the only way for people in the neighborhood to comment on specific aspects of development like roads, wetlands, street issues and such. The SEPA process is also where other agencies like WSDOT, Fire, Schools, etc. have a chance to comment.

The City of Spokane's proposed SEPA changes are **detrimental and significant**:

- SEPA **would not be required** for 30 or less single-family home developments (currently SEPA is not required for 20 homes or less).

Losing SEPA review would eliminate our ability to comment about development in our neighborhoods on projects of 30 or less. **That is impactful.....**please share your concerns!

The City of Spokane is also proposing two types of changes to the review of short plats;

1. First, the City is proposing to remove the notice of application for short plats that create only **two** lots, similar to Type I applications.
2. Second, the City is considering removing the required posted sign, but continuing a mailed notice of application for short plats creating **three to nine** lots.

**The proposed changes would include:**

- Amending the public notice to only require a mailed notice to properties within 400 feet.
- No notice in the newspaper; and
- Removing the site posting sign requirements.

**There is no mention of a requirement to notify the neighborhood council**

The 60-day agency and public comment period will run **60 days from April 4, 2022, through June 6, 2022, ending at 5:00 PM.**

**Submit comments to:**

Amanda Beck

[abeck@spokanecity.org](mailto:abeck@spokanecity.org), 509-625-6414

City of Spokane Planning Services, 6<sup>th</sup> Floor

808 W Spokane Falls Blvd.  
Spokane, WA 99201



**From:** [Planning Services Development Code](#)  
**To:** [Carmela Conroy](#)  
**Subject:** RE: Appreciation for Draft ADU Revisions  
**Date:** Friday, April 22, 2022 9:17:00 AM

---

Good morning, Ms. Conroy:

Thanks for your message. I will add it to the public record for the file, and it will be shared with the Plan Commission at the public hearing, and with the City Council at its future, unscheduled public hearing. The Plan Commission's hearing is tentatively scheduled for May 11, 2022 at 4 pm. When the agenda for the May 11 hearing is posted, you can find meeting information on the [Plan Commission webpage](#).

**Nathan Gwinn, AICP** | Assistant Planner | Planning & Development  
 509.625.6893 | [ngwinn@spokanecity.org](mailto:ngwinn@spokanecity.org) | [www.spokanecity.org](http://www.spokanecity.org)

Residential Development Code amendments project webpage: [my.spokanecity.org/projects/shaping-spokane-housing](http://my.spokanecity.org/projects/shaping-spokane-housing)

---

**From:** Carmela Conroy <carmelaconroy@yahoo.com>  
**Sent:** Wednesday, April 20, 2022 10:29 PM  
**To:** Planning Services Development Code <erapsdc@spokanecity.org>  
**Subject:** Appreciation for Draft ADU Revisions

**[CAUTION - EXTERNAL EMAIL - Verify Sender]**

Dear Neighbors:

Thank you for sharing information via email about the draft revisions to the requirements for auxiliary dwelling units (ADUs). I have been considering converting over half of my basement into an ADU. I live in a single-family residential area. My house is on a bus line. I am approaching senior citizen hood, and would feel safer having someone living on the property with me.

Two particularly salient advantages of the revisions are greater flexibility in the size of the ADU, and in eliminating the need for offstreet parking. My basement is quite large, but unsuitable for any configuration other than a studio apartment. Having greater flexibility on size allows me to include storage space for a future tenant. This might be especially useful to a medical resident or academic assigned to Spokane for a year or two.

My garage and driveway allow for little to no expansion. My being on a bus line and within walking distance of the medical centers means some tenants might not need any parking at all. There's ample street parking if needed. Eliminating the off street parking requirement will significantly reduce the cost and speed with which I can put an ADU on the market.

I appreciate your taking the time to consider these comments.

Sincerely

Carmela Conroy

US Mobile: 571-276-4238

April 21, 2022

**RE: SMC 17C.300: ACCESSORY DWELLING UNITS – REVIEW AND SUGGESTED UPDATES**

Dear Spokane Planning, Ms. Murphy, Plan Commission, and Councilmembers:

Thank you for your work in implementing the city's Housing Action Plan, and for moving the needle forward on greater housing supply.

As you're well aware, there is a critical need to increase housing supply in Spokane. We are simply failing at producing the needed numbers that will result in 6,791 new units by 2037 (or 400+ units per year) per the City's 2020 Housing Needs Assessment. Unless bold changes are made, then we will continue to push would-be home-owners and renters, and community members to the margins.

Please consider moving quickly in adopting and codifying relaxed and flexible standards for Accessory Dwelling Units (ADUs) as a preliminary, 'low-hanging fruit', opportunity. I would encourage the Plan Commission and City Council to ratify polices suggested by in RCW 36.70A.600(1)(n),(o),(p),(q),and (x) regarding additional flexibility, and lessening restrictions, for accessory dwelling units.

The draft changes to "17C.300 SMC Accessory Dwelling Units" attempt to ratify some of these policies.

**Please consider the following suggestions / modifications to the proposed draft ADU updates:**

- 17C.300.100 (B)(2) – Multiple ADUs in all Residential Zones may be permitted through a Conditional Use Permit (CUP).
- 17C.300.100 (B)(2) – Development standards of the underlying district may be modified pursuant to the provisions of this section.
- 17C.300.110 (A)(1) – Reduce minimum size of principal structure to 500 square feet.
- 17C.300.110 (A)(1)(a) – Floor area of internal ADU not more than 50% the floor area of the principal structure, or 800 square feet, whichever is greater.
- 17C.300.110 (A)(2) – *Per WA House Bill 1660* - Floor area of detached ADU not more than 850 square feet for lots less than 4,500 square feet, and 1,350 square feet as the combined floor area for both attached and detached ADUs on lots greater than 4,500 square feet.
- 17C.300.110 (B) – *Per RCW 36.70A.600(1)(p)* - Remove owner-occupancy requirements, i.e. 'Draft Option SMC 110.C.1'

Thank you for your consideration and seeking to address dire need.

With Regards,



Ryan Hughes, AICP

210 W. 32<sup>nd</sup> Ave Spokane, WA, 99203

[Rhughes509@yahoo.com](mailto:Rhughes509@yahoo.com)

**From:** [Planning Services Development Code](#)  
**To:** "Will Maupin"  
**Subject:** RE: Shaping Spokane Housing Update Comments  
**Date:** Friday, April 22, 2022 9:37:00 AM

---

Hello Mr. Maupin,

Thanks for your comment. I will add it to the public record for the phase 1 topics, and it will be shared with the Plan Commission at the public hearing for the first 3 topics – accessory dwelling units, lot size transition, and short plats – and with the City Council at its future, unscheduled public hearing. The Plan Commission’s hearing is tentatively scheduled for May 11, 2022 at 4 pm.

When the agenda for the May 11 hearing is posted, you can find meeting information on the [Plan Commission webpage](#). We will continue to update the project webpage as public hearings are scheduled and new efforts are announced.

**Nathan Gwinn, AICP** | Assistant Planner | Planning & Development  
 509.625.6893 | [ngwinn@spokanecity.org](mailto:ngwinn@spokanecity.org) | [www.spokanecity.org](http://www.spokanecity.org)

Residential Development Code amendments project webpage: [my.spokanecity.org/projects/shaping-spokane-housing](http://my.spokanecity.org/projects/shaping-spokane-housing)

---

**From:** Will Maupin <willmaupin@gmail.com>  
**Sent:** Thursday, April 21, 2022 12:43 PM  
**To:** Planning Services Development Code <erapsdc@spokanecity.org>  
**Subject:** Shaping Spokane Housing Update Comments

**[CAUTION - EXTERNAL EMAIL - Verify Sender]**

Hello, thank you for updating me on the updates to the city's approach to the housing crisis. What I see from the city is an approach. It's nothing close to a solution.

According to a report on KXLY last night, the average home price in Spokane County increased by \$30k over the past month. ONE MONTH. A friend bought a house on the lower south hill in 2018 for \$220k. Zillow estimates it could go for \$428k today. If \$220k was his max budget today, there are two homes currently listed in Spokane he could afford. Two.

This is a crisis. People who have lived in Spokane for most of their lives, who grew up here, can't afford to live here anymore. I had to re-sign my apartment lease this spring, and my rent increased by 50%. There is an old, cheap motel on 3rd that has been converted to studio apartments leasing for \$1,200+. If you earn the median income for the county, those apartments would take more than 30% of your total income. Respectfully, you can't continue farting around with phase 1.

The longer the city fails to accept this, the worse it will get. Look at the fringes of the city limits now, where development regulations are more lax. What's being built there? Totally unsustainable, completely car-dependent developments that look like the "multifamily housing midsize apartment building" on the graphic in the update, and that's well outside of phase 1.

Those won't even solve the problem, and on top of the help they do provide, they exacerbate other problems like traffic (have you tried getting around the Southgate neighborhood anytime between 2 and 6 p.m. lately?) and climate change. They're a two steps forward, one step back situation.

It's time for big and active change. In the update I saw the word "encourage" once, and it was about townhouses. The city is exploding, cost of living is skyrocketing, and the only thing you're going to "encourage" is a few more townhouses? You're going to "allow" duplexes in more zones? Cool. Go further. Encourage them, too. And then go further than that.

Change the comprehensive plan.

Make owning a surface parking lot in the city center (which looks like swiss cheese from all of those) less appealing than developing it into high density housing. "Encourage" high density urban housing.

Apply the principles of Vancouverism to the Centers and Corridors plan, and expand the plan. Then "encourage" it. In recent years we've seen buildings demolished on the Ruby/Division couplet and be replaced with things like a Panda Express and a sprawling gas station. Encourage density in places like that to the point it would be financially stupid for a developer to build one story nonsense.

Expand where airbnbs are allowed? Ban them all together.

I know there is more red tape and more bureaucratic hurdles to this process than I could ever understand. So I appreciate the fact that this process is underway at all. But I'm frustrated. I grew up here, I've spent almost my entire adult life here, and I can barely afford to stay. I have a good job, and earn good money. Two years ago, before the pandemic hit and this all blew up, I could've bought a good house in a nice neighborhood. The homes I looked at then are being listed now for literally hundreds of thousands of dollars more than they were just two short years ago. Spokane used to lose so many of its best people to bigger, more vibrant cities. Now it's going to start losing those who stayed to places they can afford, like the Tri-Cities or somewhere awful.

Thank you for your work, and know it is appreciated. But please, we need to go so much further.

- Will Maupin

**From:** [Beck, Amanda](#)  
**To:** [Mariah McKay](#)  
**Cc:** [Gwinn, Nathan](#)  
**Subject:** RE: Shaping Spokane Housing Update  
**Date:** Wednesday, April 27, 2022 9:31:00 AM  
**Attachments:** [image005.png](#)  
[image006.png](#)  
[image007.png](#)  
[image008.png](#)  
[image009.png](#)  
[image010.png](#)  
[image011.png](#)  
[image001.png](#)

Hi Mariah,

Thank you for your comments concerning ADUs and owner occupancy. And, you're comments on how to improve communications for projects like this.

Your email is now part of the public record for the project, and will be shared with the Plan Commission at the public hearing. Please be aware that proposed changes to ADUs will be going to public hearing at the May 11th Plan Commission meeting. The agenda can be accessed from the [Plan Commission webpage](#).

You can search building permit records through [Accela Citizen Access](#). I would recommend the below search parameters. Since 2008 we've gotten approximately 175 ADUs that have been permitted.

<b>Record / Permit Number:</b> <input type="text"/>	<b>Record Type:</b> Residential Building New ▼
<b>Start Date:</b> <input type="text" value="01/01/2008"/>	<b>End Date:</b> <input type="text" value="04/27/2022"/>

Thank you,  
Amanda

**Amanda Beck, AICP** | City of Spokane | Assistant Planner II  
509-625-6414 | main 509-625-6500 | [abeck@spokanecity.org](mailto:abeck@spokanecity.org) | [spokanecity.org](http://spokanecity.org)



**From:** Davis, Kirstin <[kdavis@spokanecity.org](mailto:kdavis@spokanecity.org)>  
**Sent:** Monday, April 25, 2022 11:25 AM  
**To:** Mariah McKay <[ournaturalhomes@gmail.com](mailto:ournaturalhomes@gmail.com)>  
**Cc:** Gwinn, Nathan <[ngwinn@spokanecity.org](mailto:ngwinn@spokanecity.org)>; Beck, Amanda <[abeck@spokanecity.org](mailto:abeck@spokanecity.org)>; Black, Tirrell <[tblack@spokanecity.org](mailto:tblack@spokanecity.org)>  
**Subject:** RE: Shaping Spokane Housing Update

Mariah,



Thank you for your feedback. I am sharing it with our planning team and we will do what we can to make communications more relevant and address your specific ADU questions below.

Have a great day,

Kirstin



**Kirstin Davis** | Communications Manager | Public Works and Community & Economic Development  
Desk 509.625.7773 | Mobile 509.481.7223 | [my.spokanecity.org](http://my.spokanecity.org)



**ADVISORY:** Please be advised the City of Spokane is required to comply with the Public Records Act (Chapter 42.56 RCW). As such, the information exchanged via email, including personal information, may ultimately be subject to disclosure as a public record.

---

**From:** Mariah McKay <[ournaturalhomes@gmail.com](mailto:ournaturalhomes@gmail.com)>  
**Sent:** Thursday, April 21, 2022 6:05 PM  
**To:** Davis, Kirstin <[kdavis@spokanecity.org](mailto:kdavis@spokanecity.org)>  
**Subject:** Re: Shaping Spokane Housing Update

**[CAUTION - EXTERNAL EMAIL - Verify Sender]**

Small business owners REALLY struggle to take the time to participate in public policy changes like these even though we are significantly impacted by them.

Instead of providing links to lengthy Zoom recordings and arcane procedural documents with way too much detail, it would be more helpful if city staff could contextualize and summarize what is actually going on now and ask us to briefly weigh in on that.

I understand the City is understaffed and that is impacting the level of service in planning and housing significantly. But if you are going to write and publish an email, please do so with making meaningful feedback from the end user more possible without deep diving on other websites.

That said, I support massive deregulation of the ADU housing type. Owners should not have to reside on their lots to be able to build an ADU. I also support City Issued Bonds to provide money for a loan fund that could be used to help underwrite loans for ADU development and pay for ADU ecosystem development barrier removal initiatives. In short, I would like to see this happen in our city:

<https://www.youtube.com/watch?v=569aqcdcN4A>

I would like the City to set ADU development goals, and then mobilize small-scale owners and developers to help meet those goals.

Where would one go to try and figure out how many ADUs have been built per year over the last several years?

And who would I talk to about eco-building materials like cob and aircrete meeting city code requirements?

Thanks,  
Mariah

--

**Mariah McKay** (pronouns: she/her)  
**Community Manager, Our Natural Homes**  
Mobile: 509-939-0015



Follow us on Facebook @ournaturalhomesllc  
*"Where coliving is all about community."*

On Wed, Apr 20, 2022 at 9:09 PM City of Spokane Planning <[kdavis@spokanecity.org](mailto:kdavis@spokanecity.org)> wrote:

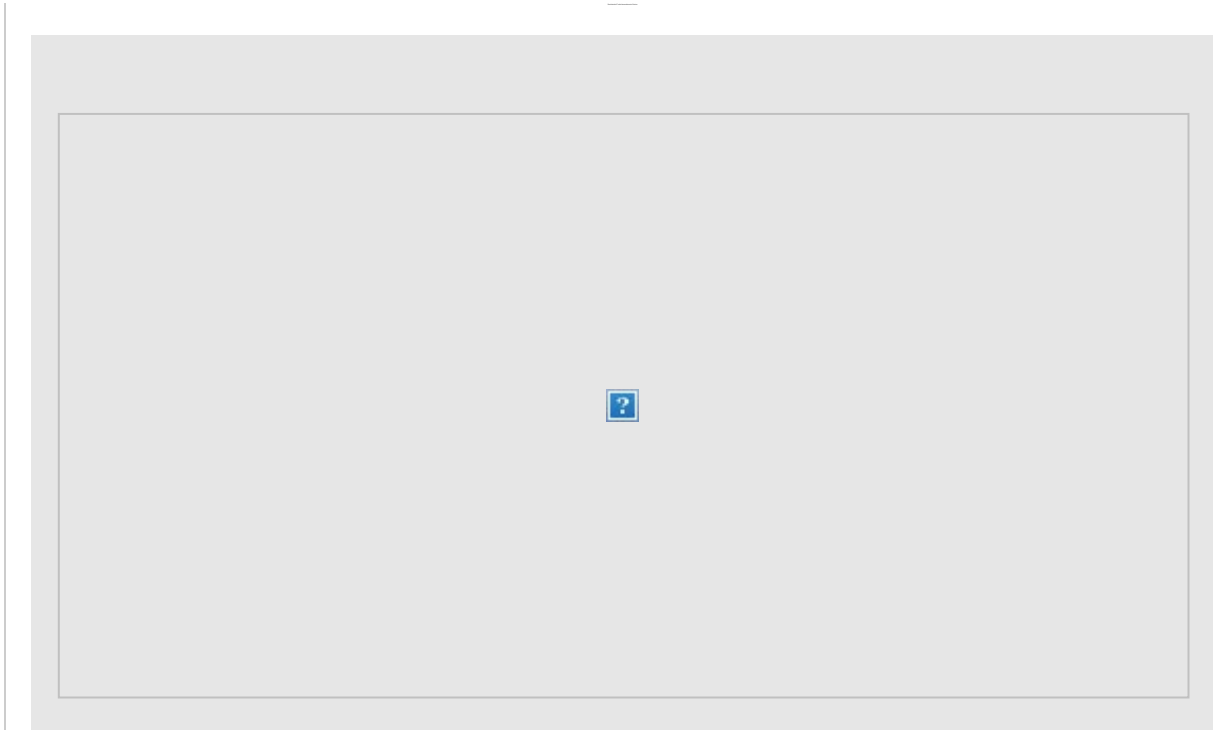

## Dear Community Member,

Thank you for your continued interest in addressing housing challenges in Spokane. You are receiving this email because you have shown interest in the Housing Action Plan and requested information about housing topics. The 2021 [Housing Action Plan](#) provided several recommendations and the City Plan Commission along with the Planning Services department have been discussing **seven initial proposed amendments** outlined on [ShapingSpokaneHousing.com](#).

## Plan Commission Meeting Recap

City Plan Commission workshops have been held to review and discuss proposed revisions to residential zoning codes including accessory dwelling units, various kinds of small-scale housing like duplexes and attached housing and lot size transition requirements. **The meeting held on April 13 reviewed draft code language related to the residential code language for accessory dwelling units and the short plat application process.** Get more information from the meeting [video](#) and view the discussion presentation at the [project webpage](#).



### Accessory Dwelling Units

Increase flexibility of development and design standards for Accessory Dwelling Units (ADU).



### Short Plat Application Process

Reduce or streamline the notification and commenting requirements.

## We want your feedback!

You can **review a description of each proposal on the [project webpage](#)**, which will be updated as the draft revisions evolve.

- **Provide written comment in email to [DevelopmentCode@spokanecity.org](mailto:DevelopmentCode@spokanecity.org).** This email list will be notified regarding additional opportunities for participation.
- **Sign up for email updates and announcements [here](#).**

## Coming Up

### Planning Services Staff at Riverfront Spring Market April 27 from 3-7 p.m.

You're invited to **ask questions and provide feedback** with City planners about the proposed Shaping Spokane Housing changes being considered right now. The **Spring Market is located in the Riverfront Pavilion** event space.

### Plan Commission Meeting on Wednesday, April 27 at 2 p.m.

The Commission will **revisit the City's residential zones**, including **provisions for additional attached housing (townhouses) and duplexes**, as well as **design standards for these and single-family residential development** types. The Commission will also **consider changes to the short plat application process** draft text.

### Attached Housing (Townhouses)

Encourage infill development, update development and

### Duplexes in Residential Single Family (RSF) Zone

Expand the permitted zoning districts and lot types, update



design standards to integrate with neighborhood character.



design standards to integrate with neighborhood character.

**Plan Commission Public Hearing on Wednesday, May 11 at 4 p.m.**

The Commission will **take testimony from the public on proposed changes** to development regulations for accessory dwelling units, lot size transition, and the short plat application process. The Commissions will also consider making a recommendation to the City Council on the proposed changes.

Please visit the [Plan Commission webpage](#) to view the agenda that contains packet materials available for review and instructions for joining the hybrid in-person/virtual meetings.

*You are receiving this email because you signed up via the [Spokane Housing Action Plan website](#), have been identified as an individual or stakeholder in the discussion, or expressed interest in receiving planning project updates from the City of Spokane. Please feel free to share this email with others who are interested in receiving [email announcements](#) about this project. To unsubscribe, please email [developmentcode@spokanecity.org](mailto:developmentcode@spokanecity.org).*



City of Spokane, Washington | 808 W Spokane Falls Blvd, Spokane, WA 99201

[Unsubscribe mariah@spokaneindependent.org](mailto:mariah@spokaneindependent.org)

[Update Profile](#) | [Constant Contact Data Notice](#)

Sent by [kdavis@spokanecity.org](mailto:kdavis@spokanecity.org) powered by



[Try email marketing for free today!](#)

**From:** [Planning Services Development Code](#)  
**To:** "Liza Mattana"  
**Subject:** RE: Manito Cannon Hill neighborhood & changing city code  
**Date:** Tuesday, April 26, 2022 2:11:00 PM

---

Good afternoon Ms. Mattana,

Thanks for your comment. I will add it to the public record for the phase 1 topics, and it will be shared with the Plan Commission at the public hearing for the first 3 topics – accessory dwelling units, lot size transition, and short plats – and with the City Council at its future, unscheduled public hearing. The Plan Commission’s hearing is scheduled for May 11, 2022 at 4 pm.

When the agenda for the May 11 hearing is posted, you can find meeting information on the [Plan Commission webpage](#). We will continue to update the project webpage as public hearings are scheduled and new efforts are announced, and I have added you to the contact list for notice of future opportunities.

Sincerely,

**Nathan Gwinn, AICP** | Assistant Planner | Planning & Development  
 509.625.6893 | [ngwinn@spokanecity.org](mailto:ngwinn@spokanecity.org) | [www.spokanecity.org](http://www.spokanecity.org)

Residential Development Code amendments project webpage: [my.spokanecity.org/projects/shaping-spokane-housing](http://my.spokanecity.org/projects/shaping-spokane-housing)

---

**From:** Liza Mattana <lizamattana@gmail.com>  
**Sent:** Friday, April 22, 2022 6:40 AM  
**To:** Planning Services Development Code <erapsdc@spokanecity.org>  
**Subject:** Manito Cannon Hill neighborhood & changing city code

**[CAUTION - EXTERNAL EMAIL - Verify Sender]**

Hi there,

I received a link from our neighborhood council meeting leaders. I wanted to say I'm all for the proposed changes to ours and other neighborhoods (like ADU, townhomes, duplexes in RSF zone) to promote density and lessen sprawl!

Please keep me posted if there are other opportunities to weigh in.

Thank you!  
 Liza Mattana  
 453 W 26th Ave, Spokane, WA 99203  
 South hill resident since 1982  
 LCHS alumni, class of 1992

**From:** [Alice Galeotti](#)  
**To:** [Planning Services Development Code](#)  
**Subject:** RE: Comment on ADU draft plan  
**Date:** Tuesday, April 26, 2022 2:46:23 PM

---

**[CAUTION - EXTERNAL EMAIL - Verify Sender]**

Nathan,

Thank you for your thorough and informative reply. Have a great rest of your week!

Alice Galeotti

On Apr 26, 2022, 2:25 PM -0700, Planning Services Development Code <erapsdc@spokanecity.org>, wrote:

Good afternoon Ms. Galeotti,

Thanks for your questions and comments. I will add your message to the public record for the ADU amendments, and it will be shared with the Plan Commission at the public hearing for the first 3 topics – accessory dwelling units, lot size transition, and short plats – and with the City Council at its future, unscheduled public hearing. The Plan Commission’s hearing is scheduled for May 11, 2022 at 4 pm.

The attached draft text proposes to remove that provision, showing additions in underlined text and deleted text struck through (page 16). A home occupation is described and regulated in sections [17C.340.100](#), [17C.340.110](#), and [17C.340.120](#) of the Spokane Municipal Code. In the March 23 workshop with the Plan Commission, the members discussed the changing nature of business practices, and some suggested this provision was no longer necessary in the ADU chapter. You may view the recording on the [project webpage](#) at the link below if you are interested.

When the agenda for the May 11 hearing is posted, you can find meeting information on the [Plan Commission webpage](#). We will continue to update the project webpage as public hearings are scheduled and new efforts are announced, and I have added you to the contact list for notice of future opportunities.

I hope this helps,

**Nathan Gwinn, AICP** | Assistant Planner | Planning & Development

509.625.6893 | [ngwinn@spokanecity.org](mailto:ngwinn@spokanecity.org) | [www.spokanecity.org](http://www.spokanecity.org)

Residential Development Code amendments project webpage: [my.spokanecity.org/projects/shaping-spokane-housing](https://my.spokanecity.org/projects/shaping-spokane-housing)

---

**From:** Alice Galeotti <agaleotti612@gmail.com>  
**Sent:** Friday, April 22, 2022 12:00 PM  
**To:** Planning Services Development Code <erapsdc@spokanecity.org>  
**Subject:** Comment on ADU draft plan

**[CAUTION - EXTERNAL EMAIL - Verify Sender]**

Good morning,

Regarding 17C.300.130 Development Standards, Sec A3, why is an ADU prohibited if the homeowner has a "home occupation"? And, what is the definition of home occupation? Does this mean I am prohibited from putting an ADU on my property if I work from a home office as a realtor, for example? Or have a business involving writing where I use my home office? This section is vague and frankly, seems unnecessary. Please explain.

Thank you,  
Alice Galeotti

**From:** [Planning Services Development Code](#)  
**To:** [DWatkins@spokanerealtor.com](mailto:DWatkins@spokanerealtor.com)  
**Subject:** RE: Comments for proposed code changes  
**Date:** Tuesday, April 26, 2022 2:45:00 PM

---

Good afternoon Darin,

Thanks for your comment. I will add it to the public record for the phase 1 topics, and it will be shared with the Plan Commission at the public hearing for the first 3 topics – accessory dwelling units, lot size transition, and short plats – and with the City Council at its future, unscheduled public hearing. The Plan Commission’s hearing is scheduled for May 11, 2022 at 4 pm.

When the agenda for the May 11 hearing is posted, you can find meeting information on the [Plan Commission webpage](#). We will continue to update the project webpage as public hearings are scheduled and new efforts are announced, and the City has you on its contact list for notice of future opportunities.

Sincerely,

**Nathan Gwinn, AICP** | Assistant Planner | Planning & Development  
 509.625.6893 | [ngwinn@spokanecity.org](mailto:ngwinn@spokanecity.org) | [www.spokanecity.org](http://www.spokanecity.org)

Residential Development Code amendments project webpage: [my.spokanecity.org/projects/shaping-spokane-housing](http://my.spokanecity.org/projects/shaping-spokane-housing)

---

**From:** Darin Watkins <[DWatkins@spokanerealtor.com](mailto:DWatkins@spokanerealtor.com)>  
**Sent:** Friday, April 22, 2022 1:19 PM  
**To:** Planning Services Development Code <[erapsdc@spokanecity.org](mailto:erapsdc@spokanecity.org)>  
**Subject:** Comments for proposed code changes

**[CAUTION - EXTERNAL EMAIL - Verify Sender]**

**A severe lack of housing in Spokane has become the greatest single challenge of our times.**

National averages show the City of Spokane should have 114,000 housing units. Instead, we have 89,000.

This leads to dramatically increased greenhouse gas emissions from commuters buying homes in neighboring communities, increases the gap in housing equity, and has been shown to be one of the key contributors to homelessness.

The proposed solutions are truly just a first step. And in many cases, simply update our current codes to match state requirements.

PLEASE support these changes. We MUST do what we can to solve our housing crisis.



**Darin Watkins**

Governmental Affairs Director

Spokane Association of REALTORS®

(509) 595-2012 (cell)

**From:** [Planning Services Development Code](#)  
**To:** [Gene Brake](#)  
**Subject:** RE: Shaping Spokane Housing  
**Date:** Tuesday, April 26, 2022 2:48:00 PM

---

Hi Gene,

Thanks for your comment. I will add it to the public record for all of the phase 1 topics, and it will be shared with the Plan Commission at the public hearing for the first 3 topics – accessory dwelling units, lot size transition, and short plats – and with the City Council at its future, unscheduled public hearing. The Plan Commission’s hearing is scheduled for May 11, 2022 at 4 pm.

When the agenda for the May 11 hearing is posted, you can find meeting information on the [Plan Commission webpage](#). We will continue to update the project webpage as public hearings are scheduled and new efforts are announced, and I have added the [genebrake.re@gmail.com](mailto:genebrake.re@gmail.com) address to the contact list for notice of future opportunities.

Sincerely,

**Nathan Gwinn, AICP** | Assistant Planner | Planning & Development  
 509.625.6893 | [ngwinn@spokanecity.org](mailto:ngwinn@spokanecity.org) | [www.spokanecity.org](http://www.spokanecity.org)

Residential Development Code amendments project webpage: [my.spokanecity.org/projects/shaping-spokane-housing](http://my.spokanecity.org/projects/shaping-spokane-housing)

---

**From:** Gene Brake <[genebrake.re@gmail.com](mailto:genebrake.re@gmail.com)>  
**Sent:** Friday, April 22, 2022 10:34 PM  
**To:** Planning Services Development Code <[erapsdc@spokanecity.org](mailto:erapsdc@spokanecity.org)>  
**Subject:** Shaping Spokane Housing

**[CAUTION - EXTERNAL EMAIL - Verify Sender]**

I do not support several parts of Phase 1 of the Housing Action Plan. I oppose and will actively work against any effort to expand Short Term Rentals, allow ADUs without the owner occupancy requirement and include duplexes in all Residential zones unless there are some limitations.

All three of these proposals will negatively impact housing availability, promote additional escalating home prices and negatively impact neighborhoods by encouraging out of area investors.

All of these will exacerbate the housing shortage and lead to net loss of affordable housing and more homeless neighbors.

Thank you,  
**Gene Brake**  
[www.genebrake.com](http://www.genebrake.com)

[www.corbinpark.net](http://www.corbinpark.net)

509-981-5555



601 W 1<sup>st</sup> Ave, Ste 1400  
Spokane, WA 99201

**"IMPORTANT NOTICE: Never trust wiring instructions sent via email. Always independently confirm wiring instructions in person or via a telephone call to a trusted and verified phone number. Never wire money without double-checking that the wiring instructions are correct."**



April 25, 2022

Spokane Planning Commission  
 808 Spokane Falls Blvd  
 Spokane WA 99201

Commission,

The Spokane Low Income Housing Consortium is a membership organization made up of over 25 organizations that design, build and support low income housing in Spokane. Our mission is to support all affordable housing and we know and unanimously support the phase one changes in Shaping Spokane!

We are writing this letter to support the changes to the Short Plat process (less notification), increasing the threshold for SEPA reviews on apartments to match the State and we believe that ADU's should be easier to produce.

I was the original sponsor of the neighborhood notification bill in 2014 and have a unique perspective on how a housing market has been stymied by folks who want to keep the status quo. Market rate apartments, house rentals and home ownership are all important to the system.

Studies and real world law changes clearly show that if you eliminate the owner occupancy requirement on ADU's, permits will go up. All three of these changes are designed to increase supply. Increasing supply in every way possible is necessary when rents and ownership have increased by over 50% in the last 24 months.

Housing is system and ownership and rental matter. These are just the first code changes in many. I urge you to pass these fast so we can get to other bigger changes.

Sincerely

A handwritten signature in blue ink that reads "Ben Stuckart".

Ben Stuckart, Executive Director  
 Spokane Low Income Housing Coalition

CC:

Steve McDonald, City of Spokane  
 Spencer Gardner, City of Spokane

**From:** [Beck, Amanda](#)  
**To:** [Carol Tomsic](#)  
**Cc:** [Gwinn, Nathan](#)  
**Subject:** RE: Comment on Residential Code Changes Plan Commission Meeting 4/27/22 at 2pm  
**Date:** Wednesday, April 27, 2022 9:38:00 AM  
**Attachments:** [image001.png](#)  
[image002.png](#)  
[image003.png](#)

---

Hi Carol,

Thank you for providing public comment on proposed revisions to residential code related to the project [Shaping Spokane Housing](#). Your email is now part of the public record for the project, and will be shared with the Plan Commission at the public hearing.

Please be aware that proposed changes to short plat notification will be going to public hearing at the May 11th Plan Commission meeting. You can find meeting information on the [Plan Commission webpage](#), which will be held as a hybrid in-person and virtual meeting.

Draft code for attached homes and duplexes are not currently scheduled for public hearing, but we will notify the email list once we have a date for those topics. Plan Commission will be further discussing design standards for all residential building types (detach and attached single-family as well as duplexes) at our meeting today, Wednesday 4/27.

Thank you,  
Amanda

**Amanda Beck, AICP** | City of Spokane | Assistant Planner II

509-625-6414 | main 509-625-6500 | [abeck@spokanecity.org](mailto:abeck@spokanecity.org) | [spokanecity.org](http://spokanecity.org)



---

**From:** Carol Tomsic <carol\_tomsic@yahoo.com>  
**Sent:** Tuesday, April 26, 2022 11:05 PM  
**To:** Gwinn, Nathan <ngwinn@spokanecity.org>; Beck, Amanda <abeck@spokanecity.org>; Plan Commission <eraplanc@spokanecity.org>; Kinnear, Lori <lkinnear@spokanecity.org>; Wilkerson, Betsy <bwilkerson@spokanecity.org>; Beggs, Breean <bbeggs@spokanecity.org>  
**Cc:** Marilyn <mdlloyd@comcast.net>; Mary Winkes - Manito/Cannon Hill <mmcspo@yahoo.com>; Cortright, Carly <ccortright@spokanecity.org>  
**Subject:** Comment on Residential Code Changes Plan Commission Meeting 4/27/22 at 2pm

**[CAUTION - EXTERNAL EMAIL - Verify Sender]**

Comment on Residential Code Changes Plan Commission Meeting 4/27/22 at 2 pm

**Duplexes in Residential Zones**

I support affordable housing. I raised my son in the Lincoln Heights neighborhood as a single-working mother. I was fortunate to buy a house before the housing prices skyrocketed. I want other families to experience the joy of home-ownership and raising a family in a walkable, bicycle-friendly neighborhood with a thriving center-core.

I also want our neighborhood to be a place where single people and empty nesters can afford to live and support our center-core.

I just ask that the city ensure developers construct housing in our neighborhood that is similar to a single-family home as to add to the quality of our established neighborhood and gently increase the density of residential zones, like stated in the info sheet.

I support smaller, more affordable duplexes in a single family neighborhood, so home-ownership remains viable in my neighborhood.

### **Attached Housing**

The Lincoln Heights neighborhood is dominated by single-family homes.

I would like to request the city notify residents of a proposed 4-unit attached house in a single-family zoning to allow public comments. It would ensure the new housing will be well-designed and add to the quality of the established neighborhood, as stated in the info sheet.

### **Short Plat Application Process**

I would like to request the city retain the notice of application for short plats that create only two lots, or for shot plats with only minor engineering review.

Our neighbors may be aware of any historic significance on the affected neighborhood lots, including historically walked across trails. I don't want our neighborhood to lose an opportunity to protect a feature on the lots during the short plat process.

Thank you!

Carol Tomsic  
resident

**From:** [Gene Brake](#)  
**To:** [Deasy, Annie](#)  
**Cc:** [Antonia DePasquale](#); [Barbara Biles](#); [Bill Heaton](#); [Black, Tirrell](#); [Charles Hansen](#); [Christopher Savage](#); [Chuck Milani](#); [Cliff Winger](#); [Comstock \(comstockneighborhoodcouncil@gmail.com\)](#); [Doug Tompkins](#); [Freibott, Kevin](#); [Byrd, Giacobbe](#); [Greg Francis](#); [Kosanke, Katie](#); [Kelly Cruz](#); [Laura Mincks](#); [McInnis, Bonnie](#); [Molly Marshall](#); [Nicola J Payette](#); [Pat Rooks](#); [Patricia Hansen](#); [Paul Kropp/Southgate](#); [Rachelle Bradley](#); [Robynn Sleep](#); [Teresa Kafentzis](#); [Terryl Black](#); [Tiffany Picotte](#); [Timothy Diko](#); [Tom Powell-Emerson Garfield](#); [Gwinn, Nathan](#)  
**Subject:** Re: Presentation - Land Use Committee  
**Date:** Thursday, April 28, 2022 7:53:09 PM

---

**[CAUTION - EXTERNAL EMAIL - Verify Sender]**

Annie,

Thank you for sharing this. I'm disappointed planning has decided to move forward with a very developer friendly plan and yet most anti neighborhood plan possible in this first Phase. These plans do nothing to increase the number of low income units, yet will absolutely result in the loss of homes when developers and investors begin buying up single family homes. We all know this wont impact most of the South Hill but will decimate the Northside neighborhoods, especially Emerson Garfield.. Where are some of the most affordable homes at present in Spokane that would be Emerson Garfield, well you can kiss them goodbye.

As we see modest historic homes bulldozed we can at least sleep well knowing developers and investors made money. :( Families? Nah, they have to live with the progress. Shameful really.

Gene Brake  
 Housing Action Subcommittee member  
 Emerson Garfield Neighborhood Council - Treasurer  
 Corbin Park Homeowners Association - Vice President

On Thu, Apr 28, 2022 at 3:01 PM Deasy, Annie <[adeasy@spokanecity.org](mailto:adeasy@spokanecity.org)> wrote:

*Good afternoon Land Use Committee Representatives,*

Nathan Gwinn from Planning Services has requested that the attached presentation slides be shared with the committee.

Best,

Annie



Annie Deasy | City of Spokane | Community Programs Coordinator

Working Remotely, Off on Fridays | 509.625.6343 | mobile 509.504.3475 | [adeasy@spokanecity.org](mailto:adeasy@spokanecity.org) | [spokanecity.org](http://spokanecity.org)



May 3, 2022

Spokane Planning Commission  
808 Spokane Falls Blvd  
Spokane WA 99201

Commission,

The Spokane Regional Continuum of Care manages and distributes \$4.3 million annually of HUD's Homelessness service funds. Housing is the end goal of all the interventions funded by the CoC. Finding someone a stable place to call home is the purpose of the CoC's work. This means that our work is intricately connected to the state of Spokane's Housing Market.

We are writing this letter to support several changes that would help increase housing inventory. These include changes to the Short Plat process, increasing the threshold for SEPA reviews on apartments, and making ADU's easier to produce.

The CoC's chairperson was the original sponsor of the neighborhood notification bill in 2014 and has a unique perspective on how our housing market has been stymied by residents who want to maintain the status quo. Reducing notification requirements for Short Plats would be one step in the right direction to increasing housing availability. CoC programs can help fewer people the more market rate rents skyrocket. Increasing the threshold for SEPA reviews to match existing state requirements makes sense and would help to increase housing availability and reduce rental rates. Studies and real-world experience looking at changes to relevant laws clearly show that if the owner occupancy requirement for ADU's is eliminated, applications for permits will increase.

Increasing supply in every way possible is necessary as rents and housing prices have increased by over 50% in the last 24 months. These three changes will help to increase the supply of housing in our community which is desperately needed. These are just a few code changes that are needed to help address the current housing crisis. We urge you to pass these changes as soon as possible so we can focus on larger changes that are needed to address this crisis that impacts our entire community.

Sincerely,

The Spokane Regional Continuum of Care

CC:

Steve McDonald, City of Spokane  
Spencer Gardner, City of Spokane





**From:** [Gardner, Spencer](#)  
**To:** [Beck, Amanda](#); [Churchill, Jackie](#); [Gwinn, Nathan](#)  
**Subject:** FW: Comments on Code Amendments  
**Date:** Wednesday, May 4, 2022 3:59:42 PM  
**Attachments:** [Building Site Coverage in RSF Limits ADU Development.pdf](#)

---

New comment for the public record. Another one to follow.

**Spencer Gardner** | Director | Planning Services  
 Office 509-625-6097 | Mobile 509-723-7554 | [my.spokanecity.org](http://my.spokanecity.org)

---

**From:** Jim Frank <jfrank@greenstonehomes.com>  
**Sent:** Wednesday, May 4, 2022 1:01 PM  
**To:** Gardner, Spencer <sgardner@spokanecity.org>  
**Cc:** Ben Stuckart <benstuckart@gmail.com>; Michelle Pappas <michelle@futurewise.org>; Darin Watkins <dwatkins@spokanerealtor.com>  
**Subject:** Comments on Code Amendments

**[CAUTION - EXTERNAL EMAIL - Verify Sender]**

Spencer Gardner and Plan Commission:

I am very interested in the code amendments necessary to encourage infill development, having been involved in these efforts for more than 10 years.

I regrettably will not be able to testify in person as I have a hearing before the NPAC committee this afternoon at the same time as the Plan Commission public hearing.

These are complex matters and it is discouraging that so little time is being allowed between the finalization of the staff and Commission recommendations and the notice provided to the public. It is also discouraging that these changes are being made without any outreach to the architects, developers and contractors who will have to navigate the code and are familiar with the restrictions that are limiting infill development in the community.

In general I assume the purpose of the recommended changes is to significantly increase infill development in the community. In order for this to be achieved two things will be necessary: First, the regularity framework must be simple, clear and understandable to those looking to make infill investment. Lack of clarity and uncertainty will discourage investment more often than the actual code substance. Second, the code must “encourage” the investment you desire not merely “permit” the investment. These are very different. While I understand this is the beginning of a process and that change will be incremental, What is being proposed in these current changes fall short on both counts.

**I am fully supportive of the recommendation to do away with the lot transition rules.** This is long overdue. The worst part of the rules is not the substance (this will probably not impact more than about 10 units per year), but the message that it sends that “small homes on small lots” are a

problem that needs to be avoided and the code is here to protect you. This message is not only blatantly false, but enables structural inequality in housing policy.

The proposed changes around short plats, ADU development and attached housing fall very short of what is necessary.

**Short Plats:** The changes being proposed add to the complexity of the regulatory framework. The process for exempting 2 lot short plat from the public notice requirement is simply not worth the effort and complexity it entails. It is far more effective to simply make a short plat a Type I permit (rather than Type II). This avoids the public notice requirement and it significantly reduces the fees. If the short plat requires SEPA then a SEPA public notice maybe required, which is a separate and normal process. A Type I permits still has engineering review where required. What is being proposed is simply not worth the effort and will not benefit more than a small number of projects. RCW 58.17 allows jurisdictions to adopt a streamlined process for short plats. The danger of adopting what has been proposed is that it will close the door to the real and necessary changes that are required.

**ADU Development:** While some of the changes proposed for ADU development are beneficial (removal of the occupancy requirement), in total the regulation is overly complex and confusing. The biggest deterrent is building site coverage. The building site coverage in the Spokane SMC is by far the most restrictive in the region. In most instances common development of a home and garage will push up against the site development standards. This is illustrated in the attached exhibit. In nearly all cases there is no “excess building site coverage” available for ADU development. In realty you need a small house on a larger lot to have available site coverage for a 600-800SF ADU. While the new code amendments allow 15% to 20% site coverage for an ADU, that is very misleading. The total of the house, garage and ADU still have to meet to code site coverage which is very restrictive. You can see on the exhibit that a small 1500SF 3 bedroom house on a 5000 SF lot will have a site coverage of 39.6%. The total allowable site coverage on a 5000SF lot is 45%, insufficient for an ADU. For this to work the site coverage in table SMC 17C.110-3 needs to be amended to 55% as a minimum. That would be consistent with Spokane County and the City of Spokane Valley. The FAR standards add even more confusion. An FAR of .5 is ridiculously low for infill development which often requires two or three level development on small lots. It is far simpler to make the changes to FAR on Table SMC 17C.110-3 applicable to all development. Other jurisdictions have greatly simplified the process around ADU development. Spokane needs to do the same.

**Attached Housing:** There are lots of nice words about allowing more attached units without going through a PUD, however you are still required to meet all of the standards in Table SMC 17C.110-3. Attached housing is not possible without revision of the lot size, lot dimensional standards, site coverage, and FAR standards. These are not addressed in any way. It is misleading to say attached housing is being allowed without the required changes to the development standards necessary for such development to occur. For example, an interior townhome unit would like require a lot size as 1500 SF, lot width of 16 feet, site coverage of 80% and FAR of 1.0. The attached housing you see happening in Kendall Yards is possible only because we received a PUD approved that exempts us from nearly all of the development standards in Table 17C.110-3.

I am all in favor of incremental approach to code development, however when we undertake revision in a narrow area we need to address it in the best long term manner.

Thanks, Jim

# Building Site Coverage in RSF Limits ADU Development

Lot Size	House, SF	Garage, SF	ADU, SF	Total Building Coverage, SF	Building Coverage, %, w/ADU	Building Coverage%.W/O add
3000	1000	320	600	1920	64%	44.0%
4350	1300	400	600	2300	52.9%	39.1%
5000	1500	480	600	2580	51.6%	39.6%
			800	2780	55.6%	
6000	1750	625	600	2975	49.6%	39.6%
			800	3175	52.9%	
7000	2000	750	600	3350	47.9%	39.3%
			800	3550	50.7%	
						Spokane County Building Site Coverage
						Spokane Valley Building Site Coverage

Lot Size	Permitted Site Coverage
3000	1500.0
	50.0%
4350	2006.3
	46.1%
5000	2250.0
	45.0%
6000	2600
	43.3%
7000	2950.0
	42.1%
	55.0%%
	50% (8du/acre) and 60% (10du/acre)

**From:** [Gardner, Spencer](#)  
**To:** [Beck, Amanda](#); [Churchill, Jackie](#); [Gwinn, Nathan](#)  
**Subject:** FW: Comments on Code Amendments  
**Date:** Wednesday, May 4, 2022 4:00:17 PM  
**Attachments:** [Building Site Coverage in RSF Limits ADU Development.pdf](#)

---

Follow up comment.

**Spencer Gardner** | Director | Planning Services  
Office 509-625-6097 | Mobile 509-723-7554 | [my.spokanecity.org](http://my.spokanecity.org)

---

**From:** Darin Watkins <DWatkins@spokanerealtor.com>  
**Sent:** Wednesday, May 4, 2022 1:22 PM  
**To:** Jim Frank <jfrank@greenstonehomes.com>  
**Cc:** Gardner, Spencer <sgardner@spokanecity.org>; Ben Stuckart <benstuckart@gmail.com>; Michelle Pappas <michelle@futurewise.org>  
**Subject:** Re: Comments on Code Amendments

**[CAUTION - EXTERNAL EMAIL - Verify Sender]**

Jim, we could not be more in support of your position. In order to facilitate more housing, we need to keep these amendments and changes as simple as possible. Many of the changes are needed to stay within the guidelines of state law.

There are many new and very reasons to be talking about infill, ADU's and other needs. Underlying it all, is the tremendous need for housing that overrides so many of our conversations. We must do everything we can as quickly as we can to relieve the suffering for so many

**Darin Watkins**

Government Affairs Director  
Spokane Association of REALTORS®  
P:  [\(509\) 326-9222 ext. 203](tel:(509)326-9222)

On May 4, 2022, at 4:01 PM, Jim Frank <[jfrank@greenstonehomes.com](mailto:jfrank@greenstonehomes.com)> wrote:

Spencer Gardner and Plan Commission:

I am very interested in the code amendments necessary to encourage infill development, having been involved in these efforts for more than 10 years. I regrettably will not be able to testify in person as I have a hearing before the NPAC committee this afternoon at the same time as the Plan Commission public hearing.

These are complex matters and it is discouraging that so little time is being allowed between the finalization of the staff and Commission recommendations and the notice provided to the public. It is also discouraging that these changes are being made without any outreach to the architects, developers and contractors who will have to navigate the code and are familiar with the restrictions that are limiting infill development in the community.

In general I assume the purpose of the recommended changes is to significantly increase infill development in the community. In order for this to be achieved two things will be necessary: First, the regularity framework must be simple, clear and understandable to those looking to make infill investment. Lack of clarity and uncertainty will discourage investment more often than the actual code substance. Second, the code must “encourage” the investment you desire not merely “permit” the investment. These are very different. While I understand this is the beginning of a process and that change will be incremental, What is being proposed in these current changes fall short on both counts.

**I am fully supportive of the recommendation to do away with the lot transition rules.** This is long overdue. The worst part of the rules is not the substance (this will probably not impact more than about 10 units per year), but the message that it sends that “small homes on small lots” are a problem that needs to be avoided and the code is here to protect you. This message is not only blatantly false, but enables structural inequality in housing policy.

The proposed changes around short plats, ADU development and attached housing fall very short of what is necessary.

**Short Plats:** The changes being proposed add to the complexity of the regulatory framework. The process for exempting 2 lot short plat from the public notice requirement is simply not worth the effort and complexity it entails. It is far more effective to simply make a short plat a Type I permit (rather than Type II). this avoids the public notice requirement and it significantly reduces the fees. If the short plat requires SEPA then a SEPA public notice maybe required, which is a separate and normal process. A Type I permits still has engineering review where required. What is being proposed is simply not worth the effort and will not benefit more than a small number of projects. RCW 58.17 allows jurisdictions to adopt a streamlined process for short plats. The danger of adopting what has been proposed is that it will close the door to the real and necessary changes that are required.

**ADU Development:** While some of the changes proposed for ADU development are beneficial (removal of the occupancy requirement), in total the regulation is overly complex and confusing. The biggest deterrent is building site coverage. The building site coverage in the Spokane SMC is by far the most restrictive in the region. In most instances common development of a home and garage will push up against the site development standards. This is illustrated in the attached exhibit. In nearly all cases

there is no “excess building site coverage” available for ADU development. In reality you need a small house on a larger lot to have available site coverage for a 600-800SF ADU. While the new code amendments allow 15% to 20% site coverage for an ADU, that is very misleading. The total of the house, garage and ADU still have to meet to code site coverage which is very restrictive. You can see on the exhibit that a small 1500SF 3 bedroom house on a 5000 SF lot will have a site coverage of 39.6%. The total allowable site coverage on a 5000SF lot is 45%, insufficient for an ADU. For this to work the site coverage in table SMC 17C.110-3 needs to be amended to 55% as a minimum.

That would be consistent with Spokane County and the City of Spokane Valley. The FAR standards add even more confusion. An FAR of .5 is ridiculously low for infill development which often requires two or three level development on small lots. It is far simpler to make the changes to FAR on Table SMC 17C.110-3 applicable to all development. Other jurisdictions have greatly simplified the process around ADU development. Spokane needs to do the same.

**Attached Housing:** There are lots of nice words about allowing more attached units without going through a PUD, however you are still required to meet all of the standards in Table SMC 17C.110-3. Attached housing is not possible without revision of the lot size, lot dimensional standards, site coverage, and FAR standards. These are not addressed in any way. It is misleading to say attached housing is being allowed without the required changes to the development standards necessary for such development to occur. For example, an interior townhome unit would like require a lot size as 1500 SF, lot width of 16 feet, site coverage of 80% and FAR of 1.0. The attached housing you see happening in Kendall Yards is possible only because we received a PUD approved that exempts us from nearly all of the development standards in Table 17C.110-3.

I am all in favor of incremental approach to code development, however when we undertake revision in a narrow area we need to address it in the best long term manner.

Thanks, Jim



# Building Site Coverage in RSF Limits ADU Development

Lot Size	House, SF	Garage, SF	ADU, SF	Total Building Coverage, SF	Building Coverage, %, w/ADU	Building Coverage%.W/O add
3000	1000	320	600	1920	64%	44.0%
4350	1300	400	600	2300	52.9%	39.1%
5000	1500	480	600	2580	51.6%	39.6%
			800	2780	55.6%	
6000	1750	625	600	2975	49.6%	39.6%
			800	3175	52.9%	
7000	2000	750	600	3350	47.9%	39.3%
			800	3550	50.7%	
						Spokane County Building Site Coverage
						Spokane Valley Building Site Coverage

Lot Size	Permitted Site Coverage
3000	1500.0
	50.0%
4350	2006.3
	46.1%
5000	2250.0
	45.0%
6000	2600
	43.3%
7000	2950.0
	42.1%
	55.0%%
	50% (8du/acre) and 60% (10du/acre)

## Beck, Amanda

---

**From:** Beck, Amanda  
**Sent:** Wednesday, May 11, 2022 9:11 AM  
**To:** Carol Tomsic  
**Cc:** Gwinn, Nathan  
**Subject:** RE: Plan Commission Hearing 5/11/22 on Phase One Residential Development Code

Hi Carol,

Thank you for providing public comment on proposed revisions to short plat notifications that are a part of [Shaping Spokane Housing](#). Your email is now part of the public record for the project, and will be shared with the Plan Commission for tonight's public hearing.

In case you need it, you can find tonight's meeting information on the [Plan Commission webpage](#), which will be held as a hybrid in-person and virtual meeting. The public hearing starts at 4:00 pm.

Thank you,  
Amanda

Amanda Beck, AICP | City of Spokane | Assistant Planner II  
509-625-6414 | main 509-625-6500 | [abeck@spokanecity.org](mailto:abeck@spokanecity.org) | [spokanecity.org](http://spokanecity.org)



---

**From:** Carol Tomsic <carol\_tomsic@yahoo.com>  
**Sent:** Tuesday, May 10, 2022 11:13 PM  
**To:** Plan Commission <eraplanc@spokanecity.org>  
**Cc:** Gwinn, Nathan <ngwinn@spokanecity.org>; Beck, Amanda <abeck@spokanecity.org>; Marilyn <mdlloyd@comcast.net>; Mary Winkes - Manito/Cannon Hill <mmcsपो@yahoo.com>  
**Subject:** Plan Commission Hearing 5/11/22 on Phase One Residential Development Code

**[CAUTION - EXTERNAL EMAIL - Verify Sender]**

Comment on the proposed changes to the Short Plat Application Process

I request the city retain the notice of application for short plats that create only two lots, or for short plats with only minor engineering review.

Our neighborhood has lots that are undeveloped and forested.

The current short plat process notification allows our neighborhood to preserve any historic significance on proposed short plats, including historically walked across trails. A 400 feet notification, without any other notification to residents within the area, may result in a loss of an opportunity to protect a feature on lots during the short plat process.

And, the current short plat process prepares our residents for the proposed code amendments changes that may occur on a lot afterwards.

Thank you  
Carol Tomsic  
resident

## Beck, Amanda

---

**From:** Planning Services Development Code  
**Sent:** Wednesday, May 11, 2022 9:07 AM  
**To:** Matt Side  
**Cc:** Gwinn, Nathan  
**Subject:** RE: Public Comment Spokane City Plan Commission hearing scheduled for 4 p.m. May 11, 2022,

Hi Matt,

Thank you for providing public comment on proposed revisions to residential code related to the project [Shaping Spokane Housing](#). Your email is now part of the public record for the project, and will be shared with the Plan Commission for tonight's public hearing, and also the future hearing for the remaining code topics.

If you're interested, you can find tonight's meeting information on the [Plan Commission webpage](#), which will be held as a hybrid in-person and virtual meeting.

Draft code for attached homes and duplexes are not currently scheduled for public hearing, but we will notify the email list once we have a date for those topics.

Thank you,  
Amanda

Amanda Beck, AICP | City of Spokane | Assistant Planner II  
509-625-6414 | main 509-625-6500 | [abeck@spokanecity.org](mailto:abeck@spokanecity.org) | [spokanecity.org](http://spokanecity.org)



---

**From:** Matt Side <matt@evoreal.com>  
**Sent:** Tuesday, May 10, 2022 8:24 AM  
**To:** Planning Services Development Code <erapsdc@spokanecity.org>  
**Subject:** Public Comment Spokane City Plan Commission hearing scheduled for 4 p.m. May 11, 2022,

**[CAUTION - EXTERNAL EMAIL - Verify Sender]**

Hello My Name is Matt Side. I am a life long resident of Spokane. I am in favor of the proposed changes the Spokane City Plan Commission is considering when it comes to accessory dwelling units and lot size transition. One of the challenges that I think most of us are very aware of is a tight housing supply making it more and more difficult for home purchasers and tenants. I appreciate the Spokane City Council and the Spokane City Plan Commission reaching out to other communities that have gone before us in creating housing opportunity. As I write this comment I am sitting at my brothers apartment in Columbia City just south of Seattle. Ten years ago this was considered a very rough part of Seattle. However, as they have allowed mixed use and stacked flat development it has quickly become a desirable place to live. It is critical to our growth as a community to create neighborhood havens that encourage reinvestment into our local economy. Townhomes, stacked flats, and Accessory Dwelling Units with fewer restrictions in addition to investing in our smaller neighborhood commercial zones will open up housing accessibility and encourage people to stay in their communities and not always have to drive across town for the services they need. The state of Washington legislature was unable this last session to pass a missing middle housing bill which was intended to help solve so many of these issues. That inability to take action at the state level reinforces the need for the local governments to make adjustments

to zoning and building regulations that allow us to leverage the property we have inside the city instead of continuing to sprawl outward. Thank you for considering these changes to Spokane.

Matt Side

509-220-3961 Cell

509-747-1101 X 3 Office

509-271-0037 Fax

[matt@evoreal.com](mailto:matt@evoreal.com)



**Spokane Tribe of Indians  
Tribal Historic Preservation Officer**

P.O Box 100 Wellpinit WA 99040

April 5, 2022

**To:** Amanda Beck, Planner II

**RE: Shaping Spokane Housing Residential Development Code Amendments for  
Accessory Dwelling units, Lots Size Transition and Short Plats**

Ms. Beck,

Thank you for contacting the Tribe's Historic Preservation Office. We appreciate the opportunity to provide a cultural consult for your project. The intent of this process is to preserve and protect all cultural resources whenever protection is feasible.

As you know that the Spokane Tribe use of these area's was extensive in years prior to arrival of euro- Americans clearly the Spokane area was a great place of cultural and economic importance to our tribe an research and plan early.

**Recommendation: Case by Case review on each project and may require cultural surveys or monitoring.**

Should additional information become available or scope of work change our assessment may be revised.

Again, thank you for this opportunity to comment and consider this a positive action that will assist in protecting our shared heritage.

If questions arise, please contact me at (509) 258 – 4222.

Regards,

Randy Abrahamson  
Tribal Historic Preservation Officer (T.H.P.O.)

**DATE:** April 12<sup>th</sup>, 2022  
**TO:** Amanda Beck, Development Services  
**FROM:** Bobby Halbig, Street Department  
**SUBJECT:** Plan Review  
**PROJECT #:** Residential Dev Code Amendments

We have reviewed the amendments and have the following comment(s).

**General**

- 1 They need to evaluate the impact of smaller lot size on the ability to accommodate driveways, tree requirements and signing.
- 2 17C.300.130.A5.2(b) needs to say that no additional off street parking as long as on street parking is available on both sides of the street according to 17H.010.120.

Val Melvin, P.E.

Gerald Okihara, P.E.

Ken Knutson, P.E.

Marcus Eveland

**From:** [Studer, Duane](#)  
**To:** [Gardner, Spencer](#); [Beck, Amanda](#); [Nilsson, Mike](#)  
**Cc:** [Morris, Mike](#); [Hanson, Rich](#); [Saywers, John](#); [Brown, Eldon](#); [Gwinn, Nathan](#); [Black, Tirrell](#)  
**Subject:** RE: NonProject DNS For Shaping Spokane Housing - Residential Development Code Revisions (sewer comment)  
**Date:** Tuesday, May 3, 2022 4:26:59 PM  
**Attachments:** [image001.png](#)  
[image002.png](#)  
[image003.png](#)  
[image004.png](#)

---

Thanks All.

I just wanted to understand the change from quantitative to qualitative language. Perhaps adding “parcels with utility mains frontage” or “parcels with direct water and sewer main frontage” would be more clear.

Much Obligated,  
Duane.

---

**From:** Gardner, Spencer <[sgardner@spokanecity.org](mailto:sgardner@spokanecity.org)>  
**Sent:** Tuesday, May 3, 2022 9:35 AM  
**To:** Beck, Amanda <[abeck@spokanecity.org](mailto:abeck@spokanecity.org)>; Nilsson, Mike <[mnilsson@spokanecity.org](mailto:mnilsson@spokanecity.org)>; Studer, Duane <[dstuder@spokanecity.org](mailto:dstuder@spokanecity.org)>  
**Cc:** Morris, Mike <[mmorris@spokanecity.org](mailto:mmorris@spokanecity.org)>; Hanson, Rich <[rahanson@spokanecity.org](mailto:rahanson@spokanecity.org)>; Saywers, John <[jsaywers@spokanecity.org](mailto:jsaywers@spokanecity.org)>; Brown, Eldon <[ebrown@spokanecity.org](mailto:ebrown@spokanecity.org)>; Gwinn, Nathan <[ngwinn@spokanecity.org](mailto:ngwinn@spokanecity.org)>; Black, Tirrell <[tblack@spokanecity.org](mailto:tblack@spokanecity.org)>  
**Subject:** RE: NonProject DNS For Shaping Spokane Housing - Residential Development Code Revisions (sewer comment)

Hi all. I agree with the previous replies. Just wanted to reiterate that the “minor engineering review” category is ultimately just a method for charging different fees and imposing different noticing requirements. The process for engineering review will be unchanged.

**Spencer Gardner** | Director | Planning Services  
 Office 509-625-6097 | Mobile 509-723-7554 | [my.spokanecity.org](http://my.spokanecity.org)

---

**From:** Beck, Amanda <[abeck@spokanecity.org](mailto:abeck@spokanecity.org)>  
**Sent:** Tuesday, May 3, 2022 8:35 AM  
**To:** Nilsson, Mike <[mnilsson@spokanecity.org](mailto:mnilsson@spokanecity.org)>; Studer, Duane <[dstuder@spokanecity.org](mailto:dstuder@spokanecity.org)>  
**Cc:** Morris, Mike <[mmorris@spokanecity.org](mailto:mmorris@spokanecity.org)>; Hanson, Rich <[rahanson@spokanecity.org](mailto:rahanson@spokanecity.org)>; Saywers, John <[jsaywers@spokanecity.org](mailto:jsaywers@spokanecity.org)>; Brown, Eldon <[ebrown@spokanecity.org](mailto:ebrown@spokanecity.org)>; Gardner, Spencer <[sgardner@spokanecity.org](mailto:sgardner@spokanecity.org)>; Gwinn, Nathan <[ngwinn@spokanecity.org](mailto:ngwinn@spokanecity.org)>; Black, Tirrell <[tblack@spokanecity.org](mailto:tblack@spokanecity.org)>  
**Subject:** RE: NonProject DNS For Shaping Spokane Housing - Residential Development Code Revisions (sewer comment)

Duane,



I attached the updated text (see Option 17G.2 on page 18-19), which Mike explained the logic behind. We drafted the new text to align with the internal review process for “easy” short plats that didn’t need to extend ROW/water/sewer/other utilities/easements versus those that require multiple reviews and require more staff time. So, we tried to create text that reflected actual processes.

Hope that addresses your questions, if not please let me know.

Thanks,  
Amanda

**Amanda Beck, AICP** | City of Spokane | Assistant Planner II

509-625-6414 | main 509-625-6500 | [abeck@spokanecity.org](mailto:abeck@spokanecity.org) | [spokanecity.org](http://spokanecity.org)



---

**From:** Nilsson, Mike <[mnilsson@spokanecity.org](mailto:mnilsson@spokanecity.org)>  
**Sent:** Tuesday, May 3, 2022 7:03 AM  
**To:** Studer, Duane <[dstuder@spokanecity.org](mailto:dstuder@spokanecity.org)>; Beck, Amanda <[abeck@spokanecity.org](mailto:abeck@spokanecity.org)>  
**Cc:** Morris, Mike <[mmorris@spokanecity.org](mailto:mmorris@spokanecity.org)>; Hanson, Rich <[rahanson@spokanecity.org](mailto:rahanson@spokanecity.org)>; Saywers, John <[jsaywers@spokanecity.org](mailto:jsaywers@spokanecity.org)>; Brown, Eldon <[ebrown@spokanecity.org](mailto:ebrown@spokanecity.org)>  
**Subject:** RE: NonProject DNS For Shaping Spokane Housing - Residential Development Code Revisions (sewer comment)

Eldon and I have been talking with Long Range Planning, the lots defined as requiring minor engineering review are those that have sewer/water mains currently adjacent to them (i.e., no main extensions required, utility easements proposed, etc.). The idea is for those parcels with standard service connections, the process can be streamlined from the engineering side. Everything else will follow our current review process.

Hope that helps clarify.

---

**From:** Studer, Duane <[dstuder@spokanecity.org](mailto:dstuder@spokanecity.org)>  
**Sent:** Monday, May 02, 2022 5:29 PM  
**To:** Beck, Amanda <[abeck@spokanecity.org](mailto:abeck@spokanecity.org)>; Nilsson, Mike <[mnilsson@spokanecity.org](mailto:mnilsson@spokanecity.org)>  
**Cc:** Morris, Mike <[mmorris@spokanecity.org](mailto:mmorris@spokanecity.org)>; Hanson, Rich <[rahanson@spokanecity.org](mailto:rahanson@spokanecity.org)>; Saywers, John <[jsaywers@spokanecity.org](mailto:jsaywers@spokanecity.org)>  
**Subject:** RE: NonProject DNS For Shaping Spokane Housing - Residential Development Code Revisions (sewer comment)

Amanda / Mike,

1. How does the “minor engineering review” in the proposed changes get quantified so that the level of effort and time to review for utilities is assessed?
2. Would there still be normal internal review time (e.g. for side sewers, water services, etc.)?

Duane.

pattern.

- Short Plat Notification
  - Notification and commenting requirements for short subdivisions would be streamlined to reduce the cost and time associated with short subdivisions.
    - For developments creating ~~only two lots~~ the requirement to send a notice of application, complete a site posting, and hold a public comment period would be removed.
    - For developments creating ~~three to nine lots~~ the requirement to send a notice of application and hold a public comment period would be retained, but the site posting requirement would be removed.

lots with minor engineering review,  
  
lots subject to standard engineering review or SEPA,

**From:** Churchill, Jackie <[jchurchill@spokanecity.org](mailto:jchurchill@spokanecity.org)>  
**Sent:** Wednesday, April 27, 2022 8:56 AM  
**Subject:** NonProject DNS For Shaping Spokane Housing - Residential Development Code Revisions

Good Morning,

Please find attached the NonProject Determination of NonSignificance and SEPA checklist for the following proposal:

**Proposal Name:** Shaping Spokane Housing – Residential Development Code Revisions

**Site Address:** Citywide

Please direct any questions or comments to Assistant Planner II, Amanda Beck at [abeck@spokanecity.org](mailto:abeck@spokanecity.org).

Thank you,



Jackie Churchill | Planning & Economic Development Services | Clerk III  
 509.625.6986 | fax 509.625.6013 | [jchurchill@spokanecity.org](mailto:jchurchill@spokanecity.org)



**LAND USE GOAL LU 1 – CITYWIDE LAND USE.**

*Offer a harmonious blend of opportunities for living, working, recreation, education, shopping, and cultural activities by protecting natural amenities, providing coordinated, efficient, and cost effective public facilities and utility services, carefully managing both residential and non-residential development and design, and proactively reinforcing downtown Spokane’s role as a vibrant urban center.*

**Land Use Policy LU 1.1 – Neighborhoods.** *Utilize the neighborhood concept as a unit of design for planning housing, transportation, services, and amenities.*

Discussion: Neighborhoods generally should have identifiable physical boundaries, such as principal arterial streets or other major natural or built features. Ideally, they should have a geographical area of approximately one square mile and a population of around 3,000 to 8,000 people. Many neighborhoods have a Neighborhood Center that is designated on the Land Use Plan Map. The Neighborhood Center, containing a mix of uses, is the most intensive activity area of the neighborhood. It includes higher density housing mixed with neighborhood-serving retail uses, transit stops, office space, and public or semi-public activities, such as parks, government buildings, and schools.

A variety of compatible housing types are allowed in a neighborhood. The housing assortment should include higher density residences developed in the form of small scale apartments, townhouses, duplexes, and rental units that are accessory to single-family homes, as well as detached single-family homes.

A coordinated system of open space, nature space, parks, and trails should be furnished with a neighborhood park within walking distance or a short transit ride of all residences. A readily accessible elementary school should be available for neighborhood children. Neighborhood streets should be narrow and tree-lined with pedestrian buffer strips (planting strips) and sidewalks. They should be generally laid out in a grid pattern that allows easy access within the neighborhood. Alleys are used to provide access to garages and the rear part of lots. Pedestrian amenities like bus shelters, benches, and fountains should be available at transit stops.

**LAND USE GOAL LU 3 – EFFICIENT LAND USE.**

*Promote the efficient use of land by the use of incentives, density and mixed-use development in proximity to retail businesses, public services, places of work, and transportation systems.*

**Land Use Policy LU 3.6 – Compact Residential Patterns.** *Allow more compact and affordable housing in all neighborhoods, in accordance with design guidelines.*

Discussion: Compact and affordable housing includes such choices as townhouses, accessory dwelling units (granny flats), live-work housing, triplexes, zero-lot line, starter, small-lot, and row houses.

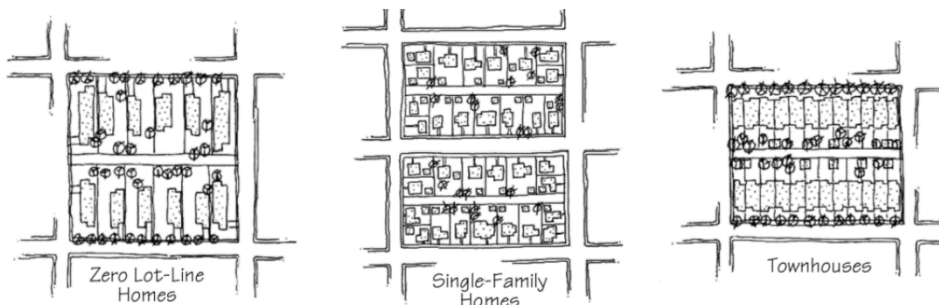

---

## HOUSING GOAL H 1 – HOUSING CHOICE AND DIVERSITY.

Provide opportunities for a variety of housing types that is safe and affordable for all income levels to meet the diverse housing needs of current and future residents.

**Housing Policy H 1.11 – Access to Transportation.** *Encourage housing that provides easy access to public transit and other efficient modes of transportation.*

Discussion: Transportation is the second largest expenditure after housing and can range from 10 to 25 percent of household expenditures. Examining where housing is located and the associated transportation costs may provide a more realistic evaluation of housing affordability in the future.

**Housing Policy H 1.18 – Distribution of Housing Options.** *Promote a wide range of housing types and housing diversity to meet the needs of the diverse population and ensure that this housing is available throughout the community for people of all income levels and special needs.*

Discussion: A variety of housing types should be available in each neighborhood. Diversity includes styles, types, size, and cost of housing. Many different housing forms can exist in an area and still exhibit an aesthetic continuity. Development of a diversity of housing must take into account the context of the area and should result in an improvement to the existing surrounding neighborhood.

**Housing Policy H 1.20 – Accessory Dwelling Units.** Allow one accessory dwelling unit as an ancillary use to single-family homes in all designated residential areas as an affordable housing option.

Discussion: Accessory dwelling units (ADUs) increase the amount and variety of available affordable housing. Increasing the variety of housing can help to satisfy changing family needs and the trend of smaller households. ADUs help provide an avenue for seniors, single parents, and families with grown children to remain in their homes and neighborhoods while obtaining extra income, security, companionship and services. Often ADUs allow a more efficient use of existing housing and infrastructure.

Accessory dwelling units should be built in a manner that does not adversely affect the neighborhood. They should be designed to be physically and visually compatible with surrounding structures.

---

## CAPITAL FACILITIES AND UTILITIES GOAL CFU 4 – SERVICE PROVISION

*Provide public services in a manner that facilitates efficient and effective delivery of services and meets current and future demand.*

**Capital Facilities and Utilities Policy CFU 4.1 – Compact Development.** *Promote compact areas of concentrated development in designated centers to facilitate economical and efficient provision of utilities, public facilities, and services.*

Discussion: Infill and dense development should be encouraged where excess capacity is available since compact systems are generally less expensive to build and maintain.

## Comment Log and Public Comments

### Substantive Public Comments Received After May 11 Plan Commission - Updated 06/06/2022

	<b>Date</b>	<b>Name</b>	<b>Topic(s)</b>	<b>Page</b>
1	5/12/2022	Joan Hunt	STR, Other	2
2	5/20/2022	Jim Haines	Attached homes, Duplexes	20
3	5/28/2022	Shari Mcevoy	ADUs	22
4	5/30/2022	Carol Tomsic	Short Plat notification	24

## Beck, Amanda

---

**From:** Beck, Amanda  
**Sent:** Thursday, May 12, 2022 12:29 PM  
**To:** Joan Hunt  
**Subject:** RE: Support for short term housing changes

Hi Joan,

Thank you for providing public comment in support of short-term rental code changes under the [Shaping Spokane Housing](#) project. These comments have been added to the public record, and will be included with the staff report to Plan Commission when a public hearing is scheduled.

You very thoughtfully lay out the complications of being a community landlord, and how the Covid pandemic impacted our housing market the past two years. We appreciate your perspective on this issue as we haven't heard as much on this topic from landlords.

Right now the draft code is in a sort of holding pattern, as we've heard a lot of push back from the public over concerns this is expanding a use that is negatively impacting the housing supply. The City is working to come up with additional draft code options that might address these concerns. Once we have additional options we would take them back to Plan Commission to workshop the language before the public hearing process. To help inform the workshop, we'll include comments received to date about short-term rentals to aid the Plan Commission in discussion on additional language.

Thanks for your investment and time as a landlord in Spokane.

Thank you,  
Amanda

Amanda Beck, AICP | City of Spokane | Assistant Planner II  
509-625-6414 | main 509-625-6500 | [abeck@spokanecity.org](mailto:abeck@spokanecity.org) | [spokanecity.org](http://spokanecity.org)



---

**From:** Joan Hunt <[craigandjoanhunt@gmail.com](mailto:craigandjoanhunt@gmail.com)>  
**Sent:** Thursday, May 12, 2022 9:39 AM  
**To:** Beck, Amanda <[abeck@spokanecity.org](mailto:abeck@spokanecity.org)>  
**Subject:** Support for short term housing changes

**[CAUTION - EXTERNAL EMAIL - Verify Sender]**

Hello, Amanda.

We are writing as property owners who are in support of allowing short term housing in areas of Spokane that are currently zoned commercial or carry other zoning designations where residential housing can occur or is currently occurring. Our property is one 8-unit, mid-century apartment building on the lower South Hill. We also co-own one short term condo unit in

a residential area. We do not fall into the category of a home-owner with a single room to rent, nor a "big corporate Airbnb" investment operator seeking to set up tens or hundreds of units in the downtown core. We are neither a solution to homelessness nor a threat to hotels.

Over the last years of the pandemic, property owners, particularly those of us who are small business owners and have a single apartment building with fewer than 10 units, have been hit very hard with the burden of supporting our citizens who are renters by keeping them housed and preventing more homelessness. The state's more than 20-month long rent moratorium, along with the post-pandemic RCW's governing how we may manage our property have left many of us with increased debt, damaged property, lost revenue, legal debt, and now, post-moratorium, the costs of repairing damaged units, or simply doing deferred maintenance on our property during a very high inflationary period. (This, of course, is one reason rents have gone up again...our cost of business has gone up as well.)

Allowing short term housing in a building such as ours that is currently zoned Commercial/RO, would have zero negative impact on our neighborhood, where the bulk of other buildings are also residential units (including one large SNAP apartment building across the street) and allow us to create even more positive impact. Unlike long-term rentals, short term housing allows us to better maintain our property, monitor the use and safety of our units, keep safety risks and damage to a minimum, and actually improve the surrounding neighborhood. We know what it takes to run our business and we feel we should have the ability to decide if short term units would help us, and how many we would need to incorporate in our building to gain that benefit.

Long term residential property management always has challenges, but became particularly difficult during the pandemic. 2 of 8 units in our building housed tenants who stopped paying rent, didn't apply for rent relief, damaged our property, and posed safety risks to others in the building and the construction workers employed on a building renovation next to our property. However, because of the prevailing state moratorium, we could not get an attorney to take our case in order to evict these tenants and even if we could have retained someone, we were told the timeline for the process would be very costly and take about 6 months if they were successful. (These were not frivolous cases; in one case, a gun was fired on two occasions on the property, and in the other, a worker was physically assaulted by our tenant, charges were pressed, and the police took the tenant to jail.) We lost other tenants in our building because of these 2 people, and when we finally were able to get the difficult tenants to vacate, we found thousands of dollars in damage in their units. (Including one broken brand new window; because of supply shortages, we had to wait 3 months just to receive the glass to repair it, which of course meant we had more lost revenue with an empty unit.) We were unable to recover any of the lost rent because the tenants moved, so we didn't qualify for any programs that were available for rent recovery. **This is just one story, but there are many like this from other owners as well.**

Short term housing can be a way for us to supplement our income to support our properties. I am not talking about drastically increasing our monthly personal income from this, I am speaking

about the need for income to simply maintain and pay our bills in order to hold on to our property. Yes, down the road we hope this increased income will become a retirement income, but still very modest by many standards. But what crime is in that - that is, to be responsible for one's own future by maintaining a small, high-quality business?

The State and City continually characterize the disease of homelessness as one that residential rental property owners somehow are responsible for curing, and now the City Council is apparently getting lots of input from those who advocate for the unhoused that changing short term rules will create even more problems, and that it shouldn't be allowed or at least should be heavily restricted or taxed even more. Selecting an arbitrary number of allowed short-term rental units in a building, or increasing fees to implement short term housing in the same, suggests that those making the rules have any idea of the economics of owning and managing a property. The intent of the State, and now our City Council, to lay the burden of homelessness at our feet is unconscionable. This problem has been around and growing since the financial crisis of 2008. Even though Spokane offers an incredible number of support options for homeless individuals, the fact that the City hasn't, even with all the non-profits, been able to come up with viable, LONG-TERM solutions to this issue, is no reason to turn to small property owners to take this burden from them. And it is farce to believe that the problem simply stems from a lack of housing. Restricting short term rentals, and increasing costs for property owners who choose this option is NOT the solution to this complex problem. Recognition is never given to the positive advantages that good quality, long and short-term housing provides in our area.

As small business owners with rental property, we create local jobs. We hire local, independant cleaners for cleaning our properties, and pay them more than twice the current minimum wage. We treat them with respect, we help them grow their businesses, (many are younger moms who want to create their own small businesses), and help them grow their hard and soft professional skills. We hire local companies to renovate and repair our property, we use a local professional property manager, and we hire a small painting company owned by a senior to do our painting (and all this at prevailing wages). We keep our property in excellent condition, it is safe, clean and monitored by us daily and we live nearby so we respond to any needs very quickly. We pay taxes, we give back to our community through charitable giving, and we spend our dollars locally with other small businesses in Spokane. We do our exterior property upkeep (lawn upkeep, snow removal, landscaping, cleaning up parking areas etc) ourselves and hire our high school aged niece and nephew to help us. We also co-own one short term condo rental unit in a residential area, and we do the same for that business. And in all this, we also pay our utility bills, our mortgages, our property taxes and for the short term rental, our city lodging and business taxes. Anyone who thinks that small business owners are lining their pockets with this work, has either never had the opportunity to talk with an owner or do this work themselves. I also challenge anyone to suggest that we tell grocery store owners, lawyers, retailers, restaurant owners or other small business owners that they have to be taxed more or limited in how they do their work because homeless persons need food, clothing and legal representation, and therefore these business owners must take on the weight of this problem.



The need for shorter term housing is real; traveling professionals doing contract work, entertainers who come to present the Best of Broadway series, families going through divorce needing housing, persons traveling to Spokane for medical care or visiting loved ones in the hospital, small groups or families traveling together, and travelers coming to spend money on tourism activities in our city are just some examples of people who want and need housing options. Hotels do not provide for the needs of every group. **And for what it may be worth, the taxes short term operators pay to the City are not insignificant.** It is not easy work, but it is satisfying to provide quality housing, to represent our city well, and improve our neighborhoods by our investment in them. We are not the terrible people we are often made out to be in news stories, nor are we mega landlords or absentee owners. (However, many local owners who were forced to sell their small rental properties during the pandemic, did indeed sell to cash investors from out of town...another sad loss created by the State, by legally binding property owners to subsidize non-paying tenants while offering no immediate balance of relief to owners, resulting in property owners who could not pay their bills being forced to sell.)

So often, property owners are cast as terrible "landlords" or "slum lords" while the homeless are cast as victims who have only come to their sad fate through no fault of their own; this is unfair to both groups, as both are diverse groups of individuals with varied needs and desires. This "good people, bad people" dynamic is simply an old trope that doesn't stand up and it is frustrating to read newspaper stories that represent such simplistic images. Of course it sells papers and makes the City look good to continue to engage in these myths (the latest story in [The Inlander](#) and quotes by Council President Beggs and Council Member Lori Kinnear are perfect examples). But the truth is that limiting short term housing, or increasing costs to those of us small owners who want to engage in it, is not a solution.

Obviously, we are in favor of expanding and modernizing the rules of short term housing. Please recognize that this method of housing is needed, it is a help to small business owners like we are, it supports investment in our local community, and it fills a need that does not exist in long term housing or hotels.

The changes brought into play by the pandemic have and will continue to shape the way people live, and it would benefit our community to recognize the larger narrative of how and why that is happening, in order to recognize the value and opportunity available in expanding short term housing options. This needs to happen concurrent with, but not as a threat to devising real, long term solutions to this problem of under housed people. We feel sure there is enough intelligence and imagination in our community to make this happen in the form of a win-win situation.

Thank you for your work on these changes; in our two conversations with individuals in the City Planning Department, we are encouraged by the level of thoughtful, intelligent work that has been done by your department to move this issue forward.

Respectfully,  
Joan and Craig Hunt  
Spokane

## Beck, Amanda

---

**From:** Joan Hunt <craigandjoanhunt@gmail.com>  
**Sent:** Thursday, May 12, 2022 12:44 PM  
**To:** Beck, Amanda  
**Subject:** Re: Support for short term housing changes

[CAUTION - EXTERNAL EMAIL - Verify Sender]

Thanks so much, Amanda.

I'm more than willing to contribute anything more if I can; I know this is challenging and efforts are being made to try to address many needs and concerns at once.

I have genuine concern that statements such as those made by Lori Kinnear and Breann Beggs in the recent Inlander article contribute to the public's perception that short term housing use is negatively impacting the local housing supply. Especially "affordable" housing, which is a topic that is in itself complex and I would venture to guess, most of the public does not understand in its true definition as outlined by HUD.

I am also very concerned that our leadership seems ill-informed as well, and I am writing to Council President Beggs and Members Kinnear and Wilkerson, who are in my district, in an effort to provide my perspective as a small business and rental property owner.

Thank you for your work; I appreciate it as well as your communication.

Sincerely,  
Joan

On Thu, May 12, 2022 at 12:29 PM Beck, Amanda <[abeck@spokanecity.org](mailto:abeck@spokanecity.org)> wrote:

Hi Joan,

Thank you for providing public comment in support of short-term rental code changes under the [Shaping Spokane Housing](#) project. These comments have been added to the public record, and will be included with the staff report to Plan Commission when a public hearing is scheduled.

You very thoughtfully lay out the complications of being a community landlord, and how the Covid pandemic impacted our housing market the past two years. We appreciate your perspective on this issue as we haven't heard as much on this topic from landlords.

Right now the draft code is in a sort of holding pattern, as we've heard a lot of push back from the public over concerns this is expanding a use that is negatively impacting the housing supply. The City is working to come up with additional draft code options that might address these concerns. Once we have additional options we would take them back to

Plan Commission to workshop the language before the public hearing process. To help inform the workshop, we'll include comments received to date about short-term rentals to aid the Plan Commission in discussion on additional language.

Thanks for your investment and time as a landlord in Spokane.

Thank you,

Amanda

**Amanda Beck, AICP** | City of Spokane | Assistant Planner II

509-625-6414 | *main* 509-625-6500 | [abeck@spokanecity.org](mailto:abeck@spokanecity.org) | [spokanecity.org](http://spokanecity.org)



---

**From:** Joan Hunt <[craigandjoanhunt@gmail.com](mailto:craigandjoanhunt@gmail.com)>  
**Sent:** Thursday, May 12, 2022 9:39 AM  
**To:** Beck, Amanda <[abeck@spokanecity.org](mailto:abeck@spokanecity.org)>  
**Subject:** Support for short term housing changes

**[CAUTION - EXTERNAL EMAIL - Verify Sender]**

Hello, Amanda.

We are writing as property owners who are in support of allowing short term housing in areas of Spokane that are currently zoned commercial or carry other zoning designations where residential housing can occur or is currently occurring. Our property is one 8-unit, mid-century apartment building on the lower South Hill. We also co-own one short term condo unit in a residential area. We do not fall into the category of a home-owner with a single room to rent, nor a "big corporate Airbnb" investment operator seeking to set up tens or hundreds of units in the downtown core. We are neither a solution to homelessness nor a threat to hotels.

Over the last years of the pandemic, property owners, particularly those of us who are small business owners and have a single apartment building with fewer than 10 units, have been hit very hard with the burden of supporting our citizens who are renters by keeping them housed and preventing more homelessness. The state's more than 20-month long rent moratorium, along with the post-pandemic RCW's governing how we may manage our property have left many of us with increased debt, damaged property, lost revenue, legal debt, and now, post-moratorium, the costs of repairing damaged units, or simply doing deferred maintenance on our property during a very high inflationary period. (This, of course, is one reason rents have gone up again...our cost of business has gone up as well.)

Allowing short term housing in a building such as ours that is currently zoned Commercial/RO, would have zero negative impact on our neighborhood, where the bulk of other buildings are also residential units (including one large SNAP apartment building across the street) and allow us to create even more positive impact. Unlike long-term rentals, short term housing allows us to better maintain our property, monitor the use and safety of our units, keep safety risks and damage to a minimum, and actually improve the surrounding neighborhood. We know what it takes to run our business and we feel we should have the ability to decide if short term units would help us, and how many we would need to incorporate in our building to gain that benefit.

Long term residential property management always has challenges, but became particularly difficult during the pandemic. 2 of 8 units in our building housed tenants who stopped paying rent, didn't apply for rent relief, damaged our property, and posed safety risks to others in the building and the construction workers employed on a building renovation next to our property. However, because of the prevailing state moratorium, we could not get an attorney to take our case in order to evict these tenants and even if we could have retained someone, we were told the timeline for the process would be very costly and take about 6 months if they were successful. (These were not frivolous cases; in one case, a gun was fired on two occasions on the property, and in the other, a worker was physically assaulted by our tenant, charges were pressed, and the police took the tenant to jail.) We lost other tenants in our building because of these 2 people, and when we finally were able to get the difficult tenants to vacate, we found thousands of dollars in damage in their units. (Including one broken brand new window; because of supply shortages, we had to wait 3 months just to receive the glass to repair it, which of course meant we had more lost revenue with an empty unit.) We were unable to recover any of the lost rent because the tenants moved, so we didn't qualify for any programs that were available for rent recovery. **This is just one story, but there are many like this from other owners as well.**

Short term housing can be a way for us to supplement our income to support our properties. I am not talking about drastically increasing our monthly personal income from this, I am speaking about the need for income to simply maintain and pay our bills in order to hold on to our property. Yes, down the road we hope this increased income will become a retirement income, but still very modest by many standards. But what crime is in that - that is, to be responsible for one's own future by maintaining a small, high-quality business?

The State and City continually characterize the disease of homelessness as one that residential rental property owners somehow are responsible for curing, and now the City Council is apparently getting lots of input from those who advocate for the unhoused that changing short term rules will create even more problems, and that it shouldn't be allowed or at least should be heavily restricted or taxed even more. Selecting an arbitrary number of allowed short-term rental units in a building, or increasing fees to implement short term housing in the same, suggests that those making the rules have any idea of the economics of owning and managing a property. The intent of the State, and now our City Council, to lay the burden of homelessness at our feet is unconscionable. This problem has been around and growing since the financial crisis of 2008. Even though Spokane offers an incredible number of support options for homeless individuals, the fact that the City hasn't, even with all the non-profits, been able to come up with viable, LONG-TERM solutions to this issue, is no reason to turn to small property owners to take this burden from them. And it is farce to believe that the problem simply stems from a lack of housing. Restricting short term rentals, and increasing costs for property owners who choose this option is NOT the solution to this complex problem. Recognition is never given to the positive advantages that good quality, long and short-term housing provides in our area.

As small business owners with rental property, we create local jobs. We hire local, independent cleaners for cleaning our properties, and pay them more than twice the current minimum wage. We treat them with respect, we help them grow their businesses, (many are younger moms who want to create their own small businesses), and help them grow their hard and soft professional skills. We hire local companies to renovate and repair our property, we use a local professional property manager, and we hire a small painting company owned by a senior to do our painting (and all this at prevailing wages). We keep our property in excellent condition, it is safe, clean and monitored by us daily and we live nearby so we respond to any needs very quickly. We pay taxes, we give back to our community through charitable giving, and we spend our dollars locally with other small businesses in Spokane. We do our exterior property upkeep (lawn upkeep, snow removal, landscaping, cleaning up parking areas etc) ourselves and hire our high school aged niece and nephew to help us. We also co-own one short term condo rental unit in a residential area, and we do the same for that business. And in all this, we also pay our utility bills, our mortgages, our property taxes and for the short term rental, our city lodging and business taxes. Anyone who thinks that small business owners are lining their pockets with this work, has either

never had the opportunity to talk with an owner or do this work themselves. I also challenge anyone to suggest that we tell grocery store owners, lawyers, retailers, restaurant owners or other small business owners that they have to be taxed more or limited in how they do their work because homeless persons need food, clothing and legal representation, and therefore these business owners must take on the weight of this problem.

The need for shorter term housing is real; traveling professionals doing contract work, entertainers who come to present the Best of Broadway series, families going through divorce needing housing, persons traveling to Spokane for medical care or visiting loved ones in the hospital, small groups or families traveling together, and travelers coming to spend money on tourism activities in our city are just some examples of people who want and need housing options. Hotels do not provide for the needs of every group. **And for what it may be worth, the taxes short term operators pay to the City are not insignificant.** It is not easy work, but it is satisfying to provide quality housing, to represent our city well, and improve our neighborhoods by our investment in them. We are not the terrible people we are often made out to be in news stories, nor are we mega landlords or absentee owners. (However, many local owners who were forced to sell their small rental properties during the pandemic, did indeed sell to cash investors from out of town...another sad loss created by the State, by legally binding property owners to subsidize non-paying tenants while offering no immediate balance of relief to owners, resulting in property owners who could not pay their bills being forced to sell.)

So often, property owners are cast as terrible "landlords" or "slum lords" while the homeless are cast as victims who have only come to their sad fate through no fault of their own; this is unfair to both groups, as both are diverse groups of individuals with varied needs and desires. This "good people, bad people" dynamic is simply an old trope that doesn't stand up and it is frustrating to read newspaper stories that represent such simplistic images. Of course it sells papers and makes the City look good to continue to engage in these myths (the latest story in [The Inlander](#) and quotes by Council President Beggs and Council Member Lori Kinnear are perfect examples). But the truth is that limiting short term housing, or increasing costs to those of us small owners who want to engage in it, is not a solution.

Obviously, we are in favor of expanding and modernizing the rules of short term housing. Please recognize that this method of housing is needed, it is a help to small business owners like we are, it supports investment in our local community, and it fills a need that does not exist in long term housing or hotels.

The changes brought into play by the pandemic have and will continue to shape the way people live, and it would benefit our community to recognize the larger narrative of how and why that is happening, in order to recognize the value and opportunity available in expanding short term housing options. This needs to happen concurrent with, but not as a threat to devising real, long term solutions to this problem of under housed people. We feel sure there is enough intelligence and imagination in our community to make this happen in the form of a win-win situation.

Thank you for your work on these changes; in our two conversations with individuals in the City Planning Department, we are encouraged by the level of thoughtful, intelligent work that has been done by your department to move this issue forward.

Respectfully,

Joan and Craig Hunt

Spokane



## Beck, Amanda

---

**From:** Joan Hunt <craigandjoanhunt@gmail.com>  
**Sent:** Friday, May 13, 2022 3:21 PM  
**To:** Beggs, Breean  
**Cc:** Kinnear, Lori; Wilkerson, Betsy; Beck, Amanda; Gardner, Spencer  
**Subject:** Re: Short Term Housing

[CAUTION - EXTERNAL EMAIL - Verify Sender]

Good Morning, President Beggs.

Thank you for your reply. I am in agreement that updating the short term rental policies is necessary and I appreciate that all voices will be considered and I look forward to a possible forum.

With regard to your statement about other people just like me who say they see larger impact to adjoining properties - I'm not exactly sure what you mean by "just like me" since I am a property owner and I'm guessing that those who may complain of negative impacts are **not** the owners/operators of short term housing? For my part I can, without a doubt, say that the quality of my experience as an owner, and the safety and quality of life in my building as it relates to those who live there have improved with the addition of shorter term guests. There hasn't been any increase in vehicle traffic or number of people in my building, but the quality of guests are professional, quiet, and there with a specific purpose. They are courteous, follow our house rules, and express appreciation for having pleasant accommodations that suit their needs.

The fact that there are many single-family unregistered/unlicensed properties is interesting; I agree it needs to be remedied. If they are operating in residential zones that already have a pathway for registration, then I believe they should be enforced and I hope that is one area that could potentially be addressed right away, even prior to code changes.

I would not have an issue registering if I were allowed to have a short term unit in my zone, and since I am currently doing a monthly rental, I treat it as I do the long-term leases. However, because of the structure of the platform, we do pay all applicable short-term housing taxes to the city. If those unregistered residences were paying comparable taxes, would those funds, along (with all the other revenue from short-term rentals) be available to put toward your affordable housing fund?

Thanks again for your reply; I know this is a mult-faceted issue and I hope the solutions can address the needs of all.

Joan

On Fri, May 13, 2022 at 7:51 AM Beggs, Breean <[bbeggs@spokanecity.org](mailto:bbeggs@spokanecity.org)> wrote:

Thanks so much Joan. We are attempting to gather all the feedback from as many stakeholders as possible to guide as as we do what is best for the entire City. Your well articulated perspective will be very helpful. Once we have an actual proposal on the table, we will also likely schedule some type of public engagement forum where we can hear from you and others in real time.

I do want to point out that the eviction moratorium imposed by the State expired last year and I don't see it coming back. The City Council also distributed tens of millions of dollars in rental assistance to landlords to mitigate some of the losses they experienced during that moratorium. I also don't see regulation of short term rentals as a solution for homeless individuals, because they need below market housing. I have heard many concerns from people just like you that short term rentals do pose larger impacts to adjoining properties than regular rentals; and, that the loss of market rate housing is making it more difficult for everyday families to find vacant rental housing.

Last I checked, there where almost 800 single family market rate residential units being diverted into short term rentals. Only a fraction of them where actually registered and licensed with the City. It seems appropriate to update our polices and enforcement and I look forward to your continued input.

Best,

Breean Beggs

---

**From:** Joan Hunt <[craigandjoanhunt@gmail.com](mailto:craigandjoanhunt@gmail.com)>

**Sent:** Thursday, May 12, 2022 3:54 PM

**To:** Beggs, Breean <[bbeggs@spokanecity.org](mailto:bbeggs@spokanecity.org)>; Kinnear, Lori <[lkinnear@spokanecity.org](mailto:lkinnear@spokanecity.org)>; Wilkerson, Betsy <[bwilkerson@spokanecity.org](mailto:bwilkerson@spokanecity.org)>

**Subject:** Short Term Housing

[CAUTION - EXTERNAL EMAIL - Verify Sender]

Council President Beggs, and Council Members Kinnear and Wilkerson,

I am writing in response to the current conversation about changes to the City Code governing short term rentals and specifically to points brought up in the May 5, 2022 article in The Inlander, "Spokane may consider tweaking its Airbnb policy - if it can figure out what the current one is"

My husband and I are property owners who are in support of allowing short term housing in areas of Spokane that are currently zoned commercial or carry other zoning designations where residential housing is currently occurring. Our property is one 8-unit, mid-century apartment building on the lower South Hill in a Commercial/RO zoning. We have been told by City Planning that based on our zone, we can enter into leases of 30 days, but no less, so we have 2 units in our building that we have furnished and offer for extended stays and advertise through Airbnb. We also co-own one condo unit (for the last 9 months), in a residential area northwest of Kendall Yards that is currently a licensed short-term rental advertised through Airbnb. We do not fall into the category of a home-owner with a single room to rent, nor a "big corporate Airbnb" investment operator seeking to set up tens or hundreds of units in the downtown core. **We do**

our best to set our rents at rates that allow us to maintain our property, pay our mortgage and taxes, pay the professionals we have to hire to do work for us, pay our professional property management company, and create some reserve for unexpected expenses, but the economics of that do not make it possible for us to charge 'affordable housing' rates as defined by the local housing authority. So we don't fall into a category of those who, if they set up a short term rental, would be denying affordable housing by doing so.

In the 4 years we've owned the property, we have taken less than \$6500 a year from the property for personal income. In that same time, we have had to make improvements and updates to the interiors of every unit in our building as well as do roof repair and chimney repairs, replace all windows, siding, railings, stairs and decking, and prune large trees. This was because when we purchased the property from my dad's estate, he and my mom had provided low rental rates (if not officially "affordable housing"), for so long, that they could not manage to keep up with the severe needs of the building, and the deterioration and resulting costs for repair and maintenance were overwhelming. The same tenants who my mom would provide birthday cards and Christmas cakes for, told us they did not report maintenance issues for fear that "our rent would be raised", which is pretty frustrating to hear, but reveals a bit of a not-uncommon mindset that we've encountered with tenants. Two of these tenants lived in the building for more than 20 years each and when we took on the building, we were dismayed at the amount of damage that existed from tenant neglect. We have done this work because we care about it, we believe we are good at it, we enjoy contributing to the neighborhood, and hope that one day it supplements our income. However, if we have an opportunity to make our lives smoother by having the option of diversifying our mix of rental options, and that allows us more income, we would like to take it.

We are also among small property owners who sustained financial losses during the more than 20-month rental moratorium. Specifically we had 2 tenants who stopped paying rent, would not apply for assistance, posed physical threats to others in the building and to workers next door to our building, and whom we could not evict because even with "just cause", no attorney would take our cases during the moratorium. Even if they had, we were told it would be very costly, and because of state laws, would take 6 months or more to go through the process of eviction. When one of these tenants finally went to jail for assaulting a construction worker next door to our building, he decided to flee town after he was released so we got our apartment back. Our cost to repair damage to the unit was \$4000, we had to wait 3 months for the glass to replace a broken window so lost time to re-rent the unit, and the tenant left owing \$2400 in unpaid rent that we could not recover. The other tenant whose "friends" visited her often, and for whom the police and paramedics were called 3 separate times for drug overdoses, and who twice fired a gun on our property, was finally convinced by our property manager to move. She left damages that cost \$3500 to repair and unpaid rent in the amount of \$2200. Because of this one tenant's

behaviour and our inability to evict her, we lost 2 other good tenants, two of whom we let out of their leases without penalty because we also feared for their safety and in good conscience could not expect them to stay when we no longer had the ability to do what was needed to provide a safe environment.

This backstory leads to why we are supportive of opening up other zoning areas to shorter-term units; our property is already being used for residential purposes, it has no negative impact on the neighborhood, we can provide a needed housing opportunity, we have more control over who is in our property, we have the freedom to immediately remove anyone who poses a danger, we have the ability to keep our units maintained by being in them more frequently and cleaning them regularly, the rent money is guaranteed prior to occupancy, we don't have the problem of squatters, and the additional income helps us keep up with rising costs for maintaining our property. With regard to costs, as an example, over the past 4 years our cost to renovate a unit has more than doubled. In 2018 we paid \$22,000 to update a 65 year-old 1 bedroom unit and today it will cost us \$48,000. The economics of keeping up a property, while paying usual costs such as professional management, mortgage, utilities, taxes, and maintenance simply do not allow us to charge the 'affordable housing' rates desired for our underhoused population. If we supplement our long-term rates with the shorter-term ones, it eases our burden and gives us a path toward a more stable business model.

President Beggs, in the Inlander article, you suggest charging additional fees of \$15 per night for short term rentals to fund affordable housing "since these units are taking away affordable housing". How do you know if these units would be priced as affordable housing by the owners if they were long-term housing versus short-term? I am aware of at least 7 studio studio units downtown currently rent for \$1000/month with \$50/month utility costs. And, if someone has to park a car, the rates are \$100/month in lots next to these buildings. If I'm correct, these costs are not consistent with affordable housing. So to assert that all units downtown are going to be affordable housing seems incorrect. Additionally, some of these units that I'm aware of are in very old buildings that have had to have extensive renovation or remodeling work to bring them to code in order for them to be habitable. Especially with inflation and supply chain issues, this is currently extremely costly work. Based on my experience as a business owner, I would guess it is not possible to charge lower rent on these units and be able to justify doing the necessary work to create this housing.

Unless the article is incorrect, it sounds like you may be thinking that needed changes will affect only two categories of persons; "big corporate Airbnb's" and "small-time homeowners renting out their rooms". I am neither of those entities, and my property is not in the downtown core. So to limit my ability to discern what works economically for me in my 8-unit building on the lower South Hill, by creating an ordinance limiting my ability to operate one unit as a short term unit because I already co-own another short term unit across town doesn't address my needs, and seems completely arbitrary; I am curious to know on what economic facts are you basing this suggestion.

Further, Council Member Kinnear, you are quoted as saying "We have almost 800 Airbnbs around"... "almost the same number of homeless in our city". Perhaps this quote is not contextualized correctly, but it sounds like you are saying that short-term housing is the reason 800 persons are unhoused in Spokane. If so, it's hard to believe that anyone who had looked into homelessness and its complexities, and anyone who had talked with rental property owners would be able to make such a correlation. And I personally feel it's a very misleading statement and a disservice to anyone reading this article who really cares about the issues and is looking for guidance about how to take a position on it.

It's also interesting that there is rarely a mention of the fact that beyond "tourism", short-term housing provides a service for a segment of the population for whom hotel stays or long term rentals don't work. Traveling professionals, health-care workers on contract, persons traveling to Spokane for extended health care, or to attend to or visit family members in the hospital for extended time, families who need intermediate housing while in the process of divorce, professionals coming to Spokane to perform in productions such as the Best of Broadway series or youth sports events all need and want options other than hotels. Additionally, those of us who have decided to offer short term housing through Airbnb pay taxes that benefit the region and state, collected and disbursed by Airbnb. From the Airbnb Site:

Airbnb [\*collects and pays\*](#) a number of taxes on your (the owner's) behalf, including:

- *The Washington Combined Sales Tax*
- *Special Host/Motel Tax*
- *Convention and Trade Center Tax*
- *Regional Transit Authority Tax*
- *Tourism Promotion Area Charges in the State of Washington*

*All locally imposed taxes on transient lodging will be collected on reservations in Washington. The Special Hotel/Motel Tax is typically 1-5% of the listing price including any cleaning fees for reservations 29 nights and shorter. Other local taxes vary and are only applicable in certain cities and counties.*

As small business owners who have long-term rentals as well as one short-term, we create local jobs. We hire local, independant cleaners for cleaning our properties, and pay them more than twice the current minimum wage. We treat them with respect, we help them grow their businesses, (many are younger moms who want to create their own small businesses), and help them grow their hard and soft professional skills. We hire local companies to renovate and repair our property, we use a local professional property manager, and we hire a small painting company owned by a senior to do our painting (and all this at prevailing wages). We keep our property in excellent condition, it is safe, clean and

monitored by us daily and we live nearby so we respond to any needs very quickly. We pay taxes, we give back to our community through charitable giving, and we spend our dollars locally with other small businesses in Spokane. We do our exterior property upkeep (lawn upkeep, snow removal, landscaping, cleaning up parking areas etc) ourselves and hire our high school aged niece and nephew to help us. We also pay our utility bills, our mortgages, our association dues and our property taxes. In our shorter term units, we provide a positive, high-quality, personal experience of Spokane hospitality which reflects well on our city. It is not necessarily always easy work, but it can be meaningful and satisfying.

Over the last 3 years, it seems like the intent of the State, and now our City Council, is to lay the burden of homelessness at our feet. In reality, this problem has been around and growing since the financial crisis of 2007-08, and the resulting fallouts from predatory lending activities have left long-lasting, complex and far-reaching problems that demand significant creativity, collaboration, and ongoing dedication to resolve for the long term. So expecting that private owners of residential rental property could suddenly have the power and responsibility to significantly impact this difficult issue is unfair and naive. Imagine trying to tell grocery store owners, restaurateurs, automobile sellers, lawyers, clothing retailers, or other small business owners who have something to offer the underhoused, that they have to be taxed more or limited in how they do their work because homeless persons need food, clothing, transportation, or legal representation, and therefore these business owners must take on the weight of solving this problem in the way that property owners, especially over the last 3 years, have been asked to.

Please consider the long-term breadth of impact your decision making will have on varied members of this community. The changes brought into play by the historic housing crisis, and then the pandemic, have and will continue to

shape the way people live, work, and engage in community, and we benefit by recognizing the larger narrative of how and why changes are happening, in order to recognize the value and opportunity available in expanding short term housing options. I believe this can happen concurrently with, but not as a threat to devising real, long term solutions to this problem of under housed people, and that it can happen via a win-win situation.

Thank you for your service to our community, and for your willingness to look at this meaningful issue.

Sincerely,

Joan Hunt

**From:** [Planning Services Development Code](#)  
**To:** [Yahoo Mail](#)  
**Subject:** RE: Shaping Spokane Housing  
**Date:** Monday, May 23, 2022 4:47:00 PM  
**Attachments:** [image001.png](#)  
[image002.png](#)  
[image003.png](#)

---

Hi Jim,

Thank you for providing public comment in support of attached homes and duplex code changes under the [Shaping Spokane Housing](#) project. These comments have been added to the public record, and will be included with the staff report to Plan Commission when a public hearing is scheduled. We appreciate your perspective on these topics as an architect.

City staff have workshopped draft code with Plan Commission (see the meetings for Dec-8, Jan-26, and Mar-9 on the above project webpage), but the Plan Commission would like further discussion on possible language changes. We're hoping to have them workshop with our Design Review Board, so we're currently trying to find a time when all of those commissioners can be in the same place, but it's looking like that could occur in July. To help inform the workshop, we'll include comments received to date about townhomes and duplexes to aid the Plan Commission in discussion.

It's not up on our project webpage just yet, but if you want to see past email updates from our Plan Commission workshops you can review them at these links:

May 19, 2022 - <https://conta.cc/3Ly9Q77>

May 6, 2022 - <https://conta.cc/3MVy7oB>

April 20, 2022 - <https://conta.cc/3K2ZOKz>

April 6, 2022 - <https://conta.cc/38akHX4>

March 16, 2022 - <https://conta.cc/3ly14eO>

January 13, 2022 - <https://conta.cc/38az9hQ>

Thank you,  
Amanda

**Amanda Beck, AICP** | City of Spokane | Assistant Planner II

509-625-6414 | main 509-625-6500 | [abeck@spokanecity.org](mailto:abeck@spokanecity.org) | [spokanecity.org](http://spokanecity.org)



---

**From:** Yahoo Mail <hainesarch@yahoo.com>

**Sent:** Friday, May 20, 2022 10:51 AM

**To:** Planning Services Development Code <erapsdc@spokanecity.org>

**Subject:** Shaping Spokane Housing

**[CAUTION - EXTERNAL EMAIL - Verify Sender]**



I have the following thoughts that I believe can have a significant impact on our housing shortage :

1. Create more duplex lots , even changing some single family zones to two family .
2. A duplex or townhouse is much cheaper to construct than two single family houses .
3. Purchasers that may not be able to afford a single family residence can join with another purchaser to buy a duplex or townhouse .

Sincerely , Jim Haines , Haines Architectural Services

**From:** [Planning Services Development Code](#)  
**To:** [Shari Mcevoy](#)  
**Subject:** RE: ADU residential  
**Date:** Tuesday, May 31, 2022 2:09:00 PM  
**Attachments:** [image001.png](#)  
[image002.png](#)  
[image003.png](#)

---

Hi Shari,

Thank you for providing public comment in support of ADU code changes under the [Shaping Spokane Housing](#) project. These comments have been added to the public record, and will be shared with City Council once a public hearing is scheduled. I'm working to get these code changes to public hearing before City Council this week, and once we have the dates final an email will be sent to our interested parties list (which you are on).

Sorry I missed your call, you caught me at lunch, but I will respond to your other email about the specific property addresses. And, you are welcome to come to City Hall to discuss with our Current Planners details on each property- they're located on the 3<sup>rd</sup> Floor.

We have talked about doing pre-approved plans for ADUs, and as you note it could speed up the permitting processes. Because this is one of our aims, we're in talks with other city departments like Building and Fire so we can work through their needs to see how we can make this happen.

Thank you,  
Amanda

**Amanda Beck, AICP** | City of Spokane | Assistant Planner II

509-625-6414 | main 509-625-6500 | [abeck@spokanecity.org](mailto:abeck@spokanecity.org) | [spokanecity.org](http://spokanecity.org)



---

**From:** Shari Mcevoy <smcevoy2222@gmail.com>  
**Sent:** Saturday, May 28, 2022 8:48 PM  
**To:** Planning Services Development Code <erapsdc@spokanecity.org>  
**Subject:** ADU residential

**[CAUTION - EXTERNAL EMAIL - Verify Sender]**

Hello,

I am thrilled to see the proposed changes in ADU's. I agree w the proposals.

I have 3 SF homes that I rent out for my retirement income. They are all in R zones which I assume is residential and will qualify for all the changes. I will start with one and then build an ADU on all 3 which will double the occupancy available. We need good landlords like me and more affordable housing that I provide. Please approve the proposals soon.

My question is :

Do you have pre approved plans for detached ADU's, attached and all varieties to speed up the permitting process?

Do you have groups of contractors skilled in building ADU's to spokane's specifications that I could contact?

Thank you,

Sincerely,

Shari McEvoy

spokane, wa

**From:** [Carol Tomsic](#)  
**To:** [Beggs, Breean](#); [Kinnear, Lori](#); [Wilkerson, Betsy](#); [Stratton, Karen](#); [Cathcart, Michael](#); [Zappone, Zack](#); [Bingle, Jonathan](#); [Gardner, Spencer](#); [Beck, Amanda](#)  
**Cc:** [Marilyn](#); [ANDREW HOYE](#); [Mary Winkes](#); [Cortright, Carly](#); [Byrd, Giacobbe](#)  
**Subject:** A Comment on the Proposed Short Plat Code Amendment/Removal of Notifications  
**Date:** Monday, May 30, 2022 10:27:36 PM

---

**[CAUTION - EXTERNAL EMAIL - Verify Sender]**

The proposed removal of the notice of application for short plats that create only two lots and up to 9 lots, or for short plats with only minor engineering review does not support neighborhoods or carefully manage residential development, a goal, and a vision in our Comprehensive Plan (Land Use Chapter 3.2, 3.3).

The proposed removal of site-posting sign requirements, notices in the newspaper, and a mailed public notice just to properties within 400 feet, goes against a priority in our Housing Action Plan, “preserve housing affordability and quality to help people thrive where they live. This priority highlights the connections between housing affordability and quality to preserve and enhance existing housing throughout Spokane and support residents in every neighborhood.”

The removal of notification requirements to our residents in our development codes is not cited as a response strategy in the Addendum to Proclamation Addressing Housing Emergency. “A reduced fee for simple short plats in SMC 8.02.066 to \$250” is mentioned. A response strategy should not take away the quality to preserve and enhance existing housing in our neighborhoods. A reduced fee is an appropriate response strategy.

The continuation of public notice on short plat applications is necessary for our residents during the housing emergency proclamation. A notice of an application helps the neighborhood know about upcoming development in the area, as stated in the Residential Development Code Initiatives, Short Plat Application Process, Info Sheet.

Our neighborhoods will be affected by the upcoming proposed changes in land use.

The city intends to increase the number of lots to be regulated as short subdivision to a maximum of nine in any urban growth area. (RCW 36.70A.040 and chapter 36.70A). The RCW states the legislative authority of any city or town *may* by local ordinance increase the number of lots. The city is not required to align to the RCW.

The city intends to review the Comprehensive Plan Land Use Policies. A proposed review was not assigned in the 2021-2022 Comprehensive Plan Amendment process but will be considered under another program.

The Phase 1 code amendments, which includes the Short Plat Application Process, are necessary updates for the second phase of codes changes, which may require Comprehensive Plan changes, increase the number of homes per acre of land, and permit a wider variety of housing.

Neighborhood councils appreciate being part of the agency notification of land use applications and permits and make necessary comments. Neighborhood councils make every

effort possible to notify and keep our residents updated on the land use changes, but all residents directly affected still need be notified by the city.

The current short plat notification allows our neighborhood to preserve any historic significance on proposed short plats. A 400 foot notification, without any other notification to residents in the area, especially on lots that are undeveloped and forested, may result in a loss of an opportunity to protect a feature on parcels during the short plat process.

In addition, not all neighborhood councils meet monthly. Some neighborhood councils did not meet at all during the pandemic. Several neighborhood councils have struggled to maintain an executive board. Land use notifications are vital. Our residents traditionally rely on the city, and posted signs, for land use notifications.

And the city has already recognized the limited ability of a neighborhood council to reach out to every single resident in their neighborhood. The revised traffic calming program was updated to include a 'convening group' to reach out to the neighborhood for a broader response. Why would the city adopt a proposed process that would do just the opposite?

Please vote to keep the current notification process in the short plats.

Thank you!

Carol Tomsic  
resident

**CITY OF SPOKANE PLAN COMMISSION  
FINDINGS OF FACT, CONCLUSIONS, AND RECOMMENDATIONS  
REGARDING SHAPING SPOKANE HOUSING TEXT AMENDMENTS TO LOT SIZE  
TRANSITION, ACCESSORY DWELLING UNITS (ADUS), AND SHORT PLAT NOTIFICATION**

A recommendation of the City of Spokane Plan Commission to the City Council to approve amendments to the Spokane Municipal Code proposed by Shaping Spokane Housing text amendments. The proposal amends the Unified Development Code (UDC) Section 17C.110.200, Lot Size, and 17C.110.225 Accessory Structures; Chapter 17C.300, Accessory Dwelling Units, specifically Sections 17C.300.100, General Regulations, 17C.300.110, Criteria, 17C.300.120, Application Procedures, 17C.300.130, Development Standards, and 17C.300.140, ADU Expiration; and to short plat notification requirements in Sections 17G.060.100, Notice of Application, 17G.060T.003, Table 17G.060-3 Type of Public Notice Required / Project Permit Review Process, 17G.060.130, Public Comment Period, and 17G.080.040, Short Subdivisions.

**FINDINGS OF FACT:**

- A. The City of Spokane adopted a Comprehensive Plan in May of 2001 that complies with the requirements of the Growth Management Act (GMA) as set forth in RCW 36.70A, including a housing element meeting the requirements of RCW 36.70A.070(2).
- B. On July 26, 2021, Resolution 2021-0062 adopted the City of Spokane Housing Action Plan as a guide for future housing planning, policy development, and regulatory and programmatic implementation measures that increase housing options that are affordable and accessible for people and families of all incomes in the City; including the Implementation Plan included as Appendix A that outlines several strategies and policies to remedy the current housing crisis.
- C. In 2021, the Washington State Legislature appropriated \$5 million for cities planning under the GMA to adopt actions to increase residential building capacity and address housing affordability. Through the resulting Housing Action Plan and Implementation (HAPI) grant program, the Department of Commerce provided grants to support communities in implementing strategies from adopted housing action plans and recommendations contained within RCW 36.70A.600.
- D. The City of Spokane was awarded a \$100,000 grant from the Department of Commerce to implement strategies from its adopted Housing Action Plan. The scope of work includes revising accessory dwelling unit (ADU) standards in chapter 17C.300 SMC to allow for additional flexibility and expand the zones that permit ADUs.
- E. MAKERS Architecture and Urban Design, LLP, a consulting firm with expertise in community planning, design guidelines and regulations, was contracted to review existing development standards for opportunities to add flexibility and clarity to regulations. The consultant worked with city staff to develop a range of alternative standards and regulations which would allow for greater flexibility in the construction of housing, including ADUs.
- F. The proposed text amendments will implement and enact measures RCW 36.70A.600 encourages cities to take in order to increase residential building capacity.

- G. The amendments to short plat notification are procedurally exempt from SEPA review per WAC 197-11-800(19).
- H. Outreach and public communication began in November 2021, reaching approximately 375 residents, and included the following among others:
  - 1. Presentations at the Land Use Subcommittee on November 18, 2021; February 17, 2022; and April 21, 2022;
  - 2. In-person booth at the Riverfront Park Winter Market on December 15 and 22, 2021;
  - 3. Presentation at Community Assembly on January 6, 2022;
  - 4. Presentation at Lincoln Heights Neighborhood Council on January 18, 2022;
  - 5. Virtual open houses on January 25 and 27, 2022;
  - 6. Planning Services Director interviews with local developers in March and April, 2022;
  - 7. Presentations at University District Development Committee and the West Hills Neighborhood Council on April 12, 2022 and
  - 8. In-person booth at the Riverfront Park Spring Market on April 6, 13, 20, and 27, 2022.
- I. Public comment, as well as agency and department comments, received prior to the May 11, 2022, Plan Commission public hearing were included in the staff report as Exhibits D and E.
- J. On November 10, 2021; December 8, 2021; January 12, 2022; January 26, 2022; February 9, 2022; February 23, 2022; March 9, 2022; March 23, 2022; April 13, 2022; and April 27, 2022, the Spokane Plan Commission held workshops to discuss draft language, receive updates on public feedback as well as city department and agency comments, and review and evaluate with city staff alternatives to proposed text changes.
- K. On March 24, 2022, the Washington State Department of Commerce and appropriate state agencies were given the required 60-day notice before adoption of proposed changes to the Unified Development Code pursuant to RCW 36.70A.106.
- L. On April 1, 2022, a notice of intent to adopt and request for SEPA agency comments was issued for the draft code pertaining to ADUs, lot size transitions, and short plat notification. The comment period ended on April 15, 2022. The Spokane Tribe of Indians issued comment noting project actions may require case by case cultural surveys.
- M. A State Environmental Protection Act (SEPA) Determination of Nonsignificance and Checklist were issued by Planning Services on April 25, 2022. The comment period ended on May 11, 2022. Two city department comments were received during the comment period.
- N. A legal notice of public hearing was published in the *Spokesman-Review* on April 27 and May 4, 2022.

Findings of Fact, Conclusion, and Recommendation  
Shaping Spokane Housing Text Amendments to  
Lot Size Transition, Accessory Dwelling Units, and Short Plat Notification

- O. The proposed text amendments were drafted and reviewed pursuant to the process established under RCW 36.70A.370 to ensure that the proposed changes will not result in unconstitutional takings of private property.
- P. Amendments to Title 17 are subject to review and recommendation by the Plan Commission.
- Q. The Plan Commission held a public hearing on May 11, 2022 to obtain public comments on the proposed amendments.
- R. During deliberations held on May 11, 2022, the Plan Commission discussed a motion to modify the maximum detached accessory dwelling unit size, from the proposed 864 square feet or 75% of the house size, whichever is greater, to a maximum of 1,200 square feet or 75% of the house size, whichever is greater. The maximum detached accessory dwelling unit size was a topic that the Plan Commission workshopped with staff on several occasions, including the possibility of removing a maximum size altogether. Ultimately, the motion failed with three aye votes, three nay votes, and one Commissioner abstaining.
- S. During deliberations held on May 11, 2022, the Plan Commission voted to modify the proposed text concerning accessory dwelling units (ADUs), recommending removing the requirement to file a covenant and deed restriction on lots with an ADU when an owner would apply for a short-term rental application. The motion passed with six aye votes and one Commissioner abstaining.
- T. During deliberations held on May 11, 2022, the Plan Commission confirmed the preference for newly subdivided lots to be held to the standards and dimensional requirements of the underlying zoning district, rather than requiring larger lots, by removing the lot size transition requirement. The motion passed by a vote of six to zero.
- U. During deliberations held on May 11, 2022, the Plan Commission discussed the nexus of notice of applications and the neighborhood council system, as it relates to the proposed amendment to short plat notification. Plan Commission found that neighborhood councils are entitled to notice of certain land use development permit applications by virtue of SMC 17G.060.090(C) and that the proposed amendments will not detract from a neighborhood council's ability to comment on short plat applications. The motion to approve the proposed amendments to short plat notification passed with six ayes votes and one nay vote.
- V. Except as otherwise indicated in the above findings, the Spokane Plan Commission adopts the findings and analysis set forth in the staff report prepared for the proposal.
- W. The Spokane Plan Commission finds that the proposed text amendments meet the decision criteria established in SMC 17G.025.010(G).



## **CONCLUSIONS:**

Based upon the draft text amendments, staff report and analysis (which is hereby incorporated into these findings, conclusions, and recommendations), SEPA review, agency and public comments received, and public testimony presented, the Spokane Plan Commission makes the following conclusions with respect to the text amendments to lot size transition, accessory dwelling units (ADUs), and short plat notification:

1. The Plan Commission finds that the proposed amendments bear a substantial relation to the public health, safety, welfare, and protection of the environment pursuant to the requirements outlined in SMC 17G.025.010(G).
2. The proposed text amendments will implement and enact measures RCW 36.70A.600 encourages cities take in order to increase residential building capacity.
3. Interested agencies and the public have had extensive opportunities to participate throughout the process and persons desiring to comment were given an opportunity to comment.
4. SEPA review was completed for the proposal, and pursuant to SEPA, any adverse environmental impacts associated with the draft regulations will be mitigated by enforcement of the City's development regulations.
5. Plan Commission concludes that the intent of including neighborhood councils to the list of entities that receive notice of applications was to give neighborhood councils standing and the ability to advocate for their neighborhood residents. As entities with standing, neighborhood councils should assume the responsibility of proactively communicating with their residents about pertinent all-city or neighborhood-specific development applications.
6. The Plan Commission finds that the proposed amendments are consistent with the applicable provisions of the Comprehensive Plan, particularly the following adopted Shaping Spokane goals and policies:
  - a. Land Use Goal LU 1 – Citywide Land Use;
  - b. Land Use Policy LU 1.1 – Neighborhoods;
  - c. Land Use Goal LU 3 – Efficient Land Use;
  - d. Land Use Policy LU 3.6 – Compact Residential Patterns;
  - e. Housing Goal H 1 – Housing Choice and Diversity;
  - f. Housing Policy H 1.11 – Access to Transportation;
  - g. Housing Policy H 1.18 – Distribution of Housing Options;
  - h. Housing Policy H 1.20 – Accessory Dwelling Units; and
  - i. Capital Facilities and Utilities Policy CFU 4.1 – Compact Development.

**RECOMMENDATION:**

In the matter of the ordinances pertaining to lot size transition, accessory dwelling units (ADUs), and short plat notification, amending the Unified Development Code of the City of Spokane;

As based on the above listed findings and conclusions, the Spokane Plan Commission takes the following actions:

1. By a vote of six to zero, recommends to the Spokane City Council the **APPROVAL** of the proposed amendments to Section 17C.110.200, Lot Size, and 17C.110.225 Accessory Structures;
2. By a vote of six to one, recommends to the Spokane City Council the **APPROVAL WITH MODIFICATION** of the proposed amendments to Chapter 17C.300, Accessory Dwelling Units, as amended during the deliberations to include the following modification:

Strike 17C.300.120(B), Covenants, from the draft text for accessory dwelling units which requires that a covenant and deed restriction be recorded with the County Assessor for lots that contain an ADU and submit for a short-term rental application.

3. By a vote of six to one, recommends to the Spokane City Council the **APPROVAL** of the proposed amendments to Sections 17G.060.100, Notice of Application, 17G.060T.003, Table 17G.060-3 Type of Public Notice Required / Project Permit Review Process, 17G.060.130, Public Comment Period, and 17G.080.040, Short Subdivisions.
4. Authorizes the President to prepare and sign on the Commission's behalf a written decision setting forth the Plan Commission's findings, conclusions, and recommendations on the proposed amendments.



[Todd Beyreuther \(May 20, 2022 17:02 PDT\)](#)

---

**Todd Beyreuther, President**

**Spokane Plan Commission**

May 20, 2022

# 2022-05-19\_PC Findings and Conclusions\_ADUs Short Plats Lot Size

Final Audit Report

2022-05-21

Created:	2022-05-19
By:	Jackie Churchill (jchurchill@spokanecity.org)
Status:	Signed
Transaction ID:	CBJCHBCAABAAKQIyLhcEIWDG5Rz_iOjBettWnr9ZVP2h

## "2022-05-19\_PC Findings and Conclusions\_ADUs Short Plats Lot Size" History

-  Document created by Jackie Churchill (jchurchill@spokanecity.org)  
2022-05-19 - 11:44:26 PM GMT - IP address: 98.225.13.193
-  Document emailed to Todd Beyreuther (tbeyreuther@spokanecity.org) for signature  
2022-05-19 - 11:44:46 PM GMT
-  Email viewed by Todd Beyreuther (tbeyreuther@spokanecity.org)  
2022-05-20 - 11:59:32 PM GMT - IP address: 107.77.205.155
-  Document e-signed by Todd Beyreuther (tbeyreuther@spokanecity.org)  
Signature Date: 2022-05-21 - 0:02:28 AM GMT - Time Source: server- IP address: 107.77.205.155
-  Agreement completed.  
2022-05-21 - 0:02:28 AM GMT



**Agenda Sheet for City Council Meeting of:**  
06/20/2022

<b>Date Rec'd</b>	6/6/2022
<b>Clerk's File #</b>	ORD C36226
<b>Renews #</b>	
<b>Cross Ref #</b>	
<b>Project #</b>	
<b>Bid #</b>	
<b>Requisition #</b>	

<b>Submitting Dept</b>	PLANNING & ECONOMIC DEVELOPMENT
<b>Contact Name/Phone</b>	AMANDA BECK 6414
<b>Contact E-Mail</b>	ABECK@SPOKANECITY.ORG
<b>Agenda Item Type</b>	First Reading Ordinance
<b>Agenda Item Name</b>	SHAPING SPOKANE HOUSING: SHORT PLAT FEES TEXT AMENDMENT

**Agenda Wording**

An Ordinance to amend Sections 08.02.064 and 08.02.066 regarding short plat application fees. The proposal would create reduced short plat fees for some application types.

**Summary (Background)**

Shaping Spokane Housing is a result of the Spokane Housing Action Plan, also guided by Mayor Woodward's July 26, 2021, Housing Emergency Proclamation and the City Council's HAP Implementation Plan. The amendment to SMC 08.02.064 and 08.02.066 creates reduced fees for some short plat applications (subdivisions of not more than nine lots) which meet minor engineering review criteria.

Lease? NO Grant related? NO Public Works? NO

**Fiscal Impact**

Neutral	\$
Select	\$
Select	\$
Select	\$

**Budget Account**

#
#
#
#

**Approvals**

<b>Dept Head</b>	GARDNER, SPENCER
<b>Division Director</b>	MACDONALD, STEVEN
<b>Finance</b>	ORLOB, KIMBERLY
<b>Legal</b>	RICHMAN, JAMES
<b>For the Mayor</b>	ORMSBY, MICHAEL

**Council Notifications**

<b>Study Session\Other</b>	6/2 Study Session
<b>Council Sponsor</b>	CM Michael Cathcart and CM Betsy Wilkerson

**Distribution List**

jrichman@spokanecity.org
abeck@spokanecity.org
tblack@spokanecity.org
tpalmquist@spokanecity.org
sgardner@spokanecity.org
smacdonald@spokanecity.org
jchurchill@spokanecity.org

**Additional Approvals**

**Purchasing**

## ORDINANCE NO. C36226

An ORDINANCE relating to permit fees for short plats amending Spokane Municipal Code (SMC) Sections 08.02.064 and 08.02.066.

WHEREAS, RCW 36.70A.600 encourages the City to take a number of actions in order to increase its residential building capacity and authorized the City to adopt a housing action plan; and

WHEREAS, as authorized by RCW 36.70A.600(2), Council Resolution RES-2021-0062 adopted the City of Spokane Housing Action Plan as a guide for future housing planning, policy development, and regulatory and programmatic implementation measures that increase housing options that are affordable and accessible for people and families of all incomes in the City; including the Implementation Plan, included as Appendix A within the Housing Action Plan, which outlines several strategies and policies to remedy the current housing crisis; and

WHEREAS, the 2020 Housing Needs Assessment completed for the Housing Action Plan indicates several facts about the housing supply and need, particularly the need to accommodate for an estimated 6,000 additional housing units by 2037; and

WHEREAS, in adopting RES-2021-0062 the City Council outlined several code amendments and permit processes that the City should enact in support of the strategies and actions recommended in the Housing Action Plan and to encourage construction of more housing within Spokane; and

WHEREAS, on July 26, 2021, the Mayor of the City of Spokane proclaimed a housing emergency and directed the City to pursue actions to expand housing types, reduce overall development costs to increase development of affordable housing, and to streamline municipal procedures to support the development cycle; and

WHEREAS, City Council finds that the proposed amendment reduces development costs for short plat applications, and streamlines municipal processes to encourage construction of more housing, and will implement actions specified in RCW 36.70A.600(1); and

WHEREAS, City Council finds that the proposed amendment supports implementation strategies of the Spokane Housing Action Plan and recommended actions from the City Council Housing Action Plan Implementation Plan; and

WHEREAS, this action is categorically exempt from the State Environmental Policy Act (SEPA) RCW 43.21 as stated in WAC 197-11-800(19); and

WHEREAS, the City has complied with RCW 36.70A.370 in the adoption of this Ordinance, avoiding any unconstitutional taking of private property; and

WHEREAS, the City Council adopts the recitals set forth herein as its findings and conclusions in support of its adoption of this ordinance; and

NOW, THEREFORE, the City of Spokane does ordain:

Section 1. That Section 08.02.064 SMC is amended to read as follows:

**Section 08.02.064 Plats**

The fees for approvals under the subdivision code are:

- A. Long Plat Extension, Phasing, Vacation, Final or Alteration.
  - 1. For a one-year extension of time on a preliminary long plat approval: Five hundred fifty dollars.
  - ~~((2. For a five-year extension of time on a preliminary plat approval: Four thousand one hundred ninety dollars.))~~
  - ~~((3))~~2. For phasing of an approved preliminary plat: Five hundred fifty dollars.
  - ~~((4))~~3. For vacation of an approved plat: Four hundred ninety dollars.
  - ~~((5))~~4. For a final long plat: Two thousand twenty-five dollars plus twenty-five dollars per lot.
  - ~~((6))~~5. For alteration of an approved preliminary or final long plat: Eighty percent of the plat fee under this schedule.
- B. Short Plat Extension, Phasing, Vacation, Final or Alteration.
  - 1. For a one-year extension of time on a preliminary short plat approval: Five hundred fifty dollars.
  - ~~((2. For a five-year extension of time on a preliminary plat approval: Four thousand one hundred ninety dollars.))~~
  - ~~((3))~~2. For phasing of an approved preliminary short plat: Five hundred fifty dollars.
  - ~~((4))~~3. For vacation of an approved plat: Four hundred ninety dollars.
  - ~~((5))~~4. For a final short plat except short plats with minor engineering review: A filing fee of one thousand eight hundred twenty dollars plus thirty dollars per lot.

5. For a final short plat with minor engineering review: A filing fee of three hundred fifty dollars plus thirty dollars per lot.
  6. For alteration of an approved preliminary or final short plat: Eighty percent of the plat fee under this schedule.
- C. Binding Site Plan Extension, Final or Alteration.
1. For a one-year extension of time on a preliminary binding site plan approval: Five hundred fifty dollars.
  2. For a final binding site plan: Two thousand nine hundred seventy dollars plus thirty dollars for each additional acre.
  3. For alteration of an approved preliminary or final binding site plan: Eighty percent of the binding site plan fee under this schedule, plus the cost of publishing the notice of hearing in the newspaper.
- D. Boundary Line Adjustment.  
For a boundary line adjustment, a filing fee of three hundred fifty dollars.
- E. Street Name Change.  
For changing the name of an existing dedicated street: One thousand three hundred fifty-five dollars.
- F. Other Matters.
1. For any other matter not listed above that requires a public hearing before the hearing examiner: One thousand eight hundred ninety-five dollars.
  2. A fee of eighty-five dollars per hour may be charged to cover the cost of a particular planning staff service for the applicant that greatly exceeds the above fees or is not covered by the fees listed above.

Section 2. That Section 08.02.066 SMC is amended to read as follows:

### **Section 08.02.066 Zoning**

Unless an action is initiated by the city council, the fees for approvals under the zoning code are:

- A. Staff preparation of a notification district map and associated documents: One hundred fifty dollars.
- B. Type I application: One thousand eighty-five dollars. In the case of building and construction permit applications, the fee is based on Article III of this chapter.

- C. Type II application, except preliminary short plats with minor engineering review: Four thousand three hundred twenty-five dollars plus sixty dollars per each additional acre.
- D. Type II application for preliminary short plats with minor engineering review: One thousand eighty-five dollars.
- ~~((D))~~ E. Type III application: Four thousand five hundred ninety dollars plus one hundred ten dollars per each additional acre.
- ~~((E))~~ F. Site plan review and/or modification: Eight hundred fifteen dollars plus five hundred fifty dollars per each additional increment of ten acres of site or portion thereof.
- ~~((F))~~ G. Optional consolidated project review: Four thousand three hundred twenty-five dollars plus two hundred fifteen dollars for each additional acre.
- ~~((G))~~ H. Planned unit development bonus density or final planned unit development:
1. Bonus density: Additional eight hundred eighty dollars if bonus density is sought.
  2. Final planned unit development: Three thousand two hundred ninety-five dollars.
- ~~((H))~~ I. Any temporary use permit: Six hundred seventy-five dollars.
- ~~((I))~~ J. Floodplain development permit: Nine hundred dollars plus fifty-five dollars per each additional acre.
- ~~((J))~~ K. Establishment of a front yard setback that is more or less than the depth required by the zoning code: Eight hundred ten dollars.
- ~~((K))~~ L. Accessory dwelling unit permit: Six hundred fifty-five dollars.
- ~~((L))~~ ~~Accessory dwelling unit permit (Type II): One thousand dollars.~~
- ~~1. In response to the ongoing local and national housing crisis, the City Council has decided to provide relief to residents and businesses regarding accessory dwelling unit (ADU) applications by waiving the permit fee associated with the construction of ADUs on lots located at least partially within ½ mile of a Center or Corridor, Context Area, or Downtown zone or CC3 zoning overlay. Distances are measured in a straight line between the zone/overlay boundary to the lot line of the site containing the development.~~
  - ~~2. This fee waiver shall expire at 5:00 p.m. on December 31, 2024.)~~
- M. Formal written interpretation of the zoning code: Five hundred eighty dollars.
- N. Any other matter not listed above that requires a public hearing before the hearing examiner: One thousand eight hundred ninety-five dollars.



- O. A fee of eighty-five dollars per hour may be charged to cover the cost of a particular planning staff service for the applicant that greatly exceeds the above fee or is not covered by the fees listed above.
- P. Short Term Rental Permit – Type A: One hundred fifty dollars. The annual renewal for a Type A permit is one hundred dollars.
- Q. Short Term Rental Permit – Type B: Four thousand five hundred ninety dollars. The annual renewal for a Type B permit is one hundred dollars.